

A high-magnification, top-down view of a silicon microchip die. The die is a square with a complex, grid-like pattern of yellow and green circuitry. The pattern consists of numerous small, interconnected lines and rectangular blocks, representing the intricate circuitry of the chip. The overall appearance is that of a dense, organized network of microscopic components.

Signetics

Linear LSI
Data
and
Applications
Manual
1985

Linear LSI Data and Applications Manual 1985

PRODUCT STATUS DEFINITIONS

DEFINITION OF TERMS

Data Sheet Identification	Product Status	Definition
Preview	Formative or In Design	This data sheet contains the design specifications for product development. Specifications may change in any manner without notice.
Advance Information	Sampling or Pre-Production	This data sheet contains advance information and specifications are subject to change without notice.
Preliminary	First Production	This data sheet contains preliminary data and supplementary data will be published at a later date. Signetics reserves the right to make changes at any time without notice in order to improve design and supply the best possible product.
No Identification Noted	Full Production	This data sheet contains final specifications. Signetics reserves the right to make changes at any time without notice in order to improve design and supply the best possible product.

Signetics reserves the right to make changes in the products contained in this book in order to improve design or performance and to supply the best possible products. Signetics also assumes no responsibility for the use of any circuits described herein, conveys no license under any patent or other right, and makes no representations that the circuits are free from patent infringement. Applications for any integrated circuits contained in this publication are for illustration purposes only and Signetics makes no representation or warranty that such applications will be suitable for the use specified without further testing or modification. Reproduction of any portion hereof without the prior written consent of Signetics is prohibited.

PREFACE

The Linear LSI Division, one of eight Signetics divisions, is a major supplier of a broad line of linear integrated circuits ranging from high-performance designs to many of the more popular industry standard devices and custom designs.

Employing Signetics' high quality processing and screening standards, the Linear LSI Division is dedicated to providing high quality Linear products to our worldwide customers. Our full product line addresses the needs of the EDP, Automotive, Military, Industrial, Consumer, and Communications markets.

The 1985 Linear LSI Data and Applications Manual provides complete technical data on our full line of interface, communications, amplifier, power conversion and control, and TV-Video products. Among these you will find new entrants such as the TDA7000 Speech Synthesizer, NE602 and NE604 cellular radio circuits, and the NE5592 dual video amplifier.

An applications section, selector guides, and cross reference guides are also included in this volume.

Although every attempt has been made to insure accuracy of information in this manual, Signetics assumes no liability for inadvertent errors.

Your suggestions for improvement in future editions are welcome.

Signetics Linear LSI Marketing

CONTENTS

SECTION 1 — INDICES

Cross Reference Guides	1-3
By Part Number	1-3
By Company	1-5
Index to Applications	1-6
By Part Number	1-6
By Product Groups	1-7
SO Package Availability	1-9
Ordering Information	1-10

SECTION 2 — QUALITY AND RELIABILITY

Quality and Reliability	2-1
--------------------------------------	-----

SECTION 3 — MILITARY

Index	3-1
Military Products	3-3
Military Process Levels	3-3

SECTION 4 — INTERFACE/DATA CONVERSION PRODUCTS

Index	4-1	
Data Converters	4-3	
Symbols and Definitions	4-3	
Selector Guide	4-4	
Analog to Digital Converters		
*ADC0801/2/3/4/5-1	8-Bit CMOS A/D Converter	4-5
NE5034	8-Bit Hi-Speed A/D Converter	4-11
NE5036	6-Bit A/D Converter, Serial Output	4-17
NE5037	6-Bit A/D Converter, Parallel Output	4-23
Digital to Analog Converters		
AM6012	12-Bit Hi-Speed Multiplying D/A Converter	4-30
DAC08 Series	8-Bit Hi-Speed Multiplying D/A Converter	4-40
MC1508-8/1408-8/1408-7	8-Bit Multiplying D/A Converter	4-50
MC3410/3510/3410C	10-Bit Hi-Speed Multiplying D/A Converter	4-56
SE/NE5018	8-Bit Microprocessor-Compatible D/A Converter	4-63
SE/NE5019	8-Bit Microprocessor-Compatible D/A Converter	4-68
NE5020	10-Bit Microprocessor-Compatible D/A Converter	4-73
SE/NE5118	8-Bit Micro-Compatible D/A Converter—Current Output	4-81
SE/NE5119	8-Bit Micro-Compatible D/A Converter—Current Output	4-85
SE/NE5410	10-Bit Hi-Speed Multiplying D/A Converter	4-89
*TDA1540D,P	14-Bit D/A with Serial Output	4-98
Comparators		
Selector Guide	4-104	
LM111/211/311	Voltage Comparator	4-105
LM119/219/319	Dual Voltage Comparator	4-107
LM/139/A/239/A/339/A	Quad Voltage Comparator	4-112
LM193/A/293/A/393/A	Low Power Dual Voltage Comparator	4-117
LM2901	Quad Voltage Comparator	4-112
LM2903	Low Power Dual Voltage Comparator	4-117
MC3302	Quad Voltage Comparator	4-112
SE/NE521	Hi-Speed Dual Dif Comparator/Sense Amp	4-122
SE/NE522	Hi-Speed Dual Dif Comparator/Sense Amp	4-126
SE/NE527	Voltage Comparator	4-130
SE/NE529	Voltage Comparator	4-134

*New product for Linear LSI since 1983 data manual.

CONTENTS

Drivers

Symbols and Definitions		4-138
MC1488	Quad Line Driver	4-140
MC1489/A	Quad Line Receiver	4-143
NE5090	Addressable Relay Driver	4-145
NE587	LED Decoder/Driver	4-150
NE589	LED Decoder/Driver	4-158
NE590	Addressable Peripheral Driver	4-166
NE591	Addressable Peripheral Driver	4-166
SA/NE594	Vacuum Fluorescent Display Driver	4-172
*PCF2100	40-Segment LCD Duplex Driver	4-176
*PCF2110	60-Segment LCD Duplex Driver	4-184
*PCF2111	64-Segment LCD Duplex Driver	4-193
*PCF2112	32-Segment LCD Static Driver	4-201
ULN2003	High Volt./Current Darlington Transistor Array	4-208
ULN2004	High Volt./Current Darlington Transistor Array	4-208

LVDT

NE5520	LVDT Signal Conditioner	4-212
--------	-------------------------	-------

Sample and Hold

Symbols and Definitions		4-216
LF198/298/398	Monolithic Sample and Hold Circuit	4-217
SE/NE5537	Sample and Hold Amplifier	4-221

SECTION 5 — COMMUNICATION

Index

.....	5-1
-------	-----

Analog and Audio Processing

NE570	Comparator	5-3
SA/NE571	Comparator	5-3
SA/NE572	Programmable Analog Comparator	5-9

Audio/Stereo

LM1870	Stereo Demodulator with Blend	5-15
NE542	Dual Low-Noise Preamp	5-19
*SA/NE602	Double Balanced Mixer and Oscillator	5-22
*SA/NE604	Low Power Narrow Band FM I.F.	5-24
NE645/646	Dolby-B Noise Reduction Circuit	5-26
NE648/649	Low Voltage Dolby-B Noise Reduction Circuit	5-30
NE650	Dolby B-Type Noise Reduction Circuit	5-34
NE660	Dolby B-Type Noise Reduction Circuit	5-38
*TDA1074A	DC-Controlled Dual Potentiometers	5-42
*TDA1522	Stereo Cassette Preamplifier (Dual)	5-51
*TDA1524A	Stereo, DC-Controlled Audio Control	5-60
*TDA3810	Spatial, Stereo, Pseudo-Stereo Processor	5-71
μA758	FM Stereo Multiplex Decoder Phase Locked Loop	5-77

FM Radio

Consumer

CA3089	FM I.F. System	5-81
*TDA7000	Single Chip FM Radio	5-86
*TDA7010T	Single Chip FM Radio, SO Package	5-91

Professional

MC1496	Balanced Modulator/Demodulator	5-96
MC1596	Balanced Modulator/Demodulator	5-96
*SA/NE602	Double Balanced Mixer and Oscillator	5-22
*SA/NE604	Low Power Narrow Band FM I.F.	5-24

FSK Modems

*NE5080	2 Megabaud FSK Transmitter, IEEE 802.4	5-99
*NE5081	FSK Receiver, IEEE 802.4	5-103

*New product for Linear LSI since 1983 data manual.

CONTENTS

IR Remote Control Transmitters and Receivers		
*SAF1032P	Remote Control Receiver	5-107
*SAF1039P	Remote Control Transmitter	5-107
*TDA3047	IR Preamplifier	5-121
*TDA3048	IR Preamplifier	5-127
Phase Locked Loops		
Symbols and Definitions 5-133		
SE/NE564	High Frequency Phase Locked Loop	5-134
SE/NE565	Phase Locked Loop	5-141
SE/NE566	Function Generator	5-146
SE/NE567	Tone Decoder/Phase Locked Loop	5-149
Speech Synthesis		
*MEA8000	Speech Synthesizer	5-159
Telephony		
*TEA1046	Transmission Interface with DTMF	5-172
Timers		
SE/NE555/SE555C	Timer	5-185
SA/SE/NE556-1/SE556-1C	Dual Timer	5-190
SA/SE/NE558	Quad Timer with C BUS Interface	5-195
*SAF3019P	Clock/Timer with I ² C Interface	5-198
*PC8573	Clock/Timer with I ² C Interface	5-208
Video/Teletext		
*SAA5030	Teletext Video Processor	5-226
*SAA5040	Teletext Acquisition and Control Circuit	5-236
*SAA5050/55	Teletext Character Generator (U.K.)	5-255
SECTION 6 — AMPLIFIERS		
Index		6-1
Companding		
NE570	Companzor	5-3
SA/NE571	Companzor	5-3
SA/NE572	Programmable Analog Companzor	5-9
Operational		
Symbols and Definitions 6-3		
Selector Guide 6-4		
LM124/224/324/SA534	Low Power Quad Op Amplifier	6-5
LM158/258/358	Low Power Dual Operational Amplifier	6-9
MC/SA145B/MC155B	General Purpose Operational Amplifier	6-13
MC3303/3403/3503	Quad Low Power Operational Amplifier	6-18
SA/SE/NE4558	Dual General Purpose Operational Amplifier	6-22
SE/NE530	High Slew Rate Operational Amplifier	6-26
SE/NE531	High Slew Rate Operational Amplifier	6-31
SA/SE/NE532	Low Power Dual Operational Amplifier	6-9
SE/NE538	High Slew Rate Operational Amplifier	6-38
SE/NE5512	Dual High Performance Operational Amplifier	6-44
SE/NE5514	Quad High Performance Operational Amplifier	6-46
SE/NE5532/A	Internally Compensated Dual Low Noise Operational Amplifier	6-48
NE5533/A/SA/SE/NE5534/A	Single and Dual Low Noise Operational Amplifier	6-59
SE/NE5535	Dual High Slew Rate Operational Amplifier	6-65
*TCA520B,D	Operational Amplifier	6-73
μA741/741C/SA741C	General Purpose Operational Amplifier	6-79
μA747/747C/SA747C	Dual Operational Amplifier	6-84
Power		
*TDA1013A	4W Audio Amplifier with DC Volume Control	6-90
*TDA1515	24W BTL Audio Amplifier	6-94
*TDA1520A	20W Hi-Fi Audio Amplifier	6-100
Transconductance		
NE5517/A	Dual Operational Transconductance Amplifier	6-106

*New product for Linear LSI since 1983 data manual.

CONTENTS

Video

SE/NE5539	Ultra High Frequency Operational Amplifier	6-118
*NE5592	Video Amplifier	6-125
SE/NE592	Video Amplifier	6-130
μA733/C	Differential Video Amplifier	6-137

SECTION 7 — POWER CONVERSION AND CONTROL

Index		7-1
Motor Control and Sensor Circuits		
NE5044	Programmable 7-Channel RC Encoder	7-3
NE5045	Seven Channel RC Decoder	7-9
NE544	Servo Amplifier	7-14
*SAA1027	Stepper Motor Driver	7-19
Switched-Mode Power Supply Circuits		
Symbols and Definitions		7-24
SE/NE5560	SMPS Single-Ended Monolithic Controller	7-25
SE/NE5561	SMPS Low Cost Controller	7-38
*SE/NE5562	SMPS Control Circuit, Single Output	7-42
*NE5568	SMPS Controller	7-46
*SG1526A/2526A/3526A	SMPS Control Circuits	7-48
SG3524	SMPS Push-Pull Controller	7-52
μA723/C/SA723C	Precision Voltage Regulator	7-57
Triac Control Circuits		
*TDA1023	Proportional Control Triac Triggering Circuit	7-62
*TDA1024	On-Off Triac Triggering Circuit	7-75

SECTION 8 — TV-VIDEO

Index		8-1
Digital Tuning System		
*SAB3035	FLL Tuning Circuit; Eight DACs	8-3
*SAB3036	FLL Tuning Circuit; No DACs	8-19
*SAB3037	FLL Tuning Circuit; Four DACs	8-35
Video Circuits		
*TDA2540	Video I.F. Amplifier Demodulator, AFT, NPN Tuners	8-51
*TDA2541	Video I.F. Amplifier Demodulator, AFT, PNP Tuners	8-59
*TDA2546A	Quasi Split Sound I.F. with Sound Demodulator	8-67
*TDA2577A	Sync Circuit with Vertical Oscillator and Driver, Negative/Positive Horizontal Output	8-72
*TDA2578A	Sync Circuit with Vertical Oscillator and Driver, Negative/Positive Horizontal Output	8-86
*TDA2593	Horizontal Combination	8-100
*TDA2594	Horizontal Combination with Transmitter I.D.	8-107
*TDA2595	Horizontal Combination with Sync Separator at 50% Amplitude (High Performance)	8-114
*TDA2653A	Vertical Deflection	8-123
*TDA3540/41	Video I.F./AFT	8-131
*TDA3651A/AQ	Vertical Deflection	8-141
*TDA3652	Vertical Deflection	8-149
*TDA4503	Small Signal Combination for B/W TV	8-154
*TDA4560	CTI (Color Transient Improvement Circuit)	8-165

SECTION 9 — APPLICATIONS

Index		9-1
Interface		
Data Conversion		
AN100	An Overview of Data Converters	9-3
AN101	Basic DACs	9-8
AN105	Digital Attenuator	9-15
AN106	Using the DAC08 Without a Negative Supply	9-16
AN109	Microprocessor Compatible DACs	9-17
Drivers		
AN112	LED Decoder Drivers: Using the NE587 and NE589	9-24
AN113	Applications Using the MC1488/1489 Line Drivers and Receivers	9-30

*New product for Linear LSI since 1983 data manual.

CONTENTS

Comparators		
AN116	Applications for the NE521/522/527/529	9-33
Signal Conditioner		
AN118	LVDT Signal Conditioner: Applications Using the NE5520	9-41
Communications		
Timers		
AN170	NE555 and NE556 Applications	9-57
AN171	NE558 Applications	9-74
Phase Locked Loops		
AN177	An Overview of Phase Locked Loops (PLL)	9-79
AN178	Modeling the PLL	9-84
AN179	Circuit Description of the NE564	9-100
AN180	The NE564: Frequency Synthesis	9-105
AN181	A 6MHz FSK Converter Design Example for the NE564	9-110
AN182	Clock Regenerator with Crystal Controlled Phase Locked VCO	9-112
AN183	Circuit Description of the NE565	9-121
AN184	Typical Applications with NE565	9-125
AN185	Circuit Description of the NE566	9-128
AN186	Waveform Generators with the NE566	9-129
AN187	Circuit Description of the NE567 Tone Decoder	9-132
AN188	Selected Circuits Using the NE567	9-137
AN189	Balanced Modulator/Demodulator Applications Using the MC1496/MC1596	9-140
AN190	Applications of Low Noise Stereo Amplifiers: NE542	9-145
AN191	Stereo Decoder Applications Using the μ A758	9-148
Compandors		
AN174	Applications for Compandors: NE570/571/SA571	9-156
AN175	Automatic Level Control: NE572	9-165
AN176	Compandor Cookbook	9-166
FSK Modems		
AN195	Applications Using the NE5080, NE5081	9-173
Amplifiers		
Operational Amplifiers		
AN165	Integrated Operational Amplifier Theory	9-181
AN166	Basic Feedback Theory	9-188
AN142	Audio Circuits Using the NE5532/33/34	9-192
AN143	Applications Using the SE/NE5535	9-200
AN150	Applications for the NE538	9-203
AN151	Applications for the NE531	9-204
AN160	Applications for the MC3403	9-205
AN144	Applications for the NE5512 and NE5514	9-208
AN145	NE5517: General Description and Applications for Use with the NE5517/A Transconductance Amplifier	9-214
AN164	Explanation of Noise	9-217
Video Amplifiers		
AN141	Using the NE592/5592 Video Amplifier	9-226
AN140	Compensation Techniques for Use with the SE/NE5539	9-231
Power Conversion and Control		
Switched Mode Power Supplies (SMPS)		
AN120	An Overview of SMPS	9-237
AN121	Forward Converter Application Using the NE5560	9-242
AN122	NE5560 Push-Pull Regulation Application	9-243
AN123	NE5561 Applications	9-245
AN124	External Synchronization for the NE5561	9-249
AN126	Applications Using the SG3524	9-250
Control Circuits		
AN131	Applications Using the NE5044 Encoder	9-252
AN132	Applications Using the NE5045 Decoder	9-254
AN133	Applications Using the NE544 Servo Amplifier	9-256
AN134	Computer Controlled Robotics Applications	9-261

CONTENTS

SECTION 10 — PACKAGE INFORMATION

Index	10-1	
Package Outlines for product with prefixes: ADC, AM, CA, DAC, LF, LM, MC, NE, SA, SE, SG, μ A, ULN		
D	SO Plastic Dual-In-Line	10-3
E	Metal Headers	10-5
F	Hermetic Cerdip	10-7
H	Metal Headers	10-8
I	Hermetic Side Braze	10-11
N	Plastic Dual-In-Line	10-11
Package Outlines for product with prefixes: OM, MAB, MAF, PC, PN, SAA, SAB, SAF, TA, TB, TC, TD, TE	10-12	
Soldering Notes	10-16	
8-Lead Dual-In-Line; Plastic (SOT-97A)	10-16	
8-Lead Dual-In-Line; Ceramic (CERDIP) (SOT-151A)	10-16	
8-Lead Dual-In-Line; Metal Ceramic (CERDIL) (SOT-153B)	10-17	
9-Lead Single-In-Line; Plastic (SOT-110B)	10-17	
9-Lead Single-In-Line; Plastic Power (SOT-131A, B)	10-18	
9-Lead Single-In-Line; Plastic (SOT-142)	10-18	
9-Lead Sil-Bent-To-Dil; Plastic Power (SOT-157B)	10-19	
12-Lead Dual-In-Line; Plastic With Metal Cooling Fin (SOT-150)	10-19	
13-Lead Sil-Bent-To-Dil; Plastic Power (SOT-141B)	10-20	
14-Lead Dual-In-Line; Plastic (SOT-27K, M, T)	10-20	
14-Lead Dual-In-Line; Ceramic (CERDIP) (SOT-73A, B, C)	10-21	
14-Lead Dual-In-Line; Metal Ceramic (CERDIL) (SOT-83B)	10-21	
16-Lead Dual-In-Line; Plastic (SOT-38)	10-22	
16-Lead Dual-In-Line; Plastic (SOT-38A)	10-22	
16-Lead Dual-In-Line; Plastic (SOT-38D, DE)	10-23	
16-Lead Dual-In-Line; Plastic (SOT-38Z)	10-23	
16-Lead Dual-In-Line; Plastic With Internal Heat Spreader (SOT-38 WE-2)	10-24	
16-Lead Quadruple-In-Line; Plastic (SOT-58)	10-24	
16-Lead Dual-In-Line; Ceramic (CERDIP) (SOT-74A, B, C)	10-25	
16-Lead Dual-In-Line; Metal Ceramic (CERDIL) (SOT-84B)	10-25	
18-Lead Dual-In-Line; Metal Ceramic (CERDIL) (SOT-85B)	10-26	
18-Lead Dual-In-Line; Plastic (SOT-102A)	10-26	
18-Lead Dual-In-Line; Plastic (SOT-102C)	10-27	
18-Lead Dual-In-Line; Plastic (SOT-102CS)	10-27	
18-Lead Dual-In-Line; Plastic (SOT-102G)	10-28	
18-Lead Dual-In-Line; Ceramic (CERDIP) (SOT-133A, B)	10-28	
20-Lead Dual-In-Line; Plastic (SOT-146)	10-29	
20-Lead Dual-In-Line; Ceramic (CERDIP) (SOT-152B, C)	10-29	
20-Lead Dual-In-Line; Metal Ceramic (CERDIL) (SOT-154B)	10-30	
22-Lead Dual-In-Line; Plastic (SOT-116)	10-30	
22-Lead Dual-In-Line; Metal Ceramic (CERDIL) (SOT-118B)	10-31	
22-Lead Dual-In-Line; Ceramic (CERDIP) (SOT-134A)	10-31	
24-Lead Dual-In-Line; Metal Ceramic (CERDIL) (SOT-86A)	10-32	
24-Lead Dual-In-Line; Ceramic (CERDIP) (SOT-94)	10-32	
24-Lead Dual-In-Line; Plastic With Internal Heat Spreader (SOT-101A, B)	10-33	
28-Lead Dual-In-Line; Metal Ceramic (CERDIL) (SOT-87A)	10-33	
28-Lead Dual-In-Line; Metal Ceramic (CERDIL) (SOT-87B)	10-34	
28-Lead Dual-In-Line; Plastic (SOT-117)	10-34	
28-Lead Dual-In-Line; Plastic (SOT-117D)	10-35	
28-Lead Dual-In-Line; Ceramic (CERDIP) (SOT-135A)	10-35	
40-Lead Dual-In-Line; Metal Ceramic (CERDIL) (SOT-88)	10-36	
40-Lead Dual-In-Line; Metal Ceramic (CERDIL) (SOT-88B)	10-36	
40-Lead Dual-In-Line; Plastic (SOT-129)	10-37	
40-Lead Dual-In-Line; Ceramic (CERDIP) (SOT-145)	10-37	
Microminiature Package Outlines		
8-Lead Mini-Pack; Plastic (SO-8, SOT-96A)	10-38	
8-Lead Mini-Pack; Plastic (VSO-8, SOT-176)	10-39	
14-Lead Mini-Pack; Plastic (SO-14, SOT-108A)	10-39	
16-Lead Mini-Pack; Plastic (SO-16, SOT-109A)	10-39	

CONTENTS

Microminiature Package Outlines Con't

16-Lead Mini-Pack; Plastic (SO-16L, SOT-162A)	10-40
20-Lead Mini-Pack; Plastic (SO-20, SOT-163A)	10-40
24-Lead Mini-Pack; Plastic (SO-24, SOT-137A)	10-41
28-Lead Mini-Pack; Plastic (SO-28, SOT-136A)	10-41
40-Lead Mini-Pack; Plastic (VSO-40, SOT-158A)	10-42
40-Lead Mini-Pack; Plastic (Opposite Bent Leads) (VSO-40, SOT-158B)	10-42

SECTION 11 — SALES OFFICES

NOTES

Section 1 Indices

INDEX

SECTION 1 — INDICES

Cross Reference Guides	1-3
By Part Number	1-3
By Company	1-5
Index to Applications	1-6
By Part Number	1-6
By Product Groups	1-7
SO Package Availability	1-9
Ordering Information	1-10

CROSS REFERENCE BY PART NUMBER

1

PART NUMBER	COMPANY	SIGNETICS
DAC 08	PMI	DAC08E, N
DAC 0800LCN	NSC	MC1408-8N
AMDAC 08	AMD	DAC08C, E
LMDAC 08	NSC	DAC08
LM 1011/1111	NSC	NE645/646
LF 111	NSC	LM111
LM 111	AMD, MOTO, NSC, TI	LM111
μA 111	FSC	LM111
LM 119	AMD, NSC	LM119
LM 124	MOTO, NSC, TI	LM124
μA 124	FSC	LM124
LM 13600	NSC	LM13600
LM 13600A	NSC	LM13600A
LM 139	AMD, NSC, TI	LM139
μA 139	FSC	LM139
DAC 1408	PMI	MC1408
LM 1408	NSC	MC1408
SSS 1408A	AMD	MC1408-7
DAC 1408-7	PMI	MC1408-7
MC 1408-7	MOTO	MC1408-7
MC 1408-8	MOTO	MC1408-8
MC 1413	MOTO	ULN2003
MC 1416	MOTO	ULN2004
MC 1455	MOTO	NE555
AM 1458	AMD	MC1458
LM 1458	NSC	MC1458
MC 1458	MOTO, TI	MC1458
μA 1458	FSC	MC1458
μPC 1458	NEC	MC1458
DS 1488	NSC	MC1488
MC 1488	MOTO, TI	MC1488
μA 1488	FSC	MC1488
DS 1489/A	NSC	MC1489/A
MC 1489/A	MOTO	MC1489/A
μA 1489/A	FSC	MC1489/A
LM 1496	NSC	MC1496
MC 1496	MOTO	MC1496
SSS 1508A	AMD	MC1508
AM 1508-8	AMD	MC1508-8
LM 1508-8	NSC	MC1508-8
MC 1508-8	MOTO	MC1508-8
LM 1558	NSC	MC1558
MC 1558	MOTO, TI	MC1558
PM 1558	PMI	MC1558
μA 1558	FSC	MC1558
LM 158	MOTO, NSC, TI	LM158
LM 1596	NSC	MC1596
LM 161	NSC	SE529
MC 1596	MOTO	MC1596
MC 1723/C	MOTO	μA723/C
MC 1733	MOTO	μA733
MC 1747/C	MOTO	μA747/C
LM 1870	NSC	LM1870
LM 193	NSC, TI	LM193
μA 193	FSC	LM139

PART NUMBER	COMPANY	SIGNETICS
ULN 2003A	SPRAGUE, TI	ULN2003
ULN 2004A	SPRAGUE, TI	ULN2004
LM 211	AMD, MOTO, NSC, TI	LM211
μA 211	FSC	LM211
LM 219	AMD, NSC	LM219
LM 224	MOTO, NSC, TI	LM224
LM 239	TI	LM239
LM 239/A	MOTO, NSC	LM239/A
PM 239/A	PMI	LM239/A
LM 258	MOTO, NSC, TI	LM258
LM 2901	MOTO, NSC, TI	LM2901
μA 2901	FSC	LM2901
LM 2903	NSC, TI	LM2903
μA 2903	FSC	LM 2903
LM 2904	NSC	SA532
LM 293	NSC, TI	LM293
LM 3089	NSC	CA3089
TCA 3089	SPRAGUE	CA3089
LM 311	AMD, INTERSIL, MOTO, NSC, TI	LM311
TL 311	TI	LM311
μA 311	FSC	LM311
μPC 311	NEC	LM311
LM 319	AMD, NSC	LM319
LM 324	INTERFIL, MOTO, NSC, TI	LM324
μA 324	FSC	LM324
μP C324	NEC	LM324
MC 3302	MOTO	MC3302
MC 3303	MOTO, TI	MC3303
μA 3303	FSC	MC3303
ULN 3304	SPRAGUE	NE555
LM 339/A	MOTO, NSC, TI	LM339/A
μA 339/A	FSC	LM339/A
μP C339	NEC	LM339
MC 3403	MOTO	MC3403
MC 3410/C	MOTO	MC3410/C
MC 3456	MOTO	NE556
MC 3503	MOTO	MC3503
MC 3510	MOTO	MC3510
LM 3524	NSC	SG3524
SG 3524	TI	SG3524
LM 358	MOTO, NSC, TI	LM358
μPC 358	NEC	LM358
LM 361	NSC	NE529
LM 387	NSC	NE542
LM 393/A	NSC, TI	LM393/A
μPC 393	NEC	LM393
LF 398	AMD, NSC	LF398
μA 398	FSC	LF398
μPC 398	NEC	LF398
μPC 4558	NEC	NE4558
RC 4558	TI	NE4558
TL 494	MOTO, TI	NE5561
μA 494	FSC	NE5561
SN 5520	TI	NE5520
NE 5532/A	TI	NE5532/A

CROSS REFERENCE BY PART NUMBER Continued

PART NUMBER	COMPANY	SIGNETICS
SE/NE 5534/A	TI	SE/NE5534/A
NE 555	INTERSIL, MOTO, TI	NE555
LM 555/C	NSC	NE555
μA 555	FSC	NE555
LM 556	NSC	NE556
NE 556	INTERSIL, MOTO, TI	NE556
μA 556	FSC	NE556
μPC 558	NEC	NE558
LM 565	MOTO, NSC	NE565
LM 566	NSC	NE566
μPC 566	NEC	NE566
LM 567	NSC	NE567
NE 592	MOTO	NE592
TL 594	TI	NE594
AM 6012	AMD	AM6012
μPC 6012	NEC	AM6012
UDN 6116-2	SPRAGUE	SA594
UDN 6128	SPRAGUE	NE594
LM 723/C	MOTO, NSC	μA723/C
μA 723	INTERSIL, FSC, TI	μA723

PART NUMBER	COMPANY	SIGNETICS
LM 733	NSC	μA733
μA 733/C	INTERSIL, FSC, TI	μA733/C
ICL 741	INTERSIL	μA741C
LM 741	MOTO, NSC	μA741
PM 741/C	PMI	μA741/C
μPC 741	NEC	μA741
μA 741	FSC, TI	μA741
SSS 741	AMD	μA741
LM 747	NSC	μA747
PM 747/C	PMI	μA747C
SSS 747	AMD	μA747
μA 747	FSC, MOTO, TI	μA747
LM 748	NSC	μA748
μA 748	FSC, TI	μA748
μA 758	MOTO, NSC	μA758
ULN 8160	SPRAGUE	NE5560
ULN 8161	SPRAGUE	NE5561
SN 7588	TI	MC1488
SN 7589/A	TI	MC1489/A
SN 76689	TI	CA3089

CROSS REFERENCE BY COMPANY

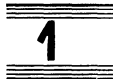

AMD	SIGNETICS
AM 1508 AM 6012 AMDAC 08 LF 398 LM 111	MC 1508 AM 6012 DAC-08C,E NE 5537 LM 111
LM 119 LM 139 LM 211 LM 311 LM 319	LM 119 LM 139 LM 211 LM 311 LM 319
SSS 1408A SSS 1508A SSS 741 SSS 747	MC 1408 MC 1508 μ A 741 μ A 747
FAIRCHILD	SIGNETICS
μ A 111 μ A 124 μ A 139 μ A 1458 μ A 1488	LM 111 LM 124 LM 139 MC 1458 MC 1488
μ A 1558 μ A 193 μ A 2901 μ A 2903 μ A 301A	MC 1558 LM 193 LM 2901 LM 2903 LM 301A
μ A 311 μ A 324 μ A 3303 μ A 339 μ A 398	LM 311 LM 324 MC 3303 LM 339 LF 398
μ A 494 μ A 555 μ A 556 μ A 723 μ A 733	NE 5561 NE 555 NE 556 μ A 723 μ A 733
μ A 741 μ A 747 μ A 748 μ A 758 μ A F111	μ A 741 μ A 747 μ A 748 μ A 758 LM 111
μ A F211 μ A F311	LM 211 LM 311
INTERSIL	SIGNETICS
ICL 741 LM 311 LM 324 NE 555 NE 556	μ A 741C LM 311 LM 324 NE 555 NE 556
MOTOROLA	SIGNETICS
LM 111 LM 124 LM 139 LM 158 LM 211	LM 111 LM 124 LM 139 LM 158 LM 211
LM 224 LM 239 LM 258 LM 2901 LM 311	LM 224 LM 239 LM 258 LM 2901 LM 311
LM 324 LM 339 LM 358 LM 565 LM 723C	LM 324 LM 339 LM 358 NE 565 μ A 723C

MOTOROLA	SIGNETICS
LM 741C MC 1408 MC 1413 MC 1416 MC 1455	μ A 741C MC 1408 ULN 2003 ULN 2004 NE 555
MC 1458 MC 1488 MC 1489 MC 1489A MC 1508	MC 1458 MC 1488 MC 1489 MC 1489A MC 1508
MC 1558 MC 1596 MC 1723 MC 1723C MC 1733	MC 1558 MC 1596 μ A 723 μ A 723C μ A 733
MC 1747 MC 1747C MC 3302 MC 3303 MC 3403	μ A 747 μ A 747C MC 3302 MC 3303 MC 3403
MC 3410 MC 3456 MC 3503 MC 3510 NE 555	MC 3410 NE 556 MC 3503 MC 3510 NE 555
NE 556 NE 565 NE 592 SE 592 TL 494	NE 556 NE 565 NE 592 SE 592 NE 5561
μ A 723 μ A 741 μ A 747 μ A 758	μ A 723 μ A 741 μ A 747C μ A 758/A
NATIONAL	SIGNETICS
DAC 0800- LCN	DAC 08EN
DAC 0807 DAC 0808 DAC 0808CN DAC 0808LD DS 1488	MC 1408-7 MC 1408-8 MC 1408-8N MC 1508 MC 1488
DS 1489 LF 111 LF 211 LF 311 LF 398	MC 1489 LM 111 LM 211 LM 311 LF 398/ NE 5537
LM 1011/ 1111 LM 111 LM 119 LM 124 LM 13600	NE 645/646 LM 111 LM 119 LM 124 LM 13600
LM 13700 LM 139 LM 1408 LM 1458 LM 1496	NE 5517 LM 139 MC 1408 MC 1458 MC 1496
LM 1508 LM 1558 LM 158 LM 1596 LM 161	MC 1508 MC 1558 LM 158 MC 1596 SE 529

NATIONAL	SIGNETICS
LM 1870 LM 193 LM 211 LM 219 LM 224	LM 1870 LM 193 LM 211 LM 219 LM 224
LM 239 LM 258 LM 2901 LM 2903 LM 2904	LM 239 LM 258 LM 2901 LM 2903 SA 532
LM 293 LM 3089 LM 311 LM 319 LM 324	LM 293 CA 3089 LM 311 LM 319 LM 324
LM 339 LM 3524 LM 358 LM 361 LM 387	LM 339 SG 3524 NE 532 NE 529 NE 542
LM 393 MC 555 LM 555C LM 556 LM 565	LM 393 NE 555 NE 555 NE 556 NE 565
LM 566 LM 567 LM 723 LM 733 LM 741	NE 566 NE 567 μ A 723 μ A 733 μ A 741
LM 747 LM 748 LMDAC 08 μ A 758	μ A 747 μ A 748 DAC 08 μ A 758/A
NEC	SIGNETICS
μ PC 1458 μ PC 1555 μ PC 311 μ PC 324 μ PC 339	MC 1458 NE 555 LM 311 LM 324 LM 339
μ PC 358 μ PC 393 μ PC 398	LM 358 LM 393 LF 398/ NE 5537
μ PC 4558 μ PC 558	NE 4558 NE 558
μ PC 566 μ PC 6012 μ PC 624 μ PC 741	NE 566 AM 6012 DAC 08C,E μ A 741C
PMI	SIGNETICS
CMP 04FP DAC 08 DAC 1408A DAC 312 OP 220	LM 339 DAC 08C,E MC 1408 AM 6012 LM 358
PM 1558 PM 239/A PM 741C PM 747C	MC 1558 LM 239/A μ A 741C μ A 747C

SPRAGUE	SIGNETICS
TCA 3089 UDN 6116-2 ULN 6128 ULN 2003 ULN 2004	CA 3089 SA 594 NE 594 ULN 2003 ULN 2004
ULN 2151 ULN 3304 ULN 8160 ULN 8161	μ A 741 NE 555 NE 5560 NE 5561
TI	SIGNETICS
LF 398 LM 111 LM 124 LM 139 LM 1458	LF 398 LM 111 LM 124 LM 139 MC 1458
LM 158 LM 193 LM 211 LM 224 LM 239	LM 158 LM 193 LM 211 LM 224 LM 239
LM 258 LM 2901 LM 2903 LM 293 LM 311	LM 258 LM 2901 LM 2903 LM 293 LM 311
LM 324 LM 339 LM 358 LM 393 LM 1458	LM 324 LM 339 LM 358 LM 393 MC 1458
MC 1558 NE 5532 NE 5532A NE 5534 NE 5534A	MC 1558 NE 5532 NE 5532A NE 5534 NE 5534A
NE 555 NE 556 RC 4558 SE 5534 SE 5534A	NE 555 NE 556 NE 4558 SE 5534 SE 5534A
SE 555 SE 556 SG 3524 SN 5520 SN 7588	SE 555 SE 556 SG 3524 NE 5520 MC 1488
SN 7589 SN 76689 TL 311 TL 494	MC 1489 MC 1489A CA 3089 LM 311 NE 5561
TL 594 μ A 723 μ A 733 μ A 741 μ A 747	NE 594 μ A 723 μ A 733 μ A 741 μ A 747
μ A 748 ULN 2003A ULN 2004A	μ A 748 ULN 2003 ULN 2004

APPLICATIONS BY PART NUMBER

DAC 08	AN106: Using the DAC 08 without a Negative Supply
MC 1488/1489	AN113: Applications Using the MC1488/1489 Line Drivers and Receivers
MC 1496/1596	AN189: Balanced Modulator/Demodulator Applications Using the MC1496/MC1596
MC 3403	AN160: Applications for the MC3403
SG 3524	AN126: Applications Using the SG3524
NE 5080/5081	AN195: Applications Using the NE5080, NE5081
NE 521	AN116: Applications for the NE521/522/527/529
NE 522	AN116: Applications for the NE521/522/527/529
NE 527	AN116: Applications for the NE521/522/527/529
NE 529	AN116: Applications for the NE521/522/527/529
NE 531	AN151: Applications for the NE531
NE 538	AN150: Applications for the NE538
NE 542	AN190: Applications of Low Noise Stereo Amplifiers: NE542
NE 544	AN133: Applications Using the NE544 Servo Amplifier
NE 555	AN170: NE555 and NE556 Applications
NE 556	AN170: NE555 and NE556 Applications
NE 558	AN171: NE558 Applications
NE 564	AN179: Circuit Description of the NE564
	AN180: The NE564: Frequency Synthesis
	AN182: Clock Regenerator with Crystal Controlled Phase Locked VCO
	AN181: A 6MHz FSK Converter Design Example for the NE564
NE 565	AN183: Circuit Description of the NE565
	AN184: FSK Demodulator with NE565
NE 566	AN185: Circuit Description of the NE566
	AN186: Waveform Generators with the NE566
NE 567	AN187: Circuit Description of the NE567 Tone Decoder
	AN188: Selected Circuits Using the NE567
NE 570/571/SA571	AN174: Applications for Companders: NE570/571/SA571
NE 572	AN175: Automatic Level Control: NE572
NE 587/589	AN112: LED Decoder Drivers: Using the NE587 and NE589
NE 592/5592	AN141: Using the NE592/5592 Video Amplifier
NE 5044	AN131: Applications Using the NE5044 Encoder
NE 5045	AN132: Applications Using the NE5045 Decoder
NE 5512/5514	AN144: Applications for the NE5512 and NE5514
NE 5517	AN145: NE5517: General Description and Applications for Use with the NE5517/A Transconductance Amplifier
NE 5520	AN118: LVDT Signal Conditioner: Applications Using the NE5520
NE 5532/33/34	AN142: Audio Circuits Using the NE5532/33/34
NE 5535	AN143: Applications Using the SE/NE5535
NE 5539	AN140: Compensation Techniques for Use with the SE/NE5539
NE 5560	AN121: Forward Converter Application Using the NE5560
	AN122: NE5560 Push-Pull Regulator Application
NE 5561	AN123: NE5561 Applications
	AN124: External Synchronization for the NE5561
μ A 758	AN191: Stereo Decoder Applications Using the μ A758

APPLICATIONS BY PRODUCT GROUPS

INTERFACE**Data Conversion**

AN100	An Overview of Data Converters
AN101	Basic DACs
AN105	Digital Attenuator
AN106	Using the DAC-08 without a Negative Supply
AN109	Microprocessor Compatible DACs

Drivers

AN112	LED Decoder Drivers: Using the NE587 and NE589
AN113	Applications Using the MC1488/1489 Line Drivers and Receivers

Comparators

AN116	Applications for the NE521/522/527/529
-------	--

Signal Conditioner

AN118	LVDT Signal Conditioner: Applications Using the NE5520
-------	--

COMMUNICATIONS**Timers**

AN170	NE555 and NE556 Applications
AN171	NE558 Applications

Phase Locked Loops

AN177	An Overview of Phase Locked Loops (PLL)
AN178	Modeling the PLL
AN179	Circuit Description of the NE564
AN180	The NE564: Frequency Synthesis
AN181	A 6MHz FSK Converter Design Example for the NE564
AN182	Clock Regenerator with Crystal Controlled Phase Locked VCO
AN183	Circuit Description of the NE565
AN184	FSK Demodulator with NE565
AN185	Circuit Description of the NE566
AN186	Waveform Generators
AN187	Circuit Description of the NE567 Tone Decoder
AN188	Selected Circuits Using the NE567
AN189	Balanced Modulator/Demodulator Applications Using the MC1496/MC1596
AN190	Applications of Low Noise Stereo Amplifiers: NE542
AN191	Stereo Decoder Applications Using the μ A758

Compandors

AN174	Applications for Compandors: NE570/571/SA571
AN175	Automatic Level Control: NE572
AN176	Compandor Cookbook

FSK Modems

AN195	Applications Using the NE5080, NE5081
-------	---------------------------------------

AMPLIFIERS**Operational Amplifiers**

AN165	Integrated Operational Amplifier Theory
AN166	Basic Feedback Theory
AN142	Audio Circuits Using the NE5532/33/34
AN143	Applications Using the SE/NE5535
AN150	Applications for the NE538
AN151	Applications for the NE531
AN160	Applications for the MC3403
AN144	Applications for the NE5512 and NE5514
AN145	NE5517: General Description and Applications for Use with the NE5517/A
	Transconductance Amplifier
AN164	Explanation of Noise

Video Amplifiers

AN141	Using the NE592/5592 Video Amplifier
AN140	Compensation Techniques for Use with the SE/NE5539

APPLICATIONS BY PRODUCT GROUPS

POWER CONVERSION AND CONTROL

Switched Mode Power Supplies (SMPS)

AN120
AN121
AN122
AN123
AN124
AN126

An Overview of SMPS
Forward Converter Application Using the NE5560
NE5560 Push-Pull Regulator Application
NE5561 Applications
External Synchronization for the NE5561
Applications Using the SG3524

Control Circuits

AN131
AN132
AN133
AN134

Applications Using the NE5044 Encoder
Applications Using the NE5045 Decoder
Applications Using the NE544 Servo Amplifier
Computer Controlled Robotics Applications

S.O. PACKAGE AVAILABILITY

LINEAR LSI DEVICES CURRENTLY AVAILABLE IN S.O. PACKAGE

1

For information regarding additional SO products released since the publication of this document, contact your local Signetics sales office.

³ DAC-08E	SO-16	NE555	SO-8
³ LF398	SOL-14	NE556	SO-14
LM1870D	SOL-20	NE5560	SO-16
LM311	SO-8	NE5561	SO-8
LM319	SO-14	NE5568	SO-8
LM324	SO-14	¹ NE558	SOL-16
LM339	SO-14	NE5592	SO-14
LM358	SO-8	NE564	SO-16
LM393	SO-8	³ NE565	SO-14
³ MC1408-8	SO-16	NE566	SO-8
MC1458	SO-8	NE567	SO-8
MC1488	SO-14	¹ NE571	SOL-16
MC1489	SO-14	NE572	SO-16
MC1489A	SO-14	² NE587	SOL-20
MC3302	SO-14	² NE589	SOL-20
MC3403	SO-14	NE592	SO-8
NE4558	SO-8	NE592	SO-14
² NE5018	SOL-24	NE592H	SO-8
³ NE5036	SO-14	NE592H	SO-14
NE5037	SO-16	¹ NE594	SOL-20
NE5044	SO-16	NE602	SO-8
NE5045	SO-16	NE604	SO-16
¹ NE5090	SOL-16	¹ NE660	SOL-20
NE521	SO-14	PCF2100	SO-28
NE522	SO-14	PCF2110T	VSO-40
NE527	SO-14	PCF2111T	VSO-40
NE529	SO-14	PCF2112T	VSO-40
NE532	SO-8	SA571	SO-16
³ NE5512	SO-8	SA572	SO-16
² NE5514	SOL-16	SA602	SO-8
NE5517	SO-16	SA604	SO-16
¹ NE5520	SOL-16	SG3524	SO-16
¹ NE5532	SOL-16	TDA7010T	SO-16
NE5534A	SO-8	μ A723C	SO-14
NE5534	SO-8	μ A741C	SO-8
³ NE5537	SO-14	μ A747C	SO-14
NE5539	SO-14	ULN2003	SO-16
		ULN2004	SO-16

NOTES:

1. SOL released in large SO package only.
2. SOL and non-standard pinout.
3. SO and non-standard pinout.

ORDERING INFORMATION

For Prefixes AM, CA, DAC, LF, LM, MC, NE, SA, SE, SG, μ A and ULN

ORDERING INFORMATION

Signetics' Linear LSI integrated circuit products may be ordered by contacting either the local Signetics sales office, Signetics representatives and/or Signetics authorized distributors. A complete listing is located in the back of this manual.

Minimum Factory Order:

Commercial Product:
 \$1000 per order
 \$250 per line item per order

Military Product:
 \$250 per line item per order

Table 1 provides part number information concerning Signetics originated products.

Table 2 is a cross reference of both the old and new package suffixes for all presently existing types, while Tables 3 and 4 provide appropriate explanations on the various prefixes employed in the part number descriptions.

As noted in Table 3, Signetics defines device operating temperature range by the appropriate prefix. It should be noted, however, that devices with a SE prefix (-55°C to $+125^{\circ}\text{C}$) indicates only its operating temperature range and *not* its military qualification status. The military qualification status of any Linear LSI product can be determined by either looking in the Military Section in this manual and/or contacting your local sales office.

Table 1 PART NUMBER DESCRIPTION

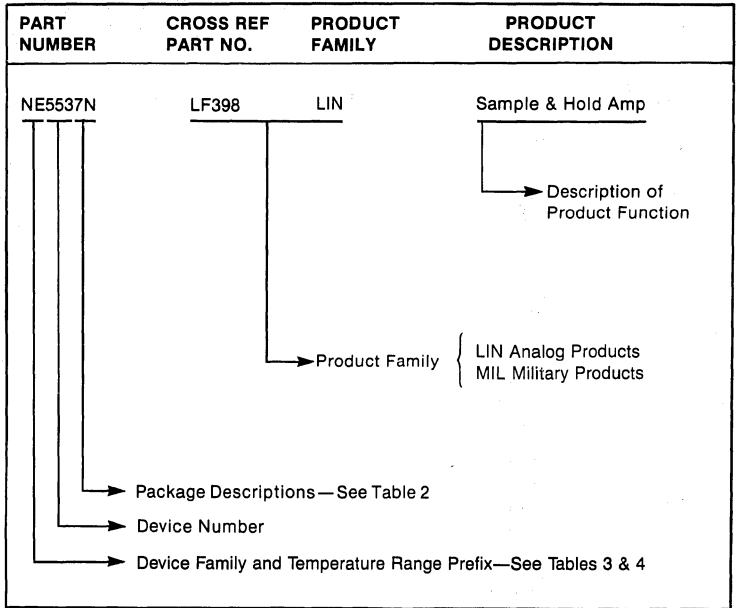

Table 2 PACKAGE DESCRIPTIONS

Old	New	PACKAGE DESCRIPTION
A,AA	N	14-lead plastic DIL
A	N-14	14-lead plastic DIL (Selected Analog products only)
B,BA	N	16-lead plastic DIL
-	D	Microminiature package (SO)
F	F	14, 16, 18, 22 and 24-lead ceramic (Cerdip) DIL
I,IK	I	14, 16, 18, 22, 28 and 4-lead ceramic DIL
K	H	10-lead TO-100
L	H	10-lead high-profile TO-100 can
NA,NX	N	24-lead plastic DIL
Q,R	Q	10, 14, 16 and 24-lead ceramic flat
T,TA	H	8-lead TO-99
U	U	SIL Plastic power
V	N	8-lead plastic DIL
XA	N	18-lead plastic DIL
XC	N	20-lead plastic DIL
XC	N	22-lead plastic DIL
XL,XF	N	28-lead plastic DIL

Table 3 SIGNETICS PREFIX AND DEVICE TEMPERATURE

PREFIX	DEVICE TEMPERATURE RANGE
N	0° to +70°C
S	-55° to +125°C
NE	0° to +70°C
SE	-55° to +125°C
SA	-40° to +85°C

Table 4 INDUSTRY STANDARD PREFIX

PREFIX	DEVICE FAMILY
AM	Linear Industry Standard
CA	Linear Industry Standard
DAC	Linear Industry Standard
JB	Mil Rel—Jan Qualified—Old Designator
JM	Mil Rel—Jan Qualified—New Designator
LF	Linear Industry Standard
LM	Linear Industry Standard
M	Mil Rel—Jan Processed
MC	Linear Industry Standard
NE	Linear Industry Standard
SA	Linear Industry Standard
SE	Linear Industry Standard
SG	Linear Industry Standard
μ A	Linear Industry Standard
ULN	Linear Industry Standard

ORDERING INFORMATION

For Prefixes OM, MAB, MAF, PC, PN, SAA, SAB, SAF, TA, TB, TC, TD AND TE

ORDERING INFORMATION

Signetics integrated circuit products may be ordered by contacting either the local Signetics sales office, Signetics representatives and/or Signetics authorized distributors.

Minimum Factory Order:

Commercial Product:
 \$1000 per order
 \$250 per line item per order

Table 1 provides part number information concerning Signetics Europroducts integrated circuits.

Table 2 provides package suffixes and descriptions for all presently existing types. Letters following the device number not used in Table 2 are considered to be part of the device number.

Table 3 provides explanations on the various prefixes employed in the part number descriptions. As noted in Table 3, Signetics Europroducts device operating temperature is defined by the appropriate prefix.

OPERATING TEMPERATURE:

The letters A to G give information about the operating temperature:

- A: Temperature range not specified. See data sheet.
e.g.: TDA2541N
- B: 0 to +70°C
e.g.: PCB8573PN
- C: -55 to +125°C
e.g.: PCC2111PN
- D: -25 to +70°C
e.g.: PCD8571PN
- E: -25 to +85°C
e.g.: PCE2111PN
- F: -40 to +85°C
e.g.: PCF2111PN
- G: -55 to +85°C
e.g.: PCG2111PN

Table 1. PART NUMBER DESCRIPTION

Part Number	Cross Ref. Part No.	Product Family	Product Description
TDA2541N		LIN	Video I.F. Amplifier
			→ Description of Product Function
			→ Product Family Linear LSI
			→ Package Description — See Table 2
			→ Device Number
			→ Device Family and Temperature Range Prefix — See Tables 3 & 4

Table 2. PACKAGE DESCRIPTION

Suffix	Package Description
N	8,14,16,18,20,24,28,40 — lead plastic DIL
D	Microminiature Package (S.O.)
F	14,16,18,22,24 — lead ceramic DIL
U	Single-in-line plastic (SIL) and SIL power
H	Metal Can

Table 3. DEVICE PREFIX AND TEMPERATURE *

Prefix	Device Family
OM	Linear circuit
MAB,MAF	Microcomputer
MEA	Microcomputer peripheral
PCx	CMOS Circuit
PNx	NMOS Circuit
SAx	Digital circuit
TAx	Linear circuit
TBx	Linear circuit
TCx	Linear circuit
TDx	Linear circuit
TEx	Linear circuit

*NOTE:
 The third letter of the prefix, in a three letter prefix, is the temperature designator.



NOTES

Section 2 Quality and Reliability

INDEX

SECTION 2 — QUALITY AND RELIABILITY

Quality and Reliability	2-1
-------------------------------	-----

QUALITY AND RELIABILITY

QUALITY AND RELIABILITY

Quality and reliability are two important measures of a product's merit. Quality is a measure of an integrated circuit's conformance to agreed-upon criteria at a given time, while Reliability is a measure of the circuit's ability to continue to conform over a period of time.

Quality

The quality of an integrated circuit is appraised by the user based on the ability of the circuit to meet the specified electrical criteria and external visual appearance. Linear LSI Division focuses on supplying to the user a product that has a high probability of meeting the user's needs through the sampling plans defined in MIL-STD-105D and the quality levels (AQL's) stated in Table II. Many of the inspection methods at critical process steps are now based on MIL-STD-883 criteria in order to build, rather than test, quality into the product.

Reliability

System performance over a period of time is the user's measure of an integrated circuit's reliability. The SUPR II Program improves system reliability by building quality into the product via additional manufacturing inspections and the offering of a burn-in screen. In addition to the SUPR II Program, Signetics performs periodic reliability testing via the SUREIII/883A Program to assure continuing uniformity and long-term reliability of all product lines. This data base is updated quarterly and is available upon request from the Linear LSI QR manager.

How Do Integrated Circuit Failures Occur?

Results from the Signetics Failure Analysis Lab over a three-year period on product returned from board checkout, system checkout, field usage and accelerated life testing are graphically presented in Figure 1. Under typical system operating conditions, random manufacturing defects, as outlined in Table 1, are the primary cause of true device failure. Also shown in Table 1 are the process controls that have been added via the SUPR II Program to minimize these defects prior to shipment to the customer. The device failure models are categorized as:

Half of the devices analyzed were found to be electrically good. They are attributed to being "false pulls" that occur during normal troubleshooting at the board and system levels.

Devices damaged by electrical over-stress account for 25% of the failures. Typical causes for electrical over-stress are incorrect board insertion, board shorts between device pins, power supply transients, and poor handling techniques.

The remaining 25% were verified to be true failures which occurred as a result of an in-process manufacturing defect or test escape.

Improved Quality Benefits

From the user's point of view, improved integrated circuit quality from the supplier means a lower cost of ownership. This cost saving can be effected through the reduction or elimination of involved incoming inspection testing, reduced PC board rework, simplified system checkout, reduced in-line inventories, and less complicated part tracking by Purchasing Management.

The SUPR II Program is Corporate in scope and covers Logic (Standard TTL, Schottky TTL, Low Power Schottky TTL, ECL, 8T Interface), Analog (Industrial, Consumer, Interface), Bipolar Memories (RAMs, ROMs, PROMs), and MOS Memories (RAMs, ROMs, Shift Registers). All package options are also available.

The SUPR II flow is detailed in Figure 5, including the test methods and Quality acceptance levels (Table 2 provides the electrical/mechanical finished product AQLs). Highlights of the flow are visual inspections, hermeticity, and burn-in, all based on MIL-STD-883 criteria.

A good example of the savings which can be achieved by purchasing tighter inspection levels is given in Figure 2. Here we are comparing the various levels of inspection (AQLs) available for device functionality and its impact on the number of PC boards which must be reworked during system manufacturing.

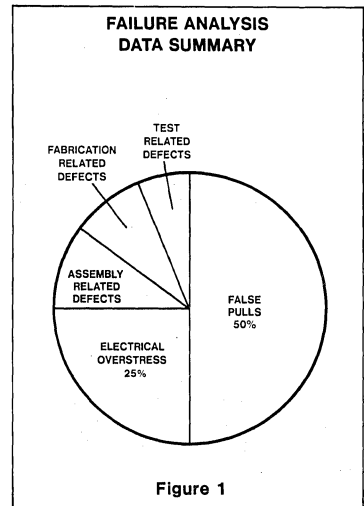

Figure 1

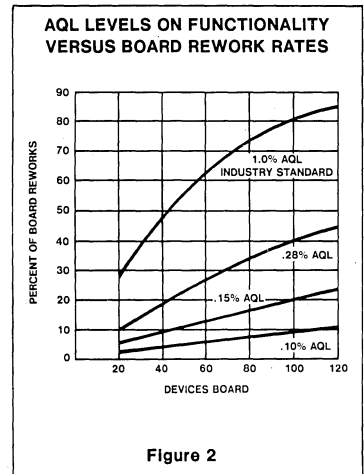

Figure 2

FAILURE MECHANISMS	CAUSES	PROCESS CONTROLS
Die Fabrication Related	Metalization Oxide Defects Mechanical Scratches Contamination	SEM Monitor Visual Stabilization Brake Burn-In
Assembly Related	Bonding, Wire, Package and Seal Defects	Preseal Visual Stabilization Bake Hermeticity
Test Related	Test Escapes	Tightened AQL Guarantees High Temperature Testing Product Characterization



QUALITY AND RELIABILITY

LEVEL B

Removal of Infant Mortality Failures

Failure rates are most severe during the first few months of operating life. This is known as the "infant mortality" phase. A system manufacturer has various options to solve problems arising from infant failures. He can ship his system to the end customer and repair field failures as they occur. He can operate the system in-house for this period and repair failures. Or he can purchase devices which have already been preconditioned to eliminate the early failures. Each customer must choose the most cost-effective method for his particular business. A considerable number of the reliability defects which cause early failures are eliminated by the manufacturing control and preconditioning steps of SUPR II Level A processing. More persistent defects can be removed by the use of "burn-in" techniques. The "burn-in" processing of SUPR II Level B effectively allows the system manufacturer to ship his equipment at Point 3 on the failure rate curve in Figure 3.

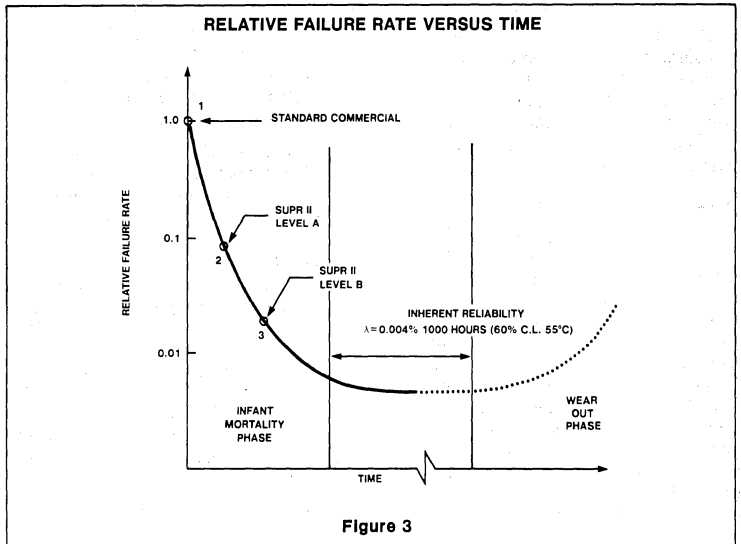

Figure 3

Burn-In Conditions

MIL-STD-883A, Method 1015 describes a number of different conditions for integrated circuit burn-in. For SUPR II Level B, Signetics has selected Condition F. This is the accelerated burn-in method derived from MIL-STD-883A, utilizing a high temperature reversed bias condition. This bias scheme is preferred for infant mortality screening, while operating conditions are generally utilized for internal reliability programs orient-

ed toward generating MTBF data for the system designer.

Integrated Burn-In Flow

Signetics SUPR II Level B burn-in is performed to provide reliability assurance equivalent to a 168-hour/125°C screen. This process has been integrated into the standard manufacturing flow to provide the customer with the most cost effective screen and significantly reduced delivery times.

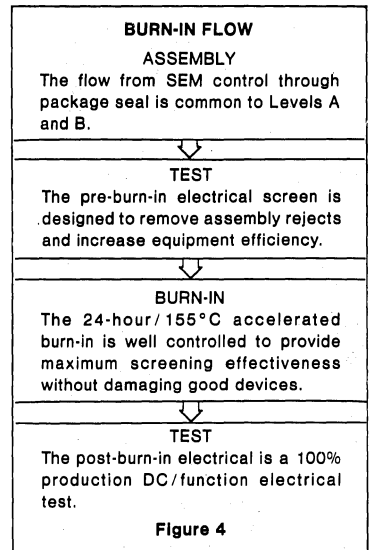

Figure 4

SURE III/883B RELIABILITY PROGRAM

Definition

Signetics is recognized as a manufacturer of reliable integrated circuits. Signetics realized long ago the need for a comprehensive reliability program to provide timely data representative of the entire

		LINEAR LSI QUALITY	
		AQL Guarantees	Process Average (PPM)
DC PARAMETRIC/FUNCTIONAL	MIN/MAX RATED OVER TEMP 25°C (Combined)	0.1	150
AC PARAMETRIC			
MECHANICAL	MAJOR/ MINOR (Combined)	0.4	150
SEAL TESTS (CERAMIC/METAL CANS ONLY)	FINE LEAK 5 x 10 ⁻⁸ cc/s GROSS LEAK (Combined)	0.4	1000

Table 2 SUPR II AQL GUARANTEE

QUALITY AND RELIABILITY

Signetics product line. Thus the establishment of a Systematic and Uniform Reliability Evaluation program, known as SURE, which provides this data in a manner unique to the industry. Furthermore, this program is provided at no cost to customers.

The SURE Program is a Signetics in-house Qualification Test Program which has been in existence since 1963. The SURE Program is designed to monitor the continuing uniformity of all Signetics products and to demonstrate via periodic qualifications that Signetics products meet or exceed the stringent long-term reliability requirements of their intended applications.

The SURE Program is reviewed and modified annually to incorporate appropriate changes in military microelectronic test programs, products and demonstrated product capabilities, and market requirements. The 1978 SUREIII/883B Reliability Program contains minor changes to the 1975 SUREII/883A Program, most significant of which is the inclusion of recent changes in military microelectronic test programs (i.e., inclusion of MIL-STD-883B, Method 5005.4 and MIL-M-38510D). The SUREIII/883B Program continues to incorporate additional environmental tests to fulfill the need for special reliability assurance of plastic products.

Data generated from this program is updated quarterly and is available from the Linear LSI Division QRA manager. Both quality and reliability have recently received major corporate focus at Signetics through the application—in all departments—of the Signetics 14-step Quality Improvement Program.

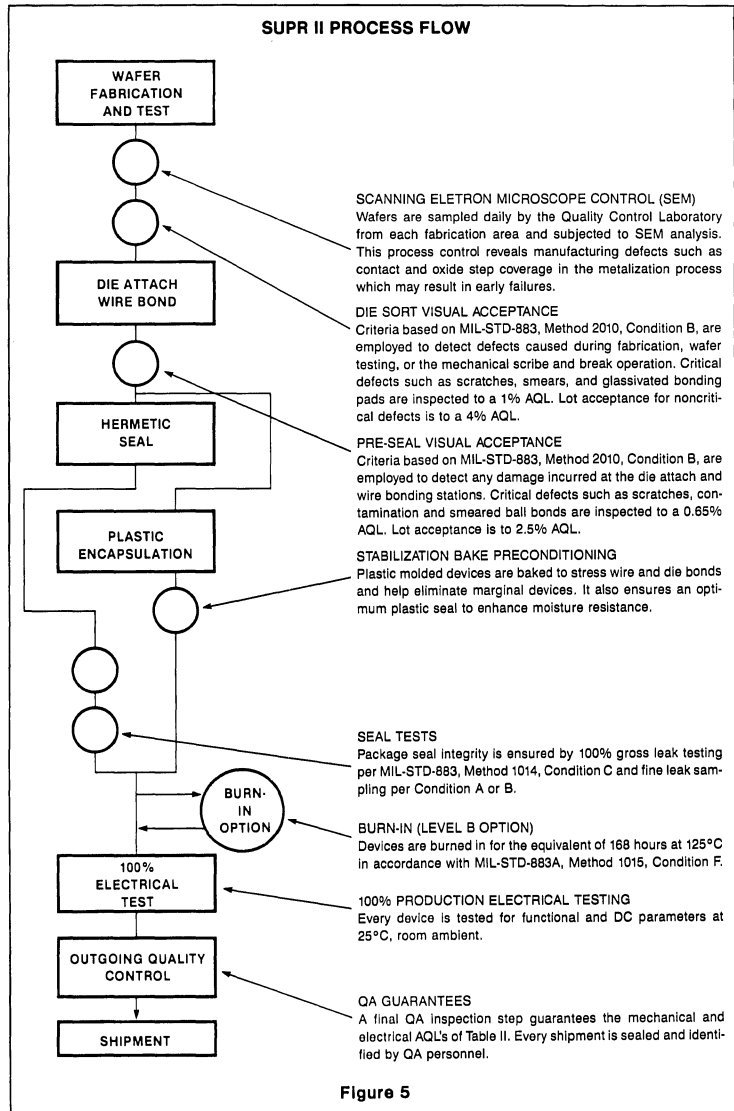

Figure 5

NOTES

Section 3 Military

INDEX

SECTION 3 — MILITARY

Index	3-1
Military Products	3-3
Military Process Levels	3-3

MILITARY PRODUCTS/PROCESS LEVELS

MILITARY PRODUCTS/PROCESS LEVELS

The Signetics MIL 38510/883 Program is organized to provide a broad selection of processing options, structured around the most commonly requested customer flows. The program is designed to provide our customers:

- Fully compliant 883B flows on all products.
- Standard processing flows to help minimize the need for custom specs.
- Cost savings realized by using standard processing flows in lieu of custom flows.
- Better delivery lead times by minimizing spec negotiation time, plus allow customers to buy product off-the-shelf or in various stages of production rather than waiting for devices started specifically to custom specs.

The following explains the different processing options available to you. Special device marking clearly distinguishes the type of screening performed.

JAN QUALIFIED (JS and JB)

JAN Qualified product is designed to give you the optimum in quality and reliability. The JAN processing level is offered as the result of the government's product standardization programs, and is monitored by the Defense Electronic Supply Center (DESC), through the use of industry-wide procedures and specifications.

JAN Qualified products are manufactured, processed and tested in a government certified facility to Mil-M-38510, and appropriate device slash sheet specifications. Design documentation, lot sampling plans, electrical test data and qualification data for each specific part type has been approved by the Defense Electronic Supply Center (DESC) and products appear on the DESC Qualified Products List (QPL 38510).

Quality conformance inspection testing, per MIL-STD-883, Method 5005, is performed according to Mil-M-38510 as follows:

- Group A; each subplot.
- Group B; one subplot for each package type every week.
- Group C; one subplot for each microcircuit group every 13 weeks.
- Group D; one subplot for each package type every 26 weeks.

NOTE: This category of part conforms to Quality Level B ($\alpha = 1.0$) of MIL-HDBK-217D.

JAN CASE OUTLINE AND LEAD FINISH	SIGNETICS MILITARY PACKAGE TYPES					
	CERAMIC					
	8-PIN	14-PIN	16-PIN	18-PIN	20-PIN	24-PIN
PB	FE	—	—	—	—	—
CB	—	F	—	—	—	—
EB	—	—	F	—	—	—
JB	—	—	—	—	—	F
DB	—	W	—	—	—	—
FB	—	—	W	—	—	—
RB	—	—	—	—	F	—
VB	—	—	—	F	—	—

All products listed are also available in Die form.

Table 1 MILITARY PACKAGE AVAILABILITY

	JS	JB	RB
	JAN Qualified		883B
	54	X	X
54LS	X	X	X
54S	X	X	X
82	—	—	X
8T	—	—	X
93XX	—	X	X
96XX	—	—	X
Analog	—	X	X
Bipolar Memory	—	X	X
Microprocessor	—	—	X

Table 2 MILITARY SUMMARY

In addition to the common specs used throughout the industry for processing and testing, JAN Qualified products also possess a requirement for a standard marking used throughout the IC industry.

By implementing this space-oriented government standardization program, Signetics complies with the trend of reducing the numerous similar Source Control Drawings (SCD's). This standardized trend results in a *single* complete and comprehensive specification, a *single* product flow, and a *single* administrative effort—for both the aerospace community and for Signetics. This effort will also result in a *single* lower price. Because the list of Signetics' qualified products will change periodically, you may wish to contact your nearest Signetics' Sales Office or refer to the *Products Qualified* under Military Specification from DESC for our current update.

JAN Class S orders will be quoted with unit price only (similar to present Class B programs). There will be no lot charges for SEM inspection, electrical testing, or Group B or D qualification. All additional charges are amortized in the unit price.

Package types currently qualified are:
 1) Cerdip—ceramic dual-in-line
 2) Cerpac—ceramic flat pack

Government Source Inspection (GSI) is a required portion of the JAN 38510 Class S specification. No alterations to this specification may be instituted. Therefore, the only

customer source inspection option is at pre-ship (verification only).

Additional program data options (such as wafer lot acceptance, attributes, Group B, D, and others) are available upon request for a nominal fee.

MIL-STD-883, LEVEL B

Processing to this option is ideal when no JAN slash sheets are released on devices required. Product is processed to MIL-STD-883 Method 5004, and is 100% electrically tested to Signetics data sheets.

Quality conformance inspection per MIL-STD-883, Method 5005, Group A, is performed on each subplot. Group A subgroup electrical parameters are those included in the detailed Signetics data book. Contact the factory for parametric subgroup assignments.

Generic quality conformance data per method 5005, Groups B, C and D, is generally available on popular device types and packages, but availability is not guaranteed. The factory must be consulted prior to ordering generic data. When available, generic data is defined as follows:

- Group B; Performed once per package type every six weeks of seal.
- Group C; Performed once per microcircuit group every 52 weeks of seal.



MILITARY PRODUCTS/PROCESS LEVELS

- Group D; Performed once per package type every 52 weeks of seal.
- Quality conformance endpoint electrical

parameters for Groups C and D are the Group A subgroups 1, 2, and 3. Copies of generic data, Groups A, B, C and D, may be ordered by customers at a nominal charge.

NOTE: This category of part conforms to Quality Level B-2 ($\pi\sigma = 6.5$ of MIL-HDBK-217D).

PROCESS LEVEL AND MARKING	PRE-CAP VISUAL	BURN IN	FUNCTIONAL TEST	DC/AC @ 25° C	DC @ TEMP	QPL	OFFSHORE
JS/JB JM38510XXXX RB SXXXX883B	2010, Cond. B	Yes	100%	100%	100%	Yes	No
	2010, Cond. B	Yes	100%	100%	100%	No	Yes

JAN Class S Product Inventory

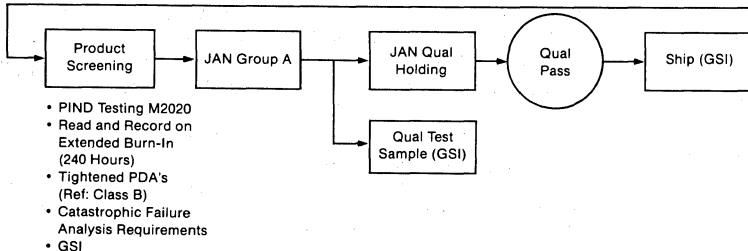
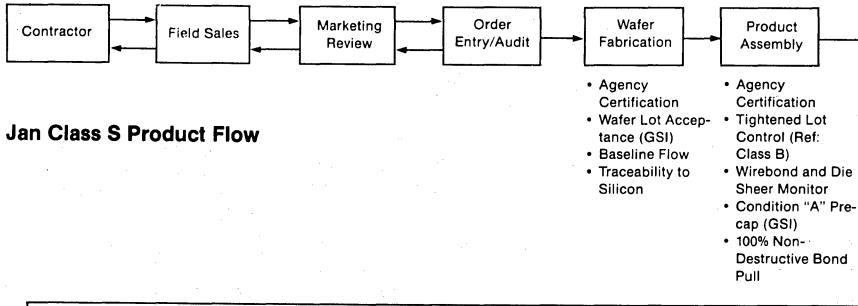
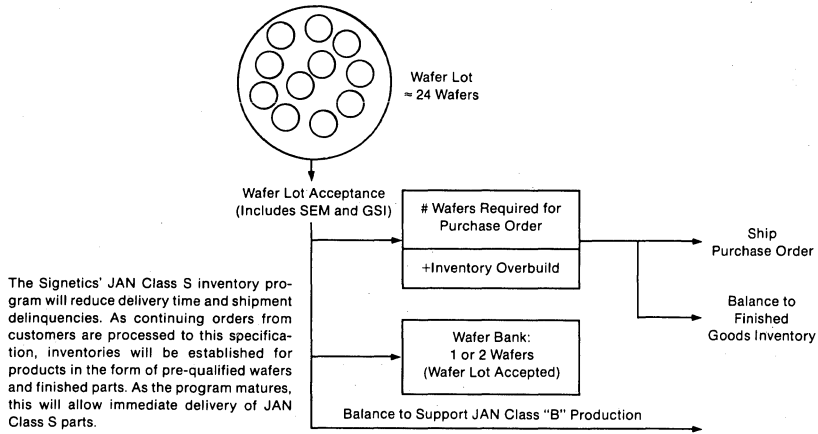

MILITARY PRODUCTS/PROCESS LEVELS

DESCRIPTION OF REQUIREMENTS AND SCREENS	MIL-M-38510 AND MIL-STD-883 REQUIREMENTS, METHODS AND TEST CONDITIONS	REQUIREMENT	PROCESSING LEVELS		
			CLASS S	JAN QUALIFIED (JB)	883B (RB)
General Mil-M-38510	The Manufacturer shall establish and implement a Products Assurance Program Plan and provide for a manufacturer survey by the qualifying activity, Para. 3.4.1.1	—	X	X	N/A
1. Pre-Certification					
A. Product Assurance Program					
B. Manufacturer's Certification					
2. Certification	Received after manufacturer has completed a successful survey, Para. 3.4.1.2	—	X	X	N/A
3. Device Qualification	Device qualification shall consist of subjecting the desired device to groups A, B, C & D of method 5005, Para. 3.4.1.2	—	X	X	N/A
4. Traceability	Traceability maintained back to a production lot Para. 3.4.6	—	X	X	X
5. Country of Origin	Devices must be manufactured, assembled, and tested within the U.S. or its territories, Para. 3.2.1	—	X	X	N/A
Screening Per Method 5004 of MIL-Std-883					
6. Non-Destructive Bond Pull	2023	100%	x	N/A	N/A
7. Internal Visual (Precap)	2010, Cond. A or B	100%	A	B	B
8. Stabilization Bake	1008, Cond. C Min	100%	x	x	x
9. Temperature Cycling	1010, cond. C; (10 cycles, -65°C to +150°C)	100%	x	x	x
10. Constant Acceleration	2001, Cond. E; (30kg in YI Plane)	100%	x	x	x
11. Visual Inspection	There is no test method for this screen; it is intended only for the removal of "Catastrophic Failures" defined as "Missing Leads, Broken Packages or Lids Off."	100%	x	x	x
12. Seal (Hermeticity)					
A. Fine	Cond. A or B (5.0 × 10 ⁻⁸ CC/Sec)	100%	x	x	x
B. Gross	Cond. C Min.	100%	x	x	x
13. Marking	Fungus inhibiting ink	100%	X	x	x
14. Particle Impact Noise Test	2020, Cond. A; per Paragraph 4.6.3 of MIL-M-38510	100%	x	N/A	N/A
15. Radiographic	2012; two views	100%	x	N/A	N/A
16. Interim Electricals (Pre Burn-In)	Per applicable Device Specification	100%	x	Optional	Optional
17. Burn-In	1015, Cond. as specified (160 hrs. Min at 125°C)	100%	240 hrs.	x	x

3

MILITARY PRODUCTS/PROCESS LEVELS

DESCRIPTION OF REQUIREMENTS AND SCREENS	MIL-M-38510 AND MIL-STD-883 REQUIREMENTS, METHODS AND TEST CONDITIONS	REQUIREMENT	PROCESSING LEVELS		
			CLASS S	JAN QUALIFIED (JB)	883B (RB)
18. Final Electricals	Per applicable Device Specification	100%	100% Read & Record	Slash Sheet	Data Sheet
a. Static Tests @ 25°C	Sub Group 1		x	x	x
b. Static Tests @ + 125°C	Sub Group 2		x	x	x
c. Static Tests @ - 55°C	Sub Group 3		x	x	x
d. Dynamic Test @ 25°C	Sub Group 4 (for Linear Products mainly)		x	x	x
e. Functional Test @ 25°C	Sub Group 7		x	x	x
f. Switching Test @ 25°C	Sub Group 9		x	x	x
g. Switching Test Temperature	Sub Groups 10, 11 (as applicable)		x	N/A	N/A
19. Percent Defective Allowable (PDA)	A PDA of 10% is a normal requirement applied against the static tests @ 25°C (A-1). This is controlled by the slash sheets for JAN products. For RB 10% is standard.	10%	5% 3% Func-tional	x	x
20. External Visual	2009	100%	x	x	x
Quality Conformance Inspection per Method 5005 of Mil-Std 883	ATTRIBUTE DATA ONLY				
21. Group A	Electrical Tests—Final Electricals (#14 above) repeated on a sample basis (Sub Groups 1 thru 12 as specified) performed in line with final electricals.	Each subplot	x	x	x
22. Group B	Package functional and constructional related test (package dimensions, resistance to solvents, internal visual & mechanical, bond strength & solderability).	Each pkg. type	Each subplot	Each week of seal	Generic
23. Group C	Die related tests (1,000 hr. operating life, temperature cycling, & constant acceleration).	Each μcircuit group	N/A	Each 13 weeks of seal	Generic
24. Group D.	Package related tests (physical dimensions, lead fatigue, thermal shock, temperature cycle, moisture resistance, mechanical shock, vibration, variable frequency, constant acceleration & salt atmosphere).	Each pkg. type	Each 26 weeks of seal	Each 26 weeks of seal	Generic

Table 5 REQUIREMENTS AND SCREENING FLOWS FOR STANDARD PRODUCTS (Cont'd)

MILITARY PRODUCTS/PROCESS LEVELS

LINEAR DEVICES

DEVICE	DESCRIPTION	PACKAGE DIP
OPERATIONAL AMPLIFIERS		
LH2101A	Dual Op Amp	F
LM101A	Hi Perf Op Amp	F,FE
LM124	Quad Op Amp	F
SE5532	Dual Op Amp	FE
SE5532A	Dual Op Amp	FE
SE5534	Low Noise Op Amp	FE
SE5534A	Low Noise Op Amp	FE
SE5537	Sample and Hold Amp	FE
SE5539	High Freq Op Amp	F
COMPARATORS		
SE521	Dual Differential Comparator	F
SE527	Voltage Comparator	F
SE529	Voltage Comparator	F
LM139/A	Quad Voltage Comparator	F
DIFFERENTIAL AMPLIFIERS		
SE592	Video Amplifier	F
μ A733	Video Amplifier	F
PHASE LOCKED LOOPS		
SE567	Tone Decoder PLL	F
TIMERS		
SE555	Timer	F, FE
SE556	Dual Timer	F
D to A CONVERTERS		
SE5018	8-Bit μ P-Comp DAC	F
SMPS CONTROL CIRCUITS		
SE5560	SMPS Controller	F

JAN M—38510			
DEVICE	SLASH SHEET	PKG	QUAL STATUS
SE555	10903BCB	F	QPL 1
SE555	10903BPB	FE	QPL 1
SE556-1	10902BCB	F	QPL 1
LH2101A	10105BEB	F	QPL 1
LM101A	10103BCB	F	QPL 1
LM101A	10103BPB	FE	QPL 1

3

NOTES

Section 4 Interface Data Conversion Products

INDEX

SECTION 4 — INTERFACE/DATA CONVERSION PRODUCTS

Index	4-1
Data Converters	4-3
Symbols and Definitions	4-3
Selector Guide	4-4
Analog to Digital Converters	
*ADC0801/2/3/4/5-1	8-Bit CMOS A/D Converter 4-5
NE5034	8-Bit Hi-Speed A/D Converter 4-11
NE5036	6-Bit A/D Converter, Serial Output 4-17
NE5037	6-Bit A/D Converter, Parallel Output 4-23
Digital to Analog Converters	
AM6012	12-Bit Hi-Speed Multiplying D/A Converter 4-30
DAC08 Series	8-Bit Hi-Speed Multiplying D/A Converter 4-40
MC1508-8/1408-8/1408-7	8-Bit Multiplying D/A Converter 4-50
MC3410/3510/3410C	10-Bit Hi-Speed Multiplying D/A Converter 4-56
SE/NE5018	8-Bit Microprocessor-Compatible D/A Converter 4-63
SE/NE5019	8-Bit Microprocessor-Compatible D/A Converter 4-68
NE5020	10-Bit Microprocessor-Compatible D/A Converter 4-73
SE/NE5118	8-Bit Micro-Compatible D/A Converter—Current Output 4-81
SE/NE5119	8-Bit Micro-Compatible D/A Converter—Current Output 4-85
SE/NE5410	10-Bit Hi-Speed Multiplying D/A Converter 4-89
*TDA1540D,P	14-Bit D/A with Serial Output 4-98
Comparators	
Selector Guide	4-104
LM111/211/311	Voltage Comparator 4-105
LM119/219/319	Dual Voltage Comparator 4-107
LM1139/A/239/A/339/A	Quad Voltage Comparator 4-112
LM193/A/293/A/393/A	Low Power Dual Voltage Comparator 4-117
LM2901	Quad Voltage Comparator 4-112
LM2903	Low Power Dual Voltage Comparator 4-117
MC3302	Quad Voltage Comparator 4-112
SE/NE521	Hi-Speed Dual Dif Comparator/Sense Amp 4-122
SE/NE522	Hi-Speed Dual Dif Comparator/Sense Amp 4-126
SE/NE527	Voltage Comparator 4-130
SE/NE529	Voltage Comparator 4-134

*New product for Linear LSI since 1983 data manual.

INDEX

Drivers		
Symbols and Definitions		4-138
MC1488	Quad Line Driver	4-140
MC1489/A	Quad Line Receiver	4-143
NE5090	Addressable Relay Driver	4-145
NE587	LED Decoder/Driver	4-150
NE589	LED Decoder/Driver	4-158
NE590	Addressable Peripheral Driver	4-166
NE591	Addressable Peripheral Driver	4-166
SA/NE594	Vacuum Fluorescent Display Driver	4-172
*PCF2100	40-Segment LCD Duplex Driver	4-176
*PCF2110	60-Segment LCD Duplex Driver	4-184
*PCF2111	64-Segment LCD Duplex Driver	4-193
*PCF2112	32-Segment LCD Static Driver	4-201
ULN2003	High Volt./Current Darlington Transistor Array	4-208
ULN2004	High Volt./Current Darlington Transistor Array	4-208
LVDT		
NE5520	LVDT Signal Conditioner	4-212
Sample and Hold		
Symbols and Definitions		4-216
LF198/298/398	Monolithic Sample and Hold Circuit	4-217
SE/NE5537	Sample and Hold Amplifier	4-221

*New product for Linear LSI since 1983 data manual.

D/A AND A/D CONVERTER—SYMBOLS AND DEFINITIONS

Absolute Accuracy Error

Absolute Accuracy Error is the difference between the theoretical analog input required to produce a given output code and the actual analog input required to produce the same code. The actual input is a range and the error is the midpoint of the measured band and the theoretical band.

Absolute Maximum Ratings

The Absolute Maximum Ratings are the operating safe zones. Exceeding these limits could cause permanent damage to the device. The device is NOT guaranteed to operate at these limits.

Conversion Speed

Conversion Speed is the speed at which a converter can make repetitive conversions.

Conversion Time

Conversion time is the time required for a complete conversion cycle of an ADC. Conversion time is a function of the number of bits and the clock frequency.

Differential Non-Linearity (DNL)

Differential Non-Linearity of a DAC is the deviation of the measured output step size from the ideal step size. In an ADC it is the deviation in the range of inputs from 1 LSB that causes the output to change from one given code to the next code. Excessive DNL gives rise to non-monotonic behavior in a DAC and missing codes in an ADC.

Differential Non-Linearity Tempco

Differential Non-Linearity Tempco is the temperature coefficient of DNL and specifies how DNL changes with temperature.

Full Scale Tempco

Full Scale Tempco in a DAC is the change of full scale output with a change of temperature. In an ADC it is the change in the input required to cause full scale transition. Expressed in ppm/degree C.

Gain Error

Gain Error is the error of the slope of the line drawn through the mid-points of the steps of the transfer function as compared to the ideal slope. It is usually measured by determining the error of the analog input voltage to cause a full scale output word with the ideal value that should cause this full scale output. This gain error is usually expressed in LSB or in percent of full scale range.

Hysteresis Error

Hysteresis Error is the code transition voltage dependence relative to the direction from which the transition is approached.

Integral Non-Linearity

Integral Non-Linearity is the difference between the ideal transfer characteristic and the actual characteristic.

Least Significant Bit (LSB)

The Least Significant Bit is the lowest order bit, or the bit with the least weight.

Missing Code

A Missing Code is a code combination that does not appear in the ADC's output range.

Monotonicity

A DAC is monotonic if its output either increases or remains the same when the input code is incremented from any code to the next higher code.

Most Significant Bit (MSB)

The Most Significant Bit is the highest order bit, or the one with the most weight.

Offset Error

Offset error is the constant error or shift from the ideal transfer characteristic of a converter. In a DAC it is the output obtained when that output should be zero. In an ADC it is the difference between the input level that causes the first code transition and what that input level should be.

Output Voltage Compliance

Output Voltage Compliance of a current output DAC is the range of acceptable voltages at the DAC output for the DAC output current to remain within its specified limits.

Power Supply Sensitivity

Power Supply Sensitivity of a DAC is the change of output current or voltage with changes in the power supply voltage. In an ADC, it is the change in the transition points from code to code with changes in the power supply voltage.

Quantizing Error

In an A/D converter there is an infinite number of possible input levels, but only 2^n output codes (n = number of bits). There will, therefore, be an error in the output code that could be as great as $1/2$ LSB because of this quantizing effect. The greatest error occurs at the transition point where the output state changes.

Relative Accuracy

Relative Accuracy is a measure of the difference of the theoretical output value with a given input after any offset and gain errors have been nulled out.

Resolution

Resolution is the number of bits at the input or output of an ADC or DAC. It is the number of discrete steps or states at the output and is equal to 2^n where n is the resolution of the converter. However, n bits of resolution does not guarantee n bits of accuracy.

Setting Time

Setting Time is the delay in a DAC from the 50 percent point on the change in the input digital code to the effected change in the output signal. It is expressed in terms of how long it takes the output to settle to and remain within a certain error band around the final value and is usually specific for full scale range changes.

Transfer Characteristic

The Transfer Characteristic is the relationship of the output to the input.

NOTE:

Refer to Section 9 (Interface Circuits) for an in-depth explanation of data converters and their applications.

CONVERTER SELECTOR GUIDES

D/A CONVERTERS

DEVICE	BITS	ACC. %	CONV. SPEED (μs)	OUTPUT		INT. REF.	INT. LATCH	PACKAGE			TEMPERATURE RANGE		COMMENTS
				V	I			N	D	F	Com'l.	Mil	
MC1408-7	8	0.39	0.07		X			X		X			
MC1408-8	8	0.19	0.07		X			X	X	X	X		
MC1508-8	8	0.19	0.07		X					X		X	
DAC08	8	0.19	0.07		X					X		X	
DAC08A	8	0.10	0.07		X					X		X	
DAC08C	8	0.39	0.07		X			X		X	X		
DAC08E	8	0.19	0.07		X			X	X	X	X		
DAC08H	8	0.10	0.07		X			X		X	X		
NE5018	8	0.19	0.2	X		X	X	X		X	X		
SE5018	8	0.19	0.2	X		X	X			X		X	
NE5019	8	0.10	0.2	X		X	X	X		X	X		
SE5019	8	0.10	0.2	X		X	X			X			
NE5118	8	0.19	2.3		X	X	X	X		X	X		
SE5118	8	0.19	2.3		X	X	X			X		X	
NE5119	8	0.10	2.3		X	X	X	X		X	X		
SE5119	8	0.10	2.3		X	X	X			X		X	
NE5020	10	0.10	5.0	X		X	X	X		X	X		
NE5410	10	0.05	0.25		X					X	X		±¼ LSB DNL
SE5410	10	0.05	0.25		X					X		X	±¼ LSB DNL
MC3410	10	0.05	0.25		X					X	X		±½ LSB DNL
MC3510	10	0.05	0.25		X					X		X	±½ LSB DNL
AM6012	12	0.05	0.25		X					X	X		±1 LSB DNL
TDA1540D	14	0.012	0.5		X	X	X			X	X		Serial Input ±½ LSB DNL

A/D CONVERTERS

DEVICE	BITS	ACC. %	CONV. SPEED (μs)	INPUT		THREE-STATE OUTPUT	INT. REF.	INT. CLOCK	PACKAGE			TEMPERATURE RANGE	
				V	I				N	F	FE	Com'l.	Mil
NE5034	8	0.19	17		X	X		X			X		
NE5036	6	0.78	23	X		X				X		X	
NE5037	6	0.78	9	X		X				X	X		X
TDA1534	14	0.012	8.5		X		X	X	X			X	
ADC0801-1	8	0.10	73	X		X		X		X		X ¹	
ADC0802-1	8	0.19	73	X		X		X		X		X ¹	
ADC0803-1	8	0.19	73	X		X		X		X		X ¹	
ADC0804-1	8	0.39	73	X		X		X		X		X ¹	
ADC0805-1	8	0.39	73	X		X	X	X		X		X ¹	

Note:

1. Automotive temperature range: -40 to +85°C

Preliminary

DESCRIPTION

The ADC0801 family is a series of five CMOS 8-bit successive approximation A/D converters using a resistive ladder and capacitive array together with an auto-zero comparator. These converters are designed to operate with microprocessor controlled buses using a minimum of external circuitry. The three-state output data lines can be connected directly to the data bus.

The differential analog voltage input allows for increased common-mode rejection and provides a means to adjust the zero scale offset. Additionally, the voltage reference input provides a means of encoding small analog voltages to the full 8 bits of resolution.

FEATURES

- Compatible with most microprocessors
- Differential inputs
- Three-state outputs
- Logic levels TTL and MOS compatible
- Can be used with internal or external clock
- Analog input range 0V to V_{CC}
- Single 5V supply
- Guaranteed specification with 1MHz clock

APPLICATIONS

- Transducer to microprocessor interface
- Digital thermometer
- Digitally-controlled thermostat
- Microprocessor-based monitoring and control systems

PIN CONFIGURATION

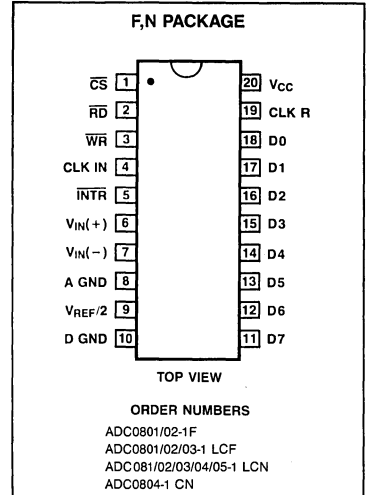

ABSOLUTE MAXIMUM RATINGS

SYMBOL & PARAMETER	RATING	UNIT
V_{CC} Supply Voltage	6.5	V
Logic Control Input Voltages	-0.3 to + 16	V
All Other Input Voltages	-0.3 to ($V_{CC} + 0.3$)	V
T_A Operating Temperature Range ADC0801/02-1 F ADC0801/02/03-1 LCF ADC0801/02/03/04/05-1 LCN ADC0804-1 CN	-55 to +125	°C
	-40 to +85	°C
	-40 to +85	°C
	0 to +70	°C
T_{STG} Storage Temperature	-65 to +150	°C
T_{SOLD} Lead Soldering Temperature (10 seconds)	300	°C
P_D Package Power Dissipation at $T_A = 25^\circ\text{C}$	875	mW

Preliminary

BLOCK DIAGRAMS

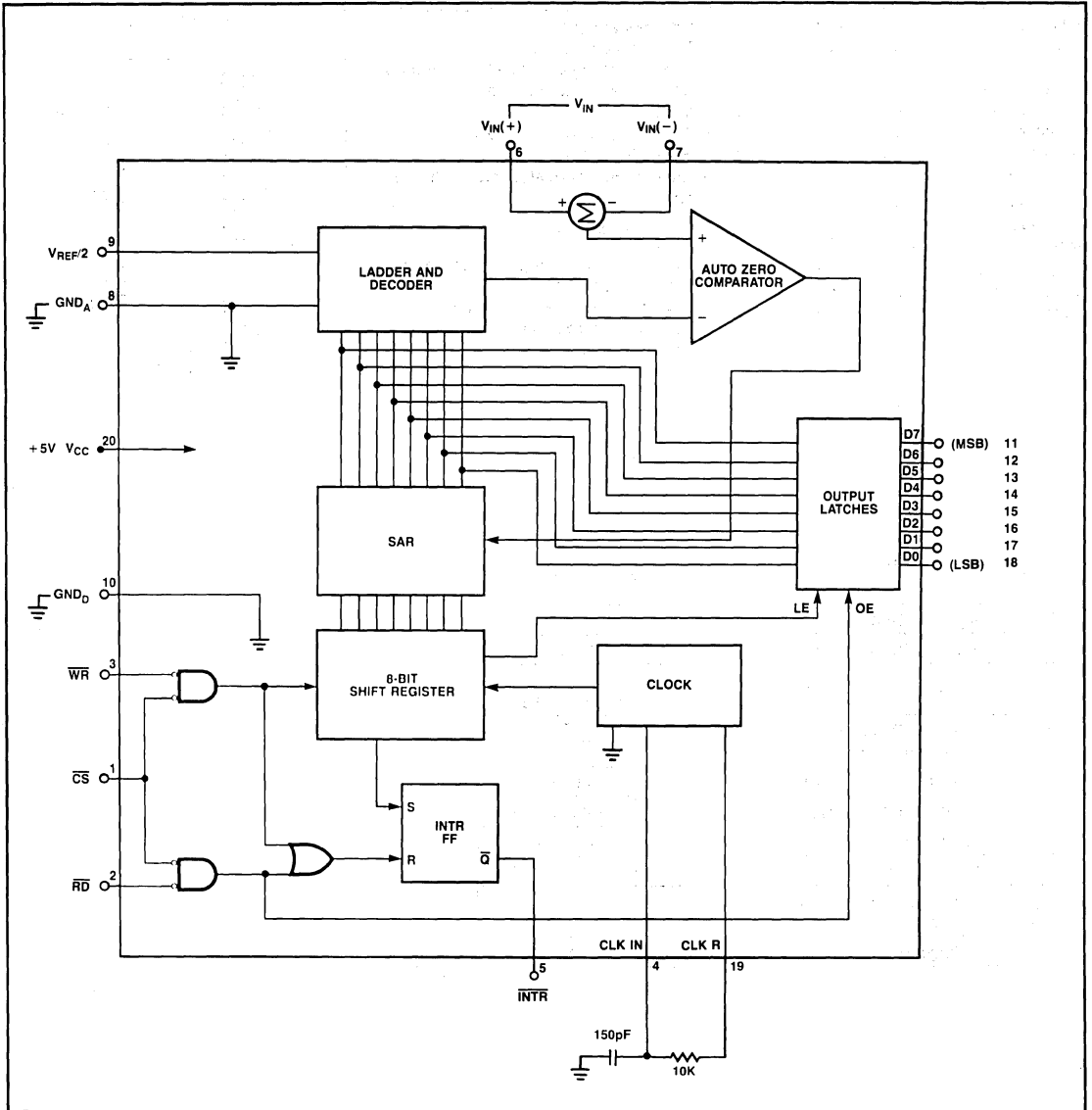

CMOS 8-BIT A/D CONVERTERS

ADC0801/2/3/4/5-1

Preliminary

DC ELECTRICAL CHARACTERISTICS $V_{CC} = 5.0V$, $f_{CLK} = 1MHz$, $T_{MIN} \leq T_A \leq T_{MAX}$, unless otherwise specified.

SYMBOL & PARAMETER	TEST CONDITIONS	ADC0801/2/3/4/5			UNIT
		Min	Typ	Max	
ADC0801 Relative Accuracy Error (Adjusted)	Full Scale Adjusted			0.25	LSB
ADC0802 Relative Accuracy Error (Unadjusted)	$\frac{V_{REF}}{2} = 2.500 V_{DC}$			0.50	LSB
ADC0803 Relative Accuracy Error (Adjusted)	Full Scale Adjusted			0.50	LSB
ADC0804 Relative Accuracy Error (Unadjusted)	$\frac{V_{REF}}{2} = 2.500 V_{DC}$			1	LSB
ADC0805 Relative Accuracy Error (Unadjusted)	$\frac{V_{REF}}{2} = \text{has no connection}$			1	LSB
$\frac{V_{REF}}{2}$ Input Resistance		400	640		Ω
Analog Input Voltage Range		-0.05		$V_{CC} + 0.05$	V
DC Common Mode Error	Over Analog Input Voltage Range		1/16	1/8	LSB
Power Supply Sensitivity	$V_{CC} = 5V \pm 10\%^1$				
CONTROL INPUTS					
V_{IH} Logical "1" Input Voltage	$V_{CC} = 5.25V_{DC}$	2.0		15	V_{DC}
V_{IL} Logical "0" Input Voltage	$V_{CC} = 4.75V_{DC}$			0.8	V_{DC}
I_{IH} Logical "1" Input Current	$V_{IN} = 5V_{DC}$		0.005	1	μA_{DC}
I_{IL} Logical "0" Input Current	$V_{IN} = 0V_{DC}$	-1	-0.005		μA_{DC}
CLOCK IN AND CLOCK R					
V_{T+} Clk In Positive-Going Threshold Voltage		2.7	3.1	3.5	V_{DC}
V_{T-} Clk In Negative-Going Threshold Voltage		1.5	1.8	2.1	V_{DC}
V_H Clk In Hysteresis (V_{T+}) - (V_{T-})		0.6	1.3	2.0	V_{DC}
V_{OL} Logical "0" Clk R Output Voltage	$I_{OL} = 360\mu A$, $V_{CC} = 4.75 V_{DC}$			0.4	V_{DC}
V_{OH} Logical "1" Clk R Output Voltage	$I_{OH} = -360\mu A$, $V_{CC} = 4.75 V_{DC}$	2.4			V_{DC}
DATA OUTPUT AND \overline{INTR}					
V_{OL} Logical "0" Output Voltage					
Data Outputs	$I_{OL} = 1.6mA$, $V_{CC} = 4.75 V_{DC}$			0.4	V_{DC}
\overline{INTR} Outputs	$I_{OL} = 1.0mA$, $V_{CC} = 4.75 V_{DC}$			0.4	V_{DC}
V_{OH} Logical "1" Output Voltage	$I_{OH} = -360\mu A$, $V_{CC} = 4.75 V_{DC}$	2.4			V_{DC}
	$I_{OH} = -10\mu A$, $V_{CC} = 4.75 V_{DC}$	4.5			V_{DC}
I_{OZL} 3-State Output Leakage	$V_{OUT} = 0V_{DC}$, $\overline{CS} = \text{Logical "1"}$	-3			μA_{DC}
I_{OZH} 3-State Output Leakage	$V_{OUT} = 5V_{DC}$, $\overline{CS} = \text{Logical "1"}$			3	μA_{DC}
I_{SC+} + Output Short Circuit Current	$V_{OUT} = 0V$, $T_A = 25^\circ C$	4.5	6		mA_{DC}
I_{SC-} - Output Short Circuit Current	$V_{OUT} = V_{CC}$, $T_A = 25^\circ C$	9.0	16		mA_{DC}
I_{CC} Power Supply Current	$f_{CLK} = 1MHz$, $V_{REF/2} = \text{Open}$ $\overline{CS} = \text{Logical "1"}$, $T_A = 25^\circ C$		3.0	3.5	mA

NOTE:

1. Analog inputs must remain within the range: $-0.05 \leq V_{IN} \leq V_{CC} + 0.05V$.

CMOS 8-BIT A/D CONVERTERS

ADC0801/2/3/4/5-1

Preliminary

AC ELECTRICAL CHARACTERISTICS

SYMBOL & PARAMETER	TO	FROM	TEST CONDITIONS	ADC0801/2/3/4/5			UNIT
				Min	Typ	Max	
Conversion Time			$f_{CLK} = 1\text{MHz}^1$	66		73	μs
f_{CLK} Clock Frequency			See Note 1.	0.1	1.0	3.0	MHz
Clock Duty Cycle			See Note 1.	40		60	%
CR Free-Running Conversion Rate			$\overline{CS} = 0, f_{CLK} = 1\text{MHz}$ INTR Tied To WR			13690	conv/s
$t_{W(WR)L}$ Start Pulse Width			$\overline{CS} = 0$	30			ns
t_{ACC} Access Time	Output	\overline{RD}	$\overline{CS} = 0, C_L = 100\text{ pF}$		75	100	ns
t_{1H}, t_{OH} Three-State Control	Output	\overline{RD}	$C_L = 10\text{ pF}, R_L = 10\text{K}$ See Three-State Test Circuit		70	100	ns
t_{W1}, t_{R1} \overline{INTR} Delay	\overline{INTR}	\overline{WD} or \overline{RD}			100	150	ns
C_{IN} Logic Input =Capacitance					5	7.5	pF
C_{OUT} Three-State Output Capacitance					5	7.5	pF

NOTE:

1. Accuracy is guaranteed at $f_{CLK} = 1\text{MHz}$. Accuracy may degrade at higher clock frequencies.

Preliminary

FUNCTIONAL DESCRIPTION

The ADC0801 through ADC0805 series of A/D converters are successive approximation devices with 8-bit resolution and no missing codes. The most significant bit is tested first and after 64 clock cycles a digital 8-bit binary word is transferred to an output latch and the $\overline{\text{INTR}}$ pin goes low, indicating that conversion is complete. A conversion in progress can be interrupted by issuing another start command. The device may be operated in a continuous conversion mode by connecting the $\overline{\text{INTR}}$ and $\overline{\text{WR}}$ pins together and holding the $\overline{\text{CS}}$ pin low. To insure start-up when connected this way, an external $\overline{\text{WR}}$ pulse is required at power-up.

As the $\overline{\text{WR}}$ input goes low, when $\overline{\text{CS}}$ is low, the SAR is cleared and remains so as long as these two inputs are low. Conversion begins between 1 and 8 clock periods after at least one of these inputs goes high. As the conversion begins, the $\overline{\text{INTR}}$ line goes high. Note that the $\overline{\text{INTR}}$ line will remain low until 1 to 8 clock cycles after either the $\overline{\text{WR}}$ or the $\overline{\text{CS}}$ input (or both) goes high.

When the $\overline{\text{CS}}$ and $\overline{\text{RD}}$ inputs are both brought low to read the data, the $\overline{\text{INTR}}$ line will go low and the three-state output latches are enabled.

The digital control lines ($\overline{\text{CS}}$, $\overline{\text{RD}}$, and $\overline{\text{WR}}$) operate with standard TTL levels and have been renamed when compared with standard A/D Start and Output Enable labels. For non-microprocessor based applications, the $\overline{\text{CS}}$ pin can be grounded, the $\overline{\text{WR}}$ pin can be interpreted as a START pulse pin, and the $\overline{\text{RD}}$ pin performs the OE (Output Enable) function.

The $V_{\text{IN}}(-)$ input can be used to subtract a fixed voltage from the input voltage. Because there is a time interval between sampling the $V_{\text{IN}}(+)$ and the $V_{\text{IN}}(-)$ inputs, it is important that these inputs remain constant, during the entire conversion cycle.

THREE-STATE TEST CIRCUITS AND WAVEFORMS

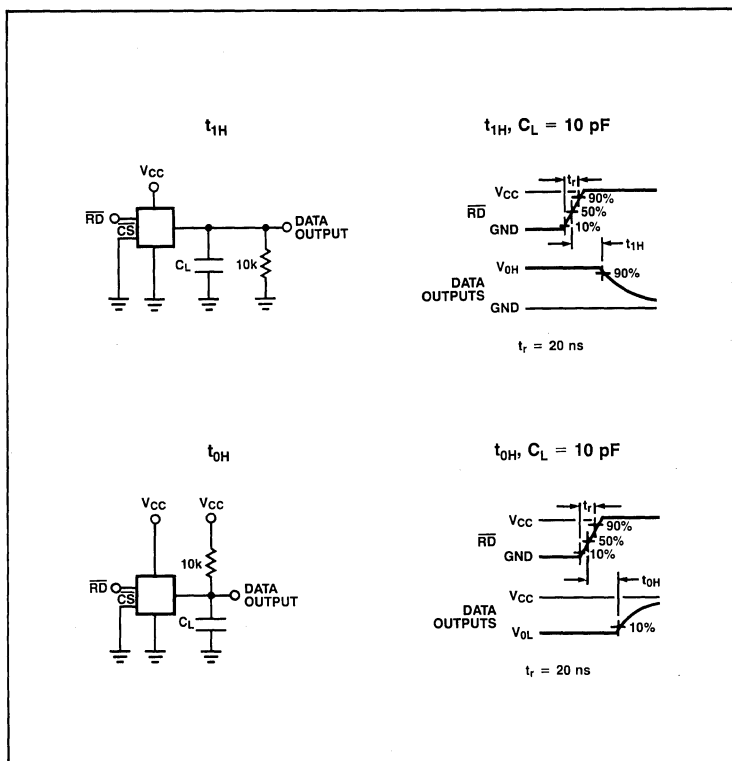

4

Preliminary

TIMING DIAGRAMS (All timing is measured from the 50% voltage points)

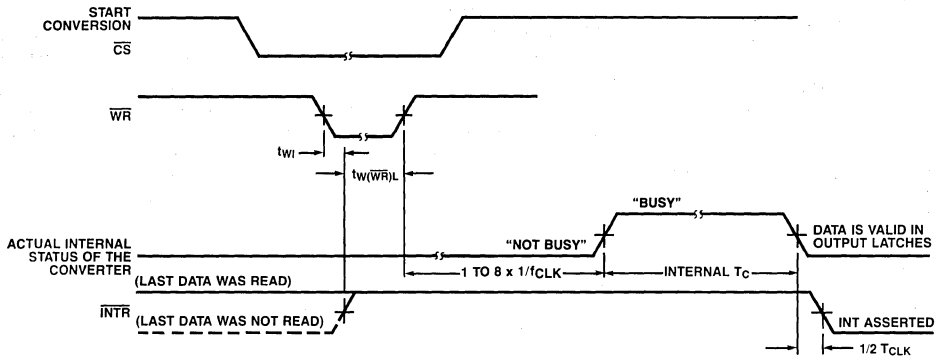

OUTPUT ENABLE AND RESET \overline{INTR}

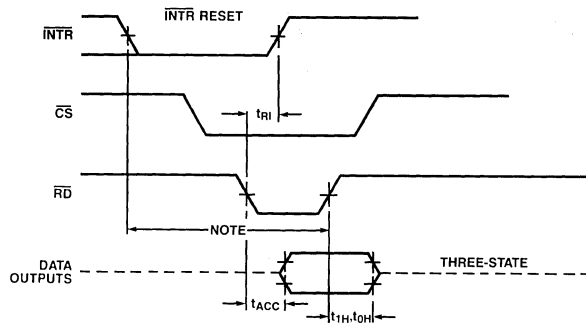

Note: Read strobe must occur 8 clock periods ($8/f_{CLK}$) after assertion of interrupt to guarantee reset of \overline{INTR} .

8-BIT HI-SPEED A/D CONVERTER

NE5034

DESCRIPTION

The NE5034 is a high-speed microprocessor-compatible 8-bit Analog-to-Digital converter. It uses the successive approximation conversion technique, and includes the comparator, reference DAC, SAR, an internal clock and three-state buffers all on the same chip.

The converter can accommodate a wide analog input voltage range, bipolar or unipolar, selectable through external input resistors. An external capacitor controls the internal clock frequency, providing conversion times down to 17µs. Faster conversion times are possible using an external clock.

Microprocessor interfacing requirements are simple, allowing analog-to-digital conversion with a minimum of external components.

FEATURES

- 8-bit resolution and accuracy
- Accepts unipolar or bipolar inputs
- Three-state output buffers for easy microprocessor interface
- Choice of internal or external clocking
- Short conversion time, 17µs typical using internal clock

APPLICATIONS

- All microprocessor-based monitoring and control systems requiring analog signal inputs.
- Typical applications include: Automated process control, machine tools, robots, test and measurement instruments, environmental controls
- Other applications include: Ratiometric A/D conversion, very high resolution A/D conversion systems requiring high speed 8-bit building blocks

PIN CONFIGURATION

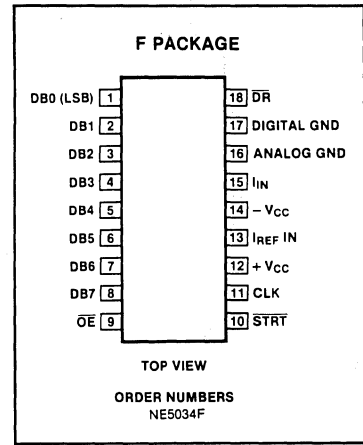

ABSOLUTE MAXIMUM RATINGS

PARAMETER	RATING	UNIT
V _{CC+} Positive supply voltage	0 to +6	V
V _{CC-} Negative supply voltage	0 to -15	V
I _{REF} Reference current	1.5	mA
I _{IN} Analog input current	5.0	mA
V _O Data output voltage	6.0	V
Analog GND to Digital GND	1.0	V
V _L Logic input voltage	-1 to V _{CC+}	V
P _D Power dissipation F package	1000	mW
T _A Operating temperature range	0 to +70	°C
T _{STG} Storage temperature range	-65 to +150	°C
T _{SOLD} Lead soldering temperature (10 seconds)	300	°C

BLOCK DIAGRAM

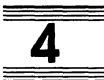
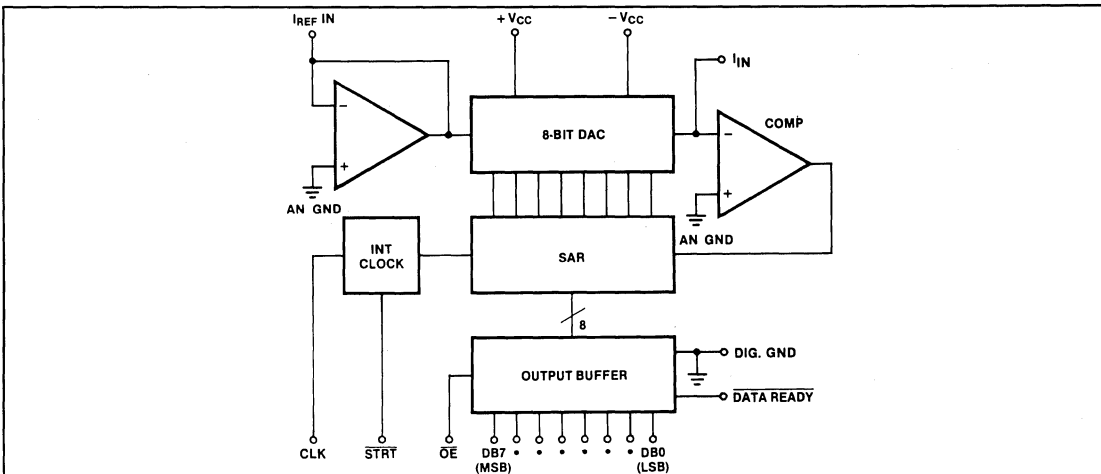

8-BIT HI-SPEED A/D CONVERTER

NE5034

DC ELECTRICAL CHARACTERISTICS +V_{CC} = 5.0V, -V_{CC} = -12V, 0°C ≤ T_A ≤ 70°C unless otherwise specified

SYMBOL AND PARAMETER	TEST CONDITIONS	MIN	TYP	MAX	UNIT
Resolution		8	8	8	Bits
Relative accuracy error ^{1,2}				± 1/2	LSB
V _{CC+} Positive supply range		4.75	5.0	5.25	V
V _{CC-} Negative supply range		-11.4	-12	-12.6	V
E _{FS} Full scale gain error	I _{REF} = 1.0mA, T _A = 25°C		± 2	± 5	LSB
E _{ZS} Zero scale offset error	I _{REF} = 1.0mA, T _A = 25°C		± 0.5	± 1	LSB
Ps _r Power supply rejection ³	I _{REF} = 1.0 mA, V _{CC} + 4.75 to + 5.25V, V _{CC} - 11.4 to - 12.6V			± 1/2	LSB
V _{IH} Logic 1 input voltage ($\overline{\text{STRT}}$ and $\overline{\text{OE}}$)		2.0			V
V _{IH} Logic 1 input voltage ext. clock		2.4			V
V _{IL} Logic 0 input voltage ($\overline{\text{STRT}}$ and $\overline{\text{OE}}$)				0.8	V
V _{IL} Logic 0 input voltage ext. clock				0.7	V
I _{IH} Logic 1 input current ($\overline{\text{STRT}}$ and $\overline{\text{OE}}$)	V _{IN} = 2.4V			20	μA
I _{IH} Logic 1 input current ext. clock	V _{IN} = 2.4V		100		μA
I _{IL} Logic 0 input current ($\overline{\text{STRT}}$ and $\overline{\text{OE}}$)	V _{IN} = 0.4V		-20	-100	μA
I _{IL} Logic 0 input current ext. clock	V _{IN} = 0.7V		-100		μA
V _{OL} Logic 0 output voltage	I _{OL} = 1.6mA, $\overline{\text{OE}}$ = 0.8V			0.4	V
V _{OH} Logic 1 output voltage	I _{OH} = 400μA, $\overline{\text{OE}}$ = 0.8V	2.4			V
I _{oz} Three-state leakage	$\overline{\text{OE}}$ = 2.0V, V _{OL} = 0V or 5V		± 10		μA
I _{CC+} Positive supply current	V _{CC} + 5V, V _{CC} - 12V		18	36	mA
I _{CC-} Negative supply current.	V _{CC} + 5V, V _{CC} - 12V		-11	-22	mA

NOTES

1. Relative accuracy is defined as the deviation of the code transition points from the ideal code transition points on a straight line drawn from zero scale to full scale of the device.
2. Specifications given in LSBs refer to the weight of the least significant bit at the 8-bit level which is 0.39% of the full scale voltage.
3. MAX change in full scale.

AC ELECTRICAL CHARACTERISTICS V₊ = +5V, V₋ = -12V, T_A = 25°C

SYMBOL & PARAMETER	TO	FROM	TEST CONDITIONS	MIN	TYP	MAX	UNIT
Internal clock frequency			C _L = 60pF (See Figure 1)		500		KHz
External clock frequency						700	KHz
T _w $\overline{\text{STRT}}$ pulse width			Clock freq. = 500KHz	400			ns
External clock pulse width positive/negative				600			ns
Set up time ¹			See Figure 3	300			ns
t _p (out data) propagation delay	data out	$\overline{\text{OE}}$	See Figure 2		50	200	ns
t _p (out $\overline{\text{DR}}$) propagation delay	data ready out	8th clock	See Figure 3		700		ns
t _p (3-state) propagation delay 3-state	high impedance o/p	$\overline{\text{OE}}$	See Figure 2		60	200	ns
t _p (DB0) propagation delay	DB0	$\overline{\text{DR}}$	See Figure 3			500	ns
t _p (SDR) $\overline{\text{STRT}}$ low to $\overline{\text{DR}}$ high	data ready high	$\overline{\text{STRT}}$ low	See Figure 3		700		ns

NOTE

1. See description of "Set up time".

TYPICAL PERFORMANCE CHARACTERISTICS

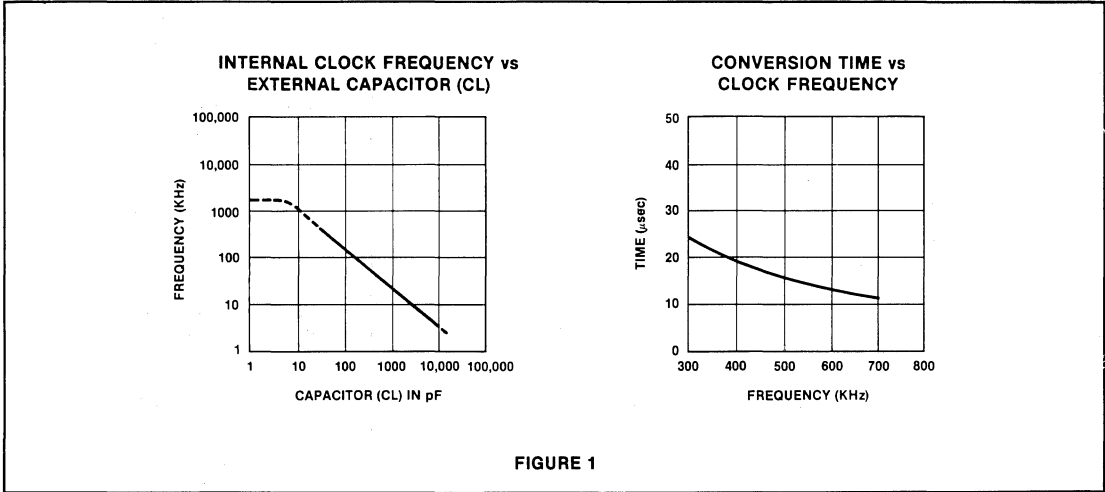

4

TEST LOAD CIRCUITS

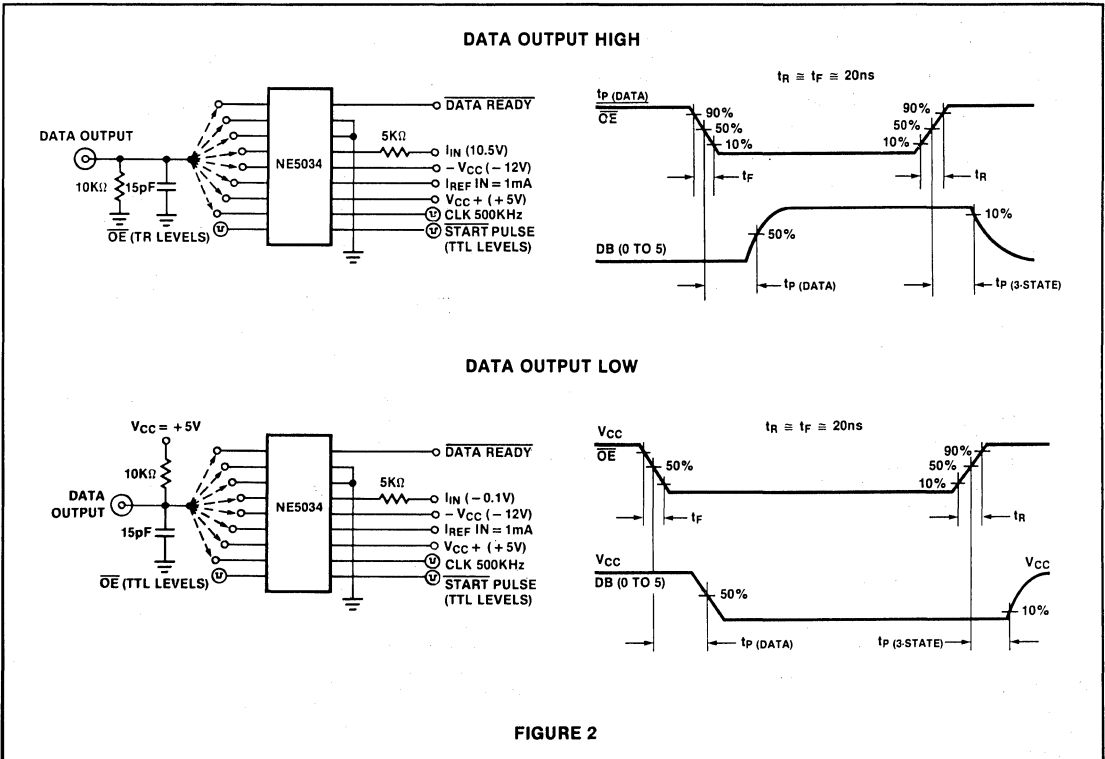

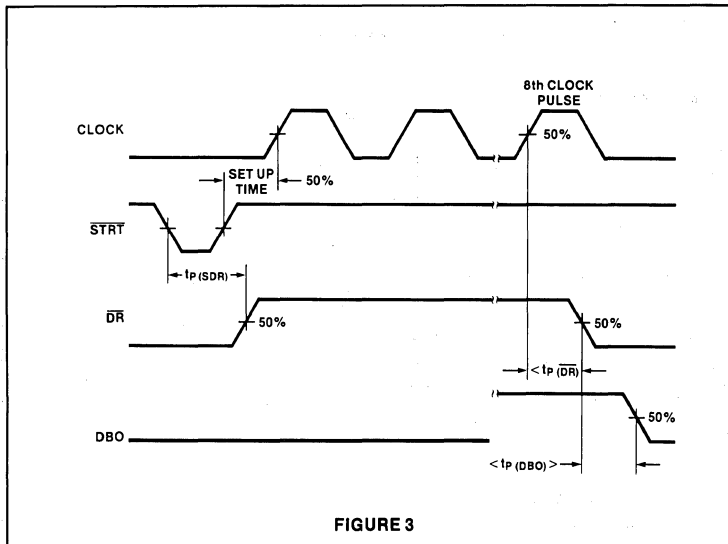

The comparator determines whether the output current of the DAC is greater or less than the input current converted from the unknown analog input voltage through an external input resistor. If the DAC output current is greater, the data latch for the trial bit is reset to a '0'; if it is less, the trial data bit stays at '1'. After all the bits from DB7 to DB0 have been tried, the SAR contains a valid 8-bit binary output code which accurately represents the unknown analog input to within $\pm 1/2$ LSB ($\pm 0.2\%$). This binary output will now remain in the SAR until another STRT pulse is applied.

During the successive-approximation sequence, the DATA READY signal remains at '1'. Upon completion of the conversion, the signal goes to a '0', indicating that data is valid and ready. If the \overline{OE} input is left at a '0' during the conversion, the DATA OUTPUT shows the conversion sequence (see short cycle section). When the \overline{OE} line is made a logic '1', the output buffers will go to a high impedance state and will remain so until the \overline{OE} is returned to a '0' state.

FUNCTIONAL PIN DEFINITIONS

DATA READY (\overline{DR})

This is an output pin used to indicate that a conversion is in progress. \overline{DR} goes to a logic "1" when STRT is at a logic "0". At the completion of a conversion \overline{DR} returns to a logic "0". There is a delay (MAX 0.5 μ s) from the time \overline{DR} goes to "0" to the time DBO data is valid.

DB0-DB7

Eight three-state data outputs each with a drive capability of one TTL load. DB0 is the LSB and DB7 is the MSB.

\overline{OE}

Output enable input. When \overline{OE} is at a logic "1" the data outputs assume a high impedance state. With \overline{OE} at a logic "0", data is placed on the outputs. Data appearing on the outputs is only valid if both \overline{OE} and \overline{DR} are at logic "0" (see note on \overline{DR} timing).

STRT

This pin is used to reset the converter and start a new conversion. A logic "0" applied to this pin for a minimum of 400ns will reset the converter to a condition with DB7 at a logic "1" and all other Data outputs at logic "0". It will also cause \overline{DR} to go to a logic "1" (see timing diagrams for delay times). Conversion will start with the 1st clock pulse after STRT returns to a

logic "1" (see notes on set up time required). A STRT pulse while a conversion is taking place will cause the conversion to be aborted and the converter will reset. (See notes on short-cycle operation.)

CLK IN

An external capacitor between this pin and ground generates the internal clock pulses. (See diagram for clock frequency vs capacitor value). In order to synchronize the internal clock, to the start pulse a diode (small signal type e.g., 1N914) should be connected between STRT and CLK IN (see Figures 4 and 5). Without this diode the start pulse could occur at a time which could cause one of the conditions described in the Note on "set up" time. Applying an external TTL-or MOS-compatible clock to this pin slaves the NE5034 to external clock frequency. In this case, the diode is not required but the "set up" time requirements should be noted.

BASIC CIRCUIT DESCRIPTION

The NE5034 is an 8-bit A/D converter which incorporates the successive-approximation conversion method. Upon receipt of the STRT pulse, successive bits, beginning with the MSB (DB7), are applied to the input of the internal 8-bit current output DAC by the I^2L successive-approximation register (SAR) (see Block Diagram).

TIMING DESCRIPTION

The timing diagram shown in Figure 7 shows the successive trial and decisions for each data bit.

With STRT at a logic "0" the converter is reset to a condition with DB7 at a logic "1", DR at a logic "1" and DB0-DB6 at logic "0".

Conversion starts after STRT returns to a logic "1". Starting with DB7 each bit is tried in turn, with the decision point being at the time of the positive going edge of the clock. Starting with the first positive edge after STRT returns to logic "1" (see note on "set up" time). The 8th positive going edge makes the decision on DB0 (LSB) and also causes \overline{DR} to return to a logic "0" to indicate the conversion is complete. (See note on \overline{DR} timing.)

SHORT-CYCLE OPERATION

In applications where less than 8 bits of resolution are required the NE5034 can be operated to achieve shorter conversion times. No hard wire changes are required to perform "short-cycling".

Conversion to X number of bits is completed at the end of X + 0.5 clock cycles (after a start pulse) \overline{DR} will still be at a logic "1" state.

\overline{OE} can be used to 3-state the outputs even during short-cycle operation.

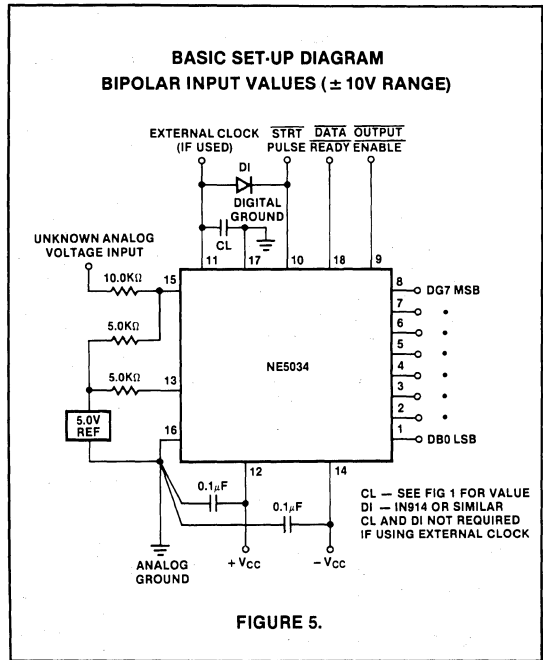
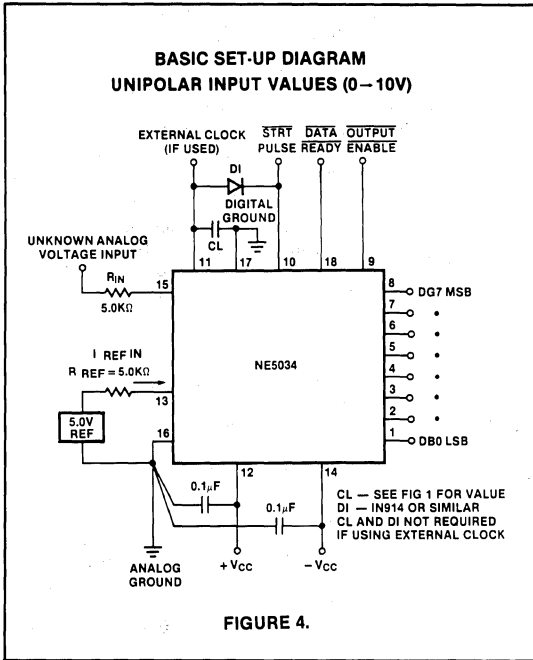

4

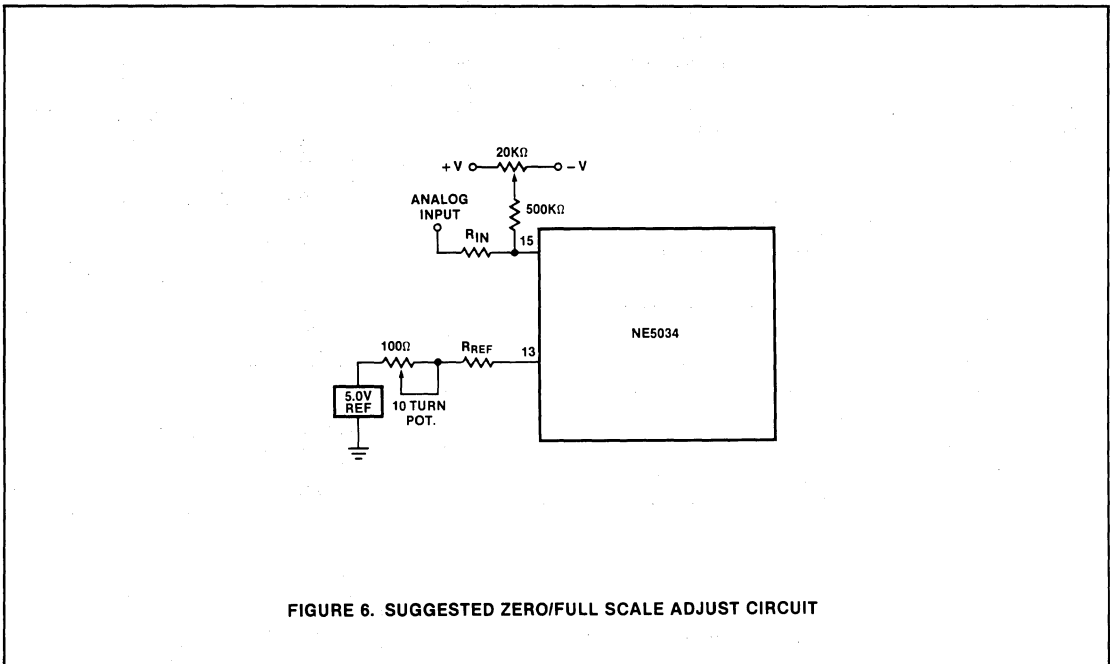

SET UP TIME

When using an external clock, the positive going edge of the start pulse must be synchronized to the clock pulse. There is a "set up" time of 300ns required between the time of the start pulse returning to a logic "1" and the next positive going edge of the clock.

If the positive edge of the start pulse occurs less than 300ns prior to the positive clock edge, one of the following conditions will occur:

- The converter recognizes the clock pulse and converts as normal.
- The conversion starts one clock pulse later.
- The conversion never starts, this will be indicated by the fact that \overline{DR} does not return to logic "0". In this case a new start pulse will be required.

DATA READY (\overline{DR}) TIMING

After \overline{DR} returns to a logic "0" indicating a conversion is complete there is a time delay of 500ns before the data at $DB0$ output (the Least Significant Bit) is valid.

ZERO OFFSET (NEGATIVE FULL SCALE) CALIBRATION PROCEDURES

- Apply continuous start pulses to the \overline{START} input.
- Apply 1/2 LSB in the case of unipolar operation, or 1/2 LSB above - FS in the case of bipolar operation to the analog input.

- Observe all data outputs after each conversion is completed.
- Adjust the potentiometer connected to I_{IN} (see Figure 6) until the LSB flickers between '0' and '1', and all other data outputs remain '0' following each conversion.

FULL SCALE (POSITIVE FULL SCALE) CALIBRATION:

- Apply continuous start pulses to the \overline{START} input.
- Apply full scale minus 1 1/2 LSB to the analog input.
- Observe all data outputs after each conversion is completed.
- Adjust the voltage applied to $V_{REF IN}$ (Figure 4) until the LSB varies between '0' and '1', and all other data outputs stay '1' after each conversion.

- NOTE:**
- Where an input of 1/2 LSB is called for, the voltage is equal to $\frac{FS}{256}$.
 - The sequence of calibration should be:
 - Zero offset
 - Full scale adjust
 - Zero offset
 - Full scale adjust

OPERATING PRECAUTIONS:

Analog and digital grounds should have separate returns. Noise and jitter on digital ground will degrade accuracy unless the input is referenced to a "clean" analog ground.

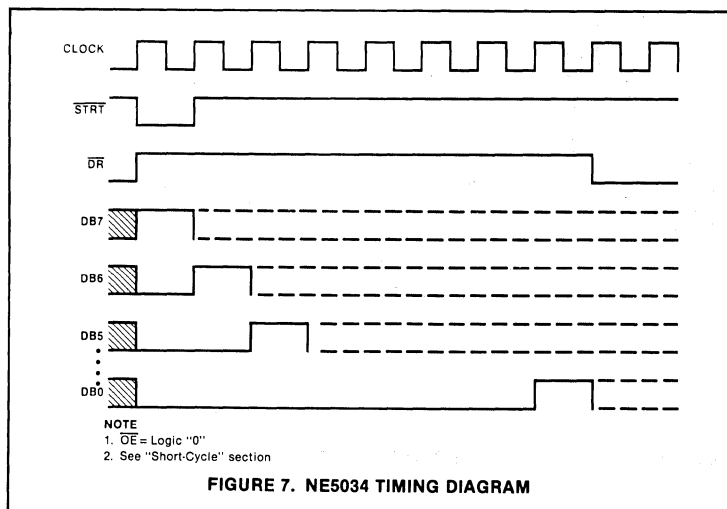

FIGURE 7. NE5034 TIMING DIAGRAM

UNIPOLAR BINARY OPERATION:

A standard connection for a 0 to 10V unipolar binary operation, with $V_{REF IN}$ equal to +5 volts, is shown in Figure 4. The NE5034 can quantize full scale ranges of 1V to 10V. It should be noted, however, that for smaller full scale ranges, the accuracy and speed will degrade.

The input voltage versus output code relationship for unipolar operation is shown in Table 1. The full scale range is 2 times $I_{REF IN}$.

Table 1. Unipolar—Binary

ANALOG INPUT NOTES 1, 2, 3	DIGITAL OUTPUT CODE	
	MSB	LSB
FS - 1 LSB	1 1 1 1 1 1 1 1	1
FS - 2 LSB	1 1 1 1 1 1 1 0	0
3/4 FS	1 1 0 0 0 0 0 0	0
1/2 FS + 1 LSB	1 0 0 0 0 0 0 1	1
1/2 FS	1 0 0 0 0 0 0 0	0
1/2 FS - 1 LSB	0 1 1 1 1 1 1 1	1
1/4 FS	0 1 0 0 0 0 0 0	0
1 LSB	0 0 0 0 0 0 0 1	1
0	0 0 0 0 0 0 0 0	0

Table 2. Bipolar—Offset Binary

ANALOG INPUT NOTES 1, 3, 4	DIGITAL OUTPUT CODE	
	MSB	LSB
+(FS - 1 LSB)	1 1 1 1 1 1 1 1	1
+(FS - 2 LSB)	1 1 1 1 1 1 1 0	0
+(1/2 FS)	1 1 0 0 0 0 0 0	0
+(1 LSB)	1 0 0 0 0 0 0 1	1
0	1 0 0 0 0 0 0 0	0
-(1 LSB)	0 1 1 1 1 1 1 1	1
-(1/2 FS)	0 1 0 0 0 0 0 0	0
-(FS - 1 LSB)	0 0 0 0 0 0 0 1	1
-FS	0 0 0 0 0 0 0 0	0

BIPOLAR (OFFSET BINARY) OPERATION:

A standard connection for a -5 to +5V or -10 to +10V bipolar operation is shown in Figure 5.

- NOTES:**
- Analog inputs shown are nominal center values of code.
 - "FS" is full scale; i.e., $2I_{REF IN}$ (Unipolar mode).
 - 1 LSB equals $(2 - 8)$ (FS).
 - "FS" is full scale; i.e., $I_{REF IN}$ (Bipolar mode).

6-BIT A/D CONVERTER (SERIAL OUTPUT)

NE5036

DESCRIPTION

The NE5036 is an easy to use, low cost, successive approximation Analog to Digital converter, fabricated in Bipolar/I²L technology, and packaged in a convenient 8-pin mini dip package.

With an external reference voltage, the NE5036 will accept input voltages between 0V and V_{REF}. Holding the START pin low for at least 8 clock pulses in duration will provide the 6-bit result of the conversion in a serial format.

FEATURES

- Three-state output buffer for easy μ Processor interfacing
- Fast successive approximation converter, 23 μ sec
- T²L compatible inputs and outputs
- Easy interface to CMOS μ Processors
- Guaranteed no missing codes over full operating range
- Single supply operation, +5V
- High Impedance analog inputs
- Positive true binary serial output

APPLICATIONS

- Temperature control
- μ P-based appliances
- Light level monitor
- Electronic toys
- Joystick interface
- μ P/Transducer interface

ABSOLUTE MAXIMUM RATINGS

PARAMETER	RATING	UNIT
V _{CC}	7	V
V _{REF}	7	V
V _{IN} (Analog)	7	V
V _{IN} (Digital)	7	V
D _{OUT}		
Three-state mode	7	V
Enabled mode	20	mA
Δ GND	± 1	V
T _A	0 to 70	°C
T _{Stg}	-65 to 150	°C
t _{Sold}	300	°C
P _D		
FE package	220	mW
N package	220	mW

PIN CONFIGURATION

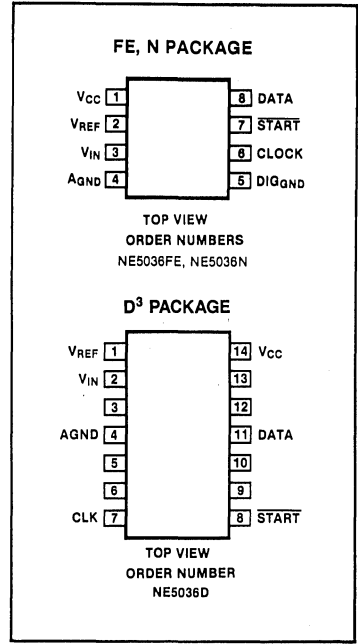

- NOTES:
1. SOL-Released in large SO package only
 2. SOL and non-standard pinout.
 3. SO and non-standard pinouts.

BLOCK DIAGRAM

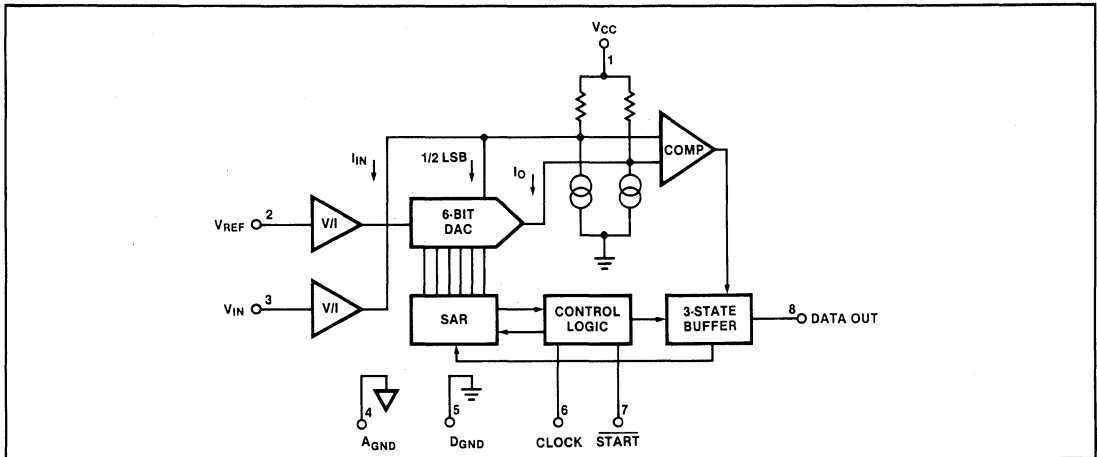

4

6-BIT A/D CONVERTER (SERIAL OUTPUT)

NE5036

DC ELECTRICAL CHARACTERISTICS $V_{CC} = 5.0V$; $V_{REF} = 2.0V$; Clock = 350kHz; $0^{\circ}C \leq T_A \leq 70^{\circ}C$ unless otherwise specified. Typical values are specified at 25°C.

SYMBOL AND PARAMETER	TEST CONDITIONS	MIN	TYP	MAX	UNIT
Resolution		6	6	6	Bits
Relative accuracy ^{1,2}			1/4	1/2	LSB
V_{CC} Positive supply voltage		+ 4.75	+ 5.0	+ 5.50	V
ϵ_{FS} Full scale gain error ^{2,3,4}	$V_{REF} = 2.0V, T_A = 25^{\circ}C$		± 1	± 2	LSB
ϵ_{ZS} Zero scale offset error ²	$V_{REF} = 2.0V, T_A = 25^{\circ}C$		$\pm 1/2$	- 1/2, + 2	LSB
P_{SR} Power supply rejection Max change in full scale ²	$V_{REF} = 2.0V$ $4.75V \leq V_{CC} \leq 5.5V$		$\pm 1/2$	± 1	LSB
I_{IN} Analog input bias current	$0 \leq V_{IN} \leq 2.5V$		1	10	μA
I_{REF} Reference bias current	$0 \leq V_{REF} \leq 2.5V$		1	10	μA
R_{IN} Analog input resistance		3	30		$M\Omega$
V_{IH} Logic '1' input voltage		2.0			V
V_{IL} Logic '0' input voltage				0.8	V
I_{IH} Logic '1' input current				10	μA
I_{IL} Logic '0' input current			1	10	μA
I_{OH} Logic '1' output current	$2.4V \leq V_{OH}$	300			μA
I_{OL} Logic '0' output current	$V_{OL} \leq 0.4V$	1.6			mA
I_{OZ} Three-state leakage current			± 0.1	± 40	μA
I_{CC} Positive supply current			14	24	mA

AC ELECTRICAL CHARACTERISTICS $V_{CC} = 5.0V$; $V_{REF} = 2.0V$; Clock = 350kHz; $0^{\circ}C \leq T_A \leq 70^{\circ}C$ unless otherwise specified. Typical values are specified at 25°C. (Refer to test figures.)

SYMBOL AND PARAMETER	TO	FROM	TEST CONDITIONS	MIN	TYP	MAX	UNIT
f_{MAX} Max clock frequency				350			kHz
T_{CONV} Conversion time						8	Clock cycles
t_W Clock pulse width				1.3			μs
t_S Setup time, START to clock ⁶	Clock	START		500			ns
$t_P(OUT)$ Propagation delay ⁵	Data out	Clock	$T_A = 25^{\circ}C, t_r = t_f < 20ns$			600	ns
$t_P(3-STATE)$ Propagation delay ⁵	Data (3-State)	START	$T_A = 25^{\circ}C, t_r = t_f < 20ns$			600	ns

NOTES

1. Relative accuracy is defined as the deviation of the code transition points from the ideal code transition points on the straight line drawn from zero scale to full scale of the device.
2. Specifications given in LSB's refer to the weight of the least significant bit at the bit level which is 1.56% of the full scale voltage.
3. Full scale gain error is the deviation of the code transition point (111110 to 111111) from its ideal value (accounting for offset error at 000000).
4. The analog input voltage (V_{IN}) range is from 0V to V_{REF} nominally, with the output remaining at 111111 even though the input may increase from V_{REF} to V_{CC} . (For optimum performance V_{REF} can be any value from 1.5V to 2.5V.)
5. The time between the specified reference points on the clock and the output waveforms with the output changing (low to high or high to low).
6. The high to low transition of the START pulse should occur at least 500ns prior to the negative edge of the clock pulse to insure its recognition. The START pulse should stay high for at least 500ns between conversions to guarantee proper recognition.

6-BIT A/D CONVERTER (SERIAL OUTPUT)

NE5036

CIRCUIT DESCRIPTION

NE5036 is a complete 6-bit, serial output, A/D converter which incorporates the successive approximation method. The chip includes the internal control logic, the successive approximation register (SAR), 6-bit DAC, comparator and the output buffer. An externally generated clock source (max freq = 350 kHz) must be provided to pin 6. An external reference voltage supplied to pin 2 sets the full scale range of the A/D converter as shown in the Block Diagram.

Upon the $\overline{\text{START}}$ pin going low, successive approximation conversion commences after the first low going edge of the clock pulse. Successive bits, beginning with the MSB (D5) are applied to the input of the internal 6-bit current output DAC by the I^2L successive approximation register.

The comparator determines whether the output current of the DAC is greater or less than the input current, converted from the unknown analog input voltage through the V/I converter. If the DAC output is greater, that bit of the DAC is set to

0 and simultaneously the output buffer goes to 0. If it is less, that bit stays at 1 and the output buffer goes to 1. After the second high to low transition of the clock pulse, the MSB (D5) data is valid. On successive clock pulses, successive bits are tried and the output buffer represents that bit. $\overline{\text{START}}$ has to stay low for at least 8 clock pulses for the conversion to be completed and to access the 6-bit result of the conversion. A conversion in process can be interrupted by issuing another $\overline{\text{START}}$ pulse.

When $\overline{\text{START}}$ is in a high state, the output buffer is in a high impedance state.

The timing diagram for the device is shown in Figure 1.

TRANSFER CHARACTERISTICS

The NE5036 is designed to have a nominal 1/2 LSB offset, so that the code transition points are located 1/2 LSB on either side of the exact analog input for a given code. Thus the first transition (000000 to 000001) will occur at an input of 1/2 LSB (15.63mV with a V_{REF} of 2.0V), plus any offset. Subsequent transition (to full scale — 111111)

will occur at 62.5 LSB (1.953V at V_{REF} of 2.0V).

The ideal transfer characteristic of NE5036 is shown in Figure 2.

LAYOUT PRECAUTIONS

Analog ground (pin 4) and Digital ground (pin 5) are not connected internally and should be connected together as close to the device as possible for optimum performance. The leads to the analog inputs should be kept as short as possible to minimize input noise pickup. Input bypass capacitors from the analog inputs to ground will eliminate noise pickup. Power supplies should be decoupled with at least 1 μ F and should be located close to the device to minimize the effects of noise spikes on V_{CC} .

The reference input and the analog voltage input must both remain stable during conversion to insure accuracy and proper operation. This can be done by adequately bypassing these inputs and/or keeping the impedance at these inputs at or below 2K-ohms.

4

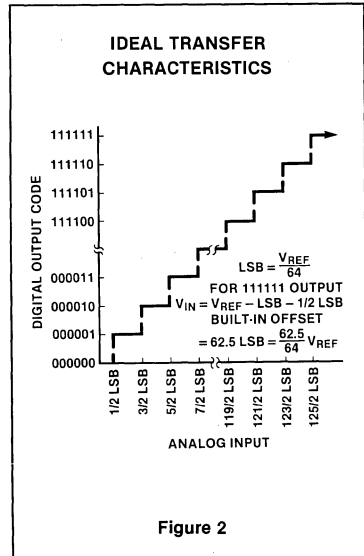
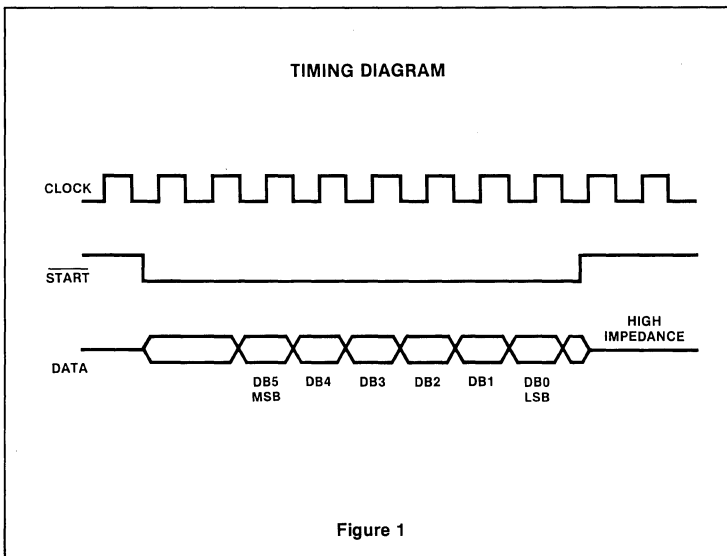

6-BIT A/D CONVERTER (SERIAL OUTPUT)

NE5036

TYPICAL PERFORMANCE CHARACTERISTICS

ZERO SCALE OFFSET ERROR vs TEMPERATURE

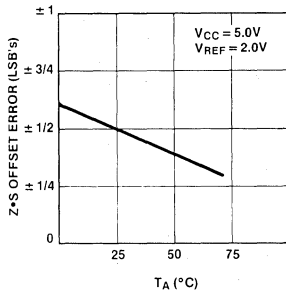

ZERO SCALE OFFSET ERROR vs V_{CC}

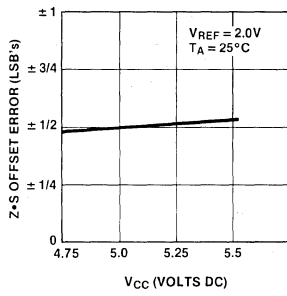

ZERO SCALE OFFSET ERROR vs V_{REF}

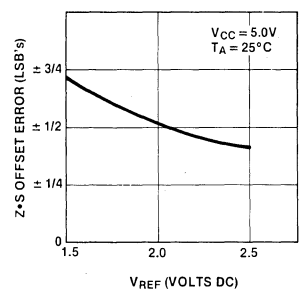

FULL SCALE GAIN ERROR vs TEMPERATURE

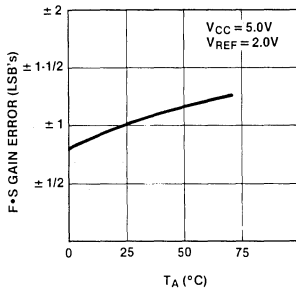

FULL SCALE GAIN ERROR vs V_{CC}

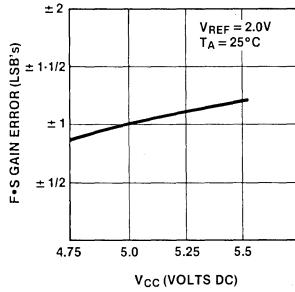

FULL SCALE GAIN ERROR vs R_{REF}

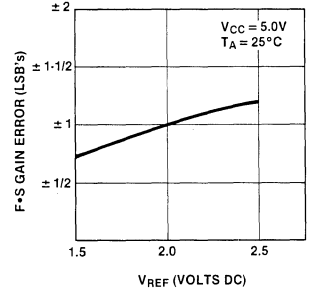

I_{OL} vs TEMPERATURE (DATA OUTPUT)

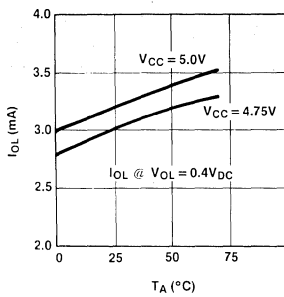

I_{OH} vs TEMPERATURE (DATA OUTPUT)

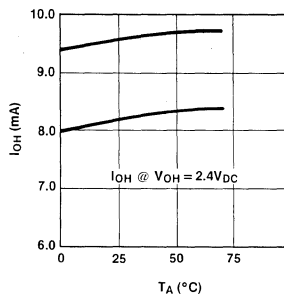

I_{CC} vs TEMPERATURE

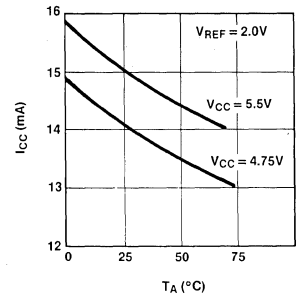

AC TEST CIRCUITS AND WAVEFORMS

PROPAGATION DELAY TIME t_p (DATA)

DATA OUTPUT (LOW TO HIGH)

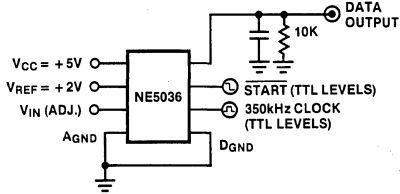

DATA OUTPUT (HIGH TO LOW)

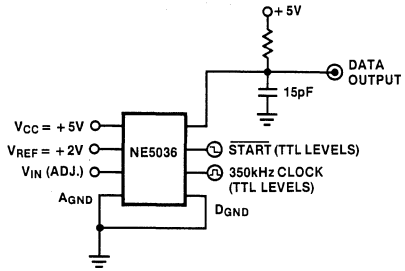

4

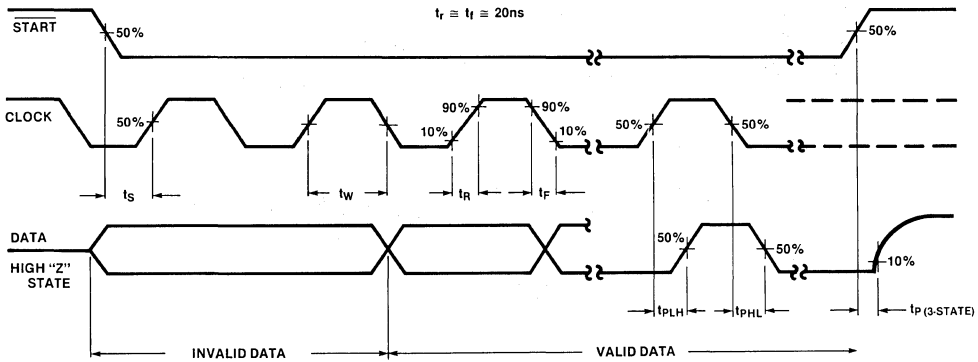

TYPICAL APPLICATION

1. BASIC NE5036 CONFIGURATION

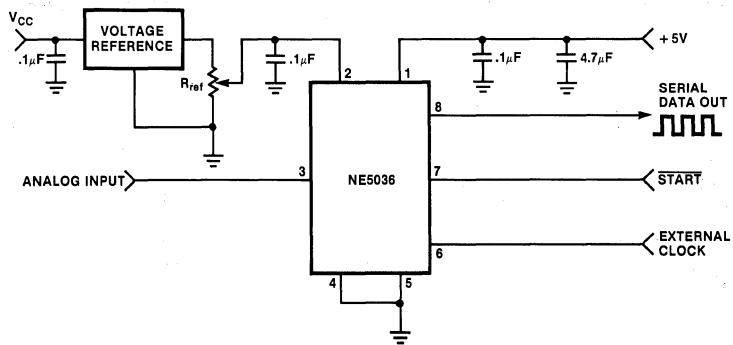

2. DIGITAL COMMUNICATIONS USING NE5036

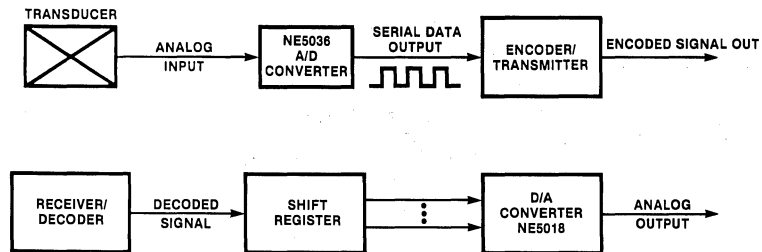

REGISTER ACCEPTS SERIAL
INPUT DATA, FEED D/A
IN PARALLEL

6-BIT A/D CONVERTER (PARALLEL OUTPUTS)

NE5037

DESCRIPTION

The NE5037 is a low cost, complete successive approximation analog to digital (A/D) converter, fabricated in Bipolar/1²L technology. With an external reference voltage, the NE5037 will accept input voltages between 0V and V_{REF}. An external START pulse of at least 300ns in duration will provide the 6-bit result of the conversion in parallel format. Full conversion with no missing codes occurs in 9 μ s.

FEATURES

- T²L compatible inputs and outputs
- Three state output buffer

- Easy interface to CMOS μ Processors
- Fast conversion—9 μ s
- Guaranteed no missing codes over full temp range
- Single supply operation, +5V
- Positive true binary outputs
- High impedance analog inputs

APPLICATIONS

- Temperature control
- μ P-based appliances
- Light level monitors
- Head position sensing
- Electronic toys
- Joystick interface

PIN CONFIGURATION

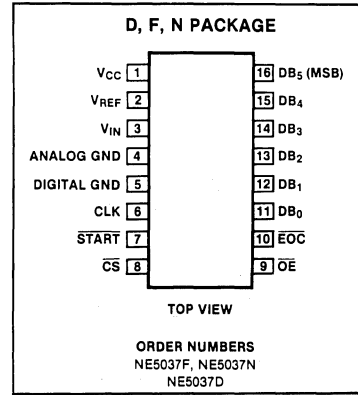

ABSOLUTE MAXIMUM RATINGS

PARAMETER	RATING	UNIT
V _{CC}	7	V
V _{REF}	7	V
V _{IN} (Analog)	7	V
V _{IN} (Digital)	7	V
D _{OUT}		
Data outputs (DB0 to DB5)		
Three-state mode	7	V
Enabled mode (each output)	5	mA
$\overline{\text{EOC}}$		
End of conversion	V _{CC}	
Δ GND	± 1	V
T _A	0 to 70	°C
T _{STG}	-65 to 150	°C
t _{SOLD}	300	°C
P _D		
Power dissipation		
F package	220	mW
N package	220	mW

BLOCK DIAGRAM

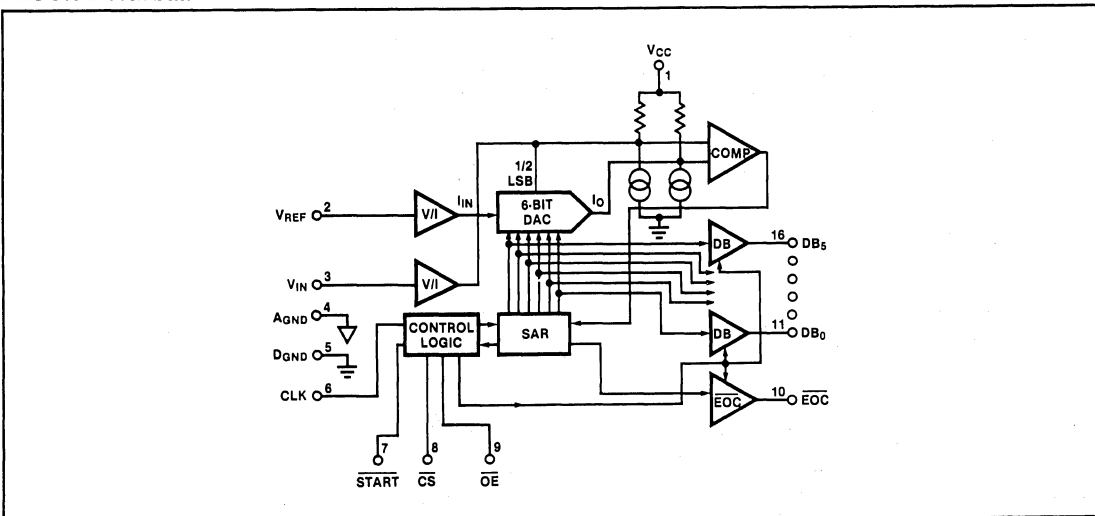

6-BIT A/D CONVERTER (PARALLEL OUTPUTS)

NE5037

DC ELECTRICAL CHARACTERISTICS $V_{CC} = 5.0V$; $V_{REF} = 2.0V$; Clock = 1MHz; $0^{\circ}C \leq T_A \leq 70^{\circ}C$ unless otherwise specified. Typical values are specified at $25^{\circ}C$.

SYMBOL AND PARAMETER	TEST CONDITIONS	MIN	TYP	MAX	UNIT
Resolution		6	6	6	Bits
Relative accuracy ^{1,2}			1/4	1/2	LSB
V_{CC} Positive supply voltage		+ 4.75	+ 5.0	+ 5.50	V
ϵ_{FS} Full scale gain error ^{2,3,4}	$V_{REF} = 2.0V, T_A = 25^{\circ}C$		± 1	± 2	LSB
ϵ_{ZS} Zero scale offset error ²	$V_{REF} = 2.0V, T_A = 25^{\circ}C$		$\pm 1/2$	- 1/2, + 2	LSB
P_{SR} Power supply rejection Max change in full scale ²	$V_{REF} = 2.0V$ $4.75V \leq V_{CC} \leq 5.5V$		$\pm 1/2$	± 1	LSB
I_{IN} Analog input bias current	$0 \leq V_{IN} \leq 2.5V$		1	10	μA
I_{REF} Reference bias current	$0 \leq V_{REF} \leq 2.5V$		1	10	μA
R_{IN} Analog input resistance		3	30		M Ω
V_{IH} Logic '1' input voltage		2.0			V
V_{IL} Logic '0' input voltage				0.8	V
I_{IH} Logic '1' input current				10	μA
I_{IL} Logic '0' input current			1	10	μA
I_{OH} Logic '1' output current ⁵	$2.4V \leq V_{OH}$	300			μA
I_{OL} Logic '0' output current ⁵	$V_{OL} \leq 0.4V$	1.6			mA
I_{OZ} Three-state leakage current			± 0.1	± 40	μA
I_{CC} Positive supply current			18	24	mA

AC ELECTRICAL CHARACTERISTICS $V_{CC} = 5.0V$; $V_{REF} = 2.0V$; Clock = 1MHz; $0^{\circ}C \leq T_A \leq 70^{\circ}C$ unless otherwise specified. Typical values are specified at $25^{\circ}C$. (Refer to AC test figures.)

SYMBOL AND PARAMETER	TO	FROM	TEST CONDITIONS	MIN	TYP	MAX	UNIT
f_{MAX} Maximum clock frequency				1			MHz
t_W Start pulse width				300			ns
Minimum positive/negative clock pulse width				300			ns
T_{CONV} Conversion time						9	Clock cycles
t_P (OUT DATA) Propagation delay ⁶	Data out	\overline{OE}	$T_A = 25^{\circ}C, t_r = t_f \leq 20ns$			500	ns
t_P (OUT EOC) Propagation delay ⁷	EOC	Clock	$T_A = 25^{\circ}C, t_r = t_f \leq 20ns$			800	ns
t_P (3-STATE) Propagation delay, 3-state	3-State Data	\overline{OE}	$T_A = 25^{\circ}C, t_r = t_f \leq 20ns$			500	ns

NOTES

- Relative accuracy is defined as the deviation of the code transition points from the ideal code transition points on a straight line drawn from zero scale to full scale of the device.
- Specifications given in LSB's refer to the weight of the least significant bit at the 6 bit level which is 1.56% of the full scale voltage.
- Full scale gain error is the deviation of the full scale code transition point (111110 to 111111) from its ideal value.
- The analog input voltage (V_{IN}) range is 0V to V_{REF} nominally, with the output remaining at 111111 even though the input may increase from V_{REF} to V_{CC} . (For optimum performance, V_{REF} can be any value from 1.5V to 2.5V.)
- The data outputs have active pull-ups. The \overline{EOC} line is open collector with a nominal 5k Ω internal pull-up resistor
- Propagation delay of data outputs is defined as the delay in the data outputs reaching their final value after the low going edge of \overline{OE} .
- Propagation delay of \overline{EOC} is defined as the delay in \overline{EOC} going low, following the low going edge of the 9th clock pulse after the start pulse.

CIRCUIT DESCRIPTION

NE5037 is a complete 6-bit, parallel output, microprocessor compatible, A/D converter which incorporates the successive approximation method. The chip includes the internal control logic, the successive approximation register (SAR), 6-bit DAC, comparator and output buffers. An externally generated clock source (max frequency = 1MHz) must be provided to pin 6.

An external reference voltage supplied to pin 2 sets the full scale range of the A/D converter.

The \overline{CS} pin must be at a low level prior to the start of the conversion process. Upon receipt of a START pulse the internal control logic resets the SAR. On the first low going edge of the clock pulse, successive approximation conversion commences. Successive bits beginning with the MSB

(D5) are supplied to the input of the internal 6-bit current output DAC by the I²L successive approximation register.

The comparator determines whether the output current of the DAC is greater or less than the input current, converted from the unknown analog input voltage through the V/I converter. If the DAC output is greater, that bit of the DAC is set to '0' and simultaneously the corresponding

6-BIT A/D CONVERTER (PARALLEL OUTPUTS)

NE5037

output buffer goes to '0'. If it is less, that bit stays at '1' and the output buffer also stays at '1'. On successive clock pulses, successive bits of the DAC are tried and the corresponding output buffer represents the bits of the DAC. On the eighth low going edge of the clock pulse (after the receipt of the start pulse). The EOC pin goes low, thereby indicating that the conversion is complete. The output data is now valid. In order to access the result of the conversion, the OE pin must be set to a low level. EOC is reset to a high state when OE is low. When OE is in a '1' state, the output buffers are in a high impedance state.

Refer to Figure 1 for the timing diagram.

TRANSFER CHARACTERISTICS

The ideal transfer characteristic of the NE5037 is shown in Figure 2.

The NE5037 is designed to have a nominal 1/2 LSB offset so that the code transition points are located 1/2 LSB on either side of the exact analog inputs for a given code.

Thus the first transition (000000 to 000001) will occur at an input of 1/2 LSB (15.63mV with a VREF of 2.0V). Subsequent transitions will occur at nominal increments of 1 LSB. The last transition (to full scale—111111) will occur at 62.5 LSB (1.953V at VREF of 2.0V).

LAYOUT PRECAUTIONS

Analog ground (pin 4) and Digital ground (pin 5) are not connected internally and

should be connected together as close to the device as possible, for optimum performance. The circuit will operate with as much as ±200mV between the two grounds but some degradation will occur. The leads to the analog inputs should be kept as short as possible to minimize noise pickup. Input bypass capacitors from the analog inputs to ground will eliminate noise pickup. Power supplies should be decoupled with at least 1µF located close to the device to minimize the effects of noise spikes.

The reference input and the analog voltage input must both remain stable during conversion to insure accuracy and proper operation. This can be done by adequately bypassing these inputs and/or keeping the impedance of these inputs at or below 2K-ohms.

4

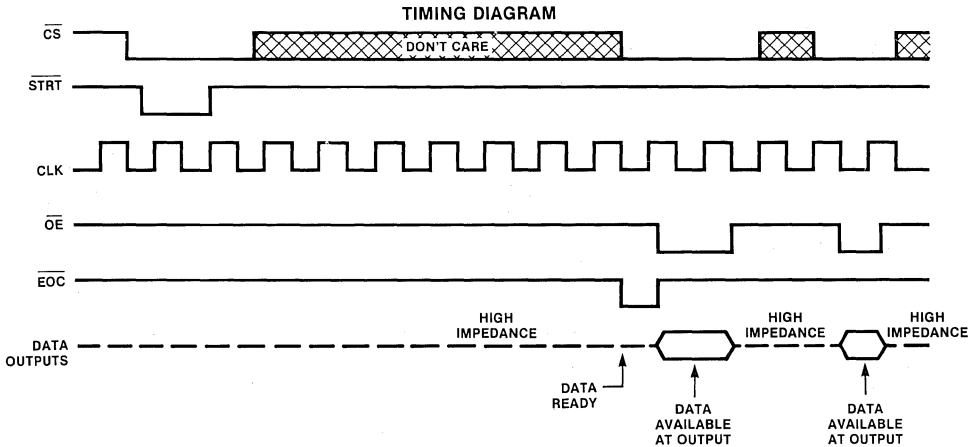

Figure 1

IDEAL TRANSFER CHARACTERISTICS

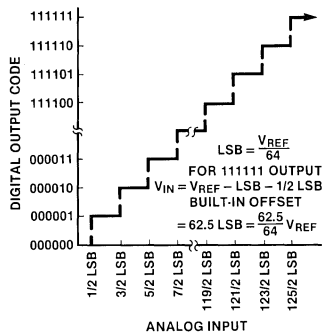
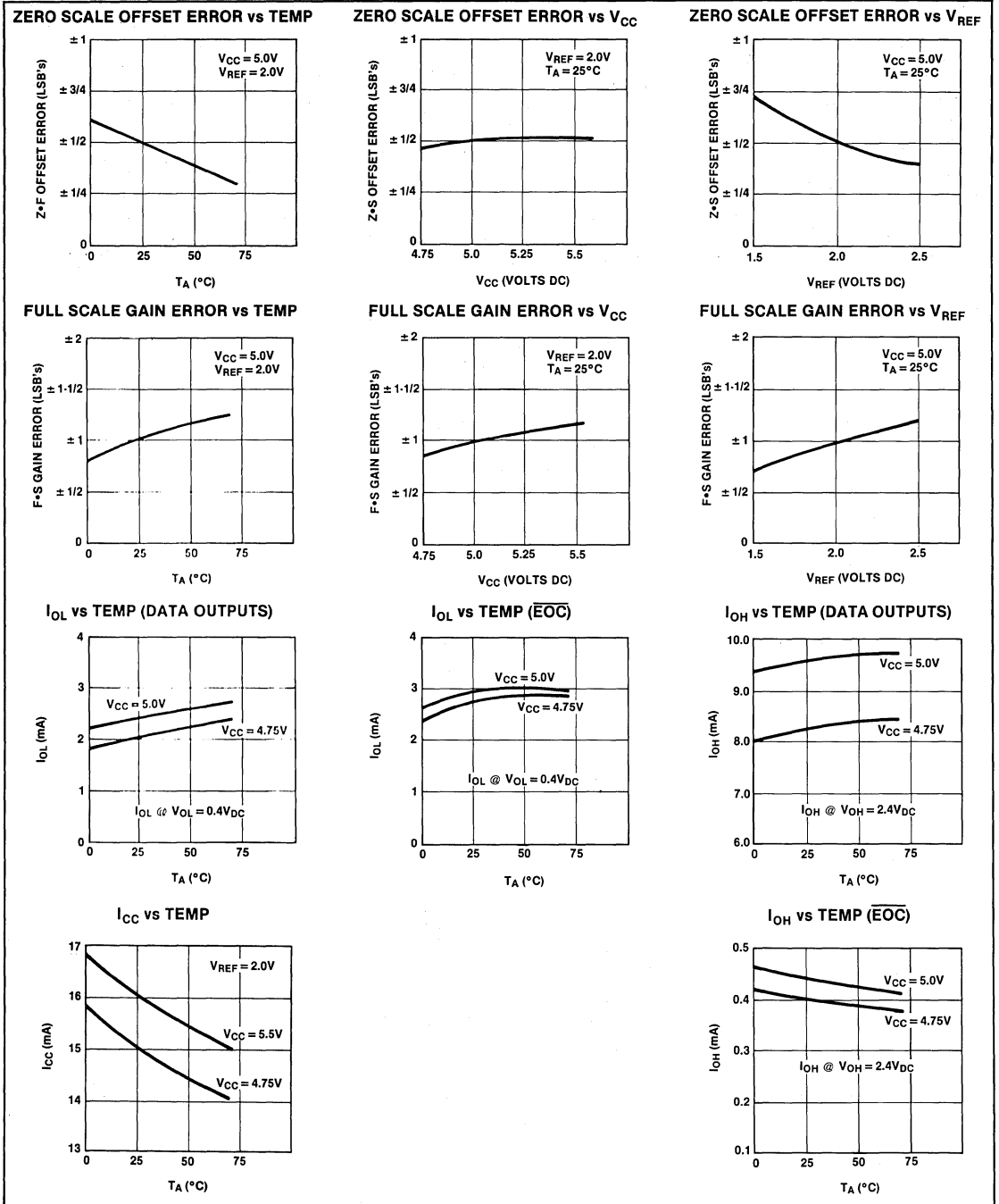

Figure 2

TYPICAL PERFORMANCE CHARACTERISTICS



AC TEST CIRCUITS AND WAVEFORMS

PROPAGATION DELAY TIME t_P (DATA) AND t_P (3-STATE)

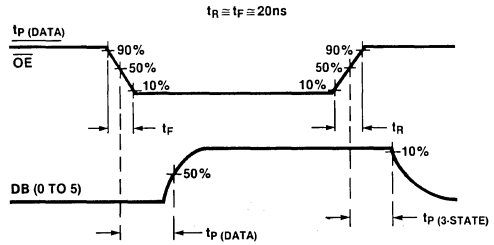
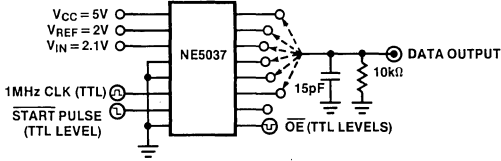

DATA OUTPUT HIGH

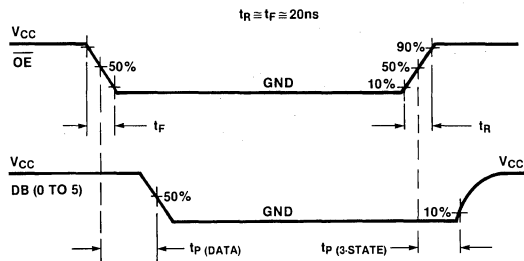
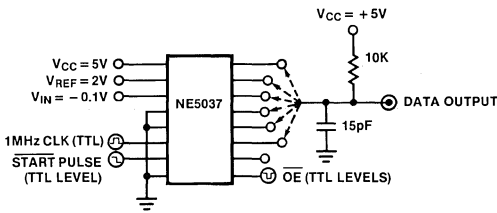

PROPAGATION DELAY TIME EOC t_P (EOC)

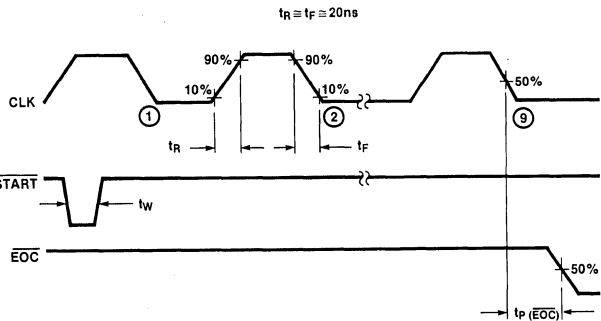
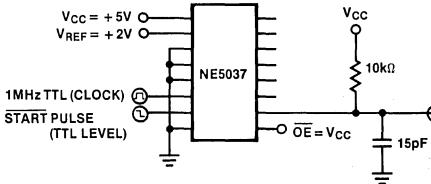

4

6-BIT A/D CONVERTER (PARALLEL OUTPUTS)

NE5037

APPLICATION

- 0 to 63°C Temperature Sensor

CIRCUIT DESCRIPTION

The temperature sensor of Figure 3A provides an input to Pin 3 of the NE5037 of 32 millivolts per degree Celsius. This 32mV is the value of one LSB for the NE5037. The LM334 is a three-terminal temperature sensor and provides a current of 1 microamp for each degree Kelvin. The 32K-ohm resistor provides the 32 millivolts for each microamp through it, while the transistor bleeds off 273 microamps of the temperature sensor (LM334) current, lowering the reading by 273 degrees Kelvin, thus converting from Kelvin to Celsius.

To read temperature, conversion is started by sending a momentary low signal to Pin 7 of the NE5037. When Pin 10 of the NE5037 goes low, conversion is complete and a low is applied to Pin 9 of the NE5037 to read data on Pins 11 through 16. Note that this temperature data is in straight binary format.

The controller can be a microprocessor in a temperature control application, or discrete circuitry in a simple temperature reporting application. A temperature reporting (digital thermometer) circuit is shown in Figure 3B. The ROMs or PROMs

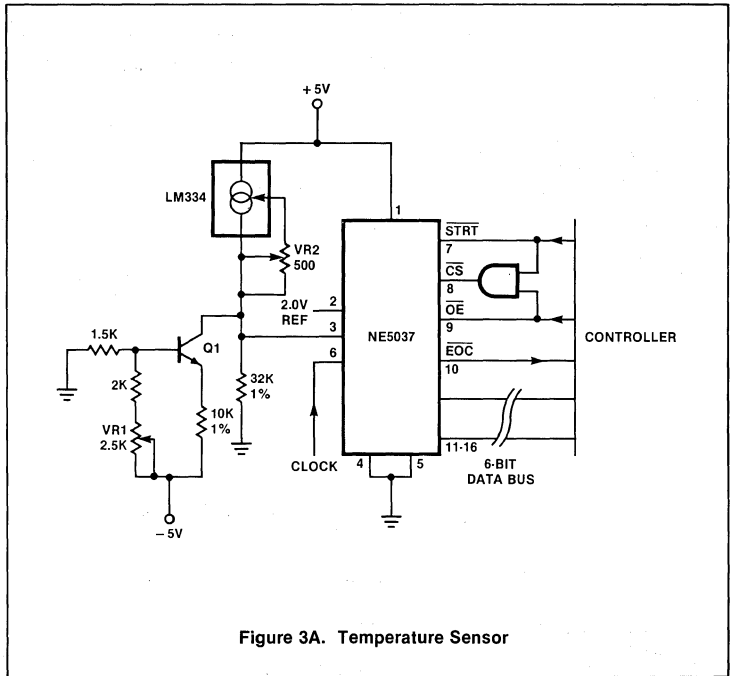

Figure 3A. Temperature Sensor

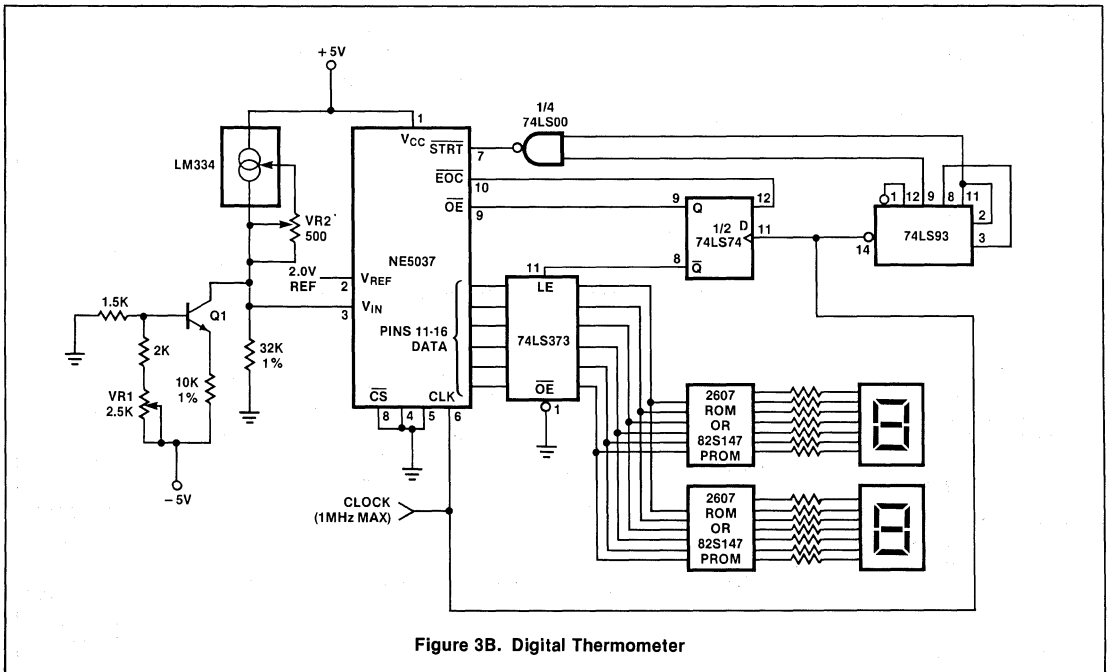

Figure 3B. Digital Thermometer

must have the correct code for converting the data from the NE5037 (used as address for the ROMs or PROMs) to the appropriate segment driver codes.

The displayed output could easily be converted to degrees Fahrenheit by the controller of Figure 3A or through the (P)ROMs of Figure 3B. When doing this, a third (hundreds) digit (P)ROM and display will, of course, be needed for displaying temperatures above 99°F.

An inexpensive clock can be made from NAND gates or inverters, as shown in Figure 3C.

CIRCUIT ADJUSTMENT

Adjust VR2 for about 1/4 of maximum resistance. With the sensor (LM334) stable at a known temperature near the lower end of the expected range of temperature readings, adjust VR1 for a drop of 2.73 volts across the (10K) emitter resistor of Q1. Set reference voltage at Pin 2 of the NE5037 for 2 volts and adjust VR2 for a digital reading corresponding to the known temperature.

Because high accuracy is not necessary in many applications, this is often all the adjustment necessary and yields an indicated temperature that is within 3

degrees Celsius of actual temperature. Should higher accuracy be required, adjustment of the NE5037 reference voltage at Pin 2 is needed. After performing the above adjustments, bring the sensor temperature to a value near the maximum expected reading (but not above 63 degrees Celsius) and adjust the reference voltage at Pin 2 of the NE5037 for a digital output indication of the known temperature. Then stabilize the sensor again at a temperature near the low end of the expected range of readings and adjust VR1 for a digital indication of that known temperature. This procedure will provide an accuracy of ± 1 degree Celsius.

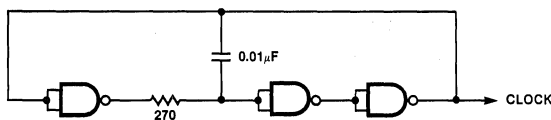

Figure 3C. Simple Clock Circuit

DESCRIPTION

The Am6012 12-Bit multiplying Digital-to-Analog converter provides high speed and 0.025% differential nonlinearity over its full commercial temperature range.

The D/A converter uses a 3-bit segment generator for the MSBs in conjunction with a 9-bit R-2R diffused resistor ladder to provide 12-bit resolution without costly trimming processes. This technique guarantees a very uniform step size (up to $\pm 1/2$ LSB from the ideal), monotonicity to 12 bits and integral nonlinearity to 0.05% at its differential current outputs.

The dual complementary outputs of the Am6012 increase its versatility, and effectively double the peak-to-peak output swing. Digital inputs, in addition, can be configured to accept all popular logic families.

While the device requires a reference input of 1mA for a 4mA full scale current, operation is nearly independent of power supply voltage shifts. The power supply rejection ratio is $\pm 0.001\%$ FS/% ΔV . The devices will work from +5, -12V to $\pm 18V$ rails, with as low as 230mW power consumption typical.

FEATURES

- 12-bit resolution
- Accurate to within $\pm 0.05\%$
- Monotonic over temperature
- Fast settling time, 250ns typical
- Trimless design for low cost
- Differential current outputs
- High-speed multiplying capability
- Full scale current, 4mA (with 1mA reference)
- High output compliance voltage, -5 to +10V
- Low power consumption, 230mW

APPLICATIONS

- CRT displays, computer graphics
- Robotics, and machine tools
- Automatic test equipment
- Programmable power supplies
- CAD/CAM systems
- Data acquisition and control systems
- Analog-to-Digital converter systems

PIN CONFIGURATION

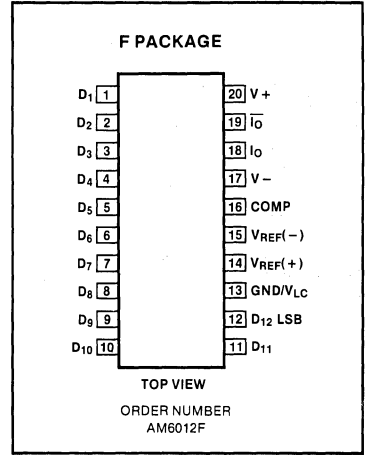

ABSOLUTE MAXIMUM RATINGS

Operating Temperature Am6012F	0°C to +70°C
Storage Temperature	-65°C to +150°C
Lead Temperature (Soldering, 60 sec)	300°C
Power Supply Voltage	$\pm 18V$
Logic Inputs	-5V to +18V
Voltage Across Current Outputs	-8V to +12V
Reference Inputs V_{14}, V_{15}	V- to V+
Reference Input Differential Voltage (V_{14} to V_{15})	$\pm 18V$
Reference Input Current (I_{14})	1.25mA

BLOCK DIAGRAM

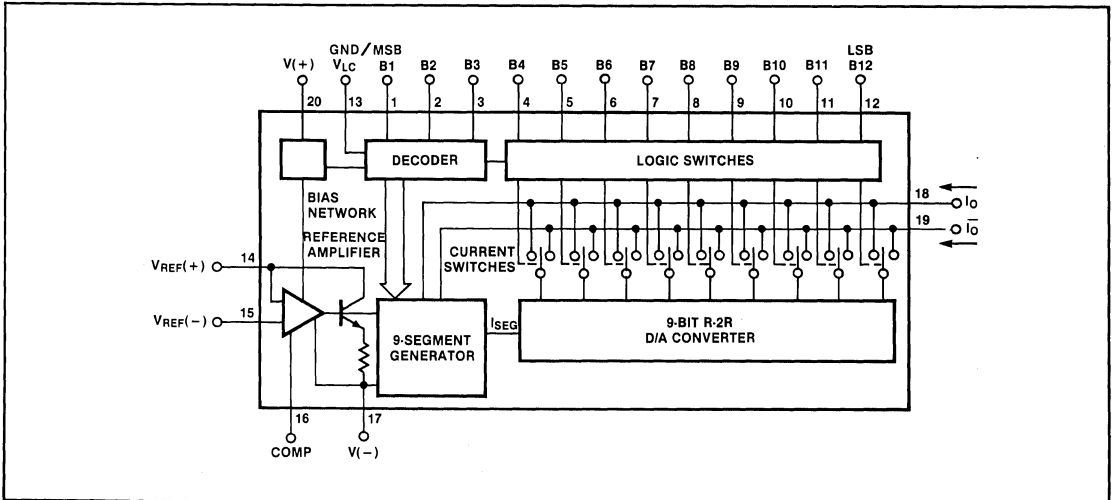

12-BIT MULTIPLYING DIGITAL-TO-ANALOG CONVERTER

Am6012

ELECTRICAL CHARACTERISTICS: $V_+ = +15V, V_- = -15V, I_{REF} = 1.0mA, 0^\circ C \leq T_A \leq 70^\circ C$

Parameter	Description		Test Conditions	Am6012F			Units
				Min.	Typ.	Max.	
	Resolution			12			Bits
	Monotonicity			12			Bits
D.N.L.	Differential Nonlinearity		Deviation from ideal step size	—	—	± .025	%FS
				12	—	—	Bits
N.L.	Nonlinearity		Deviation from ideal straight line	—	—	± .05	%FS
I_{FS}	Full Scale Current		$V_{REF} = 10.000V$ $R_{14} - R_{15} = 10.000k\Omega$ $T_A = 25^\circ C$	3.935	3.999	4.063	mA
TCI_{FS}	Full Scale Tempco			—	± 10	± 40	ppm/°C
					± .001	± .004	%FS/°C
V_{OC}	Output Voltage Compliance		D.N.L. Specification guaranteed over compliance range $R_{OUT} > 10$ megohms typ.	- 5	—	+ 10	Volts
I_{FSS}	Symmetry		$I_{FS} - I_{\overline{FS}}$	—	± 0.4	± 2.0	μA
I_{ZS}	Zero Scale Current			—	—	0.10	μA
t_s	Settling Time		To ±1/2 LSB, all bits ON or OFF, $T_A = 25^\circ C$	—	250	500	nsec
t_{PLH} t_{PHL}	Propagation Delay — all bits		50% to 50%	—	25	50	nsec
C_{OUT}	Output Capacitance			—	20	—	pF
V_{IL} V_{IH}	Logic Input Levels	Logic "0"		—	—	0.8	Volts
		Logic "1"		2.0	—	—	
I_{IN}	Logic Input Current		$V_{IN} = -5$ to +18V	—	—	40	μA
V_{IS}	Logic Input Swing		$V_- = -15V$	- 5	—	+ 18	Volts
I_{REF}	Reference Current Range			0.2	1.0	1.1	mA
I_{15}	Reference Bias Current			0	- 0.5	- 2.0	μA
dI/dt	Reference Input Slew Rate		$R_{14(eo)} = 800\Omega$ $CC = 0pF$	4.0	8.0	—	mA/μs
$PSSI_{FS+}$	Power Supply Sensitivity		$V_+ = +13.5V$ to +16.5V, $V_- = -15V$	—	± 0.0005	± .001	%FS/%
$PSSI_{FS-}$			$V_- = -13.5V$ to -16.5V, $V_+ = +15V$	—	± .00025	± .001	
V_+ V_-	Power Supply Range		$V_{OUT} = 0V$	4.5 - 18	—	18 - 10.8	Volts
I_+ I_- I_+ I_-	Power Supply Current		$V_+ = +5V, V_- = -15V$ $V_+ = +15V, V_- = -15V$	— —	5.7 - 13.7	8.5 - 18.0	
P_D	Power Dissipation		$V_+ = +5V, V_- = -15V$	—	234	312	mW
			$V_+ = +15V, V_- = -15V$	—	291	397	

4

CIRCUIT DESCRIPTION

The Am6012 is a 12-bit DAC which uses diffused resistors and requires no trimming to guarantee monotonicity over the temperature range. A segmented DAC design guarantees a more uniform step size over the temperature range than is normally available with trimmed 12-bit converters. The converter features differential high compliance current outputs, wide supply range, and a multiplying reference input.

In many converter applications, uniform step size is more important than conformance to an ideal straight line. Many 12-bit converters are used for high resolution rather than high linearity, since few transducers are more linear than $\pm 0.1\%$. All classic binarily weighted converters require $\pm 1/2$ LSB ($\pm .012\%$) linearity in order to guarantee monotonicity, which requires very tight resistor matching and tracking. The Am6012 uses conventional bipolar processing to achieve high differential linearity and monotonicity without requiring correspondingly high linearity, or conformance to an ideal straight line.

One design approach which provides monotonicity without requiring high linearity is the MOS switch-resistor string. This circuit is actually a full complement to a current switched R-2R DAC since it is slower, has a voltage output, and if implemented at the 12-bit level would use 4096 low tolerance resistors rather than a minimum number of high tolerance resistors as in the R-2R network. Its lack of speed and density for 12 bits are its drawbacks.

With the segmented DAC approach, the 4096 required output levels are composed of 8 groups of 512 steps each. Each step group is generated by a 9-bit DAC, and each of the segment slopes is determined by one of 8 equal current sources. The resistors which determine monotonicity are in the 9-bit DAC. The major carry of the 9-bit DAC is repeated in each of the 8 segments, and requires eight times lower initial resistor accuracy and tracking to maintain a given differential nonlinearity over temperature.

The operation of the segmented DAC may be visualized by assuming an input code of all zeroes. The first segment current I_0 is divided into 512 levels by the 9-bit multiplying DAC and fed to the output, I_{OUT} . As the input code increases, a new segment current is selected for each 512 counts. The previous segment is fed to output I_{OUT} where the new step group is added to it, thus ensuring monotonicity in-

dependent of segment resistor values. All higher order segments feed I_{OUT} .

With the segmented DAC approach, the precision of the 8 main resistors determines linearity only. The influence of each of these resistors on linearity is four times lower than that of the MSB resistor in an R-2R DAC. Hence, assuming the same resistor tolerances for both, the linearity of the segmented approach would actually be higher than that of an R-2R design.

The step generator or 9-bit DAC is composed of a master and a slave ladder. The slave ladder generates the four least significant bits from the remainder of the master ladder by active current splitting utilizing scaled emitters. This saves ladder resistors and greatly reduces the range of emitter scaling required in the 9-bit DAC. All current switches in the step generator are high speed fully differential switches which are capable of switching low currents at high speed. This allows the use of a binary scaled network all the way to the least significant bit which saves power and simplifies the circuitry.

Diffused resistors have advantages over thin film resistors beyond simple economy and bipolar process compatibility. The resistors are fabricated in single crystal rather than amorphous material which gives them better long term stability and tracking and much higher moisture resistance. They are diffused at 1000°C and so are resistant to changes in value due to thermal and chemical causes. Also, no burn-in is required for stability. The contact resistance between aluminum and silicon is more predictable than between aluminum and an amorphous thin film, and no sandwich metals are required to enhance or protect the contact or limit alloying. The initial match between two diffused resistors is similar to that of thin film since both are defined by photomasks and chemical etching. Since the resistors are not trimmed or altered after fabrication, their tracking and long term characteristics are not degraded.

DIFFERENTIAL vs INTEGRAL NONLINEARITY

Integral nonlinearity, for the purposes of the discussion, refers to the "straightness" of the line drawn through the individual response points of a data converter. Differential nonlinearity, on the other hand, refers to the deviation of the spacing of the adjacent points from a 1 LSB ideal spacing. Both may be expressed as either a percentage of full scale output or

as fractional LSBs or both. The graphs in Figure 1 define the manner in which these parameters are specified. The left graph shows a portion of the transfer curve of a DAC with 1/2 LSB INL and the (implied) DNL spec of 1LSB. Below this is a graphic representation of the way this would appear on a CRT screen where the Am6012 is used as a display driver. On the right is a portion of the transfer curve of a DAC specified for 2LSB INL with 1/2 LSB DNL specified and the graphic display below it.

One of the characteristics of an R-2R DAC in standard form is that any transition which causes a zero LSB change (i.e. the same output for two different codes) will exhibit the same output each time that transition occurs. The same holds true for transitions causing a 2LSB change. These two problem transitions are allowable for the standard definition of monotonicity and also allow the device to be specified very tightly for INL. The major problem arising from this error type is in A/D converter implementations. Inputs producing the same output are now represented by ambiguous output codes for an identical input. Also, 2LSB gaps can cause large errors at those input levels (assuming 1/2 LSB quantizing levels). It can be seen from the two figures that the DNL specified D/A converter will yield much finer grained data than the INL specified part, thus improving the ability of the A/D to resolve changes in the analog input.

ANALOG OUTPUT CURRENTS

Both true and complemented output sink currents are provided where $I_0 + \bar{I}_0 = I_{FR}$. Current appears at the "true" output when a "1" is applied to each logic input. As the binary count increases, the sink current at pin 18 increases proportionally, in the fashion of a "positive logic" D/A converter. When a "0" is applied to any input bit, that current is turned off at pin 18 and turned on at pin 19. A decreasing logic count increases \bar{I}_0 as in a negative or inverted logic D/A converter. Both outputs may be used simultaneously. If one of the outputs is not required it must still be connected to ground or to a point capable of sourcing I_{FR} ; do not leave an unused output pin open.

Both outputs have an extremely wide voltage compliance enabling fast direct current-to-voltage conversion through a resistor tied to ground or other voltage source. Positive compliance is 25V above V_- and is independent of the positive supply. Negative compliance is +10V above V_- .

DIFFERENTIAL LINEARITY COMPARISON

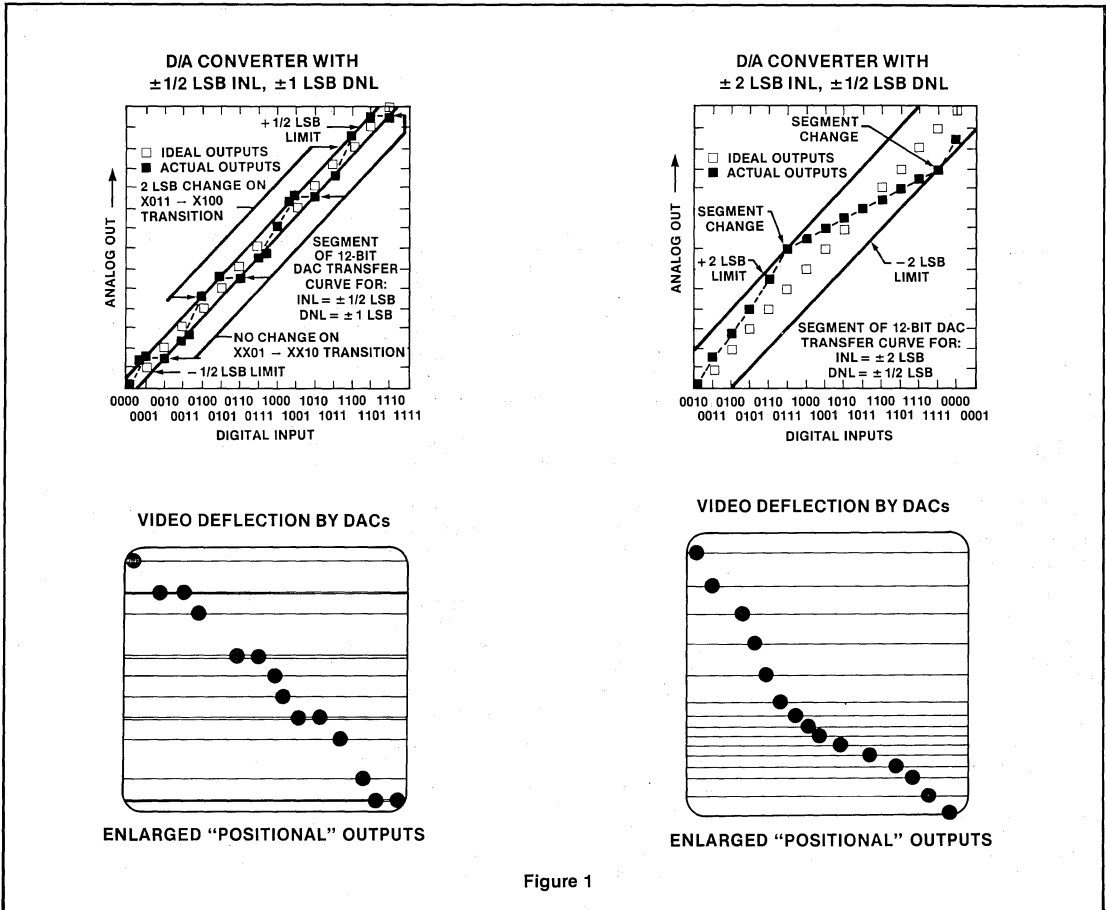

Figure 1

The dual outputs enable double the usual peak-to-peak load swing when driving loads in quasi-differential fashion. This feature is especially useful in cable driving, CRT deflection and in other balanced applications such as driving center-tapped coils and transformers.

POWER SUPPLIES

The Am6012 operates over a wide range of power supply voltages from a total supply of 20V to 36V. When operating with V-supplies of -10V or less, I_{REF} ≤ 1mA is recommended. Low reference current operation decreases power consumption and increases negative compliance, reference amplifier negative common mode

range, negative logic input range, and negative logic threshold range; consult the various figures for guidance. For example, operation at -9V with I_{REF} = 1mA is not recommended because negative output compliance would be reduced to near zero. Operation from lower supplies is possible, however at least 8V total must be applied to insure turn-on of the internal bias network.

Symmetrical supplies are not required, as the Am6012 is quite insensitive to variations in supply voltage. Battery operation is feasible as no ground connection is required; however, an artificial ground may be used to insure logic swings, etc. remain between acceptable limits.

TEMPERATURE PERFORMANCE

The nonlinearity and monotonicity specifications of the Am6012 are guaranteed to apply over the entire rated operating temperature range. Full scale output current drift is tight, typically ±10ppm/°C, with zero scale output current and drift essentially negligible compared to 1/2 LSB.

The temperature coefficient of the reference resistor R14 should match and track that of the output resistor for minimum overall full scale drift.

SETTLING TIME

The Am6012 is capable of extremely fast settling times, typically 250ns at

$I_{REF} = 1.0\text{mA}$. Judicious circuit design and careful board layout must be employed to obtain full performance potential during testing and application. The logic switch design enables propagation delays of only 25ns for each of the 12 bits. Settling time to within 1/2 LSB of the LSB is therefore 25ns, with each progressively larger bit taking successively longer. The MSB settles in 250ns, thus determining the overall settling time of 250ns. Settling to 10-bit accuracy requires about 90 to 130ns. The output capacitance of the Am6012 including the package is approximately 20pF; therefore, the output RC time constant dominates settling time if $R_L > 500\Omega$.

Settling time and propagation delay are relatively insensitive to logic input amplitude and rise and fall times, due to the high gain of the logic switches. Settling time also remains essentially constant for I_{REF} values down to 0.5mA, with gradual increases for lower I_{REF} values lies in the ability to attain a given output level with lower load resistors, thus reducing the output RC time constant.

Measurement of settling time requires the ability to accurately resolve $\pm 2\mu\text{A}$, therefore a 2.5k Ω load is needed to provide adequate drive for most oscilloscopes. At I_{REF} values of less than 0.5mA, excessive RC damping of the output is difficult to prevent while maintaining adequate sensitivity. However, the major carry from 011111111111 to 100000000000 provides an accurate indicator of settling time. This code change does not require the normal 6.2 time constants to settle to within $\pm 0.1\%$ of the final value, and thus settling times may be observed at lower values of I_{REF} .

Am6012 switching transients or "glitches" are very low and may be further reduced by small capacitive loads at the output at a minor sacrifice in settling time.

Fastest operation can be obtained by using short leads, minimizing output capacitance and load resistor values, and by adequate bypassing at the supply, reference, and V_{LC} terminals. Supplies do not require large electrolytic bypass capacitors as the supply current drain is independent of input logic states; 0.1 μF capacitors at the supply pins provide full transient protection.

APPLICATIONS INFORMATION

REFERENCE AMPLIFIER SETUP

The Am6012 is a multiplying D/A converter in which the output current is the product

of a digital number and the input reference current. The reference current may be fixed or may vary from nearly zero to +1.0mA. The full range output current is a linear function of the reference current and is given by:

$$I_{FR} = \frac{4095}{4096} \times 4 \times (I_{REF}) = 3.999 I_{REF}$$

where $I_{REF} = I_{14}$

In positive reference applications, an external positive reference voltage forces current through R14 into the $V_{REF(+)}$ terminal (pin 14) of the reference amplifier. Alternatively, a negative reference may be applied to $V_{REF(-)}$ at pin 15. Reference current flows from ground through R14 into $V_{REF(+)}$ as in the positive reference case. This negative reference connection has the advantage of a very high impedance presented at pin 15. The voltage at pin 14 is equal to and tracks the voltage at pin 15 due to the high gain of the internal reference amplifier. R15 (nominally equal to R14) is used to cancel bias current errors. (Figure 2a)

Bipolar references may be accommodated by offsetting V_{REF} or pin 15. The negative common-mode range of the reference amplifier is given by: $V_{CM-} = V- \text{ plus } (I_{REF} \times 3\text{k}\Omega) \text{ plus } 1.8\text{V}$. The positive common-mode range is $V+ \text{ less } 1.23\text{V}$.

When a DC reference is used, a reference bypass capacitor is recommended. A 5.0V TTL logic supply is not recommended as a reference. If a regulated power supply is used as a reference, R14 should be split into two resistors with the junction bypassed to ground with a 0.1 μF capacitor.

For most applications the tight relationship between I_{REF} and I_{FS} will eliminate the need for trimming I_{REF} . If required, full scale trimming may be accomplished by adjusting the value of R14, or by using a potentiometer for R14.

MULTIPLYING OPERATION

The Am6012 provides excellent multiplying performance with an extremely linear relationship between I_{FS} and I_{REF} over a range of 1mA to 1 μA . Monotonic operation is maintained over a typical range of I_{REF} from 100 μA to 1.0mA.

REFERENCE AMPLIFIER COMPENSATION FOR MULTIPLYING APPLICATIONS

AC reference applications will require the reference amplifier to be compensated using

a capacitor from pin 16 to $V-$. The value of this capacitor depends on the impedance presented to pin 14. For R14 values of 1.0, 2.5 and 5.0k Ω ; minimum values of C_C are 5, 12 and 25pF. Larger values of R14 require proportionately increased values of C_C for proper phase margin. (See Figure 2b)

For fastest response to a pulse, low values of R14 enabling small C_C values should be used. If pin 14 is driven by a high impedance such as a transistor current source, none of the above values will suffice and the amplifier must be heavily compensated which will decrease overall bandwidth and slew rate. For R14=1k Ω and $C_C=5\text{pF}$, the reference amplifier slews at 4mA/ms enabling a transition from $I_{REF}=0$ to $I_{REF}=1\text{mA}$ in 250ns.

Operation with pulse inputs to the reference amplifier may be accommodated by an alternate compensation scheme. This technique provides lowest full scale transition times. An internal clamp allows quick recovery of the reference amplifier from a cutoff ($I_{REF}=0$) condition. Full scale transition (0 to 1mA) occurs in 62.5ns when the equivalent impedance at pin 14 is 800 Ω and $C_C=0$. This yields a reference slew rate of 8mA/ μs which is relatively independent of R_{IN} and V_{IN} values.

LOGIC INPUTS

The Am6012 design incorporates a unique logic input circuit which enables direct interface to all popular logic families and provides maximum noise immunity. This feature is made possible by the large input swing capability, 40 μA logic input current, and completely adjustable logic threshold voltage. For $V- = -15\text{V}$, the logic inputs may swing between -5 and $+10\text{V}$. This enables direct interface with $+15\text{V}$ CMOS logic, even when the Am6012 is powered from a $+5\text{V}$ supply. Minimum input logic swing and minimum logic threshold voltage are given by: $V- \text{ plus } (I_{REF} \times 3\text{k}\Omega) \text{ plus } 1.8\text{V}$. The logic threshold may be adjusted over a wide range by placing an appropriate voltage at the logic threshold control pin (pin 13, V_{LC}). For TTL interface, simply ground pin 13. When interfacing ECL, an $I_{REF} \leq 1\text{mA}$ is recommended. For interfacing other logic families, see block titled "Interfacing With Various Logic Families." For general setup of the logic control circuit, it should be noted that pin 13 will sink 1.1mA typical, external circuitry should be designed to accommodate this current (Figure 3).

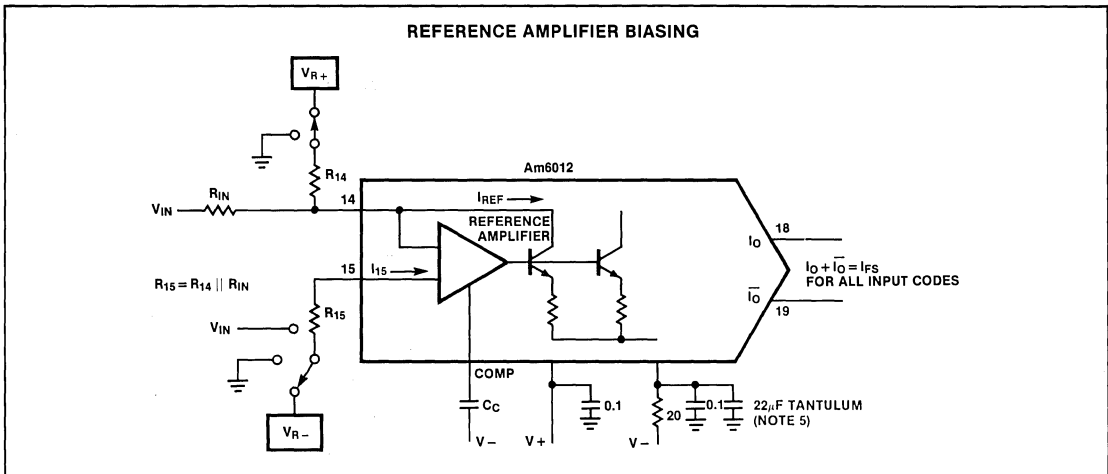

Reference Configuration	R ₁₄	R ₁₅	R _{IN}	C _C	I _{REF}
Positive Reference	V _{R+}	0V	N/C	.01μF	V _{R+} /R ₁₄
Negative Reference	0V	V _{R-}	N/C	.01μF	-V _{R-} /R ₁₄
Lo Impedance Bipolar Reference	V _{R+}	0V	V _{IN}	(Note 1)	(V _{R+} /R ₁₄) + (V _{IN} /R _{IN}) (Note 2)
Hi Impedance Bipolar Reference	V _{R+}	V _{IN}	N/C	(Note 1)	(V _{R+} - V _{IN})/R ₁₄ (Note 3)
Pulsed Reference (Note 4)	V _{R+}	0V	V _{IN}	No Cap	(V _{R+} /R ₁₄) + (V _{IN} /R _{IN})

Notes:

1. The compensation capacitor is a function of the impedance seen at the +V_{REF} input and must be at least 5pF × R_{14(eq)} in kΩ. For R₁₄ < 800Ω no capacitor is necessary.
2. For negative values of V_{IN}, V_{R+}/R₁₄ must be greater than -V_{IN} Max/R_{IN} so that the amplifier is not turned off.
3. For positive values of V_{IN}, V_{R+} must be greater than V_{IN} Max so the amplifier is not turned off.
4. For pulsed operation, V_{R+} provides a DC offset and may be set to zero in some cases. The impedance at pin 14 should be 800Ω or less.
5. For optimum settling time, decouple V₋ with 20Ω and bypass with 22μF tantalum capacitor.
6. Reference current and reference resistor — there is a 1 to 4 scale factor between the reference current (I_{REF}) and the full scale output current (I_{FS}). If V_{REF} = +10V and I_{FS} = 4mA, the value of the R₁₄ is:

$$R_{14} = \frac{4 \times 10 \text{ Volt}}{4 \text{ mA}} = 10 \text{ k}\Omega \quad R_{14} = R_{15}$$

Figure 2a

MINIMUM SIZE
COMPENSATION CAPACITOR
(I_{FS} = 4mA, I_{REF} = 1.0mA)

R _{14(EQ)} (kΩ)	C _C (pF)
10	50
5	25
2	10
1	5
.5	0

Note: A 0.01μF capacitor is recommended for fixed reference operation.

Figure 2b

REFERENCE AMPLIFIER
FREQUENCY RESPONSE

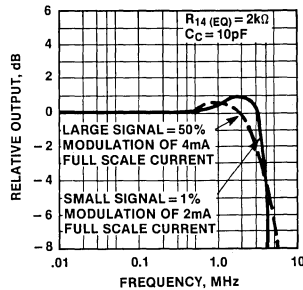

INTERFACING CIRCUITS FOR ECL, CMOS, HTL LOGIC INPUTS

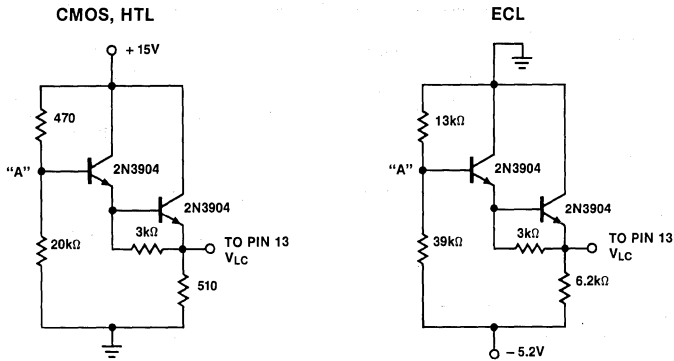

- NOTES:
1. Set the voltage "A" to the desired logic input switching threshold.
 2. Allowable range of logic threshold is typically -5V to +13.5V when operating the DAC on ±15V supplies.

Figure 3

ACCOMMODATING BIPOLAR REFERENCE

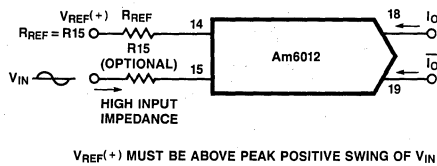
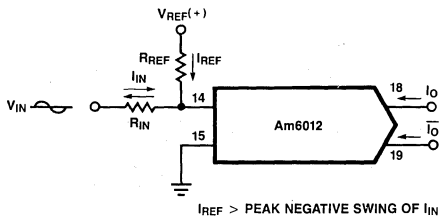

BASIC NEGATIVE REFERENCE OPERATION

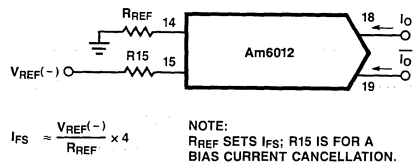

RECOMMENDED FULL-SCALE ADJUSTMENT CIRCUIT

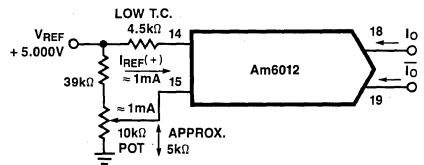

APPLICATION CIRCUITS

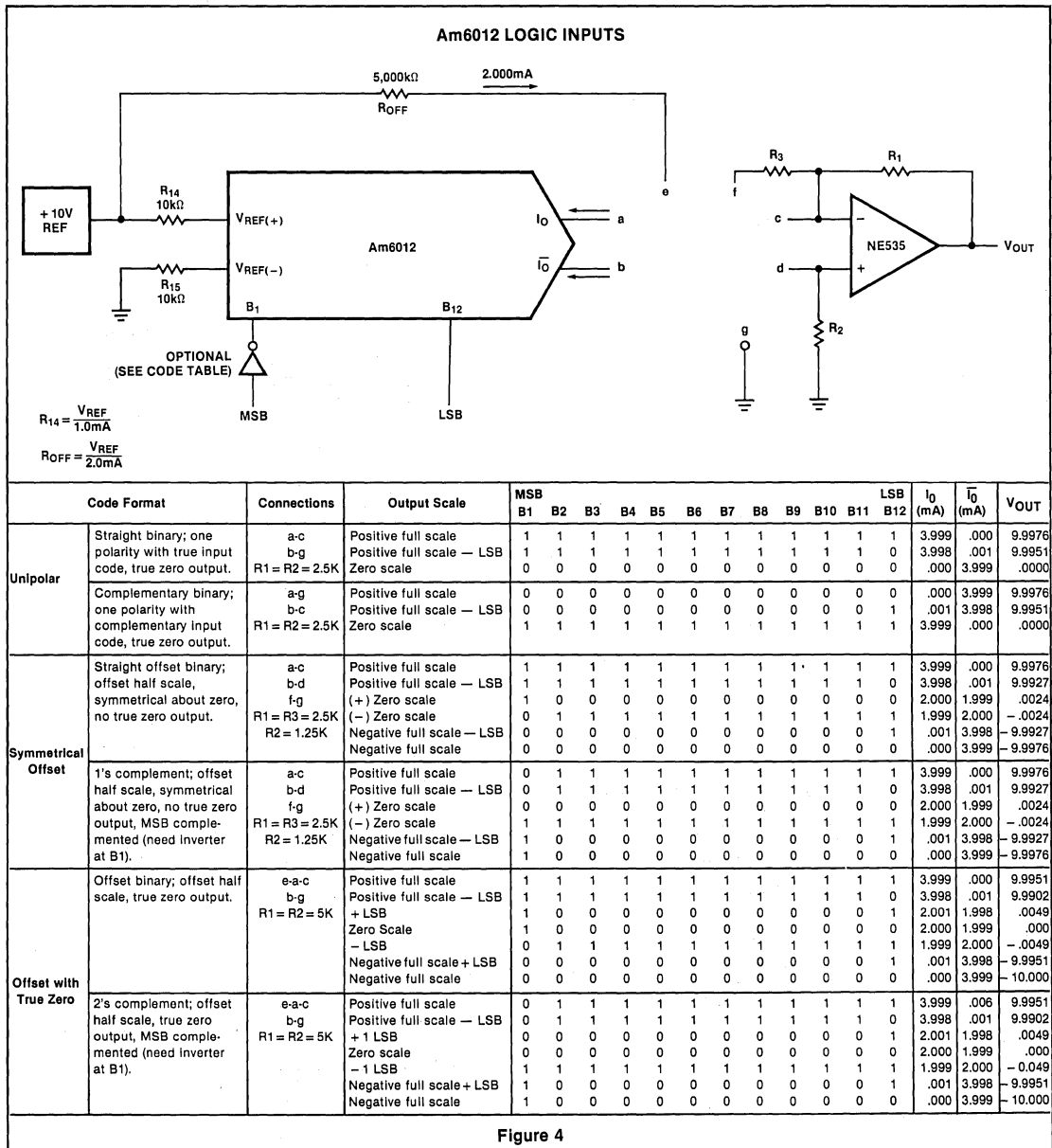
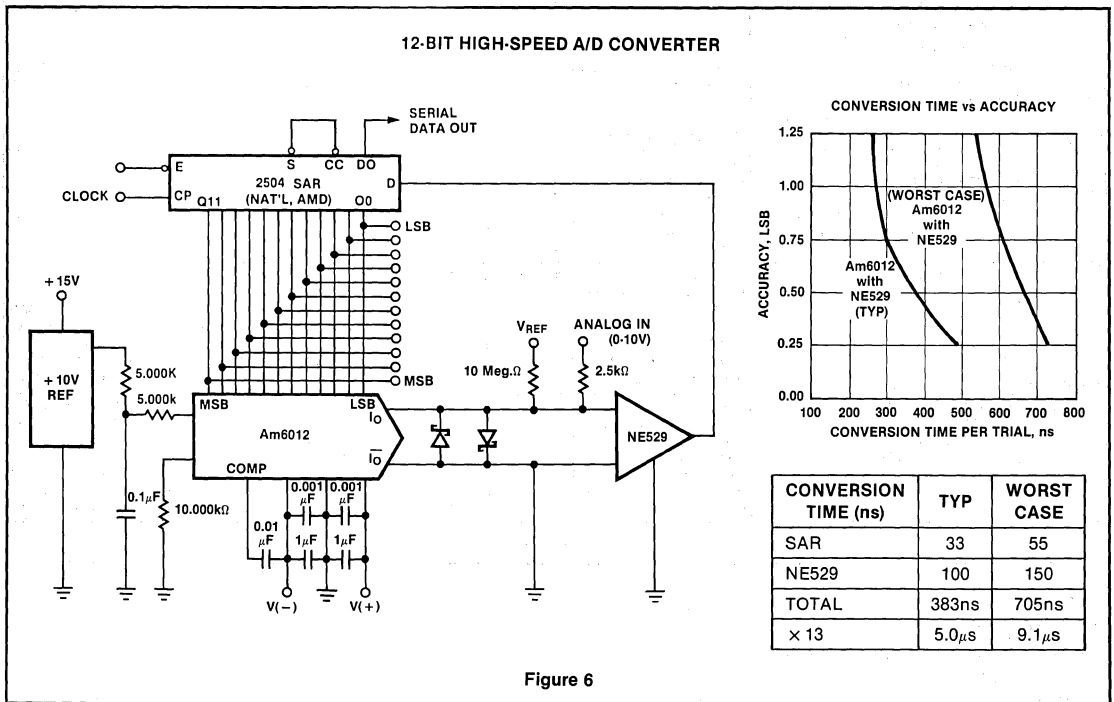
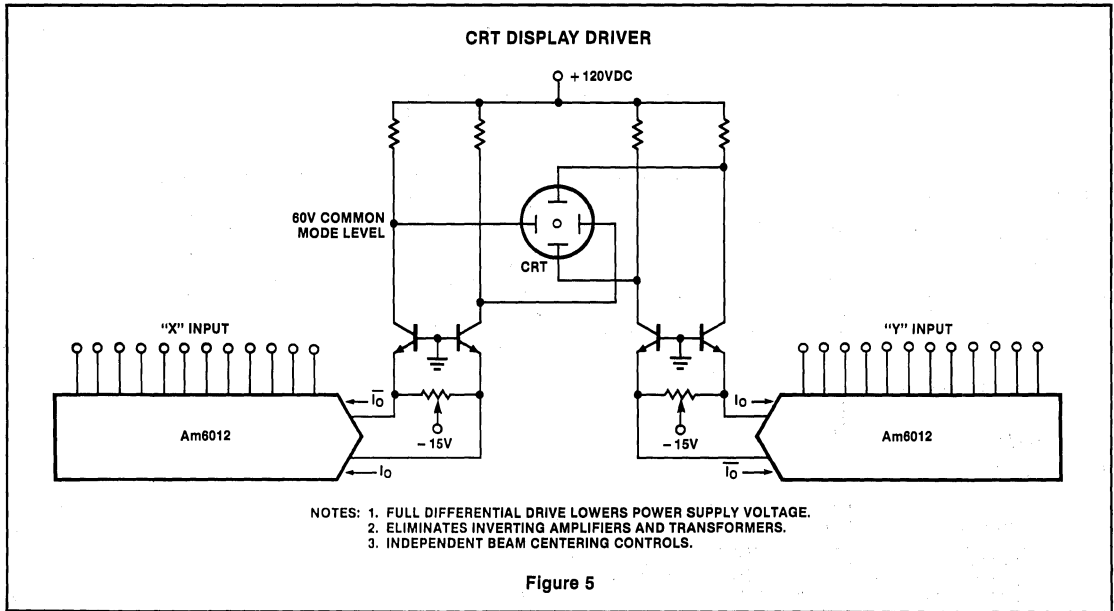

Figure 4

ADDITIONAL CODE MODIFICATIONS

- Any of the offset binary codes may be complemented by reversing the output terminal pair.

APPLICATION CIRCUITS



APPLICATION CIRCUITS

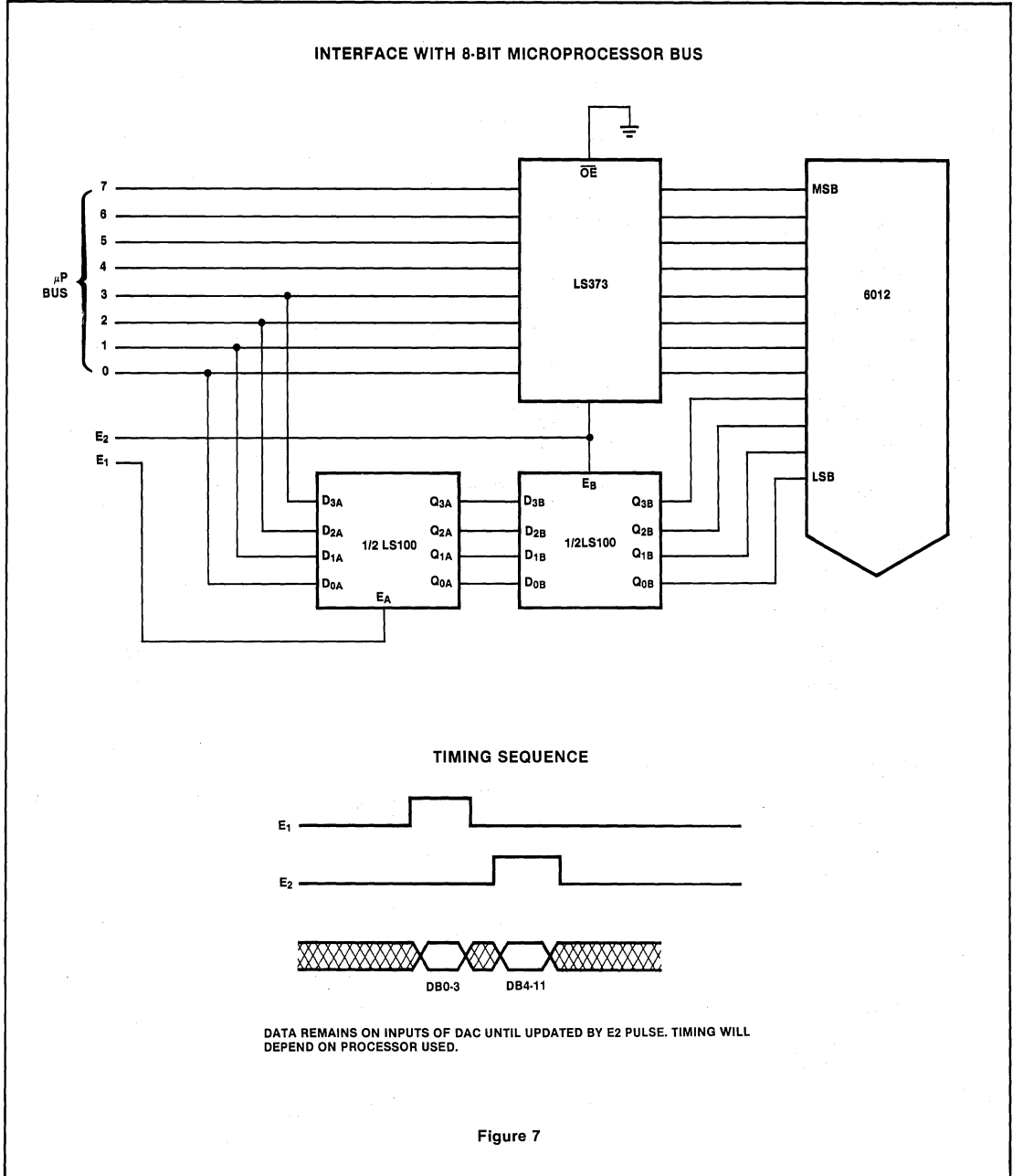

8-BIT HIGH SPEED MULTIPLYING D/A CONVERTER

DAC-08 SERIES

FORMERLY: NE5007/5008-F,N
SE5008-F

DESCRIPTION

The DAC-08 series of 8-bit monolithic multiplying Digital-to-Analog Converters provide very high speed performance coupled with low cost and outstanding applications flexibility.

Advanced circuit design achieves 70ns settling times with very low glitch and at low power consumption. Monotonic multiplying performance is attained over a wide 20 to 1 reference current range. Matching to within 1 LSB between reference and full scale currents eliminates the need for full scale trimming in most applications. Direct interface to all popular logic families with full noise immunity is provided by the high swing, adjustable threshold logic inputs.

Dual complementary outputs are provided, increasing versatility and enabling differential operation to effectively double the peak-to-peak output swing. True high voltage compliance outputs allow direct output voltage conversion and eliminate output op amps in many applications.

All DAC-08 series models guarantee full 8-bit monotonicity and linearities as tight as 0.1% over the entire operating temperature range are available. Device performance is essentially unchanged over the $\pm 4.5V$ to $\pm 18V$ power supply range, with 37mW power consumption attainable at $\pm 5V$ supplies.

The compact size and low power consumption make the DAC-08 attractive for portable and military aerospace applications.

FEATURES

- Fast settling output current—70ns
- Full scale current prematched to ± 1 LSB
- Direct interface to TTL, CMOS, ECL, HTL, PMOS
- Relative accuracy to 0.1% maximum over temperature range
- High output compliance $-10V$ to $+18V$
- True and complemented outputs
- Wide range multiplying capability
- Low FS current drift— $\pm 10ppm/^{\circ}C$
- Wide power supply range— $\pm 4.5V$ to $\pm 18V$
- Low power consumption—37mW at $\pm 5V$

APPLICATIONS

- 8-bit, $1\mu s$ A-to-D converters
- Servo-motor and pen drivers
- Waveform generators
- Audio encoders and attenuators
- Analog meter drivers
- Programmable power supplies
- CRT display drivers
- High speed modems
- Other applications where low cost, high speed and complete input/output versatility are required
- Programmable gain and attenuation
- Analog-Digital Multiplication
- Stepping motor drive

ORDERING INFORMATION

RELATIVE ACCURACY	0 to 70°C	-55 to 125°C
0.39% FS	DAC-08CN	DAC-08CF
0.19% FS	DAC-08EN	DAC-08EF
	DAC-08ED	DAC-08F
0.1% FS	DAC-08HF	DAC-08AF
	DAC-08HN	

PIN CONFIGURATION

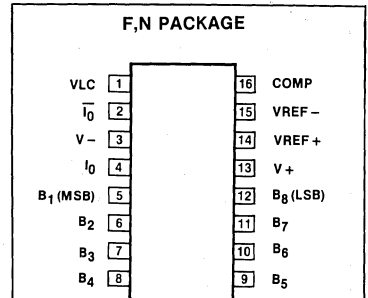

TOP VIEW

ORDER NUMBER

DAC-08AF	SE5009F
DAC-08F	SE5008F
DAC-08HF,N	NE5009F,N
DAC-08CF,N	NE5007F,N

DAC-08 ABSOLUTE MAXIMUM RATINGS

PARAMETER	RATING	UNIT
Power Supply Voltage, $V+$ to $V-$	36	V
V_5-V_{12} Digital Input Voltage	$V-$ to $V-$ plus 36V	
V_{LC} Logic Threshold Control	$V-$ to $V+$	
V_0 Applied Output Voltage	$V-$ to $+18$	V
I_{14} Reference Current	5.0	mA
V_{14}, V_{15} Reference Amplifier Inputs	V_{EE} to V_{CC}	
P_D Power Dissipation (Package Limitation)		
Ceramic Package	1000	mW
Plastic Package	800	mW
Lead Soldering Temperature (60 sec)	300	$^{\circ}C$
T_A Operating Temperature Range		
DAC-08, DAC-08A	-55 to +125	$^{\circ}C$
DAC-08C, E, H	0 to +75	$^{\circ}C$
T_{STG} Storage Temperature Range	-65 to +150	$^{\circ}C$

D³ PACKAGE

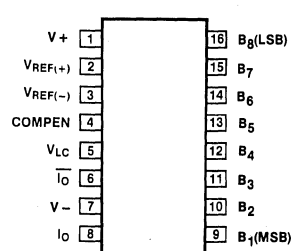

TOP VIEW

ORDER NUMBER

DAC-08ED

NOTES:

1. SOL - Released in Large SO package only.
2. SOL and non-standard pinout.
3. SO and non-standard pinouts.

BLOCK DIAGRAM

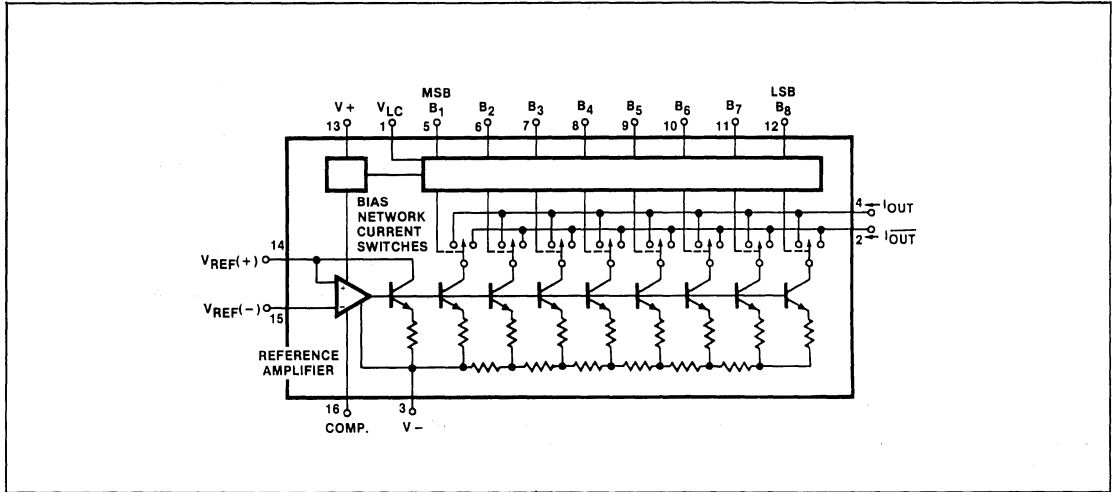

4

TEST CIRCUIT

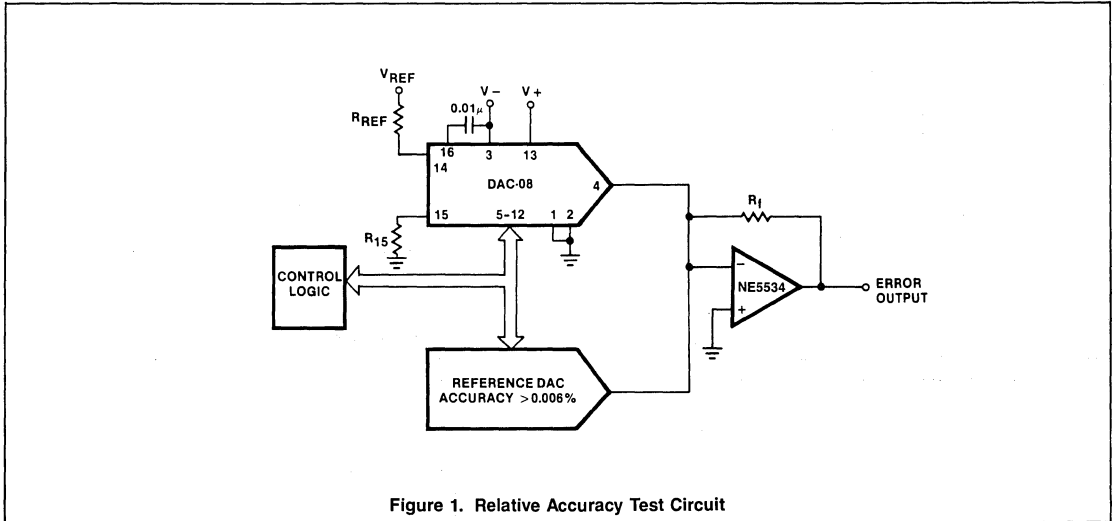
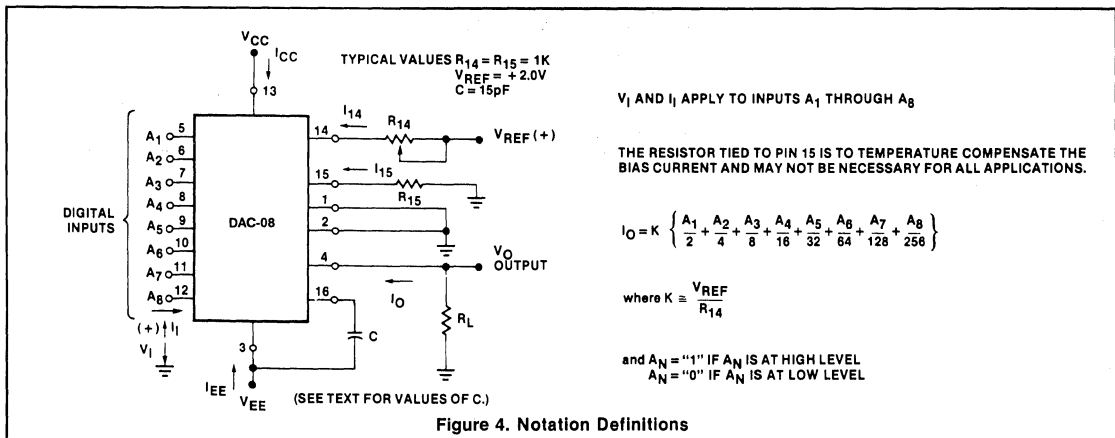
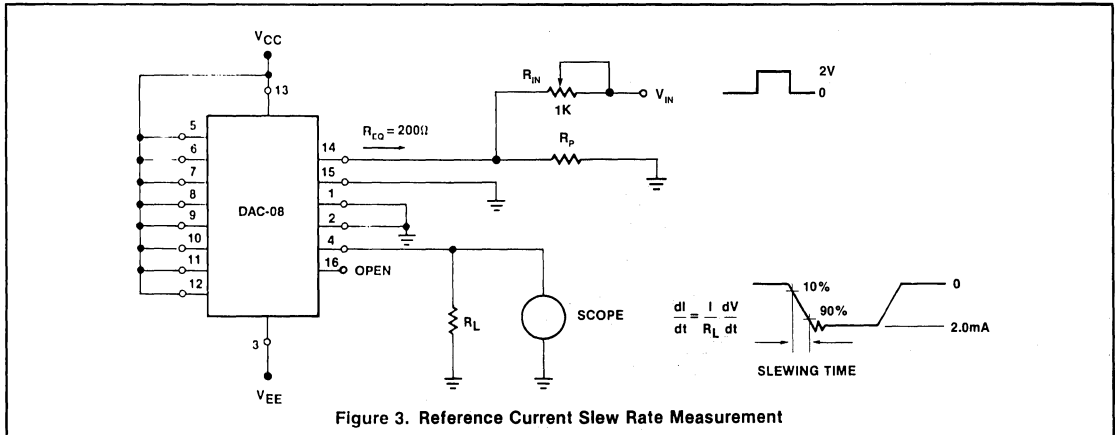
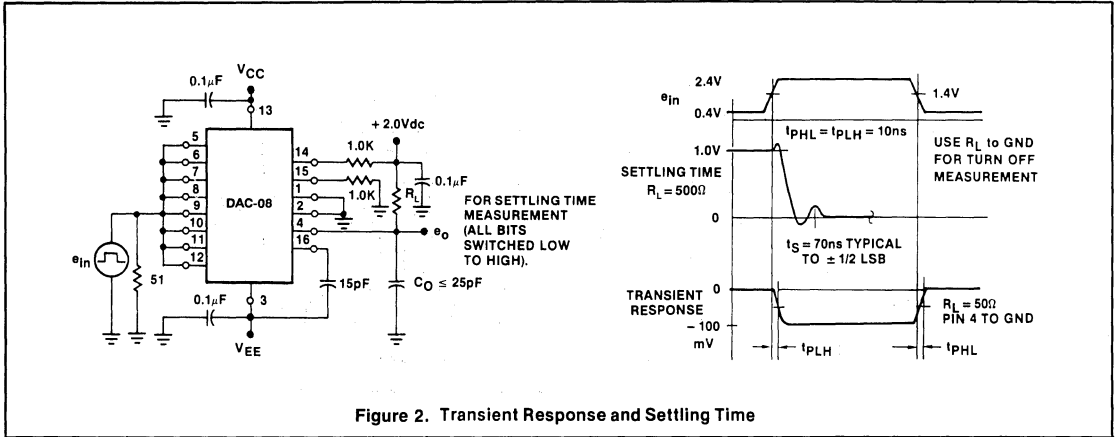

Figure 1. Relative Accuracy Test Circuit

8-BIT MULTIPLYING D/A CONVERTER

DAC-08 SERIES

TEST CIRCUITS (Cont'd)



8-BIT HIGH SPEED MULTIPLYING D/A CONVERTER

DAC-08 SERIES

ELECTRICAL CHARACTERISTICS Pin 3 must be at least 3V more negative than the potential to which R₁₅ is returned.
 V_{CC} = ±15V, I_{REF} = 2.0mA, Output characteristics refer to both I_{OUT} and I_{OUT} unless otherwise noted. DAC-08C, E, H: T_A = 0°C to 70°C. DAC-08/08A: T_A = -55°C to 125°C.

PARAMETER		TEST CONDITIONS	DAC-08C			DAC-08E DAC-08			DAC-08H DAC-08A			UNIT
			Min	Typ	Max	Min	Typ	Max	Min	Typ	Max	
	Resolution		8	8	8	8	8	8	8	8	8	Bits
	Monotonicity*		8	8	8	8	8	8	8	8	8	Bits
	Relative accuracy Differential	Over temperature range nonlinearity			±0.39 ±0.39			±0.19 ±0.19			±0.1 ±0.19	.% FS % FS
t _s	Settling time	To ±1/2 LSB, all bits switched on or off, T _A = 0°C		70	135		70	135		70	135	ns
t _{PLH} t _{PHL}	Propagation delay Low-to-high High-to-low	T _A = 25°C, each bit. All bits switched		35	60		35	60		35	60	ns
TCI _{FS}	Full scale tempco			±10			±10			±10	±50	ppm/°C
V _{OC}	Output voltage compliance	Full scale current change < 1/2 LSB	-10		+18	-10		+18	-10		+18	V
I _{FS4}	Full scale current	V _{REF} = 10.000V, R ₁₄ , R ₁₅ = 5.000kΩ,	1.94	1.99	2.04	1.94	1.99	2.04	1.984	1.992	2.000	mA
I _{FSS}	Full scale symmetry	I _{FS4} - I _{FS2}		±2.0	±16		±1.0	±8.0		±1.0	±4.0	µA
I _{ZS}	Zero scale current			0.2	4.0		0.2	2.0		0.2	1.0	µA
I _{FSR}	Full scale output current range	R ₁₄ R ₁₅ = 5.000kΩ V _{REF} = +15.0V, V ₋ = -10V V _{REF} = +25.0V, V ₋ = -12V	2.1 4.2			2.1 4.2			2.1 4.2			mA
V _{IL} V _{IH}	Logic input levels Low High	V _{LC} = 0V	2.0		0.8	2.0		0.8	2.0		0.8	V
I _{IL} I _{IH}	Logic input current Low High	V _{LC} = 0V V _{IN} = -10V to +0.8V V _{IN} = 2.0V to 18V		-2.0 0.002	-10 10		-2.0 0.002	-10 10		-2.0 0.002	-10 10	µA
V _{IS}	Logic input swing	V ₋ = -15V	-10		+18	-10		+18	-10		+18	V
V _{THR}	Logic threshold range	V _S = ±15V	-10		+13.5	-10		+13.5	-10		+13.5	V
I ₁₅	Reference bias current			-1.0	-3.0		-1.0	-3.0		-1.0	-3.0	µA
dl/dt	Reference input slew rate		4.0	8.0		4.0	8.0		4.0	8.0		mA/µs
PSSI _{FS+} PSSI _{FS-}	Power supply sensitivity Positive Negative	I _{REF} = 1mA V ₊ = 4.5 to 5.5V, V ₋ = -15V; V ₊ = 13.5 to 16.5V, V ₋ = -15V V ₋ = -4.5 to -5.5V, V ₊ = +15V; V ₋ = -13.5 to -16.5V, V ₊ = +15V		0.0003 0.002	0.01 0.01		0.0003 0.002	0.01 0.01		0.0003 0.002	0.01 0.01	%FS/%VS
I ₊ I ₋	Power supply current Positive Negative	V _S = +5V, I _{REF} = 1.0mA		3.1 -4.3	3.8 -5.8		3.1 -4.3	3.8 -5.8		3.1 -4.3	3.8 -5.8	mA
I ₊ I ₋	Positive Negative	V _S = +5V, -15V, I _{REF} = 2.0mA		3.1 -7.1	3.8 -7.8		3.1 -7.1	3.8 -7.8		3.1 -7.1	3.8 -7.8	mA
I ₊ I ₋	Positive Negative	V _S = ±15V, I _{REF} = 2.0mA		3.2 -7.2	3.8 -7.8		3.2 -7.2	3.8 -7.8		3.2 -7.2	3.8 -7.8	mA
P _D	Power dissipation	±5V, I _{REF} = 1.0mA +5V, -15V, I _{REF} = 2.0mA ±15V, I _{REF} = 2.0mA		37 122 156	48 136 174		37 122 156	48 136 174		37 122 156	48 136 174	mW

4

TYPICAL PERFORMANCE CHARACTERISTICS

OUTPUT CURRENT vs OUTPUT VOLTAGE (OUTPUT VOLTAGE COMPLIANCE)

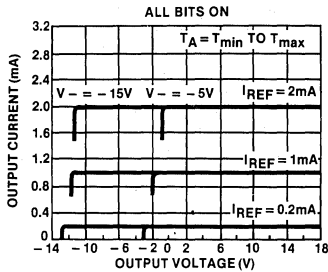

FAST PULSED REFERENCE OPERATION

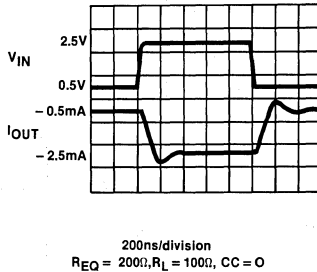

TRUE AND COMPLEMENTARY OUTPUT OPERATION

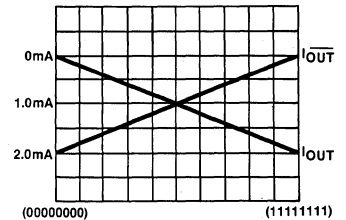

FULL SCALE SETTLING TIME

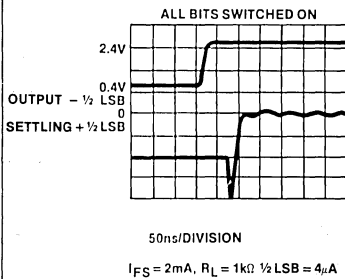

LSB SWITCHING

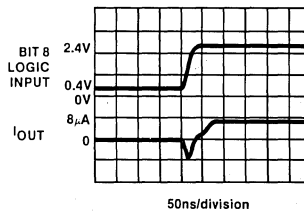

FULL SCALE CURRENT vs REFERENCE CURRENT

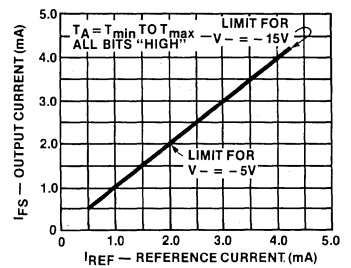

LSB PROPAGATION DELAY vs IFS

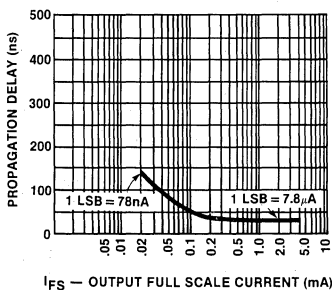

REFERENCE INPUT FREQUENCY RESPONSE

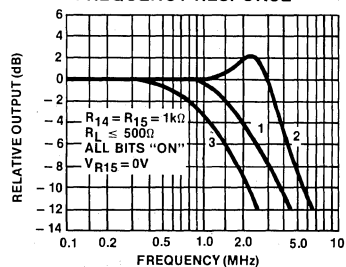

- Curve 1: $CC = 15pF, V_{IN} = 2.0V$ p-p centered at +1.0V.
- Curve 2: $CC = 15pF, V_{IN} = 50mV$ p-p centered at +200mV.
- Curve 3: $CC = 0pF, V_{IN} = 100mV$ p-p centered at 0V and applied thru 50Ω connected to pin 14, +2.0V applied to R_{14} .

TYPICAL PERFORMANCE CHARACTERISTICS (Cont'd)

REFERENCE AMP COMMON MODE RANGE ALL BITS ON

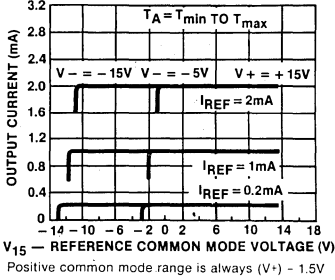

LOGIC INPUT CURRENT vs INPUT VOLTAGE

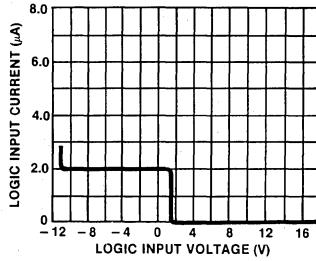

$V_{TH} - V_{LC}$ vs TEMPERATURE

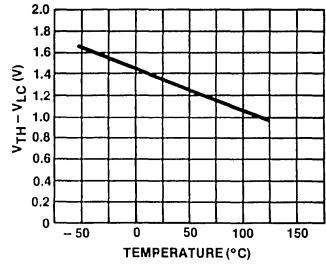

OUTPUT VOLTAGE COMPLIANCE vs TEMPERATURE

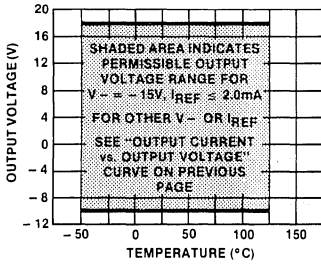

BIT TRANSFER CHARACTERISTICS

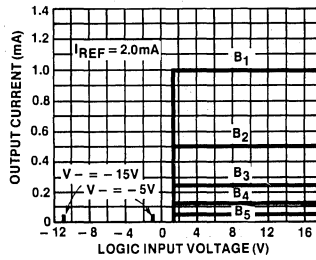

POWER SUPPLY CURRENT vs V+

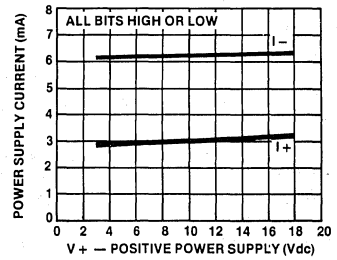

NOTE

B_1 through B_5 have identical transfer characteristics. Bits are fully switched, with less than $1/2$ LSB error, at less than $\pm 100mV$ from actual threshold. These switching points are guaranteed to lie between 0.8 and 2.0 volts over the operating temperature range ($V_{LC} = 0.0V$).

POWER SUPPLY CURRENT vs V-

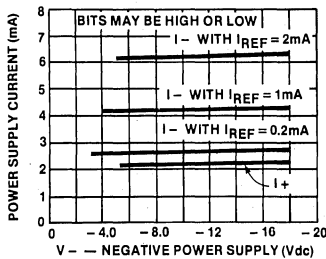

POWER SUPPLY CURRENT vs TEMPERATURE

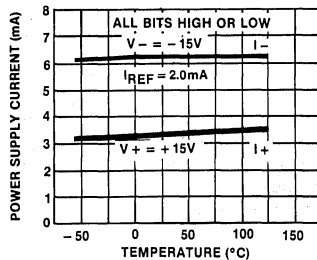

MAXIMUM REFERENCE INPUT FREQUENCY vs. COMPENSATION CAPACITOR VALUE

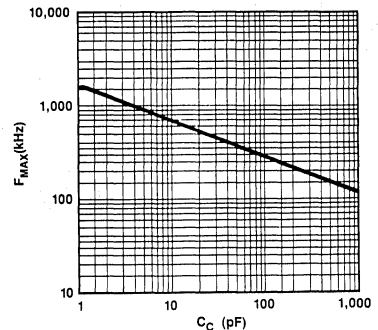

8-BIT HIGH SPEED MULTIPLYING D/A CONVERTER

DAC-08 SERIES

TYPICAL APPLICATION

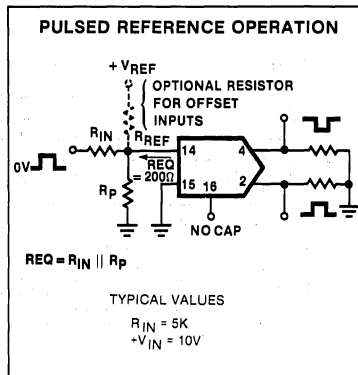

FUNCTIONAL DESCRIPTION

Reference Amplifier Drive and Compensation

The reference amplifier input current must always flow into pin 14 regardless of the setup method or reference supply voltage polarity.

Connections for a positive reference voltage are shown in Figure 1. The reference voltage source supplies the full reference current. For bipolar reference signals, as in the multiplying mode, R15 can be tied to a negative voltage corresponding to the minimum input level. R15 may be eliminated with only a small sacrifice in accuracy and temperature drift.

The compensation capacitor value must be increased as R14 value is increased. This is in order to maintain proper phase margin. For R14 values of 1.0, 2.5, and 5.0K ohms, minimum capacitor values are 15, 37, and 75pF, respectively. The capacitor may be tied to either V_{EE} or ground, but using V_{EE} increases negative supply rejection. (Fluctuations in the negative supply have more effect on accuracy than do any changes in the positive supply.)

A negative reference voltage may be used if R14 is grounded and the reference voltage is applied to R15, as shown. A high input impedance is the main advantage of this method. The negative reference voltage must be at least 3.0V above the V_{EE} supply. Bipolar input signals may be handled by connecting R14 to

a positive reference voltage equal to the peak positive input level at pin 15.

When using a DC reference voltage, capacitive bypass to ground is recommended. The 5.0V logic supply is not recommended as a reference voltage, but if a well regulated 5.0V supply which drives logic is to be used as the reference, R14 should be formed of two series resistors with the junction of the two resistors bypassed with 0.1 μ F to ground. For reference voltages greater than 5.0V, a clamp diode is recommended between pin 14 and ground.

If pin 14 is driven by a high impedance such as a transistor current source, none of the above compensation methods apply and the amplifier must be heavily compensated, decreasing the overall bandwidth.

Output Voltage Range

The voltage at pin 4 must always be at least 4.5 volts more positive than the voltage of the negative supply (pin 3) when the reference current is 2mA or less, and at least 8 volts more positive than the negative supply when the reference current is between 2mA and 4mA. This is necessary to avoid saturation of the output transistors, which would cause serious accuracy degradation.

Output Current Range

Any time the full scale current exceeds 2mA, the negative supply must be at least 8 volts more negative than the output voltage. This is due to the increased internal voltage drops between the negative supply and the outputs with higher reference currents.

Accuracy

Absolute accuracy is the measure of each output current level with respect to its intended value, and is dependent upon relative accuracy, full scale accuracy and full scale current drift. Relative accuracy is the measure of each output current level as a fraction of the full scale current after zero scale current has been nulled out. The relative accuracy of the DAC08 series is essentially constant over the operating temperature range due to the excellent temperature tracking of the monolithic resistor ladder. The reference current may drift with temperature, causing a change in the absolute accuracy of

output current. However, the DAC08 series has a very low full scale current drift over the operating temperature range.

The DAC08 series is guaranteed accurate to within $\pm 1/2$ LSB at +25°C at a full scale output current of 1.992mA. The relative accuracy test circuit is shown in Figure 1. The 12-bit converter is calibrated to a full scale output current of 1.99219mA, then the DAC08 full scale current is trimmed to the same value with R14 so that a zero value appears at the error amplifier output. The counter is activated and the error band may be displayed on the oscilloscope, detected by comparators, or stored in a peak detector.

Two 8-bit D-to-A converters may not be used to construct a 16-bit accurate D-to-A converter. Sixteen-bit accuracy implies a total of $\pm 1/2$ part in 65,536, or $\pm 0.00076\%$, which is much more accurate than the $\pm 0.19\%$ specification of the DAC08 series.

Monotonicity

A monotonic converter is one which always provides analog output greater than or equal to the preceding value for a corresponding increment in the digital input code. The DAC08 series is monotonic for all values of reference current above 0.5mA. The recommended range for operation is a DC reference current between 0.5mA and 4.0mA.

Settling Time

The worst case switching condition occurs when all bits are switched on, which corresponds to a low-to-high transition for all input bits. This time is typically 70ns for settling to within 1/2 LSB for 8-bit accuracy. This time applies when $R_L < 500$ ohms and $C_O < 25pF$. The slowest single switch is the least significant bit, which typically turns on and settles in 65ns. In applications where the DAC functions in a positive going ramp mode, the worst case condition does not occur and settling times less than 70ns may be realized.

Extra care must be taken in board layout since this usually is the dominant factor in satisfactory test results when measuring settling time. Short leads, 100 μ F supply bypassing for low frequencies, minimum scope lead length, and avoidance of ground loops are all mandatory.

SETTLING TIME AND PROPAGATION DELAY

- D₁, D₂ = IN6263 or equivalent
- D₃ = IN914 or equivalent
- C₁ = 0.01μf
- C₂, C₃ = 0.1μf
- Q₁ = 2N3904 or equivalent
- C₄, C₅ = 15pf and includes all probe and fixturing capacitance

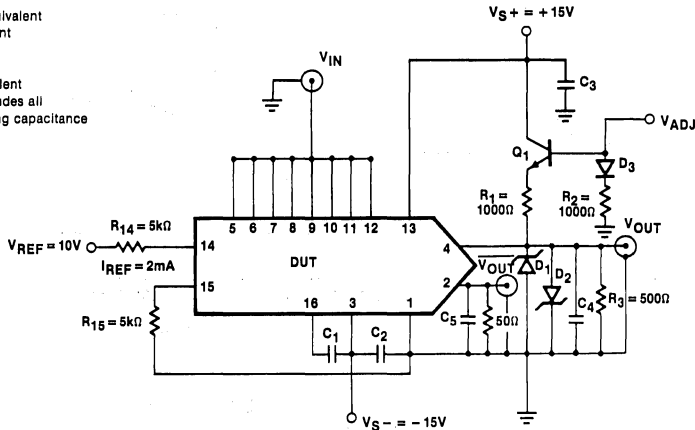

4

BASIC DAC-08 CONFIGURATION

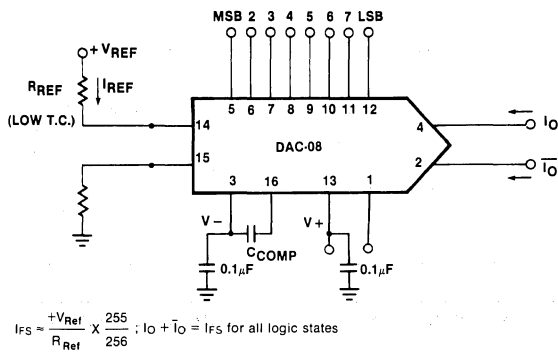

RECOMMENDED FULL SCALE AND ZERO SCALE ADJUST

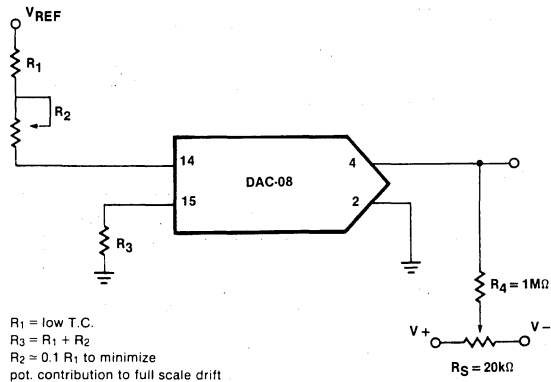

UNIPOLAR VOLTAGE OUTPUT FOR LOW IMPEDANCE OUTPUT

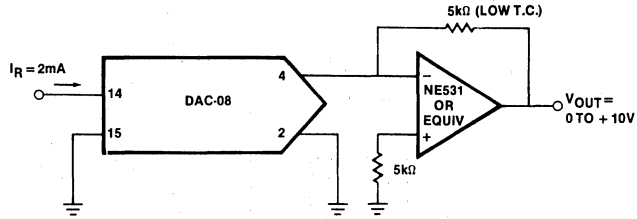

UNIPOLAR VOLT OUTPUT FOR HIGH IMPEDANCE OUTPUT

a) Positive Output

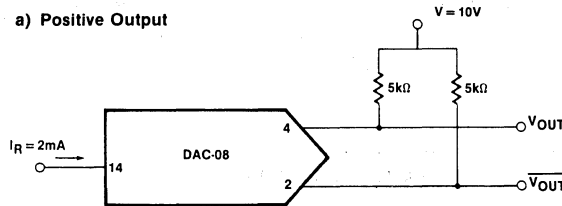

b) Negative Output

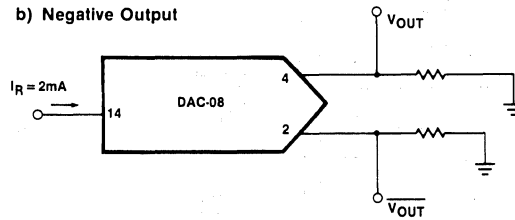

BASIC BIPOLAR OUTPUT OPERATION (OFFSET BINARY)

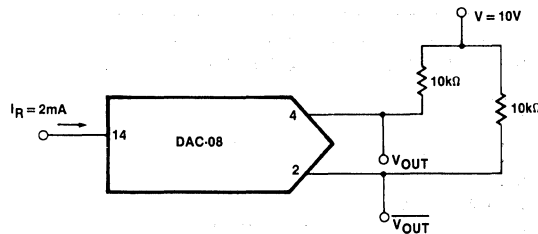

CODE CHART

	B ₁	B ₂	B ₃	B ₄	B ₅	B ₆	B ₇	B ₈	V _{OUT}	V _{OUT}
POS full scale	1	1	1	1	1	1	1	1	-9.920V	+10.000
POS f.s. - 1LSB	1	1	1	1	1	1	1	0	-9.840V	+9.920
+ Zero scale + 1LSB	1	0	0	0	0	0	0	1	-0.080V	+0.160
Zero scale	1	0	0	0	0	0	0	0	0.000	+0.080
Zero scale - 1LSB	0	1	1	1	1	1	1	1	0.080	0.000
Neg full scale - 1LSB	0	0	0	0	0	0	0	1	+9.920	-9.840
Neg full scale	0	0	0	0	0	0	0	0	+10.000	-9.920

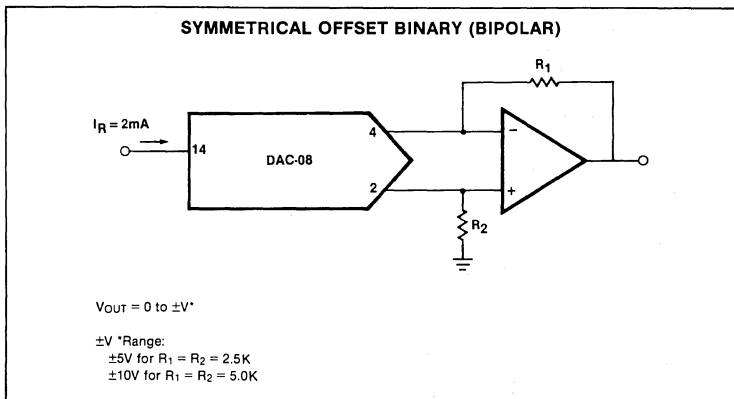

3 DIGIT BCD CONVERTER

A 3 digit BCD converter, using inexpensive 8-bit binary DACs, can achieve $\pm 0.1\%$ accuracy. The circuit shown in Figure 20 utilizes three DACs, one for each decade, to provide 0 to 999 output steps. DAC 1 contains the first four significant digits controlling the hundreds digit; DAC 2 controls the tens digit and DAC 3 steps 0 to 9. The feedback resistor (R_7) sets the zero scale at 0.00V.

The input coding is the popular 8-4-2-1 coding; i.e. the weighting ratios are 8, 4, 2 and 1. The full scale (999) BCD code is input code 100110011001.

Full scale adjustment procedure.

In the sequence below, switch on the following code combinations and adjust the indicated potentiometer for the proper output.

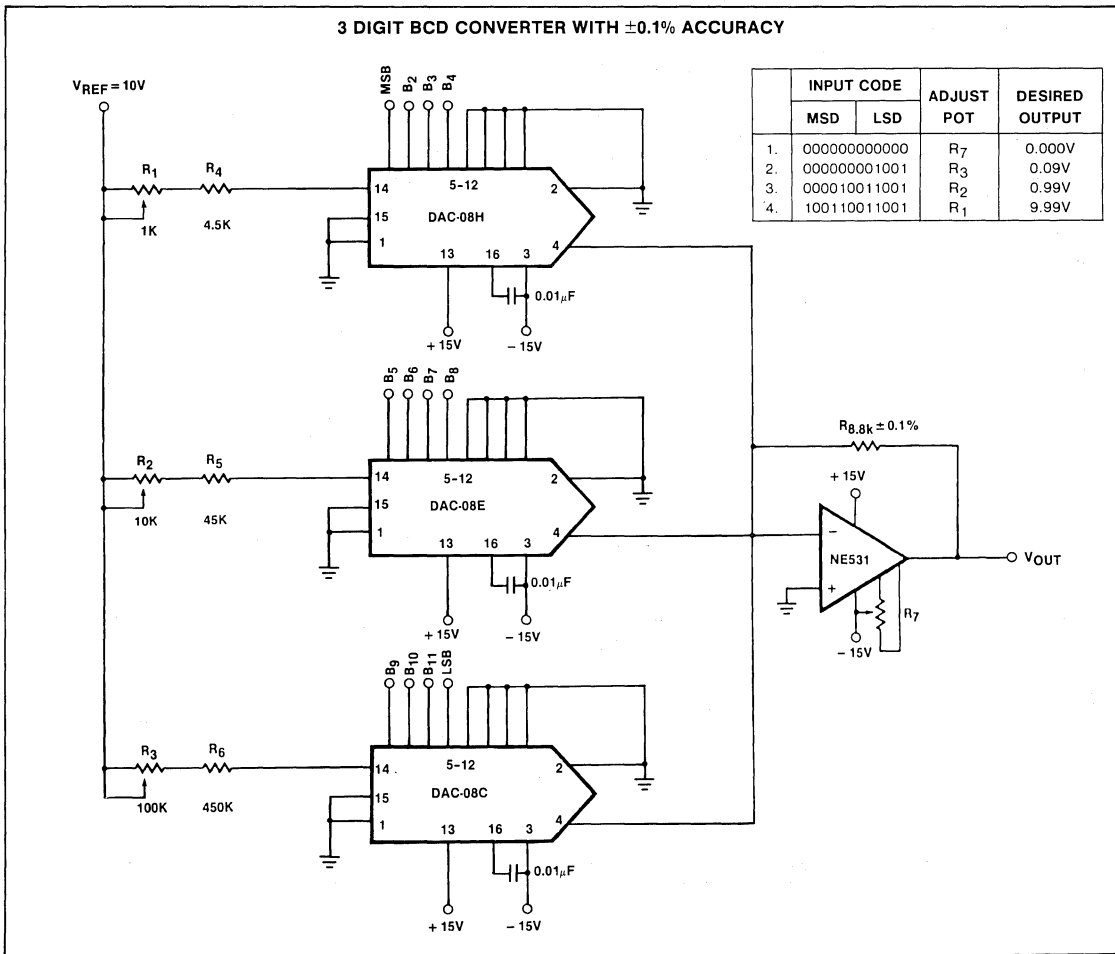

8-BIT MULTIPLYING D/A CONVERTER

MC1508-8/1408-8/1408-7

DESCRIPTION

The MC1508/MC1408 series of 8-bit monolithic digital-to-analog converters provide high speed performance with low cost. They are designed for use where the output current is a linear product of an 8-bit digital word and an analog reference voltage.

FEATURES

- Fast settling time—70ns (typ)
- Relative accuracy ±0.19% (max error)
- Non-inverting digital inputs are TTL and CMOS compatible
- High speed multiplying rate 4.0mA/μs (input slew)
- Output voltage swing +.5V to -5.0V
- Standard supply voltages + 5.0V and -5.0V to -15V
- Military qualifications pending

APPLICATIONS

- Tracking A-to-D converters
- 2½-digit panel meters and DVM's
- Waveform synthesis
- Sample and hold
- Peak detector
- Programmable gain and attenuation
- CRT character generation
- Audio digitizing and decoding
- Programmable power supplies
- Analog-digital multiplication
- Digital-digital multiplication
- Analog-digital division
- Digital addition and subtraction
- Speech compression and expansion
- Stepping motor drive
- Modems
- Servo motor and pen drivers

CIRCUIT DESCRIPTION

The MC1508/MC1408 consists of a reference current amplifier, an R-2R ladder, and 8 high speed current switches. For many applications, only a reference resistor and reference voltage need be added.

The switches are non-inverting in operation; therefore, a high state on the input turns on the specified output current component.

The switch uses current steering for high speed, and a termination amplifier consisting of an active load gain stage with unity gain feedback. The termination amplifier holds the parasitic capacitance of the ladder at a constant voltage during switching, and provides a low impedance termination of equal voltage for all legs of the ladder.

The R-2R ladder divides the reference amplifier current into binary-related components, which are fed to the switches. Note that there is always a remainder current which is equal to the least significant bit. This current is shunted to ground, and the maximum output current is 255/256 of the reference amplifier current, or 1.992mA for a 2.0mA reference amplifier current if the NPN current source pair is perfectly matched.

PIN CONFIGURATION

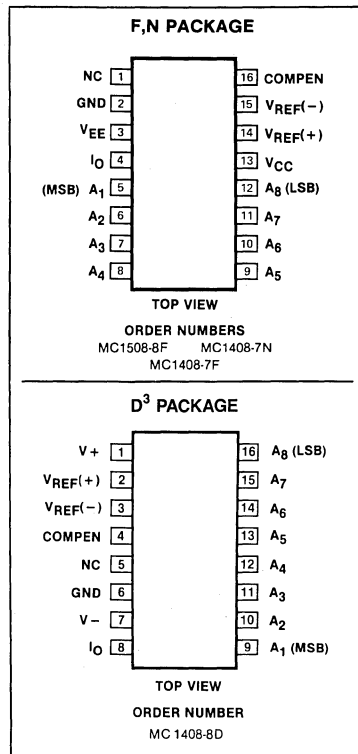

- NOTES:
1. SOL Released in Large SO package only.
 2. SOL and non-standard pinout.
 3. SO and non-standard pinouts.

ABSOLUTE MAXIMUM RATINGS TA = +25°C unless otherwise specified

PARAMETER	RATING	UNIT
V _{CC} Positive	+ 5.5	V
V _{EE} Negative	- 16.5	V
V _{5-V12} Digital Input Voltage	0 to V _{CC}	V
V ₀ Applied Output Voltage	-5.2 to + 18	V
I ₁₄ Reference Current	5.0	mA
V _{14, V15} Reference Amplifier Inputs	V _{EE} to V _{CC}	
P _D Power Dissipation (Package Limitation)		
	Ceramic Package	1000
	Plastic Package	800
	Lead Soldering Temperature (60 sec)	300
T _A Operating Temperature Range		
	MC1508	- 55 to + 125
	MC1408	0 to + 75
T _{STG} Storage Temperature Range		
		- 65 to + 150

BLOCK DIAGRAM

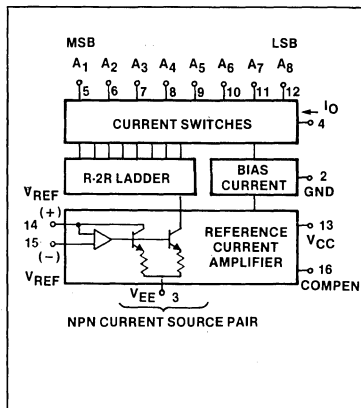

8-BIT MULTIPLYING D/A CONVERTER

MC1508-8/1408-8/1408-7

DC ELECTRICAL CHARACTERISTICS¹

Pin 3 must be 3V more negative than the potential to which R₁₅ is returned.

V_{CC} = +5.0Vdc, V_{EE} = -15Vdc, $\frac{V_{ref}}{R_{14}} = 2.0\text{mA}$
 unless otherwise specified.

MC1508: T_A = -55°C to 125°C. MC1408: T_A = 0°C to 75°C
 unless otherwise noted.

PARAMETER	TEST CONDITIONS	MC1508-8			MC1408-8			MC1408-7			UNIT
		Min	Typ	Max	Min	Typ	Max	Min	Typ	Max	
E _r Relative accuracy	Error relative to full scale I _O , Figure 3			±0.19			±0.19			±0.39	%
t _s Setting time ¹	To within 1/2 LSB, includes t _{PLH} , T _A = +25°C, Figure 4		70			70			70		ns
t _{PLH} Propagation delay time t _{PHL} Low-to-high High-to-low	T _A = +25°C, Figure 4		35	100		35	100		35	100	ns
TC _{IO} Output full scale current drift			-20			-20			-20		PPM/°C
V _{IH} Digital input logic level (MSB) V _{IL} High Low	Figure 5	2.0		0.8	2.0		0.8	2.0		0.8	Vdc
I _{IH} Digital input current (MSB) I _{IL} High Low	Figure 5 V _{IH} = 5.0V V _{IL} = 0.8V		0 -0.4	0.04 -0.8		0 -0.4	0.04 -0.8		0 -0.4	0.04 -0.8	mA
I ₁₅ Reference input bias current	Pin 15, Figure 5		-1.0	-5.0		-1.0	-5.0		-1.0	-5.0	µA
I _{OR} Output current range	Figure 5 V _{EE} = -5.0V V _{EE} = -7.0V to -15V	0 0	2.0 2.0	2.1 4.2	0 0	2.0 2.0	2.1 4.2	0 0	2.0 2.0	2.1 4.2	mA
I _O Output current	Figure 5 V _{ref} = 2.000V, R ₁₄ = 1000Ω All bits low	1.9	1.99	2.1	1.9	1.99	2.1	1.9	1.99	2.1	mA
I _{O(min)} Off-state			0	4.0		0	4.0		0	4.0	µA
V _O Output voltage compliance	E _r ≤ 0.19% at T _A = +25°C, Figure 5 V _{EE} = -5V V _{EE} below -10V		-0.6, +10 -5.5, +10	-0.55, +0.5 -5.0, +0.5		-0.6, +10 -5.5, +10	-0.55, +0.5 -5.0, +0.5		-0.6, +10 -5.5, +10	-0.55, +0.5 -5.0, +0.5	Vdc
SRI _{ref} Reference current slew rate	Figure 6		8.0			8.0			8.0		mA/µs
PSRR(-) Output current power supply sensitivity	I _{ref} = 1mA		0.5	2.7		0.5	2.7		0.5	2.7	µA/V
I _{CC} Power supply current I _{EE} Positive Negative	All bits low, Figure 5		+2.5 -6.5	+22 -13		+2.5 -6.5	+22 -13		+2.5 -6.5	+22 -13	mA
V _{CCR} Power supply voltage range V _{VEER} Positive Negative	T _A = +25°C, Figure 5	+4.5 -4.5	+5.0 -15	+5.5 -16.5	+4.5 -4.5	+5.0 -15	+5.5 -16.5	+4.5 -4.5	+5.0 -15	+5.5 -16.5	Vdc
P _D Power dissipation	All bits low, Figure 5 V _{EE} = -5.0Vdc V _{EE} = -15Vdc		34 110	170 305		34 110	170 305		34 110	170 305	mW

NOTES:
 1. All bits switched.

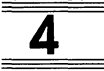

8-BIT MULTIPLYING D/A CONVERTER

MC1508-8/1408-8/1408-7

TYPICAL PERFORMANCE CHARACTERISTICS

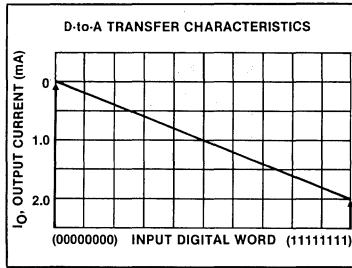

FUNCTIONAL DESCRIPTION

Reference Amplifier Drive and Compensation

The reference amplifier input current must always flow into pin 14 regardless of the setup method or reference supply voltage polarity.

Connections for a positive reference voltage are shown in Figure 1. The reference voltage source supplies the full reference current. For bipolar reference signals, as in the multiplying mode, R_{15} can be tied to a negative voltage corresponding to the minimum input level. R_{15} may be eliminated and pin 15 grounded, with only a small sacrifice in accuracy and temperature drift.

The compensation capacitor value must be increased with increasing values of R_{14} to maintain proper phase margin. For R_{14} values of 1.0, 2.5, and 5.0K ohms, minimum capacitor values are 15, 37, and 75pF. The capacitor may be tied to either V_{EE} or ground, but using V_{EE} increases negative supply rejection. (Fluctuations in the negative supply have more effect on accuracy than do any changes in the positive supply).

A negative reference voltage may be used if R_{14} is grounded and the reference voltage is applied to R_{15} , as shown in Figure 2. A high input impedance is the main advantage of this method. The negative reference voltage must be at least 3.0V above the V_{EE} supply. Bipolar input signals may be handled by connecting R_{14} to a positive reference voltage equal to the peak positive input level at pin 15.

Capacitive bypass to ground is recommended when a DC reference voltage is used. The 5.0V logic supply is not recommended as a reference voltage, but if a

well regulated 5.0V supply which drives logic is to be used as the reference, R_{14} should be formed of two series resistors and the junction of the two resistors bypassed with 0.1 μ F to ground. For reference voltages greater than 5.0V, a clamp diode is recommended between pin 14 and ground.

If pin 14 is driven by a high impedance such as a transistor current source, none of the above compensation methods apply and the amplifier must be heavily compensated, decreasing the overall bandwidth.

Output Voltage Range

The voltage at pin 4 must always be at least 4.5 volts more positive than the voltage of the negative supply (pin 3) when the reference current is 2mA or less, and at least 8 volts more positive than the negative supply when the reference current is between 2mA and 4mA. This is necessary to avoid saturation of the output transistors, which would cause serious degradation of accuracy.

Signetics' MC1508/MC1408 does not need a range control because the design extends the compliance range down to 4.5 volts (or 8 volts—see above) above the negative supply voltage without significant degradation of accuracy. Signetics' MC1508/MC1408 can be used in sockets designed for other manufacturers' MC1508/MC1408 without circuit modification.

Output Current Range

Any time the full scale current exceeds 2mA, the negative supply must be at least 8 volts more negative than the output voltage. This is due to the increased internal voltage drops between the negative supply and the outputs with higher reference currents.

Accuracy

Absolute accuracy is the measure of each output current level with respect to its intended value, and is dependent upon relative accuracy, full scale accuracy and full scale current drift. Relative accuracy is the measure of each output current level as a fraction of the full scale current after zero scale current has been nulled out. The relative accuracy of the MC1508/MC1408 is essentially constant over the operating temperature range because of the excellent temperature tracking of the monolithic resistor ladder. The reference current may drift with temperature, causing a change in the absolute accuracy of output current; however, the MC1508/MC1408 has a very low full scale current drift over the operating temperature range.

The MC1508/MC1408 series is guaranteed accurate to within $\pm 1/2$ LSB at $+25^\circ\text{C}$ at a full scale output current of 1.99mA. The relative accuracy test circuit is shown in Figure 3. The 12-bit converter is calibrated to a full scale output current of 1.99219mA; then the MC1508/MC1408's full scale current is trimmed to the same value with R_{14} so that a zero value appears at the error amplifier output. The counter is activated and the error band may be displayed on the oscilloscope, detected by comparators, or stored in a peak detector.

Two 8-bit D-to-A converters may not be used to construct a 16-bit accurate D-to-A converter. Sixteen-bit accuracy implies a total of $\pm 1/2$ part in 65,536, or $\pm 0.00076\%$, which is much more accurate than the $\pm 0.19\%$ specification of the MC1508/MC1408.

Monotonicity

A monotonic converter is one which always provides an analog output greater than or equal to the preceding value for a corresponding increment in the digital input code. The MC1508/MC1408 is monotonic for all values of reference current above 0.5mA. The recommended range for operation is a DC reference current between 0.5mA and 4.0mA.

Settling Time

The worst case switching condition occurs when all bits are switched on, which corresponds to a low-to-high transition for all input bits. This time is typically 70ns for settling to within 1/2 LSB for 8-bit accuracy. This time applies when $RL < 500$ ohms and $C_0 < 25$ pF. The slowest single switch is the least significant bit, which typically turns on and settles in 65ns. In applications where the D-to-A converter functions in a positive going ramp mode, the worst case condition does not occur and settling times less than 70ns may be realized.

Extra care must be taken in board layout since this usually is the dominant factor in satisfactory test results when measuring settling time. Short leads, 100 μ F supply bypassing for low frequencies, minimum scope lead length, good ground planes, and avoidance of ground loops are all mandatory.

TEST CIRCUITS

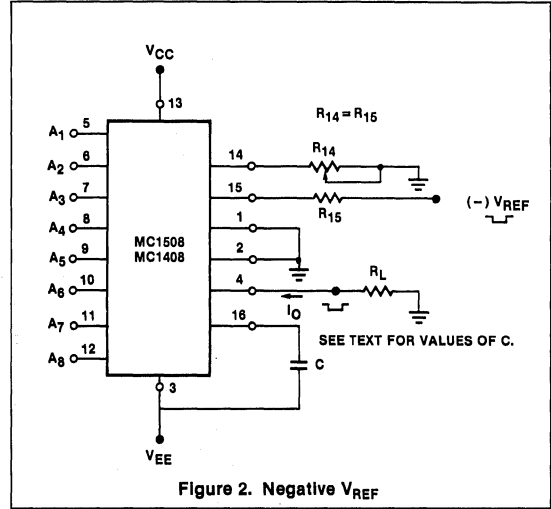
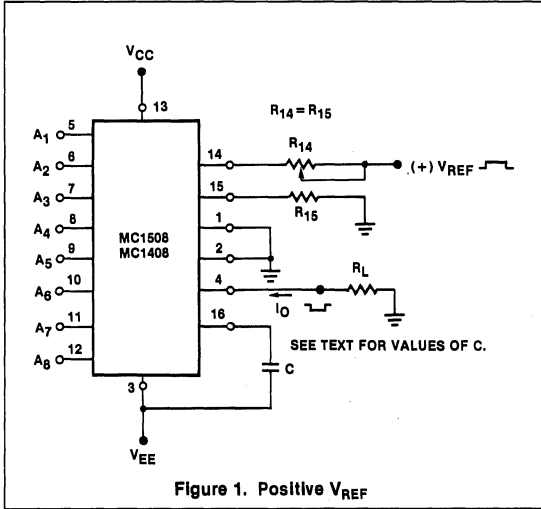

4

TEST CIRCUITS (Cont'd)

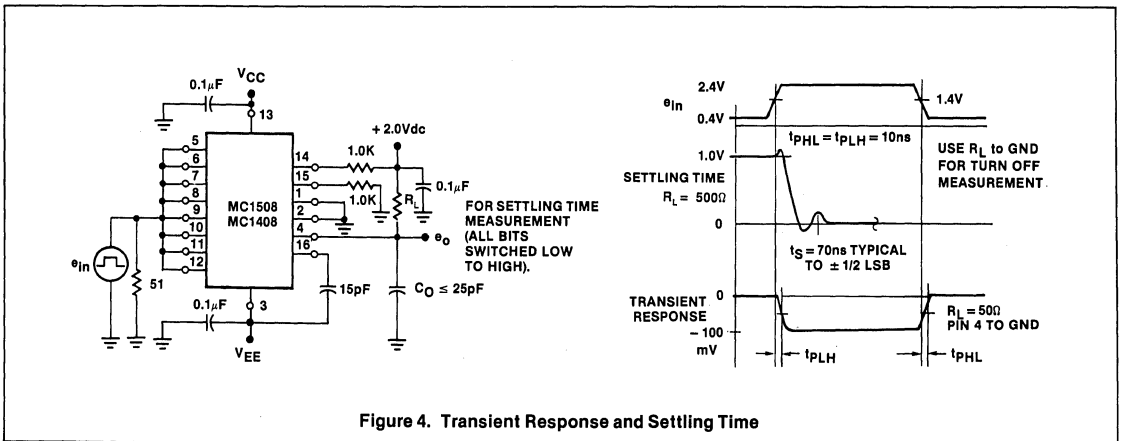
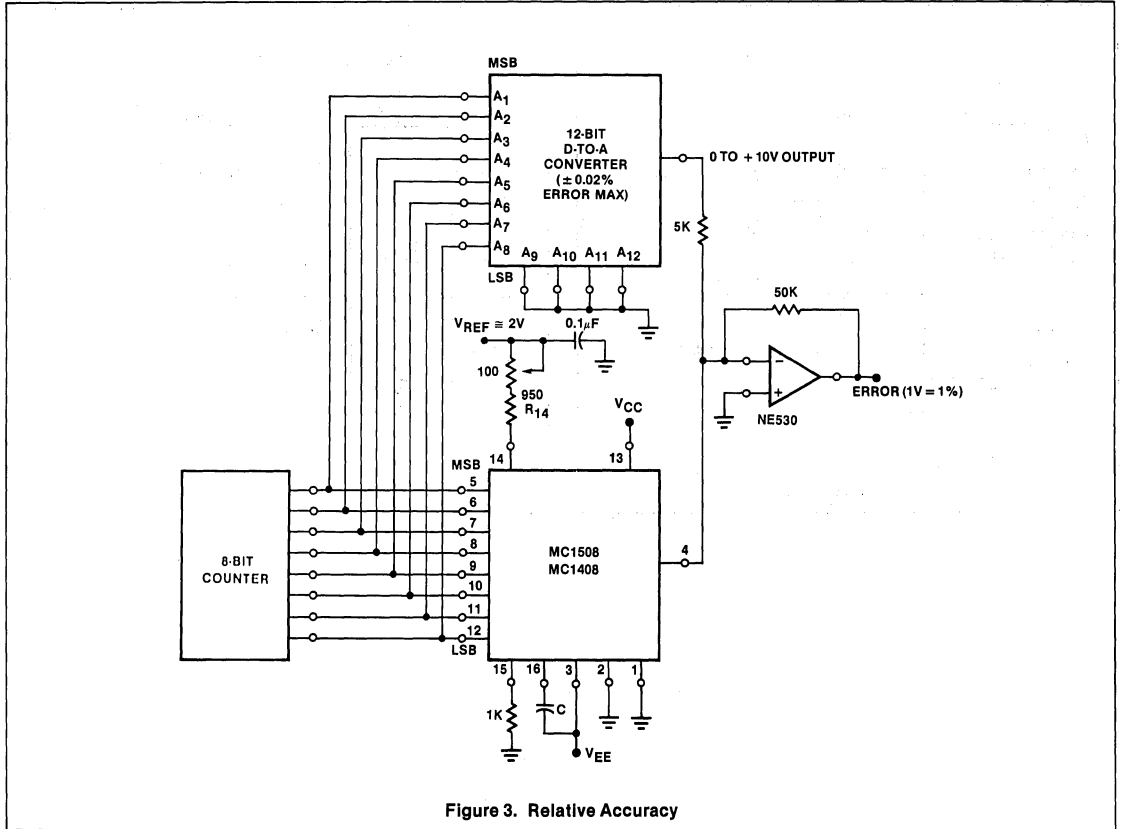

8-BIT MULTIPLYING D/A CONVERTER

MC1508-8/1408-8/1408-7

TEST CIRCUITS (Cont'd)

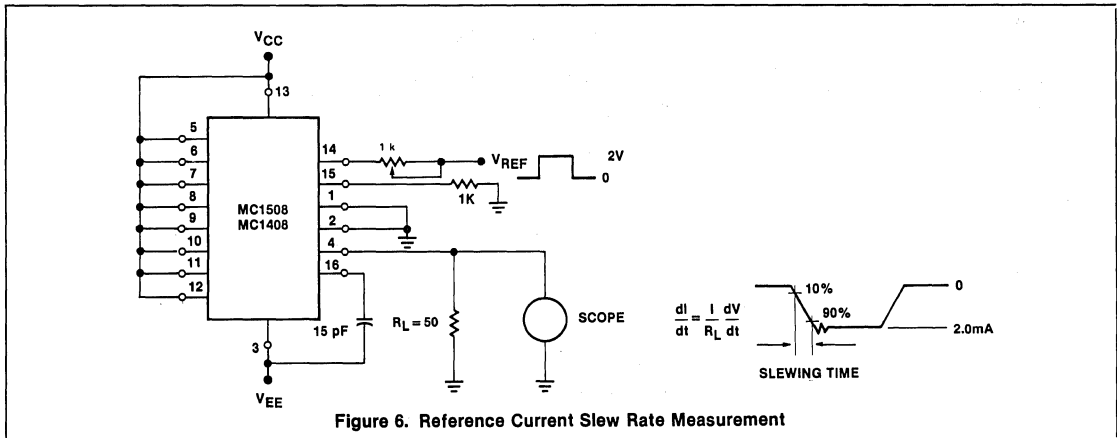
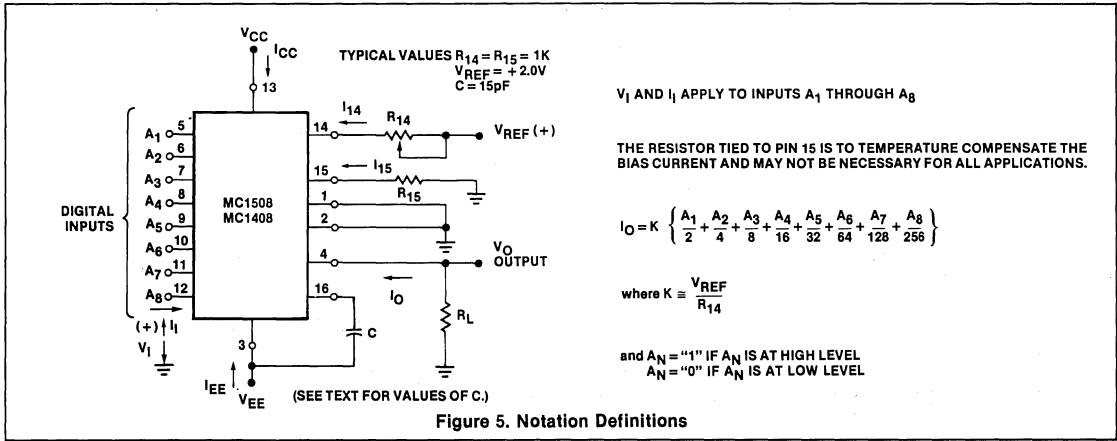

10-BIT HIGH-SPEED MULTIPLYING D/A CONVERTER

MC3410, MC3510, MC3410C

DESCRIPTION

The MC3410 series are 10-Bit Multiplying Digital-to-Analog Converters. They are capable of high-speed performance, and are used as general-purpose building blocks in cost-effective D/A systems.

The Signetics' design provides complete 10-bit accuracy without laser trimming, and guaranteed monotonicity over temperature. Segmented current sources, in conjunction with an R/2R DAC provides the binary weighted currents. The output buffer amplifier and voltage reference have been omitted to allow greater speed, lower cost, and maximum user flexibility.

FEATURES

- 10-bit resolution and accuracy ($\pm 0.05\%$)
- Guaranteed monotonicity over temperature
- Fast settling time—250ns typical
- Digital inputs are TTL and CMOS compatible
- Wide output voltage compliance range
- High-speed multiplying input slew rate—20mA/ μ s
- Reference amplifier internally compensated
- Standard supply voltages +5V and -15V

APPLICATIONS

- Successive approximation A/D converters
- High-speed, automatic test equipment
- High-speed modems
- Waveform generators
- CRT displays
- Strip CHART and X-Y plotters
- Programmable power supplies
- Programmable gain and attenuation

PIN CONFIGURATION

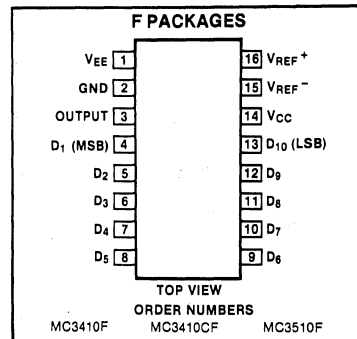

ABSOLUTE MAXIMUM RATINGS $T_A = +25^\circ\text{C}$ unless otherwise noted

SYMBOL AND PARAMETER	RATING	UNIT
V_{CC} Power Supply	+7.0	Vdc
V_{EE}	-18	Vdc
V_I Digital Input Voltage	+15	Vdc
V_O Applied Output Voltage	0.5, -5.0	Vdc
$I_{REF(16)}$ Reference Current	2.5	mA
V_{REF} Reference Amplifier Inputs	V_{CC}, V_{EE}	Vdc
$V_{REF(D)}$ Reference Amplifier Differential Inputs	0.7	Vdc
T_A Operating Temperature Range		
MC3510	-55 to +125	$^\circ\text{C}$
MC3410, 3410C	0 to +70	$^\circ\text{C}$
T_J Junction Temperature		
Ceramic Package	+175	$^\circ\text{C}$
Plastic Package	+150	$^\circ\text{C}$

BLOCK DIAGRAM

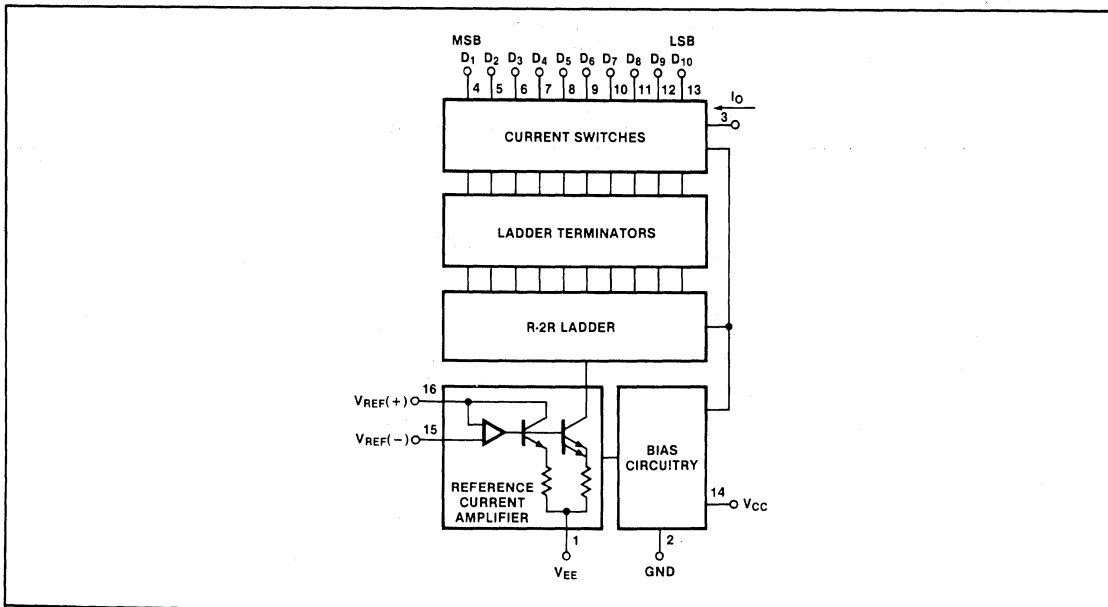

10-BIT HIGH-SPEED MULTIPLYING D/A CONVERTER

MC3410, MC3510, MC3410C

DC ELECTRICAL CHARACTERISTICS $V_{CC} = +5.0Vdc$, $V_{EE} = -15Vdc$, $\frac{V_{REF}}{R_{16}} = 2.0mA$, all digital inputs at high logic level.

MC3510: $T_A = -55^{\circ}C$ to $+125^{\circ}C$, MC3410 Series: $T_A = 0^{\circ}$ to $+70^{\circ}C$ unless otherwise noted.

SYMBOL AND PARAMETER		TEST CONDITIONS	MC3510, MC3410			MC3410C			UNIT
			Min	Typ	Max	Min	Typ	Max	
E_r	Relative accuracy (Error relative to full scale I_O)	$T_A = 25^{\circ}C$			± 0.05			± 0.1	%
					1/4			1/2	LSB
TCE_r	Relative accuracy drift (Relative to full scale I_O)			2.5			2.5		ppm/ $^{\circ}C$
	Monotonicity	Over temperature	10			10			Bits
t_s	Settling time to within $\pm 1/2$ LSB (all bits low to high)	$T_A = 25^{\circ}C$		250			250		ns
t_{PLH} t_{PHL}	Propagation delay time	$T_A = 25^{\circ}C$		35 20			35 20		ns
TCl_O	Output full scale current drift				60			70	ppm/ $^{\circ}C$
V_{IH}	Digital Input Logic Levels (All bits) High Level, Logic "1" Low Level, Logic "0"		2.0		0.8	2.0		0.8	Vdc
I_{IH} I_{IL}	Digital Input Current (All bits) High Level, $V_{IH} = 5.5V$ Low Level, $V_{IL} = 0.8V$			-0.05	+ .04 -0.4		-0.05	+ .04 -0.4	mA
$I_{REF(15)}$	Reference Input Bias Current (Pin 15)			-1.0	-5.0		-1.0	-5.0	μA
I_{OR}	Output Current Range			4.0	5.0		4.0	5.0	mA
I_{OH}	Output Current (All bits high)	$V_{REF} = 2.000V$, $R_{16} = 1000\Omega$	3.8	3.996	4.2	3.8	3.996	4.2	mA
I_{OL}	Output Current (All bits low)	$T_A = 25^{\circ}C$		0	2.0		0	4.0	μA
V_O	Output Voltage Compliance	$T_A = 25^{\circ}C$			-2.5 + 0.2			-2.5 + 0.2	Vdc
SR I_{REF}	Reference Amplifier Slew Rate			20			20		mA/ μs
ST I_{REF}	Reference Amplifier Settling Time	0 to 4.0mA, $\pm 0.1\%$		2.0			2.0		μs
PSRR(-)	Output Current Power Supply Sensitivity			0.003	0.01		0.003	0.02	%/%
C_O	Output Capacitance	$V_O = 0$		25			25		pF
C_i	Digital Input Capacitance (All bits high)			4.0			4.0		pF
I_{CC} I_{EE}	Power Supply Current (All bits low)				+ 18 -11.4 -20			+ 18 -11.4 -20	mA
V_{CC} V_{EE}	Power Supply Voltage Range	$T_A = 25^{\circ}C$	+ 4.75 -14.25	+ 5.0 -15	+ 5.25 -15.75	+ 4.75 -14.25	+ 5.0 -15	+ 5.25 -15.75	Vdc
	Power Consumption (All bits low) (All bits high)			220 200	380		220 200	380	mW

4

TYPICAL PERFORMANCE CHARACTERISTICS

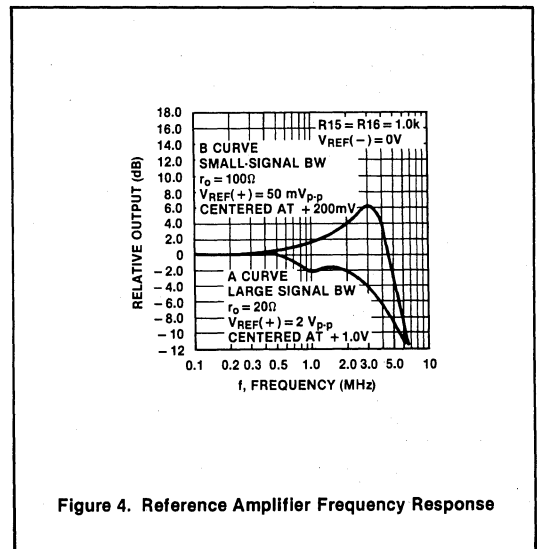
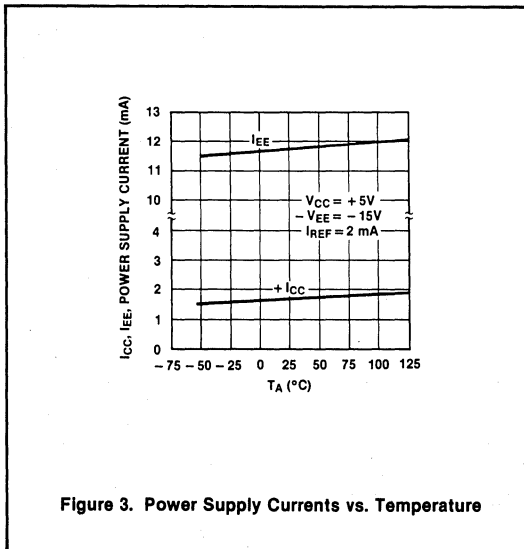
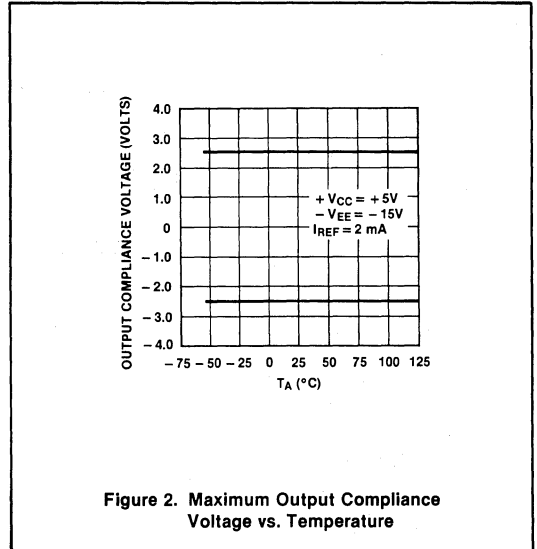
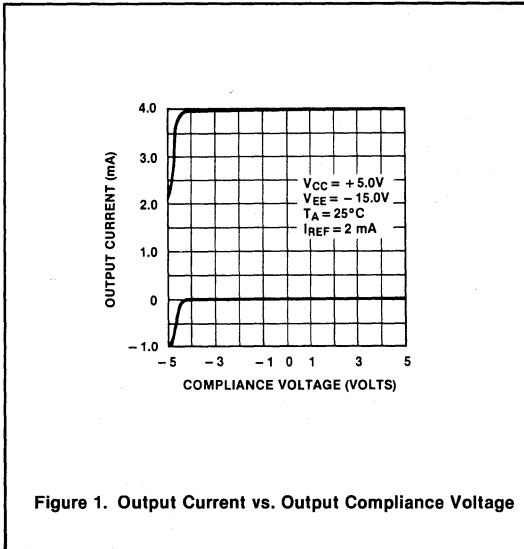

CIRCUIT DESCRIPTION

The MC3410 consists of four segment current sources which generate the 2 Most Significant Bits (MSBs), and an R/2R DAC implemented with ion implanted resistors for scaling the remaining 8 Least Significant Bits (LSBs). (See Figure 5.) This approach provides complete 10-bit accuracy without trimming.

The individual bit currents are switched ON or OFF by fully differential current switches. The switches use current steering for speed.

An on-chip high-slew reference current amplifier drives the R/2R ladder and segment decoder. The currents are scaled in such a way that, with all bits on, the maximum output current is two times 1023/1024 of the reference amplifier current, or nominally 3.996mA for a 2.000mA refer-

ence input current. The reference amplifier allows the user to provide a voltage input. Out-board resistor R16 (see Figure 6) converts this voltage to a usable current. A current mirror doubles this reference current and feeds it to the segment decoder and resistor ladder. Thus, for a reference voltage of 2.0 Volts and a 1kΩ resistor tied to Pin 16, the full scale current is approximately 4.0mA. This relationship will remain regardless of the reference voltage polarity.

Connections for a positive reference voltage are shown in Figure 6a. For negative reference voltage inputs, or for bipolar reference voltage inputs in the multiplying mode, R15 can be tied to a negative voltage corresponding to the minimum input level. For a negative reference input, R16 should be grounded (Figure 6b). In addition, the negative voltage reference must be at least 3V above the V_{EE} supply volt-

age for best operation. Bipolar input signals may be handled by connecting R16 to a positive voltage equal to the peak positive input level at Pin 15.

When a DC reference voltage is used, capacitive bypass to ground is recommended. The 5V logic supply is not recommended as a reference voltage. If a well regulated 5.0V supply, which drives logic, is to be used as the reference, R16 should be decoupled by connecting it to the +5.0V logic supply through another resistor and bypassing the junction of the two resistors with a 0.1μF capacitor to ground.

The reference amplifier is internally compensated with a 10pF feed-forward capacitor, which gives it its high slew rate and fast settling time. Proper phase margin is maintained with all possible values of R16 and reference voltages which supply

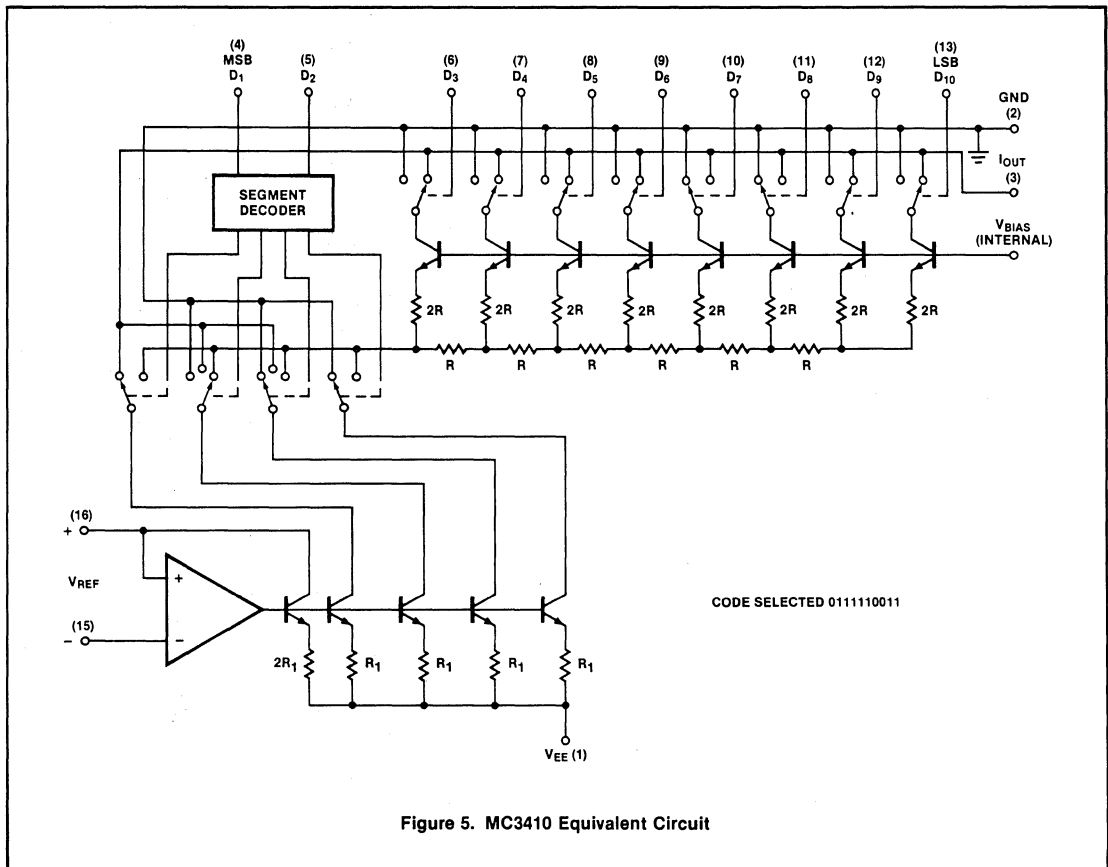
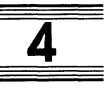
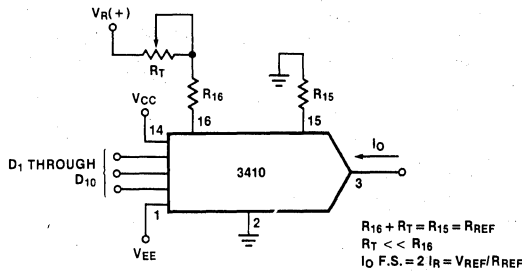
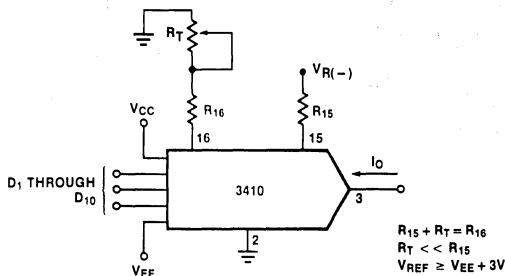

Figure 5. MC3410 Equivalent Circuit



a) POSITIVE REFERENCE VOLTAGE



b) NEGATIVE REFERENCE VOLTAGE

Figure 6. Basic Connections

2.0mA reference current into Pin 16. The reference current can also be supplied by a high impedance current source of 2.0mA. As R16 increases, the bandwidth of the amplifier decreases slightly and settling time increases. For a current source with a dynamic output impedance of 1.0MΩ, the bandwidth of the reference amplifier is approximately half what it is in the case of R16 = 1.0kΩ, and settling time is ≈ 10μs. The reference amplifier phase margin decreases as the current source value decreases in the case of a current source reference, so that the minimum reference current supplied from a current source is 0.5mA for stability.

OUTPUT VOLTAGE COMPLIANCE

The output voltage compliance ranges from -2.5 to +0.2V. As shown in Figure 2, this compliance range is nearly constant over temperature. At the temperature extremes, however, the compliance voltage may be reduced if VEE > -15V.

ACCURACY

Absolute accuracy is a measure of each output current level with respect to its intended value. It is dependent upon relative accuracy and full scale current drift. Relative accuracy, or linearity, is the measure of each output current with respect to its intended fraction of the full scale current. The relative accuracy of the MC3410 is fairly constant over temperature due to the excellent temperature tracking, of the implanted resistors. The full scale current from the reference amplifier may drift with temperature causing a change in the absolute accuracy. However, the MC3410 has a low full scale current drift with temperature.

The MC3510 and the MC3410 are accurate to within ± .05% at 25°C with a reference current of 2.0mA on Pin 16.

MONOTONICITY

The MC3410, MC3510 and MC3410C are guaranteed monotonic over temperature. This means that for every increase in the input digital code, the output current either remains the same or increases but never decreases. In the multiplying mode, where reference input current will vary, monotonicity can be assured if the reference input current remains above 0.5mA.

SETTLING TIME

The worst case switching condition occurs when all bits are switched "on," which corresponds to a low-to-high transition for all bits. This time is typically 250ns for the output to settle to within $\pm 1/2$ LSB for 10-bit accuracy, and 200ns for 8-bit accuracy. The turn-off time is typically 120ns. These times apply when the output swing is limited to a small (<0.7 Volt) swing and the external output capacitance is under 25pF.

The major carry (MSB off-to-on, all others on-to-off) settles in approximately the same time as when all bits are switched off-to-on.

If a load resistor of 625 Ohms is connected to ground, allowing the output to swing to -2.5 Volts, the settling time increases to 1.5 μ s.

Extra care must be taken in board layout as this is usually the dominant factor in satisfactory test results when measuring

settling time. Short leads, 100 μ F supply bypassing, and minimum scope lead length are all necessary.

A typical test set-up for measuring settling time is shown in Figure 7. The same set-up for the most part can be used to measure the slew rate of the reference amplifier (Figure 9) by tying all data bits high, pulsing the voltage reference input between 0 and 2V, and using a 500 Ω load resistor R_L .

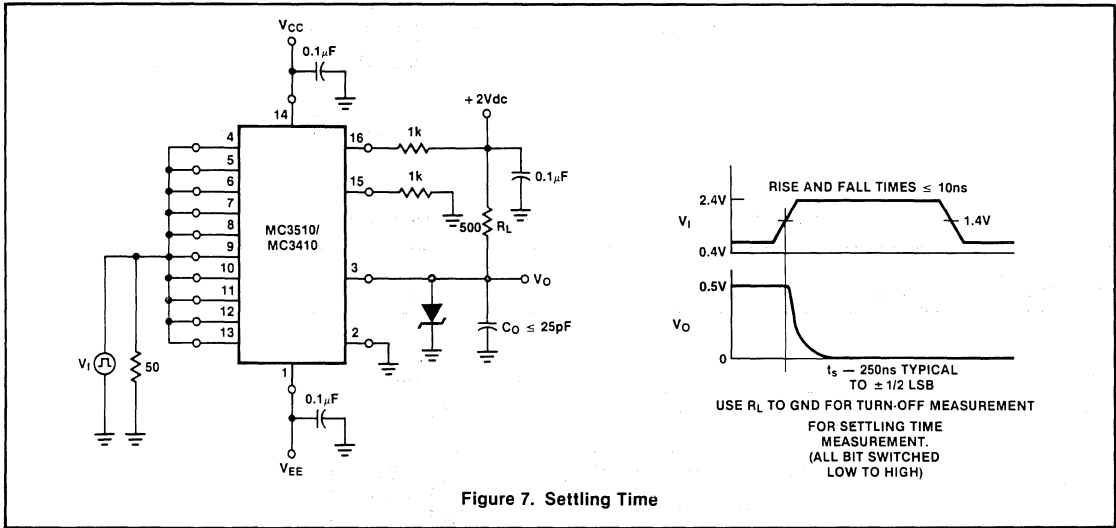

Figure 7. Settling Time

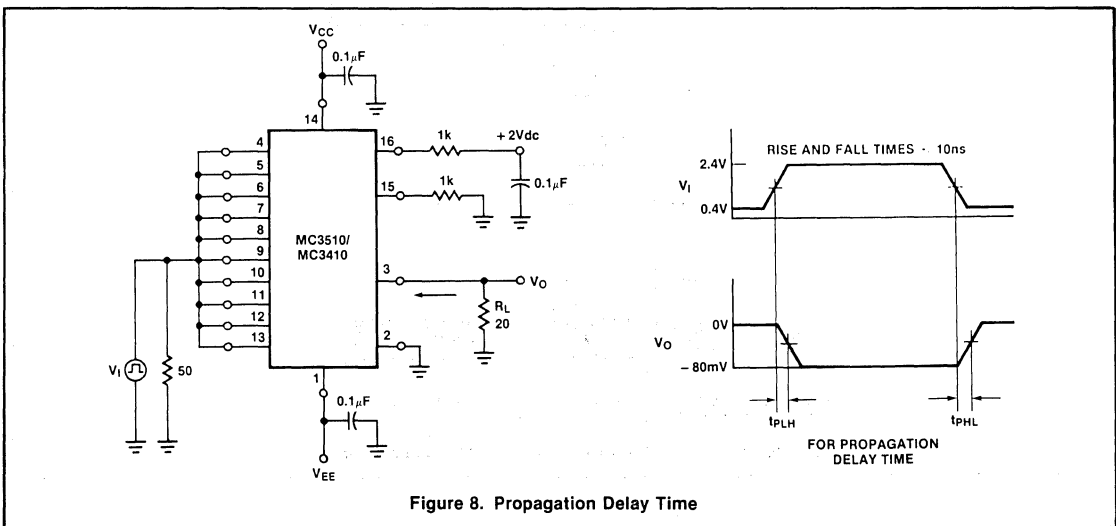
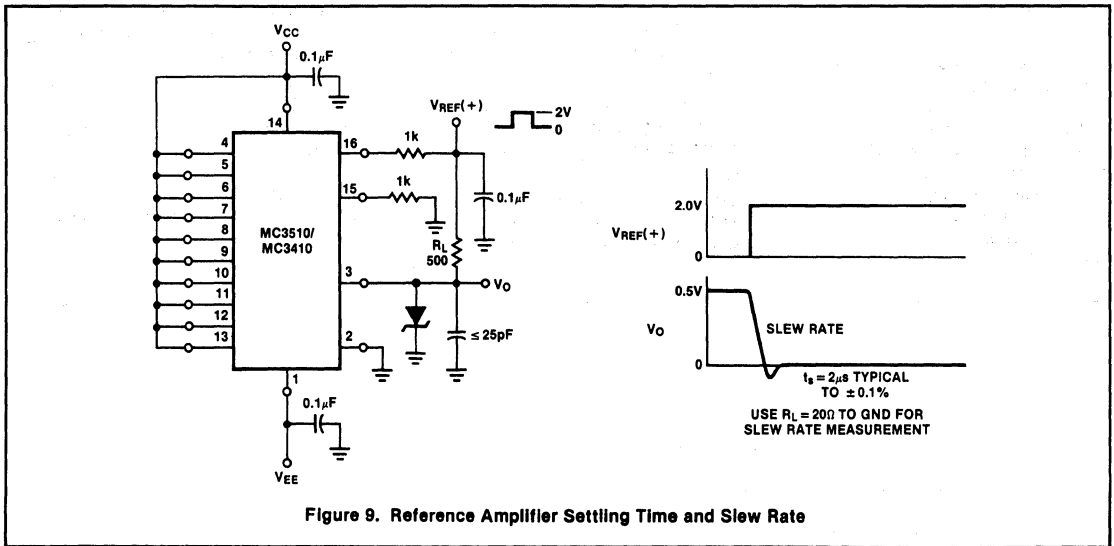
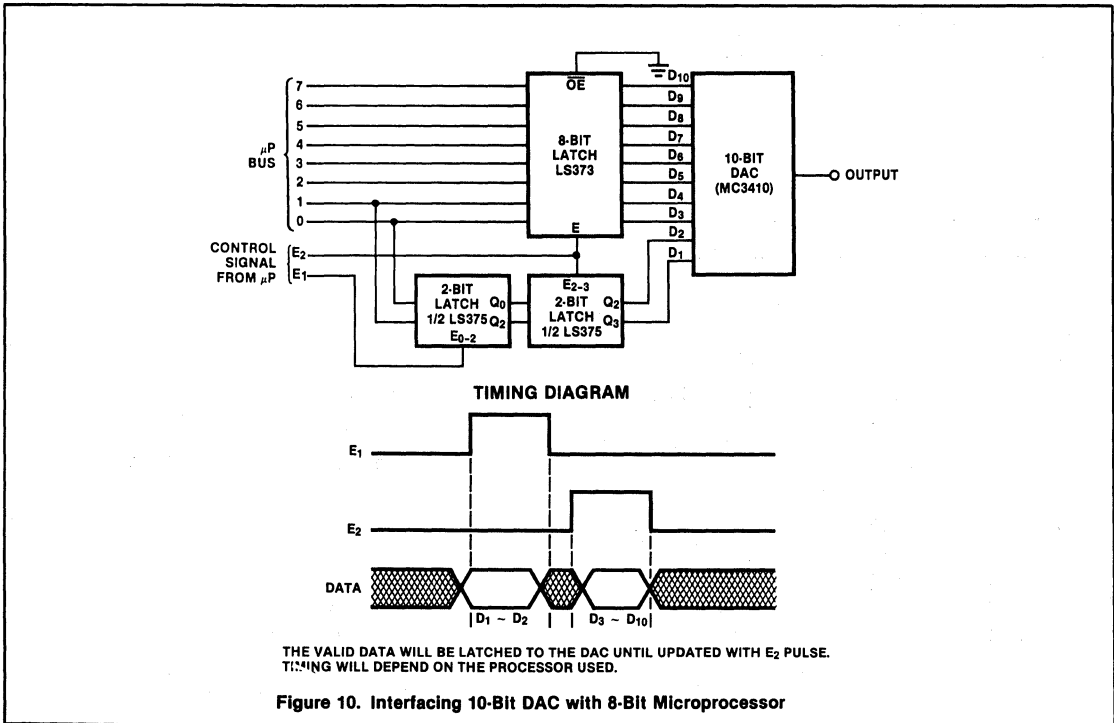

Figure 8. Propagation Delay Time



TYPICAL APPLICATIONS



8-BIT μ P-COMPATIBLE D/A CONVERTER

SE/NE5018

DESCRIPTION

The NE5018 is a complete 8-bit digital to analog converter subsystem on one monolithic chip. The data inputs have input latches, controlled by a latch enable pin. The data and latch enable inputs are ultra-low loading for easy interfacing with all logic systems. The latches appear transparent when the \overline{LE} input is in the low state. When \overline{LE} goes high, the input data present at the moment of transition is latched and retained until \overline{LE} again goes low. This feature allows easy compatibility with most micro-processors.

The chip also comprises a stable voltage reference (5V nominal) and a high slew rate buffer amplifier. The voltage reference may be externally trimmed with a potentiometer for easy adjustment of full scale, while maintaining a low temperature co-efficient.

The output of the buffer amplifier may be offset so as to provide bipolar as well as unipolar operation.

FEATURES

- 8-bit resolution
- Input latches
- Low-loading data inputs
- On-chip voltage reference
- Output buffer amplifier
- Accurate to $\pm 1/2$ LSB (.19%)
- Monotonic to 8 bits
- Amplifier and reference both short-circuit protected
- Compatible with 8085, 6800 and many other μ P's

APPLICATIONS

- Precision 8-bit D/A converters
- A/D converters
- Programmable power supplies
- Test equipment
- Measuring instruments
- Analog-digital multiplication

PIN CONFIGURATION

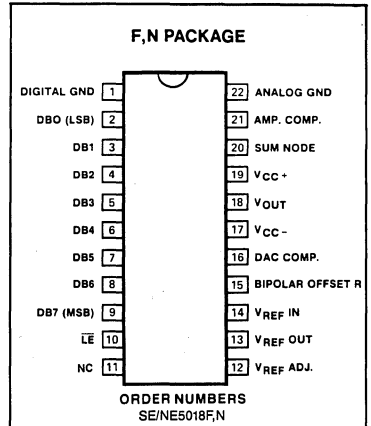

D² PACKAGE

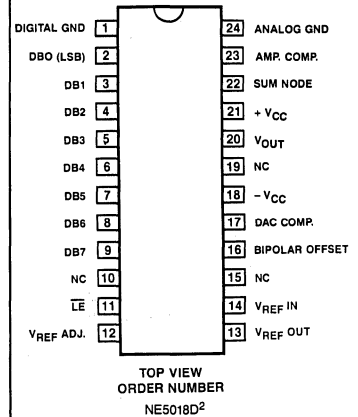

NOTES:

1. SOL-Released in Large SO package only.
2. SOL and non-standard pinout.
3. SO and non-standard pinouts.

BLOCK DIAGRAM

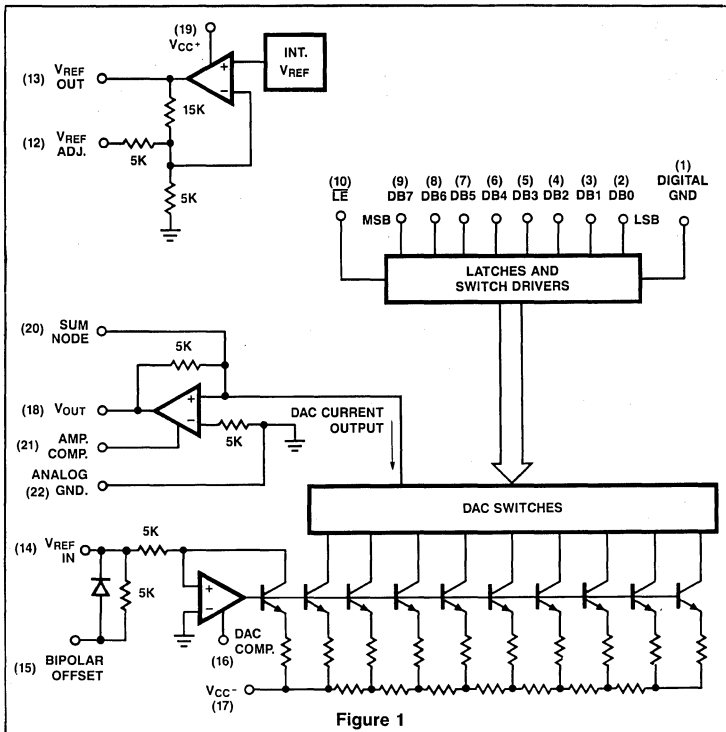

8-BIT μ P-COMPATIBLE D/A CONVERTER

SE/NE5018

ABSOLUTE MAXIMUM RATINGS

PARAMETER	RATING	UNIT	
V _{CC+}	Positive supply voltage	18	V
V _{CC-}	Negative supply voltage	-18	V
V _{IN}	Logic input voltage	0 to 18	V
V _{REFIN}	Voltage at V _{REF} input	12	V
V _{REFADJ}	Voltage at V _{REF} adjust	0 to V _{REF}	V
V _{SUM}	Voltage at sum node	12	V
I _{REFSC}	Short-circuit current to ground at V _{REF} OUT	Continuous	
I _{OUTSC}	Short-circuit current to ground or either supply at V _{OUT}	Continuous	
P _D	Power dissipation*		
	-N package	800	mW
	-F package	1000	mW
T _A	Operating temperature range		
	SE5018	-55 to +125	°C
	NE5018	0 to +70	°C
T _{STG}	Storage temperature range	-65 to +150	°C
T _{SOLD}	Lead soldering temperature (10 seconds)	300	°C

*NOTES

For N package, derate at 120°C/W above 35°C

For F package, derate at 75°C/W above 75°C

DC ELECTRICAL CHARACTERISTICS

V_{CC+} = +15V, V_{CC-} = -15V, SE5018. -55°C ≤ T_A ≤ 125°C, NE5018. 0°C ≤ T_A ≤ 70°C unless otherwise specified!
 Typical values are specified at 25°C

PARAMETER	TEST CONDITIONS	SE5018			NE5018			UNIT		
		Min	Typ	Max	Min	Typ	Max			
Resolution		8	8	8	8	8	8	Bits		
Monotonicity		8	8	8	8	8	8	Bits		
Relative accuracy				±0.19			±0.19	%FS		
V _{CC+}	Positive supply voltage	11.4	15		11.4	15		V		
V _{CC-}	Negative supply voltage	-11.4	-15		-11.4	-15		V		
V _{IN(1)}	Logic "1" input voltage	Pin 1 = 0V			2.0			V		
V _{IN(0)}	Logic "0" input voltage	Pin 1 = 0V				0.8	0.8	V		
I _{IN(1)}	Logic "1" input current	Pin 1 = 0V, 2V < V _{IN} < 18V			0.1	10	0.1	10	μA	
I _{IN(0)}	Logic "0" input current	Pin 1 = 0V, -5V < V _{IN} < 0.8V			-2.0	-10	-2.0	-10	μA	
V _{FS}	Full scale output voltage	Unipolar operation V _{REF IN} = 5.000V, T _A = 25°C		9.50	9.961	10.50	9.50	9.961	10.50	V
V _{FS}	Full scale output voltage	Bipolar operation V _{REF IN} = 5.000V, T _A = 25°C		4.5	+4.961	5.5	4.5	+4.961	5.5	V
V _{ZS}	Zero scale voltage			-5.04	-5.000	-4.960	5.04	-5.000	4.960	mV
				-30	5	+30	-30	5	+30	
I _{OS}	Output short circuit current	T _A = 25°C V _{OUT} = 0V			15	40	15	40	mA	
PSR ⁺ (out)	Output power supply rejection (+)	V ₋ = -15V, 13.5V ≤ V ₊ ≤ 16.5V, external V _{REF IN} = 5.000V			.001	.01	.001	.01	%FS / %VS	
PSR ⁻ (out)	Output power supply rejection (-)	V ₊ = 15V, -13.5V ≤ V ₋ ≤ -16.5V, external V _{REF IN} = 5.000V			.001	.01	.001	.01	%FS / %VS	
TC _{FS}	Full scale temperature coefficient	V _{REF IN} = 5.000V			20		20		ppm/°C	
TC _{ZS}	Zero scale temperature coefficient				5		5		ppm/°C	

8-BIT μ P-COMPATIBLE D/A CONVERTER

SE/NE5018

DC ELECTRICAL CHARACTERISTICS (Cont'd) $V_{CC+} = +15V, V_{CC-} = -15V, SE5018, -55^{\circ}C \leq T_A \leq 125^{\circ}C,$
 $NE5018, 0^{\circ}C \leq T_A \leq 70^{\circ}C$ unless otherwise specified.¹
 Typical values are specified at 25°C

PARAMETER	TEST CONDITIONS	SE/5018			NE5018			UNIT			
		Min	Typ	Max	Min	Typ	Max				
I_{REF} I_{REFSC}	Reference output current Reference short circuit current	Note 8 $T_A = 25^{\circ}C$ $V_{REF OUT} = 0V$			15	30	15	30	mA mA		
$PSR^{+}(REF)$ $PSR^{-}(REF)$	Reference power supply rejection (+) Reference power supply rejection (-)	$V- = -15V, 13.5V \leq V+ \leq 16.5V,$ $I_{REF} = 1.0mA$ $V+ = 15V, -13.5V \leq V- \leq 16.5V,$.003	.01	.003	.01	%VR/ %VS %VR/ %VS		
V_{REF} TC_{REF}	Reference voltage Reference voltage temperature coefficient	$I_{REF} = 1.0mA$ $I_{REF} = 1.0mA$ $T_A = 25^{\circ}C$			4.9	5.0	5.25	4.9	5.0	5.25	V ppm/°C
Z_{IN}	DAC V_{REF} IN input impedance	$I_{REF} = 1.0mA$ $T_A = 25^{\circ}C$			4.15	5.0	5.85	4.15	5.0	5.85	K Ω
I_{CC+} I_{CC-}	Positive supply current Negative supply current	$V_{CC+} = 15V$ $V_{CC-} = -15V$			7	14	-10	-15	7	14	mA mA
P_D	Power dissipation	$I_{REF} = 1.0mA, V_{CC} = \pm 15V$			255	435	255	435			mW

NOTE
 1. Refer to Figure 2.

AC ELECTRICAL CHARACTERISTICS² $V_{CC} = \pm 15V, T_A = 25^{\circ}C$

PARAMETER	TO	FROM	TEST CONDITIONS	SE/NE5018			UNIT
				Min	Typ	Max	
T_{SLH} T_{SHL}	Settling time Settling time	$\pm \frac{1}{2}$ LSB $\pm \frac{1}{2}$ LSB	Input Input	All bits low to high ³ All bits high to low ⁴			μs μs
t_{pLH} t_{pHL} t_{pLSB} t_{pLH} t_{pHL}	Propagation delay Propagation delay Propagation delay Propagation delay Propagation delay	Output Output Output Output Output	Input Input Input \overline{LE} \overline{LE}	All bits switched low to high ³ All bits switched high to low ⁴ 1 LSB change ^{3,4} low to high transition ⁵ high to low transition ⁶			ns ns ns ns ns
t_s t_h t_{pw}	Set-up time Hold time Latch enable pulse width	\overline{LE} Input	Input \overline{LE}	2, 7 2, 7 2, 7	100 50 150		ns ns ns

NOTES
 2. Refer to Figure 3.
 3. See Figure 6.
 4. See Figure 7.
 5. See Figure 8.
 6. See Figure 9.
 7. See Figure 10.
 8. For reference currents > 3mA, use of an external buffer is required.

4

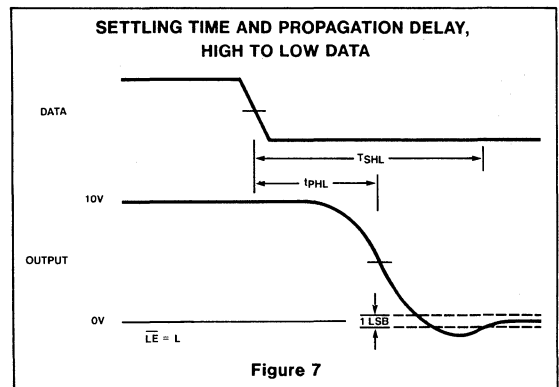
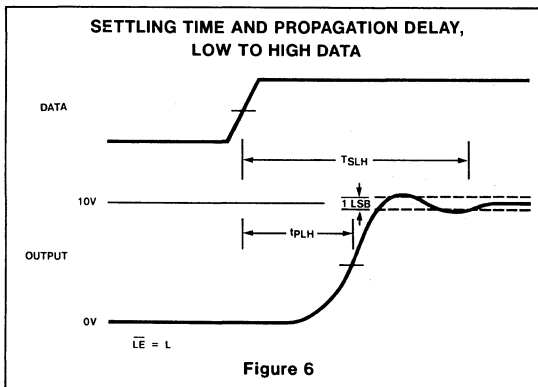
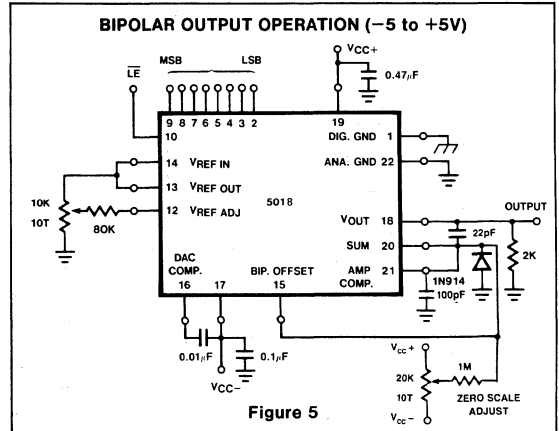
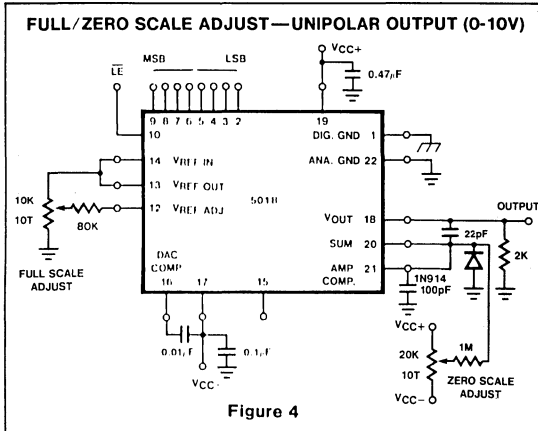
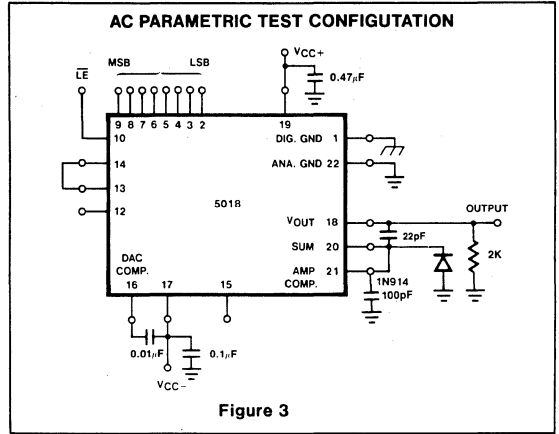
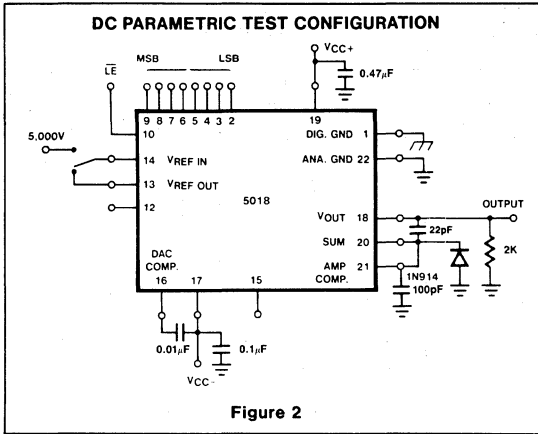

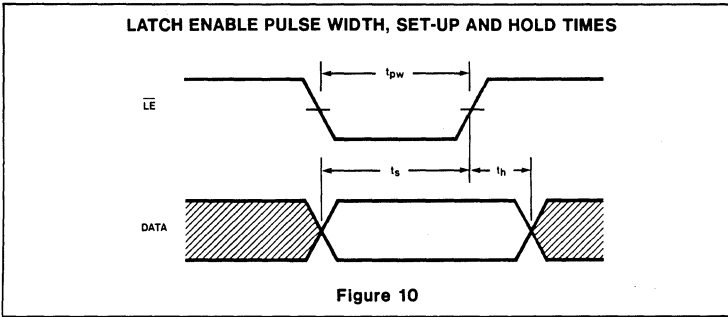
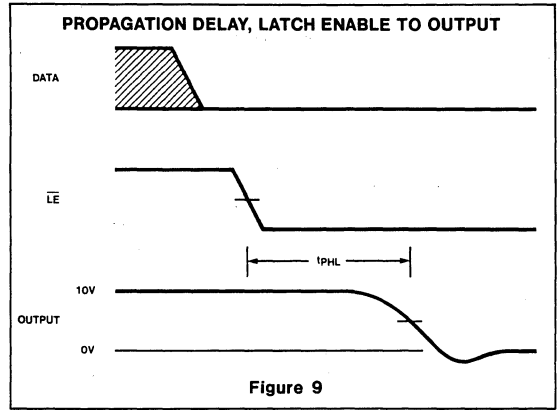
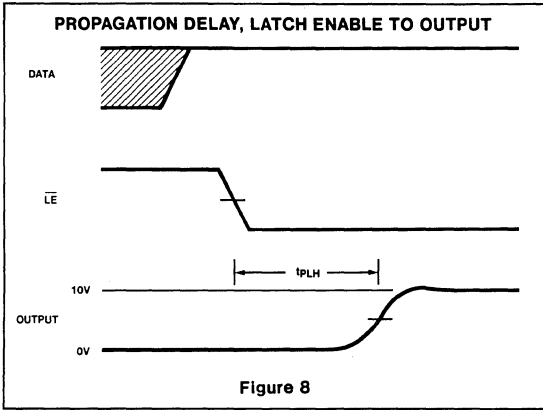

4

8-BIT μ P-COMPATIBLE D/A CONVERTER

SE/NE5019

DESCRIPTION

The NE5019 is a complete 8-bit digital to analog converter subsystem on one monolithic chip. The data inputs have input latches, controlled by a latch enable pin. The data and latch enable inputs are ultra-low loading for easy interfacing with all logic systems. The latches appear transparent when the LE input is in the low state. When LE goes high, the input data present at the moment of transition is latched and retained until LE again goes low. This feature allows easy compatibility with most micro-processors.

The chip also comprises a stable voltage reference (5V nominal) and a high slew rate buffer amplifier. The voltage reference may be externally trimmed with a potentiometer for easy adjustment of full scale, while maintaining a low temperature co-efficient.

The output of the buffer amplifier may be offset so as to provide bipolar as well as unipolar operation.

FEATURES

- 8-bit resolution
- Input latches
- Low-loading data inputs
- On-chip voltage reference
- Output buffer amplifier
- Accurate to $\pm 1/4$ LSB (.1%)
- Monotonic to 8 bits
- Amplifier and reference both short-circuit protected
- Compatible with 8085, 6800 and many other μ P's

APPLICATIONS

- Precision 8-bit D/A converters
- A/D converters
- Programmable power supplies
- Test equipment
- Measuring instruments
- Analog-digital multiplication

PIN CONFIGURATION

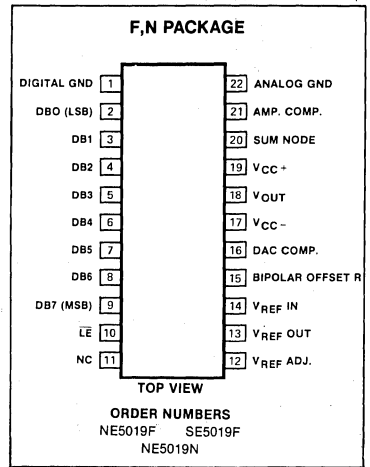

BLOCK DIAGRAM

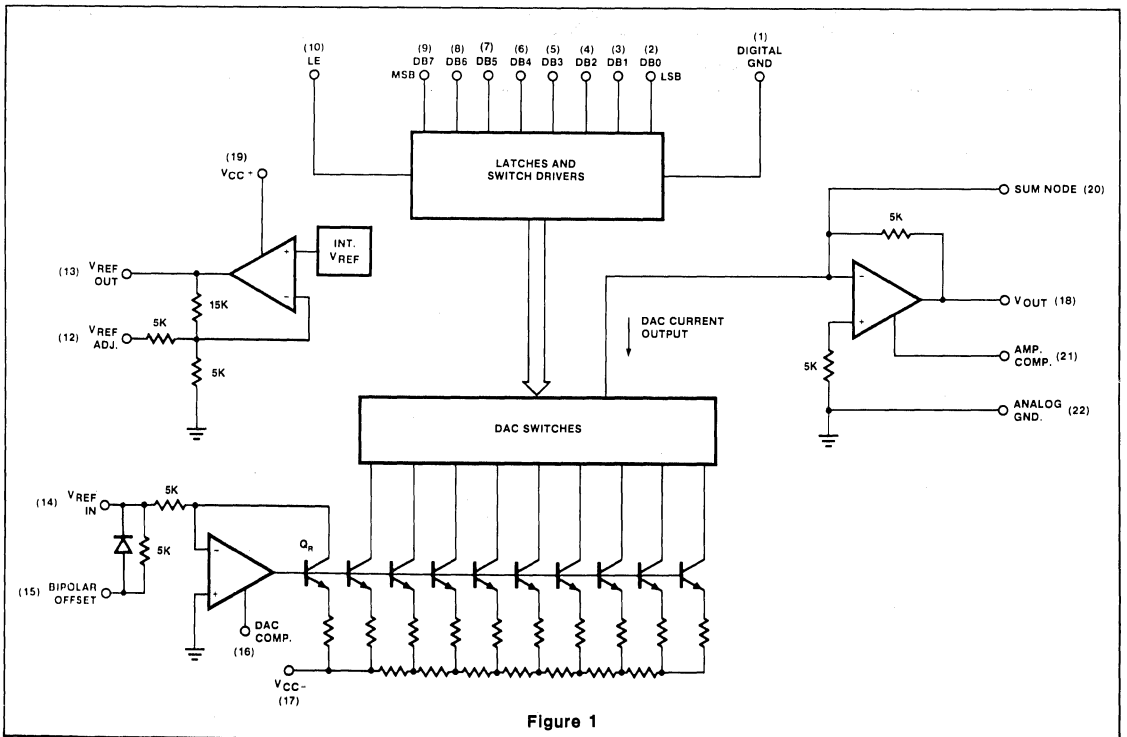

8-BIT μ P-COMPATIBLE D/A CONVERTER

SE/NE5019

ABSOLUTE MAXIMUM RATINGS

PARAMETER	RATING	UNIT	
V _{CC+}	Positive supply voltage	18	V
V _{CC-}	Negative supply voltage	-18	V
V _{IN}	Logic input voltage	0 to 18	V
V _{REFIN}	Voltage at V _{REF} input	12	V
V _{REFADJ}	Voltage at V _{REF} adjust	0 to V _{REF}	V
V _{SUM}	Voltage at sum node	12	V
I _{REFSC}	Short-circuit current to ground at V _{REF} OUT	Continuous	
I _{OUTSC}	Short-circuit current to ground or either supply at V _{OUT}	Continuous	
P _D	Power dissipation*		
	-N package	800	mW
	-F package	1000	mW
T _A	Operating temperature range		
	SE5019	-55 to +125	°C
	NE5019	0 to +70	°C
T _{STG}	Storage temperature range	-65 to +150	°C
T _{SOLD}	Lead soldering temperature (10 seconds)	300	°C

*NOTES

For N package, derate at 120°C/W above 35°C

For F package, derate at 75°C/W above 75°C

DC ELECTRICAL CHARACTERISTICS V_{CC+} = +15V, V_{CC-} = -15V, SE5019. -55°C ≤ T_A ≤ 125°C, NE5019. 0°C ≤ T_A ≤ 70°C unless otherwise specified.¹
Typical values are specified at 25°C

PARAMETER	TEST CONDITIONS	SE5019			NE5019			UNIT
		Min	Typ	Max	Min	Typ	Max	
Resolution		8	8	8	8	8	8	Bits
Monotonicity		8	8	8	8	8	8	Bits
Relative accuracy				±0.1			±0.1	%FS
V _{CC+}	Positive supply voltage	11.4	15		11.4	15		V
V _{CC-}	Negative supply voltage	-11.4	-15		-11.4	-15		V
V _{IN(1)}	Logic "1" input voltage	2.0			2.0			V
V _{IN(0)}	Logic "0" input voltage			0.8			0.8	V
I _{IN(1)}	Logic "1" input current		0.1	10		0.1	10	μA
I _{IN(0)}	Logic "0" input current		-2.0	-10		-2.0	-10	μA
V _{FS}	Full scale output voltage	9.50	9.961	10.50	9.50	9.961	10.50	V
V _{FS}	Full scale output voltage	4.5	+4.961	5.5	4.5	+4.961	5.5	V
V _{ZS}	Zero scale voltage	-5.040	-5.000	-4.960	-5.040	-5.000	-4.960	mV
		-30	5	+30	-30	5	+30	
I _{OS}	Output short circuit current		15	40		15	40	mA
PSR ⁺ (out)	Output power supply rejection (+)	V _{REF IN} = 5.000V, T _A = 25°C		.001	.01	.001 .01		%FS / %VS
PSR ⁻ (out)	Output power supply rejection (-)	V _{REF IN} = 5.000V, T _A = 25°C		.001	.01	.001 .01		%FS / %VS
TC _{FS}	Full scale temperature coefficient	V _{REF IN} = 5.000V		20		20		ppm/°C
TC _{ZS}	Zero scale temperature coefficient	V _{REF IN} = 5.000V		5		5		ppm/°C

NOTE

1. Refer to Figure 2.

8-BIT μ P-COMPATIBLE D/A CONVERTER

SE/NE5019

DC ELECTRICAL CHARACTERISTICS (Cont'd) $V_{CC+} = +15V, V_{CC-} = -15V, SE5019. -55^{\circ}C \leq T_A \leq 125^{\circ}C,$
 $NE5019. 0^{\circ}C \leq T_A \leq 70^{\circ}C$ unless otherwise specified.¹
 Typical values are specified at 25°C

PARAMETER	TEST CONDITIONS	SE5019			NE5019			UNIT
		Min	Typ	Max	Min	Typ	Max	
I_{REF} I_{REFSC}	Reference output current Reference short circuit current	Note 8 $T_A = 25^{\circ}C$ $V_{REF OUT} = 0V$				3 15	3 30	mA mA
$PSR+_{REF}$	Reference power supply rejection (+)	$V- = -15V, 13.5V \leq V+ \leq 16.5V,$ $I_{REF} = 1.0mA$.003	.01	.003 .01	%VR/ %VS
$PSR-_{REF}$	Reference power supply rejection (-)	$V+ = 15V, -13.5V \leq V- \leq 16.5V,$.003	.01	.003 .01	%VR/ %VS
V_{REF} TC_{REF}	Reference voltage Reference voltage temperature coefficient	$I_{REF} = 1.0mA$ $I_{REF} = 1.0mA$ $T_A = 25^{\circ}C$			4.9	5.0 60	5.25 60	V ppm/°C
Z_{IN}	DAC V_{REFIN} input impedance	$I_{REF} = 1.0mA$ $T_A = 25^{\circ}C$			4.15	5.0	5.85	K Ω
I_{CC+} I_{CC-}	Positive supply current Negative supply current	$V_{CC+} = 15V$ $V_{CC-} = -15V$				7 -10	14 -15	mA mA
P_D	Power dissipation	$I_{REF} = 1.0mA, V_{CC} = \pm 15V$				255	435	mW

NOTE

1. Refer to Figure 2.

AC ELECTRICAL CHARACTERISTICS² $V_{CC} = \pm 15V, T_A = 25^{\circ}C$

PARAMETER	TO	FROM	TEST CONDITIONS	SE/NE5019			UNIT
				Min	Typ	Max	
T_{SLH} T_{SHL}	Settling time Settling time	$\pm 1/2$ LSB $\pm 1/2$ LSB	Input Input	All bits low to high ³ All bits high to low ⁴		1.8 2.3	μs μs
t_{pLH} t_{pHL} t_{pLSB} t_{pLH} t_{pHL}	Propagation delay Propagation delay Propagation delay Propagation delay Propagation delay	Output Output Output Output Output	Input Input Input \overline{LE} \overline{LE}	All bits switched low to high ³ All bits switched high to low ⁴ 1 LSB change ^{3,4} low to high transition ⁵ high to low transition ⁶		300 150 150 300 150	ns ns ns ns ns
t_s t_h t_{pw}	Set-up time Hold time Latch enable pulse width	\overline{LE} Input	Input \overline{LE}	2, 7 2, 7 2, 7	100 50 150		ns ns ns

NOTES

2. Refer to Figure 3.

3. See Figure 6.

4. See Figure 7.

5. See Figure 8.

6. See Figure 9.

7. See Figure 10.

8. For reference currents > 3mA, use of an external buffer is required.

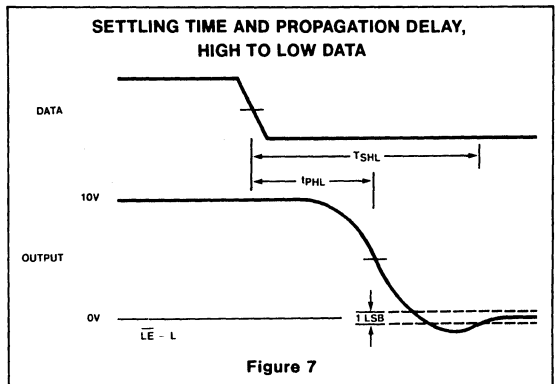
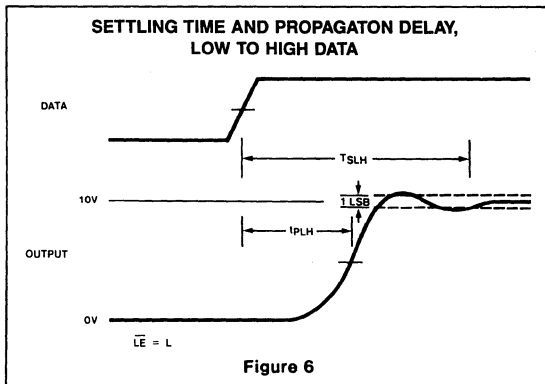
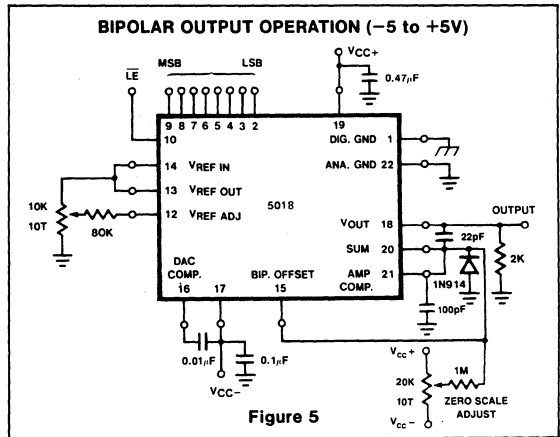
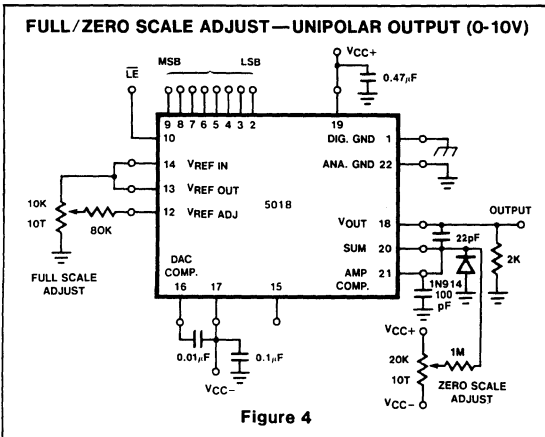
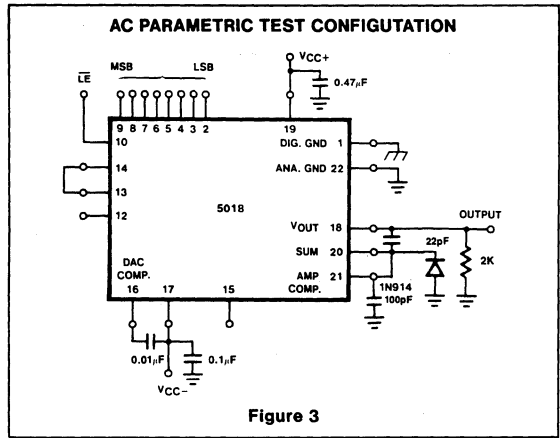
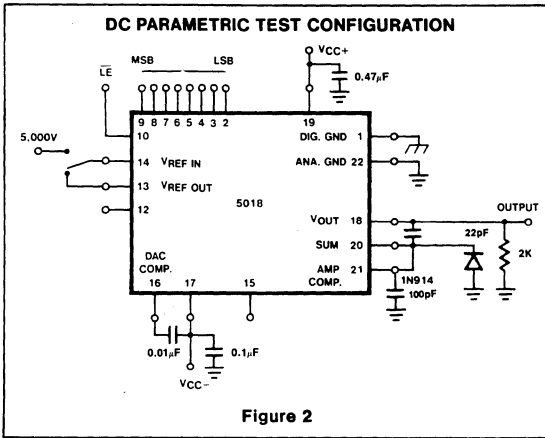

4

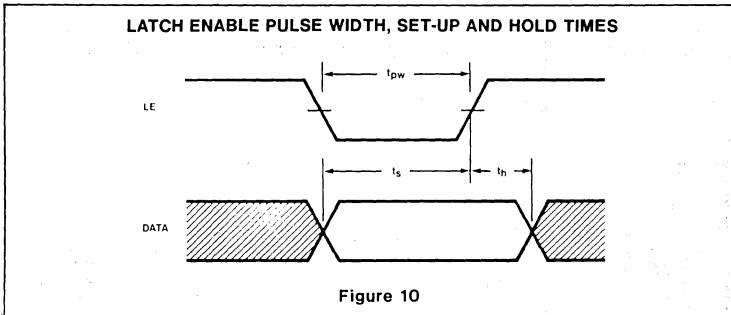
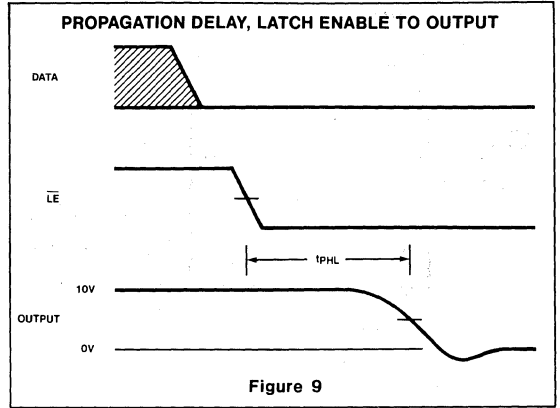
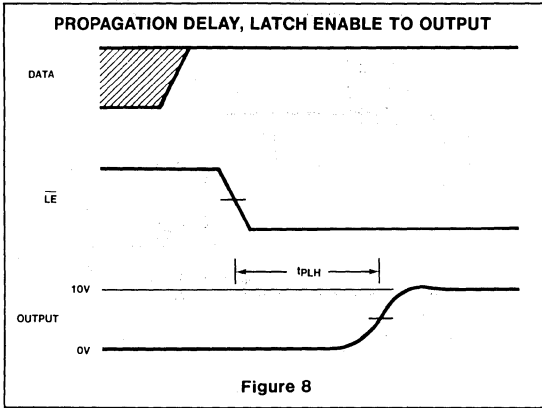

10-BIT μ P-COMPATIBLE D/A CONVERTER

NE5020

DESCRIPTION

The NE5020 is a microprocessor-compatible monolithic 10-bit digital to analog converter subsystem. This device offers 10-bit resolution and $\pm 0.1\%$ accuracy and monotonicity guaranteed over full operating temperature range.

Low loading latches, adjustable logic thresholds and addressing capability allow the NE5020 to directly interface with most microprocessor and logic controlled systems.

The NE5020 contains internal voltage reference, DAC switches and resistor ladder. Also, the input buffer and output summing amplifier are included. In addition, the matched application resistors for scaling either unipolar or bipolar output values are included on a single monolithic chip.

The result is a near minimum component count 10-bit resolution DAC system.

FEATURES

- 10-bit resolution
- Guaranteed monotonicity over operating range
- $\pm 0.1\%$ relative accuracy
- Unipolar (0V to +10V) and Bipolar ($\pm 5V$) output range
- Logic bus compatible
- 5 μ sec settling time

APPLICATIONS

- Precision 10-bit D/A converters
- 10-bit Analog to Digital converters
- Programmable power supplies
- Test equipment
- Measurement instruments

PIN CONFIGURATION

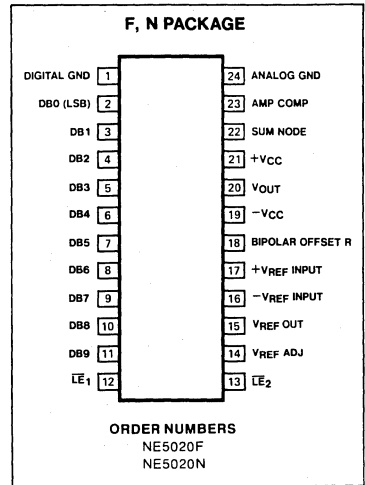

4

BLOCK DIAGRAM

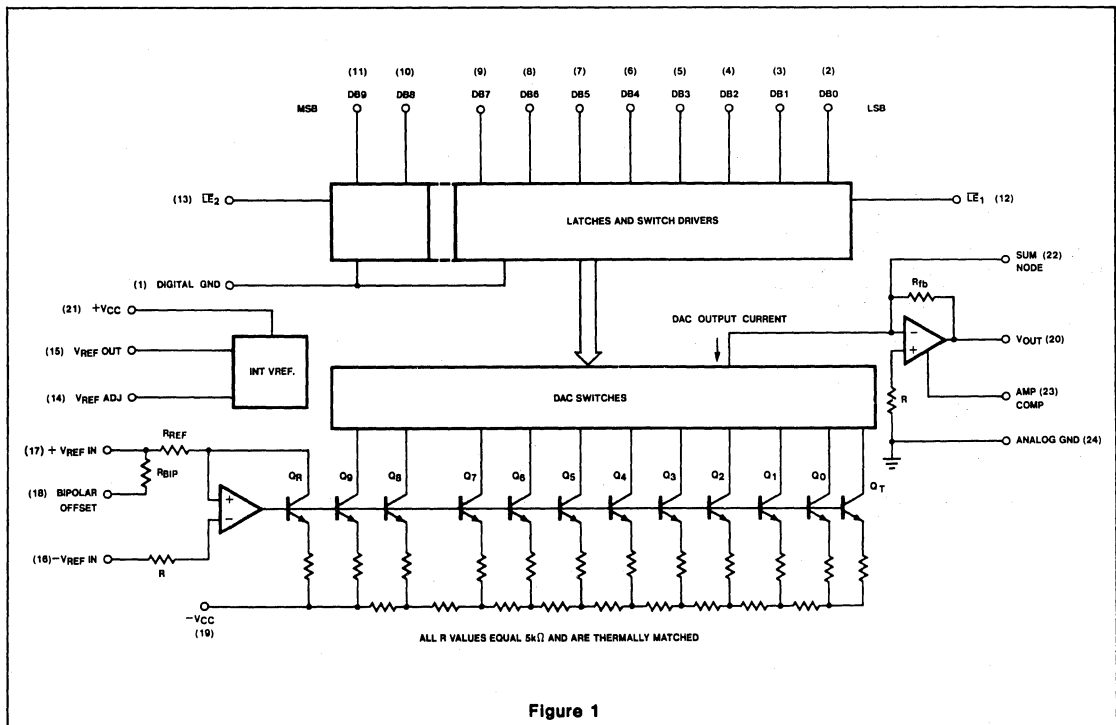

Figure 1

10-BIT μ P-COMPATIBLE D/A CONVERTER

NE5020

ABSOLUTE MAXIMUM RATINGS

PARAMETER	RATING	UNIT	
V _{CC+}	Positive supply voltage	18	V
V _{CC-}	Negative supply voltage	-18	V
V _{IN}	Logic input voltage	0 to 18	V
V _{REF IN}	Voltage at +V _{REF} input	12	V
V _{REF ADJ}	Voltage at V _{REF} adjust	0 to V _{REF}	V
V _{SUM}	Voltage at sum node	12	V
I _{REFSC}	Short-circuit current to ground at V _{REF} OUT	Continuous	
I _{OUTSC}	Short-circuit current to ground or either supply at V _{OUT}	Continuous	
P _D	Power dissipation* -N package	800	mW
	F package	1000	mW
T _A	Operating temperature range NE5020	0 to +70	°C
T _{STG}	Storage temperature range	-65 to +150	°C
T _{SOLD}	Lead soldering temperature (10 seconds)	300	°C

*NOTES

For N package, derate at 120°C/W above 35°C

For F package, derate at 75°C/W above 75°C

DC ELECTRICAL CHARACTERISTICS

V_{CC+} = +15V, V_{CC-} = -15V, 0°C ≤ T_A ≤ 70°C unless otherwise specified.¹
 Typical values are specified at 25°C

PARAMETER	TEST CONDITIONS	NE5020			UNIT
		Min	Typ	Max	
Resolution				10	Bits
Monotonicity				10	Bits
Relative accuracy				±0.1	%FS
V _{CC+}	Positive supply voltage	11.4	15	16.5	V
V _{CC-}	Negative supply voltage	-11.4	-15	-16.5	V
V _{IN(1)}	Logic "1" input voltage	2.0			V
V _{IN(0)}	Logic "0" input voltage			0.8	V
I _{IN(1)}	Logic "1" input current		0.1	10	μA
I _{IN(0)}	Logic "0" input current		-2.0	-10	μA
V _{FS}	Full scale output voltage	9.5	9.9902	10.5	V
	Unipolar operation V _{REF IN} = 5.000V, T _A = 25°C				
V _{FS}	Full scale output voltage	4.5	4.9902	5.5	V
	Bipolar operation V _{REF IN} = 5.000V, T _A = 25°C				
V _{ZS}	Zero scale voltage	-5.040	-5.000	-4.960	mV
	Unipolar operation	-30	5	+30	mV
I _{OS}	Output short circuit current		±15	±40	mA
	T _A = 25°C V _{OUT} = 0V				
PSR+(out)	Output power supply rejection (+)		.001	.01	%FS/ %VS
PSR-(out)	Output power supply rejection (-)		.001	.01	%FS/ %VS
	V ₋ = -15V, 13.5V ≤ V ₊ ≤ 16.5V, external V _{REF IN} = 5.000V				
	V ₊ = 15V, -13.5V ≤ V ₋ ≤ -16.5V, external V _{REF IN} = 5.000V				
TC _{FS}	Full scale temperature coefficient		20		ppmFS /°C
TC _{ZS}	Zero scale temperature coefficient		5		ppmFS /°C

NOTE

1. Refer to Figure 2.

10-BIT μ P-COMPATIBLE D/A CONVERTER

NE5020

DC ELECTRICAL CHARACTERISTICS (Cont'd) $V_{CC+} = +15V, V_{CC-} = -15V, 0^{\circ}C \leq T_A \leq 70^{\circ}C$ unless otherwise specified.¹
 Typical values are specified at 25°C

PARAMETER	TEST CONDITIONS	NE5020			UNIT	
		Min	Typ	Max		
I_{REF}^2	Reference output current			3	mA	
$I_{REF\ SC}$	Reference short circuit current		15	30	mA	
PSR^{+REF}	Reference power supply rejection (+)	$V_{-} = -15V, 13.5V \leq V_{+} \leq 16.5V,$ $I_{REF} = 1.0mA$.003	.01	%VR/ %VS
PSR^{-REF}	Reference power supply rejection (-)	$V_{+} = 15V, -13.5V \leq V_{-} \leq 16.5V,$ $I_{REF} = 1.0mA, T_A = 25^{\circ}C$.003	.01	%VR/ %VS
V_{REF}	Reference voltage		4.9	5.0	5.25	V
TC_{REF}	Reference voltage temperature coefficient			60		ppm/ $^{\circ}C$
Z_{IN}	DAC V_{REFIN} input impedance			5.0		k Ω
I_{CC+}	Positive supply current	$V_{CC+} = 15V$		7	14	mA
I_{CC-}	Negative supply current	$V_{CC-} = -15V$		-10	-15	mA
P_D	Power dissipation	$I_{REF} = 1.0mA, V_{CC} = \pm 15V$		255	435	mW

NOTE

1. Refer to Figure 2.
2. For $I_{REF\ OUT}$ greater than 3mA, an external buffer is required.

AC ELECTRICAL CHARACTERISTICS³ $V_{CC} = \pm 15V, T_A = 25^{\circ}C$

PARAMETER	TO	FROM	TEST CONDITIONS	NE5020			UNIT
				Min	Typ	Max	
T_{SLH}	$\pm 1/2$ LSB	Input	All bits low to high ⁴		5		μs
T_{SHL}	$\pm 1/2$ LSB	Input	All bits high to low ⁵		5		μs
t_{plh}	Output	Input	All bits switched low to high ⁴		300		ns
t_{phl}	Output	Input	All bits switched high to low ⁵		150		ns
t_{plsb}	Output	Input	1 LSB change ^{4,5}		150		ns
t_{plh}	Output	\overline{LE}	low to high transition ⁶		300		ns
t_{phl}	Output	\overline{LE}	high to low transition ⁷		150		ns
t_s	\overline{LE}	Input	3, 8	100			ns
t_h	Input	\overline{LE}	3, 8	50			ns
t_{pw}			3, 8	150			ns

NOTES

3. Refer to Figure 3.
4. See Figure 6.
5. See Figure 7.
6. See Figure 8.
7. See Figure 9.
8. See Figure 10.



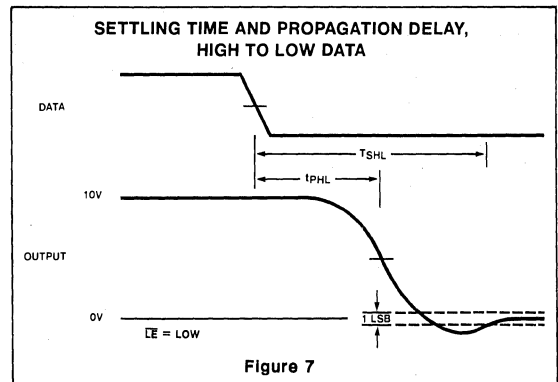
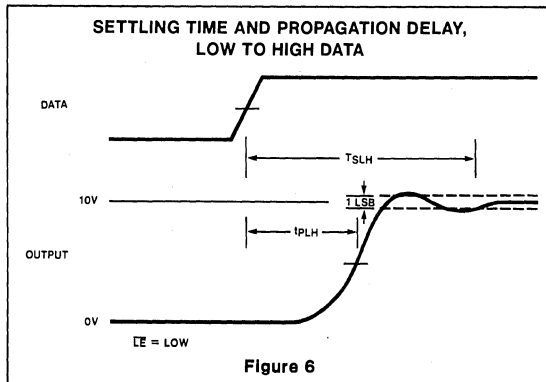
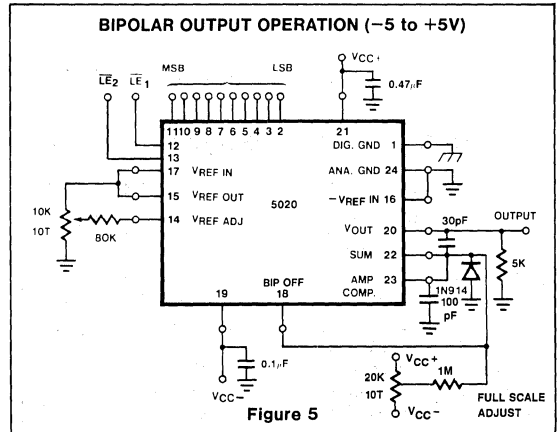
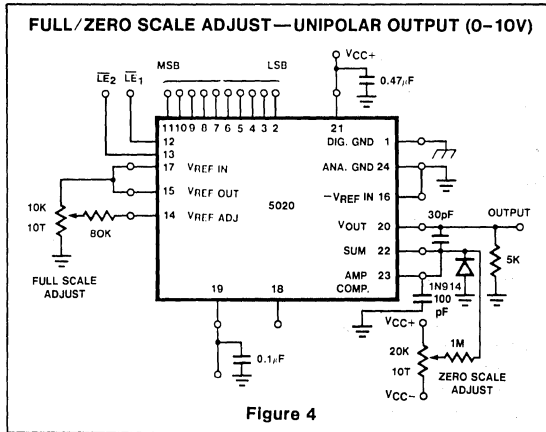
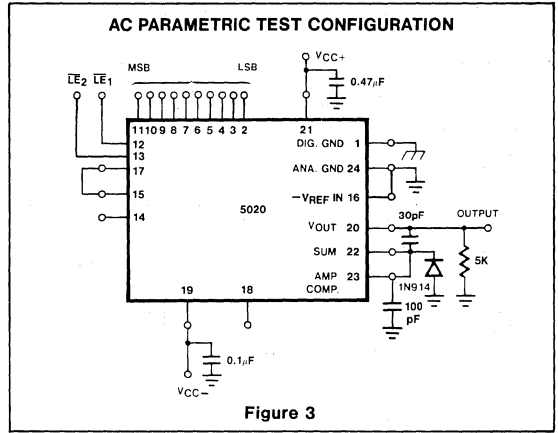
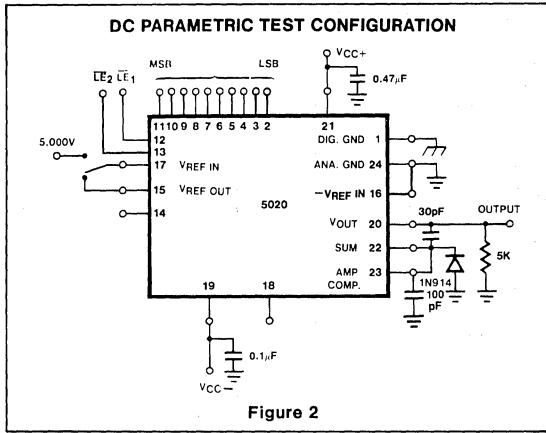

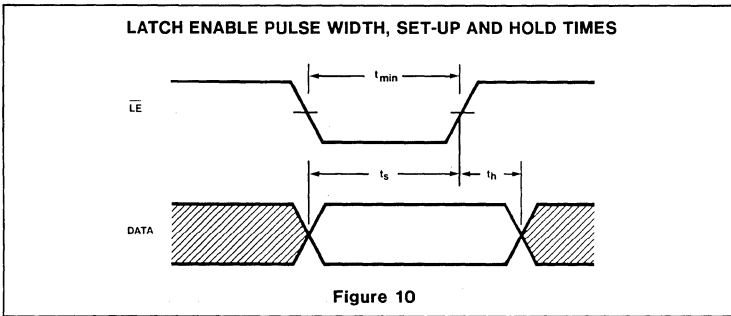
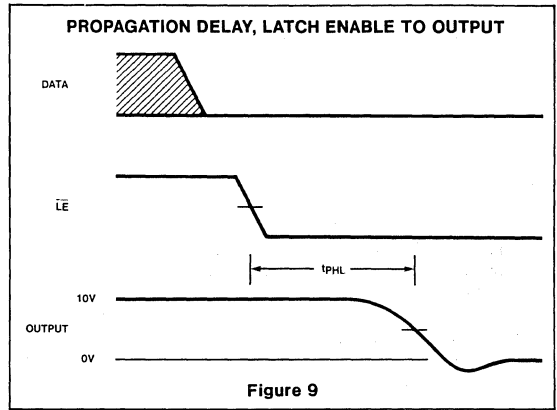
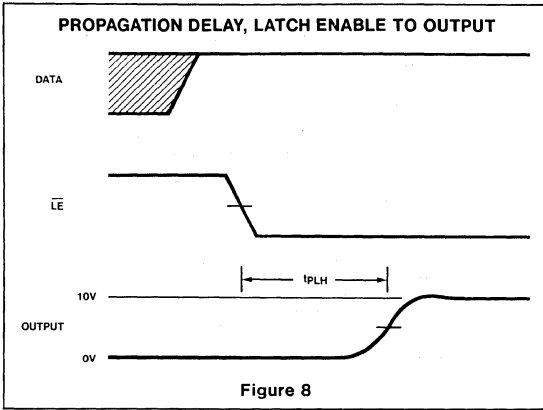

4

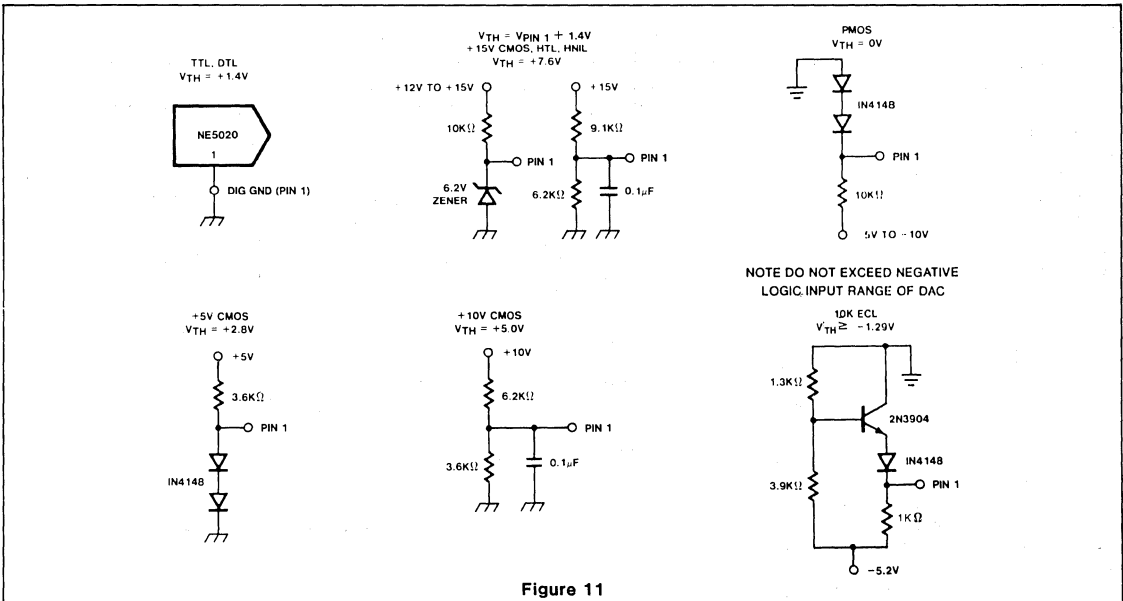

10-BIT μ P-COMPATIBLE D/A CONVERTER

NE5020

CIRCUIT DESCRIPTION

The NE5020 provides ten data latches, an internal voltage reference, application resistors, and a scaled output voltage, in addition to the basic DAC components (see block diagram, figure 1).

Latch Circuit

Digital interface with the NE5020 is readily accomplished through the use of two latch enable ports (\overline{LE}_1 and \overline{LE}_2) and ten data input latches. \overline{LE}_2 controls the two most significant bits of data (DB₉ and DB₈) while \overline{LE}_1 controls the eight lesser significant bits (DB₇ through DB₀). Both the latch enable ports (\overline{LE}) and the data inputs are static and threshold sensitive. When the latch enable ports (\overline{LE}) are high (Logic '1') the data inputs become very high impedances and essentially disappear from the data bus. Addressing the \overline{LE} with a low (Logic '0') the latches become active and adapt the logic states present on the data bus. During this state, the output of the DAC will change to the value proportional to the data bus value. When the latch enable returns to a high state, the selected set of data inputs (i.e., depending on which \overline{LE} goes high) memorize' the data bus logic states and the output changes to the unique output value corresponding to the binary word in the latch.

The data inputs are inactive and high impedance (typically requiring $-2\mu A$ for low (.8V max) or $0.1\mu A$ for high (2.0V min)) when the \overline{LE} is high. Any changes on the data bus with \overline{LE} high will have no effect on the DAC output.

The digital logic inputs (\overline{LE} and DB) for the NE5020 utilize a differential input logic system with a threshold level of +1.4 volts with respect to the voltage level on the digital ground pin (Pin 1). Figure 11 details several bias schemes used to provide the proper threshold voltage levels for various logic families.

To be compatible with a bus orientated system the DAC should respond in as short a period as possible to insure full utilization of the microprocessor, controller and I/O control lines. Figure 10 shows the typical timing requirements of the latch and data lines. This figure indicates that data on the data bus should be stable for at least 50nsec after \overline{LE} is changed to a high state.

The independent \overline{LE} (\overline{LE}_1 and \overline{LE}_2) lines allow for direct interface from an 8 bit data bus (see figure 12). Data for the two MSB's is supplied and stored when \overline{LE}_2 is activated low and returned high according to the NE5020 timing requirements. Then \overline{LE}_1 is activated low and the remaining eight LSB's of data are transferred into the DAC. With

\overline{LE}_1 returning high the loading of ten bit data word from an eight bit data bus is complete.

Occasionally the analog output must change to its data value within one data address operation. This is no problem using the NE5020 on a 16 bit bus or any other data bus with 10 or greater data bits.

This can be accomplished from an 8 bit data bus by utilizing an external latch circuit to preload the two MSB data values. Figure 13 shows the circuit configuration.

After preloading (via \overline{LE} pre-load) the external latch with the two MSB values, \overline{LE}_2 is activated low and the eight LSB's and the

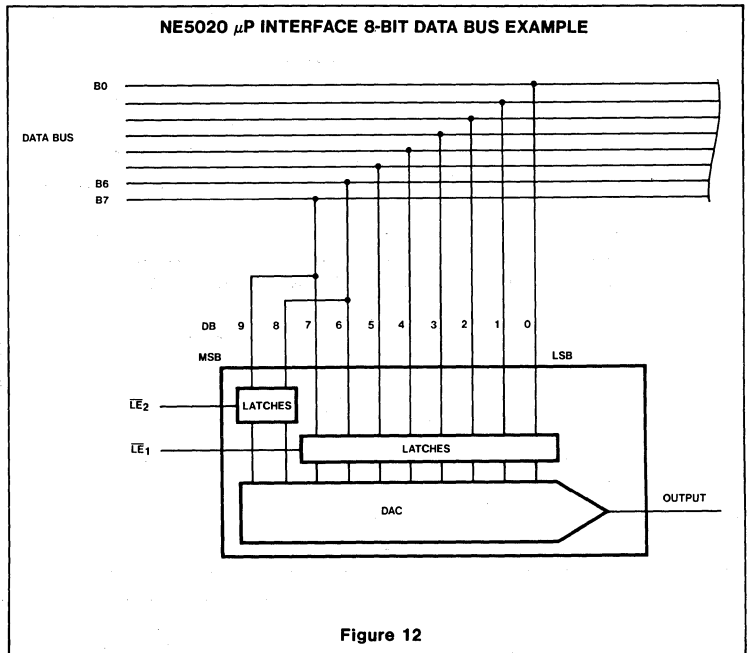

Figure 12

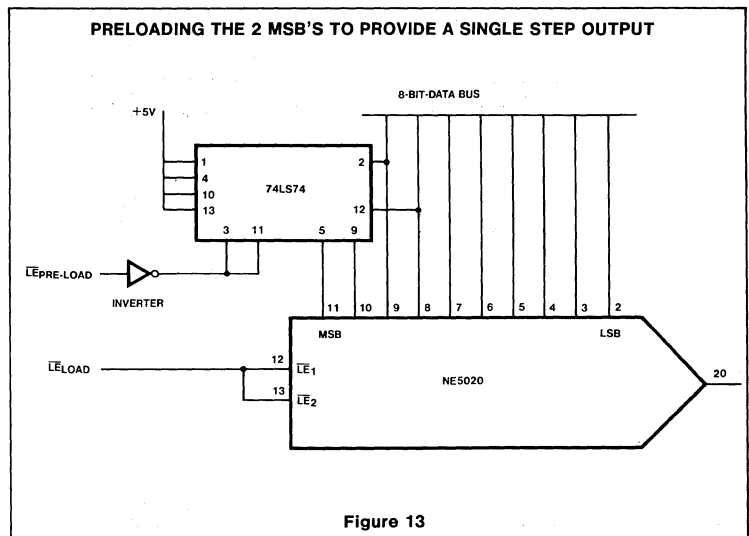

Figure 13

two MSB's are concurrently loaded into the DAC in one address operation. This permits the DAC output to make its appropriate change at one time.

Reference Interface

The NE5020 contains an internal bandgap voltage reference which is designed to have a very low temperature coefficient and excellent long term stability characteristics.

The internal bandgap reference (1.23V) is buffered and amplified to provide the 5 volt reference output. Providing a V_{REFADJ} (pin 14) allows trimming of the reference output. Utilization of the adjust circuit shown in figure 16 performs not only V_{REF} adjustment but also full scale output adjust. Notice that the V_{REFADJ} pin is essentially the sum node of an op amp and is sensitive to excessive node capacitance. Any capacitance on the node can be minimized by placing the external resistors as close as possible to the V_{REFADJ} pin and observing good layout practices.

The V_{REF} out node can drive loads greater than the DAC V_{REF} input requirements and can be used as an excellent system voltage reference. However, to minimize load effects on the DAC system accuracy, it is recommended that a buffer amplifier is used.

Input Amplifier

The DAC reference amplifier is a high gain internally compensated op amp used to convert the input reference voltage to a precision bias current for the DAC ladder network.

Figure 1 details the input reference amplifier and current ladder. The voltage to current converter of the DAC amp will generate a 1mA reference current through Q_R with a 5 volt V_{REF} . This current sets the input bias to the ladder network. Data bit 9 (DB9)(Q_9), when turned on, will mirror this current and will contribute 1mA to the output. DB8 (Q_8) will contribute 1/2 of that value or 0.5mA and so on. These current values act as current sinks and will add at the sum node to produce a DAC ladder to sum node function of:

$$I_{OUT} = \frac{2V_{REF}}{R_{REF}} \left(\frac{DB9}{2} + \frac{DB8}{4} + \frac{DB7}{8} + \frac{DB6}{16} + \frac{DB5}{32} + \frac{DB4}{64} + \frac{DB3}{128} + \frac{DB2}{256} + \frac{DB1}{512} + \frac{DB0}{1024} \right)$$

Because of the fixed internal compensation of the reference amp, the slew rate is limited to typically 0.7V/ μ sec and source impedances at the V_{REF} INPUT greater than 5k Ω should be avoided to maintain stability.

The $-V_{REF}$ INPUT pin is uncommitted to allow utilization of negative polarity reference voltages. In this mode $+V_{REF}$ INPUT is grounded and the negative reference is tied directly to the $-V_{REF}$ INPUT. The $-V_{REF}$ INPUT contains a 5k Ω resistor that matches a like resistor in the $+V_{REF}$ INPUT to reduce voltage offset caused by op amp input bias currents.

Output Amplifier and Interface

The NE5020 provides an on chip output op amp to eliminate the need for additional external active circuits. Its two stage design with feed forward compensation allows it to slew at 15V/ μ sec and settle to within $\pm 1/2$ LSB in 5 μ sec. These times are typical when driving the rated loads of $R_L \geq 5k$ and $C_L \leq 50pF$ with recommended values of $C_{FF} = 1nF$ and $C_{FB} = 30pF$. Typical input offset voltages of 5mV and 50k open loop gain insure an accurate current to voltage conversion is performed when using the on chip R_{FB} resistor. R_{FB} is matched to R_{REF} and R_{BIP} to maintain accurate voltage gain over operating conditions. The diode shown from ground to sum node prevents the DAC current switches from saturating the op amp during large signal transitions which would otherwise increase the settling time.

The output op amp also incorporates output short circuit protection for both positive and negative excursions. During this fault condition I_{OUT} will limit at $\pm 15mA$ typical. Recovery from this condition to rated accuracy will be determined by duration of short circuit and die temperature stabilization.

Bipolar Output Voltage

The NE5020 includes a thermally matched resistor, R_{BIP} , to offset the output voltage by 5 volts to obtain $-5V$ to $+5V$ output voltage range operation. This is accomplished by shorting pins 18 and 22 (see figure 14). This connection produces a current equal to $(V_{REF IN} - V_{sum node}) \div R_{BIP}$, (1mA nominal), which is injected into the sum node. Since full scale current out is approximately 2mA (1.9980mA), $(2mA - 1mA)5k = 5V$ will appear at the output. For zero DAC output currents, 1mA is still injected into sum node and $V_{OUT} = -(5k)(1mA) = -5V$. Zero scale adjust and full scale adjust are performed as described below, noting that full scale voltage is now approximately +5 volts, zero scale adjust may be used to trim $V_{OUT} = 0.00$ with the MSB high or $V_{OUT} = -5.0V$ with all bits off.

Zero Scale Adjustment

The method of trimming the small offset error that may exist when all data bits are low is shown in figure 15. The trim is the result of injecting a current from resistor R_2 that counteracts the error current. Adjusting potentiometer R_1 until V_{OUT} equals 0.000 volts in the unipolar mode or -5.000 volts in the bipolar mode (see bipolar section) accomplishes this trim.

Full Scale Adjustment

A recommended full scale adjustment circuit when using the internal voltage reference is shown in figure 16. Potentiometer R_3 is adjusted until V_{OUT} equals 9.99023V. In many applications where the absolute accu-

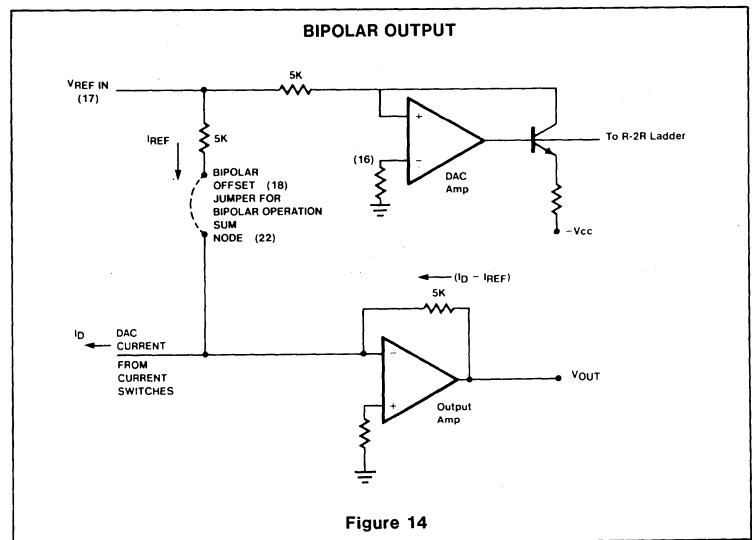
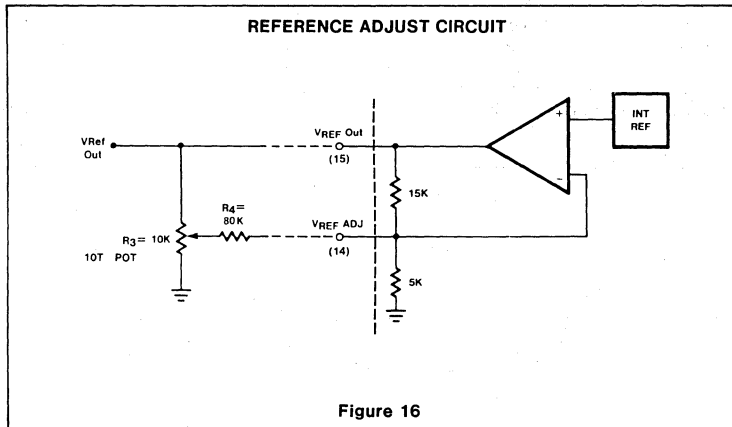
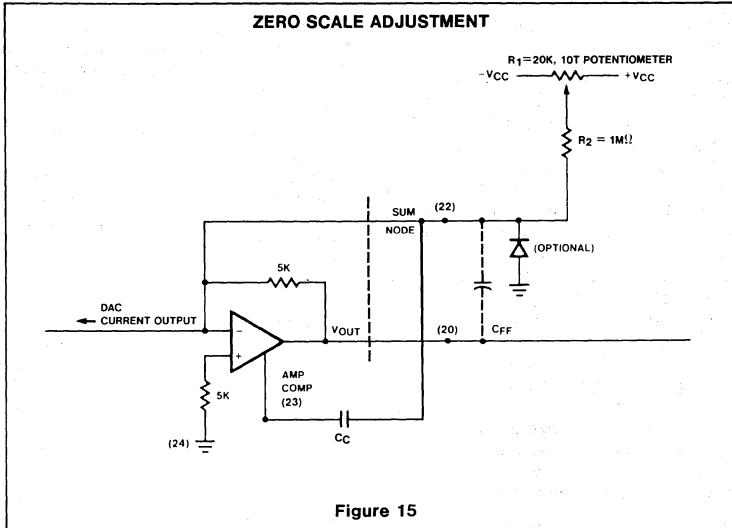

Figure 14

Accuracy of full scale is of low importance when compared to the other system accuracy factors, then this adjustment circuit is optional.

As resistors R_{REF} , R_{fb} and R_{BIP} shown in figure 1 are integrated in close proximity,

they match and track in value closely over wide ambient temperature variations. Typical matching is less than $\pm 0.3\%$ which implies that typical full scale (or gain) error is less than $\pm 0.3\%$ of ideal full scale value.



DESCRIPTION

The NE5118 is a high-speed 8-bit digital to analog converter subsystem on one monolithic chip. The data inputs have input latches, controlled by a latch enable pin. The data and latch enable inputs are ultra-low loading for easy interfacing with all logic systems. The latches appear transparent when the \overline{LE} input is in the low state. When \overline{LE} goes high, the input data present at the moment of transition is latched and retained until \overline{LE} again goes low. This feature allows easy compatibility with most micro-processors.

The chip also comprises a stable voltage reference (5V nominal). The voltage reference may be externally trimmed with a potentiometer for easy adjustment of full scale, while maintaining a low temperature co-efficient.

The output has high voltage compliance increasing versatility.

FEATURES

- 8-bit resolution
- Input latches
- Low-loading data inputs
- On-chip voltage reference
- Fast settling output current—200ns
- Accurate to $\pm 1/2$ LSB (.19%)
- Monotonic to 8 bits
- Reference short-circuit protected
- Compatible with 8086, 6800 and many other μ P's

APPLICATIONS

- Precision 8-bit D/A converters
- A/D converters
- Programmable power supplies
- Test equipment
- Measuring instruments
- Analog-digital multiplication
- CRT display drivers
- High-speed modems

PIN CONFIGURATION

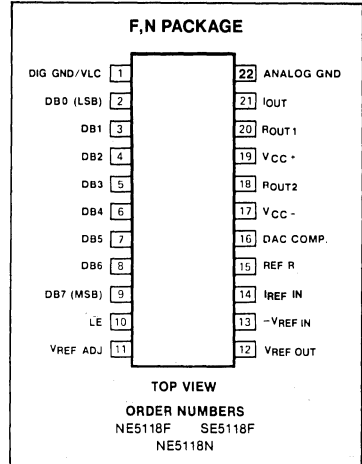

BLOCK DIAGRAM

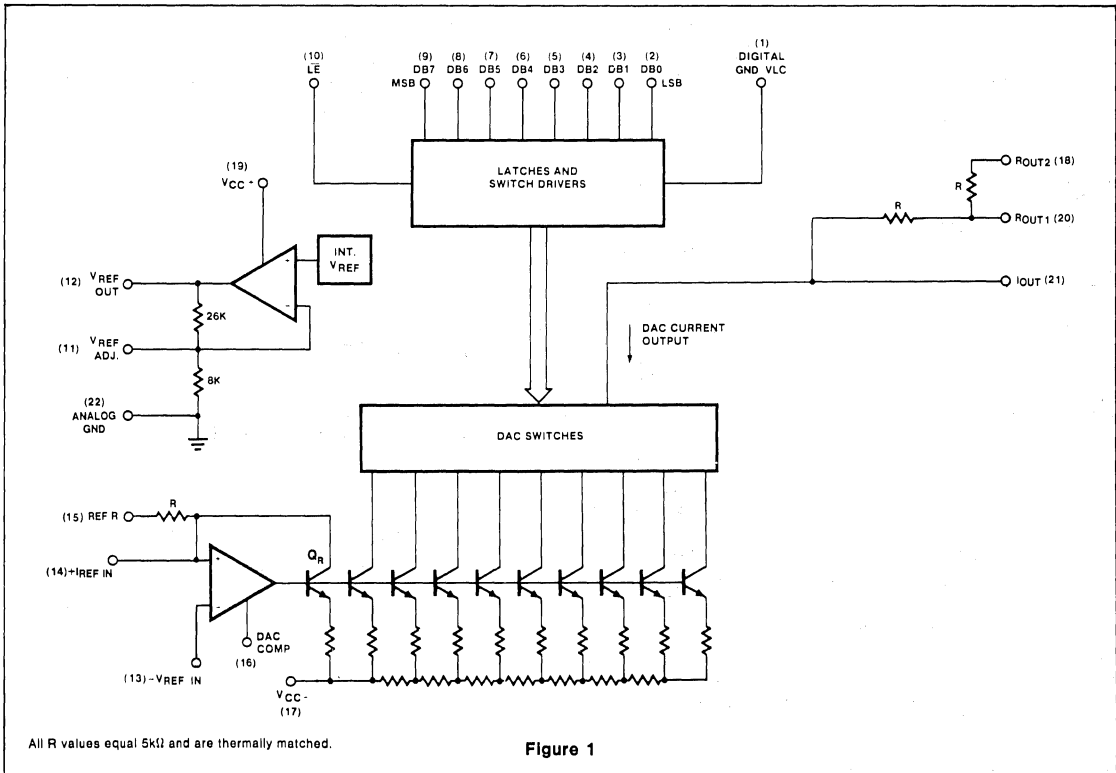

8-BIT μ P-COMPATIBLE D/A CONVERTER – CURRENT OUTPUT

SE/NE5118

ABSOLUTE MAXIMUM RATINGS

PARAMETER		RATING	UNIT
V _{CC+}	Positive supply voltage	18	V
V _{CC-}	Negative supply voltage	-18	V
V _{IN}	Logic input voltage	0 to 18	V
V _{REFIN}	Voltage at V _{REF} input	12	V
V _{REFADJ}	Voltage at V _{REF} adjust	0 to V _{REF}	V
V _{SUM}	Voltage at sum node	12	V
I _{REFSC}	Short-circuit current to ground at V _{REF} OUT	Continuous	
I _{REFIN}	Reference input current (Pin 14)	3	mA
P _D	Power dissipation*		
	-N package	800	mW
	-F package	1000	mW
T _A	Operating temperature range		
	SE5118	-55 to +125	°C
	NE5118	0 to +70	°C
T _{STG}	Storage temperature range	-65 to +150	°C
T _{SOLD}	Lead soldering temperature (10 seconds)	300	°C

*NOTES

For N package, derate at 120°C/W above 35°C
 For F package, derate at 75°C/W above 75°C

DC ELECTRICAL CHARACTERISTICS V_{CC+} = +15V, V_{CC-} = -15V, SE5118. -55°C ≤ T_A ≤ 125°C, NE5118. 0°C ≤ T_A ≤ 70°C unless otherwise specified.
 Typical values are specified at 25°C

PARAMETER	TEST CONDITIONS	SE5118			NE5118			UNIT
		Min	Typ	Max	Min	Typ	Max	
Resolution		8	8	8	8	8	8	Bits
Monotonicity		8	8	8	8	8	8	Bits
Relative accuracy				±0.19			±0.19	%FS
V _{CC+}	Positive supply voltage	11.4	15		11.4	15		V
V _{CC-}	Negative supply voltage	-11.4	-15		-11.4	-15		V
V _{IN(1)}	Logic "1" input voltage	2.0			2.0			V
V _{IN(0)}	Logic "0" input voltage			0.8			0.8	V
I _{IN(1)}	Logic "1" input current		0.1	10		0.1	10	μA
I _{IN(0)}	Logic "0" input current		-2.0	-10		-2.0	-10	μA
I _{FS}	Full scale output current	1.90	1.992	2.10	1.90	1.992	2.10	mA
I _{ZS}	Zero scale current	-6	1	+6	-6	1	+6	μA
V _{REF}	Reference voltage	4.9	5.0	5.25	4.9	5.0	5.25	V
PSR ⁺ (out)	Output power supply rejection (+)	V ₋ = -15V, 13.5V ≤ V ₊ ≤ 16.5V, external V _{REF IN} = 5.000V				.001	.01	%FS/ %VS
PSR ⁻ (out)	Output power supply rejection (-)	V ₊ = 15V, -13.5V ≤ V ₋ ≤ -16.5V, external V _{REF IN} = 5.000V				.001	.01	%FS/ %VS
TC _{FS}	Full scale temperature coefficient	V _{REF IN} = 5.000V ¹				20		ppm/°C
TC _{ZS}	Zero scale temperature coefficient	I _{REF IN} = 1.00mA ²				5		ppm/°C

NOTES

1. This is for voltage out only. See Unipolar Voltage Output schematic.
2. This is for current output mode.

DC ELECTRICAL CHARACTERISTICS (Cont'd) $V_{CC+} = +15V$, $V_{CC-} = -15V$, SE5118. $-55^{\circ}C \leq T_A \leq 125^{\circ}C$,
 NE5118. $0^{\circ}C \leq T_A \leq 70^{\circ}C$ unless otherwise specified.
 Typical values are specified at $25^{\circ}C$

PARAMETER	TEST CONDITIONS	SE5118			NE5118			UNIT		
		Min	Typ	Max	Min	Typ	Max			
I_{REF} I_{REFSC}	Reference output current Reference short circuit current	Note 1 $T_A = 25^{\circ}C$ $V_{REF OUT} = 0V$			15	3 30		15	3 30	mA mA
PSR+(REF)	Reference power supply rejection (+)	$V- = -15V$, $13.5V \leq V+ \leq 16.5V$, $I_{REF} = 1.0mA$.003	.01		.003	.01	%VR/ %VS
PSR-(REF)	Reference power supply rejection (-)	$V+ = 15V$, $-13.5V \leq V- \leq 16.5V$, $I_{REF} = 1.0mA$.003	.01		.003	.01	%VR/ %VS
TCREF	Reference voltage temperature coefficient	$I_{REF} = 1.0mA$			60			60		ppm/ $^{\circ}C$
Z_{IN}	DAC R_{REFIN} input impedance				5.0			5.0		k Ω
I_{CC+}	Positive supply current	$V_{CC+} = 15V$			7	14		7	14	mA
I_{CC-}	Negative supply current	$V_{CC-} = -15V$			-10	-15		-10	-15	mA
P_D	Power dissipation	$I_{REF} = 1.0mA$, $V_{CC} = \pm 15V$			255	435		255	435	mW

AC ELECTRICAL CHARACTERISTICS $V_{CC} = \pm 15V$, $T_A = 25^{\circ}C$

PARAMETER	TO	FROM	TEST CONDITIONS	SE/NE5118			UNIT
				Min	Typ	Max	
t_{SLH}	Settling time	$\pm \frac{1}{2}$ LSB	Input	All bits Low-to-high			ns
t_{SHL}	Settling time	$\pm \frac{1}{2}$ LSB	Input	All bits High-to-low			ns
t_{PLH}	Propagation delay	Output	Input	All bits switched Low-to-high			ns
t_{PHL}	Propagation delay	Output	Input	All bits switched High-to-low			ns
t_{PLSB}	Propagation delay	Output	Input	1 LSB change			ns
t_{PLH}	Propagation delay	Output	\overline{LE}	Low-to-high transition			ns
t_{PHL}	Propagation delay	Output	\overline{LE}	High-to-low transition			ns
t_s	Set-up time	\overline{LE}	Input	100			ns
t_h	Hold time	Input	\overline{LE}	50			ns
t_{pw}	Latch enable pulse width			150			ns

NOTES

1. For reference currents > 3mA, use of an external buffer is required.

4

8-BIT μ P-COMPATIBLE D/A CONVERTER — CURRENT OUTPUT

SE/NE5118

BIPOLAR OUTPUT OPERATION (-1mA TO +1mA)

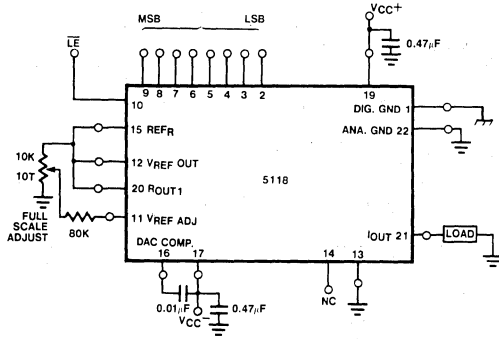

UNIPOLAR VOLTAGE OUTPUT (0 → +10V)

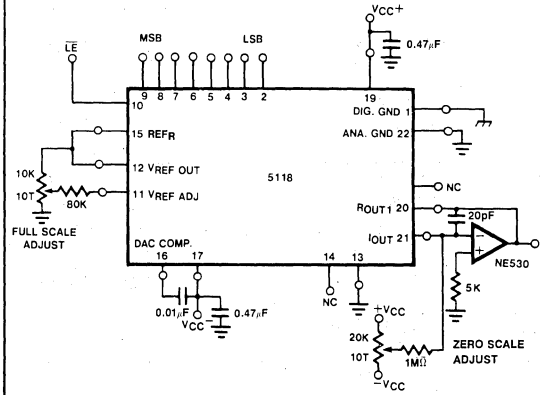

FAST VOLTAGE OUTPUT

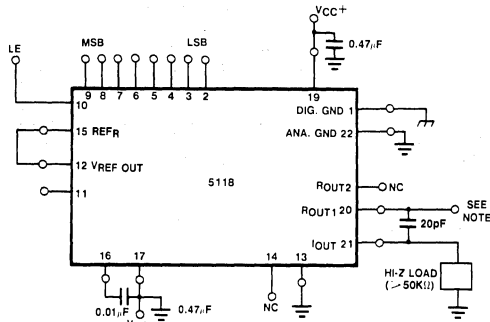

NOTE

DATA INPUT CODE	VOLTAGE OUTPUT (PIN 21)	
0 0 0 0 0 0 0 0	+10V	0V
1 1 1 1 1 1 1 1	0V	-10V
	Pin 20 tied to +10V	Pin 20 tied to 0V

BASIC UNIPOLAR CURRENT OUTPUT (0 → -2mA)

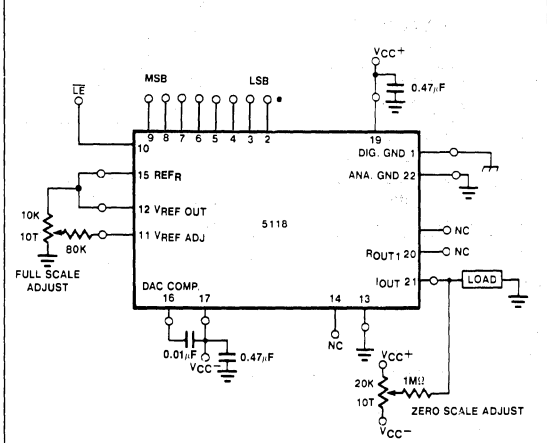

8-BIT μ P-COMPATIBLE D/A CONVERTER — CURRENT OUTPUT

SE/NE5119

DESCRIPTION

The SE/NE5119 is a high-speed 8-bit digital to analog converter subsystem on one monolithic chip. The data inputs have input latches, controlled by a latch enable pin. The data and latch enable inputs are ultralow loading for easy interfacing with all logic systems. The latches appear transparent when the LE input is in the low state. When LE goes high, the input data present at the moment or transition is latched and retained until LE again goes low. This feature allows easy compatibility with most microprocessors.

The chip also comprises a stable voltage reference (5V nominal). The voltage reference may be externally trimmed with a potentiometer for easy adjustment of full scale, while maintaining a low temperature coefficient.

The output has high voltage compliance increasing versatility.

FEATURES

- 8-bit resolution
- Input latches
- Low-loading data inputs
- On-chip voltage reference
- Fast settling output current—200ns
- Accurate to $\pm 1/4$ LSB (.1%)
- Monotonic to 8 bits
- Reference short-circuit protected
- Compatible with 8086, 6800 and many other μ P's

APPLICATIONS

- Precision 8-bit D/A converters
- A/D converters
- Programmable power supplies
- Test equipment
- Measuring instruments
- Analog-digital multiplication
- CRT display drivers
- High-speed modems

PIN CONFIGURATION

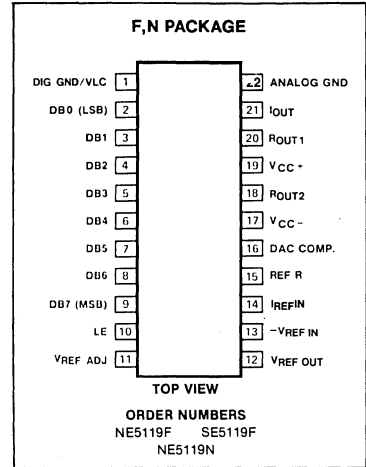

BLOCK DIAGRAM

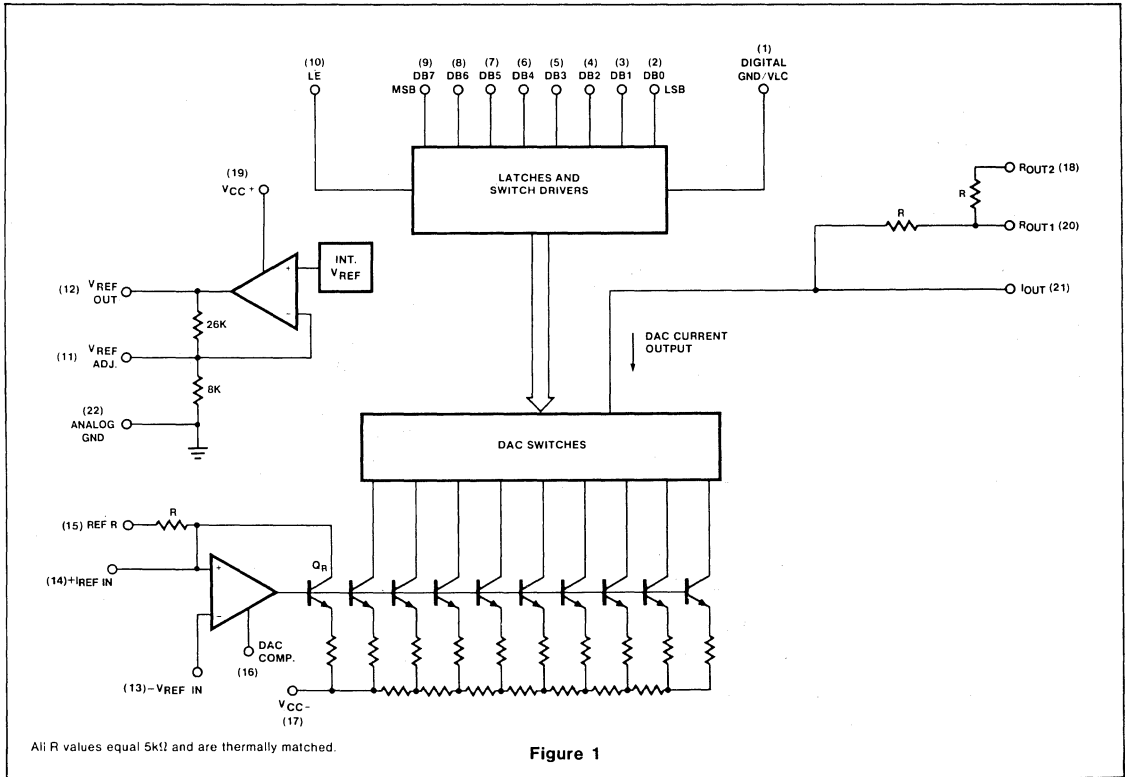

Figure 1

8-BIT μ P-COMPATIBLE D/A CONVERTER—CURRENT OUTPUT

SE/NE5119

ABSOLUTE MAXIMUM RATINGS

PARAMETER	RATING	UNIT	
V _{CC+}	Positive supply voltage	18	V
V _{CC-}	Negative supply voltage	-18	V
V _{IN}	Logic input voltage	0 to 18	V
V _{REFIN}	Voltage at R _{REF} input	12	V
V _{REFADJ}	Voltage at V _{REF} adjust	0 to V _{REF}	V
V _{SUM}	Voltage at sum node	12	V
I _{REFSC}	Short-circuit current to ground at V _{REF} OUT	Continuous	
I _{REFIN}	Reference input current (Pin 14)	3	mA
P _D	Power dissipation*		
	-N package	800	mW
	-F package	1000	mW
T _A	Operating temperature range		
	SE5119	-55 to +125	°C
	NE5119	0 to +70	°C
T _{STG}	Storage temperature range	-65 to +150	°C
T _{SOLD}	Lead soldering temperature (10 seconds)	300	°C

*NOTES

For N package, derate at 120°C/W above 35°C
 For F package, derate at 75°C/W above 75°C

DC ELECTRICAL CHARACTERISTICS V_{CC+} = +15V, V_{CC-} = -15V, SE5119, -55°C ≤ T_A ≤ 125°C, NE5119, 0°C ≤ T_A ≤ 70°C unless otherwise specified.
 Typical values are specified at 25°C

PARAMETER	TEST CONDITIONS	SE5119			NE5119			UNIT		
		Min	Typ	Max	Min	Typ	Max			
Resolution		8	8	8	8	8	8	Bits		
Monotonicity		8	8	8	8	8	8	Bits		
Relative accuracy				±0.1			±0.1	%FS		
V _{CC+}	Positive supply voltage	11.4	15		11.4	15		V		
V _{CC-}	Negative supply voltage	-11.4	-15		-11.4	-15		V		
V _{IN(1)}	Logic "1" input voltage	Pin 1 = 0V			2.0			V		
V _{IN(0)}	Logic "0" input voltage	Pin 1 = 0V		0.8			0.8	V		
I _{IN(1)}	Logic "1" input current	Pin 1 = 0V, 2V < V _{IN} < 18V		0.1	10		0.1	10	μA	
I _{IN(0)}	Logic "0" input current	Pin 1 = 0V, -5V < V _{IN} < 0.8V		-2.0	-10		-2.0	-10	μA	
I _{FS}	Full scale output current	Unipolar operation V _{REF IN} = 5.000V, T _A = 25°C		1.90	1.992	2.10	1.90	1.992	2.10	mA
I _{ZS}	Zero scale current				1			1		μA
V _{REF}	Reference voltage	I _{REF} = 1mA T _A = 25°C		4.9	5.0	5.25	4.9	5.0	5.25	V
PSR ⁺ (out)	Output power supply rejection (+)	V ₋ = -15V, 13.5V ≤ V ₊ ≤ 16.5V, external V _{REF IN} = 5.000V		.001	.01		.001	.01	%FS/ %VS	
PSR ⁻ (out)	Output power supply rejection (-)	V ₊ = 15V, -13.5V ≤ V ₋ ≤ -16.5V, external V _{REF IN} = 5.000V		.001	.01		.001	.01	%FS/ %VS	
TC _{FS}	Full scale temperature coefficient	V _{REF IN} = 5.000V ¹			20			20	ppm/°C	
TC _{ZS}	Zero scale temperature coefficient	I _{REF IN} = 1.00mA ²			5			5	ppm/°C	

NOTES

1. This is for voltage out only. See Unipolar Voltage Output schematic
2. This is for current output mode

8-BIT μ P-COMPATIBLE D/A CONVERTER — CURRENT OUTPUT

SE/NE5119

DC ELECTRICAL CHARACTERISTICS (Cont'd) $V_{CC+} = +15V$, $V_{CC-} = -15V$, SE5119, $-55^{\circ}C \leq T_A \leq 125^{\circ}C$,
 NE5119, $0^{\circ}C \leq T_A \leq 70^{\circ}C$ unless otherwise specified.
 Typical values are specified at $25^{\circ}C$

PARAMETER	TEST CONDITIONS	SE5119			NE5119			UNIT	
		Min	Typ	Max	Min	Typ	Max		
I_{REF}	Reference output current	Note 1							mA
I_{REFSC}	Reference short circuit current	$T_A = 25^{\circ}C$ $V_{REF OUT} = 0V$							mA
PSR+(REF)	Reference power supply rejection (+)	$V- = -15V, 13.5V \leq V+ \leq 16.5V,$ $I_{REF} = 1.0mA$.003	.01		.003	.01	%VR / %VS	
PSR-(REF)	Reference power supply rejection (-)	$V+ = 15V, -13.5V \leq V- \leq 16.5V,$ $I_{REF} = 1.0mA$.003	.01		.003	.01	%VR / %VS	
TCREF	Reference voltage temperature coefficient	$I_{REF} = 1.0mA$		60		60		ppm / $^{\circ}C$	
Z_{IN}	DAC R_{REFIN} input impedance		5.0			5.0		k Ω	
I_{CC+}	Positive supply current	$V_{CC+} = 15V$		7	14		7	14	mA
I_{CC-}	Negative supply current	$V_{CC-} = -15V$		-10	-15		-10	-15	mA
P_D	Power dissipation	$I_{REF} = 1.0mA, V_{CC} = \pm 15V$		255	435		255	435	mW

4

AC ELECTRICAL CHARACTERISTICS $V_{CC} = \pm 15V, T_A = 25^{\circ}C$

PARAMETER	TO	FROM	TEST CONDITIONS	SE/NE5119			UNIT
				Min	Typ	Max	
T_{SLH}	Settling time	$\pm \frac{1}{2}$ LSB	Input	All bits Low-to-high			ns
T_{SHL}	Settling time	$\pm \frac{1}{2}$ LSB	Input	All bits High-to-low			ns
t_{PLH}	Propagation delay	Output	Input	All bits switched Low-to-high			ns
t_{PHL}	Propagation delay	Output	Input	All bits switched High-to-low			ns
t_{PLSB}	Propagation delay	Output	Input	1 LSB change			ns
t_{PLH}	Propagation delay	Output	\overline{LE}	Low-to-high transition			ns
t_{PHL}	Propagation delay	Output	\overline{LE}	High-to-low transition			ns
t_s	Set-up time	\overline{LE}	Input				ns
t_h	Hold time	Input	\overline{LE}				ns
t_{pw}	Latch enable pulse width						ns

NOTES

1. For reference currents > 3mA, use of an external buffer is required.

8-BIT μ P-COMPATIBLE D/A CONVERTER—CURRENT OUTPUT

SE/NE5119

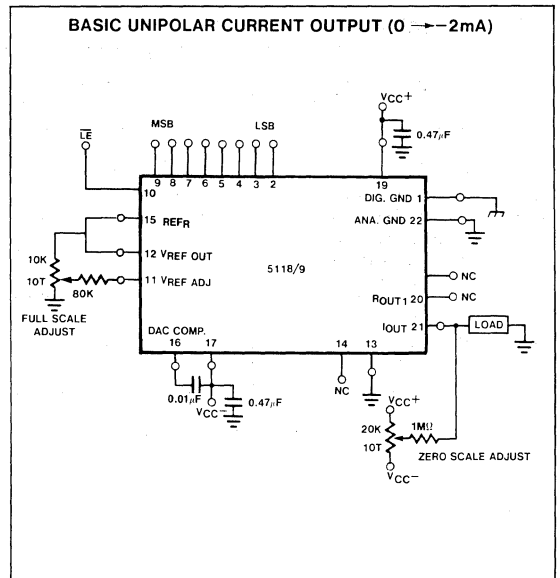
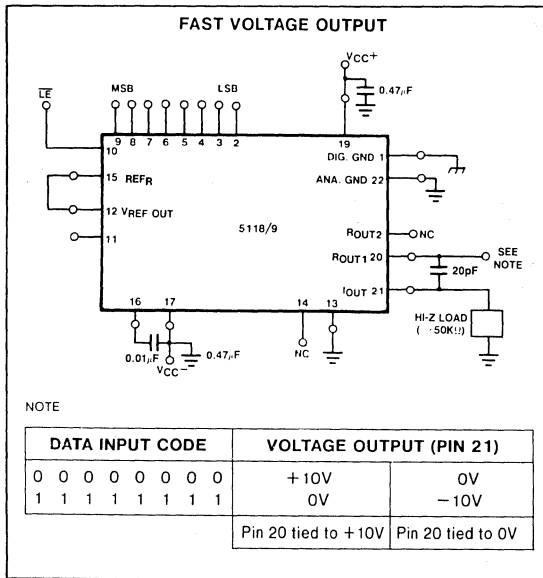
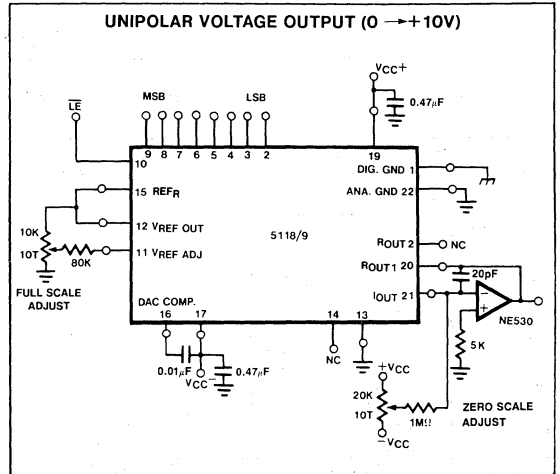
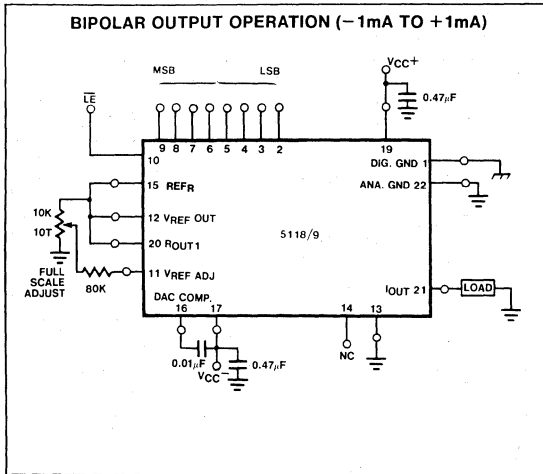

10-BIT HIGH-SPEED MULTIPLYING D/A CONVERTER

SE/NE5410

DESCRIPTION

The NE5410/SE5410 are 10-Bit Multiplying Digital-to-Analog Converters pin-and-function compatible with the industry-standard MC3410, but with improved performance. These are capable of high-speed performance, and are used as general-purpose building blocks in cost-effective D/A systems.

The NE/SE5410 provides complete 10-bit accuracy and differential nonlinearity over temperature, and a wide compliance voltage range. Segmented current sources, in conjunction with an R/2R DAC provides the binary weighted currents. The output buffer amplifier and voltage reference have been omitted to allow greater speed, lower cost, and maximum user flexibility.

FEATURES

- Pin-and-function compatible with MC3410
- 10-bit resolution and accuracy ($\pm 0.05\%$)
- Guaranteed differential non-linearity over temperature
- Wide compliance voltage range— -2.5 to +2.5V
- Fast settling time—250ns typical
- Digital inputs are TTL and CMOS compatible
- High-speed multiplying input slew rate—20mA/ μ s
- Reference amplifier internally compensated
- Standard supply voltages +5V and -15V

PIN CONFIGURATION

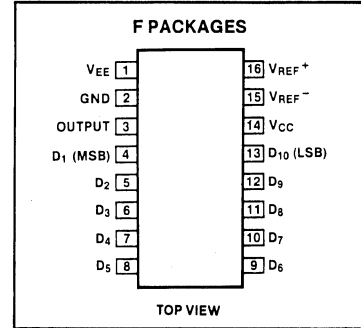

APPLICATIONS

- Successive approximation A/D converters
- High-speed, automatic test equipment
- High-speed modems
- Waveform generators
- CRT displays
- Strip CHART and X-Y plotters
- Programmable power supplies
- Programmable gain and attenuation

ABSOLUTE MAXIMUM RATINGS $T_A = +25^\circ\text{C}$ unless otherwise noted

SYMBOL AND PARAMETER	RATING	UNIT
V_{CC} Power Supply	+ 7.0	Vdc
V_{EE}	- 18	Vdc
V_i Digital Input Voltage	+ 15	Vdc
V_O Applied Output Voltage	+ 4, - 5.0	Vdc
$I_{REF(16)}$ Reference Current	2.5	mA
V_{REF} Reference Amplifier Inputs	V_{CC}, V_{EE}	Vdc
$V_{REF(D)}$ Reference Amplifier Differential Inputs	0.7	Vdc
T_A Operating Temperature Range		
SE5410	-55 to +125	$^\circ\text{C}$
NE5410	0 to +70	$^\circ\text{C}$
T_J Junction Temperature		
Ceramic Package	+ 175	$^\circ\text{C}$
Plastic Package	+ 150	$^\circ\text{C}$

BLOCK DIAGRAM

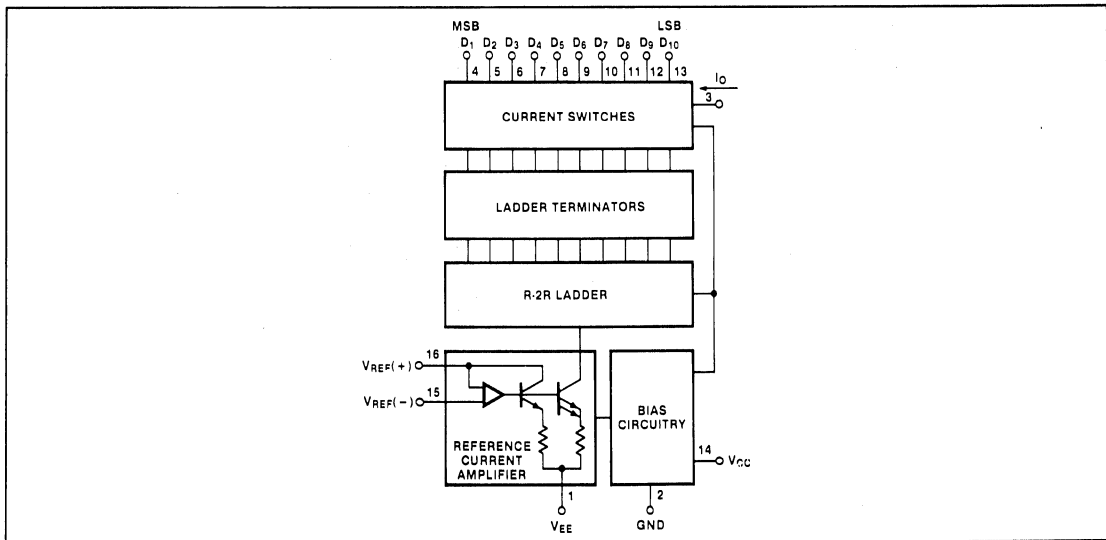

10-BIT HIGH-SPEED MULTIPLYING D/A CONVERTER

SE/NE5410

DC ELECTRICAL CHARACTERISTICS $V_{CC} = +5.0\text{Vdc}$, $V_{EE} = -15\text{Vdc}$, $I_{REF} = 2.0\text{mA}$, all digital inputs at high logic level.

SE5410: $T_A = -55^\circ\text{C}$ to $+125^\circ\text{C}$, NE5410 Series: $T_A = 0^\circ\text{C}$ to $+70^\circ\text{C}$
unless otherwise noted.

SYMBOL AND PARAMETER		TEST CONDITIONS	NE/SE5410			UNIT
			Min	Typ	Max	
E_r	Relative accuracy (Error relative to full scale I_O)	Over temperature		± 0.025	± 0.05	%
				$\pm 1/4$	$\pm 1/2$	LSB
	Differential non-linearity	Over temperature		± 0.025	± 0.05	%
				$\pm 1/4$	$\pm 1/2$	LSB
t_s	Settling time to within $\pm 1/2$ LSB (all bits low to high)	$T_A = 25^\circ\text{C}$		250		ns
t_{PLH} t_{PHL}	Propagation delay time	$T_A = 25^\circ\text{C}$		35 20		ns
TCI_O	Output full scale current drift			20	40	ppm/ $^\circ\text{C}$
V_{IH}	Digital Input Logic Levels (All bits) High Level, Logic "1" Low Level, Logic "0"		2.0		0.8	Vdc
I_{IH} I_{IL}	Digital Input Current (All bits) High Level, $V_{IH} = 5.5\text{V}$ Low Level, $V_{IL} = 0.8\text{V}$				20 -20	μA
$I_{REF(15)}$	Reference Input Bias Current (Pin 15)			-1.0	-5.0	μA
I_{OH}	Output Current (All bits high)	$V_{REF} = 2.000\text{V}$, $R_{16} = 1000\Omega$	3.937	3.996	4.054	mA
I_{OL}	Output Current (All bits low)	$T_A = 25^\circ\text{C}$		0	0.4	μA
V_O	Output Voltage Compliance	$T_A = 25^\circ\text{C}$ $E_r < 0.05\%$ relative to full scale			-2.5 +2.5	Vdc
SR I_{REF}	Reference Amplifier Slew Rate			20		mA/ μs
ST I_{REF}	Reference Amplifier Settling Time	0 to 4.0mA, $\pm 0.1\%$		2.0		μs
PSRR(-)	Output Current Power Supply Sensitivity			0.003	0.01	%/%
C_O	Output Capacitance	$V_O = 0$		25		pF
C_I	Digital Input Capacitance (All bits high)			4.0		pF
I_{CC} I_{EE}	Power Supply Current (All bits low)			+2 -12	+4 -18	mA
V_{CC} V_{EE}	Power Supply Voltage Range	$T_A = 25^\circ\text{C}$ $V_O = 0$	+4.75 -14.25	+5.0 -15	+5.25 -15.75	Vdc
	Power Consumption			190	300	mW

TYPICAL PERFORMANCE CHARACTERISTICS

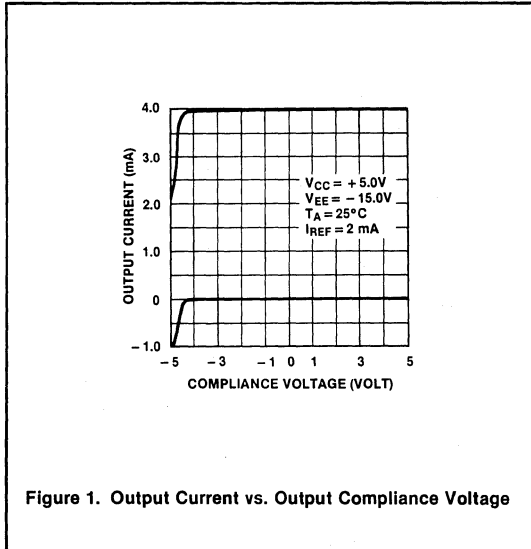

Figure 1. Output Current vs. Output Compliance Voltage

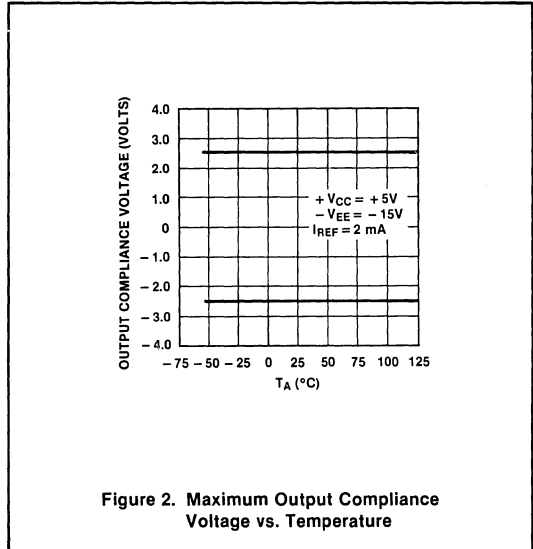

Figure 2. Maximum Output Compliance Voltage vs. Temperature

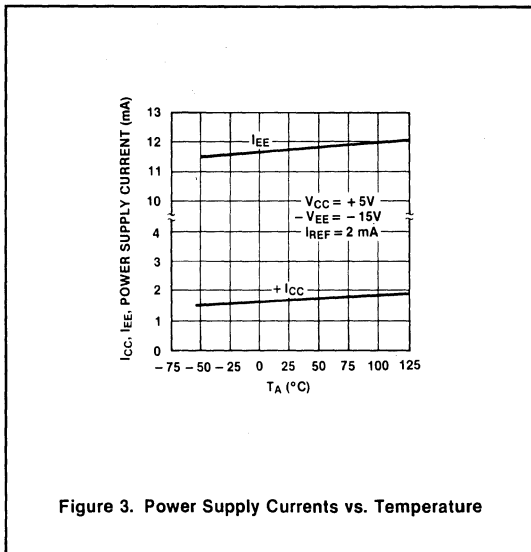

Figure 3. Power Supply Currents vs. Temperature

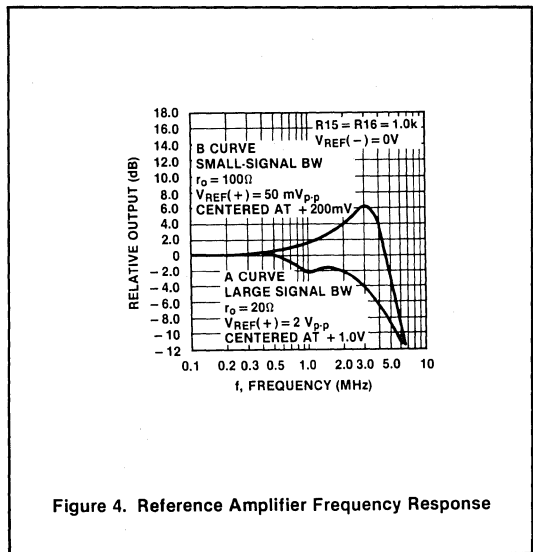

Figure 4. Reference Amplifier Frequency Response

10-BIT HIGH-SPEED MULTIPLYING D/A CONVERTER

SE/NE5410

CIRCUIT DESCRIPTION

The NE5410 consists of four segment current sources which generate the 2 Most Significant Bits (MSBs), and an R/2R DAC implemented with ion implanted resistors for scaling the remaining 8 Least Significant Bits (LSBs). (See Figure 5.) This approach provides complete 10-bit accuracy without trimming.

The individual bit currents are switched ON or OFF by fully differential current switches. The switches use current steering for speed.

An on-chip high-slew reference current amplifier drives the R/2R ladder and segment decoder. The currents are scaled in such a way that, with all bits on, the maximum output current is two times 1023/1024 of the reference amplifier current, or nominally 3.996mA for a 2.000mA refer-

ence input current. The reference amplifier allows the user to provide a voltage input: Out-board resistor R16 (see Figure 6) converts this voltage to a usable current. A current mirror doubles this reference current and feeds it to the segment decoder and resistor ladder. Thus, for a reference voltage of 2.0 Volts and a 1k Ω resistor tied to Pin 16, the full scale current is approximately 4.0mA. This relationship will remain regardless of the reference voltage polarity.

Connections for a positive reference voltage are shown in Figure 6a. For negative reference voltage inputs, or for bipolar reference voltage inputs in the multiplying mode, R15 can be tied to a negative voltage corresponding to the minimum input level. For a negative reference input, R16 should be grounded (Figure 6b). In addition, the negative voltage reference must be at least 3V above the V_{EE} supply volt-

age for best operation. Bipolar input signals may be handled by connecting R16 to a positive voltage equal to the peak positive input level at Pin 15.

When a dc reference voltage is used, capacitive bypass to ground is recommended. The 5V logic supply is not recommended as a reference voltage. If a well regulated 5.0V supply, which drives logic, is to be used as the reference, R16 should be decoupled by connecting it to the +5.0V logic supply through another resistor and bypassing the junction of the two resistors with a 0.1 μ F capacitor to ground.

The reference amplifier is internally compensated with a 10pF feed-forward capacitor, which gives it its high slew rate and fast settling time. Proper phase margin is maintained with all possible values of R16 and reference voltages which supply

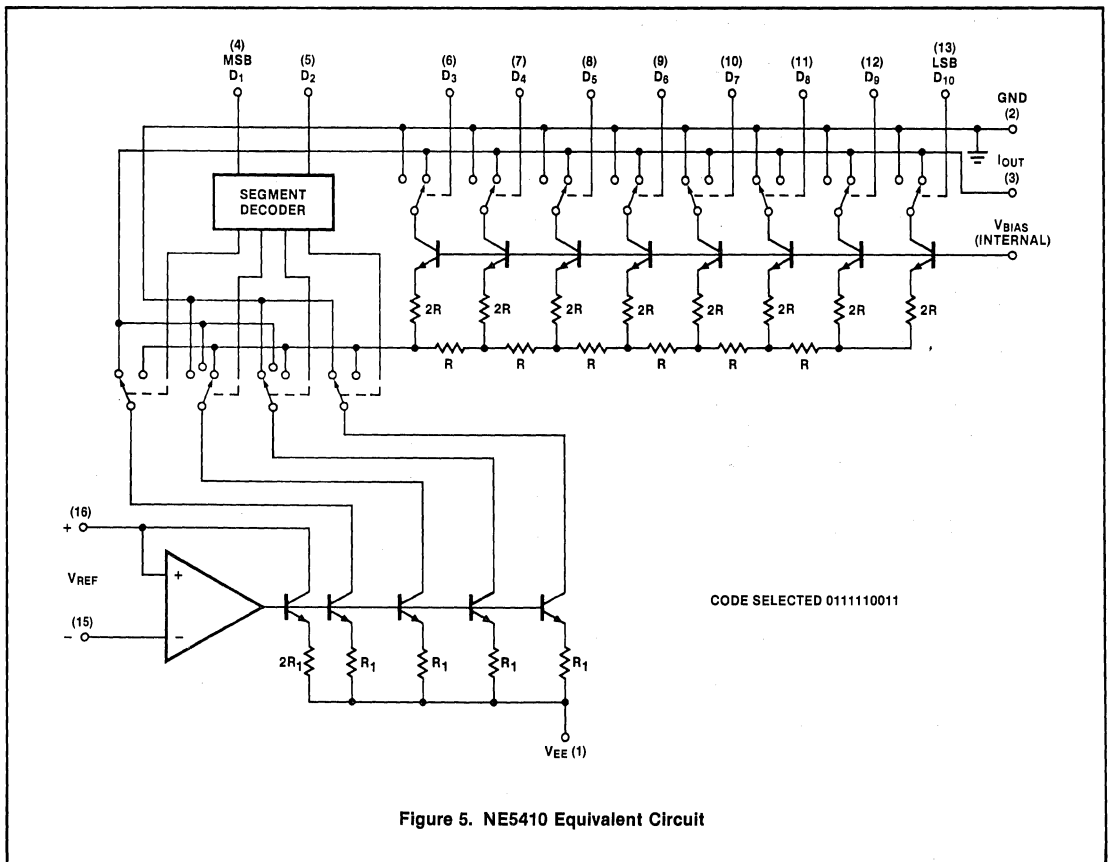
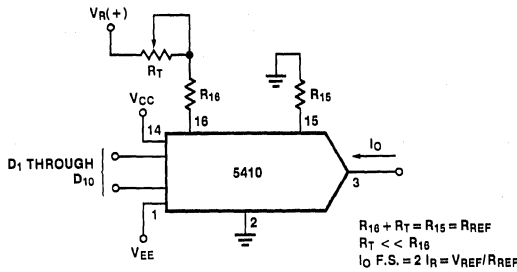
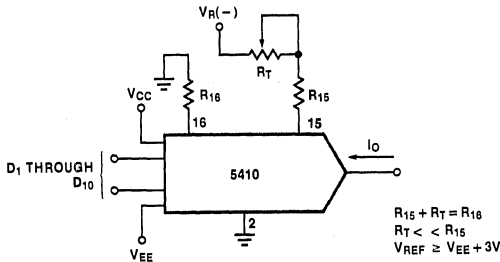

Figure 5. NE5410 Equivalent Circuit



a) POSITIVE REFERENCE VOLTAGE



b) NEGATIVE REFERENCE VOLTAGE

Figure 6. Basic Connections

2.0mA reference current into Pin 16. The reference current can also be supplied by a high impedance current source of 2.0mA. As R_{16} increases, the bandwidth of the amplifier decreases slightly and settling time increases. For a current source with a dynamic output impedance of $1.0M\Omega$, the bandwidth of the reference amplifier is approximately half what it is in the case of $R_{16} = 1.0k\Omega$, and settling time is $\approx 10\mu s$. The reference amplifier phase margin decreases as the current source value decreases in the case of a current source reference, so that the minimum reference current supplied from a current source is $0.5mA$ for stability.

OUTPUT VOLTAGE COMPLIANCE

The output voltage compliance ranges from -2.5 to $+2.5V$. As shown in Figure 2, this compliance range is nearly constant over temperature. At the temperature extremes, however, the compliance voltage may be reduced if $V_{EE} > -15V$.

ACCURACY

Absolute accuracy is a measure of each output current level with respect to its intended value. It is dependent upon relative accuracy and full scale current drift. Relative accuracy, or linearity, is the measure of each output current with respect to its intended fraction of the full scale current. The relative accuracy of the NE5410 is fairly constant over temperature due to the excellent temperature tracking, of the implanted resistors. The full scale current from the reference amplifier may drift with temperature causing a change in the absolute accuracy. However, the NE5410 has a low full scale current drift with temperature.

The SE5410 and the NE5410 are accurate to within $\pm 1/2$ LSB at $25^\circ C$ with a reference current of $2.0mA$ on Pin 16.

MONOTONICITY

The NE5410 and SE5410 are guaranteed monotonic over temperature. This means that for every increase in the input digital code, the output current either remains the same or increases but never decreases. In the multiplying mode, where reference input current will vary, monotonicity can be assured if the reference input current remains above $0.5mA$.

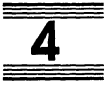

10-BIT HIGH-SPEED MULTIPLYING D/A CONVERTER

SE/NE5410

SETTLING TIME

The worst case switching condition occurs when all bits are switched "on," which corresponds to a low-to-high transition for all bits. This time is typically 250ns for the output to settle to within $\pm 1/2$ LSB for 10-bit accuracy, and 200ns for 8-bit accuracy. The turn-off time is typically 120ns. These times apply when the output swing is limited to a small (<0.7 Volt) swing and the external output capacitance is under 25pF.

The major carry (MSB off-to-on, all others on-to-off) settles in approximately the same time as when all bits are switched off-to-on.

If a load resistor of 625 Ohms is connected to ground, allowing the output to swing to -2.5 Volts, the settling time increases to 1.5 μ s.

Extra care must be taken in board layout as this is usually the dominant factor in satisfactory test results when measuring

settling time. Short leads, 100 μ F supply bypassing, and minimum scope lead length are all necessary.

A typical test set-up for measuring settling time is shown in Figure 7. The same set-up for the most part can be used to measure the slew rate of the reference amplifier (Figure 9) by tying all data bits high, pulsing the voltage reference input between 0 and 2V, and using a 500 Ω load resistor R_L .

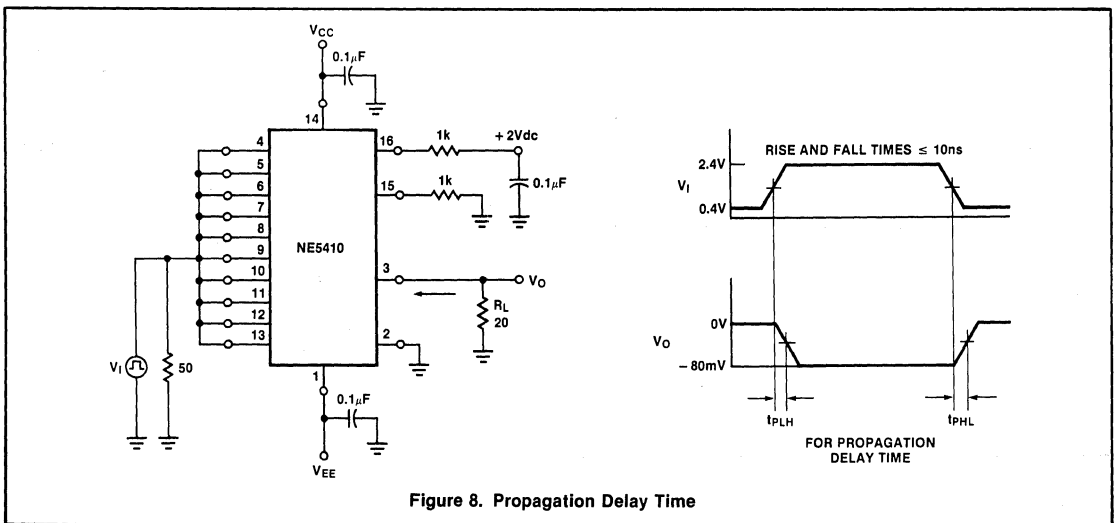
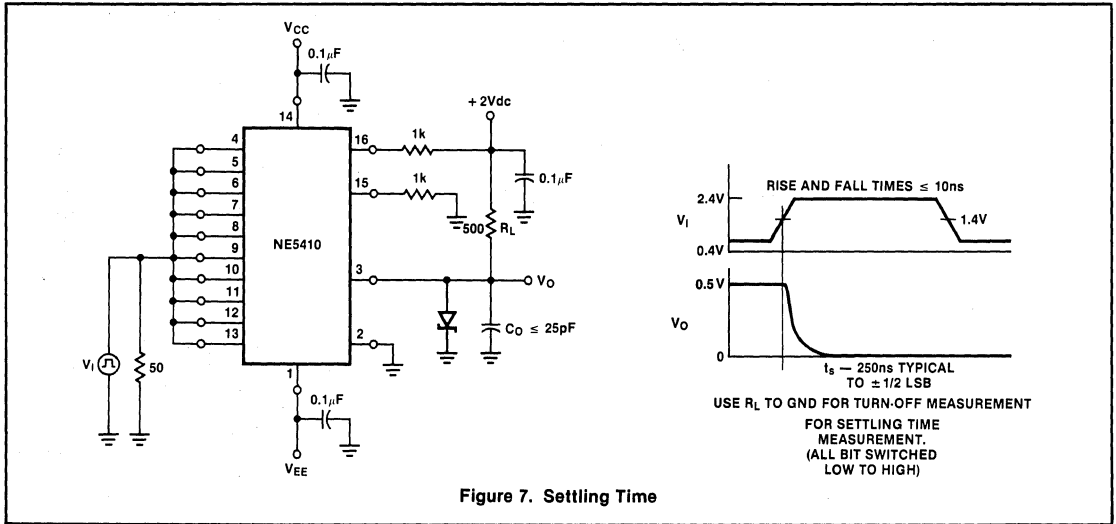

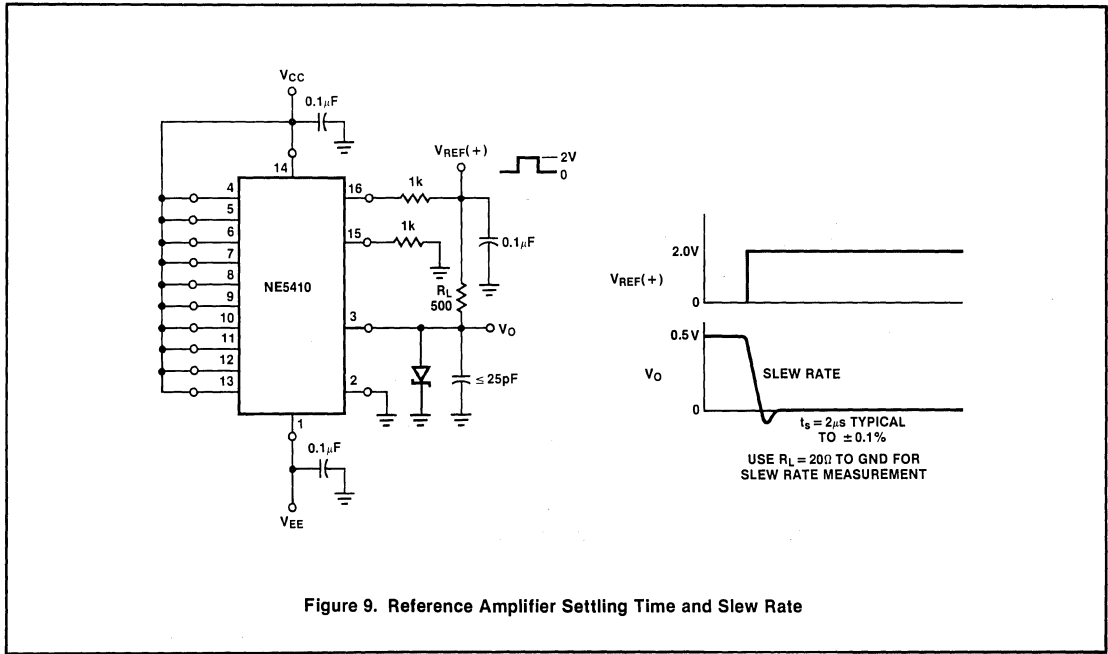

4

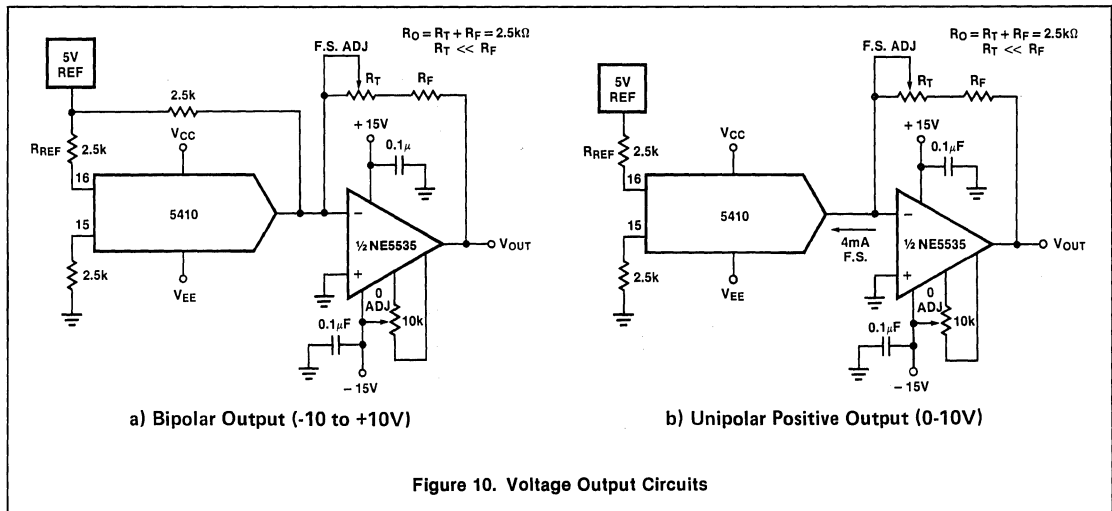

10-BIT HIGH-SPEED MULTIPLYING D/A CONVERTER

SE/NE5410

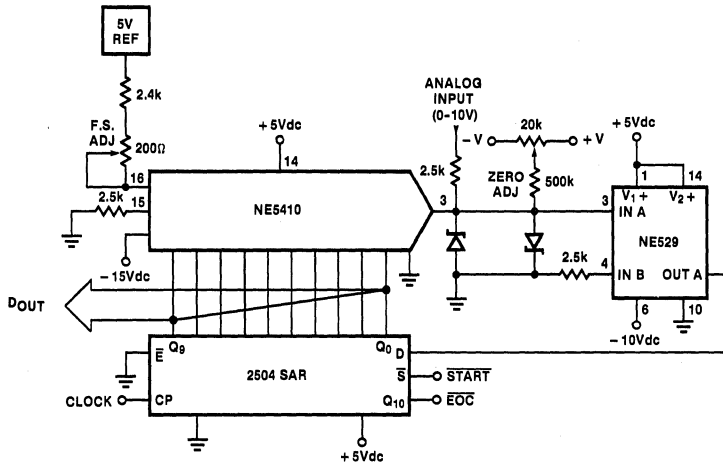

10-BIT CONVERSION TIME = 3.3 μ s WITH 3MHz CLOCK.

THIS CONVERTER USES A 2504 12-BIT SUCCESSIVE APPROXIMATION REGISTER IN THE SHORT CYCLE OPERATING MODE WHERE THE END OF CONVERSION SIGNAL IS TAKEN FROM THE FIRST UNUSED BIT OF THE SAR (Q₁₀).

Figure 11. Successive Approximation A/D Converter

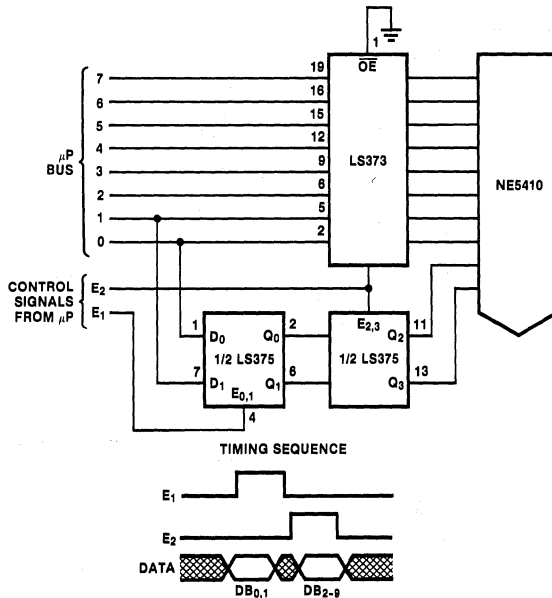

WITH THIS DOUBLE LATCH TECHNIQUE, VALID DATA WILL BE LATCHED TO THE DAC UNTIL UPDATED WITH THE E₂ PULSE. TIMING WILL DEPEND ON THE PROCESSOR USED.

Figure 12. 8-Bit μ P Bus Interface

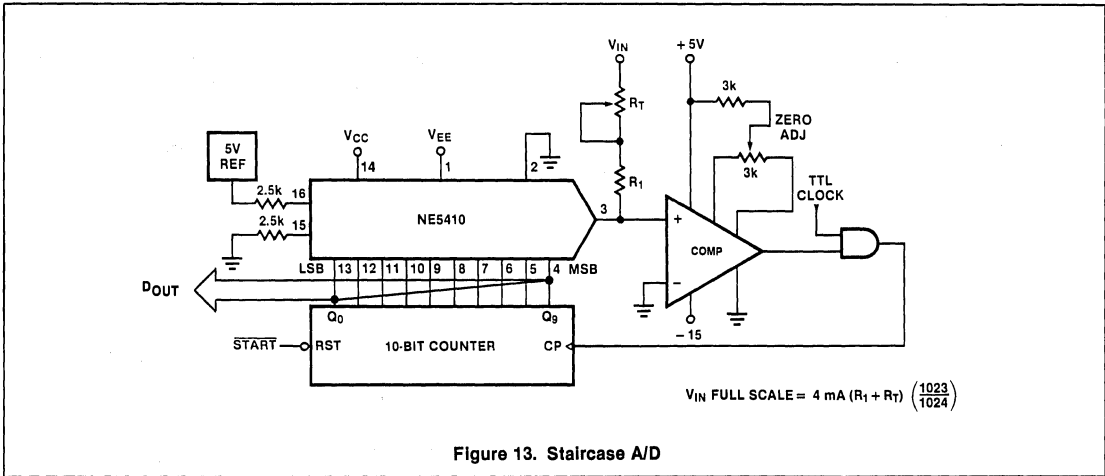

Figure 13. Staircase A/D

GENERAL DESCRIPTION

The TDA1540 is a monolithic integrated 14-bit digital to analogue converter (DAC). It incorporates a 14-bit input shift register with output latches, binary weighted current sources with switches and a reference source.

The IC features an improved switch circuitry which eliminates the need for a deglitcher circuit at the output. This results in a signal-to-noise ratio of typical 85 dB in the audio band.

QUICK REFERENCE DATA

Supply voltages			
pin 4	V_{P1}	typ.	5 V
pin 7	V_{N1}	typ.	-5 V
pin 11	V_{N2}	typ.	-17 V
Signal-to-noise ratio (full scale sine-wave) at analogue output (pin 22)	S/N	typ.	85 dB
Non-linearity at $T_{amb} = -20$ to $+70$ °C		typ.	½ LSB
Current settling time	t_{cs}	typ.	0.5 μ s
Maximum input bit rate at data input (pin 1)	BR_{max}	min.	12 Mbit/s
Maximum clock frequency at clock input (pin 28)	$f_{cl\ max}$	min.	12 MHz
Full scale temperature coefficient at analogue output (pin 22)	TC_{FS}	typ.	$\pm 30 \cdot 10^{-6}$ K ⁻¹
Operating ambient temperature range	T_{amb}		-20 to +70 °C
Total power dissipation	P_{tot}	typ.	350 mW

PACKAGE OUTLINES

TDA1540D: 28-lead DIL; ceramic (cerdip) (SOT-135A).

TDA1540P: 28-lead DIL; plastic (SOT-117BE).

FUNCTIONAL DESCRIPTION

The binary weighted current sources are obtained by a combination of a passive divider and a time division concept. Figure 1a gives the diagram of one divider stage. The total emitter current $4I$ of the passive divider is divided into four more or less equal output currents.

The output currents of the passive divider are now interchanged during equal time intervals generated by means of a shift register. The average output currents are exactly equal as a result of this operation. A ripple on the output current, caused by a mismatch of the passive divider, is filtered by an a.c. low-pass filter, requiring an external filter capacitor.

The outputs of the dividers are combined to obtain the output currents $I(\bar{I}_1)$, $I(\bar{I}_2)$ and $2I(\bar{I}_3)$ (see Fig. 1b). The current of the most significant bit is generated by an on-chip reference source. A binary weighted current network is formed by cascading the current division stages (see Fig. 2).

The interchanging pulses are generated by an on-chip oscillator and a 4-bit shift register. The binary currents are switched to the current output (pin 22) via diode-transistor switching stages; therefore, the voltage on the output pin must be $0\text{ V} \pm 10\text{ mV}$. The output current can be converted into a voltage by means of a summing amplifier.

Figure 3 represents the data input format, and an application circuit is given in Fig. 4.

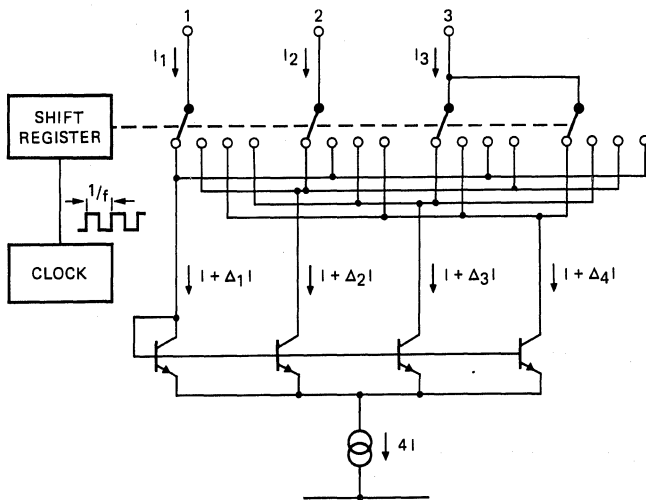
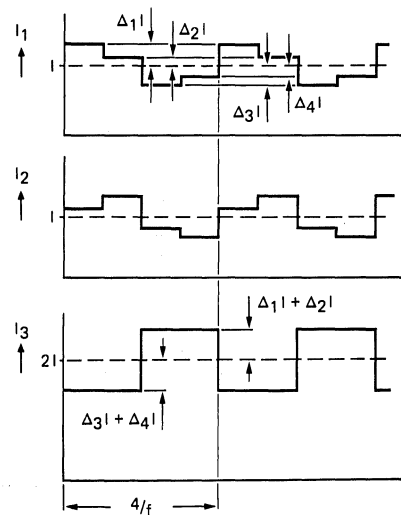

Fig. 1a Circuit diagram of one divider stage.



7Z89039

Fig. 1b Waveforms showing output currents I_1 , I_2 and I_3 of Fig. 1a.

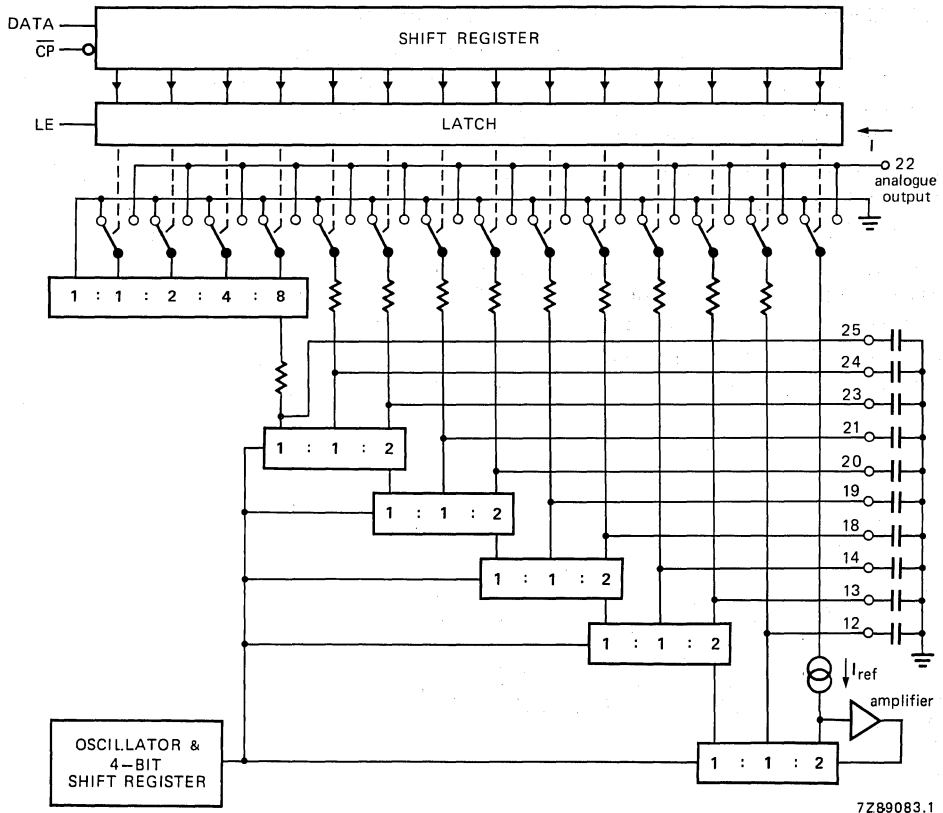

Fig. 2 Functional diagram showing cascading of current division stages.

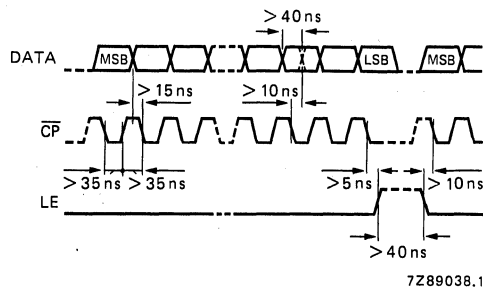

Fig. 3 Format of input signals.

RATINGS

Limiting values in accordance with the Absolute Maximum System (IEC 134)

Supply voltages

with respect to GND (pin 6)

at pin 4

 V_{P1} max. 12 V

at pin 7

 V_{N1} max. -12 V

at pin 11

 V_{N2} max. -20 V

at pin 4 with respect to pin 11

 $V_{P1}-V_{N2}$ max. 32 V

at pin 7 with respect to pin 11

 $V_{N1}-V_{N2}$ -1 to +20 V

Total power dissipation

 P_{tot} max. 600 mW

Storage temperature range

 T_{stg} -55 to +125 °C

Operating ambient temperature range

 T_{amb} -25 to +80 °C**CHARACTERISTICS** (see application circuit Fig. 4) $T_{amb} = 25$ °C; at typical supply voltages; unless otherwise specified

parameter	symbol	min.	typ.	max.	unit
Supply voltages					
with respect to GND (pin 6)					
at pin 4	V_{P1}	3	5	7	V
at pin 7	V_{N1}	-4.7	-5	-7	V
at pin 11	V_{N2}	-16.5	-17	-18	V
Supply currents					
at pin 4*	I_{P1}	-	12	14	mA
at pin 7	I_{N1}	-	-20	-24	mA
at pin 11	I_{N2}	-	-11	-13	mA
Power dissipation					
Total power dissipation	P_{tot}	-	350	410	mW
Temperature					
Operating ambient temperature range	T_{amb}	-20	-	+70	°C

* When the output current is $\frac{1}{2}I_{FS}$ ($\frac{1}{2}$ full scale output current).

parameter	symbol	min.	typ.	max.	unit
Data input DATA (pin 1)					
Input voltage HIGH	V_{IH}	2.0	—	7.0	V
Input voltage LOW	V_{IL}	0	—	0.8	V
Input current HIGH at V_{IH}	I_{IH}	—	—	50	μA
Input current LOW at V_{IL}	$-I_{IL}$	—	—	0.2	mA
Maximum input bit rate	BR_{max}	12	—	—	Mbits/s
Latch enable input LE (pin 2)					
Clock input \overline{CP} (pin 28)					
Input voltage HIGH	V_{IH}	2.0	—	7.0	V
Input voltage LOW	V_{IL}	0	—	0.8	V
Input current HIGH at V_{IH}	I_{IH}	—	—	50	μA
Input current LOW at V_{IL}	$-I_{IL}$	—	—	0.2	mA
Maximum clock frequency	$f_{CP\text{max}}$	12	—	—	MHz
Oscillator (pins 8 and 9)					
Oscillator frequency at $C_{8-9} = 820 \text{ pF}$	f_{osc}	100	160	200	kHz
Analogue output I_{out} (pin 22)					
Output voltage compliance	V_{OC}	-10	—	+ 10	mV
Full scale current	I_{FS}	3.8	4.0	4.2	mA
Zero scale current	$\pm I_{ZS}$	—	—	100	nA
Full scale temperature coefficient $T_{\text{amb}} = -20 \text{ to } +70 \text{ }^\circ\text{C}$	TC_{FS}	—	$\pm 30 \times 10^{-6}$	—	K^{-1}
Settling time to $\pm \frac{1}{2}\text{LSB}$ all bits on or off	t_{cs}	—	0.5	—	μs
Signal-to-noise ratio*	S/N	80	85	—	dB

* Signal-to-noise ratio within 20 Hz and 20 kHz of a 1 kHz full scale sinewave, generated at a sample rate of 44 kHz.

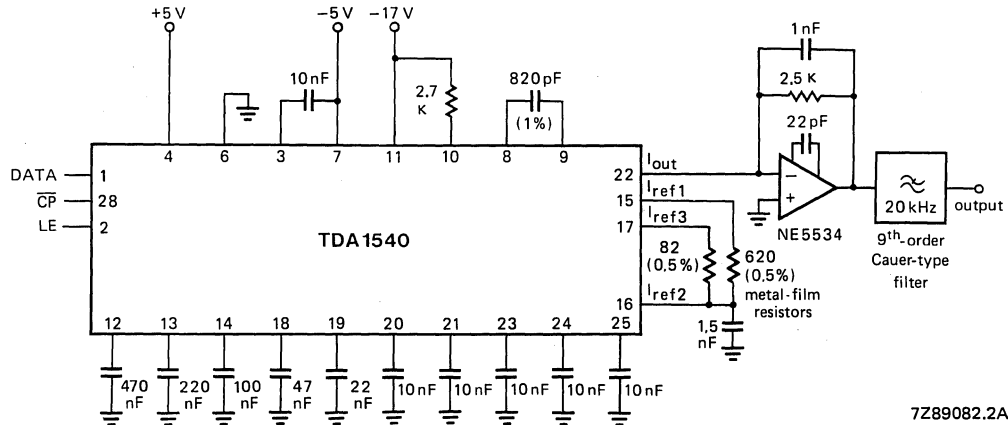

Fig. 4 Application circuit.

7Z89082.2A

PINNING

- 1 DATA data input
- 2 LE latch enable input
- 3 V_{ref1} voltage reference
- 4 V_{p1} positive supply
- 5 i.c.* frequency compensation
- 6 GND ground
- 7 V_{N1} negative supply
- 8 OSC1 } oscillator capacitor
- 9 OSC2 }
- 10 V_{ref2} voltage reference
- 11 V_{N2} negative supply
- 12 C1 } decoupling binary
- 13 C2 } weighted current
- 14 C3 } sources
- 15 I_{ref1} } current reference sources
- 16 I_{ref2} }
- 17 I_{ref3} }
- 18 C4 } decoupling binary weighted
- 19 C5 } current sources
- 20 C6 }
- 21 C7 }
- 22 I_{out} analogue output
- 23 C8 } decoupling binary
- 24 C9 } weighted current
- 25 C10 } sources
- 26 i.c.* voltage reference
- 27 i.c.* voltage reference
- 28 CP clock pulse input

* i.c.: internally connected.

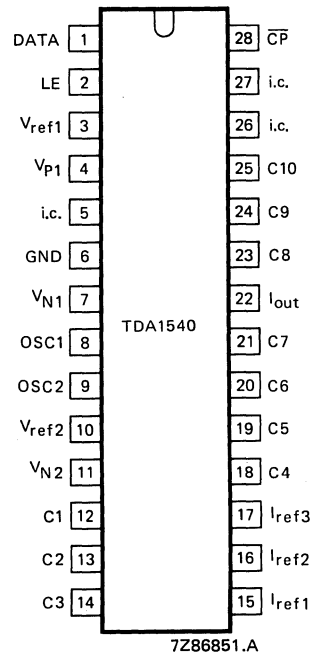

Fig. 5 Pinning diagram.

SELECTOR GUIDE

COMPARATORS

DEVICE	COM- PLEXITY	TEMP. RANGE*	MAX. INP. OFFSET VOLT (mV)	MAX. INP. CURRENT		SUPPLY VOLTAGE (V)	RESPONSE TIME (Typ.) (ns)	COMMON MODE VOLTAGE RANGE (V)	OUTPUT VOLTAGE		OUTPUT STRUCTURE	VOLTAGE GAIN (Typ.) V/mV	TTL FANOUT	MAX. DIFF. INPUT VOLTAGE (V)
				BIAS (μ A)	OFFSET (μ A)				V _{OL} Max. (V)	V _{OH} Min. (V)				
LM111 ¹	Single	M	4.00	0.15	0.02	± 15	200	± 14	0.4		O.C.	200	5	± 30
LM211	Single	I	4.00	0.15	0.02	to	200	± 14	0.4		O.C.	200	5	± 30
LM311	Single	C	10.0	0.30	0.07	+5 and GND	200	± 14	0.4		O.C.	200	5	± 30
NE527 ²	Single	C	10.0	4.00	1.0	± 5 to ± 10	16	± 5	0.5	2.7	TTL		5	± 5
SE527	Single	M	6.00	4.00	1.00	and GND	16	± 5	0.5	2.5	TTL		5	± 5
NE529 ³	Single	C	10.0	50.0	15.0	± 5 to ± 10	12	± 5	0.5	2.7	TTL		5	± 5
SE529	Single	M	6.00	36.0	9.00	and GND	12	± 5	0.5	2.5	TTL		5	± 5
LM119 ³	Dual	M	7.00	1.00	0.10	± 15	80	± 13	0.4		O.C.	40	2	± 5
LM219	Dual	I	7.00	1.00	0.10	to	80	± 13	0.4		O.C.	40	2	± 5
LM319	Dual	C	10.0	1.20	0.30	± 5 and GND	80	± 13	0.4		O.C.	40	2	± 5
LM193 ³	Dual	M	9.00	0.30	0.10	± 1 to ± 18	1300	0 to V _S - 2	0.7		O.C.	200	2	36
LM293	Dual	I	9.00	0.40	0.15	or	1300	0 to V _S - 2	0.7		O.C.	200	2	36
LM393	Dual	C	9.00	0.40	0.15	+2 to +36 GND	1300	0 to V _S - 2	0.7		O.C.	200	2	36
LM2903	Dual	I	15.0	0.50	0.20		1300	0 to V _S - 2	0.7		O.C.	100	2	36
SE/NE521 ⁴	Dual	M/C	15/10.0	40.0	12.0	+5, -5, GND	8	± 3	0.5	2.7	TTL		12	± 6
SE/NE522	Dual	M/C	15/10.0	40.0	12.0	+5, -5, GND	10	± 3	0.5		O.C.		12	± 6
LM139 ³	Quad	M	9.00	0.30	0.10		1300	0 to V _S - 2	0.7		O.C.	200	2	36
LM239	Quad	I	9.00	0.40	0.15	± 1 to ± 18 or	1300	0 to V _S - 2	0.7		O.C.	200	2	36
LM339	Quad	C	9.00	0.40	0.15	+2 to +36	1300	0 to V _S - 2	0.7		O.C.	200	2	36
LM2901	Quad	I	15.0	0.50	0.20		1300	0 to V _S - 2	0.7		O.C.	100	2	36
MC3302 ³	Quad	I	40.0	1.00	0.30	+2 to +28 GND	2000	0 to V _S - 2	0.7		O.C.	100	2	28

Notes:

1. With strobe, will work from single supply.
2. Complementary output gates with individual strobes.
3. Will operate from single or dual supplies.
4. Ultra-high speed.

*Temperature Range
 I = Industrial
 C = Commercial
 M = Military

VOLTAGE COMPARATOR

LM111/211/311

DESCRIPTION

The LM111 series are voltage comparators that have input currents approximately a hundred times lower than devices like the μ A710. They are designed to operate over a wider range of supply voltages; from standard $\pm 15V$ op amp supplies down to the single 5V supply used for IC logic. Their output is compatible with RTL, DTL, and TTL as well as MOS circuits. Further, they can drive lamps or relays, switching voltages up to 50V at currents as high as 50mA.

Both the inputs and the outputs of the LM111 series can be isolated from system ground, and the output can drive loads referred to ground, the positive supply or the negative supply. Offset balancing and strobe capability are provided and outputs can be wire OR'ed. Although slower than the μ A710 (200ns response time vs 40ns) the devices are also much less prone to spurious oscillations. The LM111 series has the same pin configuration as the μ A710 series.

FEATURES

- Operates from single 5V supply
- Maximum input bias current: 150nA (LM311 - 250nA)
- Maximum offset current: 20nA (LM311 - 50nA)
- Differential input voltage range: $\pm 30V$
- Power consumption: 135mW at $\pm 15V$
- High sensitivity—200V/mV

APPLICATIONS

- Zero crossing detector
- Precision squarer
- Positive/negative peak detector
- Low voltage adjustable reference supply
- Switching power amplifier

PIN CONFIGURATION

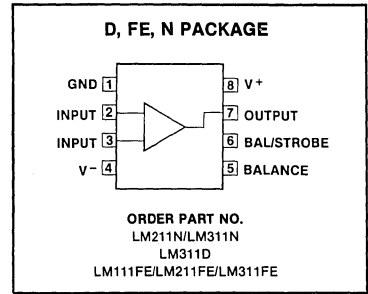

EQUIVALENT SCHEMATIC

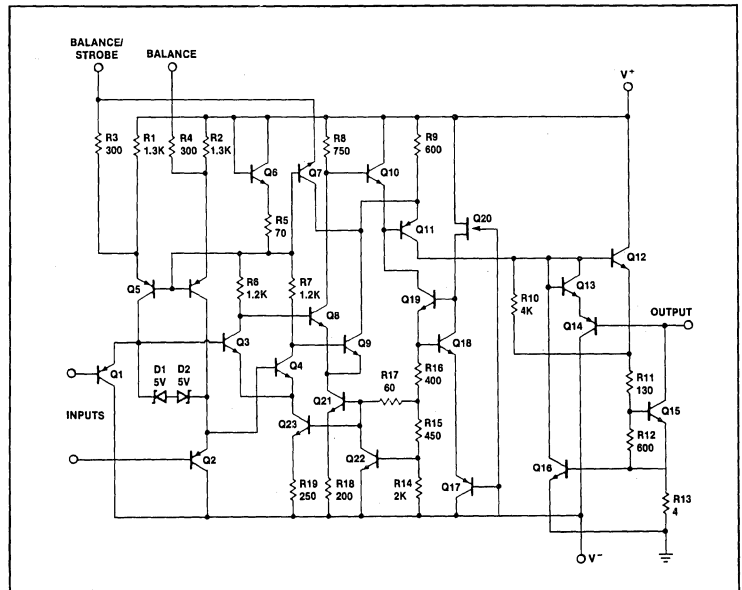

ABSOLUTE MAXIMUM RATINGS

PARAMETER	RATING	UNIT
Total supply voltage	36	V
Output to negative supply voltage:		
LM111/LM211	50	V
LM311	40	V
Ground to negative supply voltage	30	V
Differential input voltage	± 30	V
Input voltage ¹	± 15	V
Power dissipation ²	500	mW
Output short circuit duration	10	sec
Operating temperature range		
LM111	-55 to +125	$^{\circ}C$
LM211	-25 to +85	$^{\circ}C$
LM311	0 to +70	$^{\circ}C$
Storage temperature range	-65 to +150	$^{\circ}C$
Lead temperature (soldering, 10sec)	300	$^{\circ}C$

VOLTAGE COMPARATOR

LM111/211/311

DC ELECTRICAL CHARACTERISTICS 1,2,3

PARAMETER	TEST CONDITIONS	LM111/LM211			LM311			UNIT
		Min	Typ	Max	Min	Typ	Max	
Input offset voltage ⁴	T _A = 25°C, R _S ≤ 50kΩ		0.7	3.0		2.0	7.5	mV
Input offset current ⁴	T _A = 25°C		4.0	10		6.0	50	nA
Input bias current	T _A = 25°C		60	100		100	250	nA
Voltage gain	T _A = 25°C		200			200		V/mV
Response time ⁵	T _A = 25°C		200			200		ns
Saturation voltage	V _{IN} ≤ -5mV, I _{OUT} = 50mA T _A = 25°C		0.75	1.5		0.75	1.5	V
Strobe on current	T _A = 25°C		3.0			3.0		mA
Output leakage current	V _{IN} ≥ 5mV, V _{OUT} = 35V T _A = 25°C, I _{STROBE} = 3mA		0.2	10		0.2	50	nA
Input offset voltage ⁴	R _S ≤ 50kΩ			4.0			10	mV
Input offset current ⁴				20			70	nA
Input bias current				150			300	nA
Input voltage range	V = ± 15V (Pin 7 may go to 5V)	- 14.5	13.8, - 14.7	13.0	- 14.5	13.8, -14.7	13.0	V
Saturation voltage	V ₊ ≥ 4.5V, V ₋ = 0							
	V _{IN} ≤ -6mV, I _{SINK} ≤ 8mA		0.23	0.4		0.23	0.4	V
Output leakage current	V _{IN} ≥ 5mV, V _{OUT} = 35V		0.1	0.5				μA
Positive supply current	T _A = 25°C		5.1	6.0		5.1	7.5	mA
Negative supply current	T _A = 25°C		4.1	5.0		4.1	5.0	mA

NOTES

- This rating applies for ±15V supplies. The positive input voltage limit is 30V above the negative supply. The negative input voltage limit is equal to the negative supply voltage or 30V below the positive supply, whichever is less.
- The maximum junction temperature of the LM311 is 110°C. For operating at elevated temperatures, devices in the TO-5 package must be derated based on a thermal resistance of 150°C/W, junction to ambient, in the N package, a thermal resistance of 162°C/W, and °C/W for the Ceramic package. The maximum junction temperature of the LM111 is 150°C, while that of the LM211 is 110°C. For operating at elevated temperatures, devices in the TO-5 package must be derated based on a thermal resistance of 150°C/W, junction to ambient. The thermal resistance of the Cerdpip package is 110°C/W, junction to ambient.
- These specifications apply for V_S = ±15V and 0°C < T_A < 70°C unless otherwise specified. With the LM211, however, all temperature specifications are limited to -25°C ≤ T_A ≤ 85°C and for the LM111 is limited to -55°C < T_A < 125°C. The offset voltage, offset current and bias current specifications apply for any supply voltage from a single 5V supply up to ±15V supplies.
- The offset voltages and offset currents given are the maximum values required to drive the output within a volt of either supply with 1mA load. Thus, these parameters define an error band and take into account the worst case effects of voltage gain and input impedance.
- The response time specified is for a 100mV input step with 5mV overdrive.
- Do not short the strobe pin to ground; it should be current driven at 3mA to 5mA.

TYPICAL APPLICATIONS

ZERO CROSSING DETECTOR DRIVING MOS LOGIC

DETECTOR FOR MAGNETIC TRANSDUCER

TTL INTERFACE WITH HIGH LEVEL LOGIC

*Values shown are for a 0 to 30V logic swing and a 15V threshold.
 †May be added to control speed and reduce susceptibility to noise spikes.

DESCRIPTION

The LM119 series are precision high speed dual comparators fabricated on a single monolithic chip. They are designed to operate over a wide range of supply voltages down to a single 5V logic supply and ground. Further, they have higher gain and lower input currents than devices like the μ A710. The uncommitted collector of the output stage makes the LM119 compatible with RTL, DTL and TTL as well as capable of driving lamps and relays at currents up to 25mA.

Although designed primarily for applications requiring operation from digital logic supplies, the LM119 series are fully specified for power supplies up to $\pm 15V$. It features faster response than the LM111 at the expense of higher power dissipation. However, the high speed, wide operating voltage range and low package count make the LM119 much more versatile than older devices like the μ A711.

The LM119 is specified from $-55^{\circ}C$ to $+125^{\circ}C$, the LM219 is specified from $-25^{\circ}C$ to $+85^{\circ}C$, and the LM319 is specified from $0^{\circ}C$ to $+70^{\circ}C$.

FEATURES

- Two independent comparators
- Operates from a single 5V supply
- Typically 80ns response time at $\pm 15V$
- Minimum fan-out of 3 (each side)
- Maximum input current of $1\mu A$ over temperature
- Inputs and outputs can be isolated from system ground
- High common mode slew rate
- MIL-STD-883 A, B, C available

PIN CONFIGURATIONS

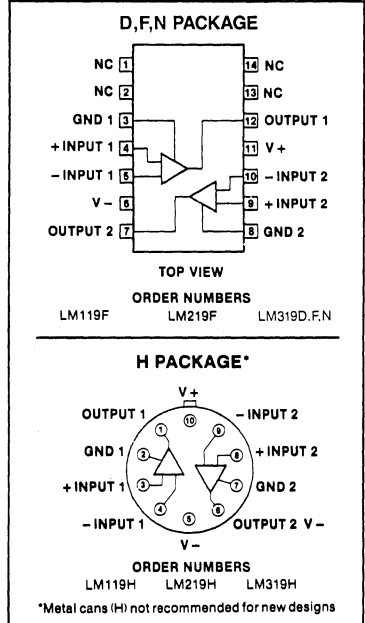

EQUIVALENT SCHEMATIC

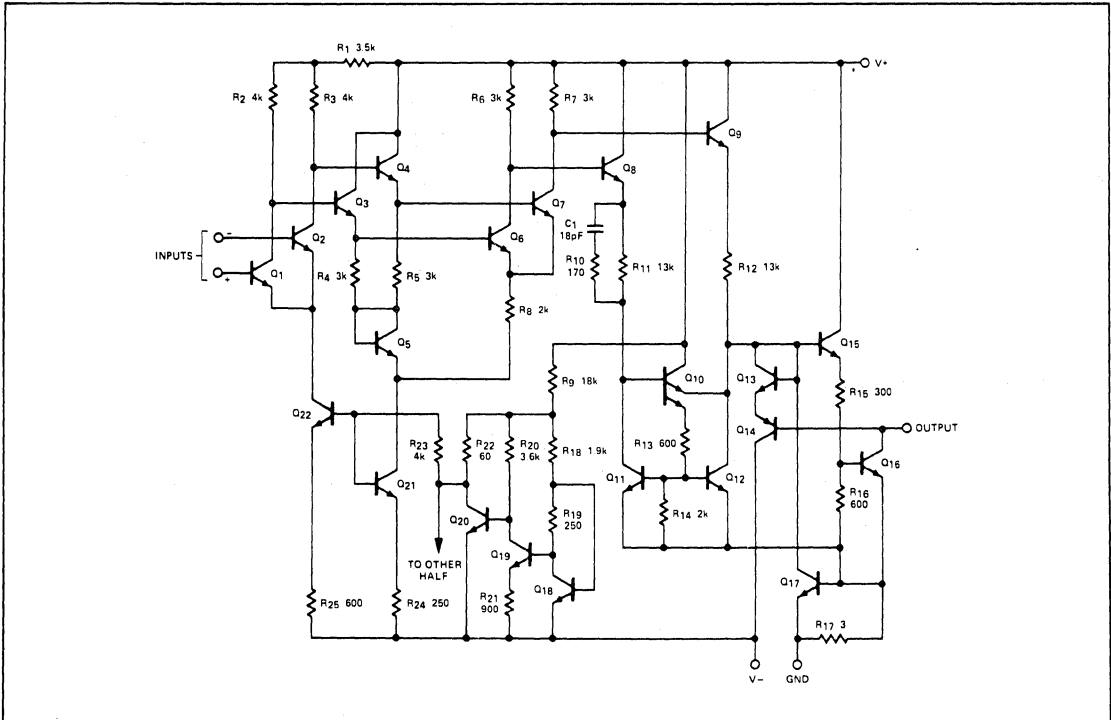

DUAL VOLTAGE COMPARATOR

LM119/219/319

ABSOLUTE MAXIMUM RATINGS

PARAMETER	RATING	UNIT
Total supply voltage	36	V
Output to negative supply voltage	36	V
Ground to negative supply voltage	25	V
Ground to positive supply voltage	18	V
Differential input voltage	±5	V
Input voltage ¹	±15	V
Power dissipation ²	500	mW
Output short circuit duration	10	s
Operating temperature range		
LM119	-55 to +125	°C
LM219	-25 to +85	°C
LM319	0 to +70	°C
Storage temperature range	-65 to +150	°C
Lead temperature (soldering, 10sec)	300	°C

NOTES

- For supply voltages less than ±15V, the absolute maximum rating is equal to the supply voltage.
- The absolute maximum junction temperature is 150°C. Device dissipation must be derated as follows:
 K package—150°C/watt above 75°C
 F package —110°C/watt above 95°C

DC ELECTRICAL CHARACTERISTICS $V_S = \pm 15V$, for $\left. \begin{array}{l} \text{LM119, } -55^\circ\text{C} \leq T_A \leq 125^\circ\text{C} \\ \text{LM219, } -25^\circ\text{C} \leq T_A \leq 85^\circ\text{C} \\ \text{LM319, } 0^\circ\text{C} \leq T_A \leq 70^\circ\text{C} \end{array} \right\}$ unless otherwise specified.

PARAMETER	TEST CONDITIONS	LM119/219			LM319			UNIT
		Min	Typ	Max	Min	Typ	Max	
V_{OS} Input offset voltage ^{1,2}	$R_S \leq 5K\Omega$, $T_A = 25^\circ\text{C}$ Over temp.		0.7	4.0 7		2.0	8.0 10	mV mV
I_{OS} Input offset current ^{1,2}	$T_A = 25^\circ\text{C}$ Over temp.		30	75 100		80	200 300	nA nA
I_B Input bias current ¹	$T_A = 25^\circ\text{C}$ Over temp.		150	500 1000		250	1000 1200	nA nA
A_V Voltage gain	$T_A = 25^\circ\text{C}$	10	40		8	40		V/mV
V_{OL} Saturation voltage	$V_{IN} = 5mV, I_{OUT} = 25mA, T_A = 25^\circ\text{C}$ $V_{IN} = 10mV, I_{OUT} = 25mA, T_A = 25^\circ\text{C}$ $V^+ \geq 4.5V, V^- = 0$ $V_{IN} = 6mV, I_{OUT} = 3.2mA$ $T_A \geq 0^\circ\text{C}$ $T_A \leq 0^\circ\text{C}$ $V_{IN} = 10mV, I_{OUT} = 3.2mA$		0.75	1.5		0.75	1.5	V V V V
I_{OH} Output leakage current	$V^- = 0V, V_{IN} = 5mV$ $V_{OUT} = 35V, T_A = 25^\circ\text{C}$ Over temp. $V^- = 0V, V_{IN} = 10mV$ $V_{OUT} = 35V, T_A = 25^\circ\text{C}$		0.2 1	2 10		0.2	10	μA μA μA
V_{IN} Input voltage range	$V_S = \pm 15V$ $V^+ = 5V, V^- = 0V$	1	±13	3	1	±13	3	V V
V_{ID} Differential input voltage				±5			±5	V
I^+ Positive supply current	$V^+ = 5V, V^- = 0V, T_A = 25^\circ\text{C}$		4.3			4.3		mA
I^+ Positive supply current	$V_S = \pm 15V, T_A = 25^\circ\text{C}$		8.0	11.5		8.0	12.5	mA
I^- Negative supply current	$V_S = \pm 15V, T_A = 25^\circ\text{C}$		3.0	4.5		3.0	5.0	mA

NOTES

- V_{OS} , I_{OS} and I_B specifications apply for a supply voltage range of $V_S = \pm 15V$ down to a single 5V supply.
- The offset voltages and offset currents given are the maximum values required to drive the output to within 1 volt of either supply with a 1mA load. Thus these parameters define an error band and take into account the worst case effects of voltage gain and input impedance.

AC ELECTRICAL CHARACTERISTICS

PARAMETER	TEST CONDITIONS	LIMITS			UNIT
		Min	Typ	Max	
Response time*	$V_S = \pm 15V, T_A = 25^\circ C$ $R_L = 500\Omega$ (see test figure)		80		ns

*NOTE

The response time specified is for a 100mV step with 5mV overdrive.

TEST CIRCUIT

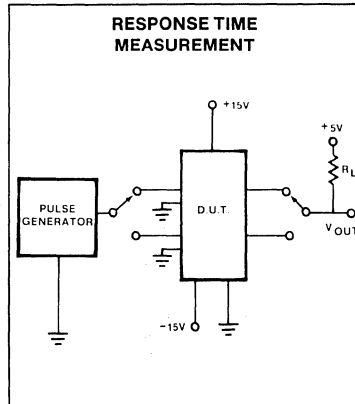

TYPICAL PERFORMANCE CHARACTERISTICS

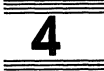
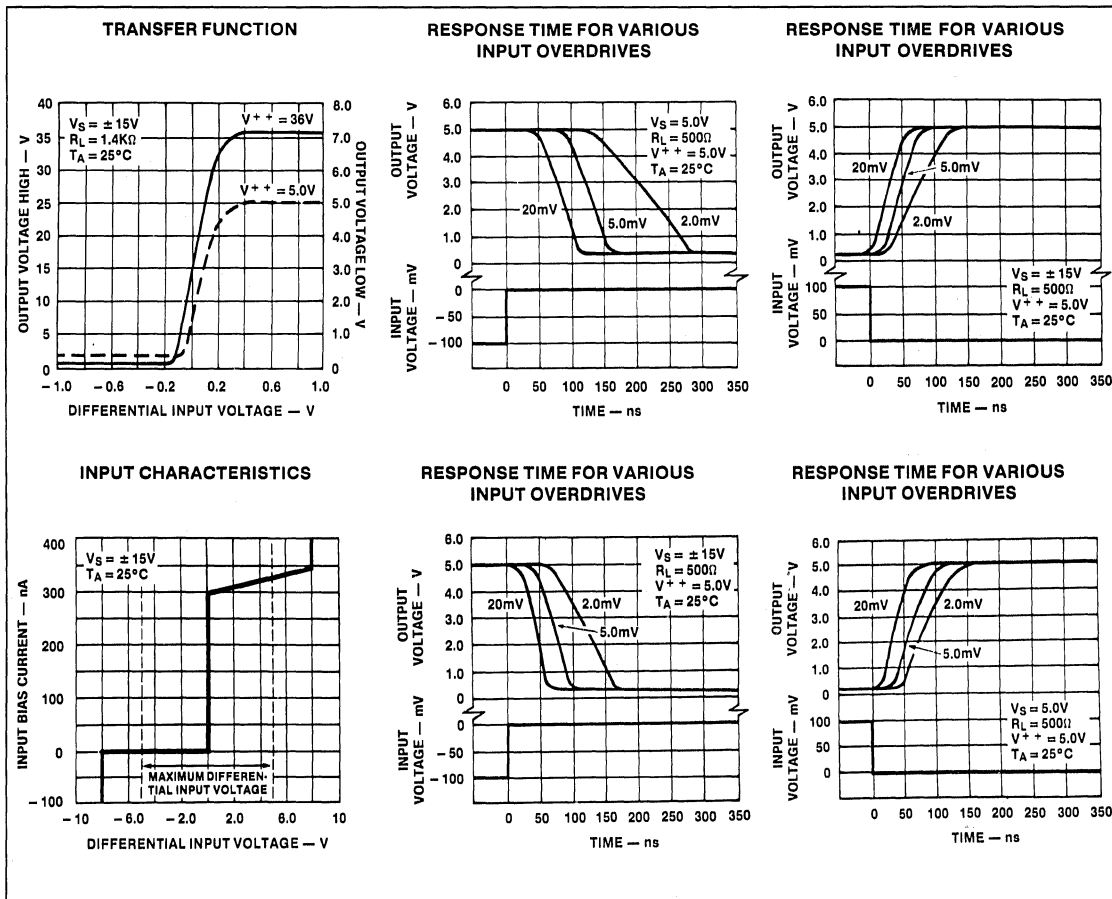

TYPICAL PERFORMANCE CHARACTERISTICS (Cont'd)

OUTPUT SATURATION VOLTAGE

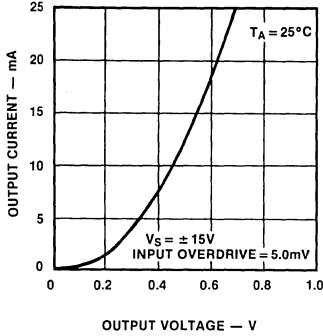

SUPPLY CURRENT

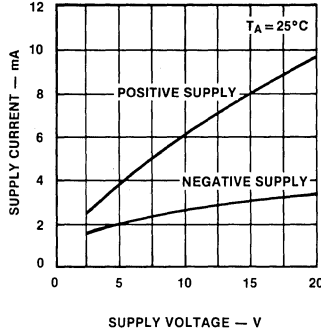

OUTPUT LIMITING CHARACTERISTICS

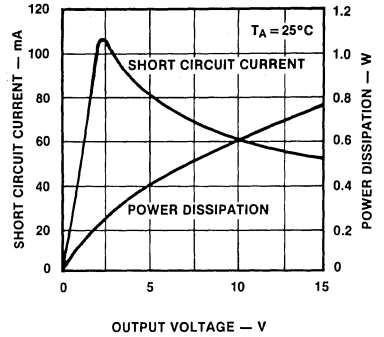

INPUT CURRENTS (LM119/219)

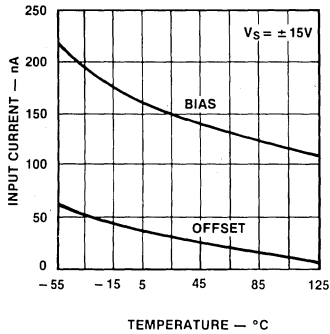

COMMON MODE LIMITS (LM119/219)

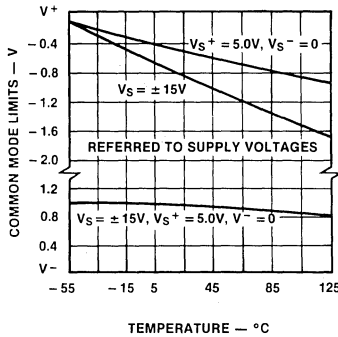

SUPPLY CURRENT (LM119/219)

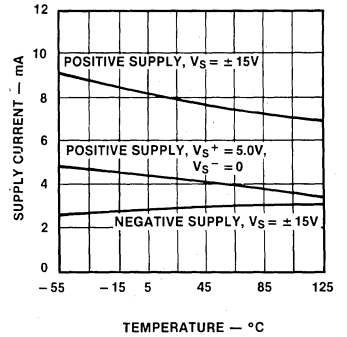

INPUT CURRENTS (LM319)

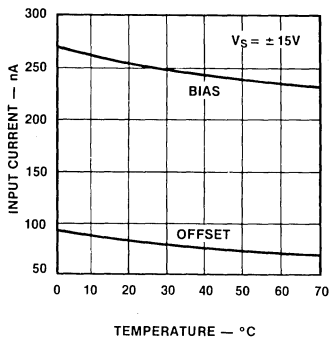

SUPPLY CURRENTS (LM319)

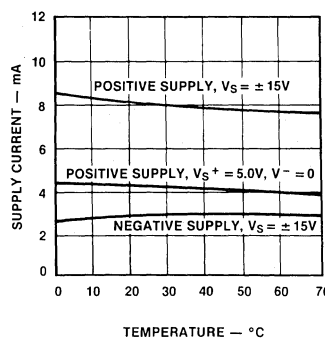

COMMON MODE LIMITS (LM319)

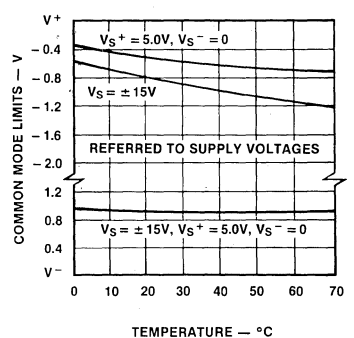

TYPICAL APPLICATIONS

RELAY DRIVER

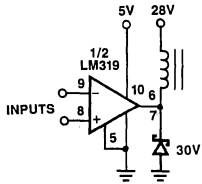

WINDOW DETECTOR

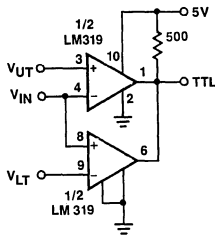

$V_{OUT} = 5V$ for $V_{LT} < V_{IN} < V_{UT}$
 $V_{OUT} = 0$ for $V_{IN} < V_{LT}$ or $V_{IN} > V_{UT}$

WIDE RANGE VARIABLE OSCILLATOR

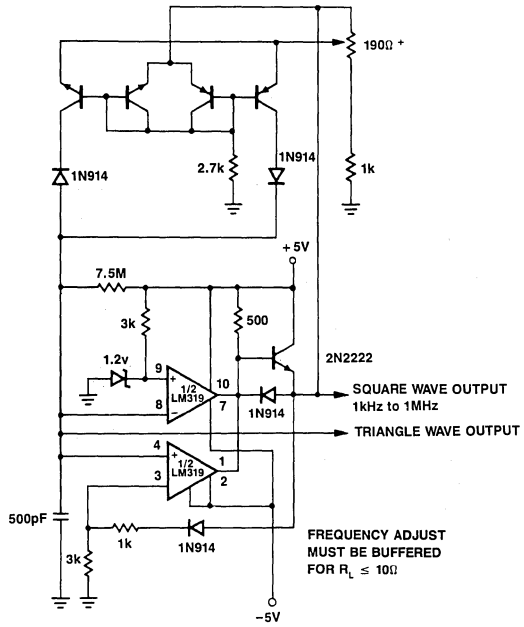

4

QUAD VOLTAGE COMPARATOR

LM139A/239A/339A/LM139/239/339/
LM2901/MC3302

DESCRIPTION

The LM139 series consists of four independent precision voltage comparators with an offset voltage specification as low as 2.0mV max for each comparator which were designed specifically to operate from a single power supply over a wide range of voltages. Operation from split power supplies is also possible and the low power supply current drain is independent of the magnitude of the power supply voltage. These comparators also have a unique characteristic in that the input common mode voltage range includes ground, even though operated from a single power supply voltage.

The LM139 series was designed to directly interface with TTL and CMOS. When operated from both plus and minus power supplies, the LM139 series will directly interface with MOS logic where their low power drain is a distinct advantage over standard comparators.

FEATURES

- Wide single supply voltage range 2.0Vdc to 36Vdc or dual supplies $\pm 1.0Vdc$ to $\pm 18Vdc$
- Very low supply current drain (0.8mA) independent of supply voltage (1.0mW/comparator at 5.0Vdc)
- Low input biasing current 25nA
- Low input offset current $\pm 5nA$ and offset voltage
- Input common-mode voltage range includes ground
- Differential input voltage range equal to the power supply voltage.
- Low output 250mV at 4mA saturation voltage
- Output voltage compatible with TTL, DTL, ECL, MOS and CMOS logic systems.

APPLICATIONS

- A/D converters
- Wide range VCO
- MOS clock generator
- High voltage logic gate
- Multivibrators

PIN CONFIGURATION

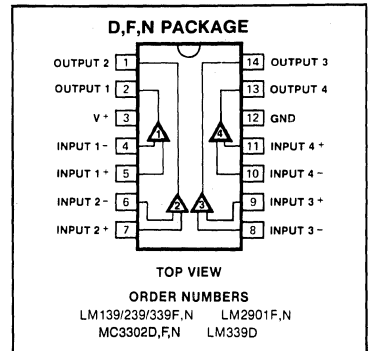

ABSOLUTE MAXIMUM RATINGS

PARAMETER	RATING	UNIT
Vcc supply voltage	36 or ± 18	
Differential input voltage	36	
Input voltage	-0.3 to +36	
Power dissipation ¹		
N package	570	mW
F package	900	mW
Output short circuit to ground ²	Continuous	
Input current (VIN < -0.3Vdc) ³	50	mA
Operating temperature range		
LM139/A	-55 to +125	°C
LM239/A	-25 to +85	°C
LM339/A	0 to +70	°C
LM2901/MC3302	-40 to +85	°C
Storage temperature range	-65 to +150	°C
Lead temperature (soldering 10 sec.)	300	°C

EQUIVALENT CIRCUIT

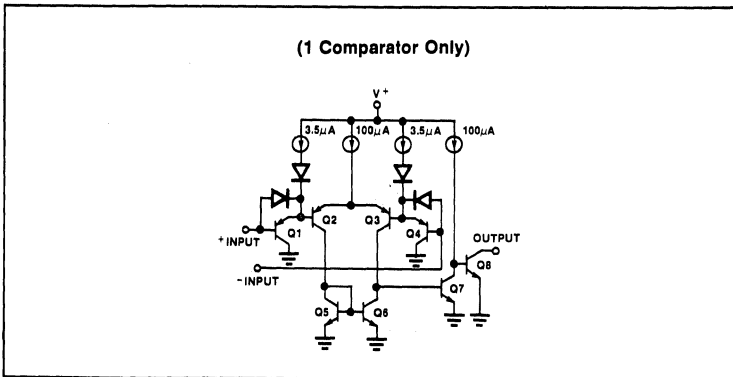

QUAD VOLTAGE COMPARATOR

LM139A/239A/339A/LM139/239/339/
LM2901/MC3302

DC ELECTRICAL CHARACTERISTICS $V_+ = 5V_{dc}$, LM139A/LM139: $-55^{\circ}C \leq T_A \leq 125^{\circ}C$ unless otherwise specified
 LM239: $-25^{\circ}C \leq T_A \leq 85^{\circ}C$ unless otherwise specified
 LM339: $0^{\circ}C \leq T_A \leq 70^{\circ}C$ unless otherwise specified
 $V_+ = 5V_{dc}$, LM339A: $^{\circ}C \leq T_A \leq 70^{\circ}C$ unless otherwise specified
 LM239A: $-25^{\circ}C \leq T_A \leq 85^{\circ}C$ unless otherwise specified
 LM2901/LM3302: $-40^{\circ}C \leq T_A \leq 85^{\circ}C$ unless otherwise specified

PARAMETER	TEST CONDITIONS	LM139A			LM239A/339A			LM139			LM239/339			LM2901			MC3302			UNIT		
		Min	Typ	Max	Min	Typ	Max	Min	Typ	Max	Min	Typ	Max	Min	Typ	Max	Min	Typ	Max			
V_{OS} Input offset voltage ⁵	$T_A = 25^{\circ}C$ Over temp.		± 1.0	± 2.0 4.0		± 1.0	± 2.0 4.0		± 2.0	± 5.0 9.0		± 2.0	± 5.0 9.0		± 2.0	± 7.0 ± 15		± 3.0	± 20 ± 40	mV		
V_{CM} Input common mode voltage range ⁶	$T_A = 25^{\circ}C$ Over temp.	0		$V_+ - 1.5$ $V_+ - 2.0$	0		$V_+ - 1.5$ $V_+ - 2.0$	0		$V_+ - 1.5$ $V_+ - 2.0$	0		$V_+ - 1.5$ $V_+ - 2.0$	0		$V_+ - 1.5$ $V_+ - 2.0$			$V_+ - 1.5$ $V_+ - 2.0$	v		
V_{IDR} Differential input ⁴ voltage ⁴	Keep all $V_{INs} \geq 0V_{dc}$ (or V_- if need)			V_+			V_+			V_+			V_+			V_+			V_+	V		
I_B Input bias current ⁷	$I_{IN(+)}$ or $I_{IN(-)}$ with output in linear range $T_A = 25^{\circ}C$ Over temp.		25	100 300		25	250 400		25	100 300		25	250 400		25	250 500		25	500 1000	nA		
I_{OS} Input offset current	$I_{IN(+)} - I_{IN(-)}$ $T_A = 25^{\circ}C$ Over temp.		± 3.0	± 25 ± 100		± 5.0	± 50 ± 150		± 3.0	± 25 ± 100		± 5.0	± 50 ± 150		± 5 ± 50	± 50 ± 200		± 5	± 100 ± 300	nA nA		
I_{OL} Output sink current	$V_{IN(-)} \geq 1V_{dc}$, $V_{IN(+)} = 0$, $V_O \leq 1.5V_{dc}$, $T_A = 25^{\circ}C$, $V_O = 800mV$, over temp.	6.0	16		6.0	16		6.0	16		6.0	16		6.0	16			6		2.0	mA	
I_{OH} Output leakage current	$V_{IN(+)} \geq 1V_{dc}$, $V_{IN(-)} = 0$, $V_O = 5V_{dc}$, $T_A = 25^{\circ}C$, $V_O = 30V_{dc}$, over temp.		0.1			0.1			0.1			0.1			0.1			0.1		1.0	nA μA	
I_{CC} Supply current	$V_+ = 28V$ $R_L = \infty$ on comparators, $T_A = 25^{\circ}C$ $V_+ \geq 30V$		0.8	2.0		0.8	2.0		0.8	2.0		0.8	2.0		0.8 1.0	2.0 2.5		.8	1.8		mA	
A_V Voltage gain	$R_L \geq 15k\Omega$, $V_+ = 15V_{dc}$	50	200		50	200		50	200		50	200		25	100		2	100			V/mV	
V_{OL} Saturation voltage	$V_{IN(-)} \geq 1V_{dc}$, $V_{IN(+)} = 0$, $I_{SINK} \leq 4mA$ $T_A = 25^{\circ}C$ Over temp.		250	400 700		250	400 700		250	400 700		250	400 700		400	400 700			150	400 700	mV	
T_{LSR} Large signal response time	$V_{IN} = TTL$ logic swing, $V_{REF} = 1.4V_{dc}$, $V_{RL} = 5V_{dc}$, $R_L = 5.1k\Omega$, $T_A = 25^{\circ}C$		300			300			300			300			300				300			ns
T_R Response time ⁸	$V_{RL} = 5V_{dc}$, $R_L = 5.1k\Omega$, $T_A = 25^{\circ}C$		1.3			1.3			1.3			1.3			1.3				1.3			μs

See notes on following page.

Signetics



QUAD VOLTAGE COMPARATOR**LM139A/239A/339A/LM139/239/339/
LM2901/MC3302**

NOTES

1. For operating at high temperatures, the LM339/339A, LM2901 and MC3302 must be derated based on a 125°C maximum junction temperature and a thermal resistance of 175°C/W which applies for the device soldered in a printed circuit board, operating in a still air ambient. The LM139/139A/239/239A must be derated on a 150°C maximum junction temperature. The low power dissipation and the "On-Off" characteristics of the outputs keep the chip dissipation very small ($P_D \leq 100\text{mW}$), provided the output transistors are allowed to saturate.
2. Short circuits from the output to $V+$ can cause excessive heating and eventual destruction. The maximum output current is approximately 20mA independent of the magnitude of $V+$.
3. This input current will only exist when the voltage at any of the input leads is driven negative. It is due to the collector-base junction of the input PNP transistors becoming forward biased and thereby acting as input diode clamps. In addition to this diode action, there is also lateral NPN parasitic transistor action on the IC chip. This transistor action can cause the output voltages of the comparators to go to the $V+$ voltage level (or to ground for a large overdrive) for the time duration that an input is driven negative. This is not destructive and normal output states will re-establish when the input voltage, which was negative, again returns to a value greater than -0.3Vdc .
4. Positive excursions of input voltage may exceed the power supply level by 17 volts. As long as the other voltage remains within the common-mode range, the comparator will provide a proper output state. The low input voltage state must not be less than -0.3Vdc (or 0.3Vdc below the magnitude of the negative power supply, if used).
5. At output switch point, $V_O \approx 1.4\text{Vdc}$, $R_G = 0\Omega$ with $V+$ from 5Vdc to 30Vdc ; and over the full input common-mode range (0Vdc to $V+ - 1.5\text{Vdc}$).
6. The input common-mode voltage or either input signal voltage should not be allowed to go negative by more than 0.3V . The upper end of the common-mode voltage range is $V+ - 1.5\text{V}$, but either or both inputs can go to 30Vdc without damage.
7. The direction of the input current is out of the IC due to the PNP input stage. This current is essentially constant, independent of the state of the output so no loading change exists on the reference or input lines.
8. The response time specified is for a 100mV input step with a 5mV overdrive. For larger overdrive signals, 300ns can be obtained, see typical performance characteristics section.

QUAD VOLTAGE COMPARATOR

LM139A/239A/339A/LM139/239/339/
LM2901/MC3302

TYPICAL APPLICATIONS

TWO-DECADE HIGH-FREQUENCY VCO

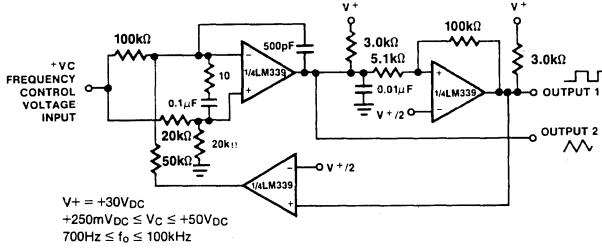

LIMIT COMPARATOR

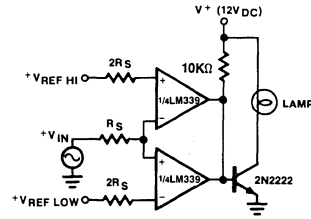

VISIBLE VOLTAGE INDICATOR

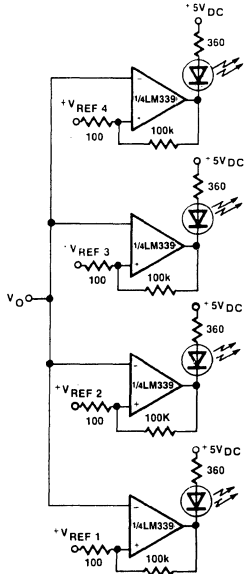

TTL TO MOS LOGIC CONVERTER

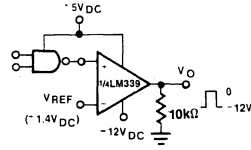

CRYSTAL CONTROLLED OSCILLATOR

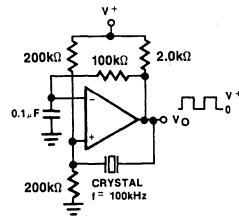

NOTE:
Inputs of unused comparators should be grounded.

4

QUAD VOLTAGE COMPARATOR

LM139A/239A/339A/LM139/239/339/
LM2901/MC3302

TYPICAL PERFORMANCE CHARACTERISTICS

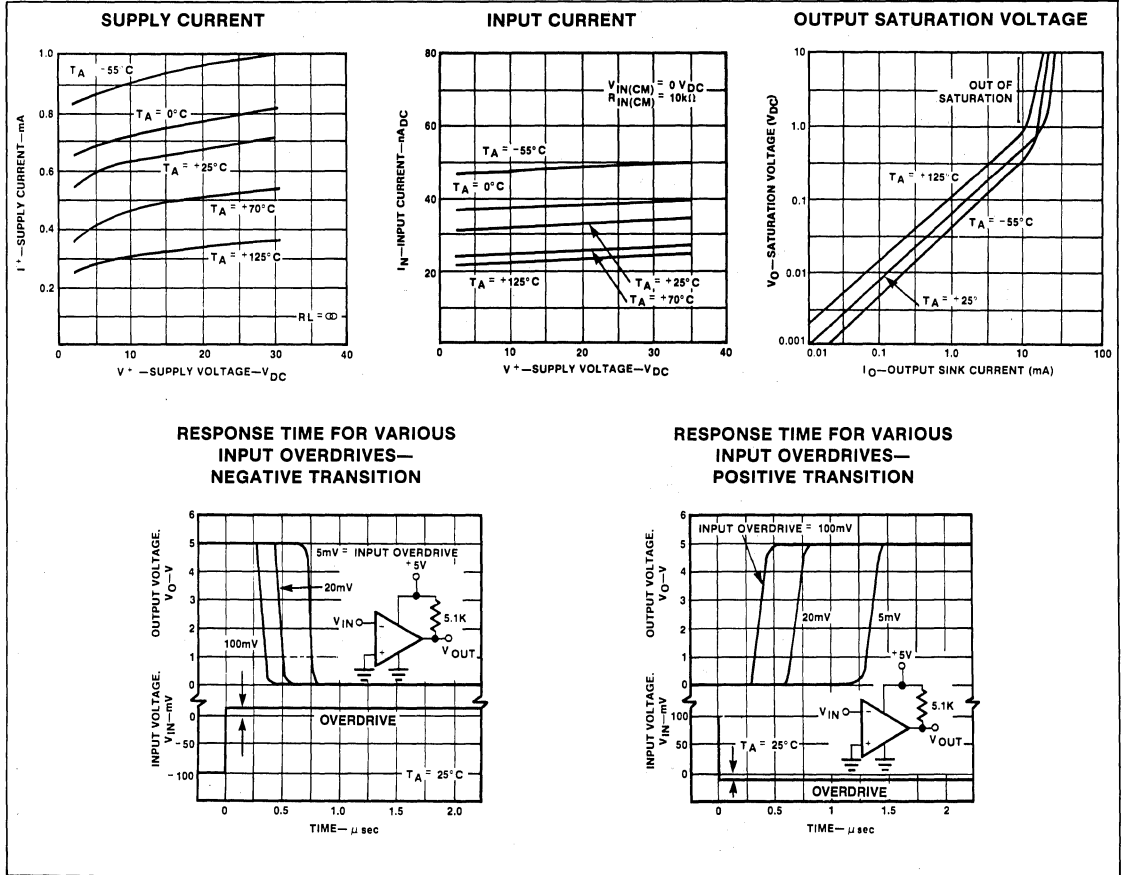

LOW POWER DUAL VOLTAGE COMPARATOR LM193/A/293/A/393/A/2903

DESCRIPTION

The LM193 series consists of two independent precision voltage comparators with an offset voltage specification as low as 2.0mV max for two comparators which were designed specifically to operate from a single power supply over a wide range of voltages. Operation from split power supplies is also possible and the low power supply current drain is independent of the magnitude of the power supply voltage. These comparators also have a unique characteristic in that the input common mode voltage range includes ground, even though operated from a single power supply voltage.

The LM193 series was designed to directly interface with TTL and CMOS. When operated from both plus and minus power supplies, the LM193 series will directly interface with MOS logic where their low power drain is a distinct advantage over standard comparators.

FEATURES

- Wide single supply voltage range 2.0Vdc to 36Vdc or dual supplies ± 1.0 Vdc to ± 18 Vdc
- Very low supply current drain (0.8mA) independent of supply voltage (2.0mW/-comparator at 5.0Vdc)
- Low input biasing current 25nA
- Low input offset current ± 5 nA and offset voltage ± 2 mV
- Input common-mode voltage range includes ground
- Differential input voltage range equal to the power supply voltage.
- Low output 250mV at 4mA saturation voltage
- Output voltage compatible with TTL, DTL, ECL, MOS and CMOS logic systems.

APPLICATIONS

- A/D converters
- Wide range VCO
- MOS clock generator
- High voltage logic gate
- Multivibrators

PIN CONFIGURATIONS

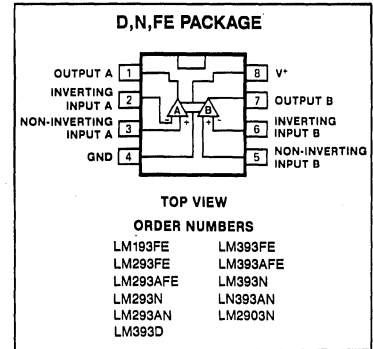

ABSOLUTE MAXIMUM RATINGS

PARAMETER	RATING	UNIT
V _{CC} supply voltage	36 or ± 18	Vdc
Differential input voltage	36	Vdc
Input voltage	-0.3 to +36	Vdc
Power dissipation ¹		
N	570	mW
FE	900	mW
Output short circuit to ground ²	Continuous	
Input current (V _{IN} < -0.3Vdc) ³	50	mA
Operating temperature range		
LM193/193A	-55 to +125	°C
LM293/293A	-25 to +85	°C
LM393/393A	0 to +70	°C
LM2903	-40 to +85	°C
Storage temperature range	-65 to +150	°C
Lead temperature (soldering 10 sec.)	300	°C

EQUIVALENT CIRCUIT

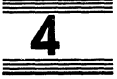
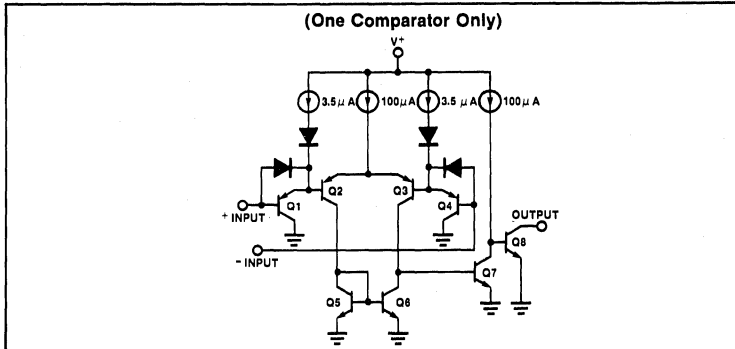

LOW POWER DUAL VOLTAGE COMPARATOR LM193/A/293/A/393/A/2903

DC ELECTRICAL CHARACTERISTICS (Cont'd) $V_+ = 5Vdc$, LM193/193A: $-55^\circ C \leq T_A \leq +125^\circ C$ unless otherwise specified.
 LM293/293A: $-25^\circ C \leq T_A \leq +85^\circ C$ unless otherwise specified.
 LM393/393A: $0^\circ C \leq T_A \leq +70^\circ C$ unless otherwise specified.
 LM2903: $-40^\circ C \leq T_A \leq +85^\circ C$ unless otherwise specified.⁷

PARAMETER	TEST CONDITIONS	LM193			LM293/393			UNIT	
		Min	Typ	Max	Min	Typ	Max		
V _{OS}	Input offset voltage ⁵		±2.0	±5.0 ±9.0		±2.0	±5.0 ±9.0	mV	
V _{CM}	Input common mode voltage range ^{6,10}	0 0		V±-1.5 V±-2.0	0 0		V±-1.5 V±-2.0	V	
V _{IDR}	Differential input voltage ⁴			V+			V+	V	
I _B	Input bias current ⁸		I _{IN(+)} or I _{IN(-)} with output in linear range T _A = 25°C Over temp.			25	250 400	nA	
I _{OS}	Input offset current		I _{IN(+)} - I _{IN(-)} T _A = 25°C Over temp.			±3.0	±5.0 ±150	nA nA	
I _{OL}	Output sink current		V _{IN(-)} ≥ 1Vdc, V _{IN(+)} = 0, V _O ≤ 1.5Vdc, T _A = 25°C		6.0	16	6.0	16	mA
I _{OH}	Output leakage current		V _{IN(+)} ≥ 1Vdc, V _{IN(-)} = 0 V _O = 5Vdc, T _A = 25°C V _O = 30Vdc, over temp.			0.1		0.1	nA µA
I _{CC}	Supply current		R _L = ∞ on both comparators T _A = 25°C V ₊ = 30V, over temp.			0.8		1	mA
A _V	Voltage gain		R _L ≥ 15KΩ, V ₊ = 15Vdc		50	200	50	200	V/mV
V _{OL}	Saturation voltage		V _{IN(-)} ≥ 1Vdc, V _{IN(+)} = 0, I _{SINK} ≤ 4mA T _A = 25°C Over temp.			250		400 700	mV
T _{LSR}	Large signal response time		V _{IN} = TTL logic swing, V _{REF} = 1.4Vdc, V _{RL} = 5Vdc, R _L = 5.1kΩ, T _A = 25°C			300		300	ns
T _R	Response time ⁹		V _{RL} = 5Vdc, R _L = 5.1kΩ, T _A = 25°C			1.3		1.3	µs

NOTES

- For operating at high temperatures, the LM393/393A and LM2903 must be derated based on a 125°C maximum junction temperature and a thermal resistance of 175°C/W which applies for the device soldered in a printed circuit board, operating in a still air ambient. The LM193/193A/293/293A must be derated based on a 150°C maximum junction temperature. The low bias dissipation and the "On-Off" characteristics of the outputs keeps the chip dissipation very small (P_D ≤ 100mW), provided the output transistors are allowed to saturate.
- Short circuits from the output to V₊ can cause excessive heating and eventual destruction. The maximum output current is approximately 20mA independent of the magnitude of V₊.
- This input current will only exist when the voltage at any of the input leads is driven negative. It is due to the collector-base junction of the input PNP transistors becoming forward biased and thereby acting as input diode clamps. In addition to this diode action, there is also lateral NPN parasitic transistor action on the IC chip. This transistor action can cause the output voltages of the comparators to go to the V₊ voltage level (or to ground for a large overdrive) for the time duration that an input is driven negative. This is not destructive and normal output states will re-establish when the input voltage, which was negative, again returns to a value greater than -0.3Vdc.

- Positive excursions of input voltage may exceed the power supply level by 17 Volts. As long as the other voltage remains within the common-mode range, the comparator will provide a proper output state. The low input voltage state must not be less than -0.3Vdc (Vdc below the magnitude of the negative power supply, if used).
- At output switch point, V_O = 1.4Vdc, R_S = 0Ω with V₊ from 5Vdc to 30Vdc; and over the full input common-mode range (0Vdc to V₊ - 1.5Vdc).
- The input common-mode voltage or either input signal voltage should not be allowed to go negative by more than 0.3V. The upper end of the common-mode voltage range is V₊ - 1.5V, but either or both inputs can go to 30Vdc without damage.
- With the LM293/293A, all temperature specifications are limited to -25°C ≤ T_A ≤ +85°C and the LM393/393A, all temperature specifications are limited to 0°C ≤ T_A ≤ +70°C. The LM2903 is limited to -40°C ≤ T_A ≤ +85°C.
- The direction of the input current is out of the IC due to the PNP input stage. This current is essentially constant, independent of the state of the output so no loading change exists on the reference or input lines.
- The response time specified is for a 100mV input step with a 5mV overdrive.
- For input signals that exceed V_{CC}, only the overdriven comparator is affected. With a 5V supply, V_{IN} should be limited to 25V max., and a limiting resistor should be used on all inputs that might exceed the positive supply.

LOW POWER DUAL VOLTAGE COMPARATOR LM193/A/293/A/393/A/2903

DC ELECTRICAL CHARACTERISTICS $V^+ = 5Vdc$, LM193/193A: $-55^\circ C \leq T_A \leq +125^\circ C$ unless otherwise specified.
 LM293/293A: $-25^\circ C \leq T_A \leq +85^\circ C$ unless otherwise specified.
 LM393/393A: $0^\circ C \leq T_A \leq +70^\circ C$ unless otherwise specified.
 LM2903: $-40^\circ C \leq T_A \leq +85^\circ C$ unless otherwise specified.⁷

PARAMETER	TEST CONDITIONS	LM193A			LM293A/393A			LM2903			UNIT
		Min	Typ	Max	Min	Typ	Max	Min	Typ	Max	
V _{OS} Input offset voltage ⁵	T _A = 25°C Over temp.		±1.0	±2.0 ±4.0		±1.0	±2.0 ±4.0		±2.0 ±9	±7.0 ±15	mV
V _{CM} Input common mode voltage range ^{6,10}	T _A = 25°C Over temp.	0 0		V+ - 1.5 V+ - 2.0	0 0		V+ - 1.5 V+ - 2.0	0 0		V+ - 1.5 V+ - 2.0	V
V _{IDR} Differential input voltage ⁴	Keep all V _{IN} s ≥ 0Vdc (or V-if need)			V+			V+			V+	V
I _B Input bias current ⁸	I _{IN(+)} or I _{IN(-)} with output in linear range T _A = 25°C Over temp.		25	100 300		25	250 400		25 200	250 500	nA
I _{OS} Input offset current	I _{IN(+)} - I _{IN(-)} T _A = 25°C Over temp.		±3.0	±25 ±100		±5.0	±50 ±150		±5 ±50	±50 ±200	nA nA
I _{OL} Output sink current	V _{IN(-)} ≥ 1Vdc, V _{IN(+)} = 0, V _O ≤ 1.5Vdc, T _A = 25°C	6.0	16		6.0	16		6.0	16		mA
I _{OH} Output leakage current	V _{IN(+)} ≥ 1Vdc, V _{IN(-)} = 0 V _O = 30Vdc Over temp. V _O = 5Vdc, T _A = 25°C		0.1	1.0		0.1	1.0		0.1	1.0	μA nA
I _{CC} Supply current	R _L = ∞ on both comparators. T _A = 25°C V+ = 30V, over temp.		0.8 1	1 2.5		0.8 1	1 2.5		0.8 1	1 2.5	mA
A _V Voltage gain	R _L ≥ 15kΩ, V+ = 15Vdc, T _A = 25°C	50	200		50	200		25	100		V/mV
V _{OL} Saturation voltage	V _{IN(-)} ≥ 1Vdc, V _{IN(+)} = 0, I _{SINK} ≤ 4mA T _A = 25°C Over temp.		250	400 700		250	400 700		400	400 700	mV
T _{LSR} Large signal response time	V _{IN} = TTL logic swing, V _{REF} = 1.4Vdc, V _{RL} = 5Vdc, R _L = 5.1kΩ, T _A = 25°C		300			300			300		ns
T _R Response time ⁹	V _{RL} = 5Vdc, R _L = 5.1kΩ, T _A = 25°C		1.3			1.3			1.3		μs

4

LOW POWER DUAL VOLTAGE COMPARATOR LM193/A/293/A/393/A/2903

TYPICAL APPLICATIONS

TWO-DECADE HIGH-FREQUENCY VCO

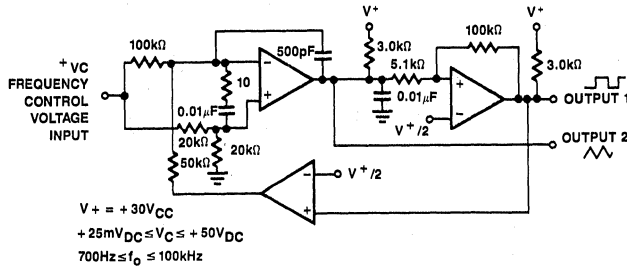

LIMIT COMPARATOR

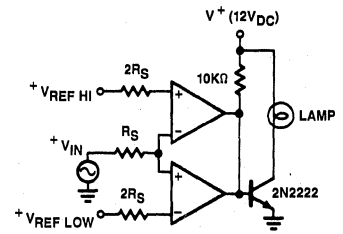

VISIBLE VOLTAGE INDICATOR

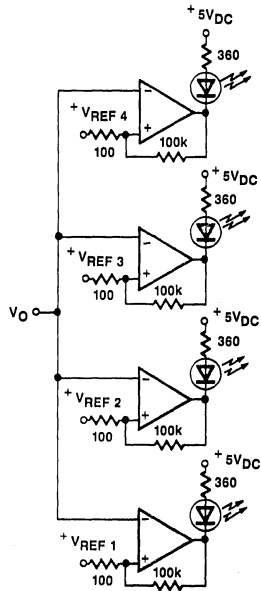

TTL TO MOS LOGIC CONVERTER

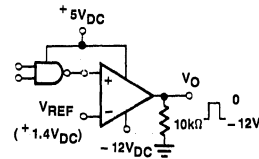

CRYSTAL CONTROLLED OSCILLATOR

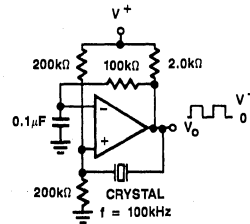

All pins of any unused comparators should be grounded.

TYPICAL PERFORMANCE CHARACTERISTICS

INPUT CURRENT

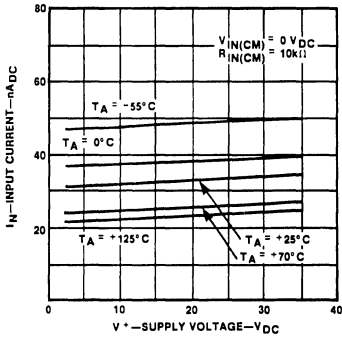

OUTPUT SATURATION VOLTAGE

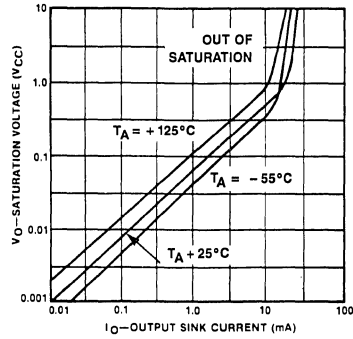

RESPONSE TIME FOR VARIOUS INPUT OVERDRIVES—NEGATIVE TRANSITION

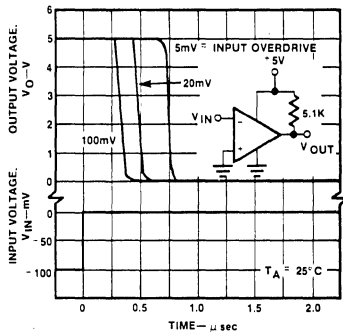

RESPONSE TIME FOR VARIOUS INPUT OVERDRIVES—POSITIVE TRANSITION

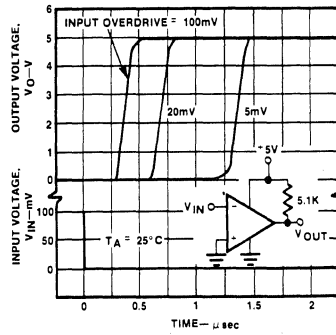

4

HIGH SPEED DUAL DIFFERENTIAL COMPARATOR/SENSE AMP

SE/NE521

FEATURES

- 12ns maximum guaranteed propagation delay
- 20 μ A maximum input bias current
- TTL compatible strobes and outputs
- Large common mode input voltage range
- Operates from standard supply voltages
- Military qualifications pending

APPLICATIONS

- MOS memory sense amp
- A-to-D conversion
- High speed line receiver

PIN CONFIGURATION

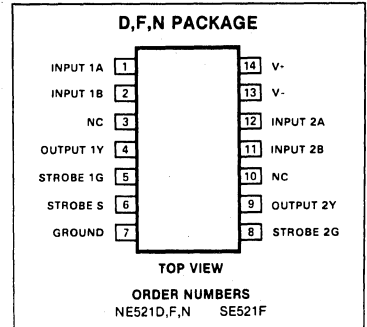

ABSOLUTE MAXIMUM RATINGS

PARAMETER	RATING	UNIT
V+	Supply voltage	V
V-	Positive	+7
	Negative	-7
V _{IDR}	Differential input voltage	± 6
V _{IN}	Input voltage	V
	Common mode	± 5
	Strobe/gate	+5.25
P _D	Power dissipation	600
T _A	Operating temperature range	mW
	NE521	0 to 70
	SE521	-55 to +125
T _{stg}	Storage temperature range	$^{\circ}$ C
	Lead temperature	-65 to +150
	(solder, 60 sec)	+300

BLOCK DIAGRAM

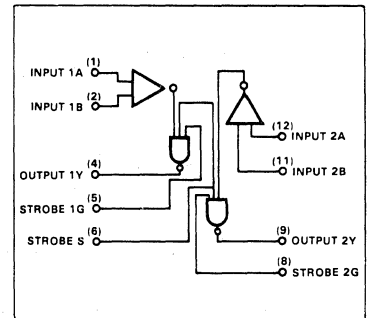

EQUIVALENT SCHEMATIC

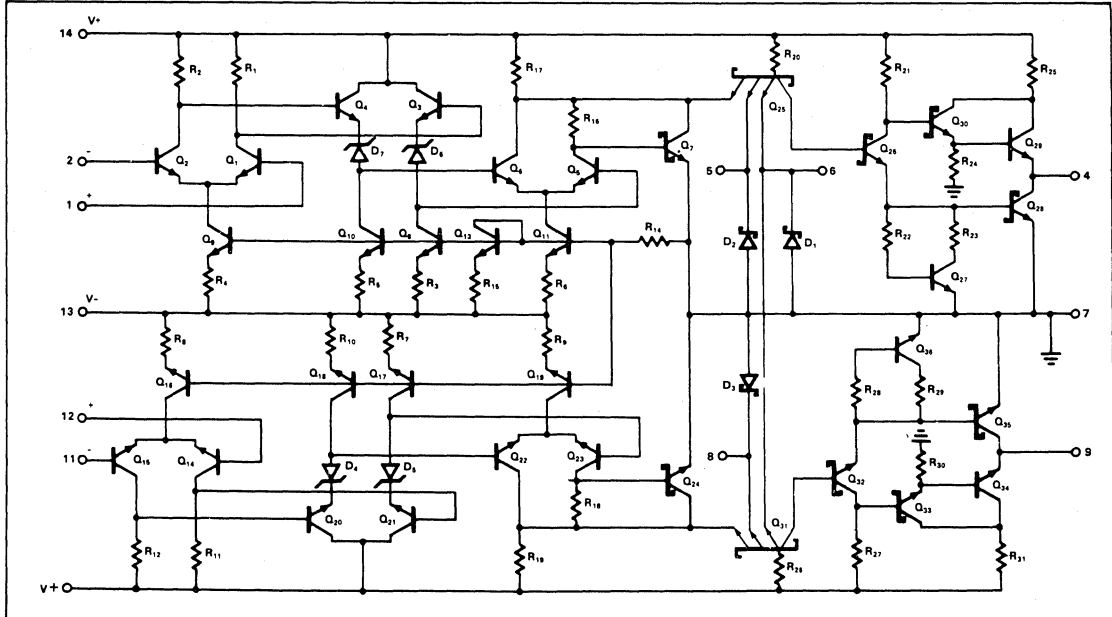

DC ELECTRICAL CHARACTERISTICS $V+ = +5V, V- = -5V, T_A = -55$ to $+125^\circ C$ unless otherwise specified

PARAMETER	TEST CONDITIONS	SE LIMITS			UNITS
		Min	Typ	Max	
V_{OS}	Input offset voltage At $25^\circ C$ Over temperature range		6	7.5 15	mV
I_{BIAS}	Input bias current At $25^\circ C$ Over temperature range		7.5	20 40	μA
I_{OS}	Input offset current At $25^\circ C$ Over temperature range		1.0	5 12	μA
V_{CM}	Common mode voltage range		± 3		V
V_{IL}	Low level input voltage At $25^\circ C$ Over temperature			0.8 0.7	V
V_{IH}	High level input voltage	2.0			V
I_{IH}	Input current High			50 100	μA μA
I_{IL}	Low			-2.0 -4.0	mA mA
V_{OH} V_{OL}	Output voltage High Low		2.5 3.4	0.5 0.5	V
$V+$ $V-$	Supply voltage Positive Negative	4.5 -4.5	5.0 -5.0	5.5 -5.5	V
I_{CC+} I_{CC-}	Supply current Positive Negative		27 -15	35 -28	mA
I_{SC}	Short circuit output current	-35		-115	mA

4

HIGH SPEED DUAL DIFFERENTIAL COMPARATOR/SENSE AMP

SE/NE521

DC ELECTRICAL CHARACTERISTICS (Cont'd) $V_+ = +5V, V_- = -5V, T_A = 0 \text{ to } 70^\circ\text{C}$ unless otherwise specified

PARAMETER	TEST CONDITIONS	NE LIMITS			UNITS
		Min	Typ	Max	
V_{OS}	Input offset voltage At 25°C Over temperature range	$V_+ = +4.75V, V_- = -4.75V$			mV
I_{BIAS}	Input bias current At 25°C Over temperature range	$V_+ = +5.25V, V_- = -5.25V$			μA
I_{OS}	Input offset current At 25°C Over temperature range	$V_+ = +5.25V, V_- = -5.25V$			μA
V_{CM}	Common mode voltage range	$V_+ = +4.75V, V_- = -4.75V$			V
I_{IH}	Input current High	$V_+ = +5.25V, V_- = -5.25V$ $V_{IH} = 2.7V$ 1G or 2G strobe Common strobe S			μA
I_{IL}	Low	$V_{IL} = 0.5V$ 1G or 2G strobe Common strobe S			mA
V_{OH} V_{OL}	Output voltage High Low	$V_I(S) = 2.0V$ $V_+ = +4.75V, V_- = -4.75V, I_{LOAD} = -1mA$ $V_+ = +5.25V, V_- = -5.25V, I_{LOAD} = 20mA$			V
V_+ V_-	Supply voltage Positive Negative	4.75 -4.75	5.0 -5.0	5.25 -5.25	V
I_{CC+} I_{CC-}	Supply current Positive Negative	$V_+ = 5.25V, V_- = -5.25V, T_A = 25^\circ\text{C}$			mA
I_{SC}	Short circuit output current	-40		-100	mA

AC ELECTRICAL CHARACTERISTICS $T_A = 25^\circ\text{C}, R_L = 280\ \Omega, C_L = 15pF, V_+ = +5V, V_- = -5V$

PARAMETER	FROM INPUT	TO OUTPUT	LIMITS			UNIT
			Min	Typ	Max	
Large Signal Switching Speed Propagation delay						ns
$t_{PLH}(D)$	Low to high ¹	Amp		8	12	
$t_{PHL}(D)$	High to low ¹	Amp		6	9	
$t_{PLH}(S)$	Low to high ²	Strobe		4.5	10	
$t_{PHL}(S)$	High to low ²	Strobe		3.0	6	
Maximum operating frequency			40	55		MHz

NOTES

- Response time measured from 0V point of $\pm 100mV$ p-p 10MHz square wave to the 1.5V point of the output
- Response time measured from 1.5V point of input to 1.5V point of the output

TYPICAL PERFORMANCE CHARACTERISTICS

RESPONSE TIME FOR VARIOUS INPUT OVERDRIVES

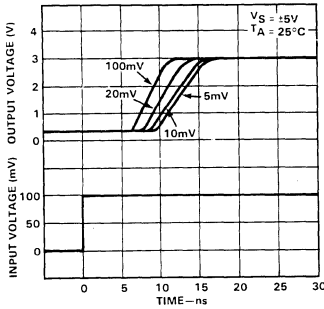

RESPONSE TIME FOR VARIOUS INPUT OVERDRIVES

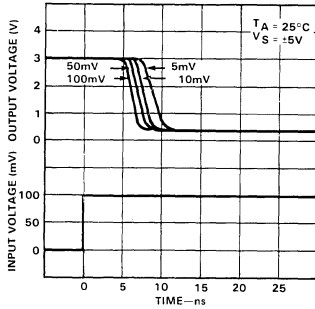

RESPONSE TIME vs TEMPERATURE

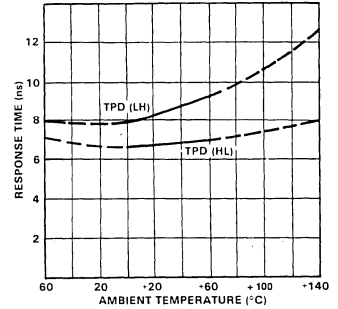

PROPAGATION DELAY FOR VARIOUS INPUT VOLTAGE

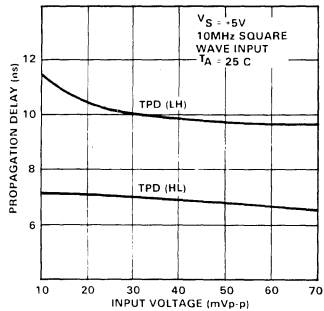

PROPAGATION DELAY FOR VARIOUS INPUT VOLTAGES

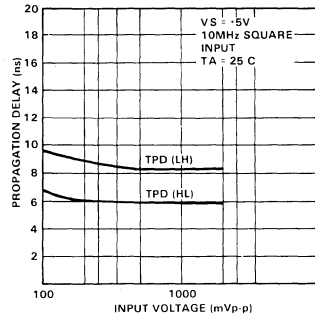

OUTPUT VOLTAGE vs AMBIENT TEMPERATURE

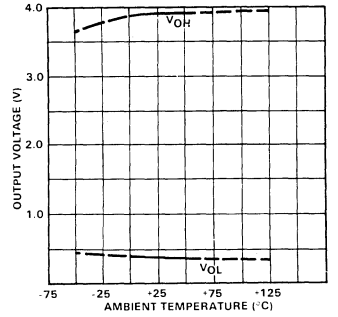

INPUT BIAS CURRENT vs AMBIENT TEMPERATURE

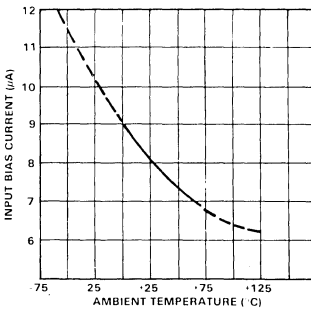

INPUT OFFSET CURRENT vs AMBIENT TEMPERATURE

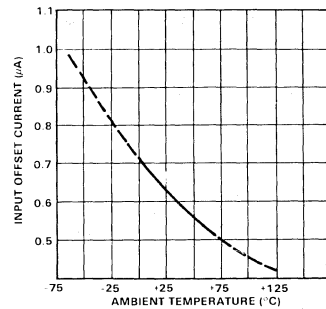

HIGH SPEED DUAL DIFFERENTIAL COMPARATOR/SENSE AMP

SE/NE522

FEATURES

- 15ns maximum guaranteed propagation delay
- 20 μ A maximum input bias current
- TTL compatible strobes and outputs
- Open collector output for wire-OR'd applications
- Large common mode input voltage range
- Operates from standard supply voltages

APPLICATIONS

- MOS memory sense amp
- A-to-D conversion
- High speed line receiver

PIN CONFIGURATION

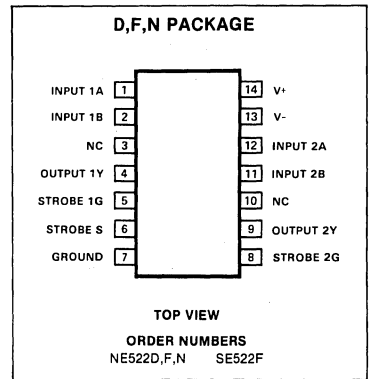

ABSOLUTE MAXIMUM RATINGS

PARAMETER	RATING	UNIT
V+	Supply voltage	V
V-	Positive	+7
	Negative	-7
V _{IDR}	Differential input voltage	± 6
V _{IN}	Input voltage	V
	Common mode	± 5
	Strobe/gate	± 5.25
P _D	Power dissipation	600
T _A	Operating temperature range NE	0 to 70
	SE	-55 to +125
T _{stg}	Storage temperature range	-65 to +150
	Lead temperature (solder, 60 sec)	+300

BLOCK DIAGRAM

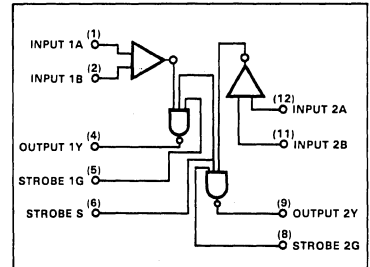

EQUIVALENT SCHEMATIC

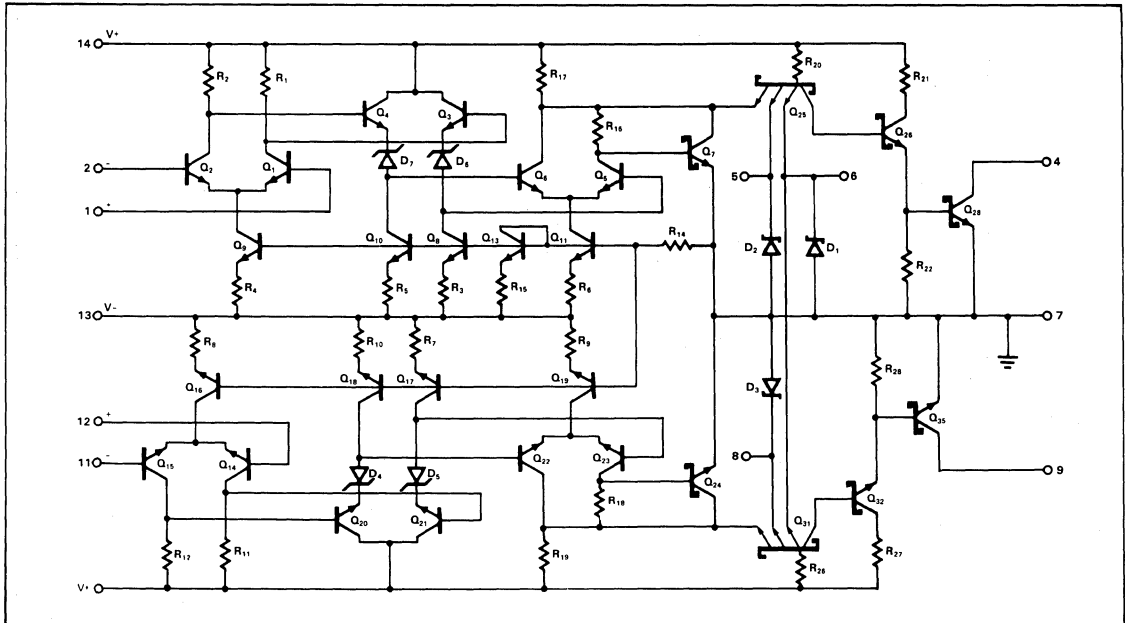

DC ELECTRICAL CHARACTERISTICS $\pm 5V \pm 10\%$, $T_A = -55$ to $125^\circ C$ unless otherwise specified

PARAMETER	TEST CONDITIONS	SE LIMITS			UNIT	
		Min	Typ	Max		
V_{OS}	Input offset voltage At $25^\circ C$ Over temperature range	$V_+ = +4.5V$, $V_- = -4.5V$		6 7.5 15.	mV	
I_{BIAS}	Input bias current At $25^\circ C$ Over temperature range	$V_+ = +5.5V$, $V_- = -5.5V$		7.5 20. 40.	μA	
I_{OS}	Input offset current At $25^\circ C$ Over temperature range	$V_+ = +5.5V$, $V_- = -5.5V$		1.0 5. 12.	μA	
V_{CM}	Common mode voltage range	$V_+ = +4.5V$, $V_- = -4.5V$	± 3		V	
V_{IL}	Low level input Voltage at $25^\circ C$ over temperature			0.8 0.7	V	
V_{IH}	High level temperature		2.0		V	
I_{IH}	Input current High	$V_+ = +5.5V$, $V_- = -5.5V$ $V_{IH} = 2.7V$ 1G or 2G strobe Common strobe S		50 100	μA μA	
I_{IL}	Low	$V_{IL} = 0.5V$ 1G 2G strobe Common strobe S		-2 -4	mA mA	
V_{OL}	Output voltage Low	$V_+ = +4.5V$, $V_- = -4.5V$ $I_{OL} = 20mA$, $T_A = 25^\circ C$ $I_{OL} = 10mA$.5 .5	V	
I_{OH}	Output current High	$V_{CC+} = +4.5$, $V_{CC-} = -4.5V$, $V_{OH} = 5.5V$		250	μA	
V_+ V_-	Supply voltage Positive Negative		4.5 -4.5	5.0 -5.0	5.5 -5.5	V
I_{CC+} I_{CC-}	Supply current Positive Negative	$V_+ = 5.5V$, $V_- = -5.5V$		27 -15	35 -28	mA

4

HIGH SPEED DUAL DIFFERENTIAL COMPARATOR/SENSE AMP

SE/NE522

DC ELECTRICAL CHARACTERISTICS (Cont'd) $\pm 5V \pm 5\%$, $T_A = 0$ to $70^\circ C$ unless otherwise specified

PARAMETER	TEST CONDITIONS	NE LIMITS			UNIT
		Min	Typ	Max	
V_{OS}	Input offset voltage At $25^\circ C$ Over temperature range	$V_+ = +4.75V, V_- = -4.75V$			mV
I_{BIAS}	Input bias current At $25^\circ C$ Over temperature range	$V_+ = +5.25V, V_- = -5.25V$			μA
I_{OS}	Input offset current At $25^\circ C$ Over temperature range	$V_+ = +5.25V, V_- = -5.25V$			μA
V_{CM}	Common mode voltage range	$V_+ = +4.75V, V_- = -4.75V$			V
I_{IH}	Input current High	$V_+ = +5.25V, V_- = -5.25V$ $V_{IH} = 2.7V$ 1G or 2G strobe Common strobe S			μA μA
I_{IL}	Low	$V_{IL} = 0.5V$ 1G 2G strobe Common strobe S			mA mA
V_{OL}	Output voltage Low	$V_+ = +5.25V, V_- = -5.25V, V_I(S) = 2.0V$ $I_{LOAD} = 20mA$			V
I_{OH}	Output current High	$V_{CC+} = +4.75,$ $V_{CC-} = -4.75V, V_{OH} = 5.25V$			μA
V_+ V_-	Supply voltage Positive Negative	4.75 -4.75	5.0 -5.0	5.25 -5.25	V
I_{CC+} I_{CC-}	Supply current Positive Negative	$V_+ = 5.25V, V_- = -5.25V, T_A = 25^\circ C$			mA

AC ELECTRICAL CHARACTERISTICS $T_A = 25^\circ C, R_L = 280\Omega, C_L = 15pF$

PARAMETER	FROM INPUT	TO OUTPUT	LIMITS			UNIT
			Min	Typ	Max	
Input resistance				4		k Ω
Input capacitance				3		pF
Large Signal Switching Speed						
Propagation delay						ns
$t_{PLH}(D)$	Low to high ¹	Amp		10	15	
$t_{PHL}(D)$	High to low ¹	Amp		8	12	
$t_{PLH}(S)$	Low to high ²	Strobe		6	13	
$t_{PHL}(S)$	High to low ²	Strobe		5	9	
Maximum operating frequency			25	35		MHz

NOTES

- Response time measured from 0V point of $\pm 100mV$ p-p 10MHz square wave to the 1.5V point of the output
- Response time measured from 1.5V point of input to 1.5V point of the output

TYPICAL PERFORMANCE CHARACTERISTICS

RESPONSE TIME FOR VARIOUS INPUT OVERDRIVES

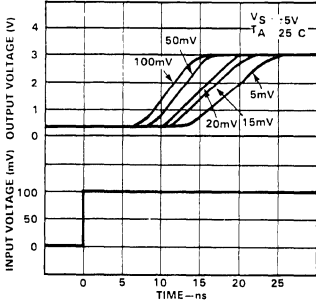

RESPONSE TIME FOR VARIOUS INPUT OVERDRIVES

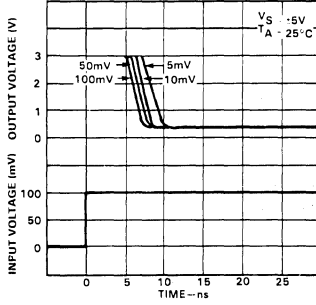

RESPONSE TIME vs TEMPERATURE

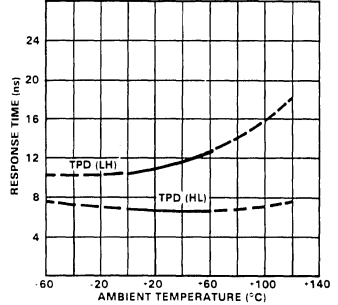

PROPAGATION DELAY FOR VARIOUS INPUT VOLTAGES

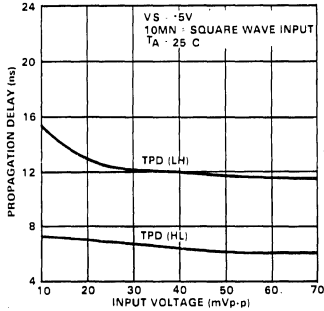

PROPAGATION DELAY FOR VARIOUS INPUT VOLTAGES

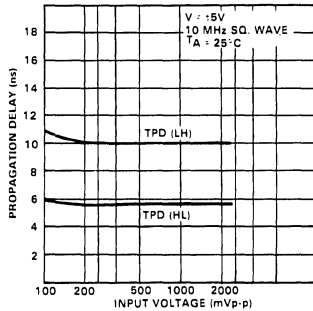

INPUT BIAS CURRENT vs AMBIENT TEMPERATURE

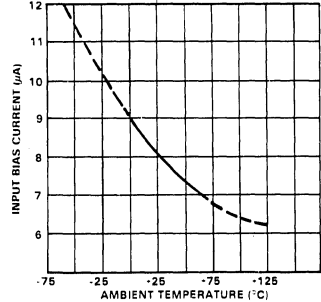

INPUT OFFSET CURRENT vs AMBIENT TEMPERATURE

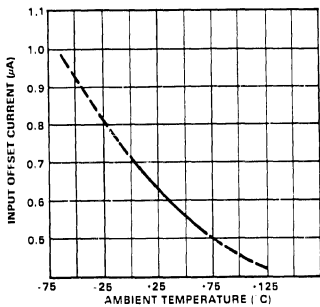

4

VOLTAGE COMPARATOR

SE/NE527

DESCRIPTION

The SE/NE527 is a high speed analog voltage comparator which, in the first time mates state-of-the-art Schottky diode technology with the conventional linear process. This allows simultaneous fabrication of high speed T2L gates with a precision linear amplifier on a single monolithic chip. The SE/NE527 is similar in design to the Signetics SE/NE529 voltage comparator except that it incorporates a "Emitter Follower" input stage for extremely low input currents. This opens the door to a whole new range of applications for analog voltage comparators.

FEATURES

- 15ns propagation delay
- Complementary output gates
- TTL or ECL compatible outputs
- Wide common mode and differential voltage range
- Mil std 883A,B,C available
- Typical Gain of 5000

APPLICATIONS

- A/D conversion
- ECL to TTL interface
- TTL to ECL interface
- Memory sensing
- Optical data coupling

BLOCK DIAGRAM

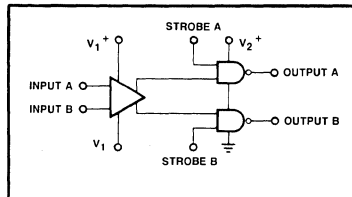

PIN CONFIGURATIONS

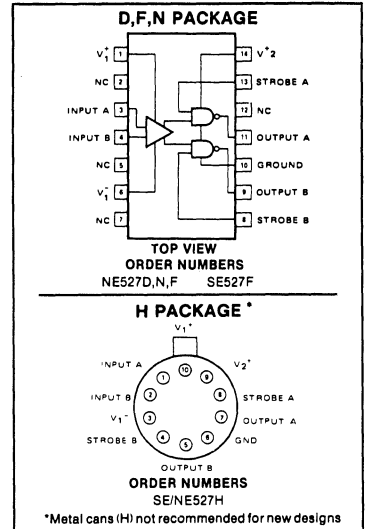

EQUIVALENT SCHEMATIC

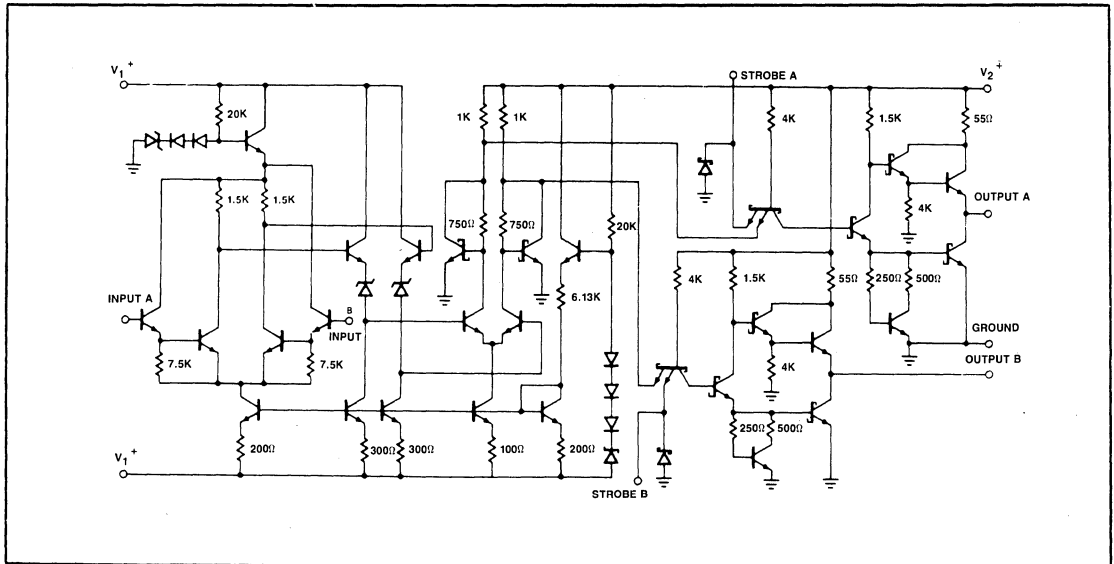

VOLTAGE COMPARATOR

SE/NE527

ABSOLUTE MAXIMUM RATINGS

PARAMETER	RATING	UNIT
Positive supply voltage (V1+)	+15	V
Negative supply voltage (V1-)	-15	V
Gate supply voltage (V2+)	+7	V
Output voltage	+7	V
Differential input voltage	±5	V
Input common mode voltage	±6	V
Power dissipation	600	mW
Operating temperature range		
NE527	0 to +70	°C
SE527	-55 to +125	°C
Storage temperature range	-65 to +150	°C
Lead temperature (soldering, 60sec)	+300	°C

DC ELECTRICAL CHARACTERISTICS $V_{1+} = 10V, V_{1-} = -10V, V_{2+} = +5.0V$

PARAMETER	TEST CONDITIONS	SE527			NE527			UNIT
		Min	Typ	Max	Min	Typ	Max	
INPUT CHARACTERISTICS								
Input offset voltage @ 25°C				4			6	mV
Over temperature range				6			10	mV
Input bias current @ 25°C				2			2	μA
Over temperature range				4			4	μA
Input offset current @ 25°C	$V_{IN} = 0V$			0.5			0.75	μA
Over temperature range				1			1	μA
Common mode voltage range				±5				V
GATE CHARACTERISTICS								
Output voltage	$V_{2+} = 4.75V, I_{SOURCE} = -1mA$ $V_{2+} = 4.75V, I_{SINK} = 10mA$	2.5	3.3		2.7	3.3		V
"1" State								
"0" State				0.5			0.5	V
Strobe inputs								
"0" Input current ¹	$V_{2+} = 5.25V, V_{STROBE} = 0.5V$			-2			-2	mA
"1" Input current @ 25°C ¹	$V_{2+} = 5.25V, V_{STROBE} = 2.7V$			50			100	μA
Over temperature range	$V_{2+} = 5.25V, V_{STROBE} = 2.7V$			200			200	μA
"0" Input voltage	$V_{2+} = 4.75V$			0.8			0.8	V
"1" Input voltage	$V_{2+} = 4.75V$	2.0			2.0			V
Short circuit								
Output current	$V_{2+} = 5.25V, V_{OUT} = 0V$	-18		-70	-18		-70	mA
POWER SUPPLY REQUIREMENTS								
Supply voltage								
V1+		5		10	5		10	V
V1-		-6		-10	-6		-10	V
V2+		4.5	5	5.5	4.75	5	5.25	V
Supply current	$V_{1+} = 10V, V_{1-} = -10V$ $V_{2+} = 5.25V$							
I1+	Over temp.			5			5	mA
I1-	Over temp.			10			10	mA
I2+	Over temp.			20			20	mA

NOTES

1. See logic function table.

4

VOLTAGE COMPARATOR

SE/NE527

AC ELECTRICAL CHARACTERISTICS $T_A = 25^\circ\text{C}$ unless otherwise specified.

PARAMETER	TEST CONDITIONS	LIMITS			UNIT
		Min	Typ	Max	
Transient response propagation delay time t_{PLH} t_{PHL}	$V_{IN} = \pm 100\text{mV}$ step		16	26	ns
			14	24	ns
Delay between output A and B			2	5	ns
Strobe delay time t_{on} Turn-on time t_{off} Turn-off time			6		ns
			6		ns

TYPICAL PERFORMANCE CHARACTERISTICS

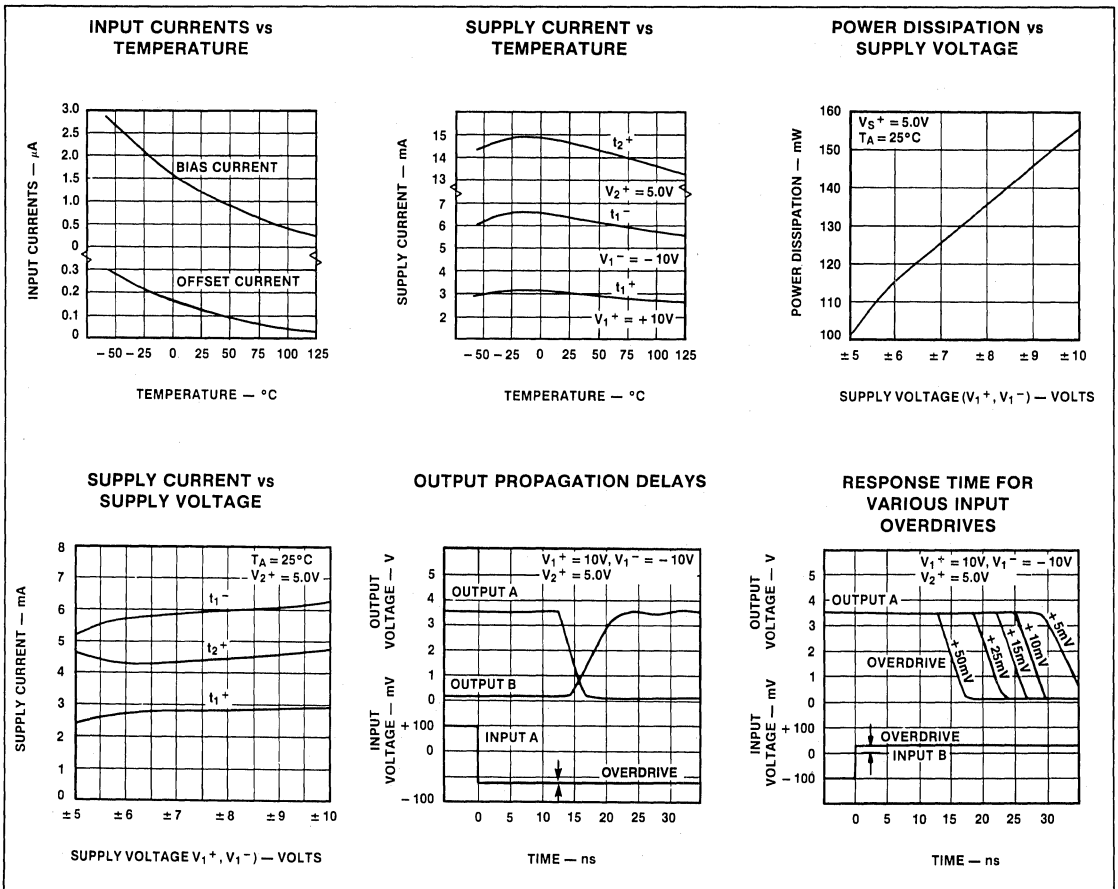

VOLTAGE COMPARATOR

SE/NE527

RESPONSE TIME TEST CIRCUIT

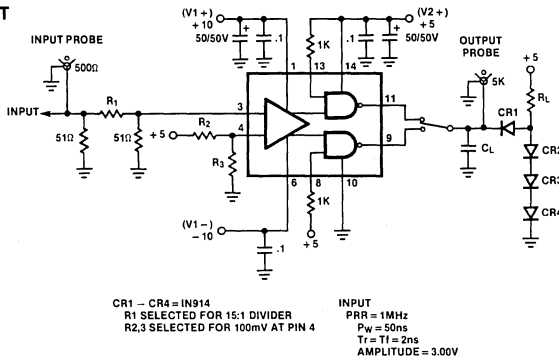

APPLICATIONS

One of the main features of the device is that supply voltages (V1+, V1-) need not be balanced, as indicated in the following diagrams. For proper operation, however, negative supply (V1-) should always be at least six volts more negative than the ground terminal (pin 6). Input Common Mode range should be limited to values of two volts less than the supply voltages (V1+ and V1-) up to

a maximum of ± 6 volts as supply voltages are increased.

It is also important to note that Output A is in phase with Input A and Output B is in phase with Input B.

NE527 LOGIC FUNCTION

V_{IN} (A+, B-)	STR 'A'	STR 'B'	OUT 'A'	OUT 'B'	COMMENT
$> V_{off}$	X	h/l	H	l/h	Read I_{ILB} , I_{IHA}
$< -V_{off}$	h/l	X	l/h	H	Read I_{ILA} , I_{IHB}

TYPICAL APPLICATIONS

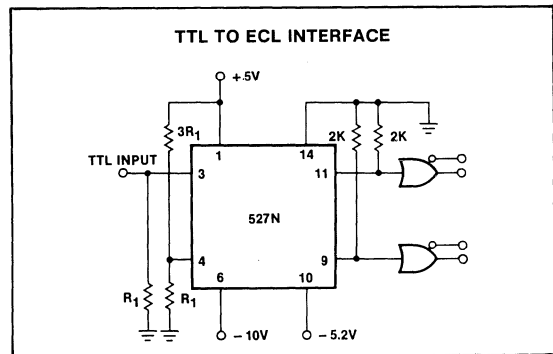
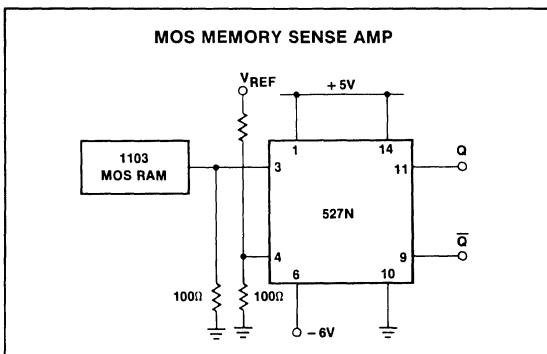
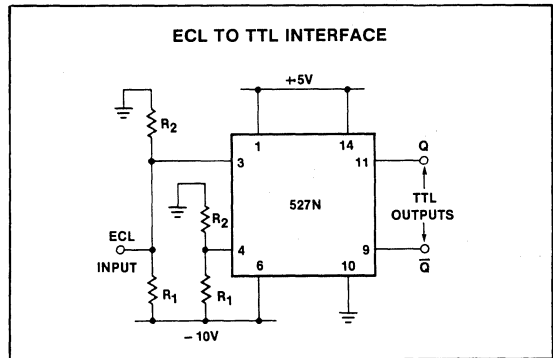
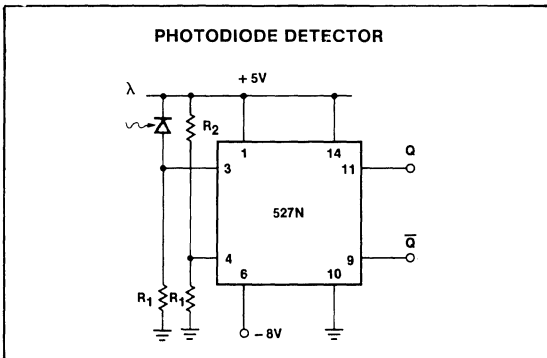

VOLTAGE COMPARATOR

SE/NE529

DESCRIPTION

The SE/NE529 is a high speed analog voltage comparator which, for the first time mates state-of-the-art Schottky diode technology with the conventional linear process. This allows simultaneous fabrication of high speed T2L gates with a precision linear amplifier on a single monolithic chip.

FEATURES

- 10ns propagation delay
- Complementary output gates
- TTL or ECL compatible outputs
- Wide common mode and differential voltage range
- Typical Gain 5000

APPLICATIONS

- A/D conversion
- ECL to TTL interface
- TTL to ECL interface
- Memory sensing
- Optical data coupling
- Mil std 883A,B,C available

ABSOLUTE MAXIMUM RATINGS

PARAMETER	RATING	UNIT
Positive supply voltage (V1+)	+15	V
Negative supply voltage (V1-)	-15	V
Gate supply voltage (V2+)	+7	V
Output voltage	+7	V
Differential input voltage	±5	V
Input common mode voltage	±6	V
Power dissipation	600	mW
Operating temperature range		
NE529	0 to +70	°C
SE529	-55 to +125	°C
Storage temperature range	-65 to +150	°C
Lead temperature (soldering, 60 sec)	+300	°C

PIN CONFIGURATION

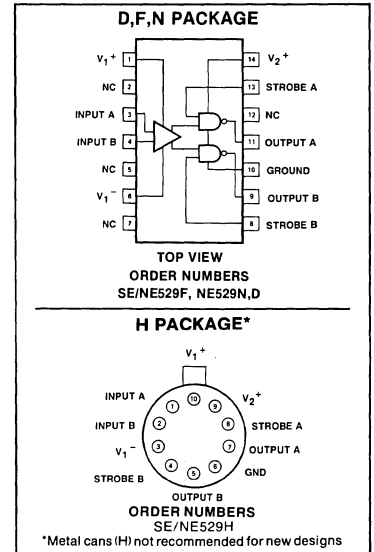

BLOCK DIAGRAM

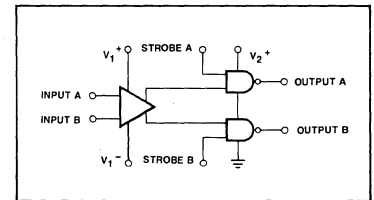

EQUIVALENT SCHEMATIC

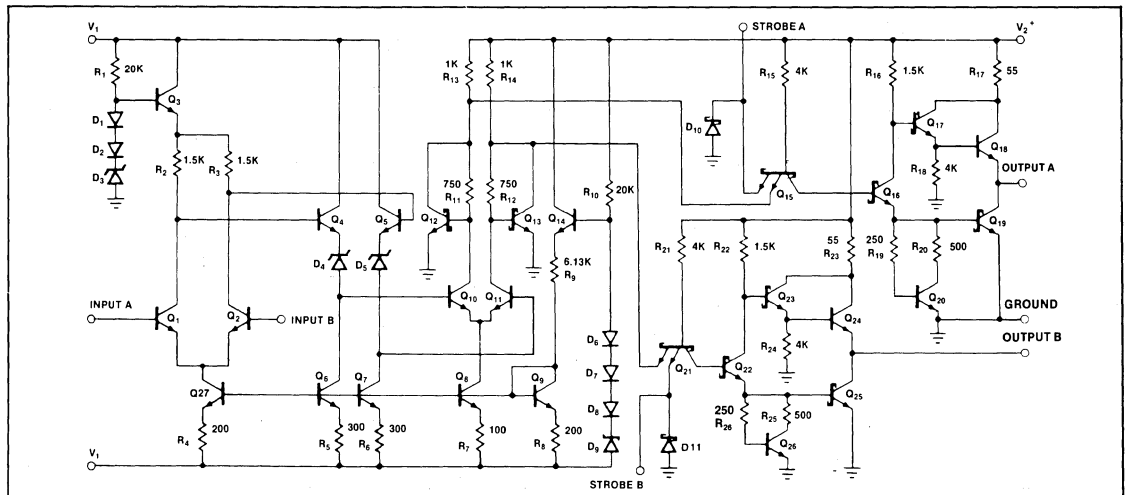

VOLTAGE COMPARATOR

SE/NE529

DC ELECTRICAL CHARACTERISTICS $V_{1+} = +10V, V_{2+} = +5.0V, V_{1-} = -10V$

PARAMETER	TEST CONDITIONS	SE529			NE529			UNIT	
		Min	Typ	Max	Min	Typ	Max		
INPUT CHARACTERISTICS Input offset voltage @25°C Over temperature range				4			6	mV	
				6			10	mV	
Input bias current @25°C Over temperature range	$V_{IN} = 0V$		5	12		5	20	μA	
				36			50	μA	
Input offset current @25°C Over temperature range Common mode voltage range	$V_{IN} = 0V$		2	3		2	5	μA	
				9			15	μA	
			0	± 5		0	± 5	V	
GATE CHARACTERISTICS Output voltage "1" state "0" state	$V_{2+} = 4.75V, I_{source} = -1mA$ $V_{2+} = 4.75V, I_{sink} = 10mA$	2.5	3.3		2.7	3.3		V	
				0.5			0.5	V	
Strobe inputs "0" Input current ¹ "1" Input current @ 25°C ¹ Over temperature range "0" input voltage "1" input voltage	$V_{2+} = 5.25V, V_{strobe} = 0.5V$ $V_{2+} = 5.25V, V_{strobe} = 2.7V$ $V_{2+} = 5.25V, V_{strobe} = 2.7V$ $V_{2+} = 4.75V$ $V_{2+} = 4.75V$			-2			-2	mA	
				50			100	μA	
				200			200	μA	
			2.0		0.8	2.0		0.8	V
									V
Short circuit Output current	$V_{2+} = 5.25V, V_{OUT} = 0V$	-18		-70	-18		-70	mA	
POWER SUPPLY REQUIREMENTS Supply voltage V_{1+} V_{1-} V_{2+}		5		10	5		10	V	
		-6		-10	-6		-10	V	
		4.5	5	5.5	4.75	5	5.25	V	
Supply current I_{1+} I_{1-} I_{2+}	$V_{1+} = 10V, V_{1-} = -10V$ $V_{2+} = 5.25V$ Over temp. Over temp. Over temp.			5			5	mA	
				10			10	mA	
				20			20	mA	

NOTES

1. See logic function table.

AC ELECTRICAL CHARACTERISTICS $T_A = 25^\circ C$

PARAMETER	TEST CONDITIONS	LIMITS			UNIT
		Min	Typ	Max	
Transient response Propagation delay time t_{PLH} t_{PHL}	$V_{IN} = \pm 100mV$ step		12	22	ns
			10	20	ns
			2	5	ns
Delay between output A and B					ns
Strobe delay time t_{ON} turn-on time t_{OFF} turn-off time			6		ns
			6		ns

4

VOLTAGE COMPARATOR

SE/NE529

TYPICAL PERFORMANCE CHARACTERISTICS

INPUT CURRENTS vs TEMPERATURE

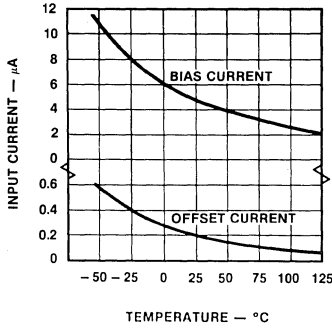

SUPPLY CURRENT vs TEMPERATURE

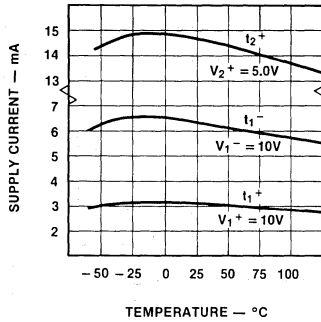

POWER DISSIPATION vs SUPPLY VOLTAGE

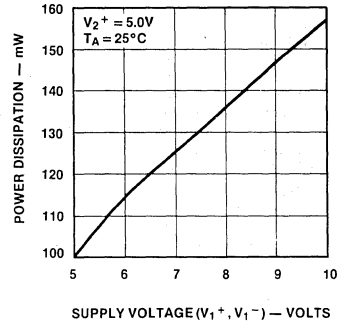

SUPPLY CURRENT vs SUPPLY VOLTAGE

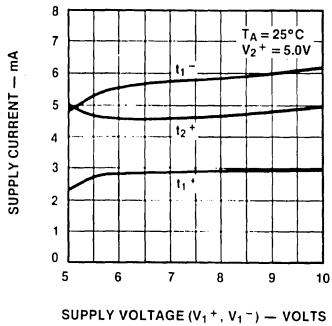

OUTPUT PROPAGATION DELAYS

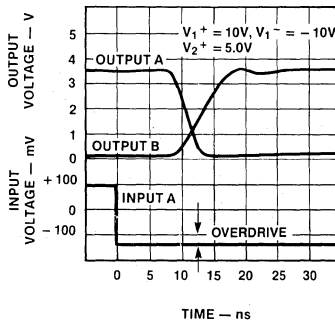

RESPONSE TIME FOR VARIOUS INPUT OVERDRIVES

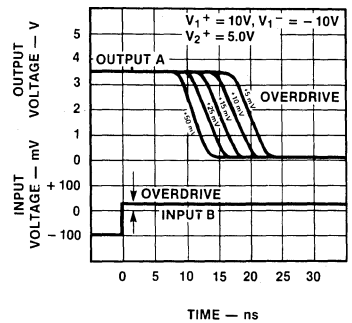

RESPONSE TIME TEST CIRCUIT

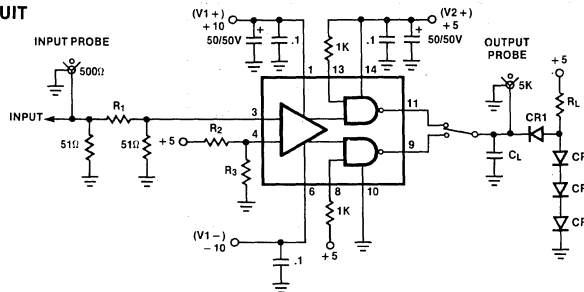

CR1 - CR4 = IN914
 R1 SELECTED FOR 15:1 DIVIDER
 R2,3 SELECTED FOR 100mV AT PIN 4

INPUT
 PRR = 1MHz
 PW = 50ns
 Tr = Tf = 2ns
 AMPLITUDE = 3.00V

VOLTAGE COMPARATOR

SE/NE529

APPLICATIONS

One of the main features of the device is that supply voltages (V_{1+} , V_{1-}) need not be balanced, as indicated in the following diagrams. For proper operation, however, negative supply (V_{1-}) should always be at least six volts more negative than the ground terminal (pin 6). Input Common Mode range should be limited to values of two volts less than the supply voltages (V_{1+} and V_{1-}) up to a maximum of ± 6 volts as supply voltages are increased.

It is also important to note that Output A is in phase with Input A and Output B is in phase with Input B.

NE529 LOGIC FUNCTION

V_{IN} (A+, B-)	STR 'A'	STR 'B'	OUT 'A'	OUT 'B'	COMMENT
$> V_{off}$	X	h/l	H	l/h	Read I_{ILB} , I_{IHA}
$< -V_{off}$	h/l	X	l/h	H	Read I_{ILA} , I_{IHB}

TYPICAL APPLICATIONS

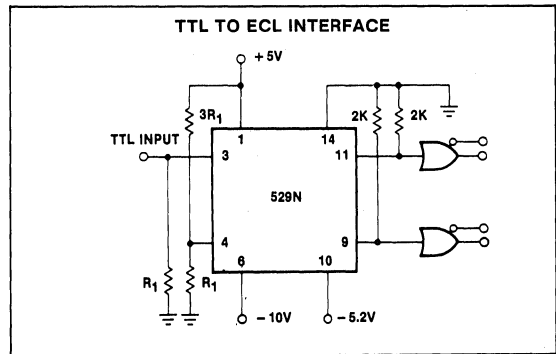
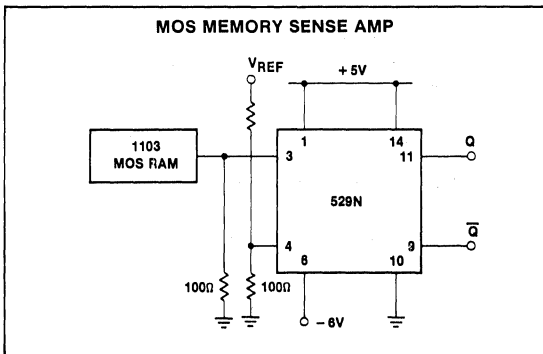
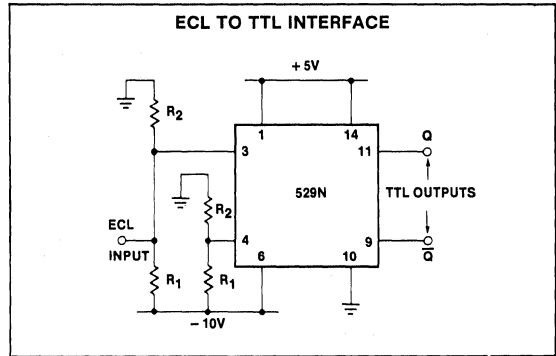
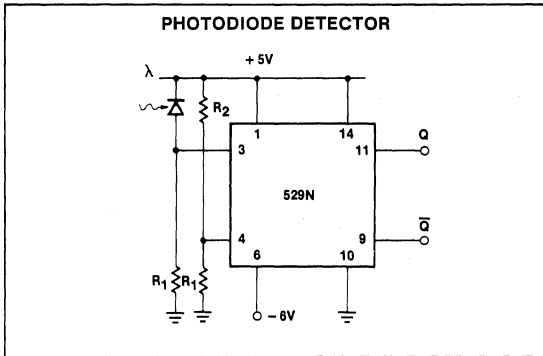

4

DISPLAY DRIVER — SYMBOLS AND DEFINITIONS

Absolute Maximum Rating

Operating safe zones. Exceeding these limits could cause permanent damage to the device and are not meant to imply that devices can operate at these limits.

BCD

Binary Coded Decimal.

\overline{BI}/RBO

Blanking Input or Ripple Blanking Output.

CE

Chip Enable.

CLR

Clear. Clear command will preset all internal circuits to a pre-determined state.

Duty Cycle

Ratio of time on to time off. Generally expressed in percentage.

F_{MAX}

The maximum clock frequency; the maximum input frequency at a clock input for the predictable performance. Above this frequency the device may cease to function.

I_B

Input Bias Current. Current into an analog circuit input, specified at a particular voltage level.

$I_{CC} (-I_{CC})$

Supply Current. The current flowing into the $+V_{CC}$ ($-V_{CC}$) supply terminal of the circuit with specified input conditions and open outputs. Input conditions are chosen to guarantee worst case operation unless specified.

I_{CEX}

Output Leakage Current. The current flowing out of or into a disabled (off) output with a specified High output voltage applied.

I_{IH}

Input High Current. The current flowing into or out of an input when a specified High level voltage is applied to that input.

I_{IL}

Input Low Current. The current flowing out of an input when a specified Low level voltage is applied to that input.

I_{OH}

Output Current Source the device can supply while maintaining a specified voltage output level.

I_{OL}

Output Low Current. The current flowing into an output when it is in the Low State.

I_{OS}

Output Short-Circuit Current. The current flowing out of an output which is in the High state when that output is shorted to ground.

I_S

Source Current. Current flowing into the V_S supply terminal of the device with specified operating conditions.

I_{SEG}

Segment Current. The amount of current supplied to each segment as a display. Current ratios are generally compared to segment 'b'.

LED

Light Emitting Diode.

Package Type Designation

See full package designations in Appendix.

Power Dissipation

The power that the device can safely handle at 15°C. The dissipation must be derated as indicated for the individual package type.

\overline{RBI}

Ripple Blanking Input.

Segment Identification

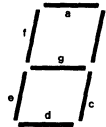

T_A

Ambient temperature range. Allowable range of the surrounding environment of the operating device.

t_h

Hold Time. The interval immediately following the active transition of the timing pulse (usually the clock pulse) or following the transition of the control input to its latching level, during which interval the data to be recognized must be maintained at the input to ensure its continued recognition. A negative hold time indicates that the current logic level may be released prior to the active transition of the timing pulse and still be recognized.

T_J

Junction Temperature. The maximum temperature of the device. 150°C is standard for silicon devices.

t_{PHL}

Propagation Delay Times. The time between the specified reference points on the input and output waveforms with the output changing from the defined HIGH level to the defined LOW level.

t_{PLH}

Propagation Delay Time. The time between the specified reference points on the input and output waveforms with the output changing from the defined LOW level to the defined HIGH level.

t_{rec}

Recovery Time. The time between the reference point on the trailing edge of an asynchronous input control pulse and the reference point on the activating edge of a synchronous (clock) pulse input such that the device will respond to the synchronous input.

t_s

Setup Time. The interval immediately preceding the active transition of the timing pulse (usually the clock pulse) or preceding the transition of the control input to its latching level, during which interval the data to be recognized must be maintained at the input to ensure its recognition. A negative setup time indicates that the correct logic level may be initiated sometime after the active transition of the timing pulse and still be recognized.

DISPLAY DRIVER — SYMBOLS AND DEFINITIONS

DISPLAY DRIVER DEFINITIONS (Cont'd)

Truth Tables

0 is logic level low

1 is logic level high

X — don't care condition — has no effect under circuit conditions listed.

Typical Value

The typical value of a particular parameter at 25°C determined by characterization of the device or sampling. Usually indicates that the particular device is not 100% tested for the parameter because it does not vary or can be determined by design and other tested variables. Occasionally typical values are given rather than min-max values because 100% testing would raise the cost of the product to a prohibitive level. If a typical value must be guaranteed to ensure specific operation, custom testing can often be provided at an additional cost to the user.

V_{BR}

Output Breakdown Voltage. Maximum voltage applied to a disabled (off) output to ensure a leakage current less than the specified value.

$V_{CC} (-V_{CC})$

Supply Voltage. The range of power supply voltage over which the device will operate safely.

V_F

Forward voltage drop of a device at a specified current level.

V_{IH}

Input High Voltage. The range of input voltages recognized by the device as a logic high.

V_{IL}

Input Low Voltage. The range of input voltages recognized by the device as a logic low.

V_{IN}

The range of voltage on any input which the device can safely handle or a specified input voltage to the device.

V_{OH}

Output High Voltage. The minimum guaranteed High voltage at an output terminal for the specified output current I_{OH} and at the minimum V_{CC} value.

V_{OL}

Output Low Voltage. The maximum guaranteed low voltage at an output terminal sinking the specified load current I_{OL} .

V_{OUT}

The range of voltage on any output which the device can safely handle or a specified output voltage to the device.

V_S

Source Voltage. A separate V_{CC} line depending on part type.

\overline{XX}

Negate Bar — when it appears over a function indicates that the "true" or valid condition of that function is a logic low level.
i.e. \overline{LE} — would require a logic high level to cause a latch enable
 \overline{LE} — would require a logic low level to cause a latch enable.

QUAD LINE DRIVER

MC1488

DESCRIPTION

The MC1488 is a quad line driver which converts standard DTL/TTL input logic levels through one stage of inversion to output levels which meet EIA Standard No. RS-232C and CCITT Recommendation V.24.

FEATURES

- Current limited output: $\pm 10\text{mA}$ Typ
- Power-off source impedance: 300Ω Min
- Simple slew rate control with external capacitor
- Flexible operating supply range
- Inputs are DTL/TTL compatible

APPLICATIONS

- Computer port driver
- Digital transmission over long lines
- Slew rate control
- TTL/DTL to MOS translation

PIN CONFIGURATION

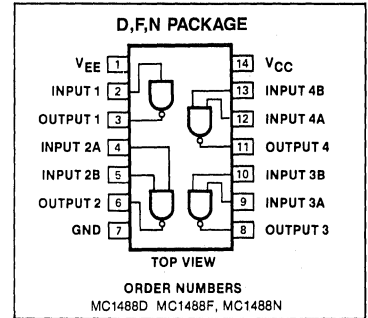

ABSOLUTE MAXIMUM RATINGS

PARAMETER	RATING	UNIT
Supply voltage V_+	+15	V
V_-	-15	V
Input voltage (V_{IN})	$-15 \leq V_{IN} \leq 7.0$	V
Output voltage	± 15	V
Power dissipation:		
F package	1000	mW
N package	800	mW
Operating temperature range	0 to +75	$^{\circ}\text{C}$
Storage temperature range	-65 to +150	$^{\circ}\text{C}$
Lead temperature (soldering, 10sec)	300	$^{\circ}\text{C}$

CIRCUIT SCHEMATIC

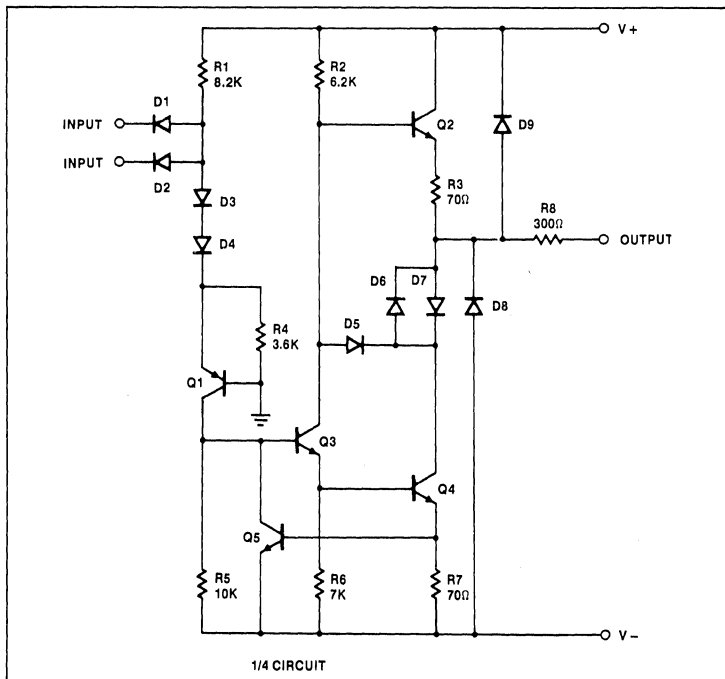

QUAD LINE DRIVER

MC1488

DC ELECTRICAL CHARACTERISTICS $V_+ = +9.0V \pm 1\%$, $V_- = -9.0V \pm 1\%$, $T_A = 0^\circ C$ to $+75^\circ C$
 unless otherwise specified.
 All typicals are for $V_+ = 9.0V$, $V_- = -9.0V$, and $T_A = 25^\circ C$.*

PARAMETER	TEST CONDITIONS	LIMITS			UNIT	
		Min	Typ	Max		
Logic "0" input current	$V_{IN} = 0V$		-1.0	-1.6	mA	
Logic "1" input current	$V_{IN} = +5.0V$.005	10.0	μA	
High level output voltage	$R_L = 3.0k\Omega$ $V_{IN} = 0.8V$	$V_+ = 9.0V$ $V_- = -9.0V$	6.0	7.0	V	
		$V_+ = 13.2V$ $V_- = -13.2V$	9.0	10.5	V	
Low level output voltage	$R_L = 3.0k\Omega$ $V_{IN} = 1.9V$	$V_+ = 9.0V$ $V_- = -9.0V$	-6.0	-6.8	V	
		$V_+ = 13.2V$ $V_- = -13.2V$	-9.0	-10.5	V	
High level output Short-circuit current	$V_{OUT} = 0V$ $V_{IN} = 0.8V$	-6.0	-10.0	-12.0	mA	
Low level output Short-circuit current	$V_{OUT} = 0V$ $V_{IN} = 1.9V$	5.0	10.0	12.0	mA	
Output resistance	$V_+ = V_- = 0V$ $V_{OUT} = \pm 2V$	300			Ω	
Positive supply current (output open)	$V_{IN} = 1.9V$	$V_+ = 9.0V, V_- = -9.0V$ $V_+ = 12V, V_- = -12V$ $V_+ = 15V, V_- = -15V$		15.0 19.0 25.0	20.0 25.0 34.0	mA mA mA
		$V_{IN} = 0.8V$		4.5 5.5 8.0	6.0 7.0 12.0	mA mA mA
Negative supply current (output open)	$V_{IN} = 1.9V$	$V_+ = 9.0V, V_- = -9.0V$ $V_+ = 12V, V_- = -12V$ $V_+ = 15V, V_- = -15V$		-13.0 -18.0 -25.0	-17.0 -23.0 -34.0	mA mA mA
		$V_{IN} = 0.8V$		-1 -1 -.01	-15 -15 -2.5	μA μA mA
Power dissipation	$V_+ = 9.0V, V_- = -9.0V$ $V_+ = 12V, V_- = -12V$		252 444	333 576	mW mW	
Propagation delay to "1" (t_{pd1})	$R_L = 3.0k\Omega, C_L = 15pF, T_A = 25^\circ C$		275	560	ns	
Propagation delay to "0" (t_{pd0})	$R_L = 3.0k\Omega, C_L = 15pF, T_A = 25^\circ C$		70	175	ns	
Rise time (t_r)	$R_L = 3.0k\Omega, C_L = 15pF, T_A = 25^\circ C$		75	100	ns	
Fall time (t_f)	$R_L = 3.0k\Omega, C_L = 15pF, T_A = 25^\circ C$		40	75	ns	

NOTE

*Voltage values shown are with respect to network ground terminal. Positive current is defined as current into the referenced pin.

4

TYPICAL PERFORMANCE CHARACTERISTICS

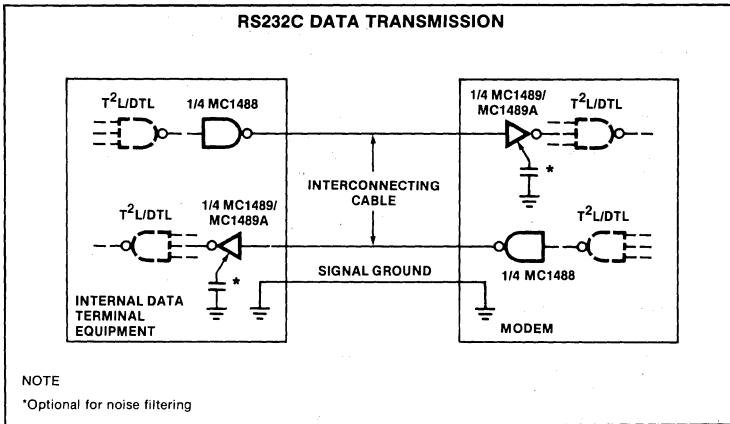
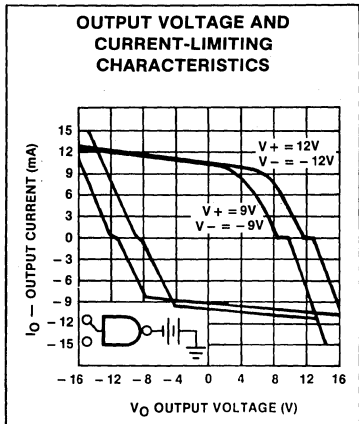

AC LOAD CIRCUIT

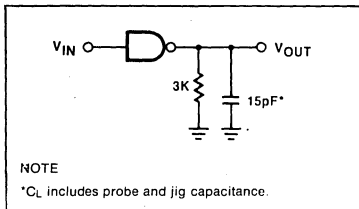

NOTE
*C_L includes probe and jig capacitance.

SWITCHING WAVEFORMS

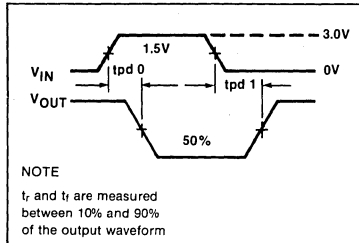

APPLICATIONS

By connecting a capacitor to each driver output the slew rate can be controlled utilizing the output current limiting characteristics of the MC1488. For a set slew rate the appropriate capacitor value may be calculated using the following relationship

$$C = I_{SC} (\Delta T / \Delta V)$$

where C is the required capacitor, I_{SC} is the short circuit current value, and ΔV/ΔT is the slew rate.

RS232C specifies that the output slew rate must not exceed 30V per microsecond. Using the worst case output short circuit current of 12mA in the above equation, calculations result in a required capacitor of 400pF connected to each output.

TYPICAL APPLICATIONS

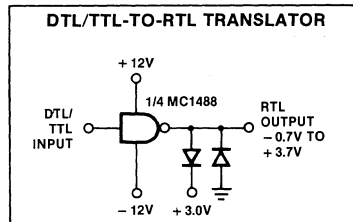
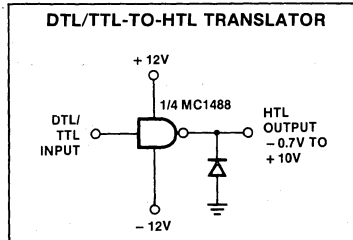
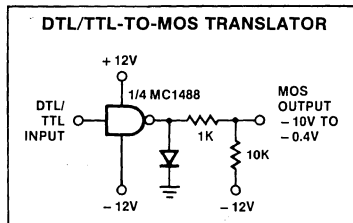

QUAD LINE RECEIVERS

MC1489/MC1489A

DESCRIPTION

The MC1489/MC1489A are quad line receivers designed to interface data terminal equipment with data communications equipment. They are constructed on a single monolithic silicon chip. These devices satisfy the specifications of EIA standard No. RS232C.

FEATURES

- Four totally separate receivers per package
- Programmable threshold
- Built-in input threshold hysteresis
- "Fail safe" operating mode
- Inputs withstand $\pm 30V$

APPLICATIONS

- Computer port inputs
- Modems
- Eliminating noise in digital circuitry
- MOS to TTL/DTL translation

PIN CONFIGURATION

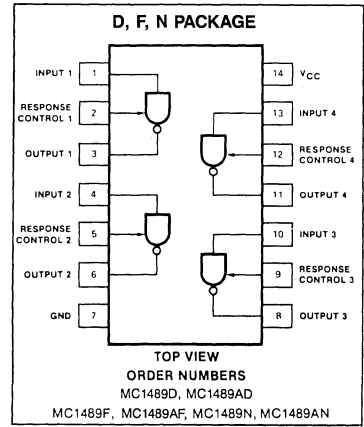

ABSOLUTE MAXIMUM RATINGS

PARAMETER	RATING	UNIT
Power supply voltage	10	V
Input voltage range	± 30	V
Output load current	20	mA
Power dissipation:		
F package	1	W
N package	800	mW
Operating temperature range	0 to +75	$^{\circ}C$
Storage temperature range	-65 to +150	$^{\circ}C$

VOLTAGE WAVEFORMS

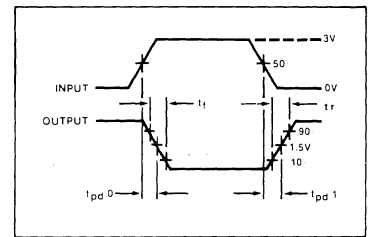

EQUIVALENT SCHEMATIC

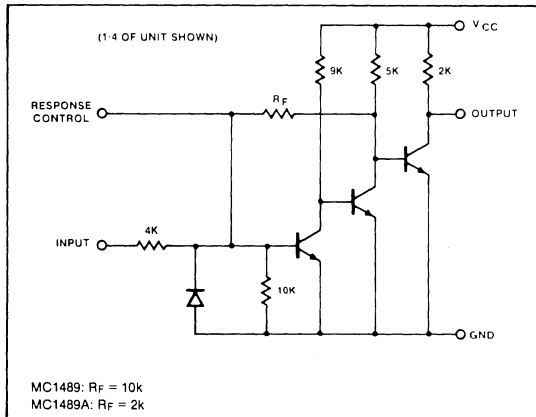

AC TEST CIRCUIT

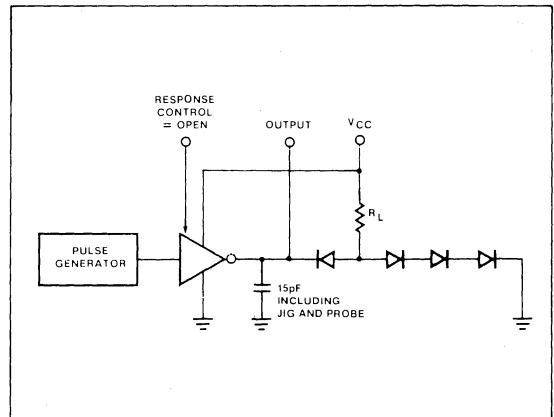

QUAD LINE RECEIVERS

MC1489/MC1489A

DC ELECTRICAL CHARACTERISTICS $V_{CC} = 5.0V \pm 1\%$, $0^\circ C \leq T_A \leq +75^\circ C$ unless otherwise specified.^{1,2}

PARAMETER	TEST CONDITIONS	MC1489			MC1489A			UNIT
		Min	Typ	Max	Min	Typ	Max	
Input high threshold voltage	$T_A = 25^\circ C$, $V_{OUT} \leq 0.45V$, $I_{OUT} = 10mA$	1.0		1.5	1.75		2.25	V
Input low threshold voltage	$T_A = 25^\circ C$, $V_{OUT} \leq 2.5V$, $I_{OUT} = -0.5mA$	0.75		1.25	0.75		1.25	V
Input current	$V_{IN} = +25V$ $V_{IN} = -25V$	+3.6	+5.6	+8.3	+3.6	+5.6	+8.3	mA
		-3.6	-5.6	-8.3	-3.6	-5.6	-8.3	
Input current	$V_{IN} = +3V$ $V_{IN} = -3V$	+0.43	+0.53		+0.43	+0.53		mA
		-0.43	-0.53		-0.43	-0.53		
Output high voltage	$V_{IN} = 0.75V$, $I_{OUT} = -0.5mA$	2.6	3.8	5.0	2.6	3.8	5.0	V
Output low voltage	Input = Open, $I_{OUT} = -0.5mA$ $V_{IN} = 3.0V$, $I_{OUT} = 10mA$	2.6	3.8	5.0	2.6	3.8	5.0	V
			0.33	0.45		0.33	0.45	
Output short circuit current	$V_{IN} = 0.75V$		3.0			3.0		mA
Supply current	$V_{IN} = 5.0V$		20	26		20	26	
Power dissipation	$V_{IN} = 5.0V$		100	130		100	130	mW

NOTES

1. Voltage values shown are with respect to network ground terminal. Positive current is defined as current into the referenced pin.
2. These specifications apply for response control pin = open.

AC ELECTRICAL CHARACTERISTICS $V_{CC} = 5.0V \pm 1\%$, $T_A = 25^\circ C$ unless otherwise specified.^{1,2}

PARAMETER	TEST CONDITIONS	MC1489			MC1489A			UNIT
		Min	Typ	Max	Min	Typ	Max	
Input to output "high" Propagation delay (t_{pd1})	$R_L = 3.9k\Omega$ (AC test circuit)		25	85		25	85	ns
	$R_L = 390\Omega$ (AC test circuit)		20	50		20	50	
Input to output "low" Propagation delay (t_{pd0})	$R_L = 3.9k\Omega$ (AC test circuit)		110	175		110	175	ns
	$R_L = 390\Omega$ (AC test circuit)		9	20		9	20	

NOTES

1. Voltage values shown are with respect to network ground terminal. Positive current is defined as current into the referenced pin.
2. These specifications apply for response control pin = open.

TYPICAL APPLICATIONS

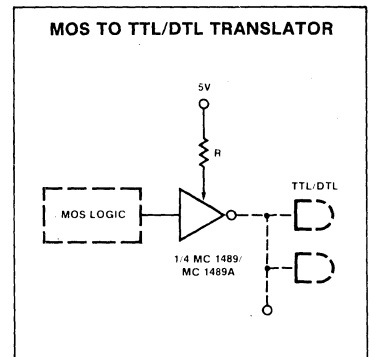
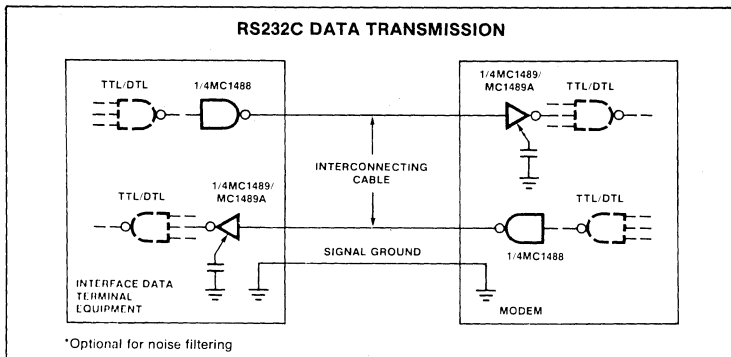

ADDRESSABLE RELAY DRIVER

NE5090

DESCRIPTION

The NE5090 addressable relay driver is a high current latched driver, similar in function to the 9934 address decoder. The device has 8 open collector Darlington power outputs, each capable of 150mA load current. The outputs are turned on or off by respectively loading a logic "1" or logic "0" into the device data input. The required output is defined by a 3 bit address. The device must be enabled by a \overline{CE} input line which also serves the function of further address decoding. A common clear input, \overline{CLR} , turns all outputs off when a logic "0" is applied. The device is packaged in a 16 pin plastic or Cerdip package.

FEATURES

- 8 high current outputs
- Low-loading bus compatible inputs
- Power-on clear ensures safe operation
- Will operate in addressable or demultiplex mode
- Allows random (addressed) data entry
- Easily expandable
- Pin compatible with 9334

APPLICATIONS

- Relay driver
- Indicator lamp driver
- Triac trigger
- LED display digit driver
- Stepper motor driver

BLOCK DIAGRAM

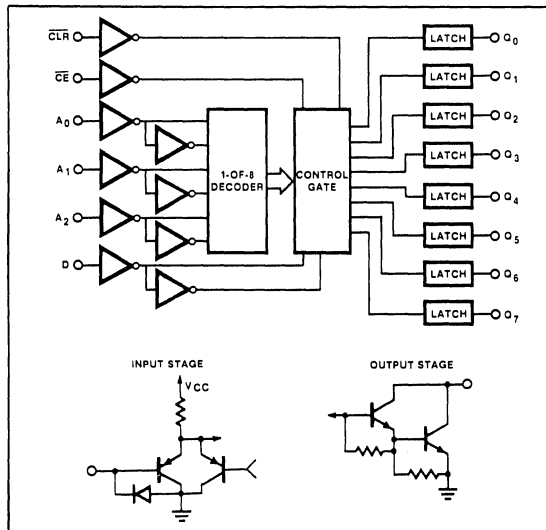

ABSOLUTE MAXIMUM RATINGS

$T_A = 25^\circ\text{C}$ unless otherwise specified.

PARAMETER	RATING	UNIT
V_{CC} Supply voltage	- 0.5 to + 7	V
V_{IN} Input voltage	- 0.5 to + 15	V
V_{OUT} Output voltage	0 to + 30	V
I_{GND} Ground current	500	mA
I_{OUT} Output current Each output	200	mA
P_D Power dissipation ¹	1	W
Ambient temperature range		$^\circ\text{C}$
T_A NE5090	0 to + 70	
T_J Junction	150	
T_{STG} Storage	- 65 to + 150	
T_{solid} Lead soldering temperature (10 sec max)	300	$^\circ\text{C}$

PIN CONFIGURATION

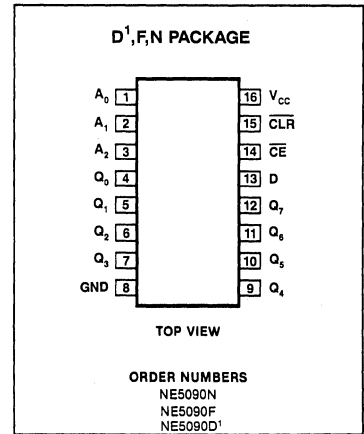

NOTES:

1. SOL - Released in Large SO package only.
2. SOL and non-standard pinout.
3. SO and non-standard pinouts.

ADDRESSABLE RELAY DRIVER

NE5090

PIN DESIGNATION

PIN NO.	SYMBOL	NAME AND FUNCTION
1-3	A0-A2	A 3-bit binary address on these pins defines which of the 8 output latches is to receive the data. The 8 device outputs.
4-7, 9-12	Q0-Q7	
13	D	The data input. When the chip is enabled, this data bit is transferred to the defined output such that: "1" turns output switch "ON" "0" turns output switch "OFF"
14	CE	The chip enable. When this input is low, the output latches will accept data. When CE goes high, all outputs will retain their existing state, regardless of address of data input conditions.
15	CLR	The clear input. When CLR goes low all output switches are turned "OFF". The high data input will override the clear function on the addressed latch.

TRUTH TABLE

INPUTS							OUTPUTS							MODE	
CLR	CE	D	A ₀	A ₁	A ₂		Q ₀	Q ₁	Q ₂	Q ₃	Q ₄	Q ₅	Q ₆	Q ₇	
L	H	X	X	X	X		H	H	H	H	H	H	H	H	Clear
L	L	L	L	L	L		H	H	H	H	H	H	H	H	Demultiplex
L	L	L	L	L	L		L	H	H	H	H	H	H	H	
L	L	L	L	L	L		H	H	H	H	H	H	H	H	
L	L	L	L	L	L		H	L	H	H	H	H	H	H	
L	L	L	L	L	L		H	H	H	H	H	H	H	H	
L	L	L	L	L	L		H	H	H	H	H	H	L	H	
H	H	X	X	X	X		Q _{N-1} →							Memory	
H	L	L	L	L	L		H	Q _{N-1} →							Addressable Latch
H	L	L	L	L	L		L	Q _{N-1} →							
H	L	L	L	L	L		Q _{N-1}	H	Q _{N-1} →						
H	L	L	L	L	L		Q _{N-1}	L	Q _{N-1} →						
H	L	L	L	L	L		Q _{N-1}	→ H							
H	L	L	L	L	L		Q _{N-1}	→ L							

X = Don't care condition
 Q_{N-1} = Previous output state
 L = Low voltage level/"ON" output state
 H = High voltage level/"OFF" output state

DC ELECTRICAL CHARACTERISTICS V_{CC} = 4.75V to 5.25V, 0°C ≤ T_A ≤ 70°C unless otherwise specified (NE5090)².

PARAMETER	TEST CONDITIONS	LIMITS			UNIT
		Min	Typ	Max	
V _{IH} V _{IL}	Input voltage High Low	2.0		0.8	V
V _{OL}	Output voltage Low I _{OL} = 150mA, T _A = 25°C Over temperature		1.05	1.30 1.50	V
I _{IH} I _{IL}	Input current High Low V _{IN} = V _{CC} V _{IN} = 0V		< 1.0 -3.0	10 -250	μA
I _{OH}	Leakage current V _{OUT} = 28V,		5	250	μA
I _{CCL} I _{CCH}	Supply current All outputs low All outputs high V _{CC} = 5.25V NE5090		35 22	60 50	mA

NOTES

- Derate power dissipation as indicated above threshold ambient temperature
 NE5090 N at 9.3mW/°C above 85°C
 NE5090 F at 7.5mW/°C above 65°C
- All typical values are at V_{CC} = 5V and T_A = 25°C

ADDRESSABLE RELAY DRIVER

NE5090

SWITCHING CHARACTERISTICS $V_{CC} = 5V, T_A = 25^\circ C, V_{OUT} = 5V, I_{OUT} = 100mA, V_{IL} = 0.8V, V_{IH} = 2.0V$

PARAMETER		TO	FROM	Min	Typ	Max	UNIT
t_{PLH} t_{PHL}	Propagation delay time Low to high ¹ High to low ¹	Output	\overline{CE}		900 130	1800 260	ns
t_{PLH} t_{PHL}	Low to high ² High to low ²	Output	Data		920 130	1850 260	ns
t_{PLH} t_{PHL}	Low to high ³ High to low ³	Output	Address		900 130	1800 260	ns
t_{PLH} t_{PHL}	Low to high ⁴ High to low ⁴	Output	\overline{CLR}		920	1850	ns
SWITCHING SETUP REQUIREMENTS							
$t_{S(H)}$ ⁵ $t_{S(L)}$ ⁵		Chip enable	High data	5	20		ns
		Chip enable	Low data	10	30		
$t_{S(A)}$ ⁶		Chip enable	Address	0	20		ns
$t_{H(H)}$ ⁵ $t_{H(L)}$ ⁵		Chip enable	High data	+ 10	0		ns
		Chip enable	Low data	+ 10	0		
$t_{pw(E)}$ ¹	Chip enable pulse width ¹			0	20		ns

NOTES

1. See Turn-On and Turn-Off Delays, Enable to Output and Enable Pulse Width timing diagram.
2. See Turn-On and Turn-Off Delays, Data to Output timing diagram.
3. See Turn-On and Turn-Off Delays, Address to Output timing diagram.
4. See Turn-Off Delay, Clear to Output timing diagram.
5. See Setup and Hold Time, Data to Enable timing diagram.
6. See Setup Time, Address to Enable timing diagram.

TIMING DIAGRAMS

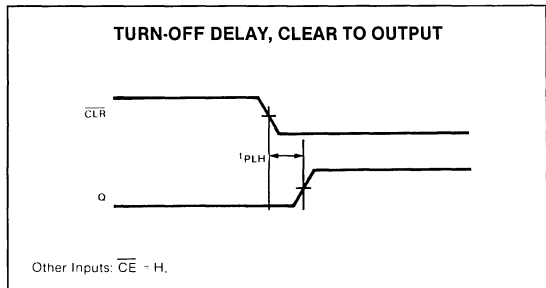
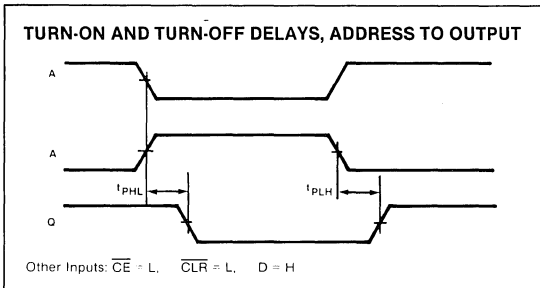
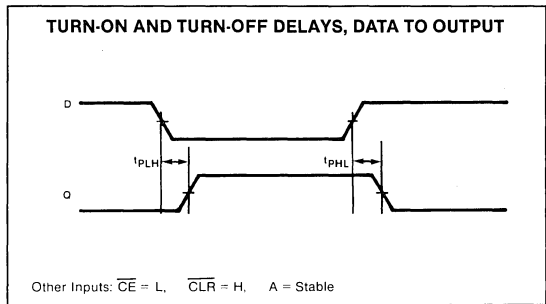
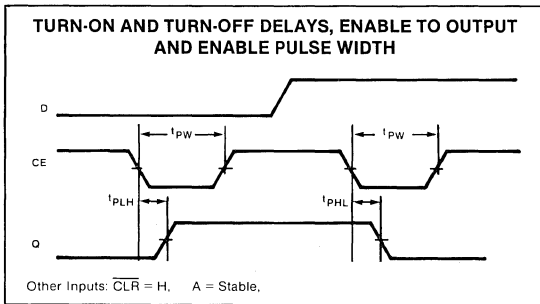

4

ADDRESSABLE RELAY DRIVER

NE5090

TIMING DIAGRAMS (Cont'd)

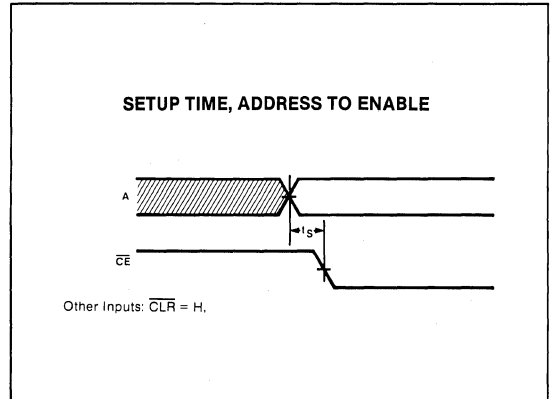
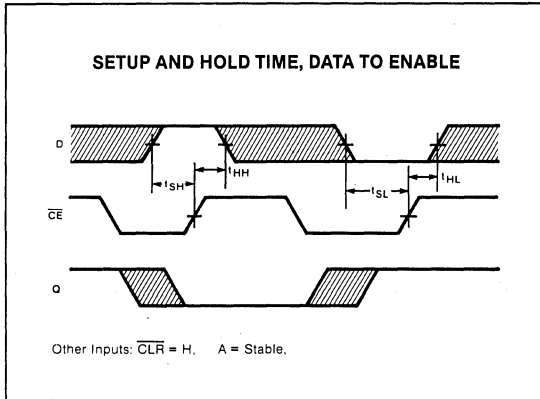

TYPICAL APPLICATIONS

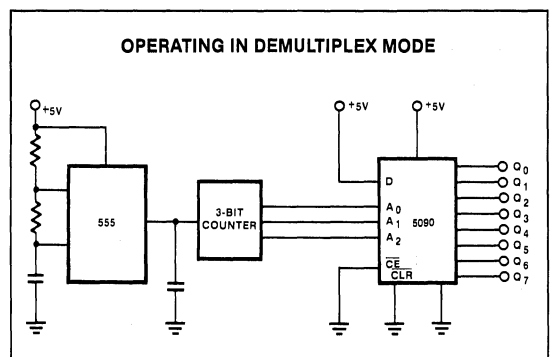
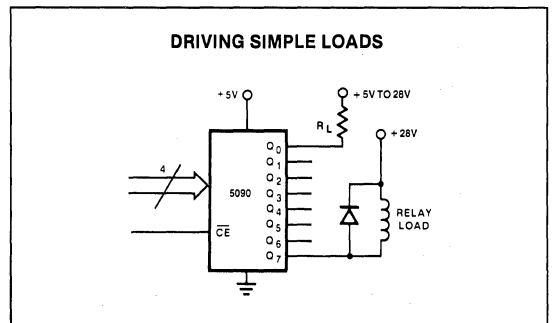
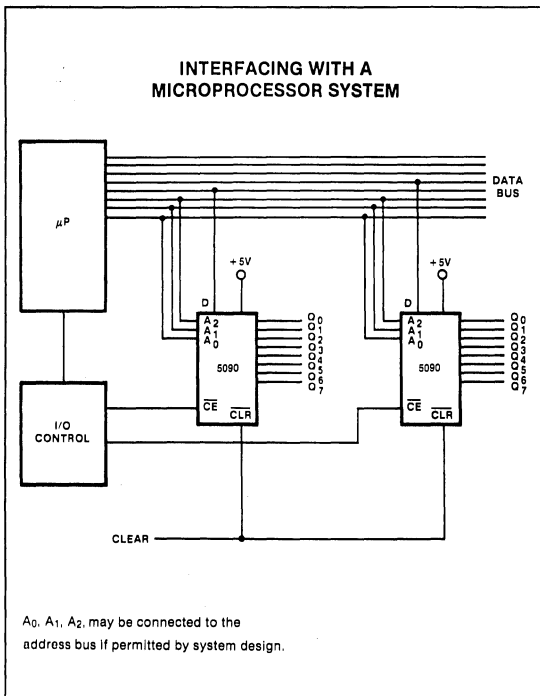

TYPICAL PERFORMANCE CHARACTERISTICS

OUTPUT VOLTAGE VS LOAD CURRENT

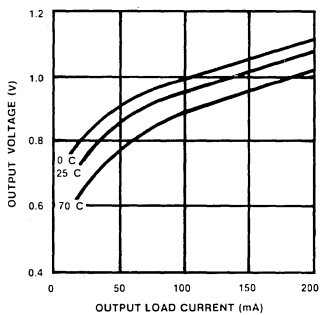

4

DESCRIPTION

The NE587 is a latch/decoder/driver for 7-segment common anode LED displays. The NE587 has a programmable current output up to 50mA which is essentially independent of output voltage, power supply voltage, and temperature. The data (BCD) inputs and \overline{LE} (latch enable) input are low-loading so that they are compatible with any data bus system. The 7-segment decoding is implemented with a ROM so that alternative fonts can be made available.

FEATURES

- Latched BCD inputs
- Low loading bus-compatible inputs
- Ripple-blanking on leading and/or trailing edge zeros

APPLICATIONS

- Digital panel meters
- Measuring instruments
- Test equipment
- Digital clocks
- Digital bus monitoring

ABSOLUTE MAXIMUM RATINGS $T_A = 25^\circ\text{C}$ unless otherwise specified

PARAMETER		RATING	UNIT
V _{CC}	Supply voltage	-0.5 to +7	V
V _{IN}	Input voltage (D ₀ - D ₃ , \overline{LE} , \overline{RBI})	-0.5 to +15	V
V _{OUT}	Output voltage (a-g, RBO)	-0.5 to +7	V
P _D	Power dissipation (25°C) ¹	1000	mW
T _A	Ambient temperature range	0 to 70	°C
T _J	Junction temperature	150	°C
T _{STG}	Storage temperature range	-65 to +150	°C
T _{SOLD}	Soldering temperature (10 sec. max)	300	°C

NOTE
 Derate power dissipation as indicated
 N package - 95°C/watt above 55°C
 F package - 100°C/watt above 50°C

BLOCK DIAGRAM

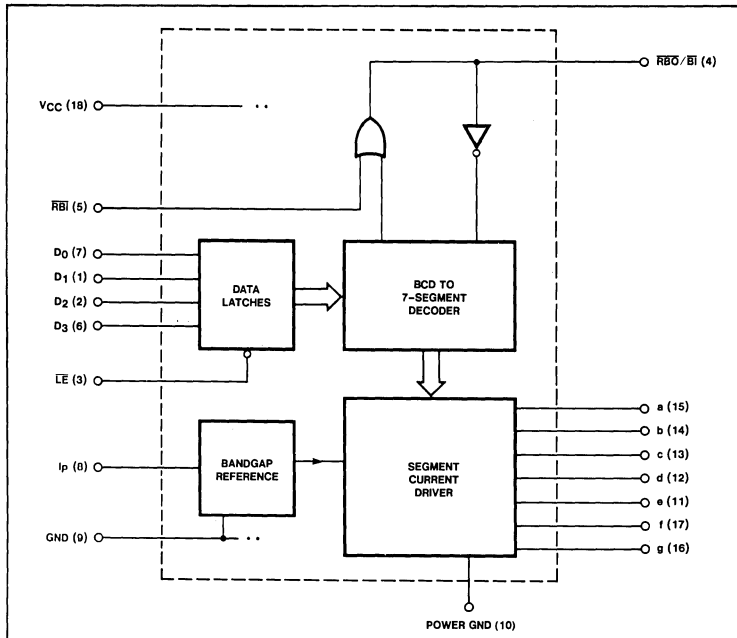

PIN CONFIGURATIONS

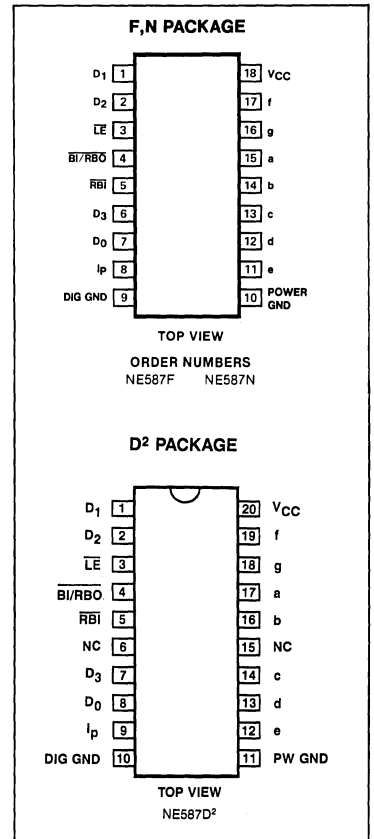

- NOTES:
 1. SOL - Released in Large SO package only.
 2. SOL and non-standard pinout.
 3. SO and non-standard pinouts.

LED DECODER/DRIVER

NE587

DC ELECTRICAL CHARACTERISTICS

$V_{CC} = 4.75$ to $5.25V$, $0^{\circ}C < T_A < 70^{\circ}C$.

Typical values are at $V_{CC} = 5V$, $T_A = 25^{\circ}C$, $R_P = 1k\Omega (\pm 1\%)$ unless otherwise stated.

PARAMETER	TEST CONDITIONS	NE587			UNIT
		Min	Typ	Max	
V_{CC} Operating supply voltage		4.75	5.00	5.25	V
V_{IH} Input high voltage	All Inputs except \overline{BI} \overline{BI}	2.0 2.0		15 5.5	V
V_{IL} Input low voltage				0.8	V
V_{IC} Input clamp voltage	$I_{IN} = -12mA$, $T_A = 25^{\circ}C$			-1.5	V
I_{IH} Input high current	Inputs $D_0 - D_3$, \overline{LE} , \overline{RBI} $V_{IN} = 2.4V$ $V_{IN} = 15V$ Input \overline{BI} (pin 4) $\overline{RBI} = H$ $V_{IN} = V_{CC} = 5.25V$		1.0 15 10	10 15 100	μA μA
I_{IL} Input low current	$V_{IN} = 0.4V$, Inputs $D_0 - D_3$ \overline{LE} , \overline{RBI}		-5 -200		μA
	Input \overline{BI} $V_{CC} = 5.25V$ $\overline{RBI} = H$, $V_{IN} = 0.4V$		-0.7		mA
V_{OL} Output low voltage	Output \overline{RBO} $I_{out} = 3.0mA$.2	.5	V
V_{OH} Output high voltage	Output \overline{RBO} $I_{OUT} = -50\mu A$ $\overline{RBI} = H$	3.5	4.5		V
I_{OUT} Output segment "ON" current	Outputs "a" thru "g" $V_{OUT} = 2.0V$	20	25	30	mA
ΔI_{OUT} Output current ratio (all outputs ON)	With reference to "b" segment $V_{OUT} = 2.0V$	0.90	1.00	1.10	
I_{OFF} Output segment "OFF" current	Outputs "a" thru "g" $V_{OUT} = 5.0V$		20	250	μA
I_{CCO} Supply current	$V_{CC} = 5.25V$ All outputs "ON" $V_{OUT} > 1V$		33	55	mA
I_{CCI} Supply current	$V_{CC} = 5.25V$ All outputs blanked		50	70	mA

NOTE

NE587 PROGRAMMING

The NE587 output current can be programmed, provided a program resistor, R_P , be connected between I_P (pin 8) and Ground (pin 9). The voltage at I_P (pin 8) is constant ($\approx 1.3V$). Thus, a current through R_P is $I_P \approx \frac{1.3V}{R_P}$, as shown in Figure 5. $\frac{I_P}{I_P}$ is 20 in the 15 to 50mA output current range.

4

LED DECODER/DRIVER

NE587

AC ELECTRICAL CHARACTERISTICS $V_{CC} = 5V$ $T_A = 25^\circ C$. $R_L = 130\Omega$, $C_L = 30pF$ including probe capacity.

PARAMETER	TEST CONDITIONS	NE587			UNIT
		Min	Typ	Max	
$t_{D_{av}}$ Propagation delay Figure 2	From data to output		135		ns
$t_{D_{av}}$ Propagation delay Figure 3	From \overline{LE} to output		135		ns
t_W Latch enable pulse width Figure 4		30			ns
t_S Latch enable setup time Figure 4	From data to \overline{LE}	20			ns
t_H Latch enable hold time Figure 4	From \overline{LE} to data	0			ns

NOTE
 $t_{D_{av}} = \frac{1}{2} (t_{HL} + t_{LH})$

TRUTH TABLE

BINARY INPUT	INPUTS						OUTPUTS								DISPLAY	
	\overline{LE}	\overline{RBI}	D ₃	D ₂	D ₁	D ₀	a	b	c	d	e	f	g	\overline{RBO}		
—	H	*	X	X	X	X	STABLE								**	STABLE
0	L	L	L	L	L	L	H	H	H	H	H	H	H	L	BLANK	
0	L	H	L	L	L	L	L	L	L	L	L	L	H	H	0	
1	L	X	L	L	L	H	H	L	L	H	H	H	H	H	1	
2	L	X	L	L	H	L	L	L	H	L	L	H	L	H	2	
3	L	X	L	L	H	H	L	L	L	L	H	H	L	H	3	
4	L	X	L	H	L	L	H	L	L	H	H	L	L	H	4	
5	L	X	L	H	L	H	L	H	L	L	H	L	L	H	5	
6	L	X	L	H	H	L	L	H	L	L	L	L	L	H	6	
7	L	X	L	H	H	H	L	L	L	H	H	H	H	H	7	
8	L	X	H	L	L	L	L	L	L	L	L	L	L	H	8	
9	L	X	H	L	L	H	L	L	L	L	H	L	L	H	9	
10	L	X	H	L	H	L	H	H	H	H	H	H	L	H	-	
11	L	X	H	L	H	H	L	H	H	L	L	L	L	H	E	
12	L	X	H	H	L	L	H	L	L	H	L	L	L	H	H	
13	L	X	H	H	L	H	H	H	H	L	L	L	H	H	L	
14	L	X	H	H	H	L	L	L	H	L	L	L	L	H	P	
15	L	X	H	H	H	H	H	H	H	H	H	H	H	H	blank	
BI	X	X	X	X	X	X	H	H	H	H	H	H	H	L	blank	

NOTES
 H = HIGH voltage level, output is "OFF"
 L = LOW voltage level, output is "ON"
 X = Don't care

* The \overline{RBI} will blank the display only if a binary zero is stored in the latches.

** $\overline{RBO/BI}$ used as an input overrides all other input conditions.

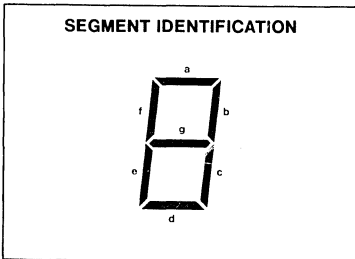

NE587 PROGRAMMING

NE587 output current can be programmed by using a programming resistor, R_p , connected between r_p (pin 8) and Gnd (pin 9). The voltage at r_p (pin 8) is constant ($\approx 1.40V$). A partial schematic of the voltage reference used in the NE587 is shown in figure 1.

Output current to program current ratio, I_O/I_p , is 20 in the 15mA to 50mA range. Note that I_p must be derived from a resistor (R_p), and not from a high impedance source such as an I_{OUT} DAC used to control display brightness.

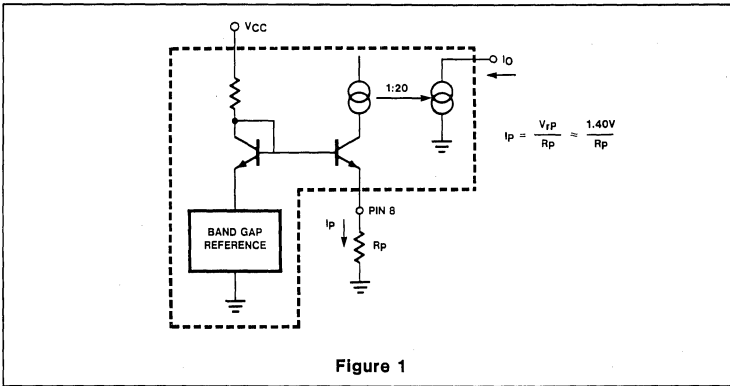

Figure 1

TIMING DIAGRAMS

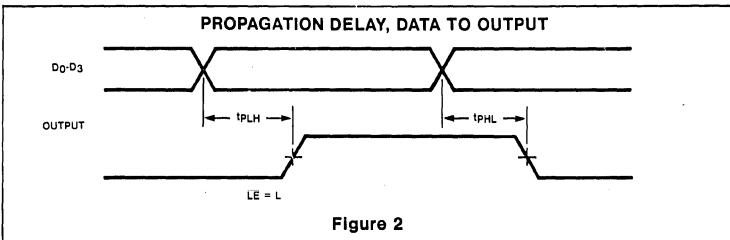

Figure 2

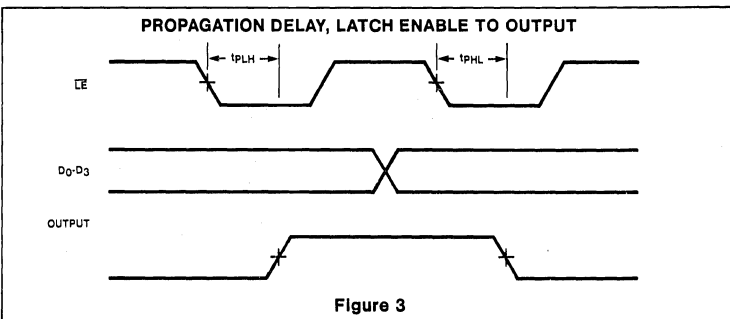

Figure 3

POWER DISSIPATION CONSIDERATIONS

LED displays are power-hungry devices, and inevitably somewhat inefficient in their use of the power supply necessary to drive them. Duty cycle control does afford one way of improving display efficiency, provided that the LEDs are not driven too far into saturation, but the improvement is marginal. Operation at higher peak currents has the added advantage of giving much better matching of light output, both from segment-to-segment and digit-to-digit.

An output current of 10 to 50mA was chosen so that it would be suitable for multiplexed operation of large size LED digits. When designing a display system, particular care must be taken to minimize power dissipation within the IC display driver. Since the output is a constant current source, all the remaining supply voltage, which is not dropped across the LED (and the digit driver, if used), will appear across the output. Thus, the power dissipation will go up sharply if the display power supply voltage rises. Clearly, then, it is good design practice to keep the display supply voltage as low as possible consistent with proper operation of the supply output current sources. Inserting a resistor or diode in series with the display supply is a good way of reducing the power dissipation within the integrated circuit segment driver, although, of course, total system power remains the same.

Power dissipation may be calculated as follows. Referring to figure 6, the two system power supplies are V_{CC} and V_S . In many cases, these will be the same voltage. Necessary parameters are:

- V_{CC} , Supply voltage to driver
- V_S , Supply voltage to display
- I_{CC} , Quiescent supply current of driver
- I_{SEG} , LED segment current
- V_F , LED segment forward voltage at I_{seg}
- K_{DC} , % Duty cycle

V_F , the forward LED drop, depends upon the type of LED material (hence the color) and the forward current. The actual forward voltage drops should be obtained from the LED display manufacturer's literature for the peak segment current selected; however, approximate voltages at nominal rated currents are:

Red	1.6 to 2.0V
Orange	2.0 to 2.5V
Yellow	2.2 to 3.5V
Green	2.5 to 3.5V

4

LED DECODER/DRIVER

NE587

TIMING DIAGRAMS (Cont'd)

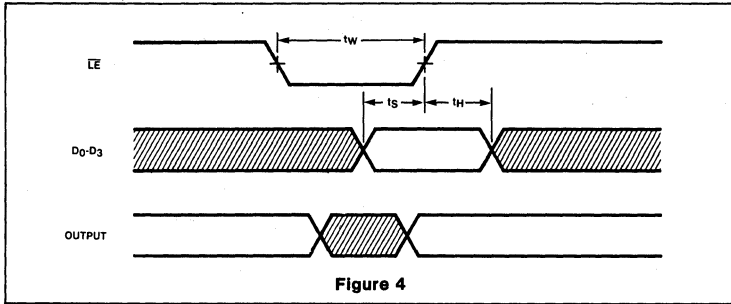

These voltages are all for single diode displays. Some early red displays had 2 series LEDs per segment; hence the forward voltage drop was around 3.5V.

Thus a maximum power dissipation calculation when all segments are on, is:

$$P_d = V_{CC} \times I_{CC} + (V_S - V_F) \times 7 \times I_{seg} \times K_{DC} \text{ mW}$$

Assuming $V_S = V_{CC} = 5.25V$
 $V_F = 2.0V$
 $K_{DC} = 100\%$

$$P_{d \text{ max}} = 5.25 \times 50 + 3.25 \times 7 \times 30 \text{ mW} = 945 \text{ mW}$$

TYPICAL PERFORMANCE CURVES

SUPPLY CURRENT VS SUPPLY VOLTAGE
NE587

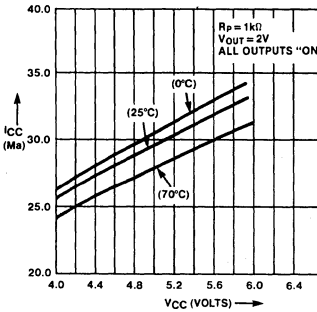

OUTPUT CURRENT VS OUTPUT VOLTAGE
NE587
Rp = 1Kohms

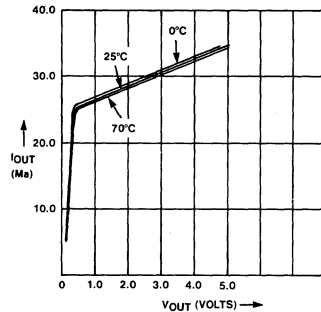

NORMALIZED OUTPUT CURRENT VS TEMPERATURE
VCC = 5.0V

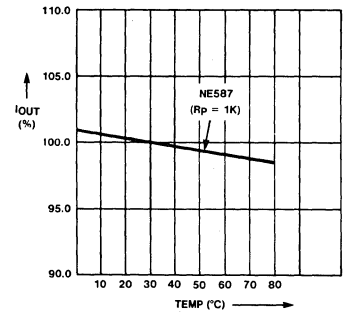

NORMALIZED OUTPUT CURRENT VS SUPPLY VOLTAGE
Vo = 2V
TA = 25°C

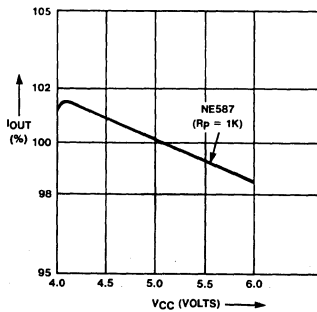

MAXIMUM POWER DISSIPATION VS TEMPERATURE

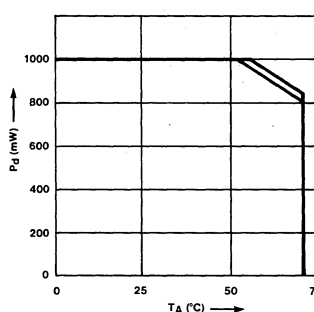

OUTPUT CURRENT VS PROGRAM RESISTOR

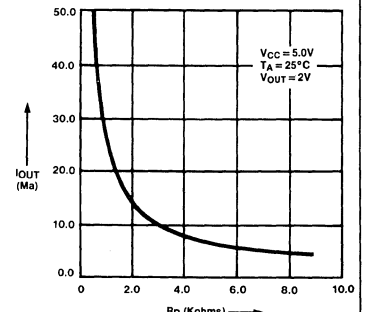

TYPICAL APPLICATIONS

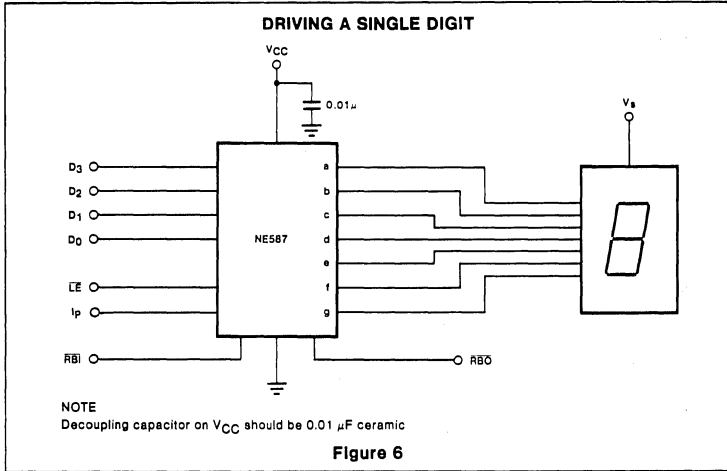

However, the average power dissipation will be considerably less than this. Assuming 5 segments are on (the average for all output code combinations), then

$$P_{d\text{ av}} = 5.0 \times 30 + 3.00 \times 5 \times 25 \text{ mW} = 525 \text{ mW}$$

Operating temperature range limitations can be deduced from the power dissipation graph. (See Typical Performance Characteristics).

However, a major portion of this power dissipation ($P_{d\text{ max}}$) is because the current source output is operating with 3.25 V across it. In practice, the outputs operate satisfactorily down to 0.5V, and so the extra voltage may be dropped external to the integrated circuit.

Suppose the worst case V_{CC}/V_S supply is 4.75 to 5.25V, and that the maximum V_E for the LED display is 2.25V. Only 2.75V is required to keep the display active, and hence 2.0V may be dropped externally with a resistor

from V_{CC} to V_S . The value of this resistor is calculated by:

$$R_S = \frac{2.0}{7 \times I_{\text{seg}}} \approx 10\Omega \text{ (}\frac{1}{2}\text{ W rating)}$$

assuming worst case I_{seg} of 30 mA

$$\begin{aligned} \text{Hence now } P_{d\text{ max}} &= V_{CC} \times I_{CC} + (V_S - V_V - R_X \times 7 \times I_{\text{seg}}) \times 7 \times X \times I_{\text{seg}} \\ &\quad \times K_{DC} \\ &= 5.25 \times 50 + 1.25 \times 7 \times 30 \text{ mW} \\ &= 525 \text{ mW} \end{aligned}$$

$$\text{and } P_{d\text{ av}} = 5.0 \times 30 + 1.25 \times 5 \times 25 = 306 \text{ mW}$$

If a diode (or 2) is used to reduce voltage to the display, then the voltage appearing across the display driver will be independent of the number of "ON" segments and will be equal to

$$V_S - V_F - nV_D, V_D \approx 0.8V$$

Where n is the number of diodes used, power dissipation can be calculated in a similar manner.

In a multiplexed display system, the voltage drop across the digit driver must also be considered in computing device power dissipation. It may even be an advantage to use a digit driver which drops an appreciable voltage, rather than the saturating PNP transistors shown in figure 9. For example a darlington PNP or NPN emitter follower may be preferable. Figure 8 shows the NE591 as the digit driver in a multiplexed display system. The NE591 output drops about 1.8V which means that the power dissipation is evenly distributed between the two integrated circuits.

Where V_S and V_{CC} are two different supplies, the V_S supply may be optimized for minimum system power dissipation and/or cost. Clearly, good regulation in the V_S supply is totally unnecessary, and so this supply can be made much cheaper than the regulated 5V supply used in the rest of the system. In fact a simple unsmoothed full-wave rectified sine wave works extremely well if a slight loss in brightness can be tolerated. A transformer voltage of about 3-4.5V rms works well in most LED display systems. Waveforms are shown below:

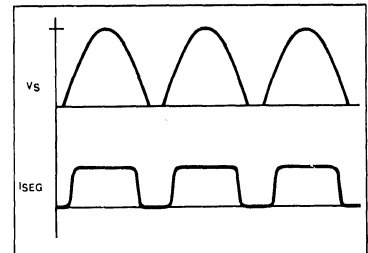

The duty cycle for this system depends upon V_S , V_F and the output characteristics of the display driver.

With
 $V_S = 4.9V \text{ pk.}$
 $V_F = 2.0V$

The duty cycle is approximately 60%.

TYPICAL APPLICATIONS (Cont'd)

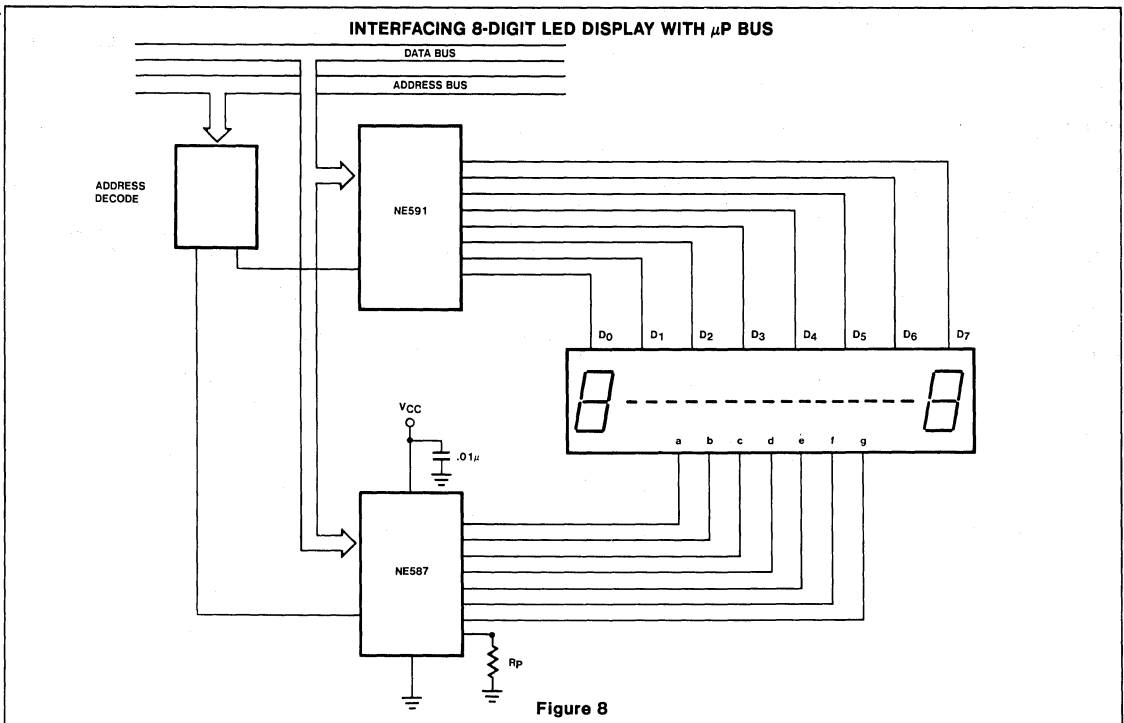
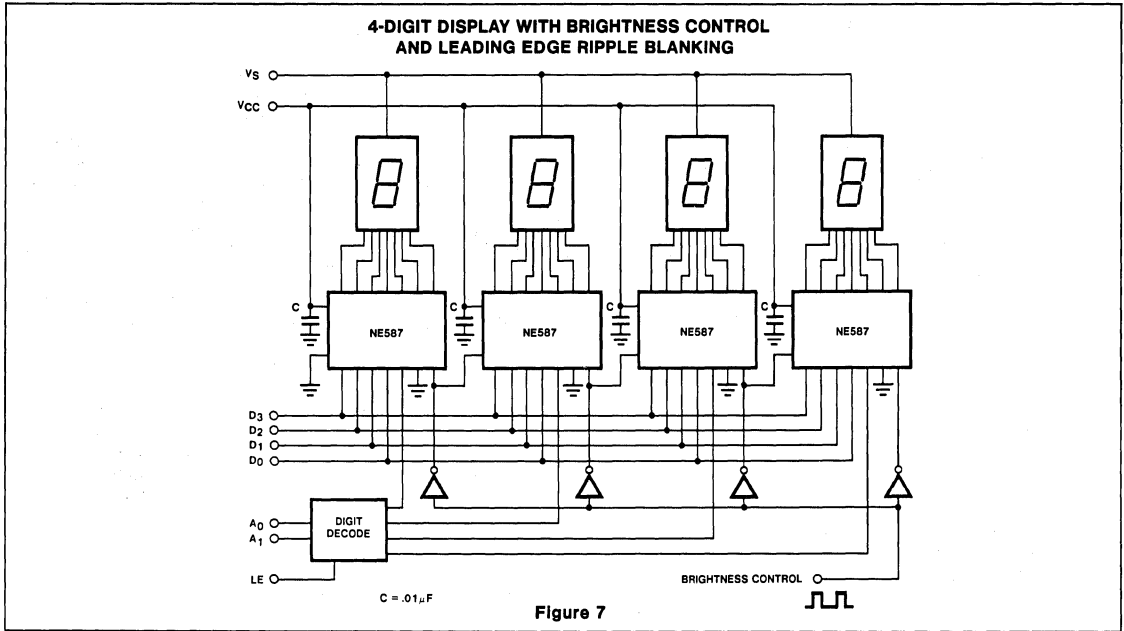

TYPICAL APPLICATIONS (Cont'd)

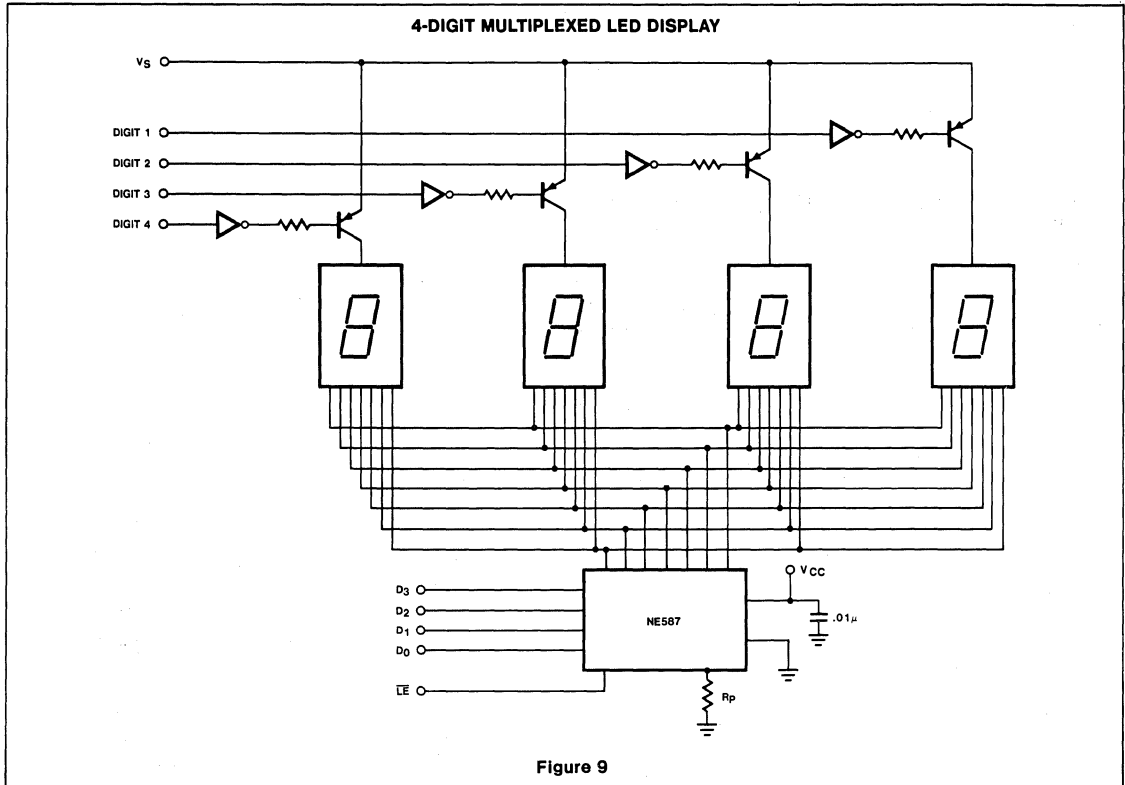

Figure 9

For additional information, refer to the Applications Section.

4

DESCRIPTION

The NE589 is a latch/decoder/driver for 7-segment common cathode LED displays. The NE589 has a programmable current output up to 50mA which is essentially independent of output voltage, power supply voltage, and temperature. The data (BCD) inputs and LE (latch enable) input are low-loading so that they are compatible with any data bus system. The 7-segment decoding is implemented with a ROM so that alternative fonts can be made available.

FEATURES

- Latched BCD inputs
- Low loading bus-compatible inputs
- Ripple-blanking on leading and/or trailing edge zeros

APPLICATIONS

- Digital panel meters
- Measuring Instruments
- Test equipment
- Digital clocks
- Digital bus monitoring

ABSOLUTE MAXIMUM RATINGS $T_A = 25^\circ\text{C}$ unless otherwise specified

PARAMETER	RATING	UNIT	
V _{CC} , V _S	Supply voltage	-0.5 to +7	V
V _{IN}	Input voltage (D ₀ - D ₃ , LE, RBI)	-0.5 to +15	V
V _{OUT}	Output voltage (a-g, RBO)	-0.5 to +7	V
P _D	Power dissipation (25°C) ¹	1000	mW
T _A	Ambient temperature range	0 to 70	°C
T _J	Junction temperature	150	°C
T _{STG}	Storage temperature range	-65 to +150	°C
T _{SOLD}	Soldering temperature (10 sec. max)	300	°C

NOTE
 Derate power dissipation as indicated
 N package - 95°C/watt above 55°C
 F package - 100°C/watt above 50°C

BLOCK DIAGRAM

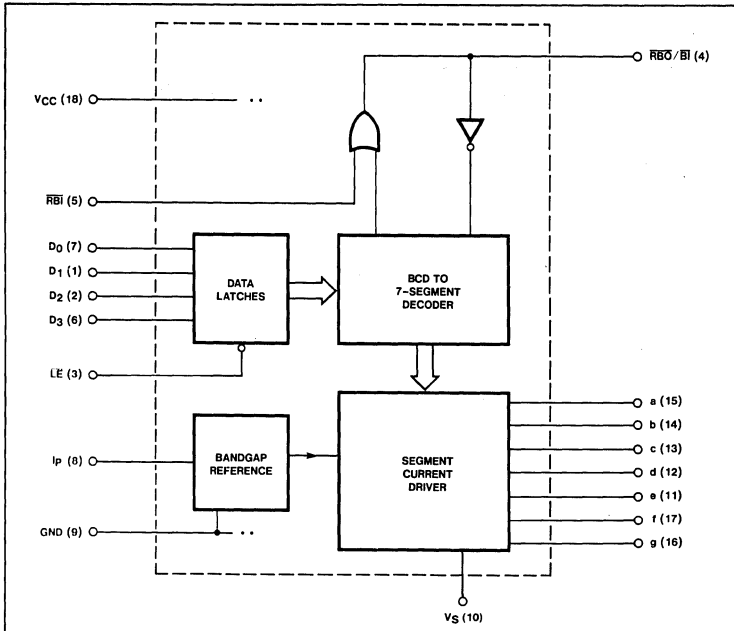

PIN CONFIGURATION

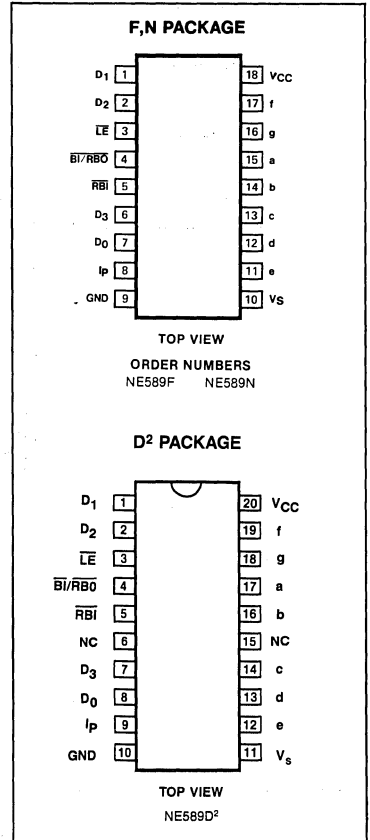

- NOTES:
 1. SOL - Released in Large SO package only.
 2. SOL and non-standard pinout.
 3. SO and non-standard pinouts.

LED DECODER/DRIVER

NE589

DC ELECTRICAL CHARACTERISTICS

 $V_{CC} = 4.75$ to $5.25V$, $0^{\circ}C < T_A < 70^{\circ}C$. Typical values are at $V_{CC} = V_S = 5V$, $T_A = 25^{\circ}C$, $R_p = 7k\Omega$ ($\pm 1\%$) unless otherwise stated.

PARAMETER	TEST CONDITIONS	NE589			UNIT
		Min	Typ	Max	
V_{CC}, V_S Operating supply voltage		4.75	5.00	5.25	V
V_{IH} Input high voltage	All Inputs except \overline{BI} \overline{BI}	2.0 2.0		15 5.5	V
V_{IL} Input low voltage				0.8	V
V_{IC} Input clamp voltage	$I_{IN} = -12mA$, $T_A = 25^{\circ}C$			-1.5	V
I_{IH} Input high current	Inputs $D_0 - D_3, \overline{LE}, \overline{RBI}$ $V_{IN} = 2.4V$ $V_{IN} = 15V$		0.1 10	10 15	μA μA
I_{IH} Input high current	Input \overline{BI} (pin 4) $\overline{RBI} = H$ $V_{IN} = V_{CC} = 5.25V$		10		μA
I_{IL} Input low current	$V_{IN} = 0.4V$, Inputs $D_0 - D_3$ $\overline{LE}, \overline{RBI}$		-5 -200		μA
I_{IL} Input low current	Input \overline{BI} $V_{CC} = 5.25V$ $\overline{RBI} = H, V_{IN} = 0.4V$		-0.7		mA
V_{OL} Output low voltage	Output $\overline{RB0}$ $I_{OUT} = 3.0mA$		0.2	0.5	V
V_{OH} Output high voltage	Output $\overline{RB0}$ $I_{OUT} = -50\mu A$ $\overline{RBI} = H$	3.5	4.5		V
I_{OUT} Output segment "ON" current	Outputs "a" thru "g" $V_{OUT} = 2.0V$	20	25	30	mA
ΔI_{OUT} Output current ratio (all outputs ON)	With reference to "b" segment $V_{OUT} = 2.0V$	0.90	1.00	1.10	
I_{OFF} Output segment "OFF" current	Outputs "a" thru "g"		20	250	μA
I_{CCO} Supply current	$V_{CC} = 5.25V$ All outputs "ON" $V_{OUT} > 1V$		25	55	mA
I_{CCI} Supply current	$V_{CC} = 5.25V$ All outputs blanked		30	65	mA

4

LED DECODER/DRIVER

NE589

AC ELECTRICAL CHARACTERISTICS $V_{CC} = V_S = 5V$ $T_A = 25^\circ C$, $R_L = 130\Omega$, $C_L = 30pF$ including probe capacity.

PARAMETER	TEST CONDITIONS	NE589			UNIT
		Min	Typ	Max	
$t_{D_{av}}$ Propagation delay Figure 2	From data to output		135		ns
$t_{D_{av}}$ Propagation delay Figure 3	From \overline{LE} to output		135		ns
t_W Latch enable pulse width Figure 4		85			ns
t_S Latch enable setup time Figure 4	From data to \overline{LE}	75			ns
t_H Latch enable hold time Figure 4	From \overline{LE} to data	0			ns

NOTE:
 $t_{D_{AV}} = \max(t_{HL} + t_{LH})$

TRUTH TABLE

BINARY INPUT	INPUTS						OUTPUTS								DISPLAY
	\overline{LE}	\overline{RBI}	D_3	D_2	D_1	D_0	a	b	c	d	e	f	g	\overline{RBO}	
—	H	*	X	X	X	X	STABLE								STABLE BLANK
0	L	L	L	L	L	L	L	L	L	L	L	L	L	L	
0	L	H	L	L	L	L	H	H	H	H	H	H	L	H	0
1	L	X	L	L	L	L	H	H	H	L	L	L	L	H	1
2	L	X	L	L	H	L	H	H	L	H	H	L	H	H	2
3	L	X	L	L	H	H	H	H	H	H	L	L	H	H	3
4	L	X	L	H	L	L	L	H	H	L	L	H	H	H	4
5	L	X	L	H	L	H	H	L	H	H	L	H	H	H	5
6	L	X	L	H	H	L	H	L	H	H	H	H	H	H	6
7	L	X	L	H	H	H	H	H	H	L	L	L	L	H	7
8	L	X	H	L	L	L	H	H	H	H	H	H	H	H	8
9	L	X	H	L	L	H	H	H	H	H	L	H	H	H	9
10	L	X	H	L	H	L	H	H	H	L	H	H	H	H	a
11	L	X	H	L	H	H	L	L	H	H	H	H	H	H	b
12	L	X	H	H	L	L	H	L	L	H	H	L	H	H	c
13	L	X	H	H	L	H	L	L	H	H	L	L	H	H	d
14	L	X	H	H	H	L	H	L	L	H	H	H	H	H	e
15	L	X	H	H	H	H	H	L	L	L	H	H	H	H	f
BI	X	X	X	X	X	X	L	L	L	L	L	L	L	L	blank

NOTES
 H = HIGH voltage level, output is "ON"
 L = LOW voltage level, output is "OFF"
 X = Don't care

* The \overline{RBI} will blank the display only if a binary zero is stored in the latches.
 ** $\overline{RBO}/\overline{BI}$ used as an input overrides all other input conditions.

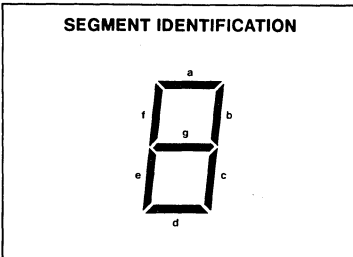

NE589 PROGRAMMING

NE589 output current can be programmed by using a programming resistor, R_p , connected between r_p (pin 8) and Gnd (pin 9). The voltage at r_p (pin 8) is constant ($\approx 1.3V$). A partial schematic of the voltage reference used in the NE589 is shown in figure 1.

Output current, to program current ratio, I_o/I_p , is 120 in the 10mA to 50mA range. Note that I_p must be derived from a resistor (R_p), and not from a high impedance source such as an I_{OUT} DAC used to control display brightness.

POWER DISSIPATION CONSIDERATIONS

LED displays are power-hungry devices, and inevitably somewhat inefficient in their use of the power supply necessary to drive them. Duty cycle control does afford one way of improving display efficiency, provided that the LEDs are not driven too far into saturation, but the improvement is marginal. Operation at higher peak currents has the added advantage of giving much better matching of light output, both from segment-to-segment and digit-to-digit.

An output current of 10 to 50mA was chosen so that it would be suitable for multiplexed operation of large size LED digits. When designing a display system, particular care must be taken to minimize power dissipation within the IC display driver. Since the output is a constant current source, which is not dropped across the LED (and the digit driver, if used), will appear across the output. Thus, the power dissipation will go up sharply if the display power supply voltage rises. Clearly, then, it is good design practice to keep the display supply voltage as low as possible consistent with proper operation of the supply output current sources. Inserting a resistor or diode in series with the display supply is a good way of reducing the power dissipation within the integrated circuit segment driver, although, of course, total system power remains the same.

Power dissipation may be calculated as follows. Referring to figure 5, the two system power supplies are V_{CC} and V_S . In many cases, these will be the same voltage. Necessary parameters are:

- V_{CC} , Supply voltage to driver
- V_S , Supply voltage to display
- I_{CC} , Quiescent supply current of driver
- I_{SEG} , LED segment current
- V_F , LED segment forward voltage at I_{seg}
- K_{DC} , % Duty cycle

V_F ; the forward LED drop, depends upon the type of LED material (hence the color) and the forward current. The actual forward voltage drops should be obtained from the LED display manufacturer's literature for the peak segment current selected; however, approximate voltages at nominal rated currents are:

Red	1.6 to 2.0V
Orange	2.0 to 2.5V
Yellow	2.2 to 3.5V
Green	2.5 to 3.5V

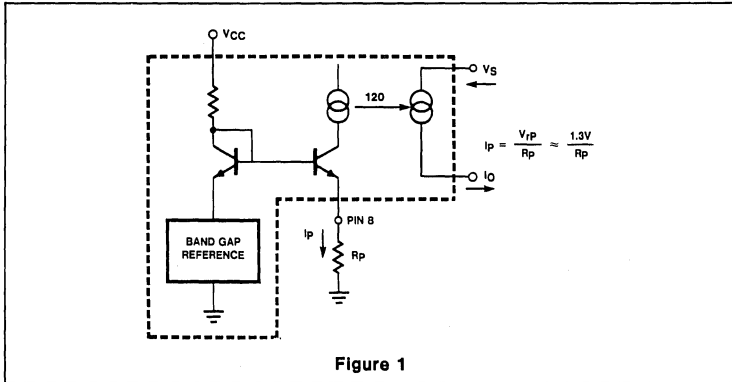

Figure 1

TIMING DIAGRAMS

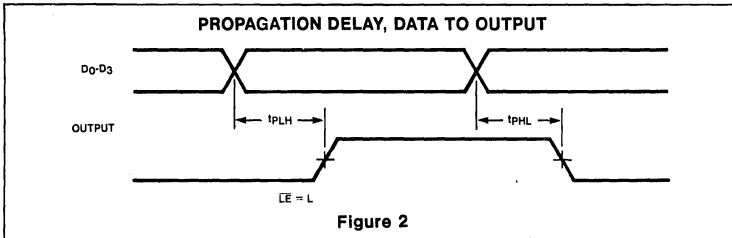

Figure 2

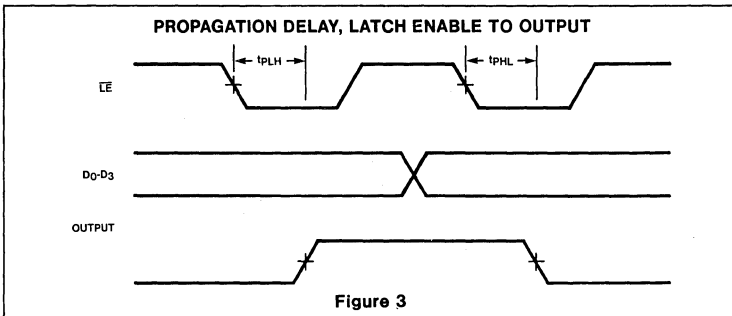
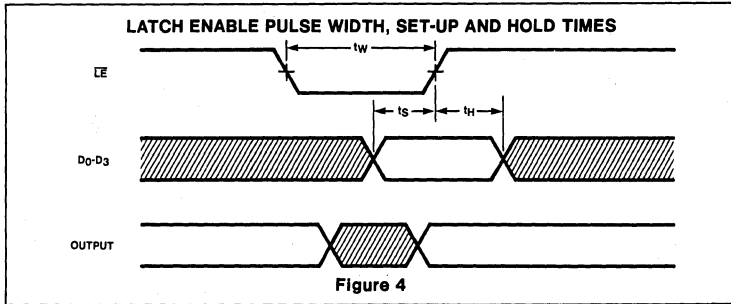

Figure 3

TIMING DIAGRAMS (Cont'd)



These voltages are all for single diode displays. Some early red displays had 2 series LEDs per segment; hence the forward voltage drop was around 3.5V.

Thus a maximum power dissipation calculation when all segments are on, is:

$$P_d = V_{CC} \times I_{CC} + (V_S - V_F) \times 7 \times I_{seg} \times K_{DC} \text{ mW}$$

Assuming $V_S = V_{CC} = 5.25V$
 $V_F = 2.0V$
 $K_{DC} = 100\%$

$$P_{d \text{ max}} = 5.25 \times 50 + 3.25 \times 7 \times 30 \text{ mW} = 945 \text{ mW}$$

TYPICAL PERFORMANCE CURVES

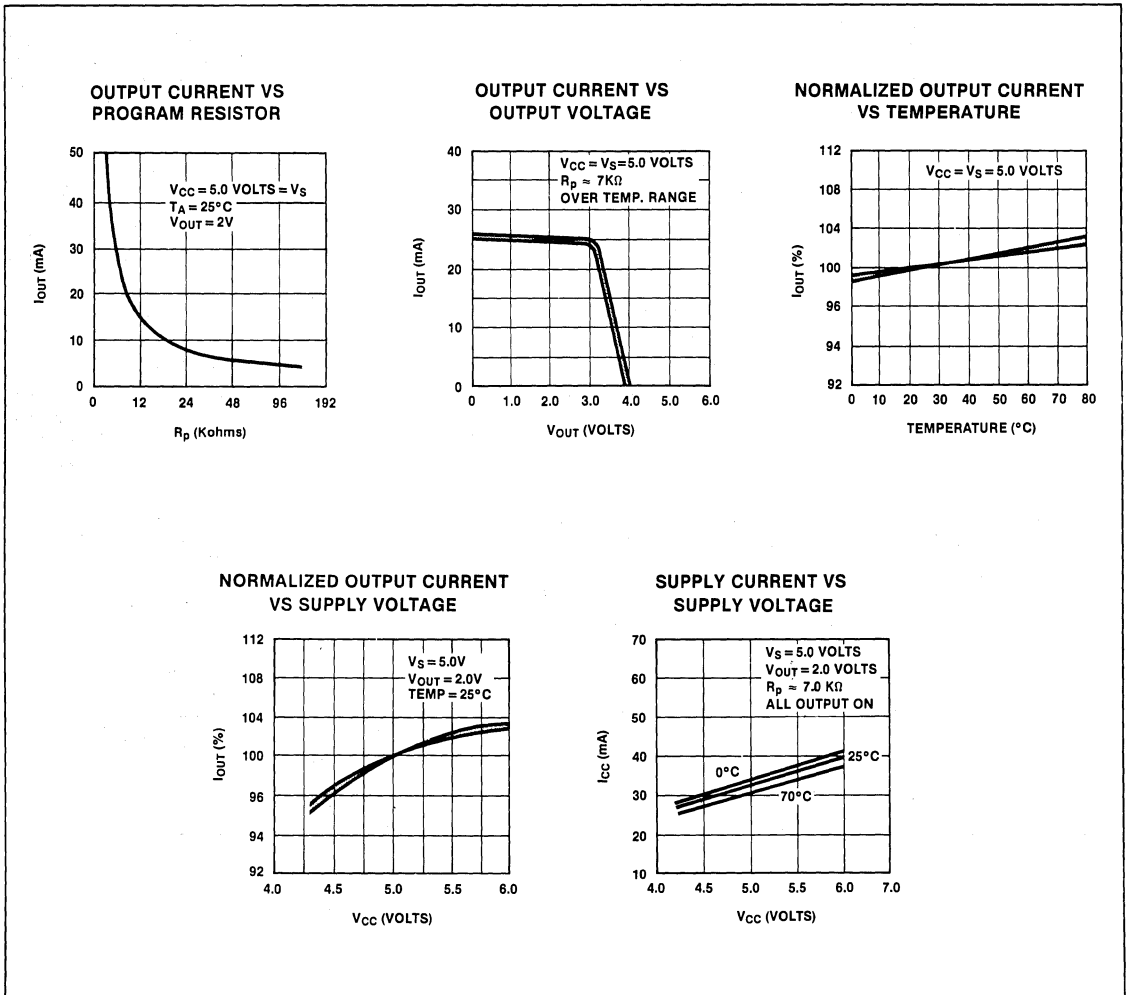

TYPICAL PERFORMANCE CURVES (Cont'd)

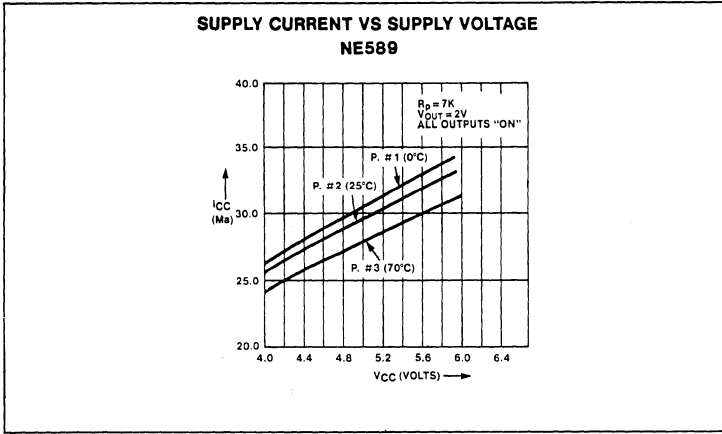

TYPICAL APPLICATIONS

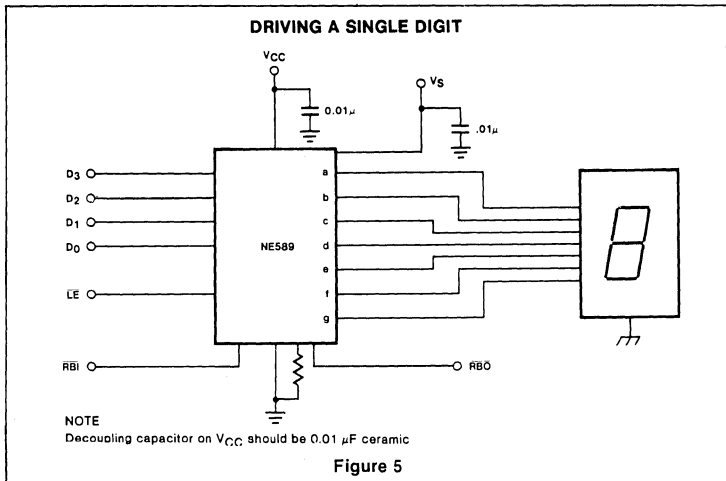

Figure 5

However, the average power dissipation will be considerably less than this. Assuming 5 segments are on (the average for all output code combinations), then

$$P_{d\text{ av}} = 5.0 \times 30 + 3.00 \times 5 \times 25 \text{ mW} = 525 \text{ mW}$$

Operating temperature range limitations can be deduced from the power dissipation graph in figure 9.

However, a major portion of this power dissipation ($P_{d\text{ max}}$) is because the current source output is operating with 3.25 V across it. In practice, the outputs operate satisfactorily down to 0.5V, and so the extra voltage may be dropped external to the integrated circuit.

Suppose the worst case V_{CC}/V_S supply is 4.75 to 5.25V, and that the maximum V_E for the LED display is 2.25V. Only 2.75V is required to keep the display active, and hence 2.0V may be dropped externally with a resistor from V_{CC} to V_S . The value of this resistor is calculated by:

$$R_S = \frac{2.0}{7 \times I_{\text{seg}}} \approx 10\Omega \text{ (}\frac{1}{2}\text{ W rating)}$$

assuming worst case I_{seg} of 30 mA

$$\begin{aligned} \text{Hence now } P_{d\text{ max}} &= V_{CC} \times I_{CC} + (V_S - V_V - R_X \times 7 \times I_{\text{seg}}) \times 7 \times X \times I_{\text{seg}} \\ &= 5.25 \times 50 + 1.25 \times 7 \times 30 \\ &= 525 \text{ mW} \end{aligned}$$

$$\text{and } P_{d\text{ av}} = 5.0 \times 30 + 1.25 \times 5 \times 25 = 306 \text{ mW}$$

If a diode (or 2) is used to reduce voltage to the display, then the voltage appearing across the display driver will be independent of the number of "ON" segments and will be equal to

$$V_S - V_F - nV_D, V_D \approx 0.8V$$

Where n is the number of diodes used, power dissipation can be calculated in a similar manner.

In a multiplexed display system, the voltage drop across the digit driver must also be considered in computing device power dissipation. It may even be an advantage to use a digit driver which drops an appreciable voltage, rather than the saturating PNP transistors shown in figure 8. For example a darlington PNP or NPN emitter follower may be preferable. Figure 7 shows the NE591 as the digit driver in a multiplexed display system. The NE591 output drops about 1.8V which means that the power dissipation is evenly distributed between the two integrated circuits.

Where V_S and V_{CC} are two different supplies, the V_S supply may be optimized for minimum system power dissipation and/or cost. Clearly, good regulation in the V_S supply is totally unnecessary, and so this supply can be made much cheaper than the regulated 5V supply used in the rest of the system. In fact a simple unsmoothed full-wave rectified sine wave works extremely well if a slight loss in brightness can be tolerated. A transformer voltage of about 3-4.5V rms works well in most LED display systems. Waveforms are shown below:

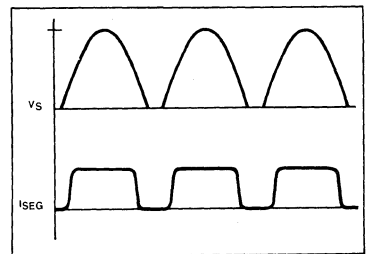

The duty cycle for this system depends upon V_S , V_F and the output characteristics of the display driver.

With
 $V_S = 4.9V \text{ pk.}$
 $V_F = 2.0V$

The duty cycle is approximately 60%.

TYPICAL APPLICATIONS (Cont'd)

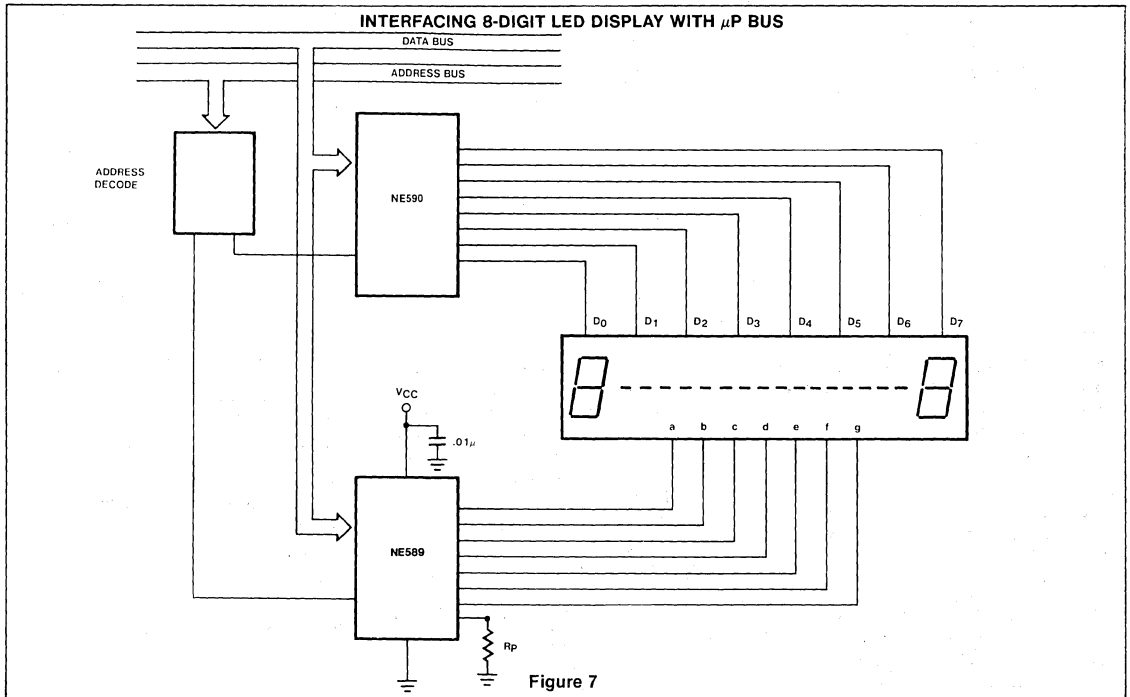
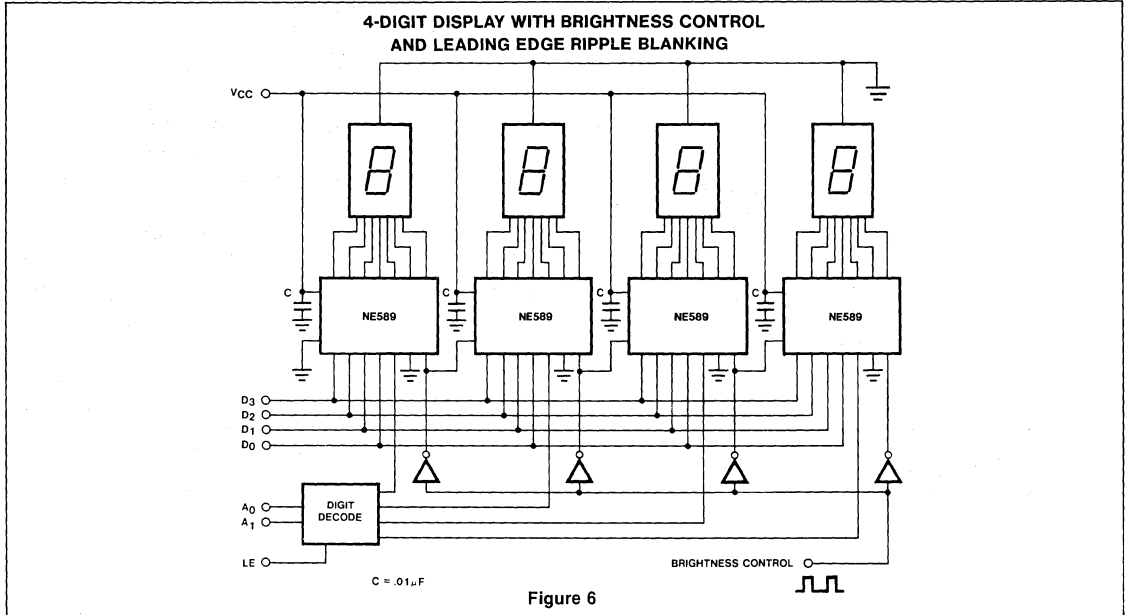

TYPICAL APPLICATIONS (Cont'd)

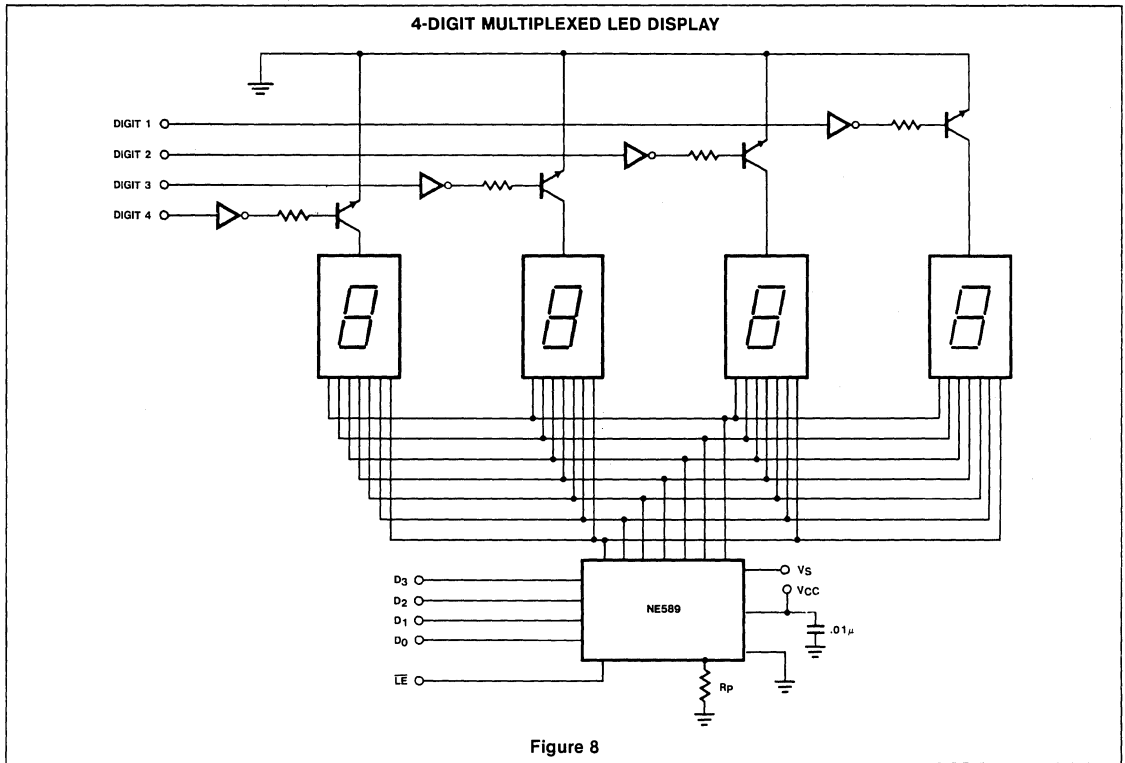

For additional information, refer to the Applications Section.

4

ADDRESSABLE PERIPHERAL DRIVERS

NE590/NE591

DESCRIPTION

The NE590/591 addressable peripheral drivers are high current latched drivers, similar in function to the 9334 address decoder. The device has 8 Darlington power outputs, each capable of 250mA load current. The outputs are turned on or off by respectively loading a logic high or logic low into the device data input. The required output is defined by a 3-bit address. The device must be enabled by a \overline{CE} input line. A common clear input, \overline{CLR} , turns all outputs off when a logic low is applied.

The NE590 has 8 open collector Darlington outputs which sink current to ground. The device is packaged in a 16-pin molded or cerdip package.

The NE591 has 8 open emitter Darlington outputs which source current to an external load from a common collector line, V_S . This V_S line need not necessarily be the same as the 5 volt V_{CC} supply. The device is packaged in an 18-pin molded or cerdip package.

FEATURES

- 8 high current outputs
- Low-loading bus compatible inputs
- Power-on clear ensures safe operation
- NE590 will operate in addressable or demultiplex mode
- Allows random (addressed) data entry
- Easily expandable
- NE590 is pin compatible with 54/74LS259

APPLICATIONS

- Relay driver
- Indicator lamp driver
- Triac trigger
- LED display digit driver
- Stepper motor driver

PIN CONFIGURATION

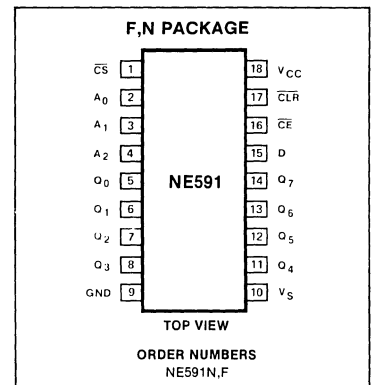
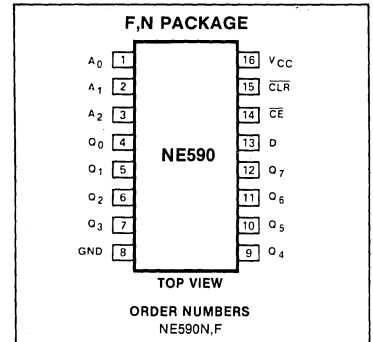

PIN DESIGNATION

590 PIN NO.	591 PIN NO.	SYMBOL	NAME & FUNCTION
1-3	2-4	A ₀ -A ₂	A 3-bit binary address on these pins defines which of the 8 output latches is to receive the data.
4-7, 9-12	5-8, 11-14	Q ₀ -Q ₇	The 8 device outputs. The NE590 has open collector Darlington outputs. The NE591 has open emitter follower outputs.
13	15	D	The data input. When the chip is enabled, this data bit is transferred to the defined output such that: "1" turns output switch "ON" "0" turns output switch "OFF" Thus in logic terms, the NE590 inverts data to the relevant output. The NE591 retains true data at the output.
14	16	\overline{CE}	The chip enable. When this input is low, the output latches will accept data. When \overline{CE} goes high, all outputs will retain their existing state, regardless of address or data input conditions.
15	17	\overline{CLR}	The clear input. When \overline{CLR} goes low all output switches are turned "OFF". On the NE590, a high data input will override the clear function on the addressed latch. On the NE591, \overline{CLR} low will override any other condition.
—	1	\overline{CS}	The chip select input provides for an additional level of address decoding.
—	10	V_S	The V_S line provides the power to all 8 output devices. It is connected to the collectors of all 8 output transistors. This pin may be connected to the V_{CC} or another supply.

ADDRESSABLE PERIPHERAL DRIVERS

NE590/NE591

TRUTH TABLE (NE590)

INPUTS							OUTPUTS							MODE	
CLR	CE	D	A ₀	A ₁	A ₂		Q ₀	Q ₁	Q ₂	Q ₃	Q ₄	Q ₅	Q ₆	Q ₇	
L	H	X	X	X	X		H	H	H	H	H	H	H	H	Clear
L	L	L	L	L	L		H	H	H	H	H	H	H	H	Demultiplex
L	L	L	H	L	L		L	H	H	H	H	H	H	H	
L	L	L	L	H	L		H	H	H	H	H	H	H	H	
L	L	H	H	L	L		H	L	H	H	H	H	H	H	
L	L	L	H	H	H		H	H	H	H	H	H	H	H	
L	L	H	H	H	H		H	H	H	H	H	H	H	L	
H	H	X	X	X	X		Q _{N-1} →							Memory	
H	L	L	L	L	L		H	Q _{N-1} →							Addressable Latch
H	L	H	L	L	L		L	Q _{N-1} →							
H	L	L	H	L	L		Q _{N-1}	H	Q _{N-1} →						
H	L	L	H	L	L		Q _{N-1}	L	Q _{N-1} →						
H	L	L	H	H	H		Q _{N-1}	→ H							
H	L	H	H	H	H		Q _{N-1}	→ L							

X = Don't care condition
 Q_{N-1} = Previous output state
 L = Low voltage level/"ON" output state
 H = High voltage level/"OFF" output state

(NE591)

INPUTS							OUTPUTS							MODE	
CLR	CE	CS	D	A ₀	A ₁	A ₂	Q ₀	Q ₁	Q ₂	Q ₃	Q ₄	Q ₅	Q ₆	Q ₇	
L	X	X	X	X	X	X	L	L	L	L	L	L	L	L	Clear
H	H	H	X	X	X	X	Q _{N-1} →							Memory	
H	H	L	X	X	X	X	Q _{N-1} →								
H	L	H	X	X	X	X	Q _{N-1} →								
H	L	L	L	L	L	L	L	Q _{N-1} →							Addressable Latch
H	L	L	H	L	L	L	H	Q _{N-1} →							
H	L	L	L	H	L	L	Q _{N-1}	L	Q _{N-1} →						
H	L	L	H	H	L	L	Q _{N-1}	H	Q _{N-1} →						
H	L	L	L	H	H	H	Q _{N-1}	→ L							
H	L	L	H	H	H	H	Q _{N-1}	→ H							

X = Don't care
 Q_{N-1} = Previous output state
 L = Low voltage level/"OFF" output state
 H = High voltage level/"ON" output state

4

ADDRESSABLE PERIPHERAL DRIVERS

NE590/NE591

ABSOLUTE MAXIMUM RATINGS T_A = 25°C unless otherwise specified.

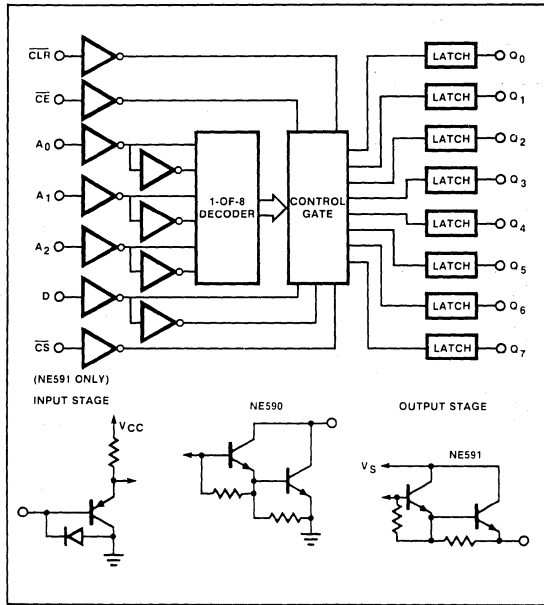

PARAMETER	RATING	UNIT
V _{CC}	Supply voltage	-0.5 to +7 V
V _{IN}	Input voltage	-0.5 to +15 V
V _{OUT}	Output voltage	V
	NE590	0 to +7
	NE591	0 to V _{CC}
V _S	Source bus voltage	V
	NE591 only	-0.5 to +7
V _S -V _{CC}	Source/supply differential voltage	V
	NE591 only	-5 to +2
I _{OUT}	Output current	mA
	Each output	300
	All outputs	1000
P _D	Power dissipation ¹	W
	Temperature range	°C
T _A	Ambient	0 to +70
T _J	Junction	165
T _{STG}	Storage	-65 to +150
T _{sold}	Lead soldering temperature (10sec max)	300 °C

DC ELECTRICAL CHARACTERISTICS V_{CC} = 4.75 to 5.25V, 0°C ≤ T_A ≤ 70°C unless otherwise specified.^{2,3}

PARAMETER	TEST CONDITIONS	LIMITS			UNIT
		Min	Typ	Max	
V _{IH} V _{IL}	Input voltage High Low	2.0		0.8	V
V _{OL} V _{OH}	Output voltage Low (NE590 only) High (NE591 only)		1.0	1.3 1.5	V
I _{IH} I _{IL}	Input current High Low		0.1	10	μA
	CE input		-25	-60	
	All other inputs		-15	-50	
I _{OH}	Leakage current	V _{OUT} = 5.25V	10	250	μA
I _{CC1} I _{CC2}	Supply current ⁴ All outputs low NE590 NE591	V _S = V _{CC} = 5V	33 15	50 50	mA
I _{CC3}	All outputs high NE590 NE591		15 30	50 50	

NOTES

- Derate power dissipation as indicated above threshold ambient temperature:
NE590N at 9.3 mW/°C above 85°C
NE590F at 7.5 mW/°C above 65°C
NE591N at 11.5 mW/°C above 100°C
NE591F at 10.7 mW/°C above 72°C

2 All typical values are at V_{CC} = 5V and T_A = 25°C.

3 For the NE591, V_S = V_{CC} in all tests.

4 Supply current for the NE591 is measured with no output load.

SWITCHING CHARACTERISTICS $V_{CC} = 5V, T_A = 25^\circ C$

PARAMETER	TO	FROM	NE590			NE591			UNIT
			Min	Typ	Max	Min	Typ	Max	
Propagation delay time									ns
t_{PLH} Low to high ⁵	Output	\overline{CE}		65	150		50	80	
t_{PHL} High to low ⁵				115	230		70	120	
t_{PLH} Low to high ⁶	Output	Data		65	130		45	70	
t_{PHL} High to low ⁶				120	240		65	100	
t_{PLH} Low to high ⁷	Output	Address		100	200		45	80	
t_{PHL} High to low ⁷				130	260		75	140	
t_{PLH} Low to high ⁸	Output	\overline{CLR}		65	130		45	140	
t_{PHL} High to low ⁸									
t_{PLH} Low to high ⁵	Output	\overline{CS}					40	80	
t_{PHL} High to low ⁵								70	
SWITCHING SET-UP REQUIREMENTS									
$t_{s(H)}$ ⁹	Chip enable	High data	210	60		50	15		ns
$t_{s(L)}$ ⁹	Chip enable	Low data	210	105		80	60		ns
$t_{s(A)}$ ¹⁰	Chip enable	Address	+ 20	- 5		+ 20	- 20		ns
$t_h(H)$ ⁹	Chip enable	High data	- 20	60		0	- 60		ns
$t_h(L)$ ⁹	Chip enable	Low data	- 20	60		+ 10	- 15		ns
$t_{s(CS)}$ ⁹	Chip enable	Low chip select				80	50		ns
$t_{pw(E)}$	Chip enable pulse width ⁵		300	140		100	50		ns

NOTES

- 5. See Turn-On and Turn-Off Delays, Enable to Output and Enable Pulse Width timing diagram.
- 6. See Turn-On and Turn-Off Delays, Data to Output timing diagram.
- 7. See Turn-On and Turn-Off Delays, Address to Output timing diagram.
- 8. See Turn-Off Delay, Clear to Output timing diagram.
- 9. See Setup and Hold Time, Data to Enable timing diagram.
- 10. See Setup Time, Address to Enable timing diagram.

4

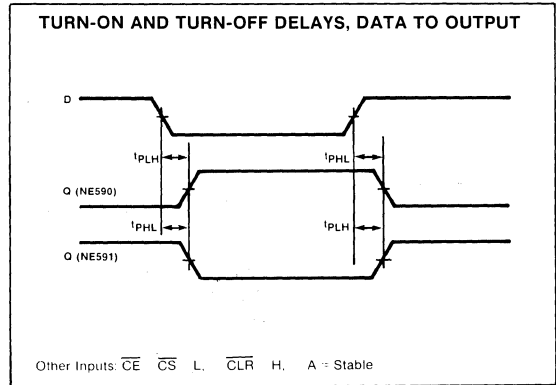
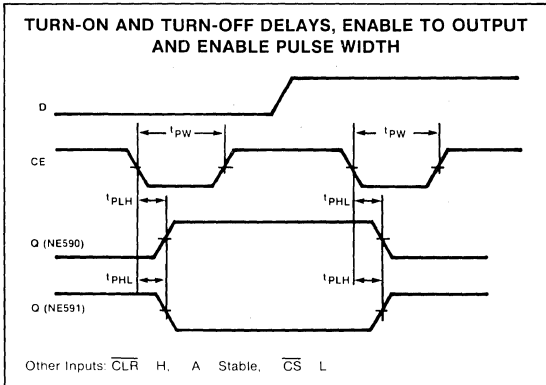

ADDRESSABLE PERIPHERAL DRIVERS

NE590/NE591

TURN-ON AND TURN-OFF DELAYS, ADDRESS TO OUTPUT

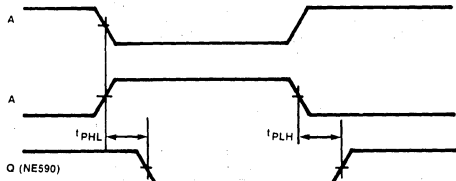

Other Inputs: $\overline{CE} = L$, $\overline{CLR} = L$, $D = H$

TURN-OFF DELAY, CLEAR TO OUTPUT

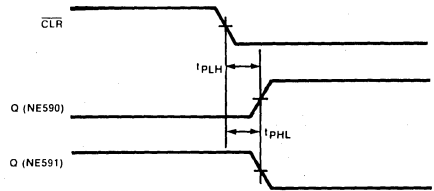

Other Inputs: $\overline{CE} = H$, $\overline{CS} = H$

SETUP TIME, ADDRESS TO ENABLE

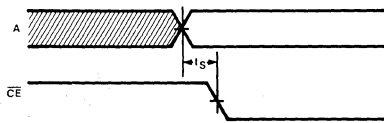

Other Inputs: $\overline{CLR} = H$, $\overline{CS} = L$

SETUP AND HOLD TIME, DATA TO ENABLE

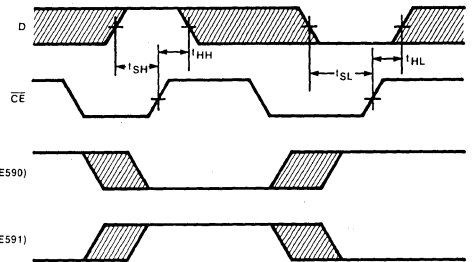

Other Inputs: $\overline{CLR} = H$, $A = \text{Stable}$, $\overline{CS} = L$

OUTPUT VOLTAGE VS LOAD CURRENT (NE590)

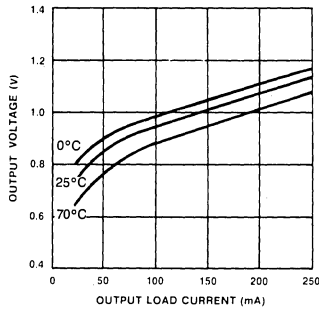

OUTPUT VOLTAGE DROP VS LOAD CURRENT (NE591)

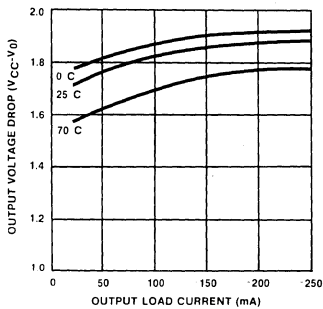

INTERFACING THE 590/591 WITH A MICROPROCESSOR SYSTEM

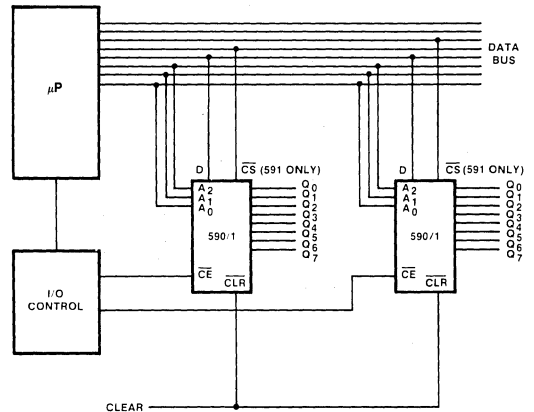

A_0 , A_1 , A_2 , and \overline{CS} may be connected to the address bus if permitted by system design.

TYPICAL APPLICATIONS (Cont'd)

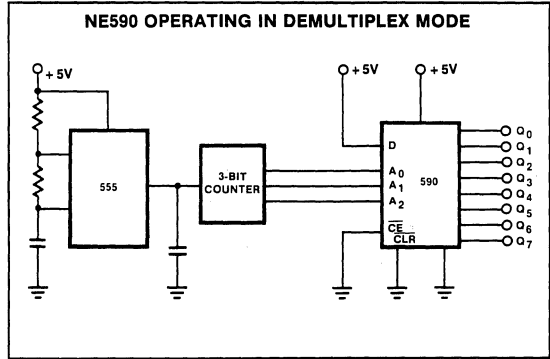
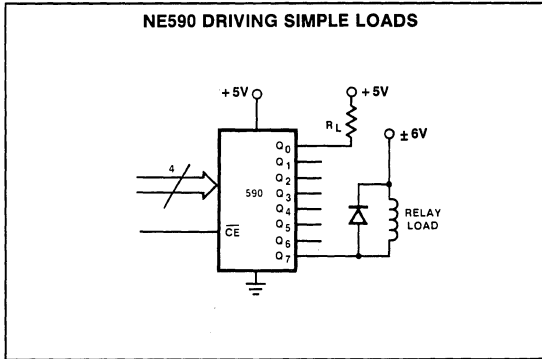

VACUUM FLUORESCENT DISPLAY DRIVER

SA/NE594

DESCRIPTION

The SA/NE594 is a display driver interface for vacuum fluorescent displays. The device is comprised of 8 drivers and a bias network and is capable of driving the digits and/or segments of most vacuum fluorescent displays.

The inputs are designed to be compatible with TTL, DTL, NMOS, PMOS or CMOS output circuitry.

There is an active pull-down circuit on each output so that display ghosting is minimized and no external components are required for most fluorescent display applications.

FEATURES

- Digit and/or segment drivers
- Active output pull-down circuitry
- High output breakdown voltage
- Low supply voltage
- Input compatible with all logic outputs

APPLICATIONS

- Digital clocks
- Dashboard displays
- Panel displays

PIN CONFIGURATION

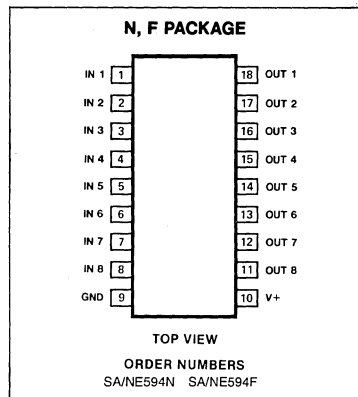

ABSOLUTE MAXIMUM RATINGS (at 25°C unless otherwise noted)

PARAMETER	RATING	UNIT
V _{CC}	Supply voltage	45 V
V _{OUT}	Output voltage	V _{CC}
V _{IN}	Input voltage	-0.3, +20 V
I _{OUT}	Output current	
	Each output	50 mA
	All outputs	200 mA
P _d	Power dissipation* (at 25°C)	800 mW
T _A	Operating temperature range	
	NE	0 to 70 °C
	SA	-40 to +85 °C
T _{STG}	Storage temperature range	+65 to +150 °C
T _J	Maximum junction temperature	-165 °C
T _{SOLD}	Lead soldering temperature (10 seconds)	300 °C

NOTE

*Derate N (Plastic) Package above 38°C at 7.14 mW/°C.
Derate F (Ceramic) Package above 75°C at 10.8 mW/°C.

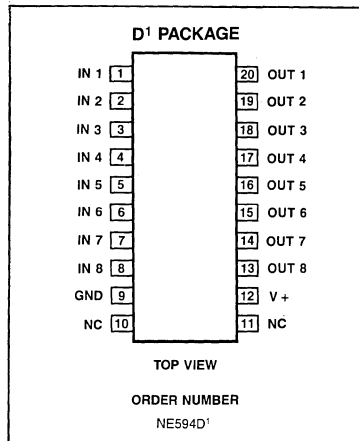

NOTES:

1. SOL - Released in Large SO package only.
2. SOL and non-standard pinout.
3. SO and non-standard pinouts.

EQUIVALENT SCHEMATIC

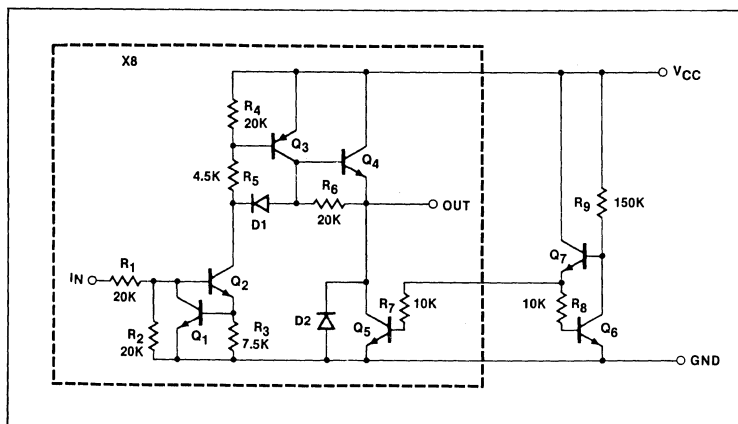

VACUUM FLUORESCENT DISPLAY DRIVER

SA/NE594

DC ELECTRICAL CHARACTERISTICS $V_{CC} = +4.75$ to $+40V$, T_A (NE) = 0 to $70^{\circ}C$, T_A (SA) = -40 to $+85^{\circ}C$ unless otherwise stated.

PARAMETER	TEST CONDITIONS	LIMITS			UNIT		
		Min	Typ	Max			
V_{CC}	Supply voltage range	4.75	35	40	V		
I_{CCH}	Supply current (all outputs high)	$V_{CC} = 40V$	$V_{IN} = 3.5V$	3	mA		
I_{CCL}	Supply current (all outputs low)	$V_{CC} = 40V$	$V_{IN} = 0.4V$	0.4	mA		
V_{IN}	Input voltage range			15	V		
V_{IH}	Input voltage to ensure logic '1'			2.6	V		
V_{IL}	Input voltage to ensure logic '0'			0.8	V		
I_{IH}	Input current to ensure logic '1'			100	μA		
I_{IL}	Input current to ensure logic '0'				μA		
I_{IN}	Input current	$V_{IN} = 2.6V$ $V_{IN} = 5.0V$ $V_{IN} = 15.0V$		60 180 .68	130 330 mA		
V_{OH}	Output high voltage	$V_{IN} = 3.5V$ $I_{OUT} = -25mA$ V_{OUT} with respect to V_{CC}	$T_A = 25^{\circ}C$ Over Temp.	$V_{CC}-1.5$ $V_{CC}-2$	$V_{CC}-1.1$ $V_{CC}-1.3$	V	
V_{OH}	Output high, <i>no load</i> voltage	$V_{IN} = 3.5V$ $I_{OUT} = 0$, $T_A = 25^{\circ}C$ V_{OUT} with respect to V_{CC}		$V_{CC}-1$	$V_{CC}-0.8$	V	
V_{OFF}	Output 'OFF' voltage level	$V_{IN} = 0.8V$ $I_{OUT} = 0$		10	200	mV	
I_{OH}	Available output current	$V_{CC} = 35V$ $V_{OUT} = 30V$ $T_A = 25^{\circ}C$	$V_{IN} = 3.5V$	-35		mA	
I_{OUT}	Output pulldown current	$V_{CC} = V_{OUT} = 35V$ Inputs open		100	200	400	μA
I_{CEX}	Output leakage current	$T_A = 25^{\circ}C$ $V_{CC} = 40V$,	$V_{IN} = 0.4V$ $V_{OUT} = 0V$		-1 -1	μA	

4

AC ELECTRICAL CHARACTERISTICS¹ $V_{CC} = 35V$, $T_A = 25^{\circ}C$

PARAMETER	TEST CONDITIONS	NE/SA594			UNIT
		Min	Typ	Max	
t_{pDLH}	Propagation delay - low to high output transition.		1	5	μS
t_{pDHL}	Propagation delay - high to low output transition.		3	10	μS
t_R	Output rise time		0.5	3	μS
t_F	Output fall time		1.5	5	μS

NOTE
1. See figure 1

SWITCHING TIMES OF DRIVERS

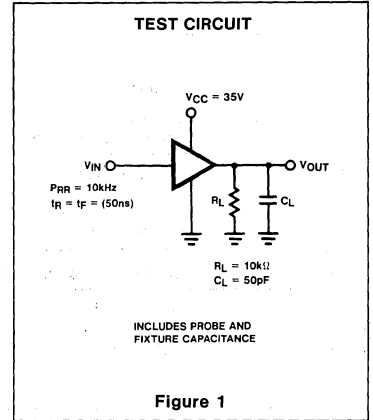
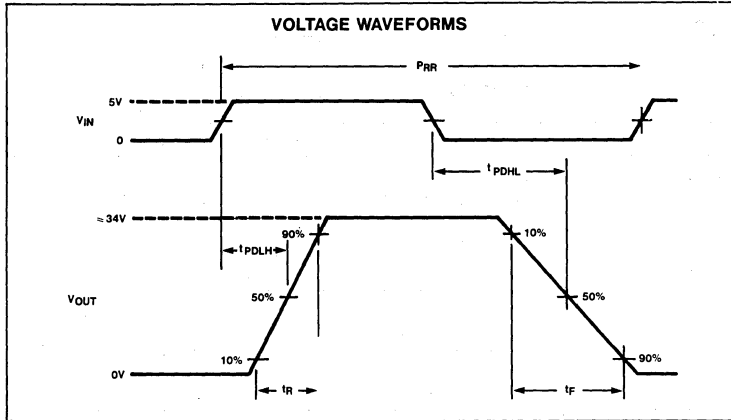

TYPICAL PERFORMANCE CHARACTERISTICS

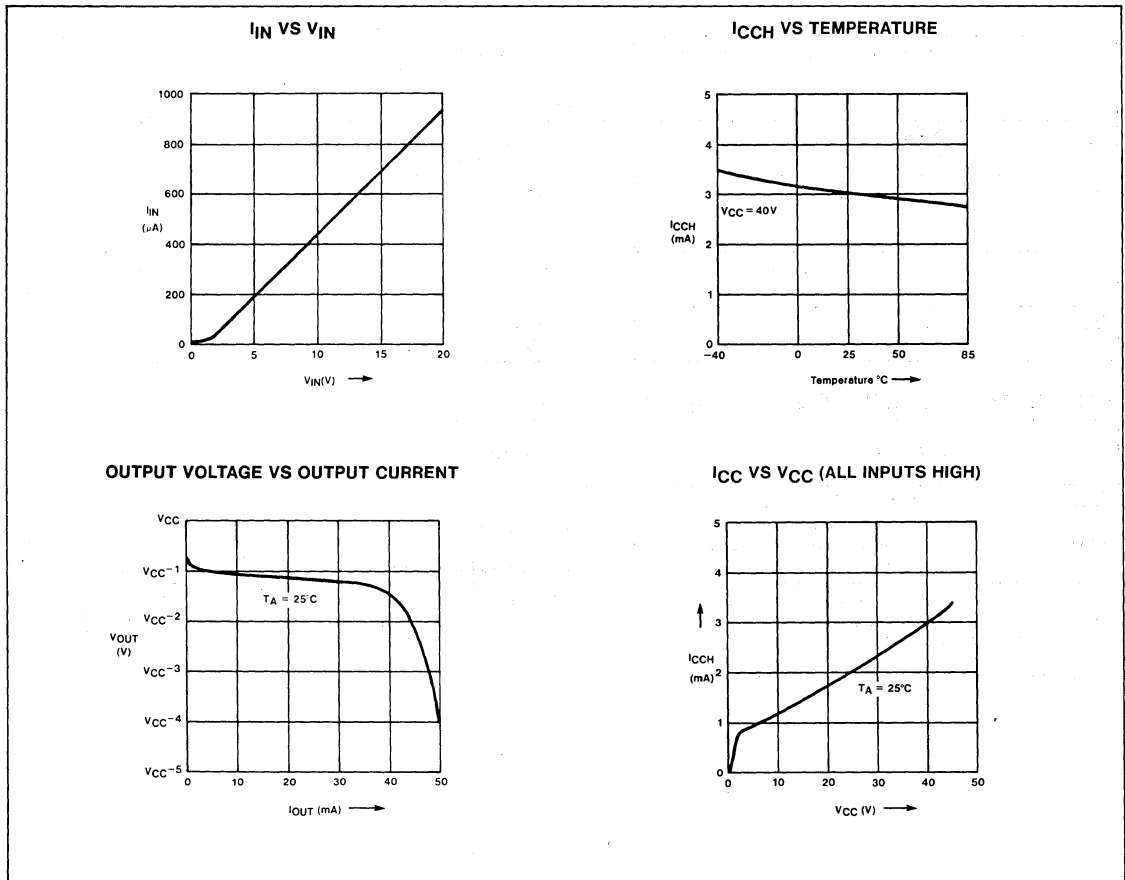

TYPICAL APPLICATION
DIGITAL CLOCK WITH ALARM

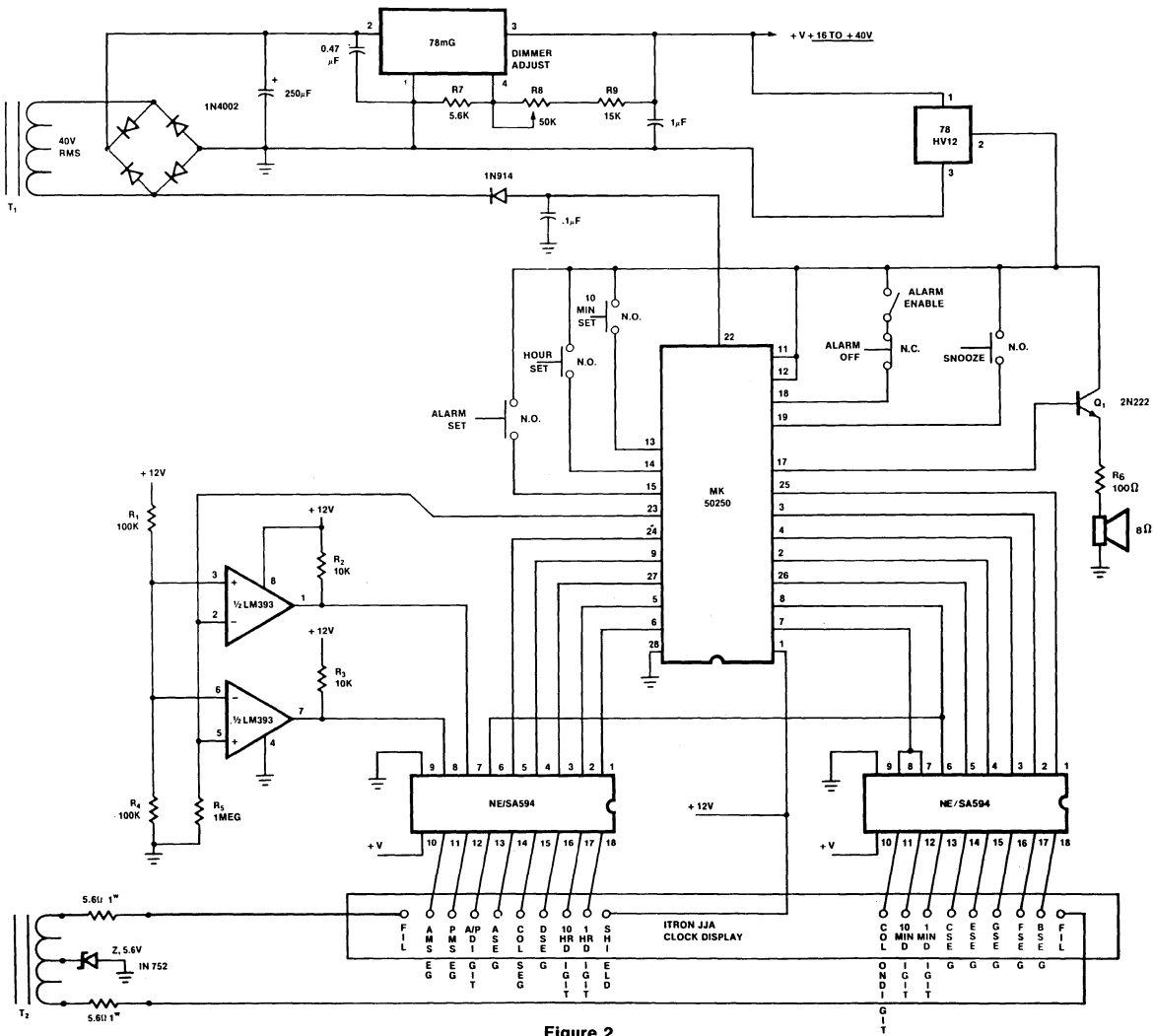

Figure 2

GENERAL DESCRIPTION

The PCF2100 is a single chip, silicon gate CMOS circuit designed to drive an LCD (Liquid Crystal Display) with up to 40 segments in a duplex manner; specially for low voltage applications. A three-line bus structure enables serial data transfer with microcontrollers. All inputs are CMOS/NMOS compatible.

Features

- 40 LCD-segment drive capability
- Supply voltage 2.25 to 6.5 V
- Low current consumption
- Serial data input
- CBUS control
- One-point built-in oscillator
- Expansion possibility

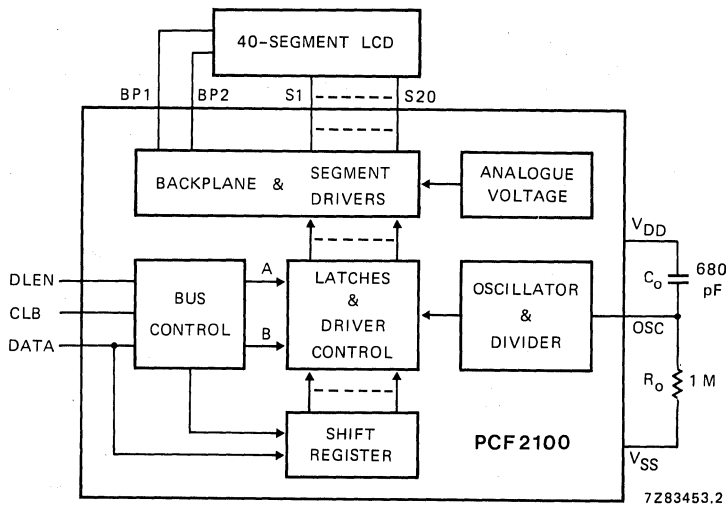

Fig. 1 Block diagram.

RATINGS

Limiting values in accordance with the Absolute Maximum System (IEC 134)

Supply voltage with respect to V_{SS}	V_{DD}	-0.3 to 8 V
Voltage on any pin	V_n	$V_{SS} - 0.3$ to $V_{DD} + 0.3$ V
Operating ambient temperature range	T_{amb}	-40 to +85 °C
Storage temperature range	T_{stg}	-55 to +125 °C

HANDLING

Inputs and outputs are protected against electrostatic charge in normal handling. However, to be totally safe, it is desirable to take normal precautions appropriate to handling MOS devices (see 'Handling MOS devices').

CHARACTERISTICS

$V_{DD} = 2,25$ to 6.5 V; $V_{SS} = 0$ V; $T_{amb} = -40$ to $+85$ °C; $R_o = 1$ M Ω ; $C_o = 680$ pF; unless otherwise specified

parameter	condition	symbol	min.	typ.	max.	unit
Supply current	no external load	I_{DD}	—	10	50	μ A
Supply current	no external load; $T_{amb} = -25$ to $+85$ °C	I_{DD}	—	—	30	μ A
Display frequency	see Fig. 8; $T = 680$ μ s	f_{LCD}	60	80	100	Hz
D.C. component of LCD drive	with respect to V_{SX}	V_{BP}	—	± 10	—	mV
Load on each segment driver			—	—	10	M Ω
			—	—	500	pF
Load on each backplane driver			—	—	1	M Ω
			—	—	5	nF
Input voltage HIGH	} see Fig. 9	V_{IH}	2	—	—	V
Input voltage LOW		V_{IL}	—	—	0,6	V
Rise time V_{BP} to V_{SX}	max. load	t_r	—	20	—	μ s
Inputs CLB , DATA , DLEN	see note on next page					
Rise and fall times	see Fig. 2	t_r, t_f	—	—	10	μ s
CLB pulse width HIGH	see Fig. 2	t_{WH}	1	—	—	μ s
CLB pulse width LOW	see Fig. 2	t_{WL}	9	—	—	μ s

CHARACTERISTICS (continued)

parameter	condition	symbol	min.	typ.	max.	unit
Data set-up time DATA → CLB	see Fig. 2	t _{SUDA}	8	—	—	μs
Data hold time DATA → CLB	see Fig. 2	t _{HDDA}	8	—	—	μs
Enable set-up time DLEN → CLB	see Fig. 2	t _{SUEN}	1	—	—	μs
Disable set-up time CLB → DLEN	see Fig. 2	t _{SUDI}	8	—	—	μs
Set-up time (load pulse) DLEN → CLB	see Fig. 2	t _{SULD}	8	—	—	μs
Busy-time from load pulse to next start of transmission	see Fig. 2	t _{BUSY}	8	—	—	μs
Set-up time (leading zero) DATA → CLB	see Fig. 2	t _{SULZ}	8	—	—	μs

Note

All timing values are referred to V_{IHmin} and V_{ILmax} (see Fig. 2). If external resistors are used in the bus lines (see Fig. 9), the extra time constant has to be added.

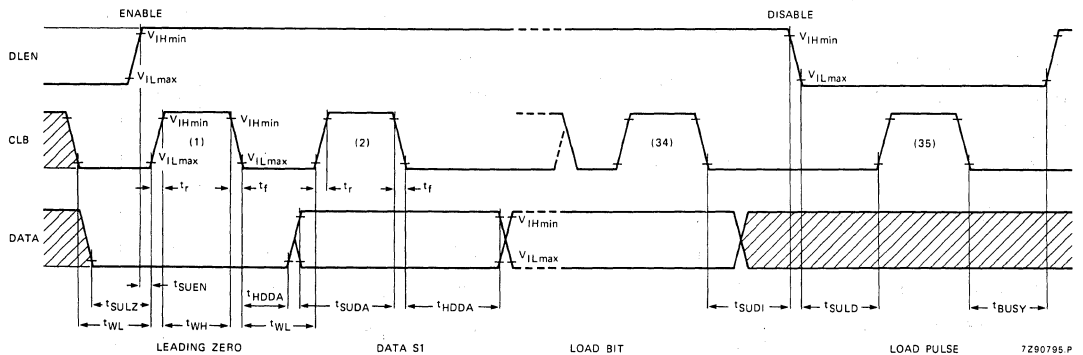

Fig. 2 CBUS timing.

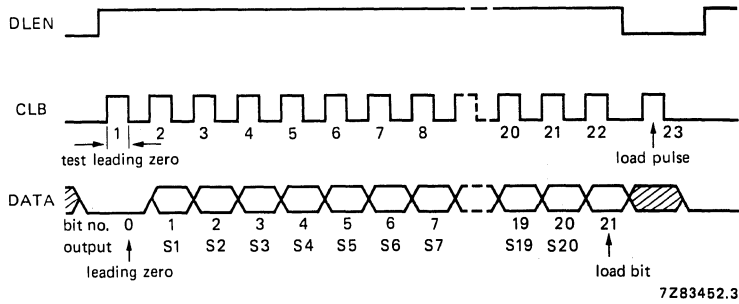

Fig. 3 CBUS data format.

Notes to Fig. 3

An LCD segment is activated when the corresponding DATA-bit is HIGH.

When DATA-bit 21 is HIGH, the A-latches (BP1) are loaded. With DATA-bit 21 LOW, the B-latches (BP2) are loaded.

CLB-pulse 23 transfers data from shift register to selected latches.

The following tests are carried out by the bus control logic:

- a. Test on leading zero.
- b. Test on number of DATA-bits.
- c. Test of disturbed DLEN and DATA signals during transmission.

If one of the test conditions is not fulfilled, no action follows the load conditions (load pulse width DLEN is LOW) and the driver is ready to receive new data.

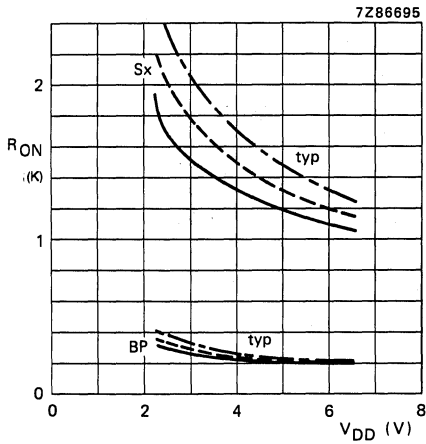

Fig. 4 Output resistance of backplane and segments.
 — $T_{amb} = -40\text{ }^{\circ}\text{C}$; - - - $T_{amb} = +25\text{ }^{\circ}\text{C}$;
 - · - · $T_{amb} = +85\text{ }^{\circ}\text{C}$.

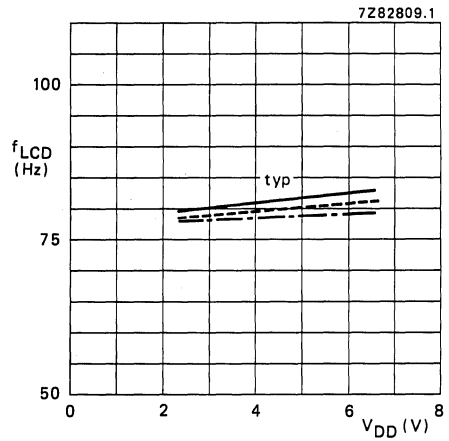

Fig. 5 Display frequency as a function of supply voltage; $R_O C_O = 680\ \mu\text{s}$.
 — $T_{amb} = -40\text{ }^{\circ}\text{C}$; - - - $T_{amb} = +25\text{ }^{\circ}\text{C}$;
 - · - · $T_{amb} = +85\text{ }^{\circ}\text{C}$.

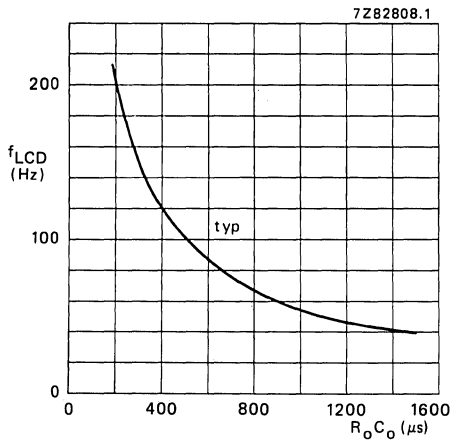

Fig. 6 Display frequency as a function of $R_O \times C_O$ time; $T_{amb} = 25\text{ }^{\circ}\text{C}$.

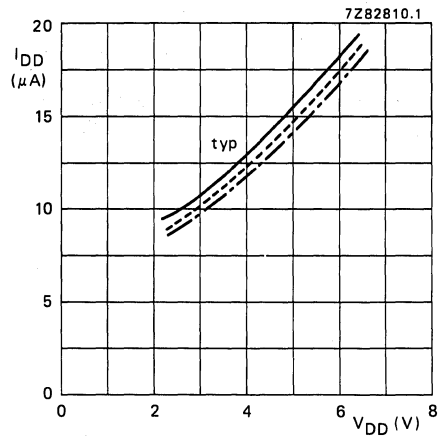

Fig. 7 Supply current as a function of supply voltage.
 — $T_{amb} = -40\text{ }^{\circ}\text{C}$; - - - $T_{amb} = +25\text{ }^{\circ}\text{C}$;
 - · - · $T_{amb} = +85\text{ }^{\circ}\text{C}$.

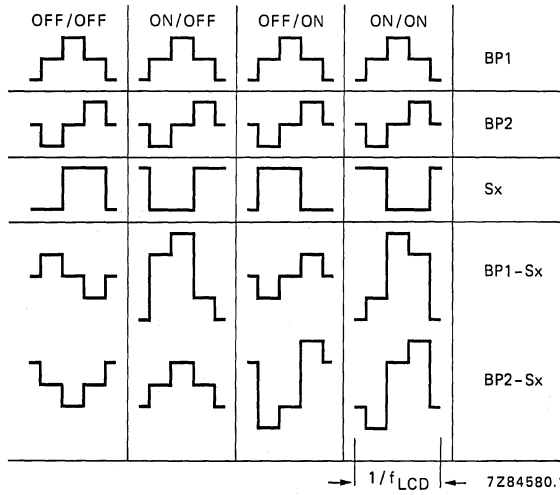

Fig. 8 Timing diagram.

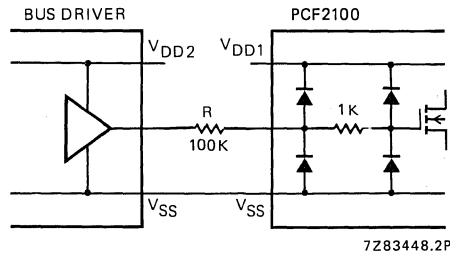
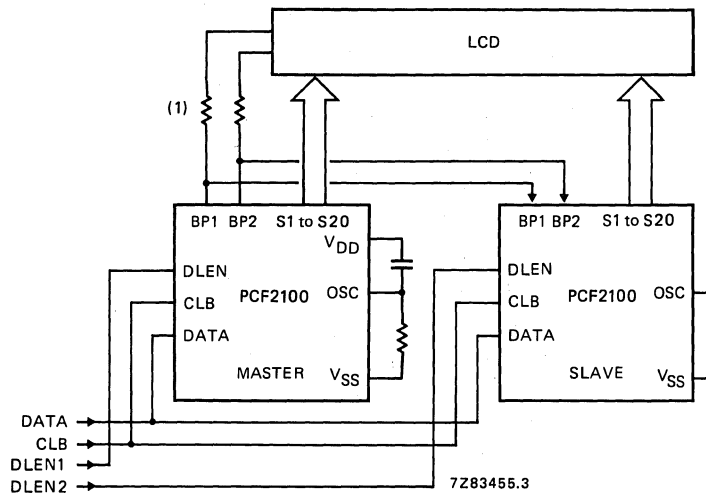

Fig. 9 Input circuitry.

Note to Fig. 9

V_{SS} line is common. In systems where it is expected that $V_{DD2} > V_{DD1} + 0.5 V$, a resistor should be inserted to reduce the current flowing through the input protection. Maximum input current $\leq 40 \mu A$.



(1) In the slave mode, the serial resistors between BP1 and BP2 of the PCF2100 and the backplane of the LCD must be $> 2.7 \text{ k}\Omega$. In most applications the resistance of the interconnection to the LCD already has a higher value.

Fig. 10 Diagram showing expansion possibility.

Note to Fig. 10

By connecting OSC to V_{SS} the BP-pins become inputs and generate signals synchronized to the single oscillator frequency, thus allowing expansion of several PCF2111, PCF2110 and PCF2100 ICs up to the BP drive capability of the master.

PCF2111 is a 64 LCD-segment driver.

PCF2110 is a 60 LCD-segment driver plus 2 LED driver outputs.

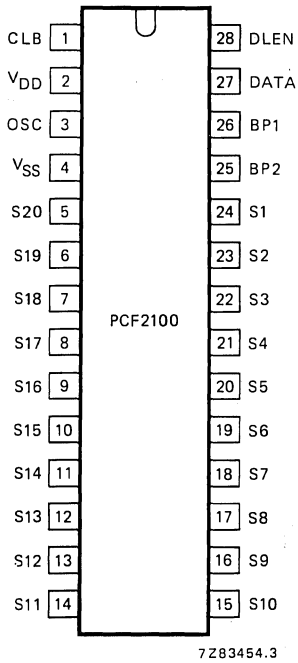

PINNING

Supply

- 2 V_{DD} Positive supply
- 4 V_{SS} Negative supply

Inputs

- 3 OSC Oscillator input
 - 27 DATA Data line
 - 28 DLEN Data line enable
 - 1 CLB Clock burst
- } CBUS

Outputs

- 26 BP1 } Backplane drivers (common of LCD)
- 25 BP2 }
- S1 to S20 LCD driver outputs



Fig. 11 Pinning diagram.

GENERAL DESCRIPTION

The PCF2110 is a single chip, silicon gate CMOS circuit designed to drive 2 LEDs (Light Emitting Diodes) and an LCD (Liquid Crystal Display) with up to 60 segments in a duplex manner; specially for low voltage applications. A three-line bus structure enables serial data transfer with microcontrollers. All inputs are CMOS/NMOS compatible.

Features

- 60 LCD-segment drive capability
- Two LED-driver outputs
- Supply voltage 2.25 to 6.5 V
- Low current consumption
- Serial data input
- CBUS control
- One-point built-in oscillator
- Expansion possibility

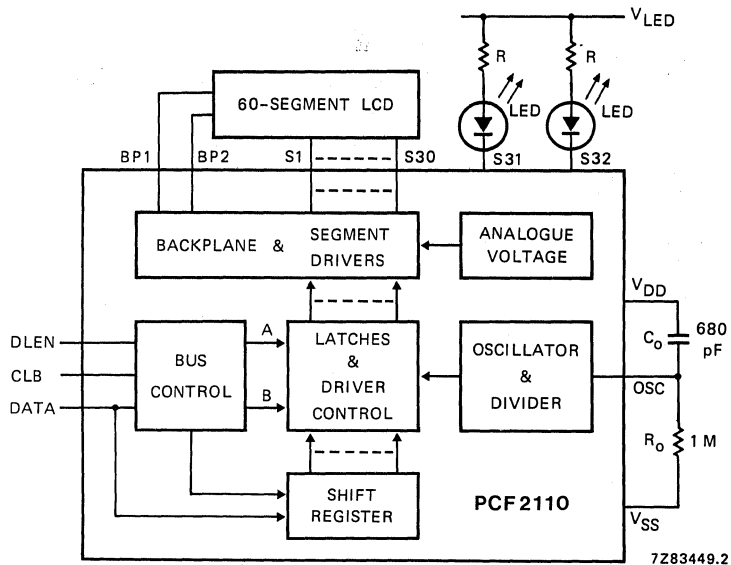

Fig. 1 Block diagram.

RATINGS

Limiting values in accordance with the Absolute Maximum System (IEC 134)

Supply voltage with respect to V_{SS}	V_{DD}	-0.3 to 8 V
Voltage on any pin	V_n	$V_{SS} - 0.3$ to $V_{DD} + 0.3$ V
Operating ambient temperature range	T_{amb}	-40 to +85 °C
Storage temperature range	T_{stg}	-55 to +125 °C

HANDLING

Inputs and outputs are protected against electrostatic charge in normal handling. However, to be totally safe, it is desirable to take normal precautions appropriate to handling MOS devices (see 'Handling MOS devices').

CHARACTERISTICS

$V_{DD} = 2.25$ to 6.5 V; $V_{SS} = 0$ V; $T_{amb} = -40$ to $+85$ °C; $R_o = 1M\Omega$; $C_o = 680$ pF; unless otherwise specified

parameter	condition	symbol	min.	typ.	max.	unit
Supply current	no external load	I_{DD}	—	10	50	μ A
Supply current	no external load; $T_{amb} = -25$ to $+85$ °C	I_{DD}	—	—	30	μ A
Display frequency	see Fig. 9; $T = 680$ μ s	f_{LCD}	60	80	100	Hz
D.C. component of LCD drive	with respect to V_{SX}	V_{BP}	—	± 10	—	mV
Load on each segment driver			—	—	10	$M\Omega$
			—	—	500	pF
Load on each backplane driver			—	—	1	$M\Omega$
			—	—	5	nF
Input voltage HIGH	} see Fig. 10	V_{IH}	2	—	—	V
Input voltage LOW		V_{IL}	—	—	0.6	V
Rise time V_{BP} to V_{SX}	max. load	t_r	—	20	—	μ s
LED outputs S31, S32	$V_{DD} = 3$ V; $T_{amb} = 25$ °C					
Output resistance	$V_{OL} = 0.2$ V; see Fig. 4	R_{out}	—	—	25	Ω
Drain voltage	N-channel OFF	V_{LED}	—	—	8	V
Drain current	maximum value	I_{LEDmax}	—	—	50	mA
Total power dissipation		P_{tot}	—	—	400	mW
Inputs CLB, DATA, DLEN	see note on next page					
Input capacitance	for SOT-129 package	C_{IN}	—	—	10	pF
	for SOT-158A package	C_{IN}	—	—	5	pF
Rise and fall times	see Fig. 2	t_r, t_f	—	—	10	μ s
CLB pulse width HIGH	see Fig. 2	t_{WH}	1	—	—	μ s
CLB pulse width LOW	see Fig. 2	t_{WL}	9	—	—	μ s

CHARACTERISTICS (continued)

parameter	conditions	symbol	min.	typ.	max.	unit
Data set-up time DATA → CLB	see Fig. 2	t _{SUDA}	8	—	—	μs
Data hold time DATA → CLB	see Fig. 2	t _{HDDA}	8	—	—	μs
Enable set-up time DLEN → CLB	see Fig. 2	t _{SUEN}	1	—	—	μs
Disable set-up time CLB → DLEN	see Fig. 2	t _{SUDI}	8	—	—	μs
Set-up time (load pulse) DLEN → CLB	see Fig. 2	t _{SULD}	8	—	—	μs
Busy-time from load pulse to next start of transmission	see Fig. 2	t _{BUSY}	8	—	—	μs
Set-up time (leading zero) DATA → CLB	see Fig. 2	t _{SULZ}	8	—	—	μs

Note

All timing values are referred to V_{IHmin} and V_{ILmax} (see Fig. 2). If external resistors are used in the bus lines (see Fig. 10), the extra time constant has to be added.

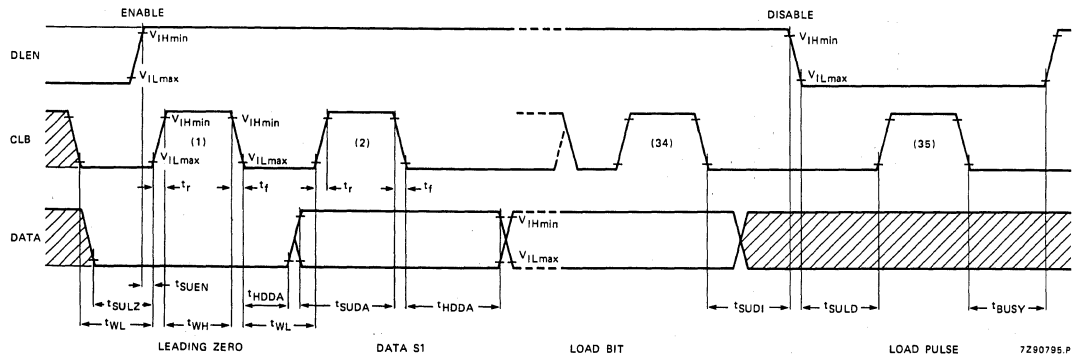

Fig. 2 CBUS timing.

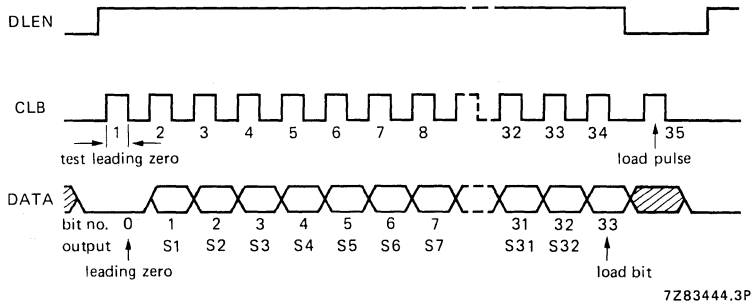

Fig. 3 CBUS data format.

Notes to Fig. 3

An LCD segment is activated when the corresponding DATA-bit is HIGH.

When DATA-bit 33 is HIGH, the A-latches (BP1) are loaded. Bits 31 and 32 contain the LED output information. With DATA-bit 33 LOW, the B-latches (BP2) are loaded and bits 31 and 32 are ignored. CLB-pulse 35 transfers data from shift register to selected latches.

The following tests are carried out by the bus control logic:

- a. Test on leading zero.
- b. Test on number of DATA-bits.
- c. Test of disturbed DLEN and DATA signals during transmission.

If one of the test conditions is not fulfilled, no action follows the load condition (load pulse with DLEN is LOW) and the driver is ready to receive new data.

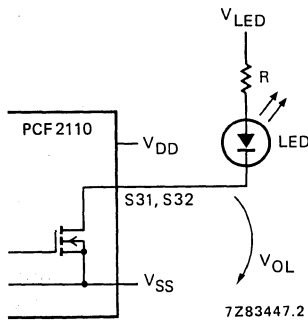

Fig. 4 LED driver circuitry.

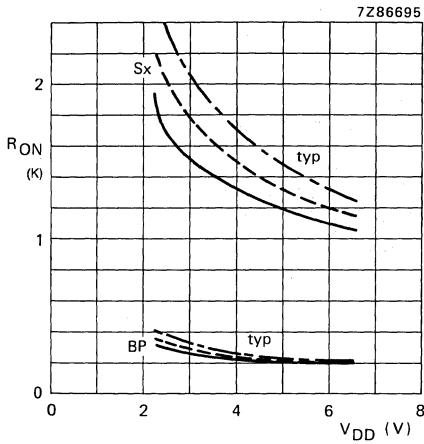

Fig. 5 Output resistance of backplane and segments.
 — $T_{amb} = -40\text{ }^{\circ}\text{C}$; - - - $T_{amb} = +25\text{ }^{\circ}\text{C}$;
 - · - · $T_{amb} = +85\text{ }^{\circ}\text{C}$.

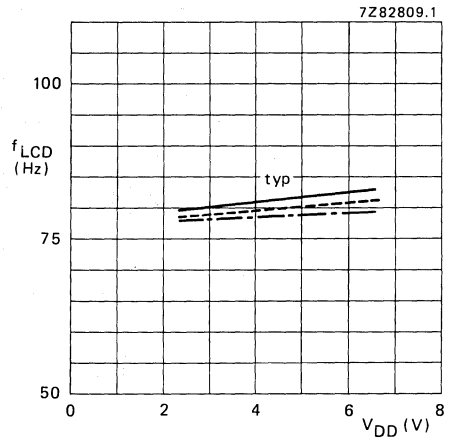

Fig. 6 Display frequency as a function of supply voltage; $R_O C_O = 680\text{ }\mu\text{s}$.
 — $T_{amb} = -40\text{ }^{\circ}\text{C}$; - - - $T_{amb} = +25\text{ }^{\circ}\text{C}$;
 - · - · $T_{amb} = +85\text{ }^{\circ}\text{C}$.

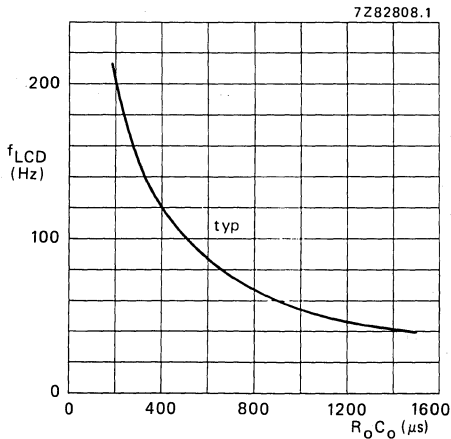

Fig. 7 Display frequency as a function of $R_O \times C_O$ time; $T_{amb} = 25\text{ }^{\circ}\text{C}$.

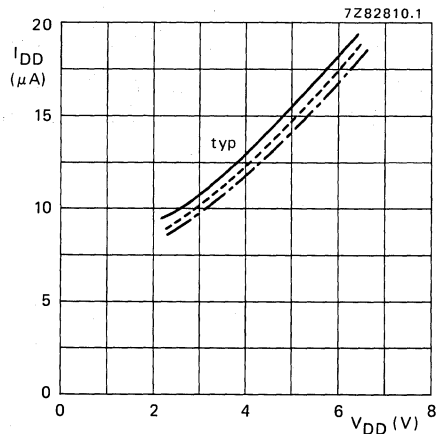

Fig. 8 Supply current as a function of supply voltage.
 — $T_{amb} = -40\text{ }^{\circ}\text{C}$; - - - $T_{amb} = +25\text{ }^{\circ}\text{C}$;
 - · - · $T_{amb} = +85\text{ }^{\circ}\text{C}$.

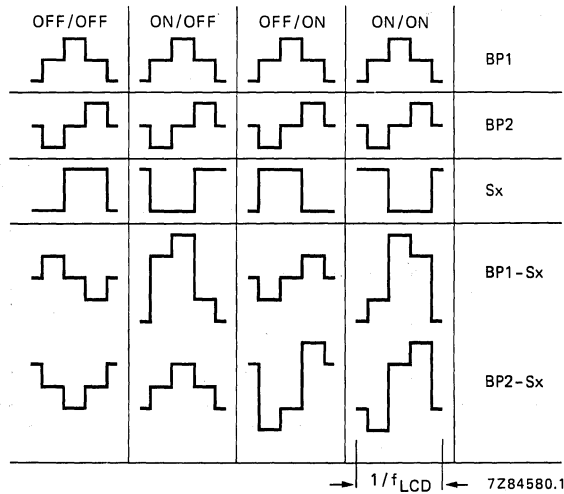

Fig. 9 Timing diagram.

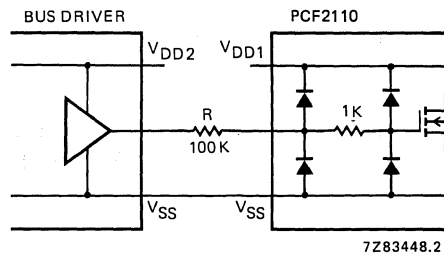
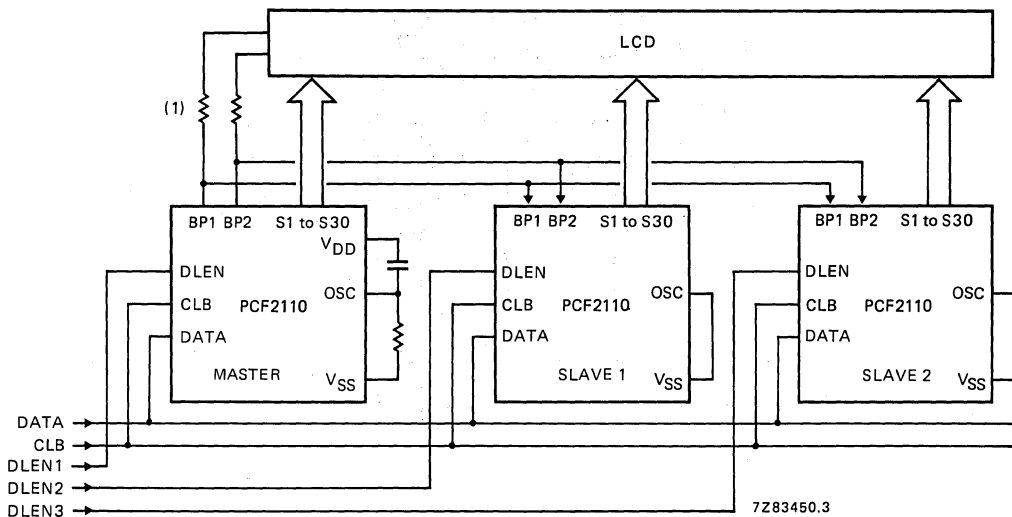

Fig. 10 Input circuitry.

Note to Fig. 10

V_{SS} line is common. In systems where it is expected that $V_{DD2} > V_{DD1} + 0.5V$, a resistor should be inserted to reduce the current flowing through the input protection. Maximum input current $\leq 40 \mu A$.



(1) In the slave mode, the serial resistors between BP1 and BP2 of the PCF2110 and the backplane of the LCD must be $> 2.7 \text{ k}\Omega$. In most applications the resistance of the interconnection to the LCD already has a higher value.

Fig. 11 Diagram showing expansion possibility.

Note to Fig. 11

By connecting OSC to V_{SS} the BP-pins become inputs and generate signals synchronized to the single oscillator frequency, thus allowing expansion of several PCF2100, PCF2110 and PCF2111 ICs up to the BP drive capability of the master.

PCF2100 is a 40 LCD-segment driver.

PCF2111 is a 64 LCD-segment driver.

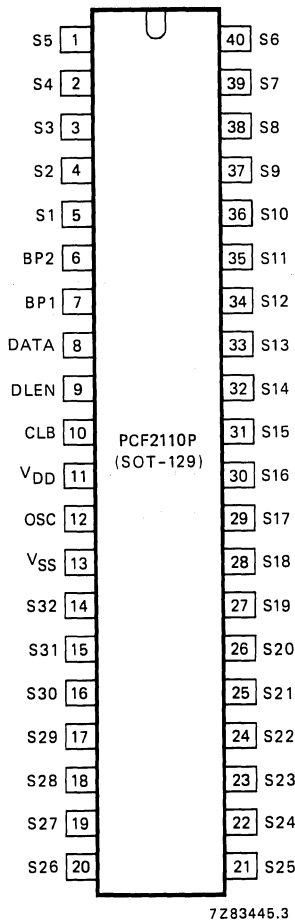

PINNING

Supply

- 11 V_{DD} Positive supply
- 13 V_{SS} Negative supply

Inputs

- 12 OSC Oscillator input
 - 8 DATA Data line
 - 9 DLEN Data line enable
 - 10 CLB Clock burst
- } CBUS

Outputs

- 7 BP1 } Backplane drivers (common of
- 6 BP2 } LCD)
- S1 to S30 LCD driver outputs
- S31, S32 LED driver outputs

Fig. 12 Pinning diagram for SOT-129 package.

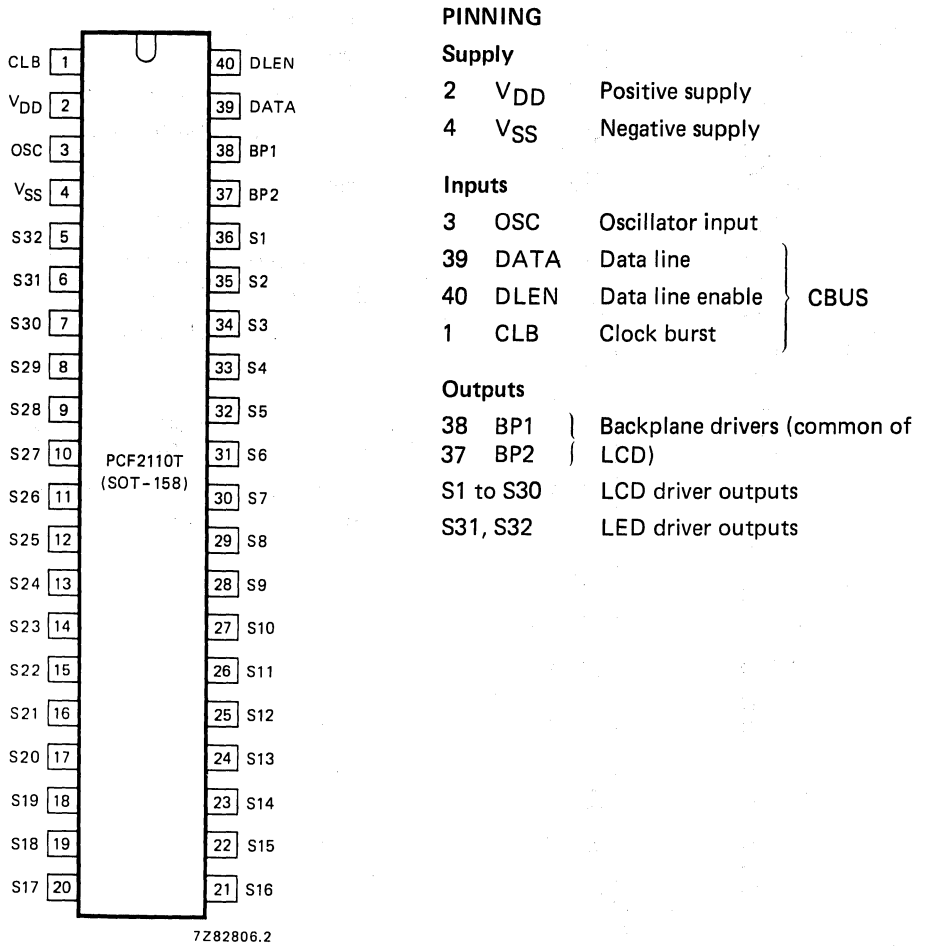

Fig. 13 Pinning diagram for VSO-40; SOT-158A package.

GENERAL DESCRIPTION

The PCF2111 is a single chip, silicon gate CMOS circuit designed to drive an LCD (Liquid Crystal Display) with up to 64 segments in a duplex manner; specially for low voltage applications. A three-line bus structure enables serial data transfer with microcontrollers. All inputs are CMOS/NMOS compatible.

Features

- 64 LCD-segment drive capability
- Supply voltage 2.25 to 6.5 V
- Low current consumption
- Serial data input
- CBUS control
- One-point built-in oscillator
- Expansion possibility

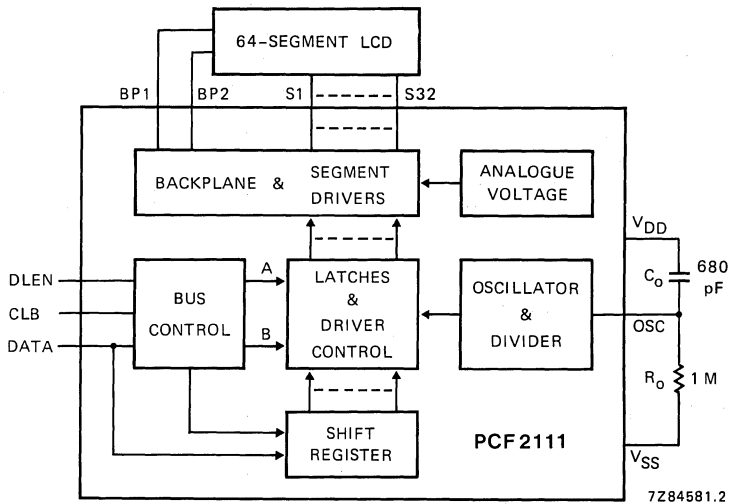

Fig. 1 Block diagram.

PACKAGE OUTLINES

PCF2111P: 40-lead DIL; plastic (SOT-129).

PCF2111T: 40-lead mini-pack; plastic (VSO-40; SOT-158A).

LCD DUPLEX DRIVER

PCF2111

RATINGS

Limiting values in accordance with the Absolute Maximum System (IEC 134)

Supply voltage with respect to V_{SS}	V_{DD}	-0.3 to 8 V
Voltage on any pin	V_n	$V_{SS} - 0.3$ to $V_{DD} + 0.3$ V
Operating ambient temperature range	T_{amb}	-40 to +85 °C
Storage temperature range	T_{stg}	-55 to +125 °C

HANDLING

Inputs and outputs are protected against electrostatic charge in normal handling. However, to be totally safe, it is desirable to take normal precautions appropriate to handling MOS devices (see 'Handling MOS devices').

CHARACTERISTICS

$V_{DD} = 2.25$ to 6.5 V; $V_{SS} = 0$ V; $T_{amb} = -40$ to $+85$ °C; $R_o = 1$ M Ω ; $C_o = 680$ pF; unless otherwise specified

parameter	condition	symbol	min.	typ.	max.	unit
Supply current	no external load	I_{DD}	—	10	50	μ A
Supply current	no external load; $T_{amb} = -25$ to $+85$ °C	I_{DD}	—	—	30	μ A
Display frequency	see Fig. 8; $T = 680$ μ s	f_{LCD}	60	80	100	Hz
D.C. component of LCD drive	with respect to V_{SX}	V_{BP}	—	± 10	—	mV
Load on each segment driver			—	—	10 500	M Ω pF
Load on each backplane driver			—	—	1 5	M Ω nF
Input voltage HIGH	} see Fig. 9	V_{IH}	2	—	—	V
Input voltage LOW		V_{IL}	—	—	0.6	V
Rise time V_{BP} to V_{SX}	max. load	t_r	—	20	—	μ s
Inputs CLB, DATA, DLEN	see note on next page					
Input capacitance	for SOT-129 package	C_{IN}	—	—	10	pF
	for SOT-158A package	C_{IN}	—	—	5	pF
Rise and fall times	see Fig. 2	t_r, t_f	—	—	10	μ s
CLB pulse width HIGH	see Fig. 2	t_{WH}	1	—	—	μ s
CLB pulse width LOW	see Fig. 2	t_{WL}	9	—	—	μ s

CHARACTERISTICS (continued)

parameter	condition	symbol	min.	typ.	max.	unit
Data set-up time DATA → CLB	see Fig. 2	t _{SUDA}	8	—	—	μs
Data hold time DATA → CLB	see Fig. 2	t _{HDDA}	8	—	—	μs
Enable set-up time DLEN → CLB	see Fig. 2	t _{SUEN}	1	—	—	μs
Disable set-up time CLB → DLEN	see Fig. 2	t _{SUDI}	8	—	—	μs
Set-up time (load pulse) DLEN → CLB	see Fig. 2	t _{SULD}	8	—	—	μs
Busy-time from load pulse to next start of transmission	see Fig. 2	t _{BUSY}	8	—	—	μs
Set-up time (leading zero) DATA → CLB	see Fig. 2	t _{SULZ}	8	—	—	μs

4

Note

All timing values are referred to V_{IHmin} and V_{ILmax} (see Fig. 2). If external resistors are used in the bus lines (see Fig. 9), the extra time constant has to be added.

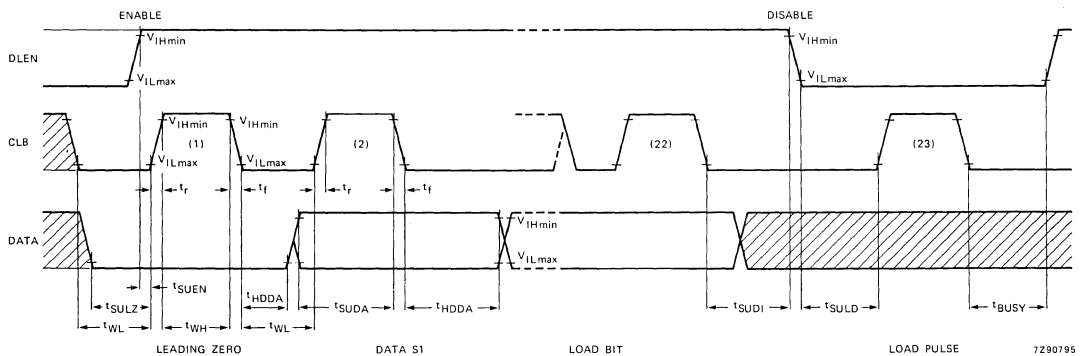

Fig. 2 CBUS timing.

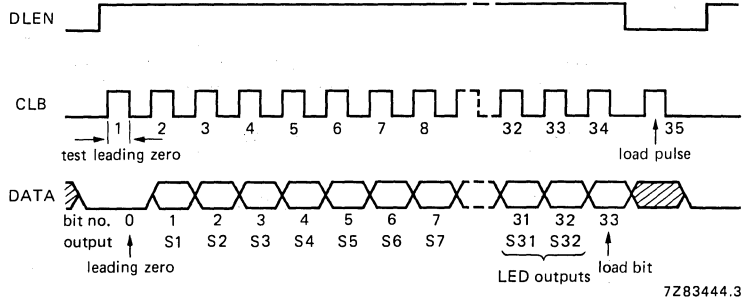

Fig. 3 CBUS data format.

Notes to Fig. 3

An LCD segment is activated when the corresponding DATA-bit is HIGH. When DATA-bit 33 is HIGH, the A-latches (BP1) are loaded. With DATA-bit 33 LOW, the B-latches (BP2) are loaded. CLB-pulse 35 transfers data from shift register to selected latches.

The following tests are carried out by the bus control logic:

- a. Test on leading zero.
- b. Test on number of DATA-bits.
- c. Test of disturbed DLEN and DATA signals during transmission.

If one of the test conditions is not fulfilled, no action follows the load condition (load pulse with DLEN is LOW) and the driver is ready to receive new data.

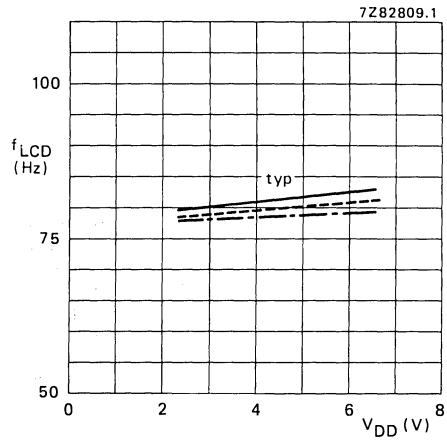
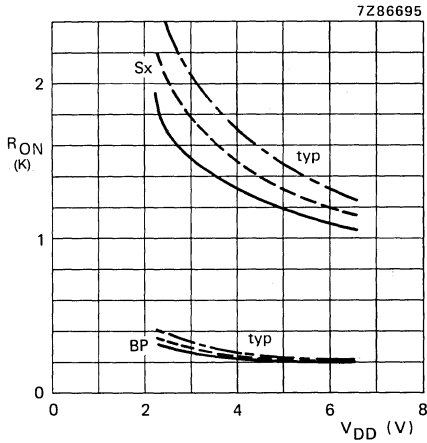

Fig. 4 Output resistance of backplane and segments.

— $T_{amb} = -40^\circ\text{C}$; --- $T_{amb} = +25^\circ\text{C}$;
 - · - · $T_{amb} = +85^\circ\text{C}$.

Fig. 5 Display frequency as a function of supply voltage; $R_O C_O = 680 \mu\text{s}$.

— $T_{amb} = -40^\circ\text{C}$; --- $T_{amb} = +25^\circ\text{C}$;
 - · - · $T_{amb} = +85^\circ\text{C}$.

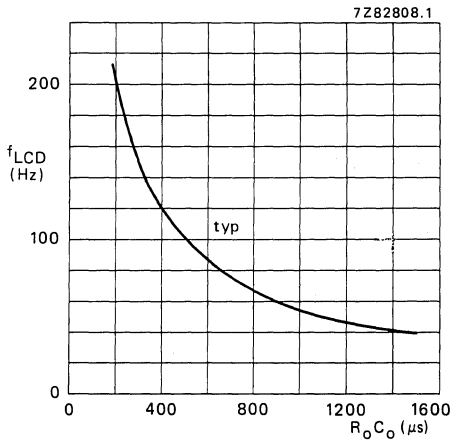

Fig. 6 Display frequency as a function of $R_O \times C_O$ time; $T_{amb} = 25^\circ\text{C}$.

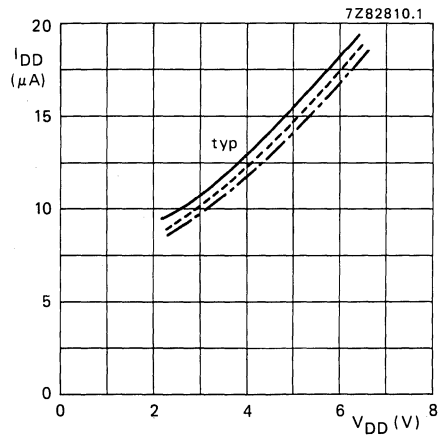

Fig. 7 Supply current as a function of supply voltage.

— $T_{amb} = -40^\circ\text{C}$; --- $T_{amb} = +25^\circ\text{C}$;
 - · - · $T_{amb} = +85^\circ\text{C}$.

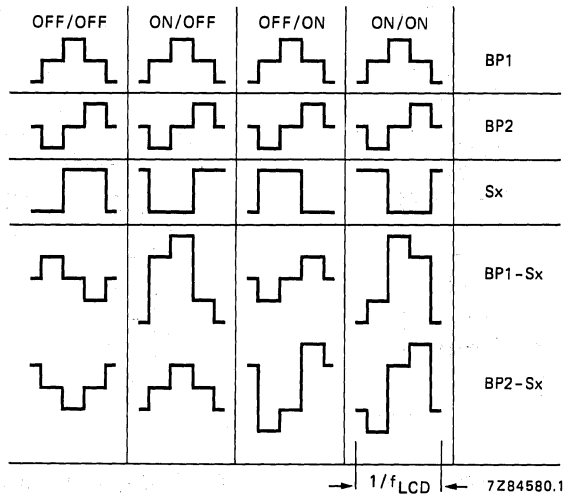

Fig. 8 Timing diagram.

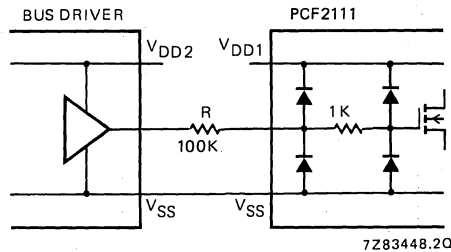
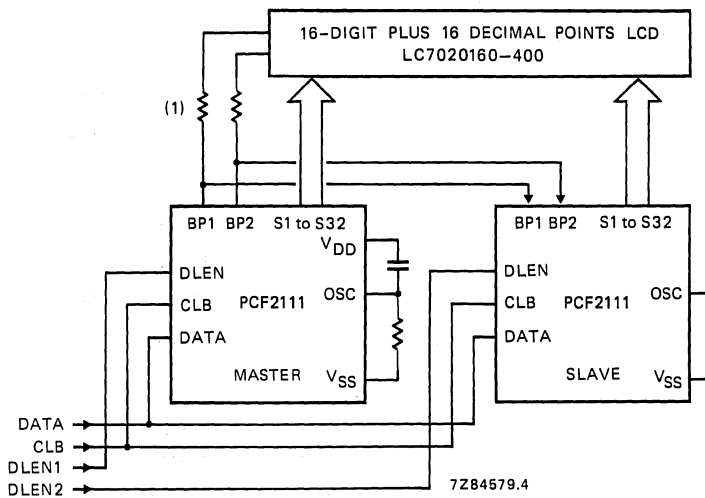

Fig. 9 Input circuitry.

Note to Fig. 9

V_{SS} line is common. In systems where it is expected that $V_{DD2} > V_{DD1} + 0.5 V$, a resistor should be inserted to reduce the current flowing through the input protection. Maximum input current $\leq 40 \mu A$.



4

(1) In the slave mode, the serial resistors between BP1 and BP2 of the PCF2111 and the backplane of the LCD must be $> 2.7 \text{ k}\Omega$. In most applications the resistance of the interconnection to the LCD already has a higher value.

Fig. 10 Diagram showing expansion possibility for a 16-digit plus 16 decimal points LCD.

Note to Fig. 10

By connecting OSC to V_{SS} the BP-pins become inputs and generate signals synchronized to the single oscillator frequency, thus allowing expansion of several PCF2111, PCF2110 and PCF2100 ICs up to the BP drive capability of the master.

PCF2100 is a 40 LCD-segment driver; PCF2110 is a 60 LCD-segment driver plus 2 LED driver outputs.

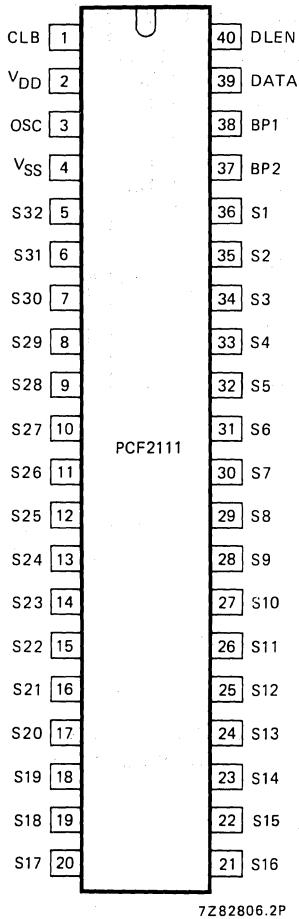

PINNING

Supply

- 2 V_{DD} Positive supply
- 4 V_{SS} Negative supply

Inputs

- 3 OSC Oscillator input
 - 39 DATA Data line
 - 40 DLEN Data line enable
 - 1 CLB Clock burst
- } CBUS

Outputs

- 38 BP1 } Backplane drivers (common of
- 37 BP2 } LCD)
- S1 to S32 LCD driver outputs

Fig. 11 Pinning diagram.

GENERAL DESCRIPTION

The PCF2112 is a single chip, silicon gate CMOS circuit designed to drive an LCD (Liquid Crystal Display) with up to 32 segments in direct drive; specially for low voltage applications. A three-line bus structure enables serial data transfer with microcontrollers. All inputs are CMOS/NMOS compatible.

Features

- 32 LCD-segment drive capability.
- Supply voltage 2.25 to 6.5 V.
- Low current consumption.
- Serial data input.
- CBUS control.
- One-point built-in oscillator.
- Expansion possibility.

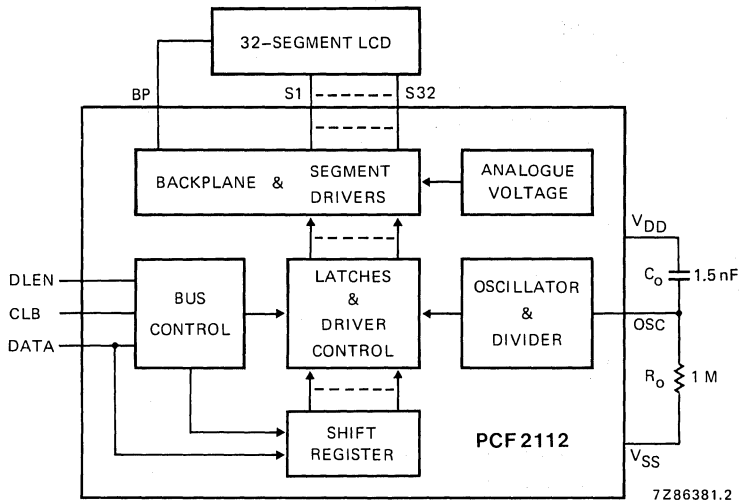

Fig. 1 Block diagram.

PACKAGE OUTLINES

PCF2112P : 40-lead DIL; plastic (SOT-129).

PCF2112T : 40-lead mini-pack; plastic (VSO-40; SOT-158A).

RATINGS

Limiting values in accordance with the Absolute Maximum System (IEC 134)

Supply voltage with respect to V_{SS}	V_{DD}	-0.3 to 8 V
Voltage on any pin	V_n	$V_{SS}-0.3$ to $V_{DD} + 0.3$ V
Operating ambient temperature range	T_{amb}	-40 to +85 °C
Storage temperature range	T_{stg}	-55 to +125 °C

HANDLING

Inputs and outputs are protected against electrostatic charge in normal handling. However, to be totally safe, it is desirable to take normal precautions appropriate to handling MOS devices (see 'Handling MOS devices').

CHARACTERISTICS

$V_{DD} = 2.25$ to 6.5 V; $V_{SS} = 0$ V; $T_{amb} = -40$ to $+85$ °C; $R_O = 1$ M Ω ; $C_O = 1.5$ nF; unless otherwise specified.

parameter	condition	symbol	min.	typ.	max.	unit
Supply current	no external load	I_{DD}	—	10	50	μ A
Supply current	no external load; $T_{amb} = -25$ to $+85$ °C	I_{DD}	—	—	30	μ A
Display frequency	$T = 1.5$ ms	f_{LCD}	30	40	50	Hz
Output resistance of each segment	} $I_O = 10$ μ A	R_S	—	—	10	k Ω
Output resistance of backplane		R_{BP}	—	—	2	k Ω
Input voltage HIGH	} see Fig. 8	V_{IH}	2	—	—	V
Input voltage LOW		V_{IL}	—	—	0.6	V
Inputs CLB,DATA,DLEN	see note on next page					
Input capacitance	for SOT-129 package	C_{IN}	—	—	10	pF
	for SOT-158A package	C_{IN}	—	—	5	pF
Rise and fall times	see Fig. 2	t_r, t_f	—	—	10	μ s
CLB pulse width HIGH	see Fig. 2	t_{WH}	1	—	—	μ s
CLB pulse width LOW	see Fig. 2	t_{WL}	9	—	—	μ s

CHARACTERISTICS (continued)

parameter	condition	symbol	min.	typ.	max.	unit
Data set-up time DATA → CLB	see Fig. 2	t_{SUDA}	8	—	—	μs
Data hold time DATA → CLB	see Fig. 2	t_{HDDA}	8	—	—	μs
Enable set-up time DLEN → CLB	see Fig. 2	t_{SUEN}	1	—	—	μs
Disable set-up time CLB → DLEN	see Fig. 2	t_{SUDI}	8	—	—	μs
Set-up time (load pulse) DLEN → CLB	see Fig. 2	t_{SULD}	8	—	—	μs
Busy-time from load pulse to next start of transmission	see Fig. 2	t_{BUSY}	8	—	—	μs
Set-up time (leading zero) DATA → CLB	see Fig. 2	t_{SULZ}	8	—	—	μs

4

Note

All timing values are referred to V_{IHmin} and V_{ILmax} (see Fig. 2). If external resistors are used in the bus lines (see Fig. 8), an extra time constant has to be added.

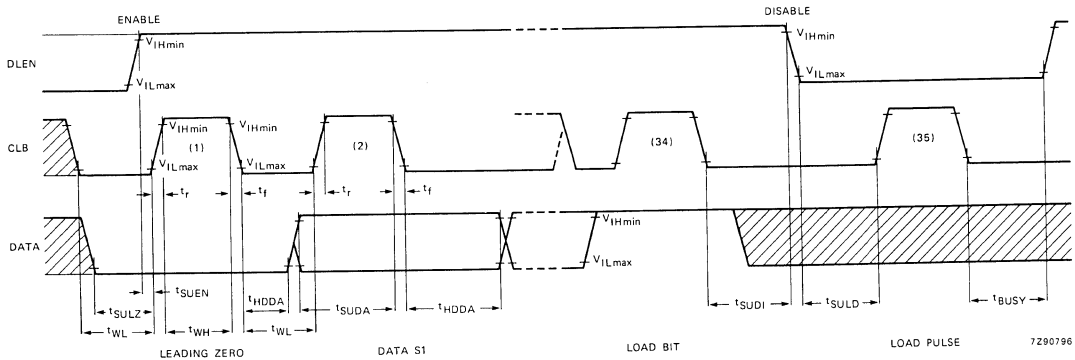

Fig. 2 CBUS timing.

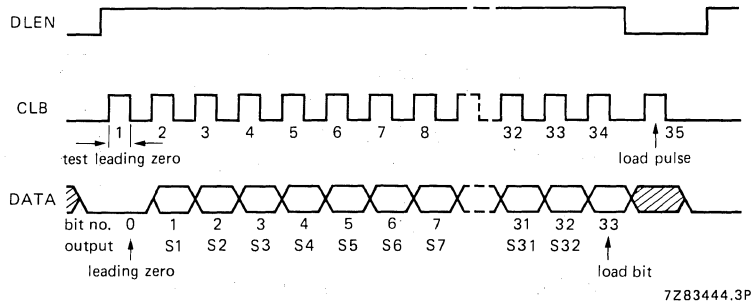

Fig. 3 Data format.

Notes to Fig. 3

An LCD segment is activated when the corresponding DATA-bit is HIGH.

When DATA-bit 33 is HIGH, the latches are loaded. CLB-pulse 35 transfers data from shift register to latches.

The following tests are carried out by the bus control logic:

- a. Test on leading zero.
- b. Test on number of DATA-bits.
- c. Test of disturbed DLEN and DATA signals during transmission.

If one of the test conditions is not fulfilled, no action follows the load condition (load pulse with DLEN is LOW) and the driver is ready to receive new data.

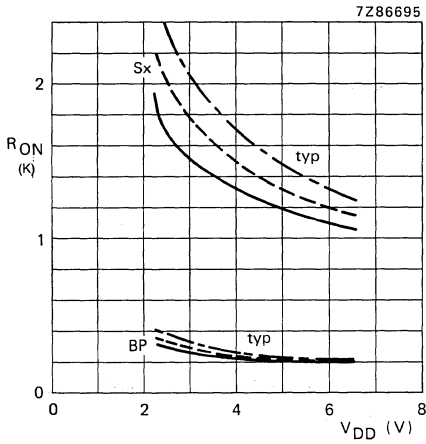

Fig. 4 Output resistance of backplane and segments.

— $T_{amb} = -40\text{ }^{\circ}\text{C}$; - - - $T_{amb} = +25\text{ }^{\circ}\text{C}$;
 - . - $T_{amb} = +85\text{ }^{\circ}\text{C}$.

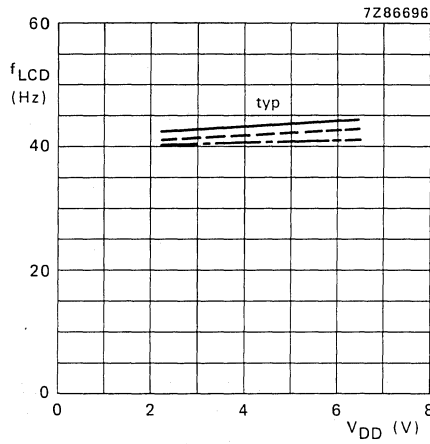

Fig. 5 Display frequency as a function of supply voltage; $R_O C_O = 1.5\text{ ms}$.

— $T_{amb} = -40\text{ }^{\circ}\text{C}$; - - - $T_{amb} = +25\text{ }^{\circ}\text{C}$;
 - . - $T_{amb} = +85\text{ }^{\circ}\text{C}$.

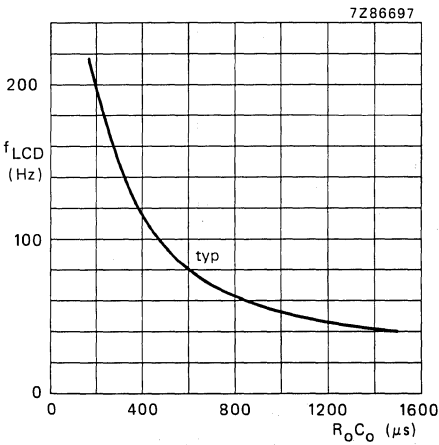

Fig. 6 Display frequency as a function of $R_O \times C_O$ time; $T_{amb} = 25\text{ }^{\circ}\text{C}$.

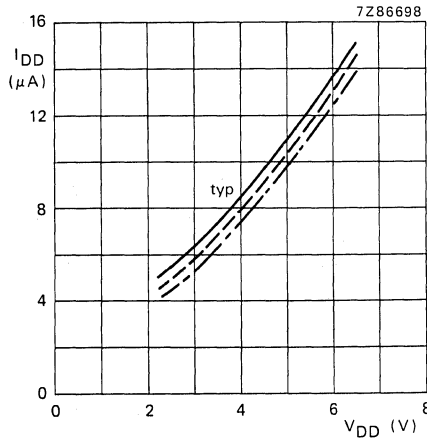

Fig. 7 Supply current as a function of supply voltage.

— $T_{amb} = -40\text{ }^{\circ}\text{C}$; - - - $T_{amb} = +25\text{ }^{\circ}\text{C}$;
 - . - $T_{amb} = +85\text{ }^{\circ}\text{C}$.

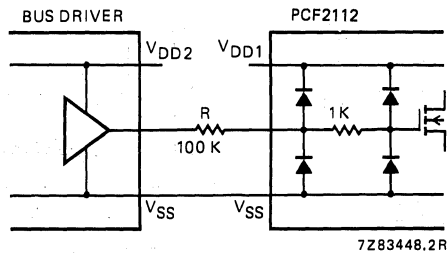
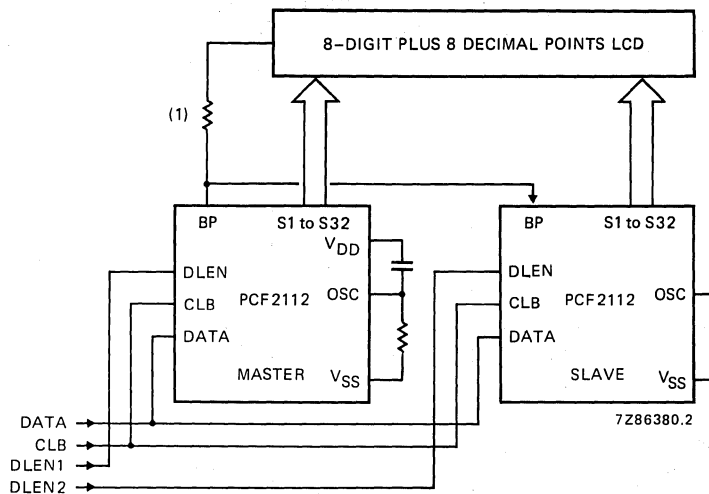

Fig. 8 Input circuitry.

Note to Fig. 8

V_{SS} line is common. In systems where it is expected that V_{DD2} > V_{DD1} + 0.5 V, a resistor should be inserted to reduce the current flowing through the input protection.

Maximum input current ≤ 40 μA.



(1) In the slave mode, the serial resistor between BP of the PCF2112 and the backplane of the LCD must be > 2.7 kΩ. In most applications the resistance of the interconnection to the LCD already has a higher value.

Fig. 9 Diagram showing expansion possibility for an 8-digit plus 8 decimal points LCD.

Note to Fig. 9

By connecting OSC to V_{SS} the BP-pin becomes input and generates signals synchronized to the single oscillator frequency, thus allowing expansion of several PCF2112 ICs up to the BP drive capability of the master.

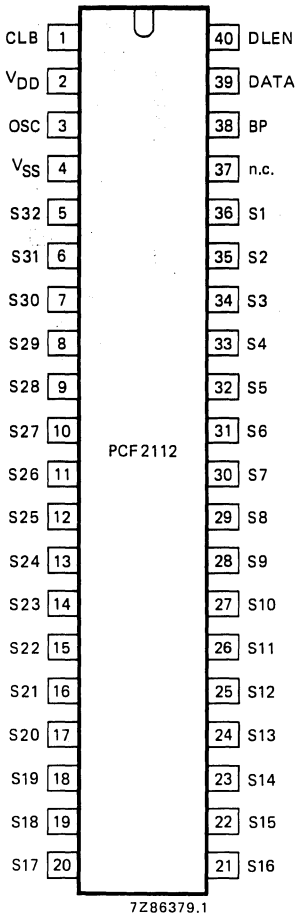

PINNING

Supply

2 V_{DD} Positive supply
 4 V_{SS} Negative supply

Inputs

3 OSC Oscillator input
 39 DATA Data line
 40 DLEN Data line enable
 1 CLB Clock burst

} CBUS

Outputs

38 BP Back plane driver (common of LCD)
 S1 to S32 LCD driver outputs
 37 n.c. not connected

Fig. 10 Pinning diagram.

DESCRIPTION

These high-voltage, high-current Darlington transistor arrays are comprised of seven silicon NPN Darlington pairs on a common monolithic substrate. All units feature open collector outputs and integral suppression diodes for inductive loads. Peak inrush currents to 600mA are allowable, making them ideal for driving tungsten filament lamps also.

The Type ULN2003 has a series base resistor to each Darlington pair, and thus allows operation directly with TTL or CMOS 5V supply voltage.

The Type ULN2004 has an appropriate series input resistor to allow its operation directly from CMOS or PMOS outputs utilizing supply voltages of 6 to 15V. The required input current is below that of the Type ULN2003.

In all cases, the individual Darlington pair collector current rating is 500mA. However, outputs may be paralleled for higher load current capability. All devices are supplied in a 16-pin dual in-line plastic package.

EQUIVALENT SCHEMATICS

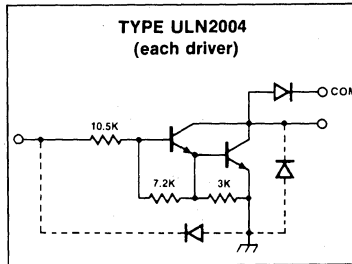
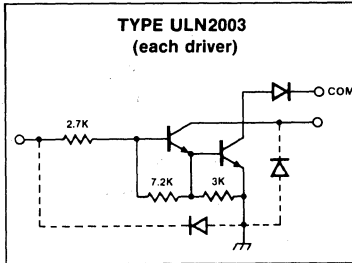

PIN CONFIGURATION

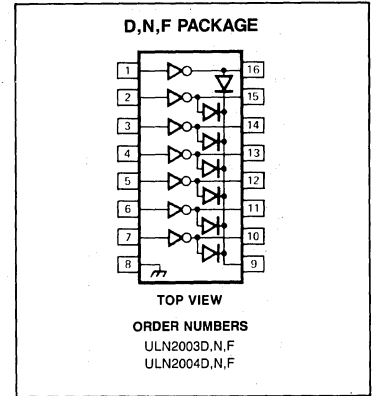

FEATURES

- Peak inrush current 600mA
- Protected internally against inductive loads
- Open collector topology
- Compatible with most logic technologies

ABSOLUTE MAXIMUM RATINGS at 25°C Free-Air temperature for any one Darlington pair unless otherwise specified.

PARAMETER	RATING	UNIT
V _{CE} Output voltage	50	V
V _{IN} Input voltage	30	V
V _{EBO} Emitter base voltage	6	V
I _C Continuous collector current	500	mA
I _B Continuous base current	25	mA
P _D Power dissipation	1.3	W
Derating factor above 25°C	95	°C/W
T _A Ambient temperature range (operating)	0 to +85	°C
T _S Storage temperature range	-65 to +150	°C

***NOTE**

Under normal operating conditions, these units will sustain 350mA per output with V_{CE(SAT)} = 1.6V at 70°C with a pulse width of 20 ms and a duty cycle of 30%.

DC ELECTRICAL CHARACTERISTICS $T_A = 25^\circ\text{C}$ unless otherwise specified.1,2,3

PARAMETER	TEST CONDITIONS	Test Fig.	LIMITS			UNIT
			Min	Typ	Max	
I _{CEX} Output leakage current Type ULN2004	V _{CE} = 50V, T _A = 70°C V _{CE} = 50V, T _A = 70°C, V _{IN} = 1V	1A	—	—	100	μA
		1B	—	—	500	μA
V _{CE(SAT)} Collector-emitter Saturation voltage	I _C = 350mA, I _B = 500μA I _C = 200mA, I _B = 350μA I _C = 100mA, I _B = 250μA	2	—	1.25	1.6	V
		2	—	1.1	1.3	V
		2	—	0.9	1.1	V
I _{IN(ON)} Input current Type ULN2003 Type ULN2004	V _{IN} = 3.85V V _{IN} = 5V V _{IN} = 12V	3	—	0.93	1.35	mA
		3	—	0.35	0.5	mA
		3	—	1.0	1.45	mA
I _{IN(OFF)} Input current	I _C = 500μA, T _A = 70°C	4	50	65	—	μA
V _{IN(ON)} Input voltage Type ULN2003 Type ULN2004	V _{CE} = 2V, I _C = 200mA V _{CE} = 2V, I _C = 250mA V _{CE} = 2V, I _C = 300mA	5	—	—	2.4	V
		5	—	—	2.7	V
		5	—	—	3.0	V
	V _{CE} = 2V, I _C = 125mA V _{CE} = 2V, I _C = 200mA V _{CE} = 2V, I _C = 275mA V _{CE} = 2V, I _C = 350mA	5	—	—	5.0	V
		5	—	—	6.0	V
		5	—	—	7.0	V
		5	—	—	8.0	V
C _{IN} Input capacitance		—	—	15	30	pF
I _R Clamp diode leakage current	V _R = 50V	6	—	—	50	μA
V _F Clamp diode forward voltage	I _F = 350mA	7	—	1.7	2	V

NOTES

- All limits stated apply to the complete Darlington series except as specified for a single device type.
- The I_{IN(OFF)} current limit guarantees against partial turn-on of the output.
- The V_{IN(ON)} voltage limit guarantees a minimum output sink current per the specified test conditions.

AC ELECTRICAL CHARACTERISTICS $T_A = 25^\circ\text{C}$ unless otherwise specified.1,2,3

PARAMETER	TEST CONDITIONS	Test Fig.	LIMITS			UNIT
			Min	Typ	Max	
t _{PLH} Turn-on delay	0.5 E _{IN} to 0.5 E _{OUT}	—	—	1.0	5	μs
t _{PHL} Turn-off delay	0.5 E _{IN} to 0.5 E _{OUT}	—	—	1.0	5	μs

NOTES

- All limits stated apply to the complete Darlington series except as specified for a single device type.
- The I_{IN(OFF)} current limit guarantees against partial turn-on of the output.
- The V_{IN(ON)} voltage limit guarantees a minimum output sink current per the specified test conditions.

TYPICAL PERFORMANCE CHARACTERISTICS

COLLECTOR CURRENT AS A FUNCTION OF SATURATION VOLTAGE

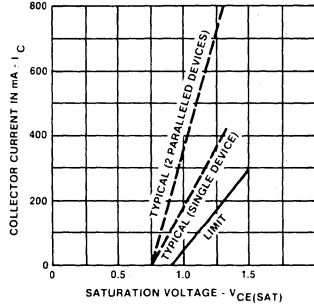

COLLECTOR CURRENT AS A FUNCTION OF INPUT CURRENT

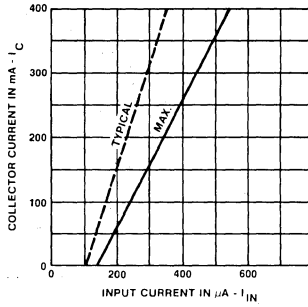

ALLOWABLE AVERAGE PACKAGE POWER DISSIPATION AS A FUNCTION OF AMBIENT TEMPERATURE

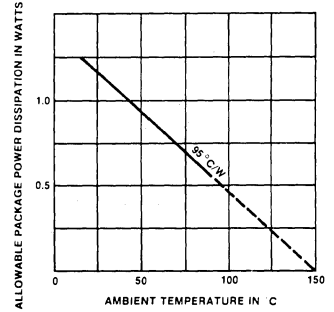

INPUT CURRENT AS A FUNCTION OF INPUT VOLTAGE FOR TYPE ULN2003

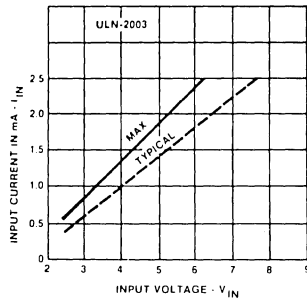

INPUT CURRENT AS A FUNCTION OF INPUT VOLTAGE FOR TYPE ULN2004

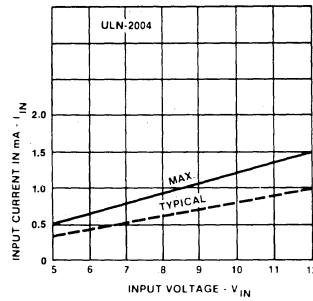

TEST FIGURES

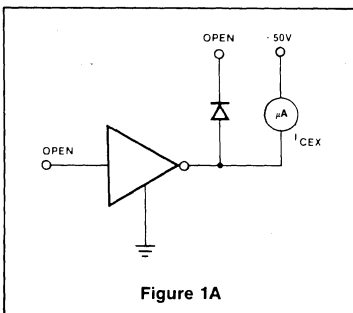

Figure 1A

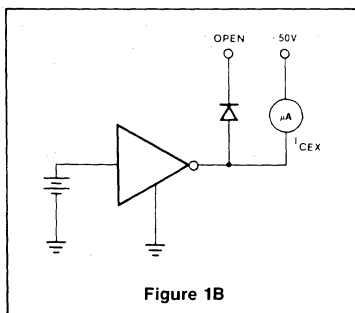

Figure 1B

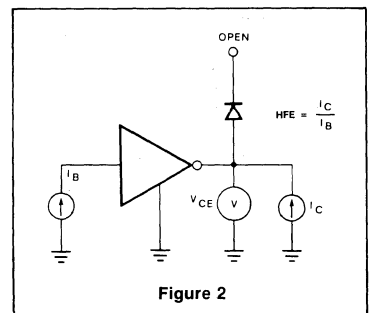
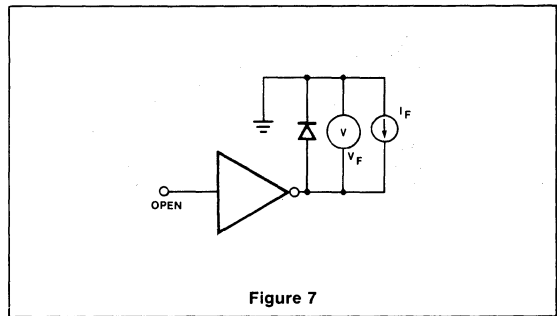
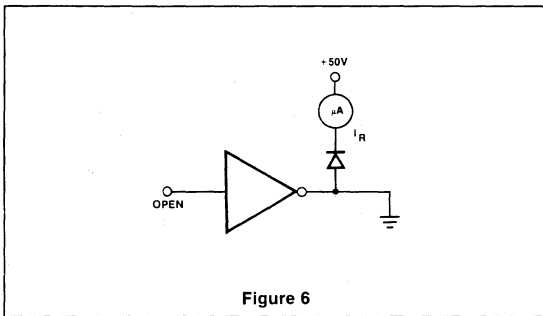
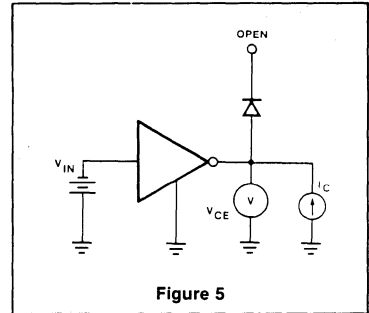
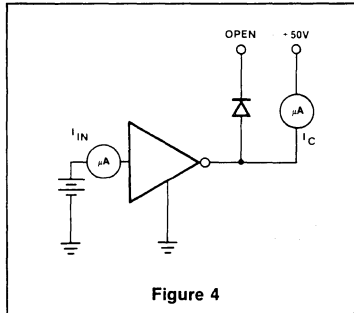
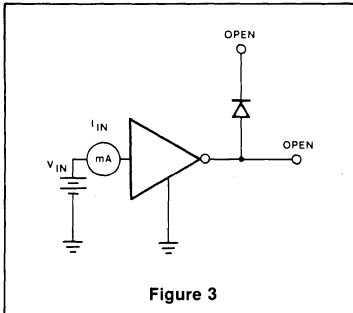

Figure 2

TEST FIGURES (Cont'd)



4

TYPICAL APPLICATIONS

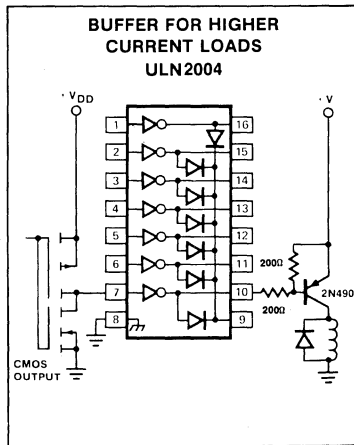
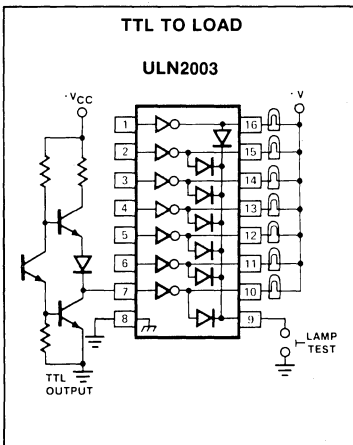

LVDT SIGNAL CONDITIONER

NE5520

DESCRIPTION

The NE5520 is a signal conditioning circuit for use with Linear Variable Differential Transformers (LVDT). The chip includes a low distortion amplitude stable sine wave oscillator with programmable frequency to drive the primary of the LVDT; a synchronous demodulator to convert the LVDT output amplitude and phase to position information; and an output amp to provide gain and filtering.

FEATURES

- Oscillator frequency: 1kHz to 20kHz
- Low distortion
- Capable of ratiometric operation
- Single supply operation 5V to 20V or dual supply $\pm 2.5V$ to $\pm 10V$
- Low power consumption

APPLICATIONS

- LVDT signal conditioning
- RVDT signal conditioning

PIN CONFIGURATION

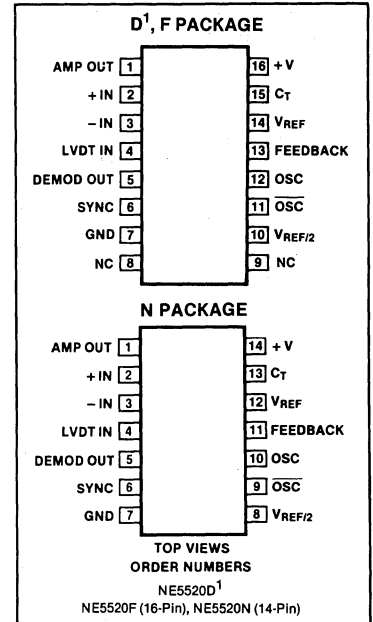

ABSOLUTE MAXIMUM RATINGS

PARAMETER	RATING	UNIT
Supply voltage	+ 20	V
Split supply voltage	± 10	V
Operating temperature range	0 to +70	$^{\circ}C$
Storage temperature range	- 65 to +165	$^{\circ}C$
Power Dissipation (Note 1)	840	mW

NOTES:

1. SOL - Released in Large SO package only.
2. SOL and non-standard pinout.
3. SO and non-standard pinouts.

BLOCK DIAGRAM

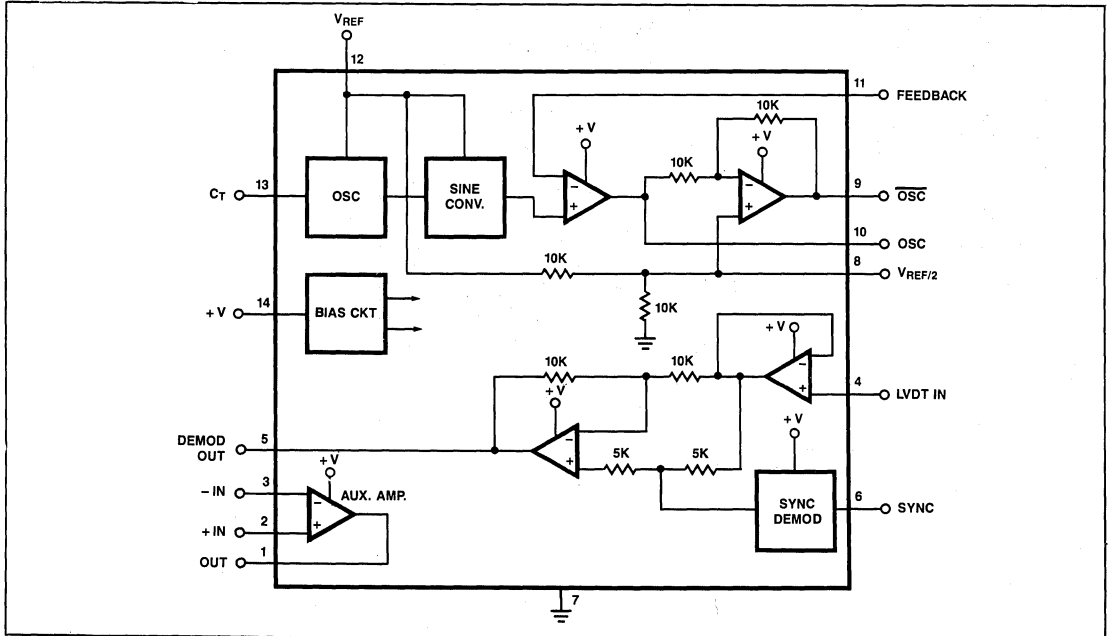

NOTES:

1. Supplied only in large SO (Small Outline) package. See package diagram.
2. Pin numbers are for N package.

LVDT SIGNAL CONDITIONER

NE5520

DC ELECTRICAL CHARACTERISTICS $T_A = 25^\circ\text{C}$, $V_R = V + = 10\text{V}$ unless otherwise specified.

PARAMETER	TEST CONDITIONS	NE5520			UNIT
		Min	Typ	Max	
Supply current	Over temp.		7.0	10	mA
Reference current	Over temp.		5.5	10	mA
Reference voltage range	Over temp.	5		V+	V
Power dissipation			120	220	mW
Oscillator section					
Oscillator output			$\frac{V_R}{8.7}$		Vrms
Sine wave distortion			4		%
Initial amplitude error				± 3	%
Tempco of amplitude				0.05	%/°C
Voltage coef. of amplitude error				2.5	%/V
Initial accuracy of osc. frequency				20	%
Tempco of frequency error			0.05		%/°C
Voltage coef. of frequency			2.5		%/V (V_R)
Oscillator output load current	Over temp.	8	15		mA (rms) mA (rms)
Demodulator section					
Linearity error	Over temp.		0.05	0.1	%
Maximum demodulator input	Over temp. range	$\frac{V_R}{2} - 0.5$		$\frac{V_R}{2} + 0.5$	V
Demodulator offset voltage	Over temp. range			65	mV
Demodulator input current	Over temp.	- 1000	- 300		nA
$V_R/2$ accuracy	Over temp.	- 3	± 0.5	+ 3	%
Auxiliary Output Amplifier					
Input offset voltage	Over temp.	- 10		10	mV
Input bias current	Over temp. range	- 500	- 300		nA
Input offset current		- 100		100	nA
Gain	$R_L = 10\text{k}\Omega$ over temp.		100		V/mV
Slew rate			1.5		V/ μsec
Gain bandwidth	$A_v = 1$		1		MHz
Output voltage swing	$R_L = 10\text{K}$ over temp.	1.5		V+ -1.5	V
Output short circuit current			50		mA

NOTE
Rating applies to ambient temperatures up to 70°C. Above 70°C derate linearly at 7.6mW/°C for the plastic package and 7.3mW/°C for the cerdip package.

4

TYPICAL PERFORMANCE CHARACTERISTICS

I_R AND I^+ vs TEMPERATURE

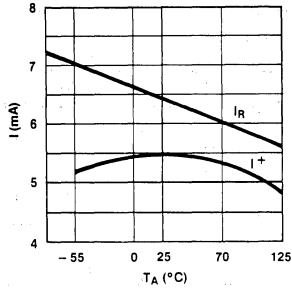

I_R AND I^+ vs VOLTAGE

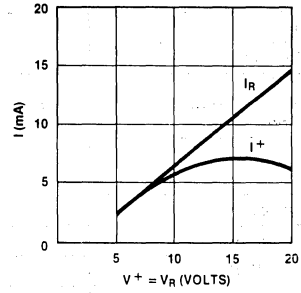

F_O vs C_T

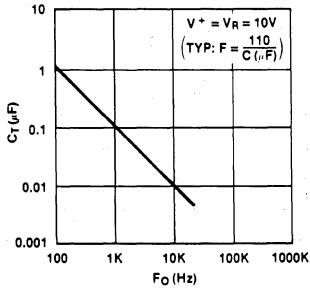

DEMODULATOR OFFSET vs TEMPERATURE (NORMALIZED TO 25°C)

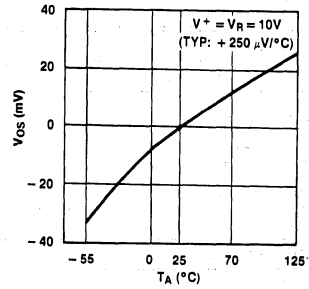

DISTORTION OF SINE WAVE vs REFERENCE VOLTAGE

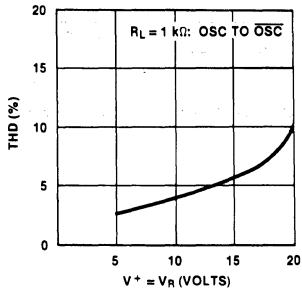

OSCILLATOR AMPLITUDE VARIATION WITH TEMPERATURE

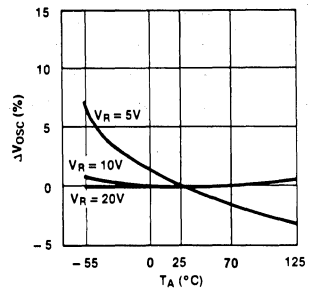

LVDT SIGNAL CONDITIONER

NE5520

TYPICAL SINGLE SUPPLY LVDT CIRCUIT

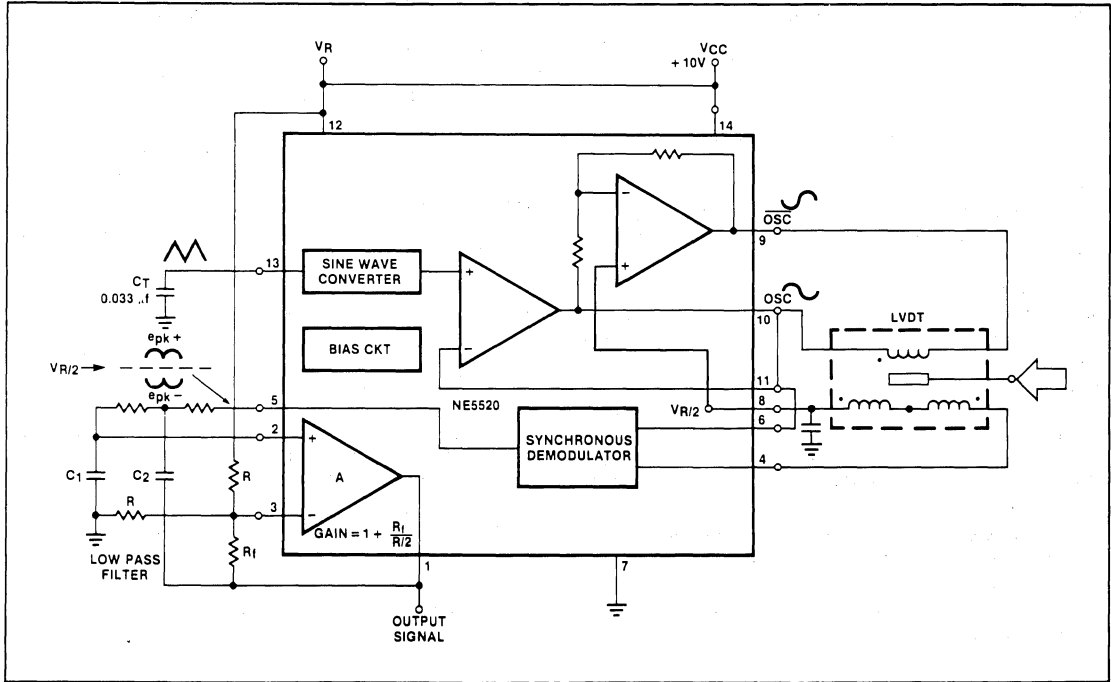

For additional information, refer to the Applications Section.

4

SAMPLE AND HOLD CIRCUITS—SYMBOLS AND DEFINITIONS

Acquisition Time

The time required to acquire a new analog input voltage with an output step of 10V. Note that acquisition time is not just the time required for the output to settle, but also includes the time required for all internal nodes to settle so that the output assumes the proper value when switched to the hold mode.

Aperture Delay Time

The time elapsed from the hold command to the opening of the switch.

Aperture Jitter

Also called "aperture uncertainty time", it's the time variation or uncertainty with which the switch opens, or the time variation in aperture delay.

Aperture Time

The delay required between "hold" command and an input analog transition, so that the transition does not affect the hold output.

Dynamic Sampling Error

The error introduced into the held output due to a changing analog input at the time the hold command is given. Error is expressed in mV with a given hold capacitor value and input slew rate. Note that this error term occurs even for long sample times.

Effective Aperture Delay

The time difference between the hold command and the time at which the input signal is at the held voltage.

Figure Of Merit

The ratio of the available charging current during sample mode to the leakage current during hold mode.

Gain Error

The ratio of output voltage swing to input voltage swing in the sample mode expressed as a percent difference.

Hold-Mode Droop

The output voltage change per unit of time while in hold. Commonly specified in V/s, $\mu\text{V}/\mu\text{s}$ or other convenient units.

Hold-Mode Feed Through

This percentage of an input sinusoidal signal that is measured at the output of a sample-and-hold when it's in hold mode.

Hold Settling Time

The time required for the output to settle within 1mV of final value after the "hold" logic command.

Hold Step

The voltage step at the output of the sample and hold when switching from sample mode to hold mode with a steady (dc) analog input voltage. Logic swing is 5V.

Sample-To-Hold Offset Error

The difference in output voltage between the time the switch starts to open, and the time when the output has settled completely. It is caused by charge being transferred to the hold capacitor switch as it opens.

Slew Rate

The fastest rate at which the sample & hold output can change (specified in $\text{V}/\mu\text{s}$).

Threshold

Level shall be defined as that level which causes the switch control to change state.

MONOLITHIC SAMPLE AND HOLD CIRCUITS

LF198/LF298/LF398

DESCRIPTION

The Signetics LF198/LF298/LF398 are monolithic sample and hold circuits which utilize high-voltage Ion Implant JFET technology to obtain ultra-high DC accuracy with fast acquisition of signal and low droop rate. Operating as a unity gain follower, DC gain accuracy is 0.002% typical and acquisition time is as low as 6 μ s to 0.01%. A bipolar input stage is used to achieve low offset voltage and wide bandwidth. Input offset adjust is accomplished with a single pin and does not degrade input offset drift. The wide bandwidth allows the LF198 to be included inside the feedback loop of 1MHz op amps without having stability problems. Input impedance of 10¹⁰ Ω allows high source impedances to be used without degrading accuracy.

P-channel junction FET's are combined with bipolar devices in the output amplifier to give droop rates as low as 5mV/min with a 1 μ F hold capacitor. The JFET's have much lower noise than MOS devices used in previous designs and do not exhibit high temperature instabilities. The overall design guarantees no feed-through from input to output in the hold mode even for input signals equal to the supply voltages.

Logic inputs are fully differential with low input current, allowing direct connection to TTL, PMOS, and CMOS. Differential threshold is 1.4V. The LF198/LF298/LF398 will operate from $\pm 5V$ to $\pm 18V$ supplies. They are available in an 8-lead TO-5 package, or an 8-pin plastic DIP.

FEATURES

- Operates from $\pm 5V$ to $\pm 18V$ supplies
- Less than 10 μ s acquisition time
- TTL, PMOS, CMOS compatible logic input
- 0.5mV typical hold step at $C_h = 0.01\mu F$
- Low input offset
- 0.002% gain accuracy
- Low output noise in hold mode
- Input characteristics do not change during hold mode
- High supply rejection ratio in sample or hold
- Wide bandwidth

APPLICATIONS

- The LF198/LF298/LF398 are ideally suited for a wide variety of sample and hold applications including data acquisition, analog-to-digital conversion, synchronous demodulation, and automatic test setup.

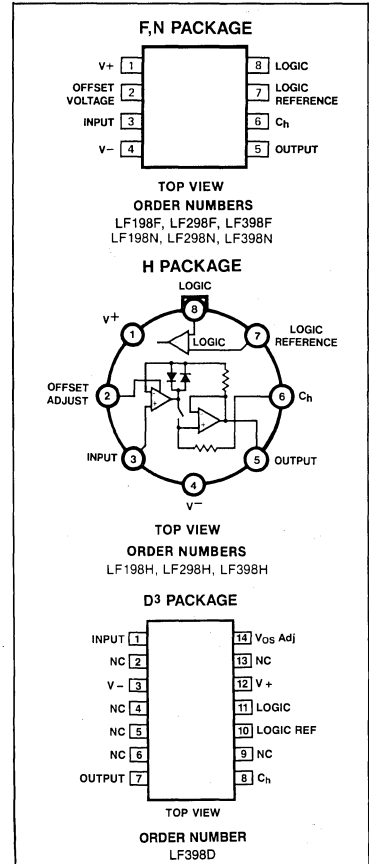

NOTES:

1. SOL - Released in Large SO package only.
2. SOL and non-standard pinout.
3. SO and non-standard pinouts.

FUNCTIONAL DIAGRAM

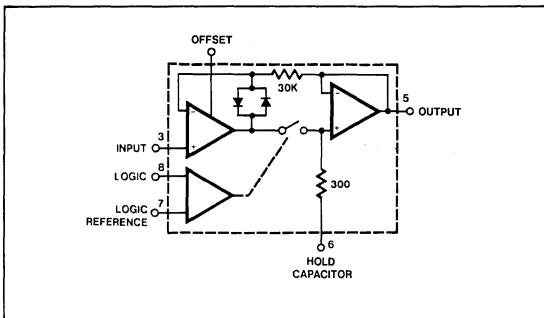

TYPICAL APPLICATIONS

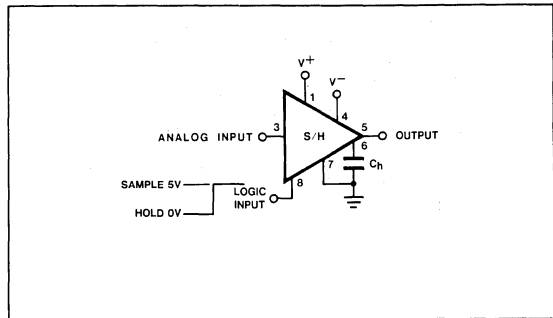

MONOLITHIC SAMPLE AND HOLD CIRCUITS

LF198/LF298/LF398

ABSOLUTE MAXIMUM RATINGS

PARAMETER	RATING	UNIT
Supply voltage	± 18	V
Power dissipation (package limitation) ¹	500	mW
Operating ambient temperature range		
LF198	-55 to +125	°C
LF298	-25 to +85	°C
LF398	0 to +70	°C
Storage temperature range	-65 to +150	°C
Input voltage	Equal to supply voltage	
Logic to logic reference differential voltage ²	+7, -30	V
Output short circuit duration	Indefinite	
Hold capacitor short circuit duration	10	sec
Lead temperature (soldering, 10sec)	300	°C

DC ELECTRICAL CHARACTERISTICS

Unless otherwise specified, the following conditions apply. Unit is in "sample" mode, $V_S = \pm 15V$, $T_j = 25^\circ C$, $-11.5V \leq V_{IN} \leq +11.5V$, $C_h = 0.01\mu F$, and $R_L = 10k\Omega$. Logic reference voltage = 0V and logic voltage = 2.5V.

PARAMETER	TEST CONDITIONS	LF198/LF298			LF398			UNIT
		Min	Typ	Max	Min	Typ	Max	
Input offset voltage ⁶	$T_j = 25^\circ C$		1	3 5		2	7 10	mV mV
Input bias current ⁶	$T_j = 25^\circ C$ Full temperature range		5	25 75		10	50 100	nA nA
Input impedance	$T_j = 25^\circ C$		10^{10}			10^{10}		Ω
Gain error	$T_j = 25^\circ C$, $R_L = 10K$ Full temperature range		0.002	0.005 0.02		0.004	0.01 0.02	% %
Feedthrough attenuation ratio at 1kHz	$T_j = 25^\circ C$, $C_h = 0.01\mu F$	86	96		80	90		dB
Output impedance	$T_j = 25^\circ C$, "HOLD" mode Full temperature range		0.5	2 4		0.5	4 6	Ω Ω
"HOLD" step ⁴	$T_j = 25^\circ C$, $C_h = 0.01\mu F$, $V_{OUT} = 0$		0.5	2.0		1.0	2.5	mV
Supply current ⁶	$T_j \leq 25^\circ C$		4.5	5.5		4.5	6.5	mA
Logic and logic reference input current	$T_j = 25^\circ C$		2	10		2	10	μA
Leakage current into hold capacitor ⁶	$T_j = 25^\circ C^5$, Hold mode		30	100		30	200	pA
Acquisition time to 0.1%	$\Delta V_{OUT} = 10V$, $C_h = 1000pF$ $C_h = 0.01\mu F$		4 20			4 20		μs μs
Hold capacitor charging current	$V_{IN} - V_{OUT} = 2V$		5			5		mA
Supply voltage rejection ratio	$V_{OUT} = 0$	80	110		80	110		dB
Differential logic threshold	$T_j = 25^\circ C$	0.8	1.4	2.4	0.8	1.4	2.4	V

NOTES

- The maximum junction temperature of the LF398 is 150°C. When operating at elevated ambient temperature, the TO-5 and plastic DIP packages must be derated based on a thermal resistance (θ_{JA}) of 150°C/W.
- Although the differential voltage may not exceed the limits given, the common-mode voltage on the logic pins may be equal to the supply voltages without causing damage to the circuit. For proper logic operation, however, one of the logic pins must always be at least 2V below the positive supply and 3V above the negative supply.
- Unless otherwise specified, the following conditions apply. Unit is in "sample" mode, $V_S = \pm 15V$, $T_j = 25^\circ C$, $-11.5V \leq V_{IN} \leq +11.5V$, $C_h = 0.01\mu F$, and $R_L = 10k$. Logic reference voltage = 0V and logic voltage = 2.5V.
- Hold step is sensitive to stray capacitive coupling between input logic signals and the hold capacitor. 1pF, for instance, will create an additional 0.5mV step with a 5V logic swing and a 0.01 μF hold capacitor. Magnitude of the hold step is inversely proportional to hold capacitor value.
- Leakage current is measured at a junction temperature of 25°C. The effects of junction temperature rise due to power dissipation or elevated ambient can be calculated by doubling the 25°C value for each 11°C increase in chip temperature. Leakage is guaranteed over full input signal range.
- The parameters guaranteed over a supply voltage of ± 5 to $\pm 18V$.

TYPICAL DC PERFORMANCE CHARACTERISTICS

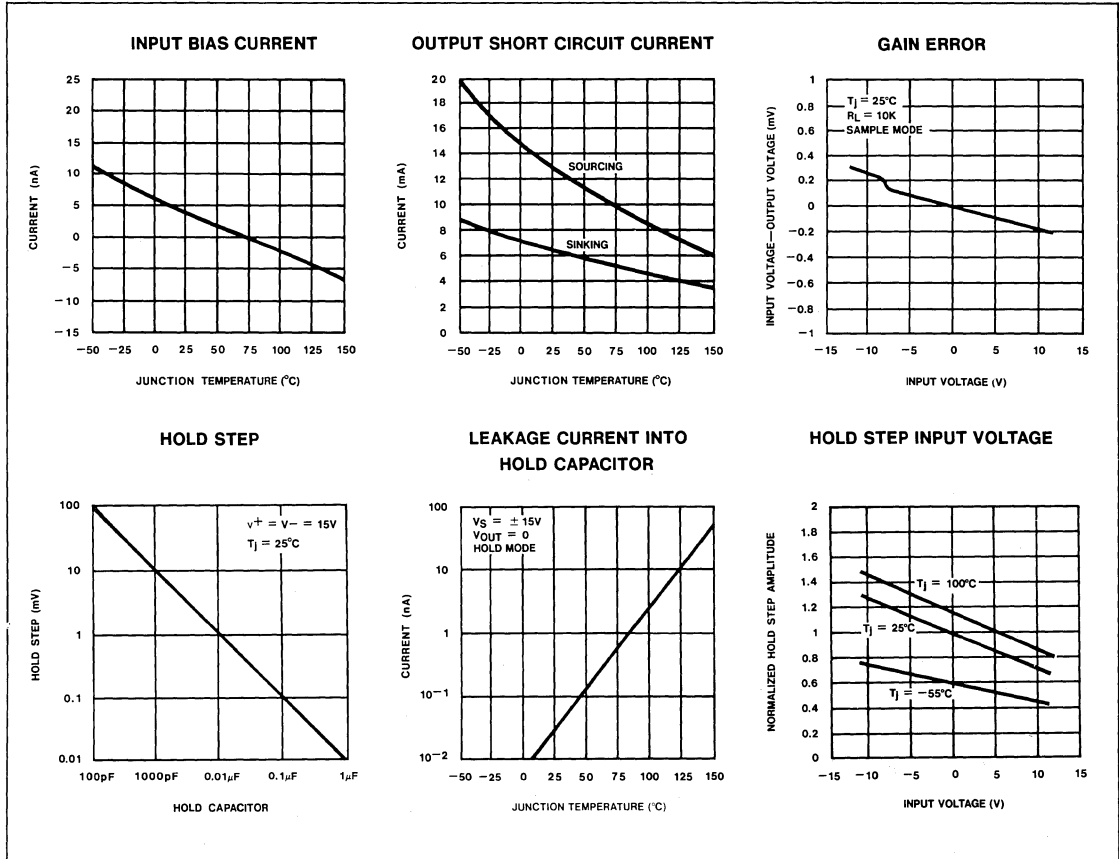

4

TYPICAL AC PERFORMANCE CHARACTERISTICS

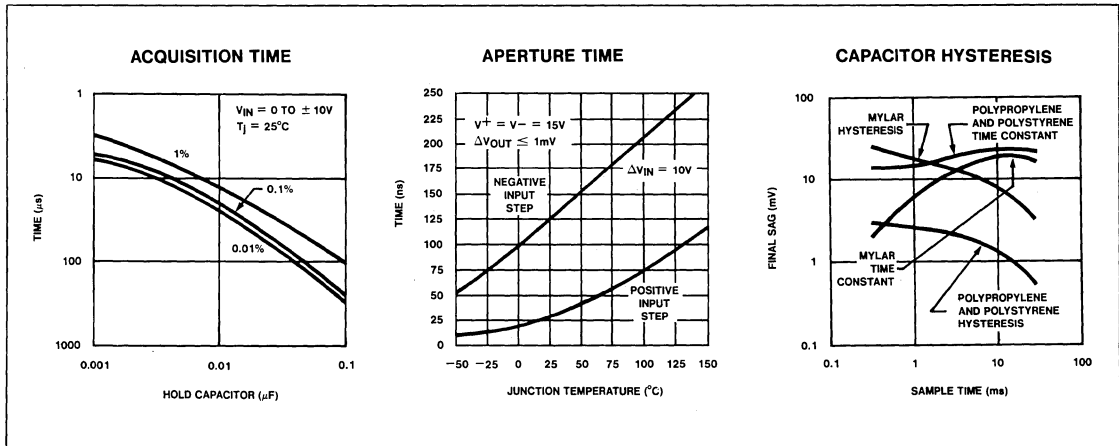

TYPICAL AC PERFORMANCE CHARACTERISTICS (cont'd)

DYNAMIC SAMPLING ERROR

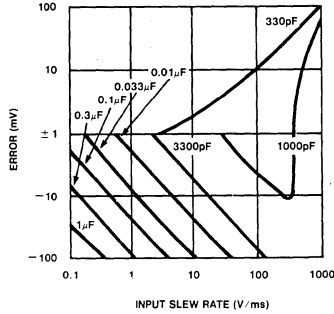

OUTPUT DROOP RATE

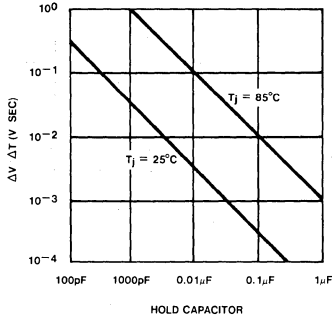

"HOLD" SETTLING TIME

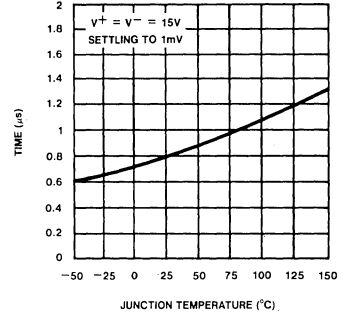

PHASE AND GAIN (INPUT TO OUTPUT, SMALL SIGNAL)

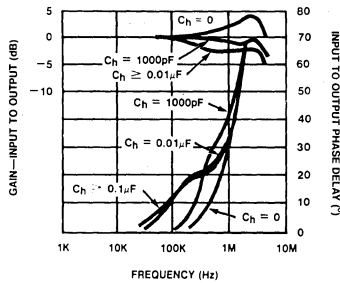

POWER SUPPLY REJECTION

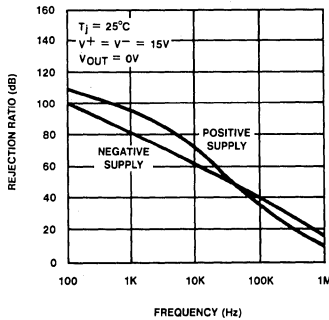

OUTPUT NOISE

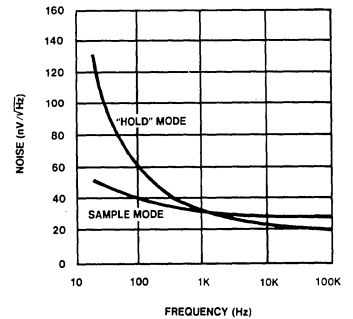

FEEDTHROUGH REJECTION RATIO (HOLD MODE)

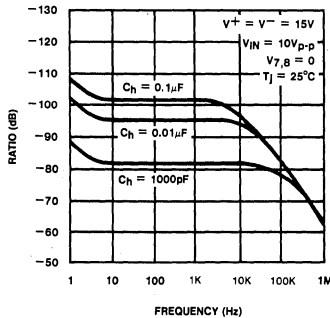

SAMPLE AND HOLD AMPLIFIER

SE/NE5537

DESCRIPTION

The NE5537 monolithic Sample and Hold amplifier combines the best features of iron implanted JFET's with bipolar devices to obtain high accuracy, fast acquisition time, and low droop rate. This device is pin compatible with the LF198, and features superior performance in droop rate and output drive capability. The circuit shown in Figure 1 contains two operational amplifiers which function as a unity gain amplifier in the Sample mode. The first amplifier has bipolar input transistors which gives the system a low offset voltage. The second amplifier has JFET input transistors to achieve low leakage current from the hold capacitor. A unique circuit design for leakage current cancellation using current mirrors gives the NE5537 a low droop rate at higher temperature. The output stage has the capability to drive a 2K Ω load. The logic input is compati-

ble with TTL, PMOS or CMOS logic. The differential logic threshold is 1.4V with the Sample mode occurring when the logic input is high. It is available in 8-lead TO-5 and 8-pin plastic DIP packages.

FEATURES

- Operates from $\pm 5V$ to $\pm 18V$ supplies
- Hold leakage current 6pA @ T_j25°C
- Less than 4 μ s acquisition time
- TTL, PMOS, CMOS compatible logic input
- 0.5mV typical hold step at C_h = 0.01 μ F
- Low input offset: 1mV (typical)
- 0.002% gain accuracy with R_L = 2k Ω
- Low output noise in hold mode
- Input characteristics do not change during hold mode
- High supply rejection ratio in sample or hold
- Wide bandwidth

ABSOLUTE MAXIMUM RATINGS

PARAMETER	RATING	UNIT
Supply voltage	± 18	V
Power dissipation (package limitation) ¹	500	mW
Operating ambient temperature range		
SE5537	-55 to +125	°C
NE5537	0 to +70	°C
Storage temperature range	-65 to +150	°C
Input voltage	Equal to supply voltage	
Logic to logic reference differential voltage ²	+7, -30	V
Output short circuit duration	Indefinite	
Hold capacitor short circuit duration	10	sec
Lead temperature (soldering, 10sec)	300	°C

NOTES

1. The maximum junction temperature of the SE5537 is 150°C and for the NE5537 is 100°C. When operating at elevated ambient temperature, the TO-5 and plastic DIP packages must be derated based on a thermal resistance (θ_{ja}) of 150°C/W.
2. Although the differential voltage may not exceed the limits given, the common mode voltage on the logic pins may be equal to the supply voltages without causing damage to the circuit. For proper logic operation, however, one of the logic pins must always be at least 2V below the positive supply and 3V above the negative supply.

BLOCK DIAGRAM

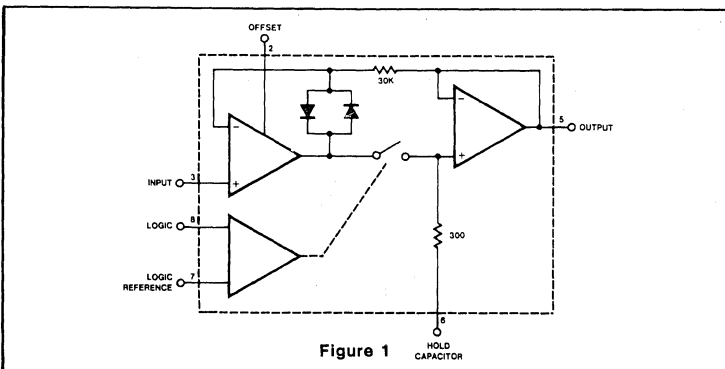
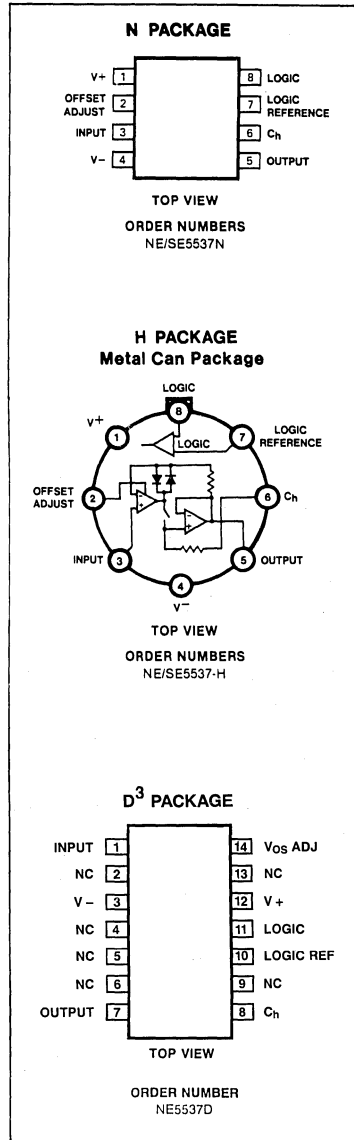

Figure 1

PIN CONFIGURATION



NOTES:

1. SOL - Released in Large SO package only.
2. SOL and non-standard pinout.
3. SO and non-standard pinouts.

SAMPLE AND HOLD AMPLIFIER

SE/NE5537

ELECTRICAL CHARACTERISTICS³

PARAMETER	TEST CONDITIONS	SE5537			NE5537			UNIT
		Min	Typ	Max	Min	Typ	Max	
Input offset voltage ⁶	$T_j = 25^\circ\text{C}$ Full temperature range		1	3		2	7	mV
				5		10	10	mV
Input bias current ⁶	$T_j = 25^\circ\text{C}$ Full temperature range		5	25		10	50	nA
				75		100	100	nA
Input impedance	$T_j = 25^\circ\text{C}$		10^{10}		10^{10}		Ω	
Gain error	$T_j = 25^\circ\text{C}$, $-10\text{V} \leq V_{IN} \leq 10\text{V}$, $R_L = 2\text{K}$ $-11.5\text{V} \leq V_{IN} \leq 11.5\text{V}$, $R_L = 10\text{K}$ Full temperature range		0.002	0.007		0.004	0.01	%
				0.02		0.02	0.02	%
Feedthrough attenuation ratio at 1kHz	$T_j = 25^\circ\text{C}$, $C_h = 0.01\mu\text{F}$	86	96		80	90		dB
Output impedance	$T_j = 25^\circ\text{C}$, "HOLD" mode full temperature range		0.5	2		0.5	4	Ω
				4		6	6	
"HOLD" Step ⁴	$T_j = 25^\circ\text{C}$, $C_h = 0.01\mu\text{F}$, $V_{OUT} = 0$		0.5	2.0		1.0	2.5	mV
Supply current ⁶	$T_j = 25^\circ\text{C}$		4.5	6.5		4.5	7.5	mA
Logic and logic reference input current	$T_j = 25^\circ\text{C}$		2	10		2	10	μA
Leakage current into hold capacitor ⁶	$T_j = 25^\circ\text{C}$ hold mode ⁵		6	50		6	100	pA
Acquisition time to 0.1%	$V_{OUT} = 10\text{V}$, $C_h = 1000\text{pF}$ $C_h = 0.01\mu\text{f}$		4			4		μs
			20			20		μs
Hold capacitor charging current	$V_{IN} - V_{OUT} = 2\text{V}$		5			5		mA
Supply voltage rejection ratio	$V_{OUT} = 0$	80	110		80	110		dB
Differential logic threshold	$T_j = 25^\circ\text{C}$	0.8	1.4	2.4	0.8	1.4	2.4	V

NOTES

- Unless otherwise specified, the following conditions apply. Unit is in "sample" mode, $V_S = \pm 15\text{V}$, $T_j = 25^\circ\text{C}$, $-11.5\text{V} \leq V_{IN} \leq 11.5\text{V}$, $C_h = 0.01\mu\text{F}$, and $R_L = 2\text{k}\Omega$. Logic reference voltage = 0V and logic voltage = 2.5V.
- Hold step is sensitive to stray capacitive coupling between input logic signals and the hold capacitor. 1pF, for instance, will create an additional 0.5mV step with a 5V logic swing and a 0.01F hold capacitor. Magnitude of the hold step is inversely proportional to hold capacitor value.
- Leakage current is measured at a junction temperature of 25°C . The effects of junction temperature rise due to power dissipation or elevated ambient can be calculated by doubling the 25°C value for each 11°C increase in chip temperature. Leakage is guaranteed over full input signal range.
- These parameters guaranteed over a supply voltage range of ± 5 to $\pm 18\text{V}$.

TYPICAL PERFORMANCE CHARACTERISTICS

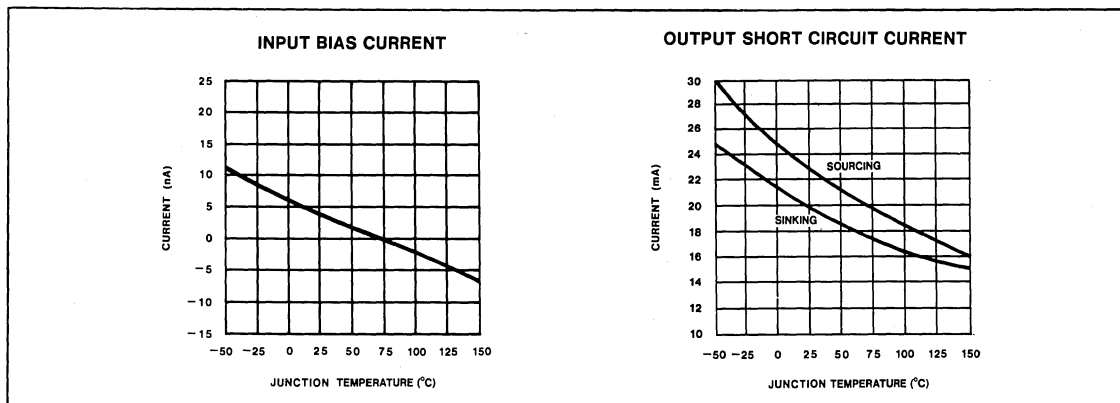

SAMPLE AND HOLD AMPLIFIER

SE/NE5537

TYPICAL PERFORMANCE CHARACTERISTICS (Cont'd.)

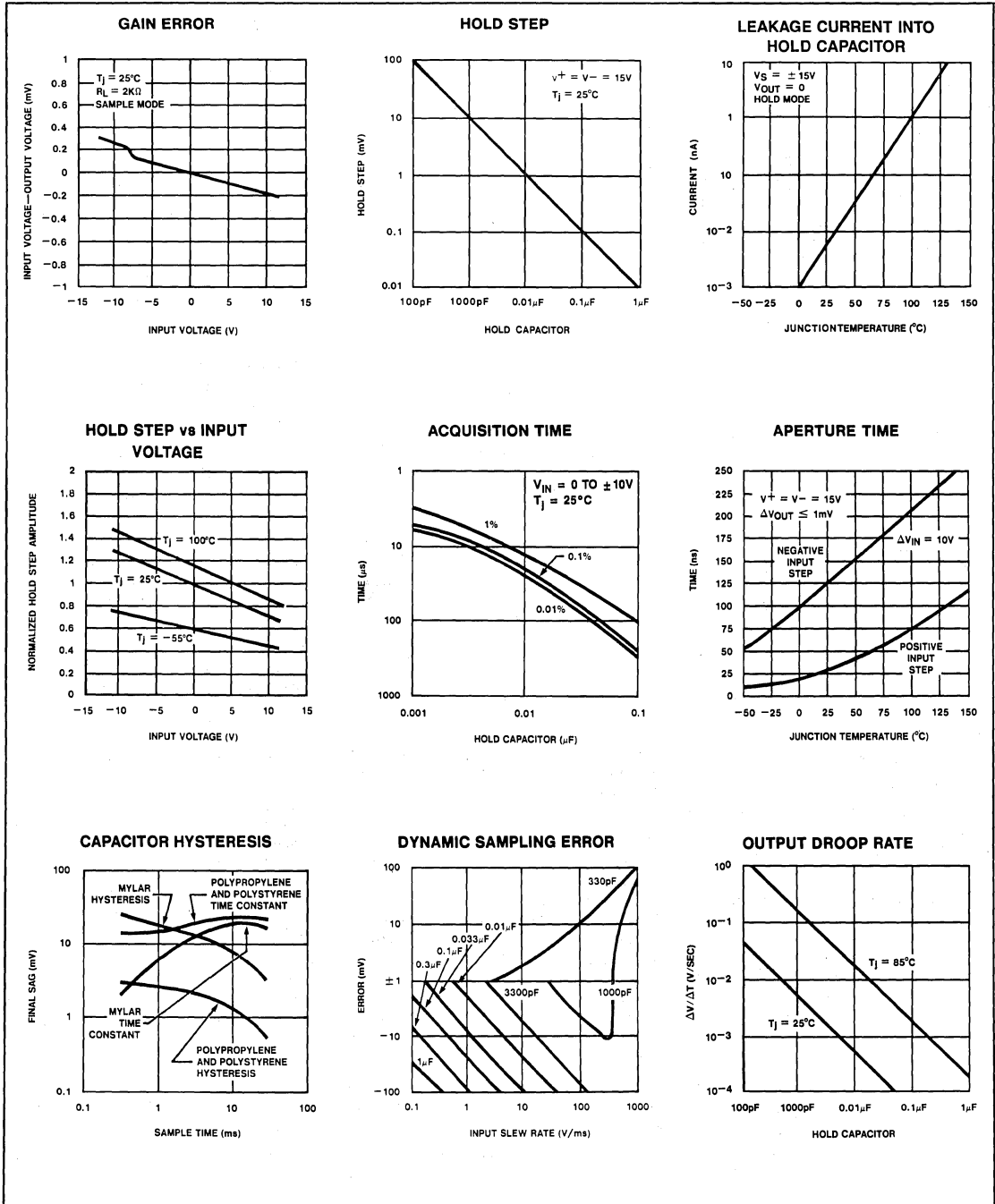

4

TYPICAL PERFORMANCE CHARACTERISTICS (Cont'd)

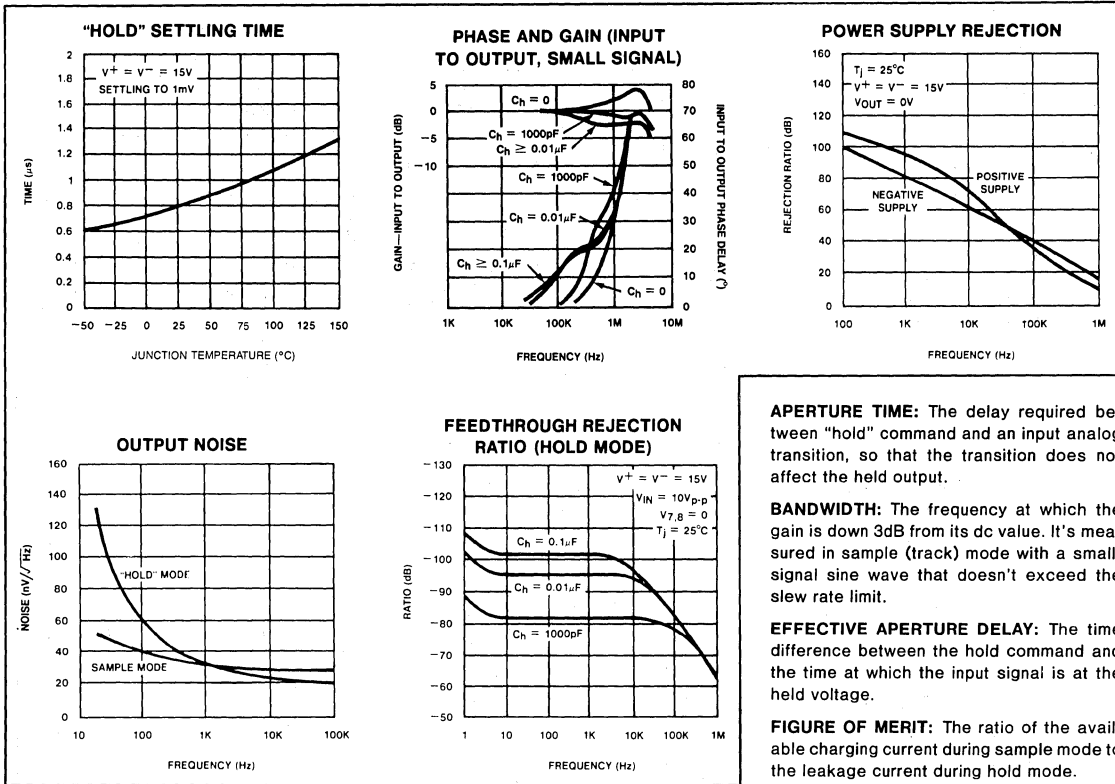

APERTURE TIME: The delay required between "hold" command and an input analog transition, so that the transition does not affect the held output.

BANDWIDTH: The frequency at which the gain is down 3dB from its dc value. It's measured in sample (track) mode with a small-signal sine wave that doesn't exceed the slew rate limit.

EFFECTIVE APERTURE DELAY: The time difference between the hold command and the time at which the input signal is at the held voltage.

FIGURE OF MERIT: The ratio of the available charging current during sample mode to the leakage current during hold mode.

HOLD-MODE DROOP: The output voltage change per unit of time while in hold. Commonly specified in V/s , $\mu V/\mu s$ or other convenient units.

HOLD-MODE FEEDTHROUGH: The percentage of an input sinusoidal signal that is measured at the output of a sample-and hold when it's in hold mode.

HOLD SETTling TIME: The time required for the output to settle within 1mV of final value after the "hold" logic command.

SAMPLE-TO-HOLD OFFSET ERROR: The difference in output voltage between the time the switch starts to open, and the time when the output has settled completely. It is caused by charge being transferred to the hold capacitor switch as it opens.

SLEW RATE: The fastest rate at which the sample & hold output can change (specified in $V/\mu s$).

HOLD STEP: The voltage step at the output of the sample and hold when switching from sample mode to hold mode with a steady (dc) analog input voltage. Logic swing is 5V.

SAMPLE AND HOLD

INTRODUCTION

For many years designers have used the sample and hold (or track and hold) to operate on analog information in a time frame which is expedient.

By sampling a segment of the information and holding it until the proper timing for converting to some form of control signal or readout allows the designer certain freedom in performing predetermined manipulative functions. Therefore, the sample and hold can be defined as a "selective analog memory cell".

The memory is volatile and will also decay with time.

When using the sample and hold method for evaluating signal information, the designer is given the added feature of eliminating outside noise elements. With the analog to digital converter products available today the "dc memory" of the sample and hold can be

easily converted to digital format and further incorporated into microprocessor based systems.

Parametric evaluation of the sample and hold will be discussed in the following paragraphs.

DEFINITION OF TERMS

ACQUISITION TIME: The time required to acquire a new analog input voltage with an output step of 10V. Note that acquisition time is not just the time required for the output to settle, but also includes the time required for all internal nodes to settle so that the output assumes the proper value when switched to the hold mode.

APERTURE DELAY TIME: The time elapsed from the hold command to the opening of the switch.

APERTURE JITTER: Also called "aperture uncertainty time", it's the time variation or uncertainty with which the switch opens, or the time variation in aperture delay.

SAMPLE AND HOLD AMPLIFIER

SE/NE5537

DYNAMIC SAMPLING ERROR: The error introduced into the held output due to a changing analog input at the time the hold command is given. Error is expressed in mV with a given hold capacitor value and input slew rate. Note that this error term occurs even for long sample times.

GAIN ERROR: The ratio of output voltage swing to input voltage swing in the sample mode expressed as a percent difference.

THRESHOLD: Level shall be defined as that level which causes the switch control to change state.

BASIC BLOCK DIAGRAM

The basic circuit concept of the sample and hold circuit incorporates the use of two (2) operational amplifiers and a switch control mechanism (which determines sample, hold or track conditions). Reference figure 1.

The block diagram of the NE5537 is a closed loop non-inverting unity gain sample and hold system. The input buffer amplifier supplies the current necessary to charge the hold capacitor, while the output buffer amplifier closes the loop such that the output voltage is identical to the input voltage (with consideration for input offset voltage, offset current, and temperature variations which are common to *all* sample and hold circuits, be they monolithic, hybrid or modular).

When the sampling switch is open (in the hold mode) the clamping diodes close the loop around the input amplifier to keep it from being overdriven into saturation.

The switch control is driven by external logic levels via a timing sequence remote from the sample and hold device. Reference figure 2. The switch control has a floating reference (pin 7), referred to as the logic reference which makes the sample and hold device compatible to several types of external logic signals (TTL, PMOS, & CMOS). The switching device operates at a threshold level of 1.4V.

The switch mechanism is on (sampling an information stream) when the logic level is high (pin 8 is 1.4 volts higher than pin 7) and presents a load of 5 microamperes to the input logic signal. The analog sampled signal is amplified, stored (in the external holding capacitor), and buffered. At the end of the sampling period the internal switch mechanism turns off (switch opens) and the "stored analog memory" information on the external capacitor (pin 6) is loaded down by an operational amplifier connected in the unity gain non-inverting configuration. This

amplifier, whose input impedance is effectively:

$$R = R_{IN}(A_{OL}) / (1 + 1/A)$$

where

R	= Effective input impedance
R_{IN}	= Open loop input impedance
A_{OL}	= Open loop gain
A	= AC loop gain

Therefore, the higher the open loop gain of the second operational amplifier, the larger the effective loading on the capacitor. The larger the load, the lower the "leakage" current and the better the droop characteristics.

In actuality the amplifiers are designed with special leakage current cancellation circuits along with FET input devices. The leakage current cancellation circuits give better high temperature operation (remember that the FET amplifiers double in required bias current for every 10 degree increase in junction temperature).

Sampling time for the NE5537 is less than $10\mu\text{sec}$, (measured to 0.1% of input signal). Leakage current is 6pA at a rate output load of 2k Ω .

BASIC APPLICATIONS

Multiplying DAC

As depicted in the block diagram of figure 3, the sample and hold circuit is used to supply a "variable" reference to the digital to analog converter. As the input reference varies, the output will change in accordance with equation 1, shown in figure 3.

Varying the input signal reference level can aid the system in performing both compression and expansion operations. The multiplying DAC's used are the Signetics SE/NE 5008; however, if the rate of change of the reference variation is kept slow enough a microprocessor compatible DAC can be incorporated, such as the NE5018 or the NE5020.

DATA ACQUISITION SYSTEMS

As mentioned earlier, the designer may wish to operate on several different segments of an "analog" signal; however he is limited by the fact that only one analog to digital converter channel is available to him. Figure 4 shows the means by which a multiplexing system may be accomplished.

APPLICATION HINTS

Hold Capacitor

A significant source of error in an accurate sample and hold circuit is dielectric absorption in the hold capacitor. A mylar cap, for

instance, may "sag back" up to 0.2% after a quick change in voltage. A long "soak" time is required before the circuit can be put back into the hold mode with this type of capacitor. Dielectrics with very low hysteresis are polystyrene, polypropylene, and Teflon. Other types such as mica and polycarbonate are not nearly as good. Ceramic is unusable with $>1\%$ hysteresis. The advantage of polypropylene over polystyrene is that it extends the maximum ambient temperature from 85°C to 100°C. The hysteresis relaxation time constant in polystyrene, for instance, is 10-50ms. If A-to-D conversion can be made within 1ms, hysteresis error will be reduced by a factor of ten.

DC Zeroing

DC Zeroing is accomplished by connecting the offset adjust pin to the wiper of a 1k Ω potentiometer which has one end tied to V^+ and the other end tied through a resistor to ground. The resistor should be selected to give $\approx 0.6\text{mA}$ through the 1k Ω potentiometer.

Sampling Dynamic Signals

Sampling errors due to moving (changing) input signals are of significant concern to designers employing sample and hold circuits. There exist finite phase delays through the sample and hold circuit causing an input-output phase differential for moving signals. In addition, the series protection resistor (300 Ω to pin 6 of the NE5537) will add an RC time constant, over and above the slew rate limitation of the input buffer/current drive amplifier. This means that at the moment the "hold" command arrives, the hold capacitor voltage may be somewhat different than the actual analog input. The effect of these delays is opposite to the effect created by delays in the logic which switches the circuit from sample to hold. For example, consider an analog input of 20 Vp-p at 10kHz. Maximum dV/dt is $0.6V/\mu\text{s}$. With no analog phase delay and 100ns logic delay, one could expect up to $(0.1\mu\text{s})(0.6V/\mu\text{s}) = 60\text{mV}$ error if the "hold" signal arrived near maximum dV/dt of the input. A positive going input would give a $\pm 60\text{mV}$ error. Now assume a 1MHz (3dB) bandwidth for the overall analog loop. This generates a phase delay of 160ns. If the hold capacitor sees this exact delay, then error due to analog delay will be $(0.16\mu\text{s})(0.6V/\mu\text{s}) = -96\text{mV}$ (analog) for a total of -36mV . To add to the confusion, analog delay is proportional to hold capacitor value while digital delay remains constant. A family of curves (dynamic sampling error) is included to help estimate errors.

4

SAMPLE AND HOLD AMPLIFIER

SE/NE5537

A curve labeled *Aperture Time* has been included for sampling conditions where the input is steady during the sampling period, but may experience a sudden change nearly coincident with the "hold" command. This curve is based on a 1mV error fed into the output.

A second curve, *Hold Settling Time* indicates the time required for the output to settle to 1mV after the "hold" command.

Digital Feedthrough

Fast rise time logic signals can cause hold errors by feeding externally into the analog input at the same time the amplifier is put into the hold mode. To minimize this prob-

lem, board layout should keep logic lines as far as possible from the analog input. Grounded guarding traces may also be used around the input line, especially if it is driven from a high impedance source. Reducing high amplitude logic signals to 2.5V will also help.

Logic signals also couple to the hold capacitor. This hold capacitor should be guarded by a P.C. card trace connected to the sample-and-hold output. This will also minimize board leakage.

SPECIAL NOTES

1. Not all definitions herein defined are measured parametrically for the NE5537, but are legitimate terms used in sample and hold systems.
2. Reference should be made to Design Engineering, volumes 23 (Nov. 8, 1978), 25 (Dec. 6, 1978) and 26 (Dec. 20, 1978) for articles written by Eugene Zuch of Datel Systems, Inc. for a further discussion of sample and hold circuits.
3. Reference also made to National Semiconductor Corporation's Special Functions Data Book (1976).

TYPICAL APPLICATIONS

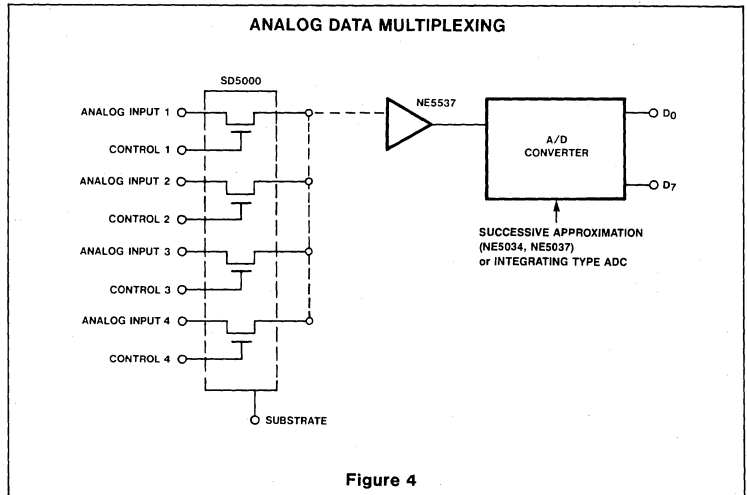
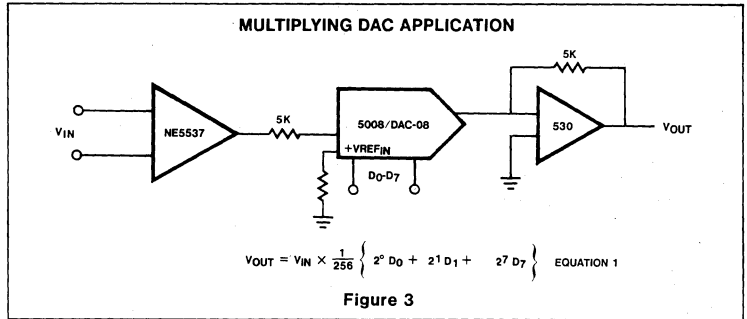
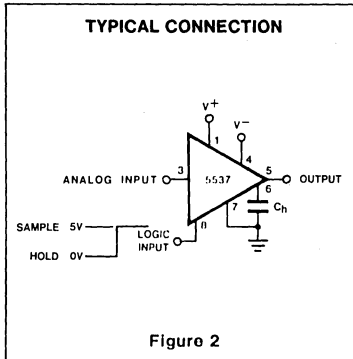

Section 5 Communication

INDEX

SECTION 5 — COMMUNICATION

Index	5-1
Analog and Audio Processing	
NE570	Compressor
SA/NE571	Compressor
SA/NE572	Programmable Analog Compressor
Audio/Stereo	
LM1870	Stereo Demodulator with Blend
NE542	Dual Low-Noise Preamp
*SA/NE602	Double Balanced Mixer and Oscillator
*SA/NE604	Low Power Narrow Band FM I.F.
NE645/646	Dolby-B Noise Reduction Circuit
NE648/649	Low Voltage Dolby-B Noise Reduction Circuit
NE650	Dolby B-Type Noise Reduction Circuit
NE660	Dolby B-Type Noise Reduction Circuit
*TDA1074A	DC-Controlled Dual Potentiometers
*TDA1522	Stereo Cassette Preamplifier (Dual)
*TDA1524A	Stereo, DC-Controlled Audio Control
*TDA3810	Spatial, Stereo, Pseudo-Stereo Processor
μA758	FM Stereo Multiplex Decoder Phase Locked Loop
FM Radio	
Consumer	
CA3089	FM I.F. System
*TDA7000	Single Chip FM Radio
*TDA7010T	Single Chip FM Radio, SO Package
Professional	
MC1496	Balanced Modulator/Demodulator
MC1596	Balanced Modulator/Demodulator
*SA/NE602	Double Balanced Mixer and Oscillator
*SA/NE604	Low Power Narrow Band FM I.F.
FSK Modems	
*NE5080	2 Megabaud FSK Transmitter, IEEE 802.4
*NE5081	FSK Receiver, IEEE 802.4
IR Remote Control Transmitters and Receivers	
*SAF1032P	Remote Control Receiver
*SAF1039P	Remote Control Transmitter
*TDA3047	IR Preamplifier
*TDA3048	IR Preamplifier

*New product for Linear LSI since 1983 data manual.

INDEX

Phase Locked Loops	
Symbols and Definitions	5-133
SE/NE564	High Frequency Phase Locked Loop
SE/NE565	Phase Locked Loop
SE/NE566	Function Generator
SE/NE567	Tone Decoder/Phase Locked Loop
Speech Synthesis	
*MEA8000	Speech Synthesizer
Telephony	
*TEA1046	Transmission Interface with DTMF
Timers	
SE/NE555/SE555C	Timer
SA/SE/NE556/-1/SE556-1C	Dual Timer
SA/SE/NE558	Quad Timer with C BUS Interface
*SAF3019P	Clock/Timer with I ² C Interface
*PC8573	Clock/Timer with I ² C Interface
Video/Teletext	
*SAA5030	Teletext Video Processor
*SAA5040	Teletext Acquisition and Control Circuit
*SAA5050/55	Teletext Character Generator (U.K.)

*New product for Linear LSI since 1983 data manual.

COMPANDOR

NE570/571/SA571

DESCRIPTION

The NE570/571 is a versatile low cost dual gain control circuit in which either channel may be used as a dynamic range compressor or expander. Each channel has a full wave rectifier to detect the average value of the signal; a linearized, temperature compensated variable gain cell; and an operational amplifier.

The NE570/571 is well suited for use in cellular radio and radio communications systems, modems, telephone, and satellite broadcast/receive audio systems.

FEATURES

- Complete compressor and expander in 1 IC
- Temperature compensated
- Greater than 110dB dynamic range
- Operates down to 6Vdc
- System levels adjustable with external components
- Distortion may be trimmed out

CIRCUIT DESCRIPTION

The NE570/571 compandor building blocks, as shown in the block diagram, are a full wave rectifier, a variable gain cell, an operational amplifier and a bias system. The arrangement of these blocks in the IC result in a circuit which can perform well with few external components, yet can be adapted to many diverse applications.

The full wave rectifier rectifies the input current which flows from the rectifier input, to an internal summing node which is biased at V_{REF} . The rectified current is averaged on an external filter capacitor tied to the C_{RECT} terminal, and the average value of the input current controls the gain of the variable gain cell. The gain will thus be proportional to the average value of the input signal for capacitively coupled voltage inputs as shown in the following equation. Note that for capacitively coupled inputs there is no offset voltage capable of producing a gain error. The only error will come from the bias current of the rectifier (supplied internally) which is less than $.1\mu A$.

$$G \propto \frac{|V_{IN} - V_{REF}|_{avg.}}{R_1}$$

$$G \propto \frac{|V_{IN}|_{avg.}}{R_1} \quad \text{or}$$

The speed with which gain changes to follow changes in input signal levels is determined by the rectifier filter capacitor. A small capacitor will yield rapid response but will not fully filter low frequency signals. Any ripple on the gain control signal will modulate the signal passing through the variable gain cell. In an expander or com-

Note:
1. Supplied only in large SO (Small Outline) package.

APPLICATIONS

- Cellular radio
- Telephone trunk compandor—570
- Telephone subscriber compandor—571
- High level limiter
- Low level expander—noise gate
- Dynamic noise reduction systems
- Voltage controlled amplifier
- Dynamic filters

PIN CONFIGURATION

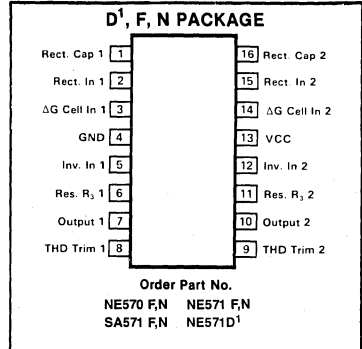

- NOTES:
1. SOL - Released in Large SO package only.
2. SOL and non-standard pinout.
3. SO and non-standard pinouts.

ABSOLUTE MAXIMUM RATINGS

PARAMETER	RATING	UNIT
Positive supply	24	Vdc
570	18	
571		
T_A Operating temperature range	0 to 70	$^{\circ}C$
NE	-40 to +85	$^{\circ}C$
SA	400	mW
P_D Power dissipation		

BLOCK DIAGRAM

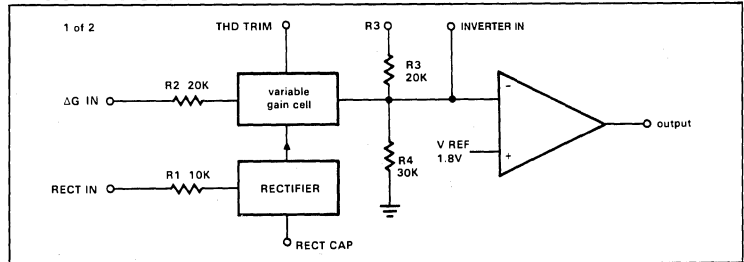

pressor application, this would lead to third harmonic distortion, so there is a tradeoff to be made between fast attack and decay times, and distortion. For step changes in amplitude, the change in gain with time is shown by this equation.

$$G(t) = (G_{initial} - G_{final}) e^{-t/\tau} + G_{final}; \quad \tau = 10K \times C_{RECT}$$

The variable gain cell is a current in, current out device with the ratio I_{OUT}/I_{IN} controlled by the rectifier. I_{IN} is the current which flows from the ΔG input to an internal summing node biased at V_{REF} . The following equation applies for capacitively coupled inputs. The output current, I_{OUT} , is fed to the summing node of the op amp.

$$I_{IN} = \frac{V_{IN} - V_{REF}}{R_2} = \frac{V_{IN}}{R_2}$$

A compensation scheme built into the ΔG cell compensates for temperature, and cancels out odd harmonic distortion. The only distortion which remains is even harmonics, and they exist only because of internal offset voltages. The THD trim terminal provides a means for nulling the internal offsets for low distortion operation.

The operational amplifier (which is internally compensated) has the non-inverting input tied to V_{REF} , and the inverting input connected to the ΔG cell output as well as brought out externally. A resistor, R_3 , is brought out from the summing node and allows compressor or expander gain to be determined only by internal components.

The output stage is capable of $\pm 20\text{mA}$ output current. This allows a $+13\text{dBm}$ (3.5V rms) output into a 300Ω load which, with a series resistor and proper transformer, can result in $+13\text{dBm}$ with a 600Ω output impedance.

A band gap reference provides the reference voltage for all summing nodes, a regulated supply voltage for the rectifier and ΔG cell, and a bias current for the ΔG cell. The low tempco of this type of reference provides very stable biasing over a wide temperature range.

The typical performance characteristics illustration shows the basic input-output transfer curve for basic compressor or expander circuits.

TYPICAL PERFORMANCE CHARACTERISTICS

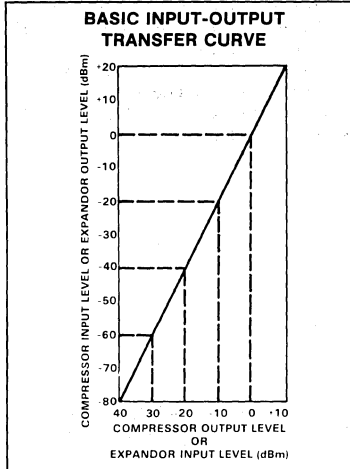

TYPICAL TEST CIRCUIT

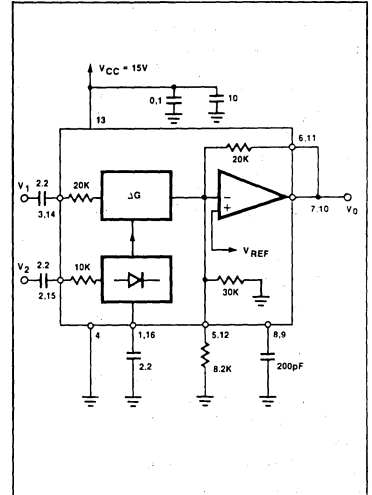

DC ELECTRICAL CHARACTERISTICS $T_A = 25^\circ\text{C}$, $V_{CC} = 15$ Except where indicated, the 571 specifications are identical to 570

PARAMETER	TEST CONDITIONS	NE570			NE/SA571 ⁵			UNIT
		Min	Typ	Max	Min	Typ	Max	
V_{CC} Supply voltage		6		24	6		18	V
I_{CC} Supply current	No signal		3.2	4.8		3.2	4.8	mA
Output current capability		± 20			± 20			mA
Output slew rate			± 5			± 5		V/us
Gain cell distortion ²	Untrimmed		.3	1.0		.5	2.0	%
	Trimmed		.05			.1		
Resistor tolerance			± 5	± 15		± 5	± 15	%
Internal reference voltage		1.7	1.8	1.9	1.65	1.8	1.95	V
Output dc shift ³	Untrimmed		± 20	± 50		± 30	± 100	mV
Expander output noise	No signal, 15Hz-20kHz ¹		20	45		20	60	μV
			-15					dBmNC
Unity gain level		-1	0	+1	-1.5	0	+1.5	dBm
Gain change ^{2,4}	$-40^\circ\text{C} < T < 70^\circ\text{C}$		± 1			± 1		dB
	$0^\circ\text{C} < T < 70^\circ\text{C}$		± 1	± 2		± 1	± 4	
Reference drift ⁴	$-40^\circ\text{C} < T < 70^\circ\text{C}$		+2, -25	-10, -40		+2, -25	+20, -50	mV
	$0^\circ\text{C} < T < 70^\circ\text{C}$		± 5	± 10		± 5	± 20	
Resistor drift ⁴	$-40^\circ\text{C} < T < 70^\circ\text{C}$		+8, -0					%
	$0^\circ\text{C} < T < 70^\circ\text{C}$		+1, -0					
Tracking error (measured relative to value at unity gain) equals $[V_O - V_O(\text{unity gain})]$ dB - V_2 dBm	Rectifier input, $V_2 = +6\text{dBm}$, $V_1 = \text{OdB}$ $V_2 = -30\text{dBm}$, $V_1 = \text{OdB}$		± 2					dB
Channel Separation		60		-5, +1		60	-1, +1.5	dB

NOTES:

1. Input to V_1 and V_2 grounded.
2. Measured at OdBm , 1kHz.
3. Expander ac input change from no signal to OdBm .
4. Relative to value at $T_A = 25^\circ\text{C}$.
5. Electrical characteristics for the SA571 only are specified over -40 to $+85^\circ\text{C}$ temperature range.

INTRODUCTION

Much interest has been expressed in high performance electronic gain control circuits. For non-critical applications, an integrated circuit operational transconductance amplifier can be used, but when high performance is required, one has to resort to complex discrete circuitry with many expensive, well matched components. This paper describes an inexpensive integrated circuit, the NE570 Compandor, which offers a pair of high performance gain control circuits featuring low distortion (< .1%), high signal to noise ratio (90dB), and wide dynamic range (110dB).

CIRCUIT BACKGROUND

The NE570 Compandor was originally designed to satisfy the requirements of the telephone system. When several telephone channels are multiplexed onto a common line, the resulting signal to noise ratio is poor and companding is used to allow a wider dynamic range to be passed through the channel. Figure 1 graphically shows what a compandor can do for the signal to noise ratio of a restricted dynamic range channel. The input level range of +20 to -80dB is shown undergoing a 2 to 1 compression where a 2dB input level change is compressed into a 1dB output level change by the compressor. The original 100dB of dynamic range is thus compressed to a 50dB range for transmission through a restricted dynamic range channel. A complementary expansion on the receiving end restores the original signal levels and reduces the channel noise by as much as 45dB.

The significant circuits in a compressor or expander are the rectifier and the gain control element. The phone system requires a simple full wave averaging rectifier with good accuracy, since the rectifier accuracy determines the (input) output level tracking accuracy. The gain cell determines the distortion and noise characteristics, and the phone system specifications here are very loose. These specs could have been met with a simple operational transconductance multiplier, or OTA, but the gain of an OTA is proportional to temperature and this is very undesirable. Therefore, a linearized transconductance multiplier was designed which is insensitive to temperature and offers low noise and low distortion performance. These features make the circuit useful in audio and data systems as well as in telecommunications systems.

BASIC CIRCUIT HOOKUP AND OPERATION

Figure 2 shows the block diagram of one half of the chip, (there are two identical

channels on the I.C.). The full wave averaging rectifier provides a gain control current, I_G , for the variable gain (ΔG) cell. The output of the ΔG cell is a current which is fed to the summing node of the operational amplifier. Resistors are provided to establish circuit gain and set the output dc bias.

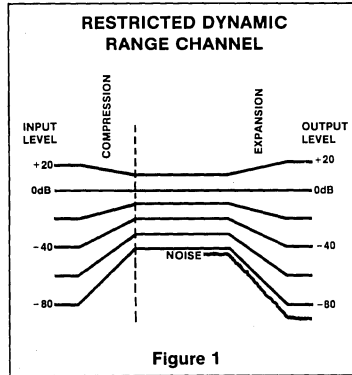

Figure 1

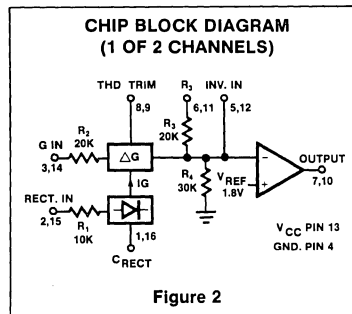

Figure 2

The circuit is intended for use in single power supply systems, so the internal summing nodes must be biased at some voltage above ground. An internal band gap voltage reference provides a very stable, low noise 1.8 volt reference denoted V_{ref} . The non-inverting input of the op amp is tied to V_{ref} , and the summing nodes of the rectifier and ΔG cell (located, at the right, of R_1 and R_2) have the same potential. The THD trim pin is also at the V_{ref} potential.

Figure 3 shows how the circuit is hooked up to realize an expander. The input signal, V_{in} , is applied to the inputs of both the rectifier and the ΔG cell. When the input signal drops by 6dB, the gain control current will drop by a factor of 2, and so the gain will drop 6dB. The output level at V_{out} will thus drop 12dB, giving us the desired 2 to 1 expansion.

Figure 4 shows the hookup for a compressor. This is essentially an expander placed in the feedback loop of the op amp. The ΔG cell is set up to provide ac feedback only, so a separate dc feedback loop is provided by the two R_{dc} and C_{dc} . The values of R_{dc} will determine the dc bias at the output of the op amp. The output will bias to:

$$V_{out\ dc} = 1 + \frac{R_{dc1} + R_{dc2}}{R_4} V_{ref} = \left(1 + \frac{R_{dc\ tot}}{30K}\right) 1.8V$$

The output of the expander will bias up to:

$$V_{out\ dc} = 1 + \frac{R_3}{R_4} V_{ref} = \left(1 + \frac{20K}{30K}\right) 1.8V = 3.0V$$

The output will bias to 3.0V when the internal resistors are used. External resistors may be placed in series with R_3 , (which will affect the gain), or in parallel with R_4 to raise the dc bias to any desired value.

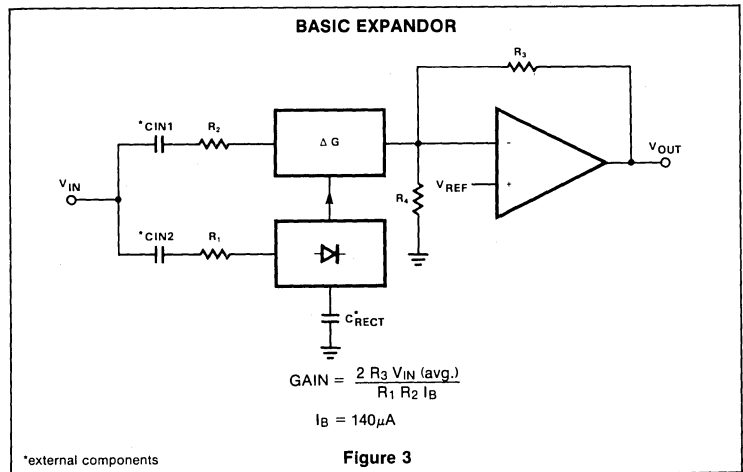
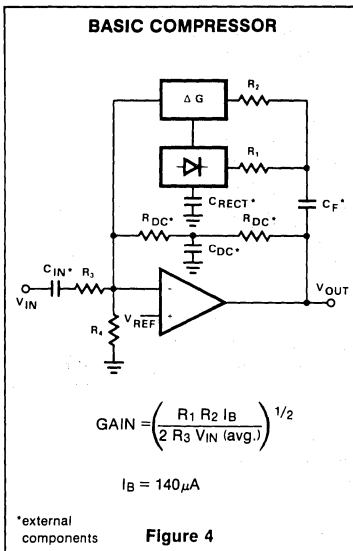

Figure 3

*external components



CIRCUIT DETAILS-RECTIFIER

Figure 5 shows the concept behind the full wave averaging rectifier. The input current to the summing node of the op amp, V_{in}/R_1 , is supplied by the output of the op amp. If we can mirror the op amp output current into a unipolar current, we will have an ideal rectifier. The output current is averaged by R_5 , C_R , which set the averaging time constant, and then mirrored with a gain of 2 to become I_G , the gain control current.

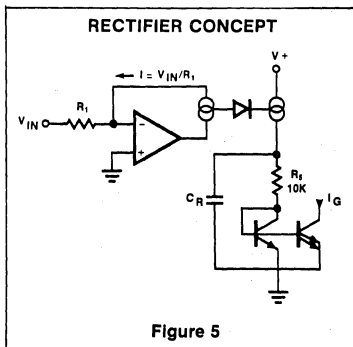
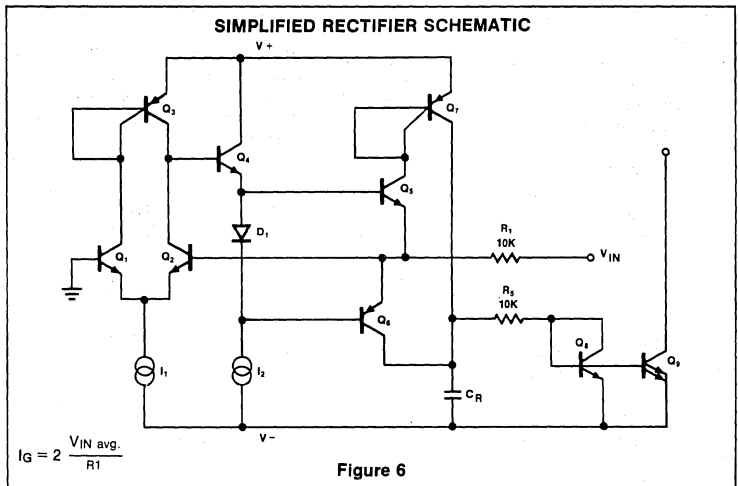

Figure 6 shows the rectifier circuit in more detail. The op amp is a one stage op amp, biased so that only one output device is on at a time. The non-inverting input, (the base of Q_1), which is shown grounded, is actually tied to the internal 1.8V V_{REF} . The inverting input is tied to the op amp output, (the emitters of Q_5 and Q_6), and the input summing resistor R_1 . The single diode between



the bases of Q_5 and Q_6 assures that only one device is on at a time. To detect the output current of the op amp, we simply use the collector currents of the output devices Q_5 and Q_6 . Q_6 will conduct when the input swings positive and Q_5 conducts when the input swings negative. The collector currents will be in error by the α of Q_5 or Q_6 on negative or positive signal swings, respectively. IC's such as this have typical npn β 's of 200 and pnp β 's of 40. The α 's of .995 and .975 will produce errors of .5% on negative swings and 2.5% on positive swings. The 1.5% average of these errors yields a mere .13dB gain error.

At very low input signal levels the bias current of Q_2 , (typically 50nA), will become significant as it must be supplied by Q_5 . Another low level error can be caused by dc coupling into the rectifier. If an offset voltage exists between the V_{in} input pin and the base of Q_2 , an error current of V_{os}/R_1 will be generated. A mere 1mv of offset will cause an input current of 100na which will produce twice the error of the input bias current. For highest accuracy, the rectifier should be coupled into capacitively. At high input levels the β of the pnp Q_6 will begin to suffer, and there will be an increasing error until the circuit saturates. Saturation can be avoided by limiting the current into the rectifier input to 250 μ A. If necessary, an external resistor may be placed in series with R_1 to limit the current to this value. Figure 7 shows the rectifier accuracy vs input level at a frequency of 1kHz.

At very high frequencies, the response of the rectifier will fall off. The rolloff will be more pronounced at lower input levels due to the increasing amount of gain required to switch between Q_5 or Q_6 conducting. The

rectifier frequency response for input levels of 0dBm, -20dBm, and -40dBm is shown in Figure 8. The response at all three levels is flat to well above the audio range.

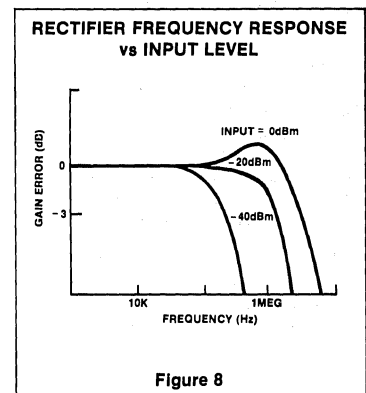
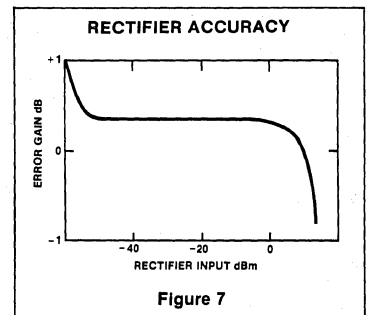

VARIABLE GAIN CELL

Figure 9 is a diagram of the variable gain cell. This is a linearized two quadrant trans-conductance multiplier^{1,2}. Q₁, Q₂ and the op amp provide a predistorted drive signal for the gain control pair, Q₃, Q₄. The gain is controlled by I_G and a current mirror provides the output current.

The op amp maintains the base and collector of Q₁ at ground potential (V_{ref}) by controlling the base of Q₂. The input current I_{IN} (= V_{IN}/R₂) is thus forced to flow through Q₁ along with the current I₁, so I_{C1} = I₁ + I_{IN}. Since I₂ has been set at twice the value of I₁, the current through Q₂ is I₂ - (I₁ + I_{IN}) = I₁ - I_{IN} = I_{C2}. The op amp has thus forced a linear current swing between Q₁ and Q₂, by providing the proper drive to the base of Q₂. This drive signal will be linear for small signals, but very non-linear for large signals, since it is compensating for the non-linearity of the differential pair Q₁, Q₂ under large signal conditions.

The key to the circuit is that this same predistorted drive signal is applied to the gain control pair Q₃ and Q₄. When two differential pairs of transistors have the same signal applied, their collector current ratios will be identical, regardless of the magnitude of the currents. This gives us:

$$\frac{I_{C1}}{I_{C2}} = \frac{I_{C4}}{I_{C3}} = \frac{I_1 + I_{IN}}{I_1 - I_{IN}}$$

plus the relationships I_G = I_{C3} + I_{C4} and I_{OUT} = I_{C4} - I_{C3} will yield the multiplier transfer function,

$$I_{OUT} = \frac{I_G}{I_1} I_{IN} = \frac{V_{IN}}{R_2} \frac{I_G}{I_1}$$

this equation is linear and temperature insensitive, but it assumes ideal transistors.

If the transistors are not perfectly matched, a parabolic, non-linearity is generated, which results in 2nd harmonic distortion. Figure 10 gives an indication of the magnitude of the distortion caused by a given input level and offset voltage. The distortion is linearly proportional to the magnitude of the offset and the input level. Saturation of the gain cell occurs at a +8dBm level. At a nominal operating level of 0dBm, a 1mV offset will yield .34% of second harmonic distortion. Most circuits are somewhat better than this, which means our overall offsets are typically about 1/2mV. The distortion is not affected by the magnitude of the gain control current, and it does not increase as the gain is changed. This second harmonic distortion could be eliminated by making perfect transistors, but since that would be difficult, we have had to resort to other methods. A trim pin has been provided

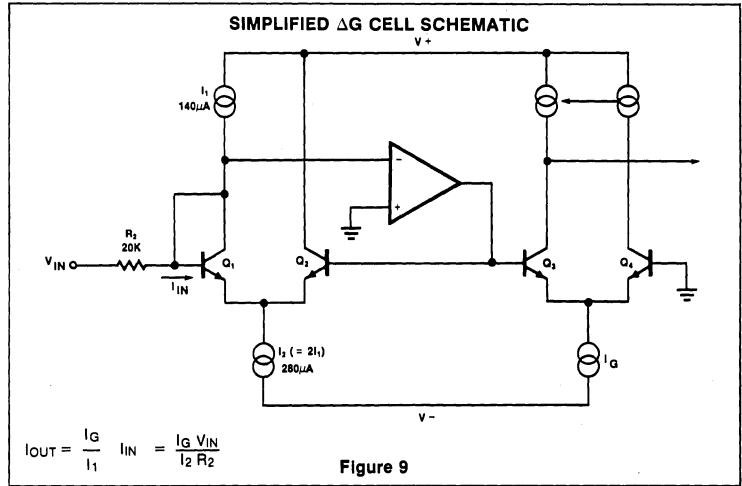

$$I_{OUT} = \frac{I_G}{I_1} I_{IN} = \frac{I_G V_{IN}}{I_2 R_2}$$

Figure 9

to allow trimming of the internal offsets to zero, which effectively eliminated second harmonic distortion. Figure 11 shows the simple trim network required.

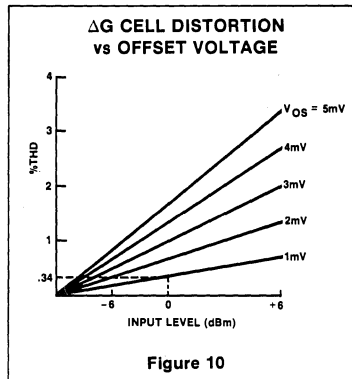

Figure 10

Figure 12 shows the noise performance of the ΔG cell. The maximum output level before clipping occurs in the gain cell is plotted along with the output noise in a 20kHz bandwidth. Note that the noise drops as the gain is reduced for the first 20dB of gain reduction. At high gains, the signal to noise ratio is 90dB, and the total dynamic range from maximum signal to minimum noise is 110dB.

Control signal feed-through is generated in the gain cell by imperfect device matching and mismatches in the current sources I₁ and I₂. When no input signal is present, changing I_G will cause a small output signal. The distortion trim is effective in nulling out any control signal feed-through, but in general, the null for minimum feed-through will be different than the null in distortion. The control signal feed-through can be trimmed independently of distortion by tying a current source to the ΔG input pin. This effectively trims I₁. Figure 13 shows such a trim network.

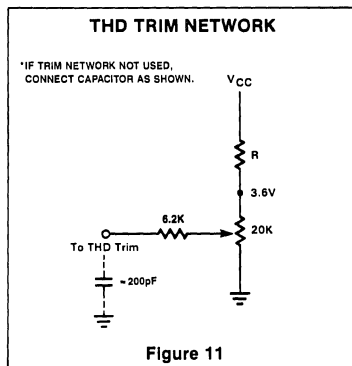

Figure 11

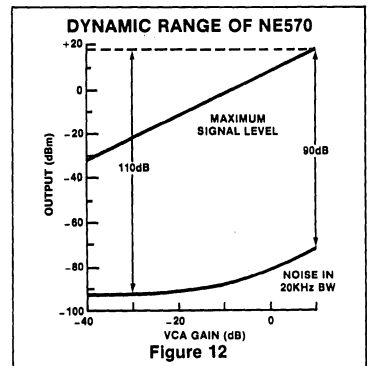
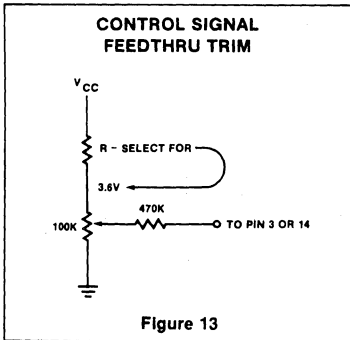
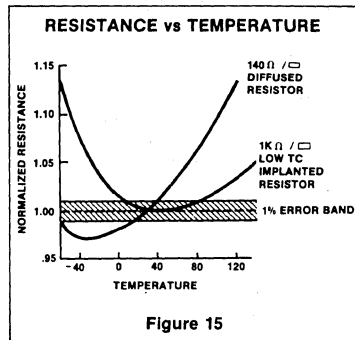

Figure 12



simple hookups, and absolute accuracy and temperature coefficient would be of no importance. However, as one starts to modify the gain equation with external resistors, the internal resistor accuracy and tempco become very significant. Figure 15 shows the effects of temperature on the diffused resistors which are normally used in integrated circuits, and the ion implanted resistors which are used in this circuit. Over the critical 0°C to 70°C temperature range, there is a 10 to 1 improvement in drift from a 5% change for the diffused resistors, to a .5% change for the implemented resistors. The implanted resistors have another advantage in that they can be made 1/7 the size of the diffused resistors due to the higher resistivity. This saves a significant amount of chip area.



OPERATIONAL AMPLIFIER

The main op amp shown in the chip block diagram is equivalent to a 741 with a 1MHz bandwidth. Figure 14 shows the basic circuit. Split collectors are used in the input pair to reduce g_m , so that a small compensation capacitor of just 10pf may be used. The output stage, although capable of output currents in excess of 20ma., is biased for a low quiescent current to conserve power. When driving heavy loads, this leads to a small amount of crossover distortion.

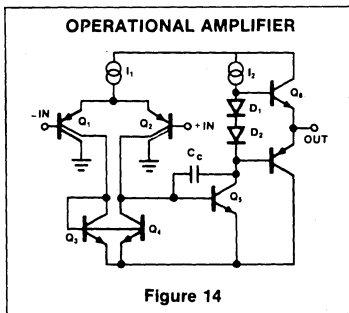

RESISTORS

Inspection of the gain equations in Figure 3 and 4 will show that the basic compressor and expander circuit gains may be set entirely by resistor ratios and the internal voltage reference. Thus, any form of resistors that match well would suffice for these

*For additional information, consult the Applications Section.

PROGRAMMABLE ANALOG COMPANDOR

SA/NE572

DESCRIPTION

The NE572 is a dual channel, high performance gain control circuit in which either channel may be used for dynamic range compression or expansion. Each channel has a full wave rectifier to detect the average value of input signal; a linearized, temperature compensated variable gain cell (ΔG) and a dynamic time constant buffer. The buffer permits independent control of dynamic attack and recovery time with minimum external components and improved low frequency gain control ripple distortion over previous compandors.

The NE572 is intended for noise reduction in high performance audio systems. It can also be used in a wide range of communication systems and video recording applications.

FEATURES

- Independent control of attack and recovery time.
- Improved low frequency gain control ripple
- Complementary gain compression and expansion with external Op Amp
- Wide dynamic range—greater than 110dB
- Temperature compensated gain control
- Low distortion gain cell
- Low noise— $6\mu V$ typical
- Wide supply voltage range—6V–22V
- System level adjustable with external components.

APPLICATIONS

- Dynamic noise reduction system
- Voltage control amplifier
- Stereo expander
- Automatic level control
- High level limiter
- Low level noise gate
- State variable filter

PIN CONFIGURATION

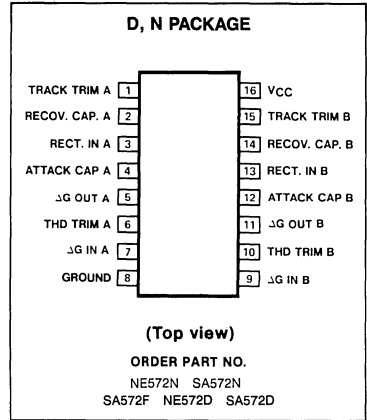

ABSOLUTE MAXIMUM RATINGS

PARAMETER	RATING	UNIT
V _{CC} Supply voltage	22	VDC
T _A Operating temperature range	0 to 70	°C
P _D Power dissipation	500	mW

BLOCK DIAGRAM

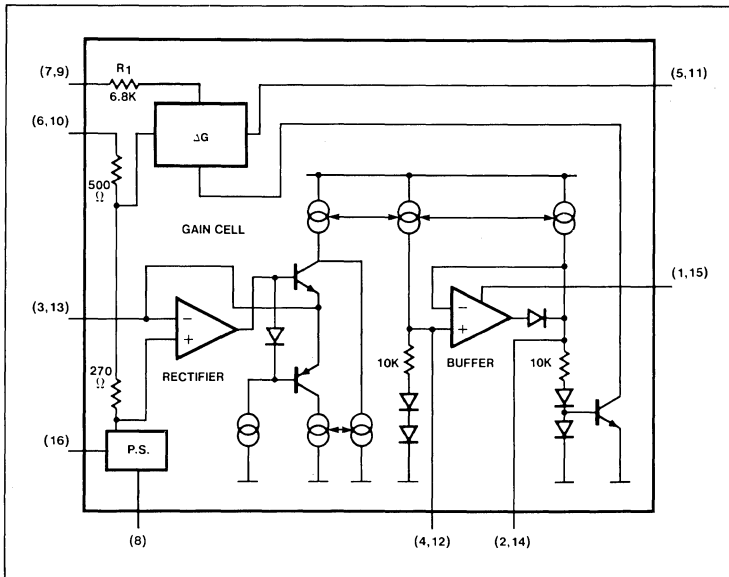

Note:
1. Supplied only in large SO (Small Outline) package.

PROGRAMMABLE ANALOG COMPANDOR

SA/NE572

ELECTRICAL CHARACTERISTICS Standard Test Conditions (unless otherwise noted) $V_{CC} = 15V$ $T_A = 25^\circ C$ Expandor mode (see test circuit) Input signals at unity gain level (OdB) = 100mV RMS at 1KHz, $V_1 = V_2$, $R_2 = 3.3K$, $R_3 = 17.3K$

PARAMETER	TEST CONDITIONS	LIMITS			UNIT
		Min	Typ	Max	
V_{CC} Supply voltage		6		22	V_{DC}
I_{CC} Supply current	No Signal			6	mA
Internal voltage reference		2.3	2.5	2.7	V_{DC}
THD (untrimmed)	1kHz $C_A = 1.0\mu F$.2	1.0	%
THD (trimmed)	1kHz $C_R = 10\mu F$.05		%
THD (trimmed)	100Hz		.25		%
No signal output noise	Input to V_1 and V_2 grounded (20-20kHz)		6	25	μV
DC level shift (untrimmed)	Input change from no signal to 100mV RMS		± 20	± 50	MV
Unity gain level		-1	0	+1	dB
Large signal distortion	$V_1 = V_2 = 400mV$		0.7	3.0	%
Tracking error (measured relative to value at unity gain output) = $[V_O - V_O(\text{unity gain})] \text{ dB} - V_2 \text{ (dBm)}$	Rectifier input $V_2 = +6\text{dB}$, $V_1 = \text{OdB}$ $V_2 = -30\text{dB}$, $V_1 = \text{OdB}$		$\pm .2$		dB
Channel crosstalk	200mV RMS into channel A, measured output on channel B	60			dB
Power supply rejection ratio	120Hz		70		dB

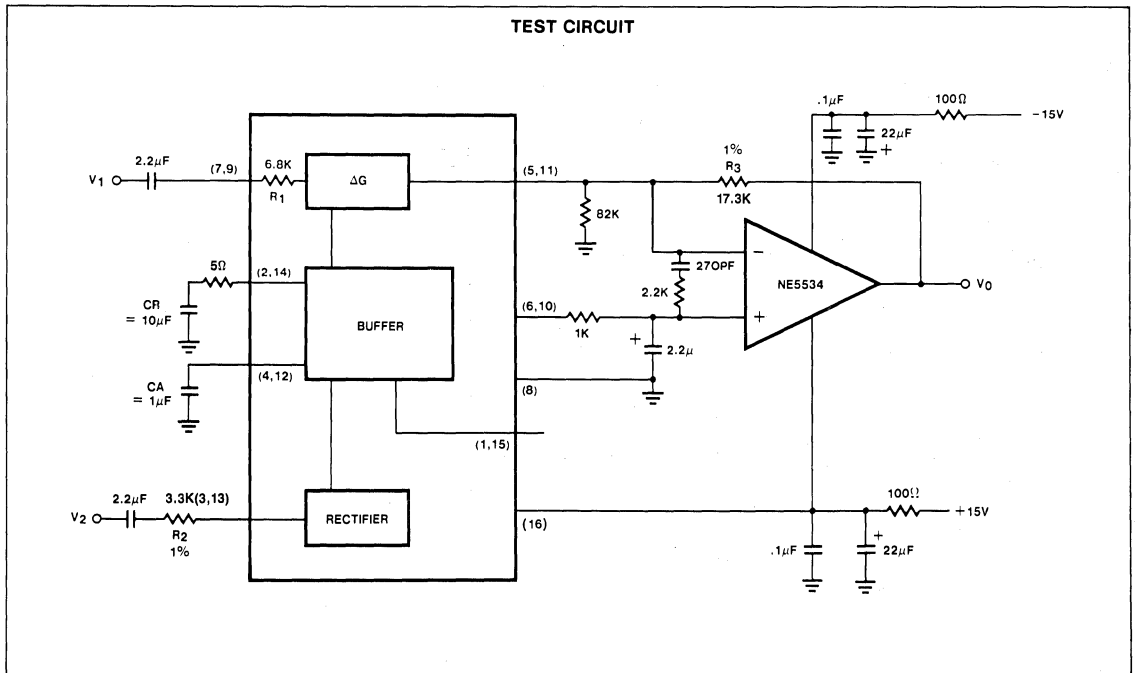

AUDIO SIGNAL PROCESSING IC COMBINES VCA AND FAST ATTACK-SLOW RECOVERY LEVEL SENSOR

In high performance audio gain control applications it is desirable to independently control the attack and recovery time of the gain control signal. This is true, for example, in compandor applications for noise reduction. In high end systems the input signal is usually split into two or more frequency bands to optimize the dynamic behavior for each band. This reduces low frequency distortion due to control signal ripple, phase distortion, high frequency channel overload and noise modulation. Because of the expense in hardware, multiple band signal processing up to now was limited to professional audio applications.

With the introduction of the Signetics NE572 this high performance noise reduction concept becomes feasible for consumer hi fi applications. The NE572 is a dual channel gain control IC. Each channel has a linearized, temperature compensated gain cell and an improved level sensor. In conjunction with an external low noise op amp for current to voltage conversion, the VCA features low distortion, low noise and wide dynamic range. The novel level sensor which provides gain control current for the VCA gives lower gain control ripple and independent control of fast attack, slow recovery dynamic response. An attack capacitor CA with an internal 10K resistor RA defines the attack time TA. The recovery time TR of a tone burst is defined by a recovery capacitor CR and an internal 10K resistor RF. Typical attack time of 4MS for the high frequency spectrum and 40MS for the low frequency band can be obtained with .1μF and 1.0μF attack capacitors respectively. Recovery time of 200MS can be obtained with a 4.7μF external capacitor. With the recovery capacitor added in the level sensor, the gain control ripple for low frequency signals is much lower than that of a simple RC ripple filter. As a result the residual third harmonic distortion of low frequency signal in a two quad transconductance amplifier is greatly improved. With the 1.0μF attack capacitor and 4.7μF recovery capacitor for a 100HZ signal the third harmonic distortion is improved by more than 10db over the simple RC ripple filter with a single 1.0μF attack and recovery capacitor, while the attack time remains the same.

The NE572 is assembled in a standard 16 pin dual in line plastic package and in oversized SO (Small Outline) package. It operates over wide supply range from 6V to 22V. Supply current is less than 6mA. The NE572 is designed for consumer application over a temperature

range 0-70°C. The SA572 is intended for applications from -40°C to +85°C.

NE572 BASIC APPLICATIONS

Description

The NE572 consists of two linearized, temperature compensated gain cells (ΔG) each with a full-wave rectifier and a buffer amplifier as shown in the block diagram. The two channels share a 2.5V common bias reference derived from the power supply but otherwise operate independently. Because of inherent low distortion, low noise and the capability to linearize large signals, a wide dynamic range can be obtained. The buffer amplifiers are provided to permit control of attack time and recovery time independent of each other. Partitioned as shown in the block diagram, the IC allows flexibility in the design of system levels that optimize DC shift, ripple distortion, tracking accuracy and noise floor for a wide range of application requirements.

Gain Cell

Figure 1 shows the circuit configuration of the gain cell. Bases of the differential pairs Q1 - Q2 and Q3 - Q4 are both tied to the output and inputs of OPA A1. The negative feedback through Q1 holds the VBE of Q1 - Q2 and the VBE of Q3 - Q4 equal. The following relationship can be derived from

the transistor model equation in the forward active region.

$$\Delta V_{BE_{Q3-Q4}} = \Delta BE_{Q1-Q2}$$

$$(V_{BE} = V_T \ln IC/IS)$$

$$V_T \ln \left(\frac{\frac{1}{2} I_G + \frac{1}{2} I_O}{I_S} \right) - V_T \ln \left(\frac{\frac{1}{2} I_G - \frac{1}{2} I_O}{I_S} \right) \\ = V_T \ln \left(\frac{I_1 + \text{lin}}{I_S} \right) - V_T \ln \left(\frac{I_2 - I_1 - \text{lin}}{I_S} \right) \quad (2)$$

where $\text{lin} = \frac{V_{in}}{R_1}$

$R_1 = 6.8K$

$I_1 = 140\mu A$

$I_2 = 280\mu A$

I_O is the differential output current of the gain cell and I_G is the gain control current of the gain cell.

If all transistors Q1 through Q4 are of the same size, equation (2) can be simplified to:

$$I_O = \frac{2}{I_2} \cdot \text{lin} \cdot I_G - \frac{1}{I_2} (I_2 - 2I_1) \cdot I_G \quad (3)$$

The first term of eqn. (3) shows the multiplier relationship of a linearized two quadrant transconductance amplifier. The second term is the gain control feed through due to the mismatch of devices. In the design this

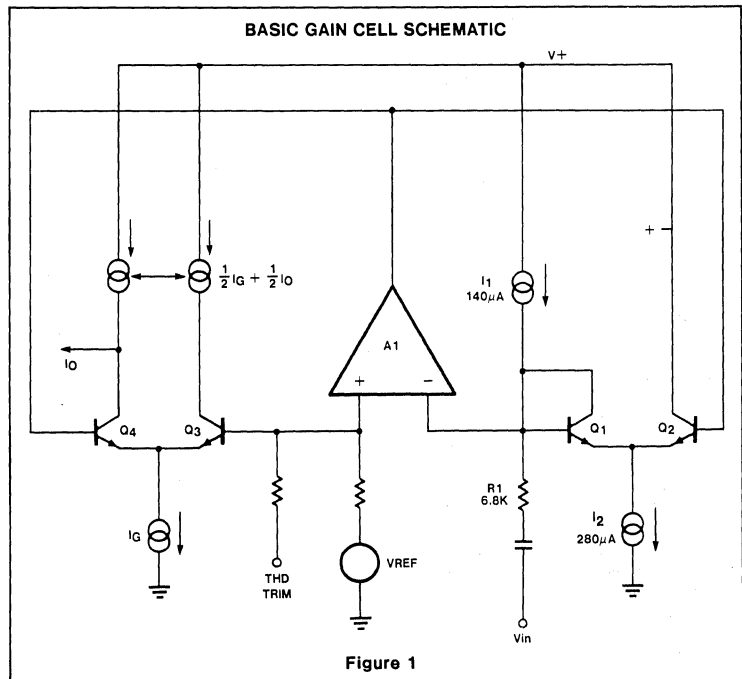

Figure 1



has been minimized by large matched devices and careful layout. Offset voltage is caused by the device mismatch and it leads to even harmonic distortion. The offset voltage can be trimmed out by feeding a current source within $\pm 25\mu\text{A}$ into the THD trim pin. The residual distortion is third harmonic distortion and is caused by gain control ripple. In a compandor system, available control of fast attack and slow recovery improves ripple distortion significantly. At the unity gain level of 100mV, the gain cell gives THD (total harmonic distortion) of .17% TYP. Output noise with no input signals is only $6\mu\text{V}$ in the audio spectrum (10KHZ-20KHZ). The output current I_O must feed the virtual ground input of an operational amplifier with a resistor from output to inverting input. The non-inverting input of the operational amplifier has to be biased at VREF if the output current I_O is dc coupled.

Rectifier

The rectifier is a full-wave design as shown in Figure 2. The input voltage is converted to current through the input resistor R2 and turns on either Q5 or Q6 depending on the signal polarity. Deadband of the voltage to current converter is reduced by the loop gain of the gain block A2. If AC coupling is used, the rectifier error comes only from input bias current of gain block A2. The input bias current is typically about 70nA. Frequency response of the gain block A2 also causes second order error at high frequency. The collector current of Q6 is mirrored and summed at the collector of Q5 to form the full wave rectified output current I_R . The rectifier transfer function is

$$\frac{V_{IN} - V_{REF}}{R_2} \tag{4}$$

If V_{in} is A.C. coupled, then the equation will be reduced to:

$$I_{RAC} = \frac{V_{in}(AVG)}{R_2}$$

The internal bias scheme limits the maximum output current I_R to be around $300\mu\text{A}$. Within a $\pm 1\text{dB}$ error band the input range of the rectifier is about 52dB.

Buffer Amplifier

In audio systems, it is desirable to have fast attack time and slow recovery time for a tone burst input. The fast attack time reduces transient channel overload but also causes low frequency ripple distortion. The low frequency ripple distortion can be improved with the slow recovery time. If different attack times are implemented in corresponding frequency spectrums in a split band audio system, high quality performance can be achieved. The buffer amplifier is designed to make this feature available with minimum external components. Refer-

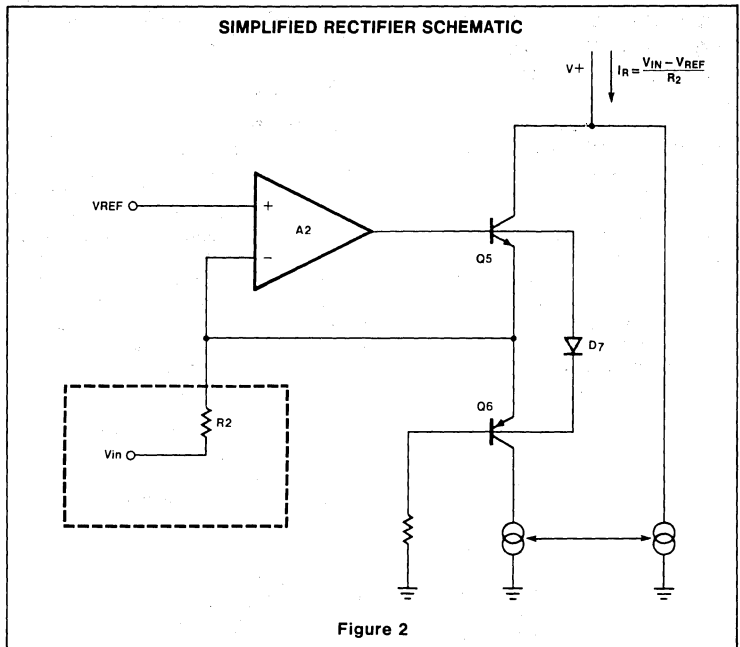

Figure 2

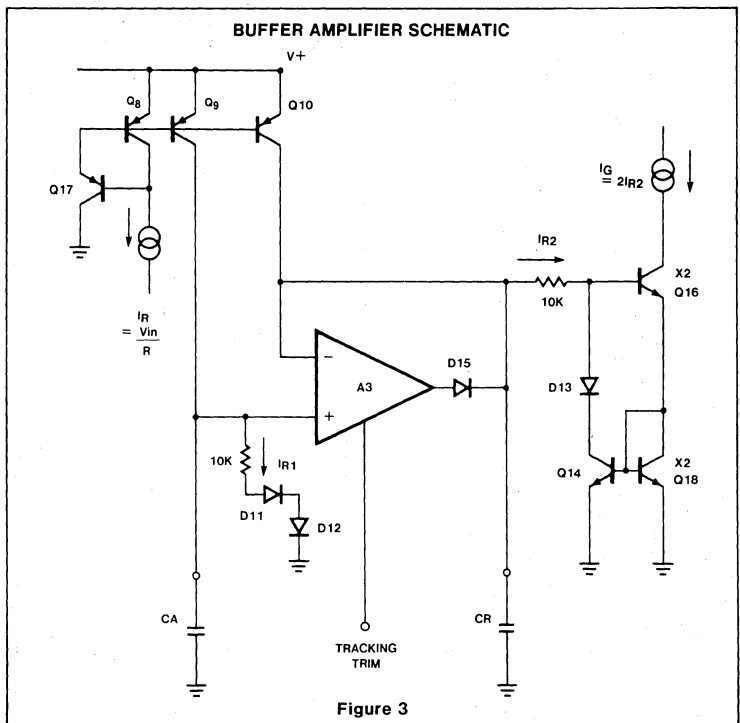

Figure 3

ring to Figure 3, the rectifier output current is mirrored into the input and output of the unipolar buffer amplifier A₃ through Q₈, Q₉ and Q₁₀. Diodes D₁₁ and D₁₂ improve tracking accuracy and provide common mode bias for A₃. For a positive going input signal, the buffer amplifier acts like a voltage follower. Therefore, the output impedance of A₃ makes the contribution of capacitor CR to attack time insignificant. Neglecting diode impedance the gain Ga(t) for ΔG can be expressed as follows.

$$G_a(t) = (G_{aINT} - G_{aFNL}) e^{-\frac{t}{\tau A}} + G_{aFNL}$$

G_{aINT} = Initial Gain

$$\tau A = R_A \cdot CA = 10K \cdot CA \quad G_{aFNL} = \text{Final Gain}$$

where τA is the attack time constant and RA is a 10K internal resistor. Diode D₁₅ opens the feedback loop of A₃ for a negative going signal if the value of capacitor CR is larger than capacitor CA. The recovery time depends only on CR • R_R. If the diode impedance is assumed negligible, the dynamic gain G_R(t) for ΔG is expressed as follows.

$$G_R(t) = (G_{RINT} - G_{RFNL}) e^{-\frac{t}{\tau R}} + G_{RFNL}$$

$$\tau R = R_R \cdot CR = 10K \cdot CR$$

where τR is the recovery time constant and R_R is a 10K internal resistor. The gain control current is mirrored to the gain cell through Q₁₄. The low level gain errors due to input bias current of A₂ and A₃ can be trimmed through the tracking trim PIN into A₃ with a current source of ±3μA.

Basic Expander

Figure 4 shows an application of the circuit as a simple expander. The gain expression of the system is given by

$$\frac{V_{OUT}}{V_{IN}} = \frac{2 \cdot R_3 \cdot V_{IN}(AVG)}{I_1 \cdot R_2 \cdot R_1} \quad (I_1 = 140\mu A) \quad (5)$$

Both the resistors R₁ and R₂ are tied to internal summing nodes. R₁ is a 6.8K internal resistor. The maximum input current into the gain cell can be as large as 140μA. This corresponds to a voltage level of 140μA • 6.8K = 952mV peak. The input peak current into the rectifier is limited to 300μA by the internal bias system. Note that the value of R₁ can be increased to accommodate higher input level. R₂ and R₃ are external resistors. It is easy to adjust the ratio of R₃/R₂ for desirable system voltage and current levels. A small R₂ results in higher gain control current and smaller static and dynamic

tracking error. However, an impedance buffer A₁ may be necessary if the input is voltage drive with large source impedance.

The gain cell output current feeds the summing node of the external OPA A₂. R₃ and A₂ convert the gain cell output current to the output voltage. In high performance applications, A₂ has to be low noise, high speed and wide band so that the high performance output of the gain cell will not be degraded. The non-inverting input of A₂ can be biased at the low noise internal reference PIN 6 or 10. Resistor R₄ is used to biased up the output DC level of A₂ for maximum swing. The output DC level of A₂ is given by

$$V_{ODC} = V_{REF} \left(1 + \frac{R_3}{R_4} \right) - V_B \frac{R_3}{R_4} \quad (6)$$

V_B can be tied to a regulated power supply for a dual supply system and be grounded for a single supply system. CA sets the attack time constant and CR sets the recovery time constant.

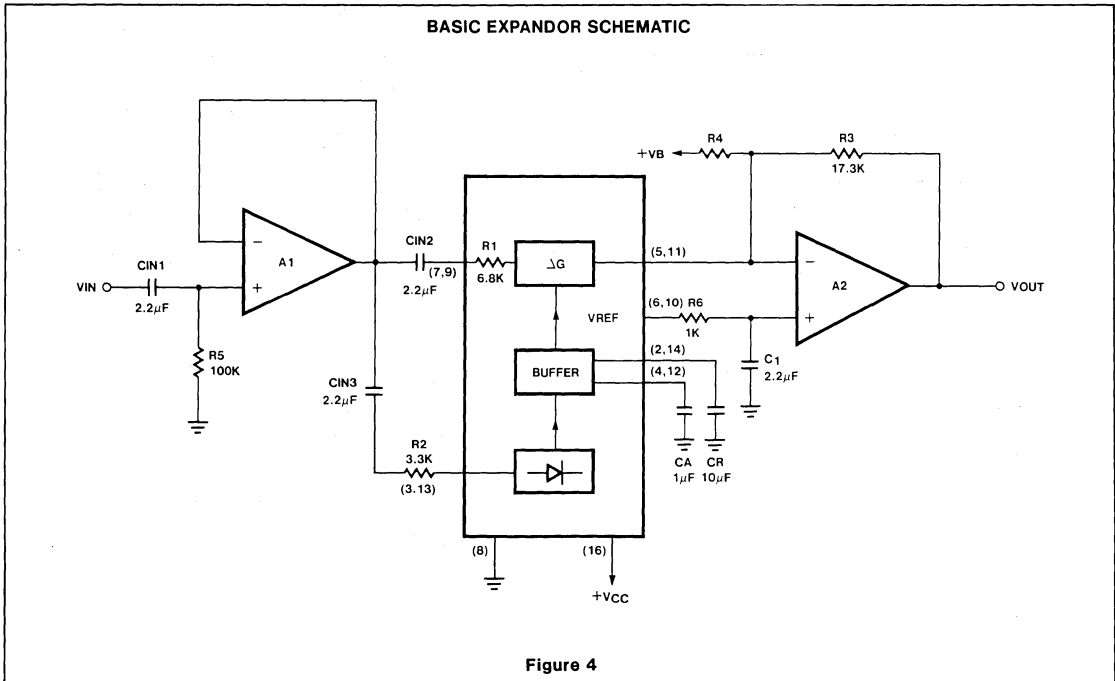

Basic Compressor

Figure 5 shows the hook-up of the circuit as a compressor. The IC is put in the feedback loop of the OPA A₁. The system gain expression is as follows:

$$\frac{V_{OUT}}{V_{IN}} = \left(\frac{1}{2} + \frac{R_2 \cdot R_1}{R_3 \cdot V_{IN} (AVG)} \right)^{1/2} \quad (7)$$

RDC1, RDC2, and CDC form a dc feedback for A₁. The output DC level of A₁ is given by

$$V_{ODC} = V_{REF} \left(1 + \frac{R_{DC1} + R_{DC2}}{R_4} \right) - V_B \cdot \left(\frac{R_{DC1} + R_{DC2}}{R_4} \right) \quad (8)$$

The zener diodes D₁ and D₂ are used for channel overload protection.

Basic Compandor System

The above basic compressor and expander can be applied to systems such as tape/disc noise reduction, digital audio, bucket brigade delay lines. Additional system design techniques such as bandlimiting, band splitting, pre-emphasis, de-emphasis and equalization are easy to incorporate. The IC is a versatile functional block to achieve a high performance audio system. Figure 6 shows the system level diagram for reference.

For additional information, refer to the Applications Section.

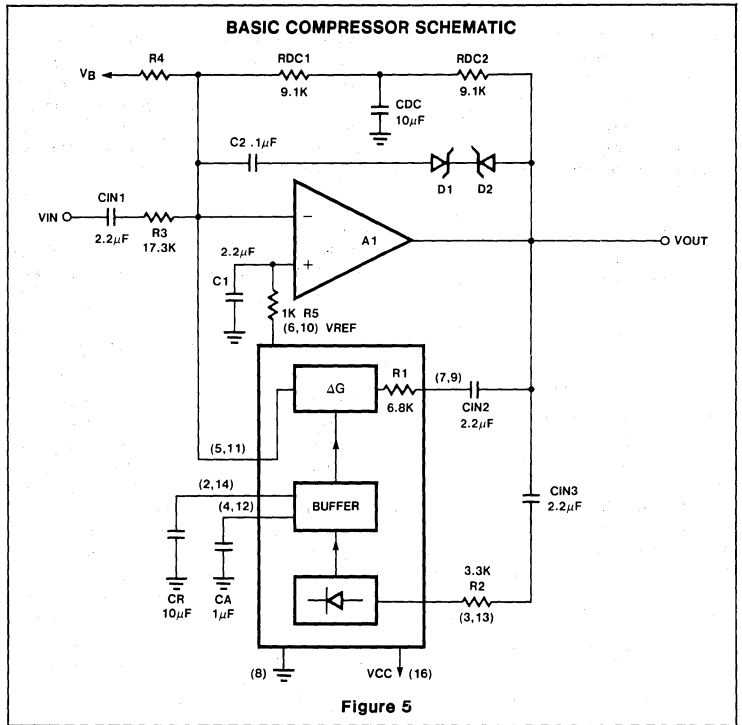

Figure 5

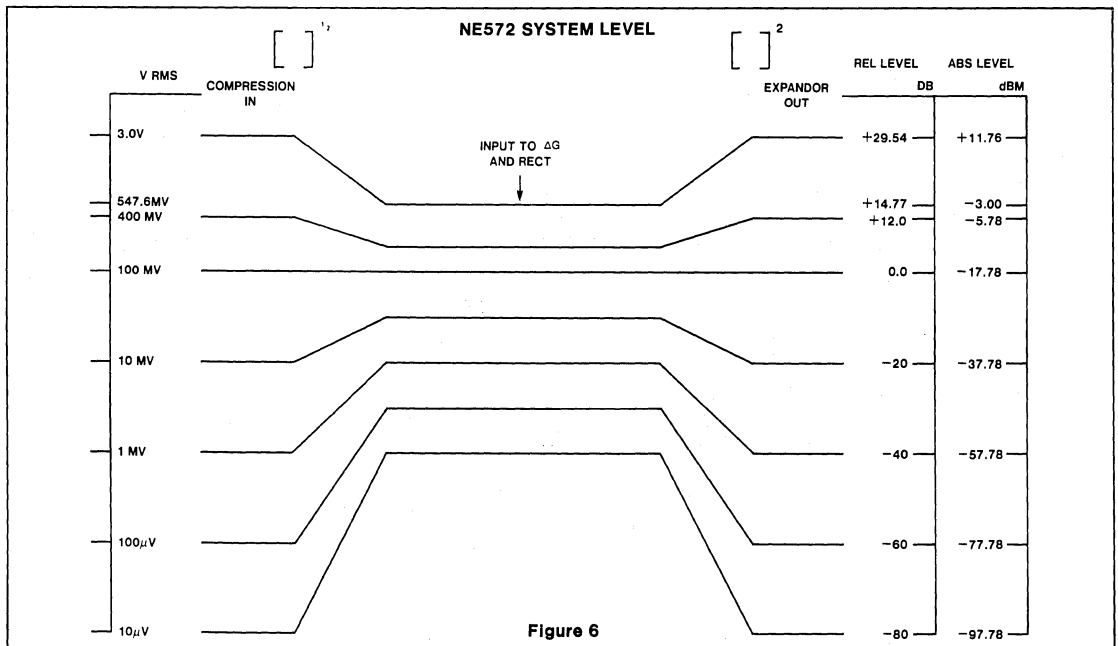

Figure 6

*For additional information, consult the Applications Section.

STEREO DEMODULATOR WITH BLEND

LM1870

DESCRIPTION

The LM1870 combination FM Stereo Demodulator and Blend Circuit is a PLL circuit with a D.C. control pin whose purpose is to reduce switching noise by decreasing separation under low signal amplitude conditions. The part is designed specifically for automobile applications where fluctuating signal strength can cause demodulation noise.

FEATURES

- Stereo blend control
- Wide input dynamic range
- Low total harmonic distortion
- VCO disable function
- Monophonic override pin
- Supply range 7V-15V

APPLICATIONS

- Auto radios
- High fidelity tuners
- High performance portable radios
- Electronic tuned radios

PIN CONFIGURATION

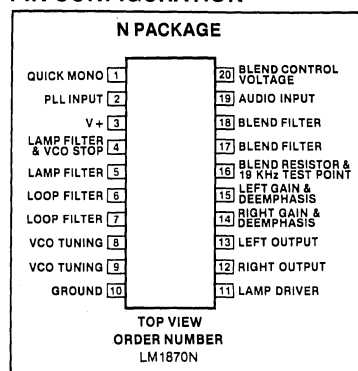

ABSOLUTE MAXIMUM RATINGS

PARAMETER	RATING	UNIT
Supply voltage, pin 3	15	V
Lamp driver voltage, pin 11	18	V
Output voltage, pin 12, 13 supply off	7	V
Quick mono input (pin 20)	V + (pin 3)	
Blend input (pin 20)	15	V
Operating temperature range	0°C to +70°C	
Power dissipation (note 1)	1	W
Storage temperature	-65°C to +125°C	
Lead temperature (soldering, 10 seconds)	300°C	

TYPICAL APPLICATION AND TEST CIRCUIT

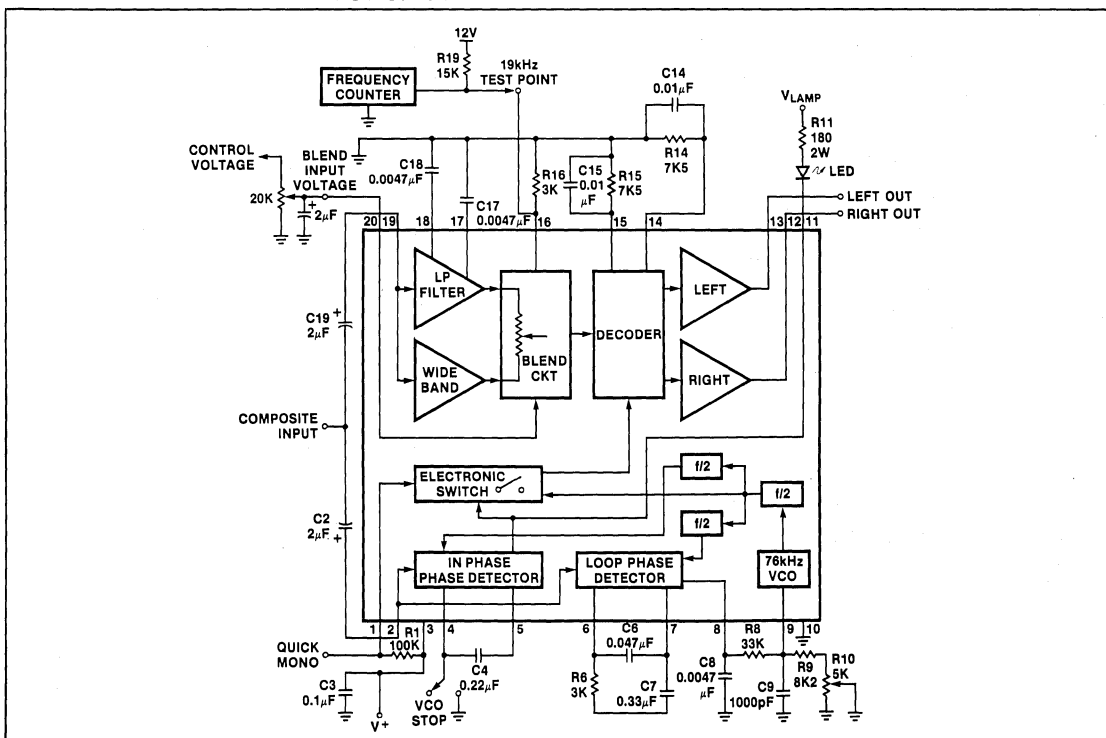

STEREO DEMODULATOR WITH BLEND**LM1870****DC ELECTRICAL CHARACTERISTICS** $T_A = 25^\circ\text{C}$, $V^+ = 8\text{V}$ unless otherwise noted (Figure 1)

SYMBOL AND PARAMETER	TEST CONDITIONS	MIN	TYP	MAX	UNIT
Operating supply voltage		7	8	15	V
Supply current			26	45	mA
Input DC voltage	Pin 19		4		V
Input DC voltage	Pin 2		1.8		V
Supply rejection		15	30		dB
Lamp leakage current	Lamp off, pin 11 = 16V		0.1	100	μA
Lamp saturation voltage	Lamp on, pin 11 @ 75mA		1.4	2.0	V
VCO stop voltage	Voltage @ pin 4 to stop VCO	0.2	0.4		V
VCO stop current	Pin 4 = 0.2V		-30	-100	μA
Blend input bias current			-2	-20	μA
Quick mono switch voltage			4		V
Quick mono bias current	Pin 1 = 8V		2		μA
Output leakage	Pin 12 or 13 = 6.5V, pin 3 = 0V		0.1	20	μA

AUDIO ELECTRICAL CHARACTERISTICS

SYMBOL AND PARAMETER	TEST CONDITIONS	MIN	TYP	MAX	UNIT
Mono gain	1kHz	-4	-1	+2	dB
Mono THD	1kHz @ 200mVrms		0.05	0.25	%
Channel balance			± 0.4	± 1.5	dB
Gain shift	Mono to stereo		± 0.1	± 1.0	dB
Channel separation	Pin 20 $\geq 1.1\text{V}$	30	45		dB
Output DC shift	Mono to stereo		± 15	± 100	mV
Input resistance	Pin 19	20	40		k Ω
Output resistance	Pin 12, 13		65	200	Ω
Ultrasonic rejection	19kHz + 38kHz		30		dB
SCA rejection	(Note 2)		70		dB
Signal to noise	1kHz @ 200mVrms MONO		68		dB

PLL ELECTRICAL CHARACTERISTICS

SYMBOL AND PARAMETER	TEST CONDITIONS	MIN	TYP	MAX	UNIT
Lamp ON voltage	19kHz on pin 2		15	20	mV
Lamp OFF voltage	19kHz on pin 2	2.5	5		mV
Lamp hysteresis			10		dB
Capture range	25mVrms on pin 2	± 2	± 4	± 6	%
Hold in range	25mVrms on pin 2		± 12		%
Input resistance	Pin 2	8	14		k Ω

STEREO DEMODULATOR WITH BLEND

LM1870

BLEND ELECTRICAL CHARACTERISTICS

SYMBOL AND PARAMETER	TEST CONDITIONS (Pin 20 from 1.1V to 0.2V)	MIN	TYP	MAX	UNIT
Stereo gain change	1kHz L = - R input	- 25	- 35		dB
Mono gain change	1kHz L = R input	- 1.5	- 0.5	0.5	dB
	10kHz L = R input	- 8	- 14	- 20	dB
Output DC shift			± 40	± 100	mV

NOTES

- For operation in ambient temperatures above 25°C, the device must be derated based on a 150°C maximum junction temperature and a thermal resistance of 125°C/W junction to ambient.
- Input is 10% SCA (74.5kHz), 9% pilot and 1kHz left or right. Rejection is ratio of 1kHz output to 1.5kHz output.

TYPICAL CHARACTERISTICS

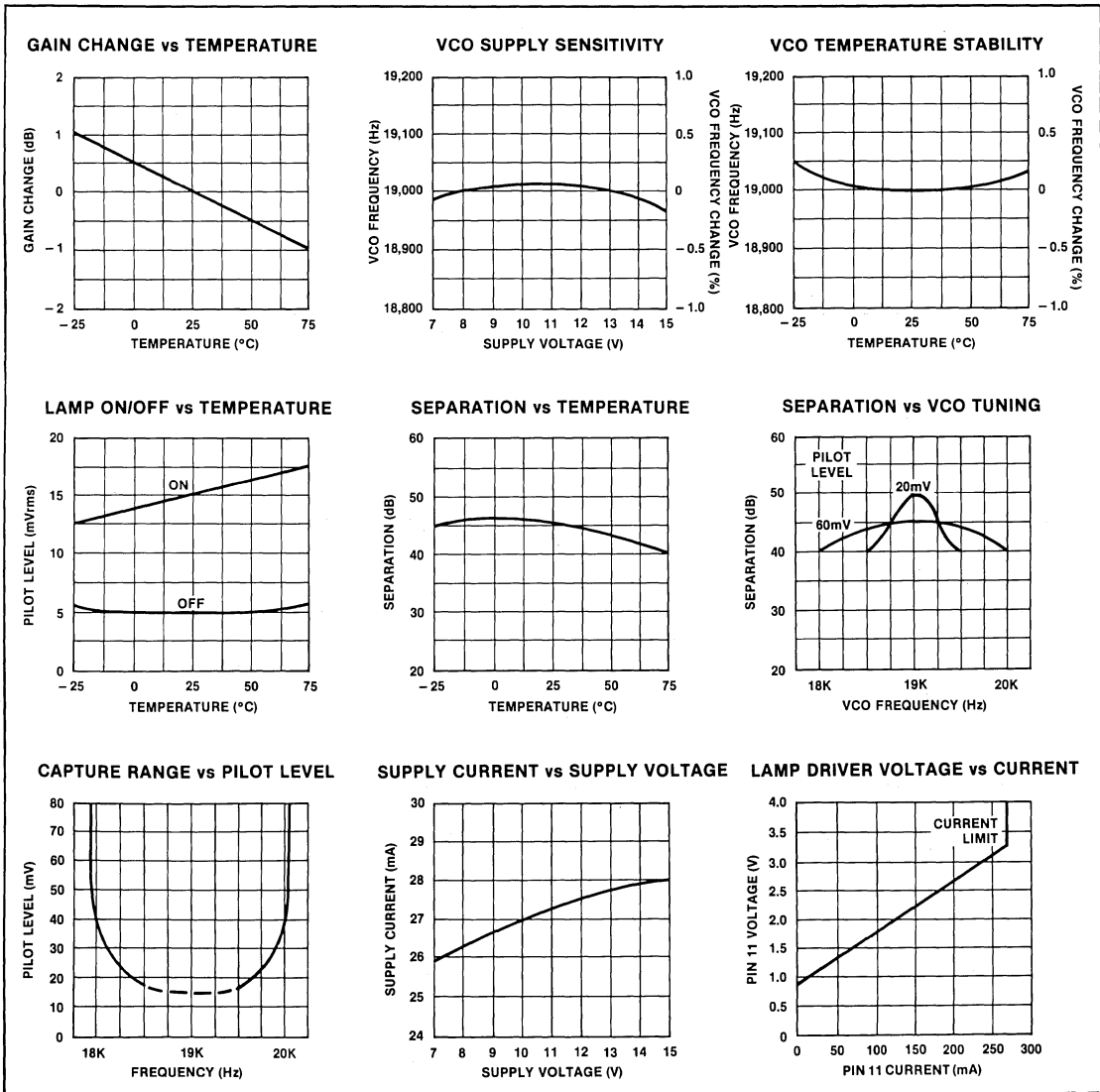

5

STEREO DEMODULATOR WITH BLEND

LM1870

GAIN vs R_L (PIN 14, 15)

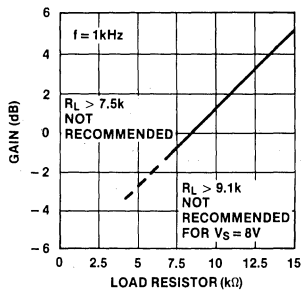

LAMP ON/OFF vs RESISTANCE PIN 4 TO 5

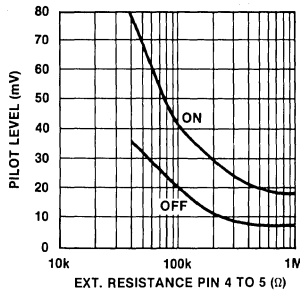

TOTAL HARMONIC DISTORTION vs INPUT LEVEL

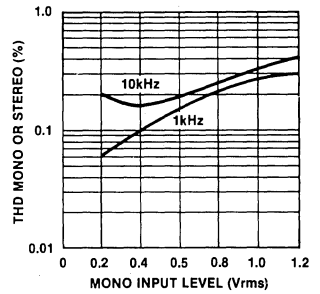

TOTAL HARMONIC DISTORTION vs FREQUENCY

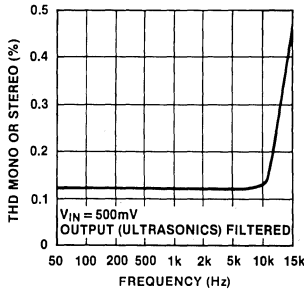

SEPARATION vs FREQUENCY

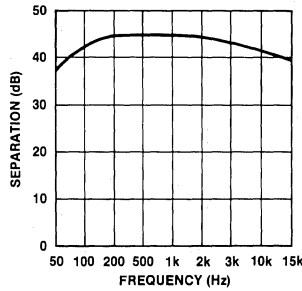

POWER SUPPLY REJECTION RATIO vs FREQUENCY

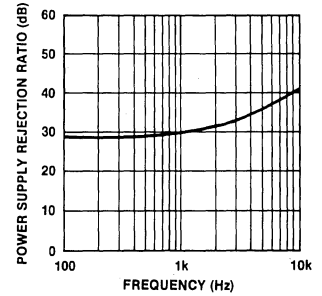

L + R FREQUENCY RESPONSE WITH BLEND CONTROL

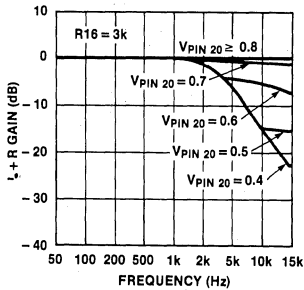

L - R GAIN vs BLEND CONTROL

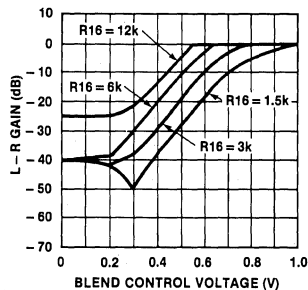

TYPICAL RADIO QUIETING CHARACTERISTIC

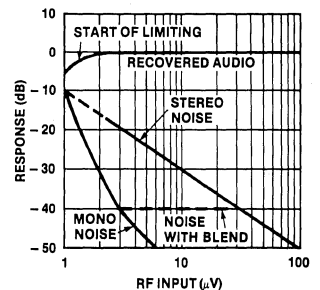

BLEND FILTER RESPONSE

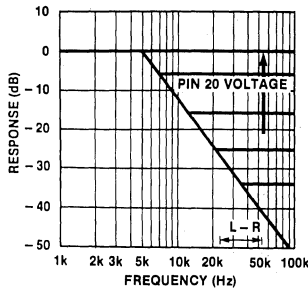

L - R GAIN AND SEPARATION vs RF INPUT LEVEL WITH BLEND

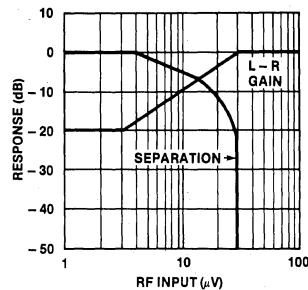

DUAL LOW-NOISE PREAMP

NE542

DESCRIPTION

The NE542 is a dual preamplifier for the amplification of low level signals in applications requiring optimum noise performance. Each of the two amplifiers is completely independent, with individual internal power supply decoupler-regulator, providing 110dB supply rejection and 70dB channel separation. Other outstanding features include high gain (104dB), large output voltage swing ($V_{CC} - 2V_{p-p}$), and internal compensation to 10dB. The NE542 operates from a single supply across the wide range of 9 to 24V.

The NE542 is ideal for use in stereo phono, tape, or microphone preamps and other applications requiring low noise amplification of small signals.

FEATURES

- Low noise— $7\mu V$ total input noise
- High gain—104dB open loop
- Single supply operation
- Wide supply range 9 to 24V
- Power supply rejection 110dB
- Large output voltage swing ($V_{CC} - 2V_{p-p}$)
- Wide bandwidth 15MHz unity gain
- Power bandwidth 100kHz (15V p-p)
- Internally compensated (stable at 10dB)
- Short circuit protected
- High slew rate $5V/\mu s$

PIN CONFIGURATION

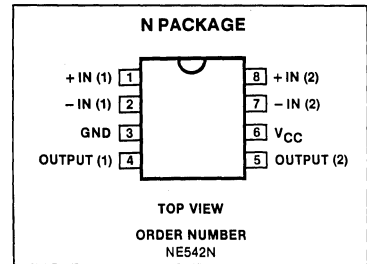

ABSOLUTE MAXIMUM RATINGS

PARAMETER	RATING	UNIT
Supply voltage	+24	V
Power dissipation	500	mW
Operating temperature range	0 to +70	°C
Storage temperature range	-65 to +150	°C
Lead temperature (soldering, 60sec)	+300	°C

EQUIVALENT CIRCUIT

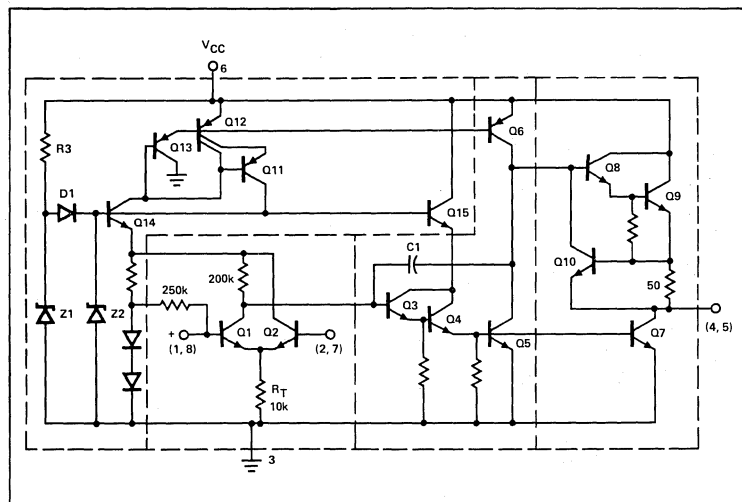

DC ELECTRICAL CHARACTERISTICS

$T_A = 25^\circ C, V_{CC} = 14V$
unless otherwise specified.

PARAMETER	TEST CONDITIONS	NE542			UNIT
		Min	Typ	Max	
Supply voltage	$V_{CC} = 9 \text{ to } 18V, R_L = \infty$	9		24	V
Supply current			9	15	mA
Input resistance			100		k Ω
Positive input			200		k Ω
Negative input					
Output resistance	Open loop		150		Ω

5

DUAL LOW-NOISE PREAMP

NE542

AC ELECTRICAL CHARACTERISTICS $T_A = 25^\circ\text{C}$, $V_{CC} = 14\text{V}$ unless otherwise specified.

PARAMETER	TEST CONDITIONS	NE542			UNIT
		Min	Typ	Max	
Voltage gain	Open loop		160,000		V/V
Input current Negative input			.5		μA
Output current	Source Sink (linear operation)	8 2	14 3		mA
Output voltage swing		$V_{CC} - 2.5$	$V_{CC} - 2$		V
Small signal bandwidth			15		MHz
Slew rate			5		V/ μs
Power bandwidth	15V p-p		100		kHz
Maximum input voltage	Linear operation, <2.5% distortion			300	mVrms
Supply rejection ratio	$f = 60, 120\text{Hz}$		100		dB
	$f = 1\text{kHz}$		110		dB
Channel separation	$f = 1\text{kHz}$	40	70		dB
Total harmonic distortion	40 dB gain, $f = 1\text{kHz}$.1	.3	%
Total equivalent input Noise	$R_S = 600\Omega$, 100 - 10,000Hz		.7	1.2	μVrms
Noise figure	$R_S = 50\text{k}\Omega$, 10 - 10,000Hz		1.2		dB
	$R_S = 20\text{k}\Omega$, 10 - 10,000Hz		1.2		dB
	$R_S = 10\text{k}\Omega$, 10 - 10,000Hz		1.5		dB
	$R_S = 5\text{k}\Omega$, 10 - 10,000Hz		2.4		dB

TYPICAL PERFORMANCE CHARACTERISTICS

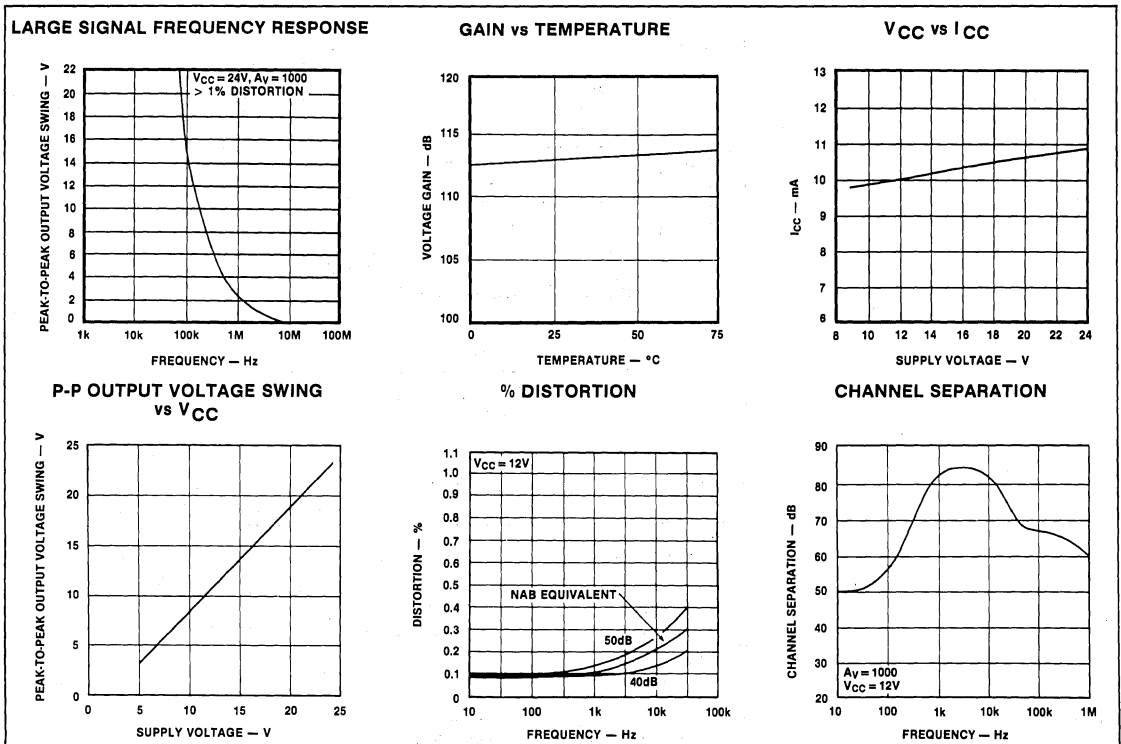

TYPICAL PERFORMANCE CHARACTERISTICS (Cont'd)

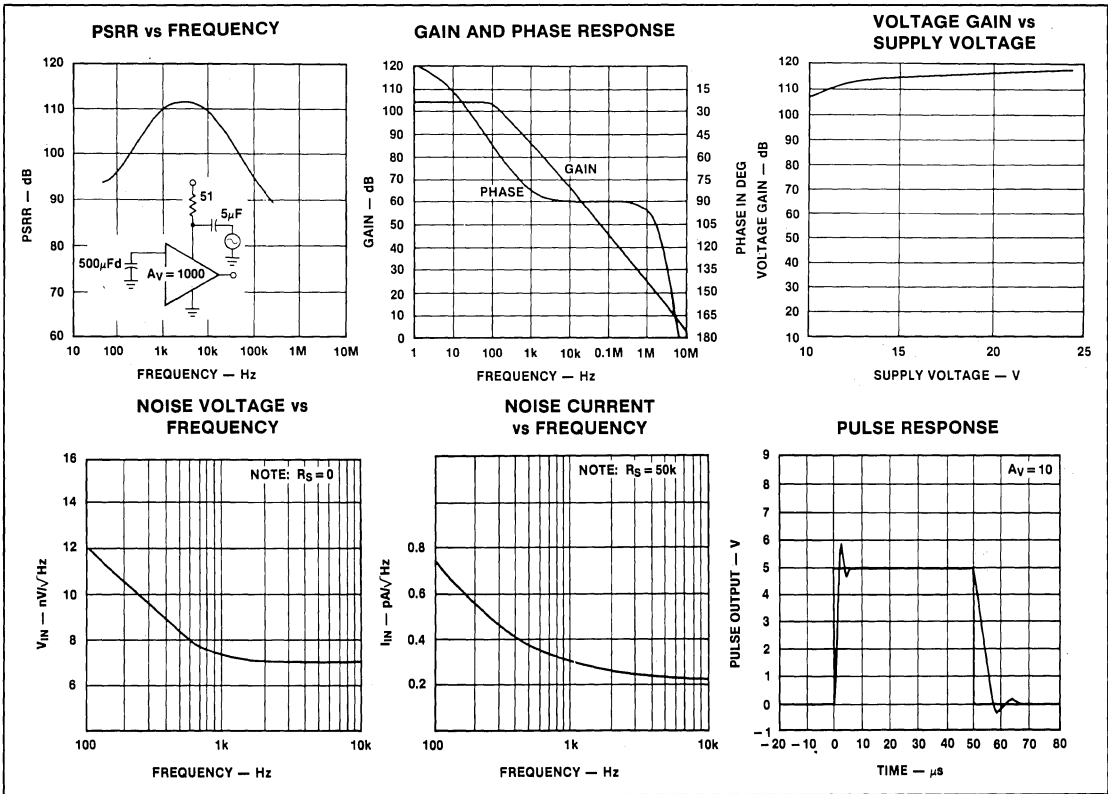

TYPICAL APPLICATIONS

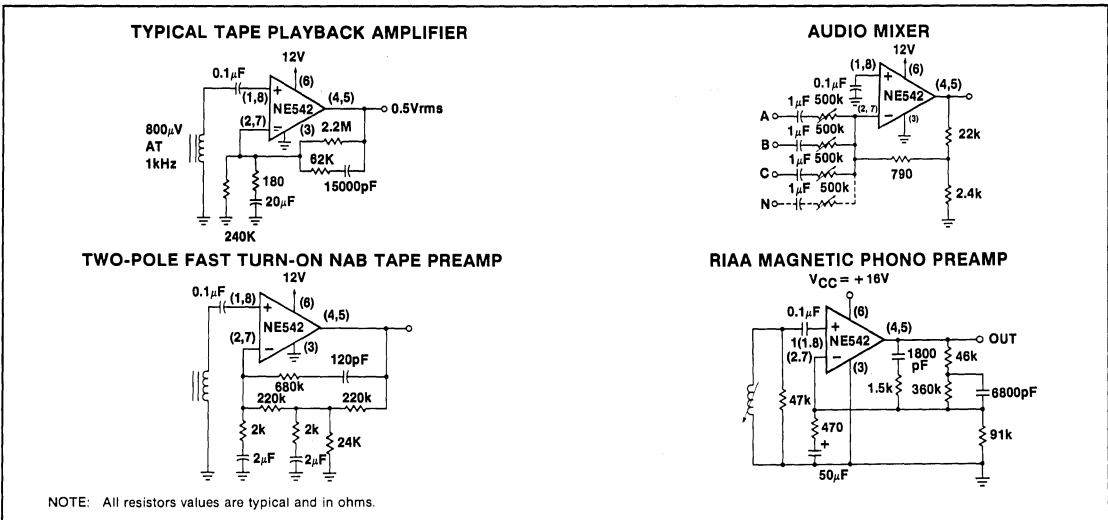

NOTE: All resistors values are typical and in ohms.

*For additional information, consult the Applications Section.

DOUBLE BALANCED MIXER AND OSCILLATOR

SA/NE602

Preliminary

DESCRIPTION

The SA/NE602 is a monolithic Double Balanced Mixer with on-board oscillator and voltage regulator. The oscillator can be used as a buffer for external injection. The design is optimized for frequency conversion applications up to 200MHz and has excellent noise and 3rd order intermodulation performance. The SA/NE602 is available in a 8 lead dual in line plastic package and 8 lead SO (Surface mounted miniature package).

FEATURES

- Low current consumption: 2.4mA typical
- High input and oscillator frequency operation up to 200MHz
- High third order intercept point: -15 dBm referred to matched input
- Excellent noise figure: 5.0dB typical at 45 MHz
- Low external count; suitable for crystal/ceramic filters

APPLICATIONS

- HF and VHF frequency conversion
- Cellular radio mixer/oscillator
- Communication receivers
- Instrumentation frequency converters
- VHF walkie talkie

PIN CONFIGURATION

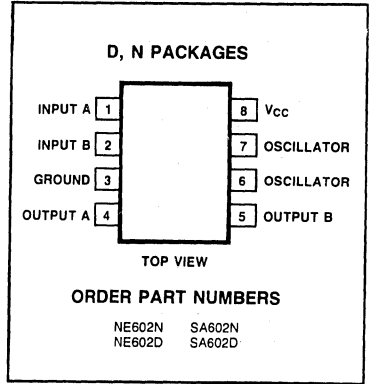

ABSOLUTE MAXIMUM RATINGS

PARAMETER	RATING	UNIT
Maximum operating voltage	9	V
Storage temperature	-65 to +150	°C
Operating temperature		
NE602	0 to +70	°C
SA602	-40 to +85	°C

BLOCK DIAGRAM

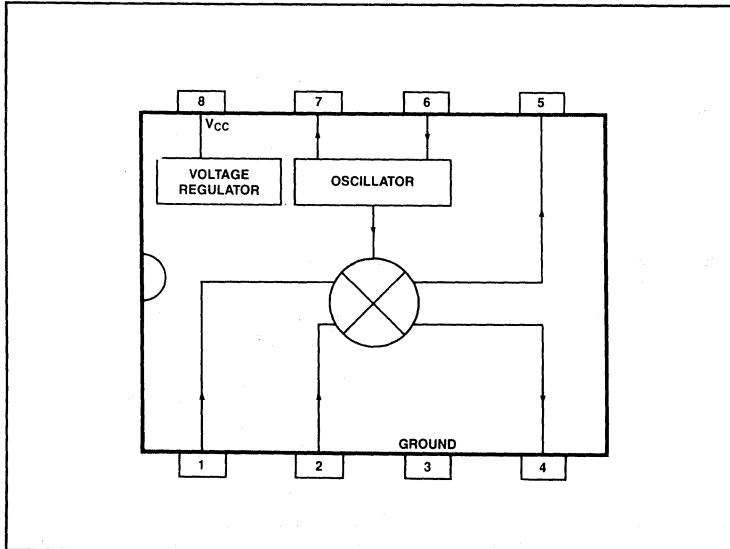

DOUBLE BALANCED MIXER AND OSCILLATOR

SA/NE602

Preliminary

DC ELECTRICAL CHARACTERISTICS: $T_A = 25^\circ\text{C}$, $V_{CC} = 6\text{V}$.

SYMBOL AND PARAMETER	SA/NE602			UNIT
	Min	Typ	Max	
Power supply voltage range	4.5	—	8.0	V
D.C. current drain	—	2.4	2.7	mA
Input signal frequency	—	—	200	MHz
Oscillator frequency	—	—	200	MHz
Noise figure @ 45MHz	—	5.0	6	dB
Third order intercept point	—	-15	-17	dBm
Mixer input resistance	1.5	—	—	k Ω
Mixer input capacitance	—	3	3.5	pF
Mixer output resistance ¹	—	2 x 1.5	—	k Ω

NOTE:

1. Each output pin is internally connected to V_{CC} through a 1.5 (nominal) k Ω resistor.

CIRCUIT DESCRIPTION

The NE602 utilizes an active double balanced mixer. The RF input port (pins 1 and 2) can be used in either a symmetrical or an asymmetrical configuration. The RF input port has a resistance of 1.5k Ω shunted by 3.0pF. In order to be used as an asymmetrical configuration, one of the two input pins (1 or 2) must be bypassed to ground with a capacitor. The RF

input port does not need any external bias and should not be DC grounded. An external DC path between pins 1 and 2 is allowed.

The local oscillator is an emitter-follower circuit and is capable of many types of oscillator configurations. Pin 6 (oscillator base) and pin 7 (oscillator emitter) do not need any external bias circuitry, but only pin 6 may have a DC

path to V_{CC} . Pin 6 can be used for external oscillator or for frequency synthesizer injection.

The NE602 output pins can be used in a single-ended or push-pull configuration. There are internal 1.5k Ω resistors connected to V_{CC} for each output pin (4 and 5); therefore no external bias is needed. Pins 4 and/or 5 may have a DC path to V_{CC} .

5

TYPICAL APPLICATION

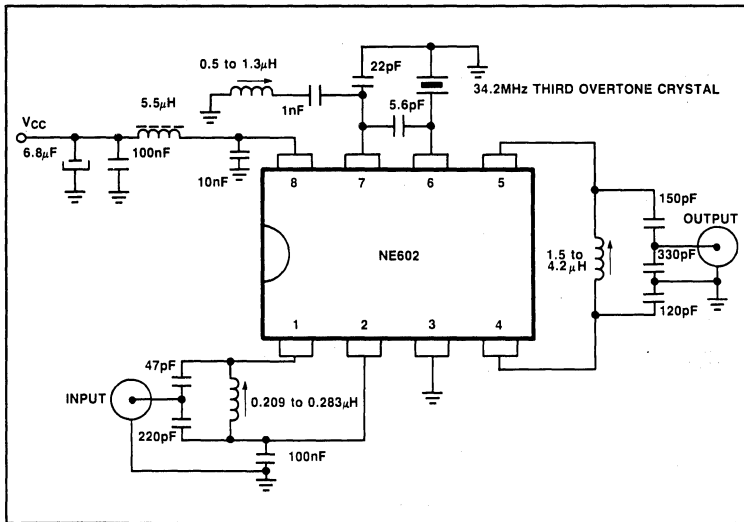

Preliminary

DESCRIPTION

The SA/NE604 is a monolithic low power FM IF system incorporating two limiting intermediate frequency amplifiers, quadrature detector, muting, logarithmic signal strength indicator, and voltage regulator. The SA/NE604 is available in a 16 lead dual-in-line plastic package and 16 lead SO (surface mounted miniature package).

FEATURES

- Low power consumption: 2.3mA typical
- Logarithmic Received Signal Strength Indicator (RSSI) with a dynamic range in excess of 90dB
- Separate data output
- Audio output with muting
- Low external count; suitable for crystal/ceramic filters
- Excellent sensitivity: 1.5µV across input pins (0.27 µV into 50Ω matching network) for 12dB SINAD (Signal to Noise and Distortion ratio) at 455kHz

APPLICATIONS

- Cellular Radio FM IF
- Communications receivers
- Intermediate frequency amplification and detection up to 10.7MHz
- RF level meter
- Spectrum analyzer

PIN CONFIGURATION

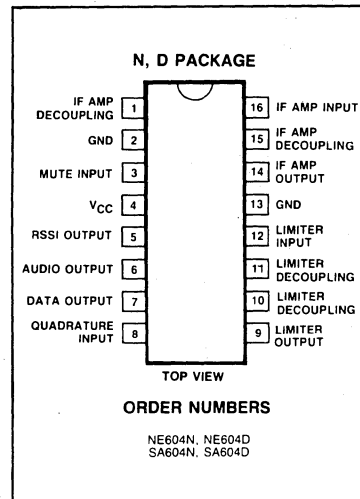

ABSOLUTE MAXIMUM RATINGS

SYMBOL AND PARAMETER	RATING	UNIT
Maximum operating voltage	9	V
Storage temperature	-65 to +150	°C
Operating temperature		
NE604	0 to +70	°C
SA604	-40 to +85	°C

BLOCK DIAGRAM

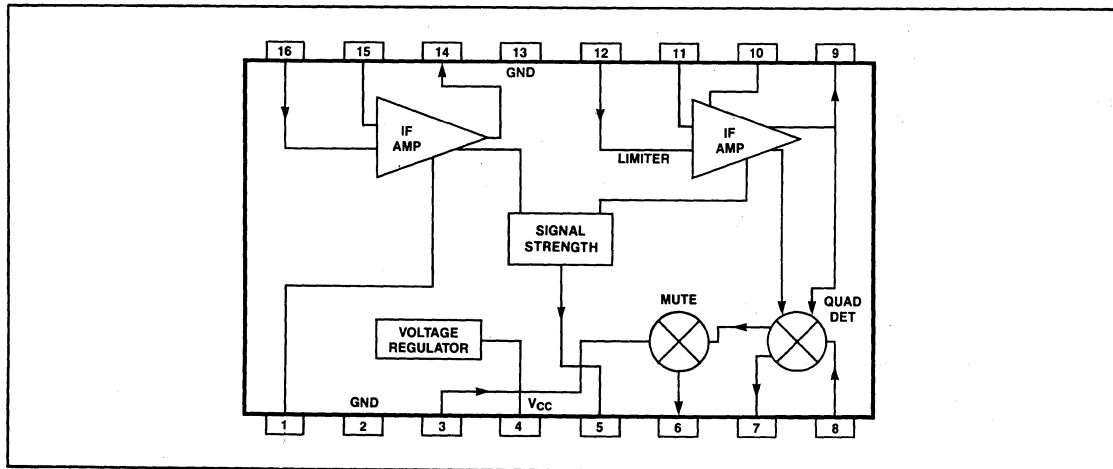

LOW POWER FM IF SYSTEM

SA/NE604

Preliminary

ELECTRICAL CHARACTERISTICS $T_A = 25^\circ\text{C}$, $V_{CC} = +6$ volts, unless otherwise stated.

SYMBOL AND PARAMETER	SA/NE604			UNITS
	Min	Typ	Max	
Power supply voltage range	4.5	-	8.0	V
D.C. current drain	-	2.3	2.7	mA
I.F. frequency	-	-	10.7	MHz
RSSI range	TBD	90	-	dB
RSSI accuracy	-	± 1.5	-	dB
I.F. input impedance	1.5	-	-	k Ω
I.F. output impedance	1.0	-	-	k Ω
Limiter input impedance	1.5	-	-	k Ω
Quadrature detector data output impedance	50	-	-	k Ω
Muted audio out impedance	-	50	-	k Ω
Mute - switch input threshold (on)	1.7	-	-	V
(off)	-	-	1.0	V

CIRCUIT DESCRIPTION

The SA/NE604's IF amplifier has a gain of 30dB, bandwidth of 15MHz, with an input impedance of 1.5k Ω and an output impedance of 1.0k Ω . The limiter has a gain of 60dB, bandwidth of 15MHz, and an input impedance of 1.5k Ω . An interstage filter between the IF Amplifier and Limiter is recommended to reduce wideband noise. The quadrature detector input (pin 8) impedance is 40k Ω .

The data (unmuted output) and audio (muted output) both have 50k Ω output impedance and their detected signals are 180 degrees out of phase with each other. The mute input (pin 3) has a very high impedance and is compatible with three and five volt CMOS and TTL levels. Little or no DC level shift occurs after muting when the quadrature detector is adjusted to the IF center frequency. Muting will attenuate the audio signal by more than 60dB and no voltage spikes will be generated by muting.

The logarithmic signal strength indicator is a current source output with maximum source current of 50 microamps. The signal strength indicator's transfer function is approximately 10 microamp per 20dB and is independent of IF frequency. The interstage filter must have a 6dB insertion loss to optimize slope linearity.

Pins 1, 16, 15, 14, 12, 11, 10, 9, and 8 do not need external bias and should not have a DC path.

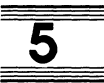

TYPICAL APPLICATION

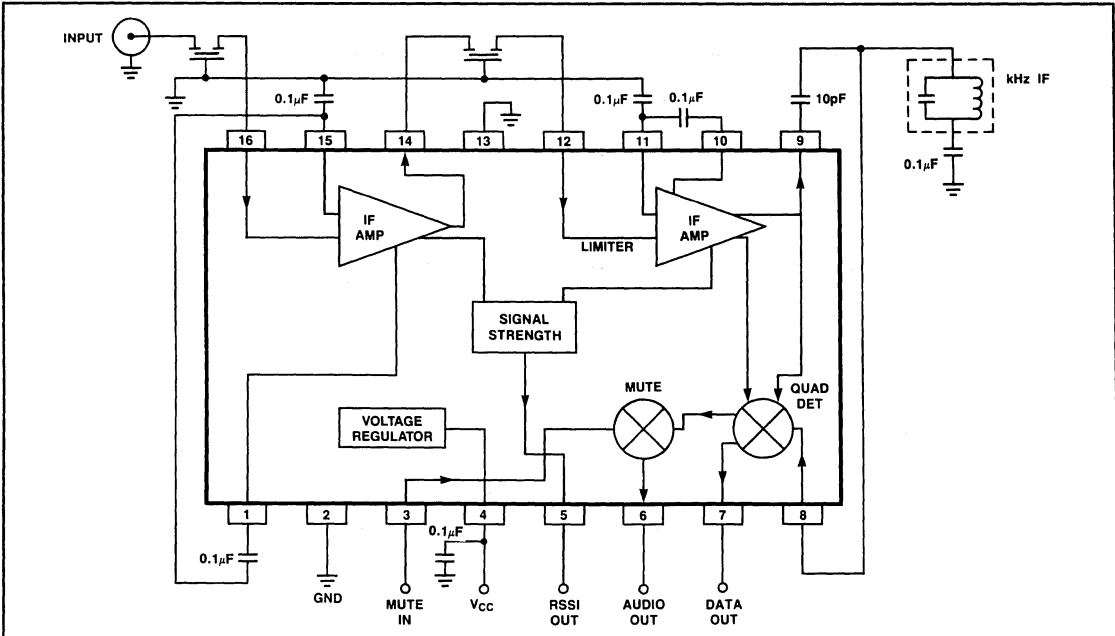

DOLBY NOISE REDUCTION CIRCUIT

NE645/46

DESCRIPTION

The NE645/646 is a monolithic audio noise reduction circuit designed as a direct replacement device for the NE645B/NE646B in Dolby® B-Type noise reduction systems. The NE645/646 is used to reduce the level of background noise introduced during recording and playback of audio signals on magnetic tape, and to improve the noise level in FM broadcast reception. This circuit is available only to licensees of Dolby Laboratories Licensing Corporation, San Francisco, California.

FEATURES

- Accurate record mode frequency response
- Excellent frequency response tracking with temperature and $V_{CC} \pm 0.4$ dB typical
- Excellent back-to-back dynamic response — D.C. shift less than 20 mV typical
- Improved stability of all op amps
- High reliability packaging

PIN CONFIGURATION

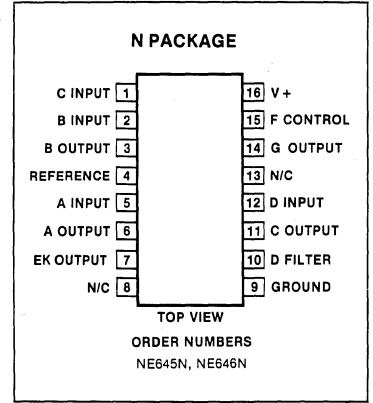

NOTE

*T.M. Dolby Laboratories Licensing Corporation.

ABSOLUTE MAXIMUM RATINGS

PARAMETER	RATING	UNIT
Supply voltage	24	V
Temperature range		
Operating	0 to +70	°C
Storage	-65 to +150	°C
Lead temperature (soldering, 60 sec)	+300	°C

BLOCK DIAGRAM

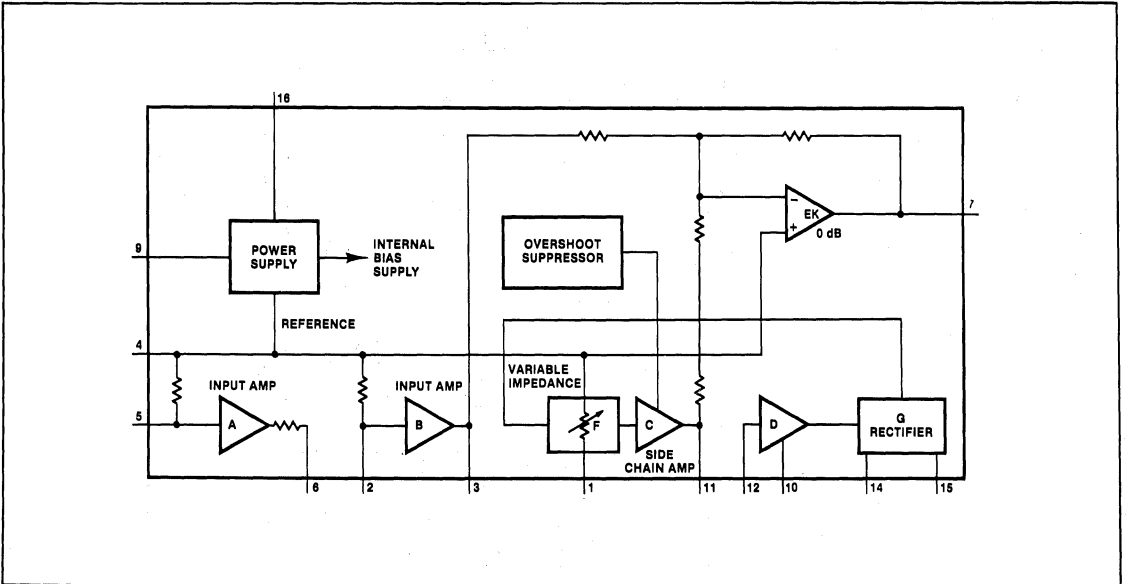

DOLBY NOISE REDUCTION CIRCUIT

NE645/46

ELECTRICAL CHARACTERISTICS

$V_{CC} = 12$ volts, $f = 20$ Hz to 20 kHz.
 All levels referenced to 580 mVrms (0 dB) at Pin 3, $T_A = +25^\circ\text{C}$
 Unless otherwise noted.

PARAMETER	TEST CONDITIONS	NE645			NE646			UNIT
		Min	Typ	Max	Min	Typ	Max	
Supply Voltage Range		8		20	8		20	V
Supply Current, I_{CC}	$V_{CC} = 12\text{V}$		16	24		16	24	mA
Voltage gain (Pins 5-3)	$f = 1$ kHz (Pins 6 and 2 connected)	24.5	26	27.5	24.5	26	27.5	dB
Voltage gain (Pins 3-7)	$f = 1$ kHz, 0 dB at pin 3, noise reduction out	-0.5	0	+0.5	-0.5	0	+0.5	dB
Distortion THD, 2nd and 3rd harmonic	$f = 20$ Hz - 10 kHz, 0dB		0.05	0.1		0.05	0.2	%
	$f = 20$ Hz - 10 kHz, +10 dB		0.15	0.3		0.2	0.5	%
Signal handling ¹ ($V_{CC} = 12\text{V}$)	1% dist at 1 kHz	+12	+15		+12	+15		dB
Signal-to-noise ratio ²	Record mode	67	72		64	72		dB
	Playback mode	77	82		74	82		dB
Record mode Frequency response (at pin 7) referenced to encode monitor point (pin 3)	$f = 1.4\text{kHz}$ 0dB -20dB -30dB	-1	0	+1	-1.5	0	+1.5	dB
		-16.6	-15.6	-14.6	-17.1	-15.6	-14.1	dB
		-23.5	-22.5	-21.5	-24.0	-22.5	-21.0	dB
	$f = 5\text{kHz}$ 0dB -20dB -30dB -40dB	-0.7	+0.3	+1.3	-1.2	+0.3	+1.8	dB
		-17.8	-16.8	-15.8	-18.3	-16.8	-15.3	dB
		-22.8	-21.8	-20.8	-23.3	-21.8	-20.3	dB
		-30.2	-29.7	-28.7	-30.2	-29.7	-28.2	dB
	$f = 20\text{kHz}$ 0dB -20dB -30dB	-0.3	+0.7	+1.7	-0.8	+0.7	+2.2	dB
		-18.3	-17.3	-16.3	-18.8	-17.3	-15.8	dB
-24.5		-23.5	-22.5	-25.0	-23.5	-22.0	dB	
Back-to-back frequency response	Using typical record mode frequency response test points	-1	0	+1	-1.5	0	+1.5	dB
Input resistance	Pin 5	35	50	65	35	50	65	k Ω
	Pin 2	3.1	4.2	5.3	3.1	4.2	5.3	k Ω
Output resistance	Pin 6	1.9	2.4	3.1	1.9	2.4	3.1	k Ω
	Pin 3		80	120		80	120	Ω
	Pin 7		80	120		80	120	Ω
Back-to-back frequency response shift	Versus temperature Versus supply voltage	0°-70°C				± 0.4		dB
		8-20V		± 0.4		± 0.4		dB

NOTES

- See maximum signal handling versus supply voltage characteristics.
- All noise levels are measured CCIR/ARM weighted using a 10K source with respect to Dolby level. See Dolby Laboratories Bulletin 19.

5

PERFORMANCE CHARACTERISTICS

THD vs FREQUENCY RECORD MODE

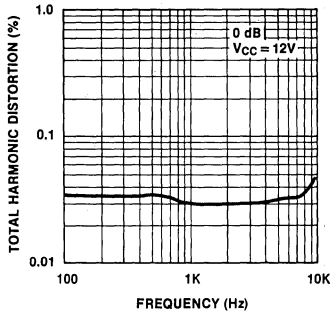

THD vs FREQUENCY RECORD MODE

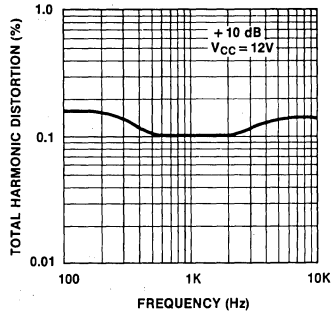

THD vs FREQUENCY PLAY MODE

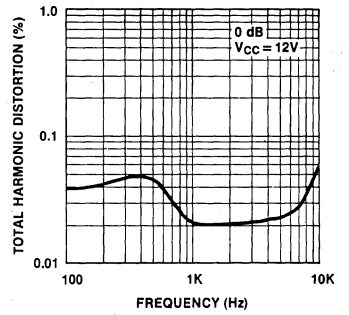

THD vs OUTPUT RECORD MODE

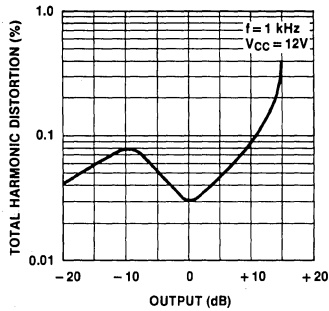

THD vs FREQUENCY NOISE REDUCTION (NR) OFF

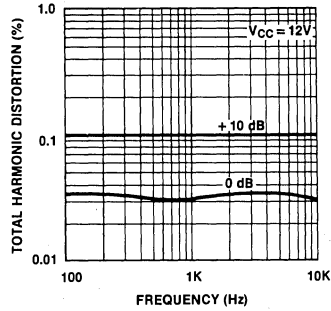

MAXIMUM SIGNAL HANDLING vs SUPPLY VOLTAGE

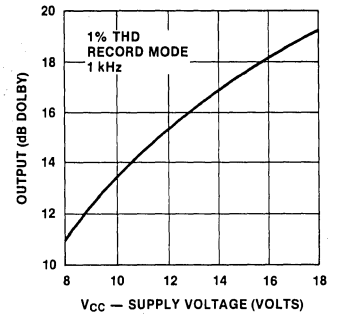

SUPPLY CURRENT vs SUPPLY VOLTAGE

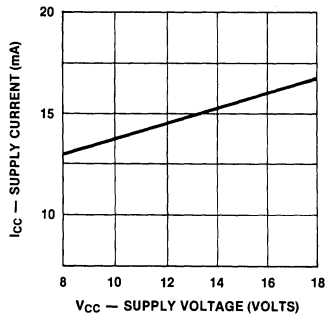

DOLBY NOISE REDUCTION CIRCUIT

NE645/46

APPLICATION INFORMATION

The NE645/646 is a direct replacement for the NE645B/646B. The NE645/646 incorporates improved design techniques to insure excellent performance required in Dolby B and C Type Audio Noise Reduction Systems. Critical component values are unchanged except for C309 on Pin 1 which is now an optional component in specific applications defined by Dolby Laboratories. All circuit parameters are guaranteed at 12V V_{CC}.

DOLBY ENCODER Output for constant level input (single tone frequency response)

Frequency (kHz)	Input Level (dB)								
	0 (Dolby Level)	-5	-10	-15	-20	-25	-30	-35	-40
0.1	0	0.1	0	0.1	0	0	0	0	0
0.14	0	0.2	0.2	0.2	0.2	0.2	0.1	0.2	0.1
0.2	0	0.3	0.4	0.5	0.5	0.6	0.6	0.5	0.5
0.3	0	0.3	0.6	1.1	1.3	1.3	1.3	1.3	1.3
0.4					2.0	2.1	2.2	2.3	2.1
0.5	0	0.3	0.8	1.8	2.6	2.9	2.9	3.0	2.9
0.6						3.6	3.7	3.8	3.7
0.7	0	0.4	0.9	2.1	3.5	4.3	4.4	4.5	4.4
0.8						4.8	5.0	5.3	5.1
0.9							5.6	5.8	5.6
1.0	0	0.4	1.0	2.3	4.2	5.7	6.1	6.3	6.2
1.2							6.9	7.1	7.1
1.4	0	0.3	0.9	2.3	4.4	6.6	7.5	7.7	7.7
2.0	0.1	0.4	0.9	2.2	4.3	7.0	8.5	8.9	8.9
3.0	0.2	0.6	0.9	1.9	3.9	6.6	8.8	9.7	9.7
5.0	0.3	0.6	1.0	1.7	3.2	5.4	8.2	10.0	10.3
7.0	0.3	0.6	1.0	1.7	2.8	4.7	7.3	9.7	10.4
10.0	0.4	0.7	1.1	1.7	2.6	4.2	6.5	9.1	10.4
14.0	0.5	0.8	1.1	1.8	2.7	4.4	6.5	8.7	10.3
20.0	0.7	0.7	1.2	1.9	2.7	4.4	6.5	8.7	10.3

NOTE

The figures given in this table are the average response of many of Dolby Laboratories' professional encoders, and are not intended to be taken as required consumer equipment performance characteristics. Thus, no inference should be drawn on the tolerances which licensees must retain in consumer equipment. The figures can, however, be used to plot typical characteristics.

5

TEST CIRCUIT NE645/646

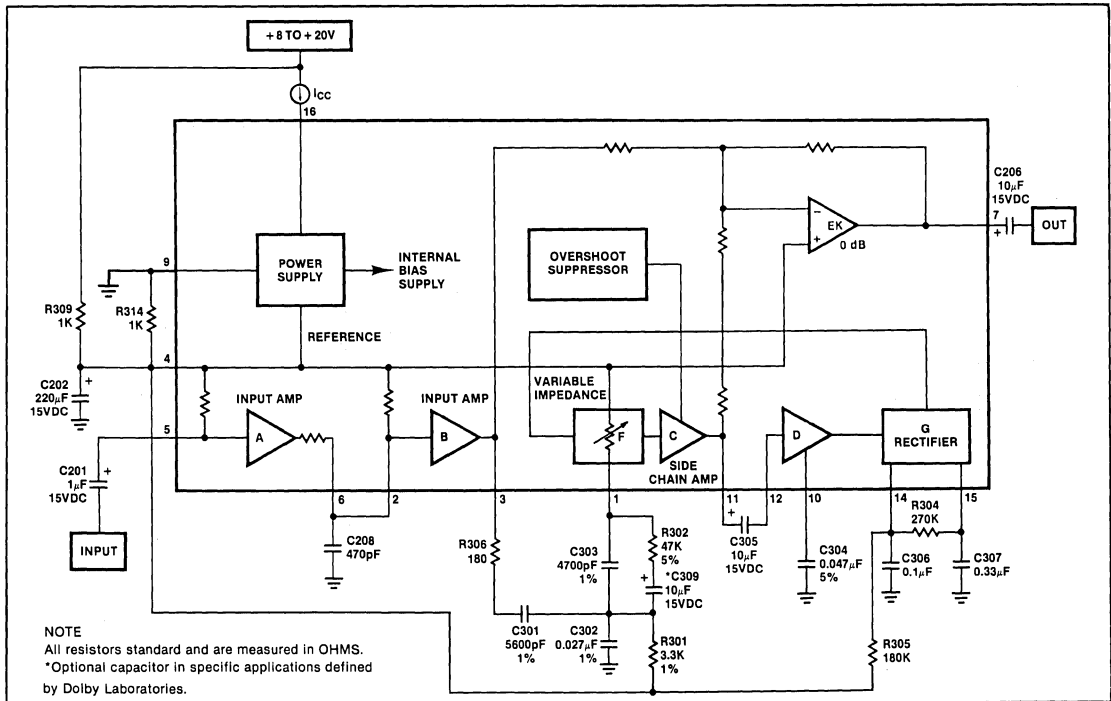

NOTE
 All resistors standard and are measured in OHMS.
 *Optional capacitor in specific applications defined by Dolby Laboratories.

LOW VOLTAGE DOLBY NOISE REDUCTION CIRCUIT

NE648/49

DESCRIPTION

The NE648/649 is an audio noise reduction circuit designed for use in low voltage entertainment systems. The circuit is used to reduce the level of background noise introduced during the recording and playback of audio signals on magnetic tape and improve the noise level in FM broadcast reception. The circuit is intended for use in automotive and portable cassette Dolby* B-Type noise reduction systems. This circuit is available only to licensees of Dolby Laboratories Licensing Corp., San Francisco.

NOTE

*T.M. Dolby Laboratories Licensing Corporation

PIN CONFIGURATION

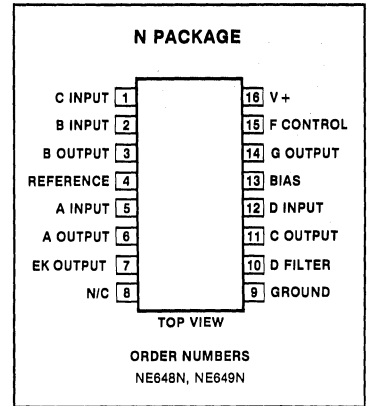

ABSOLUTE MAXIMUM RATINGS

PARAMETER	RATING	UNIT
Supply voltage	16	V
Temperature range		
Operating	-40 to +85	°C
Storage	-65 to +150	°C
Lead temperature (soldering 60sec)	+300	°C

BLOCK DIAGRAM

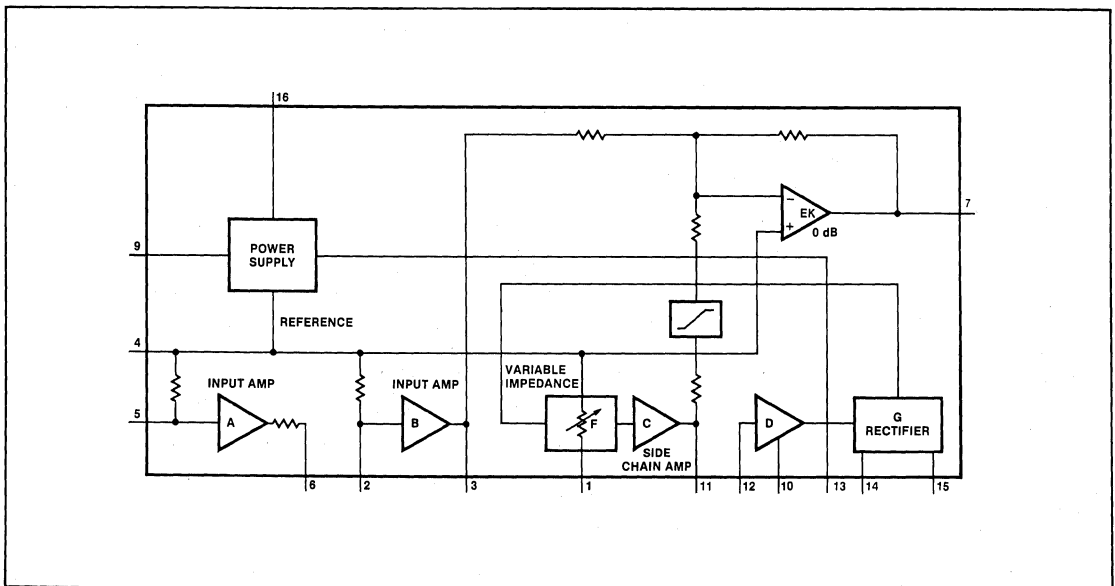

LOW VOLTAGE DOLBY NOISE REDUCTION CIRCUIT

NE648/49

DC ELECTRICAL CHARACTERISTICS $V_{CC} = 9V$, $f = 20\text{Hz}$ to 20kHz .

All levels referenced to 580mVrms (0dB) at pin 3, $T_A = +25^\circ\text{C}$ unless otherwise noted.

PARAMETER	TEST CONDITIONS	NE648			NE649			UNIT
		Min	Typ	Max	Min	Typ	Max	
Supply voltage range ³		6	9	14	6	9	14	V
Minimum voltage supply for 8dB headroom 10dB headroom	$f = 1.4\text{kHz}$ THD < 1%	6.5			6.5			V
		7.5			7.5			V
Supply Current, I_{CC}			11	18		11	18	mA
Supply Current, ¹ I_{CC}				20			20	mA
Voltage gain (pins 5-3)	$f = 1\text{kHz}$ (pins 6 and 2 connected)	24.5	26	27.5	24.5	26	27.5	dB
Voltage gain (pins 3-7)	$f = 1\text{kHz}$, 0dB at pin 3, noise reduction out	-0.5	0	+0.5	-0.5	0	+0.5	dB
Distortion	$f = 20\text{kHz}$ to 10kHz , 0dB $f = 20\text{Hz}$ to 10kHz , +10dB		0.05	0.1		0.05	0.2	%
			0.2	0.3		0.2	0.5	%
Signal Handling (See Performance Characteristics)								
Signal-to-noise ratio ²	Record (pins 6 and 2 connected)	67	72		64	72		dB
	Playback (pins 6 and 2 connected)	77	82		74	82		dB
Record mode frequency response (at pin 7) referenced to encode monitor point (pin 3)	$f = 1.4\text{kHz}$ 0dB -20dB -30dB	-1	0	+1	-1.5	0	+1.5	dB
		-16.6	-15.6	-14.6	-17.1	-15.6	-14.1	dB
		-23.5	-22.5	-21.5	-24.0	-22.5	-21.0	dB
	$f = 5\text{kHz}$ 0dB -20dB -30dB -40dB	-0.7	+0.3	+1.3	-1.2	+0.3	+1.8	dB
		-17.8	-16.8	-15.8	-18.3	-16.8	-15.3	dB
		-22.8	-21.8	-20.8	-23.3	-21.8	-20.3	dB
		-30.2	-29.7	-28.7	-30.2	-29.7	-28.2	dB
	$f = 20\text{kHz}$ 0dB -20dB -30dB	-0.3	+0.7	+1.7	-0.8	+0.7	+2.2	dB
		-18.3	-17.3	-16.3	-18.8	-17.3	-15.8	dB
-24.5		-23.5	-22.5	-25.0	-23.5	-22.0	dB	
Back-to-back frequency response	Using typical record mode response		± 1.0			± 1.5		dB
Input resistance	Pin 5	35	50	65	35	50	65	k Ω
	Pin 2	3.1	4.2	5.3	3.1	4.2	5.3	k Ω
Output resistance	Pin 6	1.9	2.4	3.1	1.9	2.4	3.1	k Ω
	Pin 3		80	120		80	120	Ω
	Pin 7		80	120		80	120	Ω
Record mode frequency response shift	Versus temperature 0 to 70°C -40 to 85°C Versus V_{CC} 6 to 14V		± 0.3					dB
			± 0.5					dB
			0.2					dB/V

NOTES

1. With electronic switching.
2. All noise levels are measured CCIR/ARM weighted using a 10K source with respect to Dolby level. See Dolby Laboratories Bulletin 19.
3. The circuit will function as low as $V_{CC} = 4.5V$ (i.e. output signal present). See graphs of I_{CC} and signal handling vs V_{CC} .

5

PERFORMANCE CHARACTERISTICS

(+10dB) THD vs FREQUENCY

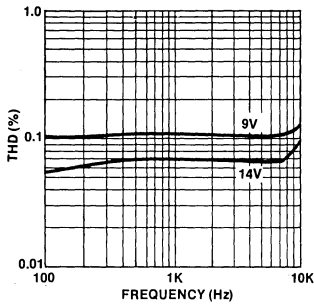

(0dB) THD vs FREQUENCY

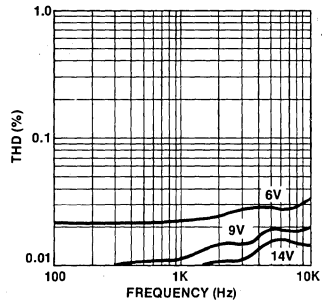

CURRENT vs SUPPLY VOLTAGE

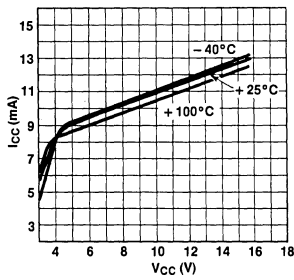

MAXIMUM SIGNAL HANDLING vs SUPPLY VOLTAGE FOR 1% THD (RECORD)

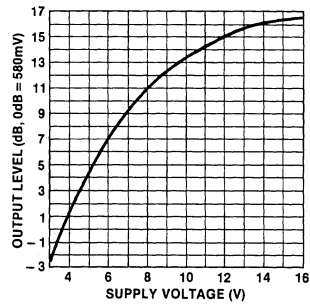

LOW VOLTAGE DOLBY NOISE REDUCTION CIRCUIT

NE648/49

DOLBY ENCODER Output for constant level input (single tone frequency response)

Frequency (kHz)	Input Level (dB)								
	0 (Dolby Level)	-5	-10	-15	-20	-25	-30	-35	-40
0.1	0	0.1	0	0.1	0	0	0	0	0
0.14	0	0.2	0.2	0.2	0.2	0.2	0.1	0.2	0.1
0.2	0	0.3	0.4	0.5	0.5	0.6	0.6	0.5	0.5
0.3	0	0.3	0.6	1.1	1.3	1.3	1.3	1.3	1.3
0.4					2.0	2.1	2.2	2.3	2.1
0.5	0	0.3	0.8	1.8	2.6	2.9	2.9	3.0	2.9
0.6						3.6	3.7	3.8	3.7
0.7	0	0.4	0.9	2.1	3.5	4.3	4.4	4.5	4.4
0.8						4.8	5.0	5.3	5.1
0.9							5.6	5.8	5.6
1.0	0	0.4	1.0	2.3	4.2	5.7	6.1	6.3	6.2
1.2							6.9	7.1	7.1
1.4	0	0.3	0.9	2.3	4.4	6.6	7.5	7.7	7.7
2.0	0.1	0.4	0.9	2.2	4.3	7.0	8.5	8.9	8.9
3.0	0.2	0.6	0.9	1.9	3.9	6.6	8.8	9.7	9.7
5.0	0.3	0.6	1.0	1.7	3.2	5.4	8.2	10.0	10.3
7.0	0.3	0.6	1.0	1.7	2.8	4.7	7.3	9.7	10.4
10.0	0.4	0.7	1.1	1.7	2.6	4.2	6.5	9.1	10.4
14.0	0.5	0.8	1.1	1.8	2.7	4.4	6.5	8.7	10.3
20.0	0.7	0.7	1.2	1.9	2.7	4.4	6.5	8.7	10.3

NOTE

The figures given in this table are the average response of many of Dolby Laboratories' professional encoders, and are not intended to be taken as required consumer equipment performance characteristics. Thus, no inference should be drawn on the tolerances which licensees must retain in consumer equipment. The figures can, however, be used to plot typical characteristics.

5

TEST CIRCUIT NE648/49

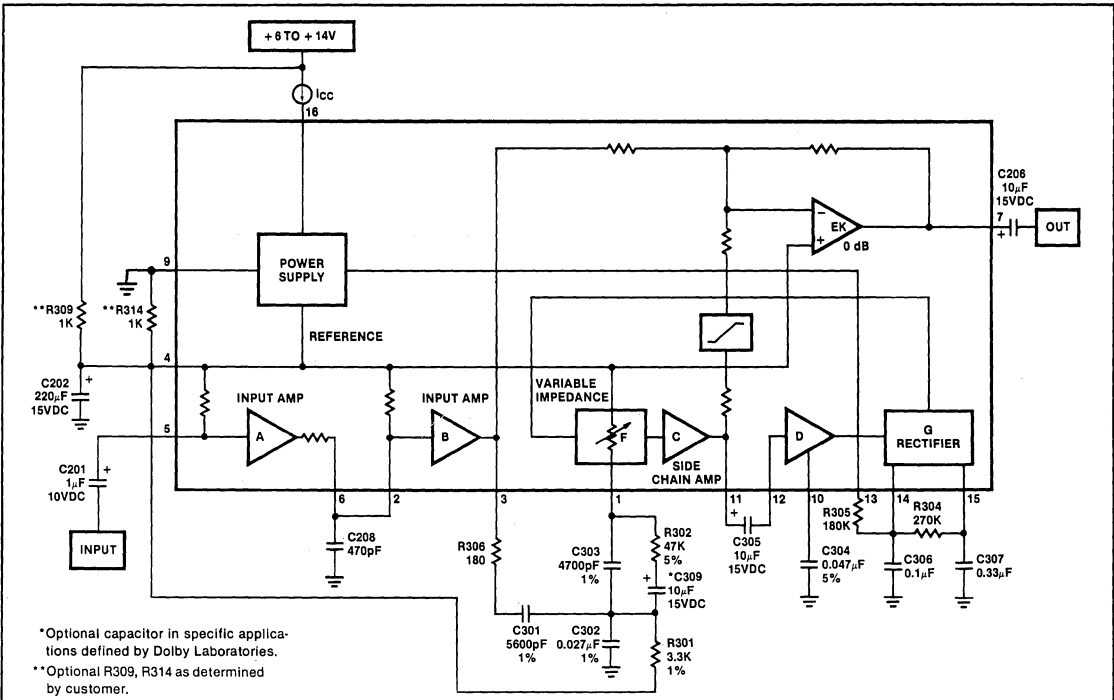

DOLBY B TYPE NOISE REDUCTION CIRCUIT

NE650

DESCRIPTION

The NE650 is a monolithic audio noise reduction circuit designed for use in Dolby® B Type noise reduction systems. The NE650 is used to reduce the level of background noise introduced during recording and playback of audio signals on magnetic tape. The NE650 features excellent dynamic characteristics over a wide range of operating conditions and is pin compatible with NE645/646. This circuit is available only to licensees of Dolby Laboratories Licensing Corp., San Francisco.

NOTE

*T.M. Dolby Laboratories Licensing Corporation.

PIN CONFIGURATION

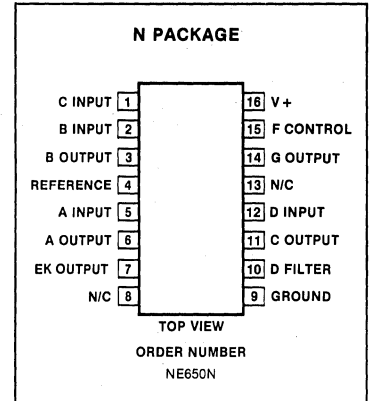

ABSOLUTE MAXIMUM RATINGS

PARAMETER	RATING	UNIT
Supply voltage	24	V
Temperature range		
Operating	0 to +70	°C
Storage	-65 to +150	°C
Lead temperature (soldering 60sec)	+300	°C

BLOCK DIAGRAM

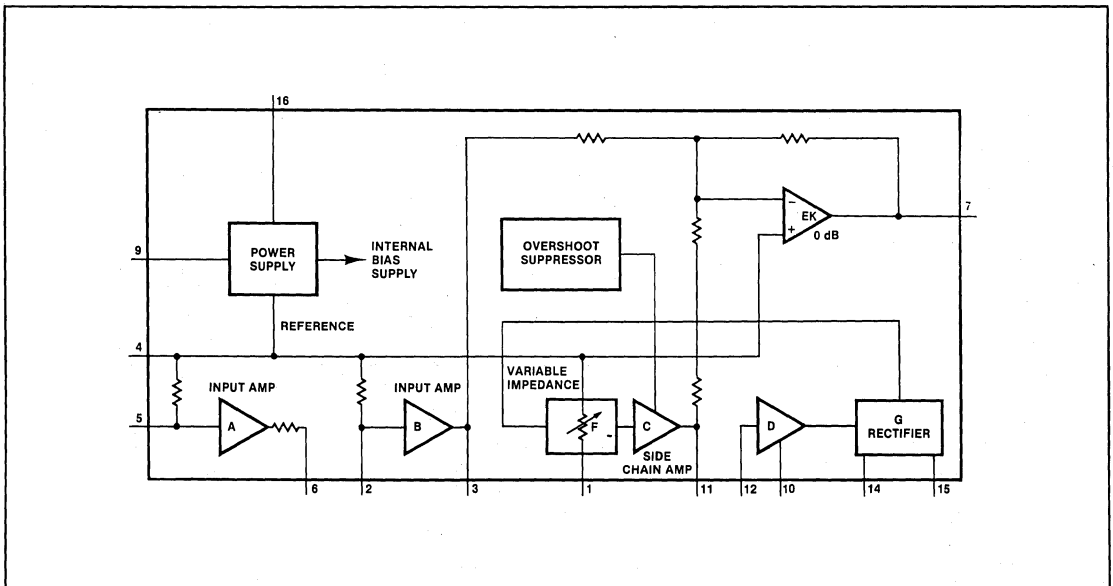

DOLBY B TYPE NOISE REDUCTION CIRCUIT**NE650****DC ELECTRICAL CHARACTERISTICS** $V_{CC} = 12V$, $f = 20Hz$ to $20kHz$.All levels referenced to 580mVrms (0dB) at pin 3, $T_A = +25^\circ C$ unless otherwise noted.

PARAMETER	TEST CONDITIONS	NE650			UNIT	
		Min	Typ	Max		
Supply voltage range		8		20	V	
Supply current, I_{CC}	Electronic switching on		16	24	mA	
Voltage gain (pins 5-3)	$f = 1kHz$ (pins 6 and 2 connected)	25.5	26	26.5	dB	
Voltage gain (pins 3-7)	$f = kHz$, 0dB at pin 3, noise reduction out	-0.5	0	+0.5	dB	
Voltage gain (pins 2-3)	$f = 1kHz$		13		dB	
Distortion THD; 2nd and 3rd harmonic	$f = 20Hz$ to $10kHz$, 0dB $f = 20Hz$ to $10kHz$, +10dB		0.05 0.15	0.1 0.3	% %	
Signal handling	1% distortion at 1kHz	+12	+15		dB	
Signal-to-noise ratio*	Record mode	68	72		dB	
	Playback mode	78	82		dB	
Back-to-back frequency response	Using typical record mode response		± 0.5		dB	
Record mode frequency response (at pin 7) referenced to encode monitor point (pin 3)	$f = 1.4kHz$ 0dB	-0.5	0	+0.5	dB	
	-20dB	-16.1	-15.6	-15.1	dB	
	-30dB	-23.5	-22.5	-21.5	dB	
	$f = 5kHz$ 0dB	-0.7	+0.3	+1.3	dB	
	-20dB	-17.3	-16.8	-16.3	dB	
	-30dB	-22.3	-21.8	-21.3	dB	
	-40dB	-30.2	-29.7	-29.2	dB	
	$f = 20kHz$ 0dB	-0.3	+0.7	+1.7	dB	
	-20dB	-18.3	-17.3	-16.3	dB	
	-30dB	-24.5	-23.5	-22.5	dB	
	Input resistance	Pin 5	35	50	65	k Ω
		Pin 2	3.1	4.2	5.3	k Ω
Output resistance	Pin 6	1.9	2.4	3.1	k Ω	
	Pin 3		80	120	Ω	
	Pin 7		80	120	Ω	
Back-to-back frequency response shift Versus T_A Versus V_{CC}	$0^\circ C$ to $-70^\circ C$ 8 to 20V		± 0.4		dB	
			± 0.4		dB	

*All noise levels are measured CCIR/ARM weighted using a 10K source with respect to Dolby level. See Dolby Laboratories Bulletin 19.

5

DOLBY B TYPE NOISE REDUCTION CIRCUIT

NE650

PERFORMANCE CHARACTERISTICS

THD vs FREQUENCY RECORD MODE

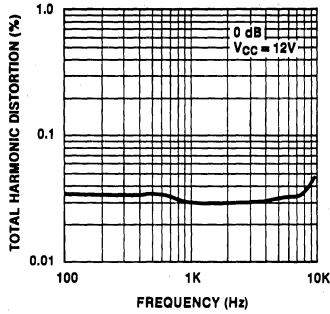

THD vs FREQUENCY RECORD MODE

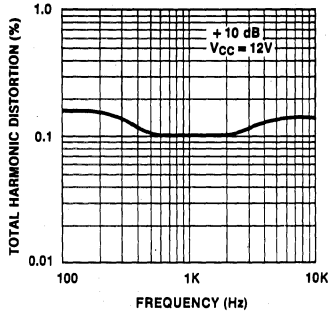

THD vs FREQUENCY PLAY MODE

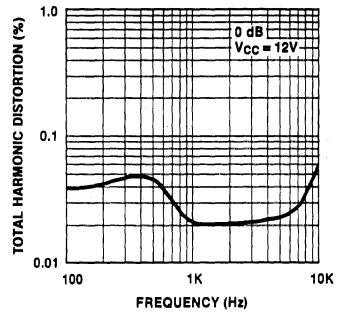

THD vs OUTPUT RECORD MODE

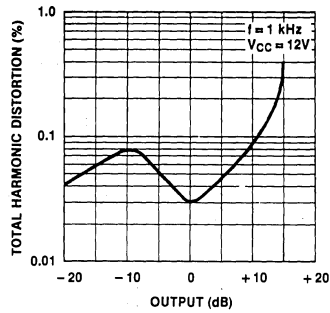

THD vs FREQUENCY NOISE REDUCTION (NR) OFF

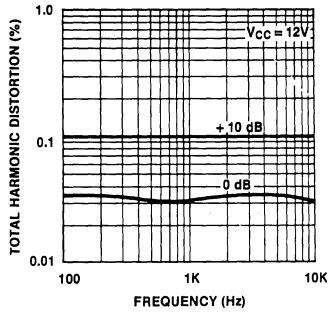

MAXIMUM SIGNAL HANDLING vs SUPPLY VOLTAGE

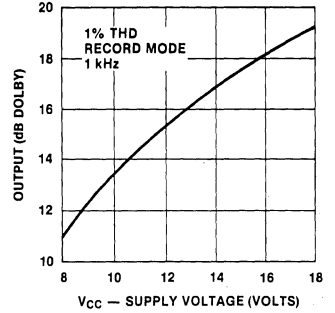

SUPPLY CURRENT vs SUPPLY VOLTAGE

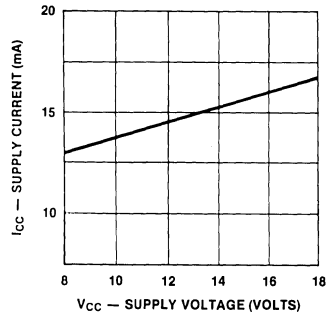

DOLBY B TYPE NOISE REDUCTION CIRCUIT

NE650

DOLBY ENCODER Output for constant level Input (single tone frequency response)

Frequency (kHz)	Input Level (dB)								
	0 (Dolby Level)	-5	-10	-15	-20	-25	-30	-35	-40
0.1	0	0.1	0	0.1	0	0	0	0	0
0.14	0	0.2	0.2	0.2	0.2	0.2	0.1	0.2	0.1
0.2	0	0.3	0.4	0.5	0.5	0.6	0.6	0.5	0.5
0.3	0	0.3	0.6	1.1	1.3	1.3	1.3	1.3	1.3
0.4					2.0	2.1	2.2	2.3	2.1
0.5	0	0.3	0.8	1.8	2.6	2.9	2.9	3.0	2.9
0.6						3.6	3.7	3.8	3.7
0.7	0	0.4	0.9	2.1	3.5	4.3	4.4	4.5	4.4
0.8						4.8	5.0	5.3	5.1
0.9							5.6	5.8	5.6
1.0	0	0.4	1.0	2.3	4.2	5.7	6.1	6.3	6.2
1.2							6.9	7.1	7.1
1.4	0	0.3	0.9	2.3	4.4	6.6	7.5	7.7	7.7
2.0	0.1	0.4	0.9	2.2	4.3	7.0	8.5	8.9	8.9
3.0	0.2	0.6	0.9	1.9	3.9	6.6	8.8	9.7	9.7
5.0	0.3	0.6	1.0	1.7	3.2	5.4	8.2	10.0	10.3
7.0	0.3	0.6	1.0	1.7	2.8	4.7	7.3	9.7	10.4
10.0	0.4	0.7	1.1	1.7	2.6	4.2	6.5	9.1	10.4
14.0	0.5	0.8	1.1	1.8	2.7	4.4	6.5	8.7	10.3
20.0	0.7	0.7	1.2	1.9	2.7	4.4	6.5	8.7	10.3

NOTE
The figures given in this table are the average response of many of Dolby Laboratories' professional encoders, and are not intended to be taken as required consumer equipment performance characteristics. Thus, no inference should be drawn on the tolerances which licensees must retain in consumer equipment. The figures can, however, be used to plot typical characteristics.

5

TEST CIRCUIT NE650

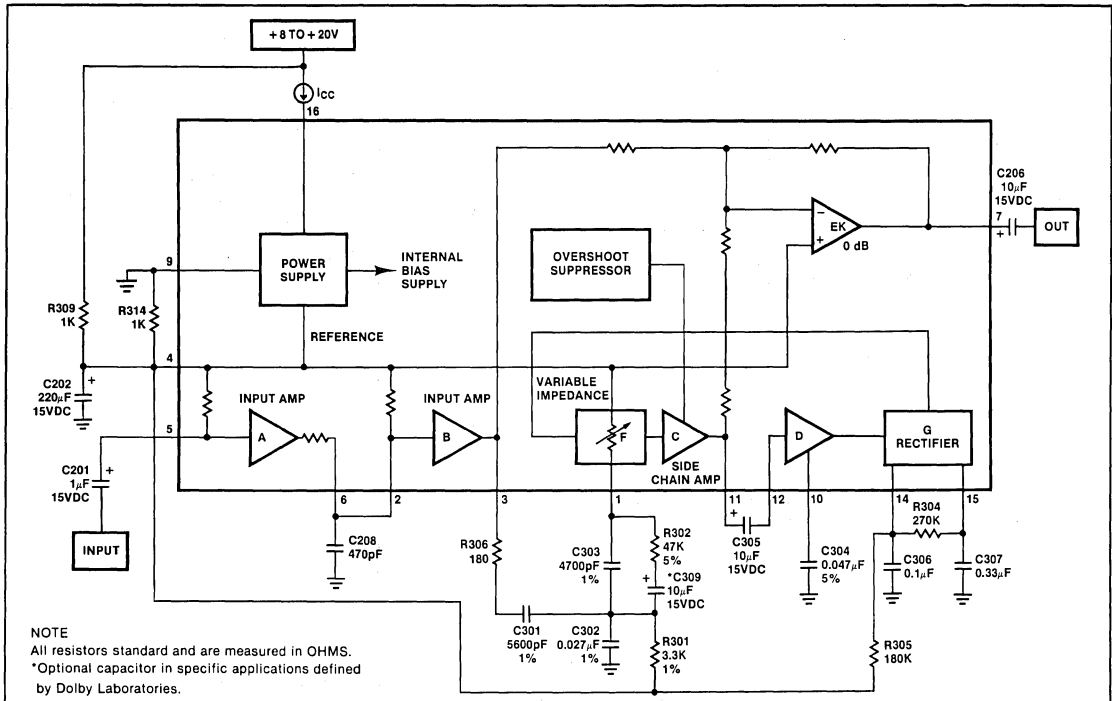

DOLBY NOISE REDUCTION SYSTEM

NE660

Preliminary

DESCRIPTION

The NE660 is a monolithic audio noise reduction circuit designed for low power supply voltage applications. It is used to reduce the level of background noise introduced during recording and playback of audio signals on magnetic tape. This circuit is available only to licensees of Dolby* Laboratories Licensing Corporation, San Francisco, California.

FEATURES

- Low voltage operation
- Large headroom (17dB typical at 1.8V)
- Single or dual supply operation
- Excellent channel to channel matching
- Low noise
- Very low distortion
- Electronic Record/Play, on/off switch
- Minimum external part count

ABSOLUTE MAXIMUM RATINGS

PARAMETER	RATING	UNIT
Supply voltage	8	V
Temperature range		
Operating	- 20 to + 70	°C
Storage	- 65 to + 150	°C

BLOCK DIAGRAM

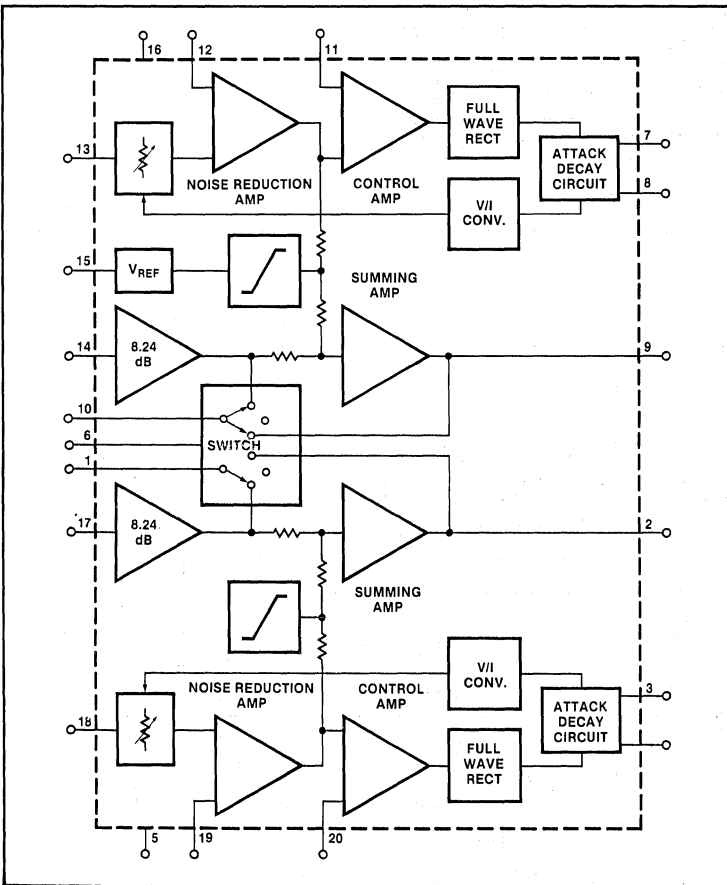

PIN CONFIGURATION

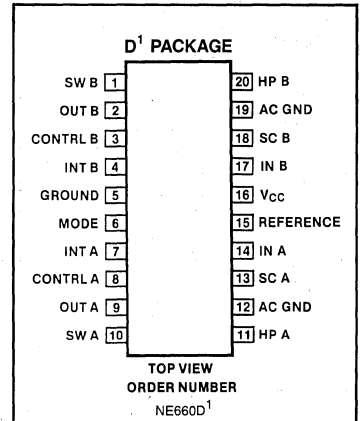

1. Switch output channel B
2. Output channel B
3. Control voltage B
4. Integrating filter B
5. Ground
6. Mode
7. Integrating filter A
8. Control voltage A
9. Output channel A
10. Switch output channel A
11. High pass filter channel A
12. AC ground channel A
13. Side chain channel A
14. Input channel A
15. Reference
16. Vcc
17. Input channel B
18. Side chain channel B
19. AC ground channel B
20. High pass filter channel B

1. SOL - Released in Large SO package only.
2. SOL and non-standard pinout.
3. SO and non-standard pinouts.

*Available only to licensees of Dolby Laboratories Corporation, San Francisco, from whom licensing and application information must be obtained. Dolby is a registered trademark of Dolby Laboratories Corporation, San Francisco, California.

DOLBY NOISE REDUCTION SYSTEM

NE660

Preliminary

ELECTRICAL CHARACTERISTICS STANDARD CONDITIONS: $V_{CC} = 3V$, frequency range: 20Hz-20kHz, $T_A = 25^\circ C$. All levels referenced to 77.5mV = 0dB at test point (T.P.) in test circuit of Fig. 1.

SYMBOL & PARAMETER	MODE	FREQ. Hz	TEST CONDITIONS	LIMITS			UNIT
				MIN	TYP	MAX	
Supply Voltage Range				1.8	3	7	V
Supply Current	Off		No input signal		6	9	mA
Voltage Gain	Off	1K	$20 \log \frac{V(\text{Pin 2 or 9})}{V(\text{Pin 17 or 14})}$	7.25	8.25	9.25	dB
Signal Handling at Output, Note 1	Off	1K	THD = 1%		20		dB
	R	1K	THD = 1%	18	22		dB
			$V_{CC} = 1.8V$, THD = 1%	12	17		dB
Distortion, Note 4	Off	1K	0dB		.02	.1	%
Distortion + Noise			+ 12dB		.03	.15	%
Distortion, Note 4	R	1K	0dB		.03	.25	%
Distortion + Noise			+ 12dB		.04	.2	%
Signal to Noise Ratio, Note 2	R		CCIR/ARM	64	69		dB
	P				80		dB
Frequency Response, Note 3	R	1K	T.P. Level = 0dB	- 1	0	+ 1	dB
		10K		- 1	+ .3	+ 1.5	dB
		2K	T.P. Level = - 25dB	- 19.5	- 18	- 16.5	dB
		10K	T.P. Level = - 30dB	- 25	- 23.5	- 22	dB
		5K	T.P. Level = - 40dB	- 30.2	- 29.7	- 28.7	dB
Channel to Channel Unbalance	R	2K	T.P. Level = - 20dB		.2	1.3	dB
Channel to Channel Crosstalk	R	2K	0dB in Channel "A"	50			dB
Ripple Rejection	R	50			48		dB
Input Resistance			No input termination	35	50	65	kOhm
Switching Thresholds (Relative to Voltage on Pin 15)	Off		Voltage at Pin 6			+ .5	V
	R				+ .8		V
	P					- .8	V
Maximum Frequency Response Shift vs. Temperature (Relative to $T_A = 25^\circ C$)	R	20Hz to 20K	$- 20 \leq T_A \leq 70^\circ C$		± 1		dB
Maximum Frequency Response Shift vs. Supply Voltage (Relative to $V_{CC} = 3V$)	R	2K	T.P. Level = - 20dB $1.8 \leq V_{CC} \leq 7V$		$\pm .2$	$\pm .6$	dB

- NOTES:
- 12dB headroom guaranteed at 1.8V; however, system remains operational to $V_{CC} \approx 1.6V$.
 - See Dolby Laboratories bulletin No. 19.
 - In DC coupled configuration when Pins 12 and 19 are connected to Pin 15, the RECORD curves might read slightly different than in AC coupled mode (Fig. 1). The variation is typically .5dB at the worst case input level/frequency combination. A slight degradation of Channel to Channel Crosstalk will also occur. When device is intended for use in DC coupled configuration, factory test is to be requested accordingly.
 - 0dB distortion is specified with each harmonic measured in a 20Hz B.W. 12dB distortion is specified as the wideband (20Hz-20kHz) measurement of the harmonics plus noise.

Preliminary

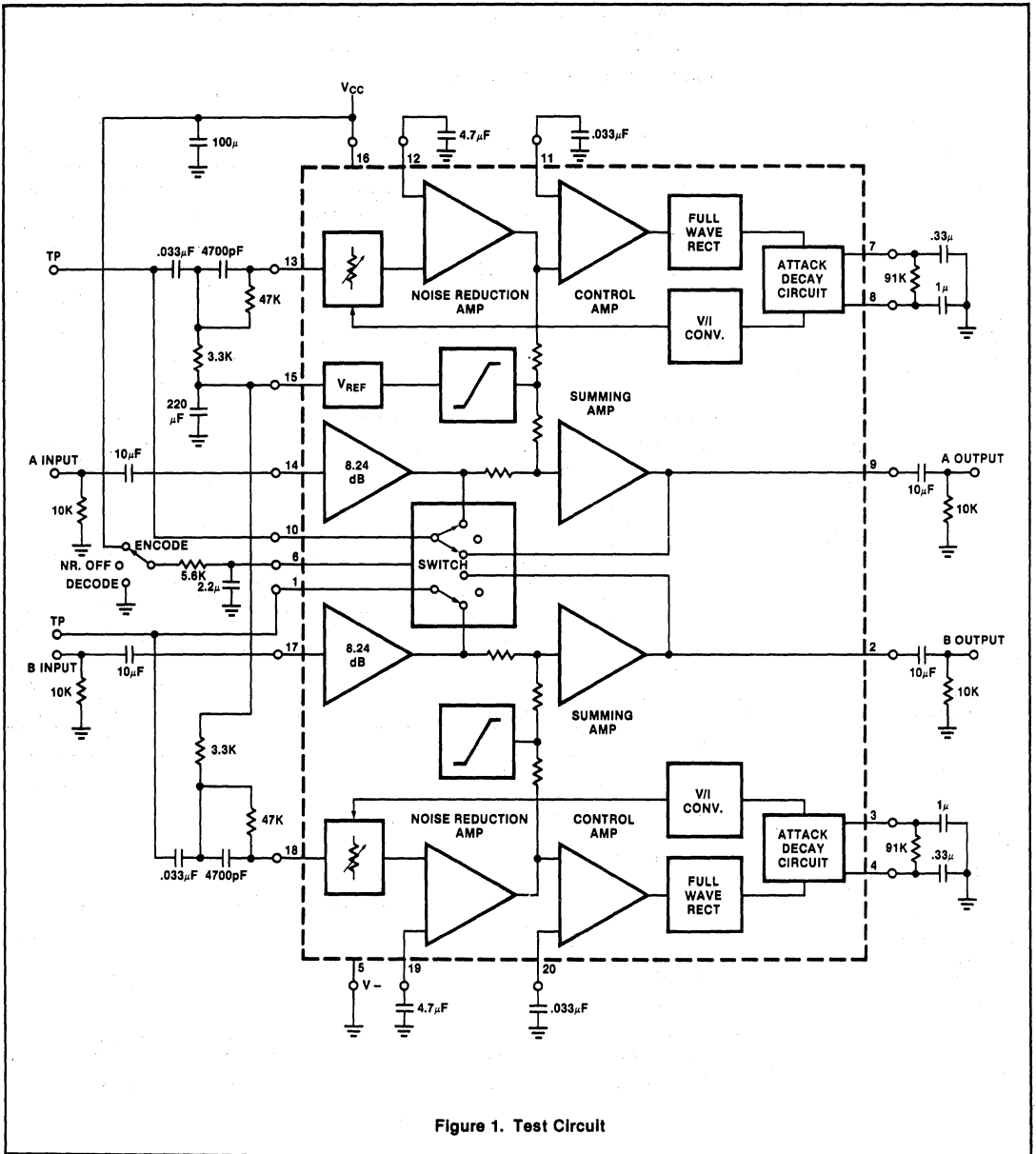
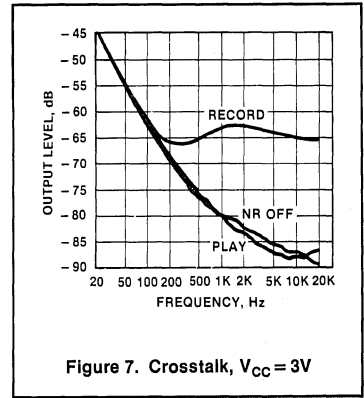
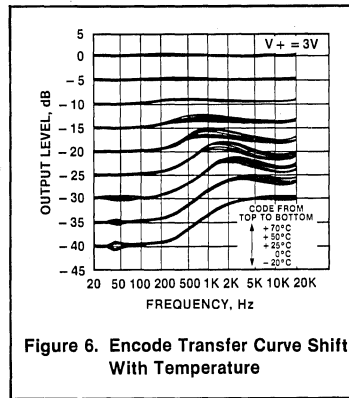
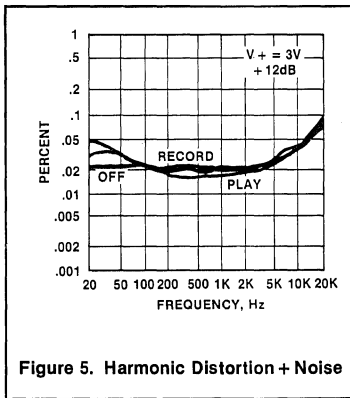
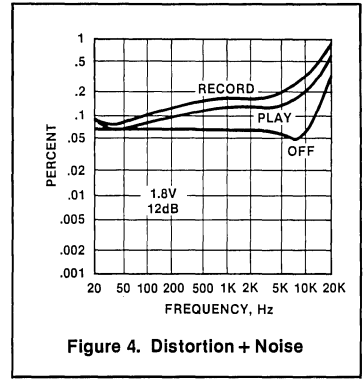
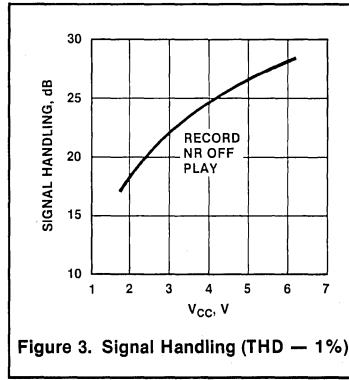
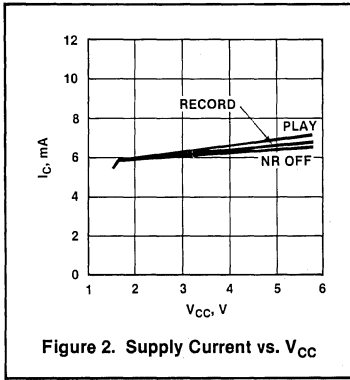

Figure 1. Test Circuit

DOLBY NOISE REDUCTION SYSTEM

NE660

Preliminary



5

GENERAL DESCRIPTION

The TDA1074A is a monolithic integrated circuit designed for use as volume and tone control circuit in stereo amplifiers. This dual tandem potentiometer IC consists of two ganged pairs of electronic potentiometers with the eight inputs connected via impedance converters, and the four outputs driving individual operational amplifiers. The setting of each electronic potentiometer pair is controlled by an individual d.c. control voltage. The potentiometers operate by current division between the arms of cross-coupled long-tailed pairs. The current division factor is determined by the level and polarity of the d.c. control voltage with respect to an externally available reference level of half the supply voltage. Since the electronic potentiometers are adjusted by a d.c. control voltage, each pair can be controlled by single linear potentiometers which can be located in any position dictated by the equipment styling. Since the input and feedback impedances around the operational amplifier gain blocks are external, the TDA1074A can perform bass/treble and volume/loudness control. It also can be used as a low-level fader to control the sound distribution between the front and rear loudspeakers in car radio installations.

Features

- High impedance inputs to both 'ends' of each electronic potentiometer
- Ganged potentiometers track within 0,5 dB
- Electronic rejection of supply ripple
- Internally generated reference level available externally so that the control voltage can be made to swing positively and negatively around a well-defined 0 V level
- The operational amplifiers have push-pull outputs for wide voltage swing and low current consumption
- The operational amplifier outputs are current limited to provide output short-circuit protection
- Although designed to operate from a 20 V supply (giving a maximum input and output signal level of 6 V), the TDA1074A can work from a supply as low as 7,5 V with reduced input and output signal levels

QUICK REFERENCE DATA

Supply voltage (pin 11)	V_P	typ.	20 V
Supply current (pin 11)	I_P	typ.	22 mA
Input signal voltage (r.m.s. value)	$V_{i(rms)}$	max.	6 V
Output signal voltage (r.m.s. value)	$V_{o(rms)}$	max.	6 V
Total harmonic distortion	THD	typ.	0,05 %
Output noise voltage (r.m.s. value)	$V_{no(rms)}$	typ.	50 μ V
Control range	$\Delta\alpha$	typ.	110 dB
Cross-talk attenuation (L/R)	α_{ct}	typ.	80 dB
Ripple rejection (100 Hz)	α_{100}	typ.	46 dB
Tracking of ganged potentiometers	ΔG_V	typ.	0.5 dB

Supply voltage range	V_P		7.5 to 23 V
Operating ambient temperature range	T_{amb}		-30 to + 80 °C

PACKAGE OUTLINE

18-lead DIL; plastic (SOT-102CS).

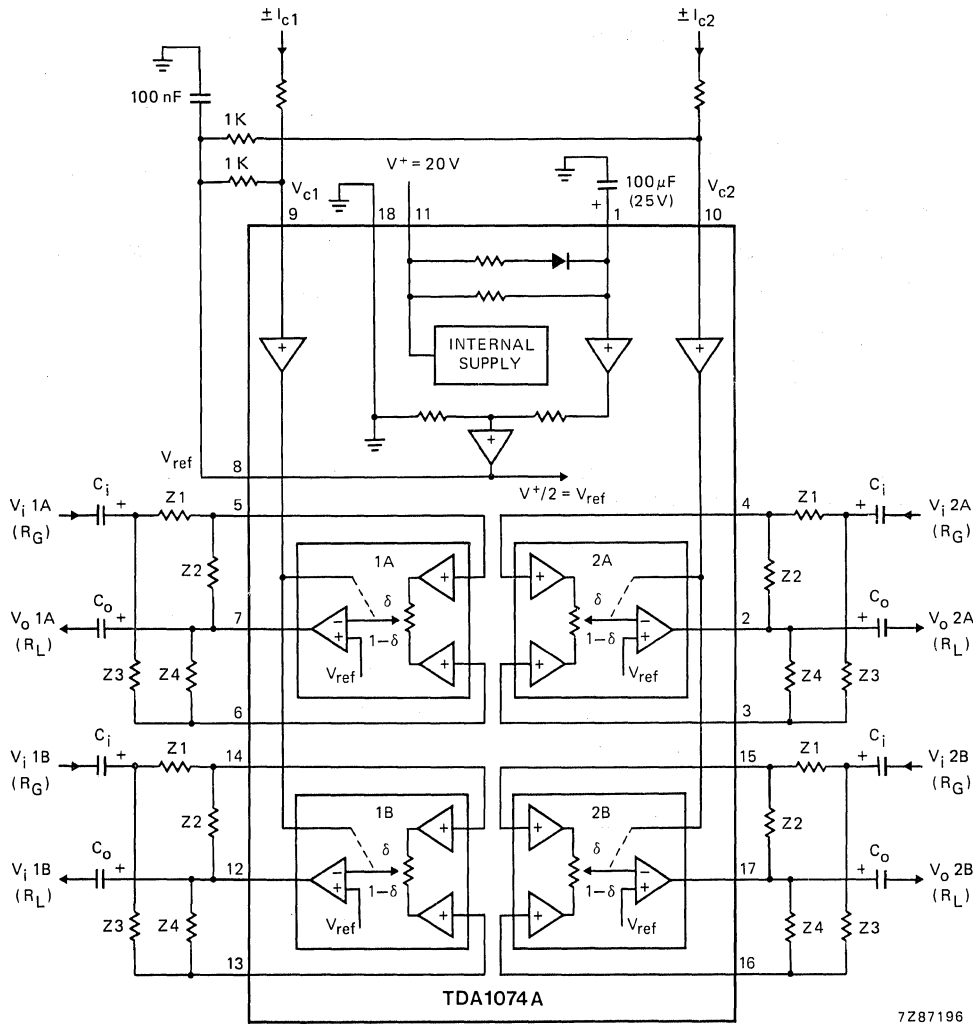

Fig. 1. Block diagram and basic external components; I_{c1} (at pin 9) and I_{c2} (at pin 10) are control input currents; V_{c1} (at pin 9) and V_{c2} (at pin 10) are control input voltages with respect to $V_{ref} = V_p/2$ at pin 8; $Z_1 = Z_2 = Z_3 = Z_4 = 22 \text{ k}\Omega$; the input generator resistance $R_G = 60 \text{ }\Omega$; the output load resistance $R_L = 4.7 \text{ k}\Omega$; the coupling capacitors at the inputs and outputs are $C_i = 2,2 \text{ }\mu\text{F}$ and $C_o = 10 \text{ }\mu\text{F}$ respectively.

RATINGS

Limiting values in accordance with the Absolute Maximum System (IEC 134)

Supply voltage (pin 11)	V_p	max.	23 V
Control voltages (pins 9 and 10)	$\pm V_{c1}; \pm V_{c2}$	max.	1 V
Input voltage ranges (with respect to pin 18) at pins 3, 4, 5, 6, 13, 14, 15, 16	V_i		0 to V_p V
Total power dissipation	P_{tot}	max.	800 mW
Storage temperature range	T_{stg}		-55 to + 150 °C
Operating ambient temperature range	T_{amb}		-30 to + 80 °C

THERMAL RESISTANCE

From crystal to ambient	$R_{th\ cr-a}$	=	80 K/W
-------------------------	----------------	---	--------

REMARK

The difference between the TDA1074 and its successor the TDA1074A is shown in Fig. 2 as the different component configuration at pin 8.

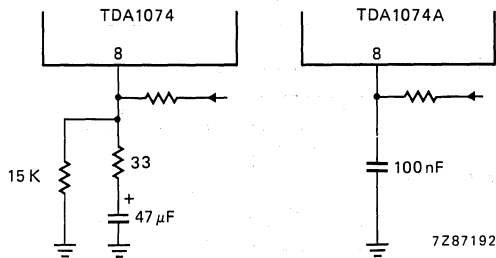

Fig. 2 Component configuration at pin 8 showing the difference between the TDA1074 and the TDA1074A.

DC CONTROLLED DUAL POTENTIOMETERS

TDA1074A

APPLICATION INFORMATION

Treble and bass control circuit

$V_p = 20\text{ V}$; $T_{amb} = 25\text{ }^\circ\text{C}$; measured in Fig. 3; $R_G = 60\text{ }\Omega$; $R_L > 4.7\text{ k}\Omega$; $C_L < 30\text{ pF}$; $f = 1\text{ kHz}$; with a linear frequency response ($V_{c1} = V_{c2} = 0\text{ V}$); unless otherwise specified

parameter	symbol	min.	typ.	max.	unit
Supply current (without load)	I_p	14	22	30	mA
Frequency response (-1 dB) $V_{c1} = V_{c2} = 0\text{ V}$	f	10	—	20 000	Hz
Voltage gain at linear frequency response ($V_{c1} = V_{c2} = 0\text{ V}$)	G_v^*	—	0	—	dB
Gain variation at $f = 1\text{ kHz}$ at maximum bass/treble boost or cut at $\pm V_{c1} = \pm V_{c2} = 120\text{ mV}$	ΔG_v^*	—	± 1	—	dB
Bass boost at 40 Hz (ref. 1 kHz) $V_{c2} = 120\text{ mV}$		—	17.5	—	dB
Bass cut at 40 Hz (ref. 1 kHz) $-V_{c2} = 120\text{ mV}$		—	17.5	—	dB
Treble boost at 16 kHz (ref. 1 kHz) $V_{c1} = 120\text{ mV}$		—	16	—	dB
Treble cut at 16 kHz (ref. 1 kHz) $-V_{c1} = 120\text{ mV}$		—	16	—	dB
Total harmonic distortion at $V_{o(rms)} = 300\text{ mV}$ $f = 1\text{ kHz}$ (measured selectively)	THD	—	0.002	—	%
$f = 20\text{ Hz to } 20\text{ kHz}$	THD	—	0.005	—	%
at $V_{o(rms)} = 5\text{ V}$ $f = 1\text{ kHz}$	THD	—	0.015	0.1	%
$f = 20\text{ Hz to } 20\text{ kHz}$	THD	—	0.05	0.1	%
Signal level at THD = 0.7% (input and output)	$V_{i;o(rms)}$	5.5	6.2	—	V
Power bandwidth at reference level $V_{o(rms)} = 5\text{ V}$ (-3 dB); THD = 0.1%	B	—	40	—	kHz
Output noise voltages signal plus noise (r.m.s. value); $f = 20\text{ Hz to } 20\text{ kHz}$	$V_{no(rms)}$	—	75	—	μV
noise (peak value); weighted to DIN 45 405; CCITT filter	$V_{no(m)}$	—	160	230	μV

* $G_v = V_o/V_i$.

Treble and bass control circuit

parameter	symbol	min.	typ.	max.	unit
Cross-talk attenuation (stereo) f = 1 kHz	α_{ct}	-	86	-	dB
f = 20 Hz to 20 kHz	α_{ct}	-	80	-	dB
Control voltage cross-talk to the outputs at f = 1 kHz; $V_{c1(rms)} = V_{c2(rms)} = 1 \text{ mV}$	$-\alpha_{ct}$	-	20	-	dB
Ripple rejection at f = 100 Hz; $V_P(rms) < 200 \text{ mV}$	α_{100}	-	46	-	dB

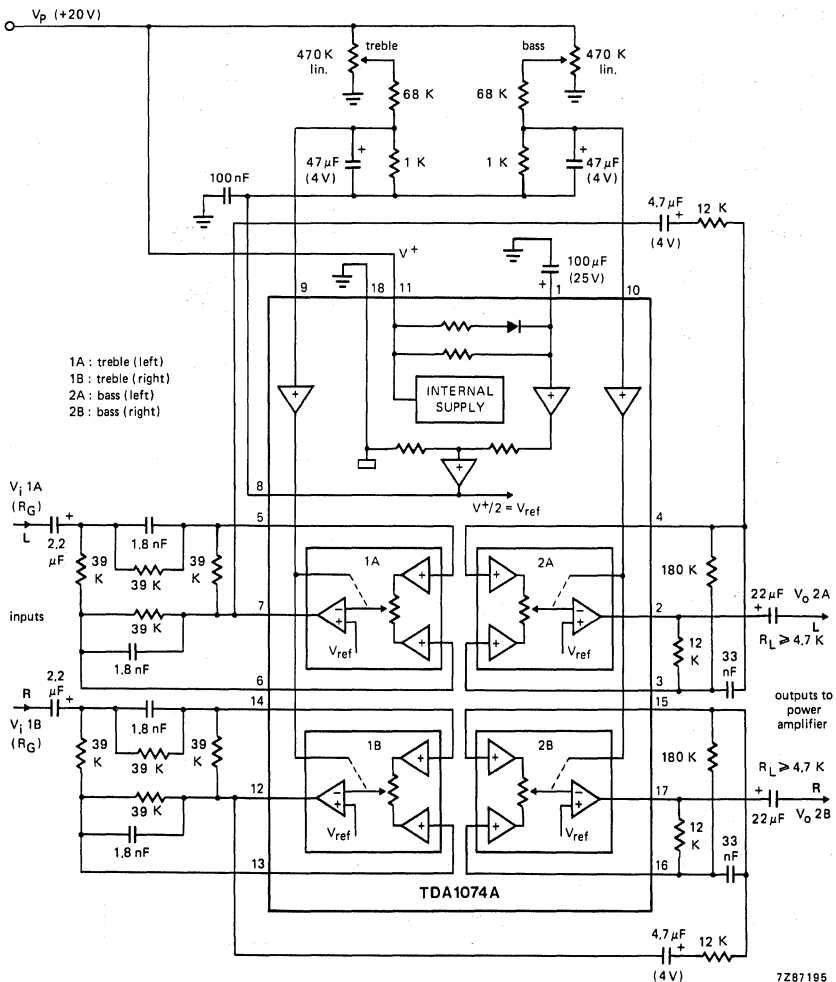

Fig. 3 Application diagram for treble and bass control.

7287195

APPLICATION INFORMATION (continued)

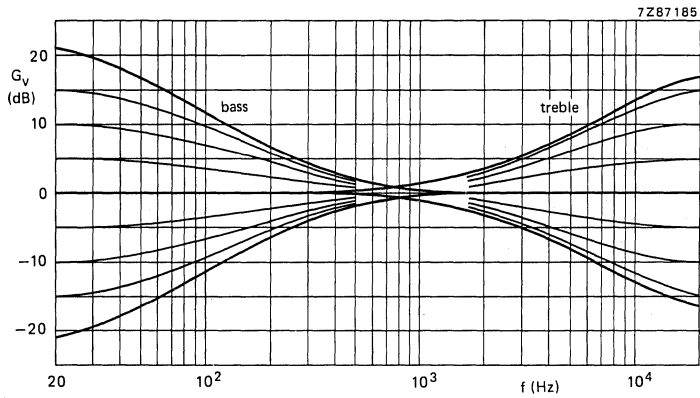

Fig. 4 Frequency response curves; voltage gain (treble and bass) as a function of frequency.

5

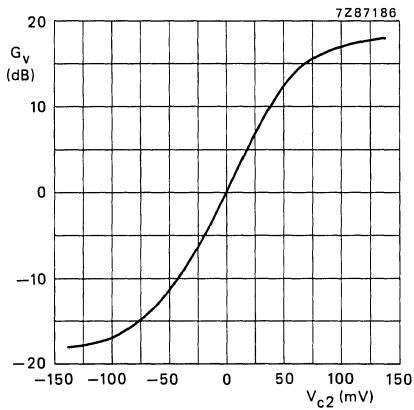

Fig. 5 Control curve; voltage gain (bass) as a function of the control voltage (V_{C2}); $f = 40$ Hz.

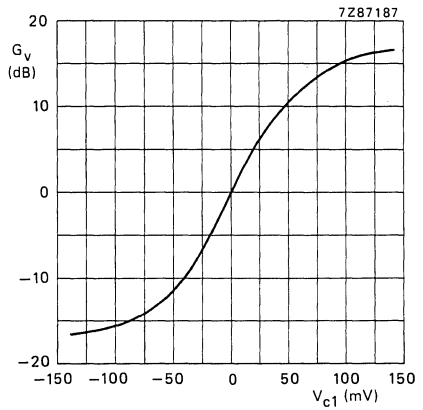
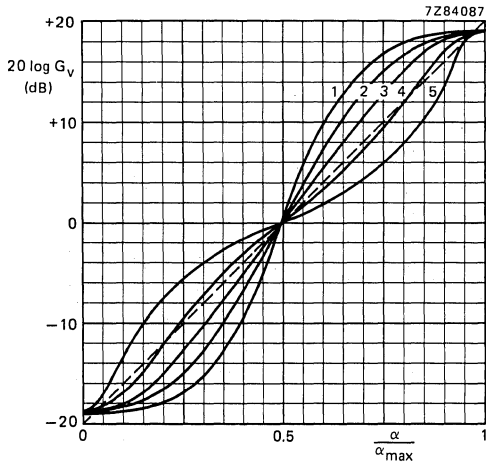

Fig. 6 Control curve; voltage gain (treble) as a function of the control voltage (V_{C1}); $f = 16$ kHz.



curve no.	value of R
1	10 kΩ
2	100 kΩ
3	220 kΩ
4	470 kΩ
5	1 MΩ

Fig. 7 Voltage gain ($G_v = V_o/V_i$) control curves as a function of the angle of rotation (α) of a linear potentiometer (R); for curve numbers see table above; $f = 40 \text{ Hz to } 16 \text{ kHz}$.

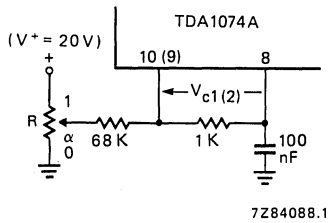

Fig. 8 Circuit diagram for measuring curves in Fig. 7.

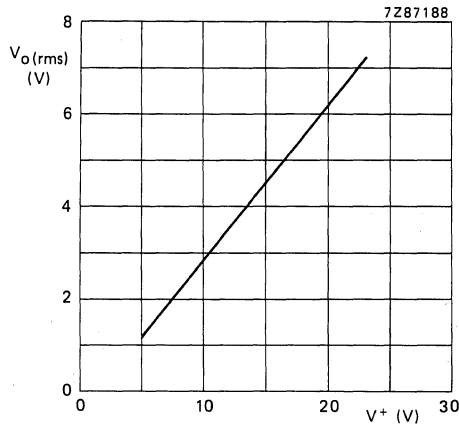

Fig. 9 Output signal level as a function of V_p ; THD = 0.7%; $f = 1 \text{ kHz}$; $V_{c1} = V_{c2} = 0 \text{ V}$.

APPLICATION INFORMATION (continued)

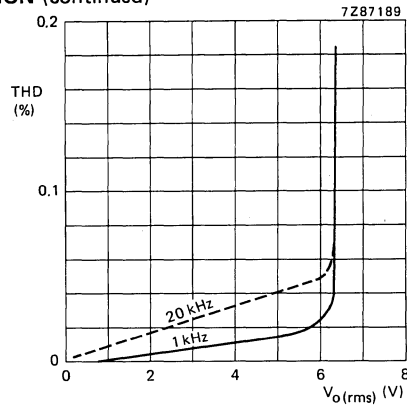

Fig. 10 Total harmonic distortion as a function of the output level; $V_p = 20$ V; $R_L = 4.7$ k Ω ; $V_{c1} = V_{c2} = 0$ V (linear, $G_{Vtot} = 1$). — $f = 1$ kHz; - - - $f = 20$ kHz.

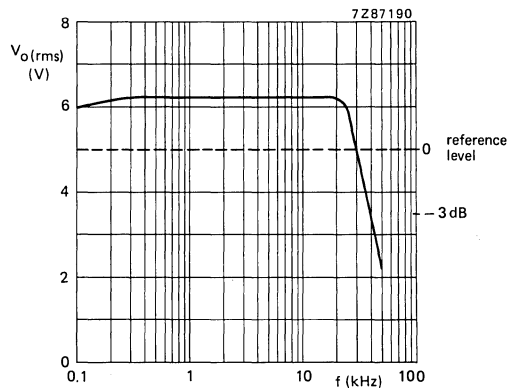

Fig. 11 Power bandwidth at THD = 0.1%; reference level is 5 V (r.m.s.).

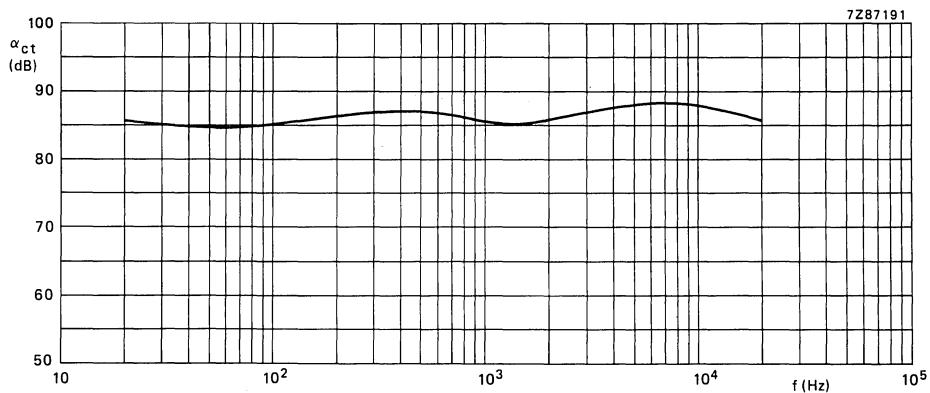
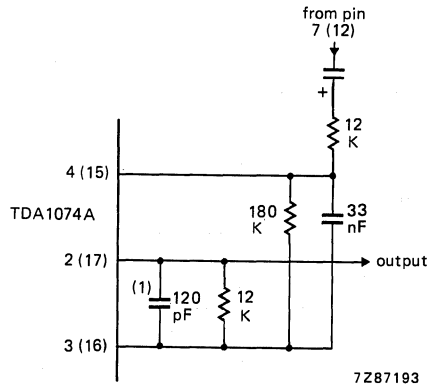

Fig. 12 Cross-talk as a function of frequency; linear treble/bass setting ($V_{c1} = V_{c2} = 0$ V); $V_i = 5$ V; $R_G = 60$ Ω ; $R_L = 4.7$ k Ω .

5

Application recommendations

1. If one or more electronic potentiometers in an IC are not used, the following is recommended:
 - a. Unused signal inputs of an electronic potentiometer should be connected to the associated output, e.g. pins 3 and 4 to pin 2.
 - b. Unused control voltage inputs should be connected directly to pin 8 (V_{ref}).
2. Where more than one TDA1074A IC are used in an application, pins 1 can be connected together; however, pins 8 (V_{ref}) may not be connected together directly.
3. Additional circuitry for limiting the frequency response in the ultrasonic range.



(1) $f_{-3\text{dB}} = 110 \text{ kHz}$ at linear setting

Fig. 13 Circuit diagram for frequency response limiting.

4. Alternative circuitry for limiting the gain of the treble control circuit in the ultrasonic range.

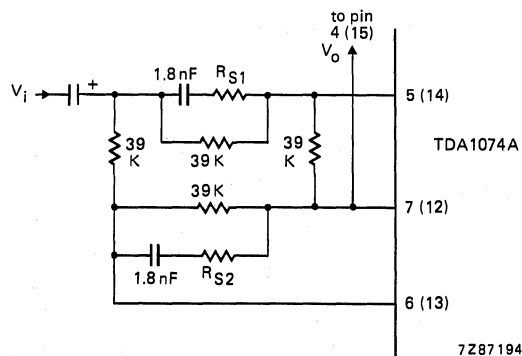

For $R_{S1} = R_{S2} = 3.3 \text{ k}\Omega$; $f_{-3\text{dB}} \cong 1 \text{ MHz}$ at linear setting
 For $R_{S1} = R_{S2} = 0 \Omega$; $f_{-3\text{dB}} \cong 100 \text{ kHz}$ at linear setting

Fig. 14 Circuit diagram for limiting gain of treble control circuit.

CASSETTE PREAMPLIFIER**TDA1522****GENERAL DESCRIPTION**

The TDA1522 is a playback amplifier for car radio/cassette players.

Features

- Two independent amplifiers with open loop gain of typ. 90 dB
- Internal d.c. feedback via a 140 k Ω resistor from output to feedback point
- A.C. characteristics that can be determined externally by an RC network
- Electronic on/off switching with transient suppression for switch on
- Head input at d.c. ground that eliminates the input coupling capacitor
- Minimal external component requirement
- Stability down to a gain of 30 dB
- Low input noise
- Low distortion
- D.C. input current < 2 μ A
- Wide supply voltage range

QUICK REFERENCE DATA

Supply voltage range (pin 8)	V _p	7.5 to 23 V
Supply current (pin 8)	I _p	typ. 5 mA
Operating ambient temperature range	T _{amb}	-30 to +85 °C
Total harmonic distortion	THD	typ. 0.05 %
Channel separation at R _S = 10 k Ω ; L _S = 0	α	min. 45 dB

5**PACKAGE OUTLINE**

9-lead SIL; plastic (SOT-142).

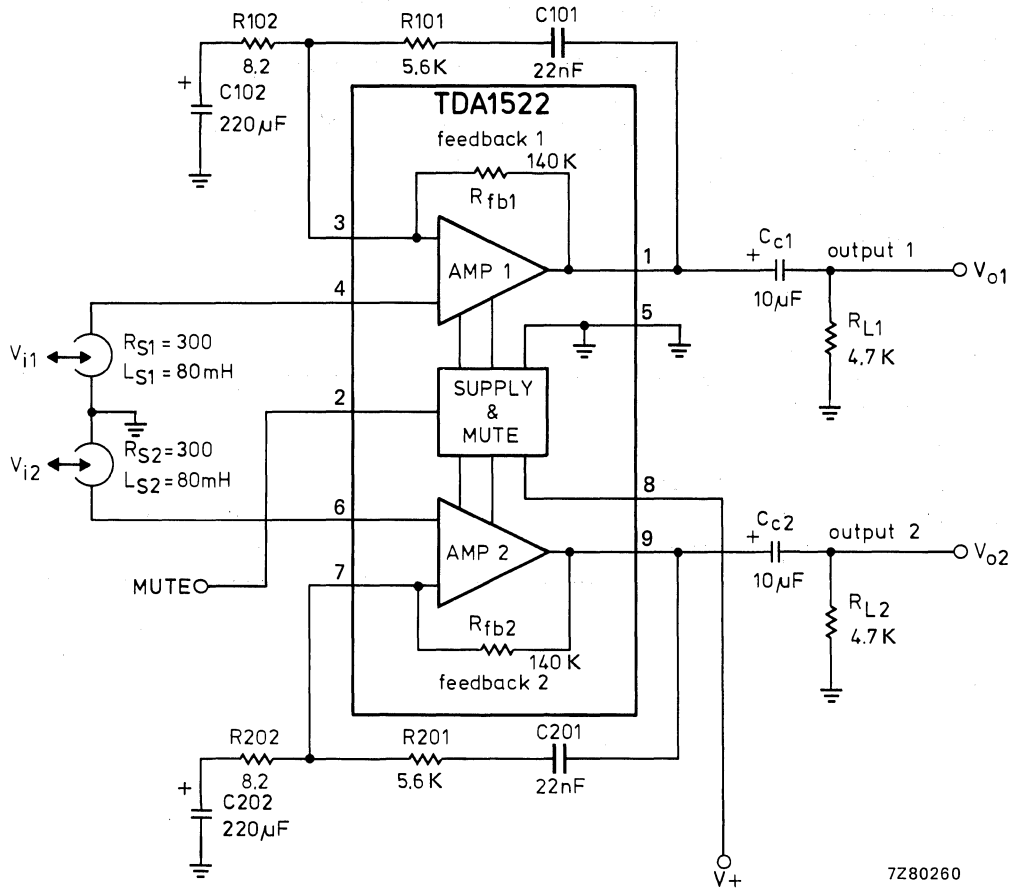

7280260

Fig. 1 Block diagram with external components; also used as test circuit.

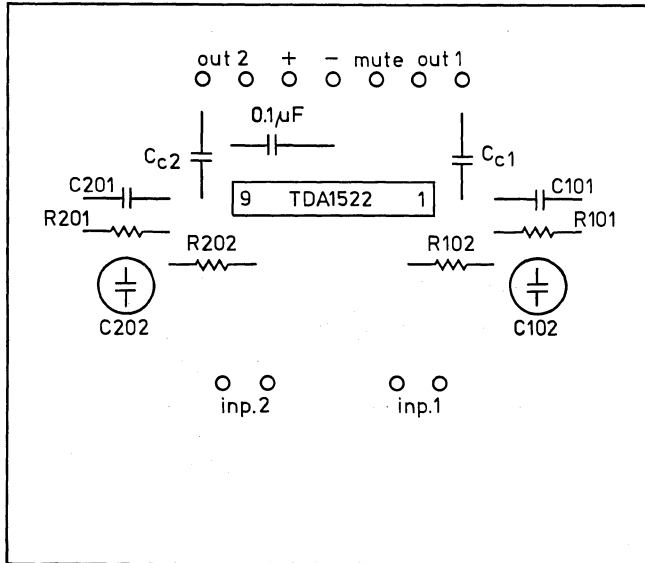

7280266

Fig. 2 Printed-circuit board component side, showing component layout for circuit of Figure 1.

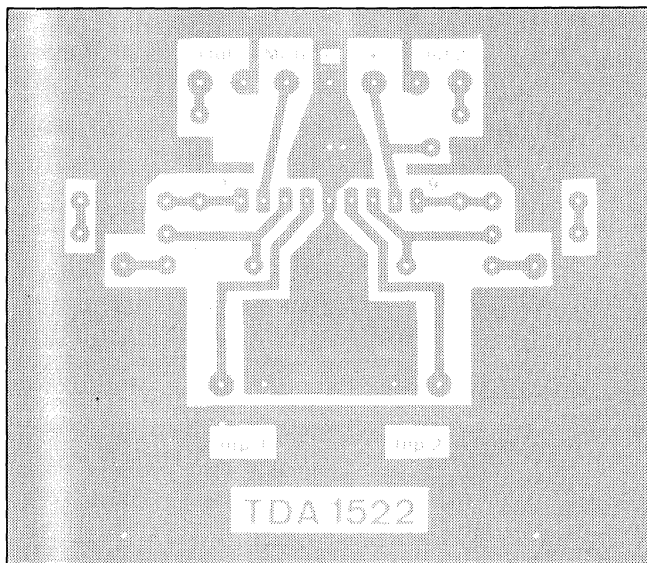

7280265

Fig. 3 Printed-circuit board, showing track side. Dimensions 75 mm x 65 mm.

CASSETTE PREAMPLIFIER

TDA1522

RATINGS

Limiting values in accordance with the Absolute Maximum System (IEC 134)

Supply voltage range (pin 8)	V_p	7.5 to 23 V
Power dissipation	P_{tot}	max. 800 mW
Feedback current (pins 3 and 7)	I_{fb}	max. 10 mA
Storage temperature range	T_{stg}	-55 to +150 °C
Operating ambient temperature range	T_{amb}	-30 to +85 °C

Note

All pins except 3 and 7 (feedback) can be connected to V_p (pin 8) or ground, (pin 5).

CHARACTERISTICS

 $V_p = 8.5$ V; $T_{amb} = 25$ °C; test circuit Fig. 1 unless otherwise specified

parameter	symbol	min.	typ.	max.	unit
Supply (pin 8)					
Supply voltage range	V_p	7.5	—	23	V
Supply current	I_p	—	5	—	mA
Inputs (pin 4 or 6)					
Noise input voltage (unweighted; r.m.s. value) at $f = 20$ Hz to 20 kHz*	$V_{n(rms)}$	—	1.6	—	μ V
Noise input voltage at $R_S = 0$; $f = 1$ kHz*, **	V_n	—	5	—	nV/\sqrt{Hz}
Noise input current at $f = 1$ kHz*, ▲	I_n	—	1.2	—	pA/\sqrt{Hz}
D.C. input current at pins 4 and 6	$-I_4; -I_6$	—	—	2	μ A
Outputs (pin 1 or 9)					
Output voltage at $V_i = 0.3$ mV; $f = 315$ Hz	V_o	—	0.72	—	V
at THD= 1%; $f = 1$ kHz	V_o	1.0	—	—	V
Output source current at $V_{2.5} \geq 7.5$ V; mute OFF	$-I_o$	5	10	—	mA
D.C. output voltage	V_o	—	3.7	—	V
Noise output voltage (weighted) at $R_S = 300 \Omega$; $L_S = 80$ mH as DIN A (r.m.s. value)	$V_{n(rms)}$	—	700	—	μ V
as CCITT (peak value)	$V_{n(m)}$	—	1200	—	μ V
as CCIR (peak value)	$V_{n(m)}$	—	1600	—	μ V
Noise output voltage (unweighted) at $R_S = 300 \Omega$; $L_S = 80$ mH as DIN 45405 (peak value)	$V_{n(m)}$	—	1800	—	μ V

* Measured in Fig. 4. ** See also Fig. 6. ▲ See also Fig. 7.

CASSETTE PREAMPLIFIER

TDA1522

parameter	symbol	min.	typ.	max.	unit
Mute on/off characteristics (pin 2)*					
Mute ON voltage at mute switch closed	V_m	0	—	1	V
Mute ON current at mute switch closed or $V_{2.5} = 0$ V	I_m	—	2.7	—	μA
Mute OFF voltage at mute switch open	V_m	7.5	—	V_p	V
Impedance					
Input impedance** at $f = 1$ kHz	$ Z_i $	200	—	—	$k\Omega$
Output impedance** at $f = 1$ kHz	$ Z_o $	—	—	1	$k\Omega$
General					
Internal feedback resistor**	R_{fb}	100	140	180	$k\Omega$
Open-loop voltage gain** at $f = 315$ Hz	G_v	—	90	—	dB
Channel separation at $R_S = 10$ $k\Omega$; $L_S = 0$; (note 1)	α	45	—	—	dB
Power supply ripple rejection at $V_{p(rms)} = 0.1$ V; $f = 100$ Hz (note 2)	RR	90	95	—	dB
Total harmonic distortion at $f = 1$ kHz; $V_o = 0.72$ V (note 3)	THD	—	0.05	—	%

Notes

1. Frequency range 300 Hz to 20 kHz.
2. Referred to the input.
3. Measured selective.

* See also Fig. 5.

** Applies to each amplifier.

5

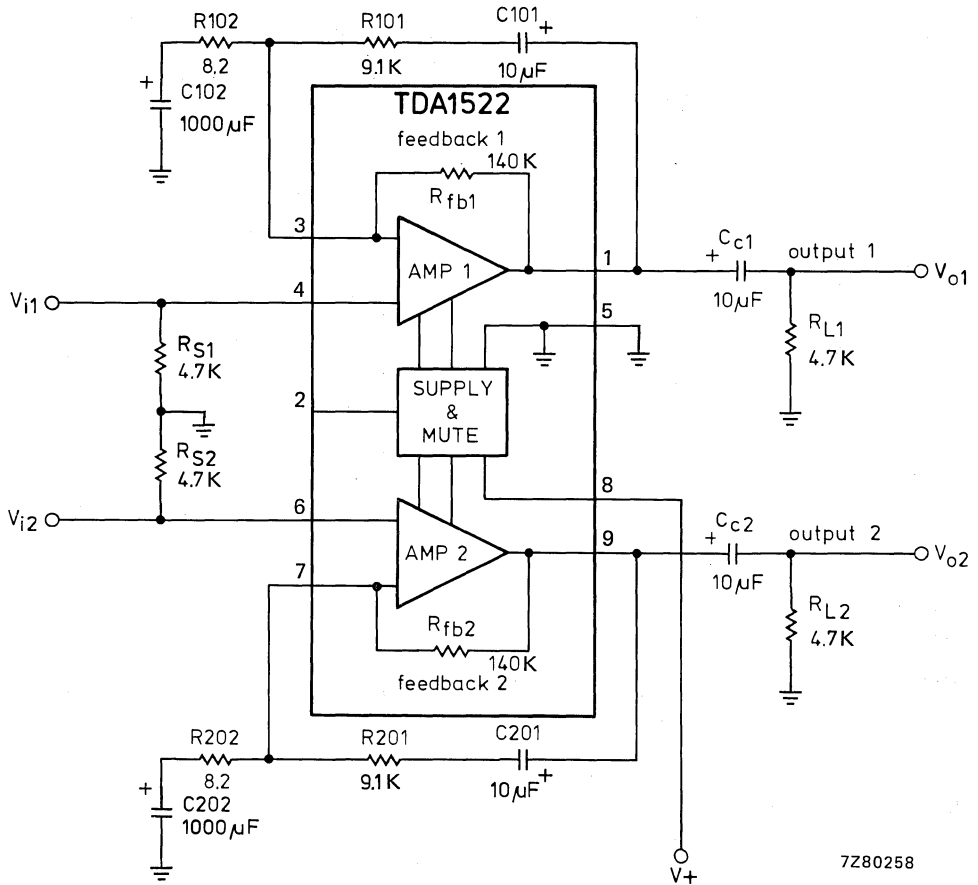

7Z80258

Fig. 4 Test circuit for noise measurement.

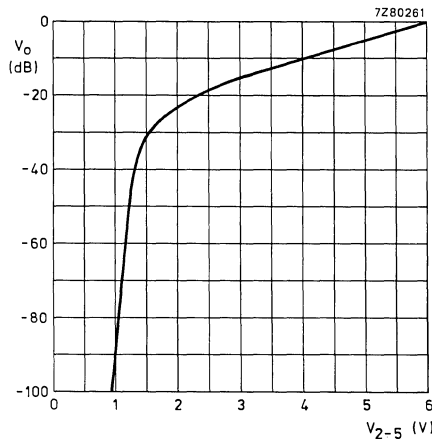

Fig. 5 Muting depth as a function of control voltage at pin 2.

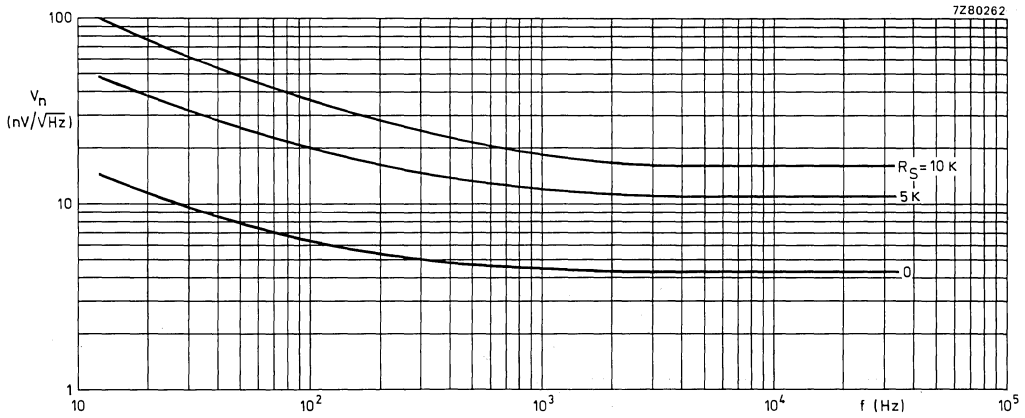

Fig. 6 Noise input voltage as a function of frequency.

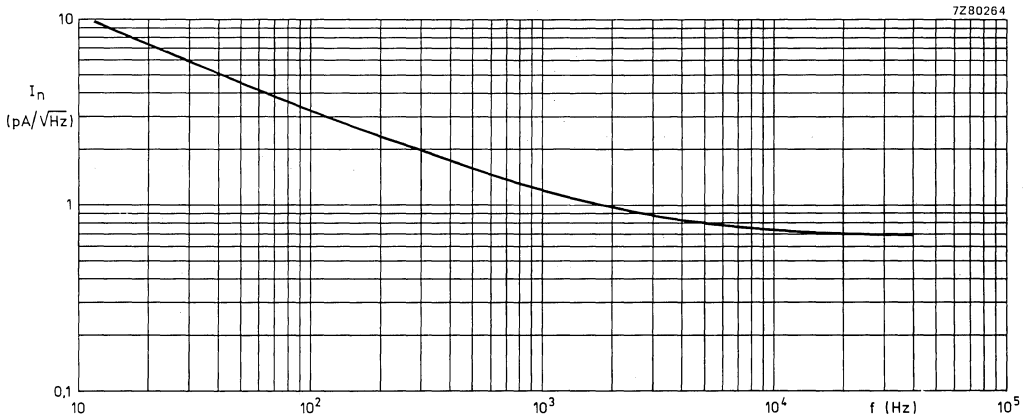

Fig. 7 Noise input current as a function of frequency.

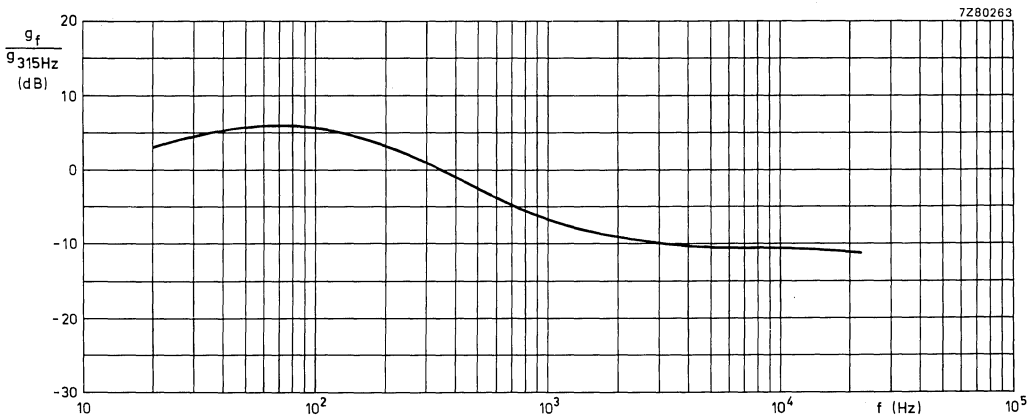
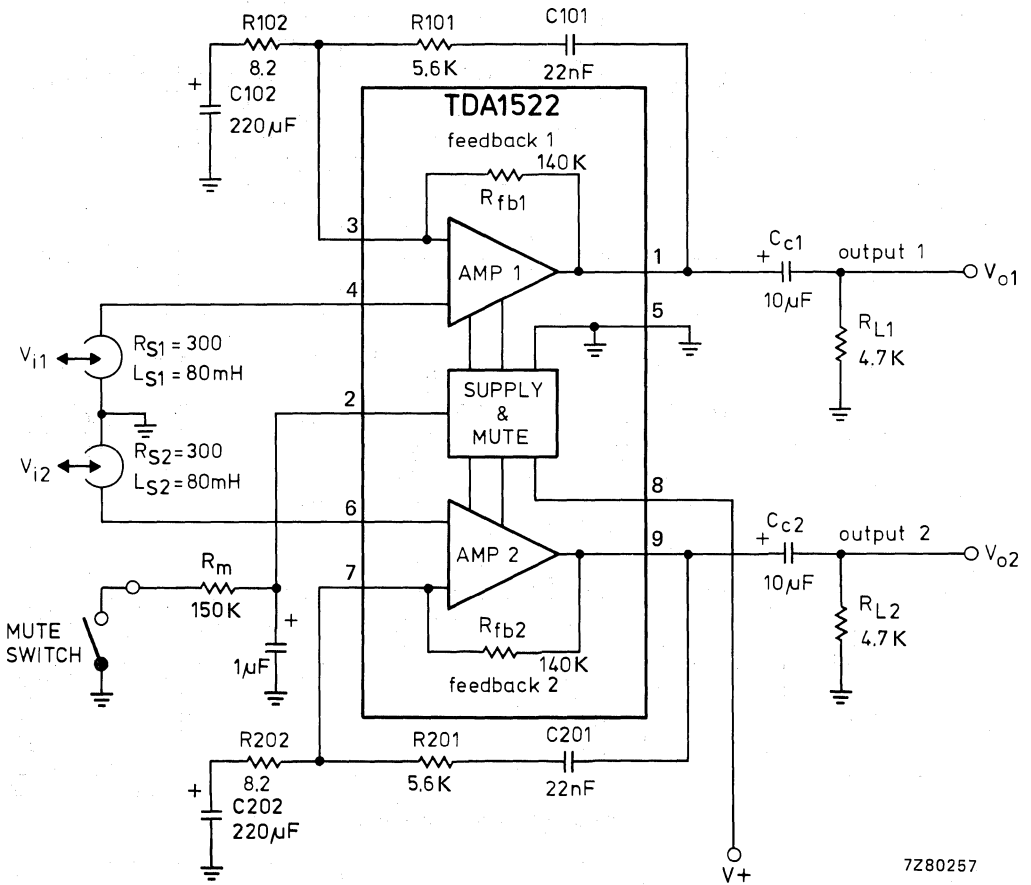

Fig. 8 Frequency response curve for the circuit in Figure 1.

5

APPLICATION INFORMATION



7Z80257

Fig. 9 Simple mute application.

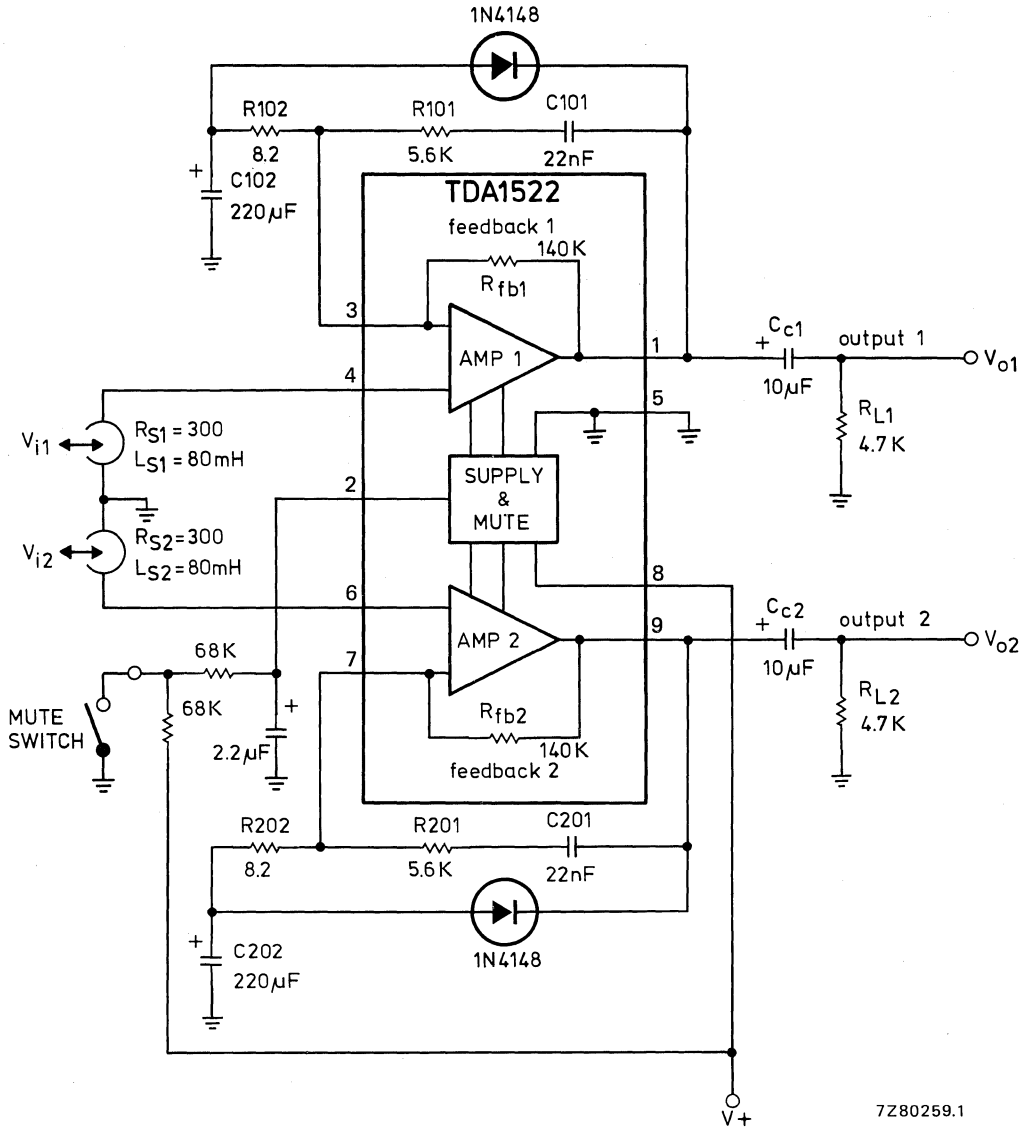

Fig. 10 Application for plop-free muting.

5

GENERAL DESCRIPTION

The device is designed as an active stereo-tone/volume control for car radios, TV receivers and mains-fed equipment. It includes functions for bass and treble control, volume control with built-in contour (can be switched off) and balance. All these functions can be controlled by d.c. voltages or by single linear potentiometers.

Features

- Few external components necessary
- Low noise due to internal gain
- Bass emphasis can be increased by a double-pole low-pass filter
- Wide power supply voltage range

QUICK REFERENCE DATA

Supply voltage (pin 3)	$V_P = V_{3-18}$	typ.	12 V
Supply current (pin 3)	$I_P = I_3$	typ.	35 mA
Maximum input signal with d.c. feedback (r.m.s. value)	$V_{i(rms)}$	typ.	2.5 V
Maximum output signal with d.c. feedback (r.m.s. value)	$V_{o(rms)}$	typ.	3 V
Volume control range	G_V		-80 to +21.5 dB
Bass control range at 40 Hz	ΔG_V	typ.	± 15 dB
Treble control range at 16 kHz	ΔG_V	typ.	± 15 dB
Total harmonic distortion	THD	typ.	0.3 %
Output noise voltage (unweighted; r.m.s. value) at $f = 20$ Hz to 20 kHz; $V_P = 12$ V; for max. voltage gain	$V_{no(rms)}$	typ.	310 μ V
for voltage gain $G_V = -40$ dB	$V_{no(rms)}$	typ.	100 μ V
Channel separation at $G_V = -20$ to +21.5 dB	α_{cs}	typ.	60 dB
Tracking between channels at $G_V = -20$ to +26 dB	ΔG_V	max.	2.5 dB
Ripple rejection at 100 Hz	RR	typ.	50 dB
Supply voltage range (pin 3)	$V_P = V_{3-18}$		7.5 to 16.5 V
Operating ambient temperature range	T_{amb}		-30 to +80 °C

PACKAGE OUTLINE

18-lead DIL; plastic (SOT-102CS).

STEREO AUDIO CONTROL

TDA1524A

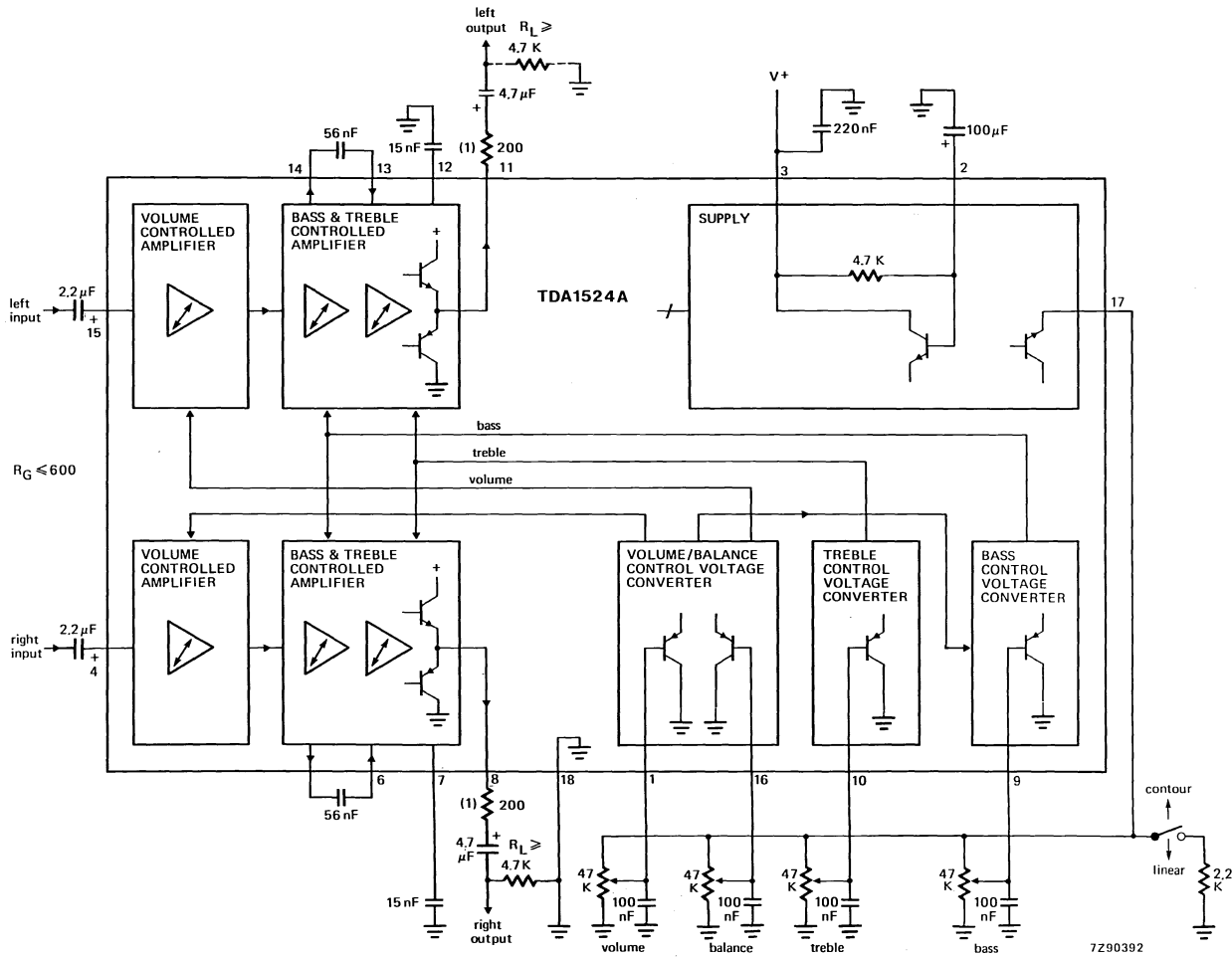

(1) Series resistor is recommended in the event of the capacitive loads exceeding 200 pF.

Fig. 1 Block diagram and application circuit with single-pole filter.



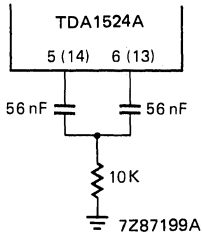

Fig. 2 Double-pole low-pass filter for improved bass-boost.

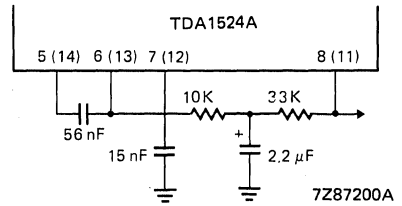

Fig. 3 D.C. feedback with filter network for improved signal handling.

RATINGS

Limiting values in accordance with the Absolute Maximum System (IEC 134)

Supply voltage (pin 3)	$V_P = V_{3-18}$	max.	20 V
Total power dissipation	P_{tot}	max.	1200 mW
Storage temperature range	T_{stg}		-55 to + 150 °C
Operating ambient temperature range	T_{amb}		-30 to + 80 °C

STEREO AUDIO CONTROL

TDA1524A

D.C. CHARACTERISTICS

$V_P = V_{3-18} = 12\text{ V}$; $T_{\text{amb}} = 25\text{ }^\circ\text{C}$; measured in Fig. 1; $R_G \leq 600\text{ }\Omega$; $R_L \geq 4.7\text{ k}\Omega$; $C_L \leq 200\text{ pF}$;
unless otherwise specified

parameter	symbol	min.	typ.	max.	unit
Supply (pin 3)					
Supply voltage	$V_P = V_{3-18}$	7.5	—	16.5	V
Supply current					
at $V_P = 8.5\text{ V}$	$I_P = I_3$	19	27	35	mA
at $V_P = 12\text{ V}$	$I_P = I_3$	25	35	45	mA
at $V_P = 15\text{ V}$	$I_P = I_3$	30	43	56	mA
D.C. input levels (pins 4 and 15)					
at $V_P = 8.5\text{ V}$	$V_{4,15-18}$	3.8	4.25	4.7	V
at $V_P = 12\text{ V}$	$V_{4,15-18}$	5.3	5.9	6.6	V
at $V_P = 15\text{ V}$	$V_{4,15-18}$	6.5	7.3	8.2	V
D.C. output levels (pins 8 and 11) under all control voltage conditions with d.c. feedback (Fig. 3)					
at $V_P = 8.5\text{ V}$	$V_{8,11-18}$	3.3	4.25	5.2	V
at $V_P = 12\text{ V}$	$V_{8,11-18}$	4.6	6.0	7.4	V
at $V_P = 15\text{ V}$	$V_{8,11-18}$	5.7	7.5	9.3	V
Pin 17					
Internal potentiometer supply voltage at $V_P = 8.5\text{ V}$	V_{17-18}	3.5	3.75	4.0	V
Contour on/off switch (control by I_{17})					
contour (switch open)	$-I_{17}$	—	—	0.5	mA
linear (switch closed)	$-I_{17}$	1.5	—	10	mA
Application without internal potentiometer supply voltage at $V_P \geq 10.8\text{ V}$ (contour cannot be switched off)					
Voltage range forced to pin 17	V_{17-18}	4.5	—	$V_P/2 - V_{BE}$	V
D.C. control voltage range for volume, bass, treble and balance (pins 1, 9, 10 and 16 respectively)					
at $V_{17-18} = 5\text{ V}$	$V_{1,9,10,16}$	1.0	—	4.25	V
using internal supply	$V_{1,9,10,16}$	0.25	—	3.8	V
Input current of control inputs (pins 1, 9, 10 and 16)	$-I_{1,9,10,16}$	—	—	5	μA

A.C. CHARACTERISTICS

$V_P = V_{3-18} = 8.5 \text{ V}$; $T_{\text{amb}} = 25 \text{ }^\circ\text{C}$; measured in Fig. 1; contour switch closed (linear position); volume, balance, bass, and treble controls in mid-position; $R_G \leq 600 \text{ } \Omega$; $R_L \geq 4.7 \text{ k}\Omega$; $C_L \leq 200 \text{ pF}$; $f = 1 \text{ kHz}$; unless otherwise specified

parameter	symbol	min.	typ.	max.	unit
Control range					
Max. gain of volume (Fig. 5)	$G_V \text{ max}$	20.5	21.5	23	dB
Volume control range; $G_V \text{ max}/G_V \text{ min}$	ΔG_V	90	100	—	dB
Balance control range; $G_V = 0 \text{ dB}$ (Fig. 6)	ΔG_V	—	-40	—	dB
Bass control range at 40 Hz (Fig. 7)	ΔG_V	± 12	± 15	—	dB
Treble control range at 16 kHz (Fig. 8)	ΔG_V	± 12	± 15	—	dB
Contour characteristics		see Figs 9 and 10			
Signal inputs, outputs					
Input resistance; pins 4 and 15 (note 1) at gain of volume control: $G_V = 20 \text{ dB}$ $G_V = -40 \text{ dB}$	$R_{i4,15}$ $R_{i4,15}$	10 —	— 160	— —	$\text{k}\Omega$ $\text{k}\Omega$
Output resistance (pins 8 and 11)	$R_{o8,11}$	—	—	300	Ω
Signal processing					
Power supply ripple rejection at $V_{P(\text{rms})} \leq 200 \text{ mV}$; $f = 100 \text{ Hz}$; $G_V = 0 \text{ dB}$	RR	35	50	—	dB
Channel separation (250 Hz to 10 kHz) at $G_V = -20 \text{ to } +21.5 \text{ dB}$	α_{cs}	46	60	—	dB
Spread of volume control with constant control voltage $V_{1-18} = 0.5 V_{17-18}$	ΔG_V	—	—	± 3	dB
Gain tolerance between left and right channel $V_{16-18} = V_{1-18} = 0.5 V_{17-18}$	$\Delta G_{V,L-R}$	—	—	1.5	dB
Tracking between channels for $G_V = 21.5 \text{ to } -26 \text{ dB}$ $f = 250 \text{ Hz to } 6.3 \text{ kHz}$; balance adjusted at $G_V = 10 \text{ dB}$	ΔG_V	—	—	2.5	dB

A.C. CHARACTERISTICS (continued)

parameter	symbol	min.	typ.	max.	unit
Signal handling with d.c. feedback (Fig. 3)					
Input signal handling					
at $V_P = 8.5$ V; THD = 0.5%; f = 1 kHz (r.m.s. value)	$V_{i(rms)}$	1.4	—	—	V
at $V_P = 8.5$ V; THD = 0.7%; f = 1 kHz (r.m.s. value)	$V_{i(rms)}$	1.8	2.4	—	V
at $V_P = 12$ V; THD = 0.5%; f = 40 Hz to 16 kHz (r.m.s. value)	$V_{i(rms)}$	1.4	—	—	V
at $V_P = 12$ V; THD = 0.7%; f = 40 Hz to 16 kHz (r.m.s. value)	$V_{i(rms)}$	2.0	3.2	—	V
at $V_P = 15$ V; THD = 0.5%; f = 40 Hz to 16 kHz (r.m.s. value)	$V_{i(rms)}$	1.4	—	—	V
at $V_P = 15$ V; THD = 0.7%; f = 40 Hz to 16 kHz (r.m.s. value)	$V_{i(rms)}$	2.0	3.2	—	V
Output signal handling (note 2 and note 3)					
at $V_P = 8.5$ V; THD = 0.5%; f = 1 kHz (r.m.s. value)	$V_{o(rms)}$	1.8	2.0	—	V
at $V_P = 8.5$ V; THD = 10%; f = 1 kHz (r.m.s. value)	$V_{o(rms)}$	—	2.2	—	V
at $V_P = 12$ V; THD = 0.5%; f = 40 Hz to 16 kHz (r.m.s. value)	$V_{o(rms)}$	2.5	3.0	—	V
at $V_P = 15$ V; THD = 0.5%; f = 40 Hz to 16 kHz (r.m.s. value)	$V_{o(rms)}$	—	3.5	—	V
Noise performance ($V_P = 8.5$ V)					
Output noise voltage (unweighted; Fig. 15)					
at f = 20 Hz to 20 kHz (r.m.s. value) for maximum voltage gain (note 4)	$V_{no(rms)}$	—	260	—	μ V
for $G_V = -3$ dB (note 4)	$V_{no(rms)}$	—	70	140	μ V
Output noise voltage; weighted as DIN 45405 of 1981, CCIR recommendation 468-2 (peak value)					
for maximum voltage gain (note 4)	$V_{no(m)}$	—	890	—	μ V
for maximum emphasis of bass and treble (contour off; $G_V = -40$ dB)	$V_{no(m)}$	—	360	—	μ V
Noise performance ($V_P = 12$ V)					
Output noise voltage (unweighted; Fig. 15)					
at f = 20 Hz to 20 kHz (r.m.s. value; note 5) for maximum voltage gain (note 4)	$V_{no(rms)}$	—	310	—	μ V
for $G_V = -16$ dB (note 4)	$V_{no(rms)}$	—	100	200	μ V
Output noise voltage; weighted as DIN 45405 of 1981, CCIR recommendation 468-2 (peak value)					
for maximum voltage gain (note 4)	$V_{no(m)}$	—	940	—	μ V
for maximum emphasis of bass and treble (contour off; $G_V = -40$ dB)	$V_{no(m)}$	—	400	—	μ V

parameter	symbol	min.	typ.	max.	unit
Noise performance ($V_P = 15\text{ V}$)					
Output noise voltage (unweighted; Fig. 15) at $f = 20\text{ Hz}$ to 20 kHz (r.m.s. value; note 5) for maximum voltage gain (note 4)	$V_{no(rms)}$	—	350	—	μV
for $G_V = 16\text{ dB}$ (note 4)	$V_{no(rms)}$	—	110	220	μV
Output noise voltage; weighted as DIN 45405 of 1981, CCIR recommendation 468-2 (peak value) for maximum voltage gain (note 4)	$V_{no(m)}$	—	980	—	μV
for maximum emphasis of bass and treble (contour off; $G_V = -40\text{ dB}$)	$V_{no(m)}$	—	420	—	μV

Notes to characteristics

- Equation for input resistance (see also Fig. 4)

$$R_i = \frac{160\text{ k}\Omega}{1 + G_V}; G_V \text{ max} = 12.$$

- Frequencies below 200 Hz and above 5 kHz have reduced voltage swing, the reduction at 40 Hz and at 16 kHz is 30%.
- In the event of bass boosting the output signal handling is reduced. The reduction is 1 dB for maximum bass boost.
- Linear frequency response.
- For peak values add 4,5 dB to r.m.s. values.

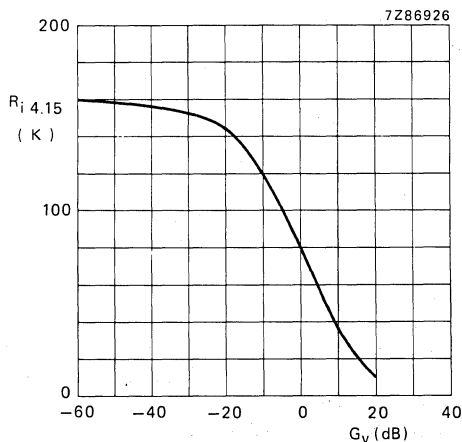

Fig. 4 Input resistance (R_i) as a function of gain of volume control (G_V). Measured in Fig. 1.

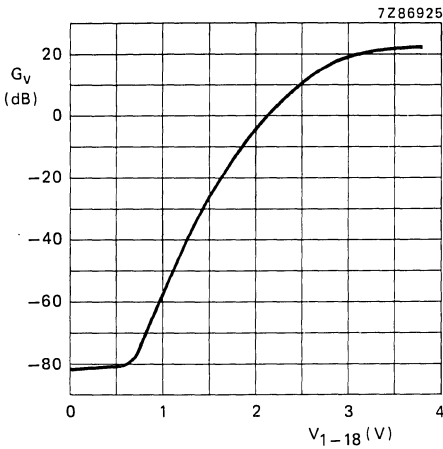

Fig. 5 Volume control curve; voltage gain (G_V) as a function of control voltage (V_{1-18}). Measured in Fig. 1 (internal potentiometer supply from pin 17 used); $V_P = 8.5$ V; $f = 1$ kHz.

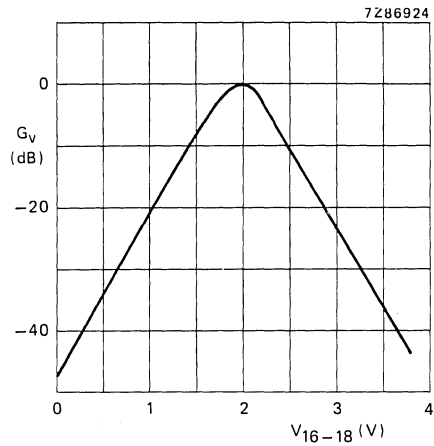

Fig. 6 Balance control curve; voltage gain (G_V) as a function of control voltage (V_{16-18}). Measured in Fig. 1 (internal potentiometer supply from pin 17 used); $V_P = 8.5$ V.

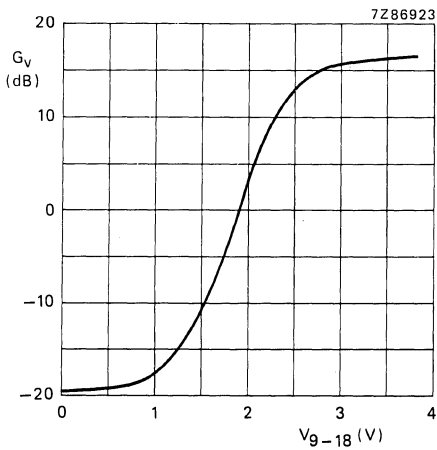

Fig. 7 Bass control curve; voltage gain (G_V) as a function of control voltage (V_{9-18}). Measured in Fig. 1 with single-pole filter (internal potentiometer supply from pin 17 used); $V_P = 8.5$ V; $f = 40$ Hz.

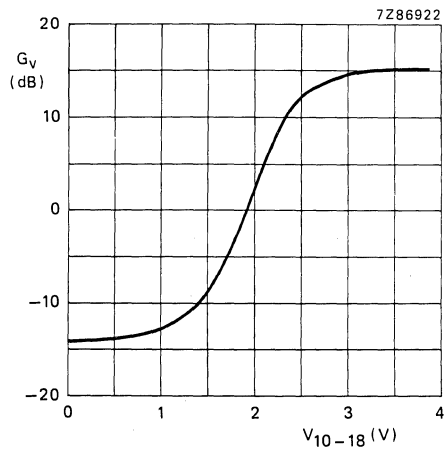

Fig. 8 Treble control curve; voltage gain (G_V) as a function of control voltage (V_{10-18}). Measured in Fig. 1 (internal potentiometer supply from pin 17 used); $V_P = 8.5$ V; $f = 16$ kHz.

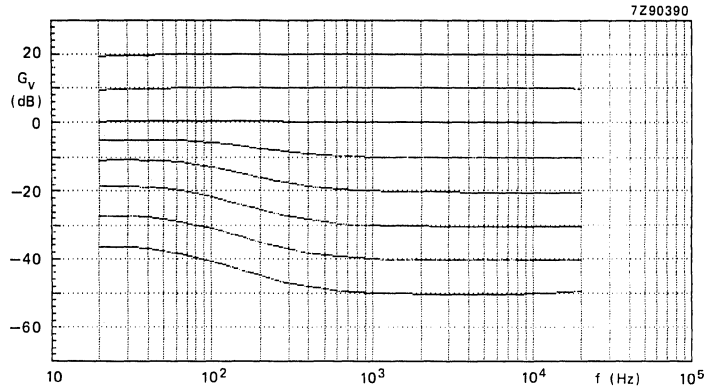

Fig. 9 Contour frequency response curves; voltage gain (G_V) as a function of audio input frequency. Measured in Fig. 1 with single-pole filter; $V_P = 8.5$ V.

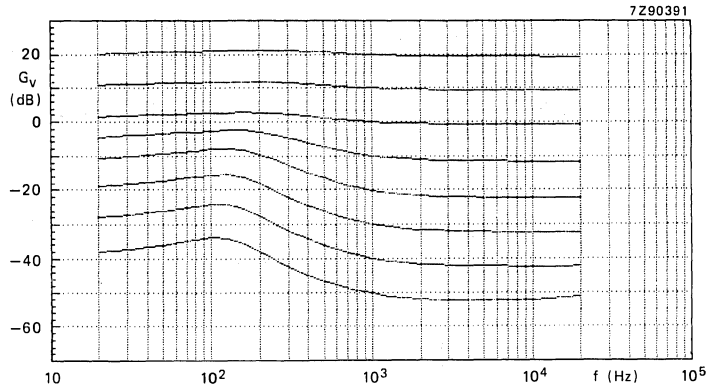

Fig. 10 Contour frequency response curves; voltage gain (G_V) as a function of audio input frequency. Measured in Fig. 1 with double-pole filter; $V_P = 8.5$ V.

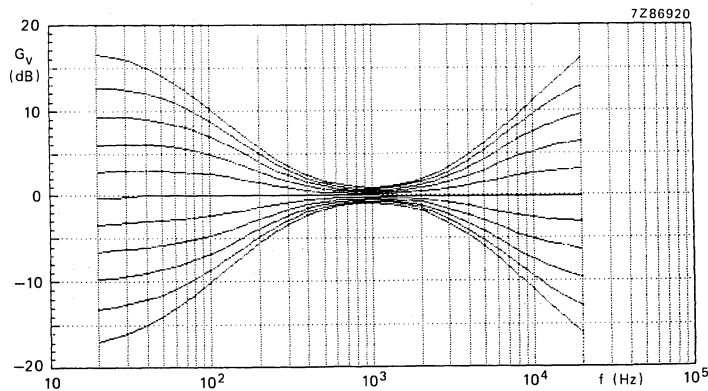

Fig. 11 Tone control frequency response curves; voltage gain (G_V) as a function of audio input frequency. Measured in Fig. 1 with single-pole filter; $V_P = 8.5$ V.

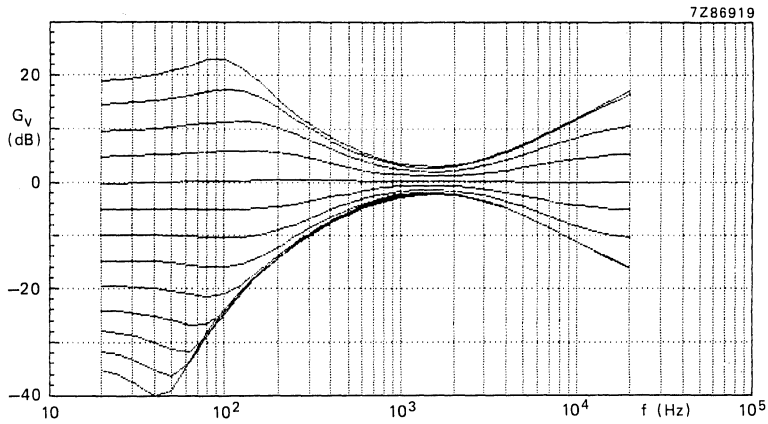

Fig. 12 Tone control frequency response curves; voltage gain (G_V) as a function of audio input frequency. Measured in Fig. 1 with double-pole filter; $V_P = 8.5$ V.

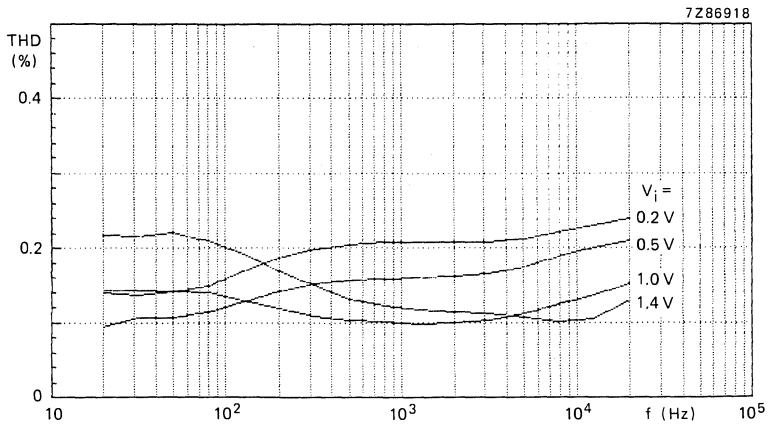

Fig. 13 Total harmonic distortion (THD); as a function of audio input frequency. Measured in Fig. 1; $V_P = 8.5$ V; volume control voltage gain at $G_V = 20 \log \frac{V_O}{V_i} = 0$ dB.

$$G_V = 20 \log \frac{V_O}{V_i} = 0 \text{ dB.}$$

5

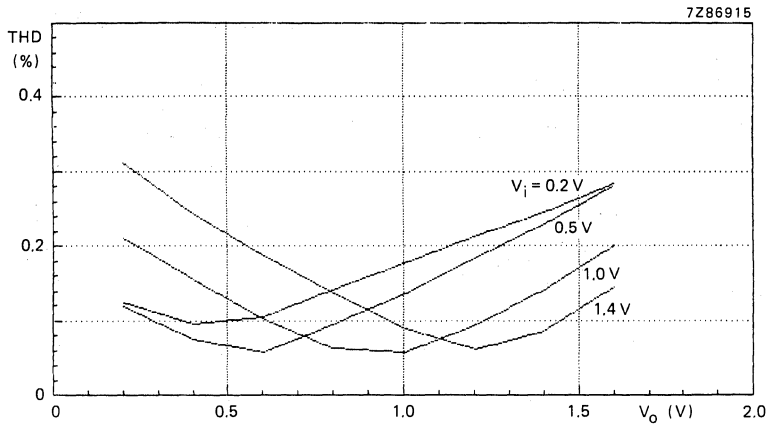
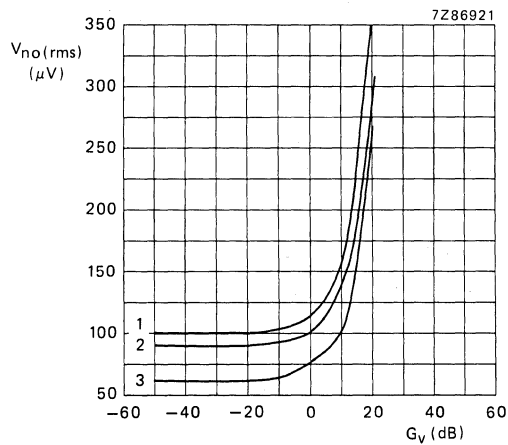

Fig. 14 Total harmonic distortion (THD); as a function of output voltage (V_o). Measured in Fig. 1; $V_p = 8.5$ V; $f_i = 1$ kHz.



- (1) $V_p = 15$ V.
- (2) $V_p = 12$ V.
- (3) $V_p = 8.5$ V.

Fig. 15 Noise output voltage ($V_{no}(rms)$; unweighted); as a function of voltage gain (G_v). Measured in Fig. 1; $f = 20$ Hz to 20 kHz.

SPATIAL, STEREO, PSEUDO-STEREO PROCESSOR

TDA3810

Preliminary

DESCRIPTION

The TDA3810 is an integrated circuit which can provide three switched functions for radio and television equipment: spatial sound from a stereo source; stereo sound from a stereo source; pseudo-stereo sound from a mono source.

FEATURES

- Three switched functions:
 - spatial
 - stereo
 - pseudo-stereo
- Muting circuit prevents LED flickering
- LED driving outputs (pins 7 and 8)
- TTL compatible inputs for selecting operating mode

PIN CONFIGURATION

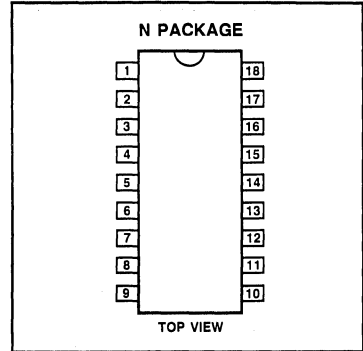

ABSOLUTE MAXIMUM RATINGS

SYMBOL AND PARAMETER	RATING	UNIT
V _{CC} Supply voltage (pin 18)	18	V
I _{CC} Supply current (pin 18)	12	mA
T _{STG} Storage temperature range	-25 to +150	°C
T _A Operating ambient temperature range	- 20 to + 70	°C
Thermal Resistance		
R _{th cr-a} From crystal to ambient	80	K/W

FUNCTIONAL PIN DESCRIPTION

PIN NO.	NAME AND FUNCTION
1	V _{REF}
2	Left channel input
3	Left channel buffer output
4	Left channel spatial feedback
5	Left channel pseudo feedback
6	Left channel output
7	Spatial indicator driver
8	Pseudo indicator driver
9	Mute
10	Ground
11	S1
12	S2
13	Right channel output
14	Right channel pseudo feedback
15	Right channel spatial feedback
16	Right channel buffer output
17	Right channel input
18	V _{DD}

TRUTH TABLE

MODE	CONTROL INPUT STATE		LED SPATIAL PIN 7	LED PSEUDO PIN 8
	PIN 11	PIN 12		
Mono pseudo-stereo	HIGH	LOW	Off	On
Spatial stereo	HIGH	HIGH	On	Off
Stereo	LOW	X	Off	Off

LOW = 0 to 0.8V (the less positive voltage)
 HIGH = 2V to V_{CC} (the more positive voltage)
 X = state is don't care

5

SPATIAL, STEREO, PSEUDO-STEREO PROCESSOR

TDA3810

Preliminary

BLOCK DIAGRAM

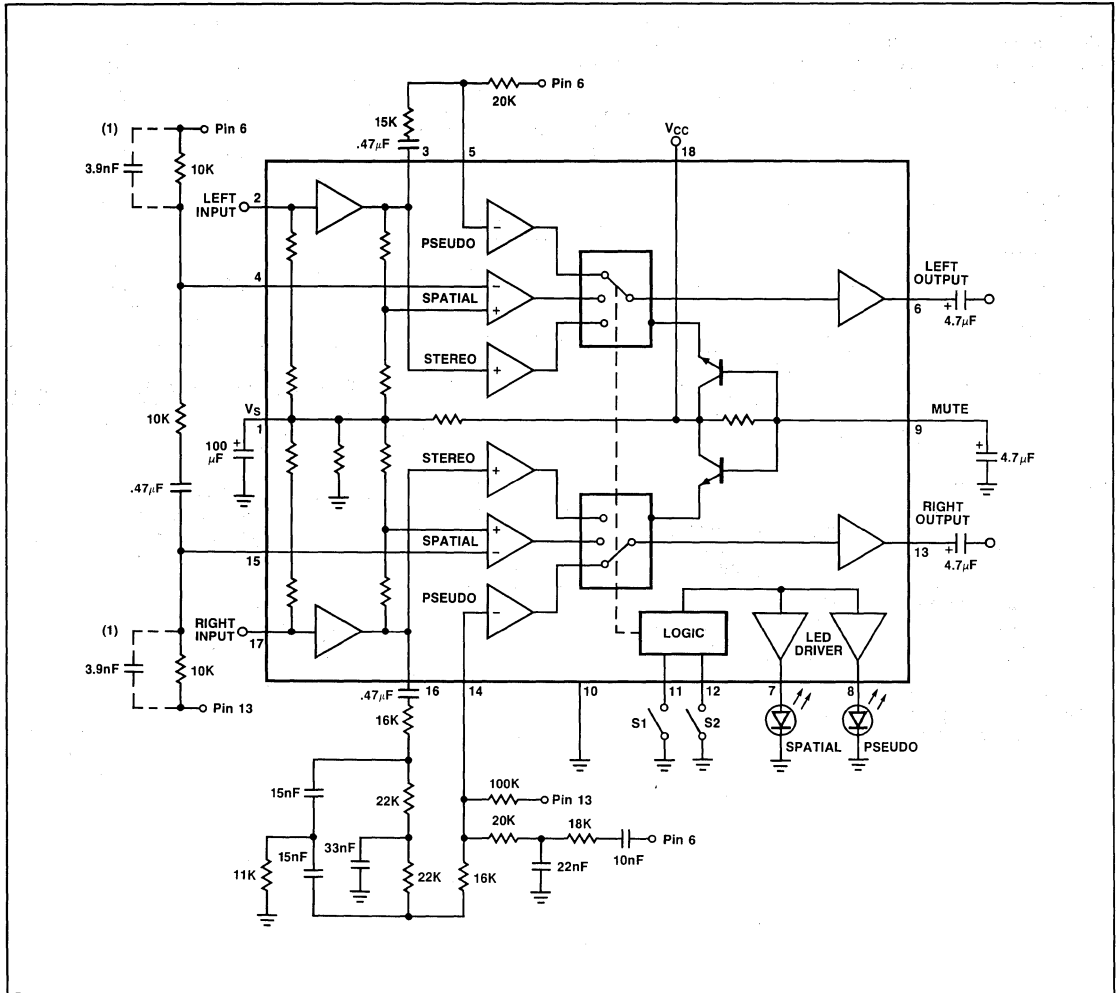

(1) Recommended in spatial mode for correction of high frequency (optimal performance)

SPATIAL, STEREO, PSEUDO-STEREO PROCESSOR

TDA3810

Preliminary

DC ELECTRICAL CHARACTERISTICS $V_{CC} = 12V$; $T_A = 25^\circ C$; Test circuit Figure 1 stereo mode (pin 11 to ground) unless otherwise specified.

SYMBOL AND PARAMETER	TEST CONDITION	TDA3810			UNIT
		Min	Typ	Max	
V_{CC} Supply voltage range	(Pin 18)	4.5		16.5	V
V_{CC} Supply current			6	12	mA
V_S Reference voltage		5.3	6	6.7	V
$V_{i(rms)}$ Input voltage	(Pin 2 or 17) THD = 0.2%			2	V
R_i Input resistance	(Pin 2 or 17)	50	75		k Ω
G_v Voltage gain V_o/V_i			0		dB
α Channel separation (R/L)		60	70		dB
THD Total harmonic distortion	$f = 40$ to 16000 Hz; $V_{o(rms)} = 1V$		0.1		%
RR Power supply ripple rejection			50		dB
$V_{n(rms)}$ Noise output voltage	(Unweighted) left and right output		10		μV
Spatial mode (Pins 11 and 12 HIGH)					
α Antiphase crosstalk			50		%
G_v Voltage gain		1.4	2.4	3.4	dB

PSEUDO-STEREO MODE The quality and strength of the pseudo-stereo effect is determined by external filter components.

SYMBOL AND PARAMETER	TEST CONDITION	TDA3810			UNIT
		Min	Typ	Max	
Control inputs		(Pins 11 and 12)			
R_i Input resistance		70	120		k Ω
$-I_i$ Switching current			35	100	μA
LED drivers (Pins 7 and 8)					
$-I_o$ Output current for LED		10	12	15	mA
V_F Forward voltage				6	V

5

SPATIAL, STEREO, PSEUDO-STEREO PROCESSOR

TDA3810

Preliminary

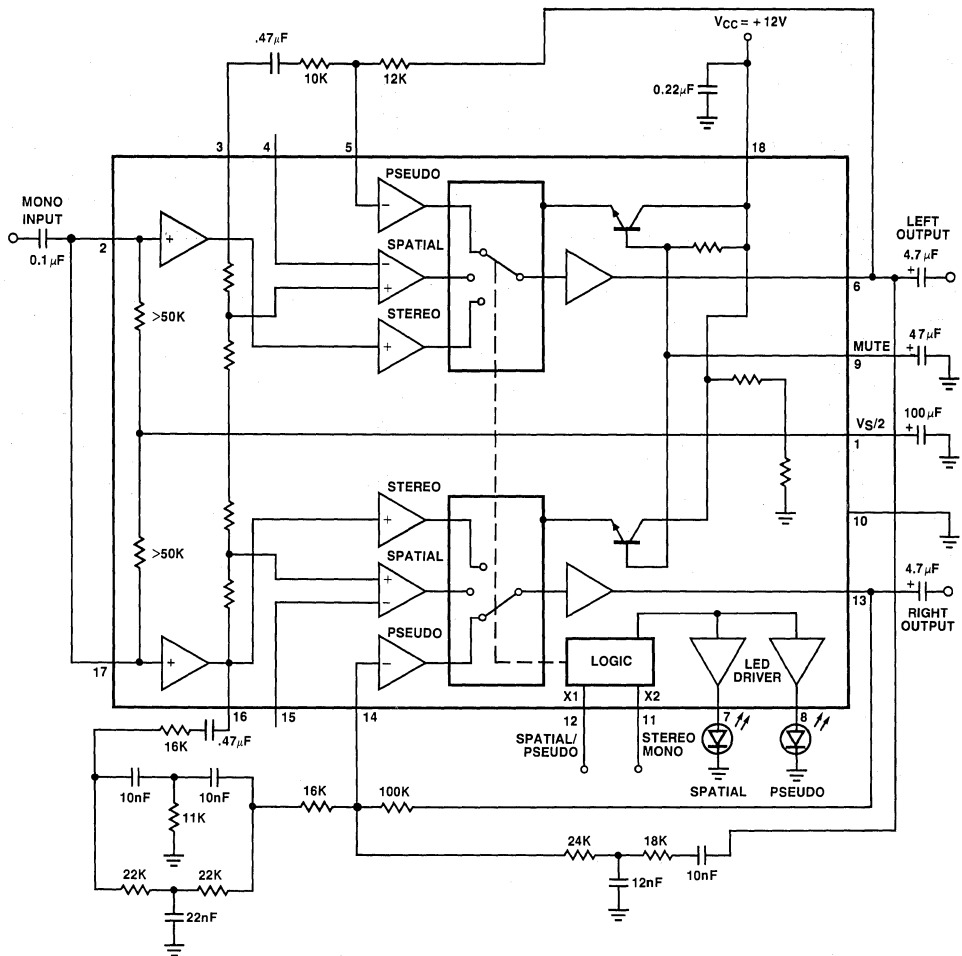
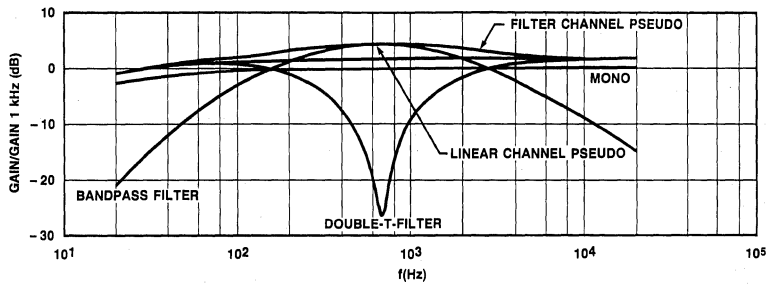

Figure 1. Pseudo Filter I

Preliminary

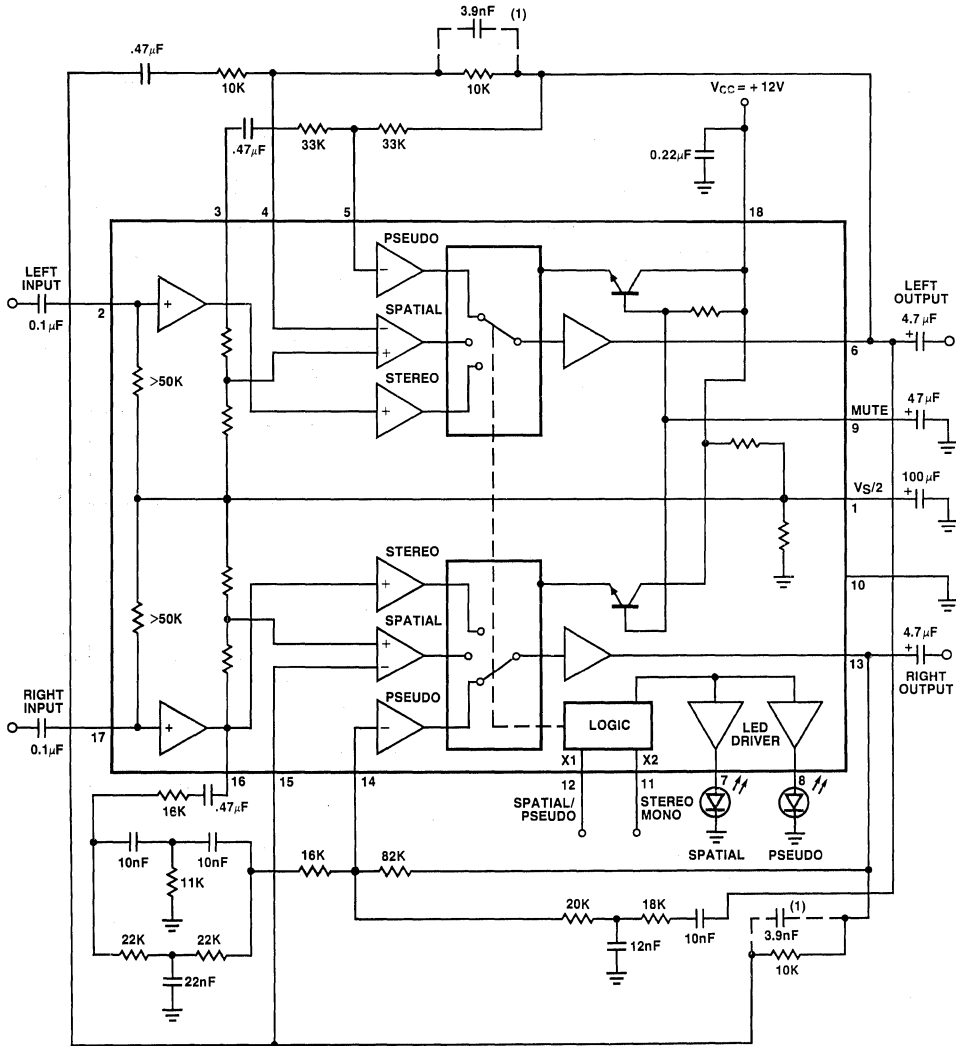
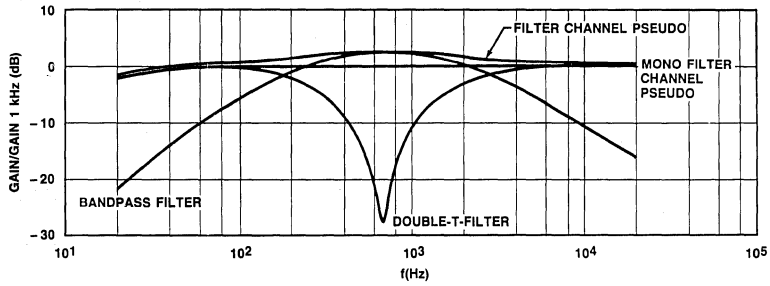

Figure 2. Pseudo Filter II

5

Preliminary

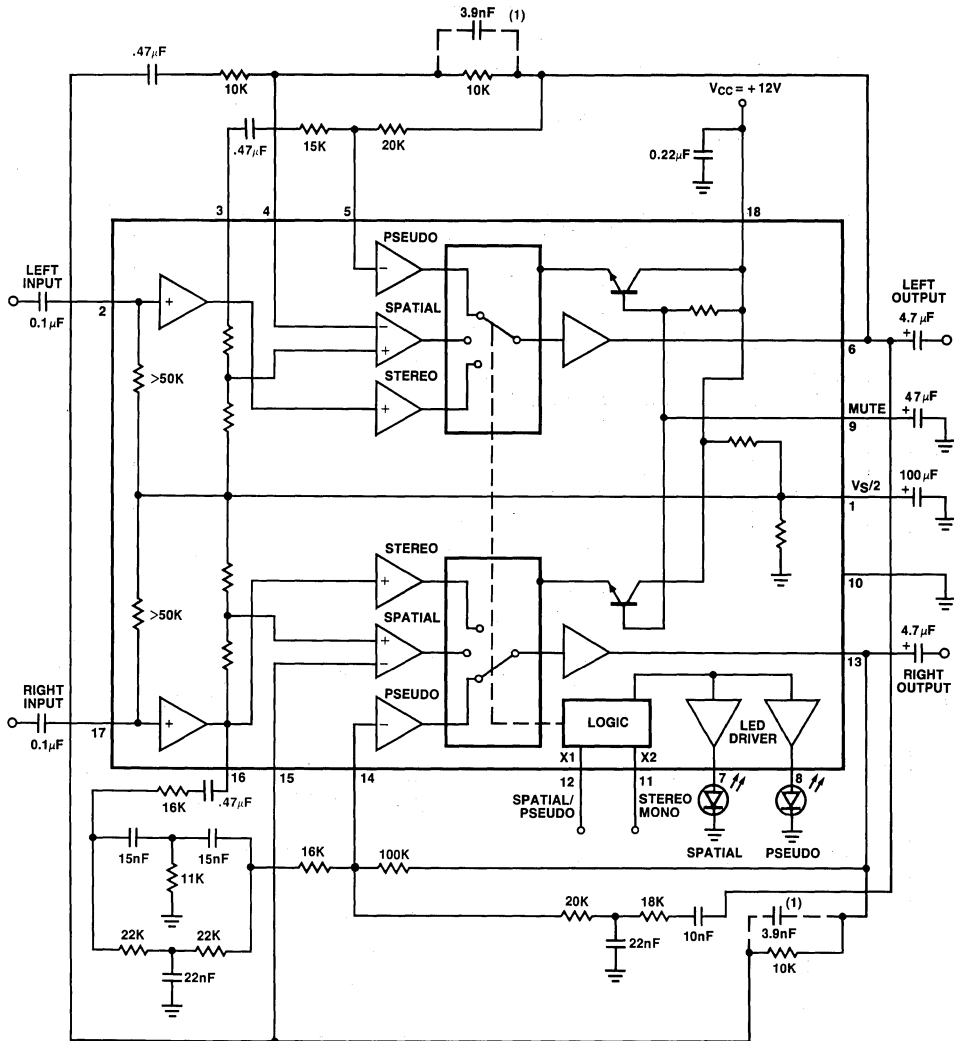
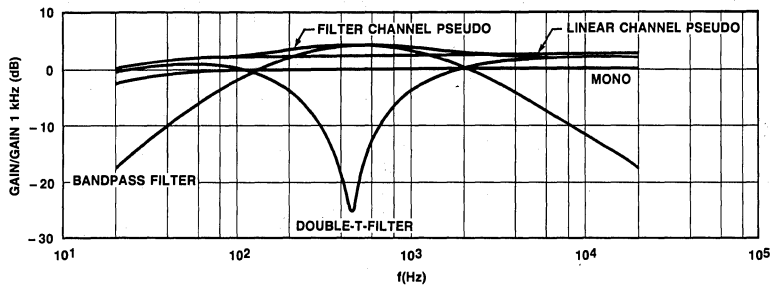

Figure 3. Pseudo Filter III

FM STEREO MULTIPLEX DECODER, PHASE LOCKED LOOP

μ A758

DESCRIPTION

The μ A758 is a monolithic phase-locked loop FM stereo multiplex decoder. The device decodes an FM stereo multiplex signal into right and left audio channels while inherently suppressing SCA information when it is contained in the composite input signal. The device includes automatic mono-stereo mode switching and drive for an external lamp to indicate stereo mode operation.

The μ A758 operates over a large voltage range and requires a minimum number of external components. A simple setting of an external potentiometer adjusts the oscillator frequency. No coils are required.

FEATURES

- 45dB channel separation
- Automatic stereo/mono switching
- 70dB SCA rejection
- 10V to 16V supply range
- High impedance input—low impedance output

PIN CONFIGURATION

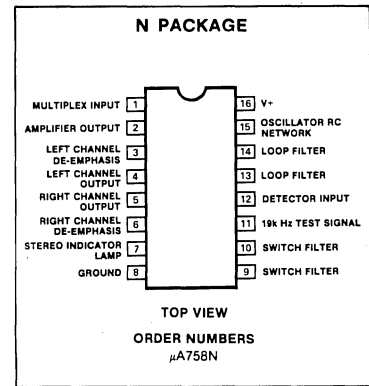

ABSOLUTE MAXIMUM RATINGS

PARAMETER	RATING	UNIT
Supply voltage	+18	V
Supply voltage (\leq 15 seconds)	+22	V
Voltage at lamp driver terminal (Lamp OFF)	+22	V
Internal power dissipation	730	mW
Operating temperature range	-40 to +85	$^{\circ}$ C
Storage temperature range	-55 to +125	$^{\circ}$ C
Lead temperature (60sec)	300	$^{\circ}$ C

BLOCK DIAGRAM

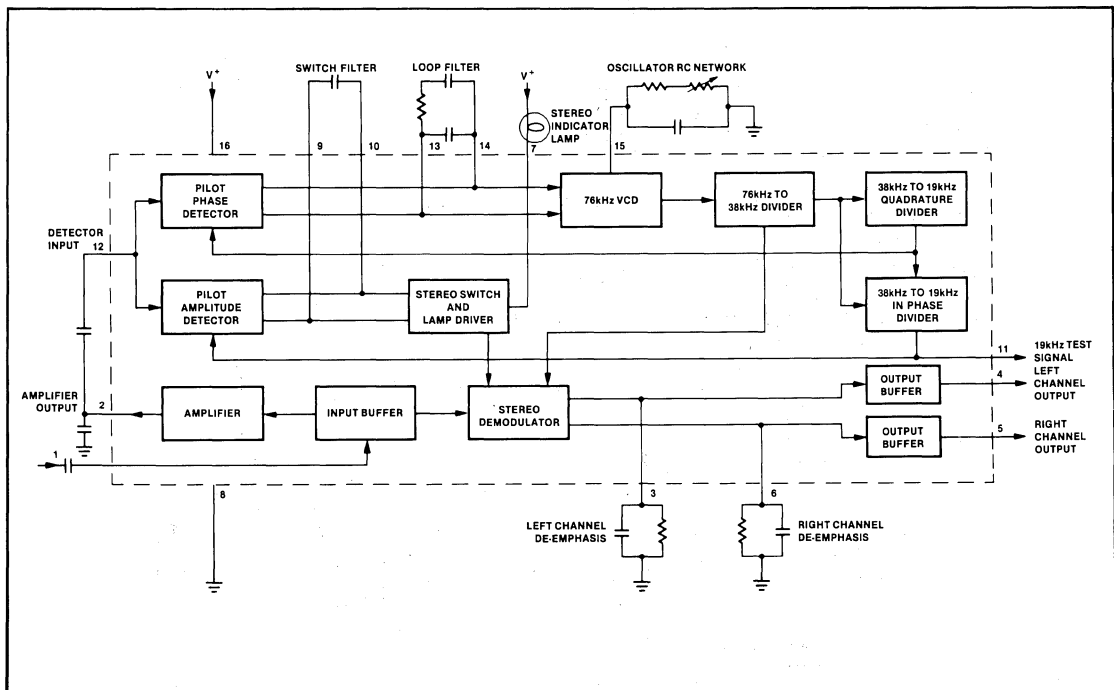

5

FM STEREO MULTIPLEX DECODER, PHASE LOCKED LOOP

μ A758

EQUIVALENT SCHEMATIC

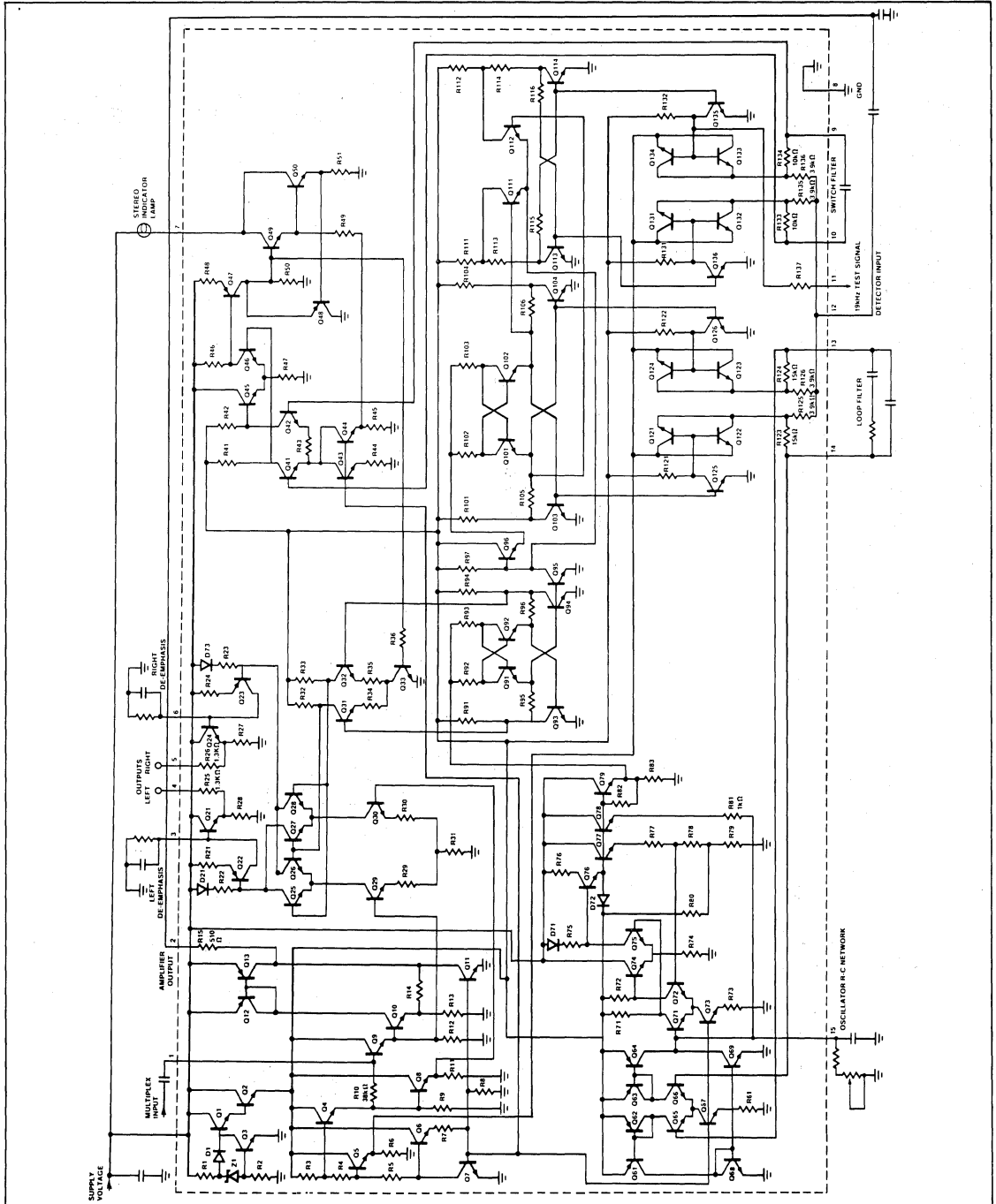

FM STEREO MULTIPLEX DECODER, PHASE LOCKED LOOP

μ A758

DC ELECTRICAL CHARACTERISTICS

$T_A = 25^\circ\text{C}$, $V_+ = +12\text{V}$, 19kHz pilot level = 30mV_{RMS}, multiplex signal (L = R, pilot OFF) = 300mV_{RMS}, modulation frequency = 400Hz or 1Hz, test circuit 1, unless otherwise specified.

PARAMETER	TEST CONDITIONS	μ A758			UNIT
		Min	Typ	Max	
I _{CC}	Supply current				
I _L	Maximum available lamp current	75	31 150	38	mA mA
V ₇	Voltage at lamp driver terminal		1.3	1.8	V
r _i	Input resistance	20	35		k Ω
r _o	Output resistance	0.9	1.3	2.0	k Ω

AC ELECTRICAL CHARACTERISTICS

PARAMETER	TEST CONDITIONS	μ A758			UNIT	
		Min	Typ	Max		
$\Delta(V_4 \& V_5)$	DC voltage shift at either output terminal		30	150	mV	
PS _{R,R}	Power supply ripple rejection		35		dB	
SEP	Channel separation	200Hz, 200mV _{RMS}	40		dB	
		100Hz	45		dB	
		400Hz	45		dB	
		10kHz	0.3	1.5	dB	
BAL.	Channel balance				dB	
A _v	Voltage gain	1kHz	0.5	0.9	V/V	
	Pilot input level	Lamp turn-on	18	25	mV _{RMS}	
		Lamp turn-off	2.0	7.0	mV _{RMS}	
	Pilot input level hysteresis	Lamp turn-off to turn-on	3.0	7.0	dB	
T.H.D.	Capture range		2.0	4.0	%	
	Total harmonic distortion	Multiplex level = 600mV _{RMS} pilot OFF	0.4	1.0	%	
	19kHz rejection		25	35	dB	
	38kHz rejection		25	45	dB	
	SCA rejection ¹			70	dB	
VCO	Tuning resistance ²		21.0	23.3	25.5	k Ω
VCO	Frequency drift	0 $^\circ\text{C} \leq T_A \leq 25^\circ\text{C}$ 25 $^\circ\text{C} \leq T_A \leq 70^\circ\text{C}$		+0.1 -0.4	± 2 ± 2	% %

NOTES

- Measured with a stereo composite signal consistency of 80% stereo, 10% pilot and 10% SCA as defined in the FCC Rules on Broadcasting.
- Total resistance from pin 15 to ground, in test circuit, required to set reference frequency at pin 11 to 19kHz \pm 10hz.

TYPICAL PERFORMANCE CHARACTERISTICS

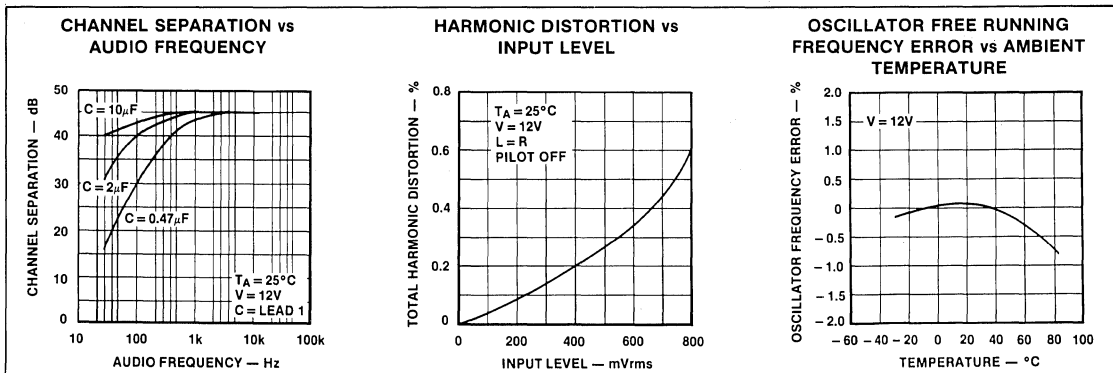

TYPICAL PERFORMANCE CHARACTERISTICS (Cont'd)

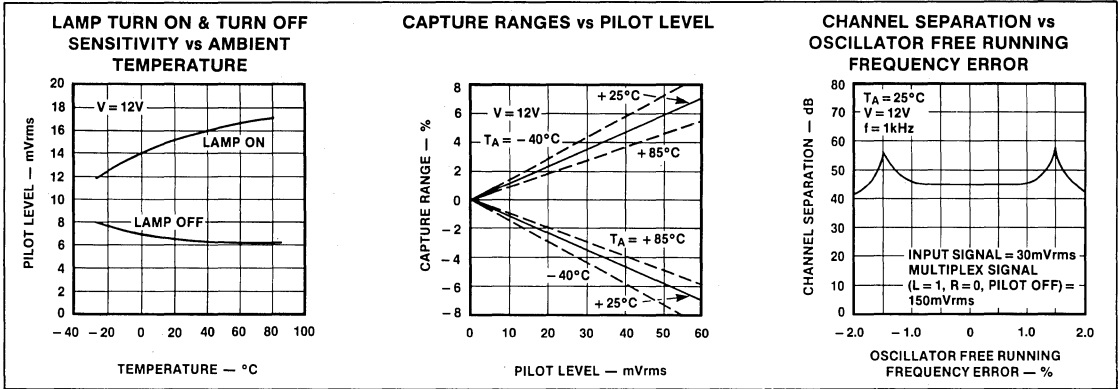

TEST CIRCUIT AND TYPICAL APPLICATION

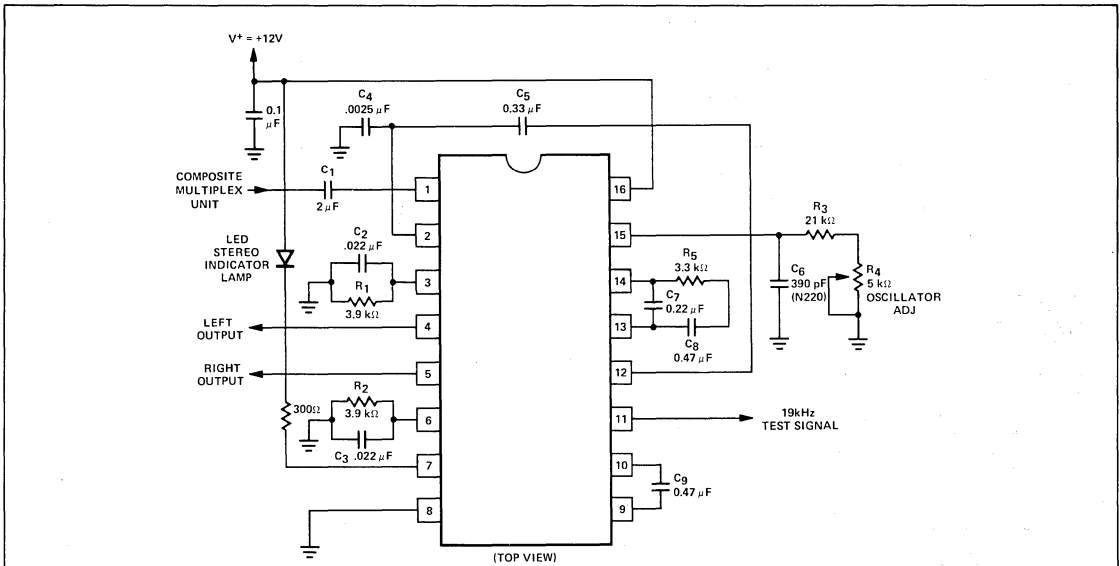

NOTE

Tolerance on resistors is $\pm 5\%$ and tolerance on capacitors is $\pm 20\%$ unless otherwise specified. C1 tolerance = +100%, -20%, C6 tolerance = $\pm 1\%$ in test circuit and $\pm 5\%$ in typical applications, R3 tolerance = $\pm 1\%$, R4 tolerance = $\pm 10\%$, R1 and R2 tolerances = $\pm 1\%$ in test circuit and $\pm 5\%$ in typical application.

DESCRIPTION

CA3089 is a monolithic integrated circuit that provides all the functions of a comprehensive FM-IF system. Figure 6 is a block diagram showing the CA3089 features, which include a three-state FM-IF amplifier/limiter configuration with level detectors for each stage, a doubly-balanced quadrature FM detector and an audio amplifier that features the optional use of a muting (squelch) circuit.

The advanced circuit design of the IF system includes desirable features such as delayed AGC for the RF tuner, an AFC drive circuit, and an output signal to drive a tuning meter and/or provide stereo switching logic. In addition, internal power supply regulators maintain a nearly constant current drain over the voltage supply range of +8 to +18 volts.

The CA3089 is ideal for high-fidelity operation. Distortion in a CA3089 FM-IF system is primarily a function of the phase linearity characteristic of the outboard detector coil.

The CA3089 utilizes a 16-lead dual-in-line plastic package and can operate over the ambient temperature range of -40°C to +85°C.

FEATURES

- **Exceptional limiting sensitivity:** 10µV typ. at -3dB point
- **Low distortion:** 0.1% typ. (with double-tuned coil)

- **Single-coil tuning capability**
- **High recovered audio:** 400mV typ.
- **Provides specific signal for control of Interchannel muting (squelch)**
- **Provides specific signal for direct drive of a tuning meter**
- **Provides delayed AGC voltage for RF amplifier**
- **Provides a specific circuit for flexible AFC**
- **Internal supply/voltage regulators**

APPLICATIONS

- **High-fidelity FM receivers**
- **Automotive FM receivers**
- **Communications FM receivers**

PIN CONFIGURATION

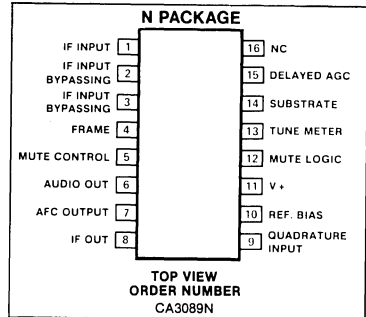

ABSOLUTE MAXIMUM RATINGS

PARAMETER	RATING	UNIT
DC supply voltage:		
Between terminals 11 and 4	18	V
Between terminals 11 and 15	18	V
DC Current (out of terminal 15)	2	mA
Device dissipation:		
Up to T _A = 60°C	600	mW
Above T _A = 60°C	derate linearly	
	6.7	mW/°C
Ambient temperature range:		
Operating	-40 to +85	°C
Storage	-65 to +150	°C
Lead temperature (during soldering):		
At distance not less than 1/32" (0.79mm) from case for 10 seconds: max	+265	°C

BLOCK DIAGRAM

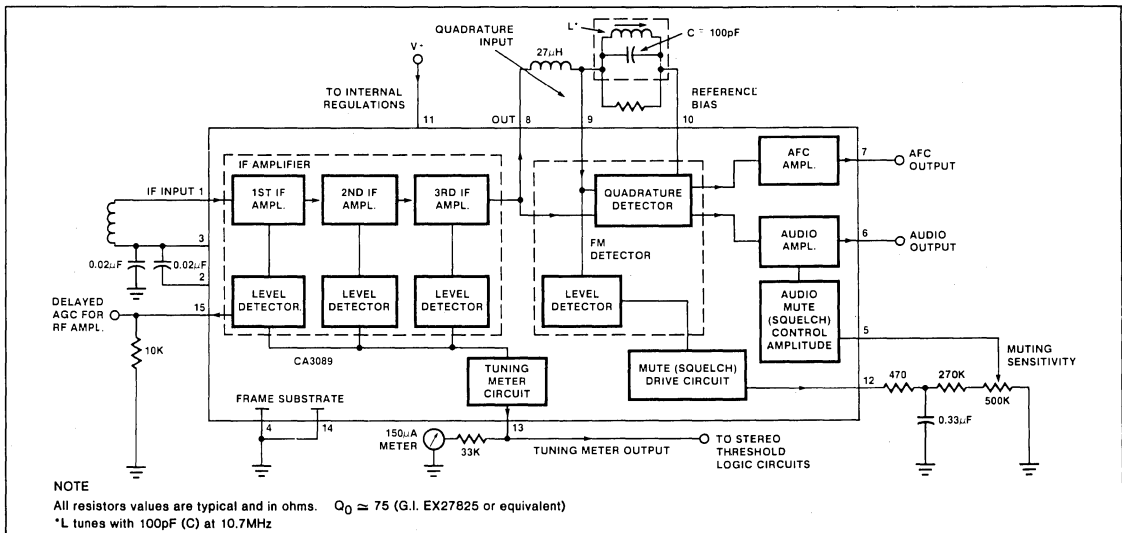

EQUIVALENT SCHEMATIC

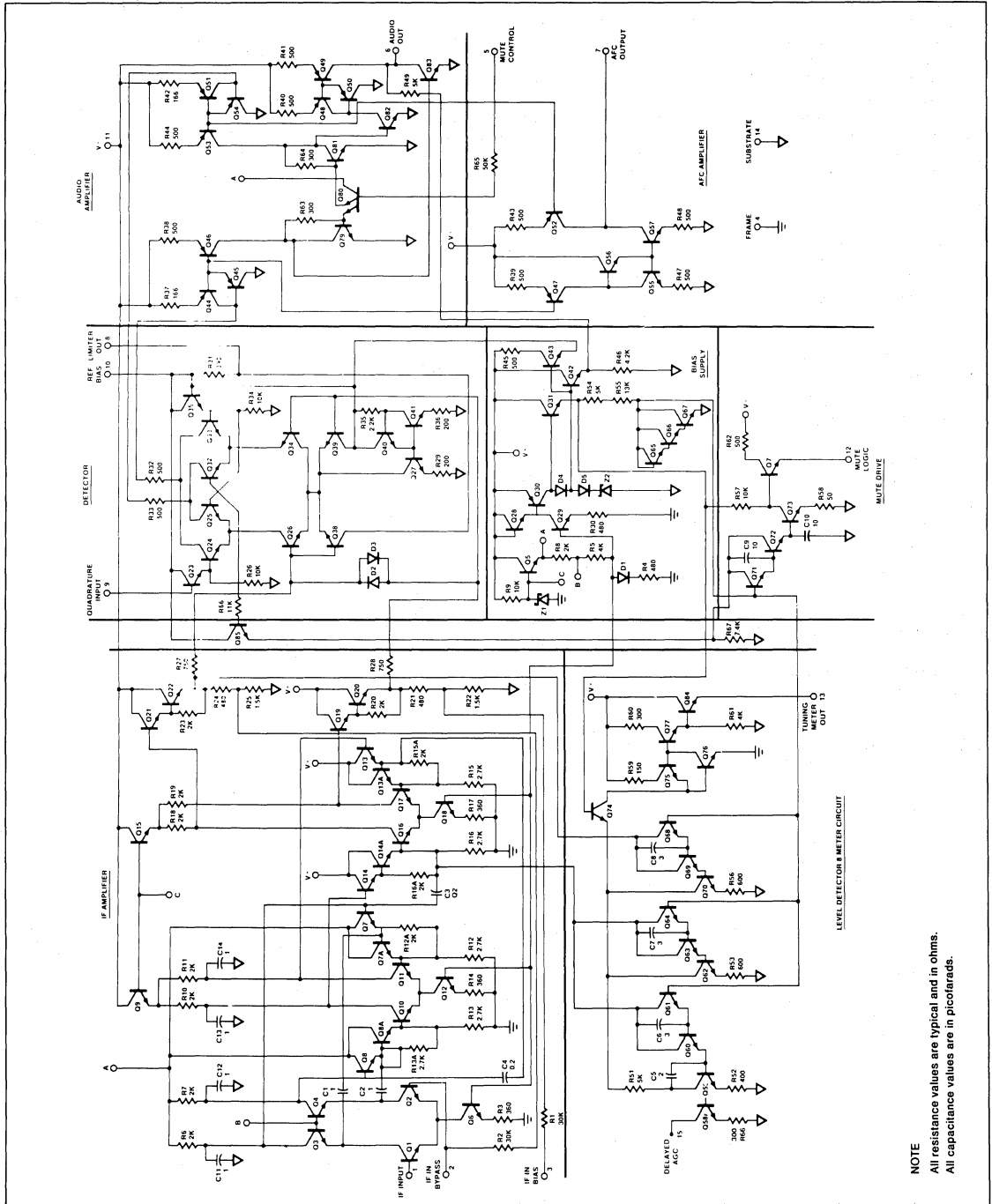

NOTE
All resistance values are typical and in ohms.
All capacitance values are in picofarads.

DC ELECTRICAL CHARACTERISTICS $T_A = 25^\circ\text{C}$, $V^+ = 12\text{V}$ unless otherwise specified.

PARAMETER	TEST CONDITIONS	CA3089D2			UNIT
		Min	Typ	Max	
STATIC (DC) CHARACTERISTICS					
I_{11} Quiescent circuit current	No signal input, non-muted	16	23	30	mA
DC Voltages: ⁴					
V_1 Terminal 1 (IF input)	No signal input, non-muted	1.2	1.9	2.4	V
V_2 Terminal 2 (ac return to input)	No signal input, non-muted	1.2	1.9	2.4	V
V_3 Terminal 3 (dc bias to input)	No signal input, non-muted	1.2	1.9	2.4	V
V_6 Terminal 6 (audio output)	No signal input, non-muted	5.0	5.6	6.0	V
V_7 Terminal 7 (A.F.C.)	No signal input, non-muted	5.0	5.6	6.0	V
V_{10} Terminal 10 (dc reference)	No signal input, non-muted	5.0	5.6	6.0	V
DYNAMIC CHARACTERISTICS					
$V_{i(lim)}$ Input limiting voltage (-3dB point) ³			10	25	μV
AMR AM Rejection (terminal 6) ⁴	$V_{IN} = 0.1\text{V}$, $F_0 = 10.7\text{MHz}$, $f_{mod} = 400\text{Hz}$, AM Mod = 30%	45	55		dB
V_O Recovered audio voltage (terminal 6) ³		400	500	600	mV
Total harmonic distortion: ¹					
THD Single tuned (terminal 6) ³			0.5	1.0	%
THD Double tuned (terminal 6) ⁴	$f_{mod} = 400\text{Hz}$, $V_{IN} = 0.1$		0.1		%
S+N/N Signal plus noise to noise ratio (terminal 6) ³	Deviation = $\pm 75\text{kHz}$ $V_{IN} = 0.1\text{V}$	60	70		dB
MU_{IN} Mute input (terminal 5)	$V_5 = 2.5\text{V}$	50	70		dB
MU_{OUT} Mute output (terminal 12)	$V_{IN} = 50\mu\text{V}$ $V_{IN} = 0\text{V}$	4.0		.5	V
MTR Meter output (terminal 13)	$V_{IN} = 0.1\text{V}$	2.5	3.5		V
	$V_{IN} = 500\mu\text{V}$	1.0	1.5		V
	$V_{IN} = 0\text{V}$.7	V
AGC Delayed AGC (terminal 15)	$V_{IN} = .01\text{V}$.5	V
	$V_{IN} = 10\mu\text{V}$	4.0	5.0		V
THD Double tuned (terminal 6) ⁴	$f_{mod} = 400\text{Hz}$, $V_{IN} = 0.1$		0.1		%

NOTES

1. THD characteristics and Audio Level are essentially a function of the phase and Q characteristics of the network connected between terminals 8,9, and 10.
2. Test circuit Figure 1.
3. Test circuit Figure 2.
4. Test circuit Figures 1 and 2.

5

TEST CIRCUITS

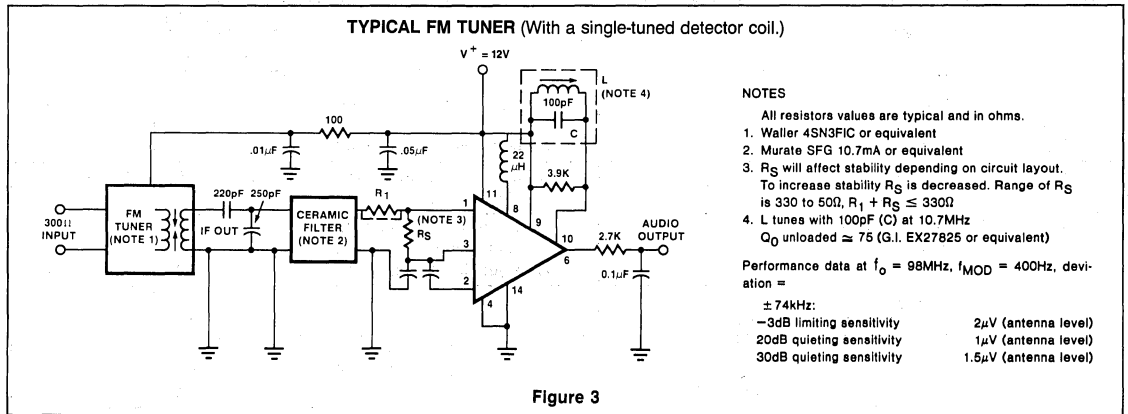

SYSTEM DESIGN CONSIDERATIONS

The CA3089 is a very high gain device and therefore careful consideration must be given to the layout of external components to minimize feedback. The input bypass capacitors should be located close to the input terminals and the values

should not be large nor should the capacitors be of the type which might introduce inductive reactance to the circuit. An example of good by-pass capacitors would be ceramic disc with values in the range of .01 to .05 microfarad.

The input impedance of the CA3089 is approximately 10,000 ohms. It is *not*

recommended to match this impedance. The value of the input termination resistor should be as low as possible without degrading system operation. The lower the value of this resistor the greater the system stability. An input terminating resistor between 50 and 100 ohms is recommended.

TYPICAL PERFORMANCE CHARACTERISTICS

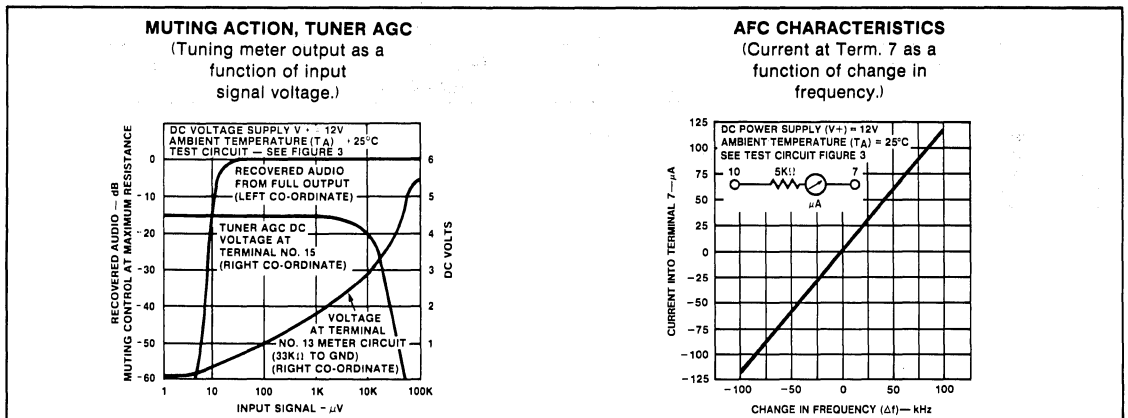

TEST CIRCUITS

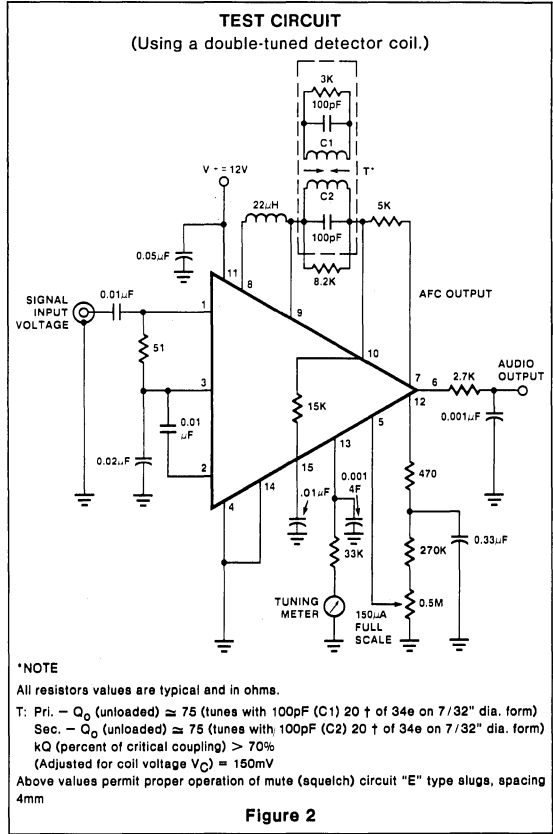
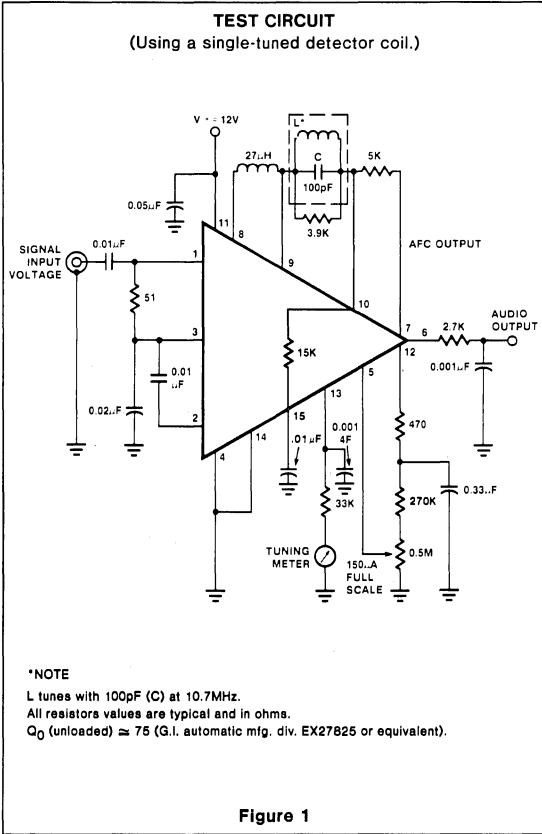

FM RADIO CIRCUIT**TDA7000****Preliminary****DESCRIPTION**

The TDA7000 is a monolithic integrated circuit for mono FM portable radios where a minimum of peripheral components is important (small dimensions and low costs).

The IC has an FLL (Frequency-Locked-Loop) system with an intermediate frequency of 70 kHz. The I.F. selectivity is obtained by active RC filters. The only function which needs alignment is the resonant circuit for the oscillator, thus selecting the reception frequency. Spurious reception is avoided by means of a mute circuit, which also eliminates too-noisy input signals. Special precautions are taken to meet the radiation requirements.

FEATURES

- R.F. input stage
- Mixer
- Local oscillator
- I.F. amplifier/limiter
- Phase demodulator
- Mute detector
- Mute switch

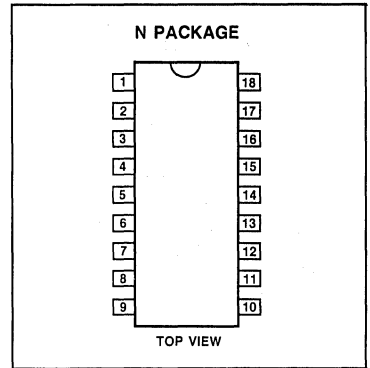
PIN CONFIGURATION**ABSOLUTE MAXIMUM RATINGS**

SYMBOL AND PARAMETER	RATING	UNIT
V_{CC} Supply voltage (pin 5)	12	V
$V_{6.5}$ Oscillator voltage (pin 6)	$V_{CC}-0.5$ to $V_{CC}+0.5$	V
Total power dissipation	See derating curve Figure 2	
T_{STG} Storage temperature range	-55 to +150	°C
T_A Operating ambient temperature range	0 to +60	°C

FUNCTIONAL PIN DESCRIPTION

PIN NO	NAME AND FUNCTION
1	Muting capacitor
2	Audio frequency output
3	Noise source
4	Loop filter capacitor
5	Supply voltage
6	VCO
7	1st integrator capacitor (to pin 9)
8	2nd integrator capacitor
9	1st integrator capacitor (to pin 7)
10	IF filter capacitor (to pin 11)
11	IF filter capacitor
12	IF limiter capacitor
13	RF input
14	Mixer
15	Current source capacitor
16	Ground
17	Demodulator capacitor
18	Correlator capacitor

FM RADIO CIRCUIT

TDA7000

Preliminary

BLOCK DIAGRAM

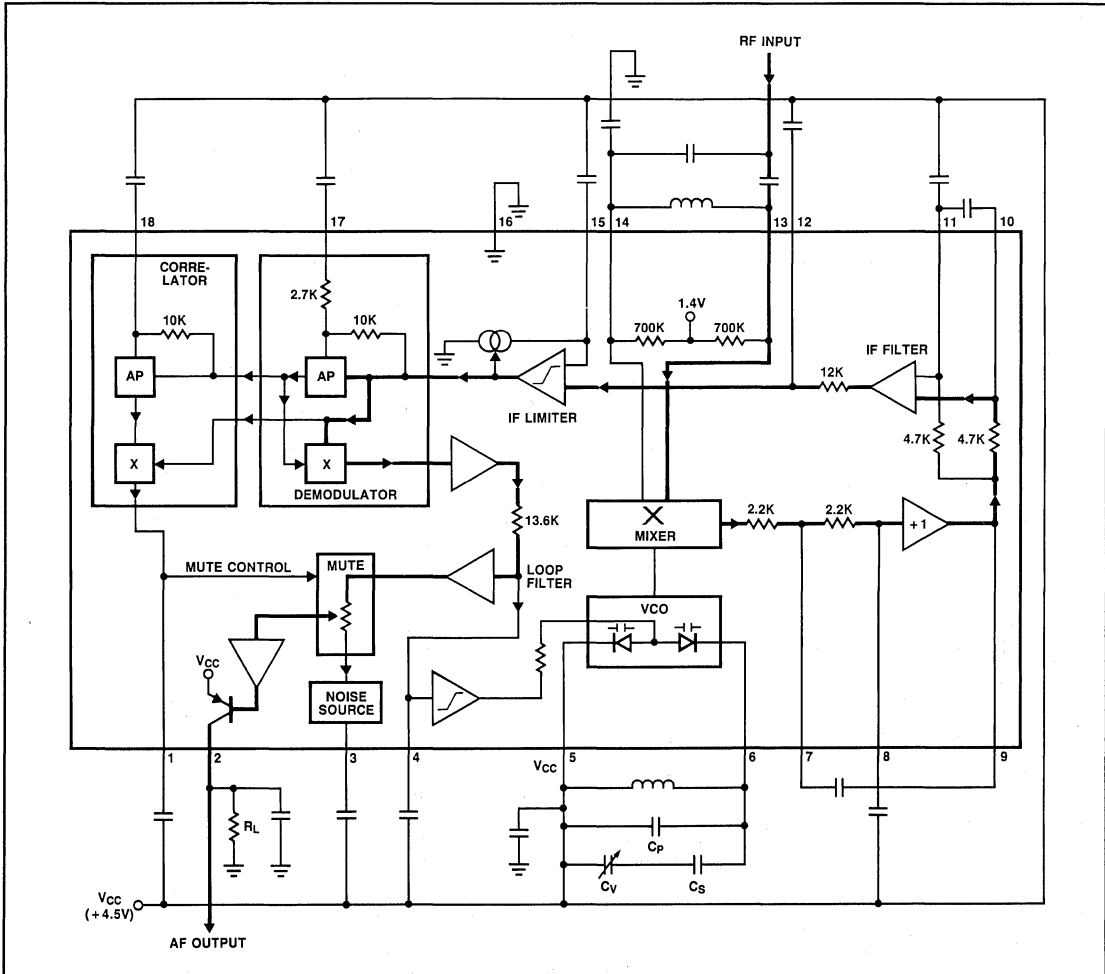

5

FM RADIO CIRCUIT

TDA7000

Preliminary

DC ELECTRICAL CHARACTERISTICS $V_{CC} = 4.5V; T_A = 25^{\circ}C$; measured in Figure 3; unless otherwise specified

SYMBOL AND PARAMETER	TEST CONDITION	TDA7000			UNIT
		Min	Typ	Max	
V_{CC} Supply voltage	(Pin 5)	2.7	4.5	10	V
I_{CC} Supply current	$V_{CC} = 4.5V$		8		mA
I_b Oscillator current	(Pin 6)		280		μA
V_{14-16} Voltage	(Pin 14)		1.35		V
I_2 Output current	(Pin 2)		60		μA
V_{2-16} Output voltage	(Pin 2) $R_L = 22\ k\Omega$		1.3		V

AC ELECTRICAL CHARACTERISTICS $V_{CC} = 4.5\ V; T_A = 25^{\circ}C$; measured in Figure 3 (mute switch open, enabled); $f_{rr} = 96\ MHz$ (tuned to max. signal at $5\ \mu V$ e.m.f.) modulated with $\Delta f = \pm 22.5\ kHz$; $f_m = 1\ kHz$; EMF = 0.2 mV (e.m.f. voltage at a source impedance of $75\ \Omega$); r.m.s. noise voltage measured unweighted ($f = 300\ Hz$ to $20\ kHz$); unless otherwise specified.

SYMBOL AND PARAMETER	TEST CONDITION	TDA7000			UNIT
		Min	Typ	Max	
EMF Sensitivity (see Figure 2) (e.m.f. voltage)	-3 dB limiting; muting disabled		1.5		μV
	-3 dB muting		6		
	S/N = 26 dB		5.5		
EMF Signal handling (e.m.f. voltage)	THD < 10%; $\Delta f = \pm 75\ kHz$		200		mV
S/N Signal-to-noise ratio			60		dB
THD Total harmonic distortion	$\Delta f = \pm 22.5\ kHz$		0.7		%
	$\Delta f = \pm 75\ kHz$		2.3		
AMS AM suppression of output voltage	(ratio of the AM output signal referred to the FM output signal) FM signal: $f_m = 1\ kHz; \Delta f = \pm 75\ kHz$ AM signal: $f_m = 1\ kHz; m = 80\%$		50		dB
RR Ripple rejection	($\Delta V_{CC} = 100\ mV; f = 1\ kHz$)		10		dB
$V_{6-5(rms)}$ Oscillator voltage (r.m.s. value)	(Pin 6)		250		mV
Δf_{osc} Variation of oscillator frequency	Supply voltage ($\Delta V_{CC} = 1V$)		60		kHz/V
S_{+300} Selectivity S_{-300}			45		dB
			35		
Δf_{rf} A.F.C. range			± 300		kHz
B Audio bandwidth	$\Delta V_O = 3\ dB$ measured with pre-emphasis ($t = 50\ \mu s$)		10		kHz
$V_{O(rms)}$ A.F. output voltage (r.m.s. value)	$R_L = 22\ k\Omega$		75		mV
R_L Load resistance	$V_{CC} = 4.5V$			22	k Ω
	$V_{CC} = 9.0V$			47	

NOTES:

1. The muting system can be disabled by feeding a current of about $20\ \mu A$ into pin 1.
2. The interstation noise level can be decreased by choosing a low-value capacitor at pin 3. Silent tuning can be achieved by omitting this capacitor.

Preliminary

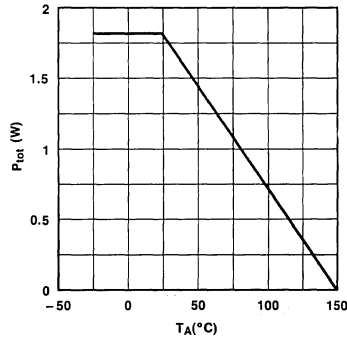

Figure 1. Power Derating Curve.

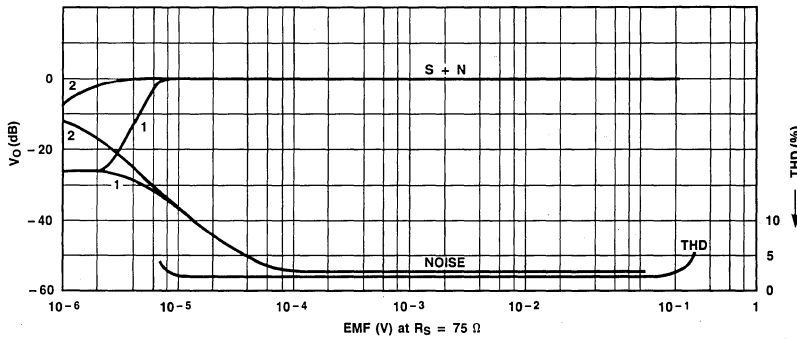

Figure 2. AF output voltage (V_O) and total harmonic distortion (THD) as a function of the e.m.f. input voltage (EMF) with a source impedance (R_S) of 75 Ω : (1) muting system enabled; (2) muting system disabled.

Conditions: 0dB = 75mV; f_{IF} = 96 MHz
 for S + N curve: $\Delta f = \pm 22.5$ kHz $f_m = 1$ kHz
 for THD curve: $\Delta f = \pm 75$ kHz $f_m = 1$ kHz

NOTES:

1. The muting system can be disabled by feeding a current of about 20 μ A into pin 1.
2. The interstation noise level can be decreased by choosing a low-value capacitor at pin 3. Silent tuning can be achieved by omitting this capacitor.

5

Preliminary

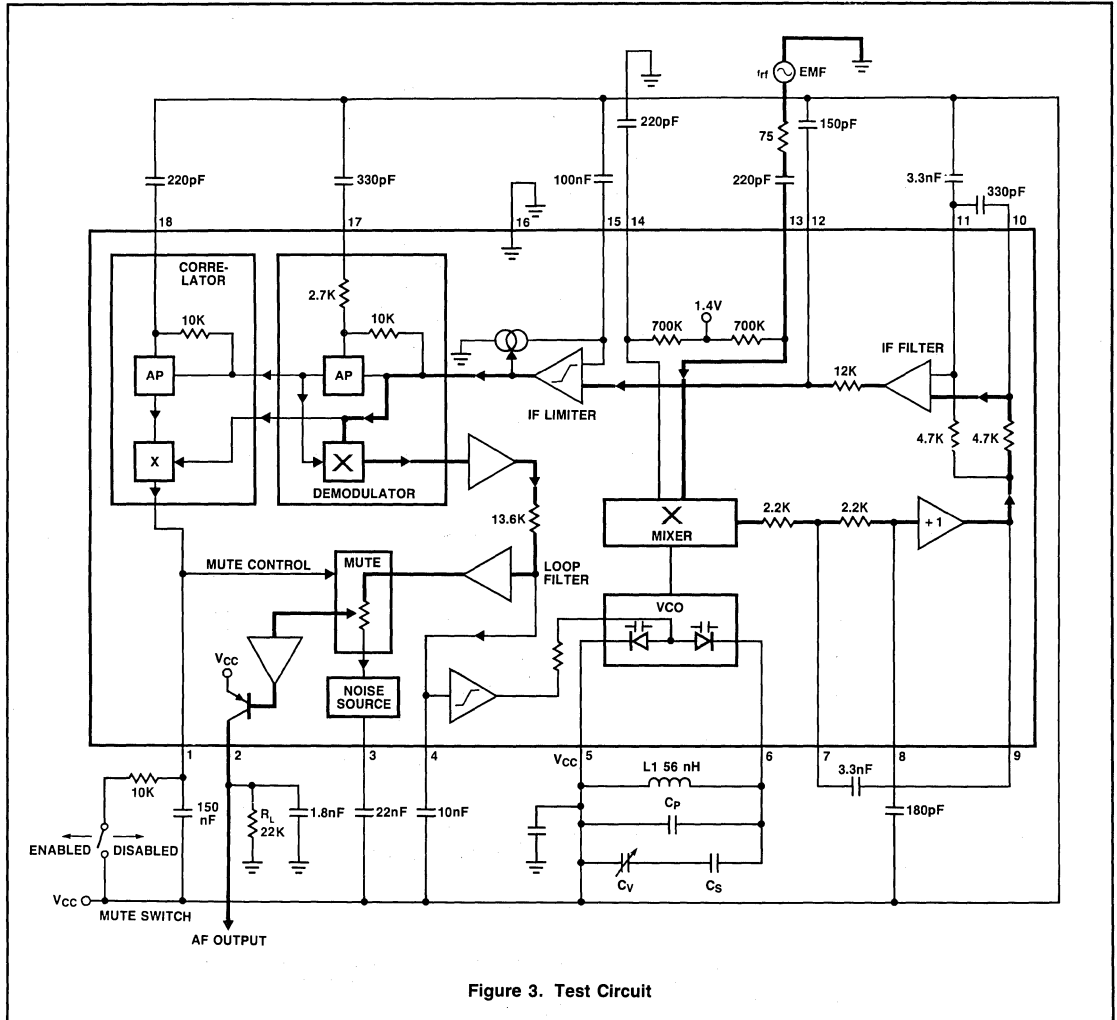

Figure 3. Test Circuit

FM RADIO CIRCUIT (SO PACKAGE)

TDA7010T

Preliminary

DESCRIPTION

The TDA7010T is a monolithic integrated circuit for mono FM portable radios, where a minimum of peripheral components is important (small dimensions and low costs).

The IC has an FLL (Frequency-Locked-Loop) system with an intermediate frequency of 70 kHz. The I.F. selectivity is obtained by active RC filters. The only function which needs alignment is the resonant circuit for the oscillator, thus selecting the reception frequency. Spurious reception is avoided by means of a mute circuit, which also eliminates too noisy input signals. Special precautions are taken to meet the radiation requirements.

FEATURES

- R.F. input stage
- Mixer
- Local oscillator
- I.F. amplifier/limiter
- Phase demodulator
- Mute detector
- Mute switch

PIN CONFIGURATION

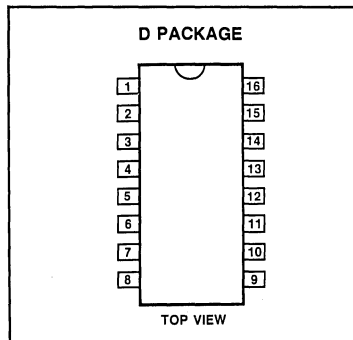

ABSOLUTE MAXIMUM RATINGS

SYMBOL AND PARAMETER	RATING	UNIT
V _{CC} Supply voltage (pin 4)	12	V
V _{B-5} Oscillator voltage (pin 5)	V _{CC} -0.5 to V _{CC} +0.5	V
Total power dissipation	See derating curve Figure 2	
T _{STG} Storage temperature range	-55 to +150	°C
T _A Operating ambient temperature range	0 to +60	°C

FUNCTIONAL PIN DESCRIPTION

PIN NO.	NAME AND FUNCTION
1	Muting capacitor
2	Audio frequency output
3	Loop filter capacitor
4	Supply voltage
5	VCO
6	1st integrator capacitor (to pin 8)
7	2nd integrator capacitor
8	1st integrator capacitor (to pin 6)
9	IF filter capacitor
10	IF limiter capacitor
11	RF input
12	Mixer
13	Current source capacitor
14	Ground
15	Demodulator capacitor
16	Correlator capacitor

5

FM RADIO CIRCUIT (SO PACKAGE)

TDA7010T

Preliminary

BLOCK DIAGRAM

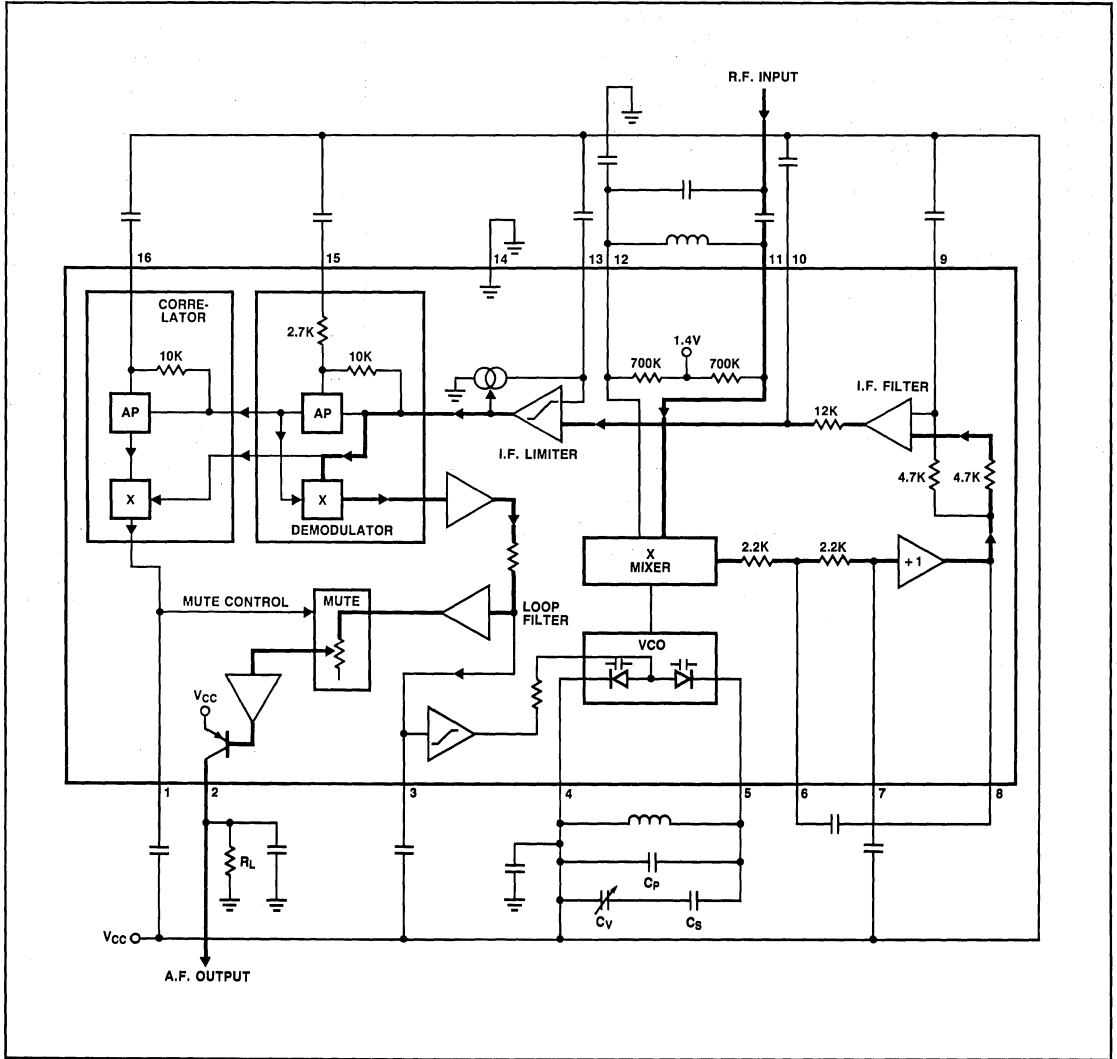

FM RADIO CIRCUIT (SO PACKAGE)

TDA7010T

Preliminary

DC ELECTRICAL CHARACTERISTICS $V_{CC} = 4.5V$; $T_A = 25^\circ C$; measured in Figure 3; unless otherwise specified.

SYMBOL AND PARAMETER	TEST CONDITION	TDA7010T			UNIT
		Min	Typ	Max	
V_{CC} Supply voltage	(Pin 4)	2.7	4.5	10	V
I_{CC} Supply current	$V_{CC} = 4.5V$		8		mA
I_5 Oscillator Current	(Pin 5)		280		μA
V_{12-14} Voltage	(Pin 12)		1.35		V
I_2 Output current	(Pin 2)		60		μA
V_{2-14} Output voltage	(Pin 2) $R_L = 22\text{ k}\Omega$		1.3		V

AC ELECTRICAL CHARACTERISTICS $V_{CC} = 4.5\text{ V}$; $T_A = 25^\circ C$; measured in Figure 3 (mute switch open, enabled); $f_{rf} = 96\text{ MHz}$ (tuned to max. signal at $5\text{ }\mu V$ e.m.f.) modulated with $\Delta f = \pm 22.5\text{ kHz}$; $f_m = 1\text{ kHz}$; $EMF = 0.2\text{ mV}$ (e.m.f. voltage at a source impedance of $75\text{ }\Omega$); r.m.s. noise voltage measured unweighted ($f = 300\text{ Hz}$ to 20 kHz); unless otherwise specified.

SYMBOL AND PARAMETER	TEST CONDITION	TDA7010T			UNIT
		Min	Typ	Max	
EMF Sensitivity (see Figure 2) (e.m.f. voltage)	-3 dB limiting; muting disabled		1.5		μV
	-3 dB muting		6		
	S/N = 26 dB		5.5		
EMF Signal handling (e.m.f. voltage)	THD < 10%; $\Delta f = \pm 75\text{ kHz}$		200		mV
S/N Signal-to-noise ratio			60		dB
THD Total harmonic distortion	$\Delta f = \pm 22.5\text{ kHz}$ $\Delta f = \pm 75\text{ kHz}$		0.7		%
			2.3		%
AMS AM suppression of output voltage	(ratio of the AM output signal referred to the FM output signal) FM signal: $f_m = 1\text{ kHz}$; $\Delta f = \pm 75\text{ kHz}$ AM signal: $f_m = 1\text{ kHz}$; $m = 80\%$		50		dB
RR Ripple rejection	($\Delta V_{CC} = 100\text{ mV}$; $f = 1\text{ kHz}$)		10		dB
$V_{5-4(rms)}$ Oscillator voltage (r.m.s. value)	(Pin 5)		250		mV
Δf_{osc} Variation of oscillator frequency	Supply voltage ($\Delta V_{CC} = 1V$)		60		kHz/V
S_{+300} Selectivity S_{-300}			43		dB
			28		
Δf_{rf} A.F.C. range			± 300		kHz
B Audio bandwidth	$\Delta V_O = 3\text{ dB}$ measured with pre-emphasis ($t = 50\text{ }\mu s$)		10		kHz
$V_{O(rms)}$ A.F. output voltage (r.m.s. value)	$R_L = 22\text{ k}\Omega$		75		mV
R_L Load resistance	$V_{CC} = 4.5V$			22	k Ω
	$V_{CC} = 9.0V$			47	

5

Preliminary

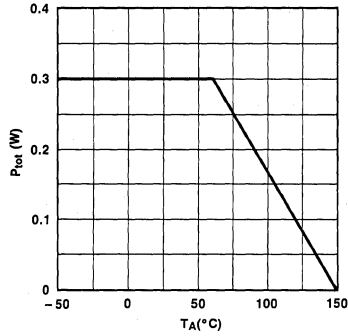

Figure 1. Power Derating Curve

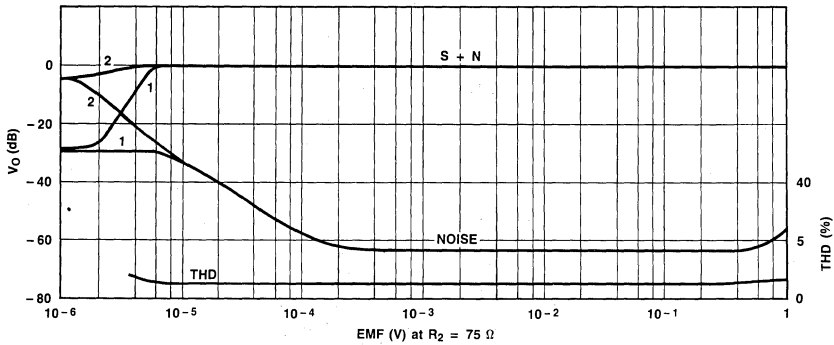

Figure 2. AF output voltage (V_o) and total harmonic distortion (THD) as a function of the E.M.F. input voltage (EMF) with a source impedance (R_s) of 75Ω : (1) muting system enabled; (2) muting system disabled.

Conditions: $0 \text{ dB} = 75\text{mV}$; $f_{rf} = 96 \text{ MHz}$
 for S + N curve: $\Delta f = \pm 22.5 \text{ kHz}$; $f_m = 1 \text{ kHz}$
 for THD curve: $\Delta f = \pm 75 \text{ kHz}$; $f_m = 1 \text{ kHz}$

NOTE:

1. The muting system can be disabled by feeding a current of about $20 \mu\text{A}$ into pin 1.

Preliminary

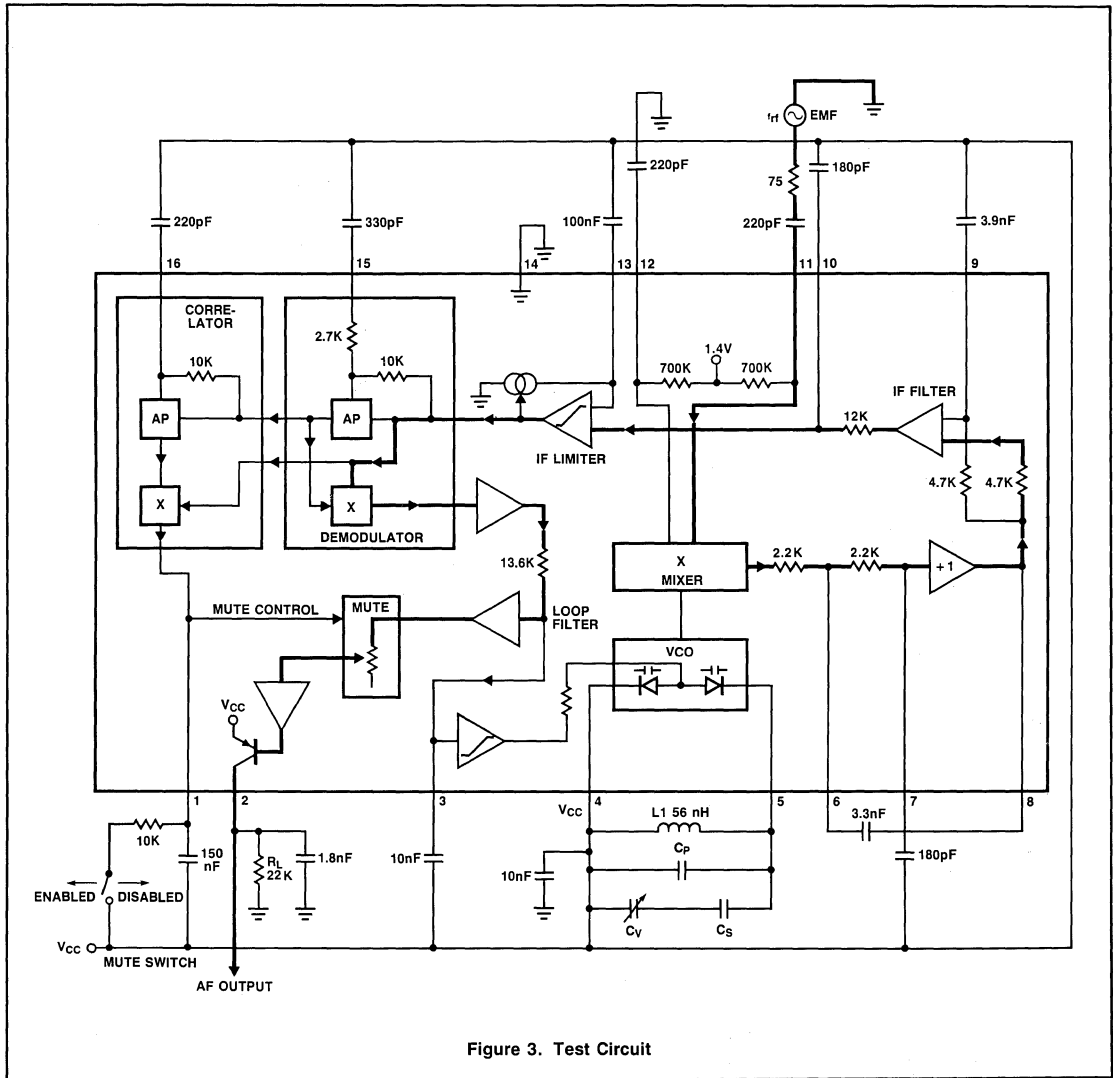

Figure 3. Test Circuit

5

BALANCED MODULATOR/DEMODULATOR

MC1496/MC1596

DESCRIPTION

The MC1496 is a monolithic Double-Balanced Modulator/Demodulator designed for use where the output voltage is a product of an input voltage (signal) and a switched function (carrier). The MC1596 will operate over the full military temperature range of -55°C to $+125^{\circ}\text{C}$. The MC 1496 is intended for applications within the range of 0°C to $+70^{\circ}\text{C}$.

FEATURES

- Excellent carrier suppression
65dB typ @ 0.5MHz
50dB typ @ 10MHz
- Adjustable gain and signal handling
- Balanced inputs and outputs
- High common-mode rejection—85dB typ

APPLICATIONS

- Suppressed carrier and amplitude modulation
- Synchronous detection
- FM detection
- Phase detection
- Sampling
- Single sideband
- Frequency doubling

PIN CONFIGURATIONS

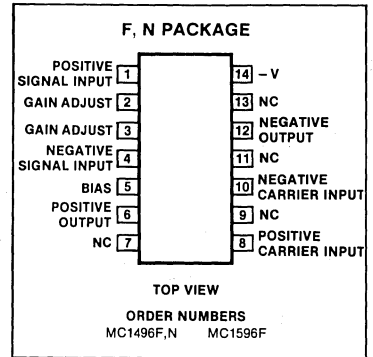

ABSOLUTE MAXIMUM RATINGS

PARAMETER	RATING	UNIT
Applied voltage	30	V
Differential input signal (V_8-V_{10})	± 5.0	V
Differential input signal (V_4-V_1)	$(5 \pm I_S R_e)$	V
Input signal (V_2-V_1, V_3-V_4)	5.0	V
Bias current (I_S)	10	mA
Power dissipation (pkg. limitation) N package	900	mW
Operating temperature range MC1496	0 to $+70$	$^{\circ}\text{C}$
MC1596	-55 to $+125$	$^{\circ}\text{C}$
Storage temperature range	-65 to $+150$	$^{\circ}\text{C}$

EQUIVALENT SCHEMATIC

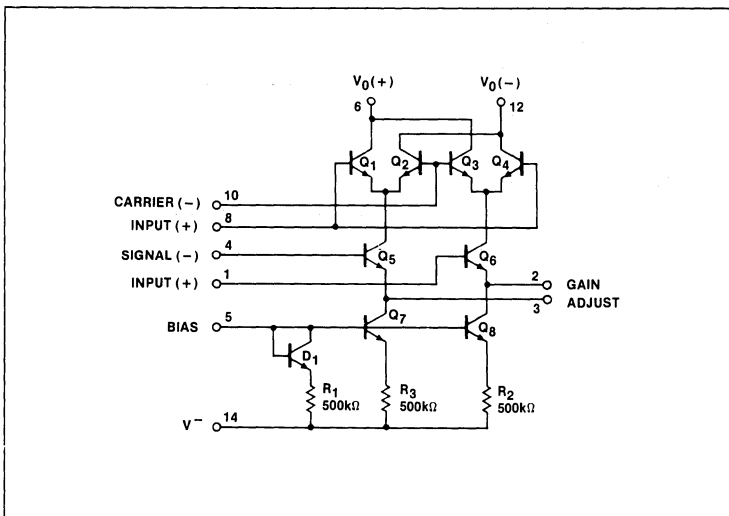

BALANCED MODULATOR/DEMODULATOR

MC1496/MC1596

DC ELECTRICAL CHARACTERISTICS

$V^+ = +12\text{Vdc}$, $V^- = -8.0\text{Vdc}$, $I_5 = 1.0\text{mAdc}$, $R_L = 3.9\text{k}\Omega$, $R_e = 1.0\text{k}\Omega$,
 $T_A = 25^\circ\text{C}$ unless otherwise specified.

PARAMETER	TEST CONDITIONS	MC1596			MC1496			UNIT
		Min	Typ	Max	Min	Typ	Max	
R_{ip} C_{ip}	Single-ended input impedance Parallel input resistance Parallel input capacitance		200 2.0			200 2.0		$\text{k}\Omega$ pF
R_{op} C_{op}	Single-ended output impedance Parallel output resistance Parallel output capacitance		40 5.0			40 5.0		$\text{k}\Omega$ pF
I_{bS} I_{bC}	Input bias current $I_{bS} = \frac{I_1 + I_4}{2}$ $I_{bC} = \frac{I_8 + I_{10}}{2}$		12 12	25 25		12 12	30 30	μA μA
I_{iOS} I_{iOC}	Input offset current $I_{iOS} = I_1 - I_4$ $I_{iOC} = I_8 - I_{10}$		0.7 0.7	5.0 5.0		0.7 0.7	7.0 7.0	μA μA
T_{clio} I_{oo}	Average temperature coefficient of input offset current Output offset current $I_6 - I_{12}$		2.0 14			2.0 15		$\text{nA}/^\circ\text{C}$ μA
T_{cloo} V_o	Average temperature coefficient of output offset current Common-mode quiescent Output voltage (Pin 6 or Pin 12)		90			90		$\text{nA}/^\circ\text{C}$ Vdc
I_{D+} I_{D-}	Power supply current $I_6 + I_{12}$ I_{14}		2.0 3.0	3.0 4.0		2.0 3.0	4.0 5.0	mAdc
P_D	DC power dissipation		33			33		mW

5

TEST CIRCUIT

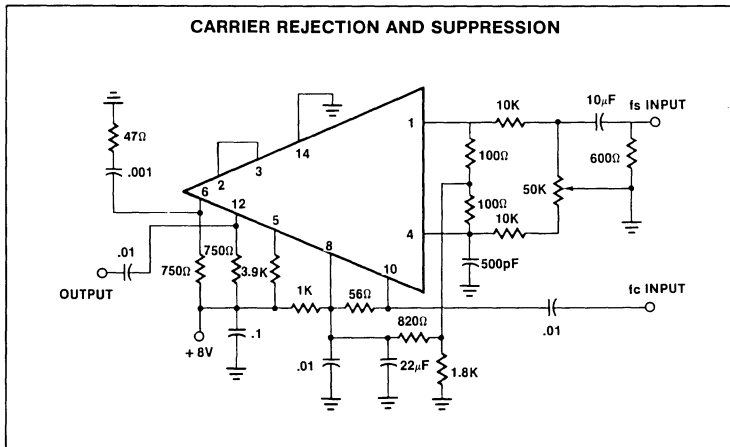

TEST CIRCUIT

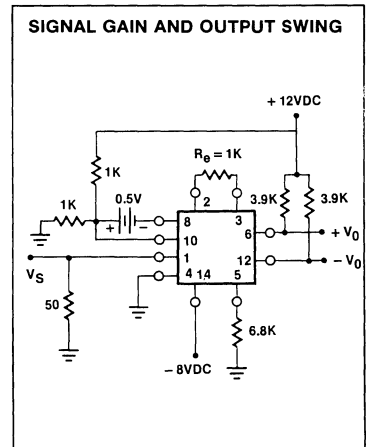

BALANCED MODULATOR/DEMODULATOR

MC1496/MC1596

AC ELECTRICAL CHARACTERISTICS $V^+ = +12Vdc$, $V^- = -9.0Vdc$. $I_S = 1.0mAdc$, $R_L = 3.9k\Omega$, $R_e = 1.0k\Omega$, $T_A = +25^\circ C$ unless otherwise specified.

PARAMETER	TEST CONDITIONS	MC1596			MC1496			UNIT
		Min	Typ	Max	Min	Typ	Max	
V _{CFT} Carrier feedthrough	$V_c = 60mV_{rms}$ sinewave and offset adjusted to zero $f_c = 1.0kHz$ $f_c = 10MHz$		40 140			40 140	μV_{rms}	
	$V_c = 300mV_{p-p}$ squarewave: Offset adjusted to zero $f_c = 1.0kHz$ Offset not adjusted $f_c = 1.0kHz$	0.04 20	0.2 100		0.04 20	0.4 200	mV_{rms}	
V _{CS} Carrier suppressions	$f_s = 10kHz$, $300mV_{rms}$ sinewave $f_c = 500kHz$, $60mV_{rms}$ sinewave $f_c = 10MHz$, $60mV_{rms}$ sinewave	50	65 50		40	65 50	dB	
BW _{3dB} Transadmittance bandwidth (Magnitude) ($R_L = 50\Omega$)	Carrier input port, $V_c = 60mV_{rms}$ sinewave $f_s = 1.0kHz$, $300mV_{rms}$ sinewave		300		300		MHz	
	Signal input port, $V_s = 300mV_{rms}$ sinewave $ V_c = 0.5Vdc$		80		80		MHz	
AV _S Signal gain	$V_s = 100mV_{rms}$; $f = 1.0kHz$ $ V_c = 0.5Vdc$	2.5	3.5		2.5	3.5	V/V	
CMV Common-mode input swing	Signal port, $f_s = 1.0kHz$		5.0		5.0		Vp-p	
ACM Common-mode gain	Signal port, $f_s = 1.0kHz$ $ V_c = 0.5Vdc$		-85		-85		dB	
DV _{OUT} Differential output voltage swing capability			8.0		8.0		Vp-p	

TEST CIRCUIT

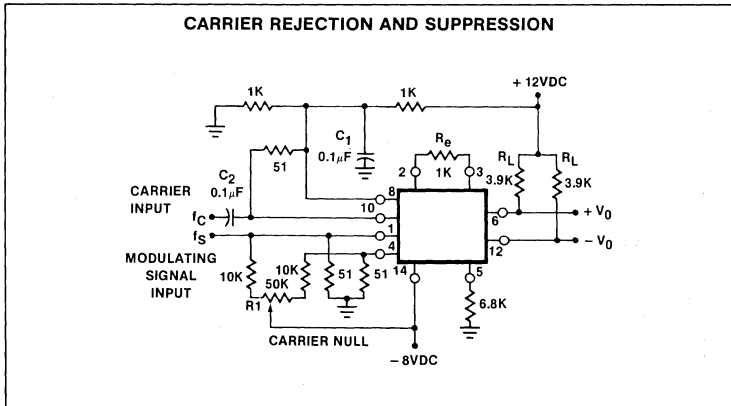

*For additional information, consult the Applications Section.

DESCRIPTION

The NE5080 is the transmitter chip, of a two chip set, designed to be the heart of an FSK modem. (The NE5081 is the receiver chip.) The chips are compatible with the IEEE 802.4 standard for a "Single Channel Phase-Continuous-FSK Bus." The specifications shown in this data sheet are those guaranteed when the transmitter is tuned for the frequencies given in the 802 standard. However, both the NE5080 and the NE5081 may be used at other frequencies. The ratio of logic high to logic low frequencies remains fixed at 1.67 to 1.00 at any center frequency.

FEATURES

- Meets IEEE 802.4 standard
- Data rates to several Megabaud
- Half or full duplex operation
- Jabber function on chip

APPLICATIONS

- Local Area Networks
- Point-to-point communications
- Factory automation
- Process control
- Office automation

PIN CONFIGURATION

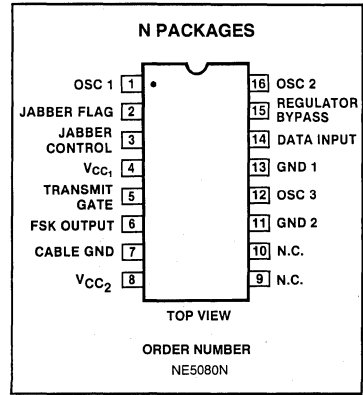

ABSOLUTE MAXIMUM RATINGS

SYMBOL & PARAMETER	RATING	UNIT
Supply Voltage V_{CC1} V_{CC2}	+ 6	V
Input Voltage Range (Data, Gate)	- 0.3 to + V_{CC}	V
Power Dissipation	800	mW
Operating Temperature Range	0 to + 70	°C
Max Junction Temperature	+ 150	°C
Storage Temperature Range	- 65 to + 150	°C
Lead Temperature (soldering, 10 sec)	300	°C

5

BLOCK DIAGRAM

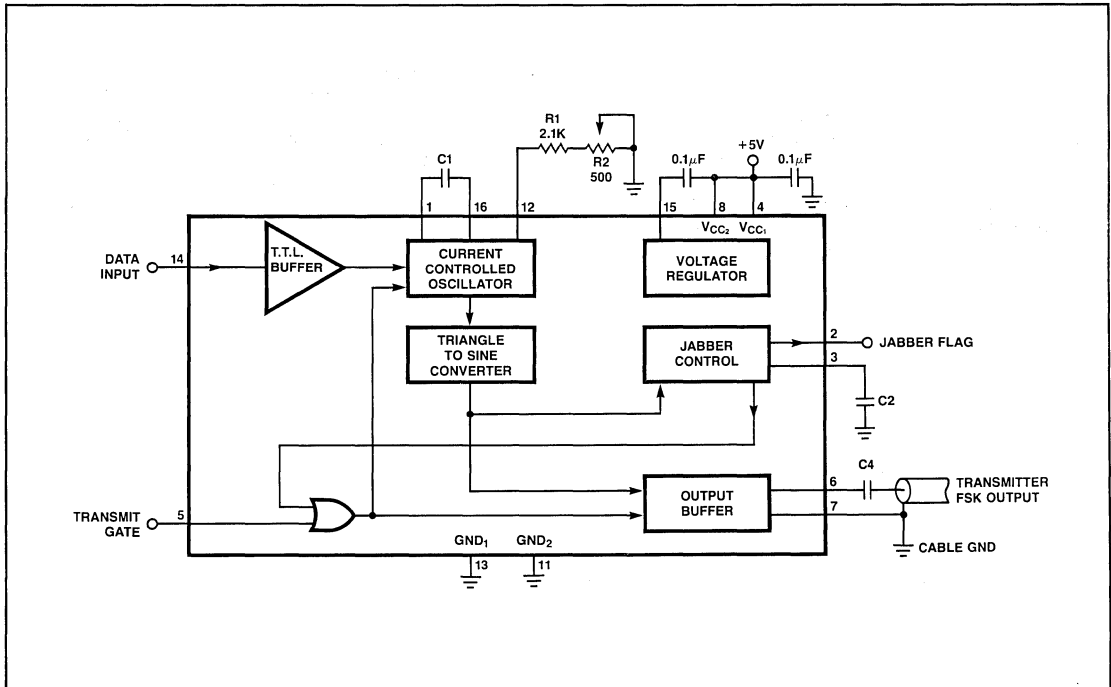

HIGH SPEED FSK MODEM TRANSMITTER

NE5080

GENERAL DESCRIPTION

The NE5080 is designed to transmit high frequency asynchronous data on coaxial cable, at rates from DC to 2 Megabaud (see note 1). The chip accepts serial data and transmits it as a periodic signal whose frequency depends on whether the data is high or low.

The device is meant to operate at a frequency of 6.25MHz for a logic high and 3.75MHz for a logic low (see note 2). The frequency is set up by external trimming components; however, the ratio of the high and low frequencies is set internally and cannot be altered.

The FSK output can be turned off by use of the transmit gate pin. When turned off, the transmitter has a high output impedance and the oscillator is disabled.

The length of time a transmitter can transmit can be controlled by the use of the Jabber control pin (see description of Jabber Control Pin).

Jabber Control Pin

During the time the transmitter is transmitting, this pin sources a current. This current can be used to set the maximum time that the transmitter can be on. There are three options that can be used:

1. Use the current to charge a capacitor. When the voltage across the cap gets to approx. 1.4V the transmitter will turn off. A logic low applied to pin 3 will reset the Jabber function; an open collector output should be used for this purpose. A logic high applied to the pin will disable the transmitter.
2. Use to externally sense the current and have external circuitry to control the length of time the transmitter is on.

NE5080 PIN FUNCTION

PIN	FUNCTION
1	OSC 1 —one end of an external capacitor used to set the carrier frequency
2	JABBER FLAG —this pin goes to a logic high if the transmitter attempts to transmit for a longer time than allowed by the Jabber control function
3	JABBER CONTROL —used to control transmit time. See note on Jabber function
4	V_{CC1} —voltage supply
5	TRANSMIT GATE —a logic low on this pin will enable the transmitter; a logic high will disable it
6	TRANSMITTER FSK OUTPUT
7	CABLE GROUND —the shield of the coax cable should be connected to this pin and to Pin 11
8	V_{CC2} —Connect to pin 4 close to device
9	No Connection
10	No Connection
11	GROUND 2 —connect to Analog ground close to device
12	OSC 3 —a variable resistor between this point and ground is used to set the carrier frequencies.
13	GROUND 1 —connect to Analog ground close to device
14	DATA INPUT
15	REGULATOR BYPASS —a bypass capacitor between this pin and V _{CC1} is required for the internal voltage regulator function
16	OSC 2 —one end of a capacitor that is between pin 1 and pin 16 and is used to set the carrier frequency

3. The pin can be tied to ground and is then not active. Transmission is then controlled solely by the signal at the transmit gate pin.

Jabber Flag Pin

This pin will go to a logic high when the Jabber Control pin is used to shut off the transmitter. It will latch and can be reset by applying a logic low to the Jabber Control pin.

Notes:

1. The NE5080 is capable of transmitting up to 1 Megabaud of differential Manchester code at a center frequency of 5MHz.
2. Although the chip is designed to meet the requirements of IEEE standard 802.4 (Token-Passing Single Channel Phase-Continuous-FSK Bus), it can be used at other frequencies. See "Determining Component Values."

HIGH SPEED FSK MODEM TRANSMITTER

NE5080

ELECTRICAL CHARACTERISTICS $V_{CC1,2} = 4.75-5.25V$ $T_A = 0^{\circ}C$ to $+70^{\circ}C$

PARAMETER	SYMBOL	TEST CONDITIONS	NE5080			UNIT
			Min.	Typ.	Max.	
Output Frequency (Logic High)	F_1	Data Input $\geq 2.0V$ (See Note 1)	6.17	6.25	6.33	MHz
Output Frequency (Logic Low)	F_0	Data Input $\leq 0.8V$ (See Note 1)	3.67	3.75	3.83	MHz
Output Amplitude	V_0	Data Input $\geq 2.0V$ or $\leq 0.8V$ Output Load = 37.5Ω	0.5		1.0	V_{RMS}
Output Impedance (gated off)	R_{off}	Transmit gate $\geq 2.0V$	100			K Ω
Output Impedance (gated on)	R_{on}	Transmit gate $\leq 0.8V$			37.5	Ω
Output Capacitance	C_0	Transmit gate $\geq 2.0V$ or $\leq 0.8V$			10	pF
Feed through	V_F	Transmit gate $\geq 2.0V$ 2.0MHz sq. wave (TTL Levels) Input			1	mV $_{RMS}$
Jabber Current	I_J	Transmit gate $\leq 0.8V$ Input $\geq 2.0V$ or $\leq 0.8V$		1.25		μA
Supply Current	I_{CC}	V_{CC1} connected to V_{CC2}		75	100	mA
LOGIC LEVELS						
Data Input						
Logic High	V_{IH}	Input high voltage	2.0			Volts
Logic Low	V_{IL}	Input low voltage			0.8	Volts
Input Current	I_{IH}	$V_{in} = 2.4V$			40	μA
Input Current	I_{IL}	$V_{in} = 0.4V$			-1.6	mA
Transmit Gate						
Logic High	V_{IH}	Input high voltage	2.0			Volts
Logic Low	V_{IL}	Input low voltage			0.8	Volts
Input Current	I_{IH}	$VG = 2.4V$			40	μA
Input Current	I_{IL}	$VG = 0.4V$			-1.6	mA
Jabber Flag						
Logic High	V_{OH}	$IOH = -400\mu A$	2.4			Volts
Logic Low	V_{OL}	$IOL = 4.0mA$			0.4	Volts
Jabber Control						
Logic High	V_{IH}	Input high voltage	2.0			Volts
Logic Low	V_{IL}	Input low voltage			0.8	Volts

NOTE

(1) Tuned per instructions in Applications section.

AC ELECTRICAL CHARACTERISTICS

SYMBOL & PARAMETER	TO	FROM	TEST CONDITIONS	NE5080			UNIT
				Min.	Typ.	Max.	
Set Up Time — T_S	Data In	Gate On	Figure 1	2	0.1		μS
Delay Time — T_A	Output Freq. Change	Data Transition	Figure 2			150	nS
Delay Time — T_B	Output Disabled	Gate Off	Figure 3		0.4	2	μS
Delay Time — T_C	Output Disabled	Jabber Control	Figure 4			100	nS
Delay Time — T_D	Jabber Flag	Jabber Control	Figure 5			100	nS
Jabber Control Reset Pulse Width (Logic Low)				100			nS

5

TIMING DIAGRAMS

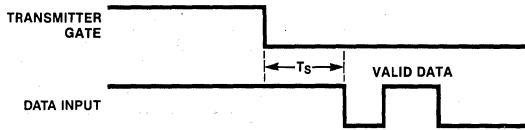

Figure 1. Set-up Time, T_S

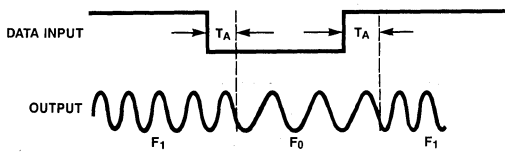

Figure 2. Delay Time, T_A

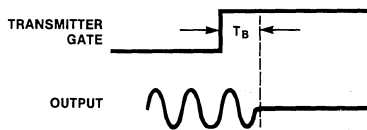

Figure 3. Delay Time, T_B

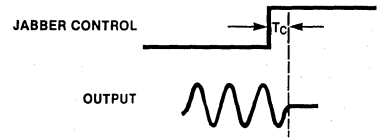

Figure 4. Delay Time, T_C

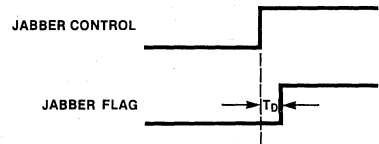

Figure 5. Delay Time, T_D

HIGH SPEED FSK MODEM RECEIVER

NE5081

DESCRIPTION

The NE5081 is the receiver chip of a two chip set designed to operate as an FSK modem (the NE5080 is the transmitter chip). The chips are compatible with the IEEE 802.4 standard for a "Single Channel Phase-Continuous-FSK Bus." The specifications given in this data sheet are those guaranteed when the receiver is tuned to the frequencies in the 802 standard. However, the receiver will work at other frequencies.

FEATURES

- Meets IEEE 802.4 standard
- Data rates to several Megabaud
- Half or full duplex operation
- Low bit rate error (10^{-12} typical)

APPLICATIONS

- Local Area Networks
- Point-to-point communications
- Factory automation
- Process control
- Office automation

PIN CONFIGURATION

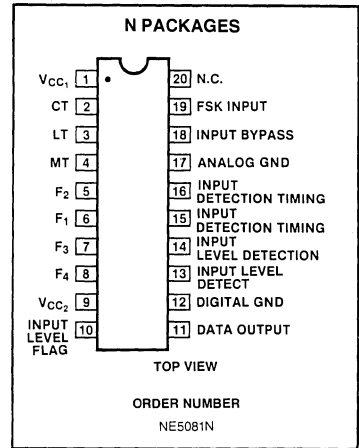

ABSOLUTE MAXIMUM RATINGS $T_A = 25^\circ\text{C}$

SYMBOL & PARAMETER	RATING	UNIT
Supply Voltage V_{CC1} V_{CC2}	+6	Volts
Input Voltage Range Output (Data, Level Detect)	-0.3 to $+V_{CC}$	Volts
Max Sink Current	20	mA
Power Dissipation	800	mW
Operating Temperature Range	0 to +70	$^\circ\text{C}$
Storage Temperature Range	-65 to +150	$^\circ\text{C}$
Lead Temperature (soldering, 10 sec)	300	$^\circ\text{C}$
Max Differential Voltage between Analog and Digital Grounds	100	mV

BLOCK DIAGRAM

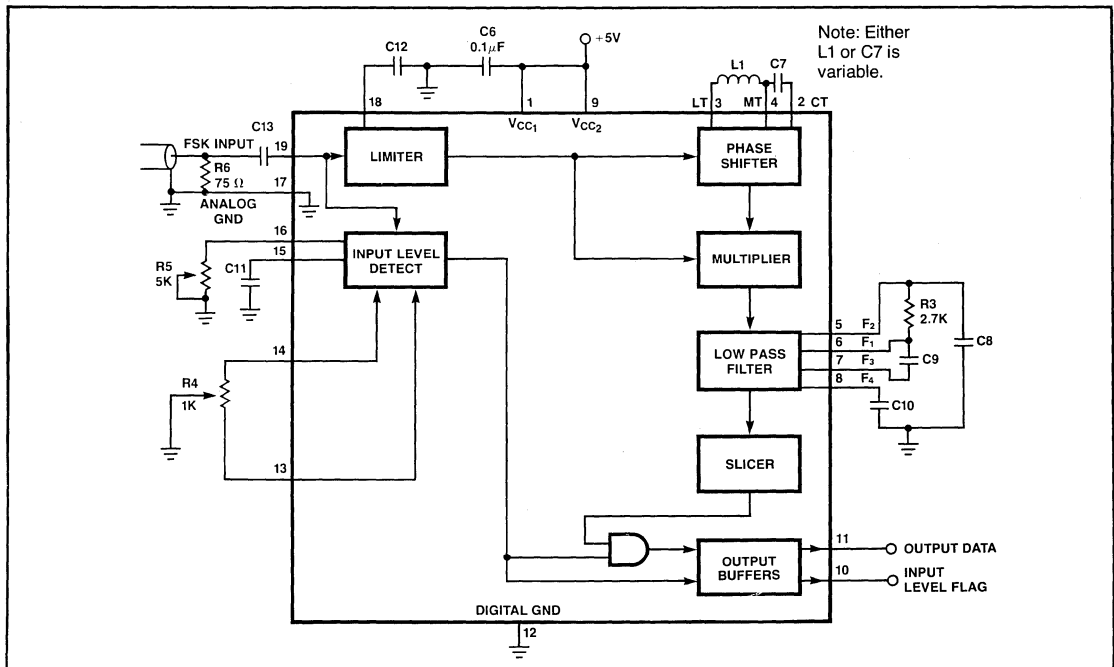

HIGH SPEED FSK MODEM RECEIVER

NE5081

GENERAL DESCRIPTION

The NE5081 will accept an FSK encoded signal and provide the demodulated digital data at the output. It is optimized to work at frequencies specified in IEEE 802.4 (Token-Passing Single Channel Phase-Continuous FSK Bus) i.e., 3.75MHz and 6.25MHz. However, it will work at other frequencies (see note 1).

Its normal acceptable input signal level range is from 16mV RMS to 1V RMS. (This can be adjusted, see note 2 below.)

The receiver will yield an undetected "Bit Error Rate" of 10^{-9} or lower when receiving signals with a 20dB signal-to-noise ratio. It has a maximum output jitter of ± 40 nSec (see definition of "Jitter" note 3).

Notes:

- The receiver can be tuned to accept different frequencies by adjustment of the LC circuit shown in Fig. 7. However, the external components have been optimized for 3.75MHz and 6.25MHz. See "Determining Component Values" for use at other frequencies.
- Input Level Detect
This is a method of turning off the output of the receiver when the input signal falls below an acceptable level. This level is adjustable within the range given in the electrical specification section. The purpose of this function is to minimize the effect of noise on receiver performance and to indicate when there is an acceptable signal present at the input. All specifications given in this data sheet are with the input level detection set at 16mV RMS.
- Jitter Definition
This is a measure of the ability of the receiver to accurately reproduce the timing of its FSK coded digital input. The spec indicates the error band in the timing of a logic level change.

NE5081 PIN FUNCTION

PIN	FUNCTION
1	V_{CC1} —should be connected to the 5 volt supply and pin 9
2	CT—one end of an external capacitor that is used to tune the receiver
3	LT—one end of an inductor that is used to tune the receiver
4	MT—the junction of the capacitor and inductor used for tuning the receiver
5	F2
6	F1
7	F3
8	F4
9	V_{CC2} —connect to Pin 1 (see Pin 1 function) close to the device
10	INPUT LEVEL FLAG—this pin is used to indicate when there is a signal at the input that is greater than the level set by the input level detection circuitry. A logic high indicates an input greater than the set level
11	DATA OUTPUT—supplies T ² L level data that corresponds to the FSK input received
12	DIGITAL GROUND—should be connected to digital ground
13 and 14	INPUT LEVEL DETECT—These pins are used to set the level of input signal that the device will accept as valid
15	INPUT DETECTION TIMING—an external capacitor between this pin and ground is used to determine the time from carrier turn-off to output disable
16	INPUT DETECTION TIMING—same as pin 15, except that a resistor goes between this pin and ground. The values of the C and R depend on the carrier frequency. The values given in this data sheet are for a 5MHz carrier center frequency
17	ANALOG GROUND—connect to analog ground close to the device
18	INPUT BYPASS—A capacitor between this pin and ground is used to bypass the input bias circuitry
19	INPUT—the FSK signal from the cable goes to this pin
20	NO CONNECTION

HIGH SPEED FSK MODEM RECEIVER

NE5081

ELECTRICAL CHARACTERISTICS $V_{CC1,2} = 4.75 - 5.25V$. External LC circuit tuned to 5MHz. Input level detect set at 16mV Rms, $T_A = 0^{\circ}C$ to $+70^{\circ}C$.

PARAMETER	SYMBOL	TEST CONDITIONS	NE5081			UNIT
			Min.	Typ.	Max.	
Logic Low Frequency	F_0	External LC tuned to 5MHz	3.67	3.75	3.83	MHz
Logic High Frequency	F_1	External LC tuned to 5MHz	6.17	6.25	6.33	MHz
Minimum Input Detect Level	IN_{DL}	Minimum input level that is detected as carrier. See Note 2 in General Description	5		50	mV RMS
LOGIC LEVELS:						
Data Output	V_{OL}	$I_{OL} = 4.0mA$ $V_{IN} > 16mV$ RMS Freq = F_0			0.4	Volts
Data Output	V_{OH}	$I_{OH} = -400\mu A$ $V_{IN} > 16mV$ RMS Freq = F_1	2.4			Volts
Data Output	V_{OH}	$I_{OH} = -400\mu A$ $V_{IN} < 5mV$ RMS Freq = F_0	2.4			Volts
Input Detect Flag	V_{OL}	$I_{OL} = 4.0mA$ $V_{IN} = 0V$ RMS			0.4	Volts
	V_{OH}	$I_{OH} = -400\mu A$ $V_{IN} > 16mV$	2.4			Volts
Supply Current	I_{CC}	$V_{CC} = 5.25V$ (V_{CC1} connected to V_{CC2}) $V_{IN} = 1.0V$ RMS Freq = F_1 or F_0			50	mA
Bit Error Rate	B.E.R	Input Signal $> 16mV$ RMS. maximum in-band noise = 1.6mV RMS		10^{-12}	10^{-9}	

5

AC ELECTRICAL CHARACTERISTICS

SYMBOL & PARAMETER	TO	FROM	TEST CONDITIONS	NE5081			UNIT
				Min.	Typ.	Max.	
Delay Time T_B	Input Level Detect Flag	Input On	Figure 1		0.05	1	μS
Delay Time T_C	Input Level Detect Flag	Input Off	Figure 1	.5	1.5	2.5	μS
Delay Time T_D	Output Enabled	Input On	Figure 2			2	μS
Delay Time T_E	Output Disabled	Input Off	Figure 2	.5	1.5	2.5	μS
Required Delay	Carrier Turn Off	Valid Data End		2			μS

TIMING DIAGRAMS

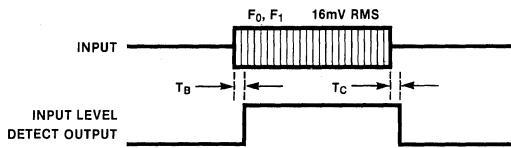

Figure 1. Delay Time, T_B , T_C

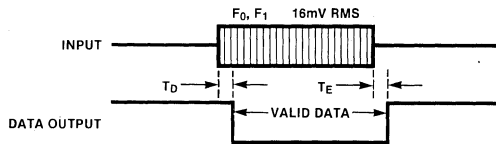

Figure 2. Delay Time, T_D , T_E

The SAF1032P (receiver/decoder) and the SAF1039P (transmitter) form the basic parts of a sophisticated remote control system (pcm: pulse code modulation) for infrared operation. The ICs can be used, for example, in TV, audio, industrial equipment, etc.

Features:

SAF1032P receiver/decoder:

- 16 programme selection codes
- automatic preset to stand-by at power 'ON', including automatic analogue base settings to 50% and automatic preset of programme selection '1' code
- 3 analogue function controls, each with 63 steps
- single supply voltage
- protection against corrupt codes.

SAF1039P transmitter:

- 32 different control commands
- static keyboard matrix
- current drains from battery only during key closure time
- two transmission modes selectable.

The devices are implemented in LOCMOS (Local Oxidation Complementary MOS) technology to achieve an extremely low power consumption.

Inputs and outputs are protected against electrostatic effects in a wide variety of device-handling situations. However, to be totally safe, it is desirable to take handling precautions into account.

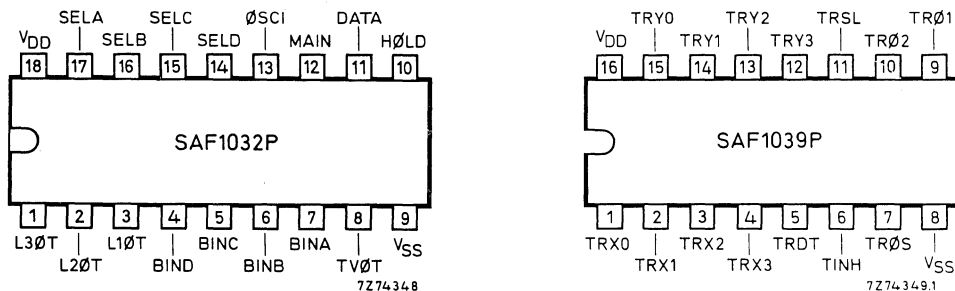

Fig. 1 Pin designations.

PACKAGE OUTLINES

SAF1032P: 18-lead DIL; plastic (SOT-102A).

SAF1039P: 16-lead DIL; plastic (SOT-38Z).

R/C RECEIVER; R/C TRANSMITTER**SAF1032P/39P****PINNING**

To facilitate easy function recognition, each integrated circuit pin has been allocated a code as shown below.

SAF1032P

1	L3ØT	linear output	10	HØLD	control input
2	L2ØT	linear output	11	DATA	data input
3	L1ØT	linear output	12	MAIN	reset input
4	BIND	binary 8 output	13	ØSCI	clock input
5	BINC	binary 4 output	14	SELD	binary 8 output
6	BINB	binary 2 output	15	SELC	binary 4 output
7	BINA	binary 1 output	16	SELB	binary 2 output
8	TVØT	on/off input/output	17	SELA	binary 1 output
9	VSS		18	VDD	

SAF1039P

1	TRX0	keyboard input	9	TRØ1	oscillator control input
2	TRX1	keyboard input	10	TRØ2	oscillator control input
3	TRX2	keyboard input	11	TRSL	keyboard select line
4	TRX3	keyboard input	12	TRY3	keyboard input
5	TRDT	data output	13	TRY2	keyboard input
6	TINH	inhibit output/mode select input	14	TRY1	keyboard input
7	TRØS	oscillator output	15	TRY0	keyboard input
8	VSS		16	VDD	

BASIC OPERATING PRINCIPLES

The data to be transmitted are arranged as serial information with a fixed pattern (see Fig. 2), in which the data bit-locations B₀ to B₄ represent the generated key-command code. To cope with IR (infrared) interferences of other sources a selective data transmission is present. Each transmitted bit has a burst of 26 oscillator periods.

Before any operation will be executed in the receiver/decoder chip, the transmitted data must be accepted twice in sequence. This means the start code must be recognized each time a data word is applied and comparison must be true between the data bits of two successively received data words. If both requirements are met, one group of binary output buffers will be loaded with a code defined by the stored data bits, and an internal operation can also take place. See operating code table.

The contents of the 3 analogue function registers are available on the three outputs in a pulse code versus time modulation format after D (digital) to A (analogue) conversion. The proper analogue levels can be obtained by using simple integrated networks. For local control a second transmitter chip (SAF1039P) is used (see Fig. 7).

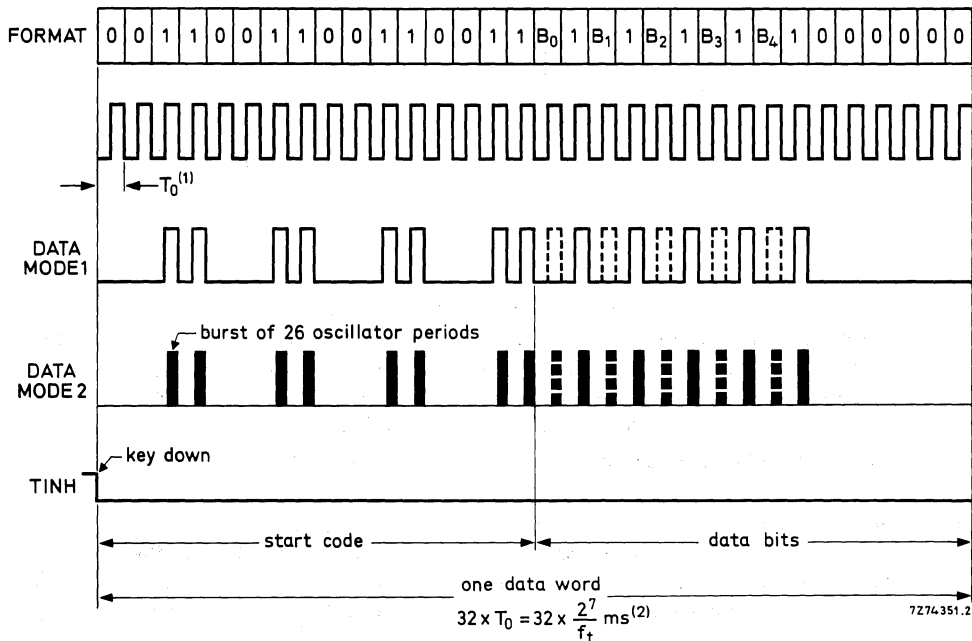

(1) T₀ = 1 clock period = 128 oscillator periods. (2) f_t in kHz.

Fig. 2 Pattern for data to be transmitted.

TIMING CONSIDERATIONS

The transmitter and receiver operate at different oscillator frequencies. Due to the design neither frequency is very critical, but correlation between them must exist. Calculation of these timing requirements shows the following.

With a tolerance of ±10% on the oscillator frequency (f_t) of the transmitter, the receiver oscillator frequency (f_r = 3 x f_t) must be kept constant with a tolerance of ±20%.

On the other hand, the data pulse generated by the pulse stretcher circuit (at the receiver side) may vary ±25% in duration.

GENERAL DESCRIPTION OF THE SAF1039P TRANSMITTER

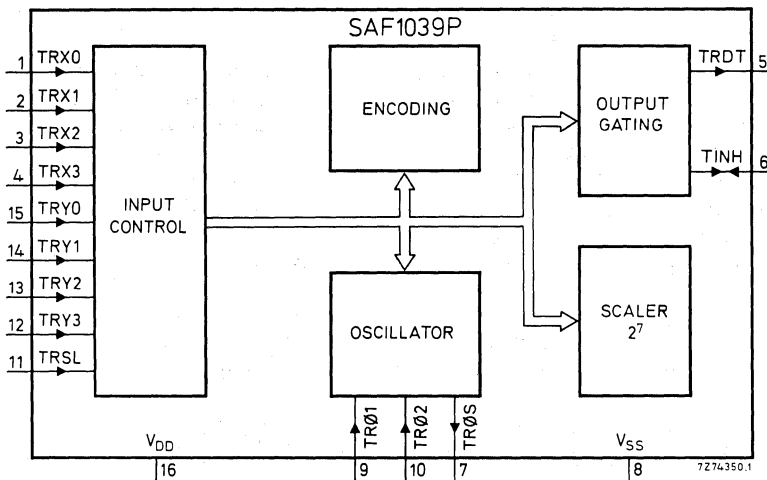

Fig. 3 Block diagram of SAF1039P transmitter.

Any keyboard activity on the inputs TRX0 to TRX3, TRY0 to TRY3 and TRSL will be detected. For a legal key depression, one key down at a time (one TRX and TRY input activated), the oscillator starts running and a data word, as shown on the previous page, is generated and supplied to the output TRDT. If none, or more than 2 inputs are activated at the same time, the input detection logic of the chip will generate an overall reset and the oscillator stops running (no legal key operation).

This means that for each key-bounce the logic will be reset, and by releasing a key the transmitted data are stopped at once.

The minimum key contact time required is the duration of two data words. The on-chip oscillator is frequency controlled with the external components R1 and C1 (see circuit Fig. 6); the addition of resistor R2 means that the oscillator frequency is practically independent of supply voltage variations. A complete data word is arranged as shown in Fig. 2, and has a length of $32 \times T_0$ ms, where $T_0 = 2^7/f_t$.

Operation mode

	DATA	FUNCTION OF TINH
1	unmodulated: LOCAL operation	output, external pull-up resistor to V _{DD}
2	modulated: REMOTE control	input, connected to V _{SS}

GENERAL DESCRIPTION OF THE SAF1032P RECEIVER/DECODER

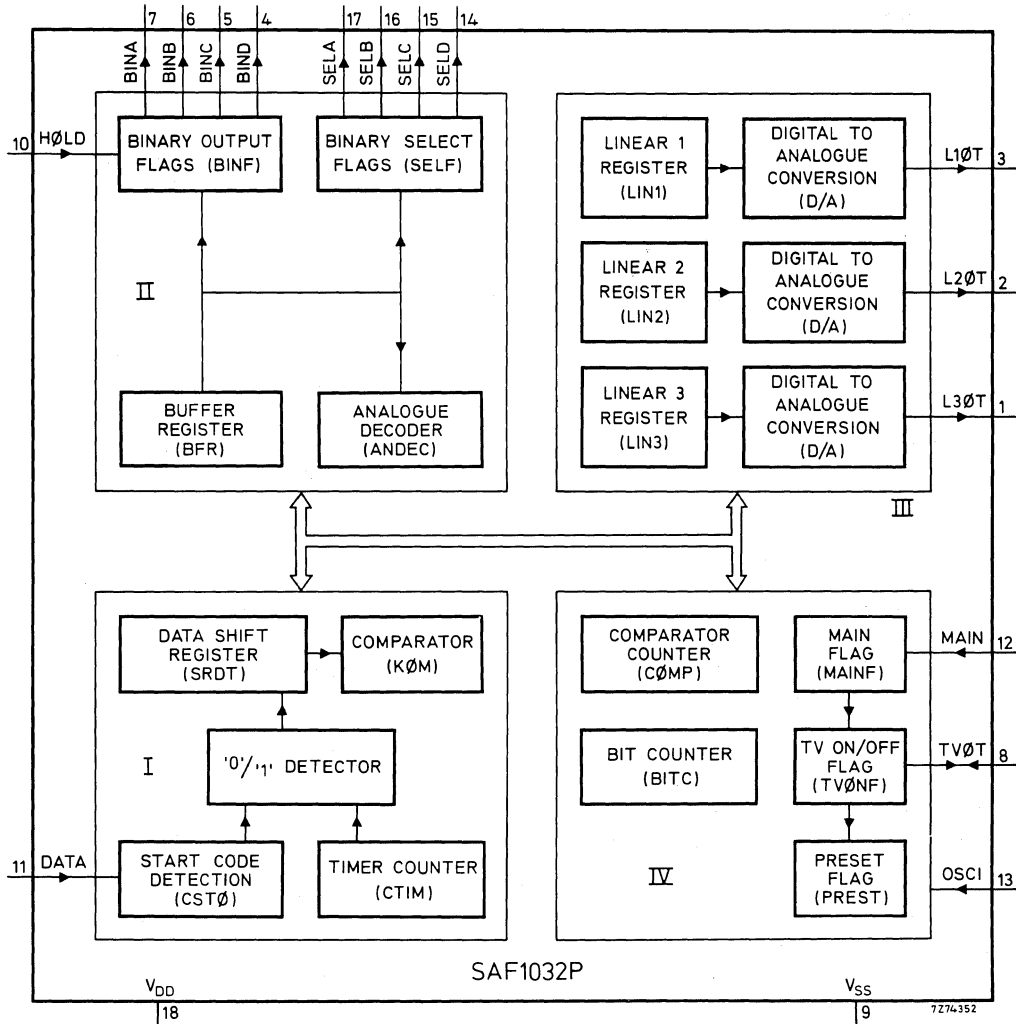

Fig. 4 Block diagram of SAF1032P receiver/decoder.

The logic circuitry of the receiver/decoder chip is divided into four main parts as shown in the block diagram above.

Part I

This part decodes the applied DATA information into logic '1' and '0'. It also recognizes the start code and compares the stored data-bits with the new data-bits accepted.

Part II

This part stores the programme selection code in the output group (BINF) and memorizes it for condition $H\emptyset LD = LOW$.

It puts the functional code to output group (SELF) during data accept time, and decodes the internally used analogue commands (ANDEC).

Part III

This part controls the analogue function registers (each 6-bits long), and connects the contents of the three registers to the analogue outputs by means of D/A conversion. During sound mute, output L1 \emptyset T will be forced to HIGH level.

Part IV

This part keeps track for correct power 'ON' operation, and puts chip in 'stand-by' condition at supply voltage interruptions.

The logic design is dynamic and synchronous with the clock frequency ($\emptyset SCI$), while the required control timing signals are derived from the bit counter (BITC).

Operation

Serial information applied to the DATA input will be translated into logic '1' and '0' by means of a time ratio detector.

After recognizing the start code (CST \emptyset) of the data word, the data bits will be loaded into the data shift register (SRDT). At the first trailing edge of the following data word a comparison (K \emptyset M) takes place between the contents of SRDT and the buffer register (BFR). If SRDT equals BFR, the required operation will be executed under control of the comparator counter (C \emptyset MP).

As shown in the operating code table on the next page, the 4-bit wide binary output buffer (BINF) will be loaded for BFR $\emptyset = '0'$, while for BFR $\emptyset = '1'$ the binary output buffer (SELF), also 4-bit wide will be activated during the data accept time.

At the same time operations involving the internal commands are executed. The contents of the analogue function registers (each 6-bits long) are controlled over 63 steps, with minimum and maximum detection, while the D/A conversion results in a pulsed output signal with a conversion period of 384 clock periods (see Fig. 5).

First power 'ON' will always put the chip in the 'stand-by' position. This results in an internal clearing of all logic circuitry and a 50% presetting of the contents of the analogue registers (analogue base value). The programme selection '1' code will also be prepared and all the outputs will be non-active (see operating output code table).

From 'stand-by' the chip can be made operational via a programme selection command, generated LOCAL or via REMOTE, or directly by forcing the TV ON/OFF output (TV \emptyset T) to zero for at least 2 clock periods of the oscillator frequency.

For POWER ON RESET a negative-going pulse should be applied to input MAIN, when V_{DD} is stabilized; pulse width $LOW \geq 100 \mu s$.

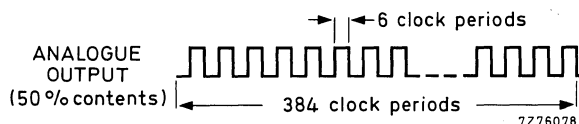

Fig. 5 Analogue output pulses.

R/C RECEIVER; R/C TRANSMITTER

SAF1032P/39P

OPERATING CODE TABLE

key-matrix position			buffer BFR					BINF (BIN.)				SELF (SEL.)				function
TRX.	TRY.	TRSL	0	1	2	3	4	A	B	C	D	A	B	C	D	
0	0	0	0	0	1	1	0	0	0	0	0	1	1	1	1	programme select + ON
0	1	0	0	0	0	1	0	1	0	0	0	1	1	1	1	
0	2	0	0	0	1	0	0	0	1	0	0	1	1	1	1	
0	3	0	0	0	0	0	0	1	1	0	0	1	1	1	1	
1	0	0	0	1	1	1	0	0	0	1	0	1	1	1	1	
1	1	0	0	1	0	1	0	1	0	1	0	1	1	1	1	
1	2	0	0	1	1	0	0	0	1	1	0	1	1	1	1	
1	3	0	0	1	0	0	0	1	1	1	0	1	1	1	1	
2	0	0	0	0	1	1	1	0	0	0	1	1	1	1	1	programme select + ON
2	1	0	0	0	0	1	1	1	0	0	1	1	1	1	1	
2	2	0	0	0	1	0	1	0	1	0	1	1	1	1	1	
2	3	0	0	0	0	0	1	1	1	0	1	1	1	1	1	
3	0	0	0	1	1	1	1	0	0	1	1	1	1	1	1	
3	1	0	0	1	0	1	1	1	0	1	1	1	1	1	1	
3	2	0	0	1	1	0	1	0	1	1	1	1	1	1	1	
3	3	0	0	1	0	0	1	1	1	1	1	1	1	1	1	
0	0	1	1	0	1	1	0	X	X	X	X	0	1	1	1	analogue base reg. (LIN3) + 1
0	1	1	1	0	0	1	0	X	X	X	X	0	0	1	1	
0	2	1	1	0	1	0	0	X	X	X	X	0	1	0	1	
0	3	1	1	0	0	0	0	X	X	X	X	0	0	0	1	
1	0	1	1	1	1	1	0	0	0	0	0	0	0	0	0	
1	1	1	1	1	0	1	0	X	X	X	X	1	0	1	1	
1	2	1	1	1	1	0	0	X	X	X	X	1	1	0	1	
1	3	1	1	1	0	0	0	X	X	X	X	1	0	0	1	
2	0	1	1	0	1	1	1	X	X	X	X	0	1	1	0	mute (set/reset)
2	1	1	1	0	0	1	1	X	X	X	X	0	0	1	0	
2	2	1	1	0	1	0	1	X	X	X	X	0	1	0	0	
2	3	1	1	0	0	0	1	X	X	X	X	0	0	0	0	
3	0	1	1	1	1	1	1	X	X	X	X	1	1	1	0	
3	1	1	1	1	0	1	1	X	X	X	X	1	0	1	0	
3	2	1	1	1	1	0	1	X	X	X	X	1	1	0	0	
3	3	1	1	1	0	0	1	X	X	X	X	1	0	0	0	

5

Note

Reset mute also on programme select codes, (LIN1) ± 1, and analogue base.

OPERATING OUTPUT CODE

	(BIN.)				(SEL.)				(L.ØT)			TVØT
	A	B	C	D	A	B	C	D	1	2	3	
'stand-by' OFF via remote	0	0	0	0	0	0	0	0	1	0	0	1
ON — 'not hold' condition non-operating	1	1	1	1	1	1	1	1	X	X	X	0
ON — 'hold' condition non-operating	X	X	X	X	1	1	1	1	X	X	X	0

RATINGS

Limiting values in accordance with the Absolute Maximum System (IEC 134)

Supply voltage	V_{DD-VSS}	-0.5 to 11 V
Input voltage	V_I	max. 11 V
Current into any terminal	$\pm I_I$	max. 10 mA
Power dissipation (per output)	P_o	max. 50 mW
Power dissipation (per package)	P_{tot}	max. 200 mW
Operating ambient temperature	T_{amb}	-40 to +85 °C
Storage temperature	T_{stg}	-65 to +150 °C

R/C RECEIVER; R/C TRANSMITTER

SAF1032P/39P

CHARACTERISTICS

T_{amb} = 0 to +85 °C (unless otherwise specified)

SAF1039P only

	symbol	min.	typ.	max.		V _{DD} V	T _{amb} °C
Recommended supply voltage	V _{DD}	7	—	10	V		
Supply current							
quiescent	I _{DD}	—	—	10	μA	10	25
operating; TR01 at V _{SS} ; outputs unloaded; one keyboard switch closed	I _{DD}	—	1	50	μA	7	65
	I _{DD}	—	—	1.7	mA	10	all
		—	0.8	—	mA	10	25
Inputs (note 1)							
TR02; TINH (note 2)							
input voltage HIGH	V _{IH}	0.8V _{DD}	—	V _{DD}	V	7 to 10	all
input voltage LOW	V _{IL}	0	—	0.2V _{DD}	V	7 to 10	all
input current	I _I	—	10 ⁻⁵	1	μA	10	25
Outputs							
TRDT; TR0S; TR01							
output current HIGH at V _{OH} = V _{DD} - 0.5 V	-I _{OH}	0.4	—	—	mA	7	all
output current LOW at V _{OL} = 0.4 V	I _{OL}	0.4	—	—	mA	7	all
TRDT output leakage current when disabled V _O = V _{SS} to V _{DD}	I _{OL}	—	—	1	μA	10	25
TINH							
output current LOW V _{OL} = 0.4 V	I _{OL}	0.4	—	—	mA	7	all
Oscillator							
maximum oscillator frequency	f _{osc}	120	—	—	kHz		
frequency variation with supply voltage, temperature and spread of IC properties at f _{nom} = 36 kHz (note 3)	Δf	—	—	0.15f _{nom}		7 to 10	all
oscillator current drain at f _{nom} = 36 kHz	I _{osc}	—	1.3	2.5	mA	10	25

5

Notes follow characteristics.

R/C RECEIVER; R/C TRANSMITTER

SAF1032P/39P

CHARACTERISTICS

T_{amb} = 0 to +85 °C (unless otherwise specified)

SAF1032P only

	symbol	min.	typ.	max.		V _{DD} V	T _{amb} °C
Recommended supply voltage	V _{DD}	8	—	10	V		
Supply current							
quiescent	I _{DD}	—	—	50	µA	10	25
operating; I _O = 0; at ∅SCI frequency of 100 kHz	I _{DD}	—	1	300	µA	10	85
operating; I _O = 0; at ∅SCI frequency of 100 kHz	I _{DD}	—	—	1	mA	10	all
Inputs							
DATA; ∅SCI; H∅LD; TV∅T (see note 4)							
input voltage HIGH	V _{IH}	0.7V _{DD}	—	V _{DD}	V	8 to 10	all
input voltage LOW	V _{IL}	0	—	0.2V _{DD}	V	8 to 10	all
MAIN; tripping levels							
input voltage increasing	V _{ti}	0.4V _{DD}	—	0.9V _{DD}	V	5 to 10	all
input voltage decreasing	V _{td}	0.1V _{DD}	—	0.6V _{DD}	V	5 to 10	all
input current; all inputs except TV∅T	I _I	—	10 ⁻⁵	1	µA	10	25
input signal rise and fall times (10% and 90% V _{DD}) all inputs except MAIN	t _r , t _f	—	—	5	µs	8 to 10	all
Outputs							
programme selection: BINA/B/C/D							
auxiliary: SELA/B/C/D							
analogue: L3∅T; L2∅T; L1∅T TV∅T (note 4)							
all open drain n-channel output current LOW at V _{OL} = 0.4 V	I _{OL}	1.6	—	—	mA	8	all
output leakage current at V _O = V _{SS} to V _{DD}	I _{OL}	—	—	10	µA	10	all

For note 4 see next page.

Notes to characteristics

1. The keyboard inputs (TRX.; TRY.; TRSL) are not voltage driven (see application information diagram Fig. 6).

If one key is depressed, the circuit generates the corresponding code. The number of keys depressed at a time, and this being recognized by the circuit as an illegal operation, depends on the supply voltage (V_{DD}) and the leakage current (between device and printed-circuit board) externally applied to the keyboard inputs.

If no leakage is assumed, the circuit recognizes an operation as illegal for any number of keys > 1 depressed at the same time with $V_{DD} = 7$ V. At a leakage due to a $1\text{ M}\Omega$ resistor connected to each keyboard input and returned to either V_{DD} or V_{SS} , the circuit recognizes at least 2 keys depressed at a time with $V_{DD} = 7$ V.

The highest permissible values of the contact series resistance of the keyboard switches is $500\ \Omega$.

2. Inhibit output transistor disabled.
3. Δf is the width of the distribution curve at $2\ \sigma$ points ($\sigma =$ standard deviation).
4. Terminal TV \emptyset T is input for manual 'ON'. When applying a LOW level TV \emptyset T becomes an output carrying a LOW level.

APPLICATION INFORMATION

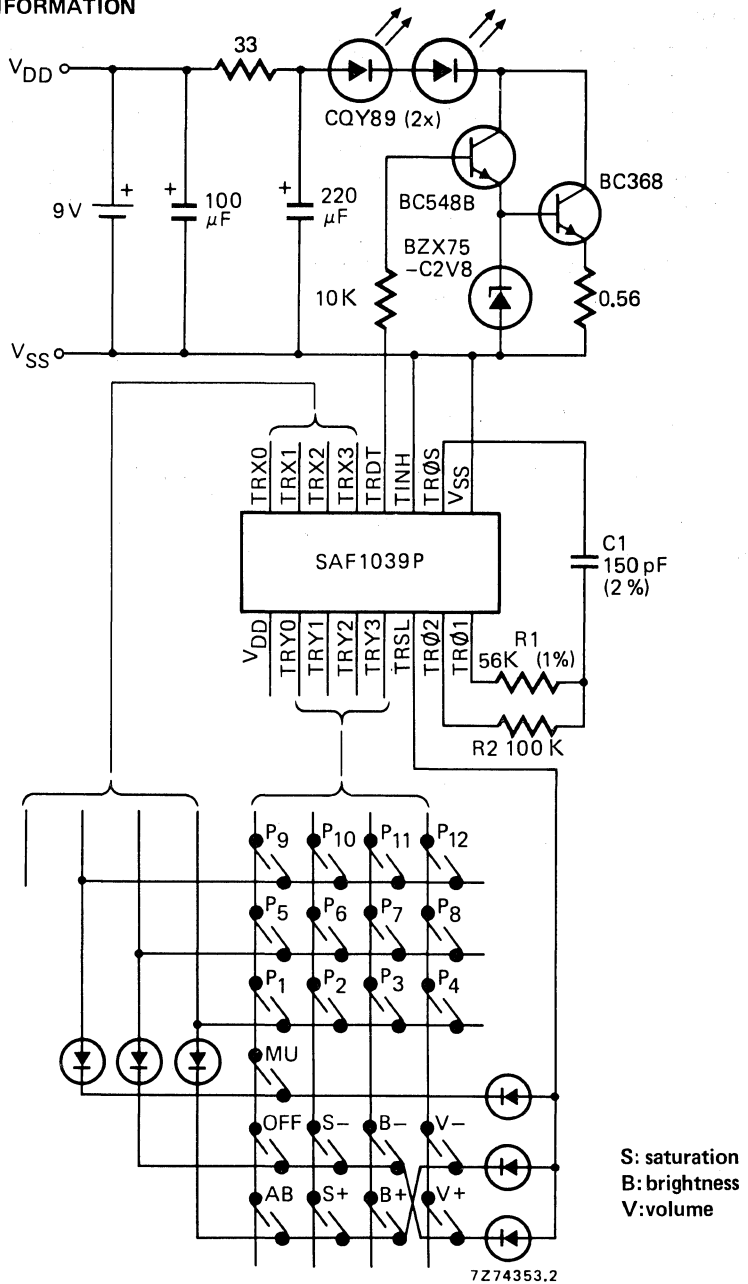
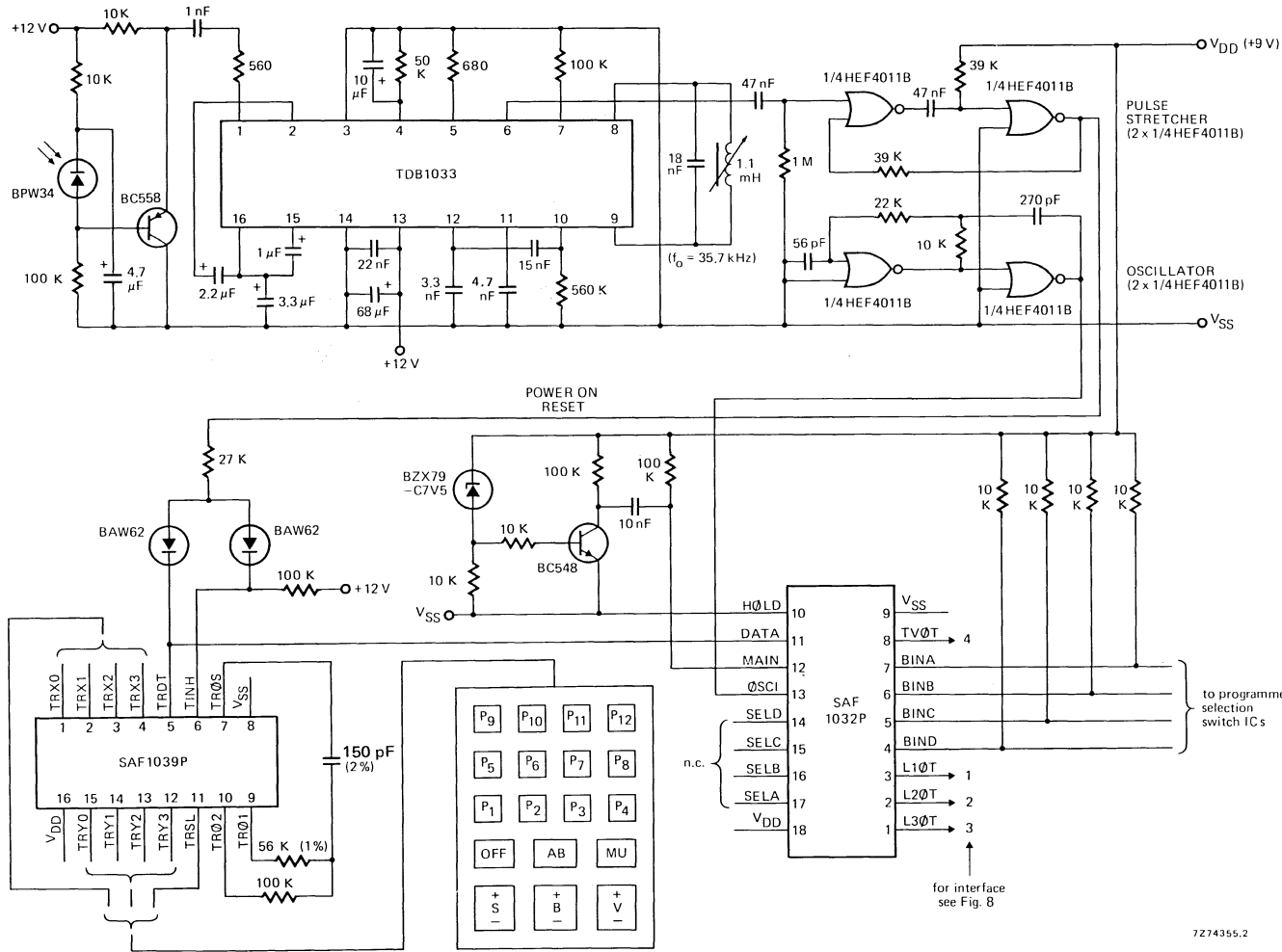
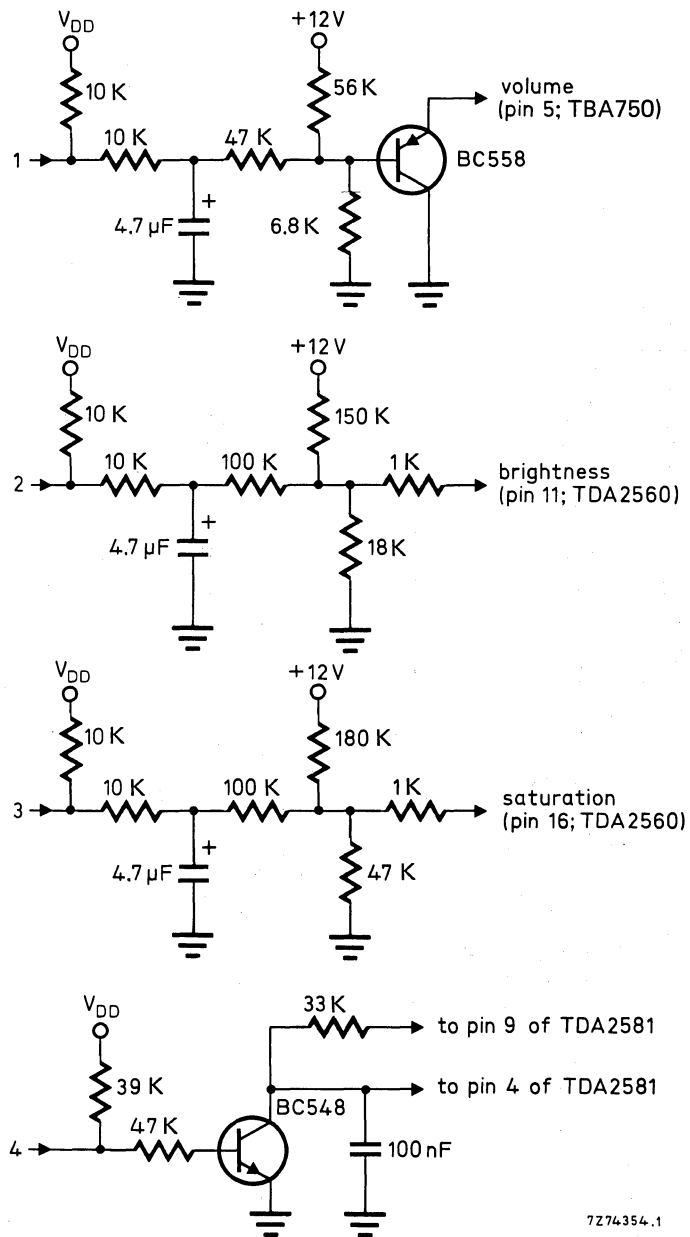

Fig. 6 Interconnection diagram of transmitter circuit SAF1039P in a remote control system, for a television receiver with 12 programmes.



7274355.2

Fig. 7 Interconnection diagram showing the SAF1032P and SAF1039P used in a TV control system.



7274354.1

Fig. 8 Additional circuits from outputs L1ØT (1), L2ØT (2), L3ØT (3) and TVØT (4) of the SAF1032P in circuit of Fig. 7.

The TDA3047 is for infrared reception with low power consumption.

Features

- H.F. amplifier with a control range of 66 dB
- Synchronous demodulator and reference amplifier
- A.G.C. detector
- Pulse shaper
- Q-factor killing of the input selectivity, which is controlled by the a.g.c. circuit
- Input voltage limiter

QUICK REFERENCE DATA

Supply voltage (pin 8)	$V_P = V_{8-16}$	typ.	5 V
Supply current (pin 8)	$I_P = I_8$	typ.	2.1 mA
Input signal (peak-to-peak value) (100% AM; $f = 36$ kHz)	$V_{2-15(p-p)}$		0.02 to 200 mV
Output signal (peak-to-peak value)	$V_{9-16(p-p)}$	typ.	4.5 V

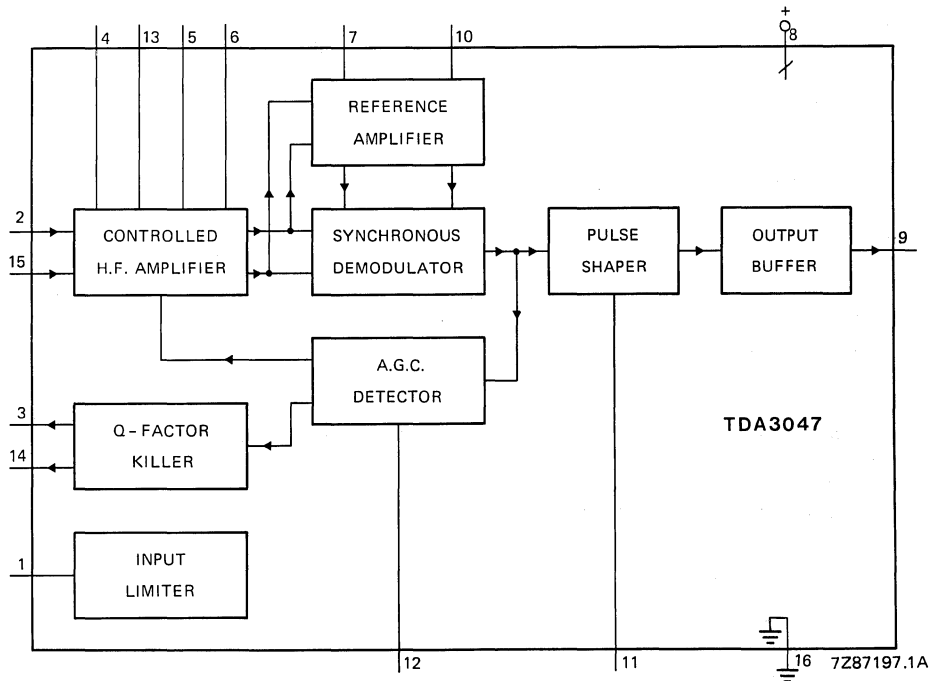

Fig. 1 Block diagram of TDA3047.

PACKAGE OUTLINE

16-lead DIL; plastic (SOT-38).

5

FUNCTIONAL DESCRIPTION**General**

The circuit operates from a 5 V supply and has a current consumption of 2 mA. The output is a current source which can drive or suppress a current of $> 75 \mu\text{A}$ with a voltage swing of 4.5 V. The Q-killer circuit eliminates distortion of the output pulses due to the decay of the tuned input circuit at high input voltages. The input circuit is protected against signals of $> 600 \text{ mV}$ by an input limiter. The typical input is an AM signal at a frequency of 36 kHz. Figures 3 and 4 show the circuit diagrams for the application of narrow-band and wide-band receivers respectively. Circuit description of the eight sections shown in Fig. 1 are given below.

Controlled h.f. amplifier

The input signal is amplified by the gain-controlled amplifier. This circuit comprises three d.c. amplifier stages connected in cascade. The overall gain of the circuit is approximately 83 dB and the gain control range is in the order of 66 dB. Gain control is initially active in the second amplifier stage and is transferred to the first stage as limiting in the second stage occurs, thus maintaining optimum signal-to-noise ratio. Offset voltages in the d.c. coupled amplifier are minimized by two negative feedback loops; these also allow the circuit to have some series resistance of the decoupling capacitor. The output signal of the amplifier is applied to the reference amplifier and to the synchronous demodulator inputs.

Reference amplifier

The reference amplifier amplifies and limits the input signal. The voltage gain is approximately 0 dB. The output signal of this amplifier is applied to the synchronous demodulator.

Synchronous demodulator

In the synchronous demodulator the input signal and reference signal are multiplied. The demodulator output current is $25 \mu\text{A}$ peak-to-peak. The output signal of the demodulator is fed to the input of the a.g.c. detector and to the input of the pulse-shaper circuit.

A.G.C. detector

The a.g.c. detector comprises two n-p-n transistors operating as a differential pair. The top level of the output signal from the synchronous demodulator is detected by the a.g.c. circuit. Noise pulses are integrated by an internal capacitor. The output signal is amplified and applied to the first and second stages of the amplifier and to the Q-factor killer circuit.

Pulse-shaper

The pulse-shaper comprises two n-p-n transistors operating as a differential pair connected in parallel with the a.g.c. differential pair. The slicing level of the pulse shaper is lower than the slicing level of the a.g.c. detector. The output of the pulse-shaper is determined by the voltage of the capacitor connected to pin 11, which is applied directly to the output buffer.

Output buffer

The voltage of the pulse-shaper capacitor is fed to the base of the first transistor of a differential pair. To obtain a correct RC-5 code, a hysteresis circuit protects the output against spikes. The output at pin 9 is active *high*.

Q-factor killer

Figure 3 shows the Q-factor killer in the narrow-band application. In this application it is necessary to decrease the Q-factor of the input selectivity particularly when large input signals occur at pins 2 and 15. In the narrow-band application the output of the Q-factor killer can be directly coupled to the input; pin 3 to pin 2 and pin 14 to pin 15.

I/R PREAMPLIFIER**TDA3047****Input limiter**

In the narrow-band application high voltage peaks can occur on the input of the selectivity circuit. The input limiter limits these voltage peaks to approximately 0.7 V. Limiting is 0.9 V max. at $I_1 = 3$ mA.

RATINGS

Limiting values in accordance with the Absolute Maximum System (IEC 134)

Supply voltage (pin 8)	$V_P = V_{8-16}$	max.	13.2 V
Output current pulse shaper (pin 11)	I_{11}	max.	10 mA
Voltages between pins*			
pins 2 and 15	V_{2-15}	max.	4.5 V
pins 4 and 13	V_{4-13}	max.	4.5 V
pins 5 and 6	V_{5-6}	max.	4.5 V
pins 7 and 10	V_{7-10}	max.	4.5 V
pins 9 and 11	V_{9-11}	max.	4.5 V
Storage temperature range	T_{stg}		-65 to + 150 °C
Operating ambient temperature range	T_{amb}		-25 to + 125 °C

5

* All pins except pin 11 are short-circuit protected.

CHARACTERISTICS

$V_P = V_{8-16} = 5 \text{ V}$; $T_{\text{amb}} = 25 \text{ }^\circ\text{C}$; measured in Fig. 4; unless otherwise specified

parameter	symbol	min.	typ.	max.	unit
Supply (pin 8)					
Supply voltage	$V_P = V_{8-16}$	4.65	5.0	5.35	V
Supply current	$I_P = I_8$	1.2	2.1	3.0	mA
Controlled h.f. amplifier (pins 2 and 15)					
Minimum input signal (peak-to-peak value) at $f = 36 \text{ kHz}$ (note 1)	$V_{2-15(p-p)}$	—	15	25	μV
at $f = 36 \text{ kHz}$ (note 2)	$V_{2-15(p-p)}$	—	—	5	μV
A.G.C. control range (without Q-killing)		60	66	—	dB
Input signal for correct operation (peak-to-peak value; note 3)	$V_{2-15(p-p)}$	0.02	—	200	mV
Q-killing inactive ($I_3 = I_{14} < 0.5 \mu\text{A}$) (peak-to-peak value)	$V_{2-15(p-p)}$	—	—	140	μV
Q-killing active ($I_{14} = I_3 = \text{max.}$) (peak-to-peak value)	$V_{2-15(p-p)}$	28	—	—	mV
Q-killing range		see Fig. 2			
Inputs					
Input voltage (pin 2)	V_{2-16}	2.25	2.45	2.65	V
Input voltage (pin 15)	V_{15-16}	2.25	2.45	2.65	V
Input resistance (pin 2)	R_{2-15}	10	15	20	$\text{k}\Omega$
Input capacitance (pin 2)	C_{2-15}	—	3	—	pF
Input limiting (pin 1) at $I_1 = 3 \text{ mA}$	V_{1-16}	—	0.8	0.9	V
Outputs					
Output voltage <i>high</i> (pin 9) at $-I_9 = 75 \mu\text{A}$	$-V_{9-8}$	—	0.1	0.5	V
Output voltage <i>low</i> (pin 9) at $I_9 = 75 \mu\text{A}$	V_{9-16}	—	0.1	0.5	V
Output current; output voltage <i>high</i> at $V_{9-16} = 4.5 \text{ V}$	$-I_9$	75	120	—	μA
at $V_{9-16} = 3.0 \text{ V}$	$-I_9$	75	130	—	μA
at $V_{9-16} = 1.0 \text{ V}$	$-I_9$	75	140	—	μA
Output current; output voltage <i>low</i> at $V_{9-16} = 0.5 \text{ V}$	I_9	75	120	—	μA
Output resistance between pins 7 and 10	R_{7-10}	3.1	4.7	6.2	$\text{k}\Omega$

Notes

1. Voltage pin 9 is *high*; $-I_9 = 75 \mu\text{A}$.
2. Voltage pin 9 remains *low*.
3. Undistorted output pulse with 100% AM input.

parameter	symbol	min.	typ.	max.	unit
Pulse shaper (pin 11)					
Trigger level in positive direction (voltage pin 9 changes from <i>high</i> to <i>low</i>)	V_{11-16}	3.75	3.9	4.05	V
Trigger level in negative direction (voltage pin 9 changes from <i>low</i> to <i>high</i>)	V_{11-16}	3.4	3.55	3.7	V
Hysteresis of trigger levels	ΔV_{11-16}	0.25	0.35	0.45	V
A.G.C. detector (pin 12)					
A.G.C. capacitor charge current	$-I_{12}$	3.3	4.7	6.1	μA
A.G.C. capacitor discharge current	I_{12}	67	100	133	μA
Q-factor killer (pins 3 and 14)					
Output current (pin 3) at $V_{12-16} = 2\text{ V}$	$-I_3$	2.5	7.5	15	μA
Output current (pin 14) at $V_{12-16} = 2\text{ V}$	$-I_{14}$	2.5	7.5	15	μA

5

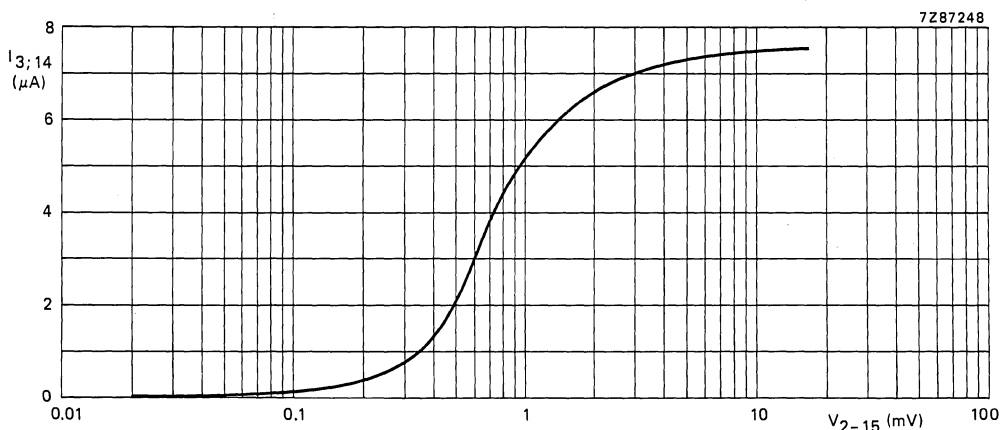
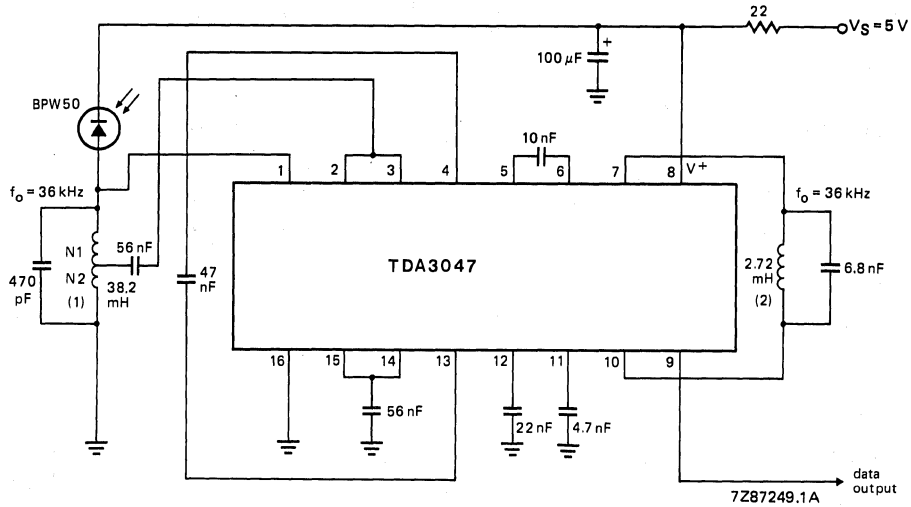

Fig. 2 Typical Q-factor killer current (pins 3 and 14) as a function of the peak-to-peak input voltage (V_{2-15}); $I_{3, 14}$ is measured to ground, $V_{2-15(p-p)}$ is a symmetrical square wave. Measured in Fig. 4; $V_P = 5\text{ V}$.



(1) N1 = 3.21
N2 = 1
Q = 16

(2) Q = 6

Fig. 3 Narrow-band receiver using TDA3047.

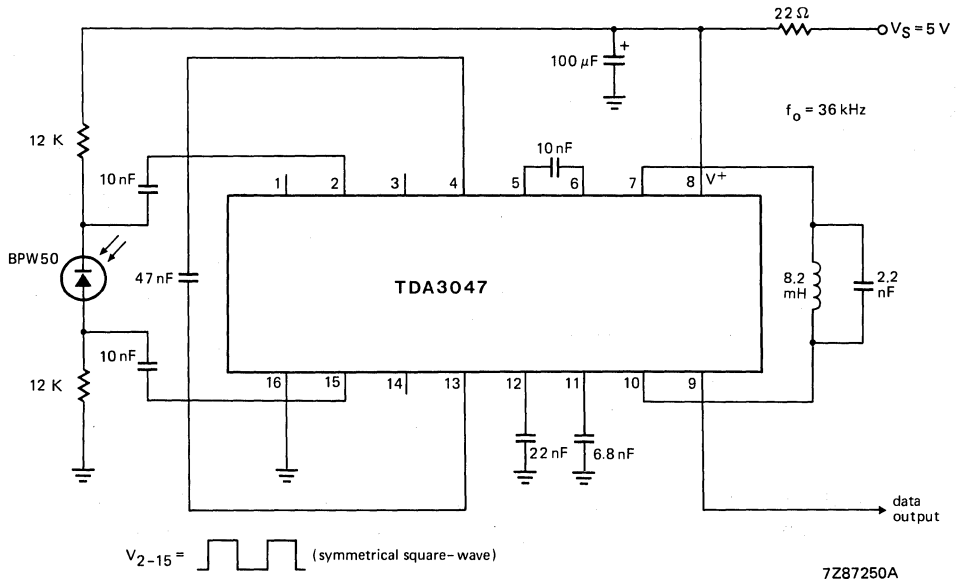

Fig. 4 Wide-band receiver with TDA3047.

For better sensitivity both 12 kΩ resistors may have a higher value.

The TDA3048 is for infrared reception with low power consumption.

Features

- H.F. amplifier with a control range of 66 dB
- Synchronous demodulator and reference amplifier
- A.G.C. detector
- Pulse shaper
- Q-factor killing of the input selectivity, which is controlled by the a.g.c. circuit
- Input voltage limiter

QUICK REFERENCE DATA

Supply voltage (pin 8)	$V_p = V_{8-16}$	typ.	5 V
Supply current (pin 8)	$I_p = I_8$	typ.	2.1 mA
Input signal (peak-to-peak value) (100% AM; $f = 36$ kHz)	$V_{2-15(p-p)}$		0,02 to 200 mV
Output signal (peak-to-peak value)	$V_{9-16(p-p)}$	typ.	4.5 V

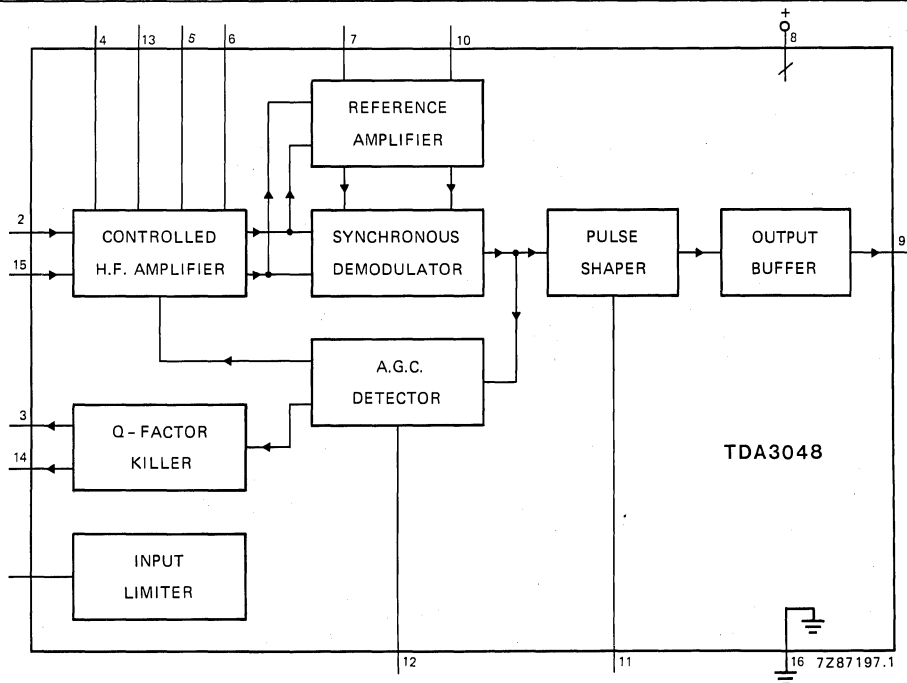

Fig. 1 Block diagram of TDA3048.

PACKAGE OUTLINE

16-lead DIL; plastic (SOT-38).

FUNCTIONAL DESCRIPTION**General**

The circuit operates from a 5 V supply and has a current consumption of 2 mA. The output is a current source which can drive or suppress a current of $> 75 \mu\text{A}$ with a voltage swing of 4,5 V. The Q-killer circuit eliminates distortion of the output pulses due to the decay of the tuned input circuit at high input voltages. The input circuit is protected against signals of $> 600 \text{ mV}$ by an input limiter. The typical input is an AM signal at a frequency of 36 kHz. Figures 3 and 4 show the circuit diagrams for the application of narrow-band and wide-band receivers respectively. Circuit description of the eight sections shown in Fig. 1 are given below.

Controlled h.f. amplifier

The input signal is amplified by the gain-controlled amplifier. This circuit comprises three d.c. amplifier stages connected in cascade. The overall gain of the circuit is approximately 83 dB and the gain control range is in the order of 66 dB. Gain control is initially active in the second amplifier stage and is transferred to the first stage as limiting in the second stage occurs, thus maintaining optimum signal-to-noise ratio. Offset voltages in the d.c. coupled amplifier are minimized by two negative feedback loops; these also allow the circuit to have some series resistance of the decoupling capacitor. The output signal of the amplifier is applied to the reference amplifier and to the synchronous demodulator inputs.

Reference amplifier

The reference amplifier amplifies and limits the input signal. The voltage gain is approximately 0 dB. The output signal of this amplifier is applied to the synchronous demodulator.

Synchronous demodulator

In the synchronous demodulator the input signal and reference signal are multiplied. The demodulator output current is $25 \mu\text{A}$ peak-to-peak. The output signal of the demodulator is fed to the input of the a.g.c. detector and to the input of the pulse-shaper circuit.

A.G.C. detector

The a.g.c. detector comprises two n-p-n transistors operating as a differential pair. The top level of the output signal from the synchronous demodulator is detected by the a.g.c. circuit. Noise pulses are integrated by an internal capacitor. The output signal is amplified and applied to the first and second stages of the amplifier and to the Q-factor killer circuit.

Pulse-shaper

The pulse-shaper comprises two n-p-n transistors operating as a differential pair connected in parallel with the a.g.c. differential pair. The slicing level of the pulse shaper is lower than the slicing level of the a.g.c. detector. The output of the pulse-shaper is determined by the voltage of the capacitor connected to pin 11, which is applied directly to the output buffer.

Output buffer

The voltage of the pulse-shaper capacitor is fed to the base of the first transistor of a differential pair. To obtain a correct RC-5 code, a hysteresis circuit protects the output against spikes. The output at pin 9 is active *low*.

Q-factor killer

Figure 3 shows the Q-factor killer in the narrow-band application. In this application it is necessary to decrease the Q-factor of the input selectivity particularly when large input signals occur at pins 2 and 15. In the narrow-band application the output of the Q-factor killer can be directly coupled to the input; pin 3 to pin 2 and pin 14 to pin 15.

Input limiter

In the narrow-band application high voltage peaks can occur on the input of the selectivity circuit. The input limiter limits these voltage peaks to approximately 0.7 V. Limiting is 0.9 V max. at $I_1 = 3 \text{ mA}$.

RATINGS

Limiting values in accordance with the Absolute Maximum System (IEC 134)

Supply voltage (pin 8)	$V_P = V_{8-16}$	max.	13.2 V
Output current pulse shaper (pin 11)	I_{11}	max.	10 mA
Voltages between pins*			
pins 2 and 15	V_{2-15}	max.	4.5 V
pins 4 and 13	V_{4-13}	max.	4.5 V
pins 5 and 6	V_{5-6}	max.	4.5 V
pins 7 and 10	V_{7-10}	max.	4.5 V
pins 9 and 11	V_{9-11}	max.	4.5 V
Storage temperature range	T_{stg}		-65 to + 150 °C
Operating ambient temperature range	T_{amb}		-25 to + 125 °C

* All pins except pin 11 are short-circuit protected.

CHARACTERISTICS

$V_P = V_{8-16} = 5\text{ V}$; $T_{\text{amb}} = 25\text{ }^\circ\text{C}$; measured in Fig. 4; unless otherwise specified

parameter	symbol	min.	typ.	max.	unit
Supply (pin 8)					
Supply voltage	$V_P = V_{8-16}$	4.65	5.0	5.35	V
Supply current	$I_P = I_8$	1.2	2.1	3.0	mA
Controlled h.f. amplifier (pins 2 and 15)					
Minimum input signal (peak-to-peak value) at $f = 36\text{ kHz}$ (note 1)	$V_{2-15(p-p)}$	—	15	25	μV
at $f = 36\text{ kHz}$ (note 2)	$V_{2-15(p-p)}$	—	—	5	μV
A.G.C. control range (without Q-killing)		60	66	—	dB
Input signal for correct operation (peak-to-peak value; note 3)	$V_{2-15(p-p)}$	0.02	—	200	mV
Q-killing inactive ($I_3 = I_{14} < 0.5\text{ }\mu\text{A}$) (peak-to-peak value)	$V_{2-15(p-p)}$	—	—	140	μV
Q-killing active ($I_{14} = I_3 = \text{max.}$) (peak-to-peak value)	$V_{2-15(p-p)}$	28	—	—	mV
Q-killing range		see Fig. 2			
Inputs					
Input voltage (pin 2)	V_{2-16}	2.25	2.45	2.65	V
Input voltage (pin 15)	V_{15-16}	2.25	2.45	2.65	V
Input resistance (pin 2)	R_{2-15}	10	15	20	$\text{k}\Omega$
Input capacitance (pin 2)	C_{2-15}	—	3	—	pF
Input limiting (pin 1) at $I_1 = 3\text{ mA}$	V_{1-16}	—	0.8	0.9	V
Outputs					
Output voltage <i>high</i> (pin 9) at $-I_9 = 75\text{ }\mu\text{A}$	$-V_{9-8}$	—	0.1	0.5	V
Output voltage <i>low</i> (pin 9) at $I_9 = 75\text{ }\mu\text{A}$	V_{9-16}	—	0.1	0.5	V
Output current; output voltage <i>low</i> $-V_{9-8} = 4.5\text{ V}$	I_9	75	120	—	μA
$-V_{9-8} = 3.0\text{ V}$	I_9	75	130	—	μA
$-V_{9-8} = 1.0\text{ V}$	I_9	75	140	—	μA
Output current; output voltage <i>high</i> $-V_{9-8} = 0.5\text{ V}$	$-I_9$	75	120	—	μA
Output resistance between pins 7 and 10	R_{7-10}	3.1	4.7	6.2	$\text{k}\Omega$

Notes

1. Voltage pin 9 is *low*; $I_9 = 75\text{ }\mu\text{A}$.
2. Voltage pin 9 remains *high*.
3. Undistorted output pulse with 100% AM input.

parameter	symbol	min.	typ.	max.	unit
Pulse shaper (pin 11)					
Trigger level in positive direction (voltage pin 9 changes from <i>high</i> to <i>low</i>)	V_{11-16}	3.75	3.9	4.05	V
Trigger level in negative direction (voltage pin 9 changes from <i>low</i> to <i>high</i>)	V_{11-16}	3.4	3.55	3.7	V
Hysteresis of trigger levels	ΔV_{11-16}	0.25	0.35	0.45	V
A.G.C. detector (pin 12)					
A.G.C. capacitor charge current	$-I_{12}$	3.3	4.7	6.1	μA
A.G.C. capacitor discharge current	I_{12}	67	100	133	μA
Q-factor killer (pins 3 and 14)					
Output current (pin 3) at $V_{12-16} = 2$ V	$-I_3$	2.5	7.5	15	μA
Output current (pin 14) at $V_{12-16} = 2$ V	$-I_{14}$	2.5	7.5	15	μA

5

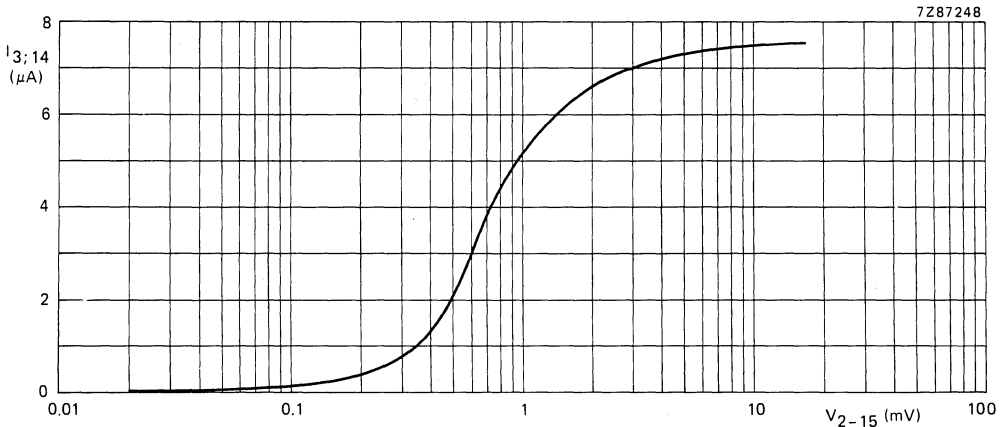
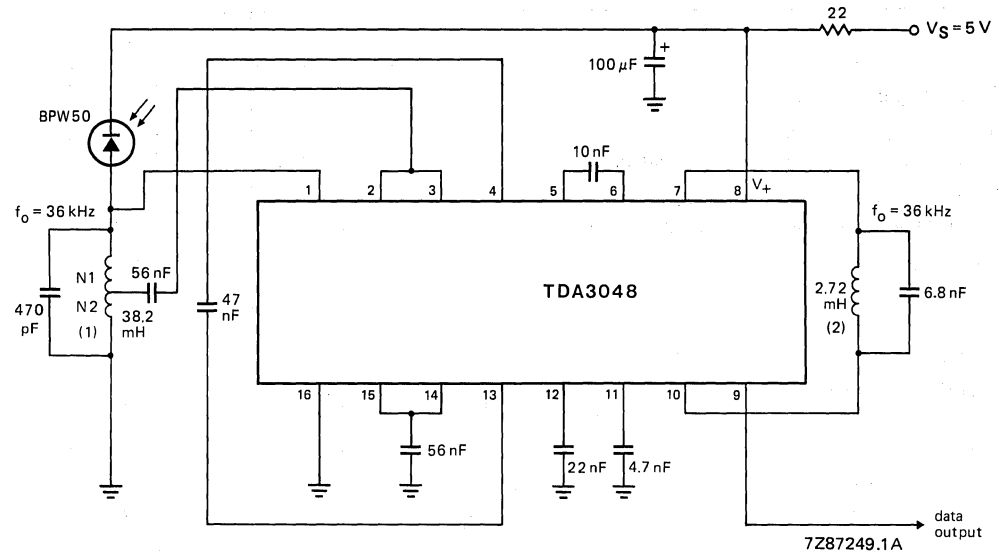

Fig. 2 Typical Q-factor killer current (pins 3 and 14) as a function of the peak-to-peak input voltage (V_{2-15}); $I_{3, 14}$ is measured to ground, $V_{2-15(p-p)}$ is a symmetrical square wave. Measured in Fig. 4; $V_P = 5$ V.

APPLICATION INFORMATION



- (1) $N1 = 3.21$
- $N2 = 1$
- $Q = 16$
- (2) $Q = 6$

Fig. 3 Narrow-band receiver using TDA3048.

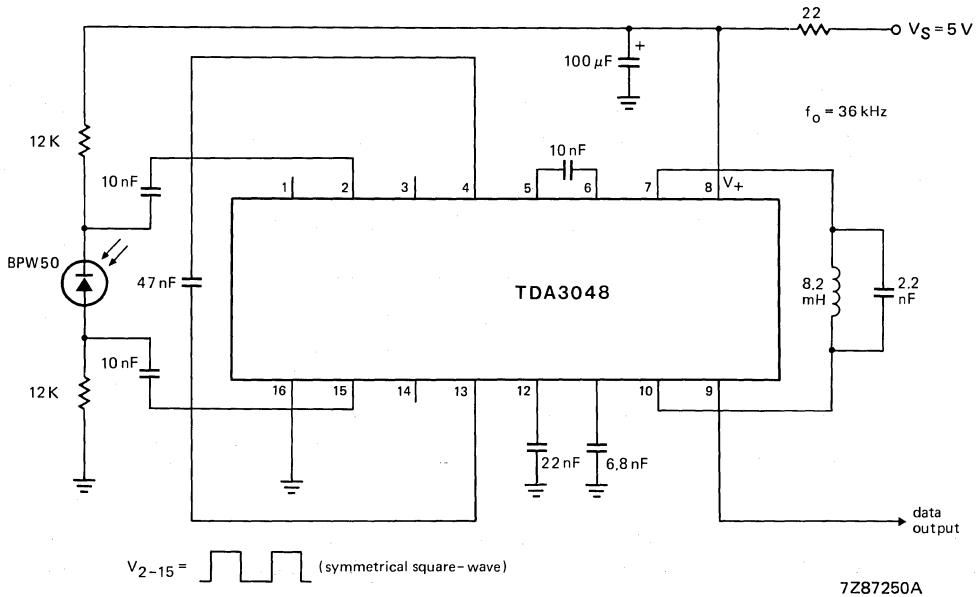

Fig. 4 Wide-band receiver with TDA3048.

For better sensitivity both 12 kΩ resistors may have a higher value.

PHASE-LOCKED LOOPS—SYMBOLS AND DEFINITIONS

Absolute Maximum Rating

Operating safe zones exceeding these limits could cause permanent damage to the device and are not meant to imply that devices can operate at these limits.

Capture Range ($2f_o$, $2\omega_o$)**

Although the loop will remain in lock throughout its lock range, it may not be able to acquire lock at the tracking range extremes because of the selectivity afforded by the low-pass filter. The capture range also is centered at f_o' with the equal deviations called the *Lock-in* or *Pull-in Ranges*. The capture range can never exceed the lock range.

Closed Loop Gain (CLG)

The output signal frequency and phase can be determined from a product of the CLG and the input signal where the CLG is given by

$$\text{CLG} = \frac{K_v}{1 + K_v} \quad (\text{Equation 1.4})$$

Damping Factor (ζ)

The standard damping constant of a second order feedback system. For the PLL, ζ refers to the ability of the loop to respond quickly to an input frequency step without excessive overshoot.

Free-Running Frequency (f_o' , ω_o')

Also called the *center frequency*, this is the frequency at which the loop VCO operates when not locked to an input signal. The "prime" superscripts are used to distinguish the free-running frequency from f_o' and ω_o' which are used for the general oscillator frequency. (Many references use f_o' and ω_o' for both the free-running and general oscillator frequency and leave the proper choice for the reader to infer from the context). The appropriate units for f_o' and ω_o' are Hz and radians per second respectively.

Lock Range ($2f_L$, $2\omega_L$)*

The range of frequencies over which the loop will remain in lock. Normally the lock range is centered at the free-running frequency unless there is some nonlinearity in the system which limits the frequency deviation on one side of f_o' . The deviations from f_o' are referred to as the *Tracking Range* or *Hold-in Range*. (See figure 1.6.) The tracking range is therefore one-half of the lock range.

Lock-Up Time (t_L)***

The transient time required for a free-running loop to lock. This time depends principally upon the bandwidth selectivity designed into the loop with the low-pass filter. The lock-up time is inversely proportional to the selectivity bandwidth. Also, lock-up time exhibits a statistical spreading due to random initial phase relationships between the input and oscillator phases.

Loop Gain (K_v)

The product of K_d , K_o , and the low-pass filters gain at dc. K_d is evaluated at the appropriate input signal level and K_o at the appropriate ω_o' . K_v has units of $(\text{sec})^{-1}$.

Loop Noise Bandwidth (B_L)

A loop property relating ω_n and τ which describes the effective bandwidth of the received signal. Noise and signal components outside this bandwidth are greatly attenuated.

Natural Frequency (ω_n)

The characteristic frequency of the loop, determined mathematically by the final pole positions in the complex plane or determined experimentally as the modulation frequency for which an underdamped loop gives the maximum frequency deviation from f_o' and at which the phase error swing is the greatest.

Package Type Designation

See full package designations in Appendix.

Phase Comparator Conversion Gain (K_d)

The conversion constant relating the phase comparators output voltage to the phase difference between input and VCO signals when the loop is locked. At low input signal levels, K_d is also a function of signal amplitude. K_d has units of volts per radian (V/rad).

Power Dissipation

The power that the device can safely handle at 25°C. The dissipation must be derated as indicated for the individual package type.

T_A

Ambient temperature range. Range of the surrounding environment of the operating device.

T_J

Junction Temperature. The maximum temperature of the device. 150°C is standard for silicon devices.

T_{SOLD}

Soldering Temperature. The temperature which can be applied to the lead frame of the device for short periods of time (normally specified for a duration of 10 sec).

T_{STG}

Storage temperature range. Temperature range that the device can be stored in a non-operating condition.

Truth Tables

0 is logic level low

1 is logic level high

X — don't care condition — has no effect under circuit conditions listed.

*Also called Synchronization Range.

**Also called Acquisition Range.

***Also called Acquisition Time.

PHASE LOCKED LOOP

SE/NE564

ELECTRICAL CHARACTERISTICS $V_{CC} = 5V, T_A = 25^\circ C, f_o = 5MHz, I_B = 400\mu A$ unless otherwise specified

PARAMETER	TEST CONDITIONS	SE564			NE564			UNIT
		Min	Typ	Max	Min	Typ	Max	
Maximum VCO frequency	$C_1 = 0$ (stray)	50	65		45	60		MHz
Lock range	Input $\geq 200mV_{rms}$ $T_A = 25^\circ C$ = $125^\circ C$ = $-55^\circ C$ = $0^\circ C$ = $70^\circ C$	40 20 50	70 30 80		40	70 70 40		% of f_o
Capture range	Input $\geq 200mV_{rms}, R_2 = 27\Omega$	20	30		20	30		% of f_o
VCO frequency drift with temperature	$f_o = 5MHz, T_A = -55^\circ C$ to $125^\circ C$ = $0^\circ C$ to $70^\circ C$ $f_o = 500KHz, T_A = -55^\circ C$ to $125^\circ C$ = $0^\circ C$ to $70^\circ C$		400 250	1000 500		400 400 850		PPM/ $^\circ C$
VCO free running frequency	$C_1 = 91pF$ $R_C = 100\Omega$ "Internal"	4	5	6	3.5	5	6.5	MHz
VCO frequency change with supply voltage	$V_{CC} = 4.5V$ to $5.5V$		3	8		3	8	% of f_o
Demodulated output voltage	Modulation frequency: 1KHz $f_o = 5MHz$, input deviation: 2% $T = 25^\circ C$ 1% $T = 25^\circ C$ = $0^\circ C$ = $-55^\circ C$ = $70^\circ C$ = $125^\circ C$	16 8 6 12	28 14 10 16		16 8	28 14 13 15		mVrms mVrms mVrms mVrms mVrms
Distortion Signal to noise ratio AM rejection	Deviation: 1% to 8% Std. condition, 1% to 10% dev. Std. condition, 30% AM		1 40 35			1 40 35		% dB dB
Demodulated Output at operating voltage	Modulation frequency: 1KHz $f_o = 5MHz$, input deviation: 1% $V_{CC} = 4.5V$ $V_{CC} = 5.5V$	7 8	12 14		7 8	12 14		mVrms mVrms
Supply current	$V_{CC} = 5V, I_1, I_{10}$		45	60		45	60	mA
Output "1" output leakage current "0" output voltage	$V_{OUT} = 5V$, Pin 16, 9 $I_{OUT} = 2mA$, Pin 16, 9 $I_{OUT} = 6mA$, Pin 16, 9		1 0.3 0.4	20 0.6 0.8		1 0.3 0.4	20 0.6 0.8	μA V V

5

TYPICAL PERFORMANCE CHARACTERISTICS

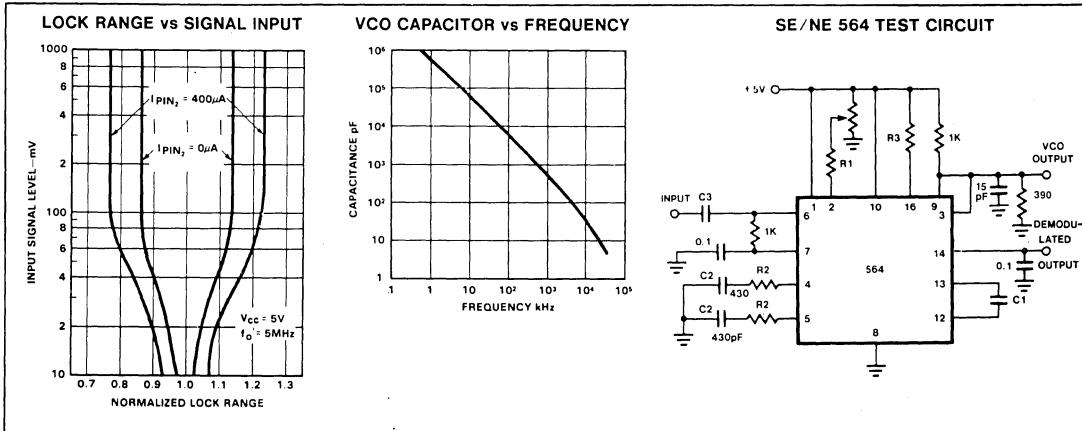

PHASE LOCKED LOOP

SE/NE564

TYPICAL NORMALIZED VCO FREQUENCY AS A FUNCTION OF PIN 2 BIAS CURRENT

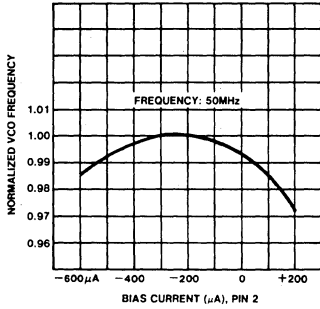

TYPICAL NORMALIZED VCO FREQUENCY AS A FUNCTION OF PIN 2 BIAS CURRENT

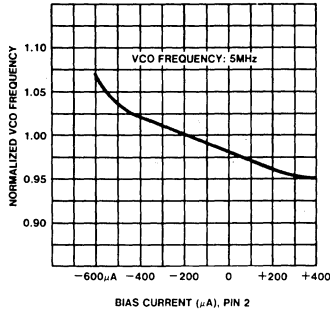

NORMALIZED VCO FREQUENCY AS A FUNCTION OF TEMPERATURE

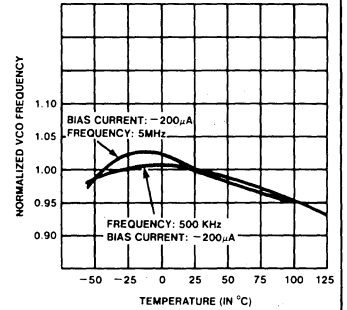

VARIATION OF THE PHASE COMPARATOR'S OUTPUT VOLTAGE VERSUS PHASE ERROR AND BIAS CURRENT (K_D)

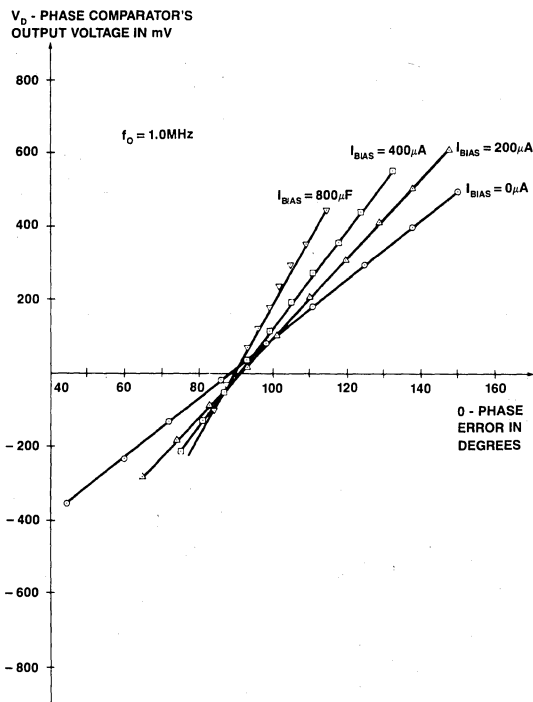

VCO OUTPUT FREQUENCY AS A FUNCTION OF INPUT VOLTAGE AND BIAS CURRENT (K_O)

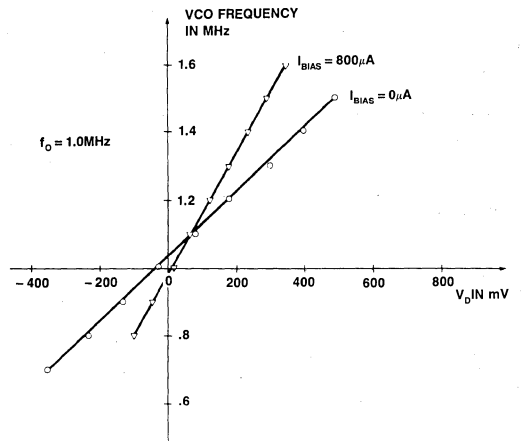

**FUNCTIONAL DESCRIPTION
(figure 1)**

The NE564 is a monolithic phase locked loop with a post detection processor. The use of Schottky clamped transistors and optimized device geometries extends the frequency of operation to greater than 50MHz. In addition to the classical PLL applications, the NE564 can be used as a modulator with a controllable frequency deviation.

The output voltage of the PLL can be written as shown in the following equation:

$$V_O = \frac{(f_{in} - f_o)}{K_{VCO}} \quad \text{Equation 1}$$

K_{VCO} = conversion gain of the VCO
 f_{in} = frequency of the input signal
 f_o = free running frequency of the VCO

The process of recovering FSK signals involves the conversion of the PLL output into logic compatible signals. For high data rates, a considerable amount of carrier will be present at the output of the PLL due to the wideband nature of the loop filter. To

avoid the use of complicated filters, a comparator with hysteresis or Schmitt trigger is required. With the conversion gain of the VCO fixed, the output voltage as given by Equation 1 varies according to the frequency deviation of f_{in} from f_o . Since this differs from system to system, it is necessary that the hysteresis of the Schmitt trigger be capable of being changed, so that it can be optimized for a particular system. This is accomplished in the 564 by varying the voltage at pin 15 which results in a change of the hysteresis of the Schmitt trigger.

For FSK signals, an important factor to be considered is the drift in the free running frequency of the VCO itself. If this changes due to temperature, according to Equation 1 it will lead to a change in the dc levels of the PLL output, and consequently to errors in the digital output signal. This is especially true for narrow band signals where the deviation in f_{in} itself may be less than the change in f_o due to temperature. This effect

can be eliminated if the dc or average value of the signal is retrieved and used as the reference to the comparator. In this manner, variations in the dc levels of the PLL output do not affect the FSK output.

VCO Section

Due to its inherent high frequency performance, an emitter coupled oscillator is used in the VCO. In the circuit, shown in the equivalent schematic, transistors Q_{21} and Q_{23} with current sources $Q_{25} - Q_{26}$ form the basic oscillator. The approximate free running frequency of the oscillator is shown in the following equation:

$$f_o \approx \frac{1}{22 R_C (C_1 + C_S)} \quad \text{Equation 2}$$

$R_C = R_{19} = R_{20} = 100\Omega$ (INTERNAL)
 C_1 = external frequency setting capacitor
 C_S = stray capacitance

Variation of V_D (phase detector output voltage) changes the frequency of the oscillator. As indicated by Equation 2, the frequency of the oscillator has a negative

EQUIVALENT SCHEMATIC

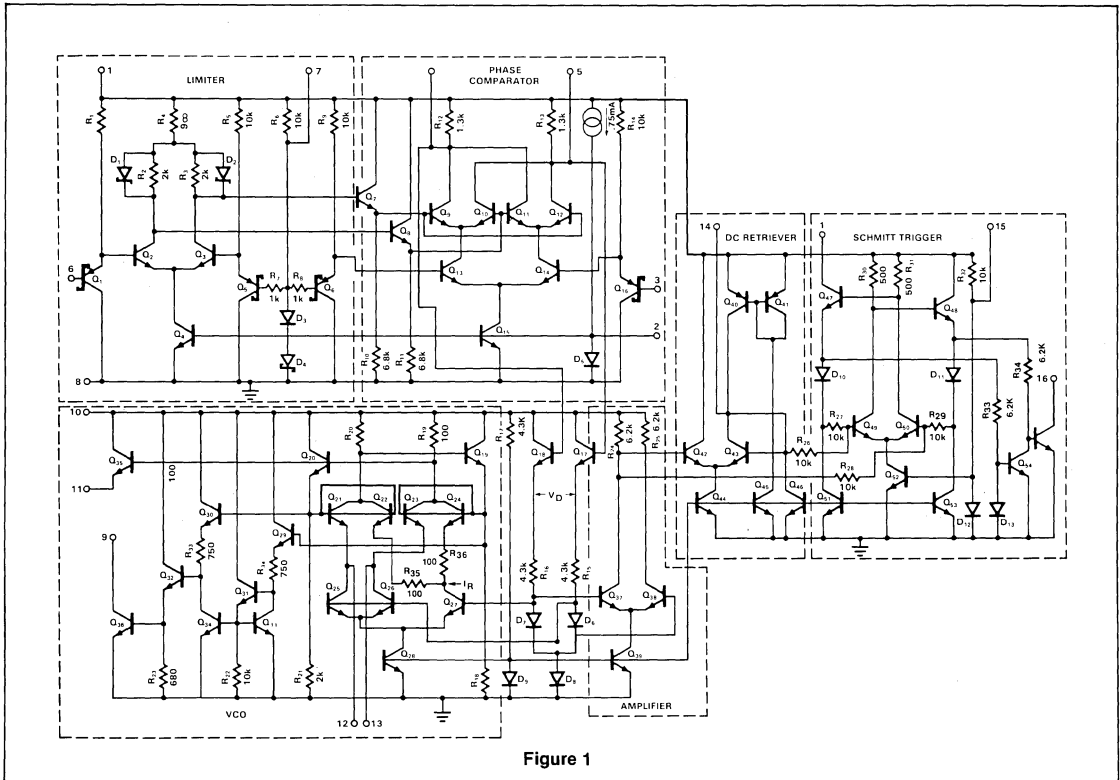

Figure 1

PHASE LOCKED LOOP

SE/NE564

temperature coefficient due to the positive temperature coefficient of the monolithic resistor. To compensate for this, a current I_2 with negative temperature coefficient is introduced to achieve a low frequency drift with temperature.

Phase Comparator Section

The phase comparator consists of a double balanced modulator with a limiter amplifier to improve AM rejection. Schottky clamped vertical PNPs are used to obtain TTL level inputs. The loop gain can be varied by changing the current in Q_4 and Q_{15} which

effectively changes the gain of the differential amplifiers. This can be accomplished by introducing a current at pin 2.

Post Detection Processor Section

The post detection processor consists of a unity gain transconductance amplifier and comparator. The amplifier can be used as a dc retriever for demodulation of FSK signals, and as a post detection filter for linear FM demodulation. The comparator has adjustable hysteresis so that phase jitter in the output signal can be eliminated.

As shown in the equivalent schematic, the dc retriever is formed by the transductance amplifier $Q_{42}-Q_{43}$ together with an external capacitor which is connected at the amplifier output (pin 14). This forms an integrator whose output voltage is shown in the following equation:

$$V_0 = \frac{g_m}{C_2} V_{in} dt \quad \text{Equation 3}$$

g_m = transconductance of the amplifier
 C_2 = capacitor at the output (pin 14)
 V_{in} = signal voltage at amplifier input

With proper selection of C_2 , the integrator time constant can be varied so that the output voltage is the dc or average value of the input signal for use in FSK, or as a post detection filter in linear demodulation.

The comparator with hysteresis is made up of $Q_{49}-Q_{50}$ with positive feedback being provided by $Q_{47}-Q_{48}$. The hysteresis is varied by changing the current in Q_{52} with a resulting variation in the loop gain of the comparator. This method of hysteresis control, which is a dc control, provides symmetric variation around the nominal value.

Design Formula

The free running frequency of the VCO is shown by the following equation:

$$f_0 = \frac{1}{25 R_C (C_1 + C_S)} \quad \text{Equation 4}$$

R_C = 100 Ω
 C_1 = external cap in farads
 C_S = stray capacitance

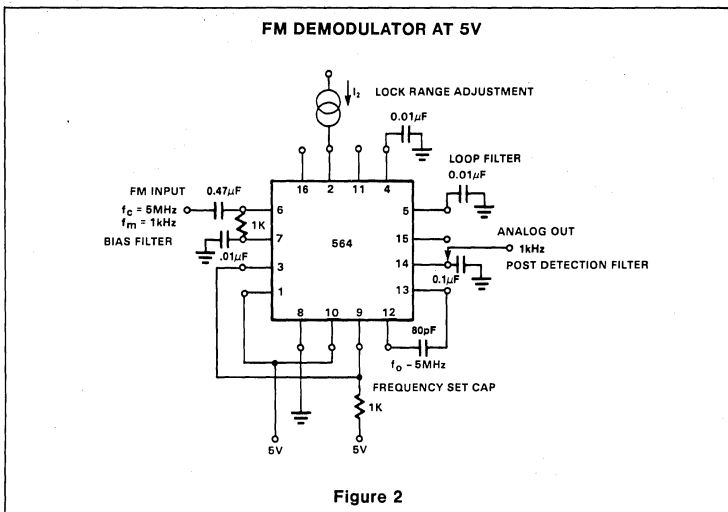

Figure 2

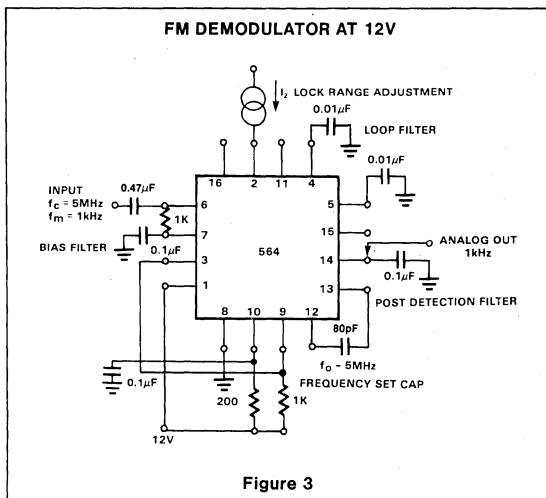

Figure 3

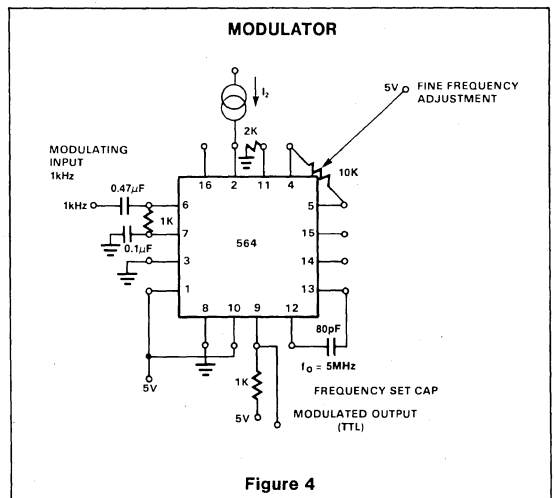

Figure 4

The loop filter diagram shown is explained by the following equation:

$$F(s) = \frac{1}{1 + sRC_3} \quad (\text{First Order}) \quad \text{Equation 5}$$

$$R = R_{12} = R_{13} = 1.3k\Omega \quad (\text{INTERNAL})^*$$

By adding capacitors to pins 4 and 5, a pole is added to the loop transfer function at

$$\omega = \frac{1}{RC_3}$$

*Refer to Figure 1.

APPLICATIONS

FM DEMODULATOR

The NE564 can be used as an FM demodulator. The connections for operation at 5V and 12V are shown in figures 2 and 3 respectively. The input signal is ac coupled with the output signal being extracted at pin 14. Loop filtering is provided by the capacitors at pins 4 and 5 with additional filtering being provided by the capacitor at pin 14. Since the conversion gain of the VCO is not very high, to obtain sufficient demodulated output signal the frequency deviation in the input signal should be 1% or higher.

MODULATION TECHNIQUES

The NE564 phase locked loop can be modulated at either the loop filter ports (pins 4 and 5) or the input port (pin 6) as shown in figure 4. The approximate modulation frequency can be determined from the frequency conversion gain curve shown in figure 5. This curve will be appropriate for signals injected into pins 4 and 5 as shown in figure 4.

FSK Demodulation

The 564 PLL is particularly attractive for FSK demodulation since it contains an internal voltage comparator and VCO which have TTL compatible inputs and outputs, and it can operate from a single 5 volt power supply. Demodulated dc voltages associated with the mark and space frequencies are recovered with a single external capacitor in a dc retriever without utilizing extensive filtering networks. An internal comparator, acting as a Schmitt trigger with an adjustable hysteresis, shapes the demodulated voltages into compatible TTL output levels. The high frequency design of the 564 enables it to demodulate FSK at high data rates in excess of 1.0M baud.

Figure 5 shows a high-frequency FSK decoder designed for input frequency deviations of ±1.0MHz centered around a free-running frequency of 10.8MHz. The value of the timing capacitance required was estimated from figure 8 to be approximately 40pF. A trimmer capacitor was added to fine tune f_o' to 10.8MHz.

The lock range graph indicates that the ±1.0MHz frequency deviations will be within the lock range for input signal levels greater than approximately 50mV with zero pin 2 bias current. While strictly this figure is appropriate only for 5MHz, it can be used as a guide for lock range estimates at other f_o' frequencies.

The hysteresis was adjusted experimentally via the 10kΩ potentiometer and 2kΩ bias arrangement to give the waveshape shown in figure 7 for 20K, 500K, 2M baud rates with square wave FSK modulation. Note the magnitude and phase relationships of the phase comparators output voltages with respect to each other and to the FSK output. The high frequency sum components of the input and VCO frequency also are visible as noise on the phase comparators outputs.

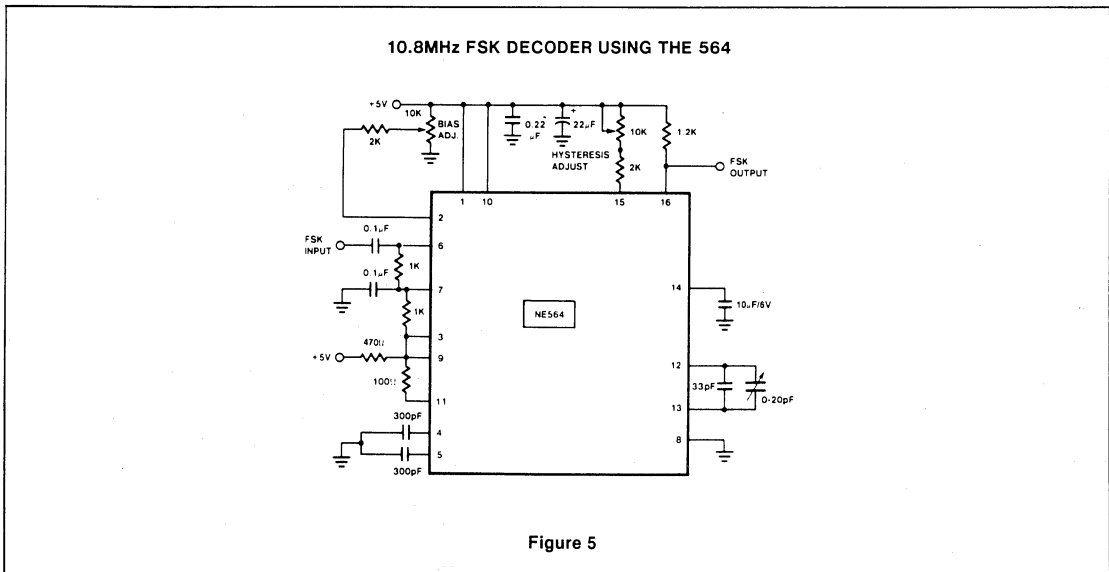

PHASE COMPARATOR (PINS 4 AND 5) AND FSK (PIN 16) OUTPUTS FOR DATA RATES OF

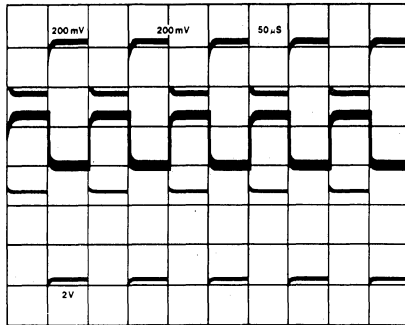

(a) 20K BAUD

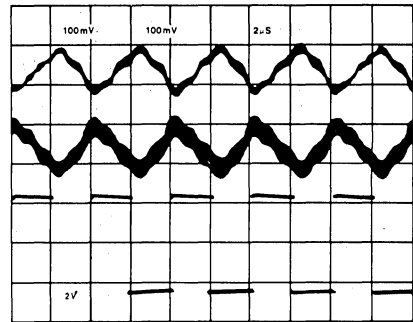

(b) 500K BAUD

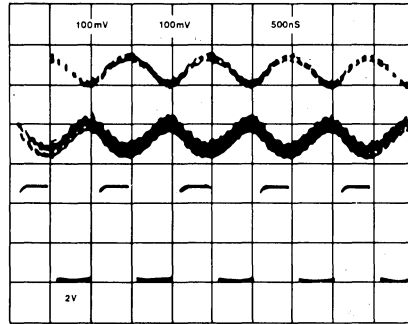

(c) 2.0M BAUD

NOTE
Top trace-pin 4
Center trace-pin 5
Bottom trace-pin 16

Figure 6

OUTLINE OF SETUP PROCEDURE

- Determine operating frequency of the VCO - .
If $+N$ in feedback loop, then $f_o = N \times f_{in}$.
- Calculate value of the VCO frequency set capacitor:
$$C_o \approx \frac{1}{2500 f_o}$$
- Set I_2 (current sinking into Pin 2) for $\approx 100 \mu A$. After operation is obtained, this value may be adjusted for best dynamic behavior.
- Check VCO output frequency with digital counter at Pin 9 of device (loop open, VCO to ϕ det.). Adjust C_o trim or frequency adj. Pin 4-5 for exact center frequency if needed.
- Close loop and inject input signal to Pin 6. Monitor Pin 3 and 6 with two channel scope. Lock should occur with $\Delta\phi_{3-6}$ equal to 90° (phase error).
- If pulsed burst or ramp frequency is used for input signal, special loop filter design may be required in place of simple single capacitor filter on Pin 4 and 5. (See PLL application section in Analog Manual.)
- The input signal to Pin 6 and the VCO feedback signal to Pin 3 must have a duty cycle of 50% for proper operation of the phase detector. Due to the nature of a balanced mixer if signals are not 50% in duty cycle, D.C. offsets will occur in the loop which tend to create an artificial or biased VCO offset.
- For multiplier circuits where phase jitter is a problem, loop filter capacitors may be increased to a value of 10-50 μF on Pin 4, 5. Also careful supply decoupling may be necessary. This includes the counter chain V_{CC} lines.

NE564
PHASE LOCKED FREQUENCY
MULTIPLIER WITH VCXO

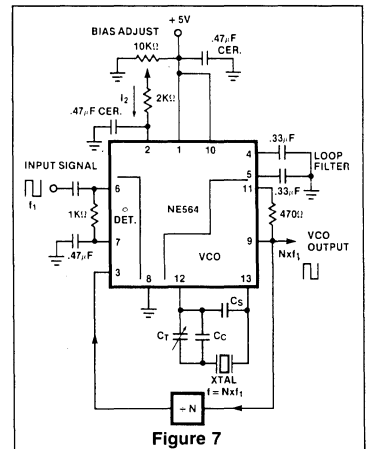

Figure 7

*For additional information, consult the Applications Section.

PHASE LOCKED LOOP

SE/NE565

DESCRIPTION

The SE/NE565 Phase-Locked Loop (PLL) is a self-contained, adaptable filter and demodulator for the frequency range from 0.001Hz to 500kHz. The circuit comprises a voltage-controlled oscillator of exceptional stability and linearity, a phase comparator, an amplifier and a low-pass filter as shown in the block diagram. The center frequency of the PLL is determined by the free-running frequency of the VCO; this frequency can be adjusted externally with a resistor or a capacitor. The low-pass filter, which determines the capture characteristics of the loop, is formed by an internal resistor and an external capacitor.

FEATURES

- Highly stable center frequency (200ppm/°C typ.)
- Wide operating voltage range (± 6 to ± 12 volts)
- Highly linear demodulated output (0.2% typ.)
- Center frequency programming by means of a resistor or capacitor, voltage or current
- TTL and DTL compatible square-wave output; loop can be opened to insert digital frequency divider
- Highly linear triangle wave output
- Reference output for connection of comparator in frequency discriminator
- Bandwidth adjustable from $< \pm 1\%$ to $> \pm 60\%$
- Frequency adjustable over 10 to 1 range with same capacitor

APPLICATIONS

- Frequency shift keying
- Modems
- Telemetry receivers
- Tone decoders
- SCA receivers
- Wideband FM discriminators
- Data synchronizers
- Tracking filters
- Signal restoration
- Frequency multiplication & division

NOTES:

1. SOL — Released in large SO package only.
2. SOL *and* non-standard pinout.
3. SO *and* non-standard pinout.

PIN CONFIGURATIONS

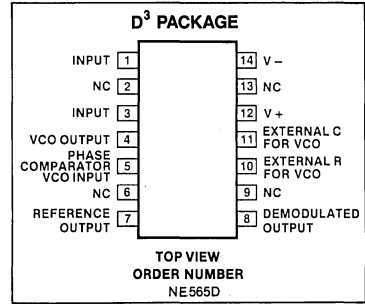
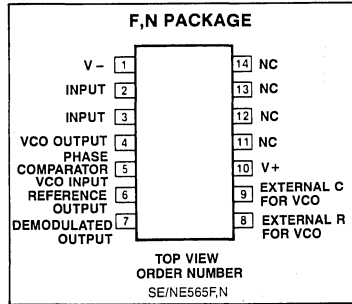

ABSOLUTE MAXIMUM RATINGS

$T_A = 25^\circ\text{C}$ unless otherwise specified.

PARAMETER	RATING	UNIT
Maximum operating voltage	26	V
Input voltage	3	V _{p-p}
Storage temperature	-65 to +150	°C
Operating temperature range		
NE565	0 to +70	°C
SE565	-55 to +125	°C
Power dissipation	300	mW

BLOCK DIAGRAM

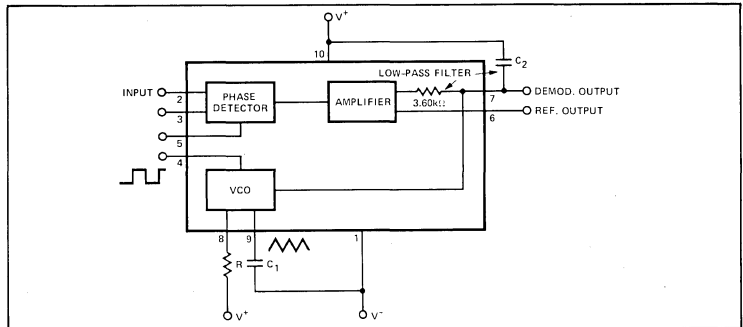

EQUIVALENT SCHEMATIC

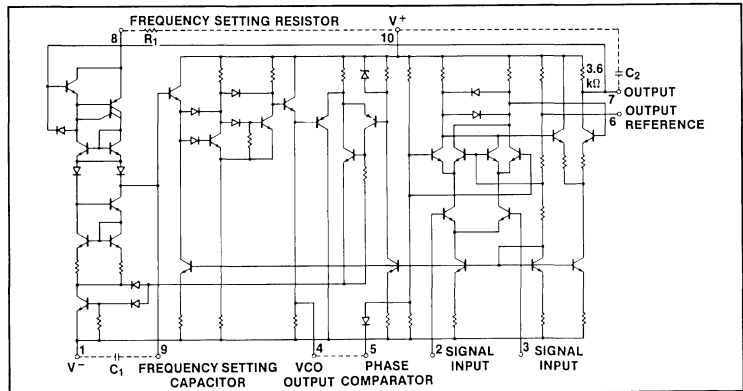

PHASE LOCKED LOOP

SE/NE565

ELECTRICAL CHARACTERISTICS $T_A = 25^\circ\text{C}$, $V_{CC} = \pm 6\text{V}$ unless otherwise specified.

PARAMETER	TEST CONDITIONS	SE565			NE565			UNIT
		Min	Typ	Max	Min	Typ	Max	
SUPPLY REQUIREMENTS Supply voltage Supply current		± 6	8	± 12 12.5	± 6	8	± 12 12.5	V mA
INPUT CHARACTERISTICS Input impedance ¹ Input level required for tracking	$f_o = 50\text{kHz}$, $\pm 10\%$ frequency deviation	7 10	10		5 10	10		$k\Omega$ mVrms
VCO CHARACTERISTICS Center frequency Maximum value Distribution ²	Distribution taken about $f_o = 50\text{kHz}$, $R_1 = 5.0k\Omega$, $C_1 = 1200\text{pF}$	300	500			500		kHz
Drift with temperature Drift with supply voltage	$f_o = 50\text{kHz}$ $f_o = 50\text{kHz}$, $V_{CC} = \pm 6$ to ± 7 volts		200 0.1	1.0		300 0.2	1.5	ppm/ $^\circ\text{C}$ %/V
Triangle wave Output voltage level Linearity		1.9	2.4 0.2	3	1.9	2.4 0.5	3	Vp-p %
Square wave Logical "1" output voltage Logical "0" output voltage	$f_o = 50\text{kHz}$ $f_o = 50\text{kHz}$	+4.9	+5.2 -0.2	+0.2	+4.9	+5.2 -0.2	+0.2	V V
Duty cycle	$f_o = 50\text{kHz}$	45	50	55	40	50	60	%
Rise time Fall time			20 50	100 200		20 50		ns ns
Output current (sink) Output current (source)		0.6 5	1 10		0.6 5	1 10		mA mA
DEMODULATED OUTPUT CHARACTERISTICS Output voltage level Maximum voltage swing ³ Output voltage swing Total harmonic distortion Output impedance ⁴ Offset voltage (V6-V7) Offset voltage vs temperature (drift) AM rejection	Measured at pin 7 $\pm 10\%$ frequency deviation	4.25	4.5 2 300	4.75	4.0	4.5 2 300	5.0	V Vp-p mVp-p % $k\Omega$ mV $\mu\text{V}/^\circ\text{C}$ dB
		250	0.2 3.6	0.75	200	0.4 3.6	1.5	
			30 50	100		50 100	200	
		30	40		40	40		

NOTES

- Both input terminals (pins 2 and 3) must receive identical dc bias. This bias may range from 0 volts to -4 volts.
- The external resistance for frequency adjustment (R1) must have a value between 2k Ω and 20k Ω .
- Output voltage swings negative as input frequency increases.
- Output not buffered.

TYPICAL PERFORMANCE CHARACTERISTICS

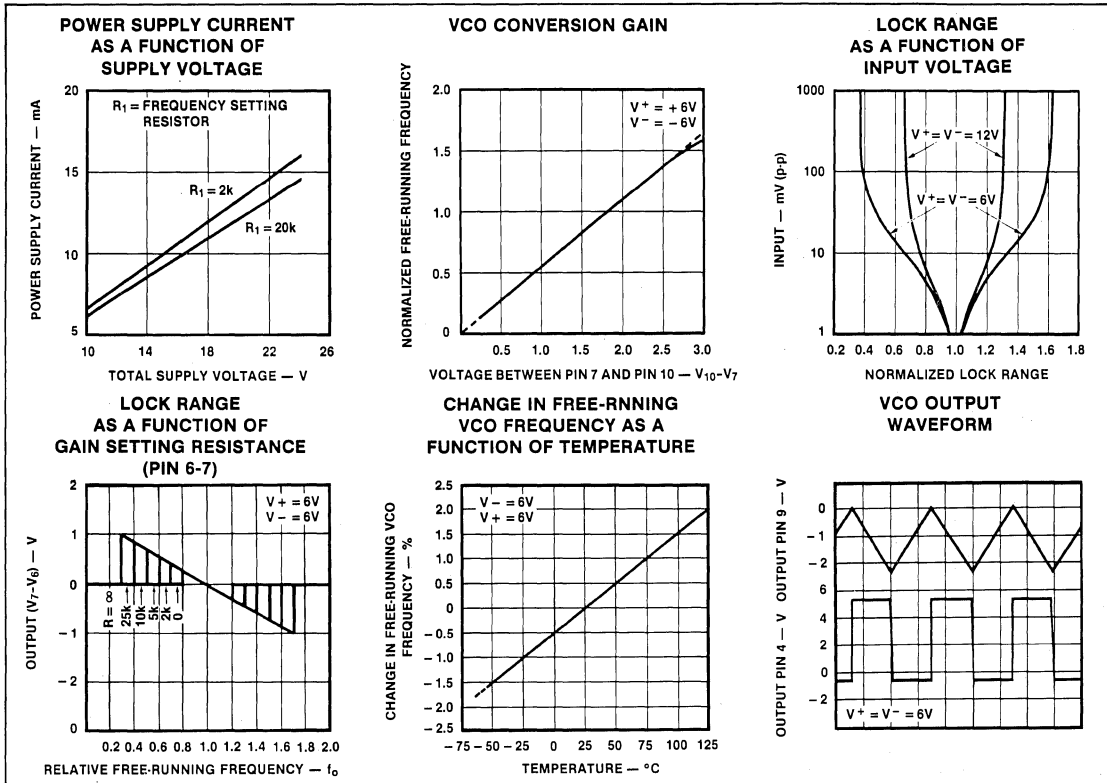

DESIGN FORMULAS
(See Figure 1)

Free-running frequency of VCO: $f_0 \approx \frac{1.2}{4R_1C_1}$ in Hz

Lock-range: $f_L \approx \pm \frac{8f_0}{V_{CC}}$ in Hz

Capture-range: $f_C \approx \pm \frac{1}{2\pi} \sqrt{\frac{2\pi f_L}{\tau}}$

where $\tau = (3.6 \times 10^3) \times C_2$

TYPICAL APPLICATIONS
FM Demodulation

The 565 Phase Locked Loop is a general purpose circuit designed for highly linear FM demodulation. During lock, the average dc level of the phase comparator output signal is directly proportional to the frequency of the input signal. As the input frequency shifts, it is this output signal which causes the VCO to shift its frequency to match that of the input. Consequently, the linearity of the phase comparator output with frequency is determined by the voltage-to-frequency transfer function of the VCO.

Because of its unique and highly linear VCO, the 565 PLL can lock to and track an input signal over a very wide bandwidth (typically $\pm 60\%$) with very high linearity (typically, within 0.5%).

A typical connection diagram is shown in Figure 1. The VCO free-running frequency is given approximately by

$f_0 \approx \frac{1.2}{4R_1C_1}$ and should be adjusted to be at the center of the input signal frequency range, C1 can be any value, but R1 should be within the range of 2000 to 20,000 ohms with an optimum value on the order of 4000 ohms. The source can be direct coupled if the dc resistances seen from pins 2 and 3 are equal and there is no DC voltage difference between the pins. A short between pins 4 and 5 connects the VCO to the phase comparator. Pin 6 provides a DC reference voltage that is close to the DC potential of the demodulated output (pin 7). Thus, if a resistance is connected between pins 6 and 7, the gain of the output stage can be reduced with little change in the DC voltage level at the output. This allows the lock range to be decreased

with little change in the free-running frequency. In this manner the lock range can be decreased from $\pm 60\%$ of f_0 to approximately $\pm 20\%$ of f_0 (at $\pm 6V$).

A small capacitor (typically $0.001\mu F$) should be connected between pins 7 and 8 to eliminate possible oscillation in the control current source.

A single-pole loop filter is formed by the capacitor C2, connected between pin 7 and the positive supply, and an internal resistance of approximately 3600 ohms.

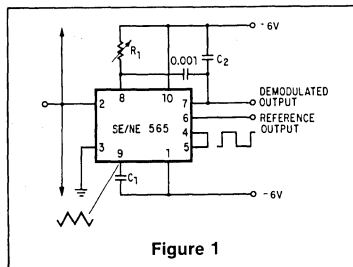

Figure 1

Frequency Shift Keying (FSK)

FSK refers to data transmission by means of a carrier which is shifted between two preset frequencies. This frequency shift is usually accomplished by driving a VCO with the binary data signal so that the two resulting frequencies correspond to the "0" and "1" states (commonly called space and mark) of the binary data signal.

A simple scheme using the 565 to receive FSK signals of 1070Hz and 1270Hz is shown in Figure 2. As the signal appears at the input, the loop locks to the input frequency and tracks it between the two frequencies with a corresponding dc shift at the output.

The loop filter capacitor C2 is chosen smaller than usual to eliminate overshoot on the output pulse, and a three-stage RC ladder filter is used to remove the carrier component from the output. The band edge of the ladder filter is chosen to be approximately half way between the maximum keying rate (in this case 300 baud or 150Hz) and twice the input frequency (approximately 2200Hz). The output signal can now be made logic compatible by connecting a voltage comparator between the output and pin 6 of the loop. The free-running frequency is adjusted with R1 so as to result in a slightly-positive voltage at the output with $f_{IN} = 1070\text{Hz}$.

The input connection is typical for cases where a dc voltage is present at the source and therefore a direct connection is not desirable. Both input terminals are returned to ground with identical resistors (in this case, the values are chosen to effect a 600-ohm input impedance).

Frequency Multiplication

There are two methods by which frequency multiplication can be achieved using the 565:

1. Locking to a harmonic of the input signal.
2. Inclusion of a digital frequency divider or counter in the loop between the VCO and phase comparator.

The first method is the simplest, and can be achieved by setting the free-running frequency of the VCO to a multiple of the input frequency. A limitation of this scheme is that the lock range decreases as successively higher and weaker harmonics are used for locking. If the input frequency is to be constant with little tracking required, the loop can generally be locked to any one of the first 5 harmonics. For higher orders of multiplication, or for cases where a large lock range is desired, the second scheme is more desirable. An example of this might be

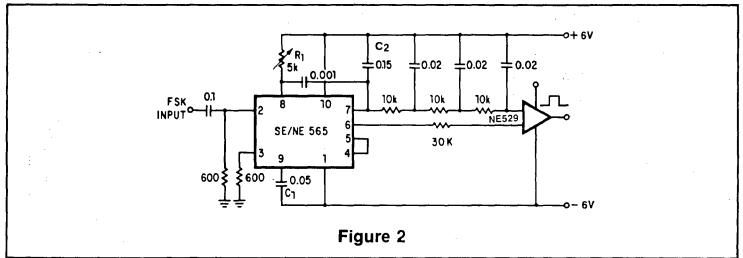

Figure 2

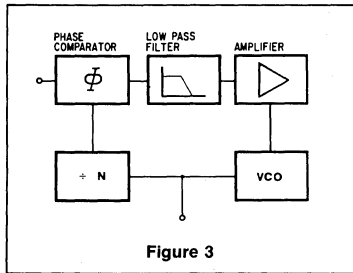

Figure 3

a case where the input signal varies over a wide frequency range and a large multiple of the input frequency is required.

A block diagram of the second scheme is shown in Figure 3. Here the loop is broken between the VCO and the phase comparator, and a frequency divider is inserted. The fundamental of the divided VCO frequency is locked to the input frequency in this case, so that the VCO is actually running at a multiple of the input frequency. The amount of multiplication is determined by the frequency divider. A typical connection scheme is shown in Figure 4. To set up the circuit, the frequency limits of the input signal must be determined. The free-running frequency of the VCO is then adjusted by means of R1 and C1 (as discussed under FM demodulation) so that the output frequency of the divider is midway between the input frequency limits. The filter capacitor, C2, should be large enough to eliminate variations in the demodulated output voltage (at pin 7), in order to stabilize the VCO frequency. The output can now be taken as the VCO squarewave output, and its fundamental will be the desired multiple of the input frequency (f_{IN}) as long as the loop is in lock.

SCA (Background Music) Decoder

Some FM stations are authorized by the FCC to broadcast uninterrupted background music for commercial use. To do this a frequency modulated subcarrier of 67kHz is used. The frequency is chosen so

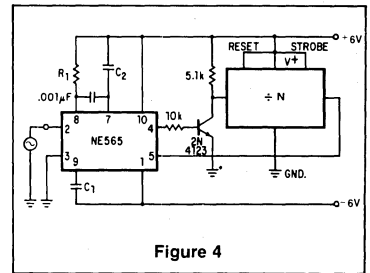

Figure 4

as not to interfere with the normal stereo or monaural program; in addition, the level of the subcarrier is only 10% of the amplitude of the combined signal.

The SCA signal can be filtered out and demodulated with the NE565 Phase Locked Loop without the use of any resonant circuits. A connection diagram is shown in Figure 5. This circuit also serves as an example of operation from a single power supply.

A resistive voltage divider is used to establish a bias voltage for the input (pins 2 and 3). The demodulated (multiplex) FM signal is fed to the input through a two-stage high-pass filter, both to effect capacitive coupling and to attenuate the strong signal of the regular channel. A total signal amplitude, between 80mV and 300mV, is required at the input. Its source should have an impedance of less than 10,000 ohms.

The Phase Locked Loop is tuned to 67kHz with a 5000 ohm potentiometer; only approximate tuning is required, since the loop will seek the signal.

The demodulated output (pin 7) passes through a three-stage low-pass filter to provide de-emphasis and attenuate the high-frequency noise which often accompanies SCA transmission. Note that no capacitor is provided directly at pin 7; thus, the circuit is operating as a first-order loop. The demodulated output signal is in the order of 50mV and the frequency response extends to 7kHz.

PHASE LOCKED LOOP

SE/NE565

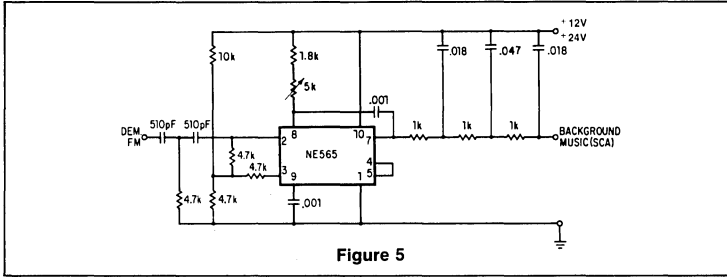

Figure 5

* For additional information, consult the Applications Section.

FUNCTION GENERATOR

SE/NE566

DESCRIPTION

The SE/NE 566 Function Generator is a voltage controlled oscillator of exceptional linearity with buffered square wave and triangle wave outputs. The frequency of oscillation is determined by an external resistor and capacitor and the voltage applied to the control terminal. The oscillator can be programmed over a ten to one frequency range by proper selection of an external resistance and modulated over a ten to one range by the control voltage, with exceptional linearity.

FEATURES

- Wide range of operating voltage (up to 24 volts) (single or dual)
- High linearity of modulation
- Highly stable center frequency (200 ppm/°C typical)
- Highly linear triangle wave output
- Frequency programming by means of a resistor or capacitor, voltage or current
- Frequency adjustable over 10 to 1 range with same capacitor

APPLICATIONS

- Tone generators
- Frequency shift keying
- FM modulators
- Clock generators
- Signal generators
- Function generators

ABSOLUTE MAXIMUM RATINGS

PARAMETER	RATING	UNIT
Maximum operating voltage	26	V
Input voltage	3	V _{P-P}
Storage temperature	-65 to +150	°C
Operating temperature range		
NE566	0 to +70	°C
SE566	-55 to +125	°C
Power dissipation	300	mW

BLOCK DIAGRAM

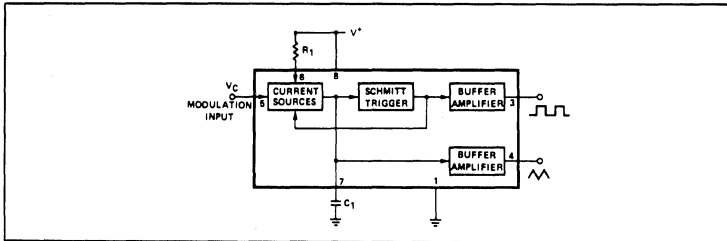

EQUIVALENT SCHEMATIC

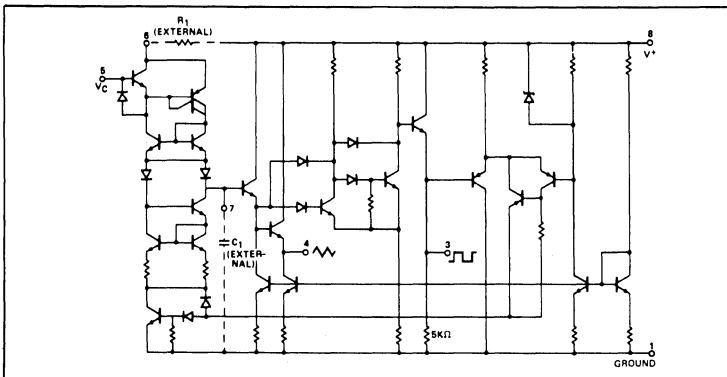

PIN CONFIGURATIONS

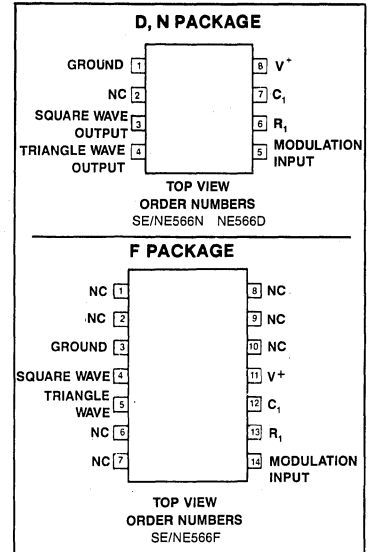

FUNCTION GENERATOR

SE/NE566

ELECTRICAL CHARACTERISTICS $T_A = 25^\circ\text{C}$; $V_{CC} = \pm 6\text{V}$ unless otherwise specified.

PARAMETER	SE566			NE566			UNIT
	Min	Typ	Max	Min	Typ	Max	
GENERAL							
Operating temperature range	-55		125	0		70	$^\circ\text{C}$
Operating supply voltage	± 6		± 12	± 6		± 12	V
Operating supply current		7	12.5		7	12.5	mA
VCO¹							
Maximum operating frequency		1			1		MHz
Frequency drift with temperature		200			300		ppm/ $^\circ\text{C}$
Frequency drift with supply voltage		.1	1		.2	2	%/V
Control terminal input impedance ²		1			1		M Ω
FM distortion ($\pm 10\%$ deviation)		0.2	0.75		0.4	1.5	%
Maximum sweep rate		1			1		MHz
Sweep range		10:1			10:1		
OUTPUT							
Triangle wave output							
Impedance		50			50		Ω
Voltage	1.9	2.4		1.9	2.4		V _{pp}
Linearity		0.2			0.5		%
Square wave input							
Impedance		50			50		Ω
Voltage	5	5.4		5	5.4		V _{pp}
Duty Cycle	45	50	55	40	50	60	%
Rise time		20			20		ns
Fall Time		50			50		ns

NOTES

- The external resistance for frequency adjustment (R_1) must have a value between 2k Ω and 20K Ω .
- The bias voltage (V_C) applied to the control terminal (pin 5) should be in the range $3/4V^+ \leq V_C \leq V^-$.

TYPICAL PERFORMANCE CHARACTERISTICS

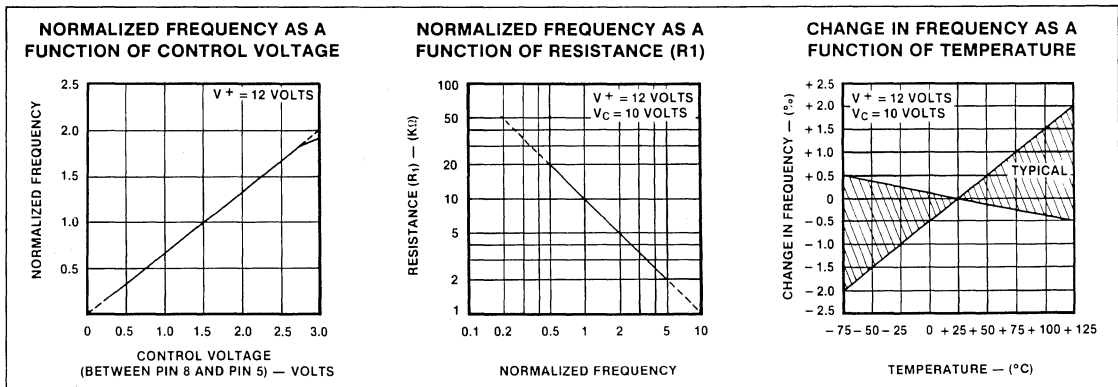

5

TYPICAL PERFORMANCE CHARACTERISTICS (Cont'd)

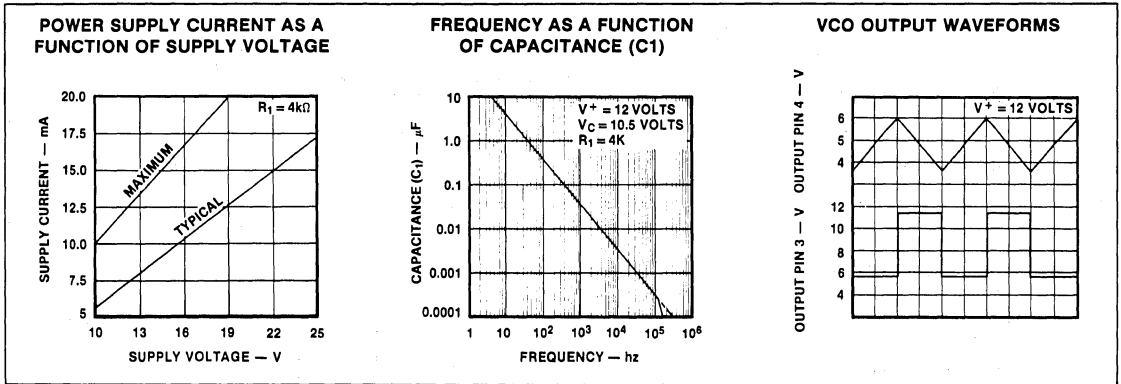

OPERATING INSTRUCTIONS

The SE/NE 566 Function Generator is a general purpose voltage controlled oscillator designed for highly linear frequency modulation. The circuit provides simultaneous square wave and triangle wave outputs at frequencies up to 1MHz. A typical connection diagram is shown in Figure 1. The control terminal (pin 5) must be biased externally with a voltage (V_C) in the range

$$3/4 V^+ \leq V_C \leq V^+$$

where V_{CC} is the total supply voltage. In Figure 1, the control voltage is set by the voltage divider formed with R_2 and R_3 . The modulating signal is then ac coupled with

the capacitor C_2 . The modulating signal can be direct coupled as well, if the appropriate dc bias voltage is applied to the control terminal. The frequency is given approximately by

$$f_o \approx \frac{2[(V^+) - (V_C)]}{R_1 C_1 V^+}$$

and R_1 should be in the range $2k\Omega < R_1 < 20k\Omega$.

A small capacitor (typically 0.001 μf) should be connected between pins 5 and 6 to eliminate possible oscillation in the control current source.

If the VCO is to be used to drive standard

logic circuitry, it may be desirable to use a dual supply as shown in Figure 2. In this case the square wave output has the proper dc levels for logic circuitry. RTL can be driven directly from pin 3. For DTL or T2L gates, which require a current sink of more than 1mA, it is usually necessary to connect a 5k Ω resistor between pin 3 and negative supply. This increases the current sinking capability to 2mA. The third type of interface shown uses a saturated transistor between the 566 and the logic circuitry. This scheme is used primarily for T2L circuitry which requires a fast fall time (<50ns) and a large current sinking capability.

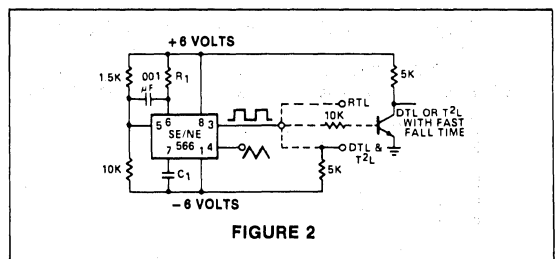
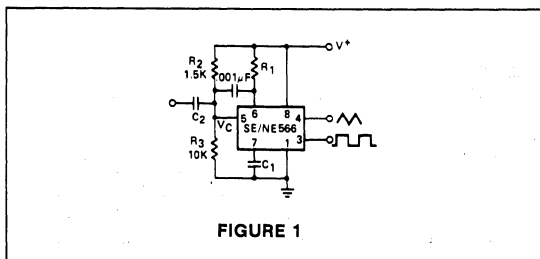

*For additional information, consult the Applications Section.

tone decoder/phase locked loop

SE/NE567

DESCRIPTION

The SE/NE567 tone and frequency decoder is a highly stable phase-locked loop with synchronous AM lock detection and power output circuitry. Its primary function is to drive a load whenever a sustained frequency within its detection band is present at the self-biased input. The bandwidth center frequency, and output delay are independently determined by means of four external components.

FEATURES

- Wide frequency range (.01Hz to 500kHz)
- High stability of center frequency
- Independently controllable bandwidth (up to 14 percent)
- High out-band signal and noise rejection
- Logic-compatible output with 100mA current sinking capability
- Inherent immunity to false signals
- Frequency adjustment over a 20 to 1 range with an external resistor
- Military processing available

APPLICATIONS

- Touch Tone® decoding
- Carrier current remote controls
- Ultrasonic controls (remote TV, etc.)
- Communications paging
- Frequency monitoring and control
- Wireless intercom
- Precision oscillator

ABSOLUTE MAXIMUM RATINGS

PARAMETER	RATING	UNIT
Operating temperature		
NE567	0 to +70	°C
SE567	-55 to +125	°C
Operating voltage	10	V
Positive voltage at input	0.5 + V _S	V
Negative voltage at input	-10	Vdc
Output voltage (collector of output transistor)	15	Vdc
Storage temperature	-65 to +150	°C
Power dissipation	300	mW

BLOCK DIAGRAM

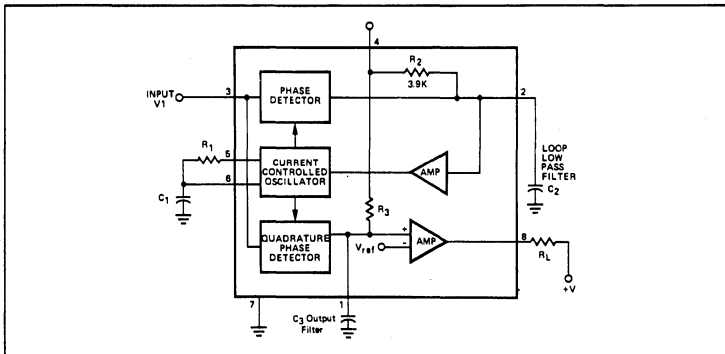

PIN CONFIGURATIONS

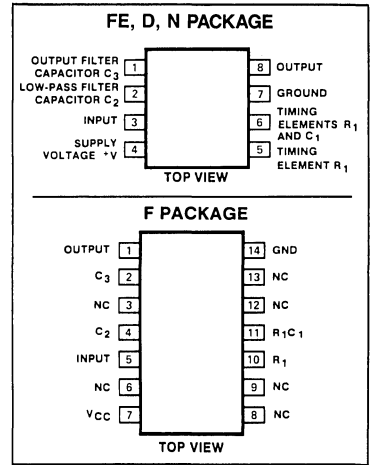

5

tone decoder/phase locked loop

SE/NE567

EQUIVALENT SCHEMATIC

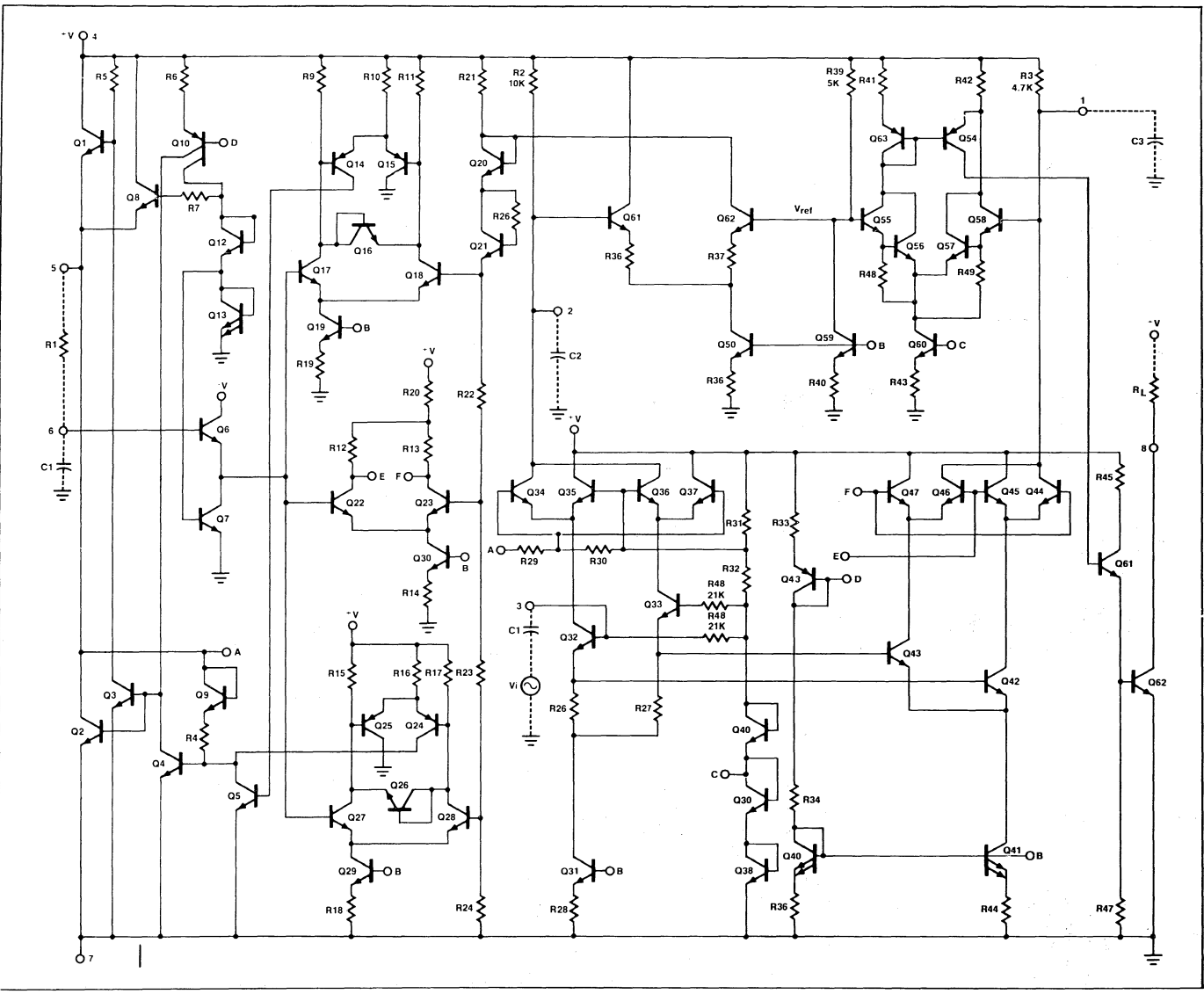

TONE DECODER/PHASE LOCKED LOOP

SE/NE567

DC ELECTRICAL CHARACTERISTICS (V+ = 5.0V; TA = 25°C unless otherwise specified.)

PARAMETER	TEST CONDITIONS	SE567			NE567			UNIT
		Min	Typ	Max	Min	Typ	Max	
CENTER FREQUENCY ¹ Highest center frequency (f _o)			500			500		kHz
Center frequency stability ²	-55 to +125°C 0 to +70°C		35±140 35±60			35±140 35±60		ppm/°C ppm/°C
Center frequency distribution	f _o = 100kHz = 1.1/R ₁ C ₁	-10	0	+10	-10	0	+10	%
Center frequency shift with supply voltage	f _o = 100kHz = 1.1/R ₁ C ₁		0.5	1		0.7	2	%/V
DETECTION BANDWIDTH Largest detection bandwidth Largest detection bandwidth skew Largest detection bandwidth— variation with temperature Largest detection bandwidth— variation with supply voltage	f _o = 100kHz = 1.1/R ₁ C ₁ V _i = 300mVrms V _i = 300mVrms	12	14 2 ±0.1	16 4	10	14 3 ±0.1	18 6	% of f _o % of f _o %/°C %/V
INPUT Input resistance Smallest detectable input voltage (V _i) Largest no-output input voltage Greatest simultaneous outband signal to inband signal ratio Minimum input signal to wideband noise ratio	 I _L = 100mA, f _i = f _o I _L = 100mA, f _i = f _o B _n = 140kHz	15 10	20 15 -6	25 25 +6 -6	15 10	20 15 +6 -6	25 25	kΩ mVrms mVrms dB dB
OUTPUT Fastest on-off cycling rate "1" output leakage current "0" output voltage Output fall time ³ Output rise time ³	 V _B = 15V I _L = 30mA I _L = 100mA R _L = 50Ω R _L = 50Ω		f _o /20 0.01 0.2 0.6 30 150	 25 0.4 1.0		f _o /20 0.01 0.2 0.6 30 150	 25 0.4 1.0	 μA V V ns ns
GENERAL Operating voltage range Supply current quiescent Supply current—activated Quiescent power dissipation	 R _L = 20kΩ	4.75	 6 11 30	9.0 8 13	4.75	9.0 7 12 35	9.0 10 15	V mA mA mW

NOTES

1. Frequency determining resistor R₁ should be between 2 and 20kΩ.
2. Applicable over 4.75 to 5.75 volts. See graphs for more detailed information.
3. Pin 8 to Pin 1 feedback R_L network selected to eliminate pulsing during turn-on and turn-off.

TYPICAL PERFORMANCE CHARACTERISTICS

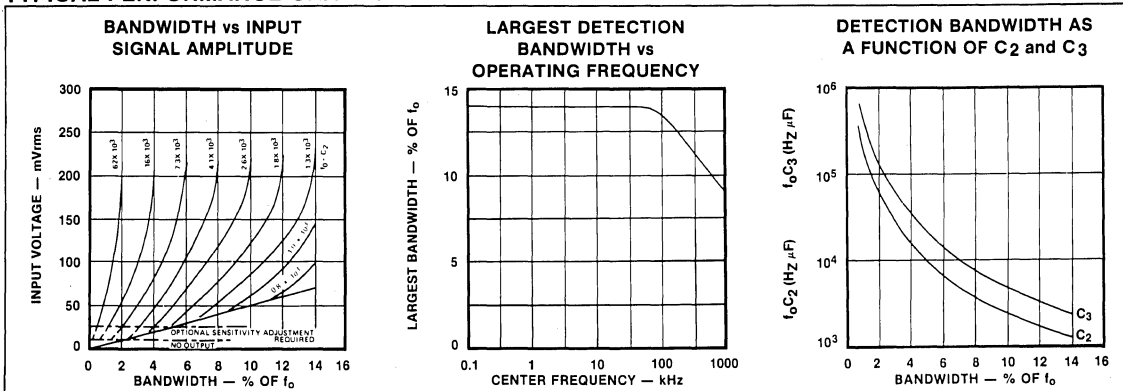

5

TONE DECODER/PHASE LOCKED LOOP

SE/NE567

TYPICAL PERFORMANCE CHARACTERISTICS (Cont'd)

TYPICAL SUPPLY CURRENT vs SUPPLY VOLTAGE

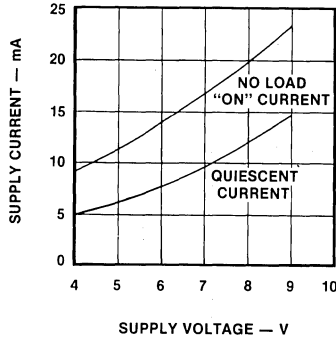

GREATEST NUMBER OF CYCLES BEFORE OUTPUT

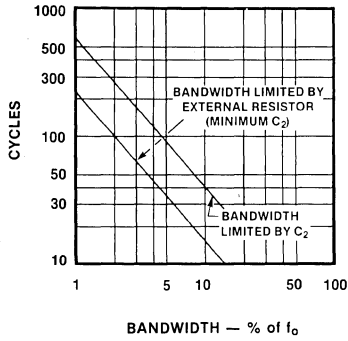

TYPICAL OUTPUT VOLTAGE vs TEMPERATURE

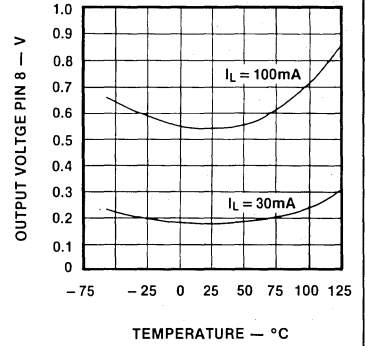

TYPICAL FREQUENCY DRIFT WITH TEMPERATURE (MEAN AND S.D.)

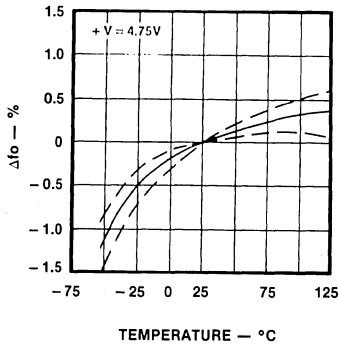

TYPICAL FREQUENCY DRIFT WITH TEMPERATURE (MEAN AND S.D.)

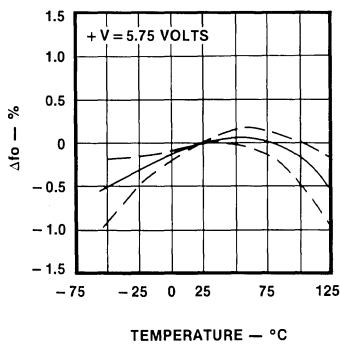

TYPICAL FREQUENCY DRIFT WITH TEMPERATURE (MEAN AND S.D.)

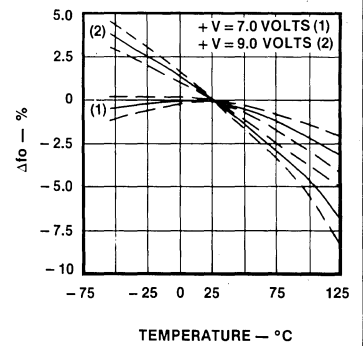

CENTER FREQUENCY TEMPERATURE COEFFICIENT (MEAN AND S.D.)

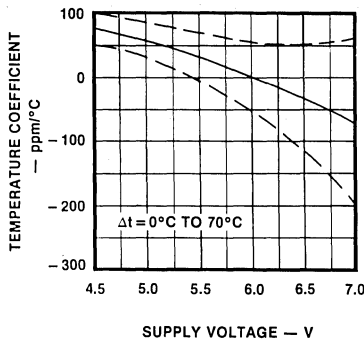

CENTER FREQUENCY SHIFT WITH SUPPLY VOLTAGE CHANGE vs OPERATING FREQUENCY

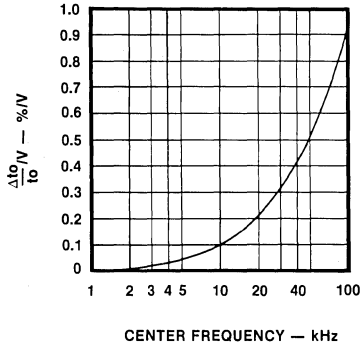

TYPICAL BANDWIDTH VARIATION WITH TEMPERATURE

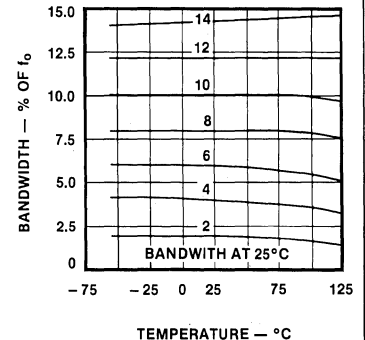

tone decoder/phase locked loop

SE/NE567

DESIGN FORMULAS

$$f_0 \approx \frac{1.1}{R_1 C_1}$$

$$BW \approx 1070 \sqrt{\frac{V_1}{f_0 C_2}} \text{ in \% of } f_0, V_1 \leq 200\text{mVrms}$$

Where

V_1 = Input Voltage (Vrms)
 C_2 = Low-Pass Filter Capacitor (μF)

PHASE LOCKED LOOP TERMINOLOGY CENTER FREQUENCY (f_0)

The free-running frequency of the current controlled oscillator (CCO) in the absence of an input signal.

Detection Bandwidth (BW)

The frequency range, centered about f_0 , within which an input signal above the threshold voltage (typically 20mVrms) will cause a logical zero state on the output. The detection bandwidth corresponds to the loop capture range.

Lock Range

The largest frequency range within which an input signal above the threshold voltage will hold a logical zero state on the output.

Detection Band Skew

A measure of how well the detection band is centered about the center frequency, f_0 . The skew is defined as $(f_{\text{max}} + f_{\text{min}} - 2f_0)/2f_0$ where f_{max} and f_{min} are the frequencies corresponding to the edges of the detection band. The skew can be reduced to zero if necessary by means of an optional centering adjustment.

OPERATING INSTRUCTIONS

Figure 1 shows a typical connection diagram for the 567. For most applications, the following three-step procedure will be sufficient for choosing the external components R_1 , C_1 , C_2 and C_3 .

1. Select R_1 and C_1 for the desired center frequency. For best temperature stability, R_1 should be between 2K and 20K ohm, and the combined temperature coefficient of the $R_1 C_1$ product should have sufficient stability over the projected temperature range to meet the necessary requirements.
2. Select the low pass capacitor, C_2 , by referring to the Bandwidth versus Input Signal Amplitude graph. If the input amplitude variation is known, the appropriate value of $f_0 C_2$ necessary to give the desired bandwidth may be found. Conversely, an area of operation may be selected on this graph and the input level and C_2 may be adjusted accordingly. For example, con-

TYPICAL RESPONSE

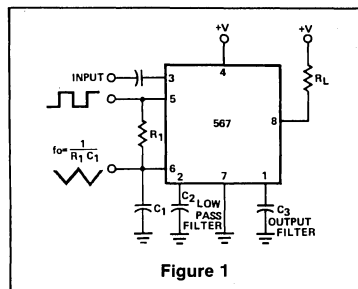
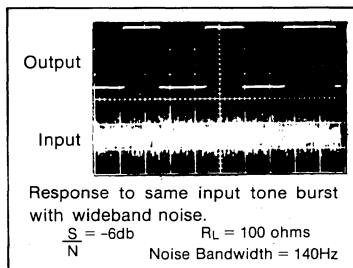
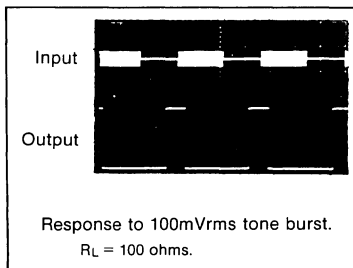

output of magnitude $(+V - 2V_{be}) \approx (+V - 1.4V)$ having a dc average of $+V/2$. A 1k Ω load may be driven from pin 5. Pin 6 is an exponential triangle of 1 volt peak-to-peak with an average dc level of $+V/2$. Only high impedance loads may be connected to pin 6 without affecting the CCO duty cycle or temperature stability.

OPERATING PRECAUTIONS

A brief review of the following precautions will help the user achieve the high level of performance of which the 567 is capable.

1. Operation in the high input level mode (above 200mV) will free the user from bandwidth variations due to changes in the in-band signal amplitude. The input stage is now limiting, however, so that out-band signals or high noise levels can cause an apparent bandwidth reduction as the in-band signal is suppressed. Also, the limiting action will create in-band components from sub-harmonic signals, so the 567 becomes sensitive to signals at $f_0/3$, $f_0/5$, etc.
2. The 567 will lock onto signals near $(2n + 1) f_0$, and will give an output for signals near $(4n + 1) f_0$ where $n = 0, 1, 2$, etc. Thus, signals at $5f_0$ and $9f_0$ can cause an unwanted output. If such signals are anticipated, they should be attenuated before reaching the 567 input.
3. Maximum immunity from noise and out-band signals is afforded in the low input level (below 200mVrms) and reduced bandwidth operating mode. However, decreased loop damping causes the worse-case lock-up time to increase, as shown by the Greatest Number of Cycles Before Output vs Bandwidth graph.
4. Due to the high switching speeds (20ns) associated with 567 operation, care should be taken in lead routing. Lead lengths should be kept to a minimum. The power supply should be adequately bypassed close to the 567 with a 0.01 μF or greater capacitor; grounding paths should be carefully chosen to avoid ground loops and

stant bandwidth operation requires that input amplitude be above 200mVrms. The bandwidth, as noted on the graph, is then controlled solely by the $f_0 C_2$ product (f_0 (Hz), C_2 (μf)).

3. The value of C_3 is generally non-critical. C_3 sets the band edge of a low pass filter which attenuates frequencies outside the detection band to eliminate spurious outputs. If C_3 is too small, frequencies just outside the detection band will switch the output stage on and off at the beat frequency, or the output may pulse on and off during the turn-on transient. If C_3 is too large, turn-on and turn-off of the output stage will be delayed until the voltage on C_3 passes the threshold voltage. (Such delay may be desirable to avoid spurious outputs due to transient frequencies.) A typical minimum value for C_3 is 2 μC .

AVAILABLE OUTPUTS (Figure 2)

The primary output is the uncommitted output transistor collector, pin 8. When an in-band input signal is present, this transistor saturates; its collector voltage being less than 1.0 volt (typically 0.6V) at full output current (100mA). The voltage at pin 2 is the phase detector output which is a linear function of frequency over the range of 0.95 to 1.05 f_0 with a slope of about 20mV per percent of frequency deviation. The average voltage at pin 1 is, during lock, a function of the inband input amplitude in accordance with the transfer characteristic given. Pin 5 is the controlled oscillator square wave

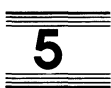

unwanted voltage variations. Another factor which must be considered is the effect of load energization on the power supply. For example, an incandescent lamp typically draws 10 times rated current at turn-on. This can cause supply voltage fluctuations which could, for example, shift the detection band of narrow-band systems sufficiently to cause momentary loss of lock. The result is a low-frequency oscillation into and out of lock. Such effects can be prevented by supplying heavy load currents from a separate supply or increasing the supply filter capacitor.

SPEED OF OPERATION

Minimum lock-up time is related to the natural frequency of the loop. The lower it is, the longer becomes the turn-on transient. Thus, maximum operating speed is obtained when C₂ is at a minimum. When the signal is first applied, the phase may be such as to initially drive the controlled oscillator away from the incoming frequency rather than toward it. Under this condition, which is of course unpredictable, the lock-up transient is at its worst and the theoretical minimum lock-up time is not achievable. We must simply wait for the transient to die out.

The following expressions give the values of C₂ and C₃ which allow highest operating speeds for various band center frequencies. The minimum rate at which digital information may be detected without information loss due to the turn-on transient or output chatter is about 10 cycles per bit, corresponding to an information transfer rate of f₀/10 baud.

$$C_2 = \frac{130}{f_0} \mu F$$

$$C_3 = \frac{260}{f_0} \mu F$$

In cases where turn-off time can be sacrificed to achieve fast turn-on, the optional sensitivity adjustment circuit can be used to move the quiescent C₃ voltage lower (closer to the threshold voltage). However, sensitivity to beat frequencies, noise and extraneous signals will be increased.

OPTIONAL CONTROLS (Figure 3)

The 567 has been designed so that, for most applications, no external adjustments are required. Certain applications, however, will be greatly facilitated if full advantage is

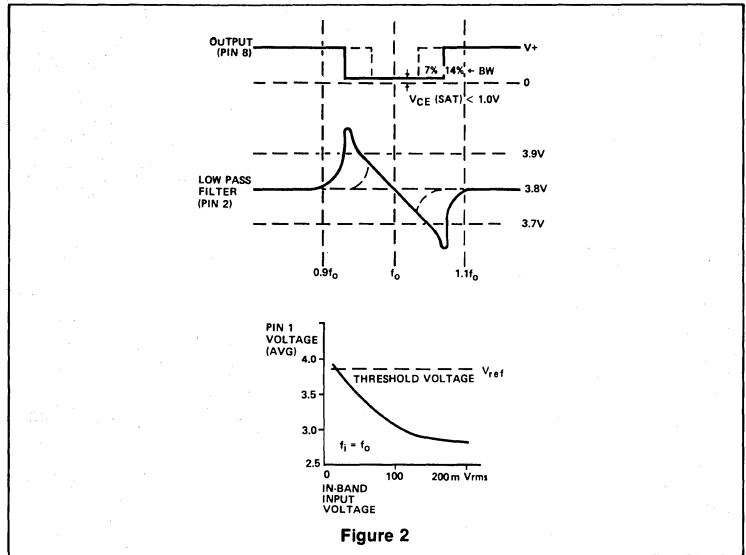

Figure 2

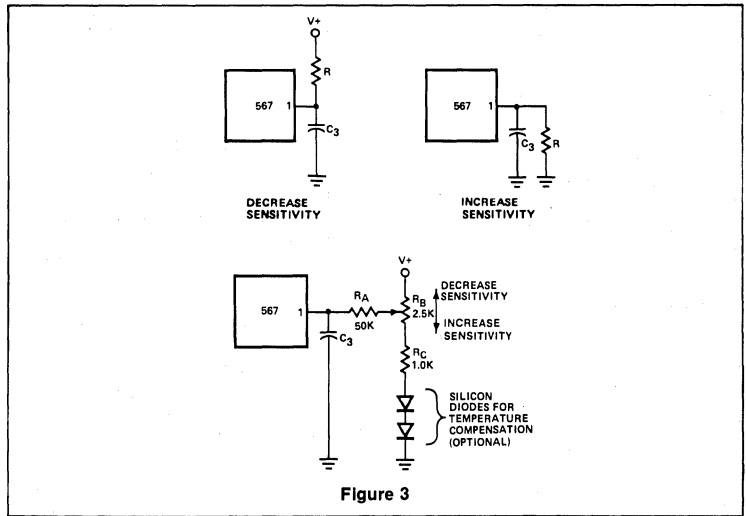

Figure 3

taken of the added control possibilities available through the use of additional external components. In the diagrams given, typical values are suggested where applicable. For best results the resistors used, except where noted, should have the same

temperature coefficient. Ideally, silicon diodes would be low-resistivity types, such as forward-biased transistor base-emitter junctions. However, ordinary low-voltage diodes should be adequate for most applications.

SENSITIVITY ADJUSTMENT

(Figure 3)

When operated as a very narrow band detector (less than 8 percent), both C_2 and C_3 are made quite large in order to improve noise and outband signal rejection. This will inevitably slow the response time. If, however, the output stage is biased closer to the threshold level, the turn-on time can be improved. This is accomplished by drawing additional current to terminal 1. Under this condition, the 567 will also give an output for lower-level signals (10mV or lower).

By adding current to terminal 1, the output stage is biased further away from the threshold voltage. This is most useful when, to obtain maximum operating speed, C_2 and C_3 are made very small. Normally, frequencies just outside the detection band could cause false outputs under this condition. By desensitizing the output stage, the outband beat notes do not feed through to the output stage. Since the input level must be somewhat greater when the output stage is made less sensitive, rejection of third harmonics or in-band harmonics (of lower frequency signals) is also improved.

CHATTER PREVENTION

(Figure 4) Chatter occurs in the output stage when C_3 is relatively small, so that the lock transient and the AC components at the quadrature phase detector (lock detector) output cause the output stage to move through its threshold more than once. Many loads, for example lamps and relays, will not respond to the chatter. However, logic may recognize the chatter as a series of outputs. By feeding the output stage output back to its input (pin 1) the chatter can be eliminated. Three schemes for doing this are given in Figure 4. All operate by feeding the first output stage (either on or off) back to the input, pushing the input past the threshold until the transient conditions are over. It is only necessary to assure that the feedback time constant is not so large as to prevent operation at the highest anticipated speed. Although chatter can always be eliminated by making C_3 large, the feedback circuit will enable faster operation of the 567 by allowing C_3 to be kept small. Note that if the feedback time constant is made quite large, a short burst at the input frequency can be stretched into a long output pulse. This may be useful to drive, for example, stepping relays.

DETECTION BAND CENTERING (OR SKEW) ADJUSTMENT

(Figure 5)

When it is desired to alter the location of the detection band (corresponding to the loop capture range) within the lock range, the

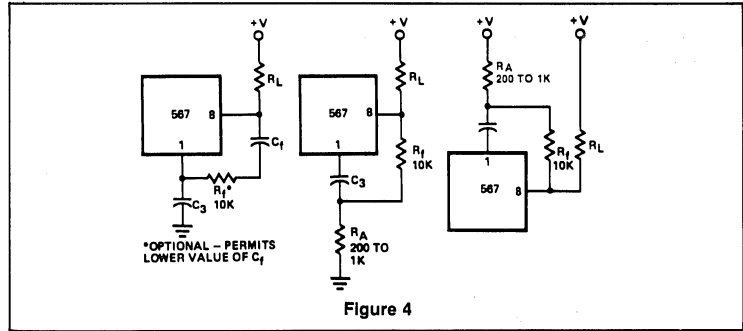

Figure 4

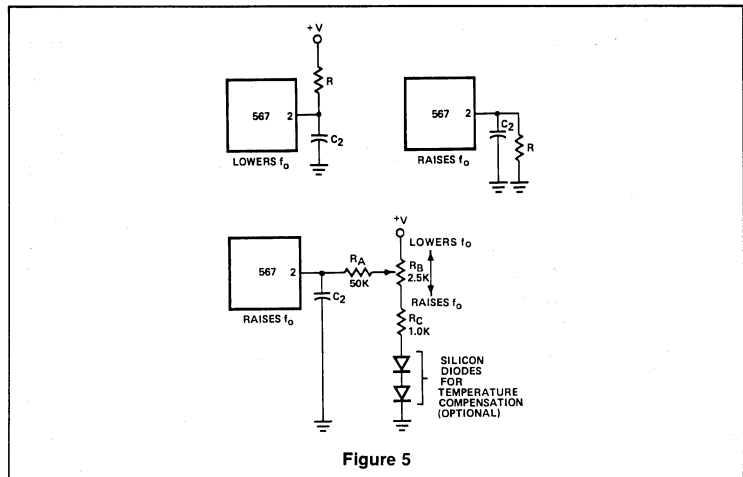

Figure 5

circuits shown above can be used. By moving the detection band to one edge of the range, for example, input signal variations will expand the detection band in only one direction. This may prove useful when a strong but undesirable signal is expected on one side or the other of the center frequency. Since R_B also alters the duty cycle slightly, this method may be used to obtain a precise duty cycle when the 567 is used as an oscillator.

ALTERNATE METHOD OF BANDWIDTH REDUCTION

(Figure 6)

Although a large value of C_2 will reduce the bandwidth, it also reduces the loop damping so as to slow the circuit response time. This may be undesirable. Bandwidth can be reduced by reducing the loop gain. This scheme will improve damping and permit faster operation under narrow-band conditions. Note that the reduced impedance level at terminal 2 will require that a larger

value of C_2 be used for a given filter cutoff frequency. If more than three 567s are to be used, the network of R_B and R_C can be eliminated and the R_A resistors connected together. A capacitor between this junction and ground may be required to shunt high frequency components.

OUTPUT LATCHING

(Figure 7)

To latch the output on after a signal is received, it is necessary to provide a feedback resistor around the output stage (between pins 8 and 1). Pin 1 is pulled up to unlatch the output stage.

REDUCTION OF C1 VALUE

(Figure 8)

For precision very low-frequency applications, where the value of C_1 becomes large, an overall cost savings may be achieved by inserting a voltage follower between the R_1 C_1 junction and pin 6, so as to allow a higher value of R_1 and a lower value of C_1 for a given frequency.

PROGRAMMING

To change the center frequency, the value of R_1 can be changed with a mechanical or solid state switch, or additional C_1 capacitors may be added by grounding them through saturating npn transistors.

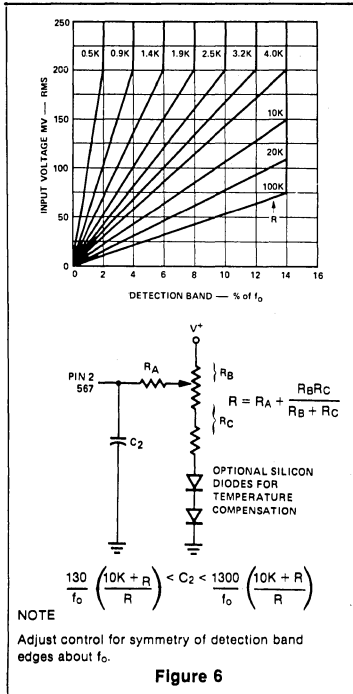

TYPICAL APPLICATIONS

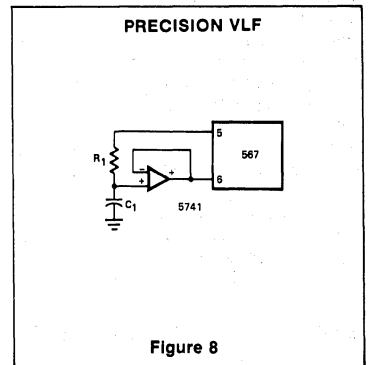
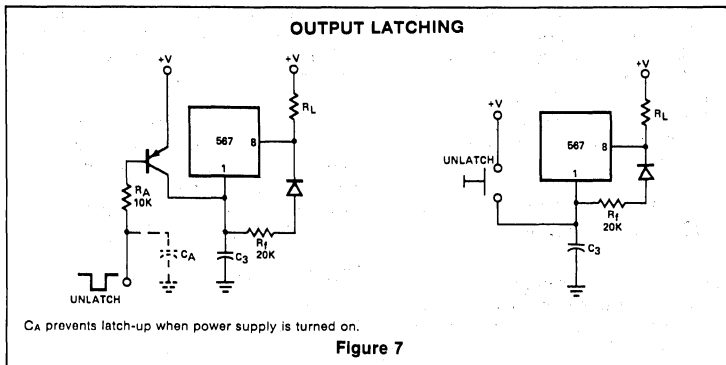
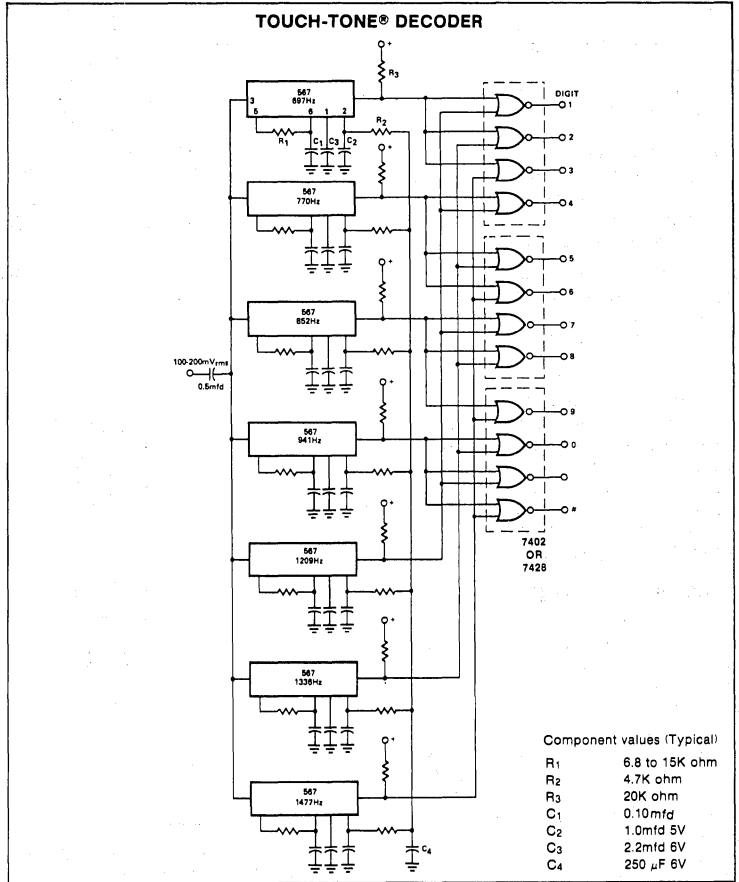

TYPICAL APPLICATIONS (Cont'd)

CARRIER-CURRENT REMOTE CONTROL OR INTERCOM

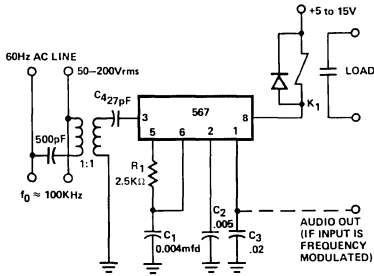

24% BANDWIDTH TONE DECODER

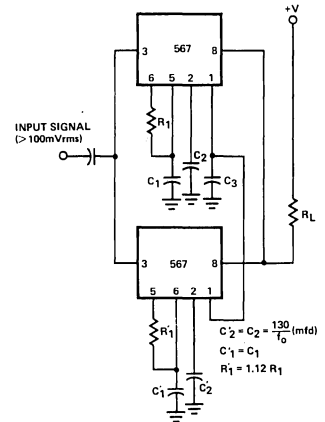

DUAL-TONE DECODER

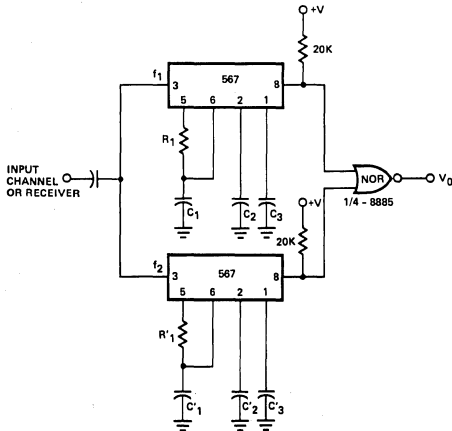

1. Resistor and capacitor values chosen for desired frequencies and bandwidth.
2. If C_3 is made large so as to delay turn-on of the top 567, decoding of sequential ($f_1 f_2$) tones is possible.

0° to 180° PHASE SHIFTER

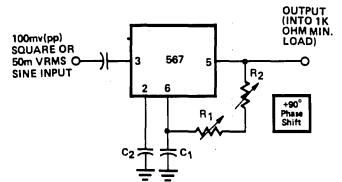

- $R_2 \approx R_1/5$
Adjust R_1 so that $\phi = 90^\circ$ with control midway

TONE DECODER/PHASE LOCKED LOOP

SE/NE567

TYPICAL APPLICATIONS (Cont'd)

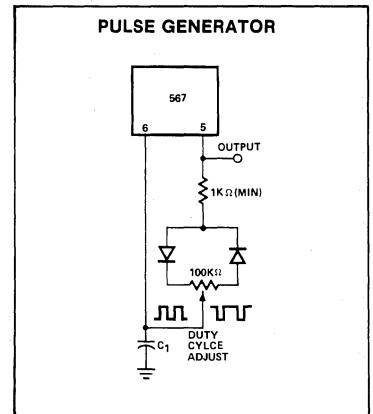
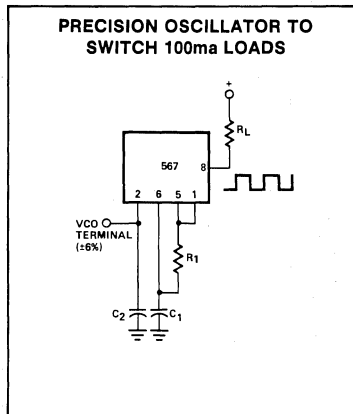
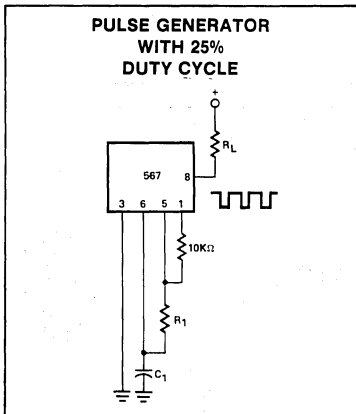
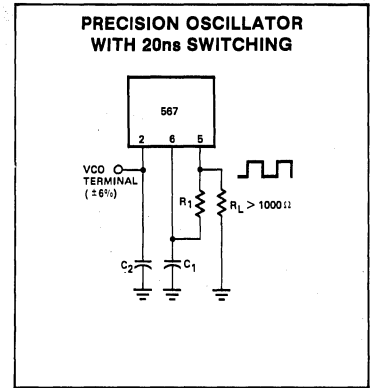
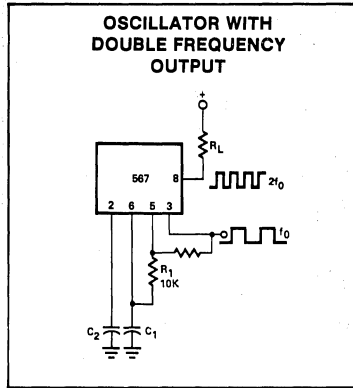
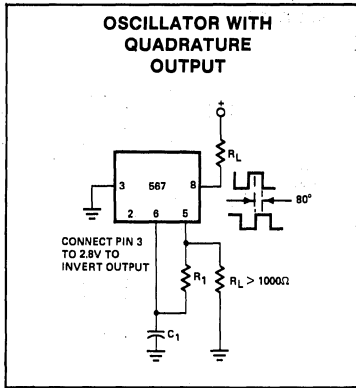

*For additional information, consult the Applications Section.

SPEECH SYNTHESIZER

MEA8000

Preliminary

DESCRIPTION

The MEA8000 is a 24-pin N MOS integrated circuit for generating good quality speech from digital code with a programmable bit rate. The circuit is primarily intended for applications in microprocessor controlled systems, where the speech code is stored separately in a Read-Only Memory. An efficient, easy-to-use speech editing and encoding system with EPROM programming capability, has been specially developed.

APPLICATIONS

- Telephony
- Automotive
- Computer response/prompt.
- Video games.
- General industrial.

FEATURES

- Microprocessor interface capability including an 8-bit data bus, an enable and a read/write input control signals.
- 32-bit data buffer holding speech frame codes.
- Digital filter of 8th order with 3 programmable formant frequencies, one fixed formant frequency, and 4 programmable formant bandwidths. 4 KHz bandwidth.
- Programmable amplitudes.
- Programmable duration of each frame: 8, 16, 32, or 64 milliseconds.
- Low data rate: average 1000 bits/sec.
- Operates from standard EPROMs/ROMs.
- Minimal external audio filter requirement.
- Crystal controlled oscillator or external (TTL) clock.
- Single +5V power supply.

PIN CONFIGURATION

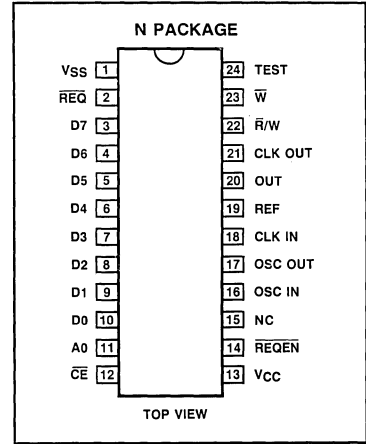

BLOCK DIAGRAM

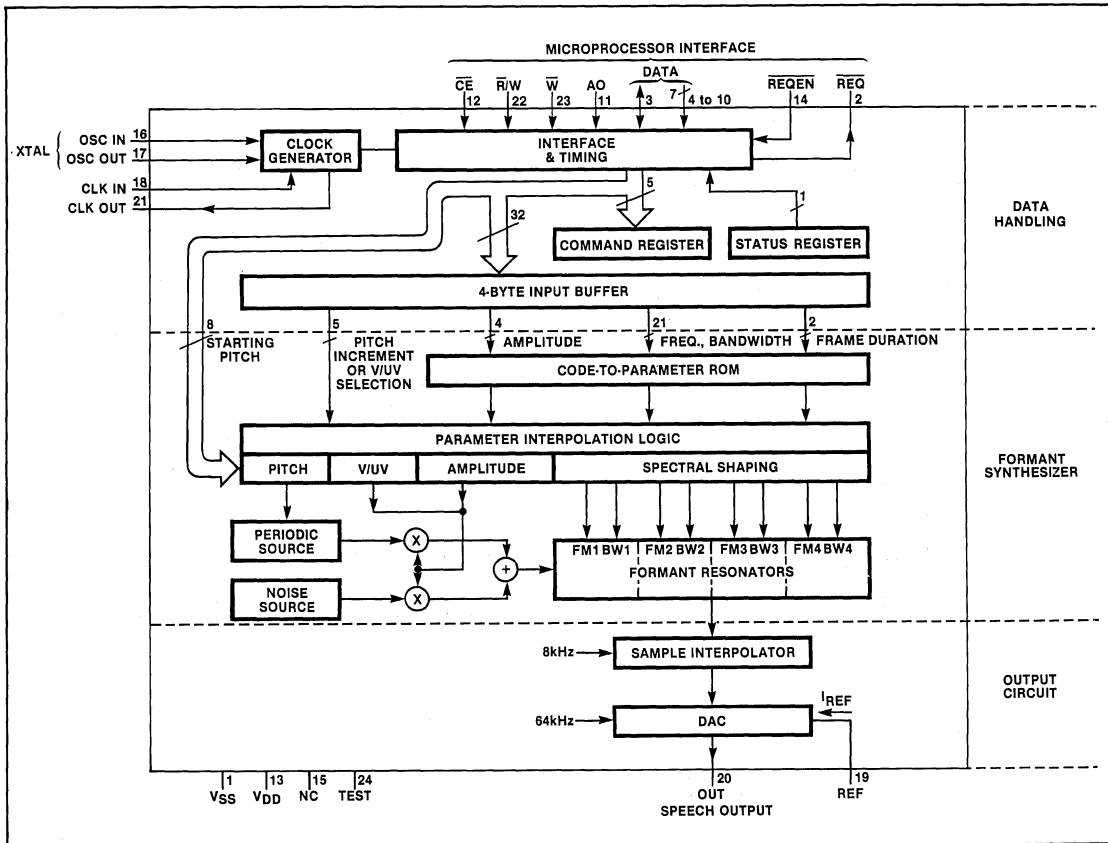

5

SPEECH SYNTHESIZER

MEA8000

Preliminary

FUNCTIONAL PIN DESCRIPTION

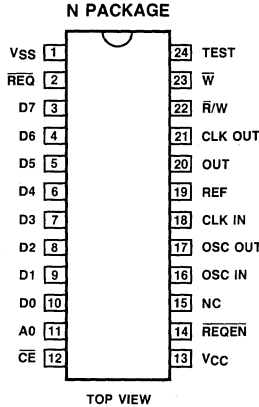

PIN NO.	SYMBOL	NAME AND FUNCTION
CONTROL		
2	REQ	DATA REQUEST output signal (open drain) which follows the inverse of the status REQ bit, but only if enabled by either the ROE bit in the command register or the external REQEN input pin.
3 to 10	D7 to D0	Data bus to which command or encoded speech parameters can be written. D7 is a bidirectional line through which the status bit can be read.
11	A0	Data/control input. Discriminates between speech code input buffer (A0 = '0') and command register (A0 = '1') during a 'write' operation.
12 22 23	CE R/W W	Chip enable, Read/Write, Write These control signals provides an easy interface to most microprocessors or microcomputers (see timing diagrams).
14	REQEN	Request enable input. REQEN = '0' enables the status REQ bit to appear inverted on the REQ output, independent of the command register.
TIMING		
16 17	OSC IN OSC OUT	Connections for internal clock oscillator. Nominal crystal frequency is 3.84 MHz. OSC IN must be tied to ground if CLK IN is used.
18 21	CLK IN CLK OUT	Clock input for external clock, TTL compatible, 3.84 MHz. Must be tied to ground when not used. A buffered output of the internal clock cycle (= CLK IN divided by 3).
OUTPUT		
19	REF	Reference Current Input pin for biasing the audio output level. This reference current can be derived from a resistor to the positive supply.
20	OUT	Speech output. This output is a 64 kHz pulse, modulated in both width and amplitude. It is configured as a current sink with a saturating voltage of about 3V.
SUPPLY		
1	V _{SS}	Ground.
13	V _{CC}	Single supply voltage. Nominally 5V, but battery operation is also possible.
15	NC	No connection.
24	TEST	Used for testing purposes. Changes other pin functions. Must be tied to ground for user operation.

SPEECH SYNTHESIZER

MEA8000

Preliminary

ABSOLUTE MAXIMUM RATING

SYMBOL AND PARAMETER	RATING	UNIT
V _{CC} Supply voltage	-0.5 to +7	V
V _I Voltage on any pin with respect to V _{SS}	-0.5 to +7	V
V _{REQ} , V _{OUT} Output voltage on pins 2 and 20	15	V
T _{STG} Storage temperature range	-20 to +125	°C
T _A Operating ambient temperature range	0 to +70	°C

DC ELECTRICAL CHARACTERISTICS T_A = 25°C: V_{CC} = 5V, unless otherwise stated. All voltages referenced to V_{SS}

SYMBOL AND PARAMETER	TEST CONDITION	MEA8000			UNIT
		Min	Typ	Max	
V _{CC} Supply voltage (note 1)	(No audio load)	4.5	5.0	5.5	V
I _{CC} Supply current			30	50	mA
D0 to D7, A0, \overline{CE} , \overline{W} , $\overline{R/W}$, REQEN, CLK IN:					
V _{IH} Input HIGH voltage		2.0		V _{CC}	V
V _{IL} Input LOW voltage		-0.5		0.8	V
I _{IR} Input Leakage current (note 2)				10	μA
C _I Input Capacitance				7	pF
D7 (I/O), CLK OUT:					
V _{OH} Output HIGH voltage	I _{OH} = -100 μA	2.4			V
V _{OL} Output LOW voltage	I _{OL} = 1.6 mA			0.4	V
C _L Output Load capacitance				50	pF
REQ:					
V _{OH} Output HIGH voltage	Open drain			13.2	V
V _{OL} Output LOW voltage	I _{OL} = 1.6 mA			0.4	V
C _L Output Load capacitance				50	pF
Audio output					
I _{REF} Reference current (note 8) - Pin 19	I _{REF} = 0 mA I _{REF} = 0.1 mA I _{REF} = 0.3 mA I _{REF} = 0.1 mA			0.3	mA
I _{OUT} Output current (peak) - Pin 20					
			100		μA
			1.7		mA
		5		mA	
V _{OUT} V _{OUT} (pin 20) for linear operation (note 3)		2.5		13.2	V
Oscillator					
f _{X TAL} Crystal frequency	Internal		3.84	4.00	MHz
f _{CLK} Clock frequency	External		3.84	4.00	MHz

NOTES

1. The circuit will continue to operate from a supply of up to 6.5V, but without necessarily meeting the specification.
2. This is also valid for V_{CC} = 0V.
3. This permits connection of the output load to a supply higher than that supplying the synthesizer.

5

SPEECH SYNTHESIZER

MEA8000

Preliminary

AC ELECTRICAL CHARACTERISTICS (note 4) (Figure 4 and 5)

SYMBOL AND PARAMETER	TEST CONDITION	MEA8000			UNIT
		Min	Typ	Max	
t _{WR} Write enable pulse width.	Clock frequency = 3.84 MHz	200			ns
t _{AS} Address set-up time.		30			ns
t _{AH} Address hold time.		30			ns
t _{DS} Data set-up time for write operation.		150			ns
t _{DH} Data hold time for write operation.		30			ns
t _{RH} Request hold time (note 5)				350	ns
t _{RN} Request next (note 6)				3	μs
t _{RD} Read enable time.		200			ns
t _{DD} Data delay for read operation (note 7)				150	ns
t _{DF} Data floating for read operation (note 7)				150	ns
t _{RV} Request valid before a write operation.		0			ns
t _{ROE} Request output enable response.				750	ns
t _{CS} Control set-up time.				20	ns
t _{CH} Control hold time.				20	ns

NOTES

4. Timing reference level is 1.5V.
5. An external pull up resistor is required, as this is an open drain output. The time (t_{RH}) to reach 2.0V is specified at a load to 5V of 3.3 kΩ and 50 pF.
6. Between two data write operations of one speech frame.
7. Levels greater than 2.0V for a '1' or less than 0.8V for a '0' are reached with a load of one TTL input and 50 pF.
8. Typical voltage level at the REF pin is 2.5V.

Preliminary

PRINCIPLE OF OPERATION

The MEA8000 voice synthesizer implements the vocal tract modeling technique of voice synthesis (also known as formant synthesis). This technique results in producing good quality speech with the lowest possible bit rates; this will in turn mean small memory size requirements.

Figure 1 shows an electronic model of the human vocal tract. A mixture of a periodic signal, representing the pitch of the original speech, and an aperiodic signal, representing the unvoiced sound in the speech, is fed via an amplifier stage to a variable filter comprising of four resonators. The amplifier controls the amplitude of the synthesized sound while the resonators model the sound in accordance with the formants in the original speech. Each resonator is controlled by two parameters, one for the resonant frequency and one for the bandwidth. The information required to control such a synthesizer system is defined by the pitch frequency, the amplitude values, the voiced/unvoiced source selection and the resonator settings. By periodic updating of this control information one can obtain a good replica of the original speech.

Operation

The MEA8000 generates speech output by suitable filtering of a relatively low frequency sawtooth waveform for voiced sounds or for random noise for unvoiced sounds.

Speech encoded parameters, controlling the on-chip periodic source and digital filter, are transmitted on the 8-bit data bus from external memory to the MEA8000 under the control of an external microprocessor or microcomputer.

At first, a byte containing the starting pitch code must be transmitted to the MEA8000. This byte goes directly to the pitch generating circuitry via the input interface logic. Subsequent pitch frequencies are then specified using the pitch increment parameter; this method of encoding pitch contributes to the low bit rate requirements.

After receiving the starting pitch code, the codes of each speech frame (32 bits), when received, are shifted into a four-byte input buffer before being translated into control parameters by the code-to-parameter ROM (See Block Diagram). The parameter interpolation logic calculates the difference, and interpolates linearly between consecutive parameters to smooth the parameter transients. The interpolation interval is decoded using the two Frame Duration (FD) bits in each speech frame. Because the FD bits specify a frame duration of 8, 16, 32 or 64ms, the resulting average bit rate is about 1000 bits/sec.

Since the on-chip output sampling rate is 64KHz, the need for an external analog output filter is greatly reduced.

Modes of Operation

1. STOP mode: characterized by a silent output and the status REQ bit set to '1'. This mode is entered from power up or by STOP command. The mode is entered automatically if at the end of an active speech frame the next four parameter bytes are not yet received while the CONT bit in the command register is a '0'. In the latter case the final speech frame will be repeated once but with a decaying amplitude and the same pitch.
2. ACTIVE mode: a speech sample is being produced.
3. CONTINUOUS mode: entered if an active speech frame is finished and new data is not supplied in time while the CONT bit in the command register is a '1'. The synthesizer will repeat the last speech frame indefinitely until all four new data bytes are received, a STOP command has been issued or the CONT command bit has been reset.

Control Signals

With the three control signals \overline{CE} , \overline{W} and \overline{RW} , provided on 3 external pins, the MEA8000 voice synthesizer chip is made compatible with most popular microprocessors and microcomputers. Please refer to the timing diagrams for timing requirements.

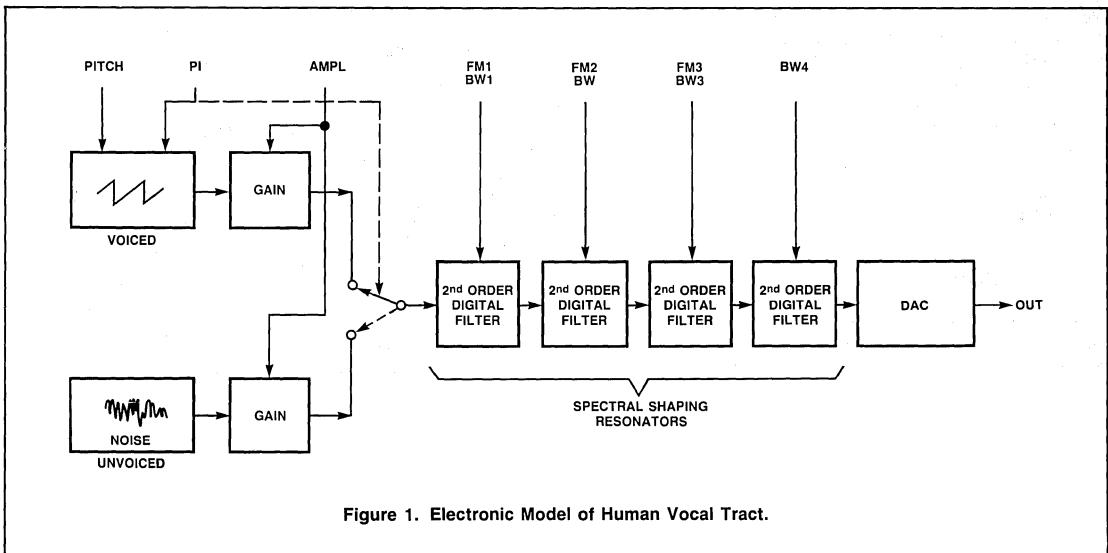

Figure 1. Electronic Model of Human Vocal Tract.

Preliminary

Addressing the MEA8000

The MEA8000 voice synthesizer chip is addressed as a peripheral device to the host microprocessor or microcomputer. The three control signals, \overline{CE} , \overline{W} , and $\overline{R/W}$ along with the A0 address input, allow the MEA8000 to

be addressed as an I/O device or as a memory device in a memory-mapped I/O system.

The input buffer and the command register are write-only while the status register is a read-only, as depicted in the following table:

\overline{CE}	\overline{W}	$\overline{R/W}$	A0	OPERATION
0	0	1	0	Write Data
0	0	1	1	Write Command Register
0	X	0	X	Read Status Register
0	1	1	X	Three-State Data Bus
1	X	X	X	Three-State Data Bus

Status Register

The MEA8000 status register consists of a single bit: REQ. The status REQ bit appears on bit 7 of the data bus, D7, when reading the status register. The REQ output carries the inverse polarity of the status REQ bit. When the status REQ bit is a "0", the MEA8000 is busy and cannot accept any write data. The MEA8000 requests more data by setting its status REQ bit to a "1"; in this case the REQ output pin is active "0" only if this output is enabled. The REQ output is enabled either by hardware by connecting REQEN pin to ground, or by software by setting the ROE bit in the command register to a "1" while holding REQEN pin high. The MEA8000 voice synthesizer chip can then be used in an interrupt driven environment or in a polled type structure.

Speech Code Input Buffer

The MEA8000 has a 32-bit (4-byte) input buffer. This buffer holds the speech encoded parameters for one speech frame.

Starting from the STOP mode — see Modes of Operation — the first data byte received by the MEA8000 will be interpreted as a starting value for the pitch. Every four successive data bytes received thereafter are treated as a group of speech code. The coded speech frame format is shown in Figure 2.

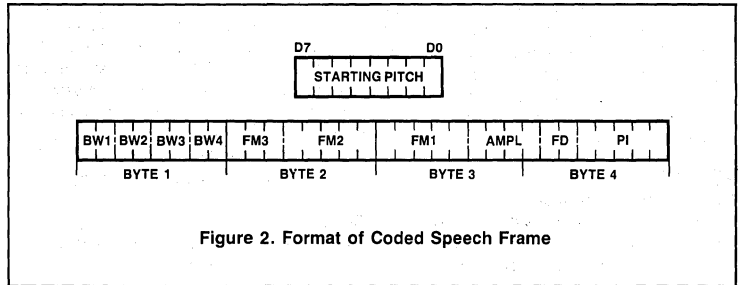

Figure 2. Format of Coded Speech Frame

Writing a data byte into the MEA8000 will, automatically, clear the status REQ bit to "0". Within a group of 4 bytes (i.e. one speech frame), the REQ output (if enabled) will be activated within 3 μ s, measured from the trailing edge of \overline{CE} or \overline{W} (depending on which is used as the write strobe — see Timing), indicating a request for the next byte within the same group. Note that this time is extended to a multiple of 8ms (8, 16, 32 or 64) after writing the fourth, or last, byte of a group. This allows the host microprocessor enough time to use polling, instead of interrupts, since the minimum time of a speech frame is 8ms.

When in the STOP mode, the MEA8000 voice synthesizer will commence producing sound after receipt of 5 bytes (Figure 2).

SYMBOL AND PARAMETER		BITS
Starting Pitch	Initial value for pitch	8
FD	Speech frame duration	2
PI	Pitch increment (rate of pitch change) or noise selection	5
AMPL	Amplitude	4
FM1	Frequency of 1st formant	5
FM2	Frequency of 2nd formant	5
FM3	Frequency of 3rd formant	3
FM4	Frequency of 4th formant (fixed at 3500 Hz)	0
BW1	Bandwidth of 1st formant	2
BW2	Bandwidth of 2nd formant	2
BW3	Bandwidth of 3rd formant	2
BW4	Bandwidth of 4th formant	2

Preliminary

Command Register

The MEA8000 has a 5-bit command register. A command word is written into the command register by performing a write operation with A0 input being set to "1".

The following explains the various command bits in the command register:

STOP results in an immediate reset of the synthesizer to the STOP mode. The ROE and CONT are not affected by this command.

CONT Continuous mode. This bit can be set or cleared only if the corresponding CONT enable bit is programmed as a '1'. In the continuous mode the synthesizer will not revert to the STOP mode if all four parameters are not received before the end of the current speech frame, but will repeat it indefinitely.

If CONT = '0', the last frame will be repeated once with decaying amplitude and the same pitch before the stop mode is entered.

ROE Request Output Enable. This bit can be set or cleared only if the corresponding ROE enable bit is a '1'. ROE determines whether the request in the status bit appears on the REQ pin. Note: the same can be achieved by connecting the REQEN pin (request enable) to a '0'.

After power on, the command register bits CONT and ROE will both be zero. Thus power on equals the command 00011010 = 1 A (hexadecimal).

D7	D6	D5	D4	D3	D2	D1	D0
			STOP	CONT enable	CONT	ROE enable	ROE
Not used			'0' = Invalid	00 = Invalid 01 = Invalid 10 = Slow stop 11 = Continue		00 = Invalid 01 = Invalid 10 = Disable REQ output 11 = Enable REQ output	
			'1' = Stop				

ROM Mapping

The external ROM that stores the speech codes of an utterance or a word (called a speech file) also stores the starting pitch byte and the file header. The header comprises three bytes, two that indicate the number of bytes in the file and one that allows additional data to be encoded for each file.

Usually, more than one speech file will be stored in a ROM. An index is made by listing the 2-byte starting addresses of each file at the beginning of the ROM. The end of the index is indicated by the bytes FF FF. Figure 3 shows examples of ROM mapping.

Power Supply

During (slow) power-up or power-down, the MEA8000 voice synthesizer will not produce any spurious sound. When powering-up the device, the MEA8000 will be in the STOP mode with command bits ROE and CONT being set to "0".

Speech Editing and Encoding System

A specially designed speech editing and encoding system, targeted for use with the MEA8000, has been developed. The system consists of a Speech Adapter Box

(SAB), a customized software package, and a general purpose personal computer.

The system is capable of programming the PROM's with the most efficient speech parameters. These parameters, when read by the MEA8000 voice synthesizer chip, will produce the best quality speech possible that this chip is capable of delivering.

Timing Diagrams

Read and write timing diagrams are depicted in Figures 4, 5, and 6. Note that for a read operation, either CE or R/W can be used as the read strobe whereas for a write operation, either CE or W can be used as the write strobe. This allows great flexibility in system design.

Figure 7 shows the timing sequence encountered when writing speech code data into the MEA8000. In the figure, data is written on the rising edge of CE. Starting in the STOP mode, the first byte to be written is the starting pitch. This is followed by 4 consecutive bytes, representing the first speech frame to be written into the MEA8000. Note that within the same frame, REQ output pin (if enabled) is activated within 3µs indicating, to the host microprocessor, its readiness to accept the next byte. After receiving the fourth byte of a speech

frame, the REQ output pin will not be activated until the frame duration period (specified by the two FD bits) has elapsed. This time is equivalent to 8, 16, 32 or 64ms.

System Configurations

Figure 8 shows a minimal system configuration for a voice application system using a general purpose microprocessor or a single chip microcomputer. In the latter case, speech code parameters are stored in the on-chip microcomputer ROM.

Figure 9 depicts a speech synthesis system using the SCN8051, 8-bit single chip microcomputer. Separate external program memory and speech parameters memory is shown, using 64K ROM chips. Note that external buffers might be needed on P0 (0-7) depending on loading conditions.

Figure 10 shows a typical audio output stage configuration using the TDA1011 audio power amplifier chip.

The oscillator/clock configurations are depicted in Figure 11.

Preliminary

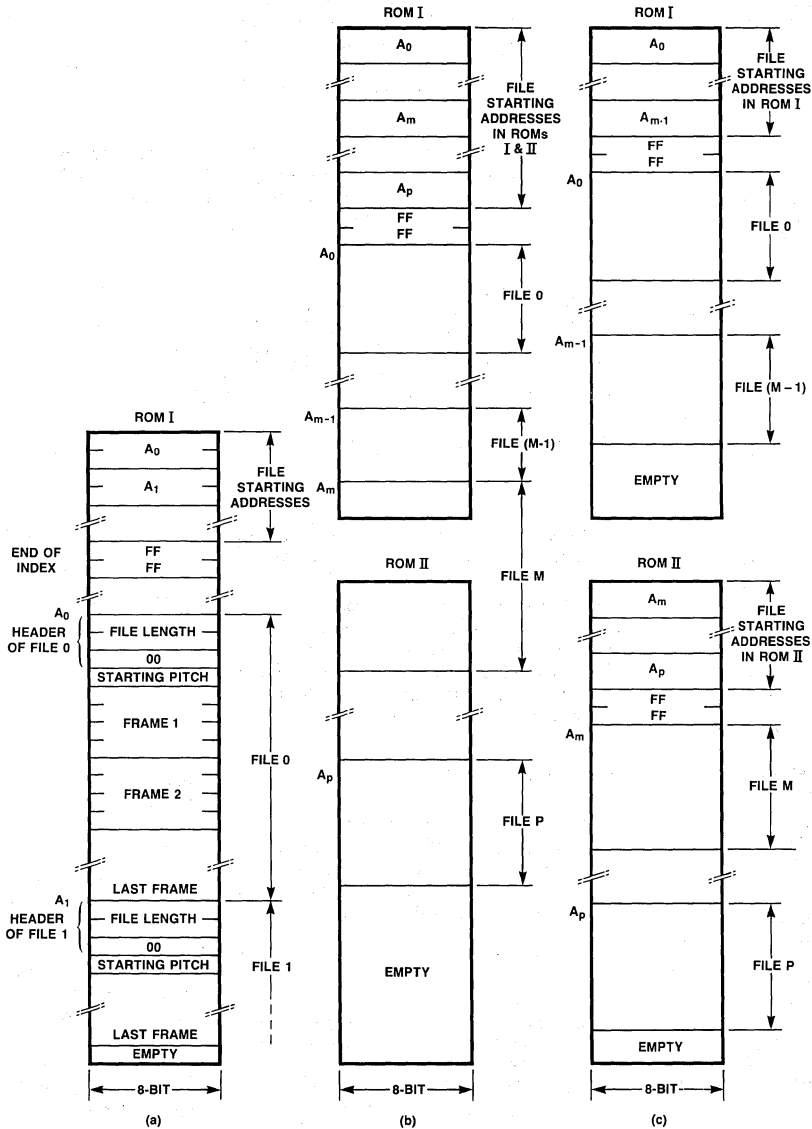

Figure 3. Examples of ROM Memory Mapping; (a) Vocabulary in One ROM, (b) and (c) Vocabulary in Two ROMs.

Preliminary

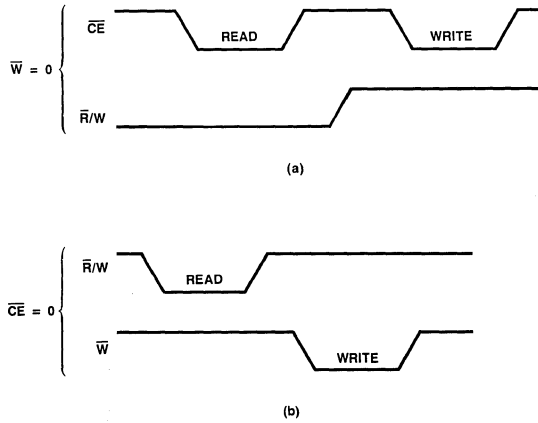

Figure 4. (a) Chip Enable (CE) Used as a Read or Write Strobe; (b) Separate Read and Write Strobes.

5

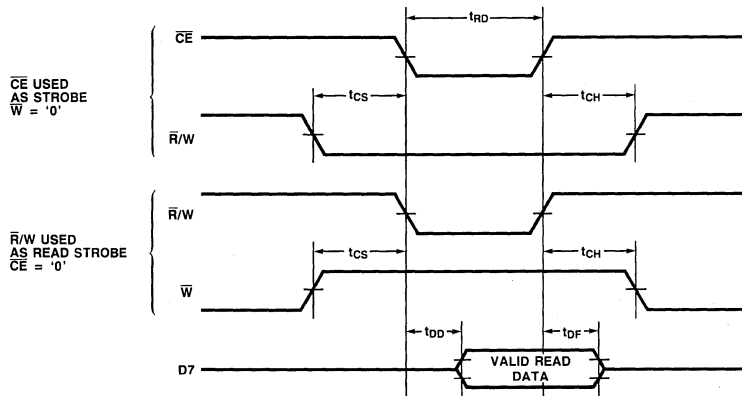

Figure 5. Read Timing

NOTES

Address input A0 is a don't care. Data bits D0 to D6 remain floating.

Preliminary

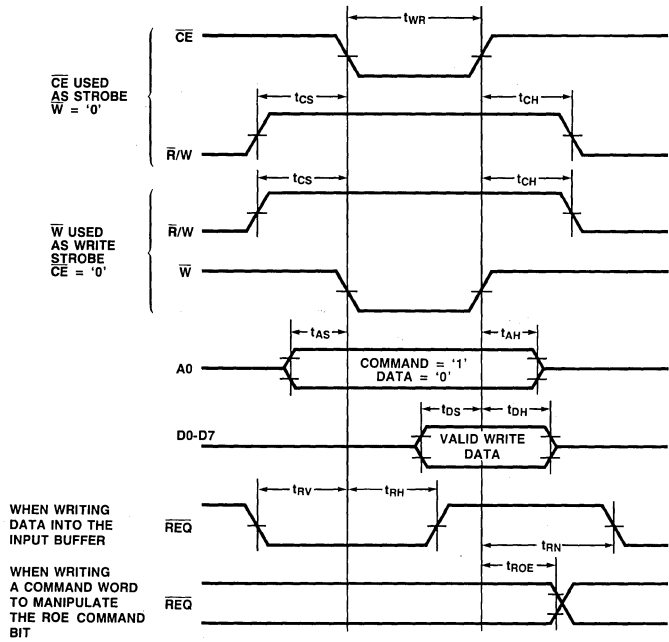

Figure 6. Write Timing

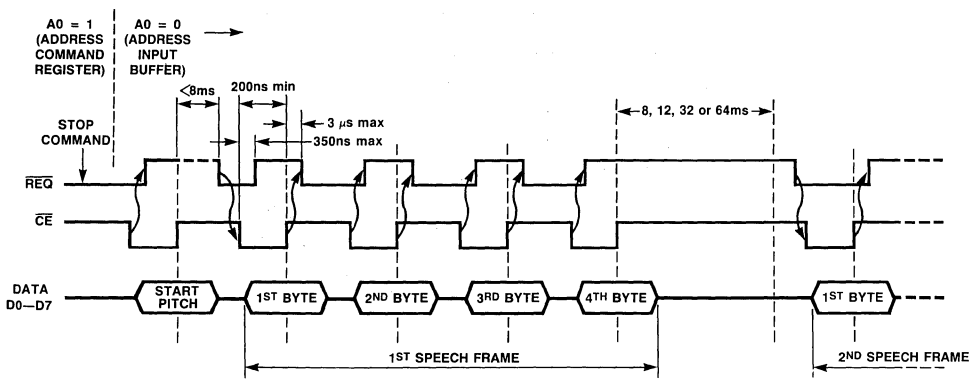
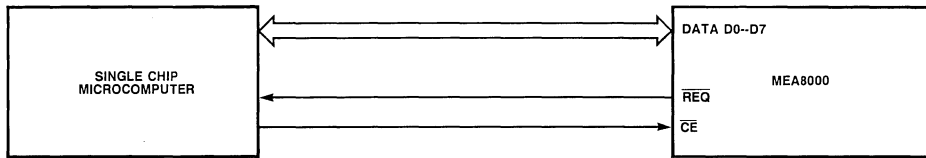
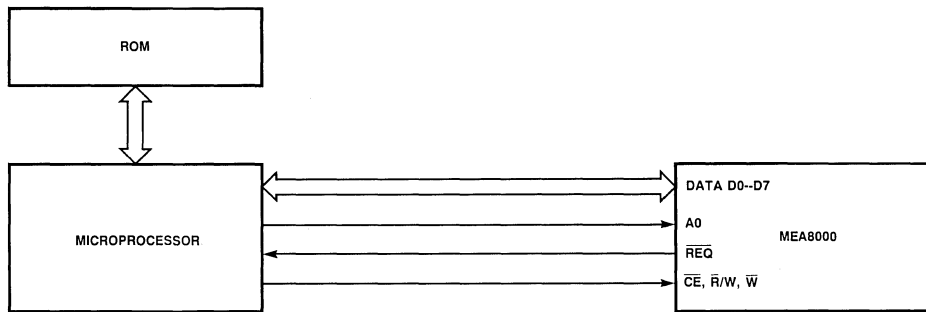

Figure 7. Speech Code Data Write Timing Sequence

Preliminary



a. Minimal System: Single Chip Microcomputer With On-chip Voice ROM.



b. MEA8000 as a Microprocessor Peripheral

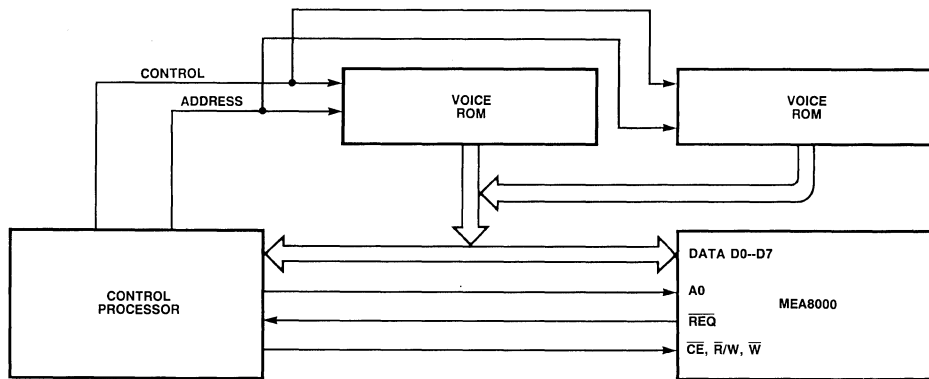

c. Applications Using Separate Voice ROMs.

Figure 8. Typical Application Configurations.

5

Preliminary

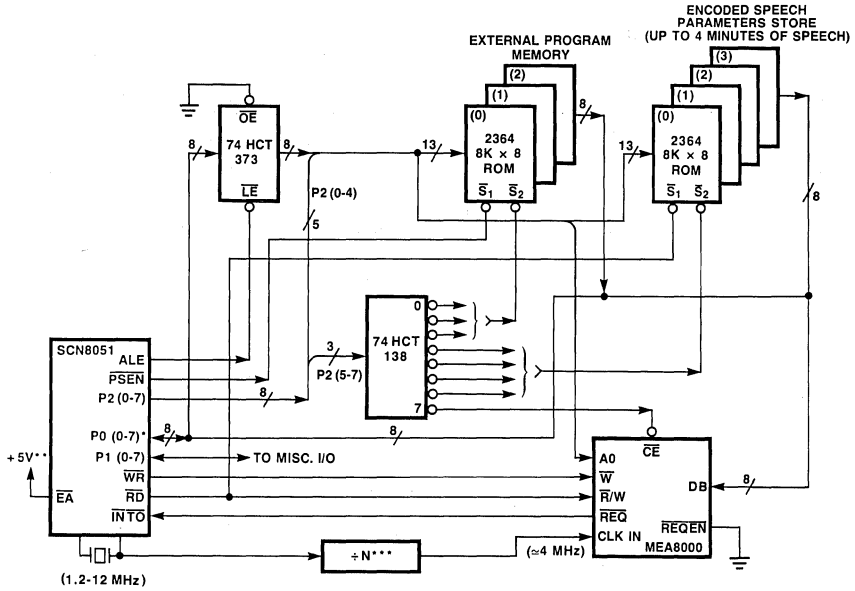

Figure 9. Speech Synthesis System Using the 8051 8-Bit Microcomputer

- *External buffers might be needed.
- **Connect EA to ground for the ROM less version (SCN 8031).
- *** $\div N$ is a single F/F when XTAL frequency is around 8 MHz

Preliminary

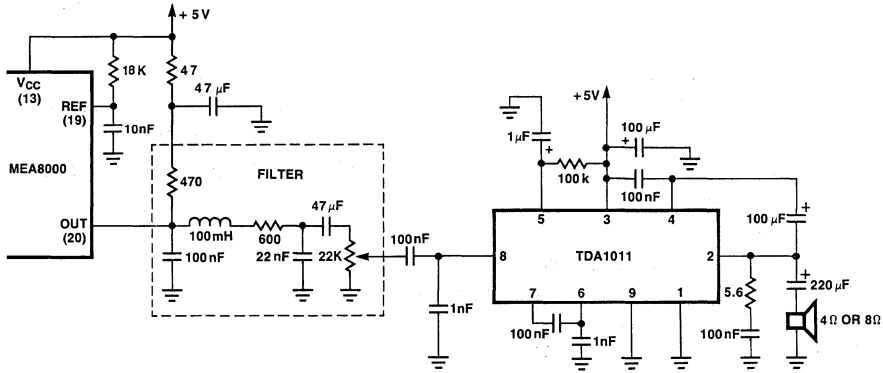

Figure 10. Audio Output Stage—Typical Configuration.

5

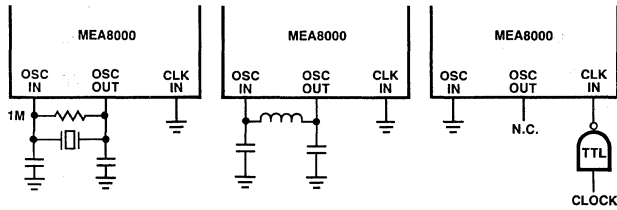

Figure 11. Oscillator/Clock Configurations

This integrated circuit is a dual-tone multi-frequency (DTMF) generator and a speech transmission circuit on a single chip. It supplies frequency combinations in accordance with CCITT recommendations for use in push-button telephones. It can be operated with a single contact keyboard or via a direct interface with a microcomputer. I²L technology allows digital and analogue functions to be implemented on the same chip.

The speech-transmission part incorporates microphone and telephone amplifiers, anti-sidetone and line adaptation. The microphone inputs, suitable for different types of transducers, are symmetrical to allow long cable connections with good immunity against radio-frequency interferences.

The logic inputs contain an interface circuit to guarantee well defined states and on and off resistance of the keyboard contacts.

The circuit features:

- stabilized DTMF levels to be set externally
- wide operating range of line current and temperature
- no individual DTMF level adjustments required
- microcomputer compatible logic inputs
- gain setting for microphone and receiver amplifiers
- internally generated electronic muting
- low spreads on amplifier gains
- low number of external components

QUICK REFERENCE DATA

Line voltage	V_L	typ.	4.8 V
Line current	I_L		10 to 120 mA
Adjustable dynamic resistance	R_i		600 to 900 Ω
Microphone signal amplification	A_M	typ.	50 dB
Telephone signal amplification	A_T	typ.	20 dB
DTMF tone levels (adjustable)			
lower frequency	V_{LG}	max.	-6 dBm
higher frequency	V_{HG}	max.	-4 dBm
Operating temperature range	T_{amb}		-25 to +85 °C

PACKAGE OUTLINES

TEA1046P : 24-lead DIL, plastic (SOT-101).

TEA1046D : 24-lead DIL, ceramic (SOT-149).

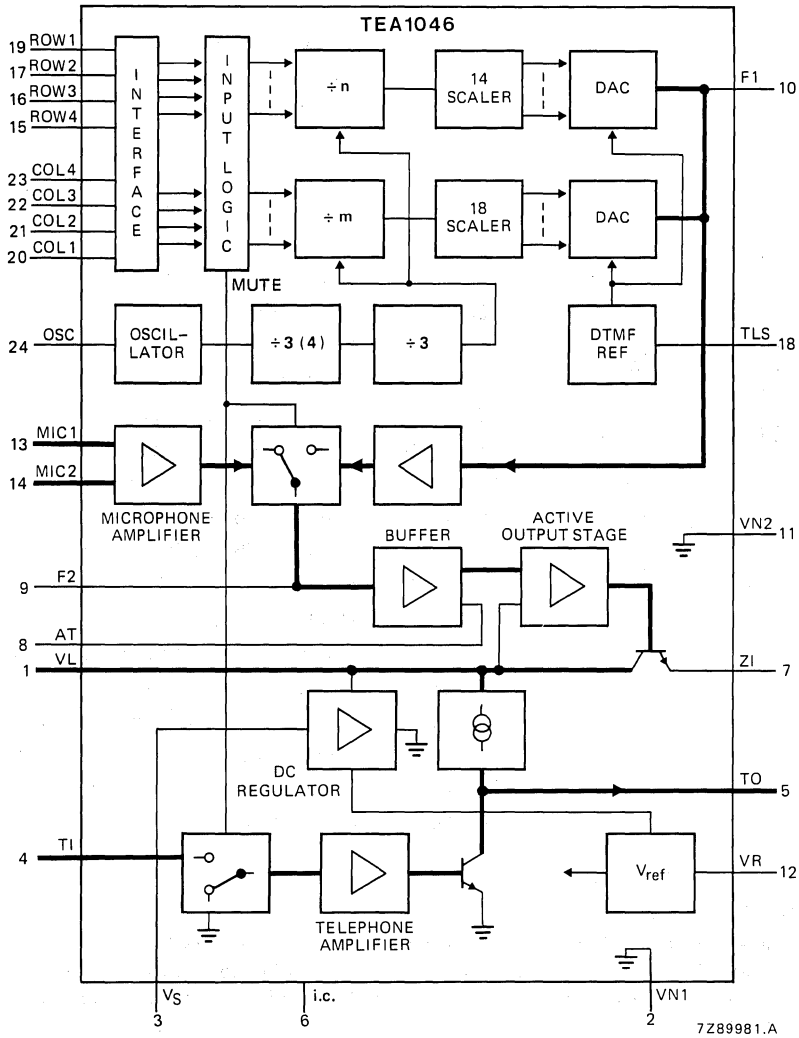

Fig. 1 Functional block diagram.

5

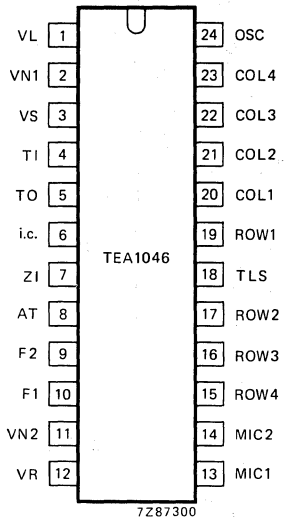

Fig. 2 Pinning diagram.

PINNING

1	VL	positive line-voltage
2	VN1	negative line-voltage
3	VS	voltage stabilizer filter
4	TI	telephone amplifier input
5	TO	telephone amplifier output
6	i.c.	internally connected
7	ZI	impedance setting input
8	AT	anti-sidetone output
9	F2	second filter
10	F1	first filter
11	VN2	negative line voltage
12	VR	reference voltage output
13	MIC1	microphone input (pos.)
14	MIC2	microphone input (neg.)
15	ROW4	row input 941 Hz/BCD input
16	ROW3	row input 852 Hz/BCD input
17	ROW2	row input 770 Hz/BCD input
18	TLS	DTMF level setting
19	ROW1	row input 697 Hz/BCD input
20	COL1	column input 1209 Hz/mute input
21	COL2	column input 1336 Hz/mute input
22	COL3	column input 1477 Hz/enable input
23	COL4	column input 1633 Hz/mute input
24	OSC	oscillator input

FUNCTIONAL DESCRIPTION

Voltage regulator (Fig. 3)

Different line lengths and feeding bridge resistances of the exchange cause a large line current range to supply this circuit. As all functions on this chip are working within a total current of 10 mA, the rest of the line current is shunted by the voltage regulator circuit. It regulates the voltage drop over the circuit on a nominal level of 4.8 V.

The capacitor connected to input VS provides a low-pass filter function to avoid influence of the audio signals on the line.

The static behaviour of the voltage regulator is expressed by:

$$V_L = V_O + (I_L - I_i) R_{13}$$

where $V_O = 4.8$ V at $T_a = 25$ °C and $R_{13} = 5$ Ω, $I_i = 10$ mA.

The dynamic impedance of the regulator is equivalent to a resistor in series with a simulated inductor:

$$Z_r(\omega) = R_{eq} + j\omega L_{eq}$$

where $R_{eq} = R_{13} = 5$ Ω
 $L_{eq} \approx 5$ H ($C_{VS} = 68$ μF).

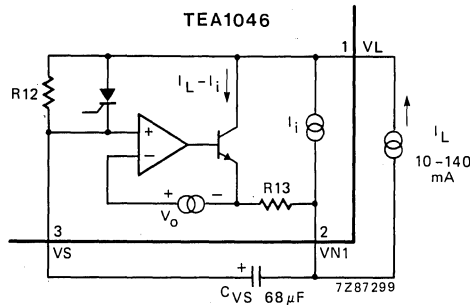

Fig. 3 Voltage regulator principle.

By connecting a resistor parallel to R12 the d.c. level (V_L) can be decreased. A resistor parallel C_{VS} increases the level (see Fig. 3). All this with respect to limited values. The shunt regulator contains a thyristor which short-circuits R12 for a short period during the switch-on time. This reduces the overshoot voltage to only 1 V above the level set by the regulator.

Active output stage

The amplifier consists of a voltage to current converter with a class-A output stage. Because of the feedback from the line to the input the circuit acts as a dynamic resistance (R_a). This resistance can be adjusted by the external resistor R_{Z1} and the value can be found by:

$$R_a = 8.93 \times R_{Z1} (\Omega)$$

The total dynamic resistance R_i equals R_a parallel with the resistance R_p of all other circuits parts, which value is approximately 7 k Ω .

With $R_{Z1} = 75 \Omega$, $R_a = 670 \Omega$ and $R_i = 610 \Omega$.

For $R_{Z1} = 120 \Omega$, $R_a = 1070 \Omega$ and $R_i = 900 \Omega$.

Microphone amplifier

Pins 13 and 14 respectively are the non-inverting and inverting inputs for the microphone. The purely symmetrical inputs are suitable for low ohmic dynamic or magnetic capsules. The input impedance equals 4 k Ω . The voltage amplification from microphone input to pin 1 (VL) is 50 dB and if a lower gain is required the attenuation for a series resistor R_{MS} will be:

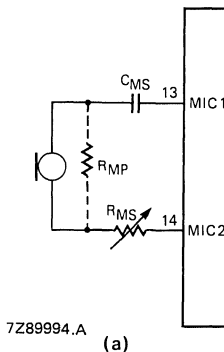

$$\frac{A_M(R_{MS} \neq 0)}{A_M(R_{MS} = 0)} = \frac{4}{4 + R_{MS}} \quad (R_{MS} \text{ in } k\Omega)$$

$$A_M = \left| \frac{V_L}{V_M} \right|$$

Fig. 4 Symmetrical microphone connection. Resistor R_{MP} may be used to lower the microphone termination resistance.

The microphone amplifier also has an excellent behaviour for connection of an electret microphone with built in FET-source follower. In this condition pin 14 is decoupled for a.c. and the amplifier is driven at pin 13. The input impedance in this asymmetrical mode is 22 kΩ. If attenuation of the amplification is required the value of R_{MA} is given by:

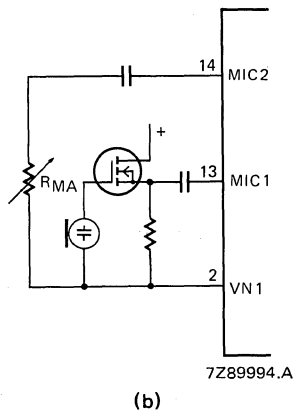

$$\frac{A_M(R_{MA} \neq 0)}{A_M(R_{MA} = 0)} = \frac{22 + R_{MA}}{22 + 11R_{MA}} \quad (R_{MA} \text{ in } k\Omega)$$

$$A_M = \left| \frac{V_L}{V_{MIC1}} \right|$$

Fig. 5 Electret microphone circuit.

Telephone amplifier and anti-sidetone network

This amplifier is a non-inverting fixed feedback amplifier with a class-A output stage. The gain is fixed and measures 20 dB from pin 4 (TI) to pin 5 (TO). The output is intended to drive capsules Z_T of nom. 350 Ω. For Z_T smaller than 350 Ω the maximum output voltage swing is determined by the bias current of 3.5 mA and Z_T. For Z_T greater than 350 Ω the maximum voltage swing is determined internally. The received line signal is attenuated by the anti-sidetone network and can be adjusted by R_{AT}. The amplification from the line to the telephone output is given by:

$$A_T = 10 \frac{R_{AT}}{R_{AT} + Z_S} \times \frac{Z_T}{Z_T + R_O} \quad (\text{see Fig. 14})$$

Z_S is the impedance of the anti-sidetone network

Z_T is the capsule impedance

R_O is the amplifier output resistance

Optimum side-tone suppression is obtained as Z_S (R_{A1}, R_{A2} and C_A) equals

$$Z_S = K \frac{Z_L \times R_i}{Z_L + R_i}$$

Z_L = line terminating impedance

R_i = output stage impedance // passive circuit impedance

K = 237

In the application of Fig. 14 the network is optimized for 5 km of twisted copper wire (φ0.5 mm) cable with a d.c. resistance of 176 Ω/km. The side-tone suppression in the range from 0 – 10 km is at least 10 dB compared with the case when no compensation is applied.

Keyboard inputs

Inputs for the logic control are compatible with different types of keyboard. Using a keyboard, tone combinations are generated:

- by connecting one of row inputs to one of the column inputs by means of a single switch of the matrix.
- or by applying a dual contact keyboard having its common row contact tied to ground and the common column contact tied to VR.

An anti-bounce circuit eliminates the switch bounce for up to 2 ms. Two key roll-over is provided by blocking other inputs as soon as one key is pressed. Single tones can be generated if the column input is connected to VR or the row input to ground. The inputs for the keyboard connections can be used for direct connection to a microcomputer. If the column inputs are interconnected and made HIGH (= VR) the row inputs are changed to another mode, allowing the circuit to be driven by 4-bit data plus an enable signal. In this mode, it is also possible to connect a separate mute enable signal on inputs COL1, 2 and 4 and a tone enable input on COL3.

Truth table microcomputer mode

row				column		tones Hz	symbol	mute
1	2	3	4	1, 2, 4	3			
H	H	H	H	L	L	—	—	off
X	X	X	X	H	L	—	—	on
H	H	H	H	H	H	697/1209	1	on
H	H	H	L	H	H	697/1336	2	on
H	H	L	H	H	H	697/1477	3	on
H	H	L	L	H	H	697/1633	A	on
H	L	H	H	H	H	770/1209	4	on
H	L	H	L	H	H	770/1336	5	on
H	L	L	H	H	H	770/1477	6	on
H	L	L	L	H	H	770/1633	B	on
L	H	H	H	H	H	852/1209	7	on
L	H	H	L	H	H	852/1336	8	on
L	H	L	H	H	H	852/1477	9	on
L	H	L	L	H	H	852/1633	C	on
L	L	H	H	H	H	941/1209	*	on
L	L	H	L	H	H	941/1336	0	on
L	L	L	H	H	H	941/1477	#	on
L	L	L	L	H	H	941/1633	D	on

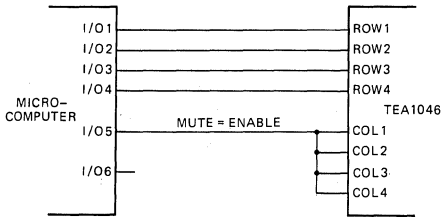
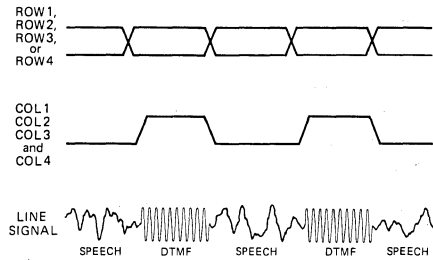

Fig. 6 Microcomputer mode.
All column inputs interconnected.



(a)
Fig. 7 Tone/speech waveform in circuit diagram Fig. 6.

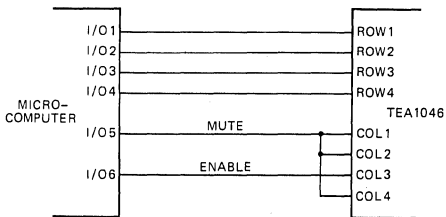
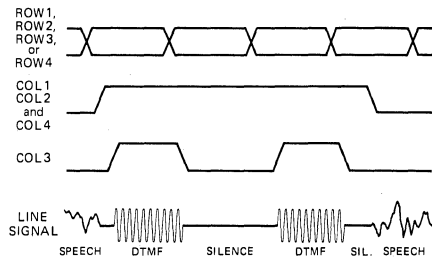
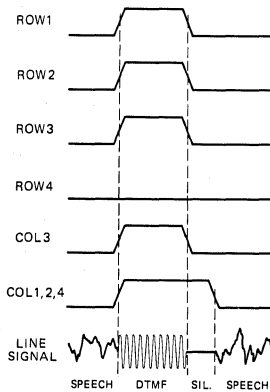

Fig. 8 Microcomputer mode.
Column inputs COL 1, 2 and 3 interconnected.



(b)
Fig. 9 Tone/speech waveform in circuit diagram Fig. 8.

7Z91000.A



7Z87296

Fig. 10 Waveform tones 697/1336 Hz (dialling number 2).

Dial tone generator

The crystal oscillator frequency is twelve or nine times the clock frequency i.e. 4.782720 MHz or 3.579 545MHz (mask option). The CCITT recommends that the tones should be within 1.5% of the specified frequencies. Many authorities however require a closer tolerance. The application using a crystal of 4.78 MHz gives a maximum dividing error of 0.11% whilst for an application with a 3.58 MHz crystal the error is 0.25% maximum.

The output from the dividers for the higher and the lower frequency tones are symmetrical square-wave pulses which contain considerable odd-numbered harmonics. The lower order odd numbered harmonics (11th and less) are eliminated by synthesising the tone frequencies as crude stepped sinewave approximations. Each half cycle of the tone waveform comprises seven discrete amplitudes for the higher frequency tone. Each amplitude increment is generated by switching on and off an individual current source for the duration of each step of the sinewave. The frequency of the tones is varied by changing the duration of each step. This circuit allows the connecting of two low-pass first order filters to pins 9 and 10 if CEPT 203 recommendations have to be achieved.

The second filter is also used for filtering the microphone signal. If lower requirements for the distortion can be applied the filter at pin 10 can be deleted. In that case the filter at pin 9 must have a lower cut-off frequency (1800 Hz) to achieve a correct pre-emphasis since the roll-off of the filters is compensated internally.

RATINGS

Limiting values in accordance with the Absolute Maximum System (IEC 134)

Supply current	I_p	max.	150 mA
Surge current ($t_p < 250 \mu s$)	I_S	max.	850 mA
Operating ambient temperature range	T_{amb}	-25 to +85	°C
Storage temperature range	T_{stg}	-55 to +125	°C
Junction temperature	T_j	max.	150 °C

CHARACTERISTICS

$T_{amb} = 25 \text{ }^\circ\text{C}$; $I_L = 15 \text{ mA}$, unless otherwise specified. See also Fig. 11.

description	symbol	min.	typ.	max.	unit
Supply					
Line voltage d.c.					
$I_L = 15 \text{ mA}$	V_L	4.5	4.8	5.1	V
$I_L = 50 \text{ mA}$	V_L	4.7	5.0	5.3	V
$I_L = 100 \text{ mA}$	V_L	5.0	5.4	6.5	V
Temperature coefficient	TC	-	-8	-	mV/K
Line current range	I_L	10	-	120	mA
Stabilized voltage (pin 3)					
$I_L = 15 \text{ mA}$	V_S	-	3.3	-	V
$I_L = 100 \text{ mA}$	V_S	-	3.8	-	V
Reference voltage (pin 12)	V_R	-	1.0	-	V

5

description	symbol	min.	typ.	max.	unit
Microphone					
Input resistance (symmetrical)	R_i 13-14	—	4	—	$k\Omega$
Input resistance (asymmetrical)	R_i 13	—	22	—	$k\Omega$
Voltage amplification $f = 800 \text{ Hz}$; $R_L = 600 \Omega$	A_M	48	50	52	dB
Temperature coefficient $I_L = 50 \text{ mA}$; $T_{amb} = -5 \text{ to } +45 \text{ }^\circ\text{C}$	TC		t.b.f.		dB
Common mode rejection ratio	CMRR	60	—	—	dB
Distortion at $V_L = 3 \text{ dBm}$	dt	—	2	—	%
Noise output voltage $Z_L = 600 \Omega$; psophometrically weighted (P53 curve)	V_{NO}	—	-70	—	dBmp
Amplification reduction during dialling	ΔA_M	—	70	—	dB
Anti-sidetone					
Voltage amplification, microphone to anti-sidetone output ($R_{AT} = 3.9 \text{ k}\Omega$)	A_{AT}	—	25.8	—	dB
Transmitter output stage					
Dynamic resistance setting range	R_i	600	—	900	Ω
Variation over line current $R_i = 600 \Omega$	ΔZ_o	—	100	—	Ω
Balance return loss from 300 up to 3400 Hz at 600Ω ($R_{Z1} = 75 \Omega$, $C_L = 10 \text{ nF}$)	BRL	20	—	—	dB
at 900Ω ($R_{Z1} = 120 \Omega$, $C_L = 30 \text{ nF}$)	BRL	20	—	—	dB
Telephone amplifier					
Voltage amplification $R_T = 350 \Omega$	A_T	18	20	22	dB
Amplification variation $f = 300 \text{ to } 3400 \text{ Hz}$	$\Delta A_T/f$	—	0	—	dB
Amplification variation $T = -5 \text{ to } +45 \text{ }^\circ\text{C}$	$\Delta A_T/T$	—	0	—	dB
Output voltage swing ($d_t = 10\%$)	$V_{o(p-p)}$	—	1300	—	mV
Output impedance	Z_o	—	5	10	Ω
Input impedance	Z_i	—	100	—	$k\Omega$
Output distortion level $< -7 \text{ dBV}$	d_o	—	2	—	%
Output noise voltage psophometrically weighted (P53 curve)	$V_{no} \text{ (rms)}$	—	—	500	μV
Bias current	I_M	3	3.5	4	mA

CHARACTERISTICS (continued)

description	symbol	min.	typ.	max.	unit
DTMF generator					
Tone frequencies					
low tones (row inputs)		697,	770,	852, 941	Hz
high tones (column inputs)		1209,	1336,	1477, 1633	Hz
Dividing error					
crystal frequency = 4.78 MHz	Δf_d	-0.04	-	+0.11	%
crystal frequency = 3.58 MHz	Δf_d	-0.25	-	-0.05	%
Tone output level					
$I_L > 10$ mA					
lower tones	V_{LG}	-	-11	-	dBm
higher tones	V_{HG}	-	-9	-	dBm
Tone output level					
$I_L > 12$ mA					
lower tones	V_{LG}	-11	-	-6	dBm
higher tones	V_{HG}	-9	-	-4	dBm
Tolerance on output level					
over temp. and current range	ΔV_o	-2	-	2	dB
Pre-emphasis higher tones					
over temp. and current range	ΔV_{HG}	1.3	2	2.7	dB
Tone delay					
after key actuation	t_d	-	10	-	μ s
Switch delay time speech/mute					
after key release	t_d	-	10	-	μ s
Switch bounce elimination					
	t_{sb}	-	2	-	ms
Keyboard inputs					
Contact off resistance					
	R_{Koff}	250	-	-	$k\Omega$
Contact on resistance					
	R_{Kon}	-	-	10	$k\Omega$
Lower frequency inputs (ROW1, 2, 3, 4)					
voltage LOW	V_{IL}	-	0.7	t.b.f.	V
voltage HIGH	V_{IH}	t.b.f.	1.7	-	V
current (d.c.) at V_{IL}	I_{IL}	-	20	1000	μ A
current (d.c.) at V_{IH}	I_{IH}	-	-	-	μ A
Higher frequency inputs (COL1, 2, 3, 4)					
voltage LOW	V_{IL}	-	0.3	t.b.f.	V
voltage HIGH	V_{IH}	t.b.f.	1.0	-	V
current (d.c.) at V_{IL}	I_{IL}	-	-	-	μ A
current (d.c.) at V_{IH}	I_{IH}	-	20	1000	μ A

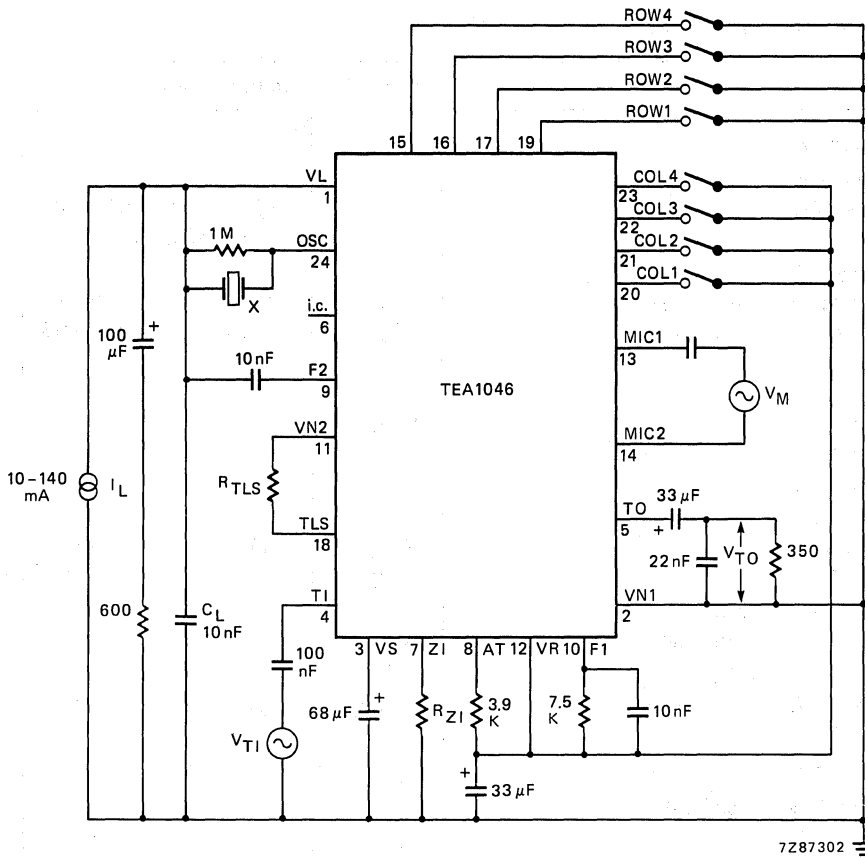

Fig. 11 Test circuit for measuring amplifier voltage gains and frequencies and levels of DTMF generator. X = 3.58 or 4.78 MHz.

$$A_M = \left| \frac{V_L}{V_M} \right| \quad (V_{T1} = 0)$$

$$A_T = \left| \frac{V_{T0}}{V_{T1}} \right| \quad (V_M = 0)$$

$$A_{AT} = \left| \frac{V_{AT}}{V_M} \right| \quad (V_{T1} = 0)$$

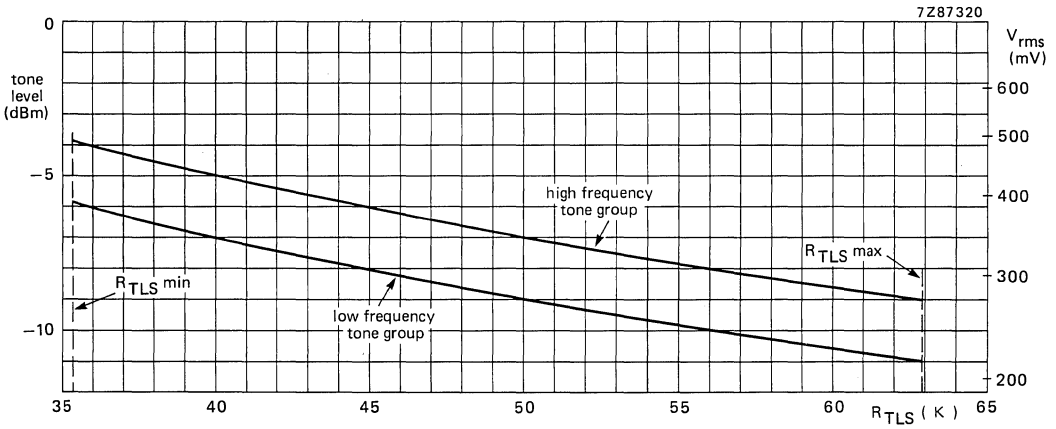

Fig. 12 DTMF level selection. The curve is valid for a dynamic impedance of 600 Ω ($R_{Z1} = 75 \Omega$).

Some values:

LOW dBm	HIGH dBm	R_{TLS} k Ω
-6	-4	35.2
-8	-6	44.8
-11	-9	62.6

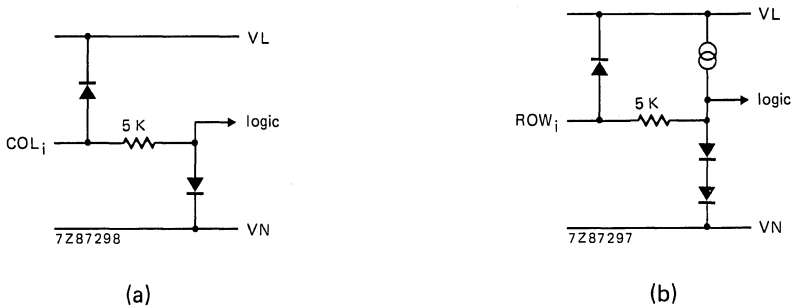

Fig. 13 Configuration inputs. (a) ROW1, 2, 3 and 4. (b) COL1, 2, 3 and 4.

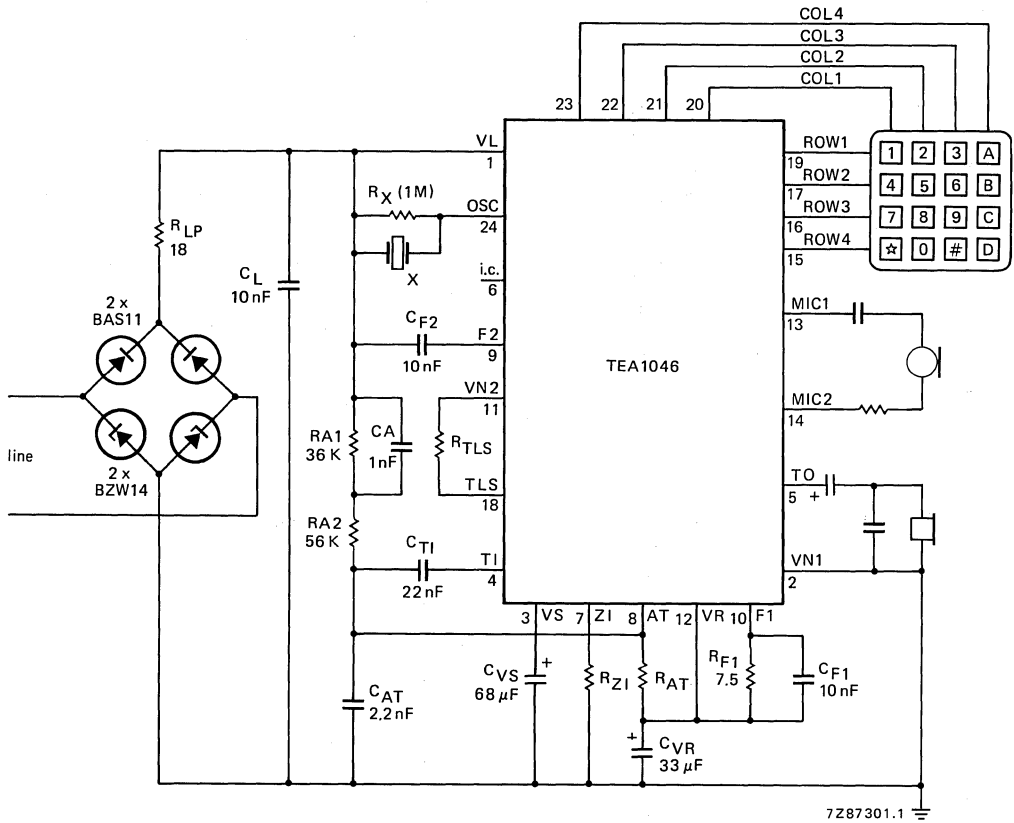

Fig. 14 Application diagram TEA1046 using dynamic transducers, R_{MS} , R_{AT} , R_{Z1} and R_{TLS} determined by transducers and system requirements.

TIMER

SE/NE555/SE555C

DESCRIPTION

The 555 monolithic timing circuit is a highly stable controller capable of producing accurate time delays, or oscillation. In the time delay mode of operation, the time is precisely controlled by one external resistor and capacitor. For a stable operation as an oscillator, the free running frequency and the duty cycle are both accurately controlled with two external resistors and one capacitor. The circuit may be triggered and reset on falling waveforms, and the output structure can source or sink up to 200mA.

FEATURES

- Turn off time less than 2 μ s
- Maximum operating frequency greater than 500kHz
- Timing from microseconds to hours
- Operates in both astable and monostable modes
- High output current
- Adjustable duty cycle
- TTL compatible
- Temperature stability of 0.005% per °C

APPLICATIONS

- Precision timing
- Pulse generation
- Sequential timing
- Time delay generation
- Pulse width modulation
- Pulse position modulation
- Missing pulse detector

ABSOLUTE MAXIMUM RATINGS

PARAMETER	RATING	UNIT
Supply voltage		
SE555	+18	V
NE555, SE555C	+16	V
Power dissipation	600	mW
Operating temperature range		
NE555	0 to +70	°C
SE555, SE555C	-55 to +125	°C
Storage temperature range	-65 to +150	°C
Lead temperature (soldering, 60sec)	300	°C

EQUIVALENT SCHEMATIC

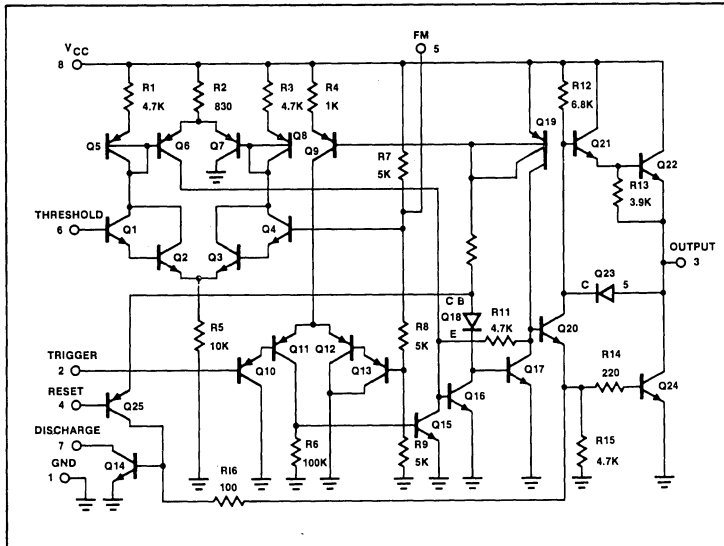

PIN CONFIGURATIONS

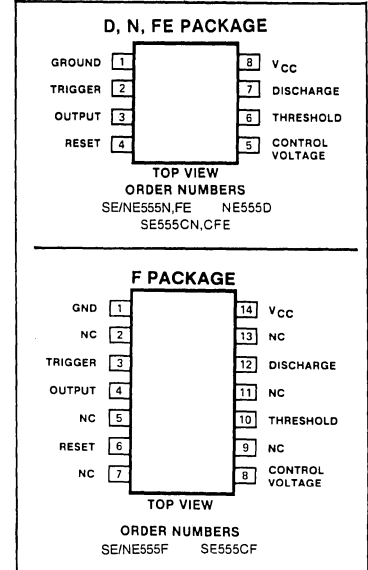

BLOCK DIAGRAM

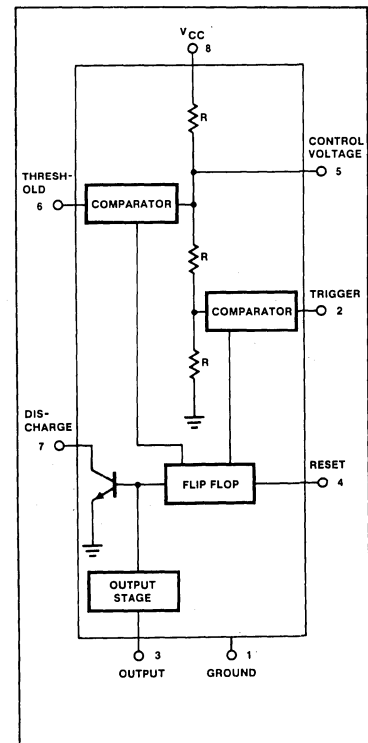

TIMER

SE/NE555/SE555C

DC ELECTRICAL CHARACTERISTICS $T_A = 25^\circ\text{C}$, $V_{CC} = +5\text{V}$ to $+15$ unless otherwise specified.

PARAMETER	TEST CONDITIONS	SE555			NE555/SE555C			UNIT	
		Min	Typ	Max	Min	Typ	Max		
Supply voltage		4.5		18	4.5		16	V	
Supply current (low state) ¹	$V_{CC} = 5\text{V}$ $R_L = \infty$		3	5		3	6	mA	
	$V_{CC} = 15\text{V}$ $R_L = \infty$		10	12		10	15	mA	
Timing error (monostable) Initial accuracy ² Drift with temperature Drift with supply voltage	$R_A = 2\text{k}\Omega$ to $100\text{k}\Omega$ $C = 0.1\mu\text{F}$		0.5	2.0		1.0	3.0	%	
			30	100		50	150	ppm/ $^\circ\text{C}$	
			0.05	0.2		0.1	0.5	%/V	
Timing error (astable) Initial accuracy ² Drift with temperature Drift with supply voltage	$R_A, R_B = 1\text{k}\Omega$ to $100\text{k}\Omega$ $C = 0.1\mu\text{F}$ $V_{CC} = 15\text{V}$		4	6		5	13	%	
			0.15	0.6		0.3	1	ppm/ $^\circ\text{C}$	
									%/V
Control voltage level	$V_{CC} = 15\text{V}$	9.6	10.0	10.4	9.0	10.0	11.0	V	
	$V_{CC} = 5\text{V}$	2.9	3.33	3.8	2.6	3.33	4.0	V	
Threshold voltage	$V_{CC} = 15\text{V}$	9.4	10.0	10.6	8.8	10.0	11.2	V	
	$V_{CC} = 5\text{V}$	2.7	3.33	4.0	2.4	3.33	4.2	V	
Threshold current ³			0.1	0.25		0.1	0.25	μA	
Trigger voltage	$V_{CC} = 15\text{V}$	4.8	5.0	5.2	4.5	5.0	5.6	V	
	$V_{CC} = 5\text{V}$	1.45	1.67	1.9	1.1	1.67	2.2	V	
Trigger current	$V_{TRIG} = 0\text{V}$		0.5	0.9		0.5	2.0	μA	
Reset voltage ⁴		0.3		1.0	0.3		1.0	V	
Reset current			0.1	0.4		0.1	0.4	mA	
Reset current	$V_{RESET} = 0\text{V}$		0.4	1.0		0.4	1.5	mA	
Output voltage (low)	$V_{CC} = 15\text{V}$		0.1	0.15		0.1	0.25	V	
	$I_{SINK} = 10\text{mA}$		0.4	0.5		0.4	0.75	V	
	$I_{SINK} = 50\text{mA}$		2.0	2.2		2.0	2.5	V	
	$I_{SINK} = 100\text{mA}$		2.5			2.5		V	
	$I_{SINK} = 200\text{mA}$							V	
	$V_{CC} = 5\text{V}$		0.1	0.25		0.3	0.4	V	
	$I_{SINK} = 8\text{mA}$		0.05	0.2		0.25	0.35	V	
Output voltage (high)	$V_{CC} = 15\text{V}$		12.5			12.5		V	
	$I_{SOURCE} = 200\text{mA}$	13.0	13.3		12.75	13.3		V	
	$I_{SOURCE} = 100\text{mA}$	3.0	3.3		2.75	3.3		V	
Turn off time ⁵	$V_{RESET} = V_{CC}$		0.5	2.0		0.5	2.0	μs	
Rise time of output			100	200		100	300	ns	
Fall time of output			100	200		100	300	ns	
Discharge leakage current			20	100		20	100	na	

NOTES

- Supply current when output high typically 1mA less.
- Tested at $V_{CC} = 5\text{V}$ and $V_{CC} = 15\text{V}$.
- This will determine the maximum value of $R_A + R_B$, for 15V operation, the max total $R = 10$ megohm, and for 5V operation, the max total $R = 3.4$ megohm.
- Specified with trigger input high.
- Time measured from a positive going input pulse from 0 to $0.8 \times V_{CC}$ into the threshold to the drop from high to low of the output. Trigger is tied to threshold.

TYPICAL PERFORMANCE CHARACTERISTICS

MINIMUM PULSE WIDTH
REQUIRED FOR TRIGGERING

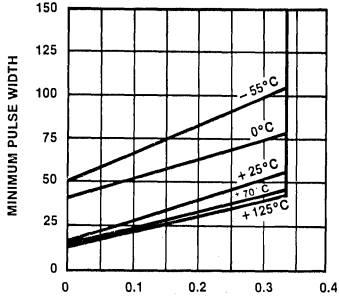

LOWEST VOLTAGE LEVEL OF TRIGGER PULSE

SUPPLY CURRENT
vs SUPPLY VOLTAGE

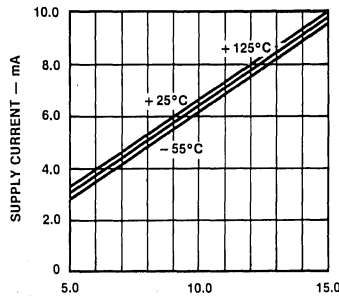

SUPPLY VOLTAGE - VOLTS

DELAY TIME
vs TEMPERATURE

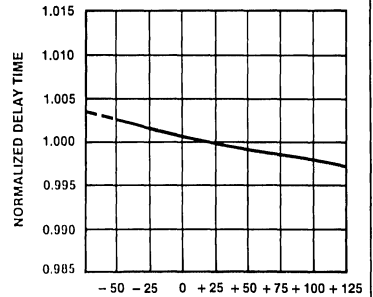

TEMPERATURE - °C

LOW OUTPUT VOLTAGE
vs OUTPUT SINK CURRENT

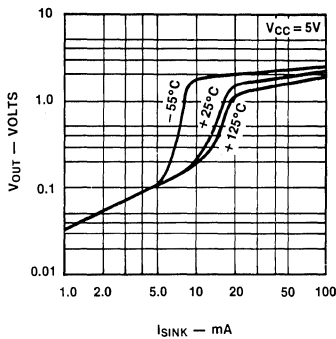

I_{SINK} - mA

LOW OUTPUT VOLTAGE
vs OUTPUT SINK CURRENT

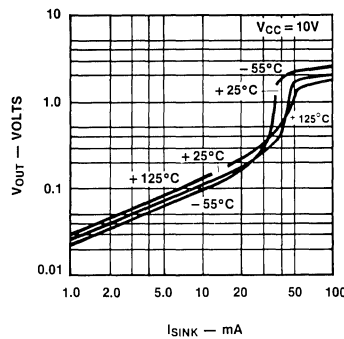

I_{SINK} - mA

LOW OUTPUT VOLTAGE
vs OUTPUT SINK CURRENT

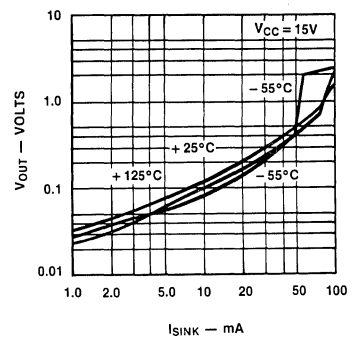

I_{SINK} - mA

HIGH OUTPUT VOLTAGE DROP
vs OUTPUT SOURCE CURRENT

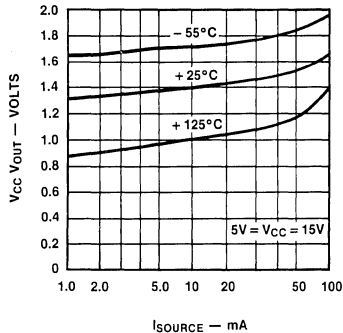

I_{SOURCE} - mA

DELAY TIME vs
SUPPLY VOLTAGE

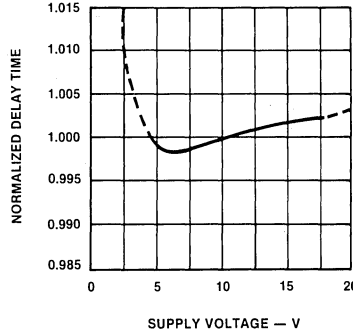

SUPPLY VOLTAGE - V

PROPAGATION DELAY
vs VOLTAGE LEVEL
OF TRIGGER PULSE

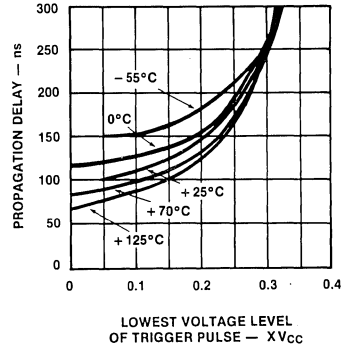

LOWEST VOLTAGE LEVEL
OF TRIGGER PULSE - XV_{CC}

5

TYPICAL APPLICATIONS

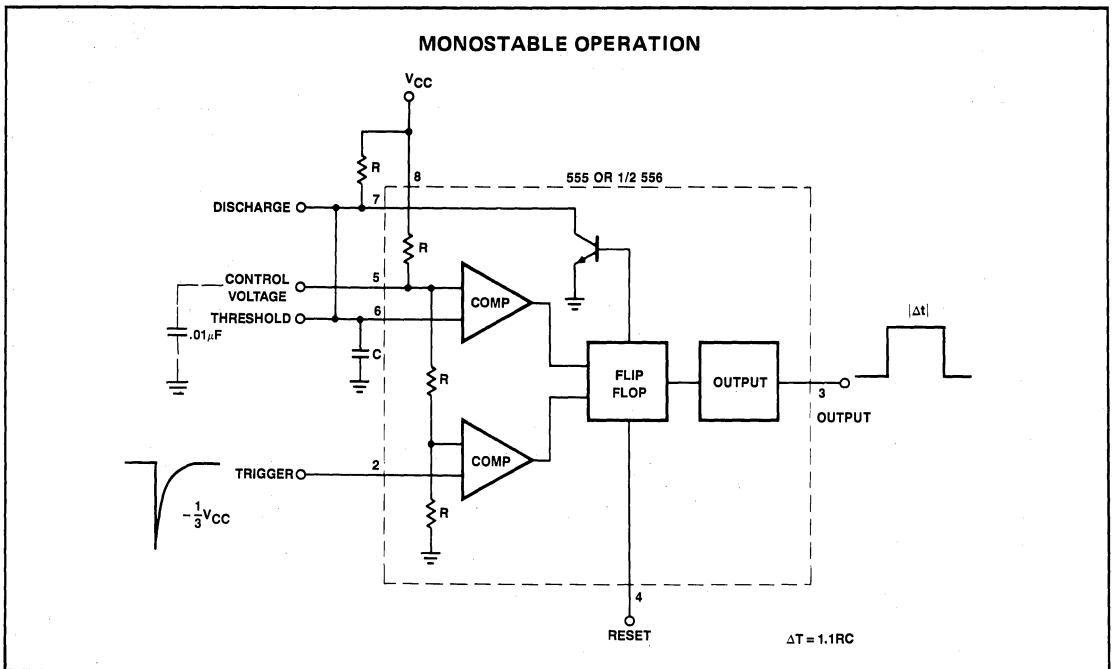
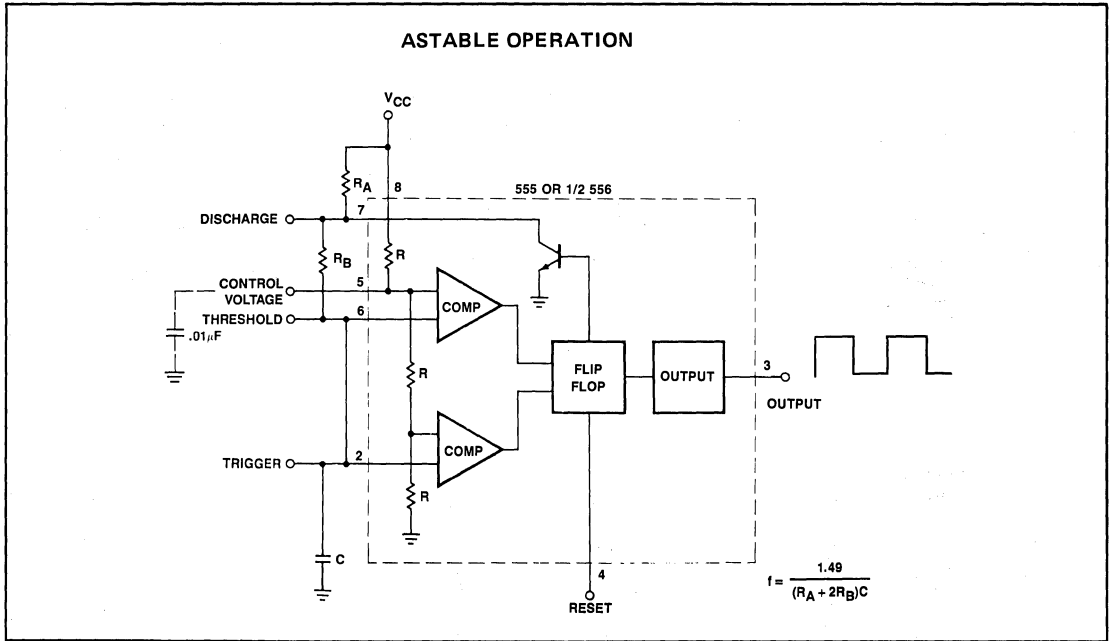

Trigger Pulse Width Requirements and Time Delays

Due to the nature of the trigger circuitry, the timer will trigger on the negative going edge of the input pulse. For the device to time out properly, it is necessary that the trigger voltage level be returned to some voltage greater than one third of the supply before the time out period. This can be achieved by making either the trigger pulse sufficiently short or by AC coupling into the trigger. By AC coupling the trigger, see Figure 1, a short negative going pulse is achieved when the trigger signal goes to ground. AC coupling is most frequently used in conjunction with a switch or a signal that goes to ground which initiates the timing cycle. Should the trigger be held low, without AC coupling, for a longer duration than the timing cycle the output will remain in a high state for the duration of the low trigger signal, without regard to the threshold comparator state. This is due to the predominance of Q₁₅ on the base of Q₁₆, controlling the state of the bi-stable flip-flop. When the trigger signal then returns to a high level, the output will fall immediately. Thus, the output signal will follow the trigger signal in this case.

TYPICAL APPLICATIONS

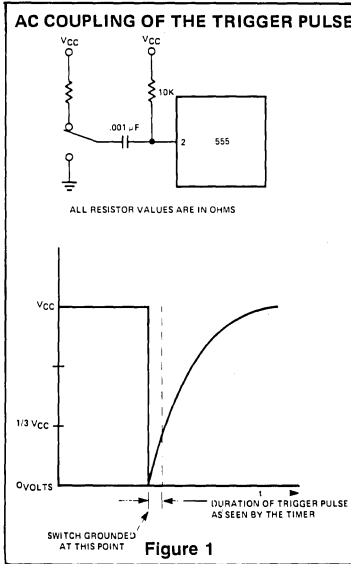

Another consideration is the "turn off time". This is the measurement of the amount of time required after the threshold reaches $2/3 V_{CC}$ to turn the output low. To explain further, Q₄ at the threshold input turns on after reaching $2/3 V_{CC}$, which then turns on Q₅, which turns on Q₆. Current from Q₆ turns on Q₁₆ which turns Q₁₇ off. This allows current from Q₁₉ to turn on Q₂₀ and Q₂₄ to give an output low. These steps cause the 2μs maximum delay as stated in the data sheet.

Also, a delay comparable to the turn off time is the trigger release time. When the trigger is low, Q₁₀ is on and turns on Q₁₁ which turns on Q₁₅. Q₁₅ turns off Q₁₆ and allows Q₁₇ to turn on. This turns off current to Q₂₀ and Q₂₄, which results in output high. When the trigger is released, Q₁₀ and Q₁₁ shut off, Q₁₅ turns off, Q₁₆ turns on and the circuit then follows the same path and time delay explained as "turn off time". This trigger release time is very important in designing the trigger pulse width so as not to interfere with the output signal as explained previously.

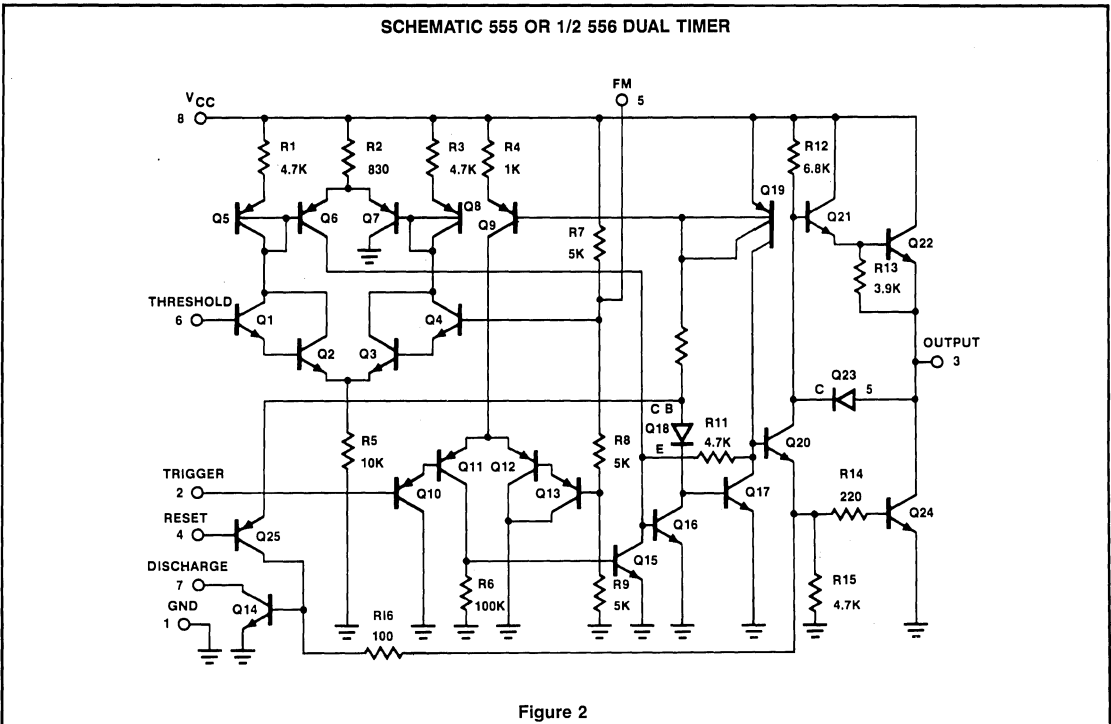

DUAL TIMER

SA/SE/NE556/SA/SE/NE556-1/SE556-1C

DESCRIPTION

Both the 556 and 556-1 Dual Monolithic timing circuits are highly stable controllers capable of producing accurate time delays or oscillation. The 556 and 556-1 are a dual 555. Timing is provided by an external resistor and capacitor for each timing function. The two timers operate independently of each other, sharing only V_{CC} and ground. The circuits may be triggered and reset on falling waveforms. The output structures may sink or source 200 mA.

APPLICATIONS

- Precision timing
- Sequential timing
- Pulse shaping
- Pulse generator
- Missing pulse detector
- Tone burst generator
- Pulse width modulation
- Time delay generator
- Frequency division
- Industrial controls
- Pulse position modulation
- Appliance timing
- Traffic light control
- Touch tone encoder

FEATURES

- Turn off time less than $2 \mu s$ (556-1, 1C)
- Maximum operating frequency greater than 500 kHz (556-1, 1C)
- Timing from microseconds to hours
- Replaces two 555 timers
- Operates in both astable and monostable modes
- High output current
- Adjustable duty cycle
- TTL compatible
- Temperature stability of 0.005% per $^{\circ}C$
- SE556 MIL-STD-883A, B, C available, N38510 (JAN planned, 38510 processing available)

PIN CONFIGURATION

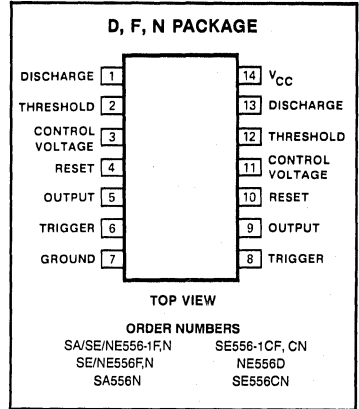

BLOCK DIAGRAM

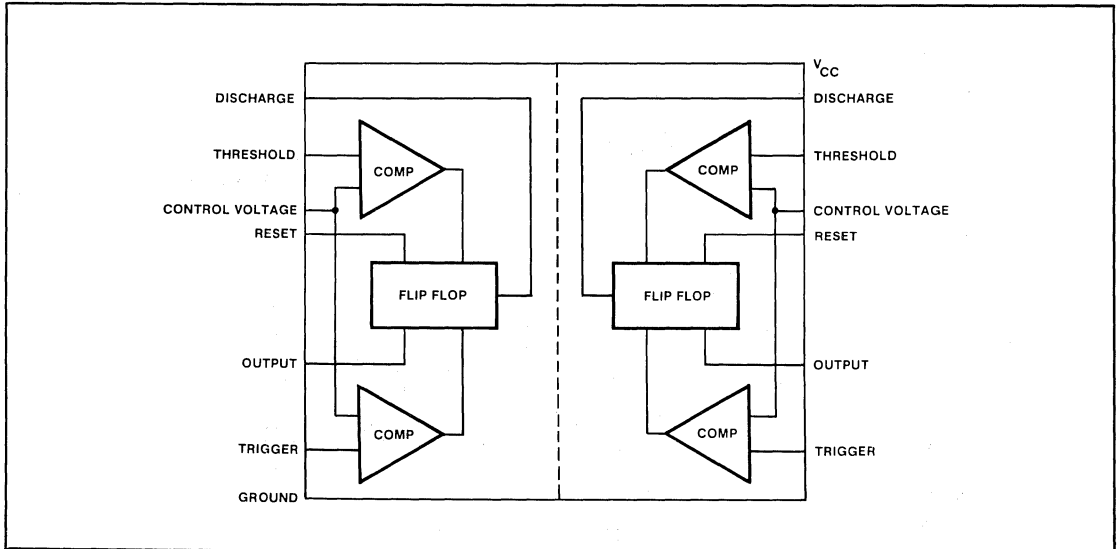

DUAL TIMER

SA/SE/NE556/SA/SE/NE556-1/SE556-1C

EQUIVALENT SCHEMATIC (Shown for one circuit only)

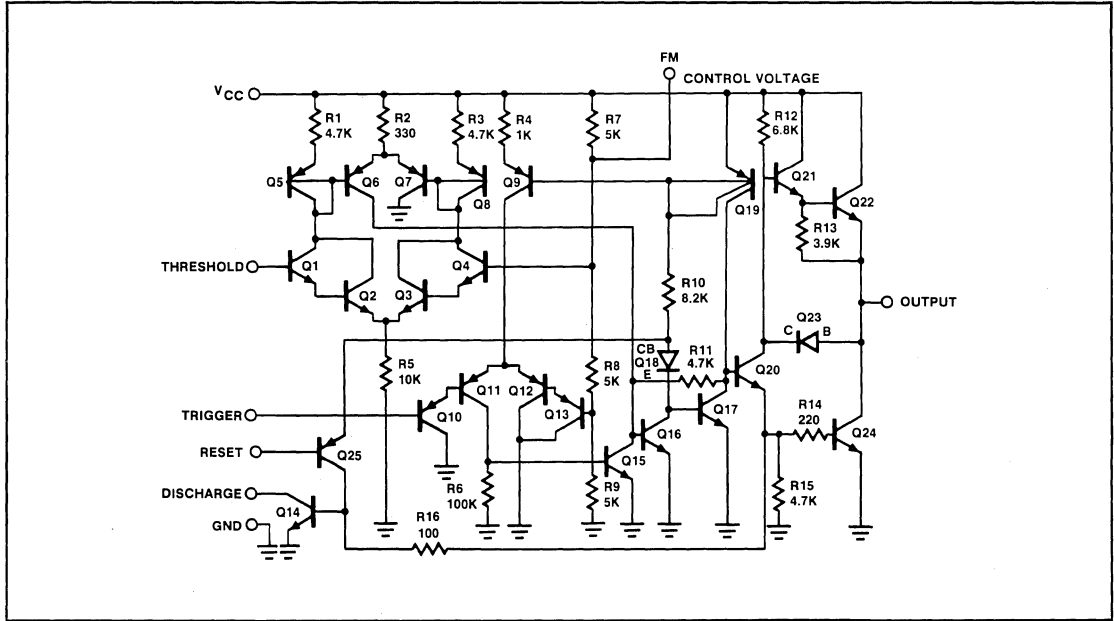

5

ABSOLUTE MAXIMUM RATINGS

PARAMETER	RATING	UNIT
Supply voltage		
SA/NE556, 556-1, SE556C, 556-1C	+ 16	V
SE556-1, 556	+ 18	V
Power dissipation	600	mW
Operating temperature range		
NE/SA556-1, NE556	0 to + 70	°C
SA556-1, SA556	- 40 to + 85	°C
SE556-1, SE556-1C, SE556, 556C	- 55 to + 125	°C
Storage temperature range	- 65 to + 150	°C
Lead temperature (soldering, 60 sec)	+ 300	°C

DUAL TIMER

SA/SE/NE556/SA/SE/NE556-1/SE556-1C

ELECTRICAL CHARACTERISTICS $T_A = 25^\circ\text{C}$, $V_{CC} = +5\text{V}$ to $+15\text{V}$ unless otherwise specified

PARAMETER	TEST CONDITIONS	SE556/556-1			SA/NE556/SE556C NE556-1/SE556-1C			UNITS
		Min	Typ	Max	Min	Typ	Max	
Supply voltage		4.5		18	4.5		16	V
Supply current (low state) ¹	$V_{CC} = 5\text{V}$, $R_L = \infty$ $V_{CC} = 15\text{V}$, $R_L = \infty$		6 20	10 24		6 20	12 30	mA mA
Timing error (monostable) Initial accuracy ² Drift with temperature Drift with supply voltage	$R_A = 2\text{k}\Omega$ to $100\text{k}\Omega$ $C = 0.1\mu\text{F}$ $T = 1.1\text{RC}$		0.5 30 0.05			0.75 50 0.1	3.0 150 0.5	% ppm/ $^\circ\text{C}$ %/V
Timing error (astable) Initial accuracy ² Drift with temperature Drift with supply voltage	$R_A, R_B = 1\text{k}\Omega$ to $100\text{k}\Omega$ $C = 0.1\mu\text{F}$ $V_{CC} = 15\text{V}$		4 400 0.15	6 500 0.6		5 400 0.3	13 500 1	% ppm/ $^\circ\text{C}$ %/V
Control voltage level	$V_{CC} = 15\text{V}$ $V_{CC} = 5\text{V}$	9.6 2.9	10.0 3.33	10.4 3.8	9.0 2.6	10.0 3.33	11.0 4.0	V V
Threshold voltage	$V_{CC} = 15\text{V}$ $V_{CC} = 5\text{V}$	9.4 2.7	10.0 3.33	10.6 4.0	8.8 2.4	10.0 3.33	11.2 4.2	V V
Threshold current ³			30	250		30	250	nA
Trigger voltage	$V_{CC} = 15\text{V}$ $V_{CC} = 5\text{V}$	4.8 1.45	5.0 1.67	5.2 1.9	4.5 1.1	5.0 1.67	5.6 2.2	V V
Trigger current	$V_{TRIG} = 0\text{V}$		0.5	0.9		0.5	2.0	μA
Reset voltage ⁵ Reset current Reset current	$V_{RESET} = 0\text{V}$	0.3	0.7 0.1 0.4	1.0 0.4 1.0	0.3	0.7 0.1 0.4	1.0 0.6 1.5	V mA mA
Output voltage (low)	$V_{CC} = 15\text{V}$ $I_{SINK} = 10\text{mA}$ $I_{SINK} = 50\text{mA}$		0.1 0.4	0.15 0.5		0.1 0.4	0.25 0.75	V V
SE556 SE556-1 NE/SA556/SE556C NE556-1/SE556-1C	$I_{SINK} = 100\text{mA}$		2.0 0.8	2.25 1.2		2.0 2.0	3.2 2.5	V V V V
	$I_{SINK} = 200\text{mA}$ $V_{CC} = 5\text{V}$ $I_{SINK} = 8\text{mA}$ $I_{SINK} = 5\text{mA}$		2.5 0.1 0.05			2.5 0.25 0.15		V V V
Output voltage (high)	$V_{CC} = 15\text{V}$ $I_{SOURCE} = 200\text{mA}$ $I_{SOURCE} = 100\text{mA}$ $V_{CC} = 5\text{V}$ $I_{SOURCE} = 100\text{mA}$	13.0 3.0	12.5 13.3 3.3		12.75 2.75	12.5 13.3 3.3		V V V
Turn off time ⁶ NE556-1/SE556-1/SE556-1C	$V_{RESET} = V_{CC}$		0.5	2.0		0.5		μs μs
Rise time of output Fall time of output			100 100	200 200		100 100	300 300	ns ns
Discharge leakage current			20	100		20	100	nA
Matching characteristics ⁴ Initial accuracy ² Drift with temperature Drift with supply voltage			0.5 10 0.1	1.0 1.0 0.2		1.0 ± 10 0.2	2.0 2.0 0.5	% ppm/ $^\circ\text{C}$ %/V

NOTES

- Supply current when output is high is typically 1.0mA less.
- Tested at $V_{CC} = 5\text{V}$ and $V_{CC} = 15\text{V}$.
- This will determine maximum value of $R_A + R_B$. For 15V operation, the maximum total R = 10 megohms, and for 5V operation, the max. total R = 3.4 megohms.
- Matching characteristics refer to the difference between performance characteristics for each timer section in the monostable mode.
- Specified with trigger input high.
- Time measured from a positive going input pulse from 0 to 0.4 V_{CC} into the threshold to the drop from high to low of the output. Trigger is tied to threshold.

TYPICAL PERFORMANCE CHARACTERISTICS

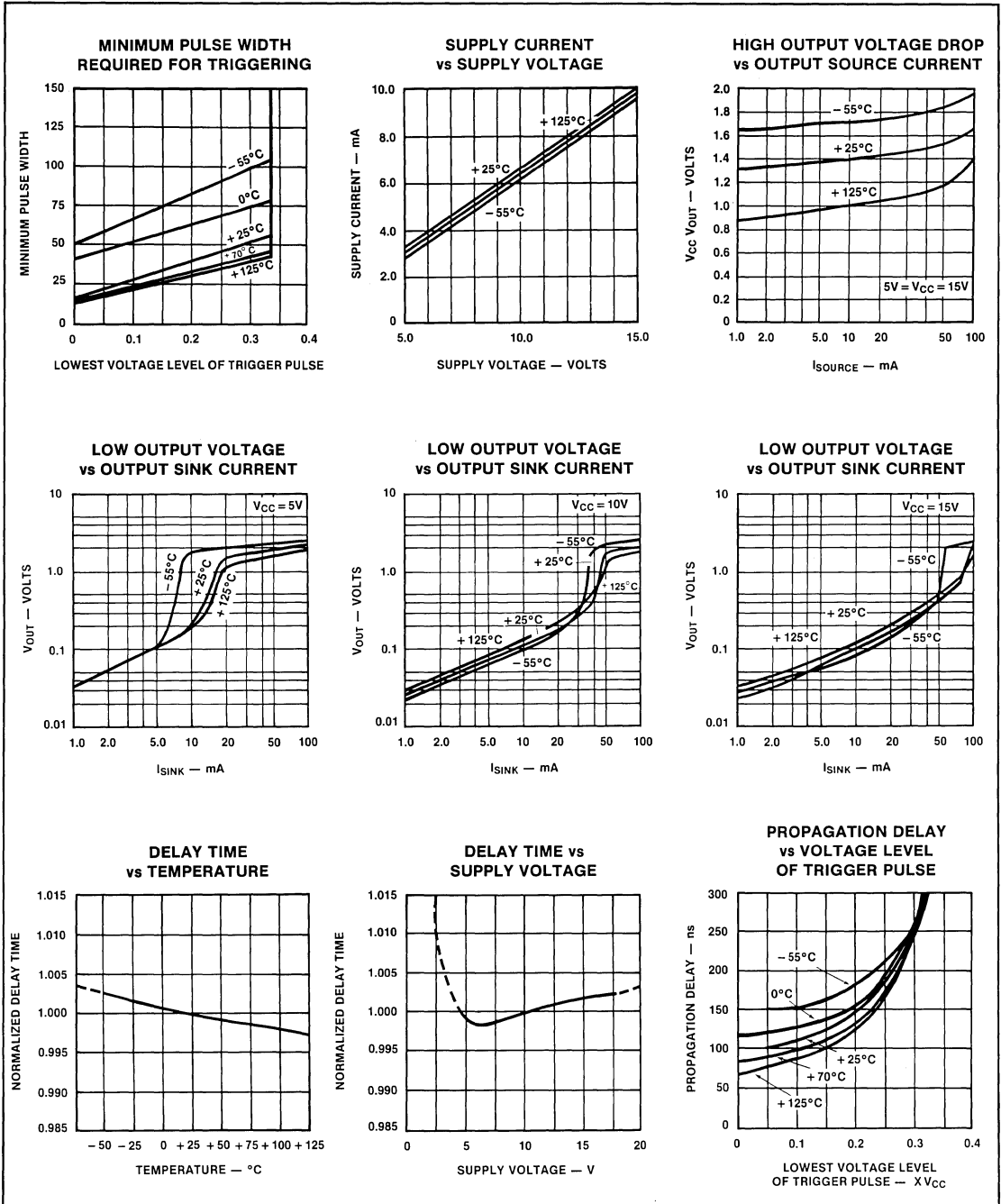

TYPICAL APPLICATIONS

One feature of the dual timer is that by utilizing both halves it is possible to obtain sequential timing. By connecting the output of the first half to the input of the second half via a .001 μ f coupling capacitor sequential timing may be obtained. Delay t_1 is determined by the first half and t_2 by the second half delay.

The first half of the timer is started by momentarily connecting pin 6 to ground. When it is timed out (determined by $1.1R_1C_1$) the second half begins. Its duration is determined by $1.1R_2C_2$.

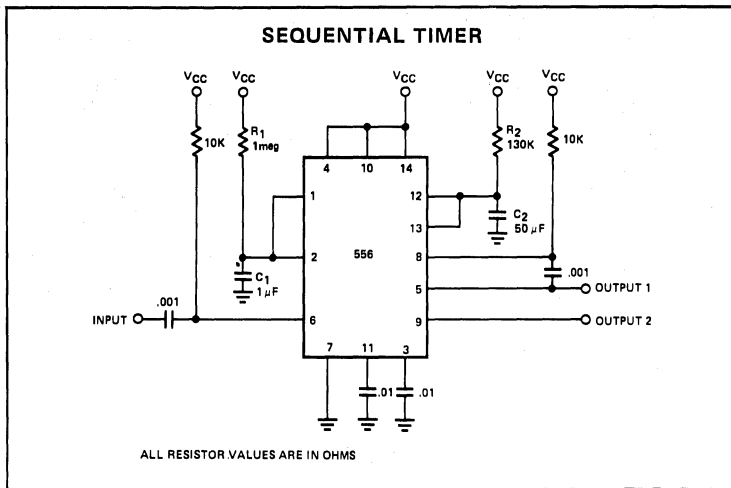

*For additional information, consult the Applications Section.

DESCRIPTION

The 558 Quad Timers are monolithic timing devices which can be used to produce four entirely independent timing functions. The 558 output sinks current. These highly stable, general purpose controllers can be used in a monostable mode to produce accurate time delays, from microseconds to hours. In the time delay mode of operation, the time is precisely controlled by one external resistor and one capacitor. A stable operation can be achieved by using two of the four timer sections.

The four timing sections in the 558 are edge triggered; therefore, when connected in tandem for sequential timing applications, no coupling capacitors are required. Output current capability of 100mA is provided in both devices.

FEATURES

- 100mA output current per section
- Edge triggered (no coupling capacitor)
- Output independent of trigger conditions
- Wide supply voltage range 4.5V to 18V
- Timer intervals from microseconds to hours
- Time period equals RC
- Military qualifications pending

APPLICATIONS

- Sequential timing
- Time delay generation
- Precision timing
- Industrial controls
- Quad one-shot

PIN CONFIGURATION

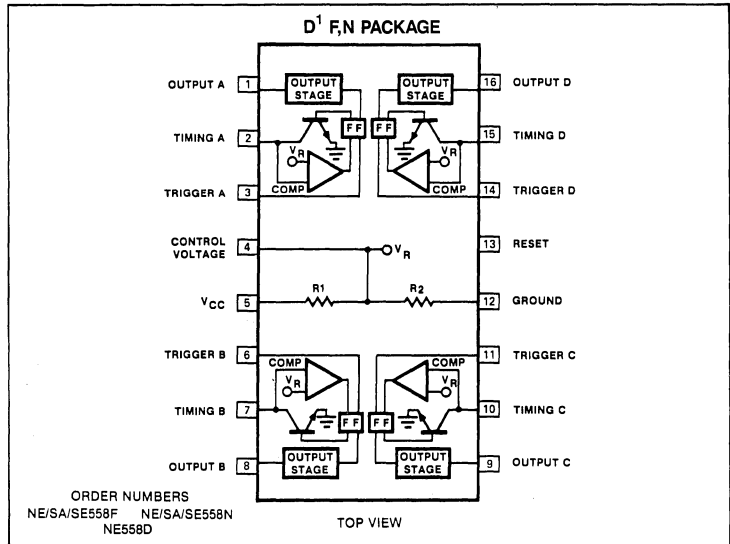

- NOTES:
1. SOL - Released in Large SO package only.
 2. SOL and non-standard pinout.
 3. SO and non-standard pinouts.

ABSOLUTE MAXIMUM RATINGS

PARAMETER	RATING	UNIT
Supply voltage		
NE/SA558	+16	V
SE558	+18	V
Power dissipation	1.25	W
Operating temperature range		
NE558	0 to +70	°C
SA558	-40 to +85	°C
SE558	-55 to +125	°C
Storage temperature range	-65 to +150	°C
Lead temperature (soldering, 60sec)	+300	°C

558 EQUIVALENT CIRCUIT

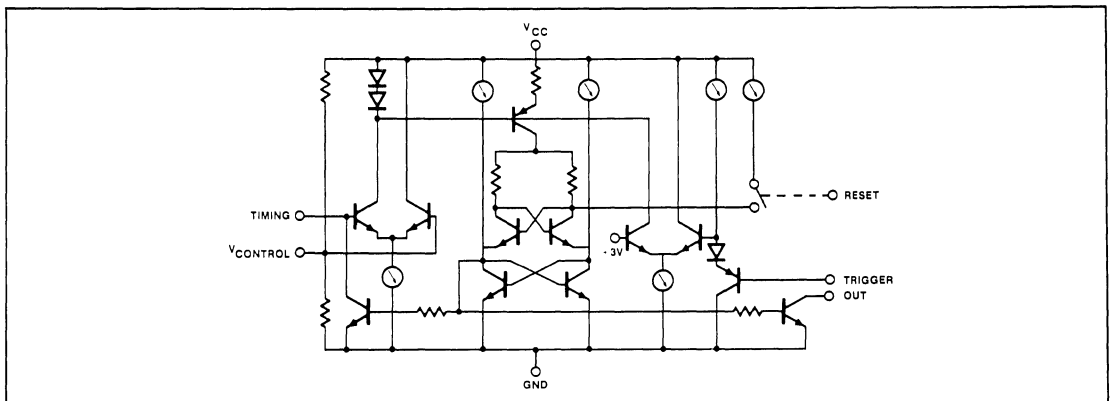

QUAD TIMER

SA/SE/NE558

ELECTRICAL CHARACTERISTICS $T_A = 25^\circ\text{C}$, $V_{CC} = +5\text{V}$ to $+15\text{V}$ unless otherwise specified.

PARAMETER	TEST CONDITIONS	SE558			SA/NE558			UNIT
		Min	Typ	Max	Min	Typ	Max	
Supply voltage		4.5		18	4.5		16	V
Supply current	$V_{CC} = \text{Reset} = 15\text{V}$		16	32		16	36	mA
Timing accuracy ($T = RC$)	$R = 2k\Omega$ to $100k\Omega$ $C = 1\mu\text{F}$							
Initial accuracy			± 1.0	3		± 2	5	%
Drift with temperature			30	100		30	150	ppm/ $^\circ\text{C}$
Drift with supply voltage			0.1	0.9		0.1	0.9	%/V
Trigger voltage ¹	$V_{CC} = 15\text{V}$ Trigger = 0V	0.8		2.4	0.8		2.4	V
Trigger current			5	30		5	100	μA
Reset voltage ²		0.8		2.4	0.8		2.4	V
Reset current	Reset		50	300		50	500	μA
Threshold voltage			0.63			0.63		$\times V_{CC}$
Threshold leakage			15			15		nA
Output voltage ³	$I_L = 10\text{mA}$ $I_L = 100\text{mA}$		0.1	0.2		0.1	0.4	V
			0.7	1.5		1.0	2.0	V
Output leakage			10	500		10	500	nA
Propagation delay			1.0			1.0		μs
Risetime of output	$I_L = 100\text{mA}$		100			100		ns
Falltime of output	$I_L = 100\text{mA}$		100			100		ns

NOTES

1. The trigger functions only on the falling edge of the trigger pulse only after previously being high. After reset the trigger must be brought high and then low to implement triggering.
2. For reset below 0.8 volts, outputs set low and trigger inhibited. For reset above 2.4 volts, trigger enabled.
3. The 558 output structure is open collector which requires a pull up resistor to V_{CC} to sink current. The output is normally low sinking current.

QUAD TIMER

SA/SE/NE558

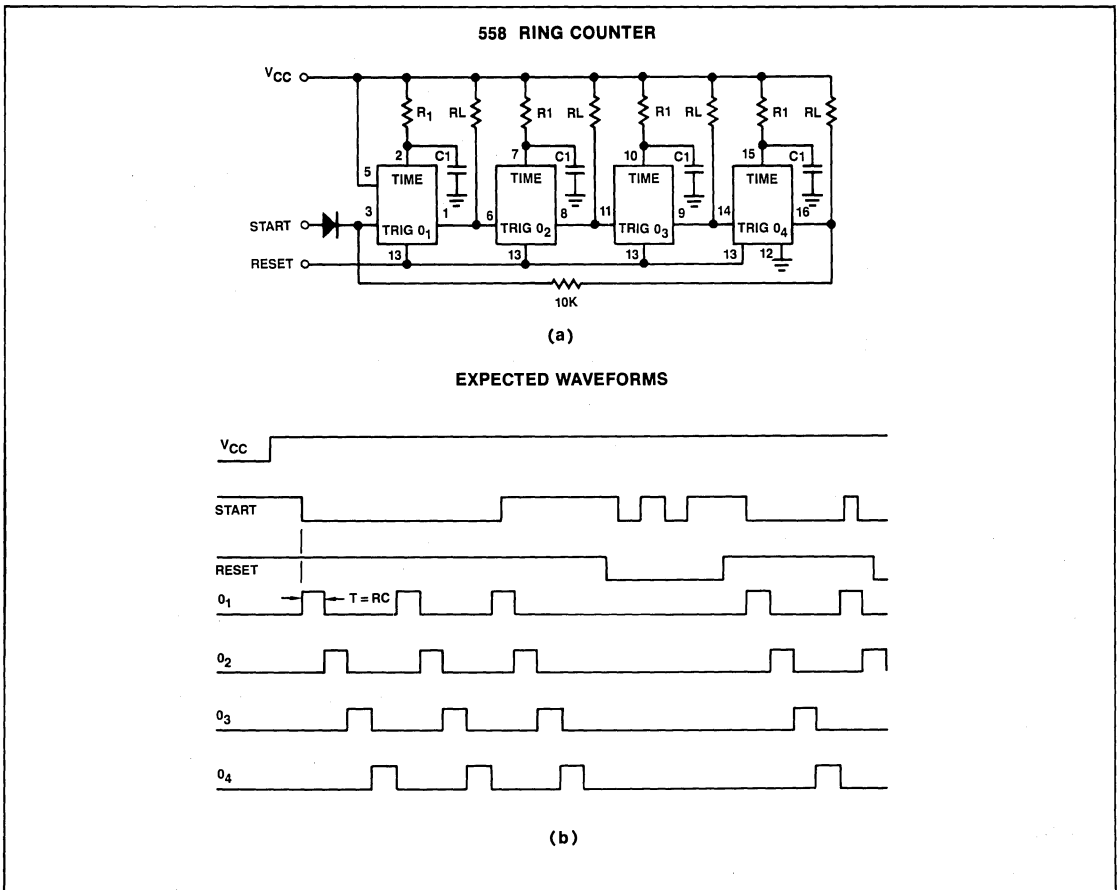
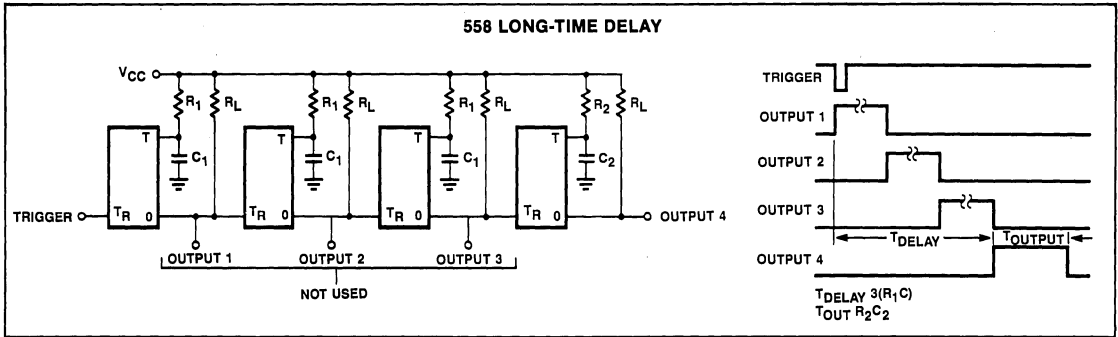

*For additional information, consult the Applications Section.

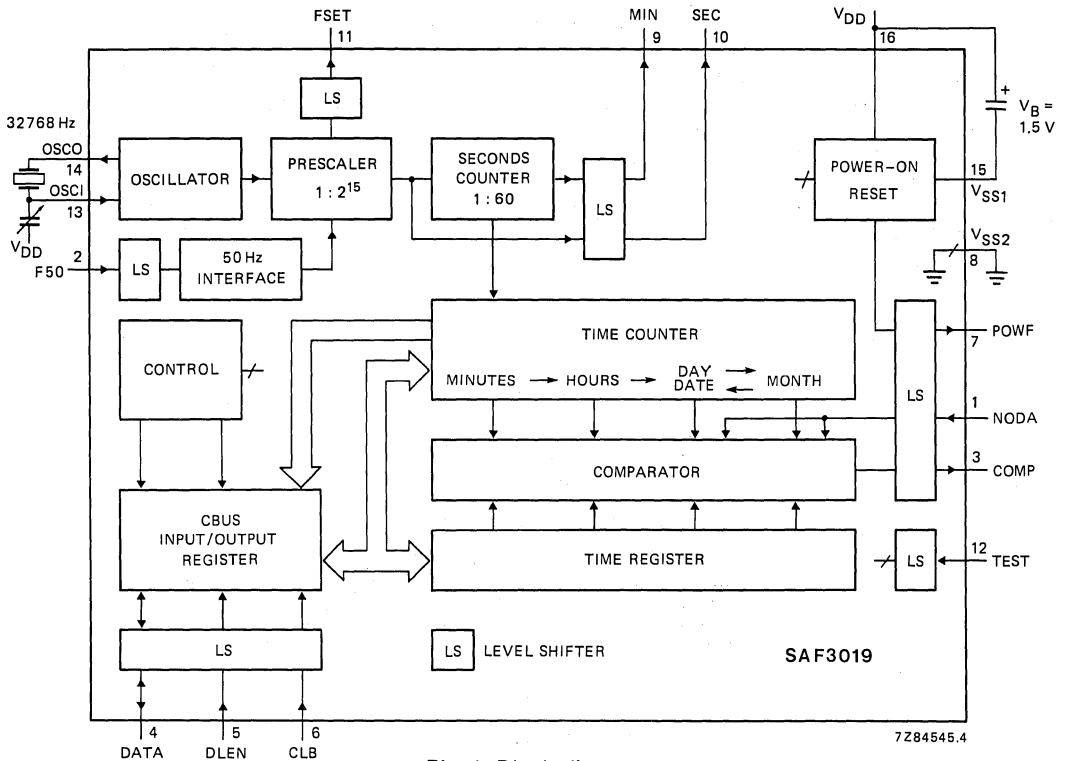

Fig. 1 Block diagram.

Features

- serial bidirectional CBUS interface for input/output of minutes, hours, day and month
- additional pulse outputs for seconds and minutes
- time register for presetting a time for alarm or remote switching functions
- battery back-up for clock function during supply interruption
- controlled either by the 50 Hz mains frequency or a crystal oscillator (automatic switch)

QUICK REFERENCE DATA

Supply voltage	V_{DD}	typ.	5 V
Battery supply voltage range	$T_{amb} = -40 \text{ to } +85 \text{ }^\circ\text{C}$	V_B	1.5 to 2.6 V
	$T_{amb} = 0 \text{ to } +70 \text{ }^\circ\text{C}$	V_B	1.3 to 2.6 V
Crystal oscillator frequency		f_{osc}	typ. 32.768 Hz
Alternative input frequency (pin 2)		f_{F50}	typ. 50 Hz
Operating ambient temperature range		T_{amb}	-40 to +85 °C

PACKAGE OUTLINE

16-lead DIL; plastic (SOT-38D, DE).

GENERAL DESCRIPTION

The SAF3019 is a C-MOS integrated circuit comprising a digital clock for minutes, hours, day and month, as well as an additional register for resetting minutes, hours, day and month. The time counter provides cycles of 28, 30 or 31 days automatically, depending on the length of the month.

The time reference is the 50 Hz mains frequency or a 32.768 Hz on-chip reference oscillator with an external crystal. If the 50 Hz mains frequency is interrupted, the circuit is automatically switched to crystal oscillator operation.

The circuit can be controlled by a microcomputer. The data transmission (e.g. TIME SET and TIME READ of the time counter and time register) is achieved via the CBUS. A microcomputer then controls the data processing and the display unit drive.

The circuit uses a 5 V supply for data transmission. If this 5 V supply is interrupted, the clock function is maintained by a 1.5 V battery. The clock can then continue to function for an extended period, because the battery load current is only a few μA .

OPERATION DESCRIPTION**Oscillator and prescaler (outputs OSCO, FSET; inputs OSCI, F50)**

The 32.768 Hz reference oscillator is achieved by connecting a quartz crystal between the output OSCO and the input OSCI (see also Fig. 7). The oscillator frequency of 32.768 Hz is divided by 256, and again by 128, in a prescaler. This results in a pulse once every second which controls the time counter. The divided-by-256 oscillator frequency (128 Hz) is available at FSET, which is used for fine-adjustment of the oscillator without loading it.

The circuit can also be operated by applying the 50 Hz mains frequency to input F50. This signal is divided-by-50 to obtain a pulse every second to drive the time counter. Input F50 has a Schmitt trigger characteristic which allows slowly rising pulses at this input.

If the mains frequency is interrupted, automatic quartz crystal operation is obtained (see Fig. 8). When the 50 Hz operation is not used, input F50 should be connected to ground (V_{SS2}).

Time counter (outputs SEC, MIN)

The one-second pulses are counted by a (no direct TIME READ) seconds counter and, after 60 seconds, they are transferred to successive counters for minutes, hours, day and month. This counter can be TIME SET and TIME READ by a microcomputer via the CBUS interface. The cycle length for the time counter is given in Table 1.

The seconds and minutes pulses are available at output SEC and MIN respectively, with a pulse ratio of 0.5.

The input/output DATA is set LOW at each transfer of seconds to the minutes counter (i.e. each minute), as long as the CBUS is not occupied by a DLEN = HIGH transmission.

DATA will be set HIGH again by a TIME ADDRESS/TIME READ or TIME SET instruction.

Table 1 Cycle lengths of time counter

unit	counting cycle	carry for following unit	content of month counter
minutes	00 59	59 → 00	1 12
hours	00 23	23 → 00	1 12
days	01 28	28 → 01 or 29 → 01*	2
	01 30	30 → 01	4, 6, 9, 11
	01 31	31 → 01	1, 3, 5, 7, 8, 10, 12
months	01 12	12 → 01	

* The day counter may be set to 29.2. by a TIME SET instruction (for a leap year), then the month transfer occurs at 1.3.

Comparator (output COMP; input NODA)

The time register for a preset switching time (alarm or remote switching) is a 24-bit memory, which can also be set and read-out via the CBUS interface. If both the times of the time counter and the time register are equal, the output COMP becomes HIGH for one minute.

It is possible to choose a comparison between time counter and the time register either based upon minutes, hours, day and month (i.e. clock time *and* date) or minutes and hours (i.e. daily). It is controlled by bit 'UC' and input NODA (see also Table 3) during setting of the month register;

comparison with date: UC = 0 *and* NODA = LOW

comparison daily: UC = 1 *or* NODA = HIGH.

CBUS interface

The data transmission of the SAF3019 to the microcomputer (TIME READ) and vice versa (TIME SET) is possible via the CBUS; DATA (input/output), DLEN (input) and CLB (input).

Data and addresses are transmitted serially via the DATA line, which are synchronized with the clock burst (CLB) pulses from the microcomputer. The duration of the data transmission is determined by the number of CLB pulses when DLEN = HIGH.

The IC includes a word format checking function, which allows the CBUS to be used for controlling other circuits as well. The following word lengths are recognized as valid transmissions:

- TIME ADDRESS (3-bits and 1 start bit);
- TIME SET (10-bits and 1 start bit).

A TIME ADDRESS instruction always has to be followed by a TIME READ (7-bits) sequence. A TIME SET instruction combines address and data. With each instruction (each TIME ADDRESS and TIME READ instruction cycle) two digits of the time counter and time register can be set. The result is, that for a complete TIME READ and TIME SET transmission, 4 cycles TIME ADDRESS/TIME READ or 4 TIME SET instructions are needed.

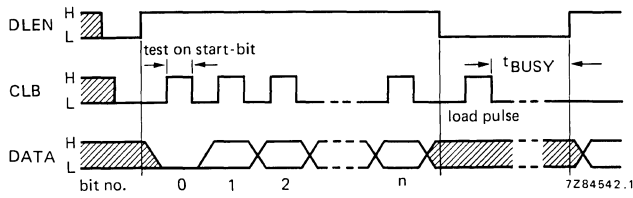

Fig. 2 CBUS data transmission.

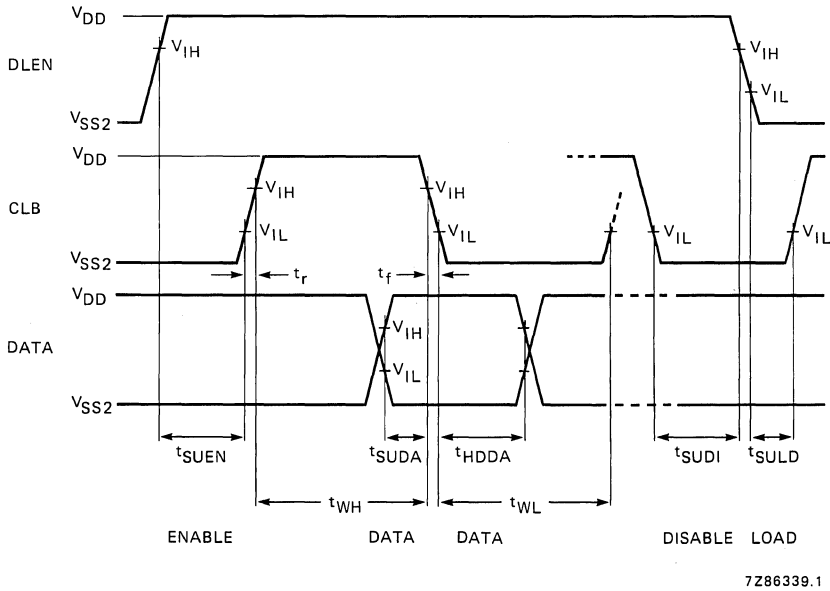

Fig. 3 CBUS timing.

TIME READ

First the bits S, A0 and A1 are transferred from the microcomputer to the SAF3019 with the TIME ADDRESS instruction. With the next instruction (TIME READ), the contents of the selected digits are transferred from the SAF3019 to the microcomputer.

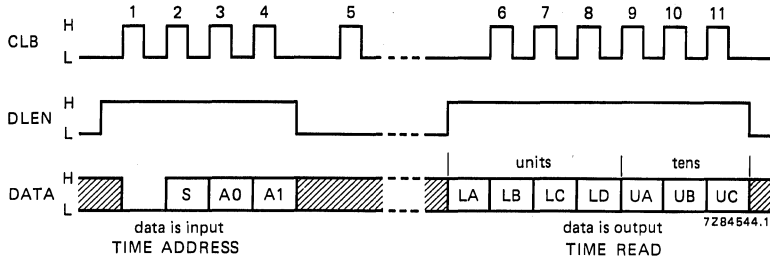

Fig. 4 TIME ADDRESS/TIME READ cycle.

Table 2 Selected digits with respect to the address bits and the TIME READ instruction function.

S	A0	A1	LA	LB	LC	LD	UA	UB	UC	instruction
0	1	1	D	D	D	D	D	D	D	minutes } hours } date } month } time read counter
0	0	1	D	D	D	D	D	D	0	
0	1	0	D	D	D	D	D	D	0	
0	0	0	D	D	D	D	D	D	0	
1	1	1	D	D	D	D	D	D	D	minutes } hours } date } month } time read register
1	0	1	D	D	D	D	D	D	0	
1	1	0	D	D	D	D	D	D	0	
1	0	0	D	D	D	D	D	D	0	

D = data bit.

TIME SET

The TIME SET instruction transfers the address bits S, A0 and A1 as well as the selected digits of the BCD-coded incoming data from the microcomputer to the SAF3019. The last bit (UC) can control special functions. A TIME SET instruction will not stop the time counter, and also will not generate a non-selected digit for transmission.

The prescaler and seconds counter are reset with the TIME SET instruction when S = 0, A0 = 0, A1 = 0 (addressed for month) and UC = 0. If the seconds counter is between 30 and 59, this instruction generates a transfer for the minutes counter. Therefore, this instruction may be used for a very simple correction of the time counter if the deviation is within ±30 seconds.

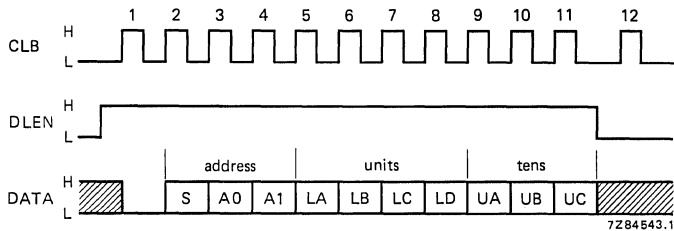

Fig. 5 Data format for TIME SET instruction.

Table 3 Selected digits with respect to the address bits and the possible TIME SET instruction function.

S	A0	A1	LA	LB	LC	LD	UA	UB	UC	instruction
0	1	1	D	D	D	D	D	D	D	minutes } hours } date } month } time set counter
0	0	1	D	D	D	D	D	D	X	
0	1	0	D	D	D	D	D	D	X	
0	0	0	D	D	D	D	D	X	1	
0	0	0	X	X	X	X	X	X	0	seconds } reset counter
1	1	1	D	D	D	D	D	D	D	minutes } hours } date } month* } month** } time set register
1	0	1	D	D	D	D	D	D	X	
1	1	0	D	D	D	D	D	D	X	
1	0	0	D	D	D	D	D	X	0	
1	0	0	D	D	D	D	D	X	1	

D = data bit; X = 1 or 0.

* Compare *with* date.

** Compare *without* date.

Level shifters

The circuit has been designed for low-voltage operation. However, to interface with the microcomputer, most inputs and outputs have level shifters to operate with the 5 V supply voltage of the microcomputer. These level shifters only function when the 5 V supply (V_{DD}) is available. The internal clock function is independent of this supply.

Power failure (output POWF)

If the supply voltage V_{DD}-V_{SS1} is below a certain internal value (V_{POWF}), the power-failure output (POWF) is set HIGH. The threshold voltage V_{POWF} is lower than the minimum battery voltage V_{DD}-V_{SS1}. This battery is required as back-up for the logic circuitry. It is impossible to have data transmission via the CBUS when V_{DD}-V_{SS1} < V_{POWF}, however, the clock will continue running as long as V_{DD}-V_{SS1} does not drop to a lower value. The CBUS is released directly when V_{DD}-V_{SS1} becomes larger than V_{POWF}, but POWF stays HIGH until the next TIME SET instruction, which sets POWF LOW again.

N.B. The 5 V supply voltage (V_{DD}-V_{SS2}) must be switched off when exchanging the battery.

TEST input

The TEST input is used for testing purposes and it is connected to ground (V_{SS2}) for normal operation.

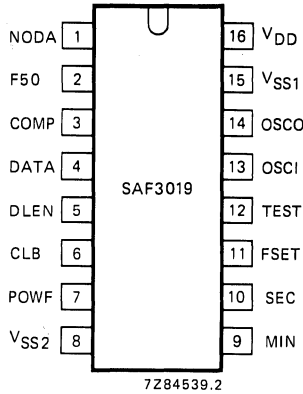

Fig. 6 Pinning diagram.

PINNING

16	V_{DD}	common positive supply (5 V; $V_B = 1.5$ V)
15	V_{SS1}	negative battery supply (V_B)
8	V_{SS2}	ground (V_{DD})
4	DATA	} CBUS (bidirectional)
5	DLEN	
6	CLB	
1	NODA	comparator mode select input
12	TEST	test mode input (normally ground)
2	F50	50 Hz mains frequency input
13	OSCI	} input and output of the on-chip oscillator
14	OSCO	
10	SEC	1 pulse per second output
9	MIN	1 pulse per minute output
3	COMP	comparator output
7	POWF	power failure output
11	FSET	frequency setting signal output (128 Hz)

RATINGS

Limiting values in accordance with the Absolute Maximum System (IEC 134)

Supply voltage ranges	$V_{DD} - V_{SS1}$	-0.5 to + 8 V
	$V_{DD} - V_{SS2}$	-0.5 to + 8 V
Voltage on any pin (except OSCI, OSCO)	V_I	$V_{SS2} - 0.6$ to $V_{DD} + 0.6$ V
Voltage on pins OSCI, OSCO	V_I	$V_{SS1} - 0.6$ to $V_{DD} + 0.6$ V
Input currents	$ I_I $	max. 10 mA
Output currents	$ I_O $	max. 10 mA
Power dissipation per output	P_O	max. 100 mW
Total power dissipation per package	P_{tot}	max. 200 mW
Operating ambient temperature range	T_{amb}	-40 to + 85 °C
Storage temperature range	T_{stg}	-65 to + 150 °C

D.C. CHARACTERISTICS

$V_{SS2} = 0$ V; $V_{DD} = 4.5$ to 5.5 V; $T_{amb} = -40$ to $+ 85$ °C; unless otherwise specified

parameter	conditions	symbol	min.	typ.	max.	unit
Supply voltage	with respect to V_{SS2}^*	V_{DD}	4.5	5	5.5	V
Battery voltage	between V_{DD} and V_{SS1} at $T_{AMB} = 0$ to 70 °C	V_B	1.5	-	2.6	V
		V_B	1.3	-	2.6	V
Time keeping battery voltage		V_{BO}	1.3	-	2.6	V
Supply current	$I_O = 0$ mA**	$-I_{SS2}$	-	-	50	μA
Battery current	$V_B = 1.5$ V	$-I_{SS1}$	-	-	10	μA
Inputs DLEN, DATA, CLB, F50, NODA						
Input voltage HIGH		V_{IH}	$0.7 V_{DD}$	-	-	V
Input voltage LOW		V_{IL}	-	-	$0.3 V_{DD}$	V
Input current at $V_I = V_{SS2}$ or V_{DD}	$V_{DD} = 5.5$ V	$ I_I $	-	-	1	μA
Input F50 hysteresis	$\Delta V = V_{IH} - V_{IL}$	ΔV	0.2	-	-	V
Outputs SEC, MIN, COMP, POWF (buffer outputs)						
Output voltage HIGH	$-I_O = 0.5$ mA	V_{OH}	$V_{DD} - 0.4$	-	-	V
Output voltage LOW	$I_O = 1.6$ mA	V_{OL}	-	-	0.4	V
Output DATA (N-channel open drain)						
Output voltage LOW	$I_O = 1.6$ mA	V_{OL}	-	-	0.4	V
Output leakage current	$V_O = 5.5$ V (HIGH)	I_{OR}	-	-	1	μA

* All outputs are available down to $V_{SS2} = V_B$ at reduced current capability.

** $V_I = V_{SS2}$ or $V_I = V_{DD}$ at all inputs; quartz crystal oscillator operation:
 $f = 32\,768$ Hz, series resistance of crystal $R_{smax} = 25$ kΩ (40 kΩ for 0 to + 70 °C), $C_L = 10$ pF.

APPLICATION INFORMATION

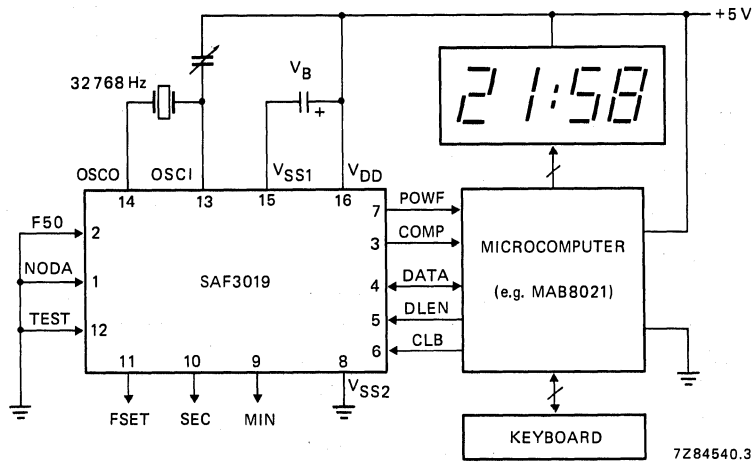

Fig. 7 Typical application of the SAF3019 in a microcomputer controlled system.

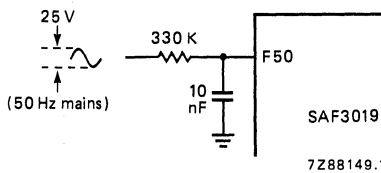

Fig. 8 Circuitry for applying the 50 Hz mains to input F50.

CLOCK/TIMER**SAF3019P****A.C. CHARACTERISTICS**
 $V_{SS2} = 0\text{ V}$; $V_{DD} = 4.5\text{ to }5.5\text{ V}$; $T_{amb} = -40\text{ to }+85\text{ }^{\circ}\text{C}$; unless otherwise specified

See Figs 2 and 3 for all timing.

parameter	conditions	symbol	min.	typ.	max.	unit
Inputs DLEN, DATA, CLB, NODA						
Rise and fall times	note 1	t_r, t_f	—	—	1	μs
CLB pulse width HIGH		t_{WH}	4	—	∞	μs
CLB pulse width LOW		t_{WL}	4	—	∞	μs
Data set-up time DATA \rightarrow CLB		t_{SUDA}	1	—	—	μs
Data hold time DATA \rightarrow CLB		t_{HDDA}	2	—	—	μs
Enable set-up time DLEN \rightarrow CLB		t_{SUEN}	2	—	—	μs
Disable set-up time CLB \rightarrow DLEN		t_{SUDI}	2	—	—	μs
Set-up time DLEN \rightarrow CLB (load pulse)		t_{SULD}	1	—	—	μs
Busy-time from load pulse to next start of transmission		t_{BUSY}	2	—	—	μs
CLB frequency		f_{CLB}	0	—	100	kHz
Input F50						
Rise and fall times	notes 1 and 2	t_r, t_f	—	—	10	ms
Pulse width HIGH		t_{WH}	30	—	—	μs
Pulse width LOW		t_{WL}	30	—	—	μs
Oscillator (OSCI, OSCO)						
Series resistance of crystal	$f = 32.768\text{ Hz}$ at $T_{amb} =$ 0 to 70 $^{\circ}\text{C}$	R_s	—	—	25	$\text{k}\Omega$
		R_s	—	—	40	$\text{k}\Omega$
Load capacitance		C_L	—	10	—	pF

Notes

1. All timing values are referred to V_{IH} and V_{IL} within a voltage swing of minimum V_{SS2} to V_{DD} .
2. The supply current I_{SS2} increases at slow rise/fall times.

GENERAL DESCRIPTION

The PCB8573 is a low threshold, monolithic CMOS circuit that functions as a real time clock/calendar in the Inter IC (I²C) bus-orientated microcomputer systems. The device includes an addressable time counter and an addressable alarm register, both for minutes, hours, days and months. Three special control/status flags, COMP, POWF and NODA, are also available. Information is transferred serially via a two line bidirectional bus (I²C). To transfer data a second supply voltage must be present. Back-up for the clock during supply interruptions is provided by a 1.2 V nickel cadmium battery. The time base is generated from a 32.768 kHz crystal-controlled oscillator.

Features

- Serial input/output bus (I²C) interface for minutes, hours, days and months
- Additional pulse outputs for seconds and minutes
- Alarm register for presetting a time for alarm or remote switching functions
- Battery back-up for clock function during supply interruption
- Crystal oscillator control (32.768 kHz)

QUICK REFERENCE DATA

Supply voltage range (logic)	V _{DD} -V _{SS1}	1.1 to 2.6 V
Supply voltage range (level shifter)	V _{DD} -V _{SS2}	2.5 to 6.0 V
Crystal oscillator frequency	f _{osc}	typ. 32.768 Hz

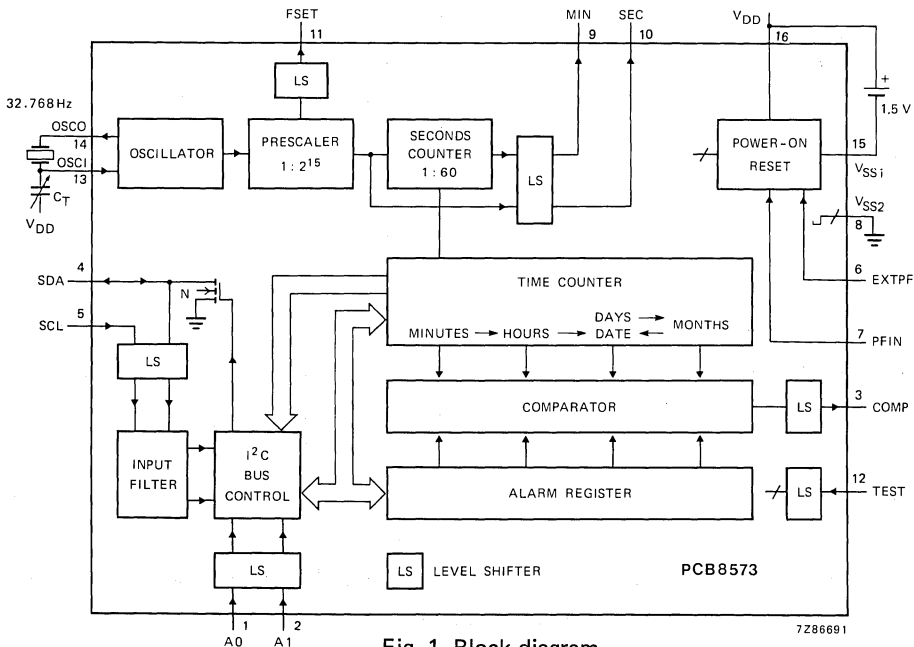

Fig. 1 Block diagram.

PACKAGE OUTLINE

16-lead DIL; plastic (SOT-38).

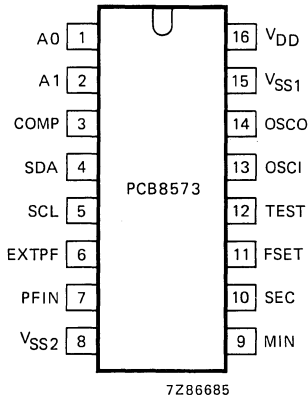

Fig. 2 Pinning diagram.

PINNING

1	A0	level shifter input
2	A1	level shifter input
3	COMP	comparator output
4	SDA	serial data line*
5	SCL	serial clock line
		} I ² C bus
6	EXTPF	external power fail flag input
7	PFIN	internal power fail flag input
8	VSS2	negative supply 2
9	MIN	one pulse per minute output
10	SEC	one pulse per second output
11	FSET	oscillator set output
12	TEST	test input; must be connected to VSS2 when not in use
13	OSCI	oscillator input
14	OSCO	oscillator input/output
15	VSS1	negative supply 1
16	VDD	common positive supply

FUNCTIONAL DESCRIPTION

The following is a functional description of the PCB8573.

Oscillator

The PCB8573 has an integrated crystal-controlled oscillator which provides the timebase for the prescaler. The frequency is determined by a single 32.768 kHz crystal connected between OSCI and OSCO. A trimmer (C_T) is connected between OSCI and VDD.

Prescaler and time counter

The prescaler provides a 128 Hz signal at the FSET output for fine adjustment of the crystal oscillator without loading it. The prescaler also generates a pulse once a second to advance the seconds counter. The carry of the prescaler and the seconds counter are available at the outputs SEC, MIN respectively, and are also readable via the I²C bus. The mark-to-space ratio of both signals is 1 : 1. The time counter is advanced one count by the falling edge of output signal MIN. A transition from HIGH to LOW of output signal SEC triggers MIN to change state. The time counter counts minutes, hours, days and months, and provides a full calendar function which needs to be corrected once every four years. Cycle lengths are shown in Table 1.

* Output open drain n-channel.

Table 1 Cycle length of the time counter

unit	number of bits	counting cycle	carry for following unit	content of month counter
minutes	7	00 to 59	59 → 00	} 2 (see note) 4, 6, 9, 11 1, 3, 5, 7, 8, 10, 12
hours	6	00 to 23	23 → 00	
days	6	01 to 28	28 → 01	
			or 29 → 01	
months	5	01 to 30	30 → 01	
		01 to 31	31 → 01	
		01 to 12	12 → 01	

Note: Day counter may be set to 29 by a write transmission with EXECUTE ADDRESS.

Alarm register

The alarm register is a 24-bit memory. It stores the time-point for the next setting of the status flag COMP. Details of writing and reading of the alarm register are included in the description of the characteristics of the I²C bus.

Comparator

The comparator compares the contents of the alarm register and the time counter, each with a length of 24 bits. When these contents are equal the flag COMP will be set 4 ms after the falling edge of MIN. This set condition occurs once at the beginning of each minute. This information is latched, but can be cleared by an instruction via the I²C bus. A clear instruction may be transmitted immediately after the flag is set and will be executed. The effect of both COMP and POWF being set is dependent upon the master software. Flag COMP information is also available at the output COMP. The comparison may be based upon hours and minutes only if the internal flag NODA (no date) is set. Flag NODA can be set and cleared by separate instructions via the I²C bus, but it is undefined until the first set or clear instruction has been received. Both COMP and NODA flags are readable via the I²C bus.

Power on/power fail detection

If the voltage $V_{DD}-V_{SS1}$ falls below a certain value the operation of the clock becomes undefined. Thus a warning signal is required to indicate that faultless operation of the clock is not guaranteed. This information is latched in a flag called POWF (Power Fail) and remains latched after restoration of the correct supply voltage until a write procedure with EXECUTE ADDRESS has been received. The flag POWF can be set by an internally generated power fail level-discriminator signal, for application with $V_{DD}-V_{SS1} > V_{TH1}$, or by an externally generated power fail signal, for application with $V_{DD}-V_{SS1} < V_{TH1}$. The external signal must be applied to the input PFIN. The input stage operates with signals of any slow rise and fall times. Internal or external controlled POWF can be selected by input EXTPF as shown in Table 2.

FUNCTIONAL DESCRIPTION (continued)

Table 2 Power fail selection

EXTPF	PFIN	function
0	0	power fail is sensed internal
0	1	test mode
1	0	power fail is sensed external
1	1	no power fail sensed

0 : connected to V_{SS1} (LOW)

1 : connected to V_{DD} (HIGH)

The external power fail control operates by absence of the $V_{DD}-V_{SS2}$ supply. Therefore the input levels applied to PFIN and EXTPF must be within the range of $V_{DD}-V_{SS1}$. A LOW level at PFIN indicates a power fail. POWF is readable via the I²C bus. A power on reset for the I²C bus control is generated on-chip, when the supply voltage $V_{DD}-V_{SS2}$ is $1.5\text{ V} < (V_{DD}-V_{SS1}) < 2.5\text{ V}$.

Interface level shifters

The level shifters adjust the 5 V operating voltage ($V_{DD}-V_{SS2}$) of the microcomputer to the internal $\geq 1.1\text{ V}$ supply voltage ($V_{DD}-V_{SS1}$) of the clock/calendar. The oscillator and counter are not influenced by the $V_{DD}-V_{SS2}$ supply voltage. If the voltage $V_{DD}-V_{SS2}$ is absent ($V_{SS2} = V_{DD}$) the output signal of the level shifter is HIGH because V_{DD} is the common mode of the $V_{DD}-V_{SS2}$ and the $V_{DD}-V_{SS1}$ supply. Because the level shifters invert the input signal, the internal circuit behaves as if a LOW signal is present on the inputs. FSET, SEC, MIN and COMP are CMOS push-pull output stages, for applications the source capability on these outputs is cut off when the supply voltage $V_{DD}-V_{SS2} = 0$.

CHARACTERISTICS OF THE I²C BUS

The I²C bus is for 2-way, 2-line communication between different ICs or modules. The two lines are a serial data line (SDA) and a serial clock line (SCL). Both lines must be connected to a positive supply via a pull-up resistor when connected to the output stages of a device. Data transfer may be initiated only when the bus is not busy.

Bit transfer (see Fig. 3)

One data bit is transferred during each clock pulse. The data on the SDA line must remain stable during the HIGH period of the clock pulse as changes in the data line at this time will be interpreted as control signals.

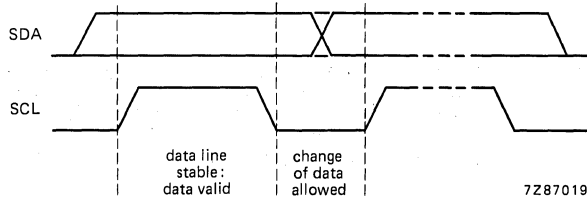

Fig. 3 Bit transfer.

Start and stop conditions (see Fig. 4)

Both data and clock lines remain HIGH when the bus is not busy. A HIGH-to-LOW transition of the data line, while the clock is HIGH is defined as the start condition (S). A LOW-to-HIGH transition of the data line while the clock is HIGH is defined as the stop condition (P).

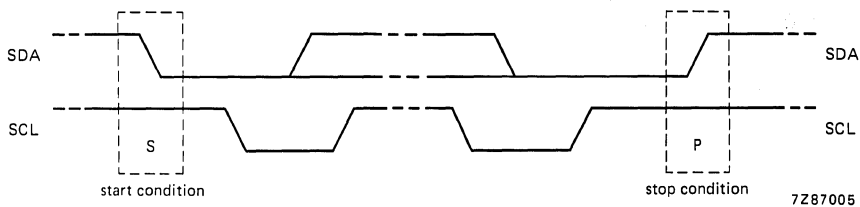

Fig. 4 Definition of start and stop conditions.

System configuration (see Fig. 5)

A device generating a message is a "transmitter", a device receiving a message is the "receiver". The device that controls the message is the "master" and the devices which are controlled by the master are the "slaves".

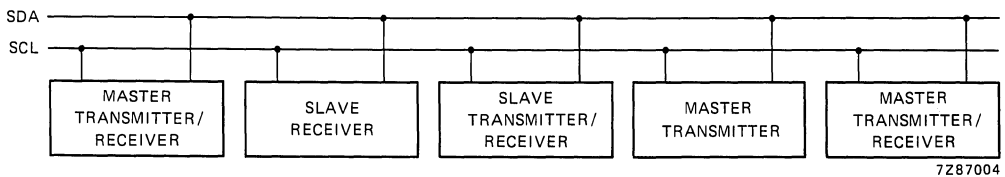

Fig. 5 System configuration.

CHARACTERISTICS OF THE I²C bus (continued)

Acknowledge (see Fig. 6)

The number of data bytes transferred between the start and stop conditions from transmitter to receiver is not limited. Each byte of eight bits is followed by one acknowledge bit. The acknowledge bit is a HIGH level put on the bus by the transmitter whereas the master generates an extra acknowledge related clock pulse. A slave receiver which is addressed must generate an acknowledge after the reception of each byte. Also a master must generate an acknowledge after the reception of each byte that has been clocked out of the slave transmitter. The device that acknowledges has to pull down the SDA line during the acknowledge clock pulse, so that the SDA line is stable LOW during the HIGH period of the acknowledge related clock pulse, set up and hold times must be taken into account. A master receiver must signal an end of data to the transmitter by *not* generating an acknowledge on the last byte that has been clocked out of the slave. In this event the transmitter must leave the data line HIGH to enable the master to generate a stop condition. (See Fig. 13 and Fig. 14.)

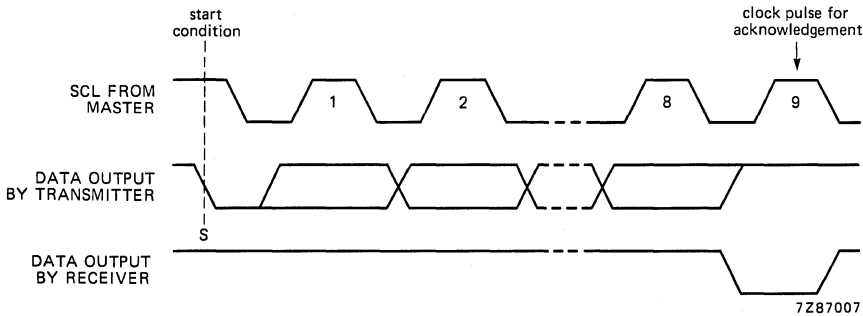

Fig. 6 Acknowledgement on the I²C bus.

Timing specifications

Within the I²C bus specifications a high-speed mode and a low-speed mode are defined. The PCB8573 operates in both modes and the timing requirements are as follows:

High-speed mode

Masters generate a bus clock with a maximum frequency of 100 kHz. Detailed timing is shown in Fig. 7.

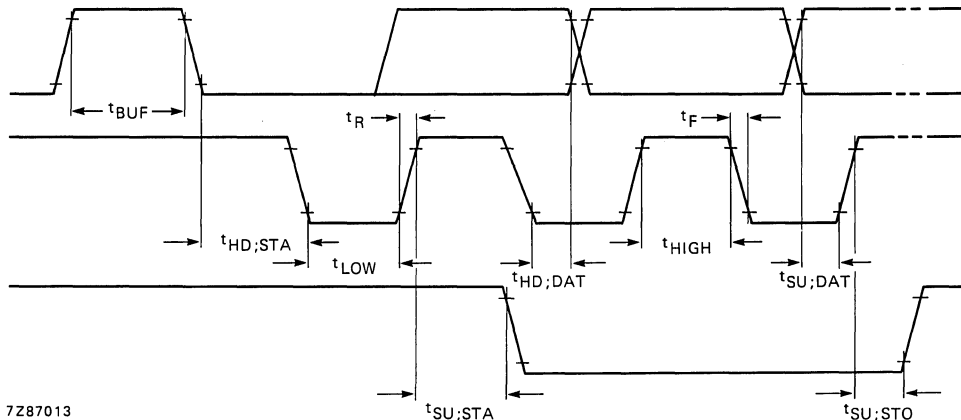

Fig. 7 Timing of the high-speed mode.

Where:

t_{BUF}	$t \geq t_{LOWmin}$	The minimum time the bus must be free before a new transmission can start
$t_{HD}; STA$	$t \geq t_{HIGHmin}$	Start condition hold time
t_{LOWmin}	$4.7 \mu s$	Clock LOW period
$t_{HIGHmin}$	$4 \mu s$	Clock HIGH period
$t_{SU}; STA$	$t \geq t_{LOWmin}$	Start condition set-up time, only valid for repeated start code
$t_{HD}; DAT$	$t \geq 0 \mu s$	Data hold time
$t_{SU}; DAT$	$t \geq 250 ns$	Data set-up time
t_R	$t \leq 1 \mu s$	Rise time of both the SDA and SCL line
t_F	$t \leq 300 ns$	Fall time of both the SDA and SCL line
$t_{SU}; STO$	$t \geq t_{LOWmin}$	Stop condition set-up time

Note

All the values referred to V_{IH} and V_{IL} levels.

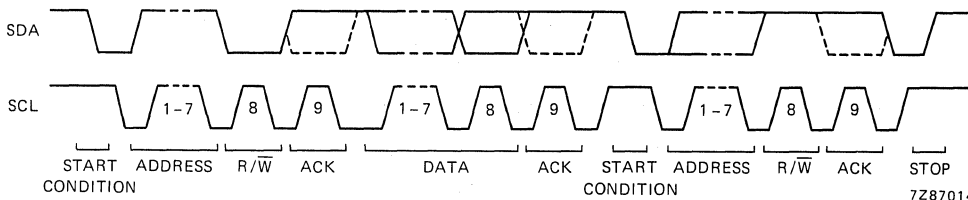

Fig. 8 Complete data transfer in the high-speed mode.

Where:

Clock t_{LOWmin}	$4.7 \mu s$
$t_{HIGHmin}$	$4 \mu s$
The dashed line is the acknowledgement of the receiver	
Mark-to-space ratio	1 : 1 (LOW-to-HIGH)
Max. number of bytes	unrestricted
Premature termination of transfer	allowed by generation of STOP condition
Acknowledge clock bit	must be provided by the master

CHARACTERISTICS OF THE I²C BUS (continued)

Low-speed mode

Masters generate a bus clock with a maximum frequency of 2 kHz; a minimum LOW period of 105 μs and a minimum HIGH period of 365 μs. The mark-to-space ratio is 1 : 3 LOW-to-HIGH. Detailed timing is shown in Fig. 9.

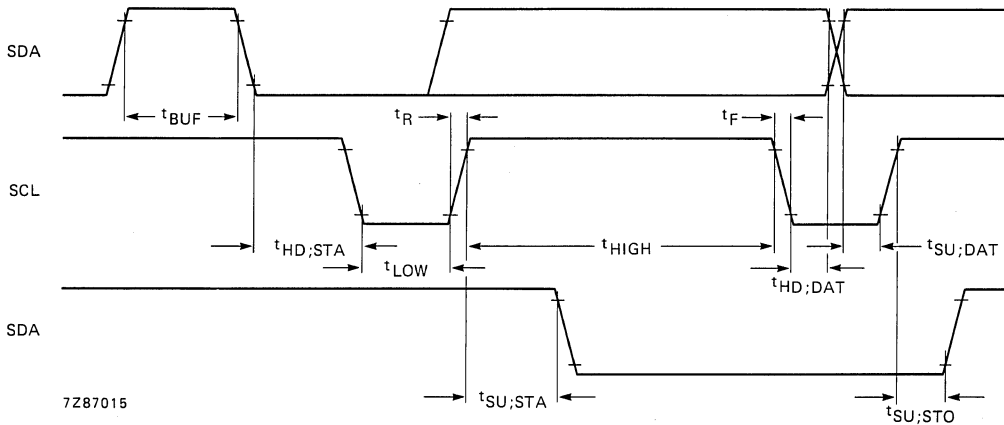

Fig. 9 Timing of the low-speed mode.

Where:

t_{BUF}	$t \geq 105 \mu s (t_{LOWmin})$
$t_{HD; STA}$	$t \geq 365 \mu s (t_{HIGHmin})$
t_{LOW}	$130 \mu s \pm 25 \mu s$
t_{HIGH}	$390 \mu s \pm 25 \mu s$
$t_{SU; STA}$	$130 \mu s \pm 25 \mu s^*$
$t_{HD; DAT}$	$t \geq 0 \mu s$
$t_{SU; DAT}$	$t \geq 250 ns$
t_R	$t \leq 1 \mu s$
t_F	$t \leq 300 ns$
$t_{SU; STO}$	$130 \mu s \pm 25 \mu s$

Note

All the values referred to V_{IH} and V_{IL} levels, for definitions see high-speed mode.

* Only valid for repeated start code.

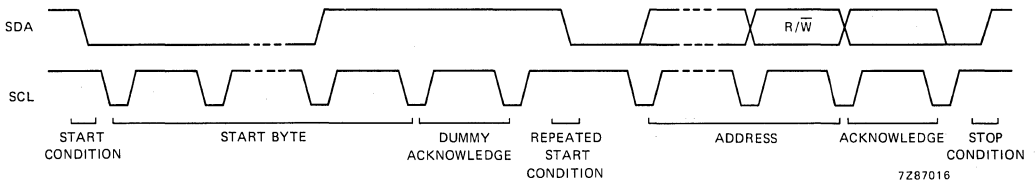

Fig. 10 Complete data transfer in the low-speed mode.

Where:

Clock t_{LOWmin}	$130 \mu s \pm 25 \mu s$
$t_{HIGHmin}$	$390 \mu s \pm 25 \mu s$
Mark-to-space ratio	1 : 3 (LOW-to-HIGH)
Start byte	0000 0001
Max. number of bytes	6
Premature termination of transfer	not allowed
Acknowledge clock bit	must be provided by master

Note

The general characteristics and detailed specification of the I²C bus are described in a separate data sheet (serial data buses) in handbook: ICs for digital systems in radio, audio and video equipment.

ADDRESSING

Before any data is transmitted on the I²C bus, the device which should respond is addressed first. The addressing is always done with the first byte transmitted after the start procedure.

Slave address

The clock/calendar acts as a slave receiver or slave transmitter. Therefore the clock signal SCL is only an input signal, but the data signal SDA is a bidirectional line. The clock calendar slave address is shown in Fig. 11.

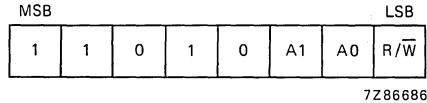

Fig. 11 Slave address.

The subaddress bits A0 and A1 correspond to the two hardware address pins A0 and A1 which allows the device 1 of 4 different addresses.

Clock/calendar READ/WRITE cycles

The I²C bus configuration for different clock/calendar READ and WRITE cycles is shown in Fig. 12 and Fig. 13.

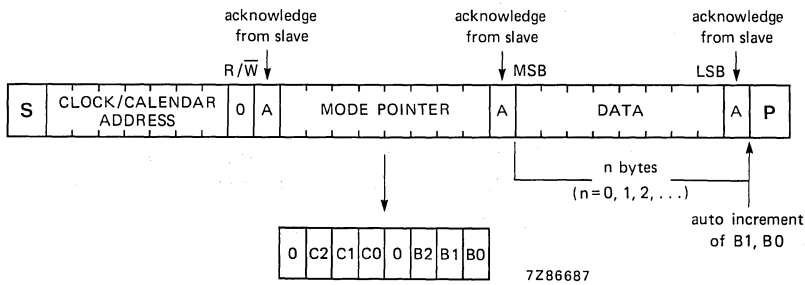

Fig. 12 Master transmitter transmits to clock/calendar slave receiver.

This mode is used to set the time counter, the alarm register and the flags. The transmission of the clock/calendar address is followed by the MODE-POINTER-WORD which contains a CONTROL-nibble (Table 3) and an ADDRESS-nibble (Table 4). The ADDRESS-nibble is valid only if the preceding CONTROL-nibble is set to EXECUTE ADDRESS. The third transmitted word contains the data to be written into the time counter or alarm register.

Table 3 CONTROL-nibble

	C2	C1	C0	function
0	0	0	0	execute address
0	0	0	1	read control/status flags
0	0	1	0	reset prescaler, including seconds counter; without carry for minute counter
0	0	1	1	time adjust, with carry for minute counter (see note)
0	1	0	0	reset NODA flag
0	1	0	1	set NODA flag
0	1	1	0	reset COMP flag

Note

If the seconds counter is below 30 there is no carry. This causes a time adjustment of max. -30 s. From the count 30 there is a carry which adjusts the time by max. + 30 s.

Table 4 ADDRESS-nibble

	B2	B1	B0	addressed to:
0	0	0	0	time counter hours
0	0	0	1	time counter minutes
0	0	1	0	time counter days
0	0	1	1	time counter months
0	1	0	0	alarm register hours
0	1	0	1	alarm register minutes
0	1	1	0	alarm register days
0	1	1	1	alarm register months

At the end of each data word the address bits B1, B0 will be incremented automatically provided the preceding CONTROL-nibble is set to EXECUTE ADDRESS. There is no carry to B2.

Table 5 shows the placement of the BCD upper and lower digits in the DATA byte for writing into the addressed part of the time counter and alarm register respectively.

Table 5 Placement of BCD digits in the DATA byte

MSB		DATA				LSB		addressed to:
upper digit		lower digit						
UD	UC	UB	UA	LD	LC	LB	LA	
X	X	D	D	D	D	D	D	hours
X	D	D	D	D	D	D	D	minutes
X	X	D	D	D	D	D	D	days
X	X	X	D	D	D	D	D	months

Where "X" is the don't care bit and "D" is the data bit.

Acknowledgement response of the clock calendar as the slave receiver is shown in Table 6.

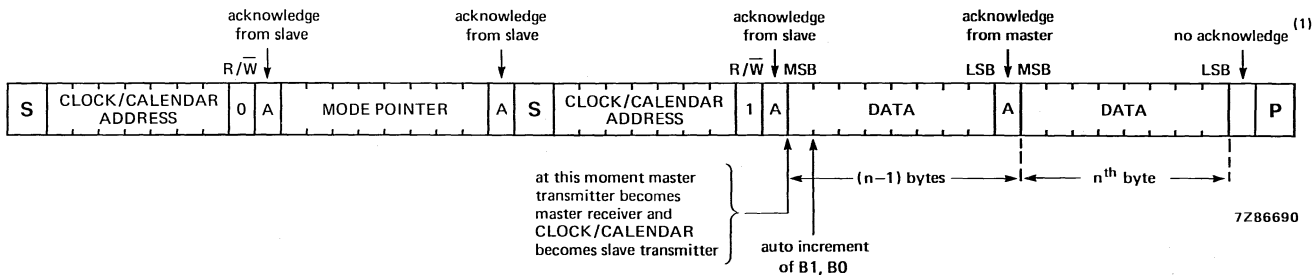

(1) The master receiver must signal an end of data to the slave transmitter by *not* generating an acknowledge on the *last byte* that has been clocked out of the slave.

Fig. 13 Master transmitter reads clock/calendar after setting mode pointer.

To read the addressed part of the time counter and alarm register, plus information from specified control/status flags, the BCD digits in the DATA byte are organized as shown in Table 7.

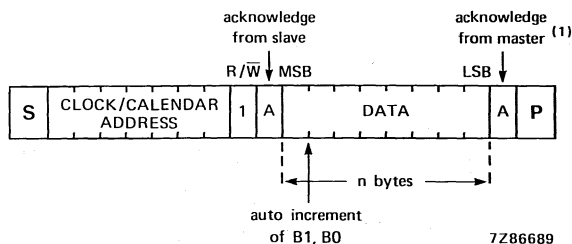

(1) The master receiver must signal an end of data to the slave transmitter by *not* generating an acknowledge on the *last byte* that has been clocked out of the slave.

Fig. 14 Master reads clock/calendar immediately after first bite.

The status of the MODE-POINTER-WORD concerning the CONTROL-nibble remains unchanged until a write to MODE POINTER condition occurs.



ADDRESSING (continued)

Table 6 Slave receiver acknowledgement

mode pointer								acknowledge on byte		
	C2	C1	C0		B2	B1	B0	address	mode pointer	data
0	0	0	0	0	X	X	X	yes	yes	yes
0	0	0	0	1	X	X	X	yes	no	no
0	0	0	1	X	X	X	X	yes	yes	no
0	0	1	0	X	X	X	X	yes	yes	no
0	0	1	1	X	X	X	X	yes	yes	no
0	1	0	0	X	X	X	X	yes	yes	no
0	1	0	1	X	X	X	X	yes	yes	no
0	1	1	0	X	X	X	X	yes	yes	no
0	1	1	1	X	X	X	X	yes	no	no
1	X	X	X	X	X	X	X	yes	no	no

Where "X" is the don't care bit.

Table 7 Organization of the BCD digits in the DATA byte

MSB				DATA				LSB		
upper digit				lower digit						
UD	UC	UB	UA	LD	LC	LB	LA	addressed to		
0	0	D	D	D	D	D	D	hours		
0	D	D	D	D	D	D	D	minutes		
0	0	D	D	D	D	D	D	days		
0	0	0	D	D	D	D	D	months		
0	0	0	*	**	NODA	COMP	POWF	control/status flags		

Where: "D" is the data bit.

* = minutes.

** = seconds.

RATINGS

Limiting values in accordance with the Absolute Maximum System (IEC 134)

Supply voltage ranges	$V_{DD}-V_{SS1}$		-0.3 to +8 V
	$V_{DD}-V_{SS2}$		-0.3 to +8 V
Voltage on pins 4 and 5		$V_{SS2}-0.8$ to $V_{DD} + 0.8$ V*	
Voltage on pins 6, 7, 13 and 14		$V_{SS1}-0.6$ to $V_{DD} + 0.6$ V	
Voltage on any other pin		$V_{SS2}-0.6$ to $V_{DD} + 0.6$ V	
Input current	I_I	max.	100 μ A
Output current	I_O	max.	10 mA
Power dissipation per output	P_O	max.	100 mW
Total power dissipation per package	P_{tot}	max.	200 mW
Operating ambient temperature range	T_{amb}		0 to +70 °C
Storage temperature range	T_{stg}		-55 to +125 °C

* Impedance min. 500 Ω .

CHARACTERISTICS

$V_{SS2} = 0\text{ V}$; $T_{amb} = 0\text{ to }+70\text{ }^{\circ}\text{C}$ unless otherwise specified

parameter	symbol	min.	typ.	max.	unit
Supply					
Supply voltage level shifter	$V_{DD}-V_{SS2}$	2.5	5	6.0	V
Supply voltage logic	$V_{DD}-V_{SS1}$	1.1	—	2.6	V
Supply current V_{SS1} at $V_{DD}-V_{SS1} = 1.5\text{ V}$	$-I_{SS1}$	—	—	10	μA
Supply current V_{SS2} at $V_{DD}-V_{SS2} = 5\text{ V}$ ($I_O = 0\text{ mA}$ on all outputs)	$-I_{SS2}$	—	—	50	μA
Inputs					
Inputs SCL, SDA, A0, A1, TEST					
Input leakage current at $V_{DD}-V_{SS2} = 6\text{ V}$; $T_{amb} = 25\text{ }^{\circ}\text{C}$					
$V_I = 6\text{ V}$	I_I	—	—	1	μA
$V_I = 0\text{ V}$	$-I_I$	—	—	1	μA
Inputs SCL, SDA, A0, A1, TEST (level shifter inputs) at $V_{DD}-V_{SS2} = 2.5\text{ to }6\text{ V}$					
Input voltage HIGH	V_{IH}	$0.7 \times V_{DD}$	—	—	V
Input voltage LOW	V_{IL}	—	—	$0.3 \times V_{DD}$	V
Inputs EXTPF, PFIN at $V_{DD}-V_{SS1} = 1.1\text{ to }2.6\text{ V}$					
Input voltage HIGH	V_{IH}	$0.7 \times V_{DD}-V_{SS1}$	—	—	V
Input voltage LOW	V_{IL}	—	—	$0.3 \times V_{DD}-V_{SS1}$	V
Input leakage current at $V_{DD}-V_{SS1} = 2.6\text{ V}$; $T_{amb} = 25\text{ }^{\circ}\text{C}$					
$V_I = V_{DD}$	I_I	—	—	0.1	μA
$V_I = V_{SS1}$	$-I_I$	—	—	0.1	μA

CHARACTERISTICS (continued)

parameter	symbol	min.	typ.	max.	unit
Outputs					
Outputs SEC, MIN, COMP, FSET (normal buffer outputs)					
Output voltage HIGH					
at $V_{DD}-V_{SS2} = 2.5$ V $-I_O = 0.1$ mA	V_{OH}	$V_{DD}-0.4$	—	—	V
at $V_{DD}-V_{SS2} = 4$ to 6 V $-I_O = 0.5$ mA	V_{OH}	$V_{DD}-0.4$	—	—	V
Output voltage LOW					
at $V_{DD}-V_{SS2} = 2.5$ V $I_O = 0.3$ mA	V_{OL}	—	—	0.4	V
at $V_{DD}-V_{SS2} = 4$ to 6 V $I_O = 1.6$ mA	V_{OL}	—	—	0.4	V
Output SDA (N-channel open drain)					
Output "ON": $I_O = 3$ mA at $V_{DD}-V_{SS2} = 2.5$ to 6 V	V_{OL}	—	—	0.4	V
Output "OFF" (leakage current) $V_O = 6$ V; $T_{amb} = 25$ °C at $V_{DD}-V_{SS2} = 6$ V					
	I_O	—	—	1	μ A
Internal threshold voltage					
Power failure detection	V_{TH1}	1	1.2	1.4	V
Power "ON" reset at $V_{SCL} = V_{SDA} = V_{DD}$	V_{TH2}	1.5	2.0	2.5	V
Rise and fall times of input signals					
Input EXTPF					
at $V_{DD}-V_{SS1} = 1.1$ to 2.6 V	t_r, t_f	—	—	1	μ s
Input PFIN					
at $V_{DD}-V_{SS1} = 1.1$ to 2.6 V (10% to 90% ($V_{DD}-V_{SS1}$))	t_r, t_f	—	—	∞	μ s
Input signals except EXTPF and PFIN					
at $V_{DD}-V_{SS2} = 2.5$ to 6 V between V_{IL} and V_{IH} levels					
rise time	t_r	—	—	1	μ s
fall time	t_f	—	—	0.3	μ s

CLOCK/TIMER**PCB8573**

parameter	symbol	min.	typ.	max.	unit
Frequency at SCL					
at $V_{DD}-V_{SS2} = 4$ to 6 V					
Pulse width LOW (see Figs 7 and 9)	t_{LOW}	4.7	—	—	μs
Pulse width HIGH (see Figs 7 and 9)	t_{HIGH}	4	—	—	μs
Noise suppression time constant at SCL and SDA output	T_I	0.25	1	2.5	μs
Input capacitance (SCL, SDA)	C_I	—	—	7	pF
Oscillator					
Integrated oscillator capacitance	C_{out}	—	40	—	pF
Oscillator feedback resistance	R_f	—	3	—	$M\Omega$
Oscillator stability for: $\Delta(V_{DD}-V_{SS1}) = 100$ mV at $V_{DD}-V_{SS1} = 1.55$ V; $T_{amb} = 25$ °C	f/f_{osc}	—	2×10^{-6}	—	—
Quartz crystal parameters					
Frequency = 32.768 kHz					
Series resistance	R_S	—	—	40	$k\Omega$
Parallel capacitance	C_L	—	9	—	pF
Trimmer capacitance	C_T	—	5.25	—	pF

APPLICATION INFORMATION

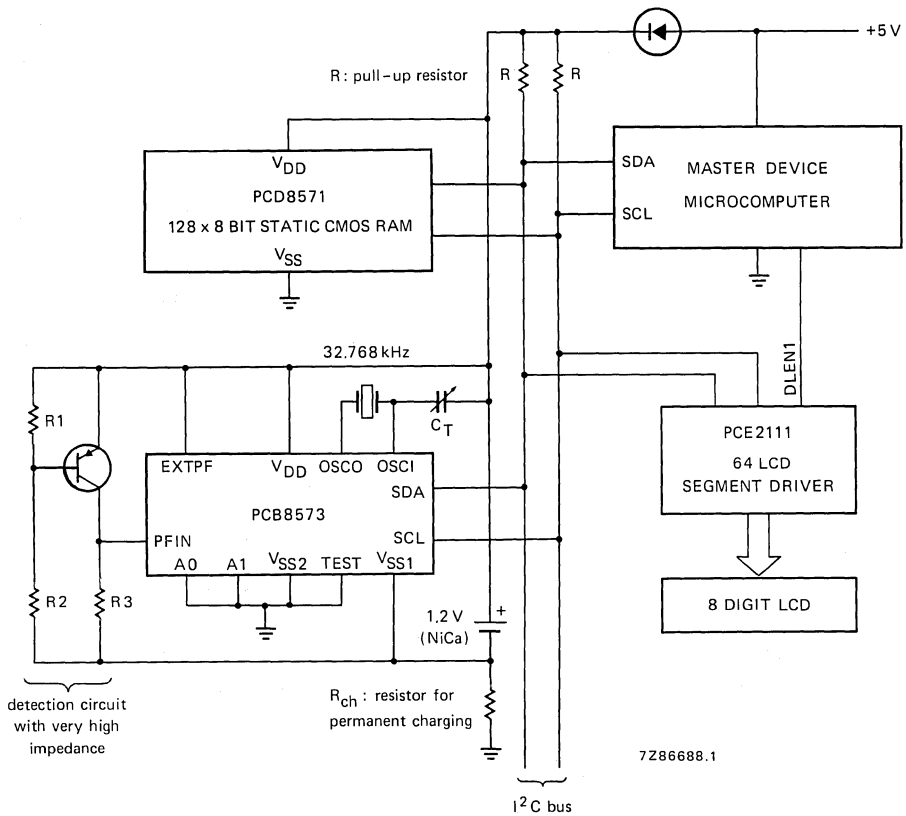

Fig. 15 Application example of the PCB8573 clock/calendar.

The SAA5030 is a monolithic bipolar integrated circuit used for teletext video processing. It is one of a package of four circuits to be used in teletext tv data systems. The SAA5030 extracts data and data clock information from the television composite video signal and feeds this to the Acquisition and Control circuit SAA5040. A 6 MHz crystal controlled phase locked oscillator is incorporated which drives the Timing Chain circuit SAA5020. An adaptive sync separator is also provided which derives line and field sync pulses from the input video in order to synchronise the timing chain.

QUICK REFERENCE DATA

Supply voltage	V_{CC}	nom.	12	V
Supply current ($V_{CC} = 12\text{ V}$)	I_{CC}	typ.	110	mA
Video input amplitude (sync-white)	$V_{16\text{video}}(\text{p-p})$	nom.	2.4	V
Teletext data input amplitude	$V_{16\text{teletext}}(\text{p-p})$	nom.	1.1	V
Sync amplitude	$V_{16\text{sync}}(\text{p-p})$	nom.	0.7	V
Operating ambient temperature range	T_{amb}		-20 to +70	$^{\circ}\text{C}$

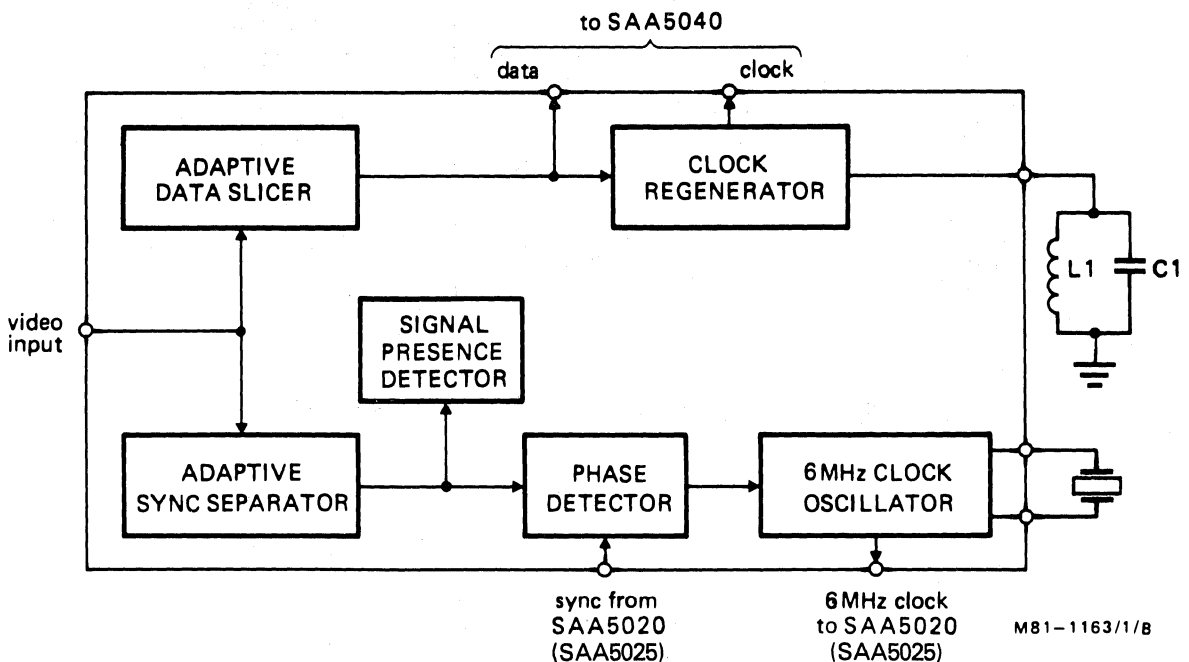
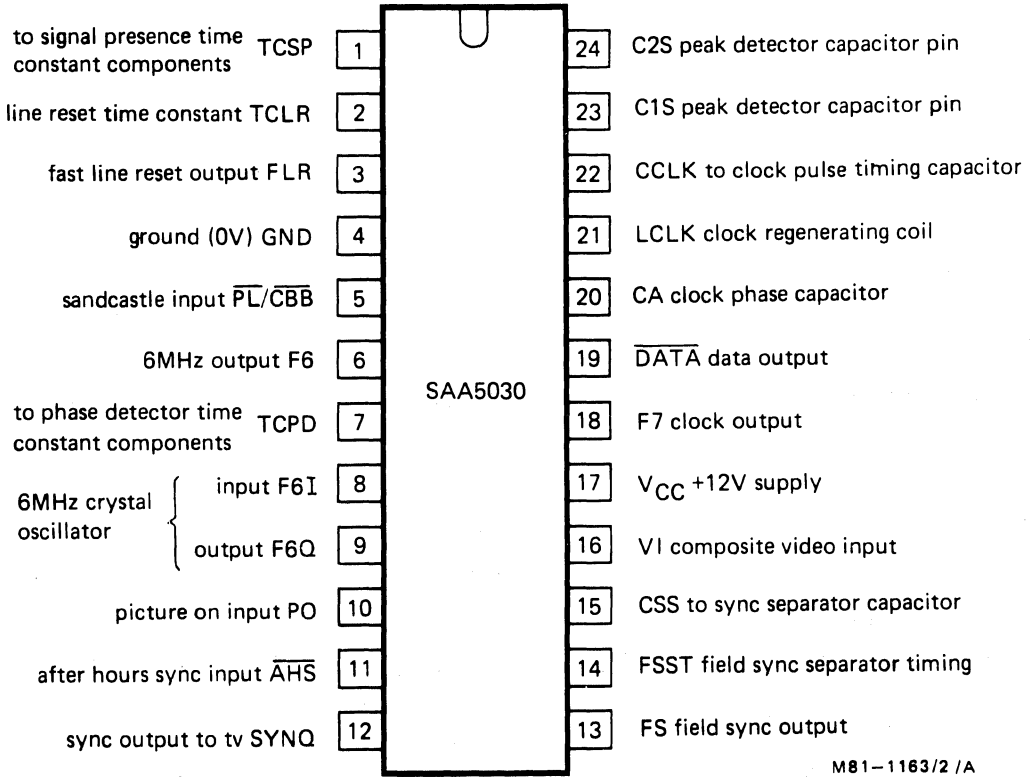

Fig.1 Block diagram

PACKAGE OUTLINE

24-lead DIL; plastic (SOT-101A with internal heat spreader).

PINNING



M81-1163/2 /A

Fig.2 Pinning diagram

TELETEXT VIDEO PROCESSOR

SAA5030

RATINGS Limiting values in accordance with the Absolute Maximum System. (IEC134)

Voltages

Supply voltage	V_{17-4}	V_{CC}	max.	13.2	V
Input voltages	V_{5-4}	V_I	max.	9.0	V
	V_{10-4}	V_I	max.	V_{CC}	V
	V_{11-4}	V_I	max.	7.5	V

Temperatures

Storage temperature range	T_{stg}	-20 to +125	°C
Operating ambient temperature range	T_{amb}	-20 to +70	°C

CHARACTERISTICS (At $T_{amb} = 25^\circ\text{C}$, $V_{CC} = 12\text{ V}$ and with external components as shown in Fig.3 unless otherwise stated).

		min.	typ.	max.	
Supply voltage	V_{CC}	10.8	12.0	13.2	V
Supply current ($V_{CC} = 12.0\text{ V}$)	I_{CC}	—	110	—	mA
Video input and sync separator					
Video input amplitude (sync to white) Fig.4	$V_{16\text{video}(p-p)}$	2.0	1.4	3.0	V
Source impedance, $f = 100\text{ kHz}$	$ Z_S $	—	—	250	Ω
Sync amplitude	$V_{16\text{sync}(p-p)}$	0.07	0.7	1.0	V
Delay through sync separator	t_d	—	0.5	—	μs
Delay between field sync datum at pin 12 and the leading edge of separated field sync at pin 13 (Note 1, Fig.4)	t_d	32	48	62	μs
Field sync output					
V_O (LOW) ($I_{13} = 20\ \mu\text{A}$)	V_{OL}	—	—	0.5	V
V_O (HIGH) ($-I_{13} = 100\ \mu\text{A}$)	V_{OH}	2.4	—	—	V

TELETEXT VIDEO PROCESSOR

SAA5030

Crystal controlled phase-locked oscillator

Measured using a crystal with the following specification e.g. catalogue number 4322 143 03241

$C_1 = 27.5 \text{ fF (typ.)}$

$C_0 = 6.8 \text{ pF (typ.)}$

$C_L = 20 \text{ pF}$

Trimability (C_L increased to 30 pF) > 750 Hz

Fundamental ESR < 50 Ω

		min.	typ.	max.	
Frequency	fF6	—	6.0	—	MHz
Holding range		1.5	3.0	—	kHz
Catching range		1.5	3.0	—	kHz
Control sensitivity of phase detector measured as voltage at pin 7 with respect to phase difference between separated syncs and phase lock pulse PL		—	0.3	—	mV/ns
Control sensitivity of oscillator measured as change in 6 MHz phase shift from pin 8 to pin 9 with respect to voltage at pin 7		—	2	—	deg/mV
Gain of sustaining amplifier, $V_{g.8}$ measured with input voltage of 100 mV _{p-p} and phase detector immobilised		2.5	—	—	V/V
Output voltage of 6 MHz signal at pin 6, measured into 20 pF load capacitance; peak-to-peak value		—	5.5	—	V
Output rise and fall times at pin 6 into 20 pF load	$t_r; t_f$	—	—	30	ns
Data slicer and clock regenerator					
Teletext data input amplitude, pin 16 (Note 2, Fig.4); peak-to-peak value		—	1.1	—	V
Data input amplitude at pin 16 required to enable amplitude gate flip-flop; peak-to-peak value		—	0.46	—	V
Attack rate, measured at pins 23 and 24 with a step to pin 16 (positive)		—	15	—	V/ μ s
(negative)		—	9	—	V/ μ s

5

TELETEXT VIDEO PROCESSOR

SAA5030

	min.	typ.	max.	
Data slicer and clock regenerator (continued)				
Decay rate, measured at pins 23 and 24 with a step input to pin 16	48	100	144	mV/ μ s
Width of clock coil drive pulses from pin 21 when clock amplitude is not being controlled (Note 3)	—	40	—	ns
Clock hangover measured at pin 18 as the time the clock coil continues ringing after the end of data (Note 4)	20	—	—	Clock Periods
Clock and data output voltages at pins 18 and 19 measured with 20 pF load capacitance; peak-to-peak value	—	5.5	—	V
Output rise and fall times at pins 18 and 19 into 20 pF loads	$t_r; t_f$	—	30	ns
Sandcastle input				
Sandcastle detector thresholds, pin 5				
Phase lock pulse (PL) on	2	—	—	V
Phase lock pulse off	—	—	3	V
Blanking pulse ($\overline{\text{CBB}}$) on	4.5	—	—	V
Blanking pulse off	—	—	5.5	V
Dual polarity sync buffer				
After hours sync ($\overline{\text{AHS}}$) pulse input pin 11				
Threshold for $\overline{\text{AHS}}$ active	1.0	—	—	V
Threshold for $\overline{\text{AHS}}$ off	—	—	2.0	V
Picture On (PO) input, pin 10				
Threshold for PO active	—	—	2.0	V
Threshold for PO off	1.0	—	—	V
Sync output, pin 12				
$\overline{\text{AHS}}$ output with pin 10 < 1 V (Note 5) peak-to-peak value	—	0.7	—	V
Composite sync output with pin 10 > 2 V (Notes 5 and 6); peak-to-peak value	—	0.7	1.0	V
Output current	—	—	3	mA
Line reset and signal presence detectors				
Schmitt trigger threshold on pin 2 to inhibit line reset output at pin 3 (syncs coincident)	—	6.2	—	V
Schmitt trigger threshold on pin 2 to permit line reset output at pin 3 (syncs non-coincident)	—	7.8	—	V
Line reset output V_{OL} ($I_3 = 20 \mu\text{A}$)	—	—	0.5	V
Line reset output V_{OH} ($-I_3 = 100 \mu\text{A}$)	2.4	—	—	V
Signal presence Schmitt trigger threshold on pin 2 below which the circuit accepts the input signal	—	6.0	—	V
Signal presence Schmitt trigger threshold on pin 2 above which the input signal is rejected.	—	6.3	—	V

Notes

1. This is measured with the dual polarity buffer external resistor connected to give negative-going syncs. The measurement is made after adjustment of the potential divider at pin 14 for optimum delay.
2. The teletext data input contains binary elements as a two level NRZ signal shaped by a raised cosine filter. The bit rate is 6.9375 M bit/s. The use of odd parity for the 8-bit bytes ensures that there are never more than 14-bit periods between each data transition.
3. This is measured by replacing the clock coil with a small value resistor.
4. This must be measured with the clock coil tuned and using a clock-cracker signal into pin 16. The clock-cracker is a teletext waveform consisting of only one data transition in each byte.
5. With the external resistor connected to the ground rail, syncs are positive-going centred on +2.3 V. With the resistor connected to the supply rail, syncs are negative-going centred on +9.7 V.
6. When the composite sync is being delivered, the level is substantially the same as that at the video input.

APPLICATION DATA

The function is quoted against the corresponding pin number

Pin No.

1. **Signal presence time constant**

A capacitor and a resistor connected in parallel between this pin and supply determine the delay in operation of the signal presence detector.

2. **Line reset time constant**

A capacitor between this pin and supply integrates current pulses from the coincidence detector; the resultant level is used to determine whether to allow FLR pulses (see pin 3).

3. **Fast line reset output (FLR)**

Positive-going sync pulses are produced at this output if the coincidence detector shows no coincidence between the syncs separated from the incoming video and the CBB waveform from the timing chain circuit SAA5020. These pulses are sent to the timing chain circuit and are used to reset its counters, so as to effect rapid lock-up of the phase locked loop.

4. **Ground (0 V)**

5. **Sandcastle input (\overline{PL} and \overline{CBB})**

This input accepts a sandcastle waveform which is formed from \overline{PL} and \overline{CBB} from the timing chain SAA5020. \overline{PL} is obtained by slicing the waveform at 2.5 V, and this, together with separated sync, are inputs to the phase detector which forms part of the phase locked loop. When the loop has locked up, the edges of \overline{PL} are nominally 2 μ s before and 2 μ s after the leading edge of separated line syncs.

\overline{CBB} is obtained by slicing the waveform at 5 V, and is used to prevent the data slicer being offset by the colour burst.

6. **6 MHz output (F6)**

This is the output of the crystal oscillator (see pins 8 and 9), and is taken to the timing chain circuit SAA5020 via a series capacitor.

7. **Phase detector time constant**

The integrating components for the phase detector of the phase locked loop are connected between this pin and supply.

APPLICATION DATA (continued)**8, 9. 6 MHz crystal**

A 6 MHz crystal in series with a trimmer capacitor is connected between these pins. It forms part of an oscillator whose frequency is controlled by the voltage on pin 7, which forms part of the phase locked loop.

10. Picture On input (PO)

The PO signal from the acquisition and control circuits SAA5040 Series is fed to this input and is used to determine whether the input video (pin 16) or the AHS waveform (pin 11) appears at pin 12.

11. After hours sync (AHS)

A composite sync waveform $\overline{\text{AHS}}$ is generated in the timing chain circuit SAA5020 and is used to synchronise the tv (see pin 10).

12. Sync output to tv

Either the input video or $\overline{\text{AHS}}$ is available at this output dependent on whether the PO signal is HIGH or LOW. In addition either signal may be positive-going or negative-going, dependent on whether the load resistor at this output is connected to ground or supply.

13. Field sync output (FS)

A pulse, derived from the input video by the field sync separator, which is used to reset the line counter in the timing chain circuit SAA5020.

14. Field sync separator timing

A capacitor and adjusting network is connected to this pin and forms the integrator of the field sync separator.

15. Sync separator capacitor

A capacitor connected to this pin forms part of the adaptive sync separator.

16. Composite video input (VI)

The composite video is fed to this input via a coupling capacitor.

17. Supply voltage (+12 V)**18. Clock output**

The regenerated clock, after extraction from the teletext data, is fed out to the acquisition and control circuits SAA5040 Series via a series capacitor.

19. Data output

The teletext data is sliced off the video waveform, squared up and latched within the SAA5030. The latched output is fed to the acquisition and control circuits SAA5040 Series via a series capacitor.

20. Clock decoupling

A 1 nF capacitor between pin 20 and ground is required for clock decoupling.

21. Clock regenerator coil

A high-Q parallel tuned circuit is connected between this pin and an external potential divider. The coil is part of the clock regeneration circuit (see pin 22).

APPLICATION DATA (continued)**22. Clock pulse timing capacitor**

Short pulses are derived from both edges of data with the aid of a capacitor connected to this pin. The resulting pulses are fed, as a current, into the clock coil connected to pin 21. Resulting oscillations are limited and taken to the acquisition and control circuits SAA5040 Series via pin 18.

23, 24 Peak detector capacitors

The teletext data is sliced with an automatic data slicer whose slicing level is the mid-point of two peak detectors working on the video signal. Storage capacitors are connected to these pins for the negative and positive peak detectors.

TELETEXT VIDEO PROCESSOR

SAA5030

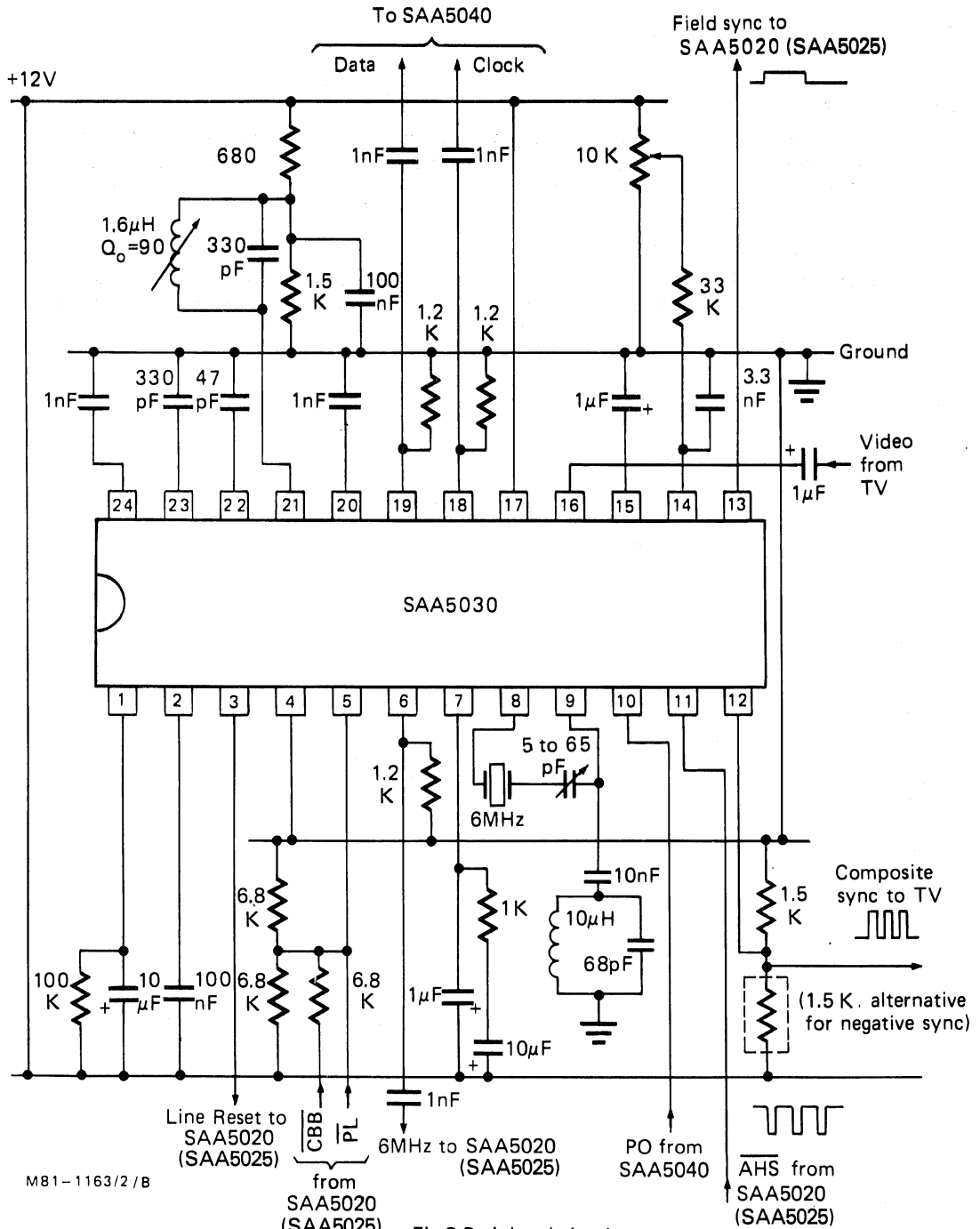

Fig.3 Peripheral circuit

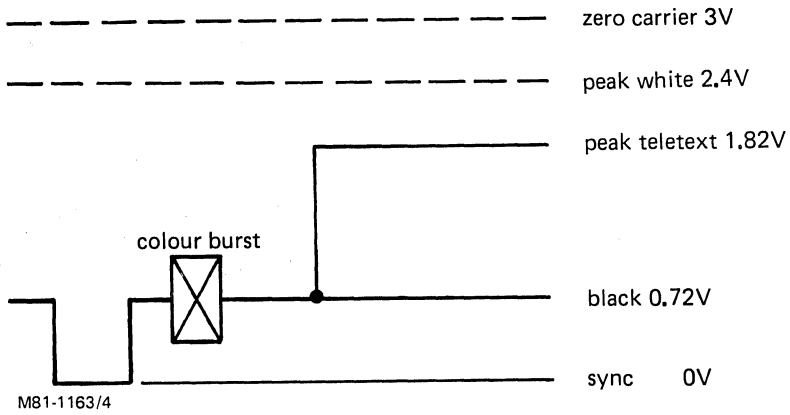

Fig.4 Part of teletext line, with burst showing nominal levels.

5

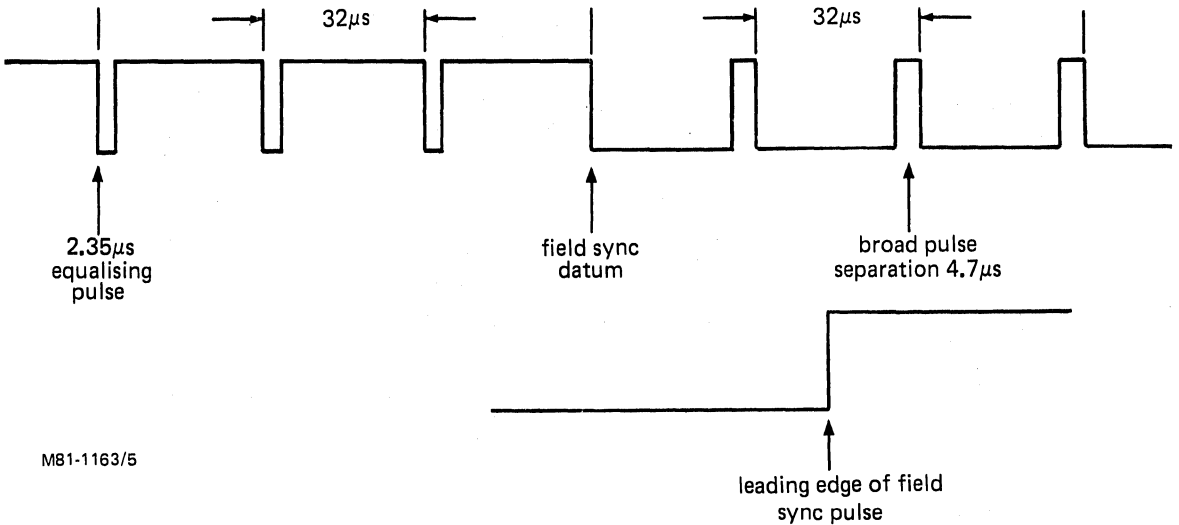

Fig.5 Detail of idealised composite sync waveform.

GENERAL

The SAA5040A, SAA5040B, SAA5040C, SAA5041, SAA5042 and SAA5043 form the SAA5040 series of MOS N-channel integrated circuits. They perform the control, data acquisition and data routing functions of the teletext system. The circuits differ in the on-screen display that is provided and in the decoding of the remote control commands. The functions of the circuits are detailed in Tables 1, 2 and 3; throughout the remainder of the data the SAA5040 is referred to when the complete series of the circuits is being described.

The SAA5040 is a 28-lead device which receives serial teletext data and clock signals from the remote control systems incorporating the SAA5012 or SAB3022, SAB3023 decoder circuits. The SAA5040 selects the required page information and feeds it in parallel form to the teletext page memory.

The SAA5040 works in conjunction with the SAA5020 timing chain and the SAA5050 series of character generators.

QUICK REFERENCE DATA

Supply voltage	V_{DD}	nom.	5	V
Supply current	I_{DD}	typ.	80	mA
Operating ambient temperature range	T_{amb}		-20 to +70	°C

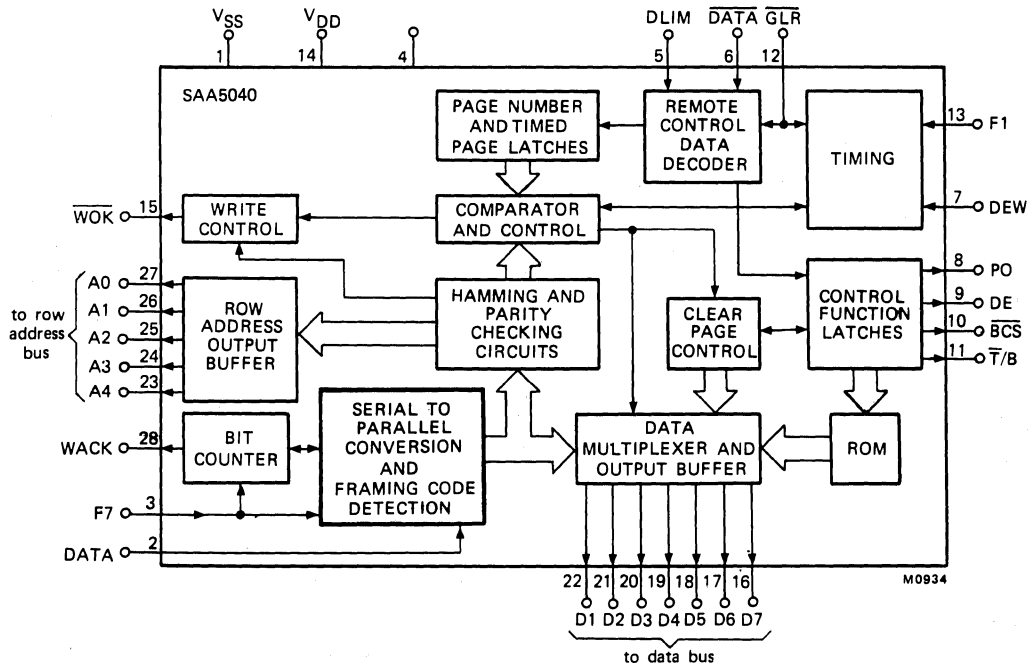

PACKAGE OUTLINE

28-lead DIL; plastic (SOT-117)

Fig.1 Block diagram.

PINNING

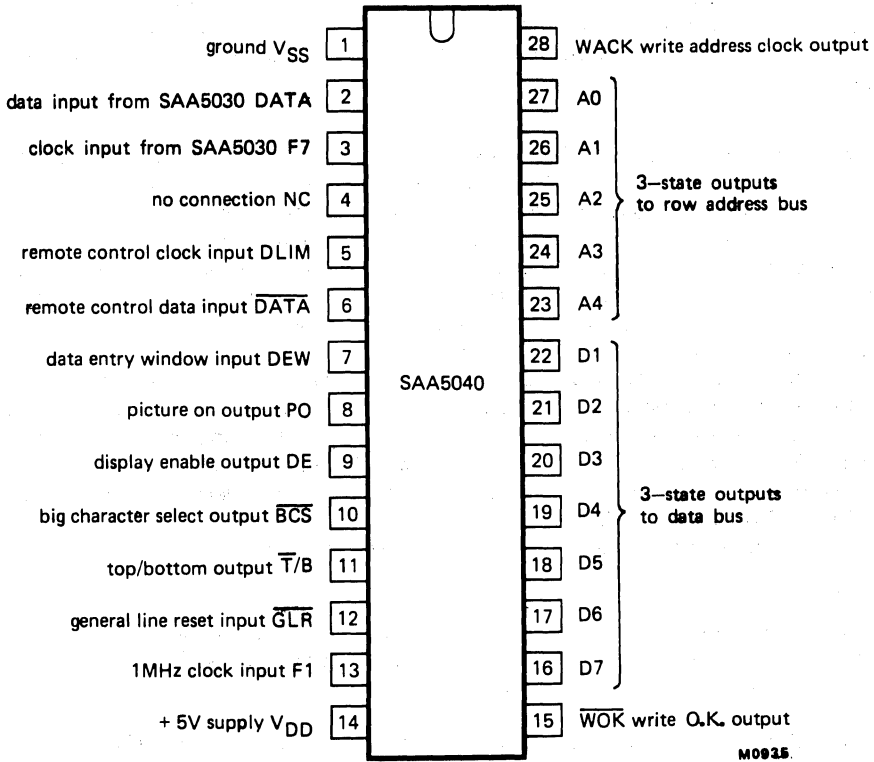

Fig.2 Pinning diagram.

DESCRIPTION

The circuit consists of two main sections.

a) Data acquisition section

The basic input to this section is the serial teletext data stream DATA from the SAA5030 video processor circuit. This data stream is clocked at a 6.9375 MHz clock rate (F7) from the SAA5030. The incoming data stream is processed and sorted so that the page of data selected by the user is written as 7-bit parallel words into the system memory. Hamming and parity checks are performed on the incoming data to reduce errors. Provision is also made to process the control bits in the page header.

b) Control section

The basic input to this section is the 7-bit serial data ($\overline{\text{DATA}}$) from the remote control decoder circuit such as the SAA5012 or SAB3012. This is clocked by the DLIM signal.

The remote control commands are decoded and the control functions are stored.

Full details of the remote control commands used in the various SAA5040 series options are given in Tables 1, 2 and 3 below. The control section also writes data into the page memory independently of the data acquisition section. This gives an on-screen display of certain user-selected functions such as page number and programme name.

The 3-state data and address outputs to the system memory are set to high impedance state if certain remote control commands are received (e.g. viewdata mode). This is to allow another circuit to access the memory using the same address and data lines. The address lines are also high impedance while the acquisition and control circuit is not writing into the memory.

Further information on the control of the complete teletext system is available.

The circuit is designed in accordance with the September 1976 Broadcast Teletext specification published by BBC/IBA/BREMA.

A typical circuit diagram of a teletext decoder is shown in Fig.7.

HANDLING

Inputs and outputs are protected against electrostatic charge in normal handling. However, to be totally safe, it is desirable to take normal precautions appropriate to handling MOS devices (see "Handling MOS devices").

RATINGS Limiting values in accordance with the Absolute Maximum System (IEC134).

Voltages (with respect to pin 1)

		min.	max.	
Supply voltage (pin 14)	V_{DD}	-0.3	7.5	V
Input voltage (all inputs)	V_I	-0.3	7.5	V
Output voltage (pin 8)	V_{O8}	-0.3	13.2	V
Output voltage (all other outputs)	V_O	-0.3	7.5	V

Temperatures

Storage temperature range	T_{stg}	-20 to +125	°C
Operating ambient temperature range	T_{amb}	-20 to +70	°C

CHARACTERISTICS

		min.	typ.	max.	
Supply voltage (pin 14)	V_{DD}	4.5	—	5.5	V

The following characteristics apply at $T_{amb} = 25\text{ }^{\circ}\text{C}$ and $V_{DD} = 5\text{ V}$ unless otherwise stated.

Supply current	I_{DD}	—	80	120	mA
----------------	----------	---	----	-----	----

Inputs

F7 DATA (pin 2), F7 CLOCK (pin 3)

Input voltage; HIGH	V_{IH}	3.5	—	5.5	V
Input voltage; LOW Note 1	V_{IL}	—	—	0.5	V
Rise time	t_r	—	—	30	ns
Fall time	t_f	—	—	30	ns
Input resistance (measured at 4 V)	R_I	2	—	18	$M\Omega$
Input capacitance	C_I	—	—	7	pF

F1 (pin 13)

Input voltage; HIGH	V_{IH}	2.4	—	V_{DD}	V
Input voltage; LOW	V_{IL}	0	—	0.6	V
Rise time	t_r	—	—	50	ns
Fall time	t_f	—	—	30	ns
Input capacitance	C_I	—	—	7	pF
Input leakage current ($V_I = 0$ to 5.5 V)	I_{IR}	—	—	10	μA

All other inputs

DLIM (pin 5), $\overline{\text{DATA}}$ (pin 6), $\overline{\text{DEW}}$ (pin 7), $\overline{\text{GLR}}$ (pin 12)

Input voltage; HIGH	V_{IH}	2.0	—	V_{DD}	V
Input voltage; LOW	V_{IL}	0	—	0.8	V
Input capacitance	C_I	—	—	7	pF
Input leakage current ($V_I = 0$ to 5.5 V)	I_{IR}	—	—	10	μA

Outputs

DE (pin 9), $\overline{\text{BCS}}$ (pin 10), $\overline{\text{T/B}}$ (pin 11) (with internal pull-up to V_{DD})

Output voltage; LOW ($I_{OL} = 400\text{ }\mu\text{A}$)	V_{OL}	0	—	0.5	V
Output voltage; HIGH $\left. \begin{array}{l} -I_{OH} = 50\text{ }\mu\text{A for pin 9} \\ -I_{OH} = 30\text{ }\mu\text{A for pin 10} \\ -I_{OH} = 20\text{ }\mu\text{A for pin 11} \end{array} \right\}$	V_{OH}	2.4	—	V_{DD}	V
Output voltage rise time	t_r	—	—	10	
Output voltage fall time	t_f	—	—	1	μs
Output capacitance	C_O	—	—	7	pF
Output current with output in HIGH state ($V_O = 0.5\text{ V}$)	$-I_O$	50	—	500	μA

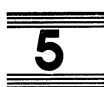

CHARACTERISTICS Continued

		min.	typ.	max.	
PO (pin 8) (with internal pull-up to V_{DD})					
Output voltage; LOW ($I_{OL} = 140 \mu A$)	V_{OL}	0	—	0.5	V
Output voltage; HIGH ($-I_{OH} = 50 \mu A$)	V_{OH}	2.4	—	V_{DD}	V
Output rise and fall time ($C_L = 40 \text{ pF}$) (Note 3)	t_r, t_f	—	—	10	μs
Output capacitance	C_O	—	—	7	pF
Output current with output in HIGH state ($V_O = 0.5 \text{ V}$)	$-I_O$	50	—	500	μA
D1 to D7 (pins 16 to 22) (3-state)					
Output voltage; LOW ($I_{OL} = 100 \mu A$)	V_{OL}	0	—	0.5	V
Output voltage; HIGH ($I_{OH} = -100 \mu A$)	V_{OH}	2.4	—	V_{DD}	V
Output rise and fall time ($C_L = 40 \text{ pF}$) (Note 3)	t_r, t_f	—	—	100	ns
Output leakage current in 'OFF' state ($V_O = 0 \text{ to } 5.5 \text{ V}$)	$\pm I_{ORoff}$	—	—	10	μA
Output capacitance	C_O	—	—	7	pF
WOK (pin 15) (3-state with internal pull-up to V_{DD})					
Output voltage; LOW ($I_{OL} = 400 \mu A$)	V_{OL}	0	—	0.5	V
Output voltage; HIGH ($-I_{OH} = 200 \mu A$)	V_{OH}	2.4	—	V_{DD}	V
Output voltage rise time } ($C_L = 80 \text{ pF}$) (Note 3)	t_r	—	—	50	ns
Output voltage fall time }	t_f	—	—	100	ns
Output current with 3-state 'OFF' ($V_O = 0.5 \text{ V}$)	$-I_{ORoff}$	80	—	500	μA
Output capacitance	C_O	—	—	7	pF
WACK (pin 28) (3-state)					
Output voltage; LOW ($I_{OL} = 1.6 \text{ mA}$)	V_{OL}	0	—	0.5	V
Output voltage; HIGH ($-I_{OH} = 100 \mu A$)	V_{OH}	2.4	—	V_{DD}	V
Output voltage rise time } ($C_L = 40 \text{ pF}$) (Note 3)	t_r	—	—	50	ns
Output voltage fall time }	t_f	—	—	300	ns
Output leakage current in 'OFF' state ($V_O = 0 \text{ to } 5.5 \text{ V}$)	$\pm I_{ORoff}$	—	—	10	μA
Output capacitance	C_O	—	—	7	pF
A0 to A2 (pins 25 to 27) (3-state)					
Output voltage; LOW ($I_{OL} = 200 \mu A$)	V_{OL}	0	—	0.5	V
Output voltage; HIGH ($-I_{OH} = 200 \mu A$)	V_{OH}	2.4	—	V_{DD}	V
Output rise and fall time ($C_L = 90 \text{ pF}$) (Note 3)	t_r, t_f	—	—	300	ns
Output leakage current in 'OFF' state ($V_O = 0 \text{ to } 5.5 \text{ V}$)	$\pm I_{ORoff}$	—	—	10	μA
Output capacitance	C_O	—	—	7	pF

TELETEXT ACQUISITION AND CONTROL CIRCUIT

SAA5040

CHARACTERISTICS (Continued)

Outputs

	min.	typ.	max.	
A3 and A4 (pins 23 and 24) (3-state)				
Output voltage; LOW ($I_{OL} = 1.6 \text{ mA}$)	V_{OL}	0	—	0.5 V
Output voltage; HIGH ($-I_{OH} = 200 \mu\text{A}$)	V_{OH}	2.4	—	V_{DD} V
Output rise and fall time ($C_L = 40 \text{ pF}$) (Note 3)	t_r, t_f	—	—	300 ns
Output leakage current in 'OFF' state ($V_O = 0$ to 5.5 V)	$+I_{ORoff}$	—	—	10 μA
Output capacitance	C_O	—	—	7 pF

TIMING CHARACTERISTICS

Teletext Data and Clock (F7 DATA + F7 CLOCK)
(Note 2 and Fig.3)

F7 Clock cycle time	TF7	144	—	—	ns
F7 Clock duty cycle (HIGH to LOW)		30	—	70	%
F7 Clock to data set-up time	tSU	—	60	—	ns
F7 Clock to data hold time	tHOLD	—	40	—	ns

Control DATA and Clock (DATA + DLIM)
(Note 3 and Fig.4)

DLIM Clock HIGH time	tCH	6.5	8	Note 4	μs
DLIM Clock LOW time	tCL	3.5	8	60	μs
DLIM to DATA set-up time	tSU	0	14	—	μs
DLIM to DATA hold time	tHOLD	8	14	—	μs

Writing Teletext data into memory during DEW
(Fig.5)

WACK cycle time	TWACK	1150	—	—	ns
WACK rising edge to WOK falling edge	tAWW	250	—	450	ns
WACK rising edge to WOK rising edge	tWRW	150	—	310	ns
WOK pulse width	tWPD	300	—	—	ns
Data output set-up time	tDW	330	—	—	ns
Data output hold time	tDH	0	—	—	ns
Row address set-up time before first WOK	tRAW	190	—	—	ns
Row address valid time after last WOK	tRWR	0	—	—	ns

5

TELETEXT ACQUISITION AND CONTROL CIRCUIT

SAA5040

TIMING CHARACTERISTICS

	min.	typ.	max.	
Writing Header information into memory during tv line 40 (Fig.6)				
This arrangement is a combined phasing of the SAA5040 and the SAA5020 and is therefore referred to F1 input. The first <u>WOK</u> is related to F1 No 14½ from the SAA5020				
F1 Clock cycle time	1000	—	—	ns
Time from F1 to <u>WOK</u> falling edge	t _{WF} 300	—	500	ns
Time from F1 to <u>WOK</u> rising edge	t _{FW} 0	—	120	ns
Data output set-up time	t _{DW} 330	—	—	ns
Data output hold time	t _{DH} 0	—	—	ns

Notes

1. These inputs may be a.c. coupled. Minimum rating is -0.3 V but the input may be taken more negative if a.c. coupled.
2. Transition times measured between 0.5 and 3.5 volt levels.
Delay times are measured from 1.5 V level.
3. Transition times measured between 0.8 and 2.0 volt levels.
Delay times are measured from 1.5 V level.
4. There is no maximum DLIM cycle time provided the DLIM duty cycle is such that t_{CLmax} requirement is not exceeded.

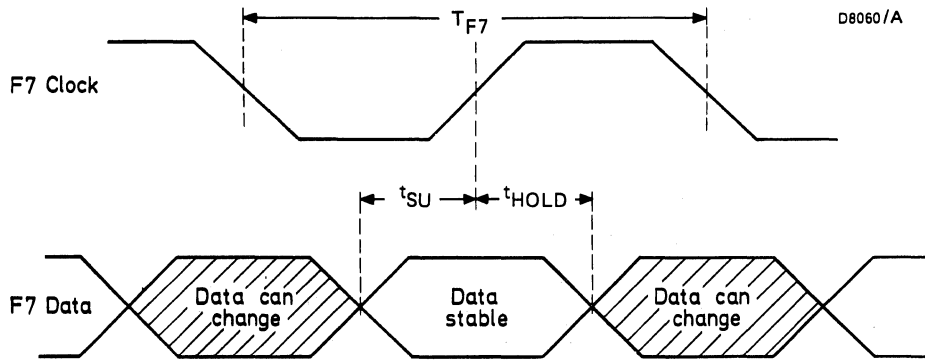

Fig.3 Teletext data timing

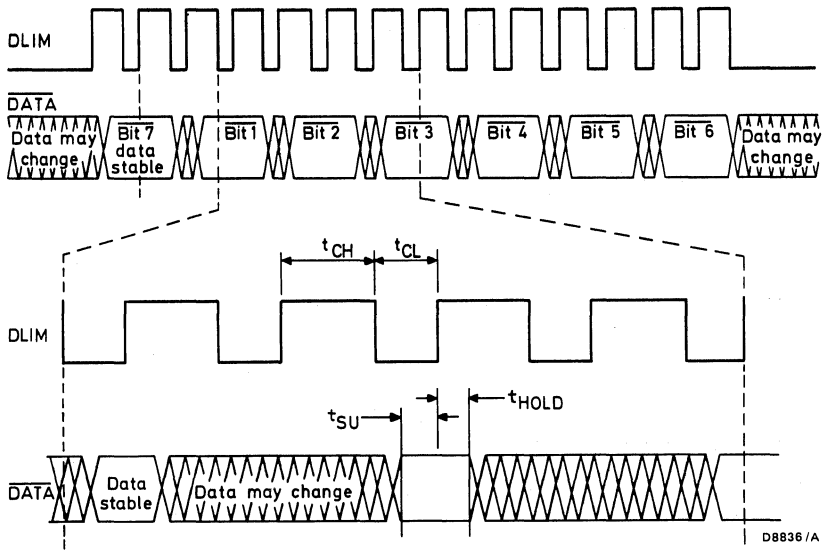
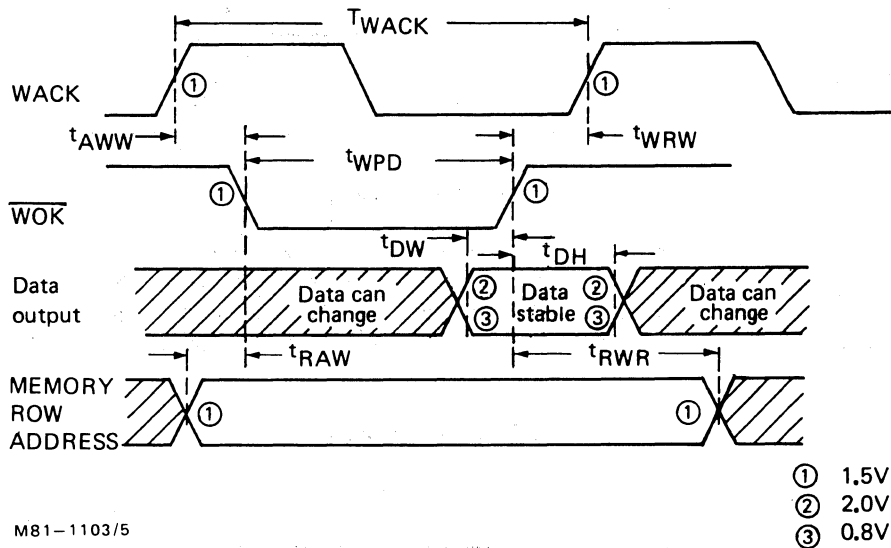
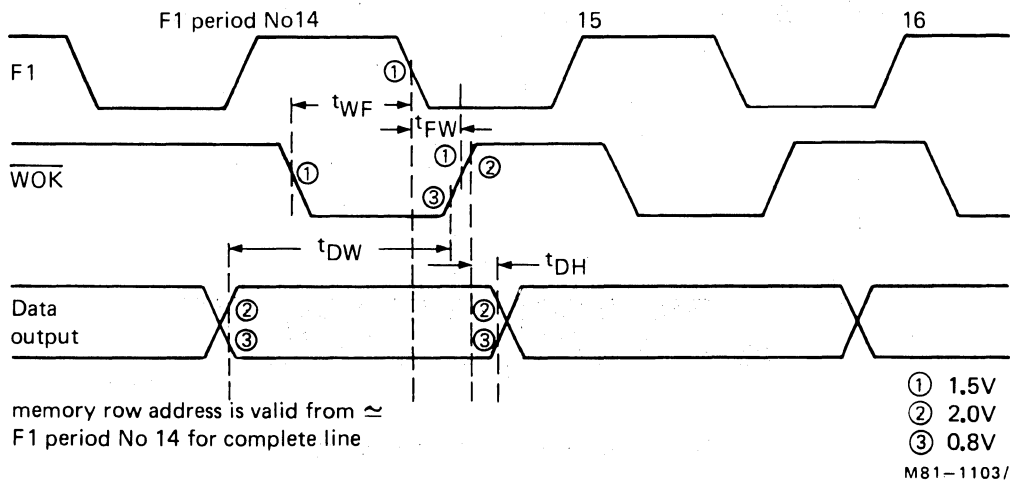

Fig.4 Remote control data input timing



M81-1103/5

Fig.5 Writing teletext data into memory during DEW



M81-1103/6

Fig.6 Writing data into memory during tv line 40

APPLICATION DATA

The function is quoted against the corresponding pin number

Pin No.

1. **V_{SS} Ground - 0 V**
2. **DATA Data input from SAA5030**
This input is a serial data stream of broadcast teletext data from the SAA5030 video processor, the data being at a rate of 6.9375 MHz.
This input from the SAA5030 is a.c. coupled with internal d.c. restoration of the signal levels.
3. **F7 Clock input from SAA5030**
This input is a 6.9375 MHz clock from the SAA5030 video processor which is used to clock the teletext data acquisition circuitry. The positive edge of this clock is nominally at the centre of each teletext data bit.
This input from the SAA5030 is a.c. coupled with internal d.c. restoration of the signal levels.
5. **DLIM Remote control clock input**
This input from the remote control receiver decoder is used to clock remote control data into the SAA5040. The positive-going edge of every second clock pulse is nominally in the centre of each remote control data bit.
6. **DATA Remote control data**
This input is a 7-bit serial data stream from the remote control receiver decoder.
This data contains the teletext and viewdata remote control user functions. The nominal data rate is 32 μ s/bit. The remote control commands used in the SAA5040 series are shown in Tables 1, 2 and 3.
7. **DEW Data entry window**
This input from the SAA5020 Timing Chain defines the period during which received teletext data may be accepted by the SAA5040. This signal is also used to enable the 5 memory address outputs (pins 23 to 27) and the 7-bit parallel data outputs (pins 16 to 22).
8. **PO Picture On**
This output to the SAA5012, SAA5030 and SAA5050 circuits is a static level used for the selection of tv picture video 'on' or 'off'. The output is HIGH for tv picture 'ON', LOW for tv picture 'OFF'. The output has an internal pull-up to V_{DD}.
9. **DE Display enable**
This output to the SAA5050 teletext character generator is used to enable the teletext display. The output is HIGH for display enabled, LOW for display disabled.
The output is also forced to the LOW state during the DEW and tv line 40 periods and when a teletext page is cleared.
The output has an internal pull-up to V_{DD}.
10. **BCS Big character select**
This output to the SAA5020 timing chain and to the SAA5050 character generator is used to select double height character format under user control. The output is HIGH for normal height characters, LOW for double height characters. It is also forced to the HIGH state on page clear.
The output has an internal pull-up to V_{DD}.
11. **T/B Top/bottom**
This output to the SAA5020 timing chain is used to select whether top or bottom half page is being viewed. The output is HIGH for bottom half page and LOW for top half page. It is also forced to the LOW state on page clear.
The output has an internal pull-up to V_{DD}.

APPLICATION DATA

12. **$\overline{\text{GLR}}$ General line reset**
This input from the SAA5020 timing chain is used as a reset signal for internal control and display counter.
13. **F1**
This input is a 1 MHz clock signal from the SAA5020 timing chain used to clock internal remote control processing and encoding circuits.
14. **V_{DD} +5 V Supply**
This is the power supply input to the circuit.
15. **$\overline{\text{WOK}}$ Write O.K.**
This 3-state output signal to the system memory is used to control the writing of valid data into the system memory. The signal is LOW to write, and is in the high impedance state when viewdata is selected. The three-state buffer is enabled at the same time as the data outputs (see below). An internal pull-up device prevents the output from floating into the LOW state when the 3-state buffer is OFF.
- 16, 17, 18, **D7 to D1, Data outputs**
19, 20, 21, These 3-state outputs are the seven bit parallel data outputs to the system memory. The
22 outputs are enabled at the following times:—
- During the data entry window (DEW) to write teletext data into the memory. The data rate is 867 kbytes per second and is derived from the teletext data clock.
 - During tv line 40 for encoded status information about user commands (e.g. programme number), to be written into the memory. This period is known as EDIL (encoded data insertion line). The data rate is 1 Mbyte per second and is derived from the 1 MHz display clock F1.
 - When the page is cleared. In this case the data output is forced to the space code (0100000) during the display period for one field. This data is held at the space code from either tv line 40 (if page clear is caused by user command), or the received teletext data line causing the clear function, until the start of the data entry window (DEW) of the next field.
- 23, 24, 25, **A4 to A0 Memory addresses**
26, 27 These 3-state outputs are the 5-bit row address to the page memory. This address specifies in which of 24 rows the teletext data is to be written. The outputs are enabled during the data entry period (DEW).
28. **WACK Write address clock**
This 3-state output is used to clock the memory address counter during the data entry period (DEW). The output is enabled only during this period. The positive-going edge of WACK is used to clock the address counter.

TELETEXT ACQUISITION AND CONTROL CIRCUIT

SAA5040

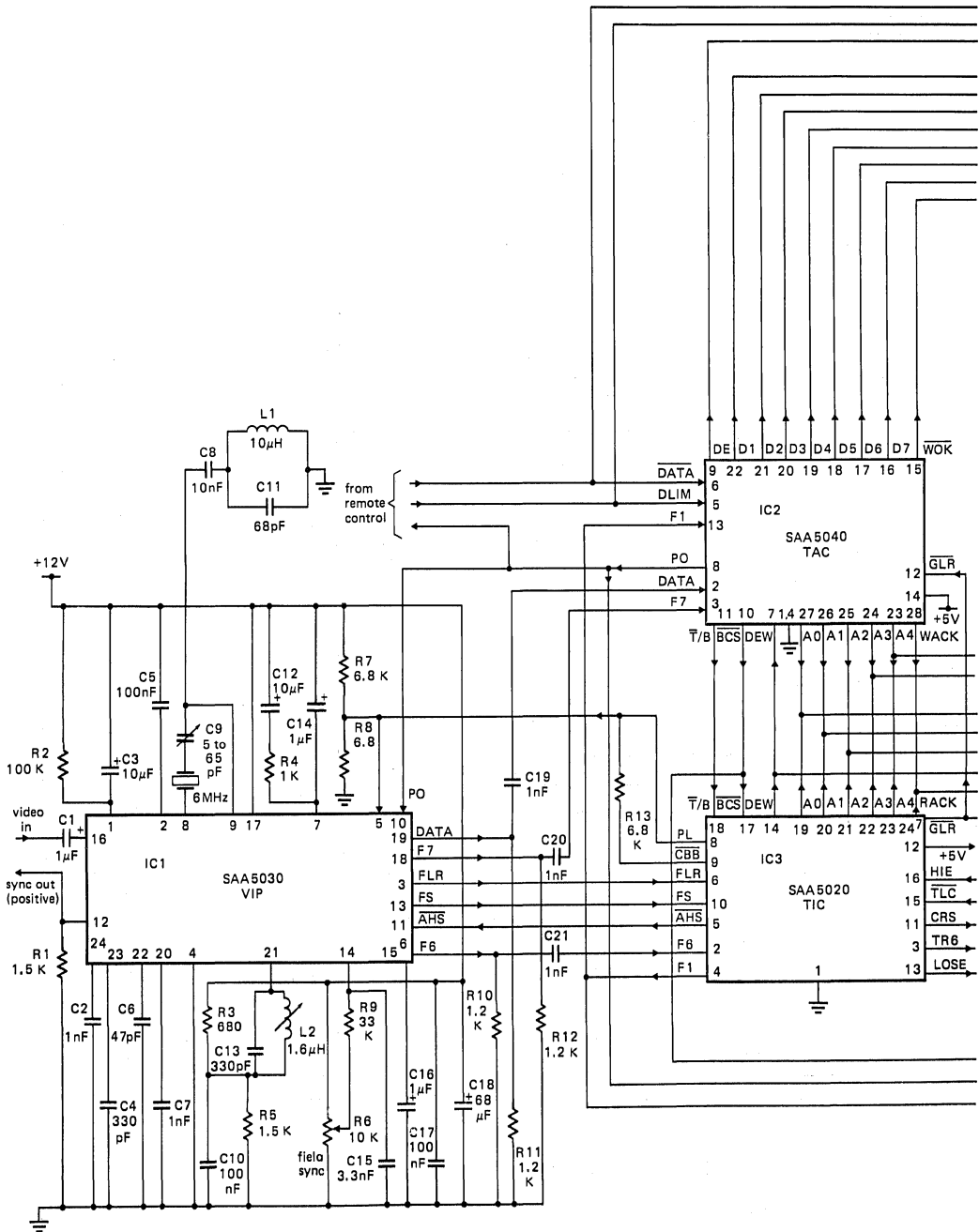

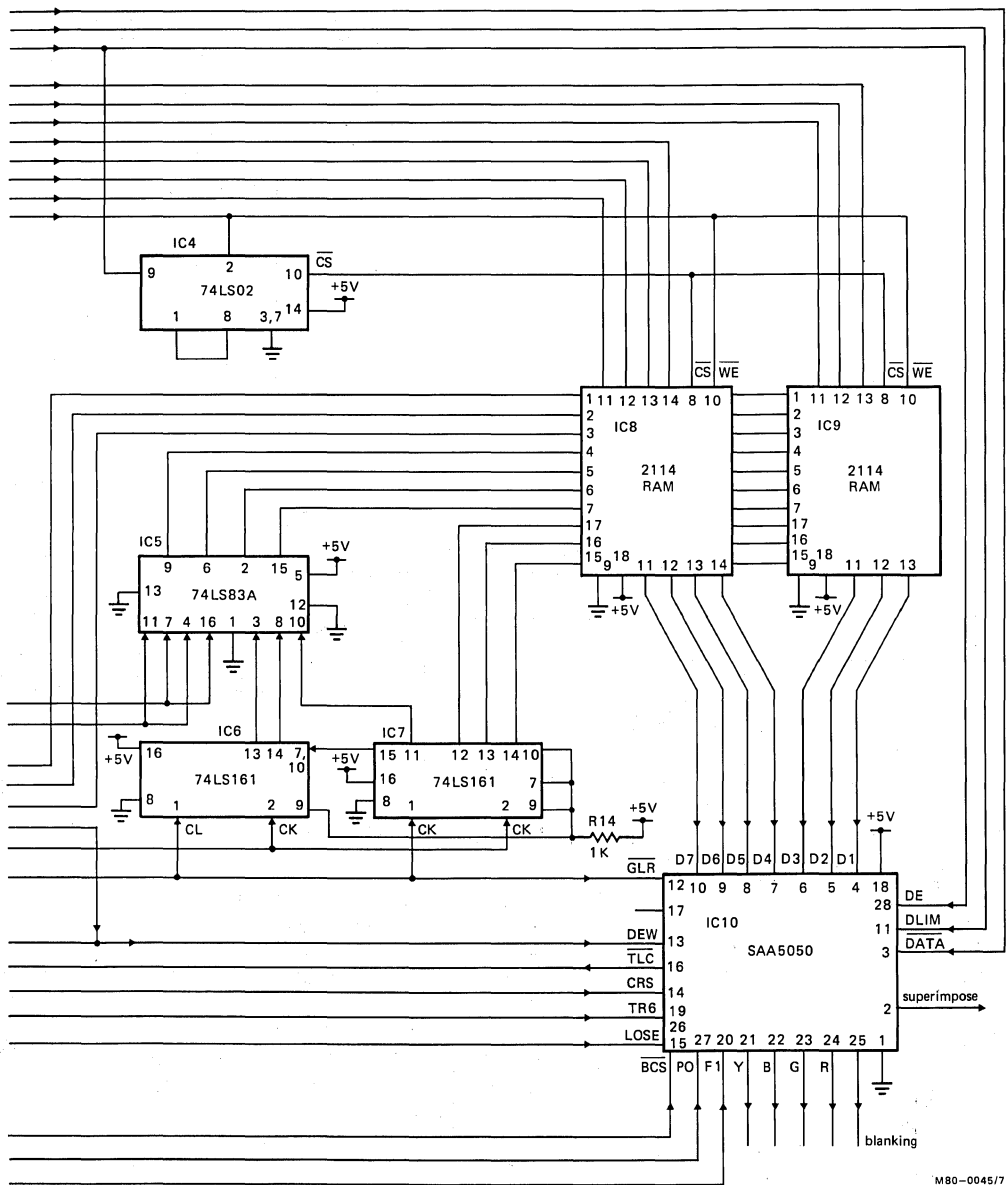

M80-0045/7

Fig.7 Typical circuit diagram of a teletext decoder.

TELETEXT ACQUISITION AND CONTROL CIRCUIT

SAA5040

TABLE 1 (Note 8)

Remote control commands used in the SAA5040A/SAA5040B/SAA5040C/SAA5043

CODE					TELEVISION MODE (b ₇ = b ₆ = 0) (Note 7)	TELETEXT MODE (b ₇ = 1, b ₆ = 0) (Note 7)
b ₅	b ₄	b ₃	b ₂	b ₁		
0	0	0	0	0	RESET (Note 1)	
0	0	0	0	1		
0	0	0	1	0		
0	0	0	1	1	TV/ON Gives programme display.	
0	0	1	0	0	STATUS Gives programme display.	STATUS Programme/header display (Note 6)
0	0	1	0	1		HOLD Stops reception of teletext. (Note 9)
0	0	1	1	0		
0	0	1	1	1	TIME Gives time display.	DISPLAY CANCEL (Note 3)
0	1	0	0	0		
0	1	0	0	1		
0	1	0	1	0		
0	1	0	1	1		
0	1	1	0	0		TAPE Resets to small characters.
0	1	1	0	1		
0	1	1	1	0		TIMED PAGE OFF
0	1	1	1	1		TIMED PAGE ON
1	0	0	0	0	PROGRAMMES (Note 2)	1 2 3 4 5 6 7 8
1	0	0	0	1		
1	0	0	1	0		
1	0	0	1	1		
1	0	1	0	0		
1	0	1	0	1		
1	0	1	1	0		
1	0	1	1	1		
1	1	0	0	0		9
1	1	0	0	1		0
1	1	0	1	0		SMALL CHARACTERS
1	1	0	1	1		LARGE CHARACTERS TOP HALF PAGE
1	1	1	0	0		LARGE CHARACTERS BOTTOM HALF PAGE
1	1	1	0	1		
1	1	1	1	0		SUPERIMPOSE (Note 6)
1	1	1	1	1		TELETEXT/ON (Note 5)

Notes for Table 1

1. Reset clears the page memory, sets page number to 100 and time code to 00.00 and resets timed page and display cancel modes.
2. Programme names are displayed for 5 s in a box at the top left of the screen in large characters. Programme commands clear the page memory except in timed page mode.

The following boxed information is displayed.

REMOTE CONTROL COMMAND b ₅ b ₄ b ₃ b ₂ b ₁	SAA5040A	SAA5040B	SAA5040C	SAA5043
1 0 0 0 0	BBC1		BBC1	Ch 1
1 0 0 0 1	BBC2		ITV	Ch 2
1 0 0 1 0	ITV		BBC2	Ch 3
1 0 0 1 1	4		BBC1	Ch 4
1 0 1 0 0	5	Gives no status box	ITV	Ch 5
1 0 1 0 1	6		VTR	Ch 6
1 0 1 1 0	7		BBC1	Ch 7
1 0 1 1 1	VCR		ITV	Ch 8
1 1 0 0 0	9		BBC2	Ch 9
1 1 0 0 1	10		BBC1	Ch 0
1 1 0 1 0	11		ITV	Ch 10
1 1 0 1 1	12		VTR	Ch 11

3. Display cancel removes the text and restores the television picture. The device then reacts to any update indicator on the selected page. An updated newflash or subtitle is displayed immediately. When an updated normal page arrives the page number only is displayed in a box at the top left of the screen. The full page of text can then be displayed when required using the teletext/on command.
4. Three number commands in sequence request a new page, and four number commands select a new time code in timed page mode. When a new page has been requested the page header turns green and the page numbers roll until the new page is captured.
5. The teletext/on command resets display cancel, hold and superimpose modes.
6. Status, timed page on, timed page off, numbers, superimpose and teletext/on commands all reset to top half page and produce a box round the header for 5 s. This allows the header to be seen if the television picture is on (e.g. newflash or display cancel modes).
7. In viewdata mode ($b_7 = b_6 = 1$) the device is disabled and teletext cannot be received. All 3-state outputs are high impedance.
8. Table 1 shows code required for functions specified. The device requires the inverse of these codes i.e. \bar{b}_7 to \bar{b}_1 . The code is transmitted serially in the following order: $\bar{b}_7, \bar{b}_1, \bar{b}_2, \bar{b}_3, \bar{b}_4, \bar{b}_5, \bar{b}_6$.
9. When hold node is selected 'HOLD' is displayed in green at the top right of the screen.
10. A 'P' is displayed before the page number at the top left of the screen (e.g. P123).

TELETEXT ACQUISITION AND CONTROL CIRCUIT

SAA5040

TABLE 2 (Note 9)

Remote control commands used in the SAA5041

CODE b ₅ b ₄ b ₃ b ₂ b ₁	TELEVISION MODE (b ₇ = b ₆ = 0) (Note 8)	TELETEXT MODE (b ₇ = 1, b ₆ = 0) (Note 8)
0 0 0 0 0 0 0 0 0 1 0 0 0 1 0 0 0 0 1 1 0 0 1 0 0 0 0 1 0 1 0 0 1 1 0 0 0 1 1 1	TIME Gives time display.	STATUS Gives header and time display. (Note 6) TIMED PAGE On/off toggle function.
0 1 0 0 0 0 1 0 0 1 0 1 0 1 0 0 1 0 1 1 0 1 1 0 0 0 1 1 0 1 0 1 1 1 0 0 1 1 1 1		TELETEXT RESET (Note 1)
1 0 0 0 0 1 0 0 0 1 1 0 0 1 0 1 0 0 1 1 1 0 1 0 0 1 0 1 0 1 1 0 1 1 0 1 0 1 1 1	PROGRAMMES (Note 10)	NUMBERS (Notes 2 and 7)
1 1 0 0 0 1 1 0 0 1 1 1 0 1 0 1 1 0 1 1 1 1 1 0 0 1 1 1 0 1 1 1 1 1 0 1 1 1 1 1		0 1 2 3 4 5 6 7 8 9 SMALL CHARACTERS LARGE CHARACTERS Top/bottom toggle function HOLD Stops reception of teletext - toggle function (Note 3) DISPLAY CANCEL (Note 4) SUPERIMPOSE NORMAL DISPLAY (Note 5)

5

Notes for Table 2

1. The teletext reset command clears the page memory, selects Page 100, goes to small characters and resets hold, timed page and display cancel modes.
2. Three number commands in sequence request a new page, and four number commands select a new time code in timed page mode. When a new page has been requested the page header turns green and the page numbers roll until the new page is captured.
3. When hold mode is selected 'HALT' is displayed in green at the top right of the screen.
4. Display cancel removes the text and restores the television picture. The SAA5041 then reacts to any update indicator on the selected page. An updated newflash or subtitle is displayed immediately. When an updated normal page arrives the page number only is displayed in a box at the top left of the screen. The full page of text can then be displayed when required using the normal display command.
5. The normal display command resets display cancel, hold and superimpose modes.
6. Status, timed page, numbers, hold, superimpose and normal display commands all reset to top half page and produce a box round the header for five seconds. This allows the header to be seen even if the television picture is on (e.g. newflash or display cancel modes).
7. An 'S' is displayed before the page number at the top left of the screen (e.g. S123).
8. In viewdata mode ($b_7 = b_6 = 1$) the SAA5041 is disabled and teletext cannot be received. All 3-state outputs are high impedance.
9. Table 2 shows code required for functions specified. The SAA5041 requires the inverse of these codes i.e. \bar{b}_7 to \bar{b}_1 . The code is transmitted serially in the following order: $\bar{b}_7, \bar{b}_1, \bar{b}_2, \bar{b}_3, \bar{b}_4, \bar{b}_5, b_6$.
10. Clear Memory occurs except in Timed Page Mode.

TELETEXT ACQUISITION AND CONTROL CIRCUIT

SAA5040

TABLE 3 (Note 9)

Remote control commands used in the SAA5042

CODE b ₅ b ₄ b ₃ b ₂ b ₁	TELEVISION MODE (b ₇ = b ₆ = 0) (Note 8)	TELETEXT MODE (b ₇ = 1, b ₆ = 0) (Note 8)
0 0 0 0 0	RESET (Note 1)	STATUS Gives header and time display. (Note 6) HOLD Stops reception of teletext - toggle function (Note 3)
0 0 0 0 1		
0 0 0 1 0		
0 0 0 1 1		
0 0 1 0 0		
0 0 1 0 1		
0 0 1 1 0		
0 0 1 1 1		
0 1 0 0 0		SMALL CHARACTERS LARGE CHARACTERS TOP HALF PAGE LARGE CHARACTERS BOTTOM HALF PAGE DISPLAY CANCEL/RECALL (Note 4) DISPLAY RECALL
0 1 0 0 1		
0 1 0 1 0		
0 1 0 1 1		
0 1 1 0 0		
0 1 1 0 1		
0 1 1 1 0		
0 1 1 1 1		
1 0 0 0 0	PROGRAMMES (Note 10)	NUMBERS (Notes 2 and 7)
1 0 0 0 1		
1 0 0 1 0		
1 0 0 1 1		
1 0 1 0 0		
1 0 1 0 1		
1 0 1 1 0		
1 0 1 1 1		
1 1 0 0 0		TIMED PAGE On/Off toggle function CLEAR MEMORY LONG TERM STORE/SMALL CHARACTERS SUPERIMPOSE TELETEXT/ON (Note 5)
1 1 0 0 1		
1 1 0 1 0		
1 1 0 1 1		
1 1 1 0 0		
1 1 1 0 1		
1 1 1 1 0		
1 1 1 1 1		

Notes for Table 3

1. Reset clears the page memory, sets page number to 100 and time code to 00.00 and resets timed page and display cancel modes.
2. Three number commands in sequence request a new page, and four number commands select a new time code in timed page mode. When a new page has been requested the page header turns green and the page numbers roll until the new page is captured.
3. When hold mode is selected 'STOP' is displayed in green at the top right of the screen.
4. Display cancel/recall removes the text and restores the television picture. The SAA5042 then reacts to any update indicator on the selected page. An updated newflash or subtitle is displayed immediately. When an updated normal page arrives the page number only is displayed in a box at the top left of the screen. The same command will then cause a normal page to be displayed, but will cancel a newflash or subtitle page. Alternatively, text can be recalled by using the teletext/on command.
5. The teletext/on command resets display cancel, hold and superimpose modes.
6. Status, timed page, numbers, superimpose and teletext/on commands all reset to top half page and produce a box round the header for five seconds. This allows the header to be seen even if the television picture is on (e.g. newflash or display cancel modes).
7. A 'P' is displayed before the page number at the top left of the screen (e.g. P123).
8. In viewdata mode ($b_7 = b_6 = 1$) the SAA5042 is disabled and teletext cannot be received. All 3-state outputs are high impedance.
9. Table 3 shows code required for functions specified. The SAA5042 requires the inverse of these codes i.e. \bar{b}_7 to \bar{b}_1 . The code is transmitted serially in the following order: \bar{b}_7 , \bar{b}_1 , \bar{b}_2 , \bar{b}_3 , \bar{b}_4 , \bar{b}_5 , \bar{b}_6 .
10. Clear Memory occurs except in Timed Page Mode.

TELETEXT CHARACTER GENERATOR

SAA5050/55

The SAA5050 series of MOS N-channel integrated circuits provides the video drive signals to the television receiver necessary to produce the teletext/viewdata display. The variants are described in the Quick Reference Data and full details of the characters sets are given in Figs. 11 to 18.

QUICK REFERENCE DATA

Supply voltage	V_{DD}	nom.	5	V
Supply current	I_{DD}	typ.	85	mA
Operating ambient temperature range	T_{amb}		-20 to +70	°C

Variant	Character set	Variant	Character set
5050	English	5054	Belgian
5051	German	5055	US ASCII
5052	Swedish	5056	Hebrew
5053	Italian	5057	Cyrillic

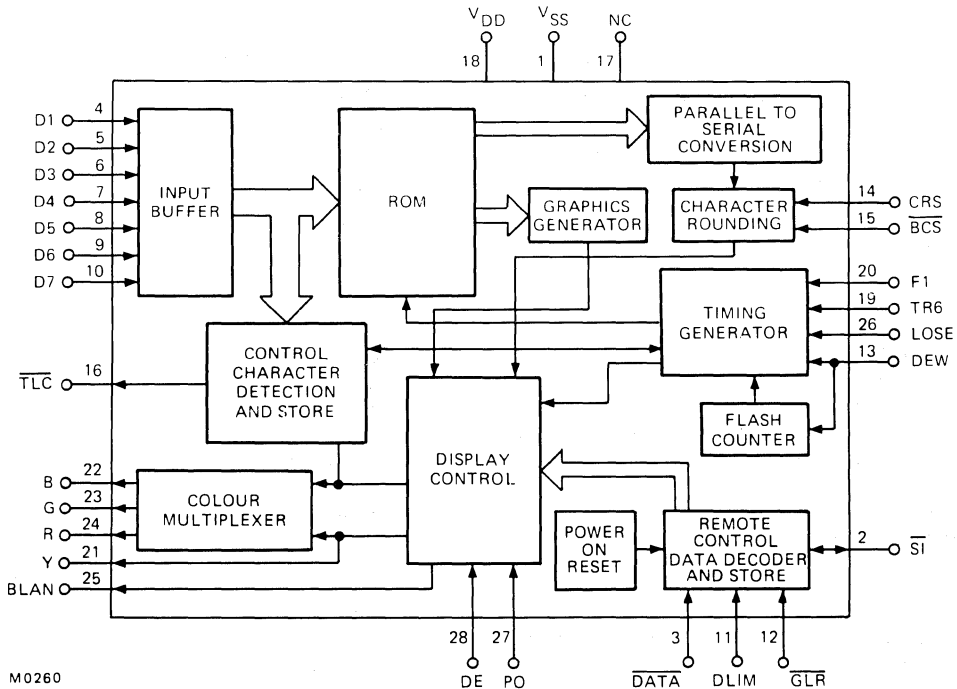
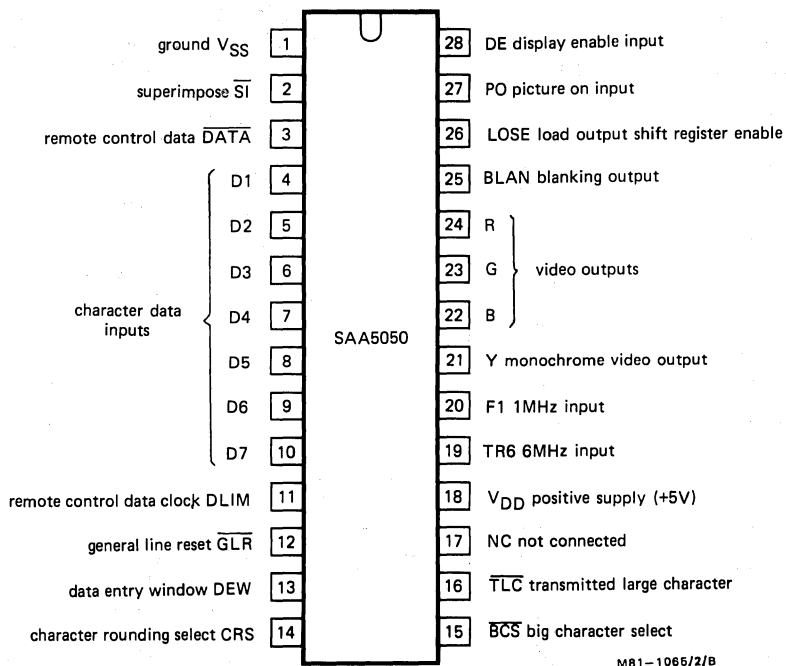

Fig.1 Block diagram

PACKAGE OUTLINE

28-lead DIL; plastic (SOT-117).



M81-1066/2/B

Fig.2 Pinning diagram

DESCRIPTION

The SAA5050 is a 28 pin device which incorporates a fast access character generator ROM (4.3 k bits), the logic decoding for all the teletext control characters and decoding for some of the remote control functions. The circuit generates 96 alphanumeric and 64 graphic characters. In addition there are 32 control characters which determine the nature of the display.

The SAA5050 is suitable for direct connection to the SAA5010, SAA5012, SAA5020 and SAA5040 Series integrated circuits.

The basic input to the SAA5050 is the character data from the teletext page memory. This is a 7 bit code. Each character code defines a dot matrix pattern. The character period is 1 μ s and the character dot rate is 6 MHz. The timings are derived from the two external input clocks F1 (1 MHz) and TR6 (6 MHz) which are amplified and re-synchronised internally. Each character rectangle is 6 dots wide by 10 TV lines high. One dot space is left between adjacent characters, and there is one line space left between rows. Alphanumeric characters are generated on a 5 x 9 matrix, allowing space for descending characters. Each of the 64 graphic characters is decoded to form a 2 x 3 block arrangement which occupies the complete 6 x 10 dot matrix (Fig.9). Graphics characters may be either contiguous or separated (Fig.10). The alphanumeric characters are character rounded, i.e. a half dot is inserted before or after a whole dot in the presence of a diagonal in a character matrix.

The character video output signals comprise a monochrome signal and RGB signals for a colour receiver. A blanking output signal is provided to blank out the television video signal under the control of the PO and DE inputs and the box control characters (see Table 3).

The monochrome data signal can be used to inlay characters into the television video. The use of the 32 control characters provides information on the nature of the display, e.g. colour. These are also used to provide other facilities such as 'concealed display' and flashing words etc. The full character set is given in Table 1.

TELETEXT CHARACTER GENERATOR

SAA5050/55

HANDLING

Inputs and outputs are protected against electrostatic charge in normal handling. However, to be totally safe, it is desirable to take normal precautions appropriate to handling MOS devices (See 'Handling MOS Devices').

RATINGS Limiting values in accordance with the Absolute Maximum System, (IEC134)

		min.	typ.	max.	
Voltages (with respect to pin 1)					
Supply voltage (pin 18)	V_{DD}	-0.3	—	7.5	V
Input voltages (all inputs + input/output)	V_I	-0.3	—	7.5	V
Output voltage (pin 16)	V_{O16}	-0.3	—	7.5	V
(all other outputs)	V_O	-0.3	—	14.0	V
Temperature					
Storage temperature range	T_{stg}		-20 to +125		°C
Operating ambient temperature range	T_{amb}		-20 to +70		°C

CHARACTERISTICS

		min.	typ.	max.	
Supply voltage (pin 18)	V_{DD}	4.5	—	5.5	V
The following parameters apply at $T_{amb} = 25^\circ\text{C}$ and $V_{DD} = 5\text{ V}$ unless otherwise stated.					
Supply current	I_{DD}	—	85	160	mA

*Inputs***Character data D1 to D7** (pins 4 to 10)

Input voltage; HIGH	V_{IH}	2.65	—	V_{DD}	V
Input voltage; LOW	V_{IL}	0	—	0.6	V

Clock inputs F1 (pin 20) **TR6** (pin 19)

Input voltage; HIGH	V_{IH}	2.65	—	V_{DD}	V
Input voltage; LOW	V_{IL}	0	—	0.6	V

Logic inputs

DATA (pin 3)	DEW (pin 13)	LOSE (pin 26)
DLIM (pin 11)	CRS (pin 14)	PO (pin 27)
$\overline{\text{GLR}}$ (pin 12)	$\overline{\text{BCS}}$ (pin 15)	DE (pin 28)

Input voltage; HIGH	V_{IH}	2.0	—	V_{DD}	V
Input voltage; LOW	V_{IL}	0	—	0.8	V

All inputs

Input leakage current ($V_I = 5.5\text{ V}$)	I_{IR}	—	—	10	μA
Input capacitance	C_I	—	—	7	pF

TELETEXT CHARACTER GENERATOR

SAA5050/55

CHARACTERISTICS (continued)

		min.	typ.	max.		
<i>Outputs</i>						
Character video outputs + Blanking output (open drain) (note 3)						
B – (pin 22), G – (pin 23), R – (pin 24), Y – (pin 21), Blanking (pin 25)						
Output voltage; LOW ($I_{OL} = 2 \text{ mA}$)	V_{OL}	–	–	0.5	V	
Output voltage; LOW ($I_{OL} = 4 \text{ mA}$)	V_{OL}	–	–	1.0	V	
Output voltage; LOW ($I_{OL} = 6 \text{ mA}$)	V_{OL}	–	–	2.0	V	
Output voltage; HIGH (note 5)	V_{OH}	V_{DD}	–	13.2	V	
Output load capacitance	C_L	–	–	15	pF	
Output fall time	} note 1 t_f	–	–	30	ns	
Variation of fall time between any outputs		Δt_f	0	–	20	ns
$\overline{\text{TLC}}$ (pin 16)						
Output voltage; LOW ($I_{OL} = 100 \mu\text{A}$)	V_{OL}	0	–	0.5	V	
Output voltage; HIGH ($-I_{OH} = 100 \mu\text{A}$)	V_{OH}	2.4	–	V_{DD}	V	
Output load capacitance	C_L	–	–	30	pF	
Output rise time	} Measured between 0.8 V and 2.0 V levels	t_r	–	–	1.0	μs
Output fall time						
<i>Input/output</i>						
$\overline{\text{SI}}$ (pin 2) (open drain)						
Input voltage; HIGH	V_{IH}	2.0	–	6.5	V	
Input voltage; LOW	V_{IL}	0	–	0.8	V	
Input leakage current ($V_I = 5.5 \text{ V}$)	I_{IR}	–	–	10	μA	
Input capacitance	C_I	–	–	7	pF	
Output voltage; LOW ($I_{OL} = 0.4 \text{ mA}$)	V_{OL}	0	–	0.5	V	
Output voltage; LOW ($I_{OL} = 1.3 \text{ mA}$)	V_{OL}	0	–	1.0	V	
Output load capacitance	C_L	–	–	45	pF	
Output voltage; HIGH state (note 2)	V_{OH}	–	–	6.5	V	

Timing characteristics

For typical display of 40 characters per line. Line rate = 64 μ s. Field rate = 20 ms.

Character data timing (Fig.4)

		min.	typ.	max.	
TR6 rising edge to F1 falling edge	t _D	6	—	60	ns
TR6 frequency	f _{TR6}	—	6	—	MHz
TR6 mark/space ratio		40:60	—	60:40	
F1 frequency	f _{F1}	—	1	—	MHz
F1 mark/space ratio		40:60	—	60:40	
Data set-up time	t _{CDS}	80	—	—	ns
Data hold time	t _{CDH}	100	—	—	ns
Delay time — character in/ character data at outputs	Graphics t _{CDG}	—	2.6	—	μ s
	Alphanumerics t _{CDA}	—	2.767	—	μ s

Display period timing (Fig.5)

F1 falling edge to LOSE rising edge	t _{LDH}	0	—	250	ns
F1 falling edge to LOSE falling edge	t _{LDL}	0	—	250	ns
LOSE rising edge to 'Display on'	t _{DON}	—	2.6	—	μ s
LOSE falling edge to 'Display off'	t _{DOFF}	—	2.6	—	μ s
'Display period'	t _{DP}	—	40	—	μ s

Line rate timing (Fig.6)

F1 rising edge to GLR falling edge	t _{DGL}	0	—	200	ns
F1 rising edge to GLR rising edge	t _{DGH}	0	—	200	ns
GLR LOW time	t _{GLP}	—	1	—	μ s
Line start* to GLR falling edge	t _{GLR}	—	5	—	μ s
Line start* to LOSE rising edge	t _{L_{SL}}	—	14.5	—	μ s
LOSE falling edge to Line start*	t _{L_{LS}}	—	9.5	—	μ s
Line period	t _{LNP}	—	64	—	μ s
LOSE HIGH time	t _{LHP}	—	40	—	μ s

Remote data input timing (Fig.8)

Assuming F1 period = 1 μ s and GLR period = 64 μ s

DLIM clock HIGH time	t _{CH}	6.5	8	(note 4)	μ s
DLIM clock LOW time	t _{CL}	3.5	8	60	μ s
DATA to DLIM set-up time	t _{DS}	0	14	—	μ s
DLIM to DATA hold time	t _{DH}	8	14	—	μ s

*Taken as falling edge of 'line sync' pulse.

Notes to characteristics

1. Fall time, t_f and Δt_f , are defined as shown and are measured using the circuit shown below:
 t_f is measured between the 9 V and 1 V levels.
 Δt_f is the maximum time difference between outputs.

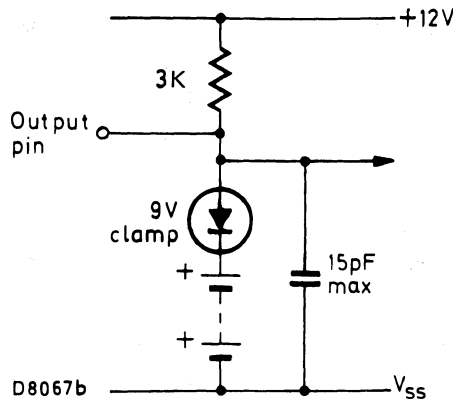
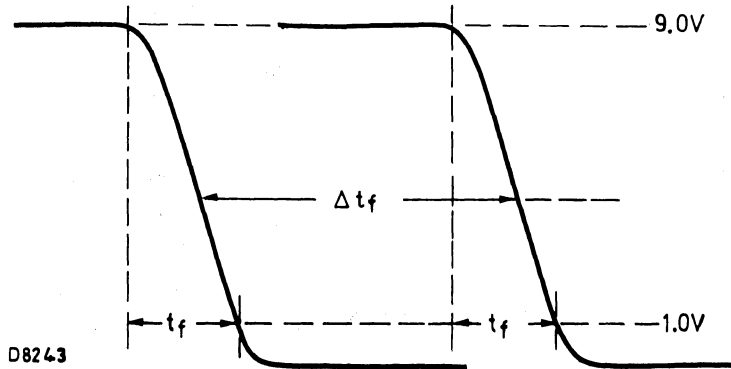

Fig.3

2. Recommended pull-up resistor for \overline{SI} is 18 k Ω .
3. The R, G, B, Y and blanking outputs are protected against short circuit to supply rails.
4. There is no maximum DLIM cycle time, provided the DLIM duty cycle is such that the t_{CL} max requirement is not exceeded.
5. With maximum pull-up voltage applied to R, G, B and BLAN outputs the leakage current will not exceed 20 μ A with the outputs in the OFF state.

SPECIAL FEATURES

Flash oscillator

The circuit generates a 0.75 Hz signal with a 3:1 ON/OFF ratio to provide the flashing character facility.

Power-on-reset

When the supply voltage is switched on, the character generator will reset to tv, conceal, and not superimpose modes.

Character rounding

The character rounding function is different for the small and double height characters. In both cases the ROM is accessed twice during the character period of $1 \mu\text{s}$. The dot information of two rows is then compared to detect the presence of any diagonal in the character matrix and to determine the positioning of the character rounding half dots.

For small characters rounding is always referenced in the same direction (i.e. row before in even fields and row after in odd fields as determined by the CRS signal).

For double height characters rounding is always referenced alternately up and down changing every line using an internally generated signal. (The CRS signal is '0' for the odd field and '1' for the even field of an interlaced tv picture).

Graphics decoder

The 64 graphics characters are decoded directly from the character data inputs and they appear on a 2×3 matrix. Figure 9 gives details of the graphics decoding.

APPLICATION DATA

The function is quoted against the corresponding pin numbers

Pin No.

1. **V_{SS} Ground - 0 V**
2. **\overline{S} Superimpose**

This is a dual purpose input/output pin. The output is an open drain transistor (capable of sinking current to V_{SS}), which is in the conducting state when superimpose mode is selected. This allows contrast reduction of the tv picture in superimpose mode if required. If the pin is held LOW, the internal 'tv mode' flip-flop is held in the 'text' state. This is for VDU applications when the remote control is not used.

3. **\overline{DATA} Remote control data**

This input accepts a 7-bit serial data stream from the remote control decoder. This data contains the teletext and viewdata remote control functions. The nominal data rate is $32 \mu\text{s/bit}$. The command codes used in the SAA5050 are shown in Table 2.

- 4,5,6 **D1 to D7 Character data**

7,8,9,
10

These inputs accept a 7-bit parallel data code from the page memory. This data selects the alphanumeric characters, the graphics characters and the control characters. The alphanumeric addresses are ROM column addresses, the graphics and control data are decoded internally.

11. **DLIM**

This input receives a clock signal from the remote control decoder and this signal is used to clock remote control data into the SAA5050. The positive-going edge of every second clock pulse is nominally in the centre of each remote control data bit (Fig.8).

12. **GLR General line reset**

This input signal from the SAA5020 Timing Chain is required for internal synchronisation of remote control data signals.

13. **DEW Data entry window**

This input signal from the SAA5020 Timing Chain is required to reset the internal ROM row address counter prior to the display period. It is also used internally to derive the 'flash' period.

APPLICATION DATA (continued)

14. **CRS Character rounding select**
This input signal from the SAA5020 Timing Chain is required for correct character rounding of displayed characters. (Normal height characters only).
15. **BCS Big character select**
This input from the SAA5040 Teletext Acquisition and Control device allows selection of large characters by remote control.
16. **TLC Transmitted large characters**
This output to the SAA5020 Timing Chain enables double height characters to be displayed as a result of control characters stored in the page memory.
18. **V_{DD} + 5 V supply**
This is the power supply input to the circuit.
19. **TR6**
This input is a 6 MHz signal from the SAA5020 Timing Chain used as a character dot rate clock.
20. **F1**
This input is a 1 MHz equal mark/space ratio signal from the SAA5020 Timing Chain. It is used to latch the 7-bit parallel character data into the input latches. It is also used to synchronise an internal divide-by 6 counter. The F1 signal is internally synchronised with TR6.
21. **Y Output**
This is a video output signal which is active in the HIGH state containing character dot information for tv display.
The output is an open drain transistor capable of sinking current to V_{SS}.
- 22,23, 24. **B,G,R outputs**
These are the Blue, Green and Red Character video outputs to the tv display circuits. They are active HIGH and contain both character and background colour information.
The outputs are open drain transistors capable of sinking current to V_{SS}.
25. **BLAN Blanking**
This active HIGH output signal provides tv picture video blanking. It is active for the duration of a box when Picture On and Display Enable are HIGH. It is also activated permanently for normal teletext display when no tv picture is required (PO LOW). The output is an open drain transistor capable of sinking current to V_{SS}. Full details given in Table 3.
26. **LOSE Load output shift register enable**
This input signal from the SAA5020 Timing Chain resets the internal control character flip-flops prior to the start of each display line.
This signal also defines the character display period.
27. **PO Picture On**
This input signal from the SAA5040 Teletext Acquisition and Control device is used to control the character video and blanking outputs. When PO is HIGH, only text in boxes is displayed unless in superimpose mode. The input is HIGH for tv picture video on, LOW for picture off. See Table 3.
28. **DE Display enable**
This input signal from the SAA5040 Teletext Acquisition and Control device is used to enable the teletext display. The input is HIGH for teletext display enabled. LOW for display cancelled. See Table 3.

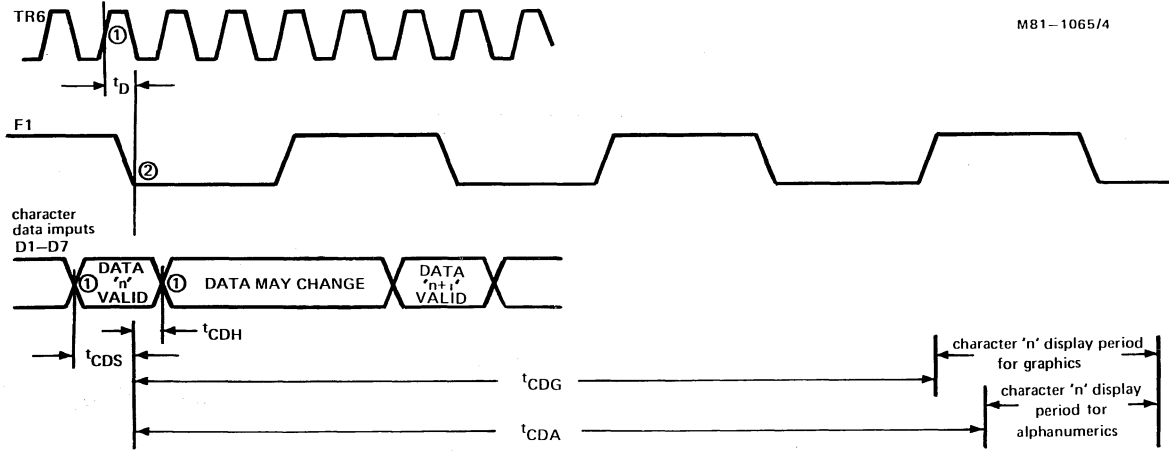

Fig.4 Character data timing (for typical 40 character display)

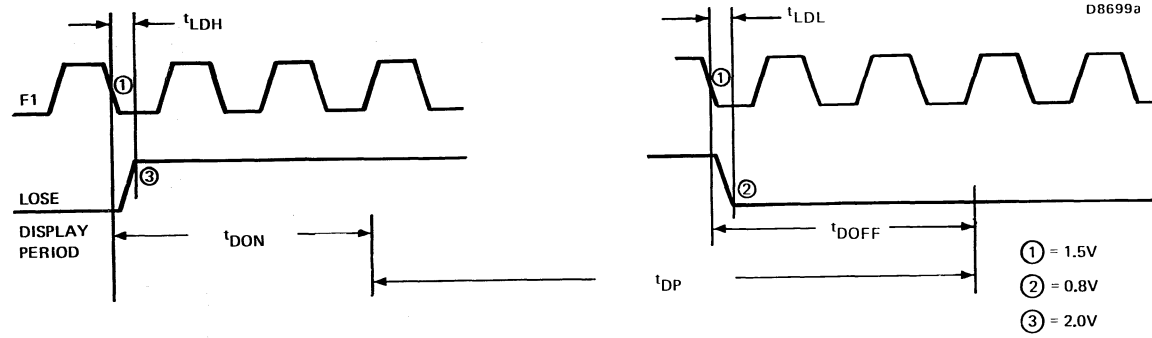

Fig.5 Display period timing (for typical 40 character display)



D8700a

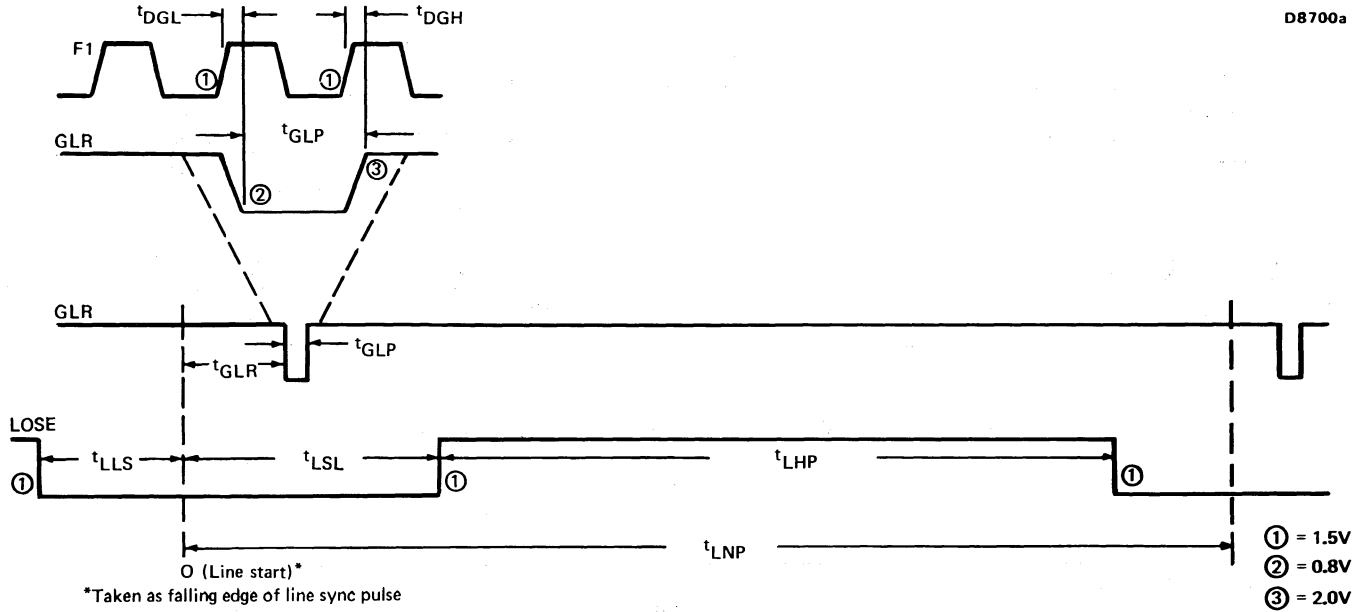
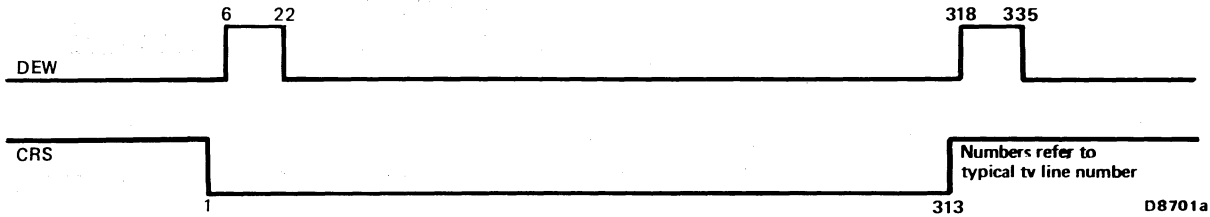
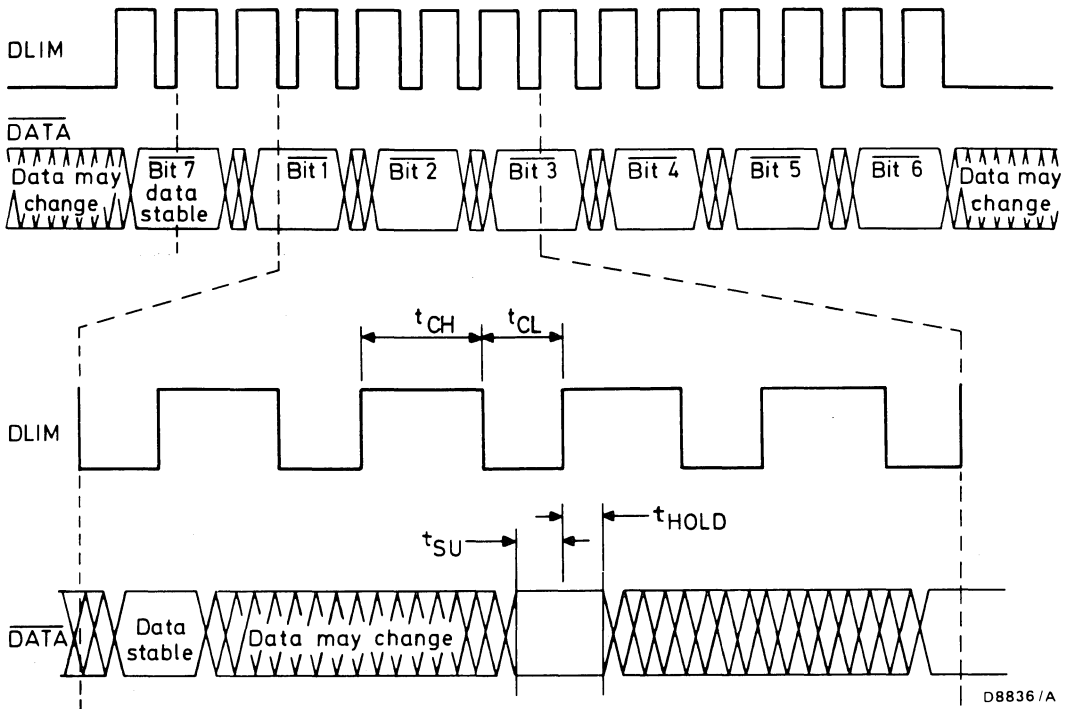

Fig.6 Line rate clocks (for line period of 64 μs)



D8701a

Fig.7 Field rate clocks (for field period of 20 ms, 312½ lines per field)



D8836/A

Fig.8 Remote control input timing

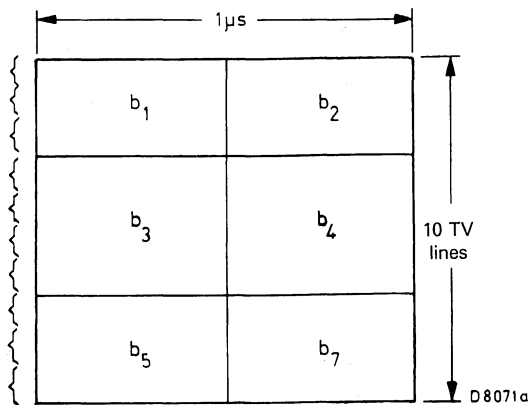

D8071a

Each cell is illuminated if particular 'bit' (b_1 , b_2 , b_3 , b_4 , b_5 , or b_7) is a '1'.
For graphics characters b_6 is always a '1' — See Table 1.

Fig.9 Graphics Character

D8703

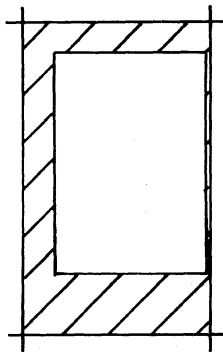
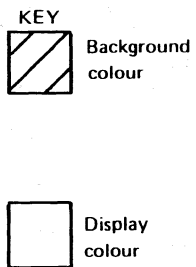

Alphanumerics character 1111111

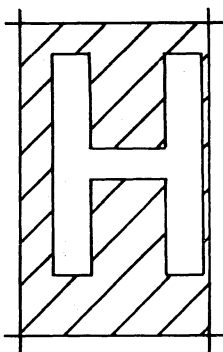

Alphanumerics or blast - through alphanumerics character 0001001

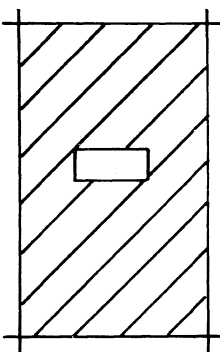

Alphanumerics character 1011010

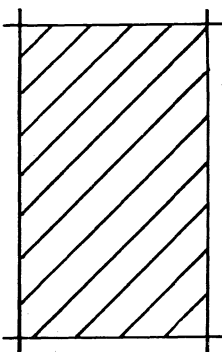

Alphanumerics and graphics 'space' character 0000010

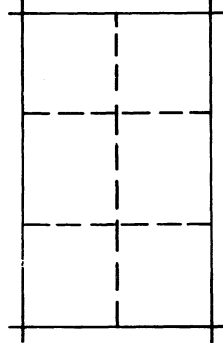

Contiguous graphics character 1111111

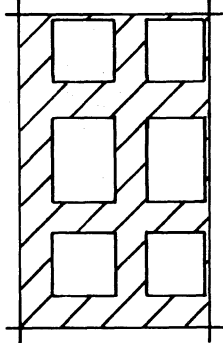

Separated graphics character 1111111

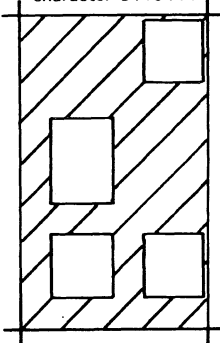

Separated graphics character 0110111

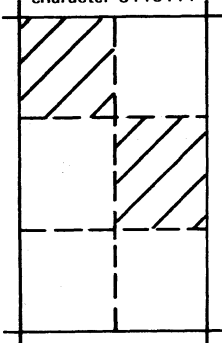

Contiguous graphics character 0110111

Fig.10 Character format

TABLE 1
Character data input decoding

D8068a

Bits				Col	0 0	0 0 ₁	0 1 ₀	0 1 ₁	1 0 ₀	1 0 ₁	1 1 ₀	1 1 ₁				
b ₇	b ₆	b ₅	b ₄	Row	0	1	2	2a	3	3a	4	5	6	6a	7	7a
0	0	0	0	0	NUL*	DLE*			0		P	-				
0	0	0	1	1	Alpha ⁿ Red	Graphics Red			1		Q	a				
0	0	1	0	2	Alpha ⁿ Green	Graphics Green			2		R	b				
0	0	1	1	3	Alpha ⁿ Yellow	Graphics Yellow			3		S	c				
0	1	0	0	4	Alpha ⁿ Blue	Graphics Blue			4		T	d				
0	1	0	1	5	Alpha ⁿ Magenta	Graphics Magenta			5		U	e				
0	1	1	0	6	Alpha ⁿ Cyan	Graphics Cyan			6		V	f				
0	1	1	1	7	Alpha ⁿ White	Graphics White			7		W	g				
1	0	0	0	8	Flash	Conceal Display			8		X	h				
1	0	0	1	9	** Steady	** Contiguous Graphics			9		Y	i				
1	0	1	0	10	** End Box	** Separated Graphics			:		Z	j				
1	0	1	1	11	Start Box	ESC			;		←	k				
1	1	0	0	12	** Normal Height	** Black Background			<		1/2	l				
1	1	0	1	13	Double Height	New Background			=		→	m				
1	1	1	0	14	SO*	Hold Graphics			>		↑	n				
1	1	1	1	15	S1*	** Release Graphics			?		#	o				

5

Control characters shown in columns 0 and 1 are normally displayed as spaces.
The SAA5050 character set is shown as example. Details of character sets are given in Figs. 11 and 12.

* These control characters are reserved for compatibility with other data codes.

** These control characters are presumed before each row begins.

Codes may be referred to by their column and row e.g. 2/5 refers to %

Character rectangle
Black represents display colour.
White represents background.

TELETEXT CHARACTER GENERATOR

SAA5050/55

TABLE 2

Remote control command codes used in the SAA5050

CODE							COMMAND	FUNCTION
b ₇	b ₆	b ₅	b ₄	b ₃	b ₂	b ₁		
0	X	X	X	X	X	X	'tv' mode	Allows text on top row of display only.
1	X	X	X	X	X	X	'Text' mode	Allows text throughout display period.
1	0	1	1	1	1	0	Superimpose	Sets Superimpose mode.
1	0	1	1	1	1	1	teletext	Resets Superimpose mode.
0	X	X	X	X	X	X	'tv' mode	Resets Superimpose mode.
1	1	X	X	X	X	X	viewdata mode	Resets Superimpose mode;
1	X	0	0	1	1	0	Reveal	Reveals for time-out (notes 3, 4).
1	X	0	1	0	1	1	Reveal set	Sets Reveal mode (note 3).
Any command apart from reveal set.								Resets Reveal mode (note 3)

X = Don't care.

Notes

- When the power is applied the SAA5050 is set into the 'tv' mode and reset out of Superimpose and Reveal modes.
- 'Text' mode is selected when \overline{SI} (pin 2) is held LOW
- Reveal mode allows display of text previously concealed by 'conceal display' control characters.
- This code is sent from the SAA5010 or the SAA5012 Series as a repeated command. Thus Reveal mode is set for as long as the Reveal key is depressed. The SAA5050 reverts to normal 'not Reveal' mode 160 ms after the last Reveal command.
- The Superimpose output is LOW only if Superimpose mode is set and the DE (display enable) input is HIGH.
- The above table shows code required for functions specified.
The SAA5010 or the SAA5012 Series transmits and the SAA5050 requires the inverse of these codes i.e. $\overline{b_7}$ to $\overline{b_1}$. The code is transmitted serially in the following order: $\overline{b_7}$ $\overline{b_1}$ $\overline{b_2}$ $\overline{b_3}$ $\overline{b_4}$ $\overline{b_5}$ $\overline{b_6}$.
For full details of remote control data coding see the SAA5010 or the SAA5012 data sheets.

TELETEXT CHARACTER GENERATOR

SAA5050/55

TABLE 3

Conditions affecting display (see note 3)

Inputs		Control data		Outputs		
Picture On (PO)	Display Enable (DE)	Superimpose Mode	Box	Text Display Enabled (i.e. R,G,B,Y outputs)	Blanking	
(a)	1	0	1 or 0	1 or 0	0	0
(b)	0	1	1 or 0	1 or 0	1	1
(c)	0	0	1 or 0	1 or 0	0 (note 2)	1
(d)	1	1	0	0	0	0
(e)	1	1	1	0	1	0
(f)	1	1	1	1	1	1
(g)	1	1	0	1	1	1

Notes

1. For tv mode (Picture On = '1', Superimpose mode not allowed) rows (a), (d) and (g) of Table 3 refer to display row 0 only. For all other rows text display is disabled and Blanking = '0'.
2. The R, G, B outputs may contain character and background colour information. The only exception is that background colours are inhibited when Blanking = '0'.
3. Valid during display period only (see Fig.5) otherwise no character or background information is displayed as blanking is determined by the Picture On. (No blanking if PO = '1').

TELETEXT CHARACTER GENERATOR

SAA5050/55



D8704

Fig. 11 SAA5050 character set (English).



Fig. 12 SAA5055 character set (US ASCII).

NOTES

Section 6 Amplifiers

INDEX

SECTION 6 — AMPLIFIERS		
Index	6-1
Companding		
NE570	Compandor	5-3
SA/NE571	Compandor	5-3
SA/NE572	Programmable Analog Compandor	5-9
Operational		
Symbols and Definitions	6-3
Selector Guide	6-4
LM124/224/324/SA534	Low Power Quad Op Amplifier	6-5
LM158/258/358	Low Power Dual Operational Amplifier	6-9
MC/SA1458/MC1558	General Purpose Operational Amplifier	6-13
MC3303/3403/3503	Quad Low Power Operational Amplifier	6-18
SA/SE/NE4558	Dual General Purpose Operational Amplifier	6-22
SE/NE530	High Slew Rate Operational Amplifier	6-26
SE/NE531	High Slew Rate Operational Amplifier	6-31
SA/SE/NE532	Low Power Dual Operational Amplifier	6-9
SE/NE538	High Slew Rate Operational Amplifier	6-38
SE/NE5512	Dual High Performance Operational Amplifier	6-44
SE/NE5514	Quad High Performance Operational Amplifier	6-46
SE/NE5532/A	Internally Compensated Dual Low Noise Operational Amplifier	6-48
NE5533/A/SA/SE/NE5534/A	Single and Dual Low Noise Operational Amplifier	6-59
SE/NE5535	Dual High Slew Rate Operational Amplifier	6-65
*TCA520B,D	Operational Amplifier	6-73
μA741/741C/SA741C	General Purpose Operational Amplifier	6-79
μA747/747C/SA747C	Dual Operational Amplifier	6-84
Power		
*TDA1013A	4W Audio Amplifier with DC Volume Control	6-90
*TDA1515	24W BTL Audio Amplifier	6-94
*TDA1520A	20W Hi-Fi Audio Amplifier	6-100
Transconductance		
NE5517/A	Dual Operational Transconductance Amplifier	6-106
Video		
SE/NE5539	Ultra High Frequency Operational Amplifier	6-118
*NE5592	Video Amplifier	6-125
SE/NE592	Video Amplifier	6-130
μA733/C	Differential Video Amplifier	6-137

*New product for Linear LSI since 1983 data manual.

10/10/10
10/10/10
10/10/10

10/10/10
10/10/10
10/10/10

10/10/10
10/10/10
10/10/10

10/10/10
10/10/10
10/10/10

10/10/10
10/10/10
10/10/10

10/10/10
10/10/10
10/10/10

10/10/10
10/10/10
10/10/10

10/10/10
10/10/10
10/10/10

10/10/10
10/10/10
10/10/10

10/10/10
10/10/10
10/10/10

10/10/10
10/10/10
10/10/10

10/10/10
10/10/10
10/10/10

10/10/10
10/10/10
10/10/10

10/10/10
10/10/10
10/10/10

10/10/10
10/10/10
10/10/10

10/10/10
10/10/10
10/10/10

10/10/10
10/10/10
10/10/10

10/10/10
10/10/10
10/10/10

10/10/10
10/10/10
10/10/10

10/10/10
10/10/10
10/10/10

10/10/10
10/10/10
10/10/10

10/10/10
10/10/10
10/10/10

OPERATIONAL AMPLIFIERS—SYMBOLS AND DEFINITIONS

Absolute Maximum Rating

Operating safe zones exceeding these limits could cause permanent damage to the device and are not meant to imply that devices can operate at these limits.

Average Input Offset Current Temperature Coefficient (TC_{IO})

The change in input offset current divided by the change to ambient temperature producing it.

Average Input Offset Voltage Temperature Coefficient (TCV_{OS})

The change in input offset voltage divided by the change in ambient temperature producing it.

Bandwidth

The frequency at which the gain is down 3dB from its dc value. It's measured in sample (track) mode with a small-signal sine wave that doesn't exceed the slew rate limit.

Common Mode Input Resistance

The resistance looking into both inputs, with inputs tied together.

Common Mode Rejection Ratio (CMRR)

The ratio of the change of input offset voltage to the input common mode voltage change producing it.

Full Power Bandwidth

The maximum frequency at which the full sine wave output might be obtained.

Input Bias Current (I_B)

The average of the two input currents at zero output voltage. In some cases, the input current is measured for either input independently.

Input Capacitance

The capacitance looking into either input terminal with the other grounded.

Input Current

The current into an input terminal.

Input Noise Voltage

The square root of the mean square narrow-band noise voltage referred to the input.

Input Offset Current

The difference in the currents into the two input terminals with the output at zero volts.

Input Offset Voltage

That voltage which must be applied between the input terminals to obtain zero output voltage. The input offset voltage may also be defined for the case where two equal resistances are inserted in series with the input leads.

Input Resistance

The resistance looking into either input terminal with the other grounded.

Input Voltage Range

The range of voltages on the input terminals for which the amplifier operates within specifications. In some cases, the input offset specifications apply over the input voltage range.

Large-Signal Voltage Gain

The ratio of the maximum output voltage swing to the change in input voltage required to drive the output to this voltage.

Output Resistance

The resistance seen looking into the output terminal with the output at null. This parameter is defined only under small signal conditions at frequencies above a few hundred cycles to eliminate the influence of drift and thermal feedback.

Output Short-Circuit Current

The maximum output current available from the amplifier with the output shorted to ground or to either supply.

Output Voltage Swing

The peak output swing, referred to zero, that can be obtained.

Package Type Designation

See full package designations in Appendix.

Phase Margin

180° minus the absolute value of the phase shift measured at the frequency at which the gain is unity.

Power Consumption

The dc power required to operate the amplifier with the output at zero and with the output at zero and with no load current.

Power Dissipation

The power that the device can safely handle at 25°C. The dissipation must be derated as indicated for the individual package type.

Power Supply Rejection Ratio

The ratio of the change in input offset voltage to the change in supply voltages producing it.

Rise Time

The time required for an output voltage step to change from 10% to 90% of its final value.

Slew Rate

The maximum rate of change of output voltage under large signal conditions.

Supply Current

The current required from the power supply to operate the amplifier with no load and the output at zero.

T_A

Ambient temperature range. Range of the surrounding environment of the operating device.

T_J

Junction Temperature. The maximum temperature of the device. 150°C is standard for silicon devices.

T_{STG}

Storage temperature range. Temperature range that the device can be stored in a non-operating condition.

T_{SOLD}

Soldering Temperature. The temperature which can be applied to the lead frame of the device for short periods of time (normally specified for a duration of 10 sec).

Temperature Stability of Voltage Gain

The maximum variation of the voltage gain over the specified temperature range.

V_{CC} (–V_{CC})

Supply Voltage. The range of power supply voltage over which the device will operate safely.

DEVICE	COM- PLEXITY	TEMP. RANGE ¹	MAX. INPUT VOLTAGE ²		MAX. INPUT CURRENT		RL = 2K MIN. A _{VOl} (V/mV)	TYP. BW A _V = 1 (MHz)	TYP. SLEW RATE (V/μs)	MAX. DIFF. INP. VOLT ³ (V)	MIN. CMRR RATIO (dB)	MIN. PSRR (dB)	SUPPLY VOLTAGE MAX. (V)	MAX. SUPPLY CURR. (mA)	MIN. OUTPUT VOLTAGE SWING (V) RL = 2K	INTERNAL COMPEN- SATION	INPUT NOISE VOLTAGE (nV/Hz) f _o = 1kHz
			OFFSET (mV)	DRIFT (μV/°C TYP.)	OFFSET (nA)	BIAS (nA)											
NE530	Single	Comm.	6	6*	40	150	50	3	35	±30	70	76	±18	3	±10	Yes	
SE530	Single	Mil.	4	6*	20	80	50	3	35	±30	70	76	±22	3	±10	Yes	
NE531	Single	Comm.	6	10*	200	1500	20 ⁵	1	35	±15	70	76	±21	10	±10 ⁵	No	
SE531	Single	Mil.	5	10*	20	500	50 ⁵	1	35	±15	70	76	±22	7	±10 ⁵	No	
NE538	Single	Comm.	6	6*	40	150	50	6	60	±30	70	76	±18	3	±10	Yes ⁷	
SE538	Single	Mil.	4	15	20	80	50	6	60	±30	70	76	±22	3	±10	Yes ⁷	
μA741	Single	Mil.	5	10*	200	500	50	1	0.5	±30	70	76	±22	2.8	±10	Yes	
μ741C	Single	Comm.	6	12*	200	500	20	1	0.5	±30	70	76	±18	2.8	±10	Yes	
NE5534/A	Single	Comm.	4	5*	300	1500	25 ⁶	10	13	±0.5	70	80	±22	8	±12 ⁶	Yes ⁸	4.5
SE5534/A	Single	Mil.	2	5*	200	800	50 ⁶	10	13	±0.5	80	86	±22	6.5	±12 ⁶	Yes ⁸	4 ■
NE5539	Single	Comm.	5		2,000	20,000			600		60	60	±12	33	2.3 ⁹ -1.7	Yes ¹⁰	4 ■
SE5539	Single	Mil.	3		1,000	13,000		1200 ⁴	600		70	60	±12	31	2.5 -2	Yes ¹⁰	4 ■
LM158	Dual	Mil.	5	7*	30	150	50	1	0.3	32	70	65	32	2	26	Yes	50
LM258	Dual	Ind.	5	7*	30	150	50	1	0.3	32	70	65	32	2	26	Yes	50 ■
LM358	Dual	Comm.	7	7*	50	250	25	1	0.3	32	65	65	32	2	26	Yes	50 ■
NE532	Dual	Comm.	7	7*	50	250	25	1	0.3	32	65	65	32	2	26	Yes	50 ■
SA532	Dual	Auto	7	7.5*	50	250	25	1	0.3	32	65	65	32	2	26	Yes	50 ■
SE532	Dual	Mil.	5	7*	30	150	50	1	0.3	32	70	65	32	2	26	Yes	50 ■
μA747	Dual	Mil.	5	10*	200	500	50	1	0.5	±30	70	76	±22	2.8	±10	Yes	
μA747C	Dual	Comm.	6	12*	200	500	25	1	0.5	±30	70	76	±18	2.8	±10	Yes	
MC1458	Dual	Comm.	6	12*	200	500	25	1	0.8	±30	70	76	±18	5.6▲	±10	Yes	
SA1458	Dual	Auto	6	12*	200	500	20	1	0.8	±30	70	76	±18	5.6	±10	Yes	
MC1558	Dual	Mil.	5	10*	200	500	50	1	0.8	±30	70	76	±22	5.6	±10	Yes	30 ■
NE4558	Dual	Comm.	6	4*	200	500	20	3	1	±30	70	76	±18	5.6	±10	Yes	30 ■
SA4558	Dual	Auto	6	4*	200	500	50	3	1	±30	70	76	±18	5.6	±10	Yes	30 ■
SE4558	Dual	Mil.	5	4*	200	500	50	3	1	±30	70	76	±22	5.6	±10	Yes	30 ■
NE5512	Dual	Comm.	5	5*	20	20	50	3	1	32	70	80	±16	5	±13	Yes	30 ■
SE5512	Dual	Mil.	2	4*	10	10	50	3	1	±32	70	80	±16	5	±13	Yes	30 ■
NE5532/A	Dual	Comm.	4	5*	150	800	25	10	9	±0.5	70	80	±22	16	±12 ⁶	Yes	6
SE5532/A	Dual	Mil.	2	5*	100	400	50	10	9	±0.5	80	86	±22	13	±12 ⁶	Yes	5 ■
NE5533	Dual	Comm.	4		300	1500	25	10	13	±0.5	70	80	±22	16	±12 ⁶	Yes ⁸	4.5▲
NE5535	Dual	Comm.	6	6*	40	150	50	1	15	±30	70	76	±18	5.6	±10	Yes	50 ■
SE5535	Dual	Mil.	4	15	20	80	50	1	15	±30	70	76	±22	5.6	±10	Yes	
LM124	Quad	Mil.	5	7*	30	150	50	1	0.3	32	70	65	32	3	26	Yes	50 ■
LM224	Quad	Ind.	5	7*	30	150	50	1	0.3	32	70	65	32	3	26	Yes	50 ■
LM324	Quad	Comm.	7	7*	50	250	25	1	0.3	32	65	65	32	3	26	Yes	50 ■
SA534	Quad	Auto	7	7*	50	250	25	1	0.3	32	65	65	32	3	26	Yes	50 ■
MC3303	Quad	Auto	8	10	75	500	20	1	0.6	±36	70	76	±18	7	±10	Yes	
MC3403	Quad	Comm.	10	10	50	500	20	1	0.6	±36	70	76	±18	7	±10	Yes	
MC3503	Quad	Mil.	5	10	50	500	50	1	0.6	±36	70	76	±18	4	±10	Yes	
NE5514	Quad	Comm.	5	5*	20	20	50	3	1	32	70	80	±16	10	±13	Yes	30 ■
SE5514	Quad	Mil.	2	4*	10	10	50	3	1	32	70	80	±16	10	±13	Yes	30 ■

Notes:

- Military: -55°C to +125°C
 Industrial: -25°C to +85°C
 Commercial: 0°C to +70°C
 Automotive: -40°C to +85°C
- Specifications guaranteed at 25°C unless otherwise indicated by the following marks:

 - Typical over full temperature range
 - ▲ Guaranteed over full temperature range
 - Typical at 25°C
3. Unless otherwise stated, max. negative input voltage cannot exceed negative power supply voltage.
4. A_V = 7
5. R = 10K
6. RL = 600Ω
7. A_V ≥ 5
8. A_V ≥ 3
9. RL = 150Ω
10. A_V > 7

LOW POWER QUAD OP AMP

LM124/224/324/SA534

DESCRIPTION

The LM124/SA534 series consists of four independent, high gain, internally frequency compensated operational amplifiers designed specifically to operate from a single power supply over a wide range of voltages. Similar to LM2902.

UNIQUE FEATURES

In the linear mode the input common-mode voltage range includes ground and the output voltage can also swing to ground, even though operated from only a single power supply voltage.

The unity gain cross frequency is temperature compensated.

The input bias current is also temperature compensated.

FEATURES

- Internally frequency compensated for unity gain
- Large dc voltage gain—(100dB)
- Wide bandwidth (unity gain)—1MHz (temperature compensated)
- Wide power supply range
Single supply—(3Vdc to 30Vdc) or dual supplies—(± 1.5 Vdc to ± 15 Vdc)
- Very low supply current drain—essentially independent of supply voltage (1mW/op amp at +5Vdc)
- Low input biasing current—(45nA dc temperature compensated)
- Low input offset voltage—(2mVdc) and offset current—(5nA dc)
- Differential input voltage range equal to the power supply voltage
- Large output voltage—(0Vdc to $V+$ —1.5Vdc swing)
- LM124 Mil std 883A,B,C available

PIN CONFIGURATION

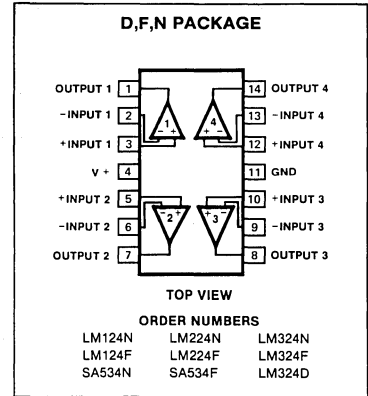

ABSOLUTE MAXIMUM RATINGS

PARAMETER	RATING	UNIT	
V+	Supply voltage	32 or ± 16	Vdc
	Differential input voltage	32	Vdc
	Input voltage	-0.3 to +32	Vdc
	Power dissipation ¹		
	N package	570	mW
	F package	900	mW
	Output short-circuit to GND		
	1 amplifier ²	Continuous	
	V+ < 15Vdc and T _A = 25°C		
	Input current (V _{IN} < -0.3V) ³	50	mA
	Operating temperature range		
	LM324	0 to +70	°C
	LM224	-25 to +85	°C
	SA534	-40 to +85	°C
	LM124	-55 to +125	°C
	Storage temperature range	-65 to +150	°C
	Lead temperature (soldering, 10sec)	300	°C

NOTES

1. For operating at high temperatures, all devices must be derated based on a +125°C maximum junction temperature and a thermal resistance of 175°C/W which applies for the device soldered in a printed circuit board, operating in a still air ambient. LM 124/224 can be derated based on a +150°C maximum junction temperature.
2. Short circuits from the output to V+ can cause excessive heating and eventual destruction. The maximum output current is approximately 40mA independent of the magnitude of V+. At values of supply voltage in excess of +15Vdc continuous short-circuits can exceed the power dissipation ratings and cause eventual destruction.
3. The direction of the input current is out of the IC due to the PNP input stage. This current is essentially constant, independent of the state of the output, so no loading change exists on the input lines.



LOW POWER QUAD OP AMP

LM124/224/324/SA534

DC ELECTRICAL CHARACTERISTICS $V_+ = 5V, T_A = 25^\circ C$ unless otherwise specified.

PARAMETER	TEST CONDITIONS	LM124/LM224			LM324/SA534			UNIT
		Min	Typ	Max	Min	Typ	Max	
V_{OS} Offset voltage ¹	$R_S = 0\Omega$ $R_S = 0\Omega$, over temp.		± 2	± 5 ± 7		± 2	± 7 ± 9	mV mV
V_{OS} Drift	$R_S = 0\Omega$		7			7		$\mu V/^\circ C$
I_{BIAS} Input current ²	$I_{IN}(+)$ or $I_{IN}(-)$ $I_{IN}(+)$ or $I_{IN}(-)$, over temp.		45 40	150 300		45 40	250 500	nA
I_B Drift	Over temp.		50			50		$pA/^\circ C$
I_{OS} Offset current	$I_{IN}(+) - I_{IN}(-)$ $I_{IN}(+) + 0 - I_{IN}(-)$, over temp.		± 3	± 30 ± 100		± 5	± 50 ± 150	nA nA
I_{OS} Drift	Over temp.		10			10		$pA/^\circ C$
V_{CM} Common mode voltage range ³	$V_+ = 30V$ $V_+ = 30V$, over temp.	0 0		$V_+ - 1.5$ $V_+ - 2$	0 0		$V_+ - 1.5$ $V_+ - 2$	V V
C_{MRR} Common mode rejection ratio	$V_+ = 30V$	70	85		65	70		dB
V_{OUT} Output voltage swing	$R_L = 2k\Omega, V_+ = +30V$, over temp.	26			26			V
V_{OH}	$R_L \leq 10k\Omega$, over temp.	27	28		27	28		V
V_{OL}	$R_L \leq 10k\Omega, V_+ = 5V$, over temp.		5	20		5	20	mV
I_{CC} Supply current	$R_L = \infty, V_{CC} = 30V$, over temp. $R_L = \infty$, on all op amps, over temp.		1.5 0.7	3 1.2		1.5 0.7	3 1.2	mA
A_{VOL} Large signal voltage gain	$V_+ = +15V$ (for large V_O swing), $R_L \geq 2k\Omega$ $V_+ = +15V$ (for large V_O swing), $R_L \geq 2k\Omega$, over temp.	50 25	100		25 15	100		V/mV V/mV
Amplifier-to-amplifier coupling ⁵	$f = 1kHz$ to $20kHz$, input referred		-120			-120		dB
PSRR	$R_S \leq 0\Omega$	65	100		65	100		dB
Output current Source	$V_{IN+} = +1Vdc, V_{IN-} = 0Vdc$, $V_+ = 15Vdc$	20	40		20	40		mA
Sink	$V_{IN+} = +1Vdc, V_{IN-} = 0Vdc$, $V_+ = 15Vdc$, over temp.	10	20		10	20		mA
	$V_{IN-} = +1Vdc, V_{IN+} = 0Vdc$, $V_+ = 15Vdc$	10	20		10	20		mA
	$V_{IN-} = +1Vdc, V_{IN+} = 0Vdc$, $V_+ = 15Vdc$, over temp.	5	8		5	8		mA
	$V_{IN+} = 0Vdc, V_{IN-} = +1Vdc$, $V_O = 200mV$	12	50		12	50		μA
I_{SC} Short circuit current ⁴		10	40	60	10	40	60	mA
Differential input voltage ⁶				V_+			V_+	V
GBW Unity gain bandwidth	$T_A = 25^\circ C$		1			1		MHz
S.R. Slew rate	$T_A = 25^\circ C$		0.3			0.3		$V/\mu s$
Noise Input noise voltage	$T_A = 25^\circ C, f = 1kHz$		40			40		nV/\sqrt{Hz}

NOTES

- $V_O \geq 1.4Vdc$, $R_S = 0\Omega$ with V_+ from 5V to 30V and over full input common mode range (0Vdc to $V_+ - 1.5V$).
- The direction of the input current is out of the IC due to the pnp input stage. This current is essentially constant, independent of the state of the output so no loading change exists on the input lines.
- The input common-mode voltage or either input signal voltage should not be allowed to go negative by more than 0.3V. The upper end of the common-mode voltage range is $V_+ - 1.5V$, but either or both inputs can go to $+32V$ without damage.
- Short circuits from the output to V_+ can cause excessive heating and eventual destruction. The maximum output current is approximately 40mA independent of the magnitude of V_+ . At values of supply voltage in excess of $+15Vdc$ continuous short-circuits can exceed the power dissipation ratings and cause eventual destruction. Destructive dissipation can result from simultaneous shorts on all amplifiers.
- Due to proximity of external components, insure that coupling is not originating via stray capacitance between these external parts. This typically can be detected as this type of capacitive increases at higher frequencies.
- The input common-mode voltage or either input signal voltage should not be allowed to go negative by more than 0.3V. The upper end of the common-mode voltage range is $V_+ - 1.5V$, but either or both inputs can go to $+32Vdc$ without damage.

LOW POWER QUAD OP AMP

LM124/224/324/SA534

EQUIVALENT SCHEMATIC

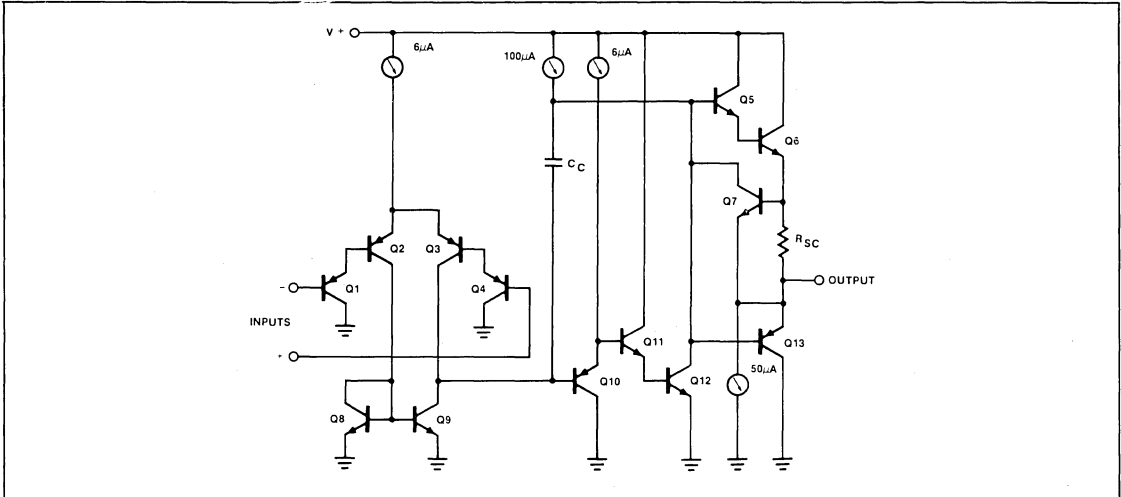

TYPICAL PERFORMANCE CHARACTERISTICS

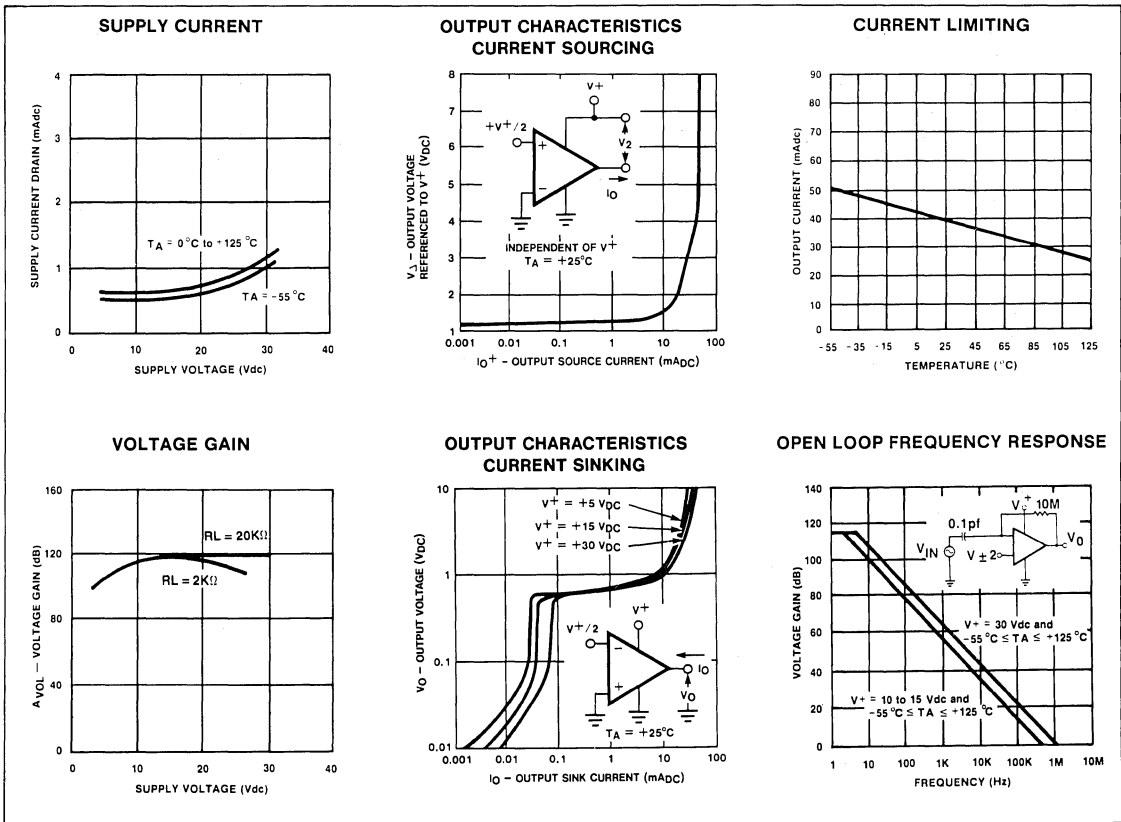

6

TYPICAL PERFORMANCE CHARACTERISTICS (Cont'd)

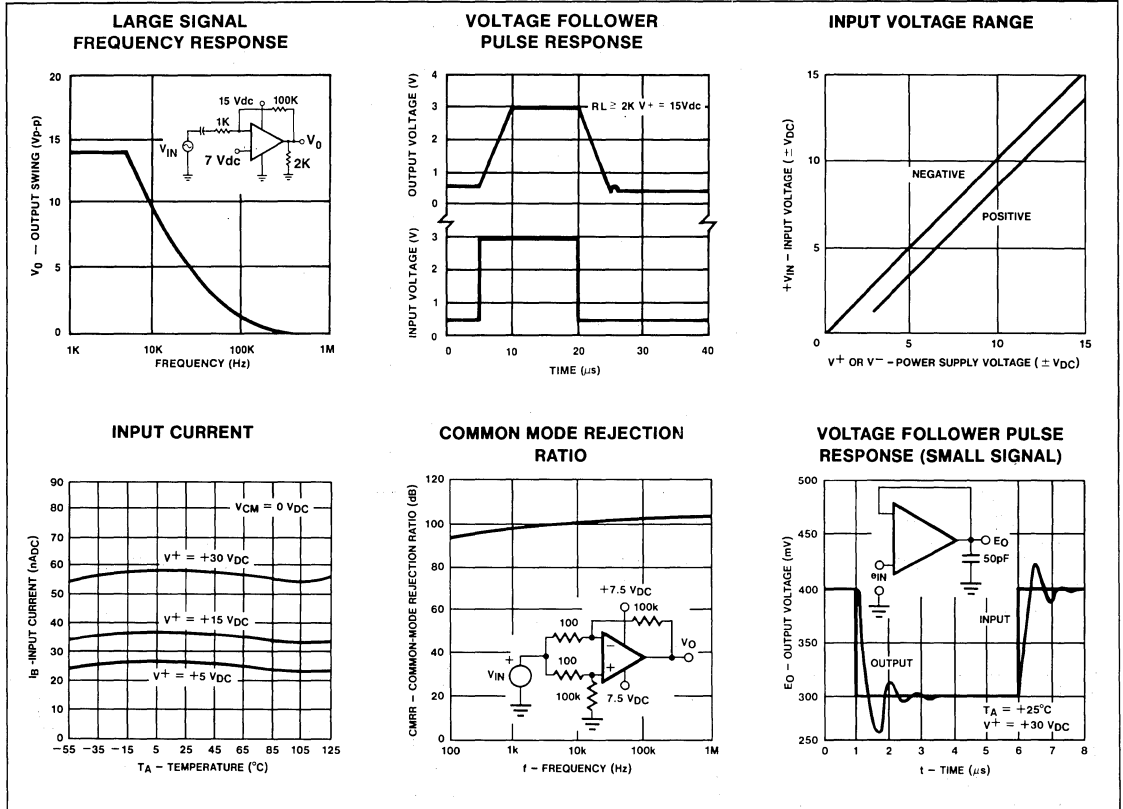

TYPICAL APPLICATIONS

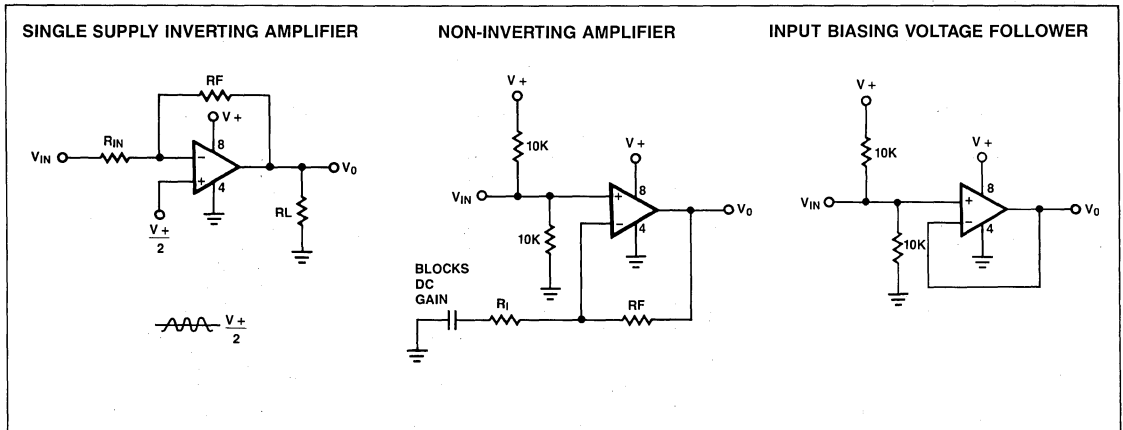

LOW POWER DUAL OPERATIONAL AMPLIFIERS SA/SE/NE532/LM158/258/358

DESCRIPTION

The 532/358 consists of two independent, high gain, internally frequency compensated operational amplifiers designed specifically to operate from a single power supply over a wide range of voltages. Operation from dual power supplies is also possible and the low power supply current drain is independent of the magnitude of the power supply voltage.

FEATURES

- Internally frequency compensated for unity gain
- Large dc voltage gain—(100dB)
- Wide bandwidth (unity gain)—1MHz (temperature compensated)
- Wide power supply range
single supply—(3Vdc to 30Vdc)
or dual supplies—(±1.5Vdc to ±15Vdc)
- Very low supply current drain (400 μ A)—essentially independent of supply voltage (1mW/op amp at +5Vdc)
- Low input biasing current—(45nA dc temperature compensated)
- Low input offset voltage—(2mVdc) and offset current—(5nA dc)

- Differential input voltage range equal to the power supply voltage
- Large output voltage—(0Vdc to V+—1.5Vdc swing)
- SE532 MIL-STD-883A,B,C available

UNIQUE FEATURES

In the linear mode the input common-mode voltage range includes ground and the output voltage can also swing to ground, even though operated from only a single power supply voltage. The unity gain cross frequency is temperature compensated. The input bias current is also temperature compensated.

ABSOLUTE MAXIMUM RATINGS

PARAMETER	RATING	UNIT
Supply voltage, V+	32 or ± 16	Vdc
Differential input voltage	32	Vdc
Input voltage	-0.3 to +32	Vdc
Power dissipation ¹		
FE package	900	mW
H package	680	mW
N package	500	mW
Output short-circuit to GND ⁵ V+ < 15 Vdc and T _A = 25°C	Continuous	
Operating temperature range		
NE532/LM358	0 to +70	°C
LM258	-25 to +85	°C
SA532N	-40 to +85	°C
SE532/LM158	-55 to +125	°C
Storage temperature range	-65 to +150	°C
Lead temperature (soldering, 10sec)	300	°C

EQUIVALENT CIRCUIT

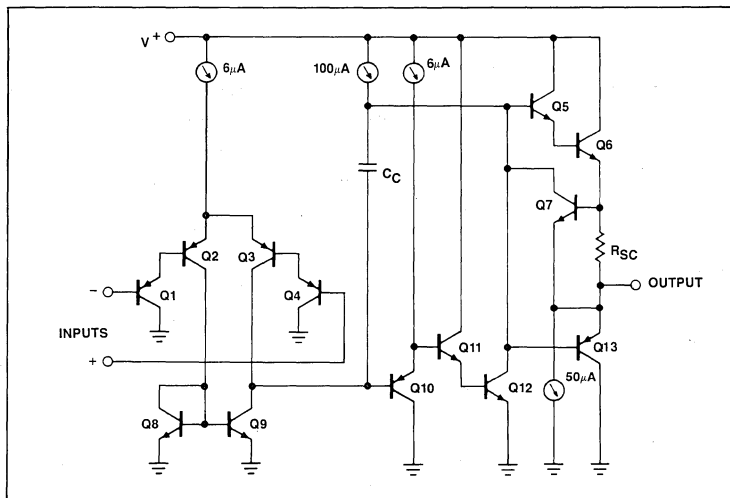

PIN CONFIGURATIONS

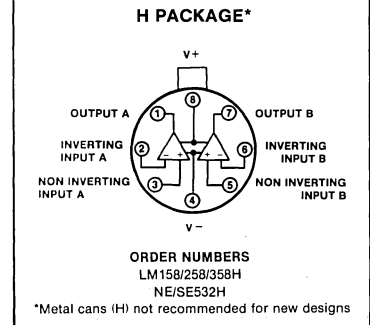
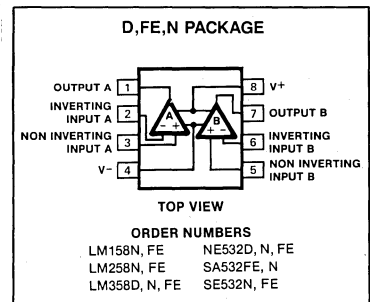

LOW POWER DUAL OPERATIONAL AMPLIFIERS SA/SE/NE532/LM158/258/358

DC ELECTRICAL CHARACTERISTICS $T_A = 25^\circ\text{C}$, $V_+ = +5\text{V}$ unless otherwise specified.

PARAMETER	TEST CONDITIONS	SE532, LM158/258			NE/SA532/LM358			UNIT	
		Min	Typ	Max	Min	Typ	Max		
V_{OS} Offset voltage ¹	$R_S \leq 0\Omega$ $R_S \leq 0\Omega$, over temp.		± 2	± 5 ± 7		± 2	± 7 ± 9	mV mV	
V_{OS} Drift	$R_S = 0\Omega$, over temp.		7			7		$\mu\text{V}/^\circ\text{C}$	
I_{OS} Offset current	$I_{IN(+)} - I_{IN(-)}$ Over temp.		± 3	± 30 ± 100		± 5	± 50 ± 150	nA nA	
I_{OS} Drift	Over temp.		10			10		$\text{pA}/^\circ\text{C}$	
I_{BIAS} Input current ²	$I_{IN(+)}$ or $I_{IN(-)}$ Over temp., $I_{IN(+)}$ or $I_{IN(-)}$		45 40	150 300		45 40	250 500	nA nA	
I_B Drift	Over temp.		50			50		$\text{pA}/^\circ\text{C}$	
V_{CM} Common mode voltage range ³	$V_+ = 30\text{V}$ Over temp., $V_+ = 30\text{V}$	0 0		$V_+ - 1.5$ $V_+ - 2.0$	0 0		$V_+ - 1.5$ $V_+ - 2.0$	V V	
C_{MRR} Common mode rejection ratio	$V_+ = 30\text{V}$	70	85		65	70		dB	
V_{OUT} Output voltage swing (V_{OH})	$R_L \geq 2\text{k}\Omega$, $V_+ = 30\text{V}$, over temp. $R_L \geq 10\text{k}\Omega$, $V_+ = 30\text{V}$, over temp.	26 27	28	20	26 27	28	20	V V mV	
V_{OUT} Output voltage swing (V_{OL})	$R_L \leq 10\text{k}\Omega$, over temp.		5	20		5	20	mV	
I_{CC} Supply current	$R_L = \infty$, $V_+ = 30\text{V}$ $R_L = \infty$ on all amplifiers, over temp.		1.0 0.5	2.0 1.2		1.0 0.5	2.0 1.2	mA mA	
A_{VOL} Large signal voltage gain	$R_L \geq 2\text{k}\Omega$, $V_{OUT} \pm 10\text{V}$, $V_+ = 15\text{V}$ (for large V_O swing) over temp.	50 25	100		25 15	100		V/mV V/mV	
PSRR Supply voltage rejection ratio	$R_S \leq 0\Omega$	65	100		65	100		dB	
Amplifier-to-amplifier coupling ⁴	$f = 1\text{kHz}$ to 20kHz (input referred)		-120			-120		dB	
Output current Source	$V_{IN+} = +1\text{Vdc}$, $V_{IN-} = 0\text{Vdc}$, $V_+ = 15\text{Vdc}$	20	40		20	40		mA	
	$V_{IN+} = +1\text{Vdc}$, $V_{IN-} = 0\text{Vdc}$, $V_+ = 15\text{Vdc}$, over temp.	10	20		10	20		mA	
	Sink	$V_{IN-} = +1\text{Vdc}$, $V_{IN+} = 0\text{Vdc}$, $V_+ = 15\text{Vdc}$	10	20		10	20		mA
	$V_{IN-} = +1\text{Vdc}$, $V_{IN+} = 0\text{Vdc}$, $V_+ = 15\text{Vdc}$, over temp.	5	8		5	8		mA	
I_{SC} Short circuit current ⁵	$V_{IN+} = 0\text{V}$, $V_{IN-} = +1\text{Vdc}$, $V_O = 200\text{mV}$	12	50		12	50		μA	
	Differential input voltage ⁶		40	60		40	60	mA	
GBW Unity gain bandwidth	$T_A = 25^\circ\text{C}$		1			1		MHz	
S.R. Slew rate	$T_A = 25^\circ\text{C}$		0.3			0.3		$\text{V}/\mu\text{s}$	
Noise Input Noise Voltage	$T_A = 25^\circ\text{C}$, $f = 1\text{kHz}$		40			40		$\text{nV}/\sqrt{\text{Hz}}$	

NOTES

- $V_O \approx 1.4\text{V}$, $R_S = 0\Omega$ with V_+ from 5V to 30V; and over the full input common-mode range (0V to $V_+ - 1.5\text{V}$).
- The direction of the input current is out of the IC due to the pnp input stage. This current is essentially constant, independent of the state of the output so no loading change exists on the input lines.
- The input common-mode voltage or either input signal voltage should not be allowed to go negative by more than 0.3V. The upper end of the common-mode voltage range is $V_+ - 1.5\text{V}$, but either or both inputs can go to $+32\text{V}$ without damage.
- Due to proximity of external components, insure that coupling is not originating via stray capacitance between these external parts. This typically can be detected as this type of capacitance coupling increases at higher frequencies.
- Short circuits from the output to V_+ can cause excessive heating and eventual destruction. The maximum output current is approximately 40mA independent of the magnitude of V_+ . At values of supply voltage in excess of $+15\text{Vdc}$, continuous short-circuits can exceed the power dissipation ratings and cause eventual destruction.
- The input common-mode voltage or either input signal voltage should not be allowed to go negative by more than 0.3V. The upper end of the common-mode voltage range is $V_+ - 1.5\text{V}$, but either or both inputs can go to $+32\text{Vdc}$ without damage.
- For operating at high temperatures, all devices must be derated based on a $+125^\circ\text{C}$ maximum junction temperature and a thermal resistance of $175^\circ\text{C}/\text{W}$ which applies for the device soldered in a printed circuit board, operating in a still air ambient.

TYPICAL PERFORMANCE CHARACTERISTICS

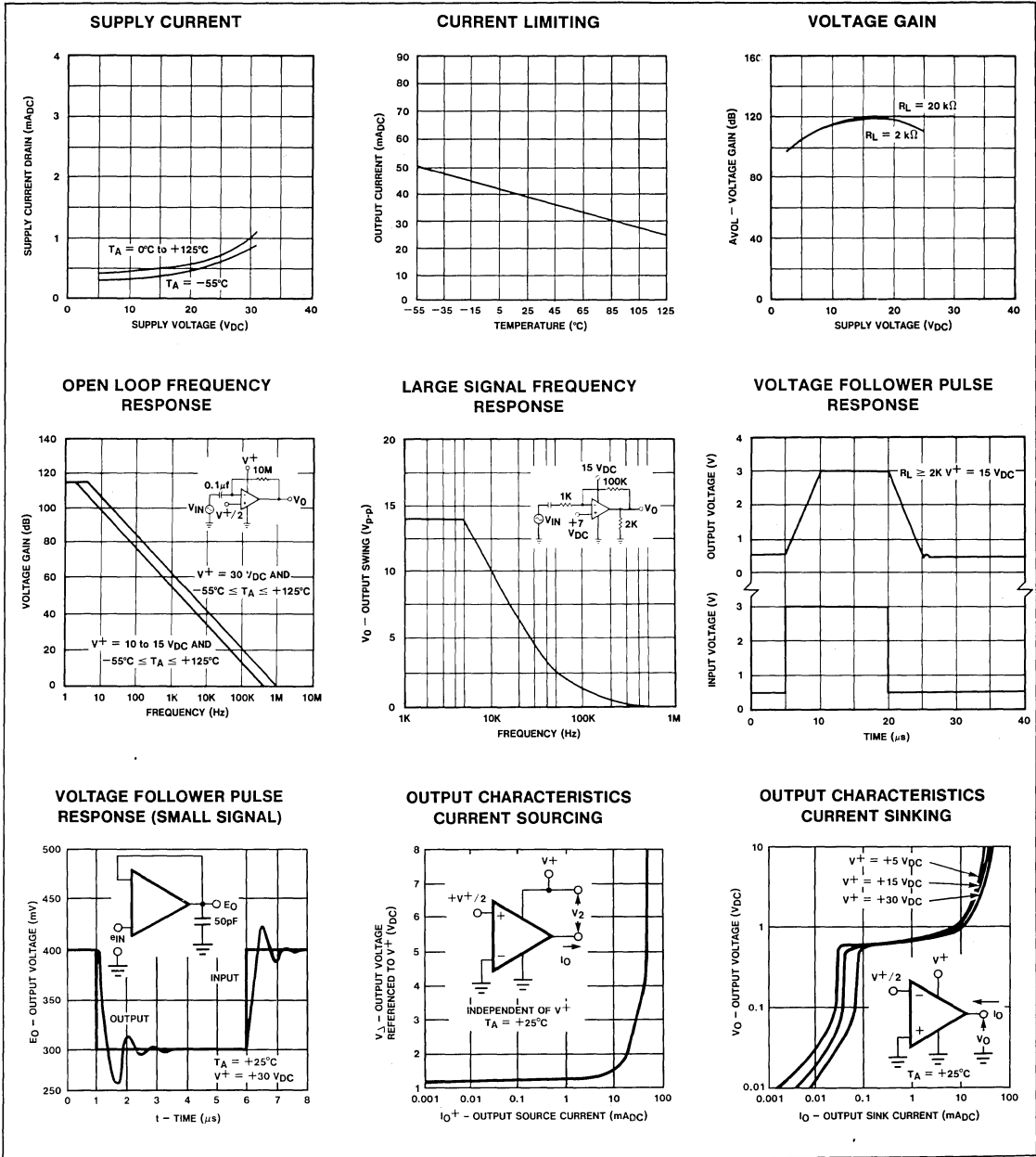

6

LOW POWER DUAL OPERATIONAL AMPLIFIERS SA/SE/NE532/LM158/258/358

TYPICAL PERFORMANCE CHARACTERISTICS (Cont'd)

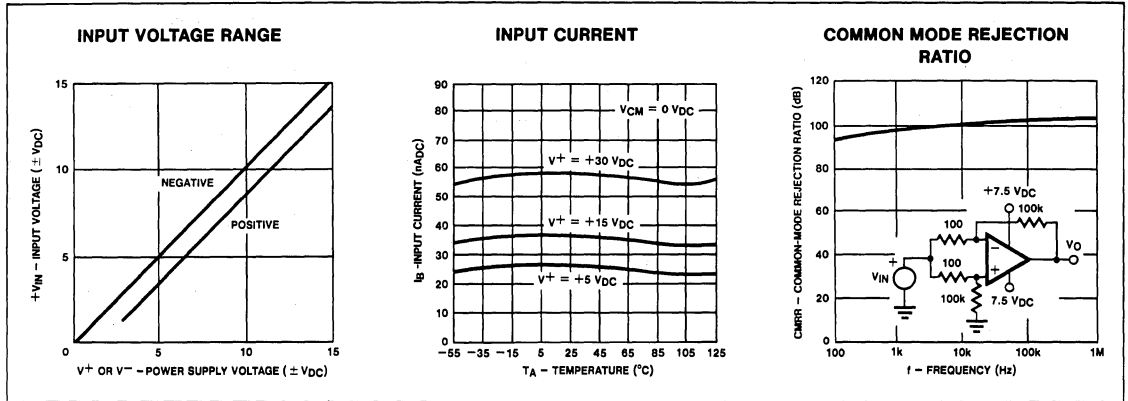

TYPICAL APPLICATIONS

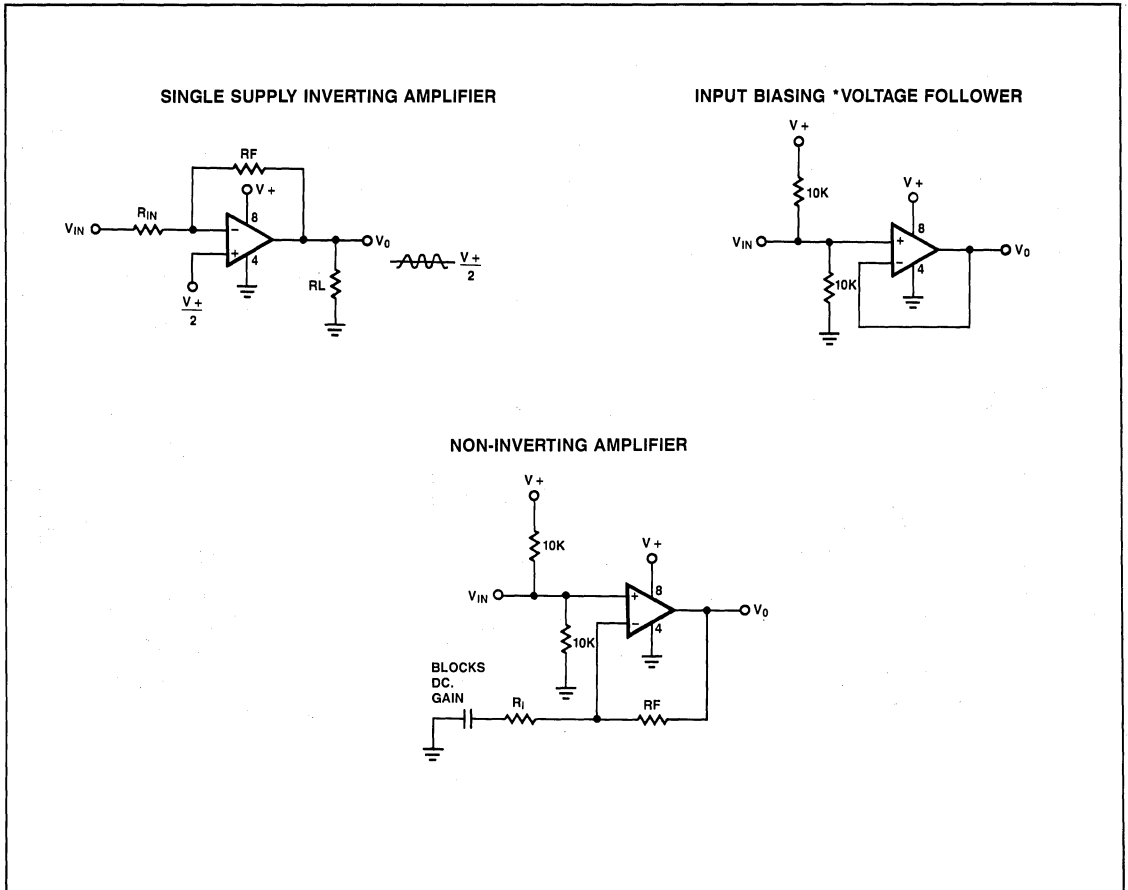

DESCRIPTION

The MC1458 is a high performance operational amplifier with high open loop gain, internal compensation, high common mode range and exceptional temperature stability. The MC1458 is short-circuit protected and allows for nulling of offset voltage.

The MC1458/SA1458/MC1558 consists of a pair of 741 operational amplifiers on a single chip.

FEATURES

- Internal frequency compensation
- Short circuit protection
- Excellent temperature stability
- High input voltage range
- No latch-up
- 1558/1458 are 2 "op amps" in space of one 741 package
- MC1558 MIL-STD-883A,B,C available

PIN CONFIGURATIONS

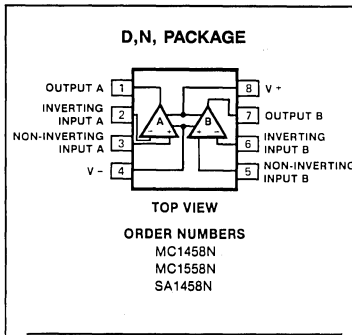

ABSOLUTE MAXIMUM RATINGS

PARAMETER	RATING	UNIT
Supply voltage		
MC1458	±18	V
SA1458	±18	V
MC1558	±22	V
Internal power dissipation		
N package	500	mW
H package ¹	800	mW
F,FE package	1000	mW
Differential input voltage	±30	V
Input voltage ²	±15	V
Output short-circuit duration	Continuous	
Operating temperature range		°C
MC1458	0 to +70	
SA1458	-40 to +85	
MC1558	-55 to +125	
Storage temperature range	-65 to +150	°C
Lead temperature (soldering 60sec)	300	°C

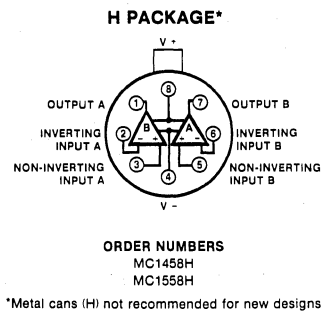

NOTES

1. Ratings based on thermal resistances, junction to ambient, of 240°C/W, 150°C/W, 110°C/W for N, H, F and FE packages respectively, and a maximum junction temperature of 150°C.
2. For supply voltages less than ±15V, the absolute maximum input voltage is equal to the supply voltage.

EQUIVALENT SCHEMATIC

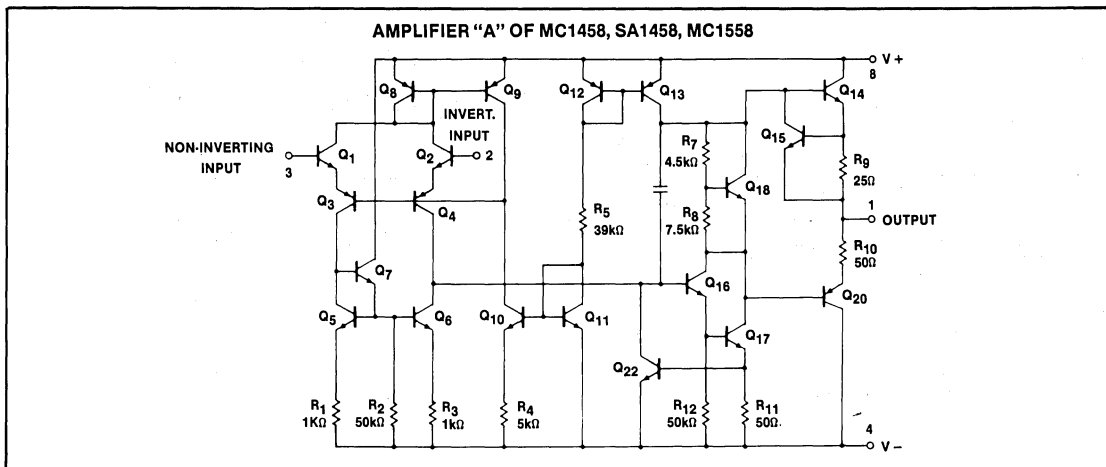

GENERAL PURPOSE OPERATIONAL AMPLIFIER

MC/SA1458/MC1558

DC ELECTRICAL CHARACTERISTICS $T_A = 25^\circ\text{C}$, $V_S = \pm 15\text{V}$, unless otherwise specified.

PARAMETER		TEST CONDITIONS	MC1558			UNIT
			Min	Typ	Max	
V_{OS}	Offset voltage	$R_S = 10\text{k}\Omega$		1.0	5.0	mV
ΔV_{OS}	Offset voltage	$R_S = 10\text{k}\Omega$, over temperature Over temperature		10	6.0	$\mu\text{V}/^\circ\text{C}$
I_{OS}	Offset current	Over temperature		20	200	nA
ΔI_{OS}	Offset current	Over temperature		0.10	500	$\text{nA}/^\circ\text{C}$
I_{BIAS}	Input bias current	Over temperature		80	500	nA
ΔI_B	Bias current	Over temperature		1.0	1500	$\text{nA}/^\circ\text{C}$
V_{OUT}	Output voltage swing	$R_L = 10\text{k}\Omega$, over temperature $R_L = 2\text{k}\Omega$, over temperature	± 12 ± 10	± 14 ± 13		V V
A_{VOL}	Large signal voltage gain	$R_L = 2\text{k}\Omega$, $V_O = \pm 10\text{V}$ $R_L = 2\text{k}\Omega$, $V_O = \pm 10\text{V}$, over temperature	50 20	100		V/mV V/mV
	Offset voltage adjustment range			± 30		mV
PSRR	Supply voltage rejection ratio	$R_S \leq 10\text{k}\Omega$		30	150	$\mu\text{V}/\text{V}$
CMRR	Common mode rejection ratio		70	90		dB
I_{CC}	Supply current			2.3	5.0	mA
V_{IN}	Input voltage range		± 12	± 13		V
P_d	Power consumption			70	150	mW
R_{OUT}	Channel separation			120		dB
I_{SC}	Output resistance			75		Ω
	Output short-circuit current		10	26	60	mA

DC ELECTRICAL CHARACTERISTICS (Cont'd) $T_A = 25^\circ\text{C}$, $V_{CC} = \pm 15\text{V}$, unless otherwise specified.¹

PARAMETER		TEST CONDITIONS	MC1458			SA1458			UNIT
			Min	Typ	Max	Min	Typ	Max	
V_{OS}	Offset voltage	$R_S = 10\text{k}\Omega$		2.0	6.0		2.0	6.0	mV
ΔV_{OS}	Offset voltage	$R_S = 10\text{k}\Omega$, over temp. Over temperature		12	7.5		12	7.5	$\mu\text{V}/^\circ\text{C}$
I_{OS}	Offset current	Over temperature		20	200		20	200	nA
ΔI_{OS}	Offset current	Over temperature		0.10	300		0.10	500	$\text{nA}/^\circ\text{C}$
I_{BIAS}	Input bias current	Over temperature		80	500		80	500	nA
ΔI_B	Bias current	Over temperature		1.0	800		1.0	1500	$\text{nA}/^\circ\text{C}$
V_{OUT}	Output voltage swing	$R_L = 10\text{k}\Omega$ $R_L = 2\text{k}\Omega$, over temp.	± 12 ± 10	± 14 ± 13		± 12 ± 10	± 14 ± 13		V V
A_{VOL}	Large signal voltage gain	$R_L = 2\text{k}\Omega$, $V_O = \pm 10\text{V}$ $R_L = 2\text{k}\Omega$, $V_O = \pm 10\text{V}$, Over temperature	25 15	200		20 15	200		V/mV V/mV
	Offset voltage adjustment range			± 30			± 30		mV
PSRR	Supply voltage rejection ratio	$R_S \leq 10\text{k}\Omega$		30	150		30	150	$\mu\text{V}/\text{V}$
CMRR	Common mode rejection ratio		70	90		70	90		dB
I_{CC}	Supply current			2.3	5.6		2.3	5.6	mA
V_{IN}	Input voltage range		± 12	± 13		± 12	± 13		V
R_{IN}	Input resistance								M Ω
P_d	Power consumption			70	170		70	170	mW
	Channel separation			120			120		dB
I_{SC}	Output short-circuit current			25			25		mA

AC ELECTRICAL CHARACTERISTICS $T_A = 25^\circ\text{C}$, $V_S = \pm 15\text{V}$, unless otherwise specified.

PARAMETER	TEST CONDITIONS	MC1458, SA1458, MC1558			UNIT
		Min	Typ	Max	
Parallel input resistance	Open loop, $f = 20\text{Hz}$	0.3			$M\Omega$
Common mode input impedance	$f = 20\text{Hz}$		200		$M\Omega$
Equivalent input noise voltage	$A_V = 100$, $R_S = 10k\Omega$, $B_W = 1.0\text{kHz}$, $f = 1.0\text{kHz}$		30		$nV \sqrt{\text{Hz}}$
Power bandwidth	$A_V = 1$, $R_L = 2.0k\Omega$, $\text{THD} \leq 5\%$, $V_{\text{OUT}} = 20\text{Vp-p}$		14		kHz
Phase margin			65		degrees
Gain margin			11		dB
Unity gain crossover frequency	Open loop		1.0		MHz
Transient response unity gain	$V_{\text{IN}} = 20\text{mV}$, $R_L = 2k\Omega$, $C_L \leq 100\text{pF}$				
Rise time			0.3		μs
Overshoot			5.0		%
Slew rate	$C \leq 100\text{pF}$, $R_L \geq 2k$, $V_{\text{IN}} = \pm 10\text{V}$		0.8		$\text{V}/\mu\text{s}$

TYPICAL PERFORMANCE CHARACTERISTICS

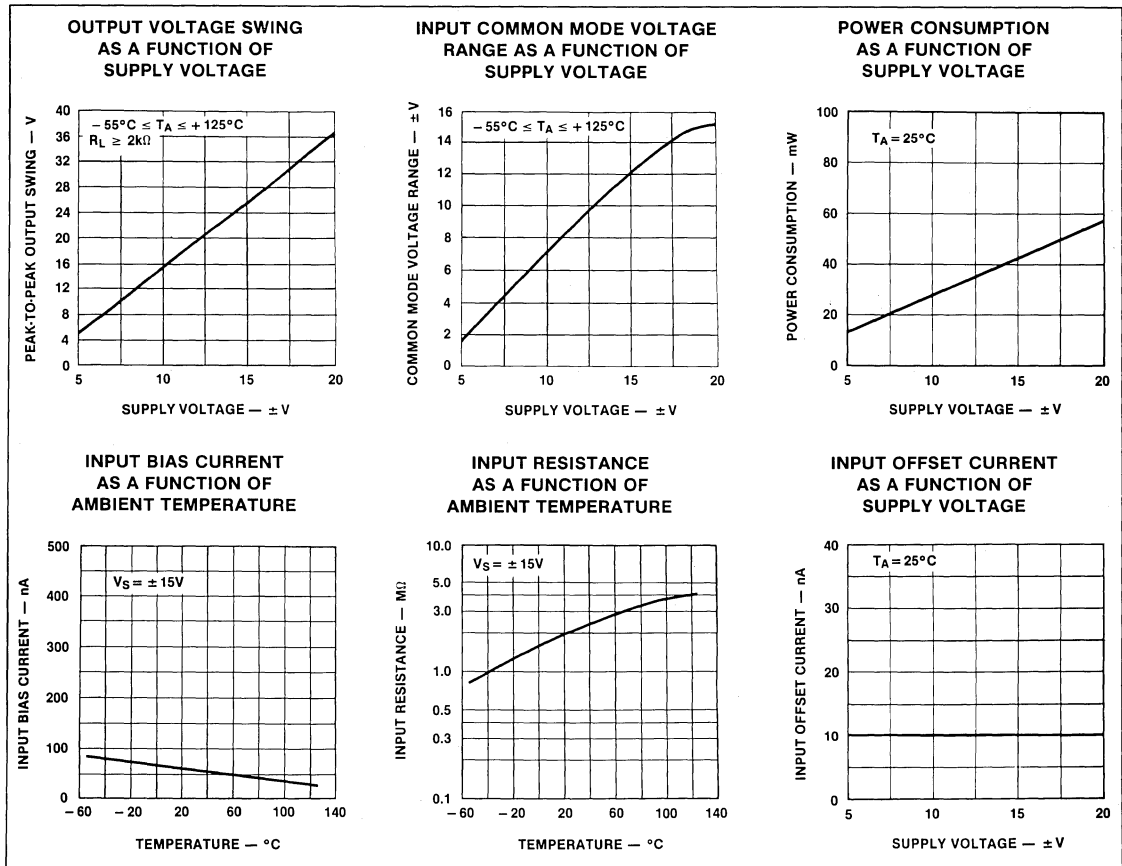

6

TYPICAL PERFORMANCE CHARACTERISTICS (Cont'd)

INPUT OFFSET CURRENT AS A FUNCTION OF AMBIENT TEMPERATURE

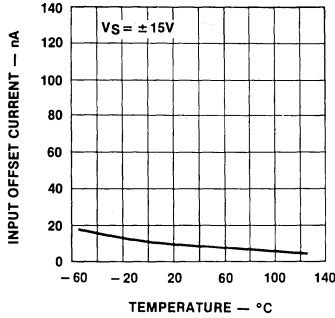

POWER CONSUMPTION AS A FUNCTION OF AMBIENT TEMPERATURE

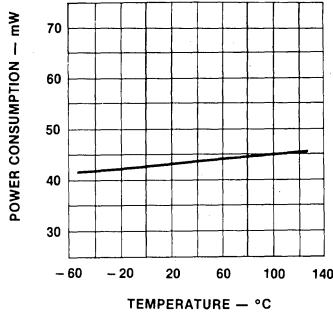

OUTPUT VOLTAGE SWING AS A FUNCTION OF LOAD RESISTANCE

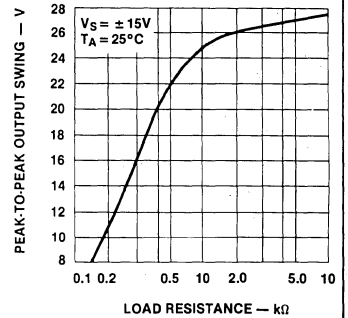

OUTPUT SHORT-CIRCUIT CURRENT AS A FUNCTION OF AMBIENT TEMPERATURE

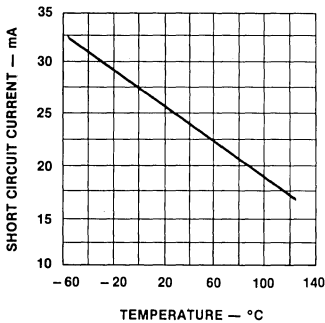

INPUT NOISE VOLTAGE AS A FUNCTION OF FREQUENCY

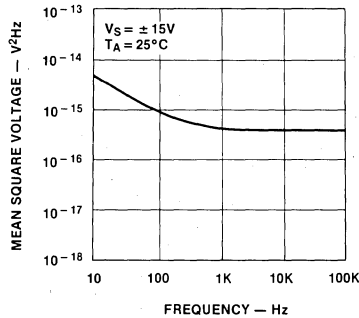

INPUT NOISE CURRENT AS A FUNCTION OF FREQUENCY

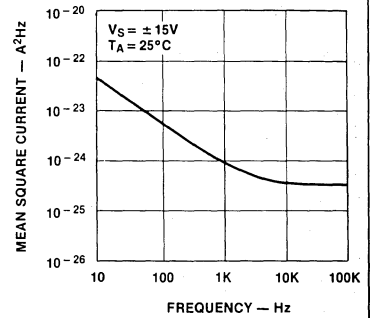

BROADBAND NOISE FOR VARIOUS BANDWIDTHS

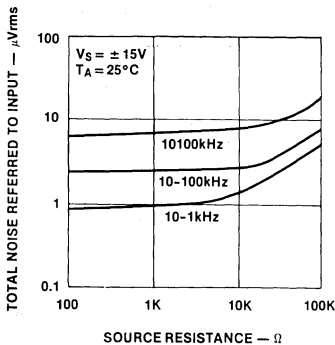

OPEN LOOP VOLTAGE GAIN AS A FUNCTION OF FREQUENCY

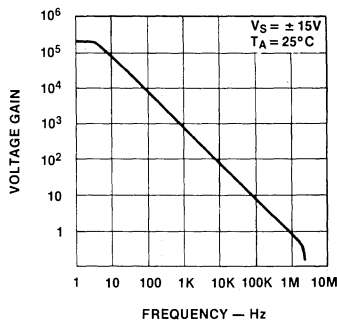

OPEN LOOP PHASE RESPONSE AS A FUNCTION OF FREQUENCY

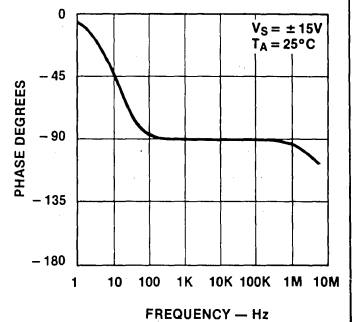

TYPICAL PERFORMANCE CHARACTERISTICS (Cont'd)

OUTPUT VOLTAGE SWING AS A FUNCTION OF FREQUENCY

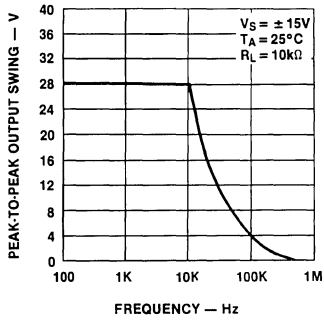

COMMON MODE REJECTION RATIO AS A FUNCTION OF FREQUENCY

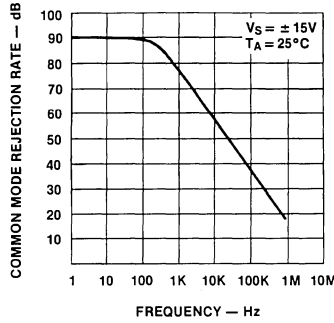

TRANSIENT RESPONSE

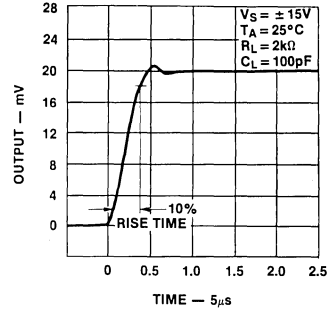

POWER BANDWIDTH (Large Signal Swing vs Frequency)

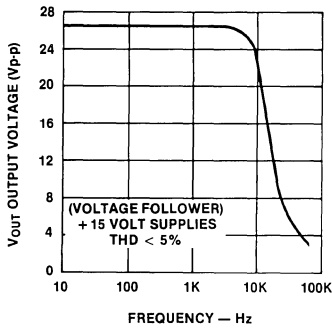

DESCRIPTION

The MC3403 is a quad operational amplifier with true differential inputs. The device has electrical characteristics similar to the popular μ A741. However, the MC3403 has several distinct advantages over standard operational amplifier types in single supply applications. The MC3403 can operate at supply voltages as low as 3.0V or as high as 32V. The common mode input range includes the negative supply, thereby eliminating the necessity for external biasing components in many applications. The output voltage range also includes the negative power supply voltage.

FEATURES

- Short circuit protected outputs
- Class AB output stage for minimal cross-over distortion
- True differential input stage
- Single supply operation: 3.0 to 32V
- Split supply operation: ± 1.5 to ± 16 V
- Low input bias currents: 500nA max
- Four amplifiers per package
- Internally compensated

PIN CONFIGURATION

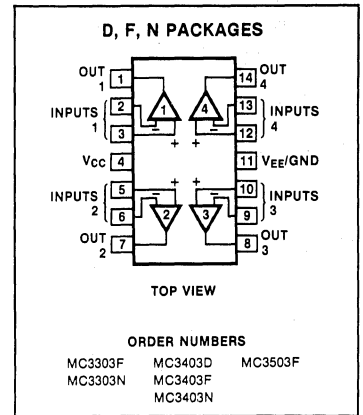

ABSOLUTE MAXIMUM RATINGS

SYMBOL AND PARAMETER	RATING	UNIT
Power supply voltages (3)		
V_{CC} Single supply	36	Vdc
V_{CC} Split supplies	+ 18	Vdc
V_{EE}	- 18	Vdc
V_{IDR} Input differential voltage range ⁽¹⁾	± 36	Vdc
V_{ICR} Input common mode voltage range ^(1,2)	± 18	Vdc
T_{stg} Storage temperature range		$^{\circ}$ C
Ceramic package	- 65 to + 150	$^{\circ}$ C
Plastic package	- 55 to + 125	$^{\circ}$ C
T_A Operating ambient temperature range		$^{\circ}$ C
MC3503	- 55 to + 125	$^{\circ}$ C
MC3403	0 to + 70	$^{\circ}$ C
MC3303	- 40 to + 85	$^{\circ}$ C
T_J Junction temperature		$^{\circ}$ C
Ceramic package	175	$^{\circ}$ C
Plastic package	150	$^{\circ}$ C

NOTES

1. Split power supplies.
2. For supply voltages less than ± 15 V, the absolute maximum input voltage is equal to the supply voltage.
3. Device not functional for single supply > 32 V or split supply $> \pm 16$ V

CIRCUIT SCHEMATIC (1/4 Shown)

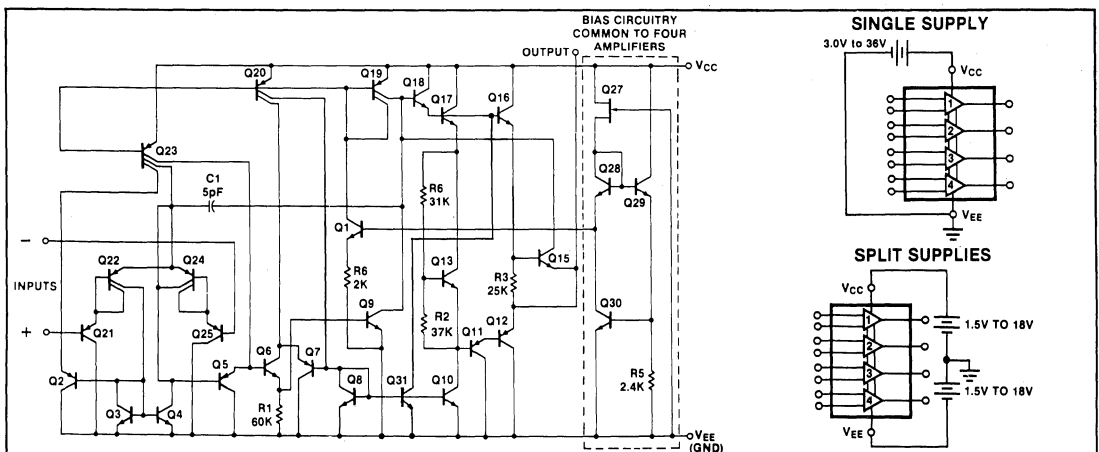

QUAD LOW POWER OPERATIONAL AMPLIFIERS

MC3303/3403/3503

ELECTRICAL CHARACTERISTICS ($V_{CC} = +15V$, $V_{EE} = -15V$ for MC3503, MC3403; $V_{CC} = +14V$, $V_{EE} = GND$ for MC3303. $T_A = 25^\circ C$ unless otherwise noted)

SYMBOL AND PARAMETER	TEST CONDITIONS	MC3503			MC3403			MC3303			UNIT
		Min	Typ	Max	Min	Typ	Max	Min	Typ	Max	
V_{IO} Input offset voltage	$T_A = T_{HIGH}$ to T_{LOW}	—	2.0	5.0	—	2.0	10	—	2.0	8.0	mV
		—	—	6.0	—	—	12	—	—	10	
I_{IO} Input offset current	$T_A = T_{HIGH}$ to T_{LOW}	—	10	50	—	10	50	—	30	75	nA
		—	—	200—	—	—	200—	—	250	—	
A_{VOL} Large signal open-loop voltage gain	$V_o = \pm 10V$, $R_L = 2.0k\Omega$ $T_A = T_{HIGH}$ to T_{LOW}	50	200	—	20	200	—	20	200	—	V/mV
		25	300	—	15	—	—	15	—	—	
I_{IB} Input bias current	$T_A = T_{HIGH}$ to T_{LOW}	—	-30	-500	—	-30	-500	—	-30	-500	nA
		—	-40	-1200	—	—	-800	—	—	-1000	
Z_o Output impedance	$f = 20Hz$	—	75	—	—	75	—	—	75	—	Ω
Z_i Input impedance	$f = 20Hz$	0.3	1.0	—	0.3	1.0	—	0.3	1.0	—	M Ω
V_{OR} Output voltage range	$R_L = 10k\Omega$ $R_L = 2.0k\Omega$ $R_L = 2.0k\Omega$ $T_A = T_{HIGH}$ to T_{LOW}	± 12 ± 10 ± 10	± 13.5 ± 13 —	—	± 12 ± 10 ± 10	± 13.5 ± 13 —	—	+12 +10 +10	+12.5 +12 —	—	V
V_{ICR} Input common mode voltage range		+13V - V_{EE}	+13.5V - V_{EE}	—	+13V - V_{EE}	+13.5V - V_{EE}	—	+12V - V_{EE}	+12.5V - V_{EE}	—	V
CMRR Common mode rejection ratio	$R_S \leq 10k\Omega$	70	90	—	70	90	—	70	90	—	dB
I_{CC}, I_{EE} Power supply current ($V_o = 0$)	$R_L = \infty$	—	2.5	4.0	—	2.5	7.0	—	2.5	7.0	mA
$\Delta I_B / \Delta T$	$T_A = T_{HIGH}$ to T_{LOW}	—	3.5	5	—	3.5	7	—	3.5	7	mA
$I_{OS\pm}$ Individual output short circuit current ²		± 10	± 30	± 45	± 10	± 20	± 45	± 10	± 30	± 45	mA
PSRR+ Positive power supply rejection ratio		—	30	150	—	30	150	—	30	150	$\mu V/V$
PSRR- Negative power supply rejection ratio		—	30	150	—	30	150	—	—	—	$\mu V/V$
$\Delta I_B / \Delta T$	$T_A = T_{HIGH}$ to T_{LOW}	—	50	—	—	50	—	—	50	—	pA/ $^\circ C$
$\Delta I_{IO} / \Delta T$ Average temperature coefficient of input offset current	$T_A = T_{HIGH}$ to T_{LOW}	—	50	—	—	50	—	—	50	—	pA/ $^\circ C$
$\Delta V_{IO} / \Delta T$ Average temperature coefficient of input offset voltage	$T_A = T_{HIGH}$ to T_{LOW}	—	10	—	—	10	—	—	10	—	$\mu V / ^\circ C$
BW_p Power bandwidth	$A_v = 1$, $R_L = 2.0k\Omega$, $V_o = 20V(p-p)$ THD = 5%	—	9.0	—	—	9.0	—	—	9.0	—	kHz
BW Small signal bandwidth	$A_v = 1$, $R_L = 10k\Omega$, $V_o = 50mV$	—	1.0	—	—	1.0	—	—	1.0	—	MHz
SR Slew rate	$A_v = 1$, $V_I = -10V$ to +10V	—	0.6	—	—	0.6	—	—	0.6	—	V/ μs
t_{TLH} Rise time	$A_v = 1$, $R_L = 10k\Omega$, $V_o = 50mV$	—	0.35	—	—	0.35	—	—	0.35	—	μs
t_{THL} Fall time	$A_v = 1$, $R_L = 10k\Omega$, $V_o = 50mV$	—	0.35	—	—	0.35	—	—	0.35	—	μs
OS Overshoot	$A_v = 1$, $R_L = 10k\Omega$, $V_o = 50mV$	—	20	—	—	20	—	—	20	—	%
ϕ_m Phase margin	$A_v = 1$, $R_L = 2.0k\Omega$, $C_L = 200pF$	—	50	—	—	50	—	—	50	—	$^\circ$
— Crossover distortion	$V_{IN} = 30mV(p-p)$, $V_{OUT} = 2.0V(p-p)$, $f = 10kHz$	—	1.0	—	—	1.0	—	—	1.0	—	%

NOTES:
 1. $T_{HIGH} = 125^\circ C$ for MC3503, $70^\circ C$ for MC3303. $T_{LOW} = -55^\circ C$ for MC3503, $0^\circ C$ for MC3403, $-40^\circ C$ for MC3303.
 2. Not to exceed maximum package power dissipation.

6

ELECTRICAL CHARACTERISTICS ($V_{CC} = 5.0V$, $V_E = GND$, $T_A = 25^\circ C$ unless otherwise noted.)

SYMBOL AND PARAMETER	TEST CONDITIONS	MC3503			MC3403			MC3303			UNIT
		Min	Typ	Max	Min	Typ	Max	Min	Typ	Max	
V_{IO} Input offset voltage		—	2.0	5.0	—	2.0	10	—	—	10	mV
I_{IO} Input offset current		—	30	50	—	30	50	—	—	75	nA
I_{IB} Input bias current		—	-200	-500	—	-200	-500	—	—	-500	nA
A_{VOL} Large signal open-loop voltage gain	$R_L = 2.0k\Omega$	10	200	—	10	200	—	10	200	—	V/mV
PSRR Power supply rejection ratio		—	—	150	—	—	150	—	—	150	$\mu V/V$
V_{OR} Output voltage range ³⁾	$R_L = 10k\Omega$, $V_{CC} = 5.0V$, $R_L = 10k\Omega$, $5.0V \leq V_{CC} \leq 30V$	3.3	3.5	—	3.3	3.5	—	3.3	3.5	—	Vp-p
I_{CC} Power supply current		—	2.5	4.0	—	2.5	7.0	—	2.5	7.0	mA
— Channel separation	$f = 1.0kHz$ to $20kHz$ (Input referenced)	—	-120	—	—	-120	—	—	-120	—	dB

NOTE

3. Output will swing to ground.

TYPICAL PERFORMANCE CURVES

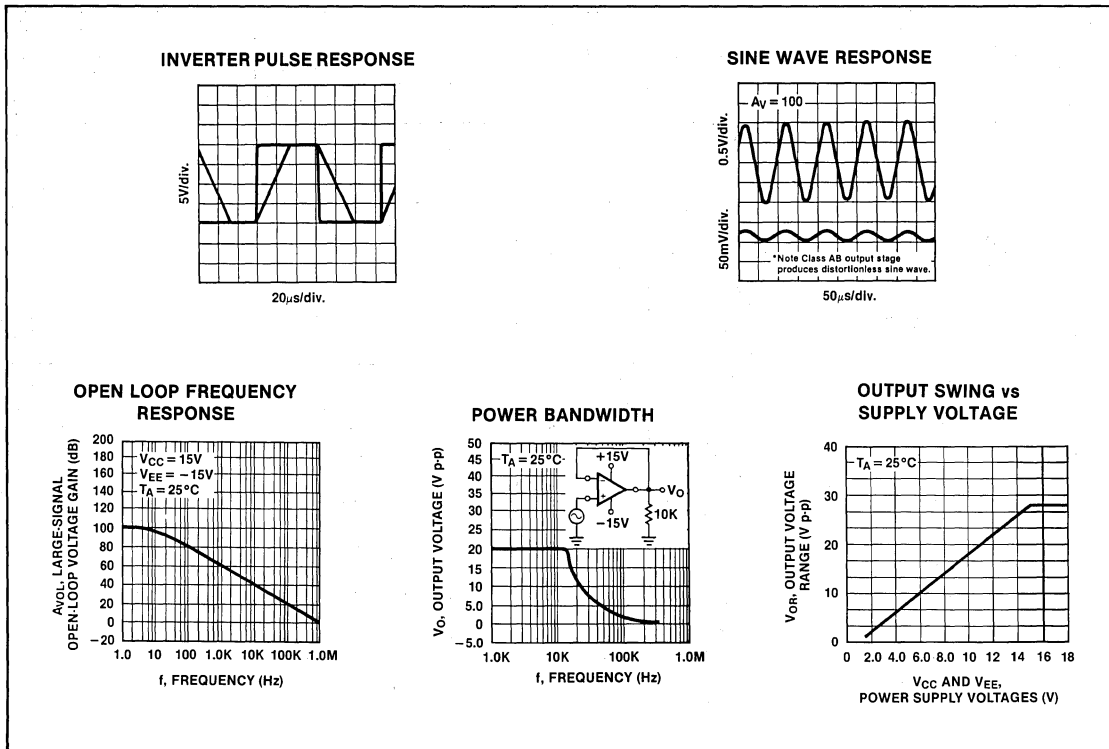

TYPICAL PERFORMANCE CURVES (Continued)

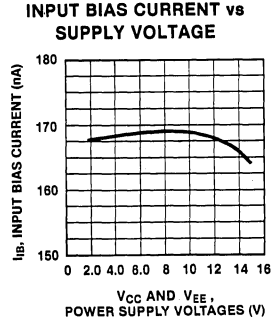
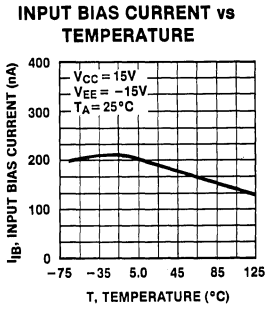

*For additional information, consult the Applications Section.

DUAL GENERAL-PURPOSE OPERATIONAL AMPLIFIER

SA/SE/NE4558

DESCRIPTION

The 4558 is a dual operational amplifier internally compensated. The use of planar epitaxial process for silicon chip construction gives the IC unique performance characteristics.

Excellent channel separation allows the use of a dual device in a single amp application, providing the highest packaging density. The SA/SE/NE4558 is a pin for pin replacement for the RC/RM/RV4558.

FEATURES

- 2 MHz unity gain bandwidth guaranteed
- Supply voltage $\pm 22V$ for SE4558 and $\pm 18V$ for NE4558
- Short circuit protection
- No frequency compensation required
- No latch-up
- Large common mode and differential voltage ranges
- Low power consumption

PIN CONFIGURATION

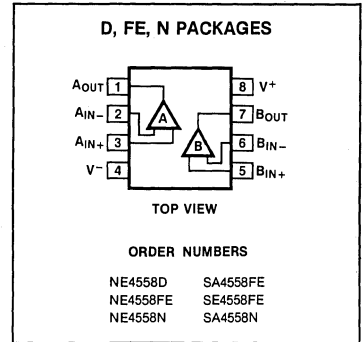

ABSOLUTE MAXIMUM RATINGS

PARAMETER	RATING	UNIT
Supply voltage		
SE4558:	± 22	V
NE4558, SA4558:	± 18	V
Internal power dissipation (Note 1)	500	mW
Differential input voltage	± 30	V
Input voltage (Note 2)	± 15	V
Storage temperature range	- 65 to + 150	$^{\circ}C$
Operating temperature range		
SE4558:	- 55 to + 125	$^{\circ}C$
SA4558:	- 40 to + 85	$^{\circ}C$
NE4558:	0 to + 70	$^{\circ}C$
Lead temperature (soldering, 60s)	300	$^{\circ}C$
Output short circuit duration (Note 3)	Indefinite	

NOTES

1. Rating applies for case temperatures to + 125 $^{\circ}C$; derate linearly at 5.6 mW/ $^{\circ}C$ for ambient temperatures above + 75 $^{\circ}C$ for SE4558.
2. For supply voltages less than $\pm 15V$, the absolute maximum input voltage is equal to the supply voltage.
3. Short circuit may be to ground on one amp only. Rating applies to + 125 $^{\circ}C$ case temperature or + 75 $^{\circ}C$ ambient temperature for NE4558 and to + 85 $^{\circ}C$ ambient temperature for SA4558.

EQUIVALENT SCHEMATIC

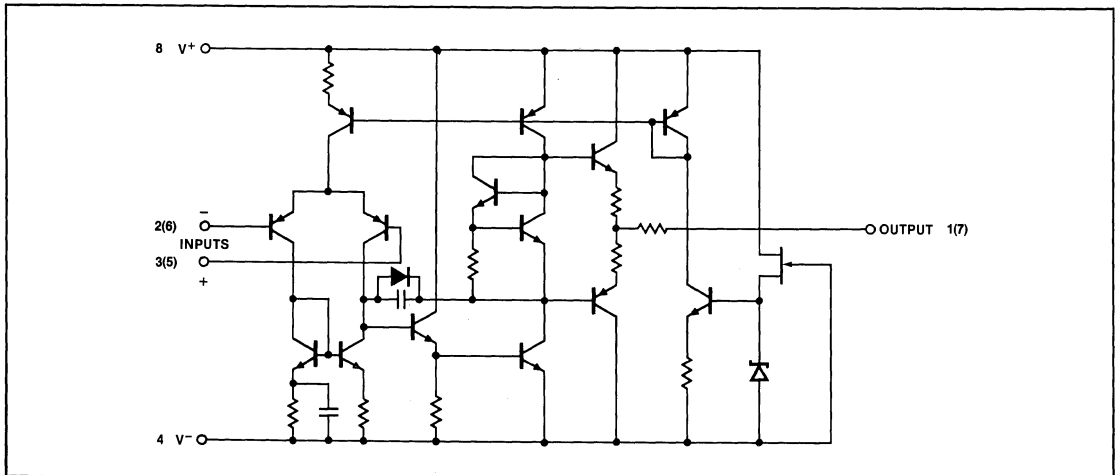

DUAL GENERAL-PURPOSE OPERATIONAL AMPLIFIER

SA/SE/NE4558

ELECTRICAL CHARACTERISTICS $V_{CC} = \pm 15V$, $T_A = 25^\circ C$ unless otherwise specified.

PARAMETER	TEST CONDITIONS	SE4558			SA/NE4558			UNIT
		Min	Typ	Max	Min	Typ	Max	
Input offset voltage	$R_S \leq 10k\Omega$		1.0	5.0		2.0	6.0	mV
$\Delta V_{OS}/\Delta T$	Over temp.		4			4		$\mu V/^\circ C$
Input offset current			50	200		30	200	nA
$\Delta I_{OS}/\Delta T$	Over temp.		20			20		$pA/^\circ C$
Input bias current			40	500		200	500	nA
$\Delta I_B/\Delta T$	Over temp.		40			40		$pA/^\circ C$
Input resistance		0.3	1.0		0.3	1.0		M Ω
Large signal voltage gain	$R_L \geq 2K\Omega$ $V_{OUT} = \pm 10V$	50,000	300,000		20,000	300,000		V/V
Output voltage swing	$R_L \geq 10k\Omega$ $R_L \geq 2k\Omega$	± 12 ± 10	± 14 ± 13		± 12 ± 10	± 14 ± 13		V
Input voltage range		± 12	± 13		± 12	± 13	V	
Common mode rejection ratio	$R_S \leq 10k\Omega$	70	100		70	100		dB
Supply voltage rejection ratio	$R_S \leq 10k\Omega$		10	150		10	150	$\mu V/V$
Power consumption (all amplifiers)	$R_L = \bullet$		100	170		100	170	mW
Transient response (unity gain)	$V_{IN} = 20mV$ $R_L = 2K\Omega$ $C_L \leq 100pF$							
Risetime			100			100		ns
Overshoot			15.0			15.0		%
Slew rate (unity gain)	$R_L \geq 2k\Omega$		1.0			1.0		V/ μs
Channel separation (gain = 100)	$f = 10kHz$ $R_S = 1k\Omega$		90			90		dB
Unity gain bandwidth (gain = 1)		2.5	3.0		2.0	3.0		MHz
θ_M phase margin	$T_A = 25^\circ C$		45			45		Degree
Input noise voltage	$f = 1kc$		25			25		nv/\sqrt{Hz}
I_{SC} short circuit	$T_A = 25^\circ C$	5	25	50	5	25	50	mA
The following specifications apply for $-55^\circ C \leq T_A \leq +125^\circ C$ for SE4558; $0^\circ C \leq T_A \leq +70^\circ C$ for NE4558; $-40^\circ C \leq T_A \leq +85^\circ C$ for SA4558								
Input offset voltage	$R_S \leq 10k\Omega$			6.0			7.5	mV
Input offset current				500			300/500*	nA
Input bias current				1500			800/1500*	nA
Large signal voltage gain	$R_L \geq 2k\Omega$ $V_{OUT} = \pm 10$	25,000			15,000			
Output voltage swing	$R_L \geq 2k\Omega$	± 10			± 10			V
Power consumption	$V_S = \pm 15V$ $T_A = HIGH$ $T_A = LOW$		90 120	150 200		90 120	150 200	mW

*SA4558

TYPICAL PERFORMANCE CURVES

INPUT BIAS CURRENT AS A FUNCTION OF AMBIENT TEMPERATURE

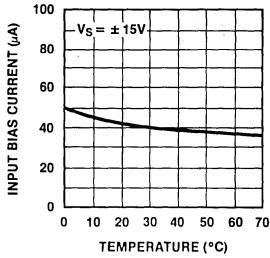

INPUT OFFSET CURRENT AS A FUNCTION OF AMBIENT TEMPERATURE

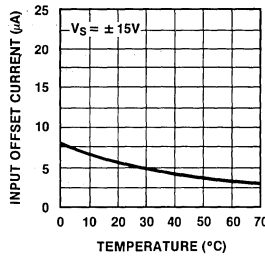

COMMON MODE RANGE AS A FUNCTION OF SUPPLY VOLTAGE

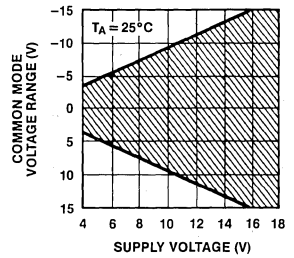

OPEN LOOP VOLTAGE GAIN AS A FUNCTION OF FREQUENCY

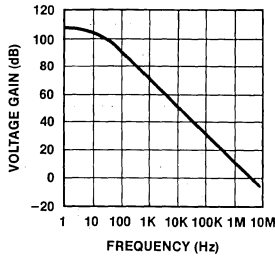

OPEN LOOP GAIN AS A FUNCTION OF TEMPERATURE

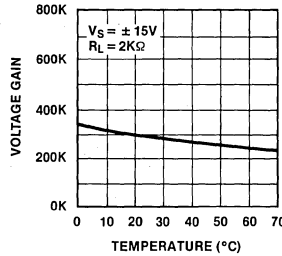

POWER CONSUMPTION AS A FUNCTION OF AMBIENT TEMPERATURE

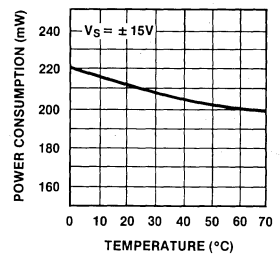

TYPICAL OUTPUT VOLTAGE AS A FUNCTION OF SUPPLY VOLTAGE

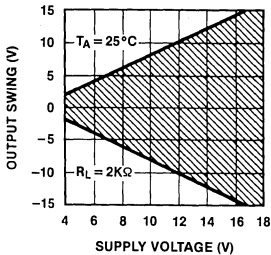

OUTPUT VOLTAGE SWING AS A FUNCTION OF LOAD RESISTANCE

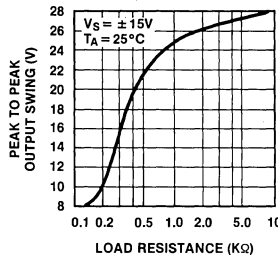

OUTPUT VOLTAGE SWING AS A FUNCTION OF FREQUENCY

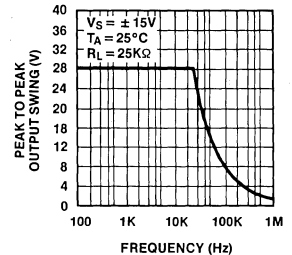

TYPICAL PERFORMANCE CURVES (Continued)

QUIESCENT CURRENT AS A FUNCTION OF SUPPLY VOLTAGE

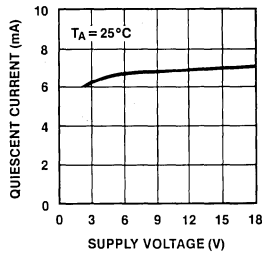

TRANSIENT RESPONSE

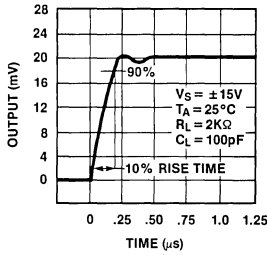

VOLTAGE FOLLOWER LARGE-SIGNAL PULSE RESPONSE

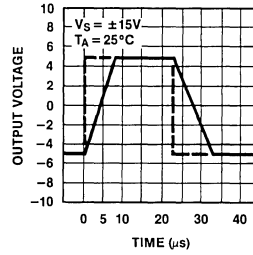

INPUT NOISE VOLTAGE AS A FUNCTION OF FREQUENCY

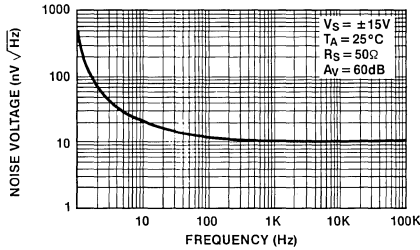

INPUT NOISE CURRENT AS A FUNCTION OF FREQUENCY

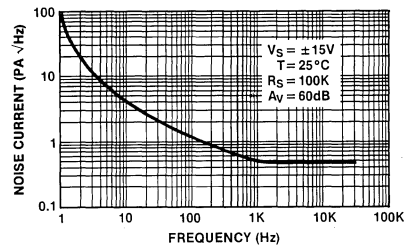

CHANNEL SEPARATION

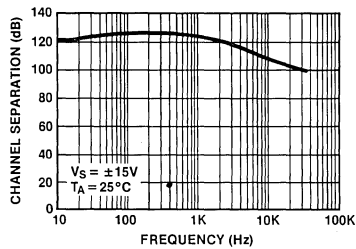

TOTAL HARMONIC DISTORTION vs OUTPUT VOLTAGE

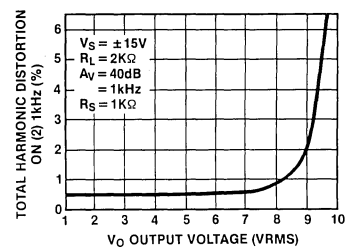

DISTORTION vs FREQUENCY
 $V_O = 1\text{vrms}$

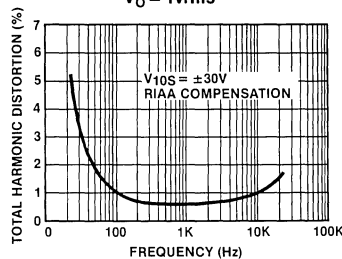

HIGH SLEW RATE OPERATIONAL AMPLIFIER

SE/NE530

DESCRIPTION

The 530 is a new generation operational amplifier featuring a high slew rate combined with improved input characteristics. Internally compensated, the SE530 guarantees slew rates of $25V/\mu s$ with 2mV maximum offset voltage. Industry standard pinout and internal compensation allow the user to upgrade system performance by directly replacing general purpose amplifiers such as the 741 and LF356 types.

FEATURES

- Gain bandwidth product—3MHz
- $35V/\mu s$ slew rate (Gain = -1)
- Internal frequency compensation
- Low input offset voltage 2mV max
- Low input bias current-60nA max
- Short circuit protection
- Offset null capability
- Large common mode and differential voltage ranges

PIN CONFIGURATIONS

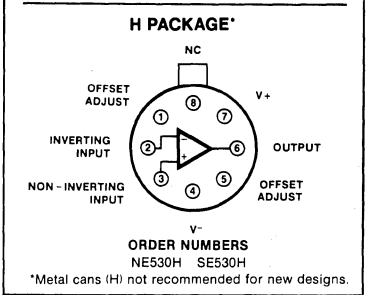
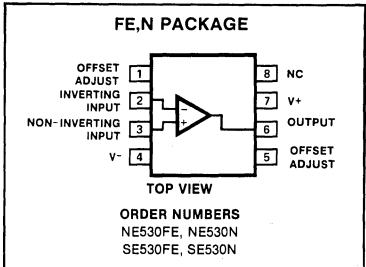

ABSOLUTE MAXIMUM RATINGS

PARAMETER	RATING	UNIT
Supply voltage		
SE530	± 22	V
NE530	± 18	V
Internal power dissipation		
N Package	500	mW
H Package	800	mW
FE Package	1000	mW
Differential input voltage	± 30	V
Input voltage	± 15	V
Operating temperature range		
SE530	-55 to +125	$^{\circ}C$
NE530	0 to +70	$^{\circ}C$
Storage temperature range	-65 to +150	$^{\circ}C$
Lead temperature range (Solder, 60sec)	300	$^{\circ}C$
Output short circuit	Indefinite	

EQUIVALENT SCHEMATIC EACH AMPLIFIER

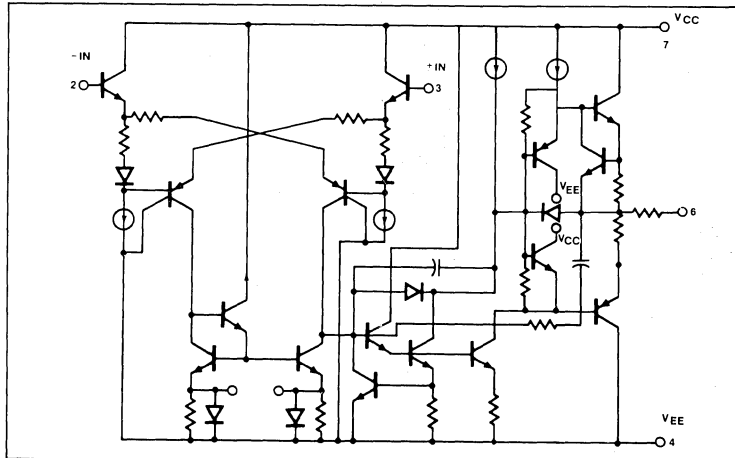

HIGH SLEW RATE OPERATIONAL AMPLIFIER

SE/NE530

DC ELECTRICAL CHARACTERISTICS $T_A = 25^\circ\text{C}$, $V_{CC} = \pm 15\text{V}$ unless otherwise specified.¹

PARAMETER	TEST CONDITIONS	SE530			NE530			UNIT
		Min	Typ	Max	Min	Typ	Max	
V_{OS} Input offset voltage	$R_S \leq 10\text{k}\Omega$ Over temperature		0.7	4.0 5.0		2.0	6.0 7.0	mV mV
ΔV_{OS} Temperature coefficient of input offset voltage	Over temperature		3	15		6		$\mu\text{V}/^\circ\text{C}$
I_{OS} Input offset current	Over temperature		5	20 40		15	40 80	nA nA
ΔI_{OS} Input offset current	Over temperature		25			40		$\text{pA}/^\circ\text{C}$
I_B Input bias current	Over temperature		45	80 200		65	150 200	nA nA
ΔI_B Input current	Over temperature		50			80		$\text{pA}/^\circ\text{C}$
R_{IN} Input resistance		3	10		1	6		$\text{M}\Omega$
V_{CM} Input common mode voltage range		± 12	± 13		± 12	± 13		V
A_{VOL} Large signal voltage gain	$R_L \geq 2\text{k}\Omega$, $V_O = \pm 10\text{V}$ Over temperature	50 25	200		50 25	200		V/mV V/mV
V_{OUT} Output voltage swing	$R_L \geq 10\text{k}\Omega$ $R_L \geq 2\text{k}\Omega$	± 12 ± 10	± 14 ± 13		± 12 ± 10	± 14 ± 13		V V
I_{SC} Output short circuit current		10	25	50	10	25	50	mA
R_{OUT} Output resistance			100			100		Ω
I_{CC} Supply current	Each amplifier Over temperature		2.0 2.2	3.0 3.6		2.0 2.2	3.0	mA mA
CMRR Common mode rejection ratio	$R_S \leq 10\text{k}\Omega$ Over temperature	70	90		70	90		dB
PSRR Power supply rejection ratio	$R_S \leq 10\text{k}\Omega$ Over temperature		30	150		30	150	$\mu\text{V}/\text{V}$

6

AC ELECTRICAL CHARACTERISTICS $T_A = 25^\circ\text{C}$, $V_{CC} = \pm 15\text{V}$ unless otherwise specified.

PARAMETER	TEST CONDITIONS	SE530/5530			NE530/5530			UNIT
		Min	Typ	Max	Min	Typ	Max	
Transient Response Small signal rise time Small signal overshoot Settling time	TO 0.1% (10V step)		.06 13 0.9			.06 13 0.9		μs % μs
Slew rate Unity gain inverting Unity gain non-inverting	$\pm 15\text{V}$ supply, $V_O = \pm 10\text{V}$, $R_L \geq 2\text{k}\Omega$	25 18	35 25		20 12	35 25		$\text{V}/\mu\text{s}$ $\text{V}/\mu\text{s}$
Power bandwidth	5% THD, $V_O = \pm 10\text{V}$, $R_L \geq 2\text{k}\Omega$	360	500		280	500		kHz
Small signal bandwidth	Open loop		3			3		MHz
Input noise voltage	$f = 1\text{kHz}$		30			30		$\text{nV}/\sqrt{\text{Hz}}$

NOTE

1. Operating temperature range for the SE530 is -55°C to $+125^\circ\text{C}$
Operating temperature range for the NE530 is 0°C to $+70^\circ\text{C}$.

TYPICAL PERFORMANCE CHARACTERISTICS

OUTPUT VOLTAGE SWING AS A FUNCTION OF SUPPLY VOLTAGE

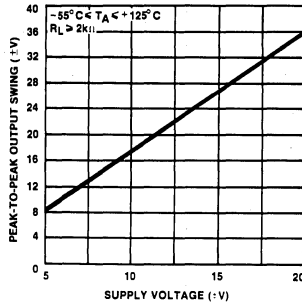

INPUT COMMON MODE VOLTAGE RANGE AS A FUNCTION OF SUPPLY VOLTAGE

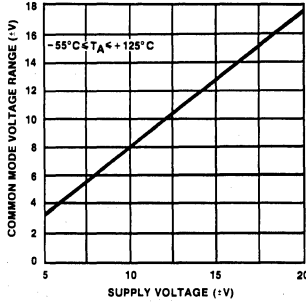

OUTPUT SHORT-CIRCUIT CURRENT AS A FUNCTION OF AMBIENT TEMPERATURE

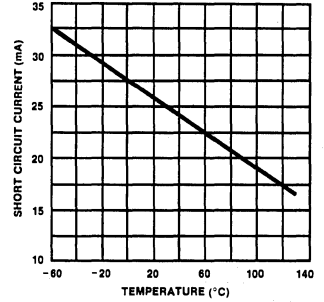

INPUT NOISE VOLTAGE AS A FUNCTION OF FREQUENCY

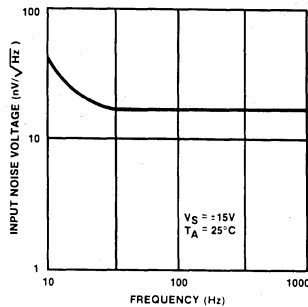

INPUT NOISE CURRENT AS A FUNCTION OF FREQUENCY

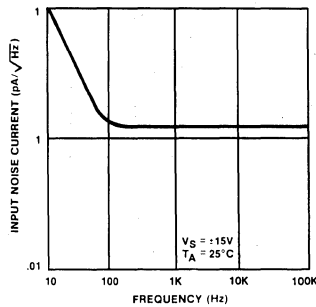

POWER CONSUMPTION AS A FUNCTION OF SUPPLY VOLTAGE (EACH AMPLIFIER)

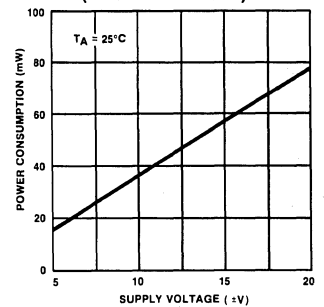

INPUT BIAS CURRENT AS A FUNCTION OF AMBIENT TEMPERATURE

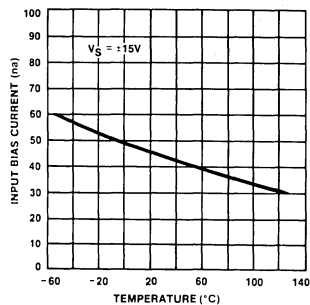

POWER CONSUMPTION AS A FUNCTION OF AMBIENT TEMPERATURE (EACH AMPLIFIER)

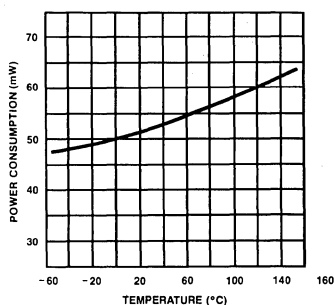

OUTPUT VOLTAGE SWING AS A FUNCTION OF LOAD RESISTANCE

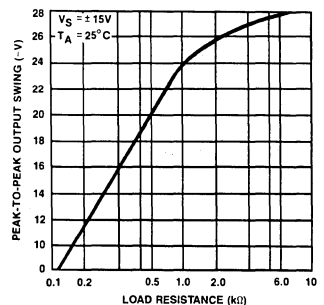

TYPICAL PERFORMANCE CHARACTERISTICS (Cont'd)

NE530 OPEN-LOOP GAIN AND PHASE vs FREQUENCY

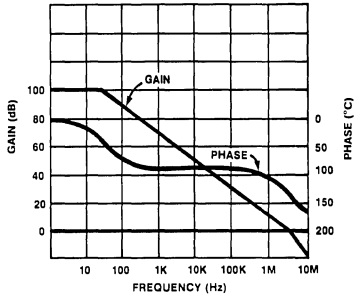

GAIN-BANDWIDTH PRODUCT AND PHASE MARGIN vs LOAD CAPACITANCE

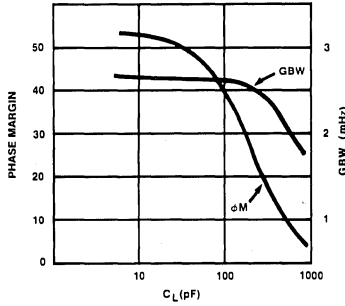

POWER BANDWIDTH

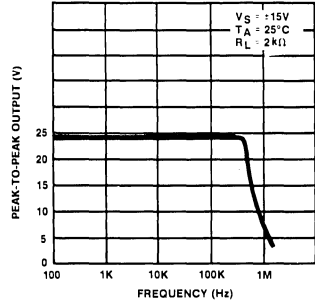

INPUT VOLTAGE STEP vs SETTLING TIME TO 10mV

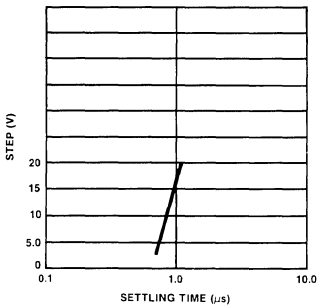

SLEW RATE—VOLTAGE FOLLOWER

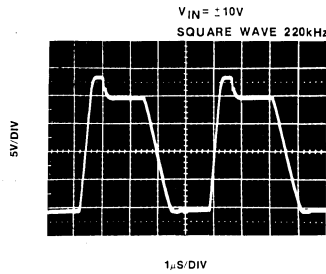

SLEW RATE (-1 AMPLIFIER)

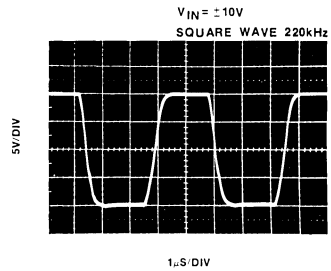

TYPICAL CIRCUIT CONNECTION

OFFSET ADJUST CIRCUIT

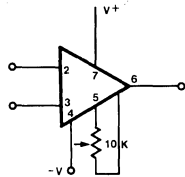

TEST LOAD CIRCUITS

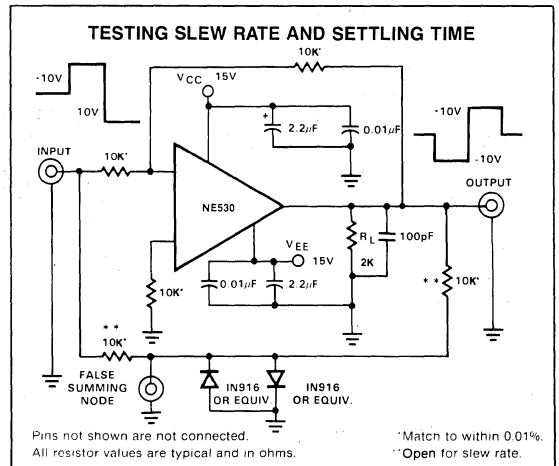
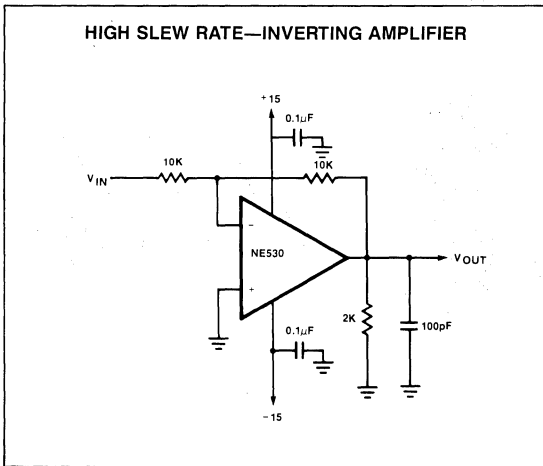
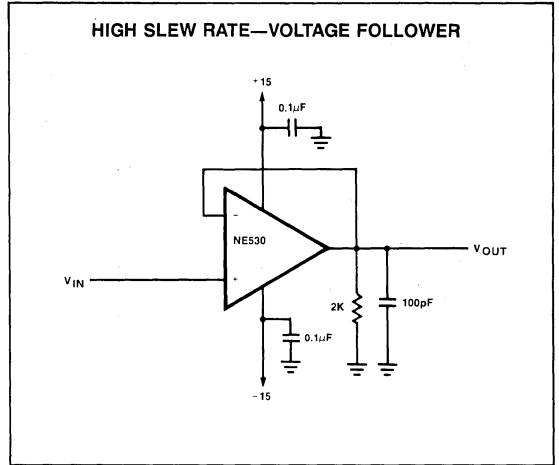
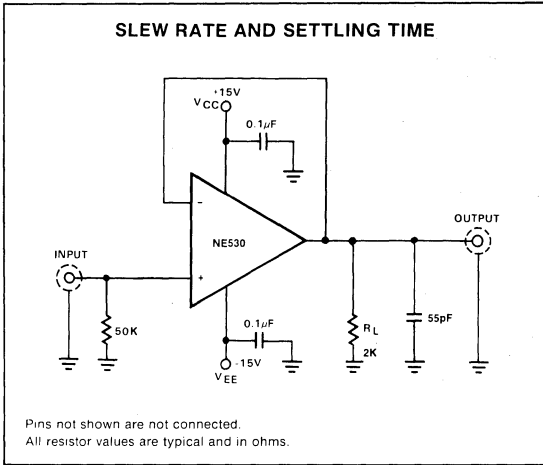

VOLTAGE WAVEFORMS

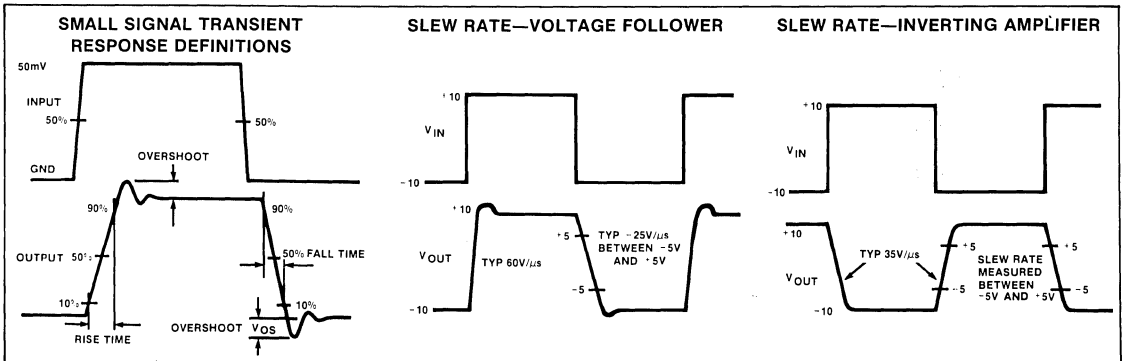

HIGH SLEW RATE OPERATIONAL AMPLIFIER

SE/NE531

DESCRIPTION

The 531 is a fast slewing high performance operational amplifier which retains dc performance equal to the best general purpose types while providing far superior large signal ac performance. A unique input stage design allows the amplifier to have a large signal response nearly identical to its small signal response. The amplifier is compensated for truly negligible overshoot with a single capacitor. In applications where fast settling and superior large signal bandwidths are required, the amplifier outperforms conventional designs which have much better small signal response. Also, because the small signal response is not extended, no special precautions need be taken with circuit board layout to achieve stability. The high gain, simple compensation and excellent stability of this amplifier allow its use in a wide variety of instrumentation applications.

FEATURES

- 35V/ μ sec slew rate at unity gain
- Pin for pin replacement for μ A709, μ A748 or LM101
- Compensated with a single capacitor
- Same low drift offset null circuitry as μ A741
- Small signal bandwidth 1MHz
- Large signal bandwidth 500KHz
- True op amp dc characteristics make the 531 the ideal answer to all slew rate limited operational amplifier applications.

PIN CONFIGURATIONS

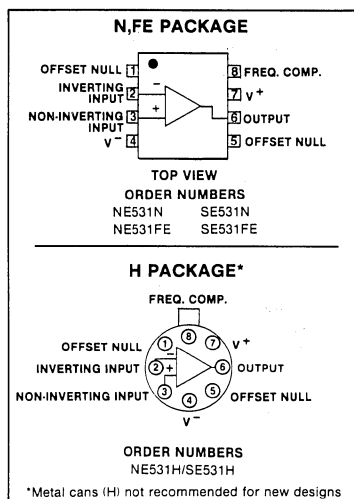

EQUIVALENT SCHEMATIC

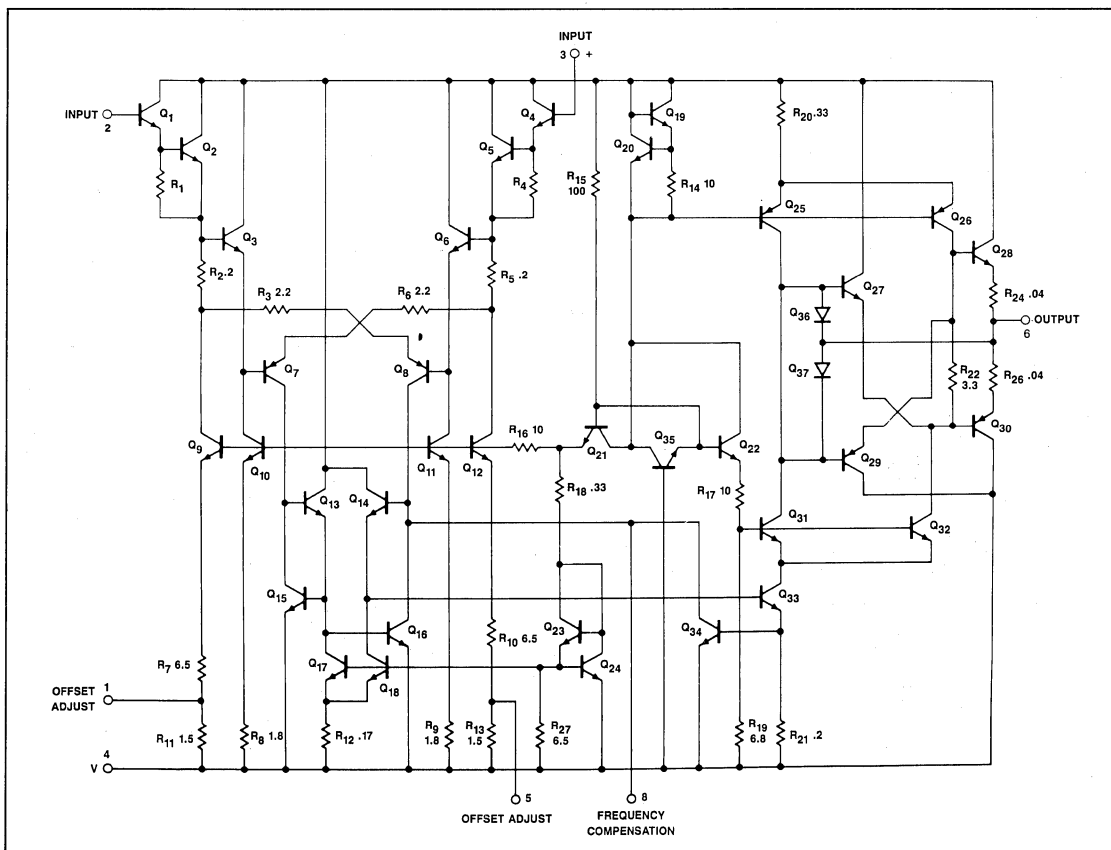

6

HIGH SLEW RATE OPERATIONAL AMPLIFIER

SE/NE531

ABSOLUTE MAXIMUM RATINGS

PARAMETER	RATING	UNIT
Supply voltage	±22	V
Internal power dissipation ¹	300	mW
Differential input voltage	±15	V
Common mode input voltage ²	±15	V
Voltage between offset null and V-	±0.5	V
Operating temperature range		
NE531	0 to +70	°C
SE531	-55 to +125	°C
Storage temperature range	-65 to +150	°C
Lead temperature (soldering, 60 sec)	300	°C
Output short circuit duration ³	indefinite	

NOTES

1. Rating applies for case temperature to 125°C, derate linearly at 6.5mW/°C for ambient temperatures above +75°C.
2. For supply voltages less than ±15V, the absolute maximum input voltage is equal to the supply voltage.
3. Short circuit may be to ground or either supply. Rating applies to +125°C case temperature or to +75°C ambient temperature.

DC ELECTRICAL CHARACTERISTICS $V_S = \pm 15V$ unless otherwise specified.

PARAMETER	TEST CONDITIONS	SE531 ¹			NE531			UNIT
		Min	Typ	Max	Min	Typ	Max	
V_{OS} Offset voltage	$R_S \leq 10k\Omega, T_A = 25^\circ C$		2.0	5.0		2.0	6.0	mV
ΔV_{OS}	$R_S \leq 10k\Omega, \text{ over temp}$ Over temp		10	6.0		10	7.5	mV $\mu V/^\circ C$
I_{OS} Offset current	$T_A = 25^\circ C$ $T_A = \text{HIGH}$ $T_A = \text{LOW}$ Over temp		30	200 200 500		50	200 200 300	nA nA nA nA/°C
ΔI_{OS}	Over temp		0.4			0.4		nA/°C
I_{BIAS} Input current	$T_A = 25^\circ C$ $T_A = \text{HIGH}$ $T_A = \text{LOW}$ Over temp		300	500 500 1500		400	1500 1500 2000	nA nA nA nA/°C
ΔI_B	Over temp		2			2		nA/°C
V_{CM} Common mode voltage range	$T_A = 25^\circ C$	± 10			± 10			V
CMRR Common mode rejection ratio	$T_A = 25^\circ C, R_S \leq 10k\Omega$ Over temp $R_S \leq 10k\Omega$	70	90		70	100		dB dB
R_{IN} Input resistance	$T_A = 25^\circ C$		20			20		MΩ
V_{OUT} Output voltage swing	$R_L \geq 10k\Omega, \text{ over temp}$	± 10	± 13		± 10	± 13		V
I_{CC} Supply current	$T_A = 25^\circ C$ T_{MAX} $T_A = 25^\circ C$			7.0 7.0 210			10 10 300	mA mA mW
P_D Power consumption	$T_A = 25^\circ C$							mW
PSRR Power supply rejection ratio	$R_S \leq 10k\Omega, T_A = 25^\circ C$ $R_S \leq 10k\Omega, \text{ over temp}$		10	150		10	150	$\mu V/V$ $\mu V/V$
R_{OUT} Output resistance	$T_A = 25^\circ C$		75			75		Ω
A_{VOL} Large signal voltage gain	$T_A = 25^\circ C, R_L \geq 10k\Omega, V_{OUT} = \pm 10V$ $R_L \geq 10k\Omega, V_{OUT} = \pm 10V, \text{ over temp}$	50 25	100		20 15	60		V/mV V/mV
V_{INN} Input noise voltage	25°C, f = 1kHz		20			20		nV/√Hz
I_{SC}	25°C	5	15	45	5	15	45	mA

NOTE:

1. Temperature range:
SE531 -55°C ≤ T_A ≤ 125°C
NE531 0°C ≤ T_A ≤ 70°C

HIGH SLEW RATE OPERATIONAL AMPLIFIER

SE/NE531

AC ELECTRICAL CHARACTERISTICS $T_A = 25^\circ\text{C}$, $V_S = \pm 15\text{V}$ unless otherwise specified.

PARAMETER	TEST CONDITIONS	NE531			SE531			UNIT
		Min	Typ	Max	Min	Typ	Max	
Full power bandwidth			500			500		kHz
Settling time (1%) (.1%)	$A_v = +1$, $V_{IN} = \pm 10\text{V}$		1.5 2.5			1.5 2.5		μs μs
Large signal overshoot	$A_v = +1$, $V_{IN} = \pm 10\text{V}$		2			2		%
Small signal overshoot	$A_v = +1$, $V_{IN} = 400\text{mV}$		5			5		%
Small signal risetime	$A_v = +1$, $V_{IN} = 400\text{mV}$		300			300		ns
Slew rate	$A_v = 100$ $A_v = 10$ $A_v = 1$ (noninverting) $A_v = 1$ (inverting)		35 35 30 35			35 35 30 35		$\text{V}/\mu\text{s}$ $\text{V}/\mu\text{s}$ $\text{V}/\mu\text{s}$ $\text{V}/\mu\text{s}$

NOTE

1. All AC testing is performed in the transient response test circuit.

TEST LOAD CIRCUITS

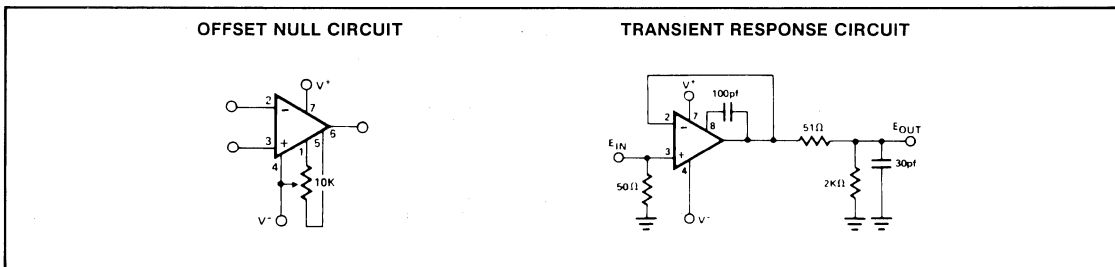

6

TYPICAL PERFORMANCE CHARACTERISTICS ($V_S = \pm 15\text{V}$, $T_A = +25^\circ\text{C}$, unless otherwise specified.)

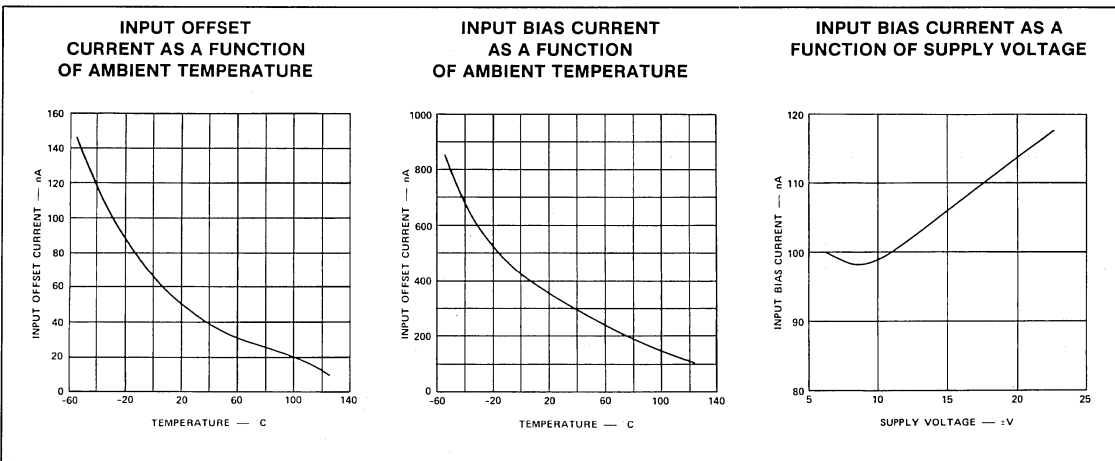

HIGH SLEW RATE OPERATIONAL AMPLIFIER

SE/NE531

TYPICAL PERFORMANCE CHARACTERISTICS (Cont'd)

CLOSED LOOP NON-INVERTING VOLTAGE GAIN AS A FUNCTION OF FREQUENCY

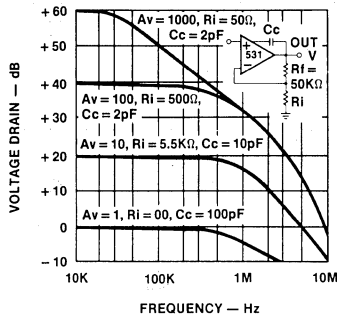

OPEN LOOP PHASE RESPONSE AND VOLTAGE GAIN AS A FUNCTION OF FREQUENCY

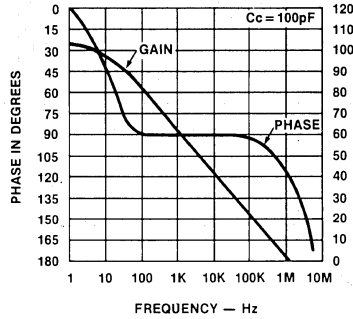

POWER CONSUMPTION AS A FUNCTION OF SUPPLY VOLTAGE

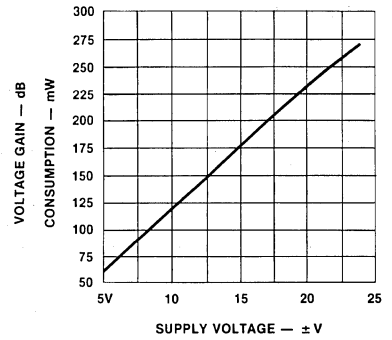

POWER CONSUMPTION AS A FUNCTION OF AMBIENT TEMPERATURE

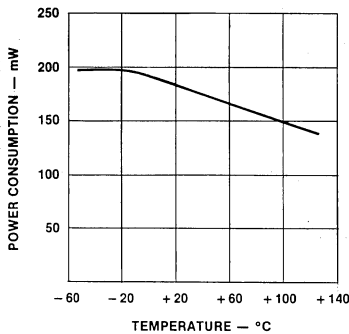

OPEN LOOP VOLTAGE GAIN AS A FUNCTION OF SUPPLY VOLTAGE

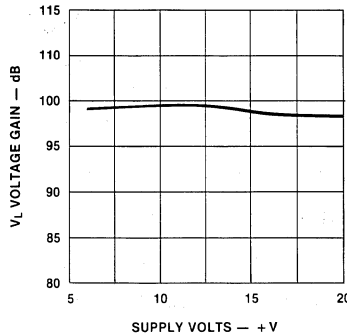

OUTPUT VOLTAGE SWING AS A FUNCTION OF SUPPLY VOLTAGE

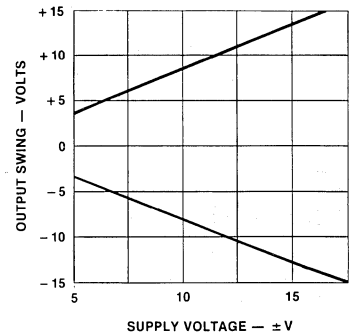

INPUT VOLTAGE RANGE AS A FUNCTION OF SUPPLY VOLTAGE

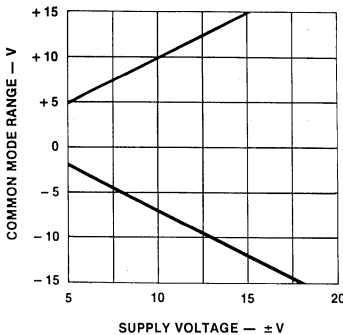

OUTPUT VOLTAGE SWING AS A FUNCTION OF FREQUENCY

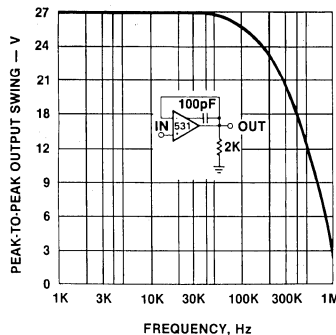

VOLTAGE FOLLOWER LARGE SIGNAL RESPONSE

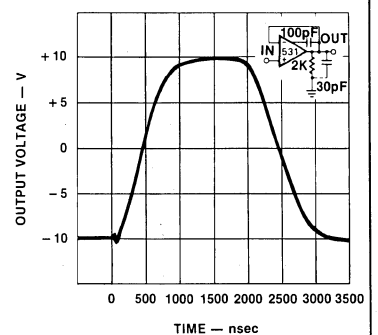

HIGH SLEW RATE OPERATIONAL AMPLIFIER

SE/NE531

TYPICAL PERFORMANCE CHARACTERISTICS (Cont'd)

**VOLTAGE FOLLOWER
TRANSIENT RESPONSE**

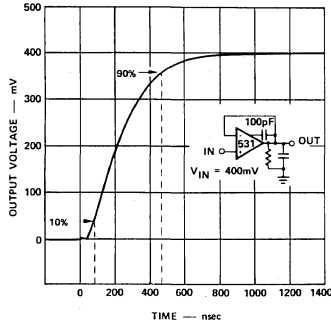

**UNITY GAIN INVERTING
AMPLIFIER LARGE SIGNAL
RESPONSE**

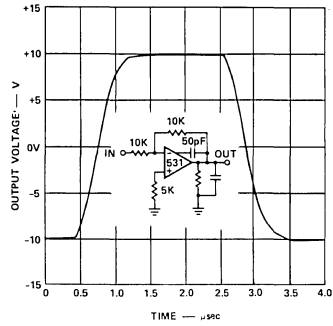

TYPICAL APPLICATIONS

**HIGH SPEED INVERTER
(10MHz BANDWIDTH)**

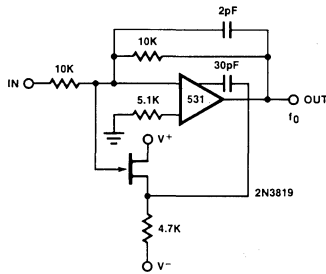

**PULSE RESPONSE
HIGH SPEED INVERTER**

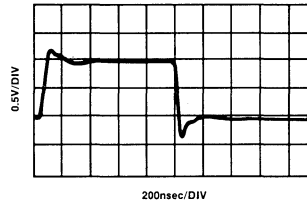

FAST SETTLING VOLTAGE FOLLOWER

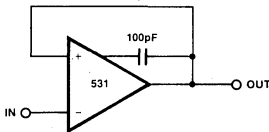

**LARGE SIGNAL RESPONSE
VOLTAGE FOLLOWER**

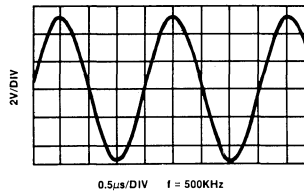

6

TYPICAL APPLICATIONS (Cont'd)

THREE POLE ACTIVE LOW PASS FILTER BUTTERWORTH MAXIMALLY FLAT RESPONSE*

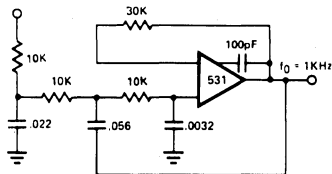

RESPONSE OF 3-POLE ACTIVE BUTTERWORTH MAXIMALLY FLAT FILTER

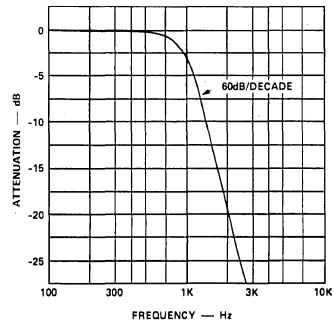

*Reference—EDN Dec. 15, 1970
Simplify 3-Pole Active Filter Design
A. Paul Brokow

PRECISION RECTIFIERS

(a) HALF WAVE

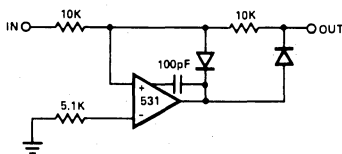

(b) FULL WAVE

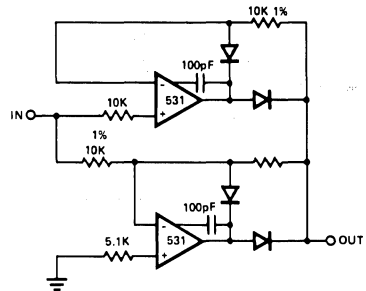

AC MILLIVOLTMETER

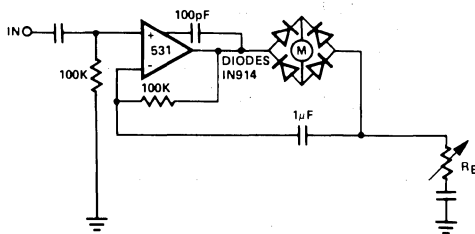

SAMPLE AND HOLD

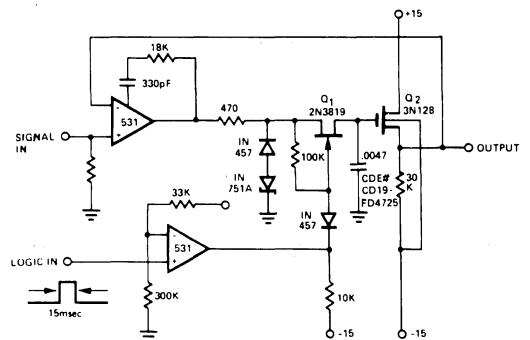

CYCLIC A TO D CONVERTER

One interesting, but, much ignored A/D converter is the cyclic converter. This consists of a chain of identical stages, each of which senses the polarity of the input. The stage then subtracts V_{ref} from the input and doubles the remainder if the polarity was correct. In Figure 1 the signal is full wave rectified and the remainder of $V_{in} - V_{ref}$ is doubled. A chain of these stages gives the gray code equivalent of the input voltage in digitized form related to the magnitude of V_{ref} . Possessing high potential accuracy, the circuit using NE531 devices settles in $5\mu s$.

TRIANGLE AND SQUARE WAVE GENERATOR

The circuit in Figure 2 will generate precision triangle and square waves. The output amplitude of the square wave is set by the output swing of the op amp A-1 and $R1/R2$ sets the triangle amplitude. The frequency of oscillation in either case is

$$f = \frac{1}{4RC} \cdot \frac{R2}{R1} \quad (3-23)$$

The square wave will maintain 50% duty cycle even if the amplitude of the oscillation is not symmetrical.

The use of the NE531 in this circuit will allow good square waves to be generated to quite high frequencies. Since the amplifier A1 runs open loop, there is no need for compensation. The triangle-generating amplifier must be compensated. The NE5535 device can be used as well, except for the lower frequency response.

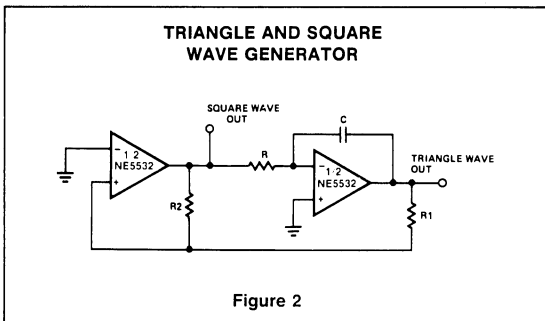
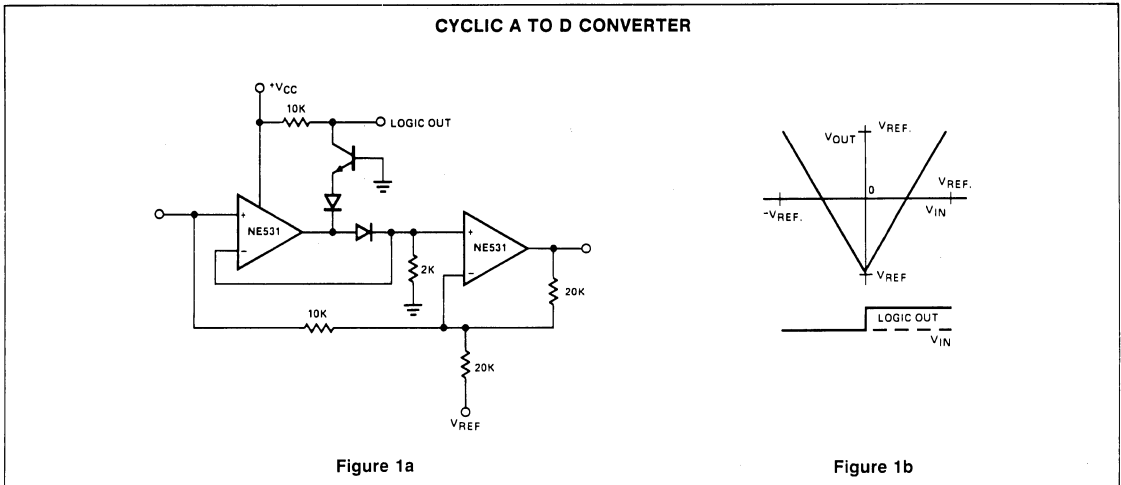

6

HIGH SLEW RATE OP AMP

SE/NE538

DESCRIPTION

The SE/NE538 is a new generation operational amplifier featuring high slew rates combined with improved input characteristics. Internally compensated for gains of 5 or larger, the SE538 offers guaranteed minimum slew rates of 40V/μs or larger. Featuring 2mV max input offset voltage, the 538 is a single amplifier. Industry standard pin out and internal compensation allow the user to upgrade system performance by directly replacing general purpose amplifiers, such as 748, 101A and 741.

FEATURES

- 2mV input offset voltage
- 80nA max input offset current
- Short circuit protected
- Offset null capability
- Large common mode and differential voltage ranges
- 60V/μs slew rate (gain of +5, -4 min)
- 6MHz gain bandwidth product (gain +5, -4 minimum)
- Internal frequency compensation (gain of +5, -4 minimum)
- Pin out: 538 same as 741 (single)

ABSOLUTE MAXIMUM RATINGS^{1,2,3}

PARAMETER	RATING	UNIT
V _{CC} Supply voltage	SE military grade	±22 V
	NE commercial grade	±18 V
P _D Internal power dissipation	FE package	1000 mW
	N package	500 mW
P _D Internal power dissipation ¹	H package	800 mW
	Differential input voltage	±30 V
Input voltage ²	±15 V	
Operating temperature range		
SE military grade	-55 to +125	°C
NE commercial grade	0 to 70	°C
Output short circuit ³	indefinite	
Storage temperature range	-65 to +150	°C
Lead temperature (solder, 60sec.)	300	°C

NOTES

1. Rating applies for thermal resistances of 240°C/W and 150°C/W junction to ambient for N and H packages. Maximum chip temperature is 150°C.
2. For supply voltages less than ±15V, the absolute maximum input voltage is equal to the supply voltage.
3. Short circuit may be to ground or either supply. Rating applies to 125°C case temperature or 75°C ambient temperature.

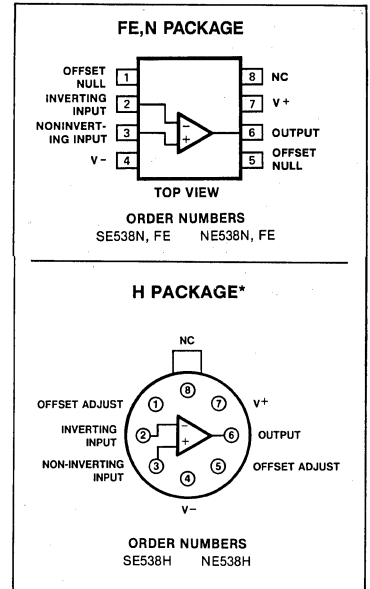

EQUIVALENT SCHEMATIC (EACH AMPLIFIER)

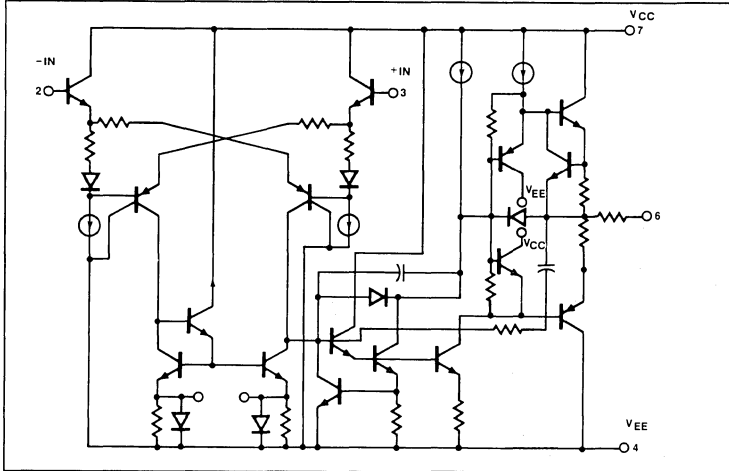

DC ELECTRICAL CHARACTERISTICS $T_A = 25^\circ\text{C}$, $V_S = \pm 15\text{V}$ unless otherwise specified.

PARAMETER	TEST CONDITIONS	SE538			NE538			UNIT
		Min	Typ	Max	Min	Typ	Max	
V_{OS} Input offset voltage	$R_S \leq 10\text{k}\Omega$ $R_S \leq 10\text{k}\Omega$, over temp.		0.7	4.0 5.0		2.0	6.0 7.0	mV mV
ΔV_{OS} Input offset voltage drift	$R_S = 0\Omega$, over temp.		4.0			6.0		$\mu\text{V}/^\circ\text{C}$
I_{OS} Input offset current	Over temp.		5	20 40		15	40 80	nA nA
ΔI_{OS} Input offset current	Over temp.		25			40		$\text{pA}/^\circ\text{C}$
I_B Input current	Over temp.		45	80 200		65	150 200	nA nA
ΔI_B Input current	Over temp.		50			80		$\text{pA}/^\circ\text{C}$
V_{CM} Input common mode voltage range		± 12	± 13		± 12	± 13		V
CMRR Common mode rejection ratio	$R_S \leq 10\text{k}\Omega$, over temp.	70	90		70	90		dB
PSRR Power supply rejection	$R_S \leq 10\text{k}\Omega$, over temp.		30	150		30	150	$\mu\text{V}/\text{V}$
R_{IN} Input resistance		3	10		1	6		$\text{M}\Omega$
A_{VOL} Large signal voltage gain	$R_L \geq 2\text{k}\Omega$, $V_{OUT} = \pm 10\text{V}$ Over temp., $R_L \geq 2\text{k}\Omega$, $V_{OUT} = \pm 10\text{V}$	50 25	200		50 25	200		V/mV V/mV
V_{OUT} Output voltage	Over temp., $R_L \geq 2\text{k}\Omega$ Over temp., $R_L \geq 10\text{k}\Omega$	± 10 ± 12	± 13 ± 14		± 10 ± 12	± 13 ± 14		V V
I_{CC} Supply current	Per amplifier Over temp., per amplifier		2 2.2	3 3.6		2 2.2	3 3.6	mA mA
P_D Power dissipation	Per amplifier Over temp., per amplifier		60 66	90 108		60 66	90 108	mW mW
I_{SC} Output short circuit current		10	25	50	10	25	50	mA
R_{OUT} Output resistance			100			100		Ω

NOTE
 Temperature Range
 SE Types $-55^\circ\text{C} \leq T_A \leq 125^\circ\text{C}$
 NE Types $0^\circ\text{C} \leq T_A \leq 70^\circ\text{C}$

6

HIGH SLEW RATE OP AMP

SE/NE538

AC ELECTRICAL CHARACTERISTICS $T_A = 25^\circ\text{C}$ unless otherwise specified.

PARAMETER	TEST CONDITIONS	SE538/SE5538			SE538/NE5538			UNIT
		Min	Typ	Max	Min	Typ	Max	
Gain bandwidth product (Gain +5, -4 minimum)			6			6		MHz
Transient response Small signal rise time Small signal overshoot			0.25 6			0.25 6		μs %
Settling time	To 0.1%		1.2			1.2		μs
Slew rate	Minimum gain = 5 Noninverting $R_L \geq 2\text{k}\Omega$	40	60			60		$\text{V}/\mu\text{s}$
Input noise voltage	$f = 1\text{kHz}, T_A = 25^\circ\text{C}$		30			30		$\text{nV}/\sqrt{\text{Hz}}$

TYPICAL PERFORMANCE CHARACTERISTICS

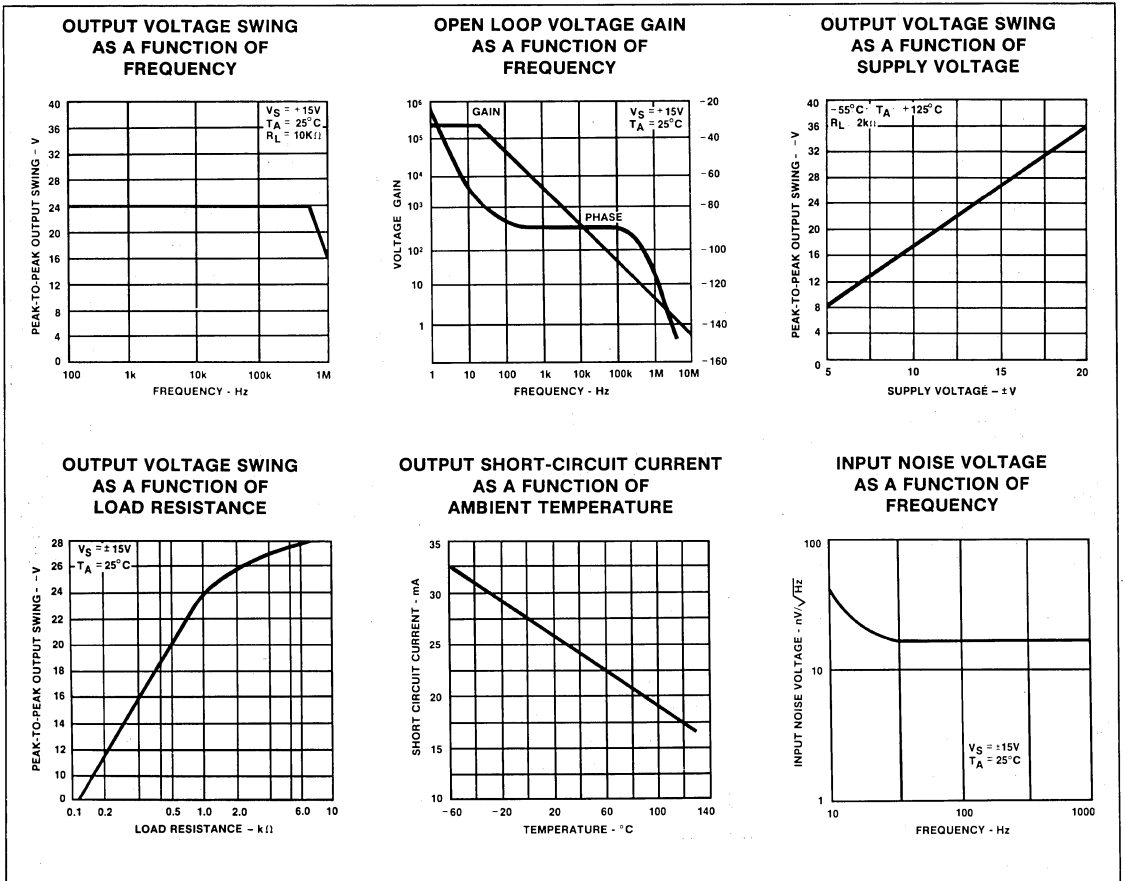

TYPICAL PERFORMANCE CHARACTERISTICS (Cont'd)

INPUT NOISE CURRENT AS A FUNCTION OF FREQUENCY

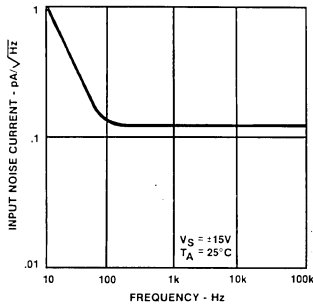

BROADBAND NOISE FOR VARIOUS BANDWIDTHS

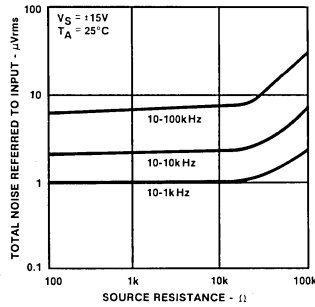

INPUT COMMON MODE VOLTAGE RANGE AS A FUNCTION OF SUPPLY VOLTAGE

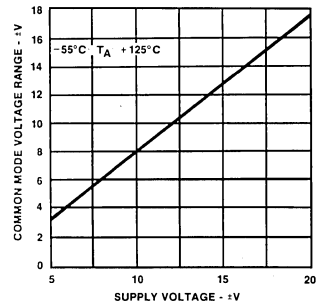

POWER CONSUMPTION AS A FUNCTION OF SUPPLY VOLTAGE

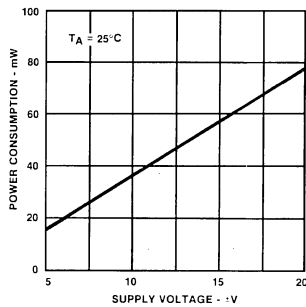

POWER CONSUMPTION AS A FUNCTION OF AMBIENT TEMPERATURE

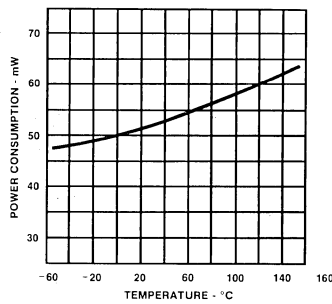

INPUT BIAS CURRENT AS A FUNCTION OF AMBIENT TEMPERATURE

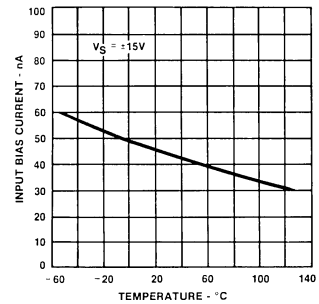

6

COMMON MODE REJECTION RATIO AS A FUNCTION OF FREQUENCY

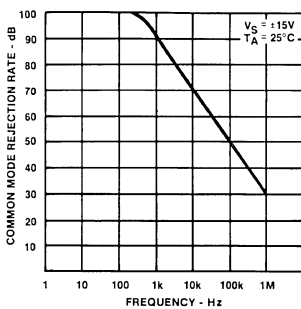

SETTLING TIME MEASUREMENT WAVEFORMS

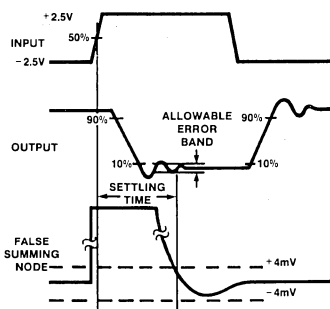

SLEW RATE MEASUREMENT VCC = ±20V

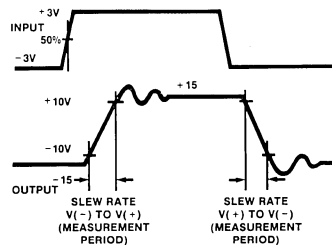

TYPICAL PERFORMANCE CHARACTERISTICS (Cont'd)

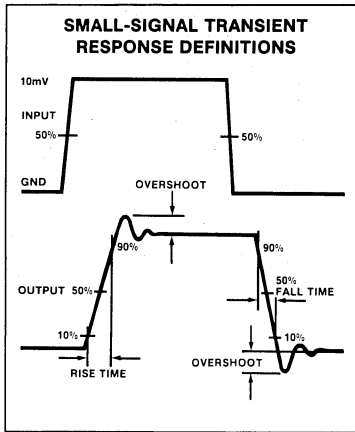

TEST LOAD CIRCUITS

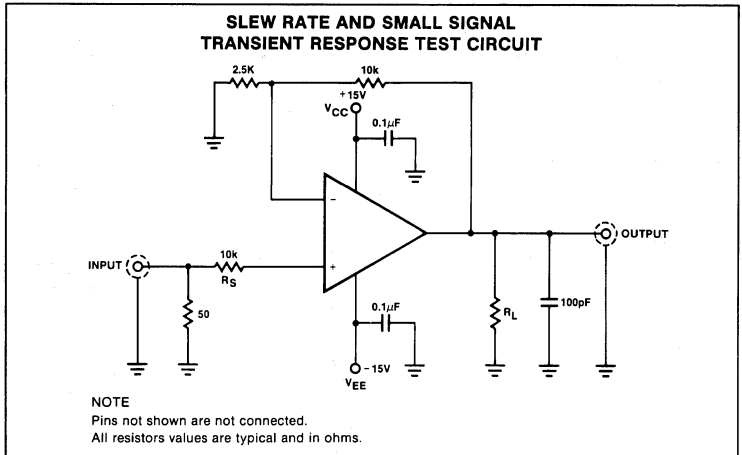

TEST LOAD CIRCUITS (Cont'd)

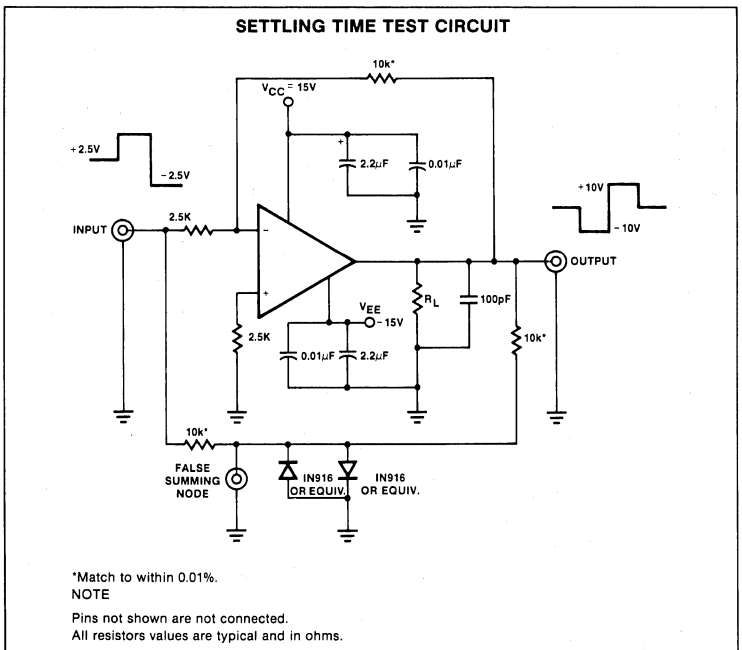

INTRODUCTION

The Signetics NE538 is an undercompensated op amp. The NE538 has a typical slew rate of 50V/μs and a gain bandwidth product of 6MHz.

The internal frequency compensation is designed for a minimum inverting gain of 4 and a minimum non-inverting gain of 5. Below these gains the NE538 will be unstable and will need external compensation (see Figure 1 and 2).

The higher slew rate of the NE538 has made this device quite appealing for high speed designs and the fact that it has a standard pinout will allow it to be used to upgrade existing systems that now use the μA741 or μ748.

Equations:

$$f_{LAG} = \frac{1 (6\text{MHz})}{10} = \frac{1}{2\pi R_L C_L}$$

$$f_{LEAD} = 6\text{MHz} = \frac{1}{2\pi R_F C_F}$$

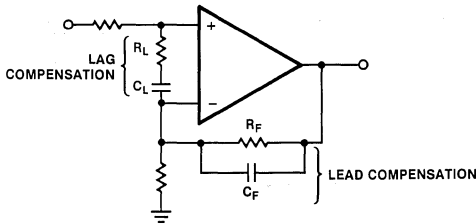

Figure 1. Non-Inverting Configuration

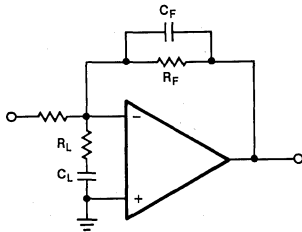

Figure 2. Inverting Configuration

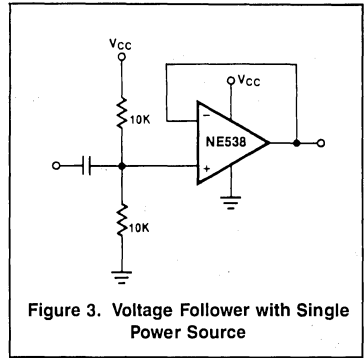

Figure 3. Voltage Follower with Single Power Source

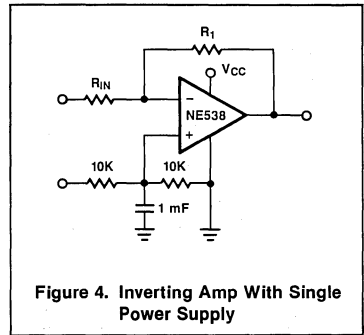

Figure 4. Inverting Amp With Single Power Supply

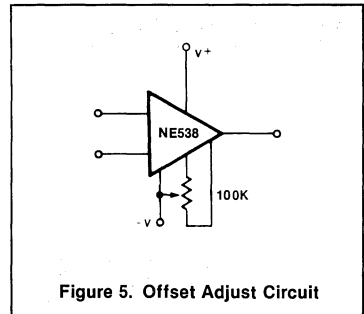
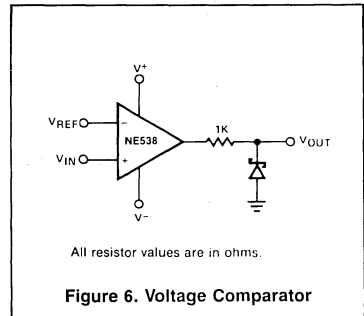

Figure 5. Offset Adjust Circuit



All resistor values are in ohms.

Figure 6. Voltage Comparator

6

DUAL HIGH PERFORMANCE OPERATIONAL AMPLIFIER

SE/NE5512

DESCRIPTION

The 5512 series of high performance operational amplifier provides very good input characteristics. These amplifiers feature low input bias and voltage characteristics such as a 108 op amp with improved CMRR and a high differential input voltage limit achieved through the use of a bias cancellation and PNP input circuits with collector to emitter clamping. The output characteristics are like those of a 741 op amp with improved slew rate and drive capability yet have low supply quiescent current.

APPLICATIONS

- AC amplifiers
- RC active filters
- Transducer amplifiers
- DC gain block
- Battery operation
- Instrumentation amplifiers

FEATURES

- Low input bias $< \pm 20nA$
- Low input offset current $< \pm 20nA$
- Low input offset voltage $< 1mV$
- Low V_{OS} temperature drift $5\mu V/^{\circ}C$
- Low input bias temperature drift $40pA/^{\circ}C$
- Low input voltage noise $30nV/\sqrt{Hz}$
- Low supply current $1.5mA/amp$
- High slew rate $1.0V/\mu s$
- High CMRR 100dB
- High input impedance $100M\Omega$
- High PSRR 110dB
- High differential input voltage limit
- No cross-over distortion
- Indefinite output short circuit protection
- Internally compensated for unity gain
- 600Ω drive capability

PIN CONFIGURATIONS

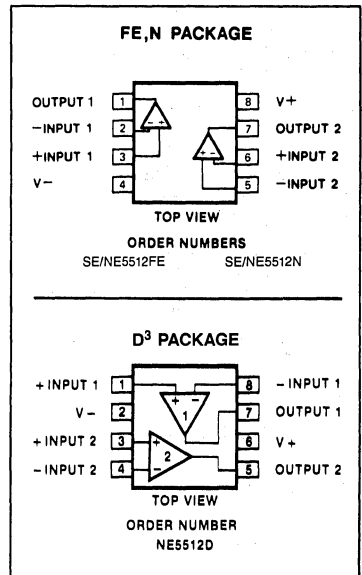

NOTES:

1. SOL - Released in large SO package only.
2. SOL and non-standard pinout.
3. SO and non-standard pinouts.

ABSOLUTE MAXIMUM RATINGS

Parameter	Rating	Unit
V_{CC} Supply Voltage	± 16	V
V_D Power dissipation	500	mW
T_A Operating temperature range		
NE5512	0 to 70	$^{\circ}C$
SE5512	-55 to +125	$^{\circ}C$
T_{STG} Storage temperature range	-65 to +150	$^{\circ}C$
T_{SOLD} Lead temperature soldering	300	$^{\circ}C$

EQUIVALENT SCHEMATIC

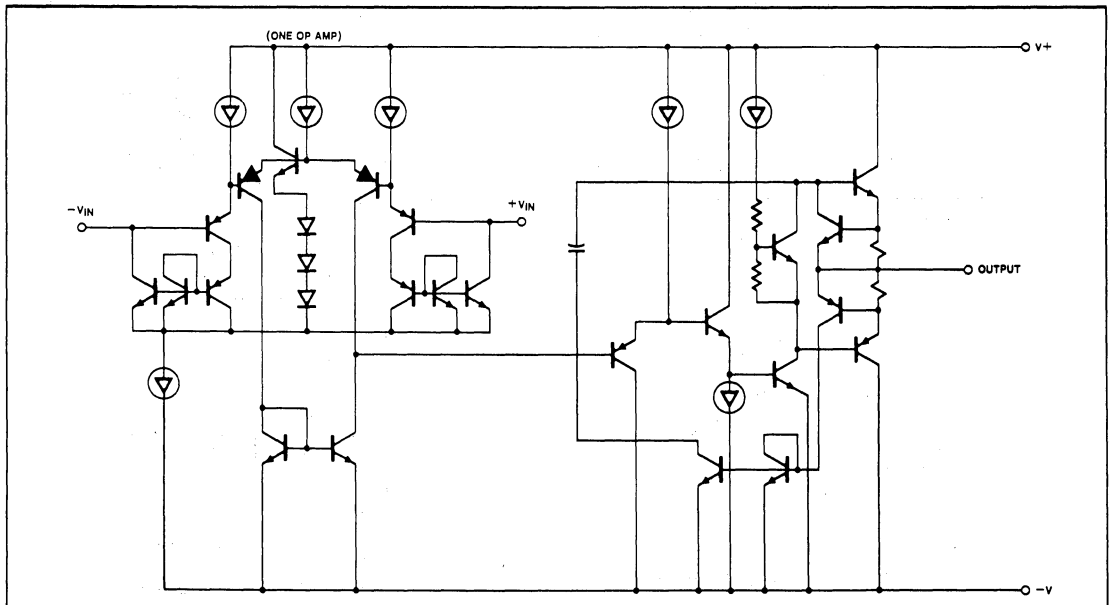

DUAL HIGH PERFORMANCE OPERATIONAL AMPLIFIER

SE/NE5512

ELECTRICAL PERFORMANCE CHARACTERISTICS $V_{CC} = \pm 15V$, F.R. = $-55^{\circ}C$ to $+125^{\circ}C$ (SE), $0^{\circ}C$ to $+70^{\circ}C$ (NE)

	PARAMETER	TEST CONDITIONS	SE5512			NE5512			UNIT
			Min	Typ	Max	Min	Typ	Max	
V_{OS}	Input offset voltage	$R_S = 100\Omega$ $T_A = +25^{\circ}C$ $T_A = F.R.$		0.7 1	2 3		1 1.5	5 6	mV
ΔV_{OS}		Over Temp.		4			5		$\mu V/^{\circ}C$
I_{OS}	Input offset current	$R_S = 100k\Omega$ $T_A = +25^{\circ}C$ $T_A = F.R.$		3 4	10 20		6 8	20 30	nA
ΔI_{OS}		Over Temp.		30			40		$pA/^{\circ}C$
I_B	Input bias current	$R_S = 100k\Omega$ $T = +25^{\circ}C$ $T_A = F.R.$		3 4	10 20		6 8	20 30	nA
ΔI_B		Over Temp.		30			40		$pA/^{\circ}C$
R_{IN}	Input resistance differential	$T_A = 25^{\circ}C$		100			100		M Ω
V_{CM}	Input common mode range	$T_A = 25^{\circ}C$ $T_A = F.R.$	± 13.5 ± 13	± 13.7 ± 13.2		± 13.5 ± 13	± 13.7 ± 13.2		V
CMRR	Input common-mode rejection ratio	$V_{CC} = \pm 15V$ $V_{IN} = \pm 13.5V$ (RM) $T_A = 25^{\circ}C$ $V_{IN} = \pm 13V$ (F.R.) $T_A = F.R.$	70	100		70	100		dB
A_{VOL} GAIN	Large-signal voltage gain	$R_L = 2k\Omega$ $T_A = 25^{\circ}C$ $V_O = \pm 10V$ $T_A = F.R.$	50 25	200		50 25	200		V/mV
S.R.	Slew rate	$T_A = 25^{\circ}C$	0.6	1			1		V/ μs
GBW	Small-signal unity gain bandwidth	$T_A = 25^{\circ}C$		3			3		MHz
θ_M	Phase margin	$T_A = 25^{\circ}C$		45			45		Degree
V_{OUT}	Output voltage swing	$R_L = 2k\Omega$ $T_A = 25^{\circ}C$ $T_A = F.R.$	± 13 ± 12.5	± 13.5 ± 13		± 13 ± 12.5	± 13.5 ± 13		V
V_{OUT}	Output voltage swing	$R_L = 600\Omega^*$ $T_A = 25^{\circ}C$ $T_A = F.R.$	± 10 ± 7.5	± 11.5 ± 9		± 10 ± 8	± 11.5 ± 9		V
I_{CC}	Power supply current	$R_L = Open$ $T_A = 25^{\circ}C$ $T_A = F.R.$		3.4 3.6	5 5.5		3.4 3.6	5 5.5	mA
P_{SRR}	Power supply rejection ratio	$T_A = 25^{\circ}C$ $T_A = F.R.$	80 80	110 100		80 80	110 100		dB
AA	Amplifier to amplifier coupling	$f = 1kHz$ to $20kHz$ $T_A = 25^{\circ}C$		-120			-120		dB
HD	Total harmonic distortion	$f = 10kHz$ $T_A = 25^{\circ}C$ $V_O = 7V_{RMS}$		0.01			0.01		%
V_{INN}	Input noise voltage	$f = 1kHz$ $T_A = 25^{\circ}C$		30			30		nV/\sqrt{Hz}
I_{IN}	Input noise current	$f = 1kHz$ $T_A = 25^{\circ}C$.2			.2		pA/\sqrt{Hz}
I_{SC}	Short circuit	$\pm 15V$ $T_A = 25^{\circ}C$		40			40		mA

NOTE
For operation at elevated temperature, N package must be derated based on a thermal resistance of $120^{\circ}W$ junction to ambient. Thermal resistance of the FE package is $125^{\circ}W$.

*For additional information, consult the Applications Section.

6

QUAD HIGH PERFORMANCE OP AMP

SE/NE5514

DESCRIPTION

The SE/NE5514 family of Quad Operational Amplifiers sets new standards in Bipolar Quad Amplifier Performance. The amplifiers feature low input bias current and low offset voltages. Pin-out is identical to LM324/LM348 which facilitates direct product substitution for improved system performance. Output characteristics are similar to a $\mu A741$ with improved slew and drive capability.

FEATURES

- Low input bias current: $< \pm 3nA$
- Low input offset current: $< \pm 3nA$
- Low input offset voltage: $< 1mV$
- Low supply current: $1.5mA/Amp$
- $1V/\mu sec$ slew rate
- High input impedance: $100M\Omega$
- High common mode impedance: $10G\Omega$
- Internal compensation for unity gain
- 600Ω drive capability (7 Vrms)

APPLICATIONS

- AC amplifiers
- RC active filters
- Transducer amplifiers
- DC gain block
- Instrumentation amplifier

ABSOLUTE MAXIMUM RATINGS

PARAMETER	RATING	UNIT
VCC	Supply voltage	± 16 V
V _{DIFF}	Differential input voltage	32 V
V _{IN}	Input voltage	0 to 32 V
	Output short to ground	Continuous
TS	Storage temperature range	-65 to +150 °C
T _{SOLD}	Lead soldering temperature	300 °C
TA	Operating temperature range	
	NE5514	0 to 70 °C
	SE5514	-55 to +125 °C

PIN CONFIGURATION

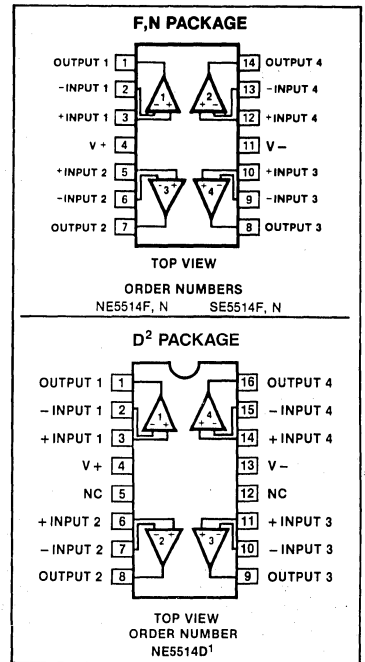

- NOTES:
1. SOL - Released in large SO package only.
 2. SOL and non-standard pinout.
 3. SO and non-standard pinouts.

EQUIVALENT SCHEMATIC

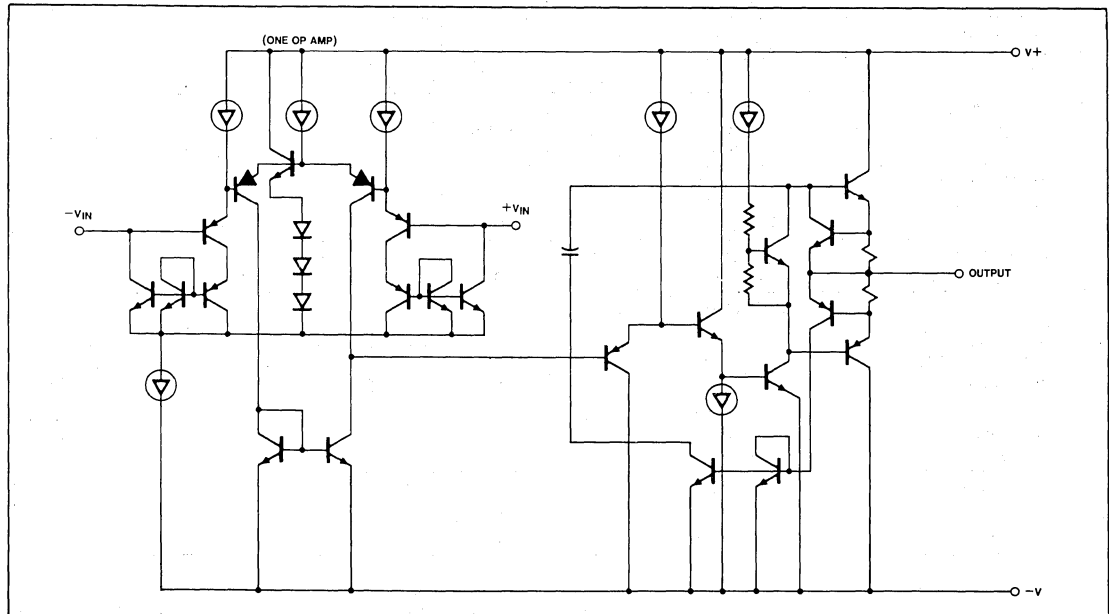

QUAD HIGH PERFORMANCE OP AMP

SE/NE5514

ELECTRICAL CHARACTERISTICS $V_{CC} = \pm 15V$, F.R. = $-55^{\circ}C$ to $+125^{\circ}C$ (SE); $0^{\circ}C$ to $70^{\circ}C$ (NE)

PARAMETER	TEST CONDITIONS	SE5514			NE5514			UNIT	
		Min	Typ	Max	Min	Typ	Max		
V_{OS}	Input offset voltage		0.7	2		1	5	mV	
ΔV_{OS}			1	3		1.5	6	$\mu V/^{\circ}C$	
I_{OS}	Input offset current		3	10		6	20	nA	
ΔI_{OS}			4	20		8	30	$\mu A/^{\circ}C$	
I_B	Input bias current		3	10		6	20	nA	
ΔI_B			4	20		8	30	$\mu A/^{\circ}C$	
R_{IN}	Input resistance differential		100			100		M Ω	
V_{CM}	Input common mode range		± 13.5	± 13.7		± 13.5	± 13.7	V	
			± 13	± 13.2		± 13	± 13.2		
CMRR	Input common-mode rejection ratio		70	100		70	100	dB	
AVOL	Large-signal voltage gain		50	200		50		V/mV	
GAIN			25			25			
S.R.	Slew rate		0.6	1		0.6	1	V/ μs	
GBW	Small-signal unity gain bandwidth			3			3	MHz	
θ_M	Phase margin			45			45	Degr	
V_{OUT}	Output voltage swing		± 13	± 13.5		± 13	± 13.5	V	
			± 12.5	± 13		± 12.5	± 13		
V_{OUT}	Output voltage swing		± 10	± 11.5		± 10	± 11.5	V	
			± 7.5	± 9		± 8	± 9		
I_{CC}	Power supply current		6	10		6	10	mA	
			7	12		7	12		
PSRR	Power supply rejection ratio		80	110		80	110	dB	
			80	100		80	100		
AA	Amplifier to amplifier coupling	$f = 1kHz$ to $20kHz$, $T_A = 25^{\circ}C$		-120			-120	dB	
HD	Total harmonic distortion	$f = 10kHz$, $T_A = 25^{\circ}C$, $V_O = 7V_{RMS}$		0.01			0.01	%	
V_{INN}	Input-noise voltage	$f = 1kHz$, $T_A = 25^{\circ}C$		30			30	nV/\sqrt{Hz}	
I_{SC}	Short Circuit	$T_A = 25^{\circ}C$	10	40	60	10	40	60	mA

NOTE

*For operation at elevated temperature, N package must be derated based on a thermal resistance of $95^{\circ}C/W$ junction to ambient.

*For additional information, consult the Applications Section.

INTERNALLY COMPENSATED DUAL LOW NOISE OP AMP

SE/NE5532/5532A

DESCRIPTION

The 5532 is a dual high-performance low noise operational amplifier. Compared to most of the standard operational amplifiers, such as the 1458, it shows better noise performance, improved output drive capability and considerably higher small-signal and power bandwidths.

This makes the device especially suitable for application in high quality and professional audio equipment, instrumentation and control circuits, and telephone channel amplifiers. The op amp is internally compensated for gains equal to one. If very low noise is of prime importance, it is recommended that the 5532A version be used which has guaranteed noise voltage specifications.

FEATURES

- Small-signal bandwidth: 10MHz
- Output drive capability: 600Ω, 10V (rms)
- Input noise voltage: 5nV/√Hz (typical)
- DC voltage gain: 50000
- AC voltage gain: 2200 at 10kHz
- Power bandwidth: 140kHz
- Slew-rate: 9V/μs
- Large supply voltage range: ±3 to ±20V
- Compensated for unity gain

PIN CONFIGURATION

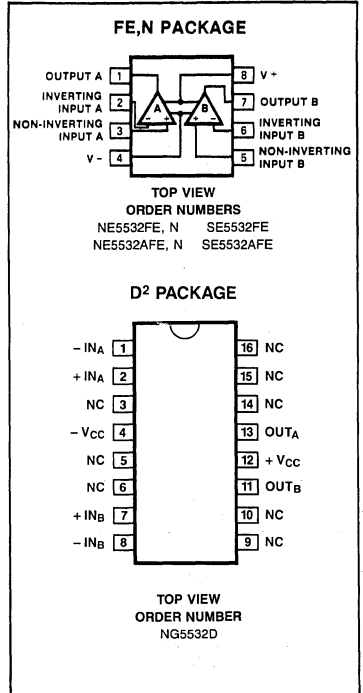

ABSOLUTE MAXIMUM RATINGS

PARAMETER	RATING	UNIT
V _S Supply voltage	±22	V
V _{IN} Input voltage	±V supply	V
V _{DIFF} Differential input voltage ¹	±.5	V
T _A Operating temperature range		
NE5532/A	0 to 70	°C
SE5532/A	-55 to +125	°C
T _{STG} Storage temperature	-65 to +150	°C
T _J Junction temperature	150	°C
P _D Power dissipation		
5532FE	1000	mW
Lead temperature (soldering, 10 sec)	300	°C

NOTES:

1. Diodes protect the inputs against over-voltage. Therefore, unless current-limiting resistors are used, large currents will flow if the differential input voltage exceeds 0.6V. Maximum current should be limited to ±10mA.
2. Thermal resistance of the FE package is 125°C/W.

EQUIVALENT SCHEMATIC (EACH AMPLIFIER)

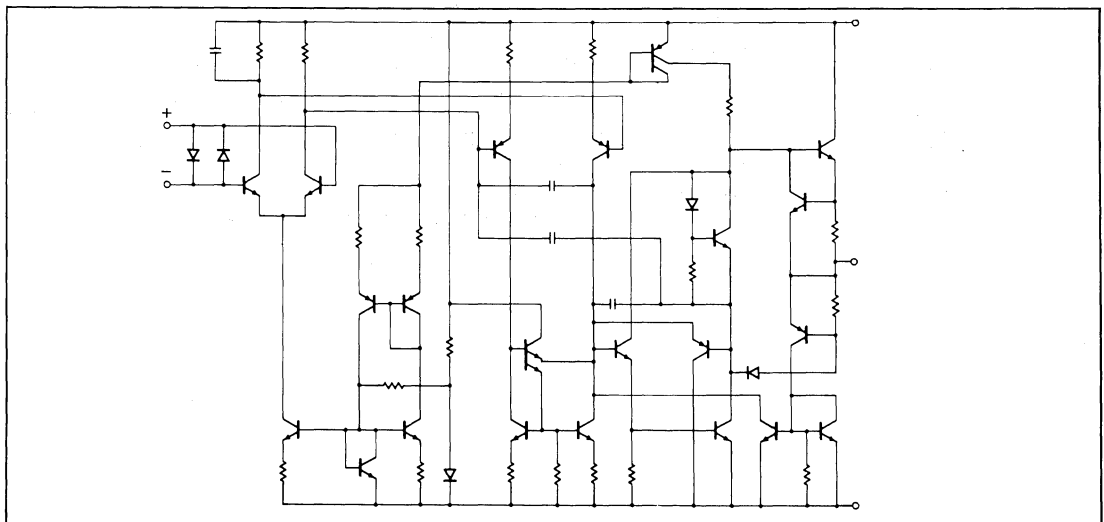

INTERNALLY COMPENSATED DUAL LOW NOISE OP AMP

SE/NE5532/5532A

DC ELECTRICAL CHARACTERISTICS $T_A = 25^\circ\text{C}$, $V_S = \pm 15\text{V}$ unless otherwise specified.^{1,2}

PARAMETER	TEST CONDITIONS	SE5532/5532A			NE5532/5532A			UNIT
		Min	Typ	Max	Min	Typ	Max	
V_{OS} Offset voltage	Over temperature		0.5	2		0.5	4	mV
$\Delta V_{OS}/\Delta T$			5	3		5	5	mV/ $\mu\text{V}/^\circ\text{C}$
I_{OS} Offset current	Over temperature			100		10	150	nA
$\Delta I_{OS}/\Delta T$			200	200		200	200	nA/ $\text{pA}/^\circ\text{C}$
I_B Input current	Over temperature		200	400		200	800	nA
$\Delta I_B/\Delta T$				5	700		5	1000
I_{CC} Supply current	Over temperature			13		8	16	mA
V_{CM} Common mode input range		± 12	± 13		± 12	± 13		V
CMRR Common mode rejection ratio		80	100		70	100		dB
PSRR Power supply rejection ratio			10	50		10	100	$\mu\text{V}/\text{V}$
A_{VOL} Large signal voltage gain	$R_L \geq 2\text{k}\Omega$, $V_O = \pm 10\text{V}$ Over temperature $R_L \geq 600\Omega$, $V_O = \pm 10\text{V}$ Over temperature	50			25	100		V/mV
		25			15			V/mV
		40			15	50		V/mV
		20			10			V/mV
V_{OUT} Output swing	$R_L \geq 600\Omega$ Over temperature $R_L \geq 600\Omega$, $V_S = \pm 18\text{V}$ Over temperature $R_L \geq 2\text{k}\Omega$ over temp.				± 12	± 13		V
		± 15	± 16		± 10	± 12		V
					± 12	± 14		V
		± 12	± 13		± 10	± 13		V
R_{IN} Input resistance		30	300		30	300		k Ω
I_{SC} Output short circuit current		10	38	60	10	38	60	mA

AC ELECTRICAL CHARACTERISTICS $T_A = 25^\circ\text{C}$, $V_S = \pm 15\text{V}$ unless otherwise specified.

PARAMETER	TEST CONDITIONS	SE/NE5532/5532A			UNIT
		Min	Typ	Max	
R_{OUT} Output resistance	$A_V = 30\text{dB}$ Closed loop $f = 10\text{kHz}$, $R_L = 600\Omega$		0.3		Ω
Overshoot	Voltage follower $V_{IN} = 100\text{mV}$ p-p $C_L = 100\text{pF}$ $R_L = 600\Omega$		10		%
Gain	$f = 10\text{kHz}$		2.2		V/mV
Gain bandwidth product	$C_L = 100\text{pF}$ $R_L = 600\Omega$		10		MHz
Slew rate			9		V/ μs
Power bandwidth	$V_{OUT} = \pm 10\text{V}$ $V_{OUT} = \pm 14\text{V}$, $R_L = 600\Omega$, $V_{CC} = \pm 18\text{V}$		140		kHz
			100		kHz

ELECTRICAL CHARACTERISTICS $T_A = 25^\circ\text{C}$, $V_S = \pm 15\text{V}$ unless otherwise specified.

PARAMETER	TEST CONDITIONS	SE/NE5532			SE/NE5532A			UNIT
		Min	Typ	Max	Min	Typ	Max	
Input noise voltage	$f_o = 30\text{Hz}$		8			8	12	$\text{nV}/\sqrt{\text{Hz}}$
	$f_o = 1\text{kHz}$		5			5	6	$\text{nV}/\sqrt{\text{Hz}}$
Input noise current	$f_o = 30\text{Hz}$		2.7			2.7		$\text{pA}/\sqrt{\text{Hz}}$
	$f_o = 1\text{kHz}$		0.7			0.7		$\text{pA}/\sqrt{\text{Hz}}$
Channel separation	$f = 1\text{kHz}$, $R_S = 5\text{k}\Omega$		110			110		dB

TYPICAL PERFORMANCE CHARACTERISTICS

OPEN LOOP FREQUENCY RESPONSE

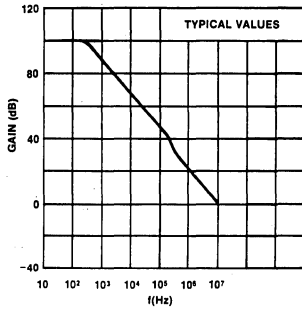

CLOSED LOOP FREQUENCY RESPONSE

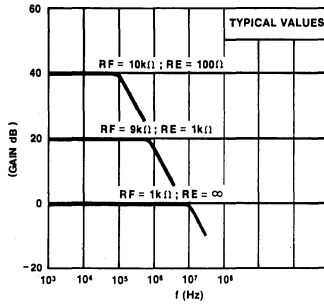

LARGE-SIGNAL FREQUENCY RESPONSE

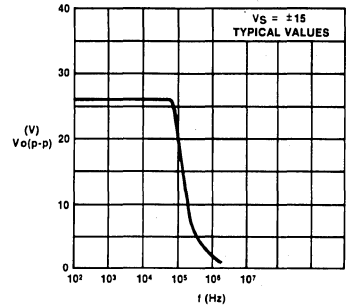

OUTPUT SHORT-CIRCUIT CURRENT

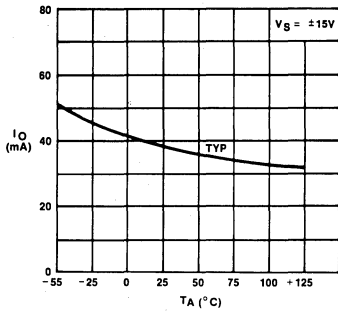

INPUT BIAS CURRENT

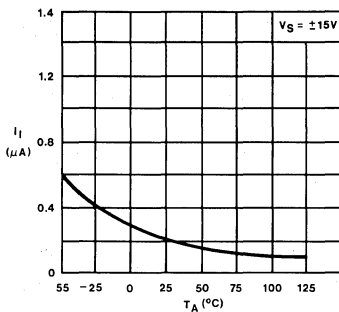

INPUT COMMON MODE VOLTAGE RANGE

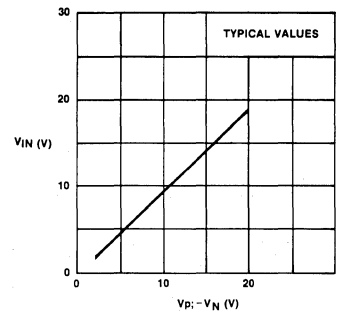

SUPPLY CURRENT

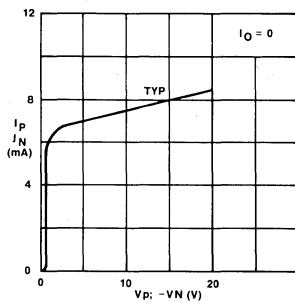

INPUT NOISE VOLTAGE DENSITY

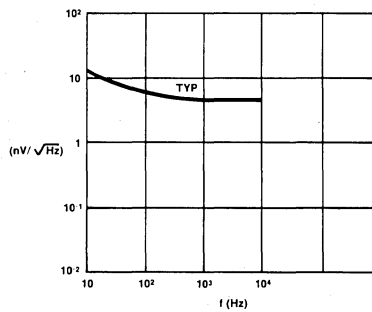

TEST CIRCUITS

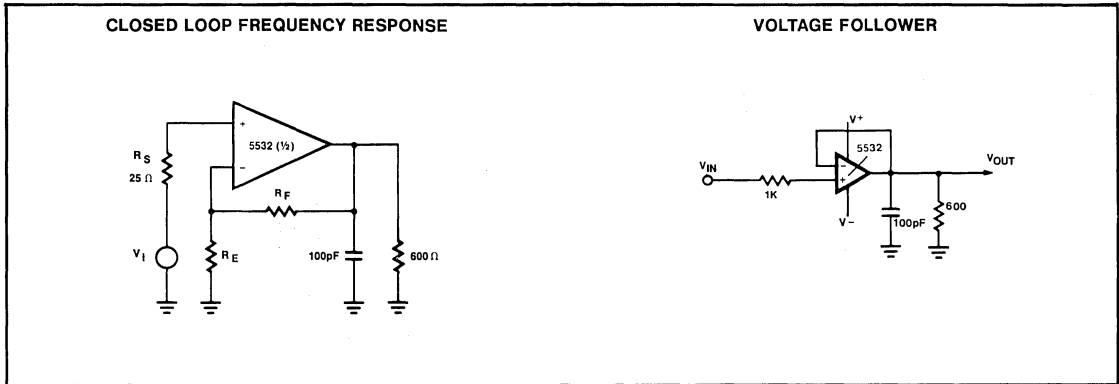

AUDIO CIRCUITS USING THE NE5532/33/34

More detailed information is available in the communications section of this manual, regarding other audio circuits. The following will explain the Signetics line of low noise op amps and show their use in some audio applications.

DESCRIPTION

The 5532 is a dual high-performance low noise operational amplifier. Compared to most of the standard operational amplifiers, such as the 1458, it shows better noise performance, improved output drive capability and considerably higher small-signal and power bandwidths.

This makes the device especially suitable for application in high quality and professional audio equipment, instrumentation and control circuits, and telephone channel amplifiers. The op amp is internally compensated for gains equal to one. If very low noise is of prime importance, it is recommended that the 5532A version be used which has guaranteed noise voltage specifications.

APPLICATIONS

The Signetics 5532 High Performance Op Amp is an ideal amplifier for use in high quality and professional audio equipment which requires low noise and low distortion.

The circuit included in this application note has been assembled on a P.C. board, and tested with actual audio input devices (Tuner and Turntable). It consists of an RIAA pre-amp, input buffer, 5-band equalizer, and mixer. Although the circuit design is not new, its performance using the 5532 has been improved.

The RIAA pre-amp section is a standard compensation configuration with low frequency boost provided by the Magnetic cartridge and the RC network in the op amp feedback loop. Cartridge loading is accomplished via R1. 47K was chosen as a typical value, and may differ from cartridge to cartridge.

The Equalizer section consists of an input buffer, 5 active variable band pass/notch (depending on R9's setting) filters, and an output summing amplifier. The input buffer is a standard unity gain design providing impedance matching between the pre amplifiers and the equalizer section. Because the 5532 is internally compensated, no external compensation is required. The 5-band active filter section is actually 5 individual active filters with the same feedback design for all 5. The main difference in all five stages is the values of C5 and C6 which are responsible for setting the center frequency of each stage. Linear pots are recommended for R9. To simplify use of this circuit, a component value table is provided, which lists center frequencies and their associated capacitor values. Notice that C5 equals (10) C6, and that the Value of R8 and R10 are related to R9 by a factor of 10 as well. The values listed in the table are common and easily found standard values.

RIAA EQUALIZATION AUDIO PREAMPLIFIER USING NE5532A

With the onset of new recording techniques along with sophisticated playback equipment, a new breed of low noise operational amplifiers was developed to complement the state-of-the-art in audio reproduction. The first ultra low noise op amp introduced by Signetics was called the NE5534A. This is a single operational amplifier with less

than $4nV/\sqrt{\text{Hz}}$ input noise voltage. The NE5534A is internally compensated at a gain of three. This device has been used in many audio preamp and equalizer (active filter) applications since its introduction early last year.

Many of the amplifiers that are being designed today are dc coupled. This means that very low frequencies (2-15Hz) are being amplified. These low frequencies are common to turntables because of rumble and tone arm resonancies. Since the amplifiers can reproduce these sub-audible tones, they become quite objectionable because the speakers try to reproduce these tones. This causes non-linearities when the actual recorded material is amplified and converted to sound waves.

The RIAA has proposed a change in its standard playback response curve in order to alleviate some of the problems that were previously discussed. The changes occur primarily at the low frequency range with a slight modification to the high frequency range. (See Figure 2). Note that the response peak for the bass section of the playback curve now occurs at 31.5Hz and begins to roll off below that frequency. The rolloff occurs by introducing a fourth R/C network occurs by introducing a fourth R/C network with a $7950\mu\text{s}$ time constant to the three existing networks that make up the equalization circuit. The high end of the equalization curve is extended to 20kHz, because recordings at these frequencies are achievable on many current discs.

NE5533/34 DESCRIPTION

The 5533/5534 are dual and single high-performance low noise operational amplifiers. Compared to other operational amplifiers

INTERNALLY COMPENSATED DUAL LOW NOISE OP AMP SE/NE5532/5532A

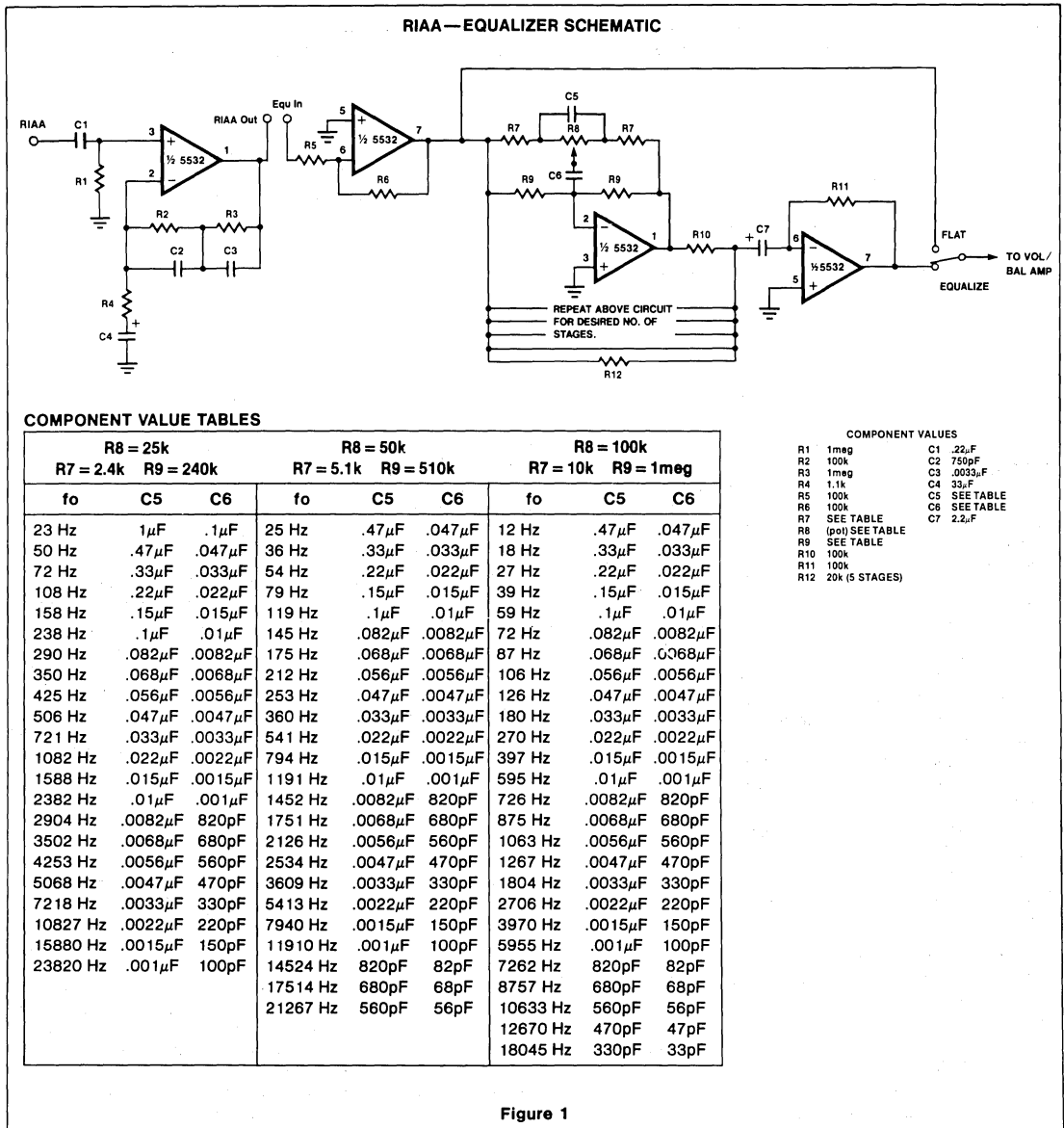

Figure 1

such as TL083, they show better noise performance, improved output drive capability and considerably higher small-signal and power bandwidths.

This makes the devices especially suitable for application in high quality and professional audio equipment, in instrumentation and control circuits and telephone channel amplifiers. The op amps are internally compensated for

gain equal to, or higher than, three. The frequency response can be optimized with an external compensation capacitor for various applications (unity gain amplifier, capacitive load, slew-rate, low overshoot, etc.) If very low noise is of prime importance, it is recommended that the 5533A/5534A version be used which has guaranteed noise specifications.

APPLICATIONS

Diode Protection of Input

The input leads of the device are protected from differential transients above ±0.6V by internal back-to-back diodes. Their presence imposes certain limitations on the amplifier dynamic characteristics related to closed-loop gain and slew rate.

INTERNALLY COMPENSATED DUAL LOW NOISE OP AMP SE/NE5532/5532A

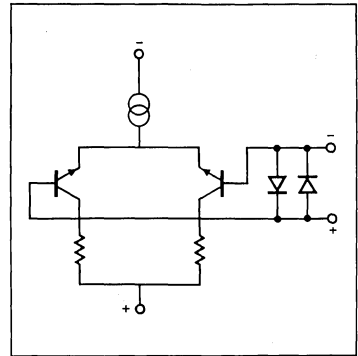
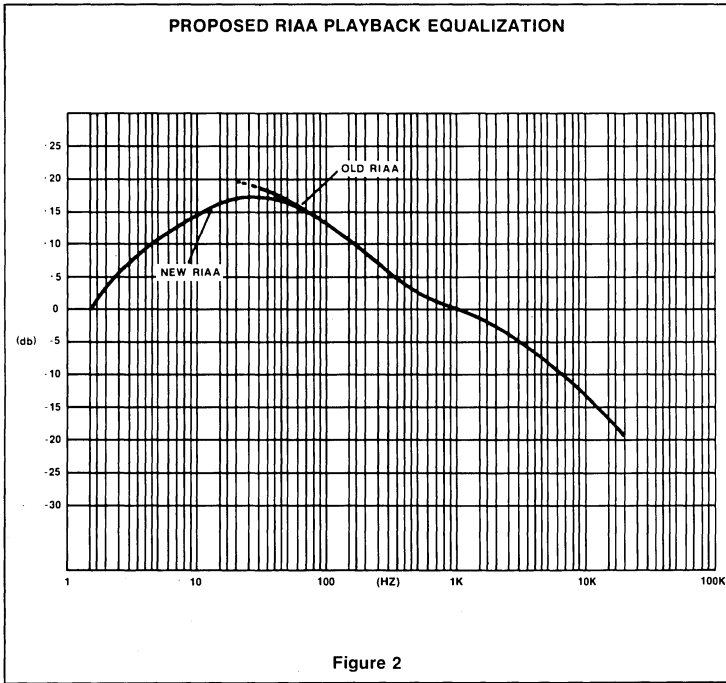

Consider the unity gain follower as an example:

Assume a signal input square wave with dV/dt of 250V per μs and 2V peak amplitude as shown. If a 22 pF compensation capacitor is inserted and the R_f, C_f circuit deleted, the device slew rate falls to approximately $7V/\mu s$. The input waveform will reach $2V/250V/\mu s$ or 8 ns, while the output will have changed (8×10^{-3}) (7) only 56 mV. The differential input signal is then $(V_{IN} - V_O) R_f/R_i + R_f$ or approximately 1V.

The diode limiter will definitely be active and output distortion will occur; therefore, $V_{in} < 1V$ as indicated.

Next, a sine wave input is used with a similar circuit.

6

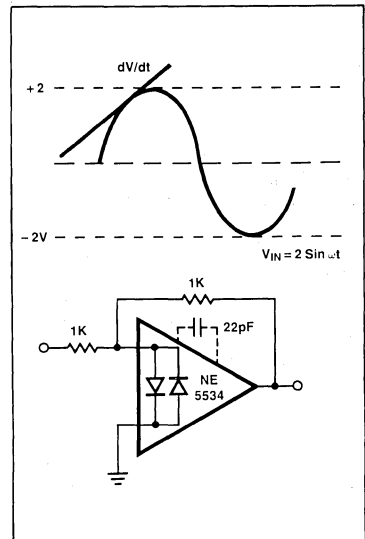
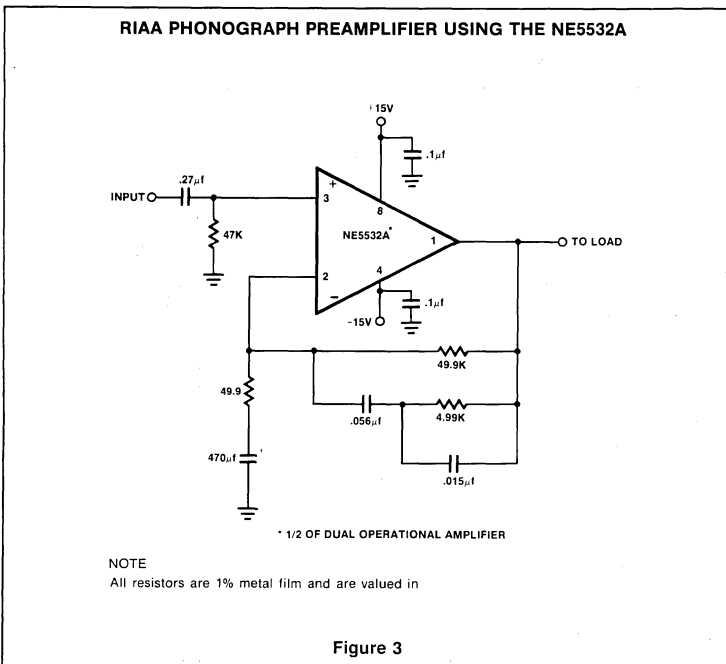

INTERNALLY COMPENSATED DUAL LOW NOISE OP AMP SE/NE5532/5532A

The slew rate of the input waveform now depends on frequency and the exact expression is

$$\frac{dv}{dt} = 2\omega \cos \omega t$$

The upper limit before slew rate distortion occurs for *small signal* ($V_{IN} < 100$ mV) conditions is found by setting the slew rate to $7V/\mu s$. That is:

$$7 \times 10^6 V/\mu s = 2\omega \cos \omega t$$

at $\omega t = 0$

$$\omega_{LIMIT} = \frac{7 \times 10^6}{2} = 3.5 \times 10^6 \text{ rad/s}$$

$$f_{LIMIT} = \frac{3.5 \times 10^6}{2\pi} \approx 560 \text{ kHz}$$

External Compensation Network Improves Bandwidth

By using an external lead-lag network, the follower circuit slew rate and small signal bandwidth can be increased. This may be useful in situations where a closed-loop gain less than 3 to 5 is indicated. A number of examples are shown in subsequent figures. The principle benefit of using the network approach is that the full slew rate and bandwidth of the device is retained, while impulse-related parameters such as damping and phase margin are controlled by choosing the appropriate circuit constants. For example, consider the following configuration:

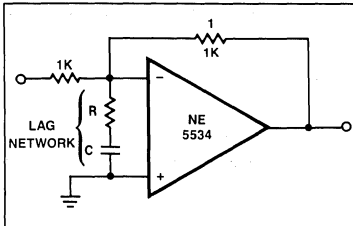

The major problem to be overcome is poor phase margin leading to instability.

By choosing the lag network break frequency one decade below the unity gain crossover frequency (30-50 MHz), the phase and gain margin are improved. An appropriate value for R is 270Ω . Setting the lag network break frequency at 5 MHz, C may be calculated

$$C = \frac{1}{2\pi \cdot 270 \cdot 5 \times 10^6}$$

118 = pF

A single pole and zero inserted in the transfer function will give an added 45° of phase margin depending on the network values.

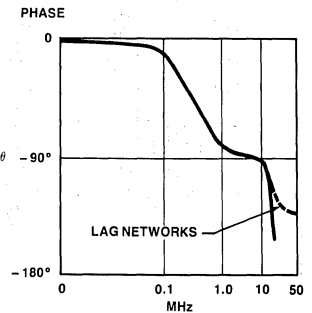
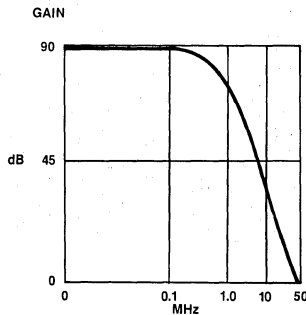
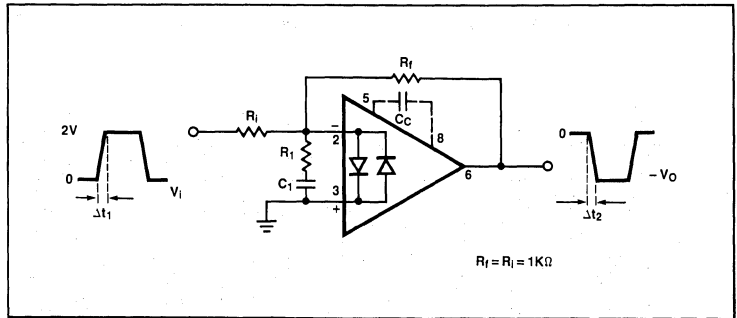

RULES AND EXAMPLES

Compensation Using Pins 5 and 8 (Limited Bandwidth and Slew Rate)

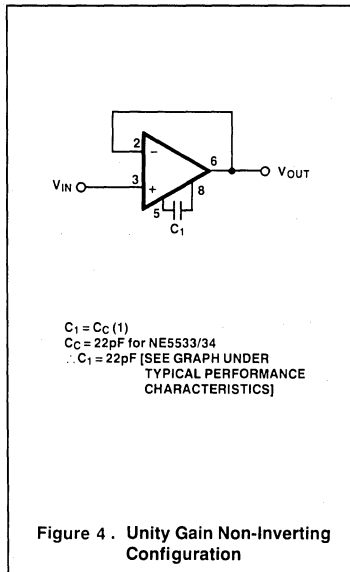

Figure 4. Unity Gain Non-Inverting Configuration

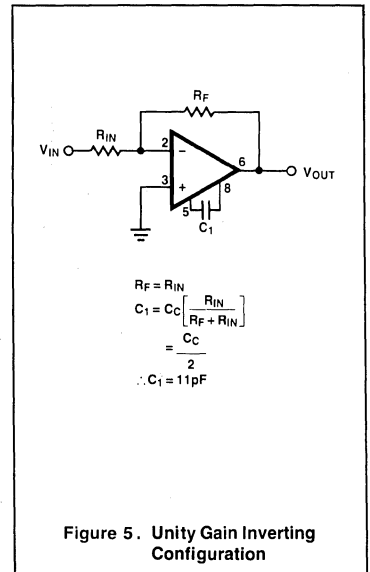
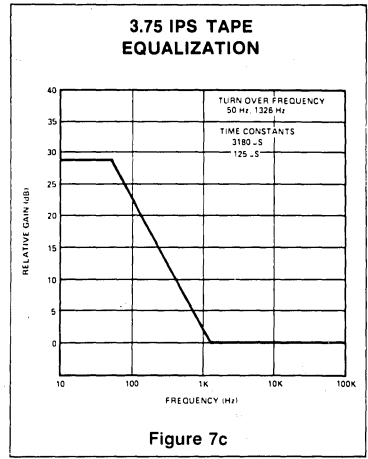
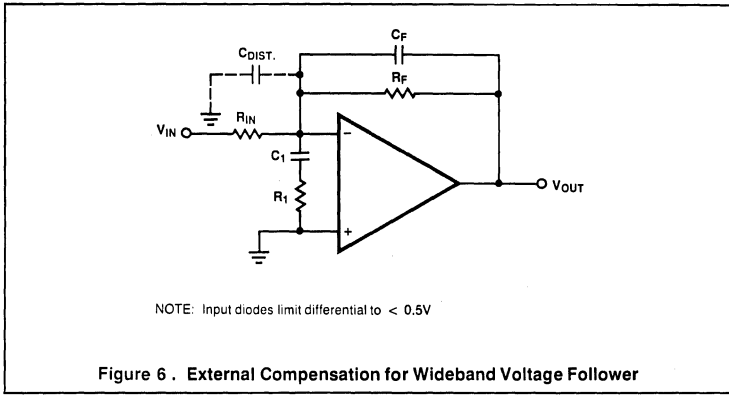

Figure 5. Unity Gain Inverting Configuration

INTERNALLY COMPENSATED DUAL LOW NOISE OP AMP SE/NE5532/5532A

External Compensation for Wideband Voltage Follower



Calculating the Lead-Lag Network

$$C_1 = \frac{1}{2\pi F_1 R_1} \quad \text{Let } R_1 = \frac{R_{IN}}{10}$$

where $F_1 = \frac{1}{10}$ (UGBW)

UGBW = 30 MHz

Shunt Capacitance Compensation

$$C_F = \frac{1}{2\pi F_F R_F}, \quad F_F \cong 30 \text{ MHz}$$

or $C_F \cong \frac{C_{DIST}}{A_{CL}}$

$C_{DIST} \cong$ Distributed Capacitance $\cong 2\text{-}3\text{pF}$

Many audio circuits involve carefully tailored frequency responses. Pre-emphasis is used in all recording mediums to reduce noise and produce flat frequency response. The most often used de-emphasis curves for broadcast and home entertainment systems are shown in Figure 7. Operational amplifiers are well suited to these applications because of their high gain and easily tailored frequency response.

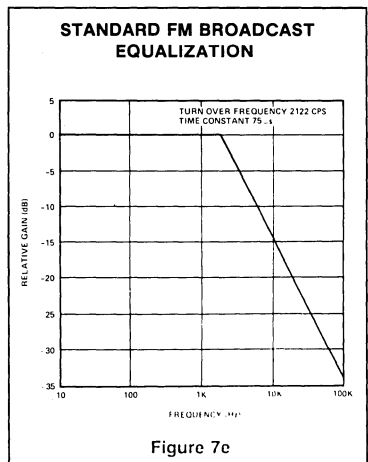
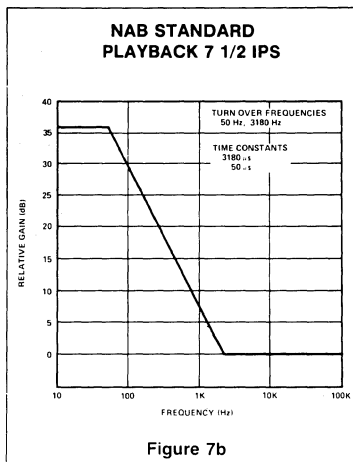
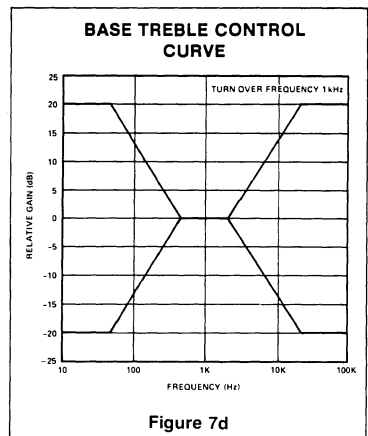
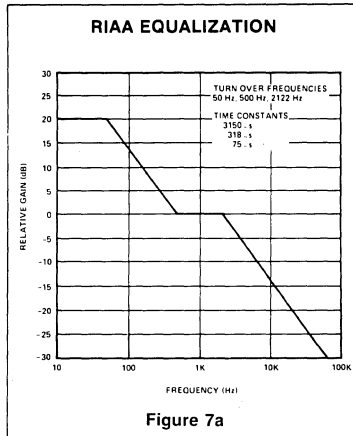

6

INTERNALLY COMPENSATED DUAL LOW NOISE OP AMP SE/NE5532/5532A

RIAA PREAMP USING THE NE5534

The preamplifier for phono equalization is shown in Figure 8 along with the theoretical and actual circuit response.

Low frequency boost is provided by the inductance of the magnetic cartridge with the RC network providing the necessary break points to approximate the theoretical RIAA curve.

RUMBLE FILTER

Following the amplifier stage, rumble and scratch filters are often used to improve overall quality. Such a filter designed with op amps uses the 2 pole Butterworth approach and features switchable break points. With the circuit of Figure 9 any degree of filtering from fairly sharp to none at all is switch selectable.

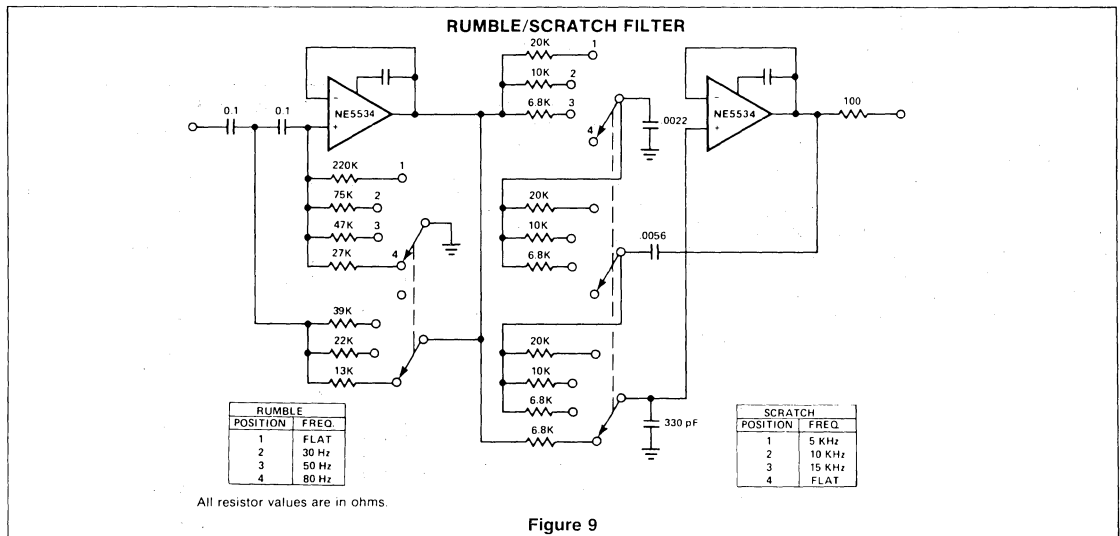
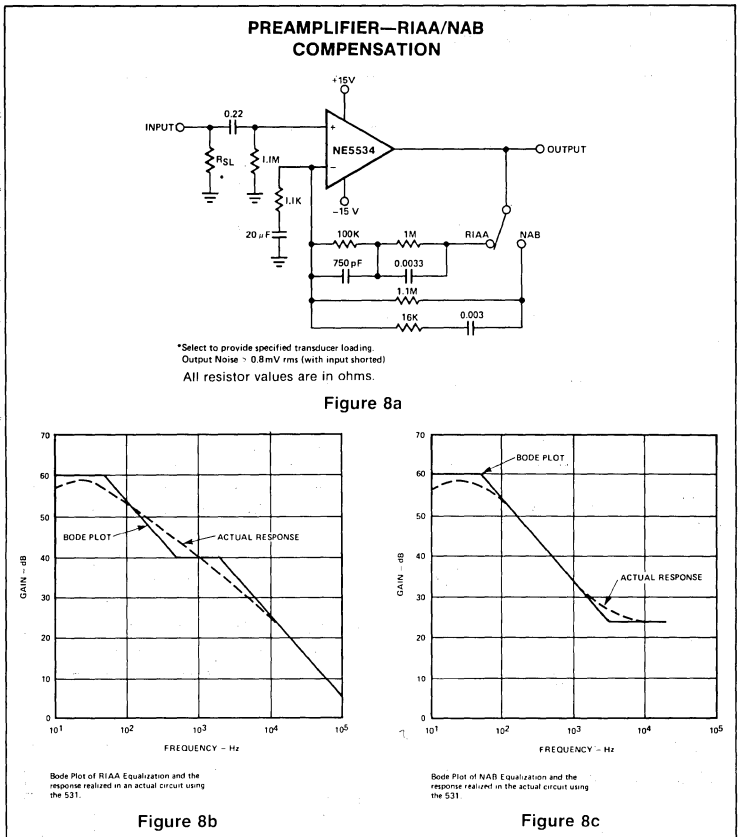
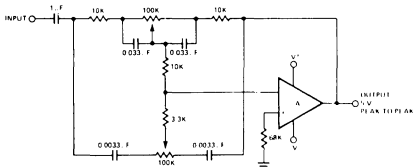

Figure 9

INTERNALLY COMPENSATED DUAL LOW NOISE OP AMP SE/NE5532/5532A

TONE CONTROL CIRCUIT FOR OPERATIONAL AMPLIFIERS



All resistor values are in ohms.

NOTES

1. Amplifier A may be a NE531 or 301. Frequency compensation, as for unity gain non-inverting amplifiers, must be used.
2. Turn-over frequency—1kHz.
3. Bass boost +20dB at 20Hz, bass cut -20dB at 20Hz, treble boost +19dB at 20kHz, treble cut -19dB at 20kHz.

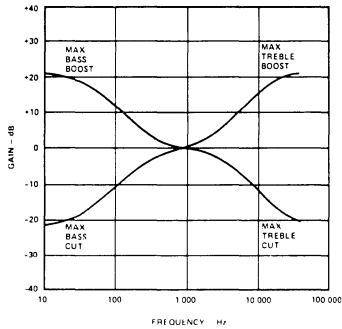

Figure 10

TONE CONTROL

Tone control of audio systems involves altering the flat response in order to attain more low frequencies or more high ones dependent upon listener preference. The circuit of Figure 10 provides 20dB of bass or treble boost or cut as set by the variable resistance. The actual response of the circuit is shown also.

BALANCE AND LOUDNESS AMPLIFIER

Figure 11 shows a combination of balance and loudness controls. Due to the non-linearity of the human hearing system the low frequencies must be boosted at low listening levels. Balance, level, and loudness controls provide all the listening controls to produce the desired music response.

VOLTAGE AND CURRENT OFFSET ADJUSTMENTS

Many IC amplifiers include the necessary pin connections to provide external offset adjustments. Many times, however, it becomes necessary to select a device not possessing external adjustments. Figure 12, 13, and 14 suggest some possible arrangements for offset voltage adjust and bias current nulling circuitry. The circuitry of Figure 14 provides sufficient current into the input to cancel the bias current requirement. Although more simplified arrangements are possible the addition of Q2 and Q3 provide a fixed current level to Q1, thus, bias cancellation can be provided without regard to input voltage level.

BALANCE AMPLIFIER WITH LOUDNESS CONTROL

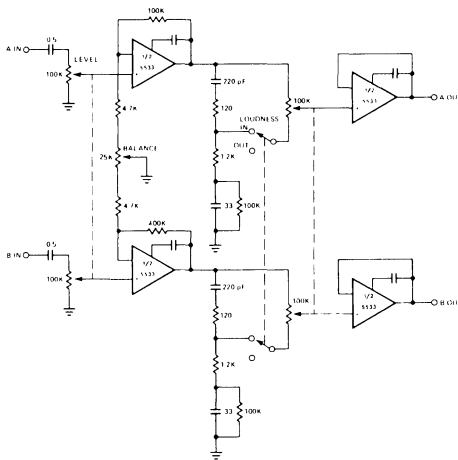

All resistor values are in ohms.

Figure 11

UNIVERSAL OFFSET NULL FOR INVERTING AMPLIFIERS

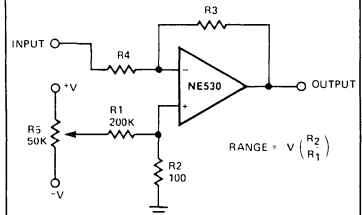

All resistor values are in ohms.

Figure 12

6

INTERNALLY COMPENSATED DUAL LOW NOISE OP AMP SE/NE5532/5532A

UNIVERSAL OFFSET NULL FOR NONINVERTING AMPLIFIERS

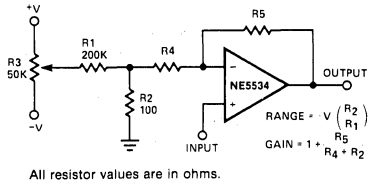

Figure 13

BIAS CURRENT COMPENSATION

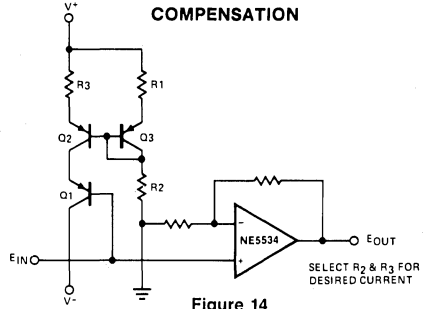

Figure 14

*For additional information, consult the Applications Section.

SINGLE AND DUAL LOW NOISE OP AMP NE5533/5533A/SA/SE/NE5534/5534A

DESCRIPTION

The 5533/5534 are dual and single high-performance low noise operational amplifiers. Compared to other operational amplifiers, such as TL083, they show better noise performance, improved output drive capability and considerably higher small-signal and power bandwidths.

This makes the devices especially suitable for application in high quality and professional audio equipment, in instrumentation and control circuits and telephone channel amplifiers. The op amps are internally compensated for gain equal to, or higher than, three. The frequency response can be optimized with an external compensation capacitor for various applications (unity gain amplifier, capacitive load, slew-rate, low overshoot, etc.) If very low noise is of prime importance, it is recommended that the 5533A/5534A version be used which has guaranteed noise specifications.

FEATURES

- Small-signal bandwidth: 10MHz
- Output drive capability: 600Ω, 10V (rms) at $V_s = \pm 18V$
- Input noise voltage: $4nV/\sqrt{Hz}$
- DC voltage gain: 100000
- AC voltage gain: 6000 at 10kHz
- Power bandwidth: 200kHz
- Slew-rate: $13V/\mu s$
- Large supply voltage range: ± 3 to $\pm 20V$

PIN CONFIGURATIONS

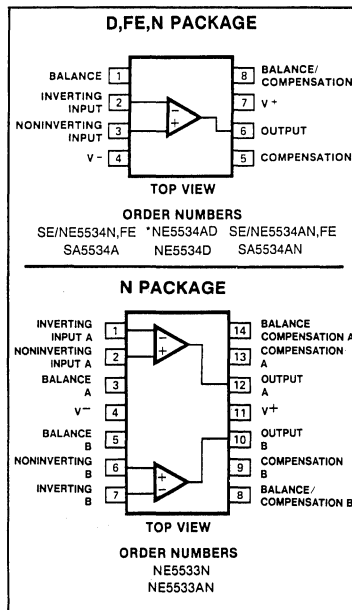

EQUIVALENT SCHEMATIC

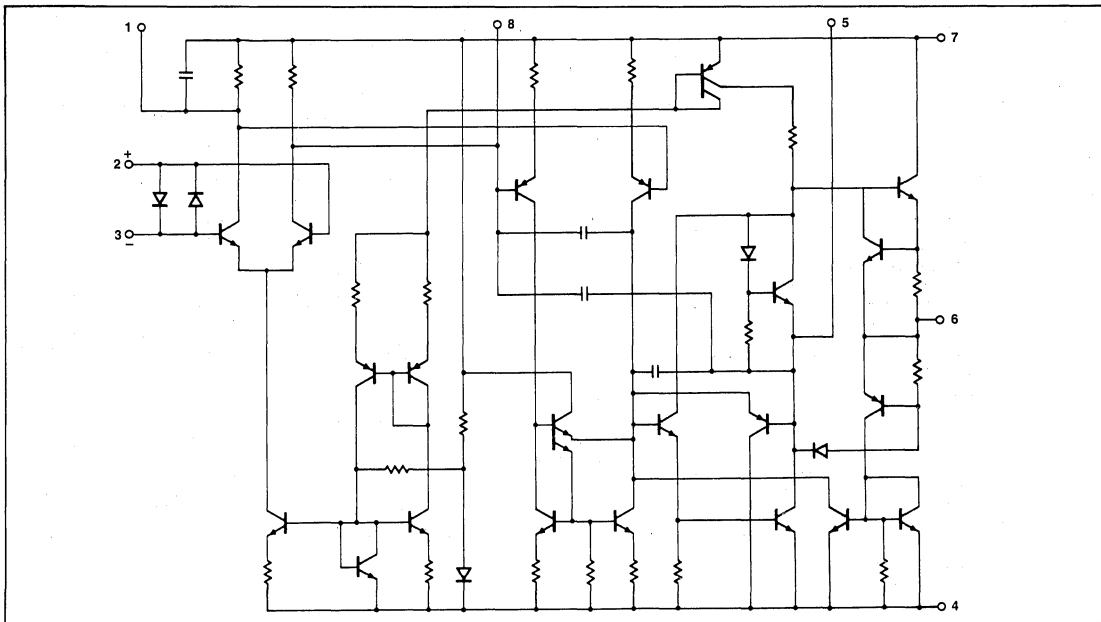

*NOTE:

This device may not be symbolled in standard format.

6

SINGLE AND DUAL LOW NOISE OP AMP NE5533/5533A/SA/SE/NE5534/5534A

ABSOLUTE MAXIMUM RATINGS

PARAMETER	RATING	UNIT
V _S Supply voltage	± 22	V
V _{IN} Input voltage	± V supply	V
V _{DIFF} Differential input voltage ¹	± 0.5	V
T _A Operating temperature range		
SE5534/5534A	- 55 to + 125	°C
NE5533/5533A/5534/5534A	0 to + 70	°C
T _{STG} Storage temperature	- 65 to + 150	°C
T _J Junction temperature	150	°C
P _D Power dissipation at 25 °C ²		
5533N, 5534N, 5534FE	800	mW
Output short circuit duration ³	indefinite	
Lead temperature (soldering, 10 sec)	300	°C

NOTES

- Diodes protect the inputs against over-voltage. Therefore, unless current-limiting resistors are used, large currents will flow if the differential input voltage exceeds 0.6V. Maximum current should be limited to ±10mA.
- For operation at elevated temperature, derate packages based on the following junction-to-ambient thermal resistances:
 - 8-pin ceramic (FE) 140°C/W
 - 14-pin ceramic (F) 110°C/W
 - 8-pin plastic (N) 162°C/W
 - 14-pin plastic (NI) 150°C/W
- Output may be shorted to ground at V_S = ±15V, T_A = 25°C. Temperature and/or supply voltages must be limited to ensure dissipation rating is not exceeded.

DC ELECTRICAL CHARACTERISTICS T_A = 25 °C, V_S = ± 15V unless otherwise specified.^{1,2}

PARAMETER	TEST CONDITIONS	SE5534/5534A			NE5533/5533A 5534/5534A			UNIT
		Min	Typ	Max	Min	Typ	Max	
V _{OS} Offset voltage	Over temperature		0.5	2		0.5	4	mV
ΔV _{OS} /ΔT			5	3		5	5	μV/°C
I _{OS} Offset current	Over temperature		10	200		20	300	nA
ΔI _{OS} /ΔT			200	500		200	400	nA pA/°C
I _B Input current	Over temperature		400	800		500	1500	nA
ΔI _B /ΔT			5	1500		5	2000	nA nA/°C
I _{CC} Supply current Per op amp	Over temperature		4	6.5		4	8	mA
					9		10	mA
V _{CM} Common mode input range		± 12	± 13		± 12	± 13		V
CMRR Common mode rejection ratio		80	100		70	100		dB
PSRR Power supply rejection ratio			10	50		10	100	μV/V
A _{VOL} Large signal voltage gain	R _L ≥ 600Ω, V _O = ± 10V Over temperature	50	100		25	100		V/mV V/mV
V _{OUT} Output swing 5534 only	R _L ≥ 600Ω Over temperature	± 12	± 13		± 12	± 13		V
	R _L ≥ 600Ω, V _S = ± 18V	± 10	± 12		± 10	± 12		V
	R _L ≥ 2kΩ	± 15	± 16		± 15	± 16		V
	Over Temperature	± 13	± 13.5		± 13	± 13.5		V
		± 12	± 12.5		± 12	± 12.5		V
R _{IN} Input resistance		50	100		30	100		kΩ
I _{SC} Output short circuit current			38			38		mA

NOTES

- For NE5533/5533A/5534/5534A, T_{MIN} = 0°C, T_{MAX} = 70°C
- For SE5534/5534A, T_{MIN} = - 55°C, T_{MAX} = + 125°C

SINGLE AND DUAL LOW NOISE OP AMP NE5533/5533A/SA/SE/NE5534/5534A

AC ELECTRICAL CHARACTERISTICS $T_A = 25^\circ\text{C}$, $V_S = \pm 15\text{V}$ unless otherwise specified.

PARAMETER	TEST CONDITIONS	SE5534/5534A			NE5533/5533A 5534/5534A			UNIT
		Min	Typ	Max	Min	Typ	Max	
R_{OUT} Output resistance	$A_V = 30\text{dB}$ closed loop $f = 10\text{kHz}$, $R_L = 600\Omega$, $C_C = 22\text{pF}$		0.3			0.3		Ω
Transient response T_R Rise time Overshoot	Voltage follower, $V_{IN} = 50\text{mV}$ $R_L = 600\Omega$, $C_C = 22\text{pF}$, $C_L = 100\text{pF}$		20 20			20 20		ns %
Transient response T_R Rise time Overshoot	$V_{IN} = 50\text{mV}$, $R_L = 600\Omega$ $C_C = 47\text{pF}$, $C_L = 500\text{pF}$		50 35			50 35		ns %
AC Gain	$f = 10\text{kHz}$, $C_C = 0$ $f = 10\text{kHz}$, $C_C = 22\text{pF}$		6 2.2			6 2.2		V/mV V/mV
Gain bandwidth product	$C_C = 22\text{pF}$, $C_L = 100\text{pF}$		10			10		mHz
Slew rate	$C_C = 0$ $C_C = 22\text{pF}$		13 6			13 6		V/ μS V/ μS
Power bandwidth	$V_{OUT} = \pm 10\text{V}$, $C_C = 0$ $V_{OUT} = \pm 10\text{V}$, $C_C = 22\text{pF}$ $V_{OUT} = \pm 14\text{V}$, $R_L = 600\Omega$ $C_C = 22\text{pF}$, $V_{CC} = \pm 18\text{V}$		200 95 70			200 95 70		kHz kHz kHz

ELECTRICAL CHARACTERISTICS $T_A = 25^\circ\text{C}$, $V_S = \pm 15\text{V}$ unless otherwise specified.

PARAMETER	TEST CONDITIONS	5533/5534			5533A/5534A			UNIT
		Min	Typ	Max	Min	Typ	Max	
Input noise voltage	$f_o = 30\text{Hz}$ $f_o = 1\text{kHz}$		7 4			5.5 3.5	7 4.5	nV/ $\sqrt{\text{Hz}}$ nV/ $\sqrt{\text{Hz}}$
Input noise current	$f_o = 30\text{Hz}$ $f_o = 1\text{kHz}$		2.5 0.6			1.5 0.4		pA/ $\sqrt{\text{Hz}}$ pA/ $\sqrt{\text{Hz}}$
Broadband noise figure	$f = 10\text{Hz} - 20\text{kHz}$, $R_S = 5\text{k}\Omega$					0.9		dB
Channel separation	$f = 1\text{kHz}$, $R_S = 5\text{k}\Omega$		110			110		dB

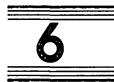

SINGLE AND DUAL LOW NOISE OP AMP NE5533/5533A/SA/SE/NE5534/5534A

TYPICAL PERFORMANCE CHARACTERISTICS

OPEN LOOP FREQUENCY RESPONSE

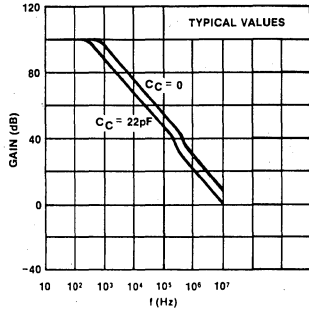

SLEW-RATE AS A FUNCTION OF COMPENSATION CAPACITANCE

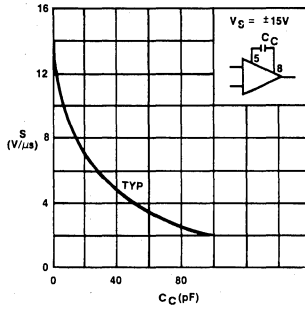

CLOSED LOOP FREQUENCY RESPONSE

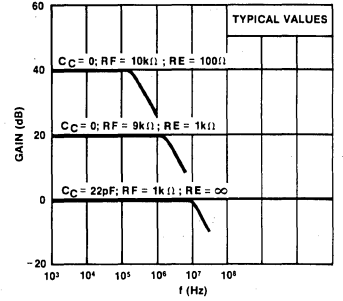

LARGE-SIGNAL FREQUENCY RESPONSE

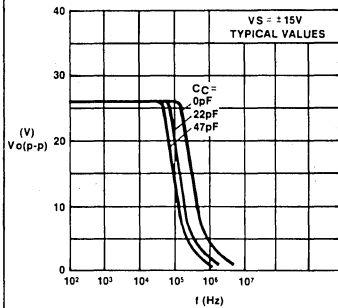

OUTPUT SHORT-CIRCUIT CURRENT

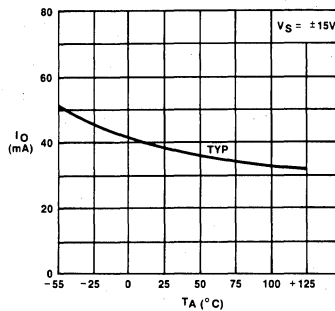

INPUT BIAS CURRENT

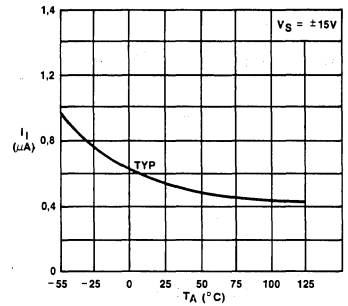

INPUT COMMON MODE VOLTAGE RANGE

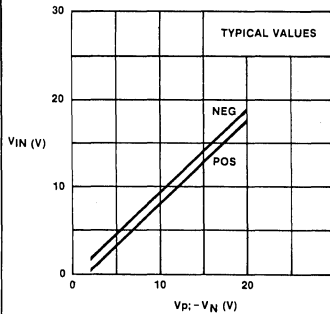

SUPPLY CURRENT PER OP AMP

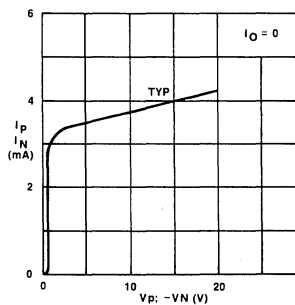

INPUT NOISE VOLTAGE DENSITY

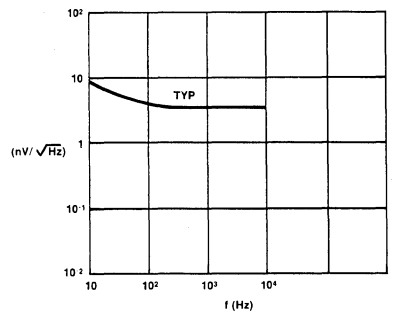

SINGLE AND DUAL LOW NOISE OP AMP NE5533/5533A/SA/SE/NE5534/5534A

TYPICAL PERFORMANCE CHARACTERISTICS (Cont'd)

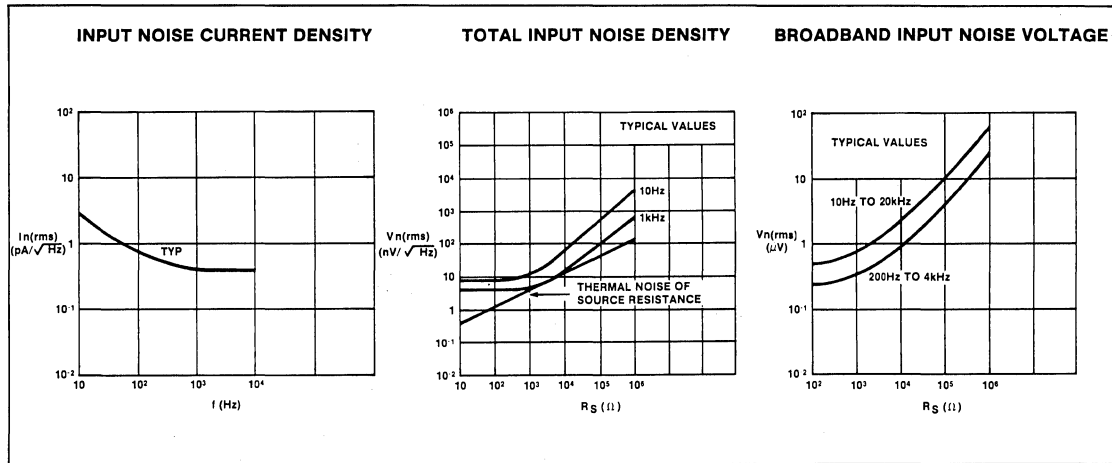

TEST LOAD CIRCUITS

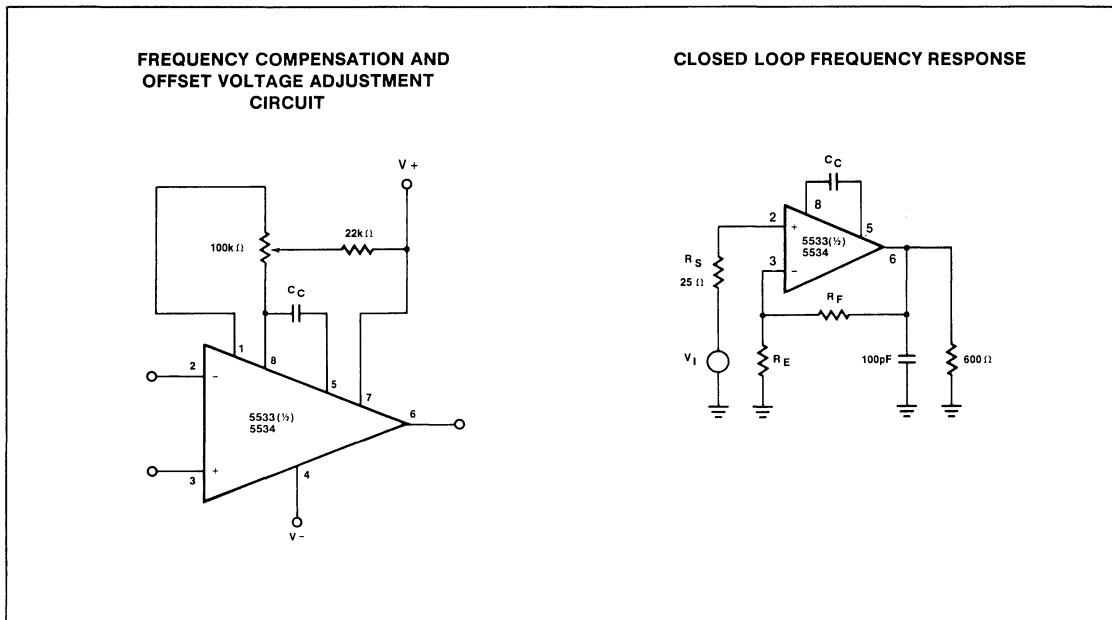

6

SINGLE AND DUAL LOW NOISE OP AMP NE5533/5533A/SA/SE/NE5534/5534A

NOISE TEST BLOCK DIAGRAM

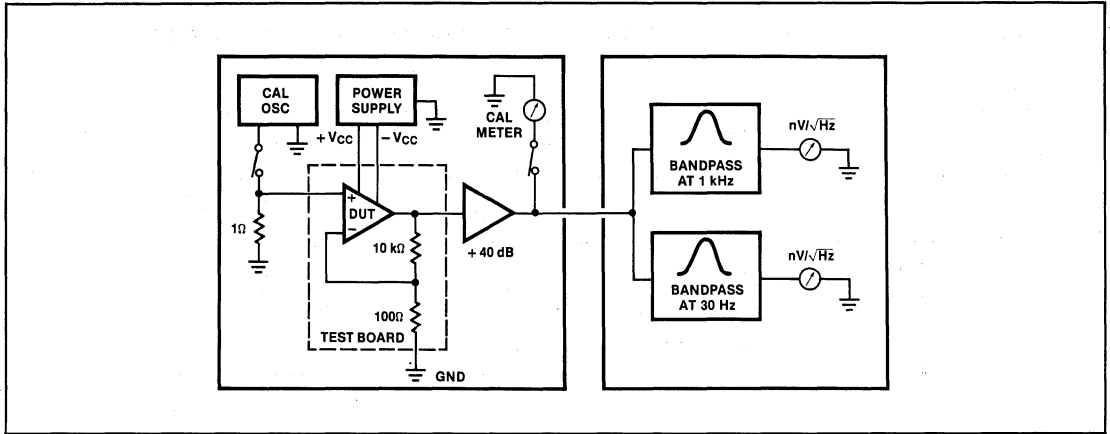

*For additional information, consult the Applications Section.

DUAL HIGH SLEW RATE OP AMP

SE/NE5535

DESCRIPTION

The 5535 is a new generation operational amplifier featuring high slew rates combined with improved input characteristics. The 5535 is a dual configuration. Internally compensated for unity gain, the SE5535 features a guaranteed unity gain slew rate of $10V/\mu s$ with 2mV maximum offset voltage. Industry standard pin out and internal compensation allow the user to upgrade system performance by directly replacing general purpose amplifiers, such as 747 and 1558.

FEATURES

- $15V/\mu s$ unity gain slew rate
- Internal frequency compensation
- Low input offset voltage—2mV
- Low input bias current 80nA max
- Short circuit protected
- Large common mode and differential voltage ranges
- Pin compatibility **5535**
747,1558
- Configuration **Dual**
- Low noise current $0.15 \text{ pA}/\sqrt{\text{Hz}}$ typ.

PIN CONFIGURATIONS

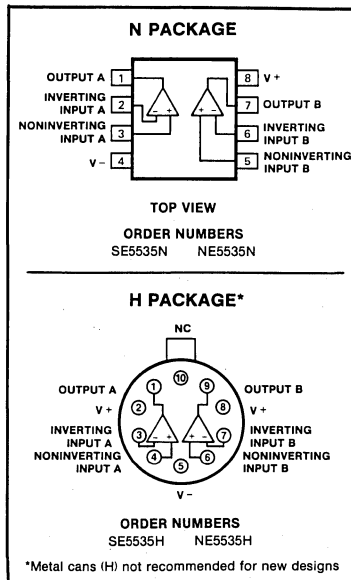

ABSOLUTE MAXIMUM RATINGS

PARAMETER	SE5535	NE5535	UNIT
Supply voltage	± 22	± 18	V
Internal power dissipation ¹			
N Package	500	500	mW
H Package	800	800	mW
F Package	1000	1000	mW
Differential input voltage	± 30	± 30	V
Input voltage ²	± 15	± 15	V
Operating temperature range	-55 to +125	0 to +70	$^{\circ}\text{C}$
Storage temperature range	-65 to +150	-65 to +150	$^{\circ}\text{C}$
Lead temperature (solder, 60sec)	300	300	$^{\circ}\text{C}$
Output short circuit ³	Indefinite	Indefinite	

NOTES

1. Rating applies for thermal resistances junction to ambient of $240^{\circ}\text{C}/\text{W}$ and $150^{\circ}\text{C}/\text{W}$ for N and H packages, respectively. Maximum chip temperature is 150°C .
2. For supply voltages less than $\pm 15\text{V}$, the absolute maximum input voltage is equal to the supply voltage.
3. Short circuit may be to ground or either supply. Rating applies to 125°C case temperature or 75°C ambient temperature.

EQUIVALENT SCHEMATIC (One Amplifier)

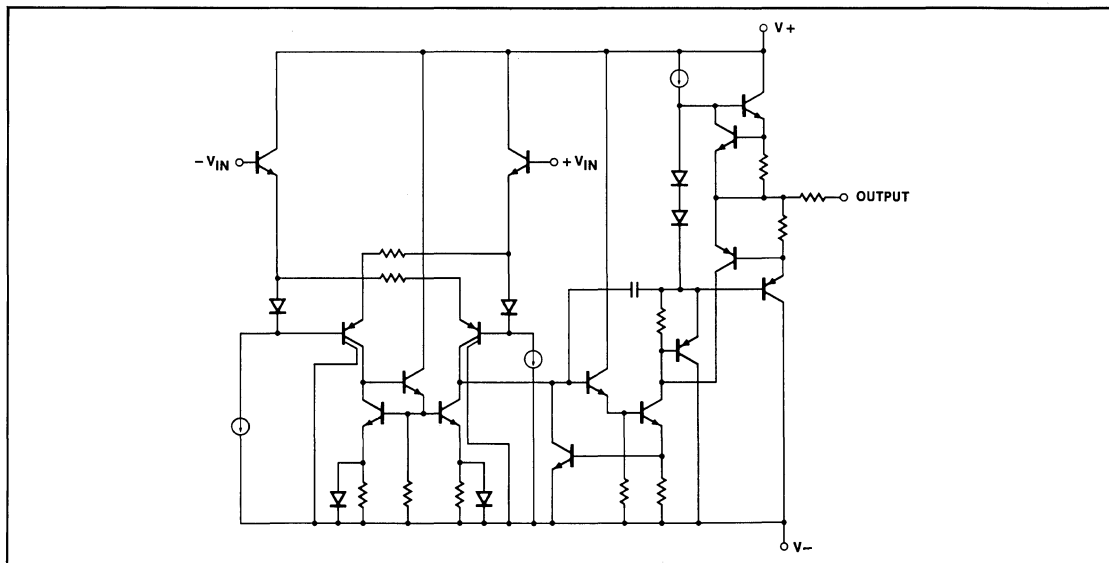

DUAL HIGH SLEW RATE OP AMP

SE/NE5535

DC ELECTRICAL CHARACTERISTICS $T_A = 25^\circ\text{C}$, $V_S = \pm 15\text{V}$ unless otherwise specified.*

PARAMETER	TEST CONDITIONS	SE5535			NE5535			UNIT
		Min	Typ	Max	Min	Typ	Max	
V_{os} Input offset voltage	$R_S \leq 10\text{k}\Omega$ $R_S \leq 10\text{k}\Omega$, over temp.		0.7	4.0 5.0		2.0	6.0 7.0	mV mV
ΔV_{os} Input offset voltage drift	$R_S = 0\Omega$, over temp.		4.0			6.0		$\mu\text{V}/^\circ\text{C}$
I_{os} Input offset current	Over temp.		5	20 40		15	40 80	nA nA
ΔI_{os} Input offset current	Over temp.		25			40		$\text{pA}/^\circ\text{C}$
I_B Input current	Over temp.		45	80 200		65	150 200	nA nA
ΔI_B Input current	Over temp.		50			80		$\text{pA}/^\circ\text{C}$
V_{CM} Common mode voltage range	$R_S \leq 10\text{k}\Omega$, over temp.	± 12	± 13		± 12	± 13		V
CMRR Common mode rejection ratio		70	90		70	90		dB
PSRR Power supply rejection	$R_S \leq 10\text{k}\Omega$, over temp.		30	150		30	150	$\mu\text{V}/\text{V}$
R_{in} Input resistance		3	10		1	6		M Ω
A_{VOL} Large signal voltage gain	$R_L \geq 2\text{k}\Omega$, $V_{OUT} = \pm 10\text{V}$ $R_L \geq 2\text{k}\Omega$, $V_{OUT} = \pm 10\text{V}$, over temp.	50	500		50	500		V/mV V/mV
V_{OUT} Output voltage	$R_L \geq 2\text{k}\Omega$, over temp. $R_L \geq 10\text{k}\Omega$, over temp.	± 10 ± 12	± 13 ± 14		± 10 ± 12	± 13 ± 14		V V
I_{CC} Supply current	Per amplifier Per amplifier, over temp.		1.8 2	2.8 3.3		1.8 2	2.8	mA mA
P_D Power dissipation	Per amplifier Per amplifier, over temp.		54 60	84 99		54 60	84	mW mW
I_{SC} Output short circuit current		10	25	50	10	25	50	mA
R_{OUT} Output resistance			100			100		Ω

*NOTE

Temperature range

SE types $-55^\circ\text{C} \leq T_A \leq 125^\circ\text{C}$

NE types $0^\circ\text{C} \leq T_A \leq 70^\circ\text{C}$

DUAL HIGH SLEW RATE OP AMP

SE/NE5535

AC ELECTRICAL CHARACTERISTICS $T_A = 25^\circ\text{C}$ unless otherwise specified.

PARAMETER	TEST CONDITIONS	SE5535			NE5535			UNIT
		Min	Typ	Max	Min	Typ	Max	
Gain/bandwidth product			1			1		MHz
Transient response								
Small signal rise time			0.25			0.25		μs
Small signal overshoot			6			6		%
Settling time	To 0.1%		3			3		μs
Slew rate	$R_L \geq 10\text{k}\Omega$, unity gain, non-inverting	10	15		10	15		$\text{V}/\mu\text{s}$
Input noise voltage	$f = 1\text{kHz}$, $T_A = 25^\circ\text{C}$		30			30		$\text{nV}/\sqrt{\text{Hz}}$

TYPICAL PERFORMANCE CHARACTERISTICS

OUTPUT VOLTAGE SWING AS A FUNCTION OF FREQUENCY

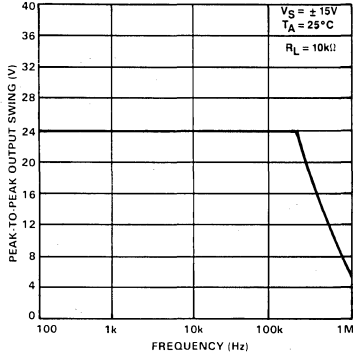

OPEN LOOP VOLTAGE GAIN AS A FUNCTION OF FREQUENCY

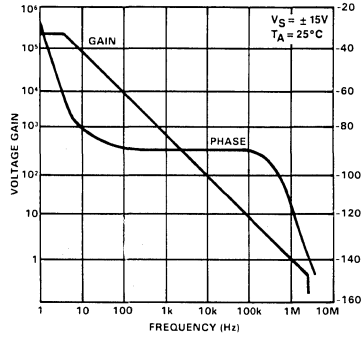

OUTPUT VOLTAGE SWING AS A FUNCTION OF SUPPLY VOLTAGE

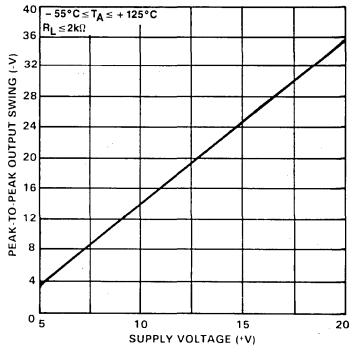

OUTPUT VOLTAGE SWING AS A FUNCTION OF LOAD RESISTANCE

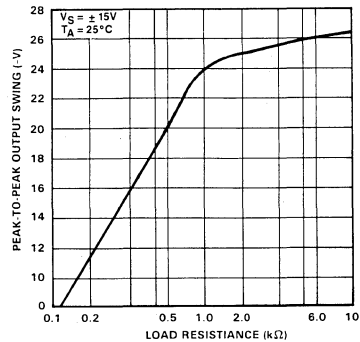

6

TYPICAL PERFORMANCE CHARACTERISTICS (Cont'd)

OUTPUT SHORT-CIRCUIT CURRENT AS A FUNCTION OF AMBIENT TEMPERATURE

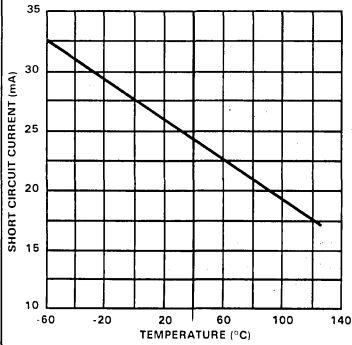

INPUT NOISE VOLTAGE AS A FUNCTION OF FREQUENCY

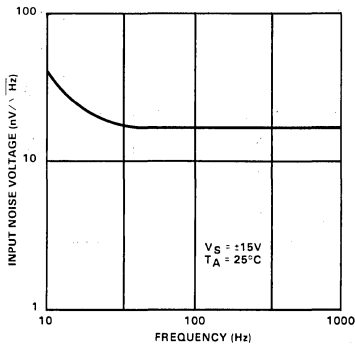

INPUT NOISE CURRENT AS A FUNCTION OF FREQUENCY

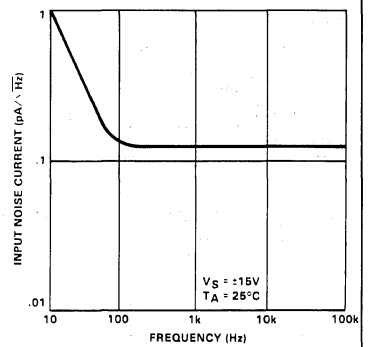

BROADBAND NOISE FOR VARIOUS BANDWIDTHS

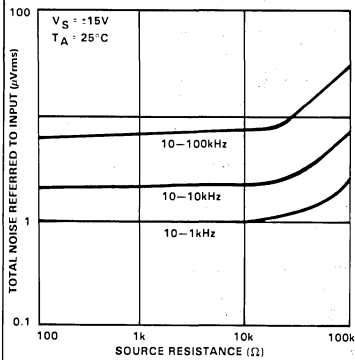

INPUT COMMON MODE VOLTAGE RANGE AS A FUNCTION OF SUPPLY VOLTAGE

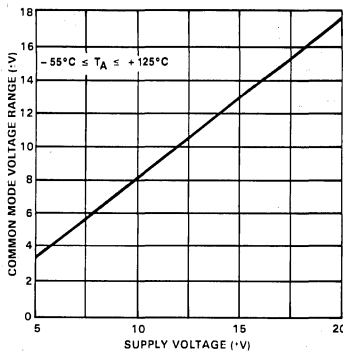

POWER CONSUMPTION AS A FUNCTION OF SUPPLY VOLTAGE

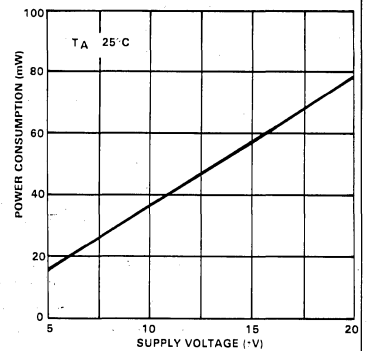

POWER CONSUMPTION AS A FUNCTION OF AMBIENT TEMPERATURE

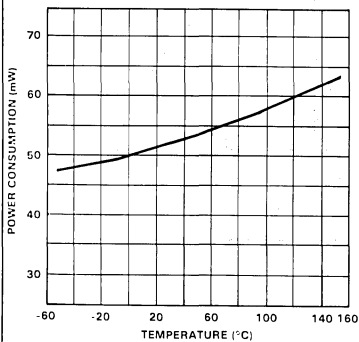

INPUT BIAS CURRENT AS A FUNCTION OF AMBIENT TEMPERATURE

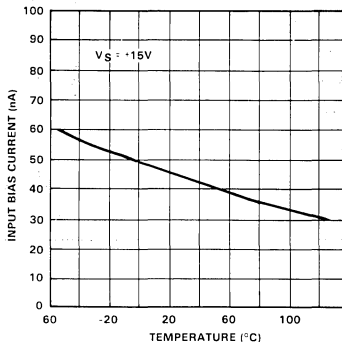

COMMON MODE REJECTION RATIO AS A FUNCTION OF FREQUENCY

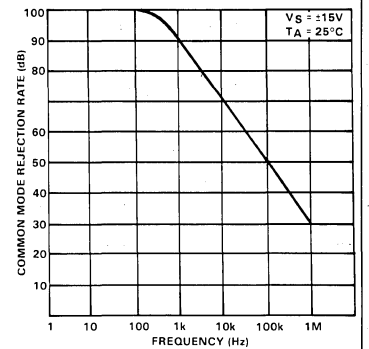

VOLTAGE WAVEFORMS

SETTLING TIME MEASUREMENT

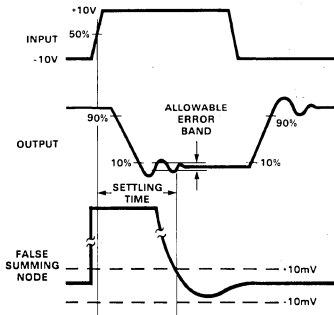

SLEW RATE MEASUREMENT

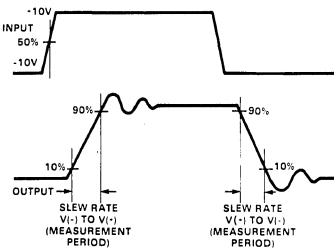

SMALL-SIGNAL TRANSIENT RESPONSE DEFINITIONS

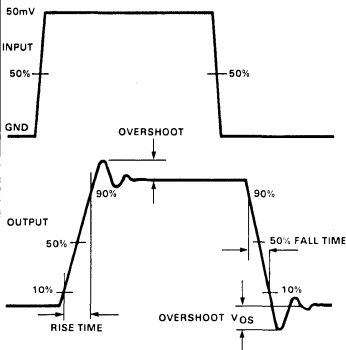

TEST CIRCUITS

SLEW RATE AND SMALL SIGNAL TRANSIENT RESPONSE

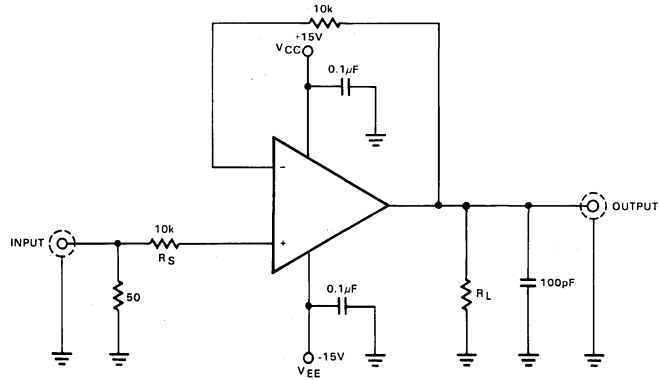

NOTE
Pins not shown are not connected.
All resistors values are typical and in ohms.

SETTLING TIME

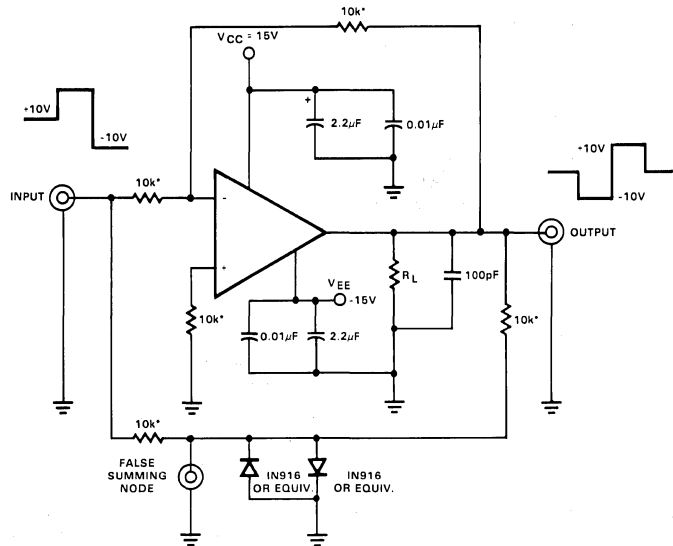

*Match to within 0.01%.
NOTE
Pins not shown are not connected.
All resistors values are typical and in ohms.

6

APPLICATIONS

Introduction

The NE5535 is a new generation monolithic op amp which features improved input characteristics. The device is compensated to unity gain and has a minimum guaranteed unity gain slew rate of 10V/μs. This is achieved by employing a clamped super beta input stage which has lower input bias current.

the positive and negative supply voltage will be equal during power up. With the NE5535, it is possible to degrade the input circuit characteristics by not applying the power supplies simultaneously. The NE5535 is capable of directly replacing the μA741 with higher input resistance which will improve such designed as active filters, sample and hold, as well as voltage followers.

ability at high frequencies. R1 should therefore always be slightly smaller than R2 to assure stable operation.

POWER AMPLIFIER

For most applications, the available power from op amps is sufficient. There are times when more power handling capability is necessary. A simple power booster capable of driving moderate loads is offered in Figure 3.

The NE5535 can be used either with single or split power supplies.

APPLICATIONS

CAPACITANCE MULTIPLIER

The circuit in Figure 1 can be used to simulate large capacitances using small value components. With the values shown and C = 10μF, an effective capacitance of 10,000μF was obtained. The Q available is

$$R1 = \frac{600mV}{ICC}$$

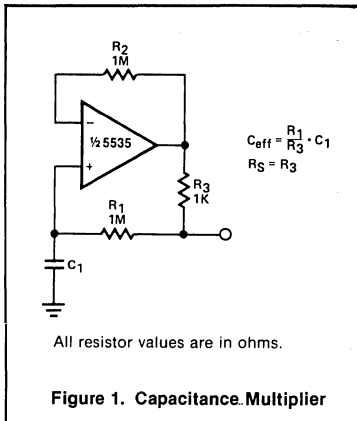

Applications

These improved parameters can be put to good use in applications such as sample and hold circuits which require low input current and in voltage follower circuits which require high slew rates. The circuit that follows will yield maximum small signal transient response and slew rate for the NE5535 at unity gain.

It is always good practice in designing a system to use dual tracking regulators to power the dual supply op amps. This will guarantee

limited by the effective series resistance. So R1 should be as large as practical.

SIMULATED INDUCTOR

With a constant current excitation, the voltage dropped across an inductance increases with frequency. Thus, an active device whose output increases with frequency can be characterized as an inductance. The circuit of Figure 2 yields such a response with the effective inductance being equal to:

$$L = R1R2C$$

The Q of this inductance depends upon R1 being equal to R2. At the same time, however, the positive and negative feedback paths of the amplifier are equal leading to the distinct possibility of insta-

The circuit as shown uses a NE5535 device. Other amplifiers may be substituted only if R1 values are changed because of the ICC current required by the amplifier. R1 should be calculated from the expression

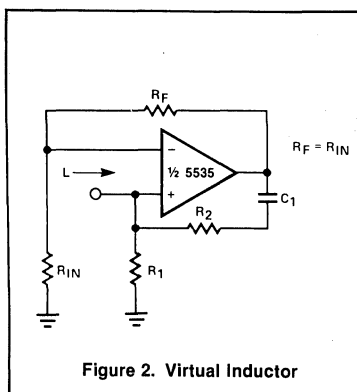
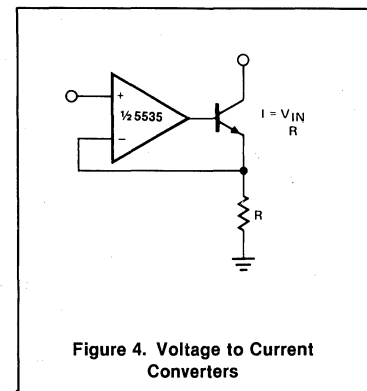
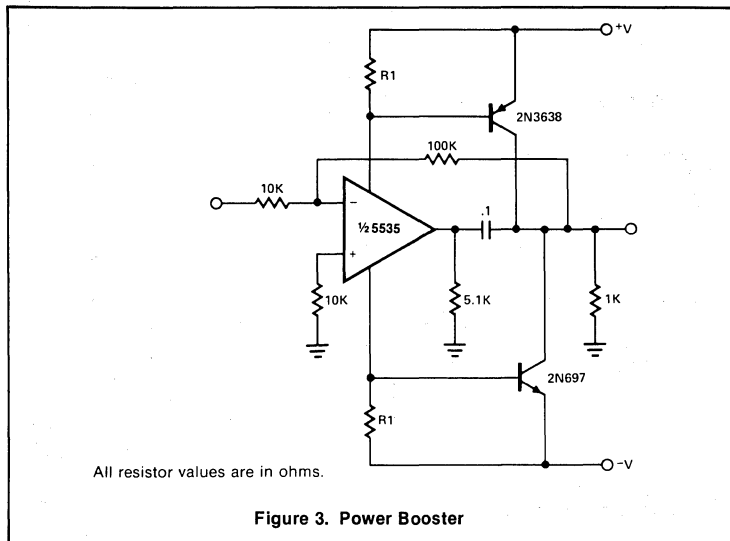

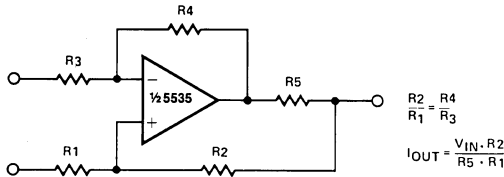

Figure 5. Voltage to Current Converter

VOLTAGE-TO-CURRENT CONVERTERS

A simple voltage-to-current converter is shown in Figure 4. The current out is $I_{out} \cong V_{in}/R$. For negative currents, a pnp can be used and, for better accuracy, a Darlington pair can be substituted for the transistor. With careful design, this circuit can be used to control currents of many amps. Unity gain compensation is necessary.

The circuit in Figure 5 has a different input and will produce either polarity of output current. The main disadvantages are the error current flowing in R2 and the limited current available.

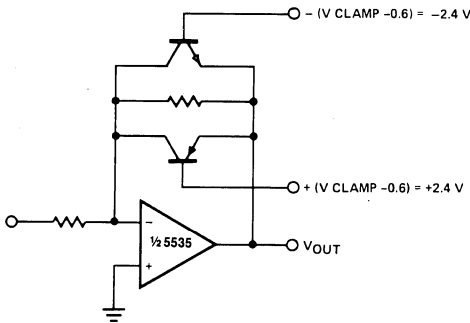

Figure 6. Active Clamp Limiting Amplifier

ACTIVE CLAMP LIMITING AMPLIFIER

The modified inverting amplifier in Figure 6 uses an active clamp to limit the output swing with precision. Allowance must be made for the V_{be} of the transistors. The swing is limited by the base-emitter breakdown of the transistors. A simple circuit uses two back-to-back zener diodes across the feedback resistor, but tends to give less precise limiting and cannot be easily controlled.

ABSOLUTE VALUE AMPLIFIER

The circuit in Figure 7 generates a positive output voltage for either polarity of input. For positive signals, it acts as a non-inverting amplifier and for negative signals, as an inverting amplifier. The accuracy is poor for input voltages under 1V, but for less stringent applications, it can be effective.

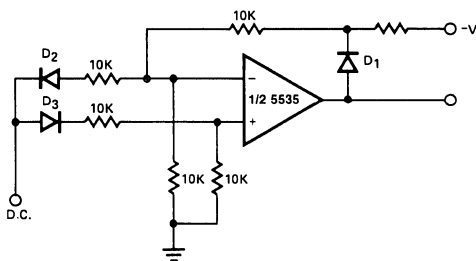

All resistor values are in ohms.

Figure 7. Absolute Value Amplifier

HALF WAVE RECTIFIER

Figure 8 provides a circuit for accurate half wave rectification of the incoming signal. For positive signals, the gain is 0; for negative signals, the gain is -1 . By reversing both diodes, the polarity can be inverted. This circuit provides an accurate output, but the output impedance differs for the two input polarities and buffering may be needed. The output must slew through two diode drops when the input polarity reverses. The NE5535 device will work up to 10kHz with less than 5% distortion.

PRECISION FULL WAVE RECTIFIER

The circuit in Figure 9 provides accurate full wave rectification. The output impedance is low for both input polarities, and the errors are small at all signal levels. Note that the output will not sink heavy currents, except a small amount through



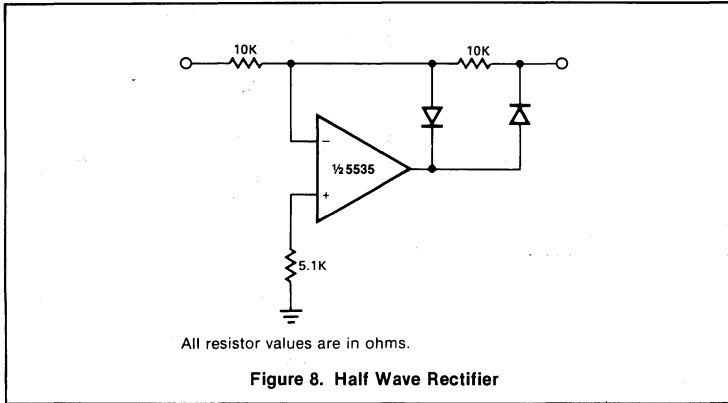

the 10kΩ resistors. Therefore, the load applied should be referenced to ground or a negative voltage. Reversal of all diode polarities will reverse the polarity of the output. Since the outputs of the amplifiers must slew through two diode drops when the input polarity changes, 741 type devices give 5% distortion at about 300Hz.

TWO-PHASE SINE WAVE OSCILLATOR

The circuit (referring to Figure 10, uses a 2-pole pass Butterworth, followed by a phase shifting single pole stage, fed back through a voltage limiter to achieve sine and cosine outputs. The values shown using 741 amplifiers give about 1.5% distortion at the sine output and about 3% distortion at the cosine output. By careful trimming of C_G and/or the limiting network, better distortion figures are possible. The component values shown give a frequency of oscillation of about 2kHz. The NE5535 should be used at higher frequencies to reduce distortion due to slew limiting.

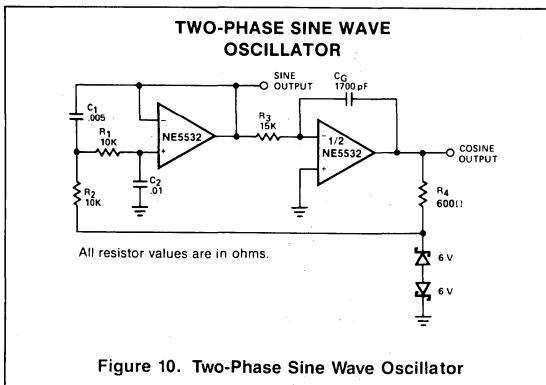
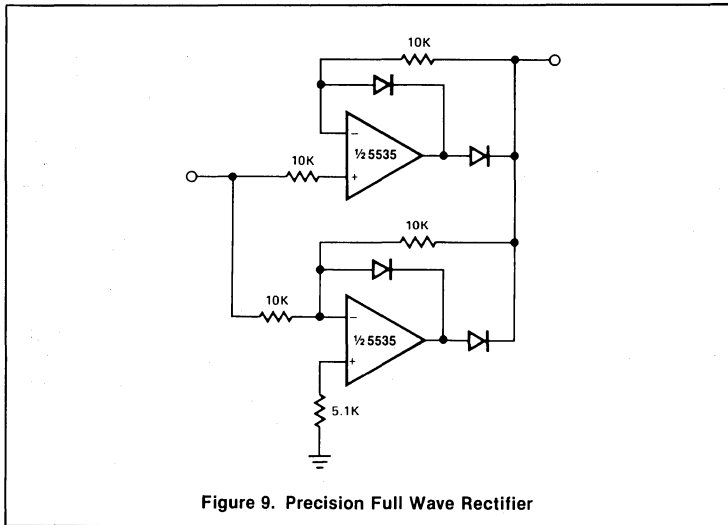

OPERATIONAL AMPLIFIER**TCA520B,D****GENERAL DESCRIPTION**

The TCA520 is a bipolar integrated operational amplifier primarily intended for low-power, low-voltage applications and as a comparator in digital systems.

Features

- wide supply voltage range
- low supply voltage operation
- low power consumption
- low input bias current
- offset compensation facility
- frequency compensation facility
- high slew rate
- large output voltage swing
- TTL compatible output

QUICK REFERENCE DATA

Supply voltage range	V_{CC}	2 to 20 V
Supply current	I_{CC}	typ. 0.8 mA
Input bias current	I_{IB}	typ. 60 nA
Output voltage range	V_O	0.1 to $V_{CC}-0.1$ V
D.C. differential voltage amplification	A_{VD}	typ. 15 000
Slew rate	S_{VOAV}	typ. 25 V/ μ s
Operating ambient temperature range	T_{amb}	-25 to + 85 °C

6**PACKAGE OUTLINES**

TCA520B : 8-lead DIL; plastic (SOT-97A).

TCA520D: 8-lead mini-pack; plastic (SO-8; SOT-96A).

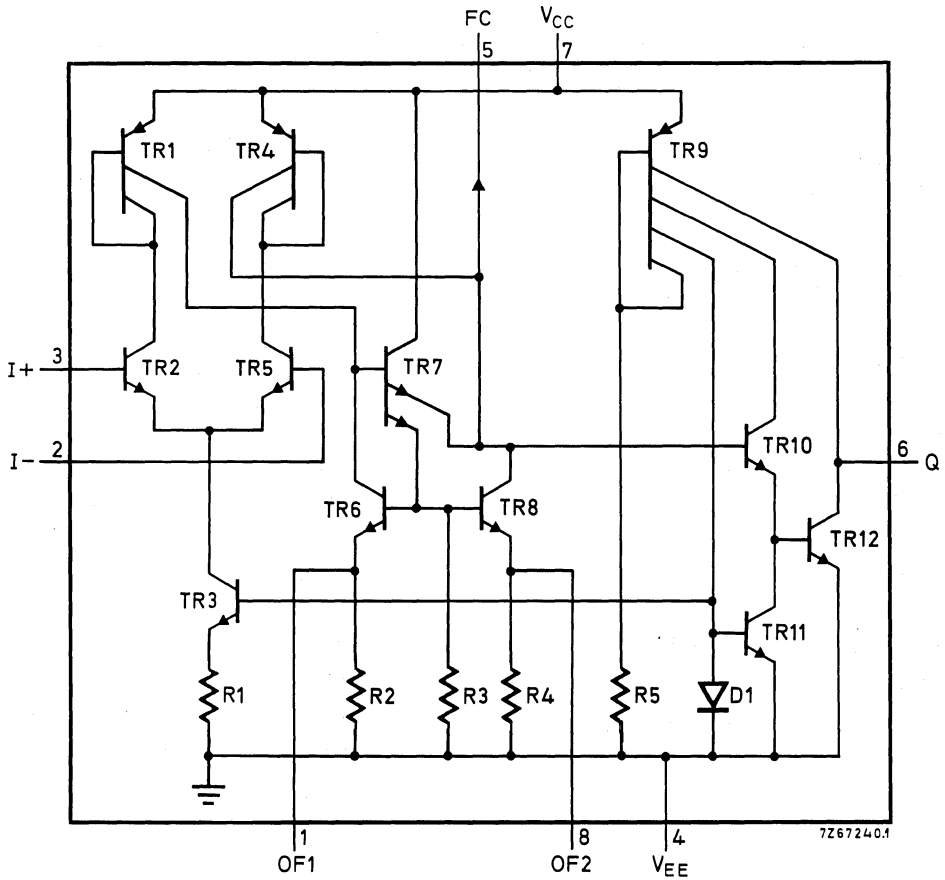
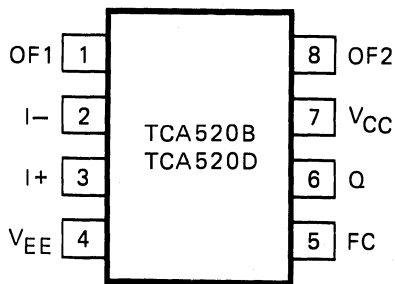

Fig. 1 Circuit diagram.



PINNING

- 1 OF1 offset compensation connection
- 2 I- inverting input
- 3 I+ non-inverting input
- 4 VEE ground connection
- 5 FC frequency compensation connection
- 6 Q output
- 7 VCC positive supply connection
- 8 OF2 offset compensation connection

Fig. 2 Pinning diagram.

OPERATIONAL AMPLIFIER

TCA520B,D

RATINGS

Limiting values in accordance with the Absolute Maximum System (IEC 134)

Supply voltage, d.c.	V_{CC}	max.	22 V
Input voltage	V_I	max.	V_{CC} V
	$-V_I$	max.	0 V
Differential input voltage	$\pm V_{ID}$	max.	7 V
Power dissipation at $T_{amb} = 85^\circ\text{C}$	P_{tot}	max.	200 mW
Storage temperature range	T_{stg}		-55 to + 125 $^\circ\text{C}$
Operating ambient temperature range	T_{amb}		-25 to + 85 $^\circ\text{C}$

CHARACTERISTICS

$V_{CC} = 5\text{ V}$; $V_{EE} = 0\text{ V}$; $T_{amb} = 25^\circ\text{C}$; R_L from Q to V_{CC} unless otherwise specified

parameter	symbol	min.	typ.	max.	unit
Supply V_{CC}; pin 7					
Supply current, unloaded	I_{CC}	0.5	0.8	1.2	mA
Inputs I+ and I-; pins 3 and 2					
Input voltage	V_I	0.9	—	$V_{CC}-0.5$	V
Input bias current	I_{IB}	—	60	250	nA
Input offset voltage	V_{IO}	—	1	6	mV
Variation with temperature	ΔV_{IO}	—	5	—	$\mu\text{V/K}$
Input offset current	I_{IO}	—	10	75	nA
Common-mode rejection ratio	k_{CMR}	70	100	—	dB
Input noise voltage at $f = 1\text{ kHz}$	$V_n(\text{rms})$	—	15	—	$\text{nV}/\sqrt{\text{Hz}}$
Input noise current at $f = 1\text{ kHz}$	$I_n(\text{rms})$	—	0.4	—	$\text{pA}/\sqrt{\text{Hz}}$
Output Q; pin 6					
Output voltage range at $R_L = 5\text{ k}\Omega$	V_Q	0.1	—	$V_{CC}-0.1$	V
Output current					
HIGH at $V_Q = V_{CC} - 0.4\text{ V}$	$-I_{OH}$	100	200	—	μA
LOW at $V_Q = 0.4\text{ V}$	I_{OL}	6	12	—	mA
D.C. voltage amplification at $R_L = 5\text{ k}\Omega$	A_{VD}	10 000	15 000	—	
A.C. voltage amplification at $f = 1\text{ kHz}$; $C_{FC} = 100\text{ pF}$	A_{vd}	—	58	—	dB
Slew rate (average rate of change of the output voltage) at $R_L = 1\text{ k}\Omega$					
$C_{FC} = 0\text{ pF}$	S_{VOAV}	—	25	—	$\text{V}/\mu\text{s}$
$C_{FC} = 100\text{ pF}$	S_{VOAV}	—	500	—	$\text{mV}/\mu\text{s}$

6

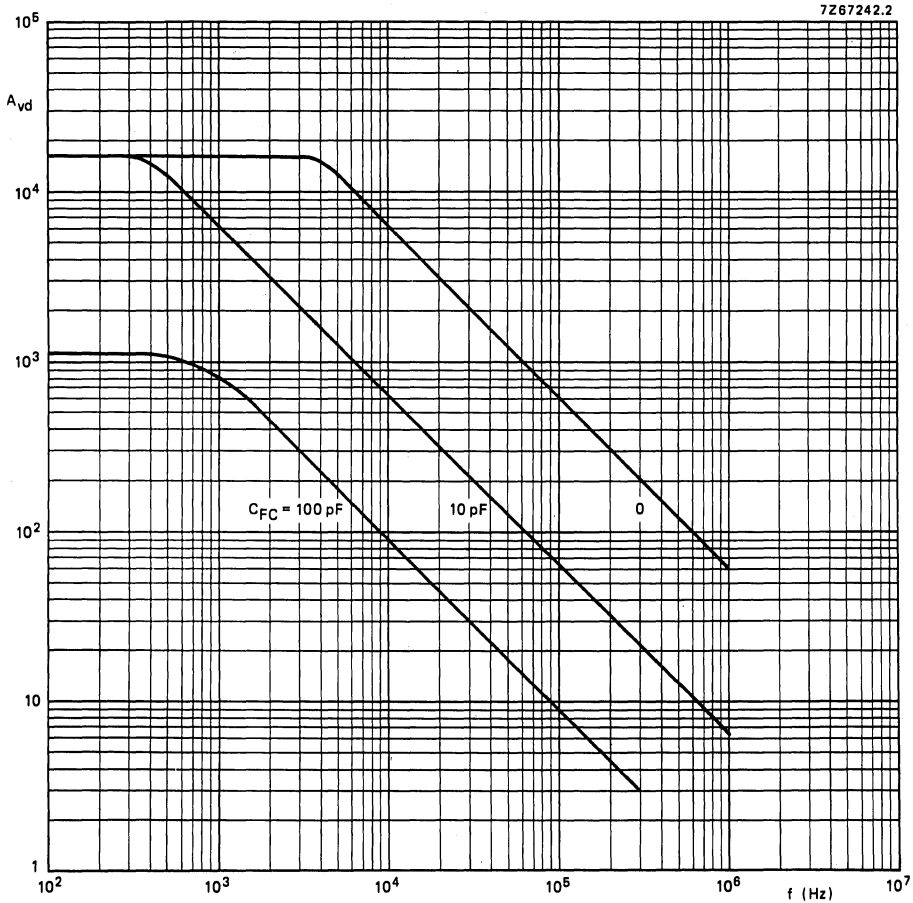

Fig. 3 Typical values of the open-loop voltage amplification as a function of frequency.

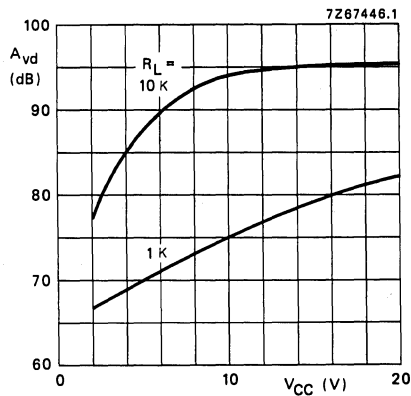

Fig. 4 Typical values of the open-loop voltage amplification as a function of supply voltage.

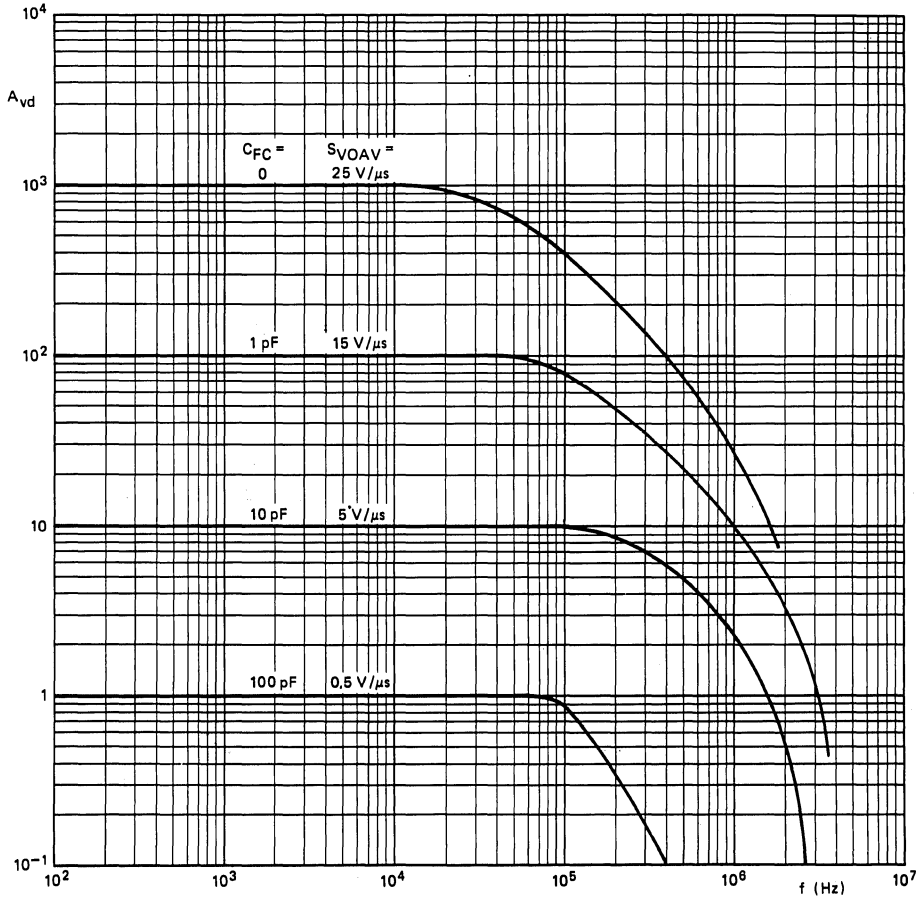

Fig. 5 Typical frequency response and slew rate for various closed-loop gains.

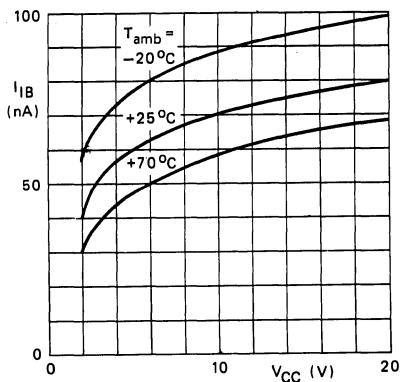

Fig. 6 Typical values of the input bias current as a function of supply voltage, with ambient temperature as a parameter.

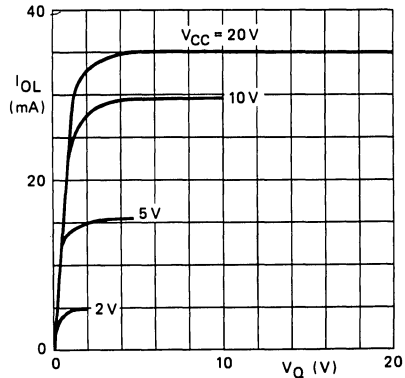

Fig. 7 Output current LOW as a function of output voltage, with supply voltage as a parameter.

6

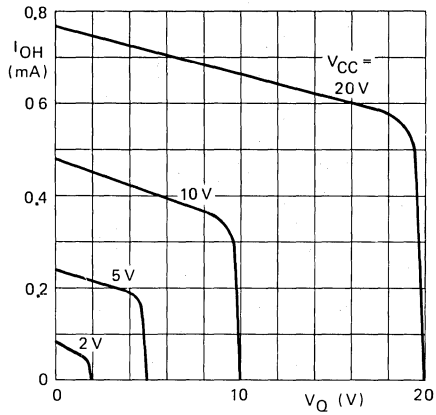

Fig. 8 Output current HIGH as a function of output voltage, with supply voltage as a parameter.

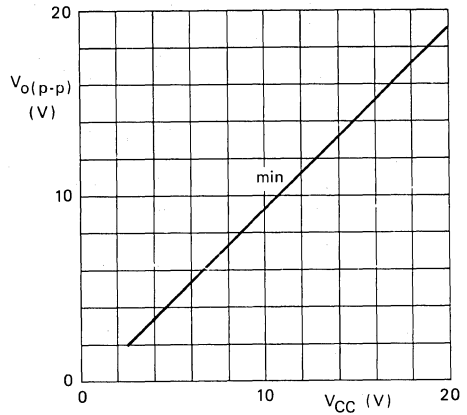

Fig. 9 Minimum values of the output voltage swing as a function of supply voltage for $R_L = 1 \text{ k}\Omega$.

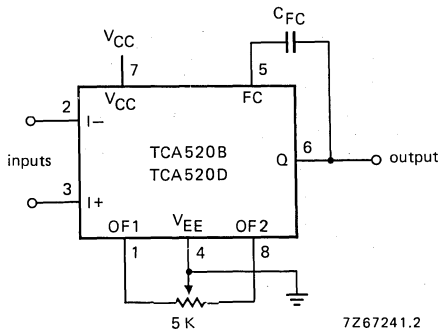

Fig. 10 Typical arrangement of the TCA520 with frequency and offset compensation.

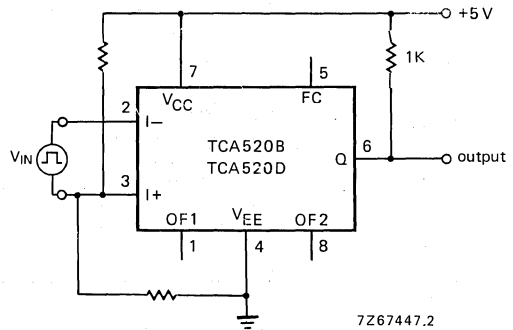

Fig. 11 Typical application of the TCA520 as a comparator.

GENERAL PURPOSE OPERATIONAL AMPLIFIER

μ A741/ μ A741C/SA741C

DESCRIPTION

The μ A741 is a high performance operational amplifier with high open loop gain, internal compensation, high common mode range and exceptional temperature stability. The μ A741 is short-circuit protected and allows for nulling of offset voltage.

FEATURES

- Internal frequency compensation
- Short circuit protection
- Excellent temperature stability
- High input voltage range

PIN CONFIGURATION

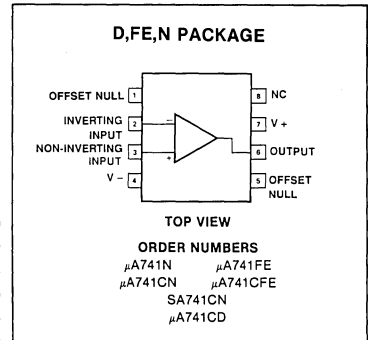

ABSOLUTE MAXIMUM RATINGS

PARAMETER	RATING	UNIT
Supply voltage		
μ A741C	± 18	V
μ A741	± 22	V
Internal power dissipation		
N package	500	mW
FE package	1000	mW
Differential input voltage	± 30	V
Input voltage ¹	± 15	V
Output short-circuit duration	Continuous	
Operating temperature range		
μ A741C	0 to +70	°C
SA741C	-40 to +85	°C
μ A741	-55 to +125	°C
Storage temperature range	-65 to +150	°C
Lead temperature (soldering 60sec)	300	°C

NOTE

1. For supply voltages less than ± 15 V, the absolute maximum input voltage is equal to the supply voltage.

EQUIVALENT SCHEMATIC

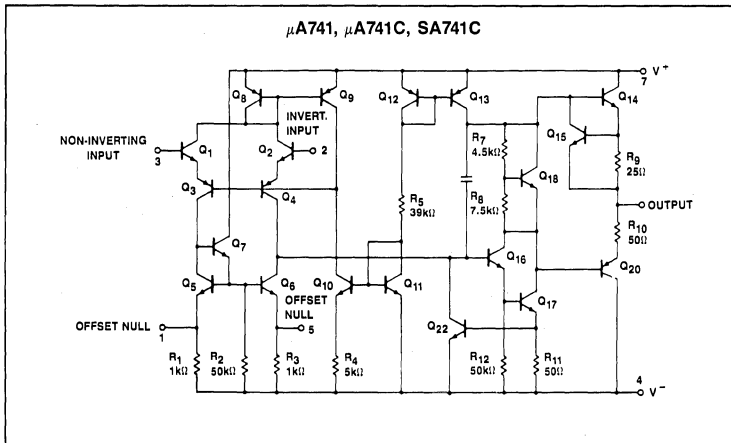

GENERAL PURPOSE OPERATIONAL AMPLIFIER

μ A741/ μ A741C/SA741C

DC ELECTRICAL CHARACTERISTICS $T_A = 25^\circ\text{C}$, $V_S = \pm 15\text{V}$, unless otherwise specified.

PARAMETER	TEST CONDITIONS	μ A741			μ A741C			UNIT
		Min	Typ	Max	Min	Typ	Max	
V_{OS}	Offset voltage		1.0	5.0		2.0	6.0	mV
$\Delta V_{OS}/\Delta T$			1.0	6.0		10	7.5	mV/ $^\circ\text{C}$
I_{OS}	Offset current		20	200		20	200	nA
$\Delta I_{OS}/\Delta T$	Over temp. $T_A = +125^\circ\text{C}$ $T_A = -55^\circ\text{C}$		7.0	200		200	300	nA
I_{BIAS}	Input bias current		80	500		80	500	nA
$\Delta I_B/\Delta T$	Over temp. $T_A = +125^\circ\text{C}$ $T_A = -55^\circ\text{C}$		30	500		1	800	nA
V_{OUT}	Output voltage swing		80	1500		1	800	nA/ $^\circ\text{C}$
V_{VOL}	Large signal voltage gain		± 12	± 14		± 12	± 14	V
			± 10	± 13		± 10	± 13	V
	Offset voltage adjustment range					± 30		mV
PSRR	Supply voltage rejection ratio		50	200		20	200	V/mV
			25			15		V/mV
	Offset voltage adjustment range			± 30				mV
CMRR	Common mode rejection ratio							dB
	Over temp.		70	90				dB
I_{CC}	Supply current		1.4	2.8		1.4	2.8	mA
	$T_A = +125^\circ\text{C}$		1.5	2.5				mA
	$T_A = -55^\circ\text{C}$		2.0	3.3				mA
V_{IN}	Input voltage range		± 12	± 13		± 12	± 13	V
R_{IN}	Input resistance		0.3	2.0		0.3	2.0	M Ω
P_d	Power consumption		50	85		50	85	mW
	$T_A = +125^\circ\text{C}$		45	75				mW
	$T_A = -55^\circ\text{C}$		45	100				mW
R_{OUT}	Output resistance			75		75		Ω
I_{SC}	Output short-circuit current		10	25		10	25	mA

PARAMETER	TEST CONDITIONS	SA741C			UNIT
		Min	Typ	Max	
V_{OS}	Offset voltage		2.0	6.0	mV
$\Delta V_{OS}/\Delta T$	$R_S = 10\text{k}\Omega$ $R_S = 10\text{k}\Omega$, over temp.		10	7.5	mV/ $^\circ\text{C}$
I_{OS}	Offset current		20	200	nA
$\Delta I_{OS}/\Delta T$	Over temp.		200	500	nA
I_{BIAS}	Input bias current		80	500	nA
$\Delta I_B/\Delta T$	Over temp.		1	1500	nA
V_{OUT}	Output voltage swing		± 12	± 14	V
	$R_L = 10\text{k}\Omega$ $R_L = 2\text{k}\Omega$, over temp.		± 10	± 13	V
A_{VOL}	Large signal voltage gain		20	200	V/mV
	$R_L = 2\text{k}\Omega$, $V_O = \pm 10\text{V}$ $R_L = 2\text{k}\Omega$, $V_O = \pm 10\text{V}$, over temp.		15		V/mV
	Offset voltage adjustment range			± 30	mV

GENERAL PURPOSE OPERATIONAL AMPLIFIER

μ A741/ μ A741C/SA741C

DC ELECTRICAL CHARACTERISTICS (Cont'd) $T_A = 25^\circ\text{C}$, $V_S = \pm 15\text{V}$, unless otherwise specified.

PARAMETER		TEST CONDITIONS	SA741C			UNIT
			Min	Typ	Max	
PSRR	Supply voltage rejection ratio	$R_S \leq 10\text{k}\Omega$		10	150	$\mu\text{V/V}$
CMRR	Common mode rejection ratio					dB
V_{IN}	Input voltage range Input resistance	(μ A741, over temp.)	± 12 0.3	± 13 2.0		V M Ω
P_d	Power consumption			50	85	mW
R_{OUT}	Output resistance			75		Ω
I_{SC}	Output short-circuit current			25		mA

AC ELECTRICAL CHARACTERISTICS $T_A = 25^\circ\text{C}$, $V_S = \pm 15\text{V}$, unless otherwise specified.

PARAMETER	TEST CONDITIONS	μ A741, μ A741C			UNIT
		Min	Typ	Max	
Parallel input resistance	Open loop, $f = 20\text{Hz}$				M Ω
Parallel input capacitance	Open loop, $f = 20\text{Hz}$		1.4		pF
Unity gain crossover frequency	Open loop		1.0		MHz
Transient response unity gain	$V_{IN} = 20\text{mV}$, $R_L = 2\text{k}\Omega$, $C_L \leq 100\text{pf}$		0.3		μs
Rise time			5.0		%
Overshoot			0.5		V/ μs
Slew rate	$C \leq 100\text{pf}$, $R_L \geq 2\text{k}$, $V_{IN} = \pm 10\text{V}$				

6

TYPICAL PERFORMANCE CHARACTERISTICS

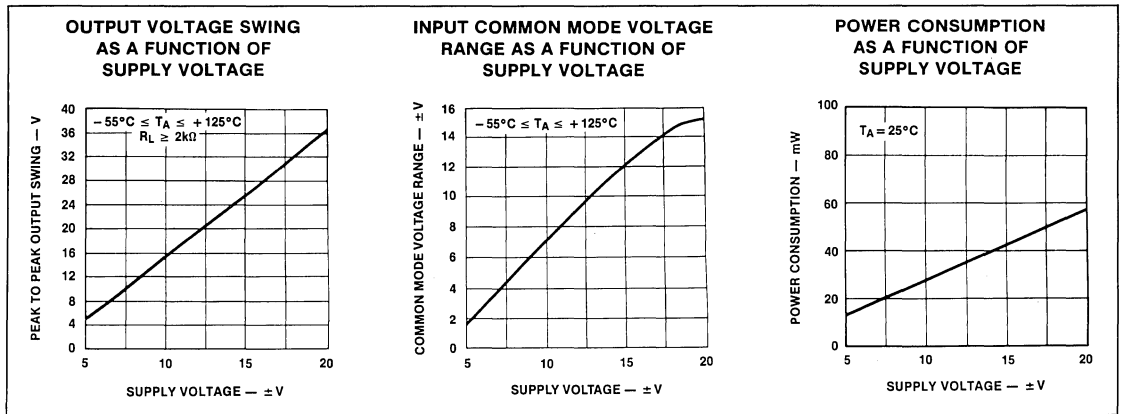

TYPICAL PERFORMANCE CHARACTERISTICS (Cont'd)

INPUT BIAS CURRENT AS A FUNCTION OF AMBIENT TEMPERATURE

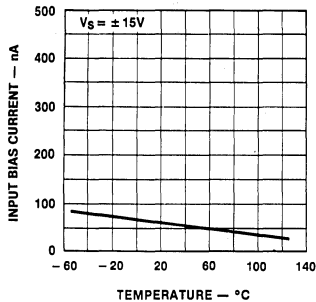

INPUT RESISTANCE AS A FUNCTION OF AMBIENT TEMPERATURE

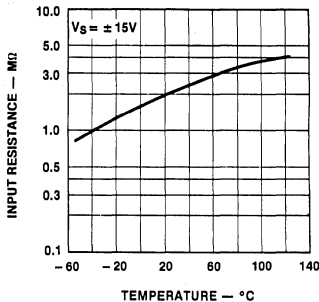

INPUT OFFSET CURRENT AS A FUNCTION OF SUPPLY VOLTAGE

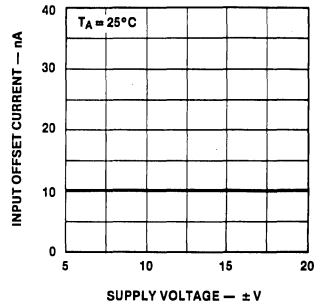

INPUT OFFSET CURRENT AS A FUNCTION OF AMBIENT TEMPERATURE

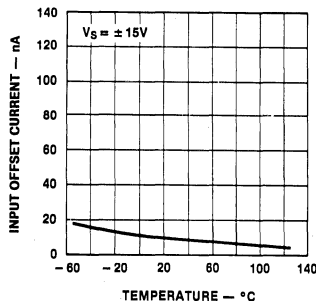

POWER CONSUMPTION AS A FUNCTION OF AMBIENT TEMPERATURE

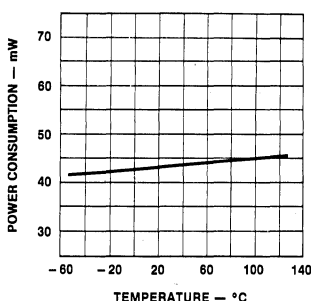

OUTPUT VOLTAGE SWING AS A FUNCTION OF LOAD RESISTANCE

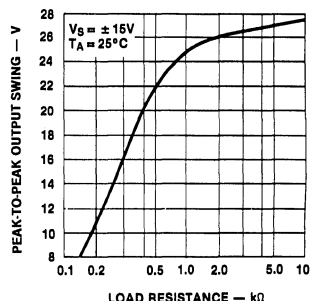

OUTPUT SHORT-CIRCUIT CURRENT AS A FUNCTION OF AMBIENT TEMPERATURE

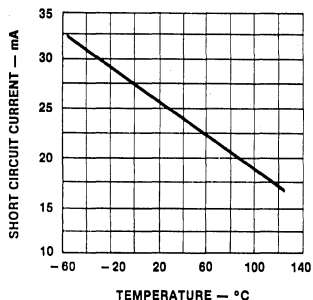

INPUT NOISE VOLTAGE AS A FUNCTION OF FREQUENCY

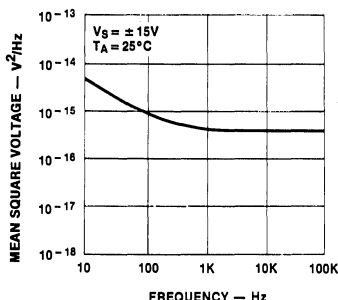

INPUT NOISE CURRENT AS A FUNCTION OF FREQUENCY

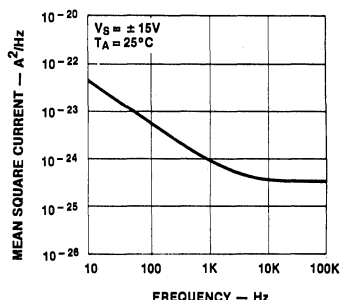

TYPICAL PERFORMANCE CHARACTERISTICS (Cont'd)

BROADBAND NOISE FOR VARIOUS BANDWIDTHS

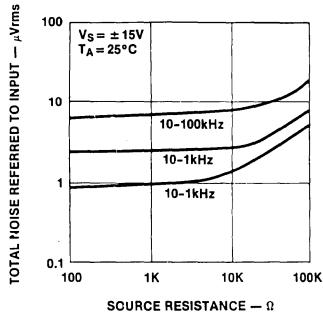

OPEN LOOP VOLTAGE GAIN AS A FUNCTION OF FREQUENCY

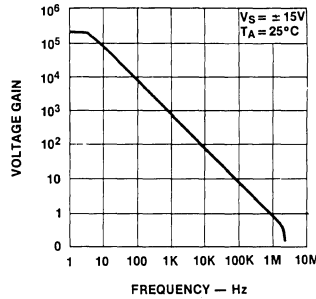

OPEN LOOP PHASE RESPONSE AS A FUNCTION OF FREQUENCY

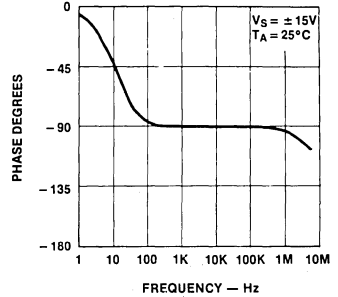

OUTPUT VOLTAGE SWING AS A FUNCTION OF FREQUENCY

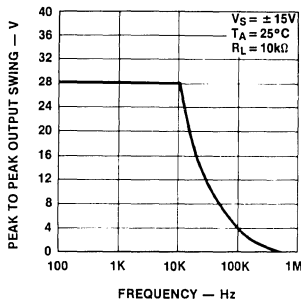

COMMON MODE REJECTION RATIO AS A FUNCTION OF FREQUENCY

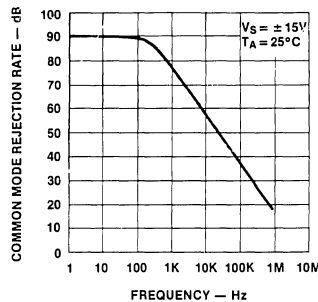

TRANSIENT RESPONSE

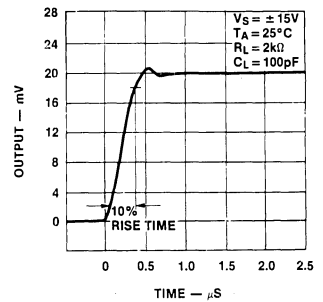

POWER BANDWIDTH (Large Signal Swing vs Frequency)

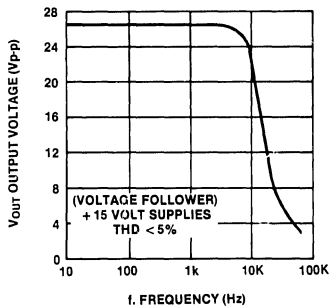

VOLTAGE OFFSET NULL

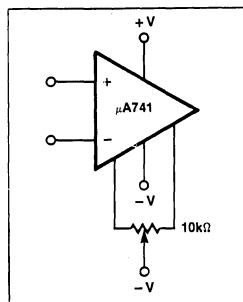

6

DUAL OPERATIONAL AMPLIFIER

μ A747/747C/SA747C

DESCRIPTION

The 747 is a pair of high performance monolithic operational amplifiers constructed on a single silicon chip. High common mode voltage range and absence of "latch-up" make the 747 ideal for use as a voltage follower. The high gain and wide range of operating voltage provides superior performance in integrator, summing amplifier, and general feedback applications. The 747 is short-circuit protected and requires no external components for frequency compensation. The internal 6dB/octave roll-off insures stability in closed loop applications. For single amplifier performance, see μ A741 data sheet.

FEATURES

- No frequency compensation required
- Short-circuit protection
- Offset voltage null capability
- Large common-mode and differential voltage ranges
- Low power consumption
- No latch-up

PIN CONFIGURATIONS

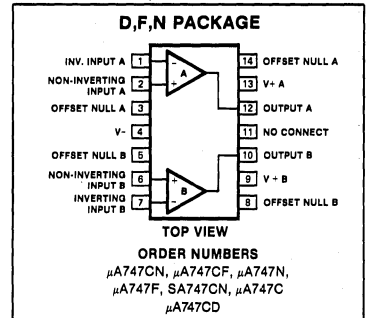

ABSOLUTE MAXIMUM RATINGS

PARAMETER	RATING	UNIT
Supply voltage		
μ A747	± 22	V
μ A747C	± 18	V
SA747C	± 18	V
Internal power dissipation		
H Package	500	mW
N,F Packages	670	mW
Differential input voltage	± 30	V
Input voltage	± 15	V
Voltage between offset null and V-	± 0.5	V
Storage temperature range	-65 to +155	$^{\circ}$ C
Operating temperature range		
μ A747	-55 to +125	$^{\circ}$ C
μ A747C	0 to +70	$^{\circ}$ C
SA747C	-40 to +85	$^{\circ}$ C
Lead temperature (soldering, 60 sec)	300	$^{\circ}$ C
Output short-circuit duration	indefinite	

EQUIVALENT SCHEMATIC

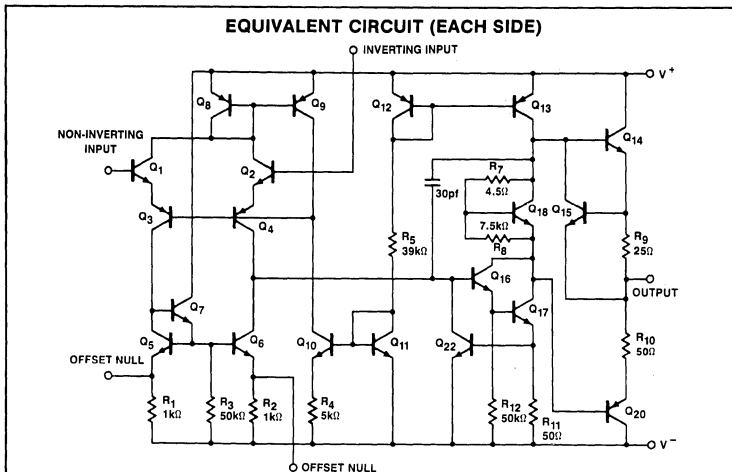

DUAL OPERATIONAL AMPLIFIER

μ A747/747C/SA747C

DC ELECTRICAL CHARACTERISTICS $T_A = 25^\circ\text{C}$, $V_S = \pm 15\text{V}$ unless otherwise specified.

PARAMETER	TEST CONDITIONS	SA747C			UNIT
		Min	Typ	Max	
V_{OS} Offset voltage	$R_S = 10\text{k}\Omega$		2.0	6.0	mV
$\Delta V_{OS}/\Delta T$	$R_S \leq 10\text{k}\Omega$, over temperature		3.0	7.5	mV $\mu\text{V}/^\circ\text{C}$
I_{OS} Offset current	Over temperature		20	200	nA
$\Delta I_{OS}/\Delta T$			300	500	nA $\text{pA}/^\circ\text{C}$
I_{BIAS} Input bias current	Over temperature			500	nA
$\Delta I_B/\Delta T$			1	1500	nA $\text{nA}/^\circ\text{C}$
V_{OUT} Output voltage swing	$R_L \geq 2\text{k}\Omega$, over temperature $R_L \geq 10\text{k}\Omega$, over temperature	± 10 ± 12	± 13 ± 14		V V
I_{CC} Supply current	Over temperature		1.7 2.0	2.8 3.3	mA mA
Power consumption	Over temperature		50 60	85 100	mW mW
Input capacitance			1.4		pF
Offset voltage adjustment range			± 15		V
Output resistance			75		Ω
Channel separation			120		dB
PSRR Supply voltage rejection ratio	$R_S \leq 10\text{k}\Omega$, over temperature		30	150	$\mu\text{V}/\text{V}$
A_{VOL} Large signal voltage gain (DC)	$R_L \geq 2\text{k}\Omega$, $V_{OUT} = \pm 10\text{V}$	25,000			V/V
CMRR	$R_S \leq 10\text{k}\Omega$, $V_{CM} = \pm 12\text{V}$ Over temperature	70			dB
I_{sc}		10	25	60	mA

AC ELECTRICAL CHARACTERISTICS $T_A = 25^\circ\text{C}$, $V_S = \pm 15\text{V}$ unless otherwise specified.

PARAMETER	TEST CONDITIONS	$\mu\text{A747}/\mu\text{A747C}/\text{SA747C}$			UNIT
		Min	Typ	Max	
Transient response	$V_{IN} = 20\text{mV}$, $R_1 = 2\text{k}\Omega$, $C_1 < 100\text{pf}$				
Risetime	Unity gain $CL \leq 100\text{pf}$		0.3		μs
Overshoot	Unity gain $CL \leq 100\text{pf}$		5.0		%
Slew rate	$R_L > 2\text{k}\Omega$		0.5		$\text{V}/\mu\text{s}$

6

DUAL OPERATIONAL AMPLIFIER

 μ A747/747C/SA747CDC ELECTRICAL CHARACTERISTICS $T_A = 25^\circ\text{C}$, $V_{CC} = \pm 15\text{V}$ unless otherwise specified.¹

PARAMETER	TEST CONDITIONS	μ A747			μ A747C			UNIT
		Min	Typ	Max	Min	Typ	Max	
V_{OS} Offset voltage	$R_S \leq 10\text{k}\Omega$		2.0	5.0		2.0	6.0	mV
$\Delta V_{OS}/\Delta T$	$R_S \leq 10\text{k}\Omega$, over temp.		3.0	6.0		3.0	7.5	$\mu\text{V}/^\circ\text{C}$
I_{OS} Offset current	$T_A = +125^\circ\text{C}$ $T_A = -55^\circ\text{C}$ Over temperature		20 7.0 85	200 200 500		20 7.0	200 300	nA nA nA
$\Delta I_{OS}/\Delta T$	Over temperature		200			200		$\text{pA}/^\circ\text{C}$
I_{BIAS} Input current	$T_A = +125^\circ\text{C}$ $T_A = -55^\circ\text{C}$ Over temperature		80 30 300	500 500 1500		80 30	500 800	nA nA nA
$\Delta I_B/\Delta T$	Over temperature		1			1		$\text{nA}/^\circ\text{C}$
V_{OUT} Output voltage swing	$R_L \geq 2\text{k}\Omega$, over temp. $R_L \geq 10\text{k}\Omega$, over temp.	± 10 ± 12	± 13 ± 14		± 10 ± 12	± 13 ± 14		V V
I_{CC} Supply current each side	$T_A = +125^\circ\text{C}$ $T_A = -55^\circ\text{C}$ Over temperature		1.7 1.5 2.0	2.8 2.5 3.3		1.7 2.0	2.8 3.3	mA mA mA mA
Power consumption	$T_A = +125^\circ\text{C}$ $T_A = -55^\circ\text{C}$ Over temperature		50 45 60	85 75 100		50 60	85 100	mW mW mW mW
Input capacitance			1.4			1.4		pF
Offset voltage adjustment range			± 15			± 15		V
Output resistance			75			75		Ω
Channel separation			120			120		dB
PSRR Supply voltage rejection ratio	$R_S \leq 10\text{k}\Omega$, over temp.		30	150		30	150	$\mu\text{V}/\text{V}$
A_{VOL} Large signal voltage gain (DC)	$R_L \geq 2\text{k}\Omega$, $V_{OUT} = \pm 10\text{V}$ Over temperature	50,000 25,000			25,000 15,000			V/V V/V
CMRR	$R_S \leq 10\text{k}\Omega$, $V_{CM} = \pm 12\text{V}$ Over temperature	70			70			dB

TYPICAL PERFORMANCE CHARACTERISTICS

OPEN LOOP VOLTAGE GAIN AS A FUNCTION OF FREQUENCY

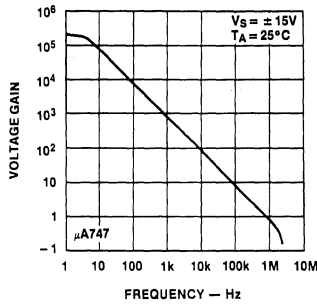

OPEN LOOP PHASE RESPONSE AS A FUNCTION OF FREQUENCY

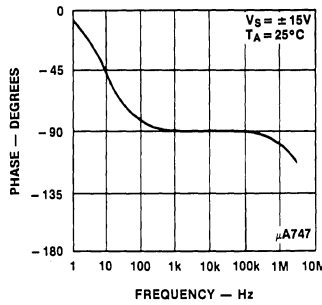

OUTPUT VOLTAGE SWING AS A FUNCTION OF FREQUENCY

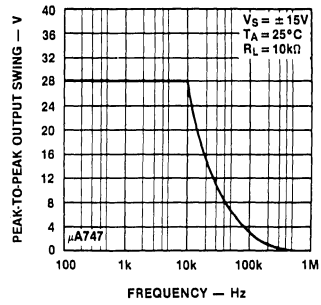

OPEN LOOP VOLTAGE GAIN AS A FUNCTION OF SUPPLY VOLTAGE

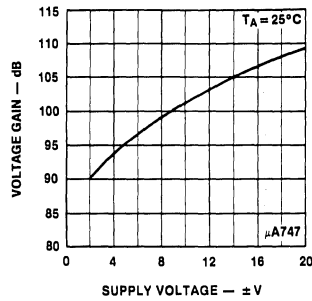

OUTPUT VOLTAGE SWING AS A FUNCTION OF SUPPLY VOLTAGE

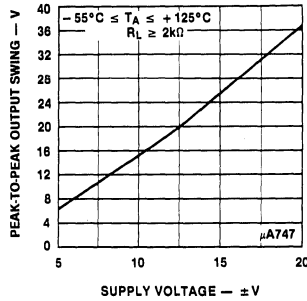

INPUT COMMON MODE VOLTAGE RANGE AS A FUNCTION OF SUPPLY VOLTAGE

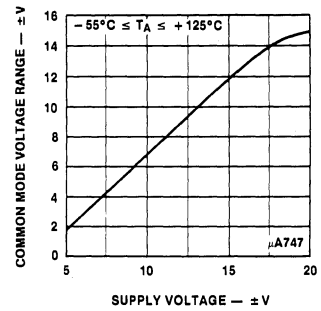

TRANSIENT RESPONSE

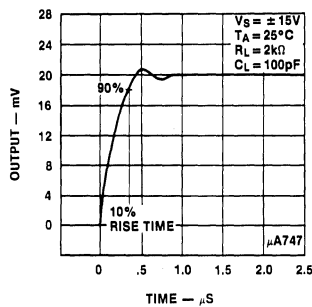

VOLTAGE FOLLOWER LARGE SIGNAL PULSE RESPONSE

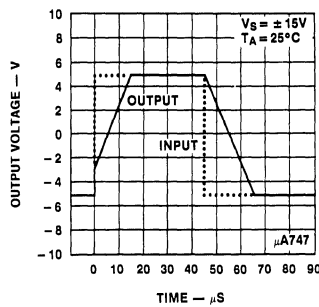

FREQUENCY CHARACTERISTICS AS A FUNCTION OF SUPPLY VOLTAGE

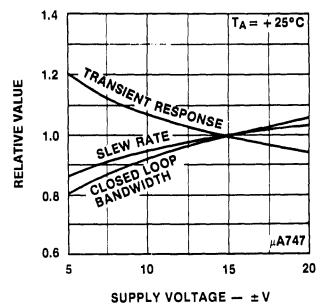

6

DUAL OPERATIONAL AMPLIFIER

μ A747/747C/SA747C

TYPICAL PERFORMANCE CHARACTERISTICS (Cont'd)

FREQUENCY CHARACTERISTICS AS A FUNCTION OF AMBIENT TEMPERATURE

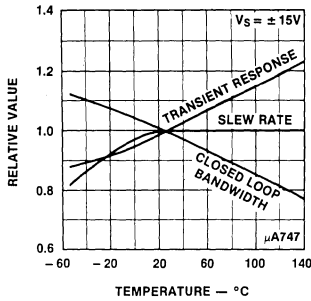

POWER CONSUMPTION AS A FUNCTION OF SUPPLY VOLTAGE

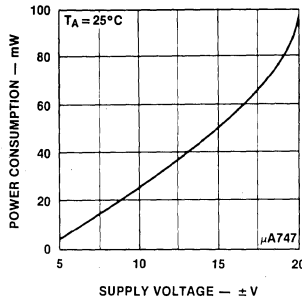

INPUT BIAS CURRENT AS A FUNCTION OF AMBIENT TEMPERATURE

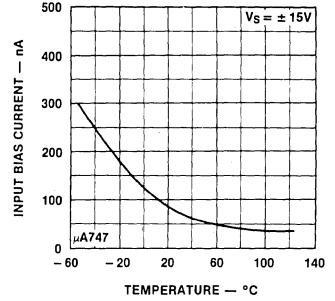

INPUT RESISTANCE AS A FUNCTION OF AMBIENT TEMPERATURE

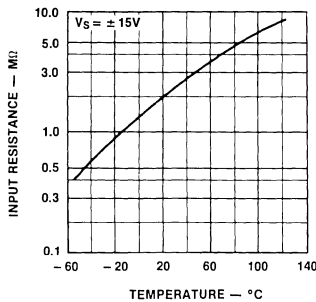

INPUT OFFSET CURRENT AS A FUNCTION OF SUPPLY VOLTAGE

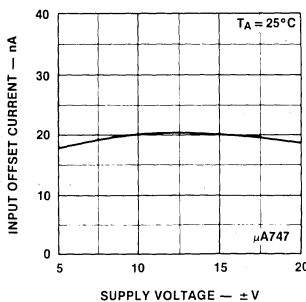

INPUT OFFSET CURRENT AS A FUNCTION OF AMBIENT TEMPERATURE

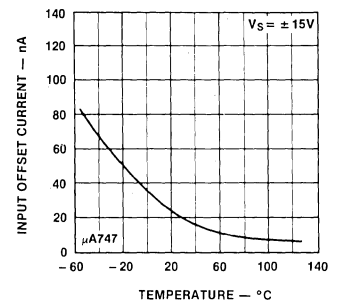

POWER CONSUMPTION AS A FUNCTION OF AMBIENT TEMPERATURE

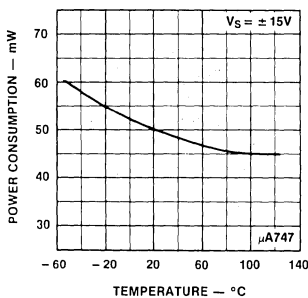

OUTPUT VOLTAGE SWING AS A FUNCTION OF LOAD RESISTANCE

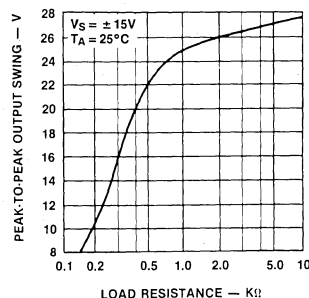

OUTPUT SHORT-CIRCUIT CURRENT AS A FUNCTION OF AMBIENT TEMPERATURE

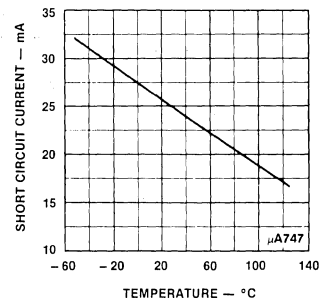

DUAL OPERATIONAL AMPLIFIER

μ A747/747C/SA747C

TYPICAL PERFORMANCE CHARACTERISTICS (Cont'd)

ABSOLUTE MAXIMUM POWER DISSIPATION AS A FUNCTION OF AMBIENT TEMPERATURE

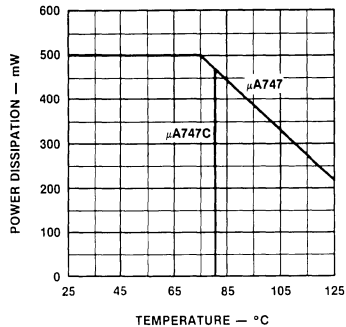

INPUT NOISE VOLTAGE AS A FUNCTION OF FREQUENCY

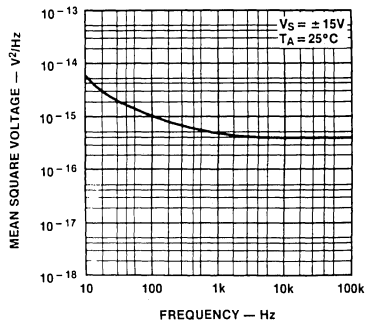

INPUT NOISE CURRENT AS A FUNCTION OF FREQUENCY

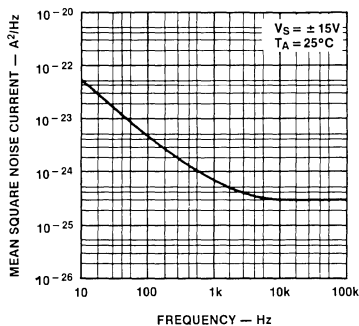

BROADBAND NOISE FOR VARIOUS BANDWIDTHS

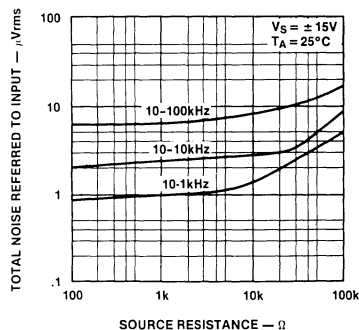

TEST CIRCUITS

TRANSIENT RESPONSE TEST CIRCUIT

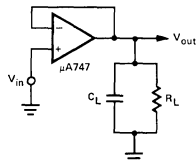

VOLTAGE OFFSET NULL CIRCUIT

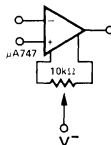

4W AUDIO AMPLIFIER WITH DC VOLUME CONTROL**TDA1013A**

The TDA1013A is a monolithic integrated audio amplifier circuit with d.c. volume control in a 9-lead single in-line (SIL) plastic package. The wide supply voltage range makes this circuit very suitable for applications in mains-fed apparatus such as television receivers and record players.

The d.c. volume control stage has a logarithmic control characteristic with a range of more than 80 dB; control can be obtained by means of a variable d.c. voltage between 3.5 and 8 V.

The audio amplifier has a well defined open loop gain and a fixed integrated closed loop gain. This offers an optimum in number of external components, performance and stability.

The SIL package (SOT-110B) offers a simple and low-cost heatsink connection.

QUICK REFERENCE DATA

Supply voltage range	V_P		15 to 35 V
Repetitive peak output current	I_{ORM}	max.	1.5 A
Total sensitivity (d.c. control at max. gain) for $P_O = 2.5$ W	V_i	typ.	55 mV

Audio amplifier

Output power at $d_{tot} = 10\%$ $V_P = 18$ V; $R_L = 8$ Ω	P_O	typ.	4.5 W
Total harmonic distortion at $P_O = 2.5$ W; $R_L = 8$ Ω	d_{tot}	typ.	0.5 %
Sensitivity for $P_O = 2.5$ W	V_i	typ.	125 mV

D.C. volume control unit

Gain control range	ϕ	>	80 dB
Signal handling at $d_{tot} < 1\%$ (d.c. control at 0 dB)	V_i	>	1.2 V
Sensitivity for $V_O = 125$ mV at max. voltage gain	V_i	typ.	55 mV
Input impedance (pin 8)	$ Z_i $	typ.	250 k Ω

PACKAGE OUTLINE

9-lead SIL; plastic (SOT-110B).

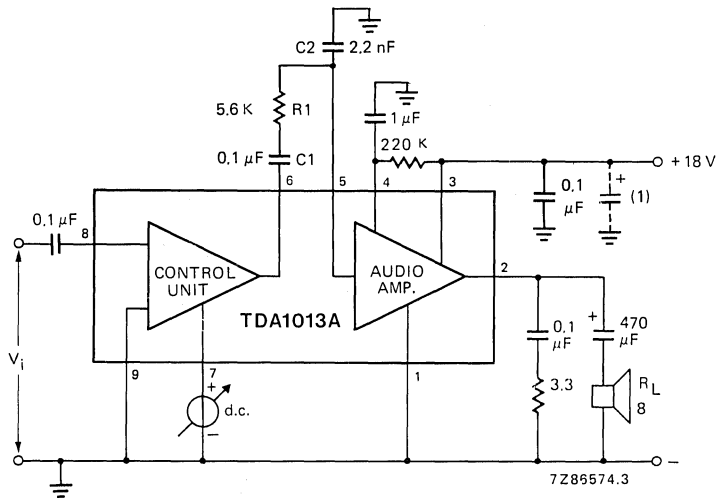

(1) Belongs to power supply.

Fig. 1 Basic application diagram also used as test circuit with R1 = 5.1 kΩ and C1 = 22 nF.

RATINGS

Limiting values in accordance with the Absolute Maximum System (IEC 134)

Supply voltage	V _P	max.	35 V
Non-repetitive peak output current	I _{OSM}	max.	3 A
Repetitive peak output current	I _{ORM}	max.	1.5 A
Storage temperature	T _{stg}		-55 to +150 °C
Crystal temperature	T _j		-25 to +150 °C
Total power dissipation			see derating curve Fig. 2

HEATSINK DESIGN

Assume V_P = 18 V; R_L = 8 Ω; T_{amb} = 60 °C (max.); T_j = 150 °C (max.); for a 4 W application into an 8 Ω load, the maximum dissipation is about 2.5 W.

The thermal resistance from junction to ambient can be expressed as:

$$R_{th\ j-a} = R_{th\ j-tab} + R_{th\ tab-h} + R_{th\ h-a} = \frac{T_{j\ max} - T_{amb\ max}}{P_{max}} = \frac{150 - 60}{2.5} = 36\ K/W.$$

Since R_{th j-tab} = 9 K/W and R_{th tab-h} = 1 K/W, R_{th h-a} = 36 - (9 + 1) = 26 K/W.



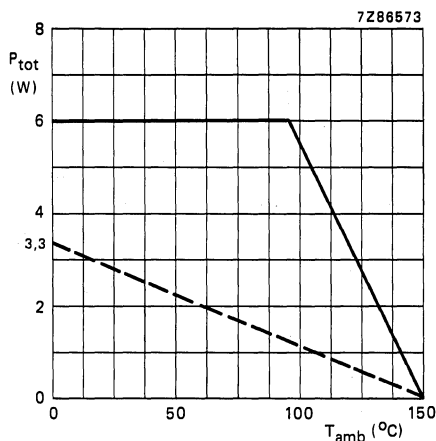

Fig. 2 Power derating curve.
 ——— infinite heatsink;
 - - - without heatsink.

CHARACTERISTICS

$V_p = 18\text{ V}$; $R_L = 8\ \Omega$; $f = 1\text{ kHz}$; $T_{amb} = 25\text{ }^\circ\text{C}$; unless otherwise specified

Supply voltage	V_p	typ. 18 V 15 to 35 V
Total quiescent current	I_{tot}	typ. 35 mA
Noise output voltage (see also note)	V_n	< 1.4 mV
Total sensitivity (d.c. control at maximum gain) for $P_o = 2.5\text{ W}$	V_i	38 to 69 mV typ. 55 mV
Frequency response (-3 dB)	f	35 Hz to 20 kHz
Audio amplifier		
Repetitive peak output current	I_{ORM}	< 1.5 A > 4 W
Output power at $d_{tot} = 10\%$	P_o	typ. 4.5 W
Total harmonic distortion at $P_o = 2.5\text{ W}$	d_{tot}	typ. 0.5 % < 1 %
Voltage gain	G_v	typ. 30 dB
Sensitivity for $P_o = 2.5\text{ W}$	V_i	typ. 125 mV > 100 k Ω
Input impedance (pin 5)	$ Z_i $	typ. 250 k Ω

Note

Measured in a bandwidth according to IEC 179-curve 'A'; $R_S = 5\text{ k}\Omega$ and d.c. control at minimum gain.

CHARACTERISTICS (continued)

D.C. volume control unit

Gain control range (see also Fig. 3)

ϕ > 80 dB

Signal handling at $d_{tot} < 1\%$
(d.c. control at 0 dB)

V_i > 1.2 V

Sensitivity for $V_o = 125$ mV at max. voltage gain

V_i typ. 55 mV

Input impedance (pin 8)

$|Z_i|$ > 100 k Ω
typ. 250 k Ω

Output impedance (pin 6)

$|Z_o|$ 100 to 400 Ω
typ. 200 Ω

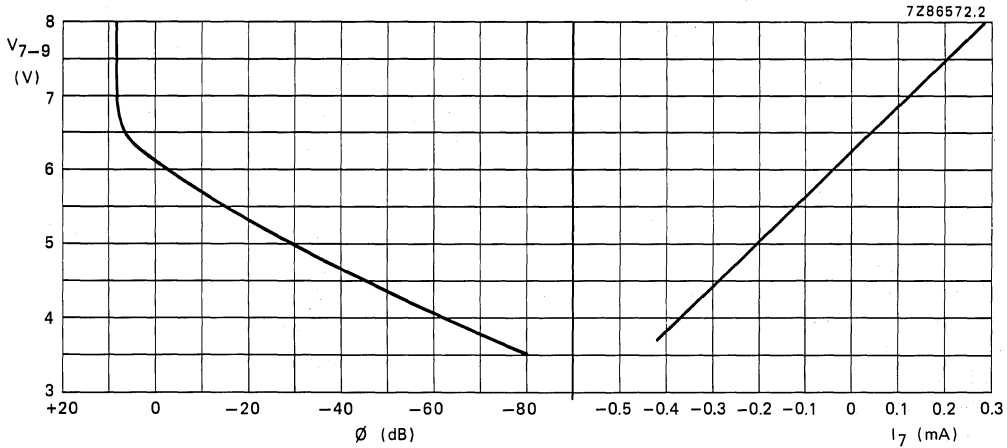

Fig. 3 Typical values gain control; V_i at pin 7.

6

24W BTL AUDIO AMPLIFIER

TDA1515

The TDA1515 is a monolithic integrated class-B output amplifier in a 13-lead single in-line (SIL) plastic power package. The device is primarily developed for car radio applications, and also to drive low-impedance loads (down to 1.6 Ω). At a supply voltage $V_p = 14.4\text{ V}$, an output power of 21 W can be delivered into a 4 Ω BTL (Bridge Tied Load), or, when used as stereo amplifier, it delivers 2 x 11 W into 2 Ω or 2 x 6.5 W into 4 Ω.

Special features are:

- flexibility in use – mono BTL as well as stereo
- high output power
- low offset voltage at the output (important for BTL)
- large usable gain variation
- very good ripple rejection
- internal limited bandwidth for high frequencies
- low stand-by current possibility (typ. 1 μA), to simplify required switches; TTL drive possible
- low number and small sized external components
- high reliability

The following currently required protections are incorporated in the circuit. These protections also have positive influence on reliability in the applications.

- load dump protection
- a.c. and d.c. short-circuit safe to ground up to $V_p = 18\text{ V}$
- thermal protection
- speaker protection in bridge configuration
- SOAR protection
- outputs short-circuit safe to ground in BTL
- reverse polarity safe

QUICK REFERENCE DATA

Supply voltage range (operating)	V_p		6 to 18 V
Supply voltage (non-operating)	V_p	max.	28 V
Supply voltage (non-operating; load dump protection)	V_p	max.	45 V
Repetitive peak output current	I_{ORM}	max.	4 A
Total quiescent current	I_{tot}	typ.	75 mA
Stand-by current	I_{sb}	typ.	0 μA
Switch-on current	I_{so}	<	100 μA
Input impedance	$ Z_i $	>	1 MΩ
Bridge tied load application (BTL)	V_p	=	14.4 13.2 V
Output power at $R_L = 4\ \Omega$ (with bootstrap)			
$d_{tot} = 0.5\%$	P_o	typ.	16 14 W
$d_{tot} = 10\%$	P_o	typ.	21 18 W
Supply voltage ripple rejection; $R_S = 0\ \Omega$; $f = 100\text{ Hz}$	RR	typ.	50 50 dB
D.C. output offset voltage between the outputs	$ \Delta V_{5-g} $	<	50 50 mV
Stereo application			
Output power at $d_{tot} = 10\%$ (with bootstrap)			
$R_L = 4\ \Omega$	P_o	typ.	6.5 6 W
$R_L = 2\ \Omega$	P_o	typ.	11 10 W
Output power at $d_{tot} = 0.5\%$ (with bootstrap)			
$R_L = 4\ \Omega$	P_o	typ.	5 4.5 W
$R_L = 2\ \Omega$	P_o	typ.	8 7.5 W
Channel separation	α	>	40 40 dB
Noise output voltage; $R_S = 10\text{ k}\Omega$; according to IEC curve-A	V_n	typ.	0.2 0.2 mV

PACKAGE OUTLINE 13-lead SIL; plastic power (SOT-141B).

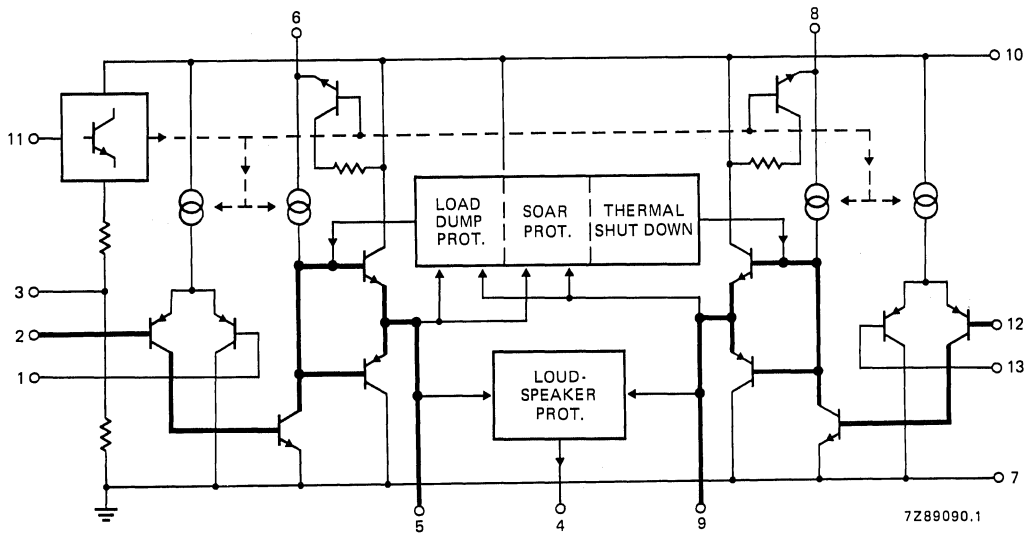

Fig. 1 Internal block diagram; the heavy lines indicate the signal paths.

RATINGS

Limiting values in accordance with the Absolute Maximum System (IEC 134)

Supply voltage; operating (pin 10)	V_P	max.	18 V
Supply voltage; non-operating	V_P	max.	28 V
Supply voltage; during 50 ms (load dump protection)	V_P	max.	45 V
Peak output current	I_{OM}	max.	6 A
Total power dissipation	see derating curve Fig. 2		
Storage temperature range	T_{stg}	-55 to + 150 °C	
Crystal temperature	T_C	max.	150 °C
A.C. and d.c. short-circuit safe voltage			max. 18 V
Reverse polarity			max. 10 V

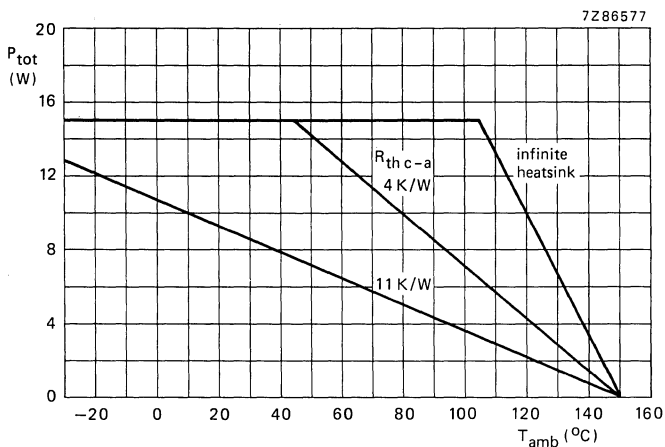

Fig. 2 Power derating curves.

HEATSINK DESIGN EXAMPLE

The derating of 3 K/W of the encapsulation requires the following external heatsink (for sine-wave drive):

21 W BTL (4 Ω) or 2 x 11 W stereo (2 Ω)

maximum sine-wave dissipation: 12 W

$T_{amb} = 65$ °C maximum

$$R_{th\ h-a} = \frac{150-65}{12} - 3 = 4 \text{ K/W.}$$

2 x 6.5 W stereo (4 Ω)

maximum sine-wave dissipation: 6 W

$T_{amb} = 65$ °C maximum

$$R_{th\ h-a} = \frac{150-65}{6} - 3 = 11 \text{ K/W.}$$

24W BTL AUDIO AMPLIFIER**TDA1515****D.C. CHARACTERISTICS**

Supply voltage range (pin 10)	V_p		6 to 18 V
Repetitive peak output current	I_{ORM}	<	4 A
Total quiescent current	I_{tot}	typ.	75 mA
Switching level 11 : OFF	V_{11}	<	1.8 V
ON	V_{11}	>	3 V
Impedance between pins 10 and 6; 10 and 8 (stand-by position $V_{11} < 1.8$ V)	$ Z_{OFF} $	>	100 k Ω
Stand-by current at $V_{11} = 0$ to 0.8 V	I_{sb}	typ. <	1 μ A 200 μ A
Switch-on current (pin 11) at $V_{11} \leq V_{10}$ (note 1)	I_{so}	typ. <	10 μ A 100 μ A

A.C. CHARACTERISTICS

$T_{amb} = 25$ °C; $V_p = 14.4$ V; $f = 1$ kHz; unless otherwise specified

Bridge tied load application (BTL); see Fig. 3

Output power at $R_L = 4$ Ω (with bootstrap) $V_p = 14.4$ V; $d_{tot} = 0.5\%$	P_o	>	15.5 W
		typ.	16 W
$V_p = 14.4$ V; $d_{tot} = 10\%$	P_o	>	20 W
		typ.	21 W
$V_p = 13.2$ V; $d_{tot} = 0.5\%$	P_o	typ.	14 W
$V_p = 13.2$ V; $d_{tot} = 10\%$	P_o	typ.	18 W
Open loop voltage gain	G_o	typ.	75 dB
Closed loop voltage gain (note 2)	G_c	typ.	40 (± 0.5) dB
Frequency response at -3 dB (note 3)	B		20 Hz to min. 20 kHz
Input impedance (note 4)	$ Z_i $	>	1 M Ω
Noise input voltage (r.m.s. value) at $f = 20$ Hz to 20 kHz $R_S = 0$ Ω	$V_{n(rms)}$	typ.	0.2 mV
$R_S = 10$ k Ω	$V_{n(rms)}$	typ. <	0.35 mV 0.8 mV
$R_S = 10$ k Ω ; according to IEC 179 curve A	V_n	typ.	0.25 mV
Supply voltage ripple rejection (note 5) $f = 100$ Hz	RR	> typ.	42 dB 50 dB
D.C. output offset voltage between the outputs	$ \Delta V_{5-g} $	<	50 mV
Loudspeaker protection (all conditions)		typ.	2 mV
maximum d.c. voltage (across the load)	$ \Delta V_{5-g} $	<	1 V
Power bandwidth; -1 dB; $d_{tot} = 0.5\%$	B		30 Hz to 30 kHz

6

24W BTL AUDIO AMPLIFIER

TDA1515

Stereo application; see Fig. 4

Output power at $d_{tot} = 10\%$; with bootstrap (note 6)

$$V_P = 14.4 \text{ V}; R_L = 4 \Omega$$

P_O	>	6 W
	typ.	6.5 W

$$V_P = 14.4 \text{ V}; R_L = 2 \Omega$$

P_O	>	10 W
	typ.	11 W

$$V_P = 13.2 \text{ V}; R_L = 4 \Omega$$

P_O	typ.	6 W
-------	------	-----

$$V_P = 13.2 \text{ V}; R_L = 2 \Omega$$

P_O	typ.	10 W
-------	------	------

Output power at $d_{tot} = 0.5\%$; with bootstrap (note 6)

$$V_P = 14.4 \text{ V}; R_L = 4 \Omega$$

P_O	typ.	5 W
-------	------	-----

$$V_P = 14.4 \text{ V}; R_L = 2 \Omega$$

P_O	typ.	8 W
-------	------	-----

$$V_P = 13.2 \text{ V}; R_L = 4 \Omega$$

P_O	typ.	4.5 W
-------	------	-------

$$V_P = 13.2 \text{ V}; R_L = 2 \Omega$$

P_O	typ.	7.5 W
-------	------	-------

Output power at $d_{tot} = 10\%$; without bootstrap

$$V_P = 14.4 \text{ V}; R_L = 4 \Omega \text{ (notes 6, 8 and 9)}$$

P_O	typ.	5.5 W
-------	------	-------

Frequency response at -3 dB (note 3)

B	40 Hz to min. 20 kHz
---	----------------------

Supply voltage ripple rejection (note 5)

RR	typ. 50 dB
----	------------

Channel separation; $R_S = 10 \text{ k}\Omega$; $f = 1 \text{ kHz}$

α	>	40 dB
	typ.	50 dB

Closed loop voltage gain (note 7)

G_c	typ.	40 dB
-------	------	-------

Noise output voltage (r.m.s. value) at $f = 20 \text{ Hz}$ to 20 kHz

$$R_S = 0 \Omega$$

$V_{n(rms)}$	typ.	0.15 mV
--------------	------	---------

$$R_S = 10 \text{ k}\Omega$$

$V_{n(rms)}$	typ.	0.25 mV
--------------	------	---------

$$R_S = 10 \text{ k}\Omega; \text{ according to IEC curve A}$$

V_n	typ.	0.2 mV
-------	------	--------

Notes

1. The internal circuit impedance at pin 11 is $> 5 \text{ k}\Omega$ if $V_{11} > V_{10}$.
2. Closed loop voltage gain can be chosen between 32 and 56 dB (BTL), and is determined by external components.
3. Frequency response externally fixed.
4. The input impedance in the test circuit (Fig. 3) is typ. $100 \text{ k}\Omega$.
5. Supply voltage ripple rejection measured with a source impedance of 0Ω (maximum ripple amplitude: 2 V).
6. Output power is measured directly at the output pins of the IC.
7. Closed loop voltage gain can be chosen between 26 and 50 dB (stereo), and is determined by external components.
8. A resistor of $56 \text{ k}\Omega$ between pins 3 and 7 to reach symmetrical clipping.
9. Without bootstrap the $100 \mu\text{F}$ capacitor between pins 5 and 6 (8 and 9) can be omitted. Pins 6, 8 and 10 have to be interconnected.

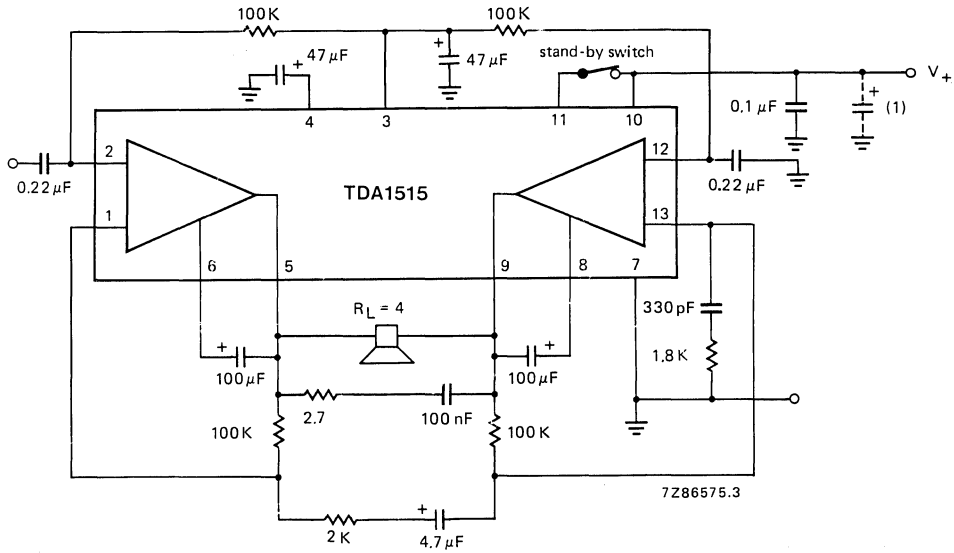

Fig. 3 Test/application circuit bridge tied load (BTL).

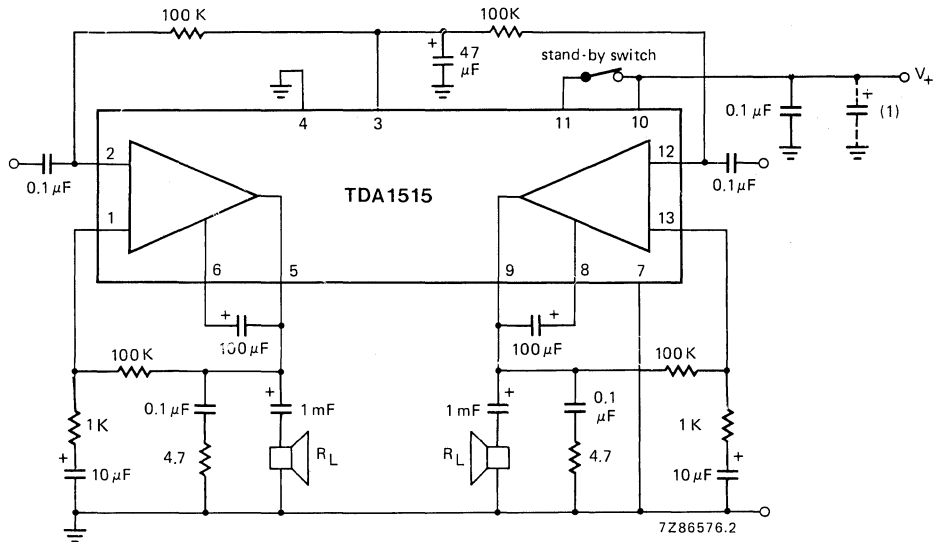

Fig. 4 Test/application circuit stereo.

1. Belongs to power supply.

20W HI-FI AUDIO AMPLIFIER**TDA1520A****GENERAL DESCRIPTION**

The TDA1520A is a monolithic integrated hi-fi audio power amplifier designed for asymmetrical or symmetrical power supplies for mains-fed apparatus.

Features

- Low input offset voltage
- Output stage with low cross-over distortion
- Single in-line (SIL) power package
- A.C. short-circuit protected
- Very low internal thermal resistance
- Thermal protection
- Very low intermodulation distortion
- Very low transient intermodulation distortion
- Complete SOAR protection

QUICK REFERENCE DATA

Supply voltage range	V_p	15 to 50 V
Total quiescent current at $V_p = 33$ V	I_{tot}	typ. 70 mA
Output power at $d_{tot} = 0.5\%$ sine-wave power		
$V_p = 33$ V; $R_L = 4 \Omega$	P_o	typ. 22 W
$V_p = 33$ V; $R_L = 4 \Omega$	P_o	> 20 W
$V_p = 42$ V; $R_L = 8 \Omega$	P_o	typ. 20 W
Closed-loop voltage gain (externally determined)	G_c	typ. 30 dB
Input resistance (externally determined by R_{g1})	R_i	typ. 20 k Ω
Signal-to-noise ratio at $P_o = 50$ mW	S/N	typ. 76 dB
Supply voltage ripple rejection at $f = 100$ Hz	RR	typ. 60 dB

PACKAGE OUTLINE

TDA1520A : 9-lead SIL; plastic power (SOT-131A).

TDA1520AQ: 9-lead SIL-bent-to-DIL; plastic power (SOT-157A).

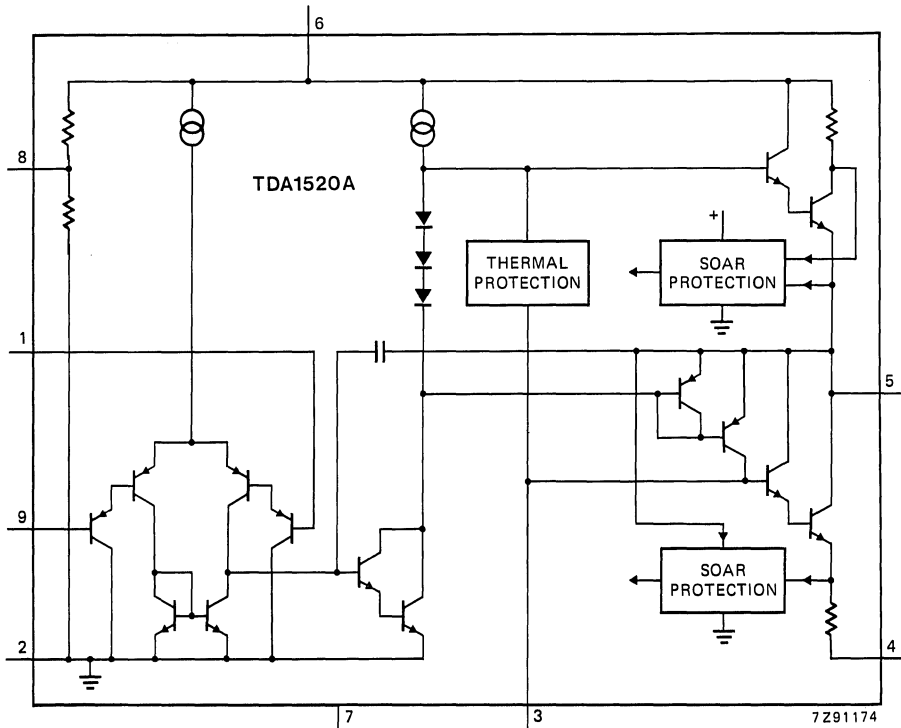

Fig. 1 Simplified internal circuit diagram.

PINNING

- 1. Non-inverting input
- 2. Input ground (substrate)
- 3. Compensation
- 4. Negative supply (ground)
- 5. Output
- 6. Positive supply (V_p)
- 7. Not connected
- 8. Ripple rejection
- 9. Inverting input (feedback)

6

RATINGS

Limiting values in accordance with the Absolute Maximum System (IEC 134)

Supply voltage	V_P	max.	50 V
Repetitive peak output current	I_{ORM}	max.	4 A
Non-repetitive peak output current	I_{OSM}	max.	5 A
Total power dissipation			see derating curve Fig. 2
Storage temperature	T_{stg}		-55 to + 150 °C
Operating ambient temperature	T_{amb}		-25 to + 150 °C
Duration of a.c. short-circuit of load ($R_L = 0 \Omega$) during full-load sine-wave drive at: $V_S = \pm 20$ V (symmetrical) and $R_{supply} = 0 \Omega$; or $V_S = 35$ V (asymmetrical) and $R_{supply} \geq 4 \Omega$	t_{sc}	max.	100 hours

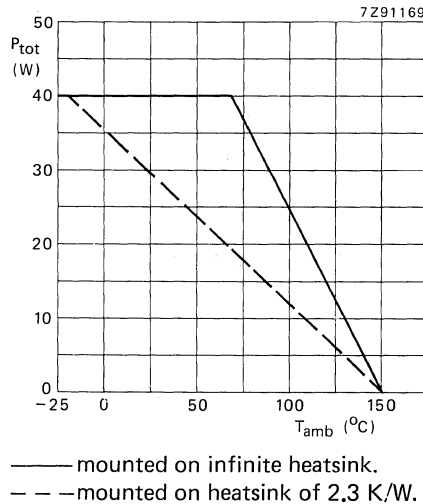

Fig. 2 Power derating curves.

THERMAL RESISTANCE

From junction to mounting base

$R_{th\ j-mb} \leq 2\text{ K/W}$

20W HI-FI AUDIO AMPLIFIER

TDA1520A

D.C. CHARACTERISTICS

Supply voltage range	V_P	15 to 50 V
Total quiescent current at $V_P = 33$ V	I_{tot}	typ. 70 mA ≤ 105 mA
Minimum guaranteed output current (peak value)	I_{ORM}	≥ 3.2 A

A.C. CHARACTERISTICS

$V_P = 33$ V; $R_L = 4 \Omega$; $f = 1$ kHz; $T_{amb} = 25$ °C; measured in test circuit of Fig. 3; unless otherwise specified

Output power

sine-wave power at $d_{tot} = 0.5\%$

$R_L = 4 \Omega$
 $R_L = 4 \Omega$
 $R_L = 8 \Omega$; $V_P = 42$ V } (Fig. 4)

P_O	typ.	22 W
P_O	>	20 W
P_O	typ.	20 W

Power bandwidth at $d_{tot} = 0.5\%$ from $P_O = 50$ mW to 10 W

B	20 Hz to 20 kHz
---	-----------------

Voltage gain

open-loop
 closed-loop

G_O	typ.	74 dB
G_C	typ.	30 dB

Internal resistance of pin 1 (at $R_{1-8} = \infty$)

R_i	>	1 M Ω
-------	---	--------------

Input resistance of test circuit at pin 1 (Fig. 3)

R_i	typ.	20 k Ω
-------	------	---------------

Input sensitivity

for $P_O = 16$ W

V_i	typ.	260 mV
-------	------	--------

Signal-to-noise ratio

at $P_O = 50$ mW; $R_{source} = 2$ k Ω
 $f = 20$ Hz to 20 kHz; unweighted
 weighted; measured according to
 IEC 179 (A-curve)

S/N	typ.	76 dB
-----	------	-------

S/N	typ.	80 dB
-----	------	-------

Ripple rejection at $f = 100$ Hz; $R_S = 0 \Omega$

RR	typ.	60 dB
----	------	-------

Total harmonic distortion at $P_O = 16$ W

d_{tot}	typ.	0.01 %
-----------	------	--------

Output resistance (pin 5)

R_O	typ.	0.01 Ω
-------	------	---------------

Input offset voltage

V_{5-8}	typ.	1 mV
	<	100 mV

Transient intermodulation distortion

at $P_O = 10$ W

d_{TIM}	typ.	0.01 %
-----------	------	--------

Intermodulation distortion at $P_O = 10$ W

d_{IM}	typ.	0.01 %
----------	------	--------

Slew rate

SR	typ.	9 V/ μ s
----	------	--------------



APPLICATION INFORMATION

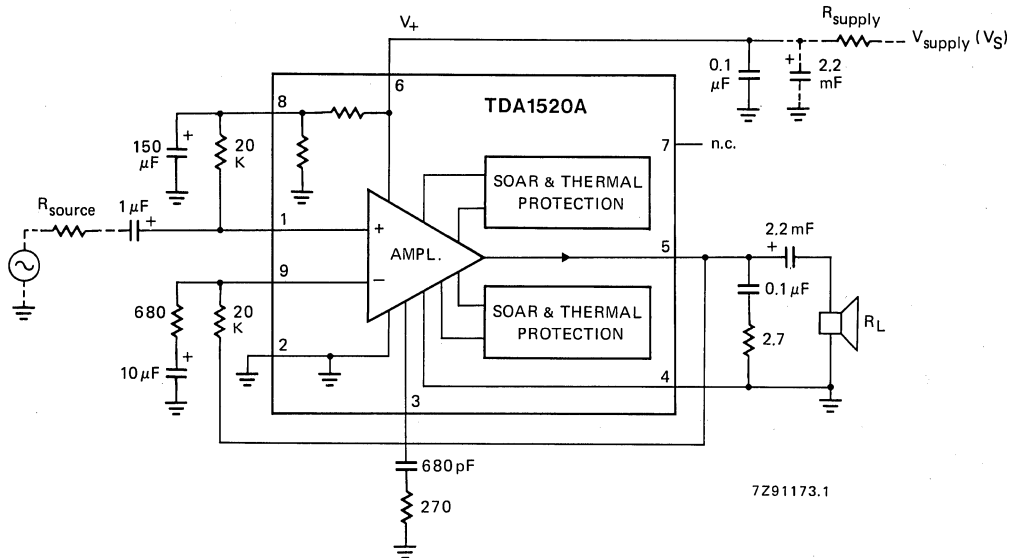

Fig. 3 Test and application circuit.

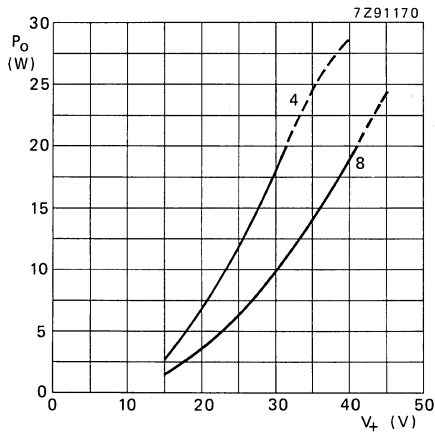

Fig. 4 Output power (P_o) versus supply voltage (V_p) at $f = 1$ kHz, $d_{tot} = 0.5\%$, $G_v = 30$ dB.

APPLICATION INFORMATION (continued)

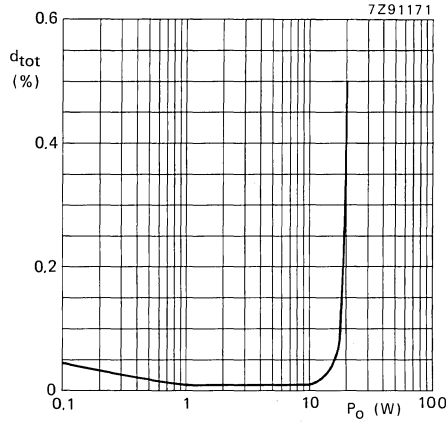

Fig. 5 Total harmonic distortion (d_{tot}) versus output power (P_o) at $V_p = 33$ V, $R_L = 4 \Omega$, $f = 1$ kHz.

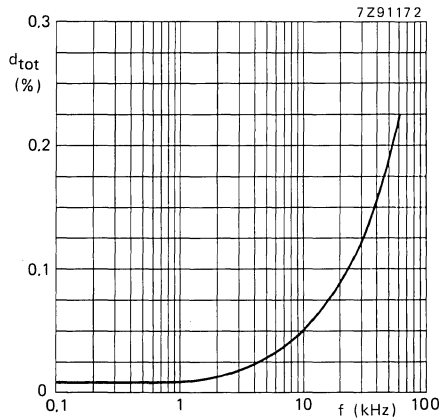

Fig. 6 Total harmonic distortion (d_{tot}) versus operating frequency (f) at $V_p = 33$ V, $R_L = 4 \Omega$, $P_o = 10$ W (constant).

6

DUAL OPERATIONAL TRANSCONDUCTANCE AMPLIFIER

NE5517/5517A

DESCRIPTION

The NE5517 contains two current controlled transconductance amplifiers, each with a differential input and push-pull output. The NE5517 offers significant design and performance advantages over similar devices for all types of programmable gain applications. Circuit performance is enhanced through the use of linearizing diodes at the inputs which enable a 10dB signal to noise improvement referenced to .5 percent THD. The NE5517 is suited for a wide variety of industrial and consumer applications and is recommended as the preferred circuit in the Dolby[®] HX (Headroom Extension) system.

Constant-Impedance-Buffers on the chip allow general use of the NE5517. These buffers are made of Darlington-Transistor and a biasing-network which changes bias current in dependence of I_{ABC} .

Therefore changes of output offset voltages are almost eliminated. This is an advantage of the NE5517 compared to LM13600. With the LM13600 a burst in the bias current I_{ABC} guides to an audible offset voltage change at the output. With the Constant-Impedance-Buffers of the NE5517 this effect can be avoided and makes this circuit preferable for high quality audio applications.

FEATURES

- Constant impedance buffers
- ΔV_{BE} of buffer is constant with amplifier I_{BIAS} change
- Pin compatible with LM13600
- Excellent matching between amplifiers
- Linearizing diodes
- High output signal-to-noise ratio

APPLICATIONS

- Multiplexers
- Timers
- Electronic music synthesizers
- Dolby[®] HX Systems
- Current-controlled amplifiers, filters
- Current-controlled oscillators, impedances

NOTE

*Dolby is a registered trademark of Dolby Laboratories Inc., San Francisco, Calif.

ABSOLUTE MAXIMUM RATINGS

PARAMETER	RATING	UNIT
Supply Voltage ¹		
NE5517	36 V _{DC} or ± 18	V
NE5517A	44 V _{DC} or ± 22	V
Power Dissipation ² T _A = 25°C		
NE5517N, NE5517AN	570	mW
Differential Input Voltage	± 5	V
Diode Bias Current (I _D)	2	mA
Amplifier Bias Current (I _{ABC})	2	mA
Output Short Circuit Duration	Indefinite	
Buffer Output Current ³	20	mA
Operating Temperature Range		
NE5517N, NE5517AN	0°C to +70	°C
DC Input Voltage	+V _S to -V _S	
Storage Temperature Range	-65°C to +150	°C
Lead Temperature (Soldering, 10 Seconds)	300	°C

PIN CONFIGURATION

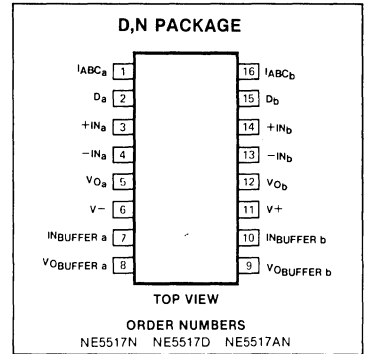

CIRCUIT SCHEMATIC

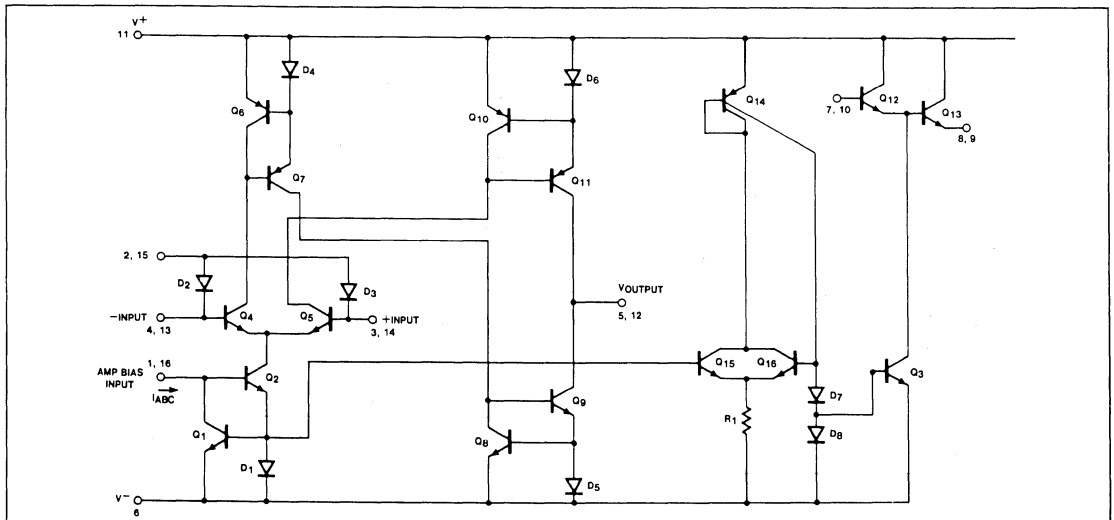

PIN DESIGNATION

PIN NO.	SYMBOL	NAME AND FUNCTION
1	I_{ABCa}	Amplifier bias input A
2	D_a	Diode bias A
3	$+IN_a$	Non-inverting input A
4	$-IN_a$	Inverting input A
5	V_{Oa}	Output A
6	$V-$	negative supply
7	$IN_{Buffer} (a)$	Buffer input A
8	$VO_{Buffer} (a)$	Buffer output A
9	$VO_{Buffer} (b)$	Buffer output B
10	$IN_{Buffer} (b)$	Buffer input B
11	$V+$	Positive supply
12	V_{Ob}	Output B
13	$-IN_b$	Inverting input B
14	$+IN_b$	Non-inverting input B
15	D_b	Diode bias B
16	I_{ABCb}	Amplifier bias input B

CONNECTION DIAGRAM

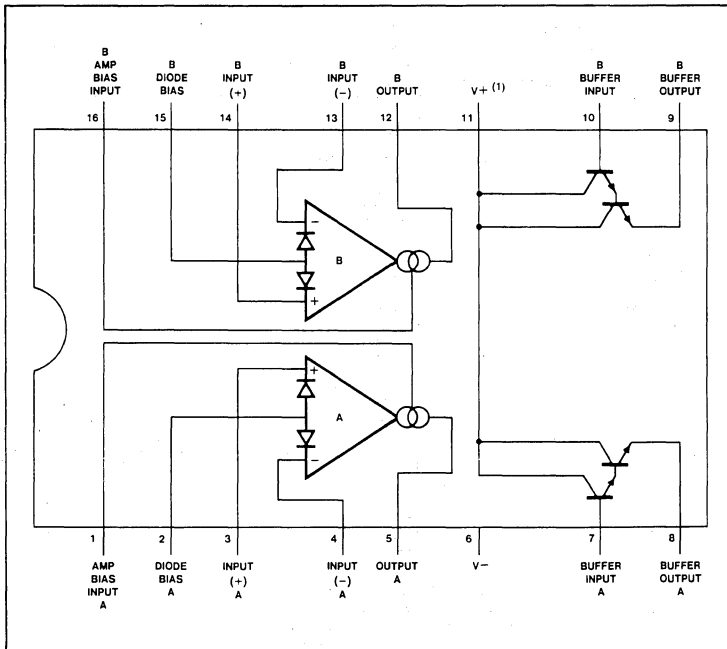

NOTE:

1. $V+$ of output buffers and amplifiers are internally connected.

6

DUAL OPERATIONAL TRANSCONDUCTANCE AMPLIFIER

NE5517/5517A

ELECTRICAL CHARACTERISTICS⁴

PARAMETER	TEST CONDITIONS	NE5517			NE5517A			UNIT
		Min	Typ	Max	Min	Typ	Max	
Input offset voltage (V_{OS})	Over temperature range $I_{ABC} = 5\mu A$		0.4	5		0.4	2	mV
			0.3	5		0.3	2	mV
$\Delta V_{OS}/\Delta T$	Avg. TC of input offset voltage		7			7		$\mu V/^\circ C$
V_{OS} including diodes	Diode bias current (I_D) = 500 μA		0.5	5		0.5	2	mV
Input offset change	$5\mu A \leq I_{ABC} \leq 500\mu A$		0.1			0.1	3	mV
Input offset current			0.1	0.6		0.1	0.6	μA
$\Delta I_{OS}/\Delta T$	Avg. TC of input offset current		0.001			0.001		$\mu A/^\circ C$
Input bias current	Over temperature range		0.4	5		0.4	5	μA
			1	8		1	7	μA
$\Delta I_B/\Delta T$	Avg. TC of input current		0.01			0.01		$\mu A/^\circ C$
Forward Transconductance (gm)	Over temperature range	6700	9600	13000	7700	9600	12000	μmho
		5400			4000			μmho
gm tracking			0.3			0.3		dB
Peak output current	$RL = 0, I_{ABC} = 5\mu A$ $RL = 0, I_{ABC} = 500\mu A$ $RL = 0,$	350	500	650	350	500	650	μA
		300			300			μA
Peak output voltage Positive Negative	$RL = \infty, 5\mu A \leq I_{ABC} \leq 500\mu A$ $RL = \infty, 5\mu A \leq I_{ABC} \leq 500\mu A$	+12	+14.2		+12	+14.2		V
		-12	-14.4		-12	-14.4		V
Supply current	$I_{ABC} = 500\mu A$, both channels		2.6	4		2.6	4	mA
V_{OS} sensitivity Positive Negative	$\Delta V_{OS}/\Delta V+$ $\Delta V_{OS}/\Delta V-$		20	150		20	150	$\mu V/V$
			20	150		20	150	$\mu V/V$
CMRR		80	110		80	110		dB
Common mode range		± 12	± 13.5		± 12	± 13.5		V
Crosstalk	Referred to input ⁵ 20Hz < f < 20kHz		100			100		dB
Diff. input current	$I_{ABC} = 0$, input = $\pm 4V$		0.02	100		0.02	10	nA
Leakage current	$I_{ABC} = 0$ (Refer to test circuit)		0.2	100		0.2	5	nA
Input resistance		10	26		10	26		K Ω
Open loop bandwidth			2			2		MHz
Slew rate	Unity gain compensated		50			50		V/ μ Sec
Buff. input current	5		0.4	5		0.4	5	μA
Peak buffer output voltage	5	10			10			V
ΔV_{BE} of buffer	6 Refer to Buffer V_{BE} test circuit		0.5	5		0.5	5	mV

NOTES

- For selections to a supply voltage above $\pm 22V$, contact factory.
- For operating at high temperatures, the device must be derated based on a 150 $^\circ C$ maximum junction temperature and a thermal resistance of 175 $^\circ C/W$ which applies for the device soldered in a printed circuit board, operating in still air.
- Buffer output current should be limited so as to not exceed package dissipation.
- These specifications apply for $V_S = \pm 15V$, $T_A = 25^\circ C$, amplifier bias current (I_{ABC}) = 500 μA , pins 2 and 15 open unless otherwise specified. The inputs to the buffers are

grounded and outputs are open.

- These specifications apply for $V_S = \pm 15V$, $I_{ABC} = 500\mu A$, $R_{OUT} = 5k\Omega$ connected from the buffer output to $-V_S$ and the input of the buffer is connected to the transconductance amplifier output.
- $V_S = \pm 15$, $R_{OUT} = 5K\Omega$ connected from Buffer output to $-V_S$ and $5\mu A \leq I_{ABC} \leq 500\mu A$.

TYPICAL PERFORMANCE CHARACTERISTICS

INPUT OFFSET VOLTAGE

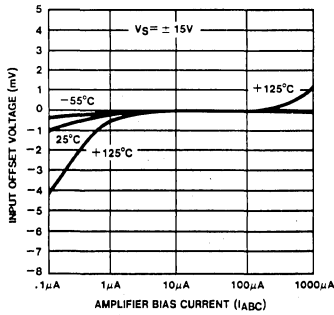

INPUT OFFSET CURRENT

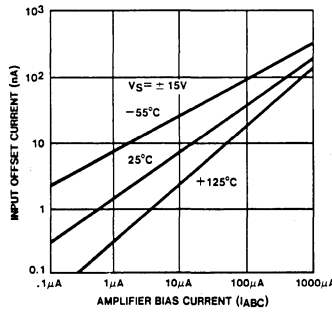

INPUT BIAS CURRENT

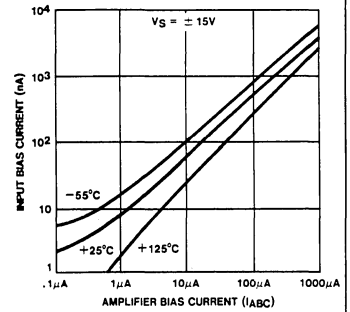

PEAK OUTPUT CURRENT

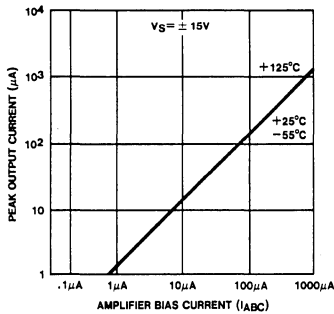

PEAK OUTPUT VOLTAGE AND COMMON MODE RANGE

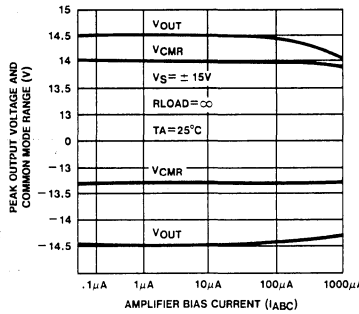

LEAKAGE CURRENT

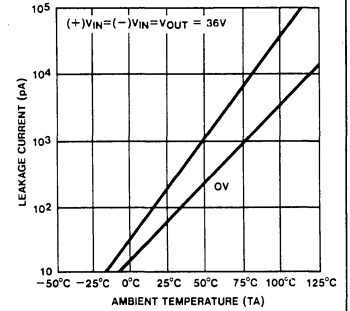

INPUT LEAKAGE

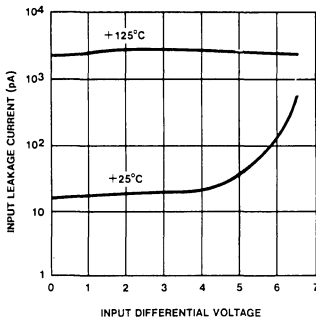

TRANSCONDUCTANCE

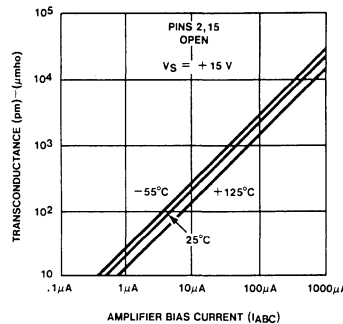

INPUT RESISTANCE

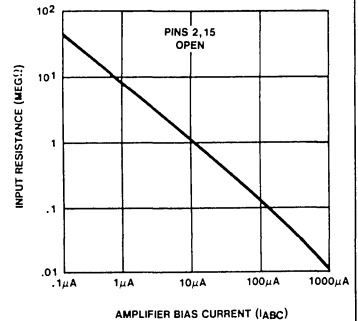

6

TYPICAL PERFORMANCE CHARACTERISTICS (Cont'd)

AMPLIFIER BIAS VOLTAGE vs AMPLIFIER BIAS CURRENT

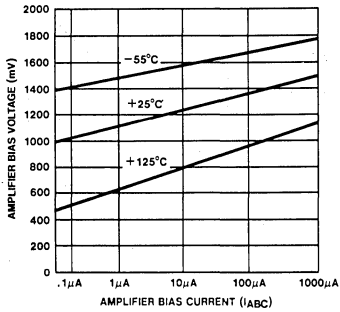

INPUT AND OUTPUT CAPACITANCE

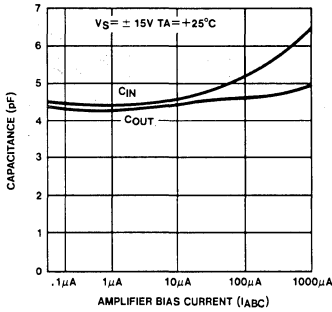

DISTORTION vs DIFFERENTIAL INPUT VOLTAGE

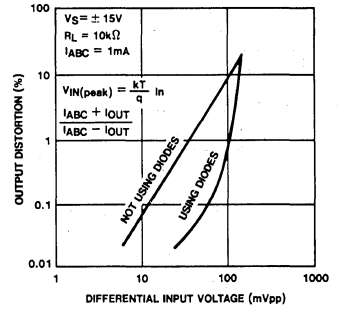

VOLTAGE vs AMPLIFIER BIAS CURRENT

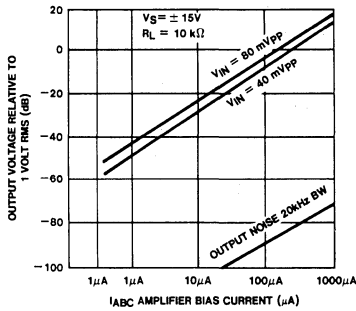

OUTPUT NOISE vs FREQUENCY

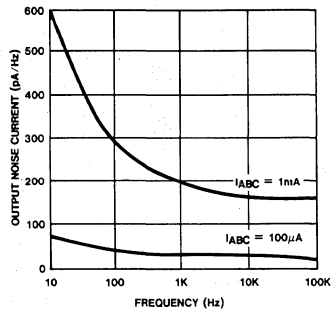

DUAL OPERATIONAL TRANSCONDUCTANCE AMPLIFIER

NE5517/5517A

TYPICAL PERFORMANCE CHARACTERISTICS (Cont'd)

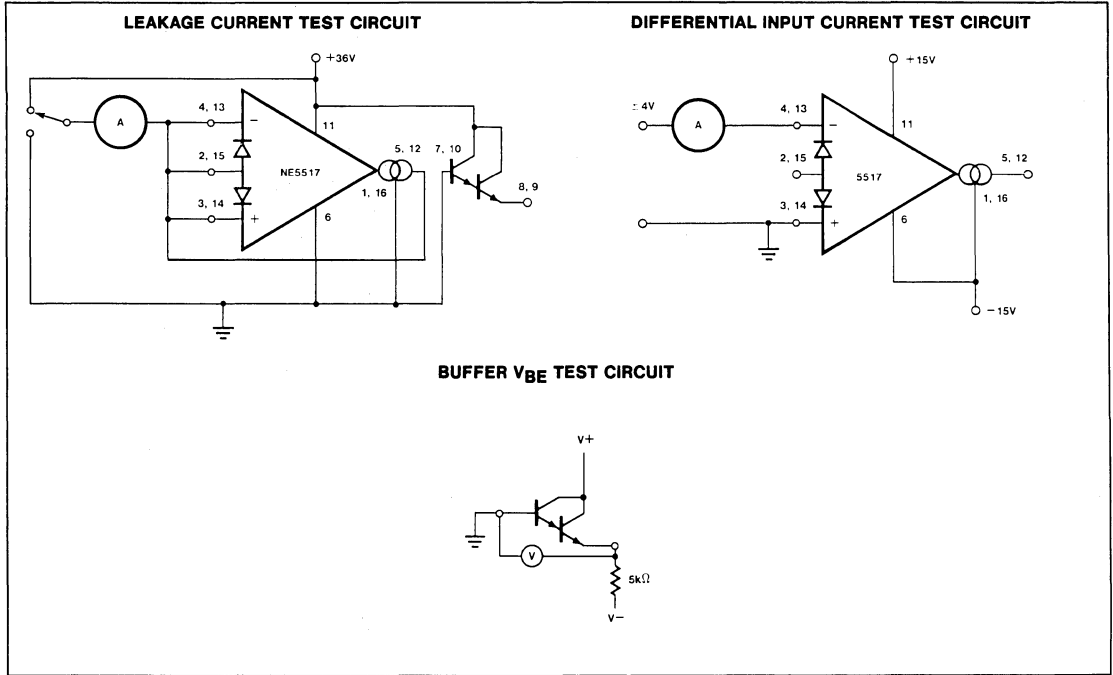

6

APPLICATIONS

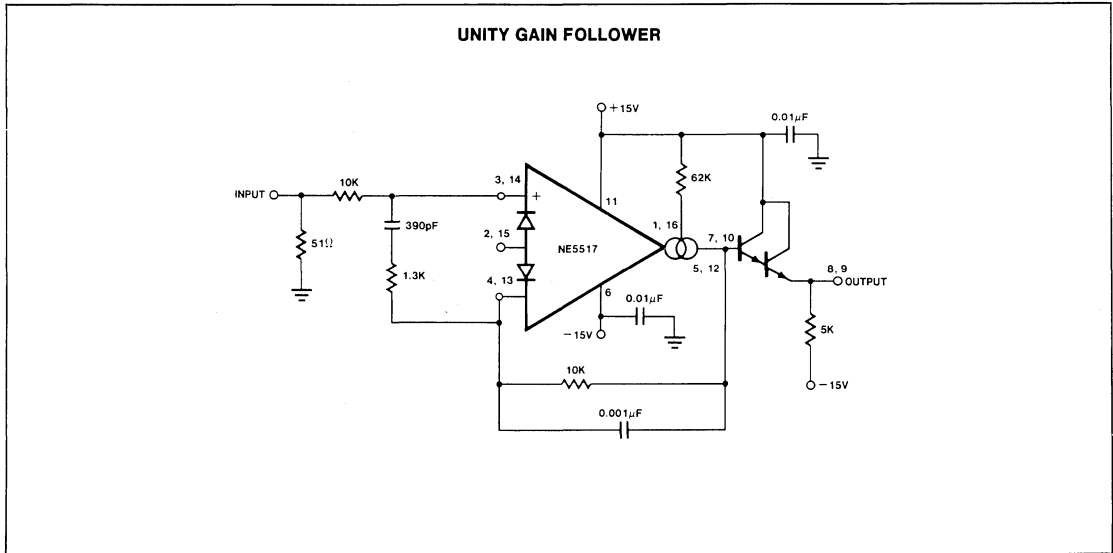

CIRCUIT DESCRIPTION

The circuit schematic diagram of one half of the NE5517, a dual operational transconductance amplifier with linearizing diodes and impedance buffers, is shown in Figure 1.

1. Transconductance Amplifier

The transistor pair Q₄ and Q₅ form a transconductance stage. The ratio of their collector currents (I₄ and I₅ respectively) is defined by the differential input voltage, V_{IN}, which is shown in equation 1.

$$V_{IN} = \frac{KT}{q} \ln \frac{I_5}{I_4} \tag{1}$$

Where V_{IN} is the difference of the two input voltages

KT ≅ 26mV at room temperature (300°K)

Transistors Q₁, Q₂ and diode D₁ form a current mirror which focuses the sum of current I₄ and I₅ to be equal to amplifier bias current I_B:

$$I_4 + I_5 = I_B \tag{2}$$

If V_{IN} is small the ratio of I₅ and I₄ will approach to unity and the Taylor series of ln function can be approximated as:

$$\frac{KT}{q} \ln \frac{I_5}{I_4} \approx \frac{KT}{q} \frac{I_5 - I_4}{I_4} \tag{3}$$

and $I_4 \approx I_5 \approx 1/2 I_B$

$$\frac{KT}{q} \ln \frac{I_5}{I_4} \approx \frac{KT}{q} \frac{I_5 - I_4}{1/2 I_B} = \frac{2KT}{q} \frac{I_5 - I_4}{I_B} = V_{IN}$$

$$I_5 - I_4 = V_{IN} \frac{(I_B)^q}{2KT} \tag{4}$$

The remaining transistors (Q₆ to Q₁₁) and diodes (D₄ to D₆) form three current mirrors that produce an output current equal to I₅ minus I₄. Thus:

$$V_{IN} \left\{ I_B \frac{q}{2KT} \right\} = I_0 \tag{5}$$

The term $\left(\frac{I_B^q}{2KT} \right)$ is then the transconductance of the amplifier and is proportional to I_B.

2. Linearizing Diodes

For V_{IN} greater than a few millivolts, equation 3 becomes invalid and the transconductance increases nonlinearly. Figure 2 shows how the internal diodes can linearize the transfer function of the operational amplifier. Assume D₂ and D₃ are biased with current sources and the input signal current is I_S. Since

$I_4 + I_5 = I_B$ and $I_5 - I_4 = I_0$, that is:

$I_4 = 1/2(I_B - I_0)$, $I_5 = 1/2(I_B + I_0)$

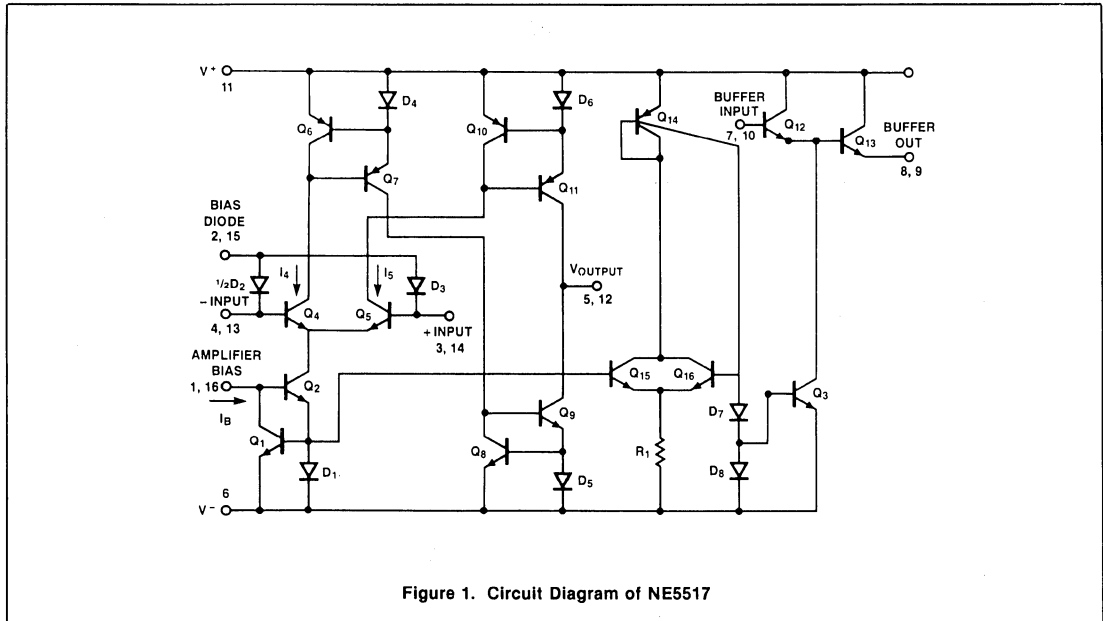

Figure 1. Circuit Diagram of NE5517

For the diodes and the input transistors that have identical geometries and are subject to similar voltages and temperatures, the following equations is true:

$$\frac{KT}{q} \ln \frac{I_D + I_S}{2} = \frac{KT}{q} \ln \frac{1/2(I_B + I_0)}{1/2(I_B - I_0)}$$

$$I_0 = I_S \frac{(2I_B)}{I_D} \text{ for } |I_S| < \frac{I_D}{2} \quad (6)$$

The only limitation is that the signal current should not exceed 1/2 I_D.

3. Impedance Buffer

The upper limit of transconductance is defined by the maximum value of I_B (2mA). The lowest value of I_B for which the amplifier will function therefore determines the overall dynamic range. At low values of I_B, a buffer with very low input bias current is desired. A Darlington amplifier with constant current source (Q₁₄, Q₁₅, Q₁₆, D₇, D₈, and R₁) suits the need.

APPLICATIONS

Voltage Controlled Amplifier

The voltage-divider R₂, R₃ divides the input voltage into small values (mV-range) so the amplifier operates in a linear manner.

It is:

$$I_{OUT} = -V_{IN} \times \frac{R_3}{R_2 + R_3} \times gm;$$

$$V_{OUT} = I_{OUT} \times R_L;$$

$$A = \frac{V_{OUT}}{V_{IN}} = -\frac{R_3}{R_2 + R_3} gm R_L;$$

$$A = -\frac{R_3}{R_2 + R_3} \times gm \times R_L \quad (3) \quad gm = 19.2 I_{ABC}$$

(gm in mS for I_{ABC} in mA)

Since gm is directly proportional to I_{ABC}, the amplification is controlled by the voltage V_C in a simple way.

When V_C is taken relative to -V_{CC} the following formula is valid:

$$I_{ABC} = \frac{(V_C - 1.2V)}{R_1};$$

The 1.2V is the voltage across two base-emitter paths in the current mirrors. This circuit is the base for many applications of the NE5517.

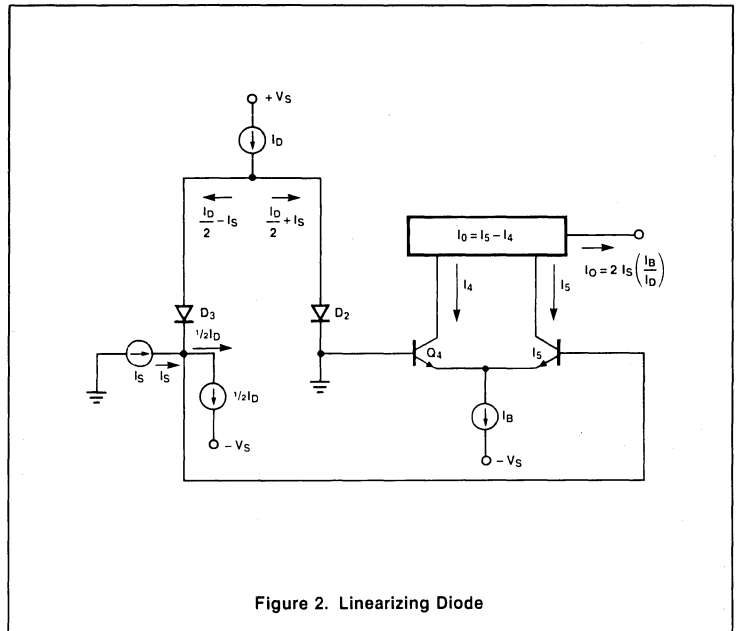

Figure 2. Linearizing Diode

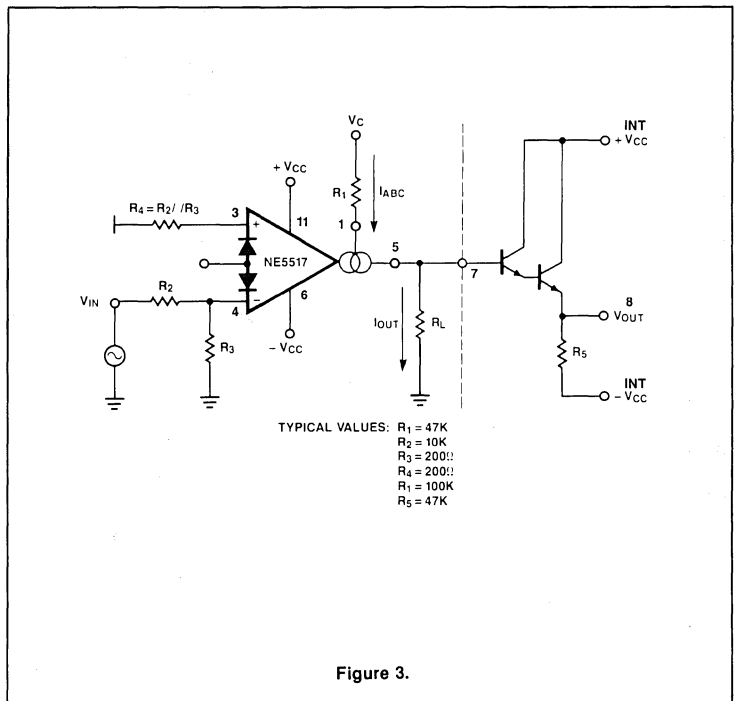

Figure 3.

Stereo Amplifier With Gain Control

Figure 4 shows a stereo amplifier with variable gain via a control input. Excellent tracking of typical 0.3dB is easy to achieve. With the potentiometer R_p , the offset can be adjusted. For AC-coupled amplifiers you can replace the potentiometer with two 510Ω resistors.

Modulators

Because the transconductance of an OTA is directly proportional to I_{ABC} , the amplification of a signal can be controlled easily. The output current is the product from transconductance \times input voltage. The circuit works up to approximately 200KHz. Modulation of 99 percent is easy to achieve.

Voltage Controlled Resistors (VCR)

The principle is based on the capability of an OTA to vary a current proportional to a controlled voltage which is according to a resistor. The circuit takes advantage of the possibility to control a resistor via gm.

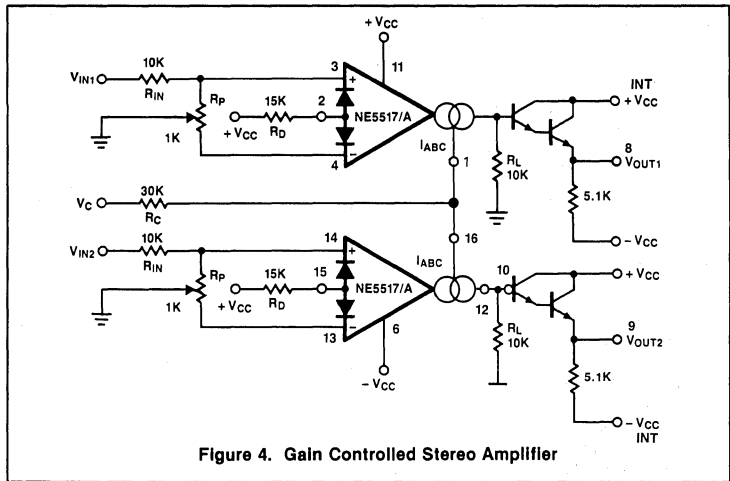

Figure 4. Gain Controlled Stereo Amplifier

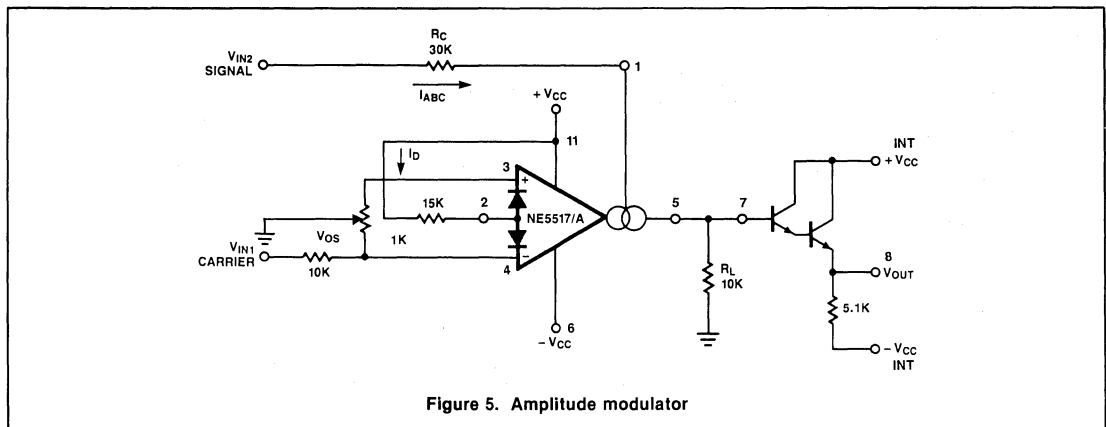

Figure 5. Amplitude modulator

Voltage Controlled Filters

Voltage controlled filters can be realized extremely easily with the help of an OTA.

Figure 8 shows the circuit for a low-pass filter. Below the corner frequency the circuit has an amplification of 0dB. Above the corner frequency the attenuation drops by 6dB/octave.

The high-pass filter is built in a similar manner, except the input is coupled via capacitor.

Voltage Controlled Oscillators

Figure 12 shows a voltage controlled triangle-square-wave-generator. With the indicated values a range from 2Hz to 200kHz is possible by varying I_{ABC} from 1mA to 10μA.

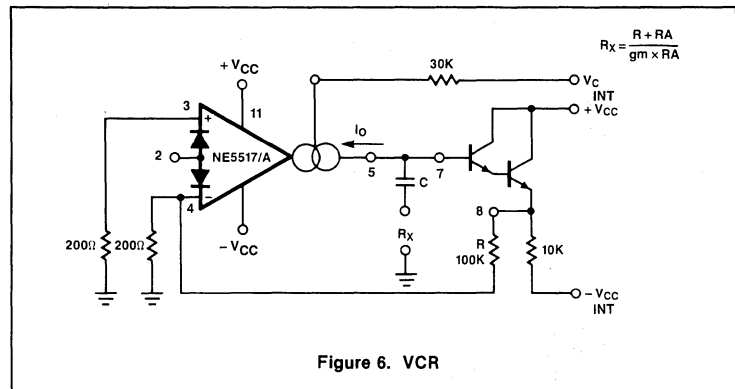

Figure 6. VCR

DUAL OPERATIONAL TRANSCONDUCTANCE AMPLIFIER

NE5517/5517A

The output amplitude is determined by $I_{OUT} \times R_{OUT}$.

Please notice the differential-input-voltage is not allowed to be above 5V.

With a slight modification of this circuit you can get the sawtooth-pulse-generator as shown in Figure 13.

Programmable Amplifier

The intention of the following application is to show how the NE5517 works in connection with a DAC. Almost all applications described above can be made digitally programmable (μP -compatible) in this way.

In the application Figure 14 the NE5118 is used, an eight-bit DAC with current output (see Section), its input-register makes this device fully μP -compatible.

The circuitry of Figure 14 consists of three functional blocks: the NE5118, which generates a control current equivalent to the applied data byte, a current mirror, and the NE5517.

The amplification is given by the following equation:

$$A = \frac{DW(10)}{256} \times \frac{I_{DAC \max}}{2 \times V_T} \times R_L$$

- DW (10) = Data word decimal
- $I_{DAC \max}$ = Maximum DAC output current (here -1mA)
- R_L = Load resistance

The equation is only valid for the amplification of the signal directly applied to the OTA. To get the gain overall A must be multiplied with the input-attenuation factor.

APPLICATION HINTS:

To hold the transconductance g_m within the linear range, I_{ABC} should be chosen not greater than 1mA. The current mirror ratio should be as accurate as possible over the entire current range. A current mirror with only two transistors is not recommended. A suitable current mirror can be built with a pnp-transistor array which causes excellent matching and thermal coupling among the transistors. The output current range of the DAC normally reaches from 0 . . . -2mA. In this application, however, the current range is set through R_{REF} (10K Ω) to 0 . . . -1mA.

$$I_{DAC \max} = 2 \times \frac{V_{REF}}{R_{REF}} = 2 \times \frac{5V}{10K} = 1mA$$

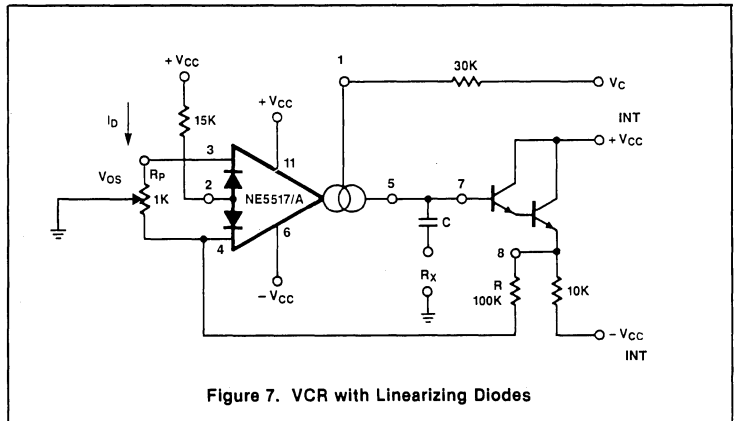

Figure 7. VCR with Linearizing Diodes

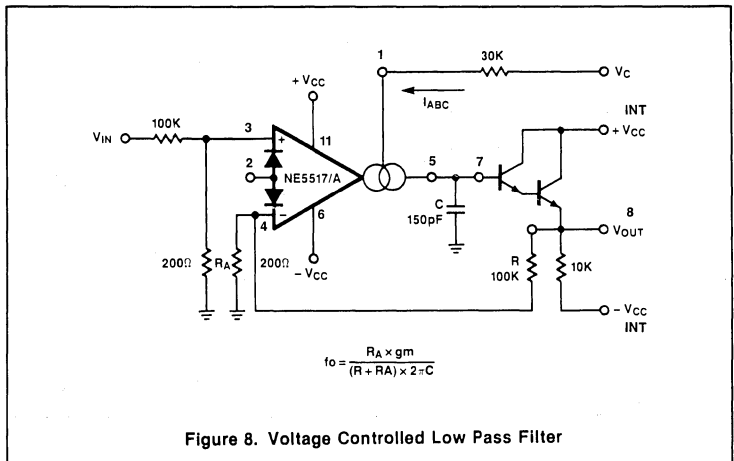

Figure 8. Voltage Controlled Low Pass Filter

$$f_o = \frac{R_A \times g_m}{(R + R_A) \times 2 \times C}$$

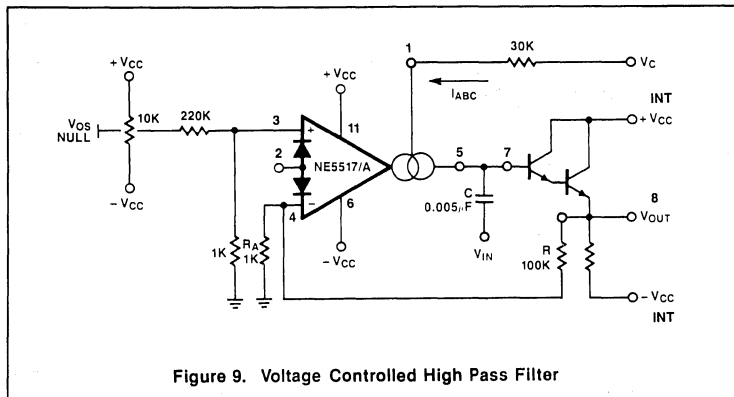

Figure 9. Voltage Controlled High Pass Filter

DUAL OPERATIONAL TRANSCONDUCTANCE AMPLIFIER

NE5517/5517A

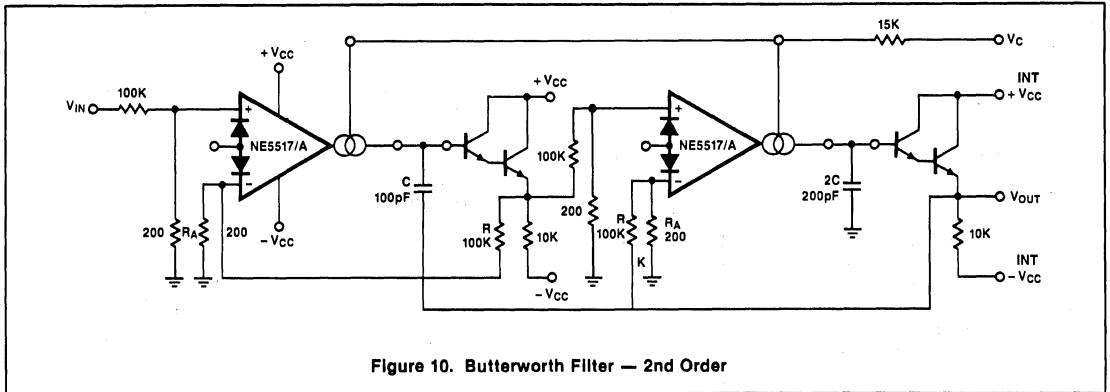

Figure 10. Butterworth Filter — 2nd Order

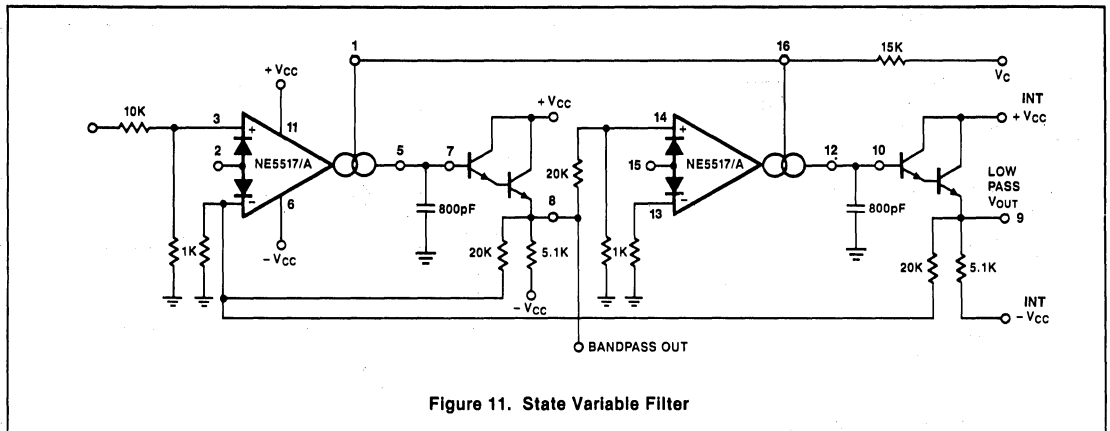

Figure 11. State Variable Filter

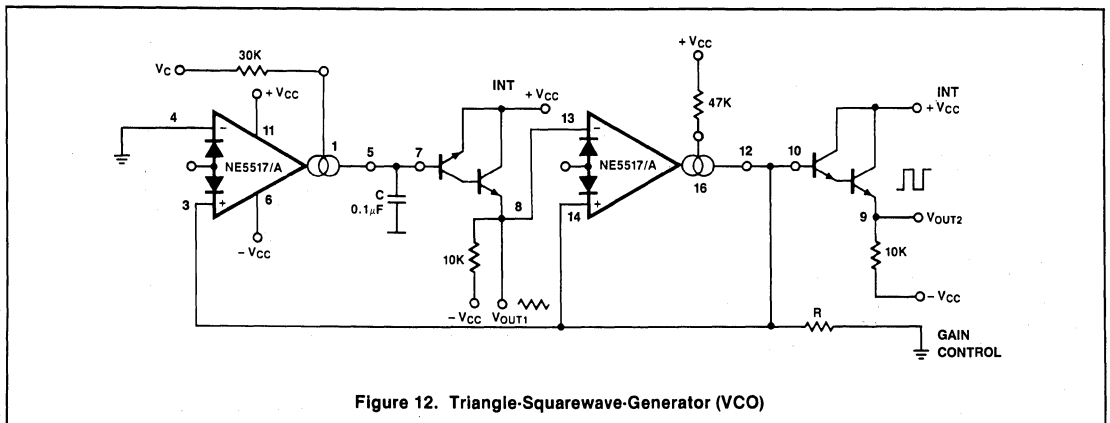

Figure 12. Triangle-Squarewave-Generator (VCO)

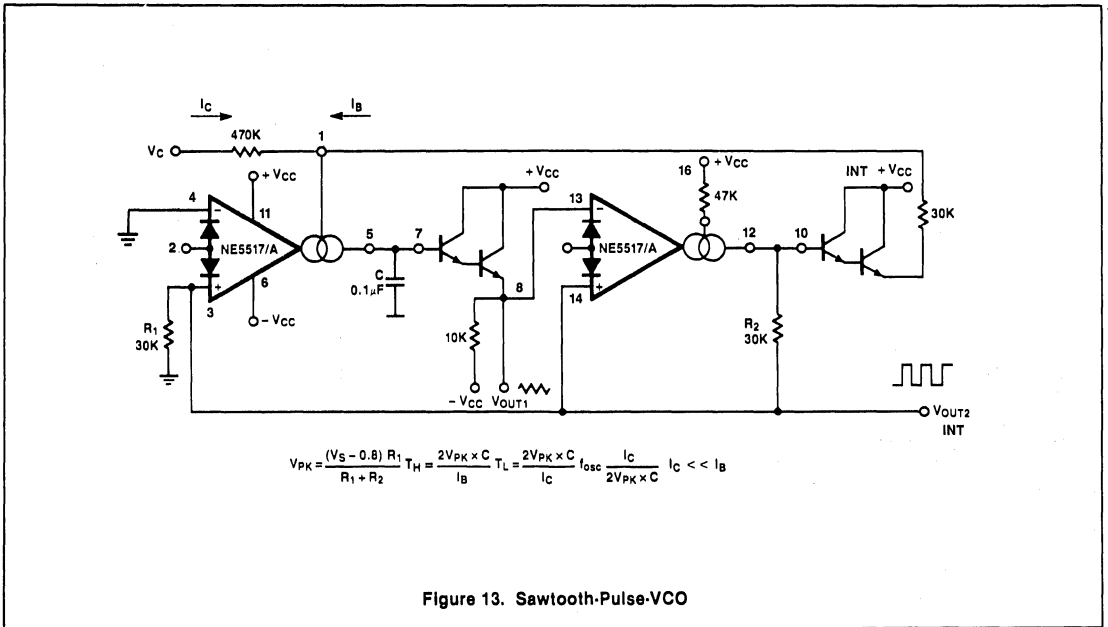

Figure 13. Sawtooth-Pulse-VCO

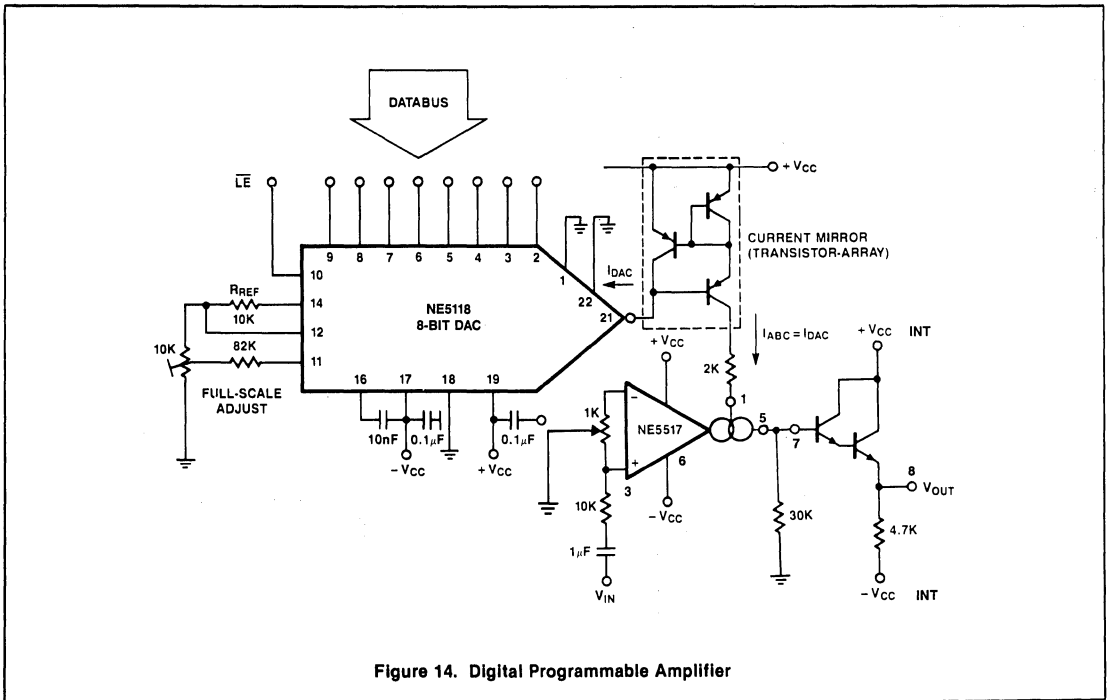

Figure 14. Digital Programmable Amplifier

*For additional information, consult the Applications Section.

ULTRA HIGH FREQUENCY OPERATIONAL AMPLIFIER

SE/NE5539

DESCRIPTION

The Signetics SE/NE5539 is a very wide bandwidth, high slew rate, monolithic operational amplifier for use in video amplifiers, RF amplifiers, and extremely high slew rate amplifiers.

Emitter follower inputs provide a true differential high input impedance device. Proper external compensation will allow design operation over a wide range of closed loop gains, both inverting and non-inverting, to meet specific design requirements.

FEATURES

- Gain bandwidth product: 1.2GHz at 17dB
- Slew rate: 600/V_μsec
- Full power response: 48MHz
- A_{vol}: 52dB typical
- 350MHz unity gain

APPLICATIONS

- Fast pulse amplifiers
- RF oscillators
- Fast sample and hold
- High gain video amplifiers (BW > 20MHz)

PIN CONFIGURATION

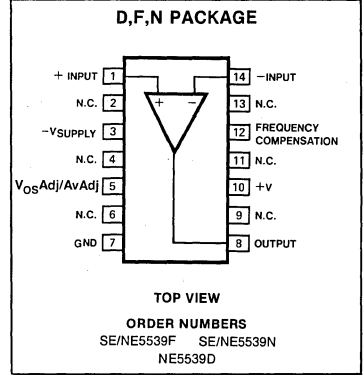

ABSOLUTE MAXIMUM RATINGS

PARAMETER	RATING	UNIT	
V _{CC}	Supply voltage	± 12	V
P _D	Internal power dissipation	550	mW
T _{STG}	Storage temperature range	-65 to +150	°C
T _J	Max junction temperature	150	°C
T _A	Operating temperature range		
	NE	0 to 70	°C
	SE	-55 to +125	°C
	Lead temperature	300	°C

EQUIVALENT CIRCUIT

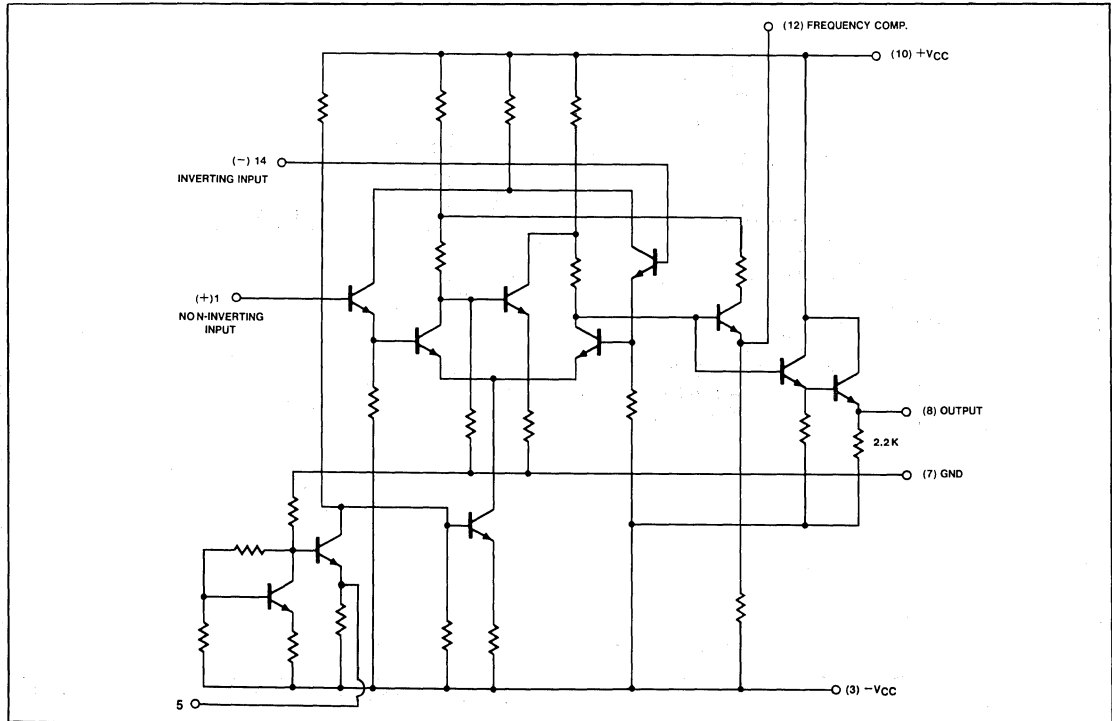

ULTRA HIGH FREQUENCY OPERATIONAL AMPLIFIER

SE/NE5539

DC ELECTRICAL CHARACTERISTICS $V_{CC} = \pm 8V$, $T_A = 25^\circ C$ unless otherwise specified

PARAMETER	TEST CONDITIONS		SE5539			NE5539			UNIT
			Min	Typ	Max	Min	Typ	Max	
V_{OS} Input offset voltage	$V_0 = 0V, R_S = 100\Omega$		Over temp	2	5				mV
			$T_A = 25^\circ C$	2	3		2.5	5	
$\Delta V_{OS}/\Delta T$				5			5	$\mu V/^\circ C$	
I_{OS} Input offset current			Over temp	.1	3				μA
			$T_A = 25^\circ C$.1	1			2	
$\Delta I_{OS}/\Delta T$.5			.5	$nA/^\circ C$	
I_B Input bias current			Over temp	6	25				μA
			$T_A = 25^\circ C$	5	13		5	20	
$\Delta I_B/\Delta T$				10			10	$nA/^\circ C$	
CMRR Common mode rejection ratio	$F = 1kHz, R_S = 100\Omega, V_{CM} \pm 1.7V$			70	80		70	80	dB
			Over temp	70	80				
R_{IN} Input impedance				100			100	k Ω	
R_{OUT} Output impedance				10			10	Ω	
V_{OUT} Output voltage swing	$R_L = 150\Omega$ to GND and 470Ω to $-V_{CC}$		+Swing			+2.3	+2.7	V	
			-Swing			-1.7	-2.2		
V_{OUT} Output voltage swing	$R_L = 2k\Omega$ to GND	Over temp	+Swing	+2.3	+3.0			V	
			-Swing	-1.5	-2.1				
		$T_A = 25^\circ C$	+Swing	+2.5	+3.1			V	
			-Swing	-2.0	-2.7				
I_{CC+} Positive supply current	$V_0 = 0, R_1 = \infty$		Over temp	14	18			mA	
			$T_A = 25^\circ C$	14	17		14		18
I_{CC-} Negative supply current	$V_0 = 0, R_1 = \infty$		Over temp	11	15			mA	
			$T_A = 25^\circ C$	11	14		11		15
PSRR Power supply rejection ratio	$\Delta V_{CC} = \pm 1V$		Over temp	300	1000			$\mu V/V$	
			$T_A = 25^\circ C$				200		1000
A_{VOL} Large signal voltage gain	$V_0 = +2.3V, -1.7V$ $R_L = 150\Omega$ to GND, 470Ω to $-V_{CC}$					47	52	57	dB
A_{VOL} Large signal voltage gain	$V_0 = +2.3V, -1.7V$ $R_L = 2K$ to GND								dB
			$T_A = 25^\circ C$				47	52	
A_{VOL} Large signal voltage gain	$V_0 = +2.5V, -2.0V$ $R_L = 2k\Omega$ to GND		Over temp	46	60				dB
			$T_A = 25^\circ C$	48	53	58			

NOTE

- Differential input voltage should not exceed 0.25 volts to prevent excessive input bias current and common mode voltage 2.5 volts. These voltage limits may be exceeded if current limit is 10mA.

6

ULTRA HIGH FREQUENCY OPERATIONAL AMPLIFIER

SE/NE5539

AC ELECTRICAL CHARACTERISTICS $V_{CC} = \pm 8V$, $R_L = 150\Omega$ to GND & 470Ω to $-V_{CC}$ unless otherwise specified.

PARAMETER	TEST CONDITIONS	SE5539			NE5539			UNIT
		Min	Typ	Max	Min	Typ	Max	
Gain bandwidth product	$A_{CL} = 7$ $V_O = 0.1$ Vp-p		1200			1200		MHz
Small signal bandwidth	$A_{CL} = 2$ $R_L = 150\Omega^1$		110			110		MHz
Settling time	$A_{CL} = 2$ $R_L = 150\Omega^1$		15			15		nSec
Slew rate	$A_{CL} = 2$ $R_L = 150\Omega^1$		600			600		V/ μ Sec
Propagation delay	$A_{CL} = 2$ $R_L = 150\Omega^1$		7			7		nSec
Full power response	$A_{CL} = 2$ $R_L = 150\Omega^1$		48			48		MHz
Full power response	$A_V = 7$, $R_L = 150\Omega$		20			20		MHz
Input noise voltage	$R_S = 50\Omega$		4			4		nV/ \sqrt{Hz}

NOTE 1: External compensation.

DC ELECTRICAL CHARACTERISTICS $V_{CC} = \pm 6V$, $T_A = 25^\circ C$ unless otherwise specified

PARAMETERS	TEST CONDITIONS	SE5539			UNIT	
		Min	Typ	Max		
V_{OS} Input offset voltage		Over temp	2	5	mV	
		$T_A = 25^\circ C$	2	3		
I_{OS} Input offset current		Over temp	.1	3	μA	
		$T_A = 25^\circ C$.1	1		
I_B Input bias current		Over temp	5	20	μA	
		$T_A = 25^\circ C$	4	10		
CMRR Common mode rejection ratio	$V_{CM} = \pm 1.3V$, $R_S = 100\Omega$	70	85		dB	
I_{CC+} Positive supply current		Over temp	11	14	mA	
		$T_A = 25^\circ C$	11	13		
I_{CC-} Negative supply current		Over temp	8	11	mA	
		$T_A = 25^\circ C$	8	10		
PSRR Power supply rejection ratio	$\Delta V_{CC} = \pm 1V$	Over temp	300	1000	$\mu V/V$	
		$T_A = 25^\circ C$				
V_{OUT} Output voltage swing	$R_L = 150\Omega$ to GND and 390Ω to $-V_{CC}$	Over temp	+ Swing	+ 1.4	+ 2.0	V
			- Swing	- 1.1	- 1.7	
		$T_A = 25^\circ C$	+ Swing	+ 1.5	+ 2.0	
			- Swing	- 1.4	- 1.8	

AC ELECTRICAL CHARACTERISTICS $V_{CC} = \pm 6V$, $R_L = 150\Omega$ to GND and 390Ω to $-V_{CC}$ unless otherwise specified

PARAMETER	TEST CONDITIONS	SE5539			UNIT
		Min	Typ	Max	
Gain bandwidth product	$A_{CL} = 7$		700		MHz
Small signal bandwidth	$A_{CL} = 2^1$		120		MHz
Settling time	$A_{CL} = 2^1$		23		ns
Slew rate	$A_{CL} = 2^1$		330		V/ μs
Propagation delay	$A_{CL} = 2^1$		4.5		ns
Full power response	$A_{CL} = 2^1$		20		MHz

NOTE 1: External compensation.

NE5539 OPEN LOOP PHASE

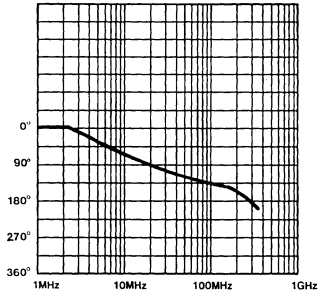

NE5539 OPEN LOOP GAIN

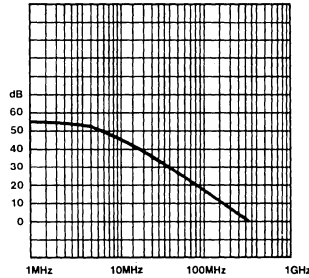

POWER BANDWIDTH (SE)

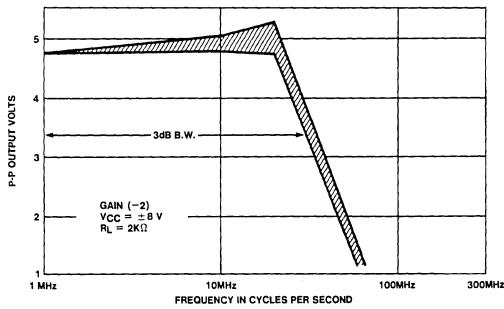

POWER BANDWIDTH (NE)

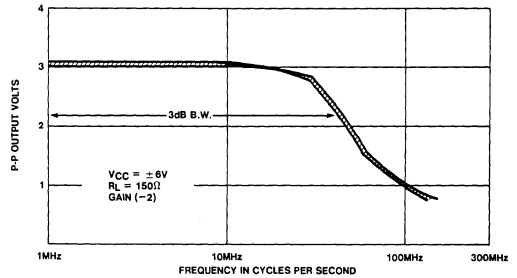

SE5539 OPEN LOOP GAIN vs FREQUENCY

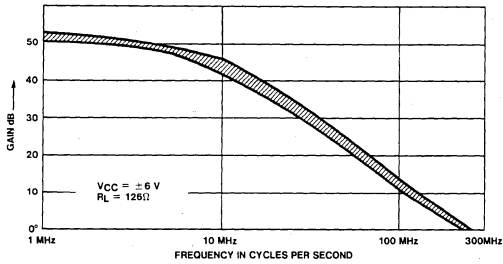

POWER BANDWIDTH

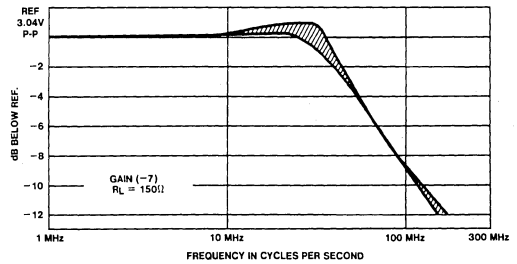

SE5539 OPEN LOOP PHASE vs FREQUENCY

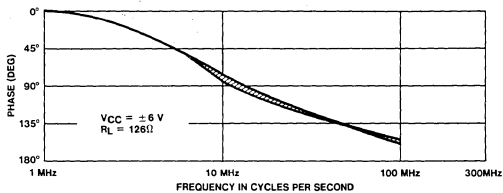

GAIN BANDWIDTH PRODUCT vs FREQUENCY

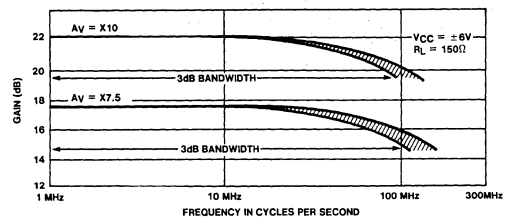

NOTE

Indicates typical distribution $-55^{\circ}\text{C} \leq T_A \leq 125^{\circ}\text{C}$

6

ULTRA HIGH FREQUENCY OPERATIONAL AMPLIFIER

SE/NE5539

CIRCUIT LAYOUT CONSIDERATIONS

As may be expected for an ultra-high frequency, wide gain bandwidth amplifier, the physical circuit layout is extremely

critical. Breadboarding is not recommended. A double-sided copper clad printed circuit board will result in more

favorable system operation. An example utilizing a 28dB non-inverting amp is shown in Figure 1.

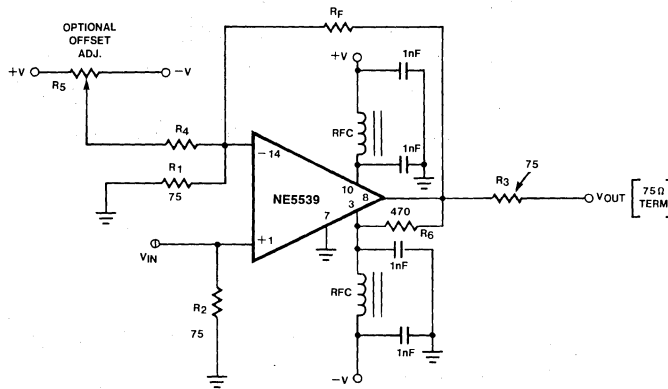

R1 = 75Ω 5% CARBON
 R2 = 75Ω 5% CARBON
 R3 = 75Ω 5% CARBON
 R4 = 36K 5% CARBON

R5 = 20K TRIMPOT (CERMET)
 Rf = 1.5K (28dB GAIN)
 R6 = 470Ω 5% CARBON

RFC 3T # 26 BUSSWIRE ON
 FERROCUBE VK 200 09/3B CORE
 BYPASS CAPACITORS
 1nF CERAMIC
 (MEPCO OR EQUIV.)

TOP PLANE COPPER¹ (Component Side)

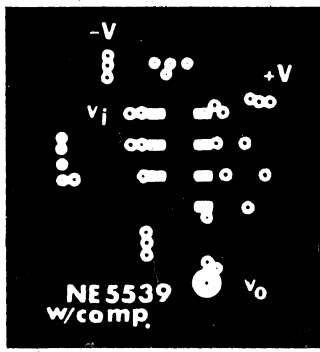

COMPONENT SIDE (Component Layout)

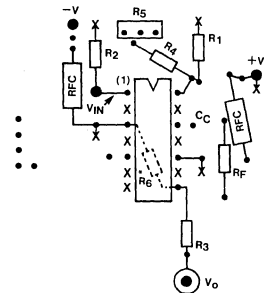

NOTE
 (X) indicates ground connection to top plane.
 * R6 is on bottom side.

BOTTOM PLANE COPPER¹

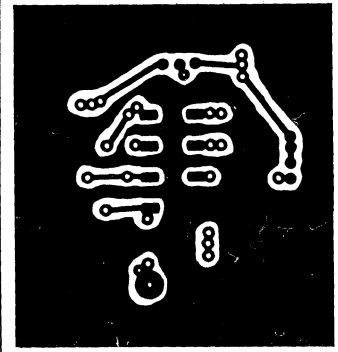

NOTE 1: Bond edges of top and bottom ground plane copper.

Figure 1. 28dB Non-Inverting Amp Sample P.C. Layout

ULTRA HIGH FREQUENCY OPERATIONAL AMPLIFIER

SE/NE5539

NE5539 COLOR VIDEO AMPLIFIER

The NE5539 wideband operational amplifier is easily adapted for use as a color video amplifier. A typical circuit is shown in Figure 2 along with vector-scope¹ photographs showing the amplifier differential gain and phase response to a standard five step modulated staircase linearity signal (Figures 3, 4 and 5). As can be seen in Figure 4, the gain varies less than 0.5% from the bottom to the top of the staircase. The maximum differential phase shown in Figure 5 is approximately +0.1°.

The amplifier circuit was optimized for a 75Ω input and output termination impedance with a gain of approximately 10 (20dB).

NOTE

The input signal was 200mV and the output 2V. V_{CC} was ±8V.

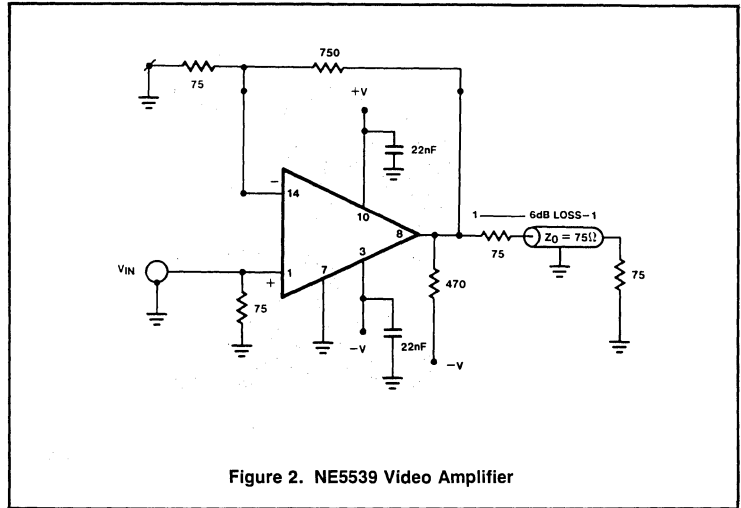

Figure 2. NE5539 Video Amplifier

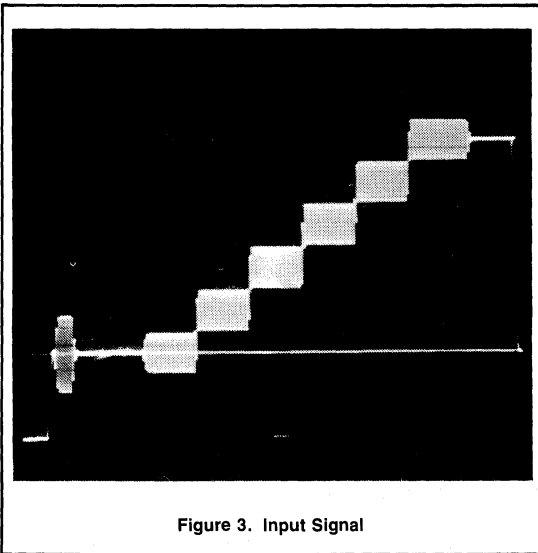

Figure 3. Input Signal

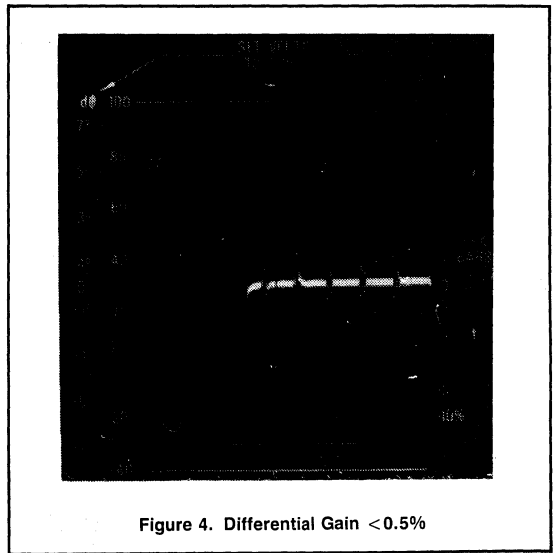

Figure 4. Differential Gain < 0.5%

NOTE:

1. Instruments used for these measurements were Tektronix, 146 NTSC test signal generator, 520A NTSC vectorscope, and 1480 waveform monitor.

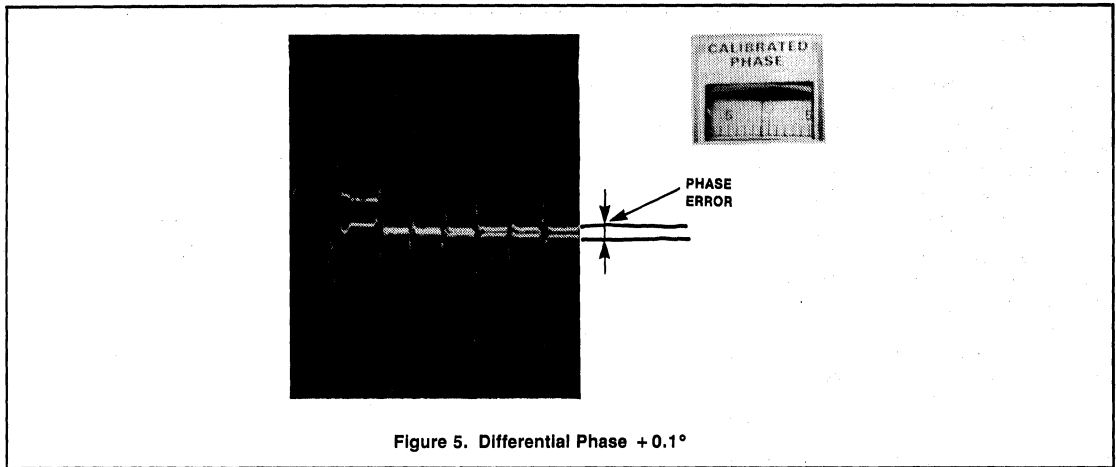
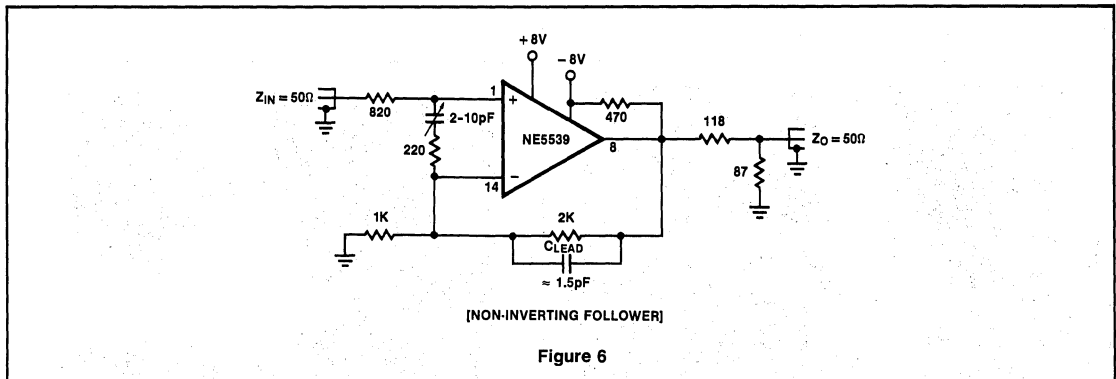

Figure 5. Differential Phase +0.1°

APPLICATIONS



[NON-INVERTING FOLLOWER]

Figure 6

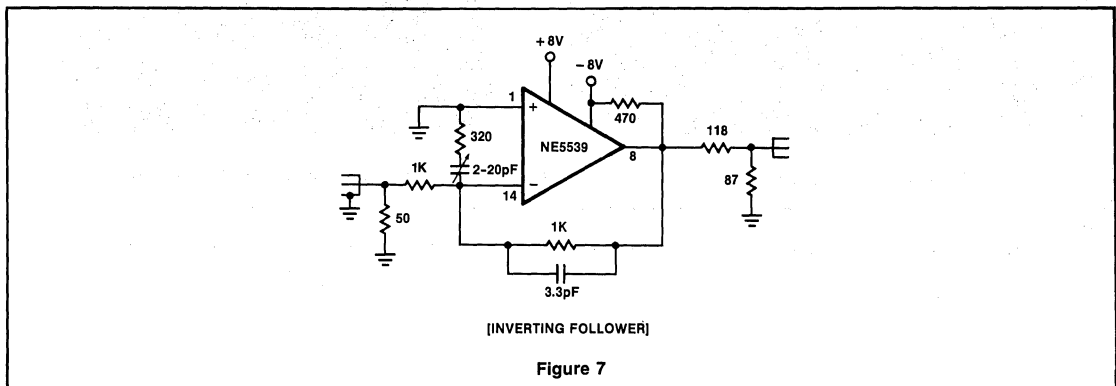

[INVERTING FOLLOWER]

Figure 7

* For additional information, consult the Applications Section.

VIDEO AMPLIFIER

NE5592

DESCRIPTION

The NE5592 is a dual monolithic, two stage, differential output, wideband video amplifier. It offers fixed gain of 400 without external components or adjustable gains from 400 to 0 with one external resistor. The input stage has been designed so that with the addition of a few external reactive elements between the gain select terminals, the circuit can function as a high pass, low pass, or band pass filter. This feature makes the circuit ideal for use as a video or pulse amplifier in communications, magnetic memories, display, video recorder systems, and floppy disk head amplifiers.

FEATURES

- 120MHz bandwidth
- Adjustable gains from 0 to 400
- Adjustable pass band
- No frequency compensation required
- Wave shaping with minimal external components

APPLICATIONS

- Floppy disk head amplifier
- Video amplifier
- Pulse amplifier in communications
- Magnetic memory
- Video recorder systems

PIN CONFIGURATION

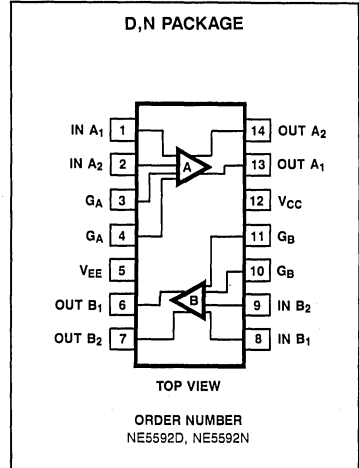

ABSOLUTE MAXIMUM RATINGS $T_A = 25^\circ\text{C}$ unless otherwise specified.

SYMBOL AND PARAMETER	RATING	UNIT
Supply voltage	± 8	V
Differential input voltage	± 5	V
Common mode		
Input voltage	± 6	V
Output current	10	mA
Operating temperature range		
NE5592	0 to +70	$^\circ\text{C}$
Storage temperature range	-65 to +150	$^\circ\text{C}$
Power dissipation	500	mW

EQUIVALENT CIRCUIT

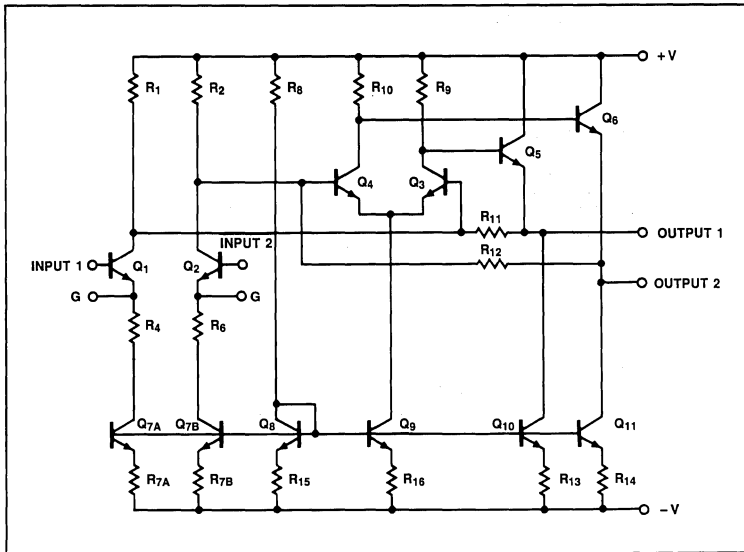

VIDEO AMPLIFIER

NE5592

DC ELECTRICAL CHARACTERISTICS $T_A = +25^\circ\text{C}$, $V_{SS} = \pm 6\text{V}$, $V_{CM} = 0$ unless otherwise specified. Recommended operating supply voltage $V_S = \pm 6.0\text{V}$. Gain select pins connected together.

PARAMETER	TEST CONDITIONS	NE5592			UNITS
		Min	Typ	Max	
Differential voltage gain	$R_L = 2\text{k}\Omega$, $V_{OUT} = 3\text{V p-p}$	400	480	600	V/V
Bandwidth	$V_{OUT} = 1\text{V p-p}$		25		MHz
Rise time				15	20
Propagation delay	$V_{OUT} = 1\text{V p-p}$		7.5	12	ns
Input resistance	BW 1kHz to 10MHz	3	14		k Ω
Input capacitance			2.5		pF
Input offset current			0.3	3	μA
Input bias current			5	20	μA
Input noise voltage			4		nV/ $\sqrt{\text{Hz}}$
Input voltage range					± 1.0 V
Common mode rejection ratio		$V_{CM} \pm 1\text{V}$, $f < 100\text{kHz}$	60	93	
Supply voltage rejection ratio	$V_{CM} \pm 1\text{V}$, $f = 5\text{MHz}$		87		dB
	$\Delta V_S = \pm 0.5\text{V}$	50	85		dB
Channel separation	$V_{OUT} = 1\text{V p-p}$; $f = 100\text{kHz}$ (output referenced) $R_L = 1\text{k}\Omega$	65	75		dB
Output offset voltage	$R_L = \infty$		0.5	1.5	V
Gain select pins open	$R_L = \infty$		0.25	0.75	V
Output common mode voltage	$R_L = \infty$	2.4	3.1	3.4	V
Output differential voltage swing	$R_L = 2\text{k}\Omega$	3.0	4.0		V
Output resistance			20		Ω
Power supply current (Total for both sides)	$R_L = \infty$		35	44	mA
THE FOLLOWING SPECS APPLY OVER TEMPERATURE		$0^\circ\text{C} \leq T_A \leq 70^\circ\text{C}$			
Differential voltage gain	$R_L = 2\text{k}\Omega$, $V_{OUT} = 3\text{V p-p}$	350	430	600	V/V
Input resistance		1	11		k Ω
Input offset current				5	μA
Input bias current				30	μA
Input voltage range				± 1.0	V
Common mode rejection ratio	$V_{CM} \pm 1\text{V}$, $f < 100\text{kHz}$	55			dB
Supply voltage rejection ratio	$R_S = \phi$				
	$\Delta V_S = \pm 0.5\text{V}$	50			dB
Channel separation	$V_{OUT} = 1\text{V p-p}$; $f = 100\text{kHz}$ (output referenced) $R_L = 1\text{k}\Omega$		75		dB
Output offset voltage	$R_L = \infty$			1.5	V
Gain select pins connected together				1.0	V
Gain select pins open					V
Output differential voltage swing		$R_L = 2\text{k}\Omega$	2.8		
Power supply current (Total for both sides)	$R_L = \infty$			47	mA

TYPICAL PERFORMANCE CHARACTERISTICS

COMMON MODE REJECTION RATIO AS A FUNCTION OF FREQUENCY

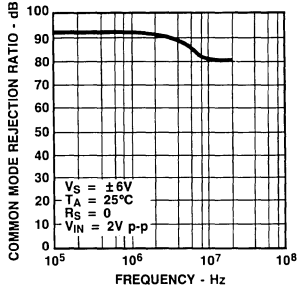

OUTPUT VOLTAGE SWING AS A FUNCTION OF FREQUENCY

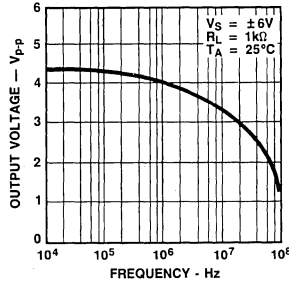

CHANNEL SEPARATION AS A FUNCTION OF FREQUENCY

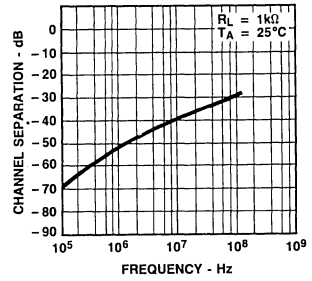

DIFFERENTIAL OVERDRIVE RECOVERY TIME

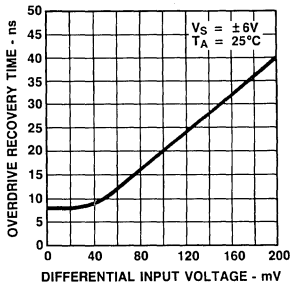

PULSE RESPONSE AS A FUNCTION OF SUPPLY VOLTAGE

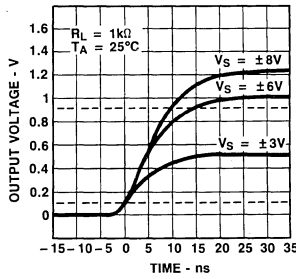

PULSE RESPONSE AS A FUNCTION OF TEMPERATURE

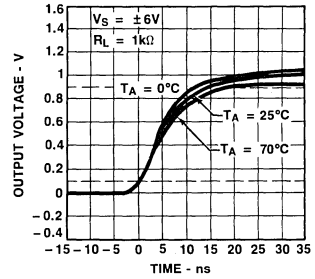

VOLTAGE GAIN AS A FUNCTION OF TEMPERATURE

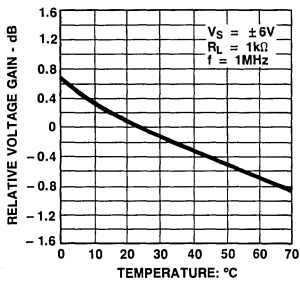

GAIN vs FREQUENCY AS A FUNCTION OF TEMPERATURE

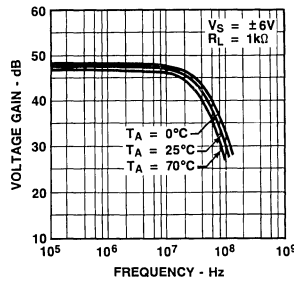

VOLTAGE GAIN AS A FUNCTION OF SUPPLY VOLTAGE

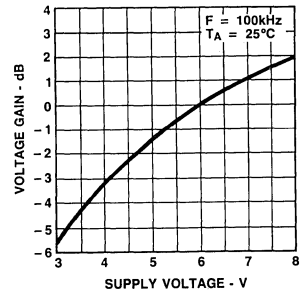

6

TYPICAL PERFORMANCE CHARACTERISTICS (Cont'd)

GAIN vs FREQUENCY AS A FUNCTION OF SUPPLY VOLTAGE

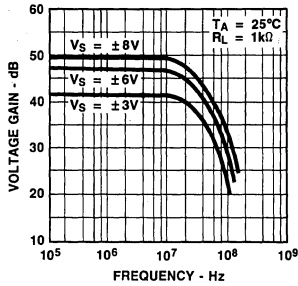

PHASE vs FREQUENCY AS A FUNCTION OF SUPPLY VOLTAGE

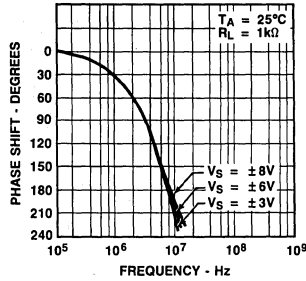

VOLTAGE GAIN AS A FUNCTION OF R_{ADJ} .

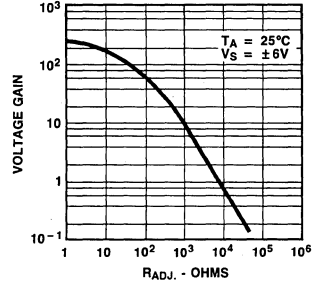

SUPPLY CURRENT AS A FUNCTION OF TEMPERATURE

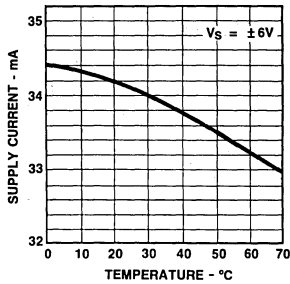

SUPPLY CURRENT AS A FUNCTION OF SUPPLY VOLTAGE

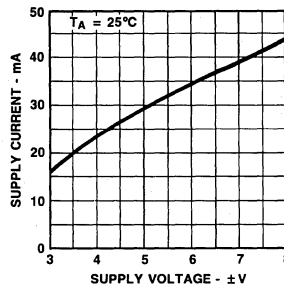

OUTPUT VOLTAGE SWING AND SINK CURRENT AS A FUNCTION OF SUPPLY VOLTAGE

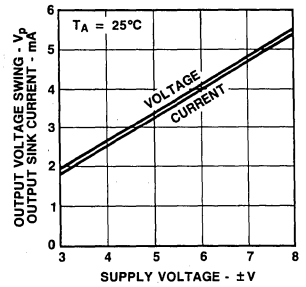

OUTPUT VOLTAGE SWING AS A FUNCTION OF LOAD RESISTANCE

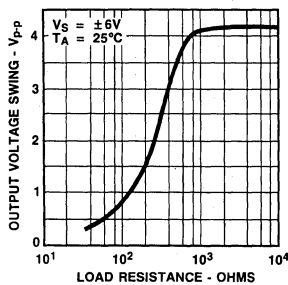

INPUT RESISTANCE AS A FUNCTION OF TEMPERATURE

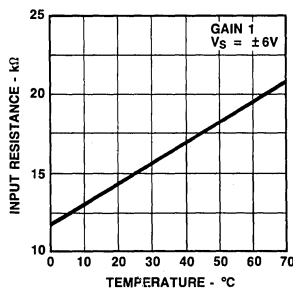

INPUT NOISE VOLTAGE AS A FUNCTION OF FREQUENCY

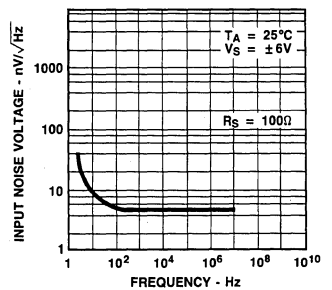

VIDEO AMPLIFIER

NE5592

TEST CIRCUITS $T_A = 25^\circ\text{C}$ unless otherwise specified

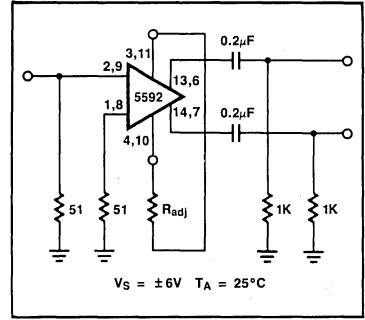
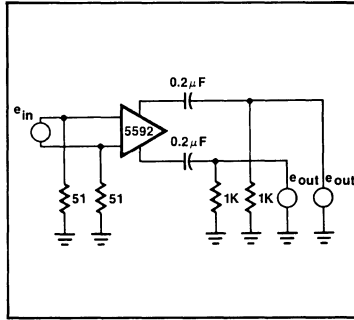
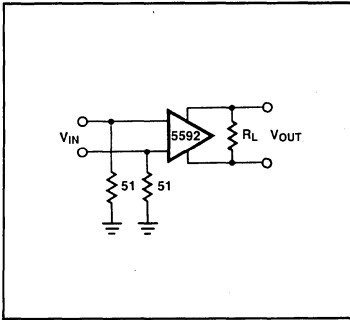

VIDEO AMPLIFIER

SE/NE592

DESCRIPTION

The SE/NE592 is a monolithic, two stage, differential output, wideband video amplifier. It offers fixed gains of 100 and 400 without external components and adjustable gains from 400 to 0 with one external resistor. The input stage has been designed so that with the addition of a few external reactive elements between the gain select terminals, the circuit can function as a high pass, low pass, or band pass filter. This feature makes the circuit ideal for use as a video or pulse amplifier in communications, magnetic memories, display, video recorder systems, and floppy disk head amplifiers. Now available in an 8-pin version with fixed gain of 400 without external components and adjustable gain from 400 to 0 with one external resistor.

FEATURES

- 120MHz bandwidth
- Adjustable gains from 0 to 400
- Adjustable pass band
- No frequency compensation required
- Wave shaping with minimal external components

APPLICATIONS

- Floppy disk head amplifier
- Video amplifier
- Pulse amplifier in communications
- Magnetic memory
- Video recorder systems

PIN CONFIGURATION

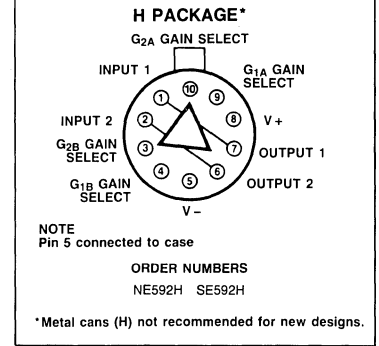
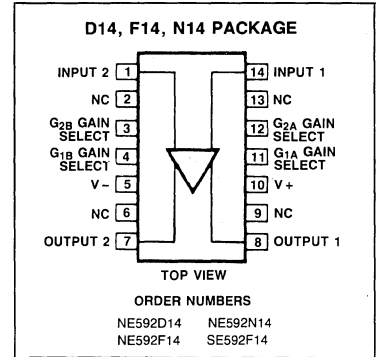

ABSOLUTE MAXIMUM RATINGS $T_A = +25^\circ\text{C}$ unless otherwise specified.

SYMBOL AND PARAMETER	RATING	UNIT
Supply voltage	± 8	V
Differential input voltage	± 5	V
Common mode Input voltage	± 6	V
Output current	10	mA
Operating temperature range		
SE592	-55 to +125	$^\circ\text{C}$
NE592	0 to +70	$^\circ\text{C}$
Storage temperature range	-65 to +150	$^\circ\text{C}$
Power dissipation	500	mW

EQUIVALENT CIRCUIT

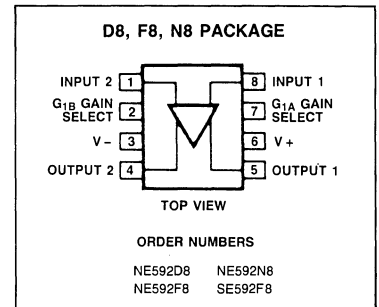
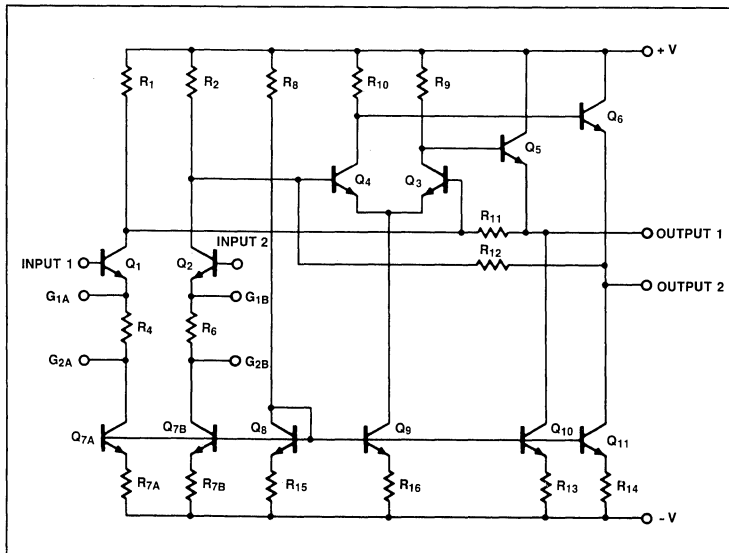

Also N8, N14, D8 and D14 package parts available in "High" gain version by adding "H" before package designation, as: NE592HD8.

VIDEO AMPLIFIER

SE/NE592

DC ELECTRICAL CHARACTERISTICS: $T_A = +25^\circ\text{C}$, $V_{SS} = \pm 6\text{V}$, $V_{CM} = 0$ unless otherwise specified. Recommended operating supply voltages $V_S = \pm 6.0\text{V}$. All specifications apply to both standard and high gain parts unless noted differently.

PARAMETER	TEST CONDITIONS	NE592			SE592			UNIT
		Min	Typ	Max	Min	Typ	Max	
Differential voltage gain, standard part Gain 1 ¹ Gain 2 ^{2,4}	$R_L = 2\text{k}\Omega$, $V_{OUT} = 3\text{V p-p}$	250 80	400 100	600 120	300 90	400 100	500 110	V/V V/V
High gain part		400	500	600				V/V
Bandwidth Gain 1 ¹ Gain 2 ^{2,4}			40 90			40 90		MHz MHz
Rise time Gain 1 ¹ Gain 2 ^{2,4}	$V_{OUT} = 1\text{V p-p}$		10.5 4.5	12		10.5 4.5	10	ns ns
Propagation delay Gain 1 ¹ Gain 2 ^{2,4}	$V_{OUT} = 1\text{V p-p}$		7.5 6.0	10		7.5 6.0	10	ns ns
Input resistance Gain 1 ¹ Gain 2 ^{2,4}	$\text{Gain } 2^4$	10	4.0 30	20	4.0 30	3.0 20	k Ω k Ω	
Input capacitance ²			2.0					2.0
Input offset current	BW 1kHz to 10MHz		0.4	5.0	0.4	3.0	μA	
Input bias current			9.0	30	9.0	20	μA	
Input noise voltage			12		12		μVrms	
Input voltage range				± 1.0		± 1.0	V	
Common mode rejection ratio Gain 2 ⁴ Gain 2 ⁴	$V_{CM} \pm 1\text{V}$, $f < 100\text{kHz}$ $V_{CM} \pm 1\text{V}$, $f = 5\text{MHz}$	60	86 60		60	86 60		dB dB
Supply voltage rejection ratio Gain 2 ⁴	$\Delta V_S = \pm 0.5\text{V}$	50	70		50	70		dB
Output offset voltage Gain 1 Gain 2 ⁴ Gain 3 ³	$R_L = \infty$			1.5 1.5		1.5 1.0		V V
Output common mode voltage	$R_L = \infty$	2.4	0.35 2.9	0.75 3.4	0.35 2.4	0.75 2.9	3.4	V
Output voltage swing differential	$R_L = 2\text{k}\Omega$	3.0	4.0		3.0	4.0		V
Output resistance			20			20		Ω
Power supply current	$R_L = \infty$		18	24		18	24	mA
THE FOLLOWING SPECS APPLY OVER TEMPERATURE		$0^\circ\text{C} \leq T_A \leq 70^\circ\text{C}$			$-55^\circ\text{C} \leq T_A \leq 125^\circ\text{C}$			
Differential voltage gain, standard part Gain 1 ¹ Gain 2 ^{2,4}	$R_L = 2\text{k}\Omega$, $V_{OUT} = 3\text{V p-p}$	250 80		600 120	200 80		600 120	V/V V/V
High gain part		400	500	600				V/V
Input resistance Gain 2 ^{2,4}		8.0			8.0			k Ω
Input offset current				6.0			5.0	μA
Input bias current				40			40	μA
Input voltage range		± 1.0			± 1.0			V

NOTES:

- Gain select pins G_{1A} and G_{1B} connected together.
- Gain select pins G_{2A} and G_{2B} connected together.
- All gain select pins open.
- Applies to 14-pin version only.

VIDEO AMPLIFIER

SE/NE592

DC ELECTRICAL CHARACTERISTICS: (cont.) $T_A = +25^\circ\text{C}$, $V_{SS} = \pm 6\text{V}$, $V_{CM} = 0$ unless otherwise specified. Recommended operating supply voltages $V_S = \pm 6.0\text{V}$. All specifications apply to both standard and high gain parts unless noted differently.

PARAMETER	TEST CONDITIONS	NE592			SE592			UNITS
		Min	Typ	Max	Min	Typ	Max	
THE FOLLOWING SPECS APPLY OVER TEMPERATURE		$0^\circ\text{C} \leq T_A \leq 70^\circ\text{C}$			$-55^\circ\text{C} \leq T_A \leq 125^\circ\text{C}$			
Common mode rejection ratio Gain 2 ⁴	$V_{CM} \pm 1\text{V}$, $f < 100\text{kHz}$	50			50			dB
Supply voltage rejection ratio Gain 2 ⁴		50			50			dB
Output offset voltage	$\Delta V_S = \pm 0.5\text{V}$							
Gain 1				1.5			1.5	V
Gain 2 ⁴				1.5			1.2	V
Gain 3 ³				1.0			1.0	V
Output voltage swing differential		$R_L = 2\text{k}\Omega$	2.8			2.5		V
Power supply current	$R_L = \infty$			27			27	mA

NOTES:

- Gain select pins G_{1A} and G_{1B} connected together.
- Gain select pins G_{2A} and G_{2B} connected together.
- All gain select pins open.
- Applies to 14-pin version only.

TYPICAL PERFORMANCE CHARACTERISTICS

COMMON MODE REJECTION RATIO AS A FUNCTION OF FREQUENCY

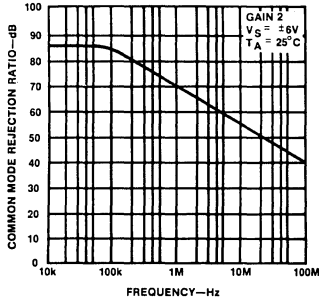

OUTPUT VOLTAGE SWING AS A FUNCTION OF FREQUENCY

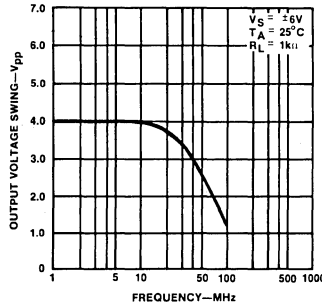

PULSE RESPONSE

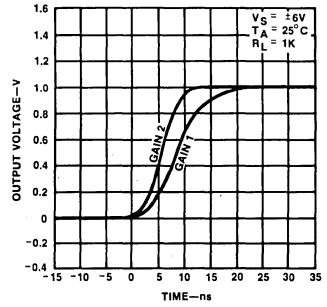

DIFFERENTIAL OVERDRIVE RECOVERY TIME

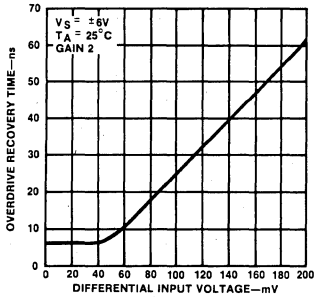

PULSE RESPONSE AS A FUNCTION OF SUPPLY VOLTAGE

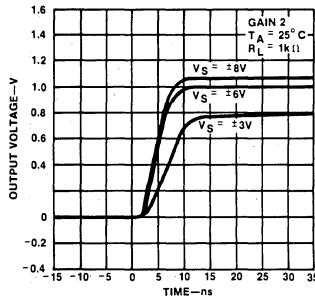

PULSE RESPONSE AS A FUNCTION OF TEMPERATURE

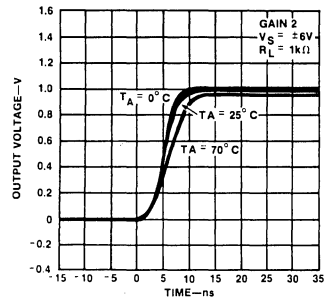

VOLTAGE GAIN AS A FUNCTION OF TEMPERATURE

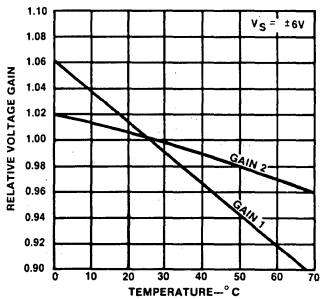

GAIN vs FREQUENCY AS A FUNCTION OF TEMPERATURE

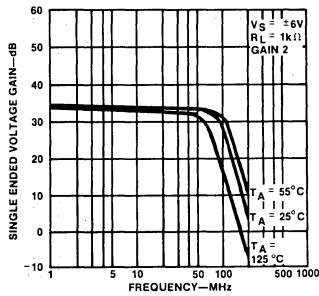

VOLTAGE GAIN AS A FUNCTION OF SUPPLY VOLTAGE

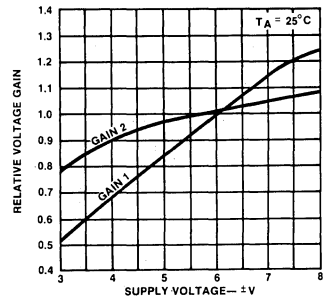

6

TYPICAL PERFORMANCE CHARACTERISTICS (Cont'd)

GAIN vs FREQUENCY AS A FUNCTION OF SUPPLY VOLTAGE

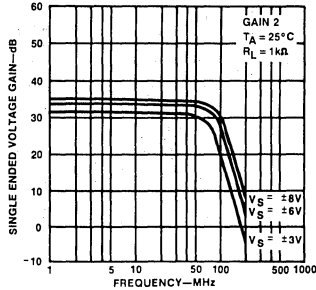

VOLTAGE GAIN ADJUST CIRCUIT

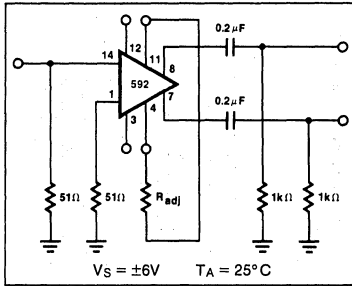

VOLTAGE GAIN AS A FUNCTION OF RADJ (FIGURE 3)

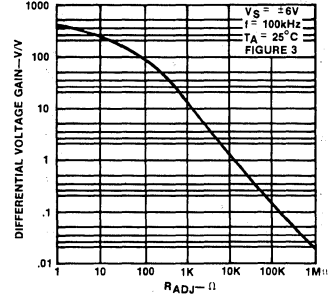

SUPPLY CURRENT AS A FUNCTION OF TEMPERATURE

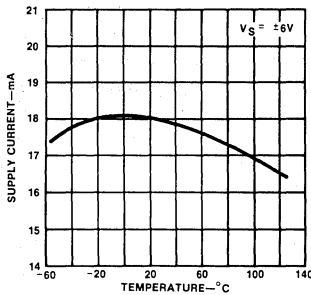

SUPPLY CURRENT AS A FUNCTION OF SUPPLY VOLTAGE

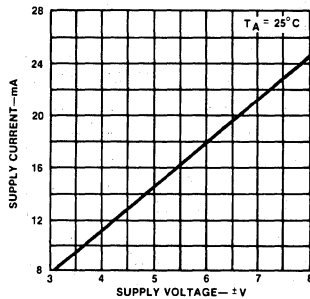

OUTPUT VOLTAGE AND CURRENT SWING AS A FUNCTION OF SUPPLY VOLTAGE

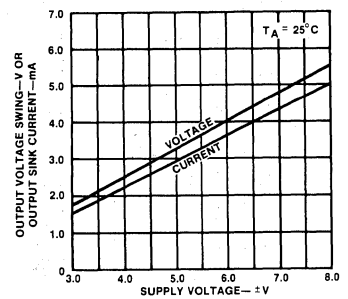

OUTPUT VOLTAGE SWING AS A FUNCTION OF LOAD RESISTANCE

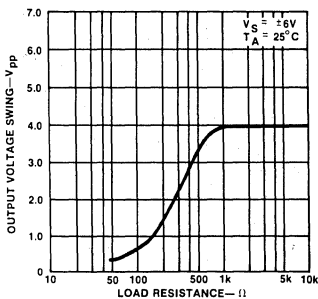

INPUT RESISTANCE AS A FUNCTION OF TEMPERATURE

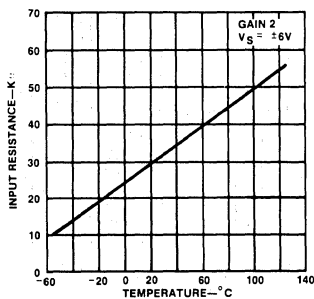

INPUT NOISE VOLTAGE AS A FUNCTION OF SOURCE RESISTANCE

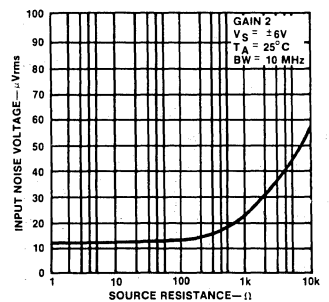

VIDEO AMPLIFIER

SE/NE592

TYPICAL PERFORMANCE CHARACTERISTICS (Cont'd)

PHASE SHIFT AS A FUNCTION OF FREQUENCY

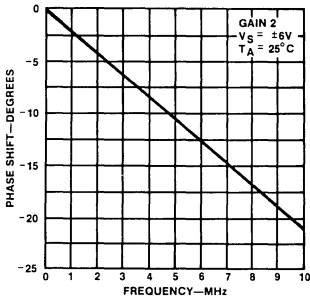

PHASE SHIFT AS A FUNCTION OF FREQUENCY

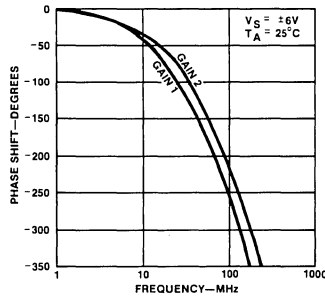

VOLTAGE GAIN AS A FUNCTION OF FREQUENCY

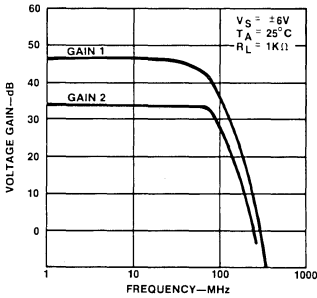

VOLTAGE GAIN AS A FUNCTION OF FREQUENCY (ALL GAIN SELECT PINS OPEN)

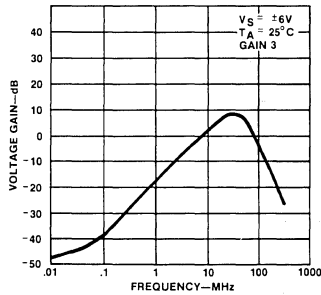

TEST CIRCUITS $T_A = 25^\circ C$ unless otherwise specified

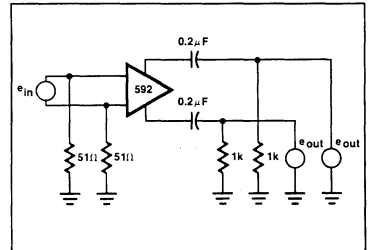
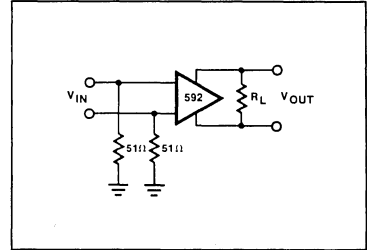

6

TYPICAL APPLICATIONS

FILTER NETWORKS

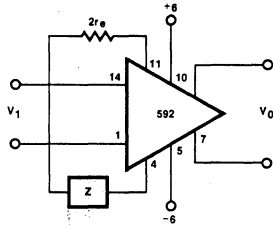

$$\frac{V_0(s)}{V_1(s)} \approx \frac{1.4 \times 10^4}{Z(s) + 2r_e}$$

$$\approx \frac{1.4 \times 10^4}{Z(s) + 32}$$

BASIC CONFIGURATION

Z NETWORK	FILTER TYPE	$\frac{V_0(s)}{V_1(s)}$ TRANSFER FUNCTION
	LOW PASS	$\frac{1.4 \times 10^4}{L} \left[\frac{1}{s + R/L} \right]$
	HIGH PASS	$\frac{1.4 \times 10^4}{R} \left[\frac{s}{s + 1/RC} \right]$
	BAND PASS	$\frac{1.4 \times 10^4}{L} \left[\frac{s}{s^2 + R/L s + 1/LC} \right]$
	BAND REJECT	$\frac{1.4 \times 10^4}{R} \left[\frac{s^2 + 1/LC}{s^2 + 1/LC + s/RC} \right]$

NOTE
In the networks above, the R value used is assumed to include $2r_e$, or approximately 32Ω .

DISC/TAPE PHASE MODULATED READBACK SYSTEMS

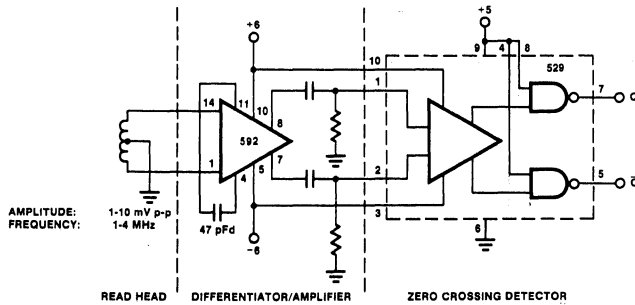

AMPLITUDE:
FREQUENCY:

1-10 mV p-p
1-4 MHz

READ HEAD DIFFERENTIATOR/AMPLIFIER ZERO CROSSING DETECTOR

DIFFERENTIATION WITH HIGH COMMON MODE NOISE REJECTION

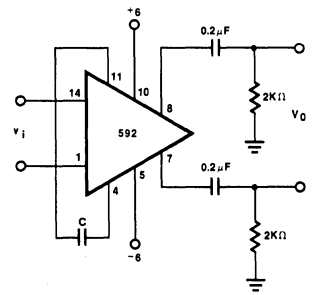

FOR FREQUENCY $F_1 \ll 1/2 \pi (32) C$
 $V_0 \approx 1.4 \times 10^4 C \frac{dV_i}{dt}$

DIFFERENTIAL VIDEO AMPLIFIER

μ A733/733C

DESCRIPTION

The 733 is a monolithic differential input, differential output, wideband video amplifier. It offers fixed gains of 10,100 or 400 without external components, and adjustable gains from 10 to 400 by the use of an external resistor. No external frequency compensation components are required for any gain option. Gain stability, wide bandwidth and low phase distortion are obtained through use of the classic series-shunt feedback from the emitter follower outputs to the inputs of the second stage. The emitter follower outputs provide low output impedance, and enable the device to drive capacitive loads. The 733 is intended for use as a high performance video and pulse amplifier in communications, magnetic memories, display and video recorder systems.

FEATURES

- 120MHz bandwidth
- 250k Ω input resistance
- Selectable gains of 10,100 and 400
- No frequency compensation required
- Mil std 883A,B,C available

APPLICATIONS

- Video amplifier
- Pulse amplifier in communications
- Magnetic memories
- Video recorder systems

PIN CONFIGURATION

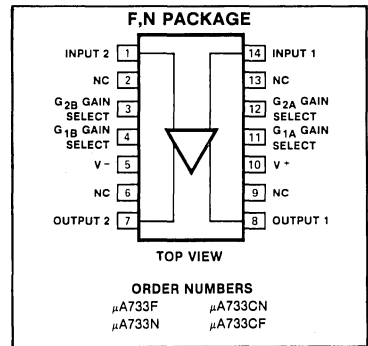

ABSOLUTE MAXIMUM RATINGS

PARAMETER	RATING	UNIT
Differential input Voltage	± 5	V
Common mode input Voltage	± 6	V
Vcc	± 8	V
Output current	10	mA
Junction temperature	+150	$^{\circ}$ C
Storage temperature range	-65 to +150	$^{\circ}$ C
Operation temperature range		
μA733C	0 to +75	$^{\circ}$ C
μA733	-55 to +125	$^{\circ}$ C
P _D Power dissipation		
K package	500	mW
N, F package	670	mW

CIRCUIT SCHEMATIC

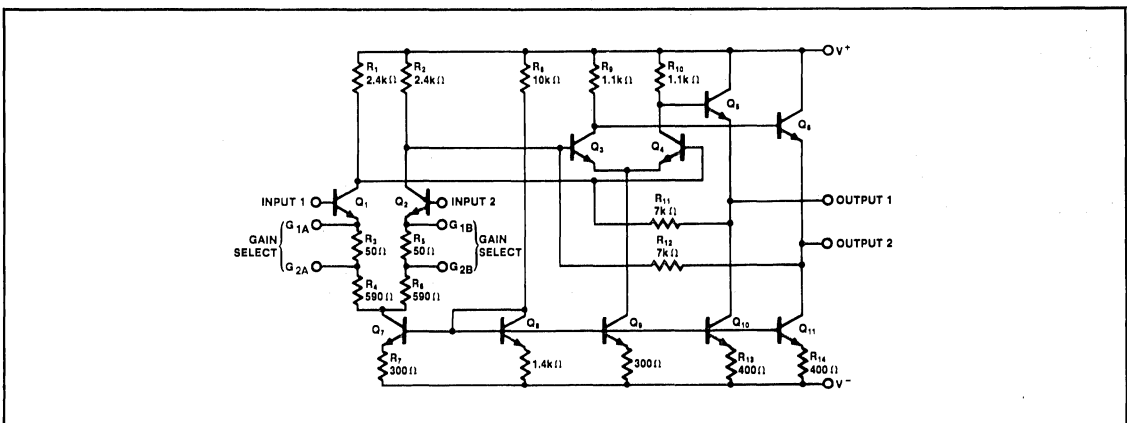

DIFFERENTIAL VIDEO AMPLIFIER

μ A733/733C

DC ELECTRICAL CHARACTERISTICS $T_A = +25^\circ\text{C}$, $V_S = \pm 6\text{V}$, $V_{CM} = 0$ unless otherwise specified.
Recommended operating supply voltages $V_S = \pm 6.0\text{V}$

PARAMETER	TEST CONDITIONS	μ A733C			μ A733			UNITS
		Min	Typ	Max	Min	Typ	Max	
Differential voltage gain	$R_I = 2\text{k}\Omega$, $V_{OUT} = 3V_{p-p}$	250	400	600	300	400	500	V/V
Gain 1 ²		80	100	120	90	100	110	V/V
Gain 2 ²		8	10	12	9	10	11	V/V
Gain 3 ³								
Bandwidth	$V_{OUT} = 1V_{p-p}$		40			40		MHz
Gain 1 ¹			90			90		MHz
Gain 2 ²			120			120		MHz
Gain 3 ³								
Rise time				10.5			10.5	ns
Gain 1 ¹				4.5	12		4.5	ns
Gain 2 ²			2.5			2.5	ns	
Gain 3 ³								
Propagation delay	$V_{OUT} = 1V_{p-p}$							
Gain 1 ¹			7.5			7.5		ns
Gain 2 ²			6.0	10		6.0	10	ns
Gain 3 ³			3.6			3.6		ns
Input resistance	Gain 2 BW = 1kHz to 10MHz	10	4.0		20	4.0		k Ω
Gain 1 ²			30			30		k Ω
Gain 2 ²			250			250		k Ω
Gain 3 ³		2.0		2.0		pF		
Input capacitance ²		0.4	5.0	0.4	3.0	μ A		
Input offset current		9.0	30	9.0	20	μ A		
Input bias current		12		12		μ Vrms		
Input noise voltage		± 1.0		± 1.0		V		
Input voltage range								
Common mode		$V_{CM} = \pm 1\text{V}$, $f \leq 100\text{kHz}$ $V_{CM} = \pm 1\text{V}$, $F = 5\text{MHz}$	60	86		60	86	
Rejection ratio	60				60			dB
Gain 2								
Supply voltage	$\Delta V_S = \pm 0.5\text{V}$	50	70		50	70		dB
Rejection ratio								
Gain 2								
Output offset voltage	$R_L = \infty$		0.6	1.5		0.6	1.5	V
Gain 1 ¹			0.35	1.5		0.35	1.0	V
Gain 2 and 3 ^{2,3}	$R_L = \infty$		2.4	2.9	2.4	2.9	3.4	V
Output common mode voltage			3.0	4.0		3.0	4.0	$V_p K_p K$
Output voltage swing, differential	$R_L = 2\text{k}$		2.5	3.6	2.5	3.6		mA
Output sink current			20			20		Ω
Output resistance	$R_L \pm \infty$		18	24	18	24		mA
Power supply current								
THE FOLLOWING SPECS APPLY OVER TEMPERATURE		$0^\circ\text{C} \leq T_A \leq 70^\circ\text{C}$			$-55^\circ\text{C} \leq T_A \leq 125^\circ\text{C}$			
Differential voltage gain	$R_I = 2\text{k}\Omega$, $V_{OUT} = 3V_{p-p}$	250		600	200		600	V/V
Gain 1 ¹		80		120	80		120	V/V
Gain 2 ²		8		12	8		12	V/V
Gain 3 ³								

DIFFERENTIAL VIDEO AMPLIFIER

μ A733/733C

DC ELECTRICAL CHARACTERISTICS (Continued)

PARAMETER	TEST CONDITIONS	μ A733C			μ A733			UNITS
		Min	Typ	Max	Min	Typ	Max	
Input resistance Gain 2 ²		8			8			k Ω
Input offset current				6			5	μ A
Input bias current				40			40	μ A
Input voltage range		± 1.0			± 1.0			V
Common mode Rejection ratio Gain 2	$V_{CM} = \pm V, F \leq 100\text{kHz}$	50			50			dB
Supply voltage Rejection ratio Gain 2	$\Delta V_S = \pm 0.5V$	50			50			dB
Output offset voltage Gain 1 ¹	$R_L = \infty$			1.5			1.5	V
Gain 2 and 3 ^{2,3}				1.5			1.2	V
Output voltage swing, differential	$R_L = 2k$	2.8			2.5			Vpk-pk
Output sink current		2.5			2.2			mA
Power supply current	$R_L \pm \infty$			27			27	mA

NOTES

- Gain select pins G_{1A} and G_{1B} connected together
- Gain select pins G_{2A} and G_{2B} connected together.
- All gain select pins open.

TYPICAL PERFORMANCE CHARACTERISTICS

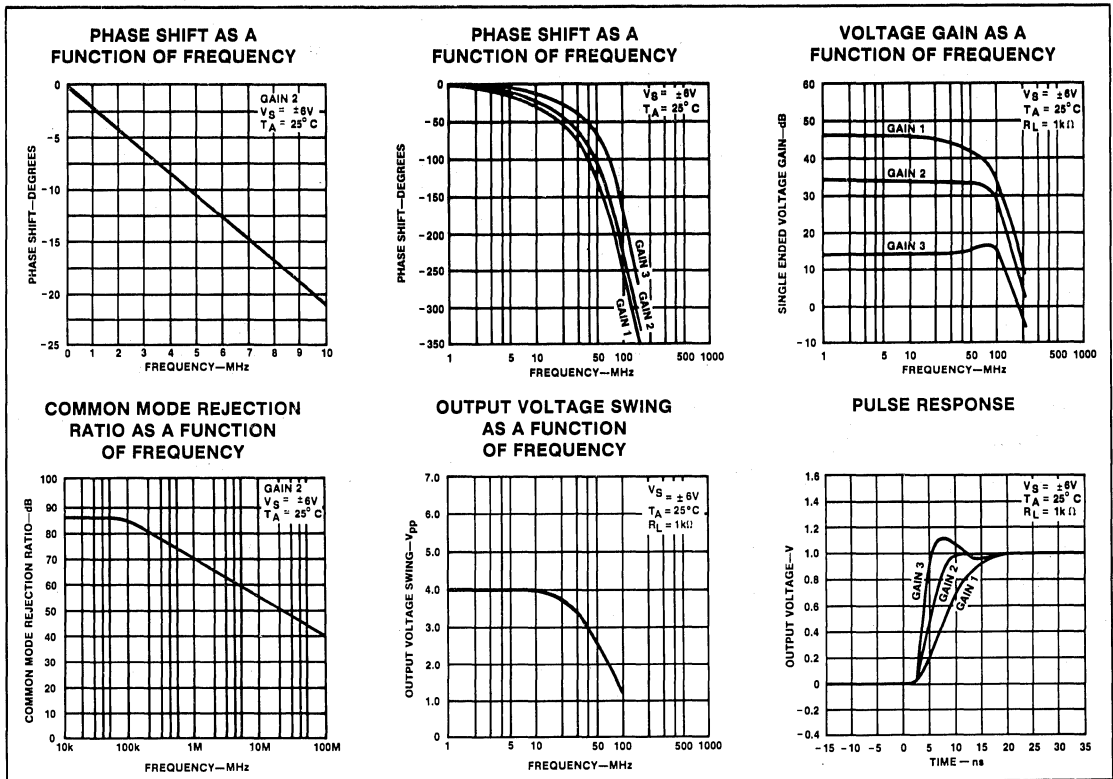

6

DIFFERENTIAL VIDEO AMPLIFIER

μ A733/733C

TYPICAL PERFORMANCE CHARACTERISTICS (Cont'd)

DIFFERENTIAL OVERDRIVE RECOVERY TIME

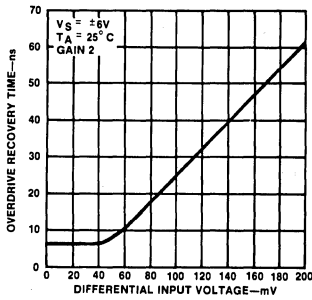

PULSE RESPONSE AS A FUNCTION OF SUPPLY VOLTAGE

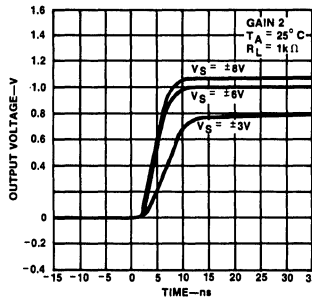

PULSE RESPONSE AS A FUNCTION OF TEMPERATURE

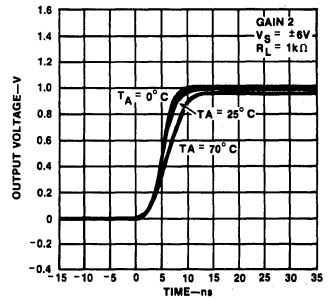

VOLTAGE GAIN AS A FUNCTION OF TEMPERATURE

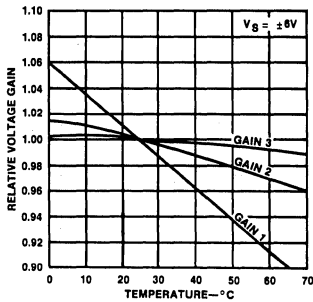

GAIN vs FREQUENCY AS A FUNCTION OF TEMPERATURE

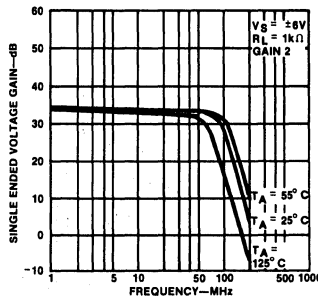

VOLTAGE GAIN AS A FUNCTION OF SUPPLY VOLTAGE

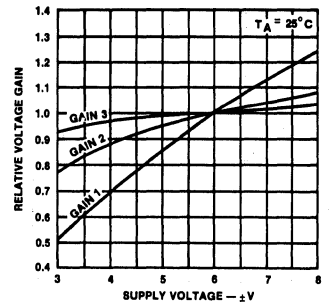

GAIN vs FREQUENCY AS A FUNCTION OF SUPPLY VOLTAGE

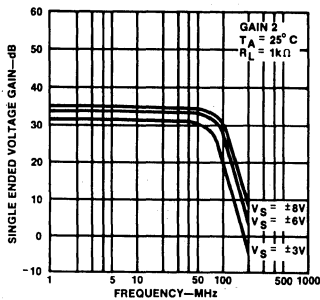

VOLTAGE GAIN ADJUST CIRCUIT

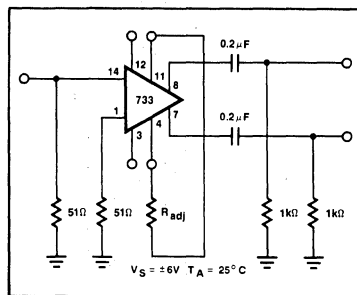

(Pin numbers apply to K Package)

VOLTAGE GAIN AS A FUNCTION OF R_{adj} (FIGURE 3)

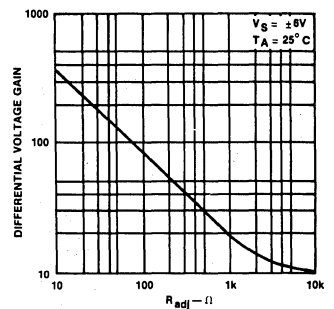

TYPICAL PERFORMANCE CHARACTERISTICS (Cont'd)

SUPPLY CURRENT AS A FUNCTION OF TEMPERATURE

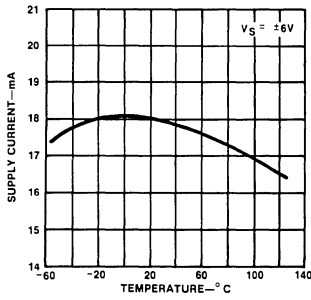

SUPPLY CURRENT AS A FUNCTION OF SUPPLY VOLTAGE

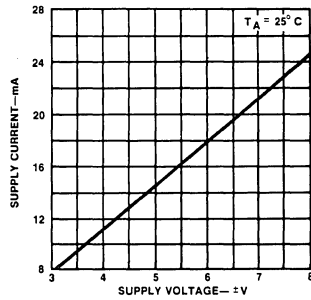

OUTPUT VOLTAGE SWING AND CURRENT SWING AS A FUNCTION OF SUPPLY VOLTAGE

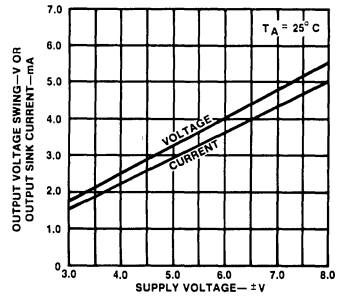

OUTPUT VOLTAGE SWING AS A FUNCTION OF LOAD RESISTANCE

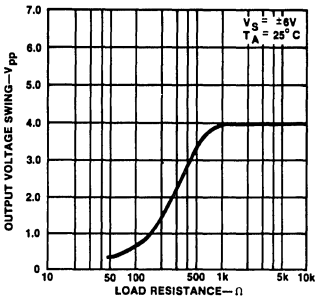

INPUT RESISTANCE AS A FUNCTION OF TEMPERATURE

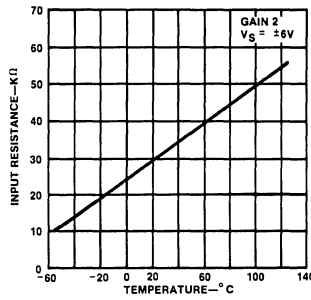

INPUT NOISE VOLTAGE AS A FUNCTION OF SOURCE RESISTANCE

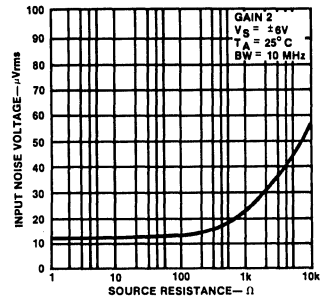

6

TEST CIRCUITS $T_A = 25^\circ\text{C}$ unless otherwise specified.

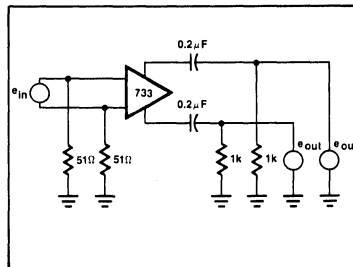
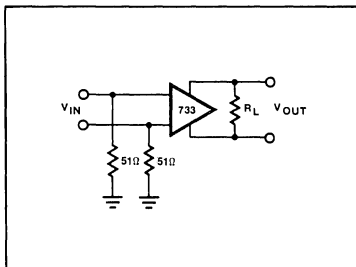

NOTES

Section 7 Power Conversion and Control

INDEX

SECTION 7 — POWER CONVERSION AND CONTROL

Index	7-1
Motor Control and Sensor Circuits	
NE5044	Programmable 7-Channel RC Encoder
NE5045	Seven Channel RC Decoder
NE544	Servo Amplifier
*SAA1027	Stepper Motor Driver
Switched-Mode Power Supply Circuits	
Symbols and Definitions	7-24
SE/NE5560	SMPS Single-Ended Monolithic Controller
SE/NE5561	SMPS Low Cost Controller
*SE/NE5562	SMPS Control Circuit, Single Output
*NE5568	SMPS Controller
*SG1526A/2526A/3526A	SMPS Control Circuits
SG3524	SMPS Push-Pull Controller
μ A723/C/SA723C	Precision Voltage Regulator
Triac Control Circuits	
*TDA1023	Proportional Control Triac Triggering Circuit
*TDA1024	On-Off Triac Triggering Circuit

*New product for Linear LSI since 1983 data manual.



DESCRIPTION

The NE5044 is a programmable parallel input, serial output pulsewidth encoder. A multiplexed dual linear ramp technique is used to allow up to 7 inputs to be converted to a serial pulsewidth modulated signal with excellent linearity and minimal crosstalk. Fixed or variable frame rates can be used, externally controlled, for ease of demodulation. An onboard 6V regulator eliminates power supply sensitivities and provides up to 20mA current capability for driving external loads.

FEATURES

- 3 to 7 channels, externally selectable
- Constant current dual linear ramp for linearity better than .3%
- Internal voltage regulator for low drift
- Wide supply range 4.5 - 16V
- Fixed or variable frame rate set by external R-C
- External control for channel gain or range
- Versatile applications; exponential rates, mixing, dual rate, reversing etc.
- Compatible with all transmission mediums

APPLICATIONS

- Radio controlled aircraft, cars, boats, trains
- Industrial controllers
- Remote controlled entertainment systems
- Security systems
- Instrumentation recorders/controls
- Remote Analog/digital data transmission
- Automotive sensor systems
- Robotics
- Telemetry

PIN CONFIGURATION

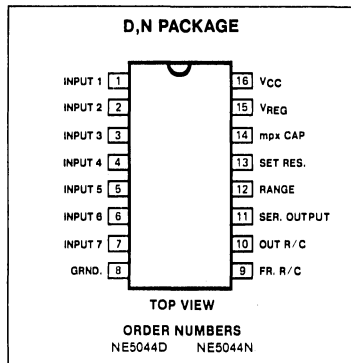

ABSOLUTE MAXIMUM RATINGS¹

PARAMETER	RATING	UNIT
VCC, Supply voltage	17	V
Regulator output current	-25	mA
Serial output peak current	30	mA
Constant current generator	-1	mA
Parallel inputs, range input	0-VREG	V
One shot input, frame generator input	0-VREG	V
Operating temperature	-20 to +75	°C
Storage temperature	-65 to +150	°C

NOTE
1. T_A = 25° unless otherwise stated.

BLOCK DIAGRAM

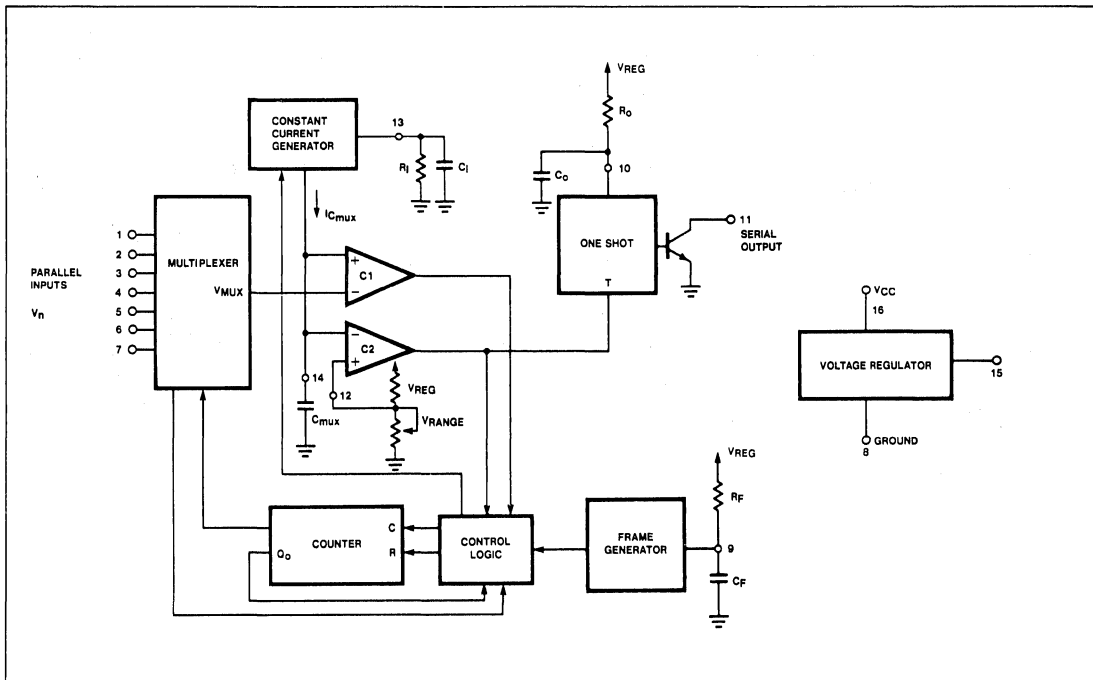

7

DC ELECTRICAL CHARACTERISTICS Test conditions $T_A = 25^\circ\text{C}$, $V_{CC} = 10\text{V}$ using Test Circuit A unless otherwise stated.

PARAMETER	TEST CONDITIONS	NE 5044			UNIT	
		Min	Typ	Max		
POWER SUPPLY REQUIREMENTS (Note 1) Power supply voltage range Power supply current	Excluding control pots and serial output currents	4.5		16	V	
			11	15	mA	
V_{REG} VOLTAGE REGULATOR Output voltage Output current Line regulation	$V_R \geq 4.5\text{V}$ $7 \leq V_{CC} \leq 16$	4.5	5.0	5.5	V	
				-20	mA	
			.005	0.2	V/V	
MULTIPLEXER Input current Input voltage range Crosstalk	$V_n = 2.5\text{v}$ $V_n - V_{Range} \geq .75\text{V}$	1.5	± 30	± 200	nA	
				5	V	
			± 1	± 5	μs	
T_n OUTPUT PULSE Position Position linearity error Position tempco Position PSR	$R_I \cdot C_{mux} = 1.25\text{ms}$ $V_n = .5V_{REG}$; $V_{RANGE} = .2V_{REG}$ $0^\circ\text{C} \leq T_A \leq 70^\circ\text{C}$ $6\text{V} \leq V_{CC} \leq 16\text{V}$	1350	1500	1650	μs	
			5		μs	
			.15		$\mu\text{s} / ^\circ\text{C}$	
			.5	1	$\mu\text{s} / \text{V}$	
T_0 I_{11} Width Saturation voltage Leakage current Range input voltage Frame time (Fixed) Inhibit threshold	$R_0C_0 = 300\mu\text{s}$ $I_0 = 25\text{mA}$ $R_I = 50\text{k}\Omega$ $R_I = 25\text{k}\Omega$ $R_F C_F = 30\text{ms}$	240	285	330	μs	
				.6	1	V
				.05	50	μA
			.75			V
			1.00			V
			17	20	23	ms
			.4	V		

NOTE

1. At supply voltages exceeding 12V, a current limiting resistor of 20 to 50 Ω in series with V_{CC} is recommended.

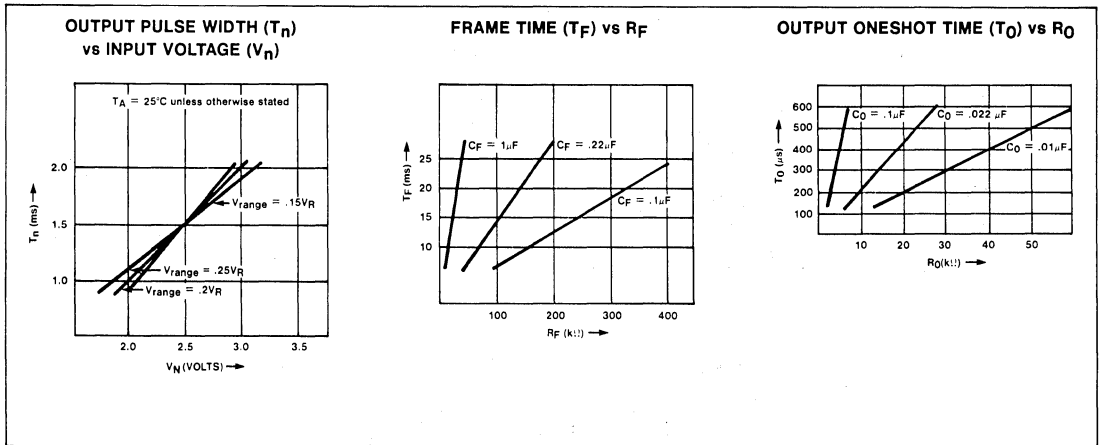

PROGRAMMABLE SEVEN CHANNEL RC ENCODER

NE5044

OUTPUT SATURATION VOLTAGE vs OUTPUT CURRENT

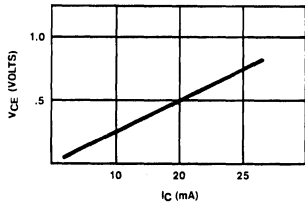

CONSTANT CURRENT vs R_I

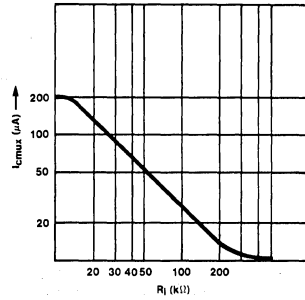

TEST CIRCUIT

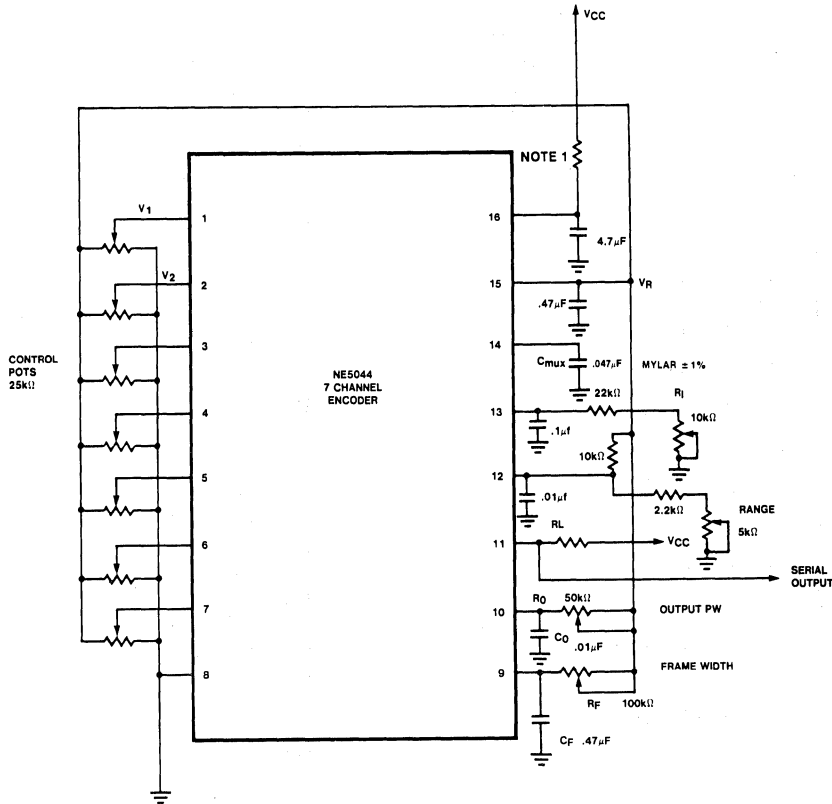

NOTE
 1. At supply voltages exceeding 12V, a current limiting resistor of 20 to 50Ω in series with V_{CC} is recommended

7

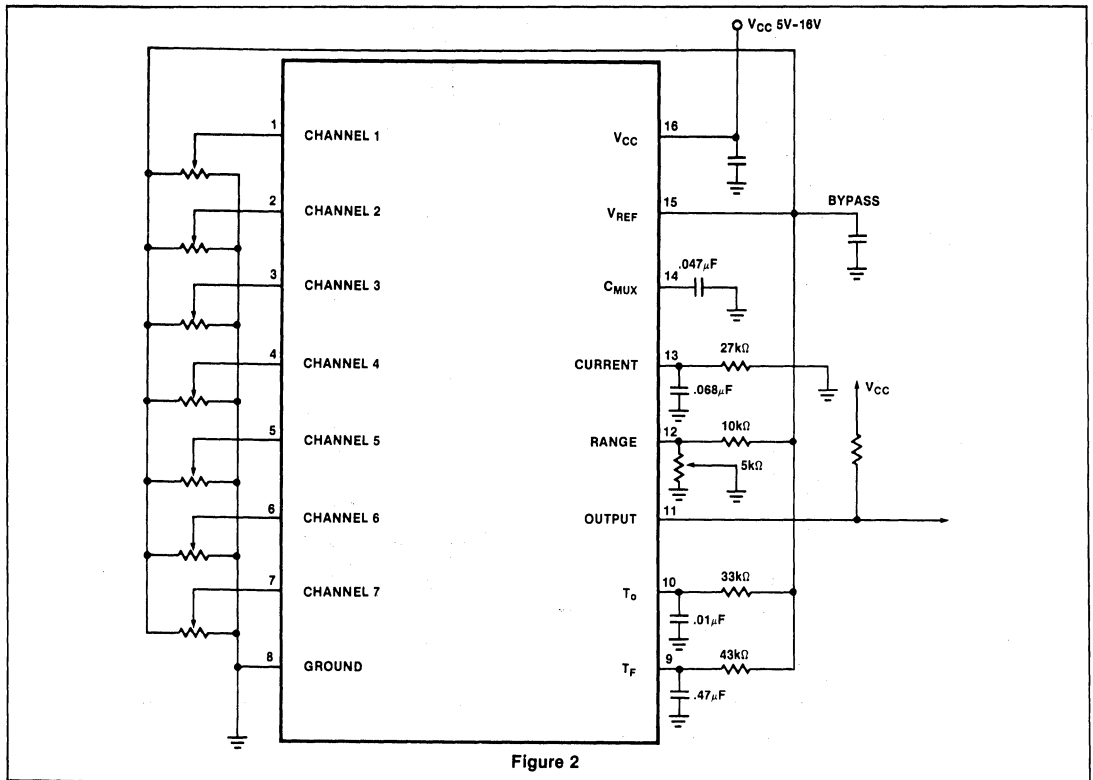
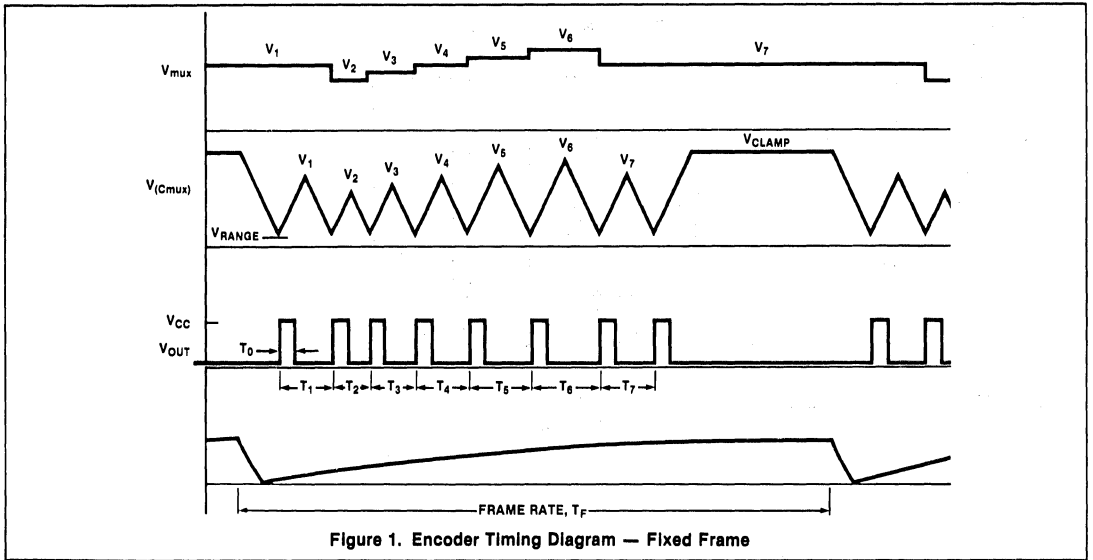

A. CIRCUIT OPERATION

The NE5044 is a programmable parallel input, serial output encoder containing all the active circuitry necessary to generate a precise pulsewidth modulated signal with 3 to 7 channels. The number of channels is externally programmable by grounding unused control inputs. A multiplexed dual linear ramp technique is used to provide excellent linearity, minimal crosstalk and low temperature drift. An onboard 5-volt regulator eliminates power supply sensitivities and has up to 20mA current capability for driving external loads. The encoder can be used in the fixed frame mode or, with the addition of one external NPN transistor, as a variable frame encoder.

The multiplexer functions as a strobed voltage follower so that each input, when active, appears as a high impedance input (> 1MΩ) and transfers the input voltage to the output. Only one of the seven inputs is active at any time and when a given input is inactive, it appears as an open circuit. The high impedance multiplexer inputs eliminate loading on control inputs and simplify mixing circuits where several controls may be mixed onto one input.

Channel 4, 5, 6 and 7 inputs may also be used to select the desired number of output pulses by grounding one or more of these pins. That is, by grounding pin 4 (channel 4 input) only the first three inputs of the encoder will be used and a 3-channel encoder results. Grounding pin 5 results in a 4-channel encoder and so on. Thus, any number of channels between 3 and 7 may be selected. Internal voltage clamping prevents encoder malfunction if any input is shorted to supply, ground or open circuited. The remaining channels will continue to be encoded except as noted above. This feature eliminates catastrophic failures due to control pot opens or shorts.

The constant current generator is a bidirectional current source whose current is set by an external resistor R_I, where:

$$I_c = \pm \frac{V_R}{2R_I}$$

The current generator alternately charges and discharges the capacitor C_{mux}. An internal feedback loop maintains a constant current and very high output impedance. This yields a typical linearity error of voltage input to pulsewidth output for the encoder of less than 0.1%. An external capacitor, C_I, is required to insure stability of the feedback loop.

Two high gain comparators, C1 and C2, compare the voltage across C_{mux} with the multiplexer output voltage and the range input voltage. The input bias currents and offset voltages of these comparators are sufficiently low so as to not influence the overall accuracy of the encoder. The comparators feed the counter control logic which in turn controls the counter and current generator. The operation of this loop is as follows: When I_c is positive (sourced from the current generator into C_{mux}) the capacitor linearly charges up until it reaches a voltage equal to the multiplexer output voltage, assume this to be the voltage at pin 1, V1. At this time the output of C1 goes high which reverses the direction of I_c (sinking into current generator from C_{mux}). C_{mux} now linearly discharges until it reaches the voltage set on pin 12, V_{range}. At this time the output of C2 goes high which again reverses the polarity of I_c, clocks the counter and triggers the output one shot. C_{mux} again charges up but now C1 goes high when C_{mux} reaches V2, the voltage on pin 2. The resulting voltage waveform on C_{mux} is a triangle wave whose positive peaks correspond to the voltages on pins 1 through 7 for the first through seventh peak and whose negative peaks are constant and equal to V_{range}. This waveform is shown in the first portion of Figure 1.

Independent control of I_c and V_{range} allows the encoder to be tailored to virtually any combination of input voltage changes and output pulsewidth changes. The functional relationships between these variables will be defined in the next section.

The frame generator controls the encoder frame time. It can operate as an astable or monostable multivibrator whose period is .66X R_FC_F. The encoder will generate a synchronizing pulse at the end of each frame. When C_{mux} reaches the seventh positive peak it reverses and discharges to the state where Q₀ is high when V_{Cmux} = V_{range}. C_{mux} again charges up but now the output of C1 is ignored, due to Q₀ being high, and charges up to V_{clamp} and remains there. The encoder will remain in this state until a pulse from the frame generator is received. If R_F and C_F are connected as shown in the Block Diagram, then the frame generator operates in the astable mode producing a narrow pulse output. This pulse allows C_{mux} to start discharging again. When C_{mux} reaches V_{range}, the counter is

clocked to the state where Q₁ is high (channel 1) and the entire process starts over. The frame period in this mode is .66 × R_FC_F and is referred to as the fixed frame mode. The variable frame mode will be discussed in the application section.

The output one-shot generates a positive pulse whose width is equal to R₀C₀. The output is an open collector, NPN transistor capable of sinking 25mA. This configuration allows the encoder to drive a wide variety of RF stages as well as providing current pulses in 2 wire communications applications.

B. ENCODER DESIGN EQUATIONS

The triangular waveform on C_{mux} has a fixed slope (constant current) and variable positive peak voltages. The time between the negative peaks of C_{mux}, which is equal to the output period for that channel, is given by:

$$T_n = \frac{2(V_n - V_{range})C_{mux}}{I_c}$$

I_c is given by:

$$I_c = \frac{V_R}{2R_I}$$

where V_R = Reference Voltage.

Additionally, V_n, the voltage on pin n, which is the control voltage for channel n, is typically the wiper voltage on a pot connected between V_R and ground. Thus V_n = X_nV_R.

V_{range} is also derived from V_R so that V_{range} = Y V_R. The resulting channel time period is:

$$T_n = \frac{2(X_n - Y)V_R \cdot C_{mux}}{(V_R/2R_I)}$$

$$T_n = 4R_I C_{mux}(X_n - Y)$$

Thus, each channel pulse width, T_n, is independent of supply voltage and depends only on external passive components.

The conversion rate, CR, for each channel is the change in output period, ΔT_n, divided by the change in input voltage for that channel, ΔV_n.

$$CR = \frac{\Delta T_n}{\Delta V_n} = \frac{\Delta T_n}{\Delta X_n} = 4 R_I C_{mux}$$



PROGRAMMABLE SEVEN CHANNEL RC ENCODER

NE5044

In most applications, the input variable X_n will have some neutral or center value about which it will vary, thus

$$X_n = X_o + x_n$$

and

$$CR = \frac{\Delta T_n}{\Delta x_n} = 4R_1 C_{mux}$$

where X_o is the neutral value for X and is assumed to be the same for all n . Now

$$T_n = 4R_1 C_{mux} (X_o - Y + x_n)$$

If we let $T_{Neutral} = 4R_1 C_{mux} (X_o - Y)$ be the neutral value for T_n , then

$$T_n = T_{Neutral} + 4R_1 C_{mux} (x_n)$$

Consider the following example to see how these design equations are used.

Assume:

$$T_{Neutral} = 1.5ms$$

$X_o = 0.5$ — Control pot in center at

$$T_n = T_{Neutral}$$

$\Delta x_n = \pm 0.1$ — Control pot resistance varies $\pm 10\%$ (of total resistance) around neutral. This should include mechanical trim if used.

$$\Delta T_n = \pm 0.5ms$$

For this example, the conversion rate is

$$CR = \frac{\Delta T_n}{\Delta x_n} = \frac{.5ms}{.1} = 5ms$$

so

$$4R_1 C_{mux} = 5ms.$$

If we let $C_{mux} = .047\mu F$

$$R_1 = \frac{5ms}{4 \times .047\mu F} = 26.5k\Omega = 27k\Omega$$

and

$$T_{Neutral} = 1.5ms = 4R_1 C_{mux} (X_o - Y)$$

$$Y = 0.5 - \frac{1.5ms}{5ms} = 0.2$$

The output pulse width is given by

$$T_o = R_o C_o$$

so if $T_o = 330\mu s$ and $C_o = .01\mu F$

$$R_o = \frac{330\mu s}{.01\mu F} = 33k\Omega.$$

The frame time constant, T_F , is given by

$$T_F = .66 R_F C_F$$

If $T_F = 20ms$ and $C_F = .47\mu F$

$$R_F = \frac{20ms}{.66 \times .47\mu F} = 62k$$

Figure 2 shows the external connections for this example.

It should be noted that the temperature stability of all the encoded times depend on the temperature coefficients of the respective external R_C time constants. No internal temperature compensation is used on the chip. The typical temperature sensitivity of T_n using wirewound resistors and polycarbonate capacitors is less than 100ppm/ $^{\circ}C$ in the $-20^{\circ}C$ to $+70^{\circ}C$ temperature range. For the above example, this corresponds to a change in T_n of $\pm 7.5\mu s$ for a change in temperature of $\pm 50^{\circ}C$.

***For additional information, consult the Applications Section.**

SEVEN CHANNEL RC DECODER

NE5045

DESCRIPTION

The NE5045 is a serial input, parallel output, decoder intended for applications in pulse width or pulse position modulation systems. The serial input pulse, either positive or negative, is shaped and amplified before being fed to the counter/decoder. An integrating type sync. separator detects pulses greater than $T_w = R_5 C_5$. The amplified input pulse triggers an internal one-shot (minimum pulse) which in turn clocks the counter-decoder, thereby enhancing system noise rejection. A missing pulse detector resets the decoder during the sync. pause. An internal voltage regulator supplies power for the radio receiver providing excellent isolation from the power supply as well as the decoder logic.

FEATURES

- Decodes up to 7 channels
- High gain input amplifier
- Externally set sync. pause and minimum pulse
- Wide supply voltage range, 3.6V-8V.
- Positive or negative pulse inputs
- Noise and flutter rejection
- Outputs reset to zero without inputs
- Compatible with all transmission mediums

APPLICATIONS

- Radio controlled aircraft, cars, boats, trains
- Industrial controllers
- Remote controlled entertainment systems
- Security systems
- Instrumentation recorders/controllers
- Remote Analog/digital data transmission
- Automotive sensor systems
- Robotics
- Telemetry

PIN CONFIGURATION

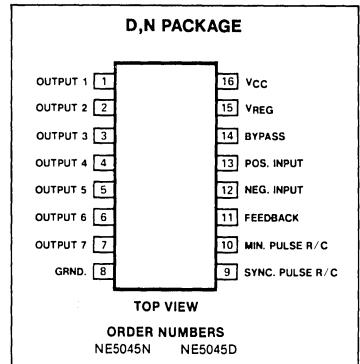

ABSOLUTE MAXIMUM RATINGS¹

PARAMETER	RATING	UNIT
V _{CC} , Supply voltage	10	V
Regulator output current	-25	mA
Decoded output current	±5	mA
Pause input voltage	0 to V _R	V
Input amplifier voltage	0 to V _R	V
Operating temperature	-20 to +75	°C
Storage temperature	-65 to +150	°C

NOTE
1. T_A = 25°C unless otherwise stated

BLOCK DIAGRAM

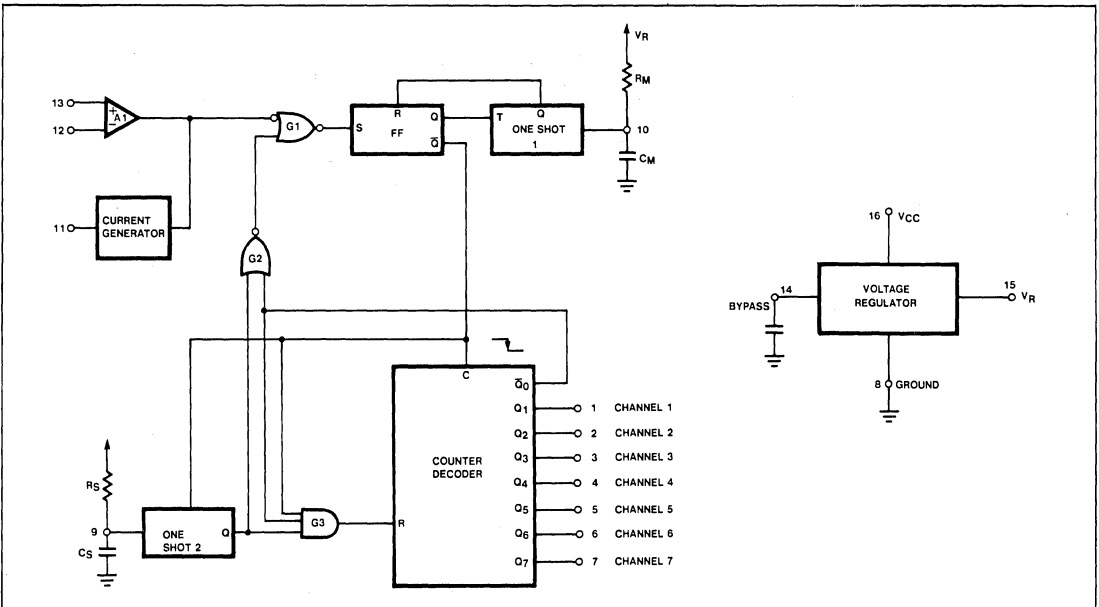

SEVEN CHANNEL RC DECODER

NE5045

DC ELECTRICAL CHARACTERISTICS Standard conditions: ($T_A = 25^\circ\text{C}$, $V_{CC} = 5.0\text{V}$ unless otherwise stated), using Test Circuit # 1

PARAMETER	TEST CONDITIONS	NE5045			UNIT
		Min	Typ	Max	
POWER SUPPLY REQUIREMENTS Power supply voltage range Power supply current	Test circuit # 1 Excluding input bias current	3.6	9.0	8.0 14.0	V mA
V_R VOLTAGE REGULATOR Output voltage Output current Line regulation Voltage drop	$V_R \geq 3.7\text{V}$ $V_{CC} = 6\text{V to } 8\text{V}$ $V_{CC} = 4\text{V}$, $I_R = -10\text{mA}$	3.7	4.1	4.5 -15 .05 1.3	V mA V/V V
T_S T_M INPUT AMPLIFIER Input bias current Input voltage range Open loop gain Feedback current Detection threshold Sync. pause time Minimum pulse time	Test circuit # 1, ΔV_{12} & 13 $R_S C_S = 6.0\text{ms}$ $R_m C_m = 500\mu\text{s}$	2.0	10 60 200 8 6.0	100 4.0 400 20 6.9	nA V dB μA mV ms μs
OUTPUTS-ALL CHANNELS V _{OL} V _{OH}	$I_{\text{SINK}} = 1\text{mA}$ $I_{\text{SOURCE}} = 2\text{mA}$	2.7	.25	.5	V V

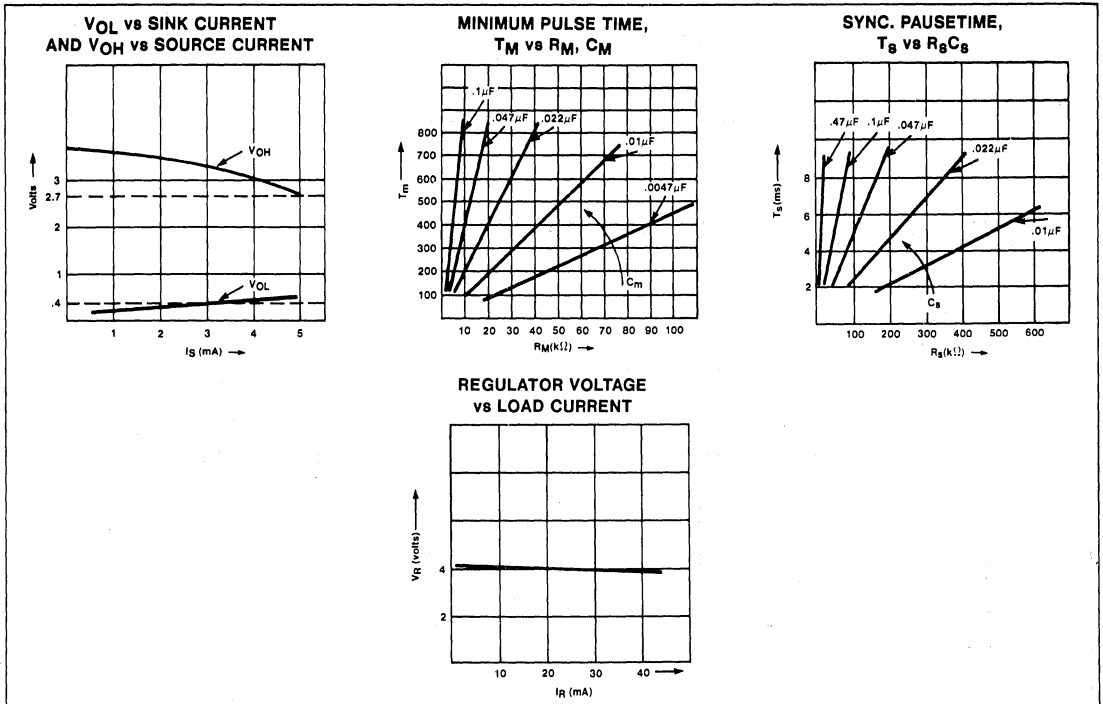

SEVEN CHANNEL RC DECODER

NE5045

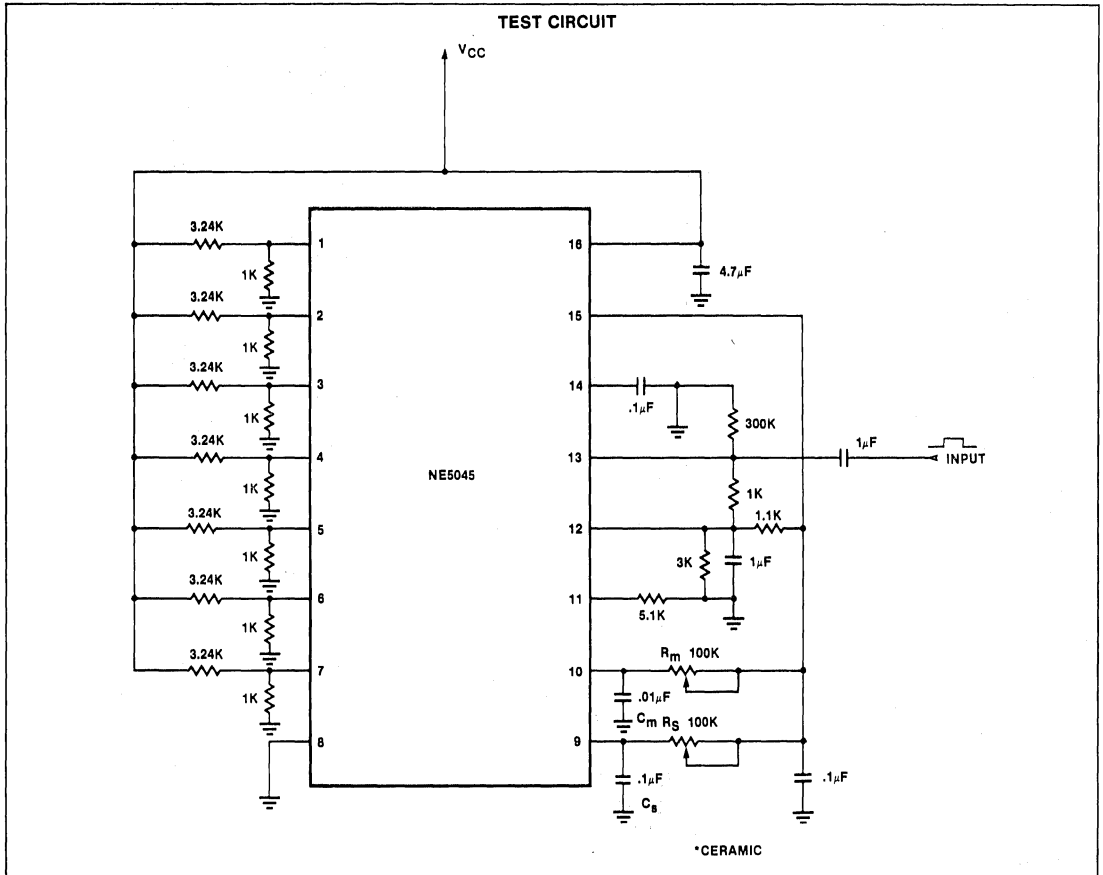

7

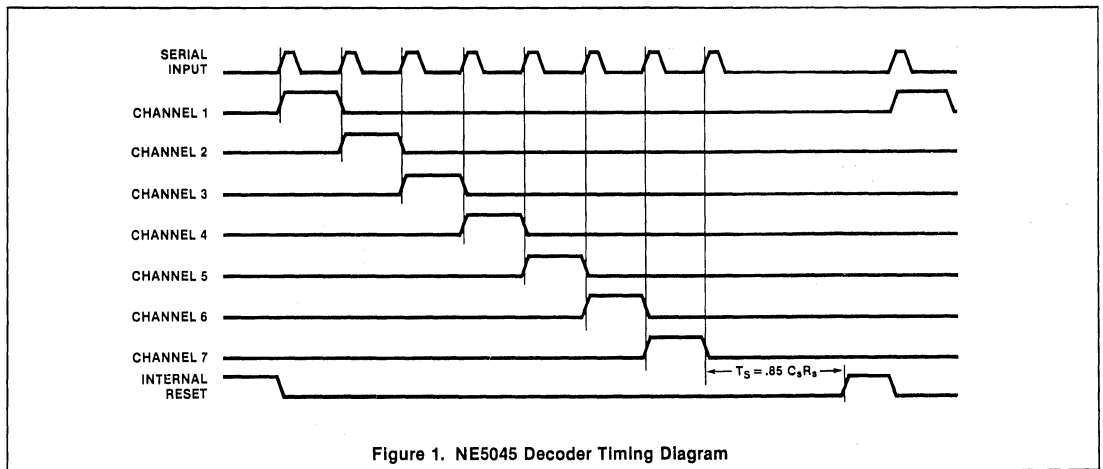

A. CIRCUIT OPERATION

The NE5045 is a serial input, parallel output decoder containing all the active circuitry necessary to separate up to 7 channels of information in a pulsewidth modulated system. An internal voltage regulator provides excellent power supply rejection for the decoder as well as a regulated output for a radio receiver if used.

The high gain input amplifier, A1 ($A_v > 60\text{dB}$), allows either positive or negative pulses to be used and has input bias currents less than 10nA. Signals as low as 10mV p-p can easily be demodulated. The feedback current generator can be used to provide positive feedback thereby creating hysteresis in the input switching levels. Hysteresis prevents false triggering due to noise or IF amplifier distortion. If positive input pulses are used, the signal would be connected to the noninverting input, pin 13. In this case, the input threshold would be set by the voltage difference between pin 12 and pin 13, established externally with a resistive divider network. Design of the divider will be covered in section B and C. Negative input signals would be coupled to pin 12, the inverting input.

The amplified signal from A1 is gated by G1 and in turn sets the FF. Assume, for the time, that G2 is low. The combination of the FF and One Shot 1 produces a minimum pulse to clock the counter-decoder for each positive edge at pin 13 which exceeds the voltage on pin 12. The width of this pulse is: $T_m = R_m C_m$. With this arrangement, the system will not respond to any pulse after the first edge and before the end of T_m . In effect the input is turned off for a period equal to T_m following the leading edge of each input pulse. The noise immunity of the decoder is thus enhanced by the ratio of T_m to the period between input pulses. Obviously T_m must be less than the shortest period between input pulses.

The counter is clocked and One Shot 2 is reset (capacitor C_s is discharged) each time the FF is set. When the FF is reset, C_s begins to charge up through R_s . The time constant $T_s = .85 R_s C_s$ is normally much larger than the time between input pulses so that the output of One Shot 2 remains low until the last pulse of a given frame is received. Figure 1 shows the timing diagram for the decoder. After the last pulse in a frame (system synchronized) \bar{Q}_o will go low and G2 will go high. The input is now disabled by G1 until One Shot 2 times out at which time G2 will go low.

This connection serves two purposes:

- (1) establishes synchronization in no more than one frame and
- (2) prevents the counter-decoder from overflowing due to extra noise pulses in a given frame. Thus any noise pulses in a frame will only affect those channels after that pulse and only in that frame.

If fewer than 7 channels of input are used then \bar{Q}_o is high after the last pulse and the counter-decoder is reset when One Shot 2 goes high.

Each channel has a totem pole output stage capable of sourcing 2mA and sinking 1mA.

The voltage regulator operates in two modes depending on the power supply voltage. If V_{CC} is greater than 5V, the voltage regulator acts as a series pass regulator with a nominal output voltage of 4.1V. When V_{CC} is less than 5V, the regulator acts as a dynamic decoupler where the bypass capacitor on pin 14 filters out line transients. The internal pass transistor acts like an emitter follower whose base is decoupled by the bypass capacitor. The value of capacitance will depend upon the degree of smoothing required and the amplitude of the line transients. If the regulator provides power for the radio receiver, this capacitor may have to be as large as 33 μ F. However if this is not done, 1 μ F should be sufficient.

B. DECODER DESIGN EQUATIONS

The design of the decoder's external circuitry is quite simple. The minimum pulse One Shot (#1) and the synchronization One Shot (#2) each have time periods given by:

$$T_m = R_m C_m$$

$$T_s = .85 R_s C_s$$

respectively. The constraints on these time periods are: $T_m <$ the minimum input pulse width or time between leading edges of the input and $T_s >$ maximum input pulse width but $T_s <$ the sync pause (time between last pulse in frame and first pulse of the following frame).

The design of the input amplifier biasing network depends upon a number of factors, including:

- 1. Pulse Polarity
- 2. Pulse Amplitude
- 3. Variations in Amplitude and Noise
- 4. Detection Threshold and Hysteresis Levels

For a very simple case, assume the input is a positive pulse train and the threshold of detection is desired to be 400mV without hysteresis. Figure 2 shows the input amplifier along with the associated biasing circuits. The resistors R_1 and R_2 set the voltage on pin 12, which should be between 2V to 5V.

$$V_{12} = V_R \frac{1}{1 + R_1/R_2}$$

The threshold is set by the voltage drop across R_3 , that is, the decoder will not be triggered until the voltage on pin 13 exceeds the voltage on pin 12.

$$V_{\text{threshold}} = V_{12} - V_{13}$$

$$V_{\text{threshold}} = V_{12} \left(\frac{1}{1 + R_4/R_3} \right)$$

If we assume $V_R = 4.1\text{V}$ and let $V_{12} = 3\text{V}$ then

$$R_1 = 1.1\text{k}$$

$$R_2 = 3.0\text{k}$$

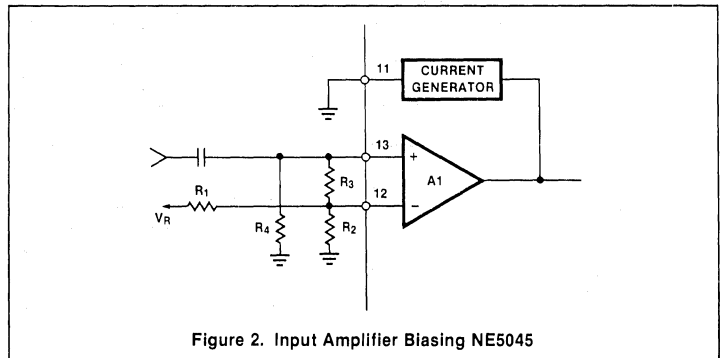

Figure 2. Input Amplifier Biasing NE5045

SEVEN CHANNEL RC DECODER

NE5045

The threshold is then set to 400mV by setting

$$R_4/R_3 = 6.5$$

R_4 should be sufficiently large so as to not load the input signal. If we let $R_3 = 51k$ then $R_4 = 330k$. Figure 3 shows the external con-

nections for a complete decoder. Note that this circuit does not have provisions for noise filtering or rejection of amplitude variations.

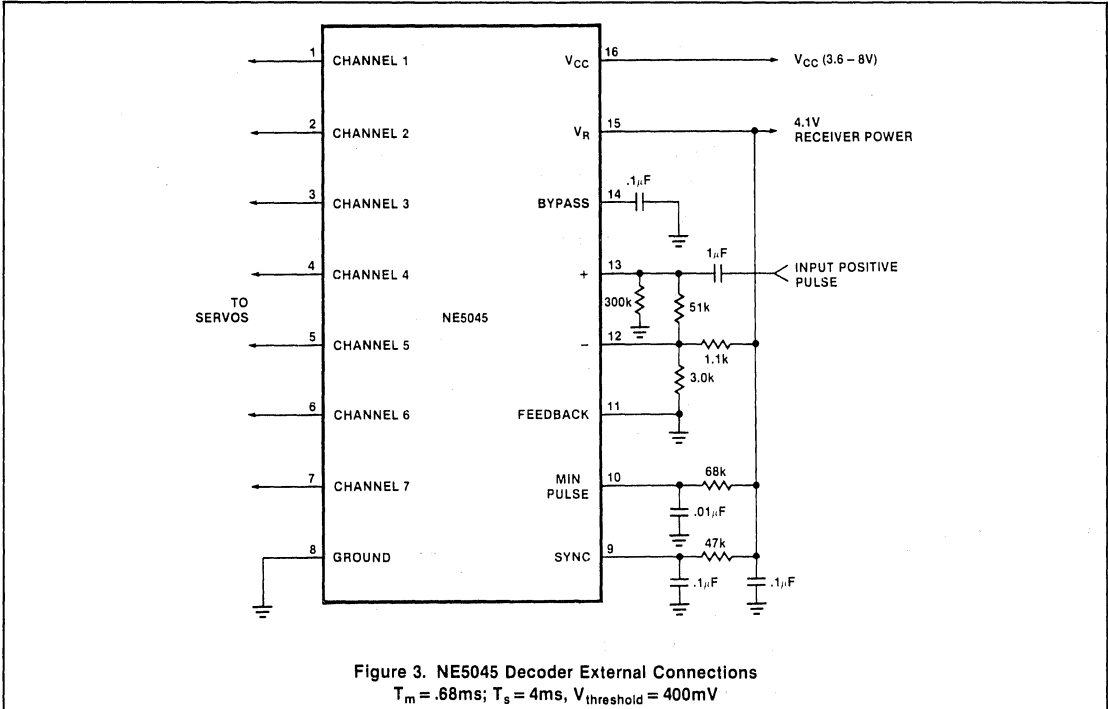

Figure 3. NE5045 Decoder External Connections
 $T_m = .68ms$; $T_s = 4ms$, $V_{threshold} = 400mV$

*For additional information, consult the Applications Section.



DESCRIPTION

The NE544 is a servo amplifier and pulse-width demodulator with internal motor drive transistors. It is designed for remote control applications in digital proportional systems but can be used in many other closed loop position control applications. It incorporates a linear one shot for improved positional accuracy and outputs for external pnp motor drive transistors.

FEATURES

- 500mA load current capability
- Bidirectional bridge output with single power supply
- Low standby power drain
- Adjustable deadband and trigger thresholds
- High linearity, 0.5% maximum error
- Output drive for external PNP transistors (optional)
- Wide supply voltage range

APPLICATIONS

- Miniature position Servo
- Robotics
- Control devices
- Remote positioning

PIN CONFIGURATIONS

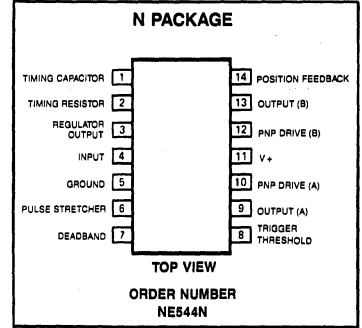

ABSOLUTE MAXIMUM RATINGS $T_A = 25^\circ\text{C}$ unless otherwise specified.

PARAMETER	RATING	UNIT	
V+	Supply voltage	6.0	V
I _O	Output current	500	mA
T _A	Operating temperature	-20 to +75	°C
T _{stg}	Storage temperature	-65 to +150	°C

BLOCK DIAGRAM

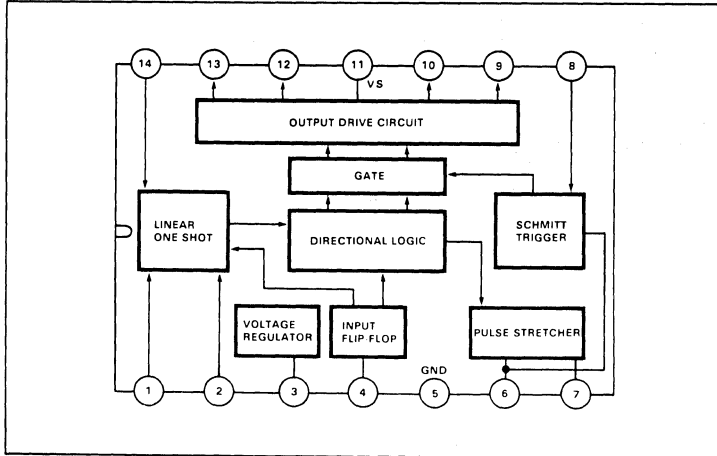

EQUIVALENT CIRCUIT SCHEMATIC

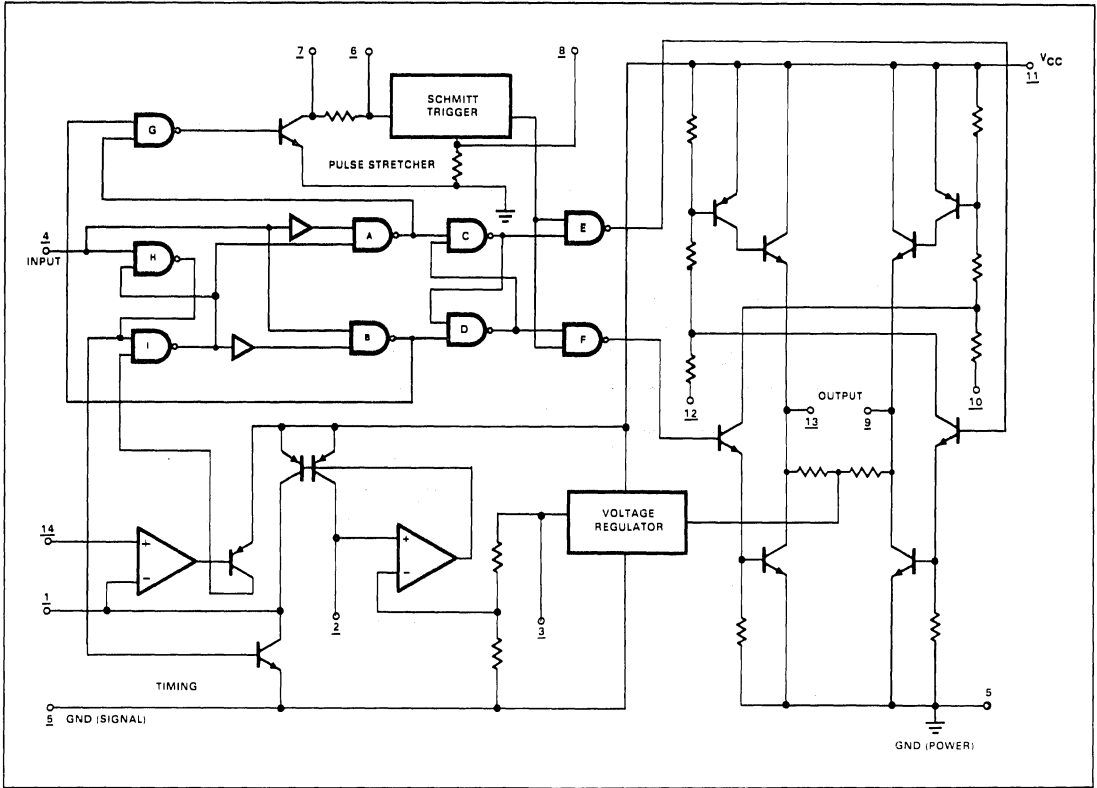

DC ELECTRICAL CHARACTERISTICS $T_A = 25^\circ\text{C}$, $V_S = 4.8\text{V}$ unless otherwise specified.

PARAMETER	TEST CONDITIONS	LIMITS			UNIT
		Min	Typ	Max	
V_{CC} Supply voltage		3.2	4.8	6	V
I_{CC} Supply current	Pin 11 Quiescent	4.2	5.5	10	mA
V_{TH} Input threshold	Pin 4		1.5		V
			1.4		
Z_{IN} Input resistance	Pin 4		18		k Ω
V_{OL} Output voltage Low	Pin 9 or 13, $I_L = 400\text{mA}$		0.3		V
V_{OH} Output voltage High			3.9		
V_{REG} Regulated voltage	Pin 3	2.1	2.5	2.9	V
ΔV_{REG} Regulation	Pin 3 $3.9\text{V} \leq V_{CC} \leq 6\text{V}$ $R_{DB} = 0$		10		mV/V
	Pin 7 Minimum dead band		1		μs
	One shot temperature coefficient		.01		%/°C
Standby output voltage	Pin 9 and 13		2.5		V
PNP drive current	Pin 10 and 12		20		mA



TYPICAL CONNECTION OF NE544N FOR LINEAR ONE SHOT TIMING

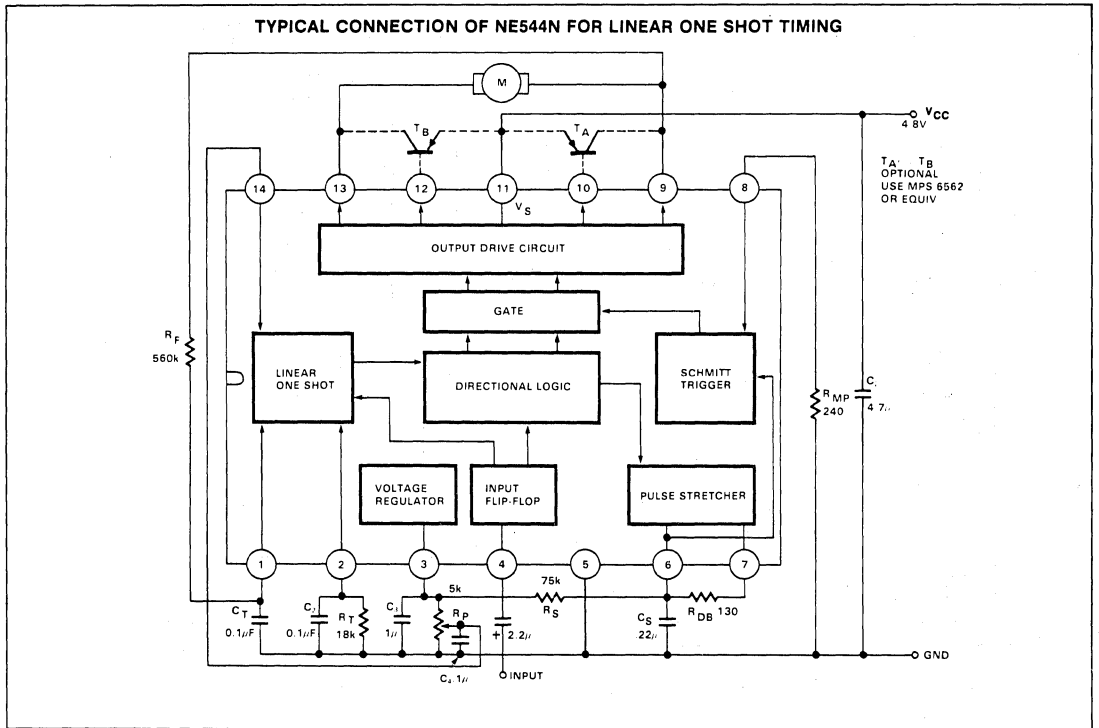

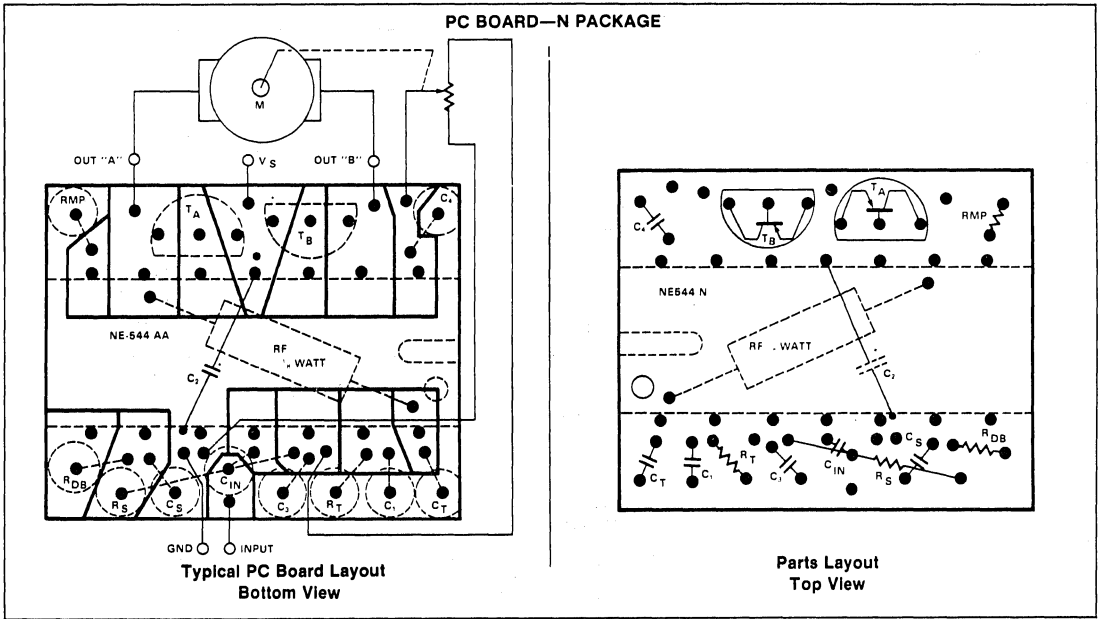

TYPICAL PERFORMANCE CHARACTERISTICS

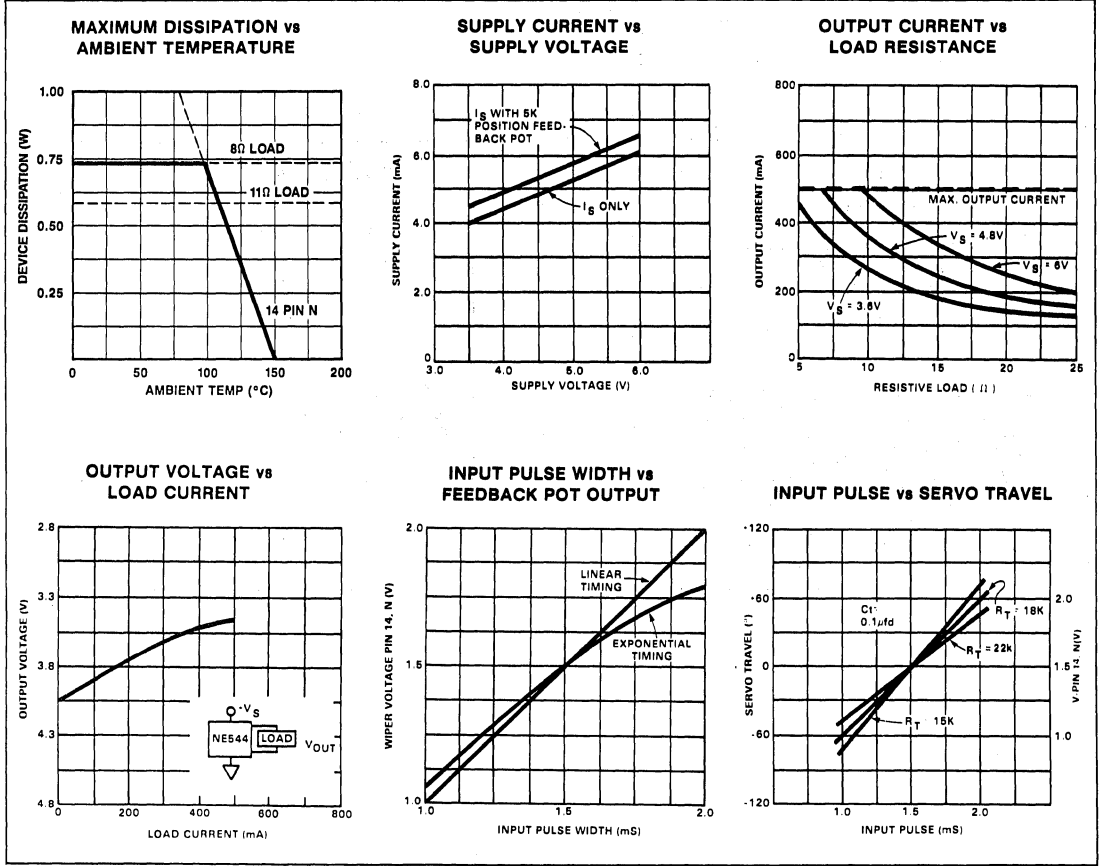

*For additional information, consult the Applications Section.

STEPPER MOTOR DRIVER**SAA1027****GENERAL DESCRIPTION**

The SAA1027 is a bipolar integrated circuit intended for driving a four-phase two-stator motor. The circuit consists of a bidirectional four-state counter and a code converter to drive the four outputs in the sequence required for driving a stepping motor.

Features

- high noise immunity inputs
- clockwise and counter-clockwise operation
- reset facility
- high output current
- outputs protected against damage by overshoot.

QUICK REFERENCE DATA

Supply voltage range	V_{CC}		9.5 to 18 V
Supply current, unloaded	I_{CC}	typ.	4.5 mA
Input voltage, all inputs			
HIGH	V_{IH}	min.	7.5 V
LOW	V_{IL}	max.	4.5 V
Input current, all inputs, LOW	I_{IL}	typ.	30 μ A
Output current LOW	I_{OL}	max.	500 mA
Operating ambient temperature range	T_{amb}		-20 to +70 $^{\circ}$ C

7**PACKAGE OUTLINE**

16-lead DIL; plastic (SOT-38A).

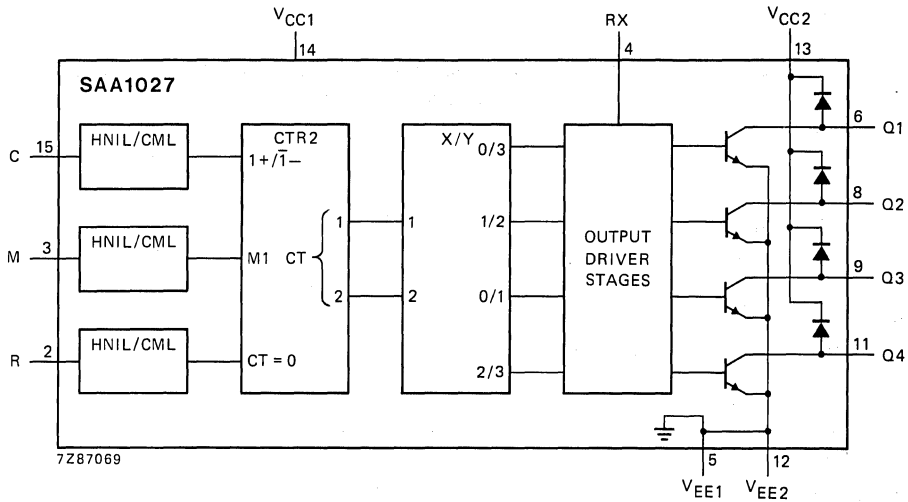

Fig. 1 Block diagram. The blocks marked HNIL/CML are high noise immunity input stages, the block marked CTR2 is a bidirectional synchronous 2-bit (4-state) counter and the block marked X/Y is a code converter. C is the count input, M the mode input to select forward or reverse counting and R is the reset input which resets the counter to content zero.

PINNING

1	n.c.	not connected
2	R	reset input
3	M	mode input
4	RX	external resistor
5	V _{EE1}	ground
6	Q1	output 1
7	n.c.	not connected
8	Q2	output 2
9	Q3	output 3
10	n.c.	not connected
11	Q4	output 4
12	V _{EE2}	ground
13	V _{CC2}	positive supply
14	V _{CC1}	positive supply
15	C	count input
16	n.c.	not connected

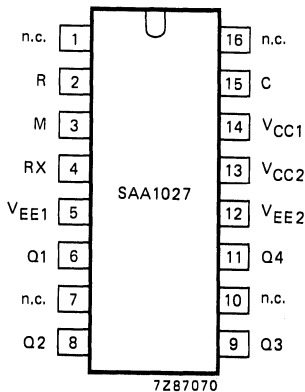

Fig. 2 Pinning diagram.

FUNCTIONAL DESCRIPTION**Count input C (pin 15)**

The outputs change state after each L to H signal transition at the count input.

Mode input M (pin 3)

With the mode input the sequence of output signals, and hence the direction of rotation of the stepping motor, can be chosen, as shown in the following table.

counting sequence	M = L				M = H			
	Q1	Q2	Q3	Q4	Q1	Q2	Q3	Q4
0	L	H	L	H	L	H	L	H
1	H	L	L	H	L	H	H	L
2	H	L	H	L	H	L	H	L
3	L	H	H	L	H	L	L	H
0	L	H	L	H	L	H	L	H

Reset input R (pin 2)

A LOW level at the R input resets the counter to content zero. The outputs take on the levels shown in the upper and lower line of the table above.

If this facility is not used the R input should be connected to the supply.

External resistor pin RX (pin 4)

The external resistor R4 connected to RX sets the base current of the output transistors. Its value has to be chosen in accordance with the required output current (see Fig. 5).

Outputs Q1 to Q4 (pins 6, 8, 9 and 11)

The circuit has open-collector outputs. To prevent damage by an overshooting output voltage the outputs are protected by diodes connected to V_{CC2}, pin 13. High output currents mainly determine the total power dissipation, see Fig. 3.

STEPPER MOTOR DRIVER

SAA1027

RATINGS

Limiting values in accordance with the Absolute Maximum System (IEC 134)

Supply voltage, d.c.	$V_{CC1}; V_{CC2}$	max.	18 V
Input voltage, all inputs	V_I	max.	18 V
Current into pin 4	I_{RX}	max.	120 mA
Output current	I_{OL}	max.	500 mA
Power dissipation	P_{tot}	see Fig. 4	
Storage temperature range	T_{stg}	-40 to +125 °C	
Operating ambient temperature range	T_{amb}	-20 to +70 °C	

CHARACTERISTICS

$V_{CC} = 9.5$ to 18 V; $V_{EE} = 0$ V; $T_{amb} = -20$ to 70 °C unless otherwise specified.

parameter	symbol	min.	typ.	max.	unit
Supply V_{CC1} and V_{CC2} (pins 14 and 13)					
Supply current at $V_{CC1} = 12$ V; unloaded; all inputs HIGH; pin 4 open	I_{CC}	2	4.5	6.5	mA
Inputs C, M and R (pins 15, 3 and 2)					
Input voltage					
HIGH	V_{IH}	7.5	—	—	V
LOW	V_{IL}	—	—	4.5	V
Input current					
HIGH	I_{IH}	—	1	—	μ A
LOW	$-I_{IL}$	—	30	—	μ A
External resistor pin RX (pin 4)					
Voltage at RX at $V_{CC} = 12$ V \pm 15%; $R_4 = 130 \Omega \pm 5\%$	V_{RX}	3	—	4.5	V
Outputs Q1 to Q4					
Output voltage LOW					
at $I_{OL} = 350$ mA	V_{OL}	—	500	1000	mV
at $I_{OL} = 500$ mA	V_{OL}	—	700	—	mV
Output current					
LOW	I_{OL}	—	—	500*	mA
HIGH at $V_Q = 18$ V	$-I_{OH}$	—	—	50	μ A

* See Figs 3 and 4.

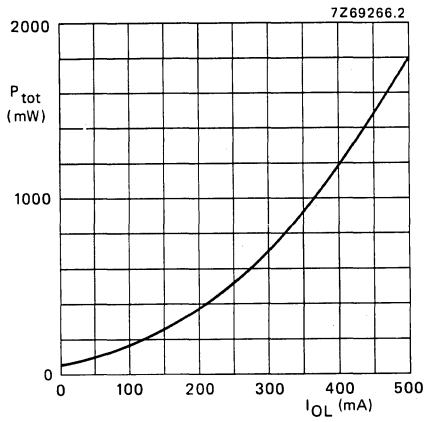

Fig. 3 Total power dissipation P_{tot} as a function of output current I_{OL} .

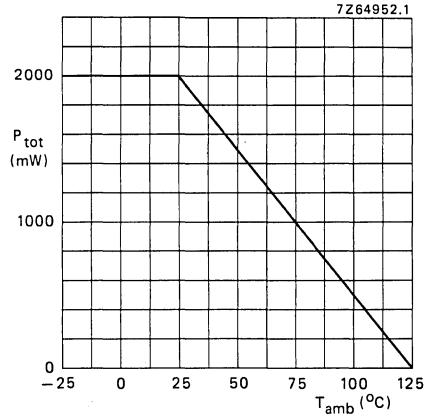

Fig. 4 Power derating curve.

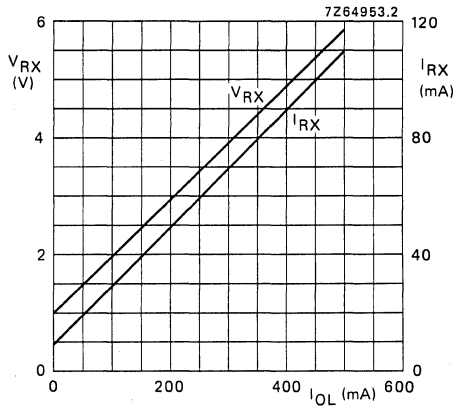

Fig. 5 Current I_{RX} into RX and voltage V_{RX} on RX as a function of required output current I_{OL} .

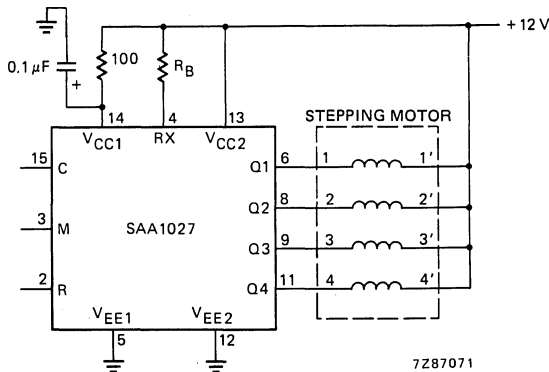

Fig. 6 Typical application of the SAA1027 as a stepping motor driver.

VOLTAGE REGULATOR—SYMBOLS AND DEFINITIONS

Absolute Maximum Rating

Operating safe zones exceeding these limits could cause permanent damage to the device and are not meant to imply that devices can operate at these limits.

Current Limiting

The ability of the amplified segment to limit the output current of the device when safe operating limits are exceeded. Measured in amperes (pre-determined).

Efficiency

Regarding a regulator, the ratio of the total power input to the usable power output. Expressed as a percentage. (For example, if a regulator has a 50 watt input and a 40 watt output, its efficiency is 80 percent).

EMI/RFI

("Electromagnetic Interference/Radio Frequency Interference") regarding regulators, magnetic field disturbance and radio frequency interference signals generated especially by SMPS devices. Measurement is generally unspecified.

Line Regulation

Sometimes referred to as "static regulation". This term refers to the changes in the output as the input is varied slowly from its rated minimum value to its rated maximum value (from 105 VAC_{RMS} to 125 VAC_{RMS}). Measured in mv/V.

Load Regulation

Sometimes referred to as "dynamic regulation". This term refers to the changes in the output when load conditions are suddenly changed (from no load to full load). Measured in mv/V.

Package Type Designation

See full package designations in Appendix.

Power Dissipation

The power that the device can safely handle at 25°C. The dissipation must be derated as indicated for the individual package type.

Power Dissipation

The ability of the regulator to tolerate excessively high levels of input power while maintaining its operation within the safe operating area of its active devices. Measured in watts.

Safe Operating Area Restriction (SOAR)

Limits the output current of the amplifier to maintain safe (no thermal runaway) operating conditions. (Accomplished through internal sensor amplifiers.)

T_A

Ambient temperature range. Range of the surrounding environment of the operating device.

T_J

Junction Temperature. The maximum temperature of the device. 150°C is standard for silicon devices.

T_{SOLED}

Soldering Temperature. The temperature which can be applied to the lead frame of the device for short periods of time (normally specified for a duration of 10 sec).

T_{STG}

Storage temperature range. Temperature range that the device can be stored in a non-operating condition.

Thermal Regulation

Referred to as changes due to ambient variations of thermal drift. Also referred to as temperature coefficient, measured in ppm/°C or mv/°C.

Thermal Shutdown

The ability of the regulator to shut itself down when the maximum die temperature is exceeded. Measured in degrees Celsius (C).

Transient Response

The ability of a regulator to respond to rapid changes in line variations, load variations, or intermittent transient input conditions. (Transient Response is often referred to as "recovery time"). Measured in milliseconds (ms).

Truth Tables

0 is logic level low

1 is logic level high

X — don't care condition — has no effect under circuit conditions listed.

V_{CC} (— V_{CC})

Supply Voltage. The range of power supply voltage over which the device will operate safely.

Voltage Limiting

The ability of the regulator to "shut down" in the event that the internal reference sources fail to function properly. Measured in Volts.

SWITCHED-MODE POWER SUPPLY CONTROL CIRCUIT

SE/NE5560

DESCRIPTION

The SE/NE5560 is a control circuit for use in switched mode power supplies. This single monolithic chip incorporates all the control and housekeeping (protection) functions required in switched mode power supplies, including an internal temperature compensated reference source, internal Zener references, sawtooth generator, pulse width modulator, output stage and various protection circuits.

FEATURES

- Stabilized power supply
- Temperature compensated reference source
- Sawtooth generator
- Pulse width modulator
- Remote on/off switching
- Current limiting
- Low supply voltage protection
- Loop fault protection
- Demagnetization/overvoltage protection
- Maximum duty cycle clamp
- Feed forward control
- External synchronization

PIN CONFIGURATION

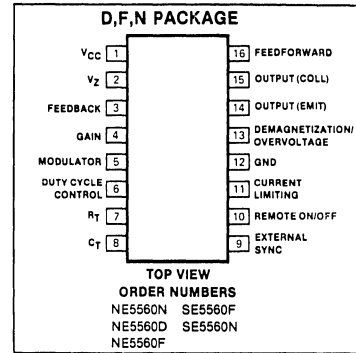

ABSOLUTE MAXIMUM RATINGS

PARAMETER	RATING	UNIT
Supply ¹		
Voltage forced mode	+18	V
Current fed mode	30	mA
Output transistor (at 20-30V max)		
Output current	40	mA
Collector voltage (Pin 15)	$V_{CC} + 1.4V$	V
Max. emitter voltage (Pin 14)	+5	V
Operating temperature (ambient)		
SE5560	-55 to +125	°C
NE5560	0 to 70	°C
Storage temperature range	-65 to +150	°C

BLOCK DIAGRAM

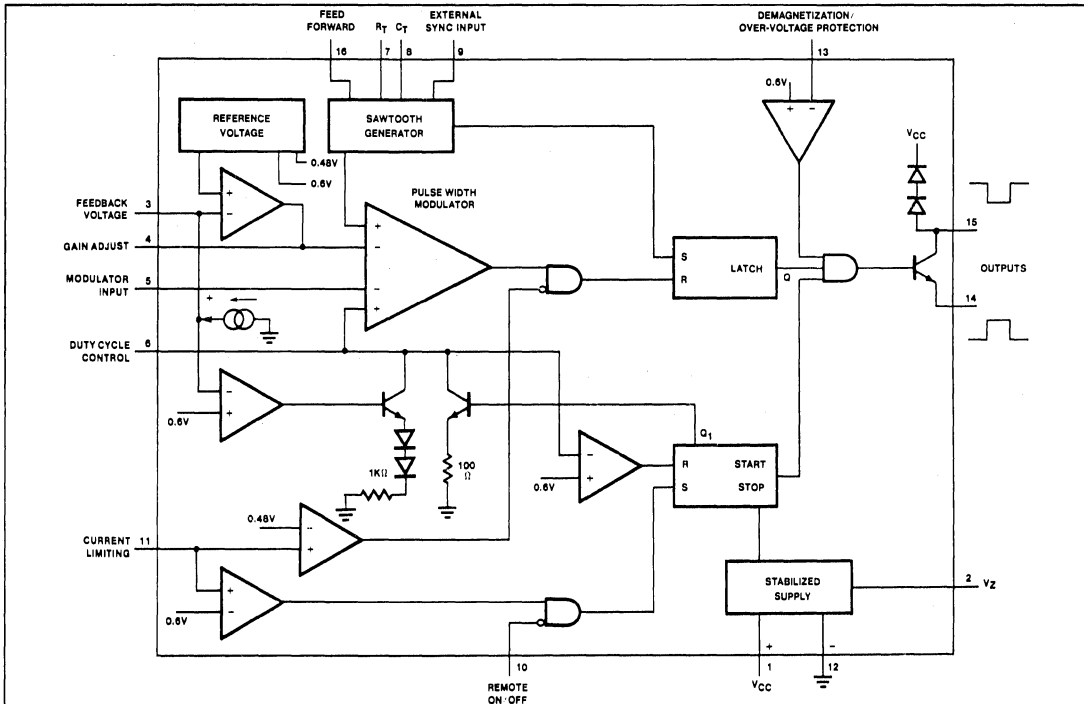

Note:

1. See Voltage/Current fed supply characteristic curve.

SWITCHED-MODE POWER SUPPLY CONTROL CIRCUIT

SE/NE5560

DC ELECTRICAL CHARACTERISTICS ($T_A = 25^\circ\text{C}$, $V_{CC} = 12\text{V}$ unless otherwise specified)

PARAMETER	TEST CONDITIONS	SE5560			NE5560			UNIT
		Min	Typ	Max	Min	Typ	Max	
Reference Sections								
Internal reference voltage (V_{ref})	25°C	3.69	3.72	3.81	3.57	3.72	3.95	V
Temperature coefficient of V_{ref}	Over temperature	3.65		3.85	3.53		4.00	V
Internal Zener reference (V_Z)	$I_L = -7\text{ mA}$	7.8	-100	8.8	7.8	-100	8.8	ppm/°C
Temperature coefficient of V_Z			8.4	200		8.4	200	V
								ppm/°C
Oscillator Section								
Frequency range	Over temperature	50		100k	50		100k	Hz
Initial accuracy oscillator	R = 5 kΩ		5			5		%
Duty cycle range	$f_o = 20\text{ kHz}$	0		98	0		98	%
Modulator								
Modulation input current	Voltage at Pin 5 = 2V Over temperature		0.2	20		0.2	20	μA
Housekeeping Function								
Pin 6, input current	at 2V Over temperature		0.2	20		0.2	20	μA
Pin 6, duty cycle limit control	(for 50% maximum duty cycle) 15 kHz to 50 kHz/ 41% of V_Z	40	50	60	40	50	60	% of duty cycle
Pin 1, low supply voltage protection thresholds		8	9.0	10.5	8	9.0	10.5	V
Pin 3, feedback loop protection trip threshold		400	600	720	400	600	720	mV
Pin 3, pull up current	at 2V Over temperature	-7	-15	-35	-7	-15	-35	μA
Pin 13, demagnetization/over voltage protection trip on threshold		470	600	720	470	600	720	mV
Pin 13, input current	at 0.25V 25°C Over temperature		-0.6	-10		-0.6	-10	μA
Pin 16, feed forward duty cycle control	Voltage at Pin 16 = 2 V_Z	30	40	50	30	40	50	% original duty cycle
*Pin 16, feed forward input current	at 16V, $V_{CC} = 18\text{V}$ 25°C Over temperature		0.2	5		0.2	5	μA
				10			10	μA
External Synchronization								
Pin 9 off		0		0.8	0		0.8	V
Pin 9 on		2		V_Z	2		V_Z	V
Pin 9 sink current	Voltage at Pin 9 = 0V, 25°C Over temperature		-65	-100		-65	-125	μA
				-125			-125	μA
Remote								
Pin 10 off		0		0.8	0		0.8	V
Pin 10 on		2		V_Z	2		V_Z	V
Pin 10 sink current	at 0V 25°C Over temperature		-85	-100		-85	-125	μA
				-125			-125	μA
Current Limiting								
Pin 11, I_{IN}	Voltage at Pin 11 = 250 mV, 25°C Over temperature		-2	-20		-2	-20	μA
Single pulse inhibit delay	Inhibit delay time for 20% overdrive at 40 mA I_{OUT}		0.7	0.8		0.7	0.8	μs
Trip Levels: Shut down, slow start		0.560	0.600	0.700	0.560	0.600	0.700	V
Current limit		0.400	0.480	0.500	0.400	0.480	0.500	V
Error Amplifier								
Output voltage swing (V_{OH})		6.2		9.5	6.2		9.5	V
Output voltage swing (V_{OL})				0.7			0.7	V
Open loop gain		54	60		54	60		dB
Feedback resistor		10k			10k			Ω
Small signal bandwidth			3			3		MHz

SWITCHED-MODE POWER SUPPLY CONTROL CIRCUIT

SE/NE5560

DC ELECTRICAL CHARACTERISTICS (Continued)

PARAMETER	TEST CONDITIONS	SE5560			NE5560			UNIT
		Min	Typ	Max	Min	Typ	Max	
Output Stage $V_{CE(SAT)}$ $I_C = 40\text{mA}$ Output current (pin 15) Max emitter voltage (pin 14)		40		0.5	40		0.5	V
		5	6		5	6		mA
								V
Supply Voltage/Current I_{CC}	$I_Z = 0$, voltage forced, $V_{CC} = 12\text{V}$, 25°C Over temp. $I_{CC} = 10\text{mA}$ current fed			10			10	mA
				15			15	mA
		V_{CC}	20		23	19		24
V_{CC}	$I_{CC} = 30\text{mA}$ current fed	20		30	20		30	V

Note:

Does not include current for timing resistors or capacitors. (See p.

- "total standby current")

TYPICAL PERFORMANCE CHARACTERISTICS

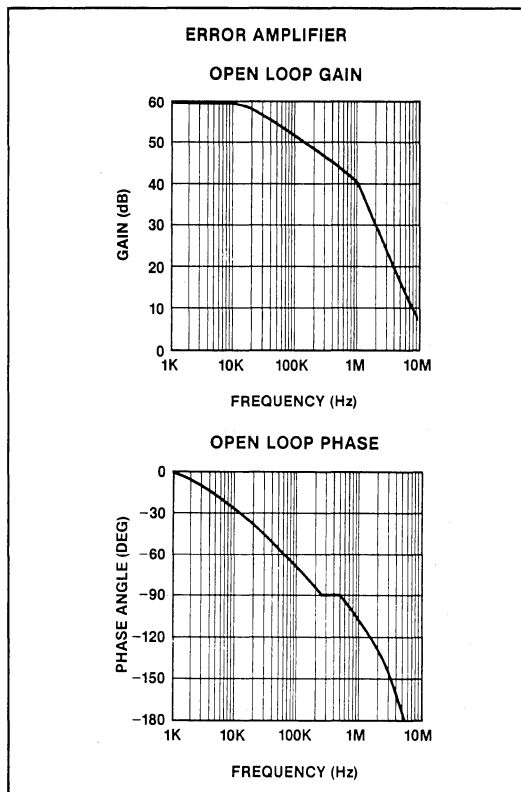

MAXIMUM PIN VOLTAGES

NE5560	
FUNCTION	MAXIMUM VOLTAGE
1. V_{CC}	See Note 1
2. V_Z	Do not force (8.4V)
3. Feedback	V_Z
4. Gain	
5. Modulator	V_Z
6. Duty Cycle Control	V_Z
7. R_T	Current force mode
8. C_T	
9. External Sync	V_Z
10. Remote On/Off	V_Z
11. Current Limiting	V_{CC}
12. GND	GND
13. Demagnetization/Overshoot	V_{CC}
14. Output (Emit)	V_Z
15. Output (Collector)	$V_{CC} + 2V_{be}$
16. Feed forward	V_{CC}

Note:

1. When voltage forced, maximum is 18V; when current fed, maximum is 30mA. See voltage/current fed supply characteristic curve.

7

TYPICAL PERFORMANCE CHARACTERISTICS (continued)

GRAPH FOR DETERMINING δ_{MAX}

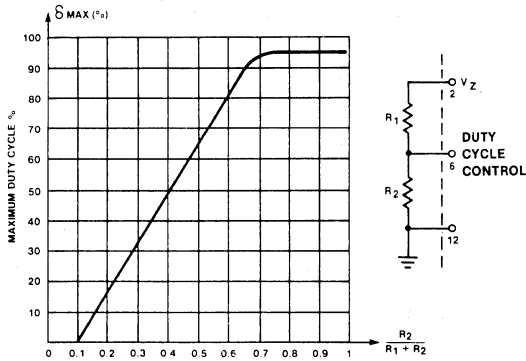

SOFT-START MIN DUTY CYCLE vs $R_1 + R_2$

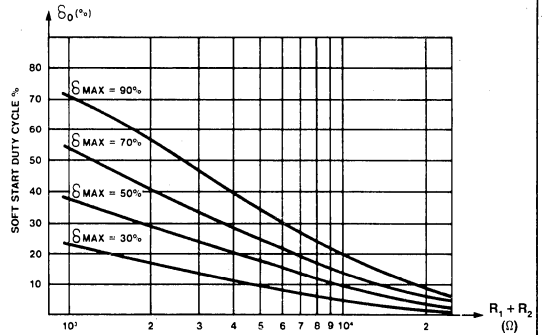

POWER DERATING CURVE

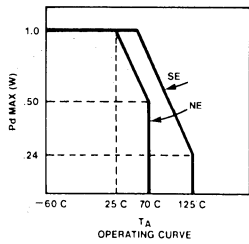

$$P_d = V_{CC} I_{CC} + (V_{CC} - V_{Z1}) I_Z + [(V_{15} - V_{14}) I_{15} \times \text{DUTY CYCLE}]$$

NE5560 VOLTAGE/CURRENT FED SUPPLY CHARACTERISTICS

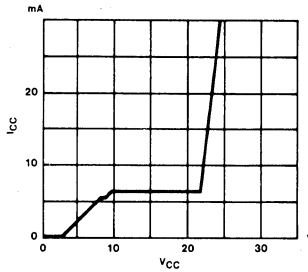

CURRENT FED DROPPING RESISTOR

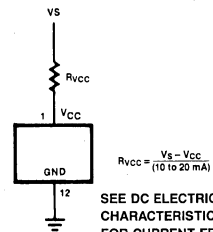

SEE DC ELECTRICAL CHARACTERISTICS FOR CURRENT FED V_{CC} RANGE.

REGULATION vs ERROR AMP CLOSED LOOP GAIN

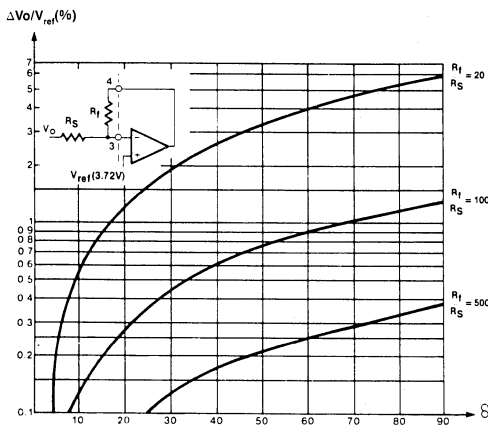

TRANSFER CURVE OF PULSE WIDTH MODULATOR DUTY CYCLE vs INPUT VOLTAGE

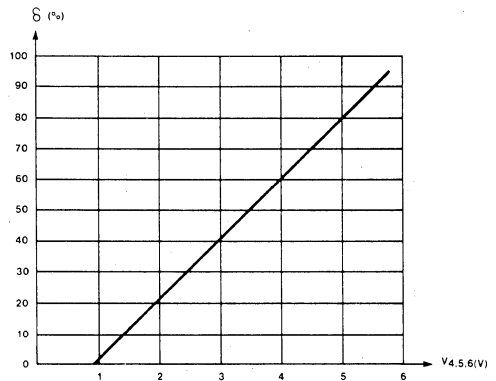

TYPICAL PERFORMANCE CHARACTERISTICS (continued)

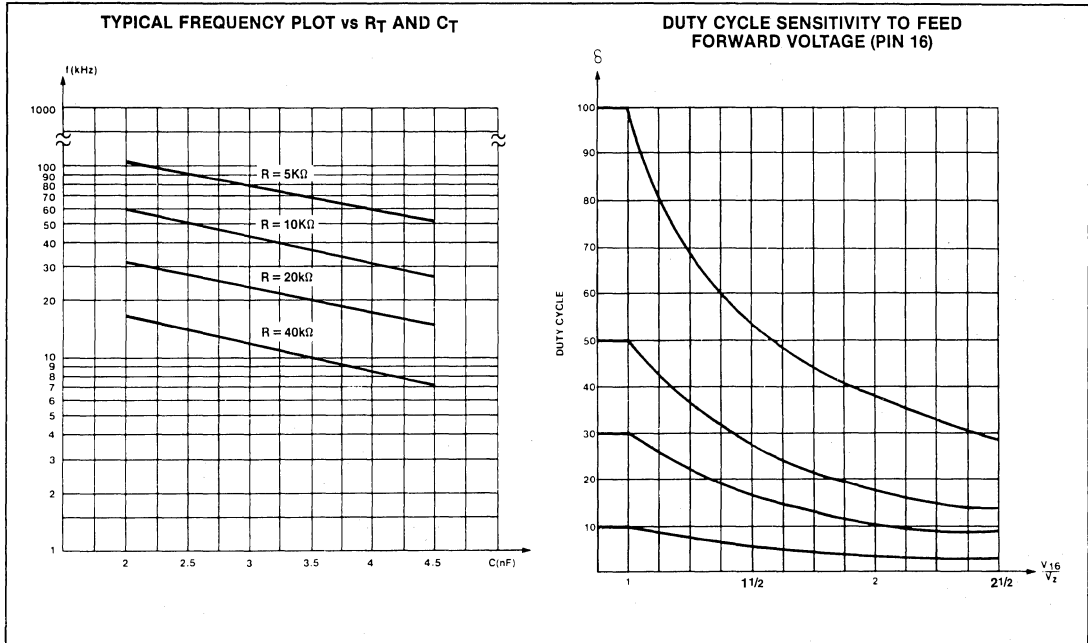

THEORY OF OPERATION

The following functions are incorporated:

- A temperature compensated reference source.
- An error amplifier with pin 3 as input. The output is connected to pin 4 so that the gain is adjustable with external resistors.
- A sawtooth generator with a TTL-compatible synchronization input (pins 7,8,9).
- A pulse-width modulator with a duty-cycle range from 0 to 95%.

(The PWM has two additional inputs:

Pin 6 can be used for a precise setting of δ max.

Pin 5 gives a direct access to the modulator, allowing for real constant current operation.)

- A gate at the output of the PWM provides a simple dynamic current limit.
- A latch that is set by the flyback of the sawtooth and reset by the output pulse of the above-mentioned gate prohibits double pulsing.
- Another latch functions as a start-stop circuit; it provides a fast switch-off and a slow start.
- A current protection circuit that operates via the start-stop circuit. This is a combined function with the current

limit circuit, therefore pin 11 has two trip-on levels; the lower one for cycle-by-cycle current limiting, the upper one for current protection by means of switch-off and slow-start.

- A TTL-compatible remote on/off input at pin 10, also operating via the start-stop circuit.
- An inhibit input at pin 13. The output pulse can be inhibited immediately.
- An output gate that is commanded by the latches and the inhibit circuit.
- An output transistor of which both the collector (pin 15) and the emitter (pin 14) are externally available. This allows for normal or inverse output pulses.
- A power supply that can be either voltage or current driven (pins 1 and 12). The internally generated stabilized output voltage V_Z is connected to pin 2.
- A special function is the so-called feed-forward at pin 16. The amplitude of the sawtooth generator is modulated in such a way that the duty cycle becomes inversely proportional to the voltage on this pin: $\delta \sim 1/V_{16}$
- Loop fault protection circuits assure that the duty-cycle is reduced to zero or a low value for open or short-circuited feedback loops.

Stabilized Power Supply (Pins 1, 2, 12)

The power supply of the NE5560 is of the well known series regulation type and provides a stabilized output voltage of typically 8.5 volts.

This voltage V_Z is also present at pin 2 and can be used for precise setting of δ max. and to supply external circuitry. Its maximum current capability is 5mA.

The circuit can be fed directly from a DC voltage source between 10.5V and 18V or can be current driven via a limiting resistor. In the latter case, internal pinch-off resistors will limit the maximum supply voltage; typical 23V for 10mA and maximum 30V for 30mA.

The low supply voltage protection is active when $V(1-12)$ is below 10.5V and inhibits the output pulse (no hysteresis).

When the supply voltage surpasses the 10.5V level, the IC starts delivering output pulses via the slow-start function.

The current consumption at 12V is less than 10mA, provided that no current is drawn from V_Z and $R(7-12) \geq 20k\Omega$.



The Sawtooth Generator

Figure 2 shows the principal circuitry of the oscillator. A resistor between pin 7 and pin 12 (ground) determines the constant current that charges the timing capacitor C(8-12).

This causes a linear increasing voltage on pin 8 until the upper level of 5.6V is reached. Comparator H sets the RS flip flop and Q1 discharges C(8-12) down to 1.1V, where comparator L resets the flip-flop. During this flyback time, Q2 inhibits the output.

Synchronization at a frequency lower than the free-running frequency is accomplished via the TTL gate on pin 9. By activating this gate ($V^9 < 2V$), the setting of the sawtooth is prevented. This is indicated in Figure 3.

Figure 4 shows a typical plot of the oscillator frequency against the timing capacitor. The frequency range of the NE5560 goes from $<50\text{Hz}$ up to $>100\text{kHz}$.

Reference Voltage Source

The internal reference voltage source is based on the bandgap voltage of silicon. Good design practice assures a temperature dependency typically $\pm 100\text{ppm}/^\circ\text{C}$. The reference voltage is connected to the positive input of the error amplifier and has a typical value of 3.72V.

Error Amp Compensation

For closed loop gains less than 40 dB, it is necessary to add a simple compensation capacitor as shown in Figures 4, 5.

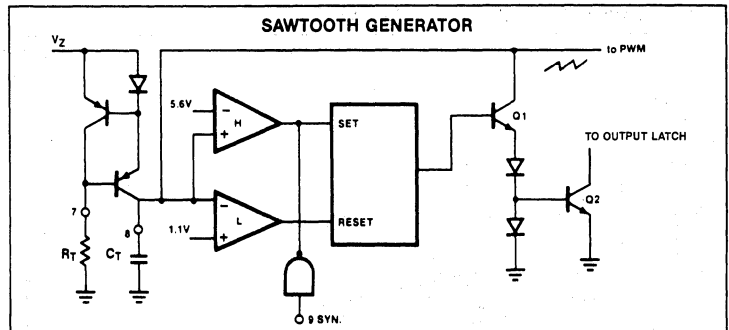

Figure 2

SAWTOOTH OSCILLATOR SYNCHRONIZATION

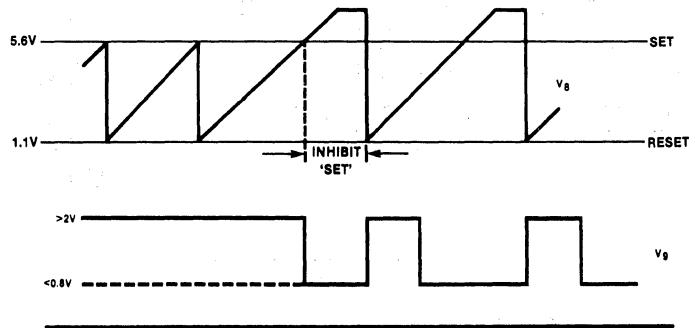

Figure 3

ERROR AMPLIFIER COMPENSATION

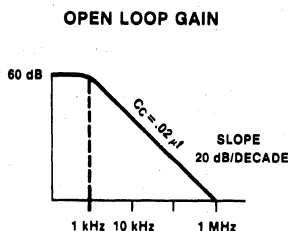

Figure 4

ERROR AMPLIFIER

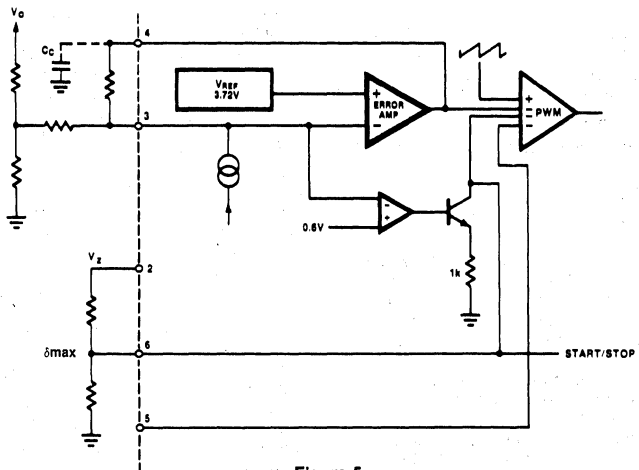

Figure 5

Error Amplifier with Loop-Fault Protection Circuits

This operational amplifier is of a generally used concept and has an open loop gain of typically 60dB. As can be seen in Figure 5, the inverting input is connected to pin 3 for a feedback information proportional to V_O .

The output goes to the PWM circuit, but is also connected to pin 4, so that the required gain can be set with R_S and $R(3-4)$. This is indicated in Figure 5, showing the relative change of the feedback voltage as a function of the duty cycle. Additionally, pin 4 can be used for phase shift networks that improve the loop stability.

When the SMPS feedback loop is interrupted, the error amplifier would settle in the middle of its active region because of the feedback via $R(3-4)$. This would result in a large duty cycle. A current source on pin 3 prevents this by pushing the input voltage high via the voltage drop over $R(3-4)$. As a result, the duty cycle will become zero, provided that $R(3-4) > 100k$. When the feedback loop is shortcircuited, the duty cycle would jump to the adjusted maximum duty cycle. Therefore, an additional comparator is active for feedback voltages at pin 3 below 0.6V. Now an internal resistor of typically 1k is shunted to the impedance on the δ_{max} setting pin 6. Depending on this impedance, δ will be reduced to a value δ_0 . This will be discussed further.

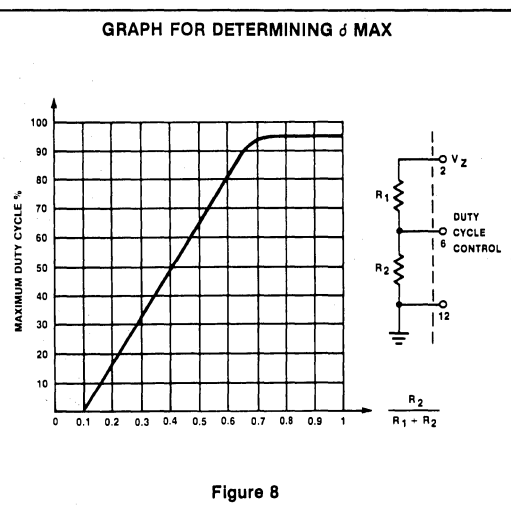
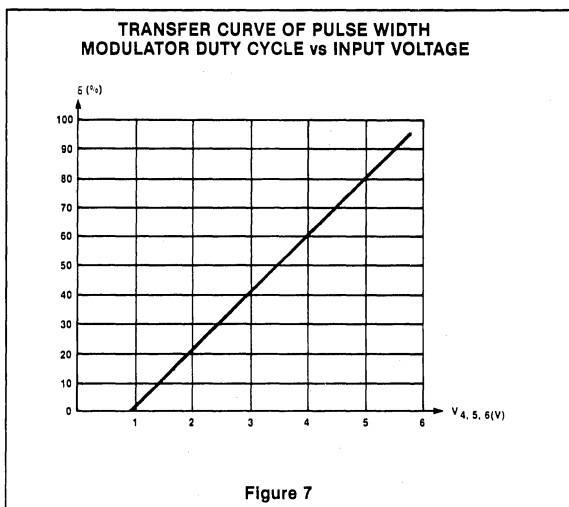
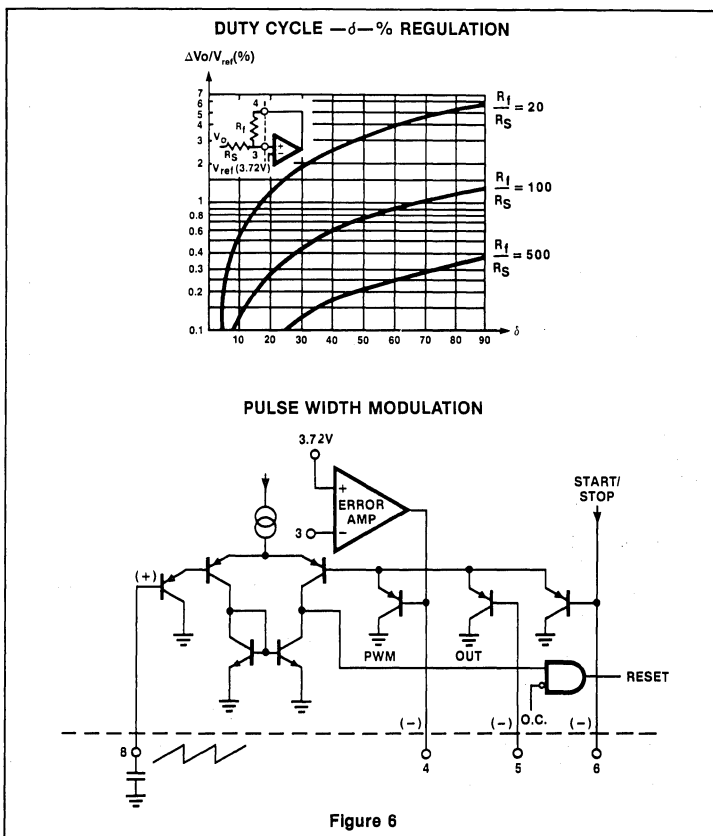

The Pulse-Width Modulator

The function of the PWM circuit is to translate a feedback voltage into a periodical pulse of which the duty cycle depends on that feedback voltage. As can be seen in Figure 6, the PWM circuit in the NE5560 is a long-tailed pair in which the sawtooth on pin 8 is compared with the LOWEST voltage on either pin 4 (error amplifier), pin 5, or pin 6 d_{max} and slow-start). The transfer graph is given in Figure 7. The output of the PWM causes the resetting of the output bistable.

Limitation of the Maximum Duty Cycle

With pins 5 and 6 not connected and with a rather low feedback voltage on pin 3, the NE5560 will deliver output pulses with a duty cycle of $\approx 95\%$. In many SMPS applications, however, this high d will cause problems. Especially in forward converters, where the transformer will saturate when d exceeds 50%, a limitation of the maximum duty-cycle is a must.

A DC voltage applied to pin 6 (PWM input) will set d_{max} at a value in accordance with Figure 7. For low tolerances of d_{max} , this voltage on pin 6 should be set with a resistor divider from V_Z (pin 2). The upper and lower sawtooth levels are also set by means of an internal resistor divider from V_Z , so forming a bridge configuration with the d_{max} setting is low because tolerances in V_Z are compensated and the sawtooth levels are determined by internal resistor matching rather than by absolute resistor tolerance. Figure 8 can be used for determining the tap on the bleeder for a certain d_{max} setting.

As already mentioned, Figure 9 gives a graphical representation of this. The value d_o is limited to the lower and the higher side;

- It must be large enough to ensure that at maximum load and minimum input voltage the resulting feedback voltage on pin 3 exceeds 0.6V.
- It must be small enough to limit the amount of energy in the SMPS when a loop-fault occurs. In practice a value of 10-15% will be a good compromise.

Extra PWM Input (Pin 5)

The PWM has an additional inverting input: pin 5. It allows for attacking the duty cycle via the PWM circuit, independently from the feedback and the d_{max} information. This is necessary when the SMPS must have a real constant current behavior, possibly with a fold-back characteris-

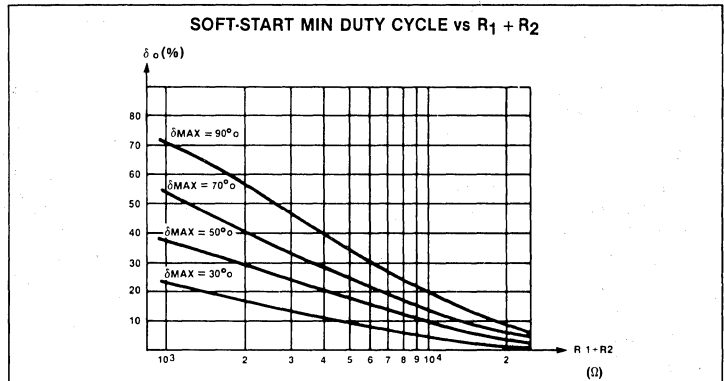

Figure 9

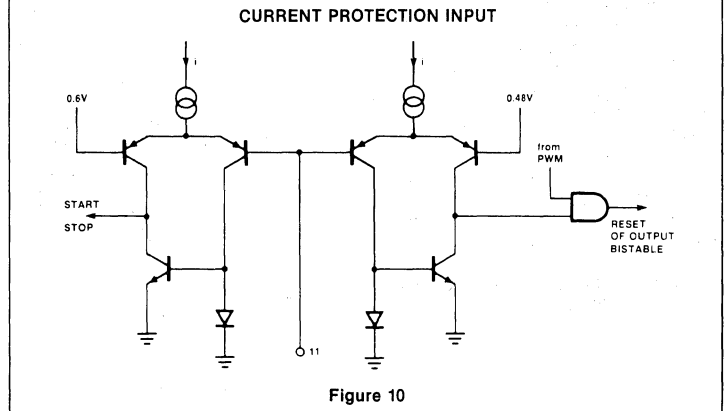

Figure 10

tic. However, the realization of this feature must be done with additional external components. When not used, pin 5 should be tied to pin 6.

Dynamic Current Limit and Current Protection (Pin 11)

In many applications, it is not necessary to have a real constant current output of the SMPS.

Protection of the power transistor will be the prime goal. This can be realized with the NE5560 in an economical way. A resistor (or a current transformer) in the emitter of the power transistor gives a replica of the collector current. This signal must be connected to pin 11. As can be seen in Figure 10, this input has two comparators with different reference levels. The output of the comparator with the lower 0.48V reference is connected to the same gate as the output of the PWM.

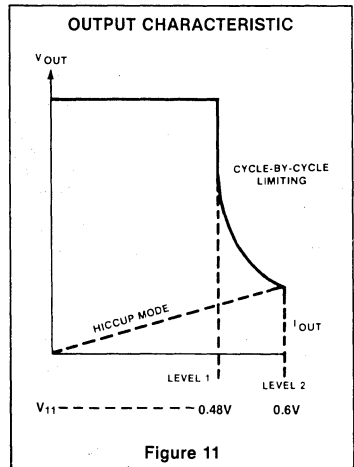

Figure 11

Remote On/Off Circuit (Pin 10)

In systems where two or more power supplies are used, it is often necessary to switch these supplies on and off in a sequential way. Furthermore, there are many applications in which a supply must be switched by a logical signal. This can be done via the TTL-compatible remote on/off input on pin 10. The output pulse is inhibited for levels below 0.8V. The output of the IC is no longer blocked when the remote on/off input is left floating or when a voltage >2V is applied. Start up occurs via the slow-start circuit.

The Output Stage

The output stage of the NE5560 contains a flip flop, a push-pull driven output transistor, and a gate, as indicated in Figure 14. The flip flop is set by the flyback of the sawtooth. Resetting occurs by a signal either from the PWM or the current limit circuit. With this configuration, it is assured that the output is switched only once per period, thus prohibiting double pulsing. The collector and emitter of the output transistor are connected to respectively pin 15 and pin 14, allowing for normal or inverted output pulses. An internally grounded emitter would cause intolerable voltage spikes over the bonding wire, especially at high output currents.

This current capability of the output transistor is 40mA peak for $V_{CE} = 0.4V$. An internal clamping diode to the supply voltage protects the collector against over-voltages. The maximum voltage at the emitter (pin 14) must not exceed +5V. A gate, activated by one of the set or reset pulses, or by a command from the start-stop circuit will immediately switch-off the output transistor by short-circuiting its base. The external inhibitor (pin 13) operates also via this base.

Demagnetization Sense

As indicated in Figure 14, the output of this NPN comparator will block the output pulse, when a voltage above 0.6V is applied to pin 13. A specific application for this function is to prevent saturation of forward converter transformers. This is indicated in Figure 15.

Feed-Forward (Pin 16)

The basic formula for a forward converter is

$$V_{OUT} = \frac{dV_{in}}{n} \quad (n = \text{transformer ratio})$$

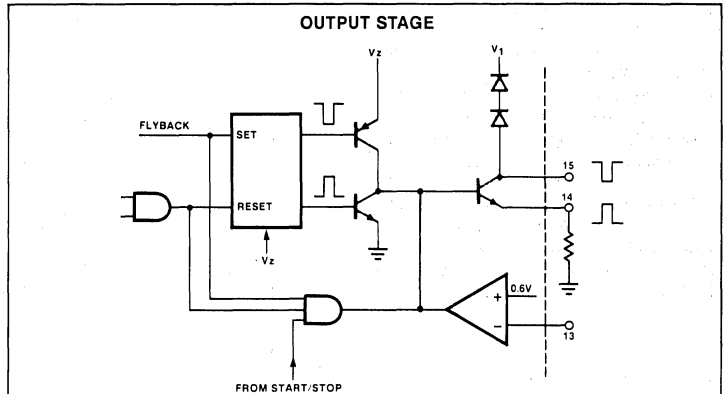

NOTE:
The signal V_{13} can be derived from the demagnetizing winding in a forward converter as shown below.

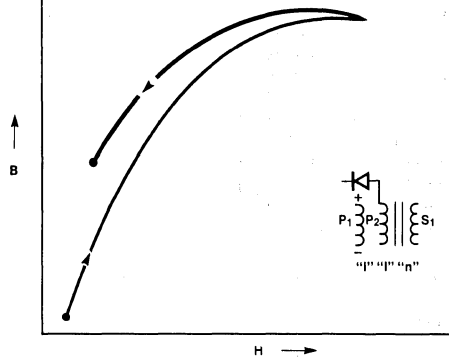

Figure 14

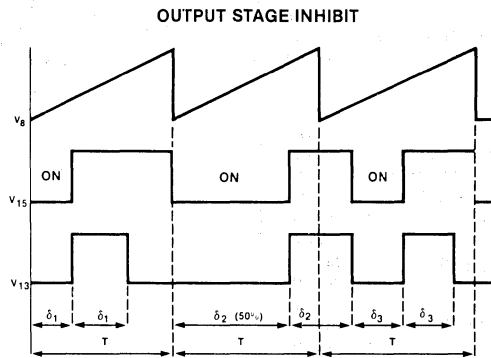

Figure 15

This means that in order to keep V_{OUT} at a constant value, the duty cycle δ must be made inversely proportional to the input voltage. A prerogative (feed-forward) with the function $\delta \sim 1/V_{IN}$ can ease the feedback-loop design.

This loop now only has to regulate for load variations, which require only a low feedback gain in the normal operation area. The transformer of a forward converter must be designed in such a way that it does not saturate, even under transient conditions, where the maximum inductance is determined by $\delta_{max} \times V_{IN\ max}$. A regulation of $\delta_{max} \sim 1/V_{IN}$ will allow for a considerable reduction or simplification of the transformer. The function of $\delta \sim 1/V_{IN}$ can be realized by using pin 16 of the NE5560.

Figure 16 shows the electrical realization. When the voltage at pin 16 exceeds the stabilized voltage V_Z (pin 2), it will increase the charging current for the timing capacitor on pin 8.

The operating frequency is not affected, because the upper trip level for sawtooth increases also. Note that the δ_{max} voltage on pin 6 remains constant because it is set via V_Z . Figure 17 visualizes the effect on δ_{max} and the normal operating duty cycle δ . For $V_{16} = 2 \times V_Z$ these duty cycles have halved. The graph for $\delta = f(V_{16})$ is given in Figure 18. (Note: V_{16} must be less than Pin 1 voltage.)

APPLICATIONS

NE/SE5560 Push-Pull Regulator

This application describes the use of the Signetics NE/SE5560 adapted to function as a push-pull switched mode regulator, as shown in Figures 19 and 20.

Input voltage range is + 12 to + 18V for a nominal output of + 30 and - 30V at a maximum load current of 1A with an average efficiency of 81%.

Features include feed forward input compensation, cycle-to-cycle drive current protection and other voltage sensing, line (to positive output) regulation < 1% for an input range of + 13 to + 18V and load regulation to positive output of < 3% for $\Delta I_L(+)$ of 0.1 to 1 Amp.

The main pulse width modulator operates to 48 kHz with power switching at 24 kHz.

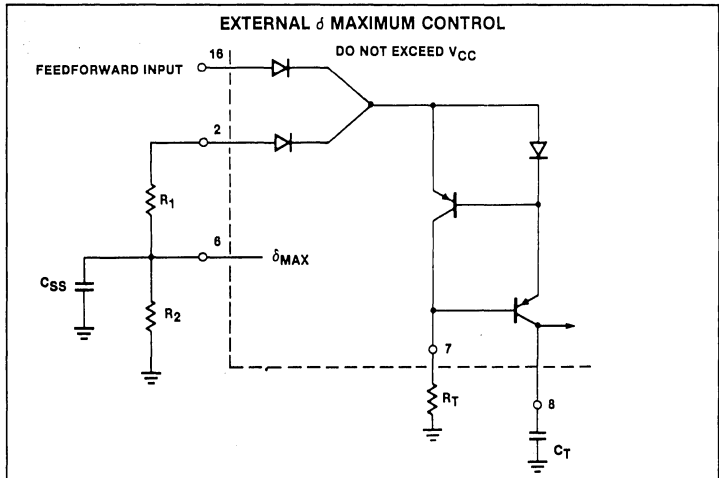

Figure 16

FEED FORWARD CIRCUITRY

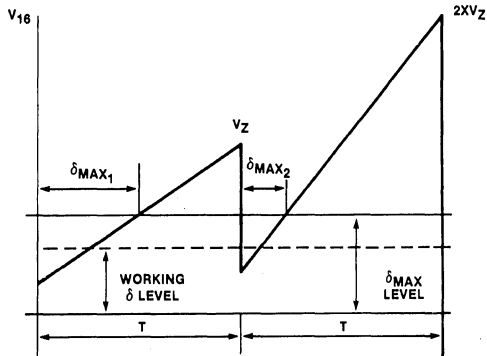

Figure 17

FEED-FORWARD REGULATION

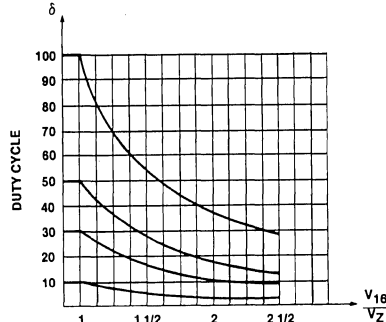
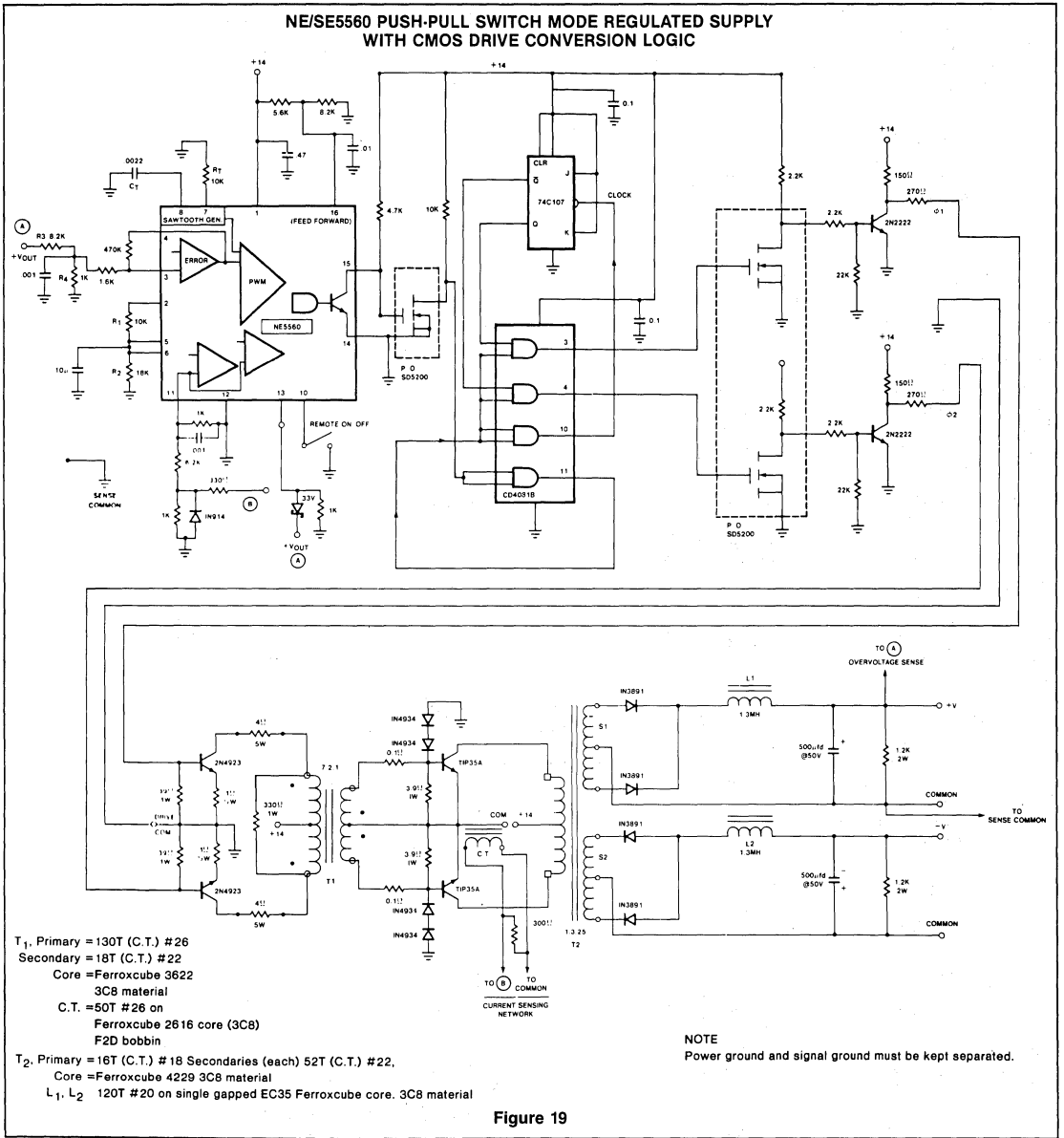

Figure 18

SWITCHED-MODE POWER SUPPLY CONTROL CIRCUIT

SE/NE5560



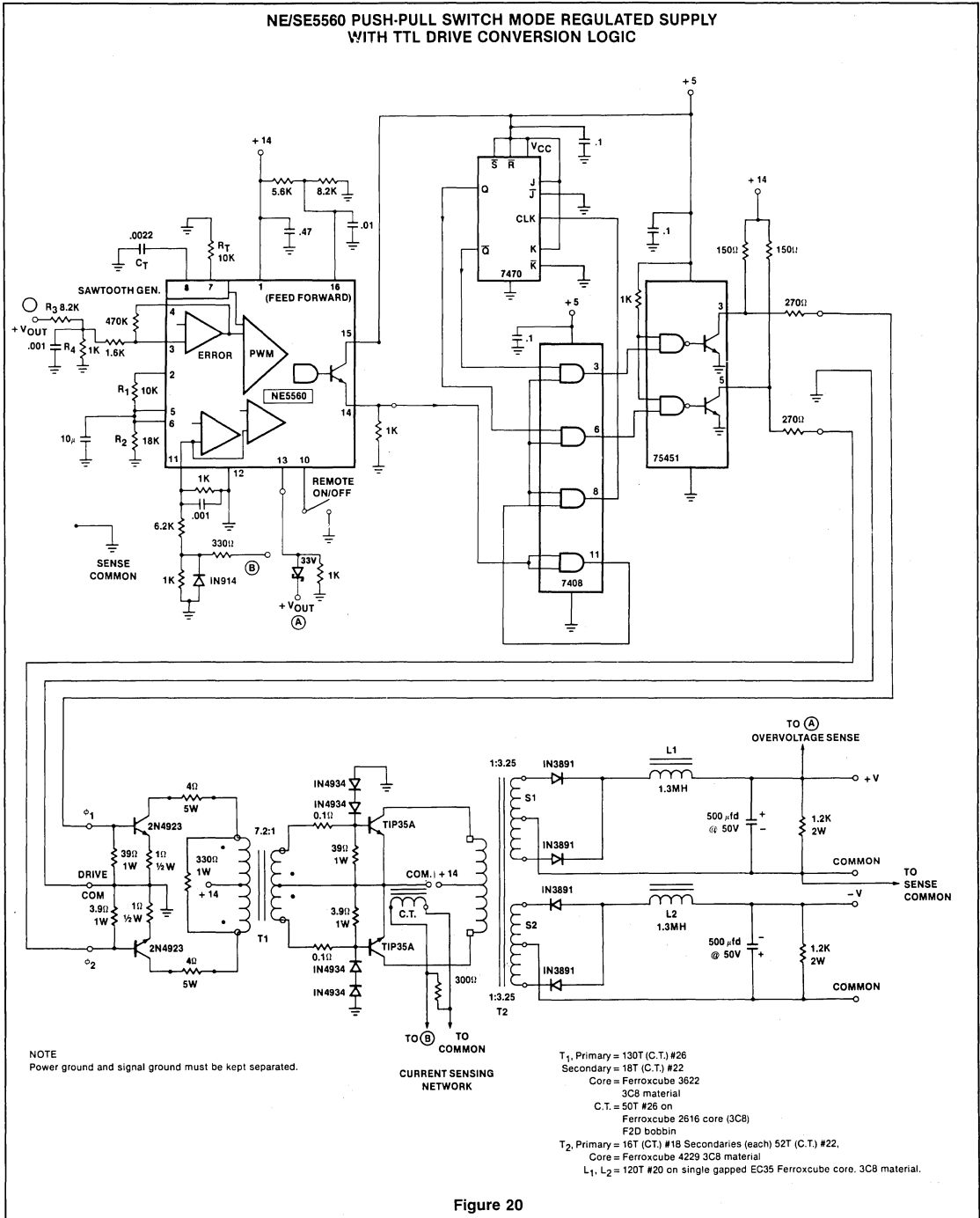

Figure 20

SWITCHED-MODE POWER SUPPLY CONTROL CIRCUIT

SE/NE5561

DESCRIPTION

The NE5561/SE5561 is a control circuit for use in switched mode power supplies. It contains an internal temperature compensated supply, PWM, sawtooth oscillator, over-current sense latch, and output stage. The device is intended for low cost SMPS applications where extensive housekeeping functions are not required.

FEATURES

- Micro-miniature (D) package
- Pulse-width modulator
- Current limiting (cycle by cycle)
- Sawtooth generator
- Stabilized power supply
- Double pulse protection
- Internal temperature compensated reference

APPLICATIONS

- Switched mode power supplies
- D/C motor controller inverter
- DC/DC converter

PIN CONFIGURATION

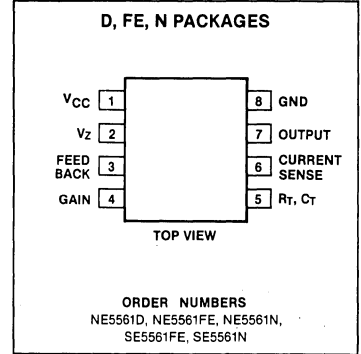

ABSOLUTE MAXIMUM RATINGS

PARAMETER	RATING	UNIT
Supply ¹		
Voltage forced mode	+ 18	V
Current fed mode	30	mA
Output transistor (at 20-30V max)		
Output current	40	mA
Output voltage	$V_{CC} + 1.4V$	V
Output duty cycle	98	%
Max. total power dissipation	0.75	W
Operating temperature range		
SE5561	- 55 to + 125	°C
NE5561	0 to 70	°C

NOTE 1: See Voltage/Current fed supply characteristic curve.

BLOCK DIAGRAM

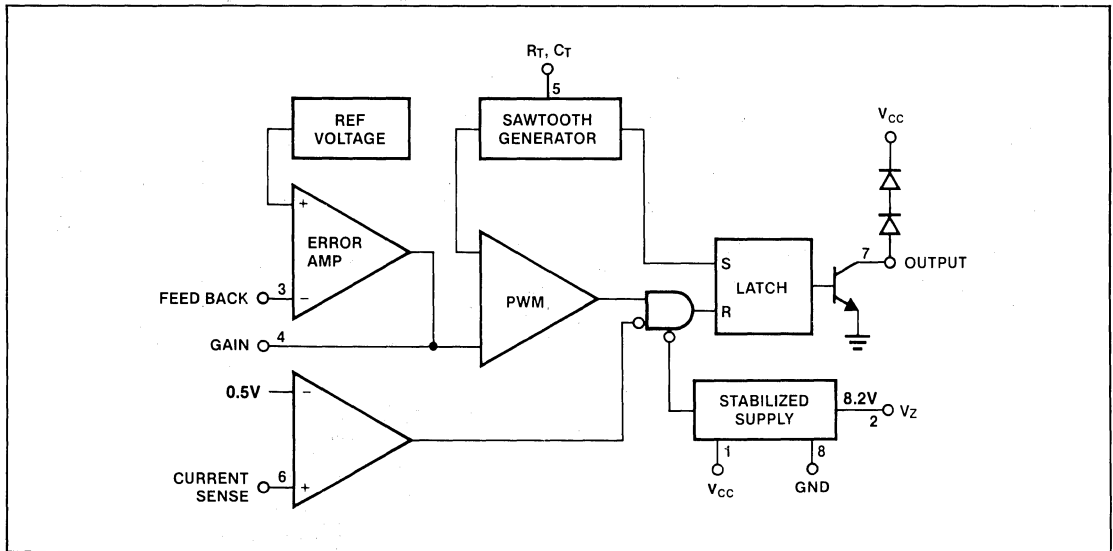

SWITCHED-MODE POWER SUPPLY CONTROL CIRCUIT

SE/NE5561

DC ELECTRICAL CHARACTERISTICS $V_{CC} = 12V$, $T_A = 25^\circ C$ unless otherwise specified.

SYMBOL AND PARAMETER	TEST CONDITIONS	SE5561			NE5561			UNIT	
		Min	Typ	Max	Min	Typ	Max		
REFERENCE SECTION									
V_{REF} Internal ref voltage	$T_A = 25^\circ C$	3.69	3.75	3.84	3.57	3.75	3.96	V	
	Over temp.	3.65		3.88	3.55		3.98	V	
V_Z Internal zener ref	$I_L = 7mA$	7.8	8.2	8.8	7.8	8.2	8.8	V	
Temp coefficient of V_{REF}			± 100			± 100		ppm/ $^\circ C$	
Temp. coefficient of V_Z			± 200			± 200		ppm/ $^\circ C$	
OSCILLATOR SECTION									
Frequency range	Over temp.	50		100k	50		100k	Hz	
Initial accuracy			12			12		%	
Duty cycle range	$f_o = 20kHz$	0		98	0		98	%	
CURRENT LIMITING (I_{IN})									
	Pin 6 = 250mV	$T_A = 25^\circ C$		-2	-10		-2	-10	μA
		Over temp.			-20			-20	μA
Single pulse inhibit delay	Inhibit delay time for 20% overdrive at	$I_{OUT} = 20mA$		0.88	1.10		0.88	1.10	μs
		$I_{OUT} = 40mA$		0.7	0.8		0.7	0.8	μs
Current limit trip level		.400	.500	.600	.400	.500	.600	V	
ERROR AMPLIFIER									
Open loop gain			60			60		dB	
Feedback resistor		10k			10k			Ω	
Small signal bandwidth			3			3		MHz	
Output voltage swing (V_{OH})		6.2			6.2			V	
Output voltage swing (V_{OL})				0.7			0.7	V	
OUTPUT STAGE									
Output current	Over temp.	20			20			mA	
V_{ce} Sat	$I_C = 20mA$, Over temp.			0.4			0.4	V	
SUPPLY VOLTAGE/CURRENT									
I_{CC}	$I_Z = 0$, voltage forced	$T_A = 25^\circ C$			10.0			10.0	mA
		Over temp.			13.0			13.0	mA
V_{CC}	$I_{CC} = 10mA$, current fed	20.0	21.0	22.0	19.0	21.0	24.0	V	
	$I_{CC} = 30mA$ current	20.0		30.0	20.0		30.0	V	
LOW SUPPLY PROTECTION									
Pin 1 threshold		8	9	10.5	8	9	10.5	V	

7

TYPICAL PERFORMANCE CHARACTERISTICS

ERROR AMPLIFIER

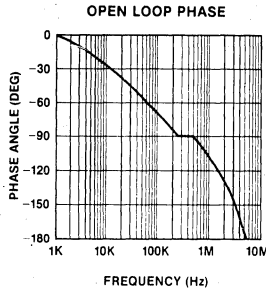
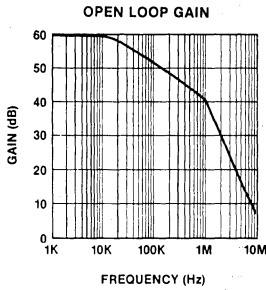

TRANSFER CURVE OF PULSE-WIDTH MODULATOR DUTY CYCLE VS INPUT VOLTAGE

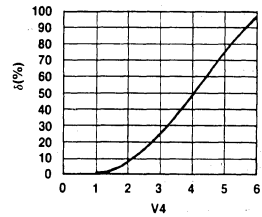

POWER DERATING CURVE

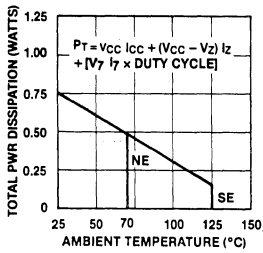

TYPICAL FREQUENCY PLOT VS R_T AND C_T

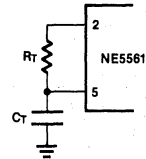
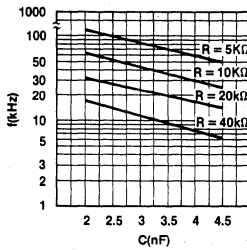

MAXIMUM DUTY CYCLE BASE VOLTAGE ON Q1

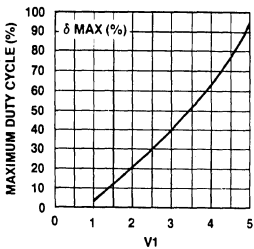

START-UP CIRCUIT

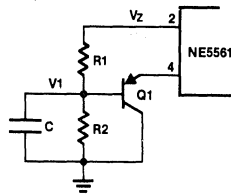

δ_{max} is a function of $t \left[\frac{R_2}{R_1 + R_2} V_Z + V_{BE Q1} \right]$

SLOW START VOLTAGE

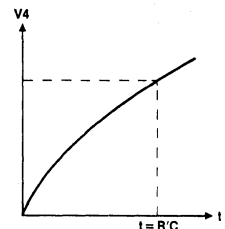

TYPICAL PERFORMANCE CHARACTERISTICS (Continued)

NE5561 VOLTAGE/CURRENT FED SUPPLY CHARACTERISTICS

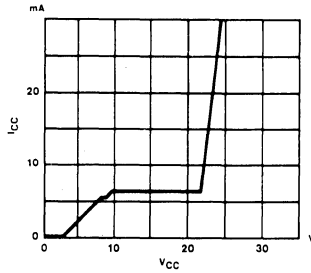

CURRENT FED DROPPING RESISTOR

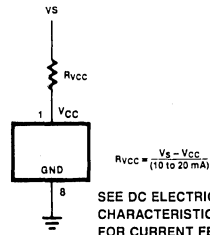

SEE DC ELECTRICAL CHARACTERISTICS FOR CURRENT FED V_{CC} RANGE.

NE5561 Start-Up

The start-up, or initial turn on, of this device requires some degree of external protective duty cycle limiting to prevent the duty cycle from initially going to the extreme maximum ($\hat{\delta} > 90\%$). Either over-current limit or slow start circuitry must be employed to limit duty cycle to a safe value during start-up. Both may be used if desired.

To implement slow-start, the start-up circuit can be used. The divider R1 and R2 sets a voltage, buffered by Q1, such that the output of the error amplifier is clamped to a maximum output voltage, thereby limiting the maximum duty cycle. The addition of capacitor C will cause this voltage to ramp up slowly when power is applied, causing the duty cycle to ramp up simultaneously.

Over-current limit may be used also. To limit duty cycle in this mode, the switch current is monitored at pin 6 and the output of the 5561 is disabled on a cycle by cycle basis when current reaches the programmed limit. With current limit control of slow-start, the duty cycle is limited to that value just allowing maximum switch current to flow. (Approximately 0.50V measured at pin 6.)

APPLICATIONS

5V, 0.5A Buck Regulator Operates from 15V

The converter design shows how simple it is to derive a TTL supply from a system supply of 15V (see Figure 1). The NE5561 drives a 2N4920 PNP transistor directly to provide switching current to the inductor.

Overall line regulation is excellent and covers a range of 12V to 18V with minimal change (< 10 mV) in the output operating at full load.

As with all NE5561 circuits, the auxiliary slow start and $\hat{\delta}_{max}$ circuit is required, as evidenced by Q1. The $\hat{\delta}_{max}$ limit may be calculated by using the relationship (Figure 5a, b).

$$\frac{R_2}{R_1 + R_2} (8.2V) = V\hat{\delta}_{(max)}$$

The maximum duty cycle is then determined from the pulse-width modulator transfer graph, and R1, R2 are defined from the desired conditions.



SWITCHED-MODE POWER SUPPLY CONTROL CIRCUIT

SE/NE5562

Preliminary

DESCRIPTION

The SE/NE5562 is a single output control circuit for Switched Mode Power Supplies. This single monolithic IC contains all control and protection features needed for full featured Switched Mode Power Supplies.

FEATURES

- Stabilized power supply
- Temperature compensated reference source
- Sawtooth generator
- Pulse width modulator
- Remote on/off switching
- Current limiting (2 levels)
- Low supply voltage, with adjustable hysteresis
- Loop fault protection
- Demagnetization/over voltage protection
- Duty cycle adjust and clamp
- Feed forward control
- External synchronization
- Total shutdown after adjustable number of overcurrent faults

PIN CONFIGURATION

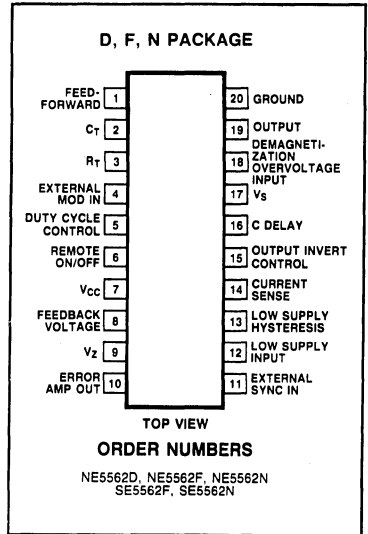

ABSOLUTE MAXIMUM RATINGS

SYMBOL AND PARAMETER	RATING	UNIT
Supply (pin 15)		
Voltage sourced	+15	V
Current sourced	30	mA
Output transistor		
Output current	100	mA
Sync (pin 11) positive		
negative		
Remote on/off (pin 6) positive		
negative		
Feedback pin (pin 8) positive		
negative		
External mod in (pin 4) positive		
negative		
Feedforward (pin 1) positive		
negative		
Error amp out (pin 10) positive		
negative		
Demag/O.V. in (pin 18) positive		
negative		
Current sense (pin 14) positive		
negative		
Low supply sense and hysteresis (Pin 12, 13) positive		
negative		

SWITCHED-MODE POWER SUPPLY CONTROL CIRCUIT

SE/NE5562

Preliminary

BLOCK DIAGRAM

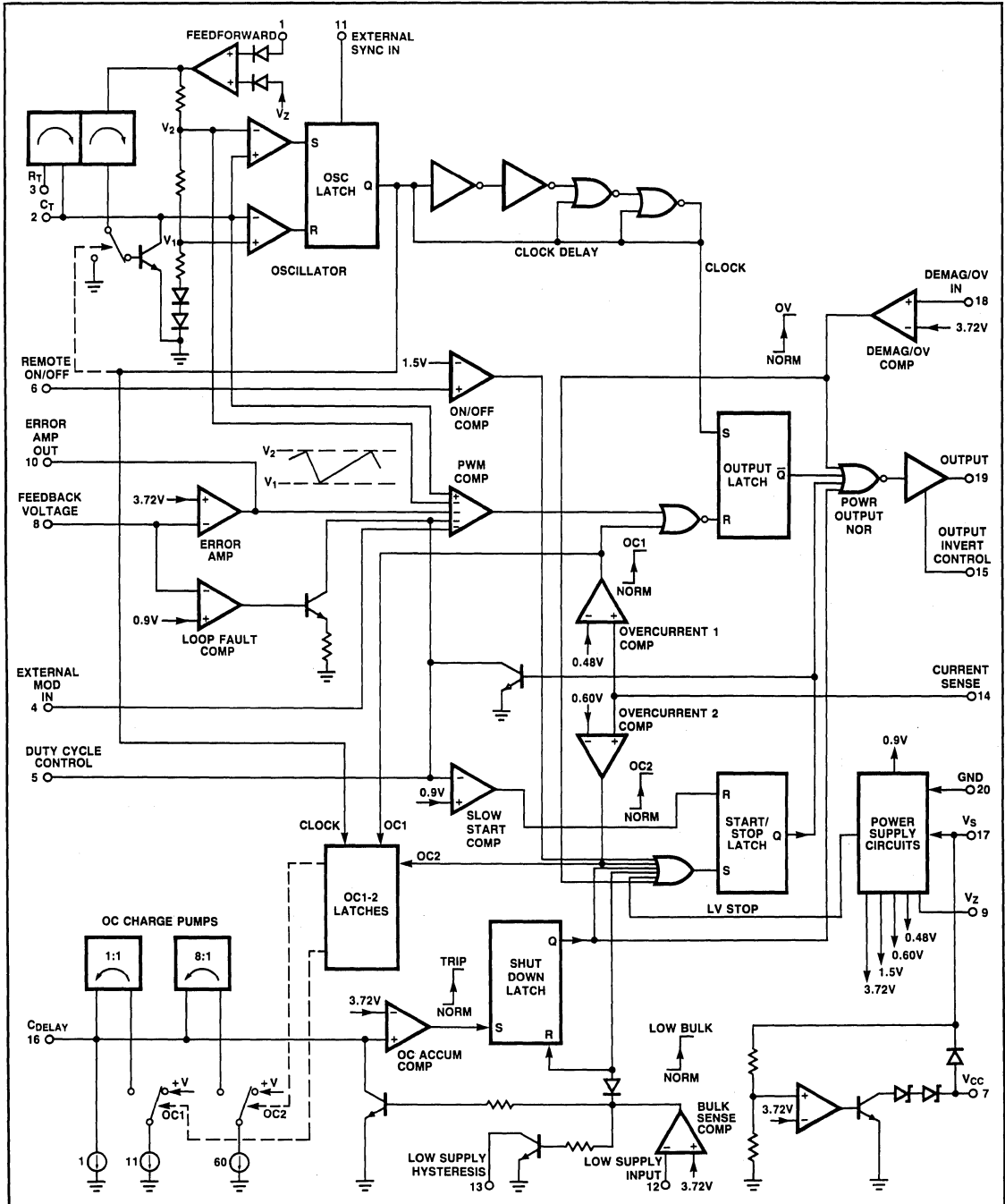

7

SWITCHED-MODE POWER SUPPLY CONTROL CIRCUIT

SE/NE5562

PreliminaryDC ELECTRICAL CHARACTERISTICS: $V_{CC} = 12V$ unless otherwise specified

SYMBOL AND PARAMETER	TEST CONDITIONS	SE5562			NE5562			UNIT
		Min	Typ	Max	Min	Typ	Max	
REFERENCE SECTION								
Reference Voltage V_R	25°C ± 50 ppm/°C (± 1%) Over Temp	3.68	3.72	3.76		3.72		V
Zener Voltage V_Z	IL = 7mA	7.22	7.60	7.98		7.60		V
OSCILLATOR SECTION								
Frequency Range				300			300	kHz
MODULATOR SECTION								
Modulator Input Current	Over Temp $V_{IN} = 1V$		2	20		2	20	μA
HOUSEKEEPING FUNCTIONS								
Deltamax Input Current	Over Temp $V_{IN} = 1V$		2	20		2	20	μA
Accuracy of Duty Cycle Control	f = 15kHz to 150kHz $V_{IN} = 55\%$ of V_Z		50			50		% of Duty Cycle
Low Supply Voltage Shutdown	V_S for Restart Condition	$V_Z + .2$	$V_Z + .7$	$V_Z + 1.5$	$V_Z + .2$	$V_Z + .7$	$V_Z + 1.7$	V
Loop Fault Protection Threshold		.72	.9	.98	.72	.9	.98	V
Demag/Over Voltage Threshold Voltage		3.60	3.72	3.84	3.60	3.72	3.84	V
Over Voltage Input Bias Current			1	10		1	10	μA
FEED FORWARD FUNCTION								
Duty Cycle Reduction at 50% Duty Cycle	Feedforward Voltage V_{FF} $V_{FF} = 2V_Z$		12.785			12.8		% of Duty Cycle
Feedforward Bias Current	Feedforward Voltage V_{FF} $V_{FF} = 2V_Z$.2	5		.2	5	μA
EXTERNAL SYNC								
"ON" Input voltage		.2		.8	.2		.8	V
"OFF" Input Voltage		2		V_Z	2		V_Z	V
Input Low Current	$V_{IN} = 0V$		1	10		1	10	μA
ERROR AMPLIFIER SECTION								
Amplifier Open Loop Gain	$R_L \geq 100K$	60	80		60	80		dB
Amplifier Bias Current			.5	5		5	5	μA
Amplifier Output Current		-1		+1	-1		+1	μA
Amplifier Output Swing		1		$V_Z - 1$	1		$V_Z - 1$	V
REMOTE ON/OFF								
"OFF" Input Voltage		0		.8	0		.8	V
"ON" Input Voltage		2		V_Z	2		V_Z	V
Input Low Current	$V_{IN} = 0V$		1	10		1	10	μA
LOW SUPPLY SHUTDOWN								
Comparator Input Bias Current	$V_{IN} = 0V$		2	10		2	10	μA
Comparator Threshold Voltage		3.50	3.72	3.90		3.72		V
V_{CE} Sat. of Hysteresis Transistor	$I_{OUT} = 1.0mA$ $V_{IN} = 3.0V$.3	.6		.3		V
C_{DELAY} Discharge Current	$V_C = 1.0V$ $V_{IN} = 3.0V$	1	10		1	10		mA

SWITCHED-MODE POWER SUPPLY CONTROL CIRCUIT

SE/NE5562

PreliminaryDC ELECTRICAL CHARACTERISTICS: $V_{CC} = 12V$ unless otherwise specified (cont)

SYMBOL AND PARAMETER	TEST CONDITIONS	SE5562			NE5562			UNIT
		Min	Typ	Max	Min	Typ	Max	
CURRENT SENSE								
OC1 Threshold Voltage		.456	.480	.504		.480		V
OC1 C_{DELAY} Charge Current	$V_{ISENS} = .510V$		10			10		μA
OC2 Threshold Voltage		.570	.600	.630	.560	.600	.640	V
OC2 C_{DELAY} Charge Current	$V_{ISENS} = .640V$		490			490		μA
C_{DELAY} Discharge Current	$V_{ISENS} = 0V$.5	1	1.5	.4	1	1.6	μA
OUTPUT STAGE								
$V_S - V_{OH}$	$11 \leq V_S \leq 15V$ $I_O = 100mA$						2	V
V_{OL}	$11 \leq V_S \leq 15V$ $I_O = 100mA$			1.5			1.5	V
V_{OL}	$11 \leq V_S \leq 15V$ $I_O = 2mA$.4			.4	V
SUPPLY VOLTAGE/CURRENT								
I_{CC}	$I_Z = 0, V_S = 15V$		7.5			7.5		mA
CURRENT FEED SHUNT REGULATOR								
V_S	$I_{IN} = 10mA$	14.25			14			V
V_S	$I_{IN} = 20mA$			16			16	V

SWITCHED-MODE POWER SUPPLY CONTROLLER

NE5568

DESCRIPTION

The NE5568 is a control circuit for use in switched mode power supplies. It contains an internal temperature-compensated supply, PWM, sawtooth oscillator, over-current sense latch, and output stage. The device is intended for low-cost SMPS applications where extensive housekeeping functions are not required. The NE5568 is a selected version of the NE5561.

FEATURES

- Micro-miniature (D) package
- Pulse width modulator
- Current limiting (cycle by cycle)
- Sawtooth generator
- Stabilized power supply
- Double pulse protection
- Internal temperature-compensated reference

APPLICATIONS

- Switch mode power supplies
- DC motor controller inverter
- DC/DC converter

PIN CONFIGURATION

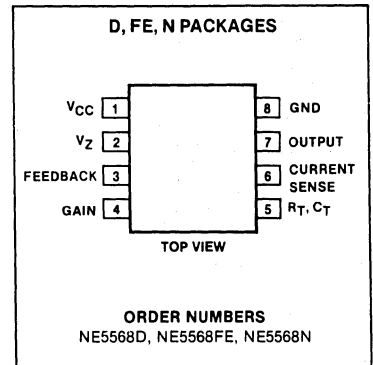

ABSOLUTE MAXIMUM RATINGS

PARAMETER	RATING	UNIT
Supply voltage, V_{CC}	18	V
Output current	40	mA
Output duty cycle	98	%
Max total power dissipation	0.75	W
Operating temperature range	0 to 70	$^{\circ}\text{C}$

BLOCK DIAGRAM

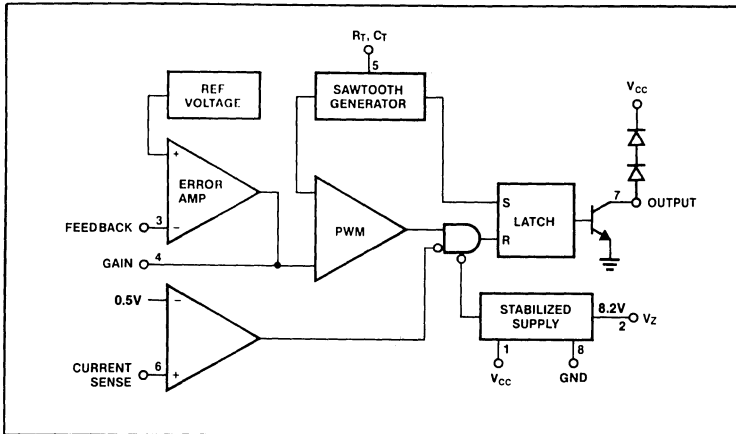

SWITCHED-MODE POWER SUPPLY CONTROLLER

NE5568

DC ELECTRICAL CHARACTERISTICS $V_{CC} = 12V$, $T_A = 25^\circ C$ unless otherwise specified.

SYMBOL AND PARAMETER	TEST CONDITIONS	NE5568			UNIT
		Min	Typ	Max	
Reference Section V_{REF} , Internal ref voltage	$T_A = 25^\circ C$	3.69	3.75	3.84	V
	Over temperature	3.66		3.87	V
V_Z , Internal zener ref	$I_L = 7mA$	7.8	8.2	8.8	V
Temperature coefficient of V_{REF}			± 100		ppm/ $^\circ C$
Temperature coefficient of V_Z			± 200		ppm/ $^\circ C$
Oscillator Section Frequency range	Over temperature	50		100k	Hz
Initial accuracy			12		%
Duty cycle range	$f_O = 20kHz$	0		98	%
Current Limiting (I_{IN})	Pin 6 = 250mV	$T_A = 25^\circ C$	- 2	- 10	μA
		Over temp.		- 20	μA
Single pulse inhibit delay	Inhibit delay time for 20% overdrive at	$I_{OUT} = 20mA$	0.88	1.10	μs
		$I_{OUT} = 40mA$	0.7	0.8	μs
Current limit trip level		0.400	0.500	0.600	V
Error Amplifier Open loop gain			60		dB
Feedback resistor		10k			Ω
Small signal bandwidth			3		MHz
V_{OH} , Output voltage swing		6.2			V
V_{OL} , Output voltage swing				0.7	V
Output Stage Output current	Over temperature	20			mA
V_{CE} , Saturation	$I_C = 20mA$, over temperature			0.4	V
	$I_C = 40mA$, over temperature			0.5	V
Supply Voltage/Current I_{CC}	$I_Z = 0$, voltage fed	$T_A = 25^\circ C$		10.0	mA
		Over temp.		13.0	mA
V_{CC}	$I_S = 10mA$, current fed	19.0	21.0	24.0	V
	$I_{CC} = 30mA$, current fed	20.0		30.0	V
Low Supply Protection Pin 1 threshold		8.0	9.0	10.5	V

NOTE

All curves and applications of NE5561 apply exactly.

7

Preliminary

DESCRIPTION

SPECIFICALLY DESIGNED for use in fixed-frequency switching regulators and other power control applications, these Switched-Mode Power Supply Control Circuits can be used to implement single-ended or push-pull switching regulators of either polarity, both transformerless and transformer coupled.

Included in these monolithic integrated circuits are a temperature-compensated voltage reference, sawtooth oscillator, error amplifier, pulse-width modulator, pulse metering and steering logic, and two 200 mA source/sink power drivers. Also included are housekeeping functions such as soft-start and low supply voltage lockout, digital current limiting, double-pulse inhibit, a data latch for single-pulse metering, adjustable deadtime, and provision for symmetry correction inputs.

For ease of interface, all digital inputs are TTL and CMOS compatible. Active LOW logic allows wired-OR connections for maximum flexibility.

The SG1526A is supplied in an 18-pin glass/ceramic (cer-DIP) hermetic package and is characterized for operation over the full temperature range of -55°C to $+125^{\circ}\text{C}$, allowing its use in military and aerospace applications. The SG2526A is rated for operation over the extended range of -40°C to $+85^{\circ}\text{C}$ recommending it for many industrial applications. The low-cost SG3526A is rated for continuous operation over the commercial temperature range of 0°C to $+70^{\circ}\text{C}$. The extended and commercial versions are furnished in either the cer-DIP package or a dual in-line plastic package with copper alloy lead frame for improved heat dissipation.

FEATURES

- 8 to 35 V Operation
- Dual 100 mA Source/Sink Outputs
- Stabilized Power Supply
- Current Limiting
- Temperature Compensated Reference Source
- Sawtooth Generator
- Low Supply Voltage Protection
- External Synchronization
- Double-Pulse Suppression
- Programmable Deadtime
- Programmable Soft Start
- 18-Pin Dual In-Line Plastic Package Or 18-Pin Cer-DIP Hermetic Package

PIN CONFIGURATION

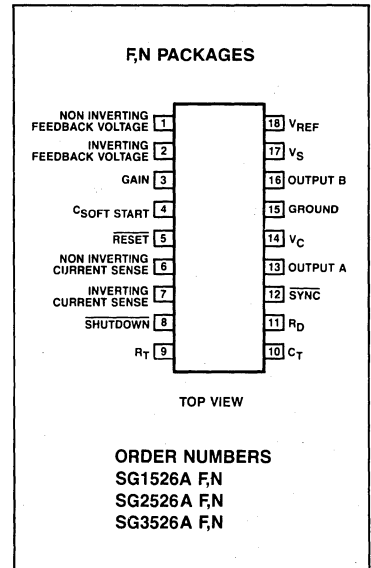

ABSOLUTE MAXIMUM RATINGS

PARAMETER	RATING	UNIT
Supply Voltage, V_S	40	V
Collector Supply Voltage, V_C	40	V
Logic Input Voltage Range, V_{IN}	-0.3 to +5.5	V
Analog Input Voltage Range, V_{IN}	-0.3 V to V_S	V
Output Current, I_O	± 200	mA
Reference Load Current, I_{REF}	50	mA
Logic Sink Current, I_{IN}	15	mA
Package Power Dissipation, P_D (Plastic DIP) (Cer-DIP)	2.3 1.9	W^{*1} W^{*1}
Storage Temperature Range, T_S	-65 to +150	$^{\circ}\text{C}$

NOTE:
 *1 Derate linearly to 0 watts at $T_A = +150^{\circ}\text{C}$.

Preliminary

BLOCK DIAGRAM

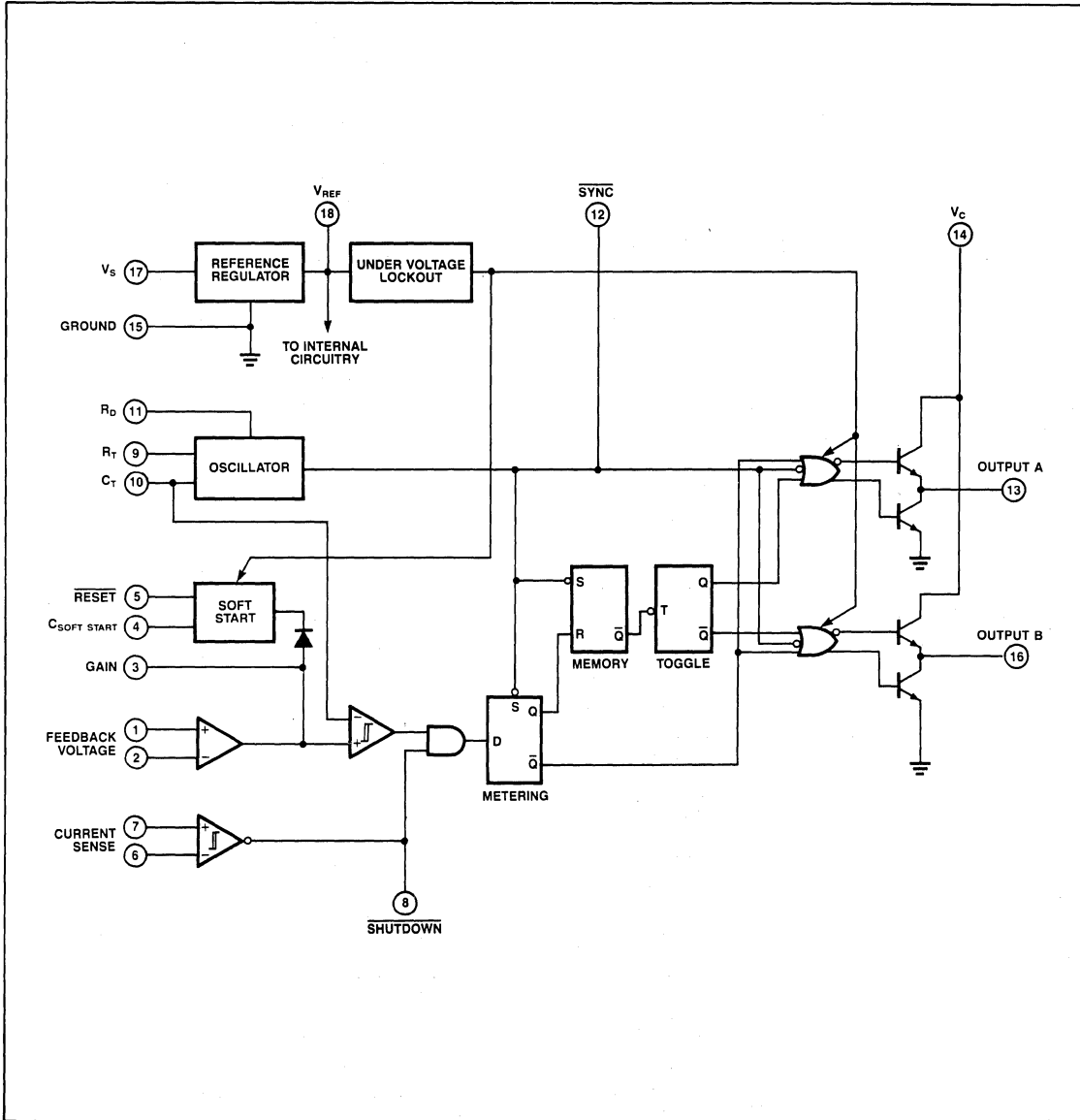

Preliminary

ELECTRICAL CHARACTERISTICS over operating temperature range, V_S 15 V (unless otherwise noted).

CHARACTERISTIC	TEST PINS	TEST CONDITIONS	LIMITS						UNITS
			SG1526A & SG2526A			SG3526A			
			Min.	Typ.	Max.	Min.	Typ.	Max.	
REFERENCE SECTION ($I_L = 0$ mA)									
Reference Voltage	18	$T_A = +25^\circ\text{C}$	4.95	5.00	5.05	4.90	5.00	5.10	V
		Over Recommended Conditions	4.90	5.00	5.10	4.85	5.00	5.15	V
Ref. Volt. Regulation	18	$V_S = 8$ to 35 V	—	10	20	—	10	30	mV
		$I_L = 0$ to 20 mA	—	10	30	—	10	50	mV
		Over Oper. Temp. Range	—	15	50	—	15	50	mV
Short Circuit Current	18	$V_{REF} = 0$ V	25	50	100	25	50	100	mA
Standby Current	17	$V_S = 35$ V, $R_T = 4.22$ k Ω , $V_S = 0.4$ V	—	18	—	—	18	—	mA
OSCILLATOR SECTION ($f = 40$ kHz, $R_T = 4.22$ k Ω , $C_T = 0.01$ μF , $R_D = 0$ Ω)									
Oscillator Frequency	9, 10	$R_T = 150$ Ω , $C_T = 20$ μF	—	—	1.0	—	—	1.0	Hz
		$R_T = 2$ k Ω , $C_T = 0.001$ μF	400	—	—	400	—	—	kHz
Initial Osc. Accuracy	9, 10	$T_A = +25^\circ\text{C}$	—	3.0	—	—	3.0	—	%
Osc. Stability	9, 10	$V_S = 8$ to 35 V	—	0.5	—	—	0.5	—	%
		Over oper. Temp. Range	—	1.0	—	—	1.0	—	%
		Other Recommended Conditions	—	2.0	—	—	2.0	—	%
Sawtooth Peak Voltage	12	$V_S = 35$ V	—	3.0	3.5	—	3.0	3.5	V
Sawtooth Valley Volt.	12	$V_S = 8.0$ V	0.5	1.0	—	0.5	1.0	—	V
Sync. Pulse Width	12	$C_L = 15$ pF	—	500	—	—	500	—	ns
ERROR AMPLIFIER ($V_{CM} = 0$ to 5.2 V)									
Input Offset Voltage	1, 2	$R_S = 2$ k Ω	—	2.0	5.0	—	2.0	5.0	mV
Input Bias Current	1, 2		—	-350	-1000	—	-350	-2000	nA
Input Offset Current	1, 2		—	35	100	—	35	200	nA
Error Amp Gain	1-3	Open Loop, $R_L = 10$ M Ω	64	72	—	60	72	—	dB
Small Signal BW	1-3	$C_L = 30$ pF	0.7	1.0	—	0.7	1.0	—	MHz
Output Voltage Swing	3	Positive Limit, $R_L = 50$ k Ω	3.6	4.2	—	3.6	4.2	—	V
		Negative Limit, $R_T = 50$ k Ω	—	0.2	0.4	—	0.2	0.4	V
Common Mode Range	1, 2	$V_S = 8.0$ V	0	—	5.2	0	—	5.2	V
Common Mode Rejection	1, 2	$R_S = 10$ k Ω	70	94	—	70	94	—	dB
Error Amp. V_S Rej.	3	$f = 120$ Hz, $\Delta V_S = 1$ Vrms	66	80	—	66	80	—	dB
HOUSEKEEPING FUNCTIONS									
Logic Voltage Levels	5, 8, 12	Logic HIGH, $I_{SOURCE} = -40$ μA	2.4	4.0	—	2.4	4.0	—	V
		Logic LOW, $I_{SINK} = 3.6$ mA	—	0.2	0.4	—	0.2	0.4	V
Input Current	5, 8, 12	$V_{IN} = 2.4$ V	—	-125	-200	—	-125	-200	μA
		$V_{IN} = 0.4$ V	—	-225	-360	—	-225	-360	μA
Shutdown Delay	8-13, 16	100mV step, 5mV overdrive, $R_S = 50$ Ω	—	300	—	—	300	—	ns
CURRENT LIMITING									
Common Mode Range	6, 7	$V_S = 18$ V	0	—	15	0	—	15	V
Sense Voltage	6, 7	$V_{CM} = 0$ to 15 V	—	100	—	—	100	—	mV
Input Current	6, 7	$V_{CM} = 0$ to 15 V	—	-3.0	—	—	-3.0	—	μA
Voltage Gain	7-8	$I_S = 360$ μA	—	68	—	—	68	—	dB

SWITCHED-MODE POWER SUPPLY CONTROL CIRCUITS

SG1526A/2526A/3526A

Preliminary

ELECTRICAL CHARACTERISTICS over operating temperature range, V_S 15 V (unless otherwise noted). (Cont'd)

CHARACTERISTIC	TEST PINS	TEST CONDITIONS	LIMITS						UNITS
			SG1526A & SG2526A			SG3526A			
			Min.	Type.	Max.	Min.	Typ.	Max.	
SOFT START SECTION									
Error Clamp Voltage	—	$V_S = 0.4$ V	—	100	400	—	100	400	mV
C_S Charging Current	4	$V_S = 2.4$ V	—	100	—	—	100	—	μ A
OUTPUT DRIVERS ($V_C = 15$ V)									
Output Voltage	12, 16	$I_{OUT} = -20$ mA	12.5	13.5	—	12.5	13.5	—	V
		$I_{OUT} = -100$ mA	—	13	—	—	13	—	V
		$I_{OUT} = 20$ mA	—	0.2	0.3	—	0.2	0.3	V
		$I_{OUT} = 100$ mA	—	1.2	—	—	1.2	—	V
Leakage Current	12, 16	$V_C = 40$ V	—	0.1	100	—	0.1	100	μ A
Rise Time	12, 16	$C_L = 1000$ pF	—	300	—	—	300	—	ns
Fall Time	12, 16	$C_L = 1000$ pF	—	200	—	—	200	—	ns

NOTES:

Negative current is defined as coming out of (sourcing) the specified device pin.

*Commercial, extended, and full temperature range devices are defined on page 2.

RECOMMENDED OPERATING CONDITIONS

Logic Supply Voltage, V_S	8 V to 35 V
Collector Voltage, V_C	4.5 V to 35 V
Output Load Current, I_O	0 to \pm 100 mA
Reference Load Current, I_L	0 to 20 mA
Oscillator Frequency, f	1 Hz to 400 kHz
Oscillator Timing Resistance, R_T	2 k Ω to 150 k Ω
Oscillator Timing Capacitance, C_T	0.001 μ F to 20 μ F
Programmed Deadtime	3% to 50%



DESCRIPTION

This monolithic integrated circuit contains all the control circuitry for a regulating power supply inverter or switching regulator. Included in a 16-pin dual-in-line package is the voltage reference, error-amplifier, oscillator, pulse width modulator, pulse steering flip-flop, dual alternating output switches and current limiting and shut-down circuitry. This device can be used for switching regulators of either polarity, transformer coupled DC to DC converters, transformerless voltage doublers and polarity converters, as well as other power control applications. The SG3524 is designed for commercial applications of 0°C to +70°C.

FEATURES

- Complete PWM power control circuitry
- Single ended or push-pull outputs
- Line and load regulation of 0.2%
- 1% maximum temperature variation
- Total supply current is less than 10mA
- Operation beyond 100kHz

PIN CONFIGURATION

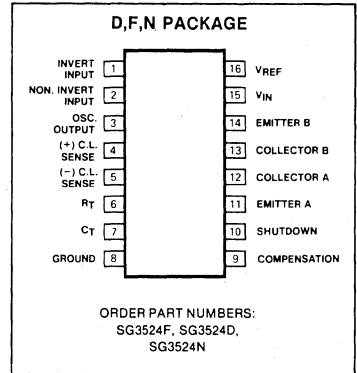

ABSOLUTE MAXIMUM RATINGS

PARAMETER	RATING	UNIT
Input voltage	40	V
Output current (each output)	100	mA
Reference output current	50	mA
Oscillator charging current	5	mA
Power dissipation		
Package limitation	1000	mW
Derate above 25°C	8	mW/°C
Operating temperature range	0 to +70	°C
Storage temperature range	-65 to +150	°C

BLOCK DIAGRAM

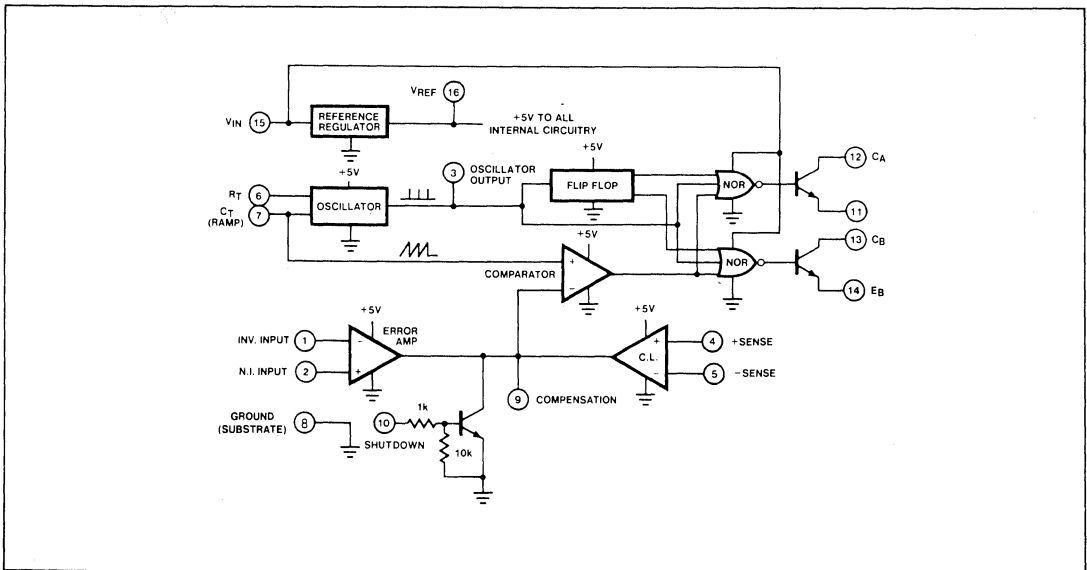

DC ELECTRICAL CHARACTERISTICS ($T_A = 0^\circ\text{C}$ to $+70^\circ\text{C}$, $V_{ON} = 20\text{V}$, and $f = 20\text{kHz}$ unless otherwise specified.)

PARAMETER	TEST CONDITIONS	SG3524			UNIT
		Min	Typ	Max	
Reference Section					
Output voltage		4.6	5.0	5.4	V
Line regulation	$V_{IN} = 8$ to 40V		10	30	mV
Load regulation	$I_L = 0$ to 20mA		20	50	mV
Ripple rejection	$f = 120\text{Hz}$, $T_A = 25^\circ\text{C}$		66		dB
Short circuit current limit	$V_{REF} = 0$, $T_A = 25^\circ\text{C}$		100		mA
Temperature stability	Over operating temperature range		0.3	1	%
Long term stability	$T_A = 25^\circ\text{C}$		20		mV/kHr
Oscillator Section					
Maximum frequency	$C_T = .001$ mfd, $R_T = 2\text{k}\Omega$		300		kHz
Initial accuracy	R_T and C_T constant		5		%
Voltage stability	$V_{IN} = 8$ to 40V , $T_A = 25^\circ\text{C}$			1	%
Temperature stability	Over operating temperature range			2	%
Output amplitude	Pin 3, $T_A = 25^\circ\text{C}$		3.5		V_P
Output pulse width	$C_T = .01$ mfd, $T_A = 25^\circ\text{C}$		0.5		μs
Error Amplifier Section					
Input offset voltage	$V_{CM} = 2.5\text{V}$		2	10	mV
Input bias current	$V_{CM} = 2.5\text{V}$		2	10	μA
Open loop voltage gain		68	80		dB
Common mode voltage	$T_A = 25^\circ\text{C}$	1.8		3.4	V
Common mode rejection ratio	$T_A = 25^\circ\text{C}$		70		dB
Small signal bandwidth	$A_V = 0\text{dB}$, $T_A = 25^\circ\text{C}$		3		MHz
Output voltage	$T_A = 25^\circ\text{C}$	0.5		3.8	V
Comparator Section					
Duty cycle	% each output "ON"	0		45	%
Input threshold	Zero duty cycle		1		V
Input threshold	Maximum duty cycle		3.5		V
Input bias current			1		μA
Current Limiting Section					
Sense voltage	Pin 9 = 2V with error amplifier set for maximum out, $T_A = 25^\circ\text{C}$	180	200	220	mV
Sense voltage T.C.			0.2		mV/ $^\circ\text{C}$
Common mode voltage		-1		+1	V
Output Section (each output)					
Collector-emitter voltage (breakdown)		40			V
Collector-leakage current	$V_{CE} = 40\text{V}$		0.1	50	μA
Saturation voltage	$I_C = 50\text{mA}$		1	2	V
Emitter output voltage	$V_{IN} = 20\text{V}$	17	18		V
Rise time	$R_C = 2\text{k}\Omega$, $T_A = 25^\circ\text{C}$		0.2		μs
Fall time	$R_C = 2\text{k}\Omega$, $T_A = 25^\circ\text{C}$		0.1		μs
Total standby current (excluding oscillator charging current, error and current limit dividers, and with outputs open)	$V_{IN} = 40\text{V}$		8	10	mA

THEORY OF OPERATION

Voltage Reference

An internal series regulator provides a nominal 5 volt output which is used both to generate a reference voltage and is the regulated source for all the internal timing and controlling circuitry. This regulator may be bypassed for operation from a fixed 5 volt supply by connecting pins 15 and 16 together to the input voltage. In this configuration, the maximum input voltage is 6.0 volts.

This reference regulator may be used as a 5 volt source for other circuitry. It will provide up to 50mA of current itself and can easily be expanded to higher currents with an external PNP as shown in Figure 1.

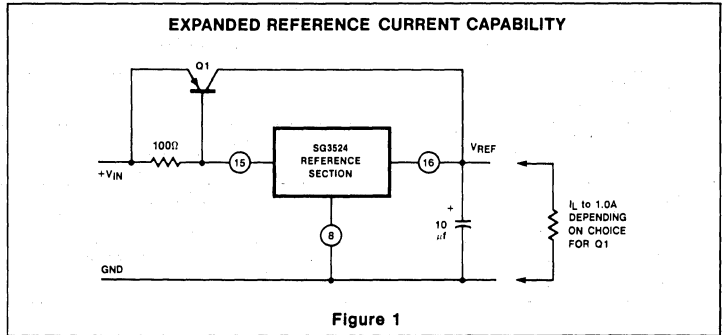

TEST CIRCUIT

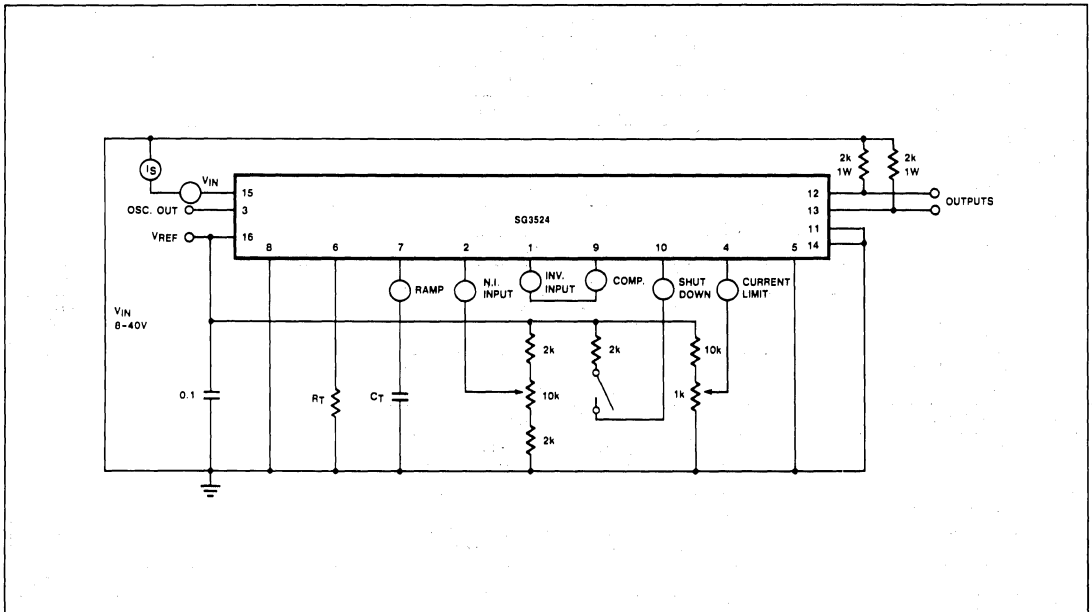

OUTPUT STAGE DEAD TIME AS A FUNCTION OF THE TIMING CAPACITOR VALUE

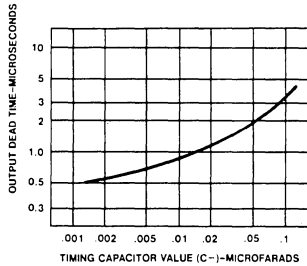

Figure 2

OSCILLATOR PERIOD AS A FUNCTION OF R_T AND C_T

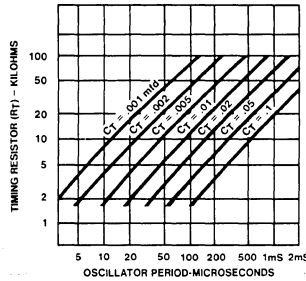

Figure 3

AMPLIFIES OPEN-LOOP GAIN AS A FUNCTION OF FREQUENCY AND LOADING ON PIN 9

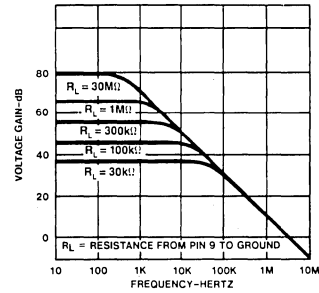

Figure 4

Oscillator

The oscillator in the SG3524 uses an external resistor (R_T) to establish a constant charging current into an external capacitor (C_T). While this uses more current than a series connected RC, it provides a linear ramp voltage on the capacitor which is also used as a reference for the comparator. The

charging current is equal to 3.6V ÷ R_T and should be kept within the range of approximately 30μA to 2mA, i.e., 1.8K < R_T < 100K.

The range of values for C_T also has limits as the discharge time of C_T determines the pulse width of the oscillator output pulse. This pulse is used (among other things) as a blanking pulse to both outputs to insure that there is no possibility of having both outputs on simultaneously during transitions. This output dead time relationship is shown in Figure 2. A pulse width below approximately 0.5 microseconds may allow false triggering of one output by removing the blanking pulse prior to the flip-flops reaching a stable state. If small values of C_T must be used, the pulse width may still be expanded by adding a shunt capacitance (≈ 100pF) to ground at the oscillator output. (Note: Although the oscillator output is a convenient oscilloscope sync input, the cable and input capacitance may increase the blanking pulse width slightly.) Obviously, the upper limit to the pulse width is determined by the maximum duty cycle acceptable. Practical values of C_T fall between .001 and 0.1 microfarad.

The oscillator period is approximately t = R_TC_T where t is in microseconds when R_T = ohms and C_T = microfarads. The use of Figure 3 will allow selection of R_T and C_T for a wide range of operating frequencies. Note that for series regulator applications, the

two outputs can be connected in parallel for an effective 0-90% duty cycle and the frequency of the oscillator is the frequency of the output. For push-pull applications, the outputs are separated and the flip-flop divides the frequency such that each outputs duty cycle is 0-45% and the overall frequency is one-half that of the oscillator.

External Synchronization

If it is desired to synchronize the SG3524 to an external clock, a pulse of ≈ +3 volts may be applied to the oscillator output terminal with R_TC_T set slightly greater than the clock period. The same considerations of pulse width apply. The impedance to ground at this point is approximately 2K ohms.

If two or more SG3524s must be synchronized together, one must be designated as master with its R_TC_T set for the correct period. The slaves should each have an R_TC_T set for approximately 10% longer period than the master with the added requirement that C_T (slave) = one-half C_T (master). Then connecting Pin 3 on all units together will insure that the master output pulse—which occurs first and has a wider pulse width—will reset the slave units.

Error Amplifier

This circuit is a simple differential-input, transconductance amplifier. The output is the compensation terminal, pin 9, which is a high impedance node (R_L ≈ 5MΩ). The gain is

$$A_v = gmR_L = \frac{8 I_C R_L}{2kT}$$

and can easily be reduced from a nominal of 10,000 by an external shunt resistance from pin 9 to ground, as shown in Figure 4.

In addition to DC gain control, the compensation terminal is also the place for AC phase compensation. The frequency response curves of Figure 4 show the uncompensated amplifier with a single pole at approximately 200Hz and a unity gain cross-over at 5MHz.

Typically, most output filter designs will introduce one or more additional poles at a significantly lower frequency. Therefore, the best stabilizing network is a series R-C combination between pin 9 and ground which introduces a zero to cancel one of the output filter poles. A good starting point is 50kΩ plus .001 microfarad.

One final point on the compensation terminal is that this is also a convenient place to insert any programming signal which is to override the error amplifier. Internal shutdown and current limit circuits are connected here, but any other circuit which can sink 200μA can pull this point to ground thus shutting off both outputs.

While feedback is normally applied around the entire regulator, the error amplifier can be used with conventional operational amplifier feedback and is stable in either the inverting or non-inverting mode. Regardless of the connections, however, input common-mode limits must be observed or output signal inversions may result. For conventional regulator applications, the 5 volt reference voltage must be divided down as shown in Figure 5. The error amplifier may also be used in fixed duty cycle applications by using the unity gain configuration shown in the open loop test circuit.



Current Limiting

The current limiting circuitry of the SG3524 is shown in Figure 6.

By matching the base-emitter voltages of Q1 and Q2, and assuming negligible voltage drop across R₁:

$$\begin{aligned} \text{Threshold} &= V_{BE}(Q1) + I_1 R_2 - V_{BE}(Q2) \\ &= I_1 R_2 \approx 200\text{mV} \end{aligned}$$

Although this circuit provides a relatively small threshold with a negligible temperature coefficient, there are some limitations to its use, the most important of which is the ±1 volt common mode range which requires sensing in the ground line. Another factor to consider is that the frequency compensation provided by R₁C₁ and Q1 provides a roll-off pole at approximately 300Hz.

Since the gain of this circuit is relatively low, there is a transition region as the current limit amplifier takes over pulse width control from the error amplifier. For testing purposes, threshold is defined as the input voltage to get 25% duty cycle with the error amplifier signaling maximum duty cycle.

In addition to constant current limiting, pins 4 and 5 may also be used in transformer-coupled circuits to sense primary current and shorten an output pulse, should transformer saturation occur. (Refer to Figure 11.) Another application is to ground pin 5 and use pin 4 as an additional shutdown terminal: i.e., the output will be off with pin 4 open and on when it is grounded. Finally, foldback current limiting can be provided with the network of Figure 7. This circuit can reduce the short-circuit current (I_{SC}) to approximately one-third the maximum available output current (I_{MAX}).

***For additional information, consult the Applications Section.**

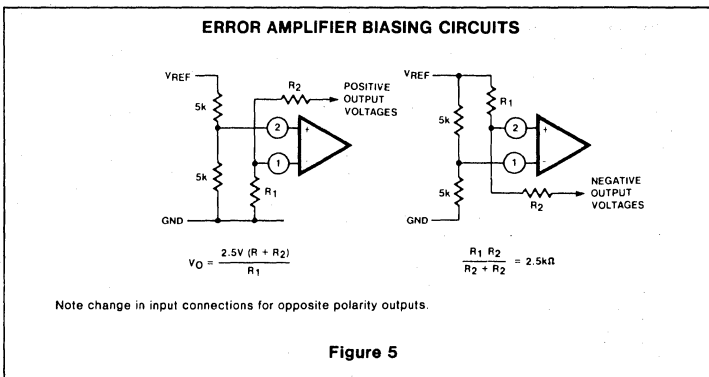

Figure 5

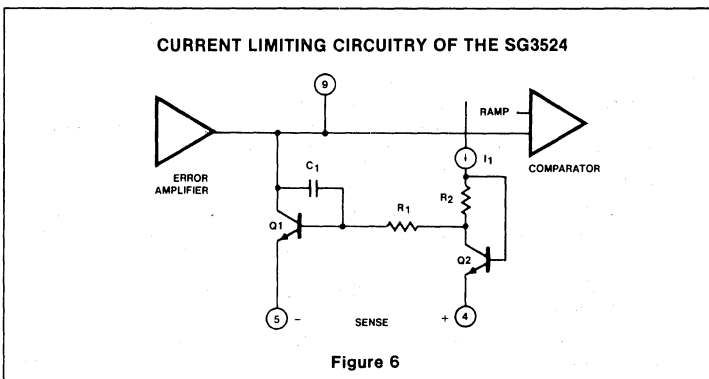

Figure 6

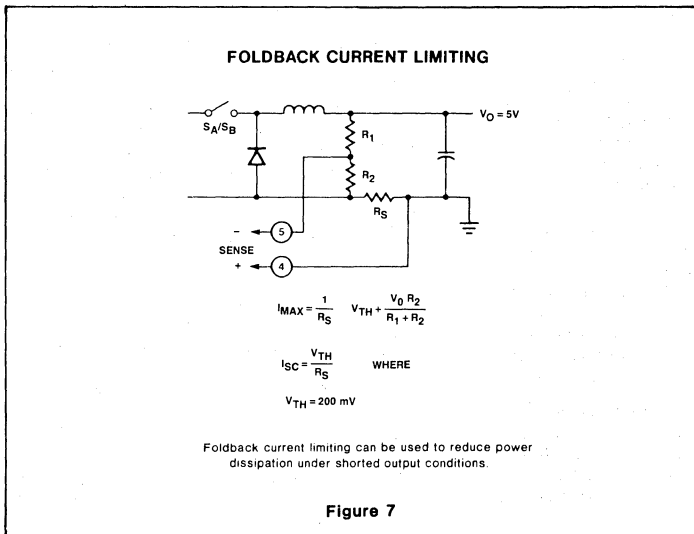

Figure 7

PRECISION VOLTAGE REGULATOR

μ A723/723C/SA723C

DESCRIPTION

The μ A723/SA723C is a Monolithic Precision Voltage Regulator capable of operation in positive or negative supplies as a series, shunt, switching or floating regulator. The 723 contains a temperature compensated reference amplifier, error amplifier, series pass transistor, and current limiter, with access to remote shutdown.

FEATURES

- Positive or negative supply operation
- Series, shunt, switching or floating operation
- .01% line and load regulation
- Output voltage adjustable from 2 to 37 volts
- Output current to 150mA without external pass transistor
- μ A723 MIL STD 88 3A, B, C available

ABSOLUTE MAXIMUM RATINGS

PARAMETER	RATING	UNIT
Pulse voltage from $V+$ to $V-$ (50 ms)	50	V
Continuous voltage from $V+$ to $V-$	40	V
Input-output voltage differential	40	V
Maximum output current	150	mA
Current from V_{REF}	15	mA
Current from V_z	25	mA
Internal power dissipation ¹	800	mW
Operating temperature range		$^{\circ}$ C
μ A723	-55 to +125	
μ A723C	0 to 70	
SA723C	-40 to +85	
Storage temperature range	-65 to +150	$^{\circ}$ C
Lead temperature	300	$^{\circ}$ C

PIN CONFIGURATIONS

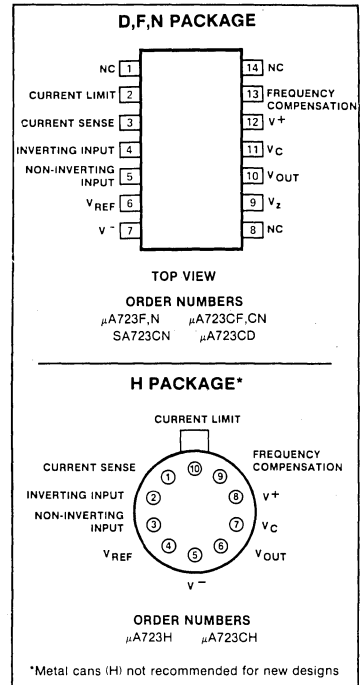

EQUIVALENT CIRCUIT

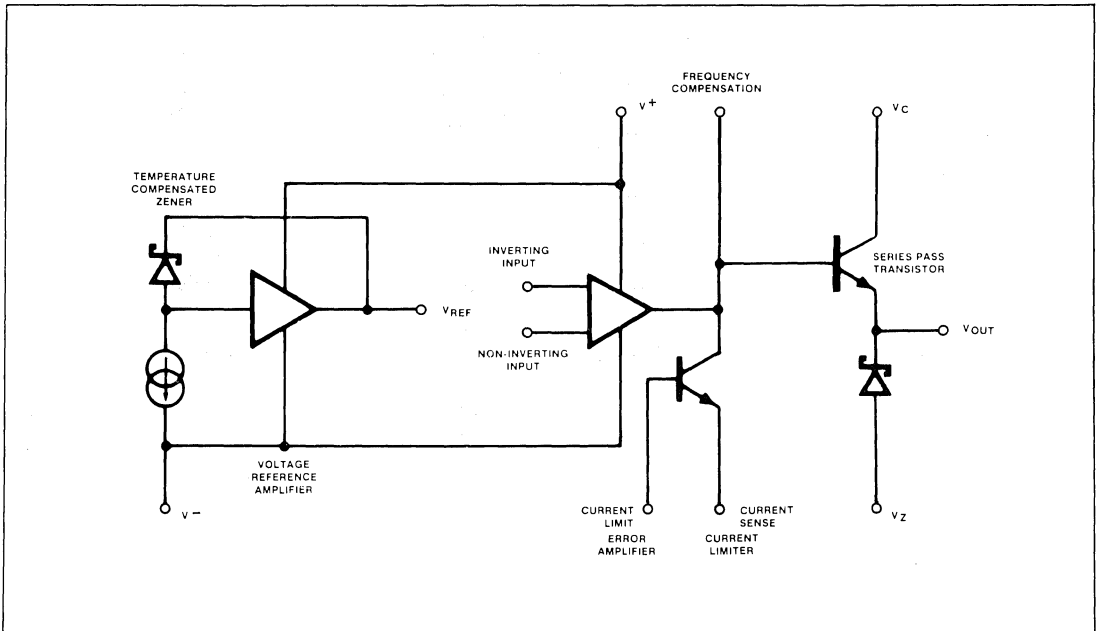

7

PRECISION VOLTAGE REGULATOR

μ A723/723C/SA723C

DC ELECTRICAL CHARACTERISTICS $T_A = 25^\circ\text{C}$ unless otherwise specified.¹

PARAMETER	TEST CONDITIONS	μ A723			μ A723C/SA723C			UNIT
		Min	Typ	Max	Min	Typ	Max	
Line regulation ²	$V_{IN} = 12\text{V to } V_{IN} = 15\text{V}$ $V_{IN} = 12\text{V to } V_{IN} = 40\text{V}$		0.01	0.1		0.01	0.1	% V_{OUT}
			0.02	0.2		0.1	0.5	% V_{OUT}
Load regulation ²	$I_L = 1\text{mA to } I_L = 50\text{mA}$ $f = 50\text{Hz to } 10\text{kHz}, C_{REF} = 0$ $f = 50\text{Hz to } 10\text{kHz}, C_{REF} = 5\mu\text{F}$		0.03	0.15		0.03	0.2	% V_{OUT}
			74			74		dB
			86			86		dB
Short circuit current limit	$R_{SC} = 10\Omega, V_{OUT} = 0$		65		65		mA	
Reference voltage		6.95	7.15	7.35	6.80	7.15	7.50	V
Output noise voltage	$BW = 100\text{Hz to } 10\text{kHz}, C_{REF} = 0$ $BW = 100\text{Hz to } 10\text{kHz}, C_{REF} = 5\mu\text{F}$		20			20		μVrms
			2.5			2.5		μVrms
Long term stability			0.1		1	0.1	%/1000hrs.	
Standby current drain	$I_L = 0, V_{IN} = 30\text{V}$		2.3	3.5		2.3	4.0	mA
Input voltage range		9.5		40	9.5		40	V
Output voltage range		2.0		37	2.0		37	V
Input-output voltage differential		3.0		38	3.0		38	V
The following specifications apply over the operating temperature ranges								
Line regulation				0.3			0.3	% V_{OUT}
Load regulation				0.6			0.6	% V_{OUT}
Average temperature coefficient of output voltage	$V_{IN} = 12\text{V to } V_{IN} = 15\text{V}$ $I_L = 1\text{mA to } I_L = 50\text{mA}$		0.002	0.015		0.003	0.015	%/ $^\circ\text{C}$

NOTES

- $V_{IN} = V^+ = V_C = 12\text{V}, V^- = 0\text{V}, V_{OUT} = 5\text{V}, I_L = 1\text{mA}, R_{SC} = 0, C_1 = 100\text{pF}, C_{REF} = 0$ and divider impedance as seen by error amplifier $\leq 10\text{k}\Omega$ when connected as shown in Figure 3.
- The load and line regulation specifications are for constant junction temperature. Temperature drift effects must be taken into account separately when the unit is operating under conditions of high dissipation.

TYPICAL PERFORMANCE CHARACTERISTICS

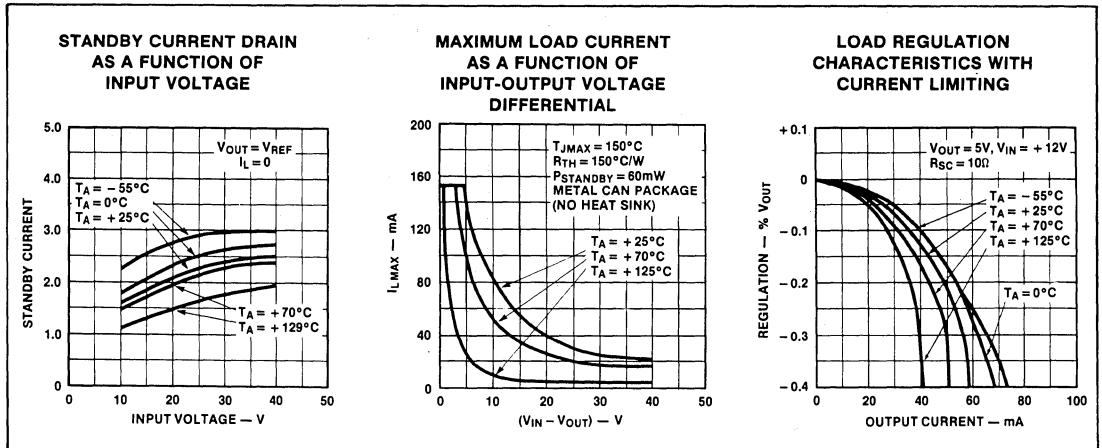

PRECISION VOLTAGE REGULATOR

μ A723/723C/SA723C

TYPICAL PERFORMANCE CHARACTERISTICS (Cont'd)

CURRENT LIMITING CHARACTERISTICS AS A FUNCTION OF JUNCTION TEMPERATURE

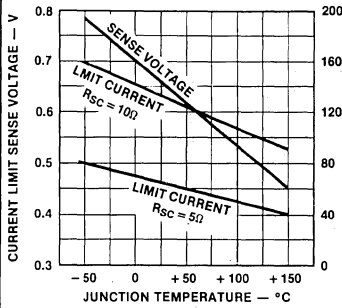

MAXIMUM LOAD CURRENT AS A FUNCTION OF INPUT-OUTPUT VOLTAGE DIFFERENTIAL

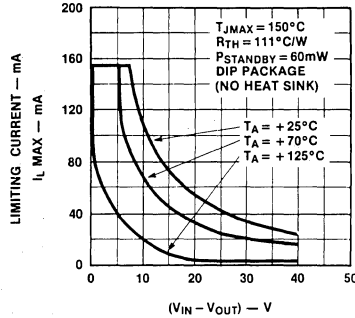

LOAD REGULATION CHARACTERISTICS WITHOUT CURRENT LIMITING

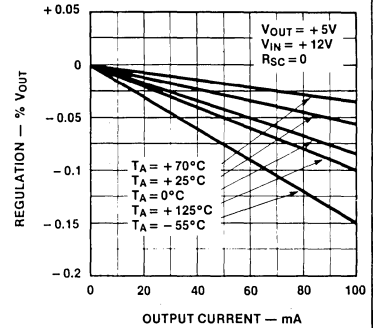

LOAD TRANSIENT RESPONSE

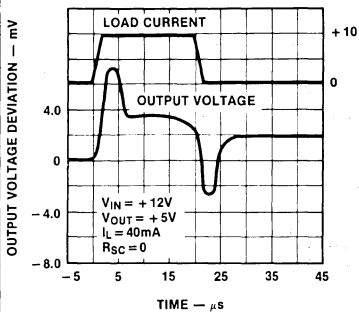

LINE REGULATION AS A FUNCTION OF INPUT-OUTPUT VOLTAGE DIFFERENTIAL

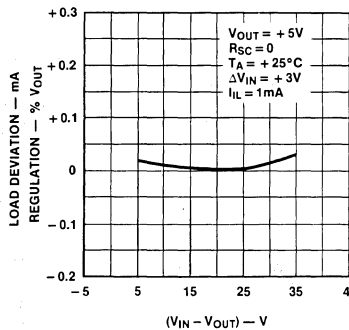

OUTPUT IMPEDANCE AS A FUNCTION OF FREQUENCY

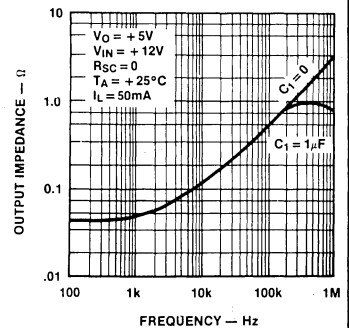

LINE TRANSIENT RESPONSE

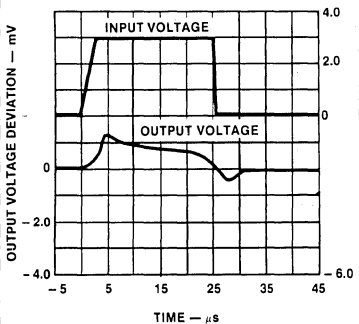

LOAD REGULATION AS A FUNCTION OF INPUT-OUTPUT VOLTAGE DIFFERENTIAL

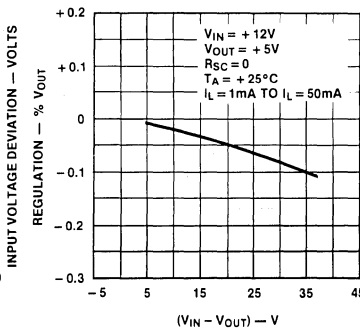

CURRENT LIMITING CHARACTERISTICS

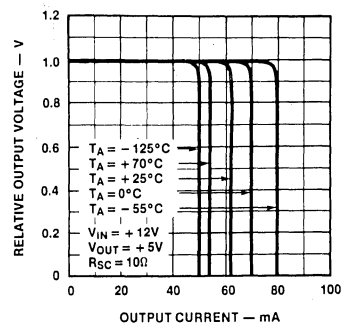

PRECISION VOLTAGE REGULATOR

μ A723/723C/SA723C

TYPICAL APPLICATIONS

LOW VOLTAGE REGULATOR
($V_{OUT} = 2$ TO 7 VOLTS)

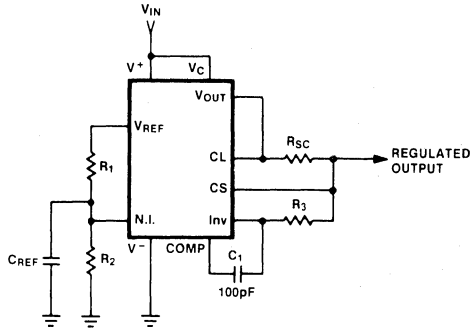

$$V_{OUT} = \left[V_{REF} \times \frac{R_2}{R_1 + R_2} \right]$$

$$R_3 = \frac{R_1 R_2}{R_1 + R_2} \text{ for minimum temperature drift}$$

NEGATIVE VOLTAGE REGULATOR

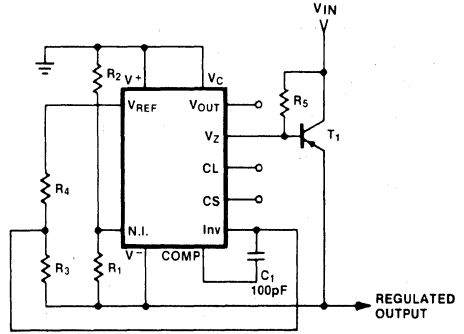

$$V_{OUT} = \left[\frac{V_{REF}}{2} \times \frac{R_1 + R_2}{R_1} \right], R_3 = R_4$$

REMOTE SHUTDOWN REGULATOR WITH CURRENT LIMITING
($V_{OUT} = 2$ TO 7 VOLTS)

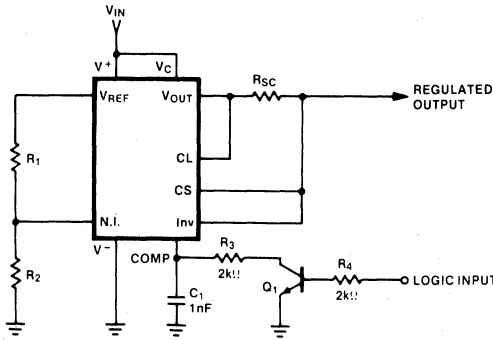

$$V_{OUT} = \left[V_{REF} \times \frac{R_2}{R_1 + R_2} \right]$$

HIGH VOLTAGE REGULATOR
($V_{OUT} = 7$ TO 37 VOLTS)

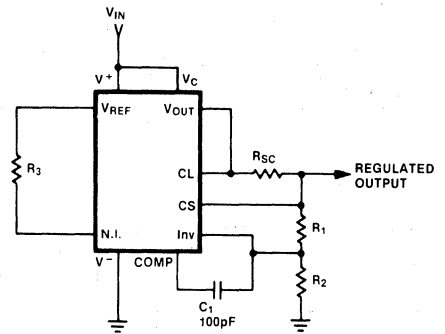

$$V_{OUT} = \left[V_{REF} \times \frac{R_1 + R_2}{R_2} \right]$$

$$R_3 = \frac{R_1 R_2}{R_1 + R_2} \text{ for minimum temperature drift}$$

R_3 may be eliminated for minimum component count

TYPICAL APPLICATIONS (Cont'd)

FOLDBACK CURRENT LIMITING REGULATOR
($V_{OUT} = 2$ TO 7 VOLTS)

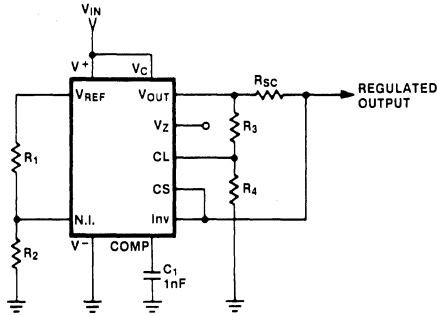

$$I_{KNEE} = \left[\frac{V_{OUT} R_3}{R_{SC} R_4} + \frac{V_{SENSE} (R_3 + R_4)}{R_{SC} R_4} \right]$$

$$V_{OUT} = \left[V_{REF} \times \frac{R_1 + R_2}{R_2} \right]$$

$$I_{SHORT\ CKT} = \left[\frac{V_{SENSE} \times (R_3 + R_4)}{R_{SC} R_4} \right]$$

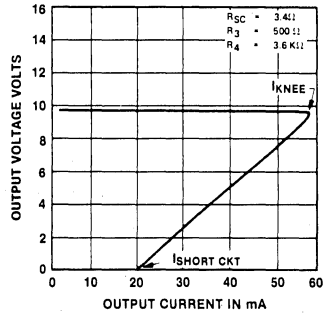

$$R_4 = \frac{V_{OUT} I_{SC}}{R_3 - V_{SENSE} (I_{KNEE} - I_{SHORT\ CKT})} - 1$$

$$R_{SC} = \frac{V_{SENSE}}{I_{SC}} \left[1 + \frac{R_3}{R_4} \right]$$

TIME PROPORTIONAL TRIAC TRIGGER**TDA1023****GENERAL DESCRIPTION**

The TDA1023 is a bipolar integrated circuit for controlling triacs in the time proportional or burst firing mode. It permits very precise temperature control of heating equipment and is especially suited for the control of panel heaters. The circuit generates positive-going trigger pulses and complies with the regulations on radio interference and mains distortion.

Special features are:

- adjustable proportional range width
- adjustable hysteresis
- adjustable trigger pulse width
- adjustable firing burst repetition time
- control range translation facility
- failsafe operation
- supplied from the mains
- provides supply for external temperature bridge

QUICK REFERENCE DATA

Supply voltage (derived from mains voltage)	V_{CC}	typ.	13.7 V
Stabilized supply voltage for temperature bridge	V_Z	typ.	8 V
Supply current (average value)	$I_{16(AV)}$	typ.	10 mA
Trigger pulse width	t_W	typ.	200 μs
Firing burst repetition time at $C_T = 68 \mu F$	T_b	typ.	41 s
Output current	$-I_{OH}^*$	max.	150 mA
Operating ambient temperature range	T_{amb}		-20 to +75 °C

* Negative current is defined as conventional current flow out of a device. A negative output current is suited for positive triac triggering.

PACKAGE OUTLINE

16-lead DIL; plastic (SOT-38).

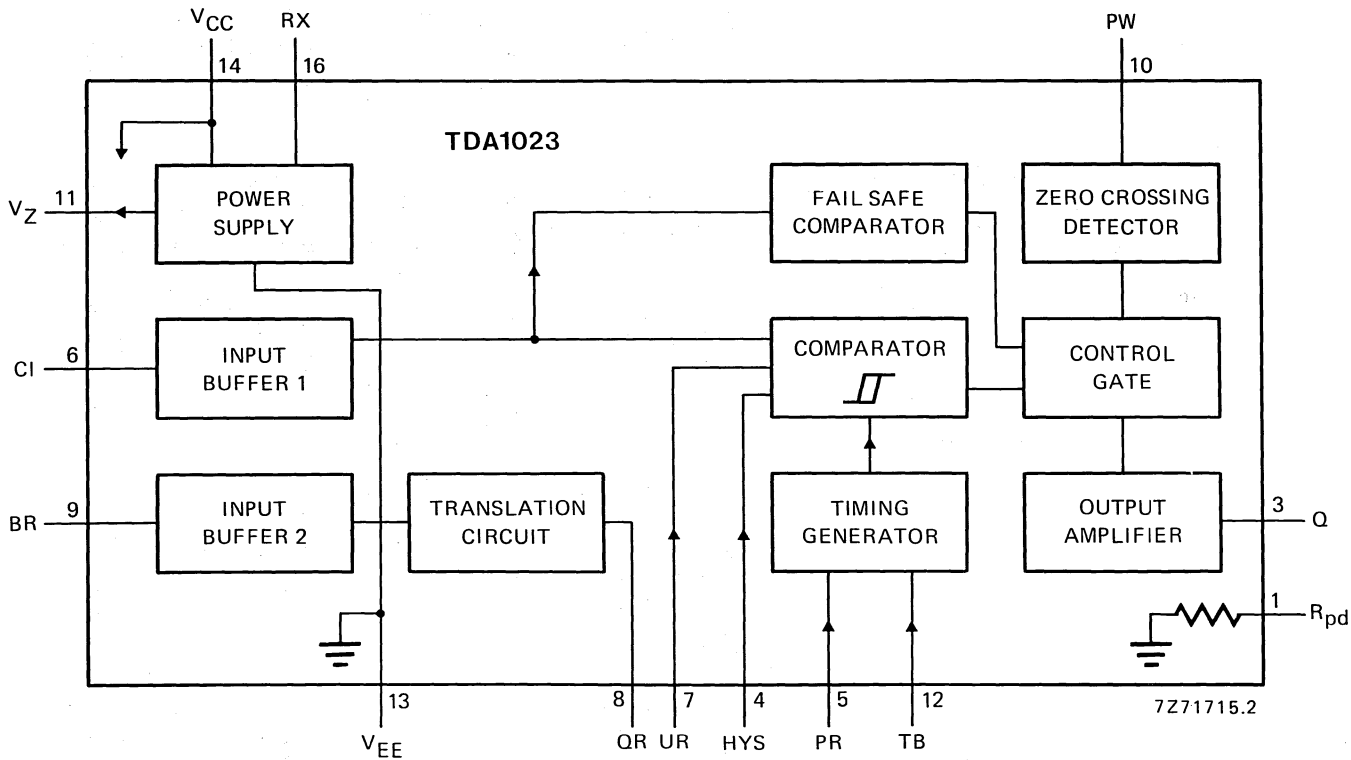

Fig. 1 Block diagram.



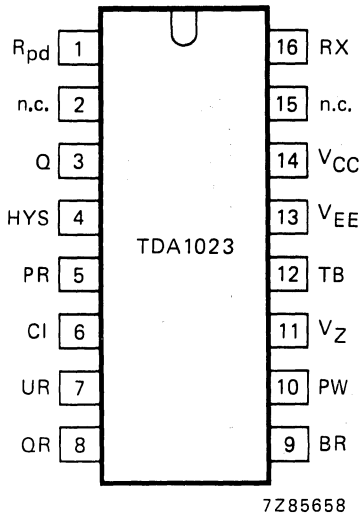

Fig. 2 Pinning diagram.

PINNING

1	R _{pd}	internal pull-down resistor connection
2	n.c.	not connected
3	Q	output
4	HYS	hysteresis control input
5	PR	proportional range control input
6	CI	Control input
7	UR	unbuffered reference input
8	QR	output of reference buffer
9	BR	buffered reference input
10	PW	pulse width control input
11	V _Z	reference supply output
12	TB	firing burst repetition time control input
13	V _{EE}	ground connection
14	V _{CC}	positive supply connection
15	n.c.	not connected
16	RX	external resistor connection

FUNCTIONAL DESCRIPTION

The TDA1023 generates pulses to trigger a triac. These trigger pulses coincide with the zero crossings of the mains voltage. This minimizes r.f. interference and transients on the mains supply. The trigger pulses come in bursts, with the net effect that the load is periodically switched on and off. This further minimizes mains pollution. The average power in the load is varied by varying the duration of the trigger pulse burst, in accordance with the voltage difference between the control input CI and the reference input, either UR or BR.

Power supply: V_{CC}, RX and V_Z (pins 14, 16 and 11)

The TDA1023 is supplied from the a.c. mains via a resistor R_D to the RX connection (pin 16); the V_{EE} connection (pin 13) is connected to the neutral line (see Fig. 4a). A smoothing capacitor C_S has to be connected between the V_{CC} and V_{EE} connections.

The circuit contains a string of stabilizer diodes between the RX and V_{EE} connections that limit the d.c. supply voltage, and a rectifier diode between the RX and V_{CC} connections (see Fig. 3).

At pin 11 the device provides a stabilized reference voltage V_Z for an external temperature sensing bridge.

The operation of the supply arrangement is as follows. During the positive half of the mains cycles the current through external voltage dropping resistor R_D charges the external smoothing capacitor C_S until RX reaches the stabilizing voltage of the internal stabilizer diodes. R_D should be chosen such that it can supply the current I_{CC} for the TDA1023 itself plus the average output current I_{3(AV)} plus the current required from the V_Z connection for an external temperature bridge, and recharge the smoothing capacitor C_S (see Figs 9 to 12). Any excess current is bypassed by the internal stabilizer diodes. Note that the maximum rated supply current must not be exceeded.

During the negative half of the mains cycles external smoothing capacitor C_S has to supply the sum of the currents mentioned above. Its capacitance must be high enough to maintain the supply voltage above the minimum specified limit.

FUNCTIONAL DESCRIPTION (continued)

Dissipation in resistor R_D is halved by connecting a diode in series (see Fig. 4b and 9 to 12).

A further reduction of dissipation is possible by using a high-quality voltage dropping capacitor C_D in series with a resistor R_{SD} (see Figs 4c and 14). A suitable VDR connected across the mains provides protection of the TDA1023 and of the triac against mains-borne transients.

Control and reference inputs CI, BR and UR (pins 6, 9 and 7)

For room temperature control (5 °C to 30 °C) the best performance is obtained by using the translation circuit. The buffered reference input BR (pin 9) is used as a reference input, and the output of the reference buffer QR (pin 8) is connected to the unbuffered reference input UR (pin 7). In this arrangement the translation circuit ensures that most of the potentiometer rotation can be used to cover the room temperature range. This provides an accurate temperature setting and a linear temperature scale.

If the translation circuit is not required, the unbuffered reference input UR (pin 7) is used as a reference input. The buffered reference input BR (pin 9) must be connected to the reference supply output V_Z (pin 11).

For proportional power control the unbuffered reference input UR (pin 7) must be connected to the firing burst repetition time control input TB (pin 12) and the buffered reference input BR (pin 9), which is inactive now, must be connected to the reference supply output V_Z (pin 11).

In all arrangements the train of output pulses becomes longer when the voltage at the control input CI (pin 6) becomes lower.

Proportional range control input PR (pin 5)

With the proportional range control input PR open the output duty factor changes from 0% to 100% by a variation of 80 mV at the control input CI (pin 6). For temperature control this corresponds with a temperature difference of only 1 K.

This range may be increased to 400 mV, i.e. 5 K, by connecting the proportional range control input PR (pin 5) to ground. Intermediate values are obtained by connecting the PR input to ground via a resistor R_5 , see Table 1.

Hysteresis control input HYS (pin 4)

With the hysteresis control input HYS (pin 4) open the device has a built-in hysteresis of 20 mV. For temperature control this corresponds with 0.25 K.

Hysteresis is increased to 320 mV, corresponding with 4 K, by grounding HYS (pin 4). Intermediate values are obtained by connecting pin 4 to ground via a resistor R_4 . See Table 1 for a set of values for R_4 and R_5 giving a fixed ratio between hysteresis and proportional range.

Trigger pulse width control input PW (pin 10)

The trigger pulse width may be adjusted to the value required for the triac by choosing the value of the external synchronization resistor R_S between the trigger pulse width control input PW (pin 10) and the a.c. mains. The pulse width is inversely proportional to the input current (see Fig. 13).

Output Q (pin 3)

Since the circuit has an open-emitter output, it is capable of sourcing current, i.e. supplying a current out of the output. Therefore it is especially suited for generating positive-going trigger pulses. The output is current-limited and protected against short-circuits. The maximum output current is 150 mA and the output pulses are stabilized at 10 V for output currents up to that value.

7

TIME PROPORTIONAL TRIAC TRIGGER**TDA1023****FUNCTIONAL DESCRIPTION** (continued)

A gate resistor R_G must be connected between the output Q and the triac gate to limit the output current to the minimum required by the triac (see Figs 5 to 8). This minimizes the total supply current and the power dissipation.

Pull-down resistor R_{pd} (pin 1)

The TDA1023 includes a 1.5 k Ω pull-down resistor R_{pd} between pins 1 and 13 (V_{EE} , ground connection), intended for use with sensitive triacs.

RATINGS

Limiting values in accordance with the Absolute Maximum System (IEC 134)

Supply voltage, d.c.	V_{CC}	max.	16 V
Supply current			
average	$I_{16(AV)}$	max.	30 mA
repetitive peak	$I_{16(RM)}$	max.	100 mA
non-repetitive peak	$I_{16(SM)}$	max.	2 A
Input voltage, all inputs	V_I	max.	16 V
Input current, CI, UR, BR, PW input	$I_{6; 7; 9; 10}$	max.	10 mA
Voltage on R_{pd} connection	V_1	max.	16 V
Output voltage, Q, QR, V_Z output	$V_{3; 8; 11}$	max.	16 V
Output current			
average	$-I_{OH(AV)}$	max.	30 mA
peak, max. 300 μ s	$-I_{OH(M)}$	max.	700 mA
Total power dissipation	P_{tot}	max.	500 mW
Storage temperature range	T_{stg}		-55 to + 150 °C
Operating ambient temperature range	T_{amb}		-20 to + 75 °C

TIME PROPORTIONAL TRIAC TRIGGER

TDA1023

	symbol	min.	typ.	max.	unit
Output Q (pin 3)					
Output voltage HIGH at $-I_{OH} = 150$ mA	V_{OH}	10	—	—	V
Output current HIGH	$-I_{OH}$	—	—	150	mA
Internal pull-down resistor R_{pd} (pin 1)					
Resistance to V_{EE}	R_{pd}	1	1.5	3	k Ω

Table 1. Adjustment of proportional range and hysteresis.
Combinations of resistor values giving hysteresis $> \frac{1}{4}$ proportional range.

proportional range mV	proportional range resistor R5 k Ω	minimum hysteresis mV	maximum hysteresis resistor R4 k Ω
80	open	20	open
160	3.3	40	9.1
240	1.1	60	4.3
320	0.43	80	2.7
400	0	100	1.8

Table 2. Timing capacitor C_T values.

effective d.c. value μF	marked a.c. specification		catalogue number*
	μF	V	
68	47	25	2222 016 90129
47	33	40	— — 90131
33	22	25	— 015 90102
22	15	40	— — 90101
15	10	25	— — 90099
10	6.8	40	— — 90098

* Special electrolytic capacitors recommended for use with TDA1023.

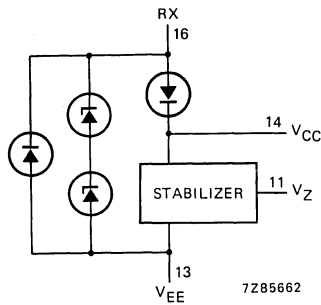

Fig. 3 Internal supply connections.

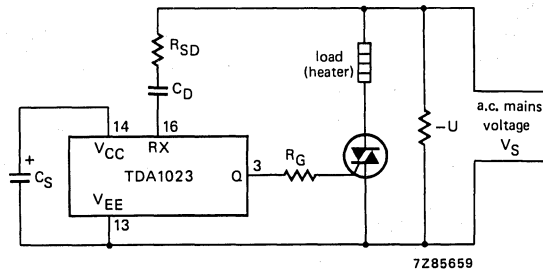
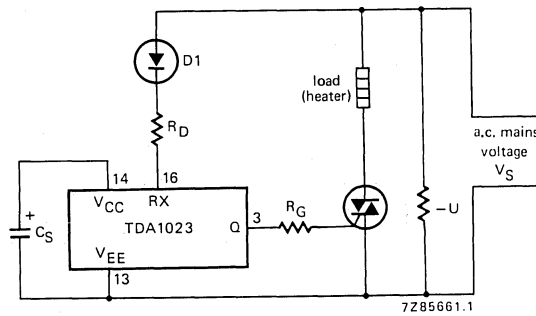
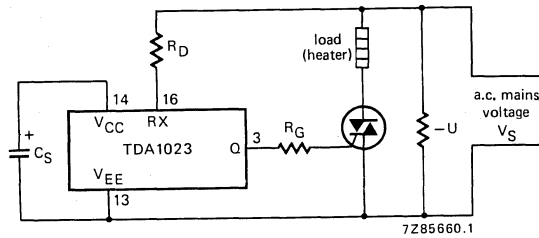

Fig. 4 Alternative supply arrangements.

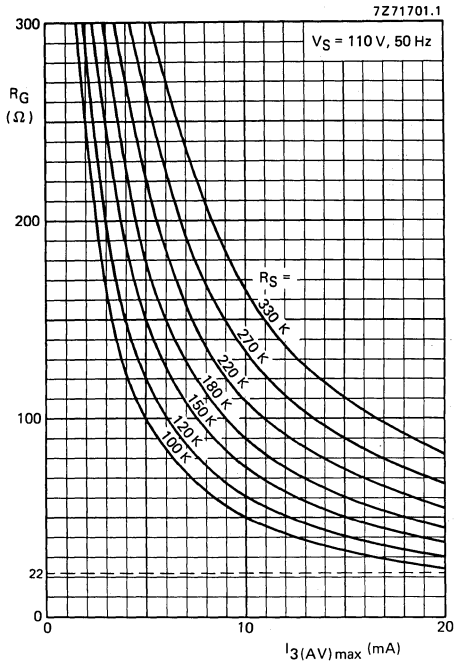

Fig. 5.

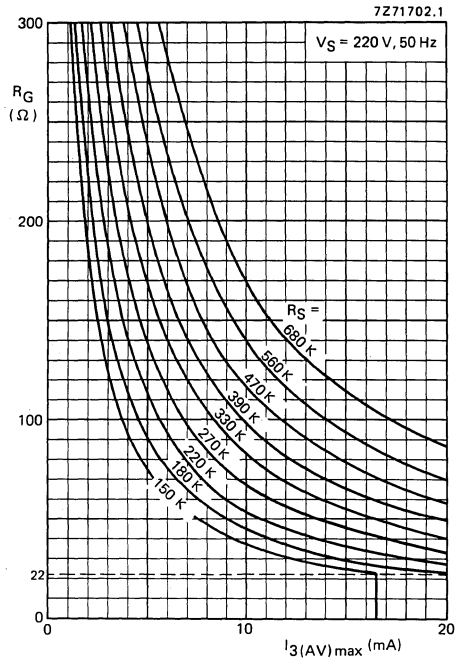

Fig. 6.

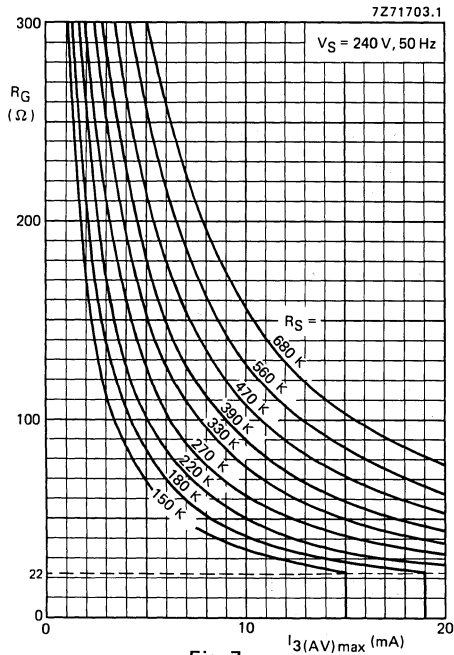

Fig. 7.

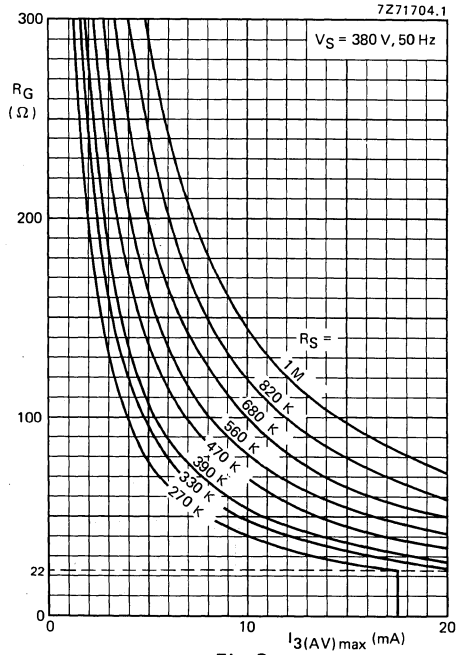

Fig. 8.

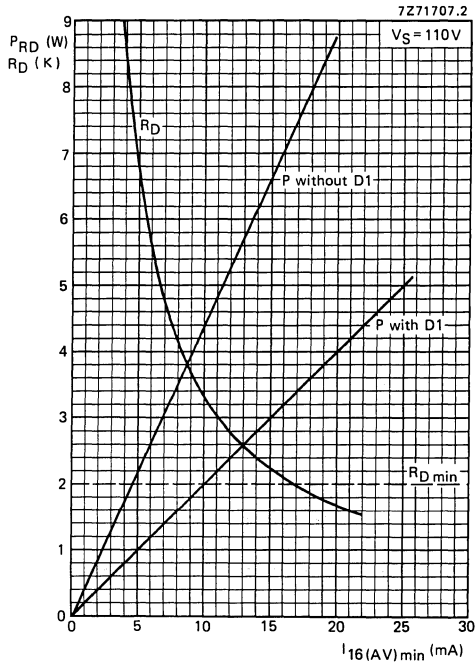

Fig. 9.

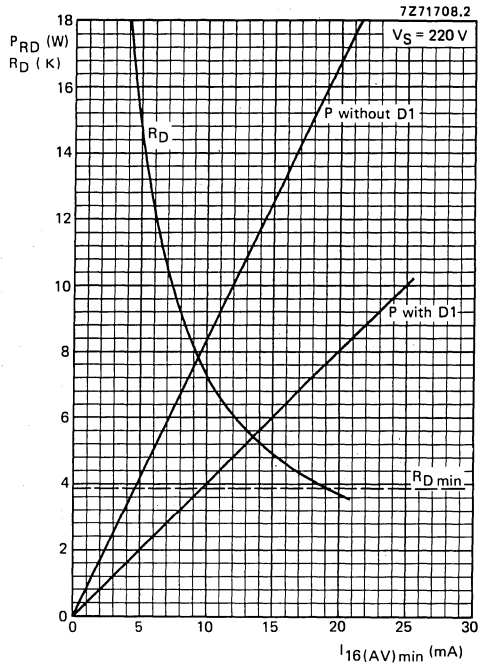

Fig. 10.

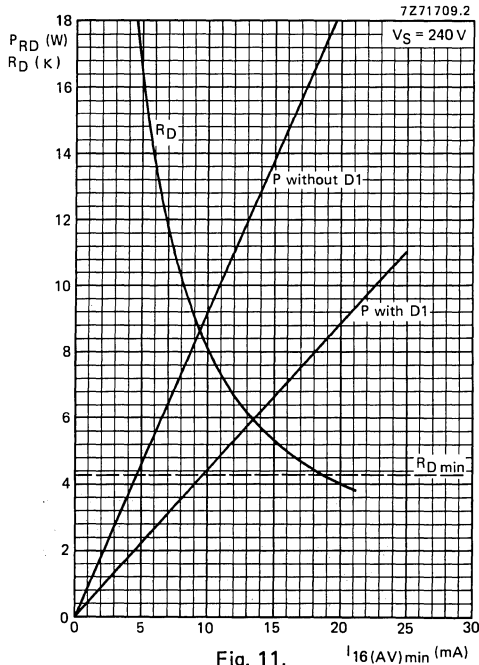

Fig. 11.

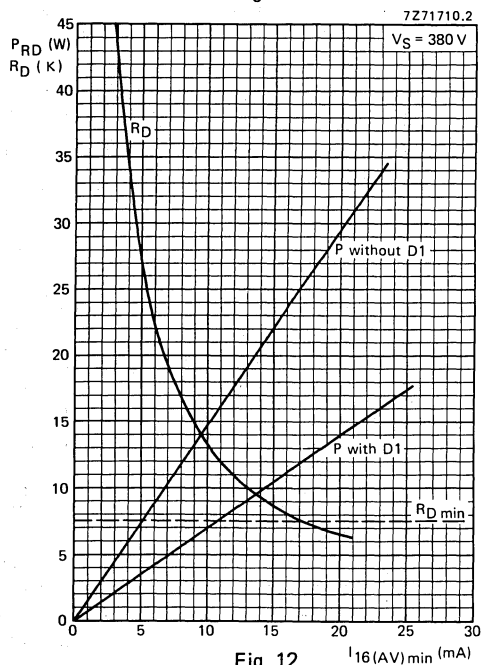

Fig. 12.

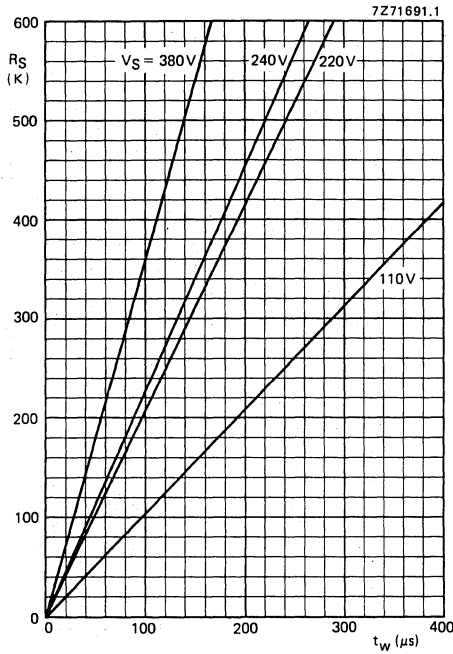

Fig. 13 Synchronization resistor R_S as a function of required trigger pulse width t_w with mains voltage V_S as a parameter.

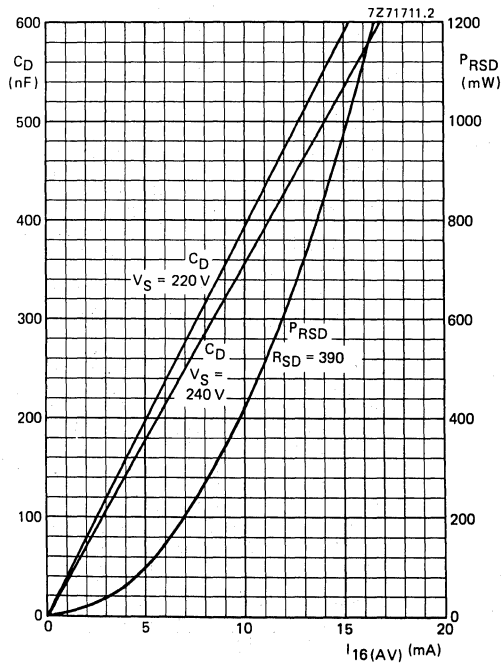

Fig. 14 Nominal value of voltage dropping capacitor C_D and power P_{RSD} dissipated in voltage dropping resistor R_{SD} as a function of the average supply current $I_{16(AV)}$ with the mains supply voltage V_S as a parameter.

APPLICATION INFORMATION

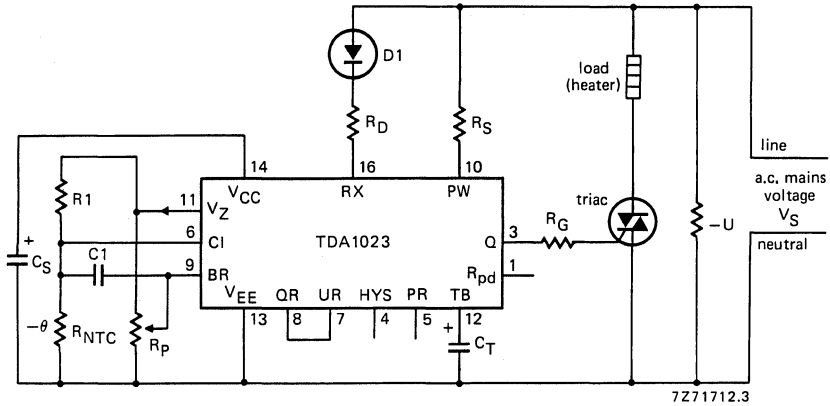

Fig. 15 The TDA1023 used in a 1200 to 2000 W heater with triac BT139. For component values see Table 3.

Conditions

Mains supply: $V_S = 220\text{ V}$

Temperature range = 5 to 30 °C

BT139 data: $V_{GT} < 1.5\text{ V}$
 $I_{GT} > 70\text{ mA}$
 $I_L < 60\text{ mA}$ } at $T_j = 25\text{ °C}$

TIME PROPORTIONAL TRIAC TRIGGER

TDA1023

Table 3. Temperature controller component values (see Fig. 15).

parameter	symbol	value	remarks
Trigger pulse width	t_w	75 μ s	see BT139 data sheet
Synchronization resistor	R_S	180 k Ω	see Fig. 13
Gate resistor	R_G	110 Ω	see Fig. 6
Max. average gate current	$I_{3(AV)}$	4.1 mA	see Fig. 8
Hysteresis resistor	R_4	n.c.	see Table 1
Proportional band resistor	R_5	n.c.	see Table 1
Min. required supply current	$I_{16(AV)}$	11.1 mA	
Mains dropping resistor	R_D	6.2 k Ω	see Fig. 10
Power dissipated in R_D	P_{RD}	4.6 W	see Fig. 10
Timing capacitor (eff. value)	C_T	68 μ F	see Table 2
Voltage dependent resistor	VDR	250 V a.c.	cat. no. 2322 593 62512
Rectifier diode	D1	BYW56	
Resistor to pin 11	R1	18.7 k Ω	1% tolerance
NTC thermistor (at 25 $^{\circ}$ C)	R_{NTC}	22 k Ω	B = 4200 K cat. no. 2322 642 12223
Potentiometer	R_p	22 k Ω	
Capacitor between pins 6 and 9	C1	47 nF	
Smoothing capacitor	C_S	220 μ F; 16 V	

If R_D and D1 are replaced by C_D and R_{SD}

Mains dropping capacitor	C_D	470 nF	} see Fig. 14
Series dropping resistor	R_{SD}	390 Ω	
Power dissipated in R_{SD}	P_{RSD}	0.6 W	
Voltage dependent resistor	VDR	250 V a.c.	cat. no. 2322 594 62512

Notes

1. ON/OFF control: pin 12 connected to pin 13.
2. If translation circuit is not required: slider of R_p to pin 7; pin 8 open; pin 9 connected to pin 11.

APPLICATION INFORMATION SUPPLIED ON REQUEST

GENERAL DESCRIPTION

The TDA1024 is a bipolar integrated circuit delivering positive pulses for triggering a triac or a thyristor. It is primarily intended for use as a static switch to replace mechanical thermostats that switch resistive loads, such as:

- central heating installations
- washing machine heaters
- water heaters
- smoothing irons

The TDA1024 provides its own d.c. supply and will supply an external circuit, e.g. a temperature sensing bridge. The circuit complies with the regulations on radio interference and mains distortion.

Its main features are:

- adjustable trigger pulse width
- adjustable hysteresis
- supplied from the mains
- provides supply for external temperature bridge
- protected inputs and output
- low supply current, low dissipation

QUICK REFERENCE DATA

Supply voltage (d.c.) (internally derived from mains voltage)	V_{CC}	typ.	6.5 V
Supply current (average value, unloaded)	$I_{RX(AV)}$	max.	1.8 mA
Output current HIGH	$-I_{OH}^*$	max.	100 mA
Output pulse width	t_w	typ.	195 μ s
Power dissipation (unloaded)	P	typ.	12 mW
Operating ambient temperature range	T_{amb}		-20 to +80 °C

* Negative current is defined as conventional current flow out of a device. A negative output current is suited for positive triac triggering.

PACKAGE OUTLINE

8-lead DIL; plastic (SOT-97A).

ZERO CROSSING TRIAC TRIGGER

TDA1024

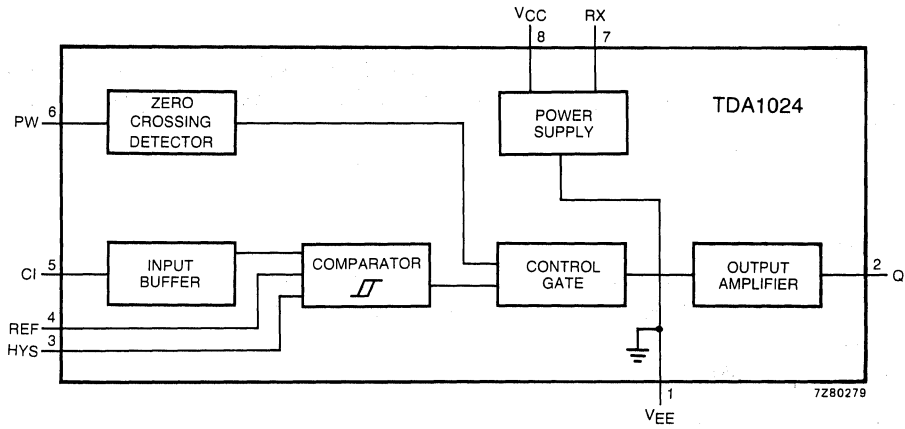

Fig. 1 Block diagram.

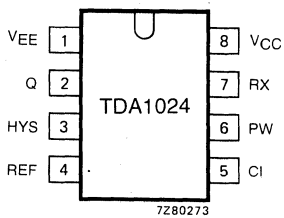

Fig. 2 Pinning diagram.

PINNING

1	V _{EE}	ground
2	Q	output
3	HYS	hysteresis control input
4	REF	reference input
5	CI	control input
6	PW	pulse width control input
7	RX	external resistor
8	V _{CC}	positive supply

ZERO CROSSING TRIAC TRIGGER

TDA1024

Signetics

7-77

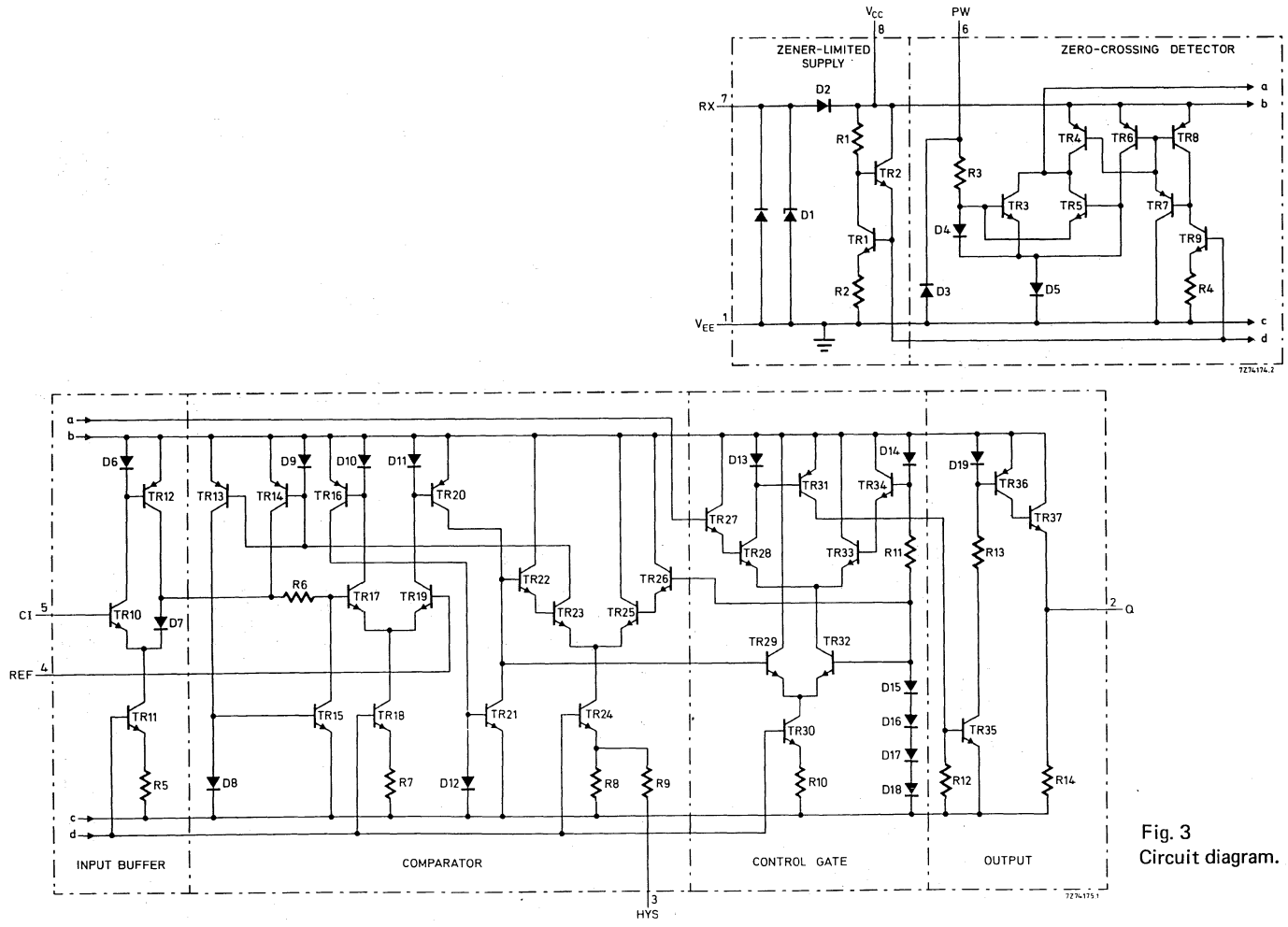

Fig. 3
Circuit diagram.

FUNCTIONAL DESCRIPTION

The TDA1024 generates positive-going output pulses to trigger a triac. These trigger pulses coincide with the zero crossings of the mains voltage. This minimizes r.f. interference and transients on the mains supply.

Supply: V_{CC} and RX (pins 8 and 7)

The TDA1024 may be supplied by an external d.c. power supply connected to V_{CC} (pin 8), but usually it is supplied directly from the mains voltage. For this purpose the circuit contains a stabilizer diode between RX and V_{EE} that limits the d.c. supply voltage (see Fig. 4). An external resistor R_D has to be connected from the mains to RX (pin 7); V_{EE} is connected to the neutral line (see Fig. 5a). A smoothing capacitor C_S has to be connected between V_{CC} and V_{EE} .

During the positive half of the mains cycles the current through external voltage-dropping resistor R_D charges the external smoothing capacitor C_S up to the stabilizing voltage of the internal stabilizer diodes. R_D should be chosen such that it can supply the current I_{CC} for the TDA1024 itself plus the average output current $-I_Q(AV)$, and recharge the smoothing capacitor C_S . Any excess current is bypassed by the internal stabilizer diode. Note that the maximum rated supply current must not be exceeded.

During the negative half of the mains cycles external smoothing capacitor C_S supplies the circuit. Its capacitance must be high enough to maintain the supply voltage above 5 V, the minimum specified limit (see Fig. 10).

Dissipation in resistor R_D is halved by connecting a diode in series (see Figs 5b and 11).

A further reduction of dissipation is possible by using a high-quality voltage-dropping capacitor C_D in series with a resistor R_{SD} (see Figs 5c and 12).

A suitable VDR connected across the mains provides protection of the TDA1024 and of the triac against mains-borne transients.

Control and reference inputs CI and REF (pins 5 and 4)

The TDA1024 produces output pulses when the CI input is at a higher potential than the REF input. For power control as a function of temperature the inputs may be connected as shown in Fig. 14.

An input buffer circuit at the CI input gives a high input impedance and a low output impedance. This makes the hysteresis of the circuit independent of the input voltage.

Hysteresis control input HYS (pin 3)

With the hysteresis control input HYS open the device has a built-in hysteresis of 20 mV. For temperature control this corresponds with a temperature difference of 0.25 K.

Hysteresis is increased to 300 mV, corresponding with a temperature difference of 4 K, by grounding HYS. Intermediate values are obtained by connecting HYS to ground via a resistor.

Pulse width control input PW (pin 6)

The output pulse width may be adjusted to the value required for the triac by choosing the value of the external synchronization resistor R_S between the pulse width control input PW and the a.c. mains. The pulse width is inversely proportional to the input current (see Fig. 13).

Output Q (pin 2)

Since the circuit has an open-emitter output, it is capable of sourcing current, i.e. supplying a current out of the output. Therefore it is especially suited for generating positive-going trigger pulses. The output is current-limited and protected against short-circuits. The maximum output current is 100 mA and the output pulses are stabilized at 4 V for output currents up to that value.

ZERO CROSSING TRIAC TRIGGER**TDA1024****FUNCTIONAL DESCRIPTION** (continued)**Output Q** (pin 2) (continued)

A gate resistor R_G must be connected between the output Q and the triac gate to limit the output current to the minimum required by the triac (see Figs 6 to 9). This minimizes the total supply current and the power dissipation.

RATINGS

Limiting values in accordance with the Absolute Maximum System (IEC 134)

Supply voltage (d.c.)	V_{CC}	max.	8 V
Supply current			
average	$I_{RX(AV)}$	max.	30 mA
repetitive peak	$I_{RX(RM)}$	max.	80 mA
non-repetitive peak ($t < 50 \mu s$)	$I_{RX(SM)}$	max.	2 A
Input voltage (all inputs)	V_I	max.	8 V
Input current (CI, REF, PW)	$I_{CI}; I_{REF}; \pm I_{PW}$	max.	10 mA
Output voltage HIGH	V_Q	max.	8 V
Output current			
average	$-I_{OH(AV)}$	max.	30 mA
peak, max. 300 μs	$-I_{OH(M)}$	max.	400 mA
Total power dissipation	P_{tot}	max.	225 mW
Storage temperature range	T_{stg}		-55 to +125 °C
Operating ambient temperature range	T_{amb}		-20 to +80 °C

ZERO CROSSING TRIAC TRIGGER

TDA1024

CHARACTERISTICS

 $V_{CC} = 5$ to 8 V; $T_{amb} = -20$ to $+80$ °C unless otherwise specified.

	symbol	min.	typ.	max.	unit
Supply: V_{CC} and RX (pins 8 and 7)					
Internally stabilized supply voltage at $I_{RX(AV)} = 10$ mA	V_{CC}	5.5	6.5	7.5	V
variation with I_{RX}	$\Delta V_{CC}/\Delta I_{RX}$	—	15	—	mV/mA
Supply current at $V_{CC} = 5.5$ V; unloaded; $f = 50$ Hz; $V_{CI} > V_{REF}$ pin 3 open (minimum hysteresis)	$I_{RX(AV)}$	—	—	1.8	mA
Supply current increase pin 3 grounded (maximum hysteresis)	$\Delta I_{RX(AV)}$	—	1.4	—	mA
Control and reference inputs CI and REF (pins 5 and 4)					
Input current, CI input, at $V_{CI} > V_{REF}$	I_{CI}	—	—	5	μ A
Input current, REF input, at $V_{REF} > V_{CI}$	I_{REF}	—	—	5	μ A
Hysteresis control input HYS (pin 3)					
Hysteresis,					
pin 3 open (minimum hysteresis)	ΔV_{CI-REF}	10	20	30	mV
pin 3 grounded (maximum hysteresis)	ΔV_{CI-REF}	150	300	500	mV
Pulse width control input PW (pin 6)					
Pulse width at $I_{PW(RMS)} = 1$ mA; $V_{CC} = 5.5$ V; $f = 50$ Hz	t_w	130	195	265	μ s
Output Q (pin 2)					
Output voltage HIGH					
at $-I_{OH} = 100$ mA	V_{OH}	4	—	—	V
at $-I_{OH} = 1$ mA	V_{OH}	1	—	—	V
Output current HIGH	$-I_{OH}$	—	—	100	mA

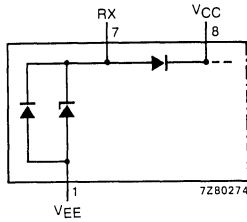
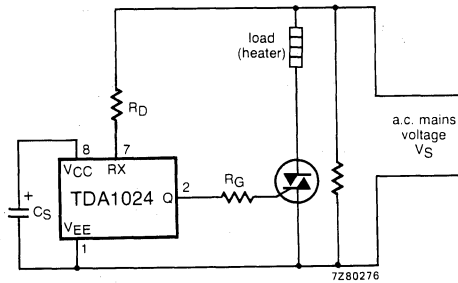
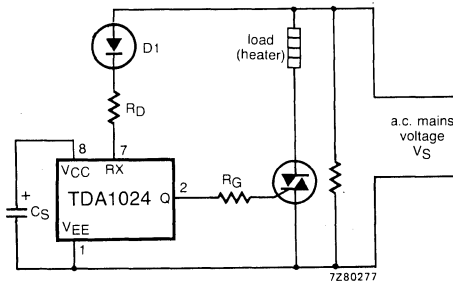

Fig. 4 Internal supply connections.



(a)



(b)

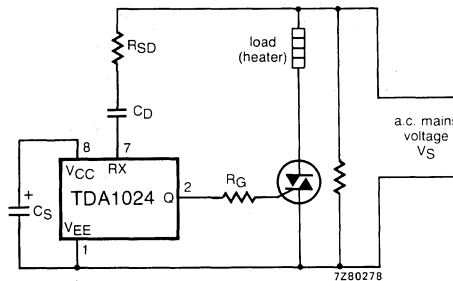

(c)

Fig. 5 Alternative supply arrangements.

ZERO CROSSING TRIAC TRIGGER

TDA1024

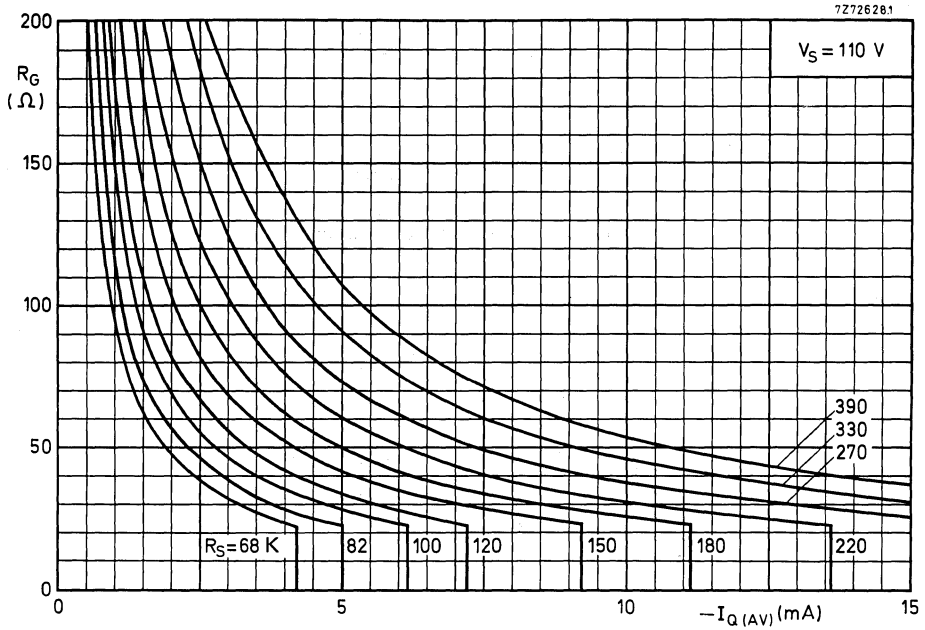

Fig. 6.

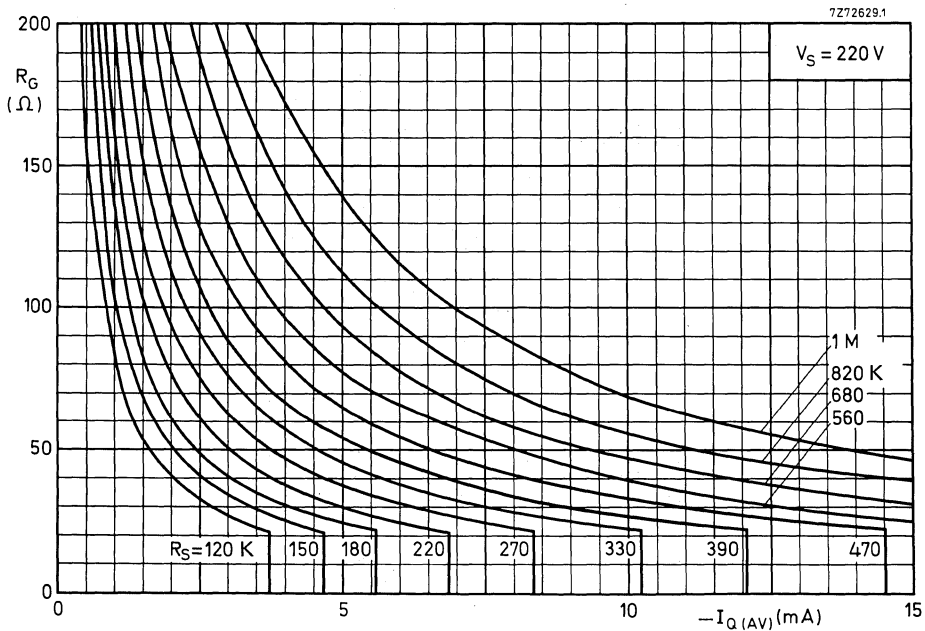

Fig. 7.

ZERO CROSSING TRIAC TRIGGER

TDA1024

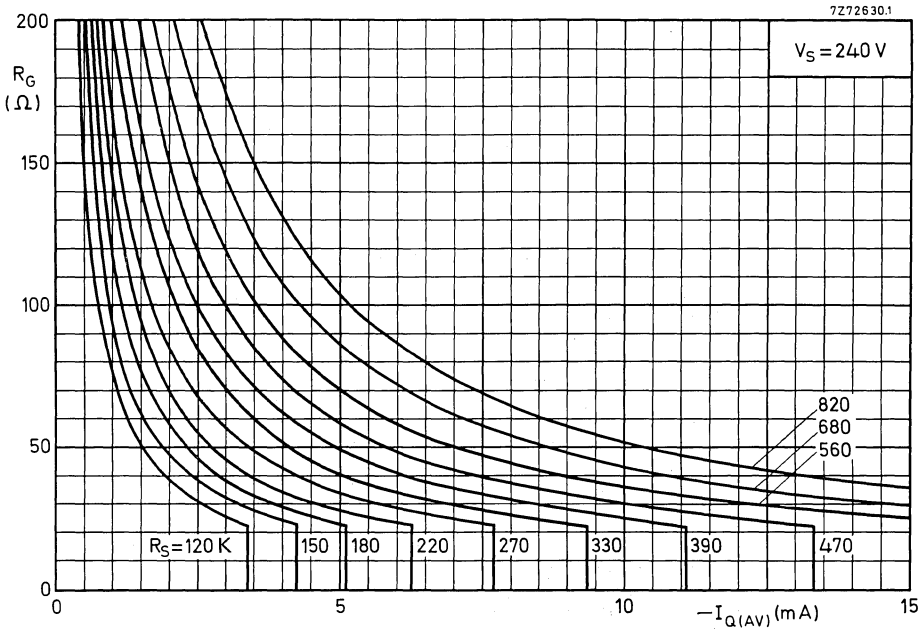

Fig. 8.

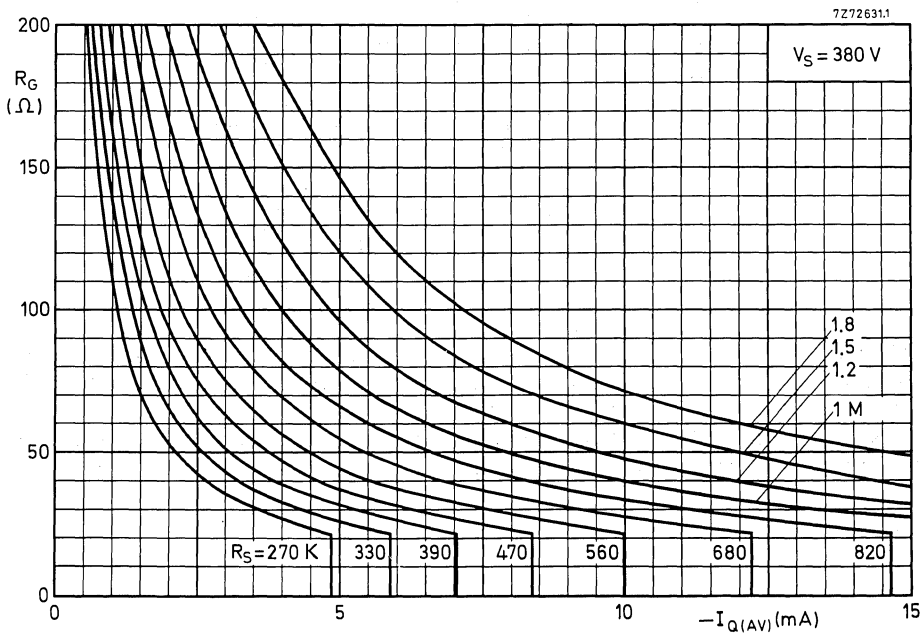

Fig. 9.

7

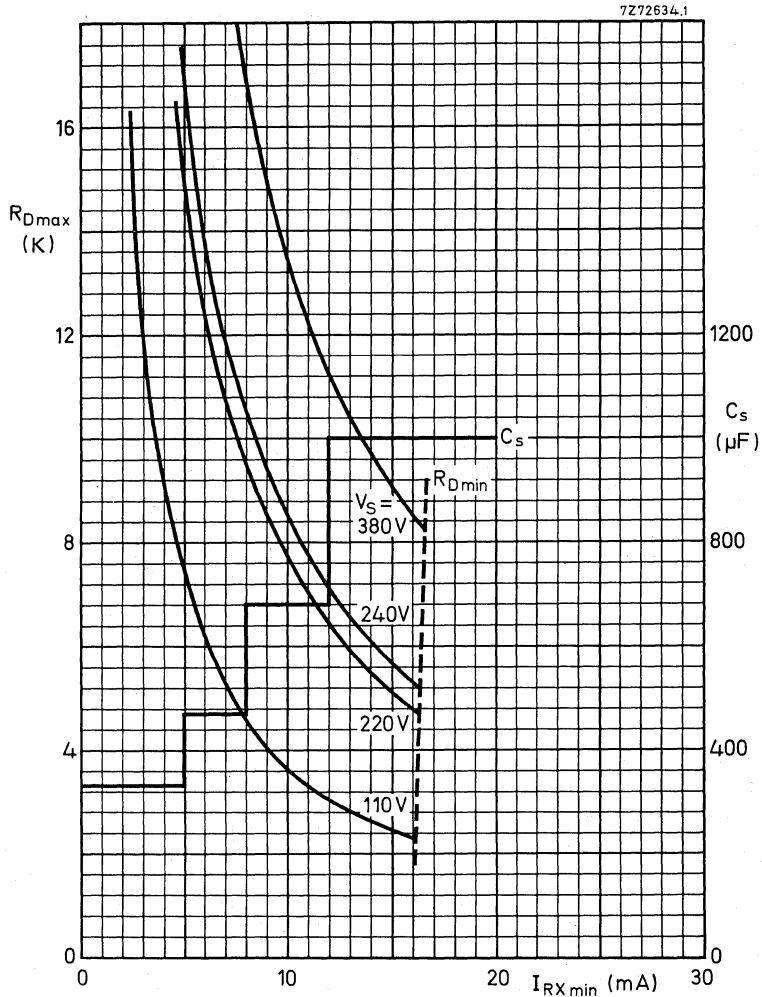
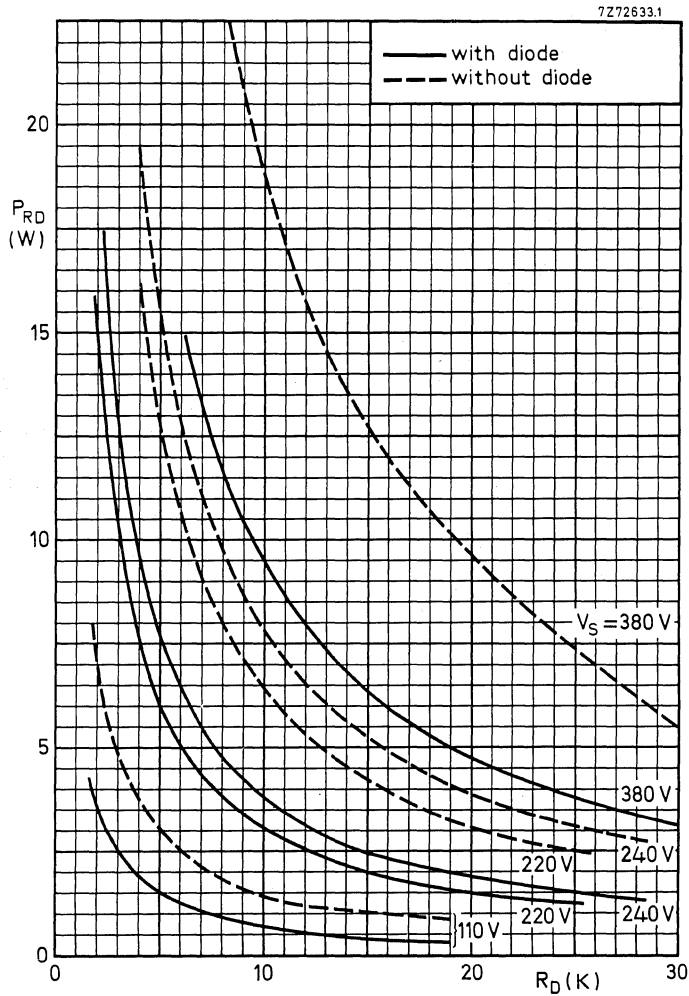

Fig. 10 Maximum value of voltage-dropping resistor R_D as a function of minimum value of the current into RX with the mains supply voltage V_S as a parameter for the supply arrangements of Figs 5a and 5b, and recommended value of smoothing capacitor C_S as a function of the current into RX for all three supply arrangements of Fig. 5. When V_{CC} is used to supply external circuitry such as a temperature-sensing bridge, the current required by that external circuitry should be added to I_{RXmin} .



7

Fig. 11 Power dissipated in voltage-dropping resistor R_D as a function of its value with the mains supply voltage V_S as a parameter, for the supply arrangements of Figs 5a and 5b.

ZERO CROSSING TRIAC TRIGGER

TDA1024

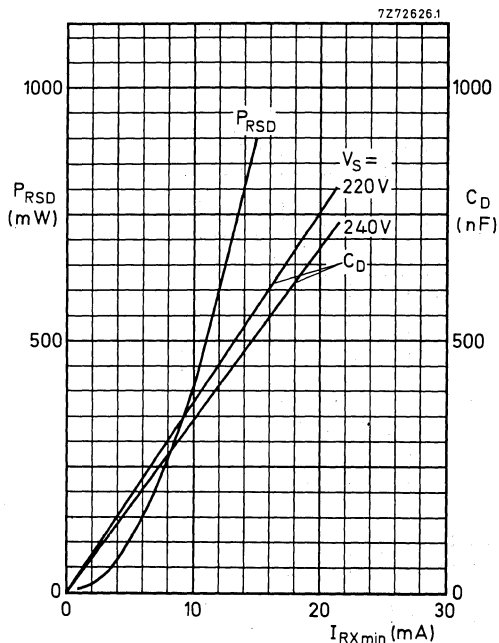

Fig. 12 Power dissipated in voltage-dropping resistor R_{SD} and dropping capacitor C_D as a function of the minimum current into RX with the mains supply voltage V_S as a parameter, for the supply arrangement of Fig. 5c. When V_{CC} is used to supply external circuitry such as a temperature-sensing bridge, the current required by that external circuitry should be added to I_{RXmin} .

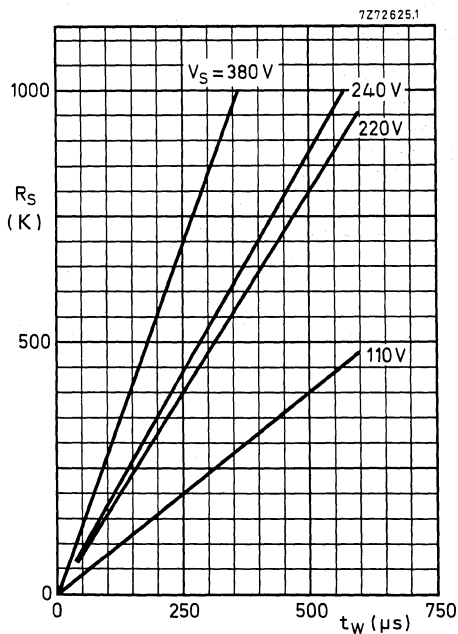

Fig. 13 Synchronization resistor R_S as a function of required trigger pulse width t_w with mains supply voltage V_S as a parameter.

Table 1

Temperature controller component values (see Fig. 14)

parameter	symbol	value	remarks
Trigger pulse width	t_w	105 μ s	see BT138 data sheet
Synchronization resistor	R_S	180 k Ω	see Fig. 13
Gate resistor	R_G	33 Ω	see Fig. 7
Average output current	$I_Q(AV)$	3.7 mA	
Min. required supply current	$I_{RX(AV)}$	6.5 mA	
Voltage-dropping resistor	R_D	10 k Ω	see Fig. 10
Power dissipated in R_D	P_{RD}	3.2 W	see Fig. 11
Voltage dependent resistor	VDR	250 V a.c.	cat. no. 2322 593 62512
Rectifier diode	D1	BYW56	
NTC thermistor (at 25 $^{\circ}$ C)	R_{NTC}	22 k Ω	B = 4200 K cat. no. 2322 642 12223
Smoothing capacitor	C_S	220 μ F; 16 V	

If R_D and D1 are replaced by C_D and R_{SD}

Voltage-dropping capacitor	C_D	270 nF	
Series dropping resistor	R_{SD}	390 Ω	
Power dissipated in R_{SD}	P_{RSD}	190 mW	
Voltage dependent resistor	VDR	250 V a.c.	cat. no. 2322 594 62512

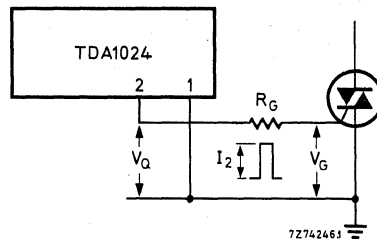
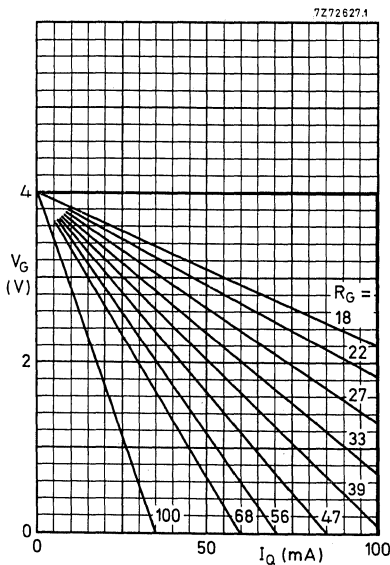

Fig. 15 Gate voltage (V_G) as a function of trigger current (I_Q) with gate resistor (R_G) load lines.

Section 8 TV-Video

INDEX

SECTION 8 — TV-VIDEO

Index	8-1
Digital Tuning System	
*SAB3035	FLL Tuning Circuit; Eight DACs
*SAB3036	FLL Tuning Circuit; No DACs
*SAB3037	FLL Tuning Circuit; Four DACs
Video Circuits	
*TDA2540	Video I.F. Amplifier Demodulator, AFT, NPN Tuners
*TDA2541	Video I.F. Amplifier Demodulator, AFT, PNP Tuners
*TDA2546A	Quasi Split Sound I.F. with Sound Demodulator
*TDA2577A	Sync Circuit with Vertical Oscillator and Driver, Negative/Positive Horizontal Output
*TDA2578A	Sync Circuit with Vertical Oscillator and Driver, Negative/Positive Horizontal Output
*TDA2593	Horizontal Combination
*TDA2594	Horizontal Combination with Transmitter I.D.
*TDA2595	Horizontal Combination with Sync Separator at 50% Amplitude (High Performance) ...
*TDA2653A	Vertical Deflection
*TDA3540/41	Video I.F./AFT
*TDA3651A/AQ	Vertical Deflection
*TDA3652	Vertical Deflection
*TDA4503	Small Signal Combination for B/W TV
*TDA4560	CTI (Color Transient Improvement Circuit)

*New product for Linear LSI since 1983 data manual.

GENERAL DESCRIPTION

The SAB3035 provides closed-loop digital tuning of TV receivers, with or without a.f.c., as required. It also controls up to 8 analogue functions, 4 general purpose I/O ports and 4 high-current outputs for tuner band selection.

The IC is used in conjunction with a microcomputer from the MAB8400 family and is controlled via a two-wire, bidirectional I²C bus.

Features

- Combined analogue and digital circuitry minimizes the number of additional interfacing components required
- Frequency measurement with resolution of 50 kHz
- Selectable prescaler divisor of 64 or 256
- 32 V tuning voltage amplifier
- 4 high-current outputs for direct band selection
- 8 static digital to analogue convertors (DACs) for control of analogue functions
- Four general purpose input/output (I/O) ports
- Tuning with control of speed and direction
- Tuning with or without a.f.c.
- Single-pin, 4 MHz on-chip oscillator
- I²C bus slave transceiver

QUICK REFERENCE DATA

Supply voltages			
(pin 16)	V _{P1}	typ.	12 V
(pin 22)	V _{P2}	typ.	13 V
(pin 17)	V _{P3}	typ.	32 V
Supply currents (no outputs loaded)			
(pin 16)	I _{P1}	typ.	32 mA
(pin 22)	I _{P2}	typ.	0.1 mA
(pin 17)	I _{P3}	typ.	0.6 mA
Total power dissipation	P _{tot}	typ.	400 mW
Operating ambient temperature range	T _{amb}		-20 to +70 °C

PACKAGE OUTLINE

28-lead DIL; plastic (SOT-117).

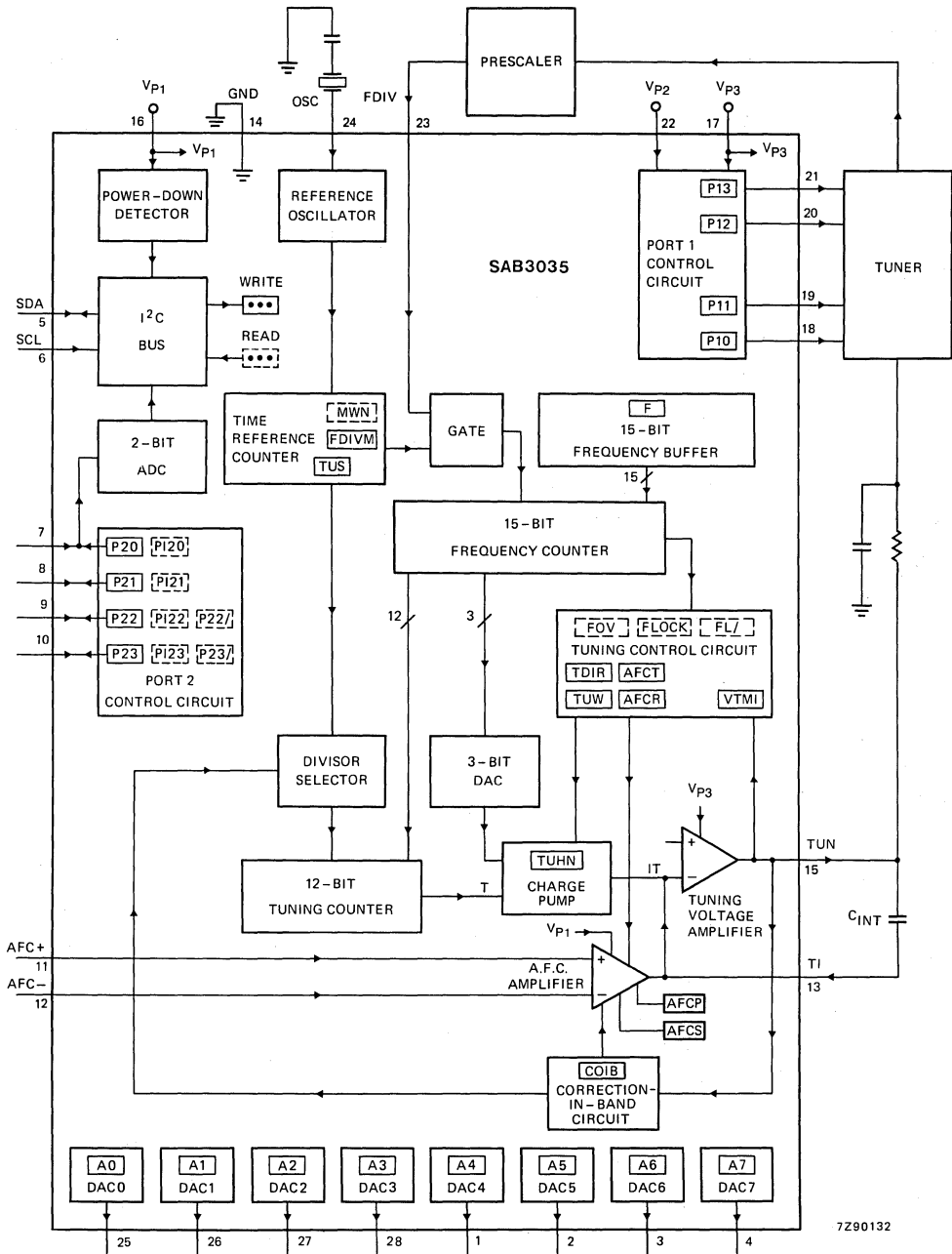

Fig. 1 Block diagram.

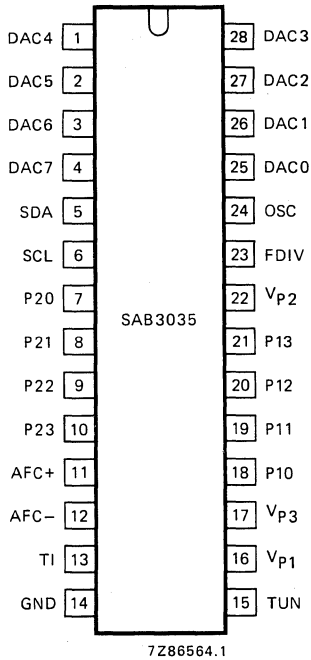

Fig. 2 Pinning diagram.

PINNING

- 1 DAC4
 - 2 DAC5
 - 3 DAC6
 - 4 DAC7
 - 5 SDA
 - 6 SCL
 - 7 P20
 - 8 P21
 - 9 P22
 - 10 P23
 - 11 AFC+
 - 12 AFC-
 - 13 TI
 - 14 GND
 - 15 TUN
 - 16 V_{P1}
 - 17 V_{P3}
 - 18 P10
 - 19 P11
 - 20 P12
 - 21 P13
 - 22 V_{P2}
 - 23 FDIV
 - 24 OSC
 - 25 DAC0
 - 26 DAC1
 - 27 DAC2
 - 28 DAC3
- outputs of static DACs
- serial data line } I²C bus
serial clock line }
- general purpose
input/output ports
- a.f.c. inputs
- tuning voltage amplifier inverting input
ground
tuning voltage amplifier output
+ 12 V supply voltage
+ 32 V supply for tuning voltage amplifier
- High-current band-selection output
ports
- positive supply for high-current band-selection output circuits
- input from prescaler
crystal oscillator input
- outputs of static DACs

FUNCTIONAL DESCRIPTION

The SAB3035 is a monolithic computer interface which provides tuning and control functions and operates in conjunction with a microcomputer via an I²C bus.

Tuning

This is performed using frequency-locked loop digital control. Data corresponding to the required tuner frequency is stored in a 15-bit frequency buffer. The actual tuner frequency, divided by a factor of 256 (or by 64) by a prescaler, is applied via a gate to a 15-bit frequency counter. This input (FDIV) is measured over a period controlled by a time reference counter and is compared with the contents of the frequency buffer. The result of the comparison is used to control the tuning voltage so that the tuner frequency equals the contents of the frequency buffer multiplied by 50 kHz within a programmable tuning window (TUW).

The system cycles over a period of 6.4 ms (or 2.56 ms), controlled by the time reference counter which is clocked by an on-chip 4 MHz reference oscillator. Regulation of the tuning voltage is performed by a charge pump frequency-locked loop system. The charge IT flowing into the tuning voltage amplifier is controlled by the tuning counter, 3-bit DAC and the charge pump circuit. The charge IT is linear with the frequency deviation Δf in steps of 50 kHz. For loop gain control, the relationship $\Delta IT/\Delta f$ is programmable. In the normal mode (when control bits TUHNO and TUHN1 are both at logic 1, see OPERATION), the minimum charge IT at $\Delta f = 50$ kHz equals $250 \mu A \mu s$ (typical).

By programming the tuning sensitivity bits (TUS), the charge IT can be doubled up to 6 times. If correction-in-band (COIB) is programmed, the charge can be further doubled up to three times in relation to the tuning voltage level. From this, the maximum charge IT at $\Delta f = 50$ kHz equals $2^6 \times 2^3 \times 250 \mu A \mu s$ (typical).

The maximum tuning current I is $875 \mu A$ (typical). In the tuning-hold (TUHN) mode (TUHN is active LOW), the tuning current I is reduced and as a consequence the charge into the tuning amplifier is also reduced.

An in-lock situation can be detected by reading FLOCK. When the tuner oscillator frequency is within the programmable tuning window (TUW), FLOCK is set to logic 1. If the frequency is also within the programmable a.f.c. hold range (AFCR), which always occurs if APCR is wider than TUW, control bit AFCT can be set to logic 1. When set, digital tuning will be switched off, a.f.c. will be switched on and FLOCK will stay at logic 1 as long as the oscillator frequency is within APCR. If the frequency of the tuning oscillator does not remain within APCR, AFCT is cleared automatically and the system reverts to digital tuning. To be able to detect this situation, the occurrence of positive and negative transitions in the FLOCK signal can be read (FL/1N and FL/0N). AFCT can also be cleared by programming the AFCT bit to logic 0.

The a.f.c. has programmable polarity and transconductance; the latter can be doubled up to 3 times, depending on the tuning voltage level if correction-in-band is used.

The direction of tuning is programmable by using control bits TDIRD (tuning direction down) and TDIRU (tuning direction up). If a tuner enters a region in which oscillation stops, then, providing the prescaler remains stable, no FDIV signal is supplied to CITAC. In this situation the system will tune up, moving away from frequency lock-in. This situation is avoided by setting TDIRD which causes the system to tune down. In normal operation TDIRD must be cleared.

If a tuner stops oscillating and the prescaler becomes unstable by going into self-oscillation at a very high frequency, the system will react by tuning down, moving away from frequency lock-in. To overcome this, the system can be forced to tune up at the lowest sensitivity (TUS) value, by setting TDIRU.

Setting both TDIRD and TDIRU causes the digital tuning to be interrupted and a.f.c. to be switched on.

The minimum tuning voltage which can be generated during digital tuning is programmable by VTMI to prevent the tuner being driven into an unspecified low tuning voltage region.

Control

For tuner band selection there are four outputs P10 to P13 which are capable of sourcing up to 50 mA at a voltage drop of less than 600 mV with respect to the separate power supply input V_{P2}.

For additional digital control, four open collector I/O ports P20 to P23 are provided. Ports P22 and P23 are capable of detecting positive and negative transitions in their input signals. With the aid of port P20, up to three independent module addresses can be programmed.

Eight 6-bit digital-to-analogue converters DAC0 to DAC7 are provided for analogue control.

Reset

CITAC goes into the power-down-reset mode when V_{P1} is below 8.5 V (typical). In this mode all registers are set to a defined state. Reset can also be programmed.

OPERATION

Write

CITAC is controlled via a bidirectional two-wire I²C bus; the I²C bus is specified in our data handbook "ICs for digital systems in radio, audio, and video equipment". For programming, a module address, R/ \bar{W} bit (logic 0), an instruction byte and a data/control byte are written into CITAC in the format shown in Fig. 3.

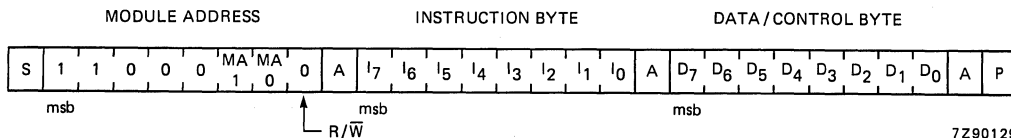

Fig. 3 I²C bus write format.

The module address bits MA1, MA0 are used to give a 2-bit module address as a function of the voltage at port P20 as shown in Table 1.

Acknowledge (A) is generated by CITAC only when a valid address is received and the device is not in the power-down-reset mode (V_{P1} > 8.5 V (typical)).

Table 1 Valid module addresses

MA1	MA0	P20
0	0	don't care
0	1	GND
1	0	½V _{P1}
1	1	V _{P1}

OPERATION (continued)

Tuning

Tuning is controlled by the instruction and data/control bytes as shown in Fig. 4.

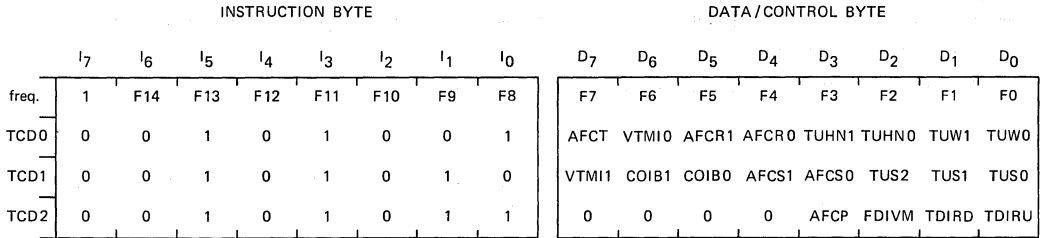

7290125

Fig. 4 Tuning control format.

Frequency

Frequency is set when bit I₇ of the instruction byte is set to logic 1; the remainder of this byte together with the data/control byte are loaded into the frequency buffer. The frequency to which the tuner oscillator is regulated equals the decimal representation of the 15-bit word multiplied by 50 kHz. All frequency bits are set to logic 1 at reset.

Tuning hold

The TUHN bits are used to decrease the maximum tuning current and, as a consequence, the minimum charge IT (at Δf = 50 kHz) into the tuning amplifier.

Table 2 Tuning current control

TUHN1	TUHN0	typ. I _{max} μA	typ. IT _{min} μA μs	typ. ΔVTUN _{min} at C _{INT} = 1 μF μV
0	0	3.5*	1*	1*
0	1	29	8	8
1	0	110	30	30
1	1	875	250	250

* Values after reset.

During tuning but before lock-in, the highest current value should be selected. After lock-in the current may be reduced to decrease the tuning voltage ripple.

The lowest current value should not be used for tuning due to the input bias current of the tuning voltage amplifier (max. 5 nA). However it is good practice to program the lowest current value during tuner band switching.

Tuning sensitivity

To be able to program an optimum loop gain, the charge IT can be programmed by changing T using tuning sensitivity (TUS). Table 3 shows the minimum charge IT obtained by programming the TUS bits at Δf = 50 kHz; TUHN0 and TUHN1 = logic 1.

Table 3 Minimum charge IT as a function of TUS

$\Delta f = 50$ kHz; TUHN0 = logic 1; TUHN1 = logic 1

TUS2	TUS1	TUS0	typ. IT_{min} mA μ s	typ. ΔV_{TUNmin} at $C_{INT} = 1 \mu F$ mV
0	0	0	0,25*	0,25*
0	0	1	0,5	0,5
0	1	0	1	1
0	1	1	2	2
1	0	0	4	4
1	0	1	8	8
1	1	0	16	16

* Values after reset.

Correction-in-band

This control is used to correct the loop gain of the tuning system to reduce in-band variations due to a non-linear voltage/frequency characteristic of the tuner. Correction-in-band (COIB) controls the time T of the charge equation IT and takes into account the tuning voltage V_{TUN} to give charge multiplying factors as shown in Table 4.

Table 4 Programming correction-in-band

COIB1	COIB0	charge multiplying factors at typical values of V_{TUN} at:			
		< 12 V	12 to 18 V	18 to 24 V	> 24 V
0	0	1*	1*	1*	1*
0	1	1	1	1	2
1	0	1	1	2	4
1	1	1	2	4	8

* Values after reset.

The transconductance multiplying factor of the a.f.c. amplifier is similar when COIB is used, except for the lowest transconductance which is not affected.

Tuning window

Digital tuning is interrupted and FLOCK is set to logic 1 (in-lock) when the absolute deviation $|\Delta f|$ between the tuner oscillator frequency and the programmed frequency is smaller than the programmed TUW value (see Table 5). If $|\Delta f|$ is up to 50 kHz above the values listed in Table 5, it is possible for the system to be locked depending on the phase relationship between FDIV and the reference counter.

Table 5 Tuning window programming

TUW1	TUW0	$ \Delta f $ (kHz)	tuning window (kHz)
0	0	0*	0*
0	1	50	100
1	0	150	300

* Values after reset.

OPERATION (continued)

A.F.C.

When AFCT is set to logic 1 it will not be cleared and the a.f.c. will remain on as long as $|\Delta f|$ is less than the value programmed for the a.f.c. hold range AFCH (see Table 6). It is possible for the a.f.c. to remain on for values of up to 50 kHz more than the programmed value depending on the phase relationship between FDIV and the reference counter.

Table 6 A.F.C. hold range programming

AFCH1	AFCH0	$ \Delta f $ (kHz)	a.f.c. hold range (kHz)
0	0	0*	0*
0	1	350	700
1	0	750	1500

* Values after reset.

Transconductance

The transconductance (g) of the a.f.c. amplifier is programmed via the a.f.c. sensitivity bits AFCS as shown in Table 7.

Table 7 Transconductance programming

AFCS1	AFCS0	typ. transconductance ($\mu A/V$)
0	0	0,25*
0	1	25
1	0	50
1	1	100

* Value after reset.

A.F.C. polarity

If a positive differential input voltage is applied to the (switched on) a.f.c. amplifier, the tuning voltage V_{TUN} falls when the a.f.c. polarity bit AFPC is at logic 0 (value after reset). At AFPC = logic 1, V_{TUN} rises.

Minimum tuning voltage

Both minimum tuning voltage control bits, VTM11 and VTM10, are at logic 0 after reset. Further details are given in CHARACTERISTICS.

Frequency measuring window

The frequency measuring window which is programmed must correspond with the division factor of the prescaler in use (see Table 8).

Table 8 Frequency measuring window programming

FDIVM	prescaler division factor	cycle period (ms)	measuring window (ms)
0	256	6.4*	5,12*
1	64	2.56	1.28

* Values after reset.

Tuning direction

Both tuning direction bits, TDIRU (up) and TDIRD (down), are at logic 0 after reset.

FLL TV TUNING CIRCUIT

SAB3035

Control

The instruction bytes POD (port output data) and DACX (digital-to-analogue converter control) are shown in Fig. 5, together with the corresponding data/control bytes. Control is implemented as follows:

P13, P12, P11, P10 Band select outputs. If a logic 1 is programmed on any of the POD bits D₃ to D₀, the relevant output goes HIGH. All outputs are LOW after reset.

P23, P22, P21, P20 Open collector I/O ports. If a logic 0 is programmed on any of the POD bits D₇ to D₄, the relevant output is forced LOW. All outputs are at logic 1 after reset (high impedance state).

DACX Digital-to-analogue converters. The digital-to-analogue converter selected corresponds to the decimal equivalent of the DACX bits X₂, X₁, X₀. The output voltage of the selected DAC is set by programming the bits AX₅ to AX₀; the lowest output voltage is programmed with all data AX₅ to AX₀ at logic 0, or after reset has been activated.

	INSTRUCTION BYTE								DATA/CONTROL BYTE							
	I ₇	I ₆	I ₅	I ₄	I ₃	I ₂	I ₁	I ₀	D ₇	D ₆	D ₅	D ₄	D ₃	D ₂	D ₁	D ₀
POD	0	0	1	0	1	0	0	0	P23	P22	P21	P20	P13	P12	P11	P10
DACX	0	0	1	0	0	X ₂	X ₁	X ₀	0	0	AX ₅	AX ₄	AX ₃	AX ₂	AX ₁	AX ₀

7Z90127

Fig. 5 Control programming.

Read

Information is read from CITAC when the R/W bit is set to logic 1. An acknowledge must be generated by the master after each data byte to allow transmission to continue. If no acknowledge is generated by the master the slave (CITAC) stops transmitting. The format of the information bytes is shown in Fig. 6.

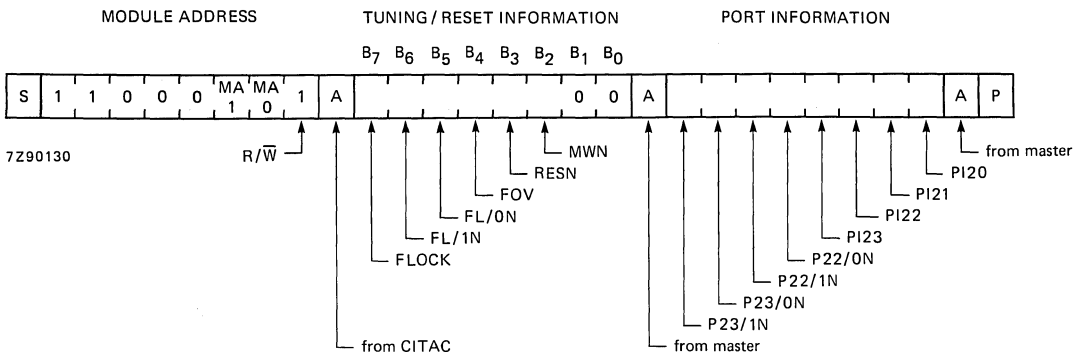

Fig. 6 Information byte format.

OPERATION (continued)

Tuning/reset information bits

- FLOCK** Set to logic 1 when the tuning oscillator frequency is within the programmed tuning window.
- FL/1N** Set to logic 0 (active LOW) when FLOCK changes from 0 to 1 and is reset to logic 1 automatically after tuning information has been read.
- FL/0N** As for FL/1N but is set to logic 0 when FLOCK changes from 1 to 0.
- FOV** Indicates frequency overflow. When the tuner oscillator frequency is too high with respect to the programmed frequency, FOV is at logic 1, and when too low, FOV is at logic 0. FOV is not valid when TDIRU and/or TDIRD are set to logic 1.
- RESN** Set to logic 0 (active LOW) by a programmed reset or a power-down-reset. It is reset to logic 1 automatically after tuning/reset information has been read.
- MWN** MWN (frequency measuring window, active LOW) is at logic 1 for a period of 1.28 ms, during which time the results of frequency measurement are processed. This time is independent of the cycle period. During the remaining time, MWN is at logic 0 and the received frequency is measured.

When slightly different frequencies are programmed repeatedly and a.f.c. is switched on, the received frequency can be measured using FOV and FLOCK. To prevent the frequency counter and frequency buffer being loaded at the same time, frequency should be programmed only during the period of MWN = logic 0.

Port information bits

- P23/1N, P22/1N** Set to logic 0 (active LOW) at a LOW-to-HIGH transition in the input voltage on P23 and P22 respectively. Both are reset to logic 1 after the port information has been read.
- P23/0N, P22/0N** As for P23/1N and P22/1N but are set to logic 0 at a HIGH-to-LOW transition.
- PI23, PI22, PI21, PI20** Indicate input voltage levels at P23, P22, P21 and P20 respectively. A logic 1 indicates a HIGH input level.

Reset

The programming to reset all registers is shown in Fig. 7. Reset is activated only at data byte HEX 06. Acknowledge is generated at every byte, provided that CITAC is not in the power-down-reset mode. After the general call address byte, transmission of more than one data byte is not allowed.

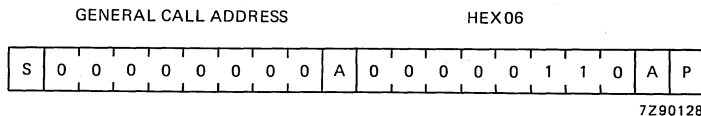

Fig. 7 Reset programming.

RATINGS

Limiting values in accordance with the Absolute Maximum System (IEC 134)

Supply voltage ranges:

(pin 16)	V_{P1}	-0.3 to +18 V
(pin 22)	V_{P2}	-0.3 to +18 V
(pin 17)	V_{P3}	-0.3 to +36 V

Input/output voltage ranges:

(pin 5)	V_{SDA}	-0.3 to +18 V
(pin 6)	V_{SCL}	-0.3 to +18 V
(pins 7 to 10)	V_{P2X}	-0.3 to +18 V
(pins 11 and 12)	$V_{AFC+}, AFC-$	-0.3 to V_{P1}^* V
(pin 13)	V_{TI}	-0.3 to V_{P1}^* V
(pin 15)	V_{TUN}	-0.3 to V_{P3}^* V
(pins 18 to 21)	V_{P1X}	-0.3 to V_{P2}^{**} V
(pin 23)	V_{FDIV}	-0.3 to V_{P1}^* V
(pin 24)	V_{OSC}	-0.3 to +5 V
(pins 1 to 4 and 25 to 28)	V_{DACX}	-0.3 to V_{P1}^* V

Total power dissipation

 P_{tot} max. 1000 mW

Storage temperature range

 T_{stg} -55 to +125 °C

Operating ambient temperature range

 T_{amb} -20 to +70 °C

* Pin voltage may exceed supply voltage if current is limited to 10 mA.

** Pin voltage must not exceed 18 V but may exceed V_{P2} if current is limited to 200 mA.

FLL TV TUNING CIRCUIT**SAB3035****CHARACTERISTICS** $T_{amb} = 25\text{ }^{\circ}\text{C}$; V_{P1} , V_{P2} , V_{P3} at typical voltages, unless otherwise specified

parameter	symbol	min.	typ.	max.	unit
Supply voltages	V_{P1}	10.5	12	13.5	V
	V_{P2}	4.7	13	16	V
	V_{P3}	30	32	35	V
Supply currents (no outputs loaded)	I_{P1}	20	32	50	mA
	I_{P2}	0	—	0.1	mA
	I_{P3}	0.2	0.6	2	mA
Additional supply currents (A) (note 1)	I_{P2A}	-2	—	I_{OHP1X}	mA
	I_{P3A}	0.2	—	2	mA
Total power dissipation	P_{tot}	—	400	—	mW
Operating ambient temperature	T_{amb}	-20	—	+70	$^{\circ}\text{C}$
I²C bus inputs/outputs					
SDA input (pin 5); SCL input (pin 6)					
Input voltage HIGH (note 2)	V_{IH}	3	—	$V_{P1}-1$	V
Input voltage LOW	V_{IL}	-0.3	—	1.5	V
Input current HIGH (note 2)	I_{IH}	—	—	10	μA
Input current LOW (note 2)	I_{IL}	—	—	10	μA
SDA output (pin 5, open collector)					
Output voltage LOW at $I_{OL} = 3\text{ mA}$	V_{OL}	—	—	0.4	V
Maximum output sink current	I_{OL}	—	5	—	mA
Open collector I/O ports					
P20, P21, P22, P23 (pins 7 to 10, open collector)					
Input voltage HIGH	V_{IH}	2	—	16	V
Input voltage LOW	V_{IL}	-0.3	—	0.8	V
Input current HIGH	I_{IH}	—	—	25	μA
Input current LOW	$-I_{IL}$	—	—	25	μA
Output voltage LOW at $I_{OL} = 2\text{ mA}$	V_{OL}	—	—	0.4	V
Maximum output sink current	I_{OL}	—	4	—	mA

FLL TV TUNING CIRCUIT

SAB3035

parameter	symbol	min.	typ.	max.	unit	
A.F.C. amplifier						
Inputs AFC+, AFC- (pins 11, 12)						
Transconductance for input voltages up to 1 V differential:						
AFCS1	AFCS2					
0	0	900	100	250	800	nA/V
0	1	901	15	25	35	μ A/V
1	0	910	30	50	70	μ A/V
1	1	911	60	100	140	μ A/V
Tolerance of transconductance multiplying factor (2, 4 or 8) when correction-in-band is used						
	ΔM_g	-20	-	+20		%
Input offset voltage						
	V_{loff}	-75	-	+75		mV
Common mode input voltage						
	V_{com}	3	-	$V_{P1}-2.5$		V
Common mode rejection ratio						
	CMRR	-	50	-		dB
Power supply (V_{P1}) rejection ratio						
	PSRR	-	50	-		dB
Input current						
	I_I	-	-	500		nA
Tuning voltage amplifier						
Input TI, output TUN (pins 13, 15)						
Maximum output voltage at $I_{load} = \pm 2.5$ mA						
	V_{TUN}	$V_{P3}-1.6$	-	$V_{P3}-0.4$		V
Minimum output voltage at $I_{load} = \pm 2.5$ mA:						
VTM11	VTM10					
0	0	VTM00	300	-	500	mV
1	0	VTM10	450	-	650	mV
1	1	VTM11	650	-	900	mV
Maximum output source current						
	$-I_{TUNH}$	2.5	-	8		mA
Maximum output sink current						
	I_{TUNL}	-	40	-		mA
Input bias current						
	I_{TI}	-5	-	+5		nA
Power supply (V_{P3}) rejection ratio						
	PSRR	-	60	-		dB

FLL TV TUNING CIRCUIT

SAB3035

CHARACTERISTICS (continued)

parameter	symbol	min.	typ.	max.	unit	
Tuning voltage amplifier (continued)						
Minimum charge I_T to tuning voltage amplifier						
TUHN1	TUHN0					
0	0	CH00	0.4	1	1.7	$\mu A \mu s$
0	1	CH01	4	8	14	$\mu A \mu s$
1	0	CH10	15	30	48	$\mu A \mu s$
1	1	CH11	130	250	370	$\mu A \mu s$
Tolerance of charge (or ΔV_{TUN}) multiplying factor when COIB and/or TUS are used						
	ΔCH	-20	-	+20	%	
Maximum current I into tuning amplifier						
TUHN1	TUHN0					
0	0	I_{T00}	1.7	3.5	5.1	μA
0	1	I_{T01}	15	29	41	μA
1	0	I_{T10}	65	110	160	μA
1	1	I_{T11}	530	875	1220	μA
Correction-in-band						
Tolerance of correction-in-band levels 12 V, 18 V and 24 V						
	ΔV_{CIB}	-15	-	+15	%	
Band-select output ports						
P10, P11, P12, P13 (pins 18 to 21)						
Output voltage HIGH at $-I_{OH} = 50 \text{ mA}$ (note 3)						
	V_{OH}	$V_{P2}-0.6$	-	-	V	
Output voltage LOW at $I_{OL} = 2 \text{ mA}$						
	V_{OL}	-	-	0.4	V	
Maximum output source current (note 3)						
	$-I_{OH}$	-	130	200	mA	
Maximum output sink current						
	I_{OL}	-	5	-	mA	
FDIV input (pin 23)						
Input voltage (peak-to-peak value) (t_{rise} and $t_{fall} \leq 40 \text{ ns}$)						
	$V_{FDIV(p-p)}$	0.1	-	2	V	
Duty cycle						
	-	40	-	60	%	
Maximum input frequency						
	f_{max}	14.5	-	-	MHz	
Input impedance						
	Z_i	-	8	-	k Ω	
Input capacitance						
	C_i	-	5	-	pF	

FLL TV TUNING CIRCUIT

SAB3035

parameter	symbol	min.	typ.	max.	unit	
OSC input (pin 24)						
Crystal resistance at resonance (4 MHz)	R_X	—	—	150	Ω	
DAC outputs 0 to 7 (pins 25 to 28 and 1 to 4)						
Maximum output voltage (no load) at $V_{P1} = 12$ V (note 4)	V_{DH}	10	—	11.5	V	
Minimum output voltage (no load) at $V_{P1} = 12$ V (note 4)	V_{DL}	0.1	—	1	V	
Positive value of smallest step (1 least-significant bit)	ΔV_D	0	—	350	mV	
Deviation from linearity	—	—	—	0.5	V	
Output impedance at $I_{load} = \pm 2$ mA	Z_o	—	—	70	Ω	
Maximum output source current	$-I_{DH}$	—	—	6	mA	
Maximum output sink current	I_{DL}	—	8	—	mA	
Power-down-reset						
Maximum supply voltage V_{P1} at which power-down-reset is active	V_{PD}	7.5	—	9.5	V	
V_{P1} rise-time during power-up (up to V_{PD})	t_r	5	—	—	μs	
Voltage level for valid module address						
Voltage level at P20 (pin 7) for valid module address as a function of MA1, MA0						
MA1	MA0					
0	0	V_{VA00}	-0.3	—	16	V
0	1	V_{VA01}	-0.3	—	0.8	V
1	0	V_{VA10}	2.5	—	$V_{P1}-2$	V
1	1	V_{VA11}	$V_{P1}-0.3$	—	V_{P1}	V

Notes to the characteristics

- For each band-select output which is programmed at logic 1, sourcing a current I_{OHP1X} , the additional supply currents (A) shown must be added to I_{P2} and I_{P3} respectively.
- If $V_{P1} < 1$ V, the input current is limited to 10 μA at input voltages up to 16 V.
- At continuous operation the output current should not exceed 50 mA. When the output is short-circuited to ground for several seconds the device may be damaged.
- Values are proportional to V_{P1} .

I²C BUS TIMING (Fig. 8)

I²C bus load conditions are as follows:

4 kΩ pull-up resistor to +5 V; 200 pF capacitor to GND.

All values are referred to V_{IH} = 3 V and V_{IL} = 1.5 V.

parameter	symbol	min.	typ.	max.	unit
Bus free before start	t _{BUF}	4	—	—	μs
Start condition set-up time	t _{SU,STA}	4	—	—	μs
Start condition hold time	t _{HD,STA}	4	—	—	μs
SCL, SDA LOW period	t _{LOW}	4	—	—	μs
SCL HIGH period	t _{HIGH}	4	—	—	μs
SCL, SDA rise time	t _R	—	—	1	μs
SCL, SDA fall time	t _F	—	—	0,3	μs
Data set-up time (write)	t _{SU,DAT}	1	—	—	μs
Data hold time (write)	t _{HD,DAT}	1	—	—	μs
Acknowledge (from CITAC) set-up time	t _{SU,CAC}	—	—	2	μs
Acknowledge (from CITAC) hold time	t _{HD,CAC}	0	—	—	μs
Stop condition set-up time	t _{SU,STO}	4	—	—	μs
Data set-up time (read)	t _{SU,RDA}	—	—	2	μs
Data hold time (read)	t _{HD,RDA}	0	—	—	μs
Acknowledge (from master) set-up time	t _{SU,MAC}	1	—	—	μs
Acknowledge (from master) hold time	t _{HD,MAC}	2	—	—	μs

Note

Timings t_{SU,DAT} and t_{HD,DAT} deviate from the I²C bus specification .

After reset has been activated, transmission may only be started after a 50 μs delay.

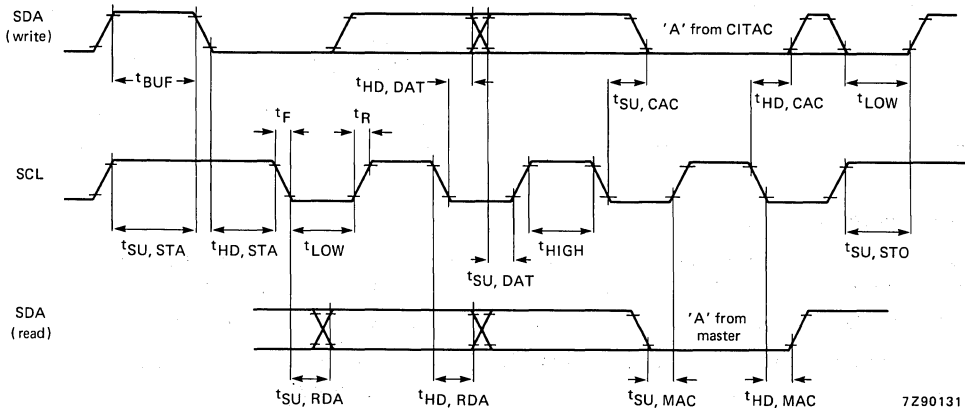

Fig. 8 I²C bus timing SAB3035.

GENERAL DESCRIPTION

The SAB3036 provides closed-loop digital tuning of TV receivers, with or without a.f.c., as required. It also controls 4 general purpose I/O ports and 4 high-current outputs for tuner band selection.

The IC is used in conjunction with a microcomputer from the MAB8400 family and is controlled via a two-wire, bidirectional I²C bus.

Features

- Combined analogue and digital circuitry minimizes the number of additional interfacing components required
- Frequency measurement with resolution of 50 kHz
- Selectable prescaler divisor of 64 or 256
- 32 V tuning voltage amplifier
- 4 high-current outputs for direct band selection
- Four general purpose input/output (I/O) ports
- Tuning with control of speed and direction
- Tuning with or without a.f.c.
- Single-pin, 4 MHz on-chip oscillator
- I²C bus slave transceiver

QUICK REFERENCE DATA

Supply voltages			
(pin 5)	V _{P1}	typ.	12 V
(pin 14)	V _{P2}	typ.	13 V
(pin 9)	V _{P3}	typ.	32 V
Supply currents (no outputs loaded)			
(pin 5)	I _{P1}	typ.	23 mA
(pin 14)	I _{P2}	typ.	0.1 mA
(pin 9)	I _{P3}	typ.	0.6 mA
Total power dissipation	P _{tot}	typ.	300 mW
Operating ambient temperature range	T _{amb}		-20 to + 70 °C

PACKAGE OUTLINE

18-lead DIL; plastic (SOT-102HE).

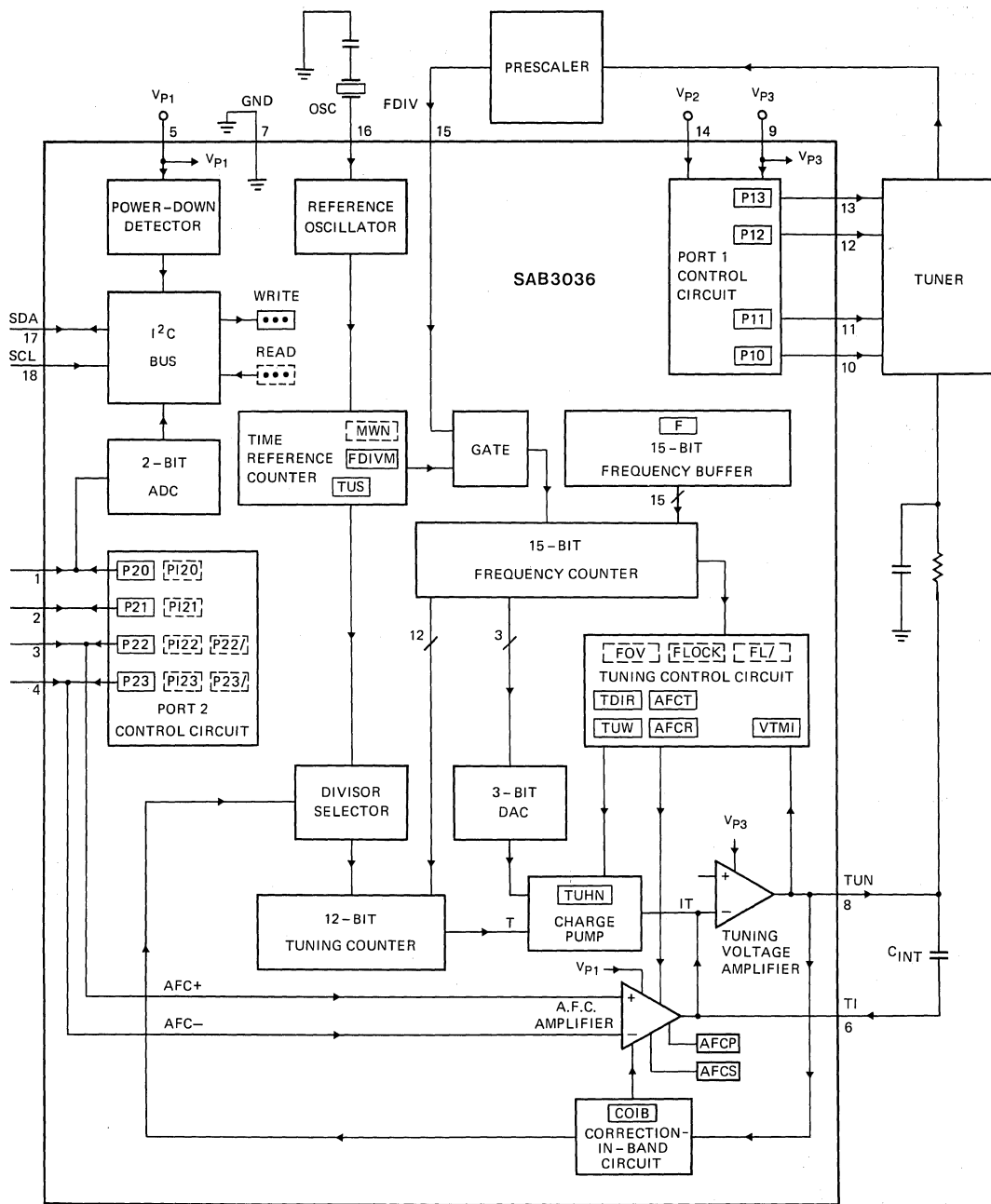

7290165

Fig. 1 Block diagram.

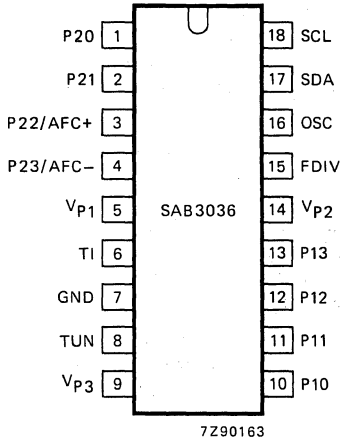

Fig. 2 Pinning diagram.

PINNING

1	P20	}	general purpose
2	P21		input/output ports
3	P22/AFC+	}	general purpose input/output
4	P23/AFC-		ports and a.f.c. inputs
5	Vp1		+ 12 V supply voltage
6	TI		tuning voltage amplifier inverting input
7	GND		ground
8	TUN		tuning voltage amplifier output
9	Vp3		+ 32 V supply for tuning voltage amplifier
10	P10	}	high-current band-selection output ports
11	P11		
12	P12		
13	P13		
14	Vp2		positive supply for high-current band-selection output circuits
15	FDIV		input from prescaler
16	OSC		crystal oscillator input
17	SDA	}	I ² C bus
18	SCL		

FUNCTIONAL DESCRIPTION

The SAB3036 is a monolithic computer interface which provides tuning and control functions and operates in conjunction with a microcomputer via an I²C bus.

Tuning

This is performed using frequency-locked loop digital control. Data corresponding to the required tuner frequency is stored in a 15-bit frequency buffer. The actual tuner frequency, divided by a factor of 256 (or by 64) by a prescaler, is applied via a gate to a 15-bit frequency counter. This input (FDIV) is measured over a period controlled by a time reference counter and is compared with the contents of the frequency buffer. The result of the comparison is used to control the tuning voltage so that the tuner frequency equals the contents of the frequency buffer multiplied by 50 kHz within a programmable tuning window (TUW).

The system cycles over a period of 6.4 ms (or 2.56 ms), controlled by the time reference counter which is clocked by an on-chip 4 MHz reference oscillator. Regulation of the tuning voltage is performed by a charge pump frequency-locked loop system. The charge IT flowing into the tuning voltage amplifier is controlled by the tuning counter, 3-bit DAC and the charge pump circuit. The charge IT is linear with the frequency deviation Δf in steps of 50 kHz. For loop gain control, the relationship $\Delta IT/\Delta f$ is programmable. In the normal mode (when control bits TUHN0 and TUHN1 are both at logic 1, see OPERATION), the minimum charge IT at $\Delta f = 50$ kHz equals $250 \mu A \mu s$ (typical).

By programming the tuning sensitivity bits (TUS), the charge IT can be doubled up to 6 times. If correction-in-band (COIB) is programmed, the charge can be further doubled up to three times in relation to the tuning voltage level. From this, the maximum charge IT at $\Delta f = 50$ kHz equals $2^6 \times 2^3 \times 250 \mu A \mu s$ (typical).

The maximum tuning current I is $875 \mu A$ (typical). In the tuning-hold (TUHN) mode (TUHN is active LOW), the tuning current I is reduced and as a consequence the charge into the tuning amplifier is also reduced.

An in-lock situation can be detected by reading FLOCK. When the tuner oscillator frequency is within the programmable tuning window (TUW), FLOCK is set to logic 1. If the frequency is also within the programmable a.f.c. hold range (AFCR), which always occurs if AFCT is wider than TUW, control bit AFCT can be set to logic 1. When set, digital tuning will be switched off, a.f.c. will be switched on and FLOCK will stay at logic 1 as long as the oscillator frequency is within AFCT. If the frequency of the tuning oscillator does not remain within AFCT, AFCT is cleared automatically and the system reverts to digital tuning. To be able to detect this situation, the occurrence of positive and negative transitions in the FLOCK signal can be read (FL/1N and FL/0N). AFCT can also be cleared by programming the AFCT bit to logic 0.

The a.f.c. has programmable polarity and transconductance; the latter can be doubled up to 3 times, depending on the tuning voltage level if correction-in-band is used.

The direction of tuning is programmable by using control bits TDIRD (tuning direction down) and TDIRU (tuning direction up). If a tuner enters a region in which oscillation stops, then, providing the prescaler remains stable, no FDIV signal is supplied to CITAC. In this situation the system will tune up, moving away from frequency lock-in. This situation is avoided by setting TDIRD which causes the system to tune down. In normal operation TDIRD must be cleared.

If a tuner stops oscillating and the prescaler becomes unstable by going into self-oscillation at a very high frequency, the system will react by tuning down, moving away from frequency lock-in. To overcome this, the system can be forced to tune up at the lowest sensitivity (TUS) value, by setting TDIRU.

Setting both TDIRD and TDIRU causes the digital tuning to be interrupted and a.f.c. to be switched on.

The minimum tuning voltage which can be generated during digital tuning is programmable by VTMI to prevent the tuner being driven into an unspecified low tuning voltage region.

Control

For tuner band selection there are four outputs P10 to P13 which are capable of sourcing up to 50 mA at a voltage drop of less than 600 mV with respect to the separate power supply input V_{P2} .

For additional digital control, four open collector I/O ports P20 to P23 are provided. Ports P22 and P23 are capable of detecting positive and negative transitions in their input signals and are connected with the AFC+ and AFC- inputs respectively. The a.f.c. amplifier must be switched off when P22 and/or P23 are used. When a.f.c. is used, P22 and P23 must be programmed HIGH (high impedance state). With the aid of port P20, up to three independent module addresses can be programmed.

Reset

CITAC goes into the power-down-reset mode when V_{P1} is below 8.5 V (typical). In this mode all registers are set to a defined state. Reset can also be programmed.

OPERATION

Write

CITAC is controlled via a bidirectional two-wire I²C bus; the I²C bus is specified in our data handbook "ICs for digital systems in radio, audio, and video equipment". For programming, a module address, R/W bit (logic 0), an instruction byte and a data/control byte are written into CITAC in the format shown in Fig. 3.

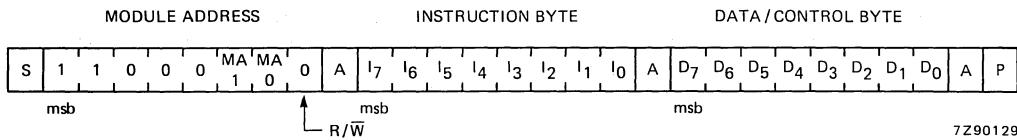

Fig. 3 I²C bus write format.

The module address bits MA1, MA0 are used to give a 2-bit module address as a function of the voltage at port P20 as shown in Table 1.

Acknowledge (A) is generated by CITAC only when a valid address is received and the device is not in the power-down-reset mode ($V_{P1} > 8.5$ V (typical)).



OPERATION (continued)

Table 1 Valid module addresses

MA1	MA0	P20
0	0	don't care
0	1	GND
1	0	½VP1
1	1	VP1

Tuning

Tuning is controlled by the instruction and data/control bytes as shown in Fig. 4.

freq.	INSTRUCTION BYTE								DATA/CONTROL BYTE							
	I ₇	I ₆	I ₅	I ₄	I ₃	I ₂	I ₁	I ₀	D ₇	D ₆	D ₅	D ₄	D ₃	D ₂	D ₁	D ₀
	1	F14	F13	F12	F11	F10	F9	F8	F7	F6	F5	F4	F3	F2	F1	F0
TCD0	0	0	1	0	1	0	0	1	AFCT	VTMI0	AFCR1	AFCR0	TUHN1	TUHN0	TUW1	TUW0
TCD1	0	0	1	0	1	0	1	0	VTMI1	COIB1	COIB0	AFCS1	AFCS0	TUS2	TUS1	TUS0
TCD2	0	0	1	0	1	0	1	1	0	0	0	0	AFCP	FDIVM	TDIRD	TDIRU

Fig. 4 Tuning control format.

729012F

Frequency

Frequency is set when bit I₇ of the instruction byte is set to logic 1; the remainder of this byte together with the data/control byte are loaded into the frequency buffer. The frequency to which the tuner oscillator is regulated equals the decimal representation of the 15-bit word multiplied by 50 kHz. All frequency bits are set to logic 1 at reset.

Tuning hold

The TUHN bits are used to decrease the maximum tuning current and, as a consequence, the minimum charge IT (at Δf = 50 kHz) into the tuning amplifier.

Table 2 Tuning current control

TUHN1	TUHN0	typ. I _{max} μA	typ. IT _{min} μA μs	typ. ΔVTUN _{min} at C _{INT} = 1 μF μV
0	0	3,5*	1*	1*
0	1	29	8	8
1	0	110	30	30
1	1	875	250	250

* Values after reset.

During tuning but before lock-in, the highest current value should be selected. After lock-in the current may be reduced to decrease the tuning voltage ripple.

The lowest current value should not be used for tuning due to the input bias current of the tuning voltage amplifier (max. 5 nA). However it is good practice to program the lowest current value during tuner band switching.

Tuning sensitivity

To be able to program an optimum loop gain, the charge IT can be programmed by changing T using tuning sensitivity (TUS). Table 3 shows the minimum charge IT obtained by programming the TUS bits at $\Delta f = 50$ kHz; TUHNO and TUHN1 = logic 1.

Table 3 Minimum charge IT as a function of TUS

$\Delta f = 50$ kHz; TUHNO = logic 1; TUHN1 = logic 1

TUS2	TUS1	TUS0	typ. IT_{min} mA μs	typ. ΔV_{TUNmin} at $C_{INT} = 1 \mu F$ mV
0	0	0	0.25*	0.25*
0	0	1	0.5	0.5
0	1	0	1	1
0	1	1	2	2
1	0	0	4	4
1	0	1	8	8
1	1	0	16	16

* Values after reset.

Correction-in-band

This control is used to correct the loop gain of the tuning system to reduce in-band variations due to a non-linear voltage/frequency characteristic of the tuner. Correction-in-band (COIB) controls the time T of the charge equation IT and takes into account the tuning voltage V_{TUN} to give charge multiplying factors as shown in Table 4.

Table 4 Programming correction-in-band

COIB1	COIB0	charge multiplying factors at typical values of V_{TUN} at:			
		< 12 V	12 to 18 V	18 to 24 V	> 24 V
0	0	1*	1*	1*	1*
0	1	1	1	1	2
1	0	1	1	2	4
1	1	1	2	4	8

* Values after reset.

The transconductance multiplying factor of the a.f.c. amplifier is similar when COIB is used, except for the lowest transconductance which is not affected.

Tuning window

Digital tuning is interrupted and FLOCK is set to logic 1 (in-lock) when the absolute deviation $|\Delta f|$ between the tuner oscillator frequency and the programmed frequency is smaller than the programmed TUW value (see Table 5). If $|\Delta f|$ is up to 50 kHz above the values listed in Table 5, it is possible for the system to be locked depending on the phase relationship between FDIV and the reference counter.



OPERATION (continued)

Table 5 Tuning window programming

TUW1	TUW0	$ \Delta f $ (kHz)	tuning window (kHz)
0	0	0*	0*
0	1	50	100
1	0	150	300

* Values after reset.

A.F.C.

When AFCT is set to logic 1 it will not be cleared and the a.f.c. will remain on as long as $|\Delta f|$ is less than the value programmed for the a.f.c. hold range AFCH (see Table 6). It is possible for the a.f.c. to remain on for values of up to 50 kHz more than the programmed value depending on the phase relationship between FDIV and the reference counter.

Table 6 A.F.C. hold range programming

AFCH1	AFCH0	$ \Delta f $ (kHz)	a.f.c. hold range (kHz)
0	0	0*	0*
0	1	350	700
1	0	750	1500

* Values after reset.

Transconductance

The transconductance (g) of the a.f.c. amplifier is programmed via the a.f.c. sensitivity bits AFCS as shown in Table 7.

Table 7 Transconductance programming

AFCS1	AFCS0	typ. transconductance ($\mu\text{A/V}$)
0	0	0.25*
0	1	25
1	0	50
1	1	100

* Value after reset.

A.F.C. polarity

If a positive differential input voltage is applied to the (switched on) a.f.c. amplifier, the tuning voltage V_{TUN} falls when the a.f.c. polarity bit AFCP is at logic 0 (value after reset). At AFCP = logic 1, V_{TUN} rises.

Minimum tuning voltage

Both minimum tuning voltage control bits, VTM11 and VTM10, are at logic 0 after reset. Further details are given in CHARACTERISTICS.

Frequency measuring window

The frequency measuring window which is programmed must correspond with the division factor of the prescaler in use (see Table 8).

Table 8 Frequency measuring window programming

FDIVM	prescaler division factor	cycle period (ms)	measuring window (ms)
0	256	6.4*	5.12*
1	64	2.56	1.28

* Values after reset.

Tuning direction

Both tuning direction bits, TDIRU (up) and TDIRD (down), are at logic 0 after reset.

Control

The instruction byte POD (port output data) is shown in Fig. 5, together with the corresponding data/control byte. Control is implemented as follows:

- P13, P12, P11, P10 Band select outputs. If a logic 1 is programmed on any of the POD bits D₃ to D₀, the relevant output goes HIGH. All outputs are LOW after reset.
- P23, P22, P21, P20 Open collector I/O ports. If a logic 0 is programmed on any of the POD bits D₇ to D₄, the relevant output is forced LOW. All outputs are at logic 1 after reset (high impedance state).

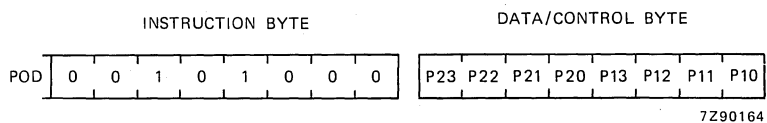

Fig. 5 Control programming.



OPERATION (continued)

Read

Information is read from CITAC when the R/W bit is set to logic 1. An acknowledge must be generated by the master after each data byte to allow transmission to continue. If no acknowledge is generated by the master the slave (CITAC) stops transmitting. The format of the information bytes is shown in Fig. 6.

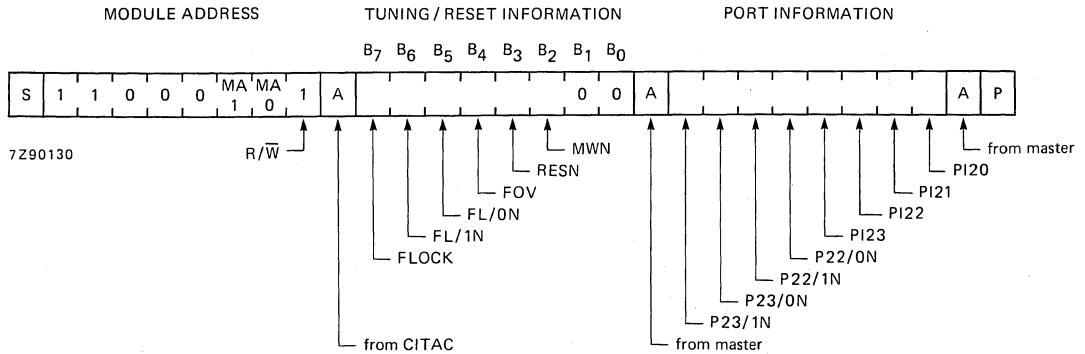

Fig. 6 Information byte format.

Tuning/reset information bits

- FLOCK** Set to logic 1 when the tuning oscillator frequency is within the programmed tuning window.
- FL/1N** Set to logic 0 (active LOW) when FLOCK changes from 0 to 1 and is reset to logic 1 automatically after tuning information has been read.
- FL/0N** As for FL/1N but is set to logic 0 when FLOCK changes from 1 to 0.
- FOV** Indicates frequency overflow. When the tuner oscillator frequency is too high with respect to the programmed frequency, FOV is at logic 1, and when too low, FOV is at logic 0. FOV is not valid when TDIRU and/or TDIRD are set to logic 1.
- RESN** Set to logic 0 (active LOW) by a programmed reset or a power-down-reset. It is reset to logic 1 automatically after tuning/reset information has been read.
- MWN** MWN (frequency measuring window, active LOW) is at logic 1 for a period of 1.28 ms, during which time the results of frequency measurement are processed. This time is independent of the cycle period. During the remaining time, MWN is at logic 0 and the received frequency is measured.
When slightly different frequencies are programmed repeatedly and a.f.c. is switched on, the received frequency can be measured using FOV and FLOCK. To prevent the frequency counter and frequency buffer being loaded at the same time, frequency should be programmed only during the period of MWN = logic 0.

Port information bits

- P23/1N, P22/1N Set to logic 0 (active LOW) at a LOW-to-HIGH transition in the input voltage on P23 and P22 respectively. Both are reset to logic 1 after the port information has been read.
- P23/0N, P22/0N As for P23/1N and P22/1N but are set to logic 0 at a HIGH-to-LOW transition.
- PI23, PI22, PI21, PI20 Indicate input voltage levels at P23, P22, P21 and P20 respectively. A logic 1 indicates a HIGH input level.

Reset

The programming to reset all registers is shown in Fig. 7. Reset is activated only at data byte HEX 06. Acknowledge is generated at every byte, provided that CITAC is not in the power-down-reset mode. After the general call address byte, transmission of more than one data byte is not allowed.

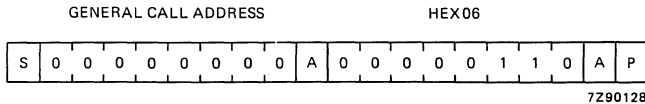

Fig. 7 Reset programming.

RATINGS

Limiting values in accordance with the Absolute Maximum System (IEC 134)

Supply voltage ranges:

(pin 5)	V_{P1}	-0.3 to + 18 V
(pin 14)	V_{P2}	-0.3 to + 18 V
(pin 9)	V_{P3}	-0.3 to + 36 V

Input/output voltage ranges:

(pin 17)	V_{SDA}	-0.3 to + 18 V
(pin 18)	V_{SCL}	-0.3 to + 18 V
(pins 1 and 2)	$V_{P20, P21}$	-0.3 to + 18 V
(pins 3 and 4)	$V_{P22, P23, AFC}$	-0.3 to V_{P1}^* V
(pin 6)	V_{TI}	-0.3 to V_{P1}^* V
(pin 8)	V_{TUN}	-0.3 to V_{P3}^* V
(pins 10 to 13)	V_{P1X}	-0.3 to V_{P2}^{**} V
(pin 15)	V_{FDIV}	-0.3 to V_{P1}^* V
(pin 16)	V_{OSC}	-0.3 to + 5 V

Total power dissipation	P_{tot}	max. 1000 mW
Storage temperature range	T_{stg}	-55 to + 125 °C
Operating ambient temperature	T_{amb}	-20 to + 70 °C

* Pin voltage may exceed supply voltage if current is limited to 10 mA.

** Pin voltage must not exceed 18 V but may exceed V_{P2} if current is limited to 200 mA.

FLL TV TUNING CIRCUIT

SAB3036

CHARACTERISTICS

 $T_{amb} = 25\text{ }^{\circ}\text{C}$; V_{P1} , V_{P2} , V_{P3} at typical voltages, unless otherwise specified

parameter	symbol	min.	typ.	max.	unit
Supply voltages	V_{P1}	10.5	12	13.5	V
	V_{P2}	4.7	13	16	V
	V_{P3}	30	32	35	V
Supply currents (no outputs loaded)	I_{P1}	14	23	40	mA
	I_{P2}	0	—	0.1	mA
	I_{P3}	0.2	0.6	2	mA
Additional supply currents (A) (note 1)	I_{P2A}	—2	—	I_{OHP1X}	mA
	I_{P3A}	0.2	—	2	mA
Total power dissipation	P_{tot}	—	300	—	mW
Operating ambient temperature	T_{amb}	—20	—	+70	$^{\circ}\text{C}$
I²C bus inputs/outputs					
SDA input (pin 17); SCL input (pin 18)					
Input voltage HIGH (note 2)	V_{IH}	3	—	$V_{P1}-1$	V
Input voltage LOW	V_{IL}	—0.3	—	1.5	V
Input current HIGH (note 2)	I_{IH}	—	—	10	μA
Input current LOW (note 2)	I_{IL}	—	—	10	μA
SDA output (pin 17, open collector)					
Output voltage LOW at $I_{OL} = 3\text{ mA}$	V_{OL}	—	—	0.4	V
Maximum output sink current	I_{OL}	—	5	—	mA
Open collector I/O ports					
P20, P21, P22, P23 (pins 1 to 4, open collector)					
Input voltage HIGH (P20, P21)	V_{IH}	2	—	16	V
Input voltage HIGH (P22, P23) AFC switched off	V_{IH}	2	—	$V_{P1}-2$	V
Input voltage LOW	V_{IL}	—0.3	—	0.8	V
Input current HIGH	I_{IH}	—	—	25	μA
Input current LOW	$-I_{IL}$	—	—	25	μA
Output voltage LOW at $I_{OL} = 2\text{ mA}$	V_{OL}	—	—	0.4	V
Maximum output sink current	I_{OL}	—	4	—	mA

FLL TV TUNING CIRCUIT

SAB3036

parameter	symbol	min.	typ.	max.	unit	
A.F.C. amplifier						
Inputs AFC+, AFC- (pins 3, 4)						
Transconductance for input voltages up to 1 V differential:						
AFCS1	AFCS2					
0	0	900	100	250	800	nA/V
0	1	901	15	25	35	μA/V
1	0	910	30	50	70	μA/V
1	1	911	60	100	140	μA/V
Tolerance of transconductance multiplying factor (2, 4 or 8) when correction-in-band is used						
	ΔM_g	-20	-	+20	%	
Input offset voltage						
	V_{loff}	-75	-	+75	mV	
Common mode input voltage						
	V_{com}	3	-	$V_{P1}-2.5$	V	
Common mode rejection ratio						
	CMRR	-	50	-	dB	
Power supply (V_{P1}) rejection ratio						
	PSRR	-	50	-	dB	
Input current (P22 and P23 programmed HIGH)						
	I_I	-	-	500	nA	
Tuning voltage amplifier						
Input TI, output TUN (pins 6, 8)						
Maximum output voltage at $I_{load} = \pm 2.5$ mA						
	V_{TUN}	$V_{P3}-1.6$	-	$V_{P3}-0.4$	V	
Minimum output voltage at $I_{load} = \pm 2.5$ mA:						
VTM11	VTM10					
0	0	V_{TM00}	300	-	500	mV
1	0	V_{TM10}	450	-	650	mV
1	1	V_{TM11}	650	-	900	mV
Maximum output source current						
	$-I_{TUNH}$	2.5	-	8	mA	
Maximum output sink current						
	I_{TUNL}	-	40	-	mA	
Input bias current						
	I_{TI}	-5	-	+5	nA	
Power supply (V_{P3}) rejection ratio						
	PSRR	-	60	-	dB	

FLL TV TUNING CIRCUIT

SAB3036

CHARACTERISTICS (continued)

parameter	symbol	min.	typ.	max.	unit
Tuning voltage amplifier (continued)					
Minimum charge I_T to tuning voltage amplifier					
TUHN1 TUHNO					
0 0	CH00	0.4	1	1.7	$\mu A \mu s$
0 1	CH01	4	8	14	$\mu A \mu s$
1 0	CH10	15	30	48	$\mu A \mu s$
1 1	CH11	130	250	370	$\mu A \mu s$
Tolerance of charge (or ΔV_{TUN}) multiplying factor when COIB and/or TUS are used					
	ΔCH	-20	-	+20	%
Maximum current I into tuning amplifier					
TUHN1 TUHNO					
0 0	I_{T00}	1.7	3.5	5.1	μA
0 1	I_{T01}	15	29	41	μA
1 0	I_{T10}	65	110	160	μA
1 1	I_{T11}	530	875	1220	μA
Correction-in-band					
Tolerance of correction-in-band levels 12 V, 18 V and 24 V					
	ΔV_{CIB}	-15	-	+15	%
Band-select output ports					
P10, P11, P12, P13 (pins 10 to 13)					
Output voltage HIGH at $-I_{OH} = 50 \text{ mA}$ (note 3)					
	V_{OH}	$V_{P2}-0.6$	-	-	V
Output voltage LOW at $I_{OL} = 2 \text{ mA}$					
	V_{OL}	-	-	0.4	V
Maximum output source current (note 3)					
	$-I_{OH}$	-	130	200	mA
Maximum output sink current					
	I_{OL}	-	5	-	mA
FDIV input (pin 15)					
Input voltage (peak-to-peak value) (t_{rise} and $t_{fall} \leq 40 \text{ ns}$)					
	$V_{FDIV(p-p)}$	0.1	-	2	V
Duty cycle					
	-	40	-	60	%
Maximum input frequency					
	f_{max}	16	-	-	MHz
Input impedance					
	Z_i	-	8	-	k Ω
Input capacitance					
	C_i	-	5	-	pF

FLL TV TUNING CIRCUIT

SAB3036

parameter	symbol	min.	typ.	max.	unit	
OSC input (pin 24)						
Crystal resistance at resonance (4 MHz)	R_X	—	—	150	Ω	
Power-down-reset						
Maximum supply voltage V_{P1} at which power-down-reset is active	V_{PD}	7.5	—	9.5	V	
V_{P1} rise-time during power-up (up to V_{PD})	t_r	5	—	—	μs	
Voltage level for valid module address						
Voltage level at P20 (pin 1) for valid module address as a function of MA1, MA0						
MA1	MA0					
0	0	V_{VA00}	-0.3	—	16	V
0	1	V_{VA01}	-0.3	—	0.8	V
1	0	V_{VA10}	2.5	—	$V_{P1}-2$	V
1	1	V_{VA11}	$V_{P1}-0.3$	—	V_{P1}	V

Notes to the characteristics

1. For each band-select output which is programmed at logic 1, sourcing a current I_{OHP1X} , the additional supply currents (A) shown must be added to I_{P2} and I_{P3} respectively.
2. If $V_{P1} < 1$ V, the input current is limited to 10 μ A at input voltages up to 16 V.
3. At continuous operation the output current should not exceed 50 mA. When the output is short-circuited to ground for several seconds the device may be damaged.
4. Values are proportional to V_{P1} .

I²C BUS TIMING (Fig. 8)

I²C bus load conditions are as follows:

4 kΩ pull-up resistor to +5 V; 200 pF capacitor to GND.

All values are referred to V_{IH} = 3 V and V_{IL} = 1.5 V.

parameter	symbol	min.	typ.	max.	unit
Bus free before start	t _{BUF}	4	—	—	μs
Start condition set-up time	t _{SU,STA}	4	—	—	μs
Start condition hold time	t _{HD,STA}	4	—	—	μs
SCL, SDA LOW period	t _{LOW}	4	—	—	μs
SCL HIGH period	t _{HIGH}	4	—	—	μs
SCL, SDA rise time	t _R	—	—	1	μs
SCL, SDA fall time	t _F	—	—	0,3	μs
Data set-up time (write)	t _{SU,DAT}	1	—	—	μs
Data hold time (write)	t _{HD,DAT}	1	—	—	μs
Acknowledge (from CITAC) set-up time	t _{SU,CAC}	—	—	2	μs
Acknowledge (from CITAC) hold time	t _{HD,CAC}	0	—	—	μs
Stop condition set-up time	t _{SU,STO}	4	—	—	μs
Data set-up time (read)	t _{SU,RDA}	—	—	2	μs
Data hold time (read)	t _{HD,RDA}	0	—	—	μs
Acknowledge (from master) set-up time	t _{SU,MAC}	1	—	—	μs
Acknowledge (from master) hold time	t _{HD,MAC}	2	—	—	μs

Note

Timings t_{SU,DAT} and t_{HD,DAT} deviate from the I²C bus specification .

After reset has been activated, transmission may only be started after a 50 μs delay.

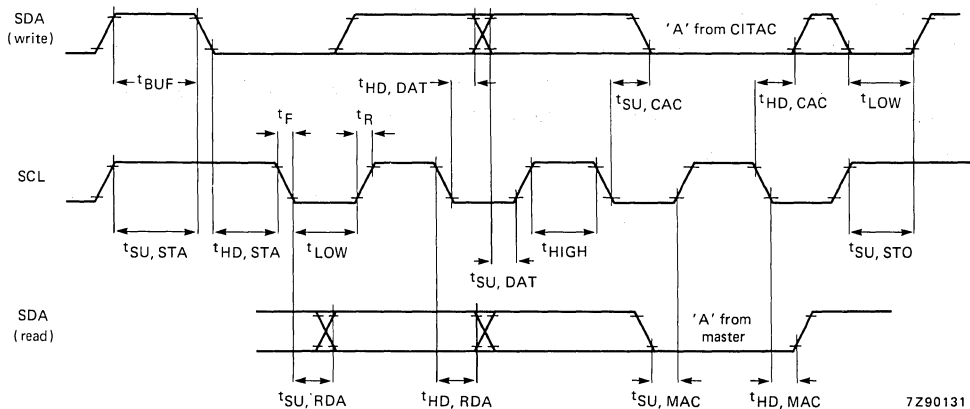

Fig. 8 I²C bus timing SAB3036.

FLL TV TUNING CIRCUIT**SAB3037****GENERAL DESCRIPTION**

The SAB3037 provides closed-loop digital tuning of TV receivers, with or without a.f.c., as required. It also controls up to 4 analogue functions, 4 general purpose I/O ports and 4 high-current outputs for tuner band selection.

The IC is used in conjunction with a microcomputer from the MAB8400 family and is controlled via a two-wire, bidirectional I²C bus.

Features

- Combined analogue and digital circuitry minimizes the number of additional interfacing components required
- Frequency measurement with resolution of 50 kHz
- Selectable prescaler divisor of 64 or 256
- 32 V tuning voltage amplifier
- 4 high-current outputs for direct band selection
- 4 static digital to analogue convertors (DACs) for control of analogue functions
- Four general purpose input/output (I/O) ports
- Tuning with control of speed and direction
- Tuning with or without a.f.c.
- Single-pin, 4 MHz on-chip oscillator
- I²C bus slave transceiver

QUICK REFERENCE DATA

Supply voltages			
(pin 13)	V _{P1}	typ.	12 V
(pin 19)	V _{P2}	typ.	13 V
(pin 14)	V _{P3}	typ.	32 V
Supply currents (no outputs loaded)			
(pin 13)	I _{P1}	typ.	30 mA
(pin 19)	I _{P2}	typ.	0.1 mA
(pin 14)	I _{P3}	typ.	0.6 mA
Total power dissipation	P _{tot}	typ.	380 mW
Operating ambient temperature range	T _{amb}		-20 to +70 °C

PACKAGE OUTLINE

24-lead DIL; plastic (SOT-101A).

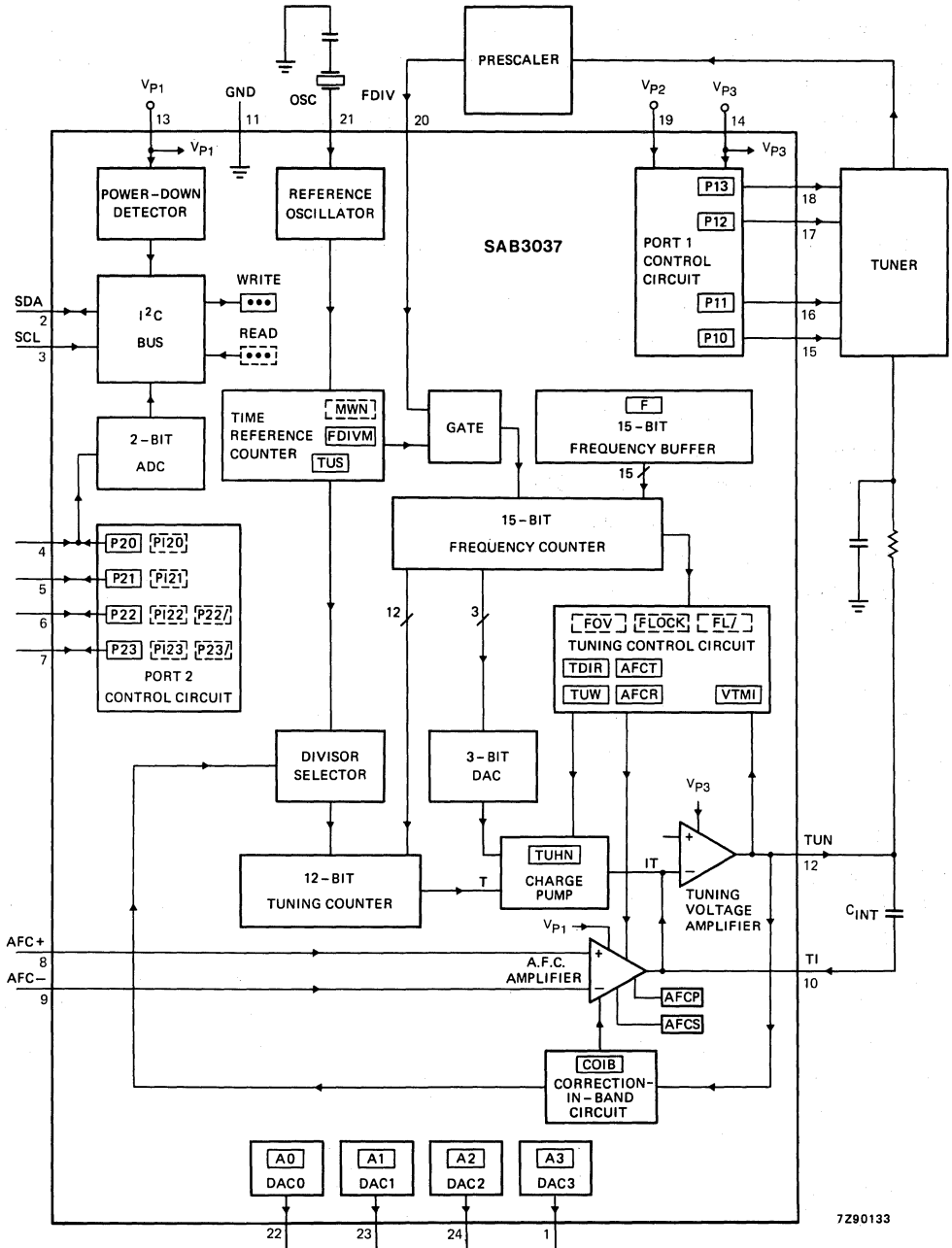

Fig. 1 Block diagram.

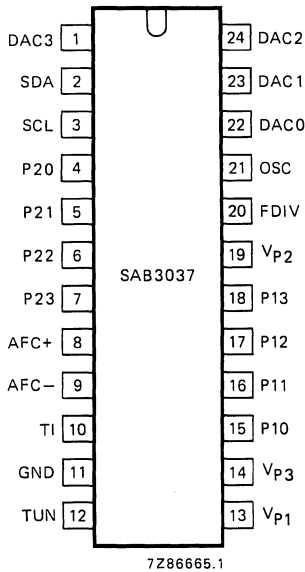

Fig. 2 Pinning diagram.

PINNING

1	DAC3	output of static DAC	
2	SDA	serial data line	} I ² C bus
3	SCL	serial clock line	
4	P20	} general purpose input/output ports	
5	P21		
6	P22		
7	P23		
8	AFC +	} a.f.c. inputs	
9	AFC -		
10	TI	tuning voltage amplifier inverting input	
11	GND	ground	
12	TUN	tuning voltage amplifier output	
13	VP1	+ 12 V supply voltage	
14	VP3	+ 32 V supply for tuning voltage amplifier	
15	P10	} high-current band-selection output ports	
16	P11		
17	P12		
18	P13		
19	VP2	positive supply for high-current band-selection output circuits	
20	FDIV	input from prescaler	
21	OSC	crystal oscillator input	
22	DAC0	} outputs of static DACs	
23	DAC1		
24	DAC2		

FUNCTIONAL DESCRIPTION

The SAB3037 is a monolithic computer interface which provides tuning and control functions and operates in conjunction with a microcomputer via an I²C bus.

Tuning

This is performed using frequency-locked loop digital control. Data corresponding to the required tuner frequency is stored in a 15-bit frequency buffer. The actual tuner frequency, divided by a factor of 256 (or by 64) by a prescaler, is applied via a gate to a 15-bit frequency counter. This input (FDIV) is measured over a period controlled by a time reference counter and is compared with the contents of the frequency buffer. The result of the comparison is used to control the tuning voltage so that the tuner frequency equals the contents of the frequency buffer multiplied by 50 kHz within a programmable tuning window (TUW).

The system cycles over a period of 6.4 ms (or 2.56 ms), controlled by the time reference counter which is clocked by an on-chip 4 MHz reference oscillator. Regulation of the tuning voltage is performed by a charge pump frequency-locked loop system. The charge IT flowing into the tuning voltage amplifier is controlled by the tuning counter, 3-bit DAC and the charge pump circuit. The charge IT is linear with the frequency deviation Δf in steps of 50 kHz. For loop gain control, the relationship $\Delta IT/\Delta f$ is programmable. In the normal mode (when control bits TUHNO and TUHN1 are both at logic 1, see OPERATION), the minimum charge IT at $\Delta f = 50$ kHz equals $250 \mu A \mu s$ (typical).

By programming the tuning sensitivity bits (TUS), the charge IT can be doubled up to 6 times. If correction-in-band (COIB) is programmed, the charge can be further doubled up to three times in relation to the tuning voltage level. From this, the maximum charge IT at $\Delta f = 50$ kHz equals $2^6 \times 2^3 \times 250 \mu A \mu s$ (typical).

The maximum tuning current I is $875 \mu A$ (typical). In the tuning-hold (TUHN) mode (TUHN is active LOW), the tuning current I is reduced and as a consequence the charge into the tuning amplifier is also reduced.

An in-lock situation can be detected by reading FLOCK. When the tuner oscillator frequency is within the programmable tuning window (TUW), FLOCK is set to logic 1. If the frequency is also within the programmable a.f.c. hold range (AFCR), which always occurs if APCR is wider than TUW, control bit AFCT can be set to logic 1. When set, digital tuning will be switched off, a.f.c. will be switched on and FLOCK will stay at logic 1 as long as the oscillator frequency is within APCR. If the frequency of the tuning oscillator does not remain within APCR, AFCT is cleared automatically and the system reverts to digital tuning. To be able to detect this situation, the occurrence of positive and negative transitions in the FLOCK signal can be read (FL/1N and FL/0N). AFCT can also be cleared by programming the AFCT bit to logic 0.

The a.f.c. has programmable polarity and transconductance; the latter can be doubled up to 3 times, depending on the tuning voltage level if correction-in-band is used.

The direction of tuning is programmable by using control bits TDIRD (tuning direction down) and TDIRU (tuning direction up). If a tuner enters a region in which oscillation stops, then, providing the prescaler remains stable, no FDIV signal is supplied to CITAC. In this situation the system will tune up, moving away from frequency lock-in. This situation is avoided by setting TDIRD which causes the system to tune down. In normal operation TDIRD must be cleared.

If a tuner stops oscillating and the prescaler becomes unstable by going into self-oscillation at a very high frequency, the system will react by tuning down, moving away from frequency lock-in. To overcome this, the system can be forced to tune up at the lowest sensitivity (TUS) value, by setting TDIRU.

Setting both TDIRD and TDIRU causes the digital tuning to be interrupted and a.f.c. to be switched on.

The minimum tuning voltage which can be generated during digital tuning is programmable by VTMI to prevent the tuner being driven into an unspecified low tuning voltage region.

Control

For tuner band selection there are four outputs P10 to P13 which are capable of sourcing up to 50 mA at a voltage drop of less than 600 mV with respect to the separate power supply input V_{P2} .

For additional digital control, four open collector I/O ports P20 to P23 are provided. Ports P22 and P23 are capable of detecting positive and negative transitions in their input signals. With the aid of port P20, up to three independent module addresses can be programmed.

Four 6-bit digital-to-analogue converters DAC0 to DAC3 are provided for analogue control.

Reset

CITAC goes into the power-down-reset mode when V_{P1} is below 8.5 V (typical). In this mode all registers are set to a defined state. Reset can also be programmed.

OPERATION

Write

CITAC is controlled via a bidirectional two-wire I²C bus; the I²C bus is specified in our data handbook "ICs for digital systems in radio, audio, and video equipment". For programming, a module address, R/W bit (logic 0), an instruction byte and a data/control byte are written into CITAC in the format shown in Fig. 3.

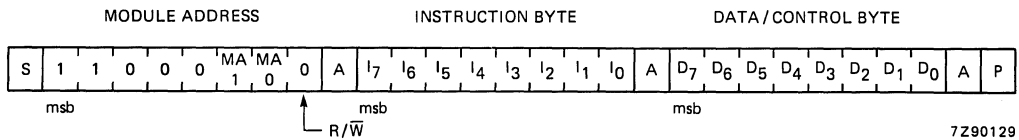

Fig. 3 I²C bus write format.

The module address bits MA1, MA0 are used to give a 2-bit module address as a function of the voltage at port P20 as shown in Table 1.

Acknowledge (A) is generated by CITAC only when a valid address is received and the device is not in the power-down-reset mode ($V_{P1} > 8.5$ V (typical)).

Table 1 Valid module addresses

MA1	MA0	P20
0	0	don't care
0	1	GND
1	0	$\frac{1}{2}V_{P1}$
1	1	V_{P1}



OPERATION (continued)

Tuning

Tuning is controlled by the instruction and data/control bytes as shown in Fig. 4.

	INSTRUCTION BYTE								DATA/CONTROL BYTE							
	I ₇	I ₆	I ₅	I ₄	I ₃	I ₂	I ₁	I ₀	D ₇	D ₆	D ₅	D ₄	D ₃	D ₂	D ₁	D ₀
freq.	1	F14	F13	F12	F11	F10	F9	F8	F7	F6	F5	F4	F3	F2	F1	F0
TCDO	0	0	1	0	1	0	0	1	AFCT	VTMI0	AFCR1	AFCR0	TUHN1	TUHN0	TUW1	TUW0
TCD1	0	0	1	0	1	0	1	0	VTMI1	COIB1	COIB0	AFCS1	AFCS0	TUS2	TUS1	TUS0
TCD2	0	0	1	0	1	0	1	1	0	0	0	0	AFCP	FDIVM	TDIRD	TDIRU

Fig. 4 Tuning control format.

7Z90125

Frequency

Frequency is set when bit I₇ of the instruction byte is set to logic 1; the remainder of this byte together with the data/control byte are loaded into the frequency buffer. The frequency to which the tuner oscillator is regulated equals the decimal representation of the 15-bit word multiplied by 50 kHz. All frequency bits are set to logic 1 at reset.

Tuning hold

The TUHN bits are used to decrease the maximum tuning current and, as a consequence, the minimum charge IT (at Δf = 50 kHz) into the tuning amplifier.

Table 2 Tuning current control

TUHN1	TUHN0	typ. I _{max} μA	typ. IT _{min} μA μs	typ. ΔVTUN _{min} at C _{INT} = 1 μF μV
0	0	3.5*	1*	1*
0	1	29	8	8
1	0	110	30	30
1	1	875	250	250

* Values after reset.

During tuning but before lock-in, the highest current value should be selected. After lock-in the current may be reduced to decrease the tuning voltage ripple.

The lowest current value should not be used for tuning due to the input bias current of the tuning voltage amplifier (max. 5 nA). However it is good practice to program the lowest current value during tuner band switching.

Tuning sensitivity

To be able to program an optimum loop gain, the charge IT can be programmed by changing T using tuning sensitivity (TUS). Table 3 shows the minimum charge IT obtained by programming the TUS bits at Δf = 50 kHz; TUHN0 and TUHN1 = logic 1.

Table 3 Minimum charge IT as a function of TUS $\Delta f = 50$ kHz; TUHN0 = logic 1; TUHN1 = logic 1

TUS2	TUS1	TUS0	typ. I_{Tmin} mA μ s	typ. ΔV_{TUNmin} at $C_{INT} = 1 \mu F$ mV
0	0	0	0.25*	0.25*
0	0	1	0.5	0.5
0	1	0	1	1
0	1	1	2	2
1	0	0	4	4
1	0	1	8	8
1	1	0	16	16

* Values after reset.

Correction-in-band

This control is used to correct the loop gain of the tuning system to reduce in-band variations due to a non-linear voltage/frequency characteristic of the tuner. Correction-in-band (COIB) controls the time T of the charge equation IT and takes into account the tuning voltage V_{TUN} to give charge multiplying factors as shown in Table 4.

Table 4 Programming correction-in-band

COIB1	COIB0	charge multiplying factors at typical values of V_{TUN} at:			
		< 12 V	12 to 18 V	18 to 24 V	> 24 V
0	0	1*	1*	1*	1*
0	1	1	1	1	2
1	0	1	1	2	4
1	1	1	2	4	8

* Values after reset.

The transconductance multiplying factor of the a.f.c. amplifier is similar when COIB is used, except for the lowest transconductance which is not affected.

Tuning window

Digital tuning is interrupted and FLOCK is set to logic 1 (in-lock) when the absolute deviation $|\Delta f|$ between the tuner oscillator frequency and the programmed frequency is smaller than the programmed TUW value (see Table 5). If $|\Delta f|$ is up to 50 kHz above the values listed in Table 5, it is possible for the system to be locked depending on the phase relationship between FDIV and the reference counter.

Table 5 Tuning window programming

TUW1	TUW0	$ \Delta f $ (kHz)	tuning window (kHz)
0	0	0*	0*
0	1	50	100
1	0	150	300

* Values after reset.

OPERATION (continued)

A.F.C.

When AFCT is set to logic 1 it will not be cleared and the a.f.c. will remain on as long as $|\Delta f|$ is less than the value programmed for the a.f.c. hold range AFCH (see Table 6). It is possible for the a.f.c. to remain on for values of up to 50 kHz more than the programmed value depending on the phase relationship between FDIV and the reference counter.

Table 6 A.F.C. hold range programming

AFCH1	AFCH0	$ \Delta f $ (kHz)	a.f.c. hold range (kHz)
0	0	0*	0*
0	1	350	700
1	0	750	1500

* Values after reset.

Transconductance

The transconductance (g) of the a.f.c. amplifier is programmed via the a.f.c. sensitivity bits AFCS as shown in Table 7.

Table 7 Transconductance programming

AFCS1	AFCS0	typ. transconductance ($\mu A/V$)
0	0	0,25*
0	1	25
1	0	50
1	1	100

* Value after reset.

A.F.C. polarity

If a positive differential input voltage is applied to the (switched on) a.f.c. amplifier, the tuning voltage V_{TUN} falls when the a.f.c. polarity bit AFCP is at logic 0 (value after reset). At AFCP = logic 1, V_{TUN} rises.

Minimum tuning voltage

Both minimum tuning voltage control bits, VTMI1 and VTMI0, are at logic 0 after reset. Further details are given in CHARACTERISTICS.

Frequency measuring window

The frequency measuring window which is programmed must correspond with the division factor of the prescaler in use (see Table 8).

Table 8 Frequency measuring window programming

FDIVM	prescaler division factor	cycle period (ms)	measuring window (ms)
0	256	6,4*	5,12*
1	64	2,56	1,28

* Values after reset.

Tuning direction

Both tuning direction bits, TDIRU (up) and TDIRD (down), are at logic 0 after reset.

Control

The instruction bytes POD (port output data) and DACX (digital-to-analogue converter control) are shown in Fig. 5, together with the corresponding data/control bytes. Control is implemented as follows:

P13, P12, P11, P10 Band select outputs. If a logic 1 is programmed on any of the POD bits D₃ to D₀, the relevant output goes HIGH. All outputs are LOW after reset.

P23, P22, P21, P20 Open collector I/O ports. If a logic 0 is programmed on any of the POD bits D₇ to D₄, the relevant output is forced LOW. All outputs are at logic 1 after reset (high impedance state).

DACX Digital-to-analogue converters. The digital-to-analogue converter selected corresponds to the decimal equivalent of the DACX bits X₁, X₀. The output voltage of the selected DAC is set by programming the bits AX₅ to AX₀; the lowest output voltage is programmed with all data AX₅ to AX₀ at logic 0, or after reset has been activated.

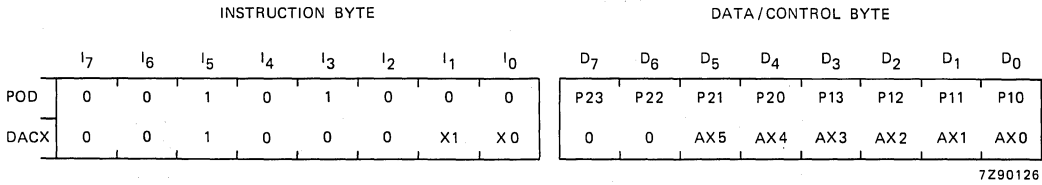

Fig. 5 Control programming.

Read

Information is read from CITAC when the R/W bit is set to logic 1. An acknowledge must be generated by the master after each data byte to allow transmission to continue. If no acknowledge is generated by the master the slave (CITAC) stops transmitting. The format of the information bytes is shown in Fig. 6.

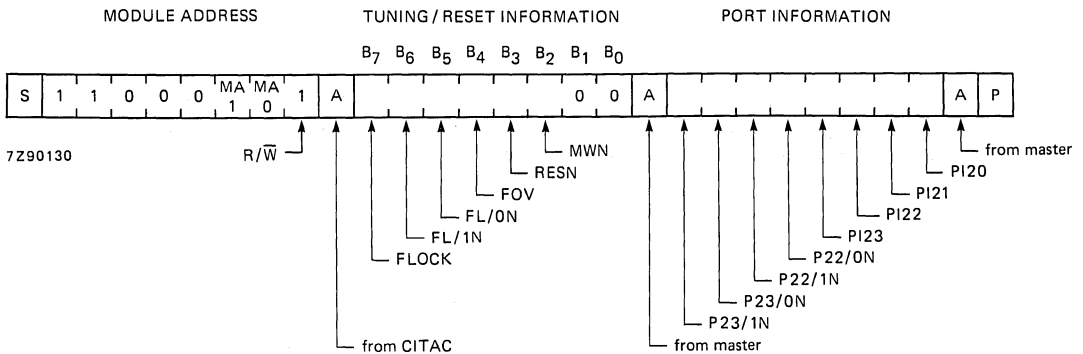

Fig. 6 Information byte format.

OPERATION (continued)

Tuning/reset information bits

- FLOCK** Set to logic 1 when the tuning oscillator frequency is within the programmed tuning window.
- FL/1N** Set to logic 0 (active LOW) when FLOCK changes from 0 to 1 and is reset to logic 1 automatically after tuning information has been read.
- FL/0N** As for FL/1N but is set to logic 0 when FLOCK changes from 1 to 0.
- FOV** Indicates frequency overflow. When the tuner oscillator frequency is too high with respect to the programmed frequency, FOV is at logic 1, and when too low, FOV is at logic 0. FOV is not valid when TDIRU and/or TDIRD are set to logic 1.
- RESN** Set to logic 0 (active LOW) by a programmed reset or a power-down-reset. It is reset to logic 1 automatically after tuning/reset information has been read.
- MWN** MWN (frequency measuring window, active LOW) is at logic 1 for a period of 1.28 ms, during which time the results of frequency measurement are processed. This time is independent of the cycle period. During the remaining time, MWN is at logic 0 and the received frequency is measured.

When slightly different frequencies are programmed repeatedly and a.f.c. is switched on, the received frequency can be measured using FOV and FLOCK. To prevent the frequency counter and frequency buffer being loaded at the same time, frequency should be programmed only during the period of MWN = logic 0.

Port information bits

- P23/1N, P22/1N** Set to logic 0 (active LOW) at a LOW-to-HIGH transition in the input voltage on P23 and P22 respectively. Both are reset to logic 1 after the port information has been read.
- P23/0N, P22/0N** As for P23/1N and P22/1N but are set to logic 0 at a HIGH-to-LOW transition.
- PI23, PI22, PI21, PI20** Indicate input voltage levels at P23, P22, P21 and P20 respectively. A logic 1 indicates a HIGH input level.

Reset

The programming to reset all registers is shown in Fig. 7. Reset is activated only at data byte HEX 06. Acknowledge is generated at every byte, provided that CITAC is not in the power-down-reset mode. After the general call address byte, transmission of more than one data byte is not allowed.

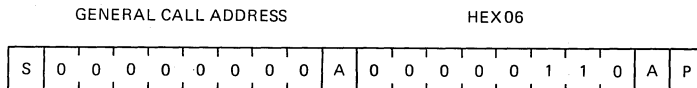

7Z90128

Fig. 7 Reset programming.

RATINGS

Limiting values in accordance with the Absolute Maximum System (IEC 134)

Supply voltage ranges:

(pin 13)	V _{P1}	-0.3 to +18	V
(pin 19)	V _{P2}	-0.3 to +18	V
(pin 14)	V _{P3}	-0.3 to +36	V

Input/output voltage ranges:

(pin 2)	V _{SDA}	-0.3 to +18	V
(pin 3)	V _{SCL}	-0.3 to +18	V
(pins 4 to 7)	V _{P2X}	-0.3 to +18	V
(pins 8 and 9)	V _{AFC+, AFC-}	-0.3 to V _{P1} *	V
(pin 10)	V _{TI}	-0.3 to V _{P1} *	V
(pin 12)	V _{TUN}	-0.3 to V _{P3} *	V
(pins 15 to 18)	V _{P1X}	-0.3 to V _{P2} **	V
(pin 20)	V _{FDIV}	-0.3 to V _{P1} *	V
(pin 21)	V _{OSC}	-0.3 to +5	V
(pins 1 and 22 to 24)	V _{DACX}	-0.3 to V _{P1} *	V

Total power dissipation

P_{tot} max. 1000 mW

Storage temperature range

T_{stg} -55 to +125 °C

Operating ambient temperature range

T_{amb} -20 to +70 °C

FLL TV TUNING CIRCUIT

SAB3037

CHARACTERISTICS

 $T_{amb} = 25\text{ }^{\circ}\text{C}$; V_{P1} , V_{P2} , V_{P3} at typical voltages, unless otherwise specified

parameter	symbol	min.	typ.	max.	unit
Supply voltages	V_{P1}	10.5	12	13.5	V
	V_{P2}	4.7	13	16	V
	V_{P3}	30	32	35	V
Supply currents (no outputs loaded)	I_{P1}	18	30	45	mA
	I_{P2}	0	—	0.1	mA
	I_{P3}	0.2	0.6	2	mA
Additional supply currents (A) (note 1)	I_{P2A}	—2	—	I_{OHP1X}	mA
	I_{P3A}	0.2	—	2	mA
Total power dissipation	P_{tot}	—	380	—	mW
Operating ambient temperature	T_{amb}	—20	—	+70	$^{\circ}\text{C}$
I²C bus inputs/outputs					
SDA input (pin 2); SCL input (pin 3)					
Input voltage HIGH (note 2)	V_{IH}	3	—	$V_{P1}-1$	V
Input voltage LOW	V_{IL}	—0.3	—	1.5	V
Input current HIGH (note 2)	I_{IH}	—	—	10	μA
Input current LOW (note 2)	I_{IL}	—	—	10	μA
SDA output (pin 2, open collector)					
Output voltage LOW at $I_{OL} = 3\text{ mA}$	V_{OL}	—	—	0.4	V
Maximum output sink current	I_{OL}	—	5	—	mA
Open collector I/O ports					
P20, P21, P22, P23 (pins 4 to 7, open collector)					
Input voltage HIGH	V_{IH}	2	—	16	V
Input voltage LOW	V_{IL}	—0.3	—	0.8	V
Input current HIGH	I_{IH}	—	—	25	μA
Input current LOW	$-I_{IL}$	—	—	25	μA
Output voltage LOW at $I_{OL} = 2\text{ mA}$	V_{OL}	—	—	0.4	V
Maximum output sink current	I_{OL}	—	4	—	mA

parameter	symbol	min.	typ.	max.	unit	
A.F.C. amplifier						
Inputs AFC+, AFC- (pins 8, 9)						
Transconductance for input voltages up to 1 V differential:						
AFCS1	AFCS2					
0	0	900	100	250	800	nA/V
0	1	901	15	25	35	μ A/V
1	0	910	30	50	70	μ A/V
1	1	911	60	100	140	μ A/V
Tolerance of transconductance multiplying factor (2, 4 or 8) when correction-in-band is used						
	ΔM_g	-20	-	+20		%
Input offset voltage						
	V_{Ioff}	-75	-	+75		mV
Common mode input voltage						
	V_{com}	3	-	$V_{P1}-2.5$		V
Common mode rejection ratio						
	CMRR	-	50	-		dB
Power supply (V_{P1}) rejection ratio						
	PSRR	-	50	-		dB
Input current						
	I_I	-	-	500		nA
Tuning voltage amplifier						
Input TI, output TUN (pins 10, 12)						
Maximum output voltage at $I_{load} = \pm 2.5$ mA						
	V_{TUN}	$V_{P3}-1.6$	-	$V_{P3}-0.4$		V
Minimum output voltage at $I_{load} = \pm 2.5$ mA:						
VTMI1	VTMI0					
0	0	V_{TM00}	300	-	500	mV
1	0	V_{TM10}	450	-	650	mV
1	1	V_{TM11}	650	-	900	mV
Maximum output source current						
	$-I_{TUNH}$	2.5	-	8		mA
Maximum output sink current						
	I_{TUNL}	-	40	-		mA
Input bias current						
	I_{TI}	-5	-	+5		nA
Power supply (V_{P3}) rejection ratio						
	PSRR	-	60	-		dB

CHARACTERISTICS (continued)

parameter	symbol	min.	typ.	max.	unit	
Tuning voltage amplifier (continued)						
Minimum charge I_T to tuning voltage amplifier						
TUHN1	TUHN0					
0	0	CH00	0.4	1	1.7	$\mu A \mu s$
0	1	CH01	4	8	14	$\mu A \mu s$
1	0	CH10	15	30	48	$\mu A \mu s$
1	1	CH11	130	250	370	$\mu A \mu s$
Tolerance of charge (or ΔV_{TUN}) multiplying factor when COIB and/or TUS are used						
	ΔCH	-20	-	+20	%	
Maximum current I into tuning amplifier						
TUHN1	TUHN0					
0	0	I_{T00}	1.7	3.5	5.1	μA
0	1	I_{T01}	15	29	41	μA
1	0	I_{T10}	65	110	160	μA
1	1	I_{T11}	530	875	1220	μA
Correction-in-band						
Tolerance of correction-in-band levels 12 V, 18 V and 24 V						
	ΔV_{CIB}	-15	-	+15	%	
Band-select output ports						
P10, P11, P12, P13 (pins 15 to 18)						
Output voltage HIGH at $-I_{OH} = 50 \text{ mA}$ (note 3)						
	V_{OH}	$V_{P2}-0.6$	-	-	V	
Output voltage LOW at $I_{OL} = 2 \text{ mA}$						
	V_{OL}	-	-	0.4	V	
Maximum output source current (note 3)						
	$-I_{OH}$	-	130	200	mA	
Maximum output sink current						
	I_{OL}	-	5	-	mA	
FDIV input (pin 20)						
Input voltage (peak-to-peak value) (t_{rise} and $t_{fall} \leq 40 \text{ ns}$)						
	$V_{FDIV(p-p)}$	0.1	-	2	V	
Duty cycle						
	-	40	-	60	%	
Maximum input frequency						
	f_{max}	14.5	-	-	MHz	
Input impedance						
	Z_i	-	8	-	$k\Omega$	
Input capacitance						
	C_i	-	5	-	pF	

parameter	symbol	min.	typ.	max.	unit	
OSC input (pin 21)						
Crystal resistance at resonance (4 MHz)	R_X	—	—	150	Ω	
DAC outputs 0 to 3 (pins 22 to 24 and pin 1)						
Maximum output voltage (no load) at $V_{P1} = 12$ V (note 4)	V_{DH}	10	—	11.5	V	
Minimum output voltage (no load) at $V_{P1} = 12$ V (note 4)	V_{DL}	0.1	—	1	V	
Positive value of smallest step (1 least-significant bit)	ΔV_D	0	—	350	mV	
Deviation from linearity	—	—	—	0.5	V	
Output impedance at $I_{load} = \pm 2$ mA	Z_o	—	—	70	Ω	
Maximum output source current	$-I_{DH}$	—	—	6	mA	
Maximum output sink current	I_{DL}	—	8	—	mA	
Power-down-reset						
Maximum supply voltage V_{P1} at which power-down-reset is active	V_{PD}	7.5	—	9.5	V	
V_{P1} rise-time during power-up (up to V_{PD})	t_r	5	—	—	μs	
Voltage level for valid module address						
Voltage level at P20 (pin 4) for valid module address as a function of MA1, MA0						
MA1	MA0					
0	0	V_{VA00}	-0.3	—	16	V
0	1	V_{VA01}	-0.3	—	0.8	V
1	0	V_{VA10}	2.5	—	$V_{P1}-2$	V
1	1	V_{VA11}	$V_{P1}-0.3$	—	V_{P1}	V

Notes to the characteristics

- For each band-select output which is programmed at logic 1, sourcing a current I_{OHP1X} , the additional supply currents (A) shown must be added to I_{P2} and I_{P3} respectively.
- If $V_{P1} < 1$ V, the input current is limited to 10 μ A at input voltages up to 16 V.
- At continuous operation the output current should not exceed 50 mA. When the output is short-circuited to ground for several seconds the device may be damaged.
- Values are proportional to V_{P1} .

I²C BUS TIMING (Fig. 8)

I²C bus load conditions are as follows:

4 kΩ pull-up resistor to +5 V; 200 pF capacitor to GND.

All values are referred to V_{IH} = 3 V and V_{IL} = 1.5 V.

parameter	symbol	min.	typ.	max.	unit
Bus free before start	t _{BUF}	4	—	—	μs
Start condition set-up time	t _{SU,STA}	4	—	—	μs
Start condition hold time	t _{HD,STA}	4	—	—	μs
SCL, SDA LOW period	t _{LOW}	4	—	—	μs
SCL HIGH period	t _{HIGH}	4	—	—	μs
SCL, SDA rise time	t _R	—	—	1	μs
SCL, SDA fall time	t _F	—	—	0.3	μs
Data set-up time (write)	t _{SU,DAT}	1	—	—	μs
Data hold time (write)	t _{HD,DAT}	1	—	—	μs
Acknowledge (from CITAC) set-up time	t _{SU,CAC}	—	—	2	μs
Acknowledge (from CITAC) hold time	t _{HD,CAC}	0	—	—	μs
Stop condition set-up time	t _{SU,STO}	4	—	—	μs
Data set-up time (read)	t _{SU,RDA}	—	—	2	μs
Data hold time (read)	t _{HD,RDA}	0	—	—	μs
Acknowledge (from master) set-up time	t _{SU,MAC}	1	—	—	μs
Acknowledge (from master) hold time	t _{HD,MAC}	2	—	—	μs

Note

Timings t_{SU,DAT} and t_{HD,DAT} deviate from the I²C bus specification .

After reset has been activated, transmission may only be started after a 50 μs delay.

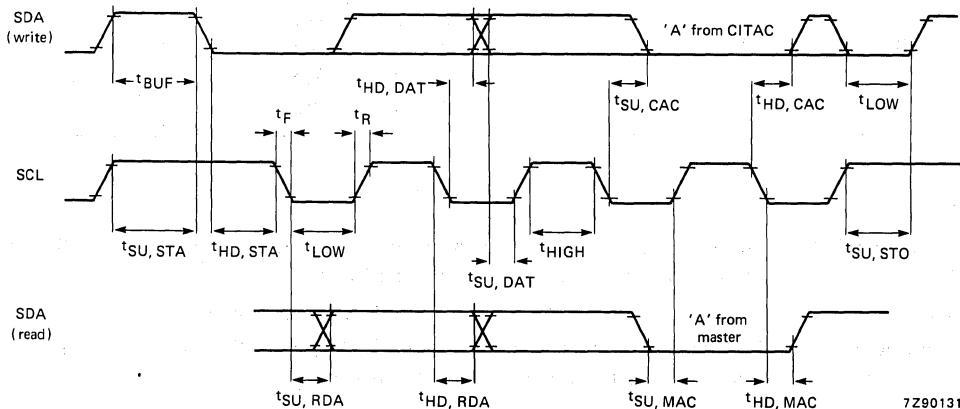

Fig. 8 I²C bus timing SAB3037.

The TDA2540 is an i.f. amplifier and demodulator circuit for colour and black and white television receivers using n-p-n tuners.

It incorporates the following functions:

- gain-controlled wide-band amplifier, providing complete i.f. gain
- synchronous demodulator
- white spot inverter
- video preamplifier with noise protection
- a.f.c. circuit which can be switched on/off by a d.c. level, e.g. during tuning
- a.g.c. circuit with noise gating
- tuner a.g.c. output (n-p-n tuners)
- VCR switch, which switches off the video output; e.g. for insertion of a VCR playback signal

QUICK REFERENCE DATA

Supply voltage	V_{11-13}	typ.	12 V
Supply current	I_{11}	typ.	50 mA
I.F. input voltage at $f = 38.9$ MHz (r.m.s. value)	V_{1-16} (rms)	typ.	100 μ V
Video output voltage (white at 10% of top sync)	$V_{12(p-p)}$	typ.	2.7 V
I.F. voltage gain control range	G_v	typ.	64 dB
Signal-to-noise ratio at $V_i = 10$ mV	S/N	typ.	58 dB
A.F.C. output voltage swing for $\Delta f = 100$ kHz	ΔV_{5-13}	typ.	10 V



PACKAGE OUTLINES

TDA2540 : 16-lead DIL; plastic (SOT-38).

TDA2540Q: 16-lead QIL; plastic (SOT-58).

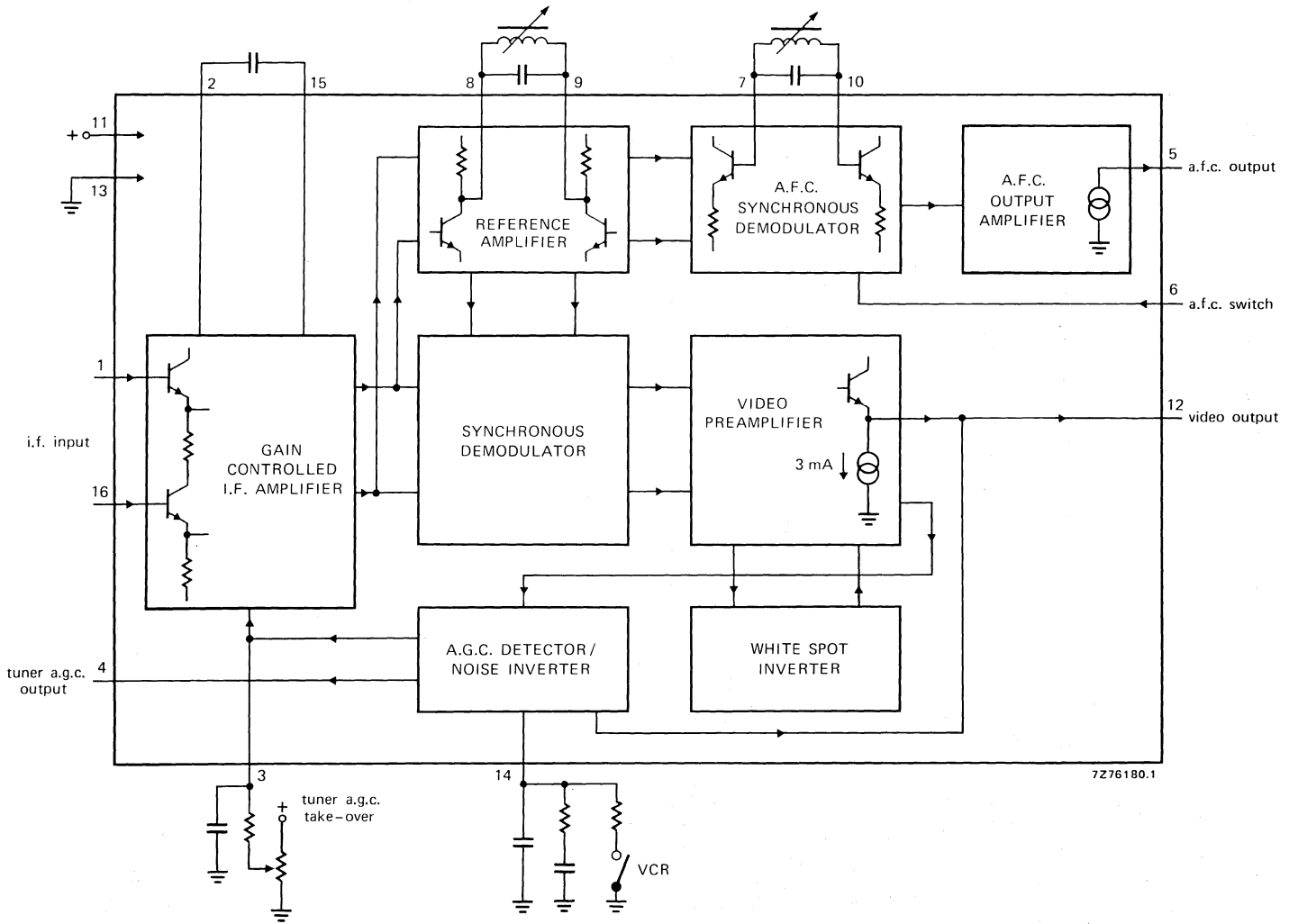

Fig. 1 Block diagram.

RATINGS

Limiting values in accordance with the Absolute Maximum System (IEC 134)

Supply voltage	V_{11-13}	max.	13.2 V
Tuner a.g.c. voltage	V_{4-13}	max.	12 V
Total power dissipation	P_{tot}	max.	900 mW
Storage temperature	T_{stg}		-55 to + 125 °C
Operating ambient temperature	T_{amb}		-25 to + 60 °C

CHARACTERISTICS (measured in Fig. 5)

Supply voltage range	V_{11-13}	typ.	12 V
			10.2 to 13.2 V

The following characteristics are measured at $T_{amb} = 25$ °C; $V_{11-13} = 12$ V; $f = 38.9$ MHz

I.F. input voltage for onset of a.g.c. (r.m.s. value)	$V_{1-16(rms)}$	typ.	100 μ V
		<	150 μ V
Differential input impedance	$ Z_{1-16} $	typ.	2 k Ω in parallel with 2 pF
Zero-signal output level	V_{12-13}	typ.	6 ± 0.3 V*
Top sync output level	V_{12-13}	typ.	3.07 V
			2.9 to 3.2 V
I.F. voltage gain control range	G_v	typ.	64 dB
Bandwidth of video amplifier (3 dB)	B	typ.	6 MHz
Signal-to-noise ratio at $V_i = 10$ mV	S/N	typ.	58 dB**
Differential gain	dG	typ.	4 %
		<	10 %
Differential phase	d ϕ	typ.	2°
		<	10°

* So-called 'projected zero point', e.g. with switched demodulator.

$$** S/N = \frac{V_o \text{ black-to-white}}{V_{n(rms)} \text{ at } B = 5 \text{ MHz}}$$

CHARACTERISTICS (continued)

Intermodulation at 1.1 MHz: blue*

> 46 dB
typ. 60 dB

yellow*

> 46 dB
typ. 50 dB

at 3.3 MHz**

> 46 dB
typ. 54 dB

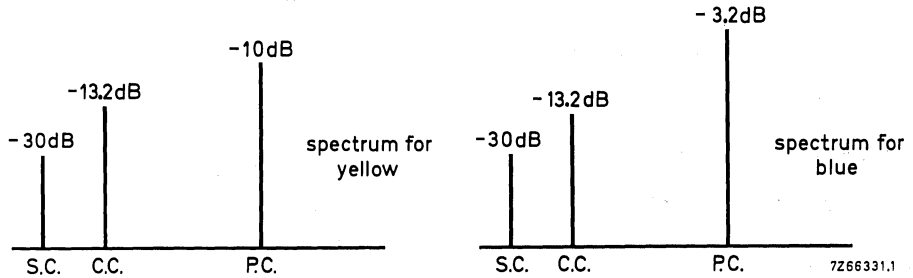

S.C.: sound carrier level
C.C.: chrominance carrier level
P.C.: picture carrier level
} with respect to top sync level

Fig. 2 Input conditions for intermodulation measurements; standard colour bar with 75% contrast.

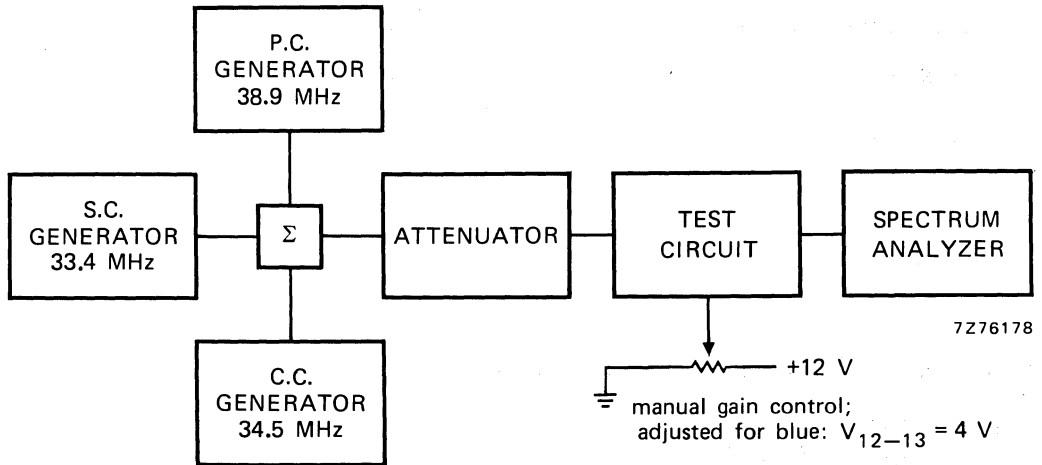

Fig. 3 Test set-up for intermodulation.

* $20 \log \frac{V_O \text{ at } 4.4 \text{ MHz}}{V_O \text{ at } 1.1 \text{ MHz}} + 3.6 \text{ dB.}$

** $20 \log \frac{V_O \text{ at } 4.4 \text{ MHz}}{V_O \text{ at } 3.3 \text{ MHz}}.$

Carrier signal at video output	typ. 4 mV
	< 30 mV
2nd harmonic of carrier at video output	typ. 20 mV
	< 30 mV
White spot inverter threshold level (Fig. 4)	typ. 6.6 V
White spot insertion level (Fig. 4)	typ. 4.7 V
Noise inverter threshold level (Fig. 4)	typ. 1.8 V
Noise insertion level (Fig. 4)	typ. 3.8 V
External video switch (VCR) switches off the output at:	V ₁₄₋₁₃ < 1.1 V

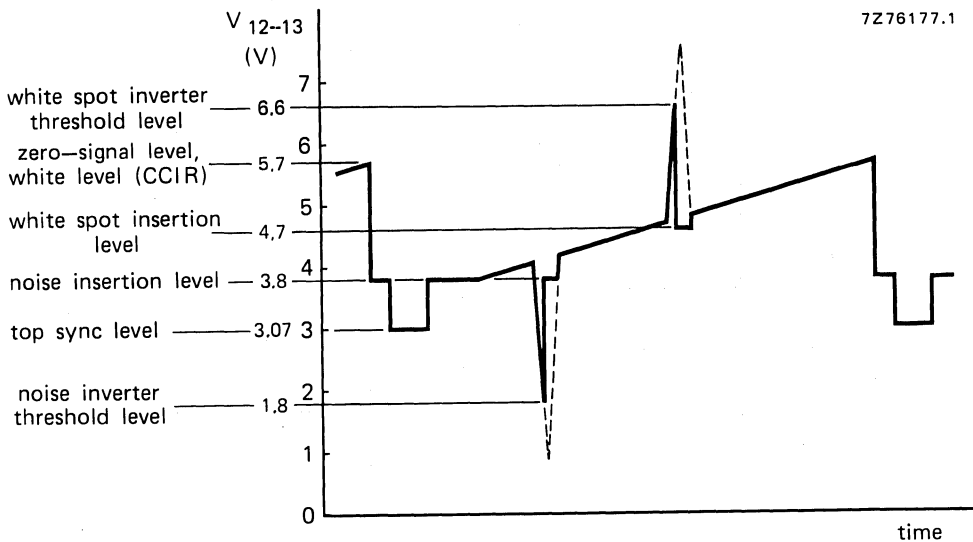

Fig. 4 Video output waveform showing white spot and noise inverter threshold levels.

Tuner a.g.c. output current range	I ₄	10 to 0 mA
Tuner a.g.c. output voltage at I ₄ = 10 mA	V ₄₋₁₃	< 0.3 V
Tuner a.g.c. output leakage current	I ₄	< 15 μA
V ₁₄₋₁₃ = 5 V; V ₄₋₁₃ = 12 V		> 10 V
Maximum a.f.c. output voltage swing	ΔV ₅₋₁₃	typ. 11 V
Detuning for a.f.c. output voltage swing of 10 V	Δf	typ. 100 kHz
		< 200 kHz
A.F.C. zero-signal output voltage (minimum gain)	V ₅₋₁₃	typ. 6 V
		4 to 8 V
A.F.C. switches on at:	V ₆₋₁₃	> 3.2 V
A.F.C. switches off at:	V ₆₋₁₃	< 1.5 V



APPLICATION INFORMATION

Signetics

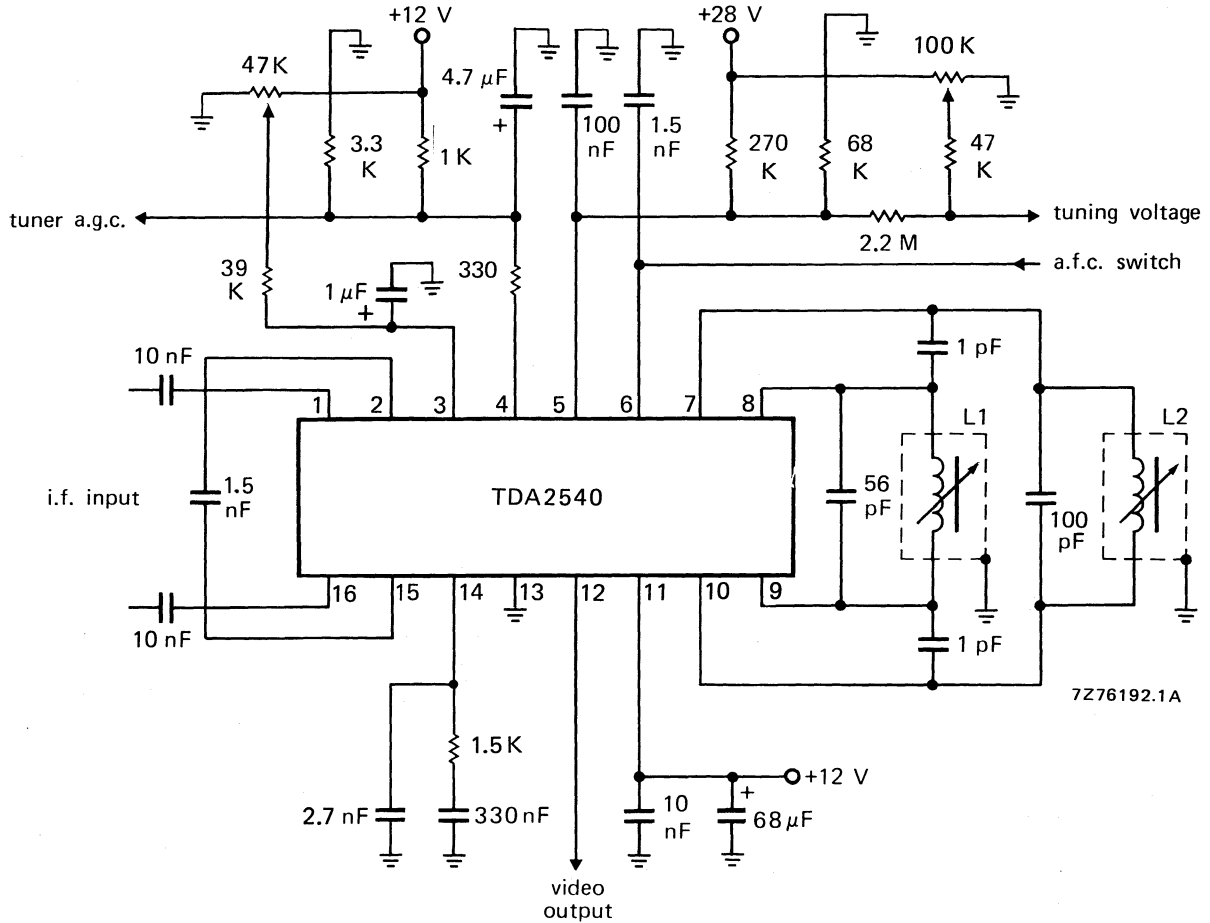

Fig. 5 Typical application circuit diagram; Q of L1 and L2 \approx 80; $f = 38,9$ MHz.

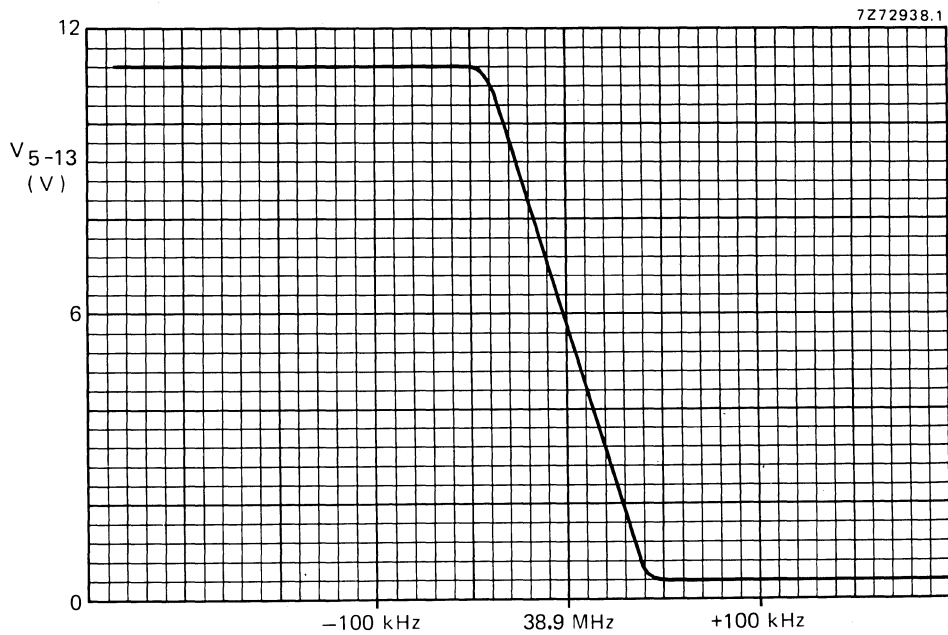
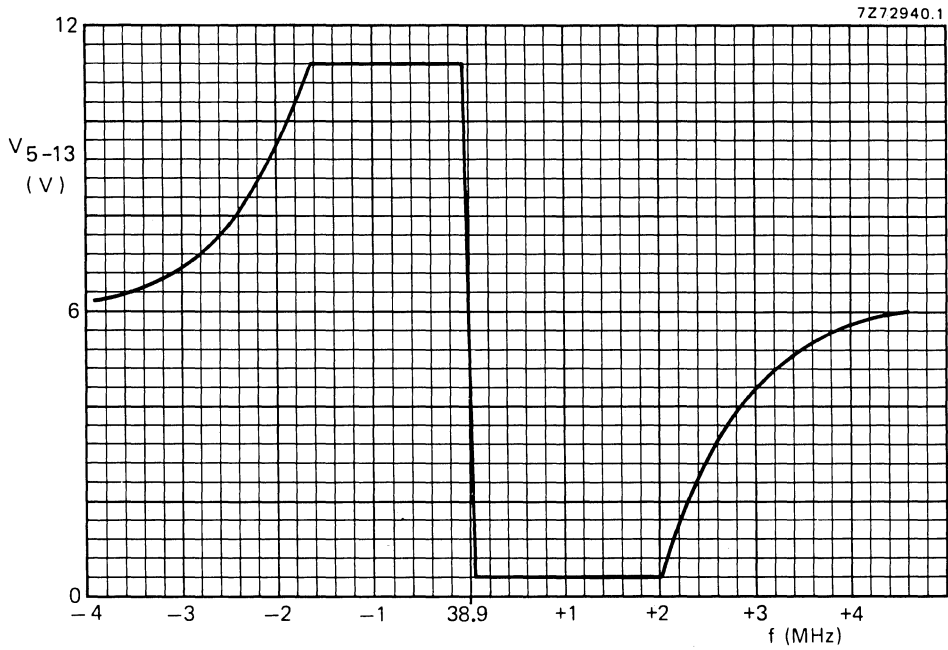

Fig. 6 A.F.C. output voltage (V_{5-13}) as a function of the frequency.

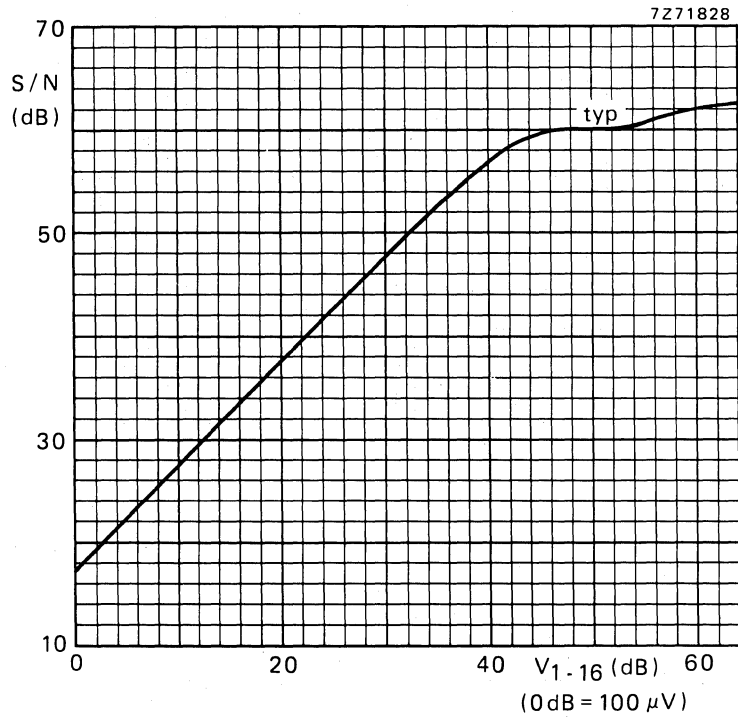

Fig. 7 Signal-to-noise ratio as a function of the input voltage (V_{1-16}).

The TDA2541 is an i.f. amplifier and demodulator circuit for colour and black and white television receivers using p-n-p tuners.

It incorporates the following functions:

- gain-controlled wide-band amplifier, providing complete i.f. gain
- synchronous demodulator
- white spot inverter
- video preamplifier with noise protection
- a.f.c. circuit which can be switched on/off by a d.c. level, e.g. during tuning
- a.g.c. circuit with noise gating
- tuner a.g.c. output (p-n-p tuners)
- VCR switch, which switches off the video output; e.g. for insertion of a VCR playback signal.

QUICK REFERENCE DATA

Supply voltage	V_{11-13}	typ.	12 V
Supply current	I_{11}	typ.	50 mA
I.F. input voltage at $f = 38.9$ MHz (r.m.s. value)	$V_{1-16(\text{rms})}$	typ.	100 μV
Video output voltage (white at 10% of top sync)	$V_{12(\text{p-p})}$	typ.	2.7 V
I.F. voltage gain control range	G_V	typ.	64 dB
Signal-to-noise ratio at $V_i = 10$ mV	S/N	typ.	58 dB
A.F.C. output voltage swing for $\Delta f = 100$ kHz	ΔV_{5-13}	typ.	10 V

PACKAGE OUTLINES

TDA2541 : 16-lead DIL; plastic (SOT-38).

TDA2541Q: 16-lead QIL; plastic (SOT-58).

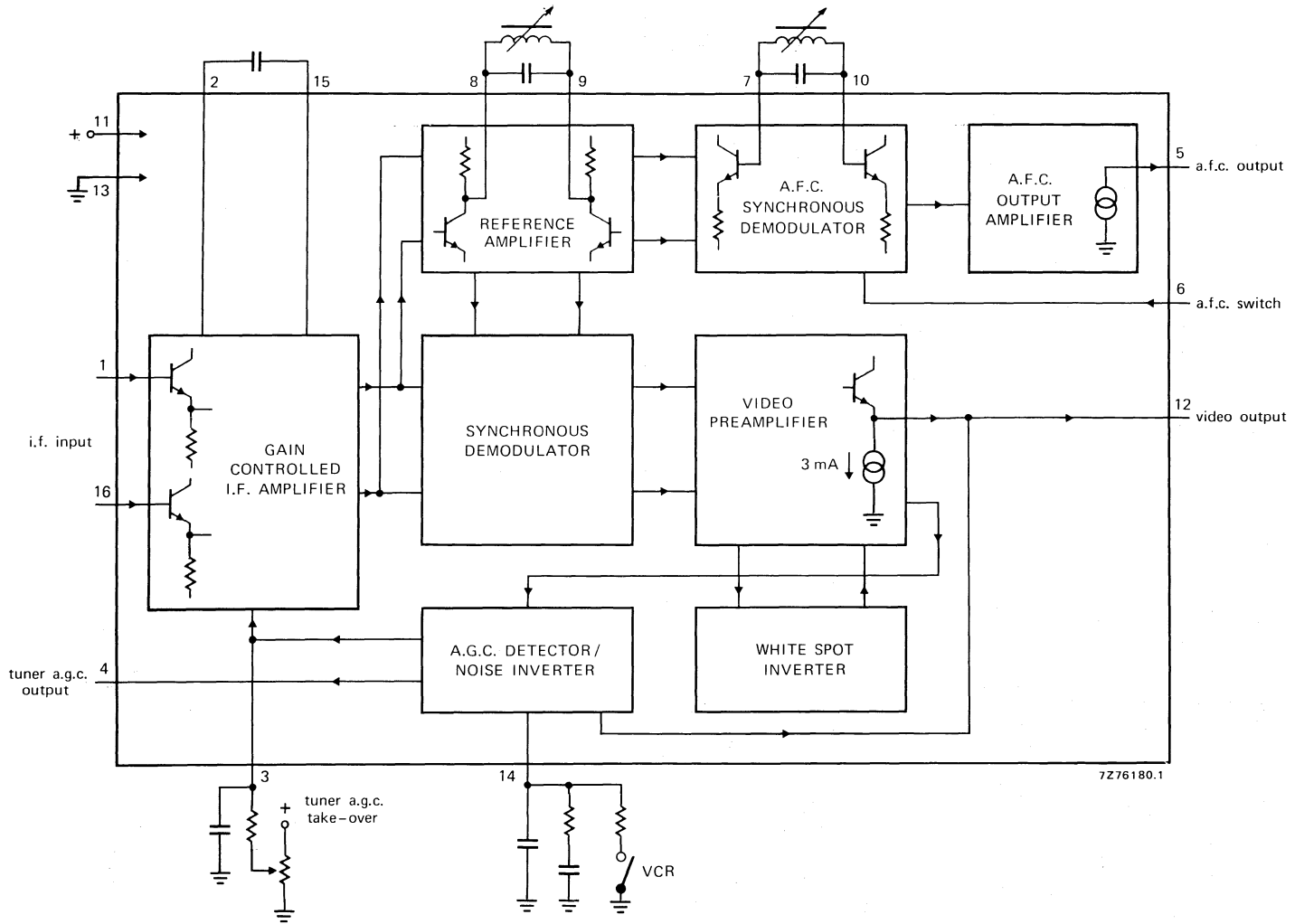

Fig. 1 Block diagram.

RATINGS

Limiting values in accordance with the Absolute Maximum System (IEC 134)

Supply voltage	V_{11-13}	max.	13.2 V
Tuner a.g.c. voltage	V_{4-13}	max.	12 V
Total power dissipation	P_{tot}	max.	900 mW
Storage temperature	T_{stg}		-55 to + 125 °C
Operating ambient temperature	T_{amb}		-25 to + 60 °C

CHARACTERISTICS (measured in Fig. 5)

Supply voltage range	V_{11-13}	typ.	12 V
			10.2 to 13.2 V

The following characteristics are measured at $T_{amb} = 25\text{ °C}$; $V_{11-13} = 12\text{ V}$; $f = 38.9\text{ MHz}$

I.F. input voltage for onset of a.g.c. (r.m.s. value)	$V_{1-16(rms)}$	typ.	100 μV
		<	150 μV
Differential input impedance	$ Z_{1-16} $	typ.	2 k Ω in parallel with 2 pF
Zero-signal output level	V_{12-13}	typ.	$6 \pm 0.3\text{ V}^*$
Top sync output level	V_{12-13}	typ.	3.07 V
			2.9 to 3.2 V
I.F. voltage gain control range	G_v	typ.	64 dB
Bandwidth of video amplifier (3 dB)	B	typ.	6 MHz
Signal-to-noise ratio at $V_i = 10\text{ mV}$	S/N	typ.	58 dB**
Differential gain	dG	typ.	4 %
		<	10 %
Differential phase	$d\varphi$	typ.	2°
		<	10°

* So-called 'projected zero point', e.g. with switched demodulator.

$$** \quad S/N = \frac{V_o \text{ black-to-white}}{V_{n(rms)} \text{ at } B = 5 \text{ MHz}}$$

CHARACTERISTICS (continued)

Intermodulation at 1.1 MHz: blue*

> 46 dB
typ. 60 dB

yellow*

> 46 dB
typ. 50 dB

at 3.3 MHz**

> 46 dB
typ. 54 dB

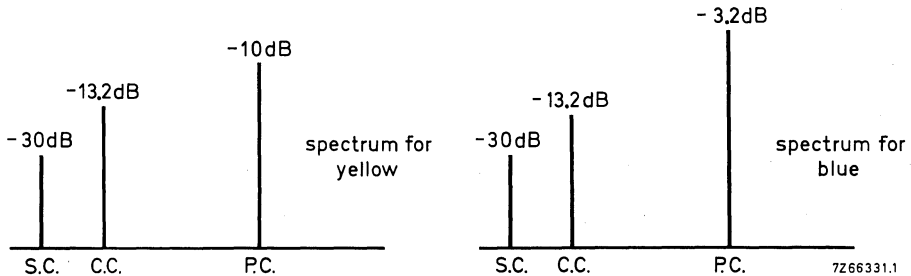

S.C. : sound carrier level
C.C. : chrominance carrier level
P.C. : picture carrier level

} with respect to top sync level

Fig. 2 Input conditions for intermodulation measurements; standard colour bar with 75% contrast.

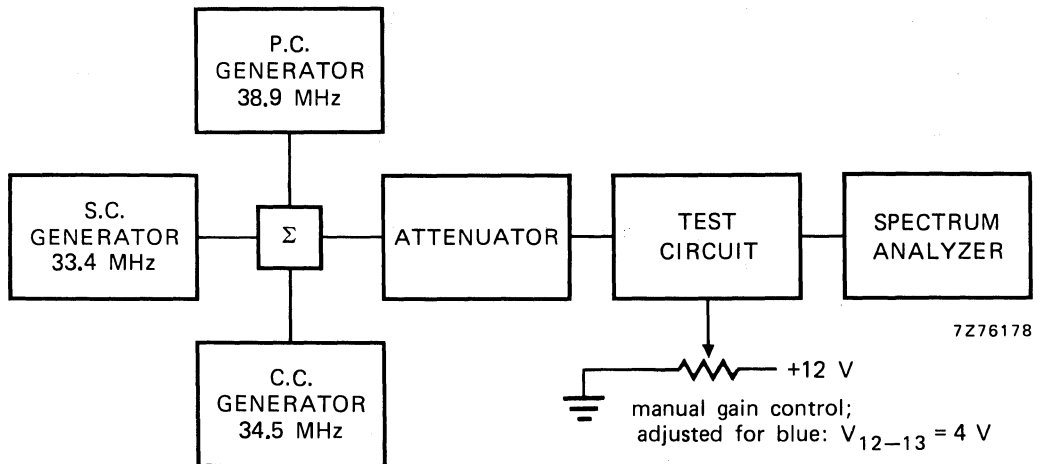

Fig. 3 Test set-up for intermodulation.

* $20 \log \frac{V_O \text{ at } 4.4 \text{ MHz}}{V_O \text{ at } 1.1 \text{ MHz}} + 3.6 \text{ dB.}$

** $20 \log \frac{V_O \text{ at } 4.4 \text{ MHz}}{V_O \text{ at } 3.3 \text{ MHz}}$

Carrier signal at video output	typ. 4 mV < 30 mV
2nd harmonic of carrier at video output	typ. 20 mV < 30 mV
White spot inverter threshold level (Fig. 4)	typ. 6.6 V
White spot insertion level (Fig. 4)	typ. 4.7 V
Noise inverter threshold level (Fig. 4)	typ. 1.8 V
Noise insertion level (Fig. 4)	typ. 3.8 V
External video switch (VCR) switches off the output at:	V_{14-13} < 1.1 V

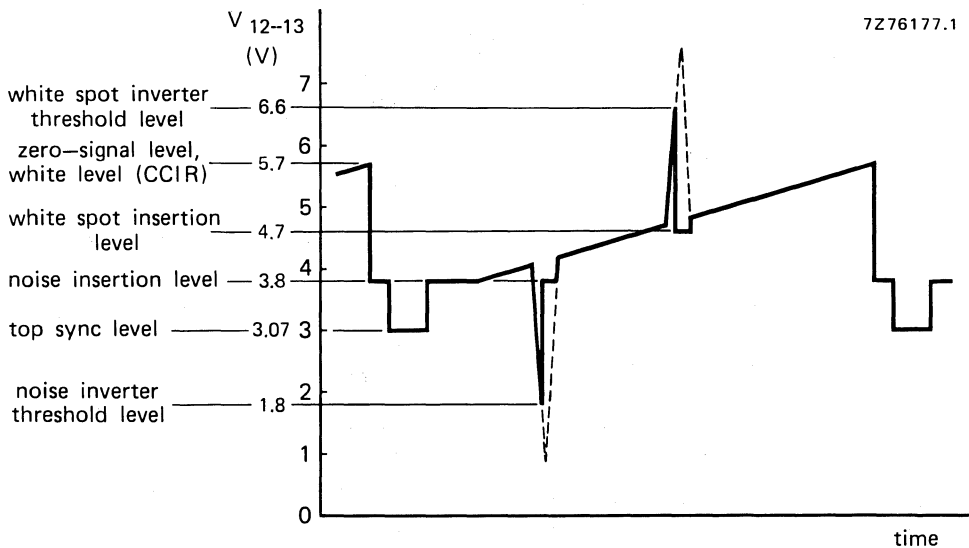

Fig. 4 Video output waveform showing white spot and noise inverter threshold levels.

Tuner a.g.c. output current range	I_4	0 to 10 mA
Tuner a.g.c. output voltage at $I_4 = 10$ mA	V_{4-13}	< 0.3 V
Tuner a.g.c. output leakage current $V_{14-13} = 11$ V; $V_{4-13} = 12$ V	I_4	< 15 μ A
Maximum a.f.c. output voltage swing	ΔV_{5-13}	> 10 V typ. 11 V
Detuning for a.f.c. output voltage swing of 10 V	Δf	typ. 100 kHz < 200 kHz
A.F.C. zero-signal output voltage (minimum gain)	V_{5-13}	typ. 6 V 4 to 8 V
A.F.C. switches on at:	V_{6-13}	> 3.2 V
A.F.C. switches off at:	V_{6-13}	< 1.5 V

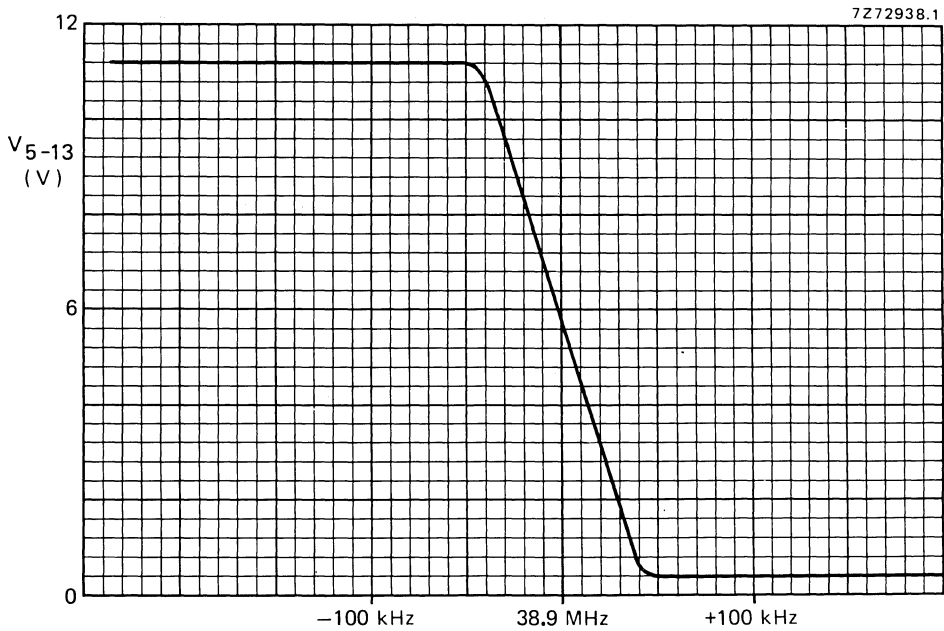
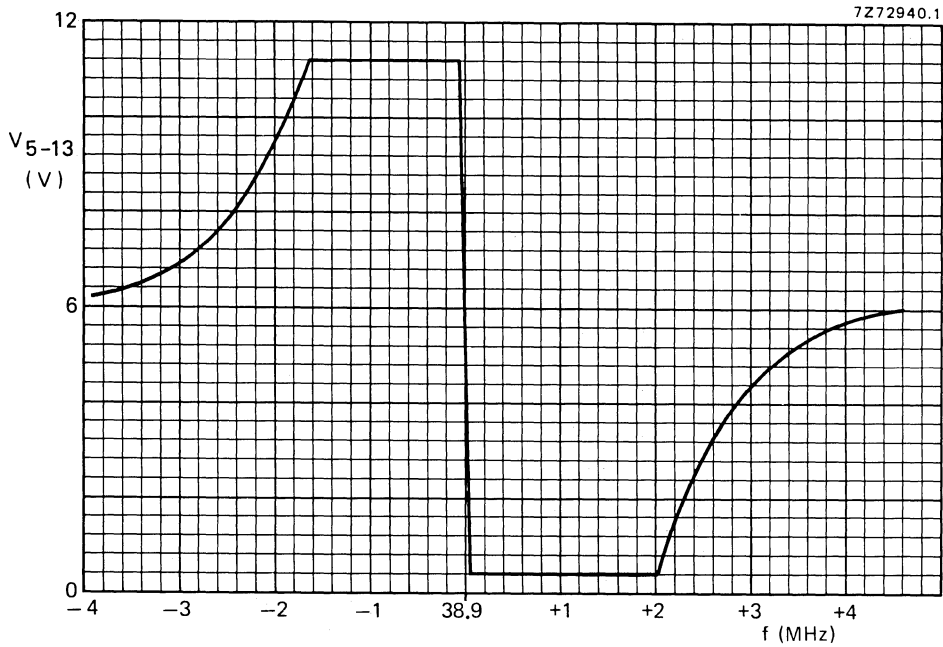

Fig. 6 A.F.C. output voltage (V_{5-13}) as a function of the frequency.

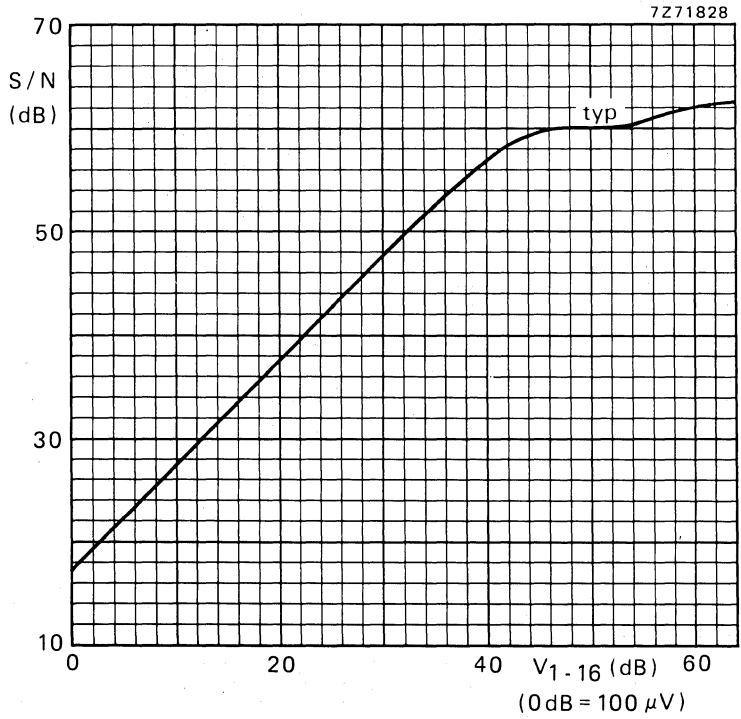

Fig. 7 Signal-to-noise ratio as a function of the input voltage (V₁₋₁₆).

QUASI-SPLIT SOUND I.F. WITH SOUND DEMODULATOR**TDA2546A****GENERAL DESCRIPTION**

The TDA2546A is a monolithic integrated circuit for quasi-split-sound processing, including 5.5 MHz demodulation, in television receivers.

Features

1st i.f. (V.C.: vision carrier plus S.C.: sound carrier)

- 3-stage gain controlled i.f. amplifier
- A.G.C. circuit
- Reference amplifier and limiter amplifier for vision carrier (V.C.) processing
- Linear multiplier for quadrature demodulation

2nd i.f. (5.5 MHz signal)

- 8-stage limiter amplifier
- Quadrature demodulator
- A.F. amplifier with de-emphasis
- AV switch

QUICK REFERENCE DATA

Supply voltage (pin 15)	$V_P = V_{15-16}$	typ.	12 V
Supply current (pin 15)	$I_P = I_{15}$	typ.	54 mA
Minimum i.f. vision carrier input voltage (r.m.s. value)	$V_{VC1-18(rms)}$	typ.	50 μ V
Output voltage; 5.5 MHz (r.m.s. value)	$V_{14-16(rms)}$	typ.	100 mV
Output voltage; 5.742 MHz (r.m.s. value)	$V_{14-16(rms)}$	typ.	45 mV
I.F. control range	ΔG_V	min.	66 dB
Signal-to-weighted-noise ratio at 5.5 MHz	S + W/W	min.	53 dB
at 5.742 MHz	S + W/W	min.	51 dB
A.F. output voltage (r.m.s. value)	$V_{O6-16(rms)}$	typ.	0.6 V

PACKAGE OUTLINES

18-lead DIL; plastic (SOT-102CS).

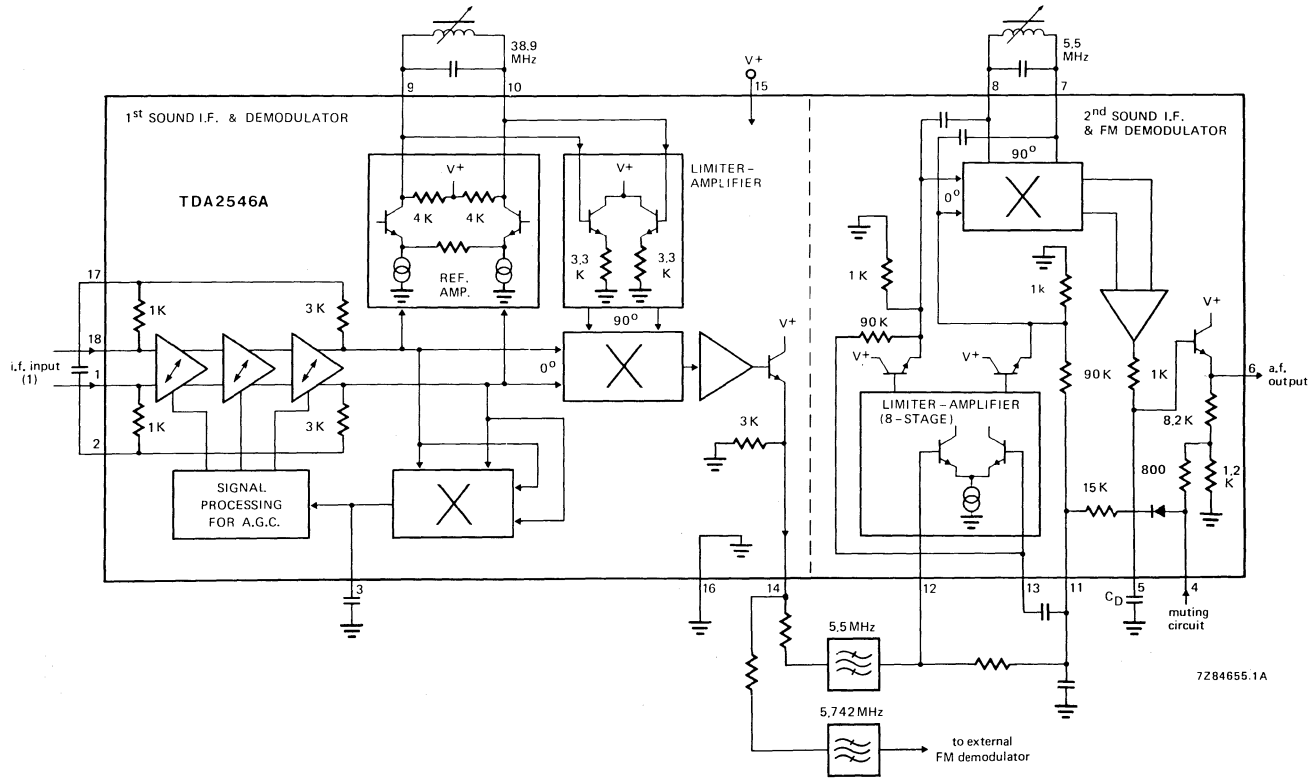

(1) I.F. signal: vision carrier (V.C.) and sound carrier (S.C.)

Fig. 1 Block diagram.

QUASI-SPLIT SOUND I.F. WITH SOUND DEMODULATOR**TDA2546A****RATINGS**

Limiting values in accordance with the Absolute Maximum System (IEC 134)

Supply voltage (pin 15)	$V_P = V_{15-16}$	max.	13.2 V
Input current (pin 4)	I_4	max.	5 mA
Storage temperature range	T_{stg}		-25 to +150 °C
Operating ambient temperature range	T_{amb}		0 to +70 °C

QUASI-SPLIT SOUND I.F. WITH SOUND DEMODULATOR**TDA2546A****CHARACTERISTICS**

$V_P = V_{15-16} = 12 \text{ V}$; $T_{\text{amb}} = 25 \text{ }^\circ\text{C}$; measured at $f_{VC} = 38.9 \text{ MHz}$, $f_{SC1} = 33.4 \text{ MHz}$,
 $f_{SC2} = 33.158 \text{ MHz}$;

Vision carrier (V.C.) modulated with 2 T/20 T pulses, line-for-line alternating with white bars; modulation depth 100% (proportional to 10% residual carrier).

Sound carriers (S.C.1, S.C.2) modulated with $f = 1 \text{ kHz}$ and $\Delta f = \pm 30 \text{ kHz}$.

Vision-to-sound carrier ratios are V.C./S.C.1 = 13 dB and V.C./S.C.2 = 20 dB.

Vision carrier amplitude (r.m.s. value) is $V_{VC} = 10 \text{ mV}$.

For measuring circuit see Fig. 2; unless otherwise specified.

parameter	symbol	min.	typ.	max.	unit
Supply (pin 15)					
Supply voltage	$V_P = V_{15-16}$	10.8	12	13.2	V
Supply current	$I_P = I_{15}$	—	54	—	mA
I.F. amplifier					
Minimum input voltage (r.m.s. value) (intercarrier signals -3 dB)	$V_{VC1-18(\text{rms})}$	—	50	—	μV
Maximum input voltage (r.m.s. value) (intercarrier signals +1 dB)	$V_{VC1-18(\text{rms})}$	—	100	—	mV
I.F. control range	ΔG_V	66	—	—	dB
Control voltage range	V_{3-16}	4	—	9	V
Input resistance	R_{1-18}	—	2	—	$\text{k}\Omega$
Input capacitance	C_{1-18}	—	2	—	pF
Intercarrier generation					
Output voltage; 5.5 MHz (r.m.s. value)	$V_{14-16(\text{rms})}$	—	100	—	mV
Output voltage; 5.742 MHz (r.m.s. value)	$V_{14-16(\text{rms})}$	—	45	—	mV
D.C. output voltage	V_{14-16}	—	5.9	—	V
Allowable load resistance at the output	R_{14-16}	7	—	—	$\text{k}\Omega$
Allowable output current	$-I_{14}$	—	—	1	mA
Frequency demodulator (measured at $f = 5.5 \text{ MHz}$)					
Input voltage for start of limiting (r.m.s. value)	$V_{12-16(\text{rms})}$	—	—	100	μV
Maximum input voltage (r.m.s. value)	$V_{12-16(\text{rms})}$	—	200	—	mV
D.C. output voltage	$V_{11,12,13-16}$	—	2.2	—	V

GENERAL DESCRIPTION

The TDA2577A separates the vertical and horizontal sync pulses from the composite TV video signal and uses them to synchronize horizontal and vertical oscillators.

Features

- Horizontal sync separator and noise inverter
- Horizontal oscillator
- Horizontal output stage
- Horizontal phase detector (sync to oscillator)
- Time constant switch for phase detector (fast time constant during catching)
- Slow time constant for noise only conditions
- Time constant externally switchable (e.g. fast for VCR)
- Inhibit of horizontal phase detector and video transmitter identification circuit during vertical oscillator flyback
- Second phase detector (φ_2) for storage compensation of horizontal deflection stage
- Sandcastle pulse generator (3-levels)
- Video transmitter identification circuit
- Stabilizer and supply circuit for starting the horizontal oscillator and output stage directly from the mains rectifier
- Duty factor of horizontal output pulse is 50% when flyback pulse is absent
- Vertical sync separator
- Bandgap 6,5 V reference voltage for vertical oscillator and comparator
- Synchronized vertical oscillator/sawtooth generator (synchronization inhibited when no video transmitter is detected)
- Internal circuit for 3% parabolic pre-correction of the oscillator/sawtooth generator. Comparator supplied with pre-corrected sawtooth and external feedback input
- Vertical comparator with internal 3% pre-correction circuit for vertical oscillator/sawtooth generator
- Vertical driver stage
- Vertical blanking pulse generator with external adjustment of pulse duration (50 Hz: 21 lines; 60Hz: 17 lines)
- Vertical guard circuit

QUICK REFERENCE DATA**Supply**

Minimum current required to start horizontal oscillator and output stage (pin 16)

I_{16} > 4 mA

Main supply voltage (pin 10)

$V_P = V_{10-9}$ typ. 12 V

Supply current

$I_P = I_{10}$ typ. 55 mA

Input signals

Sync pulse input voltage (peak-to-peak value; negative-going)

$V_{5-9(p-p)}$ 0.15 to 1 V

Output signals

Horizontal output pulse (open collector) at $I_{11} = 40$ mA

V_{11-9} < 0.5 V

Vertical output pulse (emitter-follower) at $I_1 = 10$ mA

V_{1-9} > 4 V

PACKAGE OUTLINE

18-lead DIL; plastic (SOT-102HE).

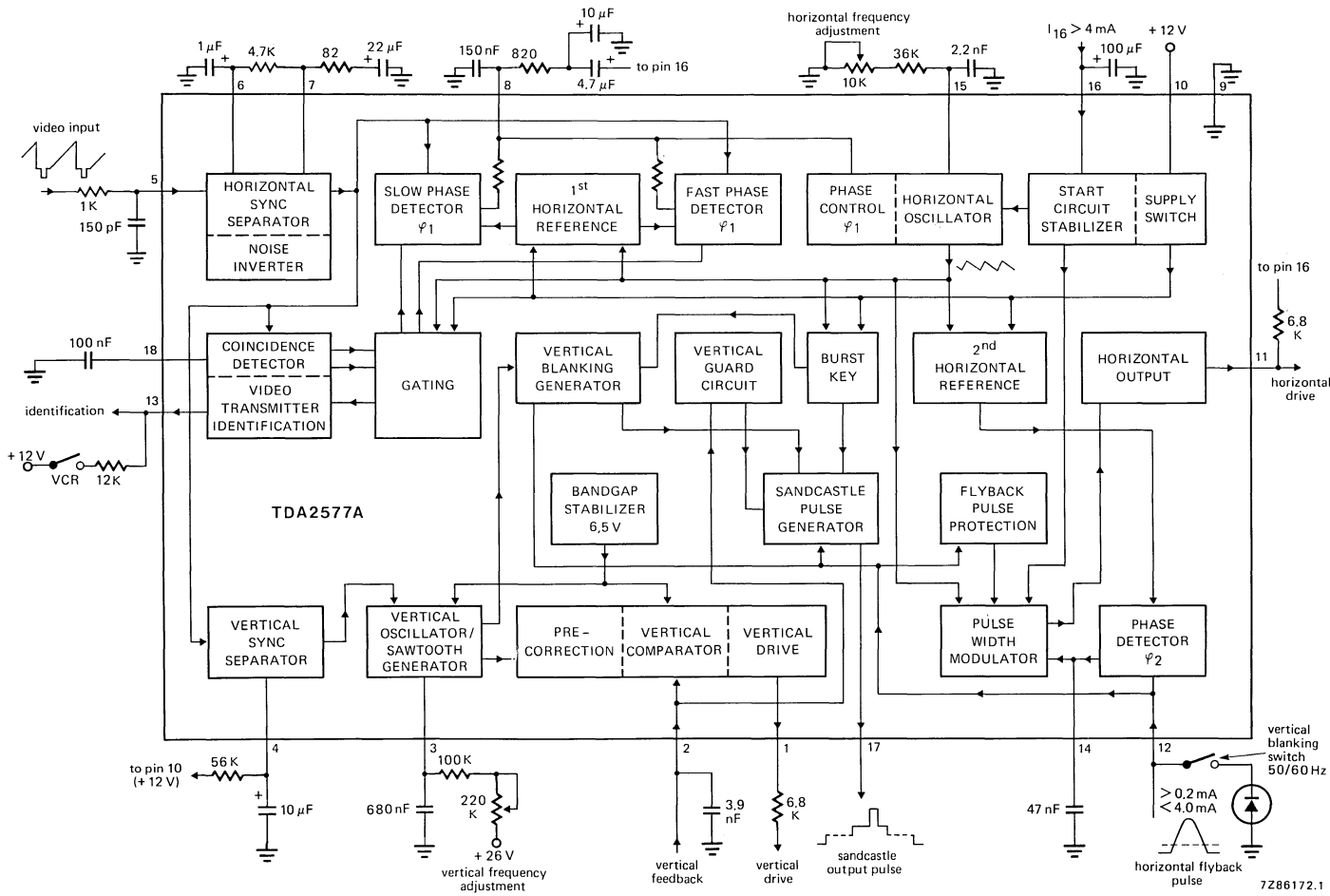

7286172.1

Fig. 1 Block diagram.



SYNCHRONIZATION CIRCUIT WITH VERTICAL OSCILLATOR & DRIVER TDA2577A

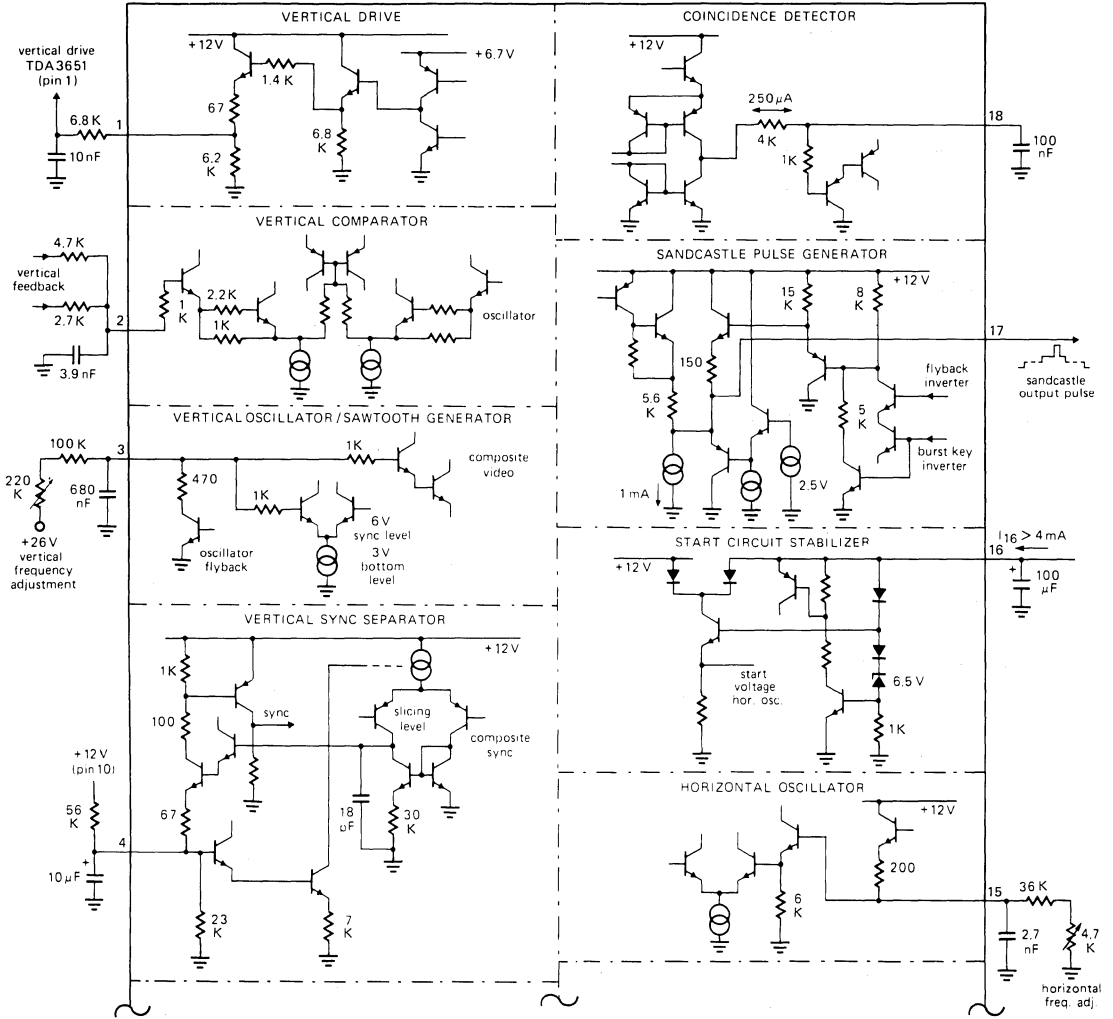

Fig. 2 TDA2577A Circuit Diagram.

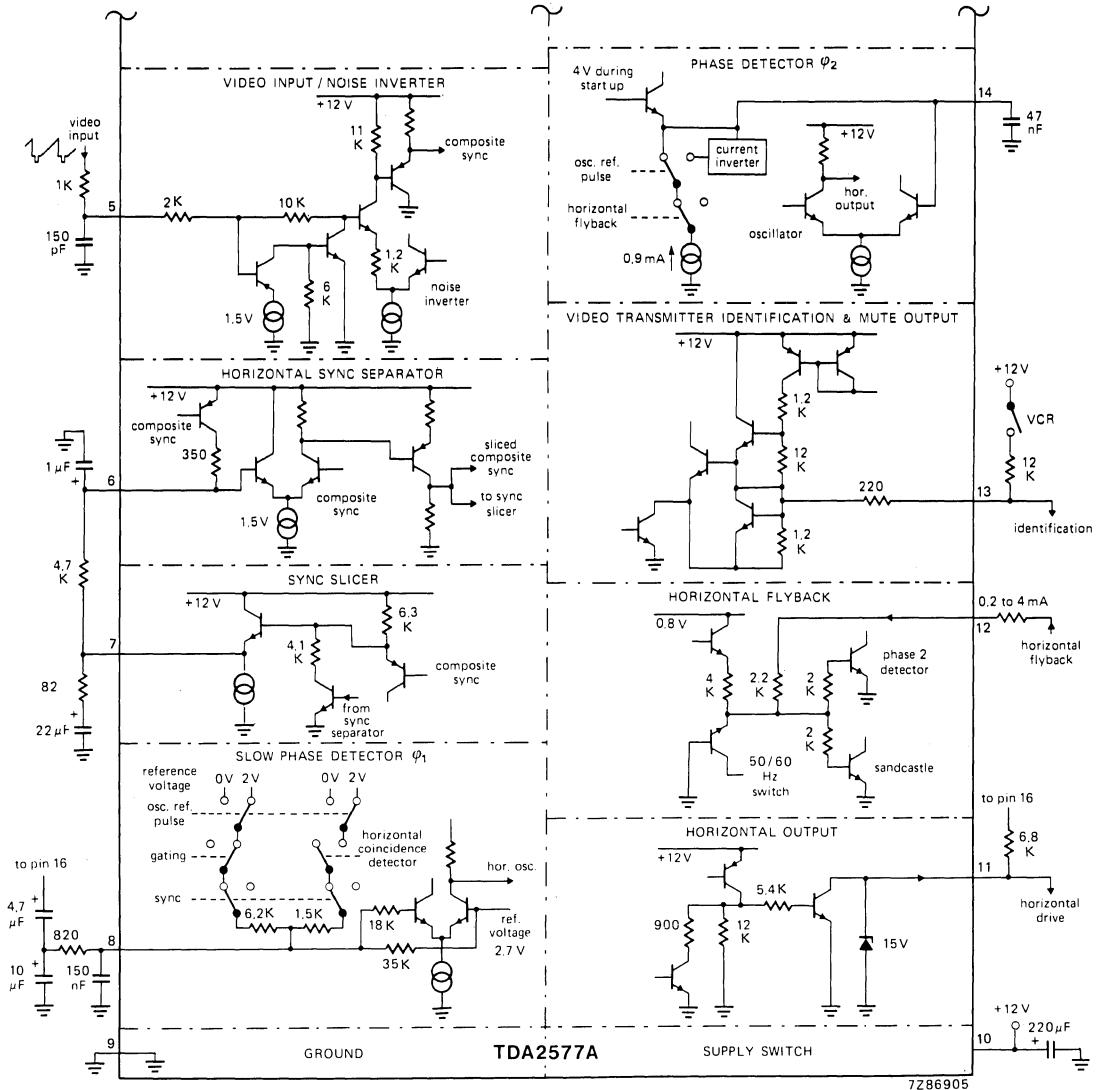

Fig. 2 TDA2577A Circuit Diagram. (Continued)

RATINGS

Limiting values in accordance with the Absolute Maximum System (IEC 134)

Start current (pin 16)	I_{16}	max.	8 mA
Supply voltage (pin 10)	$V_P = V_{10-9}$	max.	13.2 V
Total power dissipation	P_{tot}	max.	1.1 W
Storage temperature range	T_{stg}		-55 to +150 °C
Operating ambient temperature range	T_{amb}		-25 to +65 °C

THERMAL RESISTANCE

From junction to ambient in free air	$R_{th j-a}$	typ.	50 K/W
--------------------------------------	--------------	------	--------

CHARACTERISTICS $I_{16} = 5 \text{ mA}$; $V_P = 12 \text{ V}$; $T_{amb} = 25 \text{ °C}$; unless otherwise specified**Supply**

Supply current at pin 16	I_{16}		4 to 8 mA
Stabilized supply voltage (pin 16)	V_{16-9}	typ.	8.7 V 8.0 to 9.5 V
Supply current (pin 10)	I_{10}	typ.	55 mA < 70 mA
Supply voltage (pin 10)	$V_P = V_{10-9}$	typ.	12 V 10 to 13.2 V

Video input (pin 5)

Top-sync level	V_{5-9}	typ.	3.1 V 1.5 to 3.75 V
Sync pulse amplitude (peak-to-peak value) (note 1)	$V_{5-9(p-p)}$	typ.	0.6 V 0.15 to 1 V
Slicing level		typ.	50 % 35 to 65 %
Delay between video input and detector output	t_1	typ.	0.35 μs

Noise gate (pin 5)

Switching level	V_{5-9}	typ.	0.7 V < 1 V
-----------------	-----------	------	----------------

First control loop (sync to oscillator; pin 8)

Holding range	Δf	typ.	$\pm 800 \text{ Hz}$
Catching range	Δf	typ.	$\pm 800 \text{ Hz}$ $\pm 600 \text{ to } 1100 \text{ Hz}$

Control sensitivity video with respect to oscillator, burst key and flyback pulse

for slow time constant		typ.	1 kHz/ μs
for fast time constant		typ.	2.75 kHz/ μs

Second control loop (horizontal output to flyback; pin 14)

Control sensitivity; static (see note 2)	$\Delta t_d / \Delta t_o$	typ.	400 $\mu s / \mu s$
Control range	t_d		1 to 50 μs
Controlled edge			negative

Phase adjustment (via 2nd control loop; pin 14)

Control sensitivity		typ.	25 $\mu A / \mu s$
Maximum permissible control current	$\pm I_{14}$	<	50 μA

Horizontal oscillator (pin 15)

Frequency (no sync)	f_{osc}	typ.	15 625 Hz
Frequency spread ($C_{osc} = 2.2$ nF; $R_{osc} = 40$ k Ω)	Δf_{osc}	<	4 %
Frequency deviation between starting point of output signal and stabilized condition	Δf_{osc}	typ.	6 %
		<	8 %
Temperature coefficient	TC	typ.	$1 \cdot 10^{-4}$ K $^{-1}$

Horizontal output (pin 11)

Output voltage; high level	V_{11-9}	<	13.2 V
Voltage at which protection starts	V_{11-9}		13 to 15.8 V
Output voltage; low level start condition at $I_{11} = 10$ mA	V_{11-9}	typ.	0.3 V
		<	0.5 V
normal condition at $I_{11} = 40$ mA	V_{11-9}	typ.	0.3 V
		<	0.5 V

Duty factor of output signal during starting (no phase shift; voltage at pin 11 low)	δ	typ.	65 %
--	----------	------	------

Duty factor of output signal without flyback pulse	δ	typ.	50 % 45 to 55 %
--	----------	------	--------------------

Controlled edge			negative
-----------------	--	--	----------

Duration of output pulse (see Fig. 3)			$t_d + t_o + 2.5 \mu s$
---------------------------------------	--	--	-------------------------

Sandcastle output pulse (pin 17)

Output voltage during: burst key	V_{17-9}	>	10 V
		typ.	4.6 V
horizontal blanking	V_{17-9}		4.2 to 5 V
vertical blanking	V_{17-9}	typ.	2.5 V
			2 to 3 V

Pulse duration

burst key	t_p	typ.	4 μs 3.6 to 4.4 μs
-----------	-------	------	---------------------------------

horizontal blanking flyback pulse (see note 3)

vertical blanking			
for 50 Hz application ($-I_{12} : 0$ to 0.1 mA)			21 lines
for 60 Hz application ($-I_{12} : \text{typ. } 0.2$ mA)			17 lines



CHARACTERISTICS (continued)

Delay between the start of the sync at the video input and the rising edge of the burst key pulse	t_2	typ.	4.9 μs 4.5 to 5.3 μs
Coincidence detector; video transmitter identification circuit; time constant switches (pin 18); see also Fig. 2			
Detector output current	$\pm I_{18}$	typ.	300 μA
Voltage during noise (note 4)	V_{18-9}	typ.	0.3 V
Voltage level for in-sync condition	V_{18-9}	typ.	7.5 V
Switching level slow to fast	V_{18-9}	typ.	3.5 V 3.2 to 3.8 V
Switching level mute function active; φ_1 fast to slow	V_{18-9}	typ.	1.2 V 1.0 to 1.4 V
vertical period counter 3 periods fast	V_{18-9}	typ.	0.12 V 0.08 to 0.16 V
Switching level slow to fast (locking) mute function inactive	V_{18-9}	typ.	1.7 V 1.5 to 1.9 V
Switching level fast to slow (locking)	V_{18-9}	typ.	5.0 V 4.7 to 5.3 V
Switching level for VCR (fast time constant) without mute function	V_{18-9}	typ.	8.6 V 8.2 to 9.0 V
Video transmitter identification output (pin 13)			
Output voltage active (no sync) at $I_{13} = 1 \text{ mA}$	V_{13-9}	>	10 V typ. 11 V
Output voltage active (no sync) at $I_{13} = 5 \text{ mA}$	V_{13-9}	>	7 V typ. 10 V
Output voltage inactive	V_{13-9}	<	0.5 V typ. 0.1 V
VCR switching (pin 13)			
Input current for fast time constant phase detector φ_1 , with mute function active	I_{13}	typ.	0.6 mA 0.4 to 0.8 mA
Flyback input pulse (pin 12)			
Switching level	V_{12-9}	typ.	1 V
Input current	I_{12}		0.2 to 4 mA
Input pulse amplitude (peak-to-peak value)	$V_{12-9(p-p)}$	<	12 V
Input resistance	R_{12-9}	typ.	2.7 $\text{k}\Omega$
Delay time of sync pulse (measured in φ_1) to flyback at switching level; $t_{f1} = 12 \mu\text{s}$ (see also note 2 and Fig. 4)	t_o	typ.	1.3 μs

Duration of vertical blanking pulse (pin 12)

Required input current (negative) for 50 Hz application; 21 lines blanking	-I ₁₂	typ. >0.15 to <	0.2 mA 0.3 mA
for 60 Hz application; 17 lines blanking	-I ₁₂	<	0.1 mA
Maximum allowed input current	-I ₁₂	<	0.4 mA

Vertical sawtooth generator (pin 3)

Vertical frequency (no sync)	f _s	typ.	46 Hz
Frequency spread (C _{OSC} = 680 nF; R _{OSC} = 180 kΩ; at + 26 V)	Δf _s	<	4 %
Synchronization range		typ.	22 %
Input current at V _{3.g} = 6 V	I ₃	<	2 μA
Frequency shift for V _p = 10 to 13 V	Δf _s	<	0.2 %
Temperature coefficient	TC	typ.	1 · 10 ⁻⁴ K ⁻¹

Comparator (pin 2)

Input voltage; d.c. level	V _{2.9}	typ.	4.4 V 4.0 to 4.8 V
a.c. level (peak-to-peak value)	V _{2.9(p-p)}	typ.	1.6 V
Input current at V _{2.9} = 6 V	I ₂	<	2 μA
Sawtooth internal pre-correction (parabolic convex)		typ.	3 %

Vertical output stage; emitter follower (pin 1)

Output voltage at I ₁ = 10 mA	V _{1.9}	typ.	3.6 V 3.2 to 5 V
Output current	I ₁	<	20 mA

Vertical guard circuit

Activating voltage levels (vertical blanking level is 2.5 V)

switching level low	V _{2.9}	typ.	3 V 2.7 to 3.3 V
switching level high	V _{2.9}	typ.	5.7 V 5.3 to 6.1 V

**Notes to characteristics**

- Up to 1 V peak-to-peak the slicing level is constant; at amplitudes exceeding 1 V peak-to-peak the slicing level will increase.
- t_d = delay between negative transient of horizontal output pulse and the rising edge of the flyback pulse.
t_o = delay between the rising edge of the flyback pulse and the start of the current in φ₁ (pin 8).
- The duration of the flyback pulse is measured at the input switching level, which is about 1 V (t_{fl}).
- Depends on d.c. level at pin 5; value given applicable for V_{5.g} ≈ 5 V.

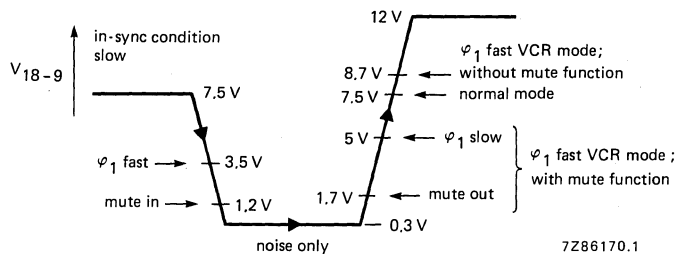

Fig. 3 Voltage levels at pin 18 (V_{18-g}).

APPLICATION INFORMATION

The TDA2577A generates the signal for driving the horizontal deflection output circuit. It also contains a synchronized vertical sawtooth generator for direct drive of the vertical deflection output stage.

The horizontal oscillator and output stage can start operating on a very low supply current ($I_{16} \geq 4 \text{ mA}$), which can be taken directly from the mains rectifier. Therefore, it is possible to derive the main supply (pin 10) from the horizontal deflection output stage. The duty factor of the horizontal output signal is about 65% during the starting-up procedure. After starting-up, the second phase detector (φ_2) is activated to control the timing of the negative-going edge of the horizontal output signal.

A bandgap reference voltage (6.5 V) is provided for supply and reference of the vertical oscillator and comparator stage.

The slicing level of the horizontal sync separator is independent of the amplitude of the sync pulse at the input. The resistor between pins 6 and 7 determines its value. A 4.7 k Ω resistor gives a slicing level at the middle of the sync pulse. The nominal top sync level at the input is 3.1 V. The amplitude selective noise inverter is activated at a level of 0.7 V.

Good stability is obtained by means of the two control loops. In the first loop, the phase of the horizontal sync signal is compared with a waveform of which the rising edge refers to the top of the horizontal oscillator signal. In the second loop, the phase of the flyback pulse is compared with another reference waveform, the timing of which is such that the top of the flyback pulse is situated symmetrically on the horizontal blanking interval of the video signal. Therefore the first loop can be designed for a good noise immunity, whereas the second loop can be as fast as desired for compensation of switch-off delays in the horizontal output stage.

The first phase detector is gated with a pulse derived from the horizontal oscillator signal. This gating (slow time constant) is switched off during catching. Also, the output current of the phase detector is increased fivefold, during the catching time and VCR conditions (fast time constant). The first phase detector is inhibited during the retrace time of the vertical oscillator.

The in-sync, out-of-sync or no video condition is detected by the video transmitter identification/coincidence detector circuit (pin 18). The voltage on pin 18 defines the time constant and gating of the first phase detector. The relationship between this voltage and the various switching levels is shown in Fig. 3. The complete survey of the switching actions is given in Table 1.

in the horizontal output stage are compensated. When no horizontal flyback signal is detected the duty factor of the horizontal output signal is 50%.

Horizontal picture shift is possible by externally charging or discharging the 47 nF capacitor connected to pin 14.

The IC also contains a synchronized vertical oscillator/sawtooth generator. The oscillator signal is connected to the internal comparator (the other side of which is connected to pin 2), via an inverter and amplitude divider stage. The output of the comparator drives an emitter-follower output stage at pin 1. For a linear sawtooth in the oscillator, the load resistor at pin 3 should be connected to a voltage source of 26 V or higher. The sawtooth amplitude is not influenced by the main supply at pin 10. The feedback signal is applied to pin 2 and compared to the sawtooth signal at pin 3. For an economical feedback circuit with less picture bounce the sawtooth signal is internally precorrected by 3% (convex) referred to pin 2. The linearity of the vertical deflection current depends upon the oscillator signal at pin 3 and the feedback signal at pin 2.

Synchronization of the vertical oscillator is inhibited when the mute output is present at pin 13.

To minimize the influence of the horizontal part on the vertical part a 6.5 V bandgap reference source is provided for supply and reference of the vertical oscillator and comparator.

The sandcastle pulse, generated at pin 17, has three different voltage levels. The highest level (11 V) can be used for burst gating and black level clamping. The second level (4.6 V) is obtained from the horizontal flyback pulse at pin 12 and used for horizontal blanking. The third level (2.5 V) is used for vertical blanking and is derived by counting the horizontal frequency pulses. For 50 Hz the blanking pulse duration is 21 lines and for 60 Hz it is 17 lines. The blanking pulse duration is set by the negative voltage value of the horizontal flyback pulse at pin 12.

The IC also incorporates a vertical guard circuit, which monitors the vertical feedback signal at pin 2. If this level is below 3 V or higher than 5.8 V, the guard circuit will insert a continuous level of 2.5 V into the sandcastle output signal. This will result in complete blanking of the screen if the sandcastle pulse is used for blanking in the TV set.

APPLICATION INFORMATION (continued)

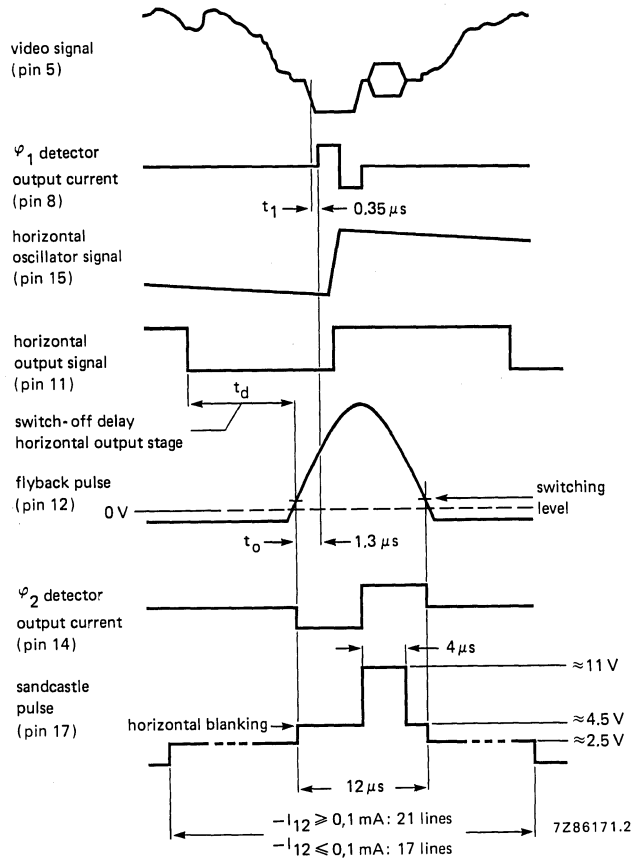

Fig. 4 Timing diagram of the TDA2577A.

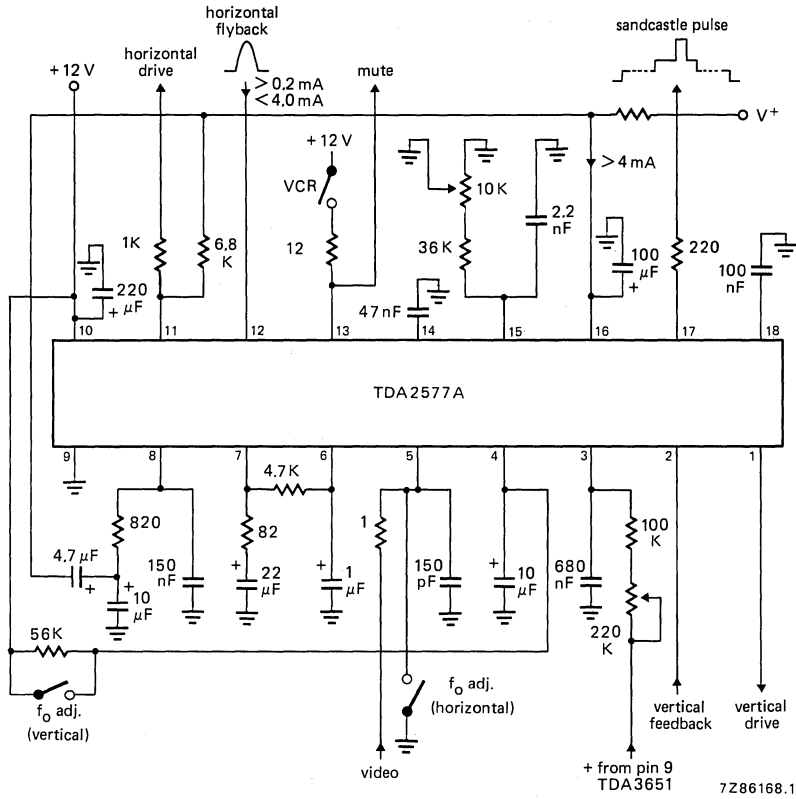

Fig. 5 Typical application circuit diagram; for combination of the TDA2577A with the TDA3651 see Fig. 7.

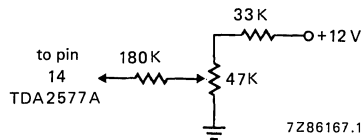
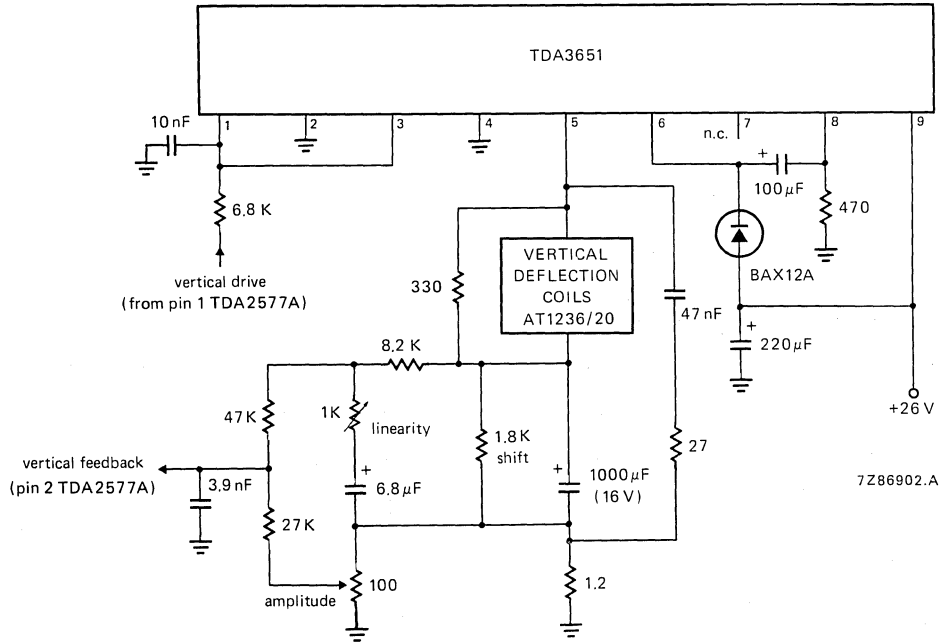

Fig. 6 Circuit configuration at pin 14 for phase adjustment.

APPLICATION INFORMATION (continued)



7Z86902.A

Fig. 7 Typical application circuit diagram of the TDA3651 (vertical output), when used in combination with the TDA2577A (90° application).

GENERAL DESCRIPTION

The TDA2578A separates the vertical and horizontal sync pulses from the composite TV video signal and uses them to synchronize horizontal and vertical oscillators.

Features

- Horizontal sync separator and noise inverter
- Horizontal oscillator
- Horizontal output stage
- Horizontal phase detector (sync to oscillator)
- Time constant switch for phase detector (fast time constant during catching)
- Slow time constant for noise only conditions
- Time constant externally switchable (e.g. fast for VCR)
- Inhibit of horizontal phase detector and video transmitter identification circuit during vertical oscillator flyback
- Second phase detector (φ_2) for storage compensation of horizontal deflection stage
- Sandcastle pulse generator (3-levels)
- Video transmitter identification circuit
- Stabilizer and supply circuit for starting the horizontal oscillator and output stage directly from the mains rectifier
- Duty factor of horizontal output pulse is 50% when flyback pulse is absent
- Vertical sync separator
- Bandgap 6.5 V reference voltage for vertical oscillator and comparator
- Synchronized vertical oscillator/sawtooth generator (synchronization inhibited when no video transmitter is detected)
- Internal circuit for 6% parabolic pre-correction of the oscillator/sawtooth generator. Comparator supplied with pre-corrected sawtooth and external feedback input
- Vertical driver stage
- Vertical blanking pulse generator
- 50/60 Hz detector
- 50/60 Hz identification output
- Automatic amplitude adjustment for 60 Hz
- Automatic adjustment of blanking pulse duration (50 Hz: 21 lines; 60 Hz: 17 lines)
- Vertical guard circuit

QUICK REFERENCE DATA**Supply**

Minimum current required to start horizontal oscillator and output stage (pin 16)

$I_{16} > 4 \text{ mA}$

Main supply voltage (pin 10)

$V_P = V_{10-9} \text{ typ. } 12 \text{ V}$

Supply current

$I_P = I_{10} \text{ typ. } 55 \text{ mA}$

Input signals

Sync pulse input voltage (peak-to-peak value; negative-going)

$V_{5-9(p-p)} 0.15 \text{ to } 1 \text{ V}$

Output signals

Horizontal output pulse (open collector) at $I_{11} = 40 \text{ mA}$

$V_{11-9} < 0.5 \text{ V}$

Vertical output pulse (emitter-follower) at $I_1 = 10 \text{ mA}$

$V_{1-9} > 4 \text{ V}$

PACKAGE OUTLINE

18-lead DIL; plastic (SOT-102HE).

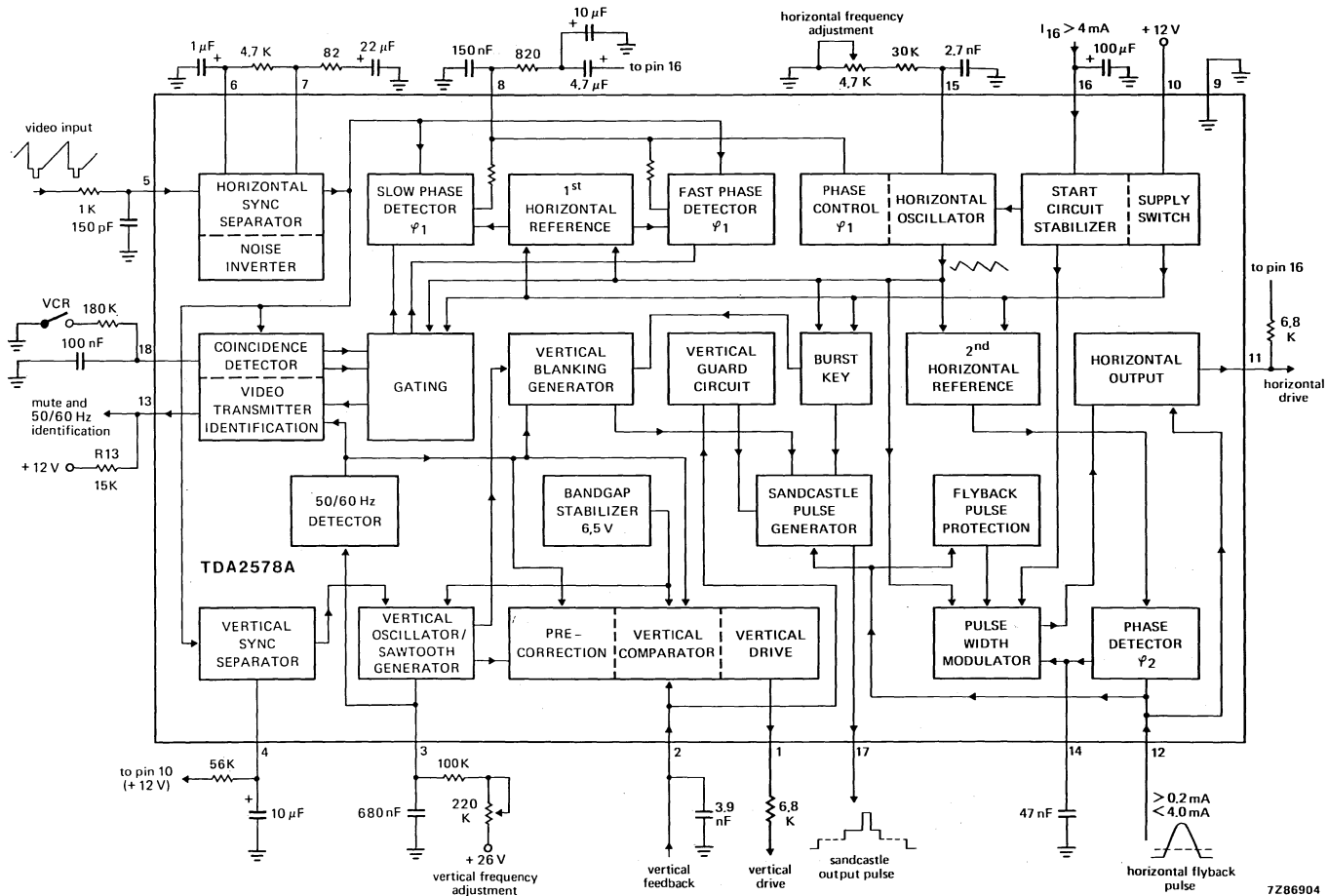
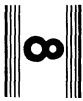

Fig. 1 Block diagram.

7286904



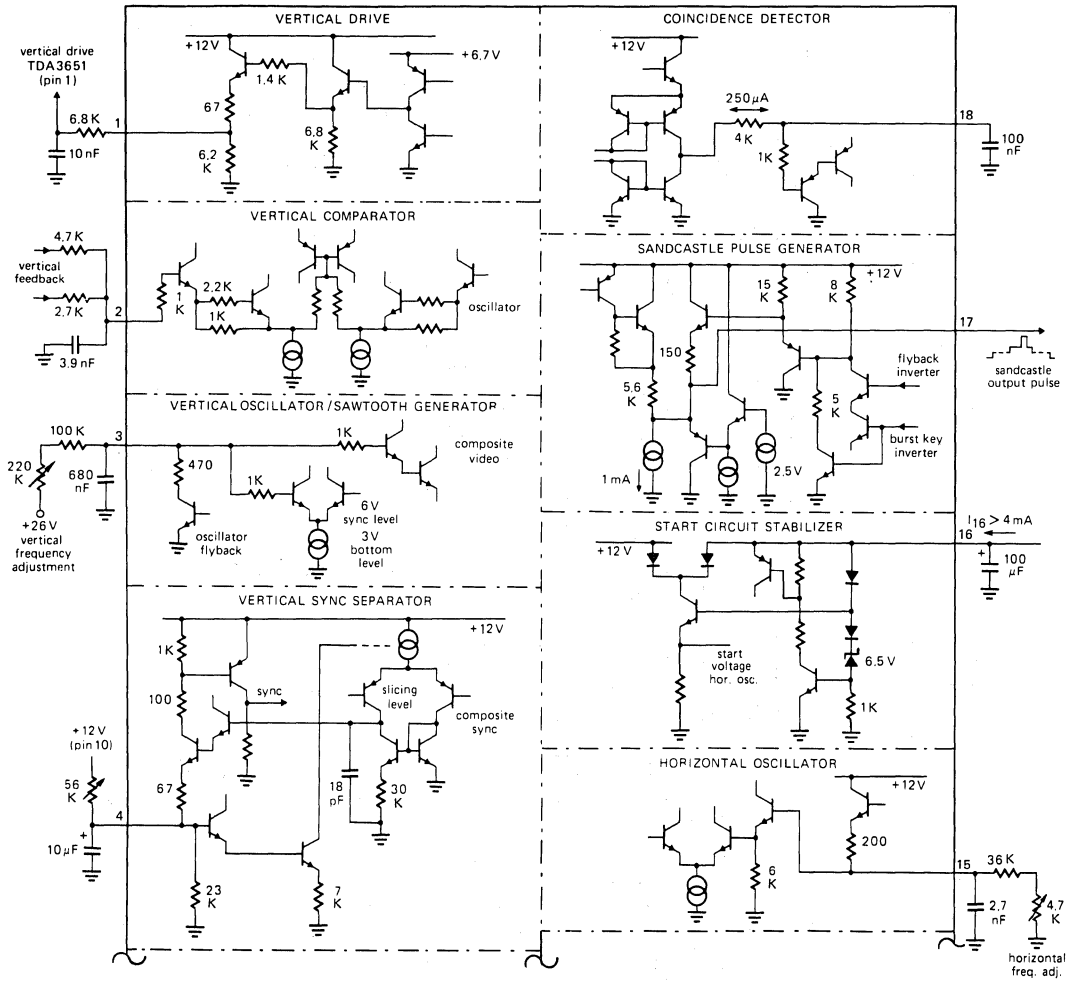

Fig. 2 TDA2578A Circuit diagram.

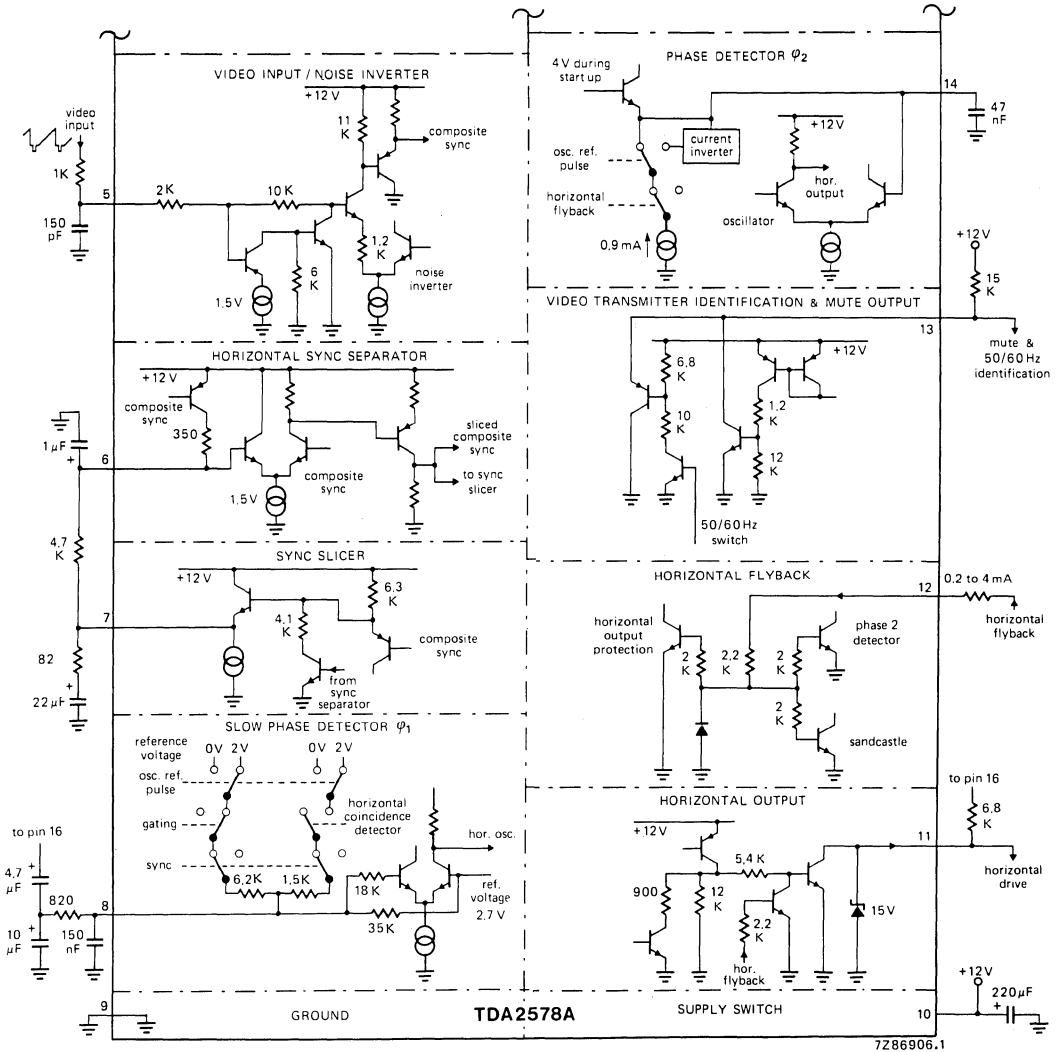

Fig. 2 TDA2578A Circuit diagram. (Continued)

RATINGS

Limiting values in accordance with the Absolute Maximum System (IEC 134)

Start current (pin 16)	I_{16}	max.	8 mA
Supply voltage (pin 10)	$V_P = V_{10-9}$	max.	13.2 V
Total power dissipation	P_{tot}	max.	1.1 W
Storage temperature range	T_{stg}		-55 to + 150 °C
Operating ambient temperature range	T_{amb}		-25 to + 65 °C

THERMAL RESISTANCE

From junction to ambient in free air	$R_{th\ j-a}$	typ.	50 K/W
--------------------------------------	---------------	------	--------

CHARACTERISTICS

 $I_{16} = 5\text{ mA}$; $V_P = 12\text{ V}$; $T_{amb} = 25\text{ °C}$; unless otherwise specified

Supply

Supply current at pin 16	I_{16}		4 to 8 mA
Stabilized supply voltage (pin 16)	V_{16-9}	typ.	8.7 V 8.0 to 9.5 V
Supply current (pin 10)	I_{10}	typ. <	55 mA 70 mA
Supply voltage (pin 10)	$V_P = V_{10-9}$	typ.	12 V 10 to 13.2 V

Video input (pin 5)

Top-sync level	V_{5-9}	typ.	3.1 V 1.5 to 3.75 V
Sync pulse amplitude (peak-to-peak value) (note 1)	$V_{5-9(p-p)}$	typ.	0.6 V 0.15 to 1 V
Slicing level		typ.	50 % 35 to 65 %
Delay between video input and detector output	t_1	typ.	0.35 μs

Noise gate (pin 5)

Switching level	V_{5-9}	typ. <	0.7 V 1 V
-----------------	-----------	-----------	--------------

First control loop (sync to oscillator; pin 8)

Holding range	Δf	typ.	$\pm 800\text{ Hz}$
Catching range	Δf	typ.	$\pm 800\text{ Hz}$ $\pm 600\text{ to }1100\text{ Hz}$

Control sensitivity video with respect to oscillator, burst key and flyback pulse

for slow time constant		typ.	1 kHz/ μs
for fast time constant		typ.	2.75 kHz/ μs

Second control loop (horizontal output to flyback; pin 14)

Control sensitivity; static (see note 2)	$\Delta t_d / \Delta t_o$	typ.	400 $\mu s / \mu s$
Control range	t_d		1 to 45 μs
Controlled edge	positive		

Phase adjustment (via 2nd control loop; pin 14)

Control sensitivity		typ.	25 $\mu A / \mu s$
Maximum permissible control current	$\pm I_{14}$	<	50 μA

Horizontal oscillator (pin 15)

Frequency (no sync)	f_{osc}	typ.	15 625 Hz
Frequency spread ($C_{osc} = 2,7$ nF; $R_{osc} = 33$ k Ω ; no sync)	Δf_{osc}	<	4 %
Frequency deviation between starting point of output signal and stabilized condition	Δf_{osc}	typ.	6 %
		<	8 %
Temperature coefficient	TC	typ.	$1 \cdot 10^{-4}$ K $^{-1}$

Horizontal output (pin 11)

Output voltage; high level	V_{11-9}	<	13.2 V
Voltage at which protection starts	V_{11-9}		13 to 15.8 V
Output voltage; low level start condition at $I_{11} = 10$ mA	V_{11-9}	typ.	0.3 V
		<	0.5 V
normal condition at $I_{11} = 40$ mA	V_{11-9}	typ.	0.3 V
		<	0.5 V
Duty factor of output signal during starting (no phase shift) $I_{16} = 4$ mA (voltage at pin 11 low)	δ	typ.	65 %
Duty factor of output signal without flyback pulse	δ	typ.	50 %
			45 to 55 %

Controlled edge positive

Duration of output pulse (see Fig. 4) t_d + horizontal flyback pulse**Sandcastle output pulse** (pin 17)

Output voltage during: burst key	V_{17-9}	>	10 V
		typ.	4.6 V
horizontal blanking	V_{17-9}		4.2 to 5 V
		typ.	2.5 V
vertical blanking	V_{17-9}		2 to 3 V
Pulse duration burst key	t_p	typ.	4 μs
			3.6 to 4.4 μs
horizontal blanking			flyback pulse (see note 3)
vertical blanking at 50 Hz at 60 Hz			21 lines
			17 lines

CHARACTERISTICS (continued)

Delay between the start of the sync at the video input and the rising edge of the burst key pulse	t_2	typ.	4.9 μs 4.5 to 5.3 μs
Coincidence detector; video transmitter identification circuit; time constant switches (pin 18); see also Fig. 3			
Detector output current	$\pm I_{18}$	typ.	300 μA
Voltage during noise (note 4)	V_{18-9}	typ.	0.3 V
Voltage level for in-sync condition	V_{18-9}	typ.	7.5 V
Switching level slow to fast	V_{18-9}	typ.	3.5 V 3.2 to 3.8 V
Switching level mute function active; φ_1 fast to slow	V_{18-9}	typ.	1.2 V 1.0 to 1.4 V
vertical period counter 3 periods fast	V_{18-9}	typ.	0.12 V 0.08 to 0.16 V
Switching level slow to fast (locking) mute function inactive	V_{18-9}	typ.	1.7 V 1.5 to 1.9 V
Switching level fast to slow (locking)	V_{18-9}	typ.	5.0 V 4.7 to 5.3 V
Switching level for VCR (fast time constant) without mute function	V_{18-9}	typ.	8.6 V 8.2 to 9.0 V
Video transmitter identification output (pin 13)			
Output voltage active (no sync) at $I_{13} = 1 \text{ mA}$	V_{13-9}	< typ.	0.5 V 0.3 V
Sink current active (no sync)	I_{13}	\leq	5 mA
Output current inactive (sync: 50 Hz)	I_{13}	<	1 μA
50/60 Hz identification (pin 13)			
$R_{13} = 15 \text{ k}\Omega$ to +12 V (note 5) at $f = 50 \text{ Hz}$ (in sync condition)	V_{13-9}	typ.	V_{10-9} V 7.6 V
at $f = 60 \text{ Hz}$ (in sync condition)	V_{13-9}	typ.	7.2 to 8 V
Flyback input pulse (pin 12)			
Switching level	V_{12-9}	typ.	1 V
Input current	I_{12}		0.2 to 4 mA
Input pulse amplitude (peak-to-peak value)	$V_{12-9(p-p)}$	<	12 V
Input resistance	R_{12-9}	typ.	2.7 $\text{k}\Omega$
Delay time of sync pulse (measured in φ_1) to flyback at switching level; $t_{f1} = 12 \mu\text{s}$ (see also note 2 and Fig. 4)	t_0	typ.	1.3 μs

SYNCHRONIZATION CIRCUIT WITH VERTICAL OSCILLATOR & DRIVER

TDA2578A

Vertical sawtooth generator (pin 3)

Vertical frequency (no sync)	f_s	typ.	46 Hz
Frequency spread ($C_{OSC} = 680$ nF; $R_{OSC} = 180$ k Ω ; at +26 V)	Δf_s	<	4 %
Synchronization range (note 6)		typ.	33 %
Input current at $V_{3-g} = 6$ V	I_3	<	3 μ A
Frequency shift for $V_P = 10$ to 13 V	Δf_s	<	0.2 %
Temperature coefficient	TC	typ.	$1 \cdot 10^{-4}$ K $^{-1}$

Comparator (pin 2)

Input voltage; d.c. level	V_{2-9}	typ.	4.4 V 4.0 to 4.8 V
a.c. level (peak-to-peak value)	$V_{2-9(p-p)}$	typ.	0.8 V
Input current at $V_{2-9} = 6$ V	I_2	<	2 μ A
Sawtooth internal pre-correction (parabolic convex)		typ.	6 %

Vertical output stage; emitter follower (pin 1)

Output voltage at $I_1 = 10$ mA	V_{1-9}	typ.	V 3.2 to 5 V
Output current	I_1	<	20 mA

Vertical guard circuit

Activating voltage levels (vertical blanking level is 2.5 V) switching level low	V_{2-9}	typ.	3.35 V 3.0 to 3.7 V
switching level high	V_{2-9}	typ.	5.15 V 4.75 to 5.55 V

Notes to characteristics

- Up to 1 V peak-to-peak the slicing level is constant; at amplitudes exceeding 1 V peak-to-peak the slicing level will increase.
- t_d = delay between positive transient of horizontal output pulse and the rising edge of the flyback pulse.
 t_o = delay between the rising edge of the flyback pulse and the start of the current in φ_1 (pin 8).
- The duration of the flyback pulse is measured at the input switching level, which is about 1 V (t_{ff}).
- Depends on d.c. level at pin 5; value given applicable for $V_{5-g} \approx 5$ V.
- For 60 Hz a p-n-p emitter clamp is activated.
- When $f_o = 46$ Hz the 50/60 Hz detector switches over to 60 Hz; video input signal at pin 5 ≈ 55 Hz.



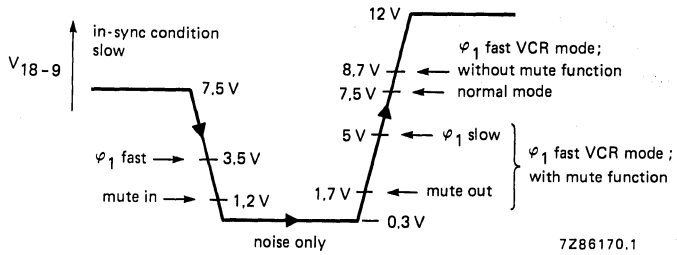

Fig. 3 Voltage levels at pin 18 (V_{18-9}).

APPLICATION INFORMATION

The TDA2578A generates the signal for driving the horizontal deflection output circuit. It also contains a synchronized vertical sawtooth generator for direct drive of the vertical deflection output stage.

The horizontal oscillator and output stage can start operating on a very low supply current ($I_{16} \geq 4 \text{ mA}$), which can be taken directly from the mains rectifier. Therefore, it is possible to derive the main supply (pin 10) from the horizontal deflection output stage. The duty factor of the horizontal output signal is about 65% during the starting-up procedure. After starting-up, the second phase detector (φ_2) is activated to control the timing of the positive-going edge of the horizontal output signal.

A bandgap reference voltage (6.5 V) is provided for supply and reference of the vertical oscillator and comparator stage.

The slicing level of the horizontal sync separator is independent of the amplitude of the sync pulse at the input. The resistor between pins 6 and 7 determines its value. A 4.7 k Ω resistor gives a slicing level at the middle of the sync pulse. The nominal top sync level at the input is 3.1 V. The amplitude selective noise inverter is activated at a level of 0.7 V.

Good stability is obtained by means of the two control loops. In the first loop, the phase of the horizontal sync signal is compared with a waveform of which the rising edge refers to the top of the horizontal oscillator signal. In the second loop, the phase of the flyback pulse is compared with another reference waveform, the timing of which is such that the top of the flyback pulse is situated symmetrically on the horizontal blanking interval of the video signal. Therefore the first loop can be designed for a good noise immunity, whereas the second loop can be as fast as desired for compensation of switch-off delays in the horizontal output stage.

The first phase detector is gated with a pulse derived from the horizontal oscillator signal. This gating (slow time constant) is switched off during catching. Also, the output current of the phase detector is increased fivefold, during the catching time and VCR conditions (fast time constant). The first phase detector is inhibited during the retrace time of the vertical oscillator.

The in-sync, out-of-sync or no video condition is detected by the video transmitter identification/coincidence detector circuit (pin 18). The voltage on pin 18 defines the time constant and gating of the first phase detector. The relationship between this voltage and the various switching levels is shown in Fig. 3. The complete survey of the switching actions is given in Table 1.

Table 1 Switching levels at pin 18.

voltage at pin 18	first phase detector φ_1				mute output at pin 13		receiving conditions
	time constant		gating		on	off	
	slow	fast	on	off			
7.5 V	X		X			X	video signal detected
7.5 to 3.5 V	X		X			X	video signal detected
3.5 to 1.2 V		X		X		X	video signal detected
1.2 to 0.1 V	X		X		X		noise only
0.1 to 1.7 V	X	*	X	*	X		new video signal detected
1.7 to 5.0 V		X		X		X	horizontal oscillator locked VCR playback with mute function
5.0 to 7.5 V	X		X			X	horizontal oscillator locked
8.7 V		X		X		X	VCR playback without mute function

Where: * = 3 vertical periods.

APPLICATION INFORMATION (continued)

The stability of displayed video information (e.g. channel number), during noise only conditions, is improved by the first phase detector time constant being set to slow.

The average voltage level of the video input on pin 5 during noise only conditions should not exceed 5.5 V otherwise the time constant switch may be set to fast due to the average voltage level on pin 18 dropping below 0.1 V. When the voltage on pin 18 drops below 100 mV a counter is activated which sets the time constant switch to fast, and not gated for 3 vertical periods. This condition occurs when a new video signal is present at pin 5. When the horizontal oscillator is locked the voltage on pin 18 increases. Nominally a level of 5 V is reached within 15 ms (1 vertical period). The mute switching level of 1.2 V is reached within 5 ms ($C_{18} = 47$ nF). If the video transmitter identification circuit is required to operate under VCR playback conditions the first phase detector can be set to fast by connecting a resistor of 180 k Ω between pin 18 and ground (see Fig. 7).

The supply for the horizontal oscillator (pin 15) and horizontal output stage (pin 11) is derived from the voltage at pin 16 during the start condition. The horizontal output signal starts at a nominal supply current into pin 16 of 3.6 mA, which will result in a supply voltage of about 5.5 V (for guaranteed operation of all devices $I_{16} > 4$ mA). It is possible that the main supply voltage at pin 10 is 0 V during starting, so the main supply of the IC can be taken from the horizontal deflection output stage. The start of the other IC functions depends on the value of the main supply voltage at pin 10. At 5.5 V all IC functions start operating except the second phase detector (oscillator to flyback pulse). The output voltage of the second phase detector at pin 14 is clamped by means of an internally loaded n-p-n emitter follower. This ensures that the duty factor of the horizontal output signal (pin 11) remains at about 65%. The second phase detector will close if the supply voltage at pin 10 reaches 8.8 V. At this value the supply current for the horizontal oscillator and output stage is delivered by pin 10, which also causes the voltage at pin 16 to change to a stabilized 8.7 V. This change switches off the n-p-n emitter follower at pin 14 and activates the second phase detector. The supply voltage for the horizontal oscillator will, however, still be referred to the stabilized voltage at pin 16, and the duty factor of the output signal at pin 12 is at the value required by the delay at the horizontal deflection stage. Thus switch-off delays in the horizontal output stage are compensated. When no horizontal flyback signal is detected the duty factor of the horizontal output signal is 50%.

Horizontal picture shift is possible by externally charging or discharging the 47 nF capacitor connected to pin 14.

The IC also contains a synchronized vertical oscillator/sawtooth generator. The oscillator signal is connected to the internal comparator (the other side of which is connected to pin 2), via an inverter and amplitude divider stage. The output of the comparator drives an emitter-follower output stage at pin 1. For a linear sawtooth in the oscillator, the load resistor at pin 3 should be connected to a voltage source of 26 V or higher. The sawtooth amplitude is not influenced by the main supply at pin 10. The feedback signal is applied to pin 2 and compared to the sawtooth signal at pin 3. For an economical feedback circuit with less picture bounce the sawtooth signal is internally pre-corrected by 6% (convex) referred to pin 2. The linearity of the vertical deflection current depends upon the oscillator signal at pin 3 and the feedback signal at pin 2.

Synchronization of the vertical oscillator is inhibited when the mute output is present at pin 13.

To minimize the influence of the horizontal part on the vertical part a 6.7 V bandgap reference source is provided for supply and reference of the vertical oscillator and comparator.

The sandcastle pulse, generated at pin 17, has three different voltage levels. The highest level (11 V) can be used for burst gating and black level clamping. The second level (4.6 V) is obtained from the horizontal flyback pulse at pin 12 and used for horizontal blanking. The third level (2.5 V) is used for vertical blanking and is derived by counting the horizontal frequency pulses. For 50 Hz the blanking pulse duration is 21 lines and for 60 Hz it is 17 lines. The blanking pulse duration and sawtooth amplitude is automatically adjusted via the 50/60 Hz detector.

The IC also incorporates a vertical guard circuit, which monitors the vertical feedback signal at pin 2. If this level is below 3.35 V or higher than 5.15 V, the guard circuit will insert a continuous level of 2.5 V into the sandcastle output signal. This will result in complete blanking of the screen if the sandcastle pulse is used for blanking in the TV set.

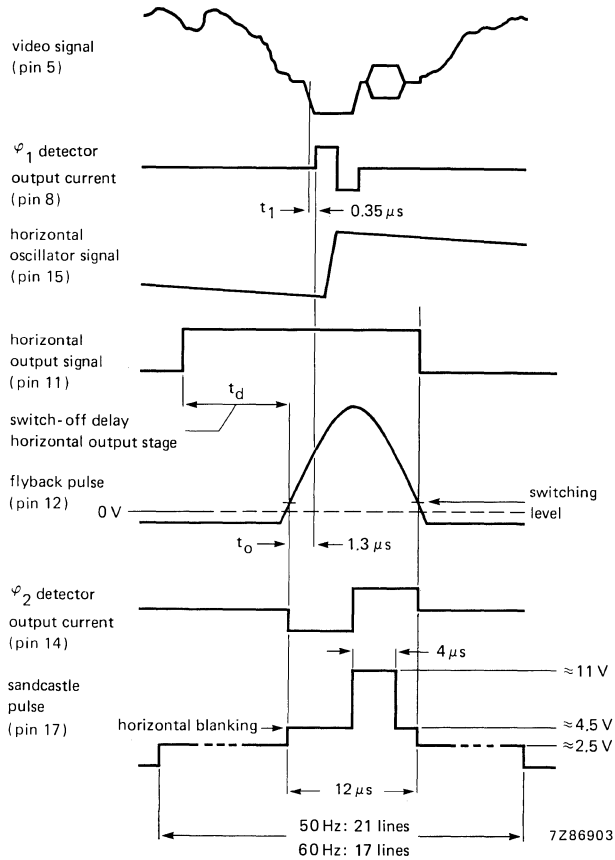
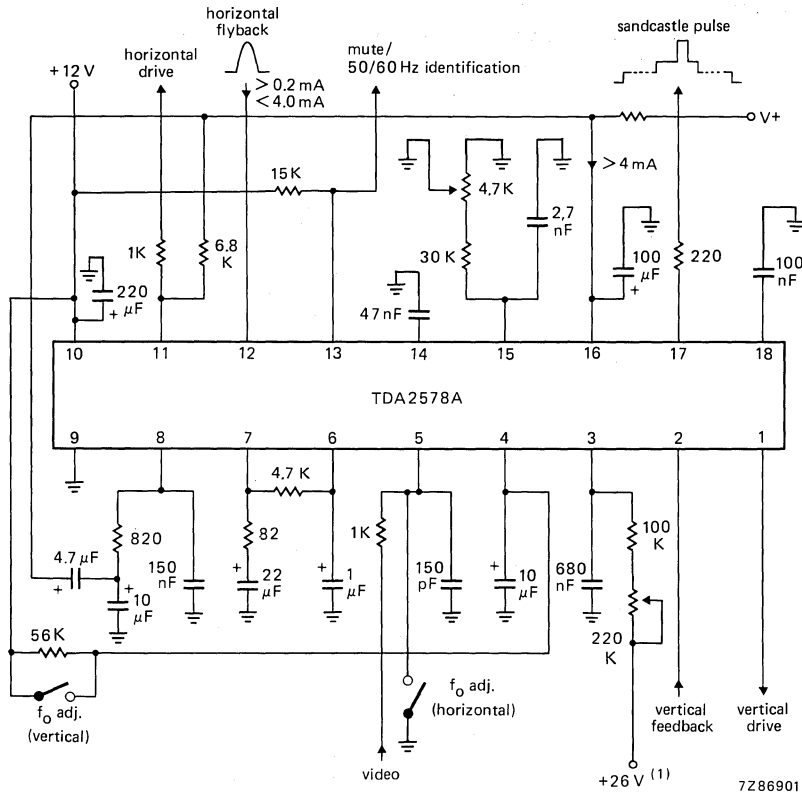

Fig. 4 Timing diagram of the TDA2578A.



APPLICATION INFORMATION (continued)



(1) ≥ 26 V for linear scan.

Fig. 5 Typical application circuit diagram; for application of the TDA2578A with the TDA3651 see Fig. 8.

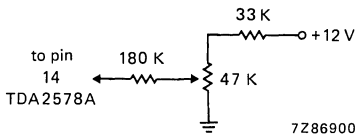

Fig. 6 Circuit configuration at pin 14 for phase adjustment.

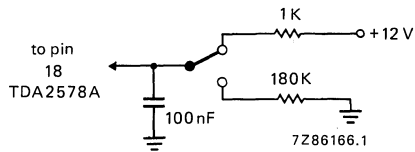

Fig. 7 Circuit configuration at pin 18 for VCR mode.
 1 kΩ resistor between pin 18 and + 12 V:
 without mute function.
 180 kΩ between pin 18 and ground:
 with mute function.

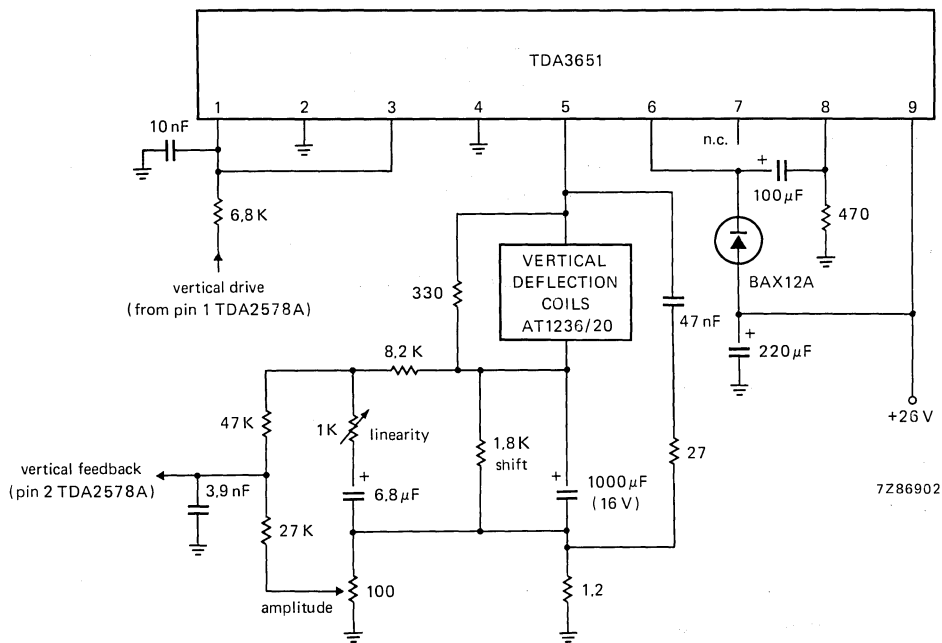

Fig. 8 Typical application circuit diagram of the TDA3651 (vertical output), when used in combination with the TDA2578A, (90° application).

The TDA2593 is a monolithic integrated circuit intended for use in colour television receivers in combination with TDA2510, TDA2520, TDA2560 as well as with TDA3500, TDA3510 and TDA3520.

The circuit incorporates the following functions:

- horizontal oscillator based on the threshold switching principle
- phase comparison between sync pulse and oscillator voltage (φ_1)
- internal key pulse for phase detector (φ_1) (additional noise limiting)
- phase comparison between line flyback pulse and oscillator voltage (φ_2)
- larger catching range obtained by coincidence detector (φ_3 ; between sync and key pulse)
- switch for changing the filter characteristic and the gate circuit (VCR-operation)
- sync separator
- noise separator
- vertical sync separator and output stage
- colour burst keying and line flyback blanking pulse generator
- phase shifter for the output pulse
- output pulse duration switching
- output stage with separate supply voltage for direct drive of thyristor deflection circuits
- low supply voltage protection

QUICK REFERENCE DATA

Supply voltage	V_{1-16}	typ.	12 V
Supply current	I_1	typ.	30 mA
Input signals			
Sync separator input voltage (peak-to-peak value)	$V_{9-16(p-p)}$		3 to 4 V
Noise separator input voltage (peak-to-peak value)	$V_{10-16(p-p)}$		3 to 4 V
Pulse duration switch input voltage			
at $t = 7 \mu s$ (thyristor driving)	V_{4-16}		9.4 to V_{1-16} V
at $t = 14 \mu s + t_d$ (transistor driving)	V_{4-16}		0 to 3.5 V
at $t = 0$ (input 4 open or $V_{3-16} = 0$)	V_{4-16}		5.4 to 6.6 V
Output signals			
Vertical sync output pulse (peak-to-peak value)	$V_{8-16(p-p)}$	typ.	11 V
Burst gating output pulse (peak-to-peak value)	$V_{7-16(p-p)}$	typ.	11 V
Line drive pulse (peak-to-peak value)	$V_{3-16(p-p)}$	typ.	10.5 V

PACKAGE OUTLINE

16-lead DIL; plastic (SOT-38).

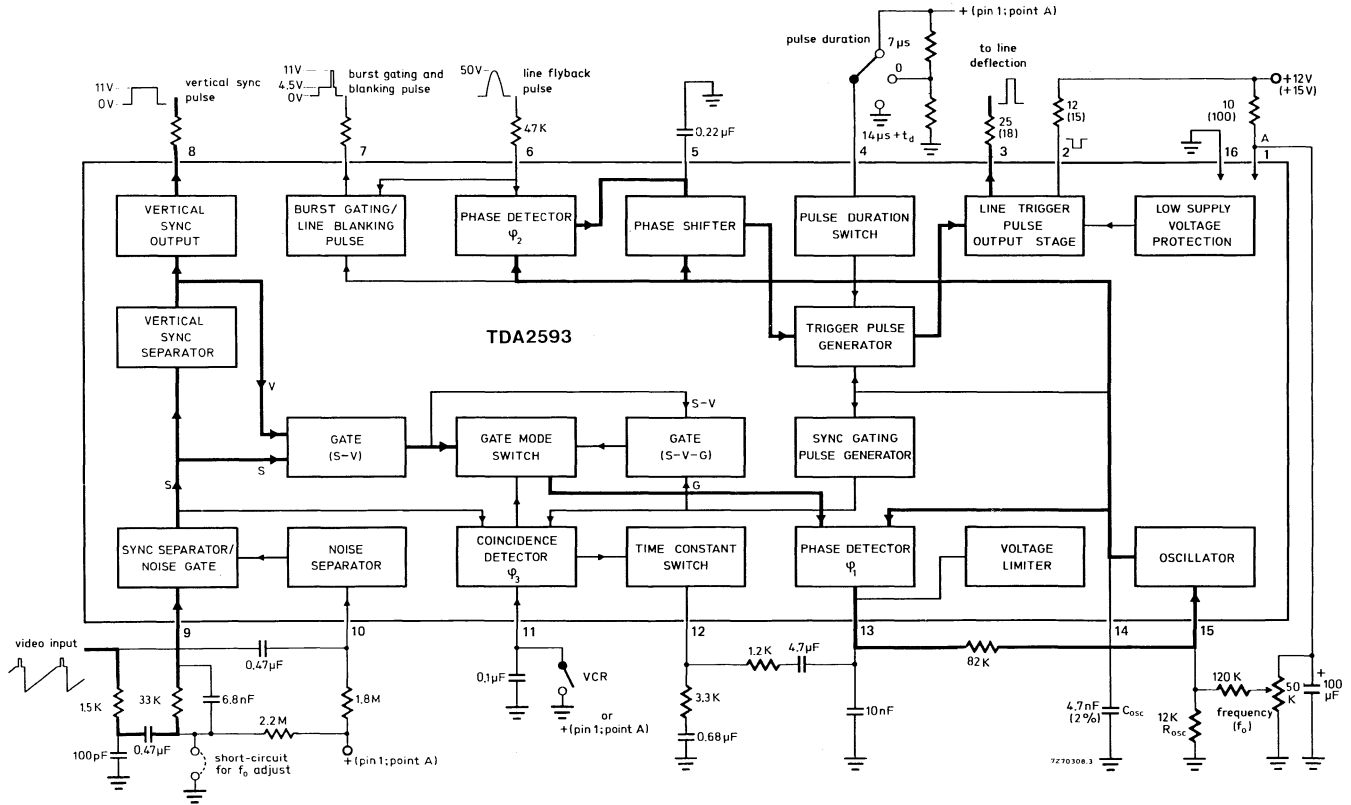

Fig. 1 Block diagram.



RATINGS

Limiting values in accordance with the Absolute Maximum System (IEC 134)

Supply voltage

at pin 1 (voltage source)	V_{1-16}	max.	13.2 V
at pin 2	V_{2-16}	max.	18 V

Voltages

Pin 4	V_{4-16}	max.	13.2 V
Pin 9	$\pm V_{9-16}$	max.	6 V
Pin 10	$\pm V_{10-16}$	max.	6 V
Pin 11	V_{11-16}	max.	13.2 V

Currents

Pins 2 and 3 (thyristor driving) (peak value)	$I_{2M,-I_{3M}}$	max.	650 mA
Pins 2 and 3 (transistor driving) (peak value)	$I_{2M,-I_{3M}}$	max.	400 mA
Pin 4	I_4	max.	1 mA
Pin 6	$\pm I_6$	max.	10 mA
Pin 7	$-I_7$	max.	10 mA
Pin 11	I_{11}	max.	2 mA
Total power dissipation	P_{tot}	max.	800 mW
Storage temperature	T_{stg}		-25 to +125 °C
Operating ambient temperature	T_{amb}		-20 to +70 °C

CHARACTERISTICS at $V_{1-16} = 12$ V; $T_{amb} = 25$ °C; measured in Fig. 1

Sync separator

Input switching voltage	V_{9-16}	typ.	0.8 V
Input keying current	I_g		5 to 100 μ A
Input leakage current at $V_{9-16} = -5$ V	I_g	<	1 μ A
Input switching current	I_g	\leq	5 μ A
Switch off current	I_g	>	100 μ A
		typ.	150 μ A
Input signal (peak-to-peak value)	$V_{9-16(p-p)}$		3 to 4 V*

* Permissible range 1 to 7 V.

HORIZONTAL COMBINATION**TDA2593****Noise separator**

Input switching voltage	V_{10-16}	typ.	1.4 V
Input keying current	I_{10}		5 to 100 μA
Input switching current	I_{10}	>	100 μA
		typ.	150 μA
Input leakage current at $V_{10-16} = -5\text{ V}$	I_{10}	<	1 μA
Input signal (peak-to-peak value)	$V_{10-16(p-p)}$		3 to 4 V*
Permissible superimposed noise signal (peak-to-peak value)	$V_{10-16(p-p)}$	<	7 V

Line flyback pulse

Input current	I_6	typ.	1 mA
			0.02 to 2 mA
Input switching voltage	V_{6-16}	typ.	1.4 V
Input limiting voltage	V_{6-16}		-0.7 to +1.4 V

Switching on VCR

Input voltage	V_{11-16}		0 to 2.5 V
	V_{11-16}		9 to V_{1-16} V
Input current	$-I_{11}$	<	200 μA
	I_{11}	<	2 mA

Pulse duration switchFor $t = 7\ \mu\text{s}$ (thyristor driving)

Input voltage	V_{4-16}		9.4 to V_{1-16} V
Input current	I_4	>	200 μA

For $t = 14\ \mu\text{s} + t_d$ (transistor driving)

Input voltage	V_{4-16}		0 to 3.5 V
Input current	$-I_4$	>	200 μA

For $t = 0$; $V_{3-16} = 0$ or input pin 4 open

Input voltage	V_{4-16}		5.4 to 6.6 V
Input current	I_4	typ.	0 μA

* Permissible range 1 to 7 V.

HORIZONTAL COMBINATION**TDA2593****Vertical sync pulse (positive-going)**

Output voltage (peak-to-peak value)	$V_{8-16(p-p)}$	>	10 V
		typ.	11 V
Output resistance	R_8	typ.	2 k Ω
Delay between leading edge of input and output signal	t_{on}	typ.	15 μ s
Delay between trailing edge of input and output signal	t_{off}	typ.	t_{on} μ s

Burst gating pulse (positive-going)

Output voltage (peak-to-peak value)	$V_{7-16(p-p)}$	>	10 V
		typ.	11 V
Output resistance	R_7	typ.	70 Ω
Pulse duration; $V_{7-16} = 7$ V	t_p	typ.	4 μ s
			3.7 to 4.3 μ s
Phase relation between middle of sync pulse at the input and the leading edge of the burst gating pulse; $V_{7-16} = 7$ V	t	typ.	2.65 μ s
			2.15 to 3.15 μ s
Output trailing edge current	I_7	typ.	2 mA

Line flyback-blanking pulse (positive-going)

Output voltage (peak-to-peak value)	$V_{7-16(p-p)}$		4 to 5 V
Output resistance	R_7	typ.	70 Ω
Output trailing edge current	I_7	typ.	2 mA

Line drive pulse (positive-going)

Output voltage (peak-to-peak value)	$V_{3-16(p-p)}$	typ.	10.5 V
Output resistance			
for leading edge of line pulse	R_3	typ.	2.5 Ω
for trailing edge of line pulse	R_3	typ.	20 Ω
Pulse duration (thyristor driving)		typ.	7 μ s
$V_{4-16} = 9.4$ to V_{1-16} V	t_p		5.5 to 8.5 μ s
Pulse duration (transistor driving)			
$V_{4-16} = 0$ to 4 V; $t_{fp} = 12$ μ s	t_p		$14 + t_d$ μ s*
Supply voltage for switching off the output pulse	V_{1-16}	typ.	4 V

Overall phase relation

Phase relation between middle of sync pulse and the middle of the flyback pulse	t	typ.	2.6 μ s**
Tolerance of phase relation	$ \Delta t $	<	0.7 μ s

* t_d = switch-off delay of line output stage.** Line flyback pulse duration: $t_{fp} = 12$ μ s.

HORIZONTAL COMBINATION

TDA2593

The adjustment of the overall phase relation and consequently the leading edge of the line drive pulse occurs automatically by phase control φ_2 .

If additional adjustment is applied it can be arranged by current supply at pin 5 such that

$$\Delta I_5 / \Delta t \quad \text{typ.} \quad 30 \mu\text{A}/\mu\text{s}$$

Oscillator

Threshold voltage low level

$$V_{14-16} \quad \text{typ.} \quad 4.4 \text{ V}$$

Threshold voltage high level

$$V_{14-16} \quad \text{typ.} \quad 7.6 \text{ V}$$

Discharge current

$$\pm I_{14} \quad \text{typ.} \quad 0.47 \text{ mA}$$

Frequency; free running ($C_{\text{osc}} = 4.7 \text{ nF}$;
 $R_{\text{osc}} = 12 \text{ k}\Omega$)

$$f_o \quad \text{typ.} \quad 15.625 \text{ kHz}$$

Spread of frequency

$$\Delta f_o / f_o < \pm 5 \%^*$$

Frequency control sensitivity

$$\Delta f_o / \Delta I_{15} \quad \text{typ.} \quad 31 \text{ Hz}/\mu\text{A}$$

Adjustment range of network in circuit (Fig. 1)

$$\Delta f_o / f_o \quad \text{typ.} \quad \pm 10 \%$$

Influence of supply voltage on frequency

$$\frac{\Delta f_o / f_o}{\Delta V / V_{\text{nom}}} < \pm 0.05 \%^*$$

Change of frequency when V_{1-16} drops to 5 V

$$\Delta f_o < \pm 10 \%^*$$

Temperature coefficient of oscillator
frequency

$$< \pm 10^{-4} \text{ Hz}/\text{K}^*$$

Phase comparison φ_1

Control voltage range

$$V_{13-16} \quad 3.8 \text{ to } 8.2 \text{ V}$$

Control current (peak value)

$$\pm I_{13M} \quad 1.9 \text{ to } 2.3 \text{ mA}$$

Output leakage current
at $V_{13-16} = 4 \text{ to } 8 \text{ V}$

$$I_{13} < 1 \mu\text{A}$$

Output resistance
at $V_{13-16} = 4 \text{ to } 8 \text{ V}$
at $V_{13-16} < 3.8 \text{ V}$ or $> 8.2 \text{ V}$

$$R_{13} \quad \text{high ohmic} \quad **$$

$$R_{13} \quad \text{low ohmic} \quad \blacktriangle$$

Control sensitivity

$$\text{typ.} \quad 2 \text{ kHz}/\mu\text{s}$$

Catching and holding range (82 k Ω between
pins 13 and 15)

$$\Delta f \quad \text{typ.} \quad \pm 780 \text{ Hz}$$

Spread of catching and holding range

$$\Delta(\Delta f) \quad \text{typ.} \quad \pm 10 \%^*$$

* Excluding external component tolerances.

** Current source.

▲ Emitter follower.

HORIZONTAL COMBINATION**TDA2593****Phase comparison φ_2 and phase shifter**

Control voltage range	V_{5-16}	5.4 to 7.6 V
Control current (peak value)	$\pm I_{5M}$	typ. 1 mA
Output resistance		high ohmic *
at $V_{5-16} = 5.4$ to 7.6 V		
at $V_{5-16} < 5.4$ V or > 7.6 V	R_5	typ. 8 k Ω
Input leakage current		
$V_{5-16} = 5.4$ to 7.6 V	I_5	$< 5 \mu\text{A}$
Permissible delay between leading edge of output pulse and leading edge of flyback pulse ($t_{fp} = 12 \mu\text{s}$)	t_d	$< 15 \mu\text{s}$
Static control error	$\Delta t/\Delta t_d$	$< 0.2 \%$

Coincidence detector φ_3

Output voltage	V_{11-16}	0.5 to 6 V
Output current (peak value)		
without coincidence	I_{11M}	typ. 0.1 mA
with coincidence	$-I_{11M}$	typ. 0.5 mA

Time constant switch

Output voltage	V_{12-16}	typ. 6 V
Output current (limited)	$\pm I_{12}$	< 1 mA
Output resistance		
at $V_{11-16} = 2.5$ to 7 V	R_{12}	typ. 0.1 k Ω
at $V_{11-16} < 1.5$ V or > 9 V	R_{12}	typ. 60 k Ω

Internal gating pulse

Pulse duration	t_p	typ. 7.5 μs
----------------	-------	------------------------

* Current source.

The TDA2594 is a monolithic integrated circuit intended for use in colour television receivers. The circuit incorporates the following functions:

- Horizontal oscillator based on the threshold switching principle.
- Phase comparison between sync pulse and oscillator voltage (φ_1).
- Internal key pulse for phase detector (φ_1) (additional noise limiting).
- Phase comparison between line flyback pulse and oscillator voltage (φ_2).
- Larger catching range obtained by coincidence detector (φ_3 ; between sync and key pulse).
- Switch for changing the filter characteristic and the gate circuit (VCR-operation).
- Sync separator.
- Noise separator.
- Vertical sync separator and output stage.
- Colour burst keying and line flyback blanking pulse generator and clamp circuit for vertical blanking.
- Phase shifter for the output pulse.
- Output pulse duration for transistor deflection systems.
- External switching off of the line trigger pulse.
- Output stage with separate supply voltage.
- Low supply voltage protection.
- Transmitter identification and muting circuit, and vertical sync switch-off.

QUICK REFERENCE DATA

Supply voltage	$V_{1-18} = V_S$	typ. 12 V
Supply current	I_1	typ. 30 mA
Input signals		
Sync separator input voltage (peak-to-peak value)	$V_{11-18(p-p)}$	typ. 3 V*
Noise separator input voltage (peak-to-peak value)	$V_{12-18(p-p)}$	typ. 3 V*
Pulse duration switch input voltage		
at $t = 14 \mu s + t_d$ (transistor driving)	V_{4-18}	0 to 3.5 V
at $t = 0$ ($V_{3-18} = 0$); input 4 open ($I_4 = 0$)	V_{4-18}	5.4 to 6.6 V
Output signals		
Vertical sync output pulse (peak-to-peak value)	$V_{8-18(p-p)}$	typ. 11 V
Burst key output pulse (peak-to-peak value)	$V_{7-18(p-p)}$	typ. 11 V
Line drive-pulse (peak-to-peak value)	$V_{3-18(p-p)}$	typ. 10 V

* Permissible range: 1 to 7 V.

PACKAGE OUTLINE

18-lead DIL; plastic (SOT-102DS).

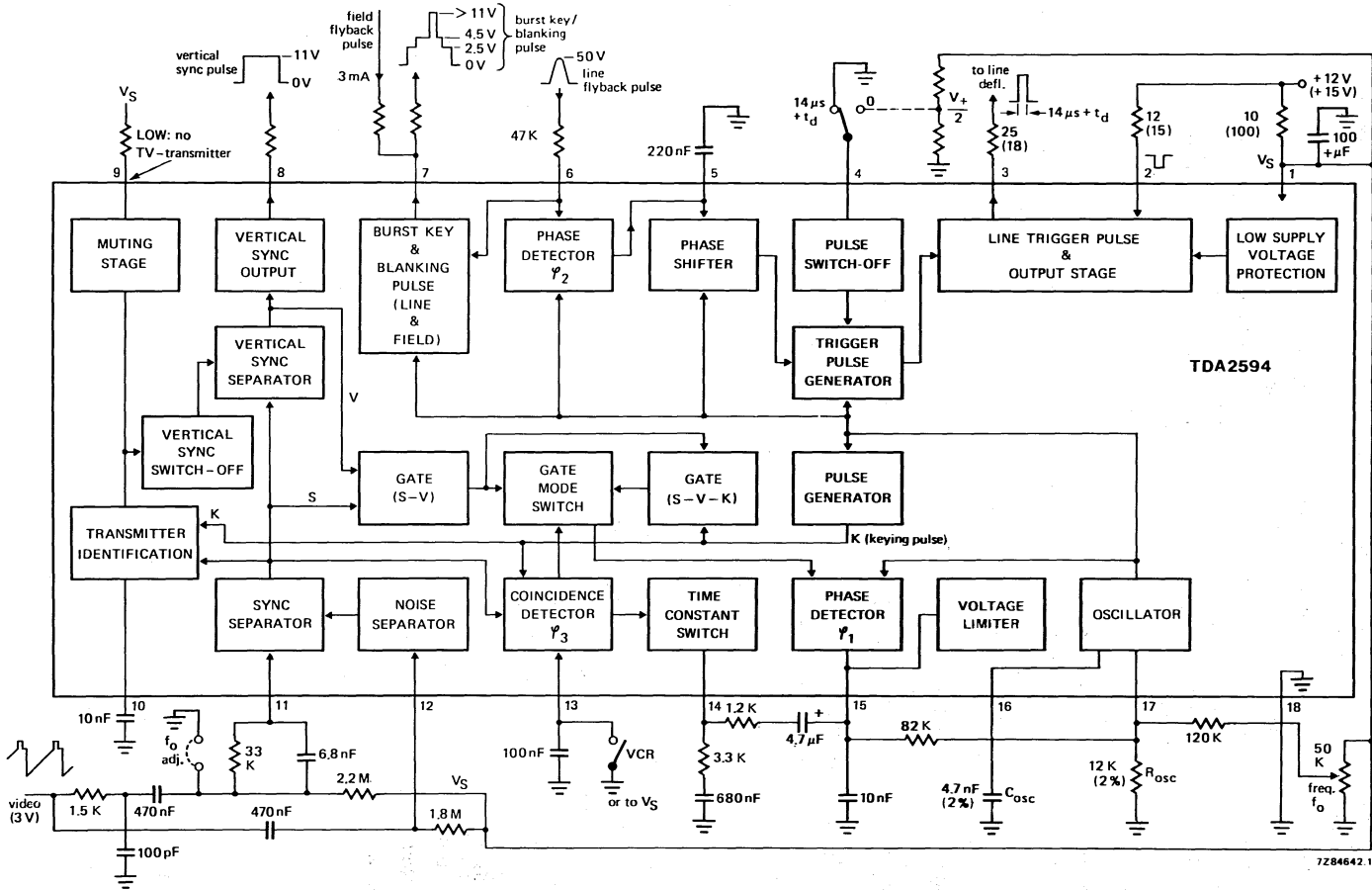

7284642.1

Fig. 1 Block diagram.

RATINGS

Limiting values in accordance with the Absolute Maximum System (IEC 134)

Supply voltage

at pin 1 (voltage source)	$V_{1-18} = V_S$	max.	13.2 V
at pin 2	V_{2-18}	max.	18 V

Voltages

Pin 4	V_{4-18}	max.	13.2 V
Pin 9	V_{9-18}	max.	18 V
	$-V_{9-18}$	max.	0.5 V
Pin 11	$\pm V_{11-18}$	max.	6 V
Pin 12	$\pm V_{12-18}$	max.	6 V
Pin 13	V_{13-18}	max.	13.2 V

Currents

Pins 2 and 3 (transistor driving) (peak value)	$I_{2M}, -I_{3M}$	max.	400 mA
Pin 4	I_4	max.	1 mA
Pin 6	$\pm I_6$	max.	10 mA
Pin 7	$-I_7$	max.	5 mA
Pin 9	I_9	max.	10 mA
Pin 13	I_{13}	max.	2 mA
Total power dissipation	P_{tot}	max.	800 mW
Storage temperature range	T_{stg}		-25 to +125 °C
Operating ambient temperature range	T_{amb}		-20 to +70 °C

CHARACTERISTICS at $V_{1-18} = 12 V$; $T_{amb} = 25 °C$; measured in Fig. 1

Sync separator (pin 11)

Input switching voltage	V_{11-18}	typ.	0.8 V
Input keying current	I_{11}		5 to 100 μA
Input leakage current at $V_{11-18} = -5 V$	I_{11}	\leq	1 μA
Input switching current	I_{11}	\leq	5 μA
Switch off current	I_{11}	\geq	100 μA
		typ.	150 μA
Input signal (peak-to-peak value)	$V_{11-18(p-p)}$		3 to 4 V*

* Permissible range 1 to 7 V.



HORIZONTAL COMBINATION

TDA2594

Noise separator (pin 12)

Input switching voltage	V_{12-18}	typ.	1.4 V
Input keying current	I_{12}		5 to 100 μA
Input switching current	I_{12}	\geq typ.	100 μA 150 μA
Input leakage current at $V_{12-18} = -5\text{ V}$	I_{12}	\leq	1 μA
Input signal (peak-to-peak value)	$V_{12-18(p-p)}$		3 to 4 V*
Permissible superimposed noise signal (peak-to-peak value)	$V_{12-18(p-p)}$	\leq	7 V

Line flyback pulse (pin 6)

Input current	I_6	\geq typ.	0.02 mA 1 mA
Input switching voltage	V_{6-18}	typ.	1.4 V
Input limiting voltage	V_{6-18}		-0.7 to +1.4 V

Switching on VCR (pin 13)

Input voltage	V_{13-18} or: V_{13-18}		0 to 2.5 V 9 to V_S V
Input current	$-I_{13}$ or: I_{13}	\leq \leq	200 μA 2 mA

Pulse switching off (pin 4)For $t = 0$; input pin 4 open or $V_{3-18} = 0$

Input voltage	V_{4-18}		5.4 to 6.6 V
Input current	I_4	typ.	0 μA

Vertical sync pulse (positive-going) (pin 8)

Output voltage (peak-to-peak value)	$V_{8-18(p-p)}$	\geq typ.	10 V 11 V
Output resistance	R_8	typ.	2 k Ω
Delay between leading edge of input and output signal	t_{on}	typ.	15 μs
Delay between trailing edge of input and output signal	t_{off}	\geq	t_{on} μs
Switching off the vertical sync pulse	V_{10-18}	\leq	3 V

Burst key pulse (positive-going) (pin 7)

Output voltage	V_{7-18}	\geq typ.	10 V 11 V
Output resistance	R_7	typ.	70 Ω
Pulse duration; $V_{7-18} = 7\text{ V}$	t_p	typ.	4 μs 3.7 to 4.3 μs
Phase relation between middle of sync pulse at the input and the leading edge of the burst key pulse; $V_{7-18} = 7\text{ V}$	t	typ.	2.65 μs 2.15 to 3.15 μs
Output trailing edge current	I_7	typ.	2 mA
Saturation voltage during line scan	V_{7-18}	\leq	1 V

* Permissible range 1 to 7 V.

HORIZONTAL COMBINATION

TDA2594

Line flyback-blanking pulse (positive-going) (pin 7)

Output voltage	V_{7-18}		4.1 to 4.9 V
Output resistance	R_7	typ.	70 Ω
Output trailing edge current	I_7	typ.	2 mA

Field flyback/blanking pulse (pin 7)

Output voltage with externally forced in current $I_7 = 2.4$ to 3.6 mA	V_{7-18}		2 to 3 V
Output resistance at $I_7 = 3$ mA	R_7	typ.	70 Ω

TV-transmitter identification output (pin 9; open collector)

Output voltage at $I_9 = 3$ mA; no TV-transmitter	V_{9-18}	\leq	0.5 V
Output resistance at $I_9 = 3$ mA; no TV-transmitter	R_9	\leq	100 Ω
Output current at $V_{10-18} \geq 3$ V; TV-transmitter identified	I_9	\leq	5 μ A

TV-transmitter identification (pin 10)

When receiving a TV signal the voltage V_{10-18} will change from ≤ 1 V to ≥ 7 V.

Line drive pulse (positive-going)

Output voltage (peak-to-peak value)	$V_{3-18(p-p)}$	typ.	10 V
Output resistance			
for leading edge of line pulse	R_3	typ.	2.5 Ω
for trailing edge of line pulse	R_3	typ.	20 Ω
Pulse duration (transistor driving) $V_{4-18} = 0$ to 3.5 V; $-I_4 \geq 200$ μ A; $t_{fp} = 12$ μ s	t_p		$14 + t_d$ μ s*
Supply voltage for switching off the output pulse	V_{1-18}	typ.	4 V

Overall phase relation

Phase relation between middle of sync pulse and the middle of the flyback pulse	Δt	typ.	2.6 ± 0.7 μ s**
--	------------	------	-------------------------

The adjustment of the overall phase relation and consequently the leading edge of the line drive pulse occurs automatically by phase control φ_2 .

If additional adjustment is applied it can be arranged by current supply at pin 5, such that:

Supplying current	$\Delta I / \Delta t$	typ.	30 μ A/ μ s
-------------------	-----------------------	------	---------------------

* t_d = switch-off delay of line output stage.

** Line flyback pulse duration $t_{fp} = 12$ μ s.

HORIZONTAL COMBINATION

TDA2594

Oscillator (pins 16 and 17)

Threshold voltage low level	V_{16-18}	typ.	4.4 V
Threshold voltage high level	V_{16-18}	typ.	7.6 V
Charging current	$\pm I_{16}$	typ.	0.47 mA
Frequency; free running ($C_{OSC} = 4.7$ nF; $R_{OSC} = 12$ k Ω)	f_o	typ.	15.625 kHz
Spread of frequency	Δf_o	\leq	± 5 % [▲]
Frequency control sensitivity	$\Delta f_o / \Delta 17$	typ.	31 Hz/ μ A
Adjustment range of network in circuit (Fig. 1)	Δf_o	typ.	± 10 %
Influence of supply voltage on frequency; reference at $V_S = 12$ V	$\frac{\Delta f_o / f_o}{\Delta V / V_{nom}}$	\leq	± 0.05 % [▲]
Change of frequency when V_S drops to 5 V; reference at $V_S = 12$ V	Δf_o	\leq	± 10 % [▲]
Temperature coefficient of oscillator frequency	TC	\leq	$\pm 10^{-4}$ K ⁻¹ [▲]

Phase comparison φ_1 (pin 15)

Control voltage range	V_{15-18}	4.1 to 7.9 V
Control current (peak value)	$\pm I_{15M}$	1.8 to 2.2 mA
Output leakage current at $V_{15-18} = 4.3$ to 7.7 V	I_{15}	\leq 1 μ A
Output resistance at $V_{15-18} = 4.3$ to 7.7 V	R_{13}	high ohmic *
at $V_{15-18} \leq 4.1$ V or ≥ 7.9 V	R_{13}	low ohmic **
Control sensitivity		typ. 2 kHz/ μ s
Catching and holding range (82 k Ω between pins 15 and 17)	Δf	typ. ± 680 Hz
Spread of catching and holding range	$\Delta(\Delta f)$	typ. ± 12 % [▲]

Phase comparison φ_2 and phase shifter (pin 5)

Control voltage range	V_{5-18}	5.4 to 7.6 V
Control current (peak value)	$\pm I_{5M}$	typ. 1 mA
Output resistance at $V_{5-18} = 5.4$ to 7.6 V	R_5	high ohmic *
Input leakage current at $V_{5-18} = 5.4$ to 7.6 V	I_5	\leq 5 μ A
Permissible delay between leading edge of output pulse and leading edge of flyback pulse ($t_{fp} = 12$ μ s)	t_d	\leq 15.5 μ s
Static control error	$\Delta t / \Delta t_d$	\leq 0.2 %

Coincidence detector φ_3 (pin 13)

Output voltage	V_{13-18}	0.5 to 6 V
Output current (peak value) without coincidence	I_{13M}	typ. 0.1 mA
with coincidence	$-I_{13M}$	typ. 0.5 mA

* Current source.

** Emitter follower.

▲ Excluding external component tolerances.

HORIZONTAL COMBINATION**TDA2594****Time constant switch (pin 14)**

Output voltage	V_{14-18}	typ.	6 V
Output current (limited)	$\pm I_{14}$	typ.	1 mA
Output resistance			
at $V_{13-18} = 3.5$ to 7 V	R_{14}	typ.	0.1 k Ω
at $V_{13-18} \leq 2.5$ V or ≥ 9 V	R_{14}	typ.	60 k Ω

Internal keying pulse

Pulse duration	t_p	typ.	7.5 μ s
----------------	-------	------	-------------

GENERAL DESCRIPTION

The TDA2595 is a monolithic integrated circuit intended for use in colour television receivers. The circuit incorporates the following functions:

- Positive video input; capacitively coupled (source impedance $< 200 \Omega$)
- Adaptive sync separator; slicing level at 50% of sync amplitude
- Internal vertical pulse separator with double slope integrator
- Output stage for vertical sync pulse or composite sync depending on the load; both are switched off at muting
- φ_1 phase control between horizontal sync and oscillator
- Coincidence detector φ_3 for automatic time-constant switching; overruled by the VCR switch
- Time-constant switch between two external time-constants or loop-gain; both controlled by the coincidence detector φ_3
- φ_1 gating pulse controlled by coincidence detector φ_3
- Mute circuit depending on TV transmitter identification
- φ_2 phase control between line flyback and oscillator; the slicing levels for φ_2 control and horizontal blanking can be set separately
- Burst keying and horizontal blanking pulse generation, in combination with clamping of the vertical blanking pulse (three-level sandcastle)
- Horizontal drive output with constant duty cycle inhibited by the protection circuit or the supply voltage sensor
- Detector for too low supply voltage
- Protection circuit for switching off the horizontal drive output continuously if the input voltage is below 4 V or higher than 8 V
- Line flyback control causing the horizontal blanking level at the sandcastle output continuously in case of a missing flyback pulse
- Spot-suppressor controlled by the line flyback control

QUICK REFERENCE DATA

Supply voltage (pin 15)	$V_{15-5} = V_P$	typ.	12 V
Sync pulse amplitude (positive video)	$V_{i(p-p)}$	min.	50 mV
Horizontal output current	I_4	max.	30 mA

PACKAGE OUTLINE

18-lead DIL; plastic (SOT-102CS).

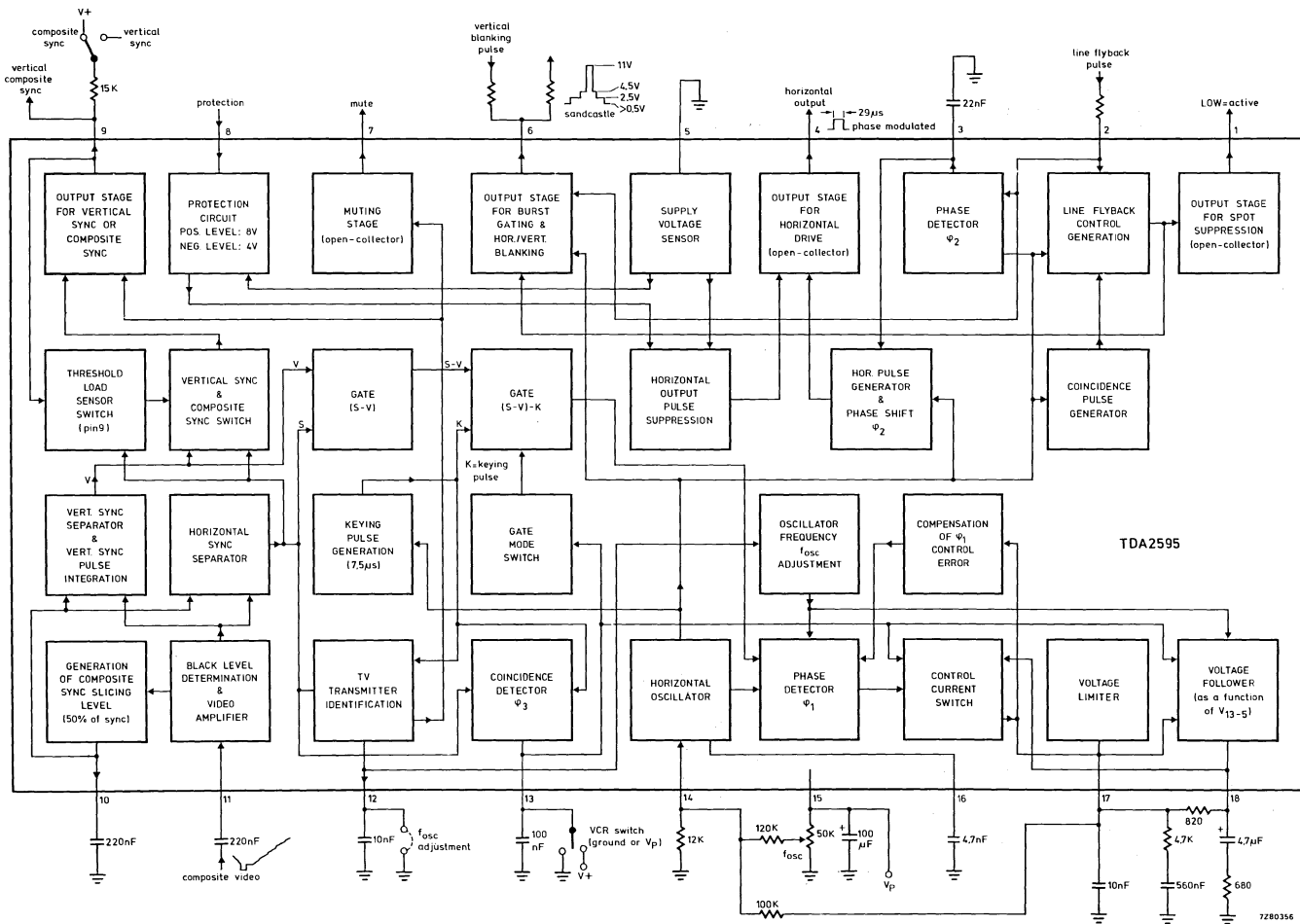

Fig. 1 Block diagram.

Signetics



RATINGS

Limiting values in accordance with the Absolute Maximum System (IEC 134)

Supply voltage (pin 15)	$V_{15-5} = V_P$	max.	13.2 V
Voltages at:			
pins 1, 4 and 7	$V_{1;4;7-5}$	max.	18 V
pins 8, 13 and 18	$V_{8;13;18-5}$	max.	V_P V
pin 11 (range)	V_{11-5}		-0.5 to + 6 V
Currents at:			
pin 1	I_1	max.	10 mA
pin 2 (peak value)	$\pm I_{2M}$	max.	10 mA
pin 4	I_4	max.	100 mA
pin 6 (peak value)	$\pm I_{6M}$	max.	6 mA
pin 7	I_7	max.	10 mA
pin 8 (range)	I_8		-5 to + 1 mA
pin 9 (range)	I_9		-10 to + 3 mA
pin 18	$\pm I_{18}$	max.	10 mA
Total power dissipation	P_{tot}	max.	800 mW
Storage temperature range	T_{stg}		-25 to + 125 °C
Operating ambient temperature range	T_{amb}		-20 to + 70 °C

CHARACTERISTICS

$V_p = 12\text{ V}$; $T_{amb} = 25\text{ }^\circ\text{C}$; measured in Fig. 1; unless otherwise specified

parameter	symbol	min.	typ.	max.	unit
Composite video input and sync separator (pin 11) (internal black level determination)					
Input signal (positive video; standard signal; peak-to-peak value)	$V_{11-5(p-p)}$	0.2	1	3	V
Sync pulse amplitude (independent of video content)	$V_{11-5(p-p)}$	50	—	—	mV
Generator resistance	R_G	—	—	200	Ω
Input current during:					
video	I_{11}	—	5	—	μA
sync pulse	$-I_{11}$	—	40	—	μA
black level	$-I_{11}$	—	30	—	μA
Composite sync generation (pin 10) horizontal slicing level at 50% of the sync pulse amplitude					
Capacitor current during:					
video	I_{10}	—	12	—	μA
sync pulse	$-I_{10}$	—	170	—	μA
Vertical sync pulse generation slicing level at 25% (50% between black level and horizontal slicing level); pin 9					
Output voltage	V_{9-5}	10	—	—	V
Pulse duration	t_p	—	190	—	μs
Delay with respect to the vertical sync pulse (leading edge)	t_d	—	45	—	μs
Pulse-mode control					
output current for vertical sync pulse (dual integrated)		no current applied at pin 9			
output current for horizontal and vertical sync pulse (non-integrated separated signal)		current applied via a resistor of 15 k Ω from V_p to pin 9			

HORIZONTAL COMBINATION

TDA2595

parameter	symbol	min.	typ.	max.	unit
Horizontal oscillator (pins 14 and 16)					
Frequency; free running	f_{osc}	—	15 625	—	Hz
Reference voltage for f_{osc}	V_{14-5}	—	6	—	V
Frequency control sensitivity	$\Delta f_{osc}/\Delta I_{14}$	—	31	—	Hz/ μA
Adjustment range of circuit Fig. 1	Δf_{osc}	—	± 10	—	%
Spread of frequency	Δf_{osc}	—	—	5	%
Frequency dependency (excluding tolerance of external components) with supply voltage ($V_P = 12 V$)	$\frac{\Delta f_{osc}/f_{osc}}{\Delta V_{15-5}/V_{15-5}}$	—	± 0.05	—	
with supply voltage drop of 5 V	Δf_{osc}	—	—	10	%
with temperature	TC	—	—	$\pm 10^{-4}$	K ⁻¹
Capacitor current during: charging	$-I_{16}$	—	1024	—	μA
discharging	I_{16}	—	313	—	μA
Sawtooth voltage timing (pin 14) rise time	t_r	—	49	—	μs
fall time	t_f	—	15	—	μs
Horizontal output pulse (pin 4)					
Output voltage LOW at $I_4 = 30 mA$	V_{4-5}	—	—	0.5	V
Pulse duration (HIGH)	t_p	—	29 ± 1.5	—	μs
Supply voltage for switching off the output pulse (pin 15)	V_P	—	4	—	V

CHARACTERISTICS (continued)

parameter	symbol	min.	typ.	max.	unit
Phase comparison φ_1 (pin 17)					
Control voltage range	V_{17-5}	3.55	—	8.3	V
Leakage current at $V_{17-5} = 3.55$ to 8.3 V	I_{17}	—	—	1	μ A
Control current for external time-constant switch	$\pm I_{17}$	1.8	2	2.2	mA
Control current at $V_{18-5} = V_{15-5}$ and $V_{13-5} < 2$ V or $V_{13-5} > 9.5$ V	$\pm I_{17}$	—	8	—	mA
Control current at $V_{18-5} = V_{15-5}$ and $V_{13-5} = 2$ to 9.5 V	$\pm I_{17}$	1.8	2	2.2	mA
Horizontal oscillator control					
control sensitivity	S_φ	6	—	—	kHz/ μ s
catching and holding range	Δf_{osc}	—	± 680	—	Hz
spread of catching and holding range	Δf_{osc}	—	± 10	—	%
Internal keying pulse at $V_{13-5} = 2.9$ to 9.5 V	t_p	—	7.5	—	μ s
Time-constant switch					
slow time-constant at	V_{13-5}	9.5	—	2	V
fast time-constant at	V_{13-5}	2	—	9.5	V
Impedance converter offset voltage (slow time-constant)	$\pm V_{17-18}$	—	—	3	mV
Output resistance					
slow time-constant	R_{18-5}	—	—	10	Ω
fast time-constant	R_{18-5}	high impedance			
Leakage current	I_{18}	—	—	1	μ A

parameter	symbol	min.	typ.	max.	unit
Coincidence detector φ_3 (pin 13)					
Output voltage					
without coincidence with composite video signal	V_{13-5}	—	—	1	V
without coincidence without composite video signal (noise)	V_{13-5}	—	—	2	V
with coincidence with composite video signal	V_{13-5}	—	6	—	V
Output current					
without coincidence with composite video signal	I_{13}	—	50	—	μA
with coincidence with composite video signal	$-I_{13}$	—	300	—	μA
Switching current					
at $V_{13-5} = V_P - 0.5 \text{ V}$	I_{13}	—	—	100	μA
at $V_{13-5} = 0.5 \text{ V}$ (average value)	$I_{13(av)}$	—	—	100	μA
Phase comparison φ_2 (pins 2 and 3) (see note 1)					
Input for line flyback pulse (pin 2)					
Switching level for φ_2 comparison	V_{2-5}	—	3	—	V
Switching level for horizontal blanking and flyback control	V_{2-5}	—	3	—	V
Input voltage limiting	V_{2-5} or:	—	-0.7 +4.5	—	V V
Switching current					
at horizontal flyback	I_2	0.01	1	—	mA
at horizontal scan	I_2	—	—	2	μA
Phase detector output (pin 3)					
Control current for φ_2	$\pm I_3$	—	1	—	mA
Control range	Δt_{φ_2}	—	19	—	μs
Static control error	$\Delta t / \Delta t_d$	—	—	0.2	%
Leakage current	I_3	—	—	5	μA

CHARACTERISTICS (continued)

parameter	symbol	min.	typ.	max.	unit
Phase comparison φ_2 (pins 2 and 3) (continued)					
Phase relation between middle of the horizontal sync pulse and the middle of the line flyback pulse at $t_{fp} = 12 \mu s$ (note 2)	Δt	—	2.6 ± 0.7	—	μs
If additional adjustment is required, it can be arranged by applying a current at pin 3, such that for applied current:	$\Delta I / \Delta t$	—	30	—	$\mu A / \mu s$
Burst gating pulse (pin 6; note 3)					
Output voltage	V_{6-5}	10	11	—	V
Pulse duration	t_p	3.7	4	4.3	μs
Phase relation between middle of sync pulse at the input and the leading edge of the burst gating pulse at $V_{6-5} = 7 V$	$t_{\varphi 6}$	2.15	2.65	3.15	μs
Output trailing edge current	I_6	—	2	—	mA
Horizontal blanking pulse (pin 6) (note 3)					
Output voltage	V_{6-5}	4.2	4.5	4.9	V
Output trailing edge current	I_6	—	2	—	mA
Saturation voltage at horizontal scan	V_{6-5sat}	—	—	0.5	V
Clamping circuit for vertical blanking pulse (pin 6; note 3)					
Output voltage at $I_6 = 2.8 mA$	V_{6-5}	2.15	2.5	3	V
Minimum output current at $V_{6-5} > 2.15 V$	I_{6min}	—	2.3	—	mA
Maximum output current at $V_{6-5} < 3 V$	I_{6max}	—	3.3	—	mA
TV-transmitter identification (pin 12)					
Output voltage no TV transmitter	V_{12-5}	—	—	1	V
TV transmitter identified	V_{12-5}	7	—	—	V

HORIZONTAL COMBINATION

TDA2595

parameter	symbol	min.	typ.	max.	unit
Mute output (pin 7)					
Output voltage at $I_7 = 3$ mA no TV transmitter	V ₇₋₅	—	—	0.5	V
Output resistance at $I_7 = 3$ mA no TV transmitter	R ₇₋₅	—	—	100	Ω
Output leakage current at $V_{12-5} > 3$ V TV transmitter identified	I_7	—	—	5	μ A
Protection circuit (beam-current/ EHT voltage protection) (pin 8)					
No-load voltage for $I_8 = 0$ (operative condition)	V ₈₋₅	—	6	—	V
Threshold at positive-going voltage	V ₈₋₅	—	8 ± 0.8	—	V
Threshold at negative-going voltage	V ₈₋₅	—	4 ± 0.4	—	V
Current limiting for $V_{8-5} = 1$ to 8.5 V	$\pm I_8$	—	60	—	μ A
Input resistance for $V_{8-5} > 8.5$ V	R ₈₋₅	—	3	—	k Ω
Response delay of threshold switch	t_d	—	10	—	μ s
Control output of line flyback pulse control (pin 1)					
Saturation voltage at standard operation; $I_1 = 3$ mA	V _{1-5sat}	—	—	0.5	V
Output leakage current in case of break in transmission	I_1	—	—	5	μ A

Notes to the characteristics

1. Phase comparison between horizontal oscillator and the line flyback pulse. Generation of a phase modulated (φ_2) horizontal output pulse with constant duration.
2. t_{fp} is the line flyback pulse duration.
3. Three-level sandcastle pulse.

VERTICAL DEFLECTION**TDA2653A**

The TDA2653A is a monolithic integrated circuit for vertical deflection in large screen colour television receivers, e.g. 30AX and PIL-S4 systems.

The circuit incorporates the following functions:

- Oscillator; switch capability for 50 Hz/60 Hz operation.
- Synchronization circuit.
- Blanking pulse generator with guard circuit.
- Sawtooth generator with buffer stage.
- Preamplicifier with fed-out inputs.
- Output stage with thermal and short-circuit protection.
- Flyback generator.
- Voltage stabilizer.

QUICK REFERENCE DATA

For 30AX system

Supply voltage (pin 9)	$V_{9-8} = V_S$	typ.	26 V
Supply current (pin 5 + pin 9)	$I_5 + I_9 = I_S$	typ.	325 mA
Output current (peak-to-peak value)	$I_6(p-p)$	typ.	2.2 A
Picture frequency	f		50 Hz/60 Hz
Sync input pulse (peak-to-peak value)	$V_{2-8}(p-p)$	\geq	1 V
Thermal resistance from junction to mounting base	$R_{th j-mb}$	\leq	5 K/W

8

PACKAGE OUTLINE

13-lead DIL; plastic power (SOT-141B).

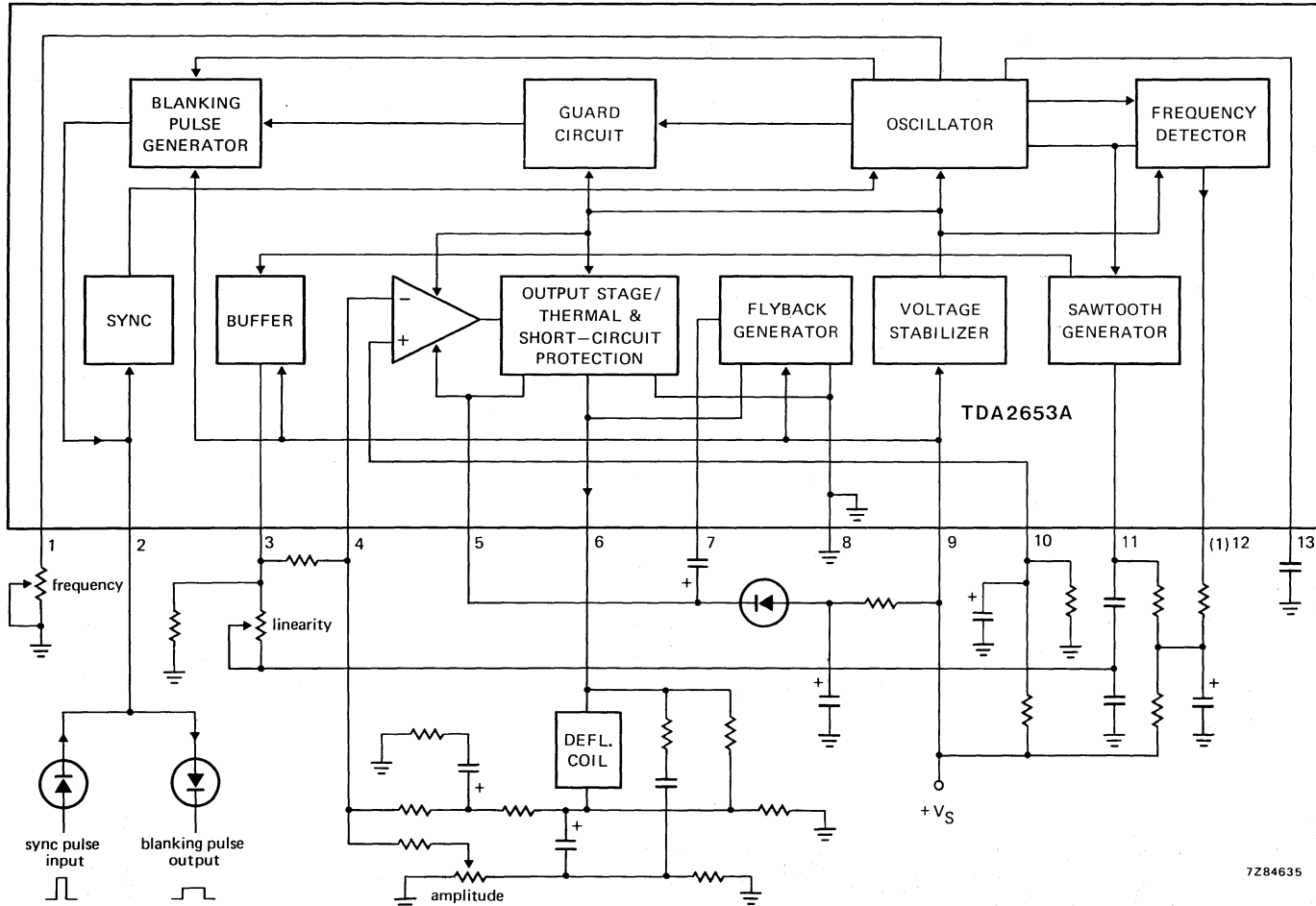

7284635

Fig. 1 Block diagram.

(1) Condition for pin 12: LOW voltage level = 50 Hz; HIGH voltage level = 60 Hz.

RATINGS

Limiting values in accordance with the Absolute Maximum System (IEC 134)

Supply voltage (pin 9)	$V_{9-8} = V_S$	max.	40 V
Supply voltage output stage (pin 5)	V_{5-8}	max.	58 V
Voltages			
Pin 3	V_{3-11}	max.	7 V
Pin 13	V_{13-8}	max.	7 V
Pins 4 and 10	$V_{4;10-8}$	max.	24 V
Pin 6	V_{6-8}	max.	58 V
	$-V_{6-8}$	max.	0 V
Pins 7 and 11	$V_{7;11-8}$	max.	40 V
Currents			
Pin 1	I_1	max.	0 mA
	$-I_1$	max.	1 mA
Pin 2	$\pm I_2$	max.	10 mA
Pin 3	I_3	max.	0 mA
	$-I_3$	max.	5 mA
Pin 7	I_7	max.	1.2 A
	$-I_7$	max.	1.5 A
Pin 11	I_{11}	max.	50 mA
	$-I_{11}$	max.	1 mA
Pin 12	I_{12}	max.	3 mA
	$-I_{12}$	max.	0 mA

Pins 5, 6 and 8: internally limited by the short-circuit protection circuit.

Total power dissipation: internally limited by the thermal protection circuit.

Storage temperature range	T_{stg}	-25 to +150 °C
Operating ambient temperature range	T_{amb}	-20 °C to limiting value

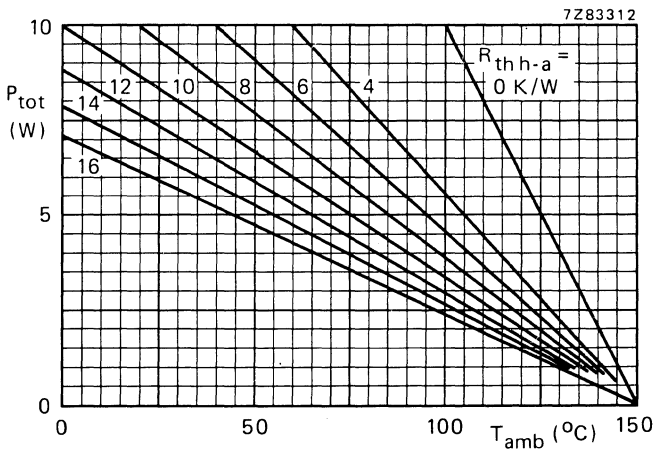

Fig. 2 Total power dissipation. $R_{th\ h-a}$ includes $R_{th\ mb-h}$ which is expected when heat-sink compound is used. $R_{th\ j-mb} \leq 5\ K/W$.

VERTICAL DEFLECTION

TDA2653A

CHARACTERISTICS

 $T_{amb} = 25\text{ }^{\circ}\text{C}$ unless otherwise specified.

Supply voltage/output stage

Supply voltage	$V_{9-8} = V_S$		9 to 30 V
Output voltage		\geq	$V_{5-8} - 2.2\text{ V}$
at $-I_6 = 1.1\text{ A}$	V_{6-8}	typ.	$V_{5-8} - 1.9\text{ V}$
at $I_6 = 1.1\text{ A}$	V_{6-8}	typ.	1.3 V
		\leq	1.6 V
Flyback generator output voltage at $-I_6 = 1.1\text{ A}$	V_{7-8}	typ.	$V_S - 2.2\text{ V}$
Peak output current	$\pm I_6$	\leq	1.2 A
Flyback generator peak current	$\pm I_7$	\leq	1.2 A

Feedback

Input quiescent current	$-I_4; I_0$	typ.	0.1 μA
-------------------------	-------------	------	-------------------

Synchronization

Sync input pulse	V_{2-8}		1 to 12 V
Tracking range		typ.	28 %

Oscillator/sawtooth generator

Oscillator frequency control input voltage	V_{1-8}		6 to 9 V
Sawtooth generator output voltage	V_{3-8}		0 to $V_S - 1\text{ V}$
	V_{11-8}		0 to $V_S - 2\text{ V}$
Sawtooth generator output current	$-I_3$		0 to 4 mA
	I_{11}	\geq	-2 μA
		\leq	+30 mA
Oscillator temperature dependency			
$T_{case} = 20\text{ to }100\text{ }^{\circ}\text{C}$	$(\Delta f/f)/\Delta T_{case}$	typ.	10^{-4} K^{-1}
Oscillator voltage dependency			
$V_S = 10\text{ to }30\text{ V}$	$(\Delta f/f)/\Delta V_S$	typ.	$4 \times 10^{-4}\text{ V}^{-1}$

Blanking pulse generator

Output voltage			
at $V_S = 24\text{ V}; I_2 = 1\text{ mA}$	V_{2-8}	typ.	18.5 V
Output current	$-I_2$	\leq	3 mA
Output resistance	R_{2-8}	typ.	410 Ω
Blanking pulse duration at 50 Hz sync	t_b	typ.	$1.4 \pm 0.07\text{ ms}$

50 Hz/60 Hz switch capability

Saturation voltage; LOW voltage level	V_{12-8}	typ.	1 V
Output leakage current	I_{12}	typ.	1 μA

Thermal resistance/junction temperature

From junction to mounting base	$R_{th\ j-mb}$	\leq	5 K/W
Junction temperature; switching point thermal protection	T_j	typ.	$150 \pm 8\ ^\circ\text{C}$

PINNING

- | | |
|--|------------------------------------|
| 1. Oscillator adjustment | 8. Ground |
| 2. Synchronization input/blanking output | 9. Positive supply (V_G) |
| 3. Sawtooth generator output | 10. Reference voltage |
| 4. Preamplifier input | 11. Sawtooth capacitor |
| 5. Positive supply of output stage | 12. 50 Hz/ 60 Hz switching voltage |
| 6. Output | 13. Oscillator capacitor |
| 7. Flyback generator output | |

APPLICATION INFORMATION

The function is described against the corresponding pin number

- 1, 13. Oscillator
The oscillator frequency is determined by a potentiometer at pin 1 and a capacitor at pin 13.
2. Sync input/blanking output
Combination of sync input and blanking output. The oscillator has to be synchronized by a positive-going pulse between 1 and 12 V. The integrated frequency detector delivers a switching level at pin 12.
The blanking pulse amplitude is 20 V with a load of 1 mA.
3. Sawtooth generator output
The sawtooth signal is fed via a buffer stage to pin 3. It delivers the signal which is used for linearity control, and drive of the preamplifier. The sawtooth is applied via a shaping network to pin 11 (linearity) and via a resistor to pin 4 (preamplifier).
4. Preamplifier input
The d.c. voltage is proportional to the output voltage (d.c. feedback). The a.c. voltage is proportional to the sum of the buffered sawtooth voltage at pin 3 and the voltage, with opposite polarity, at the feedback resistor (a.c. feedback).
5. Positive supply of output stage
This supply is obtained from the flyback generator. An electrolytic capacitor between pins 7 and 5, and a diode between pins 5 and 9 have to be connected for proper operation of the flyback generator.
6. Output of class-B power stage
The vertical deflection coil is connected to this pin, via a series connection of a coupling capacitor and a feedback resistor, to ground.
7. Flyback generator output
An electrolytic capacitor has to be connected between pins 7 and 5 to complete the flyback generator.
8. Negative supply (ground)
Negative supply of output stage and small signal part.
9. Positive supply
The supply voltage at this pin is used to supply the flyback generator, voltage stabilizer, blanking pulse generator and buffer stage.

VERTICAL DEFLECTION

TDA2653A

APPLICATION INFORMATION (continued)

10. Reference voltage of preamplifier

External adjustment and decoupling of reference voltage of the preamplifier.

11. Sawtooth capacitor

This sawtooth capacitor has been split to realize linearity control.

12. 50 Hz/60 Hz switching level

This pin delivers a LOW voltage level for 50 Hz and a HIGH voltage level for 60 Hz. The amplitudes of the sawtooth signals can be made equal for 50 Hz and 60 Hz with these levels.

The following application data are measured in Figs 3 and 4.

			30AX system (26 V) Fig. 3	30AX system (26 V/12 V) Fig. 4	PIL-S4 system Fig. 3
System supply voltages	V_{S1}	typ.	26	26	26 V
	V_{S2}	typ.	—	12	— V
System supply currents	I_{S1}	typ.	315	330	195 mA
	I_{S2}	typ.	—	—35	— mA
Output voltage	V_{6-8}	typ.	14	14.6	13.5 V
Output voltage (peak value)	V_{6-8}	typ.	42	42	49 V
Deflection current (peak-to-peak value)	$I_6(p-p)$	typ.	2.2	2.2	1.32 A
Flyback time	t_{fl}	typ.	1	0.9	1.1 ms
Total power dissipation per package	P_{tot}	typ.	4.1	4	3 W
		max.	4.8	4.8	3.4 W*
Oscillator frequency unsynchronized	f	typ.	46.5	46.5	46.5 Hz

* Calculated with $\Delta V_S = +5\%$ and $\Delta R_{yoke} = -7\%$.

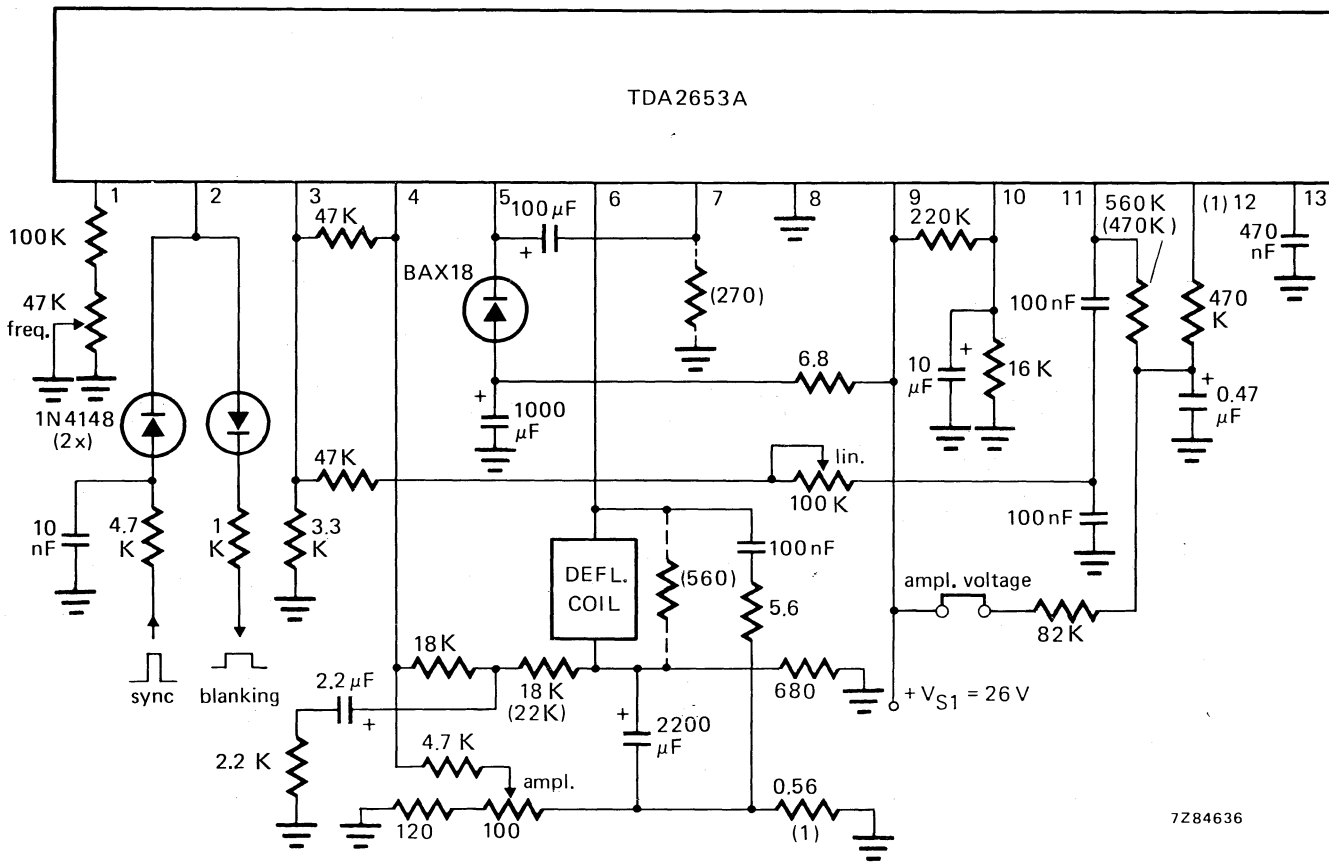

7284636

(1) Condition for pin 12: LOW voltage level = 50 Hz; HIGH voltage level = 60 Hz.

Fig. 3 Typical vertical deflection circuit for 30AX system (26 V). The values given in parentheses and the dotted components are valid for the PIL-S4 system.

Signetics



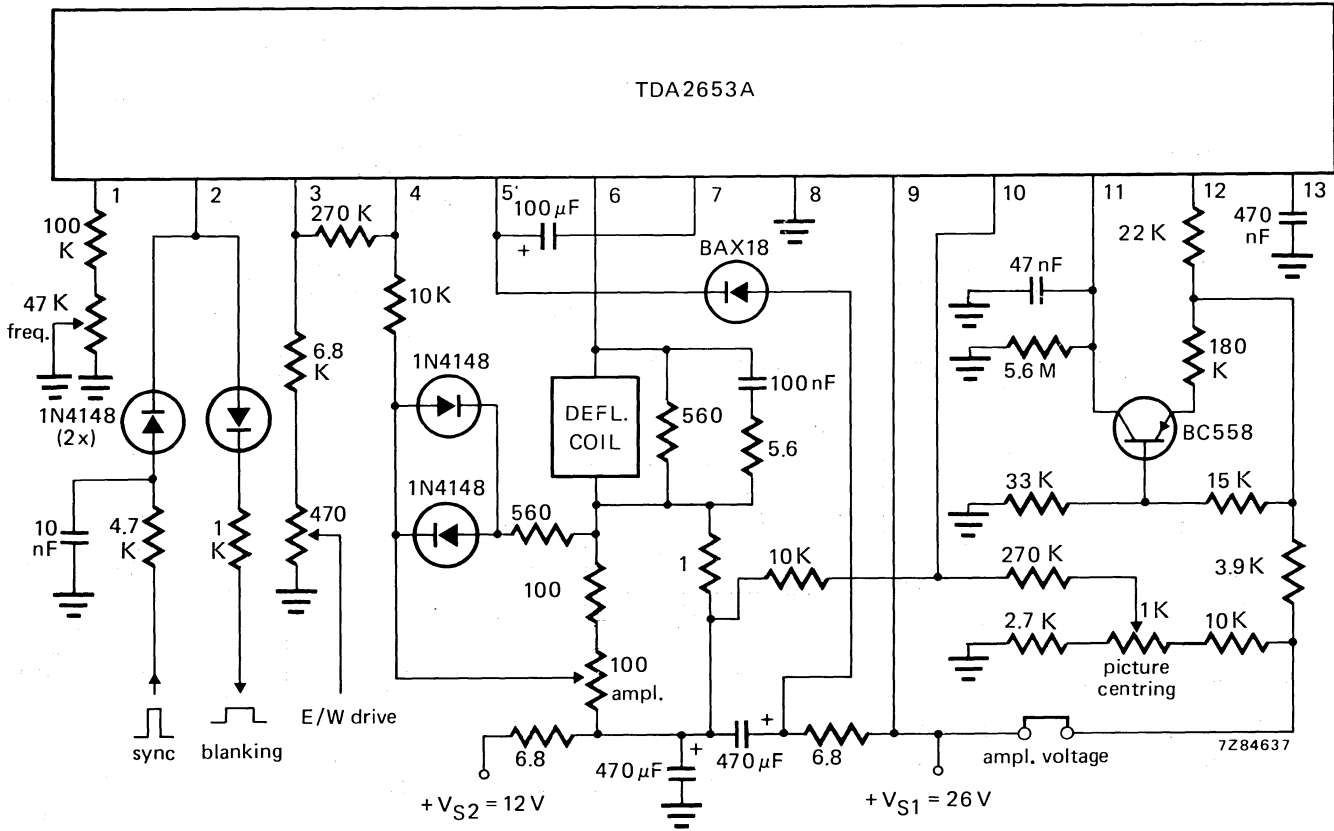

(1) Condition for pin 12: LOW voltage level = 50 Hz; HIGH voltage level = 60 Hz.

Fig. 4 Typical vertical deflection circuit for 30AX system ($V_{S1} = 26\text{ V}$, $V_{S2} = 12\text{ V}$) in quasi-bridge connection.

The TDA3540 and TDA3541 are i.f. amplifier and demodulator circuits for colour and black and white television receivers, using n-p-n tuners for the TDA3540 and p-n-p tuners for the TDA3541.

They incorporate the following functions:

- gain-controlled wide-band amplifier, providing complete i.f. gain
- synchronous demodulator with excellent intermodulation
- white spot inverter
- video preamplifier with noise protection
- a.f.c. circuit with a.f.c. on/off switch
- a.g.c. circuit with noise gating
- tuner a.g.c. output (n-p-n tuners: **TDA3540**; p-n-p tuners: **TDA3541**)
- external video switch which switches off the video output; e.g. for insertion of a VCR playback signal, by either a high or a low level.

QUICK REFERENCE DATA

Supply voltage	V_{11-13}	typ.	12 V
Supply current	I_{11}	typ.	50 mA
I.F. input sensitivity at 38.9 MHz (r.m.s. value)	$V_{1-16}(\text{rms})$	typ.	60 μV
Video output voltage (white at 10% of top sync)	$V_{12-13}(\text{p-p})$	typ.	2.7 V
I.F. voltage gain control range	G_v	typ.	64 dB
Signal-to-noise ratio at $V_i = 10 \text{ mV}$	S/N	typ.	58 dB
A.F.C. output voltage swing (peak-to-peak value)	$V_{5-13}(\text{p-p})$	typ.	10.7 V

PACKAGE OUTLINES

TDA3540; TDA3541: 16-lead DIL; plastic (SOT-38).
TDA3540Q; TDA3541Q: 16-lead QIL; plastic (SOT-58).

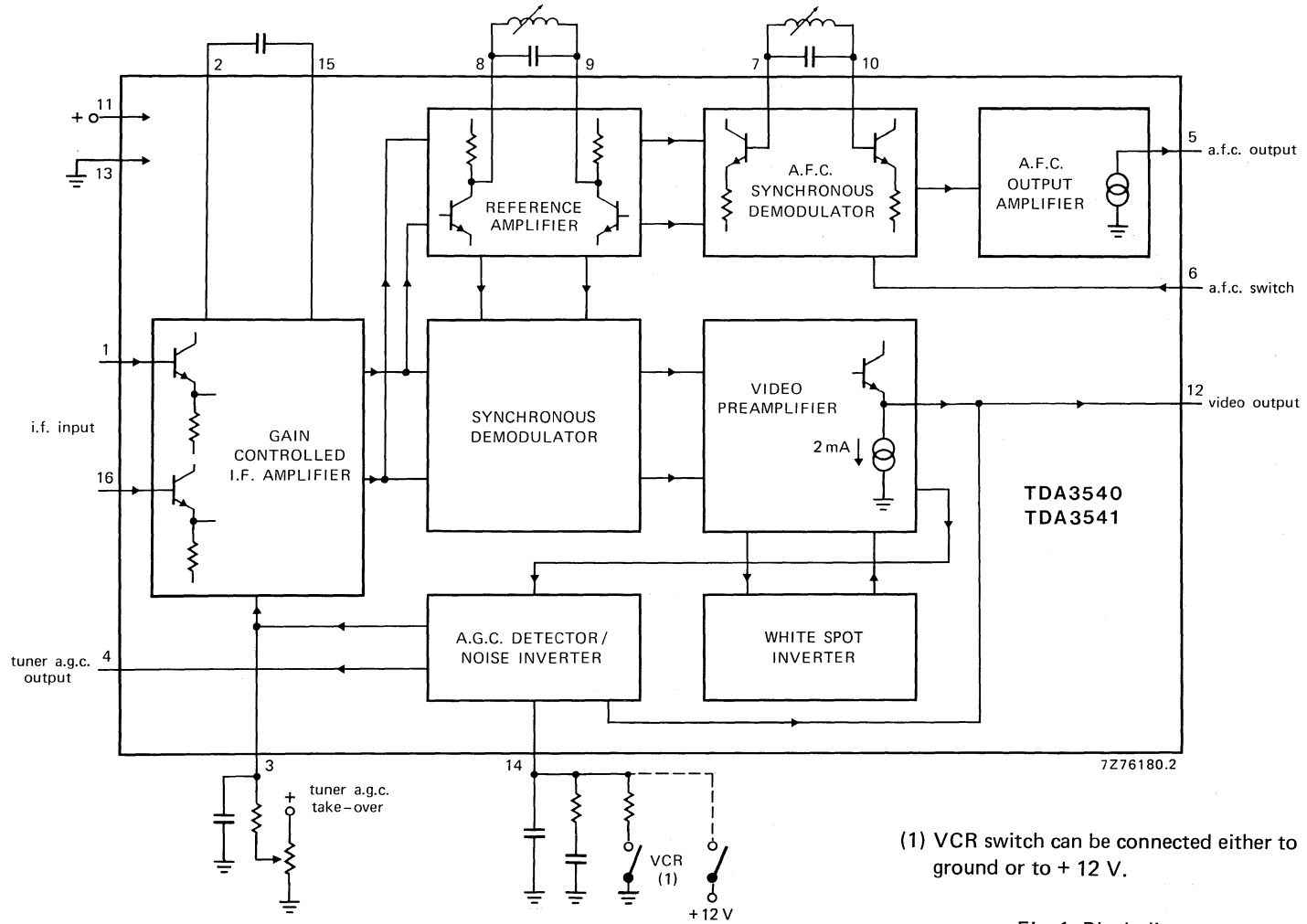

Fig. 1 Block diagram.

PINNING

- 1 - 16 Balanced i.f. input.
- 2 - 15 Decoupling capacitor for the d.c. feedback loop of the i.f. amplifier.
- 3 Adjusting pin for starting point of tuner a.g.c.
- 4 Tuner a.g.c. output.
- 5 A.F.C. output.
- 6 A.F.C. on/off switch.
- 7 - 10 A.F.C. circuitry to obtain $\pi/2$ phase shift of the reference carrier.
- 8 - 9 Circuitry for passive regeneration of the i.f. picture carrier.
- 11 Positive power supply.
- 12 Video output.
- 13 Ground.
- 14 I.F. a.g.c.; VCR switch.

RATINGS

Limiting values in accordance with the Absolute Maximum System (IEC 134)

Supply voltage	V_{11-13}	max.	13,2 V
I.F. a.g.c. voltage/VCR switch	V_{14-13}	max.	13,2 V
Tuner a.g.c. voltage	V_{4-13}	max.	12 V
A.F.C. switch voltage	V_{6-13}	max.	13,2 V
Maximum voltage level at pin 12 with VCR switch active	V_{12-13}	max.	5,0 V
D.C. output current at video output	I_{12}	max.	10 mA
Total power dissipation	P_{tot}	max.	1,2 W
Storage temperature range	T_{stg}		-65 to + 150 °C
Operating ambient temperature range	T_{amb}		-25 to + 70 °C

CHARACTERISTICS (measured in Fig. 8)

Supply voltage range	V_{11-13}	typ.	12 V 10.2 to 13.2 V
The following characteristics are measured at $T_{amb} = 25\text{ }^{\circ}\text{C}$; $V_{11-13} = 12\text{ V}$			
Current consumption (no input signal)	I_{11}	typ.	50 mA 35 to 70 mA
I.F. amplifier (note 1)			
I.F. sensitivity (onset of a.g.c.)	V_{1-16}	typ. <	60 μV 100 μV
Input resistance (differential)	R_{1-16}	typ.	2 k Ω 1.5 to 3 k Ω
Input capacitance (differential)	C_{1-16}	typ. <	2 pF 5 pF
Gain control range	G_v	typ.	64 dB
Output signal expansion for 50 dB input signal variation (note 2)	ΔV_{12-13}	<	0.5 dB
Maximum input signal	V_{1-16}	>	70 mV
Tuner a.g.c. (note 1)			
Starting point tuner a.g.c.; adjustable (note 3)			
pin 3 connected with 39 k Ω to pin 11			
TDA3540	V_{1-16}	<	3 mV
TDA3541	V_{1-16}	<	3 mV
pin 3 connected with 39 k Ω to ground			
	V_{1-16}	>	70 mV
Maximum tuner a.g.c. output current swing	I_4	>	10 mA
Input signal variation (note 4) for a tuner a.g.c. current variation of:			
9 mA to 1 mA (TDA3540)	ΔV_{1-16}	typ.	5 dB
1 mA to 9 mA (TDA3541)	ΔV_{1-16}	typ.	5 dB
Output saturation voltage at $I_4 = 7\text{ mA}$	$V_{4-13sat}$	typ. <	200 mV 300 mV
Leakage current at $V_{4-13} = 12\text{ V}$	I_4	<	1 μA
Tuner a.g.c. characteristic	see Fig. 5		
Video output (note 5)			
Zero-signal output level (note 6)	V_{12-13}	typ.	6 V 5.7 to 6.3 V
Top sync output level	V_{12-13}	typ.	2.95 V 2.80 to 3.10 V
Video output signal (peak-to-peak value) white at 10% of top sync	$V_{12-13(p-p)}$	typ.	2.7 V

Internal bias current of n-p-n emitter-follower output transistor		typ.	2 mA
			1 to 3 mA
Bandwidth of demodulated output signal	B	>	5.5 MHz
		typ.	6.5 MHz
Differential gain (note 7)	dG	typ.	3 %
		<	10 %
Differential phase (note 8)	dφ	typ.	2°
		<	10°
Residual carrier signal (r.m.s. value)	V _{12-13(rms)}	typ.	3.5 mV
		<	30.0 mV
Residual 2nd harmonic of carrier signal (r.m.s. value)	V _{12-13(rms)}	typ.	15 mV
		<	30 mV
Intermodulation (see Figs 2 and 3) at 1.1 MHz: blue (note 9)		>	56 dB
		typ.	62 dB
yellow (note 9)		>	53 dB
		typ.	57 dB
at 3.3 MHz (note 10)		>	66 dB

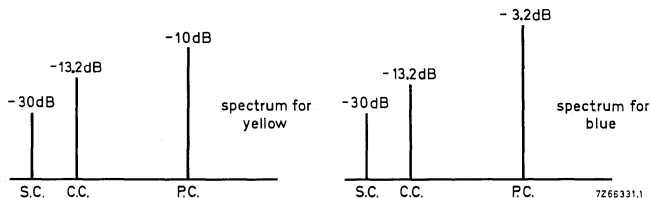

S.C. : sound carrier level
 C.C. : chrominance carrier level
 P.C. : picture carrier level

} with respect to top sync level

Fig. 2 Input conditions for intermodulation measurements; standard colour bar with 75% contrast.

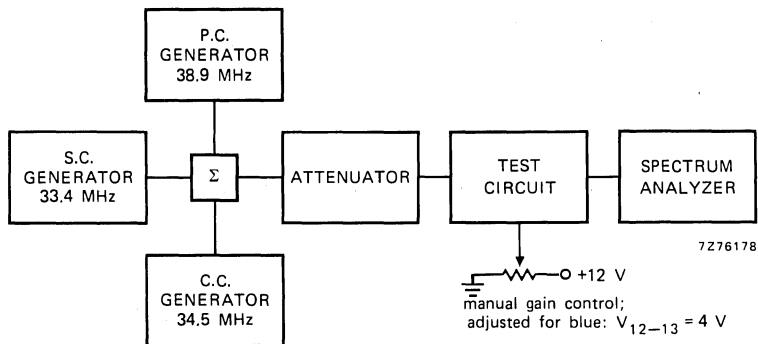

Fig. 3 Test set-up for intermodulation.

CHARACTERISTICS (continued)

Signal-to-noise ratio (note 11) at 10 mV input signal	S/N	>	50 dB
		typ.	58 dB
at end of gain control range	S/N	>	54 dB
		typ.	61 dB
as a function of the input signal	see Fig. 6		

White spot and noise inverter (see Fig. 4)

White spot inverter threshold level	V ₁₂₋₁₃	typ.	6.8 V
			6.3 to 7.3 V
White spot insertion level	V ₁₂₋₁₃	typ.	4.5 V
			4.2 to 4.8 V
Noise inverter threshold level	V ₁₂₋₁₃	typ.	1.8 V
			1.6 to 2.0 V
Noise insertion level	V ₁₂₋₁₃	typ.	3.8 V
			3.4 to 4.1 V

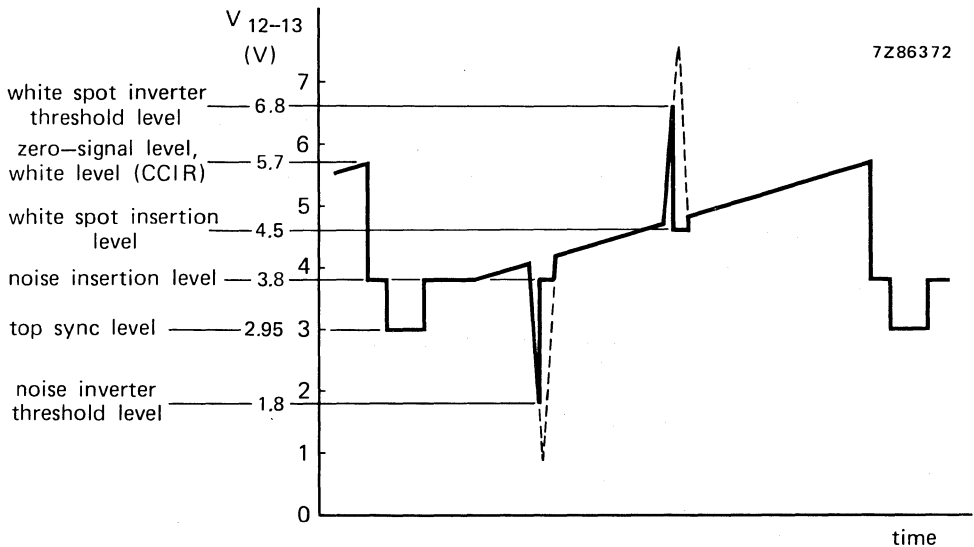

Fig. 4 Video output waveform showing white spot and noise inverter threshold levels.

VCR switch

Switches the output off: below	V ₁₄₋₁₃	typ.	1.9 V
			1.4 to 2.4 V
above	V ₁₄₋₁₃	typ.	10.7 V
			10 to 11.3 V

A.F.C. (note 12)

A.F.C. output voltage swing (peak-to-peak value)

$V_{5-13(p-p)}$	>	10 V
	typ.	10,7 V

Change of frequency for an a.f.c. output voltage swing of 10 V
at 100% picture carrier

Δf	typ.	70 kHz
	<	150 kHz

at 10% picture carrier

Δf	typ.	100 kHz
	<	200 kHz

A.F.C. output voltage when tuned at 38,9 MHz

V_{5-13}	typ.	6 V
------------	------	-----

A.F.C. output voltage (no input signal)

V_{5-13}	typ.	6 V
		4 to 8 V

A.F.C. switch switches off below

V_{6-13}	typ.	2.9 V
		1.6 to 3.5 V

Recommended a.f.c. active voltage

V_{6-13} or: pin 6 floating		3.5 to 6 V
----------------------------------	--	------------

A.F.C. switch leakage current at $V_{6-13} = 6 V$

I_6	<	1 μA
-------	---	-----------

A.F.C. output current during a.f.c. off
measured with $f_o \pm 300 kHz$ and $V_{6-13} = 1.5 V$

I_5		-2.5 to +2.5 μA
-------	--	----------------------

A.F.C. output current during a.f.c. on

I_5	>	1 mA
	typ.	2 mA

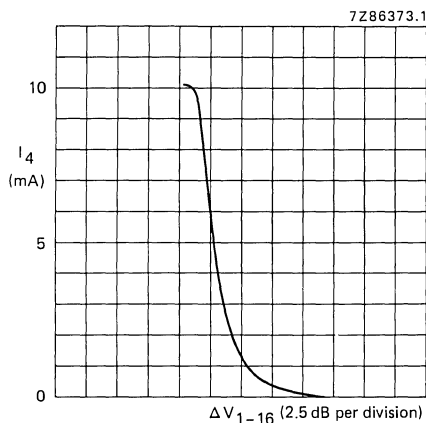

(a)

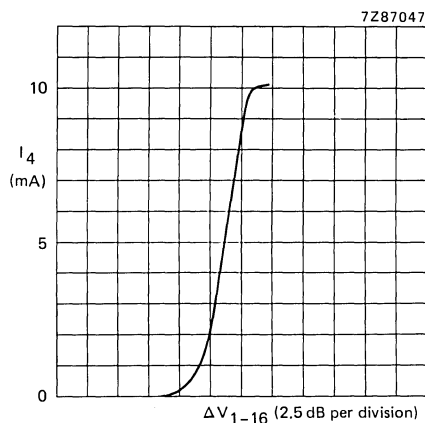

(b)

Fig. 5 Typical tuner a.g.c. characteristics;
pin 3 connected to the supply voltage (pin 11) with 39 k Ω .

a: TDA3540
b: TDA3541

CHARACTERISTICS (continued)

Notes to characteristics

1. All input signals are measured r.m.s. at top sync and 38.9 MHz.
2. Measured with 0 dB = 200 μ V.
3. Starting point of the tuner a.g.c. is defined as the input signal level where the tuner a.g.c. current is 9 mA for the TDA3540 and 1 mA for the TDA3541.
4. Measured with pin 3 connected with 39 k Ω to the supply voltage (pin 11).
5. Measured at 10 mV r.m.s. top sync input signal.
6. So-called 'projected zero point', e.g. with switched demodulator.
7. Measured according to EBU test, line 330.
The differential gain is expressed as a percentage of the difference in peak amplitudes between the largest and smallest section relative to the sub-carrier amplitude at blanking level.
8. Measured according to EBU test, line 330.
The differential phase is defined as the difference in degrees between the largest and smallest phase angle of the six sections.
9. $20 \log \frac{V_o \text{ at 4.4 MHz}}{V_o \text{ at 1.1 MHz}} + 3.6 \text{ dB.}$
10. $20 \log \frac{V_o \text{ at 4.4 MHz}}{V_o \text{ at 3.3 MHz}} .$
11. Measured with a 75 Ω source; $S/N = 20 \log \frac{V_o \text{ black-to-white}}{V_{n(rms)} \text{ at } B = 5 \text{ MHz}} .$
12. Measured with an input signal $V_{1-16} = 10 \text{ mV}$ and a.f.c. output pin 5 symmetrically loaded with 100 k Ω to the supply voltage (V_{11-13}) and 100 k Ω to ground.

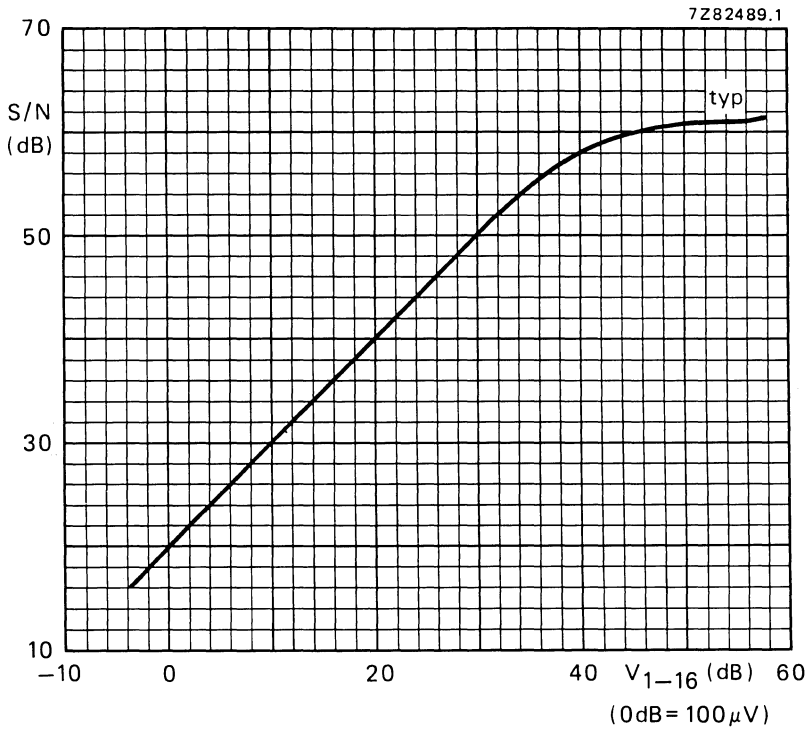

Fig. 6 Signal-to-noise ratio as a function of the input voltage (V_{1-16}).

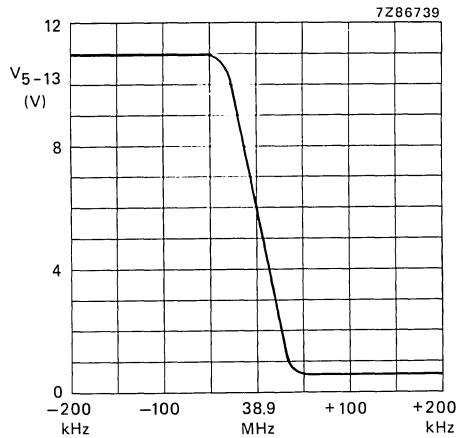
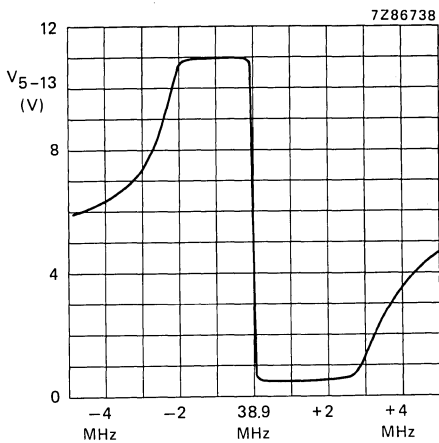
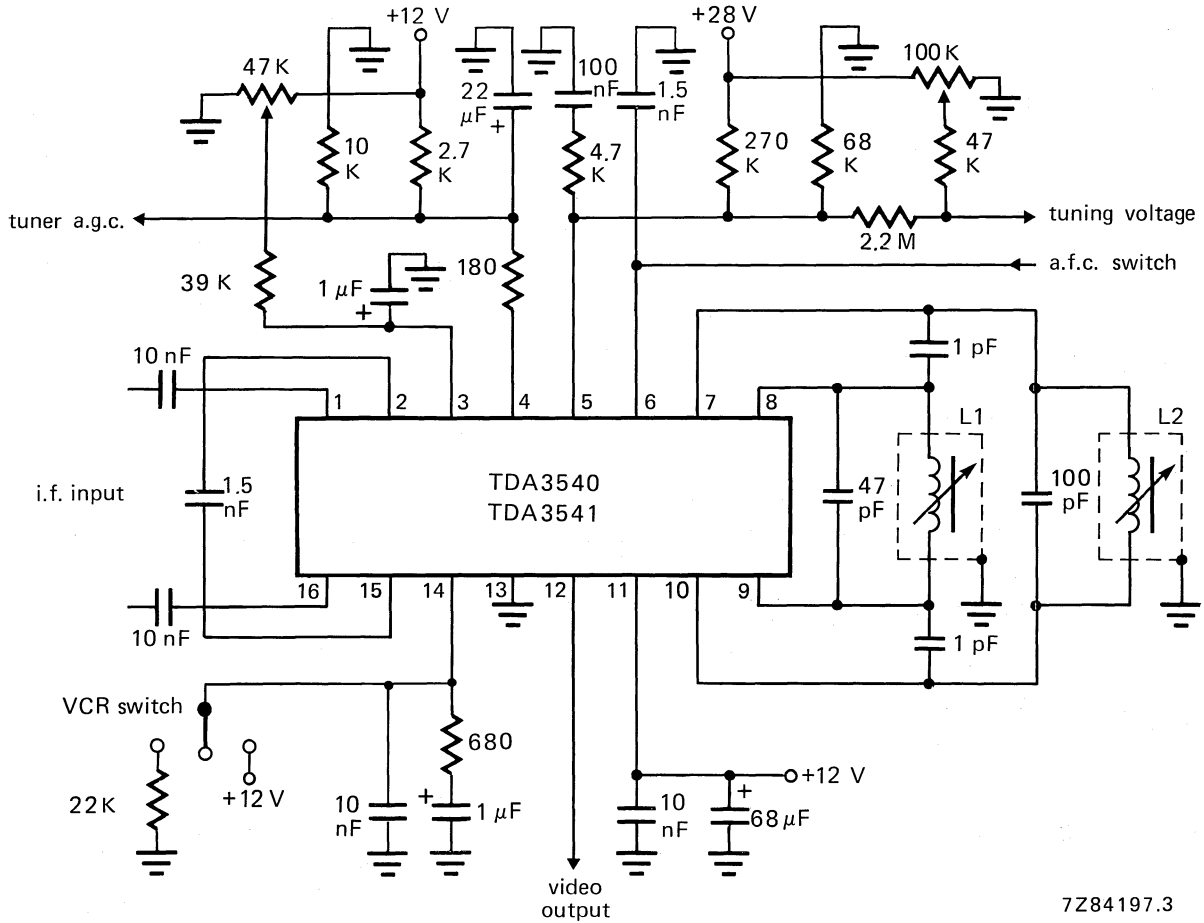

Fig. 7 A.F.C. output voltage (V_{5-13}) as a function of deviation of the i.f. vision carrier from its nominal frequency.

APPLICATION INFORMATION

Signetics



7Z84197.3

Fig. 8 Typical application circuit diagram; Q of L1 and L2 = 80; $f_o = 38.9$ MHz.

VERTICAL DEFLECTION**TDA3651A/AQ**

The TDA3651A;AQ is a vertical deflection output circuit for drive of various deflection systems with deflection currents up to 2 A peak-to-peak.

The circuit incorporates the following functions:

- Driver
- Output stage
- Thermal protection and output stage protection
- Flyback generator
- Voltage stabilizer

QUICK REFERENCE DATA

Supply voltage (pin 9)	$V_{9-4} = V_P$	0 to 50 V
Peak output voltage during flyback (pin 5)	$V_{5-4M} <$	55 V
Output current (peak-to-peak value)	$I_{5(p-p)} <$	1,5 A
Operating junction temperature	T_j max.	150 °C
Thermal resistance from junction to mounting base	$R_{th j-mb}$ typ.	3 K/W

PACKAGE OUTLINES

TDA3651A: 9-lead SIL; plastic power (SOT-131B).

TDA3651AQ: 9-lead SIL bent to DIL; plastic power (SOT-157B).

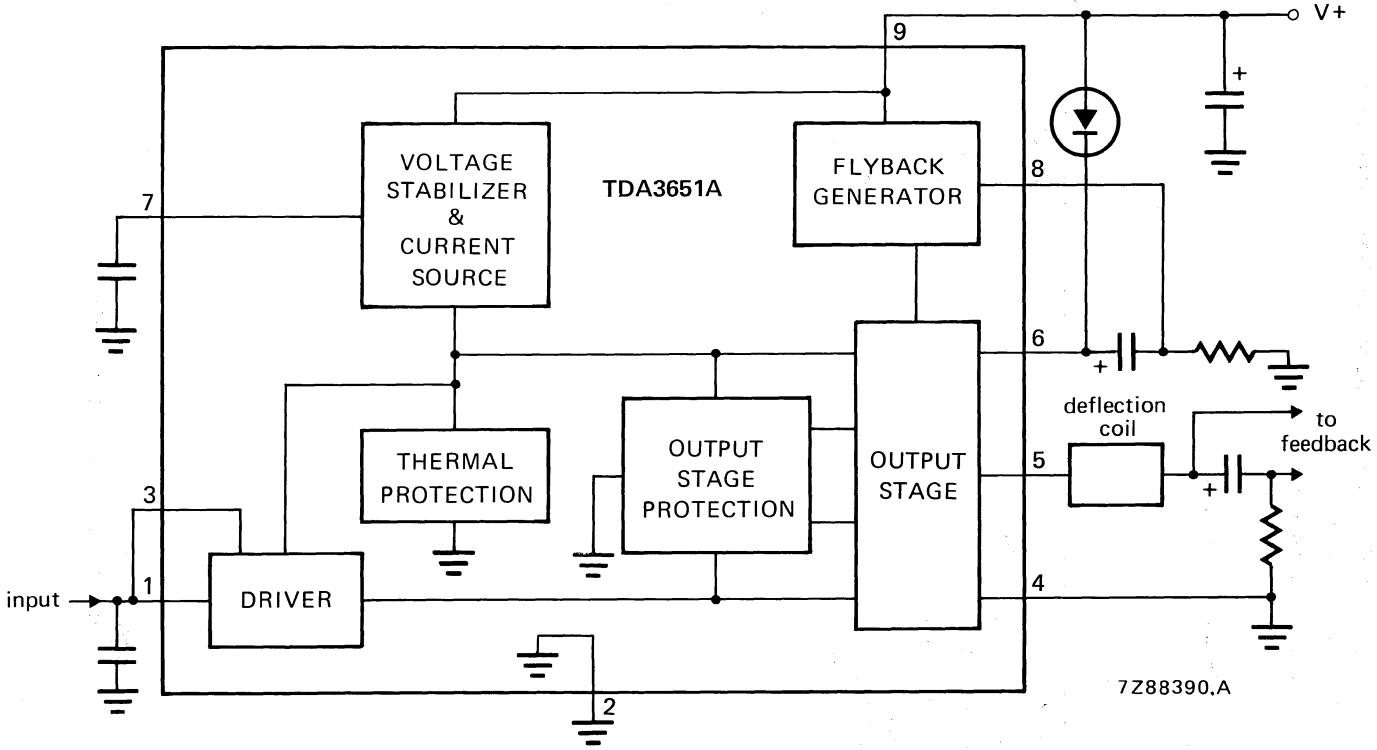

Fig. 1 Block diagram.

GENERAL DESCRIPTION**Output stage and protection circuit**

Pin 5 is the output pin. The supply for the output stage is fed to pin 6 and the output stage ground is connected to pin 4. The output transistors of the class-B output stage can each deliver 1 A maximum. The 'upper' power transistor is protected against short-circuit currents to ground, whereas, during flyback, the 'lower' power transistor is protected against too high voltages which may occur during adjustments.

Moreover, the output transistors have been given extra solidity by means of special measures in the internal circuit layout.

A thermal protection circuit is incorporated to protect the IC against too high dissipation. This circuit is 'active' at 175 °C and then reduces the deflection current to such a value that the dissipation cannot increase.

Driver and switching circuit

Pin 1 is the input for the driver of the output stage. The signal at pin 1 is also applied to pin 3 which is the input of a switching circuit. When the flyback starts, this switching circuit rapidly turns off the lower output stage and so limits the turn-off dissipation. It also allows a quick start of the flyback generator. Pin 3 is connected externally to pin 1, in order to allow for different applications in which pin 3 is driven separate from pin 1.

Flyback generator

The capacitor at pin 6 is charged to a maximum voltage, which is equal to the supply voltage V_p (pin 9), during scan.

When the flyback starts and the voltage at the output pin (pin 5) exceeds the supply voltage (pin 9), the flyback generator is activated. The V_p is connected in series (via pin 8) with the voltage across the capacitor.

The voltage at the supply pin (pin 6) of the output stage will then be maximum twice V_p . Lower voltages can be chosen by changing the value of the external resistor at pin 8.

Voltage stabilizer

The internal voltage stabilizer provides a stabilized supply of 6 V for drive of the output stage, so the drive current of the output stage is not affected by supply voltage variations. The stabilized voltage is available at pin 7.

A decoupling capacitor of 2,2 μ F can be connected to this pin.

VERTICAL DEFLECTION**TDA3651A/AQ****RATINGS**

Limiting values in accordance with the Absolute Maximum System (IEC 134)

Voltages (pins 4 and 2 externally connected to ground)

Output voltage (pin 5)	V_{5-4}	max.	55 V
Supply voltage (pin 9)	$V_{9-4} = V_P$	max.	50 V
Supply voltage output stage (pin 6)	V_{6-4}	max.	55 V
Input voltage (pins 1 and 3)	$V_{1-2}; V_{3-2}$	max.	V_P

Currents

Repetitive peak output current (pin 5)	$\pm I_{5RM}$	max.	0,75 A
Non-repetitive peak output current (pin 5)	$\pm I_{5SM}$	max.	1,5 A*
Repetitive peak flyback generator output current (pin 8)	I_{8RM}	max.	-0,75 A +0,85 A
Non-repetitive peak flyback generator output current (pin 8)	I_{8SM}	max.	-1,5 A +1,6 A*

Temperatures

Storage temperature range	T_{stg}	-65 to + 150 °C
Operating ambient temperature range	T_{amb}	-25 to + 65 °C
Operating junction temperature range	T_j	-25 to + 150 °C

CHARACTERISTICS $T_{amb} = 25\text{ °C}$; $V_P = 26\text{ V}$; pins 4 and 2 externally connected to ground; unless otherwise specified.

Output current (peak-to-peak value)	$I_{5(p-p)}$	typ.	1,2 A
		<	1,5 A
Flyback generator output current	$-I_8$	typ.	0,7 A
		<	0,85 A
Flyback generator output current	I_8	typ.	0,6 A
		<	0,75 A

Output voltages

Peak voltage during flyback	V_{5-4M}	<	55 V
Saturation voltage to supply at $-I_5 = 1\text{ A}$	$-V_{5-6sat}$	typ.	2,5 V
		<	3,0 V
Saturation voltage to ground at $I_5 = 1\text{ A}$	V_{5-4sat}	typ.	2,5 V
		<	3,0 V
Saturation voltage to supply at $-I_5 = 0,75\text{ A}$	$-V_{5-6sat}$	typ.	2,2 V
		<	2,7 V
Saturation voltage to ground at $I_5 = 0,75\text{ A}$	V_{5-4sat}	typ.	2,2 V
		<	2,7 V

* Non-repetitive duty factor maximum 3,3%.

VERTICAL DEFLECTION

TDA3651A/AQ

Supply

Supply voltage	$V_{9-2}; 4$	10 to 50 V*
Supply voltage output stage	V_{6-4}	< 55 V*
Supply current (no load and no quiescent current)	I_9	typ. 9 mA < 12 mA
Quiescent current (see Fig. 2)	I_4	typ. 38 mA 25 to 52 mA
Variation of quiescent current with temperature		typ. -0,04 mA/K

Flyback generator

Saturation voltage at $-I_g = 1,1$ A	V_{9-8sat}	typ. 1,6 V < 2,1 V
Saturation voltage at $I_g = 1$ A	V_{8-9sat}	typ. 2,5 V < 3,0 V
Saturation voltage at $I_g = 0,85$ A	V_{9-8sat}	typ. 1,4 V < 1,9 V
Saturation voltage at $I_g = 0,75$ A	V_{8-9sat}	typ. 2,3 V < 2,8 V
Flyback generator active if:	V_{5-9}	> 4 V
Leakage current	$-I_8$	typ. 5 μ A < 100 μ A
Input current for $\pm I_5 = 1$ A	I_1	typ. 230 μ A 175 to 380 μ A
Input voltage during scan	V_{1-2}	typ. 1,9 V 0,9 to 2,7 V
Input current during scan	I_3	0,01 to 2,5 mA
Input voltage during scan	V_{3-2}	0,9 to V_P V
Input voltage during flyback	V_{3-2}	0 to 0,2 V
Voltage at pin 7	V_{7-2}	typ. 6,1 V 5,6 to 6,6 V
Load current of pin 7	I_7	< 2 mA
Unloaded voltage at pin 7 during flyback	V_{7-2}	typ. 15 V
Junction temperature of switching on the thermal protection	T_j	typ. 175 $^{\circ}$ C 158 to 192 $^{\circ}$ C
Thermal resistance from junction to mounting base	$R_{th j-mb}$	typ. 3 K/W < 4 K/W
Power dissipation	see Fig. 3	
Open loop gain at 1 kHz; $R_{load} = 1$ k Ω	G_o	typ. 36 dB
Frequency response (-3 dB); $R_{load} = 1$ k Ω	f	typ. 60 kHz

* The maximum supply voltage should be chosen such that during flyback the voltage at pin 5 does not exceed 55 V.

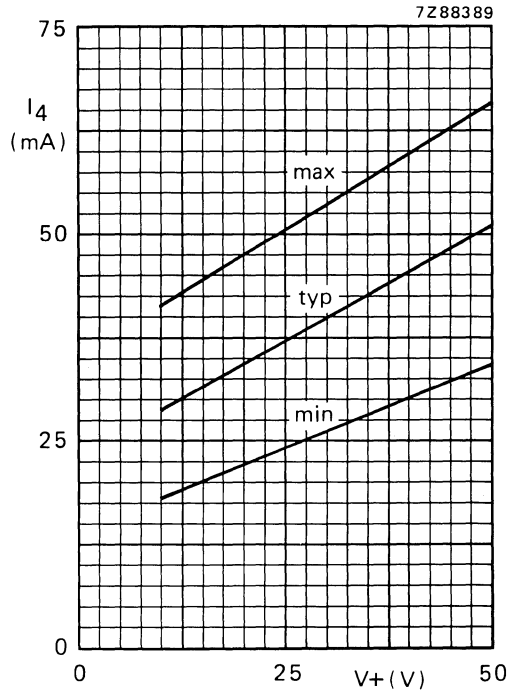

Fig. 2 Quiescent current I_4 as a function of supply voltage V_p .

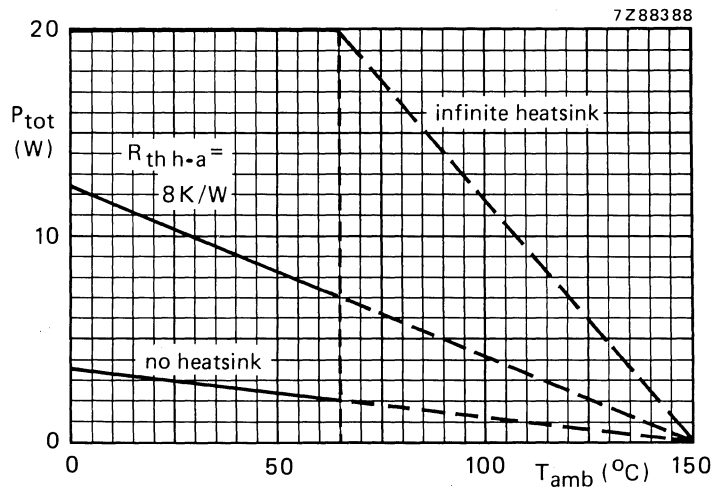

Fig. 3 Power derating curves.

APPLICATION INFORMATION

The following application data are measured in a typical application as shown in Figs 4 and 5.

Deflection current (including 6% overscan)
peak-to-peak value

$I_{5(p-p)}$ typ. 0.87 A

Supply voltage

V_{9-4} typ. 26 V

Total supply current

I_{tot} typ. 148 mA

Peak output voltage during flyback

V_{5-4M} < 50 V

Saturation voltage to supply

V_{5-6sat} typ. 2.0 V
< 2.5 V

Saturation voltage to ground

V_{5-4sat} typ. 2.0 V
< 2.5 V

Flyback time

t_{fl} typ. 0.95 ms
< 1.2 ms

Total power dissipation in IC

P_{tot} typ. 2.5 W

Operating ambient temperature

T_{amb} < 65 °C

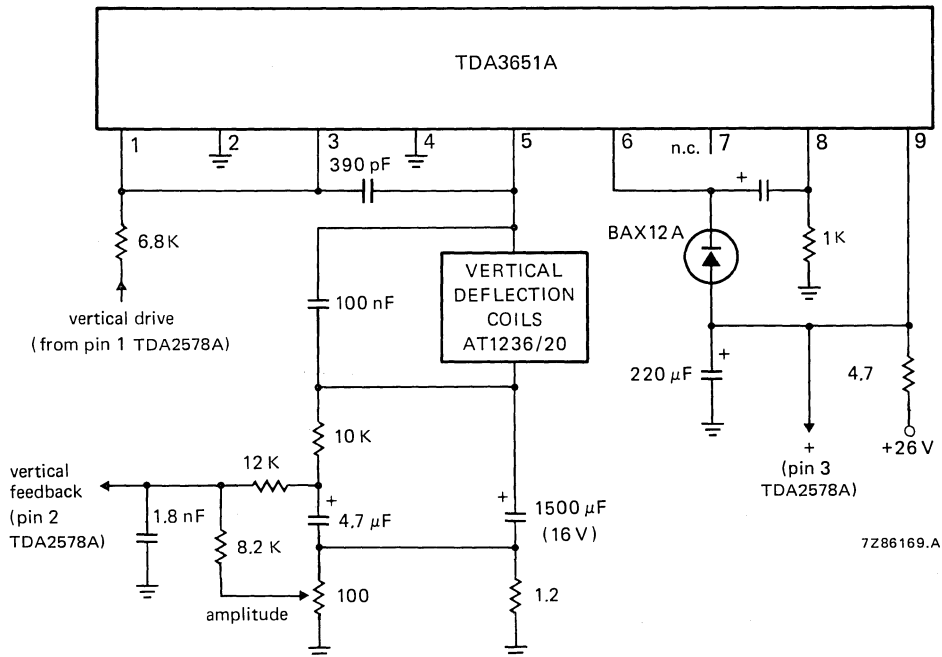

Fig. 4 Typical application circuit diagram of the TDA3651A (vertical output), when used in combination with the TDA2578A (see Fig. 5).

Note to deflection coils AT1236/20: L = 29 mH, R = 13,6 Ω; deflection current without overscan is 0.82 A peak-to-peak and EHT voltage is 25 kV.



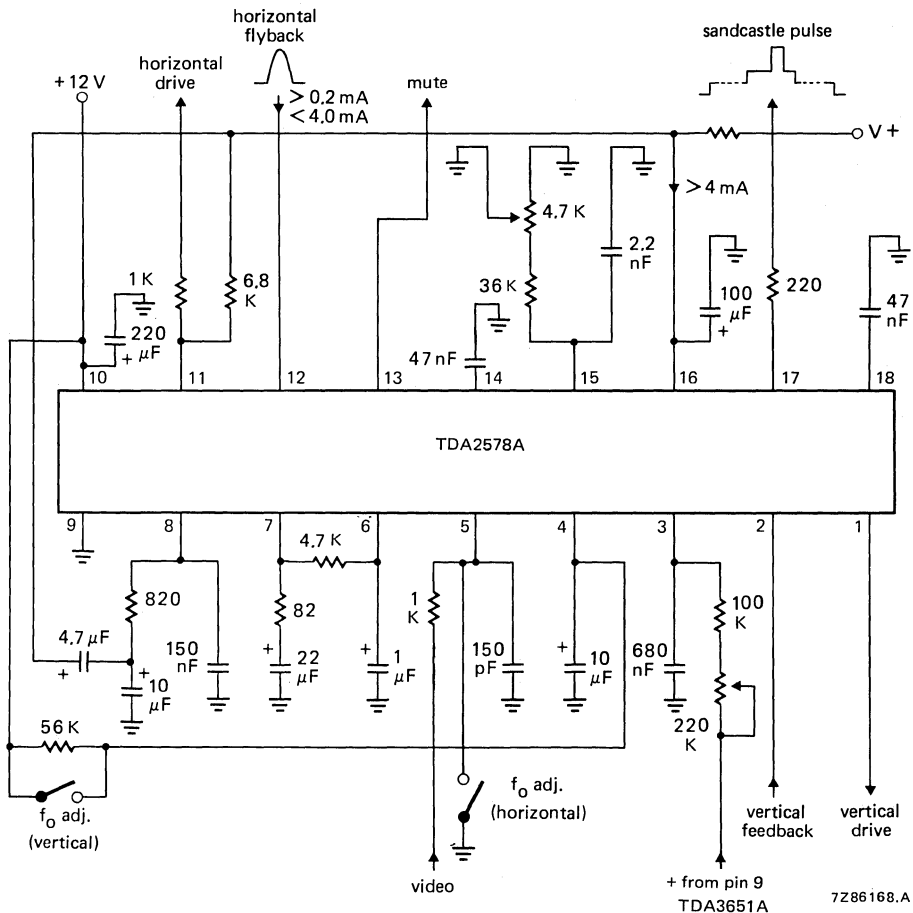

Fig. 5 Typical application circuit diagram; for combination of the TDA2578A with the TDA3651A see Fig. 4.

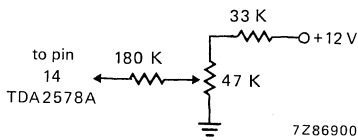

Fig. 6 Circuit configuration at pin 14 for phase adjustment.

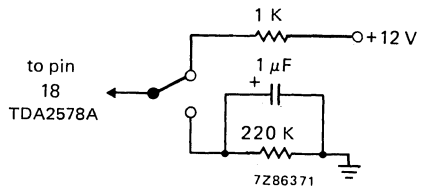

Fig. 7 Circuit configuration at pin 18 for VCR mode.

1 kΩ resistor between pin 18 and +12 V: without mute function.

220 kΩ between pin 18 and ground: with mute function.

GENERAL DESCRIPTION

The TDA3652 is an integrated power output circuit for vertical deflection in systems with deflection currents up to 3 A peak to peak.

Features

- Driver
- Output stage and protection circuits
- Flyback generator
- Voltage stabilizer

QUICK REFERENCE DATA

Supply voltage (pin 9)	$V_{9-4} = V_P$	0 to 40 V
Peak output voltage during flyback (pin 5)	V_{5-4M}	< 55 V
Output current (peak-to-peak value)	$I_5(p-p)$	max. 3 A
Operating junction temperature	T_j	max. 150 °C
Thermal resistance from junction to mounting base	$R_{th j-mb}$	max. 4 K/W

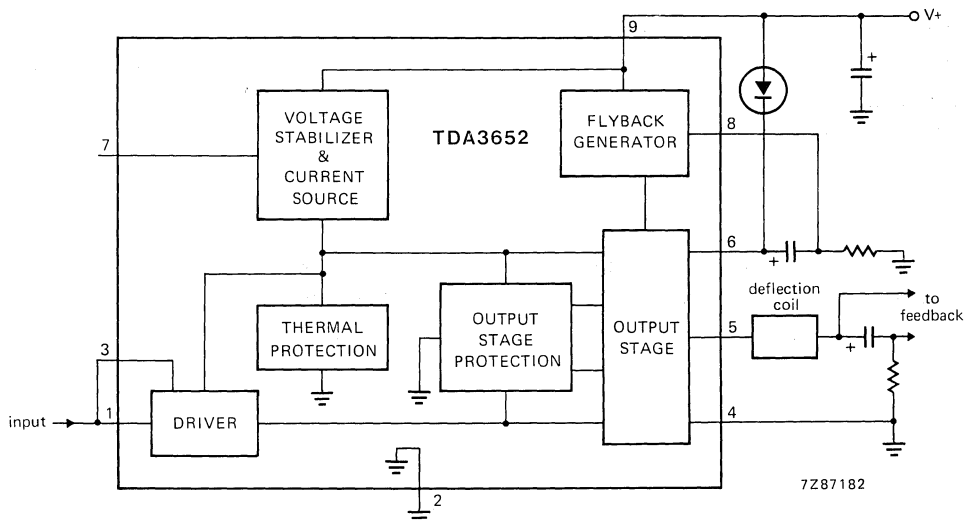

Fig. 1 Block diagram.

PACKAGE OUTLINES

TDA3652: 9-lead SIL; plastic (SOT-131B).

TDA3652Q: 9-lead SIL bent to DIL; plastic (SOT-157B).

VERTICAL DEFLECTION**TDA3652****RATINGS**

Limiting values in accordance with the Absolute Maximum System (IEC 134)

Voltages (pins 4 and 2 externally connected to ground)

Output voltage (pin 5)	V_{5-4}	0 to 55 V
Supply voltage (pin 9)	$V_{9-4} = V_P$	0 to 40 V
Supply voltage output stage (pin 6)	V_{6-4}	0 to 55 V
Driver input voltage (pin 1)	V_{1-2}	0 to V_P V*
Switching circuit input voltage (pin 3)	V_{3-2}	0 to 5.6 V

Currents

Repetitive peak output current (pin 5)	$\pm I_{5RM}$	max.	1.5 A
Non-repetitive peak output current (pin 5)	$\pm I_{5SM}$	max.	3 A**
Repetitive peak flyback generator output current (pin 8)	I_{8RM}	max.	-1.5 A +1.6 A
Non-repetitive peak flyback generator output current (pin 8)	$\pm I_{8SM}$	max.	3 A**

Temperatures

Storage temperature range	T_{stg}	-65 to +150 °C
Operating ambient temperature range	T_{amb}	-25 to +65 °C
Operating junction temperature range	T_j	-25 to +150 °C

* The maximum input voltage should not exceed the supply voltage (V_P at pin 9). In most applications pin 1 is connected to pin 3; the maximum input voltage should then not exceed 5.6 V.

** Non-repetitive duty factor maximum 3.3%.

CHARACTERISTICS

$V_P = 26\text{ V}$; $T_{amb} = 25\text{ }^\circ\text{C}$; pins 4 and 2 externally connected to ground; unless otherwise specified

parameter	symbol	min.	typ.	max.	unit
Supply					
Supply voltage; pin 9	V_P	10	—	40	V*
Supply voltage output stage; pin 6	V_{6-4}	—	—	55	V*
Supply current (no load and no quiescent current); pin 9	I_P	—	9	12	mA
Quiescent current (see Fig. 2)	I_4	25	40	65	mA
Variation of quiescent current with temperature	ΔI_4	—	-0.04	—	mA/K
Output current					
Output current (pin 5) (peak-to-peak value)	$I_{5(p-p)}$	—	2.5	3.0	A
Output current flyback generator (pin 8)	$-I_8$	—	1.35	1.6	A
Output current flyback generator (pin 8)	I_8	—	1.25	1.5	A
Output voltage					
Peak voltage during flyback	V_{5-4M}	—	—	55	V
Saturation voltage to supply at $-I_5 = 1.5\text{ A}$	$-V_{5-6sat}$	—	2.5	3.0	V
Saturation voltage to ground at $I_5 = 1.5\text{ A}$	V_{5-4sat}	—	2.5	3.0	V
Saturation voltage to supply at $-I_5 = 1\text{ A}$	$-V_{5-6sat}$	—	2.2	2.7	V
Saturation voltage to ground at $I_5 = 1\text{ A}$	V_{5-4sat}	—	2.2	2.7	V
Flyback generator					
Saturation voltage at $-I_8 = 1.6\text{ A}$	V_{9-8sat}	—	1.6	2.1	V
Saturation voltage at $I_8 = 1.5\text{ A}$	V_{8-9sat}	—	2.5	3.0	V
Saturation voltage at $-I_8 = 1.1\text{ A}$	V_{9-8sat}	—	1.4	1.9	V
Saturation voltage at $I_8 = 1\text{ A}$	V_{8-9sat}	—	2.3	2.8	V
Flyback generator active if:	V_{5-9}	4	—	—	V
Leakage current at pin 8	$-I_8$	—	5	100	μA
Input current for $I_5 = 4\text{ A}$ at pin 1 (peak-to-peak value)	$I_{1(p-p)}$	190	240	400	μA
Input voltage during scan (pin 1)	V_{1-2}	1.3	2.0	3.5	V
Input current during scan (pin 3)	I_3	0.01	—	2.5	mA

* The maximum supply voltage should be chosen such that during flyback the voltage at pin 5 does not exceed 55 V.

CHARACTERISTICS (continued)

parameter	symbol	min.	typ.	max.	unit
Flyback generator (continued)					
Input voltage during scan (pin 3)	V ₃₋₂	0.9	—	5.6	V
Input voltage during flyback (pin 3)	V ₃₋₂	0	—	0.2	V
General data					
Junction temperature of switching on the thermal protection	T _j	158	175	192	°C
Thermal resistance from junction to mounting base	R _{th j-mb}	—	—	4	K/W
Total power dissipation	P _{tot}	see Fig. 3			
Open-loop gain at 1 kHz	G _O	—	36	—	dB
Frequency response (−3 dB) at R _L = 1 kΩ	f	—	50	—	kHz

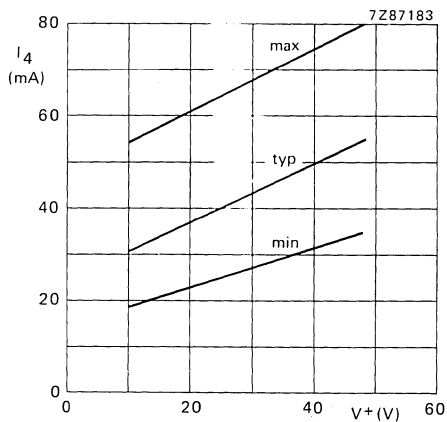

Fig. 2 Quiescent current (I_4) as a function of supply voltage (V_p).

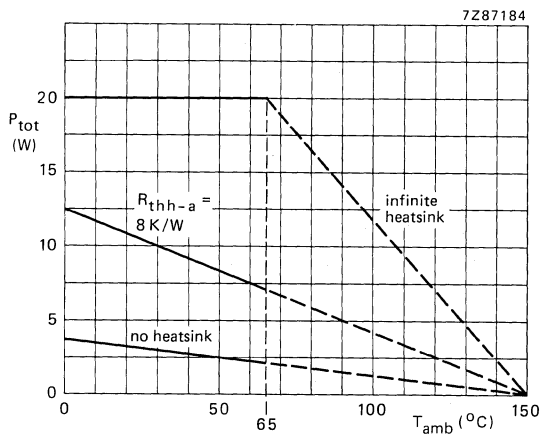

Fig. 3 Power derating curve.

APPLICATION INFORMATION

The function is described against the corresponding pin number.

1. Driver

This is the input for the driver of the output stage.

2. Negative supply (ground)**3. Switching circuit**

This pin is normally connected externally to pin 1. It is also possible to use this pin to drive the switching circuit for different applications. This switching circuit rapidly turns off the lower output stage at the end of scan and also allows for a quick start of the flyback generator.

4. Output stage ground**5 and 6. Output stage and protection circuits**

Pin 5 is the output pin and pin 6 is the output stage supply pin. The output stage is a class-B type with each transistor capable of delivering 1.5 A maximum. The "upper" output transistor is protected against short-circuit currents to ground. The base of the "lower" power transistor is connected to ground during flyback and so it is protected against too high flyback pulses which may occur during adjustments. In addition the output transistors are protected by a special layout of the internal circuit. The circuit is protected thermally against excessive dissipation by a circuit which operates at temperatures of 175 °C upwards causing the output current to drop to a value such that the dissipation cannot increase.

7. Voltage stabilizer

The internal voltage stabilizer provides a stabilized supply voltage of 6 V for drive of the output stage, so the drive current is not influenced by the various voltages of different applications.

8 and 9. Flyback generator

Pin 8 is the output pin of the flyback generator. Depending on the value of the external resistor at pin 8, the capacitor at pin 6 will be charged to a fixed level during the scan period. The maximum height of this level is equal to the supply voltage at pin 9 (V_p). When the flyback starts and the flyback pulse at pin 5 exceeds the supply voltage, the flyback generator is activated and then the supply voltage is connected in series (via pin 8) with the voltage across the capacitor. The voltage at the supply pin (pin 6) of the output stage will then be not more than twice the supply voltage.

GENERAL DESCRIPTION

The TDA4503 combines all small signal functions (except the tuner) which are required for a monochrome television receiver.

For a complete monochrome television receiver only output stages are required to be added for horizontal and vertical deflection, video and sound. The TDA4503 can also be used in simple colour television receivers. In this application an external sandcastle pulse generator is required.

It incorporates the following functions:

- vertical sync separator/oscillator
- vertical output
- coincidence detector (sound mute)
- phase detector/frequency control
- a.g.c. detector
- sync separator
- horizontal oscillator
- synchronous demodulator
- vision i.f. amplifier
- tuner a.g.c.
- d.c. volume control
- a.f.c. detector
- video output
- sound demodulator
- audio output
- gate pulse generator
- sound limiter/feedback
- 90° phase shift
- overload detector
- horizontal output

QUICK REFERENCE DATA

Supply voltage	V_{7-10}, V_{22-10}	typ.	10.5	V
Supply current	I_7	typ.	75	mA
Supply current	I_{22}	typ.	4.5	mA
Operating ambient temperature range	T_{amb}		–25 to +65	°C
Storage temperature range	T_{stg}		–25 to +150	°C
Power dissipation	P_{tot}	max.	1.7	W

PACKAGE OUTLINE

28-lead DIL; plastic, with internal heat spreader (SOT-117).

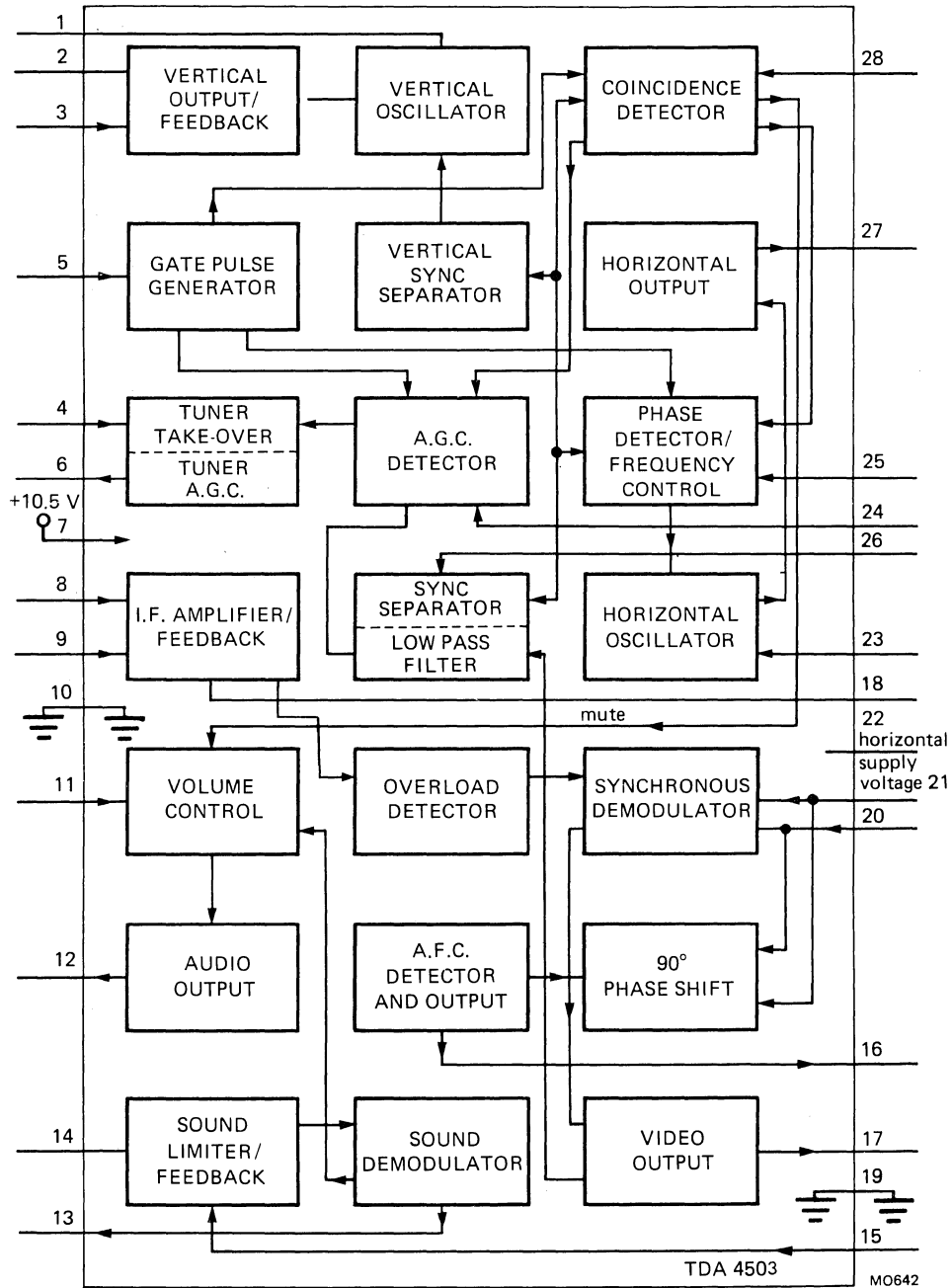

Fig. 1 Block diagram.

SMALL SIGNAL COMBINATION FOR MONOCHROME TV**TDA4503****PINNING**

Pin number	function	Pin number	function
1.	vertical oscillator	15.	sound i.f.
2.	vertical output	16.	a.f.c. output
3.	vertical feedback	17.	video output
4.	top linearity	18.	decoupling capacitor
5.	flyback pulse	19.	ground
6.	tuner a.g.c.	20.	38,5 MHz reference
7.	+10,5 V supply	21.	(38,9 MHz reference)
8.	i.f. input	22.	horizontal supply voltage
9.		23.	horizontal oscillator
10.	ground	24.	top sync detector
11.	volume control	25.	phase detector
12.	sound output	26.	sync separator
13.	6 MHz tuning (5,5 MHz tuning)	27.	horizontal output
14.	decoupling	28.	mute/coincidence detector

FUNCTIONAL DESCRIPTION (Fig. 1)

A complete black-and-white receiver can be built around this circuit by adding only the output stages for horizontal and vertical deflection with the video and sound output stages. The TDA4503 can also be used in simple colour television receivers using an external circuit to generate the sandcastle.

The block diagram (Fig. 1) depicts the various functions which are described briefly below.

The sensitivity of the i.f. amplifier is $70 \mu\text{V}$ for a peak-to-peak output voltage of 3 V (compare the TDA3541). This amplifier has a symmetrical input (pins 8 and 9) and is followed by a synchronous demodulator. The external tuned circuit is connected to pins 20 and 21. This circuit provides the information for the a.f.c. circuit, the 90° phase shift being supplied by internal RC-networks. An a.f.c. output with a voltage swing of about 9 V is obtained from pin 17 ($V_{7-10} = 10.5 \text{ V}$).

The a.g.c. detector is gated to reduce sensitivity to external electrical noise and the a.g.c. time constant network is connected to pin 24. Gain control range of the i.f. amplifier is greater than 60 dB. Adjustments of the tuner take-over point is made at pin 4. When the voltage at pin 4 is approximately 3.5 V the direction of the tuner control voltage is positive-going. When the voltage at pin 4 is approximately 8 V the direction of the tuner control voltage is negative-going.

An output signal of 3 V (p-p) is obtained from the video amplifier (top sync level 1.5 V) with negative-going sync. Since the sound signal is derived from pin 16 (see Fig. 4) the video output is not blanked during the flyback period. As shown in the application circuit (Fig. 4) the band-pass filter for the sound must be connected between video output (pin 16) and sound i.f. input (pin 15). Sound information passes through a sound limiter network and a sound demodulator circuit with an external tuned circuit for this stage connected to pin 13. The demodulator is followed by a volume control stage with a control range of 80 dB and an output amplifier with an audio output signal of 170 mV (r.m.s.) for a Δf of 7.5 kHz and at maximum volume setting.

The slicing level of the sync separator is referred to the top sync and is determined by the values of external resistors, the recommended slicing level being 30%. Noise protection is provided for the sync separator stage. Separated sync pulses are supplied to the gated phase detector which compare the sync pulses with the sawtooth voltage obtained from the horizontal flyback pulse (pin 5). During catching the gating of the phase detector is switched off and the phase detector output current is increased.

The in-sync or out-of-sync condition is detected with the coincidence detector which is also used for transmitter identification. Sound output is suppressed when no input signal is available. Clamping the voltage on pin 28 to a level of 3.5 V sets the phase detector to a high output current, short time constant mode. This is appropriate for the reception of VCR signals.

Phase detector output voltage levels maintain the horizontal oscillator at its correct operating frequency. The push-pull output (pin 27) has a typical duty cycle of 40%.

Vertical sync pulses are obtained from an internal integrating network with the vertical sawtooth being generated in the vertical oscillator. This sawtooth voltage is compared with the feedback voltage from the deflection coil via pin 3. The comparator generates the drive voltage for the vertical deflection output stage.

The TDA4503 has four supply pins. Pin 7 and pin 10 are for the main positive supply and circuit ground respectively.

Critical circuits are grounded by pin 19. Pin 22 is the supply for the horizontal oscillator. A low current supply (5 mA minimum) can be used to start the oscillator from an external high voltage supply rail.



RATINGS

Limiting values in accordance with the Absolute Maximum System (IEC134)

Supply voltage	V_{7-10}, V_{22-10}	max.	13.2	V
Total power dissipation	P_{tot}	max.	1.7	W
Storage temperature range	T_{stg}		-25 to +150	°C
Operating ambient temperature range	T_{amb}		-25 to +65	°C

CHARACTERISTICS

 $V_{7-10} = 10.5$ V, $V_{22-10} = 10.5$ V and $T_{amb} = 25$ °C unless otherwise specified

parameter	symbol	min.	typ.	max.	unit
Supply voltage	V_{7-10}	9.5	10.5	13.2	V
Supply current	I_7	—	75	—	mA
Supply voltage (horizontal oscillator)	V_{22-10}	9.5	10.5	13.2	V
Supply current (horizontal oscillator, note 1)	I_{22}	—	4.5	—	mA
Power dissipation	P_{tot}	—	850	—	mW
Vision i.f. amplifier (pin 8)					
Input sensitivity (onset of a.g.c.) at 39.5 MHz (note 2)	$V_{i(rms)}$	—	70	—	μV
Differential input resistance (note 3)	R_i	—	800	—	Ω
Differential input capacitance (note 3)	C_i	—	6	—	pF
Gain control range	ΔG	—	56	—	dB
Output signal expansion for 50 dB input signal variation (note 4)	ΔV_o	—	1	—	dB
Maximum input signal	$V_{i max}$	—	50	—	mV
Video amplifier (note 5)					
Zero signal output level (note 6)	V_{16-10}	—	5	—	V
Top sync output level (note 7)	V_{16-10}	1.2	1.4	1.6	V
Video output signal amplitude (peak-to-peak value)	$V_{16-10(p-p)}$	2.75	3.0	3.25	V
Internal bias current of n-p-n emitter follower output transistor	I_B	1.4	2.0	—	mA
Bandwidth of demodulated output signal	B	5	6	—	MHz
Video non-linearity (note 8)		—	—	10	%

CHARACTERISTICS (continued)

parameter	symbol	min.	typ.	max.	unit
Tuner a.g.c.					
Take-over voltage (pin 4) for positive-going tuner a.g.c. (n-p-n tuner)	V_{4-10}	—	3.5	—	V
Take-over voltage (pin 4) for negative-going tuner a.g.c. (p-n-p tuner)	V_{4-10}	—	8	—	V
Maximum tuner a.g.c. output swing	$I_6 \text{ max}$	2	3	—	mA
Output saturation voltage at $I_6 = 2 \text{ mA}$	$V_{6-10(\text{sat})}$	—	—	300	mV
Leakage current	I_6	—	—	1	μA
A.F.C. circuit (note 9)					
A.F.C. output voltage swing	V_{17-19}	9	—	10	V
Available output current	$\pm I_{17}$	—	1	—	mA
Output voltage at nominal tuning of the reference tuned circuit	V_{17-19}	—	5.25	—	V
Sound circuit					
Input limiting voltage when $V_O = V_{O\text{max}} - 3 \text{ dB}$ (note 10)	$V_{14 \text{ lim}}$	—	400	—	μV
Input resistance at pin 15 (note 11)	R_i	—	3	—	$\text{k}\Omega$
A.F. output signal at pin 12 (note 12) (r.m.s. value)	$V_{12-10(\text{rms})}$	170	—	240	mV
Volume control (pin 11) (Fig. 3)					
Voltage with pin 11 disconnected	V_{11-10}	—	6.5	—	V
Current pin 11 short-circuited to ground	I_{11}	—	1	—	mA
Volume control characteristic (note 13)			See Fig. 3		
Value of external control resistor	R_{11-10}	—	5	—	$\text{k}\Omega$

parameter	symbol	min.	typ.	max.	unit
Horizontal synchronization circuit					
Slicing level sync separator (note 14)		—	30	—	%
Holding range PLL		—	±1000	—	Hz
Catching range PLL		—	±600	—	Hz
Control sensitivity video to flyback (note 15)		—	2	—	kHz/μs
Horizontal oscillator					
Free running frequency	f_{osc}	—	15625	—	Hz
Spread with fixed external components	Δf_{osc}	—	—	4	%
Frequency variations due to supply voltage changes (note 16)	$\Delta f_{osc}/\Delta V$	—	0	—	%
Frequency variation with temperature	$\Delta f_{osc}/\Delta T$	—	—	1×10^{-4}	K ⁻¹
Maximum frequency shift	Δf_{osc}	—	—	10	%
Maximum frequency deviation between starting point output and nominal condition	Δf_{osc}	—	—	10	%
Horizontal (push-pull) output					
Output current	I_{27}	10	—	—	mA
Output impedance	R_{27-10}	—	200	—	Ω
Voltage when $I_{27} = 10$ mA	V_{27-10}	—	2	—	V
	V_{27-22}	—	3	—	V
Duty cycle of output pulse (note 17)	δ	0.35	0.40	0.45	
Flyback input (note 18)					
Minimum required input amplitude (peak-to-peak value)	$V_{5-10(p-p)}$	—	4	—	V
Phase detector switching voltage		—	0	—	V

CHARACTERISTICS (continued)

parameter	symbol	min.	typ.	max.	unit
Coincidence detector (mute) (note 19)					
Voltage in synchronized condition	V_{28-19}	—	9.5	—	V
Voltage in non-synchronized condition (no-signal)	V_{28-19}	—	1.0	1.5	V
Switching level to switch phase detector from slow to fast	V_{28-19}	4.5	5.0	5.5	V
Switching level to activate the 'mute' function (transmitter identification)	V_{28-19}	2.25	2.5	2.75	V
Output current; in-sync (peak-to-peak value)	$I_{28(p-p)}$	—	1	—	mA
Vertical oscillator					
Free running frequency	f_{osc}	—	47.5	—	Hz
Spread with fixed external components	Δf_{osc}	—	—	4	%
Holding range at nominal frequency		52.5	—	—	Hz
Temperature coefficient	TC	—	1×10^{-4}	—	K^{-1}
Frequency shift due to a supply voltage change from 9.5 to 12 V	$\Delta f_{osc}/\Delta V$	—	5	—	%
Vertical output (pin 2)					
Output current	I_2	1	1.3	—	mA
Output resistance	R_{2-10}	—	2	—	$k\Omega$
Feedback input (pin 3)					
D.C. input voltage	V_{3-10}	4.75	5	5.25	V
A.C. input voltage (peak-to-peak value)	$V_{3-10(p-p)}$	—	1.2	—	V
Input current	I_3	—	—	10	μA
Non-linearity of deflection current at $V_p = 10.5$ V		—	—	2.5	%

Notes to characteristics

1. It is possible to start the horizontal oscillator by supplying a current of 5 mA which can be taken from the mains rectifier, to pin 22. The main supply (pin 7) can then be derived from the horizontal output stage.
2. I.F. input voltage (r.m.s.) – value at top sync level at which the video amplitude has dropped 0,5 dB compared with the amplitude at an input signal of 10 mV.
3. The input impedance has been chosen such that a SAW-filter can be applied. 800 Ω is an acceptable compromise between the requirements for triple transient suppression and power loss.
4. Measured with 0 dB = 150 μ V.
5. Measured at 10 mV(r.m.s.) top sync input signal.
6. With switched demodulator.
7. Signal with negative-going sync with top white being 10% of the top sync amplitude (Fig. 2).
8. This figure is valid for the complete video signal amplitude (peak-white to top sync).
9. Measured with an input signal (V_{8-9}) of 10 mV(r.m.s.); the a.f.c. output (pin 7) loaded with $2 \times 100 \text{ k}\Omega$ between the supply and ground. The Q factor of the reference tuned circuit is 50.
10. Voltage at pin 15 is the r.m.s. value. Q_L of the demodulator tuned circuit is 20. Audio frequency is 1 kHz and the carrier frequency is 5.5 MHz.
11. Measured with an input signal of 1 mV(r.m.s.)
12. The tuned demodulator circuit must give an output level equal to that given in the "mute" condition.
13. Volume can be controlled using a variable resistor connected to ground (nominal 5 k Ω) or by means of a variable d.c. voltage. In this latter case the rather low impedance at pin 11 must be taken into account.

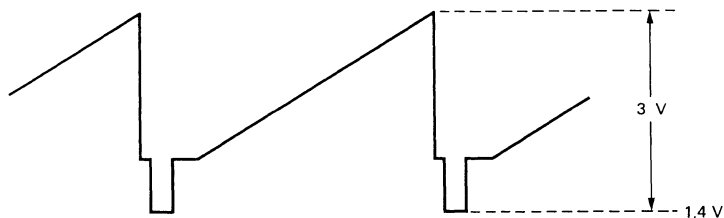

MO643

Fig. 2 Video output signal.

Notes to characteristics (continued)

14. The sync separator is noise gated. The slicing level is referred to top sync level and is independent of the video information. The value given is a percentage of the sync pulse amplitude. The slicing depends on the values of external resistors connected to pin 26.
15. Phase detector current increases by a factor of 7 during "catching" and when phase detector operates in the 'FAST' mode (pin 28). This ensures a high catching range and a higher dynamic loop gain.
16. Supply voltage variation in the range 8 to 12 V.
17. The negative-going edge of this pulse initiates the switch-off of the horizontal output transistor (simultaneous driver).
18. The circuit requires an integrated flyback pulse. The gate pulses for a.g.c. and the coincidence detector are obtained from the sawtooth.
19. The functions of in-sync/out-of-sync and transmitter identification have been combined on pin 28. For reception of VCR-signals the voltage on this pin must be fixed between 3 V and 4.5 V so that the time constant is fast and the sound is still available.

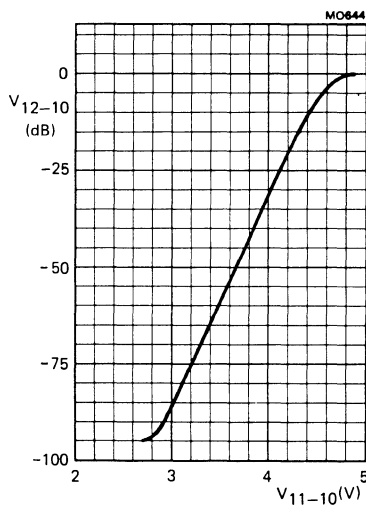
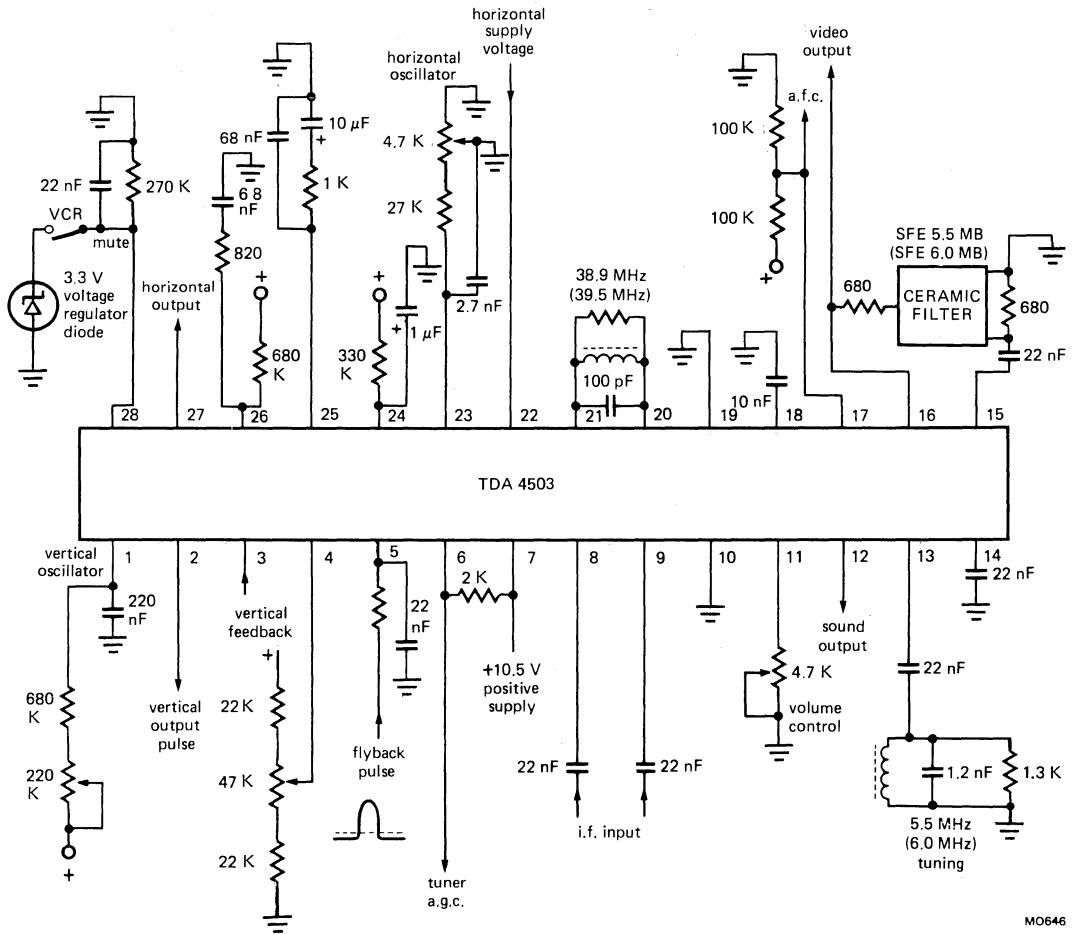

Fig. 3 Volume control characteristic at $f = 1$ kHz.

APPLICATION INFORMATION



MO646

Fig. 4 Typical application circuit.

COLOR TRANSIENT IMPROVEMENT CIRCUIT**TDA4560****GENERAL DESCRIPTION**

The TDA4560 is a monolithic integrated circuit for colour transient improvement (CTI) and luminance delay line in gyrator technique in colour television receivers.

Features

- Colour transient improvement for colour difference signals (R-Y) and (B-Y) with transient detecting-, storage- and switching stages resulting in high transients of colour difference output signals
- A luminance signal path (Y) which substitutes the conventional Y-delay coil with an integrated Y-delay line
- Switchable delay time from 720 ns to 1035 ns in steps of 45 ns
- Output for the option of velocity modulation

QUICK REFERENCE DATA

Supply voltage (pin 10)	$V_P = V_{10-18}$	typ.	12 V
Supply current (pin 10)	$I_P = I_{10}$	typ.	35 mA
(R-Y) and (B-Y) attenuation	α_{cd}	typ.	0 dB
(R-Y) and (B-Y) output transient time	t_{tr}	typ.	150 ns
Adjustable Y-delay time	t_d		720 to 1035 ns
Y-attenuation	α_Y	typ.	7 dB

PACKAGE OUTLINE

18-lead DIL; plastic (SOT-102CS).

COLOR TRANSIENT IMPROVEMENT CIRCUIT

TDA4560

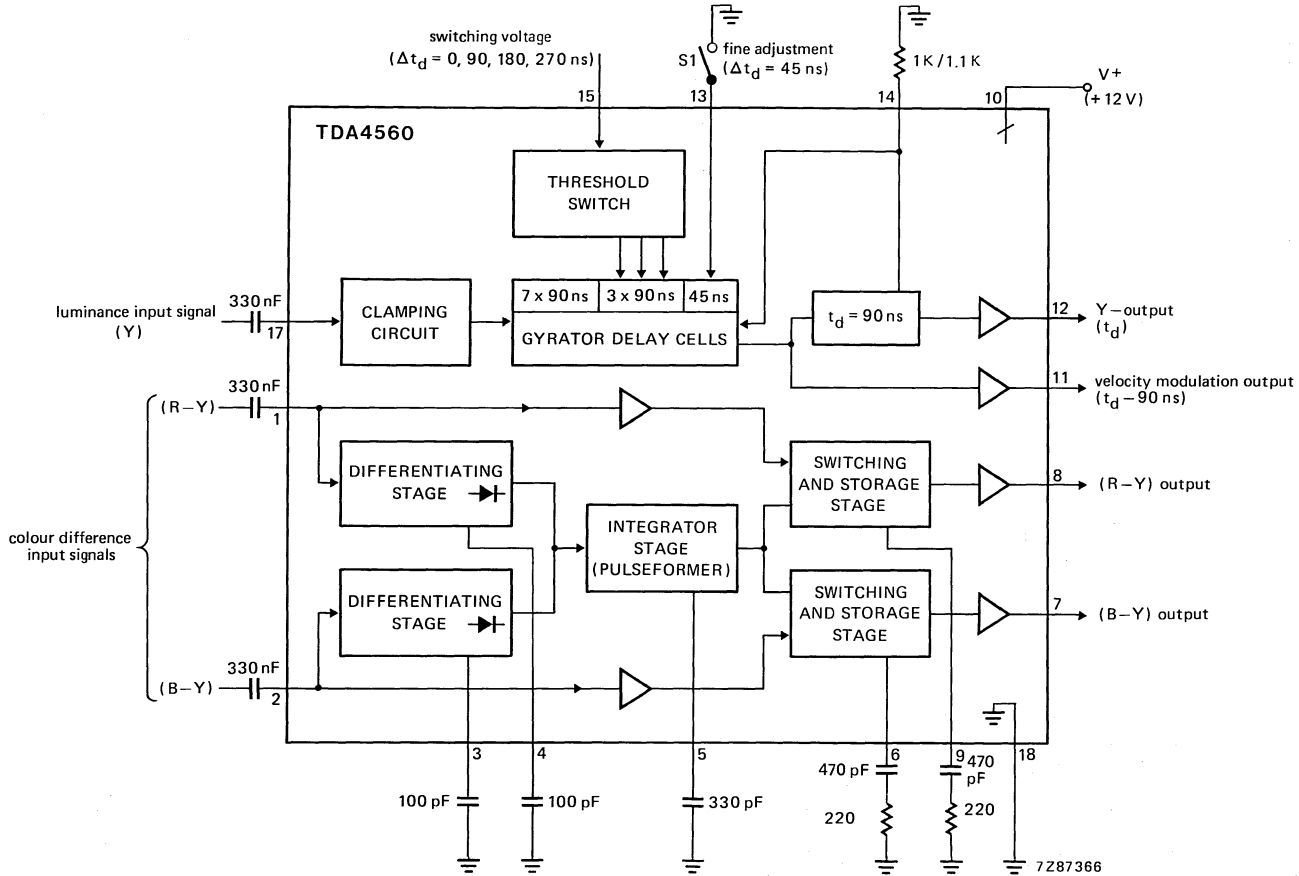

Fig. 1 Block diagram.

COLOR TRANSIENT IMPROVEMENT CIRCUIT**TDA4560****FUNCTIONAL DESCRIPTION**

The IC consists of two colour difference channels (B-Y) and (R-Y) and a luminance signal path (Y) as shown in Fig. 1.

Colour difference channels

The (B-Y) and (R-Y) colour difference channels consist of a buffer amplifier at the input, a switching stage and an output amplifier. The switching stages, which are controlled by transient detecting stages (differentiators), switch to a value that has been stored at the beginning of the transients. The differentiating stages get their signal direct from the colour difference detecting signal (pins 1 and 2). Two parallel storage stages are incorporated in which the colour difference signals are stored during the transient time of the signal. After a time of about 600 ns they are switched immediately (transient time of 150 ns) to the outputs. The colour difference channels are not attenuated.

Y-signal path

The Y-signal input (pin 17) is capacitively coupled to an input clamping circuit. Gyrator delay cells provide a maximum delay of 1035 ns including an additional delay of 45 ns via the fine adjustment switch (S1) at pin 13. Three delay cells are switched with two interstage switches dependent on the voltage at pin 15. Thus three switchable delay times of 90 ns, 180 ns or 270 ns less than the maximum delay time are available. A tuning compensation circuit ensures accuracy of delay time despite process tolerances. The Y-signal path has a 7 dB attenuation as a normal Y-delay coil and can replace this completely. The output is fed to pin 12 via a buffer amplifier. An additional output stage provides a signal of 90 ns less delay at pin 11 for the option of velocity modulation.

RATINGS

Limiting values in accordance with the Absolute Maximum System (IEC 134)

Supply voltage (pin 10)	$V_P = V_{10-18}$	max.	13.2 V
Voltage ranges to pin 18 (ground)			
at pins 1, 2, 12, 15	V_{n-18}	0 to	V_P V
at pin 11	V_{11-18}	0 to	$V_P - 3$ V
at pin 17	V_{17-18}	0 to	7 V
Voltages ranges			
at pin 7 to pin 6	V_{7-6}	0 to	5 V
at pin 8 to pin 9	V_{8-9}	0 to	5 V
Currents			
at pins 6, 9	$\pm I_{6,9}$	max.	15 mA
Total power dissipation	P_{tot}	max.	1.1 W
Storage temperature range	T_{stg}	-25 to + 150	°C
Operating ambient temperature range	T_{amb}	0 to + 70	°C

Note

Pins 3, 4, 5, 6, 9, 13 and 14 d.c. potential not published.

COLOR TRANSIENT IMPROVEMENT CIRCUIT

TDA4560

CHARACTERISTICS

$V_P = V_{10-18} = 12 \text{ V}$; $T_{\text{amb}} = 25 \text{ }^\circ\text{C}$; measured in application circuit Fig. 2; unless otherwise specified

parameter	symbol	min.	typ.	max.	unit
Supply (pin 10)					
Supply voltage	$V_P = V_{10-18}$	—	12	13.2	V
Supply current	$I_P = I_{10}$	—	35	—	mA
Colour difference channels (pins 1 and 2)					
(R-Y) input voltage (peak-to-peak value) 75% colour bar signal	V_{1-18}	—	1.05	—	V
(B-Y) input voltage (peak-to-peak value) 75% colour bar signal	V_{2-18}	—	1.33	—	V
Input resistance	$R_{1, 2-18}$	—	12	—	k Ω
(B-Y), (R-Y) signal attenuation $\frac{V_8}{V_1}, \frac{V_7}{V_2}$	α_{cd}	—	0	—	dB
Output current (emitter follower with constant current source 0.5 mA)	$-I_{7, 8}$	—	1.2	—	mA
(R-Y) and (B-Y) output signal transient time	t_{tr}	—	150	—	ns
Y-signal path (pin 17)					
Y-input voltage (composite signal) (peak-to-peak value)	$V_{17-18(p-p)}$	—	1	—	V
Input resistance	R_{17-18}	—	20	—	k Ω
Internal bias voltage	V_{17-18}	—	2.3	—	V
Input current					
during picture content	I_{17}	—	8	—	μA
during synchronizing pulse	$-I_{17}$	—	100	—	μA
Y-signal attenuation $\frac{V_{11}}{V_{17}}, \frac{V_{12}}{V_{17}}$	α_y	—	7	—	dB
Output current (emitter follower with constant current source 0.4 mA)	$-I_{11, 12}$	—	1.2	—	mA
Frequency response ($V_{15-18} = 0 \text{ V}$)					
at $R_{14-18} = 1 \text{ k}\Omega$	f_{12-17}	—	6	—	MHz
at $R_{14-18} = 1.1 \text{ k}\Omega$	f_{12-17}	—	4.5	—	MHz

COLOR TRANSIENT IMPROVEMENT CIRCUIT

TDA4560

parameter	symbol	min.	typ.	max.	unit
Y-signal path (pin 17) (continued)					
Adjustable delay (switch S1 open)					
at V ₁₅₋₁₈ = 0 to 2.5 V; R ₁₄₋₁₈ = 1 kΩ	t _d	—	640	—	ns
at V ₁₅₋₁₈ = 0 to 2.5 V; R ₁₄₋₁₈ = 1.1 kΩ	t _d	—	720	—	ns
at V ₁₅₋₁₈ = 3.5 to 5.5 V; R ₁₄₋₁₈ = 1 kΩ	t _d	—	720	—	ns
at V ₁₅₋₁₈ = 3.5 to 5.5 V; R ₁₄₋₁₈ = 1.1 kΩ	t _d	—	810	—	ns
at V ₁₅₋₁₈ = 6.5 to 8.5 V; R ₁₄₋₁₈ = 1 kΩ	t _d	—	800	—	ns
at V ₁₅₋₁₈ = 6.5 to 8.5 V; R ₁₄₋₁₈ = 1.1 kΩ	t _d	—	900	—	ns
at V ₁₅₋₁₈ = 9.5 to 12 V; R ₁₄₋₁₈ = 1 kΩ	t _d	—	880	—	ns
at V ₁₅₋₁₈ = 9.5 to 12 V; R ₁₄₋₁₈ = 1.1 kΩ	t _d	—	990	—	ns
Fine adjustment delay (switch S1 closed)					
at V ₁₃₋₁₈ = 0 V	Δt _d	—	45	—	ns
Signal delay for velocity modulation (pin 11)					
with R ₁₄₋₁₈ = 1 kΩ	t		t _d - 80 ns		
with R ₁₄₋₁₈ = 1.1 kΩ	t		t _d - 90 ns		
Thermal resistance					
From junction to ambient (in free air)	R _{th j-a}	—	—	70	K/W

APPLICATION INFORMATION

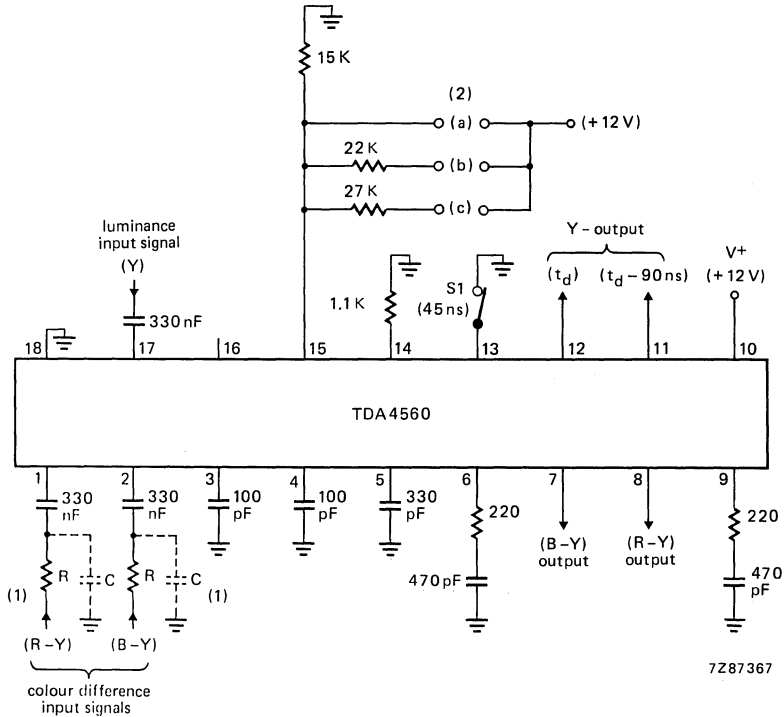

- (1) Residual carrier reduced to 20 mV peak-to-peak ($R = 1\text{ k}\Omega$, $C = 100\text{ pF}$).
- (2) Switching sequence for delay times shown in Table 1.

Fig. 2 Application diagram and test circuit.

Table 1 Switching sequence for delay times.

connection			voltage at pin 15	delay time (ns)*
(a)	(b)	(c)		
X	X	X	0 to 2.5 V	720
X	X	O	3.5 to 5.5 V	810
X	O	O	6.5 to 8.5 V	900
O	O	O	9.5 to 12 V	990

Where: X = connection closed; O = connection open.

* When switch (S1) is closed the delay time is increased by 45 ns.

Section 9 Applications

INDEX

SECTION 9 — APPLICATIONS

Index	9-1
Interface	
Data Conversion	
AN100	An Overview of Data Converters 9-3
AN101	Basic DACs 9-8
AN105	Digital Attenuator 9-15
AN106	Using the DAC08 Without a Negative Supply 9-16
AN109	Microprocessor Compatible DACs 9-17
Drivers	
AN112	LED Decoder Drivers: Using the NE587 and NE589 9-24
AN113	Using the MC1488/1489 Line Drivers and Receivers 9-30
Comparators	
AN116	Applications for the NE521/522/527/529 9-33
Signal Conditioner	
AN118	LVDT Signal Conditioner: Applications Using the NE5520 9-41
Communications	
Timers	
AN170	NE555 and NE556 Applications 9-57
AN171	NE558 Applications 9-74
Phase Locked Loops	
AN177	An Overview of Phase Locked Loops (PLL) 9-79
AN178	Modeling the PLL 9-84
AN179	Circuit Description of the NE564 9-100
AN180	The NE564: Frequency Synthesis 9-105
AN181	A 6MHz FSK Converter Design Example for the NE564 9-110
AN182	Clock Regenerator with Crystal Controlled Phase Locked VCO 9-112
AN183	Circuit Description of the NE565 9-121
AN184	Typical Applications with NE565 9-125
AN185	Circuit Description of the NE566 9-128
AN186	Waveform Generators with the NE566 9-129
AN187	Circuit Description of the NE567 Tone Decoder 9-132
AN188	Selected Circuits Using the NE567 9-137
AN189	Balanced Modulator/Demodulator Applications Using the MC1496/MC1596 9-140
AN190	Applications of Low Noise Stereo Amplifiers: NE542 9-145
AN191	Stereo Decoder Applications Using the μA758 9-148

INDEX

Compandors	
AN174	Applications for Compandors: NE570/571/SA571 9-156
AN175	Automatic Level Control: NE572 9-165
AN176	Compandor Cookbook 9-166
FSK Modems	
AN195	Applications Using the NE5080, NE5081 9-173
Amplifiers	
Operational Amplifiers	
AN165	Integrated Operational Amplifier Theory 9-181
AN166	Basic Feedback Theory 9-188
AN142	Audio Circuits Using the NE5532/33/34 9-192
AN143	Applications Using the SE/NE5535 9-200
AN150	Applications for the NE538 9-203
AN151	Applications for the NE531 9-204
AN160	Applications for the MC3403 9-205
AN144	Applications for the NE5512 and NE5514 9-208
AN145	NE5517: General Description and Applications for Use with the NE5517/A Transconductance Amplifier 9-214
AN164	Explanation of Noise 9-217
Video Amplifiers	
AN141	Using the NE592/5592 Video Amplifier 9-226
AN140	Compensation Techniques for Use with the SE/NE5539 9-231
Power Conversion and Control	
Switched Mode Power Supplies (SMPS)	
AN120	An Overview of SMPS 9-237
AN121	Forward Converter Application Using the NE5560 9-242
AN122	NE5560 Push-Pull Regulation Application 9-243
AN123	NE5561 Applications 9-245
AN124	External Synchronization for the NE5561 9-249
AN126	Applications Using the SG3524 9-250
Control Circuits	
AN131	Applications Using the NE5044 Encoder 9-252
AN132	Applications Using the NE5045 Decoder 9-254
AN133	Applications Using the NE544 Servo Amplifier 9-256
AN134	Computer Controlled Robotics Applications 9-261

INTRODUCTION

Large systems are comprised of many different subsystems, all of which must interface to complete the system. All types of circuits, including linear, digital and discrete are often used in the subsystems.

Interface circuits provide the necessary function of tying the parts of a system together. These circuits are usually not purely linear or digital but contain both types of circuit functions. For instance, sense amplifiers are designed for interface between low level memory outputs and bipolar levels, while differential comparators are designed for interface between analog systems and TTL/DTL systems. In general, this section will cover such devices as comparators, sense amplifiers, line drivers/receivers, and display drivers.

CONVERTERS

Digital communications, digital instruments and displays have created a demand for low cost reliable converters. Key factors in this demand are:

- The need to communicate with digital computers for processing and storage of analog signals.
- Severe limitations encountered in reliable analog data transmission over any considerable distance.
- The need for more easily readable displays.

General application areas for converters include: Data processing, data transmission, graphics and displays, audio systems, control systems and arithmetic operations.

Specific Applications

Test Systems

- Transistor tester (Force I_B and I_C)
- Resistor matching
- Programmable power supplies
- Programmable pulse generators
- Programmable current source
- Function generators (ROM drive)

Arithmetic Operations

- Analog division by a digital word
- Analog quotient of 2 digital words
- Analog product of 2 digital words—squaring
- Addition and subtraction with analog output
- Magnitude comparison of 2 digital words
- Digital quotient of 2 analog variables
- Arithmetic operations with words from different logic families

Graphics and Displays

- Polar to rectangular conversion
- CRT character generation
- Chart recorder driver
- CRT display driver

Data Transmission

- Modem transmitter
- Differential line driver
- Party line multiplexing of analog signals
- Multi-level 2-wire data transmission
- Secure communications (constant power dissipation)

Control Systems

- Reference level generator for setpoint controllers
- Positive peak detector
- Negative peak detector
- Disc drive head positioner
- Microfilm head positioner

Audio Systems

- Digital AVC and reverberation
- Music distribution
- Organ tone generator
- Audio tracking A/D
- Speech compression and expansion
- Audio digitizing and decoding

DAC Building Blocks

The actual implementation of a D/A system contains four separate parts: A reference quantity; a set of binary switches to simulate binary coefficients $B_1 \dots B_N$; a weighting network; and an output summing means.

Binary-Weighted Ladder Employing Voltage Switching

The disadvantages of a binary-weighted ladder employing voltage switching include: A

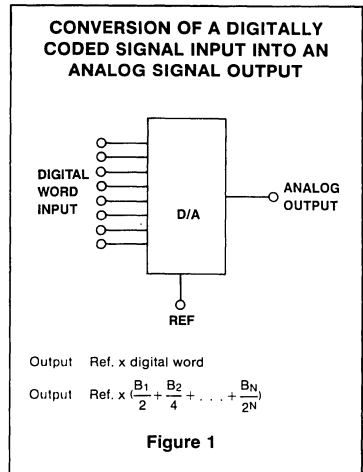

wide range of resistor values which are used in weighting the network; and nodal capacitances which are charged/discharged during conversion. See Figure 2.

R-2R Ladder Network Employing Current Switching

The advantages of this type of network include: No need for a wide range of resistor values; and current switching eliminates transients in nodal parasitic capacitances. See Figure 3.

KEY SPECIFICATIONS

Speed

The conversion process should represent the input signal with the highest fidelity and minimal lag in time (Real time applications).

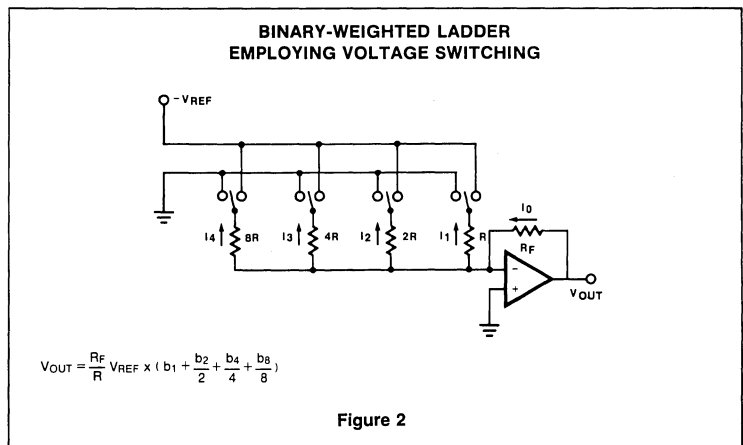

DAC PRODUCTS SUMMARY

	MC1408 7-8	DAC08 Series	SE/NE5018/19	SE/NE5118/19	NE5020	MC3410 /NE5410	AM6012
Resolution	8 bit	8 bit	8 bit	8 bit	10 bit	10 bit	12 bit
Relative Accuracy	.39/ .19	.39/ .19/ .1	.19/ .1	.19/ .1	.05	.05	.05
Settling Time	300ns	60ns	2 μ s	200ns	4 μ s	250ns	500ns
Output	I	I & \bar{T}	V	I	V	I	$\pm V$
Features	Standard	Complementary Current Outputs	Bus Compatible input latches ref voltage	High speed current out version of NE5018	8 bit bus compatible	10 bit accuracy	Com- plementary Current Outputs

Table 1

Settling Time

Settling time is a measure of a converter's speed and is defined as the elapsed time after a code transition for DAC output to reach final value within specified limits, usually $\pm 1/2$ L.S.B. See Figure 4.

Errors

Offset Error —The output voltage of DAC with zero code input. Offset can and usually is trimmed to zero with an offset zero adjust potentiometer. See Figure 5.

Gain Error —Deviation in output voltage from correct level when the input calls for a full scale output. This error may be trimmed to zero. See Figure 6.

Relative Accuracy —The maximum deviation of the DAC output relative to an ideal straight line drawn from zero to full scale -1 L.S.B. See Figure 7.

Differential Non-Linearity — Incremental error from any ideal L.S.B. analog output change when the digital input is changed 1 L.S.B.. See Figure 8.

Monotonicity —As the input code is incremented from one code to the next in sequence, the analog output will either increase or remain constant. See Figure 9.

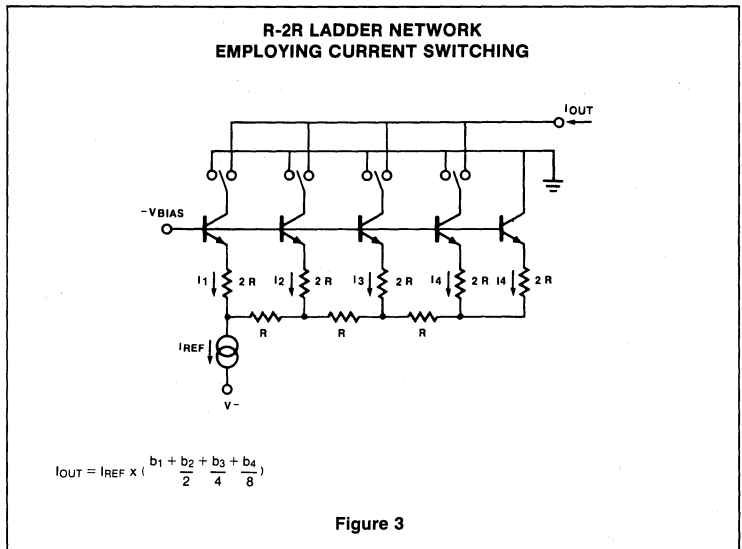

Figure 3

Stability

Stability is a measure of the independence of converter parameters with respect to variations in external conditions such as temperature and supply voltage.

Temperature Coefficient

—The effects of temperature changes of the output. Specified as %F.S. change.

Supply Rejection

—Ability to resist changes in the output with supply changes, specified as % full scale change.

Long Term Stability

—Measure of how stable the output is over a long period of time.

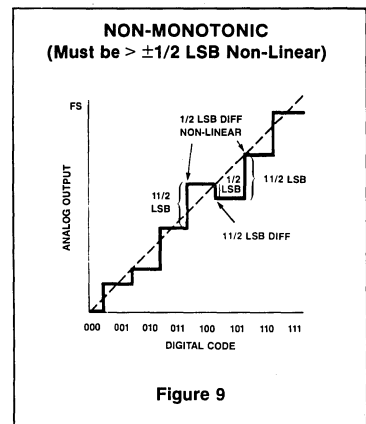
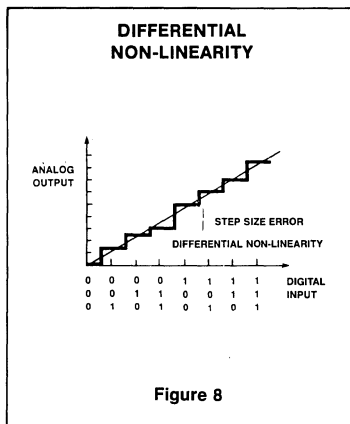
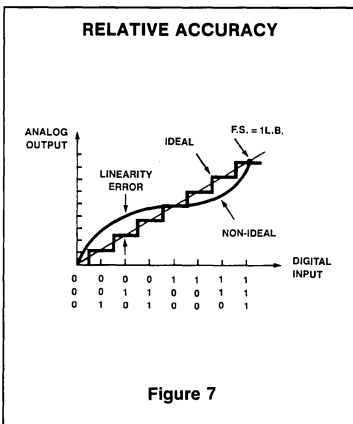
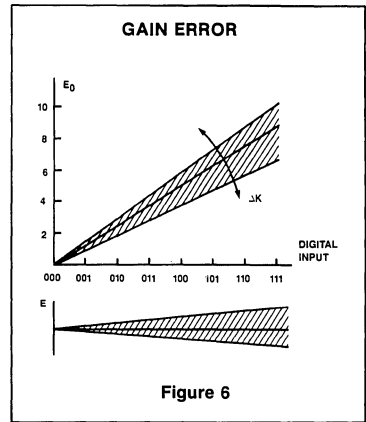
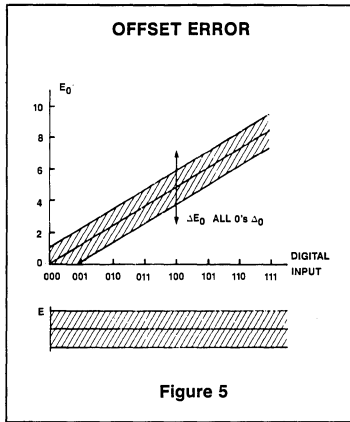
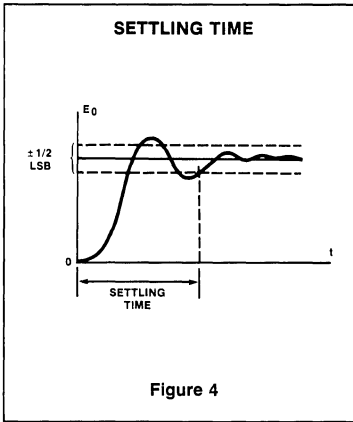

A/D CONVERTER CIRCUITS

Analog-to-Digital conversion schemes generally fall into one of three categories:

1. Feedback
 - Counting
 - Tracking (up-down)
 - Successive approximation
2. Integrating
 - Single slope
 - Dual slope
 - Triple slope
3. Multiple comparator (Flash)

The type of converter chosen for a given application depends upon many things: the accuracy required, the conversion speed necessary, the necessary immunity to noise, and cost are some of these considerations.

The successive approximation technique is the one most widely used, mainly because of its excellent tradeoffs in resolution, speed, accuracy, and cost. All of the A/D converters (ADCs) presently manufactured by Signetics are successive approximation types.

Figure 10 shows a simplified block diagram of a successive approximation A/D converter.

Upon receiving the start signal, the successive approximation register (SAR) is cleared and the most significant bit (MSB) of that register is set. The SAR output is connected to the input of the DAC, the output of which is compared with the unknown input. If the input is less than the DAC output, the MSB is cleared and the next bit is set; if the input is greater than the DAC output, the MSB is left high and the next bit is set. The input is again compared with the DAC output and the second bit cleared or left high, based on the same criteria as for the MSB. This process continues until all bits have been determined.

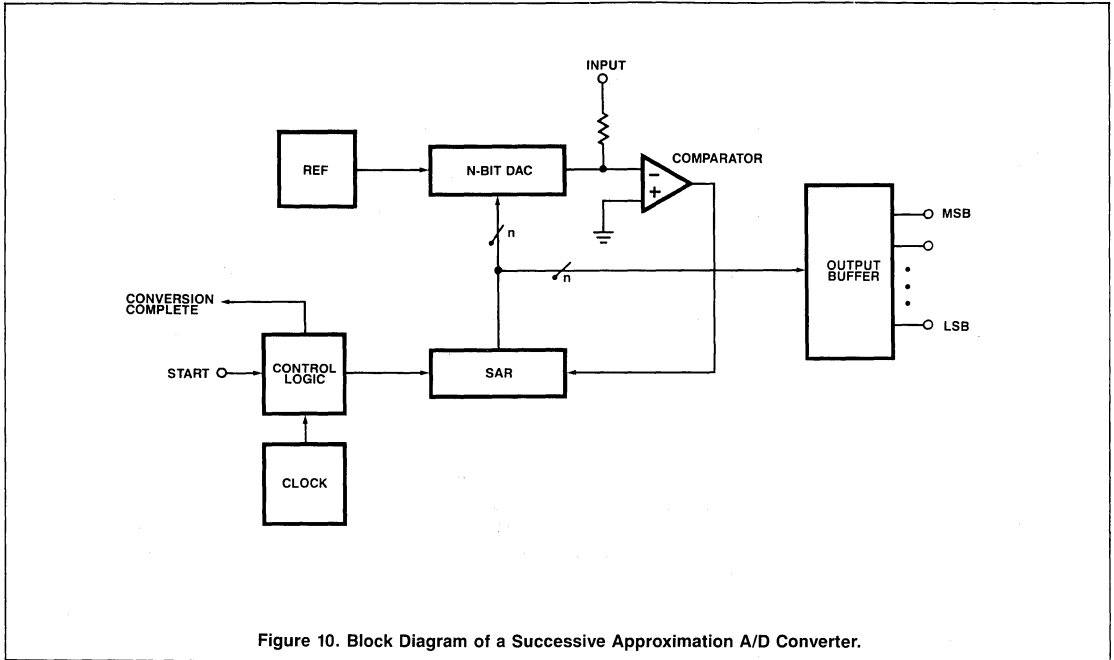

Figure 10. Block Diagram of a Successive Approximation A/D Converter.

The analog input should not change appreciably during the conversion time. If it did change during this time, the converted output would not be a true indication of the analog input. For this reason, it is common practice to use a sample-and-hold circuit at the converter analog input to hold the input value constant during the conversion process. A sample-and-hold circuit is not necessary if the signal at the input of the converter varies slowly enough and has a noise level low enough so that the input will not change a significant amount during the conversion. The allowable input change during this conversion is generally accepted as the value of 1/2 LSB (for n-bit accuracy).

Accuracy and speed are determined primarily by the properties of the DAC and the comparator. Linearity is determined primarily by the linearity of the DAC. If the DAC is non-

monotonic, one or more codes will be missing from the A/D converter's output range.

Figure 11 is the transfer function of a 3-bit binary coded A/D converter with a 0 to +10V input range. A 3-bit ADC is shown for simplicity but the principle applies to ADCs of any resolution. Note that there is a 1/2 LSB offset at the input such that the first count occurs with the input is equal the 1/2 LSB. The center of the range for the first step occurs, therefore, when the input is equal to the value of one LSB, and the error at the switch point is limited to 1/2LSB. This error is known as the quantization error as it is derived from the smallest input quantity that can be resolved. If an ADC has a specified error of 1/2 LSB maximum, this means that any transition point can be as far as 1/2 LSB from where it should be.

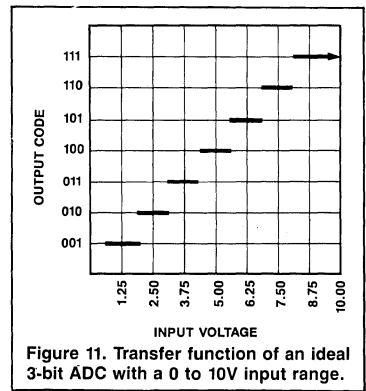

Figure 11. Transfer function of an ideal 3-bit ADC with a 0 to 10V input range.

CONSIDERATIONS FOR A/D CONVERTERS

- Analog input signal range and resolution required
- Linearity requirement and stability
- Conversion speed required
- Monotonicity requirement: Can missing codes be tolerated?
- Character of input signal: Is it noisy, sampled, filtered, slowly varying?
- Transfer characteristics (Type of coding)

A/D CONVERTER TERMS

Resolution

Resolution is the input change required to increment the output between the two adjacent codes. This term also refers to the number of bits in the output word and; hence, the number of discrete output codes the input analog signal can be broken into. Expressed in "bits" resolution.

Transfer Characteristic

The Transfer Characteristic is the relationship of the output digital word (code) to the input analog signal, i.e., Binary, BCD.

Conversion Speed

The Conversion Speed is the speed at which an ADC can make repetitive data conversions.

Quantizing Error

Quantizing Error is an inherent error in the conversion process due to finite resolution (discrete output). See Figure 12.

Offset Error

An Offset Error is shown in Figure 13.

Gain Error

A Gain Error is shown in Figure 14.

Relative Accuracy

Relative Accuracy is the deviation of an actual bit transition from the ideal transition value at any level over the range of the ADC (% F.S.). See Figure 15.

Hysteresis Error

A Hysteresis Error is the code transition voltage dependence relative to the direction from which the transition is approached.

Monotonicity

Monotonicity is when the output code either increases or remains the same for increasing analog input signals. The opposite is true in the reverse direction.

Missing Codes

A Missing Code is a code combination that is skipped. See Figure 16.

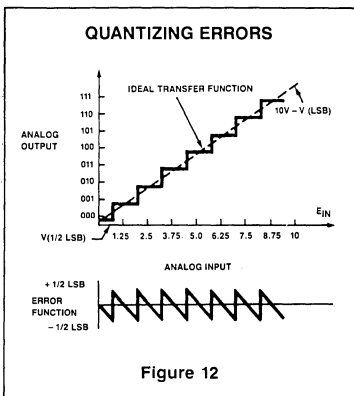

Figure 12

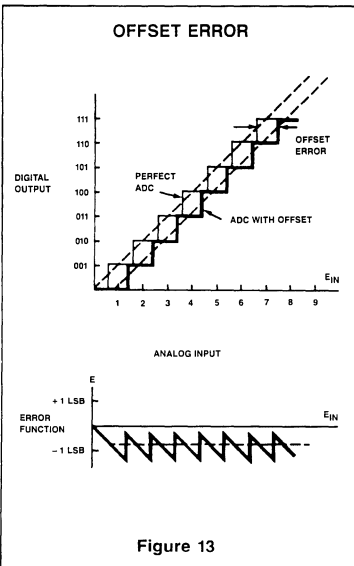

Figure 13

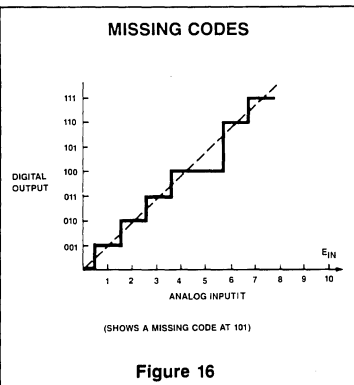

Figure 16

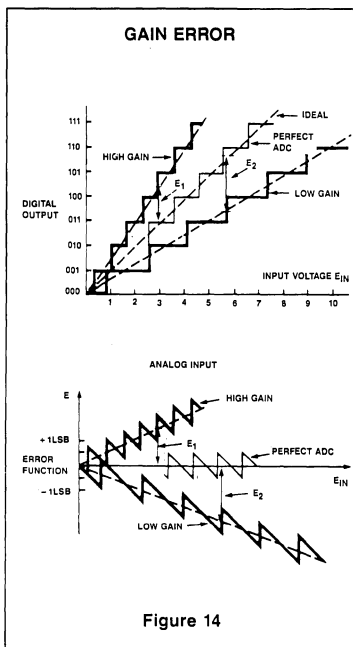

Figure 14

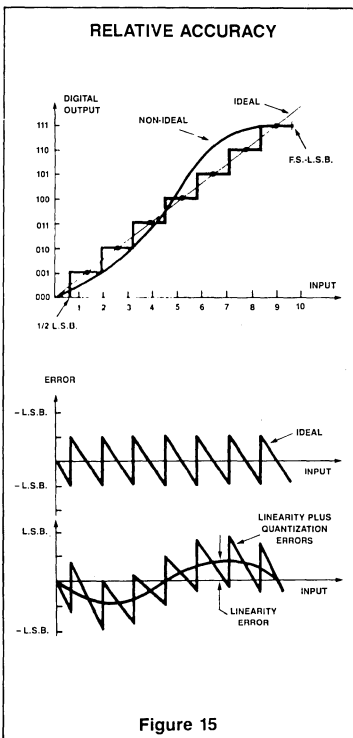

Figure 15

DAC08 SERIES

Reference Amplifier Setup

The DAC08 Series is a multiplying D-to-A converter in which the output current is the product of a digital number and the input reference current. The reference current may be fixed or may vary from nearly zero to +4.0mA. The full scale output current is a linear function of the reference current and is given by this equation where $I_{REF} = I_{14}$.

$$I_{FS} = \frac{255}{256} \cdot I_{REF}$$

In positive reference applications shown in Figure 1, an external positive reference voltage forces current through R14 into the $V_{REF}(+)$ terminal (pin 14) of the reference amplifier. Alternatively, a negative reference may be applied to $V_{REF}(-)$ at pin 15, shown in Figure 2. Reference current flows from ground through R14 into $V_{REF}(+)$ as in the positive reference case. This negative reference connection has the advantage of a very high impedance presented at pin 15. The voltage at pin 14 is equal to and tracks the voltage at pin 15 due to the high gain of the internal reference amplifier. R15 (nominally equal to R14) is used to cancel bias current errors. R15 may be eliminated with only a minor increase in error.

Bipolar references may be accommodated by offsetting V_{REF} or pin 15 as shown in Figure 3. The negative common mode range of the reference amplifier is given by the following equation.

$$V_{CM-} = V_- + (I_{REF} \cdot 1k\Omega) + 2.5V$$

When a dc reference is used, a reference bypass capacitor is recommended. A 5.0V TTL logic supply is not recommended as a reference. If a regulated power supply is used as a reference R14 should be split into 2 resistors with the junction bypassed to ground with a 0.1 μ F capacitor.

For most applications, a +10.0V reference is recommended for optimum full scale temperature coefficient performance. This will minimize the contributions of reference amplifier V_{OS} and TCV_{OS} . For most applications the tight relationship between I_{REF} and I_{FS} will eliminate the need for trimming I_{REF} . If required, full scale trimming may be accomplished by adjusting the value of R14, or by using a potentiometer for R14. An improved method of full scale trimming which eliminates potentiometer T.C. effects is shown Figure 4.

Using lower values of reference current reduces negative power supply current and increases reference amplifier negative com-

mon mode range. The recommended range for operation with a dc reference current is +0.2mA to +4.0mA.

The reference amplifier must be compensated by using a capacitor from pin 16 to V_- . For fixed reference operation, a 0.01 μ F capacitor is recommended. For variable reference applications, see section entitled Reference Amplifier Compensation for Multiplying Applications.

Multiplying Operation

The DAC08 Series provides excellent multiplying performance with an extremely linear relationship between I_{FS} and I_{REF} over a range of 4mA to 4 μ A. Monotonic operation is maintained over a typical range of I_{REF} from 100 μ A to 4.0mA.

Reference Amplifier Compensation for Multiplying Applications

AC reference applications will require the reference amplifier to be compensated using a capacitor from pin 16 to V_- . The value of this capacitor depends on the impedance presented to pin 14. For R_{14} values of 1.0, 2.5 and 5.0K Ω , minimum values of C_C are 15, 37 and 75pF. Larger values of R_{14} require proportionately increased values of C_C for proper phase margin.

For fastest multiplying response, low values of R_{14} enabling small C_C values should be used. If pin 14 is driven by a high impedance

such as a transistor current source, none of the preceding values will suffice and the amplifier must be heavily compensated, which will decrease overall bandwidth and slew rate. For $R_{14} = 1k\Omega$ and $CC = 15pF$, the reference amplifier slews at 4mA/ μ s enabling a transition from $I_{REF} = 0$ to $I_{REF} = 2mA$ in 500ns.

Operation with pulse inputs to the reference amplifier may be accommodated by an alternate compensation scheme shown in Figure 5. This technique provides lowest full scale transition times. Full scale transition (0 to 2mA) occurs in 120ns when the equivalent impedance at pin 14 is 200 Ω and $C_C = 0$. This yields a reference slew rate of 16mA/ μ s, which is relatively independent of R_{IN} and V_{IN} values.

Logic Inputs

The DAC08 design incorporates a logic input circuit which enables direct interface to all popular logic families and provides maximum noise immunity. This feature is made possible by the large input swing capability, 2 μ A logic input current and completely adjustable logic threshold voltage. For $V_- = -15V$, the logic inputs may swing between -11V and +18V. This enables direct interface with +15V CMOS logic, even when the DAC08 is powered from a +5V supply. Minimum input logic swing is given by following the equation.

$$V_- + (I_{REF} \cdot 1k\Omega) + 2.5V$$

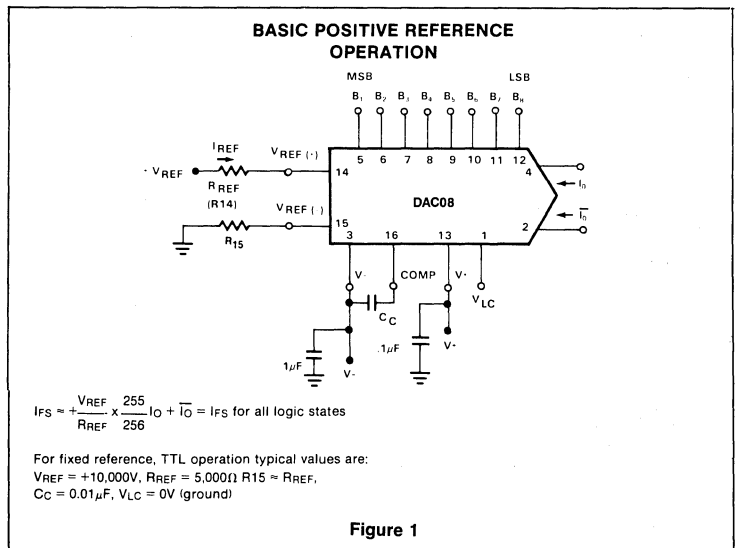

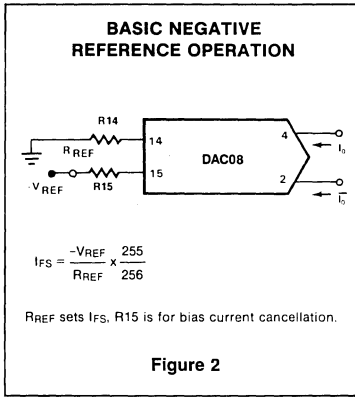

The logic threshold may be adjusted over a wide range by placing an appropriate voltage at the logic threshold control in (pin 1, V_{LC}). Figure 6 shows the relationship between V_{LC} and V_{TH} over the temperature range, with V_{TH} nominally 1.4 above V_{LC} . For TTL and DTL interface, simply ground pin 1. When interfacing ECL, an $I_{REF} = 1\text{mA}$ is recommended. For interfacng other logic families, see Figure 7. For general setup of the logic control circuit, it should be noted that pin 1 may source up to $200\mu\text{A}$. External circuitry should be designed to accommodate this current.

Fastest settling times are obtained when pin 1 sees a low impedance. If pin 1 is connected to a $1\text{k}\Omega$ divider, for example, it should be bypassed to ground by a $0.01\mu\text{F}$ capacitor.

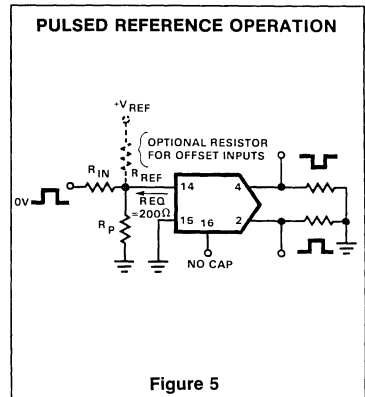

Low reference current operation decreases power consumption and increases negative compliance, reference amplifier negative common mode range, negative logic input range, and negative logic threshold range. Consult the various figures for guidance. For example, operation at -4.5V with $I_{REF} = 2\text{mA}$ is not recommended because negative output compliance would be reduced to near zero. Operation from lower supplies is possible; however, at least 8V total must be applied between pins 2 and 4, and pin 3 to insure turn-on of the internal bias network.

Symmetrical supplies are not required, as the DAC08 is quite insensitive to variations in supply voltage. Battery operation is feasible as no ground connection is required; however, an artificial ground may be useful to insure logic swings, etc., remain between acceptable limits.

Power consumption may be calculated by this equation.

$$P_D = (I_{REF} |V_{REF}|) + (I_{REF} |V_{REF}|) + (2I_{REF} |V_{REF}|)$$

A useful feature of the DAC08 design is that supply current is constant and independent of input logic states. This is useful in cryptographic applications and further serves to reduce the size of the power supply bypass capacitors.

Temperature Performance

The linearity and monotonicity specifications of the DAC08 are guaranteed to apply over the entire rated operating temperature range. Full scale output current drift is low, typically $\pm 10\text{ppm}/^\circ\text{C}$, with zero scale output current and drift essentially negligible compared to $1/2$ LSB.

Full scale output drift performance will be best with $+10.0\text{V}$ references, as V_{OS} and TCV_{OS} of the reference amplifier will be very small compared to 10.0V . The temperature

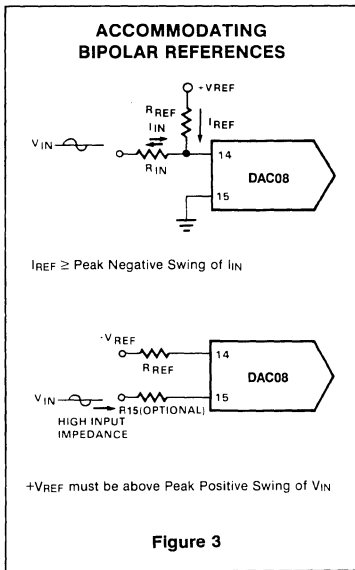

Analog Output Currents

Both true and complemented output sink currents are provided, where $I_O + \bar{I}_O = I_{FS}$. Current appears at the true output when a 1 is applied to each logic input. As the binary count increases, the sink current at pin 4 increases proportionally, in the fashion of a positive logic D-to-A converter. When a 0 is applied to any input bit, that current is turned off at pin 4 and turned on at pin 2. A decreasing logic count increases I_O as in a negative or inverted logic D-to-A converter. Both outputs may be used simultaneously. If one of the outputs is not required it must still be connected to ground or to a point capable of sourcing I_{FS} . Do not leave an unused output pin open.

Both outputs have an extremely wide voltage compliance enabling fast direct current-to-voltage conversion through a resistor tied to ground or other voltage source. Positive compliance is 36V above V^- and is independent of the positive supply. Negative compliance is given by the equation:

$$V^- - (I_{REF} \cdot 1\text{k}\Omega) + 3.0\text{V}$$

Note that lower values of I_{REF} will allow a greater output compliance.

The dual outputs enable double the usual peak-to-peak load swing when driving loads in quasi-differential fashion. This feature is especially useful in cable driving, CRT deflection and in other balanced applications such as balanced bridge A/D circuits as well as driving center-tapped coils and transformers.

Power Supplies

The DAC08 operates over a wide range of power supply voltages from a total supply of 9V to 36V . When operating at supplies of $\pm 5\text{V}$ or less, $I_{REF} \leq 1\text{mA}$ is recommended.

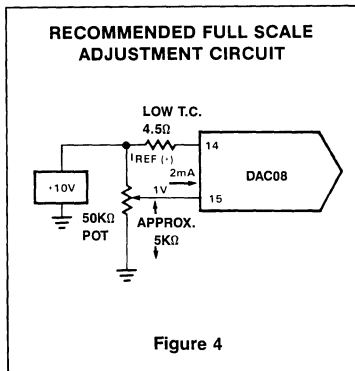

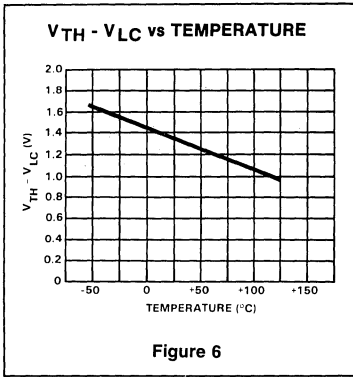

coefficient of the reference resistor R14 should match and track that of the output resistor for minimum overall full scale drift. Settling times of the DAC08 decrease approximately 10% at -55°C and an increase of about 15% at +125°C is typical.

Settling Time

The DAC08 is capable of extremely fast settling times (typically 85ns at IREF = 2.0mA).

Judicious circuit design and careful board layout must be employed to obtain full performance potential during testing and application. The logic switch design enables propagation delays of only 35ns for each of the 8 bits. Settling time to within 1/2 LSB of the LSB is therefore 35ns, with each progressively larger bit taking successively longer. The MSB settles in 85ns, thus determining the overall settling time of 85ns. Settling to 6-bit accuracy requires about 65 to 70 ns. The output capacitance, including the package, is approximately 15pF. Therefore the output RC time constant dominates settling time if RL > 500Ω.

Settling time and propagation delay are relatively insensitive to logic input amplitude and rise and fall times due to the high gain of the logic switches. Settling time also remains essentially constant for IREF values down to 1.0mA, with gradual increases for lower IREF values. The principal advantage of higher IREF values lies in the ability to attain a given output level with lower load resistors, thus reducing the output RC time constant.

Measurement of settling time requires the ability to accurately resolve ±4μA. Therefore

a 1kΩ load is needed to provide adequate drive for most oscilloscopes. The settling time fixture of Figure 8 uses a cascode design to permit driving a 1kΩ load with less than 5pF of parasitic capacitance at the measurement node. At IREF values of less than 1.0mA, excessive RC damping of the output is difficult to prevent while maintaining adequate sensitivity. However, the major carry from 01111111 to 10000000 provides an accurate indicator of settling time. This code change does not require the normal 6.2 time constants to settle to within ±0.2% of the final value; thus, settling time may be observed at lower values of IREF.

The DAC08 switching transients or glitches are very low and may be further reduced by small capacitive loads at the output at a minor sacrifice in settling time.

Fastest operation can be obtained by using short leads, minimizing output capacitance and load resistor values, and by adequate bypassing at the supply, reference and VLC terminals. Supplies do not require large electrolytic bypass capacitors as the supply current drain is dependent of input logic states. 0.1μF capacitors at the supply pins provide full transient performance.

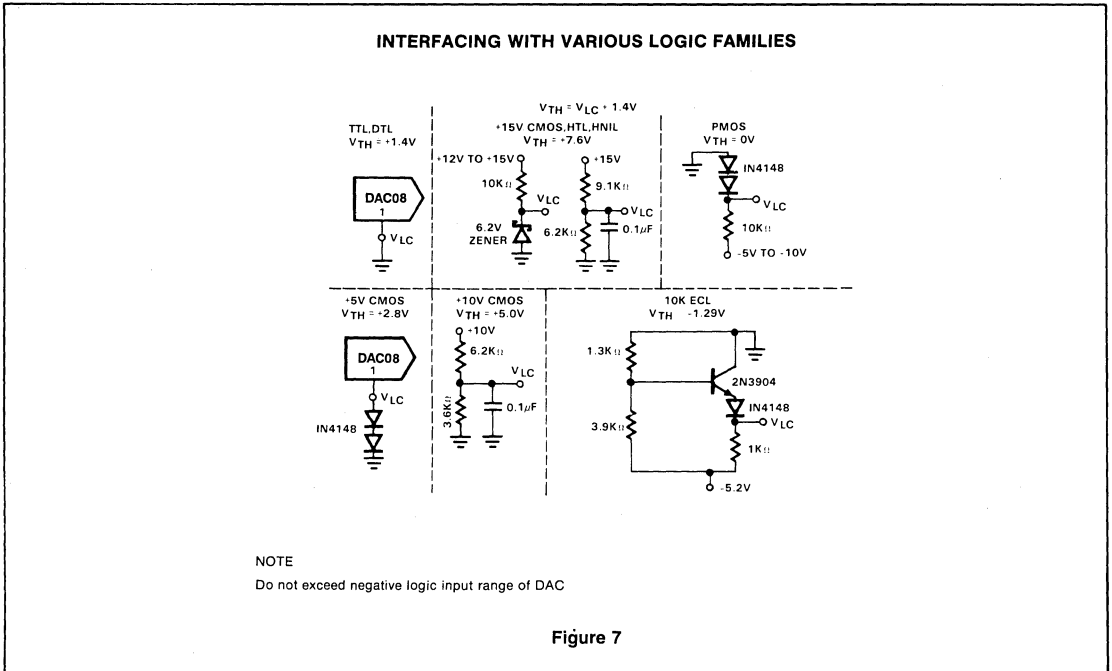

SETTLING TIME MEASUREMENT

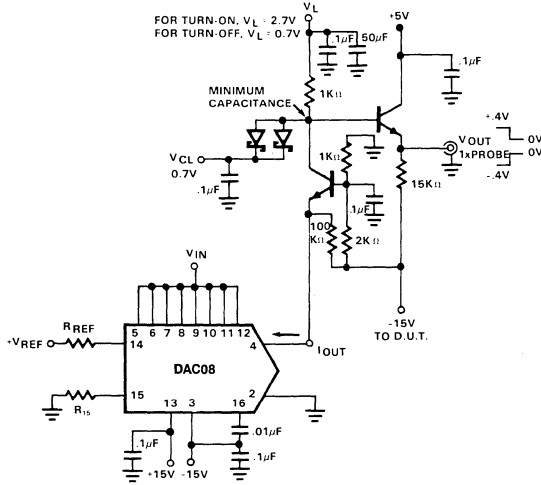
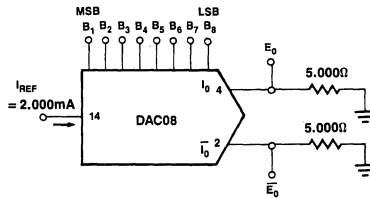

Figure 8

TYPICAL APPLICATIONS

BASIC UNIPOLAR NEGATIVE OPERATION



	B ₁	B ₂	B ₃	B ₄	B ₅	B ₆	B ₇	B ₈	I _O mA	I _O mA	E _O	E _O
Full scale	1	1	1	1	1	1	1	1	1.992	.000	-9.960	.000
Full scale - LSB	1	1	1	1	1	1	1	0	1.984	.008	-9.920	-.040
Half scale + LSB	1	0	0	0	0	0	0	1	1.008	.984	-5.040	-4.920
Half scale	1	0	0	0	0	0	0	0	1.000	.992	-5.000	-4.960
Half scale - LSB	0	1	1	1	1	1	1	1	.992	1.000	-4.960	-5.000
Zero scale + LSB	0	0	0	0	0	0	0	1	.008	1.984	-.040	-9.920
Zero scale	0	0	0	0	0	0	0	0	.000	1.992	.000	-9.960

Figure 9

TYPICAL APPLICATIONS (Cont'd)

BASIC BIPOLAR OUTPUT OPERATION

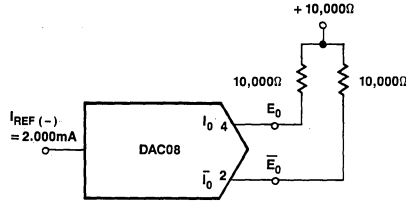

	B ₁	B ₂	B ₃	B ₄	B ₅	B ₆	B ₇	B ₈	E _O	E _O -
POS full scale	1	1	1	1	1	1	1	1	-9.920	+10.000
POS full scale - LSB	1	1	1	1	1	1	1	0	-9.840	+9.920
Zero scale + LSB	1	0	0	0	0	0	0	1	-0.080	+0.160
Zero scale	1	0	0	0	0	0	0	0	0.000	+0.080
Zero scale - LSB	0	1	1	1	1	1	1	1	+0.080	0.000
Neg full scale + LSB	0	0	0	0	0	0	0	1	+9.920	-9.840
Neg full scale	0	0	0	0	0	0	0	0	+10.000	-9.920

Figure 10

SYMMETRICAL OFFSET BINARY OPERATION

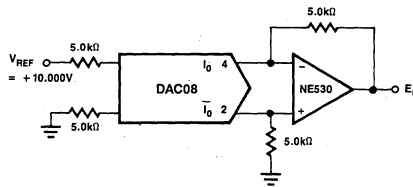

	B ₁	B ₂	B ₃	B ₄	B ₅	B ₆	B ₇	B ₈	E _O
POS full scale	1	1	1	1	1	1	1	1	+9.920
POS full scale - LSB	1	1	1	1	1	1	1	0	+9.840
(+) Zero scale	1	0	0	0	0	0	0	0	+0.040
(-) Zero scale	0	1	1	1	1	1	1	1	-0.040
Neg full scale + LSB	0	0	0	0	0	0	0	1	-9.840
Neg full scale	0	0	0	0	0	0	0	0	-9.920

Figure 11

POSITIVE LOW IMPEDANCE OUTPUT OPERATION

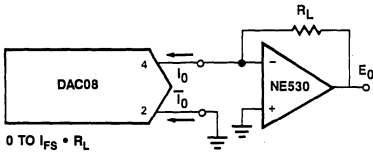

0 TO $I_{FS} \cdot R_L$
 $I_{FS} \cong \frac{255}{256} I_{REF}$

For complementary output (operation as negative logic DAC), connect inverting input of OP-amp to I_0 (pin 2), connect I_1 (pin 4) to ground.

Figure 12

NEGATIVE LOW IMPEDANCE OUTPUT OPERATION

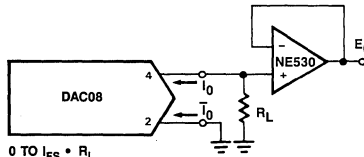

0 TO $I_{FS} \cdot R_L$
 $I_{FS} \cong \frac{255}{256} I_{REF}$

For complementary output (operation as a negative logic DAC), connect non-inverting input of OP-amp to I_0 (pin 2); connect I_1 (pin 4) to ground.

Figure 13

LOW COST 8-BIT 1 MICROSECOND A-TO-D CONVERTER

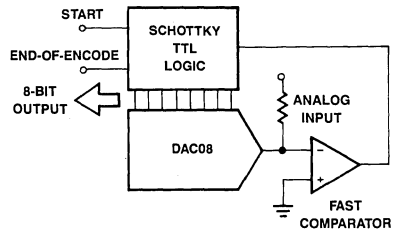
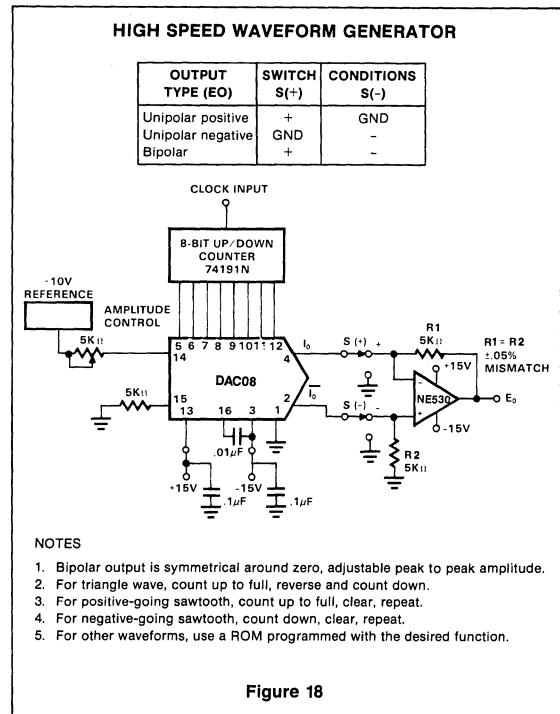
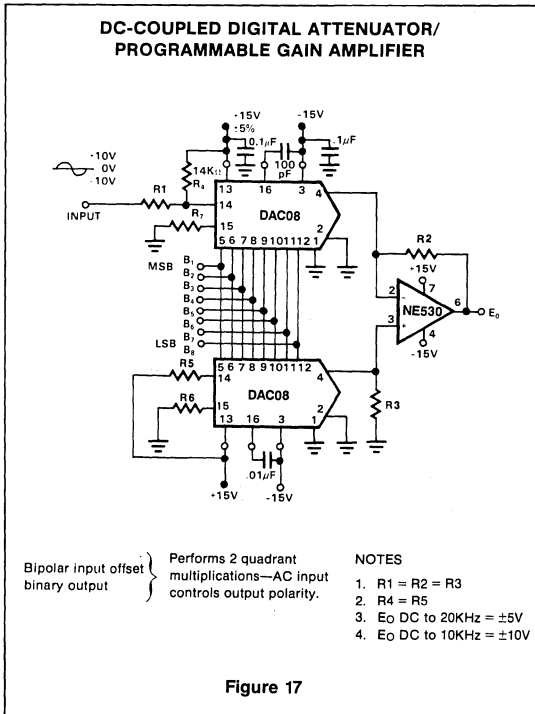
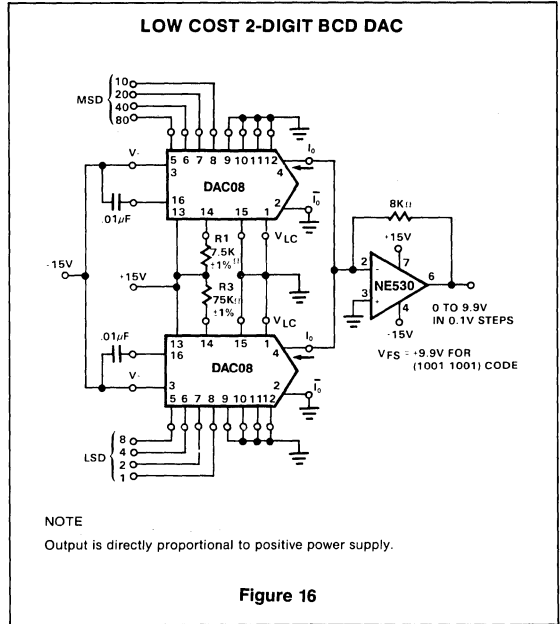
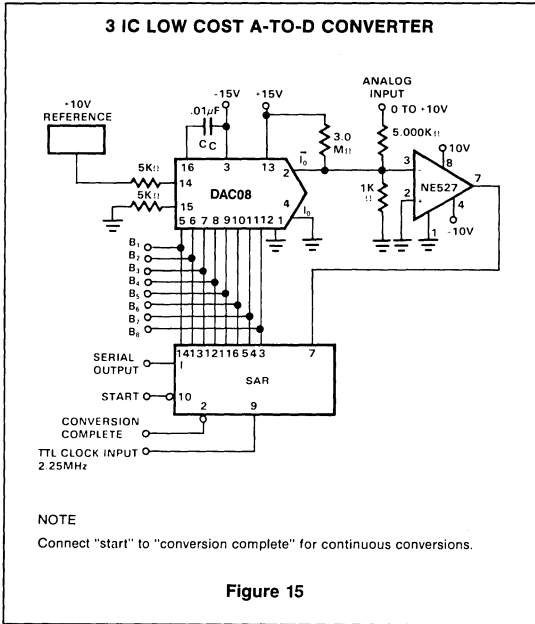

Figure 14

BASIC DACs



DIGITAL ATTENUATOR

Figure 1 shows a D-C coupled Digital Attenuator or Programmable Gain Amplifier.

Pin 14 of the DAC is a Virtual Ground. Current must always flow into Pin 14, so the current through R4 must be greater than that through R1 when the input signal is at its most negative usable value. If the input signal value goes low enough to cause the current through R1 to be greater than that through R4, output clipping will occur.

To extend the operating frequency range, the compensation cap, C_C, needs to be minimized, which implies that the resistance at Pin 14 (R1 and R4) must be minimized. If the voltage to which R4 and R5 are returned has any noise on it at all, R4 and R5 should be formed of two series resistors with the junction of them bypassed with 0.1μF to ground. Pin 15 could be grounded with a small sacrifice in accuracy and temperature drift. R6 and R7 compensate for reference amplifier input offset.

R1 and R4 should be chosen such that, when the input is at peak usable signal, the total current into Pin 14 does not exceed 4mA. When the input is most negative, R1 current must be less than R4 current (remember, pin 14 is always at 0V). Also, when the input is at its absolute positive peak value, current into pin 14 should not exceed 5mA. Minimum compensation capacitor, C_C, in pF is 15 times the parallel combination of R1 and R4 in K-ohms.

With a single DAC, there is a D C offset at the circuit output that varies with the digital word input. To eliminate this, we use a second DAC to subtract this offset at the sum node of the op-amp.

Example 1: Input signal is to be 20V p-p, centered at 0V. Maximum input frequency is to be 15kHz. Power supplies available are +/- 15V, both regulated. Determine values of all resistors for maximum gain of unity.

Solution 1: At minimum input (-10V), reference current, I_{REF} is

$$I_{REF} = \frac{15V}{R4} + \frac{(-10V)}{R1}$$

If minimum I_{REF} = 0, then

$$\frac{15V}{R4} = \frac{10V}{R1}$$

$$\text{and } R4 = (1.5)(R1),$$

Therefore, 60 percent of I_{REF} comes through R4. If we let I_{REF} go to about 3.9mA (4mA is max

recommended), R4 current is found to be

$$I_{R4} = (0.6) (3.9mA) = 2.34mA$$

and R4 = 6.4K.

The balance of the reference current I_{R1} is found to be

$$I_{R1} = 3.9mA - I_{R4}$$

or

$$I_{R1} = 3.9mA - 234mA = 1.56mA$$

and

$$R1 = 6.4K$$

Using commonly available values, and remembering that R4 current must exceed R1 current, we set

$$R1 = 6.8K$$

and R4 = 6.2K.

Maximum reference current is now

$$I_{REF} (\text{max}) = \frac{15V}{6.2K} + \frac{10V}{6.8K} = 3.9mA.$$

The parallel combination of R1 and R4 is found to be 3.24K, so minimum compensation capacitor value is

$$C_C (\text{min}) = (3.24)(15)pF = 48.6pF.$$

If we use 50pF, from the graph we find F_(max) to be 370kHz. For unity gain,

$$R2 = R1 = 6.8K$$

$$R3 = R2 = 6.8K$$

$$R5 = R1 = 6.8K$$

$$R6 = R7 = \frac{(R1)(R4)}{R1 + R4} = 3.24K$$

(use 3.3K)

Example 2: Usable input signal is 12V p-p, centered at 0V, with occasional excursion to twice this amplitude, which we do not care about. Maximum input frequency is to be 500kHz. Available power supplies are +5V logic supply, +15V, -15V, all regulated. Determine values of all resistors and C_C for maximum gain of 2.

Solution 2: To extend the frequency response, we want minimum compensation capacitor value, therefore need minimum R1 and R4 values, for which reason we want to return R4 to as low a regulated supply as is possible; we will use the 5V logic supply.

At minimum usable input,

$$I_{REF} = \frac{5V}{R4} - \frac{6V}{R1}$$

or, for

$$I_{REF} = 0, \frac{5V}{R4} = \frac{6V}{R1}$$

therefore, 55 percent of I_(REF) comes through R4, and

$$R4 = (5/6)R1.$$

Because peak input goes to +12V, this condition should not cause I_(REF) to exceed 5mA, and

$$\frac{12V}{R1} + \frac{5V}{R4} = 5mA$$

Recall that R4 = (5/6) R1

$$\frac{12V}{R1} + \frac{5}{(5/6)(R1)} = 5mA$$

$$\frac{12V}{R1} + \frac{6V}{R1} = 5mA$$

$$R1 = 3.6K$$

and R4 = (5/6) R1 = 3.0K

Because the reference source will be the 5V logic supply, which will be noisy, we will split R4 into two resistors and bypass their junction with 0.1μF to ground. Furthermore, to be sure that R4 current exceeds R1 current, we will increase R1 to 4.3K. The absolute maximum reference current is now

$$I_{REF} (\text{max}) = \frac{12V}{4.3K} + \frac{5V}{3K} = 4.46mA.$$

The parallel combination of R1 and R4 is 1.77K, so minimum compensation capacitor is

$$C_C (\text{min}) = (15)(1.77) = 26.5pF$$

If we use 27pF, the graph tells us the maximum frequency is about 490kHz, which is 2 percent lower than desired. If we wanted to further extend this frequency range, we find that we can reduce R4 to two resistors of 1.1K and 1.2K, bringing the absolute maximum reference current to

$$I_{REF} (\text{max}) = \frac{12V}{4.3K} + \frac{5V}{2.3K} = 4.96mA$$

and the maximum usable reference current becomes

$$I_{REF} = \frac{6V}{4.3K} + \frac{5V}{2.3K} = 3.57mA,$$

below the 5mA and 4mA respective desired maximum values. Now the resistance at pin 14 is the parallel combination of R1 and R4, or 1.4K, and the minimum compensation capacitor becomes

$$C_C (\text{min}) = (15)(1.4)pF = 21pF.$$

If we use 22pF, the graph tells us we can just go to 500kHz.



DAC products are designed to convert a digital code to an analog signal. Since a common source of digital signals is the data bus of a μ processor, DAC circuits that are bus compatible ease the design engineer's interface problems.

WHAT FEATURES MAKE A DEVICE BUS COMPATIBLE?

The five conditions which determine processor bus compatibility are:

- Inputs must be low loading
- Addressing must be provided
- Inputs must be latched
- Logic thresholds must be compatible
- Timing requirements should be adequate ($< 1 \mu$ sec)

Signetics microprocessor compatible DACs, the NE5018 series, meet these requirements. In addition, they provide an internal reference source. The NE5018 provides a scaled voltage output, eliminating the need for an external op amp. The NE5118 is identical to the NE5018, except it provides the user with a current output. Figure 1 shows a typical microprocessor system with analog I/O using the NE5018 to provide a programmable voltage and an NE5118 to provide a programmable current.

The following discussions detail the operation of the NE5018 and NE5118 series DAC's.

LATCH CIRCUIT

The latch circuits of the NE5018 and NE5118 are identical. Both the data inputs and latch enable (\overline{LE}) input feature ultra-low loading for ease of interfacing. The eight bit-data latch, controlled by the latch enable input, is static and level sensitive. When (\overline{LE}) is low, all the latches become transparent and the output changes as the bit pattern changes on the data bus. When the latch enable returns to its high state, the last set of inputs are held by the latch and a unique output corresponding to the binary word in the latch is produced. While the latch enable is high, the latch inputs represent a high impedance load on the data bus and changes on the data bus have no effect on the DAC output.

The digital logic input for the NE5018 and NE5118 series DAC's utilize a differential input logic system with a threshold level of + 1.4 volts with respect to the voltage level on the digital ground pin (Pin 1).

To be compatible with microprocessors, the DAC should respond in as short a period as possible to insure full utilization of the μ P and I/O data bus lines. Figure 2 gives the typical timing requirements of the latch circuits in the NE5018 and NE5118.

The voltage levels on the data bus should be stable for approximately 150ns before latch enable returns to high level. The timing diagram shows 100ns is required for set-up time and the information on the data lines should remain valid for another 50ns.

REFERENCE INTERFACE

The NE5018 and NE5118 contain an internal bandgap voltage reference which is designed to have a very low temperature coefficient and excellent long term stability characteristics.

The internal bandgap reference (1.23V) is buffered and amplified to provide the 5 volt reference output. Providing a V_{REF} (ADJ) (pin 12) allows easy trimming of the reference output (pin 13). Use of a 10K pot and series resistor, as shown in Figure 3, adjusts the gain of the buffer amplifier therefore varying the output reference voltage level.

This network can then be used as a full scale output adjust. A variation in the V_{REF} OUT of

$\sim .8V$, results in a corresponding 1.6V variation in the full scale output. This is more than adequate since the untrimmed V_{REF} OUT is typically within 200mv of the nominal 5 volts. The V_{REF} OUT will provide a maximum of 5mA drive and can be used as a reference voltage for other system components, if required.

Since a potential need exists to use the NE5018 and NE5118 as multiplying DAC's, the V_{REF} is not connected internally, allowing the use of external reference sources. To utilize the internal reference, the V_{REF} OUT (pin 13) must be jumper connected to the V_{REF} IN (pin 14). This also makes it possible to use a common reference for other D/A or A/D circuits in a system.

INPUT AMPLIFIER OF THE NE5018

The DAC reference amplifier has been designed to eliminate the need for compensation when operating from the internal reference or from an external reference which is buffered by an op amp or low impedance

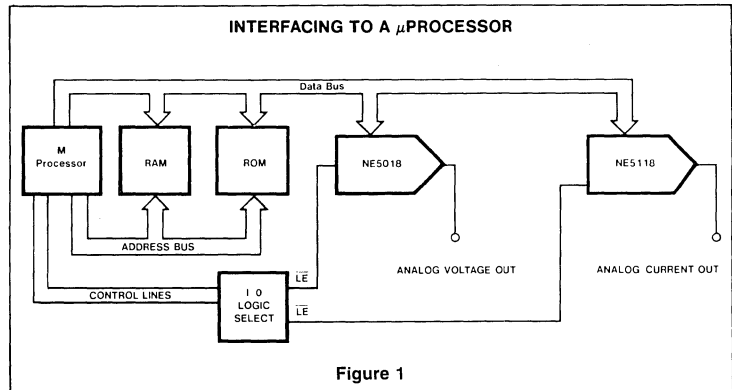

Figure 1

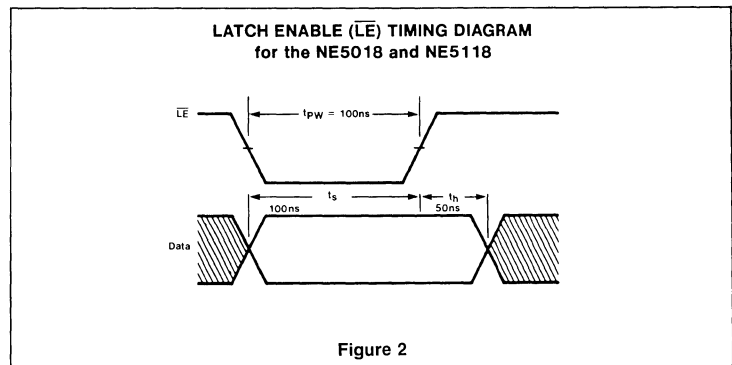

Figure 2

source. Compensation is required, however, when operating from a high impedance source. The addition of an external resistance reduces the phase margin of the amplifier making it less stable. Compensation, when required, is a single capacitor from pin 16 to ground.

Figure 4 details the input reference amplifier and current ladder. The voltage to current converter of the DAC amp will generate a 1mA reference current through Q_R with a 5 volt V_{REF} . This current sets the input bias to the ladder network. Data bit 7 (DB_7) Q_7 , when turned on, will mirror this current and will contribute 1mA to the output. DB_6 (Q_6) will contribute 1/2 of that value or .5mA, and so on. If all bits are on, the output current will be $2mA - 1$ LSB. The full scale V_{OUT} will be $(I_{OUT}R_S)$ or $(2mA - 1 \text{ LSB} \times 5K) = (10V - 1 \text{ LSB}) = 9.961V$. The overall input/output expression for the NE5018 is:

$$V_{OUT} = 2V_{REF} \times \left(\frac{DB_7}{2} + \frac{DB_6}{4} + \frac{DB_5}{8} + \frac{DB_4}{16} + \frac{DB_3}{32} + \frac{DB_2}{64} + \frac{DB_1}{128} + \frac{DB_0}{256} \right)$$

The minimum current for the ladder network to be operative in the linear region is $100\mu A$. Therefore the minimum V_{REF} input is 500mV. The slew rate of the reference amplifier is typically $.7V/\mu s$ without compensation. The input structure of the NE5118 is slightly different and will be discussed in greater detail later. Q_T provides a termination for the R-2R ladder network and does not contribute to I_{OUT} .

OUTPUT INTERFACE OF THE NE5018

The NE5018 has an internal op amp which provides a voltage output, while the NE5118 is a current output device. The NE5018 output op amp is a two stage design with feed-forward compensation. Having a slew rate $10V/\mu s$, it provides a voltage output from 0 to $10V (\pm .2\%)$ typically within $2\mu s$ (the time allowed for the output voltage to settle to within 1/2 LSB). Compensation must be provided externally as shown in Figure 5.

The addition of the optional diode between the summing node (Pin 20) and ground prevents the DAC current switches from driving the op amp into saturation during large signal

transitions which would increase the settling time.

Zero adjust circuits such as the one shown in Figure 5 may also be connected to the summing node to provide a means to zero the output when all zeros are present on the input. Not all applications require a zero adjust circuit since the untrimmed zero scale is typically less than 5mV. Excess stray capacitance at the sum node of the output op amp may necessitate the use of a feedback capacitor from V_{OUT} to the sum node (C_{FF}) to insure stability of the op amp. Typical values of C_{FF} range from 15 to 22pF. The rated load of the op amp is $\sim 2Kohm$. For stability, the load capacitance should be minimized (50pF max).

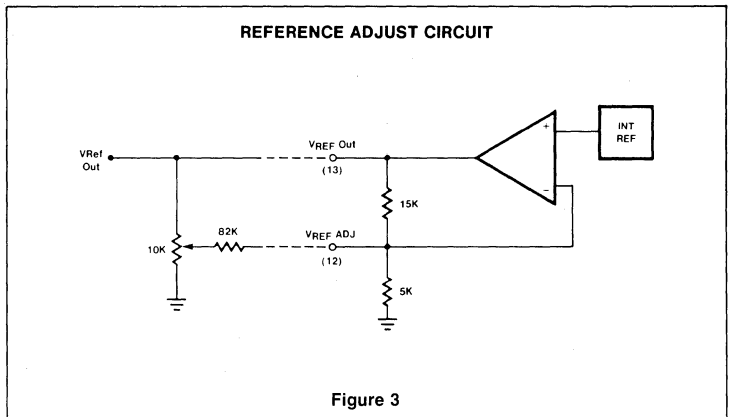

Figure 3

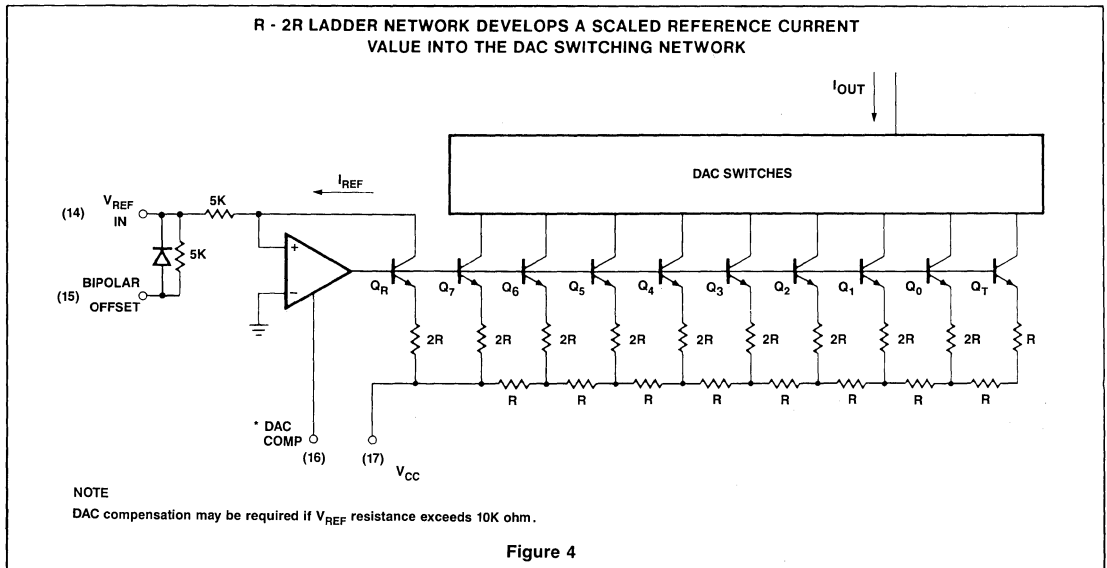

Figure 4

NOTE
DAC compensation may be required if V_{REF} resistance exceeds 10K ohm.

MODES OF OPERATION OF THE NE5018

The NE5018 has two basic modes of operation: unipolar and bipolar. When operating in the unipolar mode the output range is 0 to + 10 volts. To change from unipolar to bipolar operation the bipolar offset pin is connected to the summing node. This provides the 5 volt offset required for this mode of operation. The output now will have a range from - 5 to + 5 volts. Figure 6 details the connection of the NE5018 in the bipolar mode of operation.

With the bipolar offset pin (15) connected to the sum node pin (20), it forms a unity gain inverter with an input of + V_{REF}. The bipolar offset develops an I_{REF} current through the internal 5K resistor. This current is then fed to the sum node of the output amplifier where it is summed with the current output of the DAC ladder network. Assume for the moment that the current output of the ladder network is 0mA. With a V_{REF} equal to + 5 volts, I_{REF} is 1mA and the output of the op amp is converted to - 5V. If the DAC switches are now set to full scale, the current from the DAC ladder is 2mA. This is summed against the 1mA I_{REF} and causes the output of the op amp to swing from - 5V to + 5 volts.

$(I_{DAC} \cdot I_{REF}) 5K = (2mA \cdot 1mA) 5K = +5 \text{ volts}$

Since the bipolar offset resistor is monolithic, tracking with the 5K feedback resistor of the output amplifier is excellent.

Note that the bipolar offset pin could not be used when using the DAC in a multiplier application since the V_{OUT} would reflect an inverted input signal.

NOTES ON THE NE5118 CURRENT OUTPUT DAC

The basic operation of the NE5118 current output DAC is the same as the NE5018. The current output structure allows the user to provide a programmable current sink (I_{OUT} max of 2mA). Several jumper options provide a variety of operational modes. Figure 7 is a block diagram of the NE5118. The input logic and V_{REF} portions are identical to the NE5018.

REFERENCE INPUT AMPLIFIER

The characteristics of the reference input amplifier are identical to the NE5018; however, extended versatility of the input structure allows for both current (via pin 14) or voltage (via pin 15) reference inputs.

The maximum DAC output current is 2mA. The DAC has an internal gain of 2, limiting the maximum usable input current to 1mA. (Note: The absolute maximum input current should be limited to 5mA to prevent damage

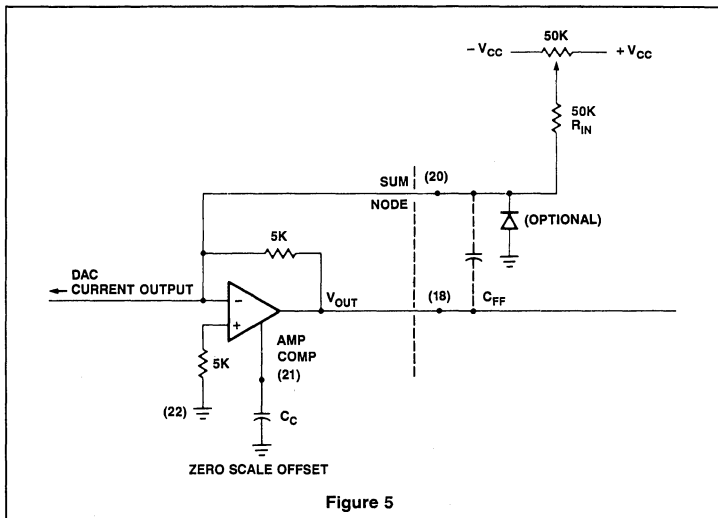

Figure 5

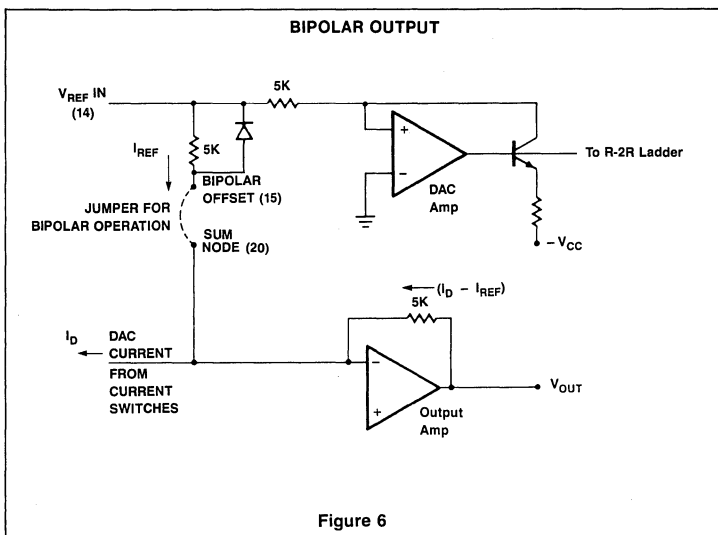

Figure 6

to the input reference amplifier). Figure 8 shows the basic operating mode of the NE5118 using an external current reference resistor (R₁) and a positive reference voltage.

This voltage can be provided by either an internal or external reference voltage. Figure 9 shows a typical connection using a voltage input directly via pin 15.

Besides a reduced parts count, use of the internal R_{REF} provides excellent tracking characteristics with the R_{OUT} resistor (pin 20) when developing a high slew rate voltage out-

put. The negative V_{REF} input must be returned to ground directly or through R₂. R₂ is optional and is used to cancel minor errors developed by the input bias currents of the reference amplifier (R₂ = R₁). A negative voltage can be the reference by using the - V_{REF} input pin as shown in Figure 10.

The positive V_{REF} is returned to ground via R_{IN} (pin 15). As with the NE5018, a compensation capacitor on Pin 16 is not required if the V_{REF} is supplied by a low impedance source.

BLOCK DIAGRAM

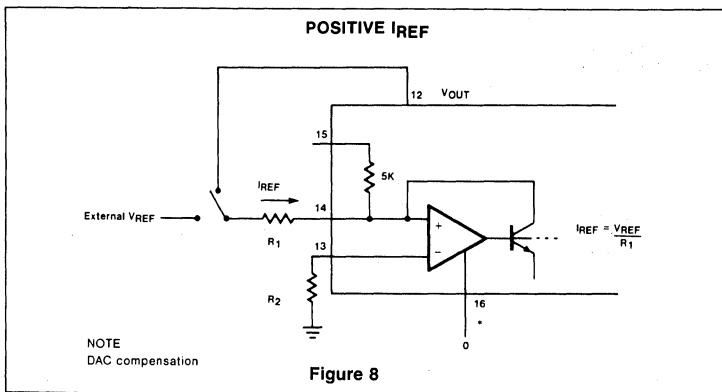
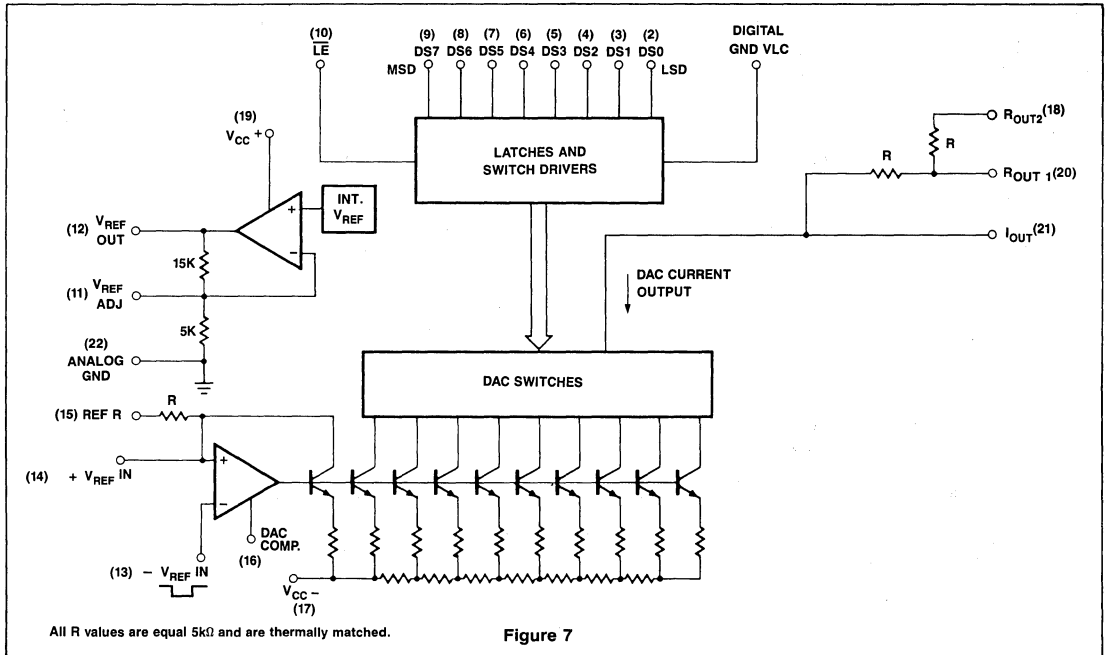

OUTPUT STRUCTURE

The output of the NE5118 is a current sink with a capacity of 2mA (full scale) capable of settling to .2% in 200ns. Internal bias and feedback resistors are also made available to ease the designer's task of interfacing.

Figure 11 shows the NE5118 using a current to voltage converter at the output to provide a high slew rate voltage output. Using the NE538 as shown can provide 60V/μs slew rate output. The diode at the inverting node of

the op amp improves the response time by preventing saturation of the op amp during large signal transitions. The feedback resistor ROUT1 (pin 20) is provided internally; this provides excellent thermal tracking characteristics with the RREF on the input.

Bipolar operation can be accomplished by connecting the VREF OUT (Pin 12) to the ROUT resistor (Pin 20)(Figure 12). The principal is the same as the NE5018 bipolar operation. The internal resistors exhibit excellent thermal tracking characteristics.

An alternate method of bipolar output operation is shown in Figure 12. The RREF and ROUT set up a current to voltage converter while two (2) external resistors provide a bipolar offset. REXT1 and REXT2 should have similar thermal tracking characteristics.

The NE5118 can provide a voltage output directly when driving a high impedance load as shown in Figure 13. With a full scale current of 2mA, pin 20 tied to +10V and a digital input of zero, the high impedance load will see +10V. For a full scale digital input, the load will see 0 volts. Since the load and the internal resistor form a voltage divider, their ratio determines full scale accuracy.

By connecting the ROUT resistor (pin 20) to ground (Figure 13), the output voltage seen by the load ranges from 0 volts as zero scale to -10 volts as full scale. Only a few of the many possible output configurations have been shown to demonstrate the NE5118 flexibility.

CIRCUIT EXAMPLES

Now that the basics of the NE5018 and the NE5118 have been discussed, let's examine some specific circuits. Figure 14 is a microprocessor controlled programmable gain amplifier, using the NE5018. The VREF output is fed to the non-inverting input to a differential amplifier. R1 + R2 set the differential gain

to 0.5. This places 2.5V DC bias on the V_{REF} input. R_2 can be made adjustable to precisely control the DC reference input. The analog input is fed to the inverting input of the differential amplifier with a gain of unity. An input of $\pm 2V$ will provide a ± 4 volt output full scale. With a maximum input of ± 2 volts. $V_{REF IN}$ will vary from .5 volts to 4.5 volts. The current ladder is always kept in the linear operating range and the output will not become distorted.

No compensation is required for the DAC reference amplifier since the $V_{REF IN}$ is fed from a low impedance source. With a compensation cap of 30pF on the output amplifier, the frequency response of the output is linear to at least 20kHz with less than .1% distortion with an input amplitude of 1V p.p. The NE5018 is seen by the μ processor as an I/O device.

In Figure 15, the N5018 and NE5118 provide a method of summing two digital words of equal weight and generating a voltage output. The latch enable feature of both devices direct connection to a data bus, using address decoding. These devices greatly reduced the total component count required to perform this operation.

The reference voltage is common to both DAC's, being provided by the NE5018. The bipolar offset resistor of the NE5018 provides the 1mA current reference for the NE5118. Using the internal resistor of the NE5018 to develop the reference current enhances the thermal tracking since the current to voltage resistor of the output op amp is also in the NE5018. Both DAC's can be addressed by a μ processor using an address decoder to select DAC A or DAC B.

Figure 16 is a schematic of the NE5118 and NE527 as a high speed programmable limit sensor (or A/D converter). A 4.8 volt zener diode is used on the comparator input to insure the input voltage range of the comparator is not exceeded. The outputs of the NE527 comparator are complementary, easing the logic interface requirement. If the strobe function is not used, the strobe inputs should be tied high, through a 10K Ω resistor.

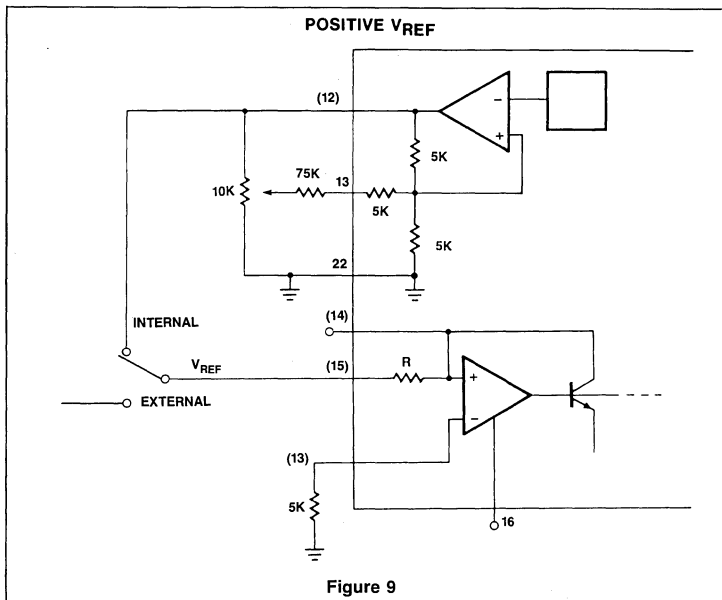

Figure 9

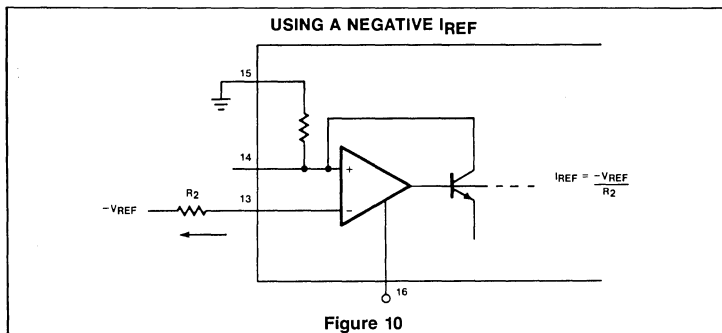

Figure 10

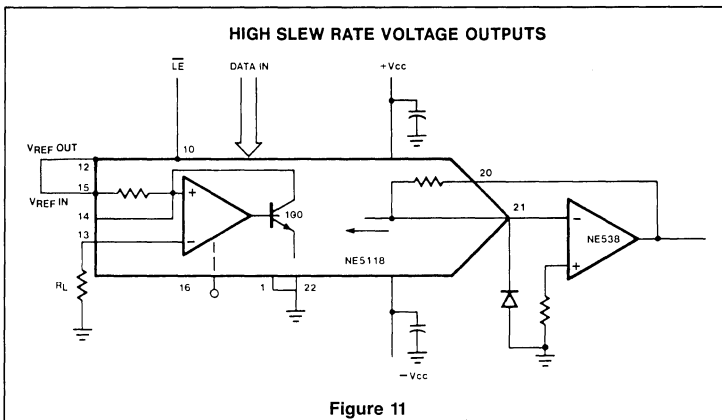
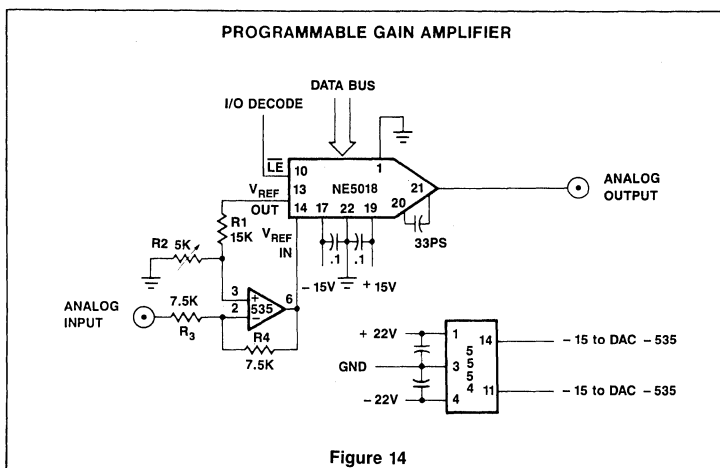
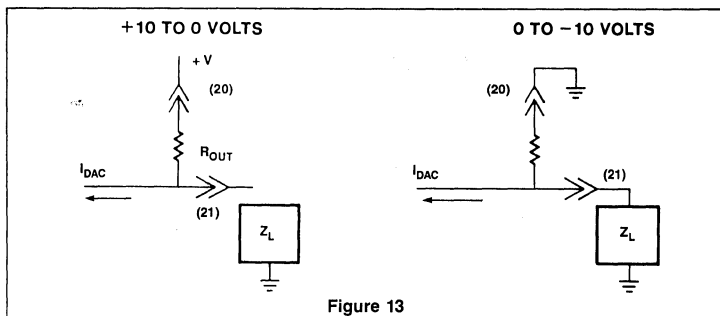
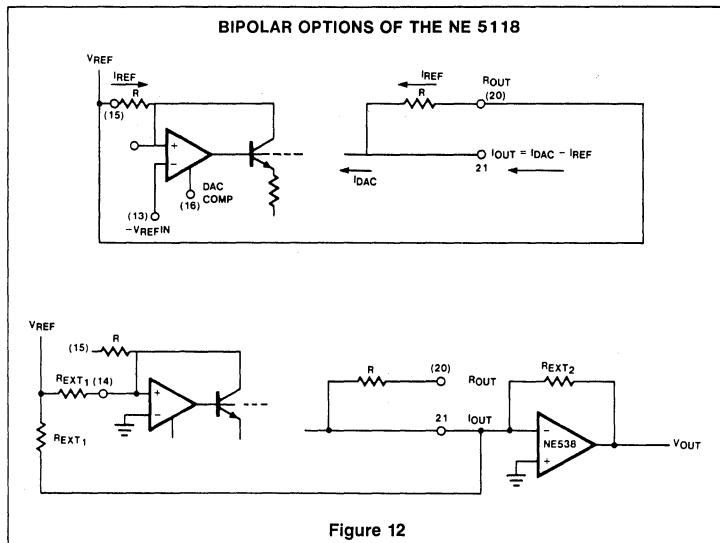
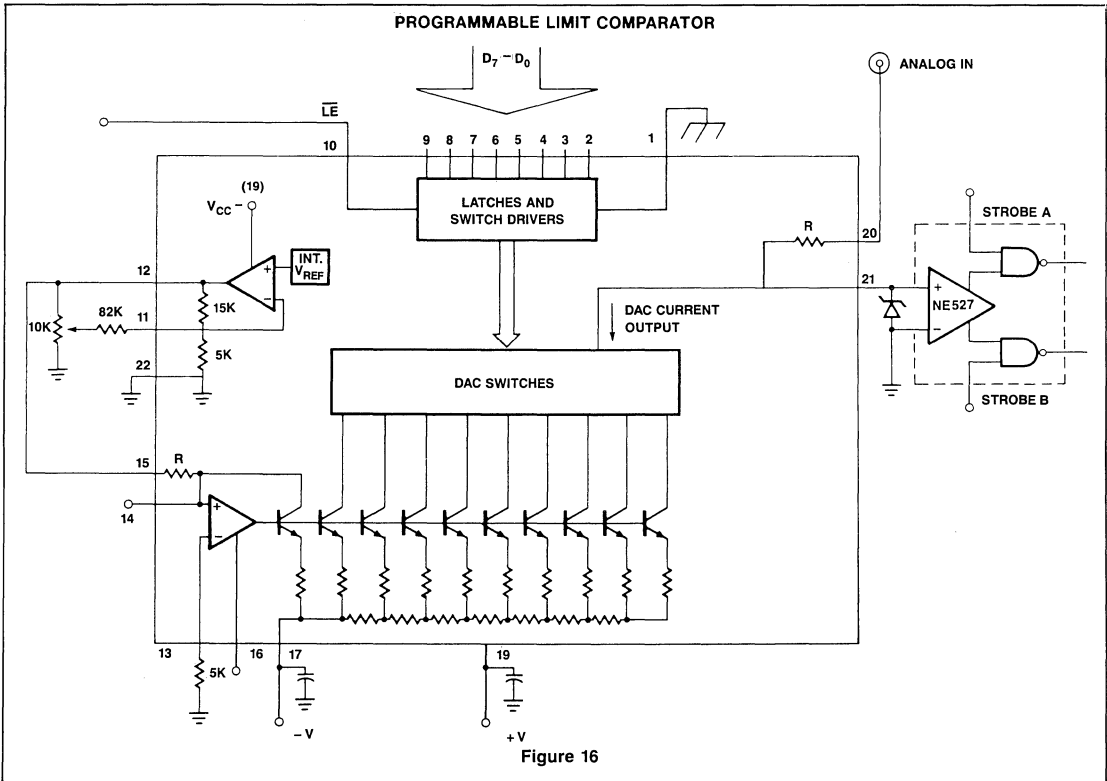
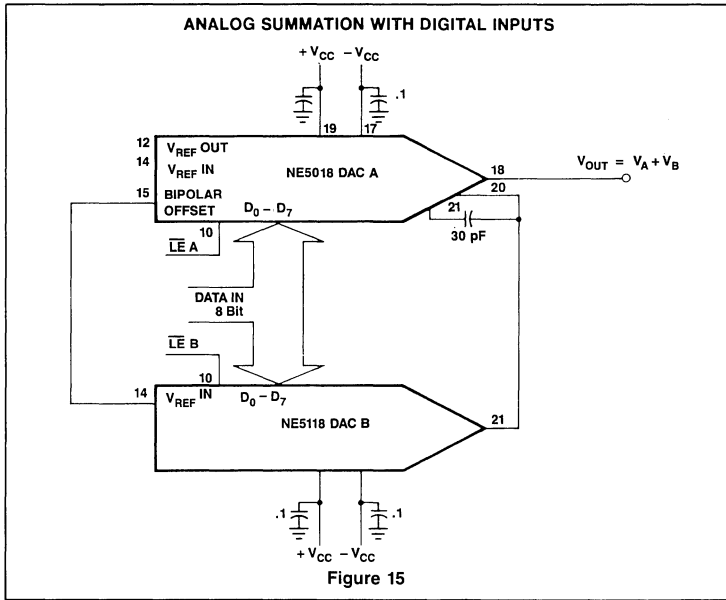

Figure 11





**LED DECODER DRIVER
NE587 and 589**

The NE587 and 589 are latchable decoder drivers for L.E.D. displays. Figure 1 provides a summary of their features.

The programmable constant current supplies (fixed or adjustable) are essentially independent of output voltage, power supply voltage, and temperature.

The data (BCD) and \overline{LE} (latch enable) inputs are low loading and thus are compatible with a data bus system.

Figure 2 shows a block diagram of the NE587. Seven segment decoding is implemented using a ROM so that alternate decoding fonts can be made available.

L.E.D. Drivers and Power Dissipation Consideration

The following discussion refers to the NE587, but is also applicable for the 589.

LED displays are power hungry devices, and, inevitably, somewhat inefficient in their use of the power supply necessary to drive them. Duty cycle control does afford one way of improving display efficiency, pro-

NE 587/589 LED DRIVERS

<ul style="list-style-type: none"> • Strobed Latch • Inputs compatible with NMOS, CMOS, DMOS, TTL • Single 5 volt supply • Constant Current Outputs 	<ul style="list-style-type: none"> • Inputs are compatible with microprocessor bus • BCD Inputs—Hexadecimal Outputs • Programmable segment current
---	---

Figure 1

vided that the LEDs are not driven too far into saturation, but the improvement is marginal. Operation at higher peak currents has the added advantage of giving much better matching of light output, both from segment-to-segment and digit-to-digit.

When designing a display system, particular care must be taken to minimize power dissipation within the IC display driver. Since the NE587 output is a constant programmed current source, all the remaining supply voltage, which is not dropped across the LED (and the digit driver, if used) will appear across the output of the NE587. Thus the power dissipation in the NE587 will go up sharply if the display power supply voltage rises. Clearly, then, it is good design practice to keep the display supply voltage as low as possible consistent with proper operation of the output current sources. Inserting a resistor or diode in series

with the display supply is a good way of reducing the power dissipation within the integrated circuit segment driver, although, of course, total system power remains the same.

Power dissipation within the NE587 may be calculated as follows. Referring to Figure 3, the two system power supplies are V_{CC} and V_S . In many cases, these will be the same voltage. Necessary parameters are:

- V_{CC} Supply voltage to driver
- V_S Supply voltage to display
- I_{CC} Quiescent supply current of driver
- I_{SEG} LED segment current
- V_F LED segment forward voltage at I_{seg}
- K_{DC} % Duty cycle

V_F , the forward LED drop, depends upon the type of LED material (hence the color) and the forward current. The actual forward

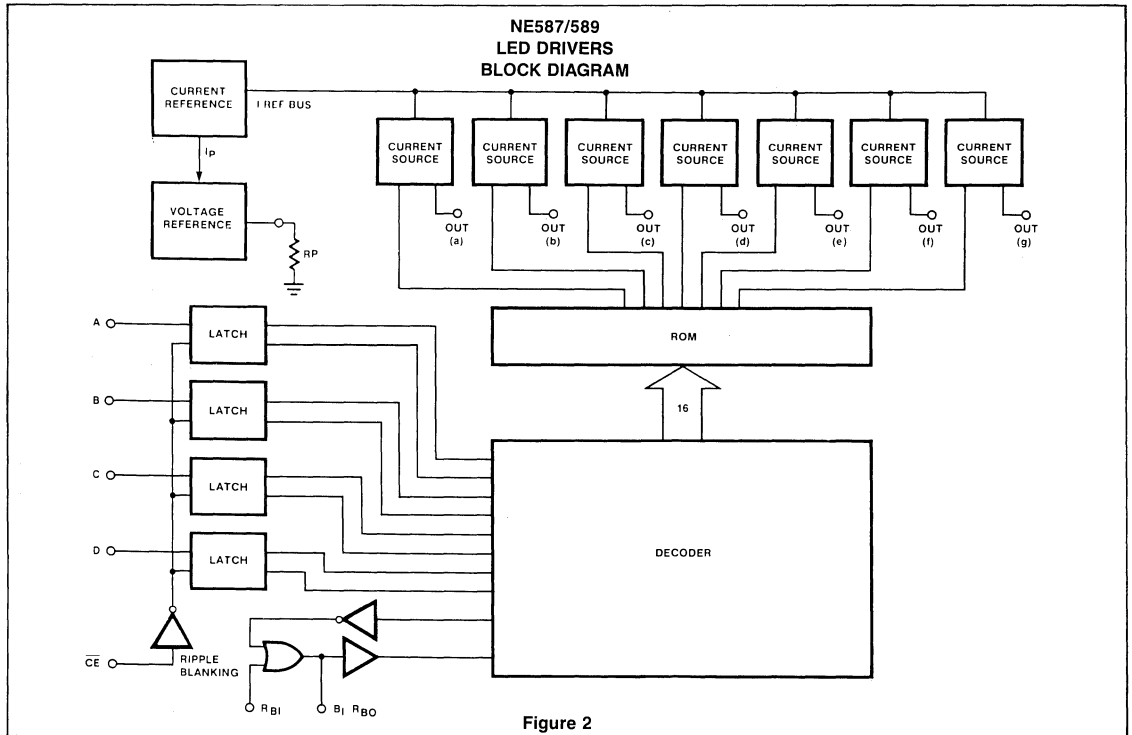
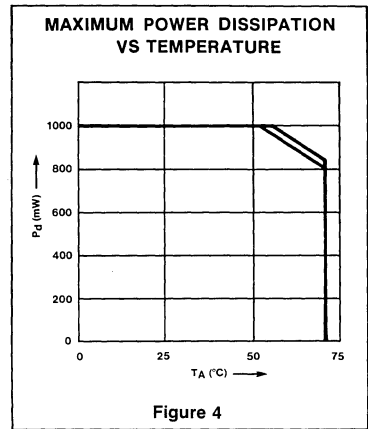
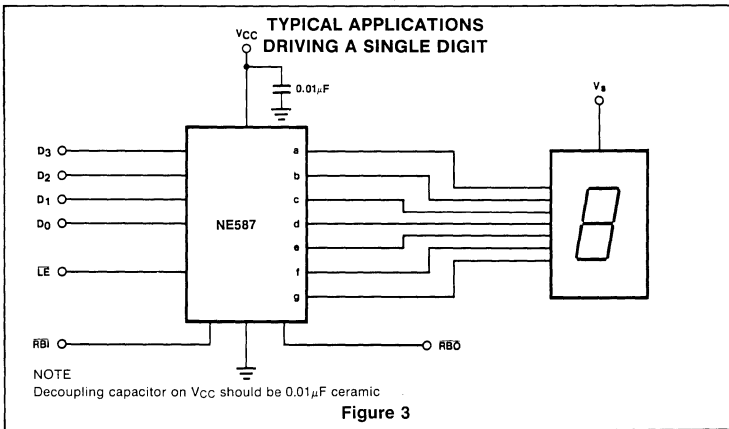

Figure 2



voltage drops should be obtained from the LED display manufacturers literature for the peak segment current selected. However, approximate voltages at nominal rated currents are:

Red	1.6 to 2.0V
Orange	2.0 to 2.5V
Yellow	2.2 to 3.5V
Green	2.5 to 3.5V

These voltages are all for single diode displays. Some early red displays had 2 series LEDs per segment, hence the forward voltage drop was around 3.5V.

Thus a maximum power dissipation calculation when all segments are on, is:

$$P_d = V_{CC} \times I_{CC} + (V_S - V_F) \times 7 \times I_{seg} \times K_{DC} \text{ mW} \quad (1)$$

Assuming $V_S = V_{CC} = 5.25V$
 $V_F = 2.0V$
 $K_{DC} = 100\%$
 $I_{seg} = 30mA$

$$P_d \text{ max} = 5.25 \times 50 + 3.25 \times 7 \times 30 \text{ mW} = 945 \text{ mW}$$

However, the average power dissipation will be considerably less than this. Assuming 5 segments are on (the average for all output code combinations), then

$$P_{d \text{ av}} = 5.0 \times 30 + 3.00 \times 5 \times 25 \text{ mW} = 525 \text{ mW}$$

Operating temperature range limitations can be deduced from the power dissipation graph in Figure 4.

However, a major portion of this power dissipation ($P_{d \text{ max}}$) is because the current source output is operating with 3.25V across it. In practice, the outputs operate satisfactorily down to 0.5V, and so the extra voltage may be dropped external to the integrated circuit.

Suppose the worst case V_{CC}/V_S supply is 4.75 to 5.25V, and that the maximum V_F for the LED display is 2.25V. Only 2.75V is required to keep the display active, and hence 2.0V may be dropped externally with a resistor from V_{CC} to V_S . The value of this resistor is calculated by using equation 2.

$$R_S = \frac{V_{DROP}}{I_{seg} \times \# \text{ of seg}} \quad (2)$$

$$\text{or } R_S = \frac{2.0}{7 \times I_{seg}} \approx 10\Omega \text{ (1/2 W rating)}$$

assuming worst case I_{seg} of 30mA
Hence now:

$$P_{d \text{ max}} = V_{CC} \times I_{CC} + (V_S - V_F - R_S \times 7 \times I_{seg}) \times 7 \times I_{seg} \times K_{DC} = 5.25 \times 50 + 1.25 \times 7 \times 30 \text{ mW} = 525 \text{ mW} \quad (3)$$

$$\text{and } P_{d \text{ av}} = 5.0 \times 30 + 1.25 \times 5 \times 25 = 306 \text{ mW}$$

If a diode (or 2) is used to reduce voltage to the display, then the voltage appearing across the display driver will be independent of the number of "ON" segments and will be equal to

$$V_S - V_F - nV_d, V_D = 0.8V$$

Where n is the number of diodes used, and so power dissipation can be calculated in a similar manner.

In a multiplexed display system, the voltage drop across the digit driver must also be considered in computing device power dissipation. It may even be an advantage to use a digit driver which drops an appreciable voltage, rather than the saturating PNP transistors shown in Figure 5. For example a Darlington PNP or NPN emitter follower may be preferable. Figure 6 shows the NE591 as the digit driver in a multiplexed display system. The NE591 output drops about 1.8V which means that the power dissipation is evenly distributed between the two integrated circuits.

Where V_S and V_{CC} are two different supplies, the V_S supply may be optimized for minimum system power dissipation and/or cost. Clearly, good regulation in the V_S supply is totally unnecessary, and so this supply can be made much cheaper than the regulated 5V supply used in the rest of the



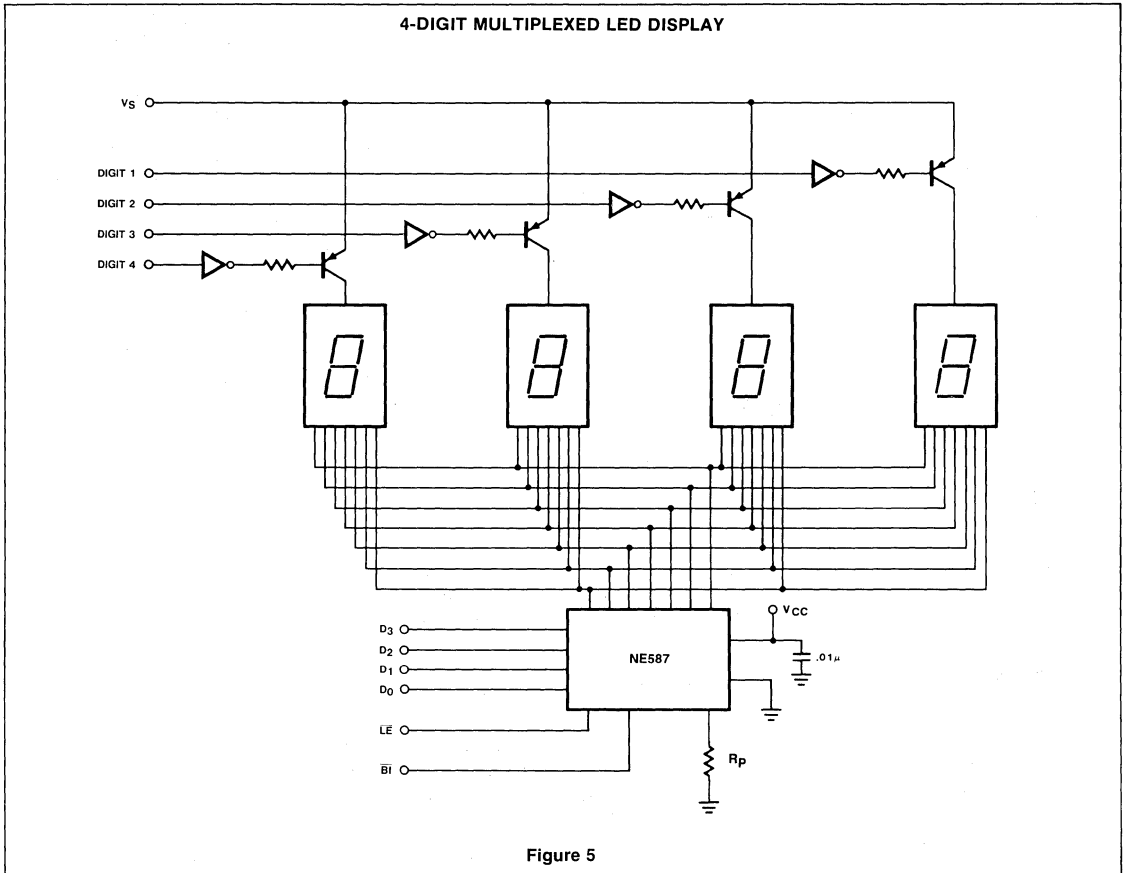

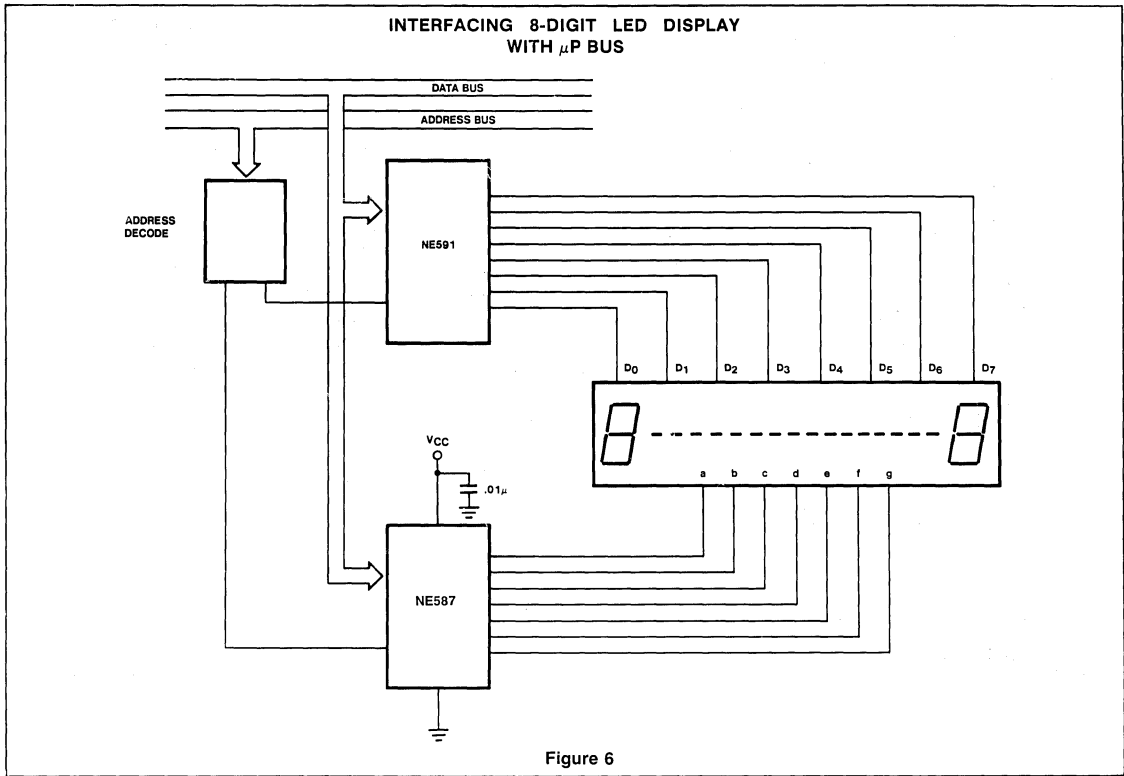

Figure 6

ADDRESSABLE PERIPHERAL DRIVERS SUPPORT μP-BASED SYSTEMS

system. In fact a simple unsmoothed full-wave rectified sine wave works extremely well if a slight loss in brightness can be tolerated. A transformer voltage of about 3-4.5Vrms works well in most LED display systems. Waveforms are shown in Figure 7.

The duty cycle for this system depends upon V_S , V_F and the output characteristics of the display driver.

With

$V_S = 4.9V$ pk.
 $V_F = 2.0V$

The duty cycle is approximately 60%.

V_S in this example was derived by the circuit shown in Figure 7. Remember that the forward voltage drop of the rectifying diode must be subtracted to arrive at the exact peak of the V_S voltage.

Figure 8 shows other typical application schemes for multiplexing LED displays.

The Signetics NE590 and NE591 addressable peripheral drivers (APDs) greatly facilitate interfacing a variety of support circuits to microprocessor based systems.

The APDs are designed to eliminate the need for many of the buffers, latches, TTL ICs, and discrete transistors currently needed to drive peripheral devices.

Figure 9 shows that each driver includes a set of input latches, a 1-of-8 demultiplexer, and a set of high current drive outputs together with the assorted chip enable and clear logic.

The low loading inputs of these drivers (typically $I_{IL} = 15\mu A$ and $I_{IH} = 1\mu A$) allow direct interfacing to the μP -bus. Eight addressable latches, which are addressed by a three bit binary code and (set/reset) by a single binary bit, allow storage of each output condition (ON/OFF), allowing the μP to continue processing after the APD has been addressed.

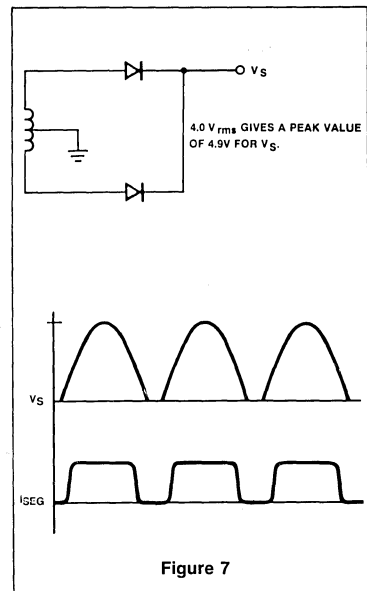

Figure 7

LED DECODER DRIVERS: USING THE NE587 AND NE589

AN112

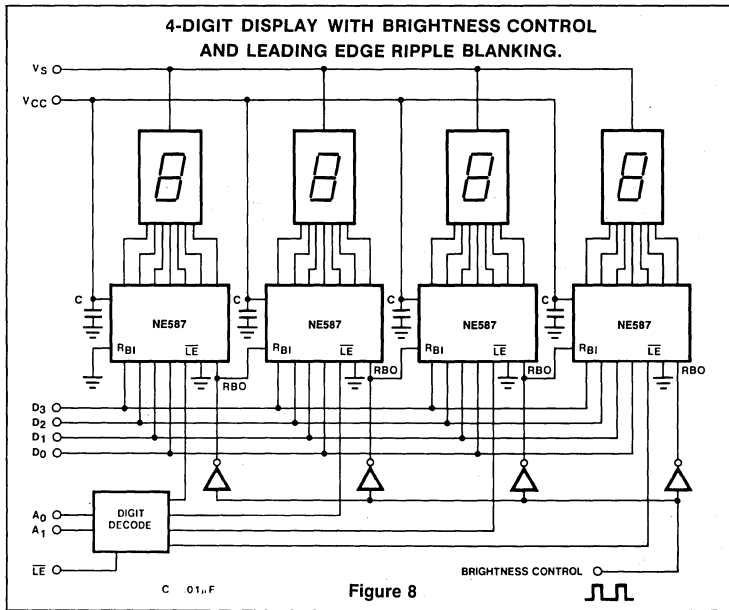

Figure 8

Driver selection is accomplished with a low active chip enable which may be derived from the I/O decoder common to all I/O devices. A low active master clear is also provided to reset all outputs simultaneously. This signal may be generated from the I/O decoder or set high when not required.

The high-current outputs of the drivers (250mA sinking with the NE590 and 250mA sourcing with the NE591) allows direct interfacing to relays, motors, lamps, LED's, and other devices or systems requiring high current drive capabilities.

Figure 10 demonstrates the use of APD's in a uP-based system. When driving LED displays, a single 8-bit word contains all the data required for defining both digit location and segment selection. The APD uses four bits—three to address one of 8 outputs and one to set the output to an ON or OFF state.

When using the NE590, ON refers to the output low state in which the output is

BLOCK DIAGRAM

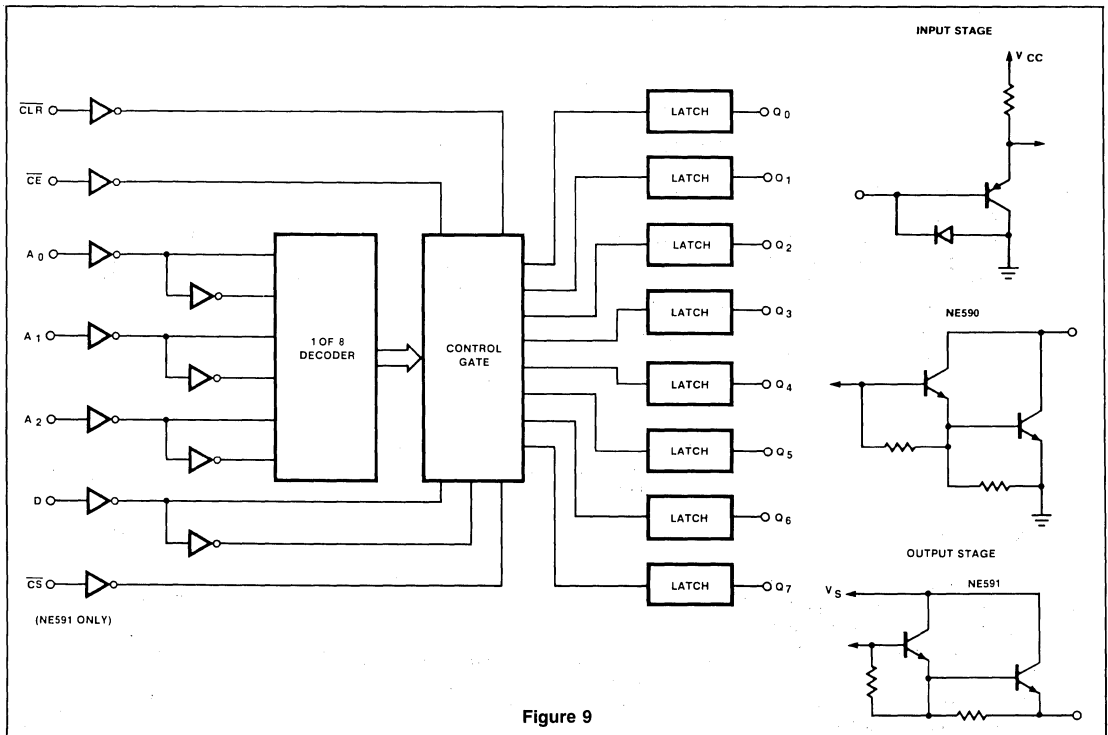

Figure 9

LINE DRIVERS AND RECEIVERS

Many types of line drivers and receivers are available today. Each device has been designed to meet specific criteria. For instance, the device may be extremely wide band or be intended for use in party line systems. Some include built in hysteresis in the receiver while others do not.

The EIA Standard

The Electronic Industries Association has produced a set of specifications dealing with the transmission of data between data terminal and communications equipment. This is EIA Standard RS-232-C and delineates much information about signal levels and hardware configurations in data systems.

MC1488/1489

As line driver and receiver the MC1488 and MC1489 meet or exceed the RS-232 specification.

Standard RS-232 defines the voltage level as being from 5 to 15 volts with positive voltage representing a logic 0. The MC1488 meets these requirements when loaded with resistors from 3k to 7k ohms.

Output slew rates are limited by RS-232 to 30 volts per microsecond. To accomplish this specification the MC1488 is loaded at its output by capacitance as shown by the typical hookup diagram of Figure 1. A graph of slew rate vs output capacitance is given in Figure 2. For the standard 30V/ μ s a capacitance of 400pF is selected.

The short circuit current charges the capacitance with the relationship.

$$C = \frac{I_{SC}\Delta T}{\Delta V}$$

Where C is the required capacitor, I_{SC} is the short circuit current value, and $\Delta V/\Delta T$ is the slew rate.

Using the worst case output short circuit current of 12mA in the above equation, calculations result in a required capacitor of 400pF connected to each output to limit the output slew rate to 30V/ μ s in accordance with the EIA standard.

The EIA standard also states that output shorts to any other conductor of the cable must not damage the driver. Thus the MC1488 is designed such that the output will withstand shorts to other conductors indefinitely even if these conductors are at worst case voltage levels. In addition to output protection, the MC1488 includes a 300 ohm resistor to ensure that the output impedance of the driver will be at least 300 ohms even if the power supply is turned off. In cases where power supply malfunction produces a low impedance to ground, the 300 ohm resistors are shorted to ground also. Output shorts then can cause excessive power dissipation. To prevent this, series diodes should be included in both supply lines as pictured in Figure 3.

The companion receiver, MC1489, is also designed to meet RS-232 specifications for receivers. It must detect a voltage from ± 3 to ± 25 volts as logic signals but cannot generate an input differential voltage of greater

than 2 volts should its inputs become open circuited. Noise and spurious signals are rejected by incorporating positive feedback internally to produce hysteresis. Featured also in the receiver is an external response node so that the threshold may be externally varied to fit the application. Figure 4 shows the shift in high and low trip points as a function of the programming resistance.

APPLICATIONS

The design of the MC1488 and MC1489 makes them very versatile with many possible applications. The MC1488 output current limiting enables the user to define the output voltage levels independent of supply voltages. Figure 5 shows the MC1488 as a TTL to MOS Translator, while Figures 6 and 7 illustrate TTL to HTL and TTL to MOS Translator.

The MC1489 response control node allows the user to modify the input threshold voltage levels. This is accomplished by adding a resistor between the response control pin and an external power supply. Figure 4 shows the shift thus provided. This feature and the fact that the inputs are designed to withstand ± 30 volts permit the use of the MC1489 for level translation as shown in the MOS to TTL translator of Figure 8. This feature is also useful for level shifting, as illustrated in Figure 9.

The response control node can also be used to filter out high frequency, high energy noise pulses. Figures 10 and 11 give typical noise pulse rejection curves for various sized external capacitors.

TYPICAL LINE DRIVER-RECEIVER APPLICATION

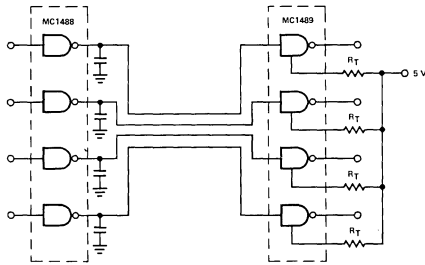

Figure 1

OUTPUT SLEW RATE vs. LOAD CAPACITANCE

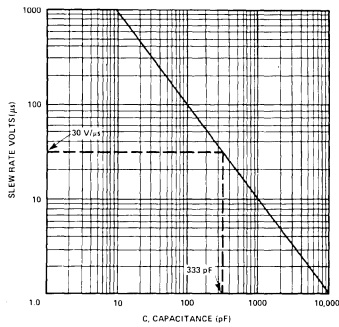

Figure 2

PROTECTION FROM POWER SUPPLY MALFUNCTION

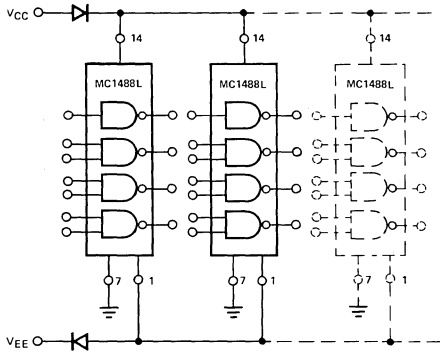

Figure 3

HYSTERESIS AS A FUNCTION OF PROGRAMMING RESISTANCE

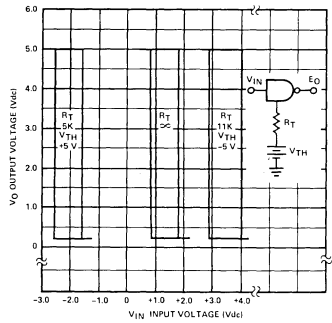
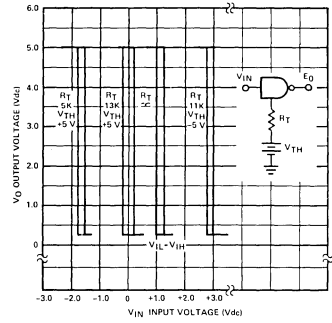
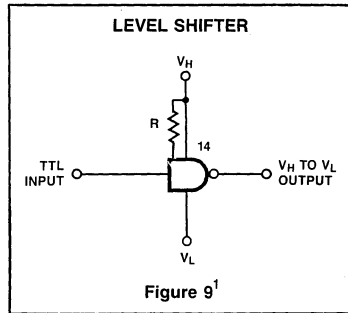
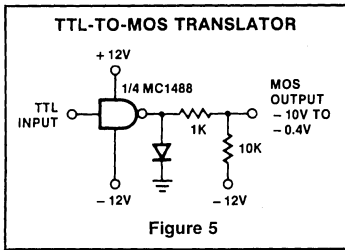
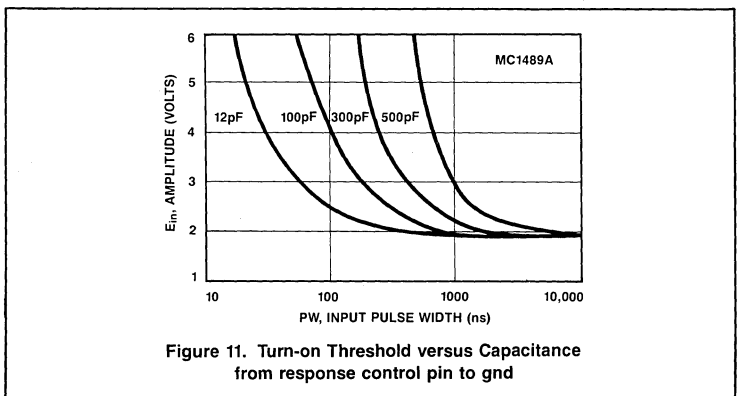
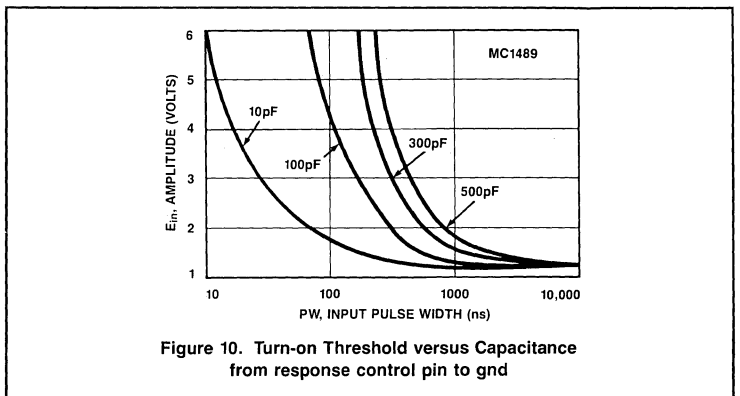
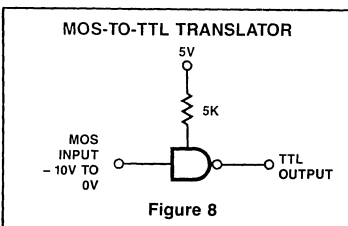
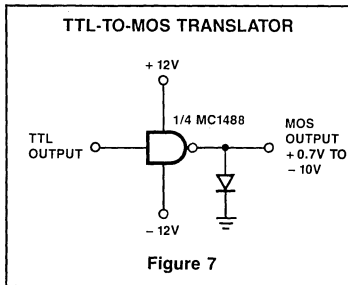
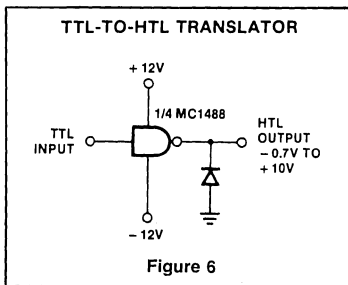

Figure 4



NOTE:
1. $V_2 \leq 5V$; $3V \leq V_H - V_L \leq 10V$.



COMPARATORS

Voltage comparators are high gain differential input—logic output devices. They are specifically designed for open loop operation with a minimum of delay time. Although variations of the comparator are used in a host of applications, all uses depend upon the basic transfer function of Figure 1. As shown, device operation is simply a change of output voltage dependent upon whether the signal input is above or below the threshold input. The threshold in this example is 0 volts.

Comparator inputs are customarily marked with plus or minus signs to indicate their polarity. For example the circuit of Figure 2 produces a logic 1 level when the non-inverting input is more positive than the reference voltage.

DEFINITIONS

Many similarities exist between operational amplifiers and the amplifier section of voltage comparators. In fact op amps can be used to implement the comparator function at low frequencies.

Thus, the characteristic definitions presented here are similar to those reviewed for op amps.

Input Offset Voltage

As with operational amplifiers, the non-ideal comparator possesses some offset voltage. The definition differs slightly in that the output structure of comparators is digital rather than linear. Hence, input offset voltage is defined for comparators as the dc voltage required at the input to force the output to the logic threshold of ensuing devices (1.2 volts for TTL).

Input Offset Current

Imbalances of input bias current arise from small variances of the junction geometry of the differential input amplifier. As for op amps, the imbalance is referred to as input offset current.

Bias Current

As with op amps the input structure of comparators is usually a differential bipolar stage. Input bias current is the average of the two input currents.

Common Mode Range

When specifying voltage comparators one of the key parameters is common mode range, which is defined as the range of voltages over which both inputs can be varied simultaneously without abnormal output voltage transitions or device degradation. This parameter

must be kept uppermost in the designer's mind because the reference and signal voltages become common mode signals at threshold. All ranges of input signals thus must be within the common mode range of the input amplifier.

Voltage Gain

Specifications of voltage gain refer to the overall gain of the device, the bulk of which occurs in the amplifier section.

In general, higher gains would be advantageous for resolving smaller input signals. Of course, the propagation delay suffers due to the more severe saturation of the transistors. Typical gains for TTL output devices are set for 5000 volts per volt. This gain provides 5 volts of output swing with 1mV input signal change for reasonable accuracy but does not contribute severely to the overload recovery delay.

Propagation Delay

Voltage comparisons of analog signals with a reference voltage usually require that the operation take as little time as possible. Long delays in the comparator cause a pulse position error at the output since the analog signal in the meantime has changed value. At low frequencies the delay is of small consequence but, at higher frequencies, transit

time becomes intolerable. Design of voltage comparator devices includes, as a prime goal, the minimizing of transit times.

Propagation delay testing is done under worst case conditions. The recovery from saturation varies depending upon the initial state of the amplifier and the overdrive. Worst case conditions begin by applying a 100mV signal on the reference terminal. With no signal applied the amplifier is in saturation in one direction. A step input pulse on the signal line of 100mV ± V_{OS} will bring the amplifier to a threshold level. Propagation delay at this point is undefined since the output has not switched.

To attain output switching a small overdrive is necessary. Propagation delay is tested in a configuration such as Figure 3. The input is a step function of 100mV plus a specified excess or overdrive signal. This causes the amplifier to be exercised from saturation in one direction to saturation in the other for worst case propagation delay. Note that larger overdrive reduces delay time as can be seen in Figure 4. An overdrive of 5mV causes 12ns delay, whereas a 100mV overdrive improves transit time to only 6ns.

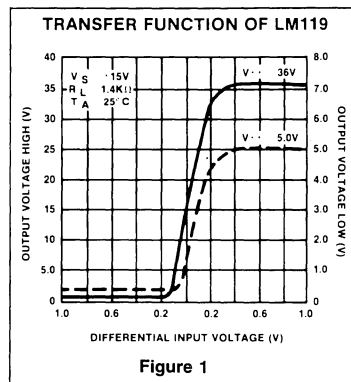

Figure 1

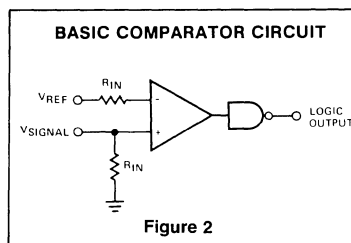

Figure 2

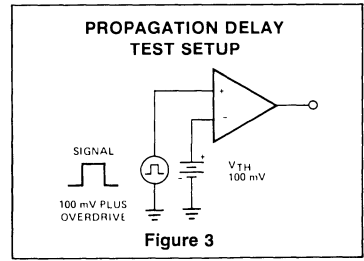

Figure 3

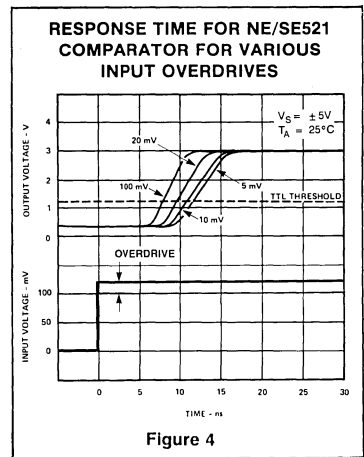

Figure 4

If the measurement were made without initial saturation (less than 100mV V threshold) the delay time would be less, due to the decreased storage times of unsaturated transistors.

STATE-OF-THE-ART

Comparator design has always been optimized for four basic parameters. They are:

1. High Speed
2. Wide Input Voltage Range
3. Low Input Current
4. Good Resolution

Unfortunately these four parameters are not compatible. For instance gain and input current can be improved by using thinner diffusions for higher beta, but only at the expense of input voltage range. Higher gain also means higher saturation for an increase in delay time. So it becomes obvious that older comparators such as the 710 were designed with the best compromises in mind using standard processing.

One method of improving overall response adds gold doping to the processing flow. The gold dopant causes a decrease in minority carrier lifetime which aids the recombination process and shortens the saturation recovery time. Unfortunately, the transistor beta is adversely affected by gold causing slightly higher bias and offset currents.

It was not until advent of the Schottky clamp that a vast improvement in speed without input degradation was possible. A very familiar term in the semiconductor industry, the Schottky barrier diode's (SBD) location is illustrated in Figure 5.

The Schottky clamped transistor is formed by paralleling the Schottky diode with the base-collector junction of the npn transistor. Without the clamp, as base drive is increased the collector voltage falls until hard saturation occurs. At this point the collector voltage is very near the emitter voltage, and stored charges in the junctions causes slow recovery from saturation after

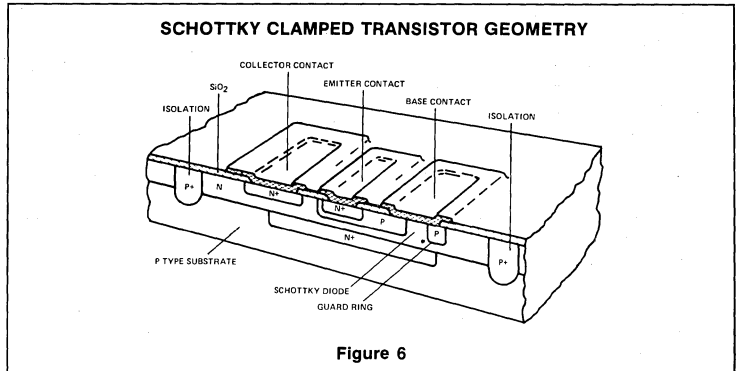

Figure 6

base drive has been removed. The forward voltage drop of the Schottky diode is 0.4 volts—less than the forward drop of silicon diodes. This difference in forward drop is used by placing the diode across the transistor base-collector junction. The Schottky diode becomes forward biased when the collector voltage falls 0.4 volts below the base voltage. Excess base drive is then

shunted into the collector circuit prohibiting the transistor from reaching classic saturation. With almost no stored charge in either the SBD or the transistor, there is a large reduction in storage time. Thus, transistor switching time is significantly reduced.

A cross sectional area of the Schottky diode is shown in Figure 6.

COMPARATOR SELECTION GUIDE							
Device	Propagation Delay (ns)	V _{OS} (mV)	I _{OS} (μA)	I _{bias} (μA)	Gain	CMR (V)	Benefits
NE521	12	7.5	5	20	5000	±3	Dual, very fast, standard supplies, TTL compatible, individual & common strobe.
NE522	15	7.5	5	20	5000	±3	Same as NE521 plus open collector outputs for additional decoding.
NE527	26	6	0.75	2	5000	±6	Fast, very low input current, differential outputs, flexible surplus wide common mode range.
NE529	22	6	5	20	5000	±6	Same as NE527 but with faster response.
LM311	200	7.5	0.05	0.25	200K	±30	High common mode input range, ±5V to ±15V supply, strobe input, open collector output.
LM319	80	8	0.2	1.2	40K	±5	Low input bias, dual, +5V to ±15V supply, open collector output.
LM339	1300	2	0.05	0.25	200K	V+ - 1.5V	High common mode input range, low input bias, quad, +5V to ±15V supply, open collector output.
LM393	1300	2	0.05	0.25	200K	V+ - 1.5V	Same as LM339 but dual.

Figure 7

NOTE Parameters are based on min/max limits at 25°C as defined in the individual data sheet.

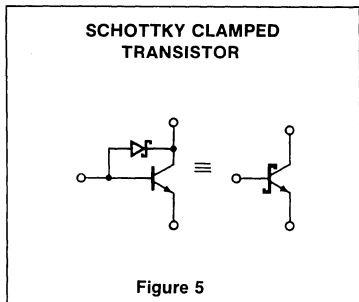

Figure 5

COMPARING THE COMPARATORS

Presently available comparator ICs range from the ultra fast SE/NE521 to the general purpose comparator fashioned from an expensive op amp. Selection of the device depends upon the application in which it will be used. Speed of conversion is often of primary importance to minimize pulse position errors of high frequency signals. At other times the requirements are much less stringent allowing the use of a general purpose comparator.

A handy reference guide to the major parameters is summarized in Figure 7. The necessary parameters can be chosen to select the proper device.

A general description of the comparator devices is included here to familiarize the user with available devices and their advantages.

SE/NE521/522 Comparators

Processed with state-of-the-art Schottky barrier diodes, the NE521/522 series devices provide good input characteristics while providing the fastest analog to TTL conversion to date. Total delay from input to output is typically 6ns with a guaranteed speed of 12ns. Additional features of this device include the dual configuration and individual output strobes to simplify system logic. The NE522, although sacrificing some speed, features open collector outputs for party line or wired-OR configurations for additional system flexibility.

NE/SE527 Comparator

Featuring darlington inputs for very low bias current, the NE527 is generically related to the NE529 comparator. Emitter follower inputs to the differential amplifier are used to trade better input parameters for slightly less speed. As Figure 7 shows, a factor of 10 improvement in I_{BIAS} is gained with a propagation delay increase of only 4ns maximum.

NE529 Comparator

The NE529 is manufactured using Schottky technology. Although a few nano seconds slower than the NE521, the NE529 features variable supplies from ± 5 to ± 10 volts with a high common mode range of ± 6 volts. Both the NE527 and NE529 Schottky comparators boast complimentary logic outputs with output A being in phase with input A. In addition, the supplies of both the NE527 and NE529 may be non-symmetrical to produce a desired shift in the common mode range.

This technique is illustrated by the ECL to TTL and TTL to ECL transistor of Figures 17 and 18 respectively. The only major require-

ment of the supplies is that the negative supply be at least 5 volts more negative than the ground terminal of the gate. This is necessary to insure that the internal bias arrangement has sufficient voltage to operate normally.

APPLICATIONS

Today's state-of-the-art ultra-high speed comparators are capable of making logic decisions in less than 10 nano seconds. They are easily applied and possess good input and power supply noise rejection. As with all linear ICs however, some preliminary steps should be taken in their use.

General Precautions

Layout

The comparator is capable of resolving sub-millivolt signals. To prevent unwanted signals from appearing at signal ports, good physical layout is required. For any high speed design, ground planes should be used to guard against ground loops and other sources of spurious signals. At high frequencies hidden signal paths become dominant. Distributed capacitance is a particular nuisance. If care is not taken to isolate output from input, distributed capacitance can couple a few millivolts into the input, causing oscillation.

Another source of spurious signals is ground current. Input structures are relatively high impedance while the gate structures of comparators run with large signal and ground currents. If this gate ground current is allowed to pass near the input signal path, the small impedances of the ground circuit will cause millivolt changes in reference or signal voltages producing errors, sustained oscillation, ringing, or excessive V_{OS} . A ground plane arranged such that output currents do not flow near input areas is highly recommended.

Power Supplies

Another general precaution that should always be exercised is power supply bypassing. As mentioned the name of the game is speed. Very high speed gates are used to produce the desired output logic levels. Maximizing response speed also requires higher current levels, giving rise to power supply noise. For this reason, good power supply bypassing very close to the device itself is always mandatory. A tantalum capacitor of 1 to 10 μ F in parallel with 500 to 1000pF will prove effective in most cases. Lead lengths should be as short as physically possible to preserve low impedances at high frequency.

Unused Inputs

Some currently available comparators such as the NE521 and NE522 are dual devices. Most often both sections of these devices

will be utilized. Should a system utilize one device, the unused inputs should be biased in a known condition. The high gain-bandwidth may otherwise cause oscillations in the unused comparator section. A low impedance should be provided from both unused inputs to ground. A resistor of relatively high impedance may then be used to supply a differential input on the order of 100mV to insure the comparator assumes a known state.

If the inverting input is tied to the positive differential voltage the gate output will be low. The strobe inputs then provide a means of utilizing the Schottky gate for other system logic functions.

If the strobe inputs are not used, they should be connected to the output of a logic gate that is always high, or to the +5 volt supply through a 5 to 10 K-ohm resistor. They should never be tied directly to the +5 volt supply as the relatively minor spiking on the supply may damage these inputs.

Common Mode Signals

Manufacturers specify the maximum voltage range over which the inputs may be taken. In addition the maximum differential voltage that may be safely applied to the inputs is specified. In the case of the NE529 comparator the differential voltage is restricted to less than ± 5 volts, with a common mode of ± 6 volts. That these two quantities interact cannot be overlooked. For instance, with both inputs at ± 4 volts the common mode restriction is satisfied. If V_{ref} is now left at +4 volts the signal input may not be taken more than 1 volt below ground because the differential signal becomes 5 volts.

It is important to observe this maximum rating since exceeding the differential input voltage limit and drawing excessive current in breaking down the emitter-base junctions of the input transistors could cause gross degradation in the input offset current and bias current parameters.

Exceeding the absolute maximum positive input voltage limit of the device will saturate the input transistor and possibly cause damage through excessive current. However, even if the current is limited to a reasonable value so that the device is not damaged, erratic operation can result.

Input Impedance

The differential bias and offset currents of comparators are minimized by design. As was pointed out for op amps, the input resistance seen by both inputs should be equal. This reduces to a minimum the contribution of offset current to threshold error. Unbalanced input impedance also adds to

the offset error due to the difference in voltage drop across the input resistances.

BASIC APPLICATIONS

The basic comparator circuit and its transfer function were presented by Figures 1 and 2.

When the input exceeds the reference voltage, the output switches either positive or negative, depending on how the inputs are connected.

The vast majority of specific applications involve only the basic configuration with a change of reference voltage. A to D converters are realized by applying the signal to one terminal and the voltage derived from a ladder network to the other. Limit detectors are likewise made from only the very basic circuit. Both are only a small deviation from the basic level detector.

Hysteresis

Normally saturated high or low, the amplifiers used in voltage comparators are seldom held in their threshold region.

They possess high gain-bandwidth products and are not compensated to preserve switching speed. Therefore, if the compared voltages remain at or near the threshold for long periods of time, the comparator may oscillate or respond to noise pulses. For instance, this is a common problem with successive approximation D/A converters where the differential voltage seen by the comparator becomes successively smaller until noise signals cause indecision. To avoid this oscillation in the linear range, hysteresis can be employed from output to input. Figure 8 defines the arrangement. Both positive and negative feedback is provided by R_{IN} and R_F .

Hysteresis occurs because a small portion of the "one" level output voltage is fed back in phase and added to the input signal. This

feedback aids the signal in crossing the threshold. When the signal returns to the threshold, the positive feedback must be overcome by the signal before switching can occur. The switching process is then assured and oscillations cannot occur. The threshold "dead zone" created by this method, illustrated in Figure 9, prevents output chatter with signals having slow and erratic zero crossings.

As shown in Figure 8, the voltage feedback is calculated from the expression:

$$V_{HYST} = \frac{E_{OUT} \cdot R_{IN}}{R_{IN} + R_F}$$

where E_{OUT} is the gate high output voltage. The hysteresis voltage is bounded by the common mode range and the ability of the gate to source the current required by the feedback network. If symmetrical hysteresis is desired an additional inverting gate is required if the comparator does not have differential outputs. The NE527 and NE529 devices provide inverted signals from differential outputs while the NE521 and NE522 devices will require the inverter. Care should be taken in the selection of the inverter that propagation delay is minimum, especially for very high speed comparators such as the NE521.

Line Receiver

Retrieving signals which have been transmitted over long cables in the presence of high electrical noise is a perfect application for differential comparators. Such systems as automated production lines and large computer systems must transmit high frequency digital signals over long distances.

If the twisted pair of the system is driven differentially from ground, the signals can be reclaimed easily via a differential line receiver.

Since the electrical noise imposed upon a pair of wires takes the form of a common mode signal, the very high common mode rejection of the NE521/522 makes the unit ideal for differential line receivers. Figure 10 depicts the simple schematic arrangement. The NE521 is used as a differential amplifier having a logic level output. Because common mode signals are rejected, noise on the cable disappears and only the desired differential signal remains. Figure 11 illustrates the NE521 response to the 200mV peak to peak 10MHz differential signal. In Figure 12 the same signal has been buried in 5 volts peak to peak of 1MHz common mode "noise."

The circuit suffers no degradation of signal. If desired several NE522 comparators may be "wired OR'd," or latched output can be built as shown in Figure 10.

The NE521 and NE529 comparators have the advantage of wider bandwidth to permit higher data rates.

Double Ended Limit (Window) Detector

Many system designs require that it be known when a signal level lies between two limits. This function is easily accomplished with a single NE522 package. The schematic and transfer curve of the circuit is shown in Figure 13.

Each half of the NE522 is referenced to the desired upper or lower voltage limit producing the desired transfer curve shown. Taking advantage of the dual configuration and the open collectors of the NE522 minimize external components and connections.

Crystal Oscillator

Any device with a reasonable gain can be made to oscillate by applying positive feedback in controlled amounts. The NE521 will lend itself to crystal control easily, provided the crystal is used in its fundamental mode. Figure 14 shows a typical oscillator circuit.

The crystal is operated in its series resonant mode, providing the necessary feedback through the capacitor to the input of the NE521. The resistor R_{adj} is used to control the amount of feedback for symmetry. Oscillations will start whenever a circuit disturbance such as turning on the power supplies occurs. The NE521 will oscillate up to 70MHz. However, crystals with frequencies higher than about 20MHz are usually operated in one of their overtones. To build an oscillator for a specific overtone requires tuned circuits in addition to the crystal to provide the necessary mode suppression. If the spurious modes are not tuned out the crystal will oscillate at the fundamental frequency. Higher frequency oscillators could be realized using

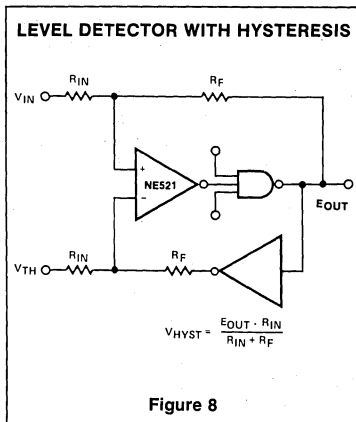

Figure 8

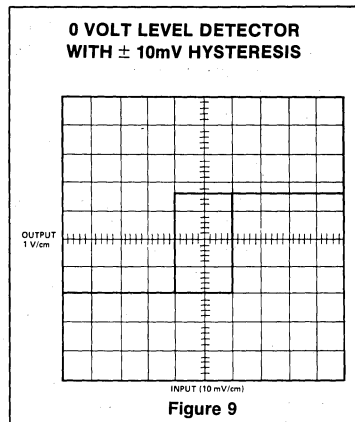
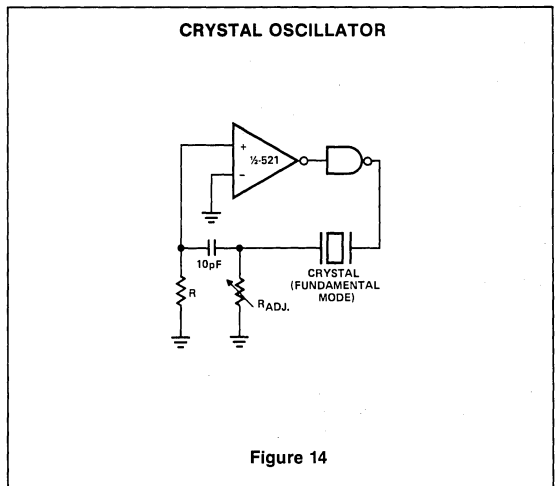
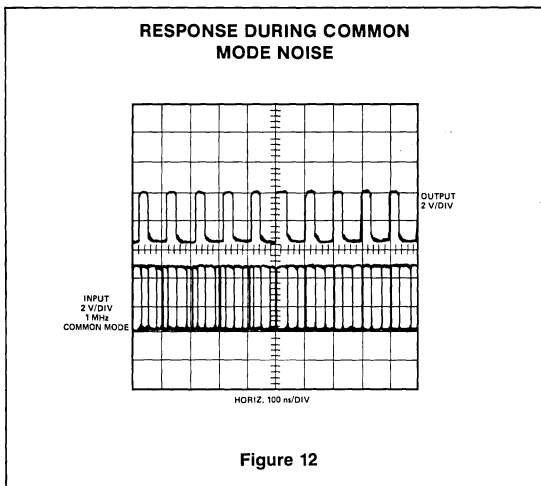
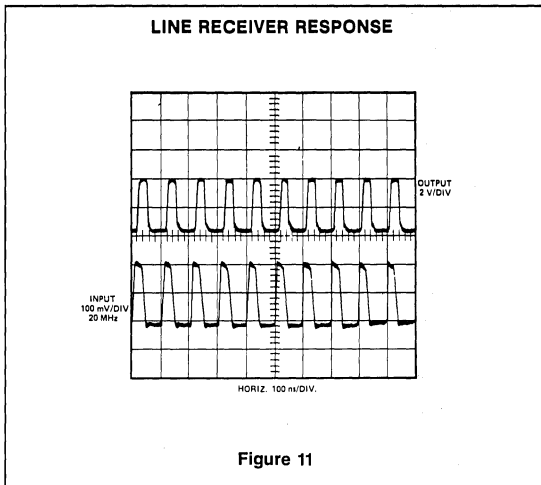
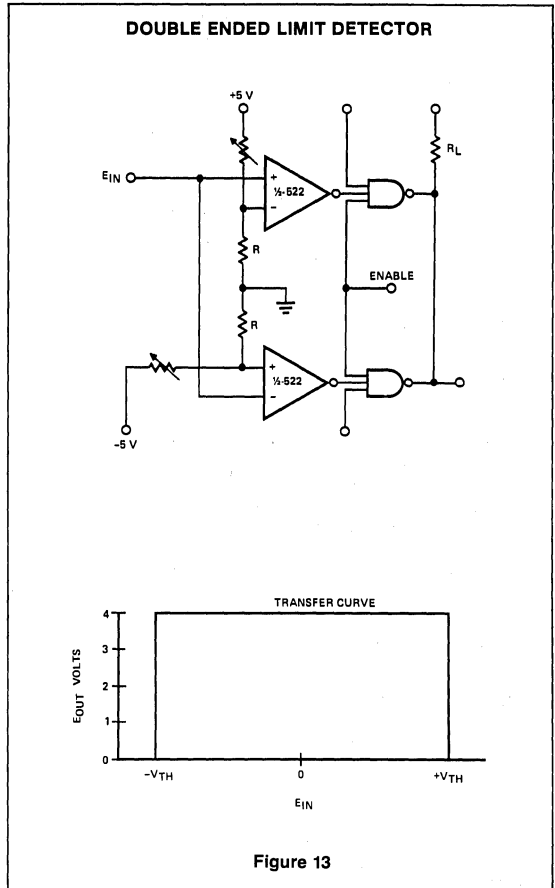
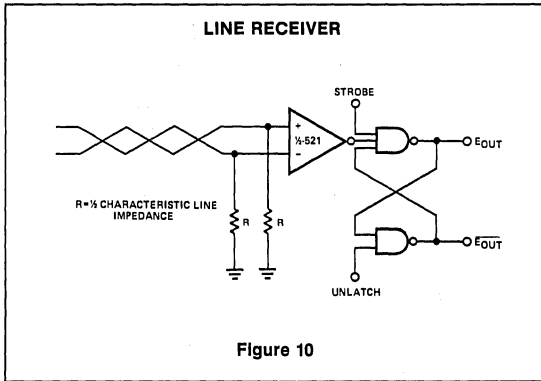

Figure 9



input and output mode suppression or tuning. The NE522 is especially desirable since the open collector topology allows the output to be collector tuned readily.

Analog to Digital Converter

There are many types of A to D converter designs, each having its own merits. However, where speed of conversion is of prime interest the multi-threshold conversion type is used exclusively. It is apparent from Figure 15, that the conversion speed of this design is the sum of the delay through the comparator and the decoding gates.

The sacrifices which must be made to obtain speed are the number of components, bit accuracy and cost. The number of comparators needed for an N-bit converter is $2^n - 1$. Although the NE521 provides two comparators per package, the length of parallel converters is usually limited to less than 4 bits. Accuracy of multi-threshold A-D converters also suffers since the integrity of each bit is dependent upon comparator threshold accuracy.

The implementation of a 3-bit parallel A-D converter is shown in Figure 16 with a 3-bit digital equivalent of an analog input shown in Figure 15.

Reference voltages for each bit are developed from a precision resistor ladder network. Values of R and 2R are chosen so that the threshold is one half of the least significant bit. This assures maximum accuracy of $\pm 1/2$ bit.

It is apparent from the schematic that the individual strobe line and duality features of the NE521 have greatly reduced the cost and complexity of the design. The speed of the converter is graphically illustrated by the photo of Figure 15. All 3-bit outputs have settled and are true a mere 15ns after the input step of 3 volts has arrived. The output is usually strobed into a register only after a certain time has elapsed to insure that all data has arrived.

Logic Interface

During the design of the NE527 and NE529 devices, particular attention was paid to the biasing network so that balanced supplies need not be provided. For example, if the "ground" terminal is set at -5.2 volts and the other supplies are adjusted accordingly, the output logic 1 state will be at -1.5 volts and logic 0 will be at -5.0 volts. With this freedom of power supply voltage, the user may adjust the output swings to match the desired logic levels even if that logic is other than TTL levels.

ECL to TTL Interface

Emitter coupled logic is very popular due to its speed. Systems are often built around standard TTL logic with those portions requiring higher speed being implemented with emitter coupled logic. As soon as such a decision is made the problem of interfacing TTL to ECL logic levels is encountered.

The standard logic output swings of ECL are -0.8V to -1.8V at room temperature. Converting these signals to TTL levels is accomplished simply by using the basic voltage comparator circuit with slight modifications. Figure 17 reveals that the power supplies have been shifted in order to shift the common mode range more negative. This insures

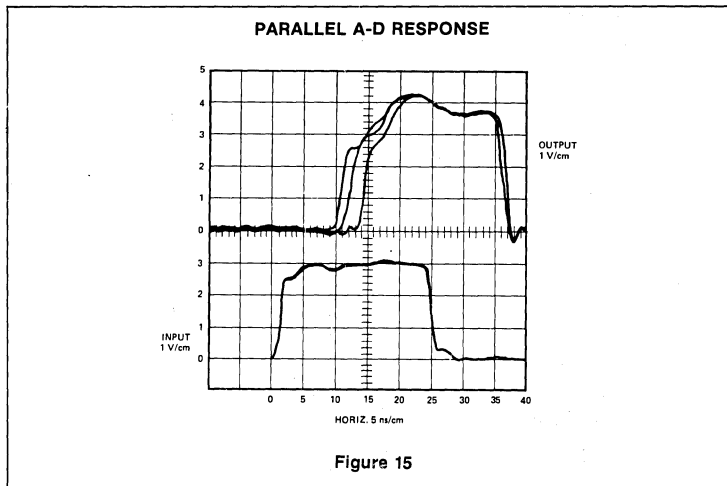

Figure 15

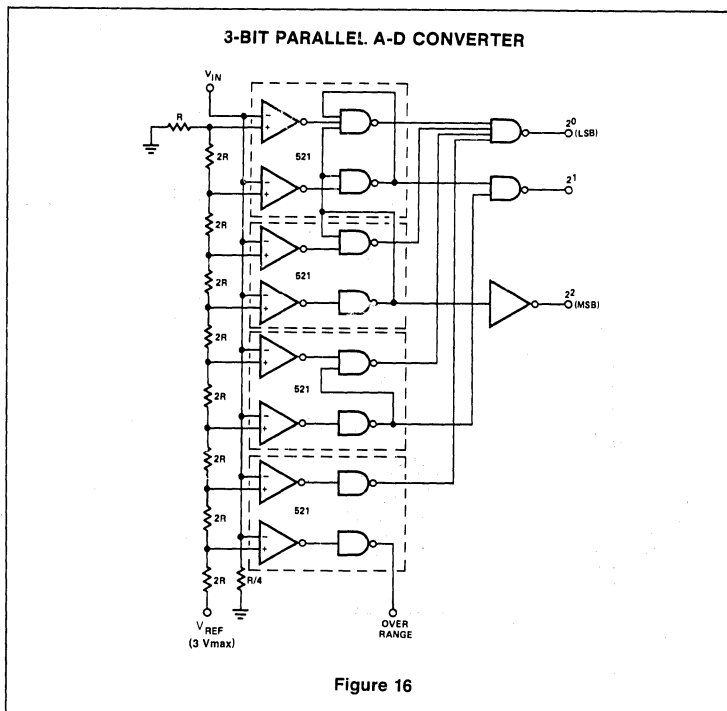

Figure 16

that the common mode range is not exceeded by the logic inputs. Since ECL is extremely fast the NE529 is usually selected because of its superior speed so that a minimum of time is lost in translation.

TTL to ECL

Operating in the reverse, TTL levels can also be converted to ECL levels by the NE529. Again the NE529 is selected as the fastest converter with the necessary power supply flexibility to accomplish the level shifting with a minimum of effort and cost.

A check of output voltage for the NE529 reveals that the voltage is slightly less than required by the ECL logic for fast switching R2 and the diode of Figure 18 raises the gate supply voltage and therefore the NE529 output voltage by 0.7 sufficient to guarantee fast switching of the translator. Resistive pull up from the NE529 output to V_{CC} can also be used with the gate supply grounded. This method is dependent upon RC time constants of distributed capacitance and is therefore much slower.

Photo Diode Detector

Responding to the presence or absence of light, the photo diode increases or decreases the current through it. Detecting the changes becomes a matter of converting light and dark currents to voltage across a resistor as shown in Figure 19. R1 is selected to be large enough to generate detectable differences between light and dark conditions. Once the signal levels are defined by R1 and the diode characteristics, the average between light and dark signals is used for V reference and is produced by the resistive divider consisting of R1 and R2. The comparator then produces an output dependent upon the presence or absence of light upon the diode.

SENSE AMPLIFIERS

Closely related to the comparator is the sense amplifier. Signals derived from the many sources, such as transducers, are not of sufficient amplitude to be compatible with subsequent logic. It then becomes necessary to amplify and convert the signal to TTL levels, which is the responsibility of the sense amplifier.

Some transducers produce an output current. It remains, then, for the user to convert these currents to TTL levels. A terminating resistor from the drain to ground provides a voltage output proportional to the current and the resistor size. Larger signals can be produced by larger resistors; but in practice resistors larger than 1k ohm are avoided because of increasing access time. Distributed capacitance forms a time constant with this output

resistance causing slow rise and fall times when the resistor is large, adding to the access time.

Virtually any voltage comparator or sense amplifier can be used. Since total time is the sum of all delays, the sense amplifier is most often the fastest available. Signetics comparators NE521 and NE522 are ideal in this application because of low input offset voltages and very fast response. Using these Schottky clamped comparators significantly reduces the total cycle time of the memory.

Design of the sense amplifier network depends upon the transducer used and the input characteristics of the sense amplifier. The significant specifications are given in Table 1.

Consideration must first be given to the differential input voltage requirements of the sense amplifier. The required reference voltage is calculated from the relationship:

$$V_{ref} \leq (I_1 - I_2) R_1 - V_{diff}$$

**Table 1
IMPORTANT SENSE
AMPLIFIER PARAMETERS**

DEVICE	V _{OS} (mV)	I _B (μA)	V _{IN} (MIN)(mV)	SPEED (NS) (V _{IN} =100mV)	GAIN
521	10	40	15	12	5000
522	10	40	15	15	5000

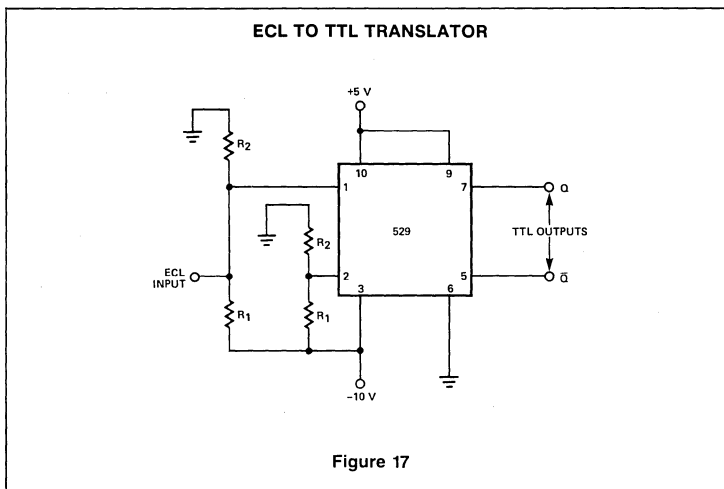

Figure 17

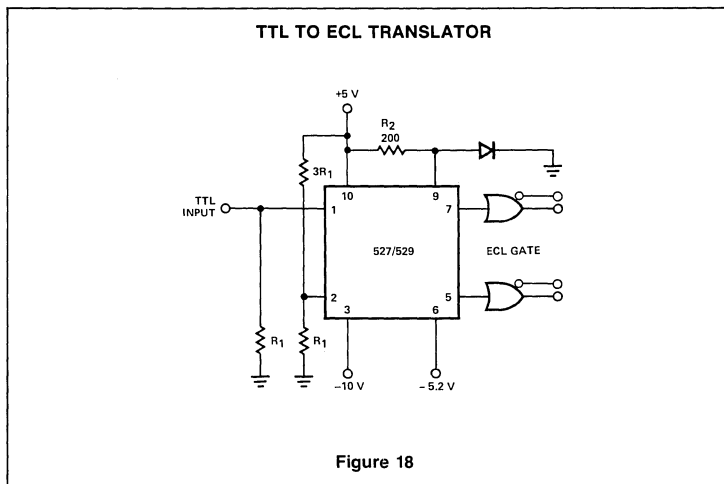
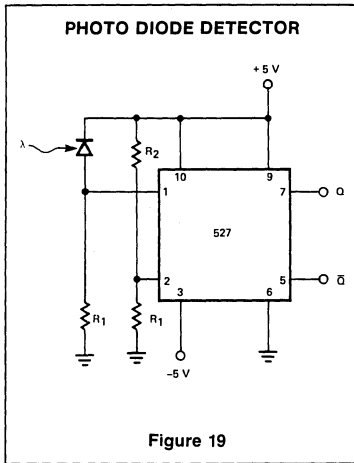

Figure 18



Where I_t is the transducer output current, I_B is sense amplifier bias current and V_{diff} is minimum differential voltage to switch the sense amplifier.

In large systems, noise coupled into the sense lines by stray capacitance can be very troublesome. Judicious layout patterns with sense lines as short as possible will help, but will not always be sufficient. One method of eliminating noise is to use a balance sense line as shown in Figure 20.

A dummy line should be run parallel to the actual sense line in as close proximity as possible. One end is connected to the sense amplifier at the V_{ref} point while the other end is left open. The normal sense line is connected as usual. Electrical noise imposed upon the pair of sense lines takes the form of a common mode signal and will be rejected by the sense amplifier. Signal currents in the sense line, on the other hand, form differential signals at the sense amp causing the output to switch.

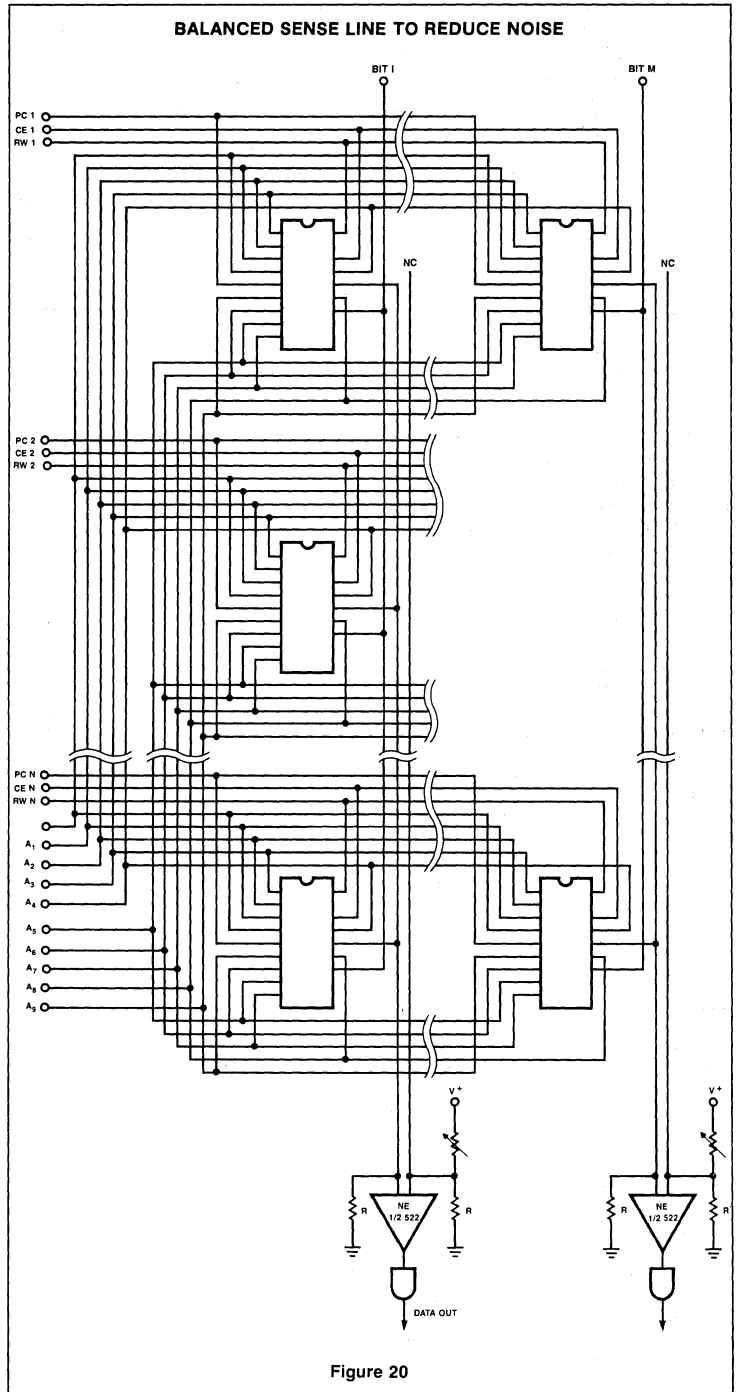

INTRODUCTION

An LVDT is an electromechanical transducer which makes possible the measurement of very small motion in a structure or mechanical device. Mechanical motion is translated to an electrical signal which contains position information much as a radio frequency carrier contains sound information. The position information from the LVDT is contained in the phase and amplitude of the output AC waveform. In order to remove the position information (demodulation), a system such as is shown in block form in Figure 1 must be used. Once signal demodulation is achieved the position data may be read out on a meter or digital display in addition to being processed by microprocessor or computer. The Signetics NE5520 is a new *Monolithic LVDT Driver-Demodulator* designed to interface with most LVDT's presently being used in the industry.

Uses will range over a large number of potential applications including the accurate measurement of position, pressure, load weight, angular position and even acceleration. Historically, LVDT's have been used in the following applications:

- Load cell
- Linear motion
- Torque cell
- Vibration
- Fluid pressure
- Accelerometer
- Inclinator
- Seismic load cell

MOTION MAY-BE

- Linear
- Rotary

The NE5520 provides sinusoidal drive to the Linear Variable Differential Transformer (LVDT), the output of which is buffered, rectified and phase demodulated to obtain both direction and displacement information in the form of a DC output signal (Figure 2).

LVDT LOADING

Due to the loosely coupled characteristics of the typical LVDT, loading effects versus frequency may be critical to a successful design. The graph (Figure 3A) shows this relationship in the form of a family of curves relative to LVDT core displacement for 400Hz and 2500Hz. From the curves it is obvious that the linearity and output level versus displacement is superior for an LVDT operated at 2500Hz with a very high impedance load (0.5 meg ohm). The

THE LVDT WITH SINEWAVE EXCITATION AND SYNCHRONOUS DEMODULATION

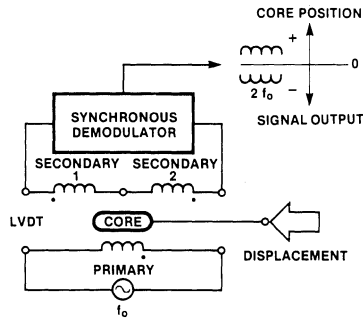

Figure 1

LVDT SYSTEM TRANSFER FUNCTION

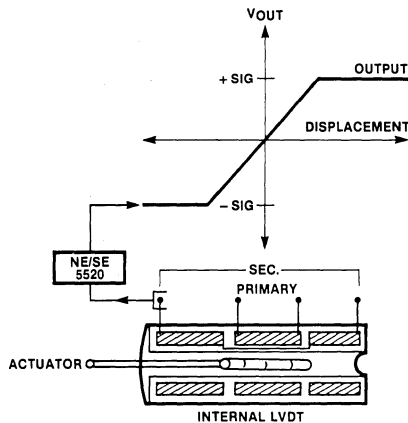

Figure 2

NE5520 demodulator presents a very high input impedance to the LVDT secondary for maximum linearity. (Fig. 3B)

LVDT INTERFACING: SIGNAL CONDITIONING IS REQUIRED

In order to obtain usable information from the LVDT a series of signal conditioning circuit operations are required. First, a stable source of constant frequency excitation voltage must be applied to the primary of the LVDT.

Next some form of demodulator is needed to extract position information from the LVDT secondary output signal. A full wave rectifier will provide usable amplitude information when adequately filtered, however, relative phase information is lacking. In order to obtain both phase and amplitude information synchronous demodulation is needed. This type of demodulator



OUTPUT CHARACTERISTICS OF A TYPICAL LVDT FOR VARIOUS LOADS AND EXCITATION FREQUENCIES

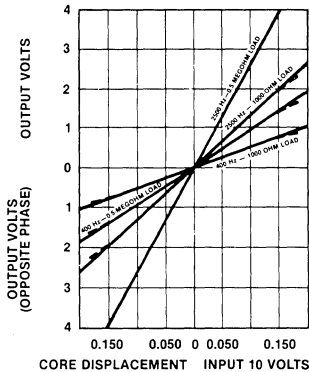

BY PERMISSION SCHAEVITZ ENGINEERING
"HANDBOOK OF MEASUREMENT AND CONTROL" BY HERCEG.

Figure 3a

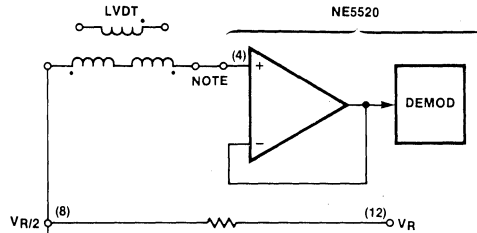

NOTE: INTERNAL BUFFER AMP PROVIDES HIGH IMPEDANCE LOAD TO SECONDARY.

Figure 3b

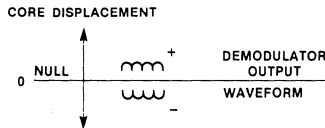

Figure 3c

exists in the Signetics NE5520. Once phase and amplitude information is obtained in the form of a polar full wave rectified signal (see Figure 3C) from the synchronous demodulator, the carrier component (actually 2nd harmonic of the carrier plus higher order spectral components) must be filtered out leaving only the true position information. This is accomplished by passing the demodulated signal through a low-pass active filter. An auxiliary operational amplifier is provided for this purpose within the NE5520, in addition to adjustable signal gain for proper full scale output (span adjustment). In addition, DC offsets are nulled by a simple offset adjustment at the auxiliary amplifier. The resulting system is a complete LVDT signal conditioner. Figure 4 shows a block diagram of the NE5520. The device

will operate in a single supply range from 5 to 20 volts DC or with split supplies of ± 5 to ± 10 volts DC. A device current, I_{CC} , of 10 milliamperes at an operating voltage of 10 volts is typical.

DESCRIPTION OF THE NE5520 (Figure 4)

The NE5520 oscillator consists of a triangle wave generator, a current source-sink circuit which switches when the capacitor voltage reaches discrete levels at $1/4$ and $3/4 V_{REF}$. The total swing being $V_{REF/2}$ volts p-p. The triangle wave is fed into a non-linear load which generates a sinusoidal waveform with low distortion. The sine wave output is then buffered by two op amps, the output of which appear on pins 9 and 10 in phase opposition. This

then is the excitation signal for the LVDT primary.

The second major functional portion of the NE5520 is the synchronous demodulator and this section performs full wave rectification in phase synchronism (pin 6) with the above oscillator output. In order to extract true position information, the phase relationship of the LVDT secondary must be obtained. This means that as the LVDT core passes through null an abrupt 180° phase change occurs. Once full wave rectification is accomplished, the resulting signal carrier frequency must be removed by filtering. Demodulator output appears on pin 5. This is accomplished by an active filter incorporating the auxiliary op amp (pins 1, 2, 3). The original position information then appears ripple free on pin 1 of the auxiliary amplifier.

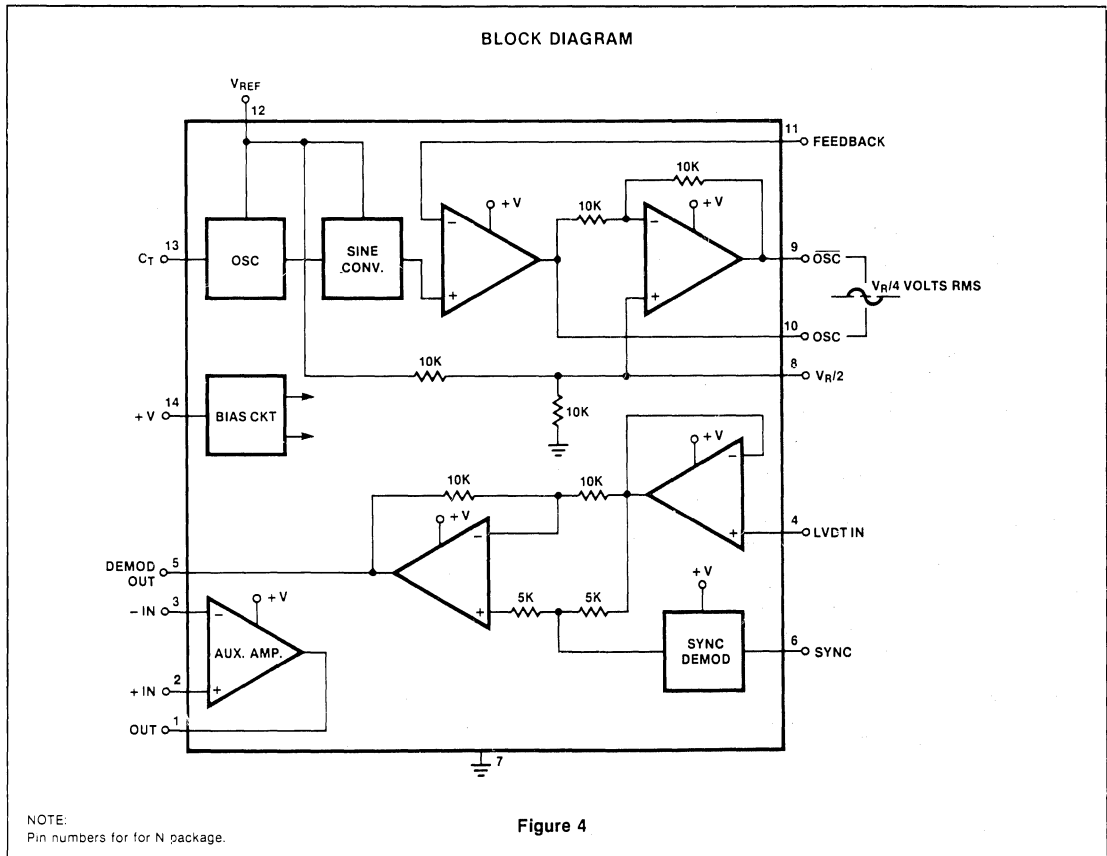

Other functions include buffer amplifier feedback in the oscillator circuit. The loop is closed with negative feedback around both amplifiers (pin 10 to 11) operating at unity gain.

The oscillator timing capacitor controls the frequency as shown in the graph, Figure 5. The frequency is related by the equation $f_{OSC} = 110/C_{T\mu F}$. Absolute output frequency will vary slightly with supply voltage.

**BIASING THE REFERENCE
VREF (PIN 12)**

The manner in which the V_R pin is biased will effect the output voltage function of the NE5520 and consideration must be given to this in order to arrive at an optimum system design. There are two basic modes of operation involved as listed below:

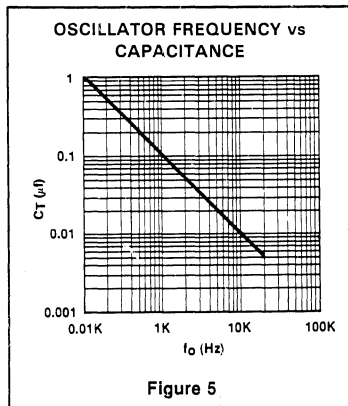

- 1) Ratiometric
- 2) Fixed Reference

With the *ratiometric mode*, pin 12 (V_{REF}) is

connected to pin 14 (+V). Since V_R controls the DC common mode voltage of the demodulator and the oscillator rms output, these magnitudes will now change with supply voltage. The DC output from pin 1, using a single ground referenced supply, will be ratiometric with the supply voltage and centered within the common mode range of the output amplifier when the LVDT transducer is at null. Single or dual supply operation will be ratiometric when +V is connected to V_R .

The alternate method of biasing is the *fixed reference* mode with pin 12 (V_R) connected to a fixed reference voltage such as +10 volts and pin 14 (+V) allowed to vary with an incoming poorly regulated supply. This might occur in automotive applications where battery voltage may vary from 10 to 14 volts. However, with a fixed reference driving V_R , DC voltage at the output will not vary with supply but will vary within the common mode limits

of the amplifier as the LVDT core traverses its path. Output voltage of pin 1 at LVDT null will be $V_R/2$. Thus, for the case mentioned with $V_R = 10$ volts, the null voltage will be +5 volts. The maximum linear swing would be 1.5-8.5 volts around this value. The fixed reference mode may be used with single or dual supply operation.

DUAL SUPPLY OPERATION

When connected to a typical LVDT transducer as shown in Figure 6, the NE5520 will exhibit an extremely linear transfer function. Very important to precision position measurement is the inherent repeatability of the system. The graphs in Figure 7A, B illustrate the highly linear transfer function and its repeatable accuracy with different supply voltages, in this case ± 6 and ± 10 volts. The transducer motion was over a range of ± 150 millinches each side of the LVDT null. Typical DC output signal is shown with an output amplifier gain of X10 in both cases. Note that linearity remains constant, however, full scale output varies with supply voltage. This is due to the increased excitor drive to the LVDT with increased reference voltage. LVDT output is a linear function of excitor amplitude on the primary winding. The addition of a single gain control may easily be added between pins 1 and 3 to reduce gain in order to retain constant output for different supply voltages (see Figure 8) or V_R may be connected to a fixed voltage. (See 'Biasing')

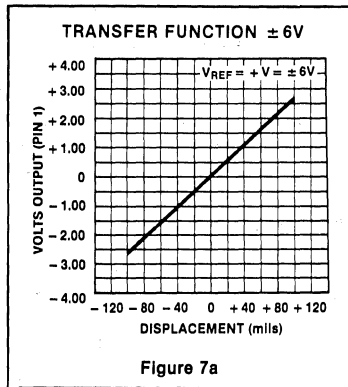

Figure 7a

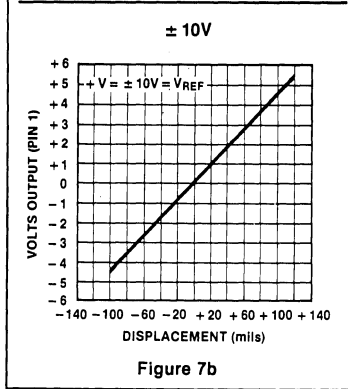

Figure 7b

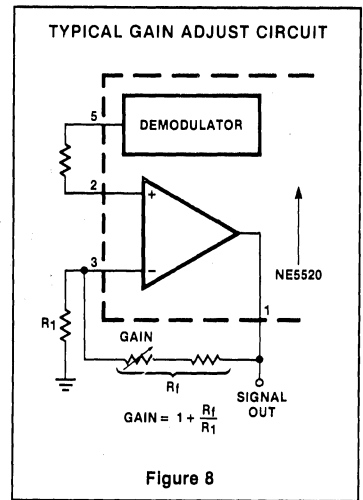

Figure 8

It is strongly recommended that dual output tracking regulated supplies be used in this type of application in order to minimize system DC offset and impaired measurement accuracy due to power supply unbalance. An optional circuit capable of automatically tracking and nulling power supply offset is shown in Figure 9. The bipolar output signal is referenced to ground.

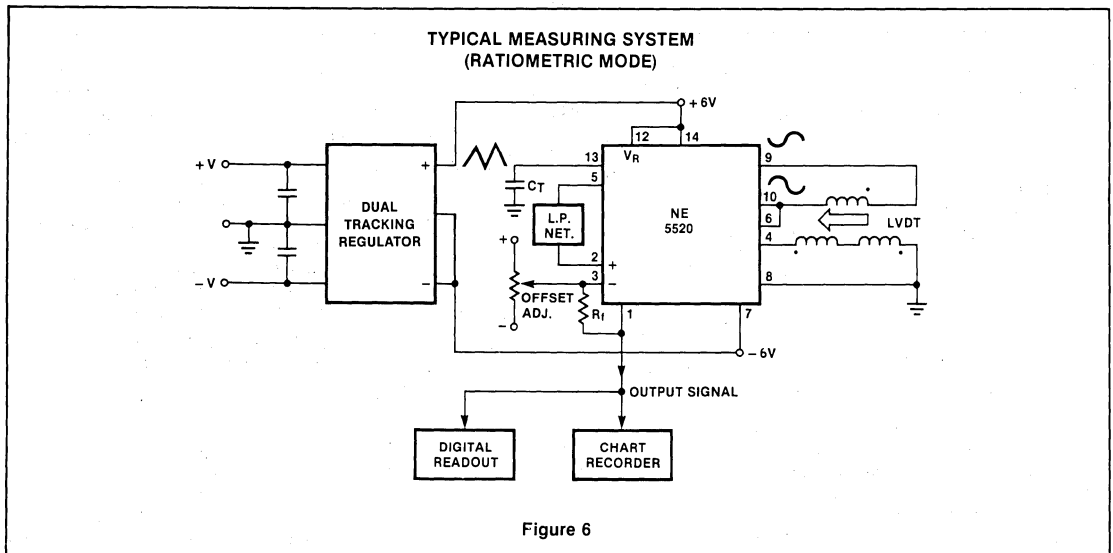
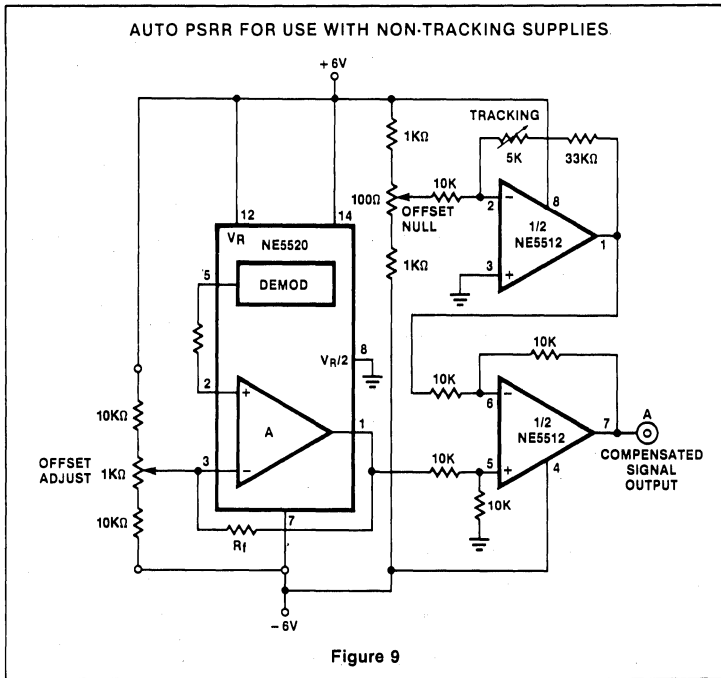

Figure 6



NULLING PROCEDURE
(Ref Fig. 9)

1. Null transducer position by observing pin 4 waveform. Set supply voltage for ± 6.00 volts.
2. Set offset adjust pot (feeds pin 3 of NE5520) for 0.00 volts DC at pin 1 of NE5520.
3. Adjust offset null pot (NE5512) for zero output on Terminal A.
4. Check for equal voltage \pm deflection when transducer is displaced equal distances from physical null position.
5. Adjust tracking control for minimum DC output change when either supply is varied over operating range at 'A'.

SINGLE SUPPLY OPERATION

Single ended supply operation requires a different circuit approach to obtain measurement system interface. Figure 10 shows a typical circuit using a single 10-volt supply. Note that the output (pin 1) of the NE5520 is now floating above ground at approximately $V_R/2$. Simple measuring circuits may be realized (Figures 11A, B, C) by placing a DC microammeter between pin 1 and a resistive divider

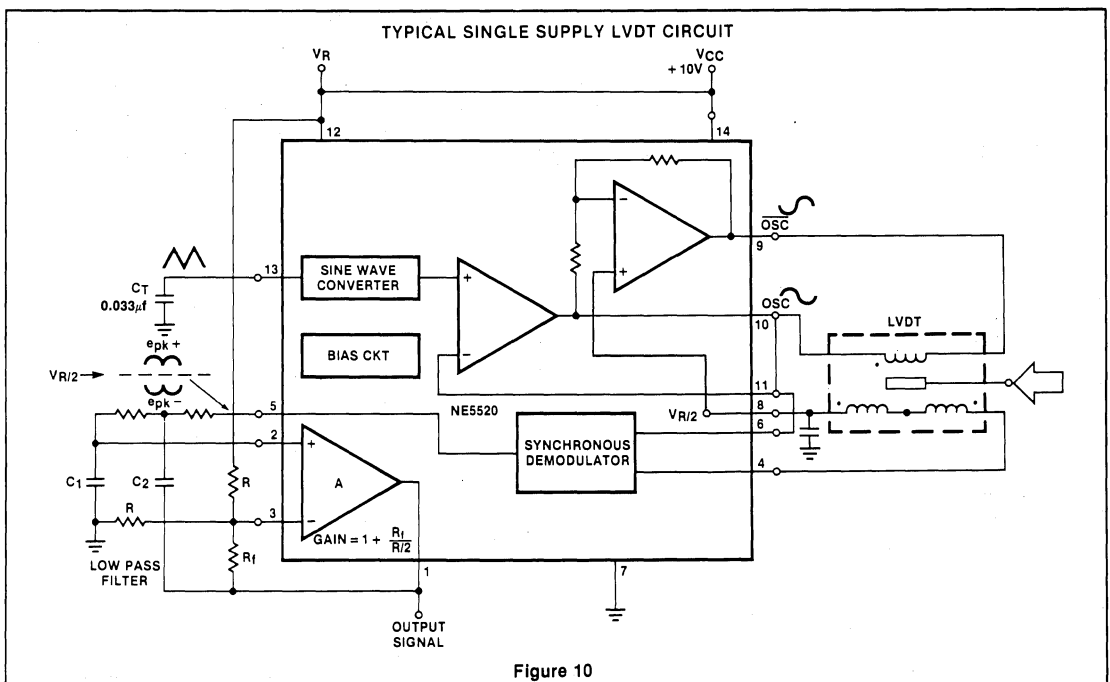

creating a bridge readout which is ratiometric with supply voltage variations. In case more precision is necessary, a buffer amplifier may be added between the voltage divider or $V_R/2$ and the readout circuit in order to minimize offset due to measuring circuit loading. DC offset due to internal tracking error in the NE5520 may be reduced by using the nulling circuit shown in Figure 12. Offset sensitivity and its effect on system accuracy will be inversely proportional to full scale signal output of the NE5520 which is a function of the DC gain of the auxiliary amplifier and LVDT output. A typical full scale output with 10-volt supply operation is $V_R/2 \pm 3.5$ volts with gain equal to 10.

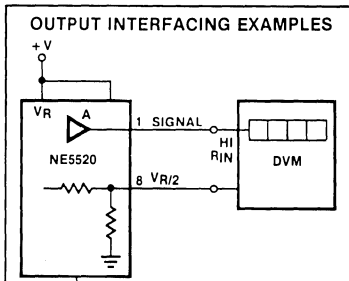

Figure 11a

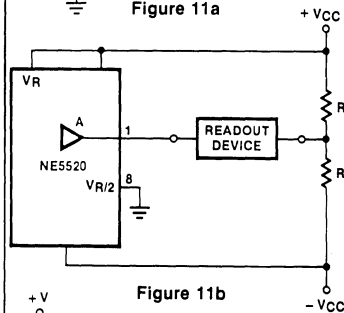

Figure 11b

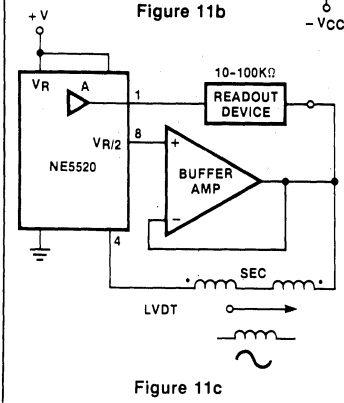

Figure 11c

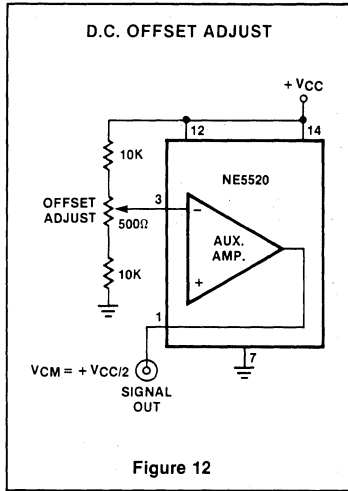

Figure 12

MATCHING THE NE5520 TO LOW IMPEDANCE LVDT'S

The NE5520 exciter output is capable of driving LVDT primary windings with a minimum impedance of 1K ohm. When a significantly lower impedance primary is driven by the device some form of step-down impedance matching or a power buffer is recommended. Figure 13 shows a step-down matching transformer approach. A transformer with primary impedance of approximately 1K ohm (audio type) with the proper secondary impedance to match the LVDT primary is used to couple

oscillator excitation. Depending on the output efficiency of the LVDT, output signal losses may occur with a corresponding loss in measuring sensitivity. The auxiliary amplifier gain may be increased to offset this loss.

A second approach makes use of a power buffer amplifier constructed from discrete transistors (2N2222, 2N3644). This circuit (Figure 14) results in less signal loss and is inexpensive. A DC decoupling capacitor must be used to prevent DC offset currents from flowing in the LVDT primary winding. A 3dB signal reduction is noted when driving a 15-ohm load to 6 volts peak to peak (10-volt operation); and 12 volts peak to peak for 20-volt supply.

NE5520 TEMPERATURE COMPENSATION

Internal offset voltages originating in the NE5520 synchronous demodulator require external compensation to obtain best measurement accuracy when operating over the full temperature range. The circuits shown (Figures 15A, B) give a simple approach using a thermistor inserted in series with the offset null resistors to reduce voltage drift to a reasonable level. These tolerances are based on ± 3.5 volts full scale output for LVDT displacements each side of physical null. A thermistor having a positive coefficient of $+0.7\%/^{\circ}\text{C}$ is used. Obviously, if the total divider resistance is changed a different thermistor resistance will be required.

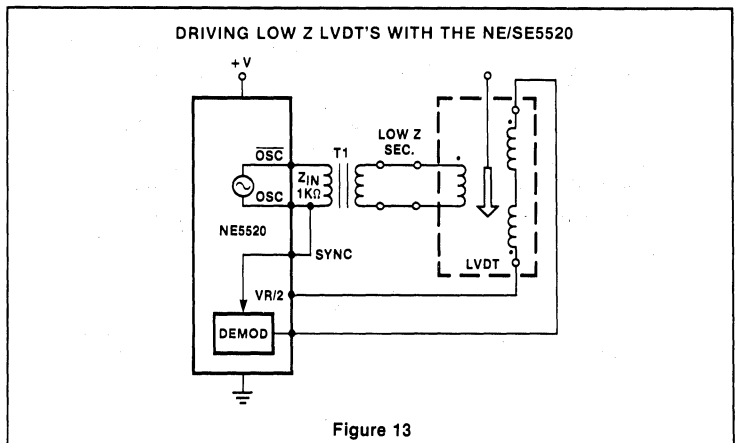
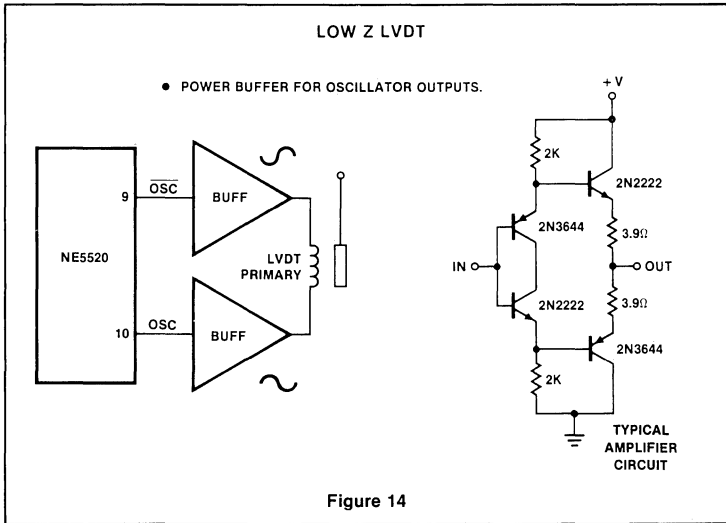

Figure 13



DEMODULATOR DISTORTION (OVERDRIVE)

When the demodulator input exceeds 2 volts peak to peak clipping distortion will increase and must be avoided by controlling oscillator drive to the primary of the LVDT. Figure 16 shows an example of a circuit for attenuating primary excitation using a 1K ohm potentiometer.

The procedure for adjusting the level is simply to:

1. Set LVDT core position for maximum output from the secondary.
2. Monitor the waveform on (pin 5 demodulator output) and adjust oscillator level for the amplitude just below clipping. Normally this should result in a maximum of 2 volts peak to peak at pin 4 of the NE5520 (25°C).

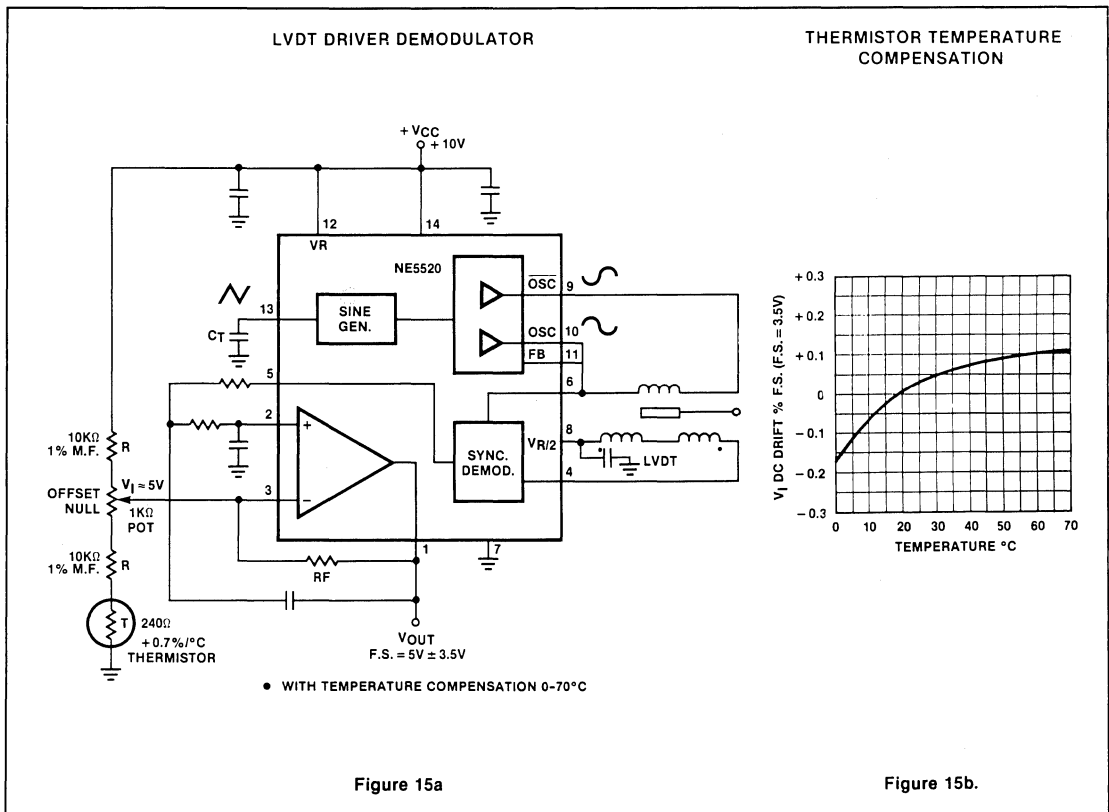

LVDT SECONDARY PHASE ANGLE COMPENSATION BY EXCITATION FREQUENCY

The LVDT has a frequency dependent phase shift associated with the particular characteristics of the device and its excitation frequency. This phase shift is in addition to the 180° shift which occurs when passing through null position.

By adjusting the frequency of the sine wave excitation a condition results which causes secondary voltage to be in phase with primary excitation. The adjustment of relative primary and secondary phase angles has several effects. First, if the primary excitation is referenced to the synchronous demodulator, as in the NE5520, optimum rectification occurs at zero phase differential between secondary AC phase and demodulator switching relative to the waveform zero crossings. Second, "Exciting an LVDT at its zero phase angle frequency results in minimum sensitivity to frequency and temperature variations" (Schaevitz Handbook of Measurement and Control, 1976).

DEMODULATOR SYNC PHASE

A second method of phase compensation of the NE5520 versus the LVDT is to use a variable phase shift network between the oscillator output and the sync input to the NE5520. This is shown in Figure 17. The oscillator frequency remains fixed and the pot is tuned for optimum demodulator phasing.

It is emphasized that an external phasing adjustment as outlined above is not always necessary. Some LVDT's operating in the 1-5kHz range will be near zero phase and will need no phase compensation. Experimental evaluation of the prototype design combined with system specifications will be the best means of making this decision.

Waveform photo in Figure 18A-B, shows the demodulator output signal when phasing of the synchronous demodulator is correct (A) and improperly adjusted (B).

Proper phasing of the sync signal to the demodulator results in optimum sensitivity and linearity.

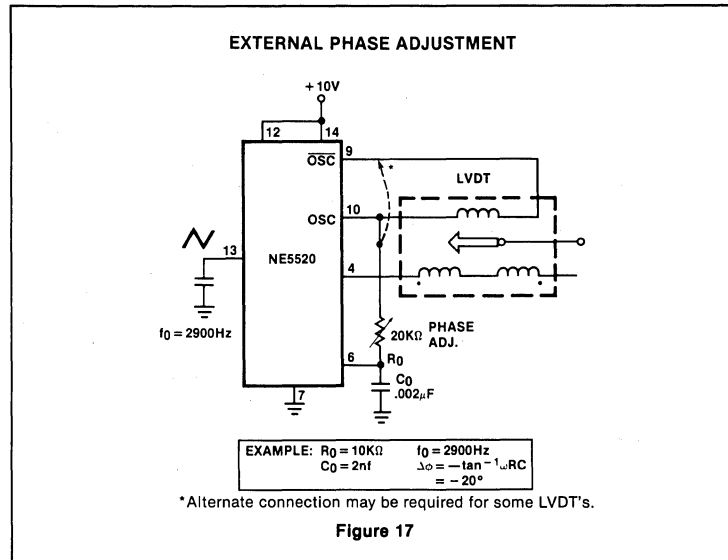
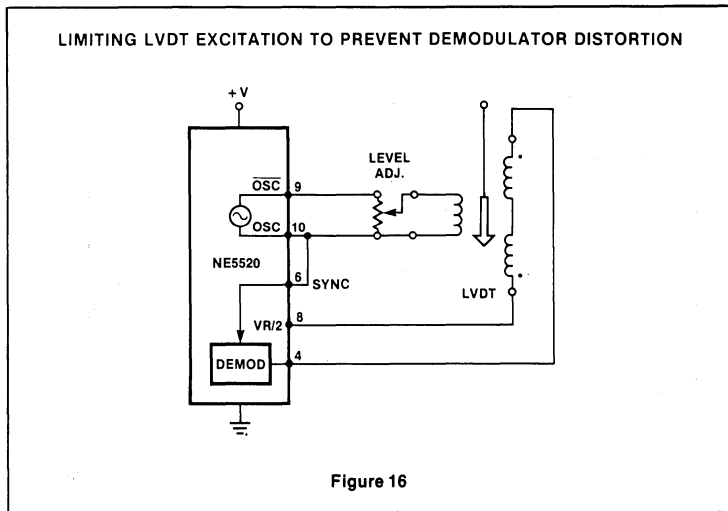

NE5520 DEMODULATOR PHASING

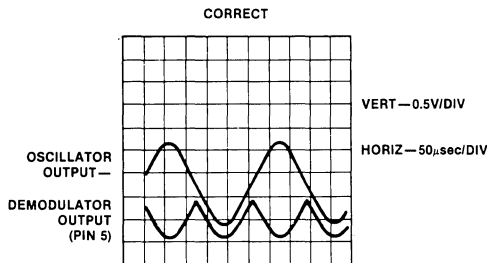

Figure 18a

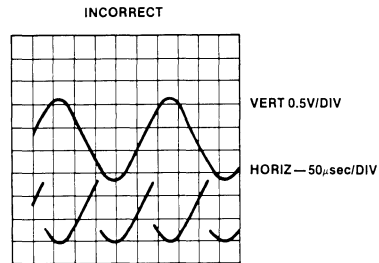

Figure 18b

NE5520 LVDT DRIVER
DEMODULATOR APPLICATIONSOPERATED WITH A SINGLE
POWER SUPPLY

The NE5520 may be operated with a single ended power supply ranging from +5 to 20 volts.

A very simple motion transducer may be constructed using the circuit shown in Figure 19A, B. The output is biased to one-half the supply voltage. This requires special interface circuitry for the signal readout. One simple method is to use a zero center meter in a bridge configuration as shown. Displacement now may be measured as a positive or negative meter reading. Readout sensitivity is a function of the particular LVDT and of the gain of the error amplifier. DC offsets may be nulled by using a simple offset adjustment circuit as indicated.

The transducer is centered in its displacement and the *offset adjust* pot set for a zero meter reading. Once this procedure is completed, the circuit is capable of making measurements based on transducer displacement. Displacement sensitivity is

a function of the LVDT transducer rated in volts-per-inch in addition to the transfer gain of the NE5520 demodulator. The input excitation is generally a fixed level as is the LVDT transducer transformer ratio. However, the auxiliary gain stage may be used to adjust the overall system sensitivity. This section of the device is also used to obtain a low-pass active filter for the smoothing of demodulator ripple. The design examples use a simple VCVS low-pass filter which allows gain and cut-off frequency to be adjusted independently. Gain equals ten in the example.

Note that using a single supply results in a DC common mode voltage at the output of one-half the reference voltage on pin 12. *This voltage V_R may be equal to but not greater than the supply voltage on pin 14.*

LVDT MEASURING CIRCUIT
USING A DUAL SUPPLY

A second mode of operation makes use of dual power supply. A common choice may be ± 5 , ± 6 , or ± 10 volts. Special consideration must be made in properly biasing the internal circuitry to operate under these conditions. Figure 20 shows a simple design for working with ± 6 -volt supplies. Special provisions for minimizing

DC power supply offsets may be made by using the NE5512 dual op amp as a tracking voltage source and difference amplifier-output buffer (see Figure 9). A second method is to use a dual tracking regulator to supply the NE5520.

LVDT IN CLOSED LOOP SERVO

The LVDT provides an excellent method of obtaining position information for closed loop servo drive systems. Pressure rollers, hydraulic drivers, and motor driven linear motion transducers are a few of the general applications which may benefit from the accuracy and speed of response inherent in the LVDT sensor.

A simple block diagram (Figure 21A) shows one possible application in which the NE5520 with LVDT sensor provides accurate position control in a closed loop servo. Linear motion from millimeters to inches of translational motion are possible using the LVDT technique.

In practice the position voltage may be the output of a D/A converter which in turn is activated digitally from a controlling microprocessor. Keyboard information or software commands are translated directly into mechanical motion (Figure 21B).

LVDT MEASURING GAUGE

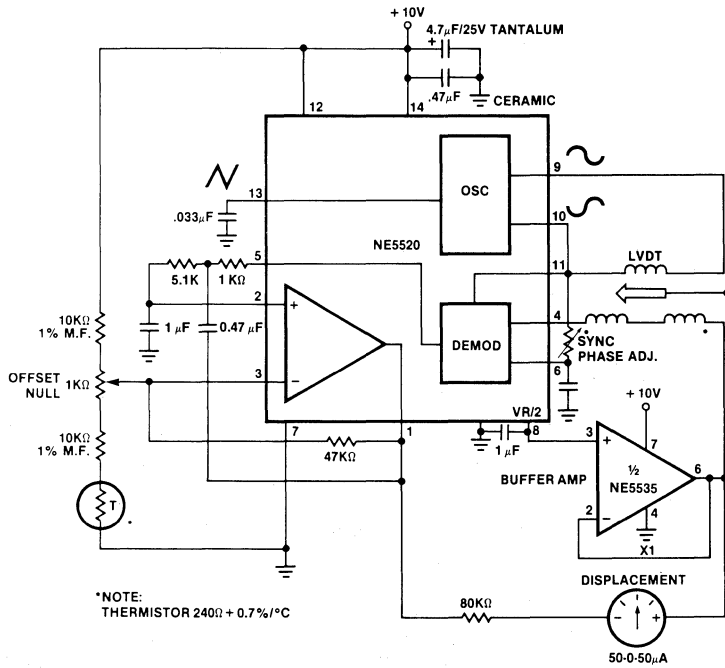

Figure 19a

USING THE LVDT SIGNAL CONDITIONER

AN118

NE5520 LVDT MEASURING CIRCUIT WITH LIMIT DETECTOR

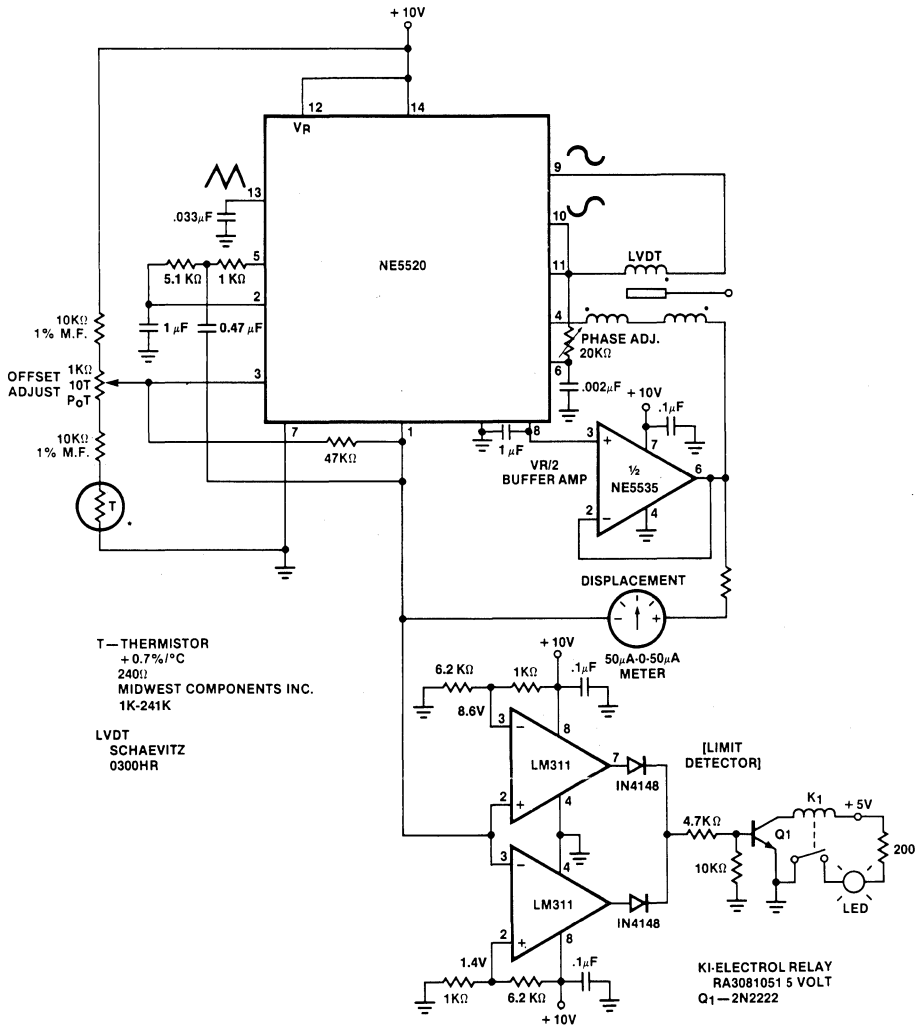

Figure 19b

USING THE LVDT SIGNAL CONDITIONER

NE5520 LVDT DRIVER-DEMODULATOR <math>f_o = 2900\text{Hz}>

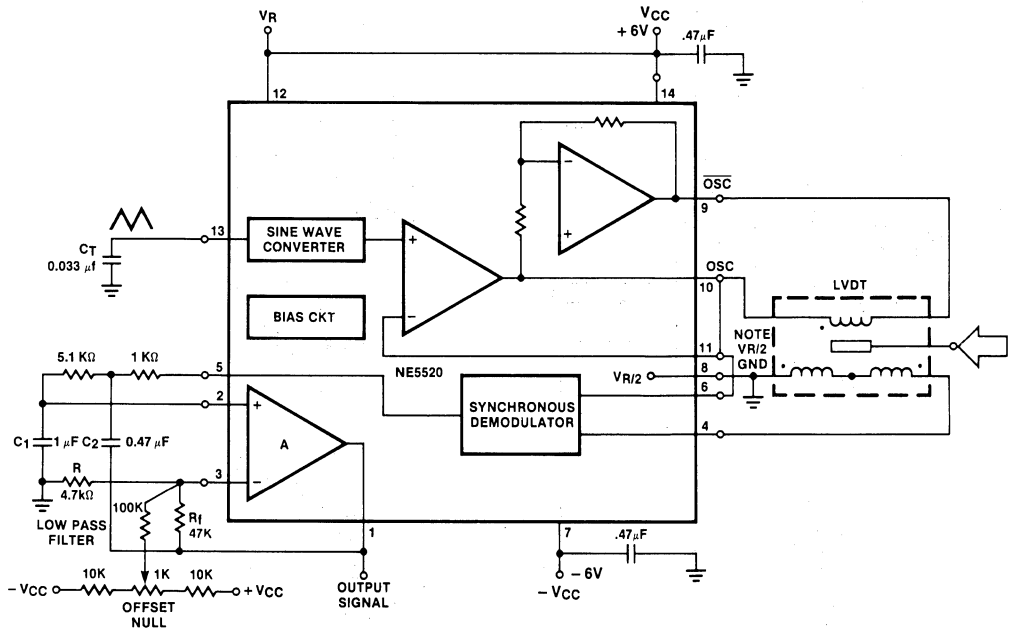

Figure 20

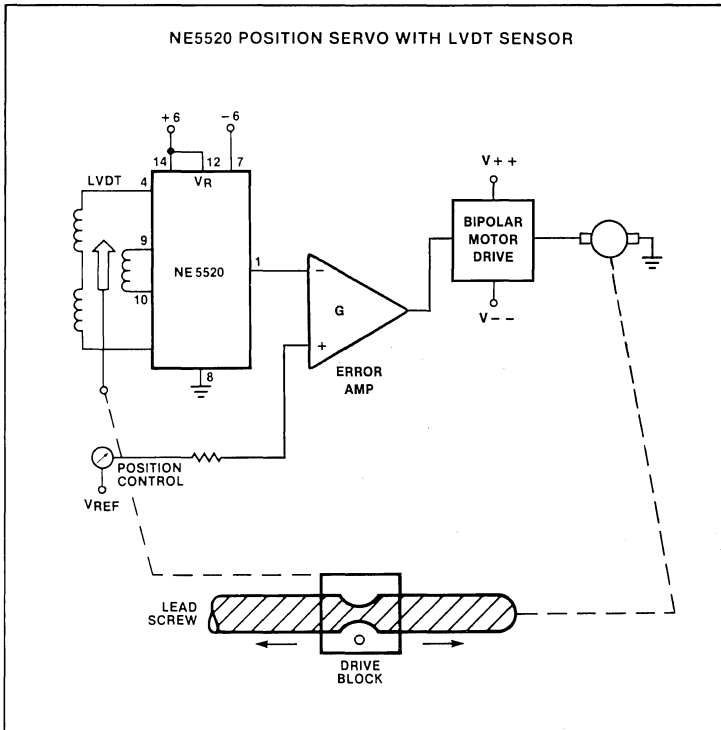

Figure 21a

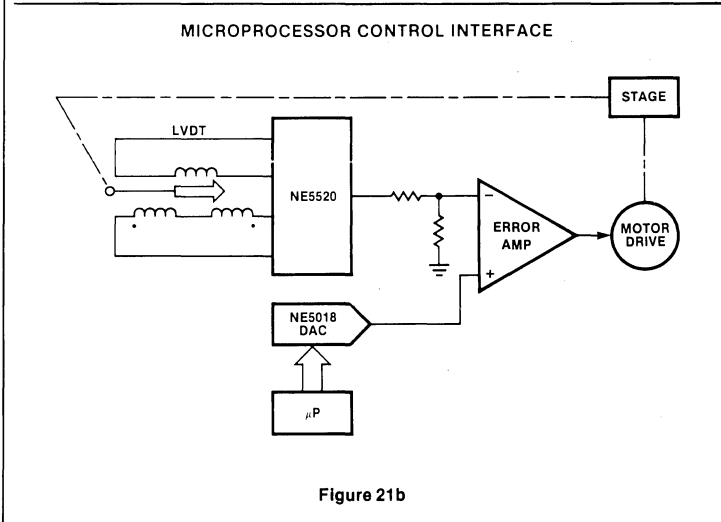

Figure 21b

LVDT SIGNAL TRANSMISSION BY CURRENT LOOP

In certain situations the demodulated output signal must be transmitted over long wires or cables before reaching the signal monitoring equipment. The receiver end may consist of chart recorders, digital panel meters and computers or microprocessors. In some systems many LVDT signals must be monitored from different locations thus requiring variable wire length between transmitter and receiver, thus a different line resistance in each case. If voltage feed were used, signal accuracy would be affected by line resistance. This need for accurate signal transmission necessitates the use of a current loop. A current loop develops a current exactly in proportion to the demodulated LVDT output voltage. It is not affected by line resistance within certain limits governed by the current generator.

One method of current loop transmission uses the $V_{R/2}$ common mode reference to create a null balance signal circuit which is converted to a bipolar current signal corresponding to the LVDT transducer null (i.e. physical displacement center null position at which zero current occurs). This method is shown in Figure 22 and requires the use of an external dual op amp, half of which is used to provide a buffered reference ($V_{R/2}$) voltage return for the current loop. With $R_2 = 200$ ohms the current loop sensitivity is 5 milliamperes per volt of input signal. In all cases, the current output to the loop receiver will remain constant with fixed input voltage (LVDT demodulator) even for varying line resistance up to 600 ohms. This resistance must include all wire and load drops in the loop. Various full scale current limits require different supply voltages and without external supplies will be limited by op amp swing characteristics, for to force a given current across $R_L + R_2$ results in an ultimate voltage limit from the op amp output in the current converter as total resistance increases.

Another method uses an external supply and discrete transistor controlled by the closed loop op amp referenced to shunt resistor R_{SH} in the emitter return circuit. This of course is a unipolar current loop. See Figure 23.

USING THE LVDT SIGNAL CONDITIONER

AN118

NE5520 WITH BIPOLAR CURRENT LOOP OUTPUT $\pm 10\text{mA F.S.}$ — SINGLE SUPPLY OPERATION

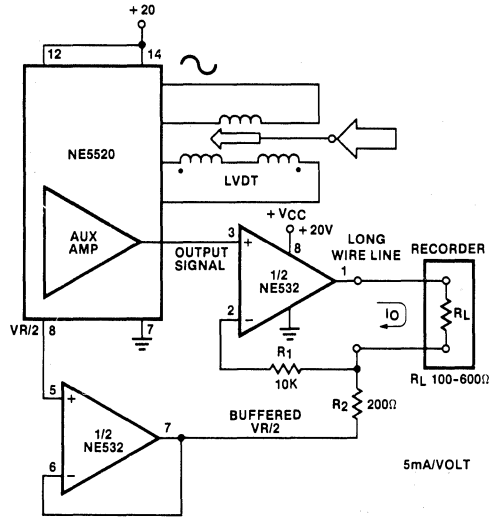
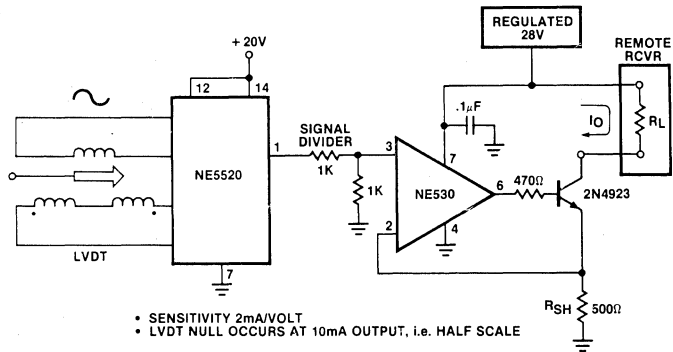

Figure 22

NE5520 WITH UNIPOLAR CURRENT SOURCE



- SENSITIVITY 2mA/VOLT
- LVDT NULL OCCURS AT 10mA OUTPUT, i.e. HALF SCALE

Figure 23

USING THE LVDT SIGNAL CONDITIONER

AN118

Some systems in common use require two wire source to include both the device operating current and the signal loop current. Thus the quiescent device current must be nulled out at the receiver end leaving the residual signal loop current. The NE5520 is not well suited to this particular application since the device standby current is approximately 10 milliamperes.

A current loop operated from supply voltage sources at the transducer location is a better choice for the operation of an output signal loop where long lines must carry locally generated LVDT signals after demodulation back to the monitor site.

POSITIONING THE NE5520 LVDT 3-WIRE REMOTE DRIVER DEMODULATOR SENSING HEAD

The NE5520 may be placed in close proximity to the LVDT provided the environment stays within device specifications. This physical arrangement allows only DC supply and low frequency signal lines (3 wires) being run between the transducer-conditioner unit and the signal processing station as shown in Figure 24.

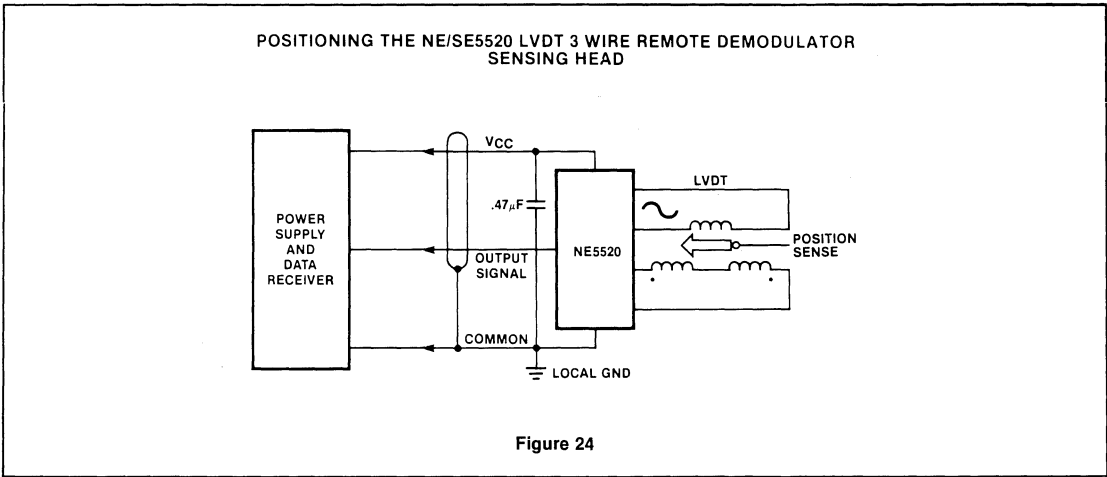

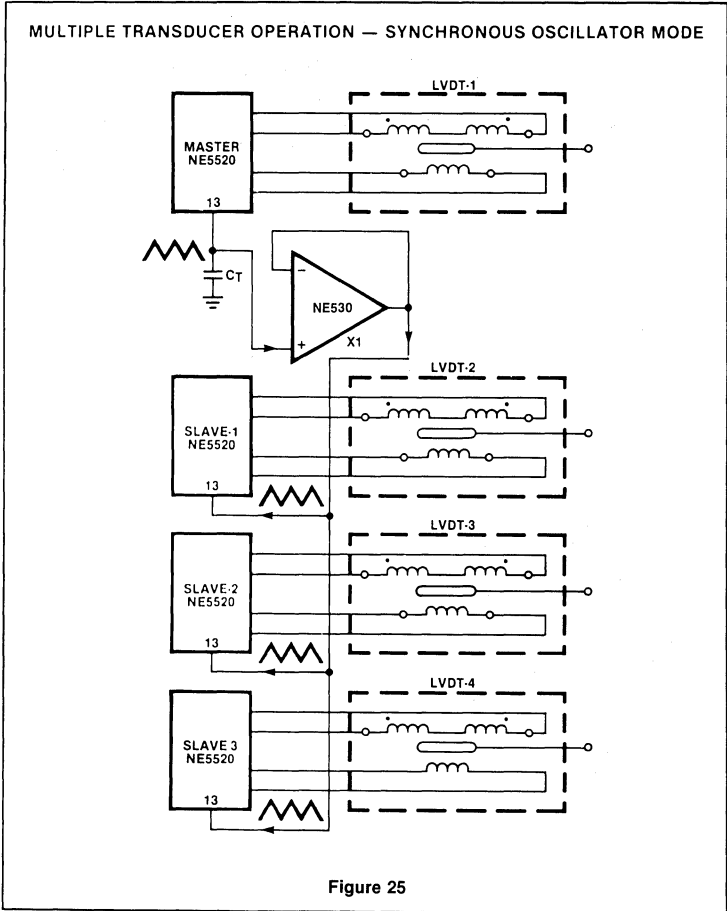

REFERENCES

Handbook of Measurement and Control, Revised Edition 1976, by Edward Hecceg, Schaevitz Engineering Publication, Pennsauken, New Jersey.

Handbook of Integrated-Circuit Operational Amplifiers, by George B. Rutkowski, Prentice Hall 1975, Englewood Cliffs, New Jersey.

INTRODUCTION

In mid 1972, Signetics introduced the 555 timer, a unique functional building block that has enjoyed unprecedented popularity. The timer's success can be attributed to several inherent characteristics foremost of which are versatility, stability and low cost. There can be no doubt that the 555 timer has altered the course of the electronics industry with an impact not unlike that of the I.C. operational amplifier.

The simplicity of the timer in conjunction with its ability to produce long time delays in a variety of applications has lured many designers from mechanical timers, op amps, and various discrete circuits into the ever increasing ranks of timer users.

DESCRIPTION

The 555 timer consists of two voltage comparators, a bistable flip-flop, a discharge transistor, and a resistor divider network. To understand the basic concept of the timer let's first examine the timer in block form as in Figure 1.

changes state and sets the flip-flop driving the output to a high state. The threshold pin normally monitors the capacitor voltage of the RC timing network. When the capacitor voltage exceeds 2/3 of the supply, the threshold comparator resets the flip-flop which in turn drives the output to a low state. When the output is in a low state, the discharge transistor is "on", hereby discharging the external timing capacitor. Once the capacitor is discharged, the timer will await another trigger pulse, the timing cycle having been completed.

The 555 and its complement, the 556 Dual Timer, exhibit a typical initial timing accuracy of 1% with a 50ppm/°C timing drift with temperature. To operate the timer as a one shot, only two external components are necessary; resistance & capacitance. For an oscillator, only one additional resistor is necessary. By proper selection of external components, oscillating frequencies from one cycle per half hour to 500KHz can be realized. Duty cycles can be adjusted from less than one percent to 99 percent over the frequency spectrum. Voltage

Q10 - Q13 comprise a Darlington differential pair which serves as a trigger comparator. Starting with a positive voltage on the trigger; Q10 and Q11 turn on when the voltage at pin 2 is moved below one third of the supply voltage. The voltage level is derived from a resistive divider chain consisting of R7, R8 and R9. All three resistors are of equal value (5K ohms). At fifteen volts supply, the triggering level would be five volts. When Q10 and Q11 turn on, they provide a base drive for Q15, turning it on. Q16 and Q17 form a bistable flip-flop. When Q15 is saturated, Q16 is 'off' and Q17 is saturated. Q16 and Q17 will remain in these states even if the trigger is removed and Q15 is turned 'off'. While Q17 is saturated, Q20 and Q14 are turned off.

The output structure of the timer is a "totem pole" design, with Q22 and Q24 being large geometry transistors capable of providing 200mA with a fifteen volt supply. While Q20 is 'off', base drive is provided for Q22 by Q21, thus providing a high output.

For the duration that the output is in a high state, the discharge transistor is 'off'. Since the collector of Q14 is typically connected to the external timing capacitor, C, while Q14 is off the timing capacitor now can charge thru the timing resistor, R_A.

The capacitor voltage is monitored by the threshold comparator (Q1 - Q4) which is a Darlington differential pair. When the capacitor voltage reaches two thirds of the supply voltage, the current is directed from Q3 and Q4 thru Q1 and Q2. Amplification of the current change is provided by Q5 and Q6. Q5 - Q6 and Q7 - Q8 comprise a diode-biased amplifier. The amplified current change from Q6 now provides a base drive for Q16 which is part of the bistable flip-flop to change states. In doing so, the output is driven "low", and Q14 the discharge transistor is turned "on" shorting the timing capacitor to ground.

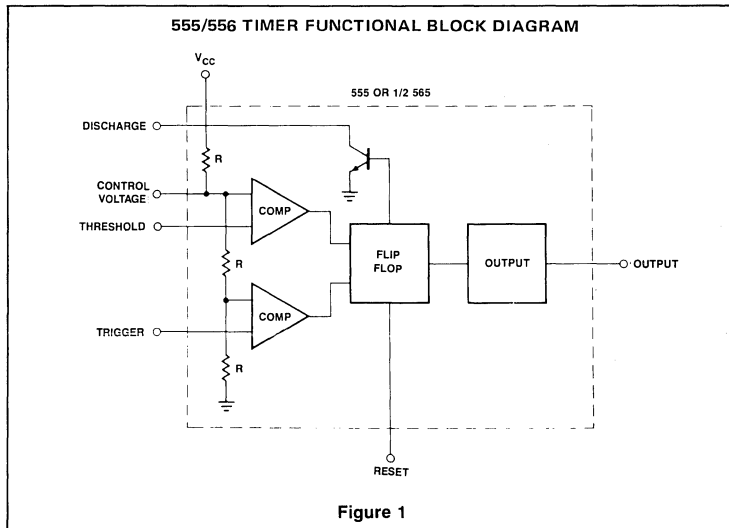

Figure 1

The resistive divider network is used to set the comparator levels. Since all three resistors are of equal value, the threshold comparator is referenced internally at 2/3 of supply voltage level and the trigger comparator is referenced at 1/3 of supply voltage. The outputs of the comparators are tied to the bistable flip-flop. When the trigger voltage is moved below 1/3 of the supply, the comparator

control of timing and oscillation functions is also available,

Timer Circuitry

The timer is comprised of five distinct circuits; two voltage comparators, a resistive voltage divider reference, a bistable flip-flop, a discharge transistor, and an output stage that is the "totem pole" design for sink or source capability.

The discussion to this point has only encompassed the most fundamental of the timer's operating modes and circuitry. Several points of the circuit are brought out to the real world which allow the timer to function in a variety of modes. It is important; more than that, it is essential that one understands all the variations possible in order to utilize this device to its fullest extent.



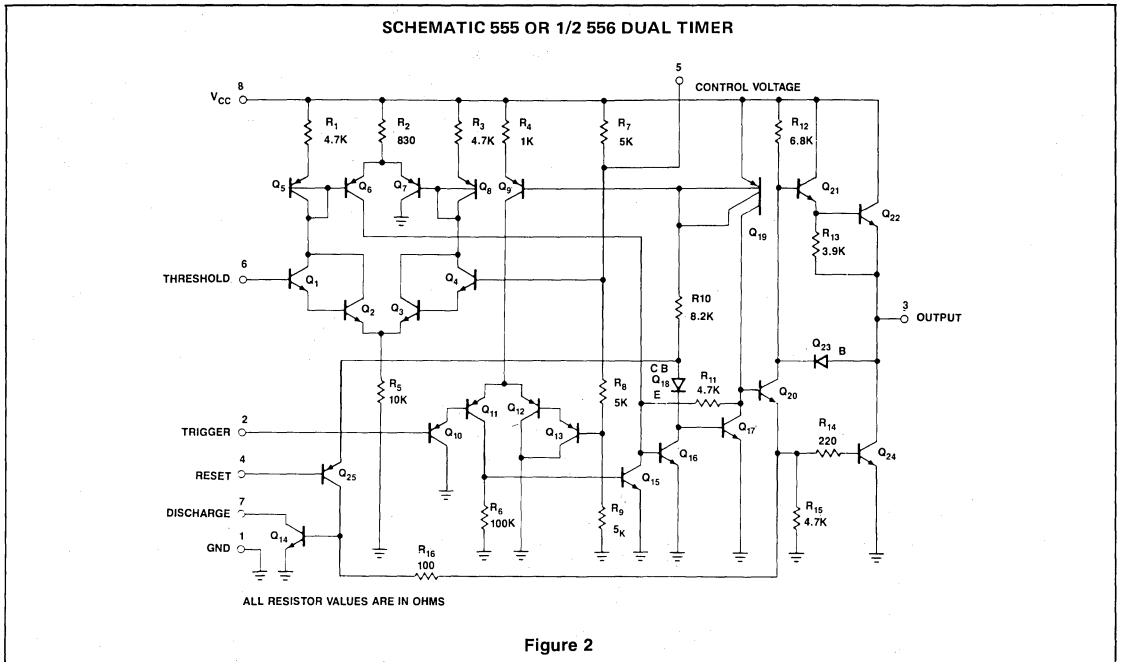

Reset Function

Regressing to the trigger mode, it should be noted that once the device has triggered and the bistable flip-flop set, continued triggering will not interfere with the timing cycle. However, there may come a time when it is necessary to interrupt or halt a timing cycle. This is the function that the reset accomplishes.

In the normal operating mode the reset transistor, Q25, is off with its base held high. When the base of Q25 is grounded, it turns on, providing base drive to Q14, turning it on. This discharges the timing capacitor, resets the flip-flop at Q17, and drives the output low. The reset overrides all other functions within the timer.

Trigger Requirements

Due to the nature of the trigger circuitry, the timer will trigger on the negative going edge of the input pulse. For the device to time out properly, it is necessary that the trigger voltage level be returned to some voltage greater than one third of the supply before the time out period. This can be achieved by making either the trigger pulse sufficiently short or by AC coupling into

the trigger. By AC coupling the trigger, see Figure 3, a short negative going pulse is achieved when the trigger signal goes to ground. AC coupling is most frequently used in conjunction with a switch or a signal that goes to ground which initiates the timing cycle. Should the trigger be held low, without AC coupling, for a longer duration than the timing cycle the output will remain in a high state for the duration of the low trigger signal, without regard to the threshold comparator state. This is due to the predominance of Q15 on the base of Q16, controlling the state of the bistable flip-flop. When the trigger signal then returns to a high level, the output will fall immediately. Thus, the output signal will follow the trigger signal in this case.

Control Voltage

One additional point of significance, the control voltage, is brought out on the timer. As mentioned earlier, both the trigger comparator, Q10 - Q13, and the threshold comparator, Q1 - Q4, are referenced to an internal resistor divider network, R7, R8, R9. This network establishes the nominal two thirds of supply voltage (Vcc) trip point for the threshold comparator and one third of

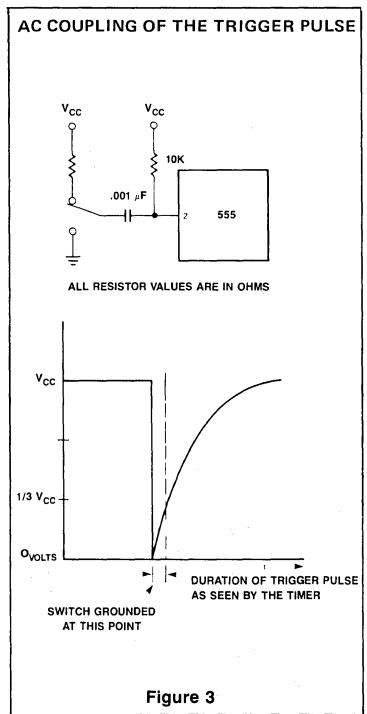

V_{cc} for the trigger comparator. The two thirds point at the junction of R₇, R₈ and the base of Q₄ is brought out. By imposing a voltage at this point, the comparator reference levels may be shifted either higher or lower than the nominal levels of one third and two thirds of the supply voltage. Varying the voltage at this point will vary the timing. This feature of the timer opens a multitude of application possibilities such as using the timer as a voltage controlled oscillator, pulse width modulator, etc. For applications where the control voltage function is not used, it is strongly recommended that a bypass capacitor (.01μF) be placed across the control voltage pin and ground. This will increase the noise immunity of the timer to high frequency trash which may monitor the threshold levels causing timing error.

Monostable Operation

The timer lends itself to three basic operating modes:

1. Monostable (one shot)
2. Astable (oscillatory)
3. Time delay

By utilizing any one or combination of basic operating modes and suitable variations it is possible to utilize the timer in a myriad of applications. The applications are limited only to the imagination of the designer.

One of the simplest and most widely used operating modes of the timer is the monostable (one shot). This configuration requires only two external components for operation (See Figure 4). The sequence of events starts when a voltage below one third V_{cc} is sensed by the trigger comparator. The trigger is normally applied in the form of a short negative going pulse. On the negative going edge of the pulse, the device triggers, the output goes high and the discharge transistor turns off. Note that prior to the input pulse, the discharge transistor is on, shorting the timing capacitor to ground. At this point the timing capacitor, C, starts charging thru the timing resistor, R. The voltage on the capacitor increases exponentially with a time constant T = RC. Ignoring capacitor leakage, the capacitor will reach the two thirds V_{cc} level in 1.1 time constants or

$$T = 1.1 RC \quad (1)$$

where T is in seconds; R is in ohms and; C is in Farads. This voltage level trips the threshold comparator, which in turn

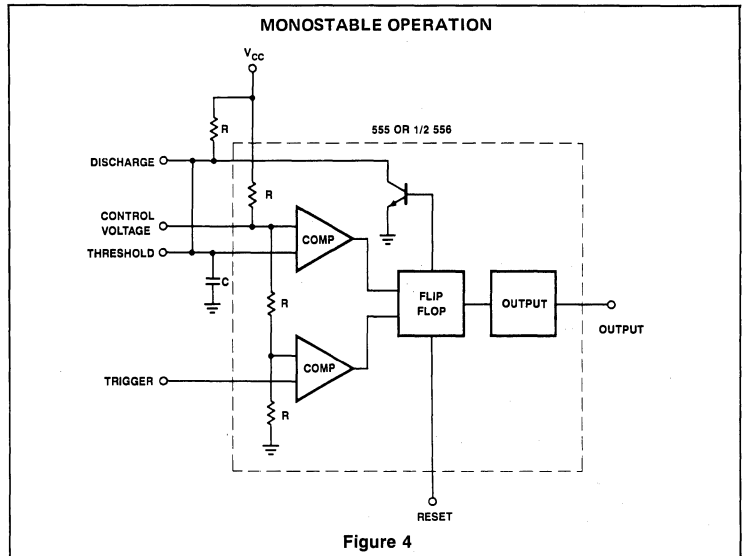

Figure 4

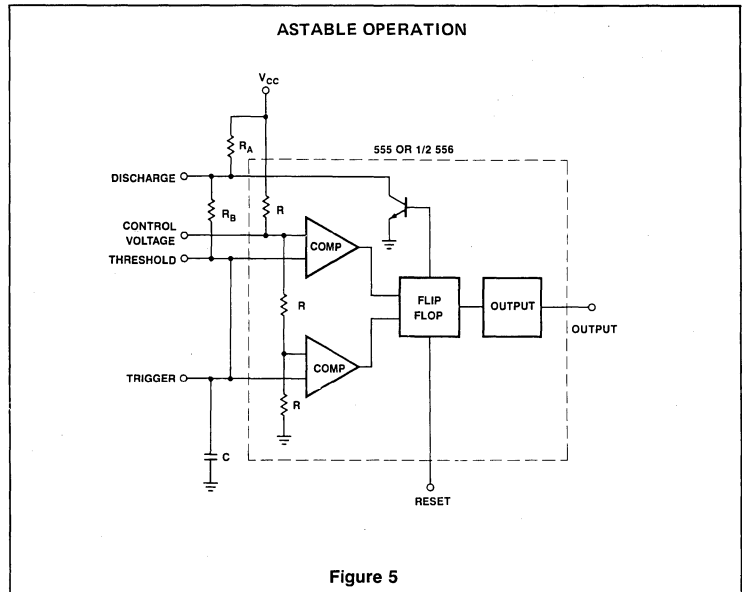

Figure 5

drives the output low and turns on the discharge transistor. The transistor discharges the capacitor, C, rapidly. The timer has completed its cycle and will now await another trigger pulse.

Astable Operation

In the astable (free run) mode, only one additional component, R_b is necessary.

The trigger is now tied to the threshold pin. At power up, the capacitor is discharged, holding the trigger low. This triggers the timer, which establishes the capacitor charge path thru R_A and R_B. When the capacitor reaches the threshold level of 2/3 V_{cc}, the output drops low and the discharge transistor turns on.

The timing capacitor now discharges thru R_B . When the capacitor voltage drops to $1/3 V_{cc}$, the trigger comparator trips, automatically retriggering the timer, creating an oscillator whose frequency is given by:

$$f = \frac{1.49}{(R_A + 2R_B) C} \quad (2)$$

Selecting the ratios of R_A and R_B varies the duty cycle accordingly. Lo and behold, we have a problem. If a duty cycle of less than fifty percent is required, then what? Even if $R_A = 0$, the charge time cannot be made smaller than the discharge time because the charge path is $R_A + R_B$ while the discharge path is R_B alone. In this case it becomes necessary to insert a diode in parallel with R_B , cathode toward the timing capacitor. Another diode is desirable, but not mandatory, this one in series with R_B , cathode away from the timing capacitor. Now the charge path becomes R_A , thru the parallel diode into C. Discharge is thru the series diode and R_B to the discharge transistor. This scheme will afford a duty cycle range from less than 5% to greater than 95%. It should be noted that for reliable operation a minimum value of $3K\Omega$ for R_B is recommended to assure that oscillation begins.

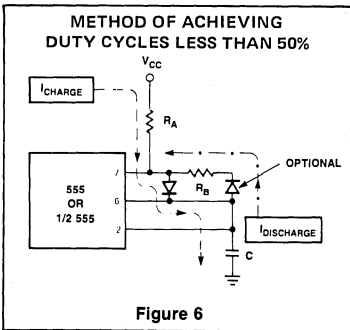

Figure 6

Time Delay

In this third basic operating mode, we aim to accomplish something a little different from monostable operation. In the monostable mode, when a trigger was applied, the output immediately changed to the high state, timed out, and returned to its pre-trigger low state. In the time delay mode, we require the output not to change state upon triggering, but at some precalculated time after trigger is received.

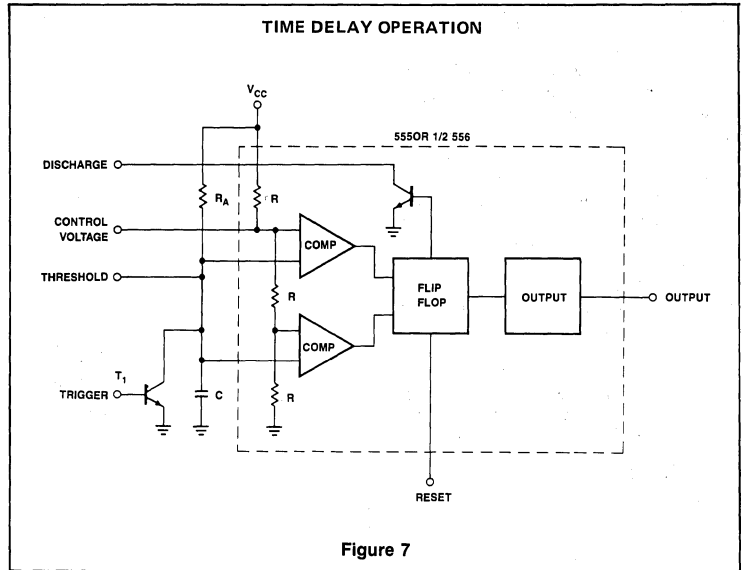

Figure 7

The threshold and trigger are tied together monitoring the capacitor voltage. The discharge function is not used. The operation sequence begins as transistor (T_1) is turned on, keeping the capacitor grounded. The trigger sees a low state and forces the timer output high. When the transistor is turned off the capacitor commences its charge cycle. When the capacitor reaches the threshold level, then and only then does the output change from its normally high state to the low state. The output will remain low until T_1 is again turned on.

GENERAL DESIGN CONSIDERATIONS

The timer will operate over a guaranteed voltage range of 4.5 volts to 15 volts DC, with 16 VDC being the absolute max. rating. Most of the devices, however, will operate at voltage levels as low as 3 VDC. The timing interval is independent of supply voltage since the charge rate and threshold level of the comparator are both directly proportional to supply. The supply voltage may be provided by any number of sources: however, several precautions should be taken. The most important, the one which provides the most headaches if not practiced, is good power supply filtering and adequate bypassing. Ripple on the supply line can cause loss of timing accuracy. The threshold level shifts causing a change of charging current. This will cause a timing error for that cycle.

Due to the nature of the output structure, a high power totem pole design, the output of the timer can exhibit large current spikes on the supply line. Bypassing is necessary to eliminate this phenomenon. A capacitor across the V_{cc} and ground, ideally, directly across the device is necessary. The size of capacitor will depend on the specific application. Values of capacitance from $.01\mu F$ to $10\mu F$ are not uncommon. Note that the bypass capacitor would be as close to the device as physically possible.

Selecting External Components

In selecting the timing resistor and capacitor, there are several considerations to be taken into account.

Stable external components are necessary for the RC network if good timing accuracy is to be maintained. The timing resistor(s) should be of the metal film variety if timing accuracy and repeatability are important design criteria. The timer exhibits a typical initial accuracy of one percent. That is, with any one RC network, from timer to timer only one percent change is to be expected. Most of the initial timing error (i.e. deviation from the formula) is due to inaccuracies of external components. Resistors range from their rated values by .01% to 10 and 20 percent. Capacitors may have a 5 to 10 percent deviation from rated capacity. Therefore, in a

system where timing is critical, an adjustable timing resistor or precision components are necessary. For best results, a good quality trim pot, placed in series with the largest feasible resistance will allow for best adjustability and performance.

The timing capacitor should be a high quality, stable component with very low leakage characteristics. *Under no circumstances should ceramic disc capacitors be used in the timing network!* Ceramic disc capacitors are not sufficiently stable in capacitance to operate properly in an RC mode. Several acceptable capacitor types are: silver mica, mylar, polycarbonate, polystyrene, tantalum or similar types.

The timer typically exhibits a small negative temperature coefficient (50ppm/°C). If timer accuracy over temperature is a consideration, timing components with a small positive temperature coefficient should be chosen. This combination will tend to cancel timing drift due to temperature.

In selecting the values for the timing resistors and capacitor, several points should be considered. A minimum value of threshold current is necessary to trip the threshold comparator. This value is .25µA. To calculate the maximum value of resistance, keep in mind that at the time the threshold current is required, the voltage potential on the threshold pin is two thirds of supply. Therefore:

$$V_{\text{potential}} = V_{\text{CC}} - V_{\text{capacitor}}$$

$$V_{\text{potential}} = V_{\text{CC}} - 2/3 V_{\text{CC}} = 1/3 V_{\text{CC}}$$

Maximum resistance is then defined as

$$R_{\text{max}} = \frac{V_{\text{CC}} - V_{\text{cap}}}{I_{\text{thresh}}} \quad (3)$$

Example: $V_{\text{CC}} = 15\text{V}$

$$R_{\text{max}} = \frac{15 - 10}{.25 (10^{-6})} = 20\text{M}\Omega$$

$V_{\text{CC}} = 5\text{V}$

$$R_{\text{max}} = \frac{5 - 3.33}{.25 (10^{-6})} = 6.6\text{M}\Omega$$

NOTE: If using a large value of timing resistor, be certain that the capacitor leakage is significantly lower than the charging current available to minimize timing error.

On the other end of the spectrum, there are certain minimum values of resistance that should be observed. The discharge transistor, Q14, is current limited at 35mA to 55mA internally. Thus, at the current limiting values, Q14, establishes high saturation voltages. When examining the currents at Q14, remember that the transistor, when turned on will be carrying two current loads. The first being the constant current thru timing resistor, R_A. The second will be the varying discharge current from the timing capacitor. To provide best operation the current contributed by the R_A path should be minimized so that the majority of discharge current can be used to reset the capacitor voltage. Hence it is recommended that a 5K ohm value be the minimum feasible value for R_A. This does not mean lower values cannot be used successfully in certain applications. Yet there are extreme cases that should be avoided if at all possible.

Capacitor size has not proven to be a legitimate design criteria. Values ranging from picofarads to greater than one thousand microfarads have been used successfully. One precaution need be utilized though. (It should be a cardinal rule that applies to the usage of all IC's.) Make certain that the package power dissipation is not exceeded. With extremely large capacitor values, a maximum duty cycle which allows some cooling time for the discharge transistor, may be necessary.

The most important characteristic of the capacitor should be as low a leakage as possible. Obviously any leakage will subtract from the charge count causing the calculated time to be longer than anticipated.

Control Voltage

Regressing momentarily, we recall that the control voltage pin is connected directly to the threshold comparator at the junction of R7, or R8. The combination of R7, R8 and R9 comprise the resistive voltage divider network that establishes the nominal 1/3 V_{CC} trigger comparator level (junction R8, R9) and the 2/3 V_{CC} level for the threshold comparator (junction R7, R8).

For most applications, the control voltage function is not used and therefore is bypassed to ground with a small capacitor for noise filtering. The control voltage function, in other applications becomes an integral part of the design. By imposing a voltage at this pin, it becomes possible to vary the threshold compar-

tor "set" level above or below the 2/3 V_{CC} nominal, hereby varying the timing. In the monostable mode, the control voltage may be varied from 45 percent to 90 percent of V_{CC}. The 45 to 90 percent figure is not firm, but only an indication to a safe usage. Control voltage levels below and above those stated have been used successfully in some applications.

In the oscillatory (free run) mode, the control voltage limitations are from 1.7 volts to V_{CC}. These values should be heeded for reliable operation. Keep in mind that in this mode the trigger level is also important. When the control voltage raises the threshold comparator level it also raise the trigger comparator level by one half that amount due to R8 and R9 of Figure 2. As a voltage controlled oscillator, one can expect ±25% around center frequency (f_o) to be virtually linear with a normal RC timing circuit. For wider linear variations around F_o it may be desirable to replace the charging resistor with a constant current source. In this manner the exponential charging characteristics of the classical configuration will be altered to linear charge time.

Reset Control

The only remaining function now is the reset. As mentioned earlier, the reset, when taken to ground, inhibits all device functioning. The output is driven low, the bistable flip-flop is reset, and the timing capacitor is discharged. In the astable (oscillatory) mode, the reset can be used to gate the oscillator. In the monostable it can be used as a timing abort to either interrupt a timing sequence or establish a standby mode (i.e. — device off during power up). It can also be used in conjunction with the trigger pin to establish a positive edge triggered circuit as opposed to the normal negative edge trigger mode. One thing to keep in mind when using the reset function is that the reset voltage (switching) point is between 0.4V and 1.0V (min/max). Therefore, if used in conjunction with the trigger, the device will be out of the reset mode prior to reaching 1 volt. At that point the trigger is in the "turn on" region, below 1/3 V_{CC}. This will cause the device to trigger immediately, effectively triggering on the positive going edge if a pulse is applied to pins 4 and 2 simultaneously.

FREQUENTLY ASKED APPLICATIONS QUESTIONS

The following is a harvest of various malades, exceptions, and idiosyncrasies that may exhibit themselves from time



to time in various applications. Rather than cast aspersions, a quick review of this list may uncover a solution to the problem at hand.

1. In the oscillator mode when reset is released the *first time constant* is approximately *twice as long as the rest*. Why?

Answer: In the oscillator mode the capacitor voltage fluctuates between 1/3 and 2/3 of the supply voltage. When reset is pulled down the capacitor discharges completely. Thus for the first cycle it must charge from ground to 2/3 Vcc which takes twice as long.

2. What is *maximum frequency of oscillations*?

Answer: Most devices will oscillate about 1M Hz. However, in the interest of temperature stability one should operate only up to about 500kHz.

3. What is *temperature drift for oscillator mode*?

Answer: Temperature drift of oscillator mode is 3 times that of one shot mode due to addition of second voltage comparator. Frequency always increases with an increasing temperature. Therefore it is possible to partially offset this drift with an offsetting temperature coefficient in the external resistor/capacitor combination.

4. Oscillator exhibits spurious *oscillations on cross over points*. Why?

Answer: The 555 can oscillate due to feedback from power supply. Always bypass with sufficient capacitance close to the device for all applications.

5. Trying to drive a *relay* but 555 *hangs up*. How come?

Answer: Inductive feedback. A clamp diode across the coil prevents the coil from driving pin 3 below a negative .6 volts. This negative voltage is sufficient in some cases to cause the timer to malfunction. The solution is to drive the relay through a diode thus preventing pin 3 from ever seeing a negative voltage.

6. Double triggering of the TTL loads sometimes occurs. Why?

Answer: Due to the high current capability and fast rise and fall times of the output a totem pole structure different from the TTL classical structure was used. Near TTL threshold

this output exhibits a cross over distortion which may double trigger logic. A 1000 pF capacitor from the output to ground will eliminate any false triggering.

7. What is the longest time I can get out of the timer?

Answer: Times exceeding an hour are possible, but not always practical. Large capacitors with low leakage specs are quite expensive. It becomes cheaper to use a countdown scheme (see Figure 15) at some point dependent on required accuracy. Normally 20 to 30 min. is the longest feasible time.

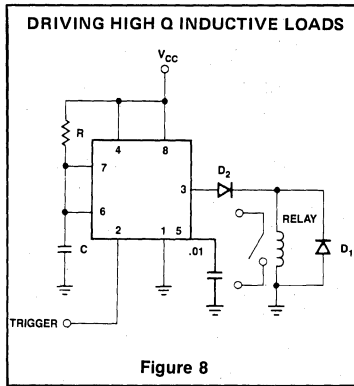

DESIGN FORMULAS

Before entering the section on specific applications it is advantageous to review the timing formulas. The formulas given here apply to the 555 and 556 devices.

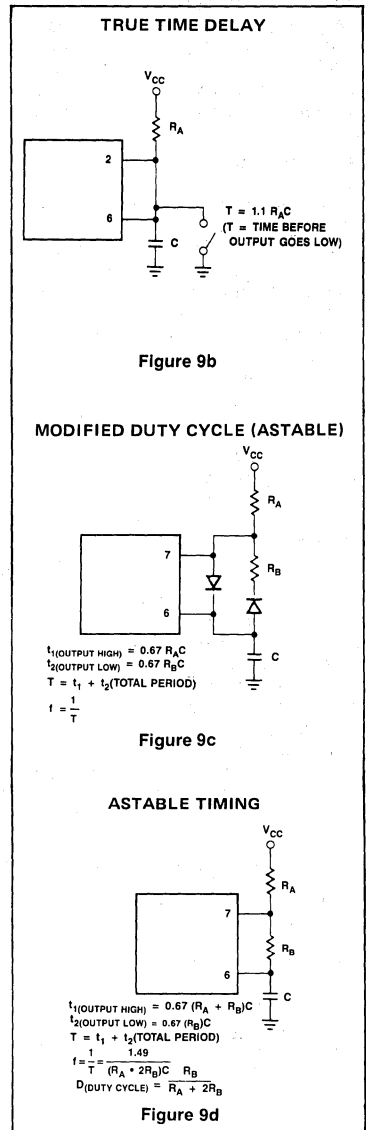
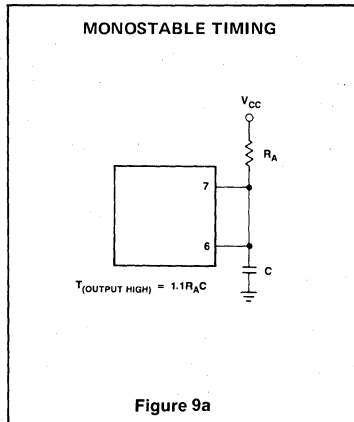

APPLICATIONS

The timer since introduction has spurred the imagination of thousands. Thus the ways in which this device has been used are far too numerous to present each one. A review of the basic operation and basic modes has previously been given. Presented here are some ingenious applications devised by our applications engineers and by some of our customers.

Missing Pulse Detector

Using the circuit of Figure 10a, the timing cycle is continuously reset by the input pulse train. A change in frequency, or a missing pulse, allows completion of the timing cycle which causes a change in the output level. For this application, the time delay should be set to be slightly longer than the normal time between pulses. Figure 10b shows the actual waveforms seen in this mode of operation.

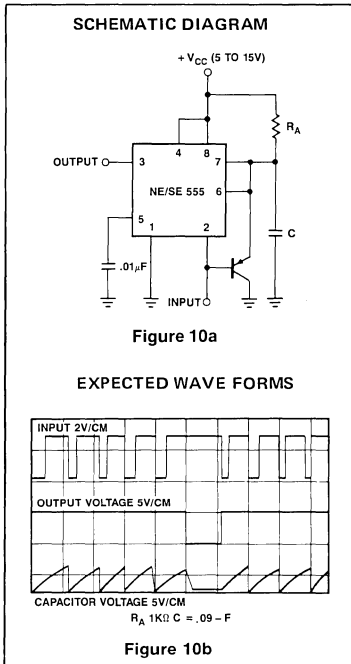

Frequency Divider

If the input frequency is known, the timer can easily be used as a frequency divider by adjusting the length of the timing cycle.

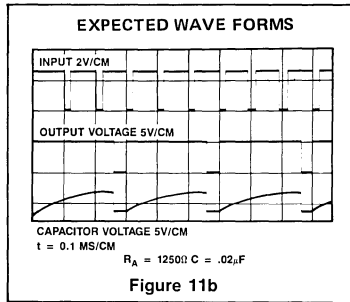
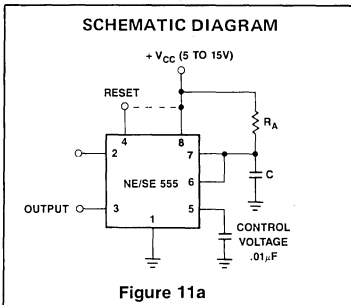

Pulse Position Modulation (PPM)

This application uses the timer connected for astable (free-running) operation. Figure 13a, with a modulating signal again applied to the control voltage terminal. Now the pulse position varies with the modulating signal, since the threshold voltage and hence the time delay is varied. Figure 13b shows the waveform generated for triangle wave modulation signal.

Figure 11b shows the waveforms of the timer in Figure 11a when used as a divide by three circuit. This application makes use of the fact that this circuit cannot be retriggered during the timing cycle.

Pulse Width Modulation (PWM)

In this application, the timer is connected in the monostable mode as shown in Figure 12a. The circuit is triggered with a continuous pulse train and the threshold voltage is modulated by the signal applied to the control voltage terminal (pin 5). This has the effect of modulating the pulse width as the control voltage varies. Figure 12b shows the actual waveform generated with this circuit.

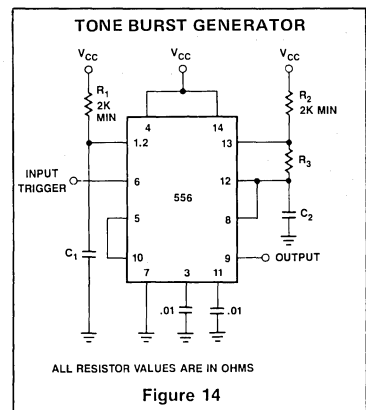
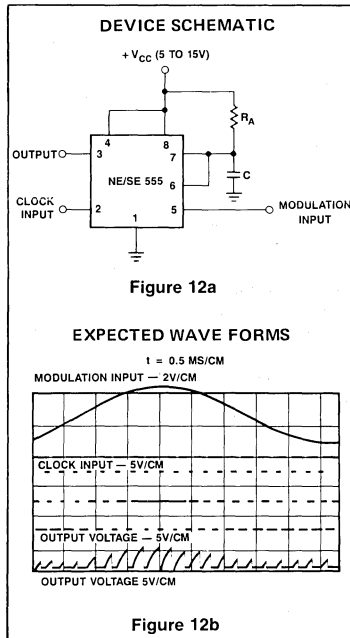
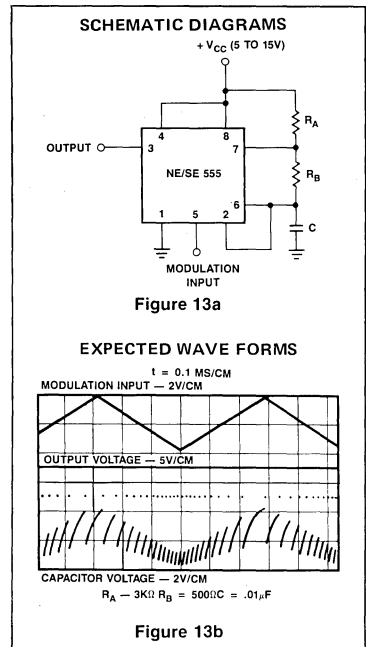

Tone Burst Generator

The 556 Dual Timer makes an excellent tone burst generator. The first half is connected as a one shot and the second half as an oscillator. (Figure 14)

The pulse established by the one shot turns on the oscillator allowing a burst to be generated.

Sequential Timing

One feature of the dual timer is that by utilizing both halves it is possible to obtain sequential timing. By connecting the output of the first half to the input of the second half via a .001 μ f coupling capacitor sequential timing may be obtained. Delay t_1 is determined by the first half and t_2 by the second half delay. (Figure 15)

The first half of the timer is started by momentarily connected pin 6 to ground. When it is timed out (determined by $1.1 R_1 C_1$) the second half begins. Its duration is determined by $1.1 R_2 C_2$.

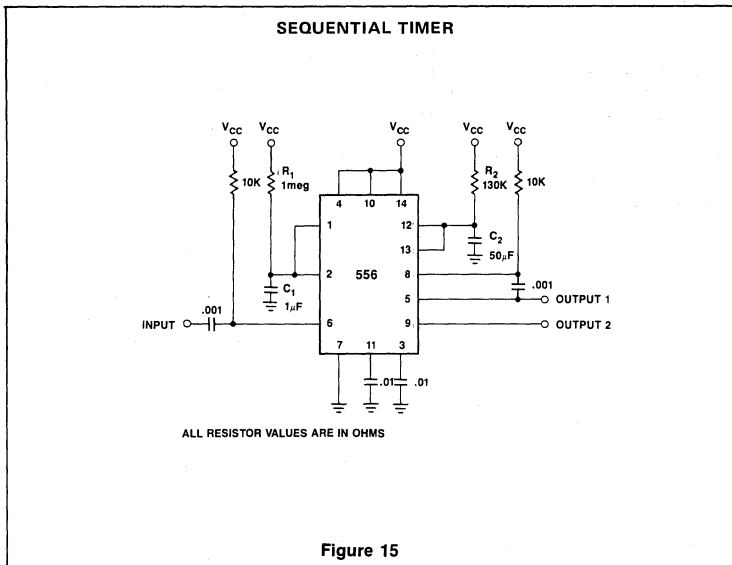

Figure 15

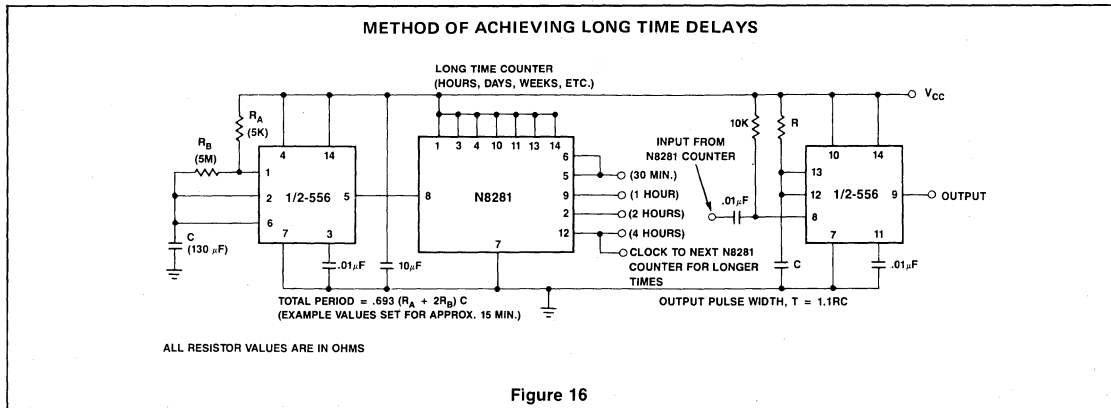

Figure 16

Long Time Delays

In the 556 timer the timing is a function of the charging rate of the external capacitor. For long time delays expensive capacitors with extremely low leakage are required, the practicality of the components involved limits the time between pulses to something in the neighborhood of twenty minutes.

To achieve longer time periods both halves may be connected in tandem with a "divide-by" network in between.

The first timer section operates in an oscillatory mode with a period of $1/f_0$. This signal is then applied to a "Divide-by-N" network to give an output with the period of N/f_0 . This can then be used to trigger the second half of the 556. The total time is now a function of N and f_0 (Figure 16).

Speed Warning Device (1)

Utilizing the "missing pulse detector" concept, a speed warning device, such as

depicted, becomes a simple and inexpensive circuit (Figure 17a).

Car Tachometer (1)

The timer receives pulses from the distributor points. Meter M receives a calibrated current thru R6 when the timer output is high. After time out the meter receives no current for that part of the duty cycle. Integration of the variable duty cycle by the meter movement provides a visible indication of engine speed (Figure 18).

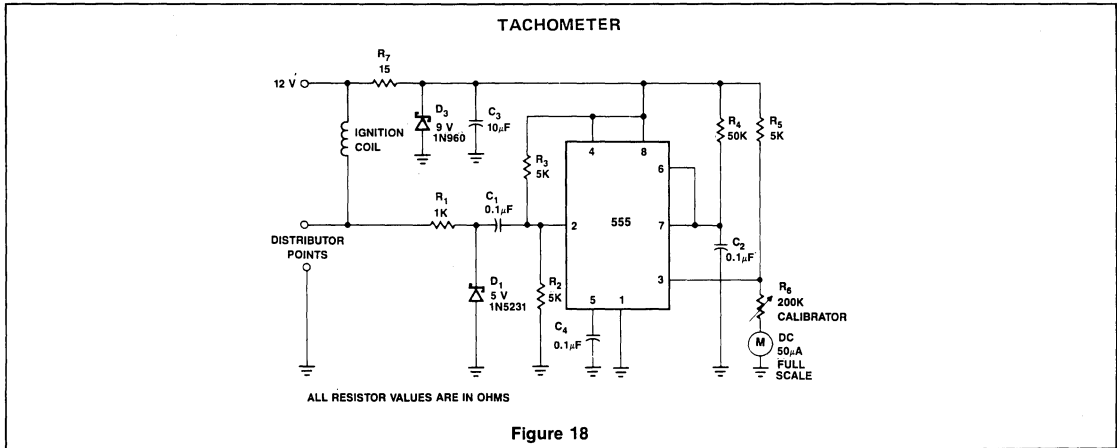
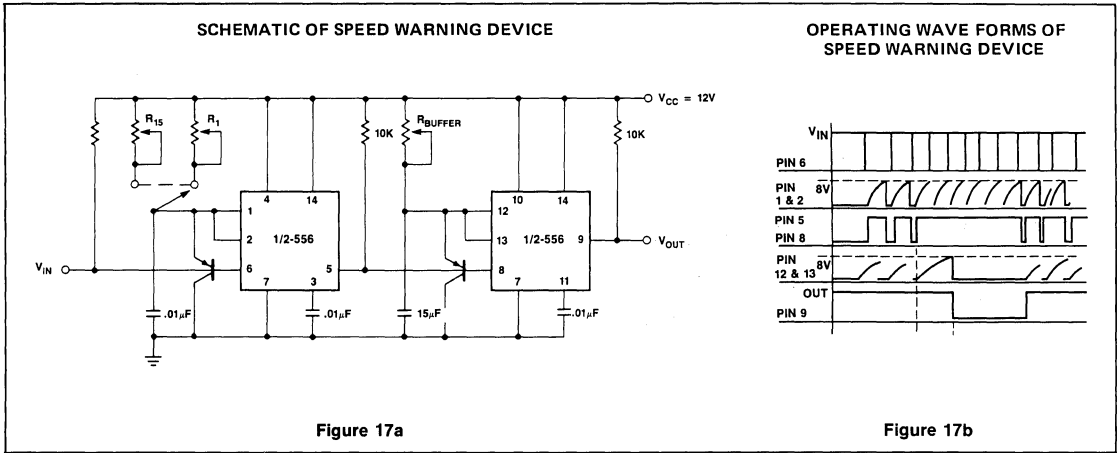

Oscilloscope Triggered Sweep

The 555 timer holds down the cost of adding a triggered sweep to an economy oscilloscope. The circuit's input op amp triggers the timer, setting its flip-flop and cutting off its discharge transistor so that capacitor C can charge. When capacitor voltage reaches the timer's control voltage ($0.33V_{CC}$), the flip-flop resets and the transistor conducts, discharging the capacitor (Figure 19).

Greater linearity can be achieved by substituting a constant current source for the frequency adjust resistor (R).

Square Wave Tone Burst Generator (4)

Depressing the pushbutton provides square-wave tone bursts whose duration depends on the duration for which the voltage at pin 4 exceeds a threshold. Components R_1 , R_2 and C_1 causes the astable action of the timer IC (Figure 6-20).

Regulated DC-to-DC Converter (2)

Regulated DC to DC converter produces 15V DC outputs from a +5V DC input. Line and load regulation is 0.1% (Figure 21).

Voltage to Pulse Duration Converter (1)

Voltage levels can be converted to pulse durations by combining an op amp and a timer IC. Accuracies to better than 1% can be obtained with this circuit (a) and the output signals (b) still retain the original frequency, independent of the input voltage (Figure 22).

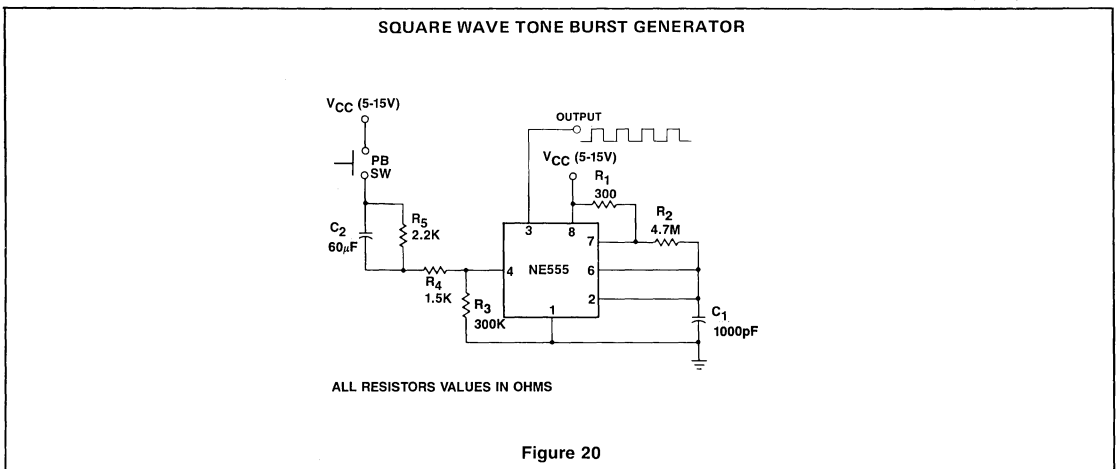
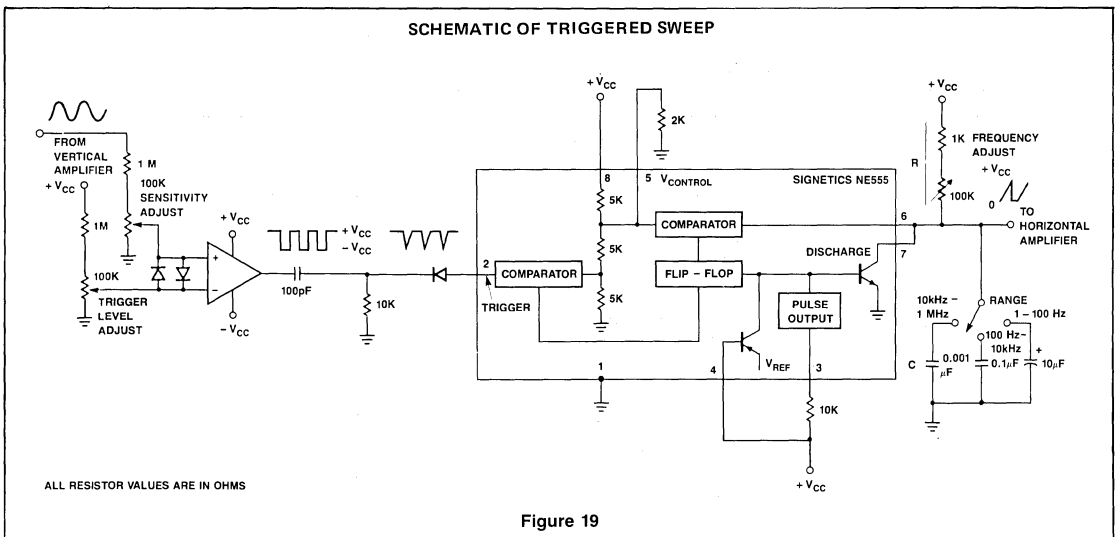

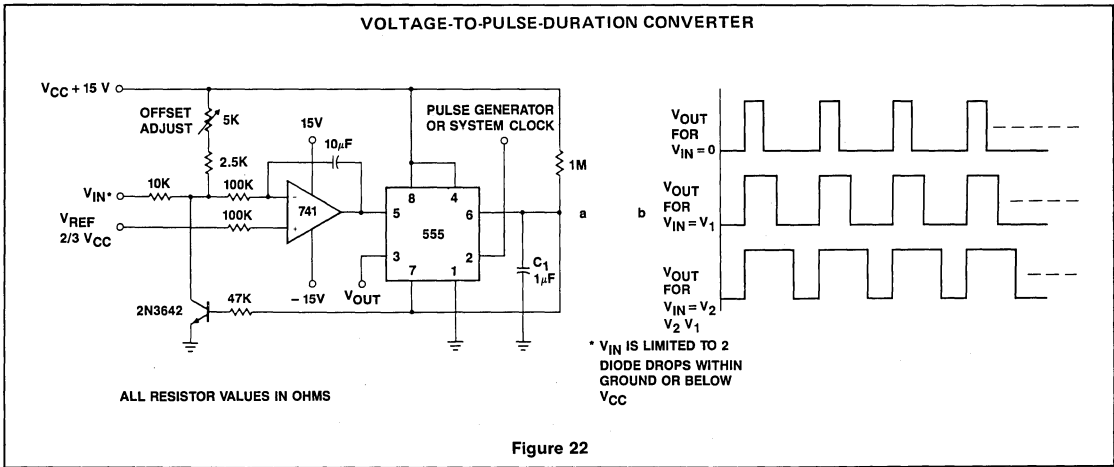
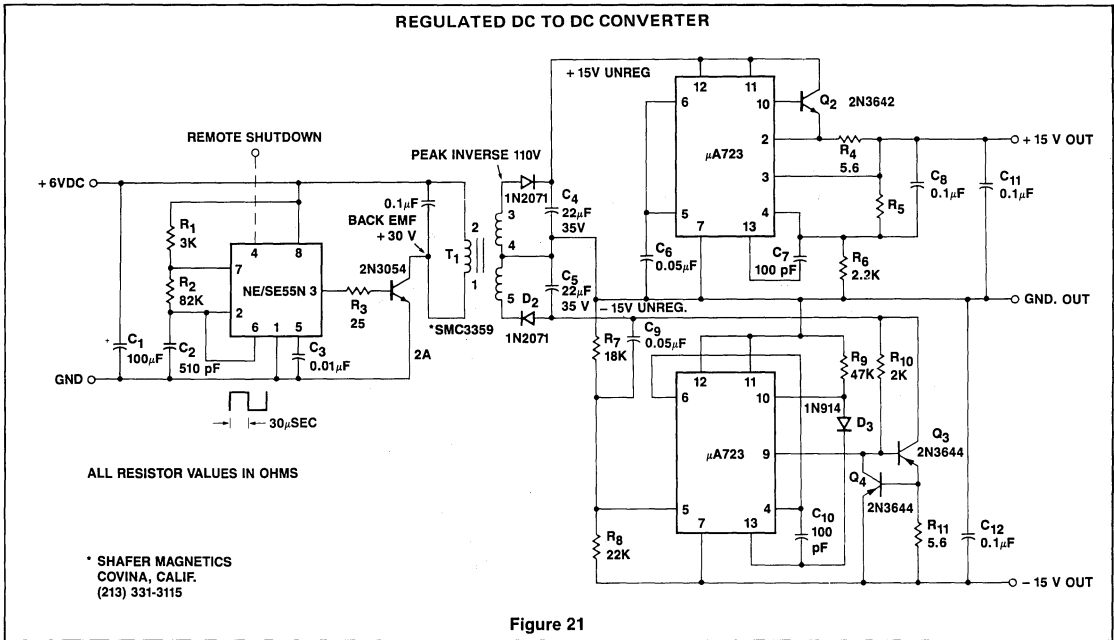

Servo System Controller (1)

To control a servo motor remotely, the 555 needs only six extra components (Figure 6-23).

Stimulus Isolator (5)

Stimulus isolator uses a photo-SCR and a toroid for shaping pulses of up to 200V at 200µA (Figure 24).

Voltage to Frequency Converter (0.2% Accuracy) (6)

Linear voltage-to-frequency converter (a) achieves good linearity over the 0 to -10V. Its mirror image (b) provides the same linearity over the 0-to +10V range but is not DTL/TTL compatible (Figure 25a & b).

VOLTAGE-TO-FREQUENCY CONVERTER (0.2% ACCURACY)

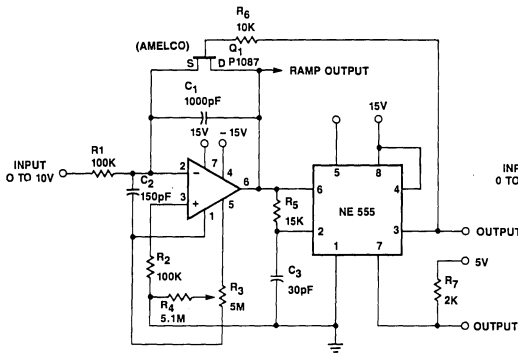

ALL RESISTOR VALUES IN OHMS

Figure 25a

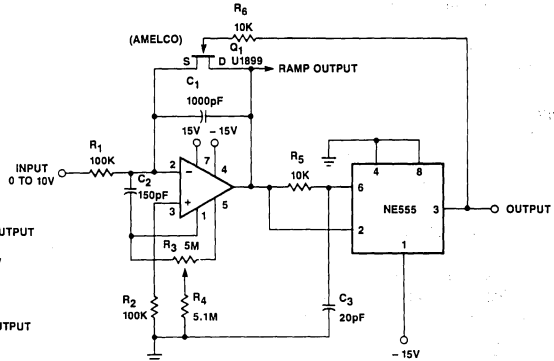

Figure 25b

Positive to Negative Converter (7)

Transformerless dc-dc converter derives a negative supply voltage from a positive. As a bonus the circuit also generates a clock signal.

The negative output voltage tracks the dc input voltage linearity (a), but its magnitude is about 3V lower. Application of a 500Ω load, (b), causes 10% change from the no-load value (Figure 26a, b, & c).

POSITIVE TO NEGATIVE CONVERTER

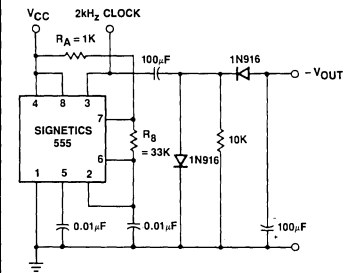

ALL RESISTOR VALUES ARE IN OHMS

Figure 26a

Auto Burglar Alarm (8)

Timer A produces a safeguard delay, allowing driver to disarm alarm and eliminating vulnerable outside control switch. The SCR prevents timer A from triggering timer B, unless timer B is triggered by strategically located sensor switches (Figure 27).

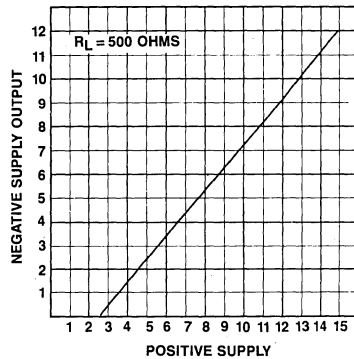

Figure 26b

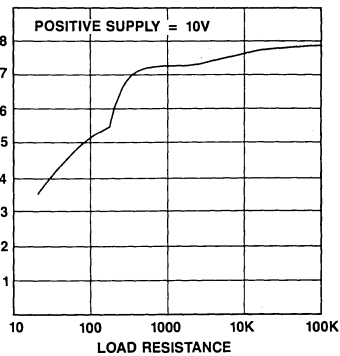

Figure 26c

Cable Tester (9)

Compact tester checks cables for open-circuit or short-circuit conditions. A differential transistor pair at one end of each cable line remains balanced as long as the same clock pulse-generated by the timer IC - appears at both ends of the line. A clock pulse just at the clock end of the line lights green light-emitting diode, and a clock pulse only at the other end lights a red LED (Figure 28).

Low Cost Line Receiver (10)

The timer makes an excellent line receiver for control applications involving relatively slow electro-mechanical devices. It can work without special drivers over single unshielded lines (Figure 29).

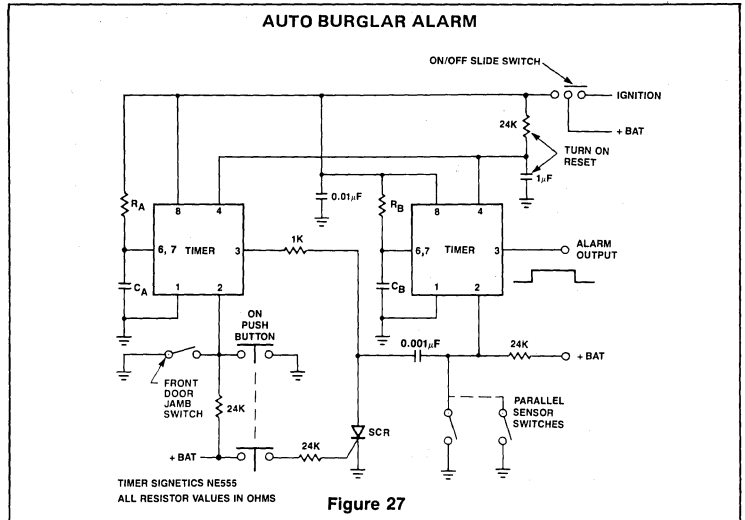

Figure 27

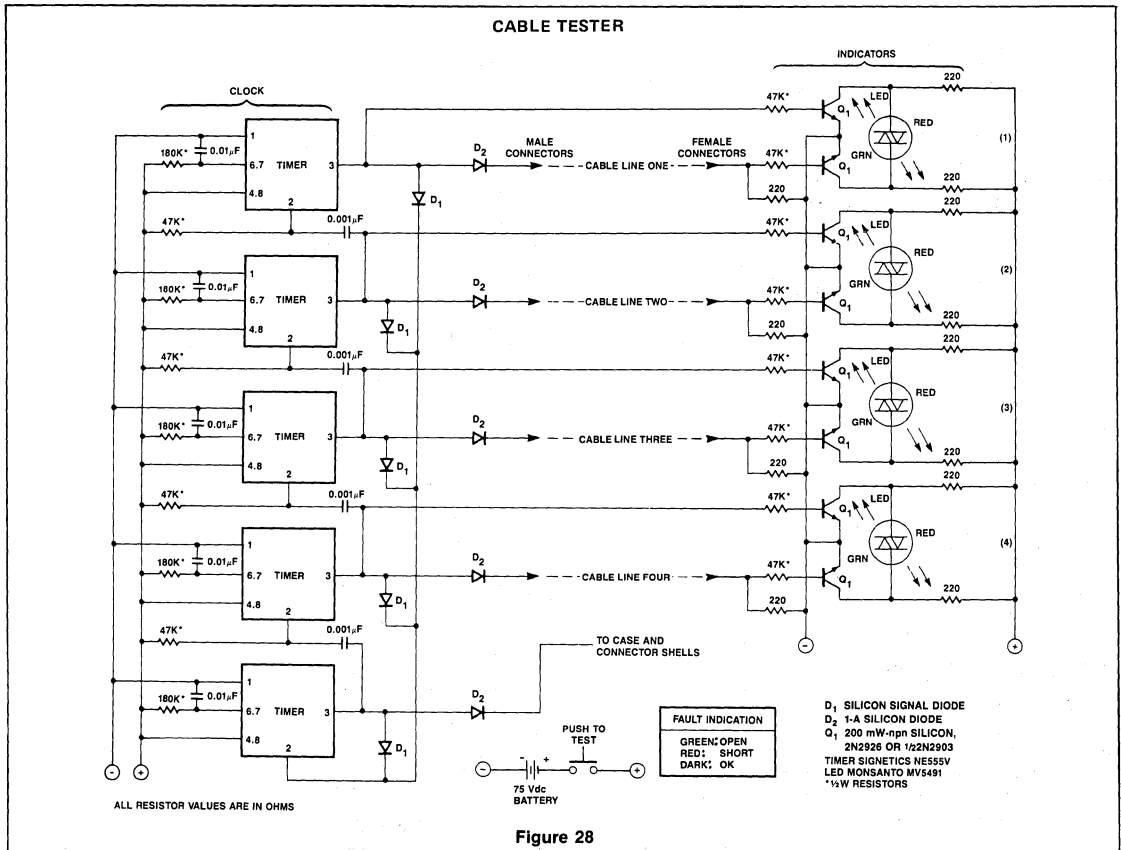
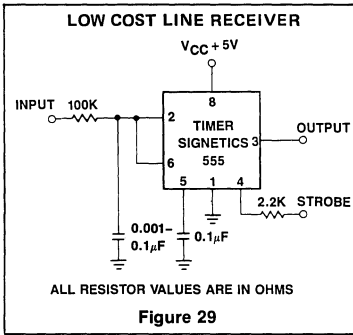

Figure 28



Temperature Control (11)

A couple of transistors and thermistor in the charging network of the 555-type timer enable this device to sense temperature and produce a corresponding frequency output. The circuit is accurate to within ± 1 Hertz over a 78°F temperature range (Figure 30a & b).

Automobile Voltage Regulator (12)

Monolithic 555-type timer is the heart of this simple automobile voltage regulator. When the timer is off so that its output (pin 3) is low, the power Darlington transistor pair is off. If battery voltage becomes too low (less than 14.4 volts in this case), the timer turns on and the Darlington pair conducts (Figure 31).

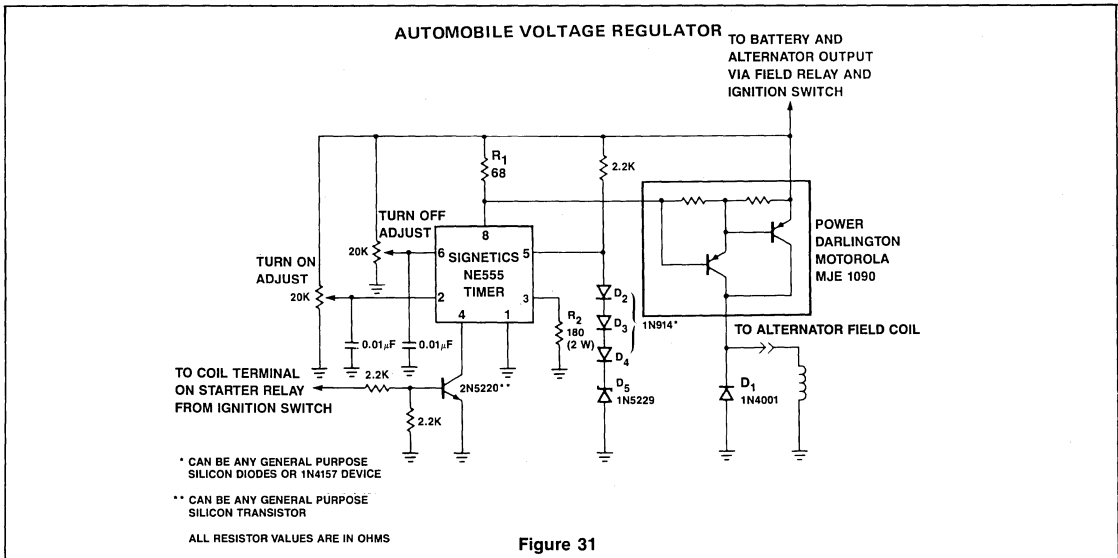
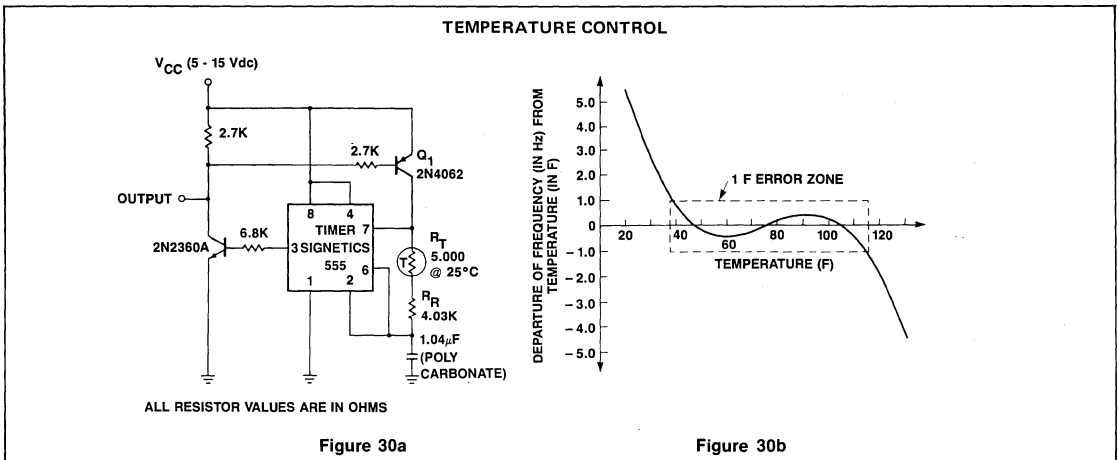

Switching Regulator (13)

The basic regulator of Figure 32 is shown here with its associated timing and pulse generating circuitry. The block diagram illustrates how the over-all regulator works. The multivibrator determines switching frequency, and the error amplifier adjusts the pulse width of the modulator to maintain output voltage at the desired level. The output resistor divider provides the sensing voltage. (Figure 35).

DC-to-DC Converter (14)

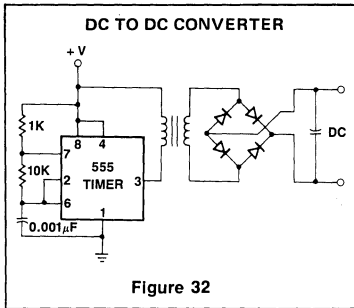

Figure 32

Ramp Generator (14)

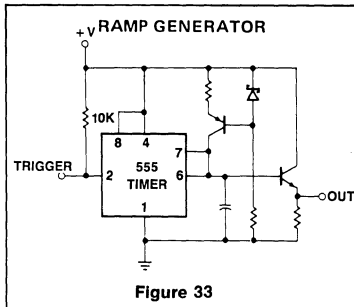

Figure 33

Audio Oscillator (14)

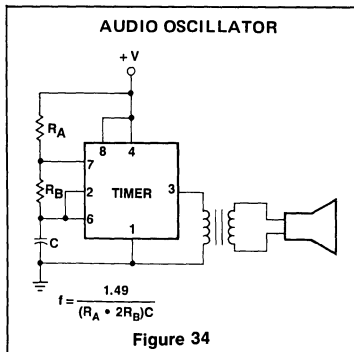

Figure 34

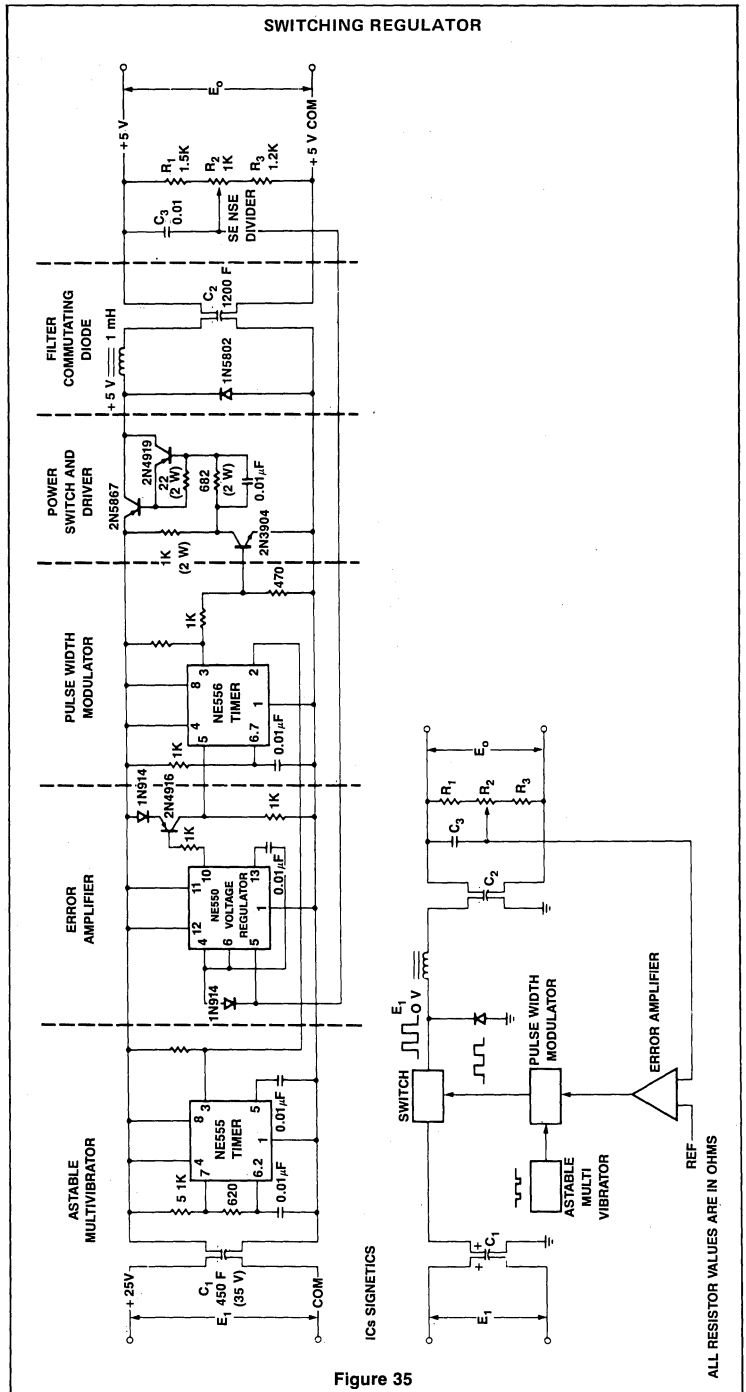

Figure 35

ALL RESISTOR VALUES ARE IN OHMS

Low Power Monostable Operation

In battery operated equipment where load current is a significant factor figure 36 can deliver 555 monostable operation at low standby power. This circuit interfaces directly with CMOS 4000 series

and 74L00 series. During the monostable time, the current drawn is 4.5mA for $T = 1.1RC$. The rest of the time the current drawn is less than $50\mu A$. Circuit submitted by Karl Imhof, Executone Inc., Long Island City, NY.

In other low power operations of the timer where V_{cc} is removed until timing

is needed, it is necessary to consider the output load. If the output is driving the base of a PNP transistor, for example, and its power is not removed, it will sink current into pin 3 to ground and use excessive power. Therefore, when driving these types of loads, one should recall this internal sinking path of the timer.

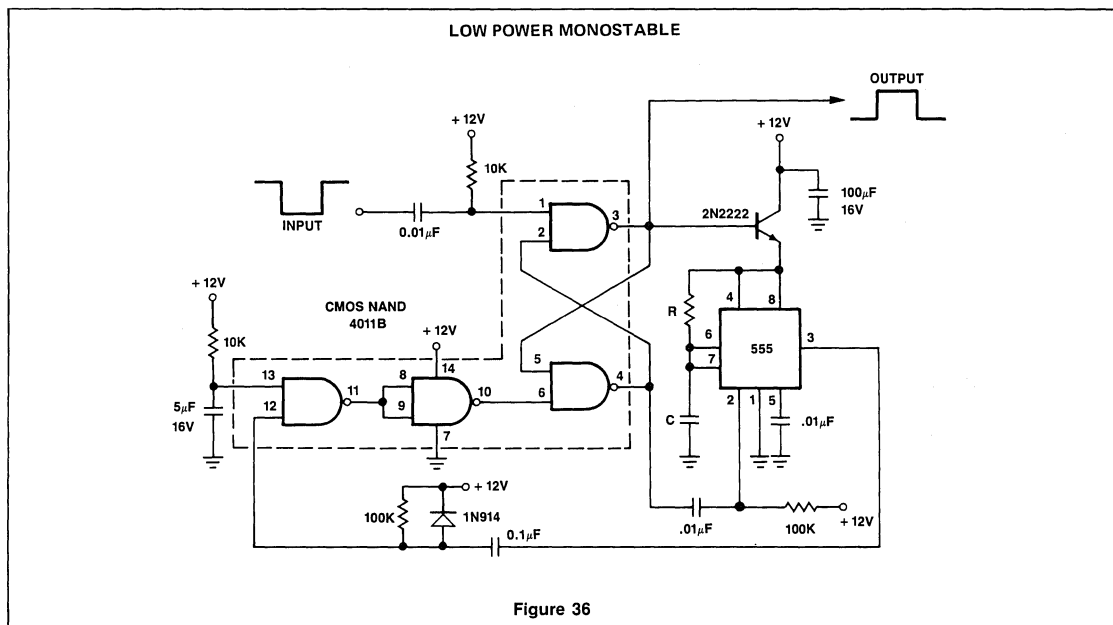

Figure 36

BIBLIOGRAPHY

1. "Unconventional Uses for IC Timers" Jim Wyland and Eugene Hnatek, *Electronic Design*, June 7, 1973, pp. 88-90.
2. "DC to DC Converter Uses The IC Timer", Robert Soloman and Robert Broadway, *EDN*, September 5, 1973, pp. 87-91.
3. "Oscilloscope Triggered Sweep: Another Job for IC Timer", Robert McDermott, *Electronics*, October 11, 1973, pp. 125.
4. "Get Square Wave Tone Bursts With a Single Timer IC", Sol Black, *Electronic Design*, September 1973, pp. 148.
5. "Toroid and Photo-SCR Prevent Ground Loops in High Isolation Biological Pulser", Joseph Sonsino, *Electronic Design*, June 21, 1973, pp. 128.
6. "Voltage to Frequency Converter Constructed With Few Components is Accurate to 0.2%", Chaim Klement, *Electronic Design*, June 21, 1973, pp. 124.
7. "Positive Voltage Changed into Negative And No Transformer is Required", Bert Pearl, *Electronic Design*, May 24, 1973, pp. 164.
8. "Pair of IC Timers Sounds Auto Burglar Alarm", Michael Harvey, *Electronics*, June 21, 1973, pp. 131.
9. "Timer IC's And LEDs form Cable Tester", L. W. Herring, *Electronics*, May 10, 1973, pp. 115.
10. "IC Timer Can Function As Low Cost Line Receiver", John Pate, *Electronics*, June 21, 1973, pp. 132.
11. "IC Timer Plus Thermister Can Control Temperature", Donald Dekold, *Electronics*, June 21, 1973, pp. 132.
12. "IC Timer Makes Economical Automobile Voltage Regulator", T. J. Fusar, *Electronics*, February 21, 1974, pp. 100.
13. "Switching Regulators, The Efficient Way to Power", Robert Olla, *Electronics*, August 16, 1973, pp. 94-95.
14. "Put The IC Timer To Work in A Myriad Of Ways", Eugene Hnatek, *EDN*, March 5, 1973, pp. 54-58.



INTRODUCTION

The 558 is a monolithic Quad Timer designed to be used in the timing range from a few microseconds to a few hours. Four entirely independent timing functions can be achieved, using a timing resistor and capacitor for each section. Two sections of the quad may be interconnected for astable operation. All four sections may be used together, in tandem, for sequential timing applications up to several hours. No coupling capacitors are required when connecting the output of one timer section to the input of the next.

FEATURES

- 100mA OUTPUT CURRENT PER SECTION
- EDGE TRIGGERED (NO COUPLING CAPACITOR)
- OUTPUT INDEPENDENT OF TRIGGER CONDITIONS
- WIDE SUPPLY VOLTAGE RANGE 4.5V TO 16V
- TIMER INTERVALS FROM MICROSECONDS TO HOURS
- TIME PERIOD EQUALS RC

CIRCUIT OPERATIONS

In the one shot mode of operation, it is necessary to supply a minimum of two external components, the resistor and capacitor for timing. The time period is equal to the product of R and C. An output load must be present to complete the circuit due to the output structure of the 558.

For astable operation, it is desirable to cross couple two devices from the 558 Quad. The outputs are direct coupled to the opposite trigger input. The duty cycle can be set by ratio of R_1C_1 to R_2C_2 from close to zero to almost 100%. An astable circuit using one timer is shown in Figure 5b.

OUTPUT STRUCTURE 558

The 558 structure is open collector which requires a pull-up resistor to V_{cc} and is capable of sinking 100mA per unit but not to exceed the power dissipation and junction temperature rating of the die and package. The output is normally low and is switched high when triggered.

output pulse width and duty cycle with an external control voltage. The range of this control voltage is from about 0.5V to V_{cc} minus 1 volt. This will give a cycle time variation of about 50:1. In a sequential timer with voltage controlled cycle time, the timing periods remain proportional over the adjustment range.

RESET

A reset function has been made available to reset all sections simultaneously to an output low state. During reset the trigger is disabled. After reset is finished, the trigger voltage must be taken high and then low to implement triggering.

The reset voltage must be brought below 0.8V to insure reset.

TEST BOARD FOR 558

The circuit layout can be used to test and characterize the 558 timer. S2 is used to connect the loads to either V_{cc} or ground. The main precaution, in layout of the 558 circuit, is the path of the discharge current from the timing capacitor to ground (pin 12). The path must be direct to pin 12 and not on the ground bus. This is to prevent voltage spikes on the ground bus return due to current switching transient. It is also wise to use good power supply by passing when large currents are being switched.

THE CONTROL VOLTAGE

The control voltage is also made available on the 558 timer. This allows the threshold voltage to be modulated, therefore controlling the

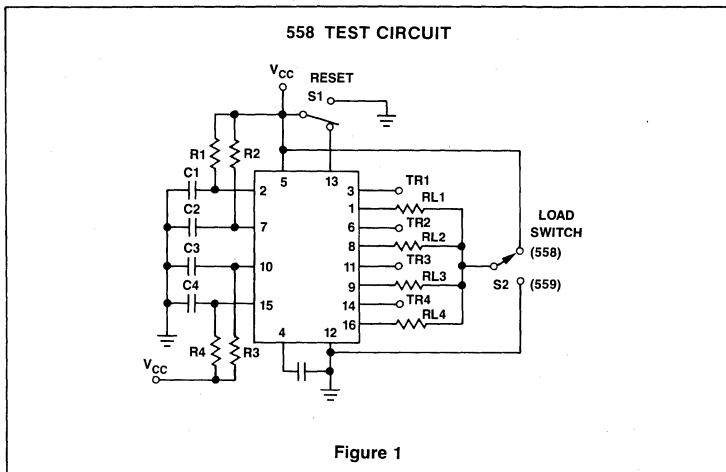

Figure 1

TEST BOARD LAYOUT

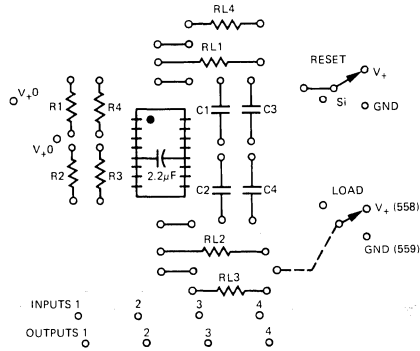

Figure 2a

FOIL SIDE

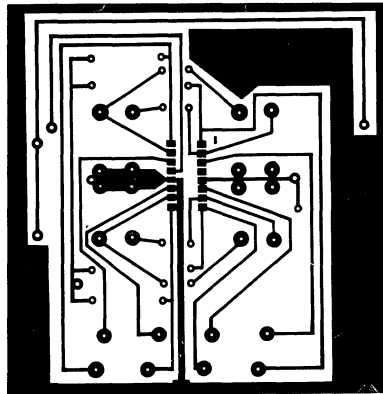
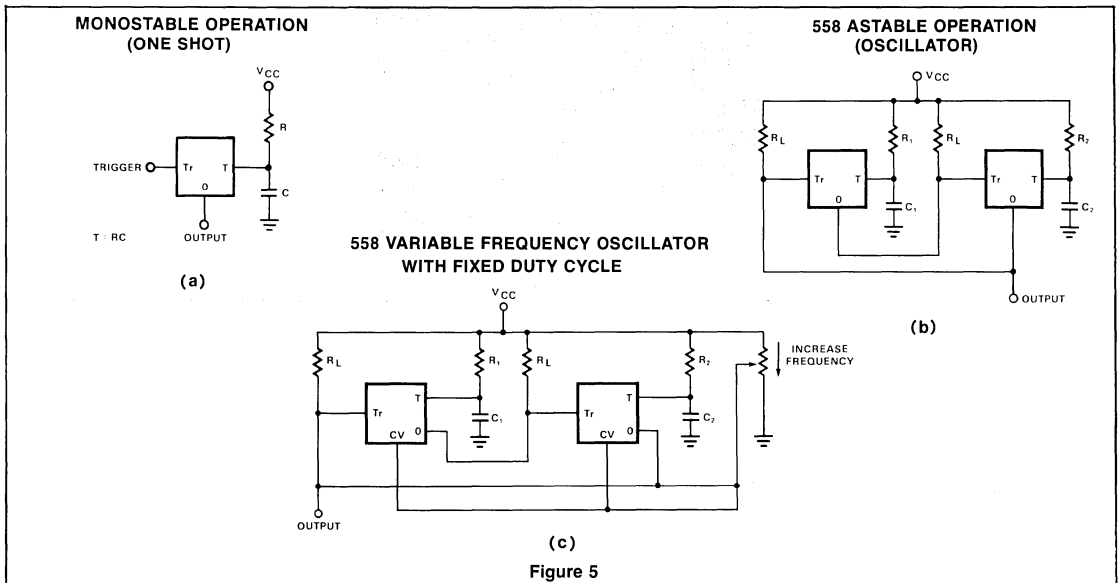
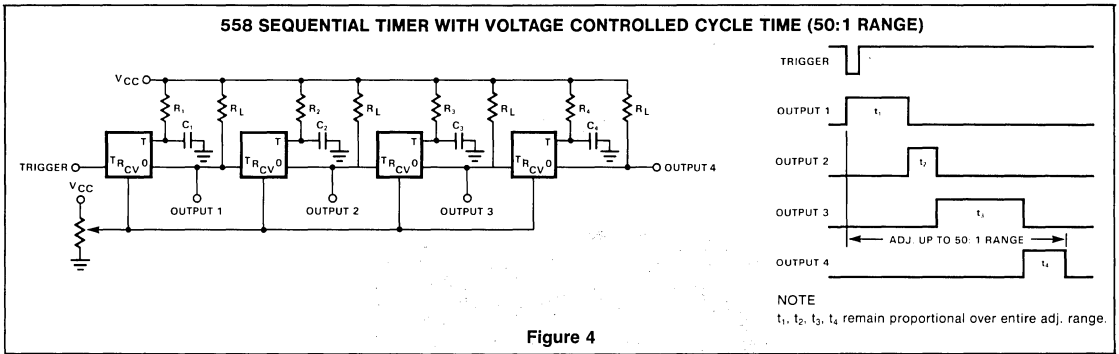
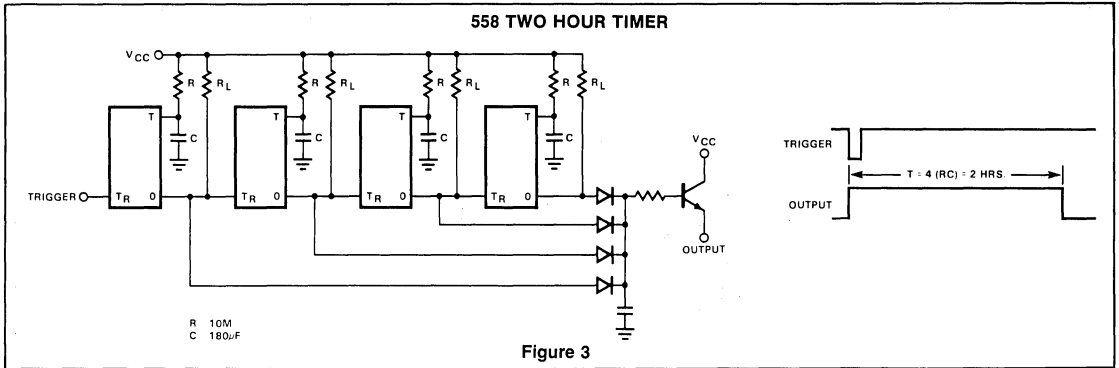
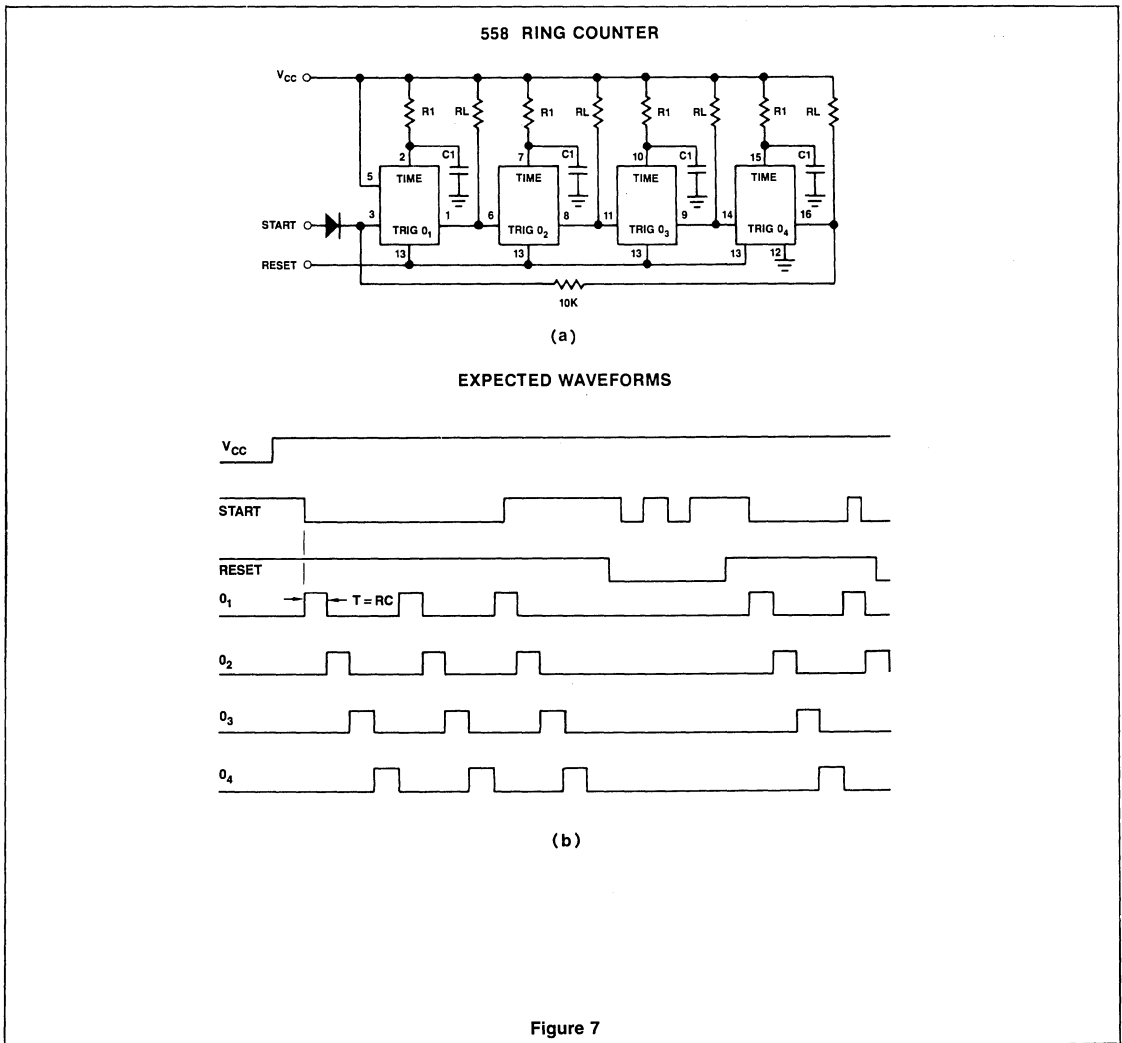
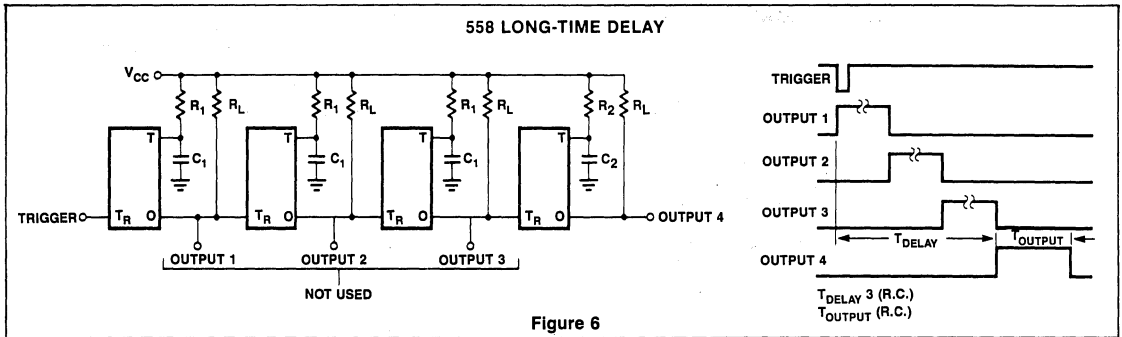

Figure 2b





NE558 400 Hz SQUARE WAVE OSCILLATOR

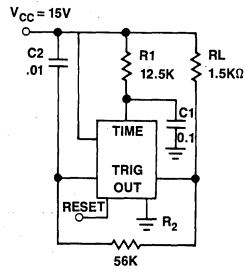

Figure 8

A single section of the Quad time may be used as a non precision oscillator. The values given are for oscillation at about 400Hz. $T_1 \approx R_1 C_1$ and $T_2 \approx 2.25 R_2 C_2$ for V_{CC} of 15 volts. The frequency of oscillation is subject to the changes in V_{CC} .

2.1 An Overview of the Phase Locked Loop (PPL)

Portions of this Phase Locked Loop section were edited by Dr. J.A. Connelly

INTRODUCTION

The basic phase locked loop (PLL) concept has been known and widely utilized since first being proposed in 1922 (1). Since that time PLLs have been used in instrumentation, space telemetry, and many other applications requiring a high degree of noise immunity and narrow bandwidth. Techniques and systems involved in these applications frequently are quite complex, requiring a high degree of sophistication. Many of the PLL applications have been at microwave frequencies and employ complex phase shifters, signal splitters, modulation, and demodulation schemes such as biphasic and quadrature. Because of the high frequencies involved in microwave applications, most all components of these PLL systems are made from discrete as opposed to integrated circuits. However in other communication system applications such as FSK and FM and AM demodulation where frequencies are below approximately 100MHz, monolithic PLLs have found wide application because of their low cost versus high performance.

A block diagram representation of a PLL is shown in Figure 1. Phase locked loops operate by producing an oscillator frequency to match the frequency of an input signal, f_i . In this locked condition, any slight change in f_i first appears as a change in phase between f_i and the oscillator frequency. This phase shift then acts as an error signal to change the frequency of the local PLL oscillator to match f_i . The locking onto a phase relationship between f_i and the local oscillator accounts for the name phase locked loop.

A MECHANICAL ANALOG TO THE PLL

To better visualize the frequency and phase relationships in a PLL, consider the mechanical system shown in Figure 2 which is a dual to the electronic PLL. This mechanical system has two identical, heavy disks with two separate center shafts attached to each disk. Each shaft is presumed to be mounted on a bearing that allows each massive disk to be rotated in either direction when some external force is applied. The shafts are coupled together by a spring whose end points are fixed to each shaft. This spring can be twisted in either direction depending upon the relative positions of the shafts. The spring cannot "kink up" due to the shafts passing through the center of the spring.

Now suppose the sequence of events shown on Figure 3 occurs to the mechanical system. The disks are simply represented like clock faces with positional reference markers. Initially both disks are stationary in a neutral position. Then the left disk, or input, is advanced slowly clockwise through an angle θ_1 from the neutral position. The right disk, or output, initially doesn't move as the spring begins to tighten. As the input continues to move and when it reaches θ_2 , the output disk just begins to turn and tracks the input with a positional phase shift error of

$$\theta_e = \theta_2. \tag{1}$$

At any point in time with both disks slowly turning at the same speed, there will be some inherent phase error between the disks, or

$$\theta_e = \theta_3 - \theta_4. \tag{2}$$

This positional phase error in the mechanical system is analogous to the phase error in the electronic PLL. When the input disk coasts to a stop, the output also gradually comes to a stop with a fixed phase error equal to that in Equation 2 or

$$\theta_e = \theta_5 - \theta_6 = \theta_3 - \theta_4. \tag{3}$$

The spring has a residual stored twist in one direction due to θ_e .

Now consider that the disks are first returned to their neutral positions. Then the input disk is instantaneously rotated through an angle of θ_1 as shown in Figure 4. The output disk can't respond instantaneously because of its large mass. It doesn't move instantaneously and the spring develops considerable torque. Then as shown in the sequence of events in Figure 4, the output disk begins accelerating after some delay due to the large phase error. It swings past the stopped position of the input disk due to its momentum, reaches a peak overshoot, and gradually oscillates about θ_1 with a damped response, finally coming to rest with some small residual phase error. The input twist of θ_1 represents the application of a step of position or phase to the system, and the response of the output disk is typical for a second-order, under-damped system. This same type of second-order behavior occurs in the PLL system for an instantaneous change of input phase.

As a final example, consider the events in Figure 5 where both disks are rotating at a constant rate. Applying a strobing light (strobotac) simultaneously to both disks

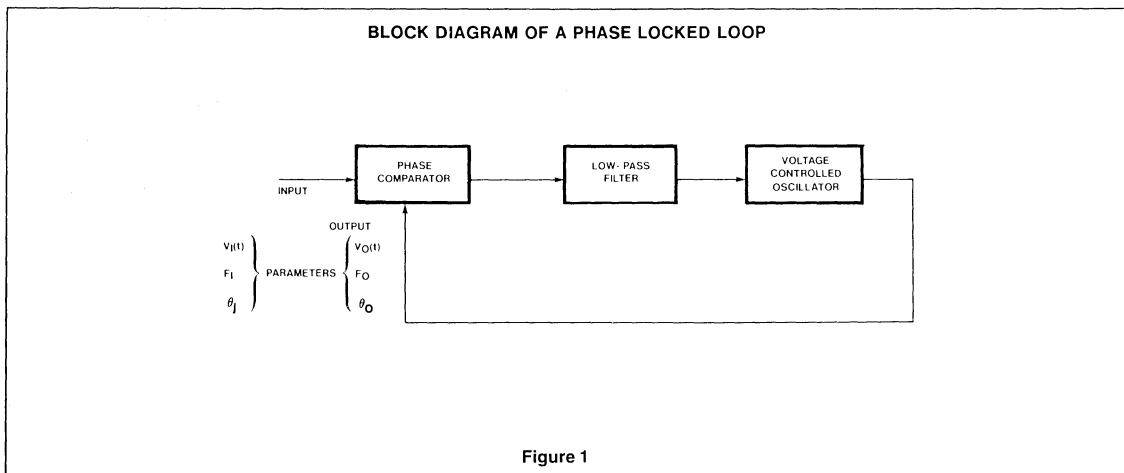
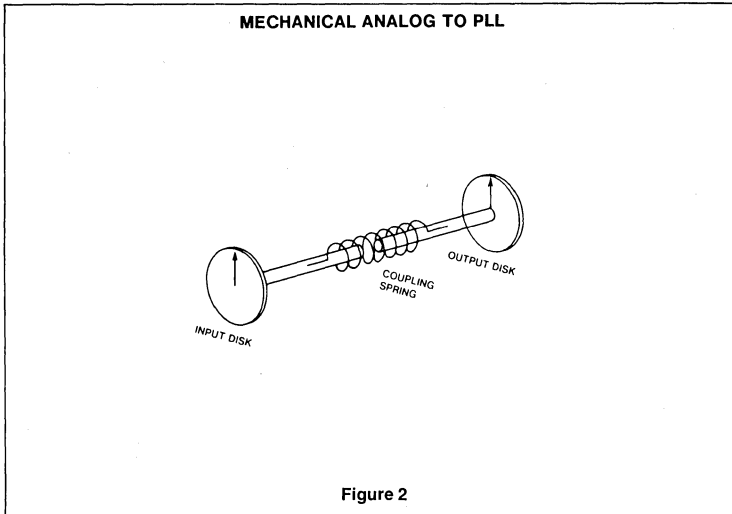
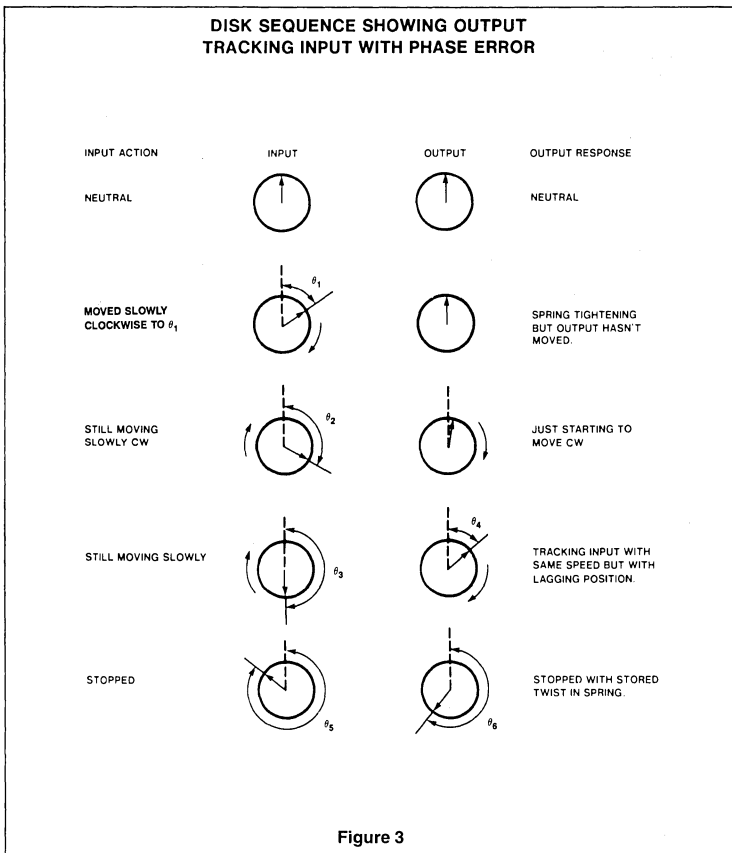

Figure 1





and adjusting its flashing rate to one flash per disk rotation will cause the positional markers to appear stationary. There will be a constant phase error in this case just as there was in Figure 3. Now suppose the revolution rate of the input disk gradually increases by a small amount to a new rate. The positional marker will appear to walk around the disk. The output first senses the increased rate of the input through an increase in the phase error. Then, after some delay, the rate of the output gradually increases to track the input. Both positional markers appear to be walking around each disk at the same rate until the stroboscopes is adjusted for the higher input and output rate. Then the strobe light again freezes the markers, producing a phase error at this higher rate that is larger than before the input rate was increased. This gradual increase in the input rate to the mechanical system simulates a ramp change in the input frequency to the PLL system. The response to the output disk simulates the behavior of the oscillator in the PLL.



If the rate of the input disk is alternately increased and decreased by some small amount compared to the nominal revolution rate, the positional markers will appear to walk both clockwise and counter clockwise, momentarily appearing stationary when the strobing light rate equals the disk revolution rate. This "walking" represents a changing phase error which is occurring at the modulation rate. Thus the phase error can be thought of as a useable demodulated output signal.

The disk-spring mechanical system is a helpful analog for visualizing frequency, phase, transient, and steady-state responses in the electronic phase locked loop system. In this example, the positions of the disk marker and rotation rates are analogous to phase and frequency in the electronic PLL system. The spring acts as a phase comparator to constantly sense the relative positions or phases of the disks. The torque developed in this spring acts as the driving force or input signal to turn the second disk.

Thus the spring torque simulates a voltage which controls the rate or frequency of the output disk or oscillator. Hence the second disk is analogous to a voltage-controlled oscillator (VCO). The large mass of the disks together with their angular momentum slows down the systems response time and simulates a low-pass filter in the electronic PLL system. This describes the lagging of the VCO free-running frequency to the input signal in an analog phase locked loop.

AN OVERVIEW OF PHASE LOCKED LOOP (PLL)

AN177

EXAMPLES OF PLL APPLICATIONS

Now consider the action of the voltage controlled oscillator, phase comparator and low pass filter in the PLL. The VCO generates a signal that is periodic. Normally, the rate or frequency of the VCO is primarily determined by the value of a capacitance connected to this oscillator. This action of starting the VCO running by itself is analogous to disconnecting the spring from one of the shafts in the mechanical system and starting the output disk rotating at a constant rate through some external means such as a motor. In the PLL system this frequency is called the oscillator's *free running frequency*, (f_0'), because it occurs when the system is unlocked and there is no coupling between input and output frequencies. With the PLL, the VCO frequency can be shifted above and below f_0' by applying a voltage to the optional fine tune input.* This signal generator property is just one of the many uses of the PLL. Specifically with integrated circuit PLLs, frequency ranges from less than 1.0Hz to more than 50MHz can be produced just by selecting the right value of capacitance from a chart on the data sheet.

Selecting f_0' and then changing it by a control voltage makes the VCO well suited for converting digital data that is represented by two different voltage levels into two different frequencies. A "1" voltage level can be related to a frequency called a mark, and an "0" level to a frequency called a space. This technique called *frequency shift keying*, or (FSK), is typical of data being transmitted over telephone and radio links where it is impractical to use dc voltage level shifts. Essentially this is what a modem (modulator-demodulator) does as it converts data to tones to go out of the system into a transmission link. Then it reverses the process and converts received tones to "1"'s and "0"'s at the receiver for the system to use. Sometimes confusion arises because different names are used for the same thing. For example,

A shift up in frequency = "1" = Mark
 A shift down in frequency = "0" = Space

If voice or music is applied to the VCO instead of digital data, the oscillator's frequency will move or modulate with the voice or music. This is frequency modulation (FM) and is simply moving the frequency in relation to some input voltage which represents intelligence. Of course as in the modem case the process has to be reversed and the PLL can do this also. The PLL is a complete working system that can be used to

* Some oscillators have frequencies controlled by an input current rather than a voltage and are referred to as current-controlled oscillators (CCO).

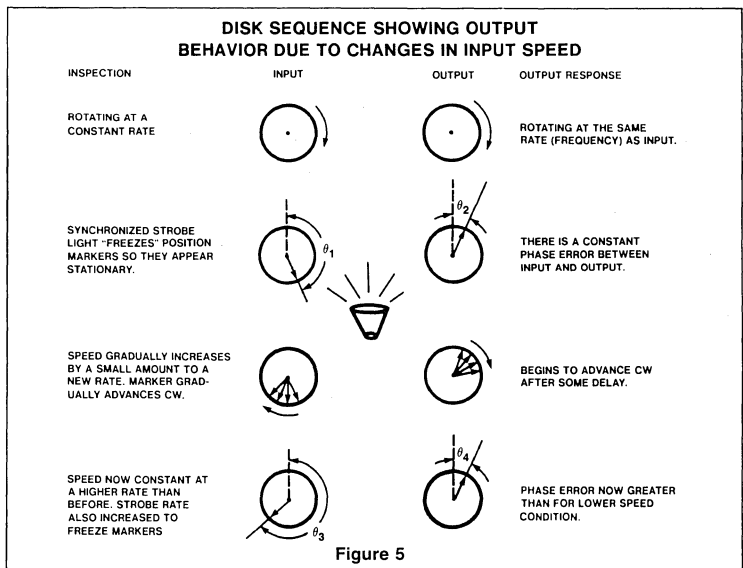
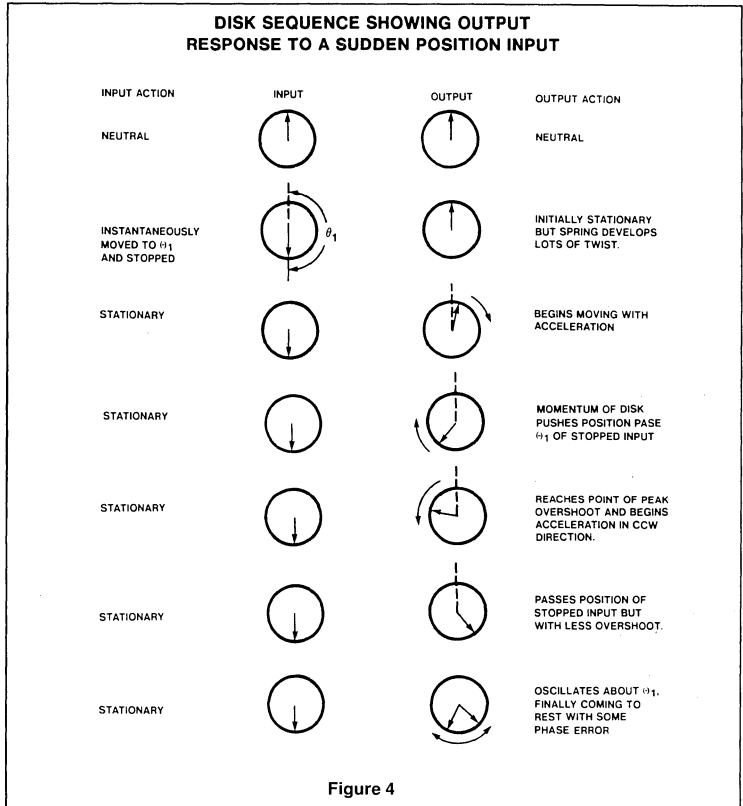

send and receive signals. In fact the PLL can create the signal, or select a signal, decode it and reproduce it. Now let's look at how this works.

The VCO is connected to a section where its frequency is put together with an incoming signal or signals. In a radio this is known as a "mixer" where signals are mixed together. In a PLL it is usually called a *Phase Comparator*. Other names for this function are *phase detector* or *multiplier* - either analog or digital. (Differences between analog and digital phase comparators will be explained later in this chapter). The purpose of this phase comparator is to produce an output which represents how far the VCO frequency is from that of the incoming signal. Comparing these frequencies and producing an error signal proportional to their difference allows the VCO frequency to shift from f_0' and become the same frequency as the input signal. This is exactly what happens with the VCO frequency - first "capturing" the input frequency, and then locking onto it. A similar type action can be visualized in the mechanical system by having the coupling spring disconnected at one end with the two disks rotating at different rates. When their rotation rates are approximately equal, the spring is suddenly connected, and the output disk's speed will gradually become equal to and track the inputs rate as in Figure 1.5.

When the VCO shifts frequency and locks to the input, the signal frequency is duplicated. If the input signal contains static or noise, the VCO output will be an exact reproduction of the signal frequency without the static or noise. Thus the PLL has accomplished signal reconditioning or recondition.

The error signal used to keep the VCO exactly synchronized with an incoming signal can be amplified, filtered, and used to "clock" the signal or give synchronizing information necessary to look at the signal. For example, in some digital memories and transmission systems, data are stored in a code and looked at or strobed at a rate which must be synchronized to the data. This strobing may be at twice or one-half the data rate. By setting f_0' equal to twice or one-half the data rate, the PLL will lock to the data and give an exact synchronized clock. This shows another application of the PLL for multiplying or dividing frequencies.

PLLs can separate a signal of one frequency from among many others as for example is done in television and radio reception. This selectivity or capture range is con-

trolled in the PLL by the low-pass filter (LPF) which allows the PLL to only see signals close to the frequency of interest. The time constant of the LPF is set easily by the selection of a resistor and capacitor network. This network determines how far away in frequency an input signal can be from f_0' and still permit the PLL to respond and capture. Once locking is activated, the PLL system will continue to track the input frequency unless the instantaneous phase error exceeds the systems capability.

The error signal which drives the VCO and keeps the system locked is a usable output. In the FSK example the oscillator's frequency is shifted with each "1" or "0" digital input. Converting these frequency shifts back to the "1" and "0" signals automatically occurs in a PLL because a mark input generates an error signal to move the VCO up to that frequency. When the mark changes to a space, the error signal jumps suddenly down, forcing the VCO to follow. The error signal then is exactly the data that generated the FSK signals. *A PLL for FSK can convert data to tones for transmission to a remote point. Then another PLL can recon-vert the data tones back to voltage levels, all without tuned circuits.*

The PLL system decodes FM signals in a similar way. The frequency variations caused by voltages from a microphone into one VCO serve as the input signal to another PLL which reverses the action since the error signal driving the second PLLs VCO is exactly the same as the original microphone voltage.

Decoding of an amplitude modulated (AM) input signal is another application of the PLL. This application is more involved than FM demodulation because a phase shift network, a second phase comparator, and another low-pass filter are required. This application is discussed in detail later in Chapters 4 and 5. However, it should be pointed out that AM demodulation with PLLs offers improved system linearity than the more commonly employed technique of nonlinear diode detection. Tone decoding is a special case of AM demodulation. When performed with PLLs, the second phase comparator is called a quadrature phase detector (QPD). The QPD produces a maximum output error voltage whenever the input and oscillator frequencies are locked to the free-running frequency, f_0' , unlike the regular phase comparator which has a nominal zero error voltage under this same condition.

These application examples show that with the PLL is a system that can:

- 1 Generate a signal
- 2 Modulate a signal (encode)
- 3 Select a signal from among many
- 4 Demodulate (decode)
- 5 Recreate (reconstitute) a signal frequency with reduced noise
- 6 Multiply and divide frequency

TYPES OF PLLS

Generally speaking the monolithic PLLs can be classified into two groups - digital and analog. While both perform as PLLs, the digital circuits are more suitable for synchronization of digital signals, clock recovery from encoded digital data streams, and other digital applications. Analog monolithic PLLs are used quite extensively in communication systems since they maintain linear relationships between input and output quantities.

The phase comparator is perhaps the most important part of the PLL system since it is here that the input and VCO frequencies are simultaneously compared. Some digital PLLs employ a two-input Exclusive-Or gate as the phase comparator. When the digital loop is locked to f_0' , there is an inherent phase error of 90° that is represented by asymmetry in the output waveform. Also the phase comparators output has a frequency component of twice the reference frequency. Because of the large logic voltage swings in digital systems, extensive filtering must be performed to remove the harmonic frequencies. For this reason, other types of digital phase comparators achieve locking by synchronizing the "edges" of the input and VCO frequency waveshapes. The phase comparator produces an error voltage that is proportional to the time difference between the edges, i.e., the phase error. This edge-triggering technique for the phase comparator produces lower output noise than with the Exclusive-Or approach. However time jitter on the input and VCO frequencies is translated into phase error jitter that may require additional filtering within the loop.

Triggering on the edges of digital signals means that only frequency (or period) is important and not duty cycle. This is a key consideration in PLL applications utilizing counters where waveshapes usually aren't symmetrical, i.e., 50% duty cycle. For the TTL family, it is easier to provide the edge matching function on the falling edges ("1" to "0") transition of the waveform. CMOS, I^2L , and ECL are better suited for leading edge triggering ("0" to "1").

Analog PLLs utilize a phase comparator which functions as a four-quadrant analog multiplier to mix the input and VCO signals. Since this mixing is true analog multiplica-

tion, the phase comparators output is a function of input and VCO signal amplitudes, frequencies, phase relationships, and duty cycles. The inherent linearity afforded by this analog multiplication makes the monolithic analog PLL well suited for many general purpose and communication system applications.

Another way of distinguishing between digital and analog phase comparators is by thinking of the similarities and differences between voltage comparators and operational amplifiers. Voltage comparators are specially designed for digital applications where response time between output levels has been minimized at the expense of system linearity. Feedback is seldom used to maintain linear system relationships, with the comparator normally running open loop. Op amps, on the other hand, are designed for a linear input-output relationship, with negative feedback being employed to further improve the system linearity.

PLL TERMINOLOGY

The following is a brief glossary of frequently encountered terms in PLL literature.

Free-running Frequency (f_0' , ω_0').

Also called the *center frequency*, this is the frequency at which the loop VCO operates when not locked to an input signal. The "prime" superscripts are used to distinguish the free-running frequency from f_0 and ω_0 which are used for the general oscillator frequency. (Many references use f_0 and ω_0 for both the free-running and general oscillator frequency and leave the proper choice for the reader to infer from the context). The

appropriate units for f_0' and ω_0' are Hz and radians per second respectively.

Lock Range ($2 f_L$, $2\omega_L$).*

The range of frequencies over which the loop will remain in lock. Normally the lock range is centered at the free-running frequency unless there is some nonlinearity in the system which limits the frequency deviation on one side of f_0' . The deviations from f_0' are referred to as the *Tracking Range* or *Hold-in Range*. (See Figure 1.6). The tracking range is therefore one-half of the lock range.

Capture Range ($2 f_C$, $2\omega_C$).**

Although the loop will remain in lock throughout its lock range, it may not be able to acquire lock at the tracking range extremes because of the selectivity afforded by the low-pass filter. The capture range also is centered at f_0' with the equal deviations called the *Lock-in* or *Pull-in Ranges*. *The capture range can never exceed the lock range.*

Lock-up Time (t_L).***

The transient time required for a free running loop to lock. This time depends principally upon the bandwidth selectivity designed into the loop with the low-pass filter. *The lock-up time is inversely proportional to the selectivity bandwidth.* Also, lock-up time exhibits a statistical spreading due to random initial phase relationships between the input and oscillator phases.

Phase Comparator Conversion Gain (K_D).

The conversion constant relating the phase comparators output voltage to the phase difference between input and VCO signals

when the loop is locked. At low input signal levels, K_D is also a function of signal amplitude. K_D has units of volts per radian (V/rad).

VCO Conversion Gain (K_O).

The conversion constant relating the oscillators frequency shift from f_0' to the applied input voltage. K_O has units of radians per second per volt (rad/sec/volt). K_O is a linear function of ω_0' and must be obtained using a formula or graph provided or experimentally measured at the desired ω_0' .

Loop Gain (K_V).

The product of K_D , K_O , and the low-pass filters gain at dc. K_D is evaluated at the appropriate input signal level and K_O at the appropriate ω_0' . K_V has units of (sec)⁻¹.

Closed Loop Gain (CLG)

The output signal frequency and phase can be determined from a product of the CLG and the input signal where the CLG is given by

$$CLG = \frac{K_V}{1+K_V} \tag{4}$$

Natural Frequency (ω_n).

The characteristic frequency of the loop, determined mathematically by the final pole positions in the complex plane or determined experimentally as the modulation frequency for which an underdamped loop gives the maximum frequency deviation from f_0' and at which the phase error swing is the greatest.

Damping Factor (ζ).

The standard damping constant of a second order feedback system. For the PLL, ζ refers to the ability of the loop to respond quickly to an input frequency step without excessive overshoot.

Loop Noise Bandwidth (B_L).

A loop property relating ω_n and ζ which describes the effective bandwidth of the received signal. Noise and signal components outside this bandwidth are greatly attenuated.

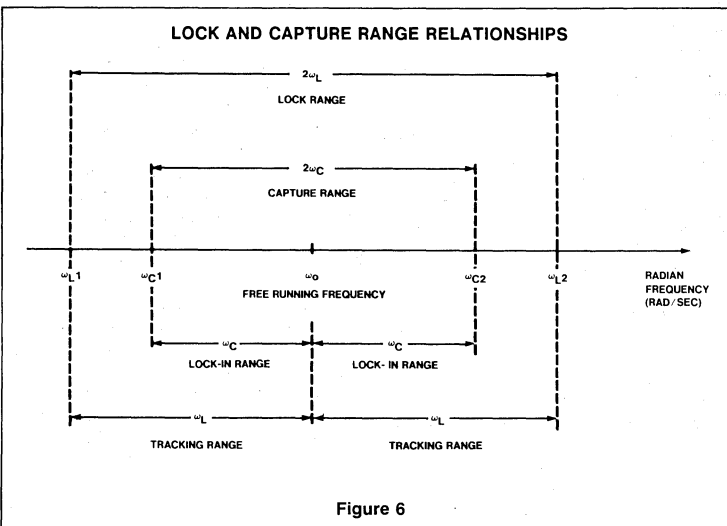

Figure 6

* Also called Synchronization Range.
 ** Also called Acquisition Range.
 *** Also called Acquisition Time.



INTRODUCTION

The phase locked loop is a feedback system comprised of a phase comparator, a low pass filter and an error amplifier in the forward signal path and a voltage-controlled oscillator (VCO) in the feedback path. The block diagram of a basic PLL system is shown in Figure 1. Perhaps the single most important point to realize when designing with the PLL is that it is a feedback system and, hence, is characterized mathematically by the same equations that apply to other, more conventional feedback systems. However, the parameters in the equations are somewhat different since the feedback error signal in the phase locked system is a phase rather than a current or voltage signal, as is usually the case in conventional feedback systems.

PHASE LOCKED LOOP OPERATION

The basic principle of the PLL operation can be briefly explained as follows:

With no signal input applied to the system, the VCO control voltage $V_d(t)$ is equal to zero. The VCO operates at a set frequency, f_0' (or the equivalent radian frequency ω_0') which is known as the free-running frequency. When an input signal is applied to the system, the phase comparator compares the phase and the frequency of the input with the VCO frequency and generates an error voltage $V_e(t)$ that is related to the phase and the frequency difference between the two signals. This error voltage is then filtered, amplified, and applied to the control terminal of the VCO. In this manner, the control voltage $V_d(t)$ forces the VCO frequency to vary in a direction that reduces the frequency difference between ω_0 and the input signal. If the input frequency ω_i is sufficiently close to ω_0 , the feedback nature of the PLL causes the VCO to synchronize or lock with the incoming signal. Once in lock, the VCO frequency is identical to the input signal except for a finite phase difference.

This net phase difference of θ_e where

$$\theta_e = \theta_o - \theta_i \quad (1)$$

is necessary to generate the corrective error voltage V_d to shift the VCO frequency from its free-running value to the input signal frequency ω_i and, thus, keep the PLL in lock. This self-correcting ability of the system also allows the PLL to track the frequency changes of the input signal once it is locked. The range of frequencies over which the PLL can maintain lock with an input signal is defined as the "lock range" of the system. The band of frequencies over which the PLL can acquire lock with an incoming signal is known as the "capture

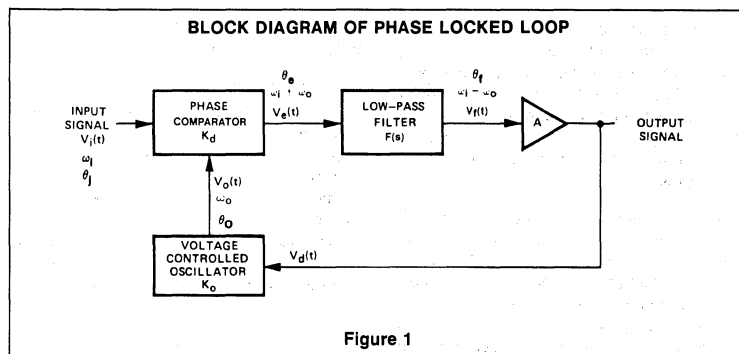

Figure 1

range" of the system and is never greater than the lock range.

Another means of describing the operation of the PLL is to observe that the phase comparator is in actuality a multiplier circuit that mixes the input signal with the VCO signal. This mix produces the sum and difference frequencies $\omega_i \pm \omega_0$ shown in Figure 1. When the loop is in lock, the VCO duplicates the input frequency so that the difference frequency component ($\omega_i - \omega_0$) is zero; hence, the output of the phase comparator contains only a dc component. The low pass filter removes the sum frequency component ($\omega_i + \omega_0$) but passes the dc component which is then amplified and fed back to the VCO. Notice that when the loop is in lock, the difference frequency component is always dc, so the lock range is independent of the band edge of the low pass filter.

LOCK AND CAPTURE

Consider now the case where the loop is not yet in lock. The phase comparator again mixes the input and VCO signals to produce sum and difference frequency components. However, the difference component may fall outside the band edge of the low pass filter and be removed along with the sum frequency component. If this is the case, no information is transmitted around the loop and the VCO remains at its initial free-running frequency. As the input frequency approaches that of the VCO, the frequency of the difference component decreases and approaches the band edge of the low pass filter. Now some of the difference component is passed, which tends to drive the VCO towards the frequency of the input signal. This, in turn, decreases the frequency of the difference component and allows more information to be transmitted through the low pass filter to the VCO. This is essentially a positive feedback mechanism which causes the VCO to snap into lock

with the input signal. With this mechanism in mind, the term "capture range" can again be defined as the frequency range centered about the VCO initial free-running frequency over which the loop can acquire lock with the input signal. The capture range is a measure of how close the input signal must be in frequency to that of the VCO to acquire lock. The "capture range" can assume any value within the lock range and depends primarily upon the band edge of the low pass filter together with the closed loop gain of the system. It is this signal capturing phenomenon which gives the loop its frequency selective properties.

It is important to distinguish the "capture range" from the "lock range" which can, again, be defined as the frequency range usually centered about the VCO initial free-running frequency over which the loop can track the input signal once lock has been achieved.

When the loop is in lock, the difference frequency component at the output of the phase comparator (error voltage) is dc and will always be passed by the low pass filter. Thus, the lock range is limited by the range of error voltage that can be generated and the corresponding VCO frequency deviation produced. The lock range is essentially a dc parameter and is not affected by the band edge of the low pass filter.

THE CAPTURE TRANSIENT

The capture process is highly complex and does not lend itself to simple mathematical analysis. However, a qualitative description of the capture mechanism may be given as follows. Since frequency is the time derivative of phase, the frequency and the phase errors in the loop can be related as

$$\Delta\omega = \frac{d\theta_e}{dt} \quad (2)$$

ASYNCHRONOUS ERROR BEAT FREQUENCY DURING THE CAPTURE PROCESS:

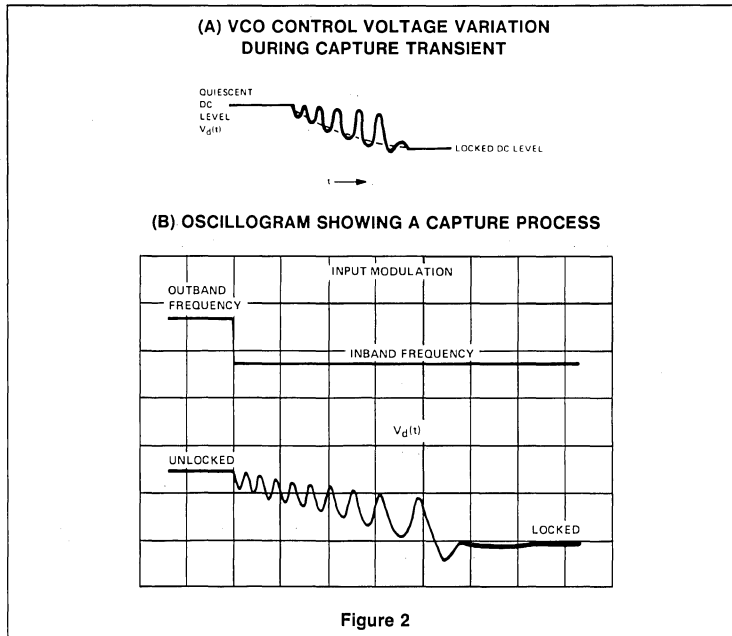

Figure 2

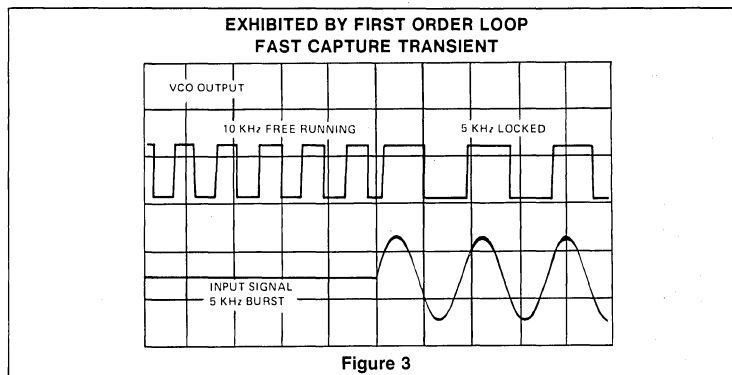

Figure 3

where $\Delta\omega$ is the instantaneous frequency separation between the signal and VCO frequencies and θ_e is the phase difference between the input signal and VCO signals. If the feedback loop of the PLL were opened between the low pass filter and the VCO control input, then for a given condition of ω_o and ω_i the phase comparator output would be a sinusoidal beat note at a fixed frequency $\Delta\omega$. If ω_j and ω_o were sufficiently close in frequency, this beat note would appear at the filter output with negligible attenuation.

Now suppose that the feedback loop is closed by connecting the low pass filter output to the VCO control terminal. The VCO frequency will be modulated by the beat note. When this happens, $\Delta\omega$ itself will become a function of time. If during this modulation process, the VCO frequency moves closer to ω_i (i.e., decreasing $\Delta\omega$), then $\frac{d\theta_e}{dt}$ decreases and the output of the phase comparator becomes a slowly varying function of time. Similarly, if the VCO is modulated away from ω_i , $\frac{d\theta_e}{dt}$ increases

and the error voltage becomes a rapidly varying function of time. Under this condition the beat note waveform no longer looks sinusoidal; it looks like a series of aperiodic cusps, depicted schematically in Figure 2(a). Because of its asymmetry, the beat note waveform contains a finite dc component that pushes the average value of the VCO toward ω_i , and lock is established. When the system is in lock, $\Delta\omega$ is equal to zero and only a steady-state dc error voltage remains.

Figure 2(b) displays an oscillogram of the loop error voltage $V_d(t)$ in an actual PLL system during the capture process. Note that as lock is approached, $\Delta\omega$ is reduced, the low pass filter attenuation becomes less, and the amplitude of the beat note increases.

The total time taken by the PLL to establish lock is called the *pull-in time*. Pull-in time depends on the initial frequency and phase differences between the two signals as well as on the overall loop gain and the low pass filter bandwidth. Under certain conditions, the pull-in time may be shorter than the period of the beat note and the loop can lock without an oscillatory error transient.

A specific case to illustrate this is shown in Figure 3. The 565 PLL is shown acquiring lock within the first cycle of the input signal. The PLL was able to capture in this short time because it was operated as a first order loop (no low pass filter) and the input tone-burst frequency was within its lock and capture range.

EFFECT OF THE LOW PASS FILTER

In the operation of the loop, the low pass filter serves a dual function:

First, by attenuating the high frequency error components at the output of the phase comparator, it enhances the interference-rejection characteristics; second, it provides a short-term memory for the PLL and ensures a rapid recapture of the signal if the system is thrown out of lock due to a noise transient. Decreasing the low pass filter bandwidth has the following effects on system performance: (Long Time Constant).

- a The capture process becomes slower, and the pull-in time increases.
- b The capture range decreases.
- c Interference-rejection properties of the PLL improve since the error voltage caused by an interfering frequency is attenuated further by the low pass filter.
- d The transient response of the loop (the response of the PLL to sudden changes of the input frequency within the capture range) becomes underdamped.

The last effect also produces a practical limitation on the low pass loop filter bandwidth and roll-off characteristics from a stability standpoint. These points will be explained further in the following analysis.

MATHEMATICALLY DEFINING PLL OPERATION

As mentioned previously, the phase comparator is basically an analog multiplier that forms the product of an RF input signal, $v_i(t)$, and the output signal, $v_o(t)$, from the VCO. Refer to Figure 1 and assume that the two signals to be multiplied can be described by

$$v_i(t) = V_i \sin \omega_i t \tag{3}$$

$$v_o(t) = V_o \sin (\omega_o t + \theta_e) \tag{4}$$

where ω_i , ω_o , and θ_e are the frequency and phase difference (or phase error) characteristics of interest. The product of these two signals is an output voltage given by

$$v_e(t) = K_1 V_i V_o (\sin \omega_i t) [\sin (\omega_o t + \theta_e)] \tag{5}$$

where K_1 is an appropriate dimensional constant. Note that the amplitude of $v_e(t)$ is directly proportional to the amplitude of the input signal V_i . The two cases of an unlocked loop ($\omega_i \neq \omega_o$) and of a locked loop ($\omega_i = \omega_o$) are now considered separately.

Unlocked State ($\omega_i \neq \omega_o$)

When the two frequencies to the phase comparator are not synchronized, the loop is not locked. Furthermore the phase angle difference θ_e in Equations 4 and 5 is meaningless for this case since it can be eliminated by appropriately choosing the time origin.

Using trigonometric identities, Equation 5 can be rewritten as

$$v_e(t) = \frac{K_1 V_i V_o}{2} [\cos(\omega_i - \omega_o)t - \cos(\omega_i + \omega_o)t] \tag{6}$$

When $v_e(t)$ is passed through the low pass filter, $F(s)$, the sum frequency component is removed, leaving

$$v_f(t) = K_2 V_i V_o \cos (\omega_i - \omega_o)t \tag{7}$$

where K_2 is a constant. After amplification, the control voltage for the VCO appears as

$$v_d(t) = AK_2 V_i V_o \cos (\omega_i - \omega_o)t \tag{8}$$

This equation shows that a beat frequency effect is established between ω_i and ω_o , causing the VCO's frequency to deviate by $\pm \Delta\omega$ from ω_o' in proportion to the signal amplitude ($AK_2 V_i V_o$) passing through the filter. If the amplitude of V_i is sufficiently large and if signal limiting or saturation does not occur, the VCO output frequency

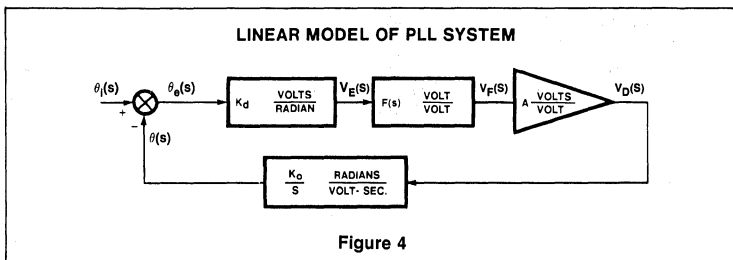

Figure 4

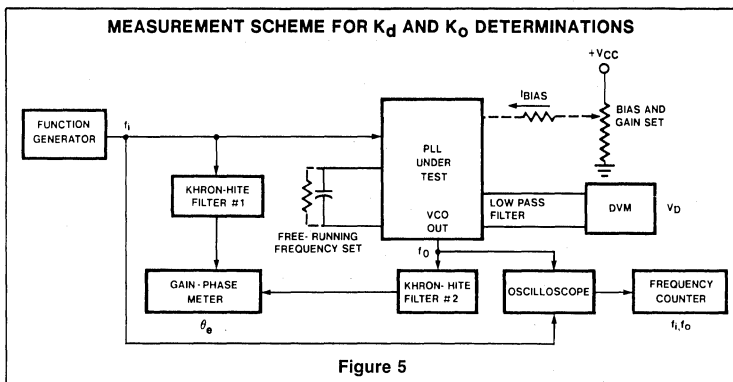

Figure 5

will be shifted from ω_o' by some $\Delta\omega$ until lock is established where

$$\omega_i = \omega_o = \omega_o' \pm \Delta\omega \tag{9}$$

If lock cannot be established, then either V_i is too small to drive the VCO to produce the necessary $\pm \Delta\omega$ deviation or ω_i is beyond the dynamic range of the VCO, i.e., $\omega_i \gg \omega_o \pm \Delta\omega$. Remedies for these no lock conditions are:

- 1 Increase V_i either internally or externally to the loop by providing additional amplification.
- 2 Increase the internal loop gain by adjusting upward (larger -3dB frequency) the response of the low-pass filter.
- 3 Shift ω_o' closer to the expected ω_i . Establishing frequency lock leads to the second case where $\omega_i = \omega_o$.

Locked State ($\omega_i = \omega_o$)

When ω_i and ω_o are frequency synchronized, the output signal from the phase comparator for $\omega_i = \omega_o = \omega$ and a phase shift of θ_e is

$$v_e(t) = K_1 V_i V_o (\sin \omega t) (\sin \omega t + \theta_e) = \frac{K_1 V_i V_o}{2} [\cos \theta_e - \cos (2\omega t + \theta_e)] \tag{10}$$

The low pass filter removes the high frequency, ac component of $v_e(t)$, leaving only the dc component. Thus,

$$v_f(t) = K_2 V_i V_o \cos \theta_e \tag{11}$$

After amplification the dc voltage driving the VCO and maintaining lock within the loop is

$$v_d(t) = V_D = AK_2 V_i V_o \cos \theta_e \tag{12}$$

Suppose ω_i and ω_o are perfectly synchronized to the free-running frequency ω_o' . For this case, V_D will be zero, indicating that θ_e must be $\pm 90^\circ$. Thus V_D is proportional to the phase difference or phase error between θ_i and θ_o centered about a reference phase angle of $\pm 90^\circ$. If ω_i changes slightly from ω_o' , the first effect will be a change in θ_e from $\pm 90^\circ$. V_D will adjust and settle out to some nonzero value to correct ω_o' ; under this condition frequency lock is maintained with $\omega_i = \omega_o$. The phase error will be shifted by some amount $\Delta\theta$ from the reference phase angle of $\pm 90^\circ$. This concept can be simplified by redefining θ_e as

$$\theta_e = \theta_r \pm \Delta\theta \tag{13}$$

where θ_r is the inherent, reference phase shift of $\pm 90^\circ$ and $\Delta\theta$ is the departure from this reference value. Now the VCO control voltage becomes

$$V_D = AK_2 V_i V_o \cos (\theta_r \pm \Delta\theta) = \pm AK_2 V_i V_o \sin \Delta\theta \tag{14}$$

Since the sine function is odd, a momentary change in $\Delta\theta$ contains information about

which way to adjust the VCO frequency to correct and maintain the locked condition. The maximum range over which $\Delta\theta$ changes can be tracked is -90° to $+90^\circ$. This corresponds to a θ_e range from 0 to 180° .

In addition to being an error signal, V_D represents the demodulated output of an FM input applied as $v_{in}(t)$ assuming a linear VCO characteristic. Thus FM demodulation can be accomplished with the PLL without the inductively tuned circuits that are employed with conventional detectors.

DETERMINING PLL MODEL PARAMETERS

Since the PLL is basically an electronic servo loop, many of the analytical techniques developed for control systems are applicable to phase locked systems. Whenever phase lock is established between $v_i(t)$ and $v_o(t)$ the linear model of Figure 4 can be used to predict the performance of the PLL system. Here θ_i and θ_o represent the phase angles associated with the input output waveshapes respectively; $F(s)$ represents a generalized voltage transfer function for the low pass filter in the s complex frequency domain; and K_d and K_o are conversion gains of the phase comparator and VCO respectively, each having units as shown. The $1/s$ term associated with the VCO accounts for the inherent 90° phase shift in the loop since the VCO converts a voltage to a frequency and since phase is the integral of frequency. Thus the VCO functions as an integrator in the feedback loop.

Specific values of K_d and K_o for all of Signetics general purpose PLLs can be found in the sections describing the particular loop of interest. However, sometimes it may be desired to determine these conversion gains exactly for a specific device. The measurement scheme shown in Figure 5 can be used to determine K_d and K_o for a loop under lock. The function of the Khron-Hite filters is to extract the fundamental sinusoidal frequency component of their square wave inputs for application to the Gain-Phase Meter. If the input signal from the Function Generator is sinusoidal, then the first Khron-Hite filter may be eliminated. It is recommended to use high impedance oscilloscope probes so as to not distort the input of VCO waveshapes, thereby potentially altering their phase relationships. The frequency counter can be driven from the scope as shown, or connected directly to the input or VCO provided its input impedance is large.

The procedure to follow for obtaining K_d and K_o is as follows:

- 1 Established the desired external bias and gain conditions for the PLL under test.

- 2 With the Function Generator turned off, set the free-running frequency of the loop via the timing capacitor and timing resistor if appropriate. Monitor f_o' with the Frequency Counter.
- 3 Turn on the Function Generator and check to make sure the amplitude of the input signal is appropriate for the particular loop under test.
- 4 Adjust the input frequency for lock. Lock is discernable on a dual-trace scope when the input and VCO waveforms are synchronized and stationary with respect to each other. One should be especially careful to check that locking has not occurred between the VCO and some harmonic frequency. Carefully inspect both waveshapes, making sure each has the same period. (If a second Frequency Counter is available, an alternate scheme can be used to confirm frequency locking. One frequency counter is used to monitor the input signal frequency, and the second counter is used for the VCO frequency. When the two counters display the same frequency, the PLL is locked).
- 5 Set the input frequency to the free-running frequency and note the Gain-Phase Meter display. It should be approximately 90° , $\pm 10^\circ$ nominally. Record the phase error, θ_e , the VCO control voltage, V_D , and the input frequency, f_i .
- 6 Adjust f_i for frequencies above and below f_o' and record θ_e and V_D for each f_i as appropriate.
- 7 Making a plot of V_D versus θ_e is useful for checking the measurement data and the systems linearity. The slope of this plot ($\Delta V_D / \Delta \theta_e$) is K_d in units of volts/degree. Multiplying this slope by $180/\pi$ gives the desired K_d in volts/radian.
- 8 A plot of $f_i = f_o$ versus V_D while the loop remains locked will check the VCO linearity. The slope of this plot is K_o at the particular free-running frequency. The units of slope taken directly from the graph are Hz/volt. Multiplying this slope figure by 2π gives the desired K_o in units of radians/volt-sec.

K_d is generally constant over wide frequency ranges, but is linearly related to the input signal amplitude. K_o is constant with input signal level but does vary linearly with f_o' . Often it is convenient to specify a normalized K_o as

$$K_o(\text{norm}) = \frac{K_o}{f_o'} \frac{\text{radians}}{\text{volt}} \quad (15)$$

The K_o value at any desired free-running frequency then can be estimated as

$$K_o (@ \text{ any } f_o') = K_o(\text{norm}) f_o' \quad (16)$$

The loop gain for the PLL system is

$$K_v = K_d K_o A \quad (17)$$

(Often when the gain A is due to an amplifier internal to the IC, A will be included in either K_d or K_o . This is further illustrated in the article on the 565 PLL.

MODELING THE PLL SYSTEM WITH VARIOUS LOW PASS FILTERS

The open loop transfer function for the PLL is

$$T(s) = \frac{K_v F(s)}{s} \quad (18)$$

Using linear feedback analysis techniques, the closed loop transfer characteristics $H(s)$ can be related to the open loop performance as

$$H(s) = \frac{T(s)}{1+T(s)} \quad (19)$$

and the roots of the characteristic system polynomial can be readily determined by root-locus techniques.

From these equations, it is apparent that the transient performance and frequency response of the loop is heavily dependent upon the choice of filter and its corresponding transfer characteristic, $F(s)$.

Zero Order Filter - $F(s) = 1$

The simplest case is that of the first order loop where $F(s) = 1$ (no filter). The closed loop transfer function then becomes

$$T(s) = \frac{K_v}{s + K_v} \quad (20)$$

This transfer function gives the root locus as a function of the total loop gain K_v , and the corresponding frequency response shown in Figure 6(a). The open loop pole at the origin is due to the integrating action of the VCO. Note that the frequency response is actually the amplitude of the difference frequency component versus modulating frequency when the PLL is used to track a frequency modulated input signal. Since there is no low pass filter in this case, sum frequency components are also present at the phase comparator output and must be filtered outside of the loop if the difference frequency component (demodulated FM) is to be measured.

First Order Filter

With the addition of a single pole low pass filter $F(s)$ of the form

$$F(s) = \frac{1}{1+\tau_1 s} \quad (21)$$

where $\tau_1 = R_1 C_1$, the PLL becomes a second order system with the root locus shown in Figure 6(b). Again an open loop pole is located at the origin because of the integrating action of the VCO. Another open loop pole is positioned on the real axis at $-1/\tau_1$ where τ_1 is the time constant of the low pass filter.



One can make the following observations from the root locus characteristics of Figure 6(b):

- a As the loop gain K_V increases for a given choice of τ_1 , the imaginary part of the closed loop poles increase; thus, the natural frequency of the loop increases and the loop becomes more and more under-damped.
- b If the filter time constant is increased, the real part of the closed loop poles becomes smaller and the loop damping is reduced.

As in any practical feedback system, excess shifts or non-dominant poles associated with the blocks within the PLL can cause the root loci to bend toward the right half plane as shown by the dashed line in Figure 6(b). This is likely to happen if either the loop gain or the filter time constant is too large and may cause the loop to break into sustained oscillations.

First Order Lag-Lead Filter

The stability problem can be eliminated by using a lag-lead type of filter, as indicated in Figure 6(c). This type of a filter has the transfer function

$$F(s) = \frac{1 + \tau_2 s}{1 + (\tau_1 + \tau_2)s} \tag{22}$$

where $\tau_2 = R_2C$ and $\tau_1 = R_1C$. By proper choice of R_2 , this type of filter confines the root locus to the left-half plane and ensures stability. The lag-lead filter gives a frequency response dependent on the damping, which can now be controlled by the proper adjustment of τ_1 and τ_2 . In practice, this type of filter is important because it allows the loop to be used with a response between that of the first and second order loops and it provides an additional control over the loop transient response. If $R_2 = 0$, the loop behaves as a second order loop and as $R_2 \rightarrow \infty$, the loop behaves as a first order loop due to a pole-zero cancellation. However, as first-order operation is approached, the noise bandwidth increases and interference rejection decreases since the high frequency error components in the loop are now attenuated to a lesser degree.

Second and Higher Order Filters

Second and higher order filters as well as active filters occasionally are designed and incorporated within the PLL to achieve a particular response not possible or easily obtained with zero or first order filters. Adding

more poles and more gain to the closed loop transfer function reduces the inherent stability of the loop. Thus the designer must exercise extreme care and utilize complex stability analysis if second order (and higher) filters or active filters are to be considered.

CALCULATING LOCK AND CAPTURE RANGES

In terms of the basic gain expression in the system, the lock range of the PLL ω_L can be shown to be numerically equal to the dc loop gain (2 sided lock range).

$$2\omega_L = 4\pi F(0) = 2K_V F(0) \tag{23}$$

where $F(0)$ is the value of the low pass filters transfer function at dc.

Since the capture range ω_C denotes a transient condition, it is not as readily derived as the lock range. However, an approximate expression for the capture range can be written as (2 sided capture range).

$$2\omega_C = 4\pi fC \approx 2K_V |F(j\omega_C)| \tag{24}$$

where $F(j\omega_C)$ is the magnitude of the low pass filter transfer function evaluated at ω_C . Solution of Equation 24 frequently involves a "trial and error" process since the capture range is a function of itself. *Note that at all times the capture range is smaller than the lock range.*

For the simple first-order lag filter of Figure 6(b) the capture range can be approximated as

$$2\omega_C \approx 2\sqrt{\frac{\omega_L}{\tau_1}} = 2\sqrt{\frac{K_V}{\tau_1}} \tag{25}$$

This approximation is valid for

$$\tau_1 \gg \frac{1}{2\omega_L} \tag{26}$$

Equations 23 and 24 show that the capture range increases as the low pass filter time constant is decreased, whereas the lock range is unaffected by the filter and is determined solely by the loop gain.

Figure 7 shows the typical frequency-to-voltage transfer characteristics of the PLL. The input is assumed to be a sine wave whose frequency is swept slowly over a broad frequency range. The vertical scale is the corresponding loop error voltage. In Figure 7(a), the input frequency is being gradually increased. The loop does not respond to the signal until it reaches a frequency ω_1 , corresponding to the lower edge of the capture range. Then, the loop suddenly locks on the input and causes a negative jump of the loop error voltage. Next, V_d varies with frequency with a slope equal to the reciprocal of VCO conversion gain ($1/K_C$) and goes through zero as $\omega_i = \omega_o'$. The loop tracks the input until the input frequency reaches ω_2 , corresponding to

the upper edge of the lock range. The PLL then loses lock and the error voltage drops to zero. If the input frequency is swept slowly back, the cycle repeats itself, but is inverted, as shown in Figure 7(b). The loop recaptures the signal at ω_3 and tracks it down to ω_4 . The total capture and lock ranges of the system are:

$$2\omega_C = \omega_3 - \omega_1 \tag{27}$$

and

$$2\omega_L = \omega_2 - \omega_4 \tag{28}$$

Note that, as indicated by the transfer characteristics of Figure 7, the PLL system has an inherent selectivity about the free-running frequency, ω_o' . It will respond only to the input signal frequencies that are separated from ω_o' by less than ω_C or ω_L , depending on whether the loop starts with or without an initial lock condition. The linearity of the frequency-to-voltage conversion characteristics for the PLL is determined solely by the VCO conversion gain. Therefore, in most PLL applications, the VCO is required to have a highly linear voltage-to-frequency transfer characteristic.

DETERMINING LOOP RESPONSE

The transient response of a PLL can be calculated using the model of Figure 4 and Equations 18 and 19 as starting points. Combining these equations gives

$$H(s) = \frac{\theta_o(s)}{\theta_i(s)} = \frac{K_V F(s)}{s + K_V F(s)} \tag{29}$$

The phase error which keeps the system in lock is

$$\theta_e(s) = \theta_i(s) - \theta_o(s) \tag{30}$$

Define a phase error transfer function

$$E(s) = \frac{\theta_e(s)}{\theta_i(s)} = 1 - \frac{\theta_o(s)}{\theta_i(s)} = 1 - H(s) \tag{31}$$

As an example of the utilization of these equations, consider the most common case of a loop employing a simple first-order lag filter where

$$F(s) = \frac{1}{1 + s\tau_1} \tag{32}$$

For this filter, Equations 29 and 31 become

$$H(s) = \frac{K_V/\tau_1}{s^2 + s/\tau_1 + K_V/\tau_1} \tag{33}$$

$$E(s) = \frac{s(s + 1/\tau_1)}{s^2 + s/\tau_1 + K_V/\tau_1} \tag{34}$$

Both equations are second order and have the same denominator which can be expressed as

$$D(s) = s^2 + s/\tau_1 + K_V/\tau_1 = s^2 + 2\zeta\omega_n s + \omega_n^2 \tag{35}$$

where ω_n and ζ are respectively the systems undamped natural frequency and damping factor defined as

$$\omega_n = \sqrt{K_V/\tau_1} \tag{36}$$

ROOT LOCUS AND FREQUENCY RESPONSE PLOTS

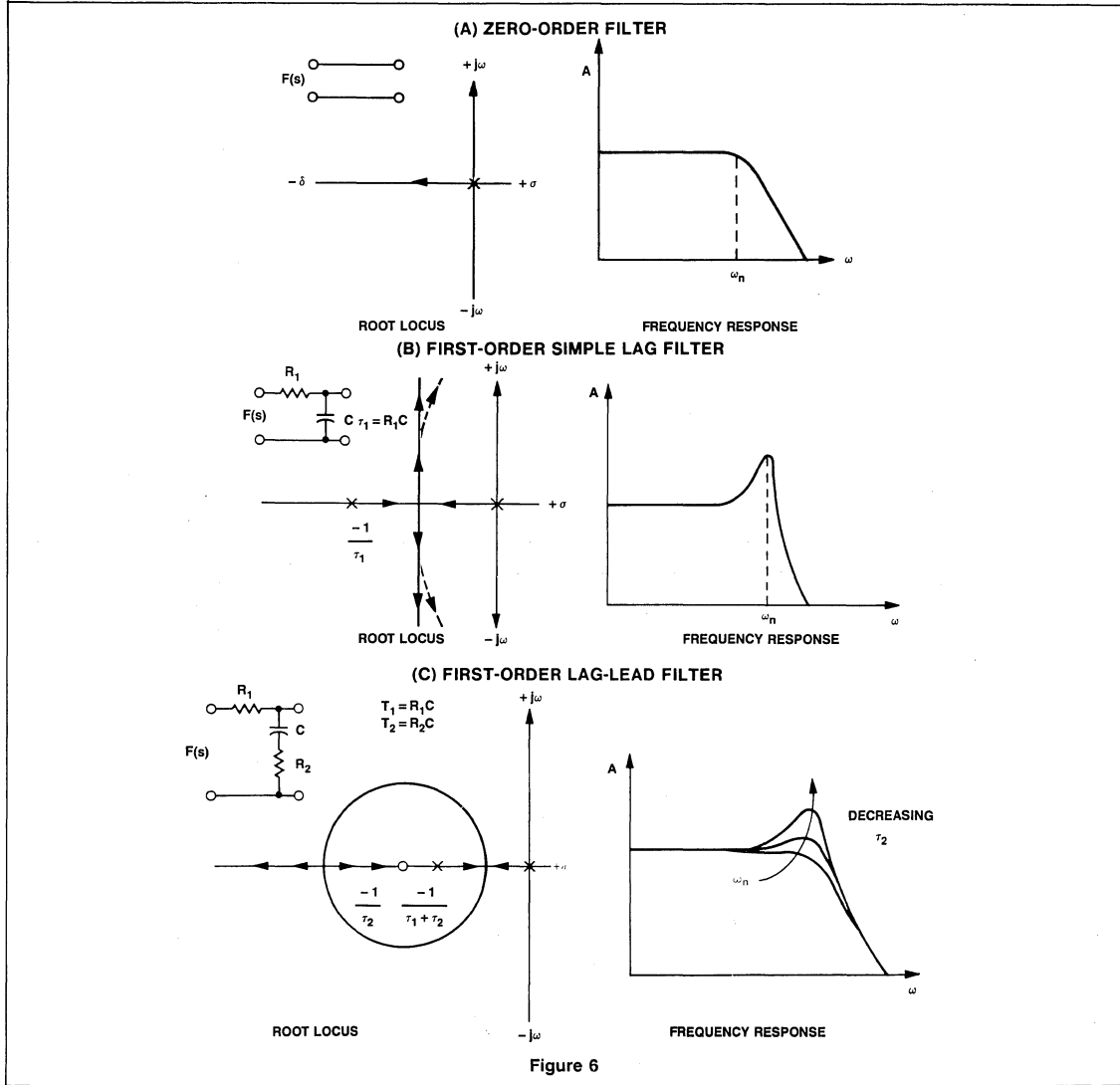

Figure 6

$$\zeta = \frac{1}{2\sqrt{K_V\tau_1}} = \frac{\omega_n}{2K_V} \quad (37)$$

The system is considered overdamped for $\zeta > 1.0$, and critically damped $\zeta = 1.0$.

Now examine this PLL systems response to various types of inputs.

Step of Phase Input

Consider a unit step of phase as the input signal. This input is shown in Figure 8 and can be thought of as simply shifting the time axis by a unit step (one radian or one degree

depending upon the working units) while maintaining the same input frequency. Mathematically this input has the form

$$\Theta_i(s) = \frac{1}{s} \quad (38)$$

The phase of VCO output and the systems phase error are represented by

$$\Theta_o(s) = \frac{H(s)}{s} = \frac{\omega_n^2}{s(s^2 + 2\zeta\omega_n s + \omega_n^2)} \quad (39)$$

$$\Theta_e(s) = \frac{E(s)}{s} = \frac{s + 2\zeta\omega_n}{s^2 + 2\zeta\omega_n s + \omega_n^2} \quad (40)$$

depending upon the working units) while maintaining the same input frequency. Mathematically this input has the form

$$\Theta_o(t) = 1 + \frac{e^{-\zeta\omega_n t}}{\sqrt{1 - \zeta^2}} \sin(\omega_n t \sqrt{1 - \zeta^2} + \Psi) \quad (41)$$

$$\text{where } \Psi = \arctan \frac{\sqrt{1 - \zeta^2}}{\zeta} \quad (42)$$

and $\zeta \neq 1$.

$$\Theta_e(t) = \frac{e^{-\zeta\omega_n t}}{\sqrt{1 - \zeta^2}} \sin(\omega_n t \sqrt{1 - \zeta^2} + \Psi) \quad (43)$$



TYPICAL PLL FREQUENCY-TO-VOLTAGE TRANSFER CHARACTERISTICS

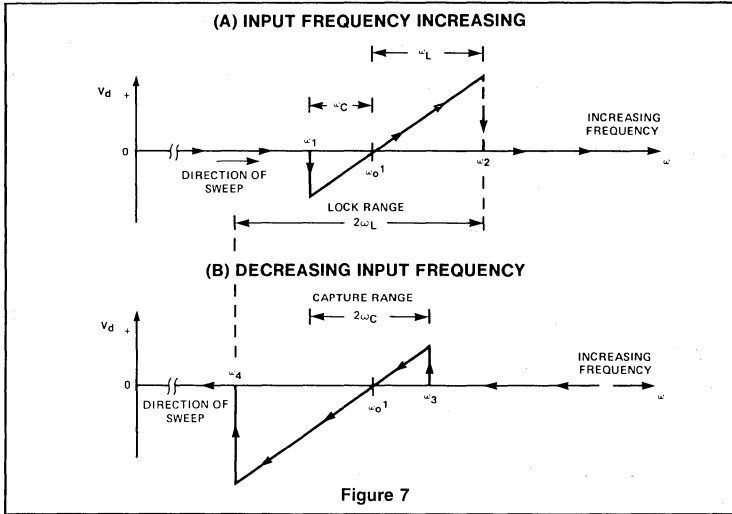

Figure 7

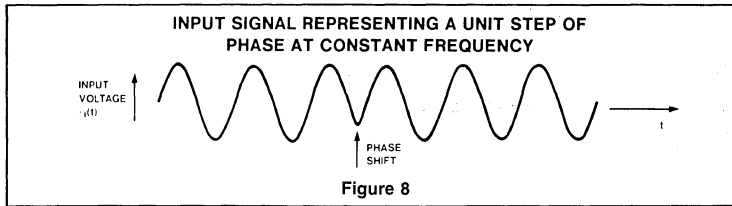

Figure 8

When $\zeta = 1$, these phase responses are

$$\theta_o(t) = 1 - (1 - \omega_n t)e^{-\omega_n t} \quad (44)$$

and

$$\theta_e(t) = (1 + \omega_n t)e^{-\omega_n t} \quad (45)$$

Figure 9 is a plot of the VCO phase response and the phase error transient for various damping factors. Note from this figure that an under-damped system has overshoot which can cause the loop to break lock if this overshoot is too large. The critical condition for maintaining lock is to keep the phase error within the dynamic range for the phase comparator of $-\pi/2$ to $\pi/2$ radians. For the under-damped case, the peak phase-error overshoot is

$$\theta_{e(max)} = e^{-\zeta\pi/\sqrt{1-\zeta^2}} \quad (46)$$

which must be less than $\pi/2$ to maintain lock. Lock can also be broken for the over-damped and critically-damped loops if the input phase shift is too large where the phase error exceeds $\pm\pi/2$ radians.

The analysis and equations given are based upon the small-signal model of Figure 4. If the

signal amplitudes become too large, one or more functional blocks in the system can saturate, causing a slow-rate type limiting action that may break lock.

The transient change in the VCO frequency due to the unit step of phase input can be found by taking the time derivative of Equation 41 or alternatively by finding the inverse Laplace transform of

$$\omega_o(s) = s\theta_o(s) = \frac{\omega_n^2}{s^2 + 2\zeta\omega_n s + \omega_n^2} \quad (47)$$

which is

$$\omega_o(t) = \frac{\omega_n e^{-\zeta\omega_n t}}{\sqrt{1-\zeta^2}} \sin \omega_n t \sqrt{1-\zeta^2} \quad (48)$$

Unit Step of Frequency Input

This type of input occurs when the input frequency is instantaneously changed from one frequency to another as is done in FSK and modem applications. For this input as shown in Figure 10,

$$\theta_i(s) = \frac{1}{s^2} \quad (49)$$

The VCO output phase is

$$\theta_o(s) = \frac{\omega_n^2}{s^2(s^2 + 2\zeta\omega_n s + \omega_n^2)} \quad (50)$$

The transient time expression for the VCO phase change is

$$\theta_o(t) = t - \frac{2\zeta}{\omega_n} + \frac{e^{-\zeta\omega_n t}}{\omega_n \sqrt{1-\zeta^2}} \sin(\omega_n t \sqrt{1-\zeta^2} + 2\Psi) \quad (51)$$

for $\zeta \neq 1$.

The time expression for the VCO frequency change for a unit step of frequency input is the same as the time response VCO phase change due to a step of phase input (Equation 41), or

$$\omega_o(t) \text{ for frequency step input} = \theta_o(t) \text{ for step input}$$

for step input

$$\omega_o(t) = 1 + \frac{e^{-\zeta\omega_n t}}{\sqrt{1-\zeta^2}} \sin(\omega_n t \sqrt{1-\zeta^2} + \Psi) \quad (52)$$

for $\zeta \neq 1$.

Unit Ramp of Frequency Input

This form of input signal represents sweeping the input frequency at a constant rate and direction as shown in Figure 11. The amplitude and phase of the input remain constant; the input frequency changes linearly with time. Since the input signal to the PLL model is a phase, a unit ramp of frequency appears as a phase acceleration type input that can be mathematically described as

$$\theta_i(s) = \frac{1}{s^3} \quad (53)$$

The VCO output phase change is

$$\theta_o(s) = \frac{\omega_n^2}{s^3(s^2 + 2\zeta\omega_n s + \omega_n^2)} \quad (54)$$

The time expression for the VCO phase change is

$$\theta_o(t) = \frac{t^2}{2} - \frac{2\zeta t}{\omega_n} + \frac{2\zeta}{\omega_n^2} \left[2\zeta(1 - \omega_n^2) + \left(\frac{1 - 4\zeta^2\omega_n^2 + 4\zeta^2\omega_n^4}{1 - \zeta^2} \right)^{1/2} \times e^{-\zeta\omega_n t} \sin(\omega_n t \sqrt{1 - \zeta^2} + \Psi') \right] \quad (55)$$

where $\Psi' = \arctan \frac{\sqrt{1-\zeta^2}}{\zeta(1-2\omega_n^2)} + \Psi$

and Ψ is given in Equation 42.

PLL BUILDING BLOCKS
VCO

Since three different forms of VCO have been used in the Signetics PLL series, the VCO details will not be discussed until the individual loops are described. However, a few general comments about VCOs are in order.

When the PLL is locked to a signal, the VCO voltage is a function of the frequency of the input signal. Since the VCO control voltage is the demodulated output during FM demodulation, it is important that the VCO voltage-to-frequency characteristic be lin-

ear so that the output is not distorted. Over the linear range of the VCO, the conversion gain is given by K_G (in radian/volt-sec)

$$k_o = \frac{\Delta\omega_o}{\Delta V_d} \quad (56)$$

Since the loop output voltage is the VCO voltage, we can get the loop output voltage as

$$\Delta V_d = \frac{\Delta\omega_o}{K_o} \quad (57)$$

The gain K_o can be found from the data sheet. When the VCO voltage is changed, the frequency change is virtually instantaneous.

Phase Comparator

All of Signetics analog phase locked loops use the same form of phase comparator - often called the doubly-balanced multiplier or mixer. Such a circuit is shown in Figure 12.

The input stage formed by transistors Q1 and Q2 may be viewed as a differential amplifier

which has an equivalent collector resistance R_c and whose differential gain at balance is the ratio of R_c to the dynamic emitter resistance, $r_{e'}$ of Q1 and Q2.

$$A_d = \frac{R_c}{r_{e'}} = \frac{R_c}{\frac{R_c}{|E|/2}} = \frac{R_c |E|}{0.052} \quad (58)$$

where $|E|$ is the total dc bias current for the differential amplifier pair.

The switching stage formed by Q3-Q6 is switched on and off by the VCO square wave. Since the collector current swing of Q2 is the negative of the collector current swing of Q1, the switching action has the effect of multiplying the differential stage output first by +1 and then by -1. That is, when the base of Q4 is positive, R_{c2} receives I_c and when the base of Q6 is positive, R_{c2} receives $i_c = i_c$. Since the circuit is called a multiplier, performing the multiplication will gain further insight into the action of the phase comparator.

Consider an input signal which consists of two added components: a component at frequency ω_i which is close to the free-running frequency and a component at frequency ω_k which may be at any frequency. The input signal is

$$v_i(t) + v_k(t) = V_i \sin(\omega_i t + \theta_i) + V_k \sin(\omega_k t + \theta_k) \quad (59)$$

where θ_i and θ_k are the phase in relation to the VCO signal. The unity square wave developed in the multiplier by the VCO signal is

$$v_o(t) = \sum_{n=0}^{\infty} \frac{4}{\pi(2n+1)} \sin [(2n+1)\omega_o t] \quad (60)$$

where ω_o is the VCO frequency. Multiplying the two terms, using the appropriate trigonometric relationships, and inserting the differential stage gain A_d gives:

$$v_e(t) = \frac{2A_d}{\pi} \left[\sum_{n=0}^{\infty} \frac{V_i}{(2n+1)} \cos [(2n+1)\omega_o t - \omega_i t - \theta_i] - \sum_{n=0}^{\infty} \frac{V_i}{(2n+1)} \cos [(2n+1)\omega_o t + \omega_i t + \theta_i] + \sum_{n=0}^{\infty} \frac{V_k}{(2n+1)} \cos [(2n+1)\omega_o t - \omega_k t - \theta_k] - \sum_{n=0}^{\infty} \frac{V_k}{(2n+1)} \cos [(2n+1)\omega_o t + \omega_k t + \theta_k] \right] \quad (61)$$

Assuming that temporarily V_k is zero, if ω_i is close to ω_o , the first term ($n = 0$) has a low frequency difference frequency component. This is the beat frequency component that feeds around the loop and causes lock up by modulating the VCO. As ω_o is driven closer to ω_i , this difference component becomes lower and lower in frequency until $\omega_o = \omega_i$ and lock is achieved. The first term then becomes

$$v_e(t) = V_E = \frac{2A_d V_i}{\pi} \cos \theta_i \quad (62)$$

which is the usual phase comparator formula showing the dc component of the phase comparator during lock. This component must equal the voltage necessary to keep the VCO at ω_o . It is possible for ω_o to equal ω_i momentarily during the lock up process and, yet, for the phase to be incorrect so that ω_o passes through ω_i without lock being achieved. This explains why lock is usually not achieved instantaneously, even when $\omega_i = \omega_o$ at $t = 0$.

If $n \neq 0$ in the first term, the loop can lock when $\omega_i = (2n+1)\omega_o$, giving the dc phase comparator component

$$V_e(t) = V_E = \frac{2A_d V_i}{\pi(2n+1)} \cos \theta_i \quad (63)$$

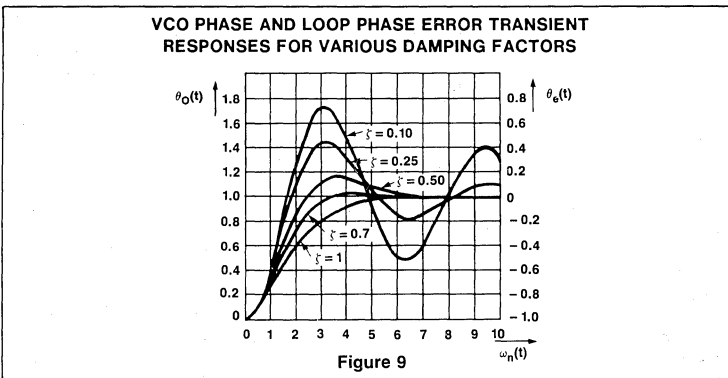

Figure 9

INPUT SIGNAL FOR A UNIT STEP OF FREQUENCY AT CONSTANT PHASE

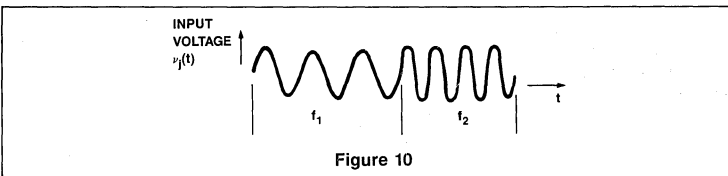

Figure 10

INPUT SIGNAL FOR A UNIT RAMP OF FREQUENCY INPUT

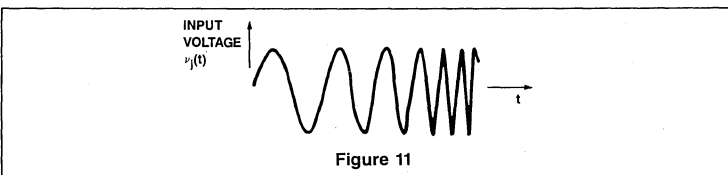

Figure 11



INTEGRATED PHASE COMPARATOR CIRCUIT

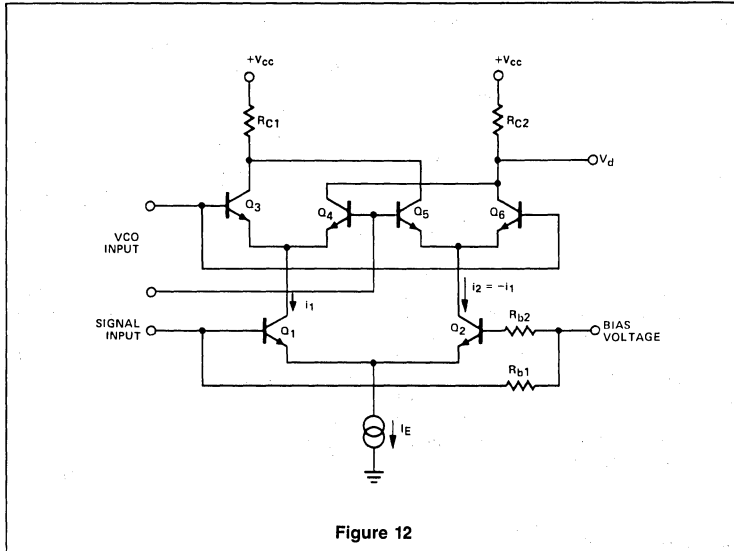

Figure 12

showing that the loop can lock to odd harmonics of the free-running frequency. The $(2n + 1)$ term in the denominator shows that the phase comparators output is lower for harmonic lock, which explains why the lock range decreases as higher and higher odd harmonics are used to achieve lock.

Note also that the phase comparators output during lock (assuming A_d is constant) also a function of the input amplitude V_i . Thus, for a given dc phase comparator output V_E , an input amplitude decrease must be accompanied by a phase change. Since the loop can remain locked only for θ_i between 0 and 180°, the lower V_i becomes, the more the lock range is reduced.

Note from the second term that during lock the lowest possible frequency is $\omega_0 + \omega_i = 2\omega_i$. A sum frequency component is always present at the phase comparator output. This component is usually greatly attenuated by the low pass filter capacitor connected to the phase comparator output. However, when rapid tracking is required (as with high-speed FM detection or FSK-frequency shift keying), the requirement for a relatively high frequency cutoff in the low pass filter may leave this component unattenuated to the extent that it interferes with detection. At the very least, additional filtering may be required to remove this component. Components caused by $n \neq 0$ in the second term are both attenuated and of much higher frequency, so they may be neglected.

Suppose that other frequencies represented by V_k are present. What is their effect for $V_k \neq 0$?

The third term shows that V_k introduces another difference frequency component. Obviously, if ω_k is close to ω_i , it can interfere with the locking process since it may form a beat frequency of the same magnitude as the desired locking beat frequency. However, suppose lock has been achieved so that $\omega_0 = \omega_i$. In order for lock to be maintained, the average phase comparator output must be constant. If $\omega_0 = \omega_k$ is relatively low in frequency, the phase θ_i must change to compensate for this beat frequency. Broadly speaking, any signal in addition to the signal to which the loop is locked causes a phase variation. Usually this is negligible since ω_k is often far removed from ω_i . However, it has been stated that the phase θ_i can move only between 0 and 180°. Suppose the phase limit has been reached and V_k appears. Since it cannot be compensated for, it will drive the loop out of lock. This explains why extraneous signals can result in a decrease in the lock range. If V_k is assumed to be an instantaneous noise component, the same effect occurs. When the full swing of the loop is being utilized, noise will decrease the lock or tracking range. This effect can be reduced by decreasing the cutoff frequency of the low pass filter so that the $\omega_0 - \omega_k$ is attenuated to a greater extent, which illustrates that noise immunity and out-band frequency rejection is improved (at the expense of capture range

since $\omega_0 - \omega_i$ is likewise attenuated) when the low pass filter capacitor is large.

The third term can have a dc component when ω_k is an odd harmonic of the locked frequency so that $(2n + 1)(\omega_0 - \omega_i)$ is zero and θ_k makes its appearance. This will have an effect on θ_i which will change the θ_1 versus frequency ω_1 . This is most noticeable when the waveform of the incoming signal is, for example, a square wave. The θ_k term will combine with the θ_i term so that the phase is a linear function of input frequency. Other waveforms will give different phase versus frequency functions. When the input amplitude V_i is large and the loop gain is large, the phase will be close to 90° throughout the range of VCO swing, so this effect is often unnoticed.

The fourth term is of little consequence except that if ω_k approaches zero, the phase comparator output will have a component at the locked frequency ω_0 at the output. For example, a dc offset at the input differential stage will appear as a square wave of fundamental ω_0 at the phase comparator output. This is usually small and well attenuated by the low pass filter. Since many out-band signals or noise components may be present, many V_k terms may be combining to influence locking and phase during lock. Fortunately, only those close to the locked frequency need be considered.

Quadrature Phase Detector (QPD)

The quadrature phase detector action is exactly the same except that its output is proportional to the sine of the phase angle. When the phase θ_i is 90°, the quadrature phase detector output is then at its maximum, which explains why it makes a useful lock or amplitude detector. The output of the quadrature phase detector is given by

$$V_q = \frac{2A_q V_i}{\pi} \sin \theta_i \tag{64}$$

where V_i is the constant or modulated AM signal and $\theta_i \approx 90^\circ$ in most cases so that $\sin \theta_i = 1$ and

$$V_q = \frac{2A_q V_i}{\pi} \tag{65}$$

This is the demodulation principle of the autodyne receiver and the basis for the 567 tone decoder operation.

INITIAL PLL SETUP CHOICES

In a given application, maximum PLL effectiveness can be achieved if the designer understands the tradeoffs which can be made. Generally speaking, the designer is free to select the frequency, lock range, capture range, and input amplitude.

LOCK-UP TIME AND TRACKING SPEED CONTROL

In tracking applications, lock-up time is normally of little consequence, but occasions do arise when it is desirable to keep lock-up time short to minimize data loss when noise or extraneous signals drive the loop out of lock. Lock-up time is of great importance in tone decoder type applications. Tracking speed is important if the loop is used to demodulate an FM signal. Although the following discussion dwells largely on lock-up time, the same comments apply to tracking speeds.

No simple expression is available which adequately describes the acquisition or lock-up time. This may be appreciated when we review the following factors which influence lock-up time.

- a Input phase
- b Low pass filter characteristic
- c Loop damping
- d Deviation of input frequency from center frequency
- e In-band input amplitude
- f Out-band signals and noise
- g Center frequency

Fortunately, it is usually sufficient to know how to improve the lock-up time and what must be sacrificed to get faster lock-up. Consider an operational loop or tone decoder where occasionally the lock-up transient is too long. What can be done to improve the situation—keeping in mind the factors that influence lock?

- a Initial phase relationship between incoming signal and VCO - This is the greatest single factor influencing the lock time. If the initial phase is wrong, it first drives the VCO frequency away from the input frequency so that the VCO frequency must walk back on the beat notes. Figure 13 gives a typical distribution of lock-up times with the input pulse initiated at random phase. The only way to overcome this variation is to send phase information all the time so that a favorable phase relationship is guaranteed at $t = 0$. For example, a number of PLLs or tone decoders may be weakly locked to low amplitude harmonics of a pulse train and the transmitted tone phase related to the same pulse train. Usually, however, the incoming phase cannot be controlled.
- b Low pass filter - The larger the low pass filter time constant, the longer will be the lock-up time. The lock-up time can be reduced by decreasing the filter time constant, but in doing so, some of the noise immunity and out-band signal rejection will be sacrificed. This is unfortunate

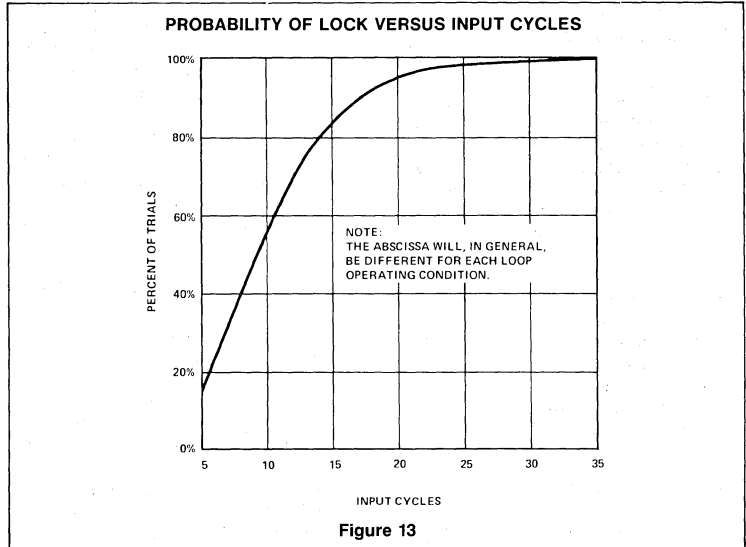

Figure 13

since this is what necessitated the use of a large filter in the first place. Also present will be a sum frequency (twice the VCO frequency) component at the low pass filter and greater phase jitter resulting from out-band signals and noise. In the case of the tone decoder (where control of the capture range is required since it specifies the device bandwidth) a lower value of low pass capacitor automatically increases the bandwidth. Speed is gained only at the expense of added bandwidth.

- c Loop damping - A simple first-order low pass filter of the form

$$F(s) = \frac{1}{1 + s\tau} \tag{66}$$

produces a loop damping of

$$\zeta = \frac{1}{2} \sqrt{\frac{1}{\tau K_V}} \tag{67}$$

Damping can be increased not only by reducing τ , as discussed above, but also by reducing the loop gain K_V . Using the loop gain reduction to control bandwidth or capture and lock ranges achieves better damping for narrow bandwidth operation. The penalty for this damping is that more phase comparator output is required for a given deviation so that phase errors are greater and noise immunity is reduced. Also, more input drive may be required for a given deviation.

- d Input frequency deviation from free-running frequency - Naturally, the further an applied input signal is from the free-running frequency of the loop, the longer it

will take the loop to reach that frequency due to the charging time of the low pass filter capacitor. Usually, however, the effect of this frequency deviation is small compared to the variation resulting from the initial phase uncertainty. Where loop damping is very low, however, it may be predominant.

- e In-band input amplitude - Since input amplitude is one factor in the phase comparators gain K_D and since K_D is a factor in the loop gain K_V , damping is also a function of input amplitude. When the input amplitude is low, the lock-up time may be limited by the rate at which the low pass capacitor can charge with the reduced phase comparator output (see d above).
- f Out-band signals and noise - Low levels of extraneous signals and noise have little effect on the lock-up time, neither improving or degrading it. However, large levels may overdrive the loop input stage so that limiting occurs, at which point the in-band signal starts to be suppressed. The lower effective input level can cause the lock-up time to increase, as discussed in e above.
- g Center frequency - Since lock-up time can be described in terms of the number of cycles to lock, fastest lock-up is achieved at higher frequencies. Thus, whenever a system can be operated at a higher frequency, lock will typically take place faster. Also, in systems where different frequencies are being detected, the higher frequencies on the average will be detected before the lower frequencies.

However, because of the wide variation due to initial phase, the reverse may be true for any single trial.

PLL MEASUREMENT TECHNIQUES

This section deals with measurements of PLL operation. The techniques suggested are meant to help the designer in evaluating the performance of the PLL during the initial setup period as well as to point out some pitfalls that may obscure loop evaluation. Recognizing that the test equipment may be limited, techniques are described which require a minimum of standard test items.

The majority of the PLL tests described can be done with a signal generator, a scope and a frequency counter. Most laboratories have these. A low-cost digital voltmeter will facilitate accurate measurement of the VCO conversion gain. Where the need for a FM generator arises, it may be met in most cases by the VCO of a Signetics PLL. Any of the loops may be set up to operate as a VCO by simply applying the modulating voltage to the low pass filter terminal(s). The resulting generator may be checked for linearity by using the counter to check frequency as a function of modulating voltage. Since the VCOs may be modulated right down to dc, the calibration may be done in steps. Moreover, loop measurements may be made by applying a constant frequency to the loop input and the modulating signal to the low pass filter terminal to simulate the effect of a FM input so that a FM generator may be omitted for many measurements.

FREE-RUNNING FREQUENCY

Free-running frequency measurements are easily made by connecting a frequency counter or oscilloscope to the VCO output of the loop. The loop should be connected in its final configuration with the chosen values of input, bypass, and low pass filter capacitors. No input signal should be present. As the free-running frequency is read out, it can be adjusted to the desired value by the adjustment means selected for the particular loop. It is important not to make the frequency measurement directly at the timing capacitor unless the capacity added by the measurement probe is much less than the timing capacitor value since the probe capacity will then cause a frequency error.

When the frequency measurement is to be converted to a dc voltage for production readout or automated testing, a calibrated phase locked loop can be used as a frequency meter.

CAPTURE AND LOCK RANGES

Figure 14(a) shows a typical measurement

CAPTURE AND LOCK RANGES

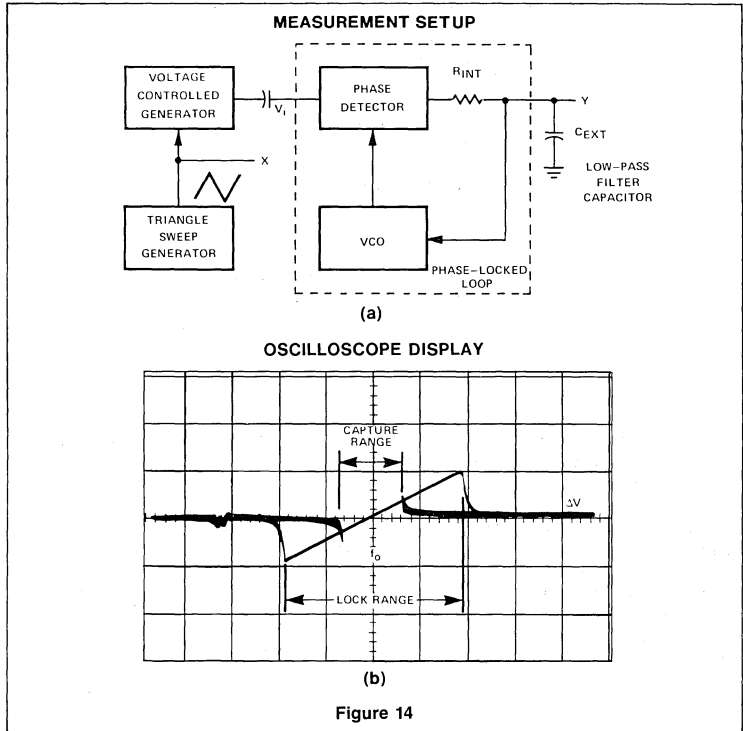

Figure 14

setup for capture and lock range measurements. The signal input from a variable frequency oscillator is swept linearly through the frequency range of interest and the loop FM output is displayed on a scope or (at low frequencies) X-Y recorder. The sweep voltage is applied to the X axis.

Figure 14(b) shows the type of trace which results. The lock range is given by the outer lines on the trace, which are formed as the incoming frequency sweeps away from the center frequency. The inner trace, formed as the frequency sweeps toward the center frequency, designates the capture range. Linearity of the VCO is revealed by the straightness of the trace portion within the lock range. The slope ($\Delta f/\Delta V$) is the conversion gain K_v for the VCO at the particular free-running frequency.

By using the sweep technique, the effect on free-running frequency, capture range, and lock range of the input amplitude, supply voltage, low pass filter and temperature can be examined.

Because of the lock-up time duration and variation, the sweep frequency must be very much lower than the free-running frequency, especially when the capture range is below 10% of the free-running frequency. Otherwise, the apparent capture and lock range will be function of sweep frequency. It is best to start sweeping as slow as possible and, if desired, increase the rate until the capture range begins to show an apparent reduction - indicating that the sweep is too fast. Typical sweep frequencies are in the range of 1/1000 to 1/100,000 of the free-running frequency. In the case of the 567, the quadrature detector output may be similarly displayed on the Y axis, as shown in Figure 15 showing the output level versus frequency for one value of input amplitude.

Capture and lock range measurements may also be made by sweeping the generator manually through the band of interest. Sweeping must be done very slowly as the edges of the capture range are approached (sweeping toward center frequency) or the

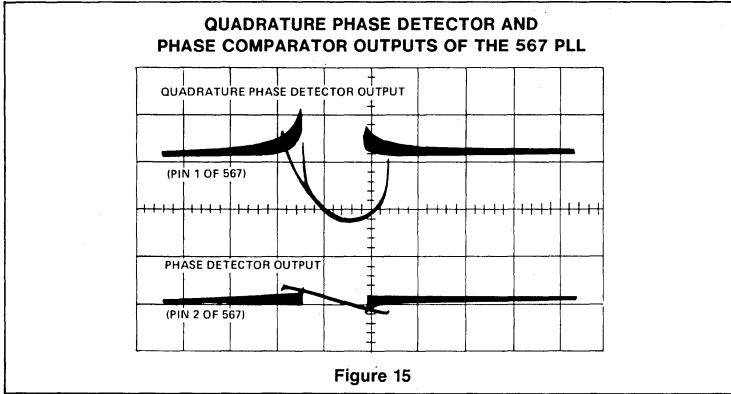

Figure 15

lock-up transient delay will cause an error in reading the band edge. Frequency should be read from the generator rather than the loop VCO because the VCO frequency gyrates wildly around the center frequency just before and after lock. Lock and unlock can be readily detected by simultaneously monitoring the input and VCO signals, the dc voltage at the low pass filter or the ac beat frequency components at the low pass filter. The latter are greatly reduced during lock as opposed to frequencies just outside of lock.

FM AND AM DEMODULATION DISTORTION

These measurements are quite straightforward. The loop is simply setup for FM detection and the test signal is applied to the input. A spectrum analyzer or distortion analyzer (HP333A) can be used to measure distortion at the FM output.

For FM demodulation, the input signal amplitude must be large enough so that lock is not lost at the frequency extremes. The data sheets give the lock (or tracking) range as a function of input signal and the optional range control adjustments. Due to the inherent linearity of the VCOs, it makes little difference whether the FM carrier is at the free-running frequency or offset slightly as long as the tracking range limits are not exceeded.

The faster the FM modulation in relation to the center frequency, the lower the value of the capacitor in the low pass filter must be for satisfactory tracking. As this value decreases, however, it attenuates the sum frequency component of the phase comparator output less. The demodulated signal will appear to have greater distortion unless

this component is filtered out before the distortion is measured.

NATURAL FREQUENCY AND DAMPING

Circuits and mathematical expressions for the natural frequencies and dampings are given in Figure 16 for two, first-order low pass filters. Because of the integrator action of the PLL in converting frequency to phase, the order of the loop always will be one greater than the order of the LPF. Hence both these first order LPFs produce a second order PLL system.

The natural frequency (ω_n) of a loop in its final circuit configuration can be measured by applying a frequency modulated signal of the desired amplitude to the loop. Figure 16 shows that the natural frequency is a function of K_d , which is, in turn, a function of input amplitude. As the modulation frequency (ω_m) is increased, the phase relationship between the modulation and recovered sine wave will go through 90° at $S_m = \omega_n$ and the output amplitude will peak.

Damping is a function of K_d , K_o , and the low pass filter. Since K_o and K_d are functions of the free-running frequency and input amplitude respectively, damping is highly dependent on the particular operating condition of the loop. Damping estimates for the desired operating condition can be made by applying an input signal which is frequency modulated within the lock range by a square wave. The low pass filter voltage is then monitored on an oscilloscope which is synchronized to the modulating waveform, as shown in Figure 17. Figure 18 shows typical waveforms displayed. The loop damping can be estimated by comparing the number and magnitude of the overshoots with the graph of Figure 19 which

gives the transient phase error due to a step in input frequency.

An expression for calculating the damping for any underdamped second-order system ($\zeta < 1.0$) when the normalized peak overshoot is known is

$$M_p = 1 + e^{-\zeta\pi/\sqrt{1-\zeta^2}} \quad (68)$$

Examination of Figure 18 shows that the normalized peak overshoot of the error voltage is approximately 1.4. Using this value for M_p in Equation 68 gives a damping of $\zeta \cong 0.28$.

Another way of estimating damping is to make use of the frequency response plot measured for the natural frequency (ω_n) measurement. For low damping constants, the frequency response measurement peak will be a strong function of damping. For high damping constants, the 3dB-down point will give the damping. Figure 19 tabulates some approximate relationships.

NOISE

The effect of input noise on loop operation is very difficult to predict. Briefly, the input noise components near the center frequency are converted to phase noise. When the phase noise becomes so great that the $\pm 90^\circ$ permissible phase variation is exceeded, the loop drops out of lock or fails to acquire lock. The best technique is to actually apply the anticipated noise amplitude and bandwidth to the input and then perform the capture and lock range measurements as well as perform operating tests with the anticipated input level and modulation deviations. By including a small safety factor in the loop design to compensate for small processing variations, satisfactory operation can be assured.

FIRST ORDER LOW PASS FILTERS

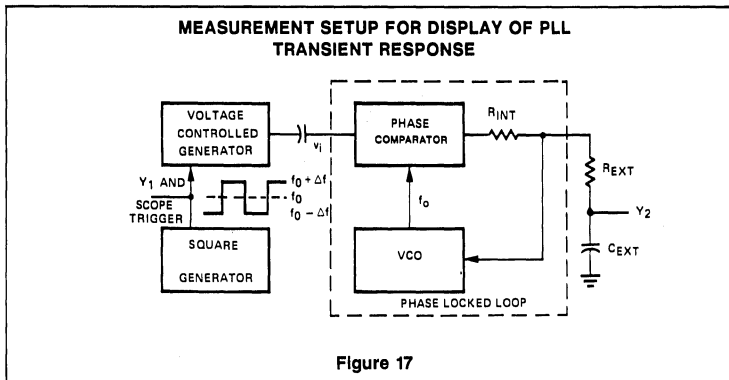
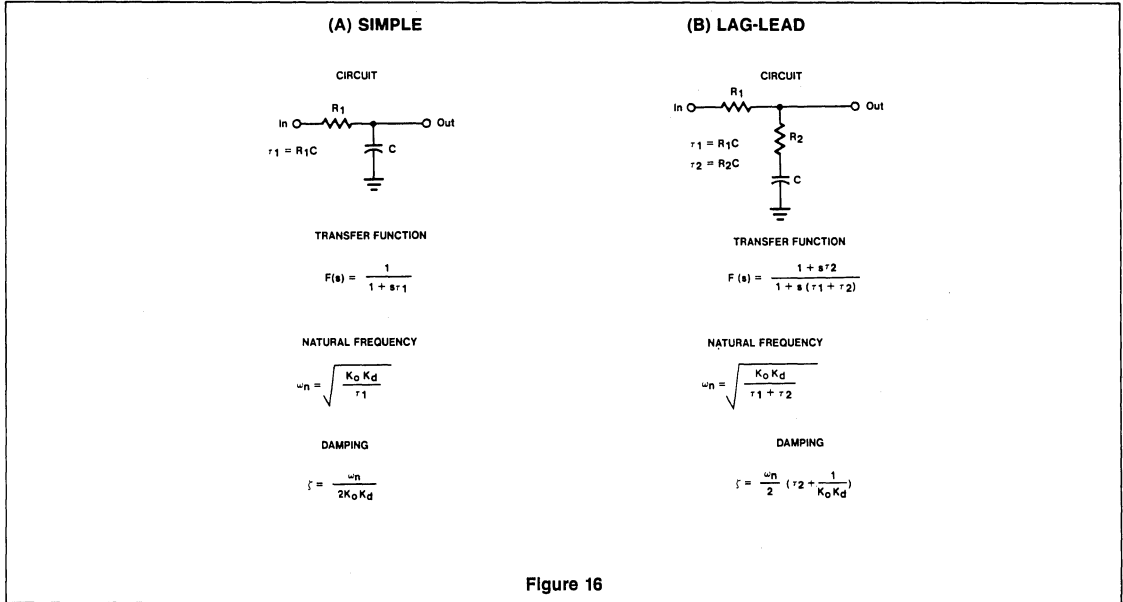

TRANSIENT RESPONSE OF PLL ERROR VOLTAGE TO SQUARE WAVE FREQUENCY MODULATION FOR VARIOUS DAMPING CONDITIONS:

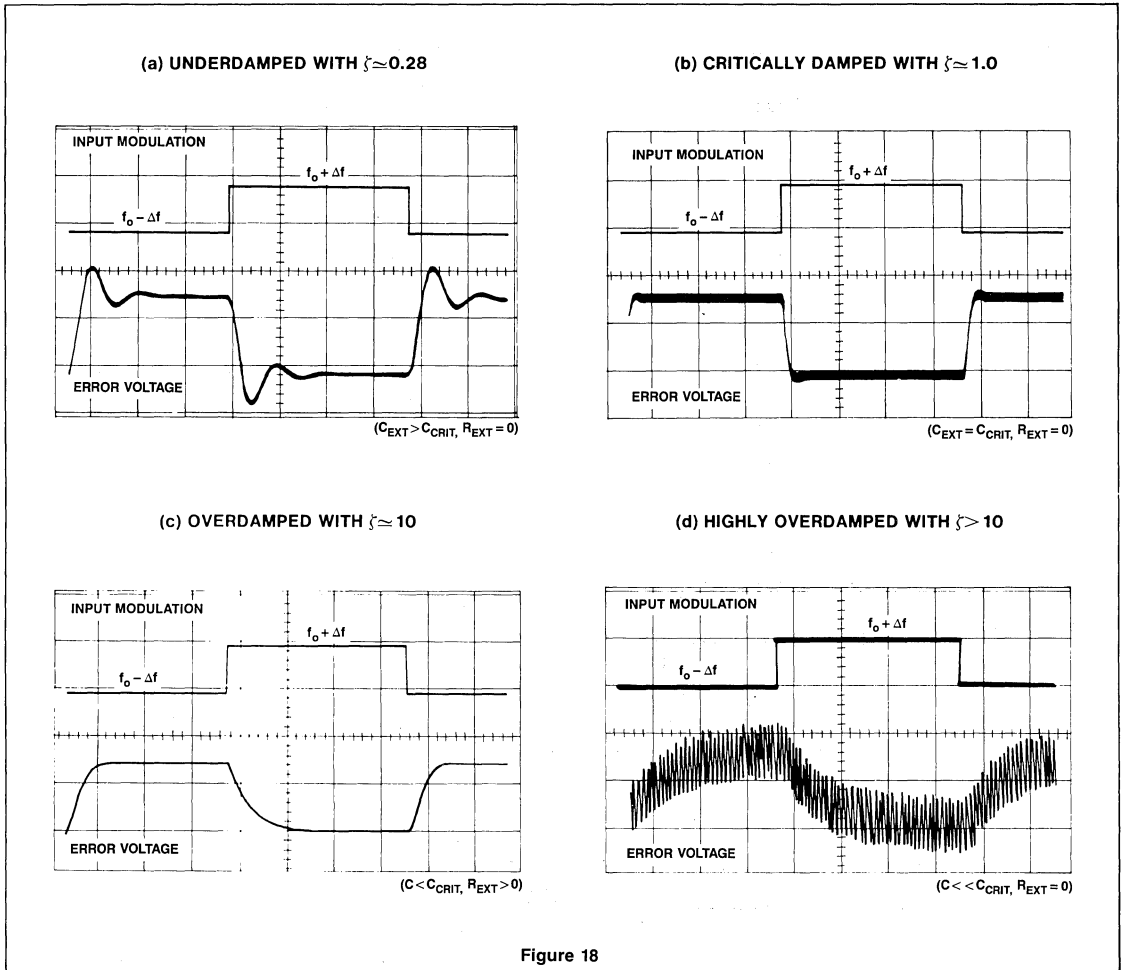

ESTIMATING THE DAMPING IN A SECOND ORDER PLL

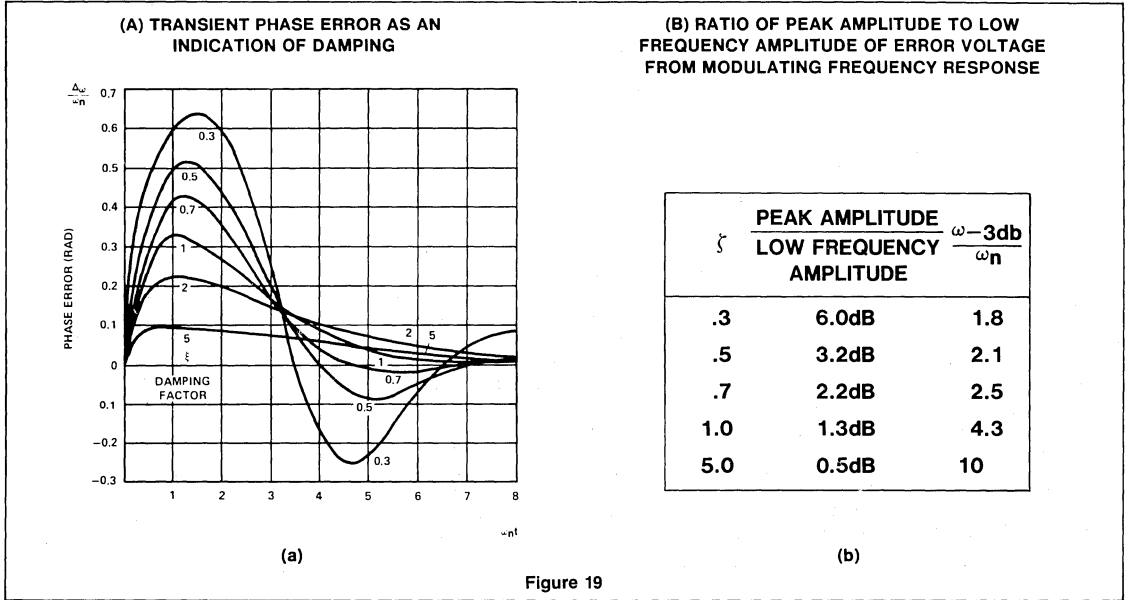

CIRCUIT DESCRIPTION OF THE 564

The 564 contains the functional blocks shown in Figure 1. In addition to the normal PLL functions of phase comparator, VCO, amplifier and low-pass filter, the 564 has internal circuitry for an input signal limiter, a dc retriever, and a Schmitt trigger. The complete circuit for the 564 is shown in Figure 1.

Limiter

The input limiter functions to produce a near constant amplitude output that serves as the input for the phase comparator. Eliminating amplitude variations in the FM input signal improves the AM rejection of the PLL. Additional features of the 564s limiter are that it is capable of accepting TTL signals, operates at high-frequencies up to 50MHz, and remains functional with variable supply voltages between 5 and 12 volts.

Signal limiting is accomplished in the 564 with a differential amplifier whose output voltage is clipped by diodes D₁ and D₂ (see Fig-

ure 2). Schottky diodes are used because their limiting occurs between 0.3 to 0.4 volts instead of the 0.6 to 0.7 volt for regular IC diodes. This lower limiting level is helpful in biasing, especially for 5 volt operation. When limiting, the dc voltage across R₂ R₃ remains at the Schottky diode voltage. Good high-frequency performance for Q2 and Q3 is achieved with current levels in the low mA range. Current-source biasing is established via the current mirror of D₅ and Q4 (See Figure 1).

Base biasing for Q3 is of concern because of the nature of the input signal which can be either a TTL digital signal of 0 to 5 volts amplitude or a low-level, ac coupled analog signal. Compatibility for either type is achieved by modifying the limiter of Figure 2 with the addition of the vertical Schottky PNP transistors Q1 and Q5 shown in Figure 3. The input signal voltage appears as a collector-base voltage for Q1 which presents no problems for either high TTL level inputs or low-level analog inputs. Q5 is in turn diode biased by D₃ and D₄ (see Figure 1) which places the base voltages of Q1 and Q5 at approximately 1.0

volt. This same biasing network establishes a 1.3 volt bias at the base of Q13 for biasing the phase comparator section. A differential output signal from the input limiter is applied to one input of the phase comparator (Q9 through Q12) after buffering the level shifting through the Q7-Q8 emitter followers.

*When operating above 5Vdc, a limiting resistor must be used from V_{CC} to pin 10 of the 564.

Phase Comparator

The phase comparator section of the 564 is shown in Figure 4. It is basically the conventional, double-balanced mixer commonly used in PLL circuits with a few exceptions. The transconductance, g_m, for the Q13-Q14 differential amplifier is directly proportional to the mirror current in Q15. Thus by externally sinking or sourcing current at pin 2, g_m can be changed to alter the phase comparators conversion gain, K_d. The nominal current injected into this node by the internal current source is 0.75mA for 5 volt operation. If the current is

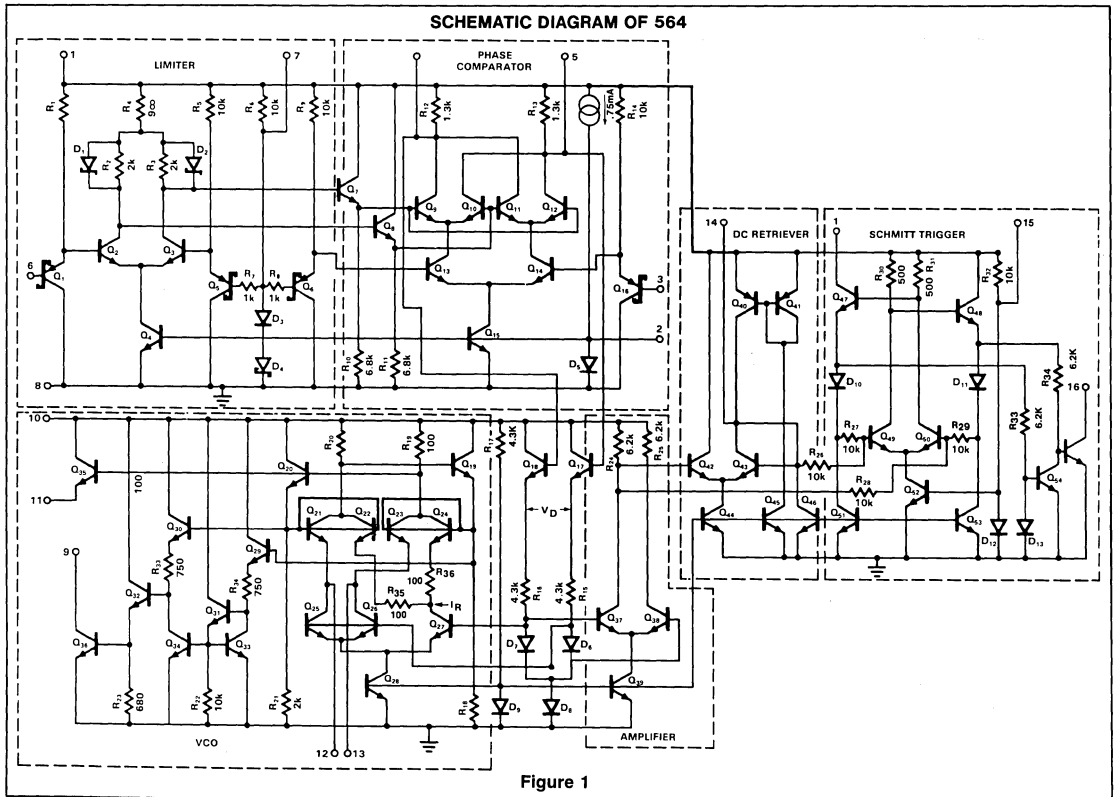
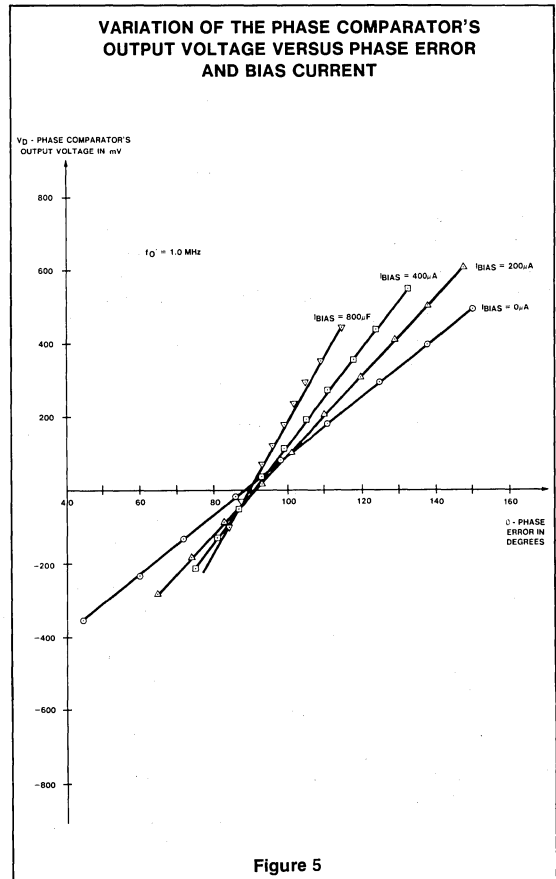
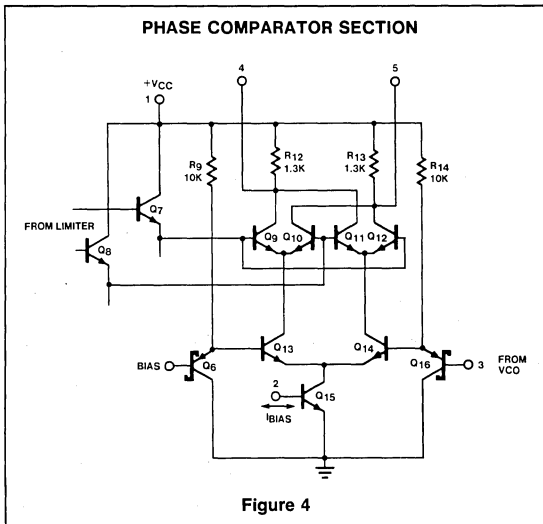
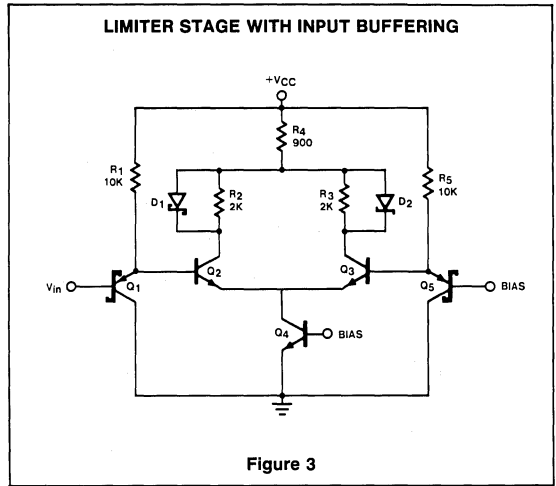
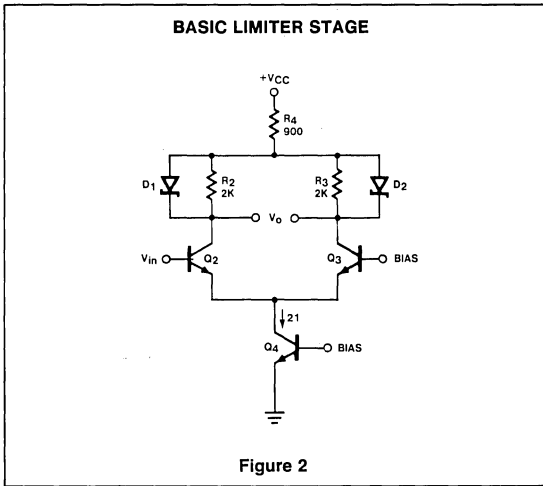

Figure 1



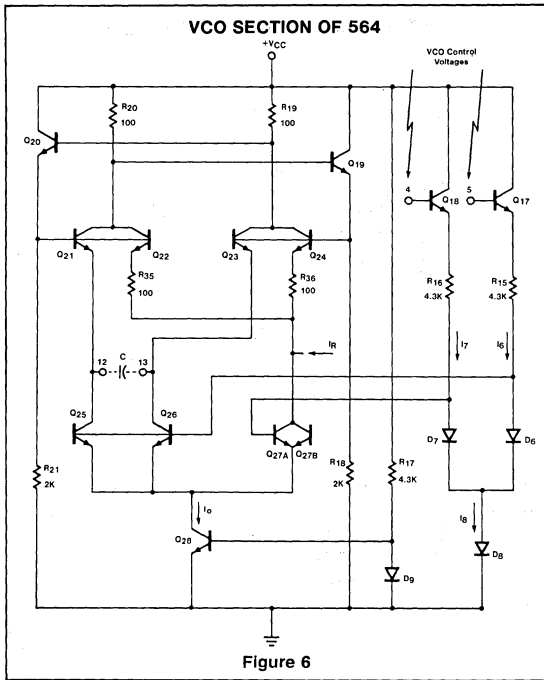

Figure 6

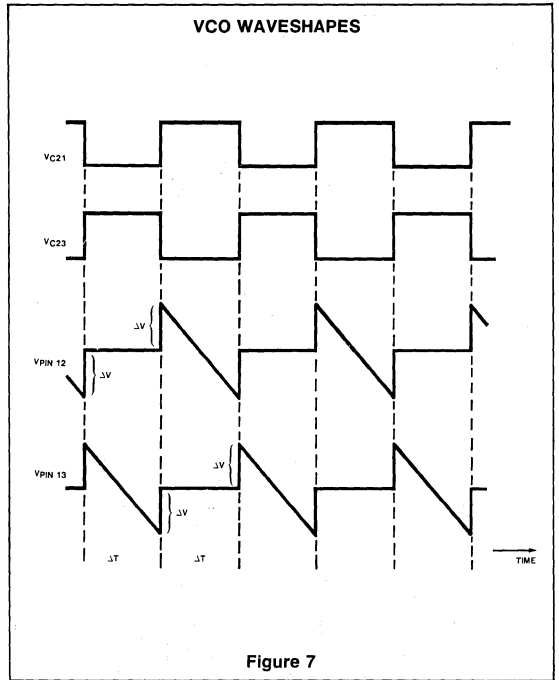

Figure 7

externally removed by gating, the phase comparator can be disabled and the VCO will operate at its free-running frequency.

The variation of K_d with bias current at pin 2 is shown in the experimental results of Figure 5. Note the inherent 90° phase error in the loop produces an approximate zero phase comparator output voltage. For any particular bias current, the slope of the line is the K_d conversion gain for the phase comparator. Numerically the data of Figure 5 can be expressed as

$$K_d \approx 0.46 \frac{\text{volts}}{\text{rad}} + 7.3 \times 10^{-4} \frac{\text{volts}}{\text{rad} \times \mu\text{A}} \times I_{\text{BIAS}} \quad (1)$$

where I_{BIAS} is in μA . Equation 1 is valid for bias current less than $800 \mu\text{A}$ where saturation occurs within the phase comparator.

The current level established in Q15 of Figure 3 determines all other quiescent currents in the phase comparator (Q9 through Q14). Currents through R_{12} and R_{13} set the common-mode output voltage from the phase comparator (pins 4 and 5). Since this common-mode voltage is applied to the VCO to establish its quiescent currents, the VCO conversion gain (K_d) also depends upon the bias current at pin 2.

VCO

The VCO is of the basic emitter-coupled astable type with several modifications included to achieve the high frequency, TTL compatible operation while maintaining low frequency drift with temperature changes. The basic oscillator in Figure 6 consists of Q19, Q20, Q21, and Q23 with current sinks of Q25 and Q26. The master current sink of Q28 keeps the total current constant by altering the ratio of currents in Q25-Q26 and the dummy current sink of Q27.

The input drive voltage for the VCO is made up of common-mode and difference-mode components from the phase comparator. After buffering the level shifting through Q17-Q18 and R_{15} - R_{16} , the VCO control voltage is applied differentially to the base of Q27 and to the common bases of Q25 and Q26.

The VCO control voltages from the phase comparator are the pin 4 and pin 5 voltages or

$$V_4 = V_{C9} = V_{B18} = V_{CM} + \frac{1}{2} V_{DM} \quad (2)$$

$$V_5 = V_{C12} = V_{B17} = V_{CM} - \frac{1}{2} V_{DM} \quad (3)$$

where V_{CM} and V_{DM} are the respective common-mode and the difference-mode voltages.

Emitter followers Q17 and Q18 convert these control voltages into control currents through D_6 and D_7 of the form

$$I_6 = \frac{1}{R_{15}} \left[V_{CM} - \frac{1}{2} V_{DM} - 3 V_{BE} \right] \quad (4)$$

$$I_7 = \frac{1}{R_{16}} \left[V_{CM} + \frac{1}{2} V_{DM} - 3 V_{BE} \right] \quad (5)$$

These individual currents are summed in D_8 and become with $R_{15} = R_{16} = R$.

$$I_8 = I = I_6 + I_7 = \frac{2}{R} (V_{CM} - 3 V_{BE}) \quad (6)$$

Writing I_6 and I_7 as functions of the total I current gives

$$I_6 = \frac{1}{2} \left(1 - \frac{V_{DM}}{R I} \right) \quad (7)$$

$$I_7 = \frac{1}{2} \left(1 + \frac{V_{DM}}{R I} \right) \quad (8)$$

Now consider variations in I_6 and I_7 while I remains constant.

Let x indicate the current imbalance such that

$$I_6 = (1 - x) I = \frac{1}{2} \left(1 - \frac{V_{DM}}{R I} \right) \quad (9)$$

$$I_7 = x I = \frac{1}{2} \left(1 + \frac{V_{DM}}{R I} \right) \quad (10)$$

where $0 \leq x \leq 1$. Thus x is defined to be

$$x = \frac{1}{2} \left(1 + \frac{V_{DM}}{R I} \right) \quad (11)$$

Currents I_6 and I_7 establish proportional currents in Q25, Q26, and Q27 in a manner

CIRCUIT DESCRIPTION OF THE NE564

similar to the analysis above since the current in Q28 is a constant, or

$$I_0 = I_{C28} = I_{E25} + I_{E26} + I_{E27A} + I_{E27B}$$

Gilbert (10) has shown that the D_7 - D_8 diode pair will cause identical differential currents to be reflected in both the Q25-Q26 and the Q27A-Q27B differential amplifier pairs. Consequently the constant current of I_0 jointly shared by the differential amplifier pairs will divide in each pair with the same x factor imbalance as in Equation 11.

$$I_{E25} + I_{E26} = xI_0 \tag{12}$$

$$I_{E25} = I_{E26} = \frac{x}{2} I_0 \tag{13}$$

$$I_{E27A} + I_{E27B} = (1-x) I_0 \tag{14}$$

$$I_{E27A} = I_{E27B} = \left(\frac{1-x}{2}\right) I_0 \tag{15}$$

Now consider placing a capacitor between the collectors of Q25 and Q26 (pins 12 and 13). Oscillation will occur with the capacitor alternately being charged by Q21 and Q23 and constantly discharged by Q25 and Q26. When the Q21 and Q22 pair conducts, Q23 and Q24 will be off causing a negative ramp voltage to appear at pin 13 and a constant voltage at pin 12 as shown in Figure 7. During the next half-cycle, the transistor roles and voltages are reversed. Capacitor discharge is

via Q25 and Q26 which act as constant-current sinks with current amplitudes as in Equation 13.

During each half-cycle, the capacitor voltage changes linearly by $2\Delta V$ volts in ΔT seconds where

$$\Delta V = 2R_{20} I_0 \left(\frac{x}{2} + \frac{1-x}{2}\right) = R_{20} I_0 \tag{16}$$

and

$$\Delta T = \frac{C_2 \Delta V}{I_{E25}} \tag{17}$$

Combining these two equations with Equation 13 gives a half period of

$$\Delta T = \frac{4C R_{20}}{x} \tag{18}$$

Utilizing Equation 11 with the ΔT expression gives the desired VCO frequency expression of

$$f_0 = f_0' \left(1 + \frac{V_{DM}}{R_I}\right) = f_0' \left[\frac{V_{DM}}{2(V_{CM} - 3V_{BE})} \right] \tag{19}$$

where f_0' is the VCO's free-running frequency given by

$$f_0' = \frac{1}{16 R_{20} C} \tag{20}$$

Equation 19 shows that the oscillator frequency is a linear function of the differential voltage from the phase comparator. Resistors R_{35} and R_{36} function to insure that an initial current imbalance exists between the Q25 -

Q26 transistor pair and the dummy Q27. This imbalance insures that the oscillator is self-starting when power is first applied to the circuit.

The VCO conversion gain is determined as

$$K_O = \frac{\partial f_0}{\partial V_{DM}} = \frac{f_0'}{R_I} \text{ Hz/volt} \tag{21}$$

which is valid as long as the transistors V_{BE} changes are small with respect to the common-mode voltage. Both f_0 and K_O are inversely proportional to R which has a strong positive temperature coefficient. An internal current I_R having an equal and opposite negative temperature coefficient is inserted into the VCO as shown in Figure 6.

Experimental determination of K_O can be found from the data of Figure 8 where K_O is the slope of either line. Numerically these results are for $I_{BIAS} = 0$.

$$K_O = 0.95 \frac{\text{MHz}}{\text{volt}} = 5.9 \times 10^6 \frac{\text{rad}}{\text{volt-sec}} \tag{22}$$

and for $I_{BIAS} = 800\mu A$

$$K_O = 1.7 \frac{\text{MHz}}{\text{volt}} = 10.45 \times 10^6 \frac{\text{rad}}{\text{volt-sec}} \tag{23}$$

It must be noted that the specific values obtained for K_O in the manner above are valid only for the 1.0MHz free-running frequency where the data was taken. However, good estimates for K_O at other free-running frequencies can be obtained by linearly scaling K_O to the desired f_0' . Thus it is sometimes convenient to define a normalized K_O as

$$K_O(\text{norm}) = \frac{K_O}{f_0'} = 5.9 \frac{\text{rad}}{\text{volt}} (I_{BIAS} = 0) = 10.45 \frac{\text{rad}}{\text{volt}} (I_{BIAS} = 800\mu A) \tag{24}$$

The K_O estimate for any bias then can be obtained by multiplying the normalized conversion gain by the desired free-running frequency, or

$$K_O (\text{any } f_0') = K_O(\text{norm}) f_0' \tag{25}$$

The additional VCO circuitry of Q29 through Q36 functions to produce the TTL and ECL compatible outputs at pins 9 and 11.

VCO OUTPUT FREQUENCY AS A FUNCTION OF INPUT VOLTAGE AND BIAS CURRENT

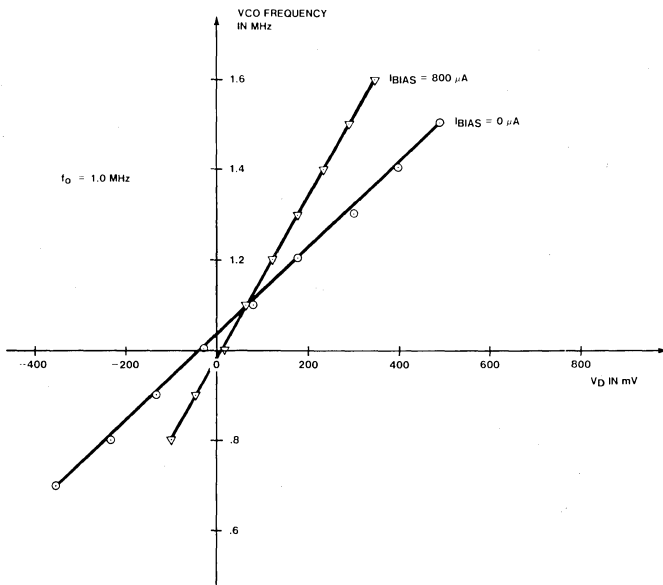

Figure 8

Amplifier

The difference-mode voltage from the phase comparator is extracted and amplified by the amplifier in Figure 1. The single-ended output from this amplifier serves as input signals for both the Schmitt Trigger and a second differential amplifier. Low-pass filtering with a large capacitance at pin 14 produces a stable dc reference level as the second input to the Schmitt Trigger. When the PLL is locked, the voltage at pin 14 is directly proportional to the difference between the input frequency and



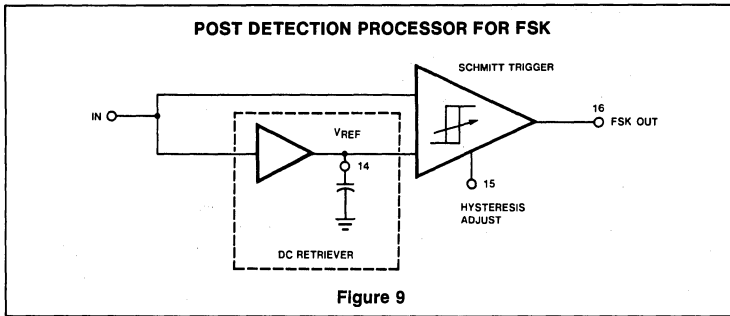

Figure 9

WAVESHAPES FOR FSK DECODING IN THE POST DETECTION PROCESSOR

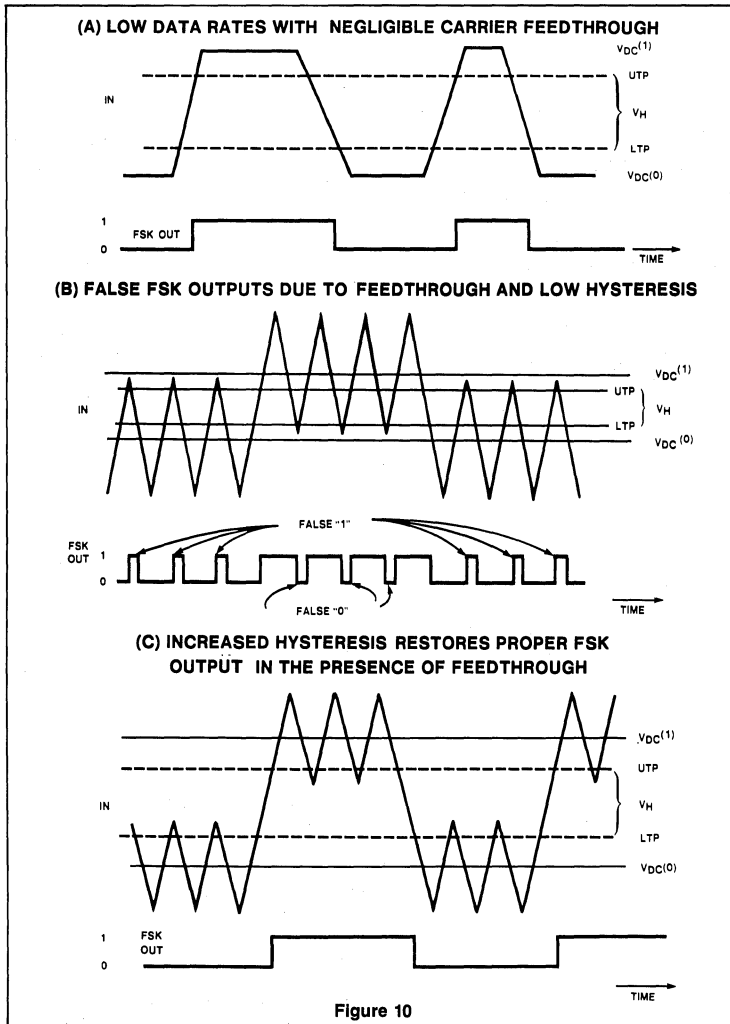

Figure 10

f_o' . Thus pin 14 provides the demodulated output for a FM input signal.

Schmitt Trigger

In FSK applications the pin 14 voltage will assume two different voltage levels corresponding to the mark and space input frequencies. A voltage comparator could be used to sense and convert these two voltage levels to logic compatible levels. However at high data rates, V_{DM} will contain a considerable amount of carrier signal which can be removed by extensive filtering. Normally this complex filtering requires quite a few components, most all of which are external to the monolithic PLL. Also since the control voltage for the comparator depends upon K_o and the deviations of the mark and space frequencies from f_o' , the filtering has to be optimized for each different system utilized. However the necessary dc reference level for the comparator is present in the PLL but buried in carrier frequency feedthrough which appears as noise in the system. A Schmitt trigger with variable hysteresis can be used successfully to decode the FSK data without the need for extensive filtering.

Consider the system shown in Figure 9 where the input signal is the single-ended output derived from the amplifier section of the 564. The dc retriever functions to establish a dc reference voltage for the Schmitt trigger. The upper and lower trigger points and adjustable hysteresis around the reference voltage giving the variable hysteresis. For very low data rates, carrier feedthrough will be negligible and the ideal situation depicted in Figure 10 results. Increased data rate produces the carrier feedthrough shown in the (b) figure where false FSK outputs result because the feedthrough amplitude exceeds the hysteresis voltage. Having the capability to increase the hysteresis as in (c) produces the desired FSK output in the presence of carrier feedthrough.

Another important factor to be considered is the temperature drift of the f_o' in the VCO. Small changes in f_o' will change the dc level of the input voltage to the Schmitt trigger. This dc voltage shift would produce errors in the FSK output in narrow-band systems where the mark and space deviations in f_{in} are less than the f_o' change with temperature. However this effect can be eliminated if the dc or average value of the amplifier signal is retrieved and used as the reference voltage for the Schmitt trigger. In this manner, variations in the f_o' with temperature do not affect the FSK output.

FREQUENCY SYNTHESIS WITH THE NE564

Frequency multiplication can be achieved with the PLL in two ways:

- a. Locking to a harmonic of the input signal.
- b. Insertion of a counter (digital frequency divider) in the loop.

Harmonic locking is simpler and usually can be achieved by setting the VCO free-running frequency to a multiple of the input frequency and allowing the PLL to lock. However, a limitation of this scheme is that the lock range decreases as successively higher and weaker harmonics are used for locking. This limits the practical harmonic locking range to multiples of approximately less than ten. For larger multiples, the second scheme is more desirable.

A block diagram of the second scheme is shown in Figure 1a. Here, the loop is broken between the VCO and the phase comparator and a counter is inserted. In this case, the fundamental of the divided VCO frequency is locked to the input reference frequency so that the VCO is actually running at a multiple of the reference frequency. The amount of multiplication is determined by the counter. An obvious practical application of this multiplication property is the use of the PLL in wide range frequency synthesizers.

In frequency multiplication applications it is important to take into account that the phase comparator is actually a mixer and that its output contains sum and difference frequency components. The difference fre-

quency is dc and is the error voltage which drives the VCO to keep the PLL in lock. The sum frequency components (of which the fundamental is twice the frequency of the input signal) if not well filtered, will induce incidental FM on the VCO output. This occurs because the VCO is running at many times the frequency of the input signal and the sum frequency component which appears on the control voltage to the VCO causes a periodic variation of its frequency about the desired multiple. For frequency multiplication it is generally necessary to filter quite heavily to remove this sum frequency component. The tradeoff, of course, is a reduced capture range and a more underdamped loop transient response.

Producing a large number of frequencies with close spacing requires a counter with a large N for the system of Figure 1(a). Large N values, in turn, require reference frequencies too low to be practical for commercially available crystals. To overcome this difficulty, a second counter (+M) is inserted as a prescaler as in Figure 1(b) to divide down the reference frequency input. This also gives more programming flexibility since the synthesized output frequencies are functions of both M and N integers, each of which can be changed separately. As an example of fractional frequency synthesis, the two counters can be set to generate an output frequency exactly 16/3 of the input reference frequency. In this case N = 16, M = 3, and the initial f_0' is set to approximately 16/3 times the reference frequency input. The output always will be

exactly 16/3 of the input frequency as long as the PLL remains in lock.

PLL frequency synthesizers based upon Figure 1b find wide applications in many types of communications systems that require precisely spaced channels having narrow bandwidths which are centered around relatively high frequencies. For example, Citizens Band (CB) transceiver applications require forty channels corresponding to forty different reference frequencies, each separated by 10kHz bandwidths and centered in the 26 - 27MHz range. Channel 4 uses 27.055MHz; Channel 5 uses 27.015MHz; Channel 6 uses 27.025MHz; and so on. These frequencies could be produced by using forty different crystals - one for each channel. However, this becomes expensive and adds unnecessary complexity to the system. Frequency mixing techniques have been employed to reduce the number of crystals needed to less than one crystal per channel. For example one common mixer design uses 14 crystals for 23 channels. As a general rule, most practical approaches that use numerous crystals and mixers to produce discrete frequencies require more than one crystal for every two channel frequencies produced. As the number of channels grows large, frequency synthesis using PLLs becomes more attractive, especially since usually only one or two crystals are needed. Frequency stability of all channels will be essentially the same as that of the crystal reference frequency. Reduced system complexity, size, weight, and power consumption are key advantages of PLL synthesizers.

FREQUENCY SYNTHESIS USING PLLs

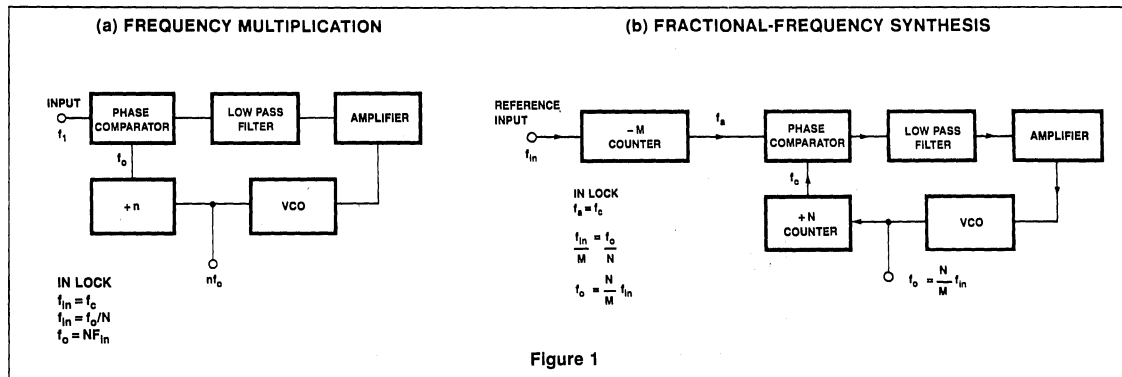

Figure 1

Since the function of frequency synthesizers is to generate frequencies and not to linearly decode or demodulate input signals, digital PLLs are more commonly used than analog loops.

Analog PLLs also can be used for frequency synthesis applications. The 564 is particularly well suited for these applications because the loop is open between the VCO output and the phase comparator input. Also the phase comparator input and VCO output are compatible with TTL counters.

NE564 FREQUENCY SYNTHESIS WITH CRYSTAL CONTROL

The system shown in Figure 2 has been used to generate frequencies of 5.4MHz and 21.6MHz from a 3.6MHz crystal-controlled source. This reference signal input is produced by using the crystal as the frequency determining element in the VCO of a second PLL. The thermal stability of all three frequencies will be same as the stability afforded by the crystal. It may be necessary to place a small detuning capacitor in parallel with the crystal to precisely tune the PLL to the crystals resonant frequency and to prevent oscillations at harmonics of the resonant frequency. The value of this tuning capacitance must always be kept considerably less than the value required to produce an f_o' without the crystal present. Otherwise the crystal will lose control and the input reference frequency will be set by the capacitor alone.

A recommendation for improved 564 operation is to utilize a divide-by-N counter in the loop which produces "square" waves for the phase comparator that have as close to a 50% duty cycle as possible. Normally counters with even N values produce square wave outputs perfectly compatible for the phase comparator. Counters for odd N values more commonly produce unsymmetrical outputs that can be less desirable inputs to the phase comparator. An easy modification to "square up" odd divide-by-N counter outputs is to insert a single toggling flip-flop stage between the counter output and the phase comparators input. This produces an effective 2N multiplication of the input frequency within the PLL. The extra factor of two is removed by a second toggle flip-flop whose input is the output from the first flip-flop. This is the same system as was previously shown in Figure 2(a) where the +N counter becomes a +2N and M = 2 for the second counter.

FSK Demodulation with the 564

The 564 PLL is particularly attractive for FSK demodulation since it contains an internal voltage comparator and VCO which

have TTL compatible inputs and outputs, and it can operate from a single 5 volt power supply. Demodulated dc voltages associated with the mark and space frequencies are recovered with a single external capacitor in a dc retriever without utilizing extensive filtering networks. An internal comparator, acting as a Schmitt trigger with an adjustable hysteresis, shapes the demodulated voltages into compatible TTL output levels. The high frequency design of the 564 enables it to demodulate FSK at high data rates in excess of 1.0M baud.

Figure 3 shows a high-frequency FSK decoder designed for input frequency deviations of ± 1.0 MHz centered around a freerunning frequency of 10.8MHz. The value of the timing capacitance required was estimated from Figure 4(a) to be approximately 40pF. A trimmer capacitor was added to fine tune f_o' to 10.8MHz.

Figure 4(b) indicates that the ± 1.0 MHz frequency deviations will be within the lock range for input signal levels greater than approximately 50mV with zero pin 2 bias current. While strictly this figure is appropriate only for 5MHz, it can be used as a guide for lock range estimates at other f_o' frequencies.

A more thorough analysis confirms these lock range conclusions and serves as a guide for designing other systems. The closed loop gain of the PLL is equal to the systems lock range and is found as the product of K_d and K_o , or

$$2\omega_L = K_v = K_d K_o \tag{1}$$

$$2\omega_L = (0.46 \frac{\text{volt}}{\text{radian}}) (0.75 \frac{\text{MHz}}{\text{volt}})$$

$$(2\pi \times 10.8 \times 10^6 \frac{\text{radian}}{\text{sec}})$$

$$2\omega_L = 3 \times 10^7 \frac{\text{radian}}{\text{sec}} \text{ (Lock range total)}$$

Thus pin 2 could be left as an open circuit and the internally set closed-loop gain would be adequate for tracking the mark and space input frequencies. However, to be safe, a bias adjustment as shown in Figure 3 is recommended to allow for K_d and K_o variations from device to device.

Designing for a capture range of approximately 700kHz gives a low-pass filter time constant of

$$\omega_c \approx \sqrt{\frac{\omega_L}{\tau}} \tag{2}$$

$$(2\pi \times 700 \times 10^3) \approx \sqrt{\frac{\omega_L = K_v}{\tau}}$$

$$\tau = 0.775$$

Therefore, choose the low-pass filter capacitor as

$$C = \frac{\tau}{R} = \frac{0.775\mu\text{s}}{1.3\text{K}} = 596\text{pF} \tag{3}$$

Two 300pF capacitors were selected for the design.

Capacitive coupling was used for the FSK input and is recommended to avoid dc feed-through. This dc voltage would act as a dc offset to shift f_o' from 10.8MHz. Balanced biasing with the 1.0k Ω resistors from pin 7 to pins 3 and 6 also is recommended to establish symmetrical, quiescent current conditions in the limiter and phase comparator sections of the 564. The 300 Ω pull-up resistor for the VCO output was found to give a rise time less than 10ns. This rise time was further reduced by adding the 100 Ω resistor between pins 9 and 11. Figure 5 shows an unmodulated 10.8MHz input signal and the VCO output. Note the approximate 90° phase lag of the VCO output.

A 0.1 μ F dc retriever capacitor (pin 14) has less than 1 ohm impedance at f_o' and represents a good compromise between high baud rates ($\sim 100\text{K}$ baud) at f_o' and higher order filtering. If very high baud rates are used, this capacitor could be made smaller with an accompanying increase in the Schmitt trigger hysteresis voltage. The hysteresis was adjusted experimentally via the 10k Ω potentiometer and 2k Ω bias arrangement to give the waveshape shown in Figure 6 for 20K, 500K, 2M baud rates with square wave FSK modulation. Note the magnitude and phase relationships of the phase comparators output voltages with respect to each other and to the FSK output. The high frequency sum components of the input and VCO frequency also are visible as noise on the phase comparators outputs.

The phase comparators outputs exhibit the waveshapes shown in Figure 7 when the FM input is changed from a square wave FSK modulation to a triangular sweep at a 100Hz modulation rate. The amplitude of the triangular sweep was increased from that used with square wave modulation, causing the loop to be driven in and out of lock. The loop is locked during the smooth, linear portions of the phase comparators waveshapes and locked during the remaining portions. Lock and capture frequencies were measured for a pin 2 bias current of 375 μ A and $f_o' = 1.08$ MHz as:

Lock: $f_{L1} = 6.2$ MHz $f_{L2} = 16.4$ MHz

Capture: $f_{C1} = 9.3$ MHz $f_{C2} = 12.2$ MHz

When the loop is locked, the phase detectors outputs represent the demodulated FM output. When unlocked, high frequency harmonics are present, increasing in amplitude until lock is achieved.



10.8 MHz FSK DECODER USING THE 564

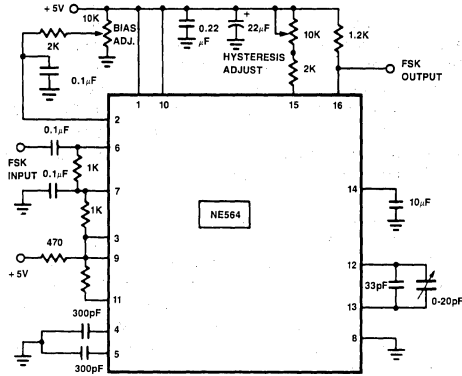
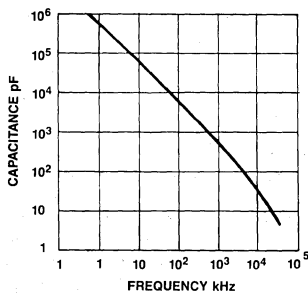

Figure 3

564 CHARACTERISTICS

(a) VCO TIMING CAPACITOR VERSUS FREQUENCY



(b) LOCK RANGE VERSUS INPUT SIGNAL LEVEL AND BIAS CURRENT

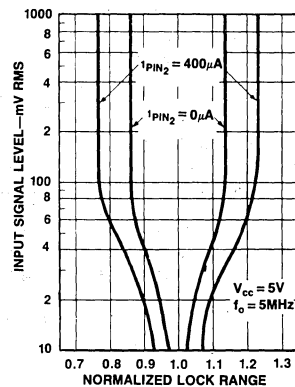

Figure 4

FREQUENCY SYNTHESIS WITH THE NE564

AN180

PLL INPUT AND VCO OUTPUT FOR PHASE AND FREQUENCY LOCK AT 10.8 MHz

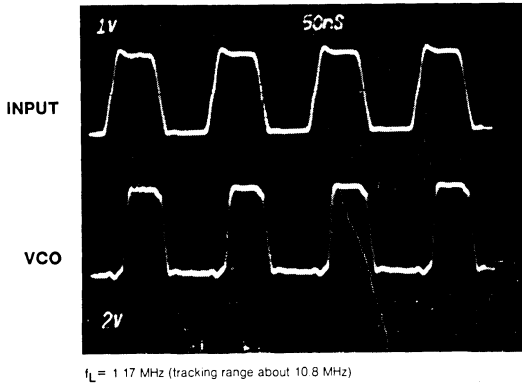

Figure 5

PHASE COMPARATOR OUTPUTS SHOWING LOCK AND CAPTURE RANGES

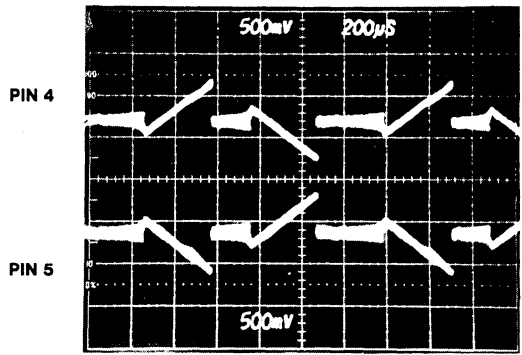

Figure 7

PHASE COMPARATOR (PINS 4 AND 5) AND FSK (PIN 16) OUTPUTS FOR DATA RATES OF

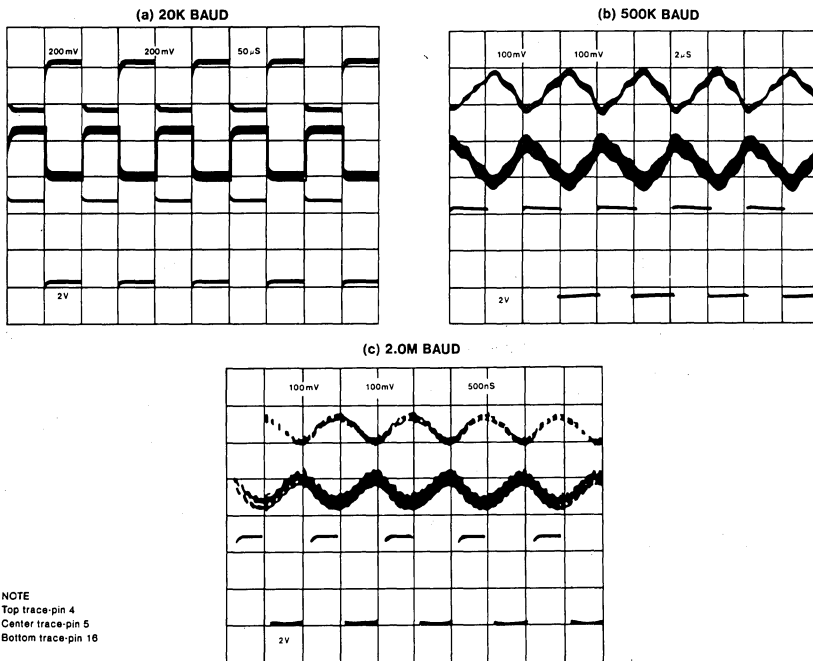

Figure 6

Design Example

It is desired to design an FSK converter operating at 6MHz with deviation of ±1%. Supply voltage is 5 volts. Input to the 564 is from a radio receiver with an amplitude of 0.5 volts_{rms}. Worst case S/N is 10dB. An overall loop damping factor of 0.5 is specified (ζ).

Using the circuit in Figure 1

First the frequency determining capacitor must be established. Using the equation

$f_0 = \frac{1}{25R_0C_0}$ where R_0 is the internal resistance in the VCO oscillator equal to 100 ohms. Given two parameters the third is calculated $f_0 = 6\text{MHz}$; therefore

$$C_0 = \frac{1}{2\pi \times 100 \times 6 \times 10^6} = 66\text{pF.}$$

A parallel 2–20pF trimmer and a 47pF ±5% fixed mica capacitor is chosen.

Next, signal level versus bias current and lock range is examined.

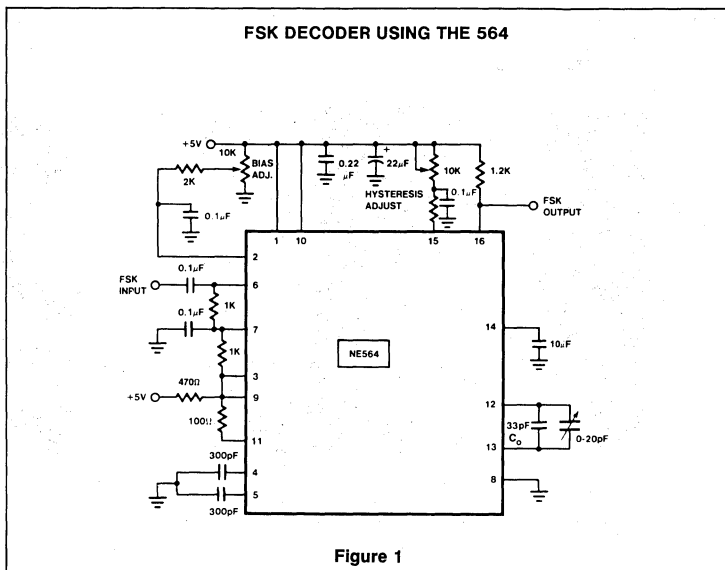

Figure 1

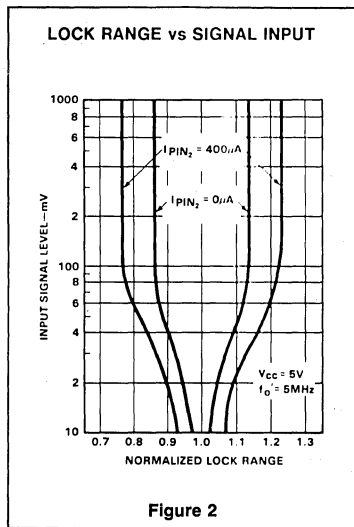

Figure 2

The signal input to the 564 is specified to be 0.5 volts_{rms}; in the lock range graph, the input level is well within the limiting region of the 564. Thus no external AM limiter circuit is required and a 10dB S/N (3.1:1) min. should provide reliable communication with a narrow deviation of ±1% (±60KHz) and there is no problem with adequate lock range as it pertains to bias current. We are free to use any loop gain necessary. The bias current sinking into pin 2 is set to an initial value of 200µA.

It's now possible to determine the damping factor of the closed loop. First the natural frequency of the loop is calculated from the relationship,

$$\omega_n = \frac{\sqrt{K_0 K_D}}{\tau} \quad (1)$$

where

K_0 = VCO conversion gain in $\frac{\text{radians}}{\text{sec} \cdot \text{volt}}$

K_D = Phase detector conversion gain in $\frac{\text{volts}}{\text{radian}}$

τ = Loop filter time constant in seconds

For $f_0 = 6\text{MHz}$ and $I_B = 200\mu\text{A}$, K_0 may be derived from Figure 3a by first constructing an extrapolated transfer line with slope one-quarter of the angle between the existing $I_B = 0$ and $I_B = 800$ plots.

Interpolation gives

$$K_0 \cong \frac{(1.48 - 1.25 \text{ MHz})}{(0.4 - 0.2 \text{ Volt})} = \frac{\Delta f_0}{\Delta V_0}$$

Multiplying Δf by 2π results in $f \cong 1.45 \times 10^6$ radians/sec at 1MHz and

$$K_0 = \frac{1.45 \times 10^6 \text{ rad/sec}}{0.2 \text{ volts}} = 7.2 \times 10^6 \frac{\text{radians}}{\text{sec} \cdot \text{volt}}$$

Next, using the K_D graph (Figure 3b), ±1 radian (–90° ± 57°); i.e., $\Delta\theta = 1$ radian, results in an output of 0.6 volts/radian.

Therefore, $K_D = \frac{0.6}{1 \text{ rad}} = 0.6 \text{ volts/radian}$ at $I_B = 200\mu\text{A}$.

The value obtained for K_0 is for data taken at 1MHz and must be multiplied by 6 in order to find the correct value.

Therefore, $K_0 = 6 \times 7.2 \times 10^6 \frac{\text{radians}}{\text{sec} \cdot \text{volt}}$

$$(6\text{MHz}) = 4.34 \times 10^7 \frac{\text{radians}}{\text{sec} \cdot \text{volt}}$$

$$K_0 K_D = K_V = (4.34 \times 10^7)(0.6) = 2.6 \times 10^7 \text{ (loop gain)}$$

The damping factor specified (0.5) is now used to determine the necessary filter time constant (pins 4, 5).

$$\zeta = \frac{1}{2\tau \sqrt{K_0 K_D}} = \frac{1}{2\sqrt{K_V}\tau} = \frac{\omega_n}{2K_V} \quad (2)$$

$$\therefore \tau = \frac{1}{(4)(2.6 \times 10^7)(0.5)^2} = 38\text{ns}$$

Note that the filters on pins 4 and 5 operate differentially with the net effect that break frequency is

$$\omega_p = \frac{1}{RC} \text{ (single pole filter - 3dB freq.)}$$

Now solving for ω_n using (1):

$$\omega_n = \left[\frac{(2.6 \times 10^7)}{(3.8 \times 10^{-8})} \right]^{1/2} = 26 \times 10^6 \text{ radians/sec}$$

$f_n = 4.14\text{MHz}$ (natural frequency of the loop and approximate one-sided capture B.W.)

The value of the loop filter capacitor may be determined by dividing the time constant by the value of the internal resistance 1.3K ohm.

$$C_L = \frac{\tau}{1.3K \text{ ohm}} = \frac{3.8 \times 10^{-8}}{1.3 \times 10^3} = 29pF$$

This value filter time constant will give a less-than-critically-damped response allowing the fast excursion in VCO frequency necessary to good FSK reception. The tradeoff between

response speed and carrier frequency harmonic rejection will have to be considered. A longer time constant gives more carrier rejection but slower response and less damping. (Refer to equation 2.)

The next step is to test the circuit under actual operating conditions with the specified FSK signal. The level on pin 15 (hysteresis adjust) must be set in the vicinity of +1.4 volts in order to attain proper FSK demodulation. Final signal tests may be carried out with

noise injected through a resistive summing network at the input (pin 6) to simulate the 10dB S/N.

Note that the loop filter response actually operates on the frequency spectrum above (+) and below (-) the carrier center frequency or center of deviation for a symmetric FM or FSK signal. This may be seen in Figure 4.

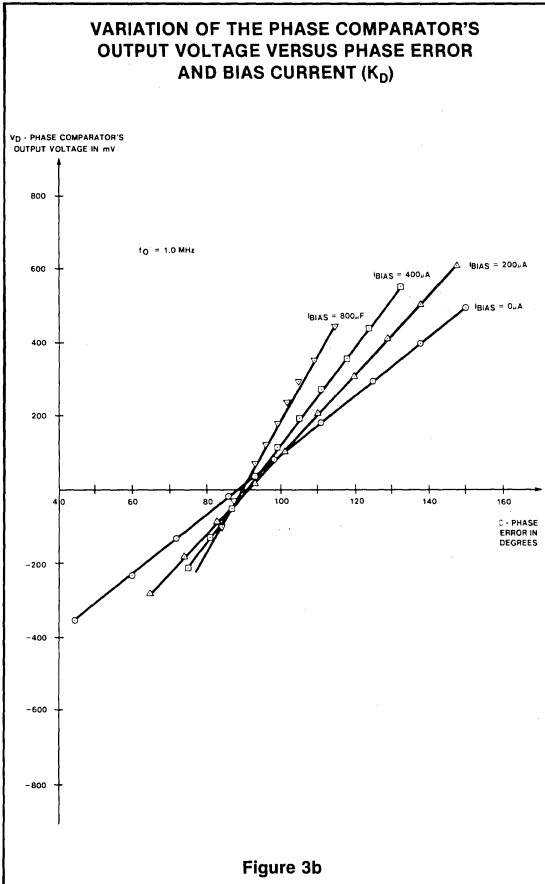

Figure 3b

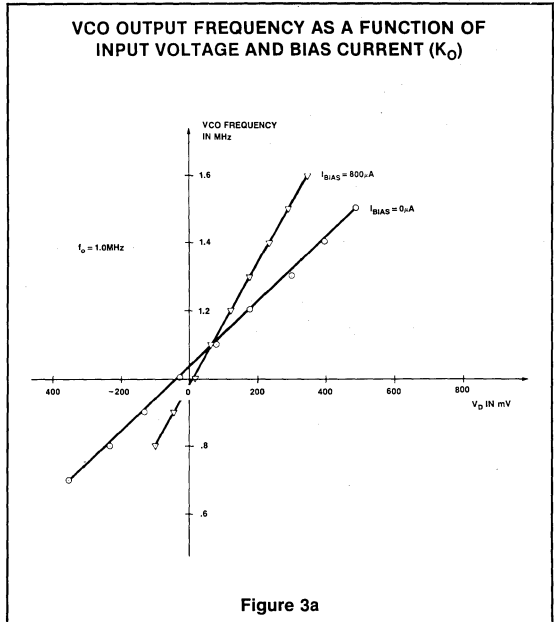

Figure 3a

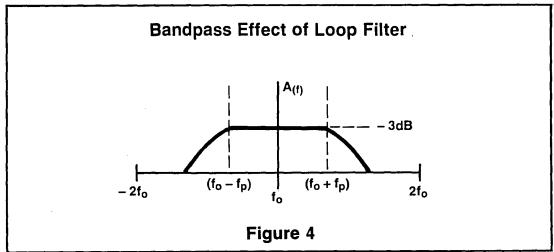

Figure 4

INTRODUCTION

In order to obtain a local clock signal in Multiplexed Data Transmission systems, a phase and frequency coherent method of signal extraction is required. A Master-Slave system using the quartz crystal as the primary frequency determining element in a phase lock loop VCO is used to reproduce a phase coherent clock from an asynchronous Data Stream.

The NE564, a versatile phase locked loop (PLL) operating at frequencies of 50MHz, has inputs and outputs designed to be TTL compatible. The Signetics NE564 is used to generate the phase locked, crystal-stabilized clock reference signal.

Its particular adaptation, for use with a crystal-controlled VCO instead of the usual R-C control elements, requires a brief review of the principles of the Phase Lock Loop design.

The NE564 Phase Locked Loop is a fully contained system, including limiter, phase detector, VCO, dc amplifiers, dc retriever and output comparator (reference figure 1). For the clock regeneration system to be discussed the portions of the NE564 implemented are the input limiter, phase detector and VCO.

The signal limiter amplifies low level inputs (until saturation is reached, which is typically 80mv p-p for the NE564). The signal limiter output is fed to the phase detector, where the "unknown" input is compared to the "known" VCO frequency of the NE564. The

differential error signal that is generated is fed through a dc amplifier and a voltage to current converter. The change in the current generated forces the VCO frequency to vary in its frequency and/or phase relationship, such that a θ of 90 degrees lagging is obtained (the actual phase relationship may be somewhat less than 90 degrees depending upon the K_dK_o (gain) product of the NE564 at the operating frequency and bias current). The external filtering incorporated at pins 4 and 5 control the dynamic frequency response and loop stability criteria.

The NE564 is a first order system; therefore, the use of single capacitors (at pins 4 and 5) will automatically create a "second order" system. An R-C series filter combination will cause a lead-lag condition that will permit dynamic selectivity, along with closed loop stability.

LOOP GAIN FUNCTIONS

The phase detector conversion gain (K_d) and the VCO conversion gain (K_o) determine, in large part, the lock range, capture range and linearity characteristics of the NE564. These device parameters are both dependent upon bias current and operating frequency. Some typical curves for each of the parameters are shown for the NE564 in figures 2 and 3. The reader should refer to the Signetics Phase Locked Loop Design and Applications Manual for a more in-depth study of these parameters and specific internal circuit configurations.

THE CLOCK REGENERATOR CIRCUIT

The basic building blocks of the clock regenerator circuit are shown in figure 4. The PLL is shown as a frequency multiplier incorporating a divide by "N" in the VCO-phase detector feedback loop (reference to the Signetics PLL Manual will provide greater in-depth explanation of a frequency multiplier). The functions of the ringing circuit and the NE527 high speed comparator will be discussed later.

The wave forms of figure 5 indicate the waveforms transmitted over a T1 line. The bipolar signal transmitted has "no" dc components induced in the transmission line (reference should be made to the effect of normal mode and common effects on signal information). When transmitted over telephone wire pairs, the resultant signal (at the receive end) will have been degraded in both waveshape and signal-to-noise ratio. Typical attenuation factors for a T1 line are -30dB per 6000 feet.

In addition, pair-to-pair cross talk can degrade signal-to-noise ratios. The energy transmitted in the bipolar system of signal transfer is centered at 772kHz (generated by the bit format).

At the receiving end the bipolar signal information is converted to a unipolar pulse train after being amplified, filtered and fed through an automatic level control circuit. Some types of PCM systems use the rectified and filtered dc (average) to control the

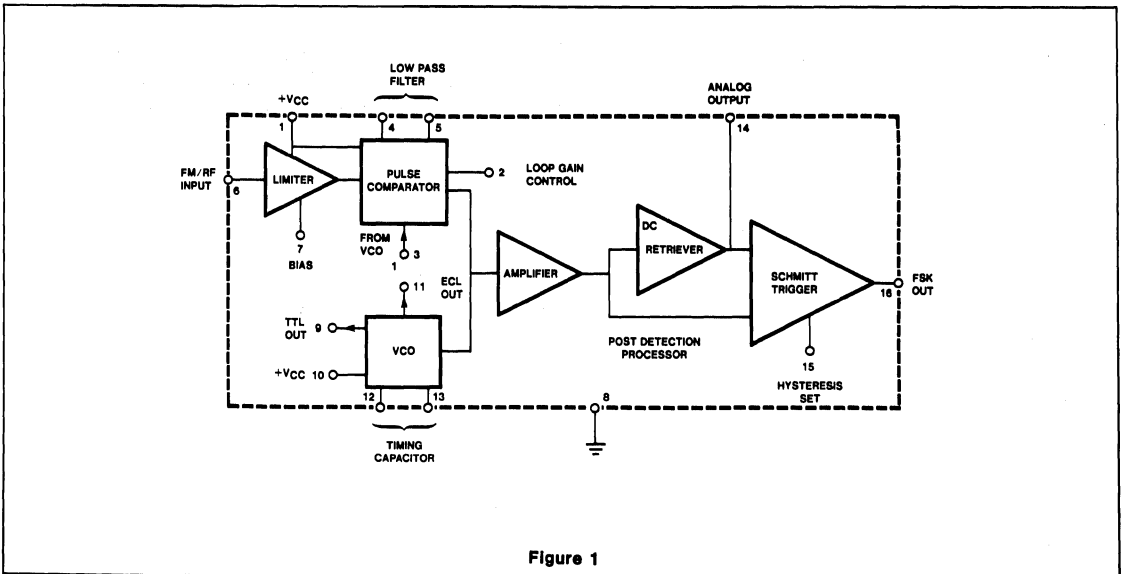

Figure 1

VARIATION OF THE PHASE COMPARATOR'S OUTPUT VOLTAGE VERSUS PHASE ERROR AND BIAS CURRENT

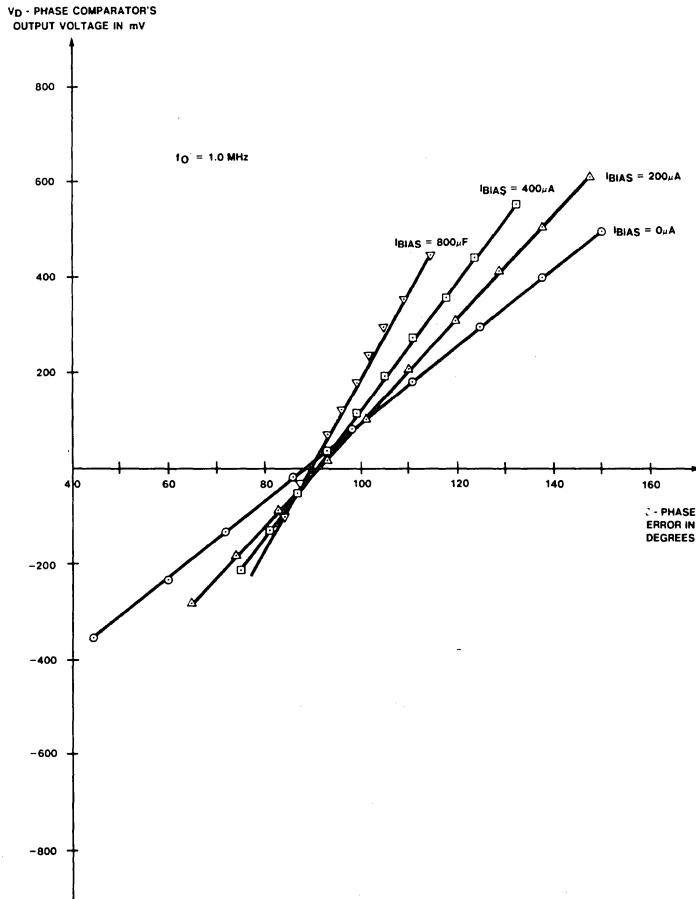

Figure 2

VCO OUTPUT FREQUENCY AS A FUNCTION OF INPUT VOLTAGE AND BIAS CURRENT

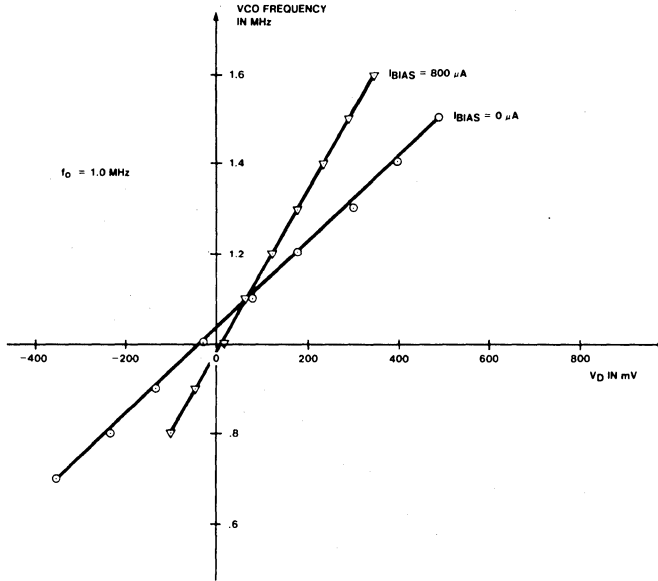

Figure 3

phase of the regenerator clock; however, in newer systems, bipolar signals are preprocessed (or preconditioned) by terminal common equipment resulting in unipolar information.

T1 Data Transmission

The bipolar signal as transmitted on a T1 line appears below with the original binary, converted unipolar and clock waveform (reference figure 5).

The bipolar signal when transmitted over standard wire pairs will be degraded both in wave shape and signal to noise by the time it reaches the signal repeater. This is due to the attenuation factor of the cable which is nearly -30dB for 6000 ft. In addition, pair to pair cross talk degrades signal to noise. The energy in the transmitted bipolar signal is centered at 772kHz due to the particular bit format. Bipolar signals have no dc offset.

At each receiving station the bipolar signal is amplified, filtered and fed through an automatic level control circuit. A full wave rectified signal is then sent to the clock regeneration circuit. This is essentially the for-

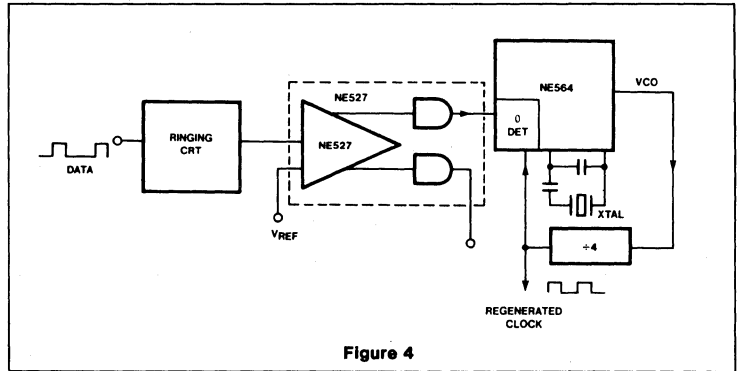

Figure 4

mat followed by some of the original T1 repeater equipment. The clock regeneration circuit described here could be adapted to this system.

THE T1 SPECTRUM

The bipolar signal is similar to NRZ data in that it does not contain carrier information. In order to give the PLL coherent frequency

information sufficient to obtain "capture" and lock, carrier components must be obtained from the data stream. The time duration of the frequency information fed to the PLL is also important in order to obtain ac-

NOTE
*The PLL clock regeneration circuit is fully compatible with NRZ data and needs no signal processing for this format.

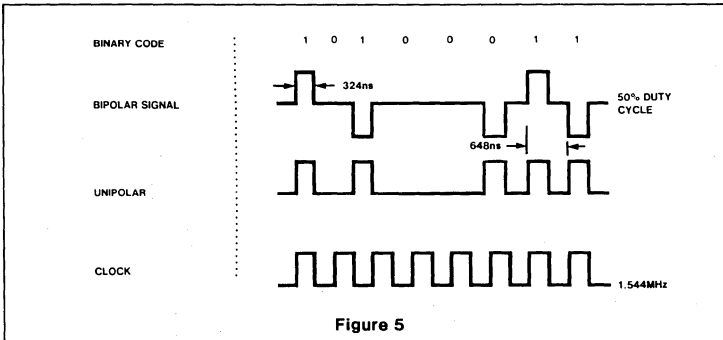

Figure 5

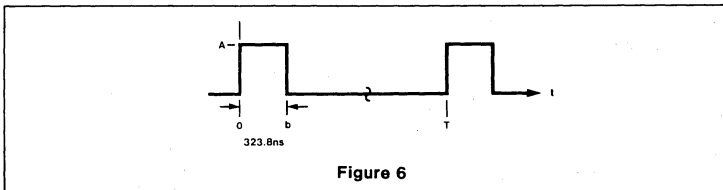

Figure 6

curate and stable information to update the PLL. In order to begin the extraction of frequency information, the positive going portions of the bipolar data signals are used to drive a class "C" transistor tank circuit (reference figure 4) which is sharply tuned to the basic clock frequency (1.544MHz). Each positive half cycle of data then starts a wave train of coherent information which is phase synchronous with each succeeding positive data bit. When the L-C tank is optimally tuned, relatively extended periods without data bits can be tolerated with minimal loss of frequency and phase information. The combination of good short term frequency stability of the high "Q" L-C tank, coupled with the long term stability of the crystal controlled VCO, is the foundation of the NE564 clock regeneration system accuracy.

It must be emphasized that data pulse synchronization of the pre-processing circuit must be frequency coherent with the fundamental period of the time base to be extracted. That is, if the time period of the clock is $\frac{1}{f_c} = T$, where f_c is the clock frequency, then the spacing between any positive code bit sequence must be $n \times T$ (reference figure 6).

Looking at the spectral analysis of the relative energy available to the clock extraction circuitry (with a worst case duty cycle of 1 of 16) will demonstrate the need for enhancing the particular desired frequency component before applying the signal to the Phase Lock Loop. For $f_0 = 1.544\text{MHz}$, the

period is $T = 647.67\text{ns}$. The pulse or bit width is 323.8ns.

Here the bit duration 323.8ns = b. The Fourier expansion of the discrete spectrum is related by the following equation.

$$F(n) = \left(\frac{Ab}{T} \right) \left| \frac{\sin\left(\frac{n\pi b}{T}\right)}{\frac{n\pi b}{T}} \right| \quad n = 0, 1, 2, \dots \quad (1)$$

The basic frequency component resulting from various bit spacing factors is defined by the equation

$$f = \frac{1}{T} \quad (2)$$

where $f = f_0 = 1.544\text{MHz}$

If we consider the special case of a single pulse present out of 16 bipolar or 32NRZ periods, then

$$\begin{aligned} T &= 16 \text{ bipolar bit times} \\ &= 16 \times 647.67\text{ns} = 10.36\mu\text{sec} \\ f &= 96.5\text{kHz} \end{aligned}$$

Accordingly, the spectral lines will be spaced in multiples of 96.5kHz. The spectrum for this particular worst case condition is shown in figure 7 below.

Solving equation 1 for the relative amplitude of the 1.544MHz spectral component with the pulse spacing shown,

$$\begin{aligned} F(16) &= \left(\frac{Ab}{T} \right) \left| \frac{\sin\left(\frac{16\pi b}{T}\right)}{\left(\frac{16\pi b}{T}\right)} \right| \\ \text{where } T &= 2nb, n = 16. \\ &= \left(\frac{Ab}{(2)(16)b} \right) \frac{\sin\left(\frac{16\pi b}{32b}\right)}{\left(\frac{16\pi b}{32b}\right)} = \frac{A}{32} \frac{2}{\pi} \\ &= (.02)A \\ &= -34\text{dB} \end{aligned}$$

It is evident that as the bit spacing increases to the point where f_0 is the 16th harmonic of the fundamental, very little f_0 energy is available to drive a phase lock regeneration circuit. $F(16)$ is a bad case since it is an even subharmonic of f_0 . The PLL will not normally lock to even harmonics; in fact, an error signal is produced which tends to force the VCO out of lock. This fact further stresses the need for preprocessing in the frequency domain. The class "C" pulsed resonant tank significantly multiplies the magnitude of the f_0 spectral component and filters out unwanted subharmonics.

The loop error voltage available from the phase detector for phase correction of the VCO is directly related to the product of the incoming coherent spectral energy multiplied in the balanced mixer with the reference signal derived from the VCO. Since the phase error information is integrated in the loop filters, the instantaneous magnitude of the dc error voltage is proportional to the time integral of coherent mixer products. Thus, as the magnitude and time duration of the desired frequency component is in-

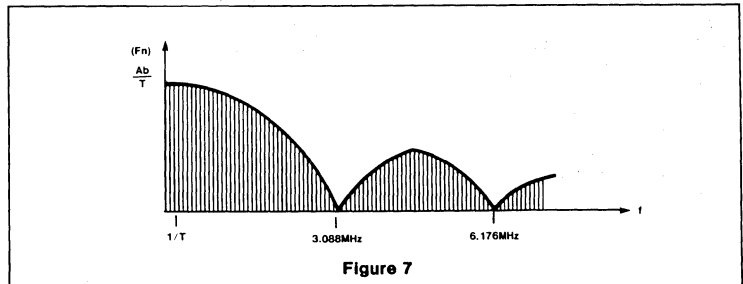

Figure 7

creased in the preprocessing circuitry, the VCO phase accuracy is greatly improved. Capture time is obviously enhanced also.

The signal from the tuned tank is buffered by a FET follower N-channel enhancement mode device (reference figure 12). This provides power gain with virtually no loading on the tank circuit and avoids degrading the "Q". The buffered signal is then fed to a high speed comparator (Signetics NE527) which allows for waveform symmetry adjustment in addition to providing a standard TTL output to drive the NE564 PLL.

In the particular circuit shown in figure 12, the 1.544MHz information is applied to the phase detector input of the NE564 Phase Lock Loop. The VCO, however, is operated at four (4) times this frequency in order to take advantage of economical and readily available crystals. The VCO signal is fed through a divide-by-four counter (74LS73) to provide the Phase Detector reference and final regenerated clock signal. To avoid loading, the clock signal (1.544MHz) is buffered by the 75451 peripheral driver which provides a high speed open collector TTL output. The input signal is AC coupled in order to reduce dc bias errors in the Phase Detector caused by "O" level variations.

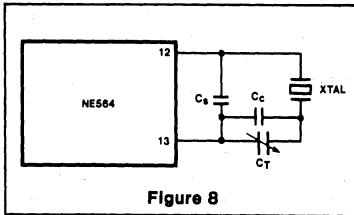

Figure 8

The Crystal

The crystal used was chosen to match the NE564 VCO drive characteristics. It is an "AT" cut oscillator crystal which operates near the anti-resonate or "parallel" mode in this circuit. The crystal may have to be fine tuned, as indicated in figure 8. The pulling characteristic of the crystal is adequate to allow for 0 to 70°C operational drift plus initial and aging accuracy tolerance factors and still retain lock between master and slave station VCXO's. The average lock range at room temperature with one of sixteen data bits present is typically 1000Hz for a 6.176MHz crystal with a capture range greater than 500Hz.

For VCO operation at 6.176MHz, C_s is 22pF, C_p is 18pF, and C_T, a 1-8pF trimmer capacitor (reference figure 8).

NE 564 CRYSTAL CONTROLLED VCO

As shown in figure 8, the crystal is operated with a series capacitor. When properly trimmed, this allows the crystal to operate near the series resonant mode. A crystal manufactured to operate in the series resonant mode will do so only if it sees a pure resistance looking into the oscillator terminals. The circuit below shows an oscillator which looks inductive with the equivalent crystal circuit and trimmer capacitor C_T (reference figure 9).

If L_O is small and the internal gain of the device high over a wide frequency range, L_O may resonate with the C_O of the crystal at a very high frequency. Under certain conditions the circuit may even tend to operate in the 3rd overtone mode unless measures are taken to roll off the circuit gain. This is the purpose of C_S in figure 8. Since the gain of the VCO is a factor in spurious oscillation, the current injected into pin 2 will also have an effect in this respect. (K₀ increases with I₂). At higher operating frequencies this parameter may become more critical in attaining stable start ups in the desired frequency mode. Obviously the size of C_S must be smaller than the value needed to cause free running near the desired frequency without the crystal connected.

CRYSTAL SPECIFICATION

Crystals may be manufactured to operate in either the series mode with no external capacitance (purely resistive load) or in the parallel mode with a specified value of load capacitance. The 564 tends to operate at a frequency above the specified value when a series mode crystal is used. For a design frequency of 6.176000MHz and zero load capacitance. Referring to figure 8, for C_S = 10pF and C_T = 10pF the average center frequency for an NE564 sample measured in the lab was 6181.192kHz. For the same C_S but with C_T equal to 80pF, f₀ measured 6176.565kHz. A second crystal showed a spread of 6176.800kHz to 6180.865kHz. The effect of the VCO was to pull the xtal to a frequency above its design value. This effect is then nearly tuned out by the external

capacitances C_S and C_T. If C_T is sufficiently increased, the crystal will see a purely resistive load and operate at its rated frequency.

A second approach is to specify a crystal which is to operate near the anti-resonate or parallel mode. Normally this is done with a certain value of external load capacitance specified by the customer which matches the existing circuit parameters. The maximum difference between series and parallel resonance for any crystal is 0.5% of f₀ (series resonant mode) For f_r = 6.126MHz, 0.5% of f_r = 30kHz. The usual value would be lower than this. (f_a = f_r√(1 + 1/Q₀²), f₀ = electromechanical coupling factor, f_a = parallel resonant frequency). The particular cut of the crystal material determines the drift response over temperature. For oscillator applications the AT cut offers the best overall stability over a wide frequency and temperature range. Final design uses second approach.

For a stability or total tolerance of ±15ppm over the rated operating range of -20°C to +70°C, a certain manufacturer's crystal actually performed as shown above. (Refer to figure 11.)

Calibration accuracy is the allowable frequency tolerance at the reference temperature, i.e. ±10ppm @ 25°C.

Third is a long term drift spec which determines the customer's maximum allowable drift due to aging effects. An acceptable value in quality crystals is ±2ppm/year.

Using our reference crystal of 6.176MHz and the above specifications, the crystal limits over a 1 year period would be:

Temperature stability:	± 15ppm x 6.176
	= ± 93HZ
Calibration tolerance:	± 10ppm x 6.176
	= ± 62HZ
@ 25°C	
Long term drift:	± 2ppm x 1 x 6.176
	= ± 12HZ
Total—	(± 167Hz)

The above figure of ±167Hz then determines the capture and lock range over which

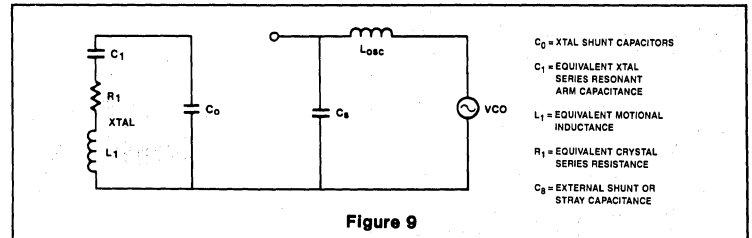
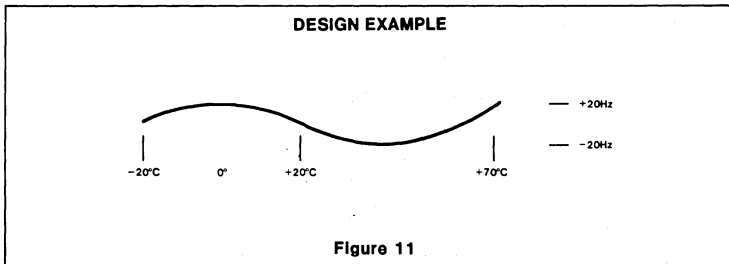
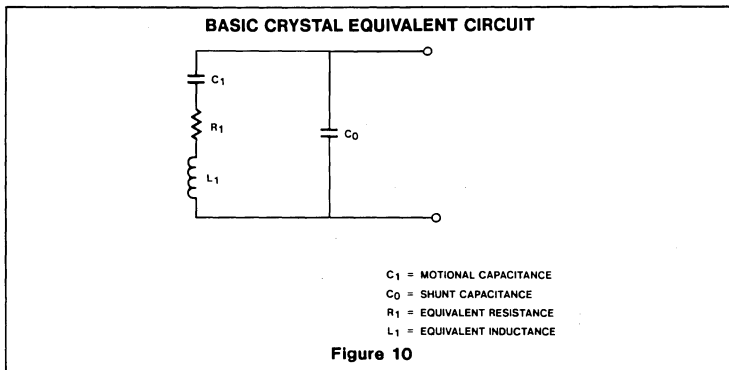

Figure 9



two crystal stabilized VCO's must track under worst case conditions when the exact same crystal specifications are used for master and slave units within an operational system.

CRYSTAL SPECIFICATIONS

'AT' CUT OSCILLATOR TYPE

Fundamental mode operation HC-33 Case (Standard)

Calibration tolerance:
± 10ppm @ 25°C

Temperature stability:
± 15ppm; -15°C to +65°C

Circuit operating condition:
Parallel resonance

Frequency specified: 6.176000MHz

Part designation:
Crown #A330 DEF-32 or equivalent

Set-up Procedure

Referring to figure 12, the following set-up procedure will aid the user in establishing proper circuit operation.

Regulated supply voltage of +5 and -6 volts are required. Current drain on the +5V line is ~ 100mA, and 6mA for the -6V.

With proper voltage applied (1), first check the supply currents to be sure they are in the

range indicated above. (2), check the operation of the NE564 VCXO by looking at pin 9 with an oscilloscope (see figure 13). A reasonably symmetric square wave should be present, having a frequency near 6.1MHz. (3), attach a DVM across the 2K resistor which feeds pin 2 of the NE564 and adjust for a reading of 2.00 volts, indicating a 1 milliampere dc current flowing into pin #2.

(The (+) lead of the DVM should be connected to the end of the 2K resistor which ties to the wiper of the 10K pot and the (-) lead to pin 2 of the 564. Reference figure 14).

(4), the exact center frequency is set by adjusting C_T , the crystal trimmer cap, for exactly 6.176000MHz with no signal input (This sets the center frequency of the VCXO to free run in the center of the capture range.).

(5), enable strobe 'A' and 'B' with a +2.7V min. to +5V max. level. Apply a standard 1.544MBS NRZ data signal to the input terminal, terminated in 50 ohms. The amplitude should be +3 to +5V (0 to peak). Set the duty cycle for 1 bit in a 16 bit period. Note the data generator must be driven from a crystal controlled master oscillator also adjusted for a center data rate of 1.544 000MBS. Monitor the buffered output of the

ringing circuit with a scope connected to the source of the SD213 (figure 15).

The waveform should appear as in figure 17.

(6), adjust tank trimmer cap C_T for a maximum amplitude and note that the cycle period should be 647 nanoseconds. (7), Now monitor the comparator output signal at pin 7 and adjust R_T for a 50% duty cycle. The same signal will appear at pin 5 of the NE527 except it will be inverted. The signal on pin 7 of the NE527 and pin 6 of the NE564 should appear as shown in figure 19. Now attach one lead of a dual trace scope to pin 7 of the NE527 and the other to pin 3 of the NE564 as shown (figure 16).

The two signals should be in phase lock with an approximate 90° differential as shown in figure 20 (data signal applied to input @ 1.544MBS). If lock does not occur, a slight trimming of the crystal trimmer C_T should correct for slight differences in master to slave crystal tolerance. It is recommended that master and slave crystals be of the exact same design and specification to insure optimal tracking over time and temperature. A recommended manufacturer and part number appears at the end of this application note for your convenience.

Once lock is attained, move one lead of the dual trace scope to the buffered output of the 75451 pin 3, leaving the other scope probe on pin 6 of the NE564. The phase locked waveform should appear as in figure 25. If a data word generator is being used, you may check overall operation for various bit patterns by synchronizing the scope trigger on the "end of word" pulse, then observe the phase error effect as different combinations are fed in.

PHASE JITTER

When operating with real time A-D data transmission, the PLL loop filters must be optimized to minimize regenerated clock jitter. A good grade of mylar capacitor is recommended as connected to pins 4 and 5 of the NE564. A simple pair of shunt connected loop filter caps of 0.33 μ F to 0.76 μ F was found to be adequate.



DATA TRANSMISSION SYSTEM CLOCK REGENERATOR

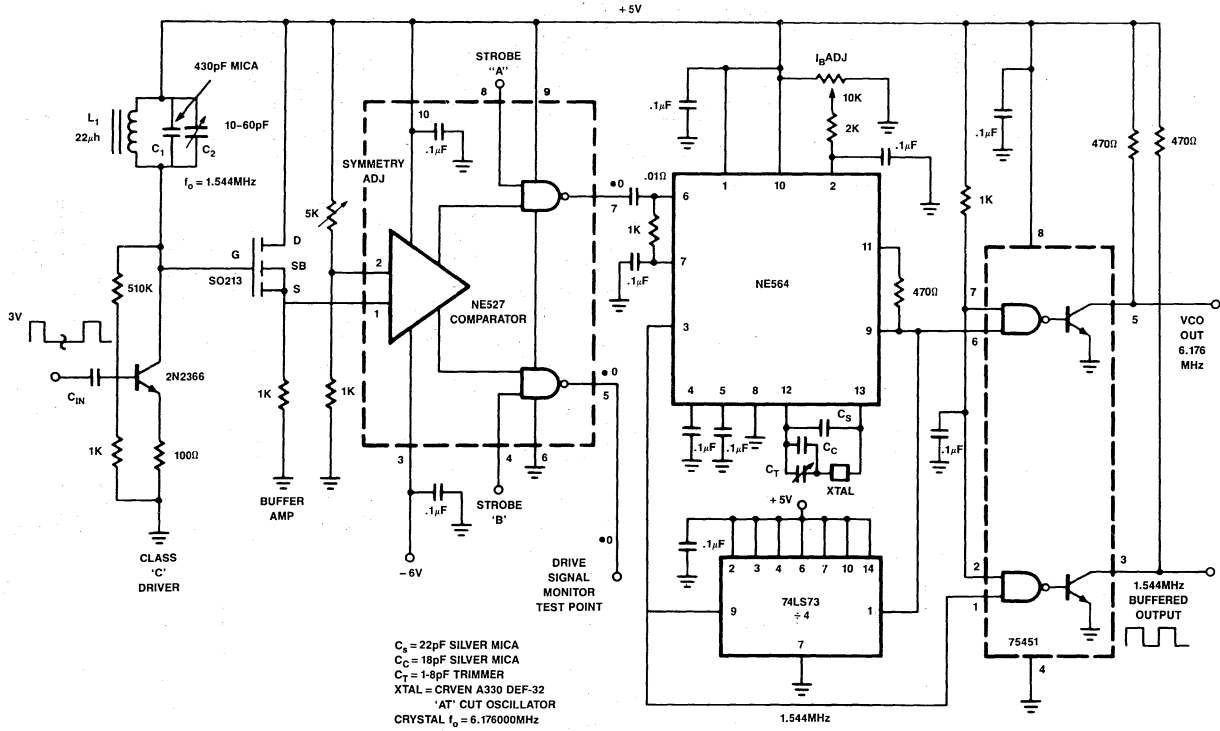
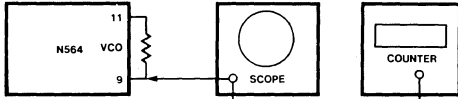

Figure 12

CHECK VCO FREE RUNNING FREQUENCY AND OUTPUT WAVESHAVE



CHECK VCO FREE RUNNING FREQUENCY AND OUTPUT WAVESHAVE.

Figure 13

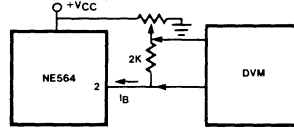

Figure 14

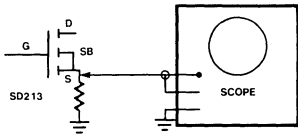

Figure 15

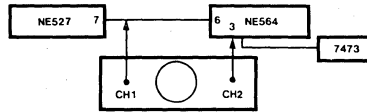

Figure 16

RINGING CIRCUIT RESPONSE (1 DATA PULSE IN 16)

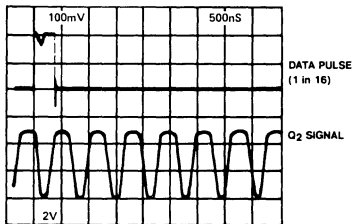

Figure 17

RINGING CIRCUIT RESPONSE (4 DATA PULSES IN 16)

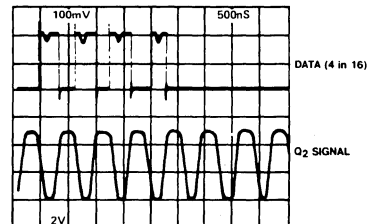

Figure 18

RINGING CIRCUIT TO SQUARE WAVE CONVERSION

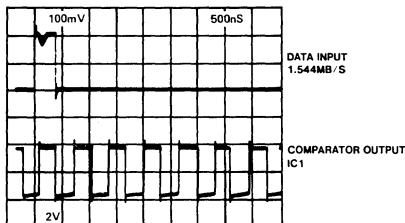

Figure 19

PHASE COMPARATOR SIGNALS (IN LOCK)

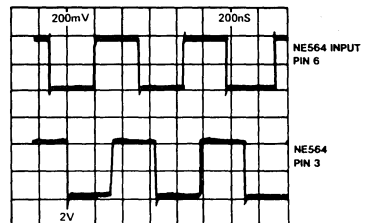
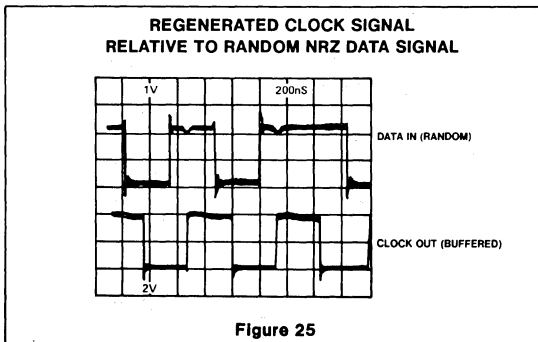
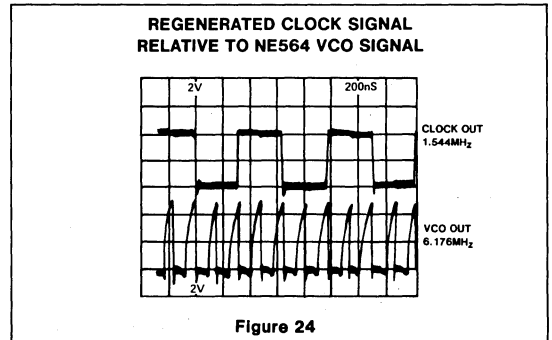
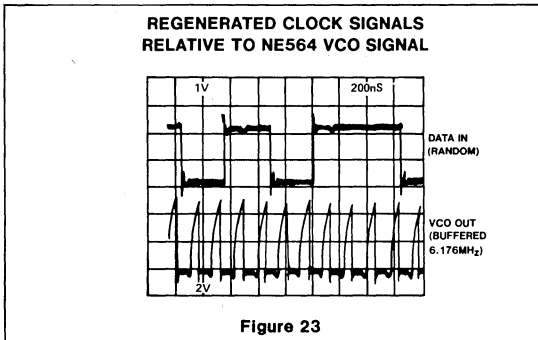
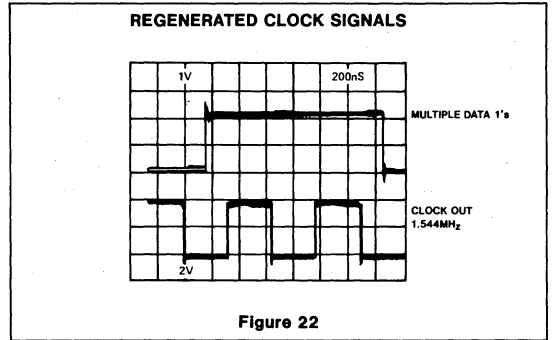
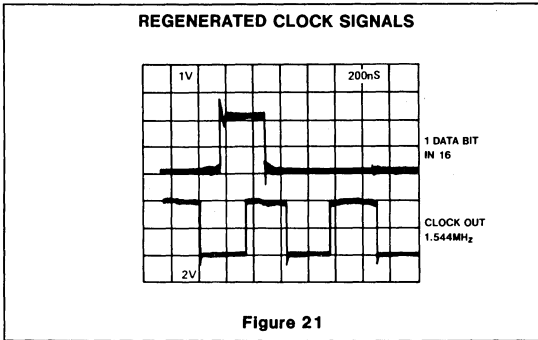

Figure 20



References

1. "Fourier Analysis" by Hwei P. Hsu. Simon & Schuster Tech Outlines
2. "Pulse and Digital Circuits" by Millman and Taub McGraw Hill
3. "Phaselock Techniques" by Floyd M. Gardner Wiley, 1966

CIRCUIT DESCRIPTION OF THE NE565 PLL

AN183

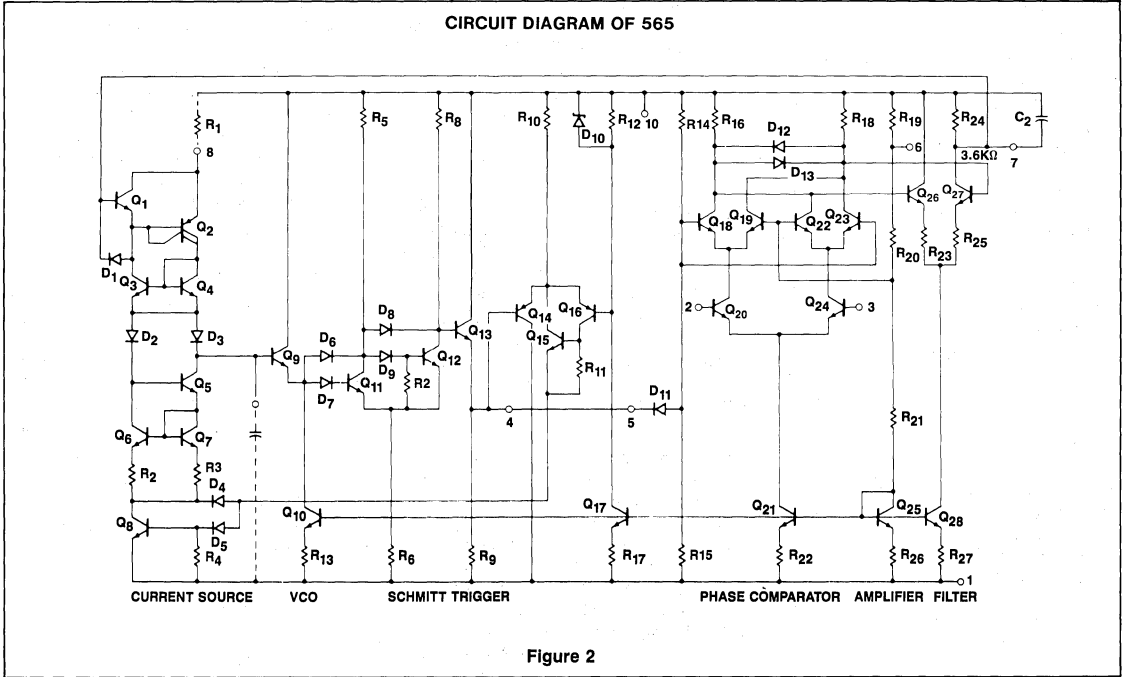

The tracking range for the 565 then becomes:

$$f_L \approx \pm \frac{\omega_L}{2\pi} \approx \pm \frac{8f_0}{V_{CC}} \text{ Hz.} \quad (7)$$

to each side of the free-running frequency, or a total lock range of:

$$2f_L \approx \frac{16f_0}{V_{CC}} \text{ Hz} \quad (8)$$

The capture range, over which the loop can acquire lock with the input signal is given approximately by:

$$2\omega_C \approx 2\sqrt{\frac{\omega_L}{\tau}} \quad (9)$$

where ω_L is the one-sided tracking range

$$\omega_L = 2\pi f_L \quad (10)$$

and τ is the time constant of the loop filter

$$\tau = RC_2 \quad (11)$$

The lock-in range can be written as:

$$f_C \approx \pm \frac{1}{2\pi} \sqrt{\frac{2\pi f_L}{\tau}} = \pm \frac{1}{2\pi} \sqrt{\frac{32\pi f_0'}{V_{CC}}} \quad (12)$$

to each side of the free-running frequency or a total capture range of:

$$f_C \approx \frac{1}{\pi} \sqrt{\frac{32\pi f_0'}{\tau V_{CC}}} \quad (13)$$

This approximation works well for narrow capture ranges ($f_C = 1/3f_L$ but becomes too large as the limiting case is approached ($f_C = f_L$).

When it is desired to operate the 565 out of its limiting mode ($V_{in} < 200\text{mV p-p}$ or 32mV rms), K_d can be estimated from the graph in Figure 3 for the specific input voltage anticipated. The previous calculations for the lock and capture ranges remain valid with the new value of K_d from the graph being used to replace the $K_d A$ product in Equation 2. In Figure 3, the dc amplifier gain A has been included in the K_d value.

For applications where both a narrow lock range and a large output voltage swing are required, it is necessary to inject a constant current into pin 8 and increase the value of R_1 . One scheme for this is shown in Figure 4. The basis for this scheme is the fact that the output voltage controls only the current through R_1 while the current through Q_1 remains constant. Thus, if most of the charging current is due to Q_1 , the total current can be varied only a small amount due to the small change in current through R_1 . Consequently, the VCO can track the input signal

over a small frequency range yet the output voltage of the loop (control voltage of the VCO) will swing its maximum value.

Diode D_1 is a Zener diode, used to allow a larger voltage drop across R_A than would otherwise be available. D_4 is a diode which should be matched to the emitter-base junction of Q_1 for temperature stability. In addition, D_1 and D_2 should have the same breakdown voltages and D_3 and D_4 should be similar so that the voltage seen across R_B and R_C is the same as that seen across pins 10 and 1 of the phase locked loop. This causes the frequency of the loop to be insensitive to power supply variations. The free-running frequency can be found by:

$$f_0' \approx \frac{2R_B}{(R_B + R_C) R_A C_1} + \frac{1}{4R_1 C_1} \text{ Hz} \quad (14)$$

and the total range is given by:

$$2f_L \approx \frac{22.4V_D(R_B + R_C)R_A f_0'}{(|V_1| + |V_2| - V_Z - V_D)[8R_B R_1 + R_A(R_B + R_C)]} \text{ Hz} \quad (15)$$

where V_D is the forward biased diode voltage ($\approx 0.7\text{V}$), V_Z is the zener diode breakdown voltage, V_1 is the positive supply voltage, and V_2 is the negative supply voltage.

PHASE COMPARATOR'S CONVERSION GAIN, K_D , FOR THE 565 AS A FUNCTION OF INPUT SIGNAL AMPLITUDE

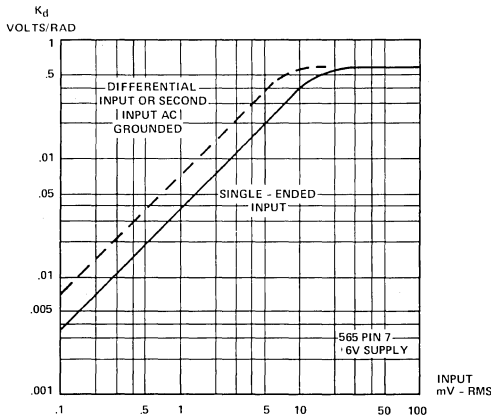

Figure 3

NARROW BANDWIDTH FM DEMODULATOR USING THE 565

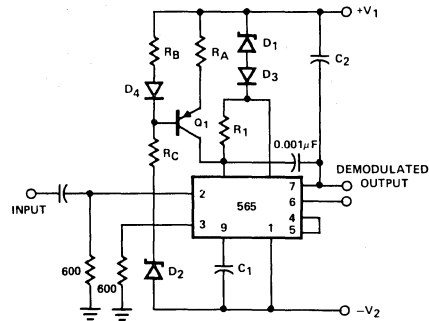

Figure 4

When the output excursion at pin 7 need be only a volt or so, diodes D_1 , D_2 and D_3 may be replaced by short circuits.

The value of R_1 can be selected to give a prescribed output voltage for a given frequency deviation.

$$R_1 = \frac{R_A(R_B+R_C) f_o'}{R_B(|V_1| + |V_2| - 0.7) \Delta f} \quad (16)$$

where Δf is the desired frequency deviation per volt of output.

In most instances, R_B and R_A are chosen to be equal so that the voltage drop across them is about 200mV. For best temperature stability, diode D_1 should be a base-collector shorted transistor of the same type as Q_1 .

When the 565 is connected normally, feedback to the VCO from the phase comparator is internal. That is, an amplifier makes the pin 8 voltage track the pin 7 (phase comparator output) voltage. Since the capacitor C_1 charge current is determined by the current through resistance R_1 , the frequency is a

function of the voltage at pin 8. It is possible, however, to bypass and swamp the internal loop amplifier so that the current into pin 8 is no longer a function of the pin 8 voltage but only of the pin 7 voltage. This makes a greater charge-discharge current variation possible, allowing a greater lock range. Figure 5 shows such a circuit in which the $\mu A741$ operational amplifier is set for a differential gain of 5, feeding current to pin 8 through the 33K Ω resistor (simulating a current source). Not only is the tracking range greatly expanded, but the output voltage as a function of frequency is five times greater than normal. In setting up such a circuit, the designer should keep in mind that for best frequency stability, the charge-discharge current should be in the range of 50 to 1500 μA which also specifies the pin 8 input current range, showing that a ratio of upper to lower lock extremes of about 30 can be achieved.

Many times it would be advantageous to be able to break the feedback connection between the output (pin 7) and the control voltage terminal (Q1) of the VCO. This can be easily done once it is seen that it is the *current*

into pin 8 which controls the VCO frequency. Replacing the external resistor R_1 with a current source, such as the Figure 6, effectively breaks the internal voltage feedback connection. The current flowing into pin 8 is now independent of the voltage on pin 8. The output voltage (on pin 7) can now be amplified or filtered and used to drive the current source by a scheme such as that shown in Figure 6. This scheme allows the addition of enough gain for the loop to stay in lock over a 100:1 frequency range, or conversely, to stay in lock with a precise phase difference (between input and VCO signals) which is almost independent of frequency variation. Adjustment of the voltage to the non-inverting input of the op amp, together with a large enough loop gain allows the phase difference to be set at a constant value between 0° and 180° . In addition, it is now possible to do special filtering to improve the performance in certain applications. For instance, in frequency multiplication applications it may be desirable to include a notch filter tuned to the sum frequency component to minimize incidental FM without excessive reduction of capture range.

CIRCUIT DESCRIPTION OF THE NE565 PLL

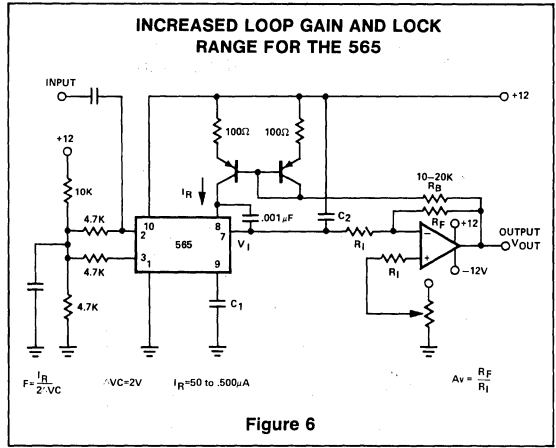
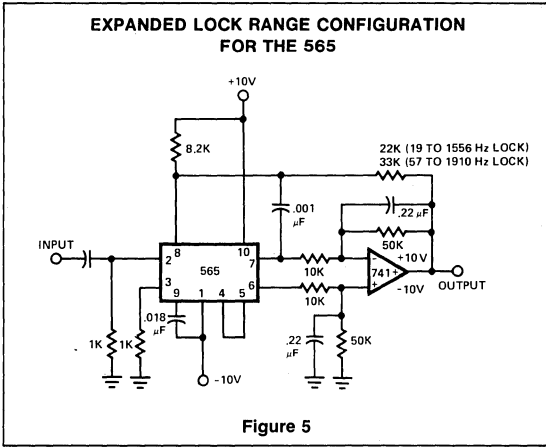

FSK DEMODULATION

FSK refers to data transmission by means of a carrier which is shifted between two preset frequencies. This frequency shift is usually accomplished by driving a VCO with the binary data signal so that the two resulting frequencies correspond to the "0" and "1" states (commonly called space and mark) of the binary data signal.

FSK Demodulation with the 565

A simple scheme using the 565 to receive FSK signals of 1070Hz and 1270Hz is shown in Figure 1. As the signal appears at the input, the loop locks to the input frequency and tracks it between the two frequencies with a corresponding dc shift at the output (pin 7).

The loop filter capacitor C_2 is chosen to set the proper overshoot on the output and a three-stage RC ladder filter is used to remove the sum frequency components. The band edge of the ladder filter is chosen to be approximately half-way between the maximum keying rate (300 baud or bits per second, or 150Hz). The free-running frequency should be adjusted (with R_1) so that the dc voltage level at the output is the same as that at pin 6 of the loop. The output signal can now be made logic compatible by connecting a voltage comparator between the output and pin 6.

The input connection is typical for cases where a dc voltage is present at the source and, therefore, a direct connection is not desirable. Both input terminals are returned to ground with identical resistors (in this case, the values are chosen to achieve a 600Ω input impedance).

A more sophisticated approach primarily useful for narrow frequency deviations is shown in Figure 2. Here, a constant current is injected into pin 8 by means of transistor Q1. This has the effect of decreasing the lock range and increasing the output voltage sensitivity to the input frequency shift. The basis for this scheme is the fact that the output voltage (control voltage for the VCO) controls only the current through R_1 , while the current through Q1 remains constant. Thus, if most of the capacitor charging current is due to Q1, the current variation due to R_1 will be a small percentage of the total charging current and, consequently, the total frequency deviation of the VCO will be limited to a small percentage of the center frequency. A 0.25μF loop filter capacitor gives approximately 30% overshoot on the output pulse, as seen in the accompanying photographs. Figure 3 shows the output of the μA710 comparator and the output of the 565 phase locked loop.

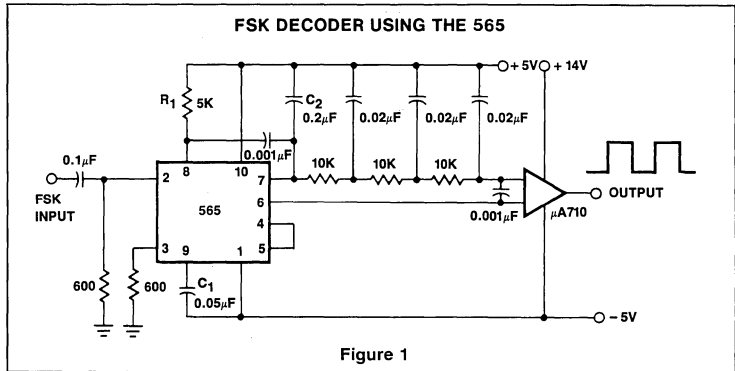

Figure 1

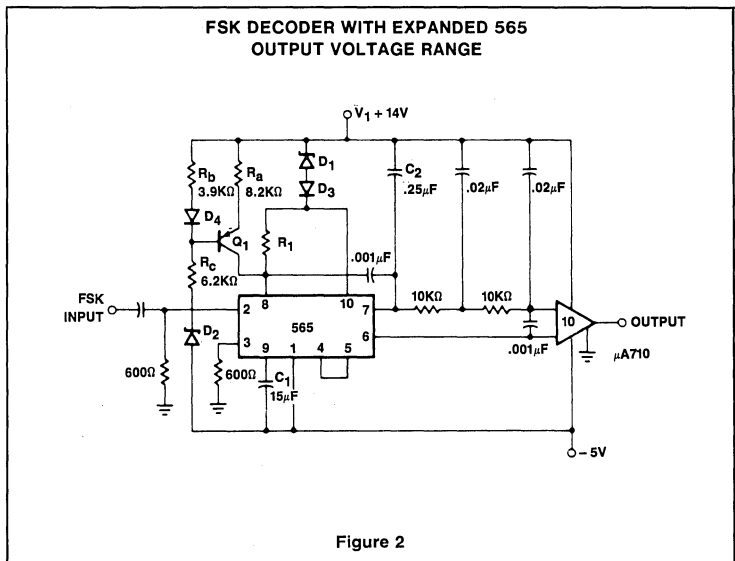
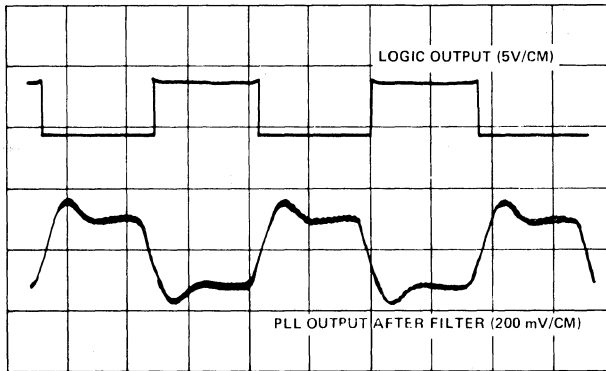
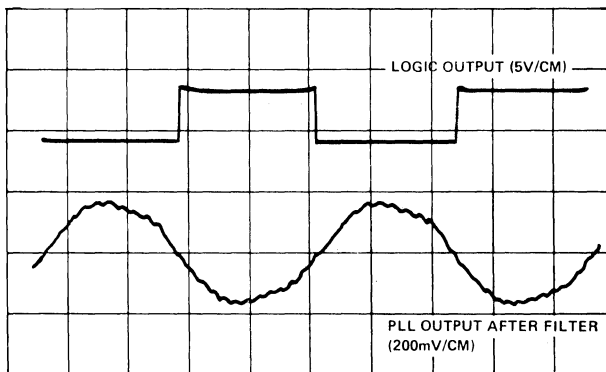

Figure 2

(a) 100 BAUD



(b) 200 BAUD



(c) 300 BAUD

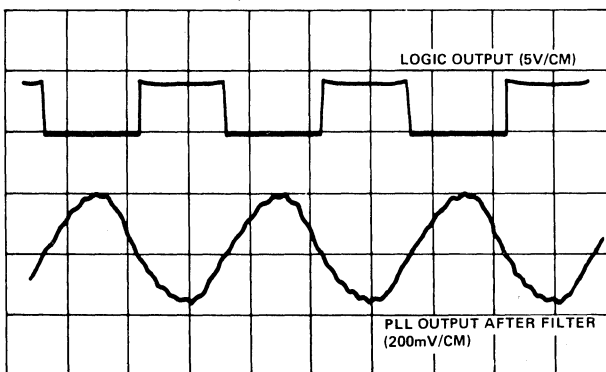
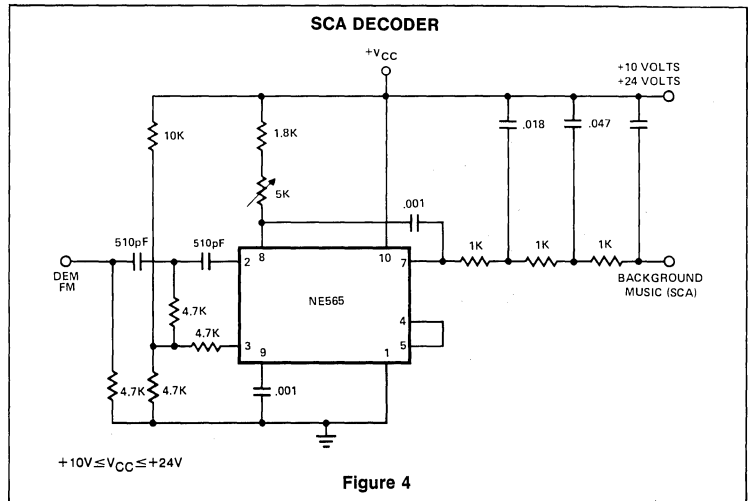

Figure 3

SCA Demodulator Using the 565

This application involves demodulation of a frequency modulated subcarrier of the main channel. A popular example here is the use of the PLL to recover the SCA (Subsidiary Carrier Authorization or storecast music) signal from the combined signal of many commercial FM broadcast stations. The SCA signal is a 67kHz frequency modulated subcarrier which puts it above the frequency spectrum of the normal stereo or monaural FM program material. By connecting the circuit of Figure 5.14 to a point between the FM discriminator and the de-emphasis filter of a commercial band (home) FM receiver and tuning the receiver to a station which broadcasts an SCA signal, one can obtain hours of commercial free background music.



CIRCUIT DESCRIPTION OF THE 566 PLL

The 566 is the voltage controlled oscillator portion of the 565. The basic die is the same as that of the 565; modified metalization is used to bring out only the VCO. The 566 circuit diagram is shown in Figure 1. Transistor Q 18 provides a buffered triangle waveform output. (The triangle waveform is available at capacitor C₁ also, but any current drawn from pin 7 will alter the duty cycle and frequency.) The square wave output is available from Q 19 by pin 4. The circuit will operate at frequencies up to 1MHz and may be programmed by the voltage applied on the control terminal (pin 5), by injecting current into pin 6, or by changing the value of the external resistor and capacitor (R₁ and C₁.)

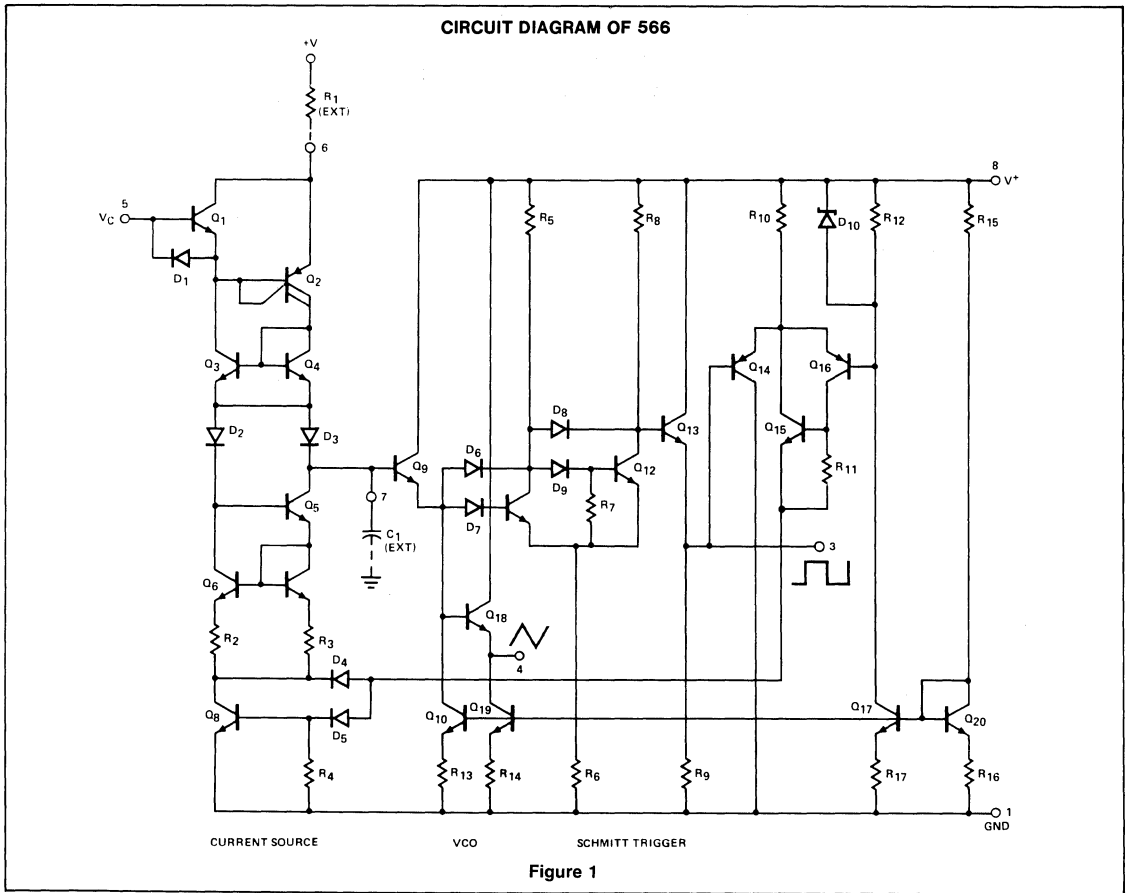

WAVEFORM GENERATORS

The oscillator portion of many of the PLLs can be used as a precision, voltage-controllable waveform generator. Specifically, the 566 Function Generator contains the oscillator of the 565 PLL. Most of the applications which follow are designs using the 566. Many of these designs can be modified slightly to utilize the oscillator section of the 564 if higher frequency performance is desired.

Ramp Generators

Figure 1 shows how the 566 can be wired as a positive or negative ramp generator. In the positive ramp generator, the external transistor driven by the pin 3 output rapidly discharges C_1 at the end of the charging period so that charging can resume instantaneously. The pnp transistor of the negative ramp generator likewise rapidly charges the timing

capacitor C_1 at the end of the discharge period. Because the circuits are reset so quickly, the temperature stability of the ramp generator is excellent. The period τ is $1/2 f_0$ where f_0 is the 566 free-running frequency in normal operation. Therefore,

$$T = \frac{1}{2f_0} = \frac{R_T C_1 V_{CC}}{5(V_{CC} - V_C)} \quad (1)$$

where V_C is the bias voltage at pin 5 and R_T is the total resistance between pin 6 and V_{CC} . Note that a short pulse is available at pin 3. (Placing collector resistance in series with the external transistor collector will lengthen the pulse.)

Sawtooth and Pulse Generator

Figure 2 shows how the pin 3 output of the 566 can be used to provide different charge and discharge currents for C_1 so that a sawtooth output is available at pin 4 and a pulse at pin 3. The pnp transistor should be well saturated to preserve good temperature stability.

The charge and discharge times may be estimated by using the formula

$$T = \frac{R_T C_1 V_{CC}}{5(V_{CC} - V_C)} \quad (2)$$

where R_T is the combined resistance between pin 6 and V_{CC} for the interval considered.

Triangle to Sine Converters

Conversion of triangle wave shapes to sinusoids is usually accomplished by diode-resistor shaping networks, which accurately reconstruct the sine wave segment by segment. Two simpler and less costly methods may be used to shape the triangle waveform of the 566 into a sinusoid with less than 2% distortion.

In Figure 3, the non-linear $I_{DS} \cdot V_{DS}$ transfer characteristic of a p-channel junction FET is used to shape the triangle waveform.

RAMP GENERATORS

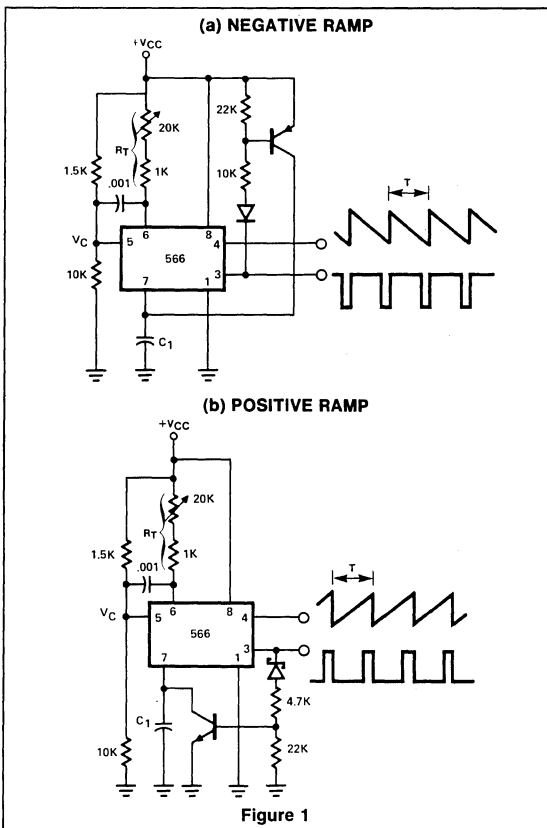

Figure 1

SAWTOOTH AND PULSE GENERATORS

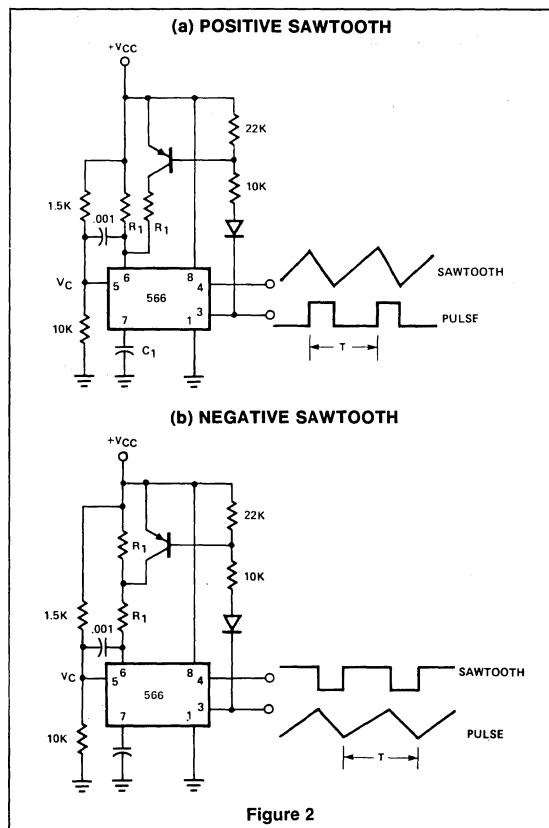

Figure 2

The amplitude of the triangle waveform is critical and must be carefully adjusted to achieve a low distortion sinusoidal output. Naturally, where additional waveform accuracy is needed, the diode-resistor shaping scheme can be applied to the 566 with excellent results since it has very good output amplitude stability when operated from a regulated supply.

Single Tone Burst Generator

Figure 4 is a tone burst generator which supplies a tone for one-half second after the power supply is activated; its intended use is a communications network alert signal. Cessation of the tone is accomplished at the

SCR, which shunts the timing capacitor C_1 charge current when activated. The SCR is gated on when C_2 charges up to the gate voltage which occurs in 0.5 seconds. Since only 70 μ A are available for triggering, the SC must be sensitive enough to trigger at this level. The triggering current can be increased, of course, by reducing R_2 (and increasing C_2 to keep the same time constant). If the tone duration must be constant under widely varying supply voltage conditions, the optional Zener diode regulator circuit can be added, along with the new value for R_2 , $R_2' = 82k\Omega$.

If the SCR is replaced by a npn transistor, the tone can be switched on and off at will at the transistor base terminal.

Low Frequency FM Generators

Figure 5 shows FM generators for low frequency (less than 0.5MHz center frequency) applications. Each uses a 566 function generator as a modulation generator and a second 566 as the carrier generator.

Capacitor C_1 selects the modulation frequency adjustment range and C_1' selects the center frequency. Capacitor C_2 is a coupling capacitor which only needs to be large enough to avoid distorting the modulating waveform.

If a frequency sweep in only one direction is required, the 566 ramp generators given in this section may be used to drive the carrier generator.

TRIANGLE-TO-SINE CONVERTERS

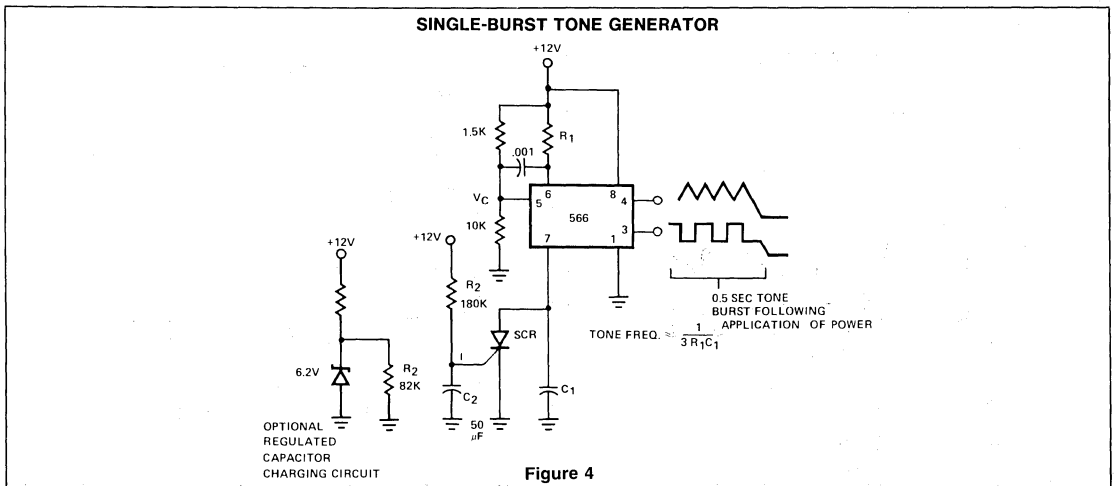
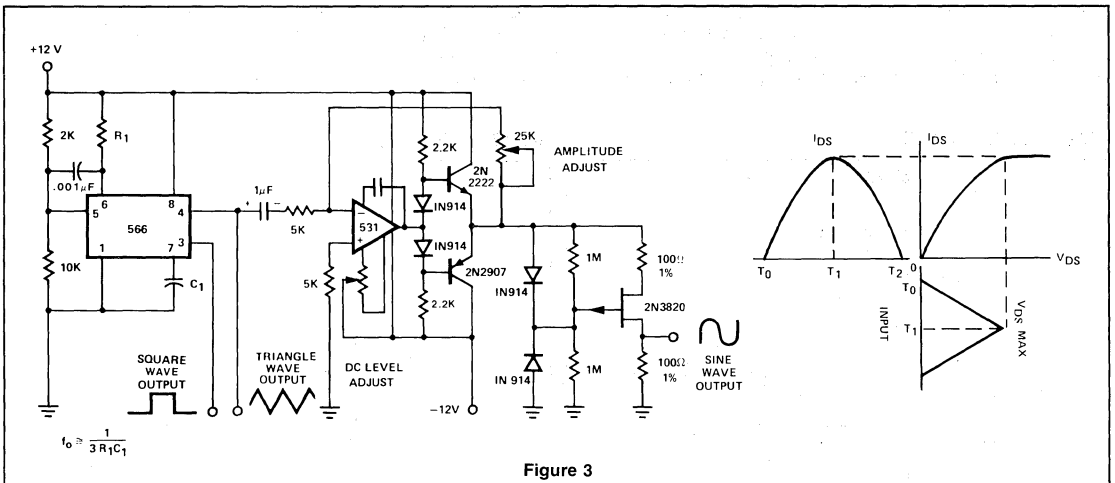

FREQUENCY MODULATED GENERATORS

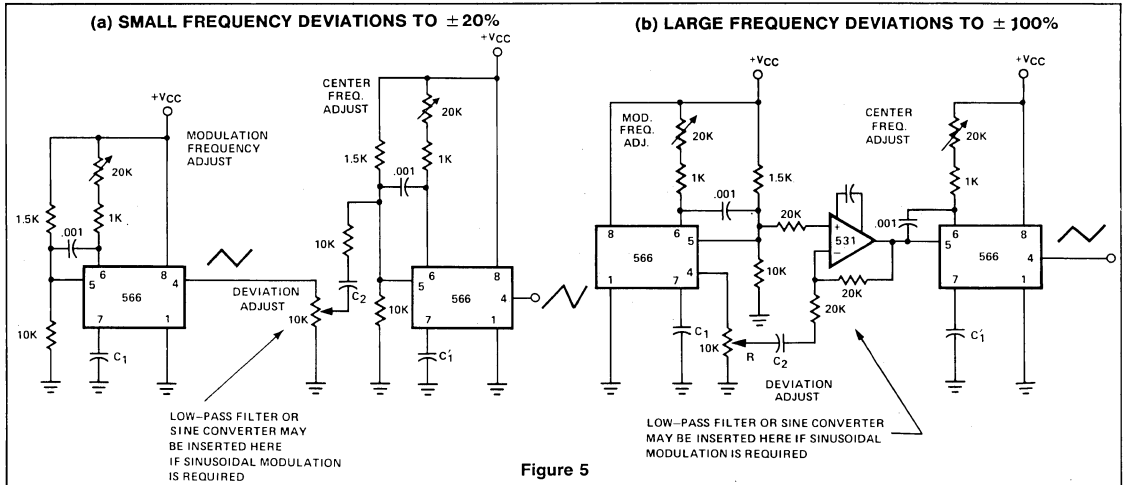

Figure 5

1. Appleton, E.V., "Automatic Synchronization of Triode Oscillators," *Proc. Cambridge Phil. Soc.*, vol. 2, pt. III, p. 231, 1922-1923.
2. Gardner, F.M., *Phaselock Techniques*, New York: Wiley, 1966.
3. Blanchard, A., *Phase-Locked Loops*, New York: Wiley, 1976.
4. Viterbi, A.J., *Principles of Coherent Communication*, New York: McGraw-Hill, 1966.
5. Connelly, J.A., *Analog Integrated Circuits: Devices, Circuits, Systems, and Applications*, New York: Wiley, 1975.
6. Grebene, A.B., *Analog Integrated Circuit Design*, New York: Van Nostrand-Reinhold, 1972.
7. Gupta, S.C., "Phase-Locked Loops," *Proc. IEEE*, vol. 63, no. 2, pp. 291-306, Feb. 1975.
8. D'Azzo, J.J. and C.H. Houpis, *Feedback Control System Analysis* (Second Edition), New York: McGraw-Hill, 1966, p. 81.
9. Gilbert, B., "A New Wideband Amplifier Technique," *IEEE J. of Solid State Ckts.*, SC-3(4), pp. 353-365, 1968.
10. Gardner, op. cit., pp. 117-119.
11. Milligan, L.V. and E. Cornicelli, "Phase Locked Loops Provide Accurate, Efficient DC Motor Speed Control," *EDN*, August 1, 1972, pp. 32-35.

CIRCUIT DESCRIPTION OF THE 567 TONE DECODER

AN187

CIRCUIT DESCRIPTION OF THE 567 TONE DECODER

The 567 is a PLL designed specifically for frequency sensing or tone decoding. The 567 has a controlled oscillator, a phase comparator and a second auxiliary or quadrature phase detector. In addition, however, it contains a power output stage which is driven directly by the quadrature phase detector output. During lock, the quadrature phase detector drives the output stage on, so the device functions as a tone decoder or frequency relay. The tone decoder free-running frequency and bandwidth are specified by the free-running frequency and capture range of the loop portion. Since a tone decoder, by definition, responds to a stable frequency, the lock or tracking range is relatively unimportant except as it limits the maximum attainable capture range. The complete circuit diagram of the 567 is shown in Figure 1.

The current controlled oscillator is shown in simplified form in Figure 2. It provides both a square wave output and a quadrature output. The control current I_c sweeps the oscillator $\pm 7\%$ of the free-running frequency, which is set by external components R_1 and C_1 .

Transistors Q1 through Q6 form a flip-flop which can switch pin 5 between V_{BE} and $+V - V_{BE}$. Thus, the R_1C_1 network is driven from a square wave of $+V - 2V_{BE}$ peak-to-peak volts. On the positive portion of the square wave, C_1 is charged through R_1 until V_1 is reached. A comparator circuit driven from C_1 at pin 6 then supplies a pulse which resets the flip-flop so that pin 5 switches to V_{BE} and C_1 is discharged until V_2 is reached. A second comparator then supplies a pulse which sets the flip-flop and C_1 resumes charging.

The total swing of the capacitor voltage, as determined by the comparator sensing voltages, is

$$V_1 - V_2 = (+V - 2V_{BE}) \left[\frac{R_{22} + R_{23}}{R_{21} + R_{22} + R_{23} + R_{24}} \right] = K (+V - 2V_{BE}) \quad (1)$$

Due to the excellent matching of integrated resistors, the resistor ratio K may be considered constant. Figure 3 shows the pin 5 and pin 6 voltages during operation. It is obvious from the proportion that $t_1 + t_2$ is independent of the magnitude of $+V$ and dependent only on the time constant R_1C_1 of the external components. Moreover, if $(V_1 + V_2)/2 = +V/2$, then $t_1 = t_2$ and the duty cycle is 50%. Note that the triangular waveform is phase shifted from the square wave.

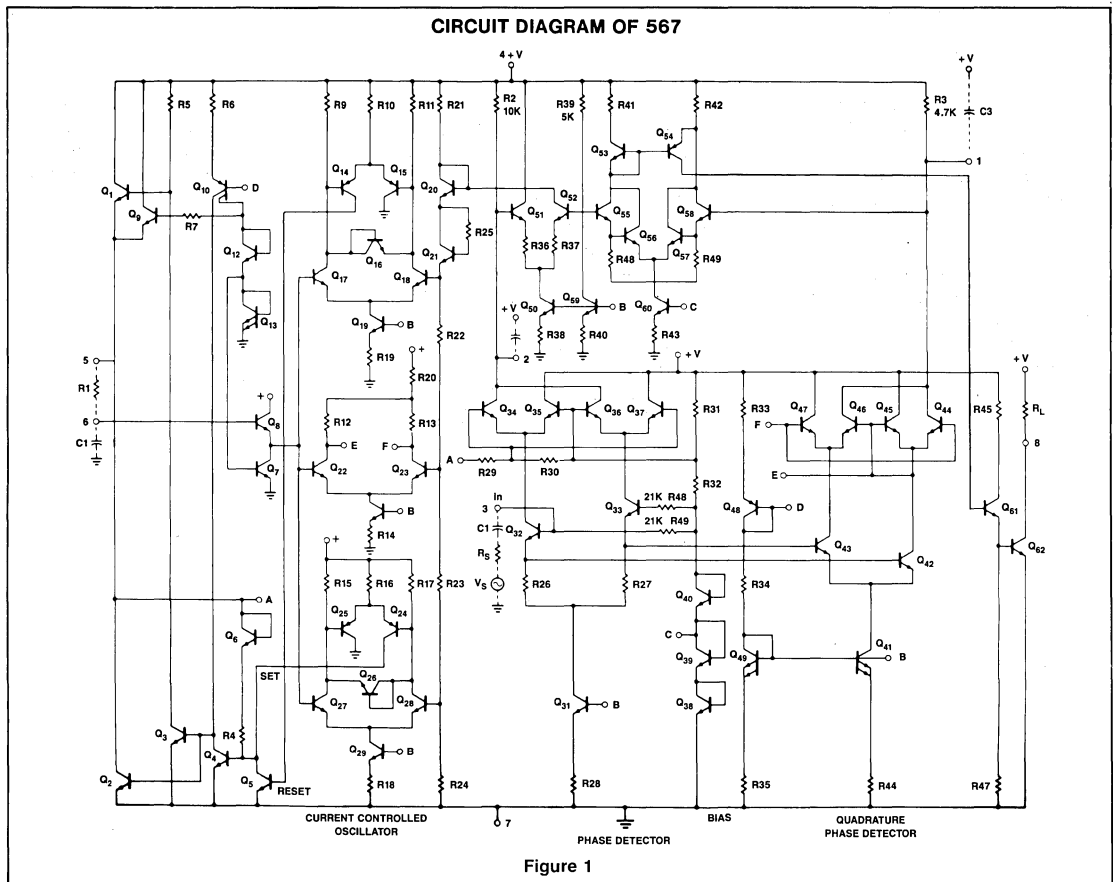

Figure 1

CIRCUIT DESCRIPTION OF THE 567 TONE DECODER

AN187

A differential stage (Q22 and Q23) amplifies the triangular wave with respect to $(V_1 + V_2)/2$ to provide the quadrature output. (Due to the exponential distortion of the triangle wave, the quadrature output is actually phase shifted about 80° , but no operating compromises result from this slight deviation from true quadrature.)

One source of error in this oscillator scheme is current drawn by the comparators from the R_1C_1 mode. An emitter follower,

therefore, is inserted at X to minimize this drain and Q21 placed in series with Q20 to drop the comparator sensing voltage one V_{BE} to compensate for the V_{BE} drop in the emitter follower.

In order to insure that the square wave drops quickly and accurately to V_{BE} , an active clamp scheme is applied to the collector of Q2. The base of Q9 is held at $2V_{BE}$ so that as Q2 is turned on its base current, its collector is held at V_{BE} . Because Q2

and Q3 have the same geometry and their base-emitter voltages are the same, the maximum Q2 current when clamped is essentially the same as the collector current of Q3 (as limited by R_5). The flip-flop was optimized for maximum switching speed to reduce frequency drift due to switching speed variations.

Current control of the frequency is achieved by making R_{21} somewhat less than R_{24} and restoring the proper voltage for 50%

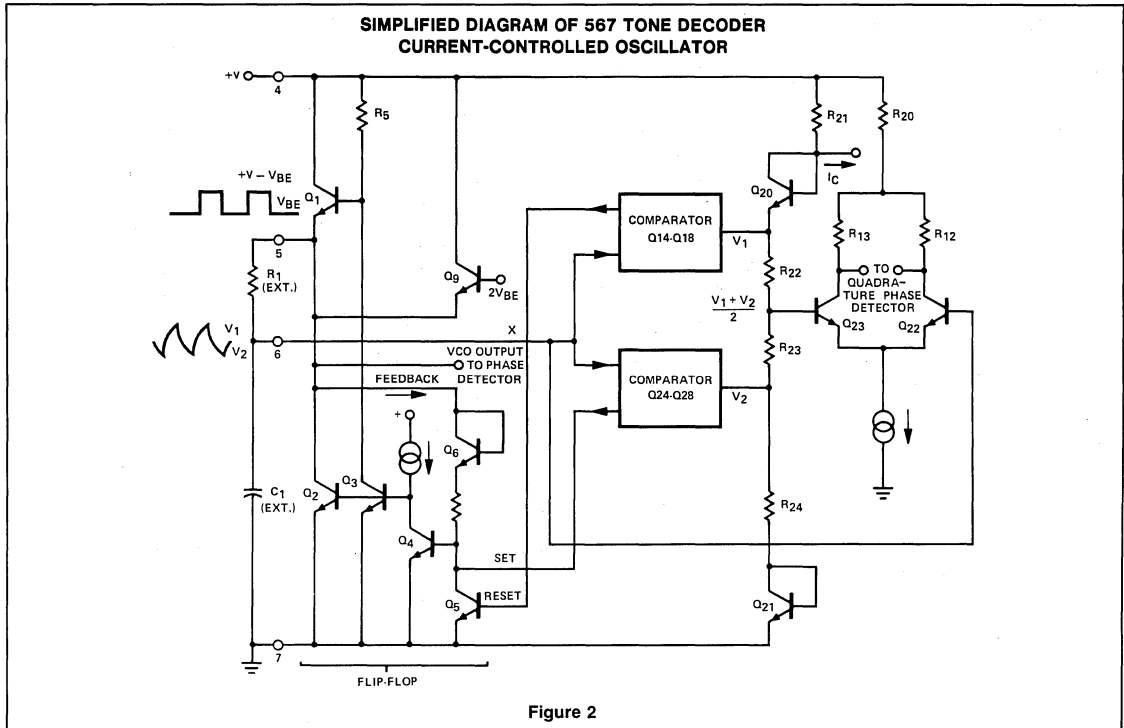

Figure 2

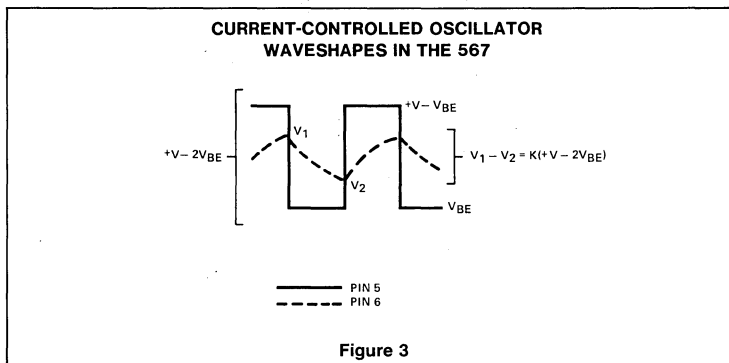

Figure 3

CIRCUIT DESCRIPTION OF THE 567 TONE DECODER

AN187

duty cycle by drawing I_C of 100 μ A for the R₂₁, Q20 junction. When I_C is then varied between 0 and 200 μ A, the frequency changes by $\pm 7\%$. Because of the slight shift in the voltage levels V_1 and V_2 with I_C , the square wave duty cycle changes from about 47% to about 53% over the control range. To avoid drift of free-running frequency with temperature and supply voltage changes when $I_C \neq 0$, I_C is also made a function of $+V - 2 V_{BE}$.

A doubly balanced multiplier formed by Q32 through Q37 (Figure 1) functions as the phase comparator. The input signal is applied to the base of Q32. Transistors Q34-Q37 are driven by a square wave taken from the CCO at the collector of Q2. Phase comparator input bias is provided by three diodes, Q38 through Q40, connected in series, assuring good bias voltage matching from run to run. Emitter resistors R₂₆ and R₂₇, in addition to providing the necessary dynamic range at the input, help stabilize the gain over the wide temperature range.

The loop dc amplifier is formed by Q51 and Q52. Having a current gain of 8, it permits even a small phase detector output to drive the CCO the full $\pm 7\%$. Therefore, full detection bandwidth can be obtained for any in-band input signal greater than about 70mV rms. However, the main purpose of high loop gain in the tone decoder is to keep the locked phase as close to $\pi/2$ as possible for all but the smallest input levels since this greatly facilitates operation of the quadrature lock detector. Emitter resistors R₃₆ and R₃₇ help stabilize the gain over the required temperature range. Another function of the dc amplifier is to allow a higher impedance level at the low pass filter terminal (pin 2) so that a smaller capacitor can be used for a given loop cutoff frequency. Once again, emitter resistors help stabilize the loop gain over the temperature range.

The quadrature phase detector (QPD), formed by a second doubly-balanced multiplier Q42-Q47, is driven from the quadrature output (E,F, in Figure 1) of the CCO. The signal input comes from the emitters of the input transistors Q32 and Q33.

The output stage, Q53 through Q62, compares the average QPD current in the low pass output filter R₃C₃ with a temperature compensated current in R₃₉ (forming the threshold voltage V_t).

Since R₃ is slightly lower in value than R₃₉, the output stage is normally off. When the lock and the QPD current I_q occurs, pin 1 voltage drops below the threshold voltage V_t and the output stage is energized.

The uncommitted collector (pin 8) of the power npn output transistor can drive both 100 - 200mA loads and logic elements, including TTL.

The K_o conversion gain for the 567 tone decoder is given by

$$K_o = 0.44 \omega_o' \frac{\text{radians}}{\text{volt-sec}} \quad (2)$$

while the K_d conversion gain depends upon the input signal level as shown in Figure 4. These parameters can be used to calculate the lock and capture range as has been illustrated previously.

The 567 tone decoder is a specialized loop which can be set up to respond to a given tone (constant frequency) within its bandwidth. The free-running frequency is set by a resistor R₁ and capacitor C₁. The bandwidth is controlled by the low pass filter capacitor C₂. A third capacitor C₃ integrates the output of the quadrature phase detector (QPD) so that the dc lock-indicating component can switch the power output stage on when lock is present. The 567 is optimized for stability and predictability of free-running frequency and bandwidth.

Two events must occur before an output is given. First, the loop portion of the 567 must achieve lock. Second, the output capacitor C₃ must charge sufficiently to activate the output stage. For minimum response time, these events must be as brief as possible.

As previously discussed, the lock time of a loop can be minimized by reducing the response time of the low pass filter. Thus, C₂ must be as small as possible. However, C₂

also controls the bandwidth. Therefore, the response time is an inverse function of bandwidth as shown by Figure 5, reprinted from the 567 data sheet. The upper curve denotes the expected worst-case response time when the bandwidth is controlled solely by C₂ and the input amplitude is 200mV rms or greater. The response time is given in cycles of free-running frequency. For example, a 2% bandwidth at a free-running frequency of 1000 cycles can require as long as 280 cycles (280ms) to lock when the initial phase relationship is at its worst. Figure 6 gives a typical distribution of response time versus input phase. Note that, assuming random initial input phase, only 30/180 = 1/6 of the time will the lock-up time be longer than half the worst case lock-up time. Figure 7 shows some actual measurements of lock-up time for a set-up having a worst case lock-up time of 27 cycles and a best-case lock-up time of four input cycles.

The lower curve on the graph of Figure 5 shows the worst-case lock-up time when the loop gain is reduced as a means of reducing the bandwidth (see data sheet, Alternate Method of Bandwidth Reduction). The value of C₂ required for this minimum response time is

$$C_2(\text{min}) = \frac{130}{f_o'} \left[\frac{10K + R_A}{R_A} \right] \mu\text{F} \quad (3)$$

It is important to note that noise immunity and rejection of out-band tones suffer somewhat when this minimum value of C₂ is used so that response time is gained at their expense. Except at very low input levels, input amplitude has only a minor effect

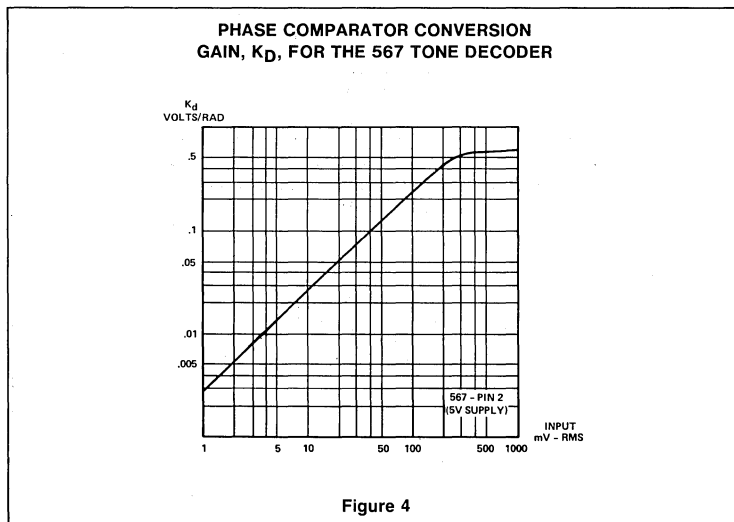

Figure 4

GREATEST NUMBER OF CYCLES BEFORE OUTPUT FOR THE 567 TONE DECODER

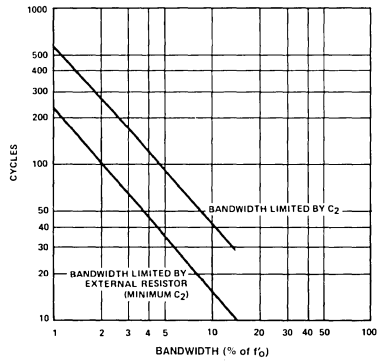

Figure 5

LOCK-UP TIME VERSUS INITIAL PHASE FOR THE 567 TONE DECODER

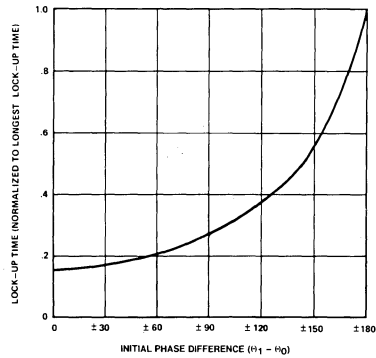

Figure 6

LOCK-UP TIME VARIATION DUE TO RANDOM INITIAL PHASE FOR THE 567 TONE DECODER

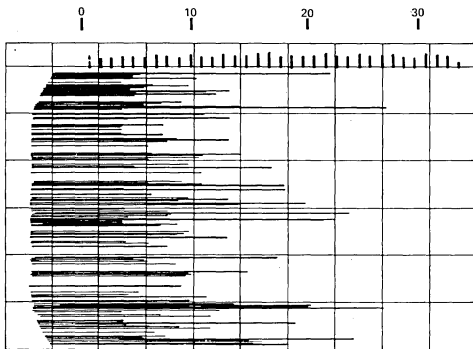

Figure 7

LOCK-UP TRANSIENT RESPONSE FOR 567 TONE DECODER

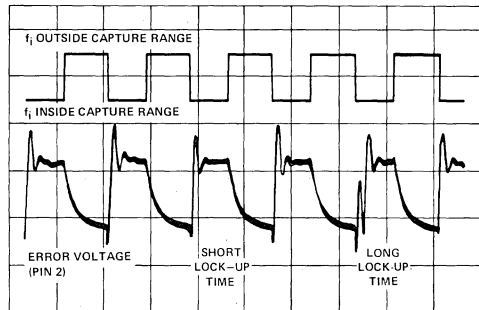

Figure 8

on the lock-up time - usually negligible in comparison to the variation caused by input phase.

Lock-up transients can be displayed on a two-channel scope with ease. Figure 8 shows the display which results. The top trace shows the square wave which either gates the input generator signal off and on (or shifts the frequency in and out of the band if you have a generator which has a frequency control input only). The lower trace shows the voltage at pin 2, the low pass filter voltage. The input frequency is offset slightly from the free-running frequency so that the locked and unlocked voltage are different. It is apparent that, while the C_2 decay during unlock is always the same, the lock transient is different each time.

This is because the turn-on repetition rate is such that a different initial phase relationship occurs with each appearance of the in-band signal. It is tempting to adjust the repetition rate so that a fast, constant lock-up transient is displayed. However, in doing so a favorable initial phase is created that is not present in actual operation. On the contrary, it is most realistic to adjust the repetition rate so that the longest lock-up time is displayed, such as the fifth lock transient shows. Once this display is achieved, the effect of various adjustments in C_2 or input amplitude is seen. However, *the repetition rate must be readjusted for worst-case lock-up after each such change.*

Once lock is achieved, the quadrature phase detector output at pin 1 is integrated

by C_3 to extract the dc component. As C_3 charges from its quiescent value V_q (see Figure 9) to its final value $(V_q + \Delta V)$, it passes through the output stage threshold, turning it on. The total voltage change is a function of input amplitude. Since the unadjusted V_q is very close (within 50mV) to V_T , the output stage turns on very soon after lock. Only a small fraction of the output stage time constant ($\tau = 4700C_3$) expires before V_T is crossed so that C_3 does not greatly influence the response time. However, as shown in Figure 9(a), the turn-off delay time can be quite long when C_3 is large. Figure 9(b) shows how desensitizing the output stage by connecting a high-value resistor between pin 1 and pin 4 (positive supply voltage) can equalize the turn-on and turn-off time. If turn-off delay is

EFFECT OF THRESHOLD VOLTAGE ADJUSTMENT ON TONE DECODER TURN-ON AND TURN-OFF DELAY

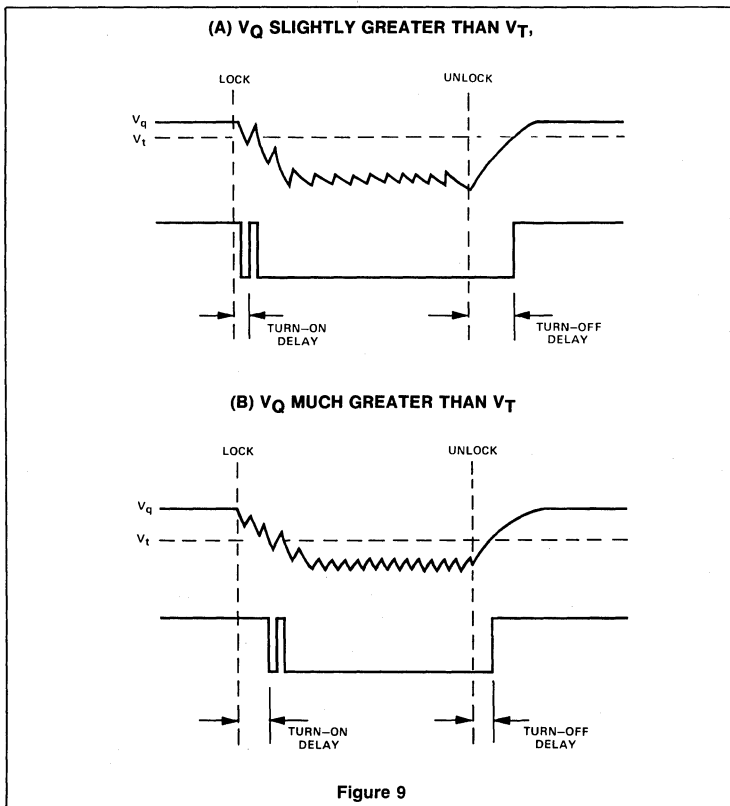

Figure 9

important in the overall response time, then desensitizing can reduce the total delay.

But why not make C_3 very small so that these delays can be totally neglected? The problem here is that the QPD output has a large second harmonic component of the free-running frequency that must be filtered out. Also, noise, outband signals, and difference frequencies formed by close out-band frequencies beating with the VCO frequency appear at the QPD output. All these must be attenuated by C_3 or the output stage will chatter on and off as the threshold is approached. The more noisy the input signal and the larger the near-band signals, the greater C_3 must be to reject them. Thus, there is a complicated relationship between the input spectrum and the size of C_3 . What

must be done, then, is to make C_3 more than sufficient for proper operation (no false outputs or missed signals) under actual operating conditions and then reduce its value in small steps until either the required response time is obtained or operation becomes unsatisfactory.

In setting up the tone decoder for maximum speed, it is best to proceed as follows:

- a After the center frequency has been set, adjust C_2 to give the desired bandwidth or, if the graph of response time in cycles (Figure 7) suggests that worst case lock-up time will be too long, incorporate the loop gain reduction scheme as an alternate means of bandwidth reduction. (See data sheet).

- b Check lock-up time by observing the waveform at pin 2 while pulsing the input signal on and off (or in and out of the band when a FM generator is used). Adjust repetition rate to reveal worst lock-up time.
- c Starting with a large value of C_3 (say 10 C_2), reduce it as much as possible in steps while monitoring the output to be certain that no false outputs or missed signals occur. The full input spectrum should be used for this test. Ignore brief transients or chatter during turn-on and turn-off as they can be eliminated with the chatter prevention feedback technique described in the data sheet.
- d Use the desensitizing technique, also described in the data sheet, to balance turn-on and turn-off delay.
- e Apply the chatter prevention technique to clean up the output.

If this procedure results in a worst-case response time that is too slow, the following suggestions may be considered:

- a Relax the bandwidth requirement.
- b Operate the entire system at higher frequency when this option is available.
- c Use two tone decoders operating at slightly different frequencies and OR the outputs. This will reduce the statistical occurrence of the worst-case lock-up time so that excessive lock-up time occurs. For example, if the lock-up time is marginal 10% of the time with one unit, it will drop to 1% with two units.
- d Control the in-band input amplitude to stabilize the bandwidth, set up two tone decoders for maximum bandwidth, and overlap the detection bands to make the desired frequency range equal to the overlap. Since both tone decoders are on only when a tone appears within the overlap range, the outputs can be ANDed to provide the desired selectivity.
- e If the system design permits, send the tone to be detected continuously at a low level (say 25mV rms) to keep the loop in lock at all times. The output stage, slightly desensitized, can then be gated on as required by increasing the signal amplitude during the on time. Naturally, the signal phase should be maintained as the amplitude is changed. This scheme is extremely fast, allowing repetition rates as fast as 1/3 to 1/2 the free-running frequency when C_3 is small. This is equivalent to ASK (amplitude shift keying).

Touch-Tone® Decoder

Touch-Tone® decoding is of great interest since all sorts of remote control applications are possible if you make use of the encoder (the pushbutton dial) that will ultimately be part of every phone. A low cost decoder can be made as shown in Figure 1. Seven 567 tone decoders, their inputs connected in common to a phone line or acoustical coupler, drive three integrated NOR gate packages. Each tone decoder is tuned, by means of R_1 and C_1 , to one of the seven tones. The R_2 resistor reduces the bandwidth to about 8% at 100mV and 5% at 50mV rms. Capacitor C_4 decouples the seven units. The seven R_2 resistors and capacitor C_4 can be eliminated at the expense of a somewhat slower response at low input voltages (50 to 100mV rms). The bandwidth can be controlled in the normal manner by selecting C_2 to be 4.7 μ F for the three lower frequencies and 2.2 μ F for the four higher frequencies.

The only unusual feature of this circuit is the means of bandwidth reduction using the R_2 resistors. An external resistor R_A can be used to reduce the loop gain and, therefore, the bandwidth. Resistor R_2 serves the same function as R_A except that instead of going to a voltage divider for dc bias, it goes to a common point with the six other R_2 resistors. In effect, the five 567s which are not being activated during the decoding process serve as bias voltage sources for the R_2 resistors of the two 567s which are being activated. Capacitor C_4 decouples the ac currents at the common point.

TONE DECODER APPLICATIONS (567)

The 567 is a special purpose PLL intended solely for use as a tone decoder. It contains a complete PLL including VCO, phase comparator, and amplifier as well as a quadrature phase detector or multiplier. If the signal amplitude at the lock frequency is above a minimal value, the driver amplifier turns on, driving a load with as much as 200mA. Thus the 567 gives an output whenever an inband tone is present. The 567 is optimized for both free-running frequency and bandwidth stability.

Dual Tone Decoder

Two 567 tone decoders connected as shown in Figure 2(a) permit decoding of simultaneous or sequential tones. Both units must be on before an output is given. R_1, C_1 and R_1, C_1' are chosen respectively for tones 1 and 2. If sequential tones (tone 1 followed by tone 2) are to be decoded, then C_3 is made very large to delay turn off of unit 1 until unit 2 has turned on and the NOR gate is activated.

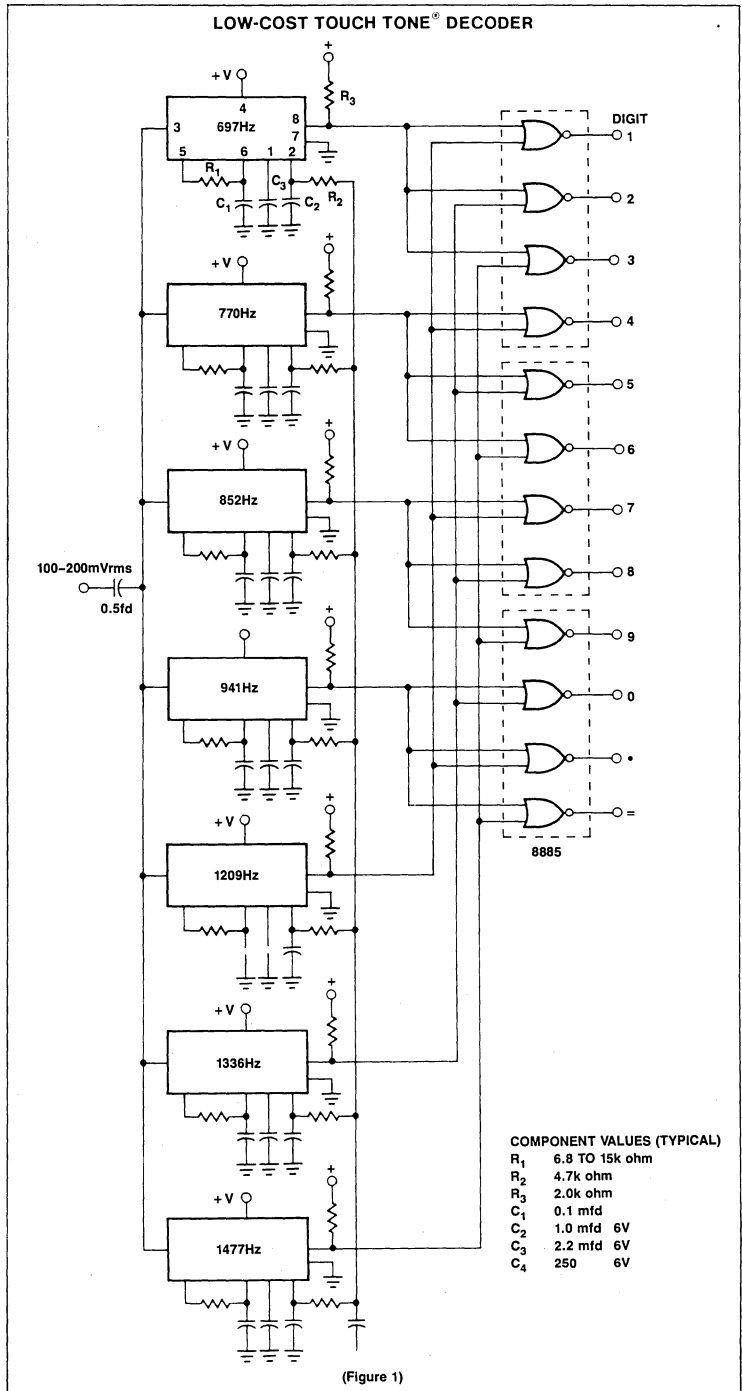

DETECTION OF TWO SIMULTANEOUS OR SEQUENTIAL TONES

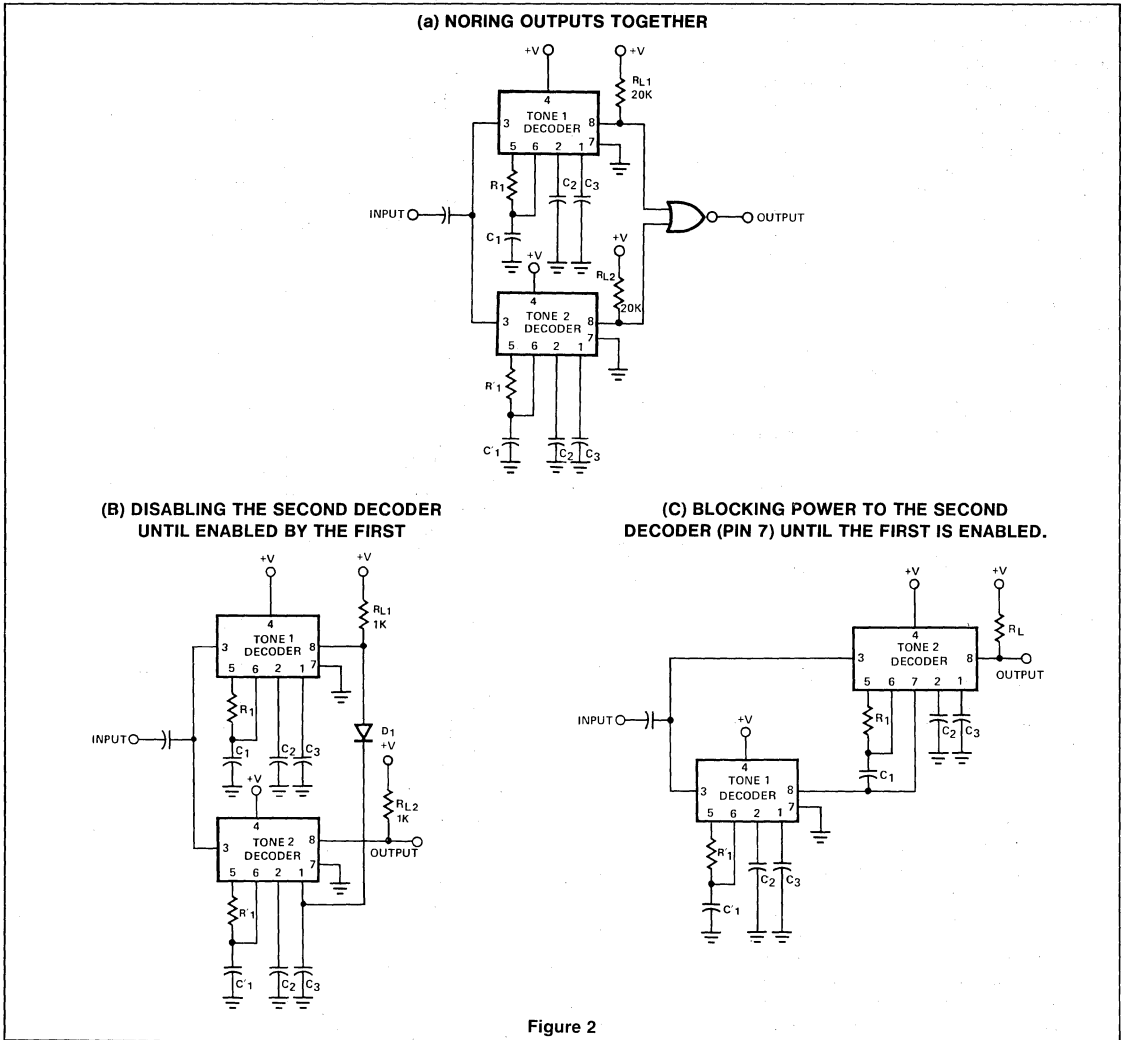

Figure 2

Note that the wrong sequence (tone 2 followed by tone 1) will not provide an output since unit 2 will turn off before unit 1 comes on. Figure 2(b) shows a circuit variation which eliminates the NOR gate. The output is taken from unit 2, but the unit 2 output stage is biased off by R_{L1} and D_1 until activated by tone 1. A further variation is given in Figure 2(c). Here, unit 2 is turned on by the unit 1 output when tone 1 appears, reducing the standby power to half. Thus, when unit 2 is on, tone 1 is or was present. If tone 2 is now present, unit 2 comes on also and an output is given. Since a transient output pulse may

appear during unit 1 turn on, even if tone 2 is not present, the load must be slow in response to avoid a false output due to tone 1 alone.

High-Speed, Narrow-Band Tone Decoder

The circuit of Figure 2(a) may be used to obtain a fast, narrow-band tone decoder. The detection bandwidth is achieved by overlapping the detection bands of the two tone decoders. Thus, only a tone within the overlap portion will result in an output. The input

amplitude should be greater than 70m rms at all times to prevent detection band shrinkage and C_2 should be between $130/f_0$ and $1300/f_0 \mu F$ where f_0 is the nominal detection frequency. The small value of C_2 allows operation at the maximum speed so that worst-case output delay is only about 14 cycles.

Low-Cost Frequency Indicator

Figure 3 shows how two tone decoders set up with overlapping detection bands can be used for a go/no-go frequency meter. Unit 1 is set 6% above the desired sensing frequency and

unit 2 is set 6% below the desired frequency. Now, if the the incoming frequency is within 13% of the desired frequency, either unit 1 or unit 2 will give an output. If both units are on, it means that the incoming frequency is within 1% of the desired frequency. Three light bulbs and a transistor allow low cost read-out.

Phase Modulator

If a phase locked loop is locked onto a signal at the free-running frequency, the phase of the VCO will be 90° with respect to the input signal. If a current is injected into the VCO terminal (the low pass filter output), the phase will shift sufficiently to develop an opposing average current out of the phase comparator so that the VCO voltage is constant and lock is maintained. When the input signal amplitude is low enough so that the loop frequency swing is limited by the phase comparator output rather than the VCO swing, the phase can be modulated over the full range of 0 to 180°. If the input signal is a square wave, the phase will be a linear function of the injected current.

A block diagram of the phase modulator is given in Figure 4(a). The conversion factor K is a function of which loop is used, as well as the input square wave amplitude. Figure 4(b) shows an implementation of this circuit using the 567.

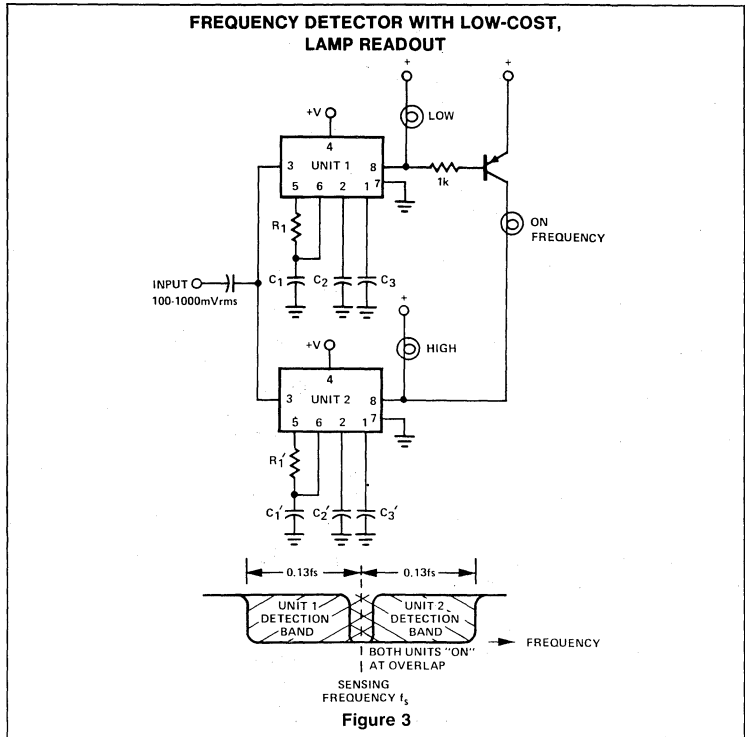

PHASE MODULATION USING THE PLL

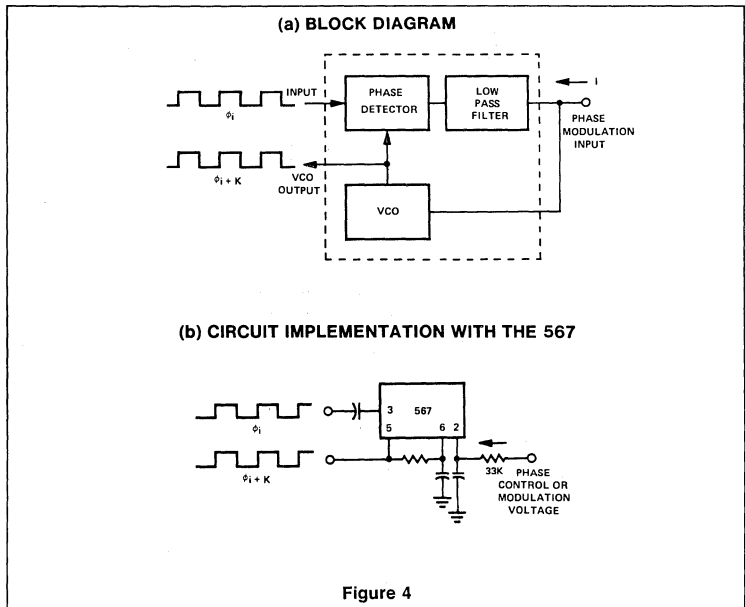

**BALANCED MODULATOR/
DEMODULATOR APPLICATIONS
USING MC1496/MC1596**

The MC1496 is a monolithic transistor array arranged as a balanced modulator-demodulator. The device takes advantage of the excellent matching qualities of monolithic devices to provide superior carrier and signal rejection. Carrier suppressions of 50dB at 10MHz are typical with no external balancing networks required.

Applications include AM and suppressed carrier modulators, AM and FM demodulators, and phase detectors.

THEORY OF OPERATION

As Figure 1 suggests, the topography includes three differential amplifiers. Internal connections are made such that the output becomes a product of the two input signals V_C and V_S .

To accomplish this the differential pairs Q1-Q2 and Q3-Q4, with their cross coupled collectors, are driven into saturation by the zero crossings of the carrier signal V_C . With a low level signal, V_S driving the third differential amplifier Q5-Q6, the output voltage will be a full wave multiplication of V_C and V_S . Thus for sine wave signals, V_{out} becomes:

$$V_{out} = E_x E_y [\cos(\omega x + \omega y)t + \cos(\omega x - \omega y)t] \quad (1)$$

As seen by $\text{font} = K (fc - fs) + K (fc + fs)$ (see Figure 2), the output voltage will contain the sum and difference frequencies of the two original signals. In addition, with the carrier input ports being driven into saturation, the output will contain the odd harmonics of the carrier signals.

BIASING

Since the MC1496 was intended for a multitude of different functions as well as a myriad of supply voltages, the biasing techniques are specified by the individual application. This allows the user complete freedom to choose gain, current levels, and power supplies. The device can be operated with single ended or dual supplies.

Internally provided with the device are two current sources driven by a temperature compensated bias network. Since the transistor geometries are the same and since V_{BE} matching in monolithic devices is excellent, the currents through Q7 and Q8 will be identical to the current set at pin 5. Figures 2 and 3 illustrate typical biasing arrangements from split and single ended supplies respectively.

Of primary interest in beginning the bias circuitry design is relating available power supplies and desired output voltages to device requirements with a minimum of external components.

The transistors are connected in a cascode fashion. Therefore sufficient collector voltage must be supplied to avoid saturation if linear operation is to be achieved. Voltages greater than 2 volts are sufficient in most applications.

Biasing is achieved with simple resistor divider networks as shown in Figure 3. This configuration assumes the presence of symmetrical supplies. Explaining the dc biasing technique is probably best accomplished by an example. Thus, the initial assumptions and criteria are set forth:

1. Output swing greater than 4 volts p-p.
2. Positive and negative supplies of 6 volts are available.
3. Collector current is 2mA. It should be noted here that the collector output current is equal to the current set in the current sources.

As a matter of convenience the carrier signal ports are referenced to ground. If desired the modulation signal ports could be ground referenced with slight changes in the bias arrangement. With the carrier inputs at dc ground, the quiescent operating point of the outputs should be at one half the total positive voltage or 3 volts for this case. Thus a collector load resistor is selected which drops 3 volts at 2mA or 1.5k ohm. A quick check at this point reveals that with

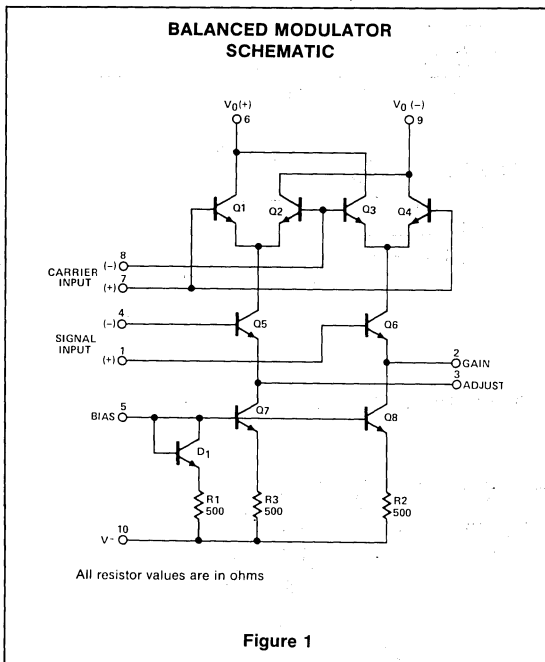

Figure 1

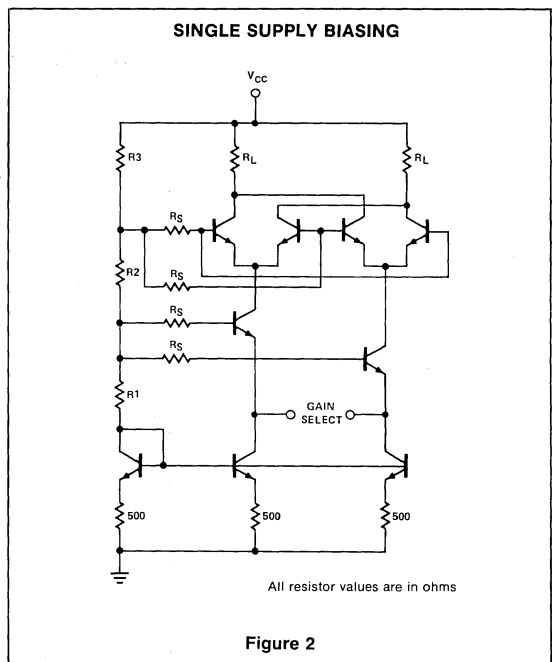

Figure 2

these loads and current levels the peak to peak output swing will be greater than 4 volts. It remains to set the current source level and proper biasing of the signal sources.

The voltage at pin 5 is expressed by

$$V_{bias} = V_{BE} = 500 \times I_s$$

where I_s is the current set in the current sources.

For the example V_{BE} is 700mV at room temperature and the bias voltage at pin 5 becomes 1.7 volts. Because of the cascode configuration both the collectors of the current sources and the collectors of the signal transistors must have some voltage to operate properly. Hence the remaining voltage of the negative supply ($-6v + 1.7v = -4.3v$) is split between these transistors by biasing the signal transistor bases at -2.15 volts.

Countless other bias arrangements can be used with other power supply voltages. The important thing to remember is that sufficient dc voltage is applied to each bias point to avoid collector saturation over the expected signal wings.

BALANCED MODULATOR

In the primary application of balanced modulation, generation of double sideband suppressed carrier modulation is accomplished. Due to the balance of both modulation and carrier inputs, the output, as mentioned, contains the sum and difference frequencies while attenuating the fundamentals. Upper and lower sideband signals are the strongest signals present with harmonic sidebands being of diminishing amplitudes as characterized by Figure 4.

Gain of the 1496 is set by including emitter degeneration resistance located as R_E in Figure 5. Degeneration also allows the maximum signal level of the modulation to be increased. In general, linear response defines the maximum input signal as

$$V_s \leq 15 \cdot R_E \text{ (Peak)}$$

and the gain is given by

$$A_{vs} = \frac{R_L}{R_E + 2r_e} \tag{2}$$

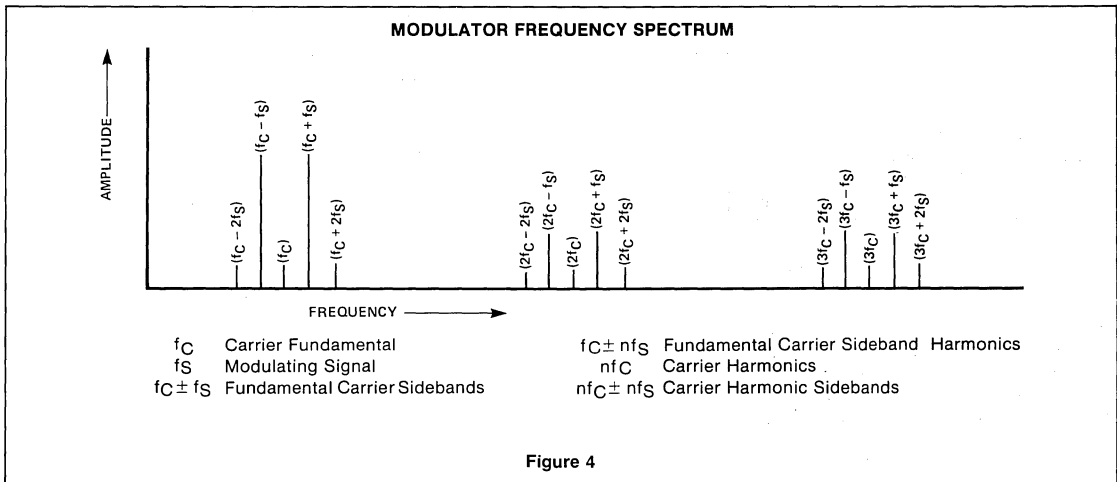
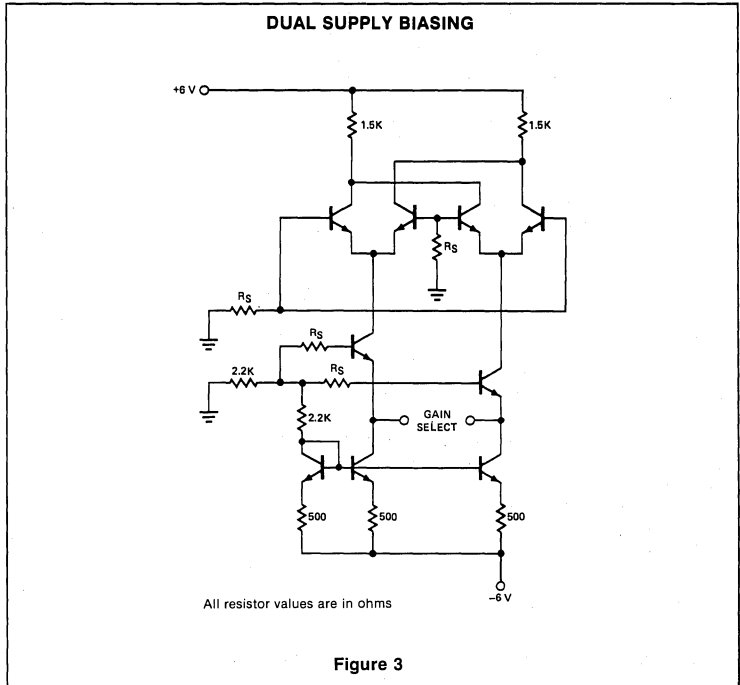

This approximation is good for high levels of carrier signals. Table 1 summarizes the gain for different carrier signals.

As seen from Table 1 the output spectrum suffers an amplitude increase of undesired sideband signals when either the modulation or carrier signals are high. Indeed, the modulation level can be increased if R_E is increased without significant consequence. However, large carrier signals cause odd harmonic sidebands (Figure 4) to increase. At the same time, due to imperfections of the carrier waveforms and small imbalances of the device, the second harmonic rejection will be seriously degraded. Output filtering is often used with high carrier levels to remove all but the desired sideband. The filter removes unwanted signals while the high carrier level guards against amplitude variations and maximizes gain. Broadband modulators, without benefit of filters, are implemented using low carrier and modulation signals to maximize linearity and minimize spurious sidebands.

AM MODULATOR

The basic current of Figure 5 allows no carrier to be present in the output. By adding offset to the carrier differential pairs, controlled amounts of carrier appear at the output whose amplitude becomes a function of the modulation signal or AM modulation. As shown, the carrier null circuit is changed from Figure 5 to have a wider range so that wider control is achieved. All connections are shown in Figure 6.

AM DEMODULATION

As pointed out in equation 1 the output of the balanced mixer is a cosine function of the angle between signal and carrier inputs. Further, if the carrier input is driven hard enough to provide a switching action, the output becomes a function of the input amplitude. Thus the output amplitude is maximum when there is 0° phase difference as shown in Figure 7.

Amplifying and limiting of the AM carrier is accomplished by IF gain block providing 55 dB of gain or higher with limiting of 400µV. The limited carrier is then applied to the detector at the carrier ports to provide the desired switching function. The signal is then demodulated by the synchronous AM demodulator (1496) where the carrier frequency is attenuated due to the balanced nature of the device. Care must be taken not to overdrive the signal input so that distortion does not appear in the recovered audio. Maximum conversion gain is reached when the carrier signals are in phase as indicated by the phase-gain relationship drawn in Figure 7. Output filtering will also be necessary to remove high frequency sum components of the carrier from the audio signal.

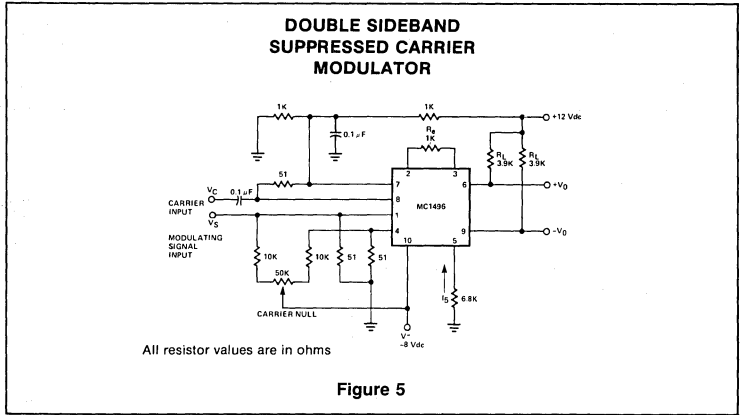

CARRIER INPUT SIGNAL (V _C)	APPROXIMATE VOLTAGE GAIN	OUTPUT SIGNAL FREQUENCY(S)
Low-level dc	$\frac{R_L V_C}{2(R_E + 2r_e) \left(\frac{KT}{q}\right)}$	f_M
High-level dc	$\frac{R_L}{R + 2r_e}$	f_M
Low-level ac	$\frac{R_L V_C (rms)}{2\sqrt{2} \left(\frac{KT}{q}\right) (R_E + 2r_e)}$	$f_C \pm f_M$
High-level ac	$\frac{0.637 R_L}{R_E + 2r_e}$	$f_C + f_M, 3f_C + f_M, 5f_C \pm f_M, \dots$

Table 1 VOLTAGE GAIN & OUTPUT SPECTRUM VS INPUT SIGNAL

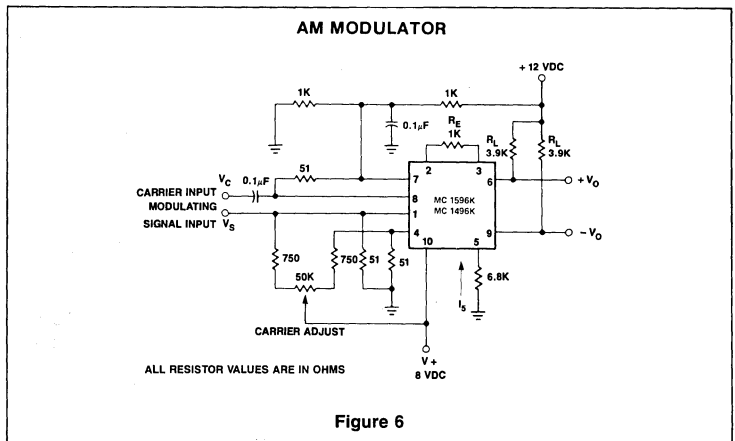

AM DEMODULATOR

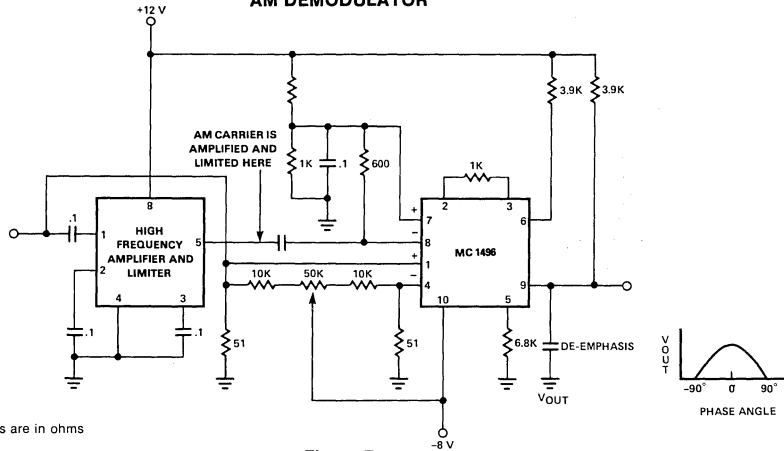

All resistor values are in ohms

Figure 7

PHASE COMPARATOR

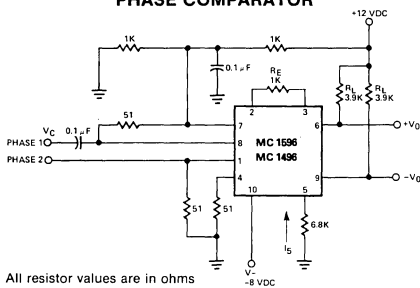

All resistor values are in ohms

Figure 8

PHASE DETECTOR ± VOLTAGES

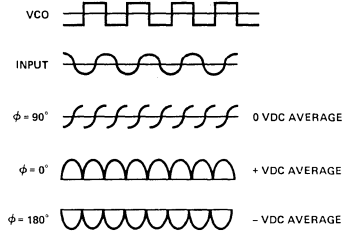

Figure 9

PHASE DETECTOR

The versatility of the balanced modulator or multiplier also allows the device to be used as a phase detector. As mentioned, the output of the detector contains a term related to the cosine of the phase angle. Two signals of equal frequency are applied to the inputs as per Figure 8. The frequencies are multiplied together producing the sum and difference frequencies. Equal frequencies cause the difference component to become dc while the undesired sum component is filtered out. The dc component is related to the phase angle by the graph of Figure 9. At 90 degrees the cosine becomes zero, while being at maximum positive or maximum negative at 0° and 180° respectively.

The advantage of using the balanced modulator over other types of phase comparators is the excellent linearity of conversion. This configuration also provides a conversion

LOW FREQUENCY DOUBLER

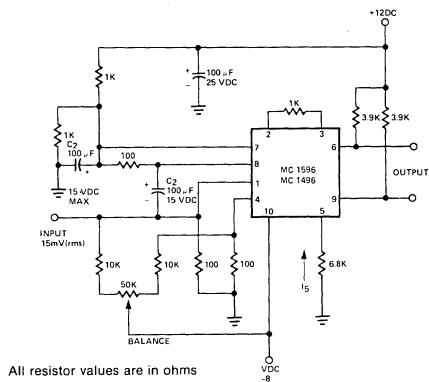

All resistor values are in ohms

Figure 10

gain rather than a loss for greater resolution. Used in conjunction with a phase locked loop for instance, the balanced modulator provides a very low distortion FM demodulator.

FREQUENCY DOUBLER

Very similar to the phase detector of Figure 8, a frequency doubler schematic is shown in Figure 10. Departure from Figure 8 is primarily the removal of the low pass filter. The output then contains the sum component which is twice the frequency of the input since both input signals are the same frequency.

APPLICATIONS OF LOW NOISE STEREO PREAMPLIFIERS: NE542

Introduction

Stereo preamplifiers have come into greater and greater demand with the increased usage of tape recorders. With stereophonic recording systems, the need increased to have multiple devices in the same package to insure greater thermal tracking and packing density, without sacrificing performance.

The NE542 qualifies as a low noise dual pre-amplifier. The NE542 is a pin dual-in-line device.

This device has greater than 100dB open loop gain and (15-20) MHz gain bandwidth product. In selecting the proper "low noise" pre-amplifier several factors must be considered.

- I Frequency shaping characteristic required.
- II Closed loop response with respect to a system reference level.
- III Response of the record/playback head.
- IV System distortion requirements.
- V Response of the tape used.

The following will deal with items I, II, IV.

When approaching the design criteria of Item 2, the designer should be concerned with the open loop device characteristics. These characteristics will aid in determining the maximum boost available, knowing that a specific loop gain (open loop gain minus closed loop gain) will be necessary to keep the system distortion low and maintain the output impedance of the "low noise" pre-amplifier constant over the required operating frequency range.

RIAA standards call for a maximum recording velocity of 21cm/sec for stereo discs. This worst case velocity describes a bound for the preamplifier gain because the input signal at this velocity is maximum.

NAB TAPE EQUALIZATION

Recording and playback characteristics of magnetic tape and record/playback heads are not flat but exhibit a loss at high frequencies and a boost at lower frequencies. To obtain an overall flat frequency response and improved signal to noise ratio, the audio signals are equalized by boosting the higher frequencies in amplitude before recording. Playback amplifiers must exhibit bass boost to remove the effects of pre-emphasis for an overall flat response.

Known as the NAB equalization curve, the standard deemphasis employs attenuation from the turnover frequency of 50Hz to the turnover frequency of 3180Hz for 7 1/2 lps recording. The slower recording speed of 3.75 lps employs turnover frequencies of 50Hz and 1326Hz. These curves are shown in Figure 1. A reference level of 800µV head sensitivity at 1kHz is also used by the NAB.

STEREO PREAMPLIFICATION

The voltage level appearing at the output of tape playback heads and some phono cartridges are too small to be useful without a large amount of low noise preamplification. In addition to providing low noise amplification, the preamplifier should possess enough open loop gain so that the RIAA and NAB equalization curves can be produced in the feedback networks of the amplifier. The following paragraphs describe the characteristics and applications of the 542. This device provides a matched pair of amplifiers which have been specifically designed to minimize amplifier noise and maximize signal to noise ratio.

542 DEVICE DESCRIPTION

The NE542 is a dual low noise amplifier with 104dB open loop gain produced by two stages of voltage gain followed by one stage of current gain.

In the design of low noise devices special attention must be focused on the input stage. If differential topography is used, the stage should be designed so that one of the differential transistors is turned off. This reduces the noise contribution by a factor of 1.4 since only one transistor is producing noise. Current sources and mirrors cannot be used for biasing loads because active elements will contribute more noise.

Implementing these observations, the first gain stage of the 542 is pictured with the complete schematic by Figure 2.

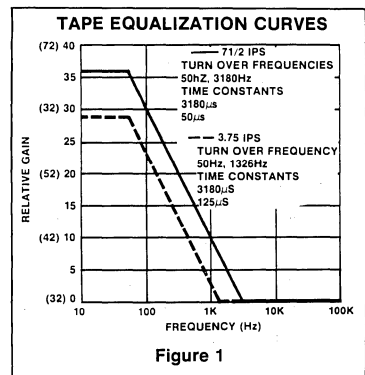

Figure 1

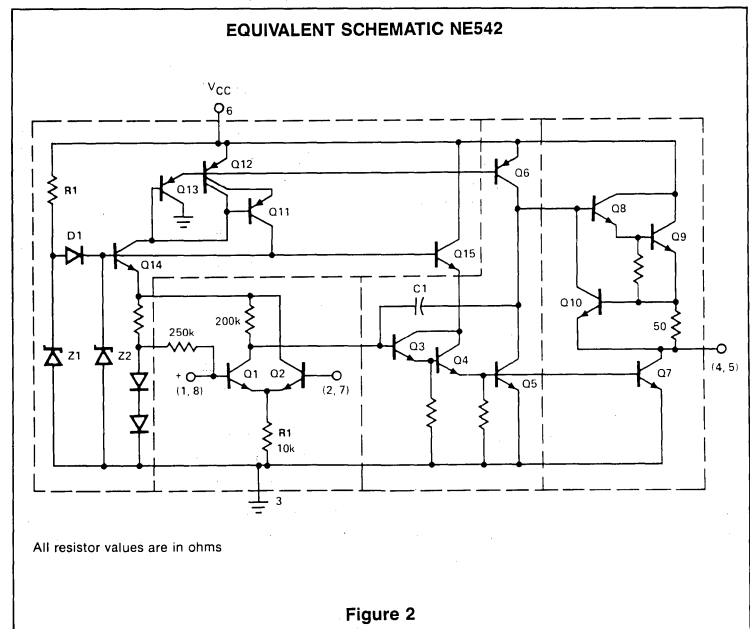

Figure 2

All resistor values are in ohms

Although the differential input configuration degrades the noise performance slightly, using differential inputs has the advantages of higher input impedance, allowing smaller capacitors and larger resistors to be used to achieve the RIAA and NAB curves.

The second stage is a common-emitter amplifier (Q5) with a current source load (Q6). The Darlington emitter-follower Q3-Q4 provides level shifting and current gain to the common-emitter stage (Q5) and the output current sink (Q7). The voltage gain of the second stage is approximately 2000 making the total gain of the amplifier typically 160,000 in the differential input configuration.

The preamplifier is internally compensated with the pole-splitting capacitor, C1. This compensates to unity gain at 15MHz. The compensation is adequate to preserve stability to a closed loop gain of 10.

BIASING

The non-inverting input has been internally biased from a 1.4 Volt internal voltage source. Following the zero differential rule of amplifiers, the output voltage will be set by the resistor feedback network (R4 and R5) of Figure 3.

The base of Q2 requires 0.5µA bias current. Hence R5 should pass 5µA minimum for stability, for an output dc voltage of $\frac{V_{CC}}{2}$ the values of R4 and R5 are:

$$R5 = \frac{2 V_{BE}}{10 I_b} = 240K \text{ Max.} \tag{1}$$

$$R4 = \left(\frac{V_{CC}}{2.8 - 1} \right) R5 \tag{2}$$

DC amplifier gain is defined by the ratio of R4 and R5. Open loop ac gain can be regained by adding a shunt capacitor across R5. The low frequency 3dB corner is then defined by the capacitor-resistor break point.

NAB Tape Preamplifier

Design of a preamplifier begins by determining the gain and output signal amplitudes in reference to the standard 800µV input signal level. For the following design example, we will use the 542 to achieve a 100mV output level at 1kHz following the 7-1/2 ips NAB equalization curve. The graph of Figure 1 has been calibrated both in absolute gain for this example and relative gain for general use.

From the given parameters, the closed loop gain becomes 32dB at the highest frequency of interest. The NAB response is achieved by adding frequency selective ac feedback as depicted by Figure 4. Resistors R4 and R5

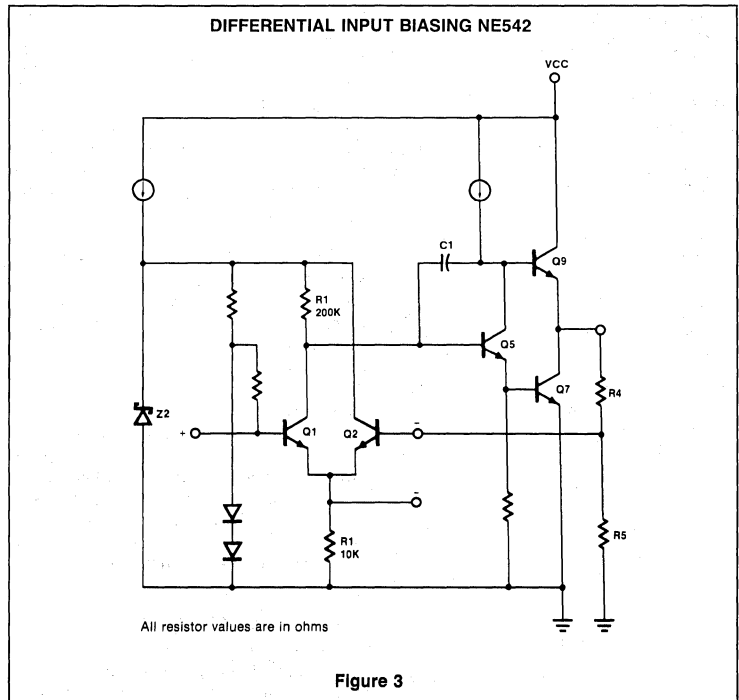

Figure 3

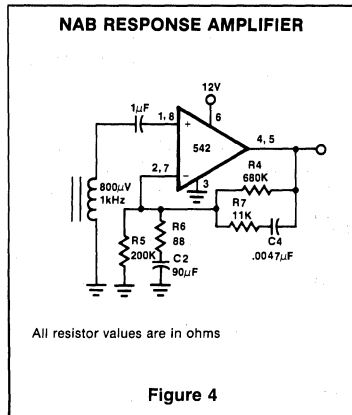

Figure 4

select the dc gain as defined by Equations 1 and 2. Placing a value of 200K upon R5, Equation 2 yields a value of 680K ohms.

The lower corner frequency is determined next by the reactance of C4 and R4 such that:

$$f_1 = \frac{.159}{C4 R4} \tag{3}$$

Solving for C4 yields a value of .0047µfd.

The upper corner frequency, f2, is similarly fixed by the reactance of C4 and R7.

$$f_2 = \frac{.159}{C4 R7} \tag{4}$$

Then solving Equation 4 for R7 defines a value of 11k ohms.

Midband gain is now fixed by the relationship.

$$A = \frac{R6 + R7}{R6} \tag{5}$$

Solving for the 1kHz gain of 42dB using 11k for R7 yields a value of 88 ohms for R6. The final calculation of the low frequency cut off of the preamp determines the size of C2.

$$C2 = \frac{.159}{f_{CUTOFF} R6} \tag{6}$$

Typical Applications

In addition to the previous detailed design examples, the following general amplifier configurations (see Figures 5 through 8) are presented. The choice of design and the device used is a function of the desired complexity and overall performance.

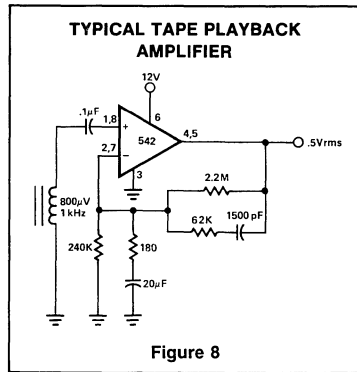
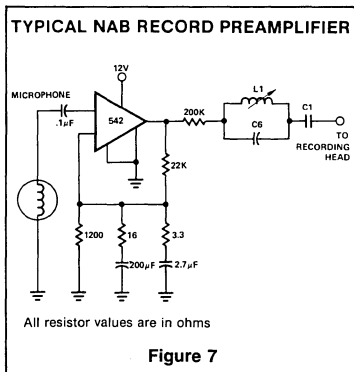
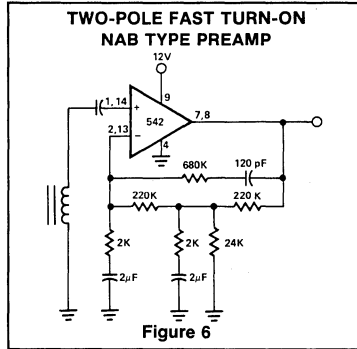
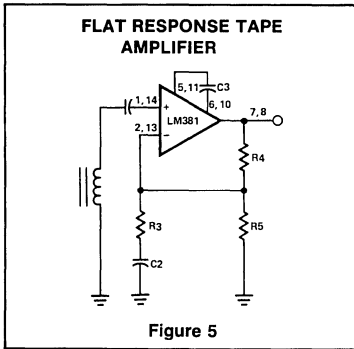

STEREO DECODER APPLICATIONS: μ A758

Introduction

The phase locked loop (PLL) has been used for many years in consumer equipment. Due to the nature of FM STEREO MULTIPLEX SYSTEMS, where prime importance is the channel separation, discrete systems lacked the tracking ability over wide temperature and voltage ranges to be done economically.

The development of the monolithic PLL and improvements in IC processing has made the Phase Locked Loop FM Stereo Multiplexer Decoder a reality.

Major Advantages

The economic advantages in using the PLL multiplex decoding system are not only cost reduction, by eliminating peripheral components, but the man hour cost reduction by eliminating turning coils, thereby eliminating tedious alignment procedures.

The cost advantages are extremely significant and are in addition to the following:

- 45 dB Channel Separation
- Automatic Stereo/Mono Switching
- Stereo Indicator Lamp Driver With Current Limiting
- High Impedance Input—Low Impedance Outputs
- 70dB SCA Rejection (Subsidiary Carrier Authorization)
- One Adjustment for Complete Alignment
- 10V to 16V Supply Voltage Range

FM Stereo Multiplex Subcarrier and Pilot

The two (2) basic signals differentiating an FM stereo multiplex signal from an FM

monaural signal are the 19kHz pilot and the 38kHz subcarrier. The frequency and phase relationship of these signals is well defined.

Earlier systems had to reconstruct the 38kHz subcarrier by using the 19kHz pilot. This system required frequency multipliers and selective filters (coils). Since maximum channel separation is directly related to proper phasing, alignment procedures were extremely critical and therefore expensive. In addition, long term stability and performance were degraded due to component aging, and temperature.

Use of the PLL as the multiplex decoder eliminated these short comings since the phase accuracy of the 38kHz signal is limited only by the loop gain of the system and the free running oscillator stability. Both of these parameters are easily controlled, providing easy, rapid adjustment and excellent long term stability.

General Description

The μ A758 is a monolithic Phase Locked Loop FM Stereo Multiplex decoder using the 16-Lead DIP N Package. This integrated circuit decodes an FM Stereo Multiplex Signal into Right and Left audio channels while inherently suppressing SCA information when it is contained in the composite input signal. Internal functions include automatic mono-stereo mode switching and drive for an external lamp to indicate stereo mode operation.

The μ A758 operates over a wide supply voltage range and uses a low number of external components. It has only one control to adjust a potentiometer to set oscillator frequency. No external coils are re-

quired. The μ A758 is suitable for all line-operated and automotive FM Stereo Receivers.

Referencing The Block Diagram

The upper row of blocks comprises the PLL which regenerates the 38kHz subcarrier, necessary for multiplex signal demodulation. The basic 76kHz generator is voltage controlled, and is divided by 2 to insure a 50% duty cycle 38kHz internally generated signal. This symmetry is necessary for maximum left/right channel separation and SCA rejection (band centered at 67kHz). Dividing the 38kHz by 2 generates the 19kHz signal necessary to lock on to the incoming pilot signal. A second 19kHz signal is generated which is in quadrature to the first internally generated 19kHz signal and in phase with the pilot. This second 19kHz is mixed in a quadrature (synchronous) phase detector to operate the stereo switch and lamp driver circuitry.

When a stereo signal is present, the stereo switch enables the stereo demodulator and when a stereo signal is not present the demodulator is disabled allowing the system to reach optimum noise performance.

Functional Operation

To aid in understanding the system operation, the μ A758 equivalent circuit has been broken down into subsections as follows. Reference Figure 2.

- I Buffer Amplifier and Bias Supplies
- II Demodulator
- III Stereo Switch and Lamp Driver
- IV Voltage Controlled Oscillator
- V Frequency Dividers
- VI Pilot Phase and Amplitude Defectors

BLOCK DIAGRAM

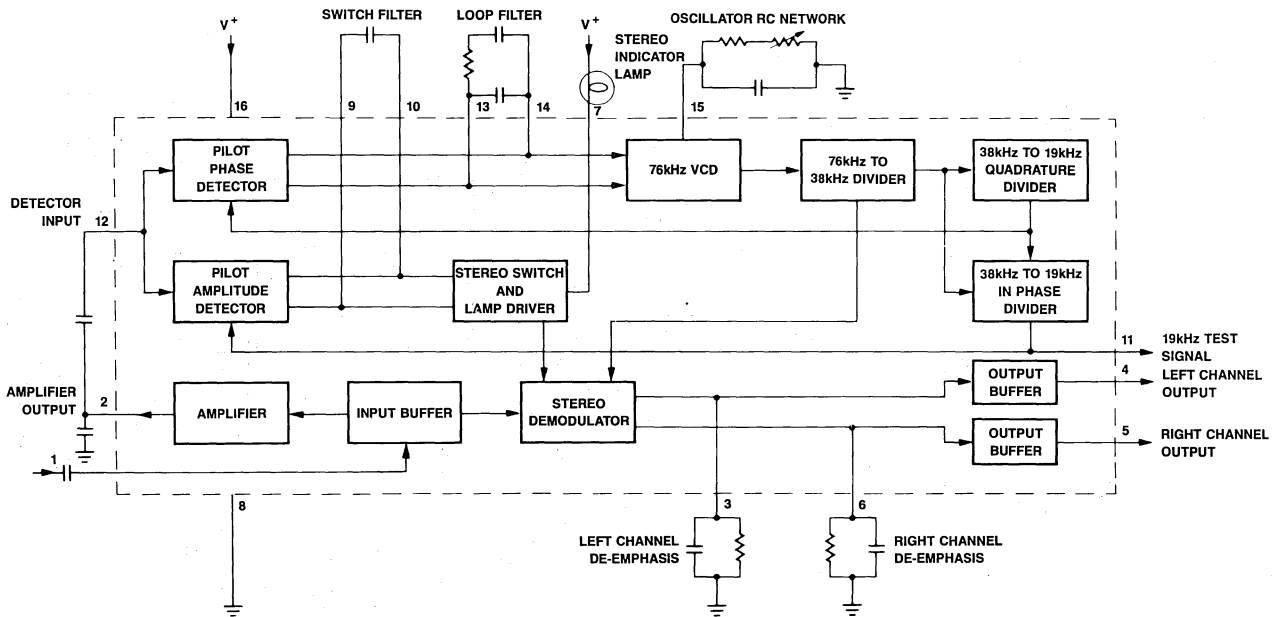

Figure 1



SIGNETICS LINEAR INTEGRATED CIRCUITS • $\mu A758$
Equivalent Circuit

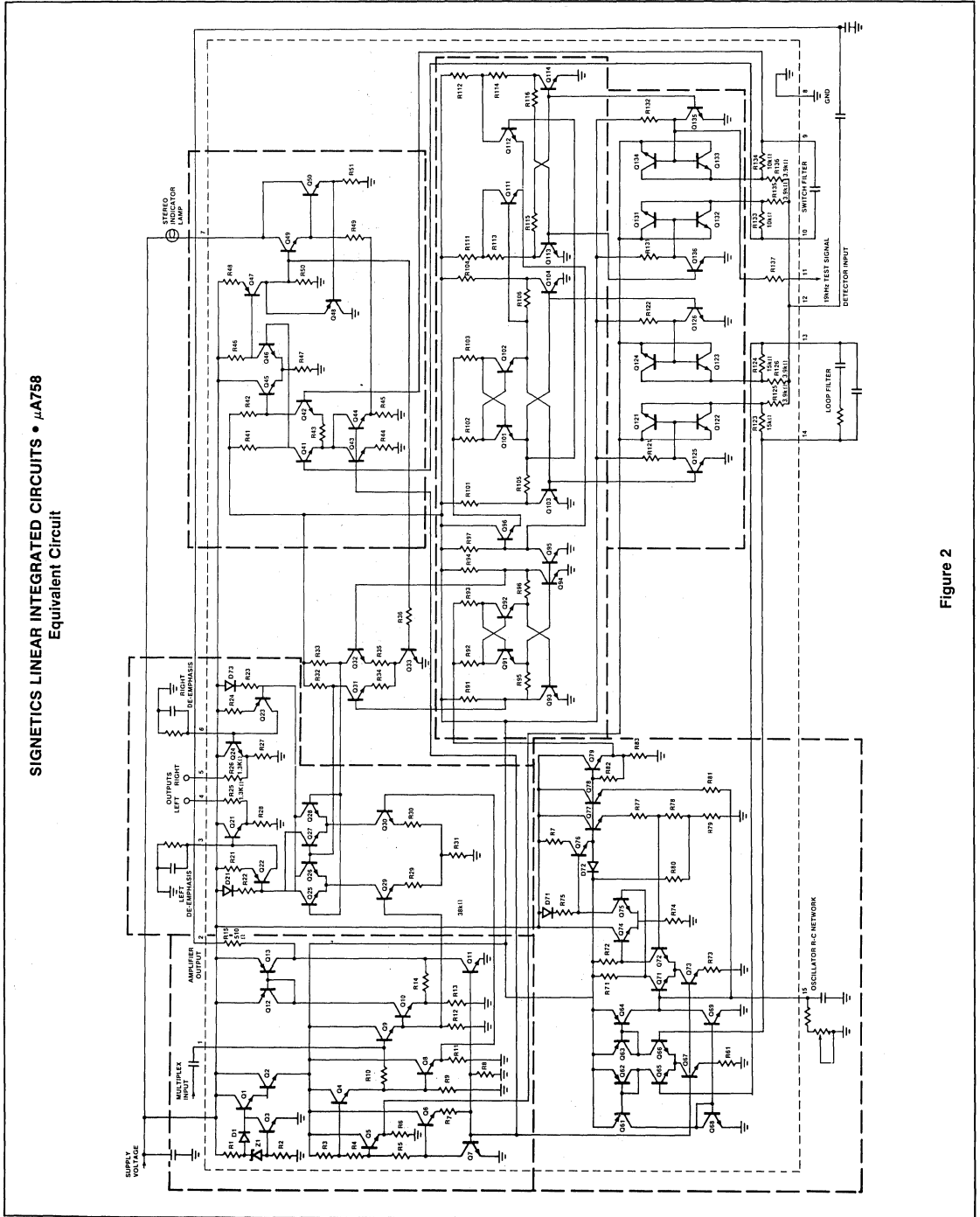

Figure 2

I Buffer Amplifier and Bias Supplies (Figure 3)

The zener diode Z, and its associated transistors generate a 6V internal voltage reference source. From this 6V reference, additional bias levels are established via resistors R3, R4, and R5. In addition transistor Q7 acts as the control source for several current mirrors; Q11 in the Buffer Amplifier, Q43 and Q44 in the Stereo Switch and Lamp Driver (III) and Q67 and Q73 in the Voltage Controlled Oscillator (IV).

The input Buffer Amplifier (Q8, Q9) level shifts the composite multiplex input signal to 2 levels each in phase with each other.

Transistors Q10 - Q13 amplify this same signal by the ratio of:

$$A = \frac{R_{14}}{R_{13}}$$

This amplified signal, the gain of which is independent of supply voltage variation, is fed to the Pilot Phase and Amplitude Detectors (VI).

II Demodulator (Figure 4)

The basic demodulator, Q25 - Q30, is a fully balanced detector similar to standard phase locked loop types. The addition of resistors R29, R30, and R31 introduces a small offset to allow a small multiplex signal in the collector of Q30. This signal compensates the cross talk components inherent to the synchronous switching demodulation process.

Switching to the left and right channels is accomplished through Q25 and Q26 when the 38kHz drive is present at their bases. This occurs when Q33 is "ON." When Q33 is off, a dc bias is placed at the bases of Q25 and Q26 through resistors R32 and R33, this automatically converts the system to mono-phonetic operation.

Supply voltage rejection is accomplished at the demodulator outputs by converting the audio to current supplies in Q23 and Q24. The voltage developed across pnp transistors is

$$V_e = (V^+ + v_{mod}) - (V_{be} + V_{D1} + [R_{22} i_{ac}] + v_{mod})$$

where V_{be} = base-emitter voltage across Q22 and Q23

v_{mod} = modulation on the power line

V_{D1} = diode drop in D21

$(R_{22})_{iac}$ = voltage drop due to current in the demodulator

Simplifying the above reduces to

$$V_e = V^+ - (V_{be} + V_{D1} + R_{22} i_{ac}) \quad (1)$$

The output voltage developed is

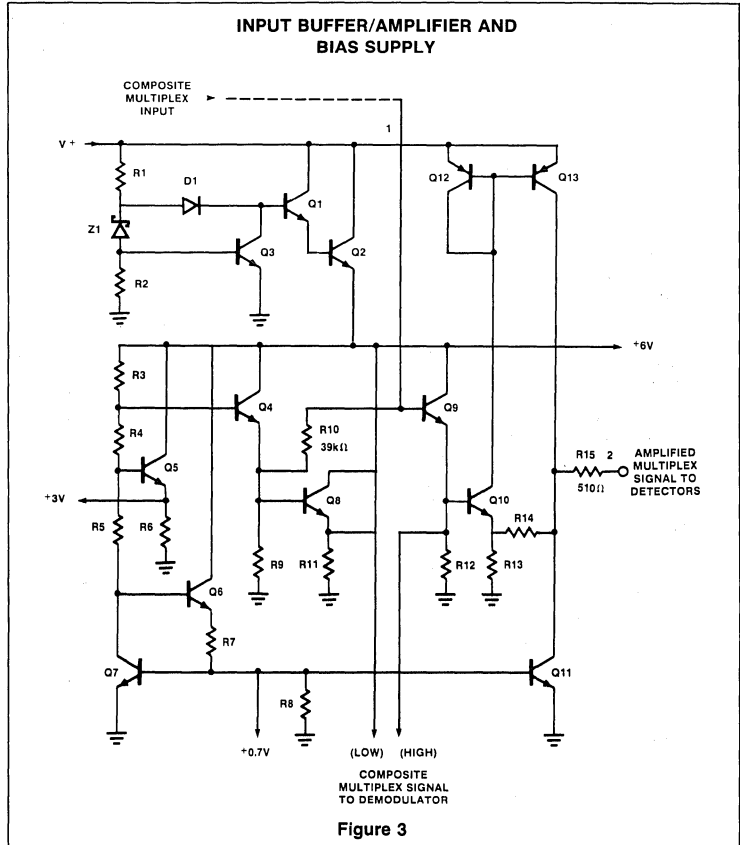

Figure 3

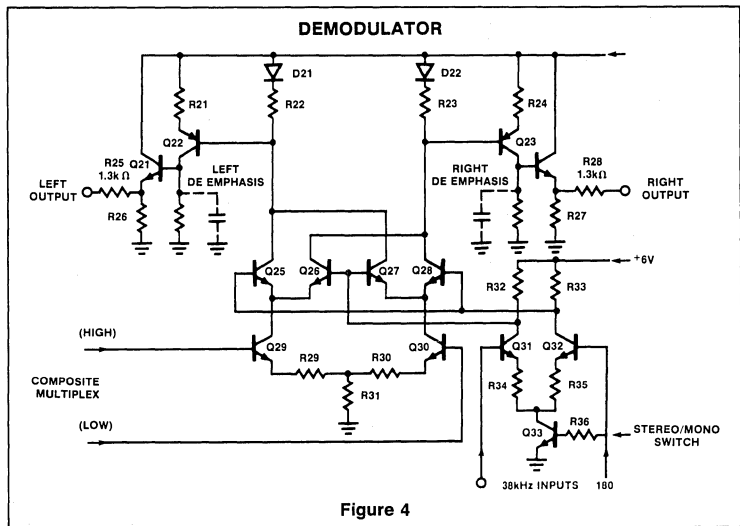

Figure 4

$$V_{out} = \left(\frac{V_e}{R_{21}} \right) R_{ext} \quad (2)$$

where R_{ext} = external resistor

The output voltage at pins 4 and 5 are provided through 1.3k resistors driven by Emitter Followers Q21 and Q24.

III Stereo Switch and Lamp Driver (Figure 5)

The pilot amplitude detector differential voltage is sensed by the differential amplifier Q41 and Q42. This pair in conjunction with their load resistors (R41, R42) control amplifiers Q45, Q46. Positive feedback action is achieved through Q47, R50, Q50 and R46 (which turns off Q44).

The turn on threshold is the differential input voltage required to overcome the offset voltage in R43 times the current summation of I_{R44} and I_{R45} . When the lamp is ON, Q44 is off and the differential voltage across R43 is reduced by the amount $(I_{R45} \times R43)$, which means a lower turn off voltage is required. This voltage difference is referred to as the switch hysteresis.

Transistors Q48 senses the current across R51 which therefore controls the maximum current in the Stereo Indicator Lamp.

$$I_{max} = \frac{V_{be} Q48}{R151} \quad (3)$$

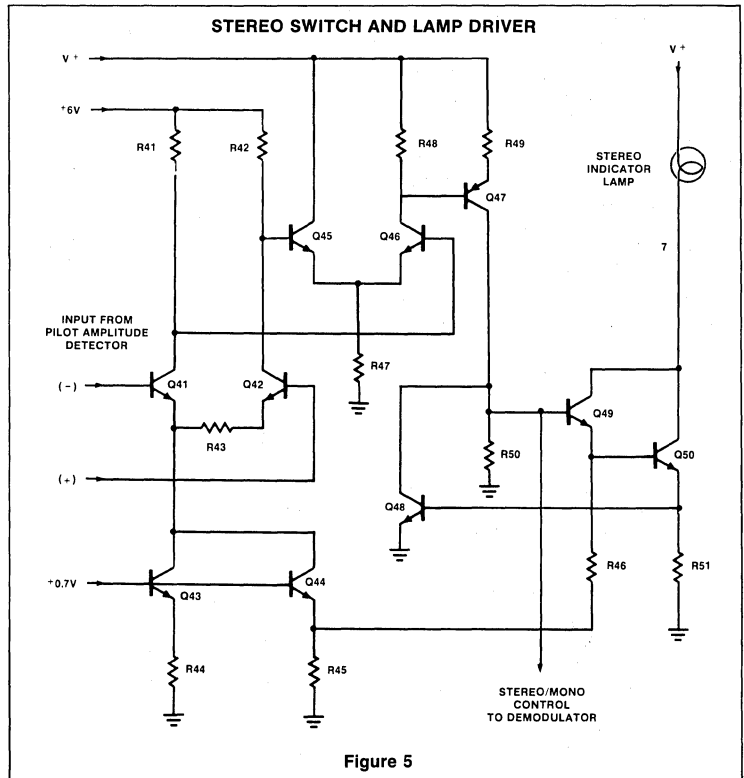

Figure 5

IV Voltage Controlled Oscillator (Figure 6)

The basic oscillator Q71-Q79 is an RC relaxation type which generates a positive low duty cycle, 76kHz output. The frequency is established by equations 4 and 5.

The control voltage from the phase detector into the transconductance amplifier Q61 - Q69 converts the differential error to a bidirectional single ended current drive to the oscillator.

Voltage on the capacitor is compared with the set voltages by the differential input stage Q71, Q72. This feeds Q74, Q75. The output of Q75 drives a PNP inverter, Q76, (whose action eliminates power supply modulation as described in the demodulator section of this note), when these set limits are reached the direction of charge reverses.

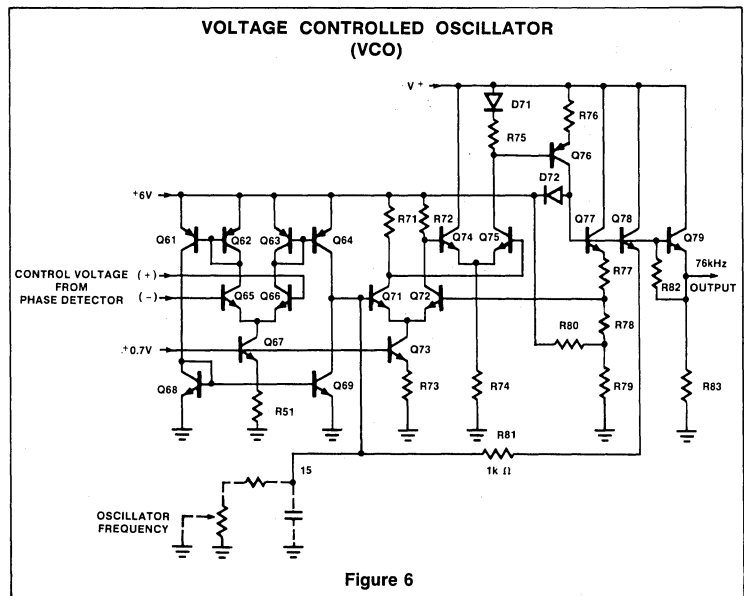

Figure 6

Lower set voltage is set by R79, R80, and the regulated 6V supply. The upper set voltage (V_H) involves two (2) additional resistors R77 and R78 and is established when Q76 turns on Q77. Both set levels are referenced to the regulated 6V supply and are therefore dependent only on resistor ratios. (Proper design layout should also eliminate temperature variations.)

Capacitor charging is through Q78 and R8 and discharging through the external fixed resistor.

Equations 4 and 5 of Figure 7 are first order expressions for the change and discharge periods.

Q79 supplies a positive output pulse necessary to operate the 38kHz dividers.

V Frequency Dividers (Figure 8)

Transistors Q91 through Q94 form a simple divide-by-two circuit which converts the pulse output from the 76kHz oscillator to a 38kHz square wave.

The divider changes state during the positive excursion of the input pulse supplied from the emitter of Q79 in the oscillator. Initially, when the input is low, Q91 and Q92 are OFF and we may arbitrarily assume Q93 is ON and Q94 is OFF.

As the potential on the input rises, Q91 starts conduction before Q92 because the emitter of Q91 is at a lower potential than the emitter of Q92. (The emitter of Q91 is connected through R95 to the collector of Q93 which is in saturation, whereas the emitter

of Q92 is at the $V_{BE(ON)}$ potential of Q93). Since Q91 is ON, the current from both R92 and R93 flows through the emitter of Q91 into R95. As this current increases, the rising voltage at the emitter of Q91 turns Q94 ON which removes base drive to Q93 and turns it OFF, thus producing a change of state in the divider. Even though the relative potentials at the emitters of Q91 and Q92 are now reversed, current continues to flow in Q91 for the duration of the positive input because Q92 is held OFF by Q91. When the input returns to a low potential,

Q91 turns OFF. The divider remains in its present state until driven by the next positive going input.

Oppositely phased 38kHz outputs to the demodulator are taken from the collectors of Q93 and Q94. Transistors Q95 and Q96 are used to drive the two 38kHz dividers.

The 38kHz Quadrature Divider has an identical configuration to the 76kHz divider. A change of state occurs with each positive excursion of the 38kHz input signal from the emitter of Q96.

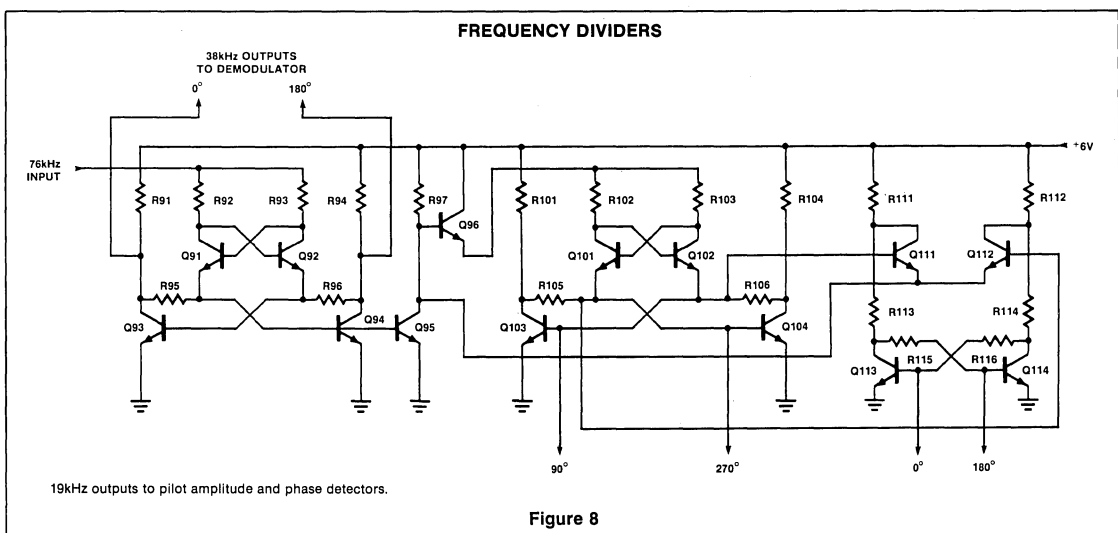
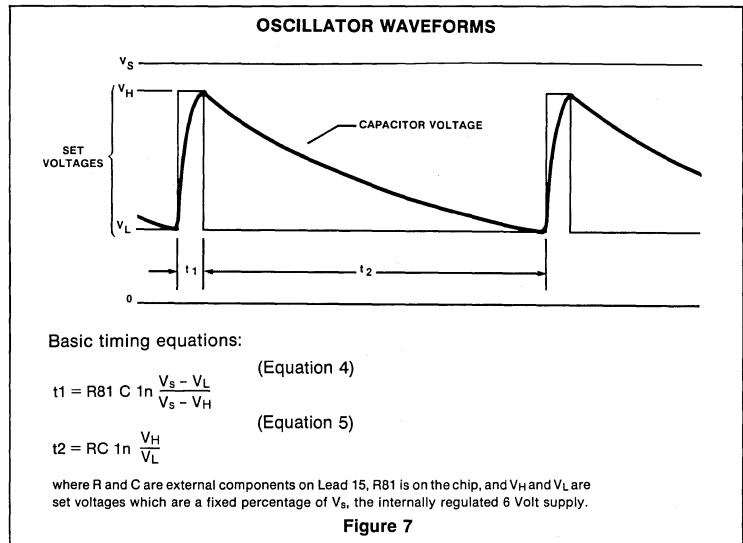

The 38kHz In-Phase divider contains a bistable pair, Q113 and Q114, steered by inputs into Q111 and Q112, (a 38kHz input from the collector of Q95, and 19kHz inputs from the bases of Q103 and Q104). If the 19kHz input to the base of Q111 is high when the 76kHz divider turns Q95 ON, Q111 conducts and removes drive to Q114, changing the state of the bistable pair, Q113 and Q114. The bistable remains in this state until the next 38kHz turn on of Q95 which, this time, turns Q112 ON, removes drive to Q113 and resets the bistable pair. The resulting 19kHz output from Q113 and Q114 is at 90 degrees to the Quadrature Divider output with no ambiguity in phasing.

Pilot Phase and Amplitude Detectors

The pilot phase detector and pilot amplitude detector as shown in Figure 9 are synchronous, balanced chopper types which develop differential output signals across external filters. Back-to-back NPN transistor pairs are used for each switch to insure minimum drop regardless of signal polarity without reliance on inverse NPN beta characteristics.

The chopper transistors (Q121 through Q124), in the phase detector are driven from the 38kHz Quadrature Divider through transistors Q125 and Q126. The input signal is supplied from lead 12 through resistors R125 and R126. A differential output is developed across the loop filter, comprised of resistors R123 and R124 and the external R-C network between leads 13 and 14.

The pilot amplitude detector (Q131 through Q136), has an identical configuration to the phase detector. Since it operates with drive which is in phase with the pilot signal (90 degrees from the drive to the phase detector), its output is proportional to the amplitude of the pilot component of the multiplex signal. The differential output at leads 9 and 10 is filtered by the external capacitor on these two leads.

A reference 19kHz square wave signal is taken from the collector of drive transistor Q136 through resistor R137 to lead 11. It has the same phasing as the pilot contained in the multiplex input signal.

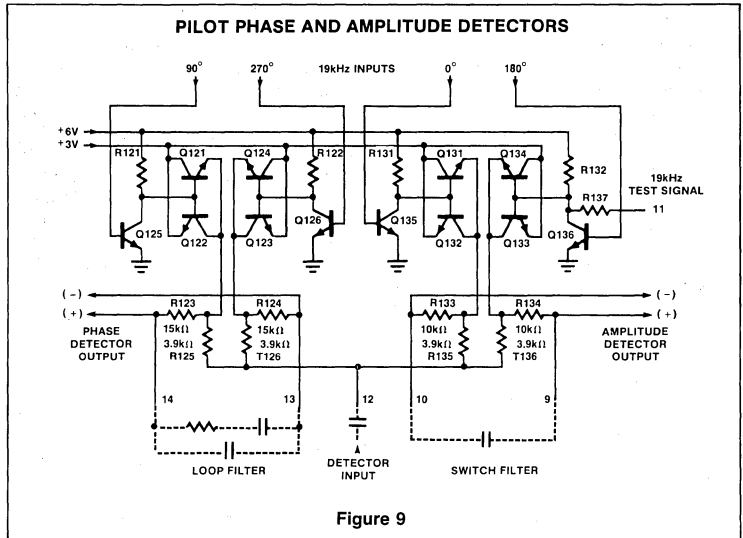
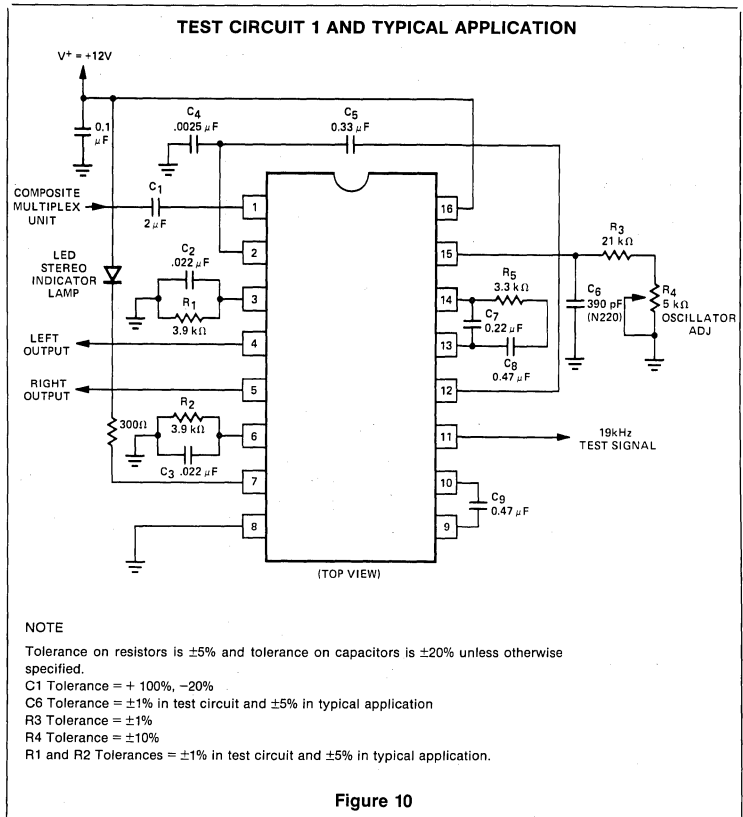

Figure 9



NOTE
 Tolerance on resistors is $\pm 5\%$ and tolerance on capacitors is $\pm 20\%$ unless otherwise specified.
 C1 Tolerance = + 100%, -20%
 C6 Tolerance = $\pm 1\%$ in test circuit and $\pm 5\%$ in typical application
 R3 Tolerance = $\pm 1\%$
 R4 Tolerance = $\pm 10\%$
 R1 and R2 Tolerances = $\pm 1\%$ in test circuit and $\pm 5\%$ in typical application.

Figure 10

TYPICAL PERFORMANCE CURVES FOR 758
(Test Circuit 1 unless Otherwise Specified)

CHANNEL SEPARATION AS A FUNCTION OF AUDIO FREQUENCY

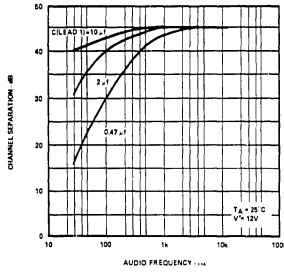

CHANNEL SEPARATION AS A FUNCTION OF OSCILLATOR FREE RUNNING FREQUENCY ERROR

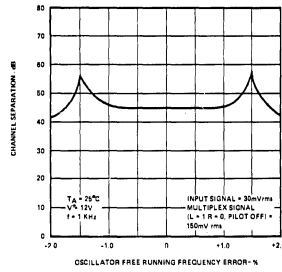

CAPTURE RANGE AS A FUNCTION OF PILOT LEVEL

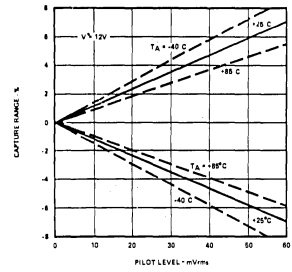

TOTAL HARMONIC DISTORTION AS A FUNCTION OF INPUT LEVEL

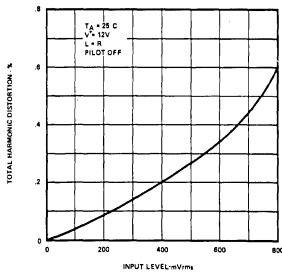

LAMP TURN ON AND TURN OFF SENSITIVITY AS A FUNCTION OF AMBIENT TEMPERATURE

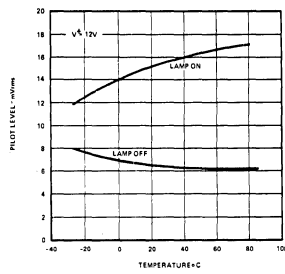

OSCILLATOR FREE RUNNING FREQUENCY ERROR AS A FUNCTION OF AMBIENT TEMPERATURE

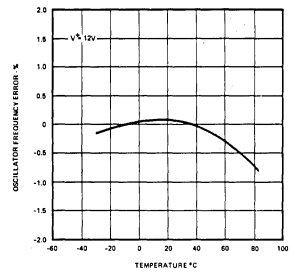

Figure 11

APPLICATIONS

The following circuits will illustrate some of the wide variety of applications for the NE570.

BASIC EXPANDOR

Figure 1 shows how the circuit would be hooked up for use as an expander. Both the rectifier and ΔG cell inputs are tied to V_{in} so that the gain is proportional to the average value of (V_{in}). Thus, when V_{in} falls 6dB, the gain drops 6dB and the output drops 12dB. The exact expression for the gain is

$$\text{Gain exp.} = \frac{2 R_3 V_{in} (\text{ave})}{R_1 R_2 I_B}; I_B = 140\mu A$$

The maximum input that can be handled by the circuit in Figure 1 is a peak of 3V. The rectifier input current can be as large as $I = 3V/R_1 = 3V/10K = 300\mu A$. The ΔG cell input current should be limited to $I = 2.8V/R_2 = 2.8V/20K = 140\mu A$. If it is necessary to handle larger input voltages than $0 \pm 2.8V$ pk, external resistors should be placed in series with R_1 and R_2 to limit the input current to the above values.

Figure 1 shows a pair of input capacitors C_{in1} and C_{in2} . It is not necessary to use both capacitors if low level tracking accuracy is not important. If R_1 and R_2 are tied together and share a common capacitor, a small current will flow between the ΔG cell summing node and the rectifier summing node due to offset voltages. This current will produce an error in the gain control signal at low levels, degrading tracking accuracy.

The output of the expander is biased up to 3V by the dc gain provided by R_3, R_4 . The output will bias up to

$$V_{out dc} = (1 + \frac{R_3}{R_4}) V_{ref}$$

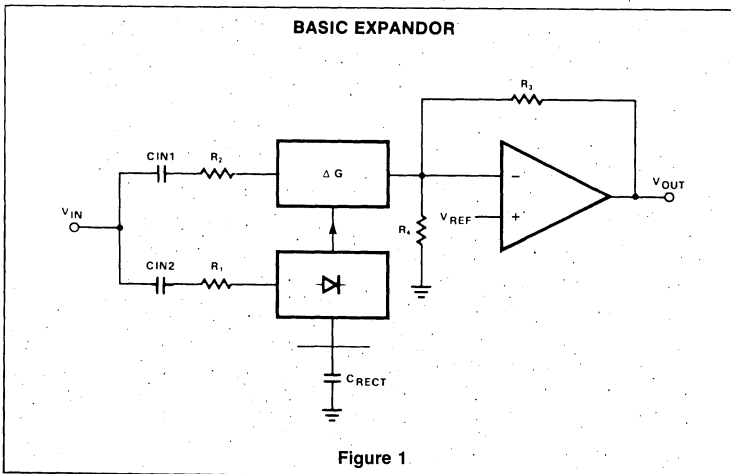

For supply voltages higher than 6V, R_4 can be shunted with an external resistor to bias the output up to $1/2 V_{CC}$.

Note that it is possible to externally increase R_1, R_2 , and R_3 , and to decrease R_3 and R_4 . This allows a great deal of flexibility in setting up system levels. If larger input signals are to be handled, R_1 and R_2 may be increased; if a larger output is required, R_3 may be increased. To obtain the largest dynamic range out of this circuit, the rectifier input should always be as large as possible (subject to the $\pm 300\mu A$ peak current restriction).

BASIC COMPRESSOR

Figure 2 shows how to use the NE570/571 as a compressor. It functions as an expander in the feedback loop of an op amp. If the input rises 6dB, the output can rise only 3dB. The 3dB increase in output level produces a 3dB increase in gain in the ΔG cell, yielding a 6dB increase in feedback current to the summing node. Exact expression for gain is

$$\text{Gain comp} = \left[\frac{R_1 R_2 I_B}{2 R_3 V_{in} (\text{ave})} \right]^{1/2}$$

The same restrictions for the rectifier and ΔG cell maximum input current still hold, which place a limit on the maximum compressor output. As in the expander, the rectifier and ΔG cell inputs could be made common to save a capacitor, but low level tracking accuracy would suffer. Since there is no dc feedback path around the op amp through the ΔG cell, one must be provided externally. The pair of resistors R_{dc} and the

capacitor C_{dc} must be provided. The op amp output will bias up to

$$V_{out dc} = (1 + \frac{2 R_{dc}}{R_4}) V_{ref}$$

For the largest dynamic range, the compressor output should be as large as possible so that the rectifier input is as large as possible (subject to the $\pm 300\mu A$ peak current restriction). If the input signal is small, a large output can be produced by reducing R_3 with the attendant decrease in input impedance, or by increasing R_1 or R_2 . It would be best to increase R_2 rather than R_1 so that the rectifier input current is not reduced.

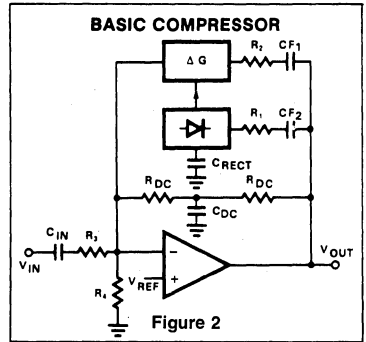

DISTORTION TRIM

Distortion can be produced by voltage offsets in the ΔG cell. The distortion is mainly even harmonics, and drops with decreasing input signal. (Input signal meaning the current into the ΔG cell.) The THD trim terminal provides a means for trimming out the offset voltages and thus trimming out the distortion. The circuit shown in Figure 3 is suitable, as would be any other capable of delivering $\pm 30\mu A$ into 100Ω resistor tied to 1.8V.

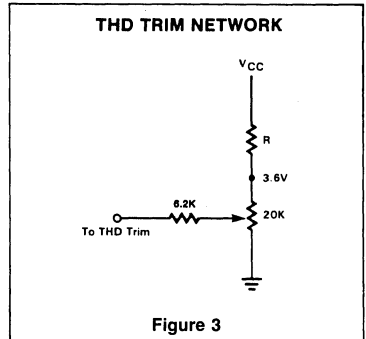

LOW LEVEL MISTRACKING

The compandor will follow a 2 to 1 tracking ratio down to very low levels. The rectifier is responsible for errors in gain, and it is the rectifier input bias current of <math><100\text{na}</math> that produces errors at low levels. The magnitude of the error can be estimated. For a full scale rectifier input signal of $\pm 200\mu\text{A}$, the average input current will be $127\mu\text{A}$. When the input signal level drops to a $1\mu\text{A}$ average, the bias current will produce a 10% or 1dB error in gain. This will occur at 42dB below the maximum input level.

It is possible to deviate from the 2 to 1 transfer characteristic at low levels as shown in the circuit of Figure 4. Either R_B or R_B , (but not both), is required. The voltage on C_{rect} is $2 \times V_{\text{be}}$ plus $V_{\text{in ave}}$. For low level inputs $V_{\text{in ave}}$ is negligible, so we can assume 1.3V as the bias on C_{rect} . If R_B is placed from C_{rect} to gnd we will bleed off a current $I = 1.3\text{V}/R_B$. If the rectifier average input current is less than this value, there will be no gain control input to the ΔG cell so that its gain will be zero and the expander output will be zero. As the input level is raised, the input current will exceed $1.3\text{V}/R_B$ and the expander output will become active. For large input signals, R_B will have little effect. The result of this is that we will deviate from the 2 to 1 expansion, present at high levels, to an infinite expansion, at low levels where the output shuts off completely. Figure 5 shows some examples of tracking curves which can be obtained. Complementary curves would be obtained for a compressor, where at low level signals the result would be infinite compression. The bleed current through R_B will be a function of temperature because of the two V_{be} drops, so the low level tracking will drift with temperature. If a negative supply is available, it would be desirable

to tie R_B to that, rather than ground, and to increase its value accordingly. The bleed current will then be less sensitive to the V_{be} temperature drift.

R_B will supply an extra current to the rectifier equal to $(V_{\text{CC}} - 1.3\text{V})/R_B$. In this case, the expander transfer characteristic will deviate towards 1 to 1 at low levels. At low levels the expander gain will stop dropping and the expansion will cease. In a compressor this would lead to a lack of compression at low levels. Figure 6 shows some typical transfer curves. An R_B value of approximately 2.5Meg would trim the low level tracking so as to match the Bell system N2 trunk compandor characteristic.

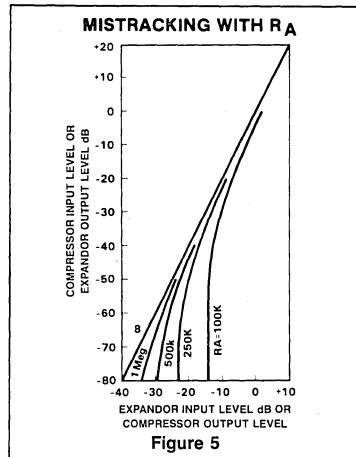
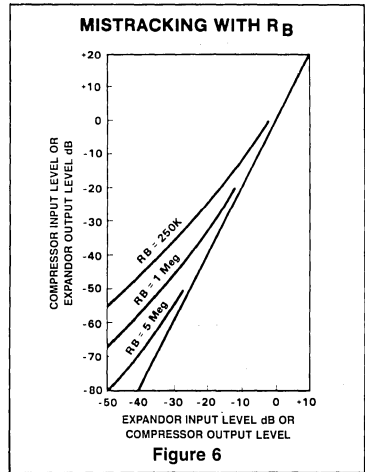

RECTIFIER BIAS CURRENT CANCELLATION

The rectifier has an input bias current of between 50 and 100na. This limits the dynamic range of the rectifier to about 60dB. It also limits the amount of attenuation of the ΔG cell. The rectifier dynamic range may be increased by about 20dB by the bias current trim network shown in Figure 7. Figure 8 shows the rectifier performance with and without bias current cancellation.

ATTACK AND DECAY TIME

The attack and decay times of the compandor are determined by the rectifier filter time constant $10\text{K} \times C_{\text{rect}}$. Figure 9 shows how the gain will change when the input signal undergoes a 10, 20, or 30dB change in level.

The attack time is much faster than the decay, which is desirable in most applications. Figure 10 shows the compressor attack envelope for a +12dB step in input level. The initial output level of 1 unit instantaneously rises to 4 units, and then starts to fall towards its final value of 2 units. The CCITT recommendation on attack and decay times for telephone system compandors defines the attack time as when the envelope has fallen to a level of 3 units, corresponding to $t = .15$ in the figure. The CCITT recommends an attack time of $3 \pm 2\text{ms}$, which suggests an RC product of 20ms. Figure 11 shows the compressor output envelope when the input level is suddenly reduced 12dB. The output, initially at a level of 4 units, drops 12dB to 1 unit and then rises to its final value of 2 units. The CCITT defines release time as when the output has risen to 1.5 units, and suggests a value of 13.5

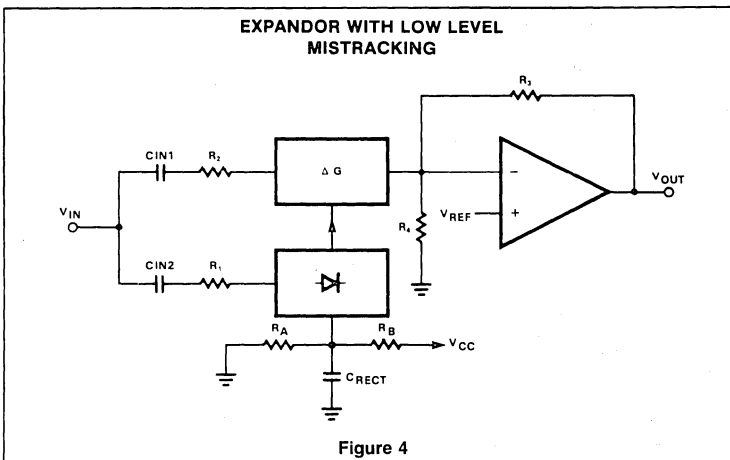

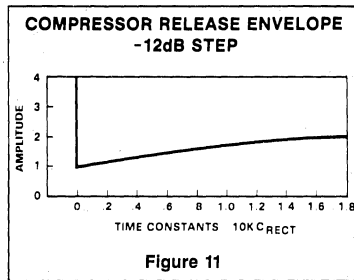
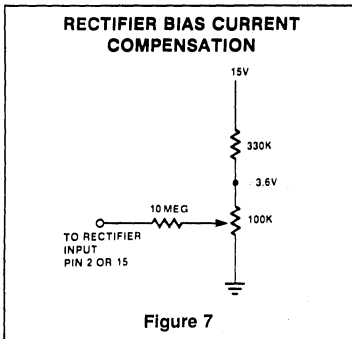

A stereo limiter can be built out of 1 NE570/571, 1 LM339 and two pnp transistors. The resistor networks R₁₂, R₁₃ and R₁₄, R₁₅, which set the limiting thresholds, could be common between channels. To gang the stereo channels together (limiting in one channel will produce a corresponding gain change in the second channel to maintain the balance of the stereo image), then pins 1 and 16 should be jumpered together. The outputs of all 4 comparators may then be tied together, and only one pnp transistor and one capacitor C₄ need be used. The release time will then be the product 5KxC₄ since two channels are being supplied current from C₄.

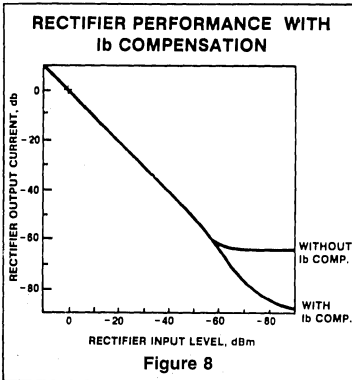

± 9ms. This corresponds to $t = .675$ in the figure, which again suggests a 20ms RC product. Since R₁ = 10K, the CCITT recommendations will be met if C_{rect} = 2μF.

There is a trade-off between fast response and low distortion. If a small C_{rect} is used to get very fast attack and decay, some ripple will appear on the gain control line and produce distortion. As a rule, a 1μF C_{rect} will produce .2% distortion at 1kHz. The distortion is inversely proportional to both frequency and capacitance. Thus, for telephone applications where C_{rect} = 2μF, the ripple would cause .1% distortion at 1kHz and .33% at 300Hz. The low frequency distortion generated by a compressor would be cancelled (or undistorted) by an expander, providing that they have the same value of C_{rect}.

USE OF EXTERNAL OP AMP

The operational amplifiers in the NE570/571 is not adequate for some applications. The slow rate, bandwidth, noise, and output drive capability can limit performance in many systems. For best performance, an external op amp can be used. The external op amp may be powered by bipolar supplies for a larger output swing.

Figure 13 shows how an external op amp may be connected. The non-inverting input must be biased at about 1.8V. This is easily accomplished by tying it to either pin 8 or 9, the THD trim pins, since these pins sit at 1.8V. An optional RC decoupling network is shown which will filter out the noise from the NE570/571 reference (typically about 10μV in 20kHz BW). The inverting input of the external op amp is tied to the inverting input of the internal op amp. The output of the external op amp is then used, with the internal op amp output left to float. If the external op amp is used single supply (+V_{CC} and ground), it must have an input common mode range down to less than 1.8V.

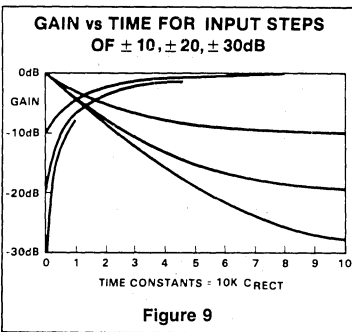

FAST ATTACK, SLOW RELEASE HARD LIMITER

The NE570/571 can be easily used to make an excellent limiter. Figure 12 shows a typical circuit which requires 1/2 of an NE570/571, 1/2 of an LM339 quad comparator, and a pnp transistor. For small signals, the ΔG cell is nearly off, and the circuit runs at unity gain as set by R₆, R₇. When the output signal tries to exceed a + or - 1V peak, a comparator threshold is exceeded. The pnp is turned on and rapidly charges C₄ which activates the ΔG cell. Negative feedback through the ΔG cell reduces the gain and the output signal level. The attack time is set by the RC product of R₁₀ and C₄, and the release time is determined by C₄ and the internal rectifier resistor, which is 10K. The circuit shown attacks in less than 1ms and has a release time constant of 100ms. R₉ trickles about .7μA through the rectifier to prevent C₄ from becoming completely discharged. The gain cell is activated when the voltage on pin 1 or 16 exceeds two diode drops. If C₄ were allowed to become completely discharged, there would be a slight delay before it recharged to > 1.2V and activated limiting action.

N2 COMPANDOR

There are four primary considerations involved in the application of the NE570/571 in an N2 compandor. These are matching of input and output levels, accurate 600Ω input and output impedances, conformance to the Bell system low level tracking curve, and proper attack and release times.

Figure 14 shows the implementation of an N2 compressor. The input level of .245V rms is stepped up to 1.41V rms by the 600Ω: 20KΩ matching transformer. The 20K input resistor properly terminates the transformer. An internal 20KΩ resistor (R₀) is provided, but for accurate impedance termination an external resistor should be used. The output impedance is provided by the 4K output resistor and the 4KΩ: 600Ω output transformer. The .275V rms output level requires a 1.4V op amp out-

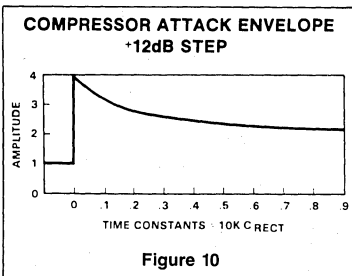

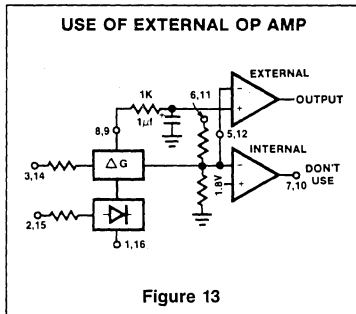
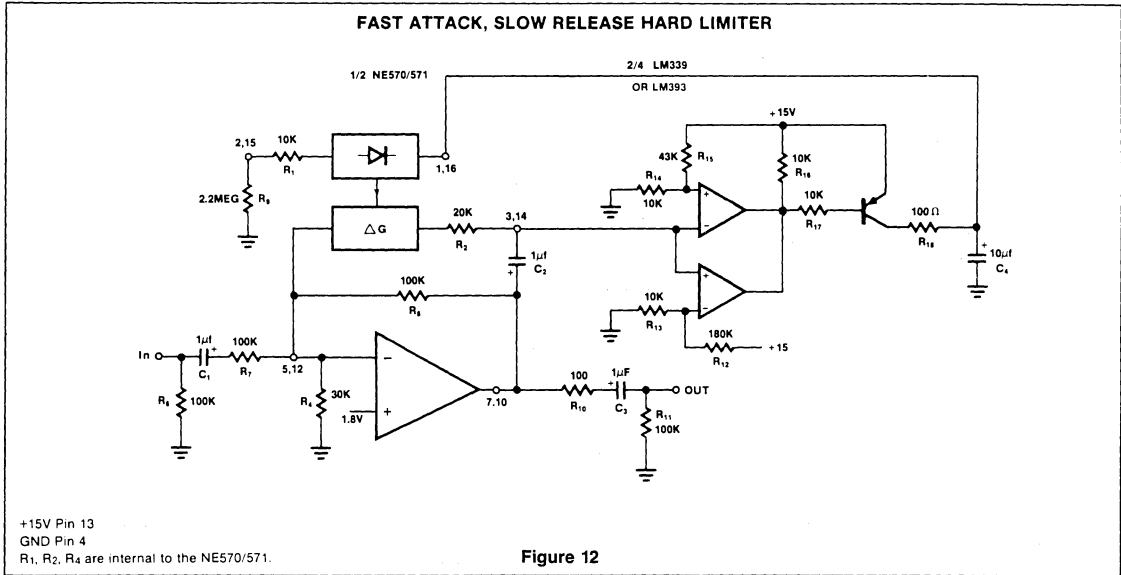

put level. This can be provided by increasing the value of R₂ with an external resistor, which can be selected to fine trim the gain. A rearrangement of the compressor gain equation (6) allows us to determine the value for R₂.

$$R_2 = \frac{\text{Gain}^2 \times 2 R_3 V_{in \text{ ave}}}{R_1 I_B} = \frac{12 \times 2 \times 20K \times 1.27}{10K \times 140\mu A} = 36.3K$$

The external resistance required will thus be 36.3K - 20K = 16.3K

The Bell compatible low level tracking characteristic is provided by the low level trim resistor from C_{rect} to V_{CC}. As shown in Figure 6, this will skew the system to a 1:1 transfer characteristic at low levels. The 2μF rectifier

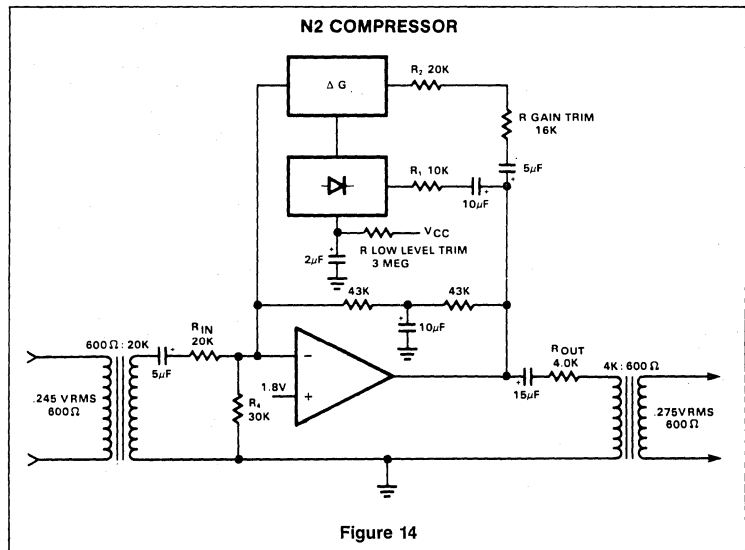

capacitor provides attack and release times of 3ms and 13.5ms respectively, as shown in Figures 10 and 11. The R-C-R network around the op amp provides dc feedback to bias the output at dc.

An N2 expander is shown in Figure 15. The input level of 3.27V RMS is stepped down to

1.33V by the 600Ω: 100Ω transformer, which is terminated with a 100Ω resistor for accurate impedance matching. The output impedance is accurately set by the 150Ω output resistor and the 150Ω: 600Ω output transformer. With this configuration the 3.46V transformer output requires a 3.46V op amp output. To obtain

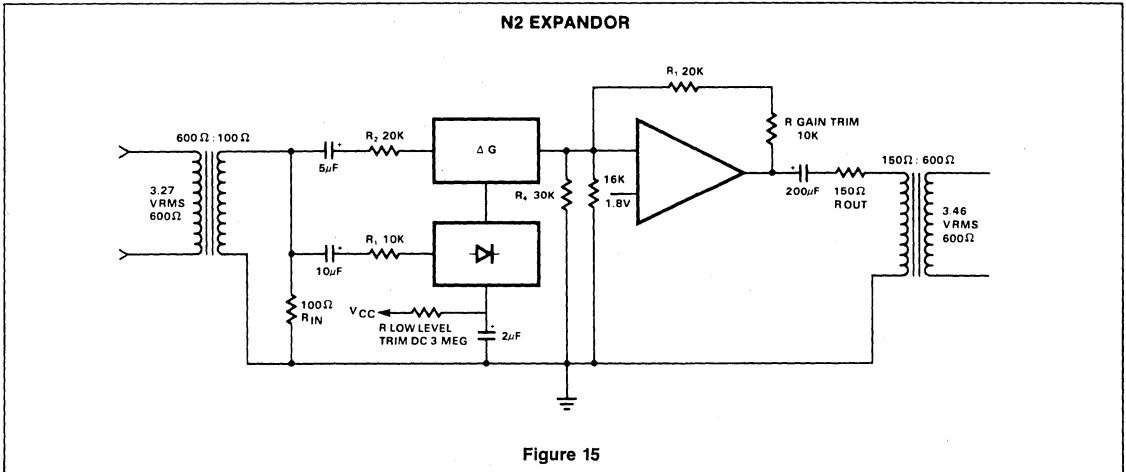

Figure 15

this output level, it is necessary to increase the value of R_3 with an external trim resistor. The new value of R_3 can be found with the expander gain equation

$$R_3 = \frac{R_1 R_2 I_B \text{ Gain}}{2 V_{IN} \text{ avg}} = \frac{10K \times 20K \times 140\mu A \times 2.6}{2 \times 1.20} = 30.3K$$

An external addition to R_3 of 10K is required, and this value can be selected to accurately set the high level gain.

A low level trim resistor from C_{rect} to V_{CC} of about 3Meg provides matching of the Bell low level tracking curve, and the 2μF value of C_{rect} provides the proper attack and release times. A 16K resistor from the summing node to ground biases the output to 7V dc.

VOLTAGE CONTROLLED ATTENUATOR

The variable gain cell in the NE570/571 may be used as the heart of a high quality voltage controlled amplifier (VCA). Figure 16 shows a typical circuit which uses an external op amp for better performance, and an exponential converter to get a control characteristic of -6dB/V. Trim networks are shown to null out distortion and dc shift, and to fine trim gain to 0dB with zero volts of control voltage.

Op amp A_2 and transistors Q_1 and Q_2 form the exponential converter generating an exponential gain control current, which is fed into the rectifier. A reference current of 150μA, (15V and $R_{20} = 100K$), is attenuated a factor of two (6dB) for every volt increase in the control voltage. Capacitor C_6 slows down gain changes to a 20ms time constant ($C_6 \times R_1$) so that an abrupt change in the control voltage will produce a smooth

sounding gain change. R_{18} assures that for large control voltages the circuit will go to full attenuation. The rectifier bias current would normally limit the gain reduction to about 70dB. R_{18} draws excess current out of the rectifier. After approximately 50dB of attenuation at a -6dB/V slope, the slope steepens and attenuation becomes much more rapid until the circuit totally shuts off at about 9 volts of control voltage. A_1 should be a low noise high slew rate op amp. R_{13} and R_{14} establish approximately a zero volt bias at A_1 's output.

With a zero volt control voltage, R_{19} should be adjusted for 0dB gain. At 1V (-6dB gain) R_9 should be adjusted for minimum distortion with a large (+10dBm) input signal. The output dc bias (A_1 output) should be measured at full attenuation (+10V control voltage) and then R_8 is adjusted to give the same value at 0dB gain. Properly adjusted, the circuit will give typically less than .1% distortion at any gain with a dc output voltage variation of only a few millivolts. The clipping level (140μA into pin 3, 14) is ±10V peak. A signal to noise ratio of 90dB can be obtained.

If several VCA's must track each other, a common exponential converter can be used. Transistors can simply be added in parallel with Q_2 to control the other channels. The transistors should be maintained at the same temperature for best tracking.

AUTOMATIC LEVEL CONTROL

The NE570 can be used to make a very high performance ALC as shown in Figure 17. This circuit hookup is very similar to the basic compressor shown in Figure 2 except that the rectifier input is tied to the input rather than the

output. This makes gain inversely proportional to input level so that a 20dB drop in input level will produce a 20dB increase in gain. The output will remain fixed at a constant level. As shown, the circuit will maintain an output level of ±1dbm for an input range of +14 to -43dbm at 1kHz. Additional external components will allow the output level to be adjusted. Some relevant design equations are:

$$\text{Output level} = \frac{R_1 R_2 I_B}{2 R_3} \left(\frac{V_{IN}}{V_{IN}(\text{avg})} \right); I_B = 140\mu A$$

$$\text{Gain} = \frac{R_1 R_2 I_B}{2 R_3 V_{IN}(\text{avg})} \text{ where}$$

$$\frac{V_{IN}}{V_{IN}(\text{avg})} = 2 \frac{\pi}{\sqrt{2}} = 1.11 \text{ (for sine wave)}$$

If ALC action at very low input levels is not desired, the addition of resistor R_X will limit the maximum gain of the circuit.

$$\text{Gain max.} = \frac{R_1 + R_X}{1.8V} \times \frac{R_2 \times I_B}{2 R_3}$$

The time constant of the circuit is determined by the rectifier capacitor, C_{rect} , and an internal 10K resistor.

$$\tau = 10K C_{rect}$$

Response time can be made faster at the expense of distortion. Distortion can be approximated by the equation.

$$THD = \left(\frac{1\mu F}{C_{rect}} \right) \left(\frac{1KHz}{f_{req.}} \right) \times .2\%$$

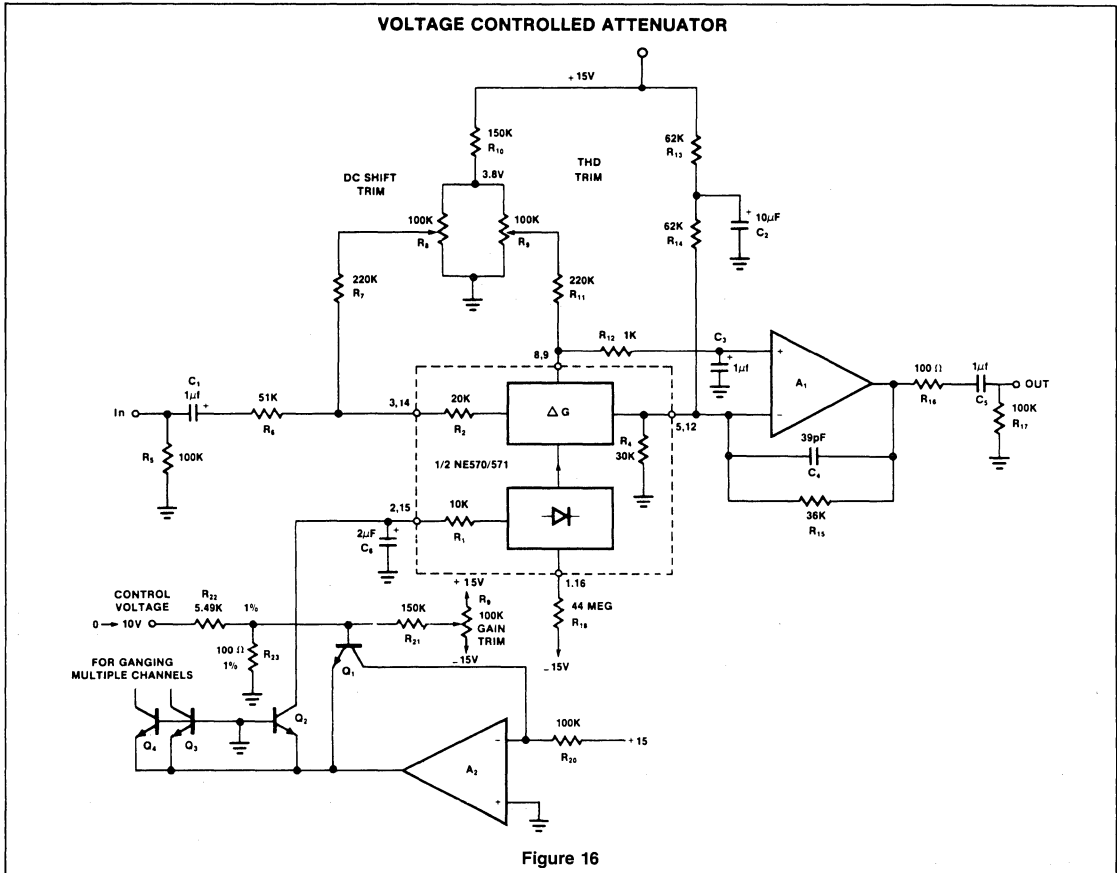

Figure 16

VARIABLE SLOPE COMPRESSOR-EXPANDOR

Compression and expansion ratios other than 2:1 can be achieved by the circuit shown in Figure 18. Rotation of the dual potentiometer causes the circuit hookup to change from a basic compressor to a basic expander. In the center of rotation, the circuit is 1:1, has neither compression nor expansion. The (input) output transfer characteristic is thus continuously variable from 2:1 compression, through 1:1 up to 1:2 expansion. If a fixed compression or expansion ratio is desired, proper selection of fixed resistors can be used instead of the potentiometer. The optional threshold resistor will make the compression or expansion ratio deviate towards 1:1 at low levels. A wide variety of (input) output characteristics can be created with this circuit, some of which are shown in Figure 18.

HI FI COMPANDOR

The NE570 can be used to construct a high performance compandor suitable for use with music. This type of system can be used for noise reduction in tape recorders, transmission systems, bucket brigade delay lines, and digital audio systems. The circuits to be described contain features which improve performance, but are not required for all applications.

A major problem with the simple NE570 compressor (Figure 2) is the limited op amp gain at high frequencies. For weak input signals, the compressor circuit operates at high gain and the 570 op amp simply runs out of loop gain. Another problem with the 570 op amp is its limited slew rate of about .6V/µs. This is a limitation of the expander, since the expander is more likely to produce large output signals than a compressor.

Figure 20 is a circuit for a high fidelity compressor which uses an external op amp and has a high gain and wide bandwidth. An input compensation network is required for stability.

Another feature of the circuit in Figure 20 is that the rectifier capacitor (C₃) is not grounded, but is tied to the output of an op amp circuit. This circuit, built around an LM324, speeds up the compressor attack time at low signal levels. The response times of the simple expander and compressor (Figures 1 and 2) become longer at low signal levels. The time constant is not simply 10K × C_{rect}, but is really

$$\left(10K + 2 \left(\frac{.026V}{V_{rect}}\right)\right) \times C_{rect}$$

When the rectifier input level drops from 0dBm to -30dBm, the time constant increases from 10.7K × C_{rect} to 32.6K × C_{rect}. In



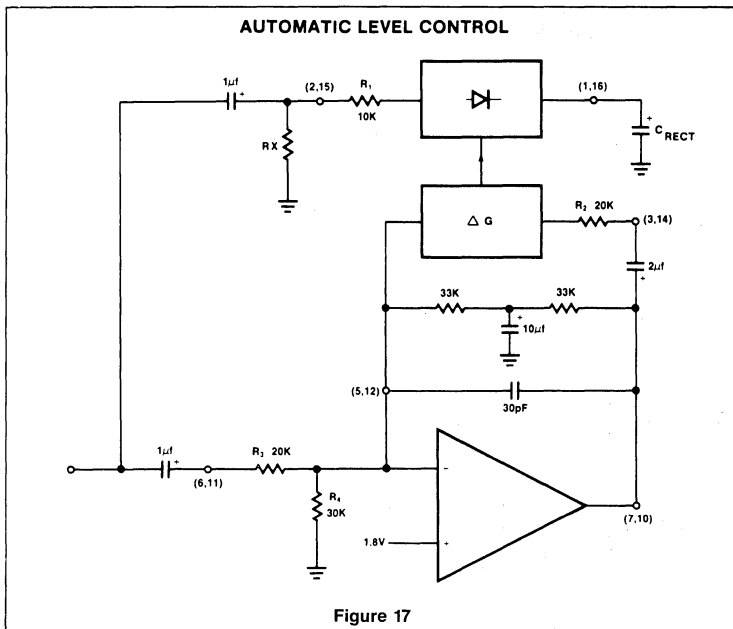

systems where there is unity gain between the compressor and expander, this will cause no overall error. Gain or loss between the compressor and expander will be a mistracking of low signal dynamics. The circuit with the LM324 will greatly reduce this problem for systems which cannot guarantee the unity gain.

When a compressor is operating at high gain, (small input signal), and is suddenly hit with a signal, it will overload until it can reduce its gain. Overloaded the output will attempt to swing rail to rail. This compressor is limited to approximately a 7V peak to peak output swing by the brute force clamp diodes D₃ and D₄. The diodes cannot be placed in the feedback loop because their capacitance would limit high frequency gain. The purpose of limiting the output swing is to avoid overloading any succeeding circuit such as a tape recorder input.

The time it takes for the compressor to recover from overload is determined by the rectifier capacitor C₉. A smaller capacitor will allow faster response to transients, but will produce more low frequency third harmonic distortion due to gain modulation. A value of 1µF seems to be a good compromise value and yields good subjective results. Of course, the expander should have exactly the same value rectifier capacitor for proper transient response. Systems which have good low frequency amplitude and phase response can use compandors with smaller rectifier capacitors, since the third harmonic distortion which is generated by the compressor will be undistorted by the expander.

Simple compandor systems are subject to a problem known as breathing. As the system is changing gain, the change in the background noise level can sometimes be heard.

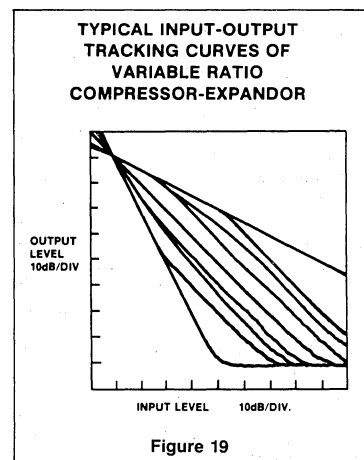
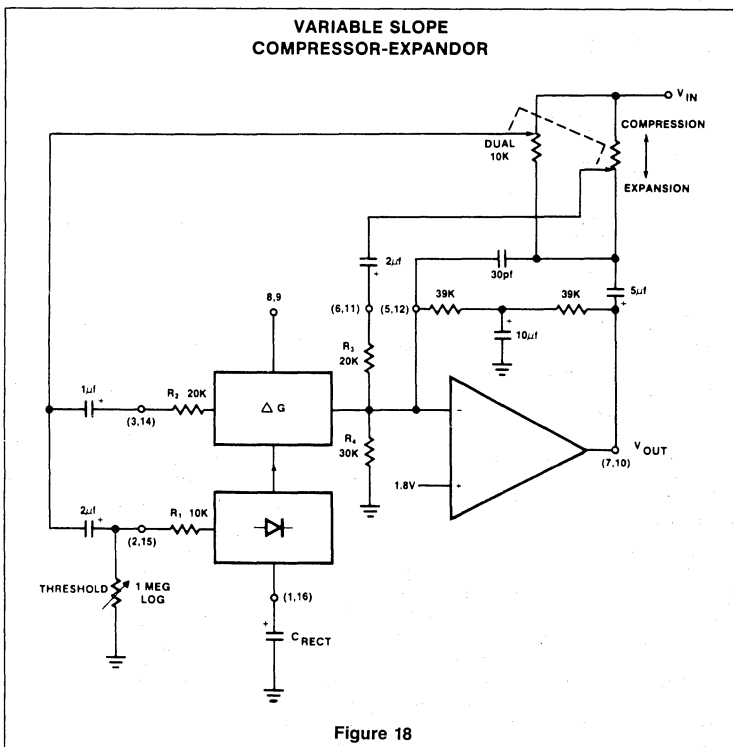

The compressor in Figure 20 contains a high frequency pre-emphasis circuit (C_2 , R_5 and C_8 , R_{14}), which helps solve this problem. Matching de-emphasis on the expander is required. More complex designs could make the pre-emphasis variable and further reduce breathing.

The expander to complement the compressor is shown in Figure 21. Here an external op amp is used for high slew rate. Both the compressor and expander have unity gain levels of 0dBm. Trim networks are shown for distortion (THD) and dc shift. The distortion trim should be done first, with an input of 0dBm at 10kHz. The dc shift should be adjusted for minimum envelope bounce with tone bursts. When applied to consumer tape recorders, the subjective performance of this system is excellent.

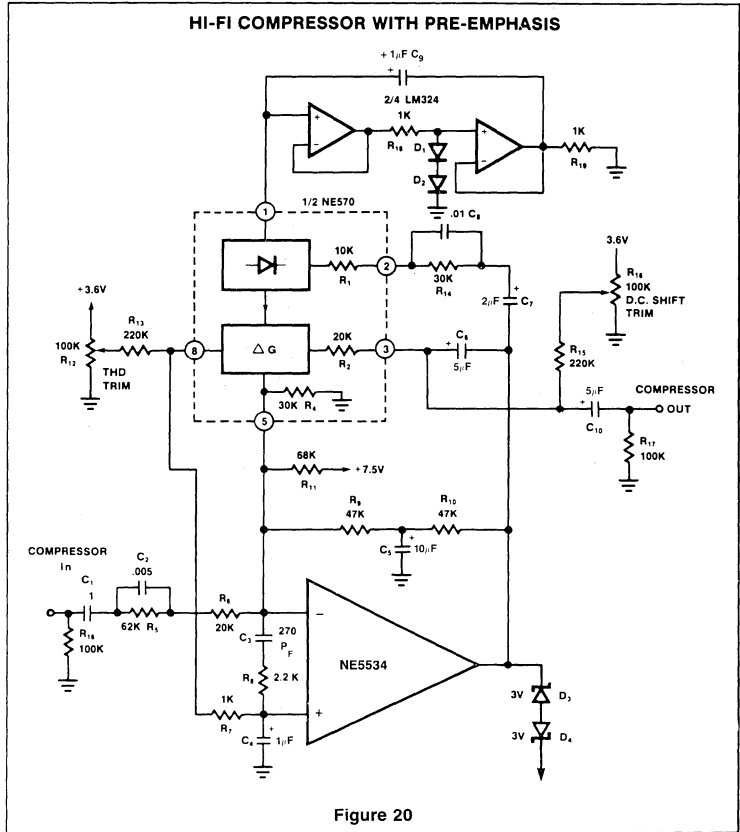
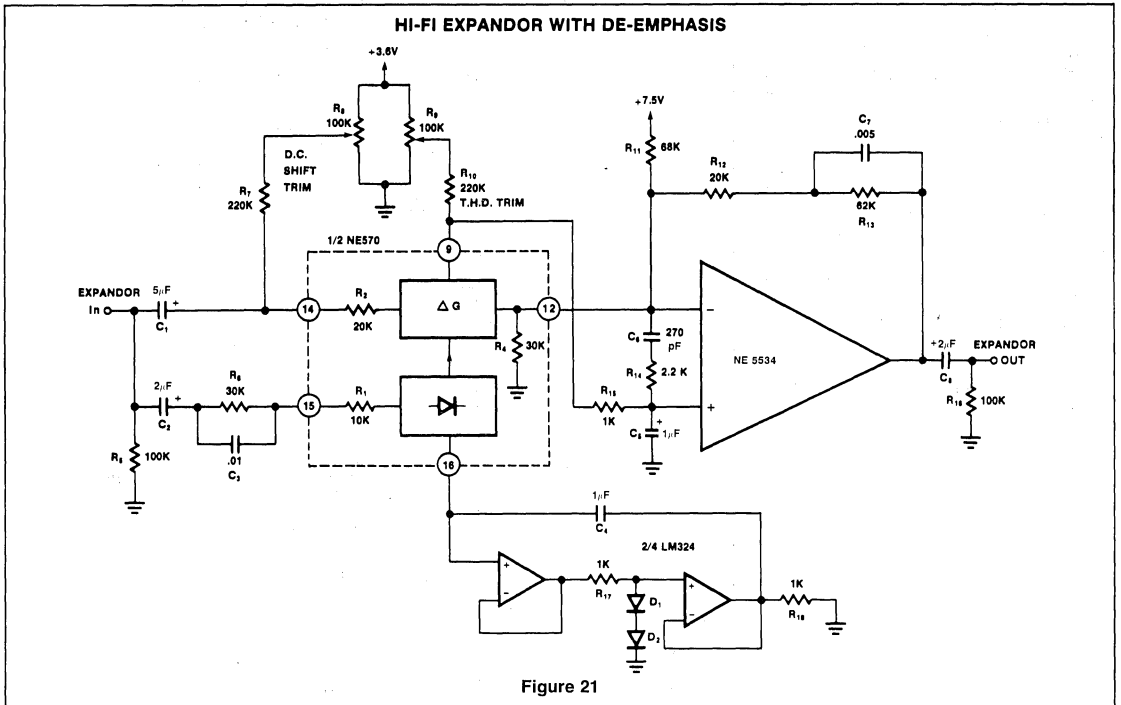

Figure 20



Compandors are versatile, low cost, dual channel gain control devices for audio frequencies. They are used in tape decks, cordless telephones, and wireless microphones performing noise reduction. Electronic organs, modems and mobile telephone equipment use compandors for signal level control.

So what is companding? Why do it at all? What happens when we do it? *Compandor* is the contraction of the two words *compressor* and *expander*. There is one basic reason to compress a signal before sending it through a telephone line or recording it on a cassette tape. It is to process that signal (music, speech, data) so that all parts of it are above the inherent noise floor of the transmission medium and yet not running into the max dynamic range limits, causing clipping and distortion. The diagrams below demonstrate the idea; they are not totally correct because in the real world of electronics the 3kHz tone is riding on the 1kHz tone. They are shown separated for better explanation.

Figure 1 is the signal from the source. Figure 2 shows the noise always in the transmission medium. Figure 3 shows the max limits of the transmission medium and what happens when a signal larger than those limits is sent through it. Figure 4 is the result of compressing the signal. (Note that the larger signal would not be clipped when transmitted.)

The received/playback signal is processed (expanded) in exactly the same-only inverted-ratio as the input signal was compressed. The end result is clean, undistorted signal with a high signal-to-noise ratio.

This document has been designed to give the reader a basic working knowledge of the

Signetics Compandor family. The analyses of three primary applications will be accompanied by "recipes" describing how to select external components (for both proper operation and function modification). Schematic and artwork for an application board are also provided. For comprehensive technical information consult the Compandor Product Guide or the Linear LSI Data Manual.

The basic blocks in a compandor are the current controlled variable gain cell (delta-G), voltage to current converter (rectifier), and operational amplifier. Each Signetics compandor package has two identical, independent channels with the following block diagrams (notice that the 570/71 is different from the 572):

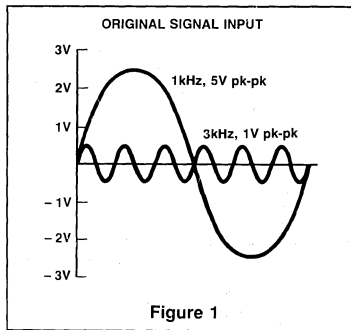

Figure 1

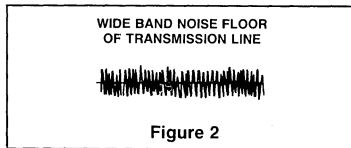

Figure 2

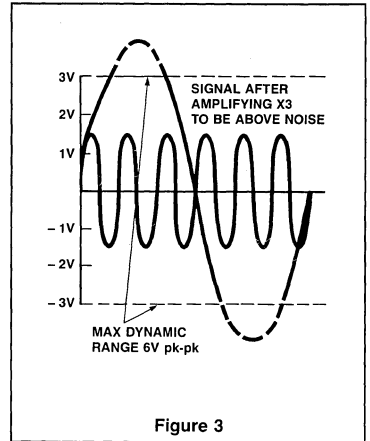

Figure 3

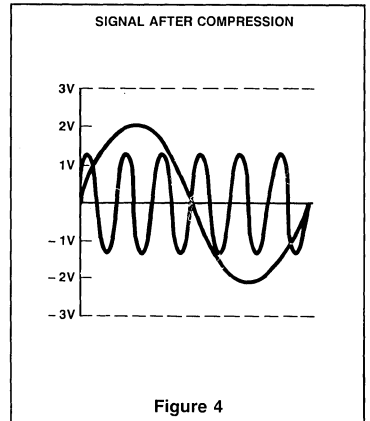
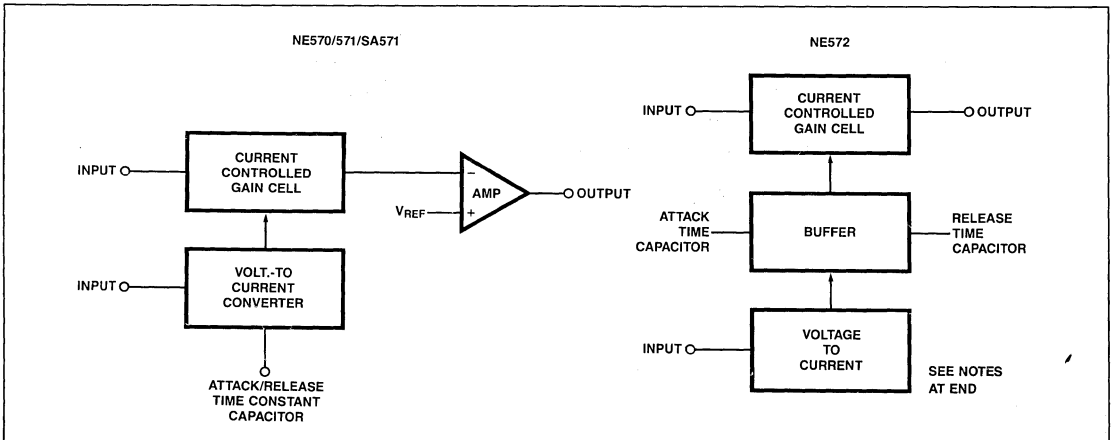

Figure 4

BLOCK DIAGRAMS



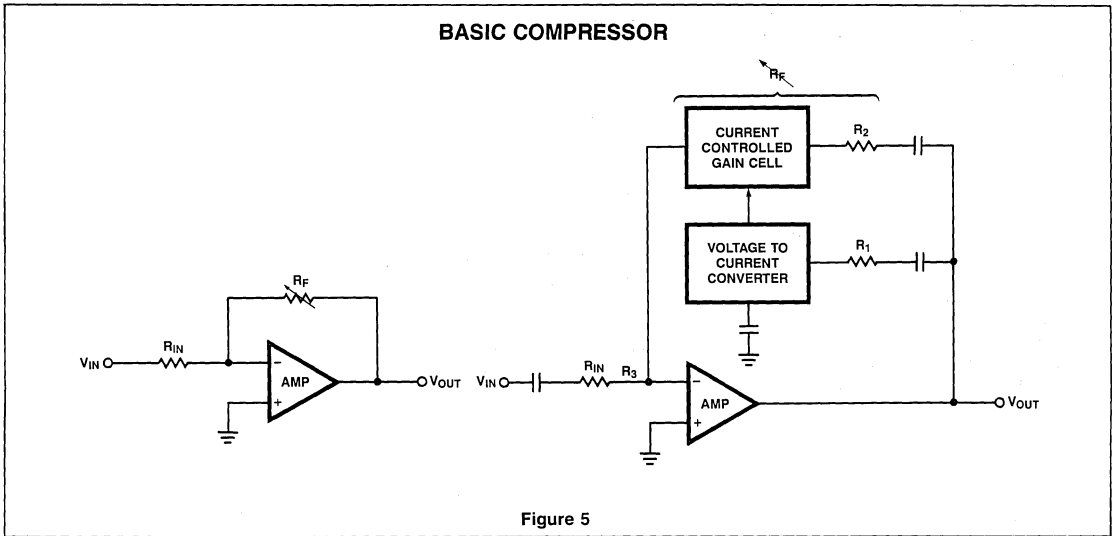

Figure 5

The operational amplifier is the main signal path and output drive.

The full wave averaging rectifier measures the AC amplitude of a signal and develops a control current for the variable gain cell.

The variable gain cell uses the rectifier control current to provide variable gain control for the operational amplifier gain block.

The compandor can function as a COMPRESSOR, EXPANDOR, and AUTOMATIC LEVEL CONTROLLER or as a complete compressor/expandor system as described in the following:

- 1) The COMPRESSOR function processes uncontrolled input signals into controlled output signals. The purpose of this is to avoid distortion caused by a narrow dynamic range medium such as: telephone lines, RF and satellite transmissions, and magnetic tape. The COMPRESSOR can also limit the level of a signal.
- 2) The EXPANDOR function allows a user to increase the dynamic range of an incoming compressed signal such as radio broadcasts.
- 3) The compressor/expandor system allows a user to retain dynamic range and reduce the effects of noise introduced by the transmission medium.
- 4) The AUTOMATIC LEVEL CONTROL (ALC) function (like the familiar automatic gain control) adjusts its gain proportionally with the input amplitude. This ALC circuit therefore transforms a widely varying input signal into a fixed amplitude output signal without clipping and distortion.

HOW TO DESIGN COMPANDOR CIRCUITS

The rest of the cookbook will provide you with basic compressor, expander, and automatic level control application information. In all of the circuits a NE570/571 has been used. If high fidelity audio or separately programmable attack and decay time are needed, the NE572 with a low noise op-amp should be used.

The COMPRESSOR (see Figure 5) utilizes all basic building blocks of the compandor. In this configuration, the variable gain cell is placed in the feedback loop of the standard inverting amplifier circuit. The gain equation is $A_v = -R_F/R_{IN}$. As shown above, the variable gain cell acts as a variable feedback resistor (R_F). (See Figure 5.)

As the input signal increases (above the crossover level of 0dBm), this variable resistor decreases in value, causing the gain to decrease, thus limiting the output amplitude. Below the crossover level of 0dBm, an increase in input signal causes the variable resistor to increase in value thereby causing the output signal's amplitude to increase.

In the compressor configuration the rectifier is connected to the output.

The complete equation for the compressor gain is:

$$\text{Gain comp.} = \left[\frac{R_1 R_2 I_B}{2 R_3 V_{IN}(\text{avg})} \right]^{1/2}$$

where: $R_1 = 10K$
 $R_2 = 20K$
 $R_3 = 20K$
 $I_B = 140\mu A$
 $V_{IN}(\text{avg}) = 0.9 (V_{IN}(\text{rms}))$

COMPRESSOR RECIPE

- 1) DC bias the output half way between the supply and ground to get maximum headroom. The circuit in Figure 6 is designed around a system supply of 6 volts so we want the output DC level to be 3 volts.

$$V_{OUT\ DC} = (1 + (2R_{DC}/R_4)) V_{REF}$$

where: $R_4 = 30K$
 $V_{REF} = 1.8V$
 R_{DC} is external

manipulating the equation we arrive at . . .

$$R_{DC} = \left(\left(\frac{V_{OUT}}{V_{REF}} \right) - 1 \right) \frac{R_4}{2}$$

Note that the $C_{(DC)}$ should be large enough to totally short out any AC in this feedback loop.

- 2) Analyze the OUTPUT signal's anticipated amplitude.
 - a) if larger than 2.8V peak, R_2 needs to be increased. (see INGREDIENTS section, below)
 - b) if larger than 3.0V peak, R_1 will also need to be increased.

By limiting the peak input currents we avoid signal distortion.

- 3) The input and output coupling caps need to be large enough not to attenuate any desired frequencies. ($X_c = 1/(6.28xf)$)



- 4) The C(rect) should be 1μF to 2μF for initial setup. This directly affects Attack and Release times.
- 5) An input buffer may be necessary if the sources' output impedance needs matching.
- 6) Pre-emphasis may be used to reduce noise-pumping, breathing, etc., if present. See the NE570/571 data sheet for specific details.
- 7) Distortion (THD) trim pins are available if the already low distortion needs to be further reduced. Refer to data sheet for trimming network. Note that if not used, the THD trim pins should have 200pF caps to ground.
- 8) At very low input signal levels, the rectifier's errors become significant and can be reduced with the Low Level Mistracking network. (This technique prevents infinite compression at low input levels.)

The EXPANDOR utilizes all the basic building blocks of the compandor (see Figure 7). In this configuration the variable gain cell is placed in the inverting input lead of the operational amplifier and acts as a variable input resistance, R_{IN} . The basic gain equation for operational amplifiers in the standard inverting feedback loop is $A_v = -R_F/R_{IN}$.

As the input amplitude increases above the crossover level of 0dBm, this variable resistor decreases in value, causing the gain to increase, thus forcing the output amplitude to increase. (Refer to Figure 10.)

Below the crossover level an increase in input amplitude causes the variable resistor to increase in value, thus forcing the output amplitude to decrease.

In the expander configuration the rectifier is connected to the input.

The complete equation for the expander gain is:

$$\text{Gain expander} = (2R_3V_{IN}(\text{avg}))/R_1R_2I_B$$

where: $R_1 = 10K$
 $R_2 = 20K$
 $R_3 = 20K$
 $I_B = 140\mu A$

$$V_{IN}(\text{avg}) = 0.9 (V_{IN}(\text{rms}))$$

$$V_{OUT DC} = (1 + R_3/R_4) V_{REF}$$

where: $R_3 = 20K$
 $R_4 = 30K$
 $V_{REF} = 1.8V$

Note that when using a supply voltage higher than 6 volts the DC output level should be adjusted. To increase the DC output level, it is recommended that R_4 be decreased by adding parallel resistance to it. (Changing R_3 would affect the expander's AC gain also and thus cause a mismatch in a companding system.)

EXPANDOR RECIPE

- 1) DC bias the output half way between the supply and ground to get maximum headroom. The circuit in Figure 8 is designed around a system supply of 6 volts so we want the output DC level to be 3 volts.

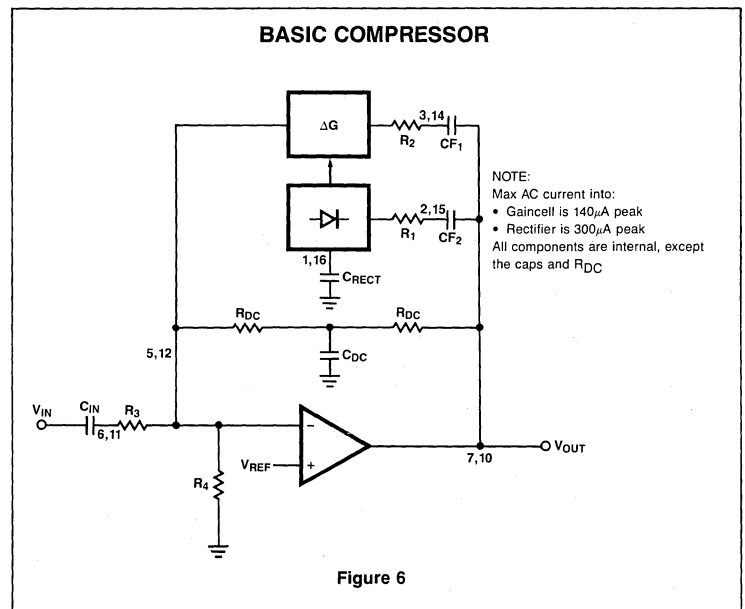

BASIC EXPANDOR

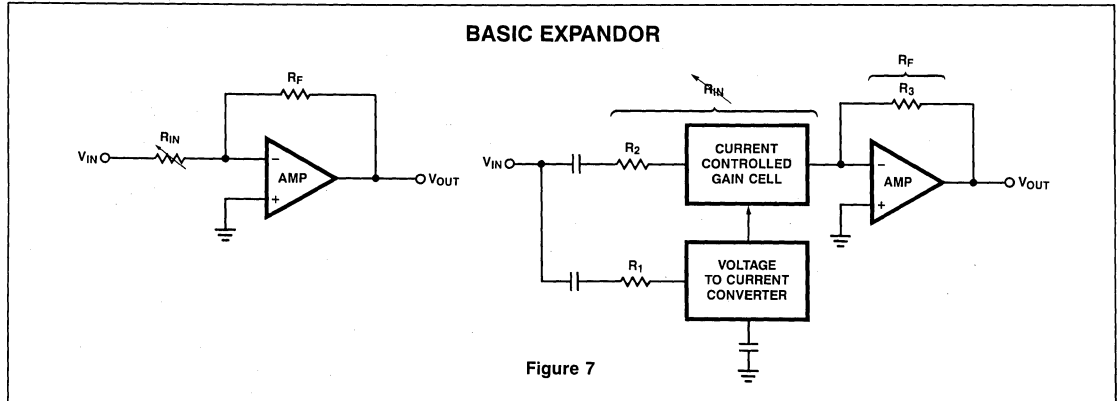

2) Analyze the input signal's anticipated amplitude:

- a) if larger than 2.8 peak, R_2 needs to be increased. (see INGREDIENTS section, below)
- b) if larger than 3.0V peak, R_1 will also need to be increased. (see INGREDIENTS, below)

By limiting the peak input currents we avoid signal distortion.

- 3) The input and output decoupling caps need to be large enough not to attenuate any desired frequencies.
- 4) The C(rect) should be $1\mu\text{F}$ to $2\mu\text{F}$ for initial setup.
- 5) An input buffer may be necessary if the sources' output impedance needs matching.
- 6) De-emphasis would be necessary if the complementary compressor circuit had been pre-emphasized (as in a tape deck application). See the HI-FI Expander application in the Linear LSI Data Manual.
- 7) Distortion (THD) trim pins are available if the already low distortion needs to be further reduced. See Linear LSI Data Manual for trimming network. Note that if not used, the THD trim pins should have 200pF caps to ground.
- 8) At very low input signal levels, the rectifier's errors become significant and can be reduced with the Low Level Mistracking network (see Linear LSI Data Manual). (This technique prevents infinite expansion at low input levels.)

Note that for very low input levels, ALC may not be desired and to limit the maximum gain, resistor R_X has been added. The modified gain equation is:

$$\text{Gain max.} = \frac{R_1 + R_X}{2 R_3} \times R_2 \times I_B$$

$$R_X \cong ((\text{desired max gain}) \times 26\text{K}) - 10\text{K}$$

INGREDIENTS

[Application guidelines for internal and external components (and input/output constraints) needed to tailor (cook) each of the three entrees (applications) to your taste.]

R_1 (10Kohms) limits input current to the rectifier. This current should not exceed an AC peak value of ± 300 microamps. An external resistor may be placed in series with R_1 if the input voltage to the rectifier will exceed $\pm 3.0\text{V}$ peak (i.e., $10\text{K} \times 300\mu\text{A} = 3.0\text{V}$).

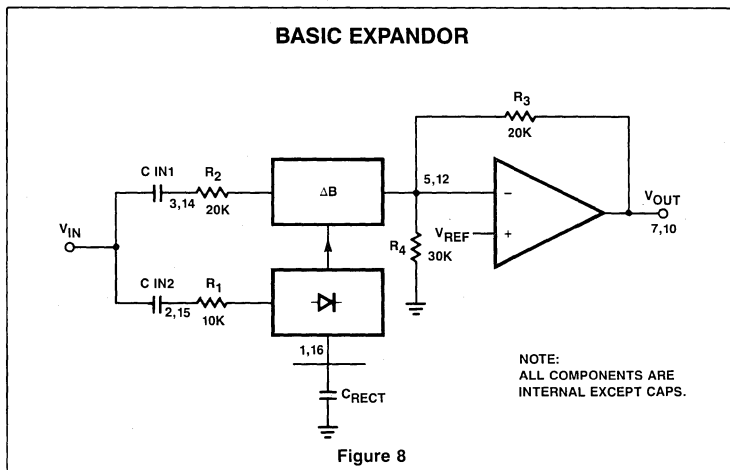

In the ALC configuration, (Figure 9), the variable gain cell is placed in the feedback loop of the operational amplifier (as in the COMPRESSOR) and the rectifier is connected to the input.

As the input amplitude increases above the crossover point, the overall system gain decreases proportionally, holding the output amplitude constant.

As the input amplitude decreases below the crossover point, the overall system gain increases proportionally, holding the output amplitude at the same constant level.

The complete gain equation for the ALC is:

$$\text{Gain} = \frac{R_1 R_2 I_B}{2 R_3 V_{IN}(\text{avg})}$$

$$\text{Output level} = \frac{R_1 R_2 I_B}{2 R_3} \left(\frac{V_{IN}}{V_{IN}(\text{avg})} \right)$$

$$\text{where } \frac{V_{IN}}{V_{IN}(\text{avg})} = \frac{\pi}{2\sqrt{2}} = 1.11 \text{ (for sine wave)}$$

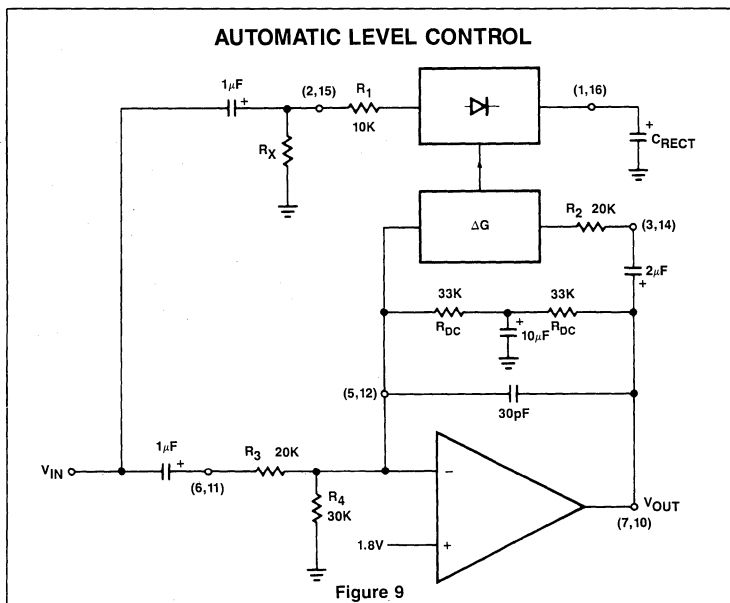

R_2 (20Kohms) limits input current to the variable gain cell. This current should not exceed an AC peak value of ± 140 microamps. Again, an external resistor has to be placed in series with R_2 if the input voltage to the variable gain cell exceeds $\pm 2.8V$ (i.e., $20K \times 140\mu A$).

R_3 (20Kohms) acts in conjunction with R_4 as the feedback resistor (R_f) (expander configuration) in the equation. (R_3 's value can be either reduced or increased externally.) However, it is recommended that R_4 be the one to change when adjusting the output DC level.

R_4 (30Kohms) acts as the input resistor (R_{IN}) in the standard non-inverting op amp circuit. (Its value can only be reduced.)

$$V_{out DC} = (1 + (R_3/R_4))V_{ref} \text{ (for the EXPANDOR)}$$

$$V_{out DC} = (1 + (2R_{DC}/R_4))V_{ref} \text{ (for the COMPANDOR,ALC)}$$

[The purpose of these DC biasing equations is to allow the designer to set the output half

way between the supply rails for largest headroom (usually some positive voltage and ground).]

C_{DC} acts as an AC shunt to ground to totally remove the DC biasing resistors from the AC gain equation.

C_F caps are AC signal coupling caps.

C_{RECT} acts as the rectifier's filter cap and directly affects the response time of the circuit. There is a trade-off, though, between fast attack and decay times and distortion.

The time constant is: $10K \times C_{RECT}$

The total harmonic distortion (THD) is approximated by:

$$THD \cong (1\mu F/C_{RECT})(1kHz/freq.) \times 0.2\%$$

NOTES:

The NE572 differs from the 570/571 in that:

1. There is no internal op amp.
2. The attack and release times are programmed separately.

SYSTEM LEVELS OF A COMPLETE COMPANDING SYSTEM

Figure 10 demonstrates the compressing and expanding functions:

Point A represents a wide dynamic range signal with a maximum amplitude of +16dB and minimum amplitude of -80dB.

Point B represents the compressor output showing a 2:1 reduction in dynamic range (-40dB is increased to -20dB, for example). Point B can also be seen as the dynamic range of a transmission medium. Transmission noise is present at the -60dB level from Point B to Point C.

Point C represents the input signal to the expander.

Point D represents the output of the expander. The signal transformation from Point C to D represents a 1:2 expansion.

SYSTEM LEVELS OF A COMPLETE COMPANDING SYSTEM

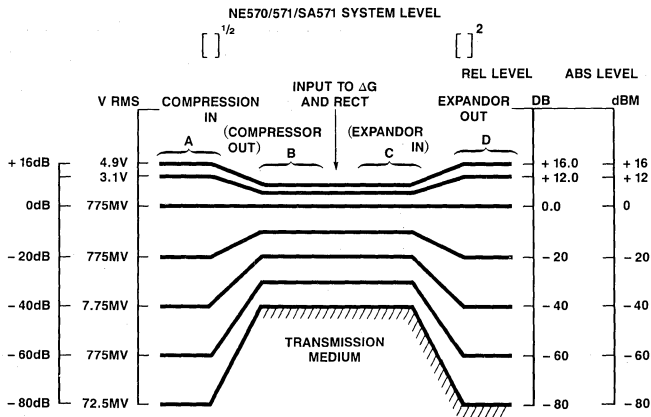
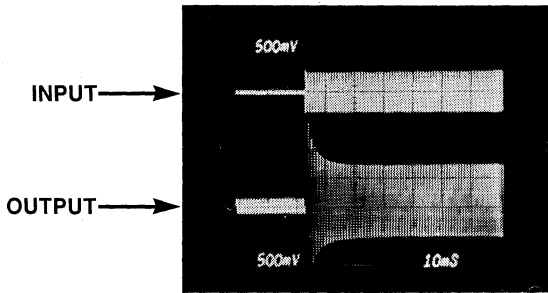

Figure 10

WHAT IS COMPANDING??

Shown here are some scope pictures of what three functions of the compandor look like in the kitchen, responding to tone bursts of varying amplitudes.



COMPRESSION 1kHz

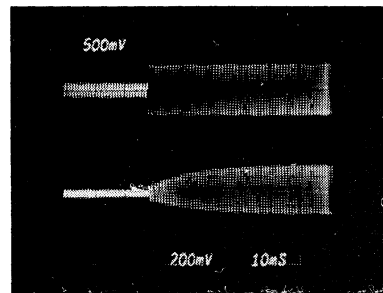

EXPANSION 1kHz

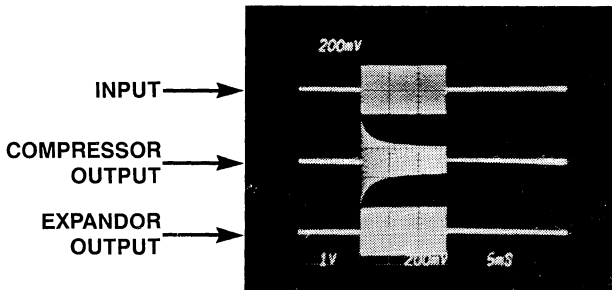

COMPANDOR SYSTEM 15kHz

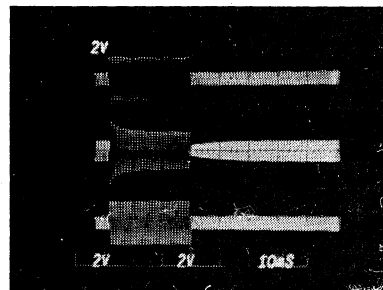

COMPANDOR SYSTEM 1kHz

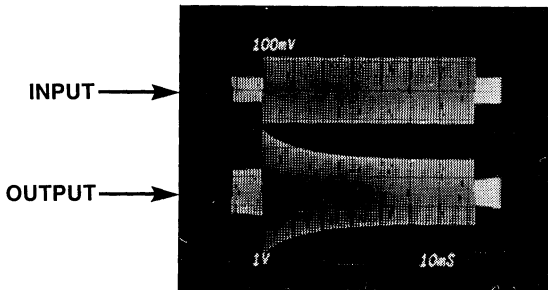

AUTOMATIC LEVEL CONTROL (SMALL SIGNAL INPUT)

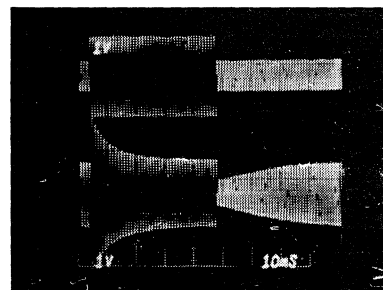

AUTOMATIC LEVEL CONTROL (LARGE SIGNAL INPUT)

Figure 11

APPLICATION BOARD

Shown below is the schematic (Figure 12) for Signetics' NE570/571 evaluation/demo board. This board provides one channel of EXPANSION and one channel of COMPRESSION (which can be switched to AUTOMATIC LEVEL CONTROL).

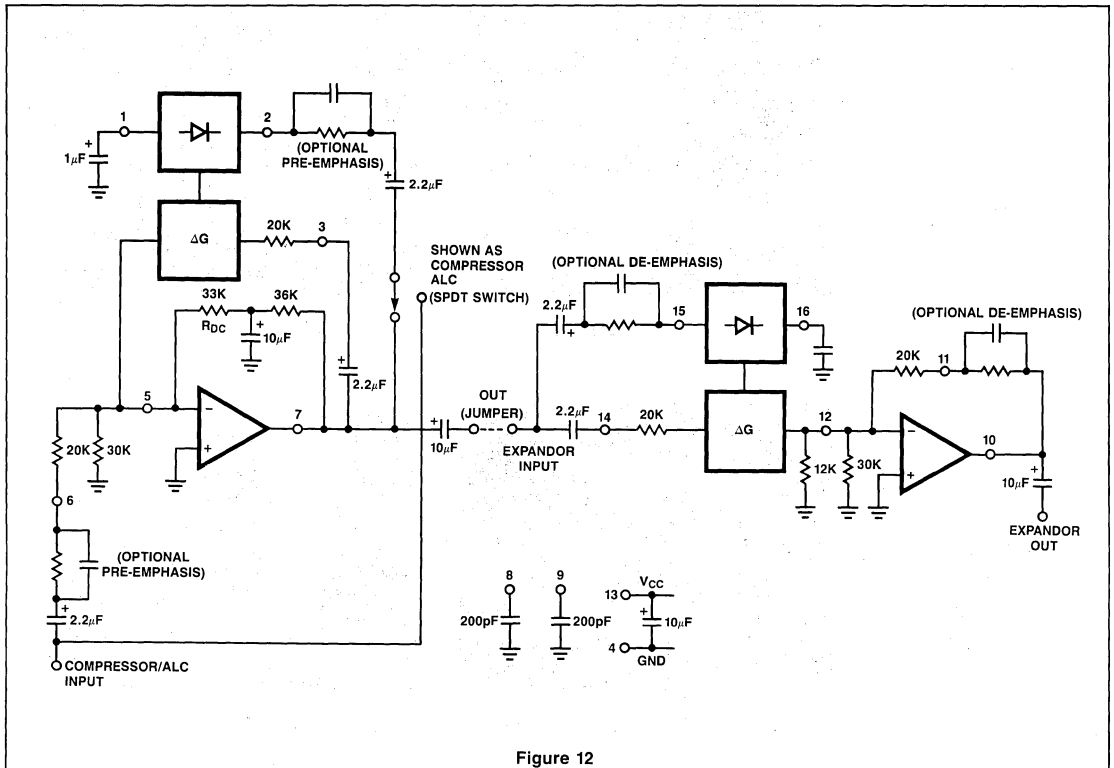

Figure 12

APPLICATIONS

Figure 1 shows a block diagram of the NE5080 and NE5081 in a simple point-to-point communications scheme. Pin 5 of the NE5080 is grounded to permanently enable transmission; grounding pin 3 disables the jabber function.

An example of a communications system block diagram using the NE5080 and the NE5081 (as in a modem) is shown in Figure 2.

The jabber function is active in this system. The NE5080 Jabber Flag (pin 2) goes high when the capacitor at pin 3 of the NE5080 charges to about 1.4 volts. This fault condition will interrupt the Transmission Controller, which will cease transmitting and write to the proper address for the decoder to put out a signal to discharge the capacitor. The Controller will then pass the token to the next node.

The transmission medium can be anything from a twisted pair to a fiber optic link. The NE5081 receives the FSK signal and converts it to a digital data stream corresponding to the data sent by the NE5080. Pin 10 of the NE5081 goes high when the signal at its input is above the threshold set by the potentiometer between pins 13 and 14 of the NE5081.

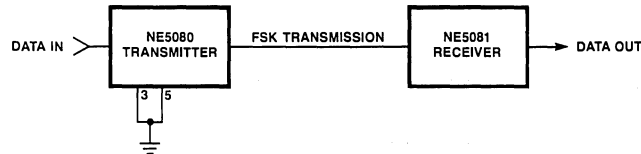

Figure 1. Point-to-Point Communications

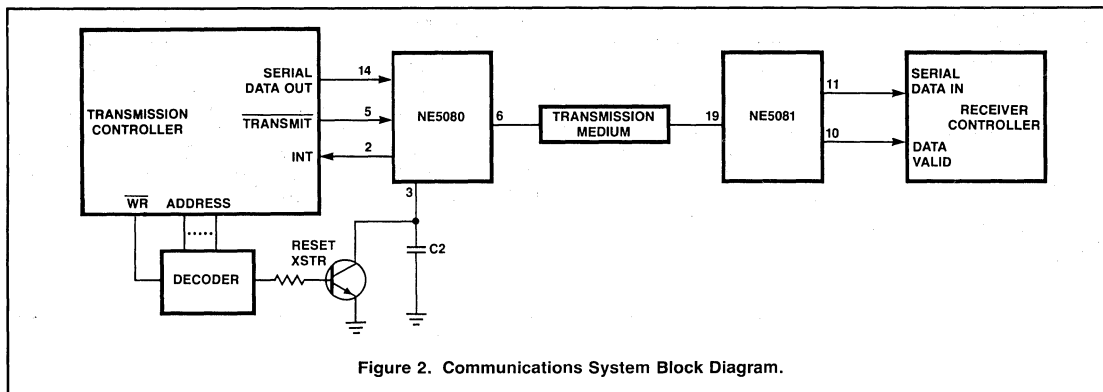

Figure 2. Communications System Block Diagram.

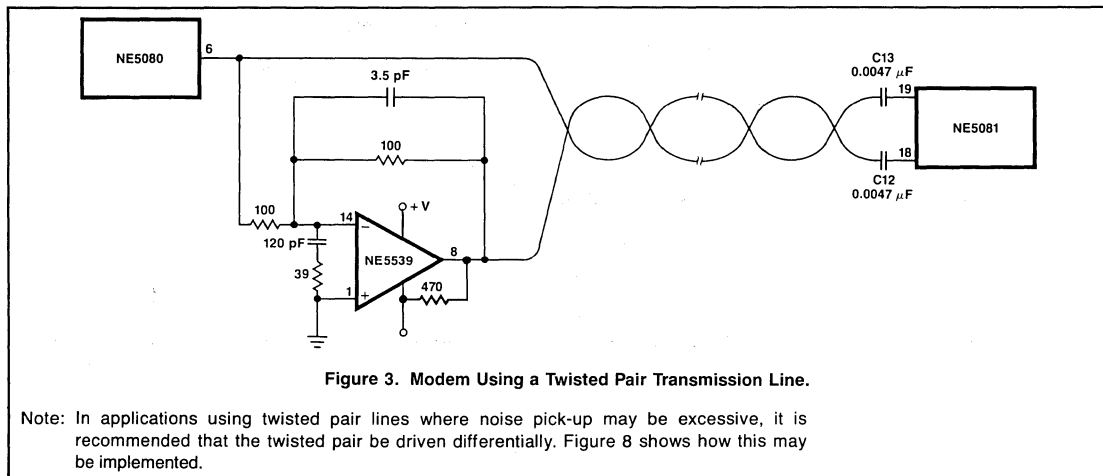

Figure 3. Modem Using a Twisted Pair Transmission Line.

Note: In applications using twisted pair lines where noise pick-up may be excessive, it is recommended that the twisted pair be driven differentially. Figure 8 shows how this may be implemented.

DC to 2 Megabaud Modem Using the NE5080 and NE5081

The NE5080 and NE5081 are designed to be used together as an asynchronous modem. They employ FSK modulation at high carrier frequencies, plus filtering to reject EMI and RFI noise that is frequently encountered in industrial and commercial environments. Figures 4 and 5 show Full and Half Duplex modems.

The carrier frequency is externally adjustable and can range from 50kHz to over 20MHz.

The modem can be used in a number of ways:

1. Multidrop party line of data transmitting and receiving devices (local area networks).
2. Point-to-point operation connecting just two transmitting/receiving devices.
3. Either of the above operated on one cable in the half duplex mode.

4. Either 1 or 2 above operated on two cables in the full duplex mode.

The 30dB dynamic range of modems built using the NE5080 and NE5081 makes it possible to attach them at any point on the cable without any gain adjustment. There is no problem with proximity to other similar modems.

The distance that can be driven varies with the type of cable used, the number of modems attached to the cable, and the carrier frequency.

Typical operation can be 100 modems randomly spaced on up to 2000 meters of RG-11 (foam) cable with a center frequency of 5MHz.

In point-to-point operation, one can drive further. Table 1 gives obtainable distances when different carrier frequencies and cables are used.

Table 1. TRANSMISSION DISTANCE FOR A SINGLE RECEIVER AS A FUNCTION OF CENTER FREQUENCY AND CABLE TYPE

Carrier Frequency	Maximum Data Rate	Cable			
		RG-59	RG-11 (Foam)	JT34125	JT3750J
1MHz	0.5 Megabaud	6000 Ft	21000 Ft	33000 Ft	50000 Ft
3MHz	1.0 Megabaud	5000 Ft	12000 Ft	20000 Ft	32000 Ft
5MHz	2.0 Megabaud	4200 Ft	9500 Ft	15000 Ft	25000 Ft

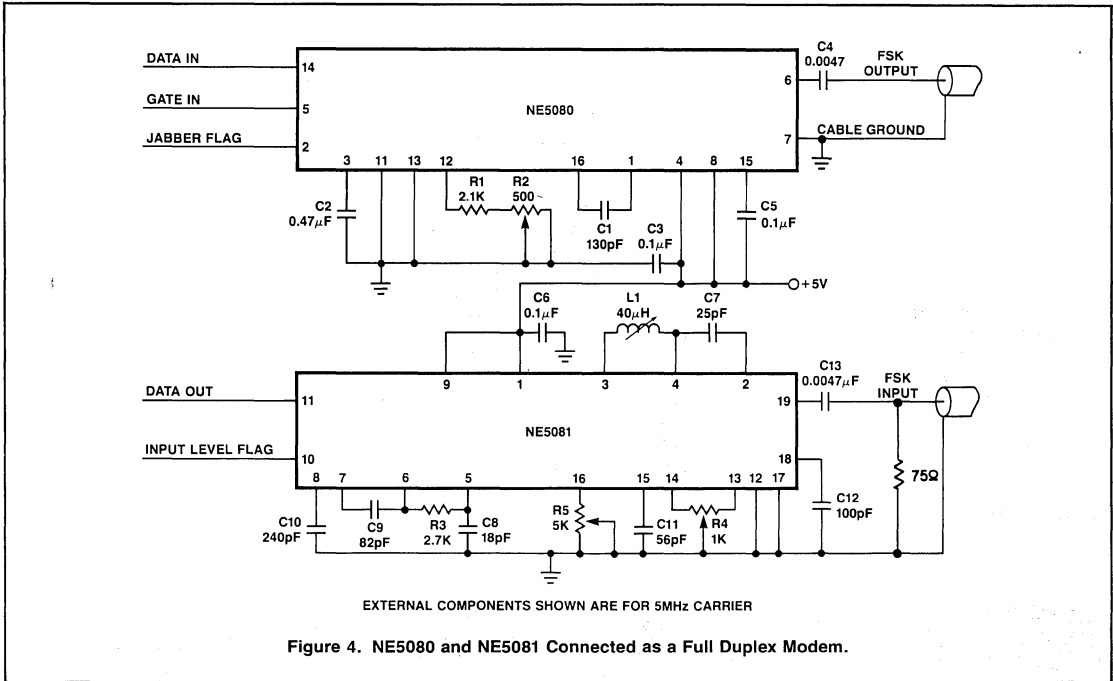

Figure 4. NE5080 and NE5081 Connected as a Full Duplex Modem.

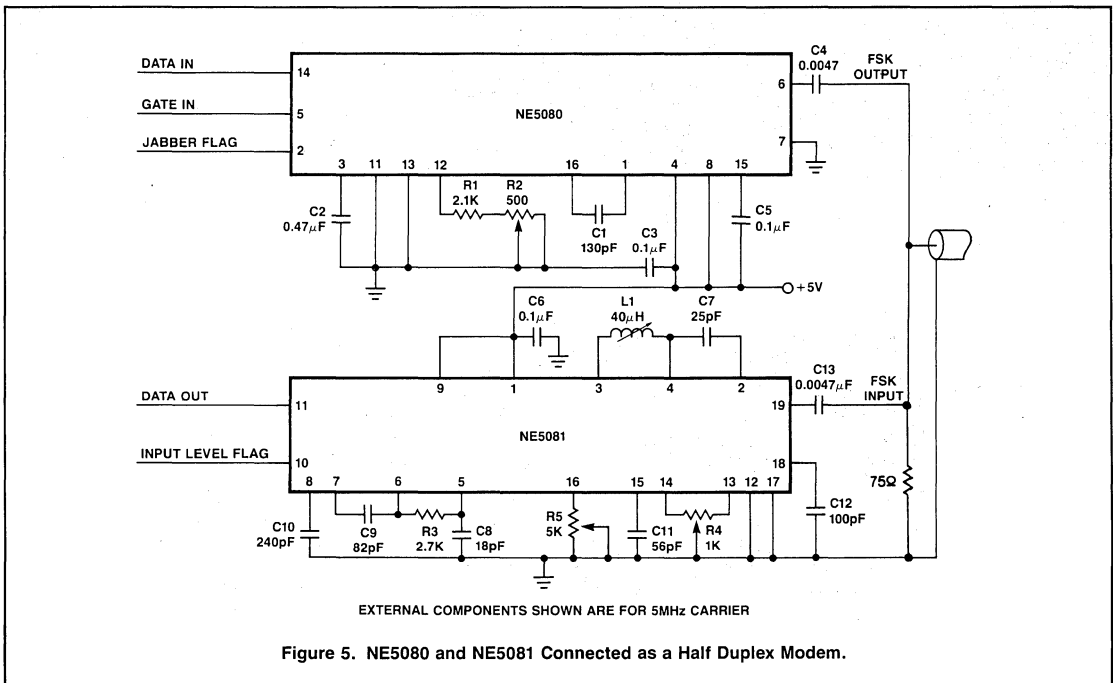

Figure 5. NE5080 and NE5081 Connected as a Half Duplex Modem.

FSK MODEM SET-UP PROCEDURES

To set up the modem per IEEE 802.4 specifications, the following sequence should be followed at $25 \pm 2^\circ\text{C}$ ambient.

TRANSMITTER SET-UP:

1. Ground Jabber Control (pin 3) and the transmit gate (pin 5) of the NE5080.
2. Turn on the power and allow the circuit to warm up for 3 minutes.
3. Hold the Data Input (pin 14) of the NE5080 at a logic high.
4. Measure the frequency at the FSK output of the transmitter (cable should be properly terminated) and adjust R2 for a frequency reading of $6.250\text{MHz} \pm 5\text{kHz}$.
5. Apply a logic low to the Data Input and check the output frequency. If the reading is not $3.750\text{MHz} \pm 40\text{kHz}$, readjust R1 until the high frequency is $6.250\text{MHz} \pm 25\text{kHz}$ and the low frequency is $3.750\text{MHz} \pm 40\text{kHz}$.

Transmitter set-up is now complete.

RECEIVER SET-UP:

6. Set Detection Timing pot R5 and Input Level Detect pot R4 at the NE5081 to mid range.
7. Apply a 5.000 MHz $1\text{V}_{\text{p-p}}$ sine wave to the receiver FSK Input.
8. Attach an oscilloscope probe to the Data Output pin of the NE5081 and adjust L1 or C7 (whichever is adjustable) until the output state alternates between high and low levels. Figures 7 and 8 indicate examples of improper tuning.
9. Set the generator to 3.750MHz , $35\text{mV}_{\text{p-p}}$.
10. Adjust Input Level Detect pot R4 until the Data Output pin is alternating between high and low levels.
11. Increase the generator output to $45\text{mV}_{\text{p-p}}$ and verify that the data output is low.
12. Decrease the generator output to $25\text{mV}_{\text{p-p}}$ and verify that the data output is high.
13. Apply a 100kHz $1\text{V}_{\text{p-p}}$ signal to the FSK Input and connect a scope probe to the Input Level Flag and another probe to

the FSK Input. Adjust Detection Timing pot R5 so that the delay from the time the FSK Input signal goes through 0 volts on the Positive to negative transition, to the time when the Input Level Flag goes from high to low, is between 0.5 and $2.5\mu\text{Sec}$. See Figure 9.

14. Final adjustment to the tuning of L1/C7 should be done by using an adjusted transmitter to transmit pseudo random data and tuning the receiver L1/C7 tank circuit for minimum jitter and symmetrical eye pattern observed on the receiver pin 8 (see Figure 10).

This concludes the receiver set-up procedure.

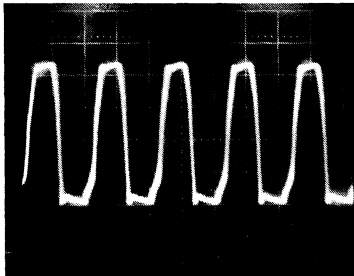

Figure 6. NE5081 Data Output When Correctly Tuned to Incoming 5MHz Carrier.

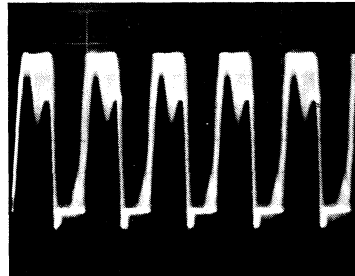

Figure 7. NE5081 Data Output When Tuned Just Below 5MHz Carrier.

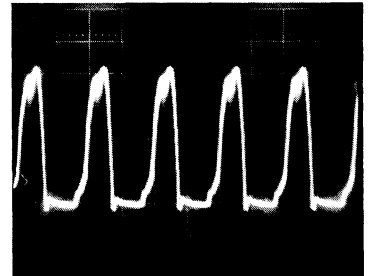

Figure 8. NE5081 Data Output Output Tuned Just Above 5MHz Carrier.

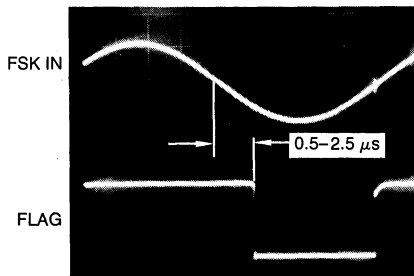

Figure 9. Correct Adjustment of Input Level Detection Timing.

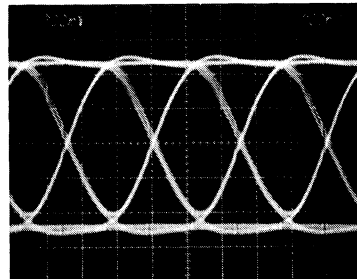

Figure 10. "Eye" Pattern at NE5081 Pin 8.

DETERMINING COMPONENT VALUES

Power supply pins of both devices should be bypassed with high quality 0.1 μ F capacitors close to the devices. Additionally, the NE5081 V_{CC2} (pin 9) should be well-decoupled from the power supply by a small inductor (about 10 μ H) and another 0.1 μ F capacitor as the NE5081 exhibits large changes in power supply current during switching.

The coupling capacitors C4 and C13 are needed to maintain input bias when a low DC impedance line is connected to the FSK Input. Too small a value for these capacitors could result in excessive signal attenuation. If these capacitors are too large, the receiver Input Level Flag may remain high for an excessive amount of time after the input signal is removed. Each transmitter and each receiver should have its own coupling capacitor. This is necessary to prevent any DC terminations from altering biases.

The external resistance at the NE5080 pin 12 should always be about 2.4 kilohms, with some adjustment allowable to compensate for the tolerance of C1 and slight differences between individual ICs.

C11 and R5 are the Carrier Detect timing components and determine how long after the FSK input signal is discontinued before the Input Level Flag goes low. R5 should not exceed 5 kilohms. With C11 set at 56 pF, a 5 kilohm R5 will allow Carrier Detect Timing adjustment to 2 μ Sec. R5 can be a fixed resistor if this timing is not critical (perhaps because of the use of an "end of data" signal). This delay is required to allow the signal to propagate through the receiver. Carrier Detect Timing should be adjusted for different center frequencies by choosing C11 according to the relationship:

$$C11 = \frac{1}{3572 f_c}$$

The Input Level Detect function can be disabled and the receiver be made to hold the Carrier Detect Flag high by removing R5 and C11 and tying pins 15 and 16 together and pulling them up to V_{CC} with a 10 kilohm resistor.

If the Jabber function is not to be used, Jabber control pin 3 of NE5080 should be grounded. If the Jabber function is to be used, a capacitor, C2, should be connected between pin 3 and ground. The value of this capacitor is determined as indicated below:

$$C2 = (0.95 \times 10^{-6}) t$$

where t is the maximum allowable transmit time in seconds.

The resistance R1, together with capacitor C1, set the transmit frequencies. The logic high frequency is fixed at about 1.67 times the logic low frequency, meaning that the logic low frequency is 0.75 times the center frequency f_c , and the logic high frequency is 1.25 times the center frequency. Note that this center frequency is never transmitted in normal operation and is sometimes referred to as the "carrier frequency."

C1 is chosen by the relationship for f_c at or below 7MHz:

$$C1 = \frac{6.5 \times 10^{-4}}{f_c}$$

Above 7MHz center frequency, this capacitor is found by modifying this equation to:

$$C1 = \frac{5.5 \times 10^{-4}}{f_c}$$

To get the characteristics that are needed for proper operation of the NE5081, it is im-

portant to keep the proper relationship between L1 and C7:

$$C7 = \frac{1}{7885 f_c}$$

$$L1 = \frac{200}{f_c}$$

Capacitor values of the filter are dependent upon operating frequencies to maintain proper characteristics:

$$C8 = \frac{9.0 \times 10^{-5}}{f_c}$$

$$C9 = \frac{4.1 \times 10^{-4}}{f_c}$$

$$C10 = \frac{1.2 \times 10^{-3}}{f_c}$$

$$C12 = \frac{5 \times 10^{-4}}{f_c}$$

Coupling capacitor values also depend upon center frequency:

$$C4 = C13 = \frac{2.5 \times 10^{-2}}{f_c}$$

In all of the above equations, capacitances are in Farads, inductances in Henrys, and frequencies in Hertz.

SOME COMMON BAUD RATES

Although intended to be used with a center frequency of 5MHz, the NE5080 and NE5081 can be used at other center frequencies. Table 2 gives minimum center frequency (f_c) for some common baud rates, together with external component values for those center frequencies. Note that it is not recommended that these devices be operated at center frequencies below 50kHz.

USING THE NE5080/NE5081 WITH A FIBER OPTIC LINK

The NE5080/NE5081 chip set is highly suitable for use in low cost fiber-optic links. There are many advantages to fiber links over open wire or coaxial cable links. These advantages include:

1. Cost savings in conductor weight and size.
2. Immunity to EMI/RFI.
3. Low crosstalk.
4. High communications security; cannot be tapped by electromagnetic induction or surface conduction.
5. Fiber-optic cable does not radiate electromagnetic energy nor disturb other communications media.
6. Extremely wide bandwidth (high channel per conductor density).
7. Low attenuation.
8. No ground loops or shifts caused by common grounds.

9. Complete electrical isolation between transmitter and receiver.
10. Cable breaks cause no shorts, making this technology useful in hazardous environments, e.g., explosive chemical facilities.
11. No damage to equipment is expected due to current surges on adjacent lines.
12. Fiber cable does not act as an antenna to pick up high electromagnetic pulses such as those caused by electrical storms.
13. Low BER (Bit Error Rate).

The circuit of Figure 11 shows a simplex fiber link between the NE5080 transmitter and the NE5081 receiver. The components shown are for a center frequency of 5MHz, although this frequency can be increased to 20MHz with proper selection of external component values. The NE5539 has a 350MHz unity gain bandwidth which may limit maximum operating frequencies in some systems.

Since the NE5081 can adequately accept signals below 10 mV at 5MHz carrier, the gain stage (within the dashed lines of Figure 11) may be eliminated if the attenuation in the link is low. If the gain stage is used, be mindful of the bandwidth trade-off at higher gains. Refer to the NE5539 data sheet for details.

The transmitter and receiver are set up as described under FSK MODEM SET-UP PROCEDURE above.

LAYOUT PRECAUTIONS

As is the case with any components using high frequencies, good layout practice is essential; poor layout can adversely affect performance. All lead lengths should be as short as is practical for all lines which carry R-F, including the tuning capacitor and resistors (C1, R1, R2) of the NE5080. Lead length is especially critical with C1, which should be mounted as close to the NE5080 as is possible. A printed circuit board with a good ground plane, both top and bottom, is also recommended (wire-wrap is NOT recommended). The ground plane should extend below tuning capacitor C1 on both top and bottom of the board, with no other trace coming between the leads of this capacitor.

Because of the high speed switching, pin 9 (V_{CC2}) of the NE5081 can exhibit a large current swing, causing vertical output jitter which may be eliminated by decoupling pin 9 with a small (10 μ H) R-F choke and a 0.05 μ F capacitor.

See Figure 12 for an example of a working layout.

Table 2. RECOMMENDED MINIMUM CENTER FREQUENCY AND COMPONENT VALUES FOR VARIOUS BAUD RATES.

BAUD RATE (KBaud)	f_c (kHz)	C1	L1	C4 C13	C7	C8	C9	C10	C11	C12
9.6	50	13nF	4mH	0.50 μ F	2.4nF	1.8nF	8.2nF	24nF	5.6nF	10nF
19.2	50	13nF	4mH	0.50 μ F	2.4nF	1.8nF	8.2nF	24nF	5.6nF	10nF
38.4	100	6.8nF	2mH	0.27 μ F	1.3nF	0.9nF	3.9nF	12nF	2.7nF	5nF
50.1	125	5.1nF	1.6mH	0.20 μ F	1.0nF	750pF	3.3nF	10nF	2.2nF	3.9nF
64.0	160	3.9nF	1.3mH	0.15 μ F	800pF	560pF	2.5nF	7.5nF	1.8nF	3nF
128	320	2nF	625 μ H	0.075 μ F	390pF	270pF	1.3nF	3.9nF	860pF	1.6nF
256	640	1nF	312 μ H	0.039 μ F	200pF	150pF	640pF	1.8nF	430pF	750pF
512	1250	510pF	160 μ H	0.02 μ F	100pF	75pF	330pF	1.0nF	220pF	390pF
1500	3750	180pF	53 μ H	6.8nF	33pF	25pF	110pF	330pF	75pF	130pF
1544	4000	160pF	50 μ H	6.8nF	33pF	22pF	100pF	300pF	68pF	125pF
2000	5K	130pF	40 μ H	5.0nF	25pF	18pF	82pF	240pF	56pF	100pF
8000	20K	33pF	10 μ H	1.2nF	6pF	5pF	20pF	62pF	15pF	25pF

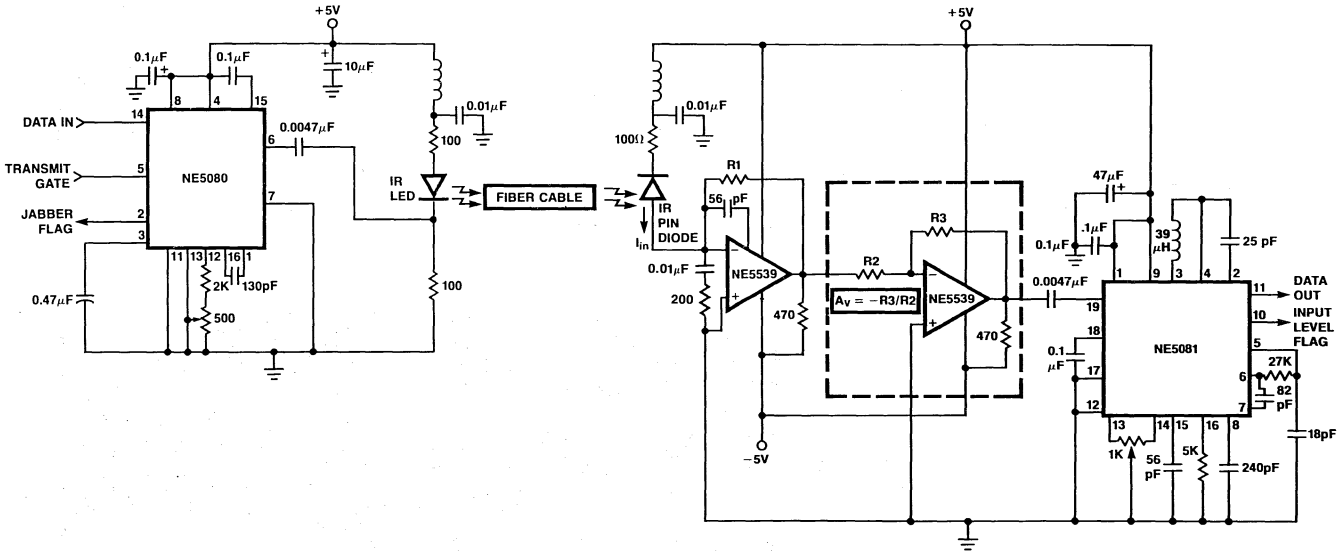
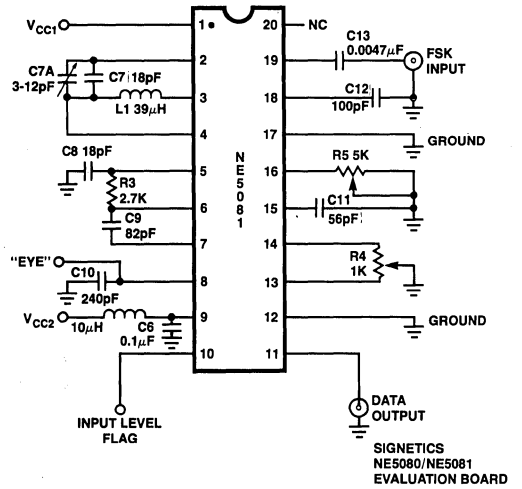
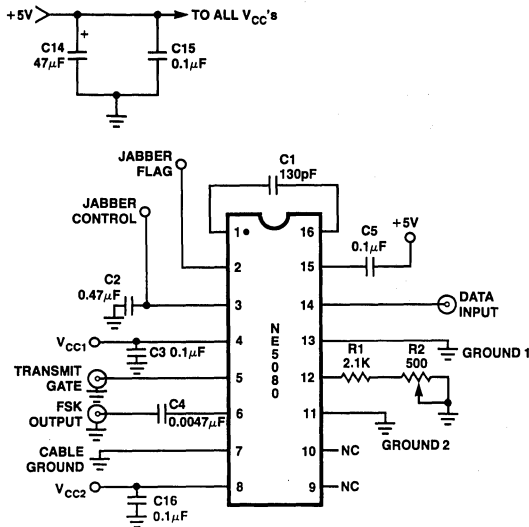

Figure 11. Simplex Fiber Optic System



Note: See NE5080 and NE5081 Block Diagram(s).

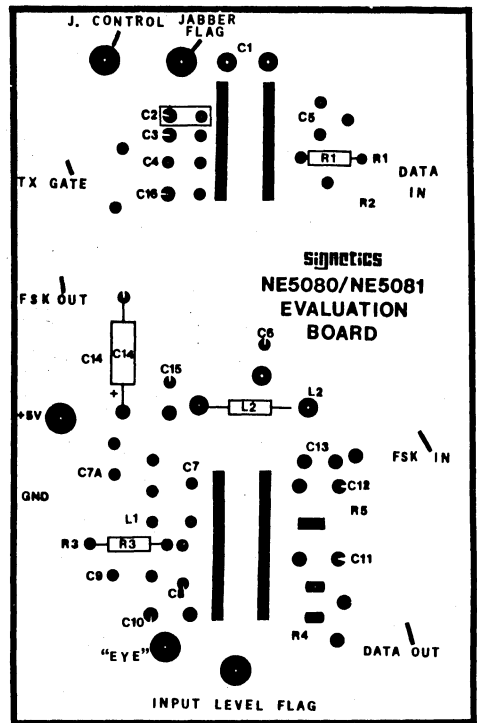
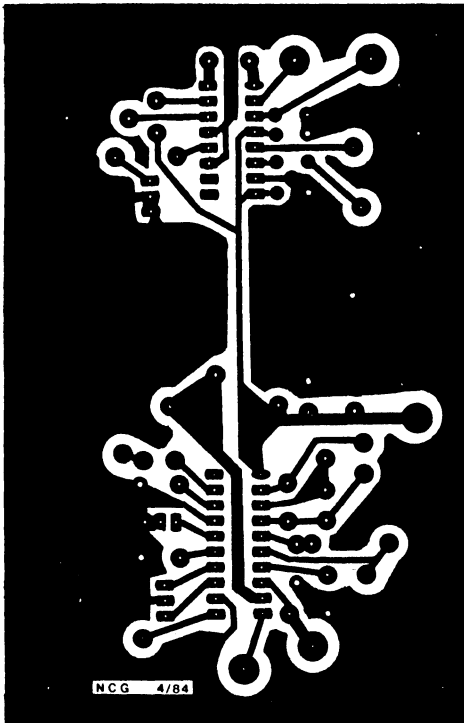

Figure 12. Components and Layout Used for Evaluation Board

INTRODUCTION

The operational amplifier was first introduced in the early 1940's. Primary usage of these vacuum tube forerunners of the ideal gain block was in computational circuits. They were fed back in such a way as to accomplish addition, subtraction, and other mathematical functions.

Expensive and extremely bulky, the operational amplifier found limited use until new technology brought about the integrated version, solving both size and cost drawbacks.

Volumes upon volumes have been and could be written on the subject of op amps. In the interest of brevity this chapter will cover the basic op amp as it is defined along with test methods and suggestive applications. Also, included is a basic coverage of the feedback theory from which all configurations can be analyzed.

THE PERFECT AMPLIFIER

The ideal operational amplifier possesses several unique characteristics. Since the device will be used as a gain block, the ideal amplifier should have infinite gain. By definition also, the gain block should have an infinite input impedance in order not to draw any power from the driving source. Additionally, the output impedance would be zero in order to supply infinite current to the load being driven. These ideal definitions are illustrated by the ideal amplifier model of Figure 1.

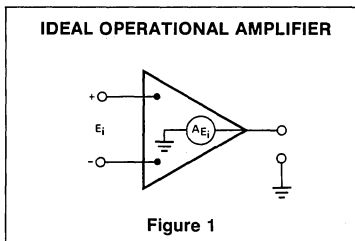

Figure 1

Further desirable attributes would include infinite bandwidth, zero offset voltage, and complete insensitivity to temperature, power supply variations, and common mode input signals.

Keeping these parameters in mind, further contemplation produces two very powerful analysis tools. Since the input impedance is infinite, there will be no current flowing at the amplifier input nodes. In addition, when feedback is employed the differential input voltage reduces to zero. These two statements are used universally as beginning points for any network analysis and will be explored in detail later on.

THE PRACTICAL AMPLIFIER

Tremendous strides have been made by modern technology with respect to the ideal amplifier. Integrated circuits are coming closer and closer to the ideal gain block. Input bias currents for instance are in the pA range for FET input amplifiers while offset voltages have been reduced to less than 1mV in many cases, in Bipolar devices.

Any device has limitations however, and the integrated circuit is no exception. Modern op amps have both voltage and current limitations. Peak to peak output voltage, for instance, is generally limited to one or two base-emitter voltage drops below the supply voltage while output current is internally limited to approximately 25mA. Other limitations such as bandwidth and slew rates are also present, although each generation of devices improves over the previous one.

DEFINITION OF TERMS

Earlier the ideal operational amplifier was defined. No circuit is ideal of course so practical realizations contain some sources of error. Most sources of error are very small and therefore can usually be ignored. It should be noted that some applications require special attention to specific sources of error.

Before the internal circuitry of the op amp is further explored it would be beneficial to define those parameters commonly referenced.

INPUT OFFSET VOLTAGE

Ideal amplifiers produce 0 volts out for 0 volts input. But, since the practical case is not perfect, there will appear a small dc voltage at the output even though no differential voltage is applied. This dc voltage is called the input offset voltage, with the majority of its magnitude being generated by the differential input stage pictured in Figure 2.

An operational amplifier's performance is in large part dependent upon the first stage. It is the very high gain of the first stage that amplifies small signal levels to drive remaining circuitry. Coincidentally, the input current, a function of beta, must be as small as possible. Collector current levels are thus made very low in the input stage in order to gain low bias currents. It is this input stage also which determines dc parameters such as offset voltage since the amplified output of this stage is of sufficient voltage levels to eclipse most subsequent error terms added by the remaining circuitry. Under balanced conditions the collector currents of Q1 and Q2 are perfectly matched, hence we may say:

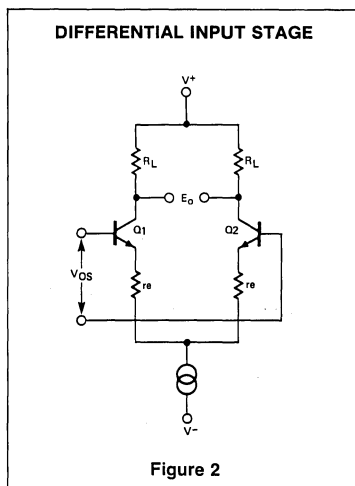

Figure 2

$$E_{OS} = I_{C2}R_L - I_{C1}R_L = 0 \tag{1}$$

In practice small differences in geometries of the base emitter regions of Q1 and Q2 will cause E_{OS} not to equal 0. Thus, for balance to be restored a small dc voltage must be added to one V_{BE} or

$$V_{OS} = V_{BE1} - V_{BE2} \tag{2}$$

where the V_{BE} of the transistor is found by

$$V_{BE} = \frac{KT}{q} \ln \left(\frac{I_E}{I_S} \right) \tag{3}$$

Reference is made to the input when talking of offset voltage. Thus, the classic definition of input offset voltage is 'that differential dc voltage required between inputs of an amplifier to force its output to zero volts.'

Offset voltage becomes a very useful quantity for the designer because many other sources of error can be expressed in terms of V_{OS} . For instance, the error contribution of input bias current can be expressed as offset voltages appearing across the input resistors.

INPUT OFFSET VOLTAGE DRIFT

Another related parameter to offset voltage is V_{OS} drift with temperature. Present day amplifiers usually possess V_{OS} drift levels in the range of $5\mu V$ to $40\mu V$ per degree C. The magnitude of V_{OS} drift is directly related to the initial offset voltage at room temperature. Amplifiers exhibiting larger initial offset voltages will also possess higher drift rates with temperature. A rule of thumb often applied is that the drift per degree C will be $3.3\mu V$ for each millivolt of initial offset. Thus, for tighter control of thermal drift, a low offset amplifier would be selected.



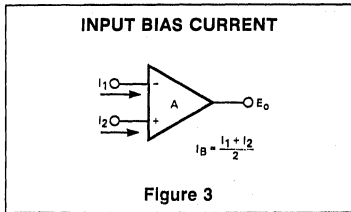

Figure 3

INPUT BIAS CURRENT

Again referring to Figure 3-2, it is apparent that the input pins of this op amp are base inputs. They must, therefore, possess a dc current path to ground in order for the input to function. Input bias current, then is 'the dc current required by the inputs of the amplifier to properly drive the first stage.'

The magnitude of I_{bias} is calculated as the average of both currents flowing into the inputs and is calculated from

$$I_B = \frac{I_1 + I_2}{2} \tag{4}$$

Bias current requirements are made as small as possible by using high beta input transistors and very low collector currents in the first stage. The trade-off for bias current is lower stage gain due to low collector current levels and lower slew rates. The effect upon slew rate is covered in detail under the compensation section.

INPUT OFFSET CURRENT

The ideal case of the differential amplifier and its associated bias current does not possess an input offset current. Circuit realizations always have a small difference in bias currents from one input to the other, however. This difference is called the input offset current. Actual magnitudes of offset current are usually at least an order of magnitude below the bias current. For many applications this offset may be ignored but very high gain, high input impedance amplifiers should possess as little I_{os} as possible because the difference in currents flowing across large impedances develops substantial offset voltages. Output voltage offset due to I_{os} can be calculated by

$$V_{out} = A_{cl}(I_{os}R_i) \tag{5}$$

Hence, high gain and high input impedances magnify directly to the output, the error created by offset current. Circuits capable of nulling the input voltage and current errors are available and will be covered later in this chapter.

INPUT OFFSET CURRENT DRIFT

Of considerable importance is the temperature coefficient of input offset current.

Even though the effects of offset are nulled at room temperature, the output will drift due to changes in offset current over temperature. Many popular models now include a typical specification for I_{os} drift with values ranging in the .5nA per degree C area. Obviously those applications requiring low input offset currents also require low drift with temperature.

INPUT IMPEDANCE

Differential and common mode impedances looking into the input are often specified for integrated op amps. The differential impedance is the total resistance looking from one input to the other while common mode is the common impedance as measured to ground. Differential impedances are calculated by measuring the change of bias current caused by a change in the input voltage.

COMMON MODE RANGE

All input structures have limitations as to the range of voltages over which they will operate properly. This range of voltages impressed upon both inputs which will not cause the output to misbehave is called the common mode range. Most amplifiers possess common mode ranges of ± 12 volts with supplies of ± 15 volts.

COMMON MODE REJECTION RATIO

The ideal operational amplifier should have no gain for an input signal common to both inputs. Practical amplifiers do have some gain to common mode signals. The classic definition for common mode rejection ratio of an amplifier is the ratio the differential signal gain to the common mode signal gain expressed in dB as shown in equation 6a.

$$CMRR(dB) = 20 \log \frac{e_o/e_i}{e_o/e_{cm}} \tag{6a}$$

The measurement CMRR as in 3-6a requires 2 sets of measurements. However, note that if e_o in equation 3-6a is held constant, CMRR becomes:

$$CMRR(dB) = 20 \log \frac{e_{cm}}{e_i} \tag{6b}$$

A new alternate definition of CMRR based on 3-6b is the ratio of the change of input

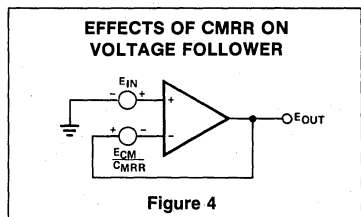

Figure 4

offset voltage to the input common mode voltage change producing it.

Figure 4 illustrates the application of the equivalent common mode error generator to the voltage follower circuit. The gain of the voltage follower with error contributions caused by both finite gain and finite common mode rejection ratio is shown in equation 7.

$$\frac{e_o}{e_{in}} = \frac{1 \pm 1/CMRR}{1 + 1/A} \tag{7}$$

where A equals open loop gain and is frequency dependent.

AC PARAMETERS

Parameter definition has up to this point, been dealing primarily with dc quantities of voltages, currents, etc. Several important ac or frequency dependent parameters will now be discussed.

An ideal gain block was defined earlier as one which would provide infinite gain and bandwidth. Real circuits approximate infinite open loop gain with low frequency gains in excess of 100dB. The very high gains achieved with present designs are possible only by cascading stages. Although providing very high open loop gain the cascading of stages results in the need for frequency compensation in closed loop configurations and reduces the open loop.

LARGE SIGNAL BANDWIDTH

The large signal or power bandwidth of an amplifier refers to its ability to provide its maximum output voltage swing with increasing frequency. At some frequency the output will become slew rate limited and the output will begin to degrade. This point is defined by

$$F_{PL} = \frac{\text{Slew Rate}}{2\pi \cdot E_{out}} \tag{8}$$

where F_{PL} is the upper power bandwidth frequency and E_{out} is the peak output swing of the amplifier.

SLEW RATE

The maximum rate of change of the output in response to a step input signal is termed slew rate. Deviation from the ideal is caused by the limitation in frequency response of the amplifier stages and the phase compensation technique used. Summing node and amplifier output capacitances must be kept to a minimum to guarantee getting the maximum slew rate of the operational amplifier. Circuit board layout must also be of high frequency quality. Power supplies should be adequately bypassed at the pins, with both low and high frequency components to avoid possible ringing. A selection of a proper capacitor in parallel with the feedback resistor may be necessary. Too small a value could result in excessive ringing and too large a value will decrease

frequency response. In general, the worst case slew rate is in the unity gain non-inverting mode (see Figure 5a). Specifications of slew rate should always reflect this worst case condition with the maximum required compensation network.

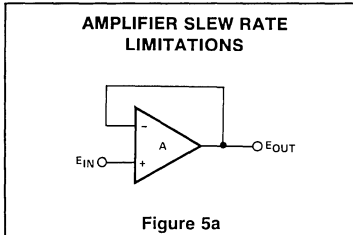

Figure 5a

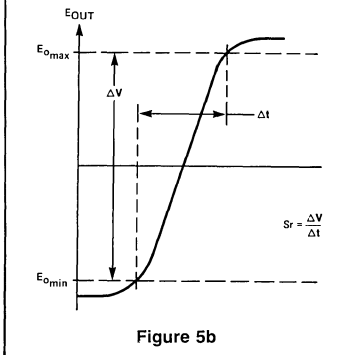

Figure 5b

FREQUENCY RESPONSE

Distributed capacitances and transit times in semiconductors cause an upper frequency limit or pole for each and every gain stage. Monolithic pnp transistors used for level shifting possess poor upper frequency characteristics and cascaded gain stages, used to approach the highest gain, subtract from the maximum frequency response. As shown in Figure 6 the open loop frequency response of the op amps shown crosses unity gain at approximately 10MHz. Closed loop response is unstable without compensation, however, so typical unity gain frequencies are readjusted by the effects of phase compensation, in this case 1MHz.

From Figure 6 it is also apparent that an amplifier has a trade off between gain and bandwidth. Higher gains are achieved at the expense of bandwidth. This trade off is a constant figure called the gain bandwidth product.

TEST METHODS

Product testing of integrated circuits uses

OPEN LOOP VOLTAGE GAIN AS A FUNCTION OF FREQUENCY

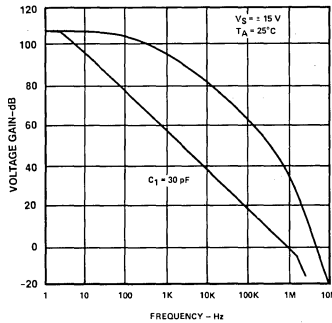

Figure 6

automatic test equipment. Large computer controlled test decks test all data sheet limits in a matter of milliseconds. Each parameter is tested in a specific circuit configuration defined by the test hardware.

A typical simplified op amp test configuration is depicted by Figure 9. Units may be classed

in several categories according to selected parameters. Even failures may be classified categorically depending upon their mode of failure.

Figures 7, 8, 10 and 11 illustrate the general test set-ups commonly used to measure CMRR, average bias current, offset voltage and current, and open loop gain, respectively. In general, the following parameters are tested under the following conditions.

COMMON MODE REJECTION

The test set-up for CMRR is given in Figure 7. Resistor values are chosen to provide sufficient sensitivity and accuracy for the device type being tested and the voltage measuring equipment being used.

The positive common mode input voltage within the range V_{CM1} is algebraically subtracted from all supply voltages and from V_O . Then V_1 is measured (V_{11}). The most negative common mode voltage within the range, V_{CM2} , is then subtracted from all the supply voltages and V_O , and V_1 is again measured (V_{12}).

Then

$$CMRR = (R_1 + R_2) / R_1 | (V_{CM1} - V_{CM2}) / V_{11} - V_{12}$$
 (9)

CIRCUIT DIAGRAM USED FOR CMRR MEASUREMENT

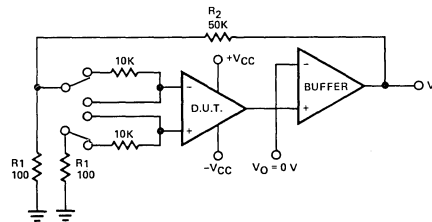

All resistor values are in ohms.

Figure 7

CIRCUIT DIAGRAM USED FOR AVERAGE BIAS CURRENT MEASUREMENT

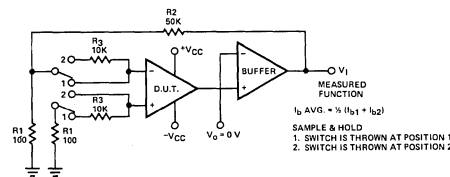

All resistor values are in ohms.

Figure 8

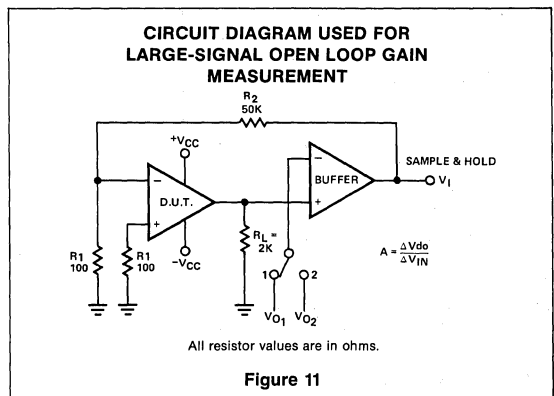
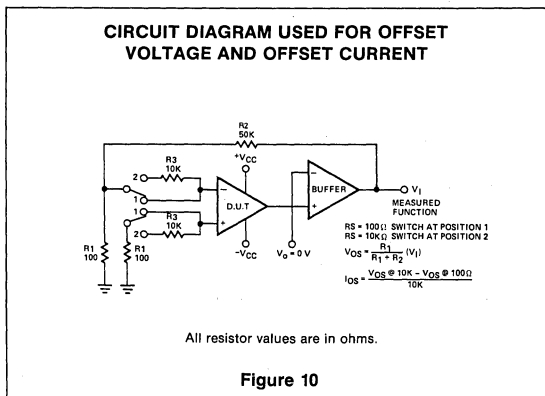
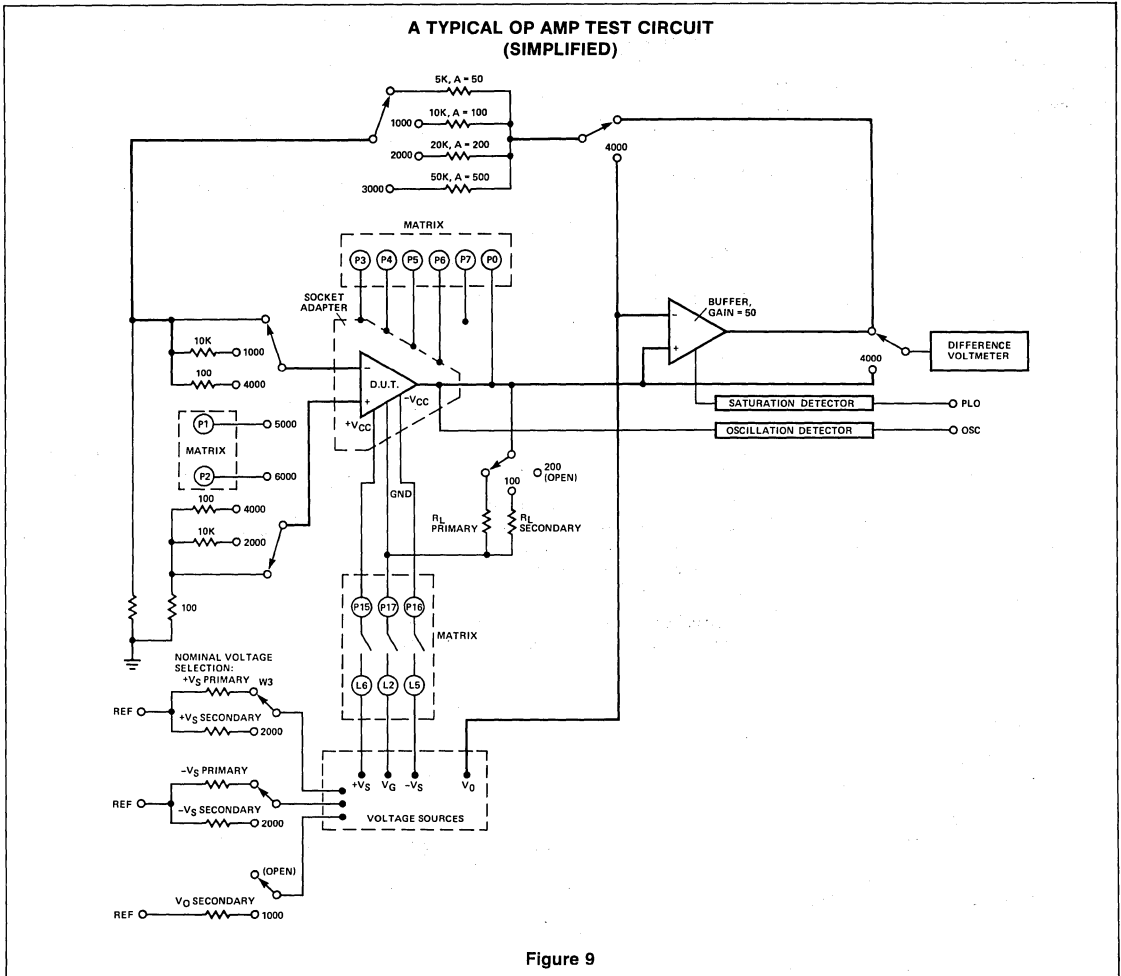

This operation is equivalent to swinging both inputs over the full common mode range, and holding the output voltage constant, but it makes the V_1 measurement much simpler.

BIAS CURRENT

Bias current is measured in the configuration of Figure 8.

With switches at position 1 and $V_0 = 0$ volts, measure V_{I1} . Move switches to position 2 and again measure V_{I2} . Calculate I_{BIAS} (average), by

$$I_{B1} = \frac{R1}{R1 + R2} \left(\frac{V_1}{R3} \right) \tag{10a}$$

$$I_{B2} = \frac{R1}{R1 + R2} \left(\frac{V_1}{R3} \right) \tag{10b}$$

$$I_{BIAS (avg)} = \frac{I_{B1} + I_{B2}}{2} = \frac{R1}{R1 + R2} \frac{V_{I1} - V_{I2}}{2R3} \tag{10c}$$

OFFSET VOLTAGE

Figure 10 is used for both offset voltage and current. With V_0 at 0 volts and the switches selecting the source impedance of 100 ohms, the offset voltage is measured at V_1 and is equal to

$$V_{os} = \frac{R1V_1}{R1 + R2} \tag{11}$$

OFFSET CURRENT

Offset current is measured by calculation of offset voltage change with a change in source impedance. With switches in position 1, measure V_{I2} . Calculate the contribution of I_{os} by

$$I_{os} = \frac{V_{I2} - V_{I1}}{R3} \tag{12}$$

SIGNAL GAIN

The signal gain of operational amplifiers is most commonly specified for the full output swing.

This is referred to as large signal voltage gain and can be measured by the circuit of Figure 11. Usually specified under a specific load determined by R_L , a signal equal to the maximum swing of the output voltage is applied to V_0 in both positive and negative directions. V_{I1} and V_{I2} are measured values of V_1 and $V_0 =$ maximum positive and maximum negative signals respectively. The gain of the device under test then becomes

$$A_{vo} = \left(\frac{R1 + R2}{R1} \right) \left(\frac{V_{O1} - V_{O2}}{V_{I1} - V_{I2}} \right) \tag{13}$$

SLEW RATE

Many other parameters are checked automatically by similar means. Only the most

important ones have been covered here. Of great interest to the designer are other parameters which do not necessarily carry minimum or maximum limits. One such parameter is slew rate. The configuration used to measure slew rate depends upon the intended application. Worst case conditions arise in the unity gain non-inverting mode.

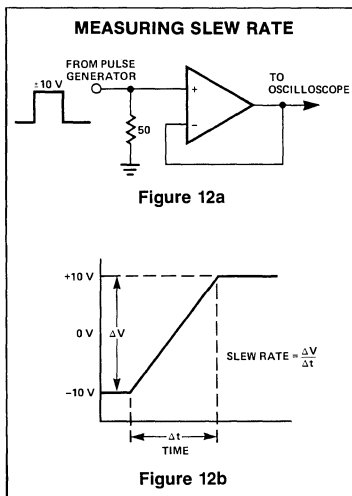

Figure 12 shows a typical bench set up for measuring the response of the output to a step input. The input step frequency should be of a frequency low enough for the output of the op amp to have sufficient time to slew from limit to limit. In addition, V_{in} must be less than absolute maximum input voltage and the wave form should have good rise and fall times. The slew rate is then calculated from the slope of the output voltage versus time or

$$SR = \frac{\Delta V_{out}}{\Delta T} \text{ in volts}/\mu s \tag{14}$$

OP AMP CURVE TRACER

Two of the most important parameters of linear integrated circuits having differential inputs are voltage gain and input offset voltage. These parameters may be read directly from a plot of the transfer characteristic of the device. This memo will describe a very simple curve tracer which, when used with an oscilloscope, will display the transfer characteristic of most Signetics linear devices.

Figure 13 shows the transfer characteristics of a typical linear device, the Signetics NE531. Note that the unit saturates at approximately +12 and -12 volts and exhibits a linear transfer characteristic between -10

and +10 volts.

From the slope of this linear portion of the transfer characteristic, and from the point

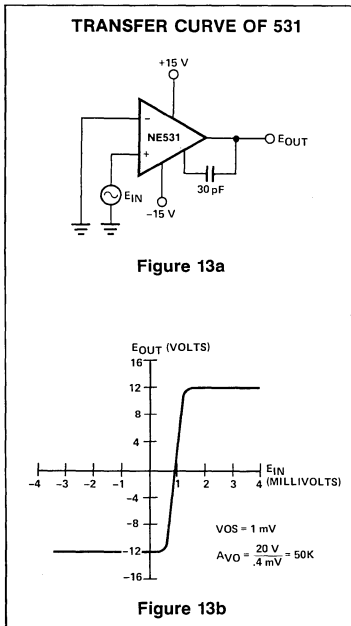

+10 volts where it crosses the E_{in} axis, the voltage gain and offset voltage may be determined. It can be seen that the voltage gain of the device under test, (D.U.T.), is 50,000 and its input offset voltage is 1.0mV.

A simple circuit to display the curves of Figure 13 on an oscilloscope is shown in Figure 14. A 60Hz, 44Vp-p sinewave is applied to the horizontal input of oscilloscope and an attenuated version of the sinewave is applied to the input of the D.U.T.

The output of the D.U.T. drives the vertical input of the scope. For providing $V+$ and $V-$ to the D.U.T., the tester uses two simple adjustable regulators, both current limited at 25mA. Input drive to the D.U.T. may be selected by means of S-2 as shown.

To use the curve tracer, first preset the $V+$ and $V-$ supplies with an accurate meter. The supply voltages are somewhat dependent on ac line regulation and should be checked periodically. The horizontal gain of the scope may be set to give a convenient readout of the peak-to-peak D.U.T. input signal corresponding to the setting of S-2. As some devices have two outputs, a second output line (vertical 2) has been provided for these devices. The transfer function of such devices will be inverted to that of Figure 13 of course.



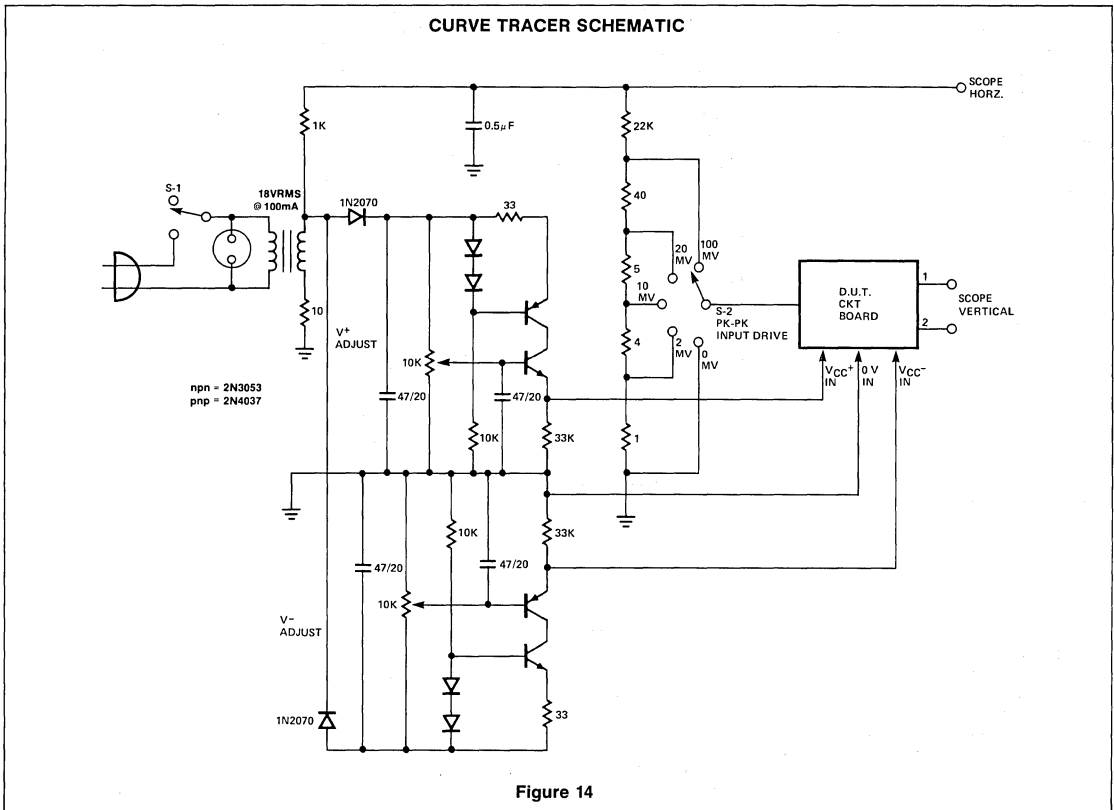

Figure 14

Simplicity and low cost are the two major attributes of this tester. It is not intended to perform highly rigorous tests for all devices. It is, however, a reasonably accurate means of determining the gains and offset voltages of most amplifiers. It will in addition, indicate the transfer curves of comparators and sense amplifiers with equivalent accuracies.

AMPLIFIER DESIGN

Linear operational amplifier IC's were introduced soon after the appearance of the first digital integrated circuits. The performance of these early devices, however, left much to be desired until the introduction of the 709 device. Even with its lack of short circuit protection and its complicated compensation requirements, the 709 gained real acceptance for the IC op amp. The 709 was designed using a three stage approach requiring both input and output stage compensation. In addition the output stage was not short circuit proof and the input stage latched up under certain conditions, requiring external protection.

Much better designs soon were introduced. Among the contenders were the 741, 748, 101, and 107 devices. All were general purpose devices with single capacitor compensation, (some were internally compensated), and all heralded input and output overstress protection. The basic design has two gain stages. By rolling off the frequency response of one of these (the second stage), so that the overall gain is unity at a frequency below the point where excess phase becomes significant, the device can be stabilized for all feedback configurations. Further, by making the first stage a voltage to current converter, with a small g_m and the second stage a current to voltage converter with a high r_m , the second stage can be rolled off at 6dB/octave with a small value capacitor in the order of 30pF, which can then be built into the device itself. This concept is shown in Figure 15.

The frequency and phase response of the pnp devices in the first stage dictate a roll off in the second stage to give a loop gain of unity at about 1.0MHz. For the unity gain feedback configuration, this implies an

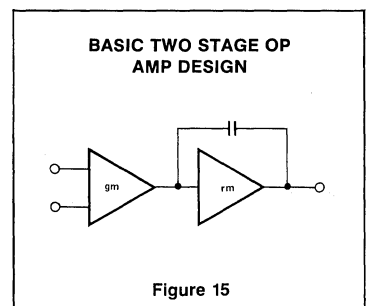

Figure 15

open loop gain of unity at this frequency. The capacitor C_c controls this parameter by looking much smaller than r_m at frequencies above a few cycles, giving a clean 6dB/octave roll off over 5 decades.

The overall gain at frequencies where the impedance of C_c dominates r_m is given by

$$A_v(\omega) = \frac{g_m r_m}{4KT} \cdot \frac{1}{\omega C_c} \tag{15}$$

Substituting the value given, we find that a capacitance of $C_c = 30\text{pF}$ gives a unity gain frequency of about 1.0MHz.

First stage large signal current also defines the slew rate for a specific compensation technique. It is this current which must charge and discharge the C_c by the expression

$$SR = \frac{dV}{dT} = \frac{I_{LS}}{C_c} \tag{16}$$

where I_{LS} is the largest signal current of the input stage. Obviously, the slew rate can be improved by increasing the first stage collector current. This would, however, reflect directly upon the bias current by increasing it.

Two serious limitations, then, of these devices for diverse applications are input bias current and slew rate. Both may be

overcome with small changes of the input structure to yield higher performance devices.

Reducing the input bias current becomes a matter of raising the transistor beta of the first stage. Several current designs boasting very low input currents use what is termed super beta input devices. These transistors have betas of 1,500 to 7,000. Bias currents under 2nA can be achieved in this way. Even though the B_{VCE0} of such transistors can be as low as 1 volt, the lower breakdowns are accounted for in the input stage by rearranging the bias technique. Bandwidths and slew rates suffer only slightly as a result of the lower current levels.

The second limitation of 741 devices is slew rate. As previously mentioned, the rate of change is dictated by the compensation capacitance as charged by the large signal current of the first stage. By altering the large

signal gm of the first stage as depicted by Figure 18, the slew rate can be dramatically increased.

The additional current supplied during large signal swings by current source I_c causes the first stage transfer function to change as shown in Figure 19. The compensation capacitor is returned to the output of the NE531 structure because the output driving source must be capable of supplying the increased current to charge the capacitor.

Large signal bandwidths with this input structure will be essentially the same as the small signal response. Full bandwidth possibilities of this configuration are still limited by the beta and f_t of the lateral pnp devices used for collector loads in the first stage. Even so, the slew rate of the NE531 and NE538 is a factor of 40 better than general purpose devices.

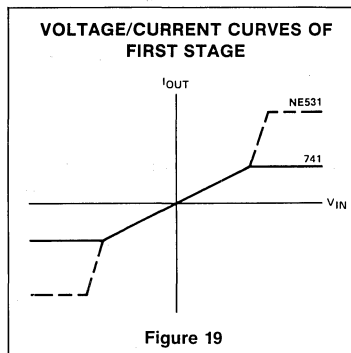
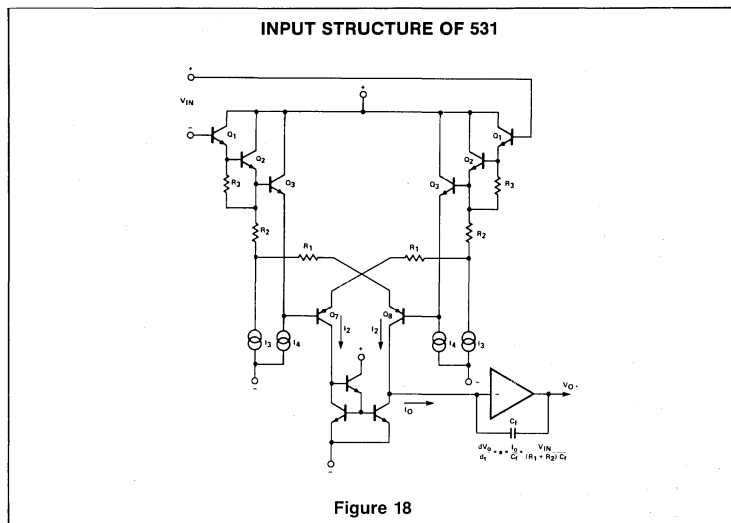

BASIC FEEDBACK THEORY

Earlier, the ideal op amp was defined. The ideal parameters are never fully realized but they present a very convenient method for the preliminary analysis of circuitry. So important are these ideal definitions that they are repeated here. The ideal amplifier possesses.

1. Infinite gain
2. Infinite input impedance
3. Infinite bandwidth
4. Zero output impedance

From these definitions two important theorems are developed:

1. No current flows into or out of the input terminals.
2. When negative feedback is applied the differential input voltage is reduced to zero.

Keeping these rules in mind, the basic concept of feedback can be explored.

VOLTAGE FOLLOWER

Perhaps the most often used and simplest circuit is that of a voltage follower. The circuit of Figure 1 illustrates the simplicity.

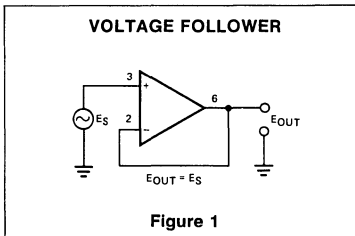

Figure 1

Applying the zero differential input theorem the voltages of pins 2 and 3 are equal and since pins 2 and 6 are tied together, their voltage is equal; hence, $E_{out} = E_{in}$. Trivial to analyze, the circuit nevertheless does illustrate the power of the zero differential voltage theorem. Because the input impedance is multiplied and the output impedance divided by the loop gain the voltage follower is extremely useful for buffering voltage sources and for impedance transformation.

The basic configuration in Figure 1 has a gain of 1 with extremely high input impedance. Setting the feedback resistor equal to the source impedance will cancel the effects of bias current if desired.

However, for most applications a direct connection from output to input will suffice. Errors arise from offset voltage, common mode rejection ratio and gain. The circuit can be used with any op amp with the required unity gain compensation, if it is required.

NON-INVERTING AMPLIFIER

Only slightly more complicated is the non-inverting amplifier of Figure 2.

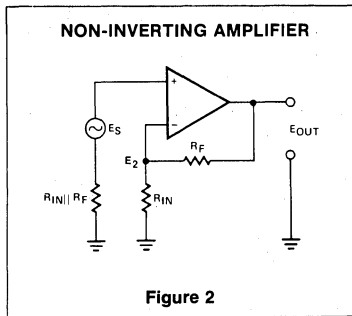

Figure 2

The voltage appearing at the inverting input is defined by

$$E_2 = \frac{E_{out} \cdot R_{in}}{R_F + R_{in}} \tag{1a}$$

Since the differential voltage is zero, $E_2 = E_s$, and the output voltage becomes

$$E_{out} = E_s \left(1 + \frac{R_F}{R_{in}} \right) \tag{1b}$$

It should be noted that as long as the gain of the closed loop is small compared to open loop gain, the output will be accurate, but as the closed loop gain approaches the open loop value more error will be introduced.

The signal source is shown in Figure 2 in series with a resistor equal in size to the parallel combination of R_{in} and R_F . This is desirable because the voltage drops due to bias currents to the inputs are equal and cancel out even over temperature. Thus overall performance is much improved.

The amplifier does not phase invert and possesses high input impedance. Again the impedances of the two inputs should be equal to reduce offsets due to bias currents.

INVERTING AMPLIFIER

By slightly rearranging the circuit of Figure 2, the non-inverting amplifier is changed to an inverting amplifier. The circuit gain is found by applying both theorems; hence, the voltage at the inverting input is 0 and no current flows into the input. Thus the following relationships hold.

$$\frac{E_s}{R_{in}} + \frac{E_o}{R_F} = 0 \tag{2a}$$

Solving for the output E_o

$$E_o = -E_s \frac{R_F}{R_{in}} \tag{2b}$$

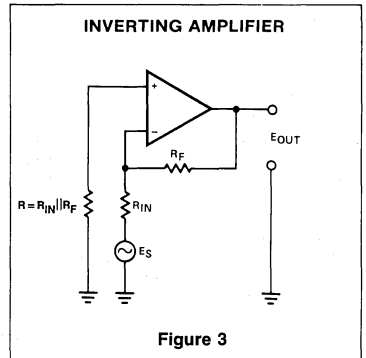

Figure 3

As opposed to the non-inverting circuits the input impedance of the inverting amplifier is not infinite but becomes essentially equal to R_{in} . This circuit has found widespread acceptance because of the ease with which input impedance and gain can be controlled to advantage, as in the case of the summing amplifier.

With the inverting amplifier of Figure 3 the gain can be set to any desired value defined by R divided by R_{in} . Input impedance is defined by the value or R_{in} and R should equal the parallel combination of R_{in} and R to cancel the effect of bias current. Offset voltage, offset current, and gain contribute most of the errors. The ground may be set anywhere within the common mode range and any op amp will provide satisfactory response.

CURRENT TO VOLTAGE CONVERTER

The transfer function of the current to voltage converter is

$$V_{out} = I_{in} R_1 \tag{3}$$

Evaluation of the circuit depends upon the virtual ground theorem developed earlier. The current flowing into the input must be the same as that flowing across R_1 , hence, the output voltage is the IR drop of R_1 .

Limitations, of course, are output saturation voltage and output current capability. The inputs may be biased anywhere within the common mode range.

DIFFERENTIAL AMPLIFIER

This circuit of Figure 5 has a gain with respect to differential signals of $R2/R1$.

The common mode rejection is dominated by the accuracy of the resistors. Other errors arise from the offset voltage, input offset current, gain and common mode rejection. The circuit can be used with any op amp discussed in this chapter with the proper compensation.

SUMMING AMPLIFIER

The summing amplifier is a variation of the inverting amplifier. The output is the sum of the input voltages, each being weighed by— R_F/R_{IN} .

The value of $R4$ may be chosen to cancel the effects of bias current and is selected equal to the parallel combination of R_F and all the input resistors.

INTEGRATOR

Integration can be performed with a variation of the inverting amplifier by replacing the feedback resistor with a capacitance. The transfer function is defined by

$$V_{OUT} = -\frac{1}{RC} \int_0^t V_{IN} \cdot dt \tag{4}$$

The gain of the circuit falls at 6dB per octave over the range in which strays and leakages are small.

Since the gain at dc is very high a method for resetting initial conditions is necessary. Switch $S1$ removes the charge on the capacitor. A relay or FET may be used in the practical circuit. Bias and offset currents and offset voltage of the switch should be low in such an application.

DIFFERENTIATOR

The differentiator of Figure 8 is another variation of the inverting amplifier. The gain increase at 6dB per octave until it intersects the amplifier open loop gain, then decreases because of the amplifier bandwidth. This characteristic can lead to instability and high frequency noise sensitivity.

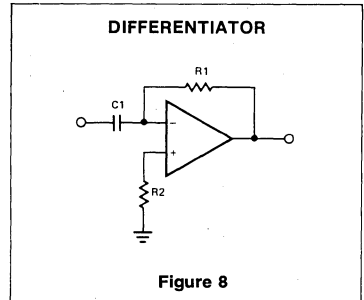
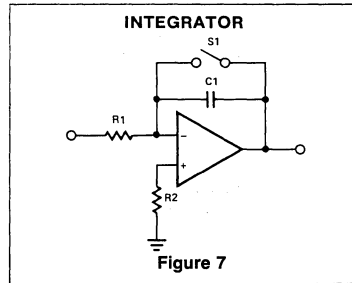
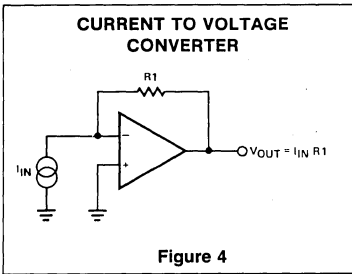

A more practical circuit is shown in Figure 9. The gain has been reduced by $R3$ and the high frequency gain reduced by $C2$ allowing better phase control and less high frequency noise. Compensation should be for unity gain.

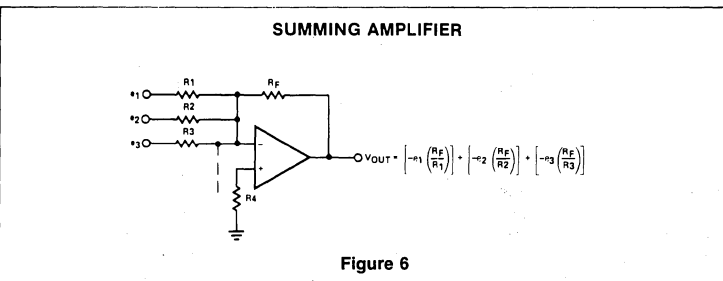
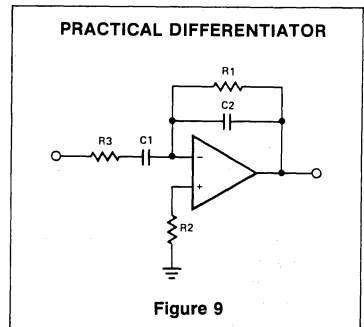
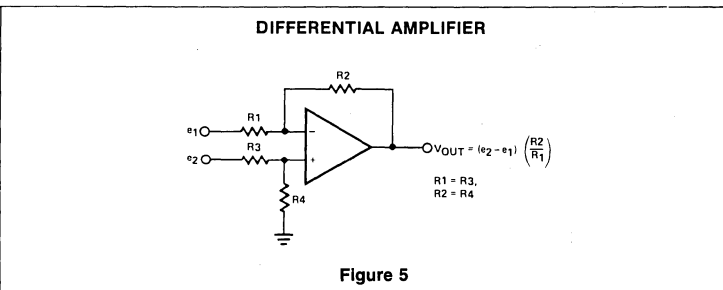

COMPENSATION

Present day operational amplifiers are comprised of multiple stages, each of which has a 3dB point or pole associated with it. Referring to Figure 10, the 3dB break points of a two stage amplifier are approximated by the Bode plot.

As with any feedback loop, the op amp must be protected from phase shifts in excess of 360°. A steady 180° phase shift is developed by the amplifier from output to inverting input. In addition the sum of all additional shifts due to amplifier poles or feedback component poles will cause the necessary additional 180° to sustain oscillation if the



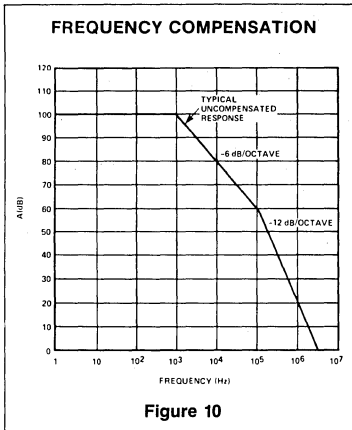

Figure 10

gain of the amplifier is greater than one for the frequency at which the 180° phase shift is reached. By adding poles and zeros to the amplifier response externally, the phase shift can be controlled to insure stability.

Many op amps now include internal compensation. These are single capacitors of 30pF typically and the amplifier will remain stable for all gains. However, since they are unconditionally stable, the compensation is larger than required for most applications. The resultant loss of bandwidth and slew rate may be acceptable in the general case but selection of an externally compensated device can add a great deal to the amplifier response if the compensation is handled properly.

In order to fully develop the point at which instability occurs a fuller understanding of phase response is necessary.

The diagram of Figure 11 depicts the phase shift of a single pole. Note that at the pole position the phase shift is 45° and that phase shift becomes 0° for a decade below the pole and -90° for a decade above the pole. This is a Bode approximation which possesses a 5.7° error at 0° and 90° but this error is usually considered small enough to be ignored. The single pole produces a maximum of 90° phase shift and also produces a frequency roll off of 20dB per decade. The addition of the second pole of Figure 12 produces an additional 90° phase shift and increases the roll off slope to -40dB per decade.

At this point phase shift could exceed 180° because unity gain is reached causing stability. For gain levels equal to A1 or 1/β, the phase shift is only 90° and the amplifier is stable. However, the gain of A2 the phase shift is 180° and the loop is unstable. Gains in

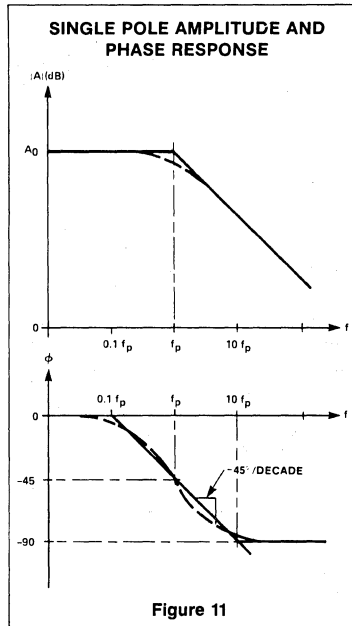

Figure 11

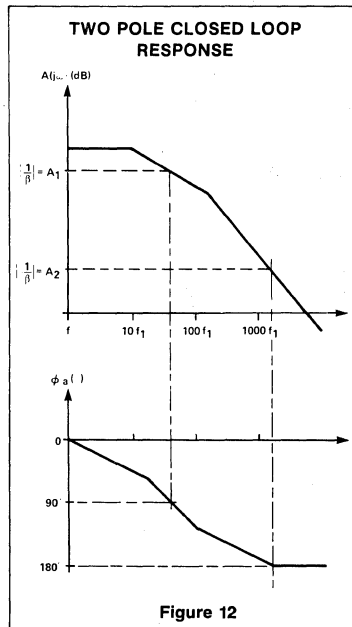

Figure 12

between A1 and A2 are marginally stable. However, as shown in Figure 13 the phase shift as it approaches 180° causes increasing frequency peaking and overshoot until sustained oscillations occur.

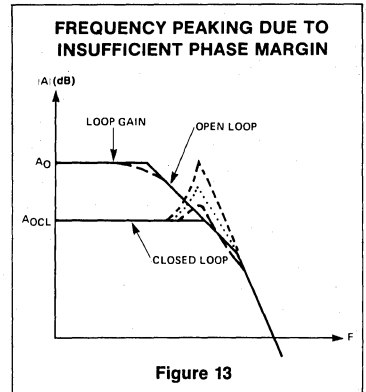

Figure 13

It is generally accepted in the interest of minimized frequency peaking to limit the phase shift of the amplifier to 135° or a phase margin of 45°. At this margin the second order response of the system is critically damped and oscillation is prevented.

Referring to Figure 14, the required compensation can be determined. Given the open loop response of the amplifier, the desired gain is plotted until it intercepts the open loop curve as shown.

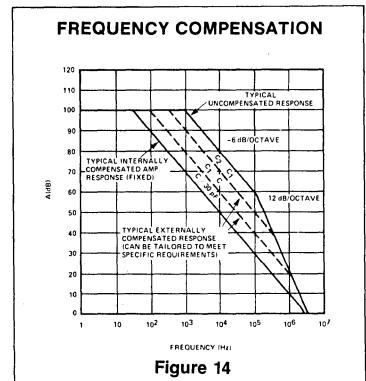
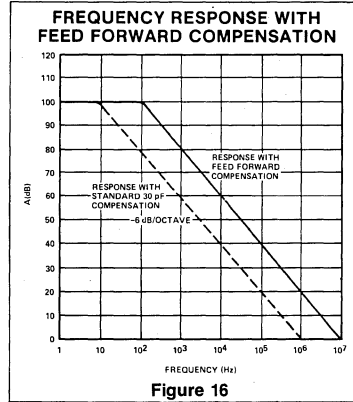
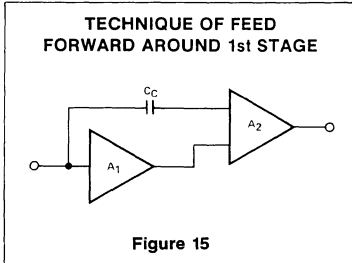

Figure 14

The phase shift for minimum peaking is 135°. Remembering that phase shift is 45° at the frequency pole the example of Figure 14 will be unstable at gains less than 20dB where phase shift exceeds 180°, and will possess excessive overshoot and ringing at gains less than 60dB where phase shift exceeds 135°. Thus, the desired compensation will move the second pole of the amplifier out in frequency until the closed loop gain intersects the open loop response before the second break of the amplifier occurs. Selecting only enough compensation to do the job assures the maximum bandwidths and slow rates of the amplifier. Additional in-depth information on compensation can be found in the reference material.

FEED FORWARD COMPENSATION

External compensation has been shown to improve amplifier bandwidth over internal compensation in the preceding section. Additional bandwidth can be realized if feed forward compensation is used. Bandwidth is limited in monolithic design by the poor frequency response of the pnp level shifters of the first stage.



The concept of feed forward compensation bypasses the input stage at high frequencies driving the higher frequency second stage directly as pictured by Figure 15. The Bode

plot of Figure 16 shows the additional response added by the feed forward technique. The response of the original amplifier requires less compensation at lower frequencies allowing an order of magnitude improvement in bandwidth. Standard compensation and feed forward are both plotted to illustrate the bandwidth improvement. Unfortunately, the use of feed forward compensation is restricted to the inverting amplifier mode.

REFERENCES

1. *OPERATIONAL AMPLIFIERS-Design & Applications*, Jerald Graeme and Gene Tobey, McGraw Hill Book Company.

AUDIO CIRCUITS USING THE NE5532/33/34

AUDIO CIRCUITS USING THE NE5532/33/34

More detailed information is available in the communications section of this manual, regarding other audio circuits. The following will explain the Signetics line of low noise op amps and show their use in some audio applications.

DESCRIPTION

The 5532 is a dual high-performance low noise operational amplifier. Compared to most of the standard operational amplifiers, such as the 1458, it shows better noise performance, improved output drive capability and considerably higher small-signal and power bandwidths.

This makes the device especially suitable for application in high quality and professional audio equipment, instrumentation and control circuits, and telephone channel amplifiers. The op amp is internally compensated for gains equal to one. If very low noise is of prime importance, it is

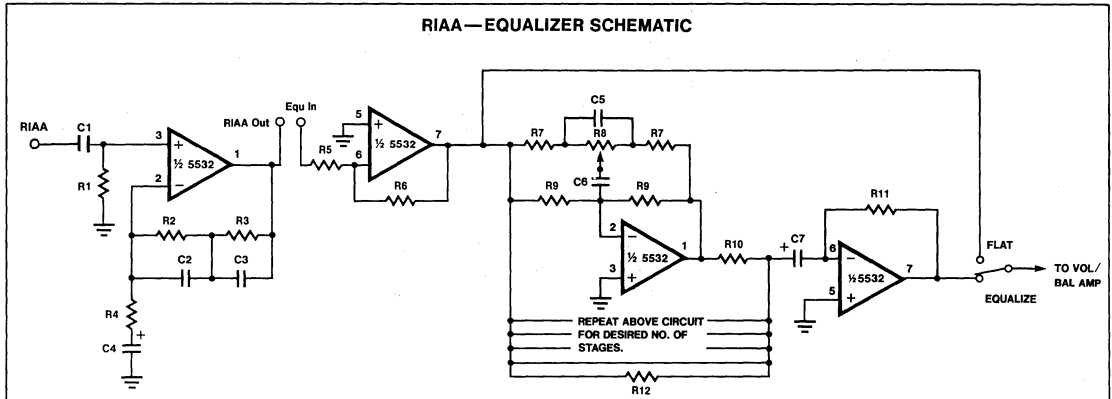

COMPONENT VALUE TABLES

R8 = 25k R7 = 2.4k R9 = 240k			R8 = 50k R7 = 5.1k R9 = 510k			R8 = 100k R7 = 10k R9 = 1meg		
fo	C5	C6	fo	C5	C6	fo	C5	C6
23 Hz	1μF	.1μF	25 Hz	.47μF	.047μF	12 Hz	.47μF	.047μF
50 Hz	.47μF	.047μF	36 Hz	.33μF	.033μF	18 Hz	.33μF	.033μF
72 Hz	.33μF	.033μF	54 Hz	.22μF	.022μF	27 Hz	.22μF	.022μF
108 Hz	.22μF	.022μF	79 Hz	.15μF	.015μF	39 Hz	.15μF	.015μF
158 Hz	.15μF	.015μF	119 Hz	.1μF	.01μF	59 Hz	.1μF	.01μF
238 Hz	.1μF	.01μF	145 Hz	.082μF	.0082μF	72 Hz	.082μF	.0082μF
290 Hz	.082μF	.0082μF	175 Hz	.068μF	.0068μF	87 Hz	.068μF	.0068μF
350 Hz	.068μF	.0068μF	212 Hz	.056μF	.0056μF	106 Hz	.056μF	.0056μF
425 Hz	.056μF	.0056μF	253 Hz	.047μF	.0047μF	126 Hz	.047μF	.0047μF
506 Hz	.047μF	.0047μF	380 Hz	.033μF	.0033μF	180 Hz	.033μF	.0033μF
721 Hz	.033μF	.0033μF	541 Hz	.022μF	.0022μF	270 Hz	.022μF	.0022μF
1082 Hz	.022μF	.0022μF	794 Hz	.015μF	.0015μF	397 Hz	.015μF	.0015μF
1588 Hz	.015μF	.0015μF	1191 Hz	.01μF	.001μF	595 Hz	.01μF	.001μF
2382 Hz	.01μF	.001μF	1452 Hz	.0082μF	820pF	726 Hz	.0082μF	820pF
2904 Hz	.0082μF	820pF	1751 Hz	.0068μF	680pF	875 Hz	.0068μF	680pF
3502 Hz	.0068μF	680pF	2126 Hz	.0056μF	560pF	1063 Hz	.0056μF	560pF
4253 Hz	.0056μF	560pF	2534 Hz	.0047μF	470pF	1267 Hz	.0047μF	470pF
5068 Hz	.0047μF	470pF	3609 Hz	.0033μF	330pF	1804 Hz	.0033μF	330pF
7218 Hz	.0033μF	330pF	5413 Hz	.0022μF	220pF	2706 Hz	.0022μF	220pF
10827 Hz	.0022μF	220pF	7940 Hz	.0015μF	150pF	3970 Hz	.0015μF	150pF
15880 Hz	.0015μF	150pF	11910 Hz	.001μF	100pF	5955 Hz	.001μF	100pF
23820 Hz	.001μF	100pF	14524 Hz	820pF	82pF	7262 Hz	820pF	82pF
			17514 Hz	680pF	68pF	8757 Hz	680pF	68pF
			21267 Hz	560pF	56pF	10633 Hz	560pF	56pF
						12670 Hz	470pF	47pF
						18045 Hz	330pF	33pF

COMPONENT VALUES

R1	1meg	C1	.22μF
R2	100k	C2	750pF
R3	1meg	C3	.0033μF
R4	1.1k	C4	33μF
R5	100k	C5	SEE TABLE
R6	100k	C6	SEE TABLE
R7	SEE TABLE	C7	2.2μF
R8	(pot) SEE TABLE		
R9	SEE TABLE		
R10	100k		
R11	100k		
R12	20k (5 STAGES)		

Figure 1

recommended that the 5532A version be used which has guaranteed noise voltage specifications.

APPLICATIONS

The Signetics 5532 High Performance Op Amp is an ideal amplifier for use in high quality and professional audio equipment which requires low noise and low distortion.

The circuit included in this application note has been assembled on a P.C. board, and tested with actual audio input devices (Tuner and Turntable). It consists of an RIAA pre-amp, input buffer, 5-band equalizer, and mixer. Although the circuit design is not new, its performance using the 5532 has been improved.

The RIAA pre-amp section is a standard compensation configuration with low frequency boost provided by the Magnetic cartridge and the RC network in the op amp feedback loop. Cartridge loading is accomplished via R1. 47k was chosen as a typical value, and may differ from cartridge to cartridge.

The Equalizer section consists of an input buffer, 5 active variable band pass/notch (depending on R9's setting) filters, and an output summing amplifier. The input buffer is a standard unity gain design providing impedance matching between the pre amplifiers and the equalizer section. Because the 5532 is internally compensated, no external compensations required. The 5-band active filter section is actually 5 individual active filters with the same feedback design for all 5. The main difference in all five stages is the values of C5 and C6 which are responsible for setting the center frequency of each stage. Linear pots are recommended for R9. To simplify use of this circuit, a component value table is provided, which lists center frequencies and their associated capacitor values. Notice that C5 equals (10) C6, and that the Value of R8 and R10 are related to R9 by a factor of 10 as well. The values listed in the table are common and easily found standard values.

RIAA EQUALIZATION AUDIO PREAMPLIFIER USING NE5532A

With the onset of new recording techniques along with sophisticated playback equipment, a new breed of low noise operational amplifiers was developed to complement the state-of-the-art in audio reproduction. The first ultra low noise op amp introduced by Signetics was called the NE5534A. This is a single operational amplifier with less than $4nV/\sqrt{\text{Hz}}$ input noise voltage. The NE5534A is internally compensated at a

gain of three. This device has been used in many audio preamp and equalizer (active filter) applications since its introduction early last year.

Many of the amplifiers that are being designed today are dc coupled. This means that very low frequencies (2-15Hz) are being amplified. These low frequencies are common to turntables because of rumble and tone arm resonances. Since the amplifiers can reproduce these sub-audible tones, they become quite objectionable because the speakers try to reproduce these tones. This causes non-linearities when the actual recorded material is amplified and converted to sound waves.

The RIAA has proposed a change in its standard playback response curve in order to alleviate some of the problems that were previously discussed. The changes occur primarily at the low frequency range with a slight modification to the high frequency range. (See Figure 2). Note that the response peak for the bass section of the playback curve now occurs at 31.5Hz and begins to roll off below that frequency. The rolloff occurs by introducing a fourth R/C network with a $7950\mu\text{s}$ time constant to the three existing

networks that make up the equalization circuit. The high end of the equalization curve is extended to 20kHz, because recordings at these frequencies are achievable on many current discs.

NE5533/34 DESCRIPTION

The 5533/5534 are dual and single high-performance low noise operational amplifiers. Compared to other operational amplifiers such as TL083, they show better noise performance, improved output drive capability and considerably higher small-signal and power bandwidths.

This makes the devices especially suitable for application in high quality and professional audio equipment, in instrumentation and control circuits and telephone channel amplifiers. The op amps are internally compensated for gain equal to, or higher than, three. The frequency response can be optimized with an external compensation capacitor for various applications (unity gain amplifier, capacitive load, slew-rate, low overshoot, etc.) If very low noise is of prime importance, it is recommended that the 5533A/5534A version be used which has guaranteed noise specifications.

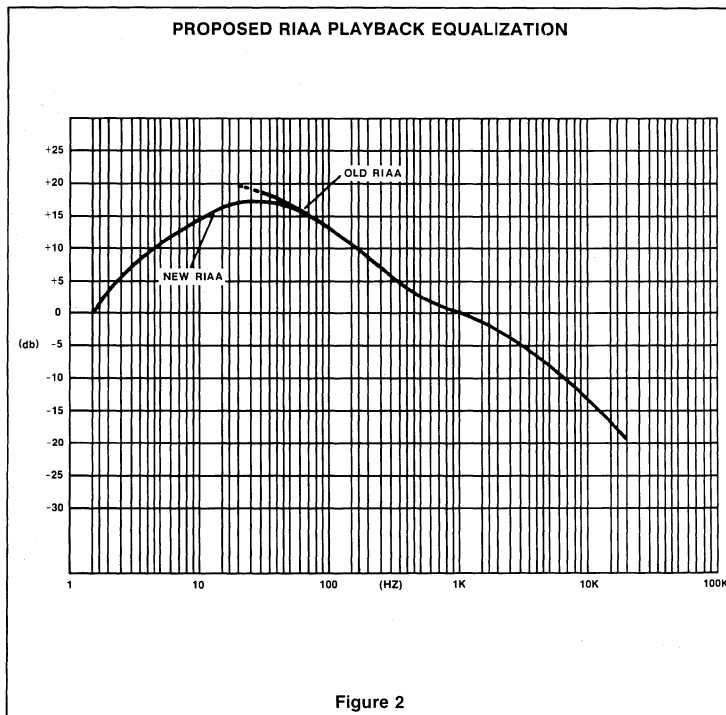

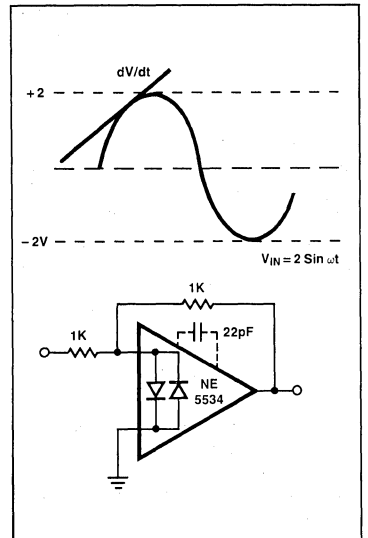
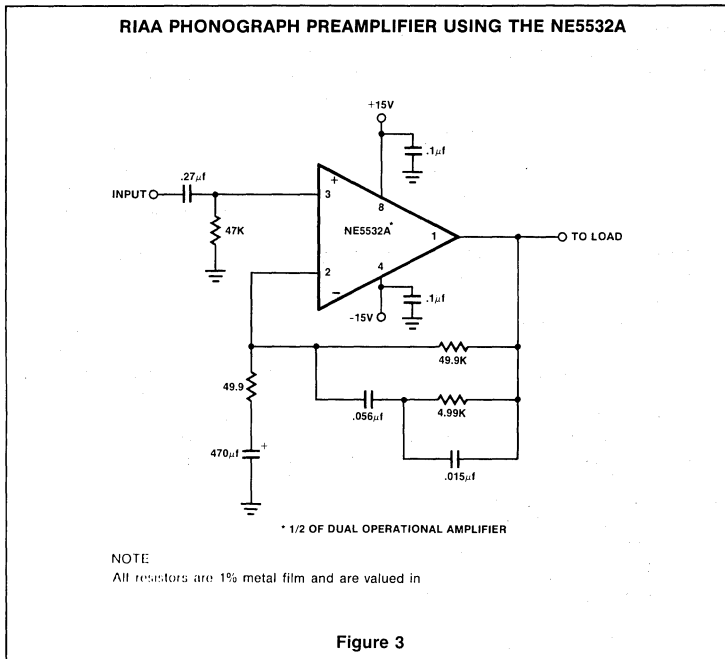

Next, a sine wave input is used with a similar circuit.

The slew rate of the input waveform now depends on frequency and the exact expression is

$$\frac{dv}{dt} = 2\omega \cos \omega t$$

The upper limit before slew rate distortion occurs for *small signal* ($V_{IN} < 100 \text{ mV}$) conditions is found by setting the slew rate to $7V/\mu\text{s}$. That is:

$$7 \times 10^6 \text{ V}/\mu\text{s} = 2\omega \cos \omega t$$

at $\omega t = 0$

$$\omega_{\text{LIMIT}} = \frac{7 \times 10^6}{2} = 3.5 \times 10^6 \text{ rad/s}$$

$$f_{\text{LIMIT}} = \frac{3.5 \times 10^6}{2\pi} \approx 560 \text{ kHz}$$

APPLICATIONS

Diode Protection of Input

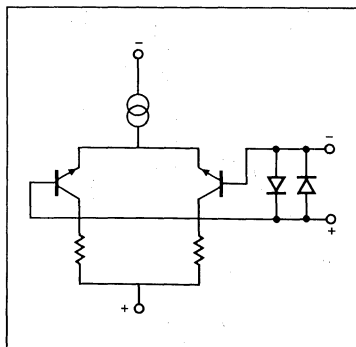

The input leads of the device are protected from differential transients above $\pm 0.6V$ by internal back-to-back diodes. Their presence imposes certain limitations on the amplifier dynamic characteristics related to closed-loop gain and slew rate.

Consider the unity gain follower as an example:

Assume a signal input square wave with dV/dt of $250V/\mu\text{s}$ and $2V$ peak amplitude as shown. If a 22 pF compensation capacitor is inserted and the R_1, C_1 circuit deleted, the device slew rate falls to approximately $7V/\mu\text{s}$. The input waveform will reach $2V/250V/\mu\text{s}$ or 8 ns , while the output will have changed $(8 \times 10^{-3}) (7)$ only 56 mV . The differential input signal is then $(V_{IN} - V_O) R_f/R_i + R_f$ or approximately $1V$.

The diode limiter will definitely be active and output distortion will occur; therefore, $V_{in} < 1V$ as indicated.

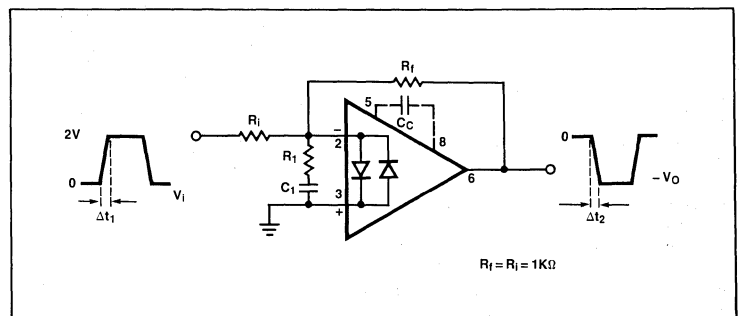

External Compensation Network Improves Bandwidth

By using an external lead-lag network, the follower circuit slew rate and small signal bandwidth can be increased. This may be useful in situations where a closed-loop gain less than 3 to 5 is indicated. A number of examples are shown in subsequent figures. The principle benefit of using the network approach is that the full slew rate and bandwidth of the device is retained, while impulse-related parameters such as damping and phase margin are controlled by choosing the appropriate circuit constants. For example, consider the following configuration:

By choosing the lag network break frequency one decade below the unity gain crossover frequency (30-50 MHz), the phase and gain margin are improved. An appropriate value for R is 270Ω. Setting the lag network break frequency at 5 MHz, C may be calculated

$$C = \frac{1}{2\pi \cdot 270 \cdot 5 \times 10^6}$$

118 = pF

A single pole and zero inserted in the transfer function will give an added 45° of phase margin depending on the network values.

Calculating the Lead-Lag Network

$$C_1 = \frac{1}{2\pi F_1 R_1} \quad \text{Let } R_1 = \frac{R_{IN}}{10}$$

where $F_1 = \frac{1}{10} (\text{UGBW})$

UGBW = 30 MHz

RULES AND EXAMPLES

Compensation Using Pins 5 and 8 (Limited Bandwidth and Slew Rate)

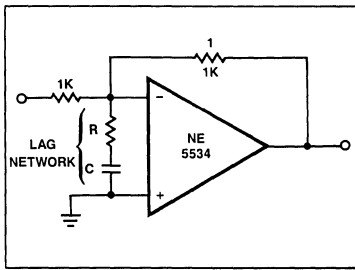

The major problem to be overcome is poor phase margin leading to instability.

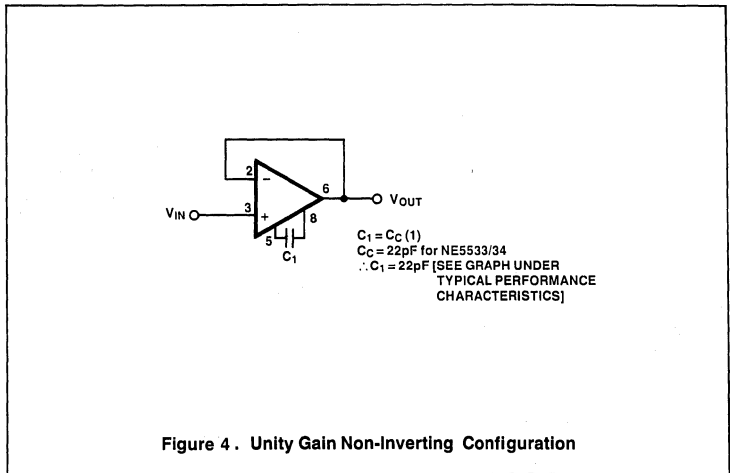
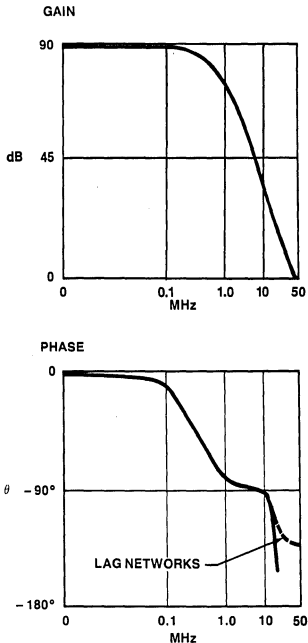

Figure 4. Unity Gain Non-Inverting Configuration

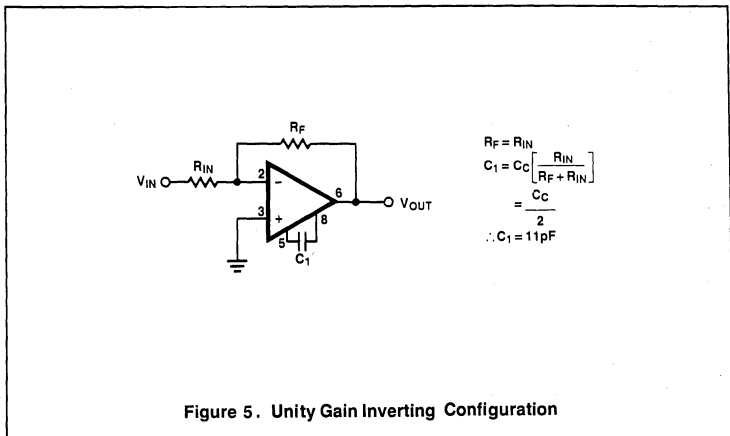
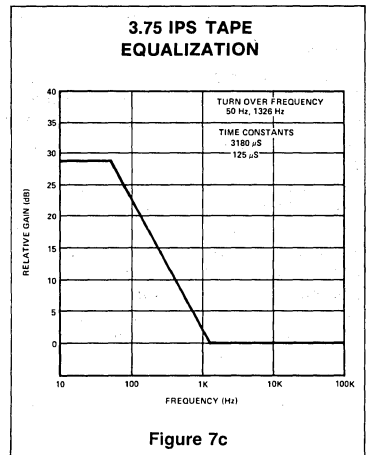
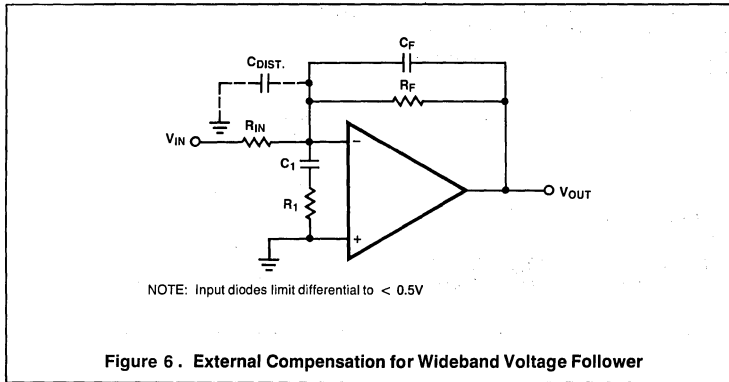

Figure 5. Unity Gain Inverting Configuration

External Compensation for Wideband Voltage Follower



Shunt Capacitance Compensation

$$C_F = \frac{1}{2\pi F_F R_F}, F_F \cong 30 \text{ MHz}$$

or
$$C_F \cong \frac{C_{DIST}}{A_{CL}}$$

$C_{DIST} \cong$ Distributed Capacitance \cong 2-3pF

Many audio circuits involve carefully tailored frequency responses. Pre-emphasis is used in all recording mediums to reduce noise and produce flat frequency response. The most often used de-emphasis curves for broadcast and home entertainment systems are shown in Figure 7. Operational amplifiers are well suited to these applications because of their high gain and easily tailored frequency response.

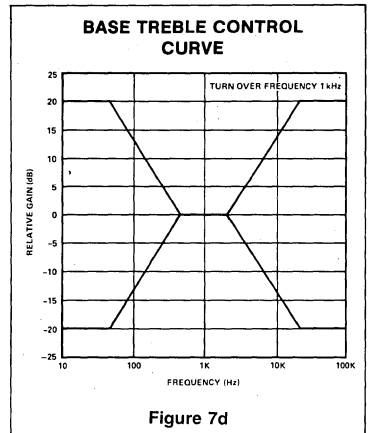
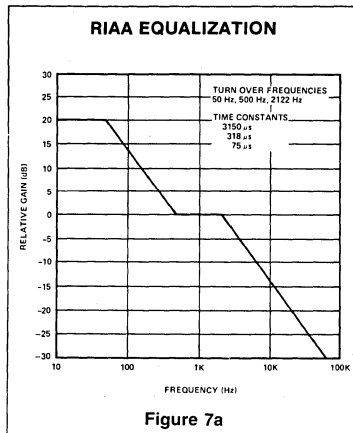

RIAA PREAMP USING THE NE5534

The preamplifier for phono equalization is shown in Figure 8 along with the theoretical and actual circuit response.

Low frequency boost is provided by the inductance of the magnetic cartridge with the RC network providing the necessary break points to approximate the theoretical RIAA curve.

RUMBLE FILTER

Following the amplifier stage, rumble and scratch filters are often used to improve overall quality. Such a filter designed with op amps uses the 2 pole Butterworth approach and features switchable break points. With the circuit of Figure 9 any degree of filtering from fairly sharp to none at all is switch selectable.

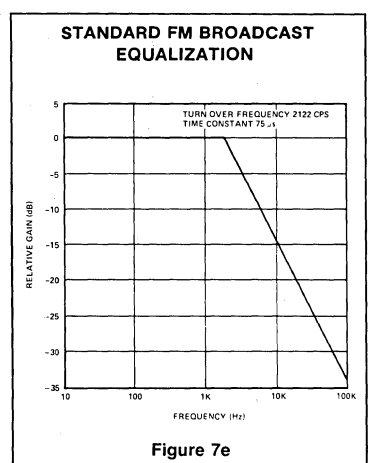
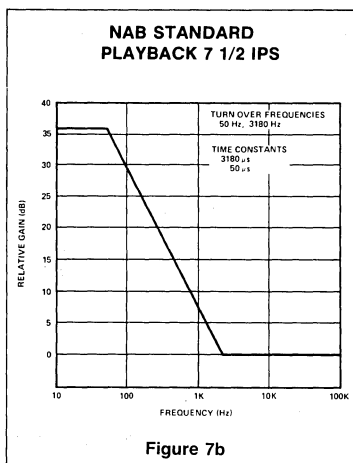

PREAMPLIFIER—RIAA/NAB COMPENSATION

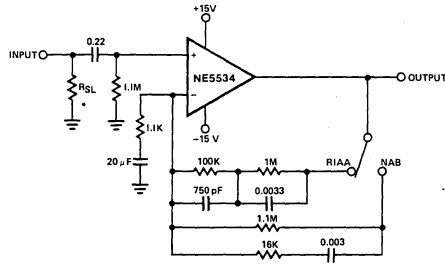

*Select to provide specified transducer loading.
Output Noise \approx 0.8mV rms (with input shorted)
All resistor values are in ohms.

Figure 8a

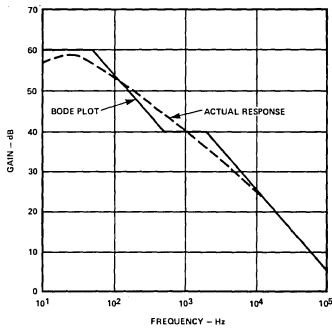

Bode Plot of RIAA Equalization and the response realized in an actual circuit using the 531.

Figure 8b

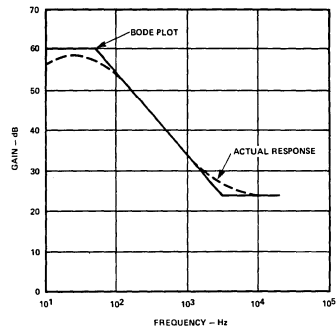

Bode Plot of NAB Equalization and the response realized in the actual circuit using the 531.

Figure 8c

RUMBLE/SCRATCH FILTER

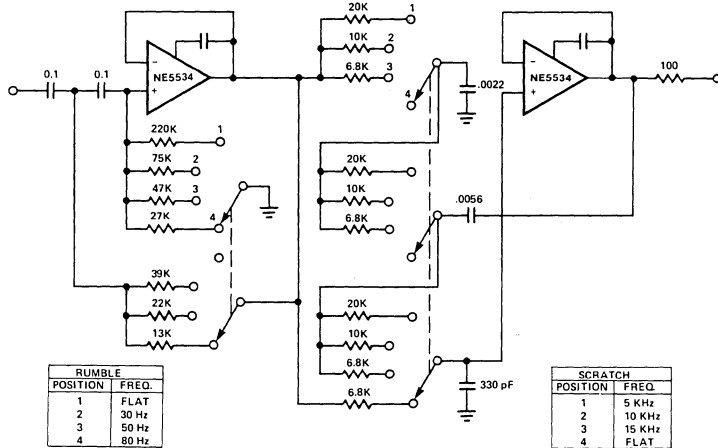

RUMBLE POSITION	FREQ.
1	FLAT
2	30 Hz
3	50 Hz
4	80 Hz

All resistor values are in ohms.

SCRATCH POSITION	FREQ.
1	5 KHz
2	10 KHz
3	15 KHz
4	FLAT

Figure 9

TONE CONTROL CIRCUIT FOR OPERATIONAL AMPLIFIERS

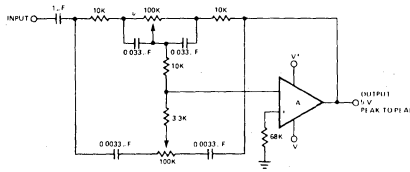

All resistor values are in ohms.

NOTES

1. Amplifier A may be a NE531 or 301. Frequency compensation, as for unity gain non-inverting amplifiers, must be used.
2. Turn-over frequency—1kHz.
3. Bass boost +20dB at 20Hz, bass cut -20dB at 20Hz, treble boost +19dB at 20kHz, treble cut -19dB at 20kHz.

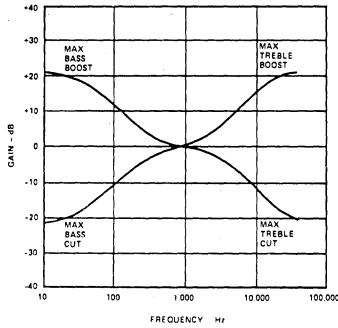

Figure 10

TONE CONTROL

Tone control of audio systems involves altering the flat response in order to attain more low frequencies or more high ones dependent upon listener preference. The circuit of Figure 10 provides 20dB of bass or treble boost or cut as set by the variable resistance. The actual response of the circuit is shown also.

BALANCE AND LOUDNESS AMPLIFIER

Figure 11 shows a combination of balance and loudness controls. Due to the non-linearity of the human hearing system the low frequencies must be boosted at low listening levels. Balance, level, and loudness controls provide all the listening controls to produce the desired music response.

VOLTAGE AND CURRENT OFFSET ADJUSTMENTS

Many IC amplifiers include the necessary pin connections to provide external offset adjustments. Many times, however, it becomes necessary to select a device not possessing external adjustments. Figure 12, 13, and 14 suggest some possible arrangements for offset voltage adjust and bias current nulling circuitry. The circuitry of Figure 14 provides sufficient current into the input to cancel the bias current requirement. Although more simplified arrangements are possible the addition of Q2 and Q3 provide a fixed current level to Q1, thus, bias cancellation can be provided without regard to input voltage level.

BALANCE AMPLIFIER WITH LOUDNESS CONTROL

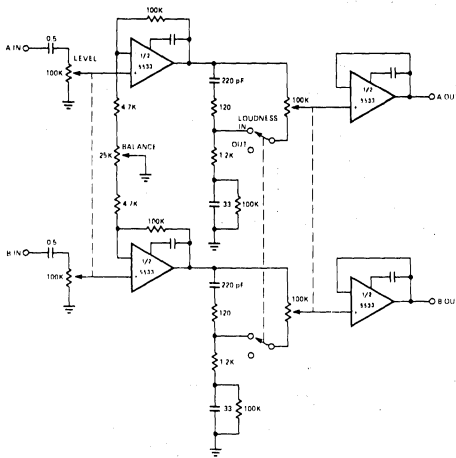

Figure 11

UNIVERSAL OFFSET NULL FOR INVERTING AMPLIFIERS

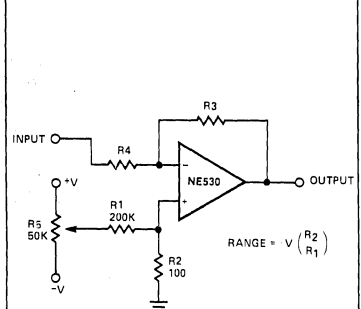

Figure 12

UNIVERSAL OFFSET NULL FOR
NONINVERTING AMPLIFIERS

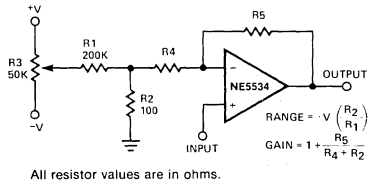

Figure 13

BIAS CURRENT
COMPENSATION

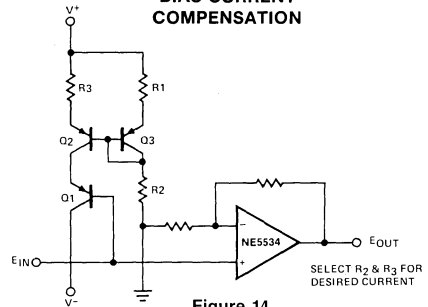

Figure 14

APPLICATIONS

Introduction

The NE5535 is a new generation monolithic op amp which features improved input characteristics. The device is compensated to unity gain and has a minimum guaranteed unity gain slew rate of 10V/μs. This is achieved by employing a clamped super beta input stage which has lower input bias current.

Applications

These improved parameters can be put to good use in applications such as sample and hold circuits which require low input current and in voltage follower circuits which require high slew rates. The circuit that follows will yield maximum small signal transient response and slew rate for the NE5535 at unity gain.

It is always good practice in designing a system to use dual tracking regulators to power the dual supply op amps. This will guarantee the positive and negative supply voltage will be equal during power up. With the NE5535, it is possible to degrade the input circuit characteristics by not applying the power supplies simultaneously. The NE5535 is capable of directly replacing the μA741 with higher input resistance which will improve such designed as active filters, sample and hold, as well as voltage followers.

The NE5535 can be used either with single or split power supplies.

leading to the distinct possibility of instability at high frequencies. R1 should therefore always be slightly smaller than R2 to assure stable operation.

POWER AMPLIFIER

For most applications, the available power from op amps is sufficient. There are times when more power handling capability is necessary. A simple power

booster capable of driving moderate loads is offered in Figure 3.

The circuit as shown uses a NE5535 device. Other amplifiers may be substituted only if R1 values are changed because of the ICC current required by the amplifier. R1 should be calculated from the expression

$$R1 = \frac{600mV}{ICC}$$

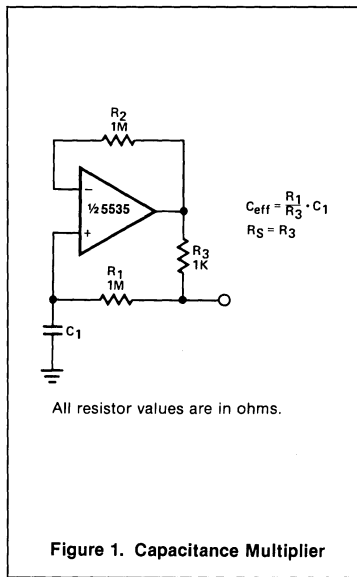

Figure 1. Capacitance Multiplier

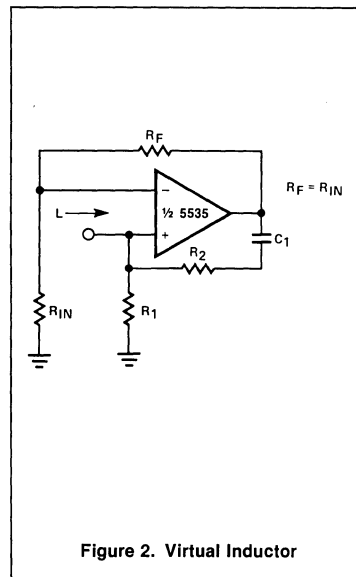

Figure 2. Virtual Inductor

APPLICATIONS

CAPACITANCE MULTIPLIER

The circuit in Figure 1 can be used to simulate large capacitances using small value components. With the values shown and C = 10μF, an effective capacitance of 10,000μF was obtained. The Q available is limited by the effective series resistance. So R1 should be as large as practical.

SIMULATED INDUCTOR

With a constant current excitation, the voltage dropped across an inductance increases with frequency. Thus, an active device whose output increases with frequency can be characterized as an inductance. The circuit of Figure 2 yields such a response with the effective inductance being equal to:

$$L = R1R2C$$

The Q of this inductance depends upon R1 being equal to R2. At the same time, however, the positive and negative feedback paths of the amplifier are equal

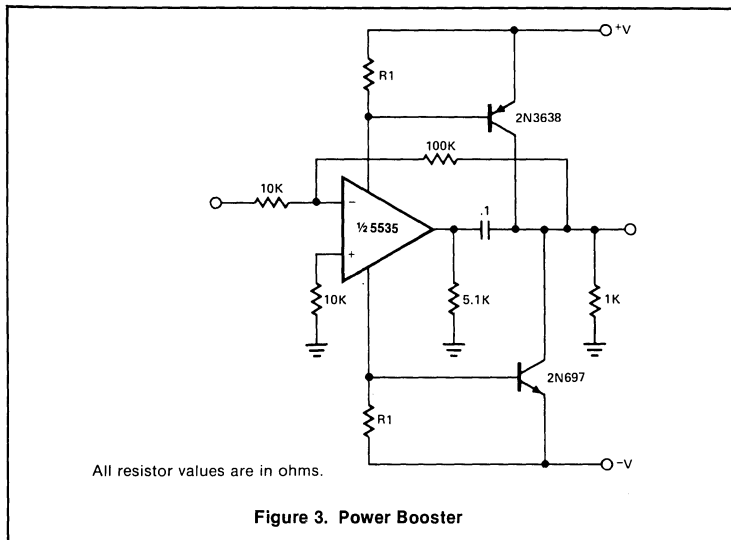

Figure 3. Power Booster

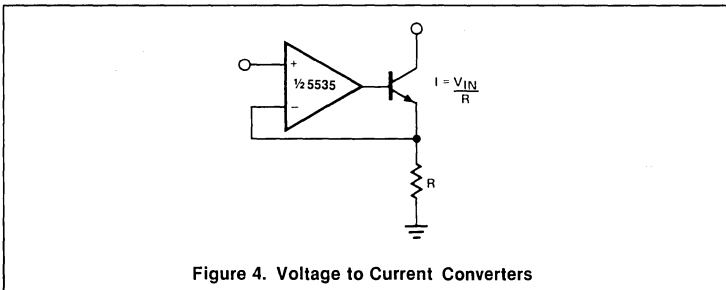

Figure 4. Voltage to Current Converters

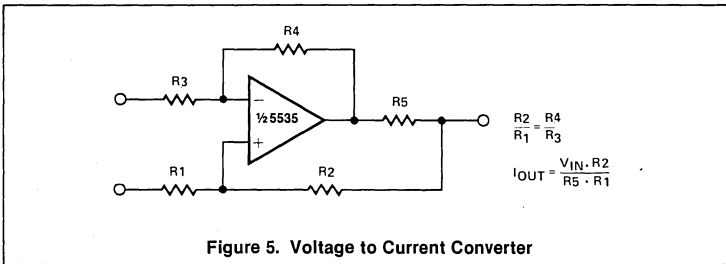

Figure 5. Voltage to Current Converter

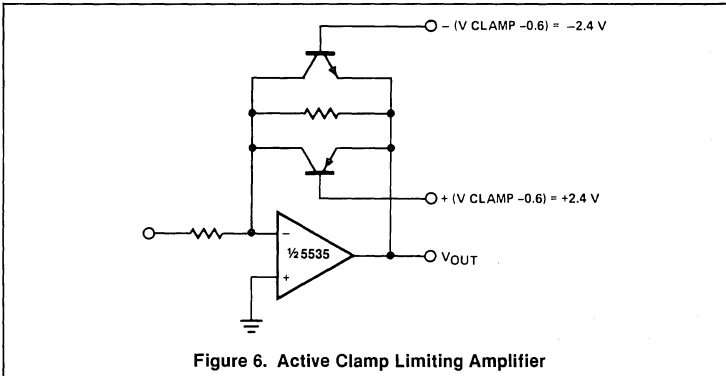
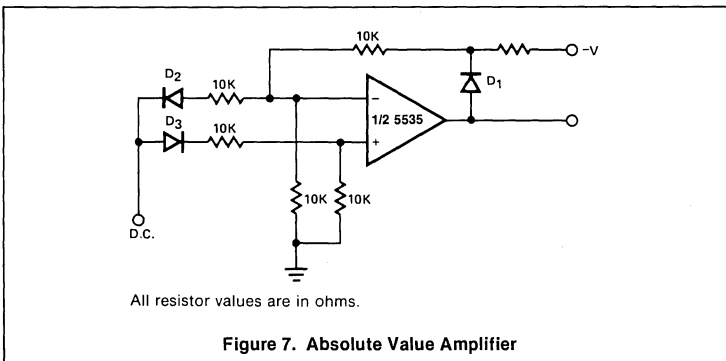

Figure 6. Active Clamp Limiting Amplifier



All resistor values are in ohms.

Figure 7. Absolute Value Amplifier

VOLTAGE-TO-CURRENT CONVERTERS

A simple voltage-to-current converter is shown in Figure 4. The current out is $I_{OUT} \equiv V_{IN}/R$. For negative currents, a pnp can be used and, for better accuracy, a Darlington pair can be substituted for the transistor. With careful design, this circuit can be used to control currents of many amps. Unity gain compensation is necessary.

The circuit in Figure 5 has a different input and will produce either polarity of output current. The main disadvantages are the error current flowing in R2 and the limited current available.

ACTIVE CLAMP LIMITING AMPLIFIER

The modified inverting amplifier in Figure 6 uses an active clamp to limit the output swing with precision. Allowance must be made for the V_{be} of the transistors. The swing is limited by the base-emitter breakdown of the transistors. A simple circuit uses two back-to-back zener diodes across the feedback resistor, but tends to give less precise limiting and cannot be easily controlled.

ABSOLUTE VALUE AMPLIFIER

The circuit in Figure 7 generates a positive output voltage for either polarity of input. For positive signals, it acts as a non-inverting amplifier and for negative signals, as an inverting amplifier. The accuracy is poor for input voltages under 1V, but for less stringent applications, it can be effective.

HALF WAVE RECTIFIER

Figure 8 provides a circuit for accurate half wave rectification of the incoming signal. For positive signals, the gain is 0; for negative signals, the gain is -1 . By reversing both diodes, the polarity can be inverted. This circuit provides an accurate output, but the output impedance differs for the two input polarities and buffering may be needed. The output must slew through two diode drops when the input polarity reverses. The NE5535 device will work up to 10kHz with less than 5% distortion.

PRECISION FULL WAVE RECTIFIER

The circuit in Figure 9 provides accurate full wave rectification. The output impedance is low for both input polarities, and the errors are small at all signal levels. Note that the output will not sink heavy currents, except a small amount through

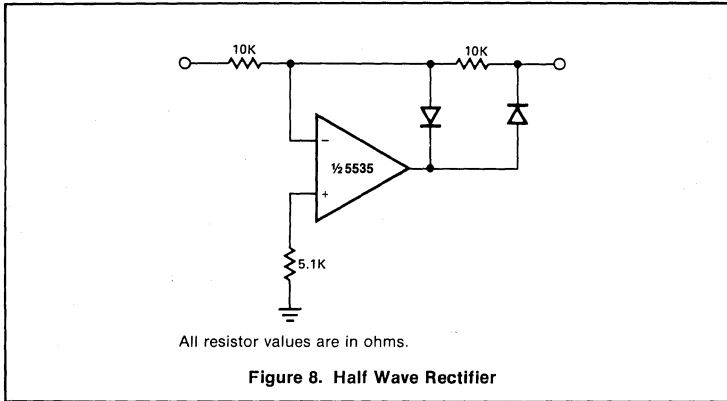

the 10kΩ resistors. Therefore, the load applied should be referenced to ground or a negative voltage. Reversal of all diode polarities will reverse the polarity of the output. Since the outputs of the amplifiers must slew through two diode drops when the input polarity changes, 741 type devices give 5% distortion at about 300Hz.

TWO-PHASE SINE WAVE OSCILLATOR

The circuit (referring to Figure 10, uses a 2-pole pass Butterworth, followed by a phase shifting single pole stage, fed back through a voltage limiter to achieve sine and cosine outputs. The values shown using 741 amplifiers give about 1.5% distortion at the sine output and about 3% distortion at the cosine output. By careful trimming of C_G and/or the limiting network, better distortion figures are possible. The component values shown give a frequency of oscillation of about 2kHz. The values can be readily selected for other frequencies. The NE5535 should be used at higher frequencies to reduce distortion due to slew limiting.

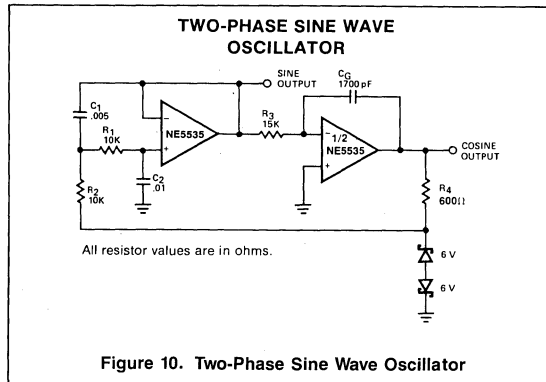
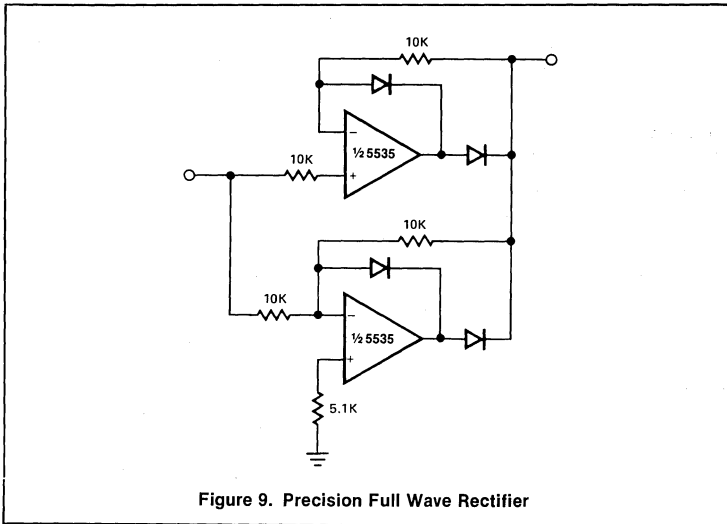

Introduction

The Signetics NE538 is the under-compensated version of the NE535. The NE538 has a typical slew rate of $50V/\mu s$ and a gain bandwidth product of 6MHz.

The internal frequency compensation is designed for a minimum inverting gain of 4 and a minimum non-inverting gain of 5. Below these gains the NE538 will be unstable and the NE535 should be used.

The higher slew rate of the NE538 has made this device quite appealing for high speed designs and the fact that it has a standard pinout will allow it to be used to upgrade existing systems that now use the $\mu A741$ or $\mu A748$.

VOLTAGE COMPARATOR

Inexpensive voltage comparators with only modest parameters are often needed. The op amp is often used in the configuration

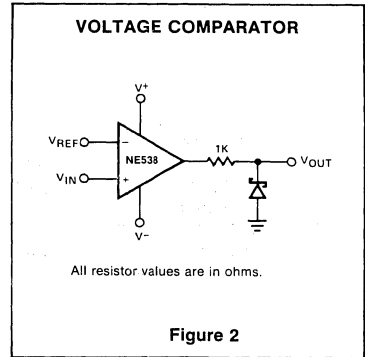
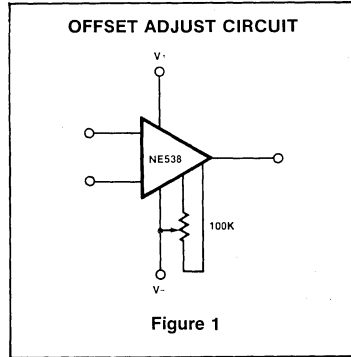

because the high gain provides good selectivity. Figure 2 shows a circuit usable with most any op amp. The zener is selected for the output voltage required (5.1 volt for TTL), and the resistor provides some current protection to

the op amp output structure. V_{ref} can be any voltage within the wide common mode range of the amplifier—another advantage of using op amps for comparators.

CYCLIC A TO D CONVERTER

One interesting, but, much ignored A/D converter is the cyclic converter. This consists of a chain of identical stages, each of which senses the polarity of the input. The stage then subtracts V_{ref} from the input and doubles the remainder if the polarity was correct. In Figure 1 the signal is full wave rectified and the remainder of $V_{in} - V_{ref}$ is doubled. A chain of these stages gives the gray code equivalent of the input voltage in digitized form related to the magnitude of V_{ref} . Possessing high potential accuracy, the circuit using NE531 devices settles in $5\mu s$.

TRIANGLE AND SQUARE WAVE GENERATOR

The circuit in Figure 2 will generate precision triangle and square waves. The output amplitude of the square wave is set by the output swing of the op amp A-1 and $R1/R2$ sets the triangle amplitude. The frequency of oscillation in either case is

$$f = \frac{1}{4RC} \cdot \frac{R2}{R1} \quad (1)$$

The square wave will maintain 50% duty cycle even if the amplitude of the oscillation is not symmetrical.

The use of the NE531 in this circuit will allow good square waves to be generated to quite high frequencies. Since the amplifier A1 runs open loop, there is no need for compensation. The triangle-generating amplifier must be compensated. The NE531 device can be used as well, except for the lower frequency response.

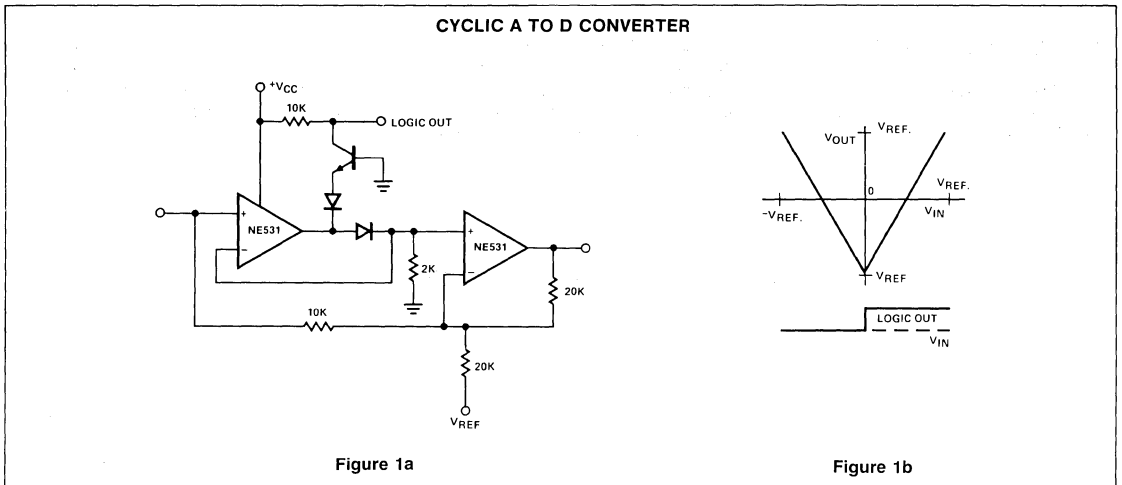

Figure 1a

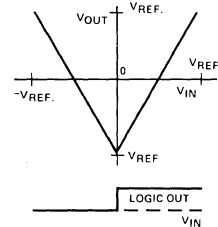

Figure 1b

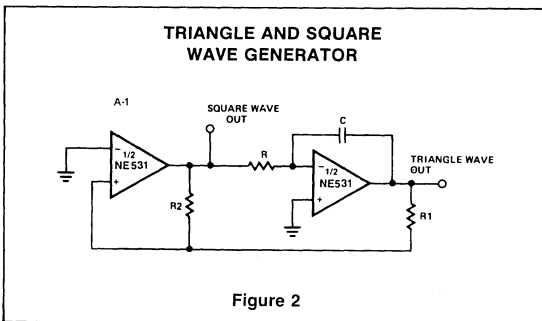
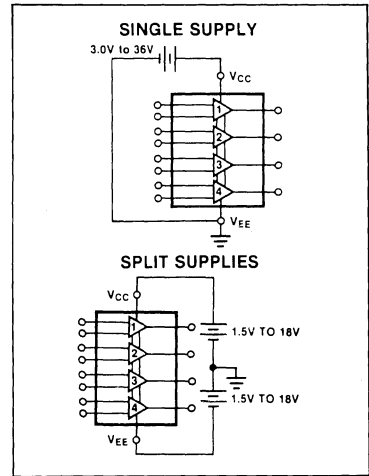
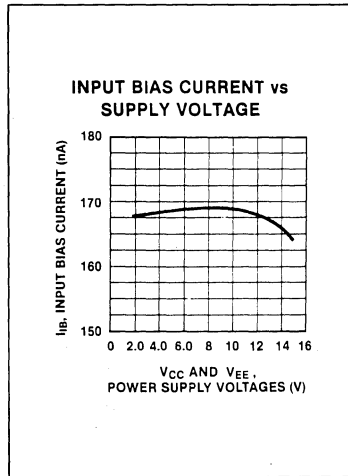

Figure 2

MC3403 DESCRIPTION

The MC3403 is a quad operational amplifier with true differential inputs. The device has electrical characteristics similar to the popular μ A741. However, the MC3403 has several distinct advantages over standard operational amplifier types in single supply applications. The MC3403 can operate at supply voltages as low as 3.0V or as high as 36V. The common mode input range includes the negative supply, thereby eliminating the necessity for external biasing components in many applications. The output voltage range also includes the negative power supply voltage.



APPLICATIONS

VOLTAGE REFERENCE

$$V_o = \frac{R_1}{R_1 + R_2} V_{cc}$$

$$V_o = \frac{1}{2} V_{cc}$$

WEIN BRIDGE OSCILLATOR

$$f_o = \frac{1}{2\pi RC}$$

FOR $f_o = 1\text{kHz}$
 $R = 16\text{k}\Omega$
 $C = 0.01\mu\text{F}$

HIGH IMPEDANCE DIFFERENTIAL AMPLIFIER

$$e_o = C(1 + a + b)(e_2 - e_1)$$

COMPARATOR WITH HYSTERESIS

$$V_{IN(L)} = \frac{R_1}{R_1 + R_2} (V_{OL} - V_{REF}) + V_{REF}$$

$$V_{IN(H)} = \frac{R_1}{R_1 + R_2} (V_{OH} - V_{REF}) + V_{REF}$$

$$H = \frac{R_1}{R_1 + R_2} (V_{OH} - V_{OL})$$

APPLICATIONS (Continued)

BI-QUAD FILTER

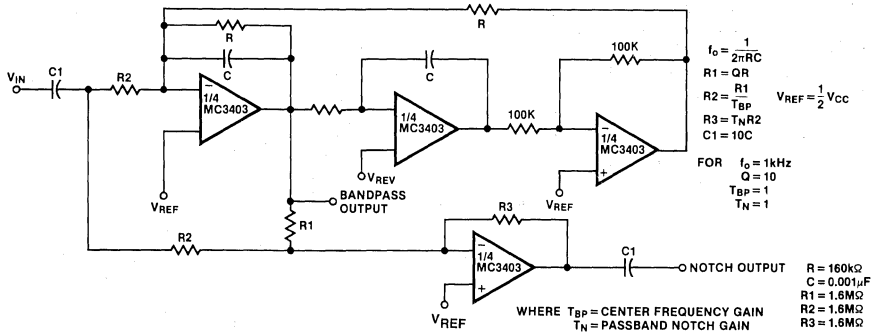

FUNCTION GENERATOR

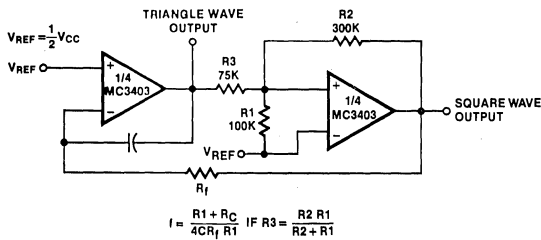

MULTIPLE FEEDBACK BANDPASS FILTER

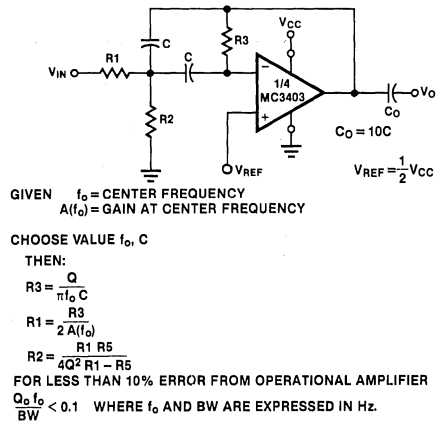

IF SOURCE IMPEDANCE VARIES, FILTER MAY BE PRECEDED WITH VOLTAGE FOLLOWER BUFFER TO STABILIZE FILTER PARAMETERS.

TYPICAL APPLICATIONS

SINGLE SUPPLY INVERTING AMPLIFIER

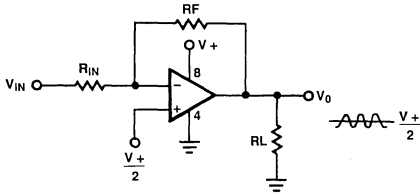

INPUT BIASING VOLTAGE FOLLOWER

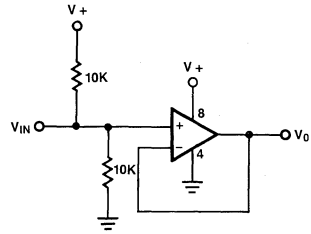

NON-INVERTING AMPLIFIER

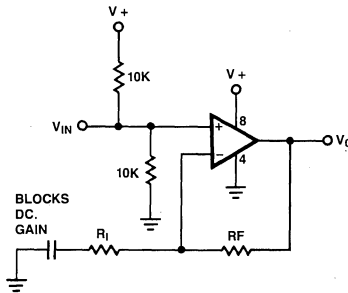

DESCRIPTION

The 5512 series of high performance operational amplifier provides very good input characteristics. These amplifiers feature low input bias and voltage characteristics such as a 108 op amp with improved CMRR and a high differential input voltage limit achieved through the use of a bias cancellation and PNP input circuits with collector to emitter clamping. The output characteristics are like those of a 741 op amp with improved slew rate and drive capability yet have low supply quiescent current.

BRIDGE TRANSDUCER AMPLIFIER

In applications involving strain gauges, accelerometers and thermal sensors a bridge transducer is often used. Frequently the sensor elements are high resistance units requiring equally high bridge resistance for good sensitivity. This type of circuit then demands an amplifier with high input impedance, low bias current and low drift. The circuit shown represents a possible solution to these general requirements (Figure 1).

For $V_S = 10$ volts, the common mode voltage is approximately +5 volts, well within the common mode limits of the NE5512.

The sensitivity of the input stage is approximately

$$\frac{R_F \cdot V_S}{2R}$$

to a change in transducer resistance ΔR . This gives a gain factor of ≈ 50 for $V_S = 10V$ and $R = 25k\Omega$. The second stage gain is $\times 100$ giving a total gain of ≈ 5000 .

Noise is minimized by shielding the transducer leads and taking special care to determine a good signal ground. Common mode noise rejection is particularly important making matched differential impedance critical. The NE5512 typically provides 100dB of common mode rejection and will considerably reduce this undesirable effect.

The following are sensitivity figures for the transducer circuits.

	$\frac{\Delta R}{R}$	$\frac{\Delta E_{out}}{E_{in}}$
leg 1	$\frac{10\Omega}{25k\Omega}$	-2.6V
	$\frac{5\Omega}{25k\Omega}$	-1.3V
leg 2	$\frac{10\Omega}{5\Omega}$	+2.4
	$\frac{5\Omega}{5\Omega}$	+1.2

Temperature compensation of the bridge element is accomplished by using low drift metal film resistors and also by providing a complimentary non-active sensor element to thermally track the offset in the active element.

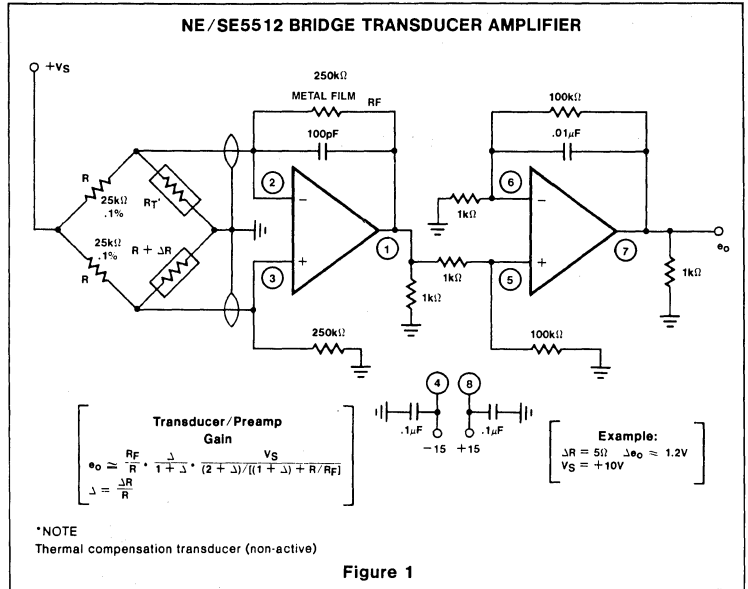

Figure 1

NE/SE5512 CURRENT TO VOLTAGE CONVERTER WITH 1% ACCURACY [SENSITIVITY: 1 VOLT PER MICROAMP]

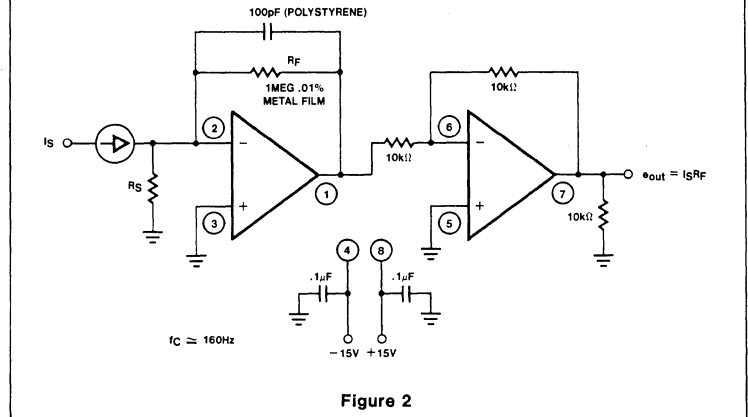

Figure 2

High frequency roll-off provides attenuation of unwanted noise above the pass band of the transducer. The shunt capacitors across both stage feedback resistors are for this purpose.

CURRENT TO VOLTAGE CONVERTER

Taking advantage of the very low bias current and offset of the NE5512 is demonstrated in its adaptation to a current to voltage converter as shown below (Figure 2).

The lower limit of measuring accuracy is determined by I_B (inverting) which is typically 6nA. In order to attain a measurement accuracy of 1% the following inequality must hold,

$$I_B \leq (0.1) I_{Smin}$$

Where I_B = input bias current, I_{Smin} = minimum measured current. For $I_B = 6nA$ and $I_{Smin} = 1\mu A$,

$$6nA \approx (0.1) 1\mu A = 10nA$$

and the inequality hold.

DC offset and current noise gain is determined by

$$\frac{R_F + R_S}{R_S}$$

which ≈ 1 for $R_S \gg R_F$.

The measured results for this circuit appear below ($V_{CC} = \pm 15$ volts).

INPUT CURRENT	OUTPUT VOLTAGE
1 μ A	1.008 Volts
5 μ A	5.00 Volts
10.00 μ A	10.00 Volts

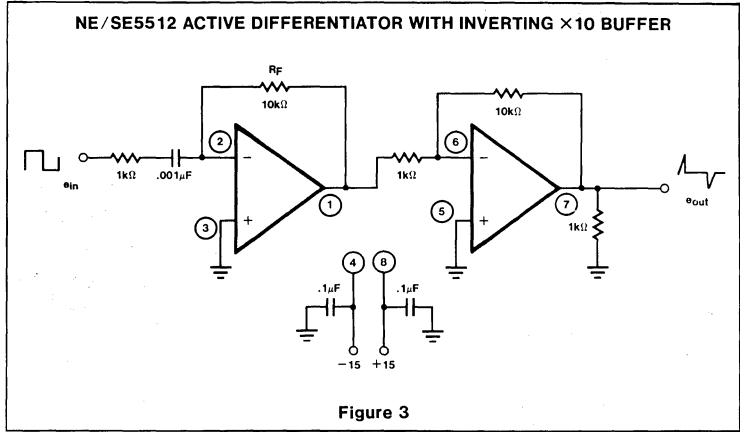

NE5512 OPERATIONAL DIFFERENTIATOR

By utilizing the very high input impedance characteristic of the NE5512, an excellent active differentiator can be realized. Using the circuit shown (Figure 3), good results were obtained as shown by the wave forms in Figures 4, 5 and 6. One of the primary problems with such circuits is the tendency towards instability and distortion either due to loading caused by input bias currents or amplifier non-linearity. In addition, gain increases with frequency requiring low input noise in the amplifier.

The relative stability is shown by the output signal wave forms mentioned above. Adding R_1 provides added compensation in the form of a zero near the amplifier unity gain frequency. Frequency range is 100Hz to 10kHz.

In order to obtain good differentiation, the network time constant, RC, must be small relative to the period of the highest frequency present at the input. Since the differentiator will attenuate the signal by a factor of ωRC which may be 100:1 in the operating region, the second amplifier stage is used to compensate for this loss. Various circuits are easily interfaced with the differentiator block due to the inherently low output impedance of the NE5512.

DIFFERENTIATOR WAVEFORMS

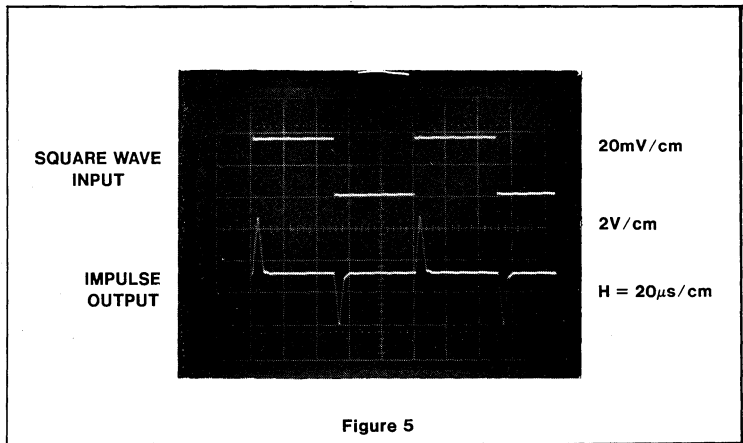
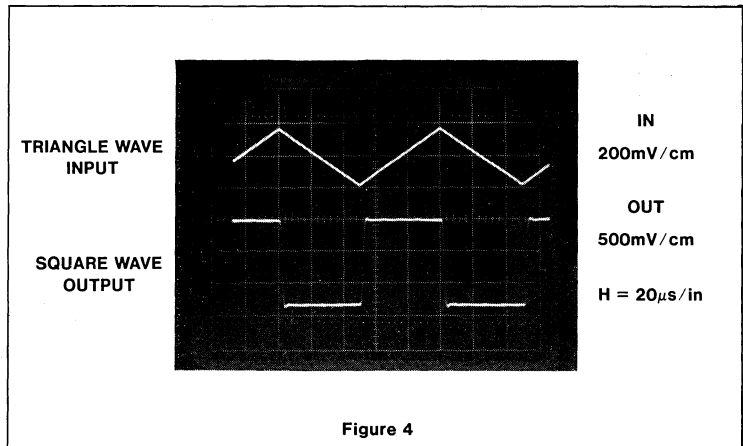

THE OPERATIONAL INTEGRATOR

The operational complement of the active differentiator is the active integrator. The NE5512 is easily adapted to this function as shown in the circuit below (Figure 7). To obtain satisfactory integration the time constant must fulfill the following requirement:

$$RC \geq 15T$$

Where T is the period of the input wave form. For the ideal integrator

$$e_{out} = \frac{1}{RC} \int e_{in} dt$$

The factor 1/RC represents an attenuation of the input signal. The low signal level is increased by using the second half of the NE5512 as a gain stage following the operational integration. The wave forms in Figures 8 and 9 show the input-output relationship for both a sine wave and a square wave function. A good integrator must exhibit a phase shift of $\approx 90^\circ$ for sine wave input over the active frequency range. For a square wave the resultant output must be a linear ramp. The circuit shown fulfills this requirement (see Figure 7). No external compensation is required since the amplifier is unity gain stable.

DIFFERENTIATOR WAVEFORMS

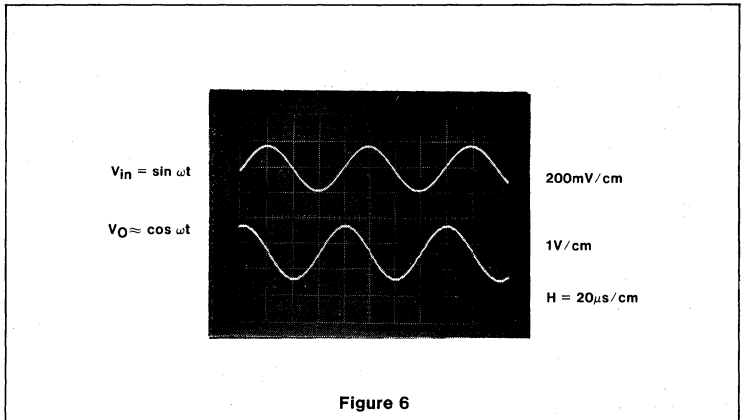

Figure 6

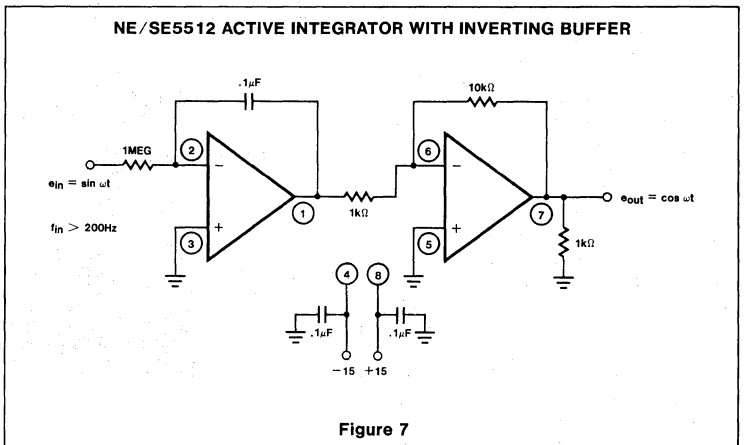

Figure 7

INTEGRATOR WAVEFORMS

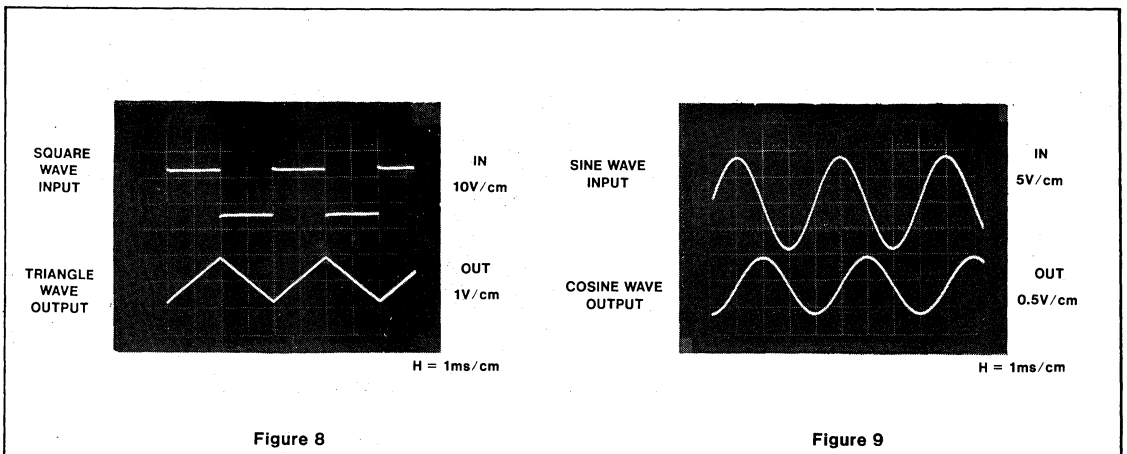

Figure 8

Figure 9

NE5514 DESCRIPTION

The SE/NE5514 family of Quad Operational Amplifiers sets new standards in Bipolar Quad Amplifier Performance. The amplifiers feature low input bias current and low offset voltages. Pin-out is identical to LM324/LM348 which facilitates direct product substitution for improved system performance. Output characteristics are similar to a μ A741 with improved slew and drive capability.

FOUR QUADRANT PHOTO-CONDUCTIVE DETECTOR AMPLIFIER

When operating a photo diode in the photo-conductive mode (reverse biased) very small currents in the micro ampere range must be sensed in the photo active operating region. Dark currents in the nano amperes are common. Generally, for this reason, J-FET input preamps are used to prevent interaction and accuracy degradation due to input bias currents.

The 5514 has sufficiently low input bias current (6na) to allow its use under these circuit constraints as shown in a possible design used to sense four quadrant motion of a light source. By proper summing of the signals from the X and Y axes, four quadrant output may be fed to an X-Y plotter, oscilloscope or computer for simulation. (See Figure 10.)

The wide input common mode voltage range of the device allows a +10 volt supply to be used to drive the signal bridge giving high sensitivity and improved signal to noise. Obviously, input balancing is critical to achieving common mode signal rejection in addition to adequate shielding of the sensor leads. The sensor head itself must be shielded and the shield grounded to signal common to avoid unwanted noise pick up from power line and other local noise sources. Amplifier response may be shaped to aid in noise reduction by more complex filter configurations. If possible the 5514 should be located in close proximity to the sensor head.

System balance may be done under dark field conditions if adequate photo detector tracking results. However, for high accuracy systems a bipolar balance adjust added to the non-inverting output stage is more desirable. With this latter method the signal bridge is balanced for a null output under uniform light field conditions using the bridge balance pot as shown. D.C. offset is then adjusted using the balance pot on the output amplifier under dark field conditions.

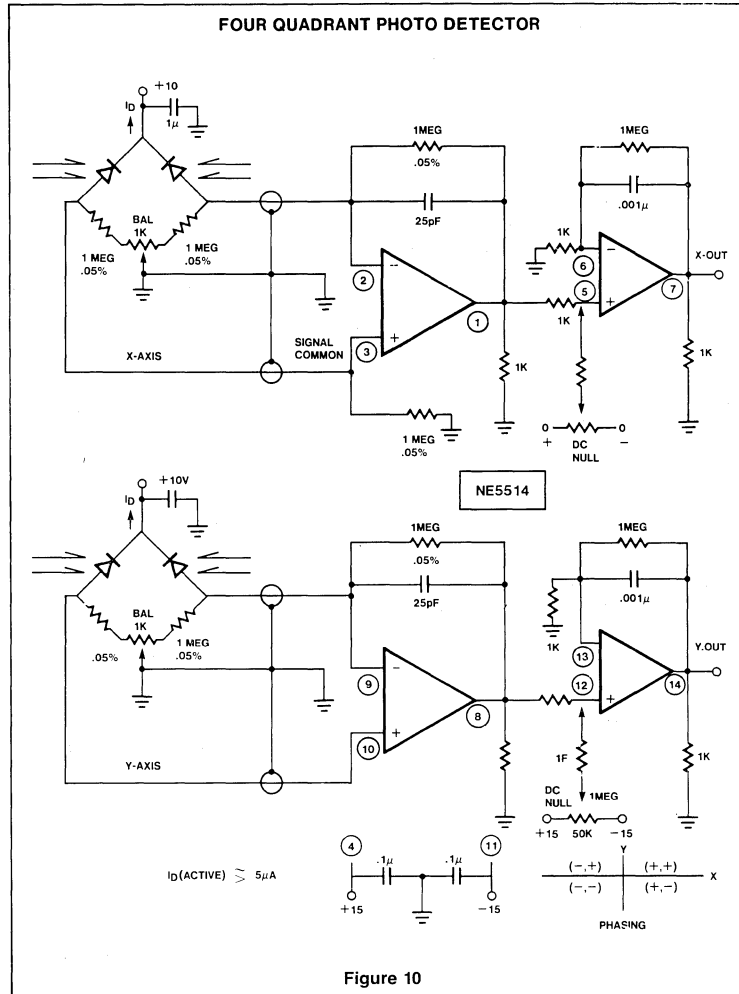

Figure 10

MULTI-TONE BANDPASS FILTER FOR PLL TONE DECODER

In the design of a multiple tone signaling system, particularly where signals are transmitted over long lines, noise and adjacent channel interference may be a significant barrier to reliable communications.

By the use of narrow band active pre-filters to attain selectivity and gain, the effective signal to noise ratio is greatly improved. The SE/NE5514 is easily adapted to such filter configurations due to its inherent stability. In addition its very high input impedance drastically reduces loading of the passive networks and allows for increased "Q" and large value resistors.

The circuit in Figure 4 demonstrates multiple feedback filters operating at four of the standard signaling frequencies. More channels may be added to increase the capacity of the system.

Test results obtained from this filter configuration were as follows:

Wide band signal to noise	63dB
Gain (Mid band)	30dB
Q (effective)	≈ 30
Output	0dBm (.775vrms)

Note that the amplifiers are operated from a single +12 volt supply and are biased to half



V_{CC} by a simple resistive divider at point B which connects to all non-inverting inputs.

4-STATION 0-50° TEMPERATURE SENSOR

By using an NPN transistor as a temperature sensing element, the NE5514 forms the basis for a multi-station temperature sensor as shown in Figure 12. The principle used is fundamental to the current voltage relationship of a forward biased junction. The current flow across the base-emitter junction is determined by absolute temperature in the following way:

$$I_E = -(I_C + I_B)$$

$$\text{and } I_E \propto I_S \exp(V_{BE}/V_T); V_T = \frac{kT}{q}$$

therefore, $V_{BE} \propto V_T \ln I_E/I_S$

Where I_E is the forward current and I_S is the saturation current inherent in the junction, I_E must be high enough such that the I_S variation with temperature is small relative to I_E (I_E >> I_S). I_S is typically .05 pA, therefore, setting I_E to 1 or 2 μA gives the desired condition.

Diode D₁ serves to substantially reduce error due to power supply variation by giving a fixed voltage reference. To calibrate the sensor adjust R₄ for "0" volts output from the NE5514 at 0°C. Adjust R₆ tracking resistor for a scale factor of 100 millivolts per °C output.

Only the transistor need be placed in the temperature controlled environment. Figure 13 shows the addition of an A/D converter and display to give a digital thermometer.

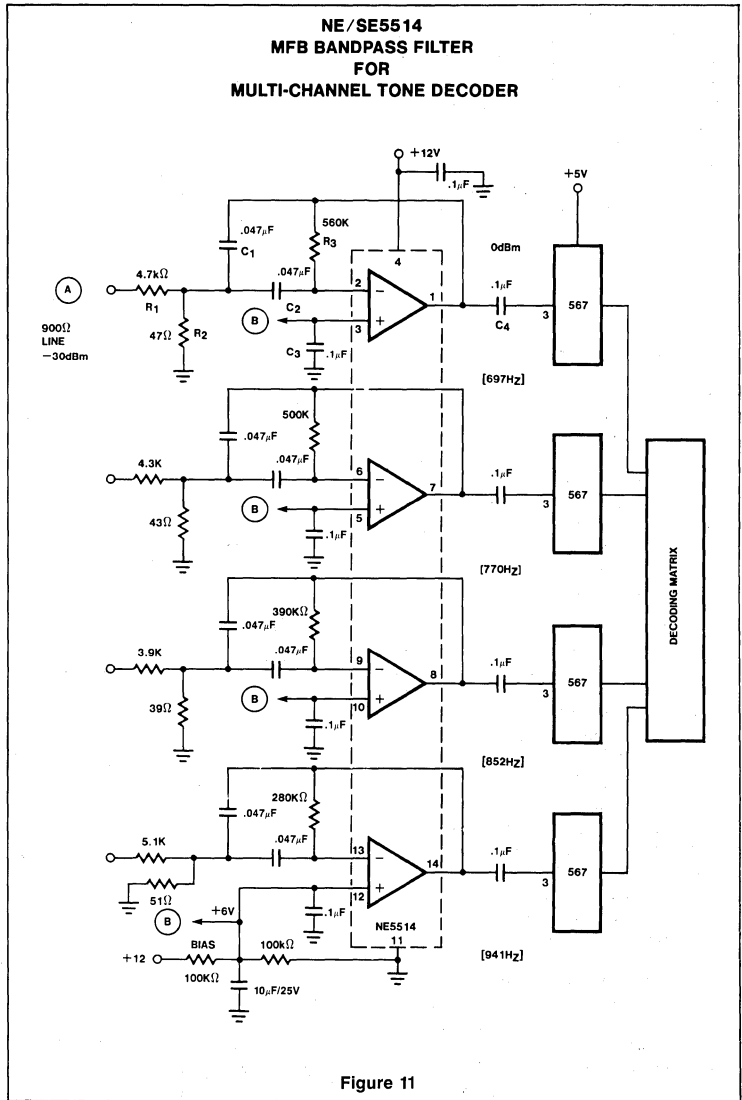

4-CHANNEL TEMPERATURE SENSOR
(0-50°C)

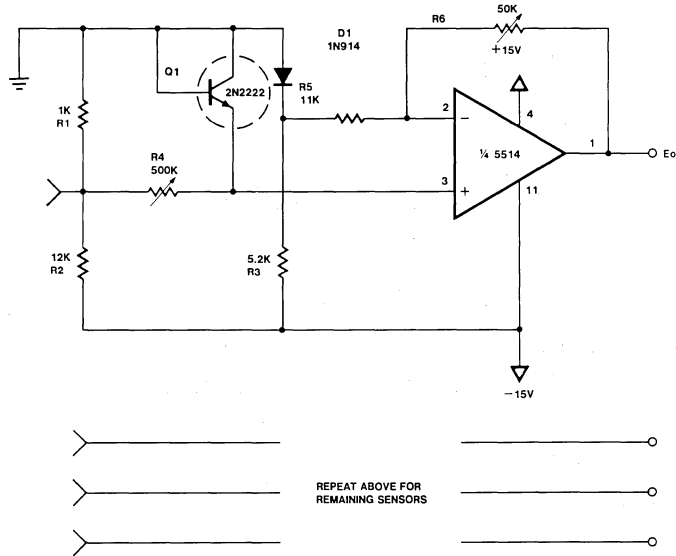

Figure 12

μP-CONTROLLED DIGITAL THERMOMETER

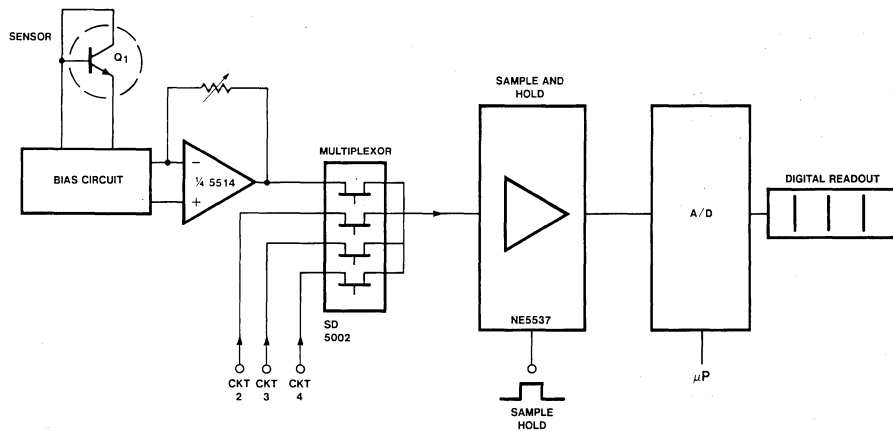

Figure 13

DESCRIPTION

The Signetics NE5517 is a truly versatile dual operational transconductance amplifier. In plain language, it is a voltage-to-current converter governed by the transconductance gm, which is equivalent to I_{out}/V_{in} . The gm is increased or decreased linearly by varying the amplifier bias current (I_{ABC}) through an external pin (see Figure 1). From the proper use of the I_{ABC} pin, many control circuits can be realized.

For more insight into the way the part operates, the transconductance can be thought of as gain and is governed by the following equation:

$$g_m = \frac{I_{out}}{V_{in}} = \frac{I_{ABCQ}}{2KT} \quad (1)$$

where the transconductance is dependent on the constant KT/q (which is 26mv at 25°C), and I_{ABC} (which is controlled by the user).

To make the device more universal and adaptable for many functions, two impedance buffers for voltage output applications are also included with the amps so that the part can be used as a programmable operational amplifier.

Linearizing diodes provide another useful option. These should be applied when large input voltages or wide temperature variations are encountered. To show the significance of the diodes, compare the difference between Equation 1 without diodes and Equation 2 with diodes:

$$\frac{I_{out}}{V_{in}} = \frac{2 I_{ABC}}{R_{in} I_D} \text{ for } I_{in} \text{ greater than } \frac{I_D}{2} \quad (2)$$

Here, it can be seen that the transconductance is not temperature dependent. R_{in} is the signal input resistance and I_{in} is the signal current. I_{in} must not exceed half the diode current (I_D , nominally 1mA). The diode current is set by a resistor tied to $+V_{CC}$. A graph showing the output distortion improvement versus differential input voltage when using the diodes is shown in Figure 2.

An advantage that the NE5517 has over similar devices is a special biasing network between the amplifier and output impedance buffers. This network eliminates output offset current changes with a sudden change in the bias current (I_{ABC}). This is particularly important in audio applications where an audible offset would be produced.

PIN. NO.	SYMBOL	NAME AND FUNCTION
1	I_{ABCa}	Amplifier bias input A
2	D_a	Diode bias A
3	$+IN_a$	Non-inverting input A
4	$-IN_a$	Inverting input A
5	I_{oa}	Output A
6	$V-$	Negative supply
7	$INBuffer(a)$	Buffer input A
8	$VOBuffer(a)$	Buffer output A
9	$VOBuffer(b)$	Buffer output B
10	$INBuffer(b)$	Buffer input B
11	$V+$	Positive supply
12	I_{ob}	Output B
13	$-IN_b$	Inverting input B
14	$+IN_b$	Non-inverting input B
15	D_b	Diode bias B
16	I_{ABCb}	Amplifier bias input B

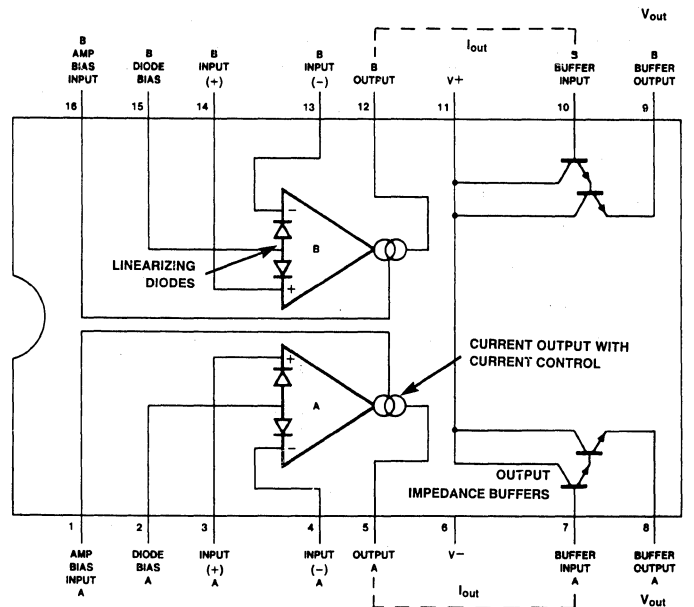

Figure 1 Pin Designation and Functional Diagram

APPLICATIONS

An application employing both amplifiers and buffers internal to the NE5517 is the adjustable triangle-square wave generator shown in Figure 3.

The center oscillating frequency is set by the capacitor C at the output of amplifier A. The output amplitude is set by the resistor R connected between the non-inverting inputs, amplifier B output, buffer B input and ground.

The oscillating frequency is varied by changing V_c , which in turn controls the amplifier bias current (I_{ABC1}). If a positive voltage is applied to V_c , the center frequency will increase linearly with increasing voltage. If a negative is applied, the center frequency will decrease

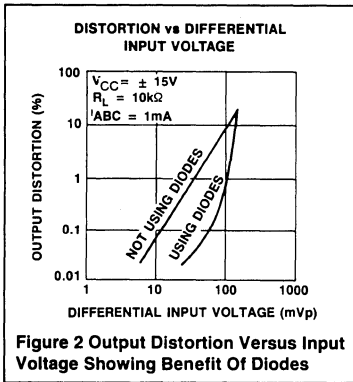

linearly with increasing negative voltage. This makes a very good programmable oscillator with variable amplitude.

By using a large value capacitor and negative control voltage, oscillations in the fractions of Hertz can be realized; a small capacitor and positive control voltage will give frequencies up to 500kHz. Graphs showing the linearity of control voltage versus frequency for different capacitor values are shown in Figure 4.

Pertinent calculations are:

$$f_c = \frac{I_{ABC1}}{4(C) (I_{ABC2}) (R)} \quad (3)$$

- Where: f_c = center frequency
- I_{ABC1} = oscillator control current
- I_{ABC2} = amplitude control current
- R = amplitude control resistor
- C = oscillator control capacitor

Also: Amplitude = $(I_{ABC2}) (R)$ (4)

Another very useful application is to use the NE5517 as a digitally programmable amplifier. The entire circuit is shown in Figure 5.

The circuit consists of a Signetics microprocessor compatible DAC, a transistor array, and the NE5517 configured as a voltage controlled amplifier. This arrangement can also be used with the VCO explained earlier to program its oscillating frequency.

The pertinent equations governing this application are as follows:

$$A_v = \frac{V_{out}}{V_{in}} = \frac{BW(10)}{256} \quad (5)$$

$$\times \frac{I_{DAC\ MAX} \times q \times R_L}{2 \times KT}$$

- Where: BW(10) = binary word decimal
- $I_{DAC\ MAX}$ = maximum DAC output current (1mA)
- R_L = load resistance (30K)
- q/KT = 38.5 at 25°C

Also:

$$I_{DAC\ MAX} = 2 \times \frac{V_{ref}}{R_{ref}} \quad (6)$$

$$= 2 \times \frac{5K}{10K} = 1mA$$

- Where: V_{ref} = supplied by DAC (5V)
- R_{ref} = referenced resistor (10K ohms)

The $I_{DAC\ MAX}$ of 1mA is used to keep the transconductance within the linear range.

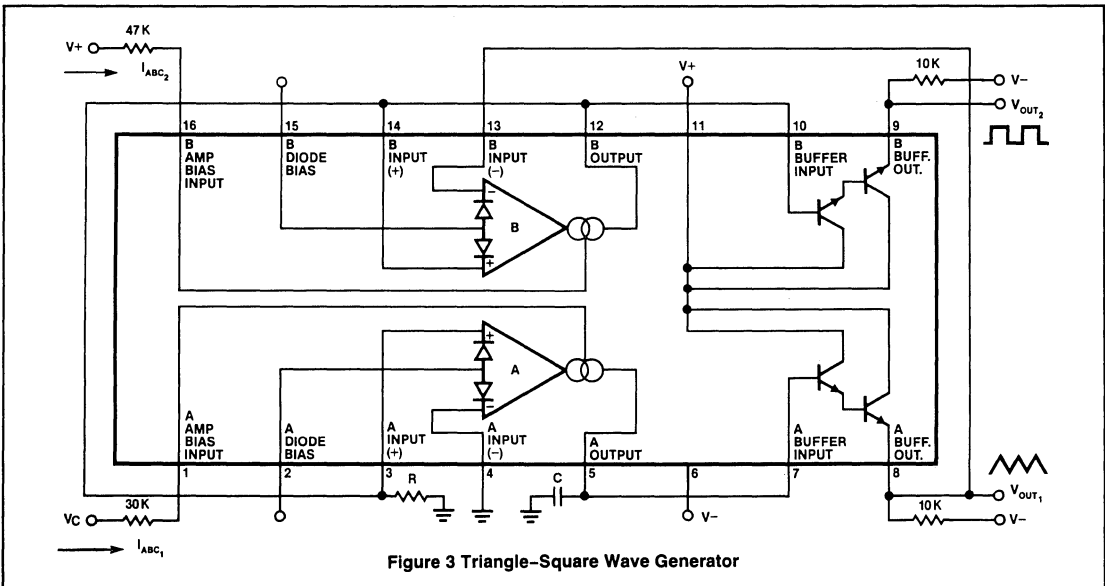

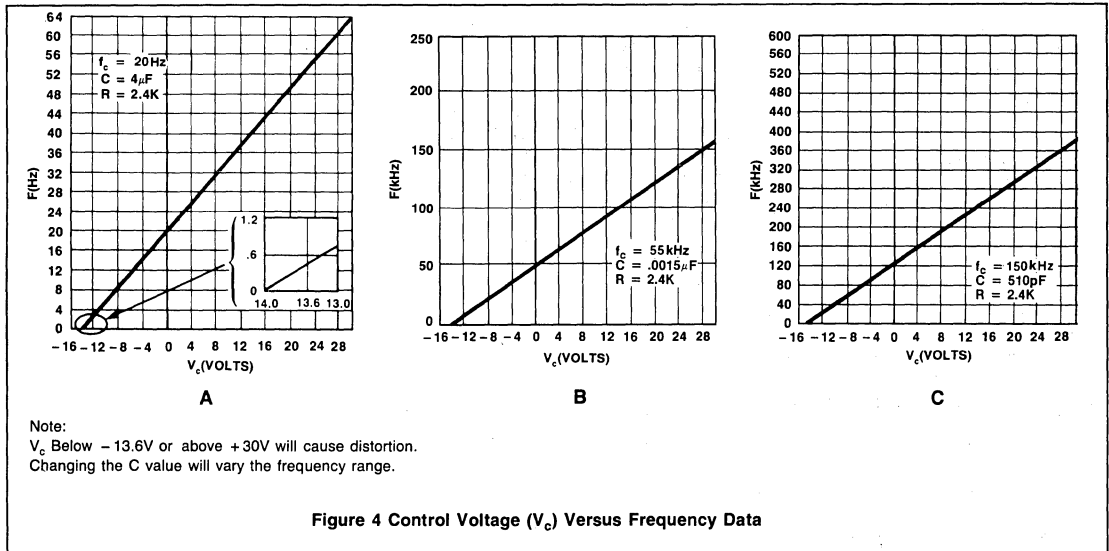

Figure 4 Control Voltage (V_c) Versus Frequency Data

The current mirror matches the current flow into the DAC and supplies the same amount to the 5517 control pin. Using a current output DAC is much faster than using a voltage output device to control the part. (If speed is not important, this can be done and the current mirror can be replaced with a resistor.) Also, the input attenuation has not been calculated into the gain equation. Therefore, equation (5) pertains to the signal after the input divider.

Many other applications for the NE5517 exist; refer to the data sheet applications section in the Signetics Linear LSI data book for numerous ideas.

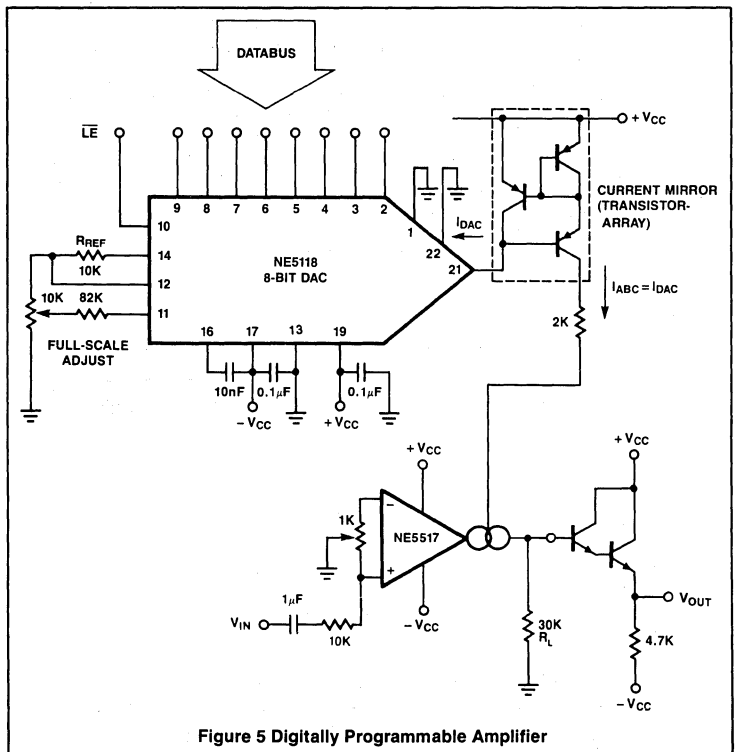

Figure 5 Digitally Programmable Amplifier

INTRODUCTION TO NOISE

Since fabrication techniques in the integrated circuit industry have improved so tremendously in the past few years, input offset voltages and bias currents are being minimized and noise parameters (whether measured at the output or referred to the input) have become a major source of concern. Reducing noise by improved process techniques and by use of peripheral component control will be the thrust of this application as a secondary effort, in understanding the noise components themselves.

An inspection of industry specifications show several methods of rating amplifier noise performance.

1. Output signal to noise ratio.
2. Output noise level (with specified loads and bandwidth).
3. Output noise level referenced to normal operating level.
4. Equivalent input noise (at a specified gain, source impedance and bandwidth).
5. Noise figure.

BASIC NOISE PROPERTIES

Noise, for purposes of this discussion, is defined as any signal appearing in an op amp's output that could not have been predicted by DC and AC input error analysis. Noise can be random or repetitive, internally or externally generated, current or voltage type, narrowband or wideband, high frequency or low frequency; whatever its nature, it can be minimized.

The first step in minimizing noise is source identification in terms of bandwidth and location in the frequency spectrum; some of the more common sources are shown in Figure 1. Some observations to be made from Figure 1 are that noise is present from DC to VHF from sources which may be identified in terms of bandwidth and frequency, noise source bandwidths overlap, making noise a composite quantity at any given frequency. Most externally caused noise is repetitive rather than random and can be found at a definite frequency. Noise effects from external sources must be reduced to insignificant levels to realize the full performance available from a low noise op amp.

EXTERNAL NOISE SOURCES

Since noise is a composite signal, the individual sources must be identified to minimize their effects. For example, 60Hz power line pickup is a common interference noise appearing at an op amp's output as a 16ms sine wave. In this and most other situations, the basic tool for external noise source frequency characterization is the oscilloscope sweep rate setting. Recognizing the oscilloscope's potential in this area, there are available several preamplifiers with variable bandwidth and frequency which allow quick noise source frequency identification. Another basic identification tool is the simple low pass filter as shown in Figure 2 where the bandpass is calculated by:

$$1) f_0 = \frac{1}{2\pi RC} \tag{1}$$

With such a filter, measurement bandpass can be changed from 10Hz to 100Hz (C = 4.7µF to 470pF), attenuating higher frequency components while passing frequencies of interest. Once identified, noise from an external source may be minimized by the methods outlined in Table 1, the external noise chart.

POWER SUPPLY RIPPLE

Power supply ripple at 120Hz is not usually thought of as noise, but it should be. In an actual op amp application, it is quite possible to have a 120Hz noise component that is equal in magnitude to all other noise sources combined, and, for this reason, it deserves a special discussion.

To be negligible, 120Hz ripple noise should be between 10nV and 100nV referred to the input of an op amp. Achieving these low levels requires consideration of three factors: the op amp's 120Hz power supply

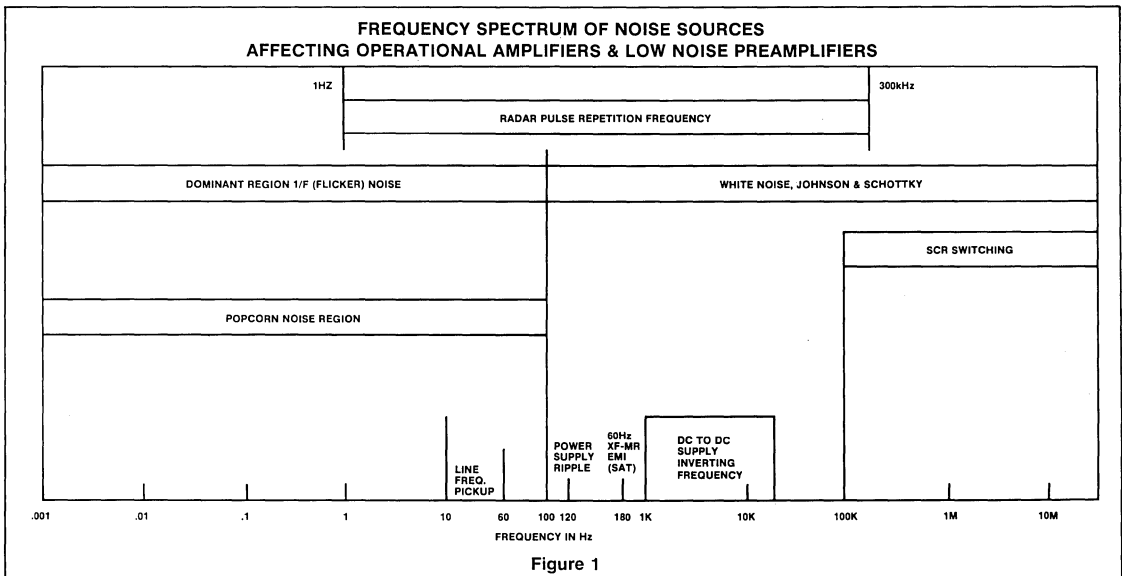
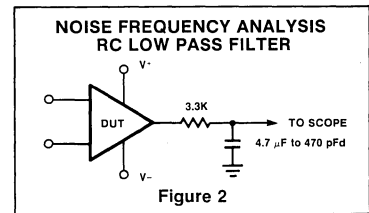

rejection ratio (PSRR), the regulator's ripple rejection ratio, and, finally, the regulator's input capacitor size.

PSRR at 120Hz for a given op amp may be found in the manufacturer's data sheet curves of PSRR versus frequency as shown in Figure 3. For the amplifier shown, 120Hz PSRR is about 74dB, and to attain a goal of 100nV referred to the input, ripple at the power terminals must be less than 5mV. Today's IC regulators provide about 60dB of ripple rejection; in this case the regulator input capacitor must be made large enough to limit input ripple to .5V.

Externally compensated low noise op amps can provide improved 120Hz PSRR in high close-loop gain configurations. The PSRR versus frequency curves of such an op amp are shown in Figure 5. When compensated for a closed loop gain of 1000, 120Hz PSRR is 115dB. PSRR is still excellent at much higher frequencies, allowing low ripple noise operation in exceptionally severe environment.

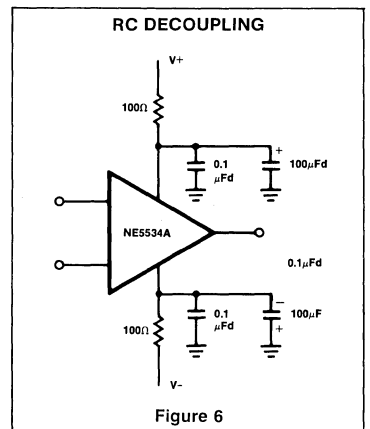
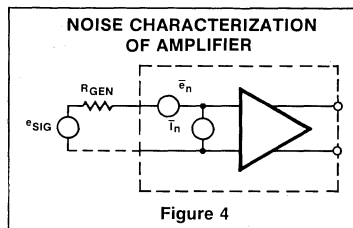
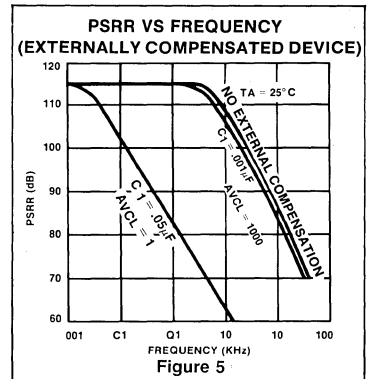
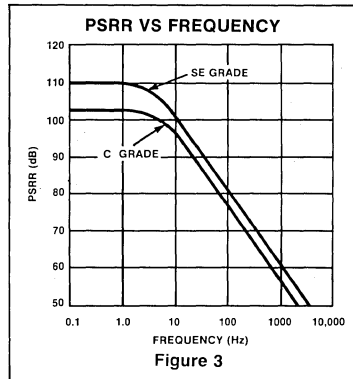

POWER SUPPLY DECOUPLING

Usually, 120Hz ripple is not the only power supply associated noise. Series regulator outputs typically contain at least 150μV of noise in the 100Hz to 10kHz range, switching types contain even more. Unpredictable amounts of induced noise can also be present on power leads from many sources. Since high frequency PSRR decreases at 20dB/decade, these higher frequency supply noise components must not be allowed to reach the op amp's power terminals. RC decoupling, as shown in Figure 6, will adequately filter most wideband noise. Some caution must be exercised with this type of decoupling, as load current changes will modulate the voltage as the op amp's supply pins.

POWER SUPPLY REGULATION

Any change in power supply voltage will have a resultant effect referred to an op amp's inputs. For the op amp of Figure 3, PSRR at DC is 110dB (3μV/V) which may be considered as a potential low frequency noise source. Power supplies for low noise op amp applications should, therefore, be both low in ripple and well-regulated. Inadequate supply regulation is often mistaken to be low frequency op amp noise.

When noise from external sources has been effectively minimized, further improvements in low noise performance are obtained by specifying the right op amp, and through careful selection and application of the peripheral components.

NOISE VOLTAGE, e_n , or more properly, EQUIVALENT SHORT-CIRCUIT INPUT RMS NOISE VOLTAGE is simply that noise voltage which would appear to originate at the input of a noiseless amplifier (referring to Figure 4) if the input terminals were shorted. It is expressed in nanovolts per root Hertz (nV/\sqrt{Hz}) at specified frequency, or in microvolts for a given frequency band. It is determined, or measured, by shorting the input terminals, measuring the output rms noise, dividing by amplifier gain, and referencing to the input. Hence the term, equivalent noise voltage. An output bandpass filter of known characteristic is used in measurements, and the measured value is divided by the square root of the bandwidth \sqrt{B} , if data is to be expressed per unit bandwidth or per root Hertz. The level of e_n is not constant over the frequency band; typically it increases at lower frequencies as shown in Figure 7. This increase is 1/f NOISE (flicker).

NOISE CURRENT, i_n , or more properly, EQUIVALENT OPEN-CIRCUIT RMS NOISE CURRENT is that noise which occurs apparently at the input of a noiseless amplifier due only to noise currents. It is expressed in picoamps per root Hertz (pA/\sqrt{Hz}) at a specified frequency or in nanoamps in a given frequency band. It is measured by shunting a capacitor or resistor across the input terminals such that the noise current will give rise to an additional

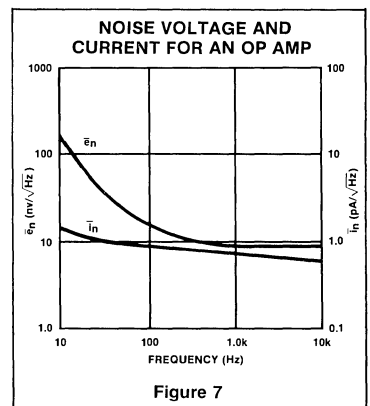

noise voltage which is $i_n \times R_{in}$ (or X_{cin}). The output is measured, divided by amplifier gain, referenced to input, and that contribution known to be due to e_n and resistor noise is appropriately subtracted from the total measured noise. If a capacitor is used at the

EXTERNAL NOISE CHART			
Source	Nature	Causes	Minimization Methods
60Hz Power	Repetitive Interference	Powerlines physically close to op amp inputs. Poor CMRR at 60Hz.	Reorientation of power wiring. Shielded transformers.
120Hz Ripple	Repetitive	inadequate ripple consideration. Poor RSRR at 120Hz	Thorough design to minimize ripple. RC decoupling at the op amp.
180Hz	Repetitive EMI	180Hz radiated from saturated 60Hz transformers.	Physical reorientation of components. Shielding. Battery power.
Radio stations	Standard AM broadcast through FM	Antenna action anyplace in system.	Shielding. Output filtering. Limited circuit bandwidth.
Relay & switch arcing	High frequency burst at switching rate.	Proximity to amplifier inputs, power lines, compensation terminals, or nulling terminals.	Filtering of HF components. Shielding. Avoidance of ground loops. Arc suppressors at switching source.
Printed circuit board contamination	Random low frequency	Dirty boards or sockets.	Thorough cleaning and humidity sealant.
Radar transmitters	High frequency gated at radar pulse repetition rate.	Radar transmitters from long range surface search to short range navigational especially near airports.	Shielding. Output filtering of frequencies >> PRR.
Mechanical vibration	Random < 100Hz	Loose connections, intermittent metallic contact in mobile equipment.	Attention to connectors and cable conditions. Shock mounting in severe environments.
Chopper frequency noise	Common mode input current at chopping frequency	Abnormally high noise chopper amplifier in system	Balanced source resistors. Use bipolar input op amps instead.

Table 1

input, there is only \bar{e}_n and \bar{i}_n X C_{IN}. The \bar{i}_n is measured with a bandpass filter and converted to pA/√Hz if appropriate; typically it increases at lower frequencies for bipolar op amps and transistors, but it increases at higher frequencies for field-effect transistors and Bi-Fet/Bi MOS op amps.

NOISE FIGURE, NF, is the logarithm of the ratio of input signal-to-noise and output signal-to-noise.

$$NF = 10 \log \frac{(S/N)_{in}}{(S/N)_{out}} \quad (2)$$

where: S and N are power or (voltage)² levels

This is measured by determining the S/N at the input with no amplifier present, and then dividing by the measured S/N at the output with signal source present.

The values of R_{gen} and any X_{gen} as well as frequency must be known to properly express NF in meaningful terms. This is because the amplifier i_n x Z_{gen} as well as R_{gen} itself produces input noise. The signal source contains some noise. However, e_{sig} is

generally considered to be noise free and input noise is present as the THERMAL NOISE of the resistive component of the signal generator impedance R_{gen}. This thermal noise is WHITE in nature as it contains constant NOISE POWER DENSITY per unit bandwidth. It is easily seen that the \bar{e}_n^2 has the units V²/Hz and that (\bar{e}_n) has the units V/√Hz

$$\bar{e}_n^2 = 4kTRB \quad (3)$$

where: T is temperature in °K
R is resistor value in ohms
B is bandwidth in Hz
k is Boltzman's constant

OPERATIONAL AMPLIFIER INTERNAL NOISE OP AMP NOISE SPECIFICATIONS

Most completely specified low noise op amp data sheets specify current and voltage noises in a 1Hz bandwidth and low frequency noise over a range of .1Hz to 10Hz. To minimize total noise, a knowledge of the

derivation of these specifications is useful. In this section, the reader is provided with an explanation of basic op amp associated random noise mechanisms and introduced to a simplified method for calculating total input-referred noise in typical applications.

RANDOM NOISE CHARACTERISTICS

Op amp associated noise currents and voltages are random. They are aperiodic and uncorrelated to each other and have Gaussian amplitude distributions, the highest noise amplitudes having the lowest probability. Gaussian amplitude distribution allows random noises to be expressed as rms quantities; multiplying a Gaussian rms quantity by six results in a peak to peak value that will not be exceeded 99.73% of the time.

The two basic types of op amp associated noises are white noise and flicker noise (1/f). White noise contains equal amounts of power in each Hertz of bandwidth. Flicker noise is different in that it contains equal amounts of power in each decade of bandwidth. This is best illustrated by spectral noise density plots



EXPLANATION OF NOISE

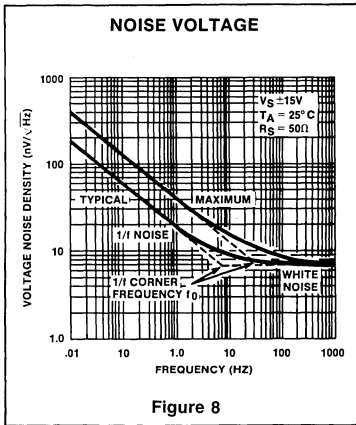

Figure 8

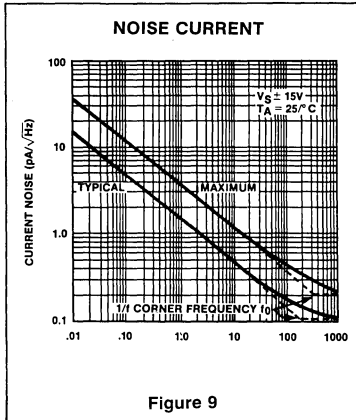

Figure 9

such as in Figure 8 and 9. Above a certain corner frequency, white noise dominates; below that frequency, flicker (1/f) noise is dominant. Low noise corner frequencies distinguish low noise op amps from general purpose devices.

SPECTRAL NOISE DENSITY

To utilize Figures 8 and 9, let us consider the definition of spectral noise density: the square root of the rate of change of mean-square noise voltage (or current) with frequency Eq. 4A.

$$e_n^2 = \frac{d}{df} (E_n)^2 \tag{4A}$$

$$i_n^2 = \frac{d}{df} (I_n)^2 \tag{4B}$$

$$E_n = \sqrt{\int_{f_L}^{f_H} e_n^2 df} \tag{5A}$$

$$I_n = \sqrt{\int_{f_L}^{f_H} i_n^2 df} \tag{5B}$$

where e_n, i_n = Spectral noise density
 E_n, I_n = Total rms noise
 f_H = Upper frequency limit
 f_L = Lower frequency limit

Conversely, the rms noise value within a given frequency band is the square root of the definite integral of the spectral noise density over the frequency band (Equation 5B). This means that three things must be known to evaluate total voltage noise (E_n) or current noise (I_n): f_H, f_L , and a knowledge of noise behavior over frequency.

WHITE NOISE

White noise sources are defined to have a noise content that is equal in each Hertz of bandwidth, and Equation 5B may be rewritten for white noise sources as:

$$E_n(\omega) = e_n \sqrt{f_H - f_L} \quad I_n(\omega) = i_n \sqrt{f_H - f_L} \tag{6}$$

It is therefore convenient to express spectral noise density in $V/\sqrt{\text{Hz}}$ or $A/\sqrt{\text{Hz}}$ where $f_H - f_L = 1\text{Hz}$. When $f_H \geq 10 f_L$, the white noise expressions may be further reduced to:

$$E_n(\omega) = e_n \sqrt{f_H} \quad I_n(\omega) = i_n \sqrt{f_H} \tag{7}$$

FLICKER NOISE & WHITE NOISE

Since flicker noise content is equal in each decade of bandwidth, total flicker noise may be calculated if noise in one decade is known. The .1Hz to 1Hz decade noise content (K) is widely used for this purpose because the white noise contribution below 10Hz is usually negligible.

$$E_n(f) \approx K \sqrt{\frac{1}{f}} \quad I_n(f) \approx K \sqrt{\frac{1}{f}} \tag{8a and b}$$

When substituted in Equation (3), the expressions may be rewritten to:

$$E_n(f) = K \sqrt{I_n \left(\frac{f_H}{f_L} \right)} \quad I_n(f) = K \sqrt{I_n \left(\frac{f_H}{f_L} \right)} \tag{9a and b}$$

When corner frequencies are known, simplified expressions for total voltage and current noise, (E_N and I_N), may be written:

$$E_N(f_H - f_L) = e_n \sqrt{f_{ce} I_n \left(\frac{f_H}{f_L} \right) + (f_H - f_L)} \tag{10}$$

$$I_N(f_H - f_L) = i_n \sqrt{f_{ci} I_n \left(\frac{f_H}{f_L} \right) + (f_H - f_L)} \tag{11}$$

where: e_n = White noise voltage in a 1Hz bandwidth
 i_n = White noise current in a 1Hz bandwidth
 f_{ce} = Voltage noise corner frequency
 f_{ci} = Current noise corner frequency
 f_H = Upper frequency limit
 f_L = Lower frequency limit

The two most important internally generated noise minimization rules are: limit the circuit bandwidth and use operational amplifiers with low corner frequencies.

NOISE SUMMATION

In the spectral density discussions, the concepts of white noise and flicker noise were introduced. In Figure 10, the complete input-referred op amp noise model, internal white and flicker noise sources are combined into three equivalent input noise generators, E_n, I_{N1} and I_{N2} . The noise current generators produce noise voltage drops across their respective source resistors, R_{S1} and R_{S2} . The source resistors themselves generate thermal noise voltages, E_{T1} and E_{T2} . Total rms input referred voltage noise, over a given bandwidth, is the square root of the sum of the squares of the five noise voltage sources over that bandwidth.

$$\sqrt{E_N^2 + (I_{N1} \cdot R_{S1})^2 + (I_{N2} \cdot R_{S2})^2 + E_{T1}^2 + E_{T2}^2} \tag{12}$$

THERMAL NOISE

Thermal (Johnson) noise is a white noise voltage generated by random movement of thermally-charged carriers in a resistance; in op amp circuits this is the type of noise produced by the source resistances in series with each input. Its rms value over a given bandwidth is calculated by:

$$E_t = \sqrt{4kTR (f_H - f_L)} \tag{13}$$

Where: k = Boltzman's constant = 1.38×10^{-23} joules/°K

T = Absolute temperature, °Kelvin

R = Resistance in ohms

f_H = Upper frequency limit in Hertz

f_L = Lower frequency limit in Hertz

At room temperature Equation 13 simplifies to:

$$E_t = 1.28 \times 10^{-10} \sqrt{R(f_H - f_L)} \tag{14}$$

To minimize thermal noise (E_{T1} and E_{T2}) from R_{S1} and R_{S2} , large source resistors and excessive system bandwidth should be avoided.

Thermal noise is also generated inside the op amp, principally from r_{bb} , the base-spreading resistances in the input stage

EXPLANATION OF NOISE

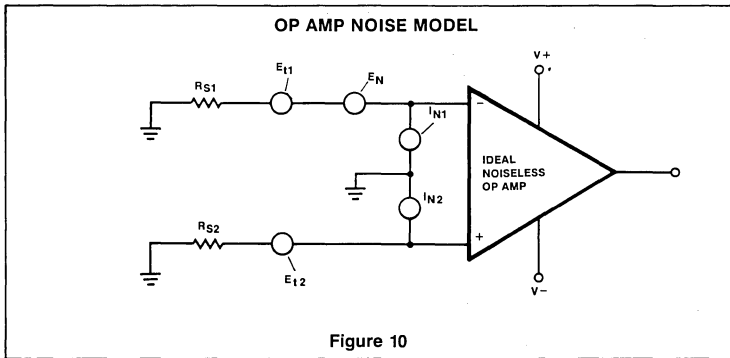

Figure 10

transistors. These noises are included in E_N , the total equivalent input voltage noise generator.

SHOT NOISE

Shot noise (Shottky noise) is a white noise current associated with the fact that current flow is actually a movement of discrete charged particles (electrons). In figure 10 I_{N1} and I_{N2} , above the $1/f$ frequency, are shot noise currents which are related to the amplifier's DC input bias currents:

$$I_{sh} = \sqrt{2qI_{BIAS} (f_H - f_L)} \quad (15)$$

where: I_{sh} = RMS shot noise value in amps
 q = Charge of an electron = 1.59×10^{-19}

I_{BIAS} = Bias current in amps
 f_H = Upper frequency limit in Hertz
 f_L = Lower frequency limit in Hertz

At room temperature Equation 15 simplifies to:

$$I_{sh} = 5.64 \times 10^{-10} \sqrt{I_{BIAS} (f_H - f_L)} \quad (16)$$

Shot noise currents also flow in the input stage emitter dynamic resistances, (r_e), producing input noise voltages. These voltages, along with the r_{bb} , thermal noise, make up the white noise portion of E_N , the total equivalent input noise voltage generator.

FLICKER NOISE

In limited bandwidth applications, flicker ($1/f$) noise is the most critical noise source. An op amp designer minimizes flicker noise by keeping current noise components in the input and second stages from contributing to input voltages noise. Equation 17 illustrates this relationship:

$$\frac{i_n \text{ second stage}}{g_m \text{ first stage}} = e_n \text{ input} \quad (17)$$

Another critical factor is corner frequency. For minimum noise the current and voltage noise corner frequencies must be low; this is crucial. As shown in Figure 11 low noise corner frequencies distinguish low noise op amps from ordinary industry standard 741 types.

POPCORN NOISE

Popcorn noise (burst noise) is a momentary change in input bias current usually occurring below 100Hz, and is caused by imperfect semiconductor surface conditions incurred during wafer processing. Minimization of this problem can be accomplished through careful surface treatment, general cleanliness, and a special three-step process known as "Triple Passivation".

Op amp manufacturers face a difficult decision in dealing with popcorn noise. Through careful low noise processing, it can be significantly reduced in almost all devices; alternatively, the processing may be relaxed, and finished devices must be individually tested for this parameter. Special noise testing takes valuable labor time, adds significant amounts to manufacturing cost, and ultimately increases the price a customer has to pay.

TOTAL NOISE CALCULATION

With data sheet curves and specifications, and a knowledge of source resistance values, total input-referred noise may be calculated for a given application. To illustrate the method, noise information from a data sheet is reproduced in Figure 12. The first step is to determine the current and voltage noise corner frequencies so that the E_N and I_N terms of Equation 12 may be calculated using Equations 10 and 11.

CORNER FREQUENCY DETERMINATION

In the input shot noise versus frequency curves of Figure 12, it may be seen that volt-

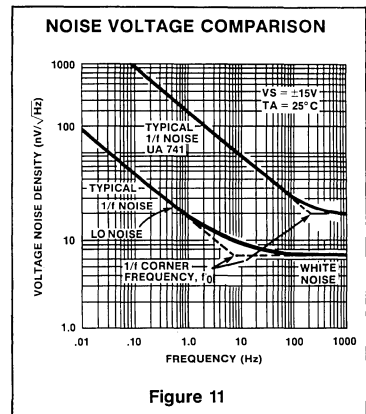

Figure 11

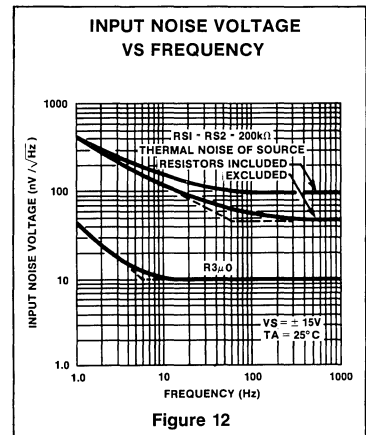

Figure 12

age noise ($R_s = 0$) begins to rise at about 10Hz. Lines projected from the horizontal (white noise) portion and sloped (flicker noise) portion intersect at 6Hz, the voltage noise corner frequency (f_{c0}). In the center curve, excluding thermal noise multiplied by 200Ω is plotted as a voltage noise. Lines projected from the horizontal portion and sloped portions intersect at 60Hz, the current noise corner frequency (f_{c0}). Equations 10 and 11 also require e_n and i_n for calculation of E_N and I_N . To find e_n and i_n , use the data sheet specification a decade or more above the respective corner frequencies; in this case e_n is $9.6 \text{ nV}/\sqrt{\text{Hz}}$ (1000Hz), and i_n is $0.12 \text{ pA}/\sqrt{\text{Hz}}$ (1000Hz).

BANDWIDTH OF INTEREST

To be summed correctly, each of the five noise quantities must be expressed over the same bandwidth, ($f_H - f_L$). At this time, assume f_H to be the highest frequency compo-



ment that must be amplified without distortion. Note that e_n , i_n , corner frequencies and bandwidth are independent of actual circuit component values. When doing noise calculations for a large number of circuits using the same op amp, these numbers only have to be calculated once.

TYPICAL APPLICATION EXAMPLE

Figure 13a shows a typical X10 gain stage with a 10kΩ source resistance. In Figure 13b, the circuit is redrawn to show five noise voltage sources. To evaluate total input-referred noise, the values of each of the five sources must be determined.

$$\begin{aligned} e_n &= 9.6 \text{ nV}/\sqrt{\text{Hz}} \\ i_n &= .12 \text{ pA}/\sqrt{\text{Hz}} \\ f_{ce} &= 6\text{Hz} \\ f_{ci} &= 60\text{Hz} \end{aligned}$$

Using Equation 14: $E_i = \sqrt{4KTR(f_H - f_L)}$

$$E_{i1} = 1.28 \times 10^{10} \sqrt{(900\Omega)(100\text{Hz})} = 0.4\mu\text{V rms}$$

$$E_{i2} = 1.28 \times 10^{-10} \sqrt{(10\text{k}\Omega)(100\text{Hz})} = .128\mu\text{V rms}$$

Next, calculate I_N using Equation 11

$$\begin{aligned} I_N &= i_n \sqrt{f_{ci} \ln\left(\frac{f_H}{f_L}\right) + (f_H - f_L)} \\ &= .12\text{pA} \sqrt{60 \ln\left(\frac{100\text{Hz}}{0.01\text{Hz}}\right) + (100 - 0.01)} \\ &= 3.066\text{pA rms} \end{aligned}$$

and:

$$I_{N1} \cdot R_{S1} \approx 3.066\text{pA} (900\Omega) = .0027\mu\text{V rms}$$

$$I_{N2} \cdot R_{S2} = 3.066\text{pA} (10\text{k}\Omega) = .0306\mu\text{V rms}$$

Finally, E_N from Equation 10

$$\begin{aligned} E_N &= e_n \sqrt{f_{ce} \ln\left(\frac{f_H}{f_L}\right) + (f_H - f_L)} \\ &= 9.6\text{nV} \sqrt{6 \ln\left(\frac{100\text{Hz}}{0.01\text{Hz}}\right) + (100 - 0.01)} \\ &= 0.120\mu\text{V rms} \end{aligned}$$

Substituting in Equation 12

$$\begin{aligned} E_{NT}(f_H - f_L) &= \sqrt{E_N^2 + I_{N1}^2 R_{S1}^2 + I_{N2}^2 R_{S2}^2 + E_{i1}^2 + E_{i2}^2} \\ &= \sqrt{(0.120\mu\text{V})^2 + (.0027\mu\text{V})^2 + (.0306\mu\text{V})^2} \\ &\quad + (.04\mu\text{V})^2 + (.128\mu\text{V})^2 \\ &= 0.183\mu\text{V rms} \end{aligned}$$

Using the factor of 6, total input-referred noise = 1.1μV peak to peak (0.01Hz to 100Hz).

741 CALCULATION EXAMPLE

The preceding calculation determined total noise in a given bandwidth using a low noise op amp. To place this level of performance into perspective, a calculation using the industry-standard 741 op amp in the circuit of Figure 13 is useful. Once again the starting point is corner frequency determination, using the data sheet curves:

$$f_{ce} = 200\text{Hz}; f_{ci} = 2\text{kHz}; e_n = 20\text{nV}/\sqrt{\text{Hz}}; i_n = .5\text{pA}/\sqrt{\text{Hz}}$$

Using these corner frequencies and noise magnitudes, E_N and I_N are calculated to be 0.88μV rms and 68pA rms respectively. Multiplying this noise current by the source resistance gives terms 2 and 3 of Equation 12 as shown below.

$$E_{NT}(f_H - f_L) = \sqrt{E_N^2 + I_{N1}^2 R_{S1}^2 + I_{N2}^2 R_{S2}^2 + E_{i1}^2 + E_{i2}^2} \quad (12)$$

Substituting in Equation 12

$$\begin{aligned} &= \sqrt{(0.88\mu\text{V})^2 + (.061\mu\text{V})^2 + (.68\mu\text{V})^2 + (0.4\mu\text{V})^2} \\ &\quad + (.128\mu\text{V})^2 \\ &= 1.12\mu\text{V rms} \end{aligned}$$

Total input-referred noise = 6.7μV peak to peak (0.01Hz to 100Hz)

This is 5.9 times that of the low noise op amp example.

The calculation examples illustrate three rules for minimizing noise in operational amplifier applications:

RULE 1. Use an op amp with low corner frequencies.

RULE 2. Keep source resistances as low as possible.

RULE 3. Limit circuit bandwidth to signal bandwidth.

NOISE PERFORMANCE

This segment shall be concerned with determining the signal to noise characteristics and the noise figure of amplifiers.

The amplifier noise is composed of thermal noise generated in the base resistance shot noise caused by the arrival of discrete charges at diode junction and 1/f noise.

For simplification these noise sources can be combined and the amplifier modeled by a noise source and a noiseless amplifier as in Figure 14.

e_n = Amplifier's equivalent mean square noise voltage /√Hz
 i_n = Amplifier's equivalent mean square noise current/√Hz

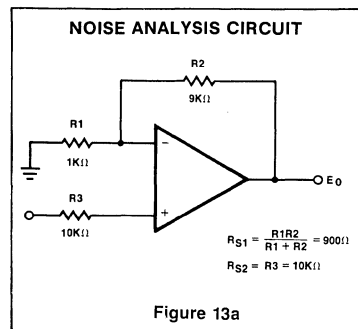

Figure 13a

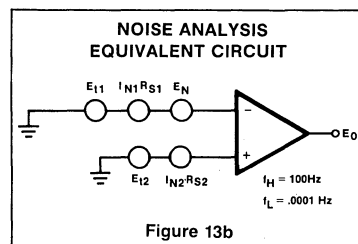

Figure 13b

The total output noise can now be computed by equation 8:

$$e_t = (e_n^2 + i_n^2 R_s^2 + 4KTR_s)^{1/2} B^{1/2} \text{ A rms volts} \quad (8)$$

*assuming R_s small compared to amplifier input.

If we now compare the total output noise to the output signal, A-Es, we find the output signal to noise ratio.

$$S/N = \frac{E_s}{(e_n^2 + i_n^2 R_s^2 + 4KTR_s)^{1/2} B^{1/2}} \quad (13)$$

The denominator of the S/N ratio is the total output noise divided by the midband gain or the equivalent input noise as shown on NE542 specification sheet.

$$E_{IN} = (e_n^2 + i_n^2 R_s^2 + 4KTR_s)^{1/2} B^{1/2} \text{ rms volts} \quad (14)$$

The S/N ratio may now be computed independent of the amplifier gain. However, the gain should be chosen to maintain linear operation of the amplifier. For example: If the input signal to the NE542 is 400μV rms from a source resistance of 680 ohm with a bandwidth of 100Hz to 10kHz, the S/N ratio becomes, in dB:

$$\begin{aligned} S/N &= 20 \log \frac{400 \mu\text{V}}{0.77 \mu\text{V}} \\ &= 54.3\text{dB} \end{aligned}$$

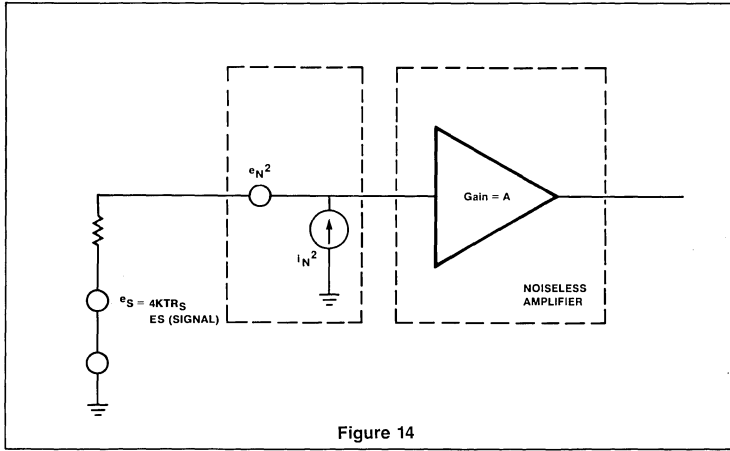

Figure 14

An amplifier gain of 68dB yields an output signal voltage of 1V rms.

For an input signal of 10mV rms, 40dB of gain, and 1V rms output, the NE542 gives a S/N ratio:

$$S/N = 20 \log \frac{10,000}{0.77} = 82.3\text{dB}$$

Another popular figure of merit for measuring the noise performance of an amplifier is noise figure. We first define noise factor (F) as

$$F = \frac{\text{Noise power input(Tot.)}}{\text{Thermal noise power}}$$

in terms of voltage this can be expressed as:

$$F = \frac{4KTR_s + (e_n^2 + i_n^2 R_s^2)}{4KTR_s} = 5.34, R_s = 680\Omega \quad (15)$$

The noise figure is now defined as:

$$N.F. = 10 \log F \text{ (dB)}$$

or

$$N.F. = 10 \log \frac{4KTR_s + e_n^2 + i_n^2 R_s^2 \text{ (dB)}}{4KTR_s} \quad (16)$$

A noiseless amplifier will, therefore, have a noise figure of "0" dB. Although the bandwidth has been eliminated from this calculation, it is still an influencing factor on the noise figure since the value of e_n and i_n will be dependent on the bandwidth of interest. This is especially true if $1/f$ or high frequency noise is in this bandwidth.

From Figures 15 and 16 we can calculate the noise figure. For the NE542 the noise figure for 100 Hz to 10Hz, 3dB bandwidth (15.7 kHz

equivalent noise bandwidth) and a source resistance of 5K ohms is:

$$N.F. = 10 \log \left(1 + \frac{e_n^2 + i_n^2 R_s^2}{4KTR_s} \right) \quad (17)$$

$$N.F. = 10 \log \left(1 + \frac{(7.2 \times 10^{-18} + (.25)^2 \times 10^{-24} \times R_s^2)}{4 \times 1.38 \times 15^2 \times 300^\circ K \times R_s} \right) = 10 \log \times$$

$$= 7.27 @ R_s = 680\Omega$$

$$= 2.07 @ R_s = 5K\Omega$$

$$= 1.25 @ R_s = 10K\Omega$$

To this point, the discussion has been limited to flat band response and no mention of the effect of equalization networks has been made. In instances where the gain of the amplifier is changing significantly across the frequency band of interest, as is the case for NAB and RIAA equalization, the noise performance is significantly improved.

The following table lists the spectral voltage and current noise densities and the respective corner frequencies for several different

operational amplifiers and low noise preamplifiers.

where I_N = total current noise over a specified bandwidth.

E_N = total voltage noise over a specified bandwidth.

E_{ti} = thermal (Johnson) noise of the source resistance.

R_S = equivalent input source (or generator) resistance.

NOTE

If R_S is a complex function, Z_S , then this function must be calculated for the R_S mean of each bandwidth considered. For example the input is a capacitor in parallel with a resistor, the input impedance is therefore:

$$Z_{in} = \frac{R}{1 + j\omega CR}$$

Therefore as the frequency varies the absolute value of Z_{in} will vary and will affect the $I_N R_S^*$, input noise value.

GENERAL EQUATIONS

Total Spectral Voltage Noise

$$E_N (f_H - f_L) = e_n \sqrt{f_{ci}} I_n \left(\frac{f_H}{f_L} \right) + (f_H - f_L) \quad (18)$$

Total Spectral Noise Current

$$I_n (f_H - f_L) = i_n \sqrt{f_{ci}} I_n \left(\frac{f_H}{f_L} \right) + (f_H - f_L) \quad (19)$$

Thermal

$$E_t = 4 KTR (f_H - f_L)$$

$$K = 1.38 \times 10^{-23} \text{ joules/}^\circ K \quad (20)$$

T = abs. temp in $^\circ K$
 k = ohms
 $f_t = 1.28 \times 10^{-10} \sqrt{R(f_H - f_L)}$ at Room Temp.

Shot at Room

$$I_{SH} = 5.64 \times 10^{-10} \sqrt{I_{bias} (f_H - f_L)} \quad (21)$$

Total Noise*

$$\left| \frac{E_N}{ENT} \right|_{f_L}^{f_H} = \sqrt{E_n^2 + (I_N R_S)^2 + I_n^2 R_S^2 + E_{t1}^2 + E_{t2}^2} \quad (22)$$

SPECTRAL VOLTAGE AND CURRENT NOISE DENSITIES

	$\mu A741$	5534	LF357	NE542	LM387
e_n (nv/ \sqrt{Hz})	40	4	12	7	9
i_n (pa/ \sqrt{Hz})	.25	.6	.01	.25	0.7
e_n fce (Hz)	200	90	50	800	850
i_n fci (Hz)	1.5k	200	1	700	2

TABLE 2

NOTES

- The current spectral noise is omitted for the LF series since current noise levels in J-FET devices are insignificant.
- The spectral current noise for the LM387 is relatively linear over the frequency spectrum of 100Hz to 10 kHz and is not specified below 100Hz.

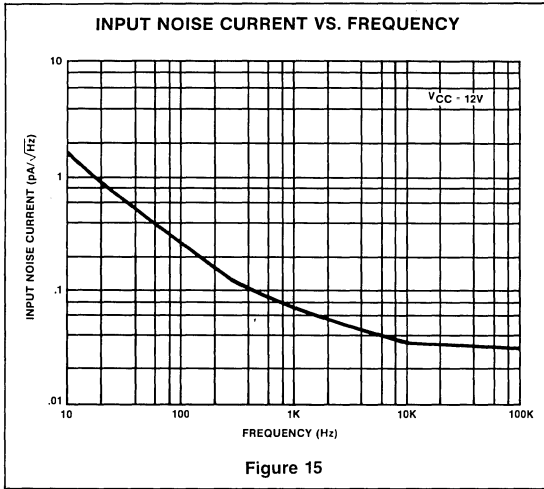

Figure 15

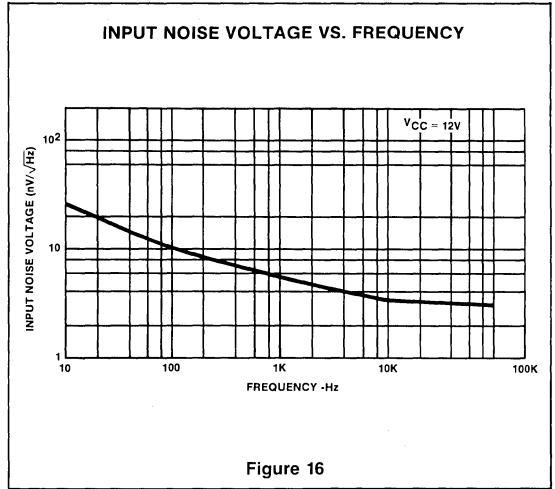

Figure 16

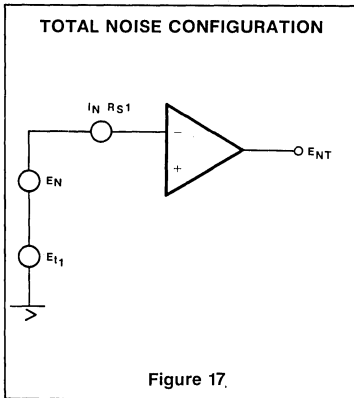

Figure 17.

Example:

In order to determine the total noise of any device the following basic procedures can be used.

1. Determine the spectral voltage noise value \bar{e}_n and the 3dB corner frequency. (If the value is not listed, but a curve given, the spectral noise value will be that value above the 3dB corner frequency on the flat portion of the curve.)
2. Determine the spectral current noise value \bar{i}_n and the 3dB corner frequency. (The same note holds true as for the spectral voltage noise, except that the corner frequencies are generally not the same.)
3. Determine the thermal noise of the input port source resistances by using the basic equal at room temperature of $E_T = 1.28 \times 10^{-10} \sqrt{R/\sqrt{\text{Hz}}}$

4. Using Equation 1, 2, and 4 and using Figure 1 as a basic block, we then can determine the total current and voltage noise at the input ports.
5. Employing Equation 5 we can then determine the total RSS voltage noise referred to the input of the amplifier.
6. If the closed loop gain of the system is known, then the total output noise is then $E_{Nout} = E_{Nin} \times A_{CL}$

Given: From Table 2, the NE5534 operating over the range of 10Hz to 1kHz and 1kHz to 10kHz, with $R_S = 10k\Omega$: determine total input noise over each bandwidth.

$$E_N (f_H - f_L) = e_n \sqrt{f_{ce} I_n \frac{f_H}{f_L} + (f_H - f_L)} \quad (18)$$

$$I_N (f_H - f_L) = i_n \sqrt{f_{c1} I_n \frac{f_H}{f_L} + (f_H - f_L)} \quad (19)$$

$$E_T = 1.28 \times 10^{-10} \sqrt{R(f_H - f_L)} \quad (21)$$

$$\left| E_{NT} \right|_{f_L}^{f_H} = \sqrt{(E_N)^2 + (I_N R_S)^2 + (E_T)^2} \quad (22)$$

For the first band (10Hz to 1kHz)

$$E_N = 4 \times 10^{-9} \sqrt{90 \ln(100) + (990)} = .15 \mu V \text{ rms}$$

$$I_N R_S = .6 \times 10^{-12} \sqrt{200 \ln(100) + (990) \times (10^4)} = .26 \mu V \text{ rms}$$

$$E_T = 1.28 \times 10^{-8} \sqrt{990} = 0.4 \mu V \text{ rms}$$

$$E_{TH} \left|_{10}^{1000} = \sqrt{(E_N)^2 + (I_N R_S)^2 + E_T^2} = 0.50 \mu V \text{ rms}$$

Using the factor of 6

$f_{\text{noise p-p}} = 3.00 \mu V$ p-p will never be exceeded in 99.73% of all cases.

For the second band (1kHz to 10kHz)

$$*E_N = 4 \times 10^{-9} \sqrt{9000} = .38 \mu V \text{ rms}$$

$$*I_N R_S = .6 \times 10^{-12} \sqrt{9000 \times (10^4)} = .58 \mu V \text{ rms}$$

$$E_T = 1.28 \times 10^{-10} \sqrt{10^4 (9000)} = 1.21 \mu V \text{ rms}$$

NOTE

* For frequencies above 1kHz only white noise is a consideration.

$$\left| E_{TH} \right|_{1\text{kHz}}^{10\text{kHz}} = \sqrt{(1.38)^2 + (.57)^2 + (1.21)^2} \mu V \text{ rms}$$

$$RSS \left| E_{TH} \right|_{1\text{kHz}}^{10\text{kHz}} = \sqrt{1.39} \mu V \text{ rms}$$

$$E_{TH_{max}} = 8.34 \mu V \text{ p-p}$$

CONCLUSION

The designer should look at the previous application note as a reasonable approach to determine system noise levels. The variations of parameters, such as resistance values, temperature, bandwidth are controllable by design procedure; however, the parametric variations of the monolithic op amps are controlled by the IC manufacturer. Signetics manufactures a wide variety of operational amplifiers designed to meet all contingencies.

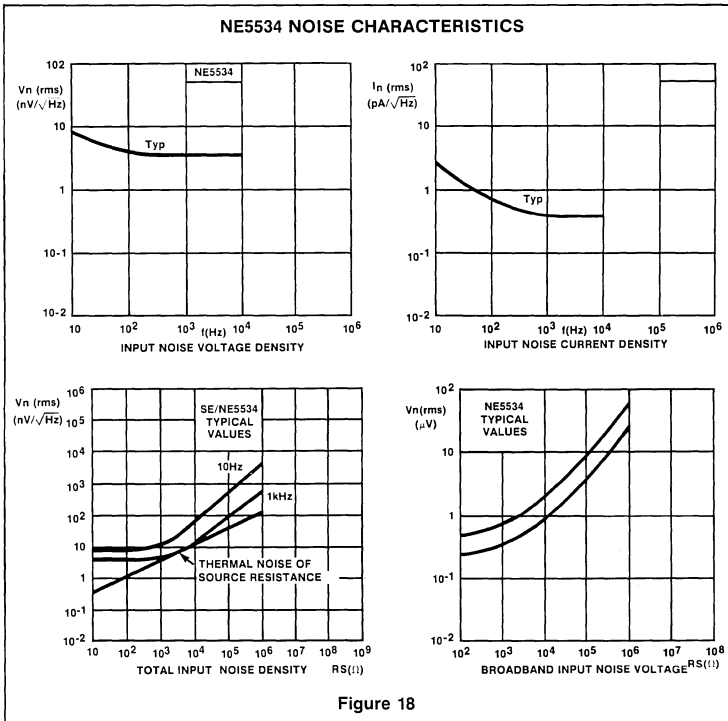

VIDEO AMPLIFIER PRODUCTS

NE/SE592 Video Amplifier

The 592 is a two stage differential output, wideband video amplifier with voltage gains as high as 400 and bandwidths up to 120MHz.

Three basic gain options are provided. Fixed gains of 400 and 100 result from shorting together gain select pins G_{1A} — G_{1B} and G_{2A}—G_{2B} respectively. As shown by Figure 1 the emitter circuits of the differential pair return thru independent current sources. This topology allows no gain in the input stage if all gain select pins are left open. Thus the third gain option of tying an external resistance across the gain select pins allows the user to select any desired gain from 0 to 400 volts per volt. The advantages of this configuration will be covered in greater detail under the filter application section.

Three factors should be pointed out at this time:

1. The gains specified are differential. Single ended gains are one half the stated value.
2. The circuit 3dB bandwidths are a function of and are inversely proportional to the gain settings.
3. The differential input impedance is an inverse function of the gain setting.

In applications where the signal source is a transformer or magnetic transducer the input bias current required by the 592 may be passed directly thru the source to ground. Where capacitive coupling is to be used, the base inputs must be returned to ground through a resistor to provide a dc path for the bias current.

Due to offset currents, the selection of the input bias resistors is a compromise. To reduce the loading on the source, the resistors should be large, but to minimize the output dc offset, they should be small — ideally 0 ohms. Their maximum value is set by the maximum allowable output offset and may be determined as follows:

1. Define the allowable output offset (assume 1.5V).
2. Subtract the maximum 592 output offset (from the data sheet). This gives the output offset allowed as a function of input offset currents (1.5V — 1.0V = 0.5V).
3. Divide by the circuit gain (assume 100). This refers the output offset to the input.
4. The maximum input resistor size is:

$$R_{MAX} = \frac{\text{Input Offset Voltage}}{\text{Max Input Offset Current}} \quad (1)$$

$$\frac{.005V}{5\mu A}$$

$$= 1.00k\Omega$$

Of paramount importance during the design of the NE592 device was bandwidth. In a monolithic device, this precludes the use of pnp transistors and standard level shifting techniques used in lower frequency devices. Thus without the aid of level shifting the output common mode voltage present on the NE592 is typically 2.9 volts. Most applications, therefore, require capacitive coupling to the load. An exception to the rule is a differential amplifier with an input common mode range greater than +2.9V as shown in Figure 2. In this circuit, the NE592 drives a NE511B transistor array connected as a differential cascode amplifier. This amplifier is capable of differential output voltages of 48V peak-to-peak with a 3dB bandwidth of approximately 10MHz (depending on the capacitive load). For optimum operation, R₁ is set for a no signal level of + 18V. The emitter resistors, R_E, were selected to give the cascode amplifier a differential gain of 10. The gain of the composite amplifier is adjusted at the gain selected point of the NE592.

Filters

As mentioned earlier, the emitter circuit of the NE592 includes two current sources.

Since the stage gain is calculated by dividing the collector load impedance by the emitter impedance, the high impedance contributed by the current sources causes the stage gain to be zero with all gain select pins open. As shown by the gain vs. frequency graph of Figure 3 the overall gain at low frequencies is a negative 48dB.

Higher frequencies cause higher gain due to distributed parasitic capacitive reactance. This reactance in the first stage emitter circuit causes increasing stage gain until at 10MHz the gain is 0dB or unity.

Referring to Figure 4, the impedance seen looking across the emitter structure includes small r_e of each transistor.

Any calculations of impedance networks across the emitters then must include this quantity. The collector current level is approximately 2mA causing the quantity of 2 r_e to be approximately 32 ohms. Overall device gain is thus given by

$$\frac{V_o(S)}{V_{IN}(S)} = \frac{1.4 \times 10^4}{Z(S) + 32} \quad (2)$$

where Z_(S) can be resistance or a reactive impedance. Table 2 summarizes the possible configurations to produce low, high, and bandpass filters. The emitter impedance is made to vary as a function of frequency by using capacitors or inductors to alter the frequency response. Included also in Table 2 is the gain calculation to determine the voltage gain as a function of frequency.

PARAMETER	NE/SE592	733
BANDWIDTH (MHZ)	120	120
GAIN	0,100,400	10,100,400
R IN (K)	4-30	4-250
V_{PP} (VOLTS)	4.0	4.0

Table 1 VIDEO AMPLIFIER COMPARISON FILE

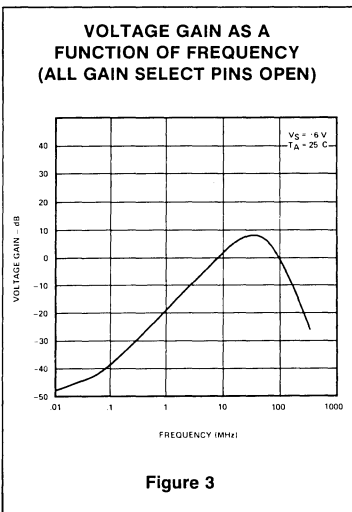
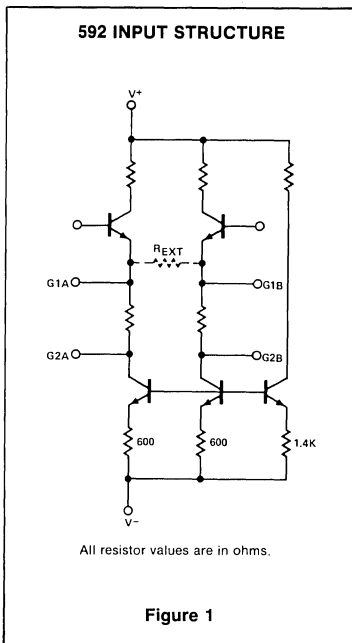

Differentiation

With the addition of a capacitor across the gain select terminals the NE592 becomes a differentiator. The primary advantage of using the emitter circuit to accomplish differentiation is the retention of the high

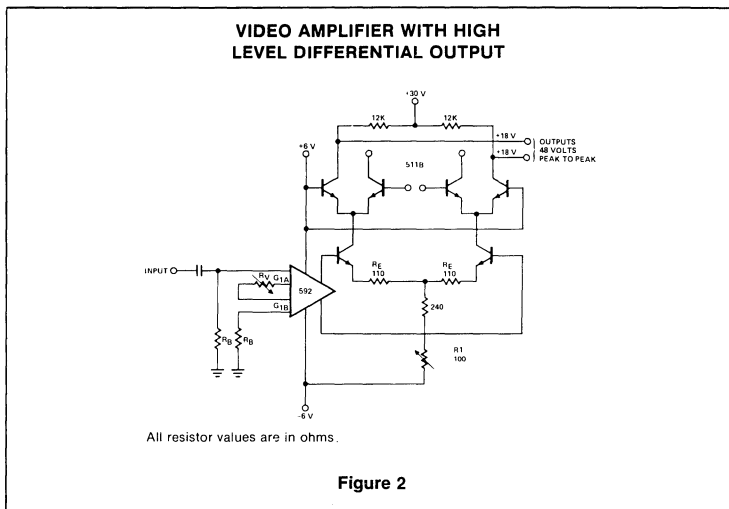

Z NETWORK	FILTER TYPE	$\frac{V_0(s)}{V_1(s)}$ TRANSFER FUNCTION
	LOW PASS	$\frac{1.4 \times 10^4}{L} \left[\frac{1}{s + R/L} \right]$
	HIGH PASS	$\frac{1.4 \times 10^4}{R} \left[\frac{s}{s + 1/RC} \right]$
	BAND PASS	$\frac{1.4 \times 10^4}{L} \left[\frac{s}{s^2 + R/L s + 1/LC} \right]$
	BAND REJECT	$\frac{1.4 \times 10^4}{R} \left[\frac{s^2 + 1/LC}{s^2 + 1/LC + s/RC} \right]$

NOTE: In the networks above, the R value used is assumed to include 2 r_e, or approximately, 32 ohms.

Table 2 FILTER NETWORKS

common mode noise rejection. Disc file playback systems rely heavily upon this common mode rejection for proper operation. Figure 5 shows a differential amplifier configuration with transfer function.

Disc file Decoding

In recovering data from disc or drum files, several steps must be taken to pre-condition the linear data. The NE592 video amplifier, coupled with the 8T20 bi-directional one-shot, provides all the signal conditioning necessary for phase encoded data.

When data is recorded on a disc, drum or tape system, the readback will be a Gaus-

sian shaped pulse with the peak of the pulse corresponding to the actual recorded transition point. This readback signal is usually 500μV p-p to 3mV p-p for oxide coated disc files and 1 to 20mV p-p for nickel-cobalt disc files. In order to accurately reproduce the data stream originally written on the disc memory, the time of peak point of the Gaussian readback signal must be determined.

The classical approach to peak-time determination is to differentiate the input signal. Differentiation results in a voltage proportional to the slope of the input signal. The zero-crossing point of the differentiator, therefore, will occur when the input signal is



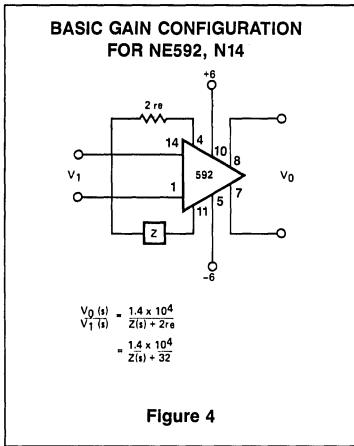

at a peak. Using a zero-crossing detector and one-shot, therefore, results in pulses occurring at the input peak points.

A circuit which provides the pre-conditioning described above is shown in Figure 6. Readback data is applied directly to the input of the first NE592. This amplifier functions as a wideband ac coupled amplifier with a gain of 100. The NE592 is excellent for this use because of its high phase linearity, high gain and ability to directly couple the unit

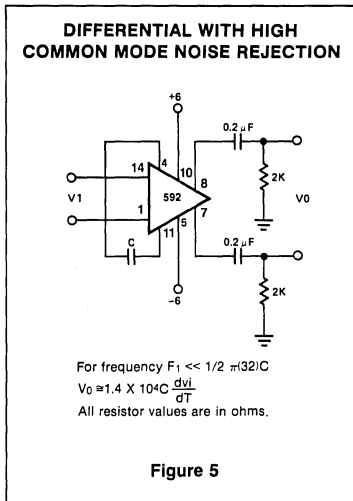

The output of the first stage amplifier is routed to a linear phase shift low pass filter. The filter is a single stage constant K filter, with a characteristic impedance of 200Ω. Calculations for the filter are as follows:

$$L = 2R/\omega c$$
 Where R = characteristic impedance (ohms)

$$C = 1/\omega c$$
 = cutoff frequency (radians/sec)

The second NE592 is utilized as a low noise differentiator/amplifier stage. The NE592 is excellent in this application because it allows differentiation with excellent common mode noise rejection.

The output of the differentiator/amplifier is connected to the 8T20 bi-directional monostable unit to provide the proper pulses at the zero-crossing points of the differentiator.

The circuit in Figure 6 was tested with an input signal approximating that of a readback signal. The results are shown in Figure 8.

with the readback head. By direct coupling of readback head to amplifier, no matched terminating resistors are required and the excellent common mode rejection ratio of the amplifier is preserved. DC components are also rejected because the NE592 has no gain at dc due to the capacitance across the gain select terminals.

Automatic Gain Control

The NE592 can also be connected in conjunction with a MC1496 balanced modulator to form an excellent automatic gain control system.

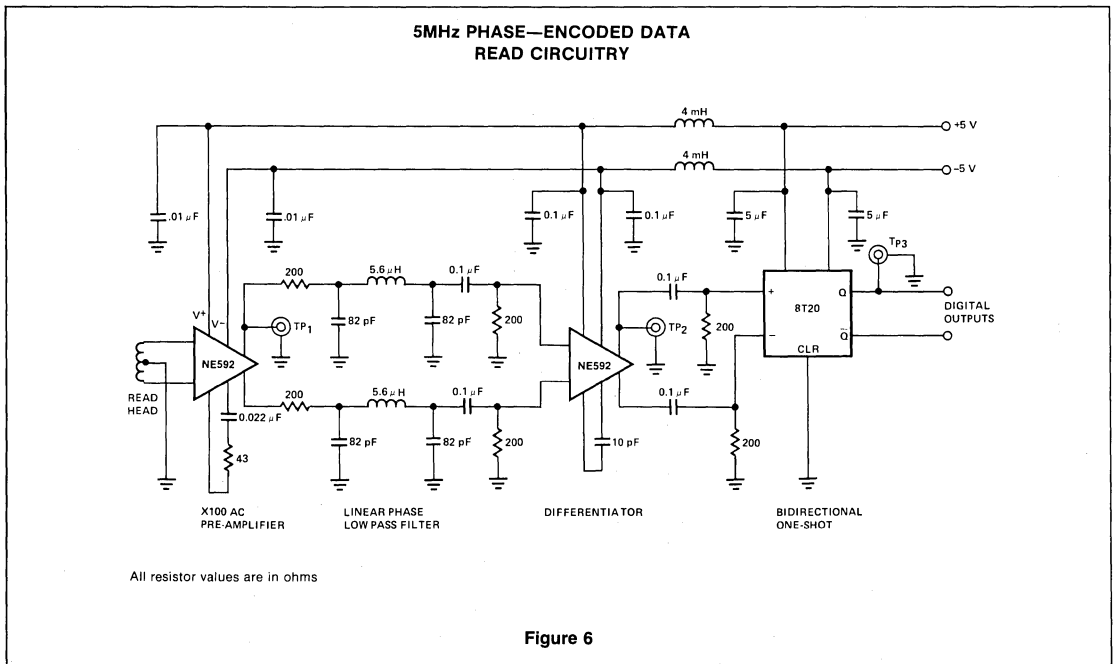

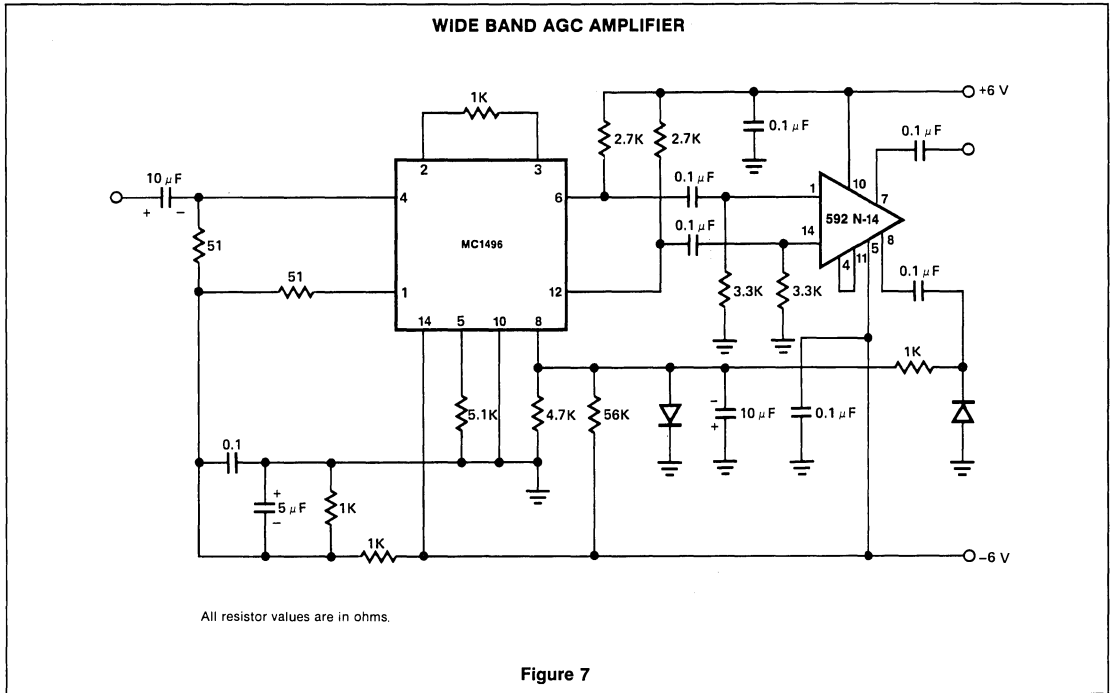

The signal is fed to the signal input of the MC1496 and RC coupled to the NE592. Unbalancing the carrier input of the MC1496 causes the signal to pass thru unattenuated. Rectifying and filtering one of the NE592 outputs produces a dc signal which is proportional to the ac signal amplitude. After filtering this control signal is applied to the MC1496 causing its gain to change.

TEST RESULTS OF DISC
FILE DECODER CIRCUIT (FIGURE 5-108)

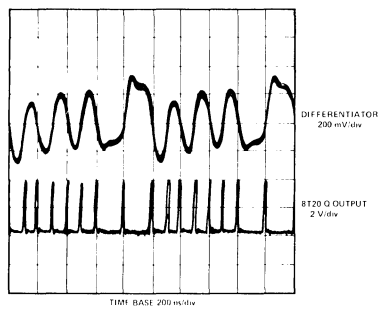
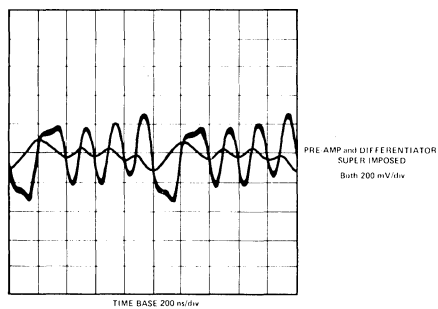
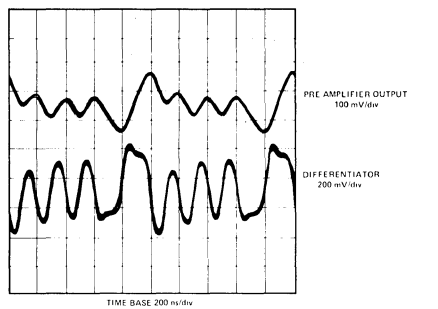

Figure 8

NE5539 DESCRIPTION

The Signetics SE/NE5539 ultra-high frequency operational amplifier is one of the fastest monolithic amplifiers made today. With a unity gain bandwidth of 350MHz and a slew rate of 600V/μs, it is second to none. Therefore, it is understandable that to attain this speed, standard internal compensation would have to be left out of its design. As a consequence, the op amp is not unconditionally stable for all closed-loop gains and must be externally compensated for gains below 17dB. Properly done, compensation need not limit slew rate. The following will explain how to use the methods available with the SE/NE5539.

LEAD AND LAG-LEAD COMPENSATION

A useful method for compensating the device for closed-loop gains below seven is to use lag-lead and lead networks as shown in Figure 1. The lead network is primarily concerned with compensating for loss of phase margin caused by distributed board capacitance and input capacitance, while lag-lead is mainly for optimizing transient response. Lead compensation modifies the feedback network and adds a zero to the overall transfer function. This increases the phase, but does not greatly change the gain magnitude. This zero improves the phase margin.

To determine components, it can be shown that the optimal conditions for amplifier stability occur when:

$$(R1)(C_{dist}) = (R_F)(C_{lead}) \quad (1)$$

However, when the stability criteria is obtained, it should be noted that the actual bandwidth of the closed-loop amplifier

will be reduced. Based on using a double-sided copper-clad printed circuit board with a distributed capacitance of 3.5pF and a unity gain configuration, C_{lead} would be 3.5pF. Another way of stating the relationship between the distributed capacitance closed-loop gain and the lead compensation capacitor is:

$$C_{lead} = C_{dist} \frac{R1}{R_F} \quad (2)$$

When bandwidth is of primary concern, the lead compensation will usually be adequate. For closed-loop gains less than seven, lag-lead compensation is necessary for stability.

If transient response is also a factor in design, a lag-lead compensation network may be necessary. (Reference Figure 1.) For practical applications, the following equations can be used to determine proper lag-lead components:

$$\frac{R_F}{R1/R_{lag}} \geq 7 \quad (4)$$

Therefore,

$$R_{lag} \leq \frac{R_F}{7 - R_F/R1} \quad (5)$$

Using the above equation will insure a closed-loop gain of seven above the network break frequency. C_{lag} may now be approximated using:

$$W_{lag} \cong \frac{2\pi(GBW)}{10} \text{ Rad/Sec} \quad (6)$$

$$W_{lag} = \frac{\pi(GBW)}{5} \text{ Rad/Sec} \quad (7)$$

Where

$$W_{lag} = \frac{1}{(R_{lag})(C_{lag})} \quad (8)$$

Therefore,

$$\frac{\pi(GBW)}{5} = \frac{1}{(R_{lag})(C_{lag})} \quad (9)$$

And

$$C_{lag} = \frac{5}{\pi R_{lag}(GBW)} \quad (10)$$

This method adds a pole and zero to the transfer function of the device, causing the actual open-loop gain and phase curve to be reshaped, thus creating a progressive improvement above the critical frequency where phase changes rapidly. (Near 70MHz; see Figures 2A and 2B.) But also, the lag-lead network can be adjusted to optimize gain peaking for transient responses. Therefore, rise time, overshoot, and settling time can be changed for various closed-loop gains. The result of using this technique is shown for a pulse amplifier in Figure 3.

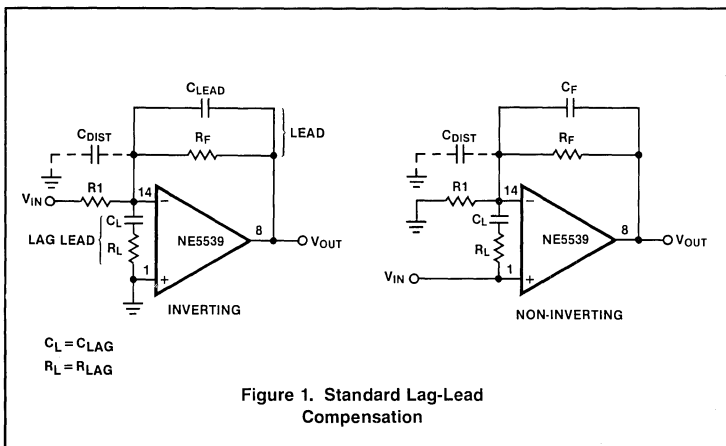

Figure 1. Standard Lag-Lead Compensation

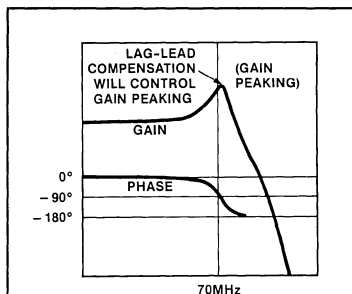

Figure 2A. Closed-Loop Inverting Gain of Seven Gain-Phase Response (Uncompensated)

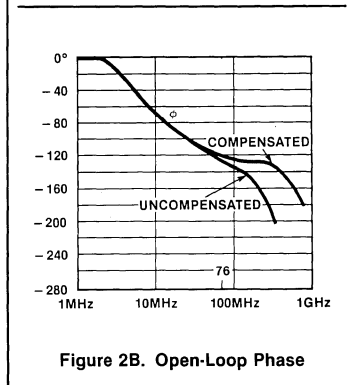
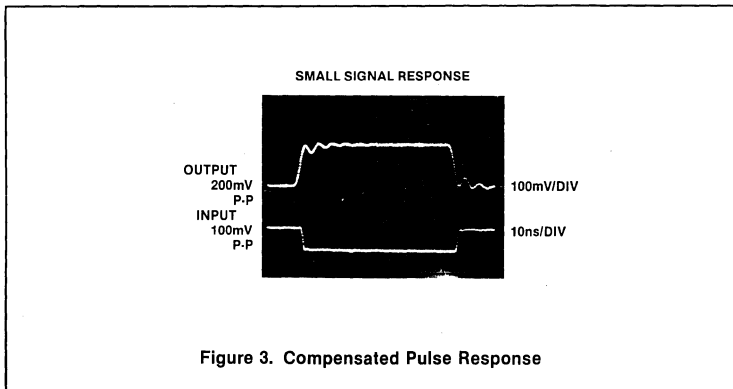

Figure 2B. Open-Loop Phase



USING PIN 12 COMPENSATION

An alternate method of external compensation is obtained by use of the SE/NE5539 frequency compensation pin. The circuits in Figure 4 show the correct way to use this pin. As can be seen, this method saves the use of one capacitor as compared to standard lag-lead and lead compensation as shown in Figure 1.

But, most important, both methods are equally effective; i.e., a good wideband amplifier below 17dB, with control over ringing and overshoot. For example, inverting and non-inverting amplifier circuits using pin 12 are shown in Figure 5. The corresponding pulse response for each circuit is shown in Figures 6 and 7 for the

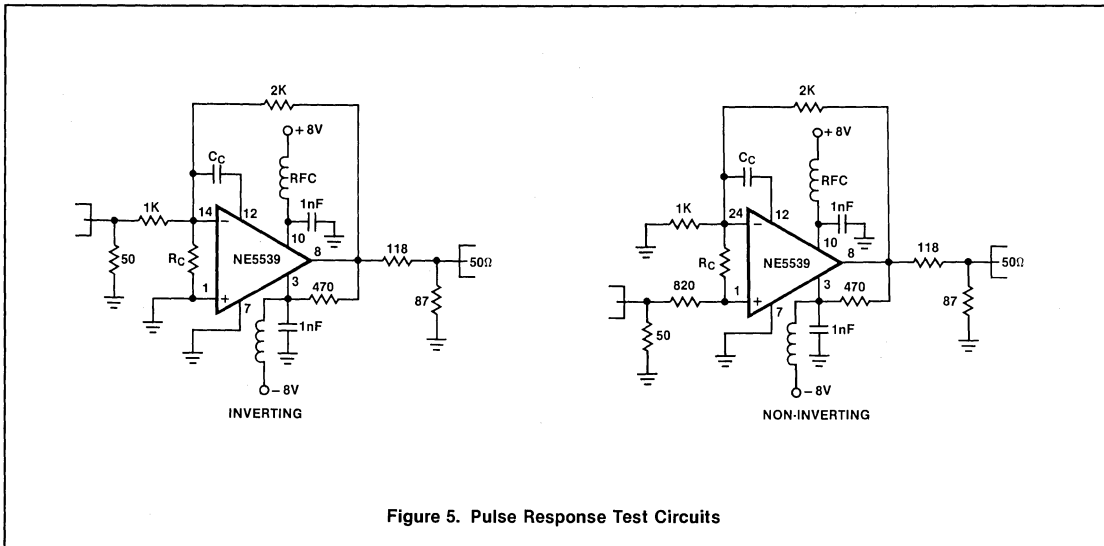
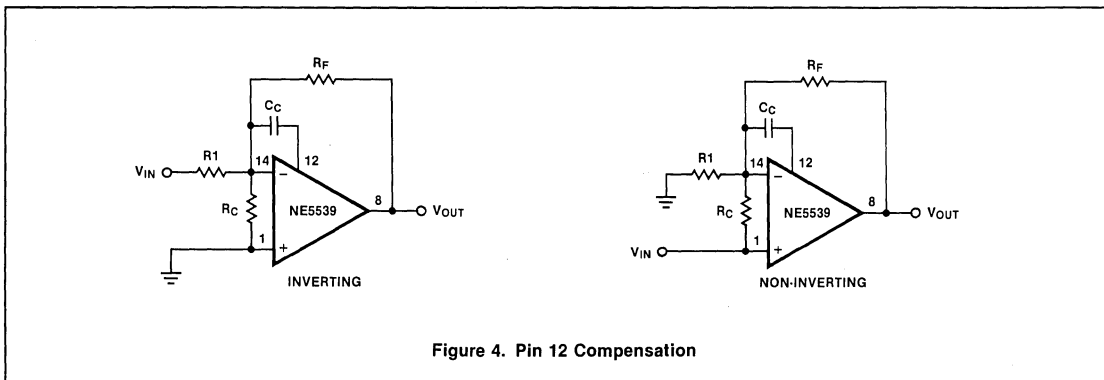

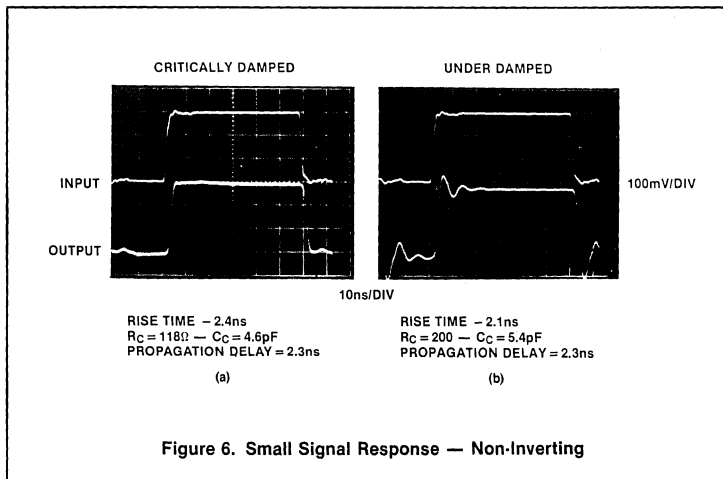

Figure 6. Small Signal Response — Non-Inverting

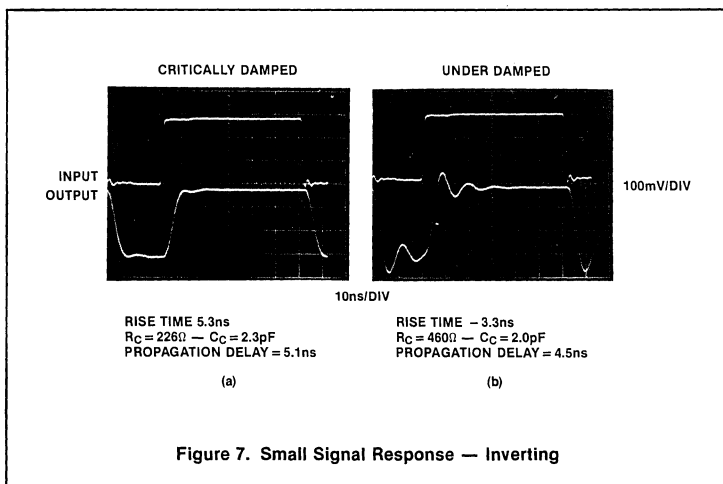
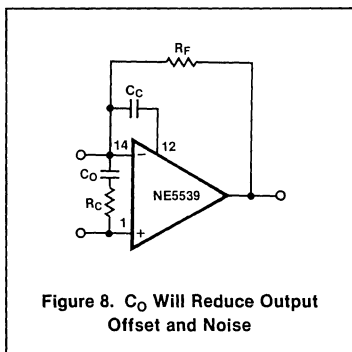

Figure 7. Small Signal Response — Inverting



network values recommended. As shown by the response photos, the overshoot and settling time can be controlled by adjusting R_C and C_C . In damping the overshoot, rise time is slightly decreased. Also, the non-inverting configuration (Figure 6) gives a very fast response time compared to the inverting mode.

If it is important to reduce output offset voltage and noise, an additional capacitor, C_O , can be added in series with the resistor (R_C) across the inputs. This should be a large value to block DC but not affect the benefits of the compensation components at high frequencies. A value of $0.01\mu F$ as shown in Figure 8 is sufficient.

INTERNAL CHARACTERISTICS OF THE SE/NE5539

In order to better understand the compensation procedure, a detailed discussion of the amplifier follows.

The complete amplifier schematic is shown in Figure 9. To clarify the effect of the compensation pin, the schematic is split into five main parts as shown in Figure 10.

Each segment in Figure 10 is defined as follows: starting from the non-inverting input, Section A_1 is the amplification from the input to the base of transistor Q_4 . A_2 is from the base of Q_4 to the summation point at the collector of Q_3 . Furthermore, A_3 represents the gain from the non-inverting input to the summation point via the common emitter side of Q_2 and Q_3 . Finally, B_F is the feedback factor of the positive feedback loop from the collector of Q_3 to the base of Q_4 .

From Figure 10, it can be seen that the total gain (A_T) is:

$$A_T = \frac{A_1 A_2}{1 - (B_F A_2)} + A_3(1 + B_F A_2)$$

Each term in this equation plays a role at different frequencies to determine the total transfer function of the device. Of particular importance is the pole in A_3 (near 340MHz) which causes a roll-off of 12dB/octave and loss of phase margin just before unity gain. This can be seen in the Bode plot in Figure 11A. To overcome this pole, a capacitor and resistor are connected as shown in Figures 12A and 12B. The compensation pin is connected to the emitter of Q_5 , which is in an emitter-follower configuration. Therefore, a reactance connected to pin 12 acts essentially as if it were connected at the base of Q_5 . Since the capacitor is connected here, it is now a component of B_F and a zero is added to the transfer function. The resistor across the input pins controls overall gain and causes A_T to cross 0dB at a lower frequency; the capacitor in the feedback loop controls phase shift and gain peaking.

To further explain, Bode plots of open-loop response and using varying capacitor values and corresponding pulse responses are shown in Figures 13A through 13F. The changes in gain and phase can readily be seen, as is the effect on bandwidth.

COMPUTER ANALYSIS

The open-loop and pulse response plots were generated using an IBM 370 computer and SPICE, a general-purpose circuit

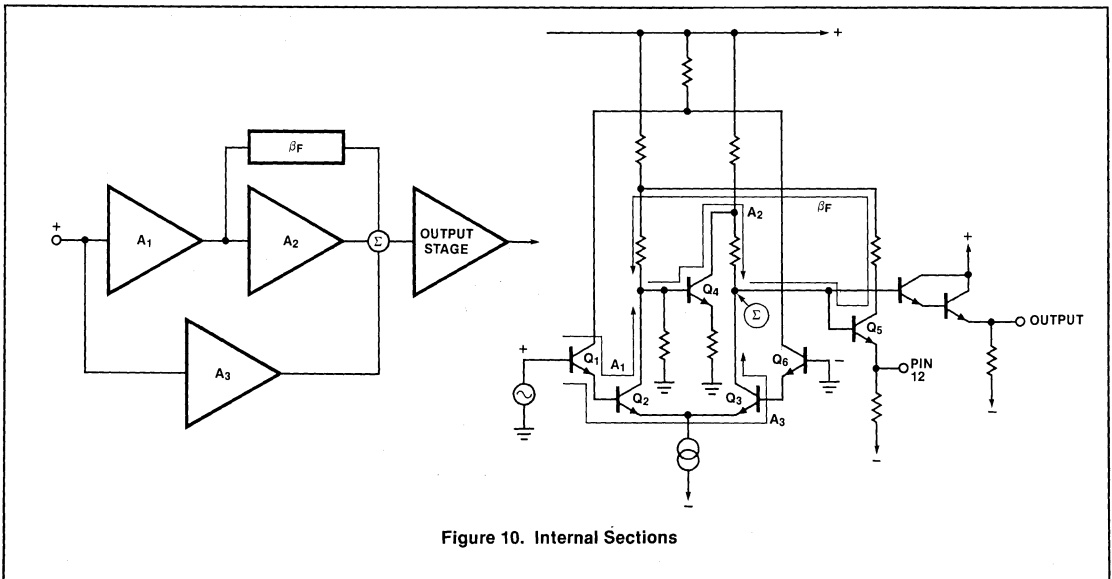
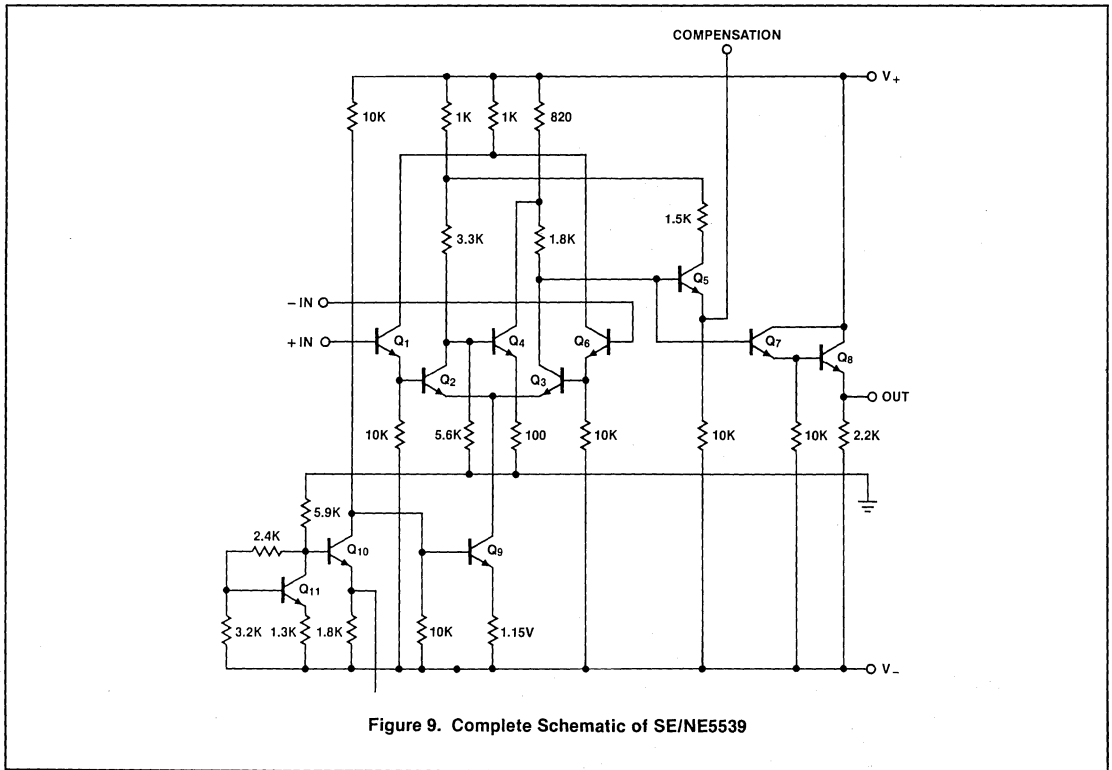

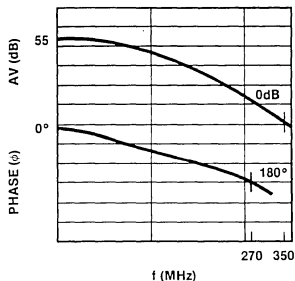

Figure 11A. Open-Loop Gain — No Compensation (Computer Simulation)

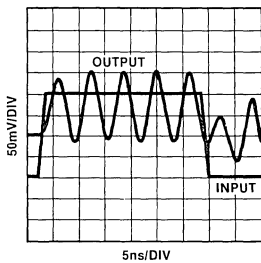

Figure 11B. Closed-Loop Non-Inverting Response — No Compensation (Computer Simulation — Oscillation is Evident)

simulation program. Each transistor in the part is mathematically modeled after actual device parameters, which were measured in the laboratory. Then these models are combined with the resistors and voltage sources through node numbers so that the computer knows where each is connected.

To indicate the accuracy of this system, the actual open-loop gain is compared to the computer plots in Figures 14 and 15. The real payoff for this system is that once a credible simulation is achieved, any outside circuit can be modeled around the op amp. This would be used to check for feasibility before breadboarding in the lab. The internal circuit can be treated like a black box and the outside circuit program altered to whatever application the user would like to examine.

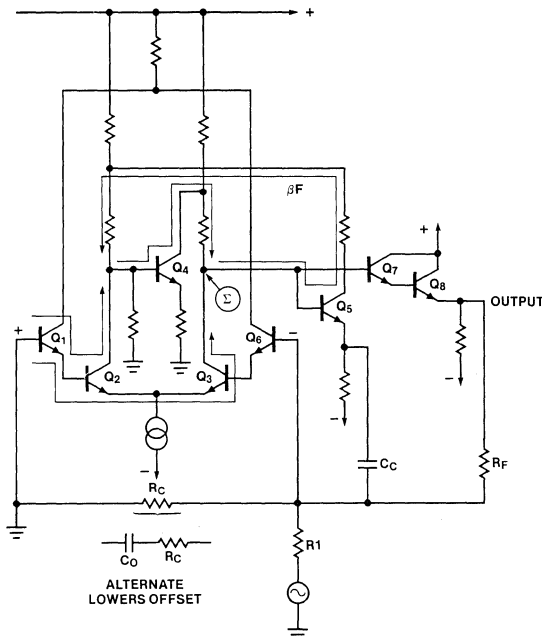

Figure 12A. Pin 12 Compensation Showing Internal Connections — Inverting

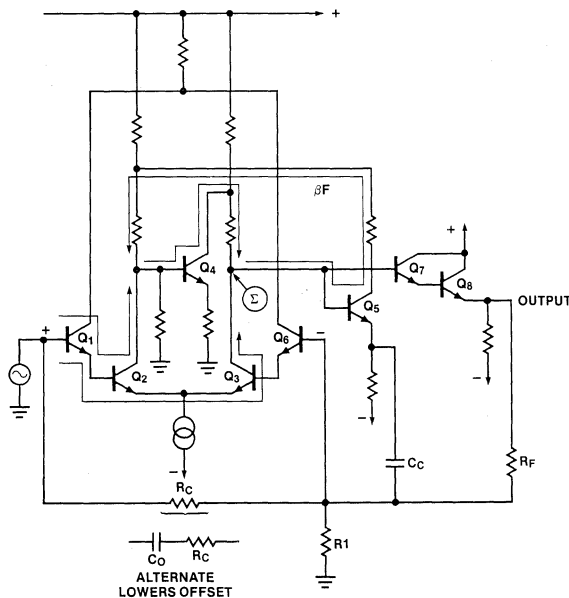

Figure 12B. Pin 12 Compensation Showing Internal Connections — Non-Inverting

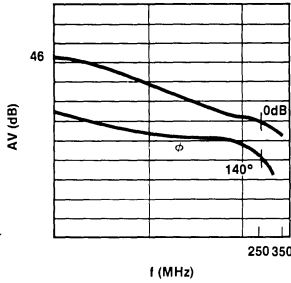

Figure 13A. Open-Loop Pin 12 Compensation — $R_C = 200\Omega$, $C_C = 1pF$, (Computer Simulation)

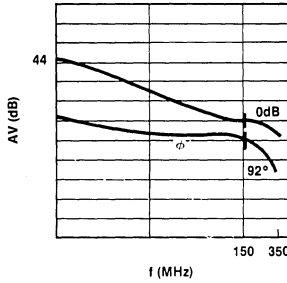

Figure 13C. Open-Loop Pin 12 Compensation — $R_C = 200\Omega$, $C_C = 2pF$ (Computer Simulation)

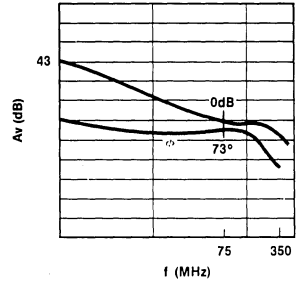

Figure 13E. Open-Loop Pin 12 Compensation — $R_C = 200\Omega$, $C_C = 3pF$ (Computer Simulation)

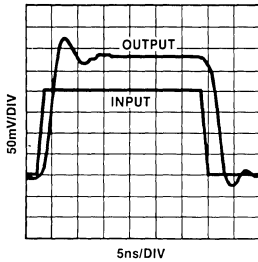

Figure 13B. Closed-Loop Non-Inverting Pulse Response — $R_C = 200\Omega$, $C_C = 1pF$, $A_V = 3$ (Computer Simulation — Underdamped)

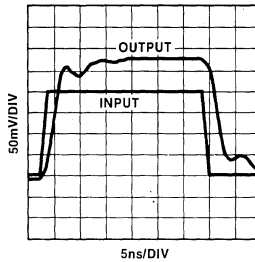

Figure 13D. Closed-Loop Non-Inverting Pulse Response — $R_C = 200\Omega$, $C_C = 2pF$, $A_V = 3$ (Computer Simulation — Critically Damped)

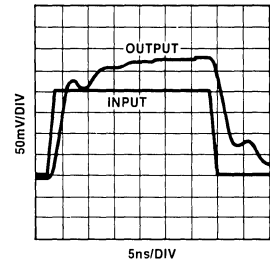

Figure 13F. Closed-Loop Non-Inverting Pulse Response — $R_C = 200\Omega$, $C_C = 3pF$, $A_V = 3$ (Computer Simulation — Overdamped)

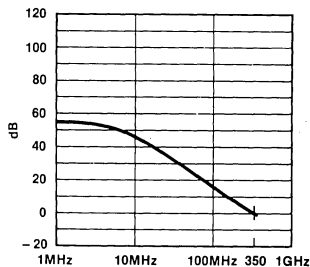

Figure 14. Actual Open-Loop Gain Measured in Lab

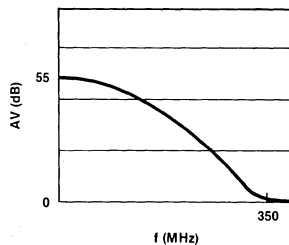

Figure 15. Computer-Generated Open-Loop Gain

REFERENCES

1. J. Millman and C. C. Halkias: *Integrated Electronics: Analog and Digital Circuits and Systems*, McGraw-Hill Book Company, New York, 1972.
2. A. Vladimirescu, Kaihe Zhang, A. R. Newton, D. O. Peterson, A. Sanquiovanni-Vincentelli: "Spice Version 2G," University of California, Berkeley, California, August 10, 1981.
3. Signetics: *Analog Data Manual 1983*, Signetics Corporation, Sunnyvale, California 1983.

Conceptually, three basic approaches exist for obtaining regulated DC voltage from an AC power source. These are:

- Shunt regulation
- Series linear regulation
- Series switched mode regulation

All required AC power line rectification

The series switched mode regulators will be referred to as switched mode power supplies or SMPS during the course of this article.

Briefly stated, if all three types of regulation can perform the same function, following are some of the key parameters to be addressed:

- From an economical point of view, cost of the system is paramount.
- From an operations point of view, weight of the system is critical.
- From a design criteria, system efficiency is the first order of business.

The series and shunt regulators operate on the same principle of sensing the DC output voltage, comparing to an internal reference level and varying a resistor (active device) to maintain the output levels within pre-specified limits.

Switched mode power supplies (SMPS) are basically DC to DC converters, operating at frequencies in the 20kHz and higher region. Basically the SMPS is a power source which utilizes the energy stored during one portion of its operating cycle to supply power during the remaining segment of its operating cycle.

Linear regulators, both shunt and series, suffer when required to supply large currents with resultant high dissipation across the regulating device. Efficiency suffers

tremendously. (Efficiencies less than 40% are typical.)

Switched mode power supplies operate at much higher levels of efficiency (generally in the order of 75% to 80%) thereby reducing significantly the energy wasted in the regulated supply. The SMPS does, however, suffer significantly in the ripple regulation it is able to maintain as opposed to a much higher degree of regulation available in series (or shunt) linear regulators.

The linear regulators obtain improved regulation by virtue of the series pass elements always conducting, as opposed to SMPS devices having their active devices operative only during a portion of the overall operating period.

Some definitions and comparisons between linear regulators and switched mode power supplies are below for reference.

REGULATION

Line Regulation: (Sometimes referred to as static regulation) refers to the changes in the output (as a percent of nominal or actual value) as the input AC is varied slowly from its rated minimum value to its rated maximum value (eg. from 105VAC_{RMS} to 125VAC_{RMS}).

Load Regulation: (Sometimes referred to as dynamic regulation) refers to changes in output (as a percent of nominal or actual value) when the load conditions are suddenly changed (eg. minimum load to full load.)

NOTE
The combination of static and dynamic regulation are cumulative; care should be taken when referring to the regulation characteristics of a power supply.

Thermal Regulation:

Referred to as changes due to ambient variations or thermal drift.

TRANSIENT RESPONSE

The ability of the regulator to respond to rapid changes in either line variations, load variations, or intermittent transient input conditions. (This parameter is often referred to as "recovery time.")

AC PARAMETERS

Voltage Limiting:

The regulator's ability to "shut down" in the event that the internal control elements fail to function properly.

Current Limiting:

Often referred to as "fold-back" where the amplifier segment of the regulator folds back the output current of the device when safe operating limits are exceeded.

Thermal Shutdown:

The regulator's ability to shut itself down when the maximum die temperature is exceeded.

GENERAL PARAMETERS

Power Dissipation:

The maximum power the regulator can tolerate and still maintain operation within the safe operating area of its active devices.

Efficiency:

The ratio (in percent) of the usable versus total power being dissipated in a regulated supply. (The losses can be ac as well as dc losses.)

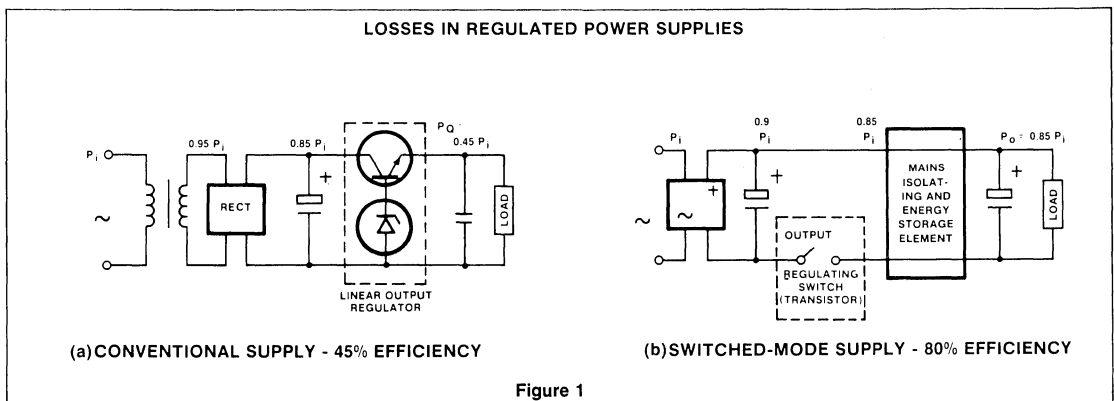

EMI/RFI:

Generation of radio frequency interference signals and magnetic field disturbance especially in SMPS devices. (Transformer and choke design are available which reduce both RFI & EMI to safe acceptance regions.)

The balance of this section will be dedicated to the discussion of the general operation of Switched Mode Power Supplies (SMPS) with emphasis on the Signetics NE5560 Control and Protection Module.

Switched-mode power supplies (SMPSs) have gained much popularity in recent years because of the benefits they offer. They are used now on a large scale in desk calculators, computers, as instrumentation supplies, etc., and it is confidently expected that the market for this type of supply will grow.

The advantages of SMPSs are low weight and small size, high efficiency, wide AC input voltage range, and low cost.

- Low weight and small size are possible because operation occurs at a frequency beyond the audible range; the inductive elements are small.
- High efficiency because, for output regulation, the power transistor is switched rapidly between saturation and cut-off and therefore has little dissipation; this eases heatsink requirements, which also contributes to weight and volume reduction. Conventional linear-regulator supplies may have efficiencies as low as 50%, or less, but efficiencies of 80% are readily achievable with SMPSs; see figure 1.
- Wide AC input voltage range because of the flexibility of varying the switching frequency in addition to the change in transistor duty cycle makes voltage adaptation unnecessary.
- Low overall cost, due to the reduced volume and dissipation, means that less material is required and smaller semiconductor devices suffice.

Switched-mode power supplies also have slight disadvantages in comparison with linear regulators, namely, somewhat greater circuit complexity, tendency to r.f.i. radiation, slower response to rapid load changes, and less ability to remove output ripple.

HOW SWITCHED-MODE POWER SUPPLIES OPERATE

The switched-mode power supply is a modern version of its forerunner, the electromechanical vibrator used in the past to supply car radios. But the new concept is much more reliable because of the far greater life-

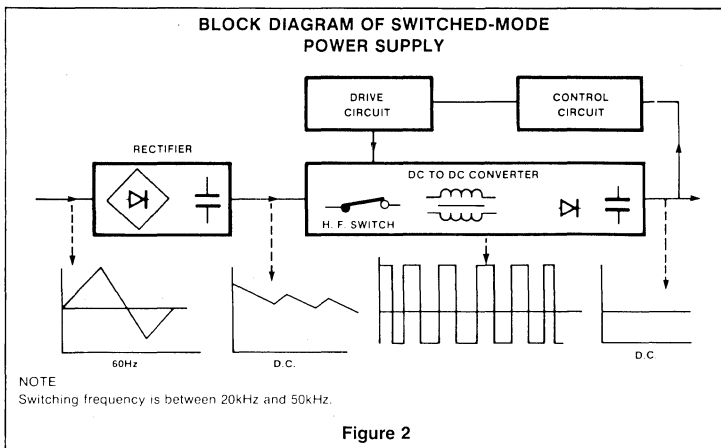

Figure 2

time of the transistor switch. Figure 2 shows the principle of the ac fed SMPS. In this system the ac voltage is rectified, smoothed, and supplied to the electronic chopper, which operates at a frequency above the audible range to prevent noise. The chopped dc voltage is applied to the primary of a transformer, and the secondary voltage is rectified and smoothed to give the required dc output. The transformer is necessary to isolate the output from the input. Output voltage is sensed by a control circuit, which adjusts the duty cycle of the switching transistor, via the drive circuit, to keep the output voltage constant irrespective of load and line voltage changes. Without the input rectifier, this system can be operated from a battery or other dc source.

Depending on the requirements of the application, the dc-to-dc converter can be one of the three basic types: flyback converter, forward converter, or push-pull (balanced) converter.

The Flyback Converter

Figure 3 shows the flyback converter circuit, and the waveforms of transistor voltage, V_{CE} , and choke current, i_L , reflected to the primary (choke double-wound for line isolation). Cycle time and transistor duty cycle are denoted T and δ , respectively. While Q_1 conducts, energy is accumulated in the choke magnetic field (i_L rising and D_1 reversed biased), and it is discharged into the output capacitor and the load during the flyback period, that is, while Q_1 is off (i_L falling and D_1 forward biased). During Q_1 conduction, C_o continues delivering energy to the load so providing smoothing action. It will be noted that only one inductive element is needed, in distinction to the converter types discussed below,

which require two. As the V_{CE} waveform shows, the peak collector voltage is twice the input voltage, V_i , for δ equal to 0.5.

The Forward Converter

A major advantage of the forward converter, particularly for low output voltage applications, is that the high-frequency output ripple is limited by the choke in series with the output. Figure 4 illustrates the circuit. During the transistor-on (or forward) period, energy is simultaneously stored in the choke L_o and passed via D_1 to the load. While Q_1 is off, part of the energy accumulated in L_o is transferred to the load through free-wheeling diode D_2 . Output capacitor C_o smoothes the ripple due to transistor switching. After transistor turn-off, the magnetic energy built up in the transformer core is returned to the dc input via the demagnetizing winding (closely coupled with the primary) and D_3 , so limiting the peak collector voltage to twice the input voltage V_i .

The Push-Pull Converter

This converter type, given in Figure 5, consists of two forward converters operating in push-pull. Diodes D_1 and D_2 rectify the rectangular secondary voltage generated by Q_1 and Q_2 being turned on during alternate half cycles. Push-pull operation doubles the frequency of the ripple current in output filter L_oC_o and so reduces the output ripple voltage. The peak transistor voltage is $2V_i$.

MAKING THE BEST CONVERTER CHOICE

There exist several versions of the three fundamental circuits described earlier.

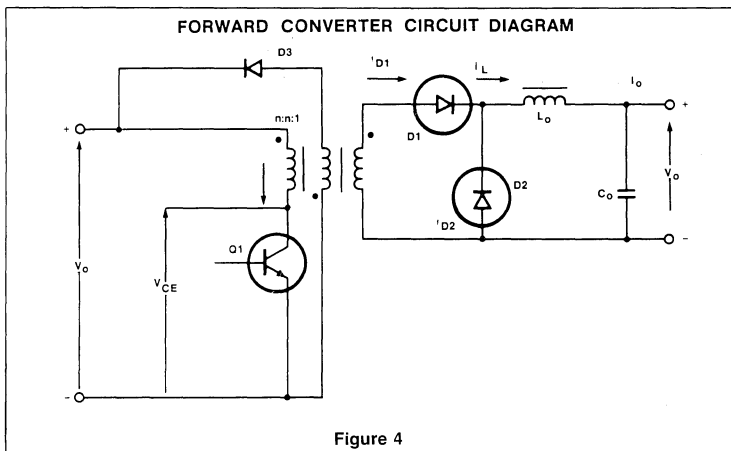
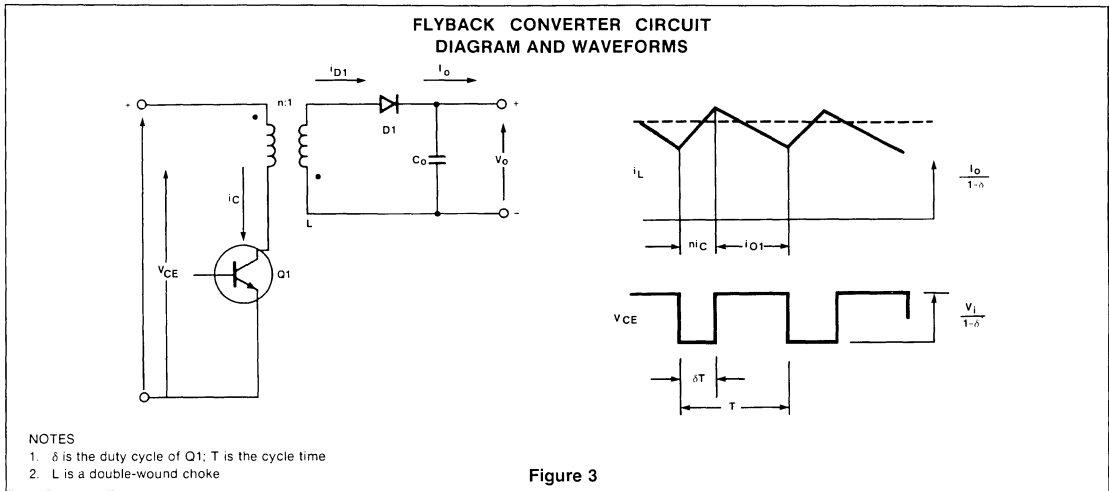

These are shown in Figure 6. Circuits IA, IIA and IIIA are the basic types. In the two-transistor circuits IB and IIB, transistors Q1 and Q2 conduct simultaneously and diodes D4, D5 limit the peak collector voltage to the level of DC input voltage V_i . Similarly in the push-pull circuits IIBB and IIIC, the collector voltage does not exceed V_i ; in circuit IIBB, Q1 and Q2 are turned on during alternate half cycles; in circuit IIIC, Q1 and Q4 are turned on in one half cycle and Q2 Q3 in the next.

Converter choice depends on application and performance requirements. The flyback converter is the simplest and least expensive; it is recommended for multi-output supplies because each output requires only one diode and one capacitor. However, smoothing may be a problem where ripple requirements are severe. The push-pull type has the most complex base drive circuit but it produces the lowest output ripple with given values of L_o and C_o .

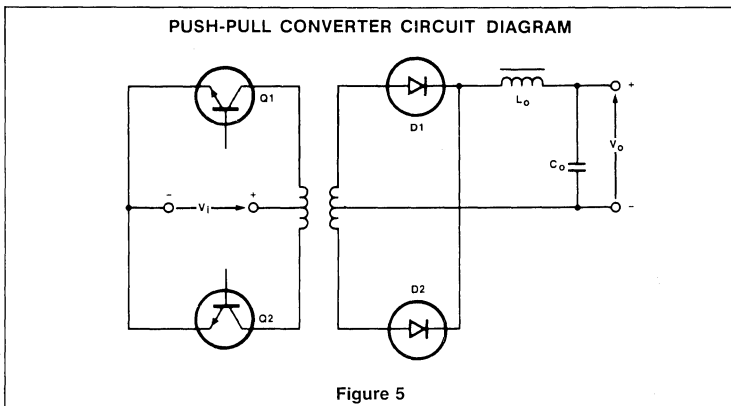

Figure 7 is a general guide for the choice of converter type, based on output voltage and power. In the case of the flyback converter, it becomes more and more difficult to keep the percentage output ripple below an acceptable level as the output power increases and the output voltage decreases; for reasons of circuit economy, however, the flyback converter is the best proposition if the output power does not exceed about 10W. For output powers higher than about 1kW, the push-pull converter is preferable.

THE CONTROL AND PROTECTION MODULE

In addition to providing adequate output voltage stabilization against line voltage



VARIOUS D.C.-TO-D.C. CONVERTER
TYPES WITH THEIR RECTIFIER SUPPLY

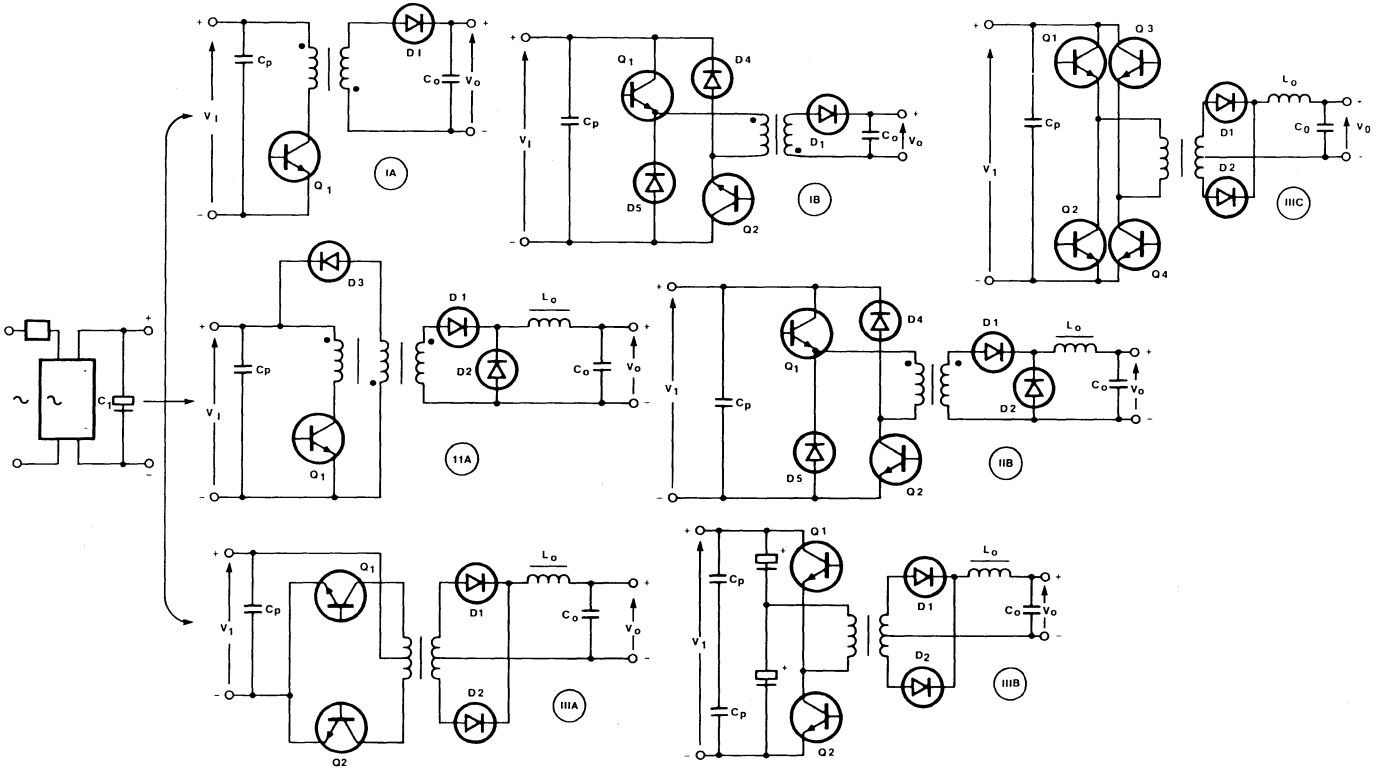

NOTES

- 1 = Flyback converter family with 1A single-transistor type and 1B two-transistor type
- 2 = Forward converter family with 2A single-transistor type and 2B two-transistor type
- 3 = Push-pull converter family with 3A conventional type, 3B single-ended type and 3C bridge type

Capacitor C_p is a high-frequency by-pass (20kHz to 50kHz switching frequency).

Figure 6

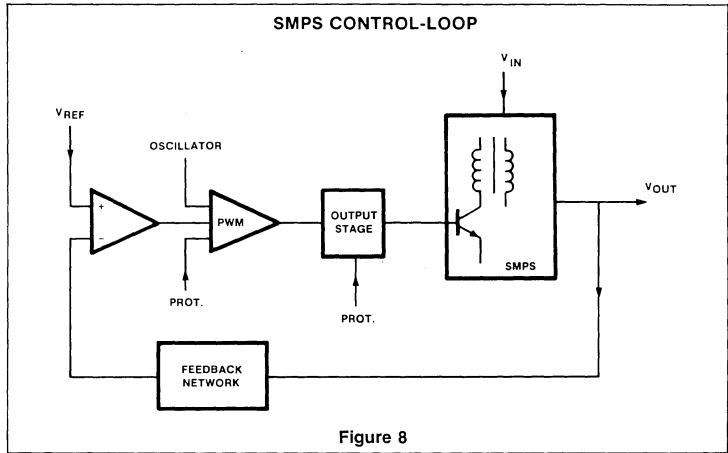
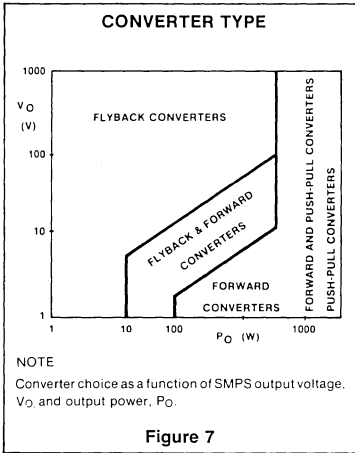

and load changes, the control module must give fast protection against overload, equipment malfunction, and the effects of switch-on immediately following switch-off. In addition the following features are desirable:

- **Soft Start:** that is, a gradual increase of the transistor duty cycle after switch-on causing a slow rise of the output voltage, which prevents an excessive inrush current due to a capacitive load or charging of the output capacitor.
- **Synchronization:** to prevent interference due to the difference in free-running frequencies (for example, in a system in which a low-power SMPS supplies the base drive circuit of the output switching transistor in a high-power SMPS).
- **Remote switch-on and switch-off:** essential for sequential switching of supply units in, for instance, a computer supply system.

The control and protection circuitry of a switched-mode power supply (SMPS) is a

crucial and complicated part of the whole supply. Integration of this circuitry on a chip will therefore ease the design of an SMPS considerably.

SMPS CONTROL-LOOP

Figure 8 shows the principal control-loop of a regulated SMPS. The output voltage V_O is sensed and via a feedback network fed to the input of an error amplifier where it is compared with a reference voltage.

The output of this amplifier is connected to an input of the pulse-width modulator PWM.

The other input of this modulator is used for an oscillator signal, which can be a saw-tooth or a triangle.

As a result, a rectangular waveform with the frequency of the oscillator is emerging at the output of the PWM.

The width of this pulse is dictated by the output voltage of the error amplifier.

After passing through an output stage, the pulse can be used to drive the power transistor of the SMPS.

When the width of the pulse is varied, also the on-time of this transistor will vary and consequently the amount of energy taken from the input voltage V_i .

So, by controlling the duty cycle δ of the power transistor, one can stabilize the output of the SMPS against line and load variations. The duty cycle δ is defined as t_{on}/T for the power transistor. Protections for over-voltage, overcurrent, etc. can be realized with additional inputs on the PWM or the output stage.

INITIAL TURN ON

It may be helpful to operate an SMPS open loop with reduced error amplifier gain. This provides an easy way to verify correct operation of control loop elements.

FORWARD CONVERTER APPLICATION USING THE NE5560

AN121

Dual Output $\pm 50V$, 1 Amp, Forward Converter for Off-line Operation

A straightforward 100 watt off-line converter, with transformer isolation to load, is shown in Figure 1.

The NE5560 is operated at a switching frequency of 75kHz allowing minimum mag-

netics and component size. Line regulation is greatly improved also by making use of pin 16, the feed forward input. Typical transformer design recommended is: T₁: Primary 60T #24, Secondary 20T #26 on a Ferroxcube #2616 (3C8) pot core wound tightly coupled for minimum leakage inductance and having adequate primary inductance for low droop in the base drive waveform. Base drive to Q2

should approach 0.5A peak for fast turn-on response and minimum losses.

T2 provides 2.4 = 1 stepdown from primary to each secondary. A primary winding of 60 turns of #26 wire wound between the two secondaries with 25 turns each of #20 wire. The recommended core is a Ferroxcube-type 3622 pot core with a 25 mil gap to prevent saturation.

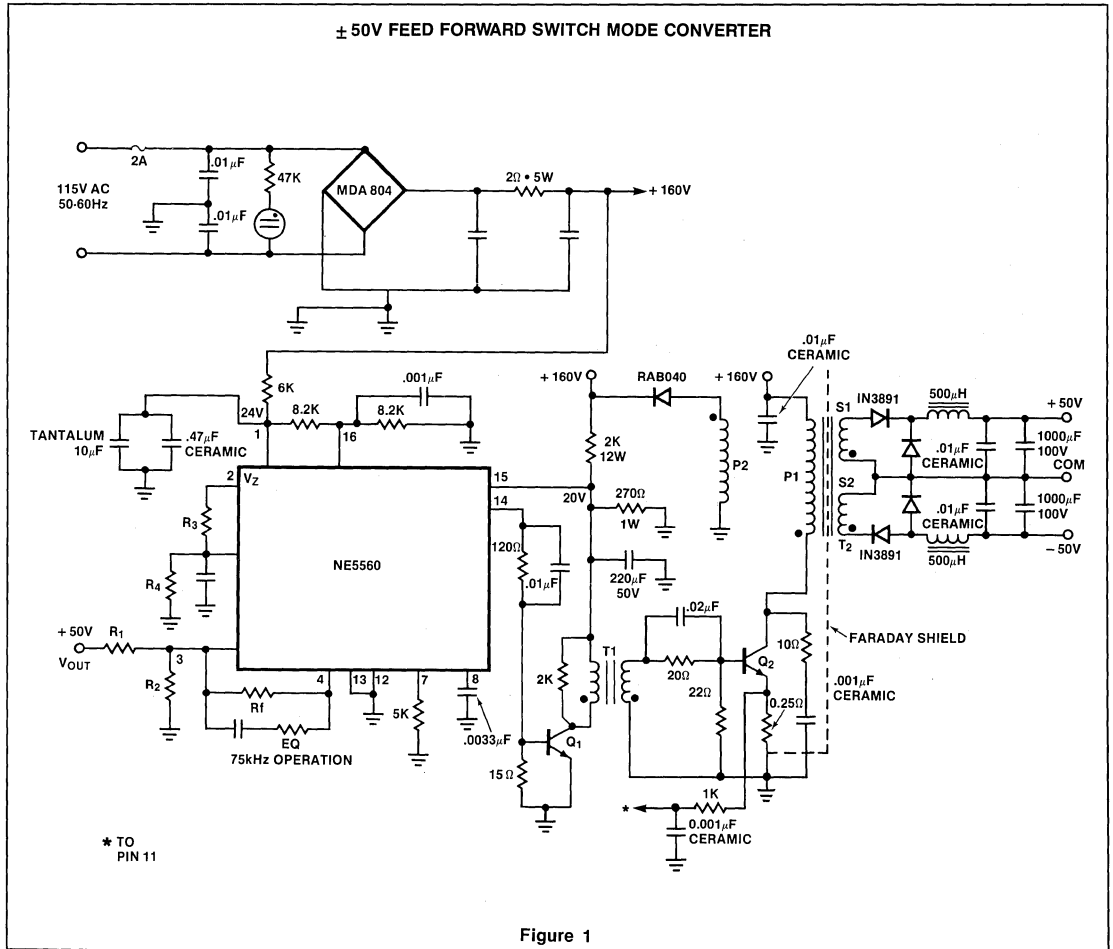

Figure 1

NE5560 PUSH-PULL REGULATOR APPLICATOR

AN122

APPLICATIONS

SE/NE5560 Push-Pull Regulator

This application describes the use of the Signetics SE/NE5560 adapted to function as a push-pull switched mode regulator, as shown in Figures 1 and 2.

Input voltage range is +12 to +18V for a nominal output of +30 and -30V at a maxi-

mum load current of 1A with an average efficiency of 81%.

Features include feed forward input compensation, cycle-to-cycle drive current protection and other voltage sensing, line (to positive output) regulation < 1% for an input range of +13 to +18V and load regulation to positive output of < 3% for $\Delta I_L(+)$ of 0.1 to 1 Amp.

The main pulse width modulator operates to 48 kHz with power switching at 24 kHz.

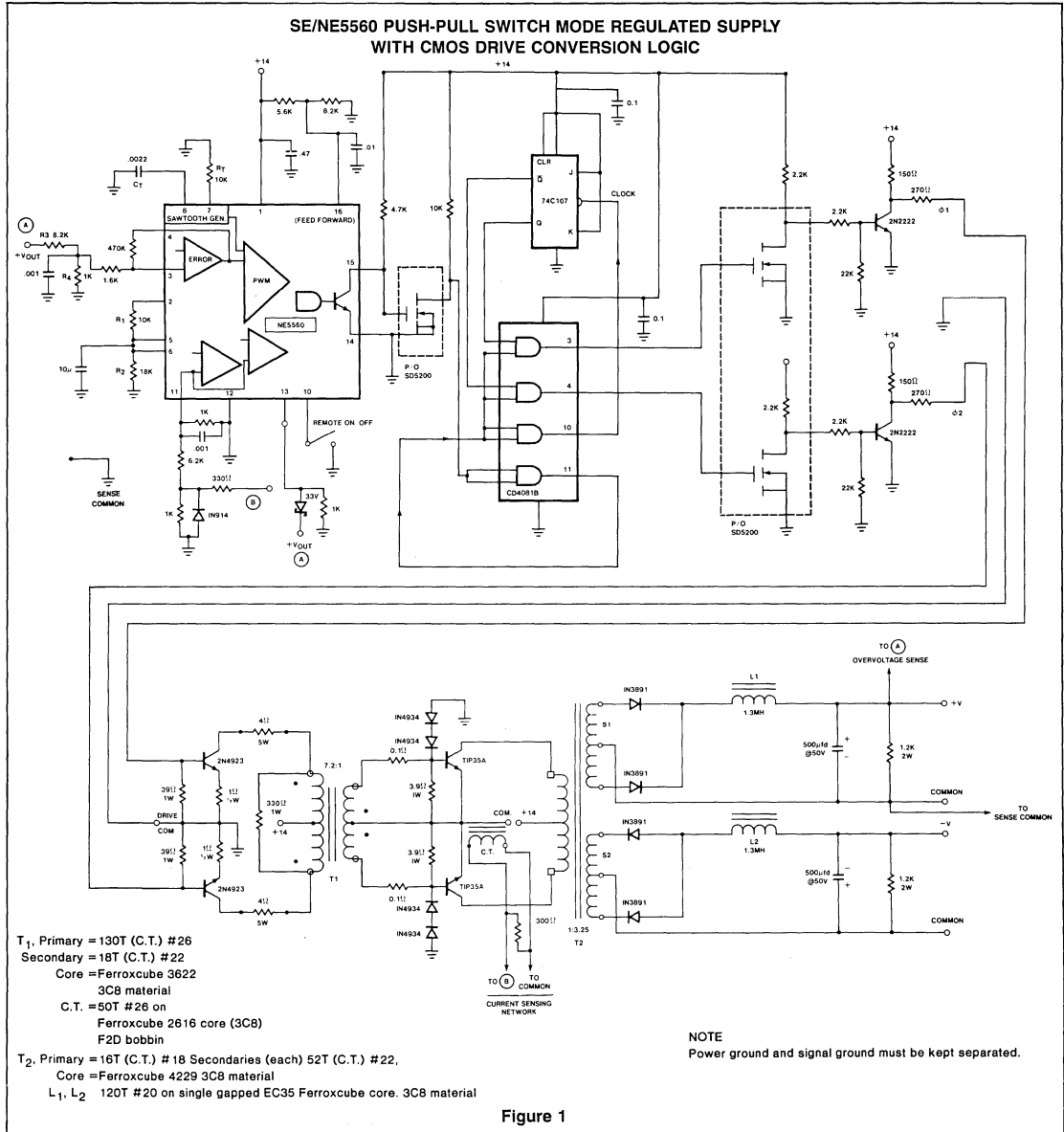

Figure 1



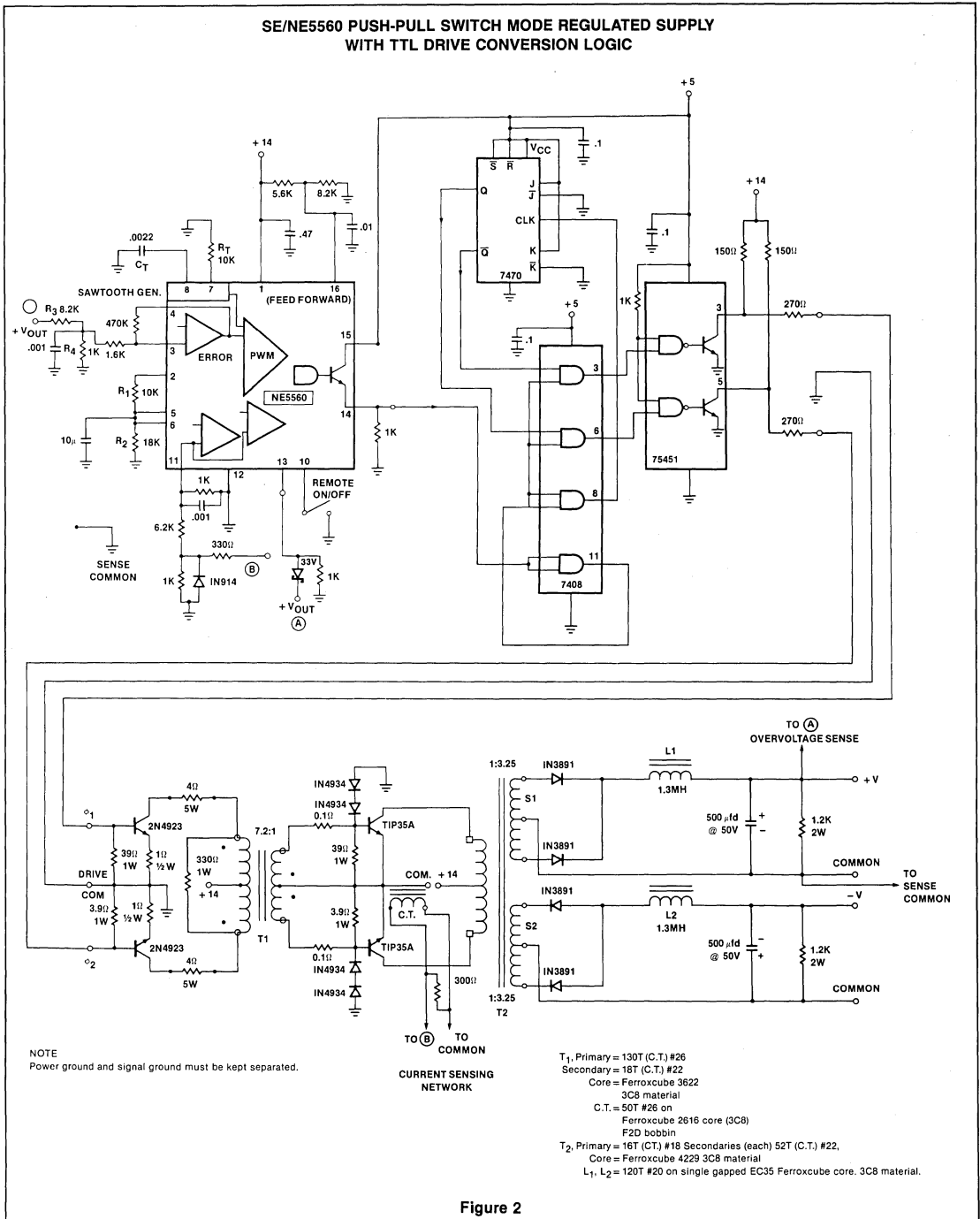

Figure 2

APPLICATIONS

5V, 0.5A Buck Regulator Operates from 15V

The converter design shows how simple it is to derive a TTL supply from a system supply of 15V (see Figure 1). The NE5561 drives a 2N4920 PNP transistor directly to provide switching current to the inductor. Overall line regulation is excellent and covers a range of 12V to 18V with minimal change (<10mV) in the output operating at full load.

As with all NE5561 circuits, the auxiliary slow start and δ_{max} circuit is required, as evidenced by Q1. The δ_{max} limit may be calculated by using the relationship.

$$\frac{R2}{R1 + R2} (8.2V) = V_{\delta(max)}$$

The maximum duty cycle is then determined from the pulse-width modulator transfer graph, and R1, R2 are defined from the desired conditions.

NE5561 Boost Converter with Output Variable (18V to 30V, 0.2A)

The circuit shown uses the NE5561 SMPS controller in a non-isolated boost converter operating from a 15V line. The addition of three transistors and one diode is necessary to complete the design (see Figure 3).

Operation is as follows. Q1 is a combination slow start and max duty cycle limit transistor. When power is first applied to the circuit, C7 in a discharged state begins to charge toward the divider voltage, V_{δ} . This $V_{\delta} + V_{BE}$ controls the voltage on pin 4, the error amp output, causing the duty cycle to be limited initially to $\hat{\delta}_0$, then to gradually approach its normal operating range, $\hat{\delta}$. The base divider is fed from V_Z , which is nominally 8.2V.

Output regulation starts at the error amplifier, with gain set by R2 (adj) and R5 combination. The error amp is stable for closed loop gain in excess of 40 dB (X100), for

which the regulation will be approximately 1%. C4 is added to the output to insure stability at gain below 40 dB. C4 creates a dominant pole at approximately 1 kHz, descending at 6 dB per octave to unity near 1 MHz. Input to the error amplifier is referenced to 3.75V and must reach this reference level for the output of the NE5561 to be active. Output voltage is then the quantity 3.75V times the divider ratio from V_{OUT} to Pin 3 as set by R2.

If the ratio is, for instance, 10:1, the output will be $\approx 37V$. If the ratio is 5:1, the output will be $\approx 18.5V$, etc.

Output to Q2 base is a square wave of variable duty cycle as determined by load demand. The internal transistor is open collector and must have a pull-up resistance, in this application the base circuit of Q2. The duty cycle $\hat{\delta}$ is a fraction between 0 and 1. The actual on-time is proportional then to $\hat{\delta} \cdot T$, where T is the period of the free-running frequency of the sawtooth generator internal the NE5561. Frequency

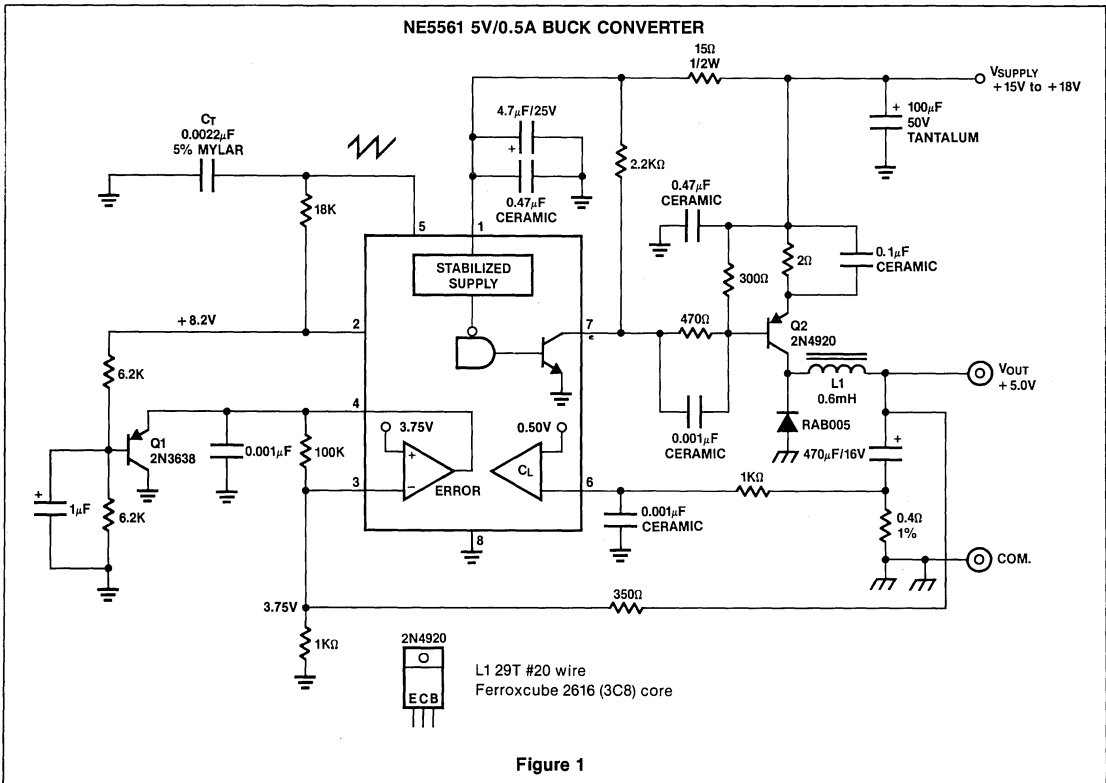

Figure 1



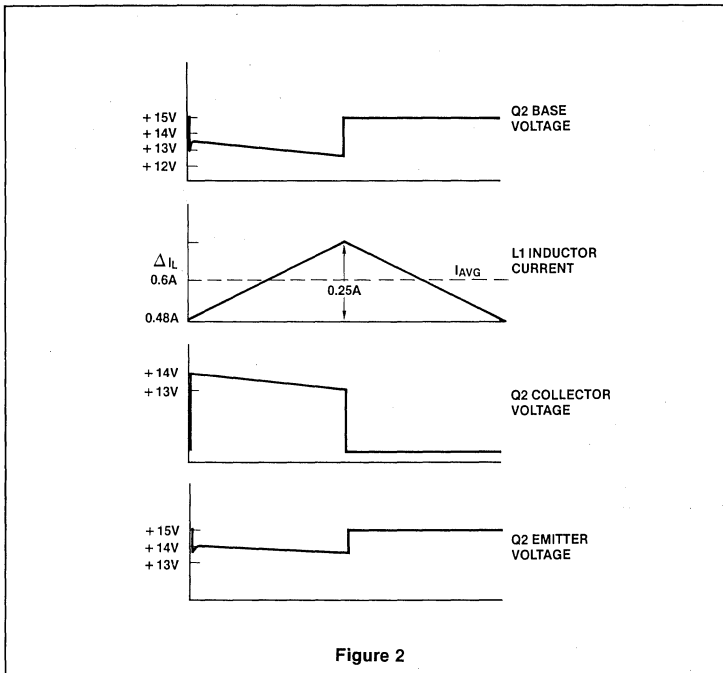
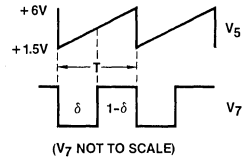

Figure 2

is set by the RC combination, $R7 \cdot C5$ with charging current supplied from V_Z (8.2V). The stabilizing effect of the internal zener supply gives a constant frequency. The sawtooth waveform is related to duty cycle as shown below.



Q3 is switched on during the saturated portion of the output waveform from pin 7 of the NE5561, termed δ , and is switched off during the remainder of the cycle ($1-\delta$).

The sawtooth frequency is set at approximately 22 kHz in this example. The NE5561 is capable of operation to 100 kHz, however.

Pin 6 of the NE5561 operates an over-current protective feature which resets the output on pin 7 if the instantaneous pin 6 voltage exceeds 0.50V. In this case, R8 determines the peak current of Q3 emitter circuit prior to shutdown. The operation of the over-current circuit is on a pulse to pulse basis, returning to normal as soon as

DC TO DC SMPS USING NE5561 VARIABLE 18V TO 30V OUT AT 0.2A

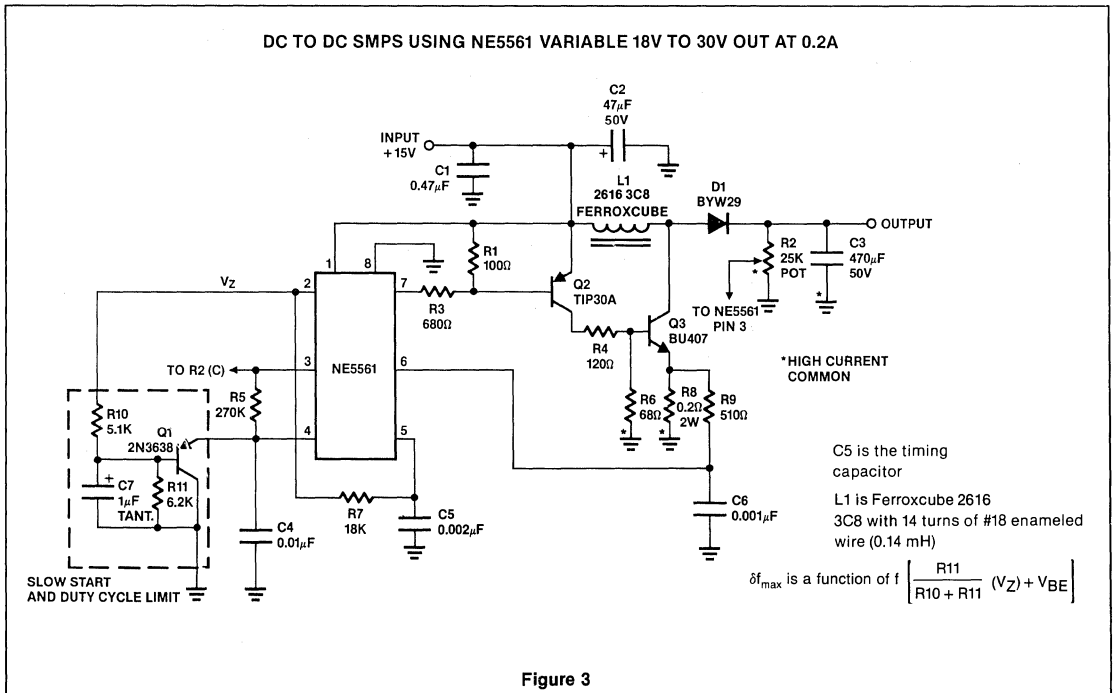

Figure 3

the pin 6 voltage falls below 0.50V. As is noted, a small degree of filtering is needed to eliminate short switching transient, allowing only the primary current waveform to be sensed.

Switching circuit operation proceeds as follows. Q3 turns on, causing magnetization current to begin increasing in L1, the switching inductor. After initial start up, C3 is charged to the output, thus with Q3 on, Diode D1 is reverse biased and does not conduct during the duty cycle, δ . C3, the output capacitor, sustains the full load current during this part of the cycle. When Q3 turns off, the magnetic field energy previously stored in L1 is discharged through D1 now forward biased. The output capacitor is incrementally charged, restoring its depleted voltage. The ripple voltage is a function of the size of C3 and its internal resistance. For minimum ripple, a low ESR (Equivalent Series Resistance) capacitor must be used, since previously mentioned peak load current flows in C3.

Single Transistor 100V, 250 mA Buck Converter

With a single 15V zener diode to limit package dissipation, the NE5561 controller may be operated directly from the rectified AC line. The following example shows the simplicity of such a converter which is capable of a nominal 100V output (see Figure 5). A base drive transformer is used to gain high voltage isolation between the NE5561 and the switching transistor, and to provide adequate base drive. A low power PNP transistor is used in an auxiliary slow start and duty cycle limiting circuit to prevent over-excitation (Q1).

Operation is as follows. Drive from the NE5561 output is fed to the primary of T1, base drive transformer, with a pulse-width modulated signal causing Q2 (BU407) to switch current to inductor, L1. As the current builds up, energy is stored in L1, coincident with the saturation period (δ) of the NE5561 output stage. During this period,

current also flows through L1 to C_O and the load. When Q2 cuts off, the choke field collapses and D1 conducts as the load is sustained by the inductor-stored energy.

V_{OUT} is sampled by the divider R7 and R8, rising until the junction of the divider is forced to 3.75V. Load variations are thus translated to duty cycle variations to maintain constant voltage at the output. The measured efficiency at 0.5A load is in ex-

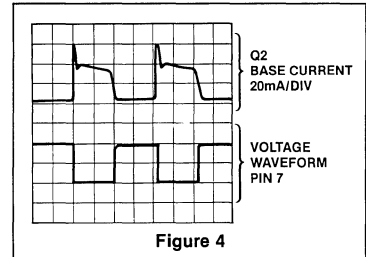

Figure 4

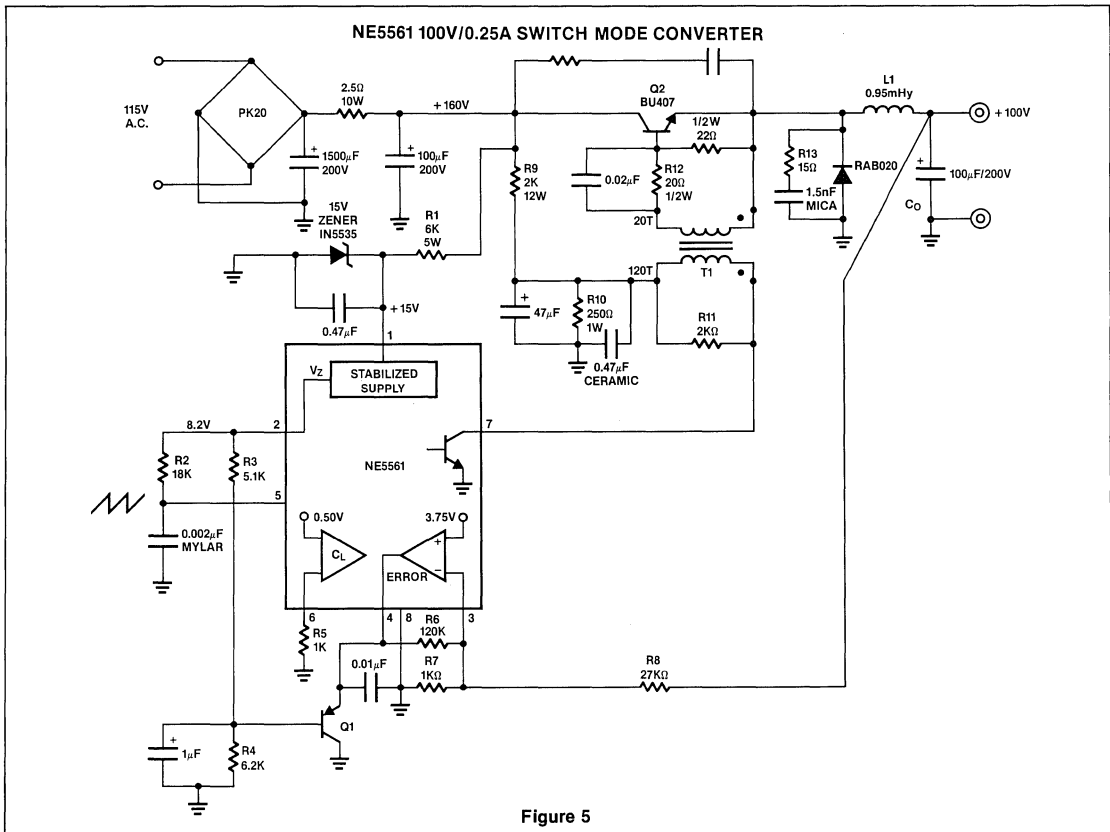

Figure 5

cess of 72%. Line regulation is good from approximately 93V to 120V.

The base current waveform driving Q2 is shown in Figure 4. This indicates that the BU407 base current rises initially to 60 mA to obtain fast turn-on, then settles to about 40 mA for the remainder of the duty cycle, δ . Reverse biasing of the emitter-base junction occurs to enhance turn-off.

Snubber networks are necessary, as shown across Q2 and commutation diode, D1, to prevent component failure during fast switching. It is critical that these networks be placed physically adjacent to the respective components they protect, and that low inductance capacitors and resistors be used as snubbers (ceramic or dura mica caps and carbon resistors).

The base drive transformer is constructed using a Ferroxcube 2616-3C8 core, with primary of 120 turns of #26 wire, and 20 turns of #26 on secondary. The primary is wound in a simple solenoidal manner, first on the bobbin, followed by a layer of mylar tape to provide voltage isolation. Next, the secondary winding is added. Primary inductance measures 45 mH with a leakage inductance of 120 μ H. It is important to have sufficient primary inductance to pre-

vent excessive droop in base drive current. Also, leakage reactance must be kept reasonably low to minimize ringing.

DC Motor Drive with Fixed Speed Control

The circuit shown in Figure 7 incorporates a simple switch mode approach to DC motor control, which is efficient and free of the dissipation problems inherent in linear drives. The NE5561 provides pulse proportional drive and speed control based on DC tachometer feedback. A simple switching circuit consisting of one transistor (2N4920 PNP) and a commutation diode is used to deliver programmed pulse energy to the motor.

A frequency of approximately 20 kHz is used to eliminate audio noise present in some switching drives. The DC tach in this example delivers 2.7V/1000 RPM. Its output is such that negative feedback occurs when this voltage is applied to the error amplifier of the NE5561, pin 3, through a suitable divider. Note that the voltage to pin 3 must be 3.75V in order to obtain servo lock. Thus, the divider from the tach output must be appropriate to maintain the proper ratio for speed control to occur.

As shown in the waveform photo (Figure 6), duty cycle varies directly with load torque demand. No load current is \approx 0.3A and full load is 0.6A. Current and voltage waveforms at 0.6A are shown in Figure 6. If desired, torque limiting may be set by feeding a derivative of motor return current back to pin 6 of the NE5561.

Operating range is 12V to 18V input for a tach output nominal variation of less than 20 mV, and approximately 4.35V for the divider values shown. The motor is a Globe 100A 565 rated at 12V DC.

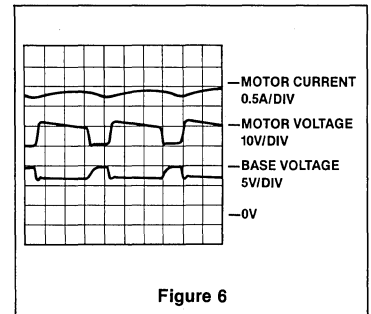

Figure 6

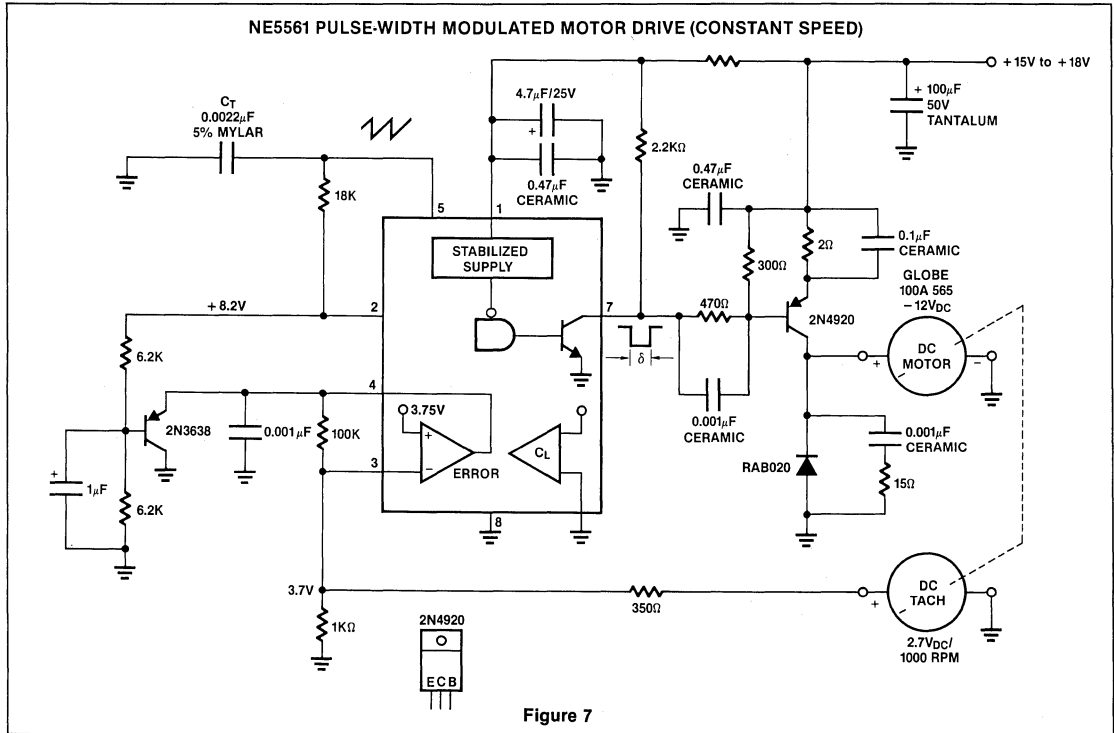
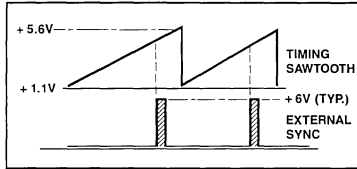

Figure 7

EXTERNAL SYNCHRONIZATION FOR THE NE5561

Synchronization of the 5561 can be accomplished by forcing the timing pin (Pin 5) above the 5.6 volt sawtooth limit comparator for a short time.



This can be accomplished with a simple diode-coupled narrow pulse source with fairly low source impedance:

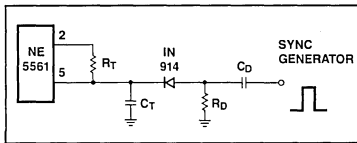

A drawback to this approach is that when the 5.6 volt threshold is reached, a discharge transistor is turned on to quickly pull the timing capacitor to ground and will also attempt to pull the pulse generator to ground. This condition can be avoided by keeping the pulse width very narrow ($0.1\mu s$) or by placing a differentiator network between the pulse generator and the diode.

The differentiator will now produce a positive going spike with the positive edge of the sync pulse, resetting the sawtooth without passing too much current through the discharge transistor. The negative spike produced by the falling edge of the clock will be blocked by the diode and will have no effect on the sawtooth ramp. A narrow sync pulse is no longer necessary while a sharp *edged* pulse is. The value of C_D should be sufficient to ensure that a 10V pulse will drive the capacitor, C_T , high enough to trip the 5.6V comparator according to:

$$C_T \Delta V_{CT} = C_D (\Delta V_{CT} - V_D)$$

This relates the magnitude of the spike to the size of the pulse. Also assume $R_D C_D < 1\mu s$.

The free run frequency of the slaved 5561 should be slightly lower than the sync frequency for proper operation.

APPLICATIONS

The capacitor-diode output circuit is used in Figure 1 as a polarity converter to generate a -5 volt supply from +15 volts. This circuit is useful for an output current of up to 20mA with no additional boost transistors required. Since the output transistors are current limited, no additional protection is necessary. Also, the lack of an inductor allows the circuit to be stabilized with only the output capacitor.

Another low-current supply is the flyback converter used in Figure 2 to generate ± 15 volts at 20mA from a +5 volt regulated line. The reference generator in the SG3524 is unused with the input voltage providing the reference. Current limiting in a flyback converter is difficult and is accomplished here by sensing current in the primary line and resetting a soft-start circuit.

In the conventional single-ended regulator circuit shown in Figure 3, the two outputs of the SG3524 are connected in parallel for effective .0-90% duty-cycle modulation. The use of an output inductor requires an R-C phase compensation network for loop stability.

Push-pull outputs are used in this transformer-coupled DC-DC regulating converter shown in Figure 4. Note that the oscillator must be set at twice the desired output frequency as the SG3524's internal flip-flop divides the frequency by 2 as it switches the P.W.M. signal from one output to the other. Current limiting is done here in the primary so that the pulse width will be reduced should transformer saturation occur.

SG3524 PUSH-PULL $\pm 50V$, 100 Watt Converter

A simple solution to off-line converter design for power audio amplifier circuits is shown in Figure 5. The SG3524 emitter outputs are used to drive directly a pair of VN3500A Power FETs in the primary side of the step down transformer at a 50kHz rate. (The main oscillator operates at 100kHz.) The transformer consists of 120T of #24 wire center-tapped at 60T. This is sandwiched between two 50 turn center-tapped secondary windings of #20 wire. Diodes are fast recovery BYW30s; the output chokes, 500 μ H wound on EC35 (3C8) pair Ferroxcube cores, provide adequate filtering in conjunction with the 1000 μ F and .01 μ F ceramic capacitors across the output.

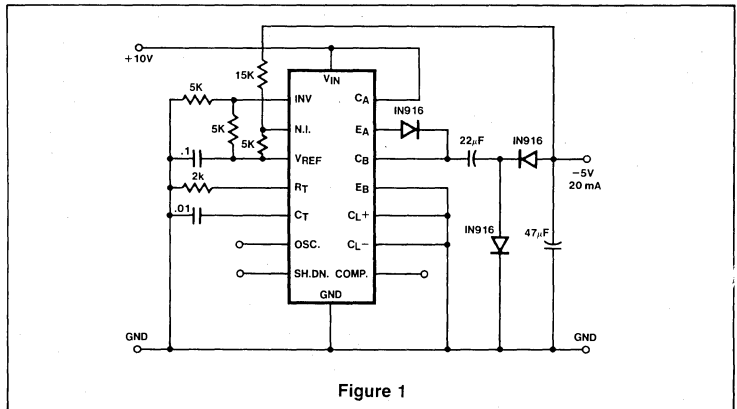

Figure 1

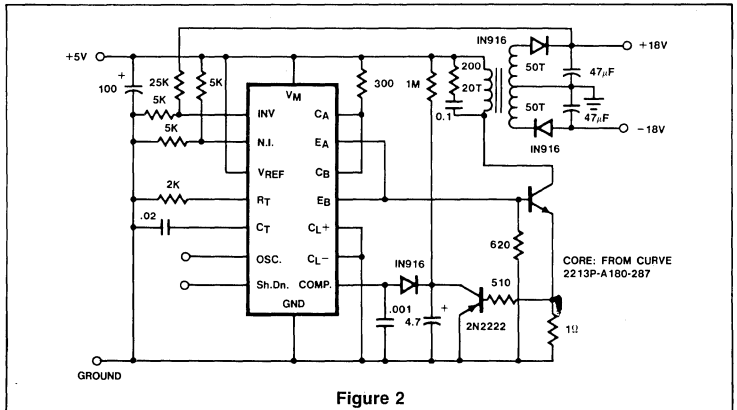

Figure 2

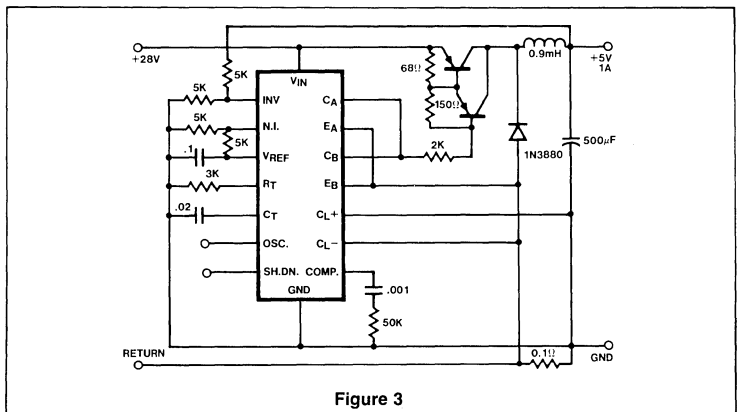

Figure 3

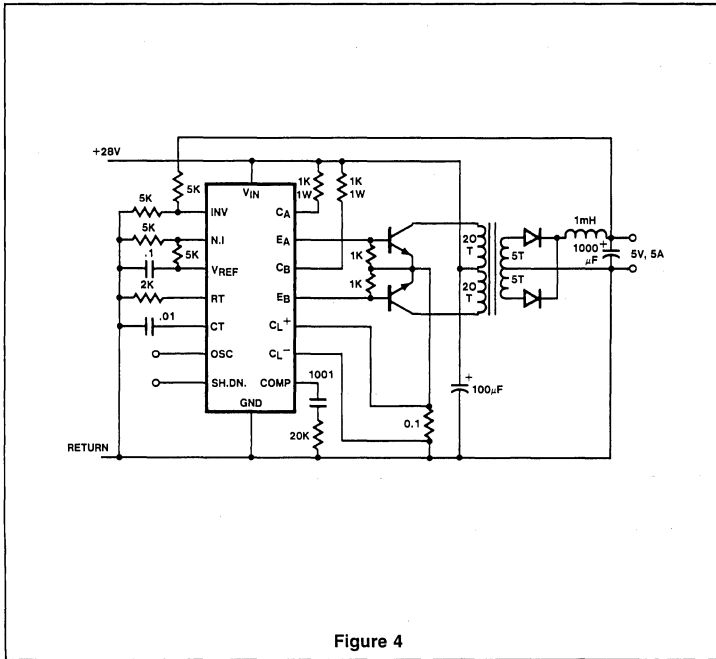

Figure 4

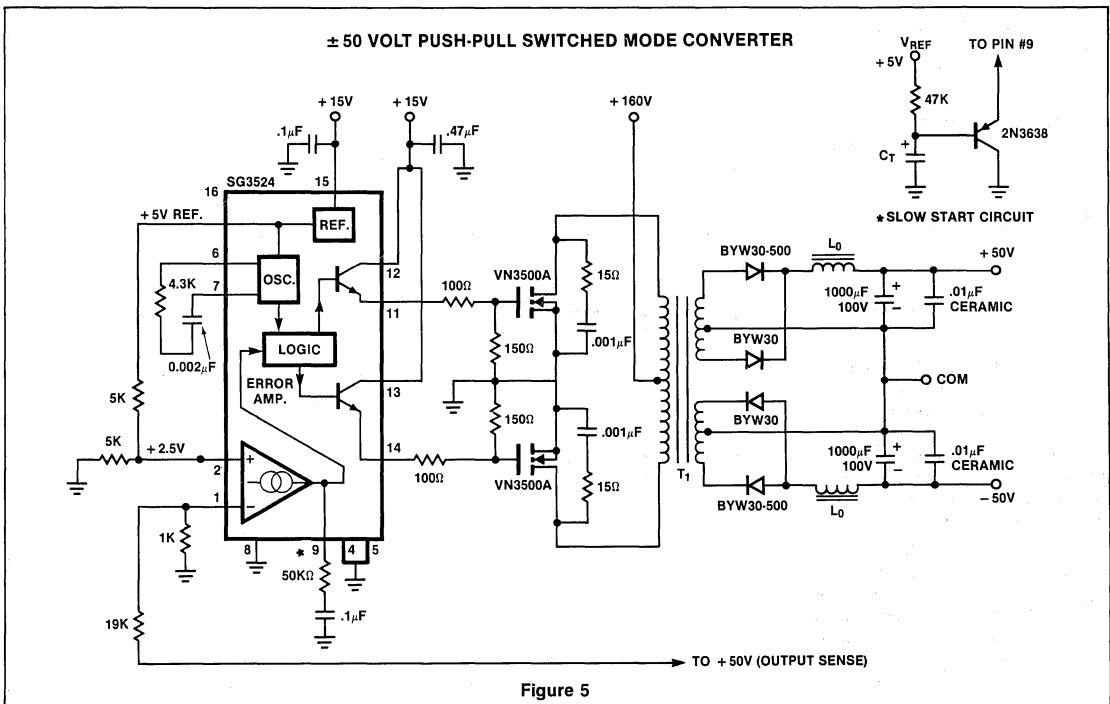

Figure 5

APPLICATIONS

The encoder inputs have been designed to accept a wide variety of signal sources. This can range from simple systems using as an input the wiper of a control pot which is connected between V_R and ground to complex systems incorporating mixing, exponential processing and/or control polarity reversing. In all cases, it must be remembered that the control inputs to the encoder look like voltage followers, that is they draw only very small currents ($>200nA$). The voltage range for these inputs is $+1.5V$ to $+5V$; however, internal clamps limit the linear control to approximately $+1.5V$ to $+3.5V$. These clamps prevent interaction between channels if one input is open circuited or shorted to supply or ground.

An example was worked out previously which utilized mechanical fine trim of the inputs (where the control pot body is rotated a small amount). In some applications, it is desirable to implement this fine trim electrically with the use of an additional pot. Many methods exist to achieve this and two are shown below.

In Figure 1 the series resistors R_T and R_C are much larger than the control pots so as to minimize nonlinearity errors and the ratio of R_T to R_C control the relative sensitivity of the control and trim pots. This scheme allows the control pot to be centered at neutral so polarity reversing can be achieved by reversing V_R and ground on the pots.

The second approach, shown in Figure 2, is a simpler method for achieving electrical trim.

$$T_n = 4R_i C_{max} \left(\frac{R_T + X_n R_C}{R_T + R_C} - Y \right)$$

$$CR = 4R_i C_{max} \left(\frac{1}{1 + R_T/R_C} \right)$$

Interfacing the 5044 encoder to the modulator of an RF transistor can be done in several ways depending on the desired output power, frequency stability and oscillator leakage. The simplest method is to use the 5044 output to directly modulate the bias current of a crystal controlled oscillator. Figure 3 shows an example of such a connection.

In a high performance system, separate oscillator, modulator and RF output stages may be required. An example of such a circuit is shown in Figure 4. In some systems, it may be required to provide additional filtering between the encoder output (Pin 11) and the RF modulator to comply with FCC regulations.

In the previous section, a design example was given for a fixed frame encoder (T_F constant). In some applications, it may be desirable to make the frame time variable, allowing the synchronization pulse, which follows the last

channel, to remain constant. The variable frame mode simplifies the synchronization pulse detector in the receiver since the pulse does not vary with the control inputs. However, the variable frame time may complicate

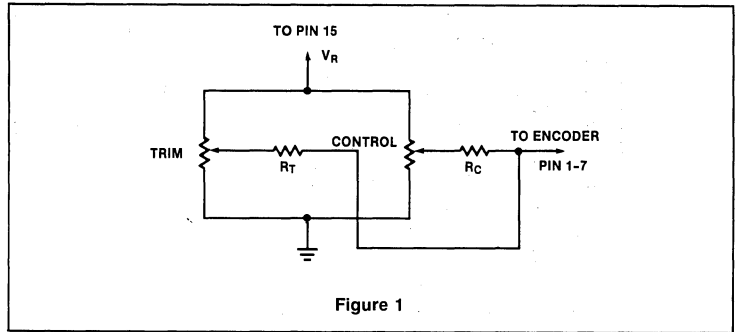

Figure 1

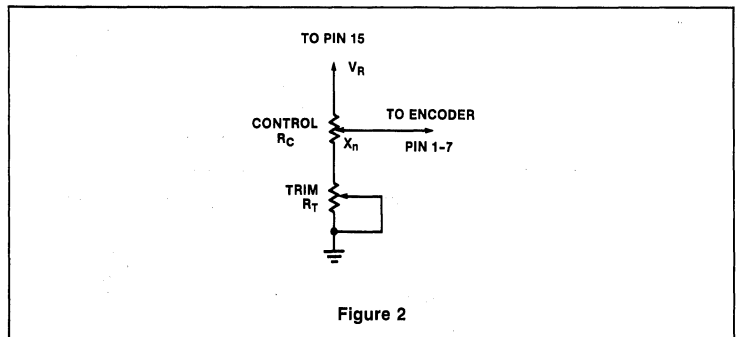

Figure 2

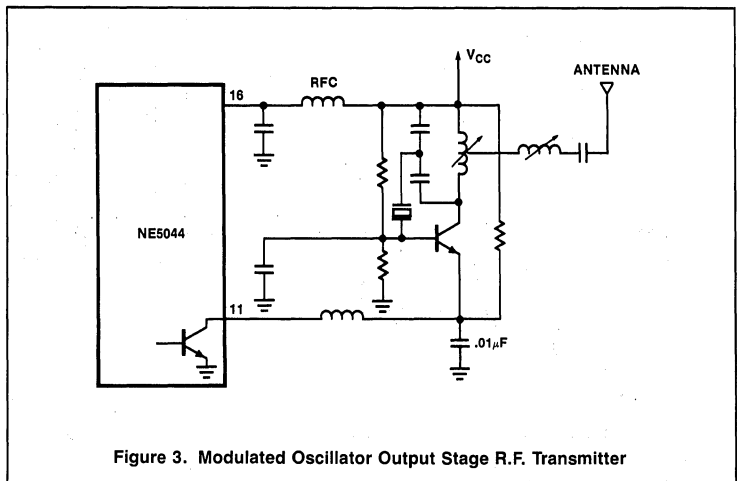

Figure 3. Modulated Oscillator Output Stage R.F. Transmitter

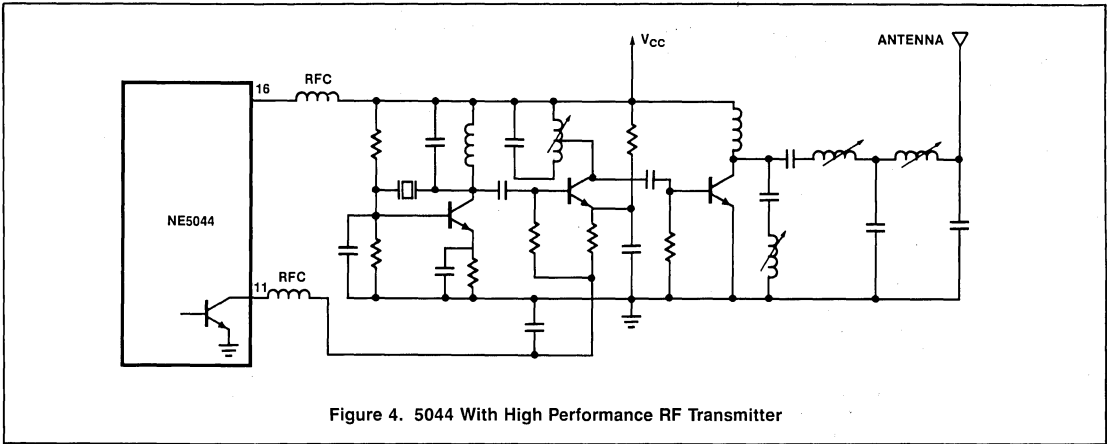

Figure 4. 5044 With High Performance RF Transmitter

the design of the pulse stretchers in the servos. The 5044 can be operated as a variable frame encoder by discharging the capacitor C_F each time the output goes high. After the last output pulse C_F is allowed to charge fully and the frame generator resets the encoder to channel 1. In this mode, the frame generator operates as a monostable multivibrator. Figure 5 shows the external connection. The sync pulse width (time between the falling edge of the last output pulse and the rising edge of the first pulse) is given by

$$T_S = .85 R_F C_F + R_1 C_{mux}$$

So if a sync pulse of 6ms is desired and $C_F = .1\mu F$, then

$$R_F = \frac{.85 \times 6ms - .047\mu F \cdot 27k\Omega}{.1\mu F} \cong 39k$$

Some applications may require an RF bypass on each of the multiplexer inputs, depending on PC board layout and the wiring between the control pots and the board. If such is the case, a $.001\mu F$ capacitor is sufficient. Pin 12 may also require a bypass capacitor of $0.1\mu F$.

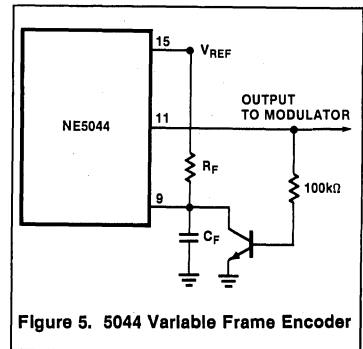

Figure 5. 5044 Variable Frame Encoder

DECODER APPLICATIONS

In most applications, the decoder input will be derived from the decoder of a radio receiver and will have the following characteristics:

1. Contain thermal noise at low levels
2. Will vary in level depending on R/F signal strength and may contain flutter

The thermal noise can be filtered with a simple RC circuit. This filter should have a cut-off frequency of about 3kHz which is approximately the bandwidth of the receiver IF amplifier. A lower cut-off frequency would limit the information rate and resolution of the system. Figure 1 shows the external connections for the decoder input amplifier in which the above-mentioned conditions are handled. Diodes D1 and D2 charge the 1μF coupling capacitor to the peak input voltage minus the fixed voltage at pin 12 and the diode drops. D2 also clamps the input signal reaching A1. The .2μF capacitor forms a filter which allows the amplitude of the input to vary over a wide range and at high rates (as a result of RF flutter in the receiver) without false triggering the decoder. When flutter occurs the baseline of the positive input pulses varies as shown in Figure 2. The .2μF charges up to the average baseline voltage but the 10k resistor does not allow it to be charged by the information pulses. Thus, so long as the pulse peaks exceed the baseline voltage by greater than the drop across diode D₂, the system will be unaffected by baseline flutter no matter what its rate is.

Positive feedback has also been incorporated in the connection of Figure 1 to provide 100mV of hysteresis on the threshold. When the input (pin 13) is low, the current generator is off and pin 11 is near ground. However, when pin 13 goes positive, the current generator turns on and approximately 150μA is sourced. This raises pin 11 by 150μA × 4.7kΩ = 0.7V. The threshold is now given by

$$\begin{aligned}
 V_{\text{threshold (on)}} &= V_{12} - V_{13} \\
 &= (V_{12} - V_{11}) \left(\frac{1}{1 + R_4/R_3} \right) \\
 &= (3 - 0.7) \left(\frac{1}{1 + 330k/51k} \right) \\
 &= 0.3V
 \end{aligned}$$

So the threshold has been reduced by 100mV or the amplifier will not turn off until the input drops below 0.3V. A low pass filter is also used in the circuit of Figure 1. The 5.6kΩ and .01μF form a 2.8kHz low pass filter to improve the noise rejection characteristics of the detector.

A particular application of the NE5045 may not require all the components shown in Figure 1, however this circuit demonstrates all the features of the decoder which may be utilized.

Figure 3 shows a decoder connected for negative input pulses without hysteresis or flutter rejection. In this case, V₁₃ is set to 3V and V₁₂ is set to 3V + V_{threshold}. If V_{threshold} = 0.4V

$$\begin{aligned}
 R_4 &= \frac{V_R - V_{12}}{V_{\text{threshold}}/51k} = \frac{4.1 - 3.4}{0.4/51k} \\
 &= 89k\Omega \approx 91k\Omega.
 \end{aligned}$$

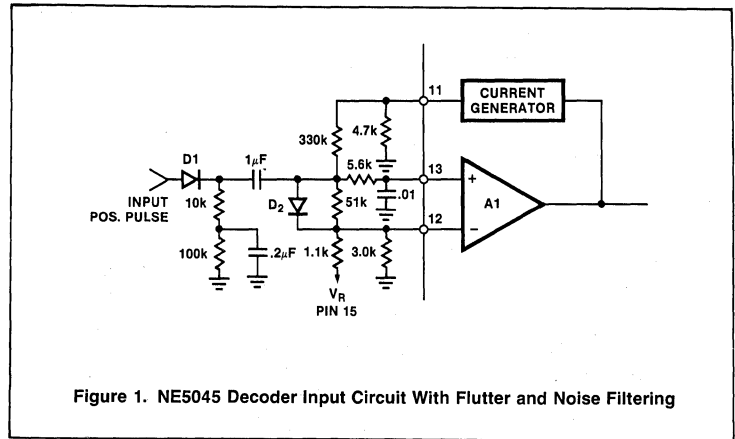

Figure 1. NE5045 Decoder Input Circuit With Flutter and Noise Filtering

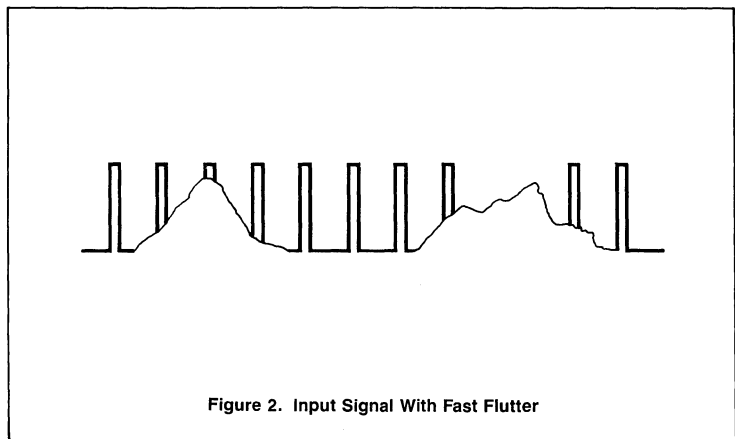

Figure 2. Input Signal With Fast Flutter

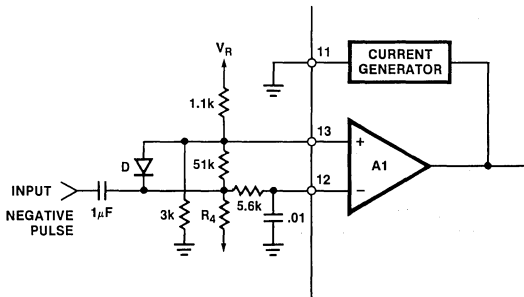

Figure 3. NE5045 Decoder With Neg. Pulse Input

APPLICATIONS

DESCRIPTION

The NE544 is a new servo amplifier design for digital proportional RC systems which incorporates the latest state-of-the-art in integrated circuit technology. The basic systems concept was developed in close cooperation with a number of leading manufacturers of radio control equipment.

The design philosophy behind the NE544 was to provide the RC servo systems designer with maximum flexibility in adapting the amplifier performance characteristic to his particular servo system and at the same time to keep the external components count low. To achieve this goal, all the basic servo amplifier functions, such as motor drive, deadband and minimum output pulse, are integrated into the IC, but can be modified over a wide range by using external transistors or padding resistors respectively. This makes it possible to use the IC for extremely low cost applications as well as for the most sophisticated RC servo systems. Additional features of the circuit are very low standby power drain (typically less than 6mA), an internal voltage regulator for improved power supply rejection and a highly accurate monostable multivibrator. This circuit may be used in 2 different charging modes: linear and exponential. In the linear charging mode, the internally generated charging current is programmable over a wide range with a resistor to ground. Usable currents range from below 10µA to above 1mA. In the exponential charging mode, the internal current source is simply bypassed with an external resistor from pin 1 to the regulator output.

The bidirectional power output stage can supply load currents up to 500mA (NE544N package only). Output drive pins for external PNP transistor provide the user with the option of increasing the motor drive by bypassing the internal compound PNP transistors.

The NE544 also provides external pins to adjust deadband and to vary the hysteresis of the Schmitt trigger. This gives the user maximum flexibility in adapting the servo amplifier to a large variety of servo motor and gear train combinations. A dynamic brake integrated into the output stage serves to suppress inductive noise spikes and helps to improve the dynamic performance.

IC PACKAGE

The NE544N has sufficient power dissipation to handle motors with a minimum of 8Ω impedance with the integrated power transistors.

OPERATION

The basic building blocks of the NE544 servo driver are shown in Figure 1.

A positive input signal applied to the input pin (4) sets the input flip-flop and starts the one shot time period. The directional logic compares the length of the input pulse to that of the internal one shot and stores the result of this comparison in a directional flip-flop. The exact difference in pulse width between input and internal one shot pulse, called the error pulse, is also fed to a pulse stretcher, deadband and trigger circuit. These circuits determine 3 important parameters:

1. *Deadband*—The minimum difference between input pulse and internally generated pulse to turn on the output
2. *Minimum output pulse*—The smallest output pulse that can be generated from the trigger circuit
3. *Pulse stretcher gain*—The relationship between error pulse and output pulse

Proper adjustment of these parameters can be achieved with external resistors and capacitors at pins 6, 7 and 8. The trigger circuit activates the gate for a precise length of time to provide drive to the bridge output circuitry in proportion to the length of the error pulse.

TYPICAL APPLICATION AS A LINEAR SERVO AMPLIFIER

Figure 2 shows a typical connection of the NE544 as a high performance servo amplifier for remote control servo applications using the 14-pin dual in-line package. The input pulse may be dc coupled if a reset is used in the receiver decoder. Output drive to the servo motor is applied through pins 9 and 13 with PNP transistors T_A and T_B optional for high performance applications. The wiper of potentiometer RP is mechanically coupled to the servo control surface providing positional feedback. The internal one shot in this application is operating in the linear charging code.

LINEAR ONE SHOT TIMING

In contrast to most conventional servo drivers which use exponential one shots, the NE544 uses a linear one shot. This makes it possible to design servo systems with very high positional accuracy and linear pulse width to position transfer functions. The timing of the linear one shot can best be explained with the help of Figure 3.

The timing cycle starts after the input pulse sets the input flip-flop and releases the reset transistor T_R. This allows current I_C to charge up capacitor C_T in a linear fashion. Current I is programmed by resistor R_T. The op amp serves as a linear voltage to current converter, with the current through R_T and C_T matched identically. The inverting input of the op amp is internally referenced to 1.8 volts so that the current I_R is given by this equation.

Equation 1

$$I_R = \frac{V_I}{R_T} = \frac{1.8V}{R_T}$$

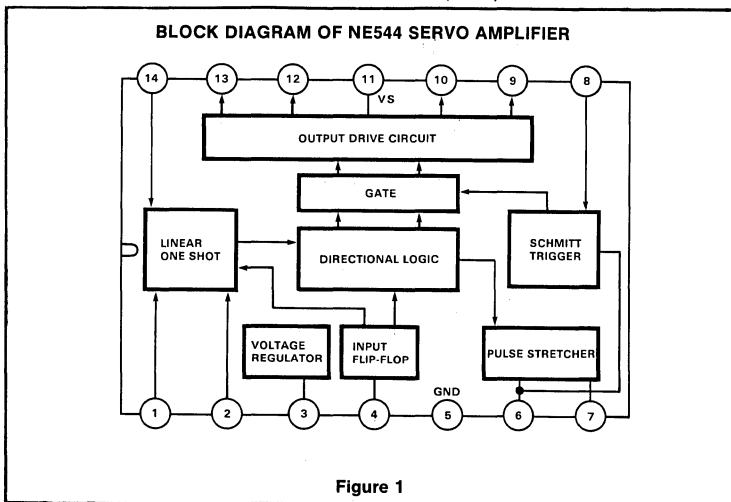

Figure 1

TYPICAL CONNECTION OF NE544AA FOR LINEAR ONE SHOT TIMING

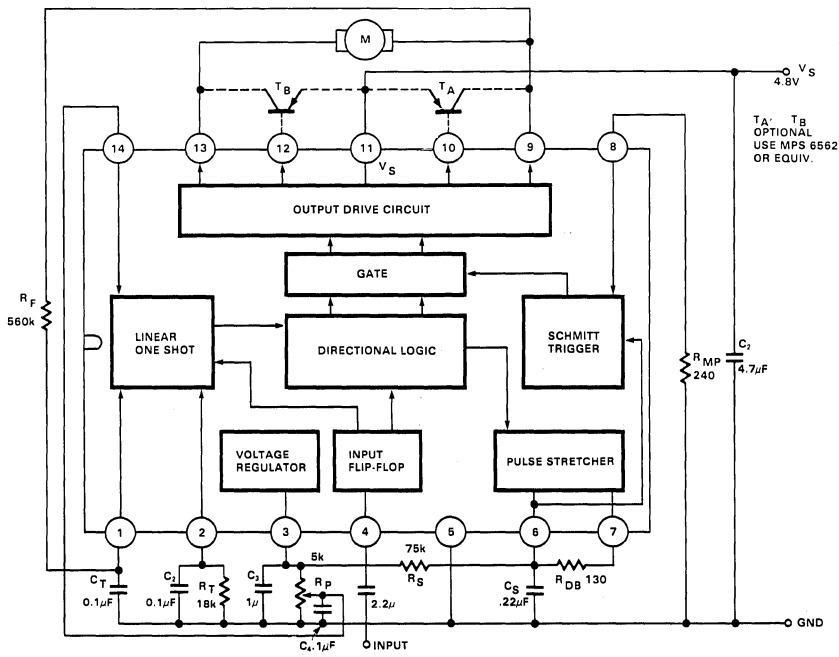

Figure 2

The timing period of the internal one shot is complete when the voltage ramp at pin 1 reaches the threshold set at pin 14. This time is given by this equation.

Equation 2

$$T = \frac{C_T V_{14}}{I_R}$$

If we substitute the typical values given in Figure 2 we obtain this equation.

Equation 3

$$T = \frac{(0.1 \times 10^{-6}F)(1.5V)}{0.1 \times 10^{-3}A} = 1.5 \times 10^{-3}sec$$

When the internal one shot has timed out, the input flip-flop is reset. The reset transistor T_R is clamped to ground as soon as the input pulse goes to zero. Figure 4 shows the relationship of the input pulse, the internal one shot pulse, the ramp at pin 1 and the error pulse for a condition where the input pulse is longer than the internal pulse.

In contrast to most conventional designs, the total value of the feedback pot R_P is no longer important, since it serves only as a voltage divider. A reasonable lower limit is $1.5k\Omega$ to keep power consumption low and to prevent loading of the voltage regulator. In the typical application a $5K$ pot is used.

SIMPLIFIED CIRCUIT DIAGRAM OF LINEAR ONE SHOT

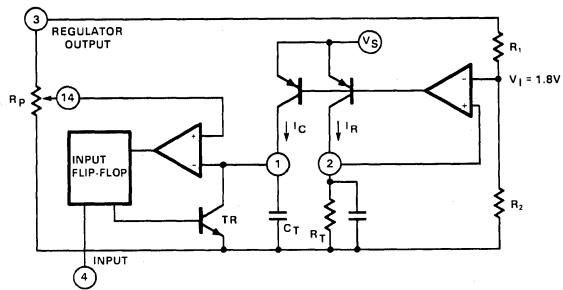

Figure 3

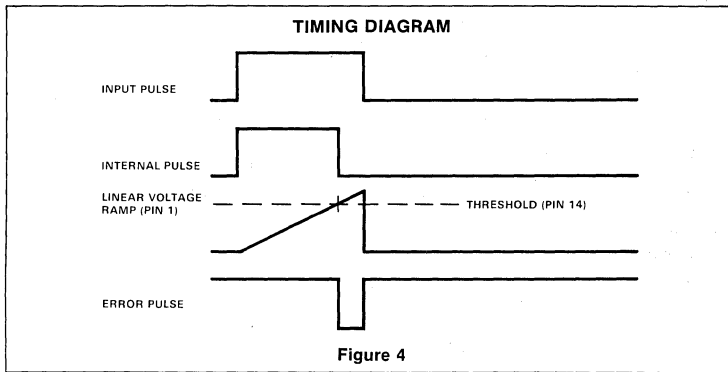

Figure 4

ADJUSTMENT OF SERVO TRAVEL

The amount of angular rotation of the feedback pot R_P (or of the servo control surface) can be changed by simply changing the charging current. Figure 5 shows a plot of the servo travel as a function of input pulse width for 3 different values of current setting resistors R_T .

It should be noted that the center position of the wiper (1.5ms) will also shift when the amount of travel is changed. This shift may be compensated by mechanical wiper adjustment or by the addition of padding resistors as described in the next paragraph.

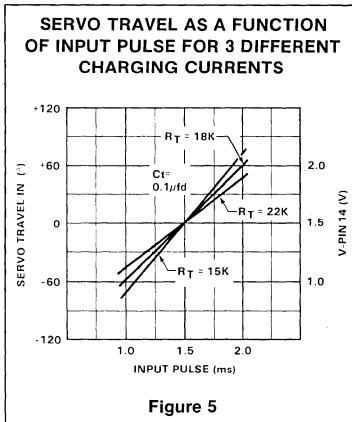

Figure 5

INCREASING SERVO TRAVEL TO MORE THAN 180°

Servo travel may be increased up to the maximum active area of the feedback pot by using padding resistors R_A and R_B as shown in Figure 6.

Figure 7 shows the values of resistors which are required to obtain a desired amount of servo travel.

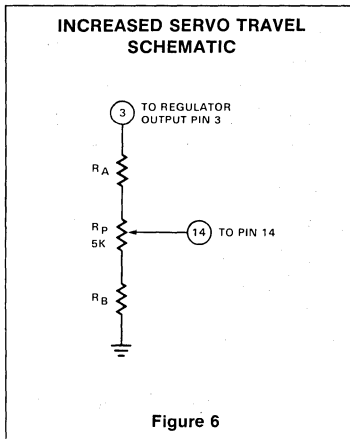

Figure 6

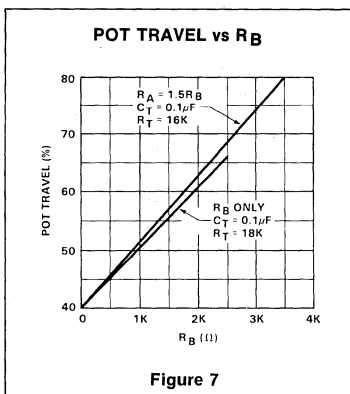

Figure 7

EXPONENTIAL TIMING OPTION

If an exponential timing characteristic is desired, the circuit shown in Figure 8 may be used.

The time constant of the one shot in this case is given by this equation.

Equation 4

$$T_E = R_T C_T \ln \frac{V_3}{V_3 - V_{14}}$$

Substituting the values shown in Figure 8 where $V_3 = 2.5V$ and $V_{14} = 1.5V$ at the center position we obtain this equation.

Equation 5

$$T = (16k\Omega) (0.1\mu F) \ln \frac{2.5V}{2.5V - 1.5V} = 1.47ms$$

The center position and servo travel can be changed as described in the previous section for linear operation.

PULSE STRETCHER

The pulse stretcher and associated circuitry shown in Figure 9 determine important servo-parameters such as minimum output pulse, deadband and error pulse to output pulse conversion gain.

Initially transistor Q_S is off and capacitor C_S is charged to the regulator voltage. An error pulse from gate G turns on transistor Q_S and discharges capacitor C_S to ground through the parallel combination of R_{DB} and R_I . The deadband is determined by the time it takes for the voltage at pin 6 to reach the trigger threshold (V_1) as shown in Figure 10.

As soon as the Schmitt trigger threshold is reached, transistor Q_S is turned off and the capacitor is discharged through a constant current source I_S until the error pulse disappears.

After the error pulse disappears, capacitor C_S is charged up through resistor R_S . The output remains turned on until the upper threshold (V_2) of the Schmitt trigger is reached. The minimum output pulse is determined by the hysteresis in the Schmitt trigger. This hysteresis may be varied over a wide range by connecting an external resistor R_{MP} from pin 8 to ground or positive supply.

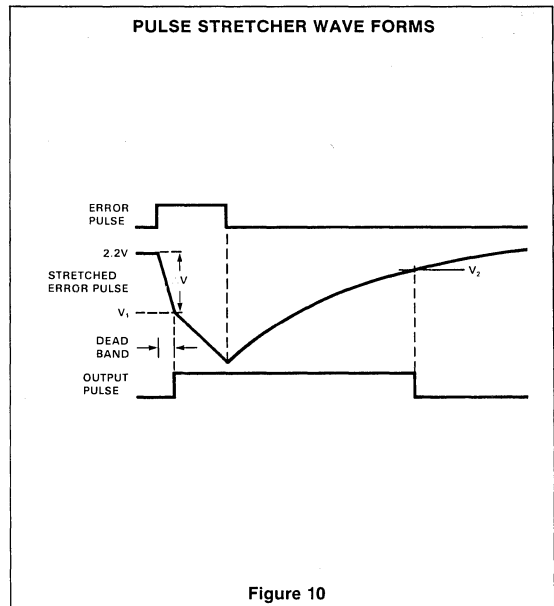
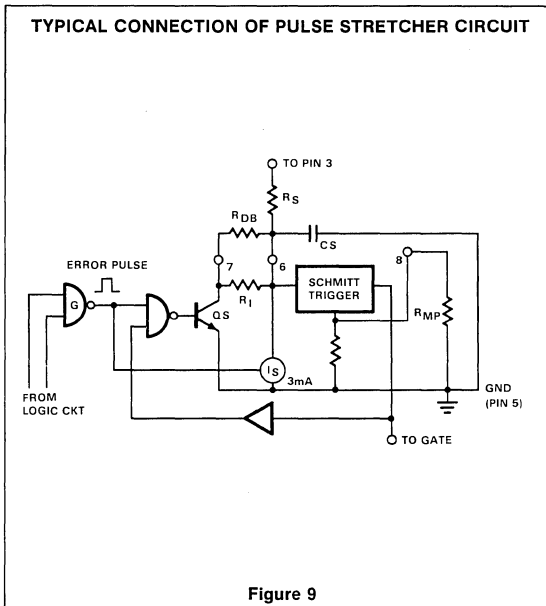
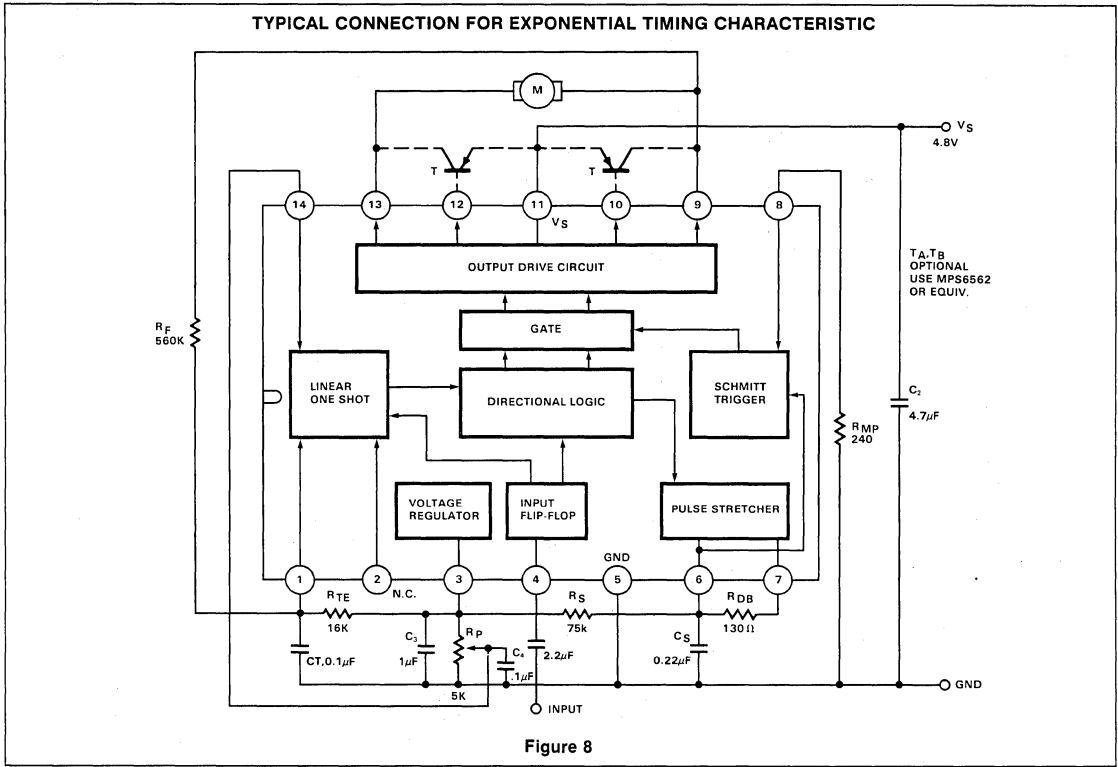

DEADBAND

Referring to Figure 10, the deadband can be calculated using these equations where T_{DB} is deadband in microseconds, C_S is the pulse stretching capacitor, I_T is the total discharge current, and ΔV is approximately .65 volts. The deadband is determined by the time it takes to discharge capacitor C_S from its initial voltage to the Schmitt trigger threshold.

Equations 6

$$T_{DB} \approx \frac{C_S \Delta V}{I_T} \text{ and } I_T \approx I_S + \frac{2.2V (R_I + R_{DB})}{R_I + R_{DB}}$$

The value of the internal deadband resistor R_I is approximately 150 Ω . I_T can be calculated with this equation.

Equation 7

$$I_T = 3\text{mA} + \frac{2.2V (150 + R_{DB})}{150 + R_{DB}}$$

For the typical values shown in Figure 2 we obtain this equation.

Equation 8

$$I_T = 3 + 27 = 30\text{mA}$$

The deadband can then be calculated using Equations 6 to obtain this equation.

Equation 9

$$T_{DB} = \frac{(2.2 \times \mu\text{F}) \cdot .65\text{V}}{30\text{mA}} = 4.8\mu\text{s}$$

The total deadband then is twice this value, i.e., $T_{DB \text{ Total}} = \pm T_{DB}$.

Figure 11 shows plots of total deadband versus R_{DB} for 3 different values of pulse stretching capacitor C_S . The value of the minimum pulse resistor R_{MP} is held constant at 240 Ω .

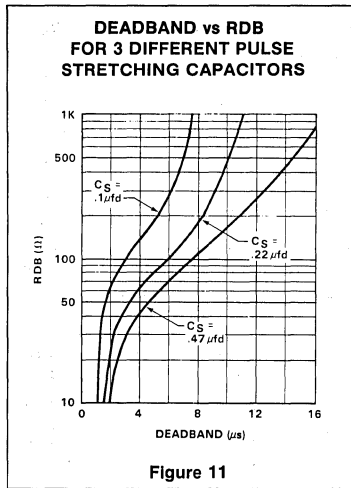

Figure 11

MINIMUM PULSE

The length of the minimum output pulse can be adjusted by changing the hysteresis of the Schmitt trigger. As can be seen from Figure 10, this will also affect the deadband. To aid in the selection of the right value of minimum pulse and deadband resistor, Table 1 may be consulted. This table gives typical values of deadband and minimum pulse for 5 combinations of R_{DB} and R_{MP} with C_S and R_S held constant at 0.22 μF and 75k Ω respectively.

If a particular application requires different values, C_S and R_S can be changed accordingly. A capacitor with low series resistance should be used for C_S . If C_S is too resistive, the minimum pulse becomes equal to the error pulse causing the servo to buzz at the rest position.

RMP	RDB	DEAD-BAND (μs)	MINIMUM PULSE (ms)
		± 7	5.0
360	130	± 5	2.5
240	130	± 5	2.0
160	82	± 3.5	1.6
100	51	± 2.3	2.0

Table 1 VALUES OF DEADBAND AND MINIMUM PULSE FOR $C_S = 0.22\mu\text{F}$ AND $R_S = 75\text{k}\Omega$

PULSE STRETCHER GAIN

For given values of R_{DB} and R_{MP} , the gain of the pulse stretcher can be adjusted with capacitor C_S and resistor R_S . The values chosen in the typical application turn the outputs fully on with an error pulse of approximately 200 μs .

The charging resistor R_S can also be connected to the positive supply voltage instead of the voltage regulator output. This usually requires somewhat tighter tolerances on R_S and C_S , but allows operation over a wide range of supply voltage since pulse stretcher gain now varies inversely with supply voltage.

FEEDBACK RESISTORS FOR CLOSED LOOP DAMPING

The amount of feedback required for good closed loop damping depends on the motor and gear train used, the desired pulse stretcher gain and the deadband. In many applications, a single feedback resistor, R_F , from pin 9 to pin 1 is sufficient, since the dynamic brake provides some damping. If the mechanical gain is very high, an additional feedback resistor from pin 13 to pin 14 may be required.

A LOW-COST ANALOG/DIGITAL PROPORTIONAL CONTROL SYSTEM FOR PERSONAL COMPUTER AND ROBOTICS APPLICATIONS

Hans Stellrecht, Dan Hariton, Dietmar Beer
 Signetics Corporation, Sunnyvale, California
 Bob Blaschold
 Linear Design, Inc., Los Altos, California

1. ABSTRACT

This paper describes an integrated circuit chip set* designed for low-cost transmission of analog and digital data. The system provides remote motion control capability and is designed for personal computer or microprocessor control applications. The control system is based on a multichannel serial bus concept and uses pulse position modulation (PPM) for information transfer. The input and output of the system interfaces directly with a personal computer.

2. OVERVIEW OF CONTROL SYSTEM DATA BUSES

With the rapid expansion of microprocessors and personal computers into virtually all areas of modern life, there is an increasing need for methods of communication between computers and remote devices. Communication is usually accomplished by parallel digital data transfer and digital/analog conversion. This method is used in the case of most stationary computer peripheral devices. For movable peripheral equipment, or when communication has to cover larger distances, various forms of serial data concepts are used. The choice of a particular serial data bus system depends on cost/performance tradeoffs and possible requirements for coding and protocol standardization. In a digital system a serial message unit typically consists of a byte of serial digital data plus additional bits for addressing, synchronization, and other management functions.

In consumer applications, where low cost is an important factor, mixed digital and analog encoding methods can offer significant advantages over other serial encoding methods. The digital proportional system^{1,2} described here uses pulse position modulation for serial data transfer. In contrast to the pure digital systems, where one message block (or frame) contains one byte of data, the digital proportional system packs several bytes into one frame. This is possible because the information is encoded in the form of pulse position.

A comparison of various data transfer methods is shown in Table 1. The first three methods are purely digital and are mostly used for commercial serial bus systems and for computer networks. The fourth, a digital proportional method, is a special-purpose serial bus. It offers advantages in consumer applications due to combined analog and digital techniques. The concept also lends itself to either amplitude or frequency modulation for remote control.

Table 1. Comparison of Data Transfer Methods

TYPE	ENCODING	TYPICAL PERFORMANCE		APPLICATION
		ACCURACY	SPEED	
Digital Bus	Parallel Data	8/16 bit	1 Mbaud	Computer Peripherals
Asynchronous or Synchronous Bus	Serial Data	8 bit	300-1200 baud	Data Communication Computer Peripherals Robotics Serial Ports (RS-232) Telephone Modems
Computer Network	Serial Data	8/16 bit	1 Mbaud	Computers Communication
Digital Proportional Bus	Serial PPM	8 bit	3500 baud	Consumer Home Control Robotics

* Signetics NE5044 and NE5045 Encoder/Decoder, NE544 Servoamplifier, and NE5018 8-bit D/A Converter.

3. DESCRIPTION OF THE ANALOG/DIGITAL PROPORTIONAL CONTROL SYSTEM

In a typical application, the system is interfaced to a personal computer through one of its peripheral 3-state I/O ports as shown in Figure 1. The 8-bit digital-to-pulse position encoder and the personal computer form the control center. In addition to the 8 data lines, 3 control lines are used to connect the computer to the pulse position encoder. The encoded information is transmitted via a standard radio control (RF) link. The signal is detected by a receiver in the remote control device or robot. The pulse position information is then decoded and processed with standard proportional circuit techniques³.

The bus control program occupies 600 bytes of memory. The rest of the computer memory is available to the user for recording and playing back the stored programs. A floppy disk drive is used for permanent storage of information.

PULSE POSITION CODING AND SERVOMOTOR CONTROL

The circuit blocks required to perform the pulse position encoding function are shown in Figure 2. The encoder contains all the active circuits necessary to convert successive 8-bit words of digital information into accurate pulse position modulated signals, for up to 7 channels. Parallel data from the computer I/O bus is latched directly to an 8-bit DAC input. A bidirectional constant current generator alternately charges and discharges the CMUX capacitor.

The resulting voltage waveform is shown in the second trace of Figure 3. Two high-gain comparators compare the multiplex capacitor (CMUX) voltage to the DAC output voltage (VA) and to the range input voltage (Vrange). The counter control logic uses the two comparator output signals to increment the channel count and to reverse the current source polarity. Under computer control, the comparator analog input signal is taken from the DAC output; under manual control, this signal is taken from the multiplex switch analog output. The multiplex switch is controlled by the channel counter, and samples the analog voltages generated by the manual joystick inputs. The encoder output waveforms are shown in Figure 3. The top trace shows the frame pulse, which controls the encoder frame time and can be operated in either variable or fixed frame mode. The lower two traces show the channel pulses and the latch enable pulses, respectively. The latch enable pulse (DE) updates the DAC input data.

Two ICs are used to perform pulse decoding and servocontrol as shown in Figure 4. The serial PPM signal, after RF detection, is decoded into parallel pulses by the decoding IC. Each channel is now a pulse-width modulated signal. This IC contains two monostable multivibrators used for frame synchronization and for increased noise immunity. Each channel pulse is then sent to a servocontrol IC, which demodulates the pulse width information into position, speed, or other control parameters³. In this circuit a servoloop is used to compare the input pulse to an internally generated pulse that is proportional to the control parameter. Negative feedback is then used to drive the servomotor output to the desired position.

4. COMPUTER CONTROLLED ROBOTICS APPLICATION

The serial data transmission and proportional control system described in this paper can be used for various applications such as remote motion control, home control, alarm systems, and remote video games. A wide choice of transmission media can be used: hardware, RF, current carrier, infrared, fiberoptics, and ultrasonic.

To take full advantage of the availability of multichannel analog data transmission, a robotics application was implemented. The system uses 7 channels. Each channel represents a robot control surface as listed below:

- A1--Forward/Backward Motion
- A2--Steering(Direction Control)
- A3--Head Rotation
- A4--Shoulder (Arm) Movement
- A5--Elbow Movement
- A6--Wrist Rotation
- A7--Hand (Claw) Open/Closed

The robot can be exercised either manually or by computer. Individual channels may be recorded and played simultaneously. Reprogramming several channels while maintaining the rest unchanged becomes possible. The robot can be "taught" or its actions can be corrected. The final result may be stored on floppy disk for future playback. In the "Play" mode, the computer sends 8 bits per channel to a PPM encoder. In the "Learn" mode, manual inputs are converted into digital data and processed by the computer. Remote sensing capability can be added to the control system by adding a feedback transmission loop. Sensor feedback data is sent back to the computer and results in a full duplex system. Sensor information can then be processed and used to make decisions for execution by the forward path.

SUMMARY

A 7-channel robotics application was used to demonstrate the versatility of a serial bus concept that uses pulse position modulation. The consumer-oriented system interfaces directly with a personal computer and can be used in many control applications that require good performance at low cost.

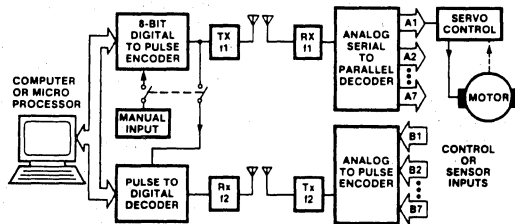

FIGURE 1. Block Diagram of the Analog/Digital Proportional Control System for Personal Computer Applications

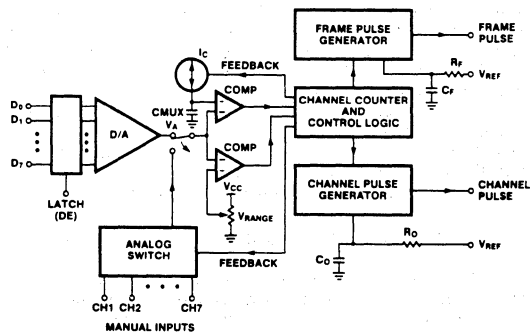

FIGURE 2. Block Diagram of the Digital to Pulse Position Encoder

ACKNOWLEDGEMENTS

The authors would like to express their appreciation to their colleagues at Signetics. In particular we thank Jock Ochiltree and Ed Ross for their support and encouragement throughout this project, and our former colleague Gary Kelson for his innovative design of the encoding and decoding concepts.

REFERENCES

1. J. Maloney, "Six Channel Digital Proportional System," R/C Modeler Magazine, October 1973.
2. F. M. Marks and W. Winter, "Radio Control for Model Builders," Hayden Book Co. Inc., 1972.
3. Hans H. Stellrecht and Robert W. Hamilton, "A Linear Servoamplifier for Remote Control Applications," IEEE Transactions on Consumer Electronics, February 1977.

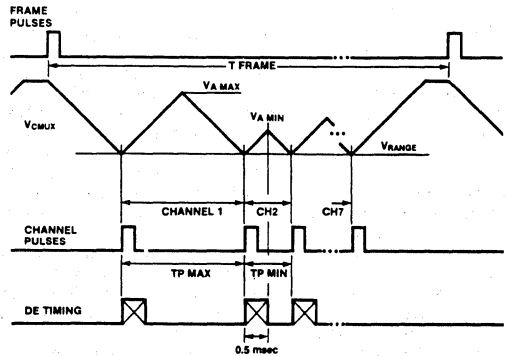

FIGURE 3. Systems Timing Diagram

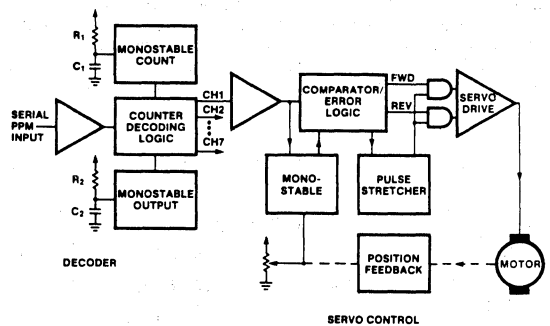

FIGURE 4. Block Diagram of the Serial to Parallel Decoder and of the Servocontrol

Section 10 Package Outline Index

INDEX

SECTION 10 — PACKAGE INFORMATION

Index	10-1
Package Outlines for product with prefixes: ADC, AM, CA, DAC, LF, LM, MC, NE, SA, SE, SG, μ A, ULN	
D	10-3
E	10-5
F	10-7
H	10-8
I	10-11
N	10-11
Package Outlines for product with prefixes: OM, MAB, MAF, PC, PN, SAA, SAB, SAF, TA, TB, TC, TD, TE	10-12
Soldering Notes	10-16
8-Lead Dual-In-Line; Plastic (SOT-97A)	10-16
8-Lead Dual-In-Line; Ceramic (CERDIP) (SOT-151A)	10-16
8-Lead Dual-In-Line; Metal Ceramic (CERDIL) (SOT-153B)	10-17
9-Lead Single-In-Line; Plastic (SOT-110B)	10-17
9-Lead Single-In-Line; Plastic Power (SOT-131A, B)	10-18
9-Lead Single-In-Line; Plastic (SOT-142)	10-18
9-Lead Sil-Bent-To-Dil; Plastic Power (SOT-157B)	10-19
12-Lead Dual-In-Line; Plastic With Metal Cooling Fin (SOT-150)	10-19
13-Lead Sil-Bent-To-Dil; Plastic Power (SOT-141B)	10-20
14-Lead Dual-In-Line; Plastic (SOT-27K, M, T)	10-20
14-Lead Dual-In-Line; Ceramic (CERDIP) (SOT-73A, B, C)	10-21
14-Lead Dual-In-Line; Metal Ceramic (CERDIL) (SOT-83B)	10-21
16-Lead Dual-In-Line; Plastic (SOT-38)	10-22
16-Lead Dual-In-Line; Plastic (SOT-38A)	10-22
16-Lead Dual-In-Line; Plastic (SOT-38D, DE)	10-23
16-Lead Dual-In-Line; Plastic (SOT-38Z)	10-23
16-Lead Dual-In-Line; Plastic With Internal Heat Spreader (SOT-38 WE-2)	10-24
16-Lead Quadruple-In-Line; Plastic (SOT-58)	10-24
16-Lead Dual-In-Line; Ceramic (CERDIP) (SOT-74A, B, C)	10-25
16-Lead Dual-In-Line; Metal Ceramic (CERDIL) (SOT-84B)	10-25
18-Lead Dual-In-Line; Metal Ceramic (CERDIL) (SOT-85B)	10-26
18-Lead Dual-In-Line; Plastic (SOT-102A)	10-26
18-Lead Dual-In-Line; Plastic (SOT-102C)	10-27
18-Lead Dual-In-Line; Plastic (SOT-102CS)	10-27
18-Lead Dual-In-Line; Plastic (SOT-102G)	10-28
18-Lead Dual-In-Line; Ceramic (CERDIP) (SOT-133A, B)	10-28
20-Lead Dual-In-Line; Plastic (SOT-146)	10-29
20-Lead Dual-In-Line; Ceramic (CERDIP) (SOT-152B, C)	10-29
20-Lead Dual-In-Line; Metal Ceramic (CERDIL) (SOT-154B)	10-30
22-Lead Dual-In-Line; Plastic (SOT-116)	10-30
22-Lead Dual-In-Line; Metal Ceramic (CERDIL) (SOT-118B)	10-31
22-Lead Dual-In-Line; Ceramic (CERDIP) (SOT-134A)	10-31

INDEX

Package Outlines for product with prefixes: Con't

24-Lead Dual-In-Line; Metal Ceramic (CERDIL) (SOT-86A)	10-32
24-Lead Dual-In-Line; Ceramic (CERDIP) (SOT-94)	10-32
24-Lead Dual-In-Line; Plastic With Internal Heat Spreader (SOT-101A, B)	10-33
28-Lead Dual-In-Line; Metal Ceramic (CERDIL) (SOT-87A)	10-33
28-Lead Dual-In-Line; Metal Ceramic (CERDIL) (SOT-87B)	10-34
28-Lead Dual-In-Line; Plastic (SOT-117)	10-34
28-Lead Dual-In-Line; Plastic (SOT-117D)	10-35
28-Lead Dual-In-Line; Ceramic (CERDIP) (SOT-135A)	10-35
40-Lead Dual-In-Line; Metal Ceramic (CERDIL) (SOT-88)	10-36
40-Lead Dual-In-Line; Metal Ceramic (CERDIL) (SOT-88B)	10-36
40-Lead Dual-In-Line; Plastic (SOT-129)	10-37
40-Lead Dual-In-Line; Ceramic (CERDIP) (SOT-145)	10-37

Microminiature Package Outlines

8-Lead Mini-Pack; Plastic (SO-8, SOT-96A)	10-38
8-Lead Mini-Pack; Plastic (VSO-8, SOT-176)	10-39
14-Lead Mini-Pack; Plastic (SO-14, SOT-108A)	10-39
16-Lead Mini-Pack; Plastic (SO-16, SOT-109A)	10-39
16-Lead Mini-Pack; Plastic (SO-16L, SOT-162A)	10-40
20-Lead Mini-Pack; Plastic (SO-20, SOT-163A)	10-40
24-Lead Mini-Pack; Plastic (SO-24, SOT-137A)	10-41
28-Lead Mini-Pack; Plastic (SO-28, SOT-136A)	10-41
40-Lead Mini-Pack; Plastic (VSO-40, SOT-158A)	10-42
40-Lead Mini-Pack; Plastic (Opposite Bent Leads) (VSO-40, SOT-158B)	10-42

PACKAGE OUTLINES

FOR PREFIXES: ADC, AM, CA, DAC, LF, LM, MC, NE, SA, SE, SG, μ A, ULN

INTRODUCTION

The following information applies to all packages unless otherwise specified on individual package outline drawings.

General

1. Dimensions shown are metric units (millimeters), except those in parentheses which are English units (inches).
2. Lead spacing shall be measured within this zone.
 - a. Shoulder and lead tip dimensions are to centerline of leads.
3. Tolerances non-cumulative.
4. Thermal resistance values are determined by utilizing the linear temperature dependence of the forward voltage drop across the substrate diode in a digital device to monitor the junction temperature rise during known power application across V_{CC} and ground. The values are based upon 120 mils square die for plastic packages and a 90 mils square die in the smallest available cavity for hermetic packages. All units were solder mounted to P.C. boards, with standard stand-off, for measurement.

PLASTIC ONLY

5. Lead material: Alloy 42 (Nickel/Iron Alloy) Olin 194 (Copper Alloy) or equivalents, solder dipped.
6. Body material: Plastic (Epoxy)
7. Round hole in top corner denotes lead No. 1.
8. Body dimensions do not include molding flash.
9. SO Packages—microminiature packages.
 - a. Lead material: Alloy-42.
 - b. Body material: Plastic (Epoxy).

HERMETIC ONLY

10. Lead material
 - a. ASTM alloy F-15 (KOVAR) or equivalent—gold plated, tin plated, or solder dipped.
 - b. ASTM alloy F-30 (Alloy 42) or equivalent—tin plated, gold plated or solder dipped.
 - c. ASTM alloy F-15 (KOVAR) or equivalent—gold plated.
11. Body Material
 - a. Eyelet, ASTM alloy F-15 or equivalent—gold or tin plated, glass body.

- b. Ceramic with glass seal at leads.
- c. BeO ceramic with glass seal at leads.
- d. Ceramic with ASTM alloy F-30 or equivalent.
12. Lid Material
 - a. Nickel or tin plated nickel, weld seal.
 - b. Ceramic, glass seal.
 - c. ASTM alloy F-15 or equivalent, gold plated, alloy seal.
 - d. BeO Ceramic with glass seal.
13. Signetics symbol, angle cut, or lead tab denotes Lead No. 1.
14. Recommended minimum offset before lead bend.
15. Maximum glass climb .010 inches.
16. Maximum glass climb or lid skew is .010 inches.
17. Typical four places.
18. Dimension also applies to seating plane.

PACKAGE OUTLINES

FOR PREFIXES: ADC, AM, CA, DAC, LF, LM, MC, NE, SA, SE, SG, μ A, ULN

PLASTIC PACKAGES			
PACKAGE CODE		$\Theta_{JA}/\Theta_{JC} (^{\circ}\text{C/W})$	DESCRIPTION
Standard Dual-in-Line Packages			
8-Pin	N	99/50	
14-Pin	N	86/48	TO-116/MO-001
16-Pin	N	83/42	MO-001
18-Pin	N	63/29	
20-Pin	N	61/24	
22-Pin	N	51/23	
24-Pin	N	52/23	MO-015
28-Pin	N	52/23	MO-015
Metal Headers			
4-Pin	E	100/20	TO-46 Header
4-Pin	E	150/25	TO-72 Header
8-Pin	H	150/25	TO-5 Header
10-Pin	H	150/25	TO 5/TO-100 Header, Short Can
10-Pin	H	150/25	TO-5/TO-100 Header, Tall Can
Cerdip Family			
8-Pin	FE	110/30	Dual-in-Line Ceramic
14-Pin	F	110/30	Dual-in-Line Ceramic
16-Pin	F	100/30	Dual-in-Line Ceramic
18-Pin	F	93/27	Dual-in-Line Ceramic
20-Pin	F	90/25	Dual-in-Line Ceramic
22-Pin	F	75/27	Dual-in-Line Ceramic
24-Pin	F	60/26	Dual-in-Line Ceramic
28-Pin	F	57/27	Dual-in-Line Ceramic
Laminated Ceramic, Side Brazed Lead			
16-Pin	I	90/25	Dip Laminate

SO Package Thermal Data

Package Type	Package Mounting Technique*	Max. Allowable Power Diss. (mW) at 25°C	Max. Allowable Power Diss. (mW) at 70°C	Thermal Resistance ($\Theta_{JA}^{\circ}\text{C/Watt}$)	
				Average	Maximum
SO-14	PCB	658	421	190	225
	Ceramic	962	645	130	165
	Ceramic w/H.S.	1471	941	85	110
SO-16	PCB	862	551	145	170
	Ceramic	1250	800	100	125
	Ceramic w/H.S.	1923	1231	65	85
SO-16L	PCB	1250	800	100	140
	Ceramic	1743	1143	70	100
	Ceramic w/H.S.	2500	1600	50	65
SO-20	PCB	1471	941	85	115
	Ceramic	2273	1454	55	85
	Ceramic w/H.S.	3572	2286	35	55
SO-24	PCB	1563	1000	80	110
	Ceramic	2000	1600	50	80
	Ceramic w/H.S.	4167	2667	30	50

PCB = Printed circuit board

Ceramic = Ceramic substrate

Ceramic w/H.S. = Ceramic substrate with heat sink and/or thermal compound

*Air gap is 0.006 inches unless thermal compound is used

PACKAGE OUTLINES

FOR PREFIXES: ADC, AM, CA, DAC, LF, LM, MC, NE, SA, SE, SG, μ A, ULN

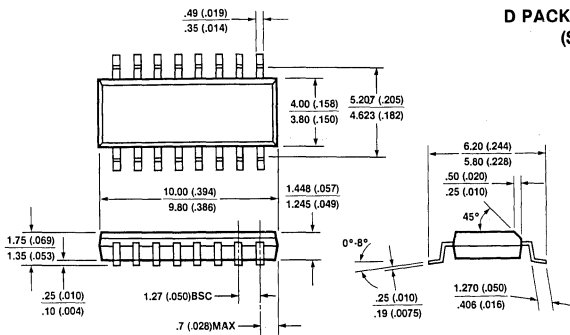
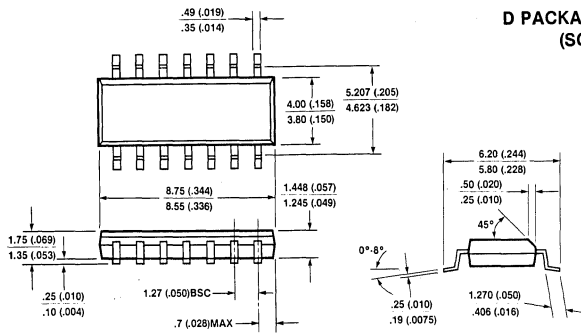
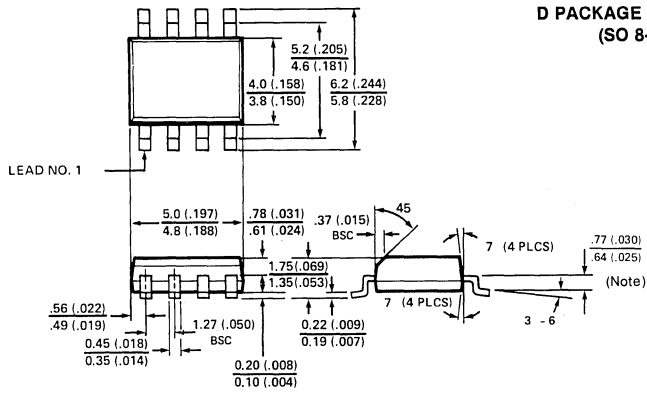

Note:
Dimensions shown are metric units (millimeters), except those in parentheses which are English units (inches).

PACKAGE OUTLINES

FOR PREFIXES: ADC, AM, CA, DAC, LF, LM, MC, NE, SA, SE, SG, μ A, ULN

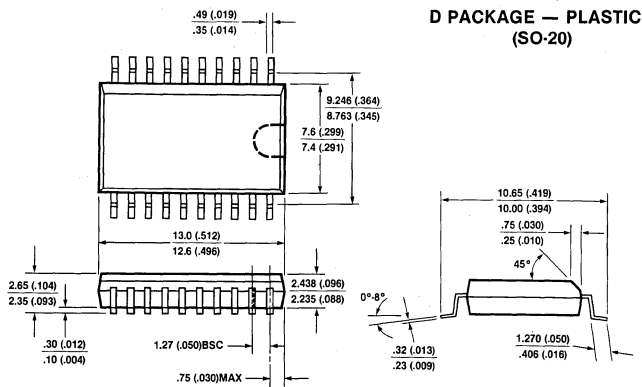
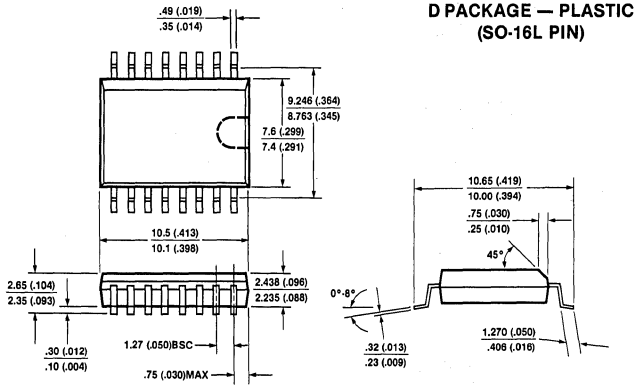

Note:
Dimensions shown are metric units (millimeters), except those in parentheses which are English units (inches).

PACKAGE OUTLINES

FOR PREFIXES: ADC, AM, CA, DAC, LF, LM, MC, NE, SA, SE, SG, μ A, ULN

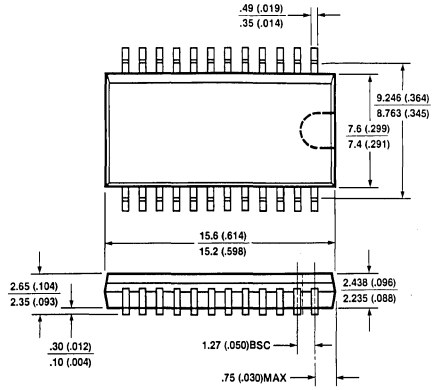

D PACKAGE-PLASTIC (SO-24)

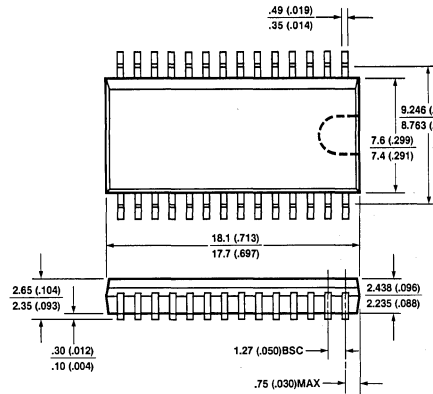
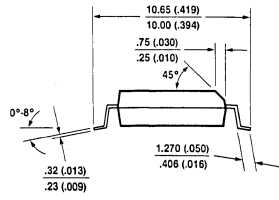

D PACKAGE-PLASTIC (SO-28)

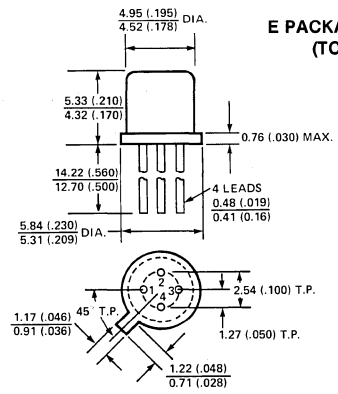
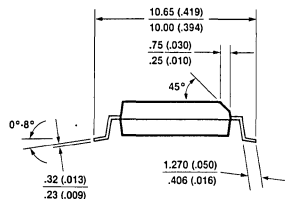

E PACKAGE — HERMETIC (TO-72 HEADER)

Note:
Dimensions shown are metric units (millimeters), except those in parentheses which are English units (inches).

PACKAGE OUTLINES

FOR PREFIXES: ADC, AM, CA, DAC, LF, LM, MC, NE, SA, SE, SG, μ A, ULN

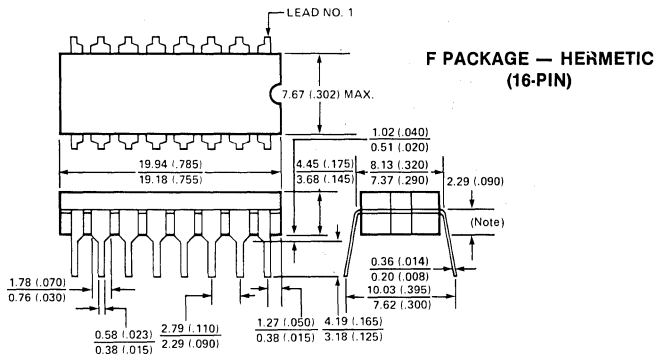
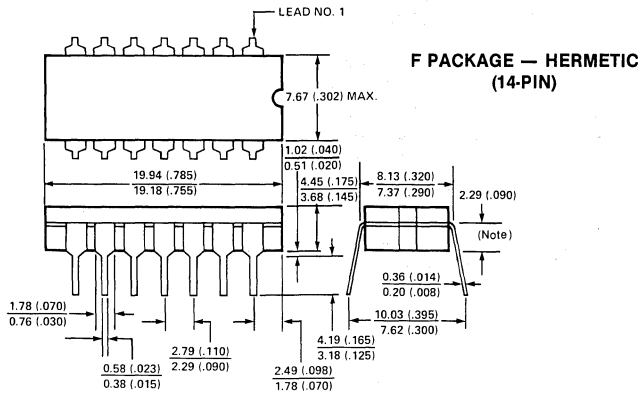
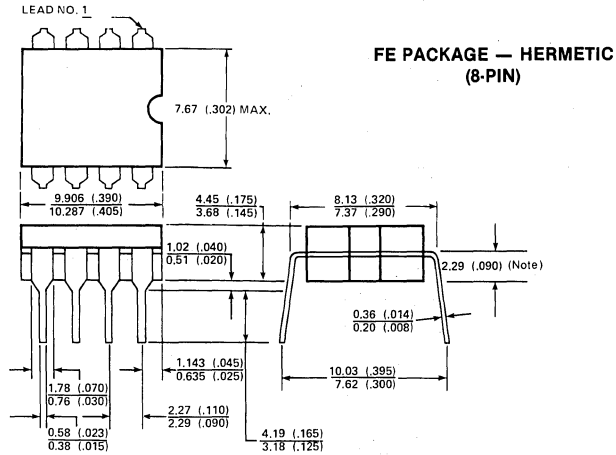

Note:
Dimensions shown are metric units (millimeters), except those in parentheses which are English units (inches).

PACKAGE OUTLINES

FOR PREFIXES: ADC, AM, CA, DAC, LF, LM, MC, NE, SA, SE, SG, μ A, ULN

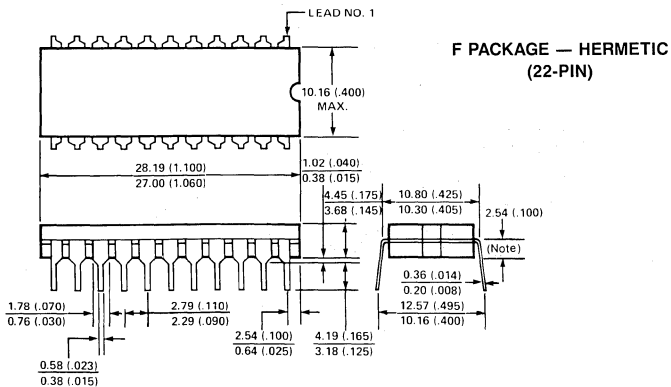
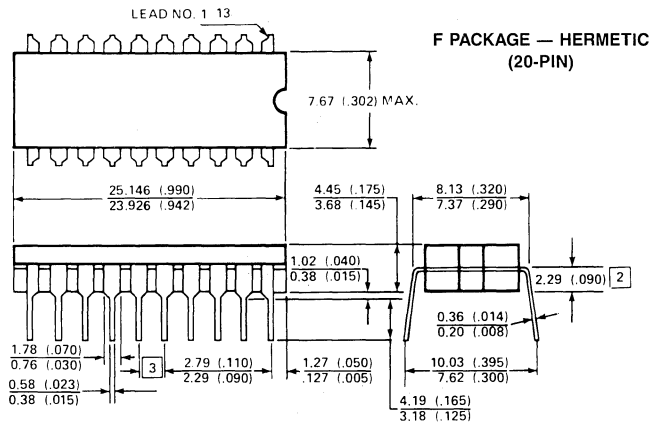
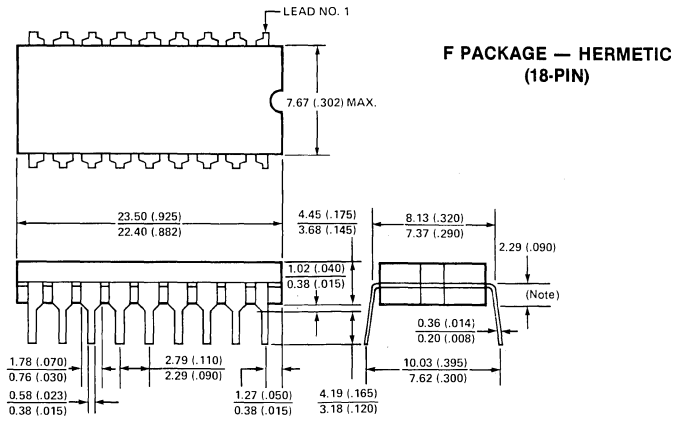

Note:
Dimensions shown are metric units (millimeters), except those in parentheses which are English units (inches).

PACKAGE OUTLINES

FOR PREFIXES: ADC, AM, CA, DAC, LF, LM, MC, NE, SA, SE, SG, μ A, ULN

**F PACKAGE — HERMETIC
(24-PIN)**

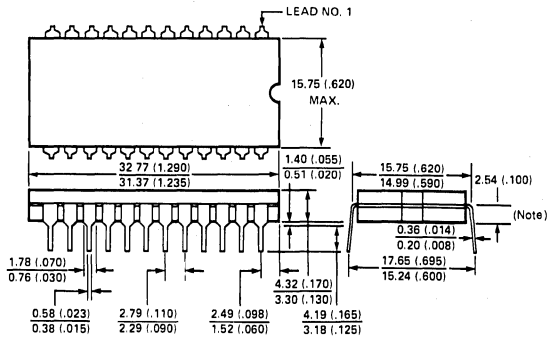

**F PACKAGE — HERMETIC
(28-PIN)**

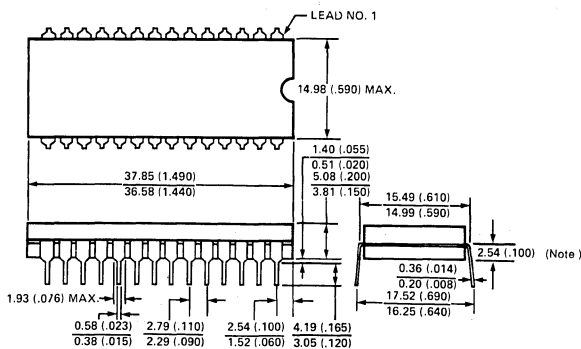

Note:
Dimensions shown are metric units (millimeters), except those in parentheses which are English units (inches).

PACKAGE OUTLINES

FOR PREFIXES: ADC, AM, CA, DAC, LF, LM, MC, NE, SA, SE, SG, μ A, ULN

**H PACKAGE — HERMETIC
8-PIN
(TO-5 HEADER)**

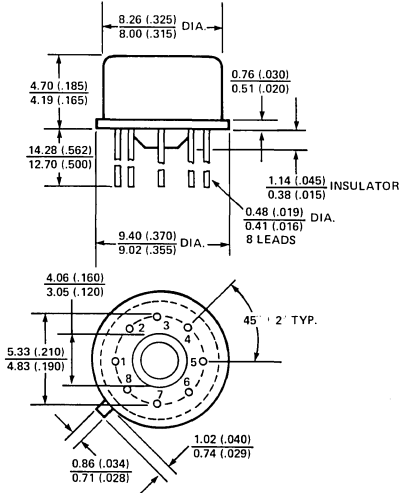

**H PACKAGE — HERMETIC
10-PIN
(TO-5/100 HEADER
SHORT CAN)**

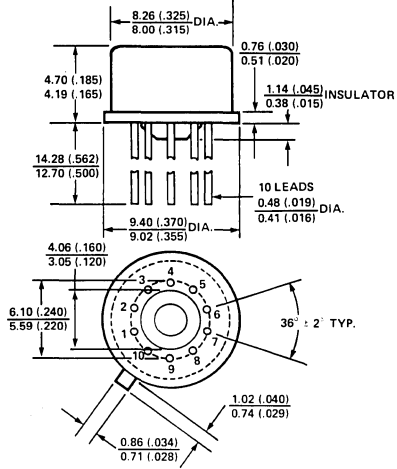

**H PACKAGE HERMETIC
10-PIN
(TO-5/100 HEADER
TALL CAN)**

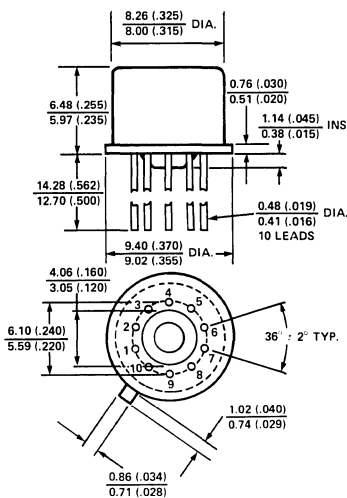

**I PACKAGE — HERMETIC
(16-PIN)**

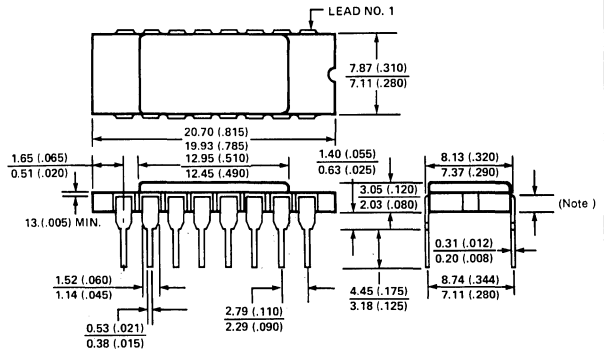

Note:

Dimensions shown are metric units (millimeters), except those in parentheses which are English units (inches).

PACKAGE OUTLINES

FOR PREFIXES: ADC, AM, CA, DAC, LF, LM, MC, NE, SA, SE, SG, μ A, ULN

**N PACKAGE — PLASTIC
(8-PIN)**

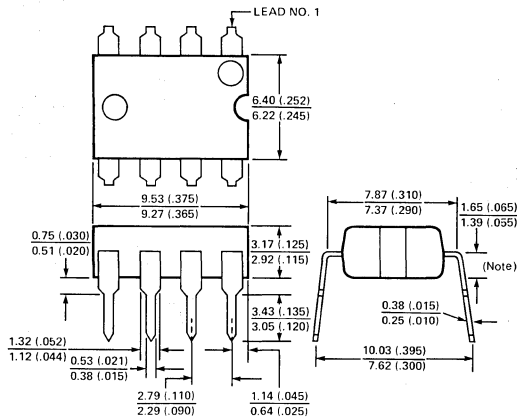

**N PACKAGE — PLASTIC
(14-PIN)**

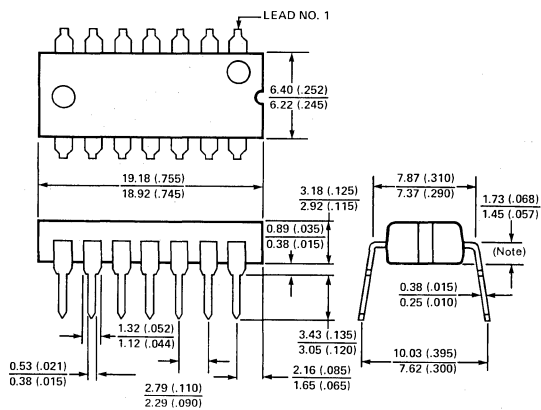

Note:
Dimensions shown are metric units (millimeters), except those in parentheses which are English units (inches).

PACKAGE OUTLINES

FOR PREFIXES: ADC, AM, CA, DAC, LF, LM, MC, NE, SA, SE, SG, μ A, ULN

N PACKAGE — PLASTIC (16-PIN)

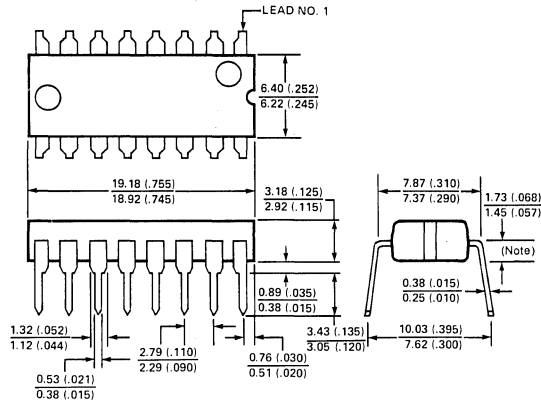

N PACKAGE — PLASTIC (18-PIN)

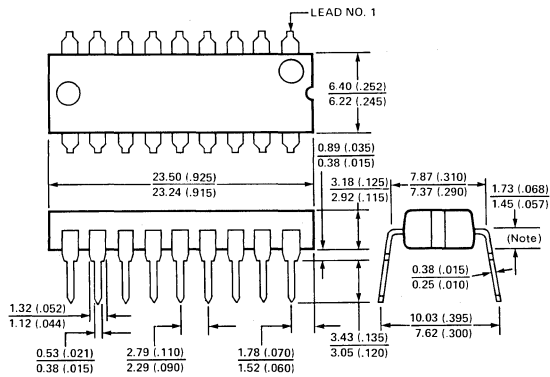

Note:
Dimensions shown are metric units (millimeters), except those in parentheses which are English units (inches).

PACKAGE OUTLINES

FOR PREFIXES: ADC, AM, CA, DAC, LF, LM, MC, NE, SA, SE, SG, μ A, ULN

**N PACKAGE — PLASTIC
(20-PIN)**

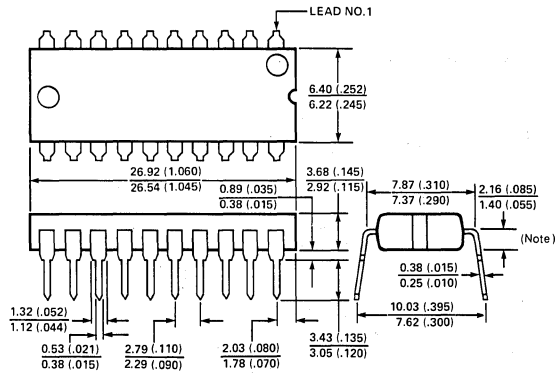

**N PACKAGE — PLASTIC
(22-PIN)**

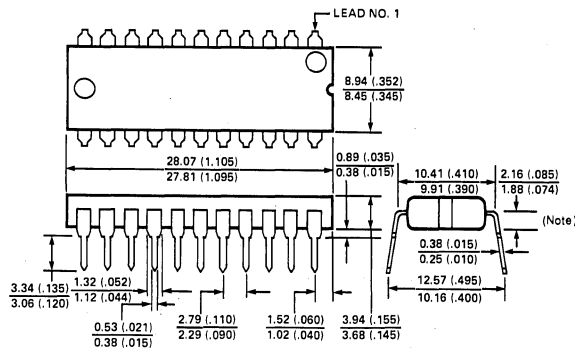

Note:
Dimensions shown are metric units (millimeters), except those in parentheses which are English units (inches).

PACKAGE OUTLINES

FOR PREFIXES: ADC, AM, CA, DAC, LF, LM, MC, NE, SA, SE, SG, μ A, ULN

**N PACKAGE — PLASTIC
(24-PIN)**

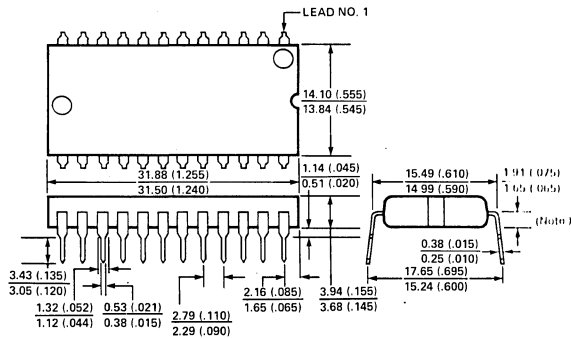

**N PACKAGE — PLASTIC
(28-PIN)**

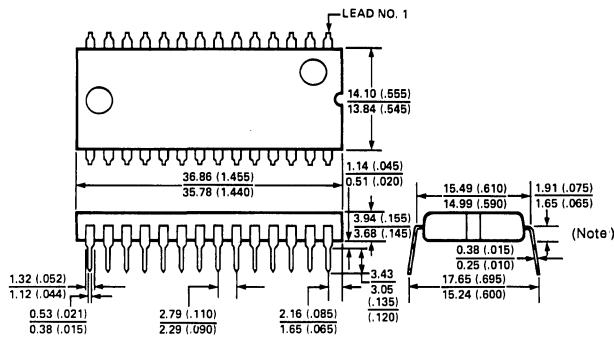

Note:
Dimensions shown are metric units (millimeters), except those in parentheses which are English units (inches).

PACKAGE OUTLINES

FOR PREFIXES OM, MAB, MAF, PC, PN, SAA, SAB, SAF, TA, TB, TC, TD, TE

SOLDERING

1. By hand

Apply the soldering iron below the seating plane (or not more than 2 mm above it).
 If its temperature is below 300 °C it must not be in contact for more than 10 seconds; if between 300 °C and 400 °C, for not more than 5 seconds.

2. By dip or wave

The maximum permissible temperature of the solder is 260 °C; this temperature must not be in contact with the joint for more than 5 seconds. The total contact time of successive solder waves must not exceed 5 seconds.
 The device may be mounted up to the seating plane, but the temperature of the plastic body must not exceed the specified storage maximum. If the printed-circuit board has been pre-heated, forced cooling may be necessary immediately after soldering to keep the temperature within the permissible limit.

3. Repairing soldered joints

The same precautions and limits apply as in (1) above.

8-LEAD DUAL IN-LINE; PLASTIC (SOT-97A)

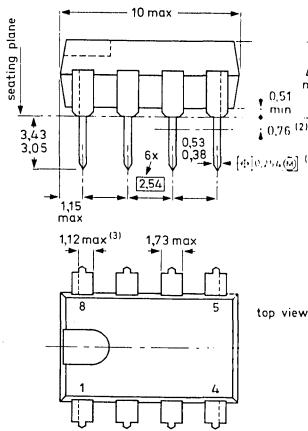

8-LEAD DUAL IN-LINE; CERAMIC (CERDIP) (SOT-151A)

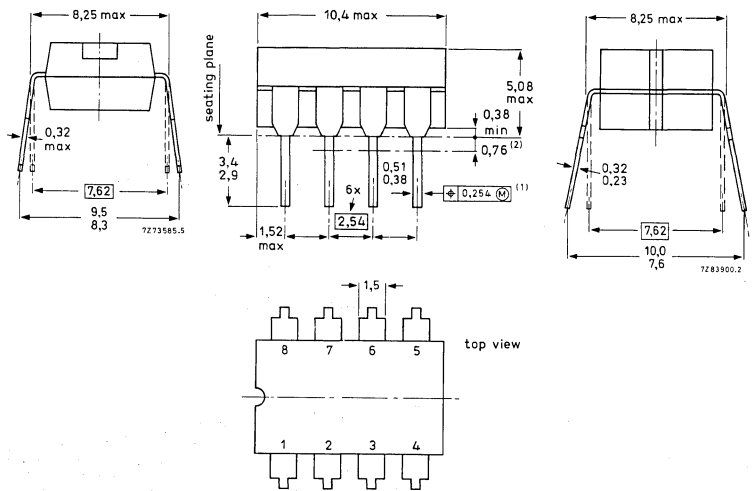

PACKAGE OUTLINES

FOR PREFIXES OM, MAB, MAF, PC, PN, SAA, SAB, SAF, TA, TB, TC, TD, TE

8-LEAD DUAL IN-LINE; METAL CERAMIC (CERDIL) (SOT-153B)

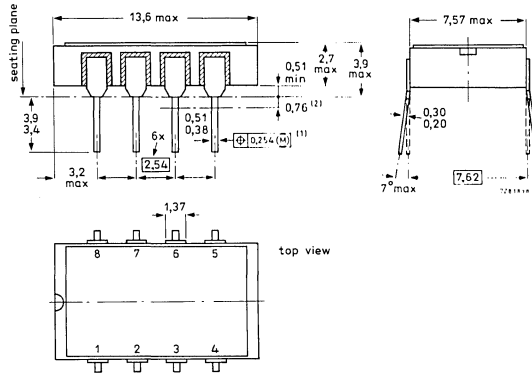

9-LEAD SINGLE IN-LINE; PLASTIC (SOT-110B)

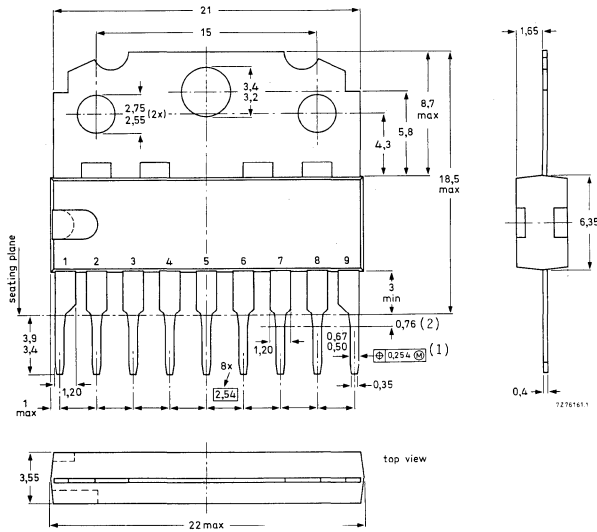

PACKAGE OUTLINES

FOR PREFIXES OM, MAB, MAF, PC, PN, SAA, SAB, SAF, TA, TB, TC, TD, TE

9-LEAD SIL-BENT-TO-DIL; PLASTIC POWER (SOT-157B)

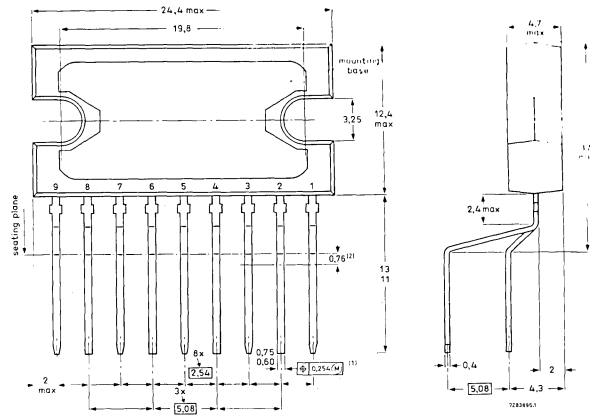

12-LEAD DUAL IN-LINE; PLASTIC WITH METAL COOLING FIN (SOT-150)

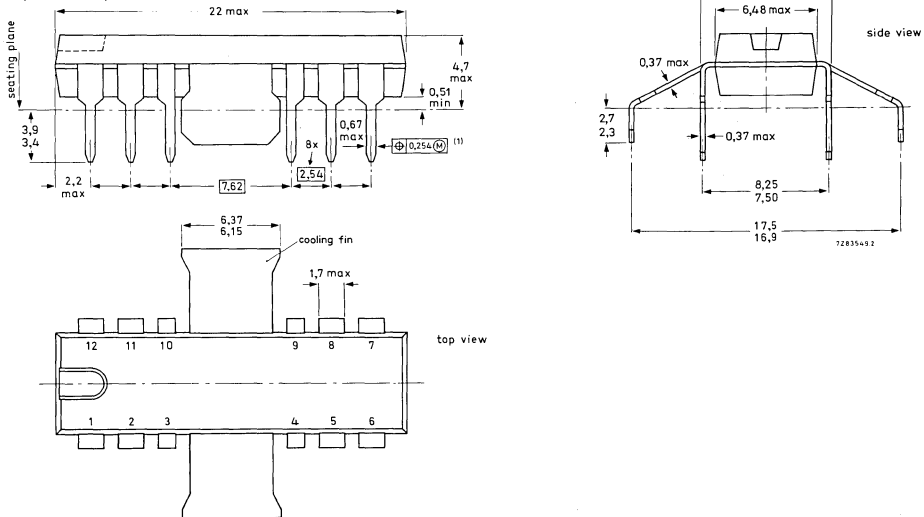

PACKAGE OUTLINES

FOR PREFIXES OM, MAB, MAF, PC, PN, SAA, SAB, SAF, TA, TB, TC, TD, TE

13-LEAD SIL-BENT-TO-DIL; PLASTIC POWER (SOT-141B)

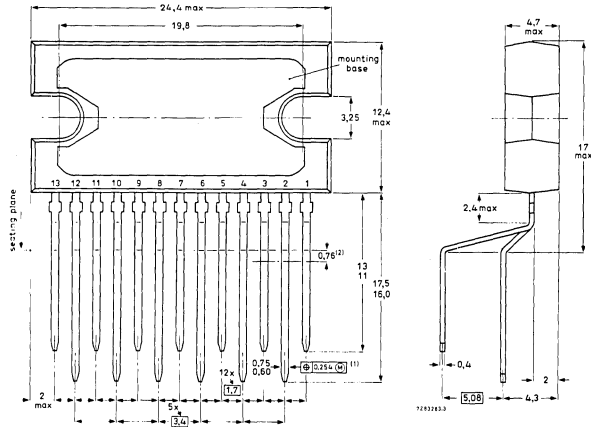

14-LEAD DUAL IN-LINE; PLASTIC (SOT-27K,M,T)

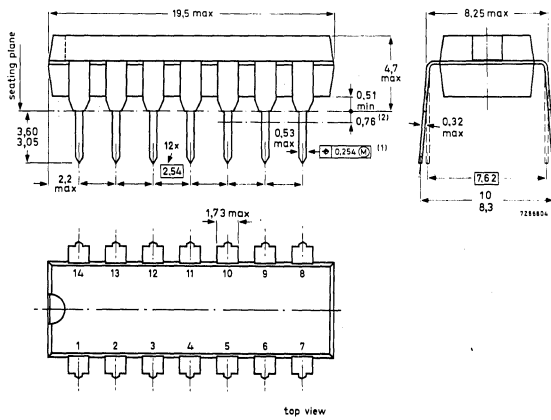

PACKAGE OUTLINES

FOR PREFIXES OM, MAB, MAF, PC, PN, SAA, SAB, SAF, TA, TB, TC, TD, TE

14-LEAD DUAL IN-LINE; CERAMIC (CERDIP) (SOT-73A,B,C)

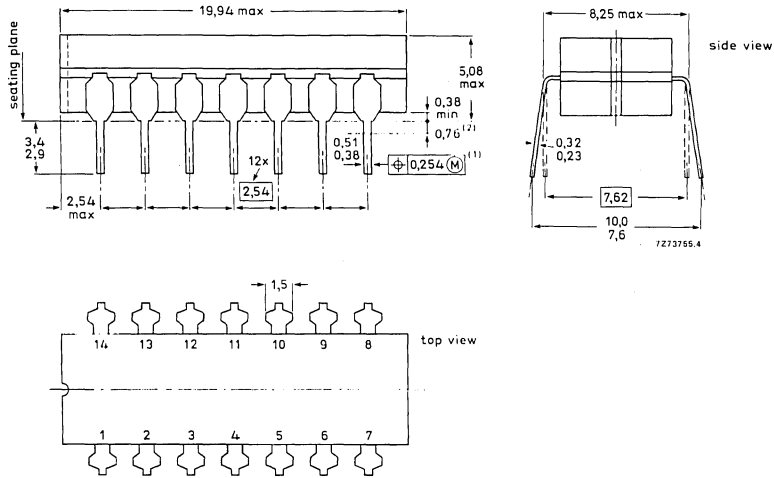

14-LEAD DUAL IN-LINE; METAL CERAMIC (CERDIL) (SOT-83B)

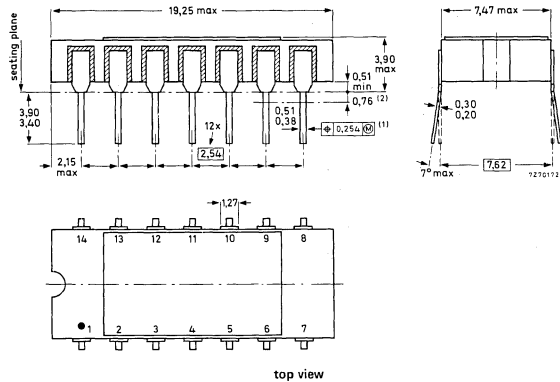

Dimensions in mm

PACKAGE OUTLINES

FOR PREFIXES OM, MAB, MAF, PC, PN, SAA, SAB, SAF, TA, TB, TC, TD, TE

16-LEAD DUAL IN-LINE; PLASTIC (SOT-38)

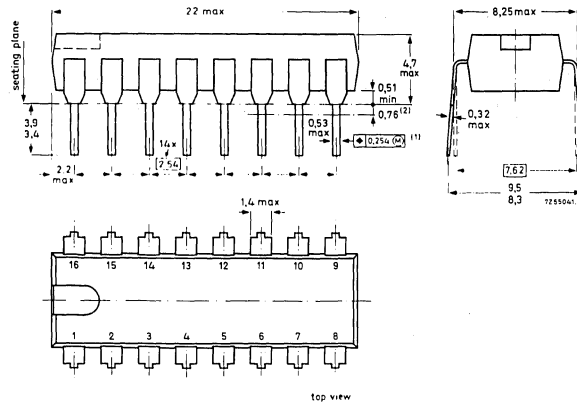

16-LEAD DUAL IN-LINE; PLASTIC (SOT-38A)

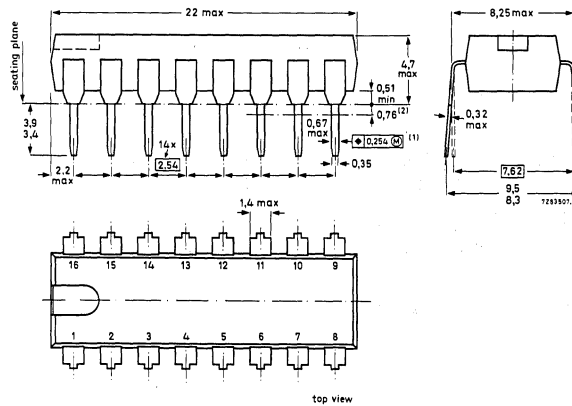

PACKAGE OUTLINES

FOR PREFIXES OM, MAB, MAF, PC, PN, SAA, SAB, SAF, TA, TB, TC, TD, TE

16-LEAD DUAL IN-LINE; PLASTIC (SOT-38D, DE)

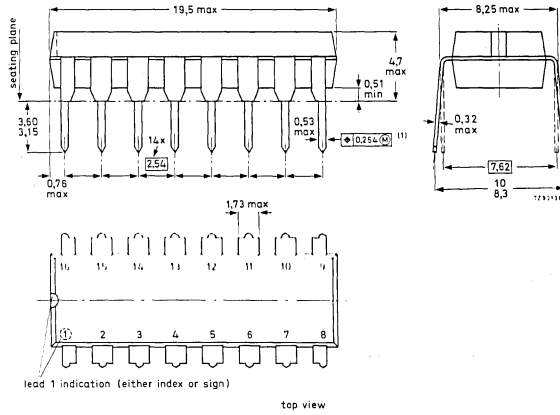

16-LEAD DUAL IN-LINE; PLASTIC (SOT-38Z)

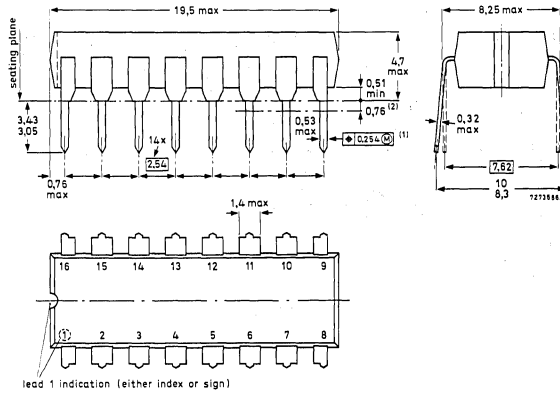

PACKAGE OUTLINES

FOR PREFIXES OM, MAB, MAF, PC, PN, SAA, SAB, SAF, TA, TB, TC, TD, TE

16-LEAD DUAL IN-LINE; PLASTIC WITH INTERNAL HEAT SPREADER (SOT-38WE-2)

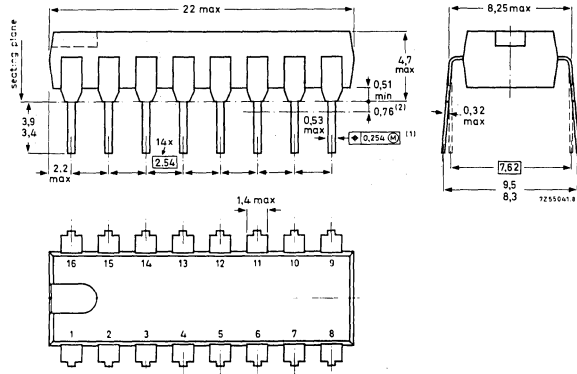

16-LEAD QUADRUPLE IN-LINE; PLASTIC (SOT-58)

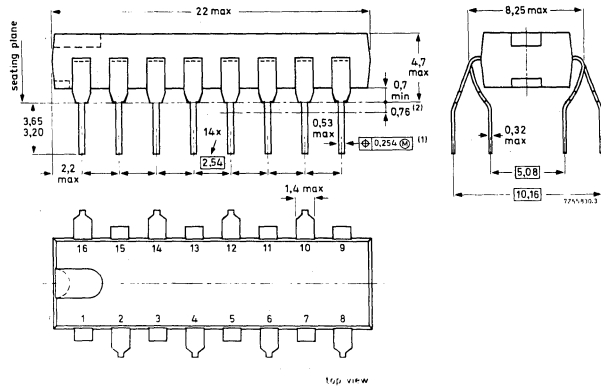

PACKAGE OUTLINES

FOR PREFIXES OM, MAB, MAF, PC, PN, SAA, SAB, SAF, TA, TB, TC, TD, TE

16-LEAD DUAL IN-LINE; CERAMIC (CERDIP) (SOT-74A,B,C)

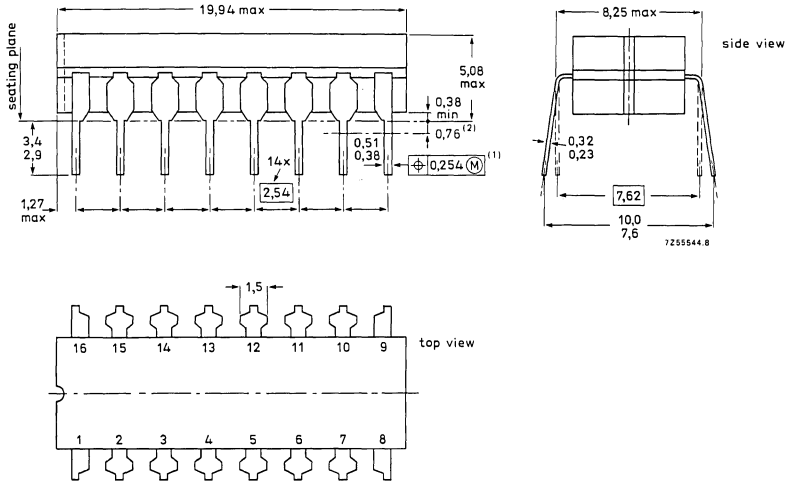

16-LEAD DUAL IN-LINE; METAL CERAMIC (CERDIL) (SOT-84B)

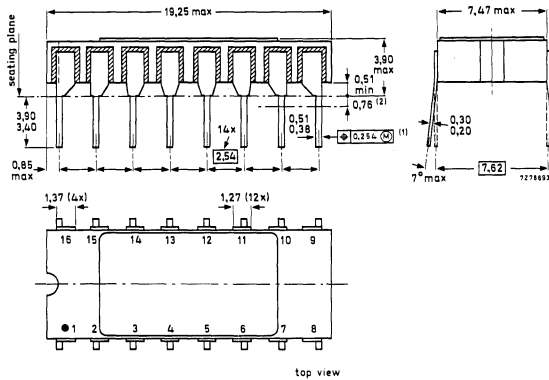

PACKAGE OUTLINES

FOR PREFIXES OM, MAB, MAF, PC, PN, SAA, SAB, SAF, TA, TB, TC, TD, TE

18-LEAD DUAL IN-LINE; METAL CERAMIC (CERDIL) (SOT-85B)

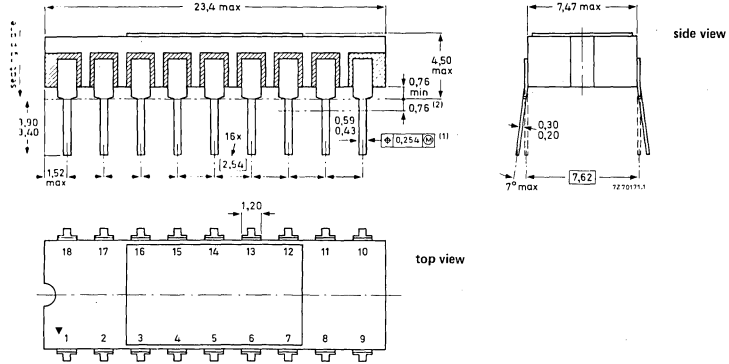

18-LEAD DUAL IN-LINE; PLASTIC (SOT-102A)

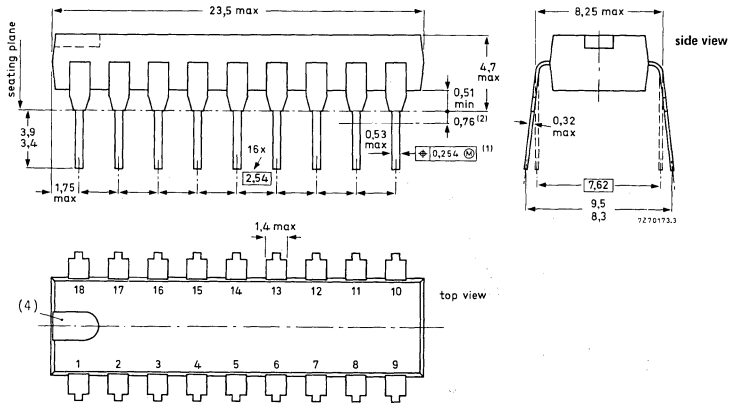

PACKAGE OUTLINES

FOR PREFIXES OM, MAB, MAF, PC, PN, SAA, SAB, SAF, TA, TB, TC, TD, TE

18-LEAD DUAL IN-LINE; PLASTIC (SOT-102C)

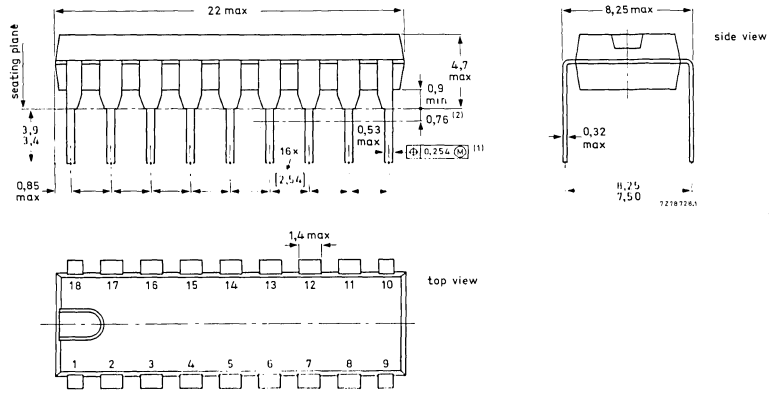

18-LEAD DUAL IN-LINE; PLASTIC (SOT-102CS)

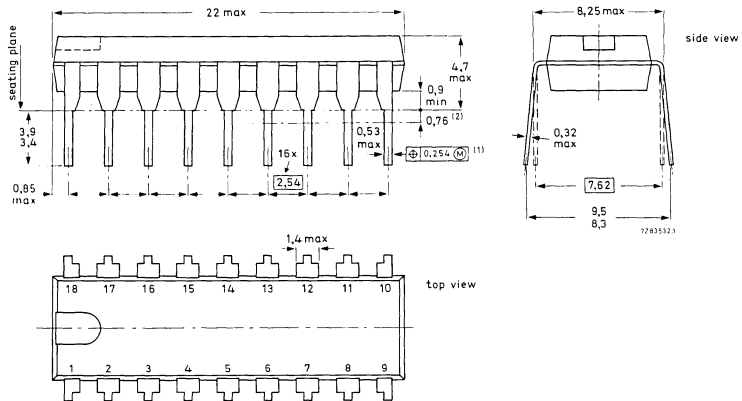

PACKAGE OUTLINES

FOR PREFIXES OM, MAB, MAF, PC, PN, SAA, SAB, SAF, TA, TB, TC, TD, TE

18-LEAD DUAL IN-LINE; PLASTIC (SOT-102G)

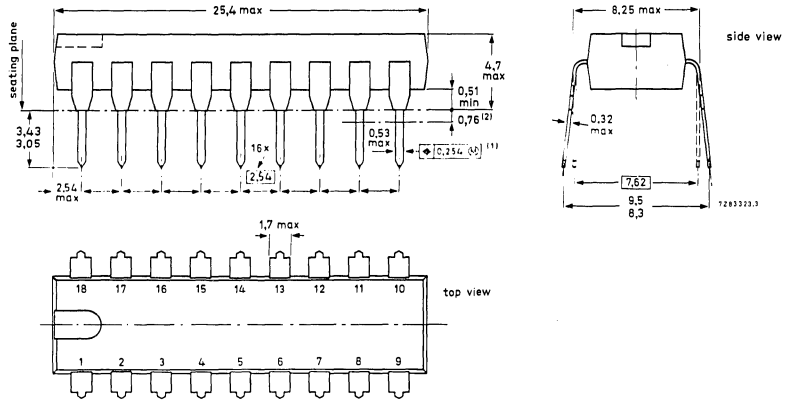

18-LEAD DUAL IN-LINE; CERAMIC (CERDIP) (SOT-133A,B)

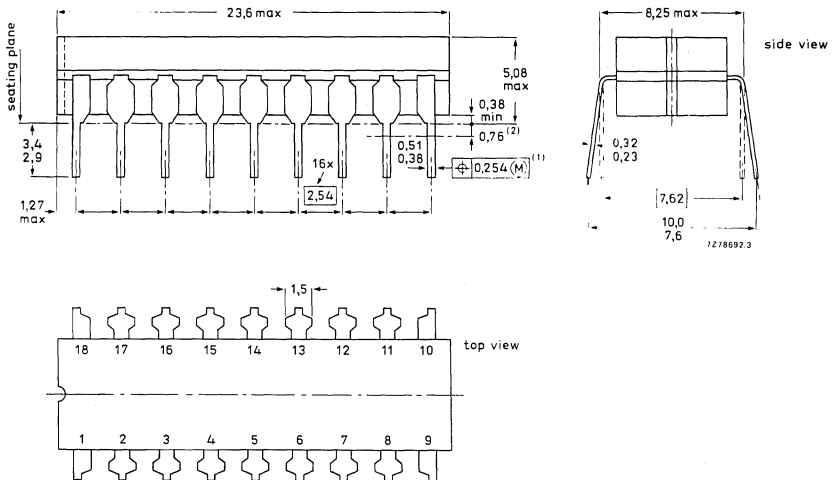

PACKAGE OUTLINES

FOR PREFIXES OM, MAB, MAF, PC, PN, SAA, SAB, SAF, TA, TB, TC, TD, TE

20-LEAD DUAL IN-LINE; PLASTIC (SOT-146)

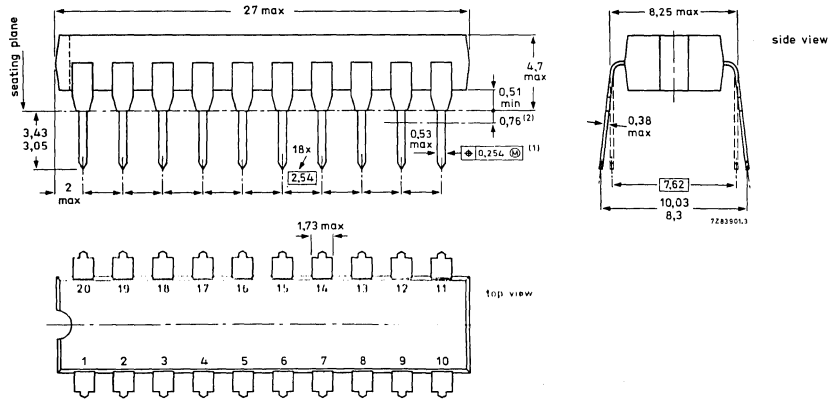

20-LEAD DUAL IN-LINE; CERAMIC (CERDIP) (SOT-152B, C)

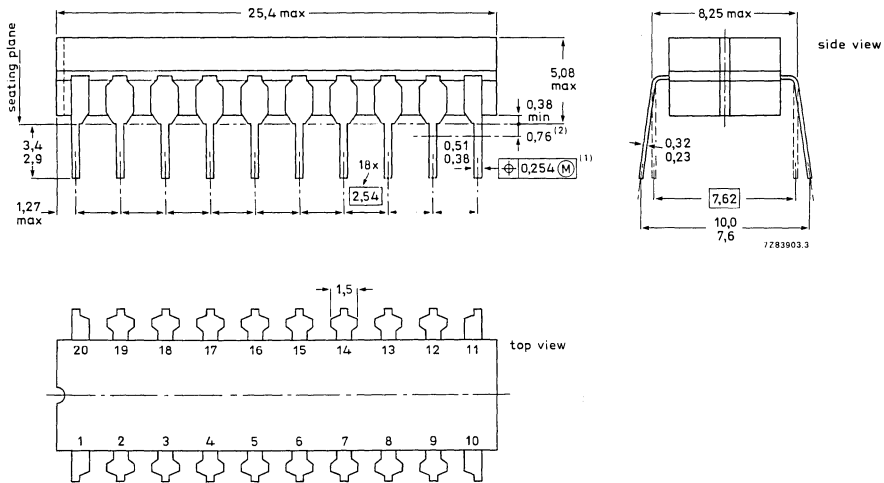

PACKAGE OUTLINES

FOR PREFIXES OM, MAB, MAF, PC, PN, SAA, SAB, SAF, TA, TB, TC, TD, TE

20-LEAD DUAL IN-LINE; METAL CERAMIC (CERDIL) (SOT-154B)

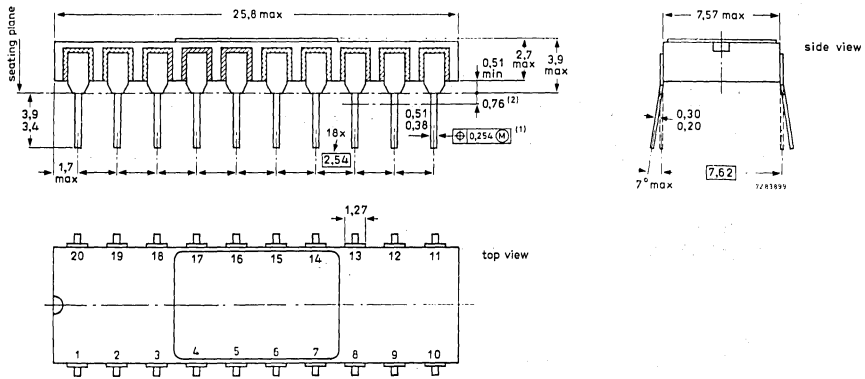

22-LEAD DUAL IN-LINE; PLASTIC (SOT-116)

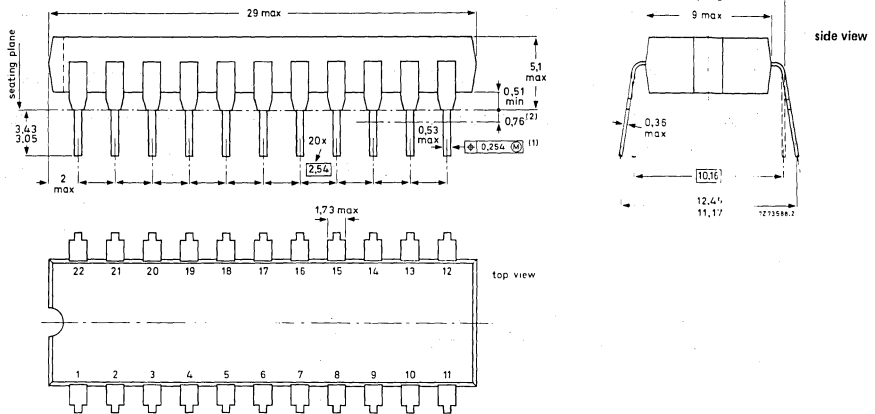

PACKAGE OUTLINES

FOR PREFIXES OM, MAB, MAF, PC, PN, SAA, SAB, SAF, TA, TB, TC, TD, TE

22-LEAD DUAL IN-LINE; METAL CERAMIC (CERDIL) (SOT-118B)

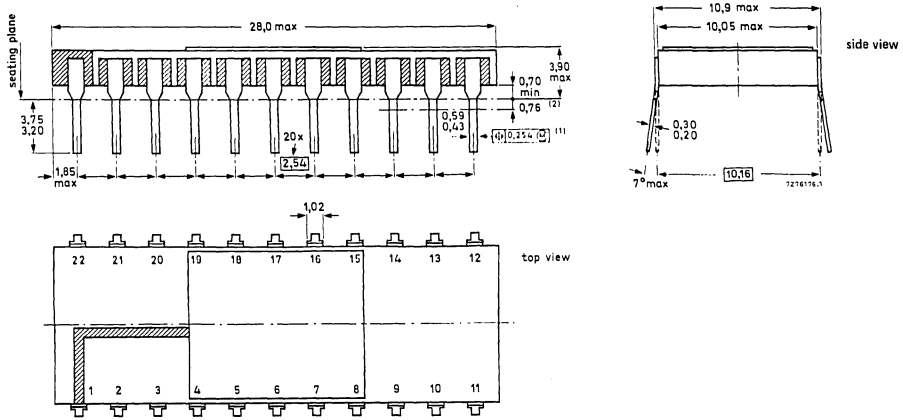

22-LEAD DUAL IN-LINE; CERAMIC (CERDIP) (SOT-134A)

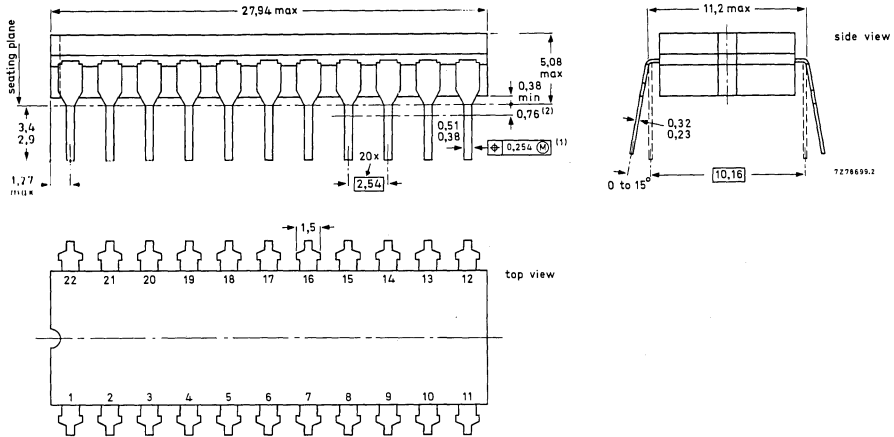

PACKAGE OUTLINES

FOR PREFIXES OM, MAB, MAF, PC, PN, SAA, SAB, SAF, TA, TB, TC, TD, TE

24-LEAD DUAL IN-LINE; METAL CERAMIC (CERDIL) (SOT-86A)

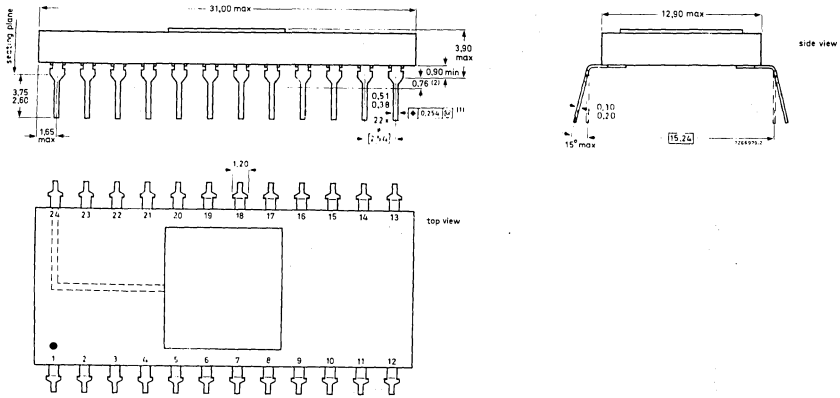

24-LEAD DUAL IN-LINE; CERAMIC (CERDIP) (SOT-94)

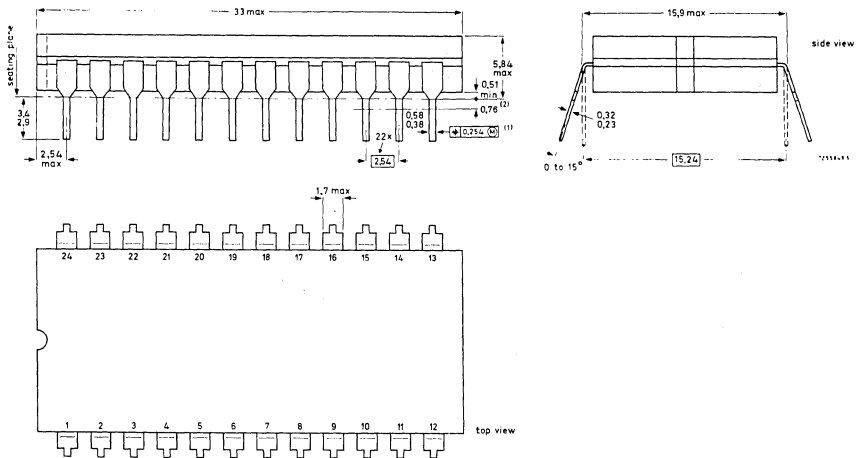

PACKAGE OUTLINES

FOR PREFIXES OM, MAB, MAF, PC, PN, SAA, SAB, SAF, TA, TB, TC, TD, TE

24-LEAD DUAL IN-LINE; PLASTIC (WITH INTERNAL HEAT SPREADER) (SOT-101A, B)

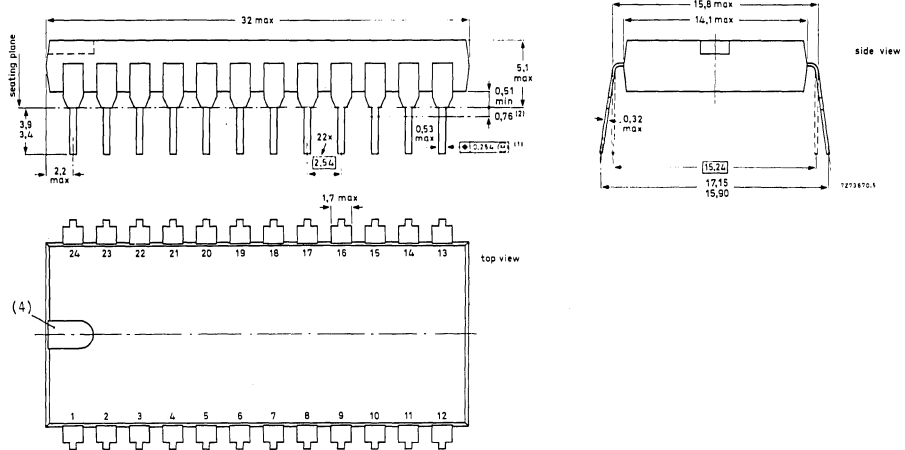

28-LEAD DUAL IN-LINE; METAL CERAMIC (CERDIL) (SOT-87A)

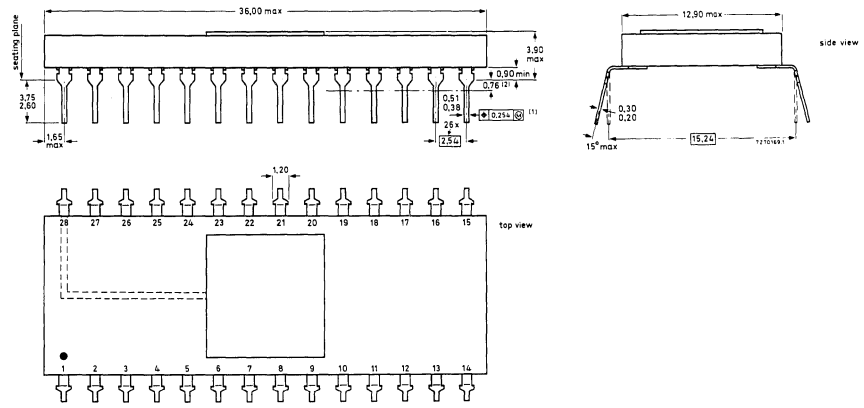

PACKAGE OUTLINES

FOR PREFIXES OM, MAB, MAF, PC, PN, SAA, SAB, SAF, TA, TB, TC, TD, TE

28-LEAD DUAL IN-LINE; METAL CERAMIC (CERDIL) (SOT-87B)

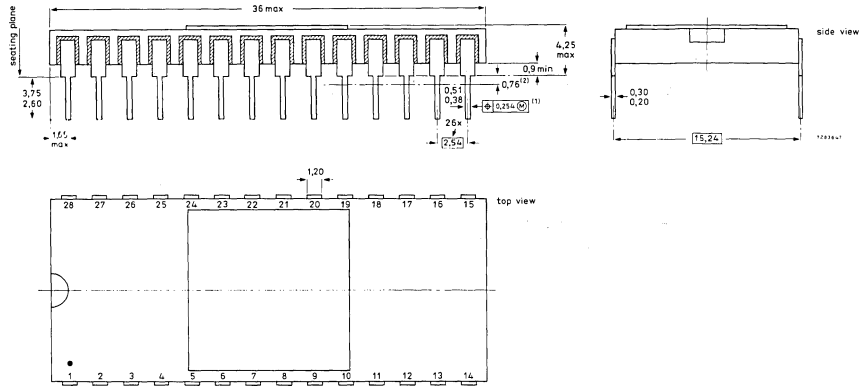

28-LEAD DUAL IN-LINE; PLASTIC (SOT-117)

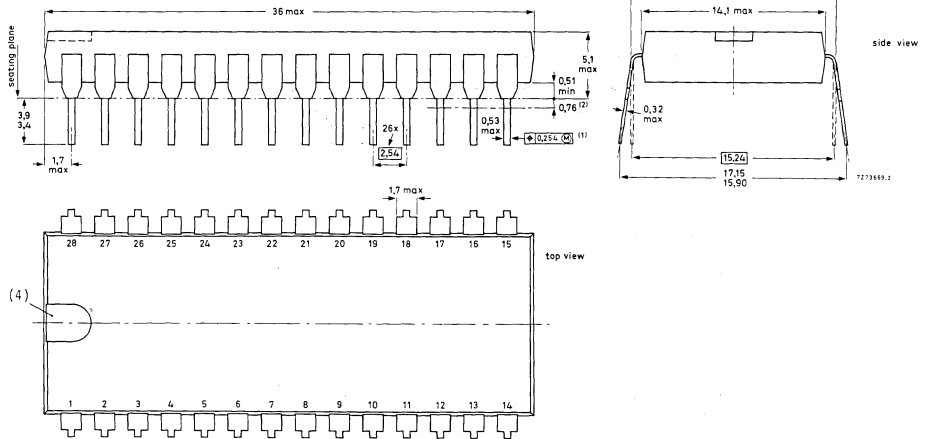

PACKAGE OUTLINES

FOR PREFIXES OM, MAB, MAF, PC, PN, SAA, SAB, SAF, TA, TB, TC, TD, TE

28-LEAD DUAL IN-LINE; PLASTIC (SOT-117D)

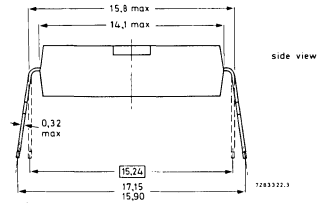
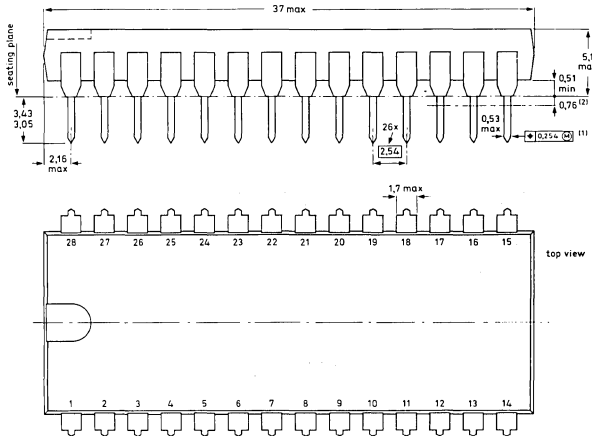

28-LEAD DUAL IN-LINE; CERAMIC (CERDIP) (SOT-135A)

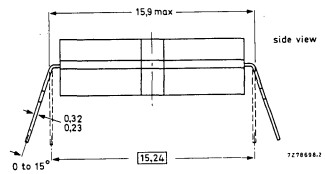
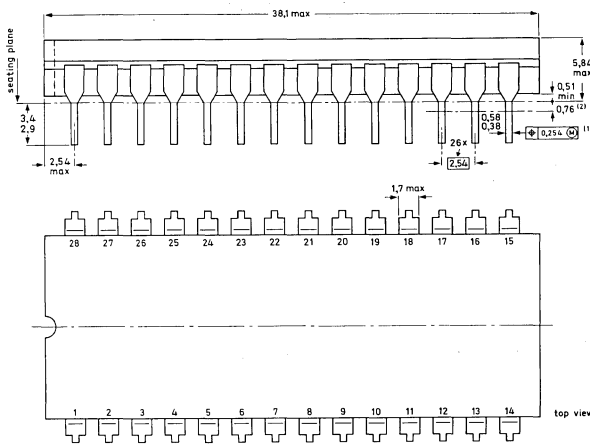

PACKAGE OUTLINES

FOR PREFIXES OM, MAB, MAF, PC, PN, SAA, SAB, SAF, TA, TB, TC, TD, TE

40-LEAD DUAL IN-LINE; METAL CERAMIC (CERDIL) (SOT-88)

NO-102 SOT-88

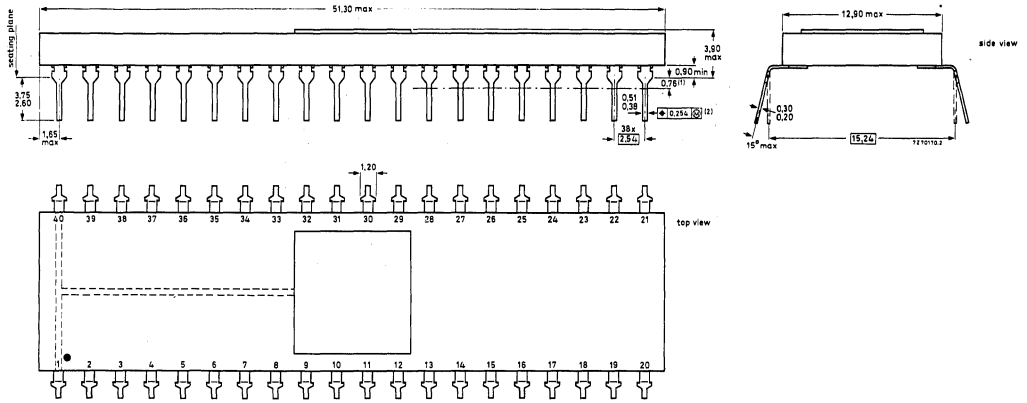

40-LEAD DUAL IN-LINE; METAL CERAMIC (CERDIL) (SOT-88B)

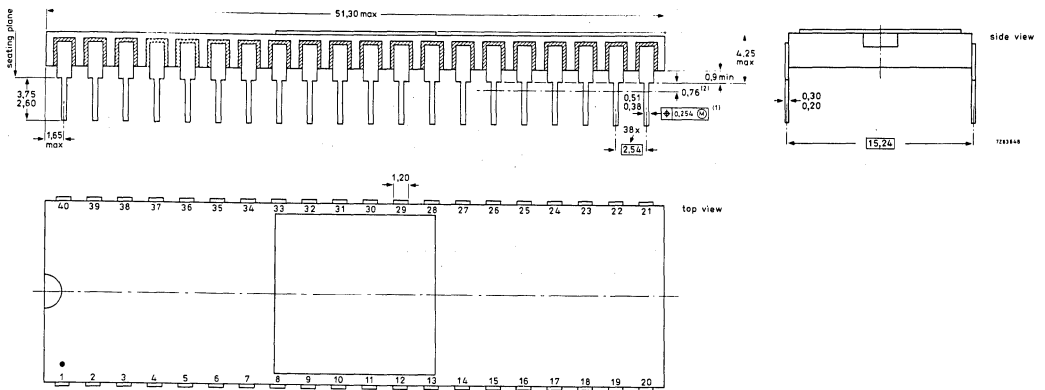

PACKAGE OUTLINES

FOR PREFIXES OM, MAB, MAF, PC, PN, SAA, SAB, SAF, TA, TB, TC, TD, TE

40-LEAD DUAL IN-LINE; PLASTIC (SOT-129)

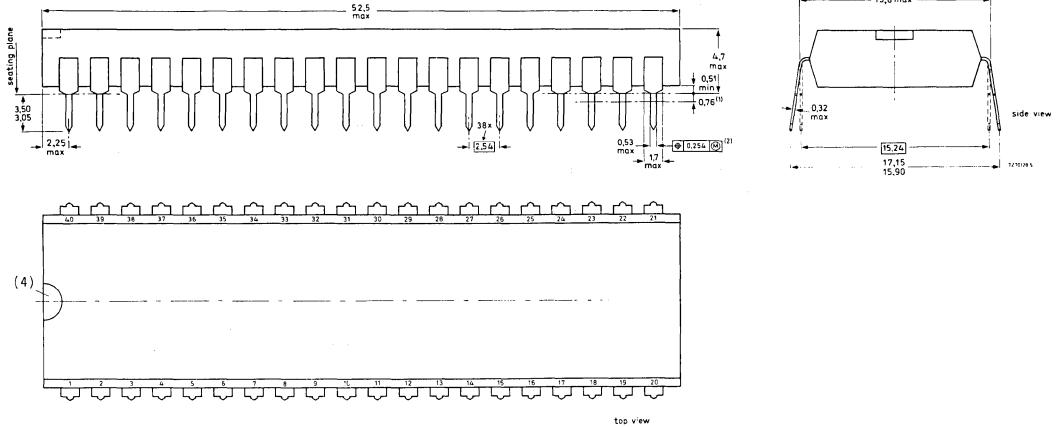

40-LEAD DUAL IN-LINE; CERAMIC (CERDIP) (SOT-145)

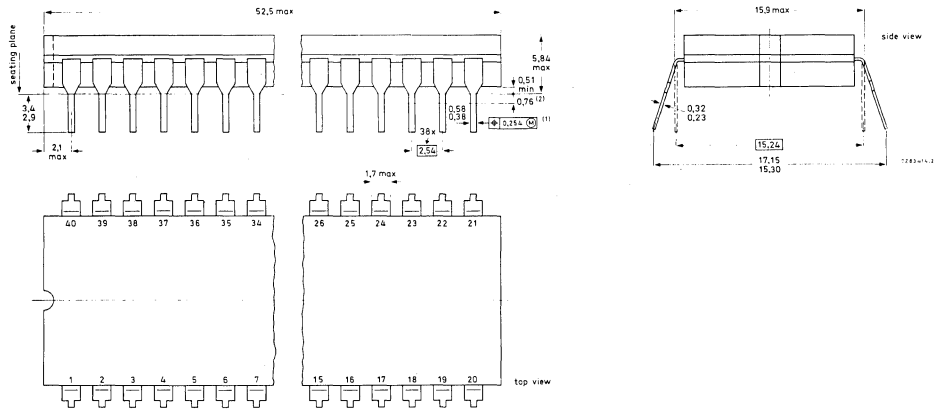

PACKAGE OUTLINES

FOR PREFIXES OM, MAB, MAF, PC, PN, SAA, SAB, SAF, TA, TB, TC, TD, TE

SOLDERING

The reflow solder technique

The preferred technique for mounting miniature components on hybrid thick or thin-film circuits is reflow soldering. Solder is applied to the required areas on the substrate by dipping in a solder bath or, more usually, by screen printing a solder paste. Components are put in place and the solder is reflowed by heating.

Solder pastes consist of very finely powdered solder and flux suspended in an organic liquid binder. They are available in various forms depending on the specification of the solder and the type of binder used. For hybrid circuit use, a tin-lead solder with 2 to 4% silver is recommended. The working temperature of this paste is about 220 to 230 °C when a mild flux is used.

For printing the paste onto the substrate a stainless steel screen with a mesh of 80 to 105 μm is used for which the emulsion thickness should be about 50 μm . To ensure that sufficient solder paste is applied to the substrate, the screen aperture should be slightly larger than the corresponding contact area.

The contact pins are positioned on the substrate, the slight adhesive force of the solder paste being sufficient to keep them in place. The substrate is heated to the solder working temperature preferably by means of a controlled hot plate. The soldering process should be kept as short as possible: 10 to 15 seconds is sufficient to ensure good solder joints and evaporation of the binder fluid.

After soldering, the substrate must be cleaned of any remaining flux.

8-LEAD MINI-PACK; PLASTIC (SO-8; SOT-96A)

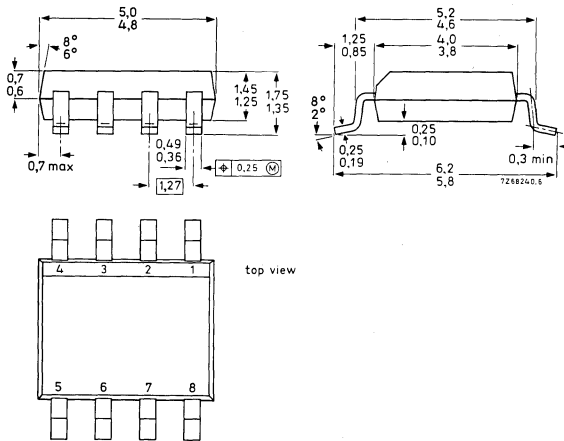

⊕ Positional accuracy.

Ⓜ Maximum Material Condition.

- (1) Centre-lines of all leads are within $\pm 0,127$ mm of the nominal position shown; in the worst case, the spacing between any two leads may deviate from nominal by $\pm 0,254$ mm.
- (2) Lead spacing tolerances apply from seating plane to the line indicated.
- (3) Only for devices with asymmetrical end-leads.

PACKAGE OUTLINES

FOR PREFIXES OM, MAB, MAF, PC, PN, SAA, SAB, SAF, TA, TB, TC, TD, TE

8-LEAD MINI-PACK; PLASTIC (VSO-8; SOT-176)

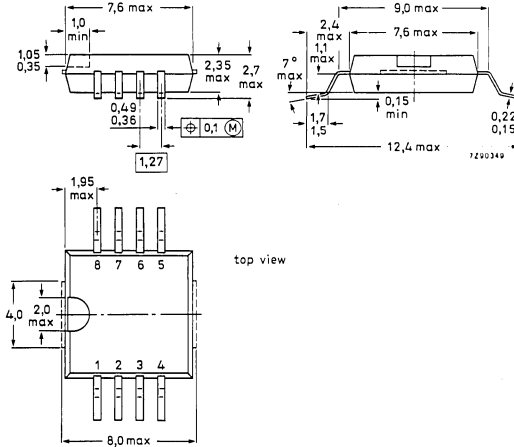

14-LEAD MINI-PACK; PLASTIC (SO-14; SOT-108A)

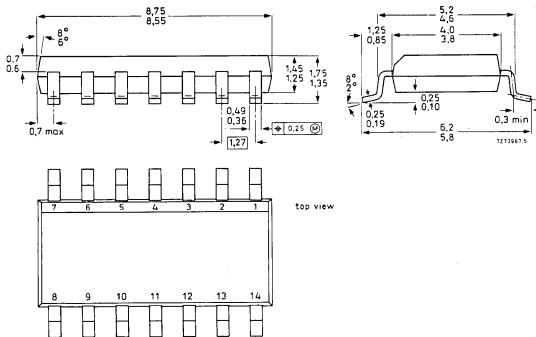

16-LEAD MINI-PACK; PLASTIC (SO-16; SOT-109A)

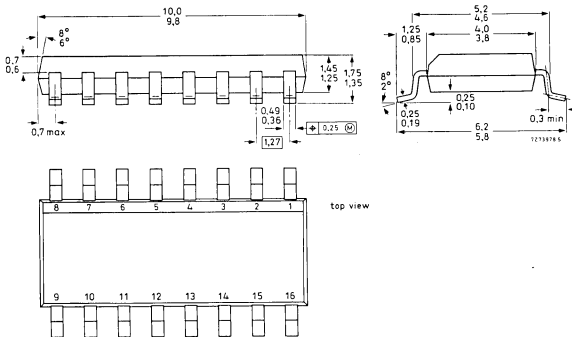

Note:
Dimensions shown are metric units (millimeters), except those in parentheses which are English units (inches).

PACKAGE OUTLINES

FOR PREFIXES OM, MAB, MAF, PC, PN, SAA, SAB, SAF, TA, TB, TC, TD, TE

16-LEAD MINI-PACK; PLASTIC (SO-16L; SOT-162A)

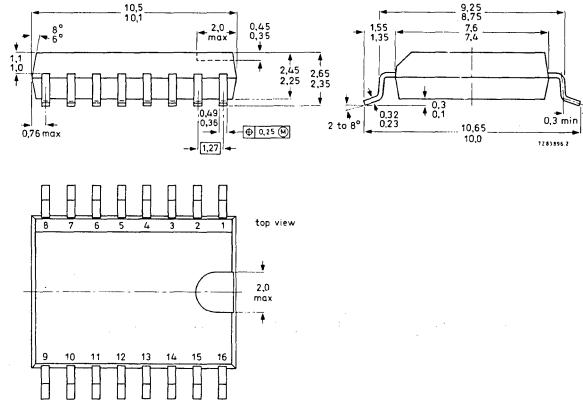

20-LEAD MINI-PACK; PLASTIC (SO-20; SOT-163A)

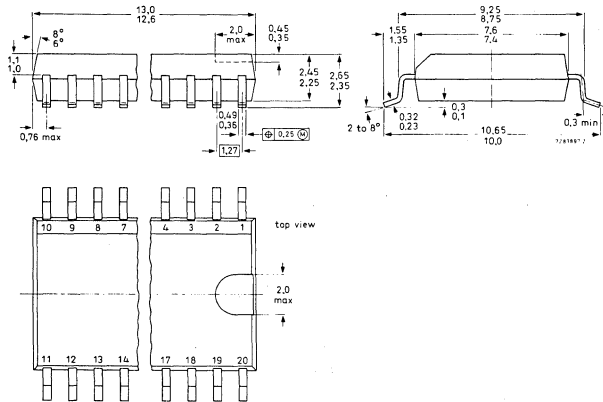

Note:
Dimensions shown are metric units (millimeters), except those in parentheses which are English units (inches).

PACKAGE OUTLINES

FOR PREFIXES OM, MAB, MAF, PC, PN, SAA, SAB, SAF, TA, TB, TC, TD, TE

24-LEAD MINI-PACK; PLASTIC (SO-24; SOT-137A)

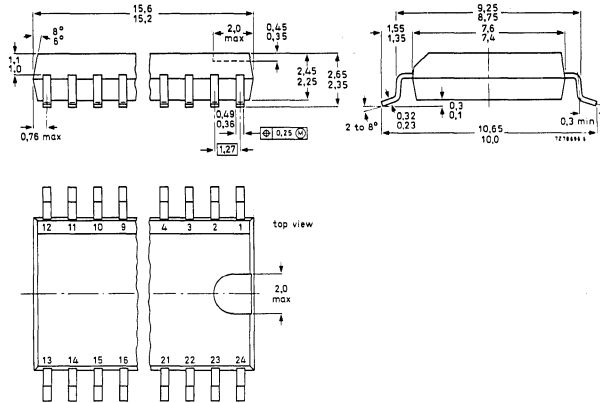

28-LEAD MINI-PACK; PLASTIC (SO-28; SOT-136A)

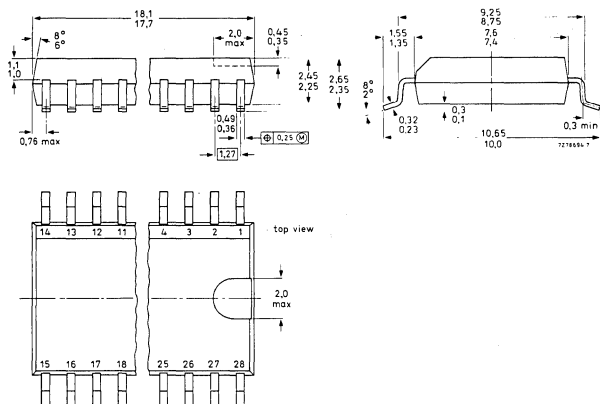

Note:
Dimensions shown are metric units (millimeters), except those in parentheses which are English units (inches).

PACKAGE OUTLINES

FOR PREFIXES OM, MAB, MAF, PC, PN, SAA, SAB, SAF, TA, TB, TC, TD, TE

40-LEAD MINI-PACK; PLASTIC (VSO-40; SOT-158A)

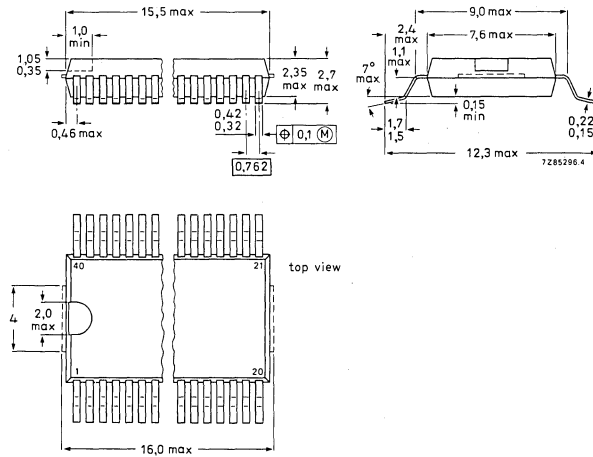

40-LEAD MINI-PACK; PLASTIC (OPPOSITE BENT LEADS) (VSO-40; SOT-158B)

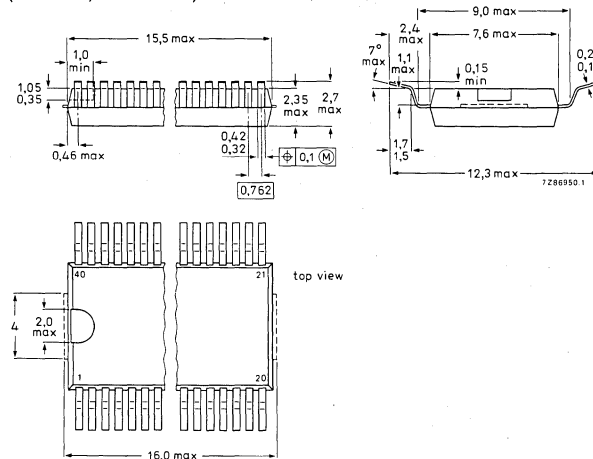

Section 11

Sales Offices

SALES OFFICES

SIGNETICS

HEADQUARTERS

811 East Arques Avenue
P.O. Box 3409
Sunnyvale, California 94088-3409
Phone: (408) 739-7700

ALABAMA

Huntsville
Phone: (205) 830-4001

ARIZONA

Phoenix
Phone: (602) 265-4444

CALIFORNIA

Canoga Park
Phone: (818) 340-1431

Cupertino
Phone: (408) 725-8100

Inglewood
Phone: (213) 670-1101

Irvine
Phone: (714) 833-8980
(213) 588-3281

San Diego
Phone: (714) 560-0242

COLORADO

Aurora
Phone: (303) 751-5011

CONNECTICUT

Danbury
Phone: (203) 748-3722

FLORIDA

Clearwater
Phone: (813) 796-7086

Ft. Lauderdale
Phone: (305) 486-6300

GEORGIA

Atlanta
Phone: (404) 953-0067

ILLINOIS

Schaumburg
Phone: (312) 843-7805

INDIANA

Kokomo
Phone: (317) 453-6462

KANSAS

Overland Park
Phone: (913) 341-8181

MARYLAND

Glen Burnie
Phone: (301) 787-0220

MASSACHUSETTS

Littleton
Phone: (617) 486-8411

MICHIGAN

Farmington Hills
Phone: (313) 476-1610

MINNESOTA

Edina
Phone: (612) 835-7455

NEW JERSEY

Parsippany
Phone: (201) 334-4405

NEW YORK

Hauppauge
Phone: (516) 348-7877

Liverpool

Phone: (315) 451-5470

Wappingers Falls

Phone: (914) 297-4074

NORTH CAROLINA

Raleigh

Phone: (919) 851-2013

OHIO

Worthington
Phone: (614) 888-7143

PENNSYLVANIA

Horsham
Phone: (215) 443-5500

TENNESSEE

Greeneville
Phone: (615) 639-0251

TEXAS

Austin
Phone: (512) 458-2591

Richardson

Phone: (214) 644-3500

CANADA

SIGNETICS CANADA, LTD.
Etobicoke, Ontario

Phone: (416) 626-6676

Nepean, Ontario

Synetics Canada, Ltd.
Phone: (613) 726-9576

REPRESENTATIVES

ARIZONA

Scottsdale

Thom Luke Sales, Inc.
Phone: (602) 941-1901

CALIFORNIA

Los Gatos

Sierra Technology
Phone: (408) 354-1626

Santa Clara

Magna Sales
Phone: (408) 727-8753

San Diego

Mesa Engineering
Phone: (619) 278-8021

CANADA

Ottawa, Ontario

Tech-Trek, Ltd.
Phone: (613) 230-3927

Pointe Claire, Quebec

Tech-Trek, Ltd.
Phone: (514) 697-3385

Richmond, B.C.

Tech-Trek
Phone: (604) 273-1800

Rexdale, Ontario

Tech-Trek, Ltd.
Phone: (416) 674-1717

CONNECTICUT

Yalesville

Kanan Associates
Phone: (203) 265-2404

FLORIDA

Pompano Beach

V/G Sales
Phone: (305) 971-0900

ILLINOIS

Schaumburg

Micro-Tex, Inc.
Phone: (312) 885-1131

IOWA

Marion

Rep. Associates Corp.
Phone: (319) 373-0152

KANSAS

Kansas City

B. C. Electronic Sales
Phone: (913) 342-1211

MARYLAND

Columbia

Delta III
Phone: (301) 730-4700

MASSACHUSETTS

Reading

Kanan Associates
Phone: (617) 944-8484

MICHIGAN

Bloomfield Hills

Enco Marketing
Phone: (313) 642-0203

MINNESOTA

Minneapolis

High Technology Sales
Phone: (612) 888-8088

MISSOURI

Bridgeton

B. C. Electronic Sales
Phone: (314) 291-1101

NEVADA

Carson City

Magna Sales
Phone: (702) 883-1471

NEW JERSEY

East Hanover

Emtec Sales, Inc.
Phone: (201) 428-0600

NEW MEXICO

Albuquerque

Power Enterprises
Phone: (505) 298-1918

NEW YORK

Ithaca

Bob Dean, Inc.
Phone: (607) 257-1111

Melville

Emtec Sales, Inc.
Phone: (516) 752-1630

OHIO

Cincinnati

Stegman Blaine Marketing, Inc.
Phone: (513) 729-1969

OREGON

Hillsboro

Western Technical Sales
Phone: (503) 640-4621

PENNSYLVANIA

Pittsburgh

Covert & Newman Co.
Phone: (412) 531-2002

TEXAS

Houston

OM Sales
Phone: (713) 789-4426

UTAH

Salt Lake City

Electrodyne
Phone: (801) 486-3801

WASHINGTON

Bellevue

Western Technical Sales
Phone: (206) 641-3900

Spokane

Western Technical Sales
Phone: (509) 922-7600

WISCONSIN

Waukesha

Micro-Tex, Inc.
Phone: (414) 542-5352

DISTRIBUTORS

ALABAMA

Huntsville

Hamilton/Avnet Electronics
Phone: (205) 837-7210

ARIZONA

Phoenix

Hamilton/Avnet Electronics
Phone: (602) 231-5100

Schweber Electronics

Phone: (602) 997-4874

Wyle Distribution Group

Phone: (602) 249-2232

CALIFORNIA

Chatsworth

Anthem Electronics
Phone: (213) 700-1000

Arrow Electronics

Phone: (213) 701-7500

Hamilton/Avnet Electronics

Phone: (818) 700-6500

Costa Mesa

Avnet Electronics
Phone: (714) 754-6111

Hamilton Electro Sales
Phone: (714) 641-4100

Culver City

Hamilton/Avnet Electronics
Phone: (213) 558-2121

Hamilton/Avnet Electronics
Military
Phone: (213) 558-2901

El Segundo

Wyle Distribution Group
Phone: (213) 322-8100

Irvine

Schweber Electronics
Phone: (714) 863-0200

Wyle Distribution Group
Phone: (714) 863-9953

Sacramento

Hamilton/Avnet Electronics
Phone: (916) 920-3150

San Diego

Anthem Electronics
Phone: (619) 453-4871

Arrow Electronics
Phone: (619) 565-4800

Hamilton/Avnet Electronics
Phone: (619) 571-7510

Wyle Distribution Group
Phone: (619) 565-9171

San Jose

Anthem Electronics Inc.
Phone: (408) 946-8000

Santa Clara

Schweber Electronics
Phone: (408) 748-4700

Wyle Distribution Group
Phone: (408) 727-2500

SALES OFFICES

Tustin

Anthem Electronics
Phone: (714) 730-8000

Arrow Electronics
Phone: (714) 838-5422

Woodland Hills

Avnet Electronics
Phone: (213) 883-0000

CANADA**Calgary, Alberta**

Hamilton/Avnet Electronics
Phone: (403) 230-3586

Zentronics
Phone: (403) 272-1021

Mississauga, Ontario

Hamilton/Avnet Electronics
Phone: (416) 677-7432

Zentronics
Phone: (416) 451-9600

Montreal, Quebec

Zentronics
Phone: (514) 735-5361

Nepean, Ontario

Zentronics
Phone: (613) 226-8840

Ottawa, Ontario

Hamilton/Avnet Electronics
Phone: (613) 226-1700

Vancouver

Zentronics
Phone: (604) 688-2533

Ville St. Laurent, Quebec

Hamilton/Avnet Electronics
Phone: (514) 331-6443

Waterloo

Zentronics
Phone: (519) 884-5700

Winnipeg

Zentronics
Phone: (204) 775-8661

COLORADO**Aurora**

Arrow Electronics
Phone: (303) 696-1111

Denver

Wyle Distribution Group
Phone: (303) 457-9953

Englewood

Hamilton/Avnet Electronics
Phone: (303) 740-1000

CONNECTICUT**Danbury**

Hamilton/Avnet Electronics
Phone: (203) 797-2800
Schweber Electronics
Phone: (203) 792-3500

Wallingtonford

Arrow Electronics
Phone: (203) 265-7741

FLORIDA**Ft. Lauderdale**

Arrow Electronics
Phone: (305) 776-7790
Hamilton/Avnet Electronics
Phone: (305) 971-2900

Hollywood

Schweber Electronics
Phone: (305) 927-0511

Palm Bay

Arrow Electronics
Phone: (305) 725-1480

St. Petersburg

Hamilton/Avnet Electronics
Phone: (813) 576-3930

Winter Park

Hamilton/Avnet Electronics
Phone: (305) 628-3888

GEORGIA**Atlanta**

Schweber Electronics
Phone: (404) 449-9170

Norcross

Arrow Electronics
Phone: (404) 449-8252
Hamilton/Avnet Electronics
Phone: (404) 447-7500
Schweber Electronics
Phone: (404) 449-9170

ILLINOIS**Elk Grove**

Schweber Electronics
Phone: (312) 364-3750

Schaumburg

Arrow Electronics
Phone: (312) 397-3440

Bensenville

Hamilton/Avnet Electronics
Phone: (312) 860-7700

INDIANA**Indianapolis**

Arrow Electronics
Phone: (317) 243-9353

Hamilton/Avnet Electronics
Phone: (317) 844-9333

KANSAS**Overland Park**

Hamilton/Avnet Electronics
Phone: (913) 888-8900

MARYLAND**Baltimore**

Arrow Electronics
Phone: (301) 247-5200

Columbia

Hamilton/Avnet Electronics
Phone: (301) 995-3500

Gaithersburg

Schweber Electronics
Phone: (301) 840-5900

MASSACHUSETTS**Bedford**

Schweber Electronics
Phone: (617) 275-5100

Burlington

Lionex Corp.
Phone: (617) 272-9400

Woburn

Arrow Electronics
Phone: (617) 933-8130
Hamilton/Avnet Electronics
Phone: (617) 273-7500

MICHIGAN**Ann Arbor**

Arrow Electronics
Phone: (313) 971-8220

Grand Rapids

Hamilton/Avnet Electronics
Phone: (616) 243-8805

Livonia

Hamilton/Avnet Electronics
Phone: (313) 522-4700
Schweber Electronics
Phone: (313) 525-8100

MINNESOTA**Eden Prairie**

Schweber Electronics
Phone: (612) 941-5280

Edina

Arrow Electronics
Phone: (612) 830-1800

Minneapolis

Arrow Electronics
Phone: (612) 830-1800
Hamilton/Avnet Electronics
Phone: (612) 932-0600

Minnetonka

Hamilton/Avnet Electronics
Phone: (612) 932-0666

MISSOURI**Earth City**

Hamilton/Avnet Electronics
Phone: (314) 344-1200

St. Louis

Arrow Electronics
Phone: (314) 567-6888

NEW HAMPSHIRE**Manchester**

Arrow Electronics
Phone: (603) 668-6968

NEW JERSEY**Cherry Hill**

Hamilton/Avnet Electronics
Phone: (609) 424-0100

Fairfield

Arrow Electronics
Phone: (201) 575-5300

Hamilton/Avnet Electronics
Phone: (201) 575-3390

Lionex Corporation
Phone: (201) 227-7960

Schweber Electronics
Phone: (201) 227-7880

Moorestown

Arrow Electronics
Phone: (609) 235-1900

NEW MEXICO**Albuquerque**

Hamilton/Avnet Electronics
Phone: (505) 765-1500

Arrow Electronics
Phone: (505) 243-4566

NEW YORK**Buffalo**

Summit Distributors
Phone: (716) 887-2800

East Syracuse

Arrow Electronics
Phone: (315) 652-1000

Hamilton/Avnet Electronics
Phone: (315) 437-2642

Hauppauge, L.I.

Arrow Electronics
Phone: (516) 231-1000

Lionex Corp.
Phone: (516) 273-1660

Liverpool

Arrow Electronics
Phone: (315) 652-1000

Melville

Hamilton/Avnet Electronics
Phone: (516) 454-6012

Rochester

Arrow Electronics
Phone: (716) 275-0300

Hamilton/Avnet Electronics
Phone: (716) 475-9130

Schweber Electronics
Phone: (716) 424-2222

Westbury, L.I.

Schweber Electronics
Phone: (516) 334-7474

NORTH CAROLINA**Raleigh**

Arrow Electronics
Phone: (919) 876-3132

Hamilton/Avnet Electronics
Phone: (919) 878-0819

Schweber Electronics
Phone: (919) 876-0000

Winston-Salem

Arrow Electronics
Phone: (919) 725-8711

OHIO**Beechwood**

Schweber Electronics
Phone: (216) 464-2970

Cleveland

Hamilton/Avnet Electronics
Phone: (216) 831-3500

Centerville

Arrow Electronics
Phone: (513) 435-5563

Dayton

Hamilton/Avnet Electronics
Phone: (513) 433-0610

Solon

Arrow Electronics
Phone: (216) 248-3990

Westerville

Hamilton/Avnet Electronics
Phone: (614) 436-5851

OKLAHOMA**Tulsa**

Quality Components
Phone: (918) 664-8812

OREGON**Hillsboro**

Wyle Distribution Group
Phone: (503) 640-6000

Lake Oswego

Hamilton/Avnet Electronics
Phone: (503) 635-8831

Tigard

Arrow Electronics
Phone: (503) 684-1690

PENNSYLVANIA**Horsham**

Lionex Corp.
Phone: (215) 443-5150

Pittsburgh

Arrow Electronics
Phone: (412) 856-7000

SALES OFFICES

Sunnyvale
Arrow Electronics
Phone: (408) 745-6600
Hamilton/Avnet Electronics
Phone: (408) 743-3366

TEXAS

Austin
Arrow Electronics
Phone: (512) 835-4180
Hamilton/Avnet Electronics
Phone: (512) 837-8911
Quality Components
Phone: (512) 835-0220

Carrollton

Arrow Electronics
Phone: (214) 380-6464

Dallas

Hamilton/Avnet Electronics
Phone: (214) 659-4111
Quality Components
Phone: (214) 387-4949
Schweber Electronics
Phone: (214) 661-5010

Houston

Arrow Electronics
Phone: (713) 530-4700
Hamilton/Avnet Electronics
Phone: (713) 780-1771
Schweber Electronics
Phone: (713) 784-3600

Sugar Land

Quality Components
Phone: (713) 491-2255

UTAH

Salt Lake City
Hamilton/Avnet Electronics
Phone: (801) 972-4300
Wyle Distribution Group
Phone: (801) 974-9953

WASHINGTON

Bellevue
Arrow Electronics
Phone: (206) 643-4800
Hamilton/Avnet Electronics
Phone: (206) 453-5844
Wyle Distribution Group
Phone: (206) 453-8300

WISCONSIN

New Berlin
Hamilton/Avnet Electronics
Phone: (414) 784-4510

Oak Creek

Arrow Electronics
Phone: (414) 764-6600

FOR SIGNETICS PRODUCTS WORLDWIDE:

ARGENTINA
Philips Argentina S.A.
Buenos Aires
Phone: 541-7141

AUSTRALIA
Philips Industries Holdings Ltd.
Lane Cove, N.S.W.
Phone: 61-2-427-0888

AUSTRIA
Osterreichische Philips Bauelemente
Wien
Phone: 43-222-93-26-2

BELGIUM
N. V. Philips & MBLE
Bruxelles
Phone: 32-02-242-7400

BRAZIL
Ibrape
Sao Paulo
Phone: 55-011-211-2600

CHILE
Philips Chilena S.A.
Santiago
Phone: 56-2-39-4001

COLOMBIA
Sadape S.A.
Bogota D.E.
Phone: 600 600

DENMARK
Miniwatt AIS
Kobenhavn N.V.
Phone: 45-01-69-1622

FINLAND
Oy Philips Ab
Helsinki
Phone: 358-1-7271

FRANCE
R.T.C. La Radiotechnique-Compelec
Paris
Phone: 33-1-355-4499

GERMANY
Valvo
Hamburg
Phone: 49-40-3296-19

GREECE
Philips S.A. Hellenique
Athens
Phone: 9215111

HONG KONG
Philips Hong Kong, Ltd.
Kwai Chung
Phone: 852-0-245121

INDIA
Philips India & Elect. Ltd.
Bombay
Phone: 91-22-295144

INDONESIA
P.T. Philips-Ralin Electronics
Jakarta
Phone: 716 131

IRELAND
Philips Electrical Ltd.
Dublin
Phone: 353-1-69-3355

ISRAEL
Rapac Electronics, Ltd.
Tel Aviv
Phone: 972-3-477115

ITALY
Philips S.p.A.
Milano
Phone: 39-2-6994

JAPAN
Signetics Japan, Ltd.
Tokyo
Phone: 813-230-1521
Osaka
Phone: 816-304-6171

KOREA
Philips Elect. Korea Ltd.
Seoul
Phone: 794-4202

MALAYSIA
Philips Malaysia Sdn. Berhad
Kuala Lumpur
Phone: 77 44 11

MEXICO
Electronica S.A. de C.V.
Mexico D.F.
Phone: 52-721-61300

NETHERLANDS
Philips Nederland B.V.
Eindhoven
Phone: 31-40-79-3333

NEW ZEALAND
Philips Electrical Ind. Ltd.
Auckland
Phone: 64-9-605914

NORWAY
Norsk AIS Philips
Oslo
Phone: 47-2-680200

PERU
Cadesa
Lima
Phone: 326070

PHILIPPINES
Philips Industrial Dev., Inc.
Makati-Rizal
Phone: 868951

PORTUGAL
Philips Portuguesa SARR
Lisboa
Phone: 351-19-68-3121

SINGAPORE
Philips Project Dev. Pte., Ltd.
Singapore
Phone: 65-253-8811

SOUTH AFRICA
E.D.A.C. (PTY), Ltd.
Johannesburg
Phone: 27-11-614-2362

SPAIN
Miniwatt S.A.
Barcelona
Phone: 301 63 12

SWEDEN
A.B. Elcoma
Stockholm
Phone: 46-08-67-9780

SWITZERLAND
Philips A.G.
Zurich
Phone: 41-01-988-2211

TAIWAN
Philips Taiwan, Ltd.
Taipei
Phone: 886-2-563-1717

THAILAND
Philips Electrical Co. of Thailand Ltd.
Bangkok
Phone: 233-6330-9

TURKEY
Turk Philips
Ticaret A.S.
Istanbul
Phone: 43 59 10

UNITED KINGDOM
Mullard, Ltd.
London
Phone: 44-01-580-6633

UNITED STATES
Signetics International Corp.
Sunnyvale, California
Phone: (408) 739-7700

URUGUAY
Luzilectron S.A.
Montevideo
Phone: 91 43 21

VENEZUELA
Industrias Venezolanas
Philips S.A.
Caracas
Phone: 58-2-36-0511

NOTES

FORTHCOMING NEW PRODUCTS BY PRODUCT GROUP

Amplifiers

LT1012	Low noise op amp with internal compensation: $0.5\mu\text{V}$ p-p noise (0.1Hz-10Hz)
LT1037	Precision op amp: high speed $11\text{V}/\mu\text{s}$; low noise: $0.13\mu\text{V}$ p-p
NE5230	Low voltage (1.8V) op amp: 8 pin 741 pin out with internal compensation
—	40 watt amplifier with 0.01% THD

Communications

NE568	150MHz phase locked loop
SAA5230	Video Input Processor II—adaptive data slicer, data clock regenerator, and sync separator
SAA5245	Computer Controlled Teletext with 525 lines
SAA5350	CRT Graphics Controller with 12×10 character cell and ROM on chip; 625 line system
TDA7030T	Low voltage tuning system for FM (to work w/TDA702T)

Interface/Data Conversion

DAC800	12-Bit, $2.5\mu\text{s}$ multiplying D/A with internal reference; V or I output
NE5030	10-Bit, $1.5\mu\text{s}$ μP compatible A/D with three-state outputs, internal reference, 5V operation
NE5170	Octal line drivers RS232C/RS423A
NE5180	Octal line receivers RS232C/RS423A/RS422
NE5181	Octal line receivers RS232C/RS423A/RS422 without filter
NE5521	Improved NE5520 LVDT for -55°C to $+125^\circ\text{C}$ operation
PCF1251	$1\mu\text{A}$ voltage fail detector: 1.15V trip point
PCF8591	8-Bit $90\mu\text{s}$ A/D and D/A converter with sample and hold, 4 channel mux, serial I/O, CMOS 2.5V to 6V. (1°C)
PNA7507	7-Bit, 20MHz Video A/D
—	Dual 16-bit D/A Converter with serial input

Power Conversion and Control

NE5562	20 pin, 5560-type SMPS for driving power FET's
SG1526B	SMPS controller with full features and dual FET drive (Sprague ULN8126 second source)

ALPHA/NUMERIC INDEX

Device	Section/Page	Device	Section/Page	Device	Section/Page
DAC 08	4-40	LM 2903	4-117	SE/NE 538	6-38
DAC 08A	4-40	LM 293/A	4-117	SE/NE 5410	4-89
DAC 08C	4-40	LF 298	4-217	NE 542	5-19
DAC 08E	4-40	SAF 3019P	5-198	NE 544	7-14
DAC 08H	4-40	SAB 3035	8-3	SE/NE 5512	6-44
DAC 08Q	4-40	SAB 3036	8-19	SE/NE 5514	6-46
ADC 0801/2/3/4/5-1	4-5	SAB 3037	8-35	NE 5517/A	6-106
TDA 1013A	6-90	TDA 3047	5-121	NE 5520	4-212
TDA 1023	7-62	TDA 3048	5-127	SE/NE 5532/A	6-48
TDA 1024	7-75	CA 3089	5-81	NE 5533/A	6-59
SAA 1027	7-19	LM 311	4-105	SA/SE/NE 5534/A	6-59
SAF 1032P	5-107	LM 319	4-107	SE/NE 5535	6-65
SAF 1039P	5-107	LM 324	6-5	SE/NE 5537	4-221
TEA 1046	5-172	MC 3302	4-112	SE/NE 5539	6-118
TDA 1074A	5-42	MC 3303	6-18	SE/NE 555	5-185
LM 111	4-105	LM 339/A	4-112	SE 555C	5-185
LM 119	4-107	MC 3403	6-18	SA/SE/NE 556	5-190
LM 124	6-5	MC 3410	4-56	SA/SE/NE 556-1	5-190
LM 139/A	4-112	MC 3410-C	4-56	SE 556-1C	5-190
MC 1408-7	4-50	MC 3503	6-18	SE/NE 5560	7-25
MC 1408-8	4-50	MC 3510	4-56	SE/NE 5561	7-38
MC/SA 1458	6-13	SG 3524	7-52	SE/NE 5562	7-42
MC 1488	4-140	SG 3526A	7-48	NE 5568	7-46
MC 1489/A	4-143	TDA 3540	8-131	SA/SE/NE 558	5-195
MC 1496	5-96	TDA 3541	8-131	NE 5592	6-125
MC 1508-8	4-50	LM 358	6-9	SE/NE 564	5-134
TDA 1515	6-94	TDA 3651A/AQ	8-141	SE/NE 565	5-141
TDA 1520A	6-100	TDA 3652	8-149	SE/NE 566	5-146
TDA 1522	5-51	TDA 3810	5-71	SE/NE 567	5-149
TDA 1524A	5-60	LM 393/A	4-117	NE 570	5-3
SG 1526A	7-48	LF 398	4-217	SA/NE 571	5-3
TDA 1540D,P	4-98	TDA 4503	8-154	SA/NE 572	5-9
MC 1558	6-13	SA/SE/NE 4558	6-22	NE 587	4-150
LM 158	6-9	TDA 4560	8-165	NE 589	4-158
MC 1596	5-96	SE/NE 5018	4-63	NE 590	4-166
LM 1870	5-15	SE/NE 5019	4-68	NE 591	4-166
LM 193/A	4-117	NE 5020	4-73	SE/NE 592	6-130
LF 198	4-217	SAA 5025	5-226	SA/NE 594	4-172
ULN 2003	4-208	SAA 5030	5-226	AM 6012	4-30
ULN 2004	4-208	NE 5034	4-11	SA/NE 602	5-22
PCF 2100	4-176	NE 5036	4-17	SA/NE 604	5-24
LM 211	4-105	NE 5037	4-23	NE 645	5-26
PCF 2110	4-184	SAA 5040	5-236	NE 646	5-26
PCF 2111	4-193	NE 5044	7-3	NE 648	5-30
PCF 2112	4-201	NE 5045	7-9	NE 649	5-30
LM 219	5-107	SAA 5050/55	5-255	NE 650	5-34
LM 224	6-5	NE 5080	5-99	NE 660	5-38
LM 239/A	4-112	NE 5081	5-103	TDA 7000	5-86
SG 2526A	7-48	NE 5090	4-145	TDA 7010T	5-91
TDA 2540	8-51	SE/NE 5118	4-81	μ A 723	7-57
TDA 2541	8-59	SE/NE 5119	4-85	SA/ μ A 723C	7-57
TDA 2546A	8-67	TCA 520B,D	6-73	μ A 733/C	6-137
TDA 2577A	8-72	SE/NE 521	4-122	μ A 741	6-79
TDA 2578A	8-86	SE/NE 522	4-126	SA/ μ A 741C	6-79
LM 258	6-9	SE/NE 527	4-130	μ A 747	6-84
TDA 2593	8-100	SE/NE 529	4-134	SA/ μ A 747C	6-84
TDA 2594	8-107	SE/NE 530	6-26	μ A 758	5-77
TDA 2595	8-114	SE/NE 531	6-31	MEA 8000	5-159
TDA 2653A	8-123	SA/SE/NE 532	6-9	PCB 8573	5-208
LM 2901	4-112	SA 534	6-5		

Signetics

a subsidiary of U.S. Philips Corporation

Signetics Corporation
811 E. Arques Avenue
P.O. Box 3409
Sunnyvale, California 94088-3409
Telephone 408 / 739-7700