

Read/Write Amplifier (with Built-in Filters) for FDDs

For the availability of this product, please contact the sales office.

Description

The CXA3071N is a monolithic IC designed for use with three-mode Floppy Disk Drives, and contains a read circuit (with a four-mode filter system), a write circuit, an erase circuit, and a supply voltage detection circuit, all on a single chip.

Features

- Single 5V power supply
- All filter, write current and other characteristics can be set with a single external resistor.
- Filter system can be switched among four modes: 1M, 1.6M/2M, which are each inner track/outer track.
- Filter characteristics can be set to Chebyshev (1dB ripple) for 1.6M, 2M/inner track only, and to Butterworth for the other modes and a custom selection can be made between Chebyshev (1dB ripple) and Butterworth for 1.6M, 2M/inner track only.
- 1M/outer track f_0 and the f_c ratio for each mode can be customized.
- Pre-amplifier voltage gain can be set to 45dB or 48dB by switching the filter mode and inner/outer track.
- Pre-amplifier and filter output are monitored with the same pins. These pins are normally set to filter output, but the pre-amplifier output can be monitored by temporarily setting the SETR pin (Pin 20) to Low.
- Time domain filter can be switched between two modes: 1M, 1.6M/2M.
In addition, the pulse width can be customized.
- Write current can be switched among six modes according to the mode and inner/outer track setting.
The current value can be customized for each mode.
- Erase current remains constant, and the current value can be customized.
- Damping resistor can be built in. Resistor can be customized between 2kΩ and 15kΩ in 1kΩ steps.
- Supply voltage detection circuit

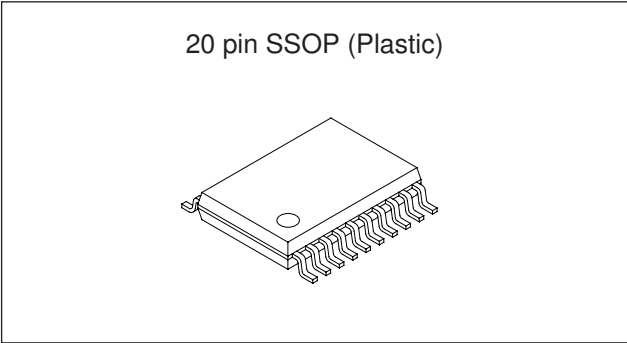

Applications

Three-mode FDDs

Structure

Bipolar silicon monolithic IC

Absolute Maximum Ratings ($T_a = 25^\circ\text{C}$)

• Supply voltage	V_{CC}	7.0	V
• Digital signal input pin voltage		-0.5 to $V_{CC} + 0.3$	V
• Power ON output applied voltage		$V_{CC} + 0.3$	V
• Erase output applied voltage		$V_{CC} + 0.3$	V
• Write head applied voltage		15	V
• Power ON output current		7	mA
• Operating temperature	T_{opr}	-20 to +75	$^\circ\text{C}$
• Storage temperature	T_{stg}	-65 to +150	$^\circ\text{C}$
• Allowable power dissipation	P_D	375	mW

Operating Conditions

Supply voltage		4.4 to 6.0	V
----------------	--	------------	---

Sony reserves the right to change products and specifications without prior notice. This information does not convey any license by any implication or otherwise under any patents or other right. Application circuits shown, if any, are typical examples illustrating the operation of the devices. Sony cannot assume responsibility for any problems arising out of the use of these circuits.

Block Diagram and Pin Configuration

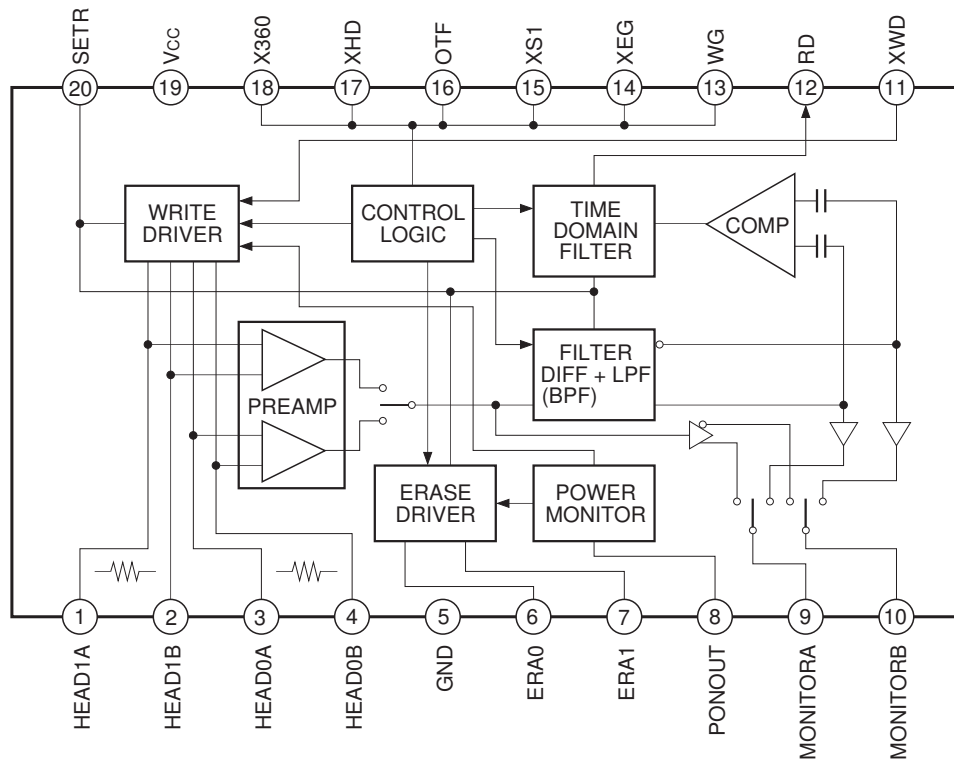

Pin Description

Pin No.	Symbol	Pin voltage	Equivalent circuit	Description
1	HEAD1A	—		<p>Magnetic head inputs/outputs. Connect the recording/playback magnetic head to these pins, and connect the center tap to V_{CC}. When the logical voltage for Pin 15 (XS1) is Low, the HEAD1 system is active; when the logical voltage is High, the HEAD0 system is active.</p>
2	HEAD1B	—		
3	HEAD0A	—		
4	HEAD0B	—		
5	GND	—		GND connection.
6	ERA0	—		Erase output for the HEAD0 system.
7	ERA1	—		Erase output for the HEAD1 system.
8	PON OUT	—		Reduced voltage detection output. This is an open collector that outputs a low signal when V _{CC} is below the specified value.
9	MONI-TORA	4.0V during filter output 3.4V during pre-amplifier output		<p>MONITOR differential outputs. These pins are set to filter output during normal read mode, but the preamplifier output can be monitored by temporarily setting Pin 20 (SETR) to Low.</p>
10	MONI-TORB	4.0V during filter output 3.4V during pre-amplifier output		

Pin No.	Symbol	Pin voltage	Equivalent circuit	Description
11	XWD	—		Write data input. This pin is a Schmitt-type input that is triggered when the logical voltage goes from High to Low.
12	RD	—		Read data output. This pin is active when the logical voltage of the write gate signal and the erase gate signal is High.
13	WG	0.5V _{CC} during read		WG signal input. The write system becomes active when the logical voltage is High. The IC is in power saving mode when the logical voltage is Low. The read system becomes active when the logical voltage is Z.
14	XEG	—		XEG signal input. The erase system becomes active when the logical voltage is Low.
15	XS1	—		Head side switching signal input. The HEAD1 system is active when the logical voltage is Low, and the HEAD0 system is active when the logical voltage is High, but only when the logical voltage for the WG signal is Z and of the XEG signal is High.
16	OTF	—		Filter inner track/outer track mode control. Outer track mode is selected when the logical voltage is High.
17	XHD	—		Filter, time domain filter and write current 1M/2M mode control. 1.6M/2M mode is selected when the logical voltage is Low.
18	X360	—		Filter, time domain filter and write current 1.6M/2M mode control. 1.6M mode is selected when the logical voltage is Low.
19	V _{CC}	—		Power supply (5V) connection.

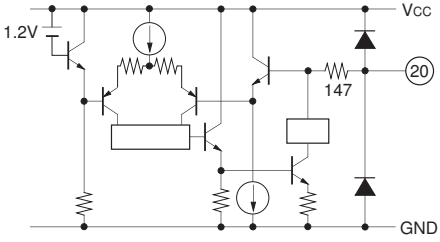
Pin No.	Symbol	Pin voltage	Equivalent circuit	Description
20	SETR	3.8V		<p>Filter cutoff frequency, time domain filter 1st monostable multivibrator pulse width, read data, write current and erase current setting resistor connection. Connect the setting resistor R between this pin and Vcc.</p>

Electrical Characteristics

Current Consumption

(Ta = 25°C, Vcc = 5V)

Item	Symbol	Conditions	Measurement circuit	Measurement point	Min.	Typ.	Max.	Unit
Current consumption in read mode	ICCR	WG = "Z"	—	—	15.0	25.0	35.0	mA
Current consumption in write/erase mode	ICCWE	WG = "H", XEG = "L"	—	—	11.0	17.0	23.0	mA
Current consumption in power saving mode	ICCPS	WG = "L"	—	—	—	1.2	2.0	mA

Power Supply Monitoring System

(Ta = 25°C)

Item	Symbol	Conditions	Measurement circuit	Measurement point	Min.	Typ.	Max.	Unit
Power supply ON/OFF detector threshold voltage	VTH		—	—	3.5	3.9	4.3	V
Power ON output saturation voltage	VSP	Vcc = 3.5V I = 1mA	—	—	—	—	0.5	V

Read System

(Ta = 25°C, Vcc = 5V)

Item	Symbol	Conditions	Measurement circuit	Measurement point	Min.	Typ.	Max.	Unit
Preamplifier voltage gain 1M/outer track	GVLO	f = 100kHz, OTF = "H", XHD = "H", X360 = "X"	1	A, B	43.1	45.0	46.6	dB
Preamplifier voltage gain 1M/inner track	GVLI	f = 100kHz, OTF = "L", XHD = "H", X360 = "X"	1	A, B	46.1	48.0	49.6	dB
Preamplifier voltage gain 1.6M, 2M/outer track	GVHO	f = 100kHz, OTF = "H", XHD = "L", X360 = "X"	1	A, B	43.1	45.0	46.6	dB
Preamplifier voltage gain 1.6M, 2M/inner track	GVHI	f = 100kHz, OTF = "L", XHD = "L", X360 = "X"	1	A, B	46.1	48.0	49.6	dB
Preamplifier frequency response	BWO	Gv/Gv0 = -3dB	1	A, B	5	—	—	MHz
Preamplifier input conversion noise voltage	ENO	Bw = 400Hz to 1MHz, Vi = 0	1	A, B	—	2.0	2.9	nV/ $\sqrt{\text{Hz}}$

Read System

(Ta = 25°C, Vcc = 5V)

Item	Symbol	Conditions	Measurement circuit	Measurement point	Min.	Typ.	Max.	Unit
Filter output voltage amplitude	VOF		1	A, B	1.4	—	—	Vp-p
Time domain filter monostable multivibrator pulse width	T1	X360 = "X", XHD = "H" (1M mode)	1	C, D	2.25	2.50	2.75	μs
		X360 = "X", XHD = "L" (1.6M/2M mode)	1	C, D	1.16	1.29	1.42	μs
Read data pulse width	T2		1	D	300	400	500	ns
Read data output low output voltage	VOL	I _{OL} = 2mA	1	D	—	—	0.5	V
Read data output high output voltage	VOH	I _{OH} = -0.4mA	1	D	2.8	—	—	V
Read data output*1 rise time	t _r	R _L = 2kΩ C _L = 20pF	1	D	—	—	100	ns
Read data output*1 fall time	t _f	R _L = 2kΩ C _L = 20pF	1	D	—	—	100	ns
Peak shift*2	PS	V _I = 0.25mVp-p to 3.5mVp-p X360 = "H", XHD = "L" OTF = "L" f = 125kHz, 2M/inner track mode	1	D	—	—	1	%

*1 Read data output: 0.5V to 2.4V

*2 Signal input level

1M, 1.6M, 2M/outer track: V_I = 0.25mVp-p to 5mVp-p1M, 1.6M, 2M/inner track: V_I = 0.25mVp-p to 3.5mVp-p

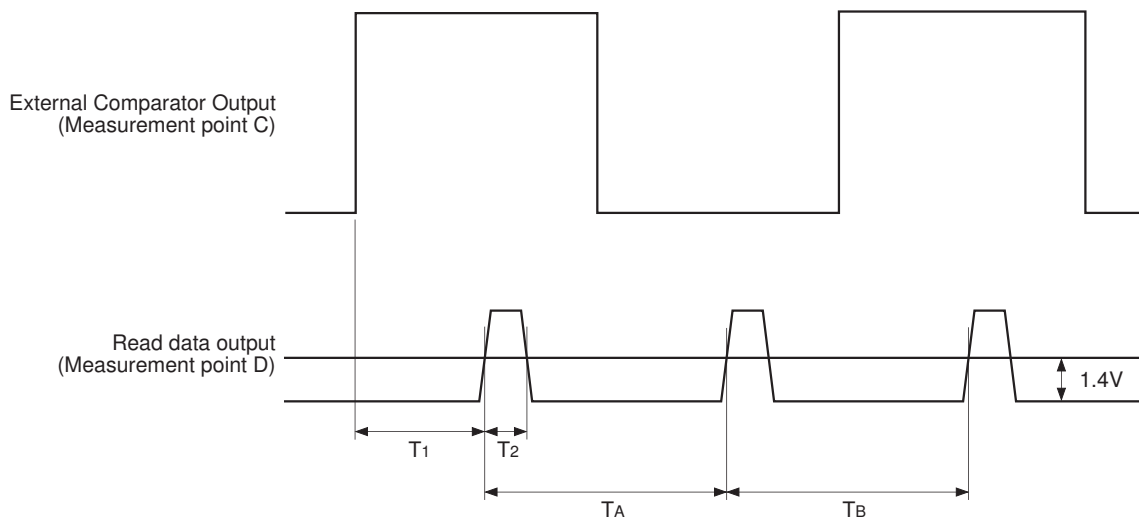

Fig. 1. 1st and 2nd monostable multivibrator pulse width precision and peak shift measurement conditions

- 1st monostable multivibrator pulse width precision

When X360 = "X" and XHD = "H":

$$ETM1 = \left(\frac{T_1}{2.5\mu s} - 1 \right) \times 100 [\%]$$

When X360 = "X" and XHD = "L":

$$ETM1' = \left(\frac{T_1}{1.29\mu s} - 1 \right) \times 100 [\%]$$

- 2nd monostable multivibrator pulse width = T2
- Peak shift

$$PS = \frac{1}{2} \left| \frac{T_A - T_B}{T_A + T_B} \right| \times 100 [\%]$$

Read System (Filters)

(Ta = 25°C, Vcc = 5V)

Item		Symbol	Conditions	Measurement circuit	Measurement point	Min.	Typ.	Max.	Unit
1M outer track	Peak frequency	f ₀₁	WG = "Z", X360 = "X" XHD = "H" OTF = "H"	1	A, B	165.6	184.0	202.4	kHz
	Peak voltage gain* ³	G _{p1}	Refer to Fig. 1 at f ₀₁	1	A, B	4.1	6.0	7.6	dB
	Frequency response (1)	G ₁₁	Refer to Fig. 1 at 1/3f ₀₁	1	A, B	-7.4	-6.9	-6.4	dB
	Frequency response (2)	G ₁₂	Refer to Fig. 1 at 3f ₀₁	1	A, B	-24.9	-23.0	-21.4	dB
1M inner track	Peak frequency	f ₀₂	WG = "Z", X360 = "X" XHD = "H" OTF = "L"	1	A, B	177.2	196.9	216.6	kHz
	Peak voltage gain* ³	G _{p2}	Refer to Fig. 1 at f ₀₂	1	A, B	4.1	6.0	7.6	dB
	Frequency response (1)	G ₂₁	Refer to Fig. 1 at 1/3f ₀₂	1	A, B	-7.4	-6.9	-6.4	dB
	Frequency response (2)	G ₂₂	Refer to Fig. 1 at 3f ₀₂	1	A, B	-24.9	-23.0	-21.4	dB
1.6M/ 2M outer track	Peak frequency	f ₀₃	WG = "Z", X360 = "X" XHD = "L" OTF = "H"	1	A, B	311.3	345.9	380.5	kHz
	Peak voltage gain* ³	G _{p3}	Refer to Fig. 1 at f ₀₃	1	A, B	4.2	6.1	7.7	dB
	Frequency response (1)	G ₃₁	Refer to Fig. 1 at 1/3f ₀₃	1	A, B	-7.4	-6.9	-6.4	dB
	Frequency response (2)	G ₃₂	Refer to Fig. 1 at 3f ₀₃	1	A, B	-25.3	-23.4	-21.8	dB
1.6M/ 2M inner track	Peak frequency	f ₀₄	WG = "Z", X360 = "X" XHD = "L" OTF = "L"	1	A, B	346.2	384.6	423.0	kHz
	Peak voltage gain* ³	G _{p4}	Refer to Fig. 1 at f ₀₄	1	A, B	5.8	7.7	9.3	dB
	Frequency response (1)	G ₄₁	Refer to Fig. 1 at 1/3f ₀₄	1	A, B	-8.3	-7.8	-7.3	dB
	Frequency response (2)	G ₄₂	Refer to Fig. 1 at 3f ₀₄	1	A, B	-37.8	-35.9	-34.3	dB

*³ G_{pn} = 20 Log₁₀ (VFilterout/VPreout)

VFilterout = Filter differential output voltage

(N = 1 to 4).

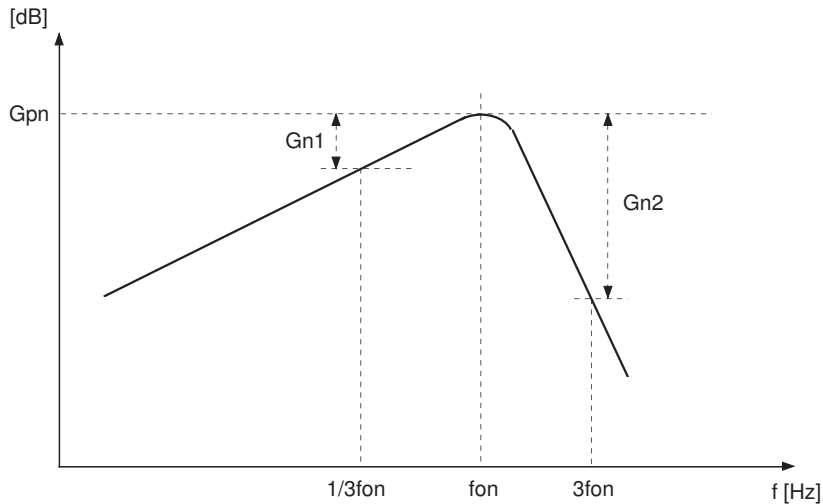

(n = 1 to 4)

Fig. 2. Filter frequency response measurement conditions

Write/Erase System

(Ta = 25°C, Vcc = 5V)

Item	Symbol	Conditions	Measurement circuit	Measurement point	Min.	Typ.	Max.	Unit
Damping resistor precision	RD	Vcc = 0V SW1 = b	2	A', B' C', D'	-20	—	+20	%
1M/outer track write current	IWLO	WG = "H", OTF = "H" XHD = "H", X360 = "X"	2	A, B C, D	8.83	9.5	10.17	mA0-p
1M/inner track write current	IWLI	WG = "H", OTF = "L" XHD = "H", X360 = "X"	2	A, B C, D	6.62	7.12	7.62	mA0-p
1.6M/outer track write current	IWMO	WG = "H", OTF = "H" XHD = "L", X360 = "L"	2	A, B C, D	7.44	8.0	8.56	mA0-p
1.6M/inner track write current	IWMI	WG = "H", OTF = "L" XHD = "L", X360 = "L"	2	A, B C, D	5.95	6.4	6.85	mA0-p
2M/outer track write current	IWHO	WG = "H", OTF = "H" XHD = "L", X360 = "H"	2	A, B C, D	4.18	4.5	4.82	mA0-p
2M/inner track write current	IWHI	WG = "H", OTF = "L" XHD = "L", X360 = "H"	2	A, B C, D	2.76	2.97	3.18	mA0-p
Write current output unbalance	DW	WG = "H"	2	A, B C, D	-1	—	+1	%
Head I/O pin leak current for writes	ILKW	WG = "H"	2	A, B C, D	—	—	10	μA
Write head pin current at saturation	ISW	WG = "H", OTF = "H" XHD = "H", X360 = "X" VSW = 1V, SW2 = b	2	A, B C, D	8.45	9.5	10.55	mA0-p
Erase current	IE	XEG = "L"	2	E, F	5.40	6.0	6.60	mA
Erase current output pin leak current	ILKE	XEG = "L"	2	E, F	—	—	10	μA

Logic Input Block

(Ta = 25°C, Vcc = 5V)

Item	Symbol	Conditions	Measurement circuit	Measurement point	Min.	Typ.	Max.	Unit
Digital signal input low input voltage	VLD		2	I, J, K, L, M	—	—	0.8	V
Digital signal input high input voltage	VHD		2	I, J, K, L, M	2.0	—	—	V
Schmitt-type digital signal input low input voltage	VLSD		2	G	—	—	0.8	V
Schmitt-type digital signal input high input voltage	VHSD		2	G	2.0	—	—	V
WG pin digital signal input high input voltage	VMHD		2	H	0.7V _{CC}	—	—	V
WG pin digital signal input low input voltage	VMLD		2	H	—	—	0.3V _{CC}	V
Digital signal input low input current	ILD	VL = 0V	2	G, H, I, J, K, L, M	-100	—	—	μA
Digital signal input high input current	IHD	VH = 5V	2	G, H, I, J, K, L, M	—	—	100	μA

Electrical Characteristics Measurement Circuit 1

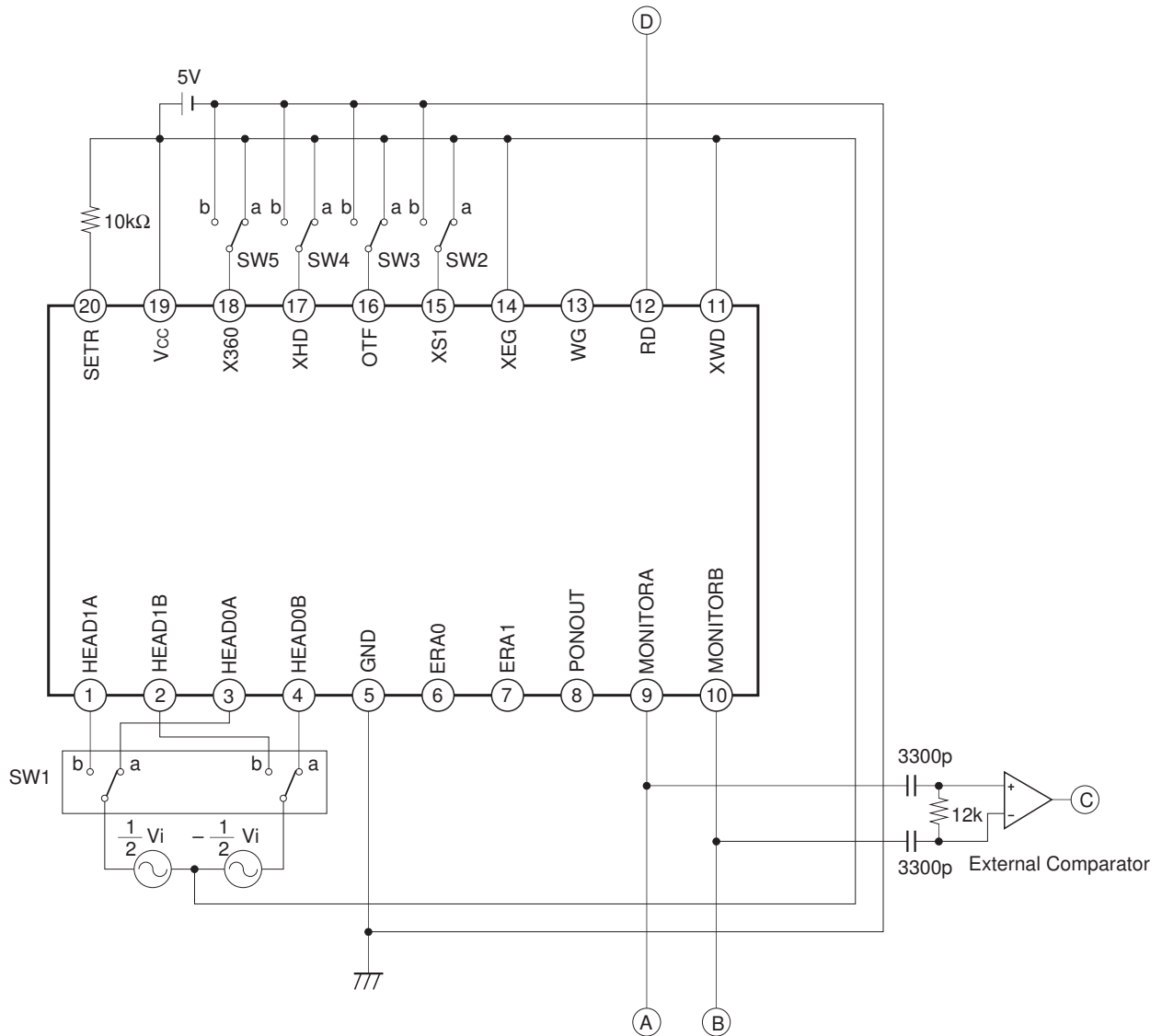

Note) Unless otherwise specified, switches are assumed to be set to "a".
 CR time constant of external comparator input stage is equivalent to the time constant of comparator input stage within the IC.

Electrical Characteristics Measurement Circuit 2

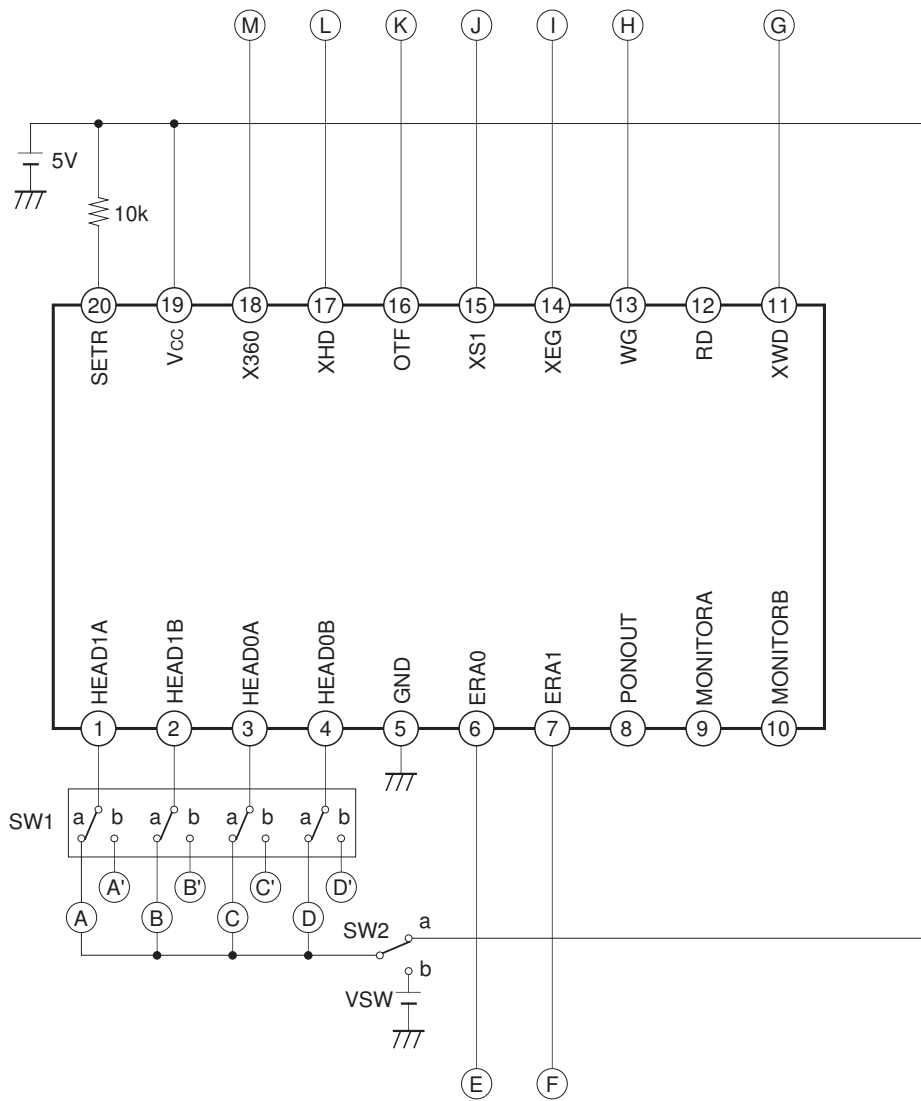

Note) Unless otherwise specified, switches are assumed to be set to "a".

Description of Operation

(1) Read system

Preamplifier

The preamplifier amplifies input signals.

The voltage gain can be switched depending on the settings of Pins 16, 17 and 18.

Filter

The filter differentiates the signals amplified by the preamplifier. The high-band noise components are attenuated by the low-pass filter.

The filters can be switched among four modes, depending on the settings of Pins 16, 17 and 18.

In 1M/outer track mode, the peak frequency f_{01} is fixed and used as a reference (1.00), and f_0 for the other three modes is switched by the internal settings of the IC.

Active filter block

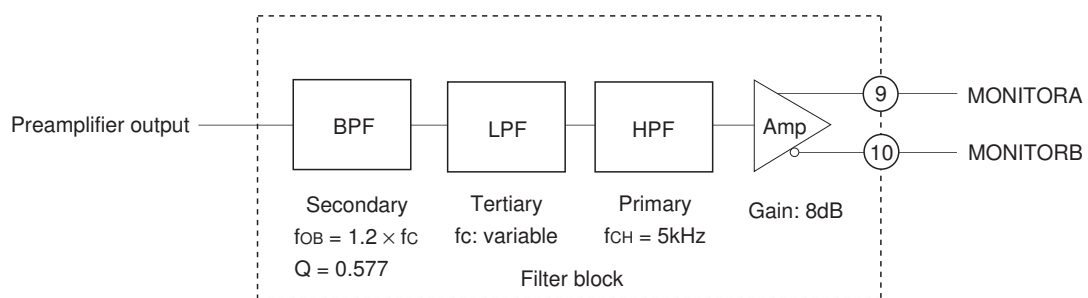

The center frequency f_{0B} of the BPF is fixed to 1.2 times the cutoff frequency f_0 of the LPF. The LPF characteristics are set to Chebyshev (1dB ripple) for 1.6M, 2M/inner track mode only, and the Butterworth for all other modes.

Pin16 OTF	Pin17 XHD	Pin18 X360	LPF characteristics	f_0 ratio
H	H	X	1M/outer track: Butterworth	1.00
L	H	X	1M/inner track: Butterworth	1.07
H	L	L	1.6M/outer track: Butterworth	1.88
L	L	L	1.6M/inner track: Chebyshev 1dB ripple	2.09
H	L	H	2M/outer track: Butterworth	1.88
L	L	H	2M/inner track: Chebyshev 1dB ripple	2.09

Monitor switching

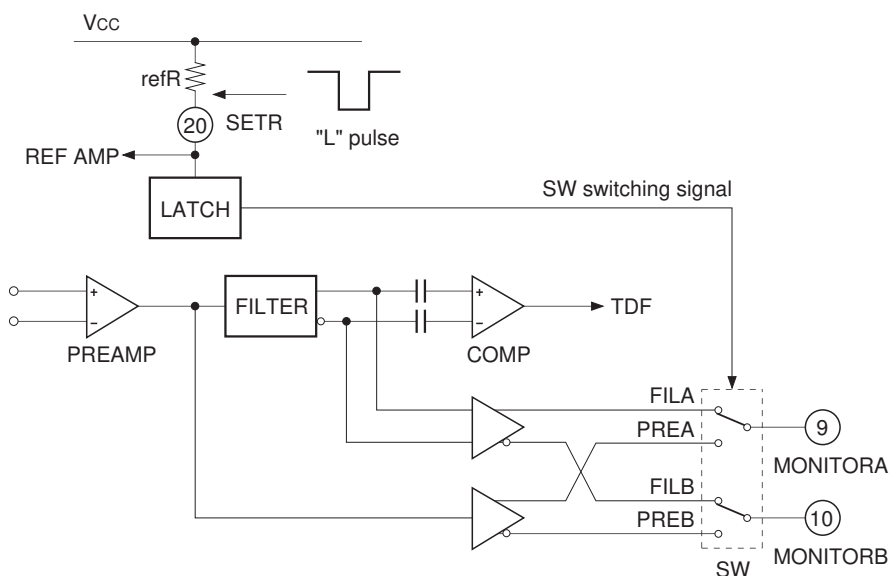

Monitor block configuration

The monitor pins are used for both the preamplifier output and filter output. These pins are set to filter output during normal read mode, but the preamplifier output can be monitored by temporarily setting the SETR pin (Pin 20) to Low.

The monitored contents are returned from the preamplifier output to the filter output by switching to write mode (WG = Z → High).

Note that the specifications for inputting a low signal to the SETR pin are the same as for the TTL input pin, but an open collector output (or open drain output) should be used while inputting the signal.

SETR (Pin 20)	MONITORA (Pin 9)	MONITORB (Pin 10)	Monitor mode
Z	FILOUTA	FILOUTB	Filter output
	PREOUTA	PREOUTB	Preamplifier output

Comparator

The comparator detects the crosspoint of the filter differential output.

Time domain filter

The time domain filter converts the comparator output to read data.

This filter is equipped with two monostable multivibrators. 1st monostable multivibrator eliminates unnecessary pulses, and 2nd monostable multivibrator determines the pulse width of the read data.

Note that the 1st monostable multivibrator pulse width T1 is fixed internally.

T1 can be switched as follows by the settings of Pins 17 and 18:

When XHD = "H" and X360 = "X": T1 (1M) = 2500 [ns]

When XHD = "L" and X360 = "L" or

XHD = "L" and X360 = "H": T1(1.6M/2M) = 1290 [ns]

The pulse width for 2nd monostable multivibrator is fixed at 400 [ns].

(2) Write system

Write data input through Pin 11 is frequency-divided by the T flip-flop and generates the recording current for the head. The recording current can be switched by the settings of Pins 17 and 18. Note that the write current I_w is fixed internally for each mode.

Furthermore, the inner/outer track write current I_w can be changed for each mode by switching Pin 16. However, the current ratio between the inner and outer tracks is fixed.

(3) Erase current

The erase current I_E is fixed internally.

Pins 6 and 7 are constant current outputs.

(4) Power ON/OFF detection system

The power ON/OFF detection system detects a reduced voltage in the supply voltage.

When V_{CC} is below the specified value, the write system and erase system cease operation, disabling the write and erase functions.

Notes on Operation

- Select the voltage gain so that the preamplifier output amplitude is 1V_{p-p} or less.
If the preamplifier output amplitude exceeds 1V_{p-p}, the filter output waveform becomes distorted.
- Observe the following point when mounting this device.
- The GND should be as large as possible.
- Connect a V_{CC} decoupling capacitor of about 0.1μF as close to the device as possible.

Application Circuit

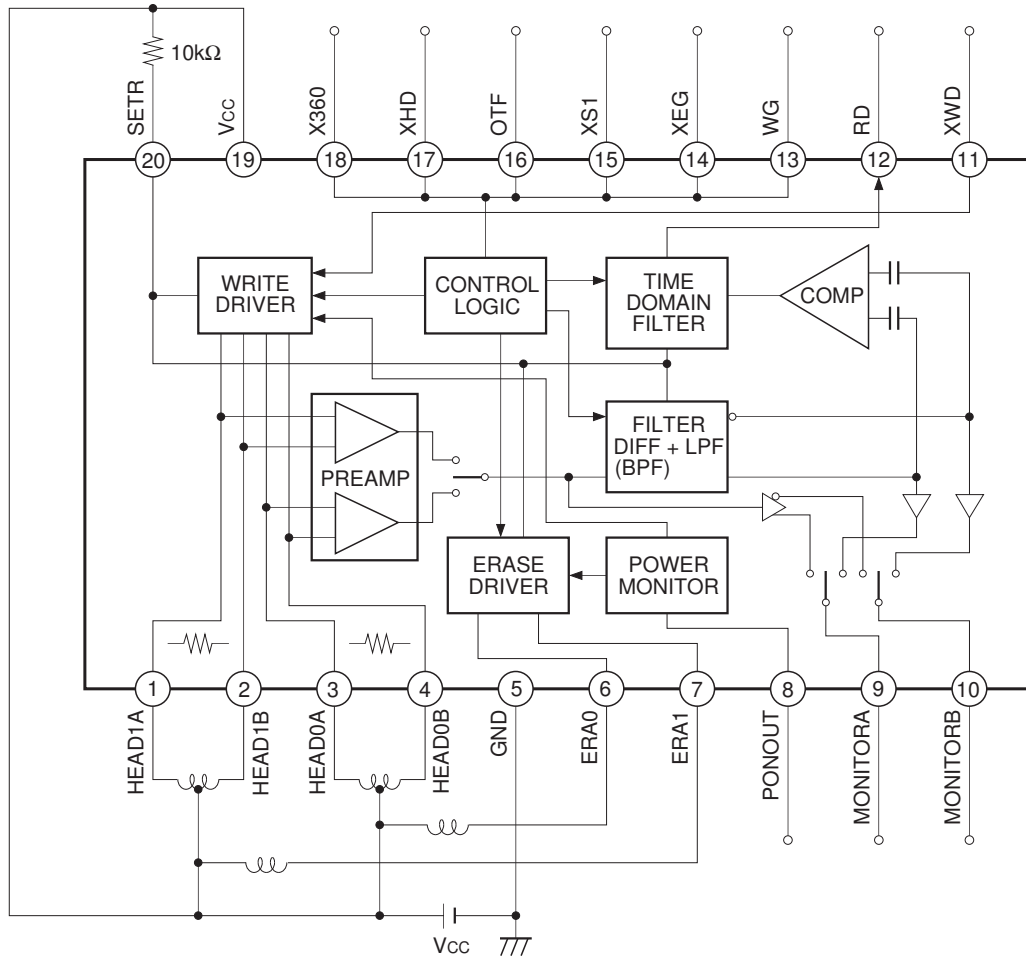

Note) When using two modes (1M and 2M), connect X360 (Pin 18) to Vcc and set XHD (Pin 17) high or low to switch modes.

Application circuits shown are typical examples illustrating the operation of the devices. Sony cannot assume responsibility for any problems arising out of the use of these circuits or for any infringement of third party patent and other right due to same.

Filter Frequency Response

The LPF characteristics are set to Chebyshev (1dB ripple) for 1.6M, 2M/inner track mode only, and to Butterworth for other modes. The 1.6M and 2M characteristics and fc ratio are identical.

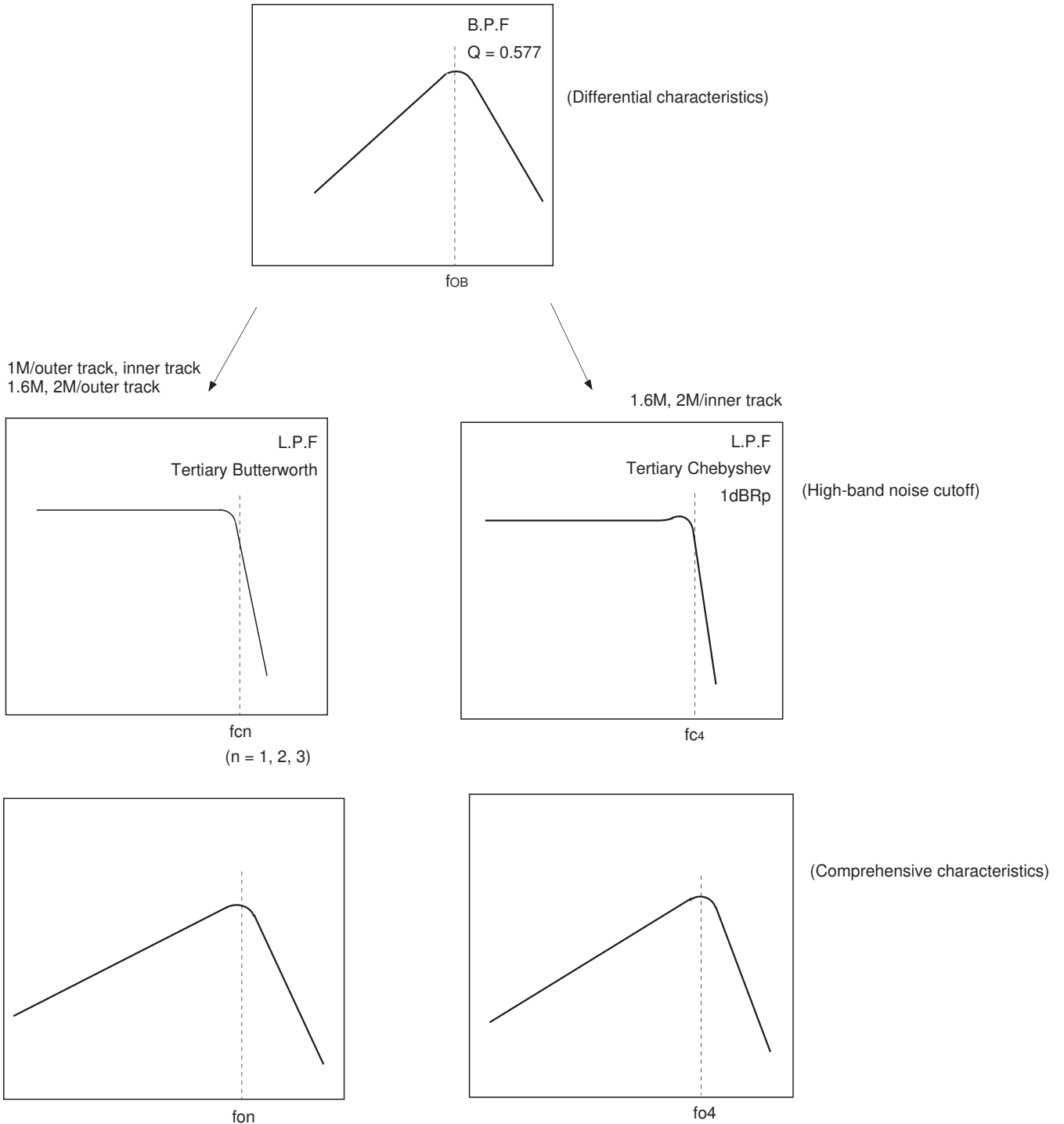

The BPF center frequency f_{0B} is fixed at 1.2 times the LPF cutoff frequency.

$$f_{0B} = 1.2f_c$$

In the comprehensive characteristics, the relationship between the peak frequencies f_0 and f_c is as follows, depending on the differences of the LPF type:

Butterworth characteristics $f_{cn} = 1.28f_{0n}$ ($n = 1, 2, 3$)

Chebyshev (1dB ripple characteristics) $f_{c4} = 1.09f_{o4}$

Custom Selection of Filters

The LPF cutoff frequency f_c in 1M/outer track mode can be customized. In addition, assuming the LPF cutoff frequency value as 1.00, the f_c ratio can be selected for the other three modes.

In addition, the LPF characteristics are set to Chebyshev (1dB ripple) for 1.6M, 2M/inner track mode only, and to Butterworth for the other modes. However, a custom selection can be made between Chebyshev (1dB ripple) and Butterworth for 1.6M, 2M/inner track mode only. (However, the 1.6M and 2M characteristics and f_c ratio are identical.)

Note that the BPF center frequency f_{0B} is fixed at 1.2 times f_c .

Mode	LPF type	f_c ratio when f_{c1} is assumed as 1
1M/outer track	Butterworth	1.0
1M/inner track	Butterworth	1.07 , 1.14, 1.23, 1.33, 1.45, 1.60, 2.00
1.6M, 2M/outer track	Butterworth	1.23, 1.33, 1.39, 1.45, 1.52, 1.60, 1.68, 1.78, 1.88 , 2.00, 2.13, 2.29, 2.46, 2.67
1.6M, 2M/inner track	Butterworth Chebyshev (1dB ripple)	1.23, 1.33, 1.39, 1.45, 1.52, 1.60, 1.68, 1.78 , 1.88, 2.00, 2.13, 2.29, 2.46, 2.67

* The boxed ratio indicates the setting for the CXA3071N.

Write Current Setting Method

Assuming the outer track as 1.00, the write current ratio is fixed within the IC for each mode.

The write current for the outer track is fixed within the IC.

The setting is for the outer track current when OTF is High, and for the inner track current when OTF is Low.

Track	Write current inner track setting ratio
1M mode	1.00, 0.92, 0.86, 0.80, 0.75 , 0.71, 0.66, 0.63
1.6M mode	1.00, 0.92, 0.86, 0.80 , 0.75, 0.71, 0.66, 0.63
2M mode	1.00, 0.92, 0.86, 0.80 , 0.75, 0.71, 0.66 , 0.63

* The boxed ratio indicates the setting for the CXA3071N.

Example of Representative Characteristics

Normalized preamplifier voltage gain and phase vs. Frequency

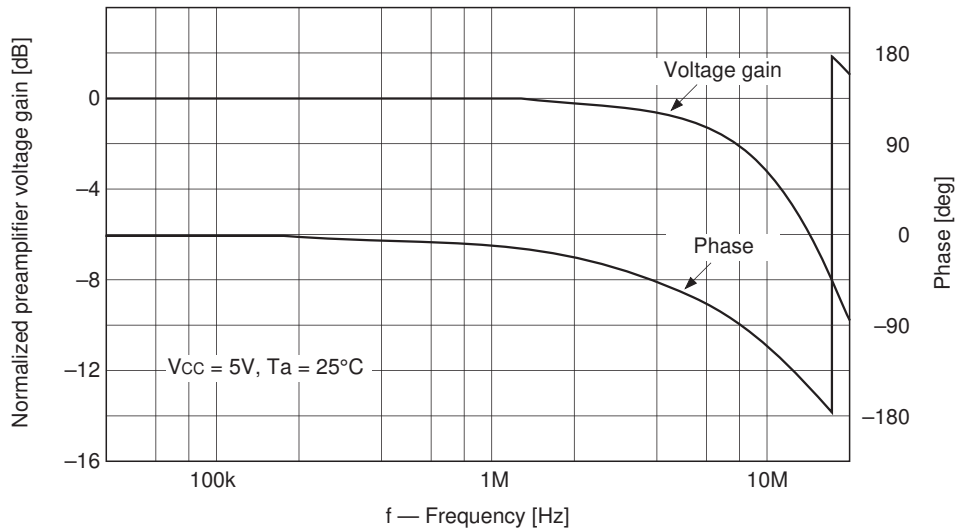

1M/outer track

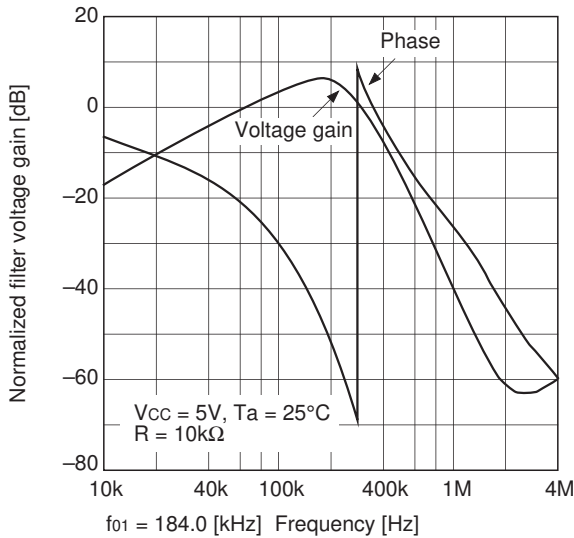

1M/inner track

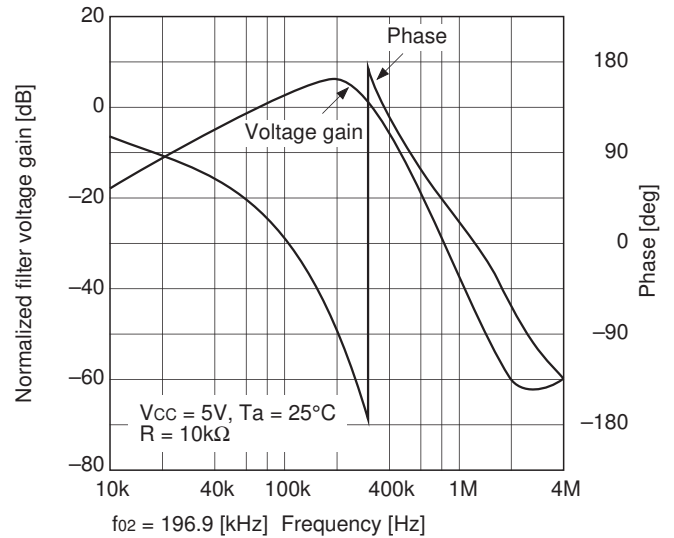

1.6M, 2M/outer track

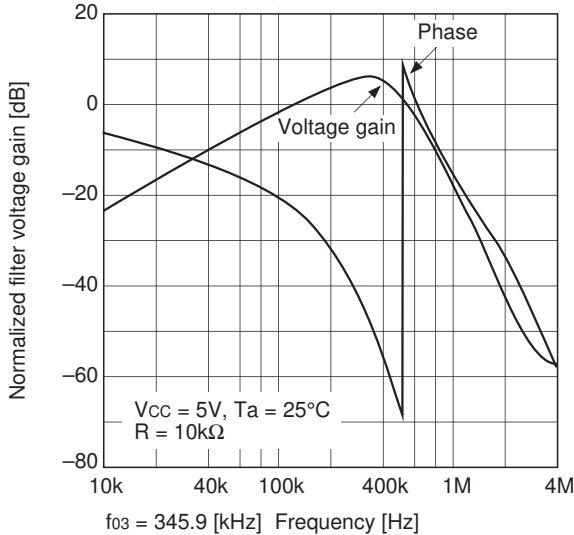

1.6M, 2M/inner track

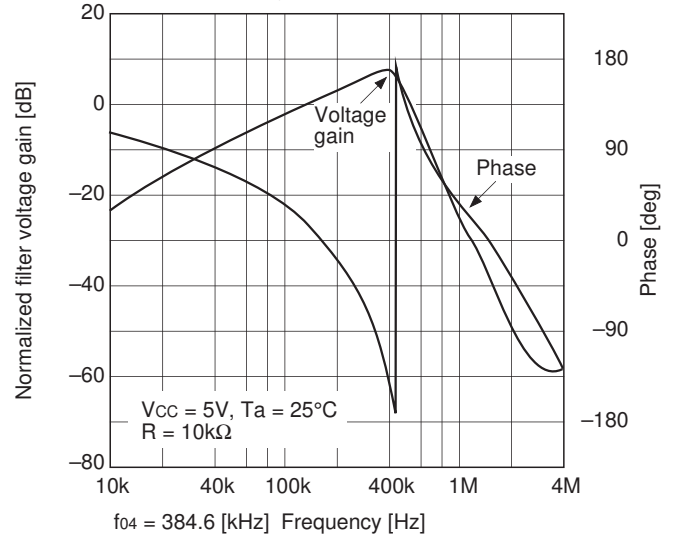

Normalized preamplifier voltage gain + filter voltage gain NGv vs. Ambient temperature Ta

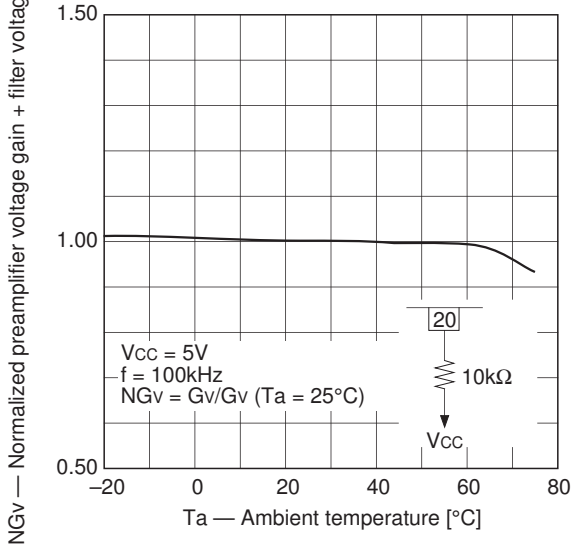

Normalized preamplifier voltage gain + filter voltage gain NGv vs. Supply voltage Vcc

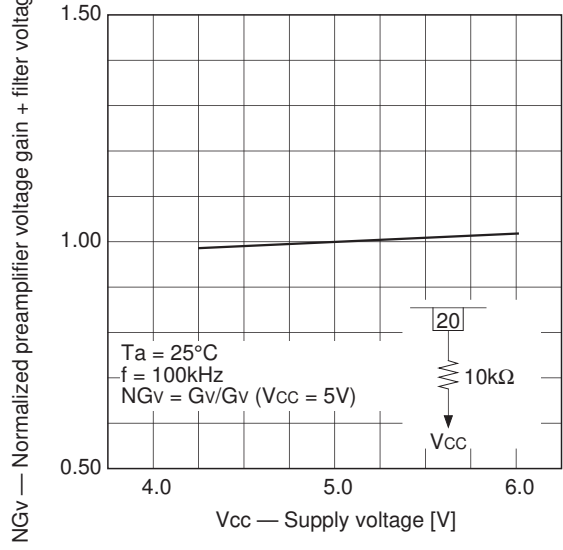

Normalized filter peak frequency Nfo vs. Ambient temperature Ta

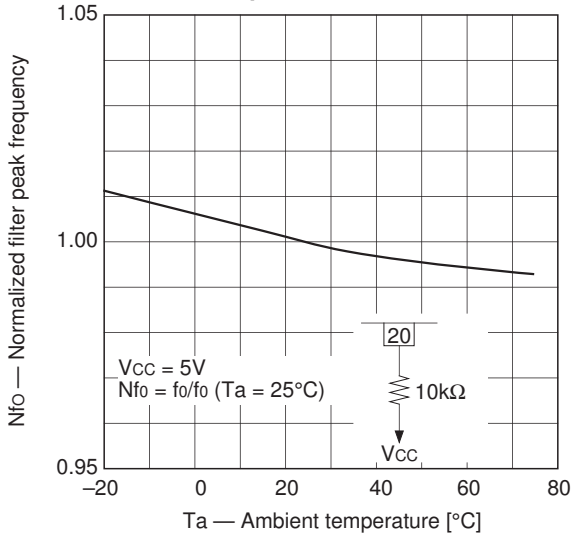

Normalized filter peak frequency Nfo vs. Supply voltage Vcc

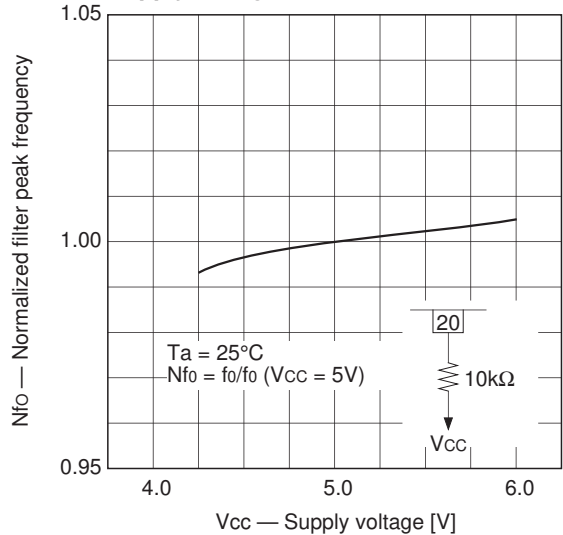

Normalized 1st monostable multivibrator pulse width NT1 vs. Ambient temperature Ta

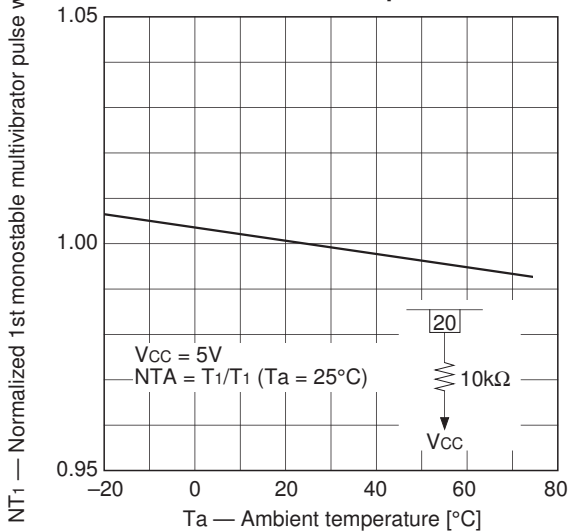

Normalized 1st monostable multivibrator pulse width NT1 vs. Supply voltage Vcc

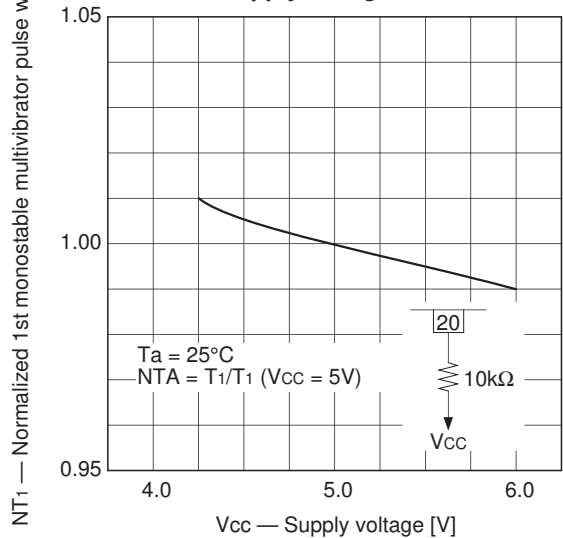

Normalized read data pulse width NT₂ vs. Ambient temperature T_a

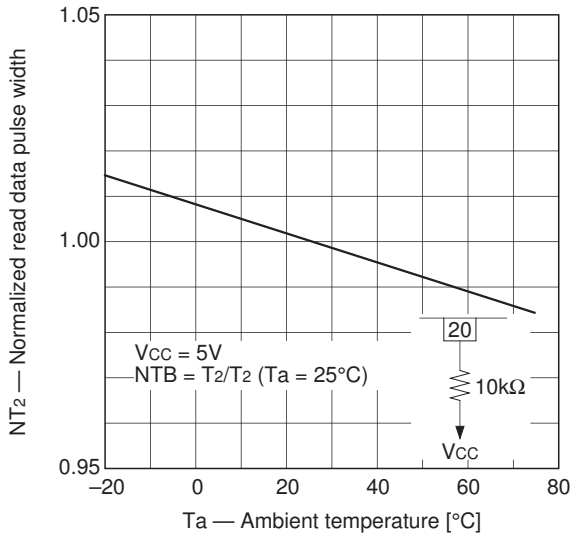

Normalized read data pulse width NT₂ vs. Supply voltage V_{CC}

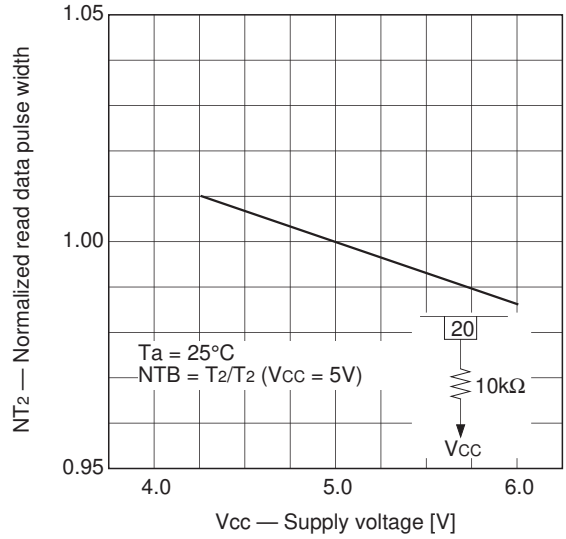

Normalized write current NI_w vs. Ambient temperature T_a

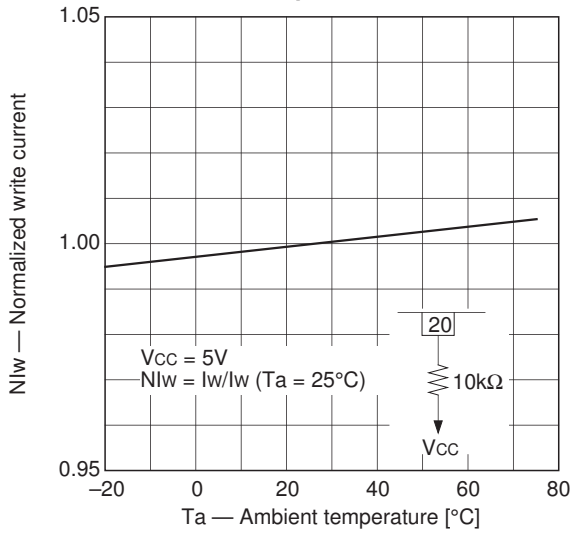

Normalized write current NI_w vs. Supply voltage V_{CC}

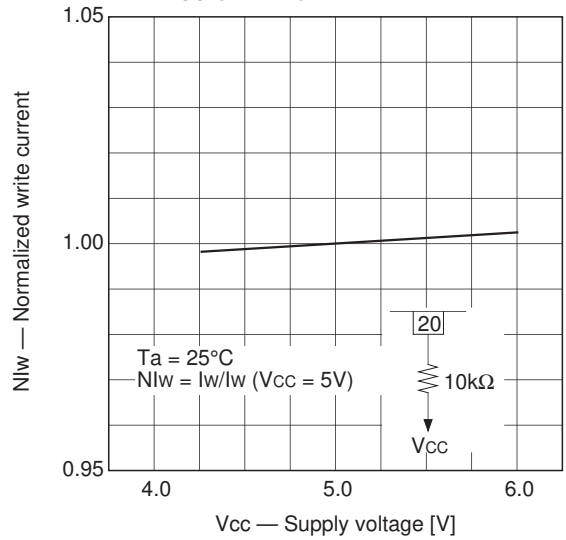

Normalized erase current NI_E vs. Ambient temperature T_a

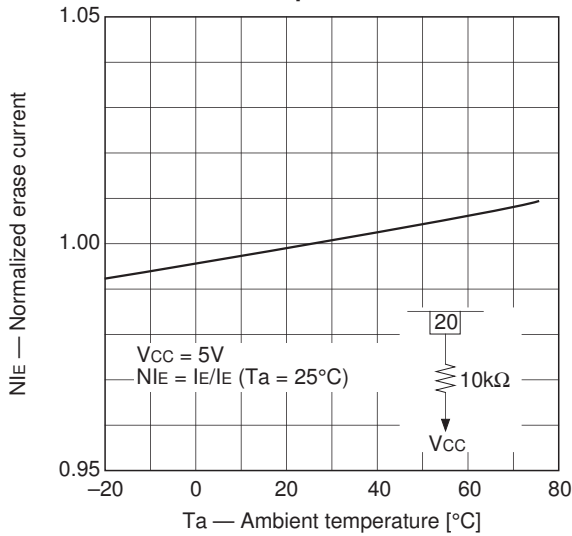

Normalized erase current NI_E vs. Supply voltage V_{CC}

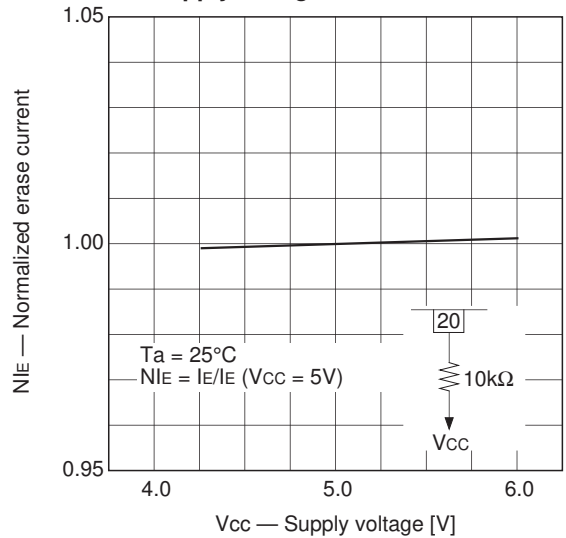

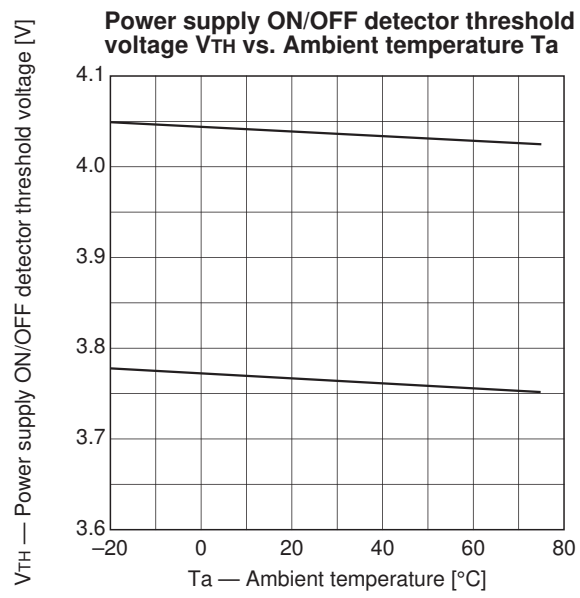

Package Outline

Unit: mm

20PIN SSOP (PLASTIC)

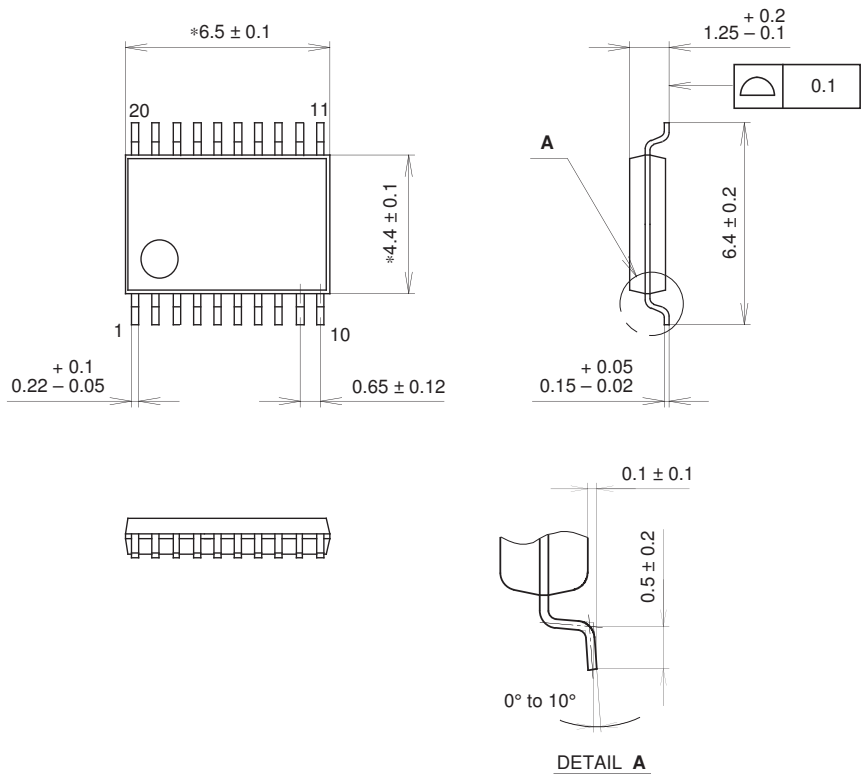

NOTE: Dimension "*" does not include mold protrusion.

PACKAGE STRUCTURE

SONY CODE	SSOP-20P-L01
EIAJ CODE	SSOP020-P-0044
JEDEC CODE	_____

PACKAGE MATERIAL	EPOXY RESIN
LEAD TREATMENT	SOLDER / PALLADIUM PLATING
LEAD MATERIAL	COPPER / 42 ALLOY
PACKAGE WEIGHT	0.1g

NOTE : PALLADIUM PLATING

This product uses S-PdPPF (Sony Spec.-Palladium Pre-Plated Lead Frame).