

WD7855/LV

Systems Logic for 80386SX PC/AT

*Compatible Desktop, Laptop, Palmtop,
and Pen-based Computers*



TABLE OF CONTENTS

Section	Title	Page
1.0	INTRODUCTION	10-1
1.1	Document Scope	10-1
1.2	Features	10-1
1.3	General Description	10-1
1.3.1	Desktop Applications	10-2
1.3.2	Portable Applications	10-2
1.3.3	WD7855/LV Power Management	10-2
1.3.3.1	Automatic CPU Speedup	10-2
1.3.3.2	CPU Sleep and Power-down.	10-2
1.3.3.3	Suspend and Resume Mode.	10-2
1.3.3.4	Peripheral Power Control	10-3
1.3.3.5	System Activity Monitor	10-3
1.3.3.6	SMI Support	10-3
1.3.3.7	Hibernation Support	10-3
1.3.3.8	Slow Refresh	10-3
1.3.3.9	DMA Stop Clock	10-3
2.0	ARCHITECTURE	10-6
2.1	Initialization And Clocking	10-6
2.2	AT Bus	10-6
2.3	Main Processor Control	10-6
2.4	Numeric Processor Control	10-6
2.5	Data Bus	10-6
2.6	Memory And EMS Control	10-6
2.7	Power Management Control	10-6
2.8	Register File	10-7
2.8.1	Lock Status Register	10-7
2.8.2	Lock/Unlock Register	10-9
2.9	VLBI Control	10-9
2.10	Cache Control	10-9
3.0	SIGNAL DESCRIPTION	10-12
4.0	INITIALIZATION AND CLOCKING	10-23
4.1	Power Up Reset	10-23
4.2	Clocking	10-23
4.2.1	Internal Clock (CLK14)	10-23
4.2.2	System Bus Clock (SYSCLK)	10-23
4.2.3	Processor Clock (CPUCLK)	10-23
4.2.4	CPU Clock (CPUCLK) Control Register	10-25



Section	Title	Page
5.0	AT BUS	10-28
5.1	Interrupt Multiplexing	10-28
5.1.1	Data Acknowledge DACK(7:5), (3:0)	10-28
5.1.2	Data Request DRQIN	10-28
5.1.3	Interrupt Requests	10-28
5.1.4	AT Address Bus, Data Bus and Terminal Count (TC) Signal	10-28
5.2	Power Management Control PMCIN	10-28
5.3	Numeric Processor	10-30
5.3.1	Numeric Processor Busy, Bus Timing, And Power Down Register	10-30
5.3.2	Numeric Processor Busy (NPBUSY) Reset	10-32
5.3.3	Numeric Processor Reset (NPRST)	10-32
5.4	DMA Control	10-33
5.4.1	Transfer Modes	10-33
5.4.2	Transfer Types	10-33
5.4.3	Autoinitialize	10-34
5.4.4	Priority	10-34
5.4.5	Extended Write	10-34
5.4.6	Base and Current Address	10-34
5.4.7	Base and Current Word Count	10-34
5.4.8	Command Register	10-36
5.4.9	Status Register	10-36
5.4.10	Request Register	10-36
5.4.11	Mask Registers	10-37
5.4.11.1	Single Mask Register	10-37
5.4.11.2	Clear Mask Register	10-37
5.4.11.3	Mask Multiple Register	10-37
5.4.12	Mode Register	10-38
5.4.13	Clear Pointer Register	10-38
5.4.14	Master Clear Register	10-39
5.4.15	DMA Mode Shadow Register	10-39
5.5	System Controller 8259 Interrupt Controllers	10-39
5.5.1	Interrupt Sequence	10-39
5.5.2	Setup - Initialization Command Words (ICW)	10-41
5.5.2.1	ICW1 - Initialization Command Word 1	10-41
5.5.2.2	ICW2 - Initialization Command Word 2	10-42
5.5.2.3	ICW3 - Initialization Command Word 3	10-42
5.5.2.4	ICW4 - Initialization Command Word 4	10-43
5.5.3	Operation	10-43
5.5.3.1	OCW1 - Operation Control Word 1	10-43
5.5.3.2	OCW2 - Operation Control Word 2	10-43
5.5.3.3	OCW3 - Operation Control Word 3	10-44



Section	Title	Page
5.6	System Controller 8254 Timer	10-44
5.6.1	Setup	10-45
5.6.1.1	Mode 0 Interrupt on Terminal Count	10-45
5.6.1.2	Mode 1 Hardware Retriggerable One Shot	10-45
5.6.1.3	Mode 2 Rate Generator	10-45
5.6.1.4	Mode 3 Square Wave Generator	10-46
5.6.1.5	Mode 4 Software Triggered Strobe	10-46
5.6.1.6	Mode 5 Hardware Triggered Strobe	10-46
5.6.2	Reading The Counter	10-46
5.6.3	Reading Status	10-46
5.6.4	Page	10-46
5.6.5	Refresh Address	10-46
5.6.6	Timer Shadow	10-47
5.7	System Controller Decode	10-47
5.8	NMI And Real Time Clock	10-48
5.8.1	Real Time Clock Address Register	10-48
5.8.2	Real-Time Clock Data Register	10-48
5.8.3	Lock Pass, Alternate A20G And Hot Reset	10-48
5.9	Port B - Parity Error And I/O Channel Check	10-49
6.0	MEMORY AND EMS CONTROL	10-50
6.1	DRAM Address And Data Bus	10-50
6.2	Memory Configuration	10-51
6.2.1	Memory Control	10-51
6.2.2	Memory Bank 7 Through Bank 0 Starting Address	10-52
6.2.3	Split Starting Address	10-53
6.2.4	RAM Shadow And Write Protect	10-56
6.2.5	High Memory Write Protect Boundary	10-58
6.2.6	DRAM Size And SMI RAM Register	10-59
6.3	Memory Timing	10-59
6.3.1	Non-page Mode DRAM Memory Timing	10-60
6.3.2	Page Mode	10-63
6.3.3	Memory Address Multiplexer	10-64
6.4	EMS	10-66
6.4.1	EMS Control And Lower EMS Boundary	10-66
6.4.2	EMS Page Register Pointer	10-67
6.4.3	EMS Page Register	10-69
7.0	CACHE CONTROLLER	10-70
7.1	Non-cachable Control	10-70
7.2	External Cache Controller	10-70
7.3	Cache Control Register	10-70
7.4	Noncachable Region 1 Upper Boundary	10-71



Section	Title	Page
	7.5 Noncacheable Region 1 Lower Boundary	10-72
	7.6 Noncacheable Region 2 Lower Boundary	10-73
	7.7 FLUSH	10-73
8.0	PORT CHIP SELECT REFRESH	10-74
	8.1 Refresh Control, Serial And Parallel Chip Selects	10-74
	8.2 RTC, PVGA, And Disk Chip Selects	10-76
	8.3 Programmable Chip Select #1 Address	10-79
	8.4 I/O Port Addresses And Chip Select Assignments	10-80
9.0	POWER MANAGEMENT CONTROL	10-82
	9.1 System Activity Monitor (SAM)	10-82
	9.2 Processor Power Down Mode	10-83
	9.3 Local Access By Keyboard Controller	10-84
	9.4 PMC Output Control Registers	10-86
	9.5 PMC Timers	10-87
	9.6 PMC Inputs	10-88
	9.7 PMC Interrupt Enable	10-89
	9.8 NMI Status	10-90
	9.9 Serial/Parallel Shadow Register	10-90
	9.10 Interrupt Controller Shadow Register	10-91
	9.11 Port 70H Shadow Register	10-92
	9.12 Activity Monitor Control Register	10-93
	9.13 Activity Monitor Mask Register	10-95
	9.14 3V Suspend (Hibernation) Shadow Registers	10-97
	9.14.1 DMA Shadow Register 1	10-97
	9.14.2 DMA Shadow Register 2	10-98
	9.14.3 DMA Shadow Register 3	10-99
	9.14.4 DMA Base Address and Count Register	10-99
	9.14.5 Timer Count	10-99
	9.15 Suspend and Resume	10-100
	9.15.1 Suspend/Resume Sequence	10-101
	9.15.1.1 Going Into Suspend Mode	10-101
	9.15.1.2 Coming Out Of Suspend Mode (Resume)	10-101
10.0	SYSTEM MANAGEMENT INTERRUPT (SMI)	10-104
	10.1 I/O Traps	10-104
	10.2 SMI I/O Trap Control Register	10-104
	10.3 SMI I/O Address Capture Register	10-106
	10.4 I/O Data/Memory Address Capture Register Low	10-107
	10.5 I/O Data/Memory Address Capture Register High	10-108
	10.6 SMI I/O Timeout	10-109
	10.7 SMI I/O Timeout Control Register	10-109
	10.8 SMI I/O Timeout Count Register 1	10-111



Section	Title	Page
	10.9 SMI I/O Timeout Count Register 2	10-112
	10.10 SMI Auxiliary Control Register	10-113
	10.11 Programmable CS2 and CS3 Control Register	10-115
	10.12 Programmable CS2 Address Register	10-116
	10.13 Programmable CS3 Address Register	10-117
11.0	DIAGNOSTIC MODE	10-118
	11.1 Diagnostic Register	10-118
	11.2 Delay Line Diagnostic Register	10-119
	11.3 Test Enable Register	10-120
	11.4 Test Status Register	10-121
12.0	DC ELECTRICAL SPECIFICATIONS	10-122
	12.1 Maximum Ratings	10-122
	12.2 DC Operating Characteristics	10-122
13.0	AC OPERATING CHARACTERISTICS	10-125
	13.1 Memory Timing	10-127
	13.1.1 80386SX Page Mode Timing	10-127
	13.1.2 80386SX Non-Page Mode 00 and Mode 01 Timing	10-132
	13.2 AT Bus Timing	10-142
	13.2.1 CPU Initiated AT Bus Cycles	10-142
	13.2.2 Entering the AT Bus	10-154
	13.2.3 Exiting the AT Bus	10-157
	13.2.4 DMA Cycles	10-162
	13.2.5 AT Bus Master	10-167
	13.2.6 AT Bus Refresh	10-172
	13.3 Processor Timing	10-174
14.0	PIN STATES DURING CHIP RESET, SUSPEND AND CPU POWER DOWN	10-181
15.0	PACKAGE DIMENSIONS	10-188
A.0	ELECTRICAL SPECIFICATIONS FOR WD7855LV	10-189
	A.1 Maximum Ratings	10-189
	A.2 DC Operating Characteristics	10-189
	A.3 AC Operating Characteristics	10-192
	A.4 80386SX Page Mode Timing	10-193
B.0	SPECIAL FEATURE REGISTERS	10-195
	B.1 Enabling the Special Features	10-195
	B.2 Enable PRIVY Register	10-195
	B.3 Disable PRIVY Register	10-195
	B.4 Busy Bypass Control Register	10-195
	B.5 Fast A20 Gate Control Register	10-196



Section	Title	Page
B.6	Fast CPU Reset Control Register	10-196
B.7	Parity Control Register	10-196
C.0	IBM FEATURES	10-197
C.1	Pin Signal Description	10-197
C.2	Cache Control Register	10-197
C.3	Noncacheable Region 2 Lower Boundary	10-198
C.4	Pin States During Chip Reset, Suspend and CPU Power Down	10-198

LIST OF TABLES

Table	Title	Page
2-1	Register Index	10-10
3-1	160-Pin MQFP - Signal/Pin Assignments	10-13
3-2	Signal Description	10-14
4-1	Clock Switch Selection	10-26
4-2	Speedup Activity	10-26
5-1	MXCTL(2:0) Decoding	10-29
5-2	Bus Timing Parameters	10-31
5-3	DMA Transfer Types	10-33
5-4	DMA Controller/Channel Function Map	10-35
5-5	Interrupt Sequence	10-39
5-6	Interrupt Controller Function Map	10-41
5-7	Control Word Format	10-45
5-8	Device Addresses	10-47
5-9	Page Register Decodes	10-47
6-1	Typical DRAM Speeds	10-59
6-2	Non-Page Mode Timing	10-62
6-3	Page Mode Wait States	10-63
6-4	Page Mode DRAM Address Multiplexer Configuration	10-64
6-5	Non-Page, Non-Interleave Address Configuration	10-65
6-6	Non-Page, 2-Way Interleave Address Configuration	10-65
6-7	Upper Page Frame Assignments	10-68
6-8	Lower Page Frame Assignments	10-68
8-1	AT Compatible 10-Bit Mode	10-78
8-2	Enhanced 16-Bit Mode	10-79
8-3	I/O Port Address and Chip Select Assignments	10-80
9-1	PMC Output Signals	10-86
9-2	PMCIN Inputs	10-89
10-1	I/O Address Status	10-106
10-2	Memory Address Status	10-107
10-3	Data Format Description	10-108
11-1	Extended Version Number	10-120



Table	Title	Page
12-1	DC Operating Characteristics	10-122
13-1	Timing Figure/Table Numbers	10-125
13-2	Signal Loading	10-126
13-3	80386SX - Page Mode Memory Timing	10-127
13-4	80386SX - Non-Page Mode 00, 01 Memory Timing	10-132
13-5	CPU Initiated AT Bus Cycles	10-142
13-6	Entering the AT Bus	10-154
13-7	Exiting the AT Bus	10-157
13-8	DMA Cycles	10-162
13-9	AT Bus Master Cycle	10-167
13-10	AT Bus Refresh Cycle, Default Timing	10-172
13-11	80386SX CPU Timing	10-174
13-12	WD7855 SMI Timing	10-180
14-1	Pin States During Chip Reset, Suspend, CPU Power Down	10-181
14-2	Power and Ground	10-187
A-1	DC Operating Characteristics	10-189
A-2	Signal Loading	10-192
A-3	80386SX - Page Mode Memory Timing	10-193
A-4	80386SX CPU Timing	10-194
C-1	Signal Description	10-197
C-2	Pin States During Chip Reset, Suspend, CPU PWD.	10-198

LIST OF FIGURES

Figure	Title	Page
1-1	Power Managed Desktop System Block Diagram	10-4
1-2	Notebook System Block Diagram	10-5
2-1	WD7855/LV Block Diagram	10-8
3-1	160-Pin MQFP Package	10-12
4-1	Clock Control	10-24
5-1	MXCTL(2:0) Multiplexing	10-29
6-1	Split Size	10-55
6-2	X_Mem = 0	10-57
6-3	X_Mem = 1	10-57
9-1	Register Access By Keyboard Controller	10-85
9-2	Suspend	10-100
9-3	Resume	10-100
9-4	Full Power Down Mode System Block Diagram	10-103
13-1	80386SX - Page Mode, First Access Read/Write	10-128
13-2	80386SX - Page Mode, Page Miss Read/Write	10-129
13-3	80386SX - Page Mode, Read Cycle Followed By A Page Hit	10-130
13-4	80386SX - Page Mode, Read After Write	10-130
13-5	80386SX - Page Mode, Read Hit Followed By A Write Hit	10-131
13-6	80386SX - Page Mode, Write Miss Cycle Following A Write Cycle	10-131
13-7	Page Read/Write Hit With Extra Wait State Enable	10-133
13-8	Read Page Hit Followed By Write Page Hit With External Cache Enable And Extra Wait State Enable	10-134
13-9	Page Read Miss With Extra Wait State Enable	10-135
13-10	Page Write Miss With Extra Wait State Enable	10-136
13-11	Read Page Miss With External Cache Enable And Extra Wait State Enable	10-137
13-12	Write Page Miss With External Cache Enable And Extra Wait State Enable	10-137
13-13	80386SX - Non-Page Mode 00, 1 Wait State Read (Pipeline) (4072H = 0001)	10-138
13-14	80386SX - Non-Page Mode 00, 1 Wait State Write (Pipeline) (4072H = 0001)	10-139
13-15	80386SX - Non-Page Mode 01, 0 Wait State Read (Pipeline) (4072H = 3560H)	10-140
13-16	80386SX - Non-Page Mode 01, 0 Wait State Write (Pipeline) (4072H = 3560H)	10-141
13-17	AT Bus I/O Or Memory Read: 8-Bit, Default Timing	10-144
13-18	AT Bus I/O Or Memory Read: 8-Bit, <u>ZEROWS</u> Asserted	10-145
13-19	AT Bus I/O Or Memory Read: 8-Bit, Extra Wait State Added	10-146
13-20	AT Bus I/O Or Memory Write: 8-Bit, Even Byte, Default Timing	10-147
13-21	AT Bus I/O Or Memory Write: 8-Bit, Odd Byte, Default Timing	10-148
13-22	AT Bus I/O Or Memory Read: 8-Bit, Word To Byte Conversion, Default Timing	10-149
13-23	AT Bus I/O Or Memory Write: 8-Bit, Word To Byte Conversion, Default Timing	10-150
13-24	AT Bus I/O Or Memory Read: 16-Bit, Default Timing	10-151
13-25	AT Bus I/O Or Memory Read: 16-Bit, 0WS Asserted And Extra Wait State Added	10-152
13-26	AT Bus I/O Or Memory Write: 16-Bit, Default Timing	10-153
13-27	80386SX CPU - BREQ Delay = 1/2 Clock	10-155



Figure	Title	Page
13-28	80386SX CPU - BREQ Delay = 1 Clock	10-155
13-29	80386SX CPU - Synchronous CPUCLK To SYSCLK	10-156
13-30	Synchronous AT Bus Cycle Completion, AT Bus Clock = CPUCLK ÷ 2	10-158
13-31	Synchronous AT Bus Cycle Completion, AT Bus Clock = CPUCLK ÷ 1	10-159
13-32	Asynchronous AT Bus Cycle Completion, BAK_DEL = -1 Or -0.5 AT Bus Clocks	10-160
13-33	Asynchronous AT Bus Cycle Completion, BAK_DEL = 0 Or +0.5 AT Bus Clocks	10-161
13-34	Basic DMA Cycle, Default Timing	10-164
13-35	DMA Cycle, 8-Bit I/O To On-Board Memory	10-165
13-36	DMA Cycle, On-Board Memory To 8-Bit I/O	10-166
13-37	AT Bus Master, Bus Acquisition/Release	10-169
13-38	AT Bus Master, Write To On-Board Memory	10-170
13-39	AT Bus Master, Read From On-Board Memory	10-171
13-40	AT Bus Refresh Cycle, Default Timing	10-173
13-41	80386SX - CPURES And NPRST During Power Up	10-175
13-42	80386SX - Coprocessor Reset (NPRST) Initiated By \overline{IOW} To Port F1	10-175
13-43	80386SX - Processor Reset (CPURES) Initiated By Sources Other Than Power Up Reset	10-176
13-44	$\overline{BUSYCPU}$ Assertion During Coprocessor Access	10-177
13-45	80386SX - Latching $\overline{BUSYCPU}$ When An Error Occurs And Clearing It With A Write To Port F0	10-178
13-46	80386SX - Miscellaneous Timing	10-179
13-47	80386SX - Input Setup And Hold Timing	10-179
13-48	80386SX - Output Delay Timing	10-179
13-49	I/O Trap Cycle With Am386SXLV	10-180
15-1	160-Pin MQFP Package Dimensions	10-188



1.0 INTRODUCTION

1.1 DOCUMENT SCOPE

This document describes the function and operation of the WD7855 and WD7855LV System Controller devices. It includes the description of external logic necessary for efficient use of these devices. In most instances the WD7855 and WD7855LV operate similarly and are referred to in this document as the System Controller. Where there are differences, the devices are identified specifically.

1.2 FEATURES

Features common to both versions of the WD7855

- Single chip AT systems logic for desktops, notebooks, palmtops
- Supports 80386SX microprocessors at speeds up to 33 MHz
- Supports static, dynamic or cached CPUs
- Flexible DRAM support: 64K, 256K, 512K x 9, 1 Mbits, 4 Mbits, 1M x 18 bits or 2M x 9 bits
- Choice of non-page or page DRAM operating modes while supporting optional extra wait states for page mode
- Up to eight banks of two-way interleave memory support
- Support for major DRAM standards, including 88-pin DRAM card modules
- User-definable, non-cachable regions
- Supports external look aside cache
- Snoop interface to support cached CPUs
- Programmable full 16-bit I/O decode
- High-speed, local video bus (VLBI) support
- Slow Refresh
- Stop DMA clock
- 0.9 micron CMOS technology
- 160-pin MQFP package
- Three fully programmable Chip Selects in addition to standard Chip Selects

- AUTOFAST (automatic CPU speedup)
- SMI and I/O trapping
- Suspend/Resume modes
- Hibernation mode
- Multiple CPU speeds
- CPU Sleep/CPU Powerdown modes
- Peripheral and I/O power control
- System Activity Monitor (SAM) for idle detection

WD7855LV Laptop Design

- Supports 3.3 volt operation with on-chip translators for 5 volt AT bus (split rail operation)

1.3 GENERAL DESCRIPTION

Western Digital's® WD7855/LV single chip ISA System Controller is designed for high-performance IBM PC/AT compatible platforms. Available for desktop, portable or low voltage (LV) applications, the WD7855/LV supports the 80386SX microprocessor operating at speeds up to 33 MHz.

The WD7855/LV incorporates seven high-performance system controller functions which include the ISA bus interface, CPU interface, flexible memory controller, DMA controller, interrupt controller, timers and advanced power management. In combination with Western Digital's support devices, the WD7855/LV provides a highly flexible and powerful desktop or portable platform design.

The WD7855/LV is designed to work with all variations of 80386SX compatible microprocessors. It supports the traditional dynamic CPUs with the industry's only Processor Power-down feature to minimize power consumption. The WD7855/LV fully supports static microprocessors such as the AMD Am386SXL with CPU Stop Clock, System Management Interrupt and I/O trapping features. The WD7855/LV incorporates special circuitry which allows for optimizing the cache performance and maintaining cache coherency with cached CPUs such as the Cyrix Cx486SLC.

1.3.1 Desktop Applications

The WD7855 provides a high performance solution with a flexible memory controller architecture, including support for eight banks of two way interleave memory and EMS 4.0 hardware. The WD7855/LV can fully support an external look-aside cache or a combination primary and secondary cache. This feature makes it particularly suitable for use with cached microprocessors such as Cyrix Cx486SLC where it maintains cache coherency via its built-in bus snooping capability. In addition, the WD7855/LV supports Video Local Bus Interface (VLBI) for enhanced graphics performance.

1.3.2 Portable Applications

The WD7855LV is an ideal choice because of its advanced power management features and power saving 3.3 volt operation which delivers long battery life in a compact footprint. This makes it a perfect choice for laptop, notebook, penbased and palmtop computers.

The eight bank memory controller on the WD7855LV provides the user with great flexibility in the selection of 3.3 volt DRAMs to meet system memory requirements in low voltage platforms. The WD7855LV memory controller supports JEDEC standard 3.3 volt DRAM in various configurations, including the JEIDA standard 88-pin DRAM card.

The WD7855/LV can be paired with the appropriate support devices from Western Digital to deliver the most efficient solution for any platform. For 5 volt desktop or portable platforms, the WD7855LV can be used with the WD76C20 Peripheral Controller and the WD76C30 I/O Controller. Alternatively, the WD7855 can be used with the WD7615 Buffer Manager device and a generic Super I/O chip to implement a low cost desktop platform. For 3.3 volt applications, the WD7855LV can be used with the WD76C20ALV and WD76C30ALV, both of which incorporate level translators (split rail operation). For sub-notebook and palmtop type applications, WD7625LV buffer manager can be added to the WD7855LV based solution to achieve a very compact footprint.

The WD7855/LV is a fourth generation system controller device derived from core chips with proven compatibility and design maturity in several of the industry's leading desktop and portable platforms. Designed with the state of the art 0.9 micron high performance CMOS process, the WD7855/LV family maintains architectural compatibility with Western Digital's WD7600 and WD7700 systems logic chip sets while incorporating many additional performance enhancements.

1.3.3 WD7855/LV Power Management

With its built-in advanced power management features, the WD7855/LV delivers the lowest system power consumption and longest battery life in portable systems. The following information summarizes the key power management features offered by the WD7855/LV architecture.

1.3.3.1 Automatic CPU Speedup

Depending on system activity, CPU speed automatically adjusts for slow speed when there is no activity and automatic speedup when activity is detected.

1.3.3.2 CPU Sleep and Power-down

The processor is dynamically powered down during the idle periods (e.g. between keystrokes) and restored when any unmasked interrupt occurs. In case of a static processor, the CPU is simply operated at zero hertz during idle periods.

1.3.3.3 Suspend and Resume Mode

Suspend is triggered by one of several user-defined events or a programmable timeout. During suspend, the system is shut down except for the WD7855/LV system memory, video memory and the video controller chip. These devices are sustained by a very slow clock until the WD7855/LV detects either the appropriate conditions or a modem ring indicator, and the power is restored.



1.3.3.4 Peripheral Power Control

All peripherals are powered down during Suspend. The WD7855 features eight user-definable and eight dedicated outputs to control the LCD panel, backlight, keyboard controller, power supply and other user-selected functions. The power consumption of disk drives can be controlled by way of the drive's built-in power modes. I/O ports are managed through software control.

1.3.3.5 System Activity Monitor

The system activity monitor watches all hardware inputs and allows better detection of idle conditions in the system following a programmable period of system inactivity.

1.3.3.6 SMI Support

Supports the high-level power management interrupt and I/O trapping for more flexible power management.

1.3.3.7 Hibernation Support

All registers within the WD7855/LV are readable including 8254 compatible timers, 8259 compatible interrupt controllers and 8237 DMA controllers. This allows for the entire system state to be easily stored to a file on the hard disk drive to allow complete system power-off and transparent restore.

1.3.3.8 Slow Refresh

Slow 120 μ s refresh is an option in both runtime and suspend operation.

1.3.3.9 DMA Stop Clock

DMA clock automatically stops when there is no DMA activity and automatically restarts on any unmasked DMA request.

FIGURE 1-1. POWER MANAGED DESKTOP SYSTEM BLOCK DIAGRAM

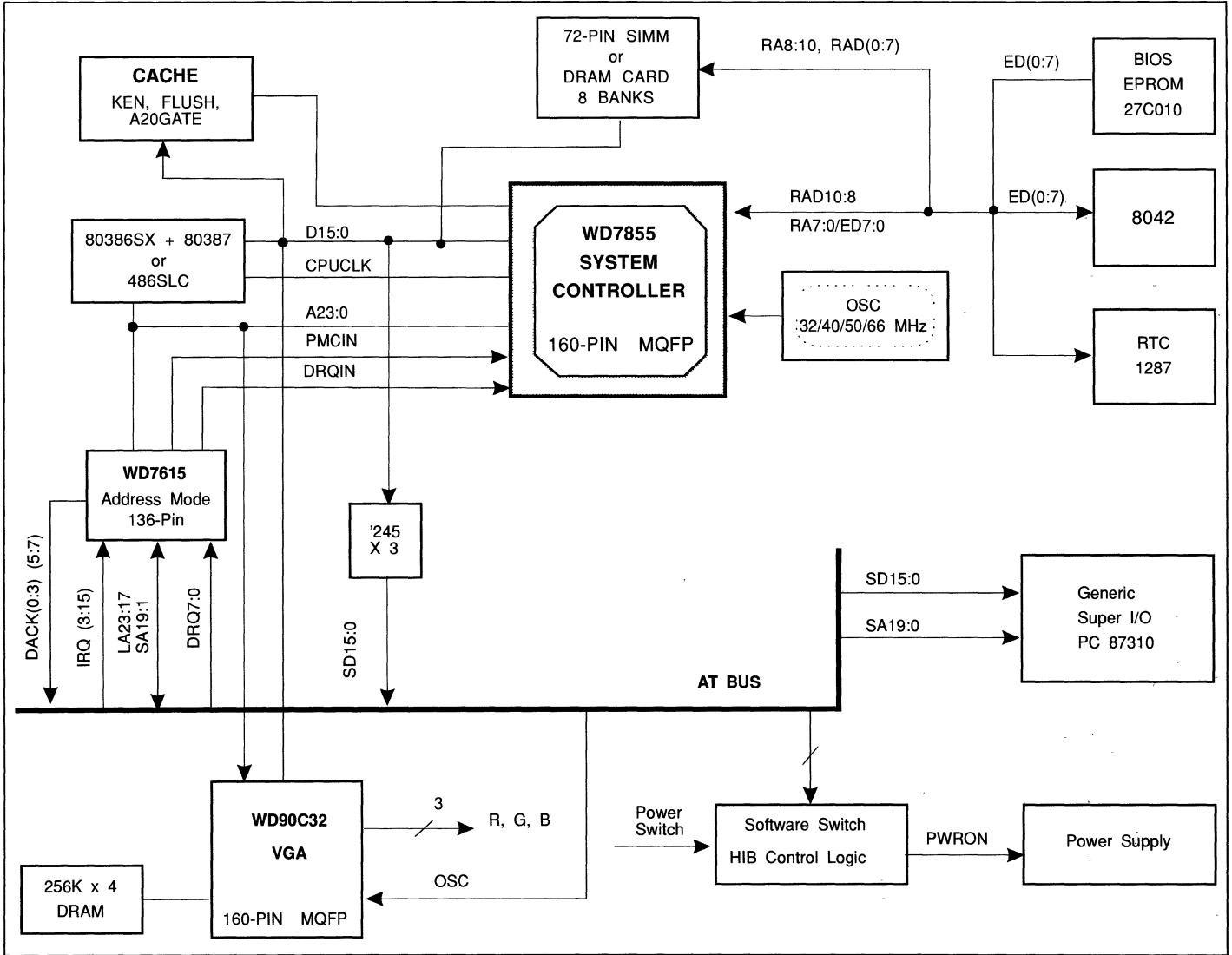

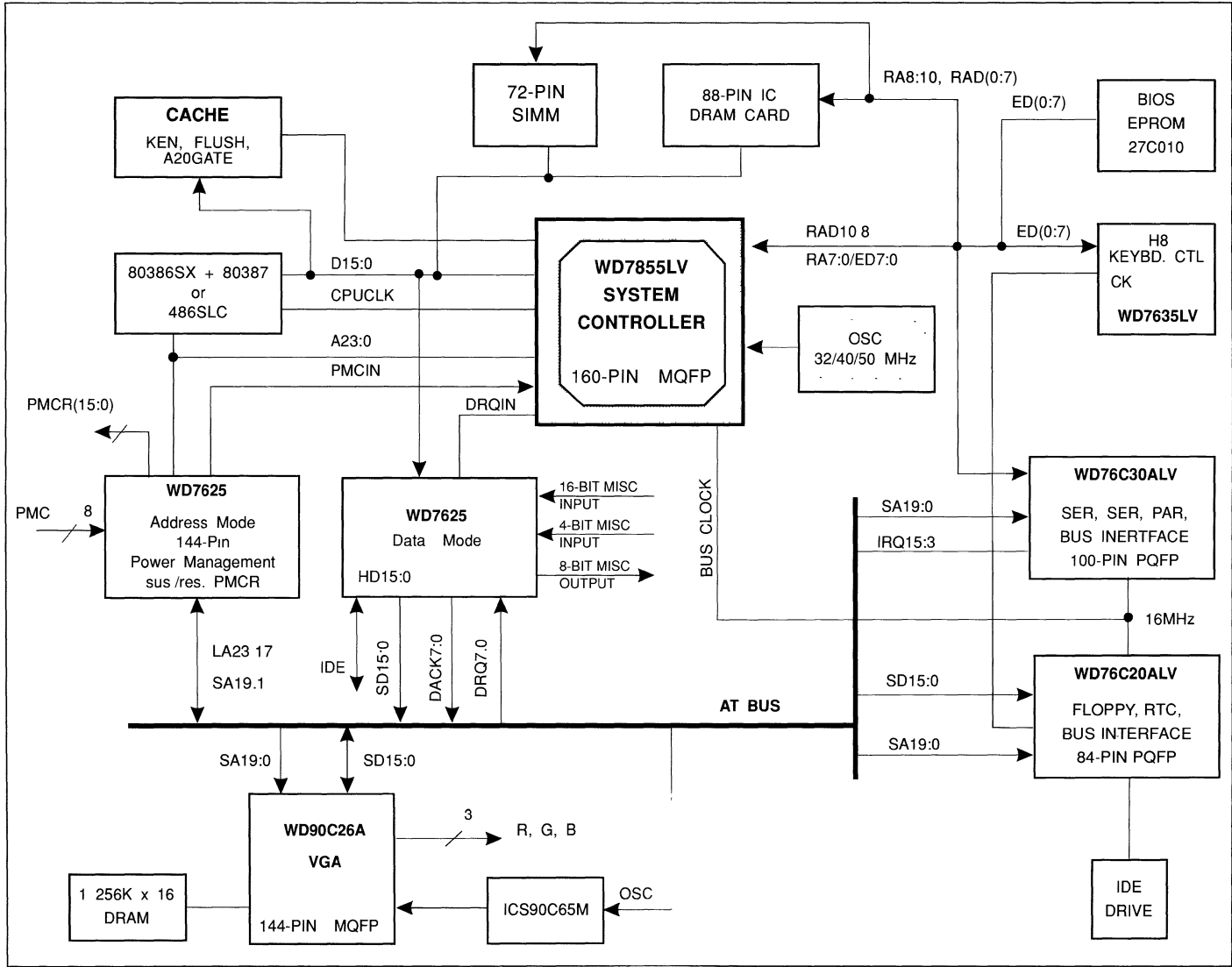

FIGURE 1-2. NOTEBOOK SYSTEM BLOCK DIAGRAM



2.0 ARCHITECTURE

All versions of the System Controller are comprised of eight major blocks:

- Initialization and clocking
- AT bus
- 80386SX processor control
- 80387SX numeric processor control
- Data bus
- Memory and EMS control
- Power Management Control
- Register File
- Video Local Bus Interface (VLBI) control
- Cache control

Sections 2.1 through 2.10 provide an overview of these blocks and are described in more detail in sections 4 through 11.

2.1 INITIALIZATION AND CLOCKING

At power up, the System Controller receives the $\overline{\text{RSTIN}}$ signal, which it uses to reset the AT bus and assert CPURES and NPRST to reset the main and numeric processors. The processor and AT bus resets are held for 84 processor clocks beyond the removal of the $\overline{\text{RSTIN}}$ signal.

CLK14 is a 14.318 MHz clock for the 8254 compatible timers and is switched by the WD76C20 to 32 KHz during a suspend and resume operation.

BCLK2 is used to generate an 8 MHz or 10 MHz bus clock and may also be used as the source for the main processor clock, CPUCLK .

2.2 AT BUS

The AT bus provides the logic necessary to control the system clock, memory read and write access, I/O read and write cycles, data bus direction, data and interrupt requests and speaker driver.

2.3 MAIN PROCESSOR CONTROL

This block controls whether the CPUCLK is to be an input or output. The WD7855/LV has the ability to reduce the processor clock rate and to stop the clock to the processor. The WD7855/LV also has the ability to power down the processor, at which time it tristates the CPUCLK , READY , HOLDR , INTRQ and NMI signals.

2.4 NUMERIC PROCESSOR CONTROL

Both System Controllers support an 80387SX processor.

2.5 DATA BUS

The Data Bus is a 16-bit (two bytes) bidirectional bus that connects to the processor's, System Controller, DRAM, and to AT data bus transceivers. The parity of each DRAM byte is indicated by DPL and DPH .

2.6 MEMORY AND EMS CONTROL

This block controls the access to 16 Mbytes of real memory or 32 Mbytes of expanded memory. Both versions of the System Controller supports non-page mode memory and independent two-way interleave page mode access to the DRAM banks.

2.7 POWER MANAGEMENT CONTROL

The Power Management Control (PMC) is internal logic which interfaces with external multiplexers and latches. It has the ability to power down only the main processor or the main processor and peripherals, conserving power essential to portable notebook/laptop computers. When in a power down state, the WD7855/LV tristates the CPUCLK , READY , HOLDR , INTRQ and NMI output signals to the main processor. Also contained within this functional block are the SMI and SAM logic.



2.8 REGISTER FILE

The register file provides software control of the interface signals. The function of each register is described in the same section as the logic block which it controls. Some registers, such as the Bus Timing and Power Down Control Register at Port Address 1872H, serve more than one area. In this instance the register description appears only in one section but is referred to in all appropriate sections.

The registers, and the section in which they are described, are listed in Table 2-1.

In most cases, the registers are addressed by all 16 address bits, A15 through A00. Within the text, when the address is expressed as a three digit number, i.e., 092H - ALT A20 GATE and HOT RESET, only address bits A09 through A00 are used, A15 through A10 are ignored. If the address is expressed as a four digit number, all 16 address bits are used.

With the exception of the EMS Registers at Port Address E072H and E872H and Port 70H Shadow Register at Port Address E472H, all registers located at Ports 1072H through FC72H are locked and inaccessible until unlocked by performing an eight-bit I/O write of DA to the Lock/Unlock Register at Port F073H. Writing anything other than DA locks the registers. The lock/unlock status can be determined by reading the Lock/Unlock Status Register at Port FC72H twice. If the T bit (bit 15) toggles, the registers are unlocked. If the registers are locked, the read cycle is directed to the AT bus, and the data is undetermined.

2.8.1 Lock Status Register

Port Address FC72H - Read only

Bits 11 through 03 are particularly useful in laptop applications by allowing the suspend/resume and Hibernation software to restore correct status to on-board devices.

15	14	13	12	11	10	09	08
T	Not Used			DMA #2 CH3 CH2 CH1 CH0			

07	06	05	04	03	02	01	00
DMA #1 CH3 CH2 CH1 CH0			P4	Not Used			

Signal Name Default
At RSTIN

All signals None

Bit 15 - T, Toggle

Changes state after every read of this port.

Bits 14:12 - Not used, state is ignored

Bits 11:08 - DMA #2, Channel Enable

This field represents the state of the Enable Bit (Mask) for channels 3 through 0 of DMA Controller #2. For a description of the Mask Registers, refer to Section 5.4.11.

1 = Channel enabled

0 = Channel disabled

Bits 07:04 - DMA #1, Channel Enable

This field represents the state of the Enable Bit (Mask) for channels 3 through 0 of DMA Controller #1. For a description of the Mask Registers, refer to Section 5.4.11.

1 = Channel enabled

0 = Channel disabled

Bit 03 - P, Parallel Port Direction

The P bit represents the state of the Direction Bit (bit 5) of the parallel port Write Control Register. For a description of this bit, refer to the WD76C30 Data Book, Section 4.3.

Bits 02:00 - Not used, state is ignored

10



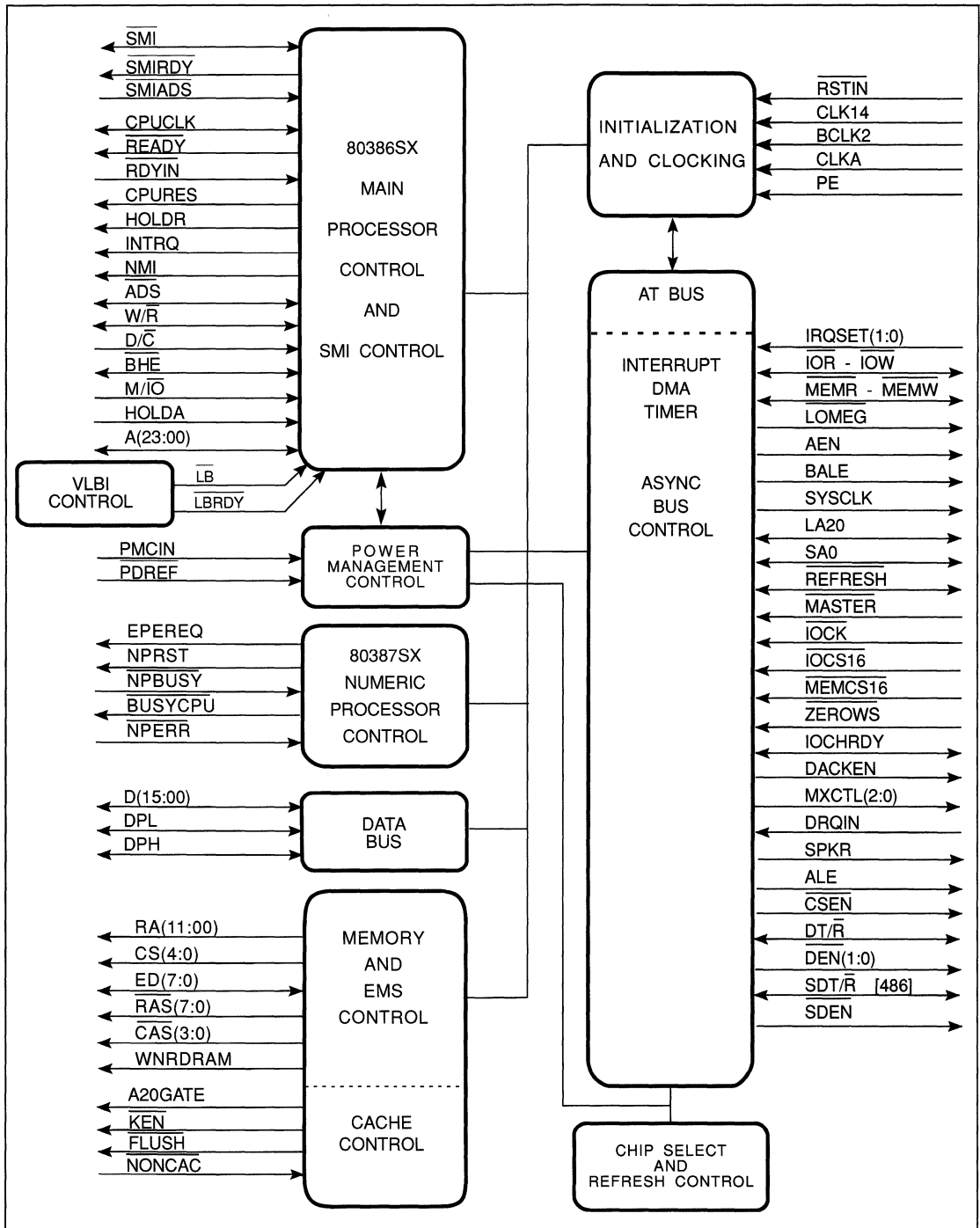

FIGURE 2-1. WD7855/LV BLOCK DIAGRAM



2.8.2 Lock/Unlock Register

Port Address F073H - Write only

15	14	13	12	11	10	09	08
Not Used							

07	06	05	04	03	02	01	00
L/UL = DA-							

Signal Name	Default
	At RSTIN

All signals None

Bits 15:08 - Not used, state is ignored

Bits 07:00 - L/UL, Lock/Unlock

L/UL = DA -
 11011010 unlocks the registers, allowing read and write access to the registers. Refer to Table 2-1 for the registers capable of being locked.

L/UL ≠ DA -
 Anything other than 11011010 locks the registers. Any attempt to access a locked register I/O port address goes to the AT bus rather than the locked register.

2.9 VLBI Control

The Video Local Bus Interface (VLBI) control is internal logic which interfaces with the WD90C56 VLBI controller. It has the ability to determine whether the current CPU cycle should be processed by the WD90C56 or other local bus devices or the WD7855/LV.

2.10 Cache Control

This functional block contains logic for controlling the cachable region for cached CPUs such as the Cyrix Cx486SLC. This functional block controls the KEN and FLUSH output signal pins.



PORT ADDRESS (HEX)	REGISTER NAME	LOCK/ UNLOCK	SECTION
000 - 01F ①	DMA Control #1 (Channel 0:3)	No	5.4, 5.6 *
020 - 03F ②	Interrupt Controller #1	No	5.5 *
040	Timer 0, Time Of Day	No	5.7 *
041	Timer 1, Refresh	No	5.7 *
042	Timer 2, Speaker	No	5.7 *
043	Control Word	No	5.7 *
060 - 06E even	Keyboard Controller	No	8.5 *
061 - 06F odd	Port B Parity Error And I/O Channel Check	No	5.9 *
070	Real-Time Clock Address Register	No	5.8.1 *
071	Real-Time Clock Data Register	No	5.8.2 *
080 - 09F	(except 092H) DMA Page Registers	No	5.6.4 *
092	ALT A20 Gate and Hot Reset	No	5.8.3 *
0A0 - 0A1 ②	Interrupt Control Slave #2	No	5.4, 5.6 *
0C0 - 0DE ①	DMA Control #2 (Channel 4:7)	No	5.4
0F0	Numeric Processor Busy Reset	No	5.3.2
0F1	Numeric Processor Reset	No	5.3.3
1072	CPU Clock Control	Yes	4.2.4
1872	Bus Timing And Power Down Control	Yes	5.3.1
2072	Refresh Control, Serial And Parallel Chip Selects	Yes	8.1
2872	RTC, PVGA And Disk Chip Selects	Yes	8.2
2C72	Bank 5 And Bank 4 Start Address	Yes	6.2.2
3072	Programmable Chip Select Address	Yes	8.3
3472	Bank 7 And Bank 6 Start Address	Yes	6.2.2
3872	Memory Control	Yes	6.2.1
3C72	DMA Shadow Register 1	Yes	9.13.1
4072	Non-page Mode DRAM Memory Timing	Yes	6.3.1
4472	DMA Shadow Register 2	Yes	9.13.2
4872	Bank 1 And Bank 0 Start Address	Yes	6.2.2
4C72	DMA Shadow Register 3	Yes	9.13.3
5072	Bank 3 And Bank 2 Start Address	Yes	6.2.2
5472	SMI Auxiliary Control Register	Yes	10.10
5872	Split Start Address	Yes	6.2.3
5C72	Programmable CS2 and CS3 Control Register	Yes	10.11
6072	RAM Shadow And Write Protect	Yes	6.2.4
6472	Programmable CS2 Address Register	Yes	10.12
6872	EMS Control And Lower EMS Boundary	Yes	6.4.1
6C72	Programmable CS3 Address Register	Yes	10.13
7072	PMC Output Control 7:0	Yes	9.3
7472	DRAM Size And SMI RAM Register	Yes	6.2.6
7872	PMC Output Control 15:8	Yes	9.3
7C72	SMI I/O Trap Control Register	Yes	10.2
8072	PMC Timers	Yes	9.4
8472	SMI I/O Address Capture Register	Yes	10.3
8872	PMC Inputs 7:0	Yes	9.5
8C72	I/O Data/Memory Address Capture Register Low	Yes	10.4
9072	NMI Status	Yes	9.7
9472	I/O Data/Memory Address Capture Register High	Yes	10.5

* Tables 8-1:3

TABLE 2-1. REGISTER INDEX



PORT ADDRESS (HEX)	REGISTER NAME	LOCK/ UNLOCK	SECTION
9872	Diagnostic	Yes	11.1
9C72	SMI I/O Timeout Control Register	Yes	10.7
A072	Delay Line	Yes	11.2
A472	SMI I/O Timeout Count Register 1	Yes	10.8
A872	Test Enable	Yes	11.3
AC72	SMI I/O Timeout Count Register 2	Yes	10.9
B072	Activity Monitor Control	Yes	9.11
B472	Noncachable Region 1, Lower Boundary	Yes	7.5
B872	DMA Control Shadow	Yes	5.4.15
BC72	Noncachable Region 1, Upper Boundary	Yes	7.4
C072	High Memory Write Protect Boundary	Yes	6.2.5
C472	Cache Control Register	Yes	7.3
C872	PMC Interrupt Enables	Yes	9.6
CC72	Noncachable Region 2, Lower Boundary	Yes	7.6
D072	Serial/Parallel Shadow Register	Yes	9.8
D472	Interrupt Controller Shadow	Yes	9.9
D872	Activity Monitor Mask	Yes	9.12
DC72	Test Status	Yes	11.4
E072	EMS Page Register Pointer	No	6.4.2
E472	Port 70H Shadow	No	9.10
E872	EMS Page Register	No	6.4.3
F072	48 MHz Oscillator Disable	Yes	8.5, Tables 8-1:3
F472	48 MHz Oscillator Enable	Yes	8.5, Tables 8-1:3
F872	Cache Flush	Yes	7.7
FC72	Lock Status	Yes	2.8.1
F073	Lock/Unlock	No	2.8.2

- ① See Table 5-4. DMA Controller/Channel Function Map
- ② See Table 5-6. Interrupt Controller Function Map

TABLE 2-1. REGISTER INDEX (Continued)



3.0 SIGNAL DESCRIPTION

The signals are listed according to their pin number in Table 3-1. The signals are grouped according to their application and described in Table 3-2.

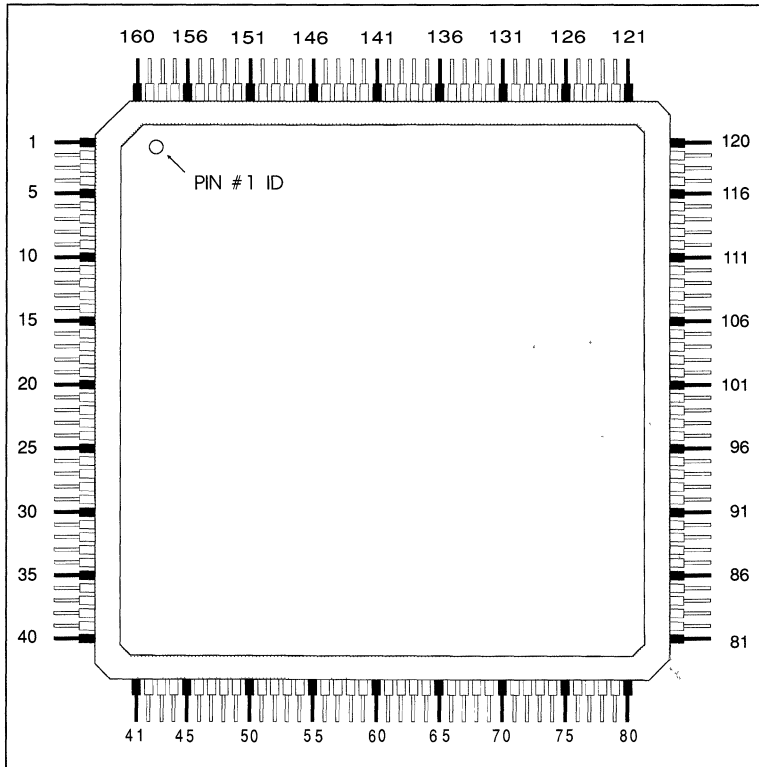

FIGURE 3-1. 160-PIN MQFP PACKAGE



PIN - NAME	PIN - NAME	PIN - NAME	PIN - NAME
1 - M $\overline{I/O}$	41 - PDREF	81 - NC	121 - CLKA/RDYIN/PE
2 - W \overline{R}	42 - PMCIN	82 - NC	122 - CPUCLK
3 - \overline{BLE}	43 - WNRDRAM	83 - NC	123 - $\overline{BUSYCPU}$
4 - A1	44 - $\overline{RAS0}$	84 - \overline{IOCK}	124 - NMI
5 - \overline{ADS}	45 - \overline{LBRDY}	85 - $\overline{IOCHRDY}$	125 - \overline{NA}
6 - A20	46 - $\overline{RAS1}$	86 - \overline{ZEROWS}	126 - INTRQ
7 - A19	47 - $\overline{CAS0}$	87 - $\overline{IOCS16}$	127 - D0
8 - A18	48 - $\overline{RAS2}$	88 - \overline{MASTER}	128 - D1
9 - A17	49 - $\overline{RAS3}$	89 - $\overline{MEMCS16}$	129 - D2
10 - VSS	50 - VSS	90 - CLK14	130 - VSS
11 - A16	51 - $\overline{CAS1}$	91 - VDDAT	131 - D3
12 - A15	52 - RA10/CS2	92 - \overline{MEMW}	132 - D4
13 - A14	53 - RA9/CS1	93 - \overline{IOW}	133 - D5
14 - A13	54 - RA8/CS0	94 - \overline{IOR}	134 - D6
15 - ALE	55 - SDT/ \overline{R} [486]	95 - LA20	135 - VDD
16 - A12	56 - VSS	96 - SA0	136 - D7
17 - A11	57 - RA7/ED7	97 - \overline{MEMR}	137 - D8
18 - VSS	58 - RA6/ED6	98 - $\overline{REFRESH}$	138 - D9
19 - VSS	59 - \overline{SDEN}	99 - BALE	139 - D10
20 - RA11	60 - NC	100 - SYSCLK	140 - \overline{NPBUSY}
21 - A10	61 - RA5/ED5	101 - AEN	141 - VSS
22 - VDD	62 - VDD	102 - VDD	142 - D11
23 - A9	63 - RA4/ED4	103 - \overline{LB}	143 - VDD
24 - A8	64 - RA3/ED3	104 - VSS	144 - D12
25 - \overline{NONCAC}	65 - NC	105 - EPERQ[VDD_VL]	145 - NC
26 - A7	66 - VDD	106 - NPRST	146 - D13
27 - A6	67 - RA2/ED2	107 - \overline{LOMEG}	147 - D14
28 - A5	68 - RA1/ED1	108 - \overline{SMI}	148 - D15
29 - A4	69 - RA0/ED0	109 - \overline{BHE}	149 - DT/ \overline{R} [VDDAT_VL]
30 - \overline{FLUSH}	70 - VSS	110 - \overline{SMIRDY}	150 - VSS
31 - A3	71 - $\overline{RAS4}$	111 - \overline{NPERR}	151 - $\overline{DEN1}$
32 - A2	72 - $\overline{RAS5}$	112 - D/C	152 - DEN0
33 - IRQSET1	73 - $\overline{CAS2}$	113 - \overline{SMIADS}	153 - A20GATE
34 - IRQSET0	74 - $\overline{RAS6}$	114 - \overline{READY}	154 - CPURES
35 - MXCTLO	75 - $\overline{RAS7}$	115 - HOLDA	155 - SPKR
36 - VDD	76 - DRQIN	116 - HOLDR	156 - VSS
37 - MXCTL1	77 - $\overline{CAS3}$	117 - NC	157 - A23
38 - MXCTL2	78 - DPH/CS4	118 - NC	158 - A22
39 - \overline{CSEN}	79 - DPL/CS3	119 - NC	159 - A21
40 - DACKEN	80 - \overline{RSTIN}	120 - BCLK2	160 - \overline{KEN}

TABLE 3-1. 160-PIN MQFP - SIGNAL/PIN ASSIGNMENTS



PIN NUMBER	MNEMONIC	I/O	DESCRIPTION
INITIALIZATION AND CLOCKING			
90	CLK14	I	Clock 14 Translate +5 CLK14 is derived from a 14.318 MHz crystal and is used internally for the 8254 compatible timers. CLK14 is externally switched to 32 KHz during a suspend and resume. For additional information, see Section 4, Initialization and Clocking.
80	$\overline{\text{RSTIN}}$	I	System Reset In Translate +3 RSTIN drives a CMOS input level Schmitt Trigger and is used to reset the entire system at powerup. For additional information, see Section 4, Initialization and Clocking.
120	BCLK2	I	Bus Clock Translate +3 BCLK2 is used to generate an 8 MHz or 10 MHz expansion bus clock. For an 8 MHz bus, BCLK2 is a 16 MHz or 32 MHz input signal. For a 10 MHz bus clock, BCLK2 is a 20 or 40 MHz input signal. BCLK2 may also be used to drive the processor clock. For additional information, see Section 4, Initialization and Clocking.
121	CLKA/ RDYIN/ PE	I	Clock A/Processor Ready In/Parity Error Translate +3 Whether pin 121 is to be used as CLKA, RDYIN or PE is determined by the Memory Control Register at Port Address 3872H. CLKA may be used as an alternate source for CPUCLK clock. For additional information, see Section 4, Initialization and Clocking. RDYIN is used in a discrete cache system and indicates a hit or miss. PE indicates a parity error from an external memory controller.
AT BUS			
33	IRQSET1	I	Interrupt Request Set 1 Translate +3 IRQSET1, along with MXCTL(2:0), selects one of the of the following: A20GT, IRQ1, IRQ(3:7), IRQ12. Refer to Table 5-1 and Figure 5-1.
<p>Translate +3 - This signal may only be connected to a 3 volt signal bus when the System Controller VDD Core pins are powered by 3.3 volts.</p> <p>Translate +5 - This signal may be connected to a 5 volt signal bus when the System Controller core is powered by 3.3 volts. These signals are internally translated and require that the VDDAT pins be connected to a +5 volt source.</p>			

TABLE 3-2. SIGNAL DESCRIPTION



PIN NUMBER	MNEMONIC	I/O	DESCRIPTION
AT BUS (Cont.)			
34	IRQSET0	I	Interrupt Request Set 0 Translate +3 IRQSET0, along with MXCTL(2:0), selects one of the following: ROM8, RESCPU, IRQ8, IRQ(9:11), IRQ14 or IRQ15. Refer to Table 5-1 and Figure 5-1.
35	MXCTL0	O	Multiplexer Control(0:2) Translate +3 MXCTL(0:2), along with DRQIN, DACKEN, IRQSET1, IRQSET0 and PMCIN, control the external multiplexer for the selection of DRQs, DACKs, IRQs, ROM8, A20GT and RESCPU. Refer to Table 5-1 and Figure 5-1.
37	MXCTL1		
38	MXCTL2		
39	$\overline{\text{CSEN}}$	O	Chip Select Enable Translate +3 When CSEN is asserted, DPH, DPL, and RA10-RA8 are used to generate one of 30 different chip selects. Refer to Table 8-3.
40	DACKEN	O	DACK Enable Translate +3 When DACKEN is asserted, MXCTL(2:0) are used to generate DACK(7:5), (3:0) and BUS_RST. Refer to Table 5-1 and Figure 5-1.
76	DRQIN	I	Multiplexed DRQ Inputs Translate +3 DRQIN, along with MXCTL(2:0), selects one of the DRQs or CLOCK_DIR_IN. Refer to Table 5-1 and Figure 5-1
85	IOCHRDY	I/O	I/O Channel Ready Translate +5 Indicates extra wait states are required for the AT bus cycles.
86	$\overline{\text{ZEROWS}}$	I	Zero Wait States Translate +5 Indicates the current AT bus cycle can be finished early.
87	$\overline{\text{IOCS16}}$	I	16-Bit I/O Cycle Translate +5 Indicates the I/O device on the AT bus is a 16-bit slave.
89	$\overline{\text{MEMCS16}}$	I	16-Bit Memory Cycle Translate +5 Indicates that the memory device on the AT bus is a 16-bit slave.
155	SPKR	O	Speaker Translate +3 SPKR drives the speaker transistor.
96	SA0	I/O	System Address 0 Translate +5 When not in Master Mode, SA0 is an output and is asserted by the System Controller to place address 00 on the AT Bus SA0 line. When in Master Mode, SA0 is an input and is asserted by the Bus Master to place address on A0.

TABLE 3-2. SIGNAL DESCRIPTION (Continued)

PIN NUMBER	MNEMONIC	I/O	DESCRIPTION
AT BUS (Cont.)			
95	LA20	I/O	<p>Early Address 20 Translate +5</p> <p>When not in Master Mode, LA20 is an output and is asserted by the System Controller to place address 20 on the AT Bus LA20 line.</p> <p>When in Master Mode, LA20 is an input and is asserted by the Bus Master to place address on A20.</p>
88	MASTER	I	<p>Master Translate +5</p> <p>MASTER is asserted by the Bus Master to indicate that a Bus Master cycle is occurring. This causes LA20, SA0, MEMR, MEMW, IOR, and IOW to be selected as input signals.</p>
15	ALE	O	<p>Address Latch Enable Translate +3</p> <p>ALE is used to clock the SA(19:1) address latches.</p>
101	AEN	O	<p>Address Enable Translate +5</p> <p>AEN is asserted by the System Controller while performing DMA and Refresh cycles.</p>
59	SDEN	O	<p>Swap Data Enable Translate +3</p> <p>SDEN enables the data transfer between high and low bytes of the AT Bus.</p>
98	REFRESH	I/O	<p>Refresh Translate +5</p> <p>As an output, REFRESH is asserted by the System Controller to refresh memory on the AT Bus.</p> <p>As an input, REFRESH is asserted by the Bus Master in conjunction with MEMR to refresh memory on the AT Bus and DRAM controlled by the System Controller.</p>
107	LOMEG	O	<p>First Megabyte Translate +3</p> <p>LOMEG is asserted when the AT bus address is below 1 Mbyte. Used with MEMR and MEMW to generate SMEMR and SMEMW.</p>
92	MEMW	I/O	<p>Memory Write Translate +5</p> <p>MEMW is an output and is asserted by the System Controller when a memory write access to the AT bus is to take place.</p> <p>MEMW is an input during Master Mode and is driven by the current Bus Master.</p>
97	MEMR	I/O	<p>Memory Read Translate +5</p> <p>MEMR is an output and is asserted by the System Controller when a memory read access to the AT bus is to take place.</p> <p>MEMR is an input during Master Mode and is driven by the current Bus Master.</p>

TABLE 3-2. SIGNAL DESCRIPTIONS (Continued)



PIN NUMBER	MNEMONIC	I/O	DESCRIPTION
AT BUS (Cont.)			
93	$\overline{\text{IOW}}$	I/O	<p>I/O Write Translate +5 $\overline{\text{IOW}}$ is an output and is asserted by the System Controller during processor or DMA access to indicate that an I/O write operation is to take place on the AT bus.</p> <p>$\overline{\text{IOW}}$ is an input during Master Mode and is driven by the current Bus Master.</p>
94	$\overline{\text{IOR}}$	I/O	<p>I/O Read Translate +5 $\overline{\text{IOR}}$ is an output and is asserted by the System Controller during processor or DMA access to indicate that an I/O read operation is to take place on the AT bus.</p> <p>$\overline{\text{IOR}}$ is an input during Master Mode and is driven by the current Bus Master.</p>
55	SDT/ $\overline{\text{R}}$ [486]	I/O	<p>Swap Data Transmit/Receive Translate +3 SDT/$\overline{\text{R}}$ controls the direction of the buffer between the low byte and high byte of the AT bus. SDT/$\overline{\text{R}}$ is tristated and pulled up by a 50K pullup resistor internal to the WD7855/LV when $\overline{\text{RSTIN}}$ at pin 80 is asserted. SDT/$\overline{\text{R}}$ pin may be forced low at reset with a 5K pulldown resistor, or an open collector or tristate driver driven by $\overline{\text{RSTIN}}$.</p> <p>SDT/$\overline{\text{R}}$ Mode - Output Forcing SDT/$\overline{\text{R}}$ high while $\overline{\text{RSTIN}}$ is low selects the SDT/$\overline{\text{R}}$ mode. Holding SDT/$\overline{\text{R}}$ high as $\overline{\text{RSTIN}}$ goes high maintains the SDT/$\overline{\text{R}}$ mode.</p> <p>When SDT/$\overline{\text{R}}$ is high, it directs data from the low byte of the AT Bus to the high byte.</p> <p>When SDT/$\overline{\text{R}}$ is low, it directs data from the high byte of the AT bus to the low byte.</p> <p>80486 Mode - Input Forcing SDT/$\overline{\text{R}}$ low while $\overline{\text{RSTIN}}$ is low selects the 80486 mode. Holding SDT/$\overline{\text{R}}$ low as $\overline{\text{RSTIN}}$ goes high, maintains the 80486 mode.</p> <p>Selecting 80486 mode sets the SRC bit in Port 1072H to 1. This causes CLKA at pin 121 to be the default processor clock source input.</p>

TABLE 3-2. SIGNAL DESCRIPTIONS (Continued)



PIN NUMBER	MNEMONIC	I/O	DESCRIPTION
AT BUS (Cont.)			
149	DT/ \bar{R} [VDDAT_VL]	I/O	<p>Data Transmit/Receive Translate +3 DT/\bar{R} controls the direction of the AT Data Bus D(15:00).</p> <p>When DT/\bar{R} is high, data is directed to the AT Bus. When DT/\bar{R} is low, data is transferred from the AT bus.</p> <p>VDDAT_VL When the AT Bus signals are powered by 3.3 volts, pin 149 must be connected to a 20K pull-down resistor. If no pull-down resistor is connected, a 5 volt AT Bus is enabled. The status of this strapping may be read at Port Address CC72H bit 02 (BS).</p>
151	$\overline{DEN1}$	O	<p>Data Bus Enable 1 Translate +3 When asserted, $\overline{DEN1}$ enables the high order byte data buffer.</p>
152	$\overline{DEN0}$	O	<p>Data Bus Enable 0 Translate +3 When asserted, $\overline{DEN0}$ enables the low order byte data buffer.</p>
100	SYSCLK	O	<p>System Clock Translate +5 The maximum frequency is 10 MHz.</p> <p>In asynchronous bus mode, SYSCLK is equal to BCLK2 divided by two when BCLK2 is less than 28 MHz, and divided by four when BCLK2 is greater than 28 MHz.</p> <p>In synchronous bus mode, SYSCLK is equal to CPUCLK divided by two or four, depending on the programming.</p>
99	BALE	O	<p>AT Bus Address Latch Enable Translate +5 Address Latch Enable for the AT bus. BALE is synchronous with the Bus Clock (BCLK2).</p>
84	\overline{IOCK}	I	<p>I/O Channel Check Translate +5 When asserted, \overline{IOCK} indicates a bus or memory error is on the AT bus and generates an NMI to the processor.</p>
MAIN PROCESSOR CONTROL			
45	\overline{LBRDY}	I	<p>Local Bus Ready Translate +3 Local bus cycle ready signal. \overline{LBRDY} can be used by an external look-aside cache controller to signal cache hits.</p>
103	\overline{LB}	I	<p>Local Bus Translate +3 Local bus cycle request signal. \overline{LB} allows an alternate device to respond to a cycle normally mapped to the AT Bus.</p>
108	\overline{SMI}	I/O	<p>System Management Interrupt Translate +3 SMI request to the processor. This mode of operation is selected by bit 13 at Port Address C472H.</p>

TABLE 3-2. SIGNAL DESCRIPTIONS (Continued)



PIN NUMBER	MNEMONIC	I/O	DESCRIPTION
MAIN PROCESSOR CONTROL (Cont.)			
109	$\overline{\text{BHE}}$	I/O	Bus High Enable Translate +3 As an input, BHE indicates a transfer of the high byte on the processor data bus. $\overline{\text{BHE}}$ is an output during DMA transfers.
110	$\overline{\text{SMIRDY}}$	O	System Management Interrupt Ready Translate +3 $\overline{\text{SMIRDY}}$ provides a ready signal to the processor during SMI cycles. $\overline{\text{SMIRDY}}$ is asserted according to the SMI CPU mode selected. This pin is not used by Cx486SLC (see pin 114).
112	$\overline{\text{D/C}}$	I	Data /Control Translate +3 $\overline{\text{D/C}}$ is asserted by the CPU to indicate the status of the current instruction cycle.
1	$\overline{\text{M/I\!O}}$	I/O	Memory or I/O Translate +3 When high, $\overline{\text{M/I\!O}}$ indicates a processor memory cycle When low, $\overline{\text{M/I\!O}}$ indicates a processor I/O cycle. When enabled during DMA or Master cycles, the System Controller drives this signal to maintain Cache coherency.
5	$\overline{\text{ADS}}$	I/O	Address Strobe Translate +3 $\overline{\text{ADS}}$ signal from the processor initiates all memory and I/O cycles in the System Controller. When enabled during DMA or Master cycles, the System Controller drives this signal to maintain Cache coherency.
113	$\overline{\text{SMIADS}}$	I	System Management Interrupt Address Strobe Translate +3 For supported CPU's $\overline{\text{SMIADS}}$ indicates that the cycle is directed to SMI memory space.
2	$\overline{\text{W/R}}$	I/O	Write/Read Translate +3 During normal CPU cycles, $\overline{\text{W/R}}$ is an input indicating whether a read or write cycle is to occur. When $\overline{\text{W/R}}$ is high, a write to memory occurs. When $\overline{\text{W/R}}$ is low, a read from memory occurs. When operating with cached processors, $\overline{\text{W/R}}$ is an output signal used to invalidate the internal CPU cache line during DMA or Master mode memory write cycles.
114	$\overline{\text{READY}}$	O	Processor Ready Translate +3 $\overline{\text{READY}}$ is an output to the processor signalling the completion of a cycle. For CPUs that do not have a separate $\overline{\text{SMIRDY}}$ pin, such as Cx486SLC, this signal is used for both SMI and non-SMI cycles.
116	HOLDR	O	Hold Request Translate +3 HOLDR is an output to the Processor requesting control of the CPU local bus.

TABL 3-2. SIGNAL DESCRIPTIONS (Continued)



PIN NUMBER	MNEMONIC	I/O	DESCRIPTION
MAIN PROCESSOR CONTROL (Cont.)			
115	HOLDA	I	Hold Acknowledge Translate +3 HOLDA is a response from the processor for the Hold Request.
122	CPUCLK	I/O	Processor Clock Translate +3 The speed of CPUCLK and whether it is to be an input or output, is selected by the CPU Clock Control Register at Port Address 1072H. It is normally selected as an output to drive the processor but may be selected as an input from an external processor clock driver.
124	NMI	O	Non-maskable Interrupt Translate +3 Processor non-maskable interrupt cycle request.
125	$\overline{\text{NA}}$	O	Next Address Translate +3 NA is asserted by the System Controller to enable the CPU to operate in the Pipeline mode.
126	INTRQ	O	Interrupt Request Translate +3 Processor interrupt cycle request.
154	CPURES	O	Main Processor Reset Translate +3 CPURES is a synchronous processor reset signal.
157:159 6:9 11:14 16:17 21 23:24 26:29 31:32 4, 3	A(23:21) A(20:17) A(16:13) A(12:11) A10 A(9:8) A(7:4) A(3:2) A1, $\overline{\text{BLE}}$	I/O	Processor Address A(23:A01) Bus Low Enable (A0) Translate +3 A(23:1) and $\overline{\text{BLE}}$ are address lines from the processor. During DMA or Master cycles, the lines are driven by the System Controller to represent the current memory address.
NUMERIC PROCESSOR CONTROL			
140	$\overline{\text{NPBUSY}}$	I	Numeric Processor Busy Translate +3 NPBUSY is the busy signal from the numeric processor.
105	EPERQ [VDD_VL]	O	Extend Processor Extension Request Translate +3 EPERQ extends PERQ to the 80386SX for IRQ13 handling. VDD_VL When the System Controller core signals are powered at 3.3 volts, pin 105 must be connected to a 20K pull-down resistor. When no pull-down resistor is connected, a 5 volt core is enabled. The status of this strapping may be read at port address CC72H bit 03 (CS).
106	NPRST	O	Numeric Processor Reset Translate +3 Reset to the numeric processor 80387SX.

TABLE 3-2. SIGNAL DESCRIPTIONS (Continued)



PIN NUMBER	MNEMONIC	I/O	DESCRIPTION
NUMERIC PROCESSOR CONTROL (Cont.)			
111	$\overline{\text{NPERR}}$	I	Numeric Processor Error Translate +3 Error signal from the numeric processor 80387SX.
123	$\overline{\text{BUSYCPU}}$	O	Coprocessor Busy Translate +3 Coprocessor Busy signal to the processor.
DATA BUS			
78	DPH/CS4	I/O	Data Parity High Byte [Chip Select 4] Translate +3 For DRAM cycles, DPH is the high byte parity bit. For I/O cycle, CS4 is bit 4 of the encoded chip select bus.
79	DPL/CS3	I/O	Data Parity Low Byte [Chip Select 3] Translate +3 For DRAM cycles, DPL is the low byte parity bit. For I/O cycle, CS3 is bit 3 of the encoded chip select bus.
148:146 144 142 139:136 134:131 129:127	D(15:13) D12 D11 D(10:7) D(6:3) D(2:0)	I/O	Data Bits (15:0) Translate +3 The Data Bits are connected directly to the Local and Numeric processors, DRAM data and AT Bus data transceivers.
MEMORY AND EMS CONTROL			
25	$\overline{\text{NONCAC}}$	I	Noncacheable Translate +3 Externally decoded non-cacheable region.
30	$\overline{\text{FLUSH}}$	O	Flush Translate +3 Flush signal to external (CPU) cache controller. FLUSH is asserted by writing any data to port address F872H.
43	WNRDRAM	O	Write Not Read To DRAM Translate +3 Write Not Read signal to DRAM.
20 52 53 54	RA11 RA10/CS2 RA9/CS1 RA8/CS0	O	DRAM Address Bits 11:8 Chip Select Bits 2:0 Translate +3 The DRAM Address Bus is multi-functional. During DRAM cycles, RA(11:0) select the DRAM row and column.
57 58 61 63 64 67 68 69	RA7/ED7 RA6/ED6 RA5/ED5 RA4/ED4 RA3/ED3 RA2/ED2 RA1/ED1 RA0/ED0	I/O	DRAM Address Bits 7:0 EDATA Bits 7:0 Translate +3 During I/O cycles, CS(2:0), along with CS4 and CS3, are decoded by external logic to one of 32 possible Chip Selects. ED(7:0) represents the data from such devices as the Keyboard Controller on the EDATA bus.

TABLE 3-2. SIGNAL DESCRIPTION (Continued)

PIN NUMBER	MNEMONIC	I/O	DESCRIPTION
MEMORY AND EMS CONTROL (Cont.)			
75 74 72 71 49 48 46 44	$\overline{\text{RAS7}}$ $\overline{\text{RAS6}}$ $\overline{\text{RAS5}}$ $\overline{\text{RAS4}}$ $\overline{\text{RAS3}}$ $\overline{\text{RAS2}}$ $\overline{\text{RAS1}}$ $\overline{\text{RAS0}}$	O	Row Address Strobe 7:0 Translate +3 RAS7:0 provide control of up to eight banks of 16 bit memory without external drivers. The outputs are strength controlled to provide optimum drive over process and load. The assertion of RAS signals is impacted by the programmed configuration of memory allowing for 2-way page interleave.
77 73 51 47	$\overline{\text{CAS3}}$ $\overline{\text{CAS2}}$ $\overline{\text{CAS1}}$ $\overline{\text{CAS0}}$	O	Column Address Strobe 3:0 Translate +3 CAS(3:0) are used to separately enable the upper and lower bytes of the active banks.
153	A20GATE	O	A20 Gate Translate +3 A20 Gate signal to external cache controller.
160	$\overline{\text{KEN}}$	O	Cache Enable Translate +3 When asserted, $\overline{\text{KEN}}$ signals non-cacheable regions decoded by the System Controller to the CPU cache controller.
POWER MANAGEMENT CONTROL			
41	PDREF	I	Power-down Refresh Translate +3 PDREF is a 64 KHz signal from the WD76C20. During power-down, PDREF is passed internally to pin 98 (REFRESH).
42	PMGIN	I	Power Management Control Input Translate +3 PMGIN is used to sample eight PMC inputs selected by MXCTL(2:0). See Table 5-1 and Figure 5-1.
MISCELLANEOUS			
10, 18, 19, 50, 56, 70, 104, 130, 141, 150, 156	VSS	I	Ground
91	VDDAT	I	5 Volts Power for signals interfaced to 5 volt busses.
22, 36, 62, 66, 102, 135, 143	VDD	I	3.3 volt or 5 Volt power (core)
60, 65, 81, 82, 83, 117, 118, 119, 145	N. C.		Not connected. Reserved for future use.

TABLE 3-2. SIGNAL DESCRIPTIONS (Continued)



4.0 INITIALIZATION AND CLOCKING

This section describes the system Master Reset (\overline{RSTIN}) operation, control of internal clock (CLK14), bus clock (SYSCLK) and the processor clock (CPUCLK).

4.1 POWER UP RESET

The system reset signal, \overline{RSTIN} , is generated externally at power up and is used to reset the entire system. When asserted, the System Controller outputs the CPURES signal to reset the Main Processor. At this time the System Controller also resets the AT bus by asserting DACKEN and $MXCTL(2:0) = 100$, which are decoded externally as BUS_RST (DACK4), see sections 5.1, 5.1.1, Table 5-1 and Figure 5-1. An external RC circuit can be used to extend the time that \overline{RSTIN} is asserted until the power supply reaches a proper level. CPURES and the AT bus reset signals are de-asserted 84 clock pulses after \overline{RSTIN} reaches its switching threshold. During \overline{RSTIN} with $\overline{BUSYCPU}$ asserted the processor may perform its self-test operation immediately following the power up reset.

4.2 CLOCKING

The System Controller makes use of five clocks, CLK14, BCLK2, CPUCLK, CLKA and SYSCLK. Figure 4-1 shows how the clocks interact with each other and the register used to select the clock and speed.

4.2.1 Internal Clock (CLK14)

CLK14 is an input signal from a 14.318 MHz crystal and is used for the control of the 8254 compatible timers. CLK14 is switched by the System Controller to 32 KHz during save and resume operations.

4.2.2 System Bus Clock (SYSCLK)

The AT bus is driven by the SYSCLK, which is derived from either the BCLK2 or CPUCLK, as selected by the Bus Timing Register at Port Address 1872H. SYSCLK is always one half or one fourth the value of the selected input clock (refer to Figure 4-1).

4.2.3 Processor Clock (CPUCLK)

The processor clock may be either an output or input, depending on whether the System Controller generates CPUCLK or an external oscillator is used. In portable applications CPU clock is most likely an output to allow AUTOFAST and Stop clock modes. At lower speeds, the System Controller may use BCLK2 to generate CPUCLK or, in a system without discrete cache, the System Controller may use CLKA to generate CPUCLK.

During reset, CPUCLK is an output.

If the CPUCLK is initially placed in the input mode it may be changed to the output mode by writing to the PMC Control Register at Port Address 7872H. The PMC control output 0 tristates the external clock oscillator. A processor reset (CPURES) is automatically generated during the clock switching process.

When the CPUCLK is an output, it may be stopped by SCHH or SCH (CPU Clock Control Register - bits 01 or 00, at Port Address 1072H) or divided down by CLK_SPD (bits 14:12). When CPUCLK is stopped it is in phase two of the 80386SX. CPUCLK is restarted by an NMI or IRQ interrupt, qualified by the normal NMI and IRQ masking circuitry or by an NMI generated PMC logic.

There are two methods for slowing the processor execution rate to provide software compatibility with programs expecting a particular CPU speed, such as game software. One method is to divide the CPUCLK by a factor of 2, 4 or 8. Dividing the clock rate may also have an effect on the CPU power consumption, so CLK_SPD also provides some choices of clock duty cycle. The other method can be used when the CPUCLK is an output or input and generated by an external oscillator. In this case, EXT_HOLD is used to extend the hold request time to the processor after every refresh.

In a system without a cache or external memory controller, CLKA is used in place of the BCLK2. This choice is determined by SRC (CPU Clock Control Register bit 15 at Port Address 1072H). SRC is set automatically at power up reset.



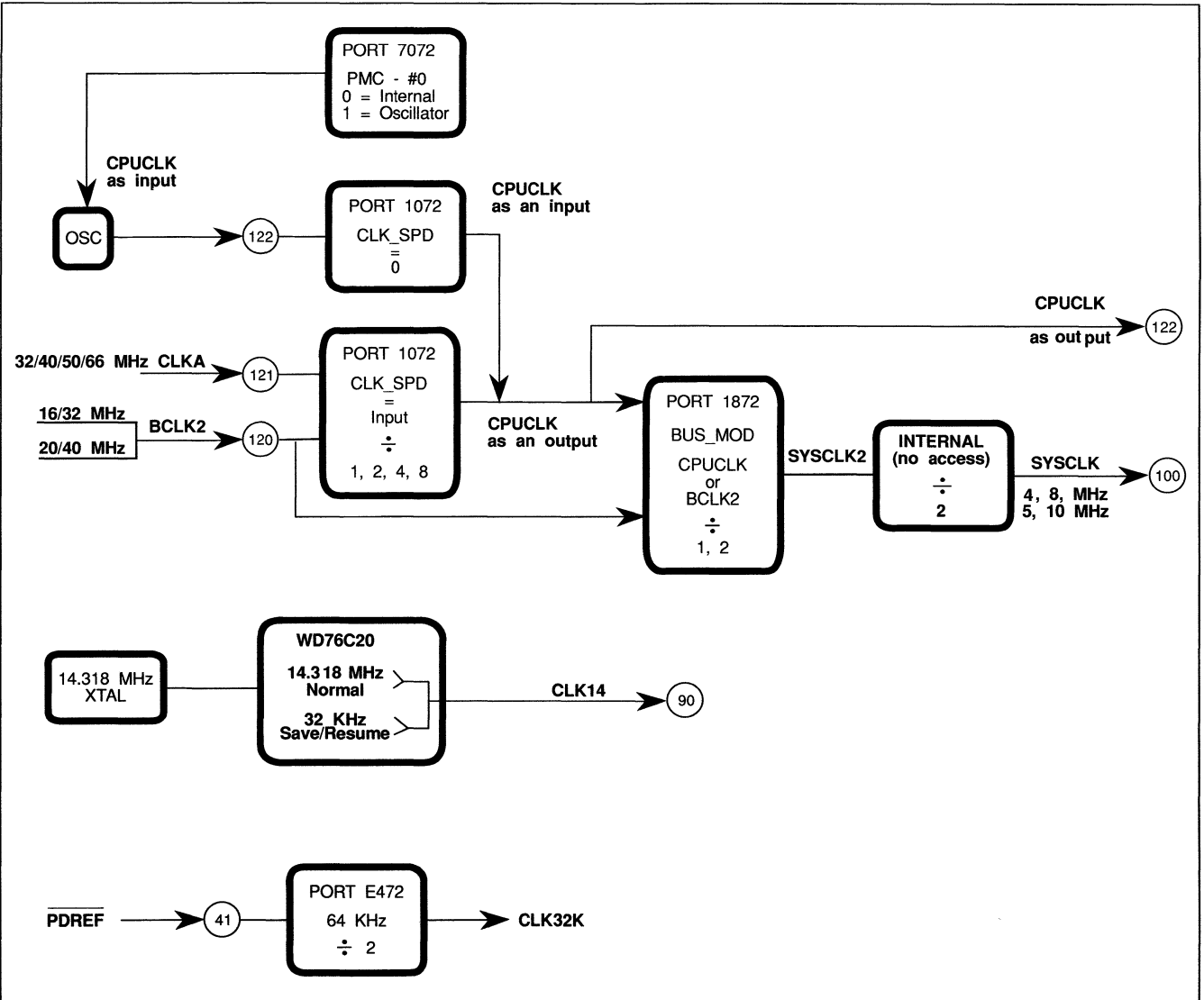

FIGURE 4-1. CLOCK CONTROL



4.2.4 CPU Clock (CPUCLK) Control Register

Port Address 1072H - Read and Write

15	14	13	12	11	10	09	08
SRC	CLK_SPD			AUT_FST	ALT_CLK_SPD		

07	06	05	04	03	02	01	00
EXT_HOLD						SCHH	SCH

Signal Name	Default At RSTIN
SRC	0/1
CLK_SPD	000/001
AUT_FST	0
ALT_CLK_SPD	000
EXTEND_HOLD	0000
Bits 03, 02	None
SCH	0
SCHH	0

Bit 15 - SRC, CPUCLK Clock Source

When CPUCLK is selected as an output by bits 14 through 12, SRC determines whether it is to be driven by BCLK2 or CLKA.

Default Value

SRC is set to 0 and BCLK2 is used as the CPUCLK clock source if CLKA does not change state within 64 clocks after RSTIN is de-asserted.

SRC is set to 1 and CLKA is used as the CPUCLK clock source if CLKA changes state within 64 clocks after RSTIN is de-asserted, or when operating in the 80486 Mode. The 80486 Mode is selected by holding SDT/R low during RSTIN transition from low to high.

SRC = 0 - BCK2 is the CPUCLK source.

SRC = 1 - CLKA is the CPUCLK source.

Bits 14:12 - CLK_SPD, CPUCLK Clock Speed

CLK_SPD determines whether CPUCLK is to be an input or output. When selecting CPUCLK as an output, CLK_SPD also determines the divisor and duty cycle values. The CLK_SPD *defaults to 000 or 001 at power up. Changing the CPUCLK from an input (CLK_SPD = 000) to an output automatically asserts the processor reset (CPURES) and the CPUCLK Driver Enable from the PMC latch is forced low, tristating the external clock oscillator. One millisecond later, CPUCLK becomes active as an output. One millisecond and 16 CPUCLK clocks (or one millisecond) later, the CPURES is de-asserted. This method allows switching the clock source while tolerating glitches in the CPUCLK, generated due to the clock driver not being able to synchronously switch the clock. The one millisecond and 16 clocks or one millisecond selection is made through the Diagnostic Register at Port 9872H.

CLK_SPD

14 13 12

- 0 0 0 - CPUCLK pin is an input, speed determined by external driving source (* Default value).
- 0 0 1 - CPUCLK pin is an output, source divided by 1 (* Default value).
- 0 1 0 - OUT, source divided by 2.
- 0 1 1 - OUT, source divided by 4, 25% duty cycle.
- 1 0 0 - OUT, source divided by 4, 75% duty cycle.
- 1 0 1 - OUT, source divided by 8, 12% duty cycle.
- 1 1 0 - OUT, source divided by 8, 88% duty cycle.

* Based upon the value of CLOCK_DIR_IN at power up (refer to Table 5-1, Figure 5-1 and section 5.1.2).



Bit 11 - AUT_FST, Automatic Processor Clock Speed Switching

When automatic CPUCLK switching is enabled, the processor clock is switched between high and low clock speeds, depending upon activity. If the external TURBO signal is de-asserted when auto switching is enabled, the CPUCLK is normally at the alternate clock or slower rate. When speedup activity occurs, the clock speed switches to the nominal clock rate, normally the higher, for a period of time determined by Table 4-2. When no further activity occurs, the clock speed switches back down to the alternate speed. If the external TURBO signal is asserted, the clock rate is set to the nominal clock rate specified by the CLK_SPD field.

A halt state also causes the clock rate to slow, unless the SCHH or SCH field is programmed to stop the clock. The clock restarts or returns to the faster rate when any interrupt occurs.

Table 4-2 shows the activity that triggers a higher clock rate.

AUT_FST = 0 -

Automatic Clock Switching is disabled. TURBO determines whether CLK_SPD or ALT_CLK_SPD is to be used as the CPU clock. Refer to Table 4-1 for the appropriate selection, as determined by TURBO.

AUT_FST = 1 -

Automatic CPUCLK Switching between CLK_SPD and ALT_CLK_SPD is enabled when TURBO is de-asserted. CLK_SPD is selected when TURBO is asserted. Refer to Table 4-1. The EXT_HOLD field must be 0000 when AUT_FST = 1.

TURBO	AUTO_FST	CPU CLOCK SPEED
0	0	CLK_SPD
0	1	CLK_SPD
1	0	ALT_CLK_SPD
1	1	CLK_SPD or ALT_CLK_SPD

TABLE 4-1. CLOCK SWITCH SELECTION

SPEEDUP ACTIVITY	TIME PERIOD
Hard disk interrupt, Hard disk or numeric processor I/O, SCSI, floppy, port B I/O	1 second
Keyboard interrupt	1 second or until next video access
Video access or processor reset	1 millisecond
Any NMI or IRQ interrupt, except keyboard or hard disk	1 millisecond

TABLE 4-2. SPEEDUP ACTIVITY

Bits 10:08 - ALT_CLK_SPD, Alternate Clock Speed

ALT_CLK_SPD

10 09 08

- 0 0 0 - CPUCLK unchanged from CLK_SPD.
- 0 0 1 - Equals source.
- 0 1 0 - Equals source div by 2.
- 0 1 1 - Equals source div by 4, 25% duty cycle.
- 1 0 0 - Equals source div by 4, 75% duty cycle.
- 1 0 1 - Equals source div by 8, 12% duty cycle.
- 1 1 0 - Equals source div by 8, 88% duty cycle.

Bits 07:04 - EXT_HOLD, Extend Processor Hold

Processor execution may be slowed for software compatibility by extending the processor hold request after refresh cycles. If the external TURBO signal is asserted, EXT_HOLD is forced to 0000. When the external TURBO signal is de-asserted, the EXT_HOLD returns to its programmed value, allowing an external TURBO switch to slow the processing speed.



EXT_HOLD

07 06 05 04

0 0 0 0 - No hold extension
 0 0 0 1 - 1 μ s hold after refresh.
 0 0 1 0 - 2 μ s hold after refresh.
 0 0 1 1 - 3 μ s hold after refresh.
 0 1 0 0 - 4 μ s hold after refresh.



1 1 0 1 - 13 μ s hold after refresh.
 1 1 1 0 - 14 μ s hold after refresh.
 1 1 1 1 - 15 μ s hold after refresh.

Bits 03:02 - Reserved for future use, must be set to zero

Bit 01 - SCHH, Stop CPUCLK at next Halt and Hold.

SCHH is applicable only for Am386SXL or other static type processors in which the clock may be stopped. This option should only be used when the clock source is the WD7855 rather than an external oscillator.

Any unmasked processor interrupt, or NMI, restarts the CPUCLK. The SCHH bit remains set and the clock will be stopped again if a halt and hold condition is detected.

SCHH = 0 -
Normal processor clock.

SCHH = 1 -
Stop processor clock at next halt and hold cycle.

Bit 00 - SCH, Stop CPUCLK at next Hold

SCH is applicable only for Am386SXL or other static type processors in which the clock may be stopped. This option should only be used when the clock source is the WD7855 instead of an external oscillator.

Any unmasked processor interrupt, or NMI, restarts the CPUCLK and sets the SCH bit to zero. DRAM refresh continues while the processor clock is stopped.

SCH = 0 -
Normal processor clock.

SCH = 1 -
Stop processor clock at next processor hold cycle.

5.0 AT BUS

This section describes the logic required to control the interrupts and timing between the AT bus and the System Controller.

5.1 INTERRUPT MULTIPLEXING

To reduce the number of pins required, the System Controller generates and outputs the MXCTL(2:0) and DACKEN signals used by external logic to multiplex the DACKs, DRQs and IRQs down to single inputs. See Figure 5-1.

MXCTL(2:0) are set to 100 during a System Reset ($\overline{\text{RSTIN}}$) to provide a Bus Reset (BUS_RST), and to determine the ROM width (ROM8) and processor clock (CPUCLK) pin direction. See Table 5-1.

5.1.1 Data Acknowledge DACK(7:5), (3:0)

For desktop systems, either a Western Digital WD7615 or a 74F138 3-to-8 Decoder uses MXCTL(2:0) to generate the DACK(7:5) and DACK(3:0), which are applied to the AT bus. The unused combination develops the AT BUS_RST (bus reset). For Laptop systems a WD7625 or 74ACT138 3-to-8 Decoder is used instead of the WD7615 or 74F138, 3-to-8 Decoder. The decoder is enabled by the DACKEN signal from the System Controller.

5.1.2 Data Request DRQIN

The MXCTL(2:0) signals are used to develop the DRQIN signal received by the System Controller by an external 74F151 8-to-1 Multiplexer for desktop systems, or by a 74ACT151 8-to-1 Multiplexer for laptop systems. The MXCTL(2:0) signals are held stable during DMA transfers. A Western Digital WD7615 may be used in place of the 74F151 and a WD7625 in place of the 74ACT151.

Immediately following a System Reset ($\overline{\text{RSTIN}}$), DRQIN input 100 is sampled. If low, the processor clock (CPUCLK) pin is an output. If high, the CPUCLK starts as an output but is switched to an input shortly after $\overline{\text{RSTIN}}$ is de-asserted. See Table 5-1 and Figure 5-1. This controls the default value of CLK_SPD in the CPU Clock (CPUCLK) Control Register at Port 1072H. See section 4.2.4.

5.1.3 Interrupt Requests

The Interrupt Requests are multiplexed by the WD76C30. The multiplexing is performed as shown in Table 5-1 and Figure 5-1, and provides the System Controller with the IRQSET1 and IRQSET0 signals.

DRQIN, IRQSET1 and IRQSET0 are sampled by the System Controller at every rising edge of SYSCLK2. This allows all DMA, DRQ and IRQ lines to be sampled within 500 ns, when SYSCLK is 8 MHz.

The ROM8 input is sampled at the completion of a $\overline{\text{RSTIN}}$ to determine ROM data width (ROM8). The RESCPU and A20GT inputs come from the 8042 keyboard controller.

5.1.4 AT Address Bus, Data Bus and Terminal Count (TC) Signal

The AT Address Bus SA(19:00) and $\overline{\text{BLE}}$ are generated from A(19:00) with external latches and tristate buffers.

The AT Data Bus SD(15:00) uses D(15:00) and external bidirectional buffers.

The TC signal is generated by the WD76C20 when DACKEN and CSEN are both asserted.

5.2 POWER MANAGEMENT CONTROL PMCIN

The power control signals are placed on the PMCIN input pin by way of an 8-to-1 multiplexer, controlled by the MXCTL(2:0) signals from the System Controller. In the WD7855/LV, the external 8:1 MUX is always used. See Figure 5-1. Bits 14 and 13 of Port 1872H (Section 5.3) control the power down of the processor and peripheral.



MXCTL 2 1 0	DRQIN	DACKEN	IRQSET0	IRQSET1	PMCCIN
000	DRQ0	DACK0	IRQ8	IRQ12	TURBO
001	DRQ1	DACK1	IRQ9	IRQ1	PROC_PWR_GOOD
010	DRQ2	DACK2	IRQ10	A20GT	LCL_REQ or User Defined
011	DRQ3	DACK3	IRQ11	IRQ3	User Defined
100	CLOCK_DIR_IN	BUS_RST	ROM8	IRQ4	User Defined
101	DRQ5	DACK5	RESCPU	IRQ5	User Defined
110	DRQ6	DACK6	IRQ14	IRQ6	User Defined
111	DRQ7	DACK7	IRQ15	IRQ7	User Defined

TABLE 5-1. MXCTL(2:0) DECODING

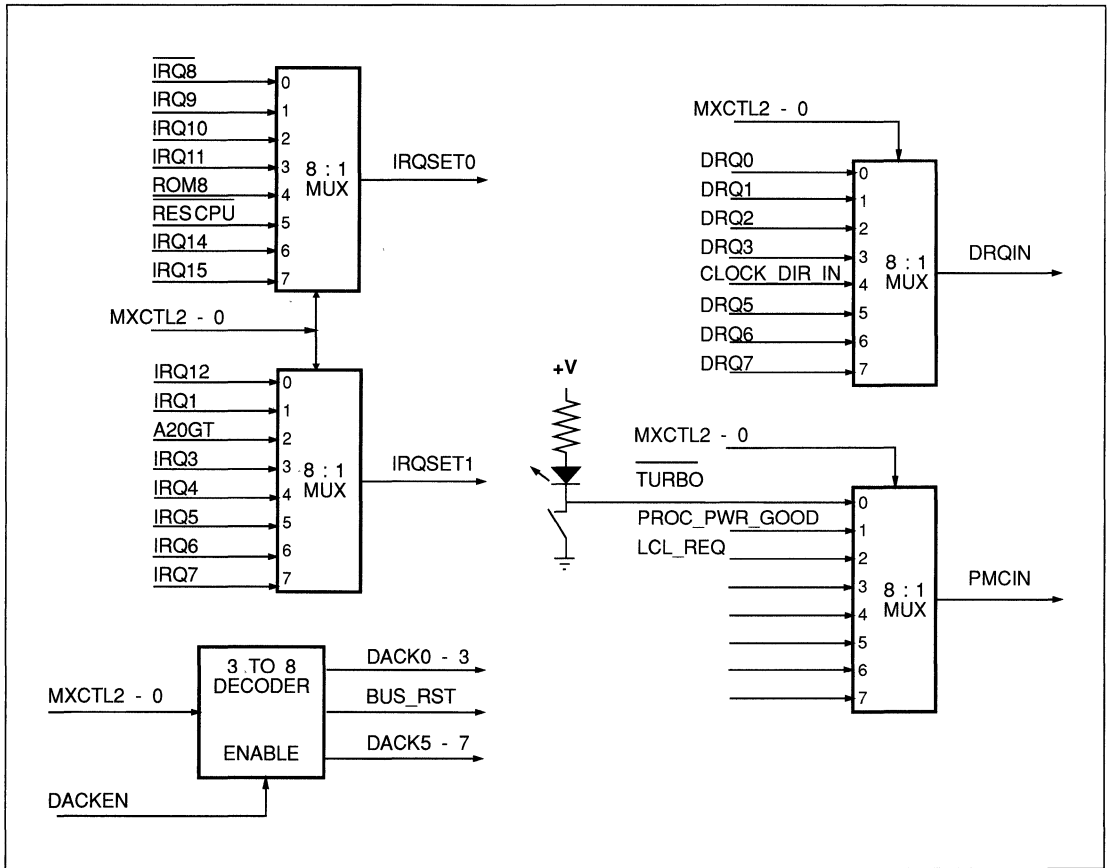

FIGURE 5-1. MXCTL(2:0) MULTIPLEXING

5.3 NUMERIC PROCESSOR

5.3.1 Numeric Processor Busy, Bus Timing, and Power Down Register

Port Address 1872H - Read and Write

15	14	13	12	11	10	09	08
	PRO_PD	FPD		BUS_MOD		BRQ_DEL	

07	06	05	04	03	02	01	00
BAK_DEL		WSI_16	WSM_16	WS18		WSM8	

Signal Name	Default At RSTIN
PRO_PD	0
FPD	0
BUS_MOD	00
BRQ_DEL	00
BAK_DEL	11
WSI_16	0
WSM_16	0
WS18	10
WSM8	10

Bit 15 - Ignored by the System Controller, may be 0 or 1.

Bit 14 - PRO_PD, Processor Power Down

When PRO_PD has been changed from zero to one, a power down sequence for the 80386SX processor is initiated at the next Halt State and the expansion bus continues to operate normally. The processor should not be powered down if DMA cycles are likely to occur. When PRO_PD is set and a halt state occurs, the processor inputs are ignored and appear to the WD7855/LV to be in the passive state.

The input buffers connected to the processor signals do not consume power even if the processor signals do not reach ground. The internal pullups on inputs connecting to the processor are disabled to reduce power. PMC output 5 from Port 7072H (Processor Power Down) is set. This can be used to control the power transistor and turn off the

power to the processor. All outputs going to the processor are tristated.

When an unmasked interrupt, DRQ or NMI occurs, PMC output 5 is reset, re-powering the processor. A voltage comparator should be used to generate a Processor Power Good (PPG) signal. The PPG signal is sampled by bit 01 of the PMC Input Register at Port Address 8872H. When PPG is high, the outputs to the processor are driven and the processor is reset.

PRO_PD = 0 - Normal processor power.

PRO_PD = 1 - Start processor power down sequence.

Bit 13 - FPD, Full Power-down

When FPD equals one and a halt state occurs, all processor and peripheral outputs except the PMC, DRAM controls and RA/ED bus are tristated and all inputs except RSTIN, CLK14 and PMC inputs are ignored. CAS before RAS refresh is performed if enabled by Port 2072H. All circuitry except the PMC and refresh timer logic is stopped and PMC output 7 (Full Power-down) from Port 7072H is set. This enables the powering down of all chips except DRAM, WD7855/LV, WD76C20, WD76C30 and WD90C2X Video Controller. The WD76C20 provides PDREF (a 64 KHz refresh signal on input pin 41) during the power-down mode. This signal is then gated by the System Controller to the REFRESH signal as an output on pin 98.

When a PMC interrupt occurs, PMC output 7 at Port 7072H is reset, enabling the power up sequence. A CPURES and BUS_RST (see Figure 5-1) are asserted until the PMCIN 01 PPG at Port 8872H input is high. The tristated outputs are restored and the inputs are no longer masked. Refer to Section 9.15 for more details regarding suspend and resume.

FPD remains a 1 until replaced by a 0.

FPD = 0 - No power down.

FPD = 1 - Full power down and in standby mode.

Bit 12 - Ignored by the System Controller, may be 0 or 1.



Bits 11:10 - BUS_MOD, Bus Mode

The System Controller defaults to mode 00 at power up. Therefore, the bus clock (SYSCLK) is controlled by BCLK2 and is asynchronous with CPUCLK (see Figure 4-1). This allows CPUCLK to be faster than SYSCLK and vary without affecting the bus timing. Normally, BCLK2 is either 16 MHz or 32 MHz. SYSCLK is divided by two regardless of the mode selected by BUS_MOD, and if BCLK2 is 16 MHz at power up, it is divided by two again, providing a SYSCLK clock rate of 4 MHz until programmed to mode 01. In mode 01, the SYSCLK rate is 8 MHz for a BCLK2 of 16 MHz. Both mode 00 and 01 are asynchronous and require the appropriate synchronization delays to be established by BRQ_DEL and BAK_DEL of this register.

In modes 10 and 11, the SYSCLK is synchronous with the CPUCLK and synchronization delays are not needed. The bus clock mode may need to be reprogrammed when the processor clock changes.

Refer to Table 5-2 for the appropriate choices according to the CPU type and speed and AT bus speed employed.

BUS_MOD

- 11 10
- 0 0 - Bus logic uses BCLK2 divided by 2.
- 0 1 - Bus logic uses BCLK2 divided by 1.
- 1 0 - Bus logic uses CPUCLK divided by 2.
- 1 1 - Bus logic uses CPUCLK divided by 1.

Bits 09:08 - BRQ_DEL, Bus Request Delay

An asynchronous AT bus state machine requires a synchronization delay at the start of the bus cycle.

Refer to Table 5-2 for the appropriate choices according to the CPU type and speed and AT bus speed employed.

BRQ_DEL

- 09 08
- 0 0 - 1 Bus clock delay
- 0 1 - .5 Bus clock delay
- 1 0 - No clock delay
- 1 1 - Reserved

Bits 07:06 - BAK_DEL, Bus Acknowledge Delay

The AT bus state machine has several options available for signaling the CPU control logic that an AT bus cycle has completed. The timing of this signal determines AT bus hold time for the data and address. Proper timing is determined by the CPU speed, AT bus speed and whether they are synchronous or asynchronous. The delay settings listed here are referenced to the trailing edge of the AT command strobe.

Refer to Table 5-2 for the appropriate choices according to the CPU type and speed and AT bus speed employed.

BAK_DEL

- 07 06
- 0 0 - No delay
- 0 1 - -.5 Bus clock delay
- 1 0 - -1 Bus clock delay
- 1 1 - +.5 Bus clock delay

CPU SPEED	AT BUS SPEED	AT BUS MODE	BUS_MOD	BRQ_DEL	BAK_DEL
33.3 MHz	8 MHz	ASYNC	0X	01	11
25.0 MHz	8 MHz	ASYNC	0X	01	00
20.0 MHz	10 MHz	SYNC	10	10	10
20.0 MHz	8 MHz	ASYNC	0X	01	00
16.0 MHz	8 MHz	SYNC	10	10	10
12.5 MHz	8 MHz	ASYNC	0X	01	10

TABLE 5-2. BUS TIMING PARAMETERS



Bit 05 - WSI16, Wait State for 16 bit I/O

WSI16 = 0 -
1 Bus clock wait state

WSI16 = 1 -
2 Bus clock wait state

Bit 04 - WSM16, Wait State for 16 bit Memory

WSM16 = 0 -
1 Bus clock wait state

WSM16 = 1 -
2 Bus clock wait state.

Bits 03:02 - WSI8, Wait State for 8 bit I/O

WSI8
03 02
0 0 - 2 Bus clock wait state.
0 1 - 3 Bus clock wait state.
1 0 - 4 Bus clock wait state
1 1 - 5 Bus clock wait state.

Bits 01:00 - WSM8, Wait State for 8 bit Memory

WSM8
01 00
0 0 - 2 Bus clock wait state.
0 1 - 3 Bus clock wait state.
1 0 - 4 Bus clock wait state
1 1 - 5 Bus clock wait state.

5.3.2 Numeric Processor Busy (NPBUSY) Reset

Port Address 0F0H - Write only

Writing any data to this port resets the 80387SX busy signal (de-asserts NPBUSY). The data is ignored.

07	06	05	04	03	02	01	00

Signal Name	Default At RSTIN
All signals	None

5.3.3 Numeric Processor Reset (NPRST)

Port Address 0F1H - Write only

Writing any data to this port asserts NPRST and resets the 80387SX. The main processor is wait stated for 128 clocks when writing to this port. The data is ignored.

07	06	05	04	03	02	01	00

Signal Name	Default At RSTIN
All signals	None



5.4 DMA CONTROL

The System Controller contains two DMA controllers. DMA Controller 1 is in the I/O address space from 000H to 00FH and is used for 8-bit transfers. DMA Controller 2 is in the I/O space from 0C0H to 0DEH and is used for 16-bit transfers. Channel 0 of DMA Controller 2 is used to cascade DMA controller #1. Table 5-4 identifies the Controller/Channel location and function.

AT Bus DMA Channel	DMA Controller	Transfer Type
0	#1 Channel 0	8-bit
1	#1 Channel 1	8-bit
2	#1 Channel 2	8-bit
3	#1 Channel 3	8-bit
4	#2 Channel 0	Cascade DMA Cont. #1
5	#2 Channel 1	16-bit
6	#2 Channel 2	16-bit
7	#2 Channel 3	16-bit

TABLE 5-3. DMA TRANSFER TYPES

5.4.1 Transfer Modes

Each DMA channel may be programmed in Single Transfer Mode, Block Transfer Mode, Demand Transfer Mode or Cascade Mode.

Refer to Section 5.4.12 - Mode Register, bits 7 and 6 for programming.

Demand Mode - 00

In demand mode, a transfer continues to take place until DRQ is de-asserted or a Terminal Count (TC) is reached. If the DRQ is de-asserted, the bus will be released. If DRQ is re-asserted, the transfer will resume. The address and word count behave as in single mode.

Single Transfer Mode - 01

In single transfer mode, the channel makes one transfer for each request. The word count is decremented, and the address is incremented or decremented at the end of each transfer. When the word count goes from 0000H to FFFFH, a Terminal Count (TC) is generated. To start a transfer, the DRQ

should be asserted until a DACK is received. If the DRQ is asserted through the cycle, only one transfer will take place. The DRQ must be de-asserted and then re-asserted to start another transfer. The bus is released between transfers.

Block Transfer Mode - 10

A transfer is started in block mode by a DRQ and continues until a TC is reached. The DRQ should be held active until DACK is asserted. Block mode should be used with caution since refresh is locked out. The address and word count behave as in single mode.

Cascade Mode - 11

Cascade mode is used to cascade DMA controller #2 to DMA controller #1, and for bus master transfers. A channel in cascade mode gets the bus when a DRQ is asserted, but the word count and address are ignored. The channel holds the bus until DRQ is de-asserted. The IOR, IOW, MEMR and MEMW signals must be generated by the bus master device. The addresses from the System Controller are tristated when the MASTER signal is asserted.

5.4.2 Transfer Types

There are three types of transfers: verify, write and read.

Refer to Section 5.4.12 - Mode Register, bits 3 and 2 for programming.

Verify - 00

A verify transfer is a pseudo transfer that does not generate IOR, IOW, MEMR or MEMW signals.

Write - 01

A write transfers data from an I/O device to memory.

Read - 10

A read transfers data from memory to an I/O device.

10



5.4.3 Autoinitialize

A channel may be programmed to autoinitialize for any transfer type. In this mode, when a TC is reached, the channel is loaded with the original word count and address and is ready to start another transfer.

Refer to Section 5.4.12 - Mode Register, bit 4 for programming.

5.4.4 Priority

Each DMA controller has two types of priority, fixed and rotating. For fixed priority, channel 0 has the highest priority and channel 3 has the lowest. In rotating priority, the last channel to be serviced has the lowest priority.

5.4.5 Extended Write

In normal timing, the $\overline{\text{MEMR}}$ or $\overline{\text{IOR}}$ pulse is two clock cycles and the $\overline{\text{MEMW}}$ or $\overline{\text{IOW}}$ is one clock cycle. If extended write is selected, the $\overline{\text{MEMW}}$ or $\overline{\text{IOW}}$ will be the same as the $\overline{\text{MEMR}}$ or $\overline{\text{IOR}}$.

5.4.6 Base and Current Address

Each channel has a 16-bit base and current address register. The current address register is loaded from the base register when the base register is loaded or when in autoinitialize mode. The current address register is incremented or decremented during a transfer.

Addresses are driven to the bus while $\overline{\text{REFRESH}}$ is asserted, indicating a refresh cycle. Only address bits A(23:16) (from the page register) and bits A(10:0) (from the refresh counter) are meaningful during refresh. The address counter is incremented on the rising edge of $\overline{\text{REFRESH}}$.

5.4.7 Base and Current Word Count

Each channel has a 16-bit base and current word count register. The current word count register is loaded from the base register when the base register is loaded or when in autoinitialize mode. The current word count is decremented during a transfer.



10-BIT MODE I/O ADDRESS IN HEX	16-BIT MODE I/O ADDRESS IN HEX	READ/WRITE	DMA CONTROLLER	FUNCTION
000	0000	Read/Write	1	Channel 0 Address
001	0001	Read/Write	1	Channel 0 Word Count
002	0002	Read/Write	1	Channel 1 Address
003	0003	Read/Write	1	Channel 1 Word Count
004	0004	Read/Write	1	Channel 2 Address
005	0005	Read/Write	1	Channel 2 Word Count
006	0006	Read/Write	1	Channel 3 Address
007	0007	Read/Write	1	Channel 3 Word Count
008	0008	Read	1	Status
008	0008	Write	1	Command Register
009	0009	Write	1	Request Register
00A	000A	Write	1	Single Mask
00B	000B	Write	1	Mode Register
00C	000C	Write	1	Clear Pointer
00D	000D	Write	1	Master Clear
00E	000E	Write	1	Clear Mask
00F	000F	Write	1	Mask All
080-09F	0080-008F			DMA Page Register
0C0	00C0	Read/Write	2	Channel 0 Address
0C2	00C2	Read/Write	2	Channel 0 Word Count
0C4	00C4	Read/Write	2	Channel 1 Address
0C6	00C6	Read/Write	2	Channel 1 Word Count
0C8	00C8	Read/Write	2	Channel 2 Address
0CA	00CA	Read/Write	2	Channel 2 Word Count
0CC	00CC	Read/Write	2	Channel 3 Address
0CE	00CE	Read/Write	2	Channel 3 Word Count
0D0	00D0	Read	2	Status
0D0	00D0	Write	2	Command Register
0D2	00D2	Write	2	Request Register
0D4	00D4	Write	2	Single Mask
0D6	00D6	Write	2	Mode Register
0D8	00D8	Write	2	Clear Pointer
0DA	00DA	Write	2	Master Clear
0DC	00DC	Write	2	Clear Mask
0DE	00DE	Write	2	Mask All
B872	B872	Read	1, 2	DMA Mode Shadow

TABLE 5-4. DMA CONTROLLER/CHANNEL FUNCTION MAP



5.4.8 Command Register

Port Addresses 008H, 0D0H - Write only

The Command Register is reset by \overline{RSTIN} or by writing any data to Port Address 00DH or 0DAH (see section 5.4.14).

07	06	05	04	03	02	01	00
		EX_WR	RO_PRI	0	CO_DIS		

Signal Name **Default At RSTIN**
 All signals 0

- Bits 07:06** - Not used, state is ignored
- Bit 05 - EX_WR**, Extended Write
- Bit 04 - RO_PRI**, Rotating Priority
- Bit 03** - Must be set to 0
- Bit 02 - CO_DIS**, Controller Disabled
- Bits 01:00** - Not used, state is ignored

5.4.9 Status Register

Port Addresses 008H, 0D0H - Read only

Bits 03:00 are reset by \overline{RSTIN} , writing any data to Port Address 00DH or 0DAH (see section 5.4.14) or when read by a Status Read Command.

Channels 7:5 are accessed at Port Address 0D0H
 Channel 4 is not available
 Channels 3:0 are accessed at Port Address 008H

07	06	05	04	03	02	01	00
CH3_DRQ	CH2_DRQ	CH1_DRQ	CH0_DRQ	CH3_TC	CH2_TC	CH1_TC	CH0_TC

Signal Name **Default At RSTIN**
 CH3_DRQ - CH0_DRQ None
 CH3_TC - CH0_TC 0

- Bit 07 - CH3_DRQ**, Channel 3, 7 DRQ active
- Bit 06 - CH2_DRQ**, Channel 2, 6 DRQ active
- Bit 05 - CH1_DRQ**, Channel 1, 5 DRQ active
- Bit 04 - CH0_DRQ**, Channel 0 DRQ active
- Bit 03 - CH3_TC**, Channel 3, 7 has reached TC
- Bit 02 - CH2_TC**, Channel 2, 6 has reached TC
- Bit 01 - CH1_TC**, Channel 1, 5 has reached TC
- Bit 00 - CH0_TC**, Channel 0 has reached TC

5.4.10 Request Register

Port Addresses 009H, 0D2H - Write only

Each channel may be started by a software request. These requests are not affected by the Mask Register. The Request Register is reset by \overline{RSTIN} or by writing any data to Port Address 00DH or 0DAH (see section 5.4.14).

Channels 7:5 are accessed at Port Address 0D2H
 Channel 4 is not available
 Channels 3:0 are accessed at Port Address 009H

07	06	05	04	03	02	01	00
					CRQ	CH#	

Signal Name **Default At RSTIN**
 All signals 0

- Bits 07:03** - Not used, state is ignored
- Bit 02 - CRQ**, Channel Requested
- Bits 01:00 - CH#**, Channel Number Requested
 - CH# 1 0
 - 0 0 - Channel 0
 - 0 1 - Channel 1, 5
 - 1 0 - Channel 2, 6
 - 1 1 - Channel 3, 7



5.4.11 Mask Registers

Each channel has a mask bit associated with it. If it is set, the channel is disabled. The bits may be set or reset by software, or set by a Terminal Count (TC) if the channel is not in autoinitialize mode. All the bits are set by a RSTIN, or by writing any data to Port Address 00DH or 0DAH (see section 5.4.14).

5.4.11.1 Single Mask Register

Port Addresses 00AH, 0D4H - Write only

Channels 7:5 are accessed at Port Address 0D4H
 Channel 4 is not available
 Channels 3:0 are accessed at Port Address 00AH

07	06	05	04	03	02	01	00
					SE_MA	CH#	

Signal Name	Default At RSTIN
All signals	1

Bits 07:03 - Not used, state is ignored

Bit 02 - SE_MA, Set Mask

SE_MA = 0 -
 Clear Mask

SE_MA = 1 -
 Set Mask

Bits 01:00 - CH#, Channel Number Requested

CH#	1	0
	0	0 - Channel 0
	0	1 - Channel 1, 5
	1	0 - Channel 2, 6
	1	1 - Channel 3, 7

5.4.11.2 Clear Mask Register

Port Addresses 00EH, 0DCH - Write only

Writing any data to these registers resets all Masks. The data is ignored.

Channels 7:5 are accessed at Port Address 0DCH
 Channel 4 is not available
 Channels 3:0 are accessed at Port Address 00EH

07	06	05	04	03	02	01	00

Signal Name	Default At RSTIN
All signals	None

Bits 07:00 - Not used, state is ignored

5.4.11.3 Mask Multiple Register

Port Addresses 00FH, 0DEH - Write only

Channels 7:5 are accessed at Port Address 0DEH
 Channel 4 is not available
 Channels 3:0 are accessed at Port Address 00FH

07	06	05	04	03	02	01	00
				CH3_MA	CH2_MA	CH1_MA	CH0_MA

Signal Name	Default At RSTIN
All signals	1

Bits 07:04 - Not used, state is ignored

Bit 03 - CH3_MA, Channel 3, 7 Mask

Bit 02 - CH2_MA, Channel 2, 6 Mask

Bit 01 - CH1_MA, Channel 1, 5 Mask

Bit 00 - CH0_MA, Channel 0 Mask



5.4.12 Mode Register

Port Addresses 00BH, 0D6H - Write only

These registers are shadowed and may be read back through DMA Shadow Registers 1:3 described in sections 9.13.(1:3).

These registers select the mode and type of transfer for each channel. Refer to sections 5.4.1 through 5.4.1.4 for a description of the Transfer Modes, sections 5.4.2 through 5.4.2.3 for a description of the Transfer Types and section 5.4.3 for a description of Autoinitialize.

Channels 7:5 are accessed at Port Address 0D6H
 Channel 4 is not available
 Channels 3:0 are accessed at Port Address 00BH

07	06	05	04	03	02	01	00
TRA_MOD		AD_DEC	AUTO	TRA_TYP	CHA#_SEL		

Signal Name	Default At RSTIN
All signals	None

Bits 07:06 - TRA_MOD, Transfer Mode

TRA_MOD
 7 6

0 0 - Demand
 0 1 - Single
 1 0 - Block
 1 1 - Cascade

Bit 05 - AD_DEC, Address Decrement

AD_DEC = 0
 Address is incremented.

AD_DEC = 1
 Address is decremented after each DMA cycle.

Bit 04 - AUTO, Autoinitialize

AUTO = 0
 Autoinitialization is disabled.

AUTO = 1
 Autoinitialization is enabled.

Bits 03:02 - TRA_TYP, Transfer Type

TRA_TYP
 3 2

0 0 - Verify
 0 1 - Write
 1 0 - Read
 1 1 - Not used

Bits 01:00 - CHA#_SEL, Channel Select

CHA#_SEL
 1 0

0 0 - Channel 0
 0 1 - Channel 1, 5
 1 0 - Channel 2, 6
 1 1 - Channel 3, 7

5.4.13 Clear Pointer Register

Port Addresses 00CH, 0D8H - Write only

Each DMA controller has a pointer flip-flop that indicates which half of the word count or address is being accessed. Each time a word count or address is written or read, the pointer changes state. When the flip-flop is reset, bits 7:0 are accessed, and when it is set, bits 15:8 are accessed. The pointer is reset by writing any data to the Clear Pointer Register, or to Port Address 00DH or 0DAH (see section 5.4.14). In either case, the data is ignored.

07	06	05	04	03	02	01	00

Signal Name	Default At RSTIN
All signals	None

Bits 07:00 - Not used, state is ignored



5.4.14 Master Clear Register

Port Addresses 00DH, 0DAH - Write only

Writing any data to the Master Clear Register will:

1. Clear the Command Register
2. Clear the Status Register
3. Clear the Request Register
4. Set the Mask Register
5. Clear the Pointer Flip-Flop

All data is ignored.

07	06	05	04	03	02	01	00

Signal Name	Default At RSTIN
All signals	None

Bits 07:00 - Not used, state is ignored

5.4.15 DMA Mode Shadow Register

Port Address B872H - Read only

This register is particularly useful in laptop applications by allowing the suspend/resume software to restore correct status to on-board devices. Refer to Section 2.8.1 and 9.14 for more information regarding the DMA Shadow registers.

15	14	13	12	11	10	09	08
DMA1 MODE							

07	06	05	04	03	02	01	00
DMA2 MODE							

Signal Name	Default At RSTIN
DMA1 MODE	0
DMA2 MODE	0

Bits 15:08 - DMA1 MODE

DMA 1 MODE contains a copy of the data written into the DMA1 Mode Register located at I/O address 00BH (see Table 5-4).

Bits 07:00 - DMA 2 MODE

DMA 2 MODE contains a copy of the data written into the DMA2 Mode Register located at I/O address 0D6H (see Table 5-4).

5.5 SYSTEM CONTROLLER 8259 INTERRUPT CONTROLLERS

The System Controller contains two interrupt controllers. Interrupt Controller 1 is in the I/O space of 020H to 021H and Interrupt Controller 2 is in the I/O space of 0A0H to 0A1H. Interrupt 2 of Interrupt Controller 1 is used to cascade Interrupt Controller 2.

5.5.1 Interrupt Sequence

1. When an interrupt arrives from a peripheral device, the interrupt may only be programmed to be edge sensitive. In this mode, the interrupt must go low and high for each interrupt. The interrupt sets the appropriate bit in the Interrupt Request Register (IRR).

System Interrupt	Interrupt Controller	Use
0	#1 Level 0	Timer
1	#1 Level 1	Keyboard
2	#1 Level 2	Cascade
3:7	#1 Level 3:7	AT Bus
8	#2 Level 0	RTC
9:12	#2 Level 1:4	AT Bus
13	#2 Level 5	Co-Processor
14:15	#2 Level 6:7	AT Bus

TABLE 5-5. INTERRUPT SEQUENCE



2. If the interrupt has not been masked off, it is passed to the priority circuit. There are three types of priority.

Fixed

In fixed priority, interrupt 0 has the highest priority and interrupt 7 has the lowest.

Automatic Rotation

In automatic rotation, the last interrupt serviced has the lowest priority.

Specific Rotation

In this mode, the lowest priority interrupt can be set by software. The next interrupt will have the highest priority. For example if interrupt 4 is set to the lowest level, the priority will be 5, 6, 7, 0, 1, 2, 3 and 4.

3. The interrupt controller sends an IRQ to the CPU.
4. The CPU responds with an INTA cycle that freezes priority.
5. The CPU sends another INTA, causing the interrupt controller to send a vector to the CPU, set the appropriate bit in the Interrupt Service Register (ISR) and clear the corresponding bit in the IRR, if it is in the edge triggered mode. As long as the bit in the ISR is set, all interrupts at the same level or lower are inhibited unless programmed for special mask mode.
6. An EOI is issued to end the interrupt. This clears the appropriate bit in the Interrupt Service Register. For the slave adapter (interrupt controller #2), two EOI's must be issued. There are three types of EOI's, Specific, Non-specific and Automatic.

Specific

An EOI is issued by software for a specific interrupt.

Non-Specific

A non-specific EOI is also issued by software. The hardware generates an EOI for the highest level active interrupt.

Automatic

An automatic EOI is a non-specific EOI that is caused by the second INTA.

The interrupt controllers may also be operated in a polled mode. In this mode, the CPU is set to disable the interrupt input. In this case, software must issue a poll command. This takes the place of an INTA, and the software can then read the interrupt level to determine the interrupt to be serviced.

When cascading is used and the slave has issued an interrupt, other interrupts from the slave are locked out. If it is desired to preserve priority in the slave (i.e., allow higher interrupts to occur when a lower interrupt is being serviced), Special Fully Nested Mode should be programmed in the master. After a non-specific EOI has been sent to the slave, the ISR should be checked to see whether any other interrupts are active. If there are no interrupts active, a non-specific EOI should be sent to the master.



Interrupt Controller	Address Hex	Function	Read/Write
1	020	ICW1	Write
1	021	ICW2	Write
1	021	ICW3	Write
1	021	ICW4	Write
1	021	OCW1	Write
1	020	OCW2	Write
1	020	OCW3	Write
1	020	IRR	Read
1	020	ISR	Read
1	021	Mask	Read
1	020, 021	Interrupt Level	Read
2	0A0	ICW1	Write
2	0A1	ICW2	Write
2	0A1	ICW3	Write
2	0A1	ICW4	Write
2	0A1	OCW1	Write
2	0A0	OCW2	Write
2	0A0	OCW3	Write
2	0A0	IRR	Read
2	0A0	ISR	Read
2	0A1	Mask	Read
2	0A0, 0A1	Interrupt Level	Read

TABLE 5-6. INTERRUPT CONTROLLER FUNCTION MAP

5.5.2 Setup - Initialization Command Words (ICW)

The interrupt controllers are set up by writing a series of Initialization Command Words (ICW). The sequence is started by writing a one to bit 4 of ICW1. If ICW4 is to be included in the sequence, a one must also be written to bit 0 of the ICW1.

5.5.2.1 ICW1 - Initialization Command Word 1

Port Addresses 020H, 0A0H - Write only

Bit 4 of this register must be set to 1 or it will be interpreted as OCW2 or OCW3.



07	06	05	04	03	02	01	00
			S_S	L_T		NC_M	ICW4

Signal Name	Default At RSTIN
All signals	None

Bits 07:05 - Not used, state is ignored

Bit 04 - S_S, Start Sequence

S_S Must be set to 1



Bit 03 - L_T, Level Trigger

The Interrupt Controller may be programmed to support Level Sensitive Mode for diagnostic adapters which may need to test this capability.

L_T = 0 -
Edge Triggered Mode is selected.

L_T = 1 -
Level Triggered Mode is selected.
EN_LVL (bit 00) in Port A872H must first be set to 1.

Bit 02 - Not Used, state is ignored

Bit 01 - N C_M, Not Cascade Mode

N C_M = 0 -
Cascade Mode selected

N C_M = 1 -
Single Mode selected

Bit 00 - ICW4, Initialization Control Word 4

ICW4 = 0 -
ICW4 not included in sequence

ICW4 = 1 -
ICW4 is included in sequence

5.5.2.2 ICW2 - Initialization Command Word 2

Port Addresses 021H, 0A1H - Write only

For Suspend/Resume or Hibernation operations this register may be read at Port Address D472H. Refer to Section 9.10.

07	06	05	04	03	02	01	00
Interrupt Vector							

Signal Name **Default At RSTIN**
All signals None

Bits 07:03 - Interrupt Vector

Bits 02:00 - Not used, state is ignored

5.5.2.3 ICW3 - Initialization Command Word 3

Port Addresses 021H - Write only

This address accesses only Interrupt Controller 1.

07	06	05	04	03	02	01	00
0	0	0	0	0	I2 H_L	0	0

Signal Name **Default At RSTIN**
All signals None

Bits 07:03 - Not used, must be set to 0

Bit 02 - I2 H_L, Interrupt 2 Has Slave

I2 H_L = 0 -
Interrupt 2 does not have the Slave

I2 H_L = 1 -
Interrupt 2 has the Slave

Bits 01:00 - Not used, must be set to 0

Port Addresses 0A1H - Write only

This address accesses only Interrupt Controller 2.

07	06	05	04	03	02	01	00
0	0	0	0	0	Slave ID		

Signal Name **Default At RSTIN**
All signals None

Bits 07:03 - Not used, must be set to 0

Bits 02:00 - Slave ID



5.5.2.4 ICW4 - Initialization Command Word 4

Port Addresses 021H, 0A1H - Write only

For Suspend/Resume or Hibernation operations this register may be read at Port Address D472H. Refer to Section 9.10.

A Slave does not have ICW4.

07	06	05	04	03	02	01	00
0	0	0	SF NM	0	0	AUT EOI	1

Signal Name **Default At RSTIN**
 All signals None

- Bits 07:05** - Not used, must be set to 0
- Bit 04 - S F N M**, Special Fully Nested Mode
 S F N M = 0 - Not Special Fully Nested Mode
 S F N M = 1 - Special Fully Nested Mode

Bits 03:02 - Not used, must be set to 0

- Bit 01 - AUT_EOI**, Auto End Of Interrupt
 AUT_EOI = 0 - Normal End Of Interrupt
 AUT_EOI = 1 - Automatic End Of Interrupt

Bit 00 - Not used, must be set to 1

5.5.3 Operation

Once the interrupt controllers are set up, they may be programmed by Operation Control Words One through Three (OCW1:3).

5.5.3.1 OCW1 - Operation Control Word 1

Port Address 021H, 0A1H - Write only

07	06	05	04	03	02	01	00
INT 7_M	INT 6_M	INT 5_M	INT 4_M	INT 3_M	INT 2_M	INT 1_M	INT 0_M

Signal Name **Default At RSTIN**
 All signals None

- Bit 07** - Interrupt 7 Mask
- Bit 06** - Interrupt 6 Mask
- Bit 05** - Interrupt 5 Mask
- Bit 04** - Interrupt 4 Mask
- Bit 03** - Interrupt 3 Mask
- Bit 02** - Interrupt 2 Mask
- Bit 01** - Interrupt 1 Mask
- Bit 00** - Interrupt 0 Mask

5.5.3.2 OCW2 - Operation Control Word 2

Port Address 020H, 0A0H - Write only

For Suspend/Resume or Hibernation operations this register may be read at Port Address D472H. Refer to Section 9.10.

07	06	05	04	03	02	01	00
EOI_CONT			0	0	INT_LEV		

Signal Name **Default At RSTIN**
 All signals None

Bits 07:05 - EOI_CONT, End Of Interrupt

- EOI_CONT
 7 6 5
- 0 0 0 - Clear Rotate On Automatic EOI
 - 0 0 1 - Non-specific EOI
 - 0 1 0 - Not used
 - 0 1 1 - Specific EOI
 - 1 0 0 - Set Rotate on Automatic EOI
 - 1 0 1 - Rotate on Non-Specific EOI
 - 1 1 0 - Set Priority
 - 1 1 1 - Rotate on Specific EOI



Bits 04:03 - Must be set to 0

Bits 02:00 - INT_LEV, Interrupt Level

To enable the setting of the interrupt level (INT_LEV), EOI_CONT must be set to 1 1 0 (Set Priority).

INT_LEV
 2 1 0
 0 0 0 - Interrupt Level 0
 ↓
 1 1 1 - Interrupt Level 7

5.5.3.3 OCW3 - Operation Control Word 3

Port Address 020H, 0A0H - Write only

For Suspend/Resume or Hibernation operations this register may be read at Port Address D472H. Refer to Section 9.10.

07	06	05	04	03	02	01	00
0	SMM	0	1	P_C	IRR_ISR		

Signal Name	Default At RSTIN
All signals	None

Bit 07 - Must be set to 0

Bits 06:05 - SMM, Special Mask Mode

SMM
 6 5
 0 0 Not used
 0 1 Not used
 1 0 Reset Special Mask Mode
 1 1 Set Special Mask Mode

Bit 04 - Must be set to 0

Bit 03 - Must be set to 1

Bit 02 - P_C, Poll Command

P_C = 0 -
 No Poll Command
 P_C = 1 -
 Poll Command

Bits 01:00 - IRR_ISR, Interrupt Request Register and Interrupt Service Register

IRR_ISR
 1 0
 0 0 - Not used
 0 1 - Not used
 1 0 - Read Interrupt Request Register
 1 1 - Read Interrupt Service Register

5.6 SYSTEM CONTROLLER 8254 TIMER

The System Controller contains an 8254 equivalent timer containing three independent counters. All the timers run off of a 1.19 MHz clock derived from the 14.318 MHz clock input. The GATE0 and GATE1 signals are tied high. The GATE2 signal is tied to register 61H, bit 0. The counters decrement when counting. The largest possible count is 0.

Each counter may be programmed for different counting modes and the count may be read back. To initialize a counter, the Control Word must be written, followed by one or two bytes of count if needed. Refer to Table 5-7 for the correct Control Word Format. Each counter may be programmed to count in BCD or binary.

I/O Address	Use	Read/Write
040H	Timer 0 Count/Status	Read/Write
041H	Timer 1 Count/Status	Read/Write
042H	Timer 2 Count/Status	Read/Write
043H	Control Word	Write

Timer Channel	Use
0	Time of Day (Interrupt)
1	Refresh Request
2	Speaker



CONTROL WORD (FORMAT 1) - I/O Address 043H - Counter Latch Command		
0	BCD Mode	000 Mode 0
1-3		001 Mode 1
		X10 Mode 2
		X11 Mode 3
		100 Mode 4
		101 Mode 5
4-5	Function	00 Counter Latch Command
		01 Read/Write Low Byte
		10 Read/Write High Byte
		11 Read/Write Low Byte then High Byte
6-7	Counter	00 Counter 0
		01 Counter 1
		10 Counter 2
CONTROL WORD (FORMAT 2) - I/O Address 043H - Read Back Command		
0		0
1		Select Counter 0
2		Select Counter 1
3		Select Counter 2
4		Latch Status
5		Latch Count
6-7		11

TABLE 5-7. CONTROL WORD FORMAT

5.6.1 Setup

Each counter may be set in one of six modes by writing a Control Word (format 1). The Control Word must specify the counter and the number of count bytes to be written. A new count may be written at any time.

5.6.1.1 Mode 0 Interrupt on Terminal Count

The counter starts when the count is loaded. When the count = 0, the counter continues counting from FFFFH in binary mode or 9999 in BCD mode. GATE = 1 enables counting. GATE = 0 disables counting.

OUT goes low when the counter starts. It goes high when the count = 0, and stays high until a new count or mode is written.

If a new count is written while the counter is counting, it will be loaded on the next clock pulse.

5.6.1.2 Mode 1 Hardware Retriggerable One Shot

The counter starts when GATE goes from low to high. When the count = 0, the counter continues counting from FFFFH in binary mode or 9999 in BCD mode.

Any time GATE goes from low to high, the counter is reloaded with the original count and the counter started.

OUT goes low when GATE goes from low to high. It goes high when the count = 0. If a new count is written while the counter is counting, it will be loaded the next time GATE goes from low to high.

5.6.1.3 Mode 2 Rate Generator

The counter starts when the count is loaded. When the count = 0, the counter is reloaded and the counter is started again. GATE = 1 enables counting. GATE = 0 disables counting. If GATE goes from low to high, the counter is reloaded.

OUT is initially high. When the count = 1, OUT goes low for one clock.

If a new count is written while the counter is counting, it will be loaded the next time the count = 0 or when GATE goes from low to high.

5.6.1.4 Mode 3 Square Wave Generator

The counter starts when the count is loaded. When the count = 0, the counter is reloaded and the counter started again. GATE = 1 enables counting. GATE = 0 disables counting. If GATE goes from low to high, the counter is reloaded.

When the counter starts, OUT is high. When the count is half done, OUT goes low. If GATE goes low then OUT will go high.

If a new count is written while the counter is counting, it will be loaded the next time the count = 0 or when GATE goes from low to high.

5.6.1.5 Mode 4 Software Triggered Strobe

The counter starts when the count is loaded. When the count = 0, the counter continues counting from FFFFH in binary mode or 9999 in BCD mode. GATE = 1 enables counting. GATE = 0 disables counting. OUT is initially high. When the count = 0, OUT goes low for one clock.

If a new count is written while the counter is counting, it will be loaded on the next clock pulse.

5.6.1.6 Mode 5 Hardware Triggered Strobe

The counter starts when the count is loaded. When the count = 0, the counter continues counting from FFFFH in binary mode or 9999 in BCD mode. GATE = 1 enables counting. GATE = 0 disables counting. If GATE goes from low to high, the counter is reloaded. OUT is high when the counter starts. When count = 0, OUT goes low for one clock. If a new count is written while the counter is counting, it will be loaded the next time the count = 0 or when GATE goes from low to high.

5.6.2 Reading The Counter

There are three ways of reading the counters:

1. The count is read directly. This mode can cause false readings due to the fact that the counter may be changing while it is read.
2. The count may be read via a Counter Latch Command. (See Control Word format 1.) This command latches the count so that it may be read without changing.
3. The count may be read via a Read Back Command. (See Control Word format 2.) This command is the equivalent of multiple Counter Latch Commands.

5.6.3 Reading Status

The status of a counter may be read by issuing a Read Back Command with data bit 4 = 0. (See Control Word format 2.) Bits 0:5 are the same as the command word for the counter. Bit 6 tells whether the last count that was written has been loaded into the counter. Bit 7 reflects the state of the OUT pin.

STATUS WORD	
0	BCD
1:3	Mode
4:5	Function
6	New Count Written
7	Out Status

5.6.4 Page

The page register is an 8-bit by 16-byte dual-ported RAM. It is used during refresh cycles and to generate address bits 16 to 23 for 8-bit DMA transfers and address bits 17 to 23 for 16-bit DMA transfers. One port of the RAM is a read-only port for DMA or refresh cycles and the other is a read/write port for the CPU.

5.6.5 Refresh Address

This block contains an 11-bit counter that is used for the address during a refresh.



5.6.6 Timer Shadow

For both Suspend/Resume and Hibernation the state of the write only registers in the timer may be read. Refer to section 9.14.5 Timer Count for details.

5.7 SYSTEM CONTROLLER DECODE

The WD7855/LV supports both the 100% IBM-AT compatible I/O decoding (10-bit mode) and the newer IBM PS/2 compatible I/O decoding (16-bit mode). The mode is selected by EN_16 (bit 05) at Port Address 2872H. Refer to Section 8.2.

Address	Decode
0087H	DMA Channel 0
0083H	DMA Channel 1
0081H	DMA Channel 2
0082H	DMA Channel 3
008BH	DMA Channel 5
0089H	DMA Channel 6
008AH	DMA Channel 7
008FH	Refresh

TABLE 5-9. PAGE REGISTER DECODES

NOTE

Page register data appears on address bits A(23:16) during refresh and 8-bit DMA cycles. For 16-bit DMA cycles (channels 5:7), the LSB of the page register does not appear.

DEVICE	10-BIT MODE ADDRESS IN HEX	16-BIT MODE ADDRESS IN HEX
DMA Controller 1 (Ch 0:3)	000:01F	0000:000F
Interrupt Controller Master	020:03F	0020:0021
Timer	040:05F	0040:0043
Port B - Parity Error And I/O Channel Check	061:06F (odd)	0061
Real-Time Clock (Address)	070	0070
Real-Time Clock (Data)	071	0071
Page Register (except 092H)	080:091 093:09F	0080:008F
ALT 20 GATE, Hot Reset (Port 92H)	092	0092
Interrupt Controller Slave	0A0:0BF	00A0:00A1
DMA Controller 2 (Ch 5:7)	0C0:0DF	00C0:00DE (even)

TABLE 5-8. DEVICE ADDRESSES

5.8 NMI AND REAL TIME CLOCK

5.8.1 Real Time Clock Address Register

Port Address 070H in 10-bit mode
0070H in 16-bit mode.

- Write only

07	06	05	04	03	02	01	00
D_NMI	RTC_A6	RTC_A5	RTC_A4	RTC_A3	RTC_A2	RTC_A1	RTC_A0

Signal Name	Default At RSTIN
D_NMI	1
RTC6 - RTC0	None

Bit 07 - D_NMI, Disable Non-Maskable Interrupt

D_NMI = 0 - Non-Maskable Interrupt enabled.

D_NMI = 1 - Non-Maskable Interrupt disabled

Bits 06:00 - RTCA6 through RTCA0, Real-Time Clock Address

RTCA6 through RTCA0 provide the 128 addresses of the Real-Time Clock area. The data selected by one of these addresses is available by reading the RTC Data Register at 071H in 10-bit mode or 0071H in 16-bit mode.

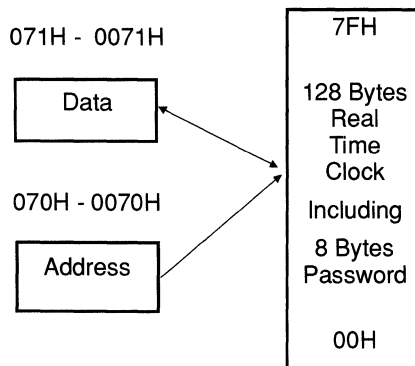

5.8.2 Real-Time Clock Data Register

Port Address 071H in 10-bit mode
0071H in 16-bit mode.

- Read and Write

Data is transferred between this register and the memory location selected by the RTC Address Register. The data bus used is selected by bit 15 of the register at Port Address 2872H (refer to section 7.2).

07	06	05	04	03	02	01	00
Real-Time Clock Data							

5.8.3 Lock Pass, Alternate A20G and Hot Reset

Port Address 092H in 10-bit mode
0092H in 16-bit mode

- Read and Write

07	06	05	04	03	02	01	00
				LOCK_PASS		ALT_A20G	HOT_RST

Signal Name	Default At RSTIN
Bits 7:4, 2	None
LOCK_PASS	0
ALT_A20G	0
HOT_RST	0

Bit 03 - LOCK_PASS

LOCK_PASS is used to prevent access to the eight byte password located in the Real-Time Clock area. The protected addresses are 38H through 3FH. Before LOCK_PASS can be set, bit 02 of the register at Port Address 2872H must be set to 0. Once LOCK_PASS is set, it can only be reset by RSTIN.

LOCK_PASS = 0 - The eight byte password area is accessible.

LOCK_PASS = 1 - The eight byte password area is not accessible.



Bit 01 - ALT_A20G, Alternate A20 Gate

Normally, the state of ALT_A20G is ORed with the external A20GT signal. If either ALT_A20G or A20GT is high, the A20 line is ungated. If both ALT_A20G and A20GT are low, A20 will be gated low.

As an option, ALT_A20G may be programmed by the Diagnostic Register at Port Address 9872H to automatically change state to match that of the Keyboard's A20GATE.

Bit 00 - HOT_RST, Hot Reset

A processor reset (CPURES) is generated 128 CPUCLKs after the HOT_RST changes from a 0 to 1. The CPURES is 16 clock pulses wide.

5.9 PORT B - PARITY ERROR AND I/O CHANNEL CHECK

Port B is accessed at any odd numbered Port Address 061H:06FH in 10-bit mode, or at 0061H in 16-bit mode. This provides access to parity error and I/O Channel Check of the expansion bus.

Bits 7:4 - Read only
 Bits 3:0 - Read and Write

07	06	05	04	03	02	01	00
PE	IOCK	OUT 2	REF_ DT	D_ IIOC	D_ PE	ENS PK	TMR 2G

Signal Name	Default At RSTIN
PE	0
IOCK	0
OUT2	NA
REFDT	1
D_IIOC	0
D_PE	0
ENSPK	0
TMR2G	0

Bit 07 - PE, Parity Error

PE = 0 - No Parity Error.
 PE = 1 - Parity Error.

Bit 06 - IOCK, I/O Channel Check from the expansion bus

IOCK = 0 - No I/O Channel Check Error.
 IOCK = 1 - I/O Channel Check Error.

Bit 05 - OUT2, from timer channel 2

OUT2 represents the state of the Timer 2 output.

Bit 04 - REF_DT, Refresh Detect

Changes state on each refresh.
 REF_DT is not affected by S_REF (bit 03 at Port Address BC72H).

Bit 03 - D_IIOC, Disable I/O Channel Check

D_IIOC = 0 - I/O channel check from the expansion bus is not disabled.
 D_IIOC = 1 - I/O channel check from the expansion bus is disabled.

Bit 02 - D_PE, Disable Parity Error Check

D_PE = 0 - Parity error checking not disabled. This may be overridden by PAR_DIS (bit 10 at Port Address 6072H) for systems without parity RAM.
 D_PE = 1 - Parity error checking disabled.

Bit 01 - ENSPK, Enable Speaker

ENSPK = 0 - Speaker is not enabled.
 ENSPK = 1 - Speaker is enabled.

Bit 00 - TMR2G, Gate for Timer Channel 2

TMR2G = 0 - Timer Channel 2 gated low.
 TMR2G = 1 - Timer Channel 2 output enabled.



6.0 MEMORY AND EMS CONTROL

This section describes the DRAM address bus and the EMS memory configuration and control registers.

6.1 DRAM ADDRESS AND DATA BUS

The memory address bus is multi-functional. During DRAM cycles, the DRAM row and column addresses are present on RA11 through RA0. During I/O cycles, RA10 through RA08 (CS2:0 and DPH, DPL) are used to decode 32 possible Chip Selects. Also, during I/O cycles to devices such as the Keyboard Controller, RA7 through RA0 become the Data Bus bits ED7 through ED0.

The RAS and CAS lines are designed to drive the DRAM array directly without the use of external drivers. RA11 through RA0 are capable of driving 350 pF at 5 volts or 220 pF at 3.3 volts. The equivalent load of two banks of 1-bit wide RAM, plus two banks of 4-bit wide RAM (48 DRAMs) are only capable of driving 350 pF at 5 volts.

The W/\bar{R} signal at pin 2 should be buffered before use. Write protection is accomplished by not asserting CAS to the local DRAM while \overline{MEMW} at pin 92 is asserted.

The on-board DRAM may be disabled so that external cards such as EMS may provide memory. The DRAM may be disabled in three stages, from 128 Kbyte to 640 Kbyte, 256 Kbyte to 640 Kbyte and 512 Kbyte to 640 Kbyte.

When disabling any on-board DRAM, the register at Port Address 6872H must not be programmed to enable the on-board Lower EMS Page Frame.

All versions of the System Controller provide support for DRAM banks to be independent or two-way page interleaved. DRAM banks that are interleaved must be of the same DRAM size.



6.2 MEMORY CONFIGURATION

6.2.1 Memory Control

Port Address 3872H - Read and Write

15	14	13	12	11	10	09	08
PG_CAS	ILV_7,5	CA		PG	ILV_6,4	ILV_3,1	ILV_2,0

07	06	05	04	03	02	01	00
EN_BNK7	EN_BNK6	EN_BNK5	EN_BNK4	SIZE_BNK7:4		SIZE_BNK3:0	

Signal Name	Default At RSTIN
PG_CAS	0
ILV_7,5	0
CA	00
PG	0
ILV_6:0	000
EN_BNK7:4	0000
SIZE_BNK7:0	0000

Bit 15 - PG_CAS, Page Mode CAS Width

PG_CAS = 0 - Read CAS pulse width is 2.5 CPUCLK clocks.

PG_CAS = 1 - Read CAS pulse width is 2 CPUCLK clocks.

Bit 14 - ILV_7, 5, Interleave Banks 7 and 5

ILV_7, 5 = 0 - Banks 7 and 5 are not interleaved.

ILV_7, 5 = 1 - Banks 7 and 5 are interleaved.

Bits 13:12 - CA, Cache Mode

Enabling the Cache Mode adds an additional wait state to the beginning of on-board read cycles.

When CA is changed, a hold acknowledge cycle is required before the change goes into effect.

CA 13 12

- 0 0 - Cache Mode not enabled. Pin 121 may be used as the alternate clock CLKA.
- 0 1 - External Cache Mode or VLBI mode enabled.
- 1 0 - External Memory Controller. Pin 121 becomes PE and is connected to the parity error line of the external memory controller.
- 1 1 - Pin 121 may be used as the alternate clock CLKA. When CAS Input Mode is enabled, PE on pin 121 becomes an input and represents an error.

Bit 11 - PG, Page Mode

PG = 0 - Non-page mode

Word interleaving is employed when bank interleaving is enabled by an ILV. Non-page mode is **not** supported in 1 Mbit by 16 chips and 2 Mbits by 16 configurations.

PG = 1 - Page mode

The WD7855/LV operates in Page Mode regardless of the state of ILV, interleaving is performed when bank interleaving is enabled by ILV.

Bit 10 - ILV_6, 4, Interleave Banks 6 and 4

Bit 09 - ILV_3, 1, Interleave Banks 3 and 1

Bit 08 - ILV_2, 0, Interleave Banks 2 and 0

Bit 07 - EN_BNK7, Enable Bank 7

EN_BNK7 = 0 - Bank 7 is disabled

EN_BNK7 = 1 - Bank 7 is enabled

Bit 06 - EN_BNK6, Enable Bank 6

EN_BNK6 = 0 - Bank 6 is disabled

EN_BNK6 = 1 - Bank 6 is enabled



Bit 05 - EN_BNK5, Enable Bank 5

- EN_BNK5 = 0 - Bank 5 is disabled
- EN_BNK5 = 1 - Bank 5 is enabled

Bit 04 - EN_BNK4, Enable Bank 4

- EN_BNK4 = 0 - Bank 4 is disabled
- EN_BNK4 = 1 - Bank 4 is enabled

Bits 03:02 - SIZE_BNK7:4, Size of Banks 7:4

Both versions of the System Controller support all DRAM sizes. Although the DRAM sizes within banks 7:4 must be the same, they may differ from those in banks 3:0. SIZE_BNK7:4 functions with bit 13 of DRAM Size and SMI RAM Register at Port 7472H.

Port 7472H bit 13 = 0

SIZE_BNK7:4	DRAM	RAS/CAS
03 02	Type	Matrix
0 0	- 64 Kbit × 16	8 X 8
0 1	- 256 Kbit × 16	9 X 9
1 0	- 1 Mbit × 16	10 X 10
1 1	- 4 Mbit × 16	12 X 11

Port 7472H bit 13 = 1

SIZE_BNK7:4	DRAM	RAS/CAS
03 02	Type	Matrix
0 0	- 512 Kbits x 16	10 X 9
0 1	- 1 Mbits x 16	12 X 8
1 0	- 2 Mbits x 16	11 X 10
1 1	- Reserved	Reserved

Bits 01:00 - SIZE_BNK3:0, Size of Banks 3:0

Both versions of the System Controller support all DRAM sizes. Although the DRAM sizes within banks 3:0 must be the same, they may differ from those in banks 7:4. SIZE_BNK3:0 functions with bit 12 of DRAM Size and SMI RAM Register at Port 7472H.

Port 7472H bit 12 = 0

SIZE_BNK3:0	DRAM	RAS/CAS
01 00	Type	Matrix
0 0	- 64 Kbit × 16	8 X 8
0 1	- 256 Kbit × 16	9 X 9
1 0	- 1 Mbit × 16	10 X 10
1 1	- 4 Mbit × 16	12 X 11

Port 7472H bit 12 = 1

SIZE_BNK3:0	DRAM	RAS/CAS
01 00	Type	Matrix
0 0	- 512 Kbits x 16	10 X 9
0 1	- 1 Mbits x 16	12 X 8
1 0	- 2 Mbits x 16	11 X 10
1 1	- Reserved	Reserved

6.2.2 Memory Bank 7 Through Bank 0 Starting Address

Port Address 4872H - Read and Write

15	14	13	12	11	10	09	08
A24	A23	A22	A21	A20	A19	A18	A17
Bank 1 Start Address							

07	06	05	04	03	02	01	00
A24	A23	A22	A21	A20	A19	A18	A17
Bank 0 Start Address							

Port Address 5072H - Read and Write

15	14	13	12	11	10	09	08
A24	A23	A22	A21	A20	A19	A18	A17
Bank 3 Start Address							

07	06	05	04	03	02	01	00
A24	A23	A22	A21	A20	A19	A18	A17
Bank 2 Start Address							

Port Address 2C72H - Read and Write

15	14	13	12	11	10	09	08
A24	A23	A22	A21	A20	A19	A18	A17
Bank 5 Start Address							

07	06	05	04	03	02	01	00
A24	A23	A22	A21	A20	A19	A18	A17
Bank 4 Start Address							



Port Address 3472H - Read and Write

15	14	13	12	11	10	09	08
A24	A23	A22	A21	A20	A19	A18	A17
Bank 7 Start Address							
07	06	05	04	03	02	01	00
A24	A23	A22	A21	A20	A19	A18	A17
Bank 6 Start Address							

The starting address of the bank must be programmed on boundaries corresponding to the bank size. Smaller banks must be placed at a higher starting address than larger banks. The size of the bank is automatically set by the type and size of the RAM. When banks are interleaved, in either page or non-page mode, the interleaved banks should be enabled and programmed to the same starting address.

The bank size is doubled for two-way interleave. For example, if bank 0 has 1 Mbit DRAMs and banks 2 and 3 have 1 Mbit DRAMs, the starting address for banks 2 and 3 should be zero. Both banks should be enabled. The size of the combined banks is 4 Mbytes, double the size of the individual banks. The starting address for bank 0 should then be at 4 Mbytes. For three banks of the same size, in which two are interleaved, the two interleaved banks must be placed at a lower starting address than the third bank.

RAM SIZE	PAGE SIZE	BANK SIZE
64 Kbits x 16	512 Bytes	128 Kbytes
256 Kbits x 16	1024 Bytes	512 Kbytes
1 Mbits x 16	2048 Bytes	2048 Kbytes
4 Mbits x 16	4096 Bytes	8192 Kbytes
512 Kbits x 16	1024 Bytes	1024 Kbytes
1 Mbit x 16 chips	512 Bytes	2048 Kbytes
2 Mbits x 16	2048 Bytes	4096 Kbytes

6.2.3 Split Starting Address

Port Address 5872H - Read and Write

15	14	13	12	11	10	09	08
EN_BNK3	EN_BNK2	EN_BNK1	EN_BNK0	DRAM_DRV	SPLIT_SIZE		
07	06	05	04	03	02	01	00
A24	A23	A22	A21	A20	A19		
Split Starting Address							

Signal Name	Default At RSTIN
EN_BNK3	0
EN_BNK2	0
EN_BNK1	0
EN_BNK0	0
DRAM_DRV	00
SPLIT_SIZE	00
Bits 01, 00	None

Bit 15 - EN_BNK3, Enable Bank 3

- EN_BNK3 = 0 - Bank 3 is disabled
- EN_BNK3 = 1 - Bank 3 is enabled

Bit 14 - EN_BNK2, Enable Bank 2

- EN_BNK2 = 0 - Bank 2 is disabled
- EN_BNK2 = 1 - Bank 2 is enabled

Bit 13 - EN_BNK1, Enable Bank 1

- EN_BNK1 = 0 - Bank 1 is disabled
- EN_BNK1 = 1 - Bank 1 is enabled

Bit 12 - EN_BNK0, Enable Bank 0

- EN_BNK0 = 0 - Bank 0 is disabled
- EN_BNK0 = 1 - Bank 0 is enabled



Bits 11:10 - DRAM_DRV, DRAM Driver Strength

Typically, 33 ohm series resistors are used on the DRAM address lines RAD(10:0) to reduce the bouncing, overshoot and undershoot. These registers are not required with the WD7855/LV and, when used, the setup time of the column address to CAS assertion is marginal.

The DRAM address driver strength may be adjusted for capacitive load. When adjusted properly, output overshoot and undershoot are minimized while still meeting worst case DRAM timing. The DRAM RAS, CAS and address buffers also automatically compensate for variations in temperature, voltage and manufacturing process.

The proper setting of DRAM_DRV is dependent upon several factors: Total load capacitance of installed DRAMs, trace lengths, bouncing, overshoot, undershoot and number of DRAM banks installed. Typically when one bank is installed, medium strength is selected. Two banks require high strength. Three or four banks require full strength.

NOTE

33 MHz or 3.3 volt designs require full strength (DRAM_DRV = 0 0).

DRAM_DRV

11 10

- 0 0 - Full strength DRAM address drive, up to 350 pF
- 0 1 - Low strength DRAM address drive, up to 100 pF
- 1 0 - Medium strength DRAM address drive, up to 180 pF
- 1 1 - High strength DRAM address drive, up to 260 pF

Bits 09:08 - SP SIZE, Split Size

The split is implemented by moving the block of memory between 0A0000H through 0FFFFFFH to another area. The destination area must start on a 512 Kbyte boundary. If BIOS is to be shadowed, the split size must be 320 Kbyte for a 64 Kbyte shadow or 256 Kbyte for a 128 Kbyte shadow, and the RAM Shadow and Write Protect Register (Port 6072H) must also be programmed.

Figure 6-1 illustrates that the memory from 0A0000H (640 Kbyte) to 100000H (1024 Kbyte) is available for remapping. The remapping may start at 100000H, providing 384 Kbyte of extended memory, or may start at 0F0000H to allow BIOS shadowing, with 320 Kbyte of extended memory. Only a single bank may be split. The bank to be split must be at least 512 Kbyte or larger.

SPLIT SIZE

09 08

- 0 0 - No split
- 0 1 - 256 Kbyte split, memory moved from 0A0000H to 0DFFFFFFH
- 1 0 - 320 Kbyte split, memory moved from 0A0000H to 0EFFFFFFH
- 1 1 - 384 Kbyte split, memory moved from 0A0000H to 0FFFFFFH

Bits 07:02 - A24:A19, Split Starting Address

Bits 01:00 - Not used, state is ignored

PROGRAMMING NOTE

BIOS Shadow requires that a split size of either 256K or 320K be allocated. The split starting address must also be programmed. This means that there must be a split or BIOS cannot be shadowed.

For a system with a full 32M of memory, this presents some unique issues. As stated previously, shadow BIOS requires both a split and split starting address. In a system with 32M of memory there is no empty area in which to assign the split starting address. There are two options: Do not shadow the BIOS in a full 32M system (i.e. assign no split), or shadow the BIOS by assigning the starting address to just below the 32M boundary (i.e. for a 64K shadow, start 320K below the 32M boundary, for a 128K shadow, start 256K below the 32M boundary.) Furthermore, to avoid conflict with the memory already at this location, program the high memory write boundary (C072H bits 07:00) to the same value as the split starting address to write protect this area. Also enable the high memory write protect (6072H bit 13). This effectively disables the top 320K or 256K of memory.



HEX ADDRESS

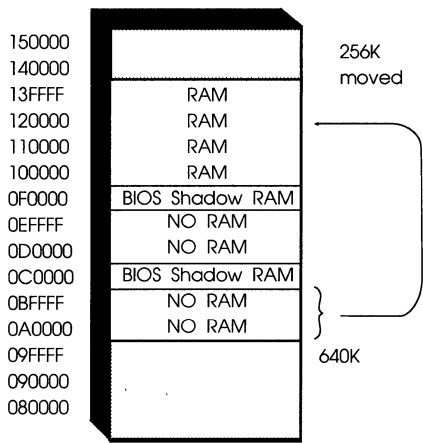

- AT STYLE -
256K Split with
64K main BIOS shadow
64K video BIOS shadow

HEX ADDRESS

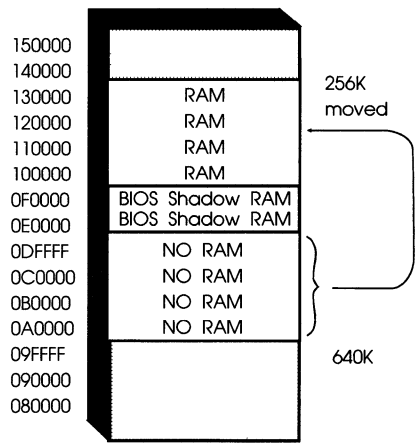

- PS/2 STYLE -
256K Split with
64K main BIOS shadow
64K video BIOS shadow

HEX ADDRESS

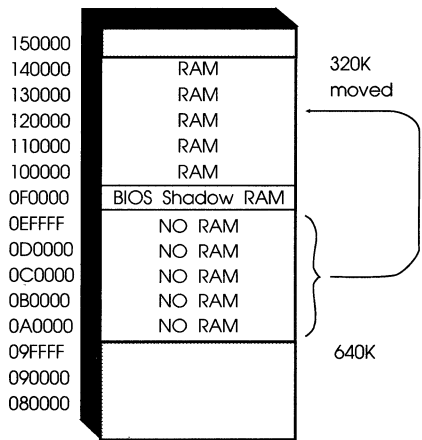

320K Split with
32K main BIOS shadow
32K video BIOS shadow

HEX ADDRESS

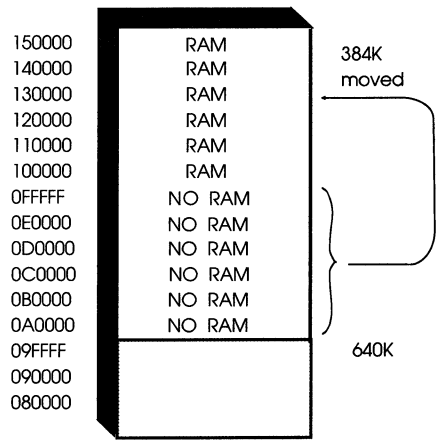

384K Split with
no shadow

FIGURE 6-1. SPLIT SIZE



6.2.4 RAM Shadow and Write Protect

Port Address 6072H - Read and Write

15	14	13	12	11	10	09	08
DIS_MEM		HM_WP	WP	INV_PAR	PAR_DIS	SHD	

07	06	05	04	03	02	01	00
X_MEM	ERS_PWS	VB_SIZ		ROM_TYP		BL_MOU	

Signal Name	Default At RSTIN
DIS_MEM	00
HM_WP	0
WP	0
INV_PAR	0
PAR_DIS	0
SHD	00
ERSPWS	0
X_MEM	0
Bit 06	0
VB_SIZ	00
ROM_TYP	00
BL_MOU	00

Bits 15:14 - DIS_MEM, Disable On-board Memory

- DIS_MEM
15 14
- 0 0 - On-board memory from 128 KB to 640 KB not disabled.
 - 0 1 - On-board memory from 512 KB to 640 KB disabled.
 - 1 0 - On-board memory from 256 KB to 640 KB disabled.
 - 1 1 - On-board memory from 128 KB to 640 KB disabled.

Bit 13 - HM_WP, High Memory Write Protect Enable

This bit enables the write protection for the memory boundary established by the register at Port C072H.

HM_WP = 0 - High memory write protect not enabled.

HM_WP = 1 - High memory write protect enabled.

Bit 12 - WP, Shadowed BIOS Write Protect Enable

WP = 0 - Write protect for shadowed BIOS not enabled.

WP = 1 - Write protect for shadowed BIOS enabled.

Bit 11 - INV_PAR, Invert Parity

INV_PAR = 0 - Normal parity when writing to on-board DRAM.

INV_PAR = 1 - Invert parity when writing to on-board DRAM.

Bit 10 - PAR_DIS, Parity Checking Disabled

Parity checking is normally enabled or disabled by D_PE at Port B (see Section 5.9). Setting PAR_DIS overrides the D_PE setting and disables parity checking. This ability is provided for systems without parity RAM.

PAR_DIS = 0 - Parity checking as selected by D_PE.

PAR_DIS = 1 - Parity checking disabled.

Bits 09:08 - SHD, Shadow BIOS

Before the BIOS can be shadowed, the SPLIT_SIZE field in the Split Starting Address Register at Port 5872H must be programmed to non-zero.

ROM at FE0000H - FFFFFFFH, the top of 16 MByte address space is never shadowed.

Option SHD 11 should be used when Video Remap Function is desired (i.e. Video BIOS in the lower half of EPROM shows up at C0000H).

64 Kbyte of system BIOS at 0F0000H - 0FFFFFFH, and up to 64 Kbyte of video BIOS at 0C0000H - 0CFFFFFFH, may be shadowed. This type of shadowing is accomplished by setting SHD = 10 and then writing the system and video BIOS into 0E0000H - 0FFFFFFH. When SHD is set to 11, the video BIOS appears at 0C0000H - 0CFFFFFFH rather than 0E0000H - 0EFFFFFFH.

The video shadow size at 0C0000H - 0CFFFFFFH is determined by VB_SIZ, the video BIOS size field.



SHD

09 08

- ☆ 0 0 - No BIOS shadowing, allows 384 KB remap.
- 0 1 - 64 KB system BIOS shadow, 0F0000H - 0FFFFFFH, allows 320 KB remap.
- 1 0 - 128 KB system BIOS shadow, 0E0000H - 0FFFFFFH, allows 256 KB remap.
- ☆ 1 1 - 64 KB system BIOS shadow, 0F0000 - 0FFFFFF and video BIOS shadow, allows 256 KB remap.

☆ See note following bits 01, 00.

Bit 07 - X_MEM, Shadow BIOS for Read/Write Memory

When SHD (bits 09 and 08) equals 11, X_MEM provides the means of using RAM from E8000H through EFFFFH not being used for video BIOS shadowing, to be used as read/write memory.

X_MEM = 0 - SHD = 11
ROM_TYP = 10 - VB_SIZ = 01

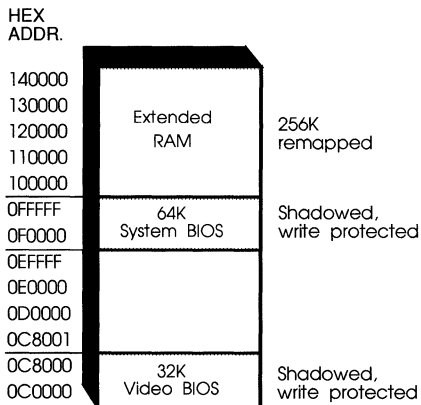

FIGURE 6-2. X_MEM = 0

X_MEM = 1 - SHD = 11
ROM_TYP = 10 - VB_SIZE = 01

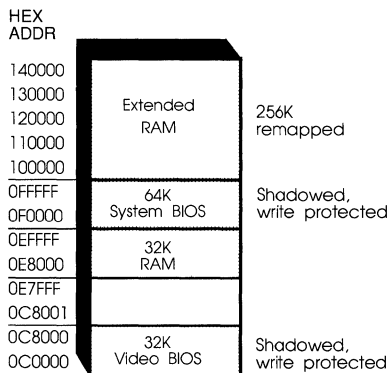

FIGURE 6-3. X_MEM = 1

Bit 06 - ERPWS, Extra RAS Precharge Wait State

ERPWS should be set to 1 when using slow DRAMs with a fast CPU clock rate. For example: 120 ns. DRAMs at 25 MHz. This should be used in conjunction with X_WS, bit 02 at Port Address B472H

ERPWS = 0 -
Extra RAS Precharge Wait State not enabled.

ERPWS = 1 -
Extra RAS Precharge Wait State enabled. Two CLK2s are added to increase the RAS precharge time in page mode.

Bits 05:04 - VB_SIZ, Video BIOS Size

- VB_SIZ ☆
- 05 04
 - 0 0 - 16 KB video BIOS
 - 0 1 - 32 KB video BIOS
 - 1 0 - 48 KB video BIOS
 - 1 1 - 64 KB video BIOS

☆ See note following bits 01, 00.

Bits 03:02 - ROM_TYP, ROM Type

For ROM type 00, $\overline{\text{CSPROM}}$ is asserted when the address is 0E0000H - 0FFFFFFH or FE0000H - FFFFFFFH.

For ROM type 01, $\overline{\text{CSPROM}}$ is asserted when the address is 0F0000H - 0FFFFFFH or FF0000H - FFFFFFFH.



For ROM type 10, CSPROM is asserted when the address is 0F0000H - 0FFFFFFH, FF0000H - FFFFFFFH or 0C0000H - 0CXFFFFH where X is determined by VB_SIZ. This allows either a 128 Kbyte BIOS with a 64 Kbyte system BIOS and a 64 Kbyte video BIOS, or a 64 Kbyte BIOS with a 32 Kbyte system BIOS and a 32 Kbyte video BIOS. The 32 Kbyte video BIOS portion must be in the bottom half of the EPROM and is accessed both at C0000H - CX000H and F0000H - FX000H. A 64 Kbyte EPROM needs addresses SA15 through SA0. A 128 Kbyte EPROM needs addresses SA16 through SA0. Neither EPROM needs translated addresses.

CSPROM is CS4 through CS0, decoded as the value of 00.

ROM_TYP
03 02

- 0 0 - 128 KB system BIOS, located at E0000H - FFFFFH
- 0 1 - 64 KB system BIOS, located at F0000H - FFFFFH
- ☆ 1 0 - 64 KB or 128 KB shared BIOS System BIOS located at F0000H - FFFFFH, video BIOS located at C0000H - CX000H
- 1 1 - Reserved

☆ See note following bits 01, 00.

Bits 01:00 - BL_MOU, Backlight Mouse Control

Enabling the Backlight Mouse Control increases the CPU speed for one second if Auto Clock Switching is on. The AUT_FST bit is located at Port 1072H bit 11. Enabling the Backlight Mouse Control also affects the Back/light and LCD timers in the PMC Timer Register at Port Address 8072H.

BL_MOU
01 00

- 0 0 - No mouse control
- 0 1 - INT12 mouse
- 1 0 - INT4 mouse
- 1 1 - INT3 mouse

☆ **NOTE**

When SHD = 11 and X_MEM = 0, or SHD = 00 and ROM_TYP = 10, the portion of 0E0000H DRAM memory that is not mapped to 0C0000H (as determined by VB_SIZ) is not accessible. Once a portion of 0E0000H segment is mapped to 0C0000H, all 0E0000H accesses go to the expansion bus without generation of CSPROM. This allows AT bus plug-in boards and/or drivers to access the E0000H segment.

6.2.5 High Memory Write Protect Boundary

Port Address C072H - Read and Write

15	14	13	12	11	10	09	08

07	06	05	04	03	02	01	00
A24	A23	A2	A21	A20	A19	A18	A17
Boundary Address							

Signal Name	Default At RSTIN
Bits 15:08	None
A24:17	00

Bits 15:08 - Not used, state is ignored

Bits 07:00 - A24:17, Boundary Address

Memory above the high memory write protect boundary is write protected when enabled by the HM_WP, bit 13 of the RAM Shadow And Write Protect Register at Port 6072H. This provides an additional write protect region for disk caching.



6.2.6 DRAM Size and SMI RAM Register

Port Address 7472H - Read and Write

This register is used to set up the starting address of the SMI DRAM and support extra DRAM types.

15	14	13	12	11	10	09	08
0	0	DRAM Type			SMI_A24	HS_RPD	SMI_R ENB

07	06	05	04	03	02	01	00
A23		A22	A21	SMI_RAM A20 A19		A18	A17 A16

Signal Name	Default At RSTIN
All signals	0

Bits 15:14 - Must be set to 0

Bits 13:12 - DRAM Type

These bits are used with Bits 3:0 of Register 3872H to determine the DRAM size of Banks 7:0.

Bit 13 is used with bits 03, 02 of 3872H for Banks 7:4.

Bit 12 is used with bits 01, 00 of 3872H for Banks 3:0.

See Section 6.2.1, Memory Configuration.

Bit 11, Reserved

Bit 10 - SMI_A24, SMI RAM Address bit 24

SMI_A24 is used in conjunction with bits 7:0 (SMI_RAM starting address A23:16) when SMI RAM is located above 16 Mbyte.

Bit 09 - HSRPD, Holdoff SMI When Reset Pending Disable

When HSRPD is set to 0, all SMI sources except I/O traps, are held off whenever a reset-pending condition is detected. The sources remain active internally but do not cause the SMI output to be asserted until the reset-pending condition is cleared.

When HSRPD is set to a 1, the reset pending condition does not gate off the assertion of SMI. Reset pending is defined as: (1) Port 92H reset pending, (2) KB controller ports 60H or 64H have been written within the last 14 μs or (3) the CPU is in a halt state.

HSRPD = 0 - SMI is held off when reset is pending

HSRPD = 1 - SMI is not held off

Bit 08 - SMI_R ENB, SMI RAM Enable

Setting SMI_R ENB enables the SMI RAM remapping and protection. The system BIOS should load the SMI service routine into the SMI RAM before setting this bit.

SMI_R ENB = 0 - SMI RAM disable

SMI_R ENB = 1 - SMI RAM enable

Bits 07:00 - SMI_RAM, SMI RAM Starting Address

SMI_RAM determine the physical location of the SMI DRAM. These are also used to read/write protect the SMI RAM when the SMI RAM Enable bit is set.

6.3 MEMORY TIMING

The DRAM timing is determined by an internal delay line for DMA and Master Mode transfers. The RAS leading edge becomes active from the active level of MEMR and MEMW. The delay line is automatically tuned to fixed delays, using the 14.318 MHz clock CLK14 as reference.

When writing to the DRAM memory timing register at Port 4072H, the memory timing mode changes immediately. The code that programs this register should be in ROM and not shadowed in RAM. This register only applies to Non-Page Mode operation and has no effect on Page Mode operations. This allows Power Management code to use this register as a scratch pad during Page Mode operations.

Except for optional extra wait states and/or extra RAS precharge timing, Page Mode timing is not programmable. Refer to registers at Port Address B472H bit 02, A872H bit 01 and 6072H bit 06 for details.



6.3.1 Non-page Mode DRAM Memory Timing

Port Address 4072H - Read and Write

15	14	13	12	11	10	09	08
	NP_MODE		NP_RAW	NP_WCAS		NP_RCAS	

07	06	05	04	03	02	01	00
	NP_RAS_HLD		NP_PWE			NP_WS	

Signal Name	Default At RSTIN
Bits 15, 07	None
NP_MODE	00
NP_RAW	0
NP_WCAS	00
NP_RCAS	00
NP_RAS_HLD	00
NP_PWE	000
NP_WS	00

Bit 15 - Not used, state is ignored

Bits 14:13 - NP_MODE, Non-Page Mode

There are two non-page modes available, Mode-00 and Mode-01. Mode-00 provides one processor clock of row address hold time and is used for 1, 2 or 3 wait state memory cycles. Mode-01 provides a half processor clock of row address hold time and is used for 0 wait state memory cycles. Because the memory timing may be adjusted in increments of half a processor clock, Mode-00 is suited for all DRAM and processor speeds.

Mode-01 provides a half processor clock row address hold time, which is usually sufficient for system speeds of 12.5 MHz and slower. This compressed timing allows zero wait state operation.

Table 6-1 shows typically required DRAM speeds and register programming values for various processor speeds. Because DRAM timing varies among manufacturers, the required DRAM speed may differ from those listed in the table.

NP_MODE

14 13

0 0 - Minimum 1 wait state.

0 1 - Minimum 0 wait state.

PROCESSOR SPEED	NP_MODE	DRAM SPEED	WAIT STATES	REGISTER 4072H
16.0 MHz	01	53 ns	0	3560H
16.0 MHz	00	80 ns	1	1025H
20.0 MHz	00	80 ns	1	1025H
20.0 MHz	00	100 ns	2	107AH
25.0 MHz	00	80 ns	2	107AH

TABLE 6-1. TYPICAL DRAM SPEEDS

Bit 12 - NP_RAW, Non-page disable Read After Write

EMS accesses and interleave miss cycles (I/O cycle to device on RAD) may add one additional wait state.

NP_RAW = 0 -

Memory read cycles immediately following a write cycle causes an automatic wait state to be added before initiating the read cycle.

NP_RAW = 1 -

Read after write cycles do not have additional wait states.

Bits 11:10 - NP_WCAS, Non-page Write CAS Delay

NP_WCAS

11 10

0 0 - CAS write delay 1.0 CLK2

0 1 - CAS write delay 1.5 CLK2

1 0 - CAS write delay 2.0 CLK2

1 1 - CAS write delay 2.5 CLK2

Bits 09:08 - NP_RCAS, Non-page Read CAS Delay

NP_RCAS

09 08

0 0 - CAS read delay 1.0 CLK2

0 1 - CAS read delay 1.5 CLK2

1 0 - CAS read delay 2.0 CLK2

1 1 - CAS read delay 2.5 CLK2

Bit 07 - Not used, state is ignored



Bits 06:05 - NP_RAS_HLD, Non-page CAS to RAS Hold Time

The RAS active delay is reduced by half a clock during writes if NP_WCAS is set to 1X, or during reads if NP_RCAS is set to 1X.

NP_RAS_HLD
06 05

- 0 0 - RAS active until 1.0 clock after CAS.
- 0 1 - RAS active until 1.5 clock after CAS.
- 1 0 - RAS active until 2.0 clock after CAS.
- 1 1 - RAS active until 2.5 clock after CAS.

Bits 04:02 - NP_PWE, Non-page CAS Pulse Width Extension

The pulse width is reduced by half a clock during writes if NP_WCAS is set to X1, or during reads if NP_RCAS is set to 1X.

NP_PWE
04 03 02

- 0 0 0 - No extension (2 CLK2 norm.)
- 0 0 1 - Extended by 0.5 CLK2
- 0 1 0 - Extended by 1.0 CLK2
- 0 1 1 - Extended by 1.5 CLK2
- 1 0 0 - Extended by 2.0 CLK2
- 1 0 1 - Extended by 2.5 CLK2
- 1 1 0 - Extended by 3.0 CLK2
- 1 1 1 - Extended by 3.5 CLK2

Bits 01:00 - NP_WS, Non-page Wait States

NP_WS makes it possible to unconditionally add wait states to all DRAM cycles. Conditional wait states may be added to read after write cycles, EMS accesses and interleave miss cycles, with NP_RAW (bit 12).

NP_WS
01 00

- 0 0 - No wait states added
- 0 1 - 1 Wait state added
- 1 0 - 2 Wait states added
- 1 1 - 3 Wait states added

TIMING	NUMBER OF CLK2'S	
	MODE-00	MODE-01
Row address to RAS	2	2
RAS width	$3 + NPH + NPHB / 2$	$1 + NPH + NPHB / 2$
Row address hold	1	0.5
Column address setup (read)	$1 + NPRF / 2$	$0.5 + NPRF / 2$
Column address setup (write)	$1 + NPWF / 2$	$1 + NPWF / 2$
RAS hold (read from CAS)	$1 + NPHB / 2 - NPRF / 2 + NPH$	$0.5 - NPRF / 2 + NPH$
RAS hold (write)	$1 + NPHB / 2 - NPWF / 2 + NPH$	$0.5 - NPWF / 2 + NPH$
CAS width (read)	$\textcircled{1} + NPCAS + NPCB / 2 - NPRF / 2$	$\textcircled{1} + NPCAS + NPCB / 2 - NPRF / 2$
CAS width (write)	$\textcircled{1} + NPCAS + NPCB / 2 - NPWF / 2$	$\textcircled{1} + NPCAS + NPCB / 2 - NPWF / 2$
RAS precharge	$2 \times (2 + NP_WS) - \text{RAS width}$	$2 \times (2 + NP_WS) - \text{RAS width}$
Column address hold	$1 - NPCB / 2$	$1 - NPCB / 2$
<p>$\textcircled{1}$ 2 if NPCAS = 0 or 1 1 if NPCAS = 2 or 3</p> <p>NPWF = Bit 10 NPRF = Bit 08 NPH = Bit 06 NPHB = Bit 05 NPCAS = Bits 04, 03 NPCB = Bit 02 NP_WS = Bits 01, 00</p>		

TABLE 6-2. NON-PAGE MODE TIMING



6.3.2 Page Mode

Table 6-3 identifies the type of DRAM cycle and number of wait states for the 80386SX processor.

	PAGE MODE DRAM CYCLE	WAIT STATES	
80386SX	Write page hit, pipeline mode	0	
	Write page hit, non-pipeline mode	1	
	Write page first access, pipeline mode ☆	1	
	Write page miss, pipeline mode	2	
	Write page miss, non-pipeline mode	3	
	Write page miss, pipeline extra RAS precharge	3	
	Write page miss, non-pipeline extra RAS precharge	4	
	Read page hit, pipeline mode	0	
	Read page hit, non-pipeline mode	1	
	Read after write page hit, pipeline mode ☆	1	
	Read page first access non-pipeline mode ☆	3	
	Read page miss, pipeline mode	3	
	Read page miss, non-pipeline mode	4	
	Read page miss, pipeline extra RAS precharge	4	
	Read page miss, non-pipeline extra RAS precharge	5	
	80386SX With Discrete Cache	Write page hit	0
		Write page first access ☆	1
Write page miss		2	
Read cache hit		0	
Read cache miss, page hit		1	
Read cache miss, page first access ☆		3	
	Read cache miss, page miss	4	
<p>☆ Equal Bank sizes, non-EMS cycle</p> <p>First access is a page mode memory cycle which immediately follows a refresh, DMA or master cycle. It is not necessary for the DRAMs to be precharged for a first access cycle, since all RAS signals have been high in the previous cycle. This shortens a first access page mode cycle by one wait state. For example, a read page miss, non-pipeline mode in 80386SX mode is four wait states. A read page miss, non-pipeline mode, <u>first access</u> in 80386SX mode is three wait states. All installed DRAMs must be the same size and configuration and the memory cycle cannot be an EMS cycle for a first access to occur.</p>			

TABLE 6-3. PAGE MODE WAIT STATES



6.3.3 Memory Address Multiplexer

The memory address multiplexer generates the DRAM row and column address. The DRAM address multiplexer is designed so that the same type socket may be used for 64 Kbyte, 256 Kbyte, 1 Mbyte or 4 Mbyte SIMM memory modules.

	RA11	RA10	RA9	RA8	RA7	RA6	RA5	RA4	RA3	RA2	RA1	RA0
	64 KBITS NON-INTERLEAVE											
ROW	A13	A22	A20	A18	A16	A15	A14	A13	A12	A11	A10	A9
COL	A13	A11	A10	A9	A8	A7	A6	A5	A4	A3	A2	A1
	64 KBITS 2-WAY INTERLEAVE OR 256K NON-INTERLEAVE											
ROW	A13	A22	A20	A18	A16	A15	A14	A13	A12	A11	A10	A17
COL	A13	A11	A10	A9	A8	A7	A6	A5	A4	A3	A2	A1
	256K 2-WAY INTERLEAVE, 1MBITS NON-INTERLEAVE OR 512 KBITS X 8 2-WAY INTERLEAVE											
ROW	A13	A22	A20	A18	A16	A15	A14	A13	A12	A11	A19	A17
COL	A13	A11	A10	A9	A8	A7	A6	A5	A4	A3	A2	A1
	1 MBITS 2-WAY INTERLEAVE, OR 4 MBITS NON-INTERLEAVE											
ROW	A11	A22	A20	A18	A16	A15	A14	A13	A12	A21	A19	A17
COL	A13	A11	A10	A9	A8	A7	A6	A5	A4	A3	A2	A1
	4 MBITS 2-WAY INTERLEAVE											
ROW	A11	A22	A20	A18	A16	A15	A14	A13	A23	A21	A19	A17
COL	A13	A11	A10	A9	A8	A7	A6	A5	A4	A3	A2	A1
	512K X 8 DRAM: NON-INTERLEAVE											
ROW	A13	A22	A19	A18	A16	A15	A14	A13	A12	A11	A10	A17
COL	A13	A11	A10	A9	A8	A7	A6	A5	A4	A3	A2	A1
	1M X 16 DRAM: NON-INTERLEAVE											
ROW	A13	A9	A19	A18	A16	A15	A14	A20	A12	A11	A10	A17
COL	A13	A11	A10	A9	A8	A7	A6	A5	A4	A3	A2	A1
	1M X 16 DRAM: 2-WAY INTERLEAVE											
ROW	A13	A10	A21	A18	A16	A15	A14	A20	A12	A11	A19	A17
COL	A13	A11	A10	A9	A8	A7	A6	A5	A4	A3	A2	A1
	2M X 8 DRAM: NON-INTERLEAVE											
ROW	A13	A21	A20	A18	A16	A15	A14	A13	A12	A11	A19	A17
COL	A13	A11	A10	A9	A8	A7	A6	A5	A4	A3	A2	A1
	2M X 8 DRAM: 2-WAY INTERLEAVE											
ROW	A13	A22	A20	A18	A16	A15	A14	A13	A12	A21	A19	A17
COL	A13	A11	A10	A9	A8	A7	A6	A5	A4	A3	A2	A1
	REFRESH ADDRESS											
ROW		A10	A9	A8	A7	A6	A5	A4	A3	A2	A1	A0

TABLE 6-4. PAGE MODE DRAM ADDRESS MULTIPLEXER CONFIGURATION



	RA11	RA10	RA9	RA8	RA7	RA6	RA5	RA4	RA3	RA2	RA1	RA0	
ROW	A13	A11	A10	A9	A8	A7	A6	A5	A4	A3	A2	A1	ALL
COL	A13	A22	A20	A18	A16	A15	A14	A13	A12	A11	A10	A9	64 Kb
COL	A13	A22	A20	A18	A16	A15	A14	A13	A12	A11	A10	A17	256 Kb
COL	A13	A22	A20	A18	A16	A15	A14	A13	A12	A11	A19	A17	1 Mb or 512 Kb x 8
COL	A13	A22	A20	A18	A16	A15	A14	A13	A12	A21	A19	A17	4 Mb

NOTE: 1M X 16 or 18 and 2M X 8 or 9 are not supported.

TABLE 6-5. NON-PAGE, NON-INTERLEAVE ADDRESS CONFIGURATION

	RA11	RA10	RA9	RA8	RA7	RA6	RA5	RA4	RA3	RA2	RA1	RA0	
ROW	A13	A11	A10	A9	A8	A7	A6	A5	A4	A3	A2	A13	ALL
COL	A13	A22	A20	A18	A16	A15	A14	A17	A12	A11	A10	A9	64 Kb
COL	A13	A22	A20	A18	A16	A15	A14	A19	A12	A11	A10	A17	256 Kb
COL	A13	A22	A20	A18	A16	A15	A14	A21	A12	A11	A19	A17	1 Mb or 512 Kb x 8
COL	A13	A22	A20	A18	A16	A15	A14	A12	A23	A21	A19	A17	4 Mb

NOTE: 1M X 16 or 18 and 2M X 8 or 9 are not supported.

TABLE 6-6. NON-PAGE, 2-WAY INTERLEAVE ADDRESS CONFIGURATION



6.4 EMS

6.4.1 EMS Control And Lower EMS Boundary

Port Address 6872H - Read and Write

15	14	13	12	11	10	09	08
INC	PF_LOC			EMS_EN			

07	06	05	04	03	02	01	00
EN_RES	A23	A22	A21	A20	A19	A18	A17
	Lower_EMS_Boundary						

Signal Name	Default At RSTIN
INC	0
PF_LOC	00
Bits 12, 09, 08	None
EMS_EN	00
EN_RES	0
A23-A17	0

Bit 15 - INC, Increment EMS Pointer

INC controls whether or not the EMS Pointer at Port E072H is to be incremented after each read or write of the EMS Page Register at Port E872H.

INC = 0 -
The EMS pointer does not increment.

INC = 1 -
EMS pointer increments after access to EMS Page Register.

Bits 14:13 - PF_LOC, Upper Page Frame Location

PF_LOC determines the starting location of a block eight frames. See Table 6-7 for the upper page frame assignments.

PF_LOC	14	13	
0 0	Upper page frame starts at C4000H		
0 1	Upper page frame starts at C8000H		
1 0	Upper page frame starts at CC000H		
1 1	Upper page frame starts at D0000H		

Bit 12 - Not used, state is ignored

Bits 11:10 - EMS_EN, EMS Enable

EMS_EN determines whether all EMS frames are to be enabled, only the upper page frames or no page frames. Tables 6-7 and 6-8 show the upper and lower page frame assignments.

EMS_EN	11	10	
0 0	Disable EMS		
0 1	Enable EMS Register programming without having to enable a Page Frame. This is useful for initializing the lower Page Frame.		
1 0	Enable upper Page Frame assignments and EMS register programming.		
1 1	Enable upper and lower Page Frame assignments and EMS register programming.		

Bits 09:08 - Not used, state is ignored

Bit 07 - EN_RES, Enable Lower Boundary

EN_RES determines whether A23 through A17 (bits 06 through 00 of this register) are to be used as the lower EMS boundary or ignored.

When the Lower_EMS_Boundary is enabled, the memory above the boundary is removed from the extended memory and reserved for EMS.

EN_RES = 0 -
Ignore Lower_EMS_Boundary

EN_RES = 1 -
Enable Lower_EMS_Boundary

Bits 06:00 - A23:17, Lower_EMS_Boundary

The Lower_EMS_Boundary provides address bits A23:17 and determines the starting address.

This address must be set to 128 Kbyte below the actual start address. For example, to start EMS at the 1 Mbyte boundary, this field should be set to 07H.



NOTE

When EMS is not desired in systems with 16 MB or more of system DRAM installed, the EMS Control And Lower Boundary Register at Port Address 6872H should be programmed with a value of 00FEH. When EMS is desired, a value of XX8XH should be programmed.

When EMS is not desired in systems with less than 16 MB of system DRAM installed, the EMS Control And Lower Boundary Register at Port Address 6872H should be programmed with a value of 0000H. When EMS is desired, a value of XX8XH should be programmed.

The EMS Page Register Pointer is used as an indirect address register. It is loaded with the EMS Page Register Number, ranging from 00 to 39 decimal. If the INC bit is set in Port 6872H, the EMS Page Register Pointer is incremented after each read or write of the EMS Page Register at Port E872H. Tables 6-7 and 6-8 shows the EMS Page Register Pointer value and the page frame assignments.

Bits 15:06 - DLT, Delay Line Test

In the Delay Line Test Mode, these bits represent the state of internal Delay Line signals.

The Delay Line Test is initiated by bit 8 (TDL) in the Test Enable Register at Port Address A872H.

Bits 05:00 - POINTER, EMS Page Register Number

Decimal number, 00 through 39. When programming this field, the hex equivalent 00 through 27H should be used.

6.4.2 EMS Page Register Pointer

Port Address E072H - Bits 15:06 Read only,
Bits 05:00 Read and Write

15	14	13	12	11	10	09	08
DLT							
16	15	14	13	12	11	10	9

07	06	05	04	03	02	01	00
DLT 8 7		POINTER					

Signal Name	Default At RSTIN
DLT	0
POINTER	0



EMS REG NUM	PF_LOC = 00	EMS REG NUM	PF_LOC = 01	EMS REG NUM	PF_LOC = 10	EMS REG NUM	PF_LOC = 11
32	E0000-E3FFF	33	E4000-E7FFF	34	E8000-EBFFF	35	EC000-EFFFF
39	DC000-DFFFF	32	E0000-E3FFF	33	E4000-E7FFF	34	E8000-EBFFF
38	D8000-DBFFF	39	DC000-DFFFF	32	E0000-E3FFF	33	E4000-E7FFF
37	D4000-D7FFF	38	D8000-DBFFF	39	DC000-DFFFF	32	E0000-E3FFF
36	D0000-D3FFF	37	D4000-D7FFF	38	D8000-DBFFF	39	DC000-DFFFF
35	CC000-CFFFF	36	D0000-D3FFF	37	D4000-D7FFF	38	D8000-DBFFF
34	C8000-CBFFF	35	CC000-CFFFF	36	D0000-D3FFF	37	D4000-D7FFF
33	C4000-C7FFF	34	C8000-CBFFF	35	CC000-CFFFF	36	D0000-D3FFF

EMS registers 32 through 39 (decimal) can be individually enabled or disabled by the EN (bit 15) of the EMS Page Register. See Port E872H description.

TABLE 6-7. UPPER PAGE FRAME ASSIGNMENTS

EMS REG NUM	HEX	DEC	EMS REG NUM	HEX	DEC
23	5C000-5FFFF	368K-384K	7	9C000-9FFFF	624K-640K
22	58000-5BFFF	352K-368K	6	98000-9BFFF	608K-624K
21	54000-57FFF	336K-352K	5	94000-97FFF	592K-608K
20	50000-53FFF	320K-336K	4	90000-93FFF	576K-592K
19	4C000-4FFFF	304K-320K	3	8C000-8FFFF	560K-576K
18	48000-4BFFF	288K-304K	2	88000-8BFFF	544K-560K
17	44000-47FFF	272K-288K	1	84000-87FFF	528K-544K
16	40000-43FFF	256K-272K	0	80000-83FFF	512K-528K
15	3C000-3FFFF	240K-256K	31	7C000-7FFFF	496K-512K
14	38000-3BFFF	224K-240K	30	78000-7BFFF	480K-496K
13	34000-37FFF	208K-224K	29	74000-77FFF	464K-480K
12	30000-33FFF	192K-208K	28	70000-73FFF	448K-464K
11	2C000-2FFFF	176K-192K	27	6C000-6FFFF	432K-448K
10	28000-2BFFF	160K-176K	26	68000-6BFFF	416K-432K
9	24000-27FFF	144K-160K	25	64000-67FFF	400K-416K
8	20000-23FFF	128K-144K	24	60000-63FFF	384K-400K

EMS registers 0 through 31 (decimal) are enabled or disabled as a block. If the EMS_EN field of Port 6872H is 11, the EMS registers 0 through 31 are enabled and the EN (bit 15) of the EMS Page Register is treated as a one. See Port E872H description.

TABLE 6-8. LOWER PAGE FRAME ASSIGNMENTS



6.4.3 EMS Page Register

Port Address E872H - Bits 14:12 Read only,
Bits 15, 11:00 Read
and Write

There are 40 EMS Page Registers accessible through Port E872H. Only EMS registers 32 through 39 are initialized to zero. EMS registers 0 through 31 are not initialized. The EMS Page Register Pointer at Port E072H provides the offset location for Port E872H.

15	14	13	12	11	10	09	08
EN	0	0	0	P11	P10	P9	P8
EMS Page Number							

07	06	05	04	03	02	01	00
P7	P6	P5	P4	P3	P2	P1	P0
EMS Page Number							

Signal Name	Default At RSTIN
EN	0
Bits 14:12	0
P11:P0	0

Bit 15 - EN, Enable EMS Page Register

EMS Page Registers 32 through 39 can be individually enabled or disabled by the EN bit. EMS Page Registers 0 through 31 are enabled or disabled as a block by the setting of the EMS_EN field in the EMS Control Register at Port 6872H. When EMS_EN equals 11, the EN bit in this register is treated as a one for the lower Page Frame.

EN = 0 -
This EMS Page Register is disabled

EN = 1 -
This EMS Page Register is enabled

Bits 14:12 - Read only, not used by the System Controller

Bits 11:00 - P11 through P00, EMS Page Number

EMS page numbers 8 through 39 and 64 through 2047 are supported for on-board memory, equal to 31.5 MBytes of EMS memory. The memory address is generated by reading the EMS Page Number from the System Controller and multiplying it by 16 Kbytes, then adding the lower 14 bits of the processor address to the product. This results in EMS page numbers zero through seven being mapped to the lower 128 Kbytes of memory and On-board extended memory being able to be accessed in real mode via the EMS logic.

EMS page numbers 2048 through 2303, equal to 4 MBytes, are used for external EMS memory, providing a method of accessing plug-in RAM or ROM cards. If P11 is 1 when an external EMS access occurs, EMS page number bits P7 through P0 are output on RA0-7/ED0-7 and the EMS chip select is asserted. The RAM/ROM card should access data on the expansion data bus, using MEMR, MEMW, MEMCS16 and IOCHRDY to make the transfer.

NOTE

When using external EMS memory with P11 = 1, EN (bit 15) must be 0. P10:0 correspond to address bits A24:14 respectively



7.0 CACHE CONTROLLER

7.1 NON-CACHABLE CONTROL

The System Controller provides the \overline{KEN} signal to an external cache controller to identify non-cachable memory regions.

Two user-definable and twelve standard non-cachable regions are provided. Ten of the twelve standard regions are 16 KB increments from C8000H - EFFFFH. These regions can be used as EMS memory or for DOS 5.0 Upper Memory Blocks and can be enabled or disabled individually. The other two standard non-cachable regions are the video BIOS area (C0000-CXFFF or E0000-EFFFF) and the system BIOS area (F0000-FFFFF). The Non-cachable control logic allows the external cached CPU caching of these regions to be enabled or disabled individually by monitoring the \overline{KEN} signal.

The two user-definable non-cachable regions can also be enabled individually. The non-cachable regions are set by the upper and lower limit registers. These regions are assigned on 4 Kbyte boundaries anywhere in the 16 MB physical address space of the 80386SX.

The typical applications of these user defined noncachable areas are the memory between 512 KB and 640 KB, and the memory accessed on the AT bus. When powered up, the WD7855/LV assumes that all the memory from 0 KB to 640 KB and 1M to 16 MB are cachable. It is necessary to have the BIOS to program the noncachable region registers.

7.2 EXTERNAL CACHE CONTROLLER

The System Controller can support an external look-aside cache controller via the \overline{LBRDY} signal on pin 45. This allows a cache to prevent memory cycles by asserting \overline{LBRDY} prior to the end of T2.

7.3 CACHE CONTROL REGISTER

Port Address C472H - Read and Write

15	14	13	12	11	10	09	08
0	0	0	0	C_BSC		HI_MEM9:8	

07	06	05	04	03	02	01	00
High Memory Location HI_MEM7:0							

Signal Name	Default At RSTIN
C_BSC	00
HI_MEM9:0	0

Bit 15:12 - Reserved, must be set to 0

Bit 11:10 - C_BSC, Core Bus Strength Control

Bits 11:10 become the Core Bus Strength Control if the Core Strap is 3 volts, as determined by bit 03 at Port Address CC72H.

Bits 11:10 are ignored if the Bus Strap is 5 volts.

C_BSC	11 10	
	0 0	- Default
	0 1	- Reserved
	1 0	- Reserved
	1 1	- Reserved



Bits 09:00 - HI-MEM, High memory region \overline{KEN} control.

HI-MEM controls whether or not \overline{KEN} is to be asserted during access to the designated high region, disabling external caching of that region.

- BIT 9 EC000H - EFFFFH
- BIT 8 E8000H - EBFFFFH
- BIT 7 E4000H - E7FFFFH
- BIT 6 E0000H - E3FFFFH
- BIT 5 DC000H - DFFFFH
- BIT 4 D8000H - DBFFFFH
- BIT 3 D4000H - D7FFFFH
- BIT 2 D0000H - D3FFFFH
- BIT 1 CC000H - CFFFFH
- BIT 0 C8000H - CBFFFFH

HI_MEM 9:0 = 0 -

\overline{KEN} is de-asserted during access to this region, disabling external caching of this region.

HI_MEM 9:0 = 1 -

\overline{KEN} is asserted during access to this region, therefore external caching of this region is allowed.

7.4 NONCACHABLE REGION 1 UPPER BOUNDARY

Port Address BC72H - Bits 15:02, 00 Read and Write
Bit 01 Read only

15	14	13	12	11	10	09	08
A23	A22	A21	A20	A19	A18	A17	A16
Upper Address Boundary							

07	06	05	04	03	02	01	00
A15	A14	A13	A12	S_REF	INT_DIS	INT_ST	SN_RDY
Upper Address Boundary							

Signal Name	Default At RSTIN
A23:12	0
S_REF	0
INT_DIS	0
INT_ST	0
SN_RDY	0

Bits 15:04 - A23:12, Upper Address Boundary

A23:12 determine the upper address boundary of the user definable noncachable region 1.

Bit 03 - S_REF, Slow Refresh

When S_REF is set, the DRAM refresh rate is slowed down to 120 ms. S_REF does not affect the refresh toggle bit REF_DT at Port B (see Section 5.9).

S_REF = 0 -
Disable Slow Refresh

S_REF = 1 -
Enable Slow Refresh

Bit 02 - INT_DIS, Interrupt Disable

When INT_DIS is set, the interrupt from the interrupt controller is disabled. The command will not take effect immediately if the interrupt request signal from the interrupt controller is active. The command will take effect immediately if the interrupt request signal is inactive. This allows control of the interrupt regardless of the Operating System Privilege Level, since 'CLI' and 'STI' CPU instructions may be trapped.



INT_DIS = 0 -
Enable hardware interrupt

INT_DIS = 1 -
Disable the hardware interrupt from the interrupt Controller

Bit 01 - INT_ST, Interrupt Disable Status

This enables reading of Interrupt Status regardless of Operating System privilege Level.

INT_ST = 0 -
Indicates the Interrupt Disable command is processed

INT_ST = 1 -
Indicates the Interrupt Disable command is pending

Bit 00 - SN_RDY, SNOOP with IOCHRDY active

During periods when the CPU Clock is slower than the AT BUS clock (slowed for power savings), the Snoop Logic may be unable to properly track the memory cycle during DMA or BUS Master Cycles. Setting SN_RDY enables the System Controller to use the IOCHRDY signal to lengthen the cycle.

SN_RDY = 0 -
Disable IOCHRDY for DMA/Master cycle

SN_RDY = 1 -
Enable IOCHRDY for DMA/Master cycle

7.5 NONCACHABLE REGION 1 LOWER BOUNDARY

Port Address B472H - Read and Write

15	14	13	12	11	10	09	08
A23	A22	A21	A20	A19	A18	A17	A16
Lower Address Boundary							

07	06	05	04	03	02	01	00
A15	A14	A13	A12	S_DCLK	X_WS	AT_BSC	
Lower Address Boundary							

Signal Name	Default At RSTIN
A23:12	0
S_DCLK	0
X_WS	0
AT_BSC	00

Bits 15:04 - A23:12, Lower Address Boundary.

A23:12 determine the lower address boundary of the user definable noncacheable region 1. Noncacheable region 1 is disabled when the upper boundary is set below the lower boundary.

Bit 03 - S_DCLK, Stop DMA Clock

Setting S_DCLK causes the DMA clock to stop while there is no DMA activity. Upon any unmasked DMA request (DRQIN), the DMA clock starts up again and continues to run until 16 DMA clocks after the end of the DMA Acknowledge (DACKEN).

S_DCLK = 0 -
Disable Stop DMA Clock

S_DCLK = 1 -
Enable Stop DMA Clock

Bit 02 - X_WS, Extra Wait State for Page Mode

If X_WS is active, an extra wait state is added to all the memory cycles. This feature allows system designers to use slower DRAMs for the System Controller without loss of huge performance, and achieve saving since the majority of the memory accesses are directly to the internal cache. X_WS may used in conjunction with ERPWS, bit 06 at Port Address 6072H.

X_WS = 0 -
Extra Wait States are not added

X_WS = 1 -
Extra Wait States are added

Bits 01:00 - AT_BSC, AT Bus Strength Control

Bits 01:00 become the AT Bus Strength Control if the Bus Strap is 3 volts as determined by bit 02 at Port Address CC72H.

Bits 01:00 are ignored if the Bus Strap is for 5 volts.

AT_BSC

11	10	
0	0	- Default
0	1	- Reserved
1	0	- Reserved
1	1	- Reserved



7.6 NONCACHABLE REGION 2 LOWER BOUNDARY

Port Address CC72H - Bits 15:12, 01:00 Read and Write
 Bits 03:02 Read only

15	14	13	12	11	10	09	08
A23	A22	A21	A20	A19	A18	A17	A16
Lower Address Boundary							

07	06	05	04	03	02	01	00
A15	A14	A13	A12	CS	BS		NR2C
Lower Address Boundary							

Signal Name	Default At RSTIN
A25:12	0
CS, BS	None
NR2C	0

Bits 15:04, A23:12 Lower Address Boundary

A23:12 are used to determine the lower address boundary of the user definable non-cachable region 2. Any address above or equal to this address is considered non-cachable.

Bit 03 - CS, Core Strap

CS represents the state of VDD_VL at pin 105

CS = 0 -
 Core Strap = 5 volts

CS = 1 -
 Core Strap = 3 volts

Bit 02 - BS, Bus Strap

BS represents the state of VDDAT_VL at pin 149

BS = 0 -
 Bus Strap = 5 volts

BS = 1 -
 Bus Strap = 3 volts

Bit 01 - Reserved

Bit 00 - NR2C, Non-cachable Region 2

NR2C = 0 -
 Disables non-cachable Region 2

NR2C = 1 -
 Enables non-cachable Region 2

7.7 FLUSH

Port Address F872H - Write Only

15	14	13	12	11	10	09	08

07	06	05	04	03	02	01	00

Signal Name	Default At RSTIN
All signals	None

The FLUSH signal at pin 30 is asserted by writing any data to this I/O port or when a DMA/MASTER Memory write occurs. Asserting the FLUSH signal invalidates all TAG entries in the cached CPU or external cache controller.

An I/O write to this port is ordinarily used by the EMS driver to clear the cache when there is a change to the EMS Page Register and also causes the System Controller to output Chip Select number 13H.



8.0 PORT CHIP SELECT AND REFRESH

This section describes refresh control logic used by the power down feature. This section also describes the registers used to control the following functions:

- Port chip select and control
- High speed hard disk access
- AT hard disk IDE mode
- Real-Time Clock bus location
- Access to the CMOS RAM password

Table 8-3 identifies the ports, their Chip Select number, I/O address and function.

8.1 REFRESH CONTROL, SERIAL AND PARALLEL CHIP SELECTS

Port Address 2072H - Read and Write

15	14	13	12	11	10	09	08
M_REF	V_RF	CBR_REF	CBR_SR	SCSI	PAR		PAR_L

07	06	05	04	03	02	01	00
SER_A			SER_AL	SER_B			SER_BL

Signal Name	Default At RSTIN
M_REF	0
V_REF	0
CBR_REF	0
CBR_SR	0
SCSI	0
PAR	00
PAR_L	0
SER_A	000
SER_AL	0
SER_B	000
SER_BL	0

Bit 15 - M_REF, Memory Refresh Power Down Mode

The refresh period may be lengthened for extended refresh DRAM while maintaining bus compatibility. When slow refresh is selected, main on-board memory is refreshed at one eighth the normal rate. In the Full Power Down mode, selected by the FPD bit in the register at Port 1872H, and M_REF = 1, the on-board DRAM is refreshed with every eighth PDREF. PDREF is a 64 KHz input signal supplied by the WD76C20.

M_REF = 0 -

Normal refresh period for main on-board memory.

M_REF = 1 -

Slow refresh main on-board memory.

Bit 14 - V_REF, Video Refresh Power Down Mode

The refresh period may be lengthened for extended refresh DRAM while maintaining bus compatibility. When slow refresh is selected, main on-board memory is refreshed at one eighth the normal rate. In the Full Power Down mode, selected by the FPD bit in the register at Port 1872H, and V_REF = 1, the on-board DRAM is refreshed with every eighth PDREF. PDREF is a 64 KHz input signal supplied by the WD76C20.

V_REF = 0 -

Normal refresh period for video memory

V_REF = 1 -

Slow refresh video memory

Bit 13 - CBR_REF, CAS Before RAS Refresh For On-board DRAM

Most standard DRAMs support this type of CAS before RAS refresh, while special DRAMs do not. CBR_REF must always be set to 1 for portable systems that support suspend/resume.

CBR_REF = 0 -

Normal refresh for on-board DRAM

CBR_REF = 1 -

CAS before RAS refresh



Bit 12 - CBR_SR, CAS Before RAS Self Refresh

CAS before RAS self refresh is supported only by special DRAMs.

CBR_SR = 0 -
No CAS before RAS self refresh

CBR_SR = 1 -
CAS before RAS self refresh of DRAM is supported during suspend and resume, where CAS is held low continuously while in suspend.

Bit 11 - SCS_I, Small Computer System Interface Chip Select

The SCSI is selected by chip select number 12. See Table 8-3.

SCSI = 0 -
SCSI chip select disabled

SCSI = 1 -
SCSI chip select at I/O port 353XH

Bits 10:09 - PAR, Parallel Port Chip Select

The parallel port is selected by chip select number 0FH and may be located at I/O address 278H through 27FH, 378H through 37FH, or 3BCH through 3BFH. Bits 10 and 09 may disable the chip select or locate it at one of three areas. See Table 8-3.

PAR
10 09

0 0 - PAR chip select disabled
0 1 - PAR chip select at I/O port 3BCH - 3BFH
1 0 - PAR chip select at I/O port 378H - 37FH
1 1 - PAR chip select at I/O port 278H - 27FH

Bit 08 - PAR_L, Parallel Port Bus Location

PAR_L = 0 -
Parallel port is located on the RA0:7/ED0:7 bus. This is typical when the WD76C30A is used.

PAR_L = 1 -
Parallel port is located on the expansion data bus. This is typical when the WD7615 is used.

Bits 07:05 - SER_A, Serial Port A Chip Select

The Serial Port A is selected by chip select number 0EH and may be located at I/O address 2E8H through 2EFH, 2F8H through 2FFH, 3E8H through 3EFH or 3F8H through 3FFH. Bits 07:05 may disable the chip select or locate it at one of the four areas. See Table 8-3.

It is possible to select the same I/O port address for Serial Port A and Serial Port B. Selecting the same address for both ports results in an unpredictable response and should not be done.

SER_A
07 06 05

0 0 0 - Serial Port A chip select disabled
0 0 1 - Serial Port A chip select at I/O port 3F8H - 3FFH
0 1 0 - Serial Port A chip select at I/O port 2F8H - 2FFH
0 1 1 - Serial Port A chip select at I/O port 3E8H - 3EFH
1 0 0 - Serial Port A chip select at I/O port 2E8H - 2EFH

Bit 04 - SER_AL, Serial A Port Bus Location

SER_AL = 0 -
Serial Port A is located on the RA0:7/ED0:7 bus. This is typical when the WD76C30A is used.

SER_AL = 1 -
Serial Port A is located on the expansion data bus.

Bits 03:01 - SER_B Serial Port B Chip Select

The Serial Port B is selected by chip select number 10 and may be located at I/O address 2E8H through 2EFH, 2F8H through 2FFH, 3E8H through 3EFH or 3F8H through 3FFH. Bits 03:01 may disable the chip select or locate it at one of the four areas. See Table 8-3.

It is possible to select the same I/O port address for Serial Port B and Serial Port A. Selecting the same address for both ports results in an unpredictable response and should not be done.

- SER_B
03 02 01
- 0 0 0 - Serial Port B chip select disabled
 - 0 0 1 - Serial Port B chip select at I/O port 3F8H - 3FFH
 - 0 1 0 - Serial Port B chip select at I/O port 2F8H - 2FFH
 - 0 1 1 - Serial Port B chip select at I/O port 3E8H - 3EFH
 - 1 0 0 - Serial Port B chip select at I/O port 2E8H - 2EFH

Bit 00 - SER_BL, Serial B Port Bus Location

- SER_BL = 0 -
Serial Port B is located on the RA0:7/ED0:7 bus. This is typical when the WD76C30A is used.
- SER_BL = 1 -
Serial Port B is located on the expansion data bus

8.2 RTC, PVGA, AND DISK CHIP SELECTS

Port Address 2872H - Read and Write

Bits 12:07 and Port Address 3072H control the use and location of the Programmable Chip Select #1.

15	14	13	12	11	10	09	08
RTC_L	FST_VGA	FST_SCSI	EN_PCS1	U_MSK1	L_MSK1		

07	06	05	04	03	02	01	00
PRG_L	HS_HD	EN_16	P/S		LK_PSW	DS_HD	DS_FLP

Signal Name	Default At RSTIN
RTC_L	0
FST_VGA	0
FST_SCSI	0
EN_PCS1	0
U_MSK1	00
L_MSK1	00
PRG_L	0
HS_HD	000
EN_16	0
P/S	000
LK_PSW	0

- DS_HD 0
- DS_FLP 0

Bit 15 - RTC_L, Real-Time Clock

The Real-Time Clock is normally on the RA0:7/ED0:7 bus but may be placed on the expansion data bus.

RTC_L = 0 -
Real-Time Clock is on the RA0:7/ED0:7 bus.

RTC_L = 1 -
Real-Time Clock is on the expansion data bus. This is the required setting when the WD76C20 is used.

Bit 14 - FST_VGA, Fast VGA Video

The performance of Western Digital PVGA display controllers may be enhanced by reducing wait states for access to video I/O. This feature should only be used with Western Digital PVGA1A, WD90C90, WD90C30, WD90C20, WD90C11 and WD90C10 devices. I/O cycles to eight-bit ports 3C0H - 1H, 3C4H - 5H and 3CEH - FH are made with one wait state cycles.

FST_VGA = 0 -
Normal PVGA control

FST_VGA = 1 -
One wait state I/O cycle to PVGA

Bit 13 - FST_SCSI, Fast SCSI

The performance of the WD33C93 SCSI Controller is enhanced by performing eight-bit accesses with one wait state rather than four wait states.

FST_SCSI = 0 -
Four Wait States

FST_SCSI = 1 -
One Wait State

Bit 12 - EN_PCS1, Enable Programmable Chip Select 1

The Programmable Chip Select logic is selected with Chip Select 11 and may be disabled or enabled. See Table 8-3.



EN_PCS1 = 0 -
Disable Programmable Chip Select #1

EN_PCS1 = 1 -
Enable Programmable Chip Select #1

Bit 11 - U_MSK1, Upper Address Bits Masked

U_MSK1 determines whether or not the upper address bits A15:10 are to be used as designated in the Programmable Chip Select Address Register at Port Address 3072H.

U_MSK1 = 0 -
A15:10 are ignored

U_MSK1 = 1 -
A15:10 are included in the address

Bits 10:08 - L_MSK1, Lower Address Bits Masked

L_MSK1 determines whether the lower four address bits A03:00 are to be used as designated in the Programmable Chip Select Address Register at Port Address 3072H.

L_MSK1
10 09 08

0 0 0 - A09:00 are included in the address

0 0 1 - A00 is ignored

0 1 0 - A00:01 are ignored

0 1 1 - A00:02 are ignored

1 0 0 - A00:03 are ignored

Bit 07 - PRG_L, Programmable Chip Select Bus Location

PRG_L = 0 -
Programmable Chip Select is on the RA0:7/ED0:7 bus

PRG_L = 1 -
Programmable Chip Select is on the expansion bus

Bit 06 - HS_HD, High Speed Hard Disk Data Transfer Rate

Enabling the high-speed data transfers results in hard disk, 16-bit data transfers to be performed at a compressed timing rate rather than at the compatible bus rate. When operating in the high-speed mode, the first data transfer is made at the compatible bus rate. Subsequent accesses to the hard disk port are made at high speed, with IOCS16 ignored and the WD76C20 hard disk chip select remaining stable.

NOTE

This feature requires the use of the WD76C20 and should only be used with Western Digital IDE drives WD-AC280, WD-AC140, WD-AC160, WD-AC2120, WD-AP4200, WD-AB130 and WD-AH260.

HS_HD = 0 -
Compatible bus timing enabled

HS_HD = 1 -
High-speed hard disk accesses enabled

Bit 05 - EN_16, Enable 16-Bit I/O Decoding

The WD7855/LV supports both the 100% IBM-AT compatible I/O decoding (10-bit mode) and the newer IBM PS/2 compatible I/O decoding (16-bit mode). The mode is selected by this bit.

EN_16 = 0 -
AT Compatible 10-bit decode. Address bits A15:10 are ignored. See Table 8-1.

EN_16 = 1 -
The enhanced 16-bit mode enabled. See Table 8-2.

Bit 04 - P/S, Primary Or Secondary Disk

The P/S bit is only used to select the floppy disk chip select address in the IDE mode. See Table 8-3, chip select numbers 08H through 0BH.

P/S = 0 -
Primary hard disk and Floppy address selected

P/S = 1 -
Secondary hard disk and Floppy address selected

Bit 03 - Reserved



Bit 02 - LK_PSW, Prevent Locking Password

Port 092H bit 3 (Lock_Pass) is used to prevent access to the CMOS RAM password area located at 38H through 3FH. Setting LK_PSW before attempting to set Lock_Pass, inhibits the setting of Lock_Pass. In this instance, it is possible to access the CMOS RAM password area. If Lock_Pass is set before LK_PSW, LK_PSW will have no effect.

LK_PSW = 0 -

Port 092H bit 3, Lock_Pass can be set.

LK_PSW = 1 -

Port 092H bit 3, Lock_Pass can not be set.

Bit 01 - DS_HD, Hard Disk Chip Select 0CH, 0DH

DS_HD = 0 -

Hard disk chip select is enabled.

DS_HD = 1 -

Hard disk chip select is not generated.

Bit 00 - DS_FLP, Floppy Disk Chip Select 08H, 09H, 0AH, 0BH

DS_FLP = 0 -

Floppy disk chip select is enabled.

DS_FLP = 1 -

Floppy disk chip select is not generated.

ADDRESS *	DEVICE
000:01F	DMA Controller 1 (Ch 0:3)
020:03F	Interrupt Controller Master
040:05F	Timer
060:06E (even)	Keyboard Port
061:06F (odd)	Port B - Parity Error And I/O Channel Check
070 bit 7	NMI Mask
070	RTC Address
071	RTC Data
080:08F, 090:091	DMA Page
093:09F	
092	ALT 20 GATE, Hot Reset Port 92
0A0:0BF	Interrupt Controller Slave
0C0:0DF	DMA Controller 2 (Ch 5:7)
0F0:0F1	Numeric Processor Clear And Reset
1F0:1F7	Hard Disk Chip Select (primary)
170:177	Hard Disk Chip Select (secondary)
278:27F	Parallel Port 3
2E8:2EF	Serial Port 4
2F8:2FF	Serial Port 2
378:37F	Parallel Port 2
3BC:3BF	Parallel Port 1
3E8:3EF	Serial Port 3
3F0:3F7	Floppy and Hard Disk (primary)
370:377	Floppy and Hard Disk (secondary)
3F8:3FF	Serial Port 1

* A15:10 are ignored.

TABLE 8-1. AT COMPATIBLE 10-BIT MODE

ADDRESS *	DEVICE
0000:000F	DMA Controller 1 (Ch 0:3)
0010:001F	AT Bus
0020:0021	Interrupt Controller Master
0022:003F	AT Bus
0040:0043	Timer
0044:005F	AT Bus
0060, 0064	Keyboard Port
0061	Port B - Parity Error And I/O Channel Check
0062, 0063	AT Bus
0065:006F	
0070 Bit 7	NMI Mask
0070	RTC Address
0071	RTC Data
0072:007F	AT Bus
0080:008F	DMA Page
0090:0091	AT Bus
0092	ALT 20 GATE, Hot Reset Port 92
0093:009F	AT Bus
00A0:00A1	Interrupt Controller Slave
00A2:00BF	AT Bus
00C0:00DE (even)	DMA Controller 2 (Ch 5:7)
00C1:00DF (odd)	AT Bus
00E0:00EF	AT Bus
00F0:00F1	Numeric Processor Clear And Reset
00F2:00FF	AT Bus
01F0:01F7	Hard Disk Chip Select (primary)
0170:0177	Hard Disk Chip Select (secondary)
0278:027F	Parallel Port 3
02E8:02EF	Serial Port 4
02F8:02FF	Serial Port 2
0378:037F	Parallel Port 2
03BC:03BF	Parallel Port 1
03E8:03EF	Serial Port 3
03F0:03F7	Floppy and Hard Disk (primary)
0370:0377	Floppy and Hard Disk (secondary)
03F8:03FF	Serial Port 1

* A15:10 equal 0

8.3 PROGRAMMABLE CHIP SELECT #1 ADDRESS

Port Address 3072H - Read and Write

15	14	13	12	11	10	09	08
A15	A14	A13	A12	A11	A10	A09	A08

Chip Select Address

07	06	05	04	03	02	01	00
A07	A06	A05	A04	A03	A02	A01	A00

Chip Select Address

Signal Name	Default At RSTIN
All signals	None

TABLE 8-2. ENHANCED 16-BIT MODE



8.4 I/O PORT ADDRESSES AND CHIP SELECT ASSIGNMENTS

Table 8-3 lists the I/O addresses and chip selects generated for each fixed port type. Address bits A15 through A10 are ignored for the I/O addresses listed with three digits. The ports are listed in the sequence of the chip select value.

I/O to the addresses listed in Table 8-3 automatically cause the System Controller to output CSEN along with the corresponding encoded chip select value on CS4:0 (DPH, DPL, RA10:8). This is decoded by either the WD76C20/ALV or discrete logic which in turn asserts individual chip select signals to the various peripherals. Some of these chip selects can be individually enabled or disabled by way of registers 2072H and 2872H.

PORT	I/O ADDRESS 10-BIT MODE (HEX)	I/O ADDRESS 16-BIT MODE (HEX)	CHIP SELECT NUMBER (HEX)	FUNCTION
ROM Chip Select	N/A	N/A	00	Chip select for BIOS ROM
Keyboard Control	060:06E even	0060, 0064	01	Chip select for 8042
Power Control	7072	7072	03	PMC Write Strobe 0
Reserved			04	Reserved
Real-time Clock	070	0070	05	RTC ALE
Real-time Clock	071	0071	06	RTC Write Strobe
Real-time Clock	071	0071	07	RTC Read Strobe
Floppy Operation Chip Select	3F2 372	03F2 0372	08	Primary address Secondary address
Floppy Chip Select	3F4, 3F5 374, 375	03F4, 03F5 0374, 0375	09	Primary address Secondary address
Floppy Control Chip Select	3F7 377	03F7 0377	0A	Primary address Secondary address (Floppy enabled, HD disabled)
Floppy and HD Control Chip Select	3F7 377	03F7 0377	0B	Primary address Secondary address (Floppy enabled, HD enabled)
Hard Disk Chip Select	1F0:1F7 170:177	01F0:01F7 0170:0177	0C	Primary address Secondary address
Hard Disk Chip Select	3F6 3F7 ① 376 377 ①	03F6 03F7 ① 0376 0377 ①	0D	Primary Address Secondary address
Serial Port A Chip Select	2E8:2EF 2F8:2FF 3E8:3EF 3F8:3FF	02E8:02EF 02F8:02FF 03E8:03EF 03F8:03FF	0E ②	
Parallel Port 0 Chip Select	278:27F 378:37F 3BC:3BF	0278:027F 0378:037F 03BC:03BF	0F	

TABLE 8-3. I/O PORT ADDRESSES AND CHIP SELECT ASSIGNMENTS



PORT	I/O ADDRESS 10-BIT MODE (HEX) ¹	I/O ADDRESS 16-BIT MODE (HEX)	CHIP SELECT NUMBER (HEX)	FUNCTION
Serial Port B Chip Select	2E8:2EF 2F8:2FF 3E8:3EF 3F8:3FF	02E8:02EF 02F8:02FF 03E8:03EF 03F8:03FF	10 ^②	
Program Chip Select 1	PROG 1	PROG 1	11	
SCSI	3530:353X	3530:353X	12	
Cache Flush	F872	F872	13	
EMS			14	External EMS
	F072	F072	15	48 MHz Clock Disabled
	F472	F472	16	48 MHz Clock Enabled
Power Control	7872	7872	17	PMC Write Strobe 1
Floppy Chip Select	3F0:3F1 370:371	03F0:03F1 0370:0371	18	Primary address Secondary address
Floppy Chip Select	3F3 373	03F3 0373	19	Primary address Secondary address
Program Chip Select 2	PROG 2	PROG 2	1A	
Program Chip Select 3	PROG 3	PROG 3	1B	
Reserved			1E	Reserved
Reserved			1F	Reserved

① IDE Hard disk enabled, floppy disabled

② The Chip Select Number is the decoded value of CS4:CS0. If the Programmed Chip Select corresponds to any other decode, the Programmed Chip Select is suppressed. If Serial Port A and B are programmed for the same address, Serial Port B Chip Select is suppressed.

TABLE 8-3. I/O PORT ADDRESSES AND CHIP SELECT ASSIGNMENTS (Continued)



9.0 POWER MANAGEMENT CONTROL

The WD7855/LV supports all PMC inputs, output and interrupt functions.

9.1 SYSTEM ACTIVITY MONITOR (SAM)

The System Activity Monitor (SAM) found in the WD7855/LV is a hardware solution to monitoring system activity. SAM was conceived to solve the problems associated with system activity detection in various operating environments such as DOS, Windows, OS/2, VCPI and Microsoft APM.

With previous System Controllers such as the WD76C10 a software approach was employed to determine system activity. This software approach was accomplished using a watchdog timer. As a part of the watchdog timer service, the sources of activity are checked and a determination is then made on the state of system activity. This approach does not consider the state of the system activity between watchdog timer interrupts. However, with SAM, the system activity state is continuously monitored through hardware, thus providing a more universal approach to activity detection.

With the help of SAM it is now possible to:

- Provide a trigger when a pre-programmed period of system inactivity time elapses.
- Enable/disable the sources that constitute system activity.
- Select either coarse or fine timeout values for system inactivity period.

System Activity

System activity denotes periods of time in which the system performs useful tasks. The sources of System Activity are:

- Unmasked pending interrupts.
- Unmasked interrupts in service.
- Access to hard disk data port.
- I/O Access to programmable chip select port.
- DMA transfers.
- Coprocessor cycles.
- A programmable PCU input.
- NMI.

SAM allows for excluding the following interrupt sources from contributing to system activity:

- IRQ0, used by DOS to keep track of the system time.
- IRQ7, used for spurious interrupts and parallel port interrupts.
- IRQ8, used by Windows, OS/2 and other multitasking environments to keep the scheduler running.
- A programmable interrupt level used as a power management interrupt.

SAM also takes into account programs such as MOUSE.COM which, in an attempt to locate a mouse on a communication port, generates interrupts on interrupt levels 3 and 4, and leaves them pending. To overcome this problem, SAM allows only the unmasked pending interrupts on 3 and 4 to constitute system activity.

Using SAM for System Power Management:

a) System Timeout Capability

SAM can be programmed to determine coarse periods of inactivity, with the minimum period as one minute, four seconds, up to a maximum period of 16 minutes. It is also possible to extend the maximum limit to any value by reading the Activity Before bit (ACTBEF) in the Activity Monitor Control Register at Port Address B072H.

On reaching the programmed period, SAM generates a Local Attention signal. Typically, the Local Attention is tied to a power management interrupt. In response to Local Attention, the power management interrupt handler makes it possible to prepare the system for a Suspend operation.

b) Responding to a Suspend Request

SAM can be programmed to determine a clean breakpoint for suspending the system upon receiving the Suspend request. At the time the Suspend request is received, it is possible that the system is busy performing an indivisible operation, and it is necessary to wait for the system to finish this indivisible operation before initiating suspend. In order to do this, control to the CPU must be relin-



quished for just enough time for the CPU to complete the operation. This is referred as Suspend arbitration.

In addition to performing Suspend arbitration, SAM is also responsible for determining the earliest opportunity to initiate the Suspend sequence. For instance, if a Suspend request is caused by a low battery condition, it is imperative that the system be placed in the suspend state as soon as possible. Here, the fine granularity of SAM may be used to determine brief periods of inactivity from as low as 7.8 milliseconds to as high as 117.2 milliseconds and establish a clean breakpoint for suspending the system.

Advantages of SAM:

1. SAM is a reliable and consistent approach to detecting system activity.
2. SAM is hardware based making it truly non-obtrusive.
3. SAM is independent of the operating environment and the execution mode of the processor.
4. SAM can perform in two modes:
 - Detection of system activity for extended periods of time for the purposes of system timeout.
 - Detection of brief periods of inactivity for initiating Suspend.
5. Programmability allows for the control of sources of system activity and setting up coarse and fine timeout values.
6. SAM generates a signal called Local Attention (LCL_ATN, PMC #4) on reaching programmed periods of timeout. This signal is generally tied to an unused IRQ level to invoke the Power Management program. Optionally, SAM can generate a System Management Interrupt (SMI on pin 108) rather than LCL_ATN.
7. SAM also carries information on DMA activity state. This is used to determine whether it is appropriate to place the processor in the Sleep Mode.
8. SAM makes it possible to read the state of the interrupt controllers and, if needed, reprogram them on Resume. This is provided to handle the spurious interrupts that are generated by devices at power-up time on Resume.

NOTE

SAM cannot be used to determine when the processor should be placed in the Sleep Mode. This determination is intimately tied to the operating environment and is handled either by Western Digital's Power Management drivers DOS/VCPI, Windows and OS/2 or by Microsoft APM.

The System Activity Monitor is controlled by the Activity Monitor Control Register at Port Address B072H, Activity Monitor Mask Register at Port Address D872H and bit 09 of the Test Enable Register at Port Address A872H.

9.2 PROCESSOR POWER DOWN MODE

The Processor Power Down Mode is initiated by setting bit 13 of the register at Port Address 1872H to one. The CPURES signal is asserted, then tristated. An internal 200K pullup resistor holds the CPURES active. The Processor Power Down (PMC #5) signal from the PMC Control Register is used to control the power converter from the processor. The WD7855/LV holds CPUCLK, $\overline{\text{READY}}$, $\overline{\text{HOLDR}}$, INTRQ and NMI low to the processor.

The same conditions used to restart a stopped clock also initiate the Power Up Mode. The Power Up Mode is entered by an unmasked DRQ, unmasked IRQ interrupt or a PMC input change, resulting in an unmasked NMI to Port 9072H. A Processor Power Good signal is then input on the PMCIN pin. After 1 ms, PMC Processor Power Good signal is checked for a logic 1 state. At this time, CPURES is driven high and the CPUCLK, $\overline{\text{READY}}$, $\overline{\text{HOLDR}}$, INTRQ and NMI signals are driven to their correct states. CPURES remains asserted for 64 additional CPUCLKs.

The PMC unit is composed of either two 74HCT273 chips and one 74HCT151 chip, or a Western Digital WD7625 Buffer Manager. The two 74HCT273 octal latches are used for the 16 PMC outputs from data bus ED(0:7) and the 74HCT151 8:1 multiplexer is used for the PMCIN signal, while the WD7625 internal multiplexers perform both functions. The PMC output latches are cleared at power up (see Figure 5-1).

9.3 LOCAL ACCESS BY KEYBOARD CONTROLLER

The keyboard processor may access the WD7855/LV internal registers by way of the PMC logic. The keyboard processor starts a local access by asserting LCL_REQ, which causes PMCIN 2 to be asserted and written in the PMC input register at Port 8872H (see Figure 5-1 and Table 9-2). The WD7855/LV arbitrates with refresh, DMA and master for a hold cycle from the processor. When the processor returns a hold acknowledge (HOLDA), the WD7855/LV asserts LCL_ACK (PMC output 3 from Port 7072H) on the ED(0:7) data bus. The keyboard processor then passes the opcode/address byte to the WD7855/LV on the data bus and drops the LCL_REQ. The WD7855/LV responds by de-asserting LCL_ACK.

If the opcode specified a register write, data high (D15:08) and data low (D07:00), bytes are passed to the WD7855/LV. If the opcode specified an I/O read, the data high and data low bytes are sent from the WD7855/LV to the keyboard processor.

All special operation registers within the WD7855/LV may be accessed in this manner without first unlocking the register. See Section 2.8.2, Port Address F073H, for Lock/Unlock Register. This method allows the keyboard processor to control speed switching and other parameters without host processor intervention.

If a particular design uses processor-power-down on a non-static CPU and also uses this local access feature, then an additional AND gate is required.

Local access during CPU power-down depends on ADDR2 coming from the CPU through the 74ACT373 bus latch. If the CPU is powered down, ADDR2 can be either high or low, depending on the last CPU address. PROC_PWR_GOOD should be ANDed with ADDR2 going to the 8742. This forces ADDR2 low, making local accesses possible during CPU power-down conditions. This also passes ADDR2 during normal operation.

Figure 9-1 shows the handshake procedure, followed by the keyboard controller and the WD7855/LV.

Figures 9-2 and 9-3 represents the power-down (suspend) and power-up (resume) sequence and control.



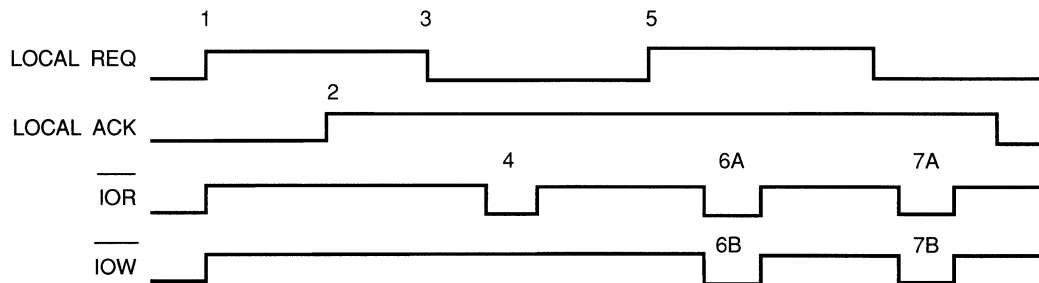

- 1 8042 Requests local data transfer
- 2 WD7855/LV returns LOCAL_ACK after receiving HOLDA from the host processor
- 3 8042 loads address and OPCODE into data register, then drops LOCAL_REQ
- 4 WD7855/LV reads address and OPCODE
- 5 8042 Reloads data register with high byte, then asserts LOCAL_REQ
- 6A WD7855/LV Reads high byte
- 7A WD7855/LV Read low byte, writes to internal register

FOR READ CYCLE OF WD7855/LV INTERNAL REGISTER:

- 6B WD7855/LV Writes high byte to 8042
- 7B WD7855/LV writes low byte to 8042

OP_CODE FORMAT

7	6	5	4	3	2	1	0
D I R	R S V	A 1 5	A 1 4	A 1 3	A 1 2	A 1 1	A 1 0

- DIR = 1 - Read register (generates IOW to 8042)
- DIR = 0 - Write register (generates IOR to 8042)

FIGURE 9-1. REGISTER ACCESS BY KEYBOARD CONTROLLER



9.4 PMC OUTPUT CONTROL REGISTERS

Port Address 7072H - Bits 07:00 are Read only

15	14	13	12	11	10	09	08

07	06	05	04	03	02	01	00
OUT 7	OUT 6	OUT 5	OUT 4	OUT 3	OUT 2	OUT 1	OUT 0

Port Address 7872H - Bits 07:00 are Read and Write

15	14	13	12	11	10	09	08

07	06	05	04	03	02	01	00
OUT F	OUT E	OUT D	OUT C	OUT B	OUT A	OUT 9	OUT 8

Signal Name Default At RSTIN
All signals None

PMC Output Control Bits 7:0

Signal Name Default At RSTIN
All signals None

PMC Output Control Bits 15:08

PMC NO.	PMC OUTPUT SIGNAL PORT 7072H	PMC NO.	PMC OUTPUT SIGNAL PORT 7872H
0H	CPU Clock Driver Enable	8H	User Defined
1H	LCD Enable	9H	User Defined
2H	Backlight Enabled	AH	User Defined
3H	LCL_ACK	BH	User Defined
4H	LCL_ATN	CH	User Defined
5H	Processor power Down	DH	User Defined
6H	Gate A20	EH	User Defined
7H	Full Power Down	FH	User Defined

TABLE 9-1. PMC OUTPUT SIGNALS



9.5 PMC TIMERS

Port Address 8072H - Read and Write

When no Keyboard or Mouse interrupts have occurred for the time specified by BL_TIMEOUT or LCD_TIMEOUT, PMC Output 1 or 2 is written to the PMC OUTPUT CONTROL 7:0 register at Port Address 7072H (see Table 9-1) to disable the LCD or Backlight. The timer is reset and the Backlight and LCD control re-enabled at the refresh cycle following a Keyboard or Mouse interrupt. The Mouse Interrupts are programmed by bits 01 and 00 (BL_MOU) in the RAM Shadow and Write Protect Register at Port Address 6072H. The same timer is used for the Backlight and LCD timeout.

The timeout delay may be programmed in increments of five seconds, to a maximum of 1,270 seconds, or 21 minutes and 10 seconds.

15	14	13	12	11	10	09	08
BL_TIMEOUT							

07	06	05	04	03	02	01	00
LCD_TIMEOUT							

Signal Name	Default At RSTIN
BL_TIMEOUT	0
LCD_TIMEOUT	0

Bits 15:08 - BL_TIMEOUT, Backlight Time Out

- 00H - Backlight always disabled
- 01H - Enabled for 5 seconds
- 02H - Enabled for 10 seconds



- FEH - enabled for 254 x 5 seconds
- FFH - Backlight enabled

Bits 07:00 - LCD_TIMEOUT, LCD Time Out

- 00H - LCD always disabled
- 01H - Enabled for 5 seconds
- 02H - Enabled for 10 seconds



- FEH - enabled for 254 x 5 seconds
- FFH - LCD enabled



9.6 PMC INPUTS

Port Address 8872H - Bits 15:08 Read and Write
 Bits 07:00 Read only

15	14	13	12	11	10	09	08
PMC_UPD	EN_LCL	AF 7	AF 6	AF 5	AF 4	AF 3	AF 2

07	06	05	04	03	02	01	00
IN 7	IN 6	IN 5	IN 4	IN 3	IN 2	IN 1	IN 0

Signal Name	Default At RSTIN
PMC_UPD	0
EN_LCL	0
AF7:AF2	0
IN7:IN0	None

Bit 15 - PMC_UPD, Enable PMC Update

PMC_UPD = 0 -
 No update cycles occur.

PMC_UPD = 1 -
 A change of state of the PMC outputs 15 through 0 (Port Address 7072H and 7872H) or the internal A20 GATE causes an update cycle of the PMC 15:0 output latch.

Bit 14 - EN_LCL, Enable Local Request

EN_LCL either enables the PMCCIN 2 to be defined by the user or to initiate a local access of the WD7855/LV internal registers from the keyboard controller.

EN_LCL = 0 -
 PMCCIN 2 is user defined.

EN_LCL = 1 -
 PMCCIN 2 is LOCAL_REQ.

Bits 13:08 - AF7:AF2, Local Attention Flags

Local attention flags AF7 through AF2 are set to indicate which PMC input(s) have caused LCL_ATN in PMC Interrupt Enable Register at Port C872H to be asserted. To clear the flag and corresponding IN bit in the PMC Inputs Register, it is necessary to clear the corresponding EA bit in PMC Interrupt Enable Register. If both an EA bit and EI bit in the PMC Interrupt Enable Register are set, both must be reset to clear the corresponding IN status and AF flag.

AF7 - AF2 = 0 -
 This PMC input did not cause LCL_ATN to be asserted.

AF7 - AF2 = 1 -
 This PMC input caused LCL_ATN to be asserted.

Bits 07:00 - IN7:IN0, PMC Inputs 7:0

The Activity Monitor Mask Register at Port Address D872H may be used to select one of the PMC inputs IN7 through IN2 as a source of activity for power management purposes.

IN7:0 are status flags which provide information about the corresponding PMC input IN7 through IN0. IN1 and IN0 represent the current state of the input, while IN7 through IN2 represent either the current state or a latched transition. An IN7 through IN2 status is unlatched when both the corresponding EI and EA bits in the PMC Interrupt Enable Register at Port C872H are reset. It becomes a latched status when either the corresponding EI or EA bit is set. See Table 9-2.



9.7 PMC INTERRUPT ENABLE

Port Address C872H - Read and Write

15	14	13	12	11	10	09	08
EI7	EI6	EI5	EI4	EI3	EI2		
Non-maskable Interrupt Enable							

07	06	05	04	03	02	01	00
EA7	EA6	EA5	EA4	EA3	EA2		
Local Attention Enable							

Signal Name	Default At RSTIN
EI7-EI2	0
EA7-EA2	0

Bits 15:10 - EI7:EI2, Non-maskable Interrupt Enable 7 through 2

EI7:EI2 enable the generation of an NMI when the corresponding PMC inputs IN_7:IN_2 at Port Address 8872H change state. For example, when EI7 is a 1 and IN_7 changes from a 0 to 1 an NMI will be generated.

EI7:EI2 = 0 - Non-maskable Interrupt not enabled

EI7:EI2 = 1 - Non-maskable Interrupt is enabled

Bits 09:08 - Not used, state is ignored

Bits 07:02 - EA7:EA2, Local Attention Enable

EA7 through EA2 enable the assertion of LCL_ATN by the corresponding IN_7 through IN_2. LCL_ATN is PMC output number 4.

EA7-EA2 = 0 - LCL_ATN is not enabled

EA7-EA2 = 1 - LCL_ATN is enabled. If LAEN at Port Address 7C72H is set, SMI will occur. Refer to Section 10.2.

Bits 01:00 - Not used, state is ignored

PMC INPUT NUMBER ①	PMC INPUT NAME	INTERRUPT ON	SETS FLAG NUMBER ②
00H	TURBO		
01H	PROC_PWR_GOOD		
02H	LCL_REQ or User Defined	Transition	IF2 or AF2
03H	User Defined	Transition	IF3 or AF3
04H	User Defined	Transition	IF4 or AF4
05H	User Defined	Transition	IF5 or AF5
06H	User Defined	Transition	IF6 or AF6
07H	User Defined	Active Edge	IF7 or AF7

① Port Address 8872H, section 9.6
 ② Port Address 9072H, section 9.8
 Port Address 8872H, section 9.6

TABLE 9-2. PMCIN INPUTS



9.8 NMI STATUS

Port Address 9072H - Read and Write

15	14	13	12	11	10	09	08
0	0	0	0	0	0	0	0

07	06	05	04	03	02	01	00
IF7	IF6	IF5	IF4	IF3	IF2	0	0
Non-maskable Interrupt Flags							

Signal Name	Default At RSTIN
IF7:IF2	0

Bits 15:08 - Not used, must be 0

Bits 07:02 - IF7:IF2, Non-maskable Interrupt Flags 7 through 2

NMI interrupt flags IF7:IF2 are set to indicate which PMC input(s), if any, have caused NMI to be asserted. To reset the flag and corresponding IN status bit in the PMC Input Register at Port Address 8872H, it is necessary to reset the corresponding bit in the PMC Interrupt Enable Register at Port Address C872H. If both an EA bit and EI bit in the PMC Interrupt Enable Register are set, both must be reset to clear the corresponding IN status and IF flag.

Bits 01:00 - Not used, must be 0

9.9 SERIAL/PARALLEL SHADOW REGISTER

Port Address D072H - Read only

The Shadow Register is particularly useful in lap-top applications by allowing the suspend/resume software to restore correct status to on-board serial and parallel devices.

15	14	13	12	11	10	09	08
SP_A Serial Port A		SP_B Serial Port B		PP_2 Parallel Port 2			

07	06	05	04	03	02	01	00
PP_0 Parallel Port 0							

Signal Name	Default At RSTIN
All signals	None

Bits 15:14 - SP_A, Serial Port A Register 2

This field represents bits 7 and 6 of Serial Port A Register 2.

Bits 13:12 - SP_B, Serial Port B Register 2

This field represents bits 7 and 6 of Serial Port B Register 2.

Bits 11:08 - PP_2, Parallel Port Register 2

This field represents bits 3:0 of Parallel Port Register 2.

Bits 07:00 - PP_0, Parallel Port Register 0

This field represents bits 7:0 of Parallel Port Register 0.



9.10 INTERRUPT CONTROLLER SHADOW REGISTER

Port Address D472H - Read only

When performing a resume operation, it may be advantageous to reset and reinitialize the interrupt controllers in the System Controller. Since many of the interrupt control registers are write only, it is impossible to determine the state of the interrupt controllers at suspend time. This register makes it possible to determine the state of selected signals internal to the master and slave interrupt controllers. With this information, when the interrupt control registers are reinitialized during resume, they can be returned to the state in which they were before suspend.

ICW2, ICW4, OCW2 and OCW3 referred to in this text is further defined in Sections 5.5.2.2, 5.5.2.4, 5.5.3.2 and 5.5.3.3.

15	14	13	12	11	10	09	08
AMT OUT	DEV		TM7	TS7	SF NM	AUT_ EOI	RA_ EOI

07	06	05	04	03	02	01	00
PLM2 Priority	PLM1 Level	PLM0 Master	PLS2 Priority	PLS1 Level	PLS0 Slave	SMM M	SMM S

Signal Name	Default At RSTIN
DEV	0
All other signals	None

Bit 15 - AMTOUT, Activity Monitor Timeout

AMTOUT represents the current state of the timeout comparator in the activity monitor. It is for test purposes only

Bits 14:13 - DEV, Device

DEV identifies the device as WD7855, WD7710 or WD76C10A and is used in conjunction with SVER at Port Address A872H. DEV and SVER are defined in Table 11.2.

Bit 12 - TM7, Master Interrupt Vector Bit 7

TM7 represents bit 7 of the Interrupt Vector in the Master Interrupt Controller as set by ICW2. Bits 6:3 of the Interrupt Vector may be read from D6:3 by a Poll Command to the Master Interrupt Controller. The Poll Command is implemented by P_C = 1 (bit 2 of OCW3).

Bit 11 - TS7, Slave Interrupt Vector Bit 7

TS7 represents bit 7 of the Interrupt Vector in the Slave Interrupt Controller as set by ICW2. Bits 6:3 of the Interrupt Vector may be read from D6:3 by a Poll Command to the Slave Interrupt Controller. The Poll Command is implemented by P_C = 1 (bit 2 of OCW3).

Bit 10 - SFNM, Special Fully Nested Mode

SFNM represents the state of ICW4 - bit 4 in the Master Interrupt Controller. The WD7855/LV does not require SFNM for the slave interrupt controller and ignores its state.

Bit 09 - AUT_EOI, Auto End Of Interrupt

AUT_EOI represents the state of ICW4 - bit 1 in the Master Interrupt Controller. The WD7855/LV does not require AUT_EOI for the slave interrupt controller and ignores its state.

Bit 08 - RA_EOI, Rotate Auto End Of Interrupt

RA_EOI indicates whether or not Rotate On Automatic End Of Interrupt has been selected in the Master Interrupt Controller by EOI_CONT (bits 7:5 of OCW2). The WD7855/LV does not require Rotate On End Of Interrupt for the slave interrupt controller and ignores its state.

RA_EOI = 0 -
Rotate On Auto End Of Interrupt has not been selected.

RA_EOI = 1 -
Rotate On Auto End Of Interrupt has been selected.

Bits 07:05 - PLM2:PLM0, Priority Level Master

PLM2:PLM0 represent the bottom priority level programmed into the Master Interrupt Controller by INT_LEV (OCW2 bits 2:0).



Bits 04:02 - PLS2:PLS0, Priority Level Slave

PLS2:PLS0 represent the bottom priority level programmed into the Slave Interrupt Controller by INT_LEV (OCW2 bits 2:0).

Bit 01 - SMMM, Special Mask Mode Master

SMMM indicates whether Special Mask Mode has been set in the Master Interrupt Controller by a write to SMM in OCW3.

SMMM = 0 -
Special Mask Mode is not enabled.

SMMM = 1 -
Special Mask Mode is enabled.

Bit 00 - SMMS, Special Mask Mode Slave

SMMS indicates whether Special Mask Mode has been set in the Slave Interrupt Controller by a write to SMM in OCW3.

SMMS = 0 -
Special Mask Mode is not enabled.

SMMS = 1 -
Special Mask Mode is enabled.

9.11 PORT 70H SHADOW REGISTER

Port Address E472H - Bits 15:12, 10:00 Read only
Bit 11 Read and Write

This register provides information on the status of interrupts and DMA which is useful for determining when the processor may be placed in the sleep mode. Two bits are also provided for generating software delays without incurring the operating system traps that would result from accessing I/O Port Address 0061H in virtual 86 mode. This register also contains a shadow of the Real Time Clock Address Register, a write only I/O port. It is necessary to access the Real Time Clock CMOS RAM during Suspend/Resume operations. This shadow of Port Address 0070H allows it to be restored to the same state it was in at suspend time.

This register can be read without first unlocking the WD7855/LV. This is important since the CLK32K, REFDET, and TODUN bits may need to be read frequently.

15	14	13	12	11	10	09	08
CLK 32K	REF DET	INTRQ	NO DMA	TOD UN	Reserved		

07	06	05	04	03	02	01	00
D NMI	RTC A6	RTC A5	RTC A4	RTC A3	RTC A2	RTC A1	RTC A0

Signal Name	Default At RSTIN
D_NMI	1
Reserved	0
All other signals	None

Bit 15 - CLK32K

CLK32K is \overline{PDREF} at input pin 41 divided by two. CLK32K may be read to provide a stable timing reference, not subject to reprogramming of the refresh rate. CLK32K has a 30.5 μ s period and 50% duty cycle.

Bit 14 - REF_DET, Refresh Detect

REF_DET is a copy of the REF_DET bit available from I/O Port Address 0061H, Bit 4 described in Section 5.9.

Bit 13 - INTRQ, Interrupt Request

INTRQ represents the state of the INTRQ output pin 126 to the CPU.

Bit 12 - NO_DMA, No DMA

NO_DMA = 0
A DMA or Bus Master Cycle has occurred within the last 61 μ s

NO_DMA = 1
A DMA or Bus Master Cycle has not occurred within the last 30.5 μ s

Bit 11 - TODUN, Time of Day Update Needed

This is a general purpose storage bit which can be written and read but has no effect on internal logic. Its purpose is to allow an SMI handler to signal the operating system that the time of day has been corrupted. This bit is checked by the Timer 0 Interrupt Handler. Note that although this bit is readable without unlocking the WD7855/LV, it cannot be written unless the WD7855/LV is unlocked.

Bits 10:08 - Reserved



Bit 07 - D_NMI, Disable Non-Maskable Interrupt Shadow

D_NMI represents the state of the D_NMI bit as it was set the last time I/O Port Address 0070H described in Section 5.8.1 was written.

Bits 06:00 - RTC_A6:RTC_A0, Real Time Clock Address Shadow

RTC_A(6:0) represents the state of the Real Time Clock Address Register as it was set the last time I/O Port Address 0070H was written.

9.12 ACTIVITY MONITOR CONTROL REGISTER

Port Address B072H - Bits 15, 13:11, 08:00 Read and Write
 Bits 14, 10, 09 Read only

For an overview of the Activity Monitor Register, see the general description of the Activity Monitor Mask Register in Section 9.13.

15	14	13	12	11	10	09	08
IRR_AE	CB12	AM_TM	ACT_LCH	IND_ET	ACT_AFT	ACT_BEF	AM_EN

07	06	05	04	03	02	01	00
Coarse Timeout Count AMC7 AMC6 AMC5 AMC4				Fine Timeout Count AMC3 AMC2 AMC1 AMC0			

Signal Name	Default At RSTIN
IRRAE	0
CB12	None
AMTM	0
ACTLCH	None
INDET	None
ACTAFT	None
ACTBEF	None
AMEN	0
AMC7:AMC0	0

Bit 15 - IRRAE, Interrupt Request Register Activity Enable

IRRAE controls whether or not the IRR (Interrupt Request Register) bits from the Interrupt Controller at Port Address 020H, 0A0H may be a source of activity (refer to Section 5.5).

IRRAE = 0 -
 No IRR bits can be used as an activity source.

IRRAE = 1 -
 IRR bits can be a source of activity. IRR8, IRR7 and IRR0 may still be masked by Port Address D872H.

Bit 14 - CB12, Counter Bit 12

For factory use only.

The activity monitor circuitry contains a 17-bit timeout counter for generating long timeouts. For test purposes, CB12 represents the twelfth bit of that counter.

Bit 13 - AMTM, Activity Monitor Test Mode

AMTM = 0 -
 Activity Monitor functions normally.

AMTM = 1 -
 Activity Monitor is in Test Mode. Activity Monitor State Machine is clocked faster than normal and nine stages of the 17-bit timeout counter are bypassed.

Bit 12 - ACTLCH, Activity Latch

This latch is always enabled, regardless of other enable bit settings. Writing a 1 to ACTLCH has no effect.

ACTLCH = 0 -
 The Activity Latch is reset by writing 0 to ACTLCH.

ACTLCH = 1 -
 Activity by an unmasked source has occurred.

Bit 11 - INDET, Inactivity Detect

Writing a 1 to INDET has no effect.

INDET = 0 -
 Writing 0 to INDET, or placing the Activity Monitor in the idle state by writing 0 to AMEN (bit 8), resets INDET, ACTAFT and ACTBEF.

INDET = 1 -
 System is idle and the Activity Monitor has requested the local attention output be set. This occurs when there has been no unmasked activity, allowing the predetermined timeout (bits 07:00) to be reached.

10



NOTE

PMCIN transitions may also cause the local attention (LCL_ATN PMC 4) output to be set.

Bit 10 - ACTAFT, Activity After INDET

ACTAFT is a read only bit and its state is ignored during writes.

ACTAFT = 0 -

Writing 0 to INDET, or placing the Activity Monitor in the idle state by writing 0 to AMEN (bit 8), resets INDET, ACTAFT and ACTBEF.

ACTAFT = 1 -

Activity has occurred after INDET had been set. This would happen when activity occurs during the time it takes to reach the interrupt service routine invoked by the local attention output request.

Bit 09 - ACTBEF, Activity Before INDET

ACTBEF is a read only bit and its state is ignored during writes.

ACTBEF = 0 -

Writing 0 to INDET, or placing the Activity Monitor in the idle state by writing 0 to AMEN (bit 8), resets INDET, ACTAFT and ACTBEF.

ACTBEF = 1 -

Activity did occur and reset the timeout counter before INDET was set. This is important if consecutive timeout periods are being counted in a service routine to obtain a system timeout period other than that available using AMC(7:0) (bits 07:00). It would be necessary for the routine to clear the software counter if ACTBEF were set, since there would have been no activity only for the period of time programmed in AMC(7:0).

Bit 08 - AMEN, Activity Monitor Enable

This is the master enable for the Activity Monitor.

AMEN = 0 -

Writing 0 to AMEN places the Activity Monitor in the idle state.

AMEN = 1 -

Writing 1 to AMEN causes the Activity Monitor to start clocking the timeout counter. Each time an unmasked source of activity is detected, the counter is cleared. If no unmasked source of activity is detected before the timeout counter reaches the value programmed by ACM(7:0), INDET and the local attention output are set. The timeout counter is then cleared and a new timeout sequence begins.

Bits 07:04 - AMC7:AMC4, Activity Monitor Counter Coarse

AMC(7:4) establish the timeout values from 64 seconds to 16 minutes in 64-second increments. These bits must only be written when the Activity Monitor is disabled (AMEN = 0). They may be read at any time.

AMC 7 6 5 4

0	0	0	0	-	0 seconds
0	0	0	1	-	1 minute, 4 seconds
0	0	1	0	-	2 minutes, 8 seconds
0	0	1	1	-	3 minutes, 12 seconds
0	1	0	0	-	4 minutes, 16 seconds
0	1	0	1	-	5 minutes, 20 seconds
0	1	1	0	-	6 minutes, 24 seconds
0	1	1	1	-	7 minutes, 28 seconds
1	0	0	0	-	8 minutes, 32 seconds
1	0	0	1	-	9 minutes, 36 seconds
1	0	1	0	-	10 minutes, 40 seconds
1	0	1	1	-	11 minutes, 44 seconds
1	1	0	0	-	12 minutes, 48 seconds
1	1	0	1	-	13 minutes, 52 seconds
1	1	1	0	-	14 minutes, 56 seconds
1	1	1	1	-	16 minutes, 0 seconds



Bits 03:00 - AMC3:AMC0, Activity Monitor Counter Fine

AMC(3:0) establish the timeout values from 7.8 milliseconds to 117.2 milliseconds in 7.8 millisecond increments. Tolerance on time delays is -0, +3.9 milliseconds. These bits must only be written when the Activity Monitor is disabled (AMEN = 0). They may be read at any time.

AMC	3	2	1	0	
	0	0	0	0	- 0 milliseconds
	0	0	0	1	- 7.8 milliseconds
	0	0	1	0	- 15.6 milliseconds
	0	0	1	1	- 23.4 milliseconds
	0	1	0	0	- 31.3 milliseconds
	0	1	0	1	- 39.1 milliseconds
	0	1	1	0	- 46.9 milliseconds
	0	1	1	1	- 54.7 milliseconds
	1	0	0	0	- 62.5 milliseconds
	1	0	0	1	- 70.3 milliseconds
	1	0	1	0	- 78.1 milliseconds
	1	0	1	1	- 85.9 milliseconds
	1	1	0	0	- 93.8 milliseconds
	1	1	0	1	- 101.6 milliseconds
	1	1	1	0	- 109.4 milliseconds
	1	1	1	1	- 117.2 milliseconds

NOTE

The fine timeout delay (AMC3 through AMC0) is added to the coarse timeout delay (AMC7 through AMC4) to obtain the total timeout delay.

9.13 ACTIVITY MONITOR MASK REGISTER

Port Address D872H - Read and Write

The activity monitor provides a hardware solution for determining inactivity in a system. Knowing when a system is inactive is key to performing such power reduction activities as suspend. When the Activity Monitor is enabled by the Activity Monitor Control Register at Port Address B072H, the Activity Monitor clocks a counter and invokes a service routine using local attention when the counter reaches a programmed timeout value. However, while the counter is being clocked, the Activity Monitor continuously monitors for any of several events that would indicate that the system is active. If any of these events occur, the counter is reset and the timeout starts over. Thus the service routine is only invoked when the system has been inactive for a programmed period of time.

To provide a high degree of flexibility in determining what is active and what is not, many sources are routed to the Activity Monitor. These include the IRR (Interrupt Request Register) and ISR (In Service Register) bits from the Interrupt Controller, the PMC inputs, NMI output, DMA (or AT Master) cycles and I/O accesses to either the numeric coprocessor, hard disk data port or programmable chip select. All of these sources are considered activity unless masked.

The interrupt input masks are controlled in the lower byte. All ISR and IRR bits are detected as activity except those specifically masked. Note, however, that ISR2 and IRR2 are not examined since they are cascade interrupts only. Also, IRR3 and IRR4 are qualified by the Mask Register in the Interrupt Controller before being passed to the Activity Monitor. The master mask for all IRR bits is the IRRAE bit in the register at Port Address B072H.

15	14	13	12	11	10	09	08
PCS M	PMC ILS	PMC IS2	PMC IS1	PMC IS0	NMI M	HDD M	COP M

07	06	05	04	03	02	01	00
IMS1	IMS0	IRR8 M	IRR7 M	IRR0 M	ISR8 M	ISR7 M	ISR0 M

Signal Name	Default At RSTIN
All signals	0

Bit 15 - PCSM, Programmable Chip Select #1 Mask

PCSM = 0 -
Read or write I/O accesses to the ports defined by the programmable chip select #1 in the WD7855/LV are considered activity.

PCSM = 1 -
Read or write I/O accesses to the ports defined by the programmable chip select #1 in the WD7855/LV are ignored.



Bit 14 - PMCILS, Power Management Control Input Level Select

PMCILS determines which logic level on the selected PMC input is to be considered active. (See bits 13:11, PMCIS2:0.)

PMCILS = 0 -
PMCIN is active low.

PMCILS = 1 -
PMCIN is active high.

Bits 13:11 - PMCIS(2:0), Power Management Control Input Select

One of the PMC inputs IN7 through IN2 at Port Address 8872H may be selected for detection as a source of activity.

NOTE

The EI and EA bits at Port Address C872H, corresponding to the selected IN signal, should be cleared to prevent the IN signal from being latched internally.

PMCIS	2	1	0	
	0	0	0	- PMC input 2 selected
	0	0	1	- PMC input 3 selected
	0	1	0	- PMC input 4 selected
	0	1	1	- PMC input 5 selected
	1	0	0	- PMC input 6 selected
	1	0	1	- PMC input 7 selected
	1	1	0	- Reserved
	1	1	1	- Disabled, no PMC inputs checked

Bit 10 - NMIM, Non-maskable Interrupt Mask

NMIM = 0 -
The NMI output is used as a source of activity.

NMIM = 1 -
The NMI output is ignored.

Bit 09 - HDDM, Hard Disk Data Port Mask

HDDM = 0 -
If the hard disk chip select has been enabled by bit 01 at Port Address 2872H, I/O read and write operations to the 16-bit hard disk data port are allowed as a source of activity.

HDDM = 1 -
The hard disk data port I/O is ignored.

Bit 08 - COPM, Coprocessor Mask

COPM = 0 -
I/O cycles to the coprocessor are treated as a source of activity. For an 80386SX system, this is when A23 is high and M/I/O is low.

COPM = 1 -
I/O to the coprocessor is ignored.

Bits 07:06 - IMS1:0, Interrupt Mask Select

The local attention generated by the Activity Monitor will be routed to an available interrupt input to invoke a service routine. That interrupt is not to be detected as a source of activity. IMS(1:0) provide a selection of four possible inputs to be used for this function and masks the corresponding IRR and ISR bits as sources of activity.

IMS	1	0	
	0	0	- IRQ5 masked
	0	1	- IRQ10 masked
	1	0	- IRQ11 masked
	1	1	- IRQ15 masked

Bit 05 - IRR8M, Interrupt Request Register 8 Mask

IRR8M = 0 -
Real-Time Clock Interrupt (IRR8) may be detected as a source of activity. Bit 15 in the Activity Monitor Control Register at Port Address B072H must also be set.

IRR8M = 1 -
Real-Time Clock Interrupt (IRR8) is ignored.

NOTE

See Test Enable Register (A872H), Section 11.3 for information about IRQ9 enable control.

See SMI Auxiliary Control Register (5472H), Section 10.10, for a definition of the activity masks for PCS2 and PCS3.



Bit 04 - IRR7M, Interrupt Request Register 7 Mask

IRR7M = 0 -
Parallel Port or Spurious Interrupt (IRR7) may be detected as a source of activity. Bit 15 in the Activity Monitor Control Register at Port Address B072H must also be set.

IRR7M = 1 -
Parallel Port or Spurious Interrupt (IRR7) is ignored.

Bit 03 - IRR0M, Interrupt Request Register 0 Mask

IRR0M = 0 -
Time Of Day Interrupt (IRR0) may be detected as a source of activity. Bit 15 in the Activity Monitor Control Register at Port Address B072H must also be set.

IRR0M = 1 -
Time Of Day Interrupt (IRR0) is ignored.

Bit 02 - ISR8M, Interrupt Service Register 8 Mask

ISR8M = 0 -
Real-Time Clock Interrupt (ISR8) may be detected as a source of activity.

ISR8M = 1 -
Real-Time Clock Interrupt (ISR8) is ignored.

Bit 01 - ISR7M, Interrupt Service Register 7 Mask

ISR7M = 0 -
Parallel Port or Spurious Interrupt (ISR7) may be detected as a source of activity.

ISR7M = 1 -
Parallel Port or Spurious Interrupt (ISR7) is ignored.

Bit 00 - ISR0M, Interrupt Service Register 0 Mask

ISR0M = 0 -
Time of Day Interrupt (ISR0) may be detected as a source of activity.

ISR0M = 1 -
Time Of Day Interrupt (ISR0) is ignored.

9.14 3V SUSPEND (HIBERNATION) SHADOW REGISTERS

The 3V suspend mode provides maximum power savings for the system. The contents of the DRAM, Chip Set Registers, CPU Registers and Video RAM are all written to the hard disk and then all voltages are shut down, including the power supply. The only logic left on in this mode is the real-time clock and a 3 volt suspend controller. The real-time clock and the 3 volt suspend controller run off of the real-time clock battery. When the resume request is sampled by the suspend controller, the suspend controller enables the power supply and resumes the system.

To maintain compatibility with the IBM AT, the timer and DMA registers cannot be read back. To overcome this, these registers are shadowed and read back through other registers. (See the descriptions for register B872H in Section 5.4.15, register D072H in Section 9.9, register D472H in Section 9.10, registers 3C72H, 4472H and 4C72H in Section 9.14.1, 9.14.2 and 9.14.3.)

9.14.1 DMA Shadow Register 1

Port Address 3C72H - Read only

15	14	13	12	11	10	09	08
AD_DEC2	AUTO 2	TRA_TYP2		TRA_MOD1		AD_DEC1	AUTO 1

07	06	05	04	03	02	01	00
TRA_TYP1		TRA_MOD0		AD_DEC0	AUTO 0	TRA_TYPO	

Signal Name	Default At RSTIN
All Signals	0

Bit 15 - AD_DEC2, Address Decrement 2

AD_DEC bit of register at Port Address 00BH for DMA channel 2.

Bit 14 - AUTO2, Autoinitialize 2

AUTO bit of register 00BH for DMA channel 2.

Bits 13:12 - TRA_TYP2, Transfer Type 2

TRA_TYP bits of register at Port Address 00BH for DMA channel 2.



Bits 11:10 - TRA_MOD1, Transfer Mode 1

TRA_MOD bits of register at Port Address 00BH for DMA channel 1.

Bit 09 - AD_DEC1, Address Decrement 1

AD_DEC bit of register at Port Address 00BH for DMA channel 1.

Bit 08 - AUTO1, Autoinitialize 1

AUTO bit of register at Port Address 00BH for DMA channel 1.

Bits 07:06 - TRA_TYP1, Transfer Type 1

TRA_TYP bits of register at Port Address 00BH for DMA channel 1.

Bits 05:04 - TRA_MOD0, Transfer Mode 0

TRA_MOD bits of register at Port Address 00BH for DMA channel 0.

Bit 03 - AD_DEC0, Address Decrement 0

AD_DEC bit of register at Port Address 00BH for DMA channel 0.

Bit 02 - AUTO0, Autoinitialize 0

AUTO bit of register at Port Address 00BH for DMA channel 0.

Bits 01:00 - TRA_TYP0, Transfer Type 0

TRA_TYP bits of register at Port Address 00BH for DMA channel 0.

Bits 15:14 - TRA_TYP6, Transfer Type 6

TRA_TYP bits of register at Port Address 0D6H for DMA channel 6.

Bits 13:12 - TRA_MOD5, Transfer Mode 5

TRA_MOD bits of register at Port Address 0D6H for DMA channel 5.

Bit 11 - AD_DEC5, Address Decrement 5

AD_DEC bit of register at Port Address 0D6H for DMA channel 5.

Bit 10 - AUTO5, Autoinitialize 5

AUTO bit of register at Port Address 0D6H for DMA channel 5.

Bits 09:08 - TRA_TYP5, Transfer Type 5

TRA_TYP bits of register at Port Address 0D6H for DMA channel 5.

Bits 07:06 - TRA_MOD3, Transfer Mode 3

TRA_MOD bits of register at Port Address 00BH for DMA channel 3.

Bit 05 - AD_DEC3, Address Decrement 3

AD_DEC bit of register at Port Address 00BH for DMA channel 3.

Bit 04 - AUTO3, Autoinitialize 3

AUTO bit of register at Port Address 00BH for DMA channel 3.

Bits 03:02 - TRA_TYP3, Transfer Type 3

TRA_TYP bits of register at Port Address 00BH for DMA channel 3.

Bits 01:00 - TRA_MOD2, Transfer Mode 2

TRA_MOD bits of register at Port Address 00BH for DMA channel 2.

9.14.2 DMA Shadow Register 2

Port Address 4472H - Read only

15	14	13	12	11	10	09	08
TRA_TYP6		TRA_MOD5		AD_DEC5	AUTO5	TRA_TYP5	

07	06	05	04	03	02	01	00
TRA_MOD3		AD_DEC3	AUTO3	TRA_TYP3		TRA_MOD2	

Signal Name

Default At RSTIN

All signals 0



9.14.3 DMA Shadow Register 3

Port Address 4C72H - Bit 15 Read and Write
Bits 14:0 Read only

15	14	13	12	11	10	09	08
SCB		EX_WR	RO_PRI		CO_DIS	TRA_MOD7	

07	06	05	04	03	02	01	00
AD_DEC7	AUTO7	TRA_TYP7		TRA_MOD6		AD_DEC6	AUTO6

Signal Name **Default At RSTIN**

All signals 0

Bit 15 - SCB, Shadow Control Bit

For more information regarding SCB see Sections 9.14.4 and 9.14.5)

SCB = 0 -
EX_WR, RO_PRI and CO_DIS from the Command Register at Port Address 0D0H is presented on bits 13, 12 and 10.

SCB = 1 -
EX_WR, RO_PRI and CO_DIS from the Command Register at Port Address 008H is presented on bits 13, 12 and 10.

Bit 14, Reserved

Bit 13 - EX_WR, Extended Write

If SCB = 0, this is EX_WR of Port Address 008H.

If SCB = 1, this is EX_WR of Port Address 0D0H.

Bit 12 - RO_PRI, Rotating Priority

If SCB = 0, this is RO_PRI of Port Address 008H.

If SCB = 1, this is RO_PRI of Port Address 0D0H.

Bit 11, Reserved

Bit 10 - CO_DIS, Controller Disabled

If SCB = 0, this is CO_DIS of Port Address 008H.

If SCB = 1, this is CO_DIS of Port Address 0D0H.

Bits 09:08 - TRA_MOD7, Transfer Mode 7

TRA_MOD bits of register at Port Address 0D6H for DMA channel 7.

Bit 07 - AD_DEC7, Address Decrement 7

AD_DEC bit of register at Port Address 0D6H for DMA channel 7.

Bit 06 - AUTO7, Autoinitialize 7

AUTO bit of register at Port Address 0D6H for DMA channel 7.

Bits 05:04 - TRA_TYP7, Transfer Type 7

TRA_TYP bits of register at Port Address 0D6H for DMA channel 7.

Bits 03:02 - TRA_MOD6, Transfer Mode 6

TRA_MOD bits of register at Port Address 0D6H for DMA channel 6.

Bit 01 - AD_DEC6, Address Decrement 6

AD_DEC bit of register at Port Address 0D6H for DMA channel 6.

Bit 00 - AUTO6, Autoinitialize 6

AUTO bit of register at Port Address 0D6H for DMA channel 6.

9.14.4 DMA Base Address and Count Register

When the SCB (bit 15 of DMA Shadow Register 3) is high, the DMA base address and base count can be read back from channels 0 through 7. When SCB is low, channels 0 through 7 represents the current address and current count.

9.14.5 Timer Count

When SCB (bit 15 of DMA Shadow Register 3) is high, the timer base count can be read back from registers at Port Addresses 040H:043H. When SCB is low, the registers at Port Addresses 040H:043H represents the timer current count. Refer to Sections 5.6 through 5.6.6



9.15 SUSPEND AND RESUME

When the WD7855/LV is in the Suspend Mode, it typically draws less than 500 μ A. Figures 9-2 and

9-3 illustrate the steps that the WD7855/LV goes through during suspend and resume.

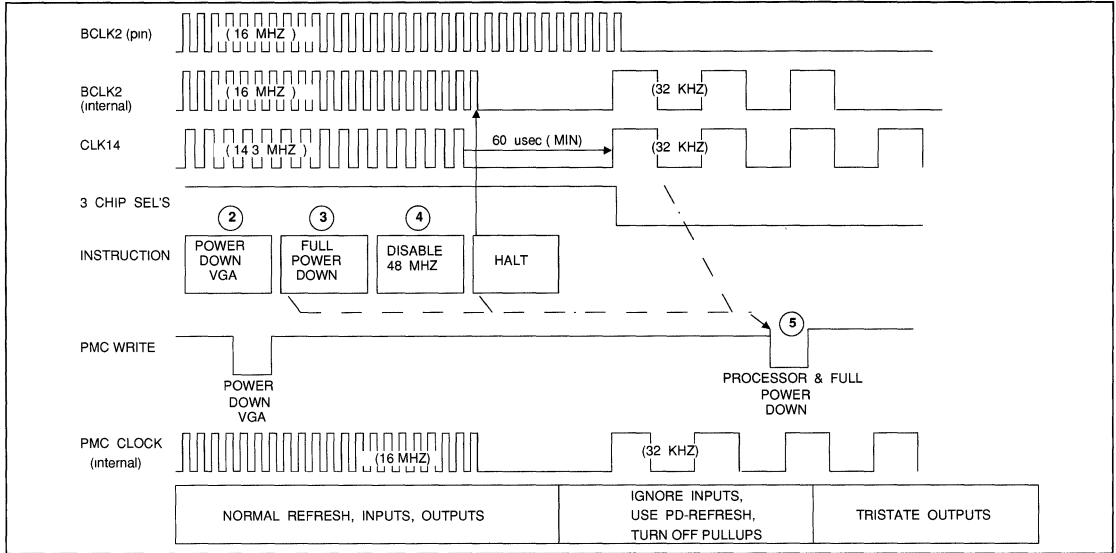

FIGURE 9-2. SUSPEND

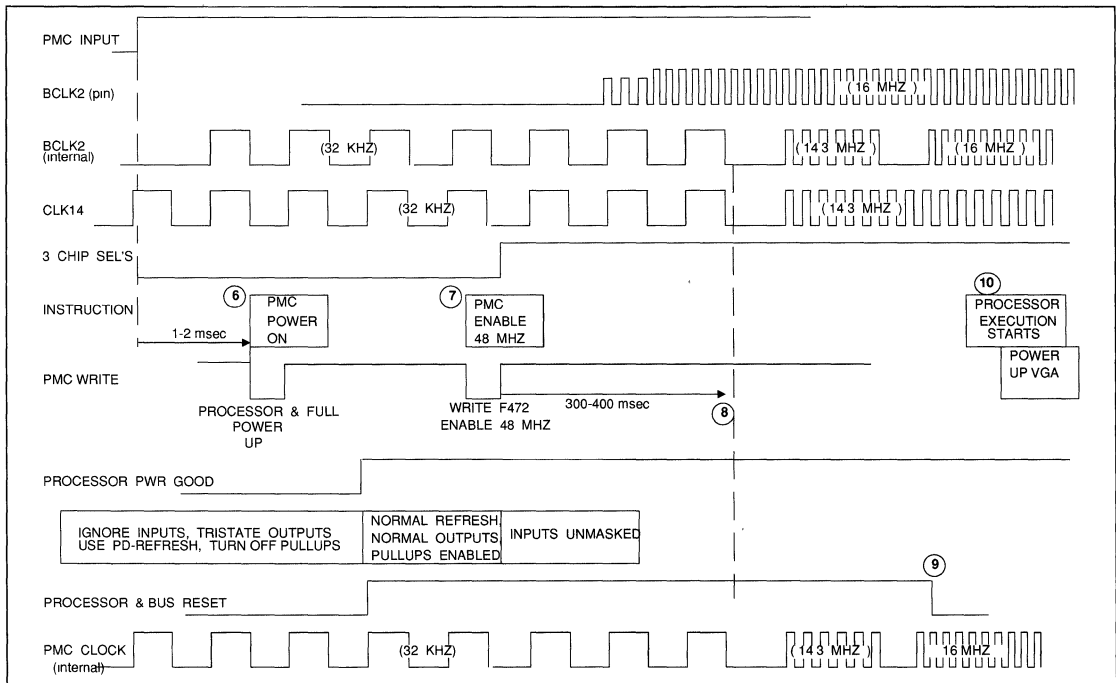

FIGURE 9-3. RESUME



9.15.1 Suspend/Resume Sequence

This section describes the suspend/resume sequence shown in Figures 9-2 and 9-3. It is an approach for a low power mode for the WD7855/LV chip set that offers the lowest power drain possible, but still allows the main system DRAM and video DRAM to be kept alive. This power-down mode requires specialized suspend/resume SMI Code software to control the operation. Figure 9-4 highlights the inter-connection within the chip set.

9.15.1.1 Going into Suspend Mode

1. A change in the PMC input signals the WD7855/LV to generate either SMI or LCL_ATN. The processor vectors to the power-down routine and the processor saves its internal states and the states of the peripherals that are to be powered down. The processor saves the states into a protected area of the system DRAM.
2. The power-down routine writes to the full-power-down bit (FPD bit 13 at Port Address 1872H) which enables the power-down sequence. The WD7855/LV switches to sampling of the PMC inputs with the 14.318 MHz clock instead of the AT BUS clock.
3. The processor then writes to an I/O register in the WD7855/LV that switches a PMC output that is connected to the PWRDN input pin of the WD90C2X. Upon assertion of the PWRDN signal, the VGA controller enters the power-down mode which refreshes the video DRAM via the AT BUS REFRESH signal. CAS before RAS refresh is the preferred way of refreshing the DRAMs because it allows lower power operation without the generation of a DRAM refresh address.
4. The processor then writes to the Disable 48 MHz register (F072H) which sends a code of 15 to the WD7855/LV encoded chip select bus (ENCSBUS). The WD76C20 decodes this write and disables its 48 MHz oscillator, glitchlessly switches the 14.318 MHz oscillator signal to a 32 KHz, 50% duty cycle signal and then disables the 14.318 MHz oscillator. The WD76C20 also asserts the CSSERA, CSSERB and CSPAR signals simultaneously which signals the WD76C30A to disable its 48 MHz oscillator. When this

oscillator is disabled, the AT BUS CLOCK, KEYBOARD CLOCK and 80287 CLOCK are disabled. The processor executes a halt instruction and the WD7855/LV detects the halt status from the processor and switches from the AT compatible refresh to the PDREF controlled refresh. The WD7855/LV then switches the AT bus compatible REFRESH output signal to reflect that of the PDREF input signal.

The PDREF input is a CMOS level clock signal that has a 124 μ s period and a low going pulse of 200 ns to 1 μ s. This signal is always active and is adequate for refreshing low power DRAMs. This signal is generated by the WD76C20.

5. Upon detecting that the 14.318 MHz clock has been changed to 32 KHz, the WD7855/LV tristates all outputs except the PMC controls, DRAM controls, RAD bus and AT bus REFRESH signal. The CPURES signal is asserted and then tristated and is pulled high through a 200K pull-up resistor. All inputs except RSTIN, CLK14 and the PMC are ignored, and all circuitry except the PMC and refresh logic is stopped.

The power is now turned off to the CPU, BUS, etc., by the assertion of the FULLPWDN PMC output from the WD7855/LV.

6. The processor-power-good PMC input must now go low in order for this state machine to start monitoring a resume condition as described in Section 9.15.1.2

9.15.1.2 Coming Out Of Suspend Mode (Resume)

1. The WD7855/LV is now sampling the PMC inputs at 32 KHz. At this time, the change of any enabled PMC input causes the FULLPWDN PMC output described in step 5 to switch, which powers up the processor, bus etc. After 1 ms (timed from the 32 KHz clock input), the WD7855/LV samples the processor-power-good PMC input. When active the CPURES is driven high and the rest of the WD7855/LV control outputs are driven to their correct states, a BUS RESET is issued also.



2. Upon detecting the power-good signal, the WD7855/LV state machine performs a write to the ENABLE 48 MHz register which sends a code of 16 on the ENCSBUS.
3. The WD76C20 receives the code, enables the 48 MHz and 14.318 MHz oscillators and de-asserts the CSSERA, CSSERB and CSPAR signals. After approximately 100 ms (enable time for the oscillators), the WD76C20 glitchlessly switches the 32 KHz signal to 14.318 MHz.
4. The WD76C30A enables its 48 MHz oscillator upon the de-assertion of its CSSERA, CSSERB and CSPAR input signals.
5. When the WD7855/LV detects that the 32 KHz has been switched to 14.318 MHz, it switches the PMC sampling to the AT BUS CLOCK. The WD7855/LV then switches from the PDREF controlled refresh to the AT compatible refresh. The WD7855/LV also switches the AT bus REFRESH signal from the PDREF input to the AT compatible refresh rate. The WD7855/LV de-asserts the CPURESET signal and the processor comes out of reset and checks the shutdown status in the RTC RAM. This tells the processor that it is coming out of full-power-down mode as opposed to a warm or cold boot. The processor then restores the states of the machine.
6. The processor writes to the WD7855/LV register that causes the WD7855/LV to de-assert its PMC output. This output is connected to PWRDN input of the WD90C2X signaling the WD90C2X to come out of the power-down mode.



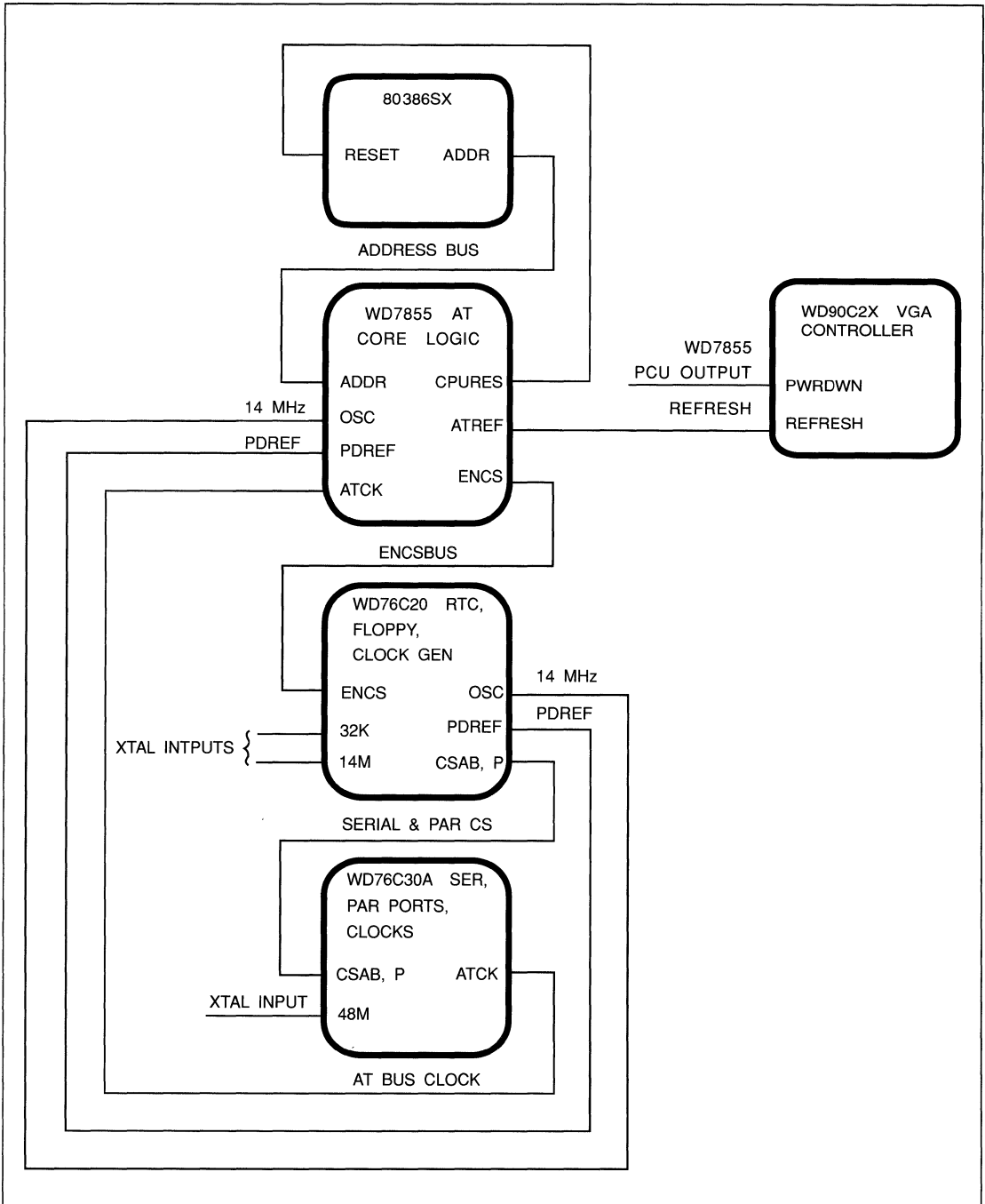

FIGURE 9-4. FULL POWER-DOWN MODE SYSTEM BLOCK DIAGRAM

10.0 SYSTEM MANAGEMENT INTERRUPT (SMI)

10.1 I/O TRAPS

In order to conserve power, certain I/O peripherals can be put to sleep when they are not in use. To accomplish this in a transparent manner, hardware must intercept (trap) any accesses made to the sleeping device and wake it up before allowing the access to proceed. The System Controller can trap accesses to I/O devices controlled by the following chip selects:

- Programmable Chip Select 1
- Programmable Chip Select 2
- Programmable Chip Select 3
- Serial Port A Chip Select
- Serial Port B Chip Select
- Parallel Port Chip Select

When access to an I/O device is trapped, the System Controller asserts the SMI pin 108 to the CPU. Control is transferred to the SMI handler routine which determines which I/O access caused the SMI handler to be invoked. The handler looks at Registers 7C72H and 8472H to determine the I/O address accessed and how many bytes have been read or written. If the I/O access was unaligned, up to three I/O transfers may have taken place since SMI only breaks CPU execution on an instruction boundary. A memory write can also occur if the CPU is executing a string input instruction. If unaligned, the memory write can also involve up to three transfers.

Registers 8C72H and 9472H contain either the data written to the I/O device or the memory address written while trapping a string input instruction. Using this information allows the SMI handler to reconstruct the events causing the I/O trap. The handler can then wake up the I/O device, repeat the I/O instruction, rewrite memory if needed, and finally exit to allow normal code execution to continue.

The SMI handler is located in SMI RAM. SMI RAM consists of 64 Kbytes of DRAM space taken from the top of the DRAM space specified by Register 7472H. Once the SMI service routine is loaded into SMI RAM space, the SMI RAM space can be hidden from system access and remapped to SMI address space 6000:0H. The only way to access the SMI address space after remap is to put the CPU in SMI mode.

10.2 SMI I/O TRAP CONTROL REGISTER

Port Address 7C72H - Bits 15:08 Read and Write
Bit 07 Read and Clear
Bits 06:00 Read only

15	14	13	12	11	10	09	08
LAEN	NAC_1:0		PCS TPE	PC2 TPE	SPA TPE	SPB TPE	PAR TPE

07	06	05	04	03	02	01	00
TRPS	IOWS	IOS_2:0			MS_2:0		

Signal Name	Default At RSTIN
LAEN	0
NAC_1:0	0
PCSTPE	0
SPATPE	0
PARTPE	0

Bit 15 - LAEN, Local Attention Enable

There are three sources that can cause the Local Attention PMC output to be asserted. One is a transition on an unmasked PMC input pin (see description for Registers 8872H and C872H). The second is a signal from the system activity monitor (see description for Registers B072H and D872H). The third is a watch-dog timer. These sources will also cause an SMI if LAEN is set high. The SMI is based on an internal version of Local Attention and occurs even if PMC updates are disabled.

LAEN = 0 -

Disables generation of $\overline{\text{SMI}}$ by a Local Attention

LAEN = 1 -

Enables $\overline{\text{SMI}}$ to be caused by a Local Attention



Bits 14:13 - NAC_(1:0), Next Address Control 1:0

NAC_(1:0) control the function of the \overline{NA} output at pin 125. These bits **must not** be changed while in SMI Mode.

NAC1	NAC0	FUNCTION
0	0	\overline{NA} is always deasserted, forcing all 80386SX cycles to be nonpipelined.
0	1	\overline{NA} is always asserted, allowing the 80386SX to run pipelined whenever possible.
1	0	Reserved setting. Do not use.
1	1	\overline{NA} is normally asserted allowing pipelined cycles. However, \overline{NA} is de-asserted during T1P (pipelined cycle) or the first T2 (nonpipelined cycle) of all I/O cycles, except coprocessor cycles. \overline{NA} is asserted again in the next T state unless SMI is active. This setting must be used if pipelining is allowed when I/O traps are enabled.

Bit 12 - PCSTPE, Programmable Chip Select Trap Enable

PCSTPE, when set to 1, enables an I/O trap to occur whenever an I/O read or write occurs at an address within the range covered by the Programmable Chip Select (See Registers 2872H and 3072H).

PCSTPE = 0 -
Disable Trap

PCSTPE = 1 -
Enable Trap

Bit 11 - PC2TPE, Programmable Chip Select 2 Trap Enable

PC2TPE, when set to 1, enables an I/O trap to occur whenever an I/O read or write occurs at an address within the range covered by the second programmable chip select (see Registers 5C72H and 6472H). This trap occurs even if the ENPCS2 bit in Register 5C72H is not set.

PC2TPE = 0 -
Disable Trap

PC2TPE = 1 -
Enable Trap

Bit 10 - SPATPE, Serial Port A Chip Select Trap Enable

SPATPE, when set to 1, enables an I/O trap to occur whenever an I/O read or write occurs at an address within the range covered by the Serial Port A Chip Select (see Register 2072H).

SPATPE = 0 -
Disable Trap

SPATPE = 1 -
Enable Trap

Bit 09 - SPBTPE, Serial Port B Chip Select Trap Enable

SPBTPE, when set to 1, enables an I/O trap to occur whenever an I/O read or write occurs at an address within the range covered by the Serial Port B Chip Select (see Register 2072H).

SPBTPE = 0 -
Disable Trap

SPBTPE = 1 -
Enable Trap

Bit 08 - PARTPE, Parallel Port Chip Select Trap Enable

PARTPE, when set to 1, enables an I/O trap to occur whenever an I/O read or write occurs at an address within the range covered by the Parallel Port Chip Select (see Register 2072H).

PARTPE = 0 -
Disable Trap

PARTPE = 1 -
Enable Trap

Bit 07 - TRPS, Trap Status

When read as a 1, TRPS indicates an I/O trap has occurred. If read as a zero, no I/O trap has occurred. The SMI handler can poll this status bit to determine if an I/O trap caused the SMI. When SMI is written as a zero, the TRPS, IOWS, IOS2:0 and MS2:0 status bits are all reset to 0, readying the I/O trap state machines to capture future I/O and memory cycles. This should be done by the SMI handler each time it services an I/O trap. Writing a 1 to TRPS has no effect.

Bit 6 - IOWS, I/O Write Status

IOWS is set when the I/O cycle that caused the trap is a write operation. This tells the SMI handler that the contents of Registers 8C72H and 9472H hold the data that was written to the I/O device. This bit is cleared during reset or when a 0 is written to TRPS.

Bits 5:3 - IOS2:0, I/O Address Status 2:0

IOS2:0 provide information about the I/O Cycles captured by the I/O trap (See Table 10-1). This information, along with the I/O address of the first transfer stored in Register 8472H, can be used to reconstruct the complete sequence that may have occurred due to an unaligned transfer. These bits are cleared during reset or when a 0 is written to TRPS.

Bits 2:0 - MS2:0, Memory Address Status 2:0

MS2:0 provide information about memory write cycles, if any, captured by the I/O trap (See Table 10-2). Memory write cycles will only be captured if an indivisible string input instruction is being executed. The status information from MS2:0, along with the memory address of the first transfer stored in Registers 8C72H and 9472H, can be used to reconstruct the complete sequence that may have occurred due to an unaligned transfer. MS2:0 are cleared during reset or when a 0 is written to TRPS.

10.3 SMI I/O ADDRESS CAPTURE REGISTER

Port Address 8472H - Read only

15	14	13	12	11	10	09	08
Captured I/O Address							
CIOA 15	CIOA 14	CIOA 13	CIOA 12	CIOA 11	CIOA 10	CIOA 09	CIOA 08

07	06	05	04	03	02	01	00
Captured I/O Address							
CIOA 07	CIOA 06	CIOA 05	CIOA 04	CIOA 03	CIOA 02	CIOA 01	CIOA 00

Signal Name	Default At RSTIN
CIOA15:0	0

Bits 15:0 - CIOA15:0, Captured I/O Address

CIOA15:0 hold the I/O address being written or read which caused the I/O trap to occur. If multiple I/O cycles were required due to an unaligned transfer, then this is the first address and may need to be adjusted as discussed in the description of the IOS2:0 bits in Register 7C72H. These bits are cleared during reset or when a 0 is written to TRPS (Register 7C72H).

IOS2	IOS1	IOS0	BIT 0 OF 8472H	TRANSFER TYPE	ADJUSTMENT TO REG. 8472H TO OBTAIN ACTUAL I/O ADDRESS
0	0	0	X	None	Only occurs after a clear
0	0	1	X	16-bit	No adjustment needed
0	1	0	X	32-bit	No adjustment needed
0	1	1	X	32-bit	Subtract 2
1	0	0	X	32-bit	Subtract 1
1	0	1	X	8-bit	No adjustment needed
1	1	0	0	16-bit	Subtract 1
1	1	0	1	16-bit	No adjustment needed
1	1	1	X	32-bit	Subtract 3

X = Don't Care

TABLE 10-1. I/O ADDRESS STATUS



10.4 I/O DATA/MEMORY ADDRESS CAPTURE REGISTER LOW

Port Address 8C72H - Read only

15	14	13	12	11	10	09	08
Memory Address or I/O Data							
MAID 15	MAID 14	MAID 13	MAID 12	MAID 11	MAID 10	MAID 09	MAID 08

07	06	05	04	03	02	01	00
Memory Address or I/O Data							
MAID 07	MAID 06	MAID 05	MAID 04	MAID 03	MAID 02	MAID 01	MAID 00

Signal Name	Default At RSTIN
MAID15:00

Bits 15:0 - MAID 15:0, Memory Address or I/O Data Bits

MAID 15:0 holds 16 bits of either the memory address being written after SMI was asserted or the I/O data being written to the I/O address which caused the I/O trap to occur. The

IOWS bit in Register 7C72H indicates the type of data. If IOWS is a 1, then this register holds data being written to the I/O device. If IOWS is 0, then this register holds the address of the memory being written, if any. This register is cleared during reset or when a 0 is written to TRPS (Register 7C72H).

When capturing the memory write address, this register holds the 16 least significant bits of the address of the first memory write cycle (Register 9472H holds the eight most significant bits). More cycles will be completed if the transfer was unaligned. Status bits MS2:0 in Register 7C72H show how many bytes were written and indicate how to adjust the captured address to get the actual address.

When capturing I/O write data, this register holds up to 16 bits of data, and Register 9472H holds the rest, if any. The data bytes may be stored in a jumbled order if it was an unaligned transfer. The format of the stored data bytes can be obtained from the IOS2:0 bits in Register 7C72H using Table 10-3.

IOS2	IOS1	IOS0	BIT 0 OF 8472H	TRANSFER TYPE	ADJUSTMENT TO REG. 8C72H AND 9472H TO OBTAIN ACTUAL MEMORY ADDRESS
0	0	0	X	None	No memory write cycles occurred
0	0	1	X	16-bit	No adjustment needed
0	1	0	X	32-bit	No adjustment needed
0	1	1	X	32-bit	Subtract 2
1	0	0	X	32-bit	Subtract 1
1	0	1	X	8-bit	No adjustment needed
1	1	0	0	16-bit	Subtract 1
1	1	0	1	16-bit	No adjustment needed
1	1	1	X	32-bit	Subtract 3

X = Don't Care

TABLE 10-2. MEMORY ADDRESS STATUS



10.5 I/O DATA/MEMORY ADDRESS CAPTURE REGISTER HIGH

Port Address 9472H - Read only

15	14	13	12	11	10	09	08
Memory Address or I/O Data							
MAID 31	MAID 30	MAID 29	MAID 28	MAID 27	MAID 26	MAID 25	MAID 24

07	06	05	04	03	02	01	00
Memory Address or I/O Data							
MAID 23	MAID 22	MAID 21	MAID 20	MAID 19	MAID 18	MAID 17	MAID 16

Signal Name **Default At RSTIN**

MAID31:16 0

Bits 15:0 - MAID 31:16, Memory Address or I/O Data Bits

MAID 31:16 holds either 8 bits of the memory address being written after SMI is asserted;

or the 16 bits of I/O data being written to the I/O address which caused the I/O trap to occur. The IOWS bit in Register 7C72H indicates the type of information. If IOWS is a 1, then this register holds data being written to the I/O device. If IOWS is 0, then this register holds the address of the memory being written, if any. This register is cleared during reset or when TRPS (Register 7C72H) is written with a 0.

When capturing the memory write address, MAID(23:16) holds the eight most significant bits of the address of the first memory write cycle (Register 8C72H holds the 16 least significant bits). More cycles will be done if the transfer is unaligned. Status bits MS(2:0) in Register 7C72H show how many bytes were written and indicate how to adjust the captured address to get the actual address.

When capturing I/O write data, this register holds 16 bits of data if it is a 32-bit I/O write. Register 8C72H holds the rest of the data. See Table 10-3.

IOS2	IOS1	IOS0	BIT 0 OF 8472H	DATA SIZE	REGISTER 9472H		REGISTER 8C72H	
					HI BYTE	LO BYTE	HI BYTE	LO BYTE
0	0	0	X	None				
0	0	1	X	16-bit			B1	B0
0	1	0	X	32-bit	B3	B2	B1	B0
0	1	1	X	32-bit	B1	B0	B3	B2
1	0	0	X	32-bit	B0	B3	B2	B1
1	0	1	0	8-bit			-	B0
1	0	1	1	8-bit			B0	-
1	1	0	X	16-bit			B0	B1
1	1	1	X	32-bit	B2	B1	B0	B3

Where: B0 = least significant byte
 B1 = next most significant byte (MSB for 16-bit data)
 B2 = next most significant byte (32-bit data only)
 B3 = most significant byte (32-bit data only)
 X = Don't Care

TABLE 10-3. DATA FORMAT DESCRIPTION



10.6 SMI I/O TIMEOUT

As a power conservation measure, it is desirable to put some I/O peripherals in the Sleep Mode when they are not in use. This may involve shutting off clocks or removing power. In order to do this, there must be a mechanism for determining that a device is not in use. In the System Controller, timers are included for each I/O device that is a candidate for power reduction measures. Each timer causes an $\overline{\text{SMI}}$ when no access is made to an I/O device for a programmable amount of time. The timers are reset by I/O read or write operations to any address which falls within the range of its chip select.

When an $\overline{\text{SMI}}$ is generated, the SMI handler takes whatever action is appropriate to power down the I/O peripheral. The handler then enables the I/O trap for that device so that it can be awakened the next time it is accessed.

10.7 SMI I/O TIMEOUT CONTROL REGISTER

Port Address 9C72H - Bits 15, 04:00 Read and Write
 Bits 14:05 Read only

15	14	13	12	11	10	09	08
FSMI	PCS ADS	PC2 ADS	SPA ADS	SPB ADS	PAR ADS	PCS TOS	PC2 TOS

07	06	05	04	03	02	01	00
SPA TOS	SPB TOS	PAR TOS	PCS TOE	PC2 TOE	SPA TOE	SPB TOE	PAR TOE

Signal Name	Default At RSTIN
All signals	0

Bit 15 - FSMI, Force $\overline{\text{SMI}}$

FSMI provides a means to invoke the SMI handler through software. When this bit is set to 1, the SMI pin 108 is asserted. FSMI should be cleared by the SMI handler before it exits to prevent another $\overline{\text{SMI}}$.

FSMI = 0 - Force $\overline{\text{SMI}}$ Disable
 FSMI = 1 - Force $\overline{\text{SMI}}$ Enable

Bit 14 - PCSADS, Programmable Chip Select Activity Detect Status

PCSADS can be polled by the SMI handler to determine if the programmable chip select I/O address range has been accessed since PCSTOS was set. If PCSADS is set, then an I/O access has occurred since the inactivity timeout was triggered. The SMI handler ignores the timeout and restarts the timeout counter. PCSADS is cleared by reset or when PCSTOE is cleared.

Bit 13 - PC2ADS, Programmable Chip Select 2 Activity Detect Status

PC2ADS can be polled by the SMI handler to determine if the second Programmable Chip Select's I/O address range has been accessed since PC2TOS was set. If PC2ADS is set, then an I/O access has occurred since the inactivity timeout was triggered. The SMI handler ignores the timeout and restarts the timeout counter. PC2ADS is cleared by reset or when PC2TOE is cleared.

Bit 12 - SPAADS, Serial Port A Chip Select Activity Detect Status

SPAADS can be polled by the SMI handler to determine if the Programmable Chip Select's I/O address range has been accessed since SPATOS was set. If SPAADS is set, then an I/O access has occurred since the inactivity timeout was triggered. The SMI handler ignores the timeout and restarts the timeout counter. SPAADS is cleared by reset or when SPATOE is cleared.

Bit 11 - SPBADS, Serial Port B Chip Select Activity Detect Status

SPBADS can be polled by the SMI handler to determine if the Programmable Chip Select's I/O address range has been accessed since SPBTOS was set. If SPBADS is set, then an I/O access has occurred since the inactivity timeout was triggered. The SMI handler ignores the timeout and restarts the timeout counter. SPBADS is cleared by reset or when SPBTOE is cleared.



Bit 10 - PARADS, Parallel Port Chip Select Activity Detect Status

PARADS can be polled by the SMI handler to determine if the programmable chip select I/O address range has been accessed since PARTOS was set. If PARADS is set, then an I/O access has occurred since the inactivity timeout was triggered. The SMI handler ignores the timeout and restarts the timeout counter. PARADS is cleared by reset or when PARTOE is cleared.

Bit 09 - PCSTOS, Programmable Chip Select Timeout Status

PCSTOS can be polled by the SMI handler to determine the source of the SMI. PCSTOS is set when an I/O access timeout has occurred for the Programmable Chip Select I/O address range. PCSTOS is cleared by reset or when PCSTOE is cleared.

Bit 08 - PC2TOS, Programmable Chip Select 2 Timeout Status

PC2TOS can be polled by the SMI handler to determine the source of the SMI. PC2TOS is set when an I/O access timeout has occurred for the second Programmable Chip Select I/O address range. PC2TOS is cleared by reset or when PC2TOE is cleared.

Bit 07 - SPATOS, Serial Port A Chip Select Timeout Status

SPATOS can be polled by the SMI handler to determine the source of the SMI. SPATOS is set when an I/O access timeout has occurred for the Serial Port A Chip Select I/O address range. SPATOS is cleared by reset or when SPATOE is cleared.

Bit 06 - SPBTOS, Serial Port B Chip Select Timeout Status

SPBTOS can be polled by the SMI handler to determine the source of the SMI. SPBTOS is set when an I/O access timeout has occurred for the Serial Port B Chip Select's I/O address range. SPBTOS is cleared by reset or when SPBTOE is cleared.

Bit 05 - PARTOS, Parallel Port Chip Select Timeout Status

PARTOS can be polled by the SMI handler to determine the source of the SMI. PARTOS is set when an I/O access timeout has occurred for the Parallel Port Chip Select I/O address

range. PARTOS is cleared by reset or when PARTOE is cleared.

Bit 04 - PCSTOE, Programmable Chip Select Timeout Enable

PCSTOE = 0 - Programmable Chip Select Timeouts disabled and PCSTOS cleared.

PCSTOE = 1 - I/O access timeout for the Programmable Chip Select I/O address range enabled.

Bit 03 - PC2STOE, Programmable Chip Select 2 Timeout Enable

PC2STOE = 0 - Programmable Chip Select 2 timeouts disabled and PC2TOS cleared.

PC2STOE = 1 - I/O access timeout for the second Programmable Chip Select I/O address range enabled.

Bit 02 - SPATOE, Serial Port A Chip Select Timeout Enable

SPATOE = 0 - Serial Port A Chip Select timeouts disabled and SPATOS cleared.

SPATOE = 1 - I/O access timeout for the Serial Port A Chip Select I/O address range enabled.

Bit 01 - SPBTOE, Serial Port B Chip Select Timeout Enable

SPBTOE = 0 - Serial Port B Chip Select timeouts disabled and SPBTOS cleared.

SPBTOE = 1 - I/O access timeout for the Serial Port B Chip Select I/O address range enabled.

Bit 00 - PARTOE, Parallel Chip Select Timeout Enable

PARTOE = 0 - Parallel Port Chip Select timeouts disabled and PARTOS cleared.

PARTOE = 1 - I/O access timeout for the Parallel Port Chip Select I/O address range enabled.



10.8 SMI I/O TIMEOUT COUNT REGISTER 1

Port Address A472H - Read and Write

15	14	13	12	11	10	09	08
SMI WUE	PCS TC4	PCS TC3	PCS TC2	PCS TC1	PCS TC0	PC2 TC4	PC2 TC3

07	06	05	04	03	02	01	00
PC2 TC2	PC2 TC1	PC2 TC0	SPA TC4	SPA TC3	SPA TC2	SPA TC1	SPA TC0

Signal Name	Default At RSTIN
All signals	0

Bit 15 - SMIWUE, SMI Wake Up Enable

SMIWUE, when set to 1, causes the assertion of SMI to wake up the processor from a power-down or stop clock state. An INTR, NMI, or DMA request continues to wake up the processor as in the WD76C10A, regardless of the state of this bit. Note that setting SMIWUE does not enable SMI to initiate a resume from suspend.

SMIWUE = 0 -
Disable SMI Wakeup

SMIWUE = 1 -
Enable SMI Wakeup

Bits 14:10 - PCSTC 4:0, Programmable Chip Select Timeout Count

PCSTC 4:0, along with the timeout clock select PCSTCS (Register AC72H), determine the time period during which an I/O peripheral, selected by the Programmable Chip Select, must not be accessed in order to be considered inactive. The timeout setting is determined as follows:

PCSTCS = 0 -
(Count in PCSTC4:0) x 4 seconds
Range: from 4 seconds to 2 minutes, 4 seconds
Error: -0, +2 seconds.

PCSTCS = 1 -
(Count in PCSTC4:0) x 40 seconds
Range: from 40 seconds to 20 minutes, 40 seconds
Error: -0, +20 seconds.

Bits 09:05 - PC2TC 4:0, Programmable Chip Select 2 Timeout Count

PC2TC 4:0, along with the timeout clock select PC2TCS (Register AC72H), determine the time period during which an I/O peripheral, selected by Programmable Chip Select 2, must not be accessed in order to be considered inactive. The timeout setting is determined as follows:

PC2TC = 0 -
(Count in PC2TC4:0) x 4 seconds
Range: from 4 seconds to 2 minutes, 4 seconds
Error: -0, +2 seconds.

PC2TC = 1 -
(Count in PC2TC4:0) x 40 seconds
Range: from 40 seconds to 20 minutes, 40 seconds
Error: -0, +20 seconds.

Bits 4:0 - SPATC4:0, Serial Port A Chip Select Timeout Count

SPATC4:0, along with the timeout clock select SPATCS (Register AC72H), determine the time period during which Serial Port A must not be accessed in order to be considered inactive. The timeout setting is determined as follows:

SPATCS = 0 -
(Count in SPATC4:0) x 4 seconds
Range: from 4 seconds to 2 minutes, 4 seconds
Error: -0, +2 seconds.

SPATCS = 1 -
(Count in SPATC4:0) x 40 seconds
Range: from 40 seconds to 20 minutes, 40 seconds
Error: -0, +20 seconds.

10



10.9 SMI I/O TIMEOUT COUNT REGISTER 2

Port Address AC72H - Read and Write

15	14	13	12	11	10	09	08
IOT CTM	SPB TC4	SPB TC3	SPB TC2	SPB TC1	SPB TC0	PAR TC4	PAR TC3

07	06	05	04	03	02	01	00
PAR TC2	PAR TC1	PAR TC0	PCS TCS	PC2 TCS	SPA TCS	SPB TCS	PAR TCS

Signal Name	Default At RSTIN
All signals	0

Bit 15 - IOTCTM, I/O Timeout Counter Test Mode

IOTCTM is for factory use only. When = 1, the timeout counters are placed into test mode.

Bits 14:10 - SPBTC4:0, Serial Port B Chip Select Timeout Count

SPBTC4:0, along with the timeout clock select SPBTCS (Register AC72H), determine the time period during which Serial Port B must not be accessed in order to be considered inactive. The timeout setting is determined as follows:

SPBTCS = 0 -
 (Count in SPBTC4:0) x 4 seconds
 Range: from 4 seconds to 2 minutes, 4 seconds
 Error: -0, +2 seconds.

SPBTCS = 1 -
 (Count in SPBTC4:0) x 40 seconds
 Range: from 40 seconds to 20 minutes, 40 seconds
 Error: -0, +20 seconds.

Bits 09:05 - PARTC4:0, Parallel Port Chip Select Timeout Count

PARTC4:0, along with the timeout clock select PARTCS (Register AC72H), determine the time period during which the parallel port must not be accessed in order to be considered inactive. The timeout setting is determined as follows:

PARTCS = 0 -
 (Count in PARTC4:0) x 4 seconds
 Range: from 4 seconds to 2 minutes, 4 seconds
 Error: -0, +2 seconds.

PARTCS = 1 -
 (Count in PARTC4:0) x 4 seconds
 Range: from 40 seconds to 20 minutes, 40 seconds
 Error: -0, +20 seconds.

Bit 04 - PCSTCS, Programmable Chip Select Timeout Clock Select

PCSTCS selects the clock to be used for the Programmable Chip Select Timeout Counter.

PCSTCS = 0 -
 A high-speed clock is used to obtain 4 second timing resolution for timeout periods of 2 minutes or less.

PCSTCS = 1 -
 A low-speed clock is used to obtain 40 second timing resolution but a longer timeout period of over 20 minutes. See the description of PCSTC4:0 (Register A472H) for more details.

Bit 03 - PC2TCS, Programmable Chip Select 2 Timeout Clock Select

PC2TCS selects the clock to be used for the second Programmable Chip Select Timeout Counter.

PC2TCS = 0 -
 A high-speed clock is used to obtain 4 second timing resolution for timeout periods of 2 minutes or less.

PC2TCS = 1 -
 A low-speed clock is used to obtain 40 second timing resolution, but a longer timeout period of over 20 minutes. See the description of PC2TC4:0 (Register A472H) for more details.



Bit 02 - SPATCS, Serial Port A Chip Select
Timeout Clock Select

SPATCS selects the clock to be used for the Serial Port A Timeout Counter.

SPATCS = 0 -
A high-speed clock is used to obtain 4 second timing resolution for timeout periods of 2 minutes or less.

SPATCS = 1 -
A low-speed clock is used to obtain 40 second timing resolution, but a longer timeout period of over 20 minutes. See the description of SPATC4:0 (Register A472H) for more details.

Bit 01 - SPBTCS, Serial Port B Chip Select
Timeout Clock Select

SPBTCS selects the clock to be used for the Serial Port B Timeout Counter.

SPBTCS = 0 -
A high-speed clock is used to obtain 4-second timing resolution for timeout periods of 2 minutes or less.

SPBTCS = 1 -
A low-speed clock is used to obtain 40 second timing resolution, but a longer timeout period of over 20 minutes. See the description of SPBTC4:0 (Register A472H) for more details.

Bit 00 - PARTCS, Parallel Port Chip Select
Timeout Clock Select

PARTCS selects the clock to be used for the Parallel Port Timeout Counter.

PARTCS = 0 -
A high-speed clock is used to obtain 4-second timing resolution for timeout periods of 2 minutes or less.

PARTCS = 1 -
A low-speed clock is used to obtain 40 second timing resolution, but a longer timeout period of over 20 minutes. See the description of PARTC4:0 (Register A472H) for more details.

10.10 SMI AUXILIARY CONTROL REGISTER

Port Address 5472H - Bits 15, 13, 11, 08, 05:00
Read and Write
Bits 07:06 Read only
Bit 12 Read and clear

15	14	13	12	11	10	09	08
TOM SK		WDO GEN	WDO GST	PCS 3M	PCS 2M	PC3 TPE	PC3 TOE

07	06	05	04	03	02	01	00
PC3 TOS	PC3 ADS	PC3 TC4	PC3 TC3	PC3 TC2	PC3 TC1	PC3 TC0	PC3 TCS

Signal Name	Default At RSTIN
All signals	0

Bit 15 - TOMSK, Timeout Mask

When set to one, TOMSK masks I/O device timeouts from causing assertion of the SMI output. If enabled, the I/O device timers continue to count down. If a timeout occurs, the SMI output is asserted after TOMSK is cleared. Also, when TOMSK is set, the I/O device timers will not detect I/O activity, thus preventing the timer from being reset.

Bit 14 - Reserved

Bit 13 - WDOGEN, Watchdog Timer Interrupt Enable

WDOGEN = 0 -
The interrupt is cleared either by writing a zero to WDOGST or WDOGEN to disable further watchdog interrupts. Note that the first interrupt after the watchdog timer is enabled can occur anytime from 62.5 ms to 125 ms later.

WDOGEN = 1 -
Enables a periodic interrupt to be generated every 125 ms. Each interrupt causes LCL_ATN to be set, so that it is useful both with or without SMI support.



Bit 12 - WDOGTS, Watchdog Timer Interrupt Status

When WDOGTS equals 1, LCL_ATN has been set due to a Watchdog Timer Interrupt Request. WDOGST is cleared by writing a zero to it. The watchdog timer continues to run and will set WDOGST at 125 ms intervals. WDOGST is also cleared when WDOGEN is set to a zero. Writing a 1 to WDOGST has no effect.

Bit 11 - PCS3M, Programmable Chip Select 3 Mask

PCS3M is an extension to the register at Port Address D872H.

PCS3M = 0 -

I/O accesses to the third Programmable Chip Select address range (see registers at Port Address 5C72H and 6C72H) may be observed as a source of activity by the system activity monitor.

PCS3M = 1 -

I/O accesses to the third Programmable Chip Select are masked from being seen by the system activity monitor. Note that the setting of ENPCS3 in the register at Port Address 5C72H has no effect on I/O activity detection.

Bit 10 - PCS2M, Programmable Chip Select 2 Mask

PCS2M is an extension to Register D872H.

PCS2M = 0 -

I/O accesses to the second Programmable Chip Select address range (see registers at Port Address 5C72H and 6472H) are allowed to be observed as a source of activity by the system activity monitor.

PCS2M = 1 -

I/O accesses to the second Programmable Chip Select are masked from being seen by the system activity monitor. Note that the setting of ENPCS2 in the register at Port Address 5C72H has no effect on I/O activity detection.

Bit 09 - PC3TPE, Programmable Chip Select 3 Trap Enable

PC3TPE = 0 -

Trap not enabled

PC3TPE = 1 -

An I/O trap will occur whenever an I/O read or write occurs at an address within the range covered by the third Programmable Chip Select (see registers at Port Address 5C72H and 6C72H). This trap occurs even if the ENPCS3 bit in the register at Port Address 5C72H is not set.

Bit 08 - PC3TOE, Programmable Chip Select 3 Timeout Enable

PC3TOE = 0 -

Programmable Chip Select 3 timeouts are disabled and PC3TOS cleared.

PC3TOE = 1 -

I/O access timeout for the third Programmable Chip Select I/O address range are enabled. The timeout count will be reset by I/O to the Programmable Chip Select 3 address range even if the ENPCS3 bit in Register 5C72H is not set.

Bit 07 - PC3TOS, Programmable Chip Select 3 Timeout Status

PC3TOS is set to 1 when an I/O access timeout has occurred for the third Programmable Chip Select I/O address range. It can be polled by the SMI handler in determining the source of the SMI. PC3TOS is cleared by reset or when PC3TOE is cleared.

Bit 06 - PC3ADS, Programmable Chip Select 3 Activity Detect Status

PC3ADS can be polled by the SMI Handler to see if the third Programmable Chip Select I/O address range has been accessed since PC3TOS was set. If PC3ADS is set, then an I/O access has occurred since the inactivity timeout was triggered. The SMI Handler would ignore the timeout and restart the timeout counter. PC3ADS is cleared by reset or when PC3TOE is cleared.



Bit 05:01 - PC3TC4:0, Programmable Chip Select 3 Timeout Count

PC3TC4:0, along with the timeout clock select PC3TCS, determine the time period during which an I/O peripheral (selected by Programmable Chip Select 3) must not be accessed in order to be considered inactive. The timeout setting is determined as follows:

PC3TCS = 0 -
 (Count in PC3TC4-0) x 4 seconds
 Range: from 4 seconds to 2 minutes, 4 seconds
 Error: -0, +2 seconds.

PC3TCS = 1 -
 (Count in PC3TC4-0) x 40 seconds
 Range: from 40 seconds to 20 minutes, 40 seconds
 Error: -0, +20 seconds.

Bit 00 - PC3TCS, Programmable Chip Select 3 Timeout Clock Select

PC3TCS selects the clock to be used for the third Programmable Chip Select timeout counter.

PC3TCS = 0 -
 A high-speed clock is used to obtain 4 second timing resolution for timeout periods of 2 minutes or less.

PC3TCS = 1 -
 A low-speed clock is used to obtain 40 second timing resolution but a longer timeout period of over 20 minutes. See the description of PC3TC4:0 for more details.

10.11 PROGRAMMABLE CS2 AND CS3 CONTROL REGISTER

Port Address 5C72H - Read and Write

15	14	13	12	11	10	09	08
PCS 2L	ENP CS2	UMS K2	2LM SK4	2LM SK3	2LM SK2	2LM SK1	2LM SK0

07	06	05	04	03	02	01	00
PCS 3L	ENP CS3	UMS K3	3LM SK4	3LM SK3	3LM SK2	3LM SK1	3LM SK0

Signal Name	Default At RSTIN
All signals	0

Bit 15 - PCS2L, Programmable Chip Select 2 Location

PCS2L = 0 -
 The device is located on the RA0:7/ED0:7 bus.

PCS2L = 1 -
 The I/O device selected by the second Programmable Chip Select is located on the expansion bus.

Bit 14 - ENPCS2, Enable Programmable Chip Select 2

ENPCS2 = 0 -
 The second Programmable Chip Select is not enabled.

ENPCS2 = 1 -
 The second Programmable Chip Select is enabled.

Bit 13 - UMSK2, Upper Address Bits Mask 2

UMSK2 = 0 -
 Bits A15:10 from the register at Port Address 6472H are ignored.

UMSK2 = 1 -
 A15:10 from the register at Port Address 6472H are compared against CPU address Bits 15:10 when qualifying the second programmable chip select.



Bits 12:08 - 2LMSK4:0, Programmable CS2
Lower Address Bits MASK4:0

2LMSK4:0 bits allow individual qualification of the lower five address bits in the register at Port Address 6472H.

2LMSK4:0 = 0 -

The corresponding bit in the register at Port Address 6472H is ignored in the comparison. This allows address ranges of up to 32 bytes to be supported (2LMSK4:0 would all be zeroes), as well as unusual requirements such as odd addresses only.

2LMSK4:0 = 1 -

The corresponding bit in the register at Port Address 6472H is compared against that CPU address bit.

Bit 07 - PCS3L, Programmable Chip Select 3
Location

PCS3L = 0 -

The device is located on the RA0:7/ED0:7 bus.

PCS3L = 1 -

The I/O device selected by the third Programmable Chip Select is located on the expansion bus.

Bit 06 - ENPCS3, Enable Programmable Chip Select 3

ENPCS3 = 0 -

The third Programmable Chip Select is not enabled.

ENPCS3 = 1 -

The third Programmable Chip Select is enabled.

Bit 05 - UMSK3, Upper Address Bits Mask 3

UMSK3 = 0 -

Bits A15:10 are ignored.

UMSK3 = 1 -

A15:10 from the register at Port Address 6C72H are compared against CPU address bits 15:10 when qualifying the third Programmable Chip Select.

Bits 04:00 - 3LMSK4:0, Programmable CS3
Lower Address Bits Mask

3LMSK4:0 allow individual qualification of the lower five address bits in the register at Port Address 6C72H.

3LMSK4:0 = 0 -

The corresponding bit in the register at Port Address 6C72H is ignored in the comparison. This allows address ranges of up to 32 bytes to be supported (3LMSK4:0 would all be zeroes), as well as unusual requirements such as odd addresses only.

3LMSK4:0 = 1 -

The corresponding bit in the register at Port Address 6C72H is compared against that CPU address bit.

10.12 PROGRAMMABLE CS2 ADDRESS REGISTER

Port Address 6472H - Read and Write

15	14	13	12	11	10	09	08
PC2 A15	PC2 A14	PC2 A13	PC2 A12	PC2 A11	PC2 A10	PC2 A9	PC2 A8

07	06	05	04	03	02	01	00
PC2 A7	PC2 A6	PC2 A5	PC2 A4	PC2 A3	PC2 A2	PC2 A1	PC2 A0

Signal Name	Default At RSTIN
All signals	0

Bits 15:00 - PC2A15:00, Programmable Chip Select 2 Address

PC2A15:00 determine the base address of the I/O device corresponding to the second programmable chip select. The register at Port Address 5C72H provides the enable for Programmable Chip Select 2 and allows selective masking of some of the address bits.



10.13 PROGRAMMABLE CS3 ADDRESS REGISTER

Port Address 6C72H - Read and Write

15	14	13	12	11	10	09	08
PC3 A15	PC3 A14	PC3 A13	PC3 A12	PC3 A11	PC3 A10	PC3 A9	PC3 A8

07	06	05	04	03	02	01	00
PC3 A7	PC3 A6	PC3 A5	PC3 A4	PC3 A3	PC3 A2	PC3 A1	PC3 A0

Bits 15:00 - PC3A15:00, Programmable Chip Select 3 Address

PC3A15:00 determine the base address of the I/O device corresponding to the third Programmable Chip Select. The register at Port Address 5C72H provides the enable for Programmable Chip Select 3 and allows selective masking of some of the address bits.

Signal Name	Default At RSTIN
All signals	0



11.0 DIAGNOSTIC MODE

Two testing modes are provided for board testing. One chip test mode is provided for leakage testing.

Tristate Output Mode

Simultaneously asserting MASTER, MEMR and MEMW with A1 and A2 low while RSTIN is asserted, causes all output pins to become tristated. The outputs remain tristated if RSTIN is de-asserted while MASTER, MEMR and MEMW are asserted. The outputs become active drivers when RSTIN is asserted and any of the MASTER, MEMR or MEMW are not asserted. The output tristate mode allows an in-circuit board tester to drive the System Controller's output pins.

I/O Pin Mapping Mode

The I/O Pin Mapping Mode provides the in-circuit tester for evaluating the connectivity of the WD7855/LV to the printed circuit board. Simultaneously asserting MASTER, MEMR, MEMW when A1 is high, A2 is low, and RSTIN is asserted, causes the WD7855/LV to switch to I/O Mapping Mode. The WD7855/LV stays in this mode if RSTIN is de-asserted while MASTER, MEMR, and MEMW are asserted.

Full Tristate Mode

Simultaneously asserting MASTER, MEMR, and MEMW with A1 low and A2 high while RSTIN is asserted, causes all the output pins of the WD7855/LV to tristate and disables all the pullup and pulldown resistors. The WD7855/LV stays in this mode if RSTIN is de-asserted while MASTER, MEMR and MEMW are asserted. The outputs become active drivers when RSTIN is asserted with either MASTER, MEMR or MEMW de-asserted. This allows the tester to test for leakage current of the device.

Pullup and Pulldown Test Mode

Simultaneously asserting MASTER, MEMR, MEMW with A1 and A2 high while RSTIN is asserted, causes all the output pins of the WD7855/LV to become tristated and enables all the pullup and pulldown resistors. The WD7855/LV stays in this mode if RSTIN is de-asserted while MASTER, MEMR and MEMW are asserted. The outputs become active drivers when RSTIN is asserted while either MASTER,

MEMR or MEMW is de-asserted. This allows the tester to test the pullup and pulldown resistors of the device.

11.1 DIAGNOSTIC REGISTER

Port Address 9872H - Read and Write

15	14	13	12	11	10	09	08
Reserved			CLK_TST	REF_MAS	AUT_20		CLK_SW

07	06	05	04	03	02	01	00
SX	DS	DIAG					

Signal Name	Default At RSTIN
Reserved	None
CLK_TST	0
REF_MAS	0
AUT_A20	0
Bit 09	None
CLK_SW	0
SX	None
DS	0
DIAG	0

Bits 15:13, Reserved

Bit 12 - CLK_TST, Clock Test

Diagnostics for factory use only.

Bit 11 - REF_MAS, Bus Master Refresh

Additional external logic may be required to support the bus master initiated refresh.

REF_MAS = 0 -

Does not support bus master initiated refresh.

REF_MAS = 1 -

Supports bus master initiated refresh.

Bit 10 - AUT_A20, Automatic Gate A20

Normally, the Alternate Gate A20 signal from Port 092H is OR'ed with the 8042 Gate A20.

When the AUT_A20 bit is set, the Alternate Gate A20 control bit automatically changes



state to match the keyboard's Gate A20. Bit 1 (ALT_A20G) of Port 092H is set or reset according to the way 8042 is programmed. When the keyboard data port is read using the D1 keyboard controller command, the state of the Gate A20 status bit is replaced by that of AUT_A20.

The state of the A20 gating signal is available on PMC output 6 by reading Port 7072H (see Table 9-1).

AUT_A20 = 0 -
Normal Alternate Gate A20

AUT_A20 = 1 -
Automatic Gate A20

Bit 09 - Not used, state is ignored.

Bit 08 - CLK_SW, Clock Switch

The short clock switch reset pulse width is 1 μ s plus 16 CPUCLKs. The 80486 processor requires a 1 ms clock switch. (See Section 4.2.3)

CLK_SW = 0 -
Short clock switch reset width

CLK_SW = 1 -
1 ms clock switch reset width

Bit 07 - SX, 80386SX Processor

At power up the System Controller samples the type of processor in the system.

SX = 0 -
80286 processor was detected.

SX = 1 -
80386SX processor was detected.

Bit 06 - DS, Diagnostic Signal

DS represents the state of the diagnostic signal selected by DIAG.

Bits 05:00 - DIAG, Diagnostic Function/Speaker Disable

DIAG selects the diagnostic function to be performed. The DS bit represents the state of the signal selected.

DIAG = 000000 - Diagnostic output disabled, speaker normal.

DIAG = 000001 - Diagnostic output disabled, speaker disabled. This is a method of disabling the speaker without hardware gates.

DIAG = 000010:111111 - Reserved

11.2 DELAY LINE DIAGNOSTIC REGISTER

Port Address A072H - Read and Write

15	14	13	12	11	10	09	08

07	06	05	04	03	02	01	00
LAT	DL	DELAY					

Signal Name	Default At RSTIN
Bits 15:08	None
LAT	0
DL	0
DELAY	None

Bit 07 - LAT, Latch Output Strength

The delay line count value (bits 05:00) is used to control the output buffer strength. The output buffer strength is normally adjusted every time the delay count changes. LAT may be used to lock the buffer strength at its present value.

LAT = 0 -
The output buffer strength is adjusted when the delay count changes.

LAT = 1 -
The output buffer strength is locked at its present value.

Bit 06 - DL, Delay Freeze

The internal self tuning delay line normally is updated by one delay element during every refresh cycle. For test purposes, the delay may be forced to stop generating calibration cycles. When delay line updates are frozen, the tester may write different delay line counter values in bits 05:00.

DL = 0 -
Normal delay line operation

DL = 1 -
Freeze delay line



Bits 05:00 - DELAY, Delay Counter Value

The delay line counter value is used to control the output buffer strength.

This register may be written to when DL (bit 06) is set to one.

11.3 TEST ENABLE REGISTER

Port Address A872H - Bits 15:10 Read only
 Bits 09:00 Read and Write

The test function bits 07:03 are for factory use only.

15	14	13	12	11	10	09	08
SVER				BF40	BC40	IRQ9 EN	TDL

07	06	055	04	03	02	01	00
OLD_ HLDA	BFC 3	BIST 3	BFC40	BIST 40	EN_ PLD	DIS FA	EN_ LVL

Signal Name	Default At RSTIN
All signals	0

Bits 15:12 - SVER, Secondary Version Number.

DEVICE PORT ADDRESS D472H			SECONDARY VERSION PORT ADDRESS A872H				
14	13	Device	15	14	13	12	Rev
0	0	WD76C10	0	0	0	0	A
0	1	WD7710/7910	0	0	0	1	B
1	0	WD7855	0	0	1	0	C
1	1	Reserved	-	-	-	-	-
			1	1	1	1	P

TABLE 11-1. EXTENDED VERSION NUMBER

Bit 11 - BF40, EMS Register Self Test Status

Bit 10 - BC40, EMS Register Self Test Status

Bit 09 - IRQ9EN, IRQ9 Enable

IRQ9EN is used to mask IRR9 and ISR9 so that the System Activity Monitor does not detect these signals. This prevents vertical retrace from being a source of activity for SAM.

IRQ9EN = 0 -
 Masking of IRR9 and ISR9 enabled

IRQ9EN = 1
 Masking disabled

Bit 08 - TDL, Test Delay Line.

Bit 07 - OLD_HLDA,
 Test bit for factory use only. Must be set to 0.

Bit 06 - BFC3,
 DMA Register file test bit, for factory use only. Must be set to 0.

Bit 05 - BIST3,
 DMA Register file test bit, for factory use only. Must be set to 0.

Bit 04 - BFC40,
 EMS Mapping RAM test bit, for factory use only. Must be set to 0.

Bit 03 - BIST40,
 EMS Mapping RAM test bit, for factory use only. Must be set to 0.

Bit 02 - EN_PLD, Enable Pulldown
 EN_PLD = 0 -
 Pulldown resistors are not enabled.
 EN_PLD = 1 -
 40K to 100K internal pulldown resistors will be enabled during processor power down or full power down on processor address lines A23:00, and on processor data lines D15:00.



Bit 01 - DISFA, Disable First Access

DISFA should be set to 1 when any of the following conditions are true:

1. 33 MHz operation.
2. External lookaside cache mode enabled (Port Address 3872H bits 13 and 12 = 01).
3. Whenever an odd number of memory banks of equal size are enabled, i.e. 3 banks of 512K X 9 memory.

DISFA = 0 -
First access Page Mode cycles are not disabled.

DISFA = 1 -
First access Page Mode cycles are disabled. Page Miss cycles occur instead.

Bit 00 - EN_LVL, Enable Level

The Interrupt Controller may be programmed to support Level Sensitive Mode for diagnostic adapters which may need to test this capability. See Section 5.5.2.1.

EN_LVL = 0 -
Level Sensitive Interrupt Mode in the 8259 Interrupt Controller is not supported. L_T (bit 3) at Port 020H has no effect.

EN_LVL = 1 -
Level Sensitive Interrupt Mode in the 8259 Interrupt Controller is supported. L_T (BIT 3) at Port 020H now controls the selection of edge-sensed or level-sensed interrupts.

11.4 TEST STATUS REGISTER

Port Address DC72H - Read only
For factory use only.

15	14	13	12	11	10	09	08
Delay Line Status CAL MED SLOW			DLT6	DLT5	DLT4	DLT3	DLT2

07	06	05	04	03	02	01	00
DLT1	DLR0	BF34	BF33	BF32	BF31	BF30	BC

Signal Name	Default At RSTIN
All signals	None

Bit 15 - CAL, Calibration

CAL = 0 -
Internal delay line has not completed initial calibration.

CAL = 1 -
Internal delay line has completed initial calibration.

Bits 14:13 - MED, SLOW, Medium and Slow

These bits provide information regarding the output buffer strength.

MED SLOW

0	0	Output buffers are set to low strength (fast WD7855/LV).
0	1	Invalid
1	0	Output buffers are set to medium strength (medium speed WD7855/LV).
1	1	Output buffers are set to full strength (slow WD7855/LV).

Bits 12:06 - DLT6:DLT0,

These bits provide information about internal nodes and are for test purposes only. Their state is dependent upon the test mode selected and the speed of the WD7855/LV.

Bits 05:01 - BF34:BF30,

These bits provide information about internal nodes and are for test purposes only. Their state is dependent upon the test mode selected and the speed of the WD7855/LV.

Bit 00 - BC

This bit provides information about internal nodes and are for test purposes only. Its state is dependent upon the test mode selected and the speed of the WD7855/LV.



12.0 DC ELECTRICAL SPECIFICATIONS

This section provides the DC Operating Characteristics for the WD7855. The parameters for the WD7855LV that differ from these are marked with an * and appear in the appendix.

12.1 MAXIMUM RATINGS

Supply Voltage (V_{DD}) with respect to V_{SS} (ground)	$V_{DD} - V_{SS} \leq 7.0$ Volts
Voltage on any pin with respect to V_{SS} (ground)	$V_{SS} - 0.3$ Volts to $V_{DD} + 0.3$ Volts
Operating Temperature	0°C (32°F) to 70°C (158°F)
Storage Temperature	-40°C (-40°F) to 125°C (257°F)
Power Dissipation	600 mW *

NOTE

Maximum limits indicate where permanent device damage occurs. Continuous operation at these limits is not intended and should be limited to those conditions specified in the DC Operating Characteristics.

Pins 84:101 pass ESD at 700V, all others pass at 2000V.

12.2 DC OPERATING CHARACTERISTICS

$T_A = 0^{\circ}\text{C}$ (32°F) to 70°C (158°F)

$V_{DDAT} = +5V \pm 2.5V$ (5%) for WD7855 *

$V_{DD} = +5V \pm 2.5V$ (5%) *

SYMBOL	CHARACTERISTIC	MIN	MAX	UNIT	CONDITIONS
IIL	Input Leakage		± 10	μA	$V_{in} = .4$ to V_{DD}
IOZ	Tristate and Open Drain Output Leakage		± 10	mA	$V_{out} = .4$ to V_{DD}
VIH	Input High Voltage	2.0		V	
VIL	Input Low Voltage		.8	V	
VIHC	CPUCLK Input High *	3.6		V	
VIL	CPUCLK Input Low		.6	V	
VIH	$\overline{\text{RSTIN}}$ Input High Voltage	V_{DD} -0.5		V	
VIL	$\overline{\text{RSTIN}}$ Input Low Voltage		0.5	V	
ICC	Supply Current *		200 140	mA mA	Inputs at 2.0V Inputs at 5.0V Outputs Open, CPUCLK = 50 MHz
			240 180	mA mA	Inputs at 2.0V Inputs at 5.0V Outputs Open, CPUCLK = 66 MHz
ICCAT	Supply Current		15 10	mA mA	Inputs at 2.0V Inputs at 5.0V
ICCSB	Typical Supply Current, Power Down Mode for WD7855/LV		.5	mA	Typical, CPUCLK Off, CLK14 = 32 KHz

TABLE 12-1. DC OPERATING CHARACTERISTICS



FOR PINS WITH INTERNAL PULLUPS:

MASTER, IOCK, IOCS16, MEMCS16, ZEROWS, IOCHRDY, RDYIN, PDREF

SYMBOL	CHARACTERISTIC	MIN	MAX	UNIT	CONDITIONS
IIL	Input Pullup Current *	-45	-160	μA	Not suspend and resume mode

TABLE 12-1. DC OPERATING CHARACTERISTICS (Continued)

M//IO, NPERR, NPBUSY, NPRST, CPURES, DPH, DPL, NONCAC, ADS, D/C, W/R

SYMBOL	CHARACTERISTIC	MIN	MAX	UNIT	CONDITIONS
IIL	Input Pullup Current *	-45	-160	μA	Not processor power down or suspend mode

TABLE 12-1. DC OPERATING CHARACTERISTICS (Continued)

PMCIN, IOCHRDY, ZEROWS, IOCS16, MEMCS16, MASTER, PDREF, REFRESH, BHE, IOR, IOW, MEMR, MEMW

SYMBOL	CHARACTERISTIC	MIN	MAX	UNIT	CONDITIONS
IIL	Input Pullup Current *	-45	-160	μA	Not suspend mode

TABLE 12-1. DC OPERATING CHARACTERISTICS (Continued)

SDT/R, CAS3, CAS2

SYMBOL	CHARACTERISTIC	MIN	MAX	UNIT	CONDITIONS
IIL	Input Pullup Current *	-45	-160	μA	RESET IN = 0

TABLE 12-1. DC OPERATING CHARACTERISTICS (Continued)**FOR PINS WITH INTERNAL PULLDOWNS:**

A(23:00), D(15:00), BLE

SYMBOL	CHARACTERISTIC	MIN	MAX	UNIT	CONDITIONS
IIL	Input Pulldown Current *	-45	-160	μA	Processor power down or suspend mode

TABLE 12-1. DC OPERATING CHARACTERISTICS (Continued)

FOR OUTPUTS:

DACKEN, D(15:00), $\overline{\text{READY}}$, CPURES, HOLDR, INTRQ, A(23:00), NMI, DPH, DPL, RA(11:08), RA7/ED7:RA0/ED0, $\overline{\text{BHE}}$, $\overline{\text{RAS}}$ (7:0), $\overline{\text{CAS}}$ (3:0), W/R, DT/R, $\overline{\text{DEN}}$ ₁, $\overline{\text{DEN}}$ ₀, SDT/R, $\overline{\text{SDEN}}$, CSEN, LOMEG, A20GATE, KEN, FLUSH, SMI

SYMBOL	CHARACTERISTIC	MIN	MAX	UNIT	CONDITIONS
VOH	Output High Voltage *	$V_{DD} - .8$		V	IOUT = -100 μ A
VOH	Output High Voltage *	2.4		V	IOUT = -2 mA
VOL	Output Low Voltage *		.4	V	IOUT = 2 mA

TABLE 12-1. DC OPERATING CHARACTERISTICS (Continued)**FOR OUTPUTS:**

MXCTL2:0

SYMBOL	CHARACTERISTIC	MIN	MAX	UNIT	CONDITIONS
VOH	Output High Voltage	$V_{DD} - .8$		V	IOUT = -100 μ A
VOH	Output High Voltage *	2.4		V	IOUT = -2 mA
VOL	Output Low Voltage *		.4	V	IOUT = 2 mA

TABLE 12-1. DC OPERATING CHARACTERISTICS (Continued)**FOR OUTPUTS:**

$\overline{\text{IOR}}$, $\overline{\text{IOW}}$, MEMR, $\overline{\text{MEMW}}$, AEN, SYSCLK, BALE, LA20, SA0

SYMBOL	CHARACTERISTIC	MIN	MAX	UNIT	CONDITIONS
VOH	Output High Voltage	2.4		V	IOUT = -3 mA
VOL	Output Low Voltage *		.5	V	IOUT = 24 mA

TABLE 12-1. DC OPERATING CHARACTERISTICS (Continued)**FOR OUTPUTS:**

$\overline{\text{REFRESH}}$, IOCHRDY

SYMBOL	CHARACTERISTIC	MIN	MAX	UNIT	CONDITIONS
VOL	Output Low Voltage *		.5	V	IOUT = 24 mA

TABLE 12-1. DC OPERATING CHARACTERISTICS (Continued)

13.0 AC OPERATING CHARACTERISTICS

The AC Operating Characteristics are divided into three major categories: Memory Timing (Section 13.1), AT Bus Timing (Section 13.2) and Processor Timing (Section 13.3).

This section provides the AC Operating Characteristics for the WD7855. The parameters for the WD7855LV that differ from these are marked with an * and appear in the appendix.

Table 13-1 lists the timing tables and figures, and their section location.

TABLE NUMBER	FIGURE NUMBER	TITLE	SECTION
13-3	13-1	80386SX - Page Mode Memory Timing	13.1.1
	↓	80386SX - Page Mode, First Access Read/Write	
13-4	13-6	80386SX - Page Mode, Write Miss Following a Write	13.1.2
	↓	80386SX - Non-Page Mode 00 and Mode 01	
	13-7	Page Read/Write Hit With Extra Wait State Enabled	
13-5	↓	80386SX - Non-Page Mode 01 - 0 Wait State Write	13.2.1
	13-16	CPU Initiated AT Bus Cycles	
	13-17	AT Bus I/O or Memory Read: 8-Bit, Default Timing	
13-6	↓	AT Bus I/O or Memory Write: 16-Bit, Default Timing	13.2.2
	13-26	Entering the AT Bus	
	13-27	80386SX CPU - BREQ Delay = 1/2 Clock	
13-7	13-28	80386SX CPU - BREQ Delay = 1 Clock	13.2.3
	13-29	80386SX CPU - Synchronous CPUCLK to SYSCLK	
	13-30	Exiting the AT Bus	
13-8	↓	Synchronous AT Bus Cycle Completion, AT Bus Clock = 1/2 CPUCLK	13.2.4
	13-33	Asynchronous AT Bus Cycle Completion, BAK_DEL = 0 or +0.5 AT Bus Cycles	
	13-34	DMA Cycles	
13-9	13-35	Basic DMA Cycle, Default Timing	13.2.5
	13-36	DMA Cycle, 8-Bit I/O to On-board Memory	
	13-37	DMA Cycle, On-board Memory to 8-Bit I/O	
13-10	13-38	AT Bus Master Cycle	13.2.6
	13-39	AT Bus Master, Bus Acquisition/Release	
	13-40	AT Bus Master, Write to On-board Memory	
13-11	13-41	AT Bus Master, Read from On-board Memory	13.3
	↓	AT Bus Refresh Cycle, Default Timing	
13-12	13-48	AT Bus Refresh Cycle, Default Timing	13.3
	13-49	80386SX CPU Timing	
	13-41	80386SX - CPURES and NPRST During Power Up	
	↓	80386SX - Output Delay Timing	
	13-48	WD7855 SMI Timing	
	13-49	I/O Trap Cycle With Am386SXLV	

TABLE 13-1. TIMING FIGURE/TABLE NUMBERS



SIGNAL	LOAD	SIGNAL	LOAD	SIGNAL	LOAD
$\overline{\text{SMI}}$	50 pF	$\overline{\text{NA}}$	50 pF	$\overline{\text{SMIRDY}}$	50 pF
$\overline{\text{KEN}}$	50 pF	A20GATE	50 pF	FLUSH	50 pF
CPURES	50 pF	$\overline{\text{NPRST}}$	50 pF	$\overline{\text{BHE}}$	50 pF
$\overline{\text{W/R}}$	50 pF	ALE	50 pF	$\overline{\text{DEN1, DENO}}$	50 pF
$\overline{\text{SDEN}}$	50 pF	$\overline{\text{DT/R}}$	50 pF	$\overline{\text{SDT/R}}$	50 pF
$\overline{\text{MXCTL(2:0)}}$	50 pF	DACKEN	50 pF	$\overline{\text{CSEN}}$	50 pF
$\overline{\text{LOMEG}}$	50 pF	SPKR	50 pF	$\overline{\text{READY}}$	50 pF
$\overline{\text{HOLDR}}$	50 pF	$\overline{\text{INTRQ}}$	50 pF	NMI	50 pF
$\overline{\text{BUSYCPU}}$	50 pF	$\overline{\text{EPEREQ}}$	50 pF	A(23:00)	60 pF
$\overline{\text{CPUCLK}}$	70 pF	$\overline{\text{SYSCLK}}$	75 pF	$\overline{\text{DPH}}$	100 pF
$\overline{\text{CAS(3:0)}}$	100 pF	D(15:00)	100 pF	$\overline{\text{IOW}}$	200 pF
DPL	100 pF	$\overline{\text{RAS(7:0)}}$	75 pF	MEMR	200 pF
$\overline{\text{IOR}}$	200 pF	$\overline{\text{MEMW}}$	200 pF	AEN	200 pF
LA20	200 pF	SA0	200 pF	RA(11:00) *	350 pF
BALE	200 pF	$\overline{\text{REFRESH}}$	200 pF		

TABLE 13-2. SIGNAL LOADING



13.1 MEMORY TIMING**13.1.1 80386SX Page Mode Timing**

Sections 13.1.1 and 13.1.2 present the memory timing for Page Mode and Non-Page Mode, for the 80386SX processor.

Categories are grouped as follows:

- 80386SX
 - Page Mode
 - Non-Page Mode 00 and 01

SYMBOL	CHARACTERISTIC	MAX 20 MHz	MAX 25 MHz	MAX 33 MHz
T200	Processor address to RAM address valid, Page Hit	34	27	27
T201	CPUCLK rise to $\overline{\text{CAS}}$ fall, 2.5 CLK CAS	31	25	20
T202	CPUCLK fall to $\overline{\text{CAS}}$ rise	24	21	21
T203	CPUCLK fall to $\overline{\text{CAS}}$ fall, 2.0 CLK $\overline{\text{CAS}}$	27	22	22
T204	Processor data to parity valid	25	20	20
T205	CPUCLK rise to RAM address valid, Page Miss	48	43	43
T206	CPUCLK rise to WNRDRAM rise	31	28	28
T207	CPUCLK fall to RAS fall, first access	27	21	21
T208	CPUCLK rise to COLUMN address valid	49	33	30
T209	CPUCLK rise to WNRDRAM fall	31	28	28
T212	CPUCLK rise to $\overline{\text{RAS}}$ rise, Page Miss	27	24	24
T213	CPUCLK fall to $\overline{\text{RAS}}$ fall, Page Miss	27	24	24
T214	CPUCLK rise to $\overline{\text{READY}}$ fall *	19	18	18
T215	CPUCLK rise to $\overline{\text{READY}}$ rise *	19	18	18

TABLE 13-3. 80386SX - PAGE MODE MEMORY TIMING

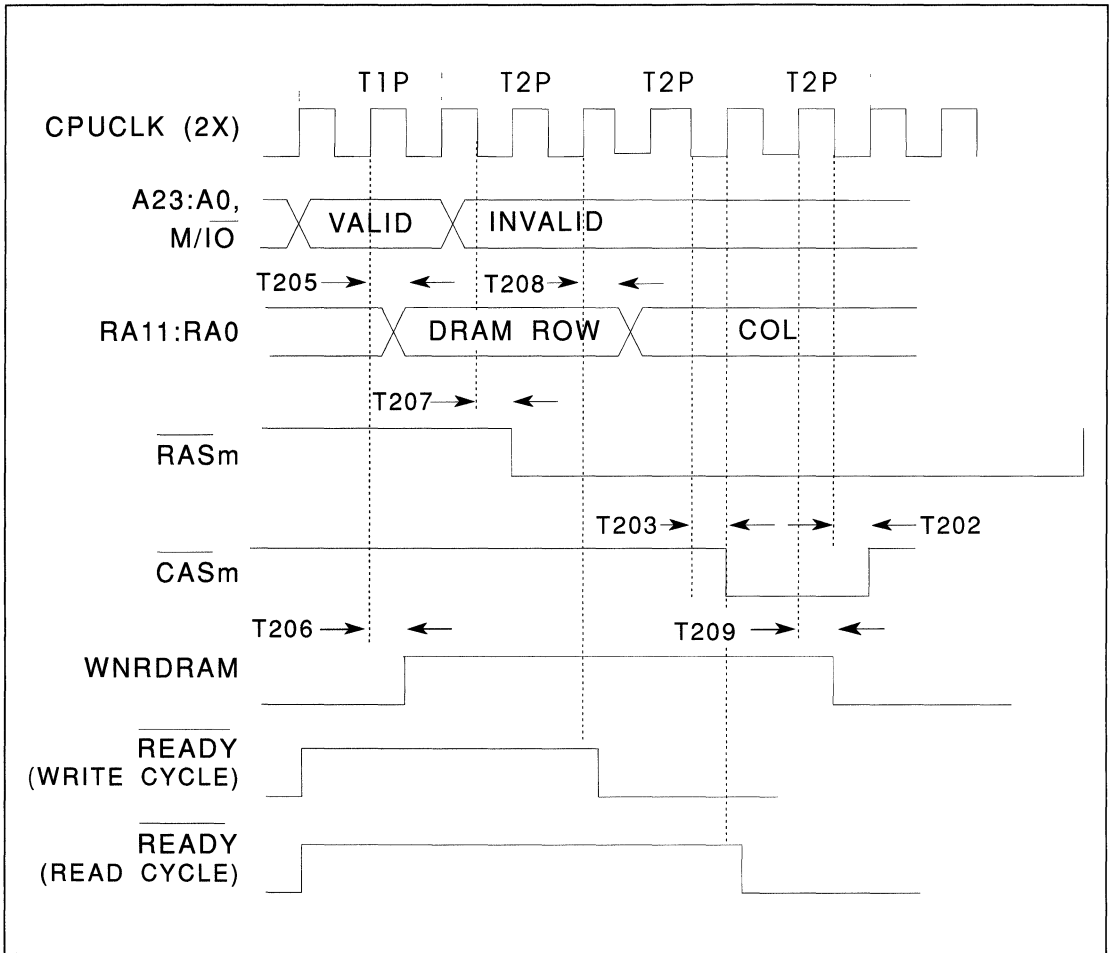

FIGURE 13-1. 80386SX - PAGE MODE, FIRST ACCESS READ/WRITE



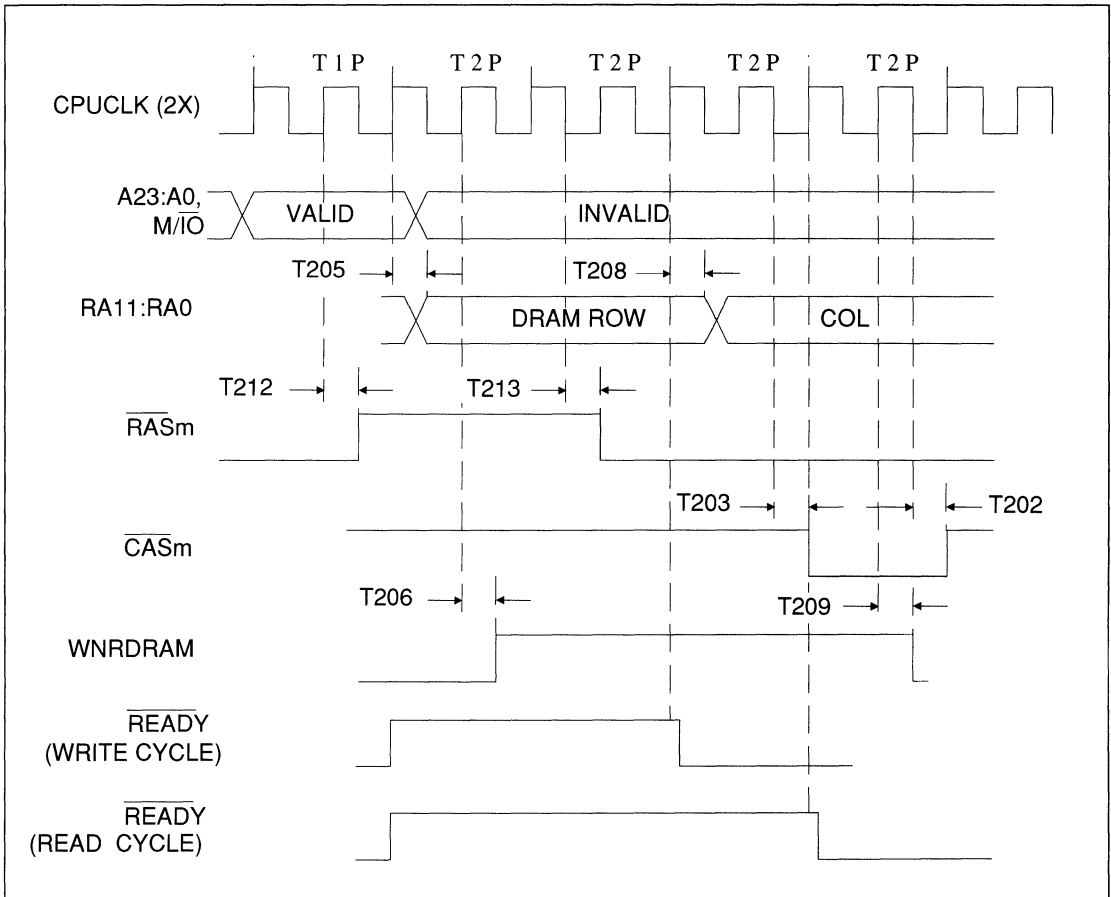

FIGURE 13-2. 80386SX - PAGE MODE, PAGE MISS READ/WRITE



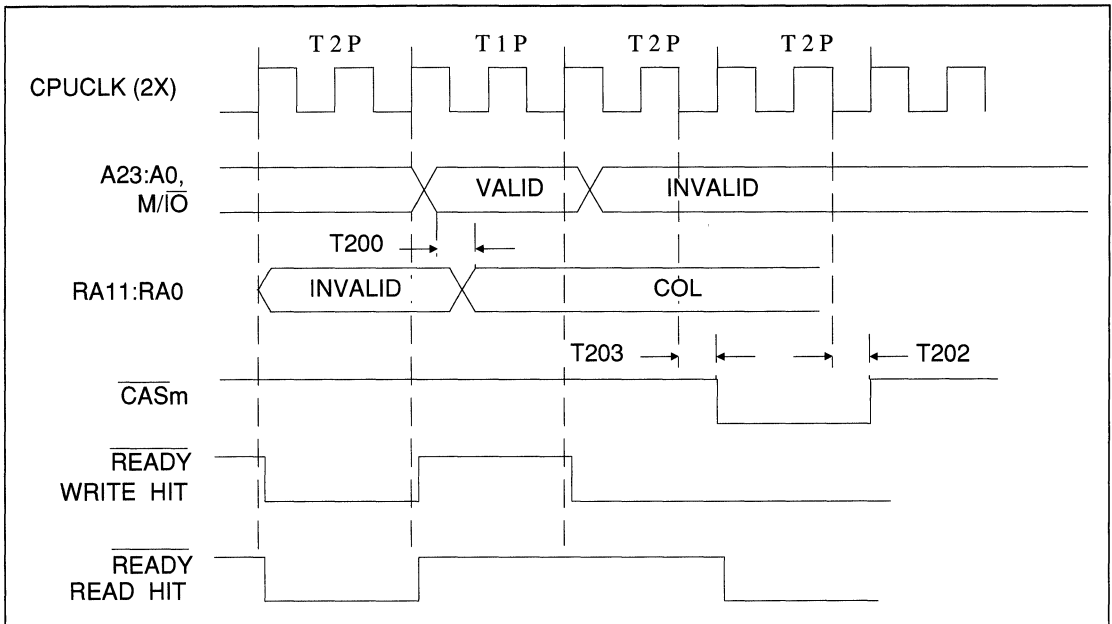

FIGURE 13-3. 80386SX - PAGE MODE, READ CYCLE FOLLOWED BY A PAGE HIT

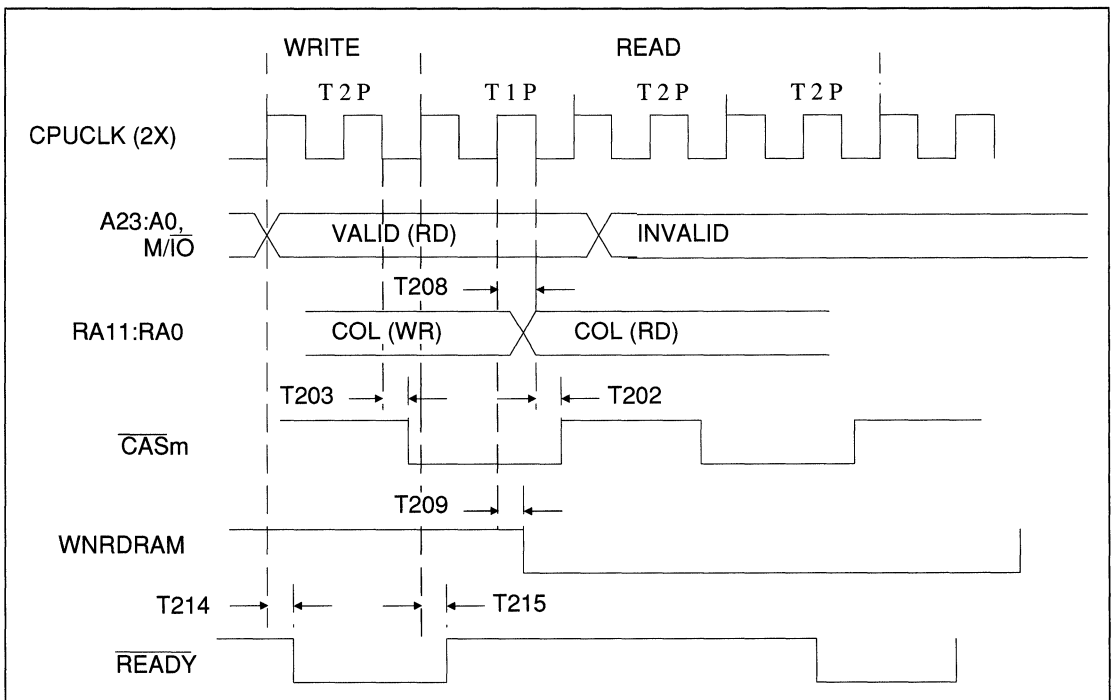

FIGURE 13-4. 80386SX - PAGE MODE, READ AFTER WRITE



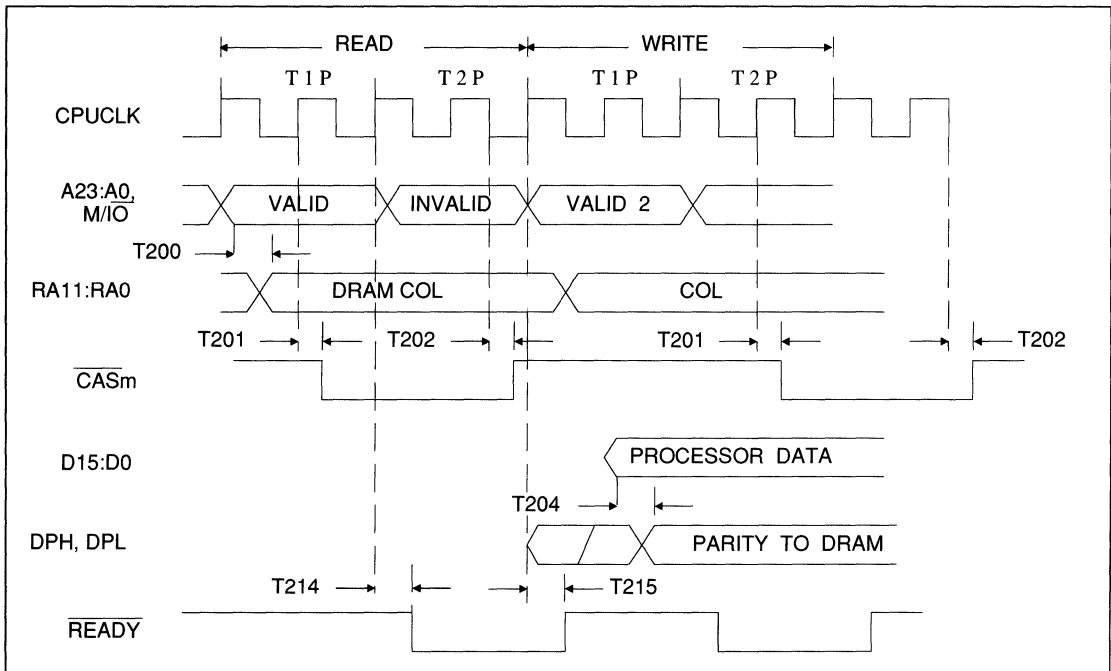

FIGURE 13-5. 80386SX - PAGE MODE, READ HIT FOLLOWED BY A WRITE HIT

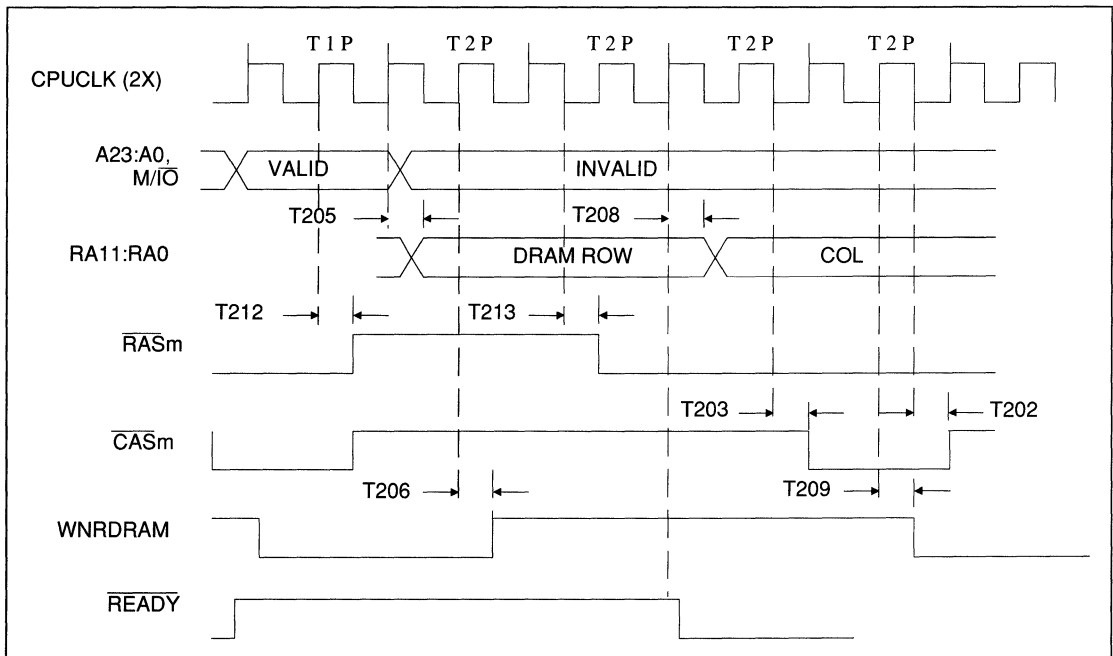

FIGURE 13-6. 80386SX - PAGE MODE, WRITE MISS CYCLE FOLLOWING A WRITE CYCLE



13.1.2 80386SX Non-Page Mode 00 and Mode 01 Timing

SYMBOL	CHARACTERISTIC	MAX 20 MHz	MAX 25 MHz	MAX 33 MHz
T204	See Table 13-3			
T214	See Table 13-3			
T215	See Table 13-3			
T240	CPUCLK rise to $\overline{\text{ROW}}$ address valid	42	42	42
T241	CPUCLK fall to $\overline{\text{CAS}}$ fall	27	27	27
T242	CPUCLK rise to $\overline{\text{CAS}}$ rise	28	24	24
T243	CPUCLK rise to $\overline{\text{WNRDRAM}}$ fall	28	28	28
T244	CPUCLK rise to $\overline{\text{WNRDRAM}}$ rise	28	28	28
T245	CPUCLK rise to $\overline{\text{RAS}}$ fall	25	23	23
T246	CPUCLK rise to $\overline{\text{RAS}}$ rise	25	23	23
T247	CPUCLK fall to $\overline{\text{RAS}}$ rise	29	29	29
T248	CPUCLK fall to COLUMN address valid	44	44	44
T249	CPUCLK rise to $\overline{\text{CAS}}$ fall	29	29	29
T260	CPUCLK rise to COLUMN address	43	41	41

TABLE 13-4. 80386SX - NON-PAGE MODE 00, 01 MEMORY TIMING



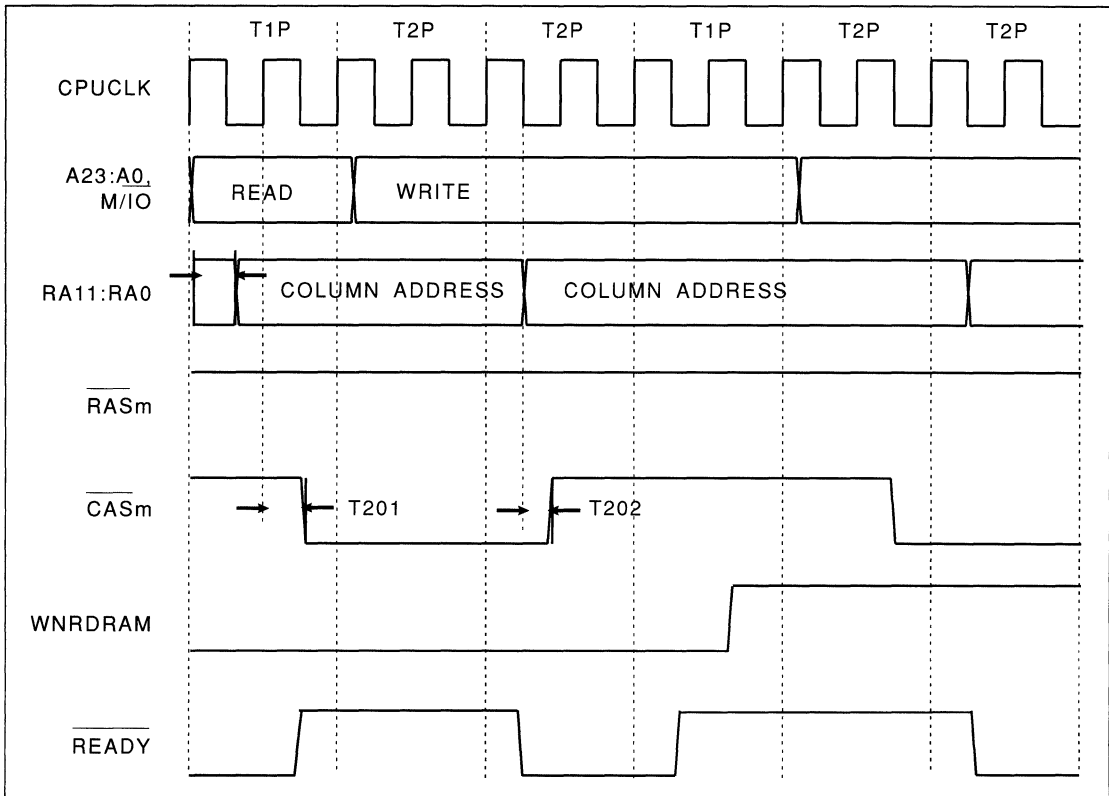

FIGURE 13-7. PAGE READ/WRITE HIT WITH EXTRA WAIT STATE ENABLE

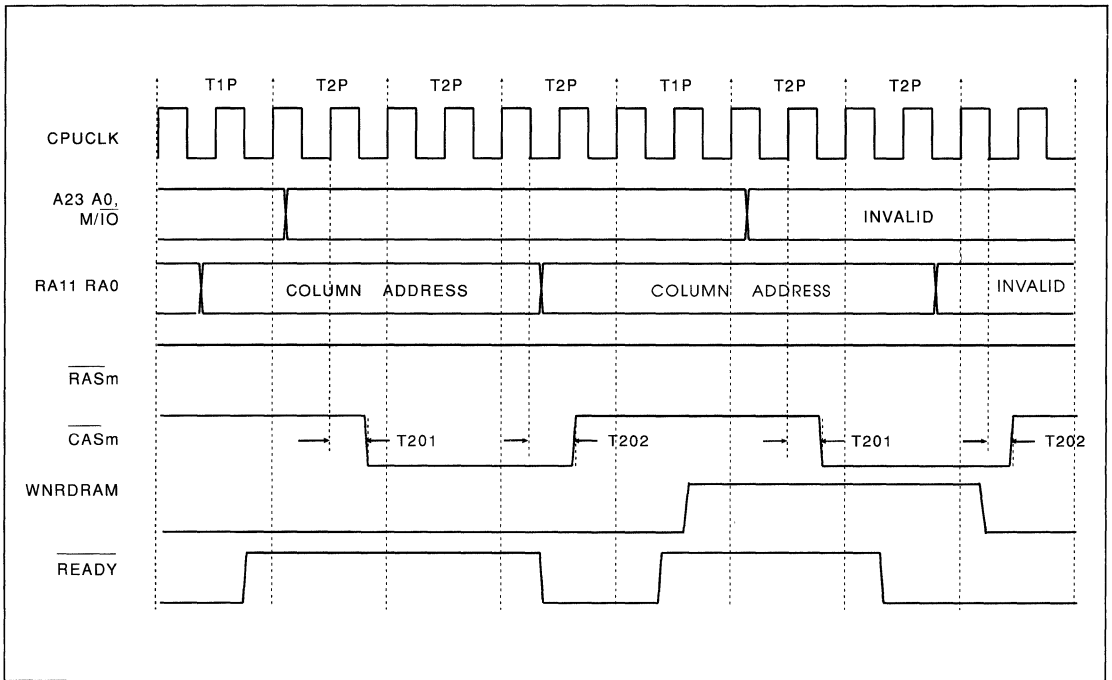

FIGURE 13-8. READ PAGE HIT FOLLOWED BY WRITE PAGE HIT WITH EXTERNAL CACHE ENABLE AND EXTRA WAIT STATE ENABLE



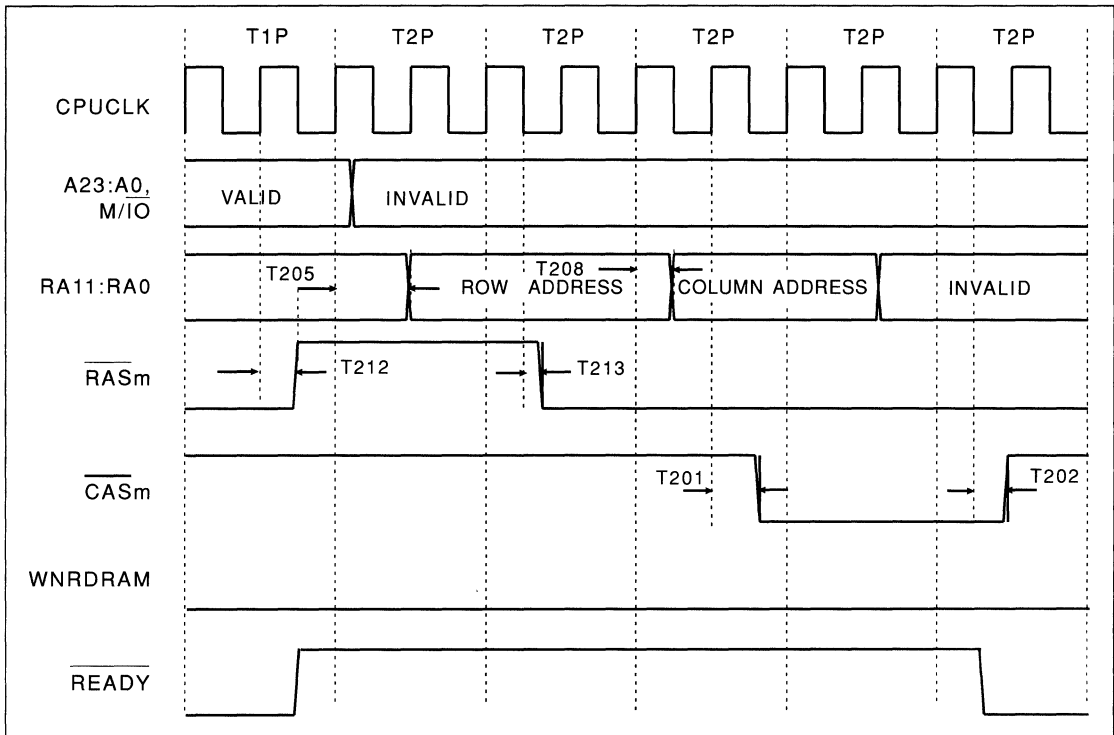

FIGURE 13-9. PAGE READ MISS WITH EXTRA WAIT STATE ENABLE



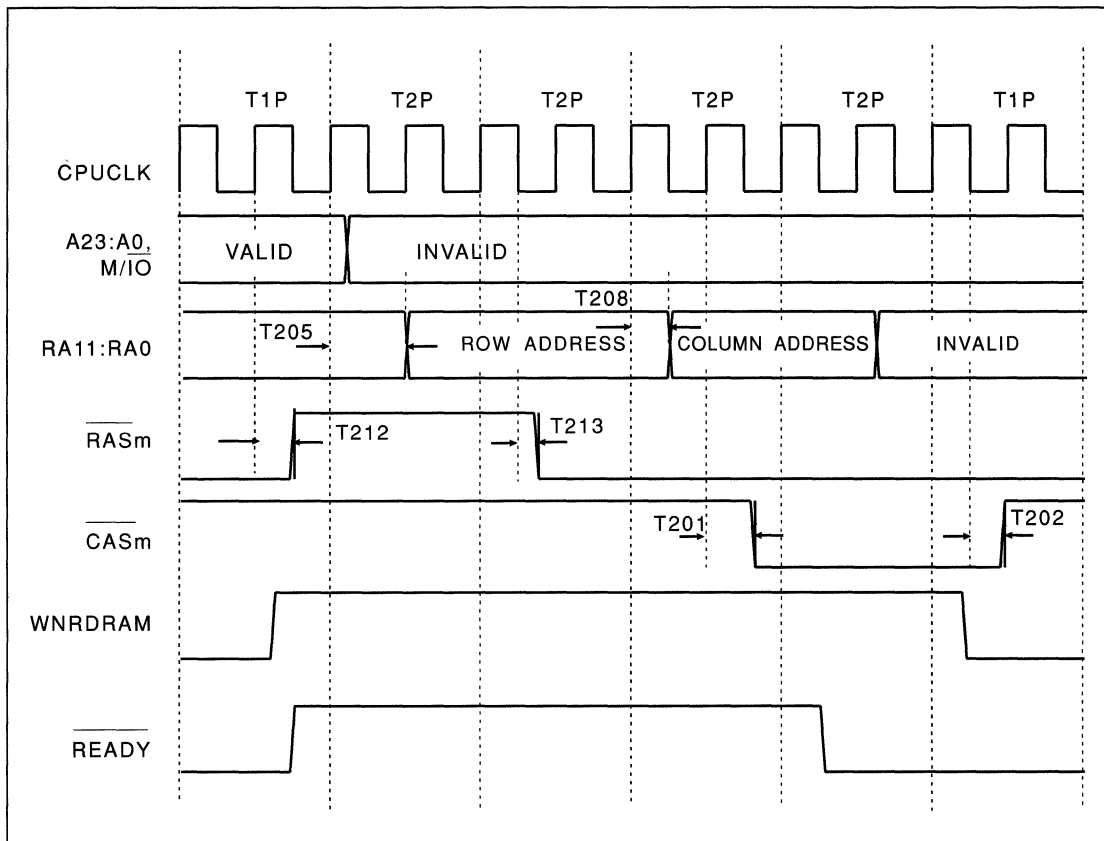

FIGURE 13-10. PAGE WRITE MISS WITH EXTRA WAIT STATE ENABLE



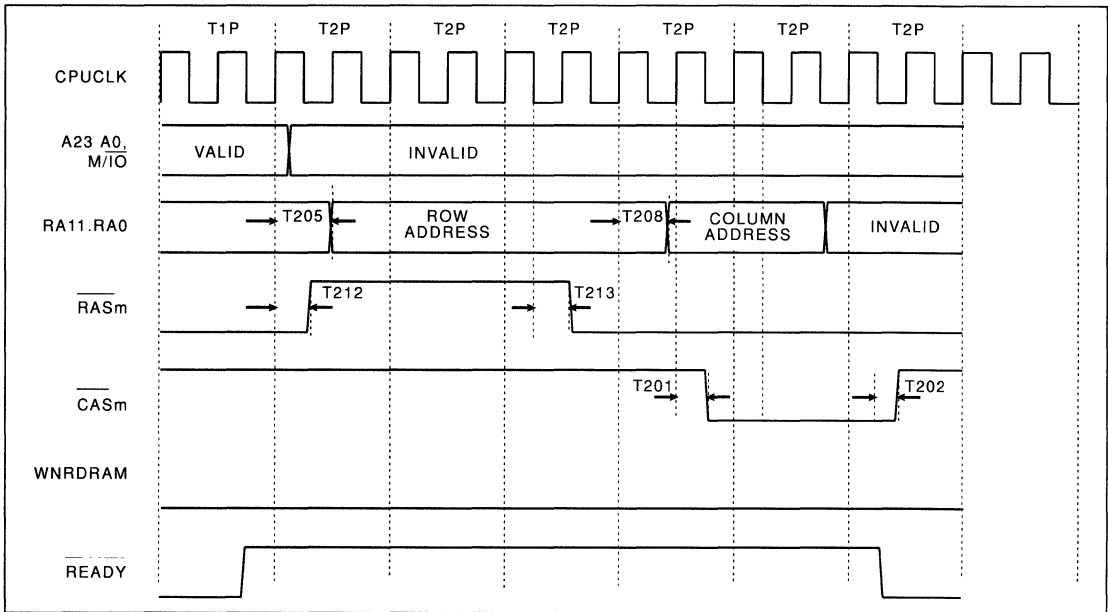

FIGURE 13-11. READ PAGE MISS WITH EXTERNAL CACHE ENABLE AND EXTRA WAIT STATE ENABLE

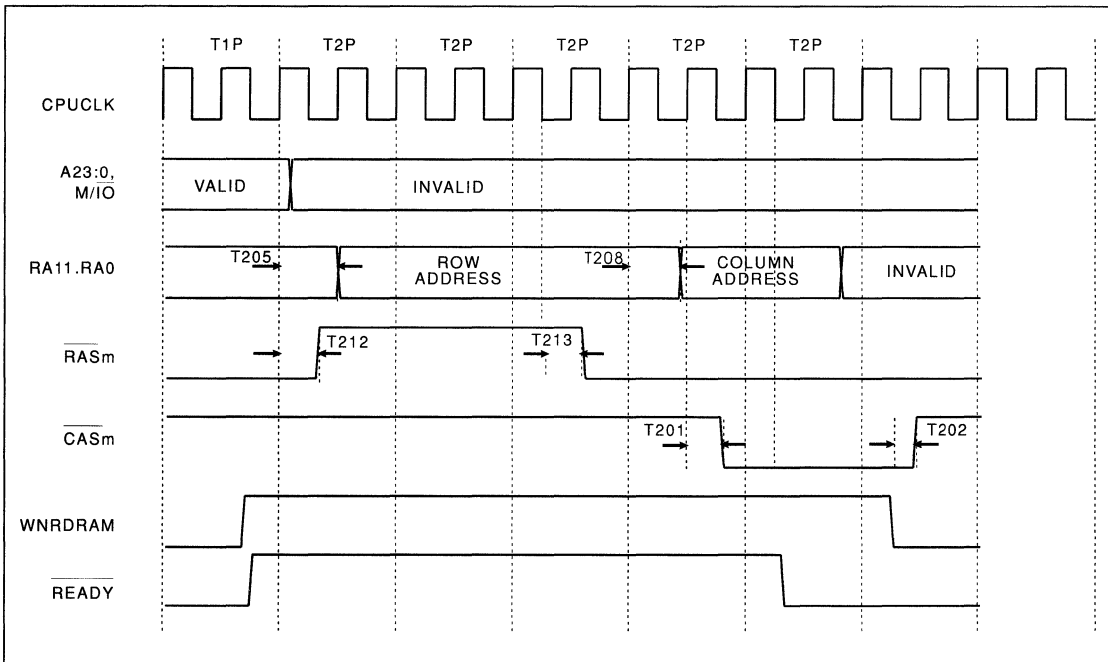
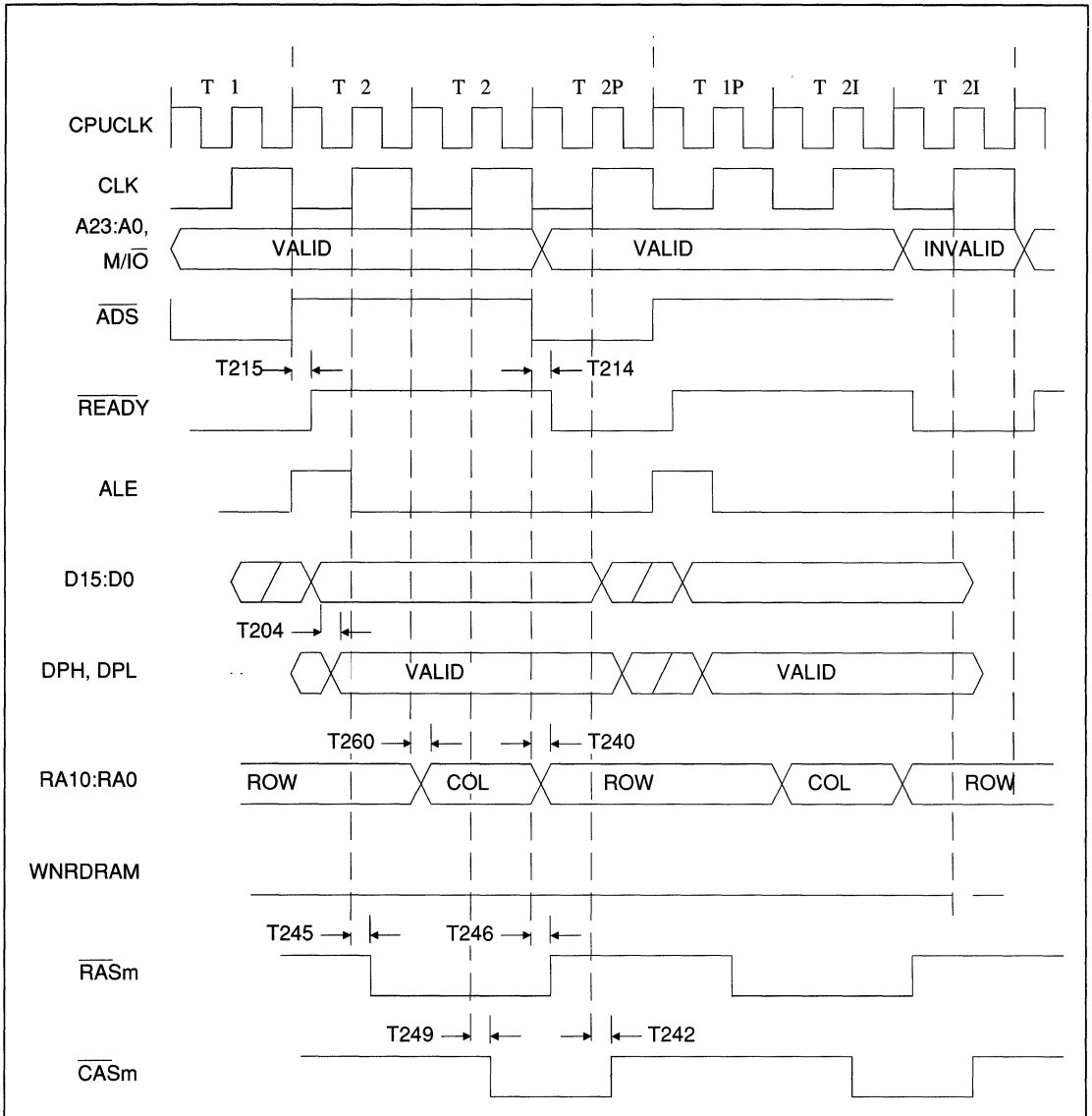

FIGURE 13-12. WRITE PAGE MISS WITH EXTERNAL CACHE ENABLE AND EXTRA WAIT STATE ENABLE





**FIGURE 13-13. 80386SX - NON-PAGE MODE 00, 1 WAIT STATE READ (PIPELINE)
(4072H = 0001)**



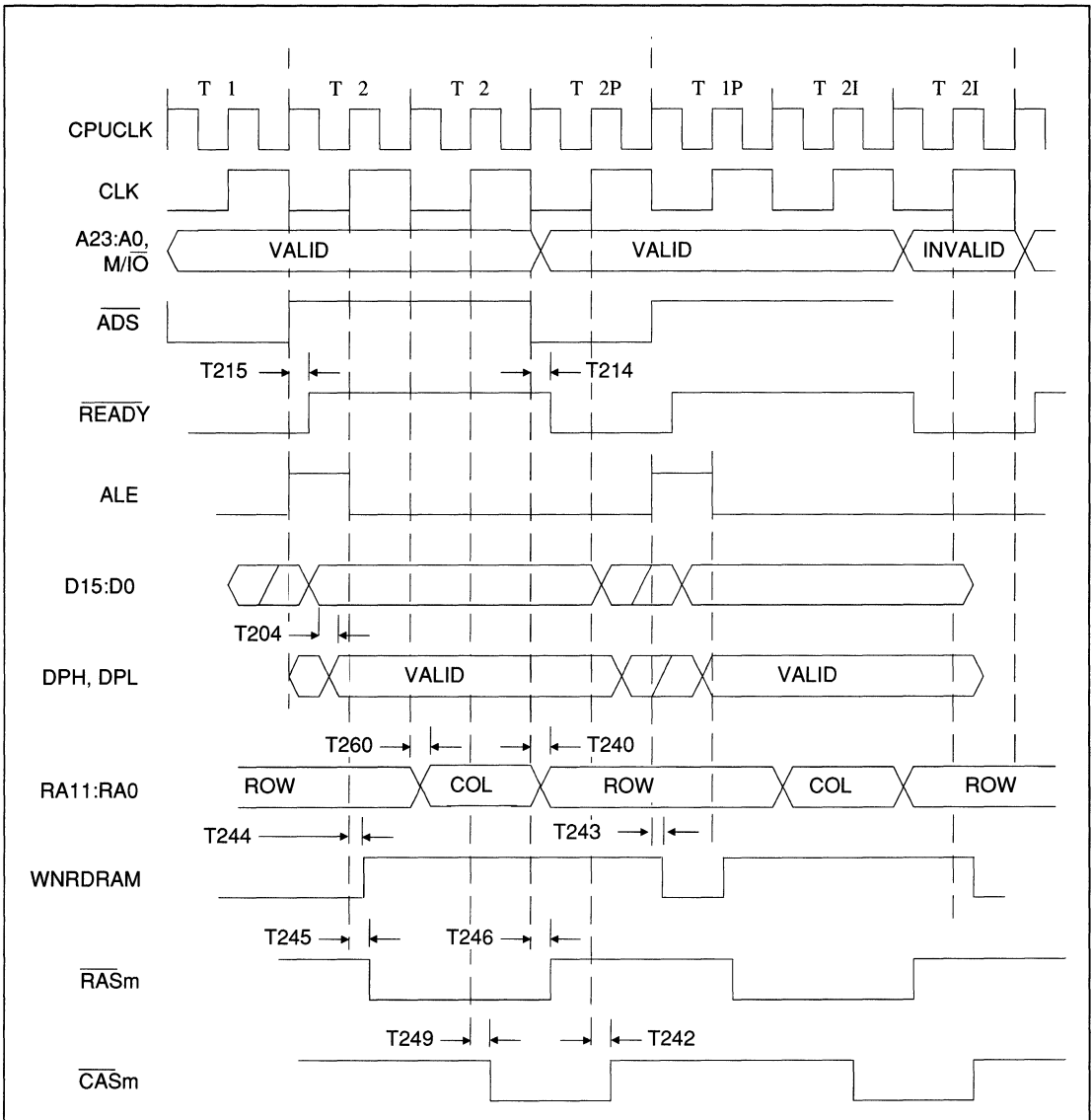

FIGURE 13-14. 80386SX - NON-PAGE MODE 00, 1 WAIT STATE WRITE (PIPELINE)
(4072H = 0001)

10



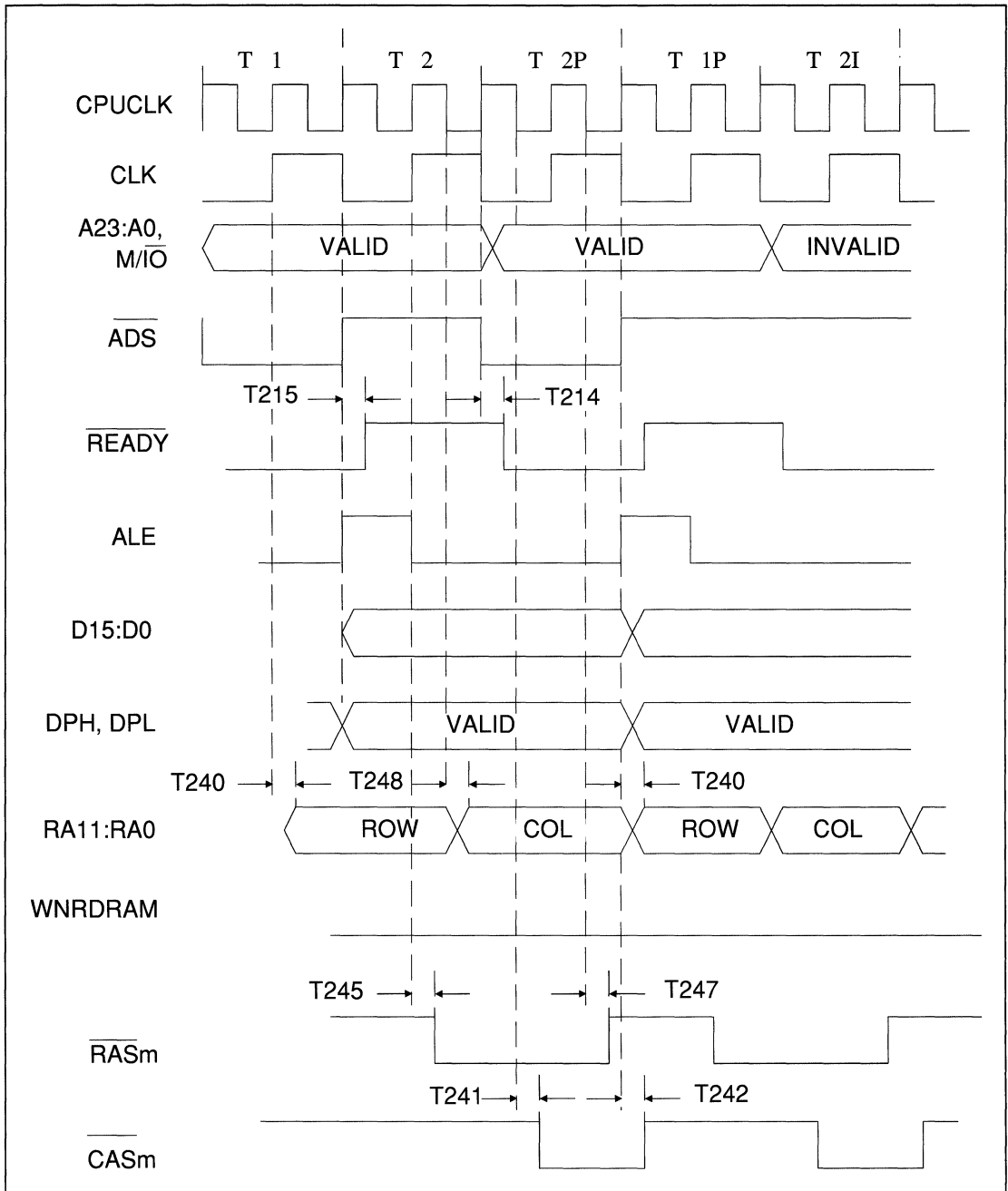

FIGURE 13-15. 80386SX - NON-PAGE MODE 01, 0 WAIT STATE READ (PIPELINE)
(4072H = 3560H)



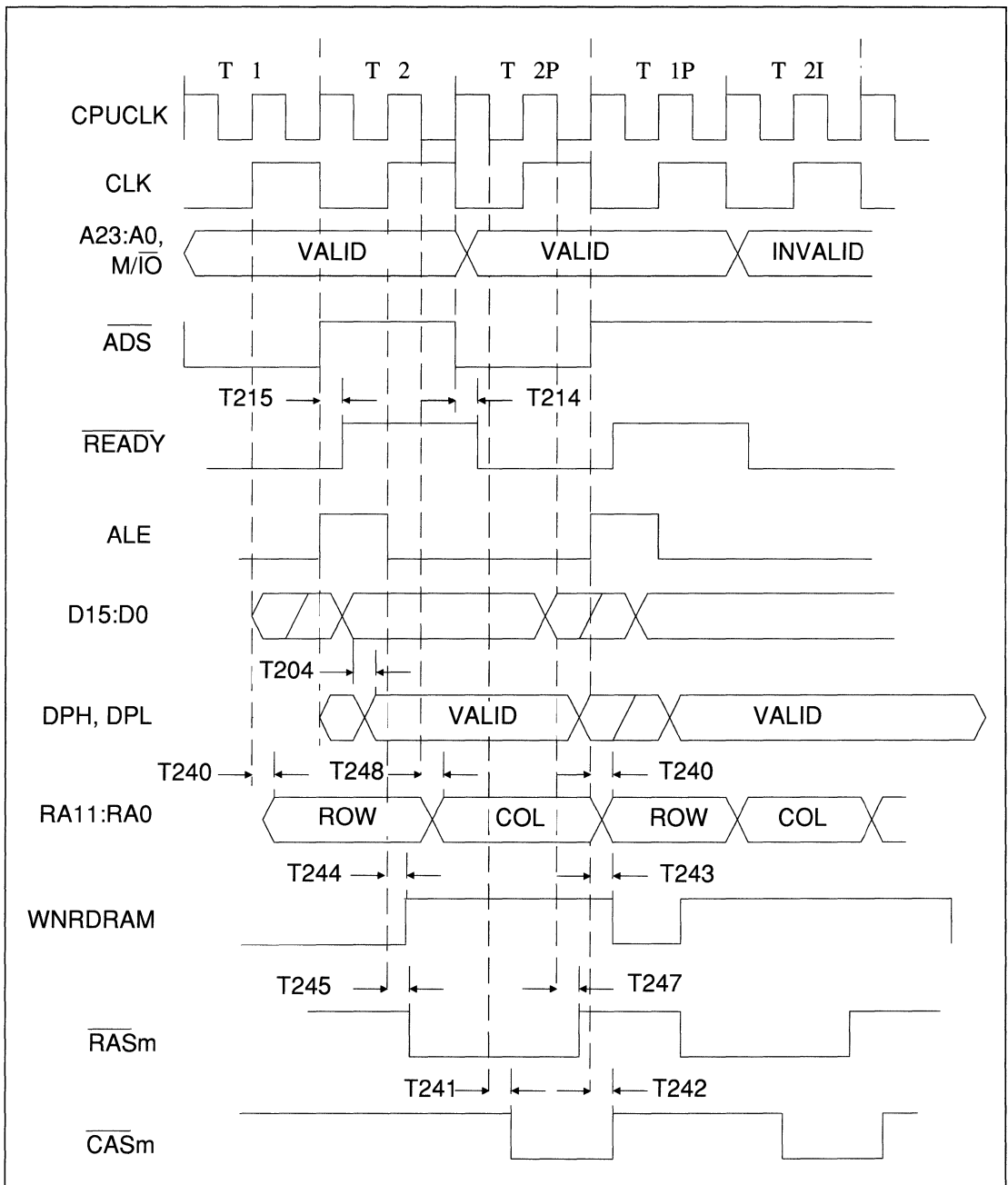

FIGURE 13-16. 80386SX - NON-PAGE MODE 01, 0 WAIT STATE WRITE (PIPELINE)
(4072H = 3560H)

10



13.2 AT BUS TIMING

The AT Bus timing is divided into six major categories:

1. CPU initiated AT Bus cycles.
2. Entering the AT Bus.
3. Exiting the AT Bus.
4. DMA cycles.

5. AT Bus Master cycles.

6. AT Bus Refresh cycle.

Some figures in this section are included only to show the sequence of the signals during certain operations. In these figures, no timing parameters are provided.

13.2.1 CPU Initiated AT Bus Cycles

SYMBOL	CHARACTERISTIC	MIN	MAX	UNITS	TEST CONDITIONS
T00	SYCLK Cycle Time	100		ns	
T01	SYCLK fall to BALE rise		12	ns	
T02	SYCLK rise to BALE fall		9	ns	
T03	SYCLK fall to MEMR fall		9	ns	8-bit cycle
T04	SYCLK rise to MEMR rise		6	ns	
T05	SYCLK fall to IOR fall		10	ns	
T06	SYCLK rise to IOR rise		7	ns	
T07	SYCLK rise to DEN0 fall		7	ns	Read Cycle
T08	SYCLK rise to DEN0 rise		11	ns	Read Cycle
T09	SYCLK rise to DEN1 fall		7	ns	Read Cycle
T10	SYCLK rise to DEN1 rise		9	ns	Read Cycle
T11	SYCLK fall to DTR fall		19	ns	Delay is number given plus (T00 × 0.25)
T12	SYCLK rise to DTR rise		14	ns	Delay is number given plus (T00 × 0.25)
T13	SYCLK fall to SDEN fall		10	ns	
T14	SYCLK rise to SDEN rise		8	ns	
T15	SYCLK fall to SDTR rise		14	ns	Delay is number given plus (T00 × 0.25)
T16	SYCLK rise to SDTR fall		11	ns	Delay is number given plus (T00 × 0.25)
T17	MEMCS16 setup time to SYCLK rise	25		ns	
T18	MEMCS16 hold time from SYCLK rise	0		ns	
T19	IOCS16 setup time to SYCLK fall	23		ns	
T20	IOCS16 hold time from SYCLK fall	0		ns	8-bit cycle
T21	IOCHRDY setup time to SYCLK rise	22		ns	
T22	IOCHRDY hold time from SYCLK rise	0		ns	

TABLE 13-5. CPU INITIATED AT BUS CYCLES

SYMBOL	CHARACTERISTIC	MIN	MAX	UNITS	TEST CONDITIONS	
T23	$\overline{\text{ZEROWS}}$ setup time to SYSCLK fall	24		ns	Total setup time is number given plus delay through AT Bus data buffers.	
T24	$\overline{\text{ZEROWS}}$ hold time from SYSCLK fall	0		ns		
T25	AT Bus data setup time to SYSCLK rise	22		ns		
T26	AT Bus data hold time from SYSCLK rise	0		ns		
T27	SYSCLK fall to $\overline{\text{MEMW}}$ fall		9	ns		
T28	SYSCLK rise to $\overline{\text{MEMW}}$ rise		5	ns		
T29	SYSCLK fall to $\overline{\text{IOW}}$ fall		10	ns		
T30	SYSCLK rise to $\overline{\text{IOW}}$ rise		8	ns		
T31	SYSCLK fall to $\overline{\text{DENO}}$ fall		10	ns		Write cycle
T32	SYSCLK fall to $\overline{\text{DENO}}$ rise		9	ns		Write cycle
T33	SYSCLK fall to $\overline{\text{DEN1}}$ fall		10	ns		Write cycle
T34	SYSCLK fall to $\overline{\text{DEN1}}$ rise		9	ns		Write cycle
T35	SYSCLK fall to $\overline{\text{SDEN}}$ rise		11	ns		
T36	SYSCLK fall to SA0 rise		16	ns		Word to byte conversion cycle
T37	SYSCLK rise to $\overline{\text{MEMR}}$ fall		6	ns		16-bit cycle
T38	$\overline{\text{IOCS16}}$ hold time from SYSCLK rise	0		ns		16-bit cycle
T39	SYSCLK high time	-4	0	ns		(T00 + 2) plus number given

TABLE 13-5. CPU INITIATED AT BUS CYCLES (Continued)

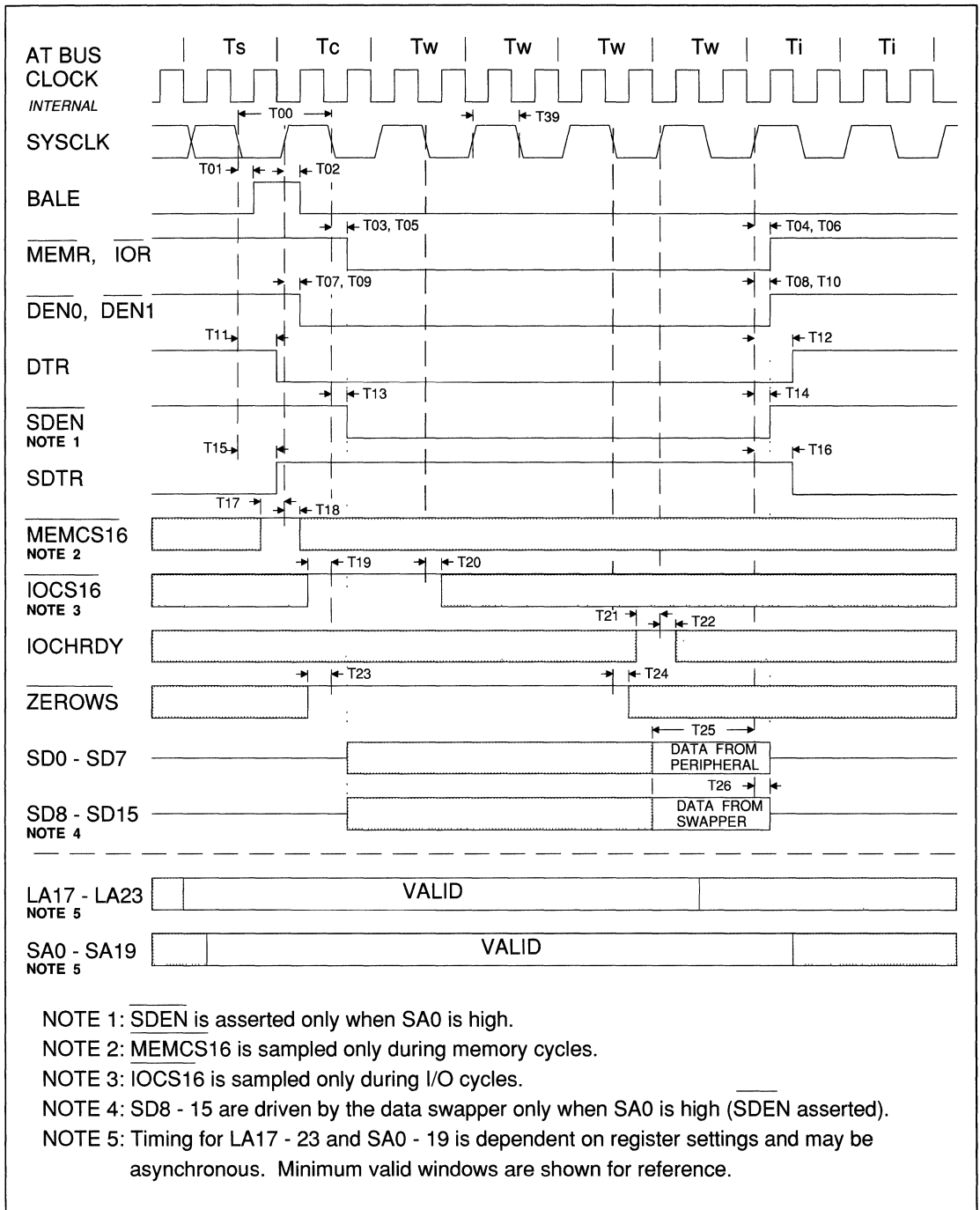

FIGURE 13-17. AT BUS I/O OR MEMORY READ: 8-BIT, DEFAULT TIMING



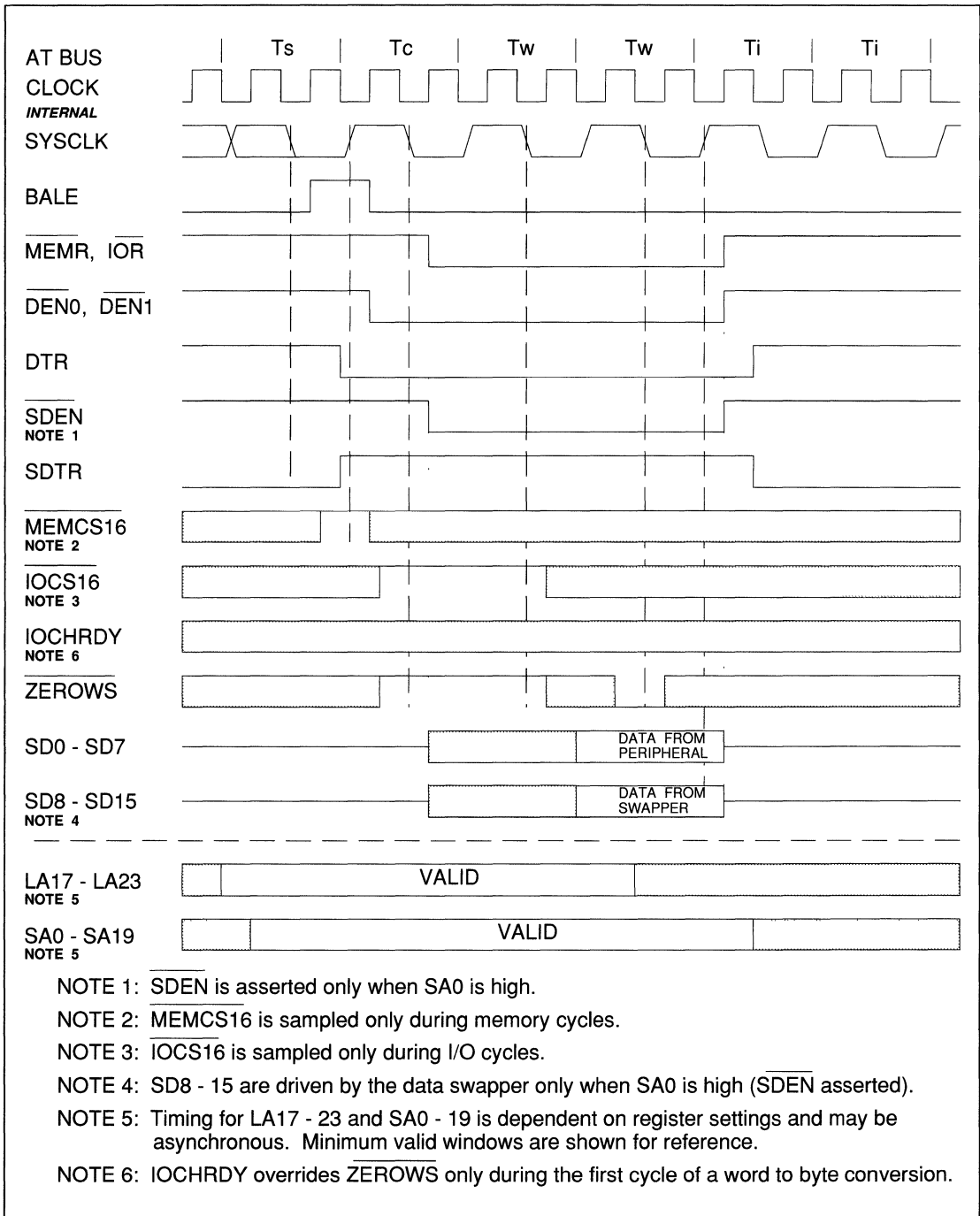

FIGURE 13-18. AT BUS I/O OR MEMORY READ: 8-BIT, $\overline{\text{ZEROWS}}$ ASSERTED



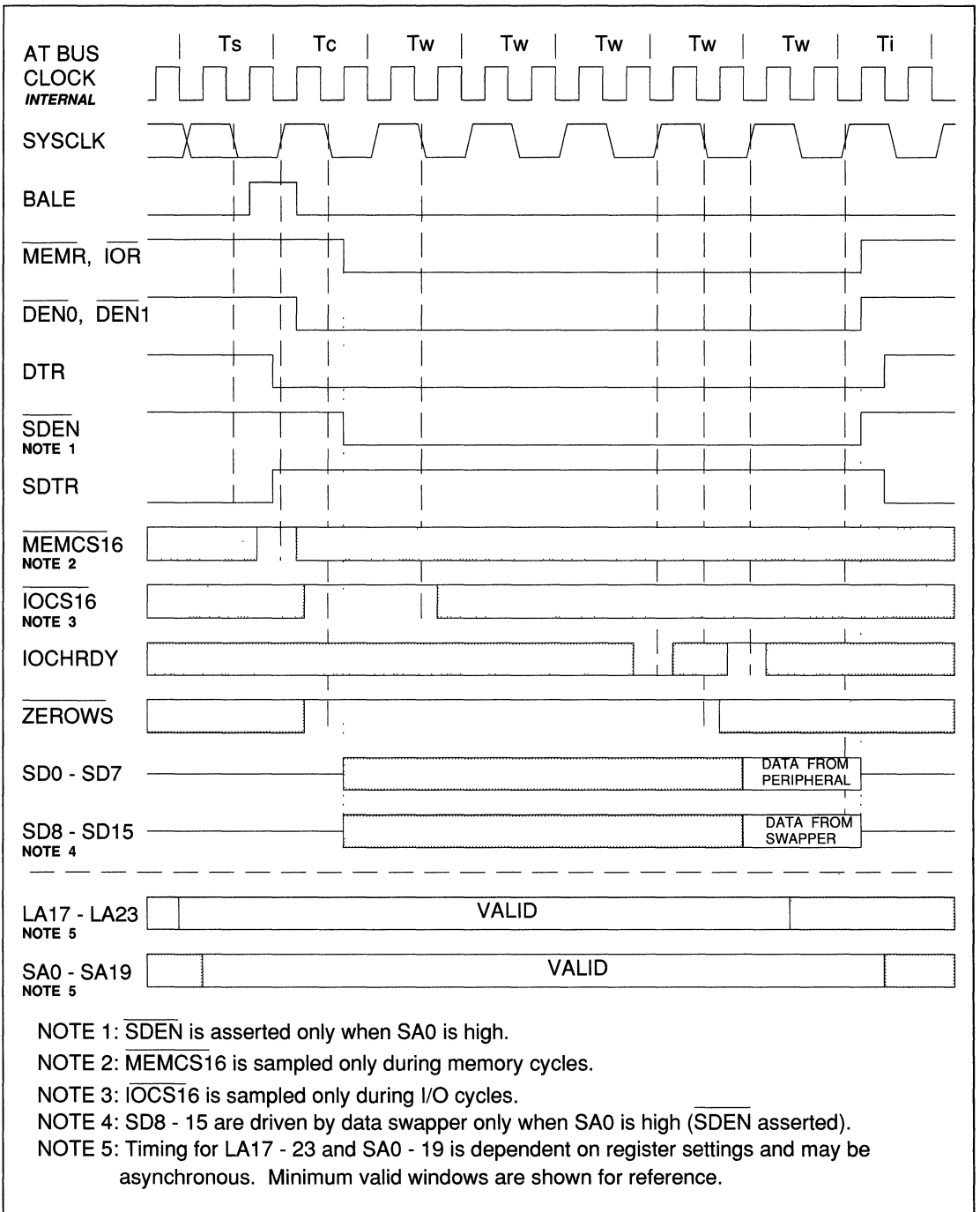

FIGURE 13-19. AT BUS I/O OR MEMORY READ: 8-BIT, EXTRA WAIT STATE ADDED



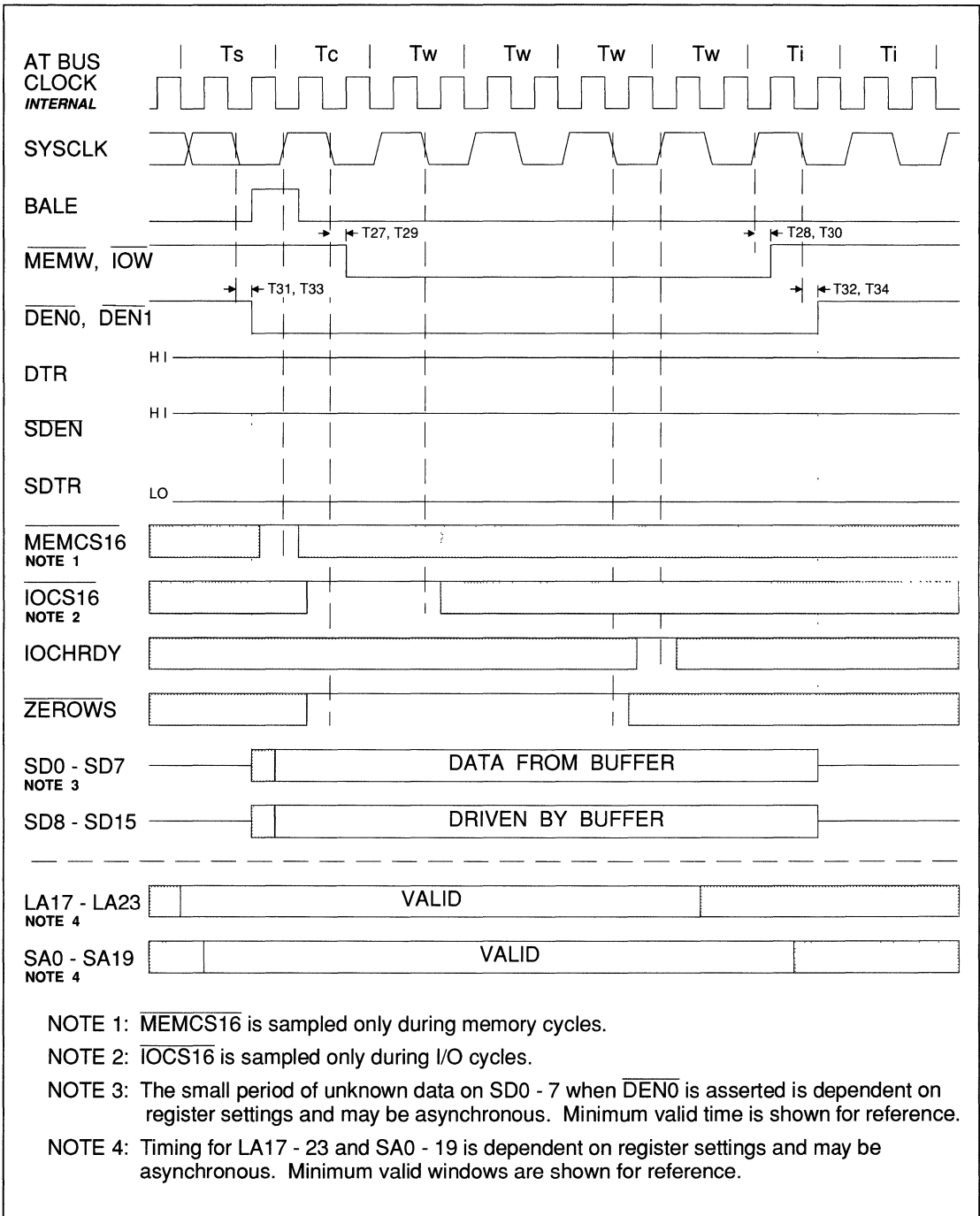

FIGURE 13-20. AT BUS I/O OR MEMORY WRITE: 8-BIT, EVEN BYTE, DEFAULT TIMING



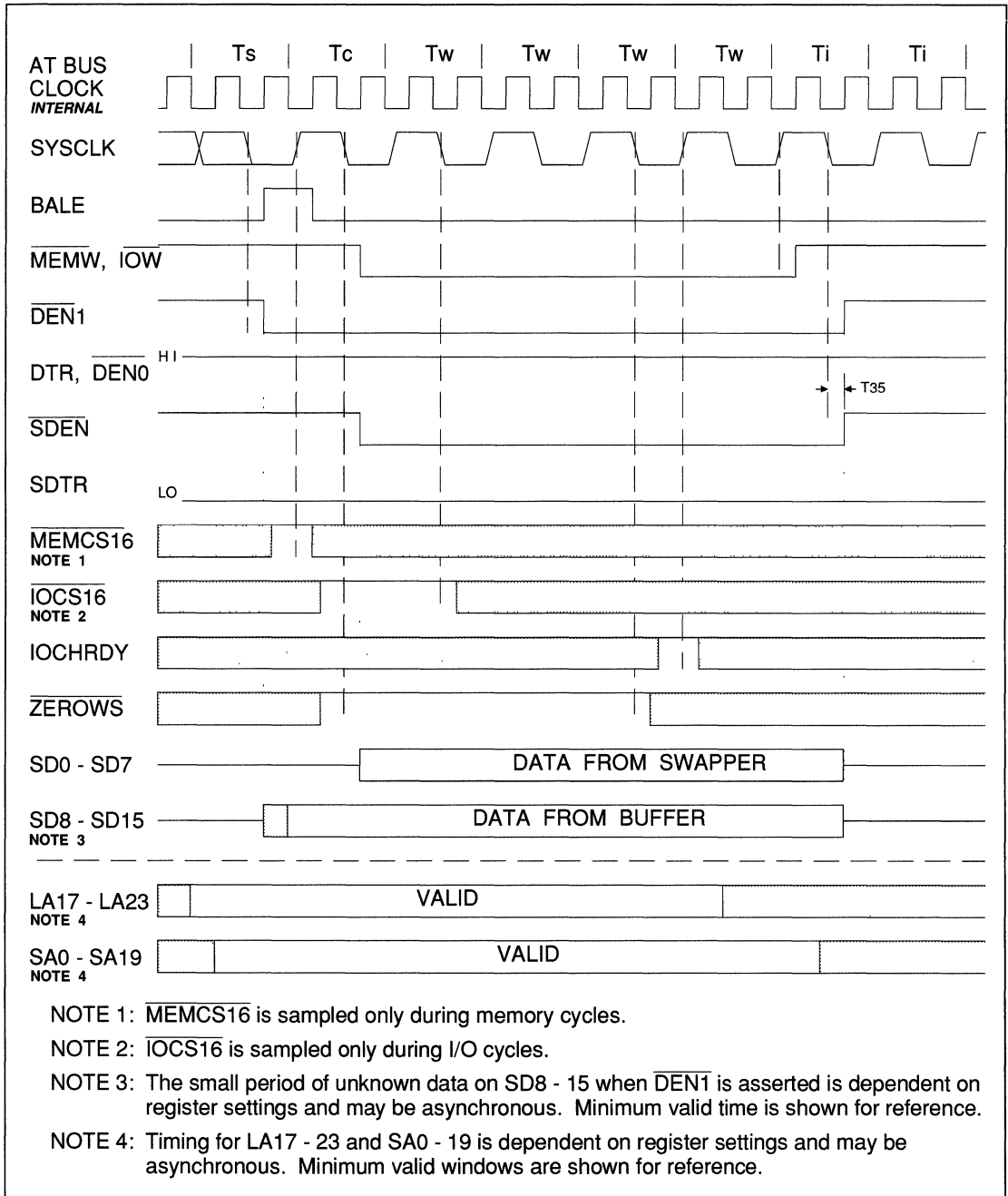

FIGURE 13-21. AT BUS I/O OR MEMORY WRITE: 8-BIT, ODD BYTE, DEFAULT TIMING



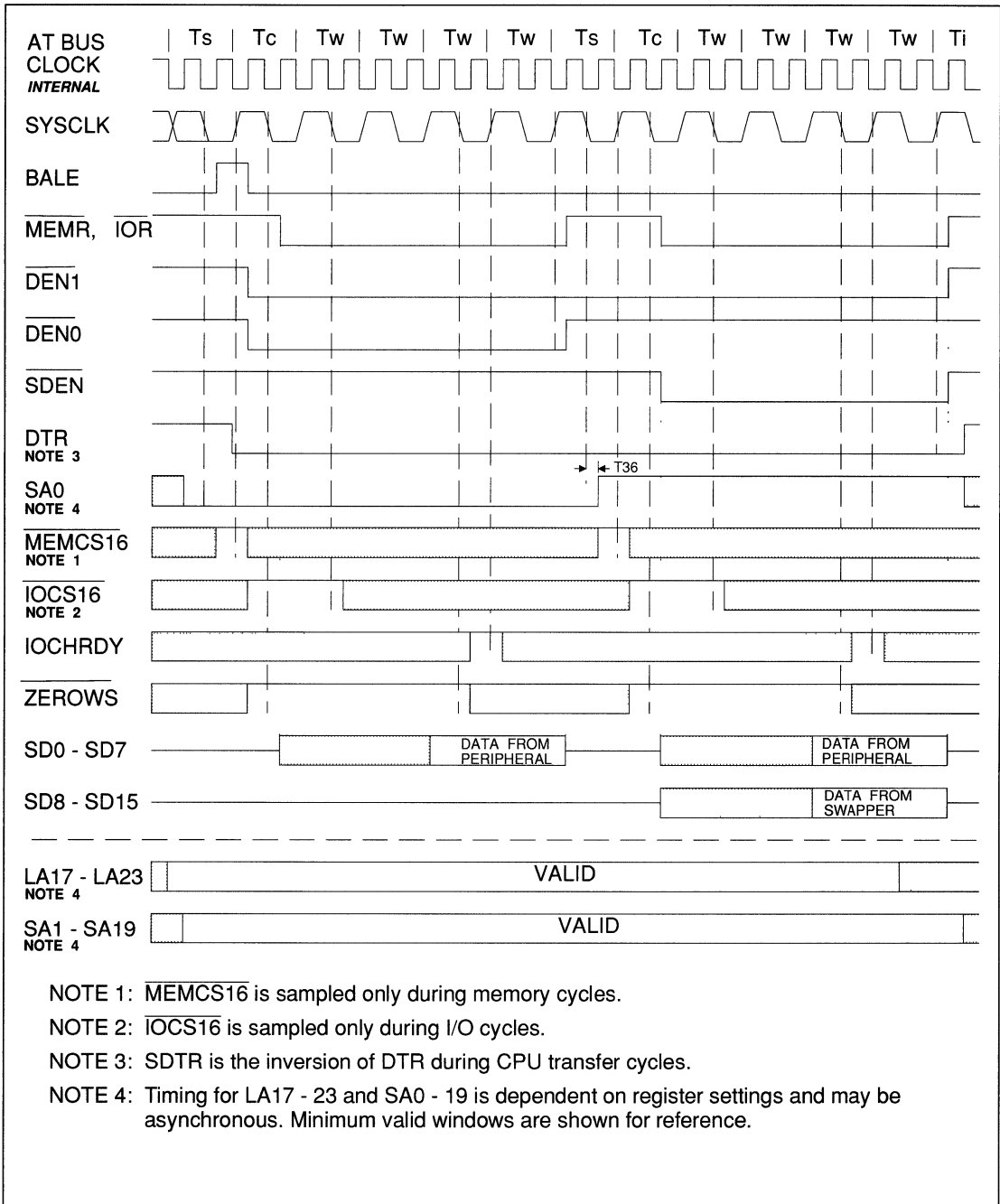

FIGURE 13-22. AT BUS I/O OR MEMORY READ: 8-BIT, WORD TO BYTE CONVERSION, DEFAULT TIMING

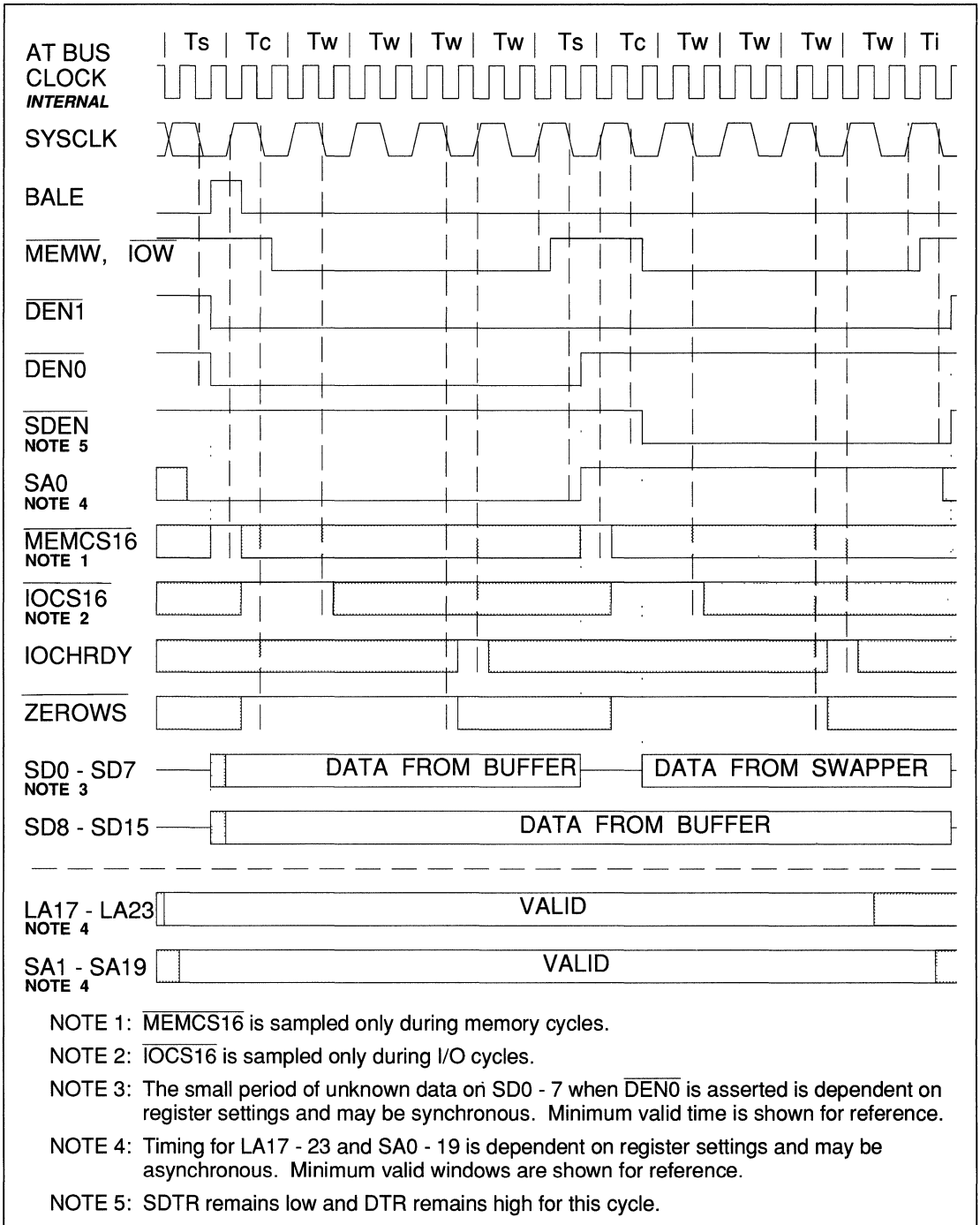
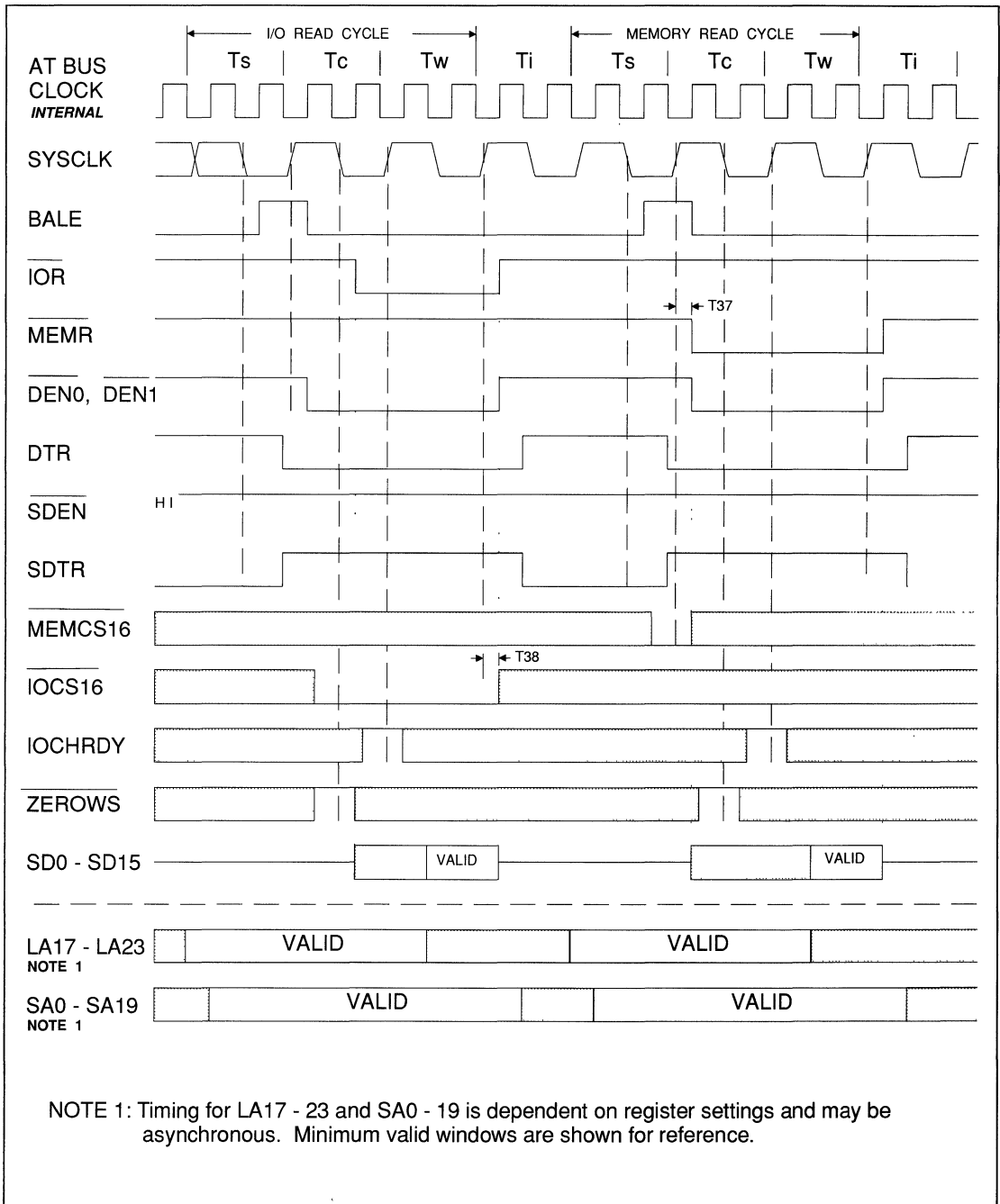

FIGURE 13-23. AT BUS I/O OR MEMORY WRITE: 8-BIT, WORD TO BYTE CONVERSION, DEFAULT TIMING





10

FIGURE 13-24. AT BUS I/O OR MEMORY READ: 16-BIT, DEFAULT TIMING

NOTE 1: Timing for LA17 - 23 and SA0 - 19 is dependent on register settings and may be asynchronous. Minimum valid windows are shown for reference.



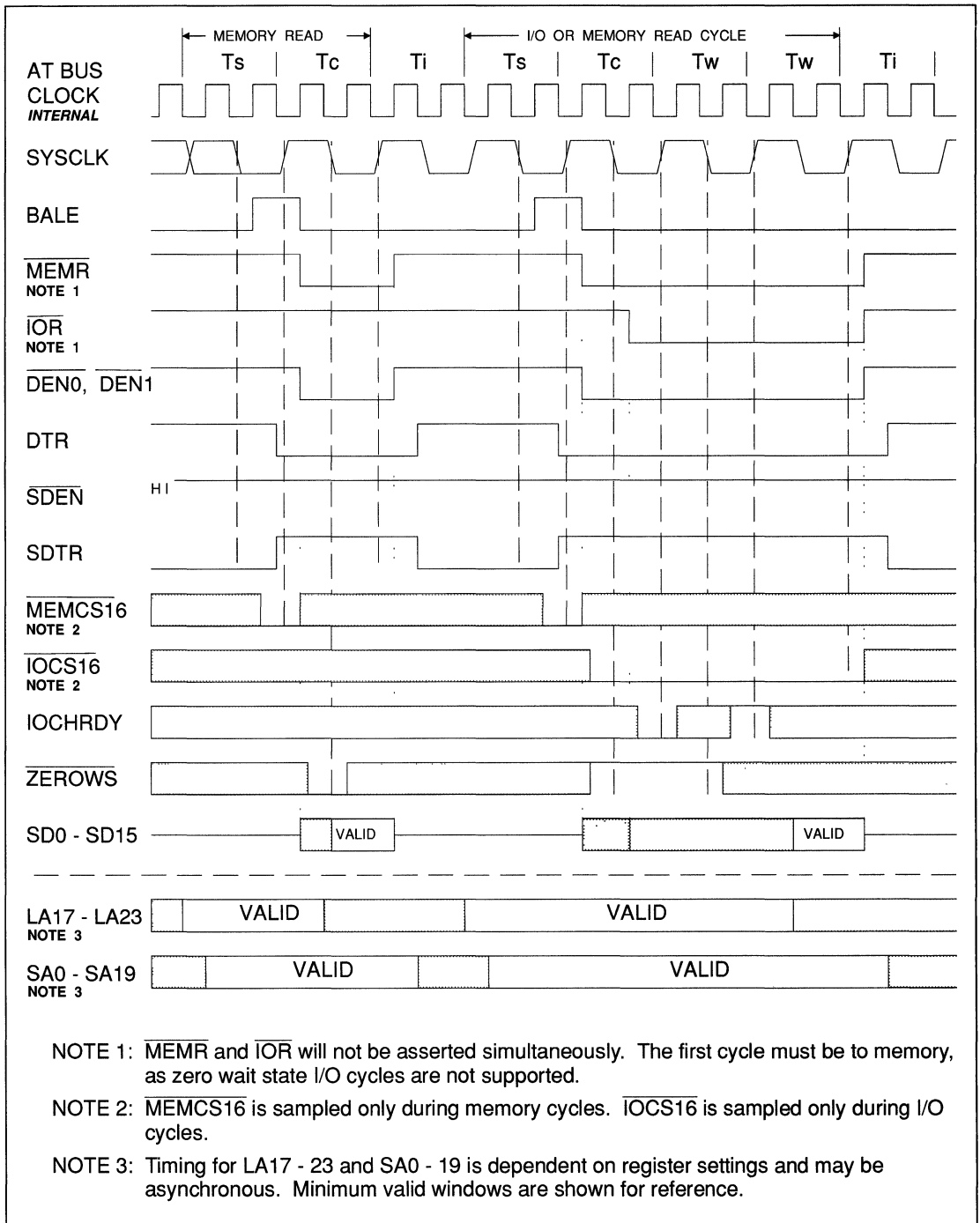
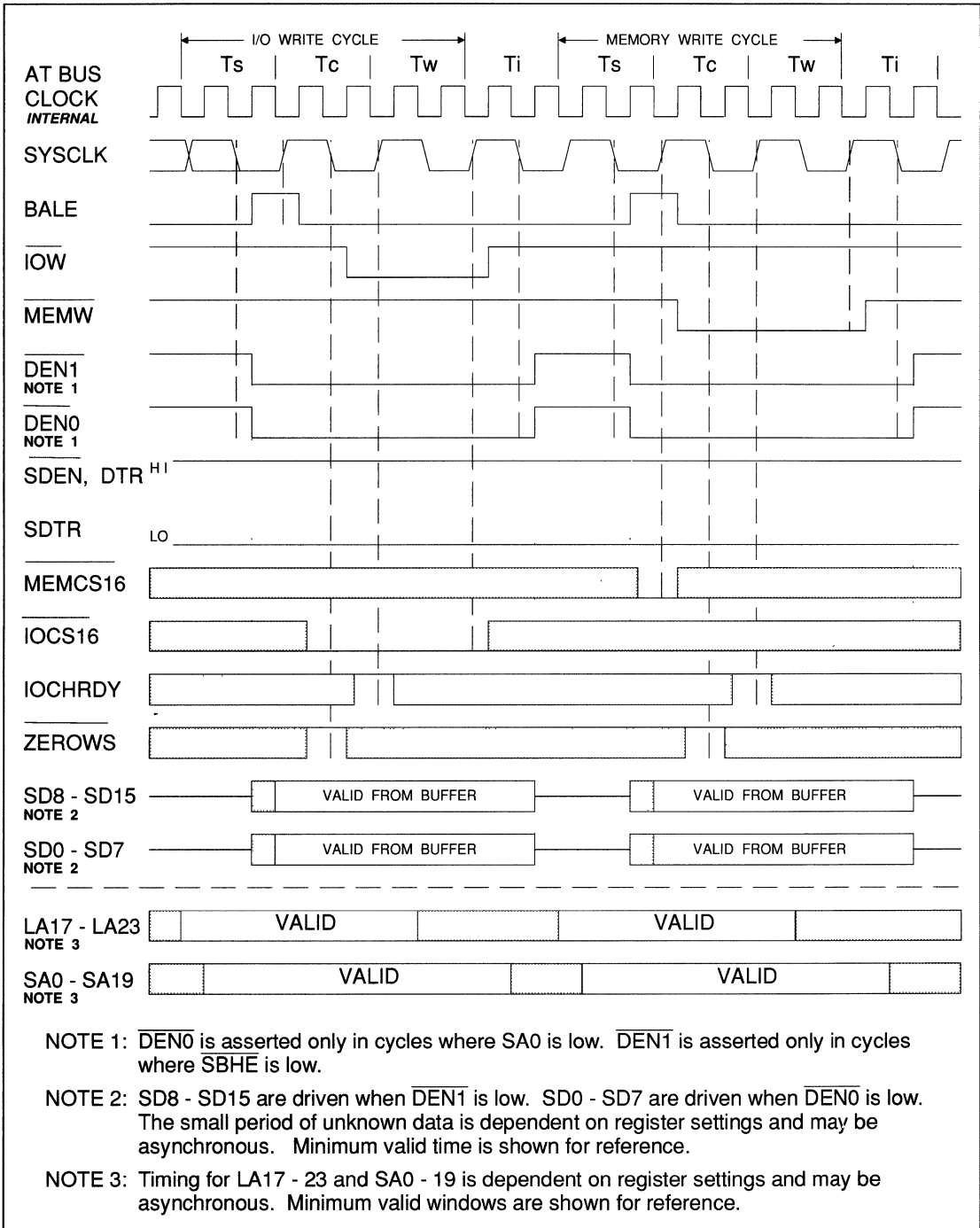

FIGURE 13-25. AT BUS I/O OR MEMORY READ: 16-BIT, 0WS ASSERTED AND EXTRA WAIT STATE ADDED





10

NOTE 1: $\overline{DEN0}$ is asserted only in cycles where SA0 is low. $\overline{DEN1}$ is asserted only in cycles where \overline{SBHE} is low.

NOTE 2: SD8 - SD15 are driven when $\overline{DEN1}$ is low. SD0 - SD7 are driven when $\overline{DEN0}$ is low. The small period of unknown data is dependent on register settings and may be asynchronous. Minimum valid time is shown for reference.

NOTE 3: Timing for LA17 - 23 and SA0 - 19 is dependent on register settings and may be asynchronous. Minimum valid windows are shown for reference.

FIGURE 13-26. AT BUS I/O OR MEMORY WRITE: 16-BIT, DEFAULT TIMING

13.2.2 Entering the AT Bus

The timing in this section is presented in the following sequence:

80386SX CPU

Asynchronous CPUCLK to SYSCLK

Synchronous CPUCLK to SYSCLK

SYMBOL	CHARACTERISTIC	MIN	MAX	UNITS	TEST CONDITIONS
T40	CPUCLK rise to SYSCLK fall 80386SX CPU mode.	4		ns	Register 1872H: BRQ_DEL = 01 BUS_MOD = 0X Delay is number given plus (T00 × 0.25)
T41	CPUCLK rise to SYSCLK fall 80386SX CPU mode.	9		ns	Register 1872H: BRQ_DEL = 00 BUS_MOD = 0X Delay is number given plus (T00 × 0.5)
T42	CPUCLK fall to SYSCLK fall 80386SX CPU mode.		29	ns	Register 1872H: BRQ_DEL = 10 BUS_MOD = 11
T43	CPUCLK rise to SYSCLK fall 80386SX CPU mode.		35	ns	Register 1872H: BRQ_DEL = 10 BUS_MOD = 10
T140	CPUCLK rise to ALE rise 80386SX CPU mode.		20	ns	
T141	CPUCLK rise to ALE fall 80386SX CPU mode.		20	ns	
T214	See TABLE 13-3				
T215	See TABLE 13-3				

TABLE 13-6. ENTERING THE AT BUS



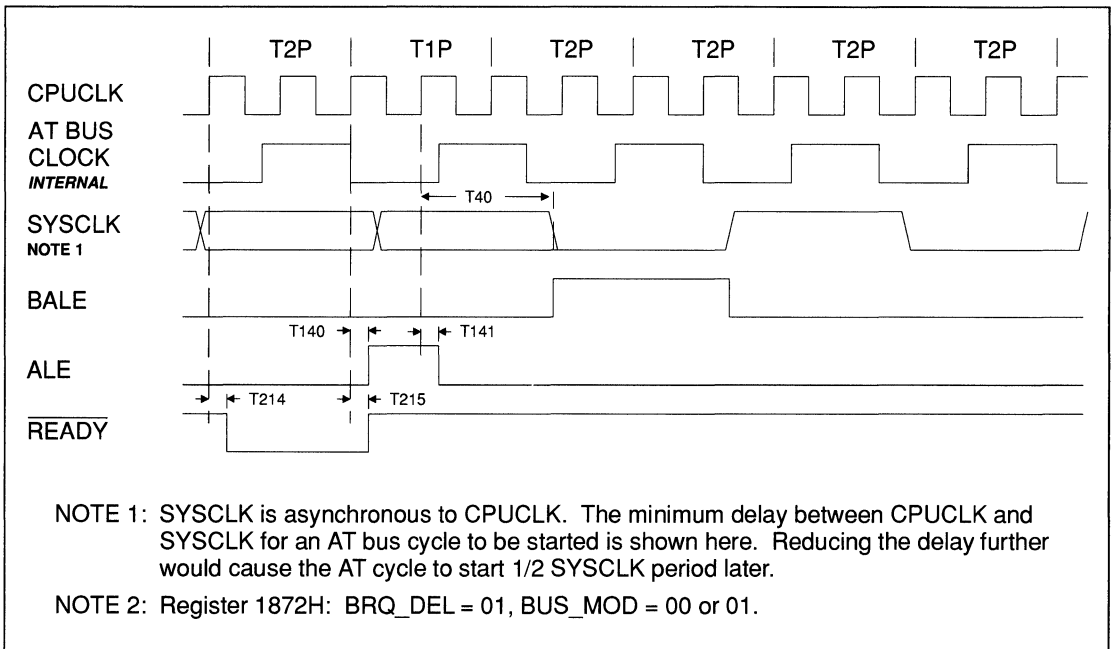

FIGURE 13-27. 80386SX CPU - BREQ DELAY = 1/2 CLOCK

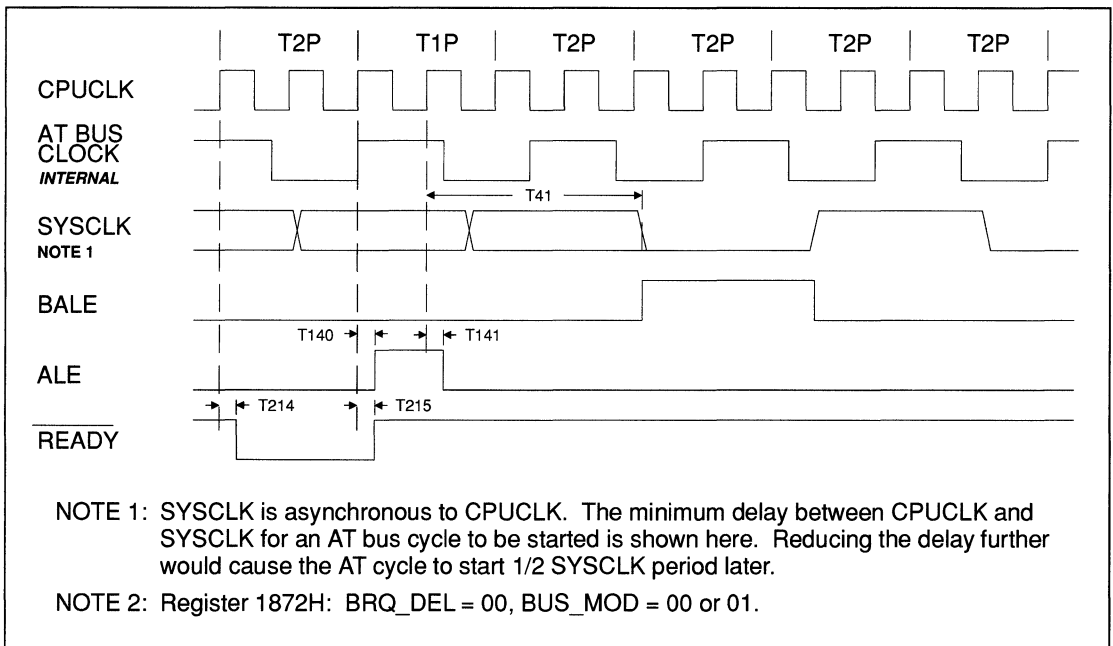

FIGURE 13-28. 80386SX CPU - BREQ DELAY = 1 CLOCK

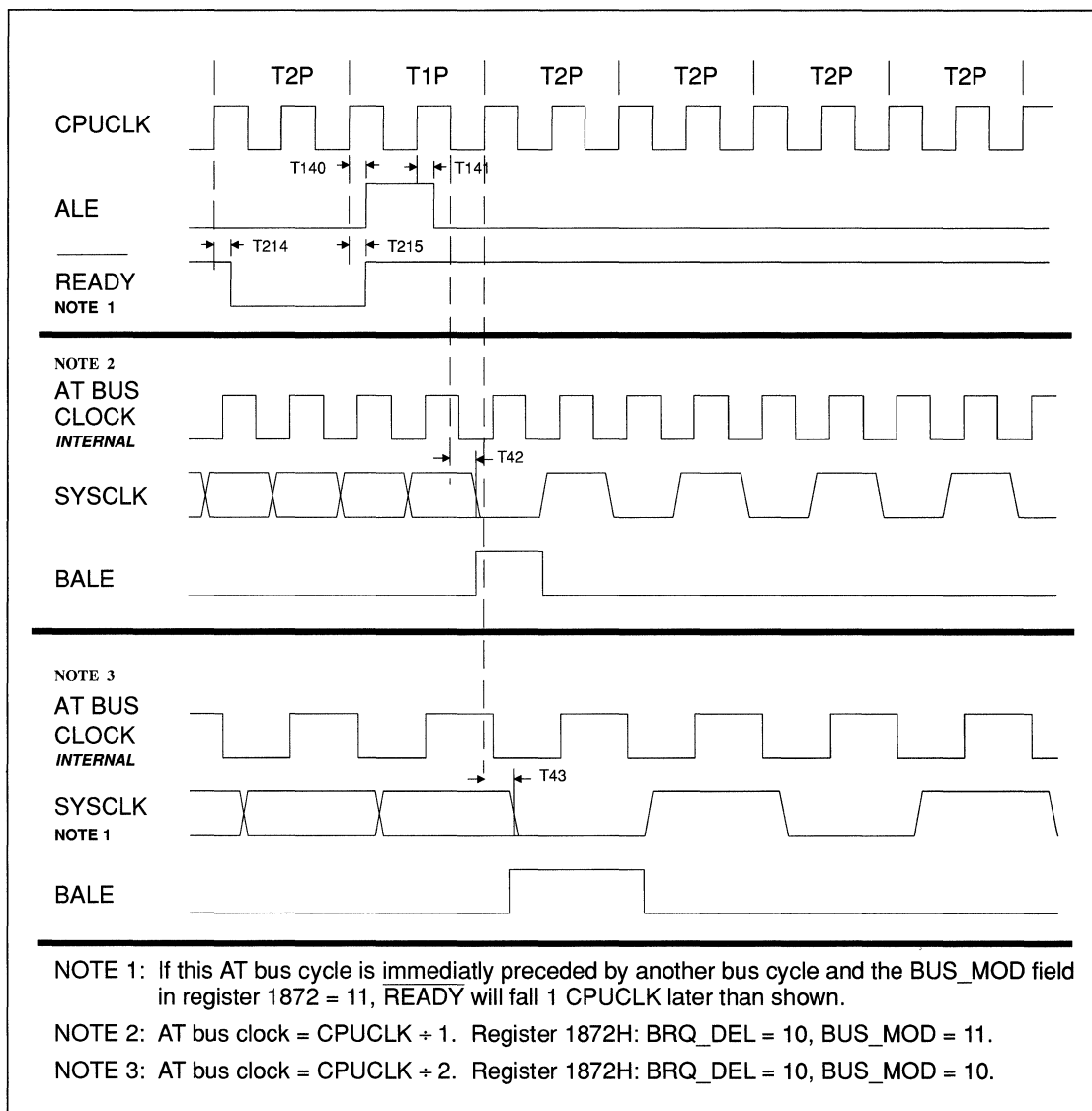

FIGURE 13-29. 80386SX CPU - SYNCHRONOUS CPUCLK TO SYSCLK



13.2.3 Exiting the AT Bus

Exiting a synchronous AT bus is covered first, followed by the asynchronous bus.

SYMBOL	CHARACTERISTIC	MIN	MAX	UNITS	TEST CONDITIONS
T46	SYSCLK fall to CPUCLK	-5		ns	Register 1872H: BAK_DEL = 10 BUS_MOD = 0X
T47	SYSCLK fall to CPUCLK	-15		ns	Register 1872H: BAK_DEL = 01 BUS_MOD = 0X Delay is number given plus (T00 × 0.25)
T48	SYSCLK rise to CPUCLK	-10		ns	Register 1872H: BAK_DEL = 00 BUS_MOD = 0X
T49	SYSCLK rise to CPUCLK	-15		ns	Register 1872H: BAK_DEL = 11 BUS_MOD = 0X Delay is number given plus (T00 × 0.25)
T214	See TABLE 13-3				
T215	See TABLE 13-3				

TABLE 13-7. EXITING THE AT BUS



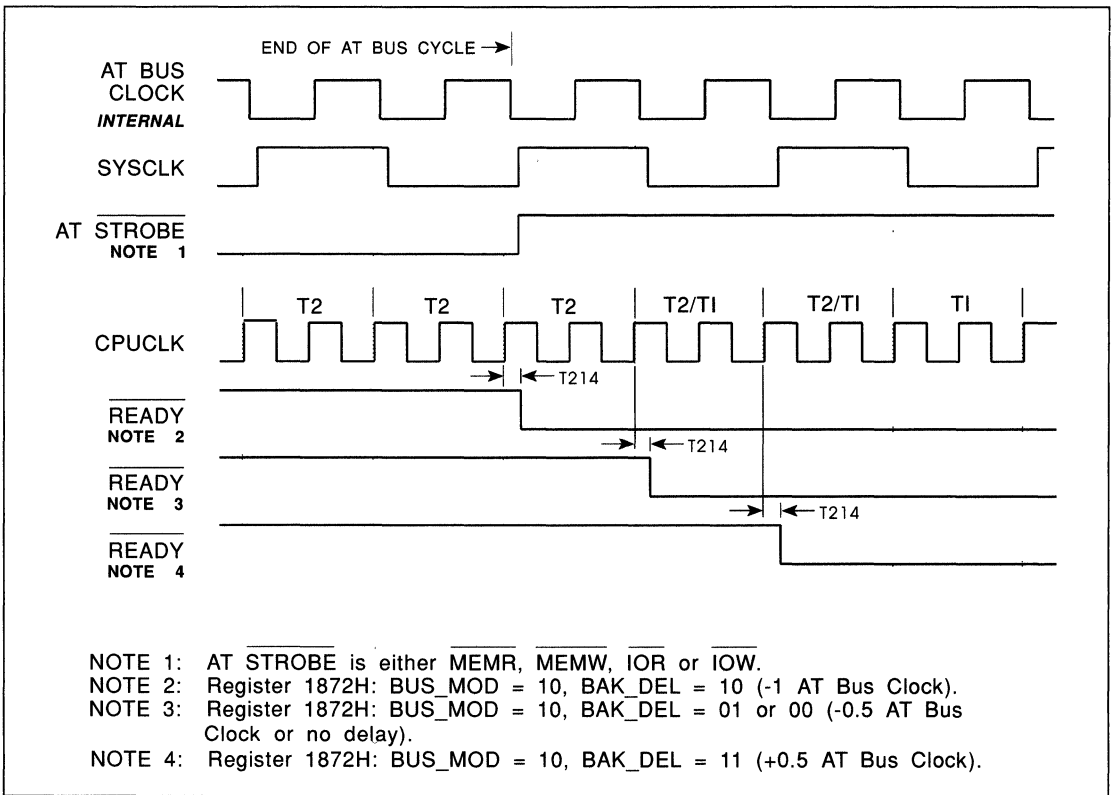

**FIGURE 13-30. SYNCHRONOUS AT BUS CYCLE COMPLETION,
AT BUS CLOCK = CPUCLK ÷ 2**



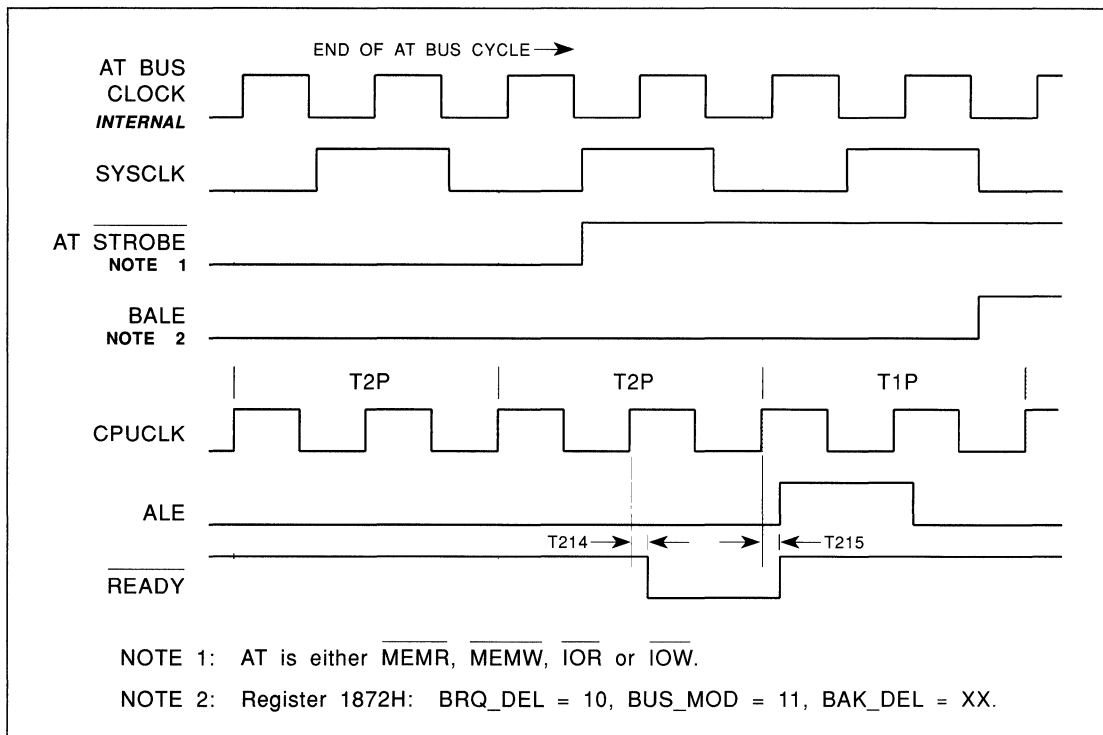

**FIGURE 13-31. SYNCHRONOUS AT BUS CYCLE COMPLETION,
AT BUS CLOCK = CPUCLK ÷ 1**



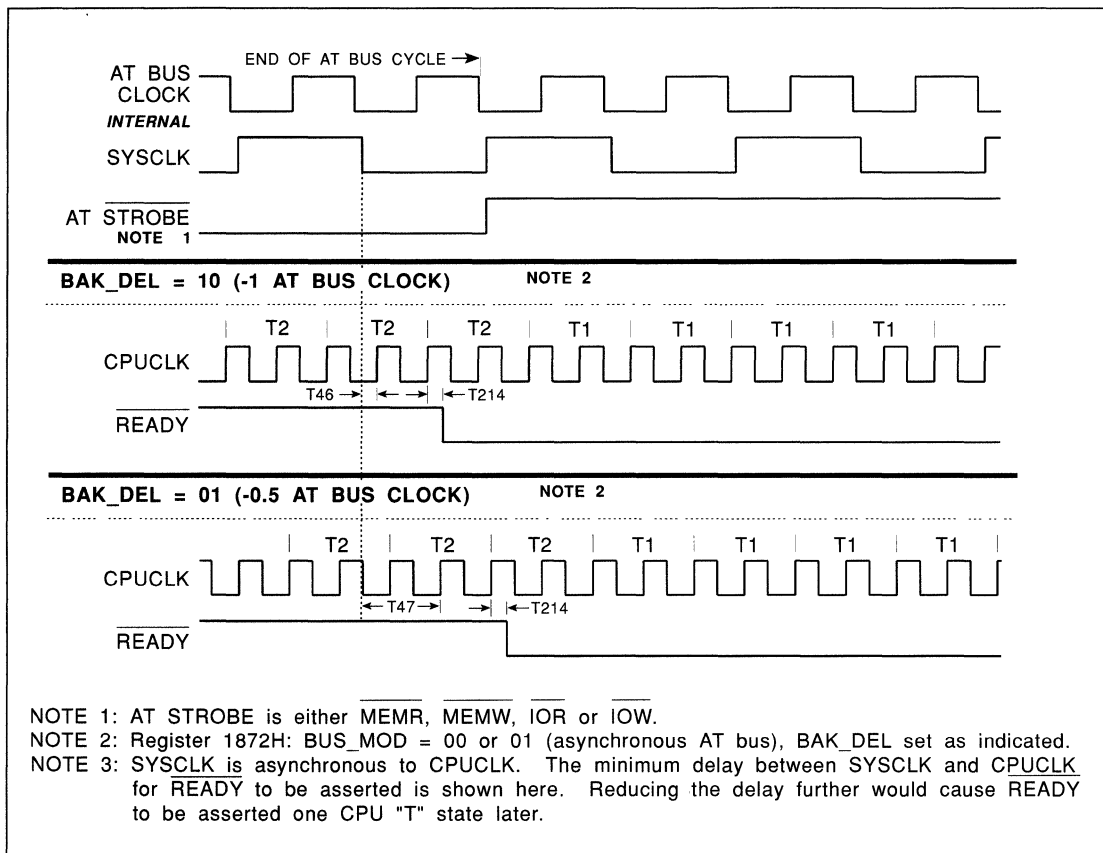
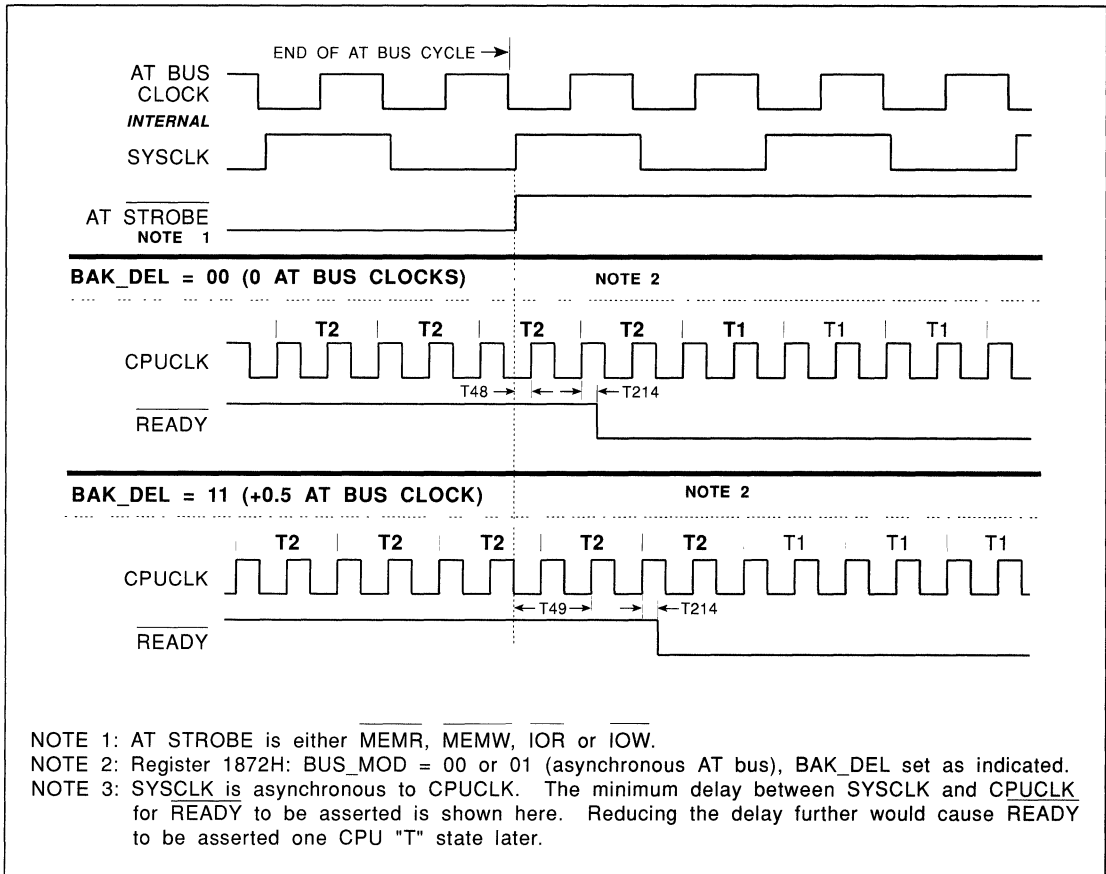

FIGURE 13-32. ASYNCHRONOUS AT BUS CYCLE COMPLETION, BAK_DEL = -1 OR -0.5 AT BUS CLOCKS





**FIGURE 13-33. ASYNCHRONOUS AT BUS CYCLE COMPLETION,
BAK_DEL = 0 OR +0.5 AT BUS CLOCKS**



13.2.4 DMA Cycles

Basic default timing is covered first, followed by 8-bit I/O to onboard memory, then onboard memory to 8-bit I/O.

SYMBOL	CHARACTERISTIC	MIN	MAX	UNITS	TEST CONDITIONS
T50	SYSClk rise to ALE valid high		15	ns	
T51	SYSClk rise to BALE valid high		15	ns	
T52	SYSClk rise to AEN valid high		15	ns	
T53	SYSClk rise to Address driven	0		ns	
T54	SYSClk rise to Address valid		60	ns	
T55	Address hold from SYSClk rise	0		ns	
T56	SYSClk rise to LA20 valid		49	ns	
T57	LA20 hold from SYSClk rise	0		ns	
T58	SYSClk rise to SA0 valid		40	ns	
T59	SA0 hold from SYSClk rise	0		ns	
T60	SYSClk rise to $\overline{\text{BHE}}$ driven	0		ns	
T61	SYSClk rise to $\overline{\text{BHE}}$ valid		36	ns	
T62	$\overline{\text{BHE}}$ hold from SYSClk rise	0		ns	
T63	SYSClk fall to MXCTL valid		2	ns	
T64	SYSClk rise to DACKEN rise		28	ns	
T65	SYSClk rise to DACKEN fall		31	ns	
T66	SYSClk rise to $\overline{\text{CSEN}}$ fall		32	ns	
T67	SYSClk rise to $\overline{\text{CSEN}}$ rise		33	ns	
T68	IOCHRDY setup to SYSClk rise	12		ns	
T69	IOCHRDY hold from SYSClk rise	0		ns	
T70	SYSClk rise to $\overline{\text{IOR}}$ fall		28	ns	
T71	SYSClk rise to $\overline{\text{IOR}}$ rise		35	ns	
T72	SYSClk rise to $\overline{\text{MEMW}}$ fall		47	ns	
T73	SYSClk rise to $\overline{\text{MEMW}}$ rise		35	ns	
T74	SYSClk rise to $\overline{\text{DEN1}}$ fall		32	ns	I/O to memory
T75	SYSClk rise to $\overline{\text{DEN1}}$ rise		42	ns	I/O to memory
T76	SYSClk rise to $\overline{\text{DEN0}}$ fall		32	ns	I/O to memory
T77	SYSClk rise to $\overline{\text{DEN0}}$ rise		42	ns	I/O to memory
T78	SYSClk rise to $\overline{\text{SDEN}}$ fall		21	ns	
T79	SYSClk rise to $\overline{\text{SDEN}}$ rise		37	ns	I/O to memory
T80	SYSClk rise to SDTR rise		30	ns	
T81	SYSClk rise to SDTR fall		20	ns	
T82	SYSClk rise to $\overline{\text{IOW}}$ fall		53	ns	
T83	SYSClk rise to $\overline{\text{IOW}}$ rise		37	ns	
T84	SYSClk rise to $\overline{\text{MEMR}}$ fall		17	ns	
T85	SYSClk rise to $\overline{\text{MEMR}}$ rise		38	ns	
T86	SYSClk rise to $\overline{\text{DEN1}}$ fall		22	ns	I/O to memory
T87	SYSClk rise to $\overline{\text{DEN1}}$ rise		116	ns	I/O to memory
T88	SYSClk rise to $\overline{\text{DEN0}}$ fall		22	ns	I/O to memory
T89	SYSClk rise to $\overline{\text{DEN0}}$ rise		116	ns	I/O to memory
T90	SYSClk rise to SDEN rise		116	ns	I/O to memory
T91	SYSClk rise to DTR rise		31	ns	
T92	SYSClk rise to DTR fall		22	ns	

TABLE 13-8. DMA CYCLES



SYMBOL	CHARACTERISTIC	MIN	MAX	UNITS	TEST CONDITIONS
T100	$\overline{\text{MEMW}}$ fall to $\overline{\text{RASn}}$ fall		27	ns	
T101	$\overline{\text{MEMW}}$ rise to $\overline{\text{RASn}}$ rise		29	ns	
T102	$\overline{\text{MEMW}}$ fall to $\overline{\text{CASn}}$ fall		108	ns	
T103	$\overline{\text{MEMW}}$ rise to $\overline{\text{CASn}}$ rise		30	ns	
T105	$\overline{\text{MEMW}}$ fall to RA(11:00) valid		100	ns	
T107	$\overline{\text{MEMW}}$ fall to W/R high		29	ns	
T108	$\overline{\text{MEMW}}$ rise to W/R low	10		ns	
T120	$\overline{\text{MEMR}}$ fall to $\overline{\text{RASn}}$ fall		28	ns	
T121	$\overline{\text{MEMR}}$ rise to $\overline{\text{RAS}}$ rise		29	ns	
T122	$\overline{\text{MEMR}}$ fall to $\overline{\text{CASn}}$ fall		110	ns	
T123	$\overline{\text{MEMR}}$ rise to $\overline{\text{CAS}}$ rise		31	ns	
T125	$\overline{\text{MEMR}}$ fall to RA(10:00) valid		100	ns	
T126	$\overline{\text{MEMR}}$ fall to DPH, DPL float		25	ns	
T127	$\overline{\text{MEMR}}$ rise to DPH, DPL driven	35		ns	
T303	D(15:00) valid to DPH, DPL valid		27	ns	
T305	D(15:00) setup to $\overline{\text{MEMR}}$ rise	18		ns	
T306	DPH, DPL setup to $\overline{\text{MEMR}}$ rise	10		ns	

TABLE 13-8. DMA CYCLES (Continued)

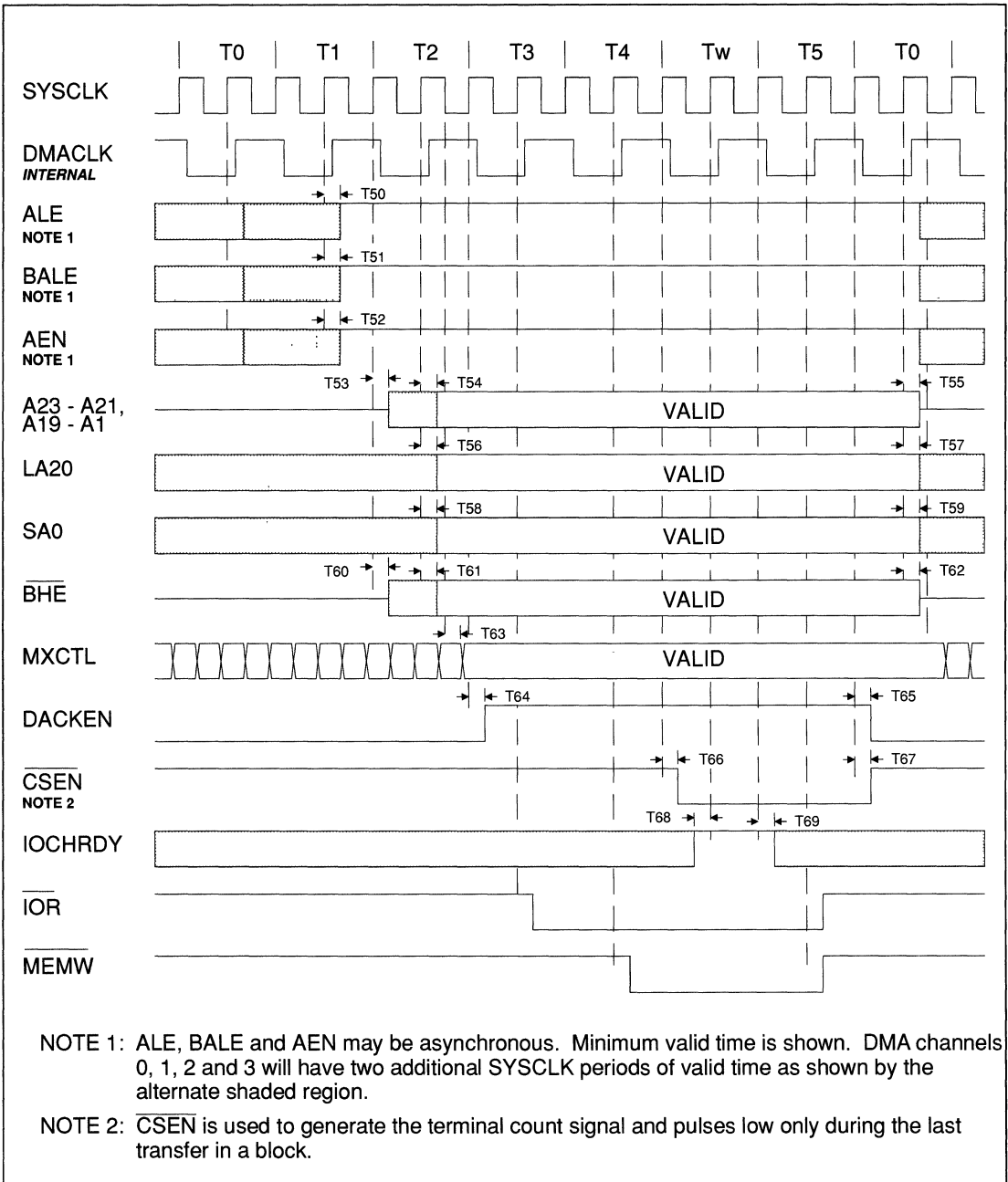

FIGURE 13-34. BASIC DMA CYCLE, DEFAULT TIMING



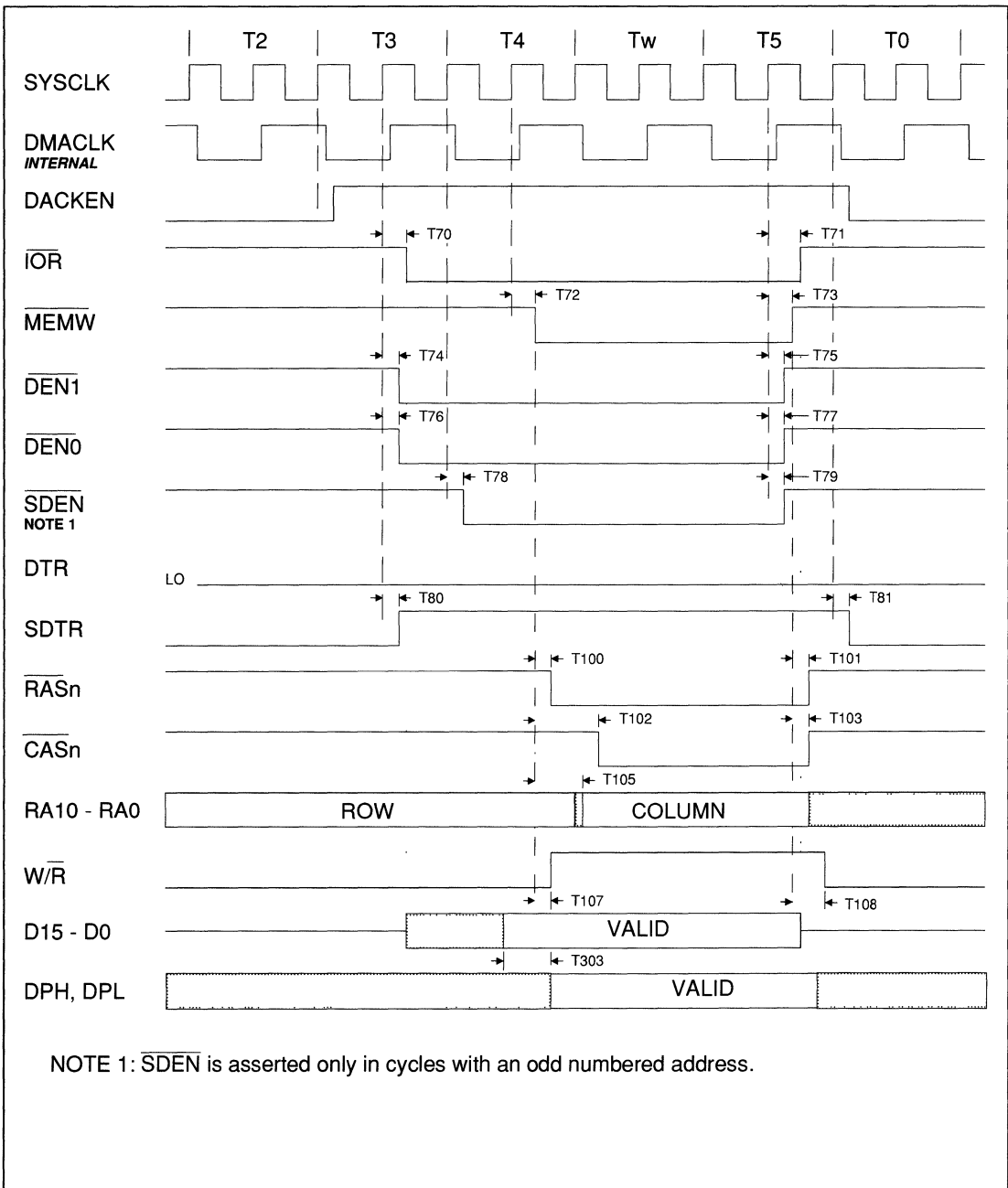

FIGURE 13-35. DMA CYCLE, 8-BIT I/O TO ON-BOARD MEMORY



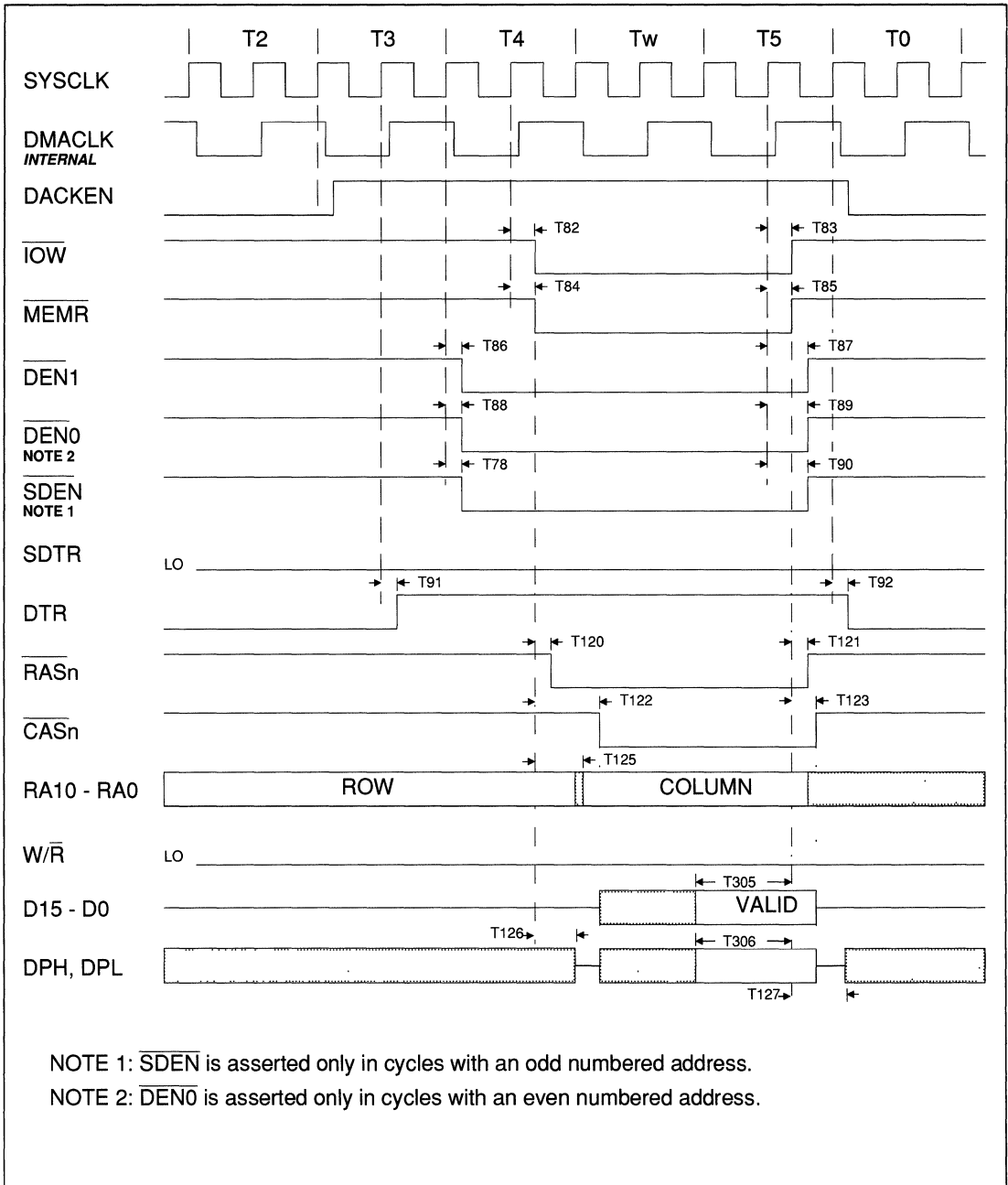

FIGURE 13-36. DMA CYCLE, ON-BOARD MEMORY TO 8-BIT I/O



13.2.5 AT Bus Master

The AT bus master timing is covered in the following sequence:

- Bus acquisition and release
- Writing to the onboard memory
- Reading from the onboard memory

SYMBOL	CHARACTERISTIC	MIN	MAX	UNITS	TEST CONDITIONS
T50	SYSCLK rise to ALE valid high		15	ns	
T51	SYSCLK rise to BALE valid high		15	ns	
T52	SYSCLK rise to AEN valid high		15	ns	
T53	SYSCLK rise to Address driven	0		ns	
T55	Address hold from SYSCLK rise	0		ns	
T60	SYSCLK rise to $\overline{\text{BHE}}$ driven	0		ns	
T61	SYSCLK rise to BHE valid		36	ns	
T62	$\overline{\text{BHE}}$ hold from SYSCLK rise	0		ns	
T63	SYSCLK fall to MXCTL valid		2	ns	
T64	SYSCLK rise to DACKEN rise		28	ns	
T65	SYSCLK rise to DACKEN fall		31	ns	
T150	$\overline{\text{MASTER}}$ fall to AEN fall		30	ns	
T151	$\overline{\text{MASTER}}$ rise to AEN rise		30	ns	
T152	$\overline{\text{MASTER}}$ fall to A(23:21), A(19:01) float		30	ns	
T153	$\overline{\text{MASTER}}$ rise to A(23:21), A(19:01) driven	15		ns	
T154	$\overline{\text{MASTER}}$ fall to LA20 float		23	ns	
T155	$\overline{\text{MASTER}}$ rise to LA20 driven	10		ns	
T156	$\overline{\text{MASTER}}$ fall to SA0 float		24	ns	
T157	$\overline{\text{MASTER}}$ rise to SA0 driven	10		ns	
T158	$\overline{\text{MASTER}}$ fall to $\overline{\text{BHE}}$ float		30	ns	
T159	$\overline{\text{MASTER}}$ rise to $\overline{\text{BHE}}$ driven	10		ns	
T160	$\overline{\text{MASTER}}$ fall to $\overline{\text{CSEN}}$ fall		32	ns	
T161	$\overline{\text{MASTER}}$ rise to $\overline{\text{CSEN}}$ rise		35	ns	
T162	$\overline{\text{MASTER}}$ fall to MEMR float		24	ns	
T163	$\overline{\text{MASTER}}$ rise to MEMR driven	10		ns	
T164	$\overline{\text{MASTER}}$ fall to MEMW, $\overline{\text{IOR}}$, $\overline{\text{IOW}}$, float		23	ns	
T165	$\overline{\text{MASTER}}$ rise to MEMW, $\overline{\text{IOR}}$, $\overline{\text{IOW}}$ driven	10		ns	
T166	A(23:21), A(19:01) setup to MEMR, MEMW	45		ns	
T167	LA20 setup to MEMR, MEMW	50		ns	
T168	$\overline{\text{BHE}}$ setup to MEMR, MEMW	0		ns	
T169	SA0 setup to MEMR, MEMW	0		ns	
T170	A(23:21), A(19:01) hold from MEMR, MEMW	15		ns	
T171	LA20 hold from MEMR, MEMW	15		ns	
T172	$\overline{\text{BHE}}$ hold from MEMR, MEMW	15		ns	
T173	SA0 hold from MEMR, MEMW	15		ns	
T174	SA0 in to A0 out delay		45	ns	
T175	$\overline{\text{MEMW}}$ fall to $\overline{\text{DEN1}}$ fall		30	ns	
T176	$\overline{\text{MEMW}}$ fall to $\overline{\text{DEN0}}$ fall		30	ns	
T177	$\overline{\text{MEMW}}$ rise to $\overline{\text{DEN1}}$ rise		83	ns	
T178	$\overline{\text{MEMW}}$ rise to $\overline{\text{DEN0}}$ rise		83	ns	

TABLE 13-9. AT BUS MASTER CYCLE



SYMBOL	CHARACTERISTIC	MIN	MAX	UNITS	TEST CONDITIONS
T179	$\overline{\text{MEMR}}$ fall to $\overline{\text{DEN1}}$ fall		85	ns	
T180	$\overline{\text{MEMR}}$ fall to $\overline{\text{DEN0}}$ fall		85	ns	
T181	$\overline{\text{MEMR}}$ rise to $\overline{\text{DEN1}}$ rise		32	ns	
T182	$\overline{\text{MEMR}}$ rise to $\overline{\text{DEN0}}$ rise		32	ns	
T183	$\overline{\text{MEMR}}$ fall to DTR rise		29	ns	
T184	$\overline{\text{MEMR}}$ rise to DTR fall		82	ns	
T190	$\overline{\text{MEMR}}$, $\overline{\text{MEMW}}$ fall to $\overline{\text{RASn}}$ fall		83	ns	
T191	$\overline{\text{MEMR}}$, $\overline{\text{MEMW}}$ rise to $\overline{\text{RASn}}$ rise		33	ns	
T192	$\overline{\text{MEMR}}$, $\overline{\text{MEMW}}$ fall to $\overline{\text{CASn}}$ fall		126	ns	
T193	$\overline{\text{MEMR}}$, $\overline{\text{MEMW}}$ rise to $\overline{\text{CASn}}$ rise		33	ns	
T194	$\overline{\text{MEMR}}$, $\overline{\text{MEMW}}$ fall to RA(10:00) column address valid		120	ns	
T196	$\overline{\text{MEMR}}$, $\overline{\text{MEMW}}$ fall to RA(10:00) row address valid		42	ns	
T197	RA(10:00) column address hold from $\overline{\text{MEMR}}$, $\overline{\text{MEMW}}$ rise	5		ns	
T300	$\overline{\text{MEMW}}$ fall to $\overline{\text{W/R}}$ rise		33	ns	
T301	$\overline{\text{MEMW}}$ rise to $\overline{\text{W/R}}$ fall	10		ns	
T302	$\overline{\text{MEMW}}$ fall to DPH, DPL valid		32	ns	
T303	D(15:00) valid to DPH, DPL valid		27	ns	
T304	DPH, DPL hold from $\overline{\text{MEMW}}$ rise	5		ns	
T305	D(15:00) setup to $\overline{\text{MEMR}}$ rise	18		ns	
T306	DPH, DPL setup to $\overline{\text{MEMR}}$ rise	10		ns	
T307	$\overline{\text{MEMR}}$ fall to DPH, DPL float		35	ns	
T308	$\overline{\text{MEMR}}$ rise to DPH, DPL driven	58		ns	

TABLE 13-9. AT BUS MASTER CYCLE (Continued)



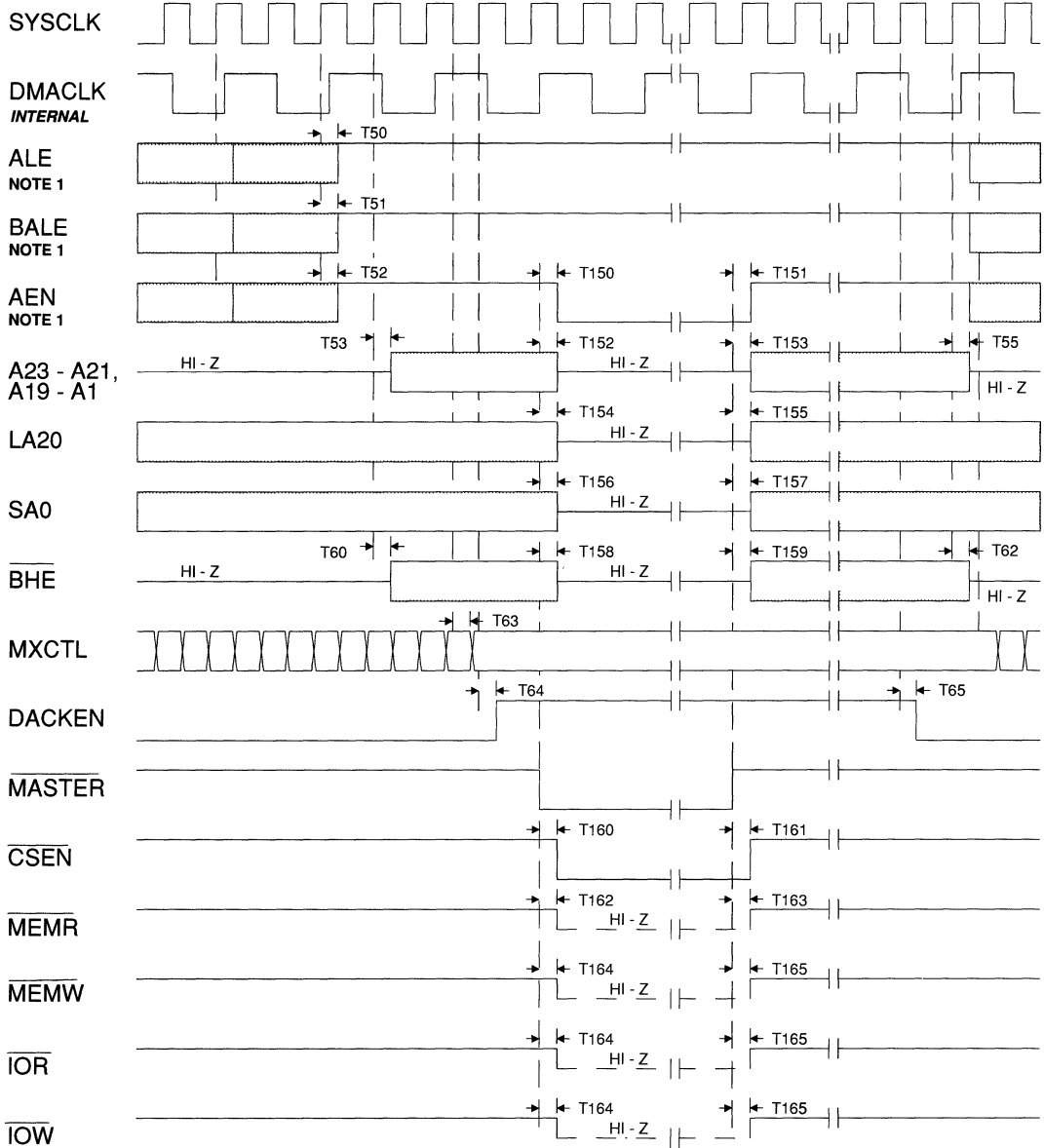

NOTE 1: The shaded regions of ALE, BALE and AEN show a possible asynchronous relationship. Minimum valid time is shown. DMA channels 0, 1, 2 and 3 will have two additional SYSCLK periods of valid HI time as shown by the alternate shading.

FIGURE 13-37. AT BUS MASTER, BUS ACQUISITION/RELEASE

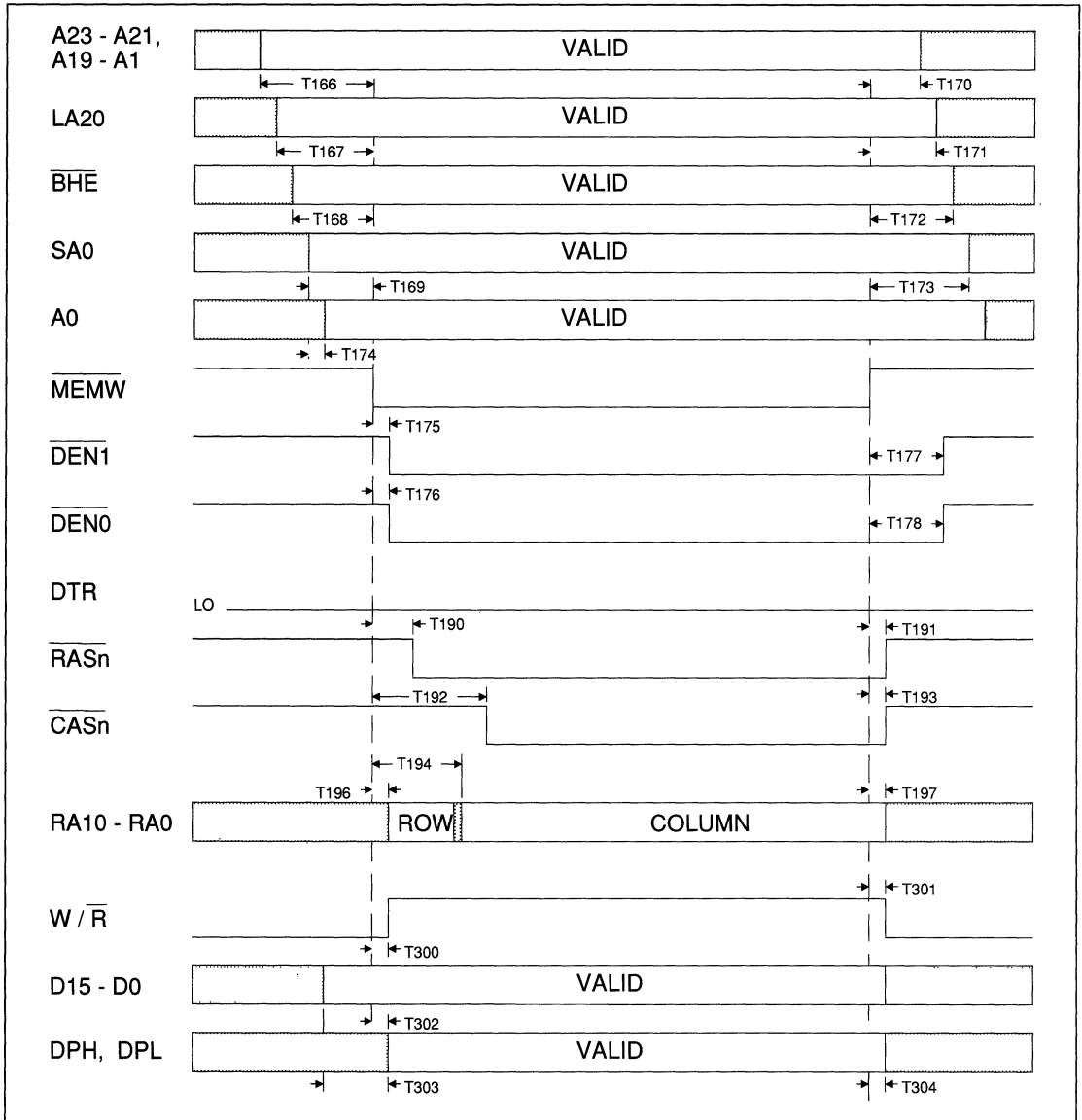

FIGURE 13-38. AT BUS MASTER, WRITE TO ON-BOARD MEMORY



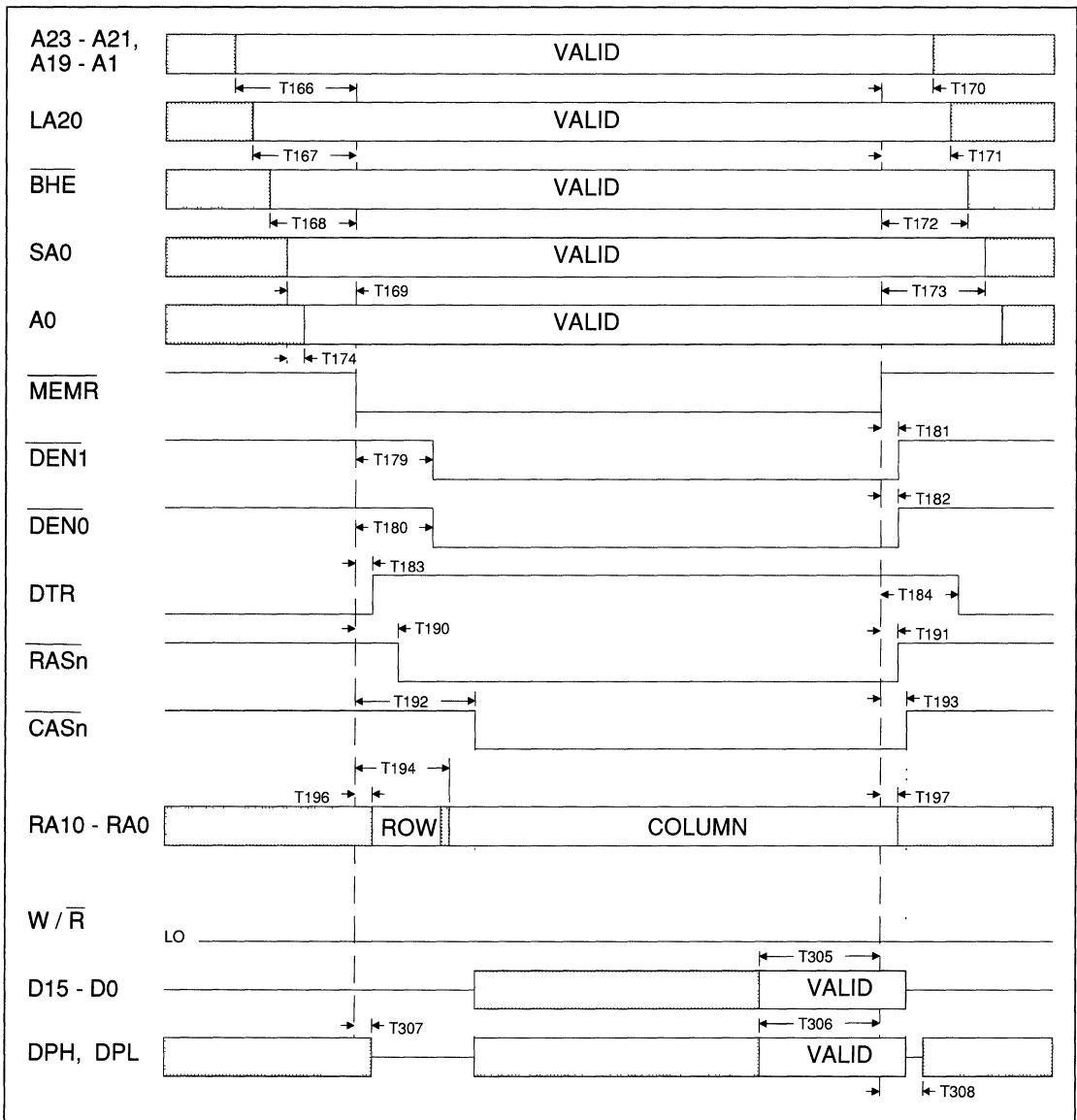

FIGURE 13-39. AT BUS MASTER, READ FROM ON-BOARD MEMORY



13.2.6 AT Bus Refresh

SYMBOL	CHARACTERISTIC	MIN	MAX	UNITS	TEST CONDITIONS
T320	REFRESH low before SYSCLK rise	4		ns	REFRESH setup is number given plus (T00 × 0.25)
T321	SYSCLK fall to $\overline{\text{REFRESH}}$ rise		16	ns	
T325	SYSCLK rise to A(23:21), A(19:16) and A(07:01) valid		35	ns	
T326	SYSCLK fall to A(23:21), A(19:16) and A(07:01) invalid	2		ns	
T327	SYSCLK rise to A20, A(15:08) valid		45	ns	
T328	SYSCLK fall to A20, A(15:08) invalid	2		ns	
T329	SYSCLK rise to LA20 valid		30	ns	
T330	SYSCLK fall to LA20 invalid	2		ns	
T331	SYSCLK rise to SA0 valid		30	ns	
T332	SYSCLK fall to SA0 invalid	2		ns	
T333	SYSCLK rise to $\overline{\text{MEMR}}$ low		8	ns	
T334	SYSCLK rise to $\overline{\text{MEMR}}$ high		7	ns	
T335	IOCHRDY setup to SYSCLK rise	23		ns	
T336	IOCHRDY hold time from SYSCLK rise	0		ns	

TABLE 13-10. AT BUS REFRESH CYCLE, DEFAULT TIMING



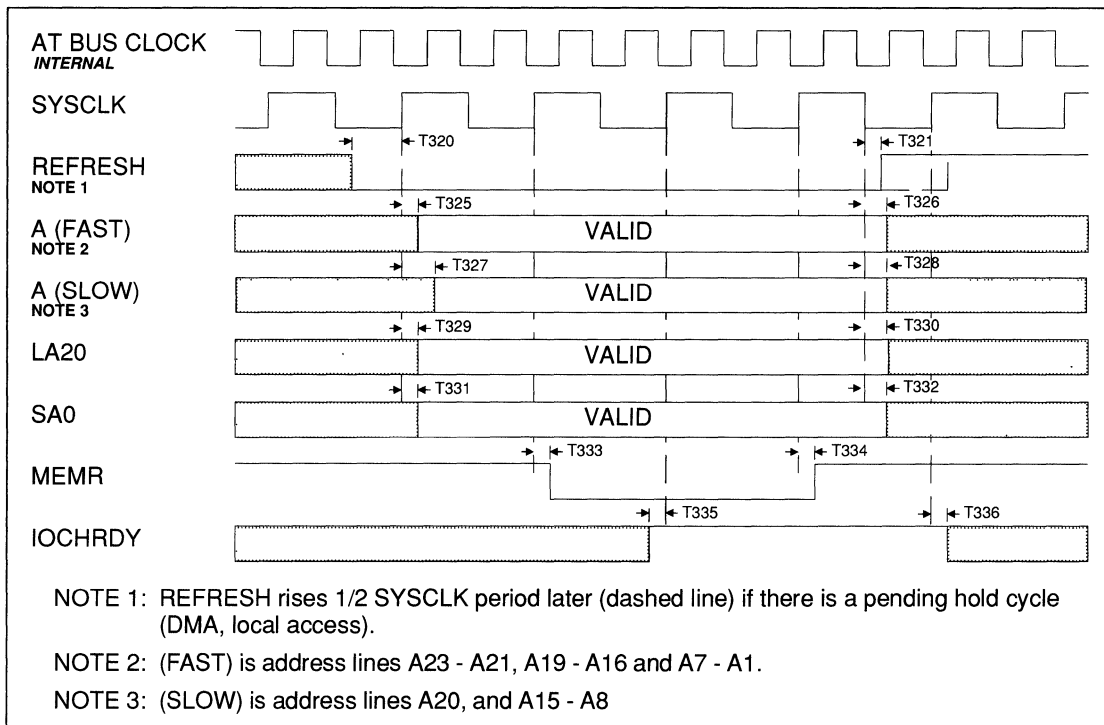

FIGURE 13-40. AT BUS REFRESH CYCLE, DEFAULT TIMING

13.3 PROCESSOR TIMING

This section covers the 80386SX CPU timing. The parameters for the WD7855LV that differ from these are marked with an * and appear in the appendix.

SYMBOL	CHARACTERISTICS	20 MHz		25 MHz		33 MHz		UNITS
		MIN	MAX	MIN	MAX	MIN	MAX	
T140	See Table 13-6							
T141	See Table 13-6							
T204	See Table 13-3							
T214	See Table 13-3							
T215	See Table 13-3							
T451	CPUCLK rise to CPURES rise delay		14		10		10	ns
T452	CPUCLK rise to CPURES fall delay		13		10		10	ns
T453	CPUCLK rise to NPRST rise delay		14		10		10	ns
T454	CPUCLK rise to <u>NPRST</u> fall delay		13		10		10	ns
T455	CPUCLK rise to <u>BUSYCPU</u> fall delay		35		35		35	ns
T456	CPUCLK rise to <u>BUSYCPU</u> rise delay		35		30		30	ns
T457	<u>NPBUSY</u> fall to <u>BUSYCPU</u> fall delay		30		30		30	ns
T458	<u>NPBUSY</u> rise to <u>BUSYCPU</u> rise delay		35		35		35	ns
T460	<u>NPERR</u> fall to <u>EPEREQ</u> rise delay		30		30		30	ns
T462	<u>ADS</u> setup time to CPUCLK rise *	14		10		10		ns
T463	<u>ADS</u> hold time from CPUCLK rise	5		4		4		ns
T464	<u>W/R</u> setup time to CPUCLK rise *	14		8		8		ns
T465	<u>W/R</u> hold time from CPUCLK rise	5		4		4		ns
T466	<u>D/C</u> setup time to CPUCLK rise *	14		6		6		ns
T467	<u>D/C</u> hold time from CPUCLK rise	5		4		4		ns
T468	<u>M/IO</u> setup time to CPUCLK rise *	17		15		15		ns
T469	<u>M/IO</u> hold time from CPUCLK rise	5		4		4		ns
T470	<u>BHE</u> setup time to CPUCLK rise	17		15		15		ns
T471	<u>BHE</u> hold time from CPUCLK rise	3		4		4		ns
T472	<u>HOLDA</u> setup time to CPUCLK rise	10		6		6		ns
T473	<u>HOLDA</u> hold time from CPUCLK rise	3		4		4		ns
T474	<u>HOLDR</u> valid delay from CPUCLK rise *		26		20		20	ns
T475	<u>DPH</u> setup time to CPUCLK rise	5		5		5		ns
T476	<u>DPH</u> hold time from CPUCLK rise	19		19		19		ns
T477	<u>D(15:00)</u> setup time to CPUCLK rise	5		5		5		ns
T478	<u>D(15:00)</u> hold time from CPUCLK rise	19		19		15		ns
T479	<u>A(23:01)</u> , <u>BLE</u> setup time to CPUCLK rise *	40		38		30		ns
T480	<u>A(23:01)</u> , <u>BLE</u> hold time from CPUCLK rise	3		4		4		ns

TABLE 13-11. 80386SX CPU TIMING



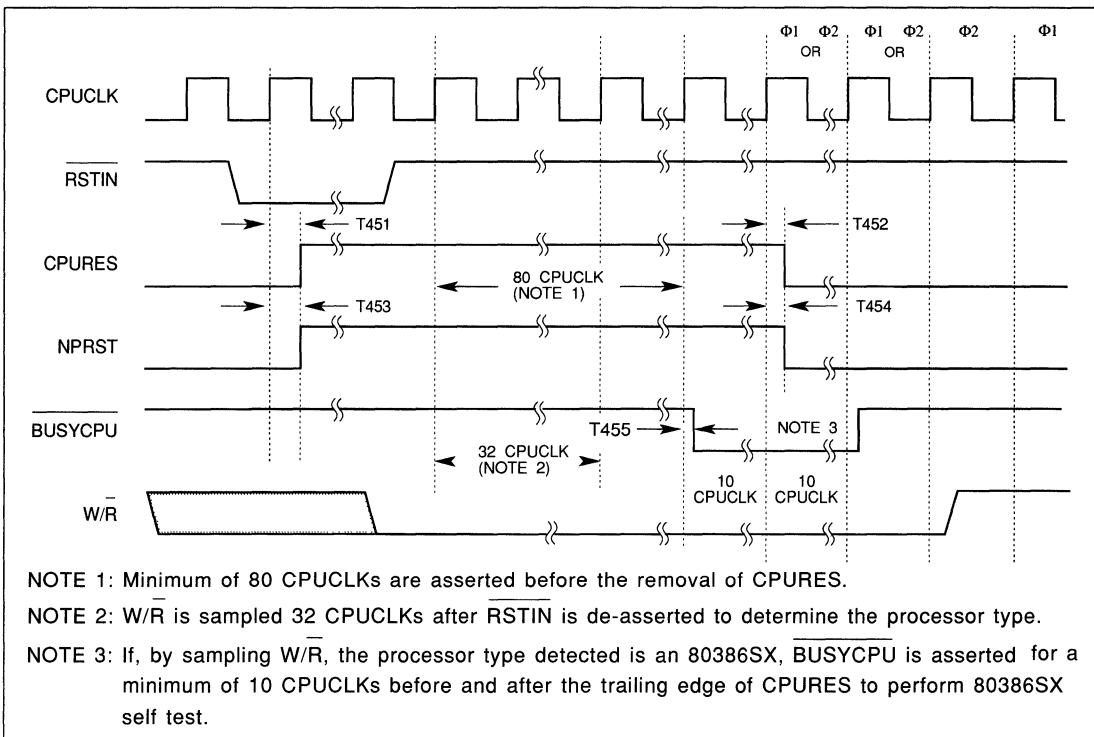

FIGURE 13-41. 80386SX - CPURES AND NPRST DURING POWER UP

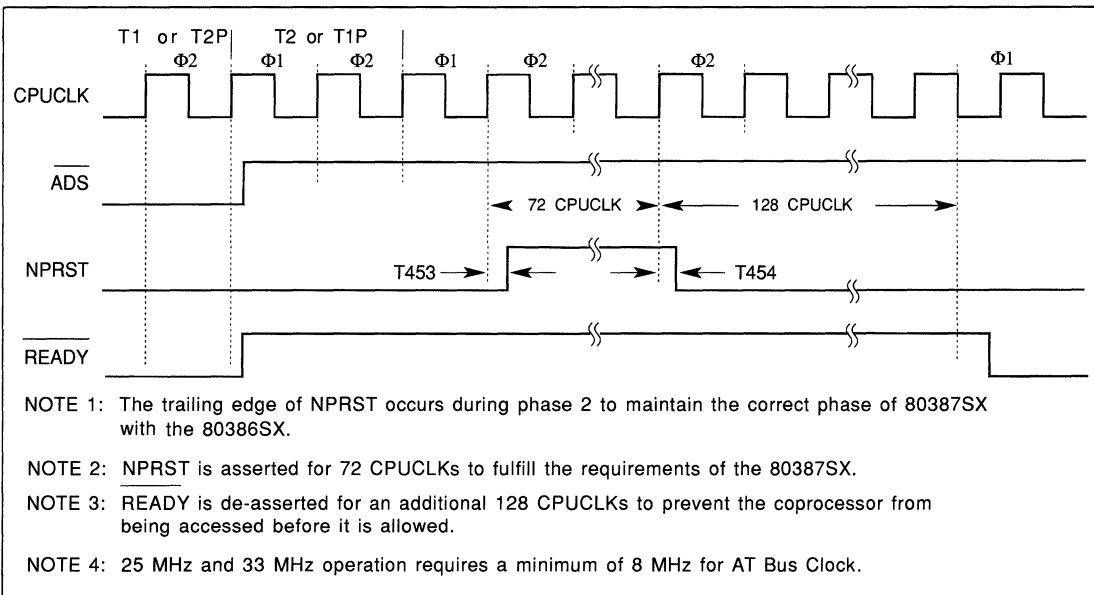

FIGURE 13-42. 80386SX - COPROCESSOR RESET (NPRST) INITIATED BY IOW TO PORT F1

10



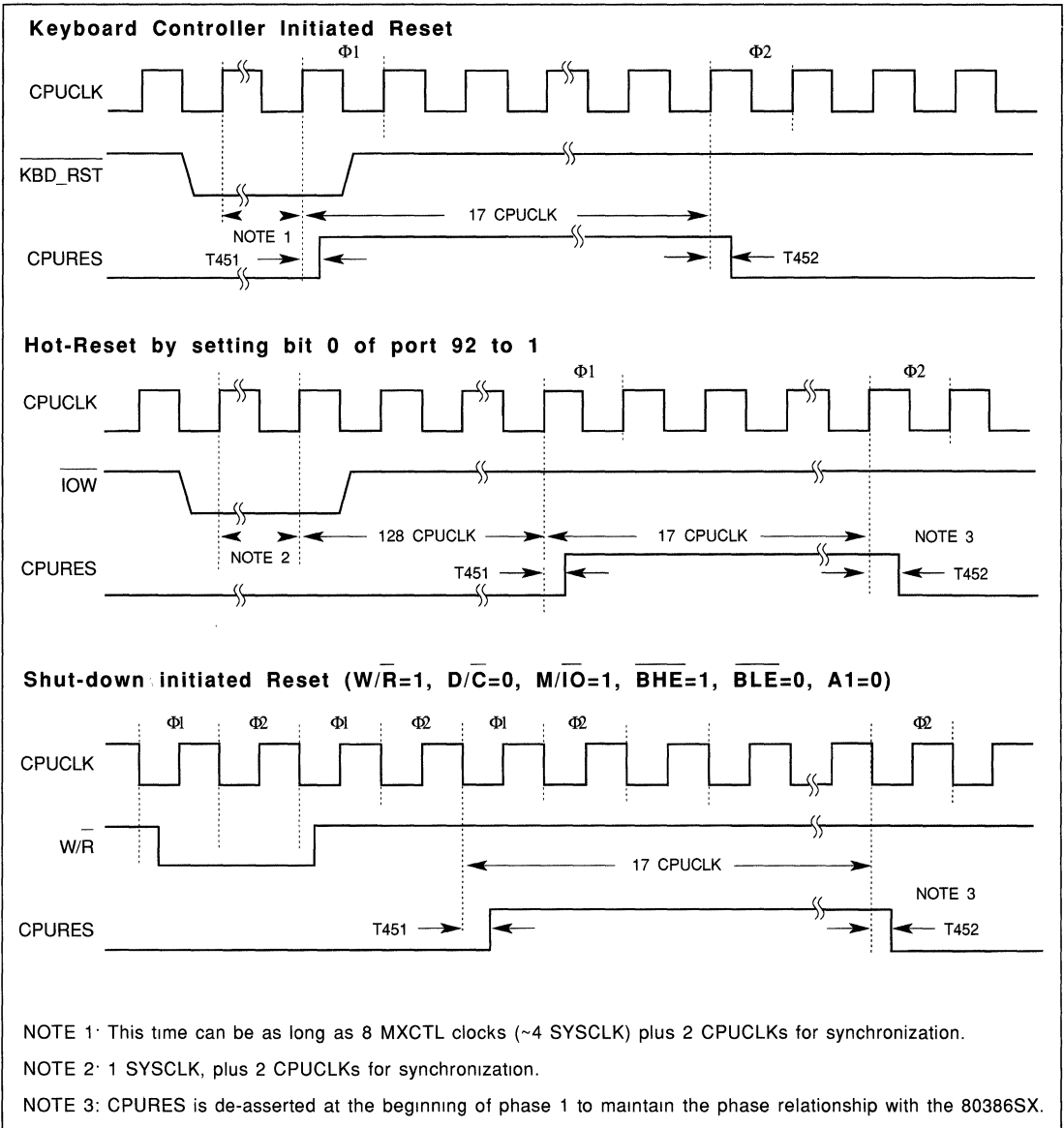

FIGURE 13-43. 80386SX - PROCESSOR RESET (CPURES) INITIATED BY SOURCES OTHER THAN POWER UP RESET



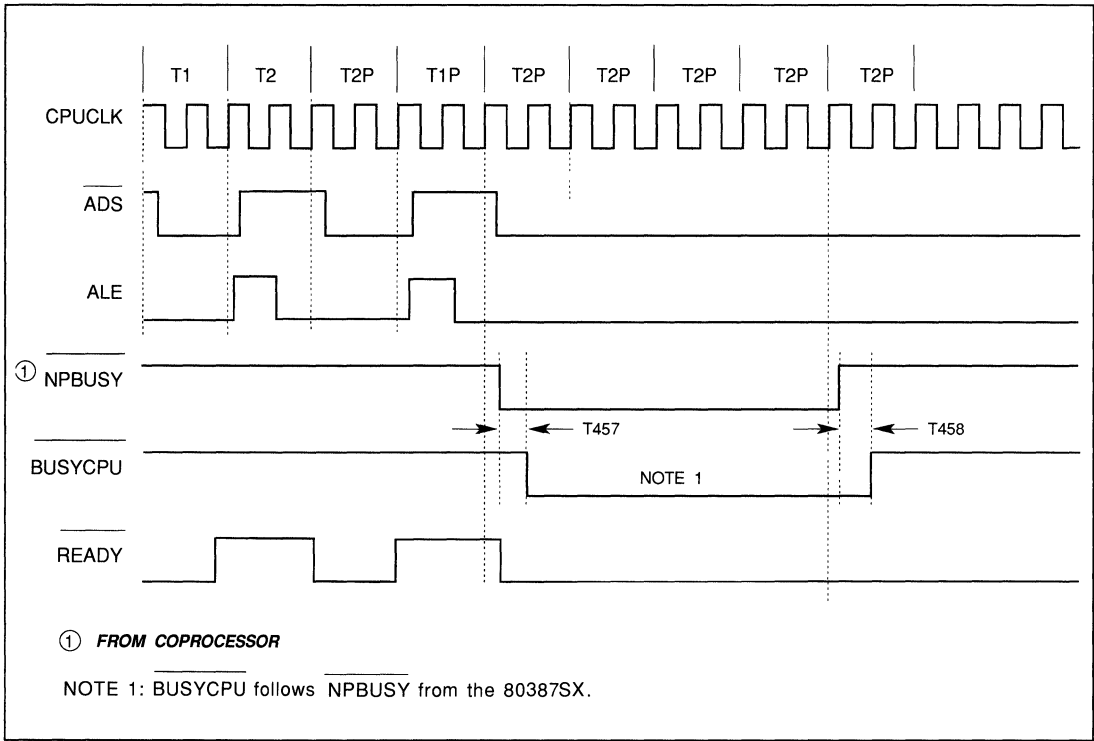

FIGURE 13-44. $\overline{\text{BUSYCPU}}$ ASSERTION DURING COPROCESSOR ACCESS

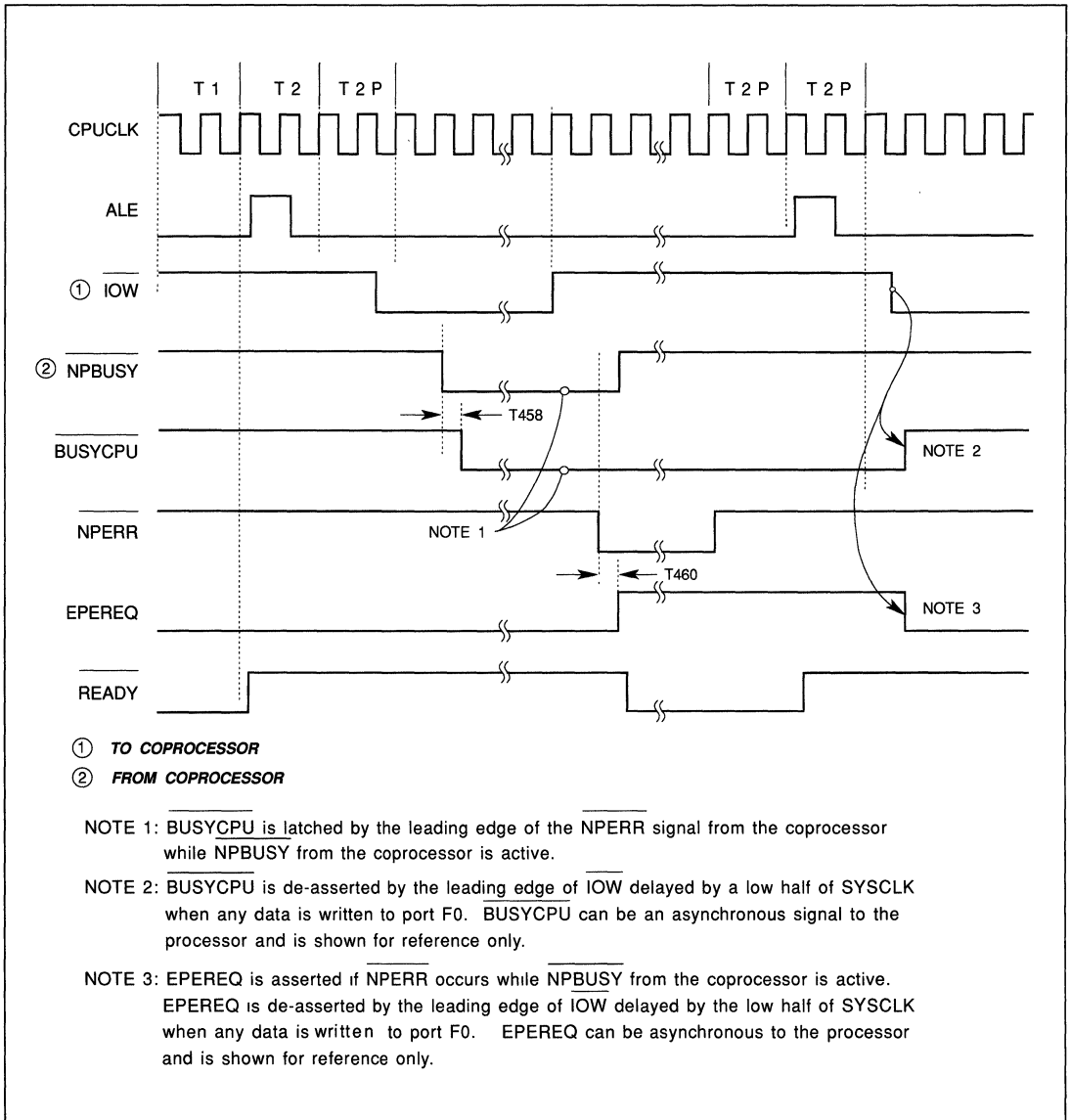

FIGURE 13-45. 80386SX - LATCHING BUSYCPU WHEN AN ERROR OCCURS AND CLEARING IT WITH A WRITE TO PORT F0



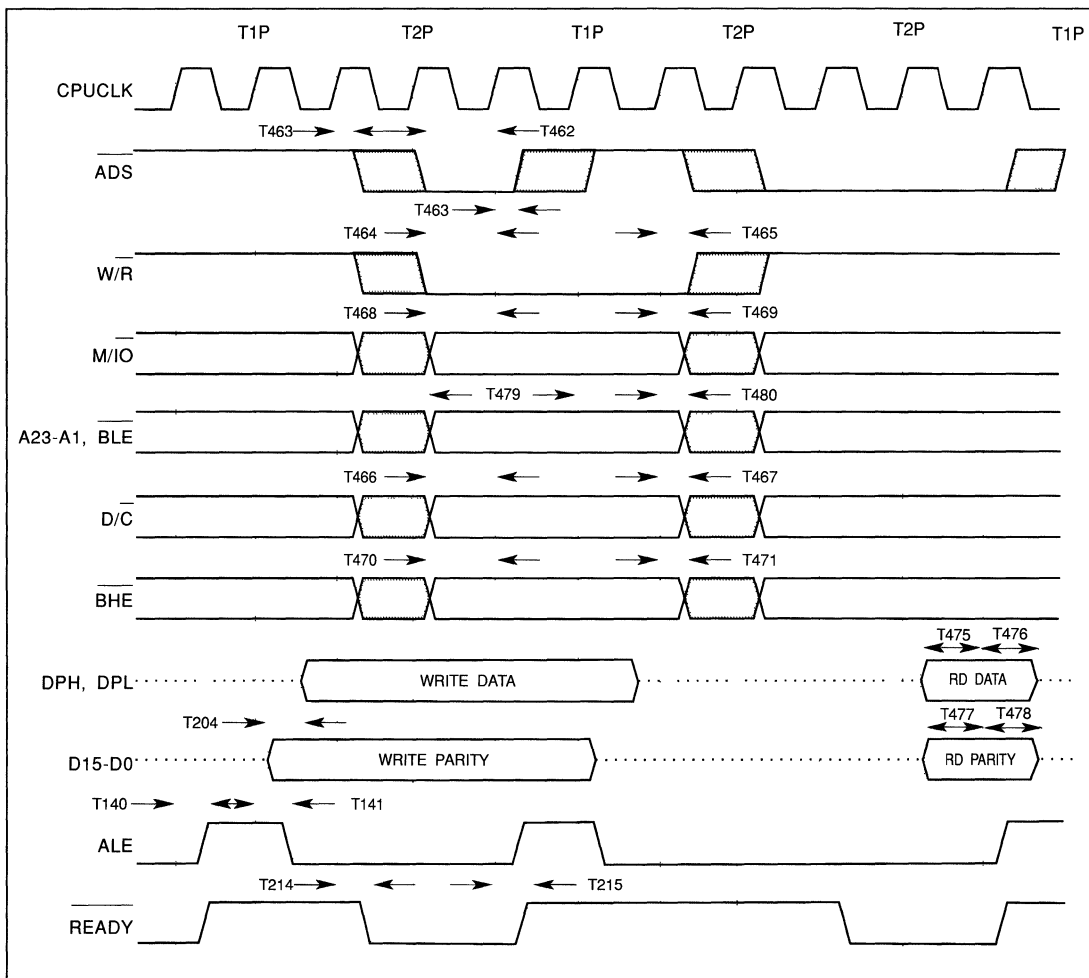

FIGURE 13-46. 80386SX - MISCELLANEOUS TIMING

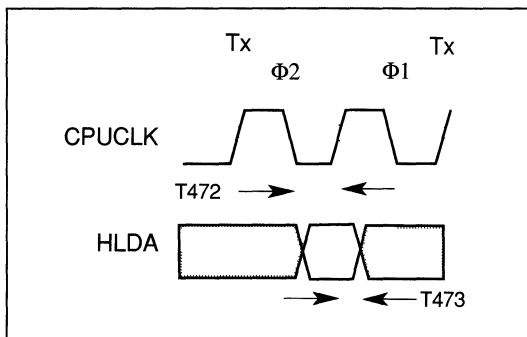

FIGURE 13-47. 80386SX - INPUT SETUP AND HOLD TIMING

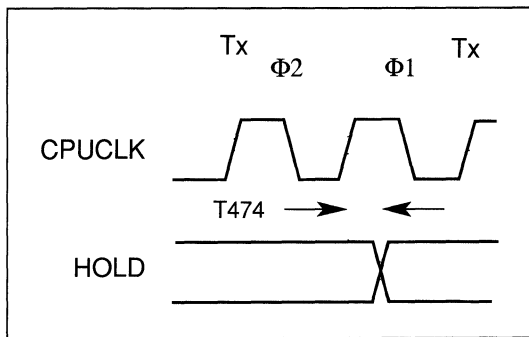

FIGURE 13-48. 80386SX - OUTPUT DELAY TIMING

SYMBOL	CHARACTERISTIC	MIN	MAX	UNIT
T350	SMIADS setup time to CPUCLK rise	10		ns
T351	CPUCLK rise to $\overline{\text{SMI}}$ low output delay		25	ns
T352	CPUCLK rise to $\overline{\text{NA}}$ output delay		15	ns
T353	CPUCLK rise to SMIRDY output delay		18	ns

TABLE 13-12. WD7855 SMI TIMING

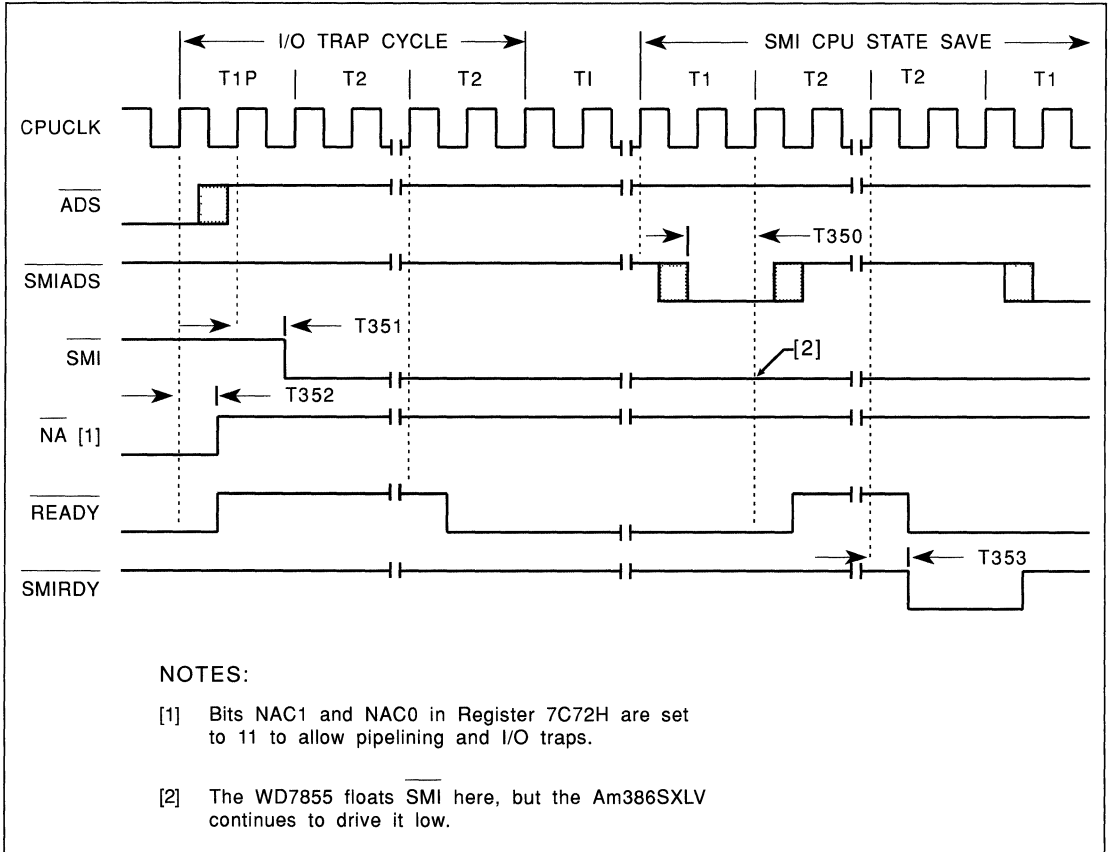

FIGURE 13-49. I/O TRAP CYCLE WITH Am386SXLV



14.0 PIN STATES DURING CHIP RESET, SUSPEND AND CPU POWER DOWN

PIN NUMBER	SIGNAL NAME	RESET STATE	PROCESSOR POWER DOWN		FULL POWER DOWN		
			Input	Output	Input	Output	
AT BUS							
94	$\overline{\text{IOR}}$ ③	High ①	I	O	IH	Z	
93	$\overline{\text{IOW}}$ ③	High ①	I	O	IH	Z	
97	$\overline{\text{MEMR}}$ ③	High ①	I	O	IH	Z	
92	$\overline{\text{MEMW}}$ ③	High ①	I	O	IH	Z	
107	$\overline{\text{LOMEG}}$	High		O		Z	
88	$\overline{\text{MASTER}}$ ③	Input	I		IH		
84	$\overline{\text{IOCK}}$ ③	Input	I		IH		
101	AEN	Low		O		Z	
100	SYSCLK	Low		O		Z	
87	$\overline{\text{IOCS16}}$ ③	Input	I		IH		
89	$\overline{\text{MEMCS16}}$ ③	Input	I		IH		
86	$\overline{\text{ZEROWS}}$ ③	Input	I		IH		
85	$\overline{\text{IOCHRDY}}$ ③	Input	I		IH		
98	$\overline{\text{REFRESH}}$ ③	High	I	O	IH	O	
99	BALE	Low		O		Z	
38	MXCTL2	High		O		O	
37	MXCTL1	Low		O		O	
35	MXCTL0	Low		O		O	
40	DACKEN	High		O		O	
33	IRQSET1	Input	I		IH		
34	IRQSET0	Input	I		IH		
76	DRQIN	Input	I		IL		
95	LA20	High ① ②	I	O	IH	Z	
96	SA0	Low ① ②	I	O	IH	Z	

①: This pin is tristated if master = 0. For test purposes, if MASTER is asserted, outputs are tristated and the pins become inputs.

②: Assumes processor address = FFFF0 during reset.

③: Internal 50 kohm pullup, disabled in power-down mode.

IH: Input internally forced high in power-down mode.

IL: Input internally forced low in power-down mode.

Z: Output tristated in power-down mode.

TABLE 14-1. PIN STATES DURING CHIP RESET, SUSPEND, CPU PWD.



PIN NUMBER	SIGNAL NAME	RESET STATE	PROCESSOR POWER DOWN		FULL POWER DOWN	
			Input	Output	Input	Output
AT BUS (Continued)						
155	SPKR	Low		O		O
149	DT/R	High		O		Z
152	DEN0	High		O		Z
151	DEN1	High		O		Z
15	ALE	High		O		Z
55	SDT/R ^⑤	Input ^⑥	I	O	IL	Z
59	SDEN	High		O		Z
39	CSEN	Low		O		O
VLBI CONTROL						
103	LB ^③	Input		Z		Z
45	LBRDY ^③	Input		Z		Z
SMI CONTROL						
110	SMIRDY	Output		Z		Z
113	SMIADS	Input	IH	Z	IH	Z
5	ADS	Input	IH	Z	IH	Z
108	SMI	Input	IH	Z	IH	Z
80386SX PROCESSOR						
122	CPUCLK	Same as BCLK2	IL	Z	IL	Z
114	READY ^③	Low		Z		Z
154	CPURES	High		Z		Z
116	HOLDR	Low		Z		Z
126	INTRQ	Low		Z		Z
124	NMI	Low		Z		Z
109	BHE ^③	Input	IH	Z	IH	Z
112	D/C	Input	IL		IL	
1	M/IO ^③	Input	IL	Z	IL	Z
115	HOLDA ^③	Low	IL		IL	
<p>③ Internal 50 kohm pullup, disabled in power-down mode.</p> <p>⑤ Internal 80 kohm pullup, disabled in processor power-down mode and in full power-down mode.</p> <p>⑥ Returns to output when RSTIN is de-asserted.</p> <p>IH Input internally forced high in power-down mode.</p> <p>IL Input internally forced low in power-down mode.</p> <p>Z Output tristated in power-down mode.</p>						

TABLE 14-1. PIN STATES DURING CHIP RESET, SUSPEND, CPU PWD. (Continued)



PIN NUMBER	SIGNAL NAME	RESET STATE	PROCESSOR POWER DOWN		FULL POWER DOWN		
			Input	Output	Input	Output	
80386SX PROCESSOR Continued							
123	BUSYCPU	High		Z		Z	
125	NA	Output		Z		Z	
157	A23 ^⑦	Input	IL	Z	IL	Z	
158	A22 ^⑦	Input	IL	Z	IL	Z	
159	A21 ^⑦	Input	IL	Z	IL	Z	
6	A20 ^⑦	Input	IL	Z	IL	Z	
7	A19 ^⑦	Input	IL	Z	IL	Z	
8	A18 ^⑦	Input	IL	Z	IL	Z	
9	A17 ^⑦	Input	IL	Z	IL	Z	
11	A16 ^⑦	Input	IL	Z	IL	Z	
12	A15 ^⑦	Input	IL	Z	IL	Z	
13	A14 ^⑦	Input	IL	Z	IL	Z	
14	A13 ^⑦	Input	IL	Z	IL	Z	
16	A12 ^⑦	Input	IL	Z	IL	Z	
17	A11 ^⑦	Input	IL	Z	IL	Z	
21	A10 ^⑦	Input	IL	Z	IL	Z	
23	A9 ^⑦	Input	IL	Z	IL	Z	
24	A8 ^⑦	Input	IL	Z	IL	Z	
26	A7 ^⑦	Input	IL	Z	IL	Z	
27	A6 ^⑦	Input	IL	Z	IL	Z	
28	A5 ^⑦	Input	IL	Z	IL	Z	
29	A4 ^⑦	Input	IL	Z	IL	Z	
31	A3 ^⑦	Input	IL	Z	IL	Z	
32	A2 ^⑦	Input	IL	Z	IL	Z	
4	A1 ^⑦	Input	IL	Z	IL	Z	
3	$\overline{\text{BLE}}$ ^⑦	Input	IL	Z	IL	Z	
2	W/R	Input	IL	Z	IL	Z	
^⑦	100 Kohm pulldown resistors are turned on when the processor is in power-down or suspend mode to prevent the data bus or address bus from floating. In normal operation these pull down resistors are turned off.						
IH	Input internally forced high in power-down mode.						
IL	Input internally forced low in power-down mode.						
Z	Output tristated in power-down mode.						

TABLE 14-1. PIN STATES DURING CHIP RESET, SUSPEND, CPU PWD. (Continued)



PIN NUMBER	SIGNAL NAME	RESET STATE	PROCESSOR POWER DOWN		FULL POWER DOWN		
			Input	Output	Input	Output	
DRAM CONTROL							
78	DPH/CS4 ④	Low	I	O	I	O	
79	DPL/CS3 ④	Low	I	O	I	O	
20	RA11	Output		O		O	
52	RA10/CS2	High ②		O		O	
53	RA9/CS1	High ②		O		O	
54	RA8/CS0	High ②		O		O	
57	RA7/ED7	High ②	I ⑨	O	I	O	
58	RA6/ED6	High ②	I ⑨	O	I	O	
61	RA5/ED5	High ②	I ⑨	O	I	O	
63	RA4/ED4	High ②	I ⑨	O	I	O	
64	RA3/ED3	High ②	I ⑨	O	I	O	
67	RA2/ED2	High ②	I ⑨	O	I	O	
68	RA1/ED1	High ②	I ⑨	O	I	O	
69	RA0/ED0	High ②	I ⑨	O	I	O	
75	$\overline{\text{RAS7}}$ ④	High		O		O	
74	$\overline{\text{RAS6}}$ ④	High		O		O	
72	$\overline{\text{RAS5}}$ ④	High		O		O	
71	$\overline{\text{RAS4}}$ ④	High		O		O	
49	$\overline{\text{RAS3}}$ ④	High		O		O	
48	$\overline{\text{RAS2}}$ ④	High		O		O	
46	$\overline{\text{RAS1}}$ ④	High		O		O	
44	$\overline{\text{RAS0}}$ ④	High		O		O	
②	Assumes processor address = FFFFF0 during reset.						
④	Internal 50 kohm pullup, disabled in processor power-down mode and in full power-down mode.						
⑨	Bidirectional buffer.						
IH	Input internally forced high in power-down mode.						
IL	Input internally forced low in power-down mode.						
Z	Output tristated in power-down mode.						

TABLE 14-1. PIN STATES DURING CHIP RESET, SUSPEND, CPU PWD. (Continued)



PIN NUMBER	SIGNAL NAME		RESET STATE	PROCESSOR POWER DOWN		FULL POWER DOWN	
				Input	Output	Input	Output
DRAM CONTROL (Continued)							
77	$\overline{\text{CAS3}}$	⑤	Input ⑧		O	IH	Z
73	$\overline{\text{CAS2}}$	⑤	Input ⑧		O	IH	Z
51	$\overline{\text{CAS1}}$	④	High		O		O
47	$\overline{\text{CAS0}}$	④	High		O		O
43	WNRDRAM		Output		Z		Z
CACHE CONTROL							
153	A20GATE		Output		Z		Z
25	$\overline{\text{NONCAC}}$		Input	IL		IL	
30	$\overline{\text{FLUSH}}$		Output		Z		Z
160	KEN		Output		Z		Z
INITIALIZATION AND CLOCKING							
90	CLK14		Input	I		I	
120	BCLK2		Input	I		IL	
80	$\overline{\text{RSTIN}}$		Input	I		I	
POWER MANAGEMENT CONTROL							
42	PMCIN	③	Input	I		I	
41	$\overline{\text{PDREF}}$	③	Input	I		I	
<p>③ Internal 50 kohm pullup, disabled in power-down mode.</p> <p>④ Internal 50 kohm pullup, disabled in processor power-down mode and in full power-down mode.</p> <p>⑤ Internal 80 kohm pullup, disabled in processor power-down mode and in full power-down mode.</p> <p>⑧ In 80486 mode ($\overline{\text{CAS2}}$ low at trailing edge of $\overline{\text{RSTIN}}$) this remains an input after $\overline{\text{RSTIN}}$ is de-asserted. In 80386 mode ($\overline{\text{CAS2}}$ high at trailing edge of $\overline{\text{RSTIN}}$) it switches to output after $\overline{\text{RSTIN}}$ is de-asserted.</p> <p>IH Input internally forced high in power-down mode.</p> <p>IL Input internally forced low in power-down mode.</p> <p>Z Output tristated in power-down mode.</p>							

TABLE 14-1. PIN STATES DURING CHIP RESET, SUSPEND, CPU PWD. (Continued)



PIN NUMBER	SIGNAL NAME	RESET STATE	PROCESSOR POWER DOWN		FULL POWER DOWN		
			Input	Output	Input	Output	
DATA BUS							
121	CLKA/RDYIN/PE	Input					
148	D15 ^⑦	Input	IL	Z	IL	Z	
147	D14 ^⑦	Input	IL	Z	IL	Z	
146	D13 ^⑦	Input	IL	Z	IL	Z	
144	D12 ^⑦	Input	IL	Z	IL	Z	
142	D11 ^⑦	Input	IL	Z	IL	Z	
139	D10 ^⑦	Input	IL	Z	IL	Z	
138	D9 ^⑦	Input	IL	Z	IL	Z	
137	D8 ^⑦	Input	IL	Z	IL	Z	
136	D7 ^⑦	Input	IL	Z	IL	Z	
134	D6 ^⑦	Input	IL	Z	IL	Z	
133	D5 ^⑦	Input	IL	Z	IL	Z	
127	D0 ^⑦	Input	IL	Z	IL	Z	
132	D4 ^⑦	Input	IL	Z	IL	Z	
131	D3 ^⑦	Input	IL	Z	IL	Z	
129	D2 ^⑦	Input	IL	Z	IL	Z	
128	D1 ^⑦	Input	IL	Z	IL	Z	
NUMERIC PROCESSOR CONTROL							
105	EPEREQ	Low		Z		Z	
106	NPRST	High		Z		Z	
111	NPERR ^③	Input	IH		IH		
140	NPBUSY ^③	Input	IH		IH		
③	Internal 50 kohm pullup, disabled in power-down mode.						
⑦	100 Kohm pulldown resistors are turned on when the processor is in power-down or suspend mode to prevent the data bus or address bus from floating. In normal operation these pull down resistors are turned off.						
IH	Input internally forced high in power-down mode.						
IL	Input internally forced low in power-down mode.						
Z	Output tristated in power-down mode.						

TABLE 14-1. PIN STATES DURING CHIP RESET, SUSPEND, CPU PWD. (Continued)



Pin Number	Signal Name
10	VSS
18	VSS
19	VSS
50	VSS
56	VSS
70	VSS
104	VSS
130	VSS
141	VSS
150	VSS
156	VSS
22	VDD
36	VDD
62	VDD
66	VDD
102	VDD
135	VDD
143	VDD
91	VDDAT

TABLE 14-2. POWER AND GROUND

15.0 PACKAGE DIMENSIONS

Figure 15-1 Illustrates the 160-Pin MQFP package showing the dimensions in inches.

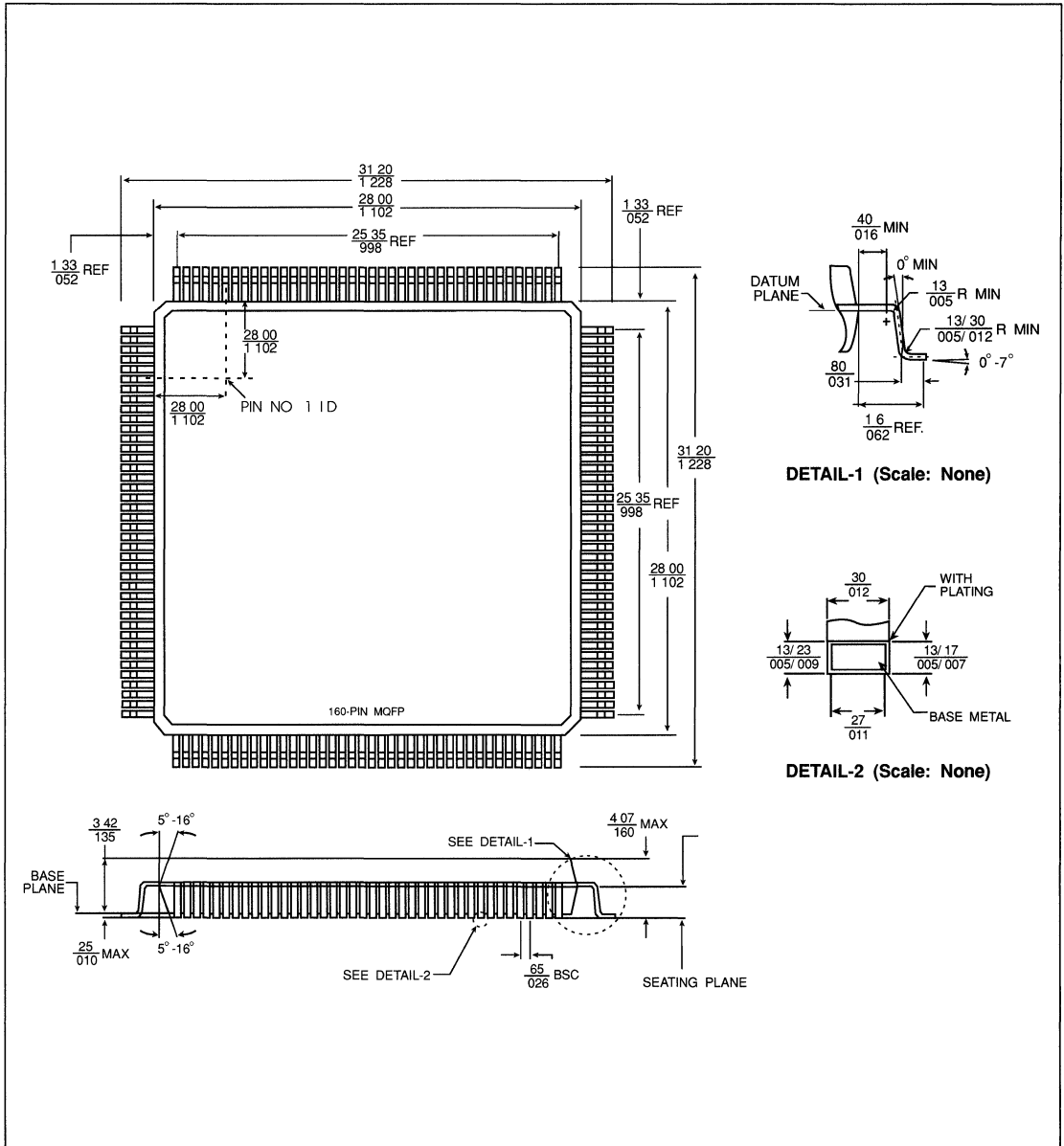

FIGURE 15-1. 160-PIN MQFP PACKAGE DIMENSIONS



APPENDIX

A.0 ELECTRICAL SPECIFICATIONS FOR WD7855LV

This section provides the Operating Characteristics for the WD7855LV. The parameters that differ from the WD7855 are marked with an *.

A.1 MAXIMUM RATINGS

Supply Voltage (V_{DD}) with respect to V_{SS} (ground)	$V_{DD} - V_{SS} \leq 7.0$ Volts
Voltage on any pin with respect to V_{SS} (ground)	$V_{SS} - 0.3$ Volts to $V_{DD} + 0.3$ Volts
Operating Temperature	0°C (32°F) to 70°C (158°F)
Storage Temperature	-40°C (-40°F) to 125°C (257°F)
Power Dissipation	400 mW *

NOTE

Maximum limits indicate where permanent device damage occurs. Continuous operation at these limits is not intended and should be limited to those conditions specified in the DC Operating Characteristics.

A.2 DC OPERATING CHARACTERISTICS

$T_A = 0^{\circ}\text{C}$ (32°F) to 70°C (158°F)

$V_{DDAT} = +3.3\text{V} \pm 0.3\text{V}$ for WD7855LV *

$V_{DD} = +3.3\text{V} \pm 0.3\text{V}$ for WD7855LV *

SYMBOL	CHARACTERISTIC	MIN	MAX	UNIT	CONDITIONS
IIL	Input Leakage		± 10	μA	$V_{in} = .4$ to V_{DD} $V_{out} = .4$ to V_{DD}
IOZ	Tristate And Open Drain Output Leakage		± 10	μA	
VIH	Input High Voltage	2.0		V	
VIL	Input Low Voltage		.8	V	
VIHC	CPUCLK Input High *	V_{DD} -0.8		V	
VIL	CPUCLK Input Low		.6	V	
VIH	RSTIN Input High Voltage	V_{DD} -0.5		V	
VIL	RSTIN Input Low Voltage		0.5	V	
ICC	Supply Current *		150 100	mA mA	Inputs at 2.0V Inputs at 3.3V Outputs Open, CPUCLK = 50 MHz
ICCAT	Supply Current		15 7	mA mA	Input at 2.0 V Input at 3.3V
ICCSB	Typical Supply Current, Power Down Mode for WD7855/LV		.5	mA	Typical, CPUCLK Off, CLK14 = 32 KHz

TABLE A-1. DC OPERATING CHARACTERISTICS



FOR PINS WITH INTERNAL PULLUPS:

MASTER, IOCK, IOCS16, MEMCS16, ZEROWS, IOCHRDY, RDYIN, PDREF

SYMBOL	CHARACTERISTIC	MIN	MAX	UNIT	CONDITIONS
IIL	Input Pullup Current *	-27	-90	μA	Not suspend and resume mode

TABLE A-1. DC OPERATING CHARACTERISTICS (Continued)

M/IO, NPERR, NPBUSY, NPRST, CPURES, DPH, DPL, NONCAC, ADS, D/C, W/R

SYMBOL	CHARACTERISTIC	MIN	MAX	UNIT	CONDITIONS
IIL	Input Pullup Current *	-27	-90	μA	Not processor power-down or suspend mode

TABLE A-1. DC OPERATING CHARACTERISTICS (Continued)

PMCIN, IOCHRDY, ZEROWS, IOCS16, MEMCS16, MASTER, PDREF, REFRESH, BHE, IOR, IOW, MEMR, MEMW

SYMBOL	CHARACTERISTIC	MIN	MAX	UNIT	CONDITIONS
IIL	Input Pullup Current *	-27	-90	μA	Not suspend mode

TABLE A-1. DC OPERATING CHARACTERISTICS (Continued)

SDT/R, CAS3, CAS2

SYMBOL	CHARACTERISTIC	MIN	MAX	UNIT	CONDITIONS
IIL	Input Pullup Current *	-27	-90	μA	RESET IN = 0

TABLE A-1. DC OPERATING CHARACTERISTICS (Continued)

FOR PINS WITH INTERNAL PULLDOWNS:

A(23:00), D(15:00), BLE

SYMBOL	CHARACTERISTIC	MIN	MAX	UNIT	CONDITIONS
IIL	Input Pulldown Current *	-27	-90	μA	Processor power-down or suspend mode

TABLE A-1. DC OPERATING CHARACTERISTICS (Continued)



FOR OUTPUTS:

DACKEN, D(15:00), READY, CPURES, HOLDR, INTRQ, A(23:00), NMI, DPH, DPL, RA(11:08), RA7/ED7:RA0/ED0, BHE, RAS(7:0), CAS(3:0), W/R, DT/R, DEN1, DEN0, SDT/R, SDEN, CSEN, LOMEG, A20GATE, KEN, FLUSH, SMI

SYMBOL	CHARACTERISTIC	MIN	MAX	UNIT	CONDITIONS
VOH	Output High Voltage *	$V_{DD} - 0.2$		V	IOUT = -100 μ A
VOH	Output High Voltage *	2.4		V	IOUT = -1 mA
VOL	Output Low Voltage *		.4	V	IOUT = 1.5 mA

TABLE A-1. DC OPERATING CHARACTERISTICS (Continued)**FOR OUTPUTS:**

MXCTL2:0

SYMBOL	CHARACTERISTIC	MIN	MAX	UNIT	CONDITIONS
VOH	Output High Voltage	$V_{DD} - .8$		V	IOUT = -200 μ A
VOH	Output High Voltage *	2.4		V	IOUT = -3 mA
VOL	Output Low Voltage *		.4	V	IOUT = 3 mA

TABLE A-1. DC OPERATING CHARACTERISTICS (Continued)**FOR OUTPUTS:**

IOR, IOW, MEMR, MEMW, AEN, SYSCLK, BALE, LA20, SA0

SYMBOL	CHARACTERISTIC	MIN	MAX	UNIT	CONDITIONS
VOH	Output High Voltage	2.4		V	IOUT = -3 mA
VOL	Output Low Voltage *		.5	V	IOUT = 12 mA

TABLE A-1. DC OPERATING CHARACTERISTICS (Continued)**FOR OUTPUT:**

REFRESH, IOCHRDY

SYMBOL	CHARACTERISTIC	MIN	MAX	UNIT	CONDITIONS
VOL	Output Low Voltage *		.4	V	IOUT = 12 mA

TABLE A-1. DC OPERATING CHARACTERISTICS (Continued)

A.3 AC OPERATING CHARACTERISTICS

This section provides the WD7855LV AC Operating Characteristics for the 80386SX Page Mode and 80386SX CPU Mode. The parameters that differ from the WD7855 are marked with an *.

SIGNAL	LOAD	SIGNAL	LOAD	SIGNAL	LOAD
$\overline{\text{SMI}}$	50 pF	$\overline{\text{NA}}$	50 pF	$\overline{\text{SMIRDY}}$	50 pF
$\overline{\text{KEN}}$	50 pF	$\overline{\text{A20GATE}}$	50 pF	$\overline{\text{FLUSH}}$	50 pF
$\overline{\text{CPURES}}$	50 pF	$\overline{\text{NPRST}}$	50 pF	$\overline{\text{BHE}}$	50 pF
$\overline{\text{W/R}}$	50 pF	$\overline{\text{ALE}}$	50 pF	$\overline{\text{DEN1}}, \overline{\text{DENO}}$	50 pF
$\overline{\text{SDEN}}$	50 pF	$\overline{\text{DT/R}}$	50 pF	$\overline{\text{SDT/R}}$	50 pF
$\overline{\text{MXCTL(2:0)}}$	50 pF	$\overline{\text{DACKEN}}$	50 pF	$\overline{\text{CSEN}}$	50 pF
$\overline{\text{LOMEG}}$	50 pF	$\overline{\text{SPKR}}$	50 pF	$\overline{\text{READY}}$	50 pF
$\overline{\text{HOLDR}}$	50 pF	$\overline{\text{INTRQ}}$	50 pF	$\overline{\text{NMI}}$	50 pF
$\overline{\text{BUSYCPU}}$	50 pF	$\overline{\text{EPEREQ}}$	50 pF	$\overline{\text{A(23:00)}}$	60 pF
$\overline{\text{CPUCLK}}$	70 pF	$\overline{\text{SYSCLK}}$	75 pF	$\overline{\text{DPH}}$	100 pF
$\overline{\text{CAS(3:0)}}$	100 pF	$\overline{\text{D(15:00)}}$	100 pF	$\overline{\text{IOW}}$	200 pF
$\overline{\text{DPL}}$	100 pF	$\overline{\text{RAS(7:0)}}$	100 pF	$\overline{\text{MEMR}}$	200 pF
$\overline{\text{IOR}}$	200 pF	$\overline{\text{MEMW}}$	200 pF	$\overline{\text{AEN}}$	200 pF
$\overline{\text{LA20}}$	200 pF	$\overline{\text{SA0}}$	200 pF	$\overline{\text{RA(11:00)}}$ *	220 pF
$\overline{\text{BALE}}$	200 pF	$\overline{\text{REFRESH}}$	200 pF		

TABLE A-2. SIGNAL LOADING



A.4 80386SX PAGE MODE TIMING

SYMBOL	CHARACTERISTIC	MAX 20 MHz	MAX 25 MHz
T200	Processor ADDRESS to RAM address valid, Page Hit	34	27
T201	CPUCLK rise to $\overline{\text{CAS}}$ fall, 2.5 CLK CAS	31	25
T202	CPUCLK fall to $\overline{\text{CAS}}$ rise	24	21
T203	CPUCLK fall to $\overline{\text{CAS}}$ fall, 2.0 CLK CAS	27	22
T204	Processor data to parity valid	25	20
T205	CPUCLK rise to RAM address valid, Page Miss	48	43
T206	CPUCLK rise to WNRDRAM rise	31	28
T207	CPUCLK fall to $\overline{\text{RAS}}$ fall, first access	27	21
T208	CPUCLK rise to COLUMN address valid	49	33
T209	CPUCLK rise to WNRDRAM fall	31	28
T212	CPUCLK rise to $\overline{\text{RAS}}$ rise, Page Miss	27	24
T213	CPUCLK fall to $\overline{\text{RAS}}$ fall, Page Miss	27	24
T214	CPUCLK rise to $\overline{\text{READY}}$ fall *	25	25
T215	CPUCLK rise to $\overline{\text{READY}}$ rise *	25	25

TABLE A-3. 80386SX - PAGE MODE MEMORY TIMING

This table covers the 80386SX CPU timing. The WD7855LV parameters that differ from the WD7855 are marked with an *.

SYMBOL	CHARACTERISTIC	20 MHz		25 MHz		UNITS
		MIN	MAX	MIN	MAX	
T140	See Table 13-6					
T141	See Table 13-6					
T204	See Table 13-3					
T214	See Table 13-3					
T215	See Table 13-3					
T451	CPUCLK rise to CPURES rise delay		14	12		ns
T452	CPUCLK rise to CPURES fall delay		13	12		ns
T453	CPUCLK rise to NPRST rise delay		14	10		ns
T454	CPUCLK rise to NPRST fall delay		13	10		ns
T455	CPUCLK rise to $\overline{\text{BUSYCPU}}$ fall delay		35	35		ns
T456	CPUCLK rise to $\overline{\text{BUSYCPU}}$ rise delay		35	30		ns
T457	$\overline{\text{NPBUSY}}$ fall to $\overline{\text{BUSYCPU}}$ fall delay		30	30		ns
T458	$\overline{\text{NPBUSY}}$ rise to $\overline{\text{BUSYCPU}}$ rise delay		35	35		ns
T460	$\overline{\text{NPERR}}$ fall to EPEREQ rise delay		30	30		ns
T462	$\overline{\text{ADS}}$ setup time to CPUCLK rise *	14		14		ns
T463	$\overline{\text{ADS}}$ hold time from CPUCLK rise	5		4		ns
T464	$\overline{\text{W/R}}$ setup time to CPUCLK rise *	14		12		ns
T465	$\overline{\text{W/R}}$ hold time from CPUCLK rise	5		4		ns
T466	$\overline{\text{D/C}}$ setup time to CPUCLK rise *	14		10		ns
T467	$\overline{\text{D/C}}$ hold time from CPUCLK rise	5		4		ns
T468	$\overline{\text{M/IO}}$ setup time to CPUCLK rise *	17		19		ns
T469	$\overline{\text{M/IO}}$ hold time from CPUCLK rise	5		4		ns
T470	$\overline{\text{BHE}}$ setup time to CPUCLK rise	17		15		ns
T471	$\overline{\text{BHE}}$ hold time from CPUCLK rise	3		4		ns
T472	HOLDA setup time to CPUCLK rise *	10		10		ns
T473	HOLDA hold time from CPUCLK rise	3		4		ns
T474	HOLDR valid delay from CPUCLK rise *		26		26	ns
T475	DPH setup time to CPUCLK rise	5		5		ns
T476	DPH hold time from CPUCLK rise	19		19		ns
T477	D(15:00) setup time to CPUCLK rise	5		5		ns
T478	D(15:00) hold time from CPUCLK rise	19		19		ns
T479	A(23:01), $\overline{\text{BLE}}$ setup time to CPUCLK rise *	42		42		ns
T480	A(23:01), $\overline{\text{BLE}}$ hold time from CPUCLK rise	3		4		ns

TABLE A-4. 80386SX CPU TIMING



B.0 SPECIAL FEATURE REGISTERS

This section describes the registers peculiar to the special features. Except for Port Addresses F073H and FC72H all Port Addresses described in this section are peculiar to these special features.

B.1 ENABLING THE SPECIAL FEATURES

To enable the special features, the WD7855/LV must first be unlocked by writing DAH to the Lock/Unlock Register at Port Address F073H and then writing DA00H to the Lock Status Register at Port Address FC72H. As stated in Section 2.8.1, Port Address FC72H is normally a read only register, but will respond to a write value of DA00H.

These registers are described in detail in Sections 2.8, 2.8.1 and 2.8.2.

B.2 ENABLE PRIVY REGISTER

Port Address 0FBH - Write only

The special features must first be enabled, as described in Section B.1, and then writing any data to this register enables PRIVY. When PRIVY is enabled, 4 KB of RAM, starting at 0F0000H to 0F0FFFH, is enabled for both read and write access.

7	6	5	4	3	2	1	0
PRIVY ENABLED							

Signal Name	Default At RSTIN
All signals	None

B.3 DISABLE PRIVY REGISTER

Port Address 0F9H - Write only

Writing any data to this register disables PRIVY. When PRIVY is disabled, the 4 KB RAM is treated as the rest of memory in the F000H segment.

7	6	5	4	3	2	1	0
PRIVY DISABLE							

Signal Name	Default At RSTIN
All signals	None

B.4 BUSY BYPASS CONTROL REGISTER

Port Address 0ECH - Read and Write

Before the Bypass Mode can be enabled or disabled, PRIVY must first be set by writing any data to Port Address 0FBH.

Bypass Mode is enabled by writing any data to Port Address 0ECH.

When the Bypass Mode is enabled, ERROR from the Numeric Processing Unit (NPU) does not cause an IRQ13 and the BUSY signal is not sent to the CPUBUSY output without modification.

Bypass Mode is disabled by reading Port Address 0ECH.

7	6	5	4	3	2	1	0
BUSY BYPASS							

Signal Name	Default At RSTIN
All signals	None



B.5 FAST A20 GATE CONTROL REGISTER

Port Address 0EEH - Read and Write

Before the special feature FAST A20 GATE can be enabled or disabled, PRIVY must first be set by writing any data to Port Address 0FBH.

FAST A20 GATE is enabled by writing any data to Port Address 0EEH.

The special feature FAST A20 GATE is ORed with the A20GT signal from the Keyboard Controller and with Port 92 A20 gate signal.

FAST A20 GATE is disabled by reading Port Address 0EEH.

7	6	5	4	3	2	1	0
Special Feature FAST A20 GATE							

Signal Name	Default At RSTIN
All signals	None

B.6 FAST CPU RESET CONTROL REGISTER

Port Address 0EFH - Read only

Before the FAST CPU RESET can be initiated, PRIVY must be set by writing any data to Port Address 0FBH.

A processor reset is initiated by reading Port Address 0EFH. The processor reset pulse is 16 CPUCLKs. This processor reset signal is ORed with the Hot Reset at Port 092H and with the Keyboard Controller processor reset.

7	6	5	4	3	2	1	0
FAST CPU RESET CONTROL							

Signal Name	Default At RSTIN
All signals	None

B.7 PARITY CONTROL REGISTER

Port Address 0F2H - Write only

Before normal/inverted parity can be changed, PRIVY must be set by writing any data to Port Address 0FBH.

7	6	5	4	3	2	1	0
	PAR I/N	CHIP SELECT 1FH					

Signal Name	Default At RSTIN
All signals	None

Writing to any bit with PRIVY set also initiates a Chip Select 1FH on the encoded chip select pins CS(4:0). Section 8.4 describes the encoded chip selects.

Bit 6 - PAR I/N, Parity Inversion

- PAR I/N = 0 - Parity is inverted at the next write of on-board memory.
- PAR I/N = 1 - Normal parity is generated.



C.0 IBM FEATURES

This section describes the pin signals and register bits peculiar to IBM 386SLC and 486SLC2 applications.

C.1 PIN SIGNAL DESCRIPTION

PIN NUMBER	MNEMONIC	I/O	DESCRIPTION
108	PWI	O	System Management Interrupt Translate +3 PWI request to the processor. This mode of operation is selected by bit 13 of Port Address C472H.
145	$\overline{\text{DFSREQ}}$	O	Dynamic Frequency Shift Request Translate +3 DFSREQ is asserted by the System Controller to request a change in the CPUCLK frequency or duty cycle.
156	$\overline{\text{DFSRDY}}$	I	Dynamic Frequency Shift Ready Translate +3 DFSRDY is the response to the $\overline{\text{DFSREQ}}$ by the processor, indicating permission to change the CPUCLK frequency. When the WD7855/LV samples $\overline{\text{DFSRDY}}$ it will change the CPUCLK frequency.

TABLE C-1. SIGNAL DESCRIPTION

C.2 CACHE CONTROL REGISTER

Port Address C472H - Read and Write

15	14	13	12	11	10	09	08
DFS	0	PWI	0	C_BSC		HI_MEM9.8	

07	06	05	04	03	02	01	00
High Memory Location HI_MEM7-0							

Signal Name	Default At RSTIN
DFS	0
PWI	0

Bit 15 - DFS, Dynamic Frequency Shift

When DFS is enabled, any request to change the CPUCLK speed or duty cycle from AUTOFAST or writing to Port 1072H causes the WD7855/LV to generate a $\overline{\text{DFSREQ}}$ to the processor. Upon receiving a $\overline{\text{DFSRDY}}$ from the processor, the CPUCLK will be changed.

DFS = 0 -
DFS disabled.

DFS = 1 -
DFS enabled.

Bit 13 - PWI, Not SMI protocol.

For IBM applications this bit must be set to 1.

PWI = 0 -
AMD/Cyrix SMI mode enabled.

PWI = 1 -
PWI mode enabled.

For bits 14, 12:00 refer to Section 7.3



C.3 NONCACHEABLE REGION 2 LOWER BOUNDARY

Port Address CC72H - Read and Write

15	14	13	12	11	10	09	08
A23	A22	A21	A20	A19	A18	A17	A16
Lower Address Boundary							

07	06	05	04	03	02	01	00
A15	A14	A13	A12	CS	BS	E_PWI	NR2C
Lower Address Boundary							

Signal Name	Default At RSTIN
A25:12	0
CS, BS	None
E_PWI	0
NR2C	0

Bit 01 - E_PWI

E_PWI controls how the System Controller is to determine the end of an SMI/PWI interrupt. In AMD and Cyrix implementation pin 108 (SMI) is bidirectional and can be used to make this determination. In IBM implementation this pin is an output only (PWI) and the end of an SMI is determined internally.

E_PWI = 0 -
Standard setting for AMD and Cyrix CPUs.

E_PWI = 1 -
Required for IBM CPUs.

For bits 15:02 and 00 refer to Section 7.6

C.4 PIN STATES DURING CHIP RESET, SUSPEND AND CPU POWER DOWN

Table C-2 presents the status of pins 108, 145 and 156 during chip reset, suspend and CPU power down. This is a continuation of Table 14-1.

PIN NUMBER	SIGNAL NAME	RESET STATE	PROCESSOR POWER DOWN		FULL POWER DOWN		
			Input	Output	Input	Output	
PROCESSOR							
108	PWI	Input	IH	Z	IH	Z	
145	DFSREQ	High		Z		Z	
156	DFSRDY	Input	IL		IL		
IH	Input internally forced high in power-down mode.						
IL	Input internally forced low in power-down mode.						
Z	Output tristated in power-down mode.						

TABLE C-2. PIN STATES DURING CHIP RESET, SUSPEND, CPU PWD.

NOTE

For IBM applications Table 13-2 Signal Loading would include DFSREQ as 50 pF.

Table 14-2 Power and Ground would not include pin 156 as VSS. This pin is DFSRDY.

