

# COMPUTERS

## *a n d* AUTOMATION

COMPUTERS AND DATA PROCESSORS, AND THEIR CONSTRUCTION, APPLICATIONS, AND IMPLICATIONS, INCLUDING AUTOMATION

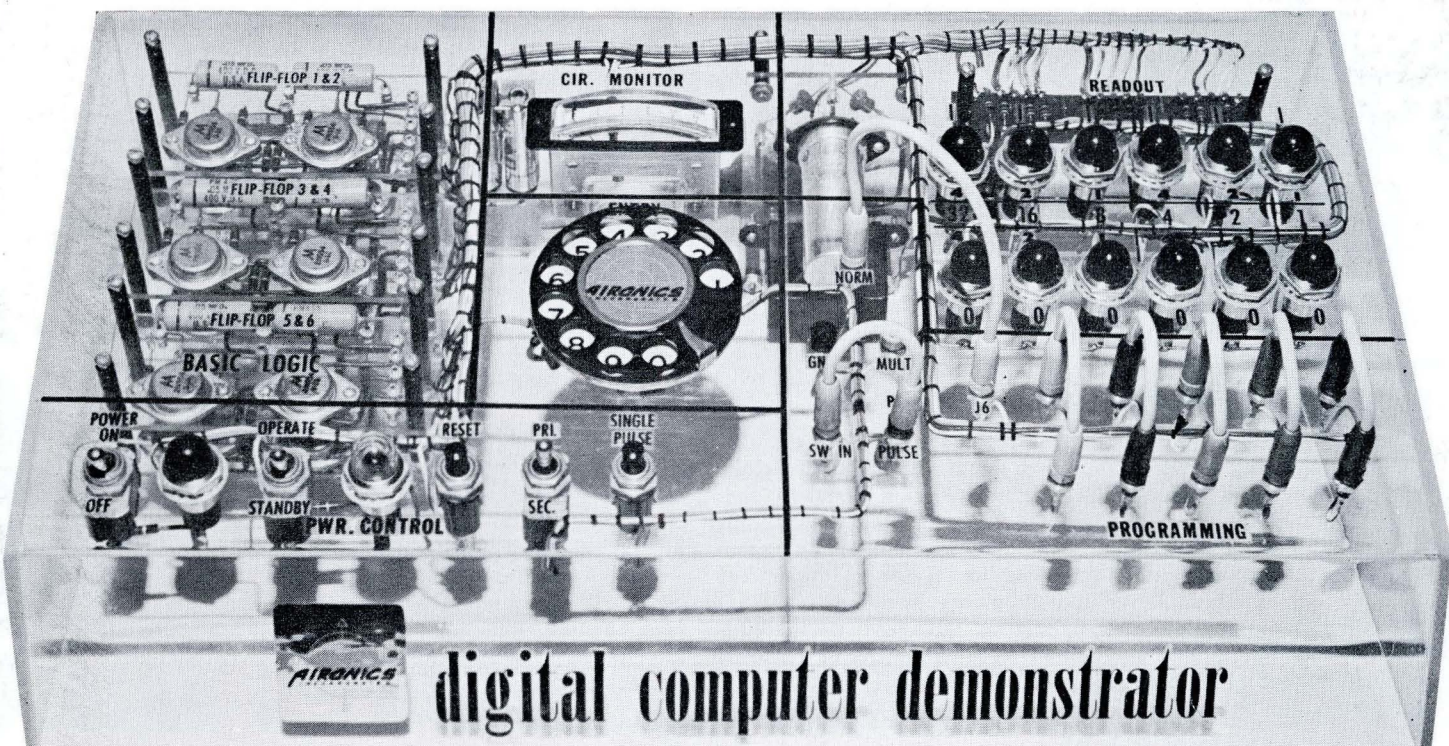

What Business Needs Most from Manufacturers of  
Electronic Data Processors

Undetected Errors in 5-Unit Code Transmission  
and Their Elimination

Automation — Its Evolution and Future Direction

NOVEMBER

1960

VOL. 9 - NO. 11 & 11B

---

# Applied Mathematicians and Computer Programmers to Participate in Advanced Space Programs

The Missile and Space Vehicle Department of General Electric — a recognized leader in the development of instrumented re-entry vehicles — is now pursuing a number of even more advanced space programs. Basic to progress in these programs is the solution of a diversity of interesting mathematical problems. These include trajectory and navigation studies and analysis of flight telemetry data and space communications.

## APPLIED MATHEMATICIANS

The applied mathematics group provides consulting services to our entire engineering staff. Salary and professional growth are given corresponding emphasis. Desirable experience and background would include strong analytical ability, extensive knowledge of advanced techniques in numerical analysis for computers, and experience in mathematical investigations on advanced engineering programs. MS or PhD in Mathematics or Theoretical Physics required.

*The work is in a growing analog facility which includes Electronic Associates and Reeves Analog Equipment, a combined Analog-Digital Facility and a passive element analog computer.*

For further information regarding opportunities here, write Mr. D. G. Curley, Div. 21-MK.

*Diversified Positions for:*

## SENIOR DIGITAL COMPUTER PROGRAMMERS

As Senior Programmers at the Missile and Space Vehicle Department you will have all the advantages of an extensive computer facility which centers around an IBM 7090. The work covers analysis and programming for technical data systems, flight test data systems and advanced space programs. Requirements include ability to direct junior programmers, a BS or advanced degree, minimum of 2 years experience on a large scale, binary computer.

## ANALOG COMPUTER PROGRAMMERS

BSEE, Physics or Math degree required. Will plan sequence of computer operation, determine the circuitry for engineering problems, set up and operate computer.

MISSILE AND SPACE VEHICLE DEPARTMENT

GENERAL  ELECTRIC

3198 Chestnut Street, Philadelphia 4, Pa.

# this is the language of **ALTA C**

$$Y = A * X + B * \text{SIN}(n * t + r)$$

01267R	0	01675	0101	TMA	01675	00463	TMA	C/H/TL,F260	\$
01270L	0	01676	0102	TMQ	01676	00464	TMQ	C/H/TL,13	\$
01270R	0	01034	0200	JMPL	01034	00465	JMP	FLOUT,FLOUT	\$
						00466		END TAC	\$
01271L	0	01677	0101	TMA	01677	00467	CALL	POWREP(KP/ILE,4,3,KBIN)	
01271R	0	01092	0110	TAM	01092	00468	TMA	C/H/TL, KBIN	\$
01272L	0	01625	0101	TMA	01625	00469	TAM	POWREP,POWREP +2\$	
01272R	0	01051	0110	TAM	01051	00470	TMA	D/3 B15\$	
01275L	0	01700	0101	TMA	01700	00471	TAM	POWREP,POWREP +1\$	
01273R	0	01620	0102	TMQ	01620	00472	TMA	C/H/TL, KP/ILE	\$
01274L	0	01030	0200	JMPL	01030	00473	TMQ	D/4 B15\$	
						00474	JMP	POWREP,POWREP \$	
01274R	0	01701	0101	TMA	01701	00475	DO	300 J # 1, 3	
01275L	1	30000	0301	TDXLC	00000,03	00476	TMA	C/H/TL, 512	\$
01275R	0	01702	0101	TMA	01702	00477	TDXLC	.3X \$	
01276L	1	40000	0301	TDXLC	00000,04	00478	TMA	C/H/TL, 512 +3\$	
						00479	TDXLC	.4X \$	
						00480	ASGN	13272DJ,(P)	\$
01276R	0	01623	0101	TMA	01623	00481	KSUM(J) # 0		
01277L	1	30000	0110	TAM	00000,03	00482	TMA	D/70 B15\$	
						00483	TAM	0.3X \$	
01277R	0	01615	0101	TMA	01615	00484	DO	300 I # 1, 4	
01300L	0	01724	0110	TAM	01724	00485	TMA	H/00010\$	
						00486	TAM	1 \$	
						00487	ASGN	13277DJ,(P)	\$
						00488	300 KSUM(J) # KSUM(J) + KBIN(I,J)		
						00489	ASGN	103005N,(P)	\$
01300H	1	40000	0101	TMA	00000,04	00490	TMA	0.4X \$	
01301L	1	30000	1001	AMS	00000,03	00491	AMS	0.3X \$	
01301R	1	40001	0332	AIXOL	00001,04	00492	AIXO	1.4X \$	
01302L	0	01615	0101	TMA	01615	00493	TMA	H/00010\$	
01302R	0	01724	1001	AMS	01724	00494	AMS	1 \$	
01303L	0	01633	1110	SMA	01633	00495	SMA	H/00050\$	
01303H	0	01300	2211	JANX	01300	00496	JAN	13277DJ\$	
01304L	1	40004	0333	SIXOL	00004,04	00497	SIXO	4.4X \$	
01304R	1	40004	0332	AIXOL	00004,04	00498	AIXO	4.4X \$	
01305L	0	01703	0103	TMD	01703	00499	TMD	C/H/TL, 512 +3; C/JMP, 13272DJ\$	
01305R	1	30001	0330	AIXJ	00001,03	00500	AIXJ	1.3X \$	
01306L	1	30003	0333	SIXOL	00003,03	00501	SIXO	3.3X \$	
01306R	1	40014	0333	SIXOL	00014,04	00502	SIXO	12.4X \$	
						00503	DO	310 J # 1, 3	
01307L	0	01615	0101	TMA	01615	00504	TMA	H/00010\$	
01307R	0	01721	0110	TAM	01721	00505	TAM	J \$	
01310L	0	01704	1000	AM	01704	00506	AM	C/H/TL, 512 +3B15\$	
01310R	0	01617	0102	TMQ	01617	00507	TMQ	H/8000FFFFF\$	
01311L	0	01467	2032	EIS	01467	00508	EIS	2X \$	
01311R	1	30000	0301	TDXLC	00000,03	00509	TDXLC	.3X \$	
						00510	ASGN	13304DJ,(P)	\$

## \* THE PHILCO ALGEBRAIC TRANSLATOR

Photograph of print-out of an ALTAC compilation run on the PHILCO 2000

ALTAC is the Philco mathematical language compiler which operates in conjunction with TAC, the Philco Translator Assembler-Compiler . . . a powerful, computer-oriented language with extensive library features. ALTAC is also compatible with FORTRAN II\* . . . permitting thousands of existing programs to be run on the Philco 2000 Computer without change. It produces a fast, efficient running

program. TAC language inserts may be included at will in ALTAC language programs. ALTAC is now in full operation at customer installations. Philco automatic programming techniques enable you to learn and use the Philco 2000 Computer faster. For more complete information, write:

PHILCO CORPORATION • GOVERNMENT & INDUSTRIAL GROUP  
COMPUTER DIVISION, 3900 WELSH ROAD, WILLOW GROVE, PA.

# PHILCO

Famous for Quality the World Over

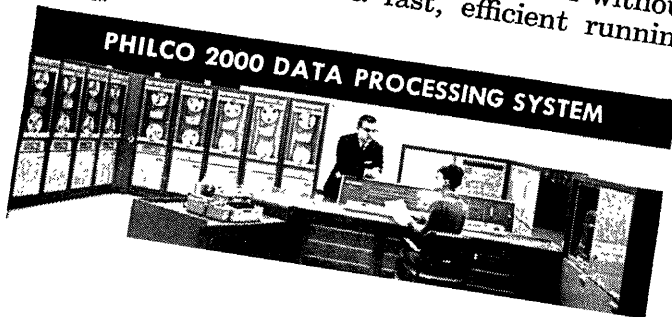

\*REG. IBM

# COMPUTERS *and* AUTOMATION

COMPUTERS AND DATA PROCESSORS, AND THEIR CONSTRUCTION,  
APPLICATIONS, AND IMPLICATIONS, INCLUDING AUTOMATION

Volume 9  
Number 11

NOVEMBER, 1960

Established  
September 1951

EDMUND C. BERKELEY *Editor*  
NEIL D. MACDONALD *Assistant Editor*  
MOSES M. BERLIN *Assistant Editor*  
PATRICK J. MCGOVERN *Assistant Editor*

CONTRIBUTING EDITORS

ANDREW D. BOOTH  
NED CHAPIN  
JOHN W. CARR, III  
ALSTON S. HOUSEHOLDER

ADVISORY COMMITTEE

MORTON M. ASTRAHAN  
HOWARD T. ENGSTROM  
GEORGE E. FORSYTHE  
RICHARD W. HAMMING  
ALSTON S. HOUSEHOLDER  
HERBERT F. MITCHELL, JR.  
SAMUEL B. WILLIAMS

SALES AND SERVICE DIRECTOR

WENTWORTH F. GREEN  
439 So. Western Ave. OR 815 Washington St.  
Los Angeles 5, Calif. Newtonville 60, Mass.  
DUnkirk 7-8135 DEcatur 2-5453

ADVERTISING REPRESENTATIVES

*Los Angeles 5* WENTWORTH F. GREEN  
439 So. Western Ave. DUnkirk 7-8135  
*Chicago 10* REX GAY  
18 E. Division St. MIchigan 2-0778  
*San Francisco 5* A. S. BABCOCK  
605 Market St. YUkon 2-3954  
*Elsewhere*  
WENTWORTH F. GREEN  
439 So. Western Ave. OR 815 Washington St.  
Los Angeles 5, Calif. Newtonville 60, Mass.  
DUnkirk 7-8135 DEcatur 2-5453

COMPUTERS and AUTOMATION is published 13 times a year (monthly except two issues in June) at 815 Washington St., Newtonville 60, Mass., by Berkeley Enterprises, Inc. Printed in U.S.A.

SUBSCRIPTION RATES: (United States) \$7.50 for 1 year, \$14.50 for 2 years; (Canada) \$8.00 for 1 year, \$15.50 for 2 years; (Foreign) \$8.50 for 1 year, \$16.50 for 2 years. Address all Editorial and Subscription Mail to Berkeley Enterprises, Inc., 815 Washington St., Newtonville 60, Mass.

ENTERED AS SECOND CLASS MATTER at the Post Office at Boston, Mass.

POSTMASTER: Please send all Forms 3579 to Berkeley Enterprises, Inc., 815 Washington St., Newtonville 60, Mass.

Copyright, 1960, by Berkeley Enterprises, Inc.

CHANGE of ADDRESS: If your address changes, please send us both your new address and your old address (as it appears on the magazine address imprint), and allow three weeks for the change to be made.

*Vol. 9, No. 11B*

News of Computers and Data Processors:  
ACROSS THE EDITOR'S DESK

. . . . . inserted between pages 8 and 9  
and between pages 24 and 25

FRONT COVER

Digital Computer Demonstrator . . . . . 1,20

ARTICLES

What Business Needs Most from Manufacturers of Electronic Data Processors, BENJAMIN CONWAY . . . 6  
Undetected Errors in 5-Unit Code Transmission and Their Elimination, JAMES F. HOLMES . . . . . 10  
Automation — Its Evolution and Future Direction (Part 1), JAMES T. CULBERTSON . . . . . 14

READERS' AND EDITOR'S FORUM

Daedalus: "Complete-The-Square" Computer — Correction, S. F. GRISOFF . . . . . 20  
Four Prefixes for Sizes, FRANK LEARY . . . . . 20  
First International Conference on Automatic Control: Picture . . . . . 20  
The Social Responsibilities of Computer People — Reports and Discussions at the Meeting of the Association for Computing Machinery, August, 1960 (Part 2) . . . 20  
Changes in Commercial Computers Anticipated in Coming Years . . . . . 22  
Calendar of Coming Events . . . . . 23

REFERENCE INFORMATION

Books and Other Publications, M. M. BERLIN . . . . . 25  
Essential Special Terms in Computers and Data Processing — Suggested List, and Definitions (Part 3) . . . 27  
New Patents, R. R. SKOLNICK . . . . . 30

INDEX OF NOTICES

Advertising Index . . . . . 30  
Back Copies . . . . . 28  
Computer Directory . . . . . 26  
Glossary of Computer Terms . . . . . 29  
Manuscripts . . . . . 27  
Reference and Survey Information . see August, page 2  
Statement of Ownership and Management . . . . . 22  
Who's Who Entry Form . . . . . 29

# WORKING PARTNERS

## ROCKETDYNE AND SOUNDCRAFT INSTRUMENTATION TAPES

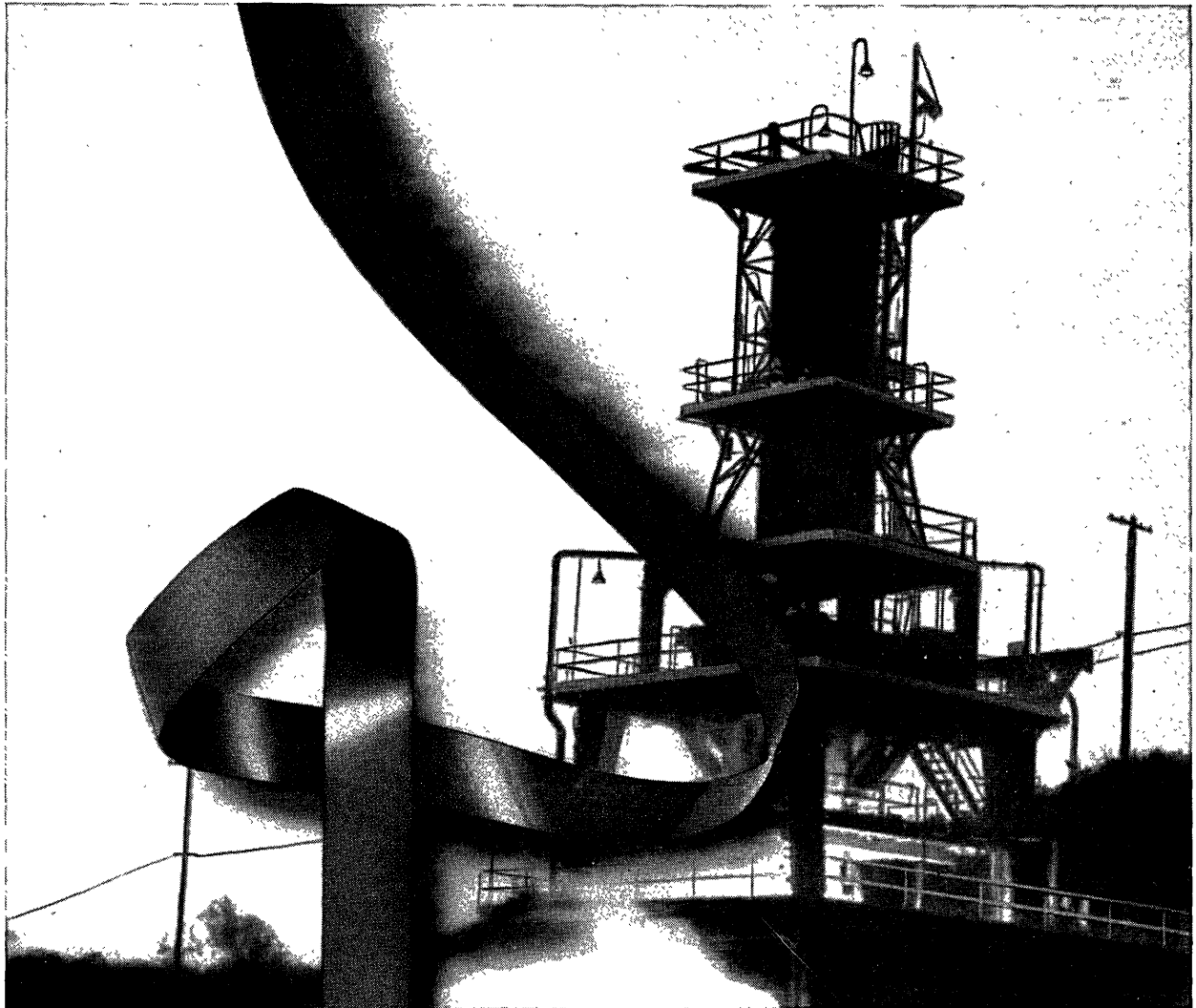

At North American Aviation's Rocketdyne division, the recording of rocket engine performance on static stands, calls for the use of only the most reliable of instrumentation tapes, like Soundcraft. Why? Because Soundcraft Instrumentation Tapes combine exact physical and electrical properties so necessary to assure absolute reliability of performance—as a direct result of being manufactured in the world's most modern tape plant under the most advanced quality control system.

In short, experience has proven that Soundcraft Instrumentation Tapes *work best* in recording of critical rocket testing operations. Why not let precision-made, error-free Soundcraft Instrumentation Tapes go to work for you? Complete literature on request.

**REEVES SOUNDCRAFT CORP.** Great Pasture Rd., Danbury, Conn. • Chicago: 28 E. Jackson Blvd. ■  
Los Angeles: 342 N. LaBrea • Toronto: 700 Weston Rd. ■

# What Business Needs Most From Manufacturers of Electronic Data Processors

Benjamin Conway  
Director, Management Advisory Services  
Price Waterhouse & Co.  
New York, N.Y.

(Reprinted with permission from the *N.A.A. Bulletin*, August, 1960, vol. 41, no. 12,  
published by the National Association of Accountants,  
505 Park Ave., New York 22, N.Y.)

It might be well to consider briefly the requests businessmen are now making of equipment manufacturers before proceeding to what might be required in the near future. Some of these points may seem trivial or obvious, but they are very real to present and potential users of electronic equipment and, although it may seem that we are severely criticizing business machine manufacturers, this is not true. The manufacturers have done a fine job in their equipment design and improvements, in their research programs, and in their efforts to help prospective users. The points being made now are to help the manufacturer raise his already high standard of performance.

## User Needs as Related to Present Equipment

First and perhaps foremost, business users would like to have accurate specifications on the proposed system. Most users in the past were reasonably sympathetic with the manufacturers' design and production difficulties and would accept small variations from the original specifications. However, when this particular piece of equipment or that special feature failed to materialize or when design changes necessitated major increases in cost, industry users began to balk. It seems only fair that, when a user has sunk several hundred thousand dollars in preparing for a computing system, he should receive the system for which he has prepared.

An important point and one which may have stopped many prospective users almost before they started is the high initial cost of an electronic data processing application. The costs of systems analysis, systems design and coding, site preparation, "debugging," and systems testing add up to a very substantial sum. When to this is added the rental costs for the equipment when the system is producing little useful work during the low initial loading and the parallel operation periods, the total cost gets to be very high indeed. Many people feel that the manufacturers should attempt to revise their rental structure so that only low rental costs are incurred at these early stages and that the rentals could then rise above current figures as the

system becomes more and more productive. Perhaps this could be achieved by reducing initial costs and increasing second and third shift rentals. In any case, no matter how it is arranged, a new approach to rental structure would be welcomed.

To further reduce initial costs, I believe that the manufacturer should attempt to introduce programming aids at a very early point in the installation. Experience in the past has tended to show that service routines, automatic coding routines and so on, have not been available when the effort first got under way. Because of this, most user programming groups have had to work in machine coding and have had to develop their own service and housekeeping routines. We know that the situation has been greatly improved and that most manufacturers have large programming research staffs. However, there is still a feeling that these staffs do not always produce routines which business feels it needs. This lack of communication can be overcome by the better utilization of users groups; the manufacturers should encourage the setting up of a type of liaison with these groups so that their programming efforts will yield practical results.

Another point at which the manufacturer and the user of electronic data processing equipment have not always seen eye-to-eye in the past concerns equipment delivery dates. This has tended to work in one of two ways. The first has been that the equipment delivery has been delayed. When this happens, the user is forced to keep an expensive programming group sitting around idly. Alternatively, the user has often hopelessly underestimated the time required for programming and conversion. In this case the system is installed before it can be used effectively, another costly procedure. Since the user has often relied heavily upon the manufacturer's representative for technical assistance in setting up his timetable, the user, perhaps illogically, blames the manufacturer for this state of affairs. The answer from the manufacturer's viewpoint, of course, is that he should, through his technical representatives, assist the user in drawing up a realistic program timetable and also that he should set reasonable delivery dates for himself.

Still a further requirement that industry would place upon the manufacturer is that of providing adequate breakdown coverage. A computing system which is not functioning is the nightmare with which executives often have to live. Their lot would be considerably improved if they knew that time was always available to them locally on similar equipment. If this ideal cannot be achieved, the manufacturer should at least provide standby equipment of his own at some reasonably located point. It should never be necessary, say, for a user in San Francisco to have to fly his personnel and tapes to New York in order to keep his paperwork processes functioning.

Among yet other important matters on which the manufacturer should supply information are adequate details for site preparation and air conditioning. I do not know why manufacturers should be so modest in this respect, but I have knowledge of at least two installations for which the space recommended by the manufacturer had to be considerably increased to provide good working conditions. It is much easier to allow extra space at the planning stage than to have to create it when the program is well under way.

In the areas of programming training and aids, the manufacturer has his greatest non-machine responsibilities. The manufacturer's representative is expected to take a group of inexperienced people and train them in an art which is, to say the least, complex. To do this, the representative, himself, must be fully trained, both from the theoretical and practical viewpoints. He must also be aware of the principles of teaching, since knowledge and the communication of that knowledge are two entirely different things. In addition, the representative must be backed by adequate training material such as programming manuals, programming sheets, templates for charting, visual displays and so on. It is to the manufacturer's advantage that this material be well prepared, since nothing can destroy the confidence of a beginner more than to see a programming manual full of errors and corrections.

As a good installation is almost as vital to the manufacturer as to the user, it is also desirable that the training courses be adequately supervised and the participants be tested at its close. Also, where required, the manufacturer's representative should be prepared to comment upon the suitability of any individual where, during the training course, it becomes apparent that such an individual may not fit into a programming group. Characteristics such as over-aggressiveness, disinclination to work and inability to work under pressure may show up during a prolonged training period, even when the individual concerned has passed all the theoretical testing procedures. These characteristics, which may cause trouble in a working group, should be commented upon.

Very importantly, routines should be available which will assist the user in program "debugging" and, fairly obviously, adequate machine time should be made available to a prospective user in order that he can "debug" and systems-test his initial programs prior to delivery. If the manufacturer feels that he cannot increase present "debugging" time free of charge, he should endeavor to work out some arrangement by which the extra time would be granted and paid back at a later date by the manufacturer taking time on the user's equipment.

Wherever possible, the manufacturer's technical representative or representatives assisting a user should not be changed at least until the initial programs are operating satisfactorily. Even if the replacement is of equal calibre to the replaced man it can be a time-consuming business to bring him up to the required state of knowledge. If replacement is unavoidable, the user will obviously take a reasonable point of view but, if he believes that the company is being used as a training ground for the manufacturer, unpleasantness will probably arise.

The manufacturer must also ensure that the computer is adequately maintained. This requires not only the services of an expert maintenance man or team but also the establishing of an adequate source of parts and supplies on the user's premises to cover all but major breakdowns. It also requires the setting up of a preventive maintenance program at times suitable to both the user and the manufacturer.

### — And Future Requirements

The foregoing material has dealt with present requirements and existing equipment. Now let us turn to some of the requirements that industry will be making in the near future. Let us consider first companies now uncommitted, the potential users. For the companies in this category, cost is probably of major importance since most large companies, or companies in which money for new projects is fairly reasonably available, will already, in one way or another, have made their approach to electronic data processing. These presently potential users, then, would be intensely interested in cheaper equipment than is now available. While it is true that modern systems offer far more for the computing dollar than earlier machines, this second-generation equipment has not decreased the basic cost at the lower end of the scale. Rather, the tendency has been more to introduce a new category of equipment with medium and medium-large costs which can perform as much work as the previous large-scale systems. This is evidently a step in the right direction and should be continued throughout the entire gamut of electronic machines. What is needed in addition, however, is that there should be a class of machines which will do the work now done by the present medium and small-scale tape-and-card systems at much lower total costs. With modern computer logical designs and extensive use of transistors, it would seem that this should not be too difficult for manufacturers to achieve. If this is not so, the manufacturers should make announcements to this effect. There is a large group of potential users awaiting such equipment.

Through talking to representatives of many users, we feel that this reduction in cost is a much more desirable trend than aiming at increasing machine capacity and capability. Responsible people in industry feel that it will be many years before they have learned to use the capabilities of present equipment. Hence, they remain comparatively unimpressed by the announcements of machines which will operate in micro-micro-seconds instead of in micro-seconds. These people feel that most of the features that they require in computing systems are presently available, although not always in the same systems. A consolidation of such features as core memory, parallel rather than serial transfer of data within the computer, adequate internal control checks, faster input-output equipment, a greater degree of

simultaneity between input, processing and output, and the ability to perform multiple programming seems to be much more important than a fantastic increase in the speed of internal processing.

A major cost associated with electronic data processing when operating in a decentralized company is that of communications. This is an area in which industry would like to see some major improvements. At present wire communication networks are tied up by the relatively slow speed of transmitting information and the very slow speed of receiving the information. These networks would be speeded greatly if a paper tape or punched card transmission could be recorded directly to magnetic tape, and could be speeded even more if data were transmitted on a magnetic tape to magnetic tape basis. These tapes should, of course, be compatible with the computing system. Among other requirements of a communications system, would be the ability to perform some editing of the information while it is being transmitted and better methods of error detection and correction than are currently available.

It was said above that most of the features of electronic data processing equipment which are considered desirable by industry can be found in one or more of the modern computers. There is one area, however, in which many users feel that much can be done. I am referring to the area of random access. If a random access system of several million character capacity could be developed at approximately the same total system cost as with mass magnetic tape storage, then present methods of processing could be completely changed and many applications not presently suitable for electronic data processing would fall easily into place.

The storage of information on numerous reels of magnetic tape necessitates multiple machine runs, a great deal of lost time in having to pass the same tapes through the system many times, and extra time spent in sorting and collating. It creates difficulties in interrogation of information contained in the tape files and may, in cases in which these interrogations need to be answered immediately, require the addition of expensive off-line interrogation units or voluminous print-outs in order that normal processing should not be unduly disturbed. Large random access systems at the level of cost I have indicated would obviate the necessity for all this and would, therefore, greatly simplify electronic data processing and, at the same time, increase the usefulness of the systems. There would be no need to sort incoming items; they could be handled in the order in which they arrive. There would be no need for multiple master files or numerous machine runs and all the processing, including file maintenance, would be performed in a single run. I do not know what the manufacturers have "in the mill" for the development of truly large, truly cheap random access systems, but it does seem to me, and to others, that in the area of machine design this could prove to be the most fruitful from the users' viewpoint.

The area which would seem to promise most, outside of the actual equipment, has been mentioned briefly earlier. It is automatic coding. At this point, I want to broaden the area to include a universal machine language and the development of systems packages. It just seems unreasonable to us that different groups of people have to go through the same gropings, through the efforts of systems analysis

and design, through the drudgery of coding without being able to take full advantage of the experiences of others in similar work. When we consider, for example, the many public utilities which, completely independently and often in a most amateurish manner, have developed systems for customer accounting functions, the waste of time and money involved becomes incredible. Customer accounting may vary from one utility to another but the essential character of the job remains the same. A generalized program developed by a professional group which could then have been adapted to the particular needs of any one utility could have resulted in the savings to each user of many thousands of dollars, and the savings to the industry as a whole could perhaps run into the millions. We are aware that, as a practical matter, utilities which have had to struggle along on their own might not be too interested in joining a combined industry group now, but we feel that they could be so persuaded if it could be effectively demonstrated to them that such participation would benefit them in the development of new applications and, just as importantly, in the revisions of the programming of existing applications. We believe, however, that the impetus for this must come from the machine manufacturers. We are aware that some manufacturers have industry specialists who do help to carry the experiences of one company to another, but we feel that this falls short of the goals which can be attained.

By and large manufacturers have tended to shy away from the broad "language" area as being outside their sphere of responsibility or as being impracticable of development by them but we believe that this is untrue. We feel that there is sufficient work of a like nature within each industry or group of industries to make the development of the systems approach a worthwhile and important endeavor. We feel, furthermore, that manufacturers who do develop the systems approach will have a tremendous competitive advantage over others. Costs of this could perhaps be borne by the manufacturer and industry group.

These then we feel are the three basic future requirements for manufacturers:

1. To develop cheaper equipment at all levels of equipment capabilities, especially the medium and small scale systems.
2. To develop random access systems which are gigantic in comparison to modern equipment and at a price not far out of line with tape storage.
3. To develop the systems package encompassing both the systems and the machine rather than the machine alone.

#### Mutual Interests of Manufacturers and Users

Let us not forget, however, that industry feels that these are additional requirements on the manufacturer and that he should continue to supply and improve upon these services. We know of many instances in which machine selection has been made on the basis of service supplied in the past rather than on the characteristics of the machine in question. As acknowledged at the start, what has been said on these pages is not meant to be a criticism of manufacturers. They have performed well in the past, but much remains to be done in the future and both manufacturer and user will benefit from further, substantial progress.



# COMPUTERS

*a n d* A U T O M A T I O N

D A T A P R O C E S S I N G • C Y B E R N E T I C S • R O B O T S

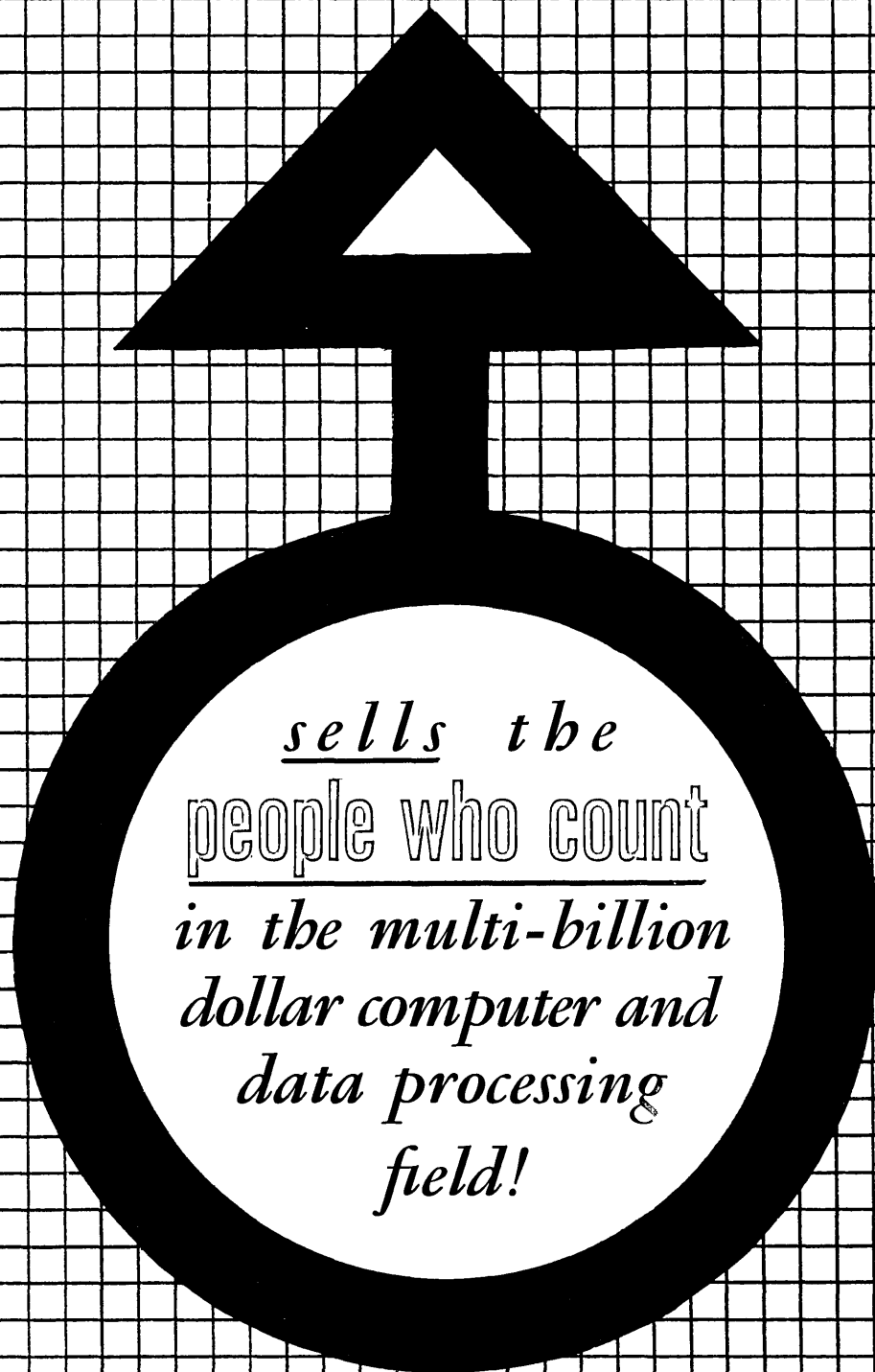

Perhaps the Key Reason Why  
**COMPUTERS AND AUTOMATION**  
 Is Read By The PEOPLE WHO COUNT  
 Is That It Was Founded And Is  
 Edited By Edmund C. Berkeley —  
 Pioneer Computer Mathematician

### EDITOR'S BACKGROUND

- Author of "Giant Brains or Machines that Think", John Wiley and Sons, 1949
- Co-author of "Computers — Their Operation and Applications", Reinhold Publishing Co., 1956
- Author of "Symbolic Logic and Intelligent Machines", Reinhold Publishing Co., 1959
- Maker and Designer of small computing machines including the Brainiac® electric brain construction kits, Simon (miniature complete automatic digital computer), Relay Moe (tit-tat-toe playing machine pictured in Life Magazine, March 19, 1956), etc.
- Fellow of the Society of Actuaries; Harvard 1930 A.B., summa cum laude in mathematics; author of many articles and papers in New York Times Magazine, Scientific American, Record of the American Institute of Actuaries, Journal of Symbolic Logic, etc.
- Entered computer field in 1938.
- Founded "Computers and Automation" in 1951.

## The Computer & Data Processing Field Is Huge!

When Edmund C. Berkeley founded **COMPUTERS and AUTOMATION** in 1951, the industry was just starting to flex its muscles! Now it is estimated that the computer and data processing market will be "between five billion and nine billion dollars over the next five years".

**COMPUTERS AND AUTOMATION**  
 Is The Only Monthly Trade Publica-  
 tion Serving Both Builders And  
 Buyers In This Mushrooming Multi-  
 Billion Dollar Industry

### 1. Computer BUILDER Subscribers include:

Addressograph Multigraph, Aladdin Electronics, Alwac, American Machine and Foundry, Ampex, Arnold Engineering, Automatic Electric, Beckman Instruments, Bendix Aviation, Bristol Company, Bryant Gage and Spindle, Burroughs, Clary Multiplier, Computer Control, Datamatic, Daystrom Systems, Electronic Associates, EpSCO, Ferranti Electric, Ford Instrument, General Controls, General Electric, General Kinetics, Goodyear, Haller Raymond and Brown, International Business Machines, Jet Propulsion Labs, Lear, Leeds & Northrup, Link Aviation, Litton Industries, Melpar, Minneapolis-Honeywell, National Cash Register, Northrop Aircraft, Packard Bell, Panellit, George A. Philbrick Researches, Philco, Potter Instrument, Ramo-Wooldridge, Raytheon Mfg., Reeves Instrument, Royal McBee, Sperry-Rand, Stromberg Carlson, Sylvania Electric Products, Telemeter Magnetics, Texas Instrument, Westinghouse . . .

### 2. Computer BUYER Subscribers include:

Arthur Anderson & Company, Blue Cross, Ebasco Services, Price Waterhouse, Bank of America, First National Bank of Boston, Bank of New York, Chase-Manhattan, First National Bank of Atlanta, Provident Trust, Equitable Life Assurance Society, Great Western, Metropolitan Life, Penn. Mutual, U.S. Life, Battelle Memorial Institute, Brookhaven National Laboratory, Bureau of the Census, National Bureau of Standards, Los Alamos Scientific Laboratory, National Weather Record Center, Port of New York Authority, Railroad Retirement Board, Rand, U.S. Air Force, U.S. Security Service, U.S. Army Tank Ordnance Center, U.S. Navy, David Taylor Model Basin, University of California, Kansas State College, Mass. Institute of Technology, San Diego State College, Wayne State University, University of Wisconsin, Ford Motor, General Motors, General Tire and Rubber, American Cyanamid, Eastman Kodak, Owens Corning Fiberglass, Monsanto Chemical, Allis Chalmers, Cutler Hammer, Diehl Mfg., Western Electric, Westinghouse, Calloway Mills, Kellogg, Briggs and Stratton, United Shoe, Atlantic Refining, Esso Research, Pan American, Sun Oil, Texas Eastern Transmission, Bethlehem Steel, Continental Can, U.S. Steel, American Tel. and Tel., Arizona Public Service, Bell Telephone Labs., Consolidated Edison, Florida Power, Pacific Gas and Electric, Johns Mansville, Boeing Airplane, Convair, Douglas Aircraft, Grumman, Hughes Aircraft, Lockheed, North American Aviation, Reaction Motors, American Airlines, Hawaiian Airlines, Pennsylvania Railroad.

# Companies and Products Advertised in COMPUTERS and AUTOMATION

(Below is a partial list ranging from  
June 1959 to September 1960)

Advertiser	Product Advertised
Burroughs	Computers, Components, Photoreader, Employment Opportunities
RCA	Transistors, Cores, Employment Opportunities, Cells, memory planes, memory cores, systems
ESC	Pulse Transformers, Delay Lines
General Electric	Tubes, Capacitors, Consulting Service
Knolls Atomic Power Lab.	Employment Opportunities
Semiconductor Products Dept.	Employment Opportunities
Missile and Space Vehicle Dept.	Employment Opportunities
Apparatus Sales Office	Power Supplies
Heavy Military Electronics Dept.	Employment Opportunities
Ampex	Tape, Tape Handlers
C. P. Clare	Relays, Wiring Services, Stepping Switches, Insulation
Bendix Corp.	Digital Computing Systems, Paper Tape Reader, Couplers, Employment Opportunities
Honeywell Datamatic	Computers, Employment Opportunities, Data Processing System, Rentals
Aeronautic Systems	Employment Opportunities
Royal McBee	Computers
Ramo-Woolbridge	Capacitors, Employment Opportunities, Computers, Computer Services
System Development Corp.	Employment Opportunities
Arnold Engineering	Cores, Magnets
Audio Devices	Tape
Autonetics	Employment Opportunities
Philco	Computers, Data Processing Systems, Employment Opportunities
Sylvania Electric	Employment Opportunities
Lockheed Aircraft	Employment Opportunities
Technical Operations	Employment Opportunities
Space Technology Labs	Employment Opportunities
C-E-I-R, Inc.	Employment Opportunities, Consulting Services
Di/An Controls	Cores, Buffers, Interlocks, Logic Squares
NJE Corp.	Power Supplies
Computer Control Co.	Memory, Modules, K Pacs
International Business Machines	Employment Opportunities
Boeing Aircraft	Employment Opportunities
Reeves Soundcraft	Tape, Kit to Check Recording Equipment
National Cash Register Co.	Computers, Circuitry, Memories, Employment Opportunities
Dialight	Indicator Lights
Packard Bell	Computers
Raytheon Mfg. Co.	Transistors
Potter Instrument	Computers and Data Processing Systems, Components, Alphanumeric Printer
John Wiley & Sons	Books
Underwood	Servotypers
John Diebold	Consulting Services
Chrysler Corp.	Employment Opportunities
Republic Aviation	Employment Opportunities
Aerojet General	Employment Opportunities
Reinhold Publishing Corp.	Books
Wheeler Fairchild, Inc.	Magnetic Storage Drums
Douglas Aircraft	Employment Opportunities
Ferranti Electric, Inc.	Delay Lines
Mitro Corp.	Employment Opportunities
Sandia Corp.	Employment Opportunities
Hughes Aircraft, Co.	Memo-Scope Oscilloscope
Computer Systems, Inc.	Computers
Texas Instruments Inc.	Employment Opportunities
Norden Div., United Aircraft	Employment Opportunities
Bell Aircraft Corp.	Employment Opportunities
Information Systems, Inc.	Employment Opportunities
Burr & Co.	Equity Capital
Dynacor, Inc.	Bobbin Cores
Clary Corp.	Computers
Library of Science	Books
F. W. Sickles	Delay Lines
Addo-X	Adding and Posting Machines
Adams Assoc., Inc.	Electronic Data Processing, Consulting Services
Cambridge Communications Corp.	Abstracts on Cards
Electralab Printed Elec. Corp.	Printed Wiring, Circuit Assemblies

## COMPUTERS and AUTOMATION Will Be Read By Even More People Who Count

During 1961, we plan that the circulation of **COMPUTERS and AUTOMATION** will reach at least 5000 copies, as compared with 2600 subscribers in 1957, 3700 in 1958, and 4000 in 1959 and 1960. A continuing circulation campaign promises to add numbers of new subscribers to our audience. All new subscriptions are regularly paid for at \$7.50 a year, assuring a top-quality as well as a top-quantity computer-minded audience. About 500 key decision-makers working at computer builders and at computer buyers have been included on a controlled basis in order to assure a very important marketing audience.

## COMPUTERS and AUTOMATION Editorial Coverage is Expanding, Too

Each issue of **COMPUTERS and AUTOMATION** includes new articles, new reference information, and new ideas, to make it as complete, informative, and stimulating to computer people as we can make it. Greater emphasis than ever before is being placed on news of computers and data automation . . . new surveys, new applications, new products, new devices, new ideas about computers and data processors . . . everything we can think of to help our readers do their jobs better, more quickly, and more profitably.

In February 1960, **COMPUTERS and AUTOMATION** went to 24 "issues" a year — a dozen regular letterpress issues closing the 1st of the previous month, and a dozen photo-offset issues "News of Computers and Data Processors: Across the Editor's Desk" closing the 15th of the previous month. The two "issues" are published together at the beginning of the current month, except that in June they are published separately.

# COMPUTERS AND AUTOMATION

## ADVERTISING RATES

	<i>One Time</i>	<i>Six Times 5% Discount</i>	<i>Twelve Times 10% Discount</i>
1 page	\$330.00	\$313.50	\$297.00
$\frac{2}{3}$ page	260.00	247.00	234.00
$\frac{1}{2}$ page	190.00	180.50	171.00
$\frac{1}{3}$ page	140.00	133.00	126.00
$\frac{1}{4}$ page	105.00	99.75	94.50
$\frac{1}{8}$ page	80.00	76.00	72.00

## COMPUTERS and AUTOMATION

### ADVERTISING REPRESENTATIVES

*Middle Atlantic States*  
535 Fifth Ave.

MUrray Hill 2-4194

*Washington 6, D.C.*  
1519 Connecticut Ave.

MILTON L. KAYE  
New York 17, N.Y.

ROBERT CADEL  
COlumbia 5-9727  
*Elsewhere*

*San Francisco 5*  
605 Market St.

*Los Angeles 5*  
439 S. Western Ave.  
THE PUBLISHER

A. S. BABCOCK  
YUkon 2-3954

W. F. GREEN  
DUnkirk 7-8135

Berkeley Enterprises, Inc.  
815 Washington St., Newtonville 60, Mass.  
DEcatur 2-5453 or 2-3928

## "ACROSS THE EDITOR'S DESK"

---

### COMPUTERS AND AUTOMATION

---

Volume 9  
Number 11B

NOVEMBER 2, 1960

Established  
September 1951

---

Published by Berkeley Enterprises, Inc., 815 Washington St., Newtonville 60, Mass.

---

#### ELECTROSTATIC PRINTER PRINTS 300 UP TO 1000 CHARACTERS PER SECOND

Burroughs Corp.  
Detroit 32, Mich.

An electronic teleprinter, which prints at the rate of 50 words per-second or 3000 words per minute, is at this company. Some of the machines are currently being employed in the U. S. Air Force Weather Observation and Forecasting system, and Global Communications program, and in projects for other branches of the government. Burroughs will ship some 50 of these machines by the end of 1960.

Printing by the electrostatic teleprinter is accomplished by a row of solid-state electronic print heads in matrix form that charge paper with electrostatic character images. These images pick up powered ink as the paper passes through an ink bath and are fixed in hard, permanent copy when the paper passes over heated pressure rollers. The ordinary hammering type faces, typical of some impact printers, are eliminated.

Since the paper never touches the print heads, and the only moving parts are associated with the paper advance mechanism, the life and maintenance of the teleprinter is enhanced. In long distance communications and data processing systems utilizing existing local and long distance telephone lines, the high speed printer minimizes circuit time and operational costs.

The teleprinter records alpha-numeric or symbolic characters at rates up to 300 characters per second on roll paper 72 characters wide. It can be used as a readout from electronic computers, or operated from input signals from polka dot, punched or magnetic tapes, or telegraphic signals. It has capabilities of speeds up to 1000 characters per second.

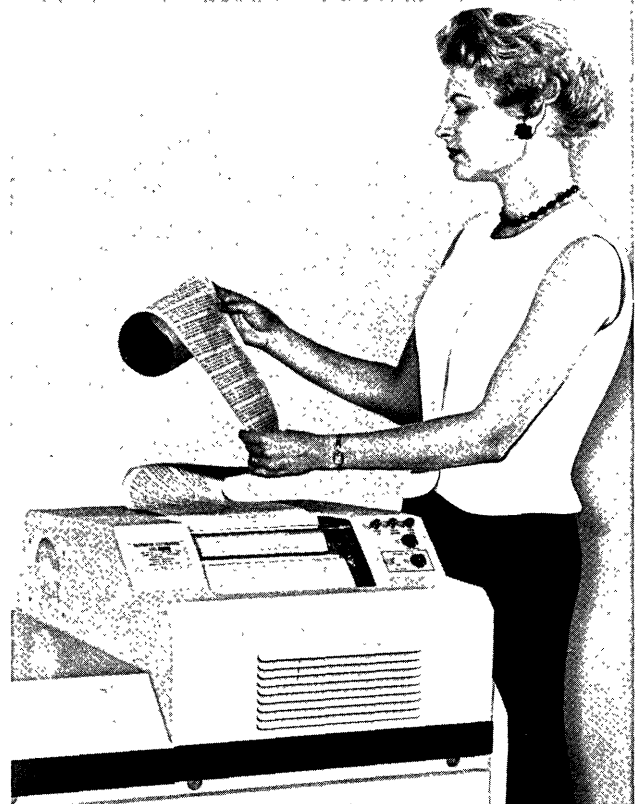

## OPTICAL READING MACHINE

International Business Machines Corp.  
Data Processing Div.  
White Plains, N.Y.

An optical reader of numbers and marks, which reads at the rate of 480 characters per second, has been developed by this company. The machine is identified as the IBM 1418 Reader. As many as 400 documents a minute may be read. The printed data is automatically translated into machine language for direct input to an IBM 1401 computer.

The 1418 reads numbers printed ten characters to the inch in a standard IBM type by 407, 408, or 409 accounting machines, the 1403 printer, or an electric typewriter. It can also read numbers in the elongated 407 type style, commonly used by credit card printers, which is seven characters to the inch. In addition, the 1418 can be equipped for mark-reading -- in which vertical markings made with ordinary pencil or dark inks represent specific information determined by the format of the document.

The optical character reader handles documents of various sizes and thicknesses. Forms can be anywhere from 5 7/8" to 8 3/4" wide by 2 3/4" to 3 2/3" high. Their thickness can vary from that of bond paper to IBM card stock. Any printed documents within these dimensions -- premium notices, imprinted charge slips, telephone bills, tax notices, coupons, and continuous-card forms, for example -- can be used as direct input to the 1418-equipped 1401 system.

As the documents feed into the 1418, they are separated and aligned, one document at a time. Each form then feeds individually onto a revolving drum, where it is held flat by a vacuum. As the drum revolves, the complete surface of the form passes under a lens system.

The standard machine contains one optical reading station, which will read a single type style from any line on the document. Available optionally are either a second reading station or a mark-reading station. With the second reading station, two lines can be read in one pass of a document through the machine. These lines can be in the same or different type styles.

The 1418 employs a scanning method which recognizes a practical range of print quality. The characteristics by which each number is identified are contained within the solid-state circuitry of the reader. The light image of a character is converted into electrical impulses which are compared and matched with internal logic patterns. Numerical characters are individually recognized in this way and transferred one at a time to the magnetic core storage of the 1401 system.

Once in storage, the data from the printed forms can be processed and the results produced as punched cards, magnetic tape, or printed reports by the 1401. The forms from which the data were read are fed by the 1418 into its appropriate sorter pockets.

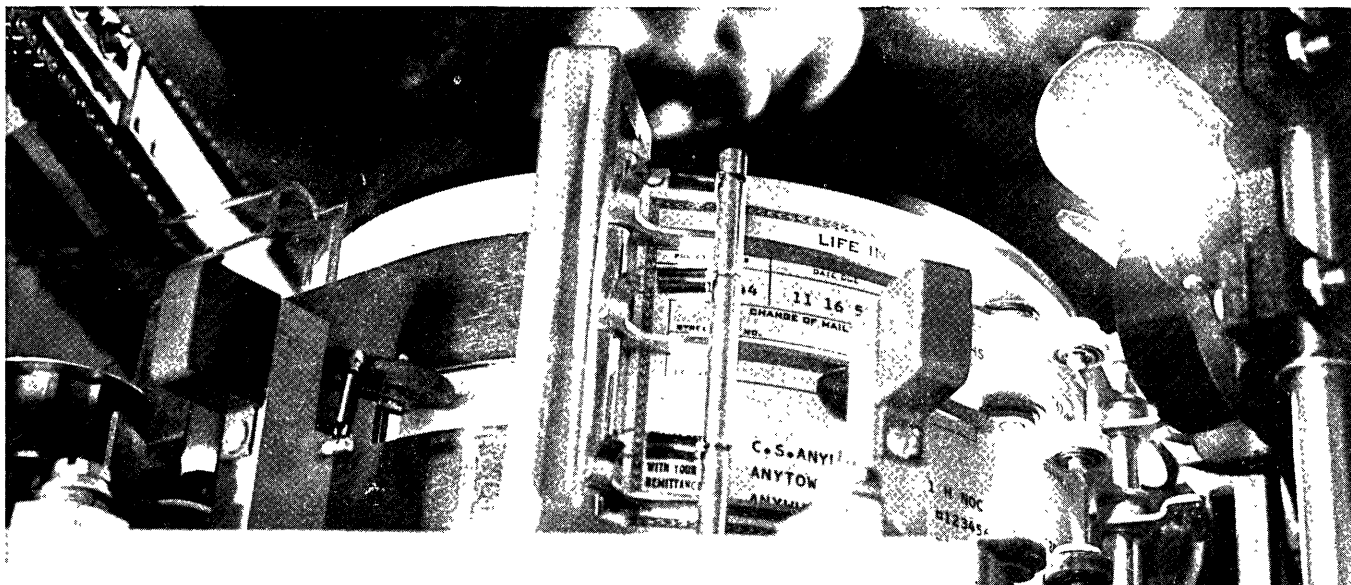

International Business Machines Corp.  
Data Processing Div.  
White Plains, N.Y.

An electronic "law library" which readily locates legal information was demonstrated to members of the American Bar Association at their recent convention. An IBM 650 data processing system provided in minutes facts that would have taken many hours to find by conventional methods.

The electronic system was able to search for, find and print out -- upon request -- the full text of laws from various states on health and hospitals.

The data processing unit had stored on magnetic tape the full text of Pennsylvania statutes on public health and all statutory sections of the 1200-page Hospital Law Manual. This was done by first recording the statutes on punched cards and then transferring them -- via the 650 computer and an attached card reader -- to the tape in the form of magnetized bits.

Any one of the five tape units in the system can be called into operation through instructions previously stored in the computer's magnetic drum memory. The magnetic drum serves as storage for both the program of instructions, which controls the operations performed on the data, and those portions of the data being worked on. The magnetic tape, which can be read by the computer at the rate of 15,000 characters per second, serves as a permanent storage for the statutory information. This information can be called into the computer for processing by the program of instructions.

On each 2400-foot reel of tape it is possible to record more than 2,000 pages of running English text. This means that the equivalent of a 2,000-page legal tome will take up less than 1 1/2 inches of shelf space, the width of the reel in its canister.

After the text of the statutes was placed on tape, the computer -- acting on instructions from the magnetic drum -- analyzed the text and constructed an alphabetical list of the total vocabulary (eliminating common words such as "and," "the," "or," etc.).

The computer associated with every non-common word the identification number of the statute or statutes in which it appeared. The list of words and associated statute numbers is the information which the computer processes in looking for an answer to a query.

To find the statutory section relevant to a legal issue, an inquiry for the computer is framed. The inquiry consists of words, or groups of words, which are expected to be found within the desired statutes.

Receiving the inquiry via the card reader, the computer searches the vocabulary list which has been placed, along with the statute identification numbers, on magnetic tape. The statute identification numbers associated with each of the selected inquiry words are compared by the computer. If the same number is found in all of the selected word records, then this indicates that the statute contains all the selected words -- and has the information being sought.

For example, an attorney might want to know what statutes in the Hospital Law Manual touch on the taxation of charitable hospitals. An inquiry would be framed -- it might contain the words "charitable," "taxation," "exemption," "hospital" -- and given to the machine. The numbers of all statutes containing all these words would be listed, and, if desired, the statutes would be printed out in full.

---

NEW DATA PROCESSING UNIT WILL HANDLE  
720,000 SAVINGS ACCOUNTS

The Philadelphia Saving Fund Society  
Philadelphia, Penna.

This bank has installed an IBM RAMAC data processing equipment, which will handle accounting on 720,000 of the bank's savings accounts (largest number in any U.S. savings bank). Deposits are more than a billion dollars.

The computer already has currently in its memory all the facts and figures on some 400,000 of the bank's savings accounts.

In addition to deposit accounting, the machine will shortly do the accounting on more than 25,000 of the bank's mortgage loans, calculate the payroll for the bank's nearly 750 employees, and handle many other accounting jobs now done with conventional punch-card equipment.

The machine was tested extensively for several weeks. As the equipment and procedures became ready, various groups of accounts were switched over to the machine from conventional punch-card equipment. This will continue until most of the bank's accounting procedures are automated, the culmination of several years' planning and effort.

The 1960 Eastern Joint Computer Conference will take place in New York at the Hotel New Yorker and Manhattan Center, Tuesday, December 13 to Thursday, December 15. Following is the program:

I. Tuesday, December 13 9:30 - 11:40 A.M.

- 0) Opening Remarks: N. Rochester, Conference Chairman, IBM and E. C. Kubie, Program Chairman, CUC
- 1) "A Logical Machine for Measuring Problem Solving Ability" - Charles R. Langmuir, Psychological Corporation
- 2) "A Method of Voice Communication With a Digital Computer" - S. R. Petrick and H. M. Willett, Air Force Cambridge Res. Labs.
- 3) "FILTER - A Topological Pattern Separation Computer Program" - Daphne Innes, Lawrence Radiation Lab.
- 4) "Redundancy Exploitation in the Computer Solution of Double-Crostics" - Edwin S. Spiegelthal, Consultant

II. Tuesday, December 13 2:00 - 4:05 P.M.

- 1) "A Computer for Weather Data Acquisition" - Paul Meissner, J. Cunningham and C. Kettering, National Bureau of Standards
- 2) "A Survey of Digital Methods for Radar Data Processing" - F. H. Krantz and W. D. Murray, Burroughs Corp.
- 3) "The Organization and Program of the BMEWS Checkout Data Processor" - A. Eugene Miller, Auerbach Electronics Corp. and Max Goldman, RCA
- 4) "Ultra-High Speed Dynamic Display System for Digital Data" - Burton G. Tregub, Melpar
- 5) "High Speed Data Transmission Systems" - R. G. Matteson and J. D. Barnard, Stromberg-Carlson Company

III. Wednesday, December 14 9:00 - 11:05 A.M.

- 1) "Parallel Computing With Vertical Data" - William Shooman, Systems Development Corp.
- 2) "The TABSOL Concept" - T. F. Kavanagh, General Electric Company
- 3) "Theory of Files" - Lionello Lombardi, University of California
- 4) "Polyphase Merge Sorting - An Advanced Technique" - R. L. Gilstad, Minneapolis-Honeywell Regulator Co.
- 5) "The Use of Binary Computer For Data

IV. Wednesday, December 14 2:00 - 4:30 P.M.

- 1) "High Speed Printer and Plotter" - Frank T. Innes, Briggs Assoc., Inc.
- 2) "A Description of the IBM 7074 System" - R. R. Bender, D. T. Doody and P. N. Stoughton, IBM Poughkeepsie
- 3) "The RCA 601 System" - D. L. Nettleton and K. K. Kozarsky, RCA
- 4) "Associative Self-Sorting Memory" - R. R. Seeber, Jr., IBM, Poughkeepsie
- 5) "UNIVAC - RANDEX II - Random Access Data Storage System" - G. J. Axel, Remington Rand
- 6) "Hot-Wire Anemometer Paper Tape Reader" - John H. Jory, Soroban Engineering, Inc.

V. Thursday, December 15 9:00 - 11:05 A.M.

- 1) "Data Processing Techniques in Design Automation" - W. L. Gordon, Minneapolis-Honeywell
- 2) "Impact of Automation on Digital Computer Design" - W. A. Hannig and T. L. Mayes, General Electric Co.
- 3) "Calculated Waveforms For Tunnel Diode Locked Pair" - H. R. Kaupp and D. R. Crosby, RCA
- 4) "On Iterative Factorization in Network Analysis by Digital Computer" - W. H. Kim, C. V. Freiman and W. Mayeda, Columbia University
- 5) "A Computer-Controlled Dynamic Servo Test System" - V. A. Kaiser and J. L. Whittaker, Douglas Aircraft Co.

VI. Thursday, December 15 2:00 - 4:05 P.M.

- 1) "The Flying Spot Scanner as an Input Sensor to a Character Reading System" - J. S. Bryan, J. B. Chatten, F. P. Keiper and C. F. Teacher, Philco Corp.
- 2) "Use of a Digital/Analog Arithmetic Unit Within a Digital Computer" - Donald Wortzman, IBM
- 3) "PB-250 A High Speed Serial General Purpose Digital Computer Using Magnetostrictive Delay Line Storage" - Robert Mark Beck, Packard Bell Computer Corp.
- 4) "The Instruction Unit of the Stretch Computer" - R. T. Blosk, IBM Poughkeepsie
- 5) "The Printed Motor: A New Approach to Intermittent and Continuous Motion Devices in Data Processing Equipment" - R.P. Burr, Circuit Research Company



COMPUTERS TO PREDICT ON ELECTION NIGHT:  
KENNEDY OR NIXON?

CBS NEWS  
Columbia Broadcasting System  
New York, N.Y.

Electronic computer systems will be used again in November 1960 as tools to help analyze returns and report up-to-the-minute probabilities on election races much faster and more comprehensively than in any previous election.

Using data from the 1956 election, the network has demonstrated how with their new system they would have been able to make a reasonably accurate prediction on the outcome of the last election after receiving the first 1% of the returns -- at least an hour earlier than they did four years ago.

Stored in an IBM 7090 computer are the results of a year of preliminary research by computer mathematicians, supported by political scientists from major universities in 16 states. This mass of information covers more than 500 precincts and 75 marginal Congressional Districts.

These voting areas were selected because most of them report early on election night and because they are a representative sample of the total voting population. The information includes not only historical voting records for every national election back to 1928 but also much other data such as racial, religious, income and residential characteristics of the voters.

This stored information, together with special reports that will be received directly from CBS News reporters in the same 500 early-reporting precincts on election night, will constitute the two entirely new types of data for the network's analyses and predictions.

Other questions based on voter characteristics rather than past elections can also be considered, including "How solid is the South?"; "Is labor voting as a block?"; "Are farm states voting as a block?"; "Is Nixon getting more votes than the Republican House candidates?"; "How does this compare by regions?"; "How can the size of turnout be explained?"; "Are voters dividing on religious lines?"; "Is Nixon winning the traditional strong Republican areas that are indispensable to him?"

There is no official government procedure for getting vote returns on election night. In fact, the official results are

not known for days or weeks. The news media themselves have assumed the responsibility of collecting unofficial returns in a few hours after the polls close.

For this job of processing election returns, CBS News election headquarters studio will be equipped with an IBM RAMAC 305 with many special transmitting and computing features.

As reports come in to the studio from wire service teletypes and the network's own telephone correspondents, coded cards will be punched on card punch machines. The cards will be rushed by conveyor belt within eight seconds to the 305, which will search its 10 million-character disk file memory, check the information against previous data, print reports for the correspondents and flash the latest national voting results on a light-board for the video audience.

---

SPECIAL-PURPOSE COMPUTER MEASURES WEATHER TO  
AID FUEL DEALERS' SCHEDULING

HRB-Singer, Inc.  
North Plainfield, N.J.

A "weather computer" providing effective data for efficient dealer management of fuel delivery scheduling, in regions where fuel is used for heating only, has been developed by this company.

The device includes a totalizer of fuel use, which continually indicates gallons of fuel consumed by all customers over a selected period of time. By comparing total gallons consumed with the number of gallons delivered to customers over the same period, the dealer can tell if his deliveries are ahead or behind his customers' needs. The machine records, in weather units, accurate data, which is used to schedule deliveries to customers using fuel for heating.

Weather conditions are measured by a simple-to-install, compact, roof-top device that integrates atmospheric conditions consisting of temperature variations, sunshine, clouds, winds, snow and rain, and relays this data through a low-voltage lead-in wire to the recording unit in the dealer's office.

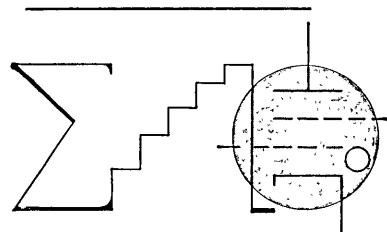

INSURANCE COMPANY MAKES ITS RATE BOOK  
CALCULATIONS AUTOMATIC

Burroughs Corp.  
Detroit, Mich.

The preparation of a lengthy and complex ordinary rate book -- covering 40 insurance plans and six riders -- has been made automatic at Minnesota Mutual Life Insurance Company, St. Paul, Minn.

The company estimates that this project -- handled by a Burroughs magnetic tape system -- represents the equivalent of 30 clerks operating desk calculators for six months. Savings over earlier tabulating machine and manual methods are estimated at \$35,000.

Results of the rate book program take the form of 200 pages of numerical information, including rate book premiums and non-forfeiture values for a wide range of life and term insurance policies, plus endowment, retirement and annuity plans.

The Burroughs 205 automatically computes all premiums -- standard, special class, income disability, double indemnity, etc. -- for all ages of all policies. In addition, the computer works out the cash values and mean reserves of policies at various ages, and calculates reduced paid-up policy values, and the number of years and days a policy will remain in effect after premium payments have been halted.

The basic computer program which covers life and endowment policies -- about one half of the rate book volume -- is triggered by a single card. This input card contains the age limits of a policy, the description of a particular payment plan, and tells how long premiums are payable as well as the date on which benefits expire.

The basic program consists of 3,000 steps, plus 50 20-word working areas which contain various tables, interest rates, etc. It takes the computer approximately six hours to calculate the rates for a complete life plan for all issue ages -- from zero to 65.

Another program handles annuities, which includes annual premium-deferred and single premium-immediate annuities, computed on life, installment and cash refund bases.

Two other programs calculate tables and information concerning income endowments and term policies. The large assortment of term insurance plans includes level, decreasing term and special riders. About two hours are required for calculation of endowment plans,

which reach full value at the end of a specified number of years or at a certain age.

The rate book programs punch out cards for off-line listing of the appropriate data for selected years; an on-line listing of all reserve and non-forfeiture information for every possible duration of a policy is also prepared for future reference.

The off-line listing then becomes the master sheet for direct offset reproduction. Extra copies of rate book sheets are also made so that the pertinent rate page can be inserted into a policy, making its preparation faster, simpler.

Minnesota Mutual Life's four rate book programs were programmed and coded by Assistant Actuary William H. Gilbert in four months.

A pioneer in the application of electronic data processing to insurance problems, Minnesota Mutual Life recently completed conversion to its Consolidated Functions Approach program -- a one-pass approach to a major group of related applications. These include billing and accounting for premiums and loan interest, dividend calculation and notice preparation, and commission calculation.

The company maintains some 220,000 policy records on magnetic tape, and uses its Burroughs 205 to bill nearly 1,000,000 premiums a year.

---

MOVIE THEATER TICKETS  
FROM VENDING MACHINES

Universal Controls, Inc.  
New York, N.Y.

Thousands of motion picture theatres may soon sell admission tickets with vending machines. This is suggested by the introduction of a "Vendaticket" machine, made by this company, which makes possible the sale of theater tickets without the presence of an operator. It combines the functions of an electronic currency identifier, automatic ticket issuer, and an electro-mechanical change maker in one integrated mechanism.

The machine can also be adapted to sell tickets at air terminals, bus and railroad stations, stadiums and parks.

## JOINT USERS GROUP

H. M. Semarne (POOL)  
Chairman, Public Relations Comm.,  
Joint Users Group  
Department A-270  
Douglas Aircraft Co., Inc.  
Santa Monica, Calif.

H. S. Bright (TUG)  
Member, Public Relations Comm.,  
Joint Users Group  
Westinghouse Bettis Laboratories  
P. O. Box 1468  
Pittsburgh 30, Penna.

W. M. Carlson (AIChE)  
Member, Public Relations Comm.,  
Joint Users Group  
Engineering Dept.  
duPont Company  
Wilmington 98, Del.

On Saturday, August 27, in Milwaukee, Wisc., representatives of various computer user groups held a second meeting at which they decided that there be formed an organization, provisionally known as the Joint Users Group. Immediate consideration was given to an invitation to organize within the Association for Computing Machinery. Further action on this matter is expected at the next Joint Users Group meeting, 16 December 1960, in New York.

At the first meeting, held in May, the representatives of seventeen computer user groups had agreed that the need exists for the establishment of communication among such groups, and a resolution defining this need had been adopted and published.

The second meeting produced almost unanimous ratification of this resolution by the fifteen groups represented and the following statement was approved:

"The objective of the Joint Users Group is the establishment of communication among computer user groups to promote study, exchange of information and cooperative effort in areas of common interest.

"These areas include:

1. Common programming languages and other means of communication between computing machines.
2. Establishment and maintenance of standards for communication and

distribution of computer programs and techniques.

3. Exchange of information on problems arising from the operation of a computer installation.
4. Communication of methods and techniques for comparing the effectiveness of computer problem solving techniques.
5. Consideration of hardware standards in cooperation with other interested agencies."

At the Milwaukee meeting, an invitation was received from the Council of the ACM to the Joint Users Group "to organize within the ACM and to take advantage of the facilities and services of the ACM to implement this multiple objective".

The consensus of those present seemed to favor some form of affiliation with the ACM. An Affiliation Committee selected at the meeting reported the recommendation that the offer of the ACM Council be accepted. However, in the face of various contemplated developments, the assembly could not decide which of several possible alternative forms of affiliation would be to the advantage of all concerned.

A committee on by-laws, a committee to study communication between user groups, and other working committees were appointed and charged with reporting their recommendations at the next meeting of the Joint Users Group. At this meeting it is hoped the question of affiliation and some questions of communication between groups will be resolved. This next meeting is planned for Friday, 16 December 1960, in New York City, one day after the Eastern Joint Computer Conference.

For further information regarding past or forthcoming meetings, write Jerry L. Koory, System Development Corp., 2500 Colorado Ave., Santa Monica, Calif.

Organizations represented at this meeting included:

ACM (Association for Computing Machinery)  
ASA (American Statistical Association)  
Alwac Users (Alwac III-E)  
CO-OP (CDC 1604) (Note: of Control Data Corp.)  
CODASYL (Conference on Data Systems Languages)  
CUE (Datatron 220) (Note: of Burroughs)  
Datamatic-1000 Users Organization (Note: of Minneapolis-Honeywell)  
Exchange (Bendix G-15)  
FAST (Fielddata Systems)  
LINC (Univac LARC) (Note: Univac: of Sperry Rand)

POOL (LGP-301) (Note: of Royal Precision)  
POUCHE (Program Distribution Service of  
the American Institute of Chemical  
Engineering)  
RCA 501 Users Group  
RUG (Recomp III) (Note: of Autonetics)  
SHARE (IBM 704/709/7090)  
TUG (Philco 2000)  
USE (Univac 1103A, 1105)  
Univac Users Association

---

NEW SIGNATURE SCRAMBLING DEVICE TO  
BLOCK BANK PASSBOOK FORGERY

Dr. H. J. Wall  
Manager of RCA Applied Research  
Radio Corp. of America  
Camden, N. J.

A scrambling device which makes it virtually impossible to forge passbook signatures in the withdrawal of savings bank deposits and, at the same time, substantially reduces customer waiting time at tellers' windows has been developed.

Known as Signaguard, the device reproduces a passbook signature as an unrecognizable mass of broken lines. When the passbook is presented at the teller's window, the device returns the signature to its original appearance for comparison with the customer's signature on the withdrawal slip.

Banks are expected to use the device in conjunction with electronic data processing systems situated in their main offices.

This would eliminate the need for duplicate records of signature and account status in each branch office and also would do away with time-consuming withdrawal checking procedures.

The new protection system makes use of fiber optics -- glass tubes that carry light and images around bends and corners.

It so effectively scrambles a signature that even a bonafide depositor, much less an aspiring forger, cannot decipher the name on a lost passbook, he said. The imprint is produced as mixed segments of lines thousands of an inch in diameter, corresponding to the diameter of the tubes.

As a double check, a secret number can be attached to the name. This effectively foils

forgery attempts by persons who know the depositor well and can duplicate his signature.

The new device will make savings bank accounting foolproof. Another of its advantages is the elimination of tub files -- files containing cards on all depositors -- which each teller must consult before completing a withdrawal. This would make for more room and less confusion in the banks, and would eliminate the time required to refer to such files for signature comparison and account checking.

Signaguard may be likened to a cable or telephone wires, with each individual wire being a glass tube instead of copper wire. Each tube picks up a small segment of the signature and transmits it to the other end of the tube via a devious route. This scatters signature segments throughout the unintelligible mass that is imprinted on sensitized paper at the other end of the tube.

In the bank the fiber optics tube is reversed to bring the scrambled signature back to its original form for comparison with the signature submitted to the teller.

Use of Signaguard in conjunction with the bank's central computer system would permit a teller to complete a banking transaction without leaving his window.

The teller would check the scrambled and withdrawal slip signatures, then punch the necessary information into his window calculating machine, modified to feed the information via telegraph or telephone lines into the computer in the main office. The computer would perform whatever arithmetic is necessary and update the passbook, returning this information directly to the teller at the window. Should the withdrawal slip call for more than the account balance the computer would make this known.

Under this centralized system, the depositor could transact business at any window in any branch of his bank and could avoid a long wait because his name was Jones and the "J" window was the only one designated to serve him. The net result would be a reduction of the time necessary to carry on the banking procedure by spreading the work load among several windows.

Applications, other than in savings banks, are contemplated for Signaguard. It may be employed in identification cards for commercial bank depositors, for retail credit cards, etc.

---

Cleveland Graphite Bronze Div.  
Clevite Corp.  
Cleveland, Ohio

A new source of electricity for ignition systems in small gasoline engines and other purposes has been developed by this company.

The new device is smaller than a man's fist and contains two ceramic parts that convert a single, short motion into a 20,000-volt charge. In power lawn mowers, outboard motors, portable generators, and other compact power equipment, it will perform a job that now requires a magneto, points, coil and condenser.

The Clinton Engine Corp. is introducing the device on a new engine in its 1961 line for power lawn and garden equipment.

The device has been named a "Spark Pump" (trade mark) because it produces a spark each time pressure is applied to it. A Spark Pump, a switch, and a spark plug constitute a complete ignition system for a small motor.

In addition to simplifying the ignition process, the Spark Pump produces a constant high voltage at all engine speeds. This means that many engines can be started with a single turn of the familiar starting cord, without the need for complex starting mechanisms.

A demonstration model of the Spark Pump, when squeezed with ordinary handshake pressure, generates a spark hot enough to jump across a quarter-inch gap.

The basis for the new power source is piezoelectricity. Some natural crystals, such as quartz, will emit a tiny electric current when twisted or bent. Cut into paper-thin slices, such crystals have long been used as the pick-up elements that translate phonograph needle vibrations into electrical impulses that can be amplified and played through a loudspeaker.

Many years ago this company found out how to grow these crystals artificially, and in recent years has developed a new ceramic material (trade marked PZT) that does the same work but better.

The Spark Pump is the first device using piezoelectricity to create a spark twice as powerful as that produced by an ordinary magneto and condenser.

B. H. Ciscel, General Mgr.  
Chance Vought, Electronics Div.  
Dallas, Texas

A new, compact electronic device which significantly increases the effectiveness of radar for aircraft, ships or land bases has been developed.

The device -- called a "video correlator" -- makes it possible to acquire a distinct radar target image under circumstances in which the image otherwise would be obscured on the radar screen, company officials said. It achieves this by correlation of the available signal power to provide a clear target signal at the radar's maximum operating range.

The Correlator is adaptable to sea or land-based radar, airborne radar and other systems. It can be installed in existing radar systems with very little modification and at very low cost compared to that of the basic radar equipment.

The video correlator performs post-detector correlation of the video signal. Its basic function is the sorting of target pulses out of noise and interference, based on a uniform time-spacing or delay between successive video pulses or the pulse repetition period of the radar.

Key elements of the device are two matched magnetostrictive delay lines and their associated coincidence gates. All characteristics of the raw video signal are retained without distortion.

The correlator increases radar effectiveness by sorting out and correlating only those radar pulses which bounce back from a target and by eliminating signals caused by noise and interference. Since target pulses are received at uniform time intervals and the noise and interference are either irregular or occur at a different time spacing, the correlator, using a delay principle, selects only those signals which come from the target.

Performance capability of the video correlator has been proved by several hundred hours of operation both in the laboratory and in flight tests. The device now is available in production quantities and can be tailored for any existing radar.

## HIGH-SPEED DATA TRANSMISSION SYSTEM USING TELEPHONE LINES

Digitronics Corp.  
Albertson, Long Island, N.Y.

A new electronic system which transmits data over the regular telephone network at a speed of 1,500 words per minute has been developed by this company.

This new development, called the Digitronics Dial-o-verter System, was created to function with the Bell System Data-Phone 200.

The system makes possible the transmission and receipt of volumes of data, to and from many remote locations, at high speed, with more accuracy, and at lower cost than has been available to date.

The new system can replace low-speed, electro-mechanical equipment. Currently, data may be transmitted over private telephone or telegraph lines at a speed of 6 to 10 characters per second, while the new system operates via Data-Phone at a speed of 150 characters per second.

Using the new system a person can simply dial when he is ready to send or receive data in machine language. This system can bring information from plants to data processing centers, or from office to office, with more flexibility than private telephone or telegraph lines.

For greater accuracy, the system checks the line for transmission, before it permits data to be sent. Other features, designed to assure reliable data transmission, include error reporting, error retransmission options, and double parity.

The Dial-o-verter System can read or write data via punched paper tape, punched cards or magnetic tape. It can transmit data in one medium at one point, and have it received in another medium at the other point.



### INTERNAL REVENUE SERVICE CALCULATIONS TO BE AUTOMATIZED

International Business Machines Corp.  
New York, N.Y.

One of the largest accounting systems in the world will soon be under automatic control, this company announced after successfully bidding for the conversion contract.

The proposed Internal Revenue Service system involves a large computing center to

be established in Martinsburg, West Virginia, with smaller computers in regional areas. It will handle all forms of Federal taxes and cross check such data as individual income tax returns, W2 forms, corporate income tax statements, dividend payment notices, and interest payment notices.

In preparing its bid on the system, which will get under way in late 1961, IBM employed a simulation program for timing and cost evaluation of a number of equipment configurations. More than 50 systems specialists were put to work on the voluminously detailed study.

USE OF COMPUTERS IN BIOLOGY AND MEDICINE  
IS DISCUSSED

The following is the "Digital Computers" section of the program of the Annual Conference on Electrical Techniques in Medicine and Biology held by the Institute of Radio Engineers in Washington, D. C., on October 31, November 1-2, 1960.

Session on Digital Computers  
Chairman: G. N. Webb

- 1: Introduction to Digital Computers and Automatic Programming, R. S. Ledley, National Science Foundation, New York, N.Y.
- 2: The use of Computers in Medical Research at the National Institutes of Health, N. Z. Shapiro, National Institutes of Health, Bethesda, Md.
- 3: Problems Arising in the Digital Interpretation of Electrocardiogram Data, R. J. Arms, National Bureau of Standards, Washington, D. C.
- 4: Recording of Bioelectronic Signals for Digital Computer Analysis, H. Zimmer, Georgetown University Hospital, Washington, D. C.
- 5: A Digital Computer Program for Simulating Chemical and Biological Systems, D. Garfinkel, University of Pennsylvania, Philadelphia, Pa.
- 6: Computer Simulation of Reactions between Bound Chemicals, D. Irving, P. Markstein and J. D. Rutledge, IBM Research Center, Yorktown Heights, N.Y.
- 7: Automatic Programming to Assist Simulation, J. B. Wilson, National Science Foundation, New York, N.Y.

---

AUTOMATIC READING OF LETTER ADDRESSES  
ON ENVELOPES

Post Office Department  
Washington 25, D.C.

The new postal machine that "reads" the addresses on letters is being improved to handle addresses which are printed entirely in capital letters -- and postal zone numbers, too -- Postmaster General Arthur E. Summerfield disclosed today.

The Postmaster General's disclosure followed a recent progress inspection of the machine at the Alexandria, Va. plant of the

Farrington Mfg. Co., developers of the first automatic address reading device for the Postal Service.

At present, the machine can read only those addresses which are printed in conventional capital and small letter style ("upper and lower case"). It ignores postal zone numbers.

However, new refinements are being added which should make reading of capital letter addresses and zone numbers possible.

This is of far-reaching significance, Mr. Summerfield said, because a large part of the nation's mail is addressed by mailing equipment which prints entirely in capital letters. This is particularly true of some major types of business mail, such as advertising materials sent through the mails.

The necessity of reading postal zone numbers, which are invaluable in the speedy handling and delivery of mail, is obvious.

Including the present capacity of the machine to read the conventional type "upper and lower case" printed addresses, together with its anticipated ability to handle capital letter addresses and zone numbers, the device should be able to handle all kinds of commercial correspondence quickly, the Postmaster General observed.

In addition to reading addresses on letters, the machine sorts them into destination slots. In fact, it is able already to read and sort 9,000 letters an hour to 40 destinations, and this capacity will be increased as the machine is developed further.

The Farrington "Automatic Address Reader" has been under continuous development since 1954. An experimental model was successfully tested and demonstrated by the Post Office Department as early as 1957.

As a result, the Post Office Department awarded a contract to the Intelligent Machines Research Corp., Farrington subsidiary at Alexandria, for development of an even more advanced transistorized experimental model. This is the model which the Postmaster General viewed during his recent inspection. Delivery of this newest device in condition to begin preliminary testing on "live" mail is expected early in 1961. The modifications permitting reading of capital letters and zone numbers are expected to be incorporated by August 1961.

Through its character-sensing apparatus, the Farrington Automatic Address Reader already is developed to the point where it can recognize typewritten, imprinted or printed

addresses, single or double spaced, staggered or flush in upper and lower case almost anywhere on the face of a standard size envelope.

The Farrington machine "reads" an entire city and state line, spelled out or abbreviated, as the letter passes before the "eye" of the machine, rather than reading the address letter by letter, as required by some commercial applications. The new development recognizes the city and state by the general shape of the letters, just as one person can recognize another by his overall physical appearance rather than by identifying individual features.

"Including these latest developments, I now feel that electronic reading and sorting of mail to fully automate postal operations, a major objective of the Post Office Department, is just around the corner," Postmaster General Summerfield observed.

---

PHOTOGRAPHIC FILM STORING  $6 \times 10^8$  BITS  
PER SQUARE INCH

Eastman Kodak Co.  
Rochester 4, N.Y.

A high-resolution film, exposed with present optics, is capable of storing 600 million bits of information per square inch. This means that the entire contents of the Encyclopedia Britannica could be stored on a single 4-inch square piece of film.

Photography, the recording medium that as of now stores the greatest amount of information in the smallest space, is the key to the Air Force's new translating machine, the Photoscopic Language Translator (see August "Computer and Automation") that translates Russian to English at the rate of 40 words per minute.

Special glass disks, coated with a high-resolution photographic emulsion, are the heart of the translating machine.

An entire 55,000 word vocabulary is stored in a  $3/8$ -inch channel printed on a ten-inch glass disk. The channel is scanned vertically and horizontally by electronics until the machine matches a Russian word -- fed in with punched tape -- to its English equivalent, which is then printed automatically on a typewriter.

Modifications of the machine will enable it to translate more than 2,400 Russian words per minute with greater precision and better grammar than it does now at the slower rate.

At present the English translation emerges in a rough but meaningful form for refinement by human translators.

When more of the capacity of the photographic disk is used, it will store about 500,000 Russian words and idioms on a single surface. Words are printed in a line code of bars and spaces.

The glass disks are coated with high-resolution emulsion, then inspected microscopically for any flaws in the surface.

Even with a 500,000 word vocabulary the disk barely scratches the surface of photography's information storage capacity.

---

RADAR DATA COMPUTER TO ELIMINATE  
SHIP COLLISIONS AT SEA

Goodyear Aircraft Corp.  
Akron, Ohio

The Maritime Administration will negotiate a contract with Goodyear Aircraft Corp. for the development of a radar unit that will eliminate, or minimize, the possibility of ship collisions at sea.

Vice Admiral Ralph E. Wilson, chairman of the Maritime Board and Maritime Administration, U. S. Department of Commerce, said the project is part of a continuing research and development program to improve efficiency and safety aboard American merchant vessels.

Goodyear Aircraft plans that the experimental radar data computer will be worked out at its Litchfield Park, Ariz., installation.

The computer will be designed to plot the projected courses of as many as 10 ships simultaneously, and to sound an alarm when collision distances fall below predetermined minimums. It also would indicate an appropriate maneuver to enable the ship equipped with the computer to avoid all vessels in the nearby area.

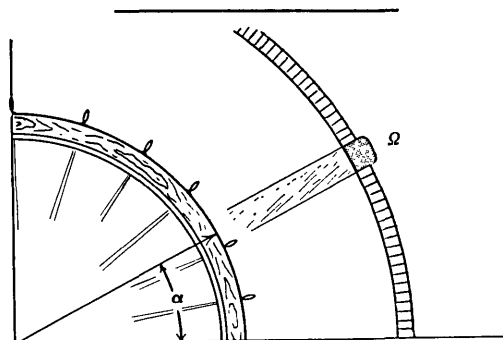



For engineering, for research, for business data processing in companies both large and small... The new, fully-transistorized

# RPC-4000

## ELECTRONIC COMPUTING SYSTEM

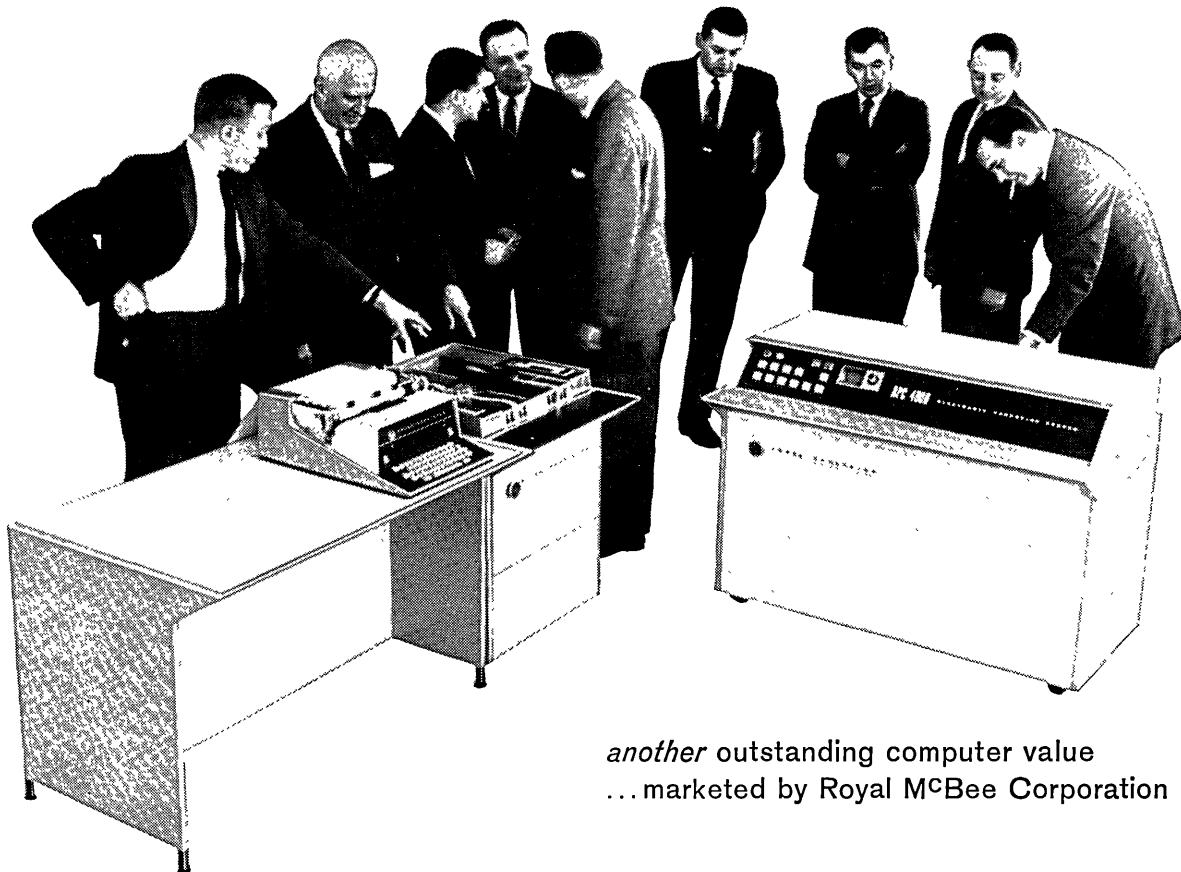

*another* outstanding computer value  
... marketed by Royal McBee Corporation

**Advanced design:** fully transistorized—with important new computer design concepts that provide the largest memory, greatest problem-solving capacity and flexibility in the low- or medium-priced field. Entire system—computer, input-output typewriter and tape punch-read console—have been specially designed as a unit. **High-speed computing ability:** extra large capacity (8008 words) magnetic drum memory, with special fast access features. Computing speeds of up to 230,000 operations per minute. **Ultra high speed input-output:** 500 characters per second photoelectric punched paper tape reader, and 300 characters per second paper tape punch available as optional equipment. **Easy to use:** maximum results can be obtained by non-technical personnel. Users benefit from free training, continuing assistance, an extensive library of programs. Versatile command structure provides programming speed and flexibility. **Low in cost:** priced just above the small-scale computers, the RPC-4000 outperforms computers costing many times more. **Economical to install and**

**operate:** no site preparation, air-conditioning or special maintenance required. Plugs into any standard wall outlet. **Multiple application ability:** designed to perform engineering, scientific and research calculations, as well as business data processing and management control functions.

The RPC-4000 is a product of the Royal Precision Corporation, and is marketed by the Data Processing Division of Royal McBee. It is the latest member of the growing family of electronic computers from the people whose LGP-30 has become the world's leading small-scale computer.



**Royal Precision Corporation**

Royal Precision is jointly owned by the Royal McBee and General Precision Equipment Corporations. RPC-4000 sales and service are available coast-to-coast, in Canada and abroad through Royal McBee Data Processing offices. For full specifications, write **ROYAL MCBEE CORPORATION**, data processing division, Port Chester, N.Y.

# Undetected Errors in 5-Unit Code Transmission and Their Elimination

James F. Holmes

Lybrand, Ross, and Montgomery

New York 4, N.Y.

A great many articles are being published concerning data communications as input-output media to data processing operations. The majority of them cover high-speed communications using microwave and 6, 7, and 8 unit codes with speeds in excess of 3000 bits per second. What about the old work horse, the five-unit code for telegraphic communications up to 100 words per minute?

The five-unit, or Baudot, code has been in use for a long time. Telegraphic communications serve a definite need, especially for those who require continual communications for general as well as for data purposes and whose operations are scattered and individually not large enough to support high-speed equipment.

Admittedly, the Baudot code causes some problems, especially in detecting errors. There is, however, a solution and, wonder of wonders in this day and age, the costs of the solution are either negligible or zero. The following discussion deals with the solution to the "undetected" error problem.

The tests referred to were run by Western Union Telegraph Co. American Telephone and Telegraph has stated that they will participate in a code reassignment discussion if enough interest can be generated. Work in the area of code reassignment is now being done in Europe on the basis of a complete change. This paper proposes a code called the "L" code which appears to be the simplest and to require the least number of changes. A system will be installed in late 1960 in the United States using the "L" code.

## The 5-Unit Baudot Code

The punched paper tape 5-unit Baudot code has been in use in telegraphic communications for approximately 80 years, and has proved reliable for administrative message traffic. However, data transmission requirements in recent years have shown certain inadequacies existing with the standard Baudot code assignments.

The original assignment of codes was made on the basis that the most commonly used letters should be assigned the simplest codes. This assignment leads to some rather peculiar and interesting transmission errors. Table 1 shows a standard assignment of coding.

How will a character be changed upon the loss or gain of a single pulse? It is possible to make a schedule showing just which characters will result from a given character by the gain or loss of a single pulse.

Control codes for data transmission must be chosen very carefully, as will be noted from such a schedule.

## Errors

For example, a particular data application demonstrating unfortunate choice of control codes is the choice of M for one function and N to denote an opposite function. For instance, "M" may be used to denote manual input requiring special handling or card insertion at the data center, while "N" may denote normal input for fully automatic processing. The code for M is - - 0 0 0; the code for N is - - 0 0 -; accordingly, an "M" or "N" may be changed each to the other through the loss or gain of a single pulse (one to the other) in the standard code assignment.

More complicating errors are possible with the assignment of upper case (numeric characters). The loss or gain of a single pulse will convert

5 to 9	0 to 1 or 8
8 to 7 or 0	2 to 1
9 to 5	6 to 1
7 to 1 or 8	1 to 0, 6, 2 or 7

This is a vast array of possible numeric to numeric changes which are difficult to detect under the most ideal conditions and may in themselves produce compensating errors. The possibility of these simple changes which may be compensating has raised the demand for error-detecting devices from every quarter.

## Error Detection and Correction

The equipment manufacturers are willing and eager to produce error-detecting and error-correcting devices. Many designs are presently available and some have been marketed. However, basic economics indicate that there will be no mad rush to install such devices. Inasmuch as the

**Table 1**  
**5-UNIT CODE —**  
**STANDARD "A" CODE ASSIGNMENT**

(In the codes as shown, a "0" stands for a punched hole or a pulse and a "-" stands for no punch or no pulse.)

	Code					Meaning	
	1	2	3	4	5	Lower	Upper
						Case	Case
5 Singles:	0	-	-	-	-	E	3
	-	0	-	-	-	LINE FEED	
	-	-	0	-	-	SPACE	
	-	-	-	0	-	CAR RET	
	-	-	-	-	0	T	5
10 Doubles:	0	0	-	-	-	A	—
	-	0	0	-	-	I	8
	-	-	0	0	-	N	,
	-	-	-	0	0	O	9
	0	-	0	-	-	S	'
	-	0	-	0	-	R	4
	-	-	0	-	0	H	#
	0	-	-	0	-	D	\$
	-	0	-	-	0	L	)
	0	-	-	-	0	Z	"
10 Triples:	0	0	0	-	-	U	7
	-	0	0	0	-	C	:
	-	-	0	0	0	M	.
	0	-	0	0	-	F	!
	-	0	-	0	0	G	&
	0	0	-	0	-	J	BELL
	-	0	0	-	0	P	0
	0	-	-	0	0	B	?
	0	0	-	-	0	W	2
	0	-	0	-	0	Y	6
5 Quadruples:	0	0	0	0	-	K	(
	-	0	0	0	0	V	;
	0	0	0	-	0	Q	1
	0	-	0	0	0	X	/
	0	0	-	0	0	FIGURES	
1 Quintuple:	0	0	0	0	0	LETTERS	
1 Blank:	-	-	-	-	-	BLANK	

number of errors generated in the communications system is relatively small, some of the economic factors to consider are:

1. The human error rate in data creation is the biggest variable.
2. Communications-equipment error rate is lower than that in the conventional data-conversion equipment, such as tape-to-card converters.
3. The information transmitted is, in almost every case, accounting information made up of a vast number of individual problems. Error rates are tolerated on a conventional tabulating processing system; and the communications system does not normally introduce any appreciable change in the tolerable error rate.

Errors fall into two general categories, i.e., *detected errors*, and *undetected errors*. In communications terminology generally a detected error is one in which a character is changed to a completely invalid or non-sense character; and an undetected error is one in which a character is changed to another valid character such as numeric converted to numeric. A relatively high detected-error rate may be tolerable while an undetected-error rate of any magnitude is intolerable. If it is assumed that normal detectable transmission error rates are tolerable in present accounting applications, it then is necessary to eliminate the relatively small proportion of undetected errors.

Most available error-detecting devices require manual intervention and are generally inefficient in "line time." The system may be one in which transmission continues until an "end of block" signal indicates a check point, at which time an error may be detected, stops both the transmitter and the reperforator and, at the same time, actuates a visual and audible signal. The signal calls an operator, who manually resets the received tape to the end of the previous block, "letters out" the errored block and signals for a re-send of the errored block. This type of operation may prove satisfactory in point-to-point transmission where high utilization of equipment and circuitry is not a requirement but, in any case, it is an inefficient use of personnel, equipment and circuits and is not practicable for "switched" tape systems.

Many systems, even those large enough for switching operations, cannot afford the personnel time, equipment or circuits necessary to ensure "error free" transmissions. Frequently, private wire telegraph systems are installed for transmission of both administrative and data messages, on the theory that the data will "ride free" on previous administrative communications costs. This means high utilization of circuits, personnel, and equipment.

#### Requirements for Ideal Error Detection

The ideal error detection system for data messages on a 5-unit telegraph system, whether it be TWX, WUX, Telex or private wire, will have the following characteristics:

1. Will cost nothing
2. Will not add to line time
3. Will eliminate compensating errors
4. Will indicate all errors
5. Will provide for message reconstruction at the receive end.

#### Results of Tests

Recent studies have indicated that an error detection system is possible which will closely follow the above five requirements. These studies have shown that:

1. Ninety percent of all errors are the result of the loss or gain of a single pulse with about 88 percent being the loss of a single pulse;
2. Individual circuits exhibit a general pattern; for example, an error on a particular circuit may generally be the loss of the fifth pulse;

3. Error rates for data messages on a telegraph communications system can be as low as 1 in 500,000 characters;
4. Undetected errors are about 1 in 7 of all errors.<sup>1</sup>

The economic problems involved in providing low-cost error detecting devices, coupled with the generally low incidence of error in normal telegraphic communications, indicates that an approach other than additional equipment is needed to overcome the undetected error problem. A recent study has shown that a system does exist within the structure of the 5-unit code to reduce the undetected error rate to a maximum of 1 in 500.<sup>1</sup>

### Reassignment of Coding

In the Baudot code (Table 1), the fact that almost all errors are the result of the loss or gain of a single pulse, coupled with the 5-channel code configuration, provides an economical solution to the undetected error problem. The solution is a reassignment of coding to place all numeric characters into the 10 triples. The keyboard layout remains the same.

The coding reassignment requiring the least mechanical change is an exchange of six pairs of characters listed below:

J and R	C and I	G and Q
B and O	E and F	M and T

A calculation shows that this code reassignment would prevent the change of a numeric character to another numeric character through the loss or gain of a single pulse. Further analysis, however, shows that an exchange of vowel for vowel has also been eliminated, with the exception of a possible change of an A to U and vice versa. In order to keep the cost of mechanical coding changes to existing equipment at a minimum, it may be assumed that the elimination of the A to U possibility may be disregarded.

In order to follow through with the reduction of undetected alphabetic errors, it would be desirable to eliminate such errors as changing *full* to *fall*, *fur* to *far*, *Jun.* to *Jan.*; so it is reasonable to propose one additional subsequent coding change, A and F. A calculation then shows no change of vowel to vowel or numeric to numeric for the loss or gain of any single pulse. In other words, when an error is encountered, the proposed coding change will yield a consonant for a vowel and vice versa or, in the case of numerics, a non-sense or invalid character in place of the numeric, thus virtually eliminating compensating numerical error possibilities. Numerical errors may be easily detected in existing tape-to-card and tape-to-magnetic-tape converters, computers and other devices, using the proposed reassigned coding.

### The L Code

The actual resulting changes in the A code, producing the L code, are shown in Table 2.

The effect of the L code can be shown in an illustrative example as follows, assuming an extremely poor system with an error rate of 1 in 10,000 characters, consisting of 14 circuits operating at 75 words per minute, 9 hours per day at 90% utilization:

Condition	The A Code	The L Code
100% transmission	3,402,000 char/day	3,402,000 char/day
90% utilization	3,061,800 char/day	3,061,800 char/day
Errored characters	306 char/day	306 char/day
Undetected errors	44 char/day	0* char/day

\* (An undetected error might be expected once every 11 days on the basis of a maximum rate of 1 in 500.)

Table 2

Code	Meaning
0 - - - -	A --
- - - - 0	M .
0 0 - - -	F !
- 0 0 - -	C :
- - - 0 0	B ?
- 0 - 0 -	J BELL
- 0 0 0 -	I 8
- - 0 0 0	T 5
0 - 0 0 -	E 3
- 0 - 0 0	Q 1
0 0 - 0 -	R 4
0 - - 0 0	O 9
0 0 0 - 0	G &

The proposed reassigned coding (referred to hereinafter as "L" — for "logical" — code) is essentially a data-transmission requirement. It is not to be expected that existing 5-channel systems would be changed to the "L" code immediately or in the foreseeable future but, rather, that "off line" data conversion equipment be changed. There is, however, no reason not to install entire new systems which would use the "L" code.

Equipment is presently available which can be used "on line" for transmission in the standard code for administrative purposes and includes the use of a third shift to provide numeric data transmission in a reassigned code.<sup>2</sup>

### Loss of Complete Characters

There is an additional area of error in data transmission that is encountered in normal operation. This is the loss of a complete character, shifting data out of field without actual loss of any significant digit by such happenings as the dropping of spaces affecting the field which defines the numerical unit. For example, a 1 shifted a column to the left will be interpreted by computers or data equipment as 10.

A simple pulse generator connected to the receiving leg will keep the receiving equipment in synchronization with the previous rhythm before loss of line signal. This will maintain synchronization upon restoration of the line signal, and will insert blanks for the lost characters in the received tape. The blanks can then be detected as errors using other equipment.

The cost of the pulse generator or teleprinter synchronizing set<sup>3</sup> will be proportional to the number of start-stop pulses that must be generated upon signal loss. Equipment is presently available that will generate up to 20 start-stop pulses<sup>3</sup> but for normal day-to-day operation synchronizing equipment producing 3 to 5 start-stop pulses would be sufficient. Radio transmissions would require the higher-order teleprinter synchronizing set.

A small inexpensive pulse generator could be incorporated within the receiving unit distributor circuitry at a very minor increase in monthly rental.

The teleprinter equipment most readily adaptable to the "L" coding is the type 28 line of teleprinter equipment manufactured by the Teletype Corporation. Studies are presently under way to determine the cost of conversion of existing type 28 equipment.

Other off-line data-preparation equipment may be obtained from the manufacturer using the "L" coding at no increase in costs. Tape-to-card converters can be made adaptable to the "L" code through the plugboard.

### Summary

The "L" code will provide the following:

1. Rapid error detection
2. Possibility of message (character) reconstruction at the receiving end
3. Available at little or no cost
4. Can be transmitted on existing systems utilizing off-line equipment for data preparation
5. Will eliminate undetected errors
6. Will eliminate compensating errors
7. Does not increase line time.

The proposed adoption of the "L" code does not provide for on-line error correction, which is felt to be time consuming and uneconomical. The inclusion of teleprinter synchronizing circuitry with the receiving distributor will maintain synchronization upon loss of the line signal.

The adoption of the "L" code and inclusion of a simple teleprinter synchronization device would virtually eliminate the problems existing in transmission of data using standard teleprinter circuits and equipment.

### Notes

- 1 *Error-Checking Possibilities Concealed Within the 5-unit Code*, by R. Steeneek, *Western Union Technical Review*, Vol. 14, No. 2, April, 1960, pp. 69-71.
- 2 *Teleprinter for Reliable Transmission of Numbers*, by S. Augustin, *Electrical Communications*, Vol. 35, No. 4, 1959, pp. 245-246.
- 3 *Teleprinter Synchronizing Set SYZ-634*, by W. Schiebeler, *Electrical Communications*, Vol. 35, No. 4, 1959, pp. 247-250.

The author acknowledges with gratitude the assistance of The Western Union Telegraph Co. in obtaining test data.

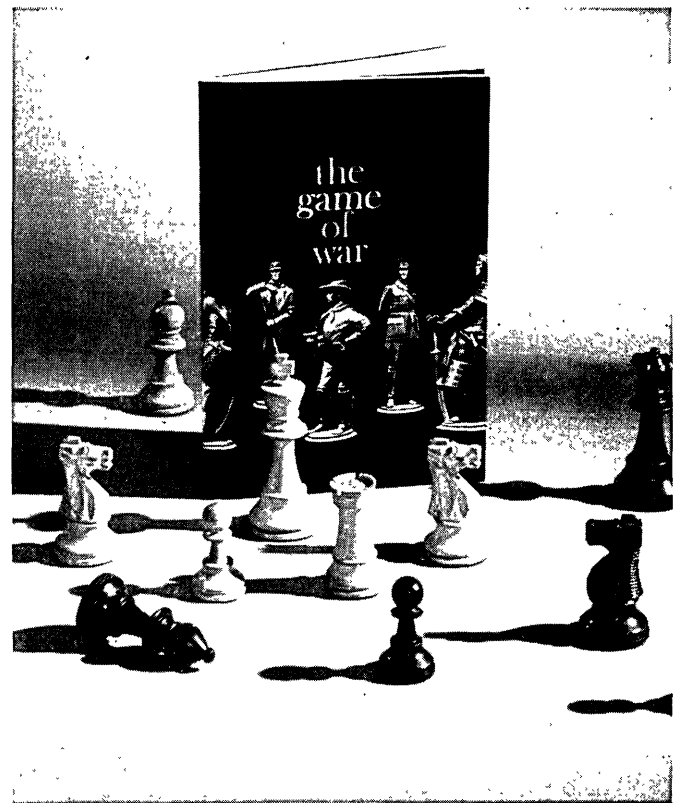

## rattling good history

"War," wrote Thomas Hardy, "makes rattling good history; but Peace is poor reading." Scientists at *Project Omega*, in Washington, taking a pioneering part in the ancient and honorable tradition of war gaming that stretches from the first chess of 3,000 years ago to modern stochastic models, are writing rattling good history in both fields, war and peace.

*Synthetic history*, they call it: the application of advanced mathematical thought, and the digital computer simulation of war or in support of map battles, have brought *Project Omega* to the frontiers of new developments in gaming, for Army, Navy, Air Force, OCDM and ARPA, as well as business and industrial sponsors.

For your free copy of THE GAME OF WAR, an illustrated history of the highlights of war gaming over 3,000 years, illustrated with authentic warriors of the periods, write to James L. Jenkins.

**Technical Operations,  
Incorporated**



3600 M Street Northwest Washington 7, D. C.

# AUTOMATION — ITS EVOLUTION AND FUTURE DIRECTION

## Part 1

James T. Culbertson, Math. Dept.  
California State Polytechnic College  
San Louis Obispo, Calif.

The term "automation" is a new word introduced about 1947 to replace the more unwieldy word "automatization." The limits to its meaning are not yet settled, but roughly speaking, any improvement in process control by automatic devices constitutes automation.

An early clear-cut example of automation is the discovery in 1713 of automatic valve control by the ingenious boy, Humphry Potter, who had the monotonous job of opening and closing the valves on a Newcomen steam engine. He found a way to fasten the valve handles to the piston rod by wires so that the valves were turned on and off at the right moments, thus replacing human control by automatic control. Later automation of the steam engine included automatic control of its speed by Watt's governor, and modern examples are too numerous and well known to be worth mention.

Ordinarily "automation" is any improvement in the control of some activity or process by non-human, i.e., automatic means, but sometimes the term is defined more narrowly. Thus some say there is no automation unless the control is based on feedback or self-correction. This would exclude many cases of automatic control, e.g., where the steps in some process are timed and sequence-controlled by, say, magnetic tape (there being no feedback except perhaps in some trivial sense); this happens in various completely automatic milling operations. Feedback is usually involved, however, both in complicated and simple cases of automatic control. Information about the output is continuously fed back into the servomechanism which corrects its output accordingly.

Another limitation on the use of the word "automation" is that sometimes it means merely "the use of electronic equipment," but this usage imposes an undesirable restriction. The precise definition is of not too much importance, however, since what actually constitutes automation is fairly well agreed upon. But we should be careful to distinguish between automation and *mechanization*, which designates a more primitive process. Likewise, mechanization is to be distinguished from the even more primitive *tool using*.

Starting at the very beginning, we may think of ten stages leading to complete automation. These are rather arbitrarily chosen and overlap considerably, but they may help give a picture of the developments leading up to the present and into the future.

### Stage 1. No Agents.

Life on the earth is believed to have started very gradually developing from the "primordial soup" about 1500

million years ago. Prior to that time there were no individuals of any kind, i.e., no agents. There was nobody doing anything.

### Stage 2. Agents but No Tools.

First complex self-perpetuating chemicals, then more and more complex viruses, bacteria, and single celled organisms arose, and there were, definitely, individuals or agents that were active or doing things. A very gradual evolution proceeded for many millions of years and animals became more and more complex. There were individuals or agents but they used no implements. There was just behavior, bodies moving around, but no artificial bodily extensions, or tools. We may be safe in believing that prior to, say, 200 million B. C. no tool was ever used except perhaps accidentally or in some trivial way.

### Stage 3. Agents Occasionally Using Tools but Never Making Tools.

As animals evolved further, their behavior became more complex and, at this stage, natural objects conveniently at hand were occasionally used as tools.

One of the most interesting present-day examples is the burrowing wasp, *Ammophila*. The female digs out a burrow, lays her eggs in it, then stings a caterpillar which she also puts in as food for the young when they hatch. She then seals the entrance with dirt, and finishes off the job by hammering down the dirt with a pebble. Here a suitable pebble is selected and definitely used as a tool.

Except for a very few cases like this, however, the use of implements by invertebrates, and in fact by any animals below the birds and mammals, seems practically non-existent.

The Darwin finches of the Galapagos Islands are persistent tool users. These birds feed on insects embedded in the bark of trees. They select cactus spines which they hold in their beaks and use to pry out their victims. If spines cannot be found, they will use other handy utensils such as twigs, which they can break off from bushes.<sup>1</sup>

Elephants sometimes break off branches with which to scratch their backs. Monkeys like to roll stones down hill on those who take too great an interest in them. Baboons throw stones at scorpions to kill them. Apes sometimes use a straw as a dining utensil, putting the end of the straw on an ant hill, waiting until a line of ants walks onto it, and then licking off the ants<sup>2</sup>. Also they use sticks to get out-of-reach objects.

"With my gun-bearer N'Gombie I crept through the bush and found eight chimpanzees — six of them al-

most full-grown — sitting in a circle at the edge of a small clearing. . . . They were making a lot of noise and kept beating and pushing each other aside, but for a time I could not see what they were up to. . . . Watching through my binoculars, I could see that the chimps were sitting round the entrance to one of these nests. Each ape held a long twig, which it poked down the hole and withdrew coated with honey. There was only one hole, and though for the most part they took turns at using their twigs, quarrels were constantly breaking out, and those who had licked off most of their honey tried to snatch the newly-coated twigs. We watched them for over half an hour at a range of fifty yards, before creeping away as silently as we had come, so as not to disturb the party. This is one of the few examples I have known of a wild animal employing a tool.”<sup>3</sup>

We need not consider, of course, the cases where domestic or captive animals are *taught* to use implements.

It is only with the evolution of man that we find any extensive use of implements. Anthropologists believe that man's ancestors became quite proficient users of ready-to-hand weapons and other implements at least ten million years before they *made* any of them.

“There is evidence suggesting that some of the early Hominidae beginning to walk upright on open ground but possessing brains no larger than typical apes, may have been anatomically well enough equipped to use tools. Insofar as they were adapted to life on the ground, they would be capable of using improvised tools and weapons, as do baboons and chimpanzees when circumstances demand. . . . The Hominidae may have remained for millions of years at the stage of occasional tool-users.”<sup>1</sup>

#### Stage 4. Agents Collecting and Using Tools but not Making Tools.

Using implements more and more frequently man's ancestors reached a point where they became collectors of sharp stones for cutting food, nice sized stones for throwing, handy sticks for clubs, and so forth. There does not seem to be any record of any tool collecting by the lower animals, except perhaps for stones in the crops of poultry and a few similar borderline cases.

#### Stage 5. Agents Making Muscle-Powered Tools.

Except for a very few extremely simple examples, there seems to be no tool making by animals. Psychologists have shown that chimpanzees sometimes have the insight to assemble a very simple implement. In one experiment two sticks are in the cage and the ape tries first one of them and then the other but neither is long enough to reach the bananas outside the cage. But one stick is hollowed out at one end so the other stick can fit into it to make one long stick. The ape discovers this and then uses the long stick to get the bananas. After doing it once, of course he does it very quickly next time, and will even chew a stick down a bit if it doesn't fit into the other one<sup>2</sup>. This is about the limit, though, of “tool making” among the apes, and animals below the apes do not seem to make any tools at all. Man is practically unique as a tool-making animal.

It has been estimated that human tool-making began about two million years ago. At first it was irregular and incidental but then about one million B.C. it became a routine daily procedure or tribal occupation.

*Stone Age.* The first artifacts were stone, and stone remained the favorite raw material for a remarkably long time. The stone age ended at different times in different places. Thus the stone age lasted until 3000 B.C. with the Greeks and until 2000 B.C. in Western Europe, while the Australian natives were still in the stone age one hundred years ago.

The first standard tool of the Old Stone Age was a large almond-shaped general-purpose implement chipped so as to fit nicely into the hand. From this primitive hand ax other more specialized implements such as scrapers, cutters, borers, and shaped and pointed flints, and the mortar and pestle gradually evolved.

Although men made only stone instruments at first, they soon used these primary tools to work other material, especially wood, into implements long before the stone age ended. Putting a wooden handle on the ax was a tremendous step forward, and then came flint-tipped spears and other utensils and weapons. Progress was extremely slow by modern standards.

In the New Stone Age (10,000 to 2,000 B.C. in Western Europe) the stone implements became polished and specialized, and also there were wooden mallets, wedges, needles, digging sticks, fire drills, paddles, ladles, shovels, boomerangs, etc. During this period the bow and arrow and the wheel were invented and hunters made rather ingenious traps and animal snares.

*Bronze Age.* Copper was the first metal to be used as a raw material. The discovery that it could be melted and poured into stone or clay molds revolutionized the tool-making industry. Tin was soon added to form bronze, which was harder and made better edged tools and weapons.

The first metal implements were made in the Near East approximately 4000 B.C.; for the Greeks the Bronze Age began about 3000 B.C. Implements of the Stone Age were re-made with bronze, and in addition there were made the first swords, picks, files, saws, oars to row with (instead of just paddles), plows, looms for weaving, potters' wheels, and a great variety of new utensils such as hair brushes, paint brushes, balances for weighing, calipers, and writing and drawing instruments. The first cities were built and man began to lead a more complicated life.

The first devices using animal power were perhaps the New Stone Age sledges, but later plows and war chariots were also animal powered.

*Iron Age.* About 1000 B.C. man learned to smelt iron ores, a very abundant raw material, and the number and variety of implements was greatly increased. For the first time there were hinged tongs, scissors, pliers, anvils for making nails, metal drills, blocks for drawing wire, planes, simple and compound pulleys, cog wheels, water screws and bucket wheels for irrigation, presses for extracting olive oil, battering rams, etc. Improvements were made in all types of implements.

*Medieval and Modern Times.* Medieval to modern times added to the muscle-powered tools and implements: improved hand presses (for printing), hand pumps (to remove water from mines), tread mills, hydraulic presses, a new type of lock and key, electrostatic machines, the obstetrical forceps and many other instruments.

All tools under discussion here are muscle-powered, though many power-driven devices, discussed in stage 6, had already been made by this time.

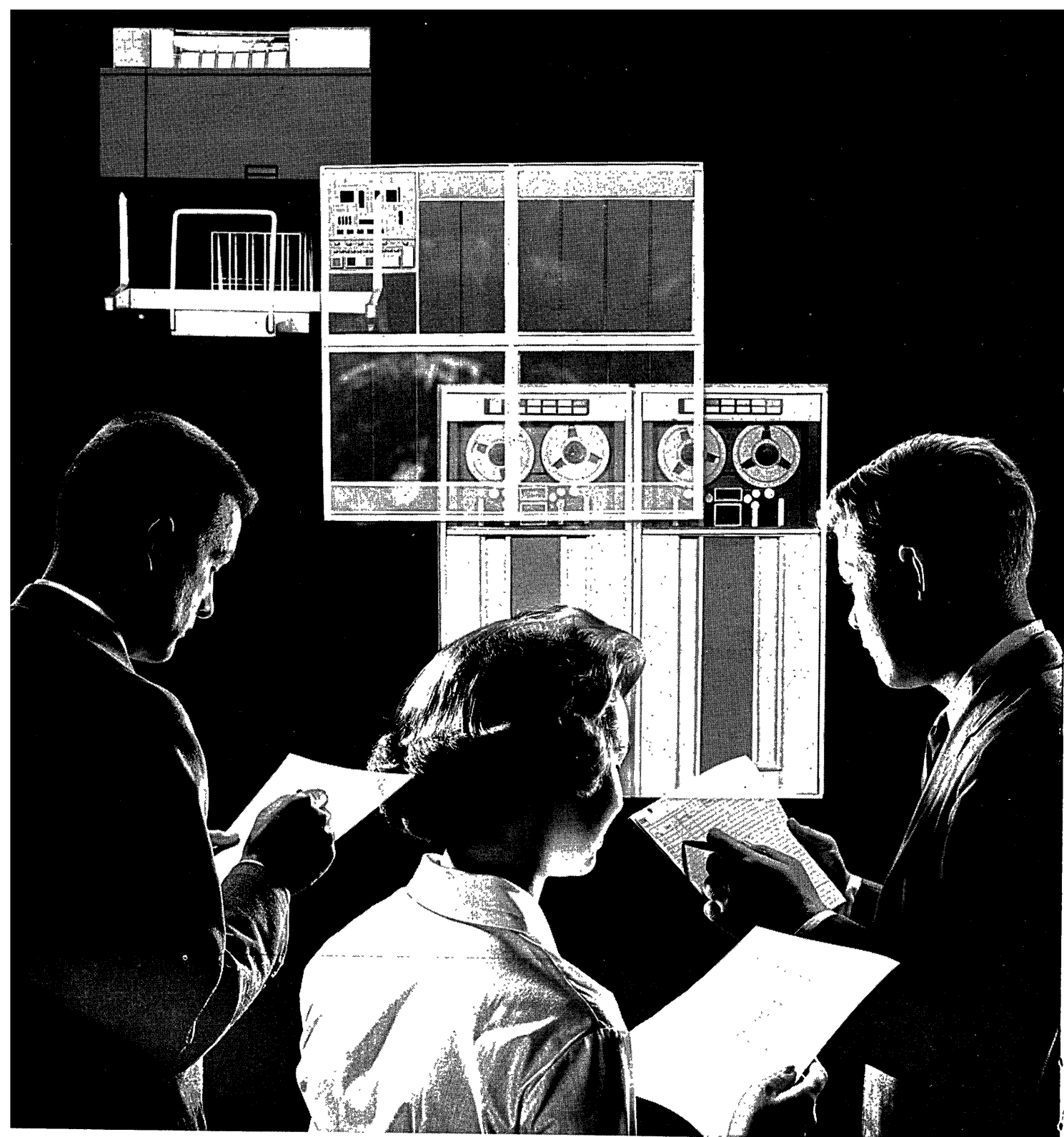

At an IBM Datacenter, customer programmers use ready-made programs to help solve data processing problems.

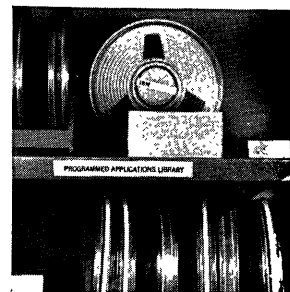

The Programmed Applications Library will make complete industry programs available.



Prog  
probl  
to IB



# 'ghost writers' for computers

*Expert IBM programmers help customers cut costs*

Working behind the scenes at IBM is an unusual group of over 300 men and women. They're specialists who develop computer instructions, or "programs."

It is what they "write" that lets you translate business and engineering language into the language that makes sense to a computer.

Programming is a demanding process. And it takes time. It took, for example, the equivalent of 45 man-years to develop the FORTRAN (FORMula TRANslator) systems which IBM released in 1957. Containing 75,000 programmed instructions, FORTRAN is *still* the most widely used system for solving scientific problems on IBM computers.

## **New system to use everyday business language**

IBM programmers are now implementing COBOL\*, the COmmon Business Oriented Language translator. This, like the IBM Commercial Translator introduced last year, is a programming system in which everyday business language becomes the language of computer instructions. The result of all these machine languages is a saving in programming costs that might easily equal 40% of a customer's data processing system investment.

## **Other methods of lowering your costs**

Every IBM customer is entitled to many programming systems on a no-cost basis. In addition to the ob-

vious advantages, use of these systems permits you to put your computer to work sooner... and frees your staff to concentrate on systems design and methods of operation, instead of on programming details.

IBM offers the largest free selection of programming systems available to industry. The list is being enlarged and the programs improved almost daily.

## **You can get 2,000 tested programs**

Many IBM customers are members of SHARE and GUIDE... progressive and independent IBM user organizations. Through these groups, they exchange experiences and ideas, and eliminate duplication of programming effort. SHARE and GUIDE members developed and contributed a large number of the 2,500 tested programs currently available through the IBM Program Library. This library is established to distribute IBM-written programs and programs contributed by IBM customers.

Your IBM Representative will help you put these programs to work. Ask him about them.

*\*This is a joint effort of computer manufacturers and users under the guidance of the Department of Defense.*

The IBM logo is centered within a large, solid black triangle that points downwards. The letters 'IBM' are in a bold, white, sans-serif font. A small registered trademark symbol (®) is located at the bottom right of the letter 'M'.

*balanced data processing*



Programming routines that translate business problems into computer language are provided to IBM customers without charge.

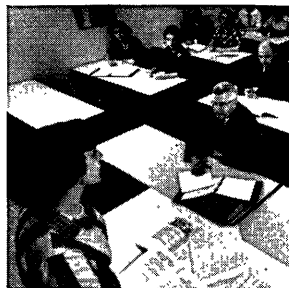

An IBM programmer teaches customers the latest programming techniques.

aplica-  
make  
pro-

The construction of muscle-powered devices continues to the present with typewriters, hand-cranked ditto machines, hand punches, bumper jacks, rotary can openers, and various other gadgets.

Many muscle-powered machines of not long ago, such as threshing machines, horse-drawn reapers and binders, pedal-driven sewing machines and lathes, hand-operated wringers, old fashioned hair clippers, and cranked adding machines have now become almost obsolete because of mechanization.

The humanly operated machines are extensions of our limbs and fingers such that our muscular power is increased or directed in some improved way. Thus the club or lever may be thought of as an extension of the arm. Likewise the needle is better than mere fingers in pushing thread through cloth, and we can mix eggs better using a hand egg beater than we can using just our fingers.

#### Stage 6. Mechanization. Driving the Tools with Non-muscular Power.

Mechanization means the use of water power, steam, electricity, or some other non-muscular force to drive tools, implements or machinery of any kind.

In some cases the power may be stored up indirectly by muscle power, as when a watch is wound by hand. Thereafter, however, it runs directly by tension in the spring and is considered an example of mechanization; similarly, for pendulum clocks wound up by lifting weights. In a previous article we discussed the history of these watches, clocks, orreries and automata.<sup>4</sup> They are relatively weak though powered cousins to the power-driven machinery of the industrial revolution.

The great age of mechanization began about 1750 in England with the first Industrial Revolution or widespread transition from muscle-powered machines to power-driven machinery, powered by water, steam and later electricity. But examples of mechanization extend back far before this. Earliest perhaps, but quite trivial, is gravity, such as rolling wagons down a hill and drifting boats down a stream. Later came a very simple but commercially important example — the discovery or invention of the sail boat during the Bronze Age.

The first full-fledged case of mechanization seems to be the water mill introduced in the Iron Age, principally for grinding grain into flour. The first primitive water wheels developed 3 or 4 hp., but the Roman engineers soon made wheels yielding up to 60 hp. The miller living by the stream became an important industrialist. A little later windmills were also used. Muscle, wind, and water however remained the only industrial prime movers until steam power was introduced. One other vital, or rather lethal, example prior to the Industrial Revolution needs to be mentioned, namely, the gun, which works on the same principle as the internal combustion engine except that instead of the piston there is a bullet. Firearms were invented about 1330.

Large factory industrialization began with some inventions in the cotton textile industry — the flying shuttle (1733), spinning jenny (1765), power loom (1780) and so forth. Since then there has been a steady increase in mechanization in all fields. Food processing plants, chemical plants, glass and bottling works, ceramic, plastics and tool-making factories, quarries, foundries, tanneries,

breweries, wineries, distilleries, dairies, printing plants, bakeries, canneries, sugar refineries, laundries, silk mills, steel mills, saw mills, paper mills, and many others became partly mechanized and then more and more mechanized. Large factories were built. For practically all industrial tools, power other than muscular could be used as the economics of the situation demanded. These developments are well known and too numerous to be worth mentioning. This mechanization was greatly enhanced by the two accompanying industrial improvements — interchangeable parts and the assembly line. Big industries arose in England, Europe and America.

The first uses of steam power for mechanization seem to be Somerset's "water commanding engine" for lifting water (1650) and Savory's steam pump for mines (1698). Newcomen's steam engine (about 1710) made 12 strokes per minute and developed about 6 hp. Later Newcomen engines had 15 inch cylinders and were rated up to 80 hp. Watt invented the modern piston and cylinder steam engine about 1760, making the first really successful one in 1780, which led to a practical locomotive in 1830 and then the steamboat. Several decades later big high-speed steam and hydraulic turbines led to large generators for the new, much handier, prime mover, electricity. Though the dynamo was invented by Faraday in 1831, there were no commercial power plants until the 1880's. First used for Edison's electric lights, these rapidly provided more and more power for industry. Before the turn of the century came gasoline and internal combustion. Now we have another very important substitute for muscular power, nuclear energy, extremely powerful and perhaps the last prime mover.

To call such prime movers "substitutes" for muscle is, of course, an understatement. They also extrapolate the muscular possibilities. No amount of muscle could throw a satellite into an orbit.

#### Stage 7. Simple Automation. Artificial Guidance or Control of Processes, Tools, or Machinery.

Automation implies replacing human observation and guidance by artificial observation and guidance. Usually automation means automatic control of power driven machinery — machines running other machines by automatic controls. Thus most cases of automation are also cases of mechanization. As is often said, mechanization replaces human brawn while automation goes a step further and replaces human brain. Mechanization and automation together can replace men by machines in industry.

Borderline cases are hard to classify. Are Hero's lamps (60 A.D.) with automatically advancing wicks examples of automation? Hero also made a heat-operated device which opened temple doors after the priest had lit the fire and closed them when the fire died out.

The Roman mileage indicator is a good example of automation. At first road distances were recorded by counting wheel-revolutions, one spoke of a chariot wheel being painted black. This was tedious and also difficult, especially with the Roman number system and a fast driver. Then about 100 A.D. they invented a famous automatic mileage indicator, so devised that one marble dropped through a hole with each revolution of the wheel. Counting marbles at the end of the trip gave the distance traveled.

[To be continued in the December issue of  
*Computers and Automation*]

Do you get  
what you pay for  
with Honeywell 800...?

...YOU  
GET  
MUCH  
MORE!

*The ability to do up to  
8 jobs simultaneously*



We say Honeywell 800 will process more data per dollar per working day than any high-speed electronic system now on any office floor (or on any drawing board). We can afford to say this, because Honeywell 800 lets you process up to 8 jobs all at once. And we're including *big, company-size* jobs — like running off a payroll, scheduling production, controlling inventory, or preparing a complete sales analysis. Each job has its own program, too. No complicated system of priorities or costly super-program is needed. In a way, you get up to 8 individual computers to work with.

You can see how this versatility (we call it Automatic Parallel Processing) cuts operating time and costs to the bone. To find out more about this Automatic Parallel Processing and many other design "firsts" built into Honeywell 800, just write Minneapolis-Honeywell, Datamatic Division, Wellesley Hills 81, Mass.

**Honeywell**



*Electronic Data Processing*

# Readers' and Editor's Forum

## FRONT COVER: DIGITAL COMPUTER DEMONSTRATOR

The front cover shows a "digital computer demonstrator," in a lucite case, for use in schools, lecturing, etc. It is able to add, subtract, multiply, and divide in the binary number system. It does not have a memory; it has a single input. The theory and procedure are explained in a manual. Total weight, 12 pounds; power consumption, about 5 watts; size, 19" by 19" by 13". It is made by Aironics, Inc., Hialeah, Fla.

## DAEDALUS: "COMPLETE-THE-SQUARE" COMPUTER — CORRECTION

S. F. Grisoff  
Poughkeepsie, N.Y.

With reference to the article on page 8B of the August 2 issue, "Daedalus: Complete-the-Square Computer" I wish to point out an erroneous statement made.

The last statement says that "a skilled human player can outplay the machine — especially if he has the first move." This is not so. In this game with four dots on a side, it can be proved that the *second* player has a strategy which will assure him getting the majority of points (five in this case). Furthermore, the proof can be extended to the game with  $n$  dots on a side ( $n \geq 2$ ), and in this case the second player is *assured* either of  $\frac{[(n-1)^2 + 1]}{2}$  points (a majority) if  $n$  is even, or of  $\frac{(n-1)^2}{2}$  points (exactly half) if  $n$  is odd. Note that these are his minimum scores using his optimal strategy, and if the first player does not play exactly right, the second player may get many more.

The optimal strategy mentioned is simply that the second player moves circularly symmetric to the first player's last move. The results of this are obvious.

The optimal strategy for the first player is to sacrifice a box immediately putting the burden of play on the second player. However, he can never make up that box. If he does not do this he will lose more than he should.

## FOUR PREFIXES FOR SIZES

Frank Leary  
Associate Editor, Electronics  
McGraw-Hill Publishing Co.  
New York, N.Y.

In connection with your glossary of terms, the scientific community, urged by the National Bureau of Standards, is adopting four new prefixes:

pico- for  $10^{-12}$ , related to the printer's term *pica*, meaning "a point," and probably related to the French *pic*, a point  
nano- for  $10^{-9}$ , from the Greek *nanos*, "a dwarf"  
giga- for  $10^9$ , from the Latin *gigas*, "a giant"  
tera- for  $10^{12}$ , from the Greek *teras*, "a monster"

## FIRST INTERNATIONAL CONFERENCE ON AUTOMATIC CONTROL: PICTURE

I. From O. Hugo Schuck  
Director of Research  
Minneapolis Honeywell Regulator Group  
Minneapolis 40, Minn.

I am greatly impressed with the picture on the front cover of your September, 1960, issue of *Computers and Automation*. It is the best I have seen of the plenary session of the IFAC Congress, which I attended as a U.S. delegate.

The picture I took is not nearly so good, nor wide angle, and I would much like to get a copy of yours. Will you please advise what you can do to make my record more complete, as I use it to give talks to various interested community groups?

## II. From The Editor

I am glad that you liked the picture on the front cover of the September 1960 issue of *Computers and Automation*. This picture came to us from the Press Department of the Soviet Embassy, Washington, D.C.; as a matter of fact it was assembled from two pictures. I would suggest that you ask them for prints of the two photographs from which our front cover was made, and I feel sure that they will cooperate with you and give you prints.

## THE SOCIAL RESPONSIBILITIES OF COMPUTER PEOPLE — REPORTS AND DISCUSSIONS AT THE MEETING OF THE ASSOCIATION FOR COMPUTING MACHINERY, AUGUST, 1960

(Part 2)

(Continued from the October 1960 issue of *Computers and Automation*, page 32)

## THE SOCIAL RESPONSIBILITIES OF COMPUTER PEOPLE AND PEACE ENGINEERING

Edmund C. Berkeley  
(Condensed Report)

The president of a large eastern college said the other day to a friend of mine, a professor there, "I think your

suggestion of having a Peace Engineering Group of 30 or 40 people here at the university is excellent. I should like for it to be started. We are doing so much work here connected with defense purposes and with government purposes in general that I think a Peace Engineering Group would be desirable, so as to balance the situation."

This incident struck me as a very good indication of what is happening in this country. I think the argument about the necessity for peace is just about won. The deterrent of modern weapons has become so great that no rational country dares to resort to war. The United Nations is increasingly encouraged to intervene, work, and conciliate so as to avoid war. Many people in the U.S. government and many people all through the United States, I believe, have concluded that peace is necessary, and believe that it is possible to achieve peace, and to remove the threat of nuclear death for everybody in the world, via a process of controlled disarmament with inspection.

The change in the underlying opinion of the country — as reflected by that college president — is particularly important because it contradicts a good deal of what passes for news in the headlines of newspapers.

With regard to the duties, responsibilities, and professional capacities of people in the computer field, we are arriving at the new area of application: controlled disarmament with inspection; conversion from war industry to peace industry. This greatly enlarges the territory in which computers can be applied.

In the July issue of "Computers and Automation" appeared an article "Computers and Data Processing in a National Peace Agency." The bulk of this article was verbatim reproduction of a bill, HR9305, calling for a National Peace Agency, and indicates a number of new areas for the application of computers and data processing.

One of the specific provisions: "The Agency shall undertake programs to carry out the purpose of this act, including among others, programs . . . for development and application of communications and advanced computer techniques for analyzing the problems involved in inspection of national budgets and economic indicators as they bear upon disarmament inspection systems."

Computer people may be expected to see the importance of devoting some of their time, energy, and professional capacity to the applications of computers and data processing in peace engineering. This is a good objective for computer people eager to make contributions to the social benefits of computers and data processors.

### THE "HALL OF DISCUSSION"

Because of interest at the end of the first meeting, it was decided to hold a "hall of discussion" on the following evening. Among the topics discussed or scheduled for discussion that evening were the following:

1. Is it possible to define a code of ethics applicable to the social responsibilities of computer people, independently of any religious considerations?

In the discussion on this question, the view was expressed by one of the invited speakers that, independent of any belief in God or the immortality of the human soul, it was necessary to be concerned about the responsibilities of people to society. However, it was also suggested that a system of fully effective ethics should necessarily start from

or be based on a belief in God and the sacredness of the human soul; otherwise it might limp.

2. Should a salesman for a computer manufacturer tell all the truth and nothing but the truth?

3. If a computer manufacturer knows that his computer is going to become obsolete before very long, should he say this to a prospect for a computer?

4. Do computer people have special responsibilities to make known to non-computer people the powers of computers and their limitations? Are computer people especially responsible for avoiding exaggeration about computers and data processors? In cases where different computer people hold different views about the powers of computers, should there be a way of settling these views, so that the press and the public are not unduly disturbed?

It might be desirable to have a permanent public relations committee in the Association for Computing Machinery. The function of such a committee would be to help members of the press and other non-computer people to understand what computers can and cannot do, and over the next five or ten years, may or may not do — so that alarmist reactions among readers of newspapers and other magazines can be avoided.

5. What will be the social impacts of data processing and computers on people who will be displaced from their jobs as a result of computers? What can computer people do to soften or modify these social impacts?

6. The Soviet Union is planning to use computers in the operation of a planned economy, and this may lead to considerable advantages for the Soviet Union. Should the

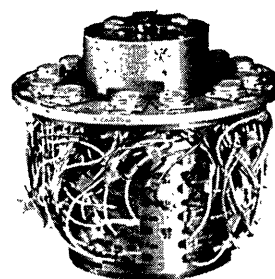

**WHEELER  
FAIRCHILD INC.**

**MAGNETIC**

**STORAGE DRUMS**

A 6" drum, 100 tracks, 150 heads, 3600 RPM, stores 500,000 bits Manchester, overall size 10" x 12" with sealed cover. Designed to Military specifications. Similar to drum delivered to Naval Ordnance Test Station. Some other customers include Link Aviation, Norden, Burroughs Corp., Stanford Research Institute.

**A LEADING MANUFACTURER OF HIGH QUALITY  
DATA STORAGE DRUMS SINCE 1951**

**WHEELER - FAIRCHILD, INC.**

610 So. Arroyo Parkway

Pasadena, Calif.

Murray 1-6721

United States make use of computers for auxiliary planning of the economy of the United States?

7. What is likely to be the impact of computers on industry as instruments of control here and there in the management of industry?

8. Computers and data processors are being used in intelligence operations. We can foresee a time when a vast computing or data processing system will have information on every person in the country, as a part of intelligence operations. This is likely to interfere with the personal privacy of individuals. What should we advocate in regard to this question?

9. When a computer provides numbers, answers, or decisions — "Multivac says . . ." — does this lead to less personal responsibility and personal judgment? Is there a tendency to take refuge in the verdict of a computer in regard to a difficult question?

## CHANGES IN COMMERCIAL COMPUTERS ANTICIPATED IN COMING YEARS

I. From C. G. Stiefvater  
Bridgeport, Conn., October 3, 1960

We are trying to ascertain what will be the future trends or innovations in electronic data processing equipment. In order to establish valid indicators, we are contacting knowledgeable people in this field to obtain their ideas or opin-

ions. If possible for you to do so, would you please tell us if your organization has done any research in the following areas:

1. The changes in commercial computers which are anticipated in the coming years.
2. The future impact of different-size computers and the market composition of such equipment.
3. The factors affecting the short-term and long-term growth of computers.

We would appreciate any information which you could provide in these areas. We will have to wrap up the study by the week of October 10, and any prompt consideration you can give to this matter would be quite beneficial.

## II. From the Editor

Nearly everything which we find out is published in the pages of *Computers and Automation*. We would suggest that you look through the last dozen issues of *Computers and Automation*, and the indexes of the last few years (usually published in the January issue), and after you have done this, if you ask us any specific questions which you may have, we shall be glad to try to answer them.

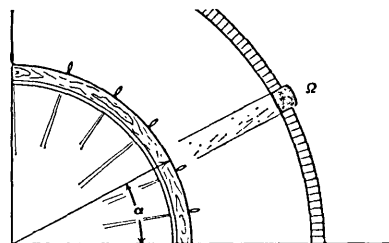

## COMPUTER SERVICES

You can solve your computer problems quickly and economically by using our 32K-word storage IBM 704. Whether you need long or short runs, they can be readily scheduled on our machine at the same attractive rate for every shift—**\$275 per hour**, including all peripheral equipment and operators.

Bring your program and work in our Client's Room between runs—Or mail us your program with instructions for running it and we will mail back the printout within 24 hours—Or simply leave your entire problem in the hands of our capable mathematical analysts and programmers.

If you need pipe stress, structural stress, flow analysis, or curve fitting, one of our general programs might well be just what you are looking for.

To use our prompt, efficient computer services, write or call us collect, Hilltop 5-4321, extension 1449.

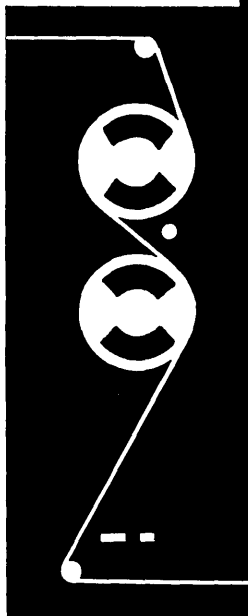

**ELECTRIC BOAT** GROTON, CONNECTICUT  
A DIVISION OF **GENERAL DYNAMICS**

## STATEMENT OF OWNERSHIP AND MANAGEMENT OF COMPUTERS AND AUTOMATION

*Computers and Automation* is published 13 times a year (monthly except 2 issues in June) at Boston, Mass.

1. The names and addresses of the publisher, editor, managing editor, and business manager are:

Publisher, Berkeley Enterprises, Inc., 815 Washington St., Newtonville 60, Mass.

Editor, managing editor, and business manager, Edmund C. Berkeley, 34 Otis St., Newtonville 60, Mass.

2. The owner is: Berkeley Enterprises, Inc., 815 Washington St., Newtonville 60, Mass.

Stockholders holding one percent or more of the stock are:

Edmund C. Berkeley, 34 Otis St., Newtonville 60, Mass.

Max S. Weinstein, 25 Highland Drive, Albany 3, N.Y.

3. The known bondholders, mortgagees, and other security holders owning or holding one percent or more of the total amount of bonds, mortgages, or other securities are: None.

Edmund C. Berkeley, Editor

SWORN TO and subscribed before me, a notary public in the Commonwealth of Massachusetts, on September 23, 1960.

Esther W. McHugh, Notary Public

My commission expires October 31, 1964.

# CALENDAR OF COMING EVENTS

- Oct. 31-Nov. 2, 1960: 13th Annual Conference on Elec. Techniques in Medicine and Biology, Sheraton Park Hotel, Washington, D.C.; contact G. N. Webb, Rm. 547, CSB, Johns Hopkins Hosp., Baltimore 5, Md.
- Oct. 31 — Nov. 4, 1960: 7th Institute of Electronics in Management, featuring Current Developments in Automatic Data Processing Systems, American University, Washington, D.C.; contact Dr. Lowell H. Hattery, Director, 7th Inst. on Electronics in Management, The American University, 1901 F St., N. W., Washington 6, D.C.
- Nov. 5, 1960: Meeting of the Society for Industrial and Applied Mathematics, Univ. of Pennsylvania, Physical Sciences Bldg., 33rd & Chestnut Sts., Philadelphia, Pa.; contact Dean Gillette, Bell Telephone Laboratories, Inc., Whippany, N. J.
- Nov. 15-17, 1960: Northeast Research & Engineering Meeting (NEREM), Commonwealth Armory & Sheraton Plaza Hotel, Boston, Mass.; contact J. H. Mulligan, Jr., Dept. of EE, NYU, New York 53, N.Y.
- December 13-15, 1960: Eastern Joint Computer Conference, New Yorker Hotel, New York City; contact Dr. Nathaniel Rochester, IBM, Yorktown Heights, N.Y.
- Jan. 16-19, 1961: ISA Winter Instrument-Automation Conference & Exhibit, conference at Sheraton-Jefferson Hotel, exhibit at Kiel Auditorium, St. Louis, Mo.; contact William H. Kushnick, Exec. Dir., ISA, 313 Sixth Ave., Pittsburgh 22, Pa.
- Feb. 1-3, 1961: Winter Convention on Military Electronics, featuring Communications, Telemetry, Data Handling and Display, Los Angeles, Calif.; contact Dr. John J. Meyers, Hoffman Electronics Corp., Military Products Div., 3717 S. Grand Ave., Los Angeles 7, Calif.
- Feb. 15-17, 1961: International Solid State Circuits Conference, Univ. of Pa. and Sheraton Hotel Philadelphia, Pa.; contact Jerome J. Suran, Bldg. 3, Rm. 115, General Electric Co., Syracuse, N. Y.
- Mar. 20-23, 1961: IRE International Convention, Coliseum and Waldorf-Astoria Hotel, New York, N. Y.; contact Dr. G. K. Neal, IRE, 1 E. 79 St., New York 21, N. Y.
- April, 1961: Joint Automatic Techniques Conference, Cincinnati, Ohio; contact J. E. Eiselein, RCA Victor Div., Bldg. 10-7, Camden 2, N.J.
- Apr. 19-21, 1961: S. W. IRE Reg. Conf. and Elec. Show, Dallas, Tex.; contact R. W. Olson, Texas Instruments Co., 6000 Lemmon Ave., Dallas 9, Tex.
- May 2-4, 1961: Electronic Components Conference, Jack Tar Hotel, San Francisco, Calif.
- May 7-8, 1961: 5th Midwest Symposium on Circuit Theory, Univ. of Ill., Urbana, Ill.; contact Prof. M. E. Van Valkenburg, Dept. EE, Univ. of Illinois, Urbana, Ill.
- May 9-11, 1961: Western Joint Computer Conference, Ambassador Hotel, Los Angeles, Calif.; contact Dr. W. F. Bausier, Ramo-Wooldridge Co., 8433 Fallbrook Ave., Canoga Park, Calif.
- May 22-24, 1961: National Telemetering Conference, Chicago, Ill.
- May 22-24, 1961: Fifth National Symposium on Global Communications (GLOBECOM V), Hotel Sherman, Chicago, Ill.; contact Donald C. Campbell, Tech. Program Comm., I.T.T.—Kellogg, 5959 S. Harlem Ave., Chicago 38, Ill.
- June, 1961: Joint Automatic Control Conference, Univ. of Colorado, Boulder, Colo.; contact Dr. Robert Kramer, Elec. Sys. Lab., M.I.T., Cambridge 39, Mass.
- July 16-22, 1961: 4th International Conf. on Medical Electronics & 14th Conf. on Elec. Tech. in Med. & Bio., Waldorf Astoria Hotel, New York, N.Y.; contact Dr. Herman P. Schwan, Univ. of Pa., School of Electrical Eng., Philadelphia, Pa.
- Aug. 22-25, 1961: WESCON, San Francisco, Calif.; contact Business Mgr., WESCON, 1435 La Cienega Blvd., Los Angeles, Calif.
- Sept. 6-8, 1961: National Symposium on Space Elec. & Telemetry, Albuquerque, N.M.; contact Dr. B. L. Basore, 2405 Parsifal, N.E., Albuquerque, N.M.
- Sept. 6-8, 1961: International Symposium on the Transmission and Processing of Information, Mass. Inst. of Technology, Cambridge, Mass.; contact Peter Elias, RLE, MIT, Cambridge 39, Mass.
- Sept. 6-8, 1961: 1961 Annual Meeting of the Association for Computing Machinery, Statler Hotel, Los Angeles, Calif.; contact Benjamin Handy, Chairman Local Arrangements Committee, Litton Industries, Inc., 11728 W. Olympic Blvd., W. Los Angeles, Calif.
- Sept. 11-15, 1961: The Third International Congress on Cybernetics, Namur, Belgium; contact Secretariat of The International Association for Cybernetics, 13, rue Basse Marcelle, Namur, Belgium.

Make over 200 Small  
Computing and Reasoning  
Machines with . . .

# BRAINIAC

## ELECTRIC BRAIN CONSTRUCTION KIT, 1960 MODEL

WHAT COMES WITH YOUR BRAINIAC® KIT? All 33 experiments from our original Geniac® kit (1955), with exact wiring templates for each one. All 13 experiments from the former Tyniac kit. 156 entirely new experiments (Brainiacs) with their solutions. Over 600 parts, as follows: 6 Multiple Switch Discs; Mounting Panel; 10 Flashlight Bulbs; 2 Multiple Socket Parts, each holding 5 bulbs; 116 Wipers, for making good electrical contact (novel design, patented, no. 2848568); 70 Jumpers, for transfer contacts; 50 feet of Insulated Wire; Flashlight Battery; Battery Box; nuts, bolts, sponge rubber washers, hard washers, screwdriver, spintite blade, etc. ALSO: 256 page book, "Brainiacs" by Edmund C. Berkeley, including chapters on: an introduction to Boolean Algebra for designing circuits; "How to go from Brainiacs and Geniacs to Automatic Computers"; complete descriptions of 201 experiments and machines; over 160 circuit diagrams; list of references to computer literature.

This kit is an up-to-the-minute introduction to the design of arithmetical, logical, reasoning, computing, puzzle-solving, and game-playing circuits—for boys, students, schools, colleges, designers. It is simple enough for intelligent boys to assemble, and yet it is instructive even to engineers, because it shows how many kinds of computing and reasoning circuits can be made from simple components. This kit is the outcome of 11 years of design and development work with Geniacs and small robots by Berkeley Enterprises, Inc. With this kit and manual you can easily make over 200 small electric brain machines that display intelligent behavior and teach understanding first-hand. Each one runs on one flashlight battery; all connections with nuts and bolts; no soldering required. (Returnable for full refund if not satisfactory.) . . . Price \$18.95

### WHAT CAN YOU MAKE WITH A BRAINIAC KIT?

#### LOGIC MACHINES

Syllogism Prover  
James McCarty's Logic Machine  
AND, OR, NOT, OR ELSE, IF . . . THEN, IF AND ONLY  
IF, NEITHER . . . NOR Machines  
A Simple Kalin-Burkhart Logical Truth Calculator  
The Magazine Editor's Argument  
The Rule About Semicolons and Commas  
The Farnsworth Car Pool

#### GAME-PLAYING MACHINES

Tit-Tat-Toe  
Black Match  
Nim  
Sundorra 21  
Frank McChesney's Wheeled Bandit

COMPUTERS — to add, subtract, multiply, divide, . . . ,  
using decimal or binary numbers.  
— to convert from decimal to other scales of notation and  
vice versa, etc.

Operating with Infinity  
Adding Indefinite Quantities  
Factoring Any Number from 45 to 60  
Prime Number Indicator for Numbers 1 to 100  
Thirty Days Hath September  
Three Day Weekend for Christmas  
Calendar Good for Forty Years 1950 to 1989  
Money Changing Machine  
Four by Four Magic Square  
Character of Roots of a Quadratic  
Ten Basic Formulas of Integration

#### PUZZLE-SOLVING MACHINES

The Missionaries and the Cannibals  
The Daisy Petal Machine  
Calvin's Eenie Meenie Minnie Moe Machine  
The Cider Pouring Problem  
The Mysterious Multiples of 76923, of 369, etc.  
Bruce Campbell's Will  
The Fox, Hen, Corn, and Hired Man  
The Uranium Shipment and the Space Pirates  
General Alarm at the Fortress of Dreadeerie  
The Two Suspicious Husbands at Great North Bay

The Submarine Rescue Chamber Squalux  
The Three Monkeys Who Spurned Evil  
Signals on the Mango Blossom Special  
The Automatic Elevator in Hoboken  
Timothy's Mink Traps  
Josephine's Man Trap  
Douglas Macdonald's Will  
Word Puzzle with TRICK

#### QUIZ MACHINES

The Waxing and the Waning Moon  
Intelligence Test  
Guessing Helen's Age  
Geography Quiz  
Mr. Hardstone's Grammar Test  
Solving Right Triangles

#### SIGNALING MACHINES

The Jiminy Soap Advertising Sign  
The Sign that Spells Alice  
Tom, Dick, and Harry's Private Signaling Channels  
Jim's and Ed's Intercom

#### CRYPTOGRAPHIC MACHINES

Secret Coder  
Secret Decoder  
Lock with 65,000 Combinations  
Lock with 15,000,000 Combinations  
The General Combination Lock  
Leonard's Two-Way Coding Machine

### . . . AND MANY MORE

MAIL THIS REQUEST or a copy of it ..

Berkeley Enterprises, Inc.  
815 Washington Street, R149, Newtonville 60, Mass.

Please send me BRAINIAC KIT K18, including manual,  
instructions, over 600 parts, templates, circuit diagrams, etc.

I enclose \$18.95 for the kit plus ..... for handling and  
shipping (30c, east of Mississippi; 80c, west of Mississippi;  
\$1.80, outside U.S.). I understand the kit is returnable in  
seven days for full refund if not satisfactory (if in good  
condition).

My name and address are attached.



# BOOKS and OTHER PUBLICATIONS

Moses M. Berlin  
Cambridge, Mass.

**W**E PUBLISH HERE citations and brief reviews of books and other publications which have a significant relation to computers, data processing, and automation, and which have come to our attention. We shall be glad to report other information in future lists if a review copy is sent to us. The plan of each entry is: author or editor / title / publisher or issuer / date, publication process, number of pages, price or its equivalent / comments. If you write to a publisher or issuer, we would appreciate your mentioning Computers and Automation.

Ulam S. M. / *A Collection of Mathematical Problems* / Interscience Publishers, Inc., 250 Fifth Ave., New York 1, N. Y. / 1960, printed, 150 pp, \$5.00

This is an advanced book stating problems from the following branches of mathematics: Set Theory, including infinite sets and projective algebras; Algebra; Metric Spaces; Topological Spaces; Topological Groups; and Analysis; Physical Systems; and, Computing Machines as a Heuristic Aid. "The problems listed are regarded as unsolved in the sense that the author does not know the answers." The author reports on using computing machines for checking intelligent guesses in mathematical physics, combinatorial analysis, number theory, etc. A bibliography is included.

Reifler, Erwin, W. Ryland Hill, David L. Johnson, and others / *Linguistic and Engineering Studies in Automatic Language Translation of Scientific Russian into English* / University of Washington Press, Seattle 5, Wash. / 1960, printed, 658 pp., \$10.00

A summary of the fundamental problems, procedures and achievements of a lexicographical research project to establish an automatic system for machine translation other than the electronic computer systems previously used, is presented. In two parts, *Linguistic Analysis and Engineering Analysis*, the report includes: an outline of the project; the selected Russian texts used; the use of the IBM 650 computer for the study of syntax; dictionary card processing procedures; and five appendices consisting mainly of research papers. Two of the appendices are entitled "A Coding and Operational Program for Machine Translation Using a High-Capacity Optical Memory", and "The Design of a Practical Russian-English Mechanical Translator".

Young, J. Z. / *Doubt and Certainty in Science — A Biologist's Reflections on the Brain* / Galaxy Book Series, Oxford University Press, New York, N. Y. / 1960, printed, 168 pp, \$1.50

A part of this book, first published in 1951, is devoted to a discussion of memory stores — of the human being and of the machine. The author couples this part with some opinions on the framework of society, and the interconnection between the human nervous system and the electronic system of computers. The text was first presented as eight lectures; the book also contains a list of references and an index.

Diamond, Solomon / *Information and Error* / Basic Books, Inc., 59 Fourth Ave., New York 3, N. Y. / 1960, printed, 307 pp, \$5.00

The aim of this book is to provide a student of psychology who does not have much mathematical preparation with information about the level of statistics which is of importance in the study of psychology. The text, with examples, analogies, style, and humor, serves as an introduction to statistical analysis, including, in thirteen chapters, variance, probability, proportions, chi-square, product moment correlation, factor analysis and a discussion on handling nonnormal data, etc. An appendix includes tables. A glossary of symbols, a list of formulas, and an index are included.

Alt, Franz L., editor; Calvin Gotlieb, N. A. Phillips, Y. Bar-Hillel, A. C. Samuel, R. Fatehchand, G. W. Reitwiesner, contributors / *Advances in Computers* / Academic Press, Inc., 111 Fifth Ave., New York 3, N. Y. / 1960, printed, 316 pp, \$10.00.

This is the first volume of a series reporting progress; this book contains six important, full surveys on the following topics: General-Purpose Programming for Business Applications; Numerical Weather Prediction; The Present Status of Automatic Translation of Languages; Programming Computers to Play Games; Machine Recognition of Spoken Words; and Binary Arithmetic. Lists of references, subject index, and name index are included.

*Information Processing: Proceedings of the International Conference on Information Processing Unesco, Paris, 15-20 June 1959* / UNESCO Publications Center, 801 Third Avenue., New York 22, N. Y. / 1960, printed, 520 pp, \$25.00.

This large book (12" by 9", in small print) publishes the complete proceedings of the conference, giving 61 papers (in English or French), preceded by summaries in English, French, German, Russian, and Spanish, and completed by reports of the discussion. In addition, there are summaries in English or French, of the 65 lectures given at various specialized meetings. The seven divisions are: Methods of Digital Computers, Common Symbolic Language for Computers, Automatic Translation of Languages, Pattern Recognition and Machine Learning, Logical Design of Computers, Special Session on Computer Techniques of the Future, and Miscellaneous Topics. A subject index and a list of participants are included.

Flagle, Charles D., William H. Huggins, Robert H. Roy / *Operations Research and Systems Engineering* / The Johns Hopkins Press, Baltimore 18, Md. / 1960, printed, 889 pp, \$14.50.

This book is a compendium on the meaning, use, and importance of the fields of operations research and systems engineering. The first part of the book, "Perspectives," includes seven papers which discuss the background and history relating to the development of these fields; part two, "Methodologies," contains sixteen papers including, "Simplified Models in Operations Research," "Electronic Digital Computers," and, "System Dynamics"; part three, "Case Studies," contains four papers and includes "Simulation of Tactical War Games." Index.

Ivall, T. E. / *Electronic Computers — Principles and Applications, Second Edition* / Philosophical Library, Inc., 15 East 40 St., New York 16, N. Y. / 1960, printed, 263 pp, \$15.00.

The major part of this book is devoted to discussions and descriptions of the circuitry and construction of digital and analog computers. Following the discussions, applications are enumerated. Among the fourteen chapters are: "Evolution of the Computer," "General Principles of Computing," "Recent Developments," and "Computers of the Future," Index.

Booth, Andrew D., editor / *Progress in Automation* / Academic Press, Inc., 111 Fifth Ave., New York 3, N. Y. / 1960, printed, 231 pp, \$8.50.

In this first volume of a series on automation in Great Britain, an introduction by the editor and ten papers on related topics are given. Among the papers, are: "Analogue-to-Digital Conversion Techniques," "Application of Electronics to Process Control Systems," "The Ferranti System of Machine Tool Control," and, "The E. M. I. System of Machine Tool Control." A name index and subject index are included.

Langer, Rudolph E., editor / *Frontiers of Numerical Mathematics* / The University of Wisconsin Press, 811 State St., Madison, Wisconsin / 1960, photo-offset, 132 pp, \$3.50.

Eight invited papers were delivered at a Symposium conducted by the Mathematics Res. Center, U. S. Army, and the Nat'l. Bureau of Standards. The objective of this symposium was to survey the future and identify some of the mathematical problems which will have to be faced in the lines of scientific advance. The eight speakers were asked to outline the impending mathematical tasks as they saw them. Eighteen invited discussants also took part in the symposium, and the discussions of the papers are also reported.

The titles of the papers and the authors are: Stress Analysis in the Plastic Range, William Prager; Some Mathematical Problems of Nuclear Reactor Theory, Garrett Birkhoff; Numerical Problems of Contemporary Celestial Mechanics, Zdenek Kopal; Aeroelasticity, Lee Arnold; Operations Research, Philip M. Morse; Mathematical Bottlenecks in Theoretical Chemistry, J. O. Hirschfelder; Magneto-hydrodynamics, S.

# THE COMPUTER DIRECTORY AND BUYERS' GUIDE 1960

6th Annual Issue,

the only directory in the  
computer field,  
a regular issue of  
**Computers and Automation**

## CONTENTS:

Part 1, ROSTER OF ORGANIZATIONS. Each entry gives:

Name of organization / Address / Telephone number / Types of computers, data processors, accessories, components, services, etc., produced or offered / Approximate number of employees / Year organization was established

(over 700 organization entries)

Part 2, BUYERS' GUIDE: ROSTER OF PRODUCTS AND SERVICES. Each expanded bold-face entry gives:

Name or identification of product or service / Brief description (20 to 50 words) / Uses / Price range, between . . . and . . .

Other entries are cross-references.

(Over 2000 product and service entries in total)

This is your indispensable guide to organizations, products, and services in the computer field — useful to you the whole year.

Send for your own copy now —

## MAIL THIS COUPON

(or a copy of it)

To: Computers and Automation  
815 Washington St., R149  
Newtonville 60, Mass.

Please send us a copy of the 1960 Computer Directory. We enclose \$6.00. Returnable in 7 days for full refund if not satisfactory.

Name .....

Title .....

Organization .....

Address .....

Chandrasekhar, The Solution of Systems of Partial Differential Equations Arising in Meteorology, J. Smagorinsky.

Vajda, S. / An Introduction to Linear Programming and the Theory of Games / John Wiley & Sons, Inc., 440 Fourth Ave., New York 16, N. Y. / 1960, printed, 76 pp, \$2.25.

Part I of this book includes seven chapters on linear programming — an introduction, information about graphical representation, the simplex method, duality, etc. Appendix I presents a proof of the Fundamental Theorem of Duality. Part II of the book on Game Theory includes short chapters on fundamental concepts, graphical representation, non-zero-sum games, and infinite games. Appendix II presents a proof of the so-called Main Theorem of the Theory of Games. Index.

Haley, A. C. D., and W. E. Scott, editors, and 7 more authors / Analogue and Digital Computers / Philosophical Library, Inc., 15 East 40 St., New York 16, N. Y. / 1960, printed, 308 pp, \$15.00.

This book presents basic information on the design and construction of analog and digital computing systems. The ten chapters include: Introduction to Computers; Operation and Applications of Analogue Computers; Number Representation in Digital Computers; Operation of a Digital Computer; Circuit Elements and Computer Units; Storage; Programming. Index.

Bibbero, Robert J. / Dictionary of Automatic Control / Reinhold Pub. Corp., 430 Park Ave., New York 22, N. Y. / 1960, printed, 282 pp, \$6.00.

This dictionary of automatic control terminology includes, besides definitions, a condensed discussion of each term. The subjects included are: control theory and basic concepts; computers and data processing; industrial machine and process control; aircraft and missile control and telemetering; and control components and design factors. A classified index supplements the regular alphabetic listing, classifying terms under the five main subjects.

Félix, Lucienne / The Modern Aspect of Mathematics / Basic Books, Inc., 59 Fourth Ave., New York 3, N. Y. / 1960, printed, 194 pp, \$5.00.

The "revolution" in mathematics, led by the fictional Nicolas Bourbaki, is chronicled in this book. The authoress, who is in close contact with the group of Frenchmen involved in the reorganization of mathematics — from general algebra to topology — has compiled six chapters on the new trends in, and the new pedagogic point of view on, the subject. A glossary of symbols, two appendices and an index are included.

Journal of Mathematical Analysis and Applications / Academic Press, Inc., 111 Fifth Ave., New York 3, N. Y. / 1960, (vol. 1), printed, \$16.00.

This publication, designed to provide a medium for the rapid publication of mathematical papers, will include papers devoted to the mathematical treatment of questions

arising in physics, chemistry, biology, and engineering. To minimize delays between receipt and publication, each of the Associate Editors may accept manuscripts. Among the Associates are, N. Levinson, M. I. T., G. Birkhoff, Harvard Univ., H. N. Shapiro, N. Y. U., and L. Zadeh, U. of Cal., Berkeley. Dr. R. Bellman, RAND Corp., serves as the Editor.

Forsythe, George E., and Wolfgang R. Wasow / Finite-Difference Methods for Partial Differential Equations / John Wiley & Sons, Inc., 440 Fourth Avenue., New York 16, N. Y. / 1960, printed, 444 pp, \$11.50.

This book concentrates on the more important finite-difference methods for solving partial differential equations, including initial-value and boundary-value problems, and other topics relevant to the solution of problems using computers. The contents include: Introduction to Partial Differential Equations and Computers; Hyperbolic Equations in Two Independent Variables; Parabolic Equations; Elliptic Equations; Initial-Value Problems in more than Two Independent Variables; Index; and a comprehensive Bibliography. The major topics are subdivided into many sections. A graduate course in partial differential equations is not necessary to the understanding of this book, but "a good course in advanced calculus and some knowledge of matrix theory" is advocated for understanding the book. This book is intended primarily for persons wishing to understand the numerical analysis underlying the use of difference methods.

Kells, Lyman M. / Elementary Differential Equations, 5th Edition, / McGraw-Hill Book Co., Inc., 330 West 42 St., New York 36, N. Y. / 1960, printed, 318 pp, \$6.25.

From an introduction to the subject, including definitions and elementary problems, to a final chapter on applications of partial differential equations, this book discusses in detail and with a care for rigor, the major topics, including: first order equations, Laplace transforms, solutions by series, and partial differential equations. Answers to the problems in each chapter, are given after the text. An index is included.

Jonscher, A. K., / Principles of Semiconductor Device Operation / John Wiley & Sons, Inc., 440 Fourth Ave., New York 16, N. Y. / 1960, printed, 168 pp, \$5.00.

A discussion is presented, of injection, decay, and transport of "excess carrier," densities in semiconductors. The six chapters are: Outline of Semiconductor Theory, Non-Equilibrium Carrier Densities, Transport of Excess Carrier Densities in a Homogeneous Medium, Theory of  $p-n$  Junctions and Junction Diodes, Theory of Multi-Junction Structures, and Carrier Flow in Inhomogeneous Media. Eight appendices contain information about various topics including vector operators, and the error function complement; a list of symbols follows the text. Index. The author is at General Electric Co., Ltd., Research Laboratories, Wembley, England.

# Essential Special Terms in Computers and Data Processing — Suggested List, and Definitions

## Part 3

(From: *Glossary of Terms in Computers and Data Processing*, 5th edition of the Computers and Automation glossary / Edmund C. Berkeley and Linda L. Lovett / Berkeley Enterprises, Inc., 815 Washington St., Newtonville 60, Mass. / July 1960, 96 pages, photo-offset, \$3.95 to nonsubscribers, \$1.85 to subscribers.)

### VI. Operation

check digit(s) — One or more digits carried along with a machine word (i.e., a unit item of information handled by the machine), which report information about the other digits in the word in such fashion that if a single error occurs (excluding two compensating errors), the check will fail and give rise to an error alarm signal. For example, the check digit may be 0 if the sum of other digits in the word is odd, and the check digit may be 1 if the sum of other digits in the word is even. It is possible to choose check digits for rows and columns in a block of characters recorded on magnetic tape, for example, in such a way that any single error of a 1 for a 0 or a 0 for a 1, can be located automatically by row and column, and eliminated automatically by the computer.

automatic checking — Computers. Provision, constructed in hardware, for automatically verifying the information, transmitted, manipulated or stored by any device or unit of the computer. Automatic checking is "complete" when every process in the machine is automatically checked; otherwise it is partial. The term "extent of automatic checking" means either (1) the relative proportion of machine processes which are checked, or (2) the relative proportion of machine hardware devoted to checking.

computing efficiency — Computer Operation. The ratio obtained by dividing (1) the total number of hours of correct machine operation (including time when the program is incorrect through human mistakes) by (2) the total number of

hours of scheduled computer operation including time when the machine is undergoing preventive maintenance. Same as "operating ratio," which see.

on-line (adjective) — Equipment. Operating in time with and under the direct control of the central equipment. If the central equipment is an automatic computer, and if the automatic computer is not operating in real time, then on-line operation does not imply real-time operation. But if a computer is part of another process taking place in real-time, then on-line operation implies real-time operation. For example, data from wind tunnel experiments may be fed into the computer directly from observing instruments, and the computer may report results of the experiment within a few seconds from the time the experiment is finished: this is on-line operation.

### VII. Representation of Information

digit — 1. One of the symbols 0, 1, 2, 3, 4, 5, 6, 7, 8, 9, used in numbering in the scale of ten. 2. One of these symbols and sometimes also letters expressing integral values ranging from 0 to  $n-1$  inclusive, used in a scale of numbering to the base  $n$ .

character — Digital Computers. 1. A decimal digit 0 to 9, or a letter A to Z, either capital or lower case, or a punctuation symbol, or any other single symbol (such as appear on the keys of a typewriter) which a machine may take in, store, or put out. 2. One of a set of basic or elementary unit symbols which, singly or in sequences of two or more, may express information and which a computer may accept. 3. A representation of such a symbol in a pattern of ones and zeros representing a pattern of positive and negative pulses or states.

notation (in the sense "scale of notation" or "positional notation" for numbers) — Arithmetic. A systematic method for stating quantities in which any number is represented by a sum of coefficients times multiples of the successive powers

of a chosen base number  $n$  (sometimes more than one). If a quantity is written in the scale of notation  $n$ , then the successive positions of the digits report the powers of  $n$ . Thus 379 in the scale of 10 or decimal notation means 3 hundreds, 7 tens, and 9. The number 379 in the scale of 16 (used in some computers) means 3 times sixteen squared, plus 7 times sixteen, plus 9 (which in decimal notation would be 889). 1101 in the scale of two means 1 eight, 1 four, 0 twos and 1 one (which in decimal notation would be 13). In writing numbers, the base may be indicated by a subscript (expressed always in decimal notation) when there may be doubt about what base is employed. For example,  $11.101_2$  means two, plus one, plus one half, plus one eighth, but  $11.101_3$  means three plus one, plus one third, plus one twenty-seventh. Names of scales of notation which have had some significant consideration are:

Base	Name
2	binary
3	ternary
4	quaternary, tetral
5	quinary
10	decimal
12	duodecimal
16	hexadecimal, sexiddecimal
32	duotricenary
2,5	biquinary

The digits used for "ten" and "eleven" are ordinarily "t" and "e"; beyond eleven, uniformity of nomenclature has apparently not yet developed.

binary notation — The writing of numbers in the scale of two. Positional notation for numbers using the base 2. The first dozen numbers zero to eleven are written in binary notation as 0, 1, 10, 11, 100, 101, 110, 111, 1000, 1001, 1010, 1011. The positions of the digits designate powers of two; thus 1010 means 1 times two cubed or eight, 0 times two squared or four, 1 times two to the first power or two, and 0 times two to the zero power or one; this is equal to one eight plus no four's plus one two plus no ones, which is ten.

---

## MANUSCRIPTS

WE ARE interested in articles, papers, reference information, and discussion relating to computers and automation. To be considered for any particular issue, the manuscript should be in our hands by the first of the preceding month.

ARTICLES: We desire to publish articles that are factual, useful, understandable, and interesting to many kinds of people engaged in one part or another of the field of computers and automation. In this audience are many people who have expert knowledge of some part of the field, but who are laymen in other parts of it.

Consequently, a writer should seek to explain his subject, and show its context and significance. He should define unfamiliar terms, or use them in a way that makes their meaning unmistakable. Ordinarily, the length should be 1000 to 3000 words. A

suggestion for an article should be submitted to us before too much work is done.

PAYMENTS: In many cases, we make small token payments for articles, if the author wishes to be paid. The rate is ordinarily  $\frac{1}{2}$ c a word, the maximum is \$15, and both depend on length in words, whether printed before, etc.

All suggestions, manuscripts, and inquiries addressed to: *The Editor*, COMPUTERS and AUTOMATION, 815 Washington Street, Newtonville 60, Mass.

# IN THE COMPUTER FIELD WHO? WHAT? WHERE?

*Answers,*

*Basic Source Information,  
Available to You from*

## COMPUTERS and AUTOMATION

24 "issues" per year,  
distributed 13 times a year

### PEOPLE:

Mailing plates for over 22,000 computer people. We address your envelopes.  
\$19.00 per M

### ORGANIZATIONS:

The Computer Directory and Buyers' Guide, 1960 (the June, 1960, issue of COMPUTERS and AUTOMATION): over 700 organization listings, over 2000 product and service listings. \$6.00

### GLOSSARY OF TERMS AND EXPRESSIONS IN THE COMPUTER FIELD:

Over 860 careful, clear, understandable definitions. 5th cumulative edition. (20 or more copies, 10% discount.) \$3.95

### BACK COPIES:

(For nine years of publication.)  
If available, \$1.25 each, except Directory issues June 1955 to 1959, \$4.00 each; June, 1960, \$6.00.

### SUBSCRIPTIONS:

U.S.A. one year \$7.50; two years \$14.50; add 50c per year for Canada, \$1.00 per year elsewhere.

### BULK SUBSCRIPTIONS:

These rates apply to prepaid subscriptions to COMPUTERS and AUTOMATION coming in together direct to the publisher.

#### BULK SUBSCRIPTION RATES (United States)

Number of Simultaneous Subscriptions	Rate for Each Subscription, and Resulting Saving:	
	One Year	Two Years
7 or more	\$5.70 - 24%	\$10.00 - 31%
4 to 6	6.30 - 16	11.00 - 24
3	6.80 - 9	12.20 - 16
2	7.10 - 5	13.20 - 9

For Canada, add 50 cents for each year; outside of the United States and Canada, add \$1.00 for each year.

*Send prepaid orders or requests for more information to:*

COMPUTERS and AUTOMATION  
815 Washington St., Newtonville 60, Mass.  
If not satisfactory, returnable in seven days for full refund.

coded decimal (adjective) — Computers. A form of notation by which each decimal digit separately is converted into a pattern of binary ones and zeros. For example, in the "8-4-2-1" coded decimal notation, the number twelve is represented as 0001 0010 (for 1, 2) whereas in pure binary notation it is represented as 1100. Other coded decimal notations are known as: "5-4-2-1," "excess three," "2-4-2-1," etc. Following are the codes for the decimal digits 0 to 9 in each of the mentioned systems:

Decimal	8-4-2-1	5-4-2-1	Excess three	2-4-2-1
0	0000	0000	0011	0000
1	0001	0001	0100	0001
2	0010	0010	0101	0010
3	0011	0011	0110	0011
4	0100	0100	0111	0100
5	0101	1000	1000	1011
6	0110	1001	1001	1100
7	0111	1010	1010	1101
8	1000	1011	1011	1110
9	1001	1100	1100	1111

biquinary notation — Numbers. A scale of notation in which the base is alternately 2 and 5. For example, the number 3671 in decimal notation is 03 11 12 01 in biquinary notation; the first of each pair of digits counts 0 or 1 units of five, and the second counts 0, 1, 2, 3, or 4 units. Roman numerals are essentially a biquinary notation, except that different letters are used in each place, V and I in the first place, X and L in the second place, C and D in the third, etc.; for example, the biquinary number 03 11 12 01 is in Roman numerals MMM-DCLXXI. Biquinary notation expresses the representation of numbers by the abacus, and by the two hands and five fingers of man: and has been used in some automatic computers.

binary digit — A digit in the binary scale of notation. This digit may be only 0 (zero) or 1 (one). It is equivalent to an "on" condition or an "off" condition, a "yes" or a "no," etc.

bit — A binary digit; a smallest unit of information; a "yes" or a "no"; a single pulse in a group of pulses; a single magnetically polarized spot in a group of such spots. This word is derived from the "b" in "binary" and the "it" in "digit"; the word replaces the obsolete blend word "bigit," and takes on added meaning from the word "bit" meaning "small piece."

machine language — Computers. 1. Information in the physical form which a computer can handle. For example, punched paper tape is machine language, while printed characters on paper are not usually machine language. 2. Numbers or instructions expressed in a form that a computer can process at once without conversion, translation, or programmed interpretation. Note that a punched card containing an instruction in punched holes that requires programmed interpretation is "in machine language" by the first meaning and is

"not in machine language" by the second meaning.

machine word — Digital Computers. A unit of information of a standard number of characters, which a machine regularly handles in each transfer. For example, a machine may regularly handle numbers or instructions in units of 36 binary digits: this is then the "machine word." See also "information word."

### VIII. Mathematics and Logic

fixed-point calculation — Computers. Calculation using or assuming a fixed or constant location of the decimal point or the binary point in each number.

floating-point calculation — Computers. Calculation taking into account varying location of the decimal point (if base 10) or binary point (if base 2), and consisting of writing each number by specifying separately its sign, its coefficient, and its exponent affecting the base. For example, in floating-point calculation, the decimal number -638,020,000 might be reported as  $-6.3802,8$ , since it is equal to  $-6.3802 \times 10^8$ .

complement — 1. Arithmetic. A quantity which is derived from a given quantity, expressed in notation to the base  $n$ , by one of the following rules. (a) Complement on  $n$ : subtract each digit of the given quantity from  $n-1$ , add unity to the rightmost digit, not zero and perform all resultant carries. For example, the twos complement of binary 11010 is 00110; the twos complement of 0001 1010 is 1110 0110; the tens complement of decimal 679 is 321; the tens complement of 000679 is 999321. (b) Complement on  $n-1$ : subtract each digit of the given quantity from  $n-1$ . For example, the ones complement of binary 11010 is 00101; the ones complement of 00011010 is 11100101; the nines complement of decimal 679 is 320; the nines complement of 000679 is 999320. The complement is frequently employed in computers to represent the negative of the given quantity. 2. Boolean Algebra. The element equal to the universe element except the stated element; the result of the operation NOT. . . or ALL EXCEPT. . . The complement of a Boolean element  $a$  is NOT- $a$ , or  $a'$ , or  $\sim a$ .

parameter — 1. Mathematics. A constant or variable which enters fundamentally into a mathematical function and which has the property that its different values produce different functions. For example, the function  $y = ax + b$  has two parameters,  $a$  and  $b$ ; when  $a$  and  $b$  are constant,  $y = ax + b$  represents a line, but the choice of values of  $a$  and  $b$  determines the angles and distances at which the line cuts the coordinate axes. 2. Digital Computer Programming. In a subroutine, a quantity which may be given different values when the subroutine is used in different parts of one main routine, but which usually remains unchanged throughout any one such use. For example, a parameter may specify

## WHO'S WHO IN THE COMPUTER FIELD

From time to time we bring up to date our "Who's Who in the Computer Field." We are currently asking all computer people to fill in the following Who's Who Entry Form, and send it to us for their free listing in the Who's Who that we publish from time to time in *Computers and Automation*. We are often asked questions about computer people — and if we have up to date information in our file, we can answer those questions.

If you are interested in the computer field, please fill in and send us the following Who's Who Entry Form (to avoid tearing the magazine, the form may be copied on any piece of paper).

Name? (please print) .....  
 Your Address? .....  
 Your Organization? .....  
 Its Address? .....  
 Your Title? .....  
 Your Main Computer Interests?

- ( ) Applications
- ( ) Business
- ( ) Construction
- ( ) Design
- ( ) Electronics
- ( ) Logic
- ( ) Mathematics
- ( ) Programming
- ( ) Sales
- ( ) Other (specify):

.....  
 Year of birth? .....  
 College or last school? .....  
 Year entered the computer field? .....  
 Occupation? .....  
 Anything else? (publications, distinctions, etc.) .....

.....  
 .....  
 .....  
 .....  
 .....  
 .....  
 .....

When you have filled in this entry form please send it to: Who's Who Editor, *Computers and Automation*, 815 Washington Street, Newtonville 60, Mass.

the number of characters in an item, the position of the decimal point, the number of columns in a field, the number of times a certain cycle of operations is to be repeated, etc. To use a subroutine successfully in many different programs requires that the subroutine be adaptable by changing its parameters.

**Boolean algebra** — An algebra like ordinary algebra but dealing instead with classes, propositions, on-off circuit elements, etc., associated by operators AND, OR, NOT, EXCEPT, IF . . . THEN, etc., and permitting computations and demonstration, as in any mathematical system, making use of symbols efficient in calculation. This algebra was named after George Boole, famous English mathematician (1815-1864).

**AND** — 1. Logic (and Boolean Algebra). A logical (or Boolean algebra) operator which has the property that if P and Q are two statements, then the statement "P AND Q" is true or false precisely according to the following table of possible combinations:

P	Q	P AND Q
false	false	false
false	true	false
true	false	false
true	true	true

The AND operator is often represented by a centered dot (\*), or by no sign, as in P\*Q, PQ. 2. Circuits. A connection between two circuits A and B or two circuit elements A and B which passes a signal if and only if both A and B contain the signal.

**inclusive OR** — Logic. A logical operator which has the property that if P and Q are two statements, then the statement P or Q is true if and only if P is true or if Q is true or if both P and Q are true. See also under "OR."

**NOT** — Logic. A logical operator that has the property that if P is a statement, then the statement "NOT-P" ("it is not the case that P"), is true if the statement P is false, and false if the statement P is true. The NOT operator is often represented as follows: P' (read "P prime"),  $\bar{P}$  (read "P dash"), or  $\sim P$  (read "tilde P").

**exclusive OR** — Logic. A logical operator that has the property that if P and Q are two statements, then the statement P OR ELSE Q is true precisely according to the following table of possible combinations:

P	Q	P OR ELSE Q
false	false	false
false	true	true
true	false	true
true	true	false

The exclusive OR operator, the OR ELSE operator, has the property: P OR ELSE Q is equivalent to P AND NOT Q, OR Q AND NOT P, and accordingly may be written in symbols P\*Q' v P'Q.

# NEW GLOSSARY OF COMPUTER TERMS

Computers and Automation's Fifth Edition (1960) of the:

## GLOSSARY OF TERMS IN COMPUTERS AND DATA PROCESSING

96 pages long, this edition contains over 860 computer terms and expressions with their definitions, EXPLAINED so that people new to the computer field can understand them. (Our last edition, October, 1956, contained 490 terms.) This will be an invaluable guide to "understanding your way around" the computer field. Returnable for full refund within 10 days if not satisfactory.

## SPECIAL COMBINATION OFFER:

Each monthly issue of *Computers and Automation* now has 12 additional pages of "News of Computers and Data Processors: ACROSS THE EDITOR'S DESK." Of course, articles, ideas, forum, reference information, surveys, etc., are all there still; and the June issue is the annual edition of "THE COMPUTER DIRECTORY AND BUYER'S GUIDE." Regular subscription rate, U.S.A., one year, \$7.50.

**SPECIAL COMBINATION OFFER:** both our new Glossary and *Computers and Automation* for one year, \$7.90. You save 30%.

— Mail this coupon, or a copy of it —  
 To: COMPUTERS AND AUTOMATION, 815 Washington St., R 149, Newtonville 60, Mass.

Please send me the new Glossary. I have checked the arrangement which applies:

Subscriber Already \$1.85  
 Nonsubscriber 3.95

Returnable for full refund within 10 days if not satisfactory.

Please send me the special combination offer of *Computers and Automation* for one year and the Glossary when printed. I enclose \$7.90.

Other requests (please explain)

My name and address are *attached*.

# NEW PATENTS

RAYMOND R. SKOLNICK

Reg. Patent Agent

Ford Inst. Co., Div. of Sperry Rand Corp.  
Long Island City 1, New York

THE following is a compilation of patents pertaining to computers and associated equipment from the "Official Gazette of the United States Patent Office," dates of issue as indicated. Each entry consists of: patent number / inventor(s) / assignee / invention. Printed copies of patents may be obtained from the U.S. Commissioner of Patents, Washington 25, D.C., at a cost of 25 cents each.

May 10, 1960 (Cont'd)

- 2,936,116 / Phil. A. Adamson, San Gabriel, and Howard L. Engel and Eldred C. Nelson, Los Angeles, Calif. / Hughes Aircraft Co., a corp. of Del. / An electronic digital computer.
- 2,936,117 / Elmer L. Younker, Madison, N.J. / Bell Telephone Lab., Inc., New York, N.Y. / A high speed switching circuit employing slow acting components.
- 2,936,118 / George B. Greene, Berkeley, Charles M. Hill, Piedmont, Eugene P. Hamilton, Richmond, and William B. Bennett, Berkeley, Calif., and William P. Steed, Philadelphia, Pa. / Marchant Research, Inc., a corp. of Calif., / An electronic digital computer.
- 2,936,119 / Dana M. Collier and Leighton A. Meeks, Oak Ridge, Tenn., and James P. Palmer, Stony Brook, N.Y. / U.S.A. as represented by the U.S. Atomic Energy Comm. / A simultaneous differential equation computer.
- 2,936,120 / Samuel D. Bedrosian, Haver-town, and Frank P. Simmons, Devon, Pa. / Burroughs Corp., Detroit, Mich. / A great circle and celestial data computer.

May 17, 1960

- 2,936,951 / Austin J. Maher, Jr., Brooklyn, N.Y. / Sperry Rand Corp., Ford Inst.

Co., Div., a corp of Del. / A method and apparatus for accurate analog integration of time functions.

- 2,936,956 / Martin Kassel, Berlin — Charlottenburg, Germany / Kienzle Apparate G.m.b.H., Villingen / Schwarzwald, Germany / An electronic computer for converting single electrical pulses into pulse sequences each composed of a predetermined number of pulses.
- 2,937,288 / Frederic C. Williams and George B. Chaplin, Romiley, Eng. / National Research Dev. Corp., London, Eng. / A shift register circuit.
- 2,937,289 / Richard W. Aldrich, Liverpool, and Jerome J. Suran, Syracuse, N.Y. / General Elec. Co., a corp. of N.Y. / A digital to analog converter.
- 2,937,290 / Kan Chen, Wilkesburg, Pa. / Westinghouse Electric Corp., East Pittsburgh, Pa. / An anti-coincident circuit.
- 2,937,291 / Leonard R. Harper, Poughkeepsie, N.Y. / I.B.M. Corp., New York, N.Y. / A single shot bistable circuit.
- 2,937,363 / Robert I. Roth, Mount Pleasant, N.Y. / I.B.M. Corp., New York, N.Y. / A data processing machine.
- 2,937,364 / Milton Rosenberg, Santa Monica, Calif. / Telemeter Magnetics, Inc., a corp. of Calif. / A magnetic memory system.
- 2,937,366 / John C. Sims, Jr., Springhouse, Pa., / Sperry Rand Corp., a corp. of Del. / A pulse group synchronizer.

May 24, 1960

- 2,937,810 / William A. Wadsworth, Towaco, N.J. / Bell Telephone Lab., Inc., New York, N.Y. / A serial digital computer circuit for summing successive increments.
- 2,938,193 / John P. Eckert, Jr., Gladwyne, and Marvin Jacoby, Norristown, Pa. / Sperry Rand Corp., a corp. of Del. / A code generator.

May 31, 1960

- 2,938,666 / Philip S. Rand, Redding Ridge, Conn. / Sperry Rand Corp., a corp. of Del. / A record sensing means.
- 2,938,667 / Fritz A. Deutsch, East Orange, N.J. / Monroe Calculating Machine Co., Orange, N.J. / A combination card feed and sensing means.

- 2,938,668 / Byron L. Havens, Closter, and Charles R. Borders, Alpine, N.J. / I.B.M. Corp., New York, N.Y. / A serial-parallel binary-decimal adder.
- 2,939,001 / William J. Deerhake, Dumont, and Byron L. Havens, Closter, N.J. / I.B.M. Corp., New York, N.Y. / A regenerative data storage system.
- 2,939,081 / Jane H. Dennis, Cambridge, Mass. / Philco Corp., Philadelphia, Pa. / An information storage system.
- 2,939,082 / Norman Nesenoff, Flushing, N.Y. / Sperry Rand Corp., Ford Inst. Co., Div., a corp. of Del. / An electronic function generator.
- 2,939,117 / Edgar A. Brown, Owego, N.Y. / I.B.M. Corp., New York, N.Y. / A magnetic core storage device with flux controlling auxiliary windings.
- 2,939,119 / Theodor Einsele, Sindelfingen, Germany / I.B.M. Corp., New York, N.Y. / A core storage matrix.
- 2,939,120 / Eugeni Estrems, Saint Mandé, and Maurice Papo, Paris, Fr. / I.B.M. Corp., New York, N.Y. / A data processing machine having a multiple step program device for controlling the sequence of the operations.

June 7, 1960

- 2,939,631 / Albert Burstein, Philadelphia, Pa. and Arnold M. Spielberg, Haddonfield, N. J. / R.C.A., a corp. of Del. / A data input control system.
- 2,939,634 / Joseph A. Beek, Jr., Palos Verdes, and Glenn E. Hagen, Manhattan Beach, Calif. / Alwac International, Inc., a corp. of Panama / A computer data control system.
- 2,939,758 / Loring P. Crosman, Wilton, Conn. / Sperry Rand Corp., a corp. of Del. / A magnetic data recording apparatus.
- 2,940,066 / William F. Steagall, Merchantville, N. J. / Sperry Rand Corp., a corp. of Del. / A bistable device.
- 2,940,067 / Cecil B. Shelman, Fort Worth, Tex. / General Dynamics Corp., San Diego, Calif. / A magnetic circuit for performing logical functions.
- 2,940,068 / Rudy C. Stiefel, New York, N. Y. / Sperry Rand Corp., Ford Inst. Co. Div., a corp. of Del. / A large scale memory device.

## ADVERTISING INDEX

Following is the index of advertisements. Each item contains: Name and address of the advertiser / page number where the advertisement appears / name of agency if any.

- Bendix Computer Div., Los Angeles 45, Calif. / Page 31 / Shaw Advertising, Inc.
- Berkeley Enterprises, Inc., 815 Washington St., Newtonville 60, Mass. / Page 24 / —
- Electric Boat, A Div. of General Dynamics, Groton, Conn. / Page 23 / D'Arcy Advertising Co.
- General Electric Co., Missile & Space Vehicle Dept., 3198 Chestnut St., Philadelphia 4, Pa. / Page 2 / Deutsch & Shea, Inc.
- International Business Machines Corp., Data Processing Div., 112 E. Post Rd., White Plains, N.Y. / Pages 16, 17 / Marsteller, Rickard, Gebhardt & Reed, Inc.

- Minneapolis-Honeywell, Datamatic Div., Wellesley Hills 81, Mass. / Page 19 / Batten, Barton, Durstine & Osborn
- National Cash Register Co., Dayton 9, Ohio / Page 32 / McCann-Erickson, Inc.
- Philco Corp., Government & Industrial Group, Computer Div., 3900 Welsh Rd., Willow Grove, Pa. / Page 3 / Maxwell Associates, Inc.
- Reeves Soundcraft Corp., Great Pasture Rd., Danbury, Conn. / Page 5 / The Wexton Co., Inc.
- Royal McBee Corp., Data Processing Div., Port Chester, N.Y. / Page 9 / C. J. LaRoche & Co.
- Technical Operations, Inc., 3600 M St., N.W., Washington 7, D.C. / Page 13 / Dawson MacLeod & Stivers
- Wheeler-Fairchild, Inc., 610 So. Arroyo Parkway, Pasadena, Calif. / Page 21 / —

# BENDIX G-20

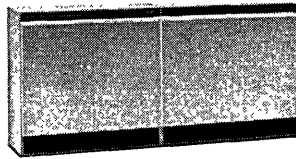

## WITH ORGANIZATION CHART DESIGN



## MEANS PRACTICAL EXPANDABILITY IN

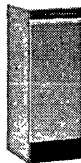

## BALANCE WITH APPLICATION GROWTH

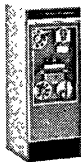
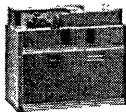

Just as the organization chart of any enterprise provides the framework for dynamic growth and adaptation, so "organization chart" design provides the framework for unparalleled expandability in the Bendix G-20 data processing system. This means that your G-20 can economically match; step by step, your expanding scientific or business computational workloads ... without sacrificing system balance. • Key to the organization chart efficiency of the Bendix G-20 is the ability of the Central Processor to "delegate" routine data handling tasks to control buffers, acting as "line supervisors." Thus freed, the Central Processor can make most efficient use of its high computation speed, its ability to schedule program priorities and

direct accessory equipment assignments. • The ability to employ many control buffers gives new meaning to expandability in the Bendix G-20. Up to 70 input/output units can be directed by each of these "line supervisors." The Bendix G-20 has a complete line of accessory equipment including keyboard, paper tape, punched cards, high speed line printers, and 2 million word magnetic tape units. • Memory represents another dimension of G-20 expandability, ranging from 4,096 to 32,768 words. • Investigate the organization chart design of the Bendix G-20. See how it provides balanced, *practical* expandability ... at a cost that assures unequalled data processing performance per dollar invested. • *For detailed literature write:*

Bendix Computer Division  
DEPT. D-27 LOS ANGELES 45, CALIFORNIA



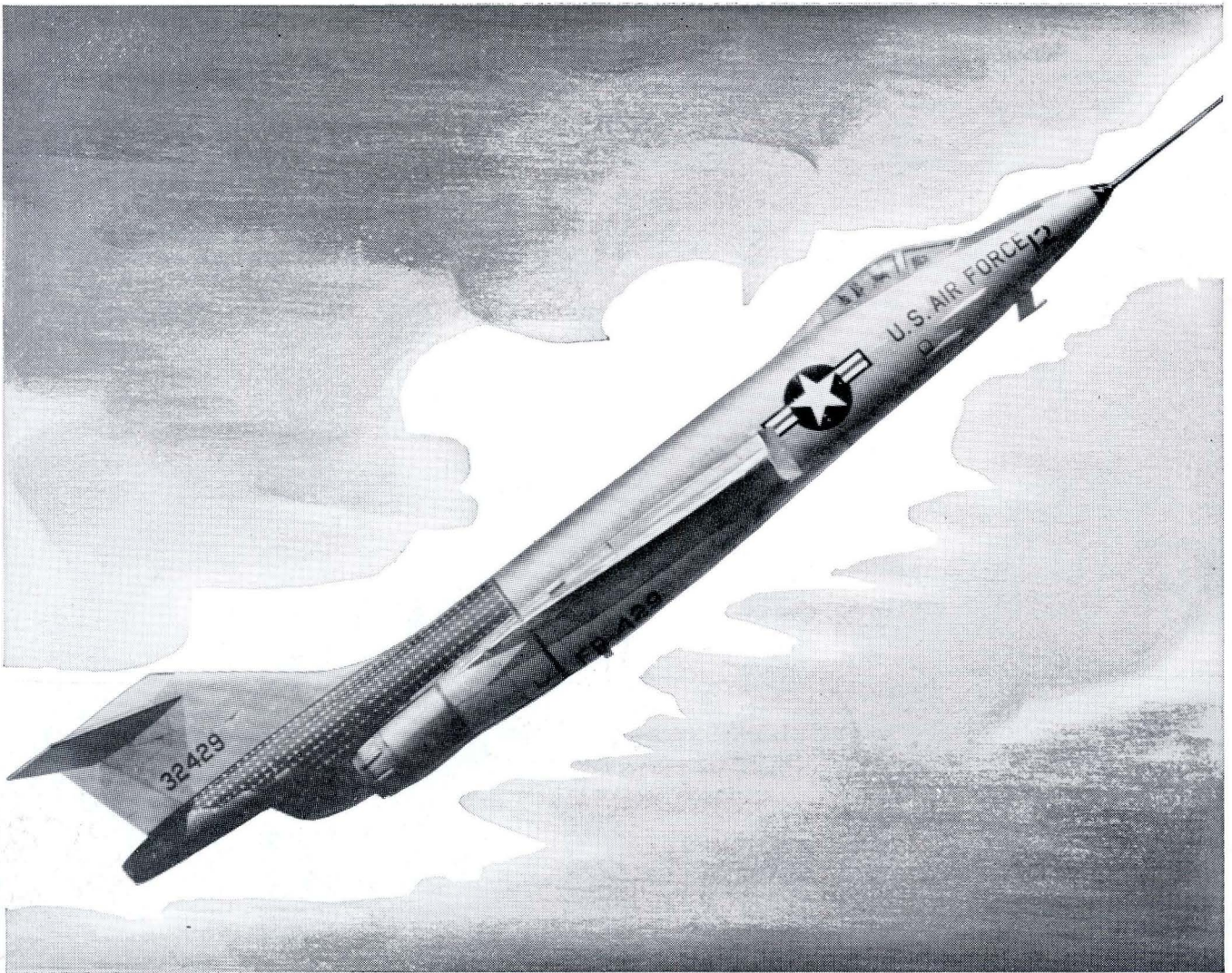

National has had many years' experience making significant contributions to the defense effort, including airborne components.

# COMPARE THIS OPPORTUNITY WITH WHAT YOU ARE NOW DOING!

## HERE'S WHAT *National's* NEW MILITARY RESEARCH AND DEVELOPMENT PROGRAM OFFERS.

This operation will interest any engineer or scientist possessing enough self-confidence—ability and experience—to develop projects initially and carry them through to completion.

### WHO WE'RE LOOKING FOR

National is looking for military-oriented scientists and engineers who hold a B.S. degree or advanced degrees. You should be working in electronic, electro-mechanical, mechanical, physics, optics, mathematics, or other related areas. Preference will be given to those who have had several years' experience dealing with prime contractors and government agencies.

As a member of National's New Military Development Team—you will be working initially with our Military Proposal Group. As proposals become specific projects, your responsibility will continue through the contractual stage for technical liaison, fulfillment of contractual obligations including hardware development, meanwhile retaining sufficient flexibility to continue your proposal efforts.

### WHY YOU SHOULD INVESTIGATE

National's new Military Research and Development Program offers you unusual latitude in responsibility. It offers you the chance to participate in military projects

from start to finish. Furthermore, you now have the opportunity to join an operation still in its formative stage—yet backed by one of the world's most successful . . . most reputable corporations.

**COMPLETE INFORMATION** is yours by sending your résumé to Mr. T. F. Wade, Technical Placement Section F5-5. The National Cash Register Company, Dayton 9, Ohio. All correspondence will be kept strictly confidential.

THE NATIONAL CASH REGISTER COMPANY, DAYTON 9, OHIO

ONE OF THE WORLD'S MOST SUCCESSFUL CORPORATIONS

76 YEARS OF HELPING BUSINESS SAVE MONEY

\* TRADEMARK REG. U.S. PAT. OFF.

*National*\*

ELECTRONIC DATA PROCESSING  
DIVERSIFIED CHEMICAL PRODUCTS  
ADDING MACHINES • CASH REGISTERS  
ACCOUNTING MACHINES • NCR PAPER