



Technical manual for the Exchangeable Disc Drive Series 30

Document reference 30/issue E

Part number of technical manual 188-054

**Data Recording Instrument Company Limited
Hawthorne Road, Staines, Middlesex TW18 3BJ, England
Telephone: Staines 51388 (std code 0784) Telex: 263156**

Designed and produced by the technical publications group, Data Recording, printed in England, © copyright 1974

document reference
30/issue E consists of
the following pages:

30/i/issue 5	30/5.12/issue 4
30/ii/issue 5	30/5.13/issue 4
30/vii/issue 2	30/5.14/issue 4
30/viii/issue 2	30/5.15/issue 4
30/1.1/issue 4	30/5.16/issue 4
30/1.2/issue 4	30/5.17/issue 4
30/1.3/issue 3	30/5.18/issue 4
30/1.4/issue 3	30/5.19/issue 1
30/1.5/issue 3	30/5.20/issue 1
30/1.6/issue 3	0000/6.1/issue 1
30/2.1/issue 3	30/7.1/issue 4
30/2.2/issue 3	30/7.2/issue 4
30/2.3/issue 3	30/7.3/issue 3
30/2.4/issue 3	30/7.4/issue 3
30/2.5/issue 4	30/7.5/issue 3
30/2.6/issue 4	30/7.6/issue 3
30/2.7/issue 4	30/7.7/issue 3
30/2.8/issue 4	30/7.8/issue 3
30/2.9/issue 4	30/7.9/issue 3
30/3.1/issue 4	30/7.10/issue 3
30/3.2/issue 4	30/7.11/issue 3
30/3.3/issue 4	30/7.12/issue 3
30/3.4/issue 4	30/7.13/issue 3
30/4.1/issue 4	30/7.14/issue 3
30/4.2/issue 4	30/7.15/issue 3
30/4.3/issue 3	30/7.16/issue 3
30/4.4/issue 3	30/7.17/issue 3
30/4.5/issue 3	30/7.18/issue 3
30/4.6/issue 3	30/7.19/issue 3
30/4.7/issue 3	30/8.1/issue 4
30/4.8/issue 3	30/8.2/issue 4
30/4.9/issue 4	30/8.3/issue 4
30/4.10/issue 4	30/8.4/issue 4
30/4.11/issue 4	30/8.5/issue 4
30/4.12/issue 4	30/8.6/issue 4
30/4.13/issue 5	30/8.7/issue 4
30/4.14/issue 5	30/8.8/issue 4
30/4.15/issue 4	30/8.9/issue 3
30/4.16/issue 4	30/8.10/issue 3
30/4.17/issue 4	30/8.11/issue 4
30/4.18/issue 4	30/8.12/issue 4
30/4.19/issue 5	30/8.13/issue 4
30/4.20/issue 5	30/8.14/issue 4
30/4.21/issue 4	30/8.15/issue 4
30/4.22/issue 4	30/8.16/issue 4
30/4.23/issue 4	30/8.17/issue 3
30/4.24/issue 4	30/8.18/issue 3
30/4.25/issue 4	30/8.19/issue 4
30/4.26/issue 4	30/8.20/issue 4
30/4.27/issue 4	30/9.1/issue 1
30/4.28/issue 4	30/9.2/issue 1
30/4.29/issue 5	30/9.3/issue 1
30/4.30/issue 5	30/9.4/issue 1
30/4.31/issue 1	30/9.5/issue 2
30/4.32/issue 1	30/9.7/issue 1
30/4.33/issue 1	30/9.8/issue 1
30/5.1/issue 4	30/9.9/issue 1
30/5.2/issue 4	30/9.11/issue 1
30/5.3/issue 4	30/9.13/issue 1
30/5.4/issue 4	30/9.15/issue 1
30/5.5/issue 4	30/9.17/issue 1
30/5.6/issue 4	
30/5.7/issue 4	
30/5.8/issue 4	
30/5.9/issue 4	
30/5.10/issue 4	
30/5.11/issue 4	

FIRST FOLD

INSERT
CORNER
HERE

SECOND FOLD

postage will
be paid
by licensee

do not affix postage stamps
if posted in Great Britain,
Channel Islands or Northern Ireland

BUSINESS REPLY SERVICE
Licence number HL469

The manager, technical publications group
Data Recording Instrument Co Ltd
Hawthorne Road
Staines
Middlesex
TW18 3BJ

2

THIRD FOLD

FIRST FOLD

INSERT
THIS
CORNER

TECHNICAL MANUAL FOR.....

SERIAL NUMBER ISSUE

ERRORS NOTED

SUGGESTIONS FOR IMPROVEMENT

NAME OF SENDER

ADDRESS

1.1 LIST OF CONTENTS

page	section	title
1.1	1.1	LIST OF CONTENTS
1.3	1.2	GENERAL DESCRIPTION
1.3	1.3	MODEL 33
1.3	1.4	MODEL 33F
1.4	1.5	SERIES 30 PARAMETERS
1.4	1.5.1	Disc cartridge
1.4	1.5.2	Recording format
1.4	1.5.3	Bit capacities
1.4	1.5.4	Access times
1.5	1.5.5	Data transfer
1.5	1.6	POWER REQUIREMENTS
1.5	1.7	PHYSICAL CHARACTERISTICS
1.6	1.8	CONNEXIONS
1.6	1.8.1	Interface signals and connexions
1.6	1.8.2	Power connexions

TABLE 1.1

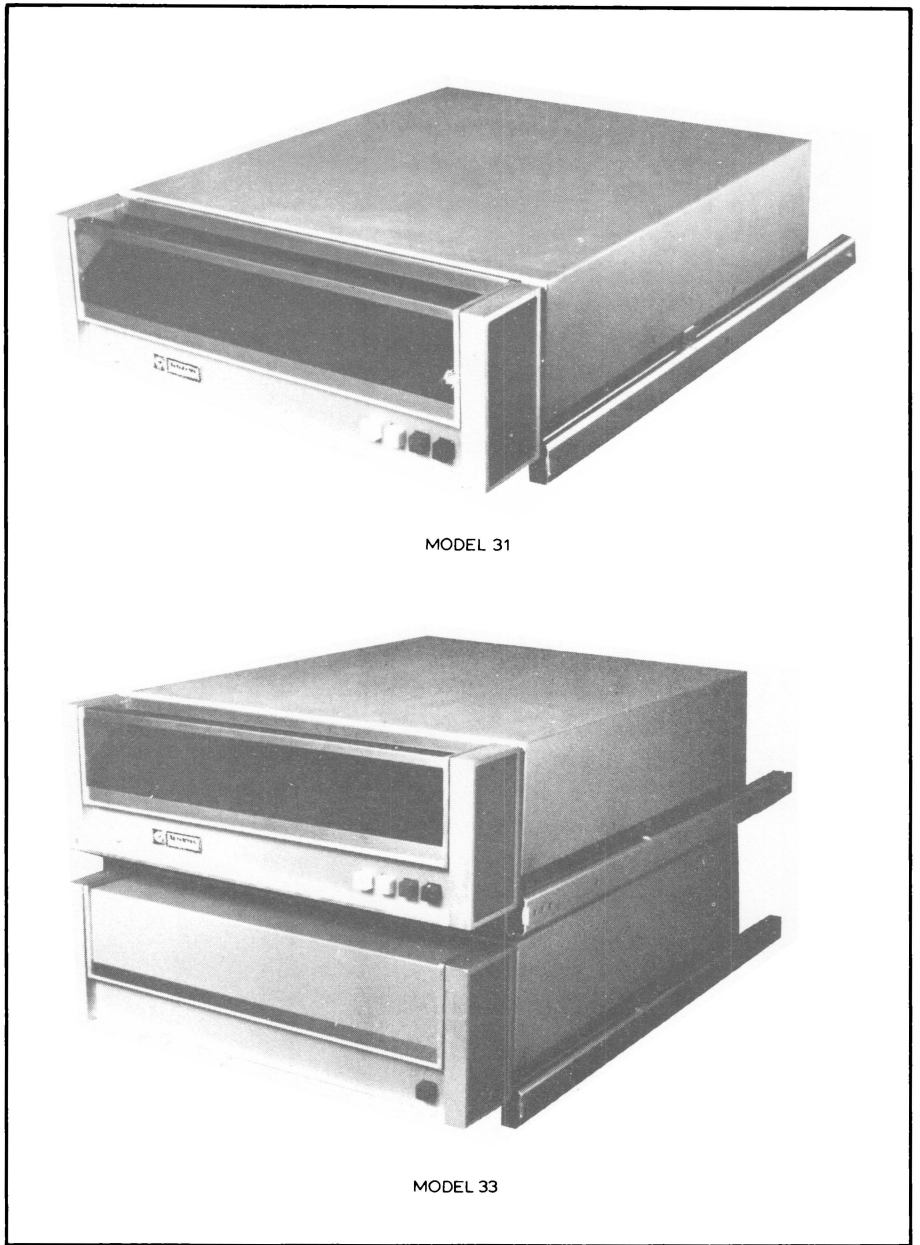

FIGURE 1.1 SERIES 30 DISC DRIVES

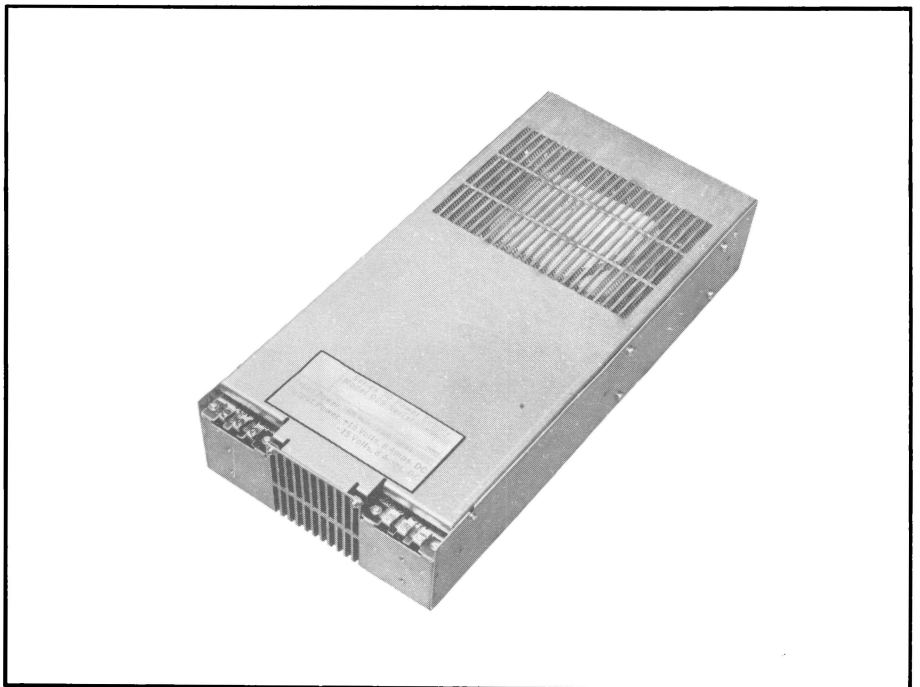

FIGURE 1.2 MODEL 029 POWER SUPPLY

1. 2 GENERAL DESCRIPTION

The Data Recording series 30 disc drive is a random-access data-storage device, for use in small computer systems, data acquisition systems, terminals and other storage applications. The series 30 is a compact, light-weight unit, available in three physical configurations, suitable for rack-cabinet installations (flush and extended) and desk-top use.

The drive uses a standard single-disc cartridge, on which it writes 406 data tracks. The standard-density model 31 provides 12 million bits of on-line storage; with the high-density option it can store 24 million bits. The maximum average head-positioning time is 70 milliseconds. Disc speed is 1500 rev/min and average rotational delay (latency) is 20 milliseconds. Formatting of recorded data is controlled entirely by the operating system. The recording method is double-frequency, NRZ.

The standard-density model has a data-transfer rate of 781 kilobits per second, giving a packing density of 43 bits/mm (1100 bits/inch); when used in an IBM system the data-transfer rate is 720 kilobits/second, giving a packing density of 40 bits/mm (1020 bits/inch).

The high-density model has a data-transfer rate of 1562 kilobits per second giving a packing density of 87 bits/mm (2200 bits/inch); when used in an IBM system the data-transfer rate is 1440 kilobits per second, giving a packing density of 80 bits/mm (2040 bits/inch).

The user who interchanges disc cartridges between series 30 drives and other drives should check that the transfer rates and packing densities correspond.

There are no potentiometers, belts or pulleys in the series 30. It requires only ± 15 volts direct-current power.

1. 3 MODEL 33

The model 33 consists of two separate disc drives; one of the drives uses an exchangeable disc, the other a fixed disc. The fixed-disc drive is a model 33F, details of which are given in section 1. 4. Both drives can operate independently and head positioning can be overlapped. Selection between the two drives is carried out by the standard daisy-chain select logic.

This manual refers only to the standard model and options, because the model 33 is, in effect, two series 30s and differs only as described in section 1. 4.

1. 4 MODEL 33F

Instead of a plexiglass door, the model 33F has a metal front-panel which is held in position by the top cover of the drive. The door-lock interlock and carriage interlock are not fitted; the front panel should not be opened by the operator.

When the top cover of the model 33F is removed by the service engineer there is no interlock to prevent the front panel from being opened during spindle rotation. To ensure that the spindle has stopped turning, allow 30 seconds after switching off the drive before removing the front panel.

The load/run switch, load, ready and check indicators are omitted; the write-protect (or power) pushbutton/indicator remains.

The cartridge-receiver mechanism is unchanged. The plug-in printed-circuit boards are interchangeable between the model 33F and standard series 30 drives provided that they contain the same options.

The model 33F goes through a normal start-up sequence on receipt of power.

1. 5 SERIES 30 PARAMETERS

1. 5. 1 Disc cartridge

type	single-disc magnetic cartridge
disc diameter	356 mm (14 inch)
lateral track density	4 tracks per mm (100 tracks per inch, 0. 010 inch centre-to-centre track spacing)

TABLE 1. 2

1. 5. 2 Recording format

tracks	406 (200 plus 3 spares on each side of the disc)
cylinders	203 (two tracks each)
sectors	3248 (using an 8-sector disc); 12, 16 and 24 sector divisions available

TABLE 1. 3

1. 5. 3 Bit capacities

	standard density	high density
bits per disc	12 million bits (6 million each side)	24 million bits (12 million each side)
bit density (innermost track)	43 bits/mm (1100 bits/inch)	87 bits/mm (2200 bits/inch)
bits per cylinder	60 000	120 000
bits per track	30 000	60 000
bits per sector (with 8 sectors)	3750	7500

TABLE 1. 4

1. 5. 4 Access times

disc speed	1500 rev/min ($\pm 1\%$)				
average latency	20 ms, half rotation				
head positioning, maximum (includes settling time)	<table border="0"> <tr> <td rowspan="3" style="font-size: 3em; vertical-align: middle;">}</td> <td>15 ms, adjacent tracks</td> </tr> <tr> <td>70 ms, average</td> </tr> <tr> <td>135 ms, 200-track movement</td> </tr> </table>	}	15 ms, adjacent tracks	70 ms, average	135 ms, 200-track movement
}	15 ms, adjacent tracks				
	70 ms, average				
	135 ms, 200-track movement				

TABLE 1. 5

1.5.5 Data transfer

	standard density	high density
transfer code	double-frequency recording	double-frequency recording
transfer rate	781 or 720 kilobits/second	1562 or 1440 kilobits/second

TABLE 1.6

1.6 POWER REQUIREMENTS

voltages	+15 and -15 volts dc ($\pm 5\%$)
peak current duration (occurring at a frequency not greater than one peak every 100 ms)	9 amps each supply
worst case average	4 amps each supply, averaged over any 200 millisecond period

TABLE 1.7

1.7 PHYSICAL CHARACTERISTICS

Standard rack-mounted model	
width	483 mm (19 inches)
depth	584 mm (23 inches)
height	178 mm (7 inches)
weight (without slides)	16 kg (35 pounds)

TABLE 1.8

1. 8 CONNEXIONS

1. 8. 1 Interface signals and connexions

signal function	pin
track address bit 1	LL
" " bit 2	N
" " bit 4	RR
" " bit 8	J
" " bit 16	X
" " bit 32	FF
" " bit 64	T
" " bit 128	BB
restore	VV
strobe	SS
head select	AA
write gate	EE
write data and clock	B
write-protect input	H
write-protect-status	P
erase gate	K
drive ready	U
ready to seek, read, or write	F
address acknowledge	NN
illegal-address interlock	XX
seek incomplete	TT
sector marks	W
index marks	Y
sector-address bit 1	CC
" " bit 2	JJ
" " bit 4	KK
" " bit 8	MM
" " bit 16	UU
pseudo-sector mark	S
write check	HH
read clock	A
read data	C
read gate	E
select-drive, 1	L
" " 2	R
" " 3	V
" " 4	Z
high-density indication	M
daisy-chain cable terminator (+5 V)	PP
ground	D
ground	DD
ground	WW

TABLE 1. 9

1. 8. 2 Power connexions

signal function	pin
ground	C
+15 V (for high-current power stages)	K
+15 V (for the low-current circuits)	H
-15 V (for high-current power stages)	R
-15 V (for the low-current circuits)	P

TABLE 1. 10

2.1 LIST OF CONTENTS

page	section	title
2.1	2.1	LIST OF CONTENTS
2.2	2.2	GENERAL
2.2	2.3	UNPACKING
2.2	2.4	INSTALLATION
2.2	2.4.1	Cabinet mounting
2.5	2.4.2	Initial setting-up
2.5	2.4.3	Select-drive line and attention line
2.6	2.4.4	Interface connexions
2.7	2.4.5	Daisy-chain connexions
2.7	2.4.6	Power connexions
2.9	2.5	ENVIRONMENT
2.9	2.5.1	Operating environment
2.9	2.5.2	Storage environment

TABLE 2.1

2.2 GENERAL

Series 30 disc drives are normally mounted in a 483 millimetre (19 inch)-rack cabinet; a table-top option is available. When mounted in a rack cabinet, the disc drive should be supported on slide rails and be equipped with a front panel assembly that is attached to the rack cabinet.

Slide rails allow the disc drive to be pulled out from the rack cabinet far enough to raise the motherboard assembly, with the rear-panel cable-connectors, to an elevated servicing position. The slide rails should be within three degrees of horizontal.

2.3 UNPACKING

The first part of the unpacking procedure should be carried out outside the operating environment:

- (a) Do not destroy packing materials as they are reusable
- (b) Cut the two straps, strip off the brown tape and unfold the flaps of the outer case
- (c) Remove the two slides (these are included only for rack-mounted drives)
- (d) Remove the top cushioned-board and lift out the technical manual
- (e) Lift the drive from the case leaving lower cushioned-board in the outer case

The following procedure should be carried out inside the operating environment

- (f) Open the polythene bag
- (g) Remove the sachet of desiccant
- (h) Cut the polythene bag around the drive and remove the bag
- (j) Release and remove the shipping restraint by removing the two screws securing it to the drive cross-member

2.4 INSTALLATION

2.4.1 Cabinet mounting

The drive may be mounted in a cabinet either flush (figure 2.1), or extended (figure 2.2).

To install the drive in a cabinet, reference should be made to figures 2.1 and 2.2 and the following procedure adopted.

- (a) Attach each slide as follows:
 - (i) Slacken four slide-adjustment screws and adjust slide brackets to suit depth of cabinet
 - (ii) Attach slide brackets to cabinet mounting rails with four fillister-head screws (10-32 UNF x 0.312 inch), plain washers and lock-washers
 - (iii) Tighten slide adjustment screws

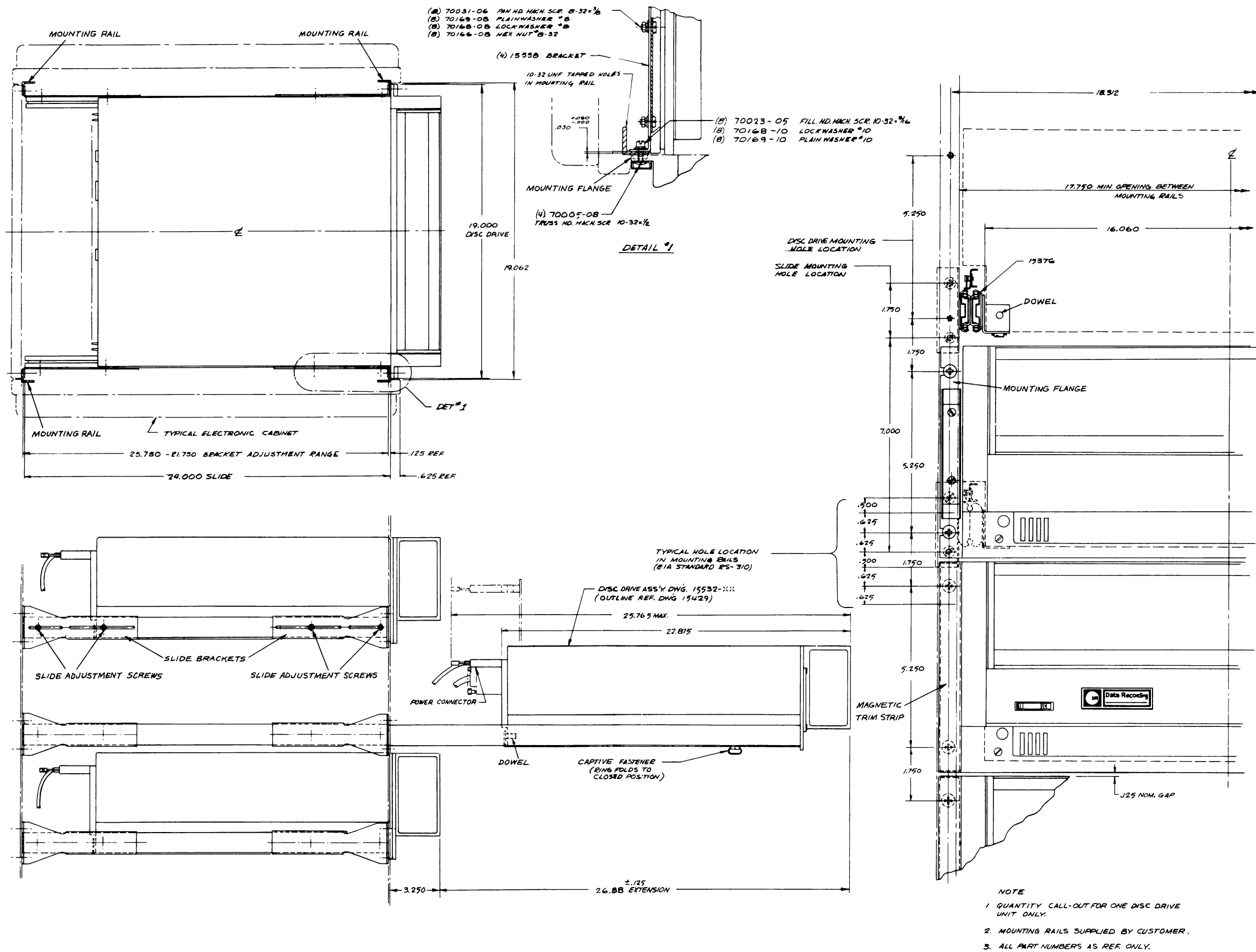

FIGURE 2.2 EXTENDED-FRONT RACK MOUNTING

- (b) Pull slides out to fully extended position
- (c) Engage rear of drive on dowels located on brackets at rear of slides
- (d) Lower front of drive onto slides and make secure with the two fasteners which are captive in the slides
- (e) Lay fastener rings flat
- (f) Slide drive into cabinet and secure with four phillips-truss-head screws (10-32 UNF x 0.5 inch)
- (g) Fit magnetic trim strips over front panel mounting flanges

2.4.2 Initial setting-up

- (a) If the drive is rack-cabinet mounted, pull out the drive from the cabinet until the slides are fully extended
- (b) Remove the top cover
- (c) Using a screwdriver, remove the head clamp (shipping restraint)
- (d) It is recommended that the heads should now be cleaned (see section 5.3.1)
- (e) Make all connections to the drive with power OFF. Ensure that the select-drive line is connected to the appropriate pin (likewise the attention line if used)
- (f) If for any reason it is found necessary to lift the card cage, ensure that the securing screws are fully tightened when the cage is lowered. Failure to do so may cause read or write errors in the data system

2.4.3 Select drive line and attention line

The select-drive-line jumper plug must be plugged into the sockets appropriate to the address of the drive in the system. If an attention line is used, its jumper-plug must be plugged into the sockets which match those used for the select-drive line, see figure 2.3.

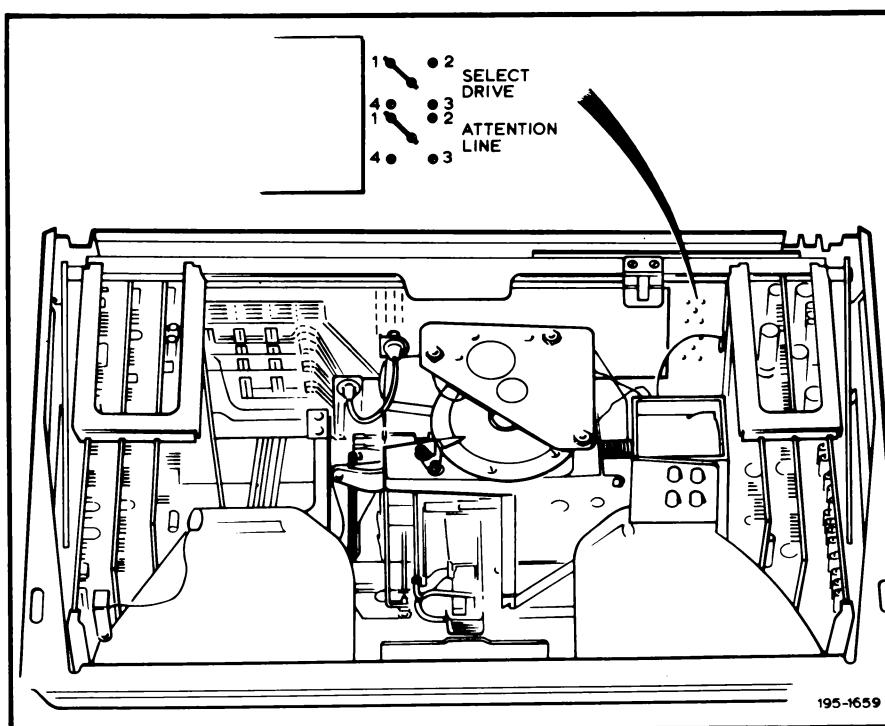

FIGURE 2.3 SELECT DRIVE AND ATTENTION LINE SOCKETS

A standard series 30 has two interface connectors on the rear panel. They are connected pin-for-pin (see figure 2. 4).

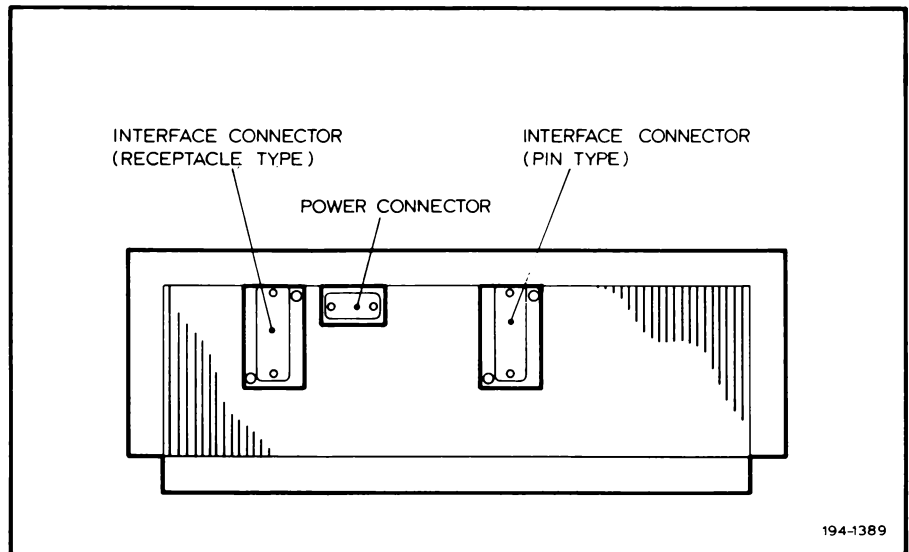

FIGURE 2. 4 REAR VIEW OF DISC DRIVE

Part numbers for the cable connector that fits the pin-type connector on the drive are given in table 2. 2.

item	Winchester type	part number
connector on cable, oval cable-hole, (without contacts)	MRAC 42S JTD H8 (can use MRAC 42S JTC H8)	00500516
alternative connector, round cable-hole	MRAC 42S JTD H (can use MRAC 42S JTC H)	00500614
socket contacts	100-1024S	00500529

TABLE 2. 2

Part numbers for the cable connector that fits the socket-type connector on the drive are given in table 2. 3.

item	Winchester type	part number
connector on cable, oval cable-hole (without contacts)	MRAC 42P JTD H8 (can use MRAC 42P JTC H8)	00500517
alternative connector, round cable-hole	MRAC 42P JTD H (can use MRAC 42P JTC H)	00500615
pin contacts	100-1024 P	00500528

TABLE 2. 3

2.4.5 Daisy-chain connexions

The maximum recommended cable lengths, indicated in figure 2.5, are long enough in most applications; even if the external equipment and the four disc drives are distributed in three cabinets.

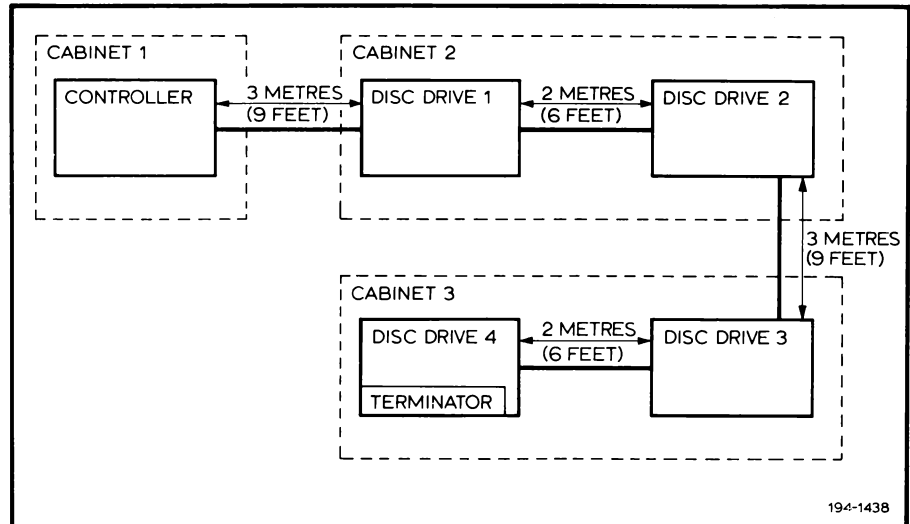

FIGURE 2.5 MAXIMUM CABLE LENGTHS

One recommended daisy-chain cabling arrangement, using the Data Recording flat cable, is shown in figure 2.6. Cable terminators, 035 and 036, are matched to the flat cable and may be ordered by number. Blank terminators are also available; in this case the customer is required to choose and install resistors to match the cable.

2.4.6 Power connexions

Series 30 disc drives require +15 and -15 volts dc, regulated within 5%. Most commonly-available power supplies capable of supplying the required current are suitable.

There is no power switch on series 30 drives; application of power is controlled from the external equipment. The rear-panel power-connector must not be removed while power is on. It is essential to switch both positive and negative supplies simultaneously. Failure to do so may cause damage to the drive.

In the disc drive, both the +15 and -15 volts are distributed separately to the high-current power circuits and to the low-current logic and amplifier circuits. In order to avoid common impedance, separate leads should be used for these high-level and low-level circuits. If the power cable must exceed 1,5 metres (about 5 feet) in length, 30 000 microfarad buffer capacitors, located within 0,75 metres (about 2.5 feet) of the disc drive, should be used in both leads.

Wires used for the power connexions should not be lighter than 16 awg. For the single ground connexion a flat braid 14 awg should be used. The five leads should be twisted together.

Data Recording offer a power-supply unit, model 029, which provides power for two disc drives. Details of the power supply unit are given in chapter 9. A mains-input cable is included with the power-supply unit. A power cable, 032, is available for connecting the power-supply unit to the disc drive.

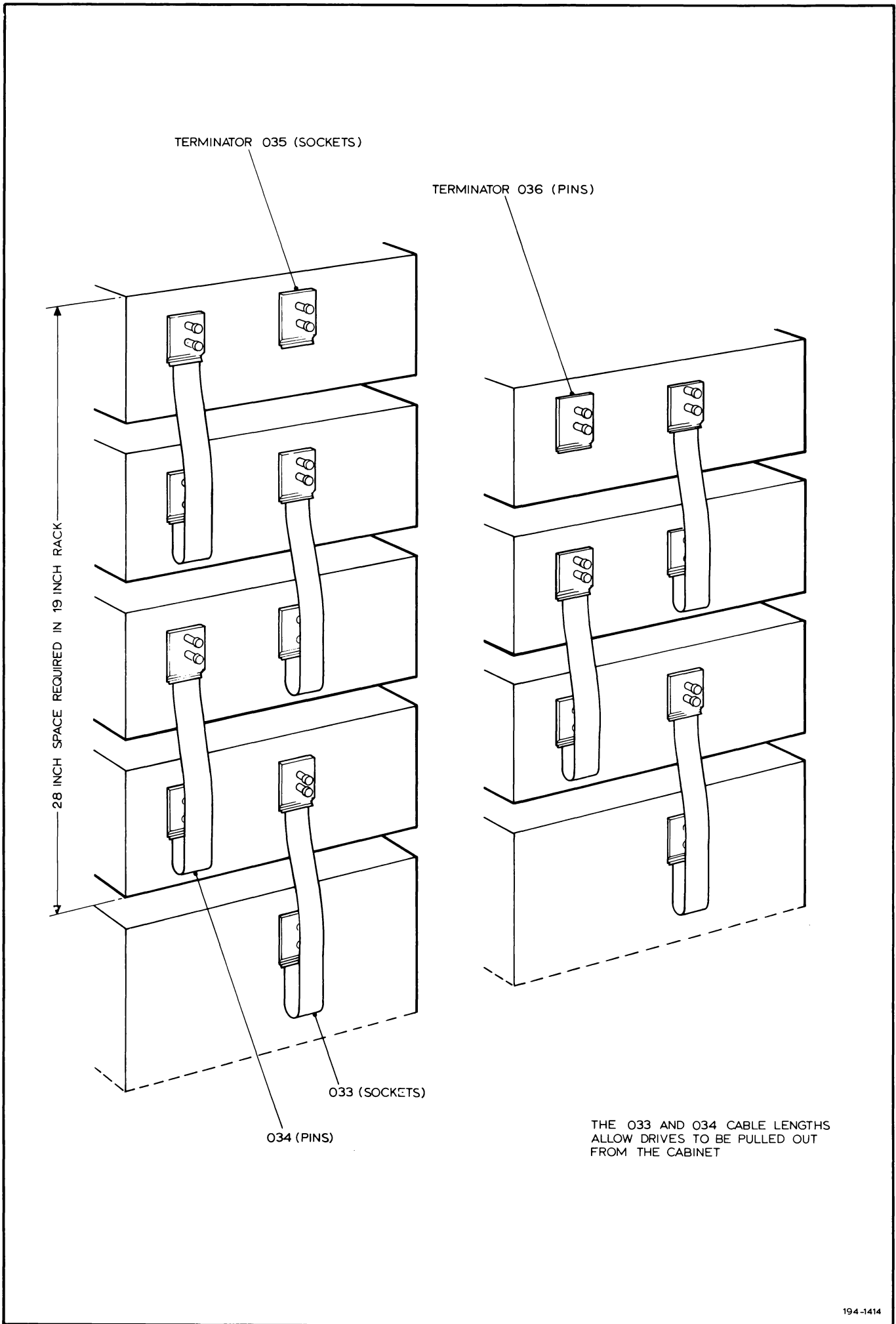

THE O33 AND O34 CABLE LENGTHS ALLOW DRIVES TO BE PULLED OUT FROM THE CABINET

194-1414

FIGURE 2. 6 DAISY-CHAIN CABLING ARRANGEMENT

Power-cable pin assignments are given in chapter 1. The power-connector part-numbers are given in table 2. 4.

item	Winchester type	part number
connector on cable (without contacts)	MRAC 14S JTC H13	00500518
socket contacts	100-1014S	00500531

TABLE 2. 4

2. 5 ENVIRONMENT

2. 5. 1 Operating environment

temperature	+16°C to +36°C
relative humidity	20% to 80% (non-condensing)

TABLE 2. 5

The temperature range given in table 2. 5 is a commonly-used range. Apart from an absolute upper limit of 40°C, the series 30 can operate over any normal office range of 20 centigrade degrees and is guaranteed disc-cartridge interchangeability.

An additional 5 centigrade degrees is acceptable at the lower end of the 20 centigrade degree temperature range for read operations; if these additional 5 centigrade degrees are to be used for write operations the drive must first cycle-up and be at READY status for 30 minutes before writing occurs.

If a temperature limit is exceeded during writing, the data may not be readable on a drive operating at the opposite end of the range; disc-cartridge interchangeability may be impaired.

2. 5. 2 Storage environment

temperature	-40°C to +65°C
relative humidity	10% to 90% (non-condensing)

TABLE 2. 6

3.1 LIST OF CONTENTS

page	section	title
3.1	3.1	LIST OF CONTENTS
3.2	3.2	CONTROLS AND INDICATORS
3.2	3.2.1	The load/run switch
3.2	3.2.2	The load indicator
3.2	3.2.3	The ready indicator
3.3	3.2.4	The check indicator
3.3	3.2.5	The write-protect button and power indicator options
3.3	3.2.5.1	The write-protect button
3.3	3.2.5.2	The power indicator
3.3	3.2.6	Servo-release switch
3.3	3.3	OPERATING PRECAUTIONS
3.3	3.4	OPERATING PROCEDURE
3.4	3.5	THE DOOR INTERLOCK
3.4	3.6	HANDLING AND STORING DISC CARTRIDGES

TABLE 3.1

3.2 CONTROLS AND INDICATORS

The series 30, has one control switch and four indicator lights. The mechanical interlock flag, shown in figure 3.1, is visible and the door is locked shut whenever the power to the drive is off or when the disc is rotating.

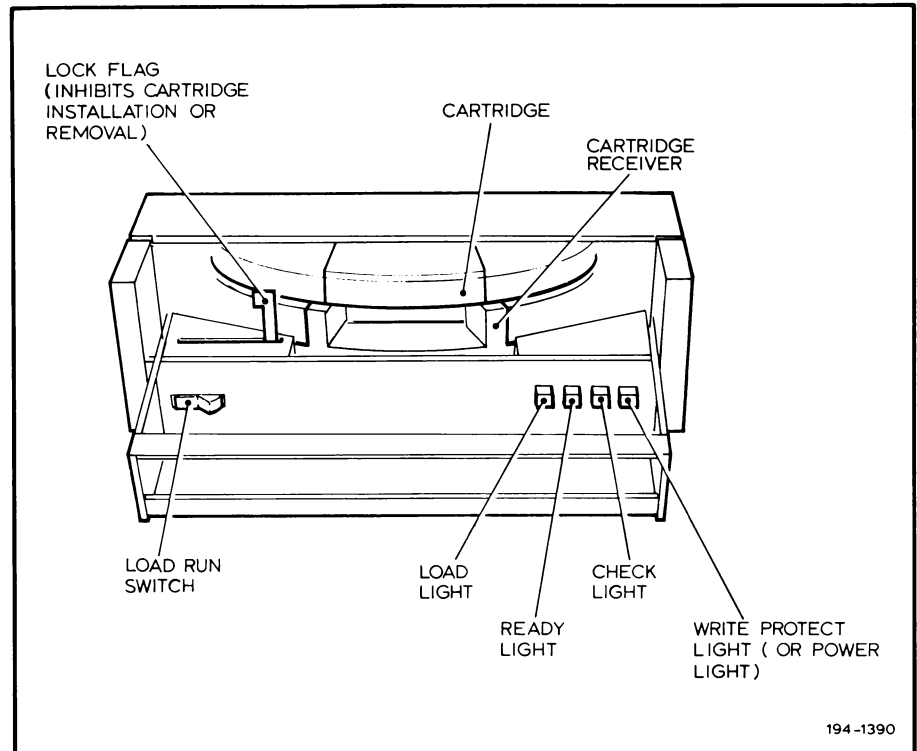

FIGURE 3.1 CONTROLS AND INDICATORS

3.2.1 The load/run switch

The load/run switch is a two position rocker type switch that provides a means for starting and stopping the drive. Cartridges may be removed and inserted when the load light is on and the switch is in the LOAD position. With a cartridge inserted, switching to the RUN position starts the drive and brings the disc up to its normal operating speed in about 60 seconds. When the switch is moved to the LOAD position, the disc decelerates to stop in about 20 seconds, after which the load light goes on, the door interlock releases, and the door can be opened. The following cautions should be observed:

- (a) Switching to the LOAD position during a write operation results in garbling of data. It is the responsibility of the operator to make sure that a write operation is not in progress, before switching to LOAD
- (b) A disc cartridge must not be loaded when the load/run switch is in the RUN position. (This could occur only if the load/run switch were switched to the RUN position after the door of the disc drive has been opened.) This practice can result in damage to the disc-interlock switch and the disc cartridge

3.2.2 The load indicator

The load indicator is a white signal light which indicates that the spindle is not rotating, and that cartridges can be loaded, or unloaded. The light goes out whenever the load/run switch is set to the RUN position.

3.2.3 The ready indicator

The ready indicator is a yellow signal light which indicates that the drive is ready to accept and execute seek, read, or write commands from the external equipment. The light goes on when the disc is turning at its correct speed, the heads are loaded and no other conditions are present that would prevent seeking, reading or writing. The light remains on throughout seek, read or write operation. The light goes out as soon as the load/run switch is set in the LOAD position.

- 3.2.4 The check indicator The check indicator is an orange signal light which indicates that, owing to some abnormal condition, the drive is incapable of writing. The lamp will illuminate if VOLTAGE ERROR is hi or if the write-check flipflop is set. To reset the flipflop, move the load/run switch to LOAD and then back to RUN.
- 3.2.5 The write-protect button and power indicator options The series 30 drive can be supplied with either a write-protect button (section 3.2.5.1) or a power-indicator lamp (section 3.2.5.2).
- 3.2.5.1 The write-protect button The write-protect button is a red, backlighted, momentary-contact pushbutton switch. Write-protect is used to protect against inadvertent writing. The switch glows and writing is inhibited whenever the load/run switch is changed from the LOAD to RUN position or when the external equipment sends a write-protect command. Write protect is turned off, to allow writing, by the operator depressing the protect switch. The operator can set write protect, at any time, by moving the load/run switch to LOAD and then back to RUN. (Write protect is also set when voltage-error becomes true).
- 3.2.5.2 The power indicator The power indicator is a red signal light, which glows when operating power is present.
- 3.2.6 The power indicator The power indicator is a red signal light, which glows when operating power is present. The indicator is located in the write-protect button position when the latter facility is left off by option.
- 3.2.7 Servo-release switch The servo-release switch is for use by the service engineer only. It is a bias-switch, located inside the drive, which allows the engineer to override the positioner servo and manually move the carriage to any cylinder.
- 3.3 OPERATING PRECAUTIONS The following precautions and practices should be observed while operating the series 30:
- (a) Keep the door of the series 30 closed to exclude dust
 - (b) A sustained audible tinging or scratching sound may be caused by head-to-disc contact. If it persists, discontinue use of that cartridge and investigate the cause
 - (c) The operator should not force or attempt to override the door interlock. This interlock is described in section 3.5
- 3.4 OPERATING PROCEDURE The following procedure should be used to load and unload a disc cartridge (except on the model 33F). If, in the following procedure, the equipment door is locked shut, or the cartridge cannot be installed or removed because of the lock flag, do not force anything (the interlock is described in section 3.5).
- (a) Observe that front-panel load light is on
 - (b) Open the door to gain access to the cartridge receiver. With all conditions normal, the lock flag, shown in figure 3.1, is down. When the door is opened, the cartridge receiver moves up and comes to rest in a slightly slanted position, ready to receive a cartridge
 - (c) Install a cartridge, making sure that it slides in all the way, without forcing or twisting
 - (d) Close the door
 - (e) Set the load/run switch to the RUN position

- (f) Observe the load light go out
- (g) Allow the drive about 60 seconds to complete its start-up cycle; then the yellow ready light goes on
- (h) When the ready light is on, proceed to access or read or write data
- (j) If the ready light does not come on, or the orange check light glows, there is a problem
- (k) When the disc drive operation is complete, set the load/run switch to LOAD. Wait for the load light to go on (about 20 seconds)
- (m) The door can now be opened and the cartridge removed. If another cartridge is not to be loaded, shut the door to prevent dust from entering the drive

3.5 THE DOOR INTERLOCK

The disc drive door is locked and the lock flag is up while the disc is turning or when power is off. Disc rotation can be identified by the load light being out. The loss-of-power condition can be recognized when no front-panel lights are illuminated. The operator should never attempt to force open the door.

If a cartridge must be removed from the disc drive while the lock flag is up, the procedure is as follows:

- (a) Remove the top cover
- (b) Move the head carriage to the rear-most location, at cylinder 000
- (c) With a thin rod, pull the door-lock bail toward the right-hand side of the drive
- (d) When the bail has released the door, the lock flag will be lowered and the door can be opened
- (e) Hold the lock flag down while removing or inserting a cartridge

3.6 HANDLING AND STORING DISC CARTRIDGES

The following practices should be observed when handling and storing disc cartridges. Refer to the manufacturer's instructions for more detailed maintenance and cleaning procedures.

- (a) The cartridge-access door should be closed when it is out of the disc drive. Closure creates a positive dust seal and immobilizes the disc
- (b) Cartridges can be stored flat or on edge. Several can be stacked on top of one another but avoid heavy top-loading
- (c) The type 2315 cartridge is usually provided with a frame (on the front edge) that is designed to hold labels without the use of adhesives. It is better to renew a label than to alter one

4.1 LIST OF CONTENTS

page	section	title
4.1	4.1	LIST OF CONTENTS
4.2	4.2	GENERAL
4.2	4.3	THE READ/WRITE HEADS
4.5	4.4	INTERFACE LINES
4.5	4.4.1	Standard input-lines
4.7	4.4.2	Standard output-lines
4.9	4.4.3	Optional lines
4.10	4.5	DRIVE CAPABILITY OF OUTPUT LINES
4.10	4.6	INPUT GATES
4.11	4.7	RECORDING FORMAT
4.12	4.7.1	Typical write and read operations
4.14	4.8	CONTROL
4.14	4.8.1	Power-on condition
4.14	4.8.2	Initial power-on (power-up reset)
4.15	4.8.3	Load/run reset
4.16	4.8.4	Restore operation
4.18	4.8.5	Start-up and speed-control
4.23	4.8.6	Carriage-velocity control
4.28	4.8.7	Seek operation
4.31	4.9	READ/WRITE OPERATION
4.31	4.9.1	Head selection
4.31	4.9.2	Write operation
4.32	4.9.3	Erase operation
4.32	4.9.4	Read operation
4.32	4.9.5	Data separation
4.32	4.9.6	Write check
4.33	4.9.7	Write protect

TABLE 4.1

4.2 GENERAL

The series 30 disc drive consists of the functional units illustrated in the block diagram, figure 4.1. The disc drive turns the disc at 1500 rev/min, precisely aligns the heads over the required tracks and reads and writes data on the disc surfaces.

There are four basic assemblies:

- (a) integral disc-spindle, drive motor and blower
- (b) head positioner, which includes read/write heads, head-carriage, actuator, position transducer, servo motor and head-load/unload mechanism.
- (c) cartridge receiver and access door
- (d) electronics

The assemblies are located round a rigid baseplate. The whole of the interior of the drive is kept clean by a continuous flow of filtered air introduced through the cartridge; the cartridge itself is maintained at a slight positive pressure to prevent the entry of unfiltered air.

4.3 THE READ/WRITE HEADS

The two read/write heads read or write data on the disc by means of standard electromagnetic recording technique. One head functions on the top surface of the disc and the other on the bottom surface. The heads are physically laid out as shown in figure 4.2. Each read/write head consists of three separate precisely-mounted head coils: one performs the reading or writing function, the other two erase to limit the width of data tracks written on the disc surfaces.

In their operating position, the heads fly about 3 micrometres (120 microinches) from the surfaces of the standard-density disc; the heads fly closer to the surfaces of high-density drives. The heads are mounted on two arms that move from the periphery of the disc towards its centre, locating the heads over any one of the 203 cylinders. The heads are loaded to their operating positions by a solenoid-operated mechanism, and are maintained there by spring pressure. Initial loading of the heads is controlled by the start-up logic and takes place when the disc is turning at about 1800 rev/min to ensure the presence of stable boundary-layers of air between the heads and disc surfaces. The heads are unloaded when the run/load switch is switched from RUN to LOAD. Unloading also occurs if the disc speed falls below 1464 rev/min.

The read/write circuits perform the amplification and signal-conditioning necessary for the translation between interface data signal voltages and head currents. The upper head or lower head is selected by the head-select interface line.

In a write operation, a single input-line delivers multiplexed clock and data pulses; one complete pulse corresponding to each flux transition. The write circuits, activated by the write gate, allow current to pass through the write head and write one flux transition for each pulse. The erase heads, activated by the erase gate, trim the written track to 0,130 mm (0.005 inch) [0,180 mm (0.007 inch) with high-density option].

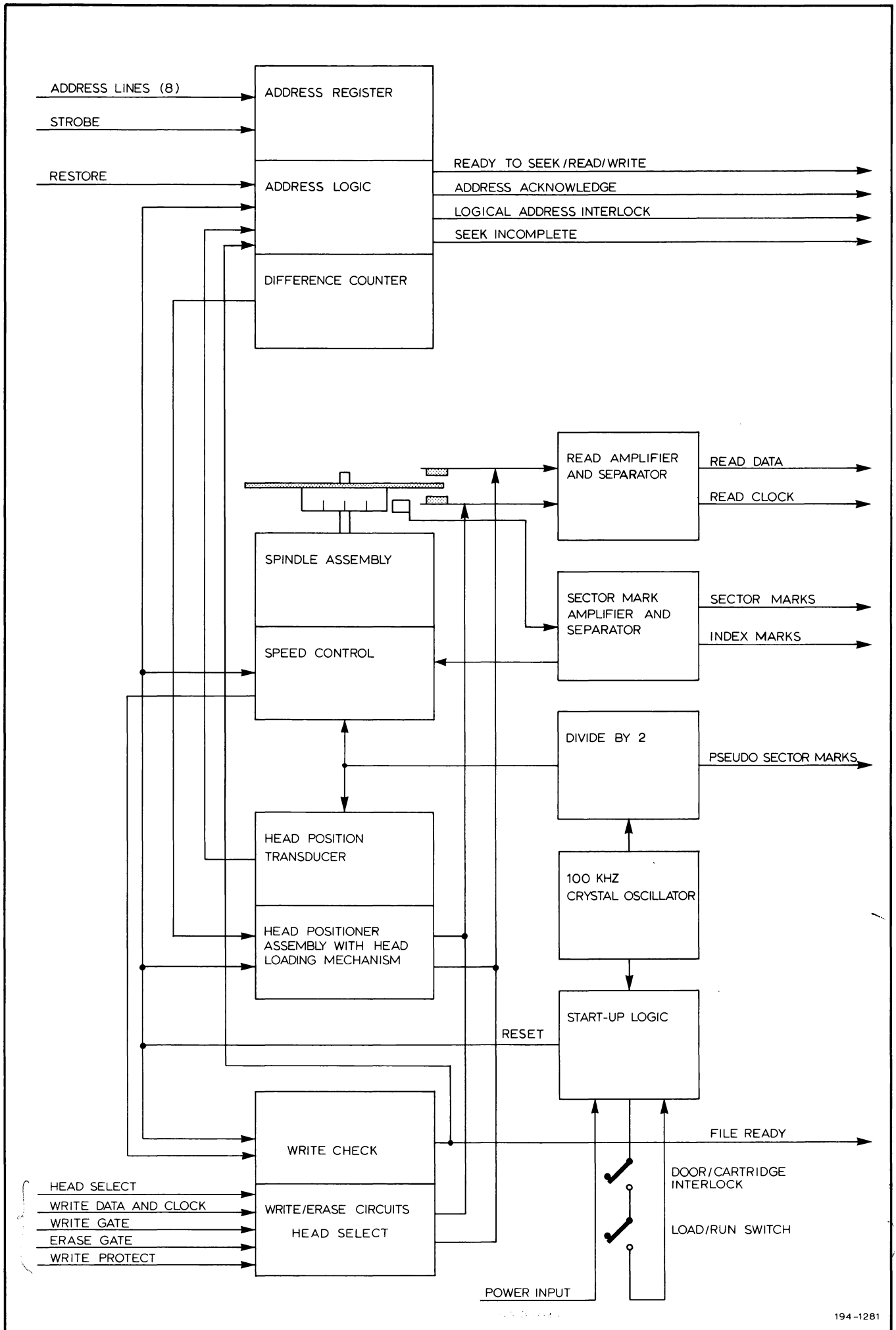

FIGURE 4.1 SERIES 30 BLOCK DIAGRAM

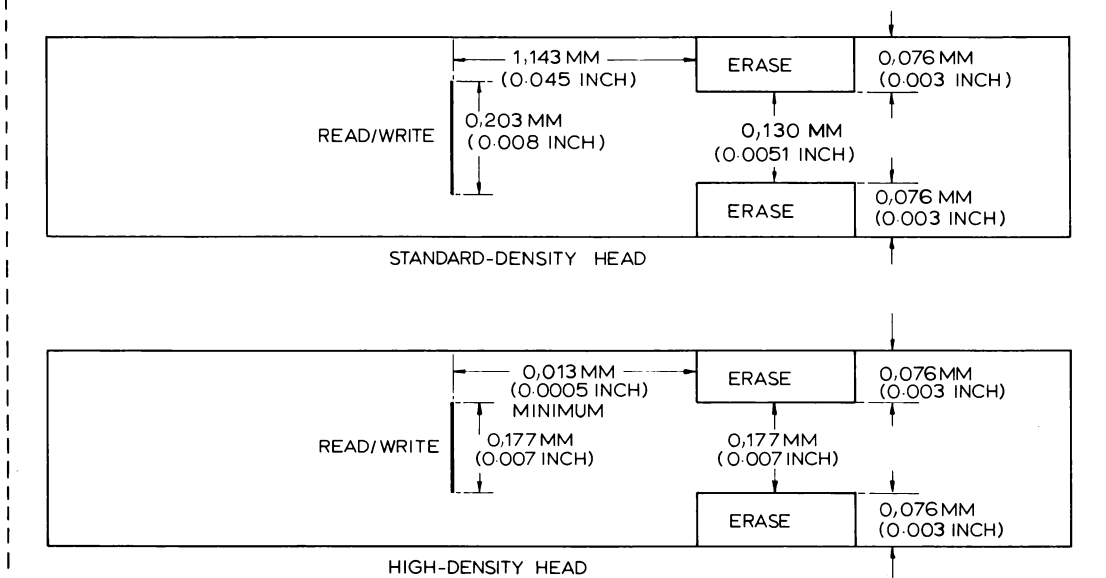
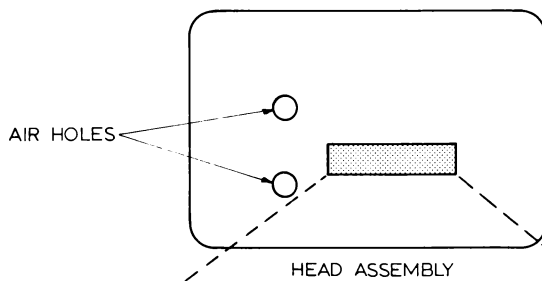
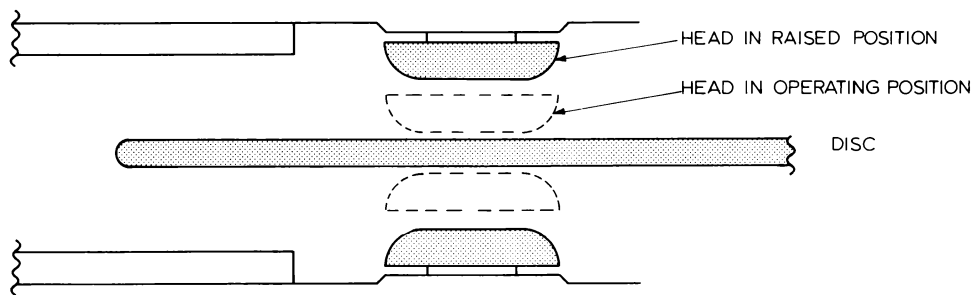

FIGURE 4.2 READ/WRITE HEAD

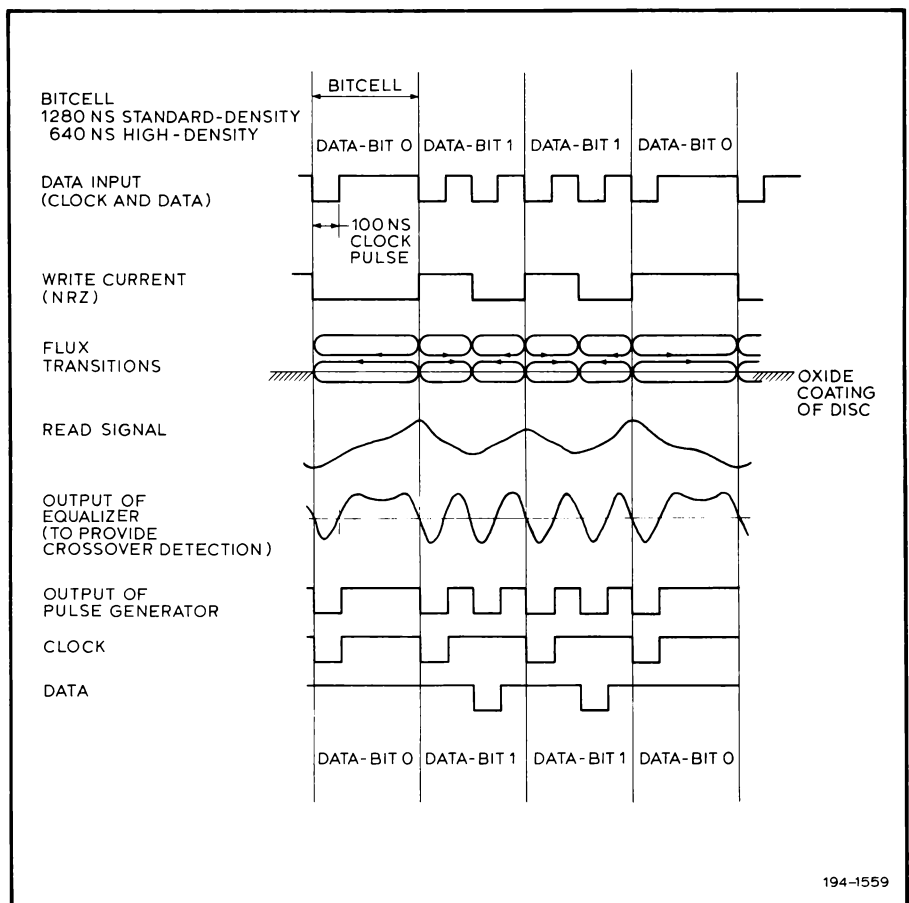

FIGURE 4. 3 DATA TIMING

In a read operation, head-current pulses generated by passage of flux transitions beneath the heads are of alternating sign. The read-circuits amplify, shape, and separate these pulses into distinct clock and data-pulse streams before delivering them to the interface lines. Data-pulse separation is accomplished by a read-data and clock separation-circuit, based on flipflop logic. The format of each data record, controlled by the external equipment, includes a preamble which establishes synchronization for the data and clock separation-circuit.

4. 4 INTERFACE LINES

A list of interface lines and pin numbers is provided in chapter 1.

4. 4. 1 Standard input-lines

- (a) Track address comprises eight lines which carry an 8-bit binary absolute track address. The lines are strobed with the strobe signal to initiate a seek operation. The address lines are held low no longer than five microseconds after the trailing edge of the strobe signal
- (b) The restore line carries a signal calling for head-positioner restore (return to cylinder 000). When this line is strobed by the strobe signal, a restore operation is initiated. Whatever address is on the address lines at this time (for later-production drives this should be zero: the external equipment should send a zero address signal at the same time as a restore signal), the heads move to cylinder 000 and an address-acknowledge signal is sent. (If an invalid address is on the address lines when restore is issued, the address-acknowledge signal is suppressed and the logical-address-interlock signal is sent.) The restore signal is settled prior to the leading edge of the track-address strobe signal, and held no longer than five microseconds after the trailing edge of the strobe signal

- (c) The strobe signal is used for sampling the track-address lines and the restore line. The leading edge of the strobe appears only after the appropriate signals have fully settled. The strobe is held until either the address-acknowledge signal or the logical-address-interlock signal is issued by the disc drive. This may be as soon as 22,5 microseconds or as late as 47,5 microseconds after the leading edge of the strobe. When the address-acknowledge or the logical-address-interlock is sent, the strobe signal is removed within 5 microseconds. Rise and fall time of the strobe signal is compatible with commercially available dtl and ttl integrated circuits
- (d) The head-select line allows the selection of one of the two heads for reading or writing. The signal on this line is held for the entire duration of a read or write operation. Lo selects the upper head, hi selects the lower head
- (e) The write-gate line turns on write current in the head that has been selected. This signal is applied at least two microseconds prior to writing the first flux-transition, and held for the entire duration of the write operation. Lo for write current, hi inhibits write current. If the drive is not fitted with an erase-gate interface line, the write-gate line also turns on erase current
- (f) The write data and clock line accepts multiplexed data and clock pulses for double-frequency recording, one complete pulse for each recorded flux-reversal. Pulses have a minimum width of 100 nanoseconds, the leading edge has a transition time of not more than 50 nanoseconds. This line is held hi when not writing. Write pulses swing between hi and lo (+5 volts and 0 volts nominal).
- (g) The read-gate line enables the read-clock and read-data output lines. The read gate must be held lo during the read operations
- (h) The select lines. In order to perform the selection of one particular unit in a system where more than one drive is used, four select lines and a corresponding internal jumper are accommodated. These lines select and activate the input/output lines of the jumpered unit either in a daisy-chain or party-line configuration. Selection is accomplished by applying a lo to the desired input line
- (j) The write-protect line prevents writing by disabling the write amplifier. Write-protect is set when the load/run switch is moved from LOAD to RUN. It may also be set by the write-protect input line and is set by voltage-error going hi. When this line goes lo for a minimum duration of 350 nanoseconds, it sets write protect and inhibits the write capability. Write protect is reset by the operator momentarily depressing the protect switch
- (k) The erase-gate line turns on erase current in the selected head; lo for erase current, hi inhibits erase current

- (a) File ready, when lo indicates that the disc drive is in the following condition:
- (i) The drive is supplied with the required power
 - (ii) A disc cartridge is loaded
 - (iii) The door is closed
 - (iv) The load/run switch in the RUN position
 - (v) The disc is rotating at the correct speed
 - (vi) The heads are loaded
 - (vii) The write-check signal is hi
- (b) Ready to seek, read, or write (ready-to-s/r/w), when lo indicates that the disc drive is in the file-ready condition and is not in the process of executing a seek operation. Following a seek command to a valid address (other than the present address), or a restore command, the ready-to-seek/read/write line goes hi (not less than 2,5 microseconds after detecting the leading edge of the strobe signal). The return of the ready-to-seek/read/write line to lo indicates that the seek (or restore) operation has been completed, the read/write heads are fully settled and the drive is ready to accept a read, write, or another seek command. This line does not change when the present cylinder is readdressed
- (c) The address-acknowledge line signals to the external equipment that a command to move the heads to a specified address has been accepted, and that execution of the command has started. The signal is sent at a minimum of 22,5 microseconds after the strobe signal even if there is no change from the previous address. The address-acknowledge signal is a pulse with a minimum width of 2,5 microseconds and a maximum width of 7,5 microseconds. It is not issued if a command to move to a track position greater than 202 is received: in this case, execution is suppressed, and a logical-address-interlock signal is issued instead. The address lines, as well as the strobe signal, must be held until either the address-acknowledge or the logical-address-interlock signal is issued by the disc drive
- (d) The logical-address-interlock pulse indicates that a command to move the heads to a track address greater than 202 has been received and the command is therefore not executable. The strobe signal must be removed within 5 microseconds after receipt of this signal. The logical-address-interlock signal has the same timing relationships as the address-acknowledge signal
- (e) Seek incomplete, when lo indicates that, owing to some malfunction, a seek operation has not been completed. This signal level is maintained until a restore command is received and executed by the drive
- (f) The sector-marks line supplies one 5 microsecond lo pulse for each of the sector slots as they pass the sector transducer. The leading edge is used as reference. The index-slot, which serves as the marker for the first sector, is suppressed in this line and fed instead to the index-marks line

- (g) The index-marks line supplies one 5 microsecond lo pulse per disc revolution to provide sector identification. The leading edge of this pulse follows the leading edge of the last sector pulse by a nominal 610 microseconds and signifies that the sector mark following this pulse is the sector mark for the first sector on the track
- (h) The pseudo-sector-marks line supplies 50 kHz clock pulses to the interface. The pseudo-sector marks can be used to further divide the tracks between the sector marks so that variable-length blocks of data can be written according to external-equipment requirements
- (j) The write-protect-status line provides an indication to the external equipment of write-protect status. Lo indicates that the write capability is inhibited. The operator can change the status manually by depressing the momentary-action protect pushbutton on the front panel, thereby establishing the write capability
- (k) Write check, when lo indicates that one or more of the following conditions is present:
 - (i) write-current without a lo write-gate line
 - (ii) write-gate line lo without write-current
 - (iii) write and select for both heads
 - (iv) erase-current without a lo erase-gate line
 - (v) erase-gate line lo without erase-current
 - (vi) write or erase-gate lo when ready-to-seek/read/write is hi

When write check is set true by one of the above listed conditions, execution of all external commands is suppressed. To reset write-check, which is also visually indicated by the front-panel check lamp, the operator must move the load/run switch to the LOAD position and then return it to the RUN position

The write-check line is also used to notify the external equipment that the supplied voltage to the drive has dropped to less than a nominal 13,5 volts. If this occurs during a write operation it may be desirable to rewrite the affected record. Reset is not required when write-check is caused by voltage fluctuation

- (m) Read-clock pulses represent clock signals during reading. Pulse-width is nominally 100 nanoseconds with a minimum of 50 nanoseconds and a maximum of 150 nanoseconds. The leading negative-going edge is used for reference
- (n) Read-data pulses represent data signals that have been separated from clock signals during reading. Pulse-width is nominally 100 nanoseconds with a minimum of 50 nanoseconds and a maximum of 150 nanoseconds. The leading negative-going edge is used for reference.

- (p) High-density indication, when lo indicates that the disc drive has the high-density option installed. On a standard-density disc drive this line floats hi
- (q) Sector-address comprises five lines which define, in binary-encoded form, the sector under the read/write head. This address is derived from a five-bit binary sector counter. The counter is advanced by the leading edge of each sector mark and is reset to zero by the leading edge of the sector mark following the index mark. The status of the sector-address counter can be unambiguously evaluated if the readout occurs at the trailing edge of the sector mark signal

In the zero state the counter output-lines are hi, indicating the reset state

4.4.3 Optional lines

- (a) The attention line option may be supplied to give either positive or negative output signals as required. These attention-line options occupy four lines in the daisy-chain interface. The four standard interface-lines used for these four attention lines are given in table 4.2; the signals in the line-replaced column of the table are not available if the attention-option is fitted

attention line	pin	line replaced
attention unit 1	H	write-protect input
attention unit 2	M	high-density indication
attention unit 3	S	pseudo-sector marks
attention unit 4	XX	logical-address interlock

TABLE 4.2

An internal attention-jumper-plug is added in each drive. This jumper plug connects that drive to one of these four attention lines. The attention-line number and the select-line number must correspond

The attention-line signal is a logical combination of internal disc-drive signals and informs the external equipment when the drive changes status: if the drive becomes ready (file-ready), completes a seek operation (ready-to-seek/read/write) fails to complete a seek operation (seek-incomplete) or accepts a cylinder address (address-acknowledge)

If an attention line having negative-signal outputs is used, the attention line is lo in the not-ready state and goes hi when the drive reaches the ready status. The attention line goes lo at the start of a seek operation and returns to hi at the completion of the seek

The completion of the seek occurs when the read/write heads are settled over the new cylinder, or on detection of a seek-incomplete condition. In the event of a seek to the present cylinder-address, the attention line presents a pulse coincident with the address-acknowledge pulse. In the event of an invalid cylinder-address, the address-acknowledge pulse is suppressed and a pulse corresponding to the address-acknowledge pulse is presented on the attention line; the seek-incomplete line is also set lo by an invalid address and must be reset by a restore operation

If an attention line having positive signal outputs is used, the attention line is hi in the not-ready status and goes lo when the disc drive reaches the ready status. The output level of attention-line-positive is in the opposite polarity, but generally operates as explained in the description of attention-line-negative.

(b) The interrupt option. With this option, file-ready, ready-to-look/read/write, and seek-incomplete are not conditioned by the select line. Therefore they present their status to the interface at all times. This option requires special cabling.

4.5 DRIVE CAPABILITY OF OUTPUT LINES

(a) Read clock and read data output lines are driven as shown in figure 4.4. The lo output level is +0,5 volt maximum at 95 milliamps sink current. The hi output level is +3,2 volts minimum with external pull-up resistor.

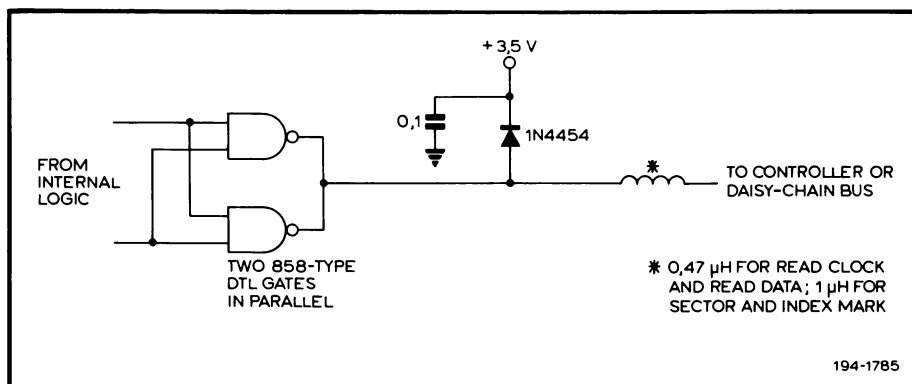

FIGURE 4.4 OUTPUT DRIVER CIRCUIT OF READ CLOCK, READ DATA, SECTOR MARK AND INDEX MARK LINES

(b) All other output lines are driven as shown in figure 4.5. The lo output level is +0,5 volt maximum at 95 milliamps sink current. The hi output level is +4,5 volts minimum with no external load current.

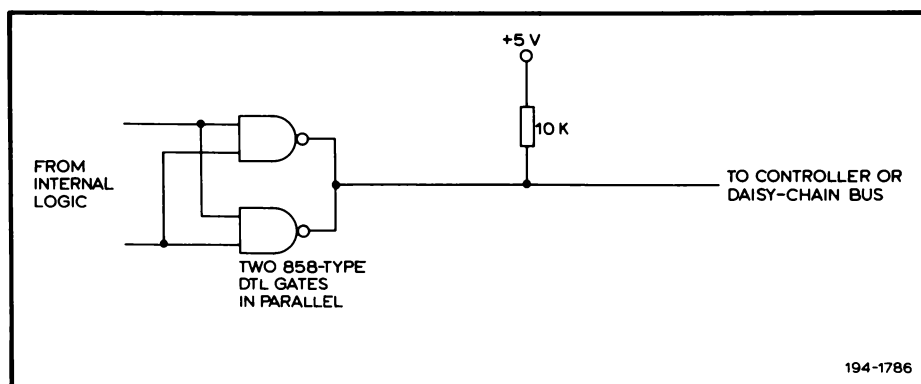

FIGURE 4.5 OUTPUT DRIVER CIRCUIT

4.6 INPUT GATES

The series 30 disc drives use 380-type nor gates as the input circuits. The 380-type integrated circuit is from the Utilogic family and because of its circuit structure has a higher input threshold in the lo state compared with most commercially available DTL or TTL circuits. This ensures a higher noise margin on all input lines. In addition, the 380 input circuit loads the signal transmission lines with significantly less input current, causing a lesser amount of local reflexions on the line in a daisy-chain configuration.

The input of the 380 circuit has to be pulled-up in the hi state. For this reason it cannot be driven by an open-collector-driver stage without collector resistance.

Figure 4.6 shows the input circuit used in the series 30.

The lo input threshold level is +1,4 volts minimum with no load current. The hi input threshold level is +2,7 volts maximum at a load current of 180 microamps with an external pull-up resistor.

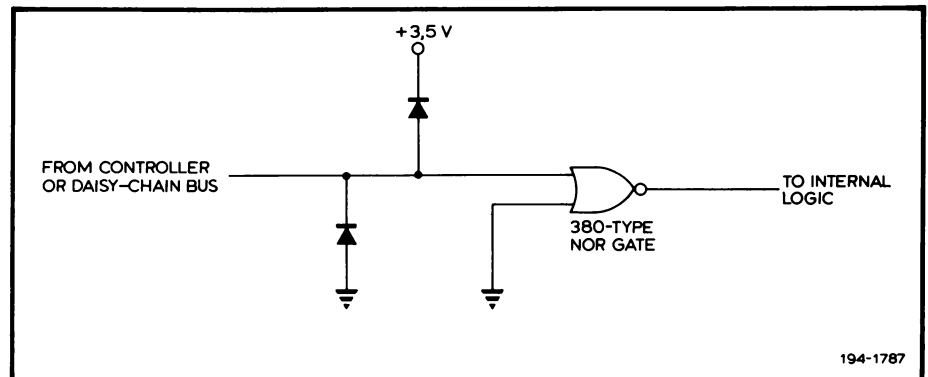

FIGURE 4.6 STANDARD INPUT CIRCUIT

4.7 RECORDING FORMAT

Each system's formatting requirements are likely to be significantly different. The example given in subsections (a) to (g) should be regarded as a suggested method of determining the data format. The factors considered in this example, which affect the amount of time available for writing data between sector marks, are based on inner track timing and are the minimum times to be considered.

- (a) Physical location of erase and write coils: in a recording head, the erase coils are located on either side of and behind the write coil with respect to the direction of disc rotation. The resulting delay between writing and erasing on the same part of the disc surface is 65 microseconds on a standard-density drive and 25 microseconds on a high-density drive. When these coils are activated and deactivated at the same time, there is a nominal gap of unerased data and a glitch on the disc surface that must be considered.
- (b) Location of the sector-mark slots on the disc hub: the variation in the positions of these slots on individual discs will affect the amount of time available. Disc cartridge manufacturers specify this variation at $\pm 0^{\circ}12'$ or $\pm 22,5$ microseconds.
- (c) Alignment of sector transducer in relationship to each head: there will be up to ± 5 microseconds variation in this alignment on individual disc drives.
- (d) Sector jitter and CE cartridge variation: this may be as much as ± 10 microseconds.
- (e) Preamble used for synchronising the data and clock separation circuits and for providing the required time intervals: the preamble consists of a stream of zeros followed by a single one bit. The preamble must be started when the write gate is set true and must allow a minimum of 6 microseconds of preamble to be read (for synchronising the separation circuits) prior to the single one bit.

- (f) Speed variation: only the overspeed tolerance, which shortens the amount of available time, is considered.
- (g) All check characters that are used to ensure validity of data are considered as part of the data record.

Table 4.3 is a summary of the various times discussed in subsections (a) to (g).

	time in microseconds
physical location of erase and write coils	65 (25 on high density drive)
location of sector-mark slots	45
alignment of sector transducer	10
sector jitter	20
preamble for synchronisation of separation circuits	6
nominal time per revolution	40 000

TABLE 4.3

The formula for calculating the minimum amount of recording time per sector is:

$$\frac{(40\ 000 \times 0,99) - (65+45+10+20+6)}{n}$$

where n is the number of sectors and 0,99 is the allowance for 1% disc speed variation.

For example, on a disc with 8 sectors the equation will be:

$$\frac{(40\ 000}{8} \times 0,99) - 146 = 4804 \text{ microseconds.}$$

The actual maximum data length is equal to the next smaller whole number of computer words that will fit within 4804 microseconds at the disc recording bit rate. For instance; at a data transfer rate of 781 kHz, the maximum number of bits in one sector of an 8 sector format, may be calculated thus $\frac{4804}{1} \times \frac{781}{1000}$ which is

3751 bits or 312 twelve-bit words or 234 sixteen-bit words.

4.7.1 Typical write and read operations

Reference should be made to figure 4.7 and the foregoing calculations.

- (a) For a write operation, proceed as follows:
 - (i) Detect sector mark
 - (ii) Wait 65 microseconds until end of erase zone
 - (iii) Turn on write and erase gates if not already on
 - (iv) Write preamble for 61 microseconds. Minimum preamble consists of a stream of zeros followed by a single one bit.
 - (v) Write data including any header and cyclic redundancy check characters

- (vi) Continue writing zeros
 - (vii) Detect sector mark
 - (viii) Wait 65 microseconds
 - (ix) Turn off write and erase gates if not writing next sector
- (b) For a read operation, proceed as follows:
- (i) Detect sector mark
 - (ii) Wait 102 microseconds
 - (iii) Turn on read gate
 - (iv) Read preamble and data including any header and cyclic redundancy check characters
 - (v) Turn off read gate.

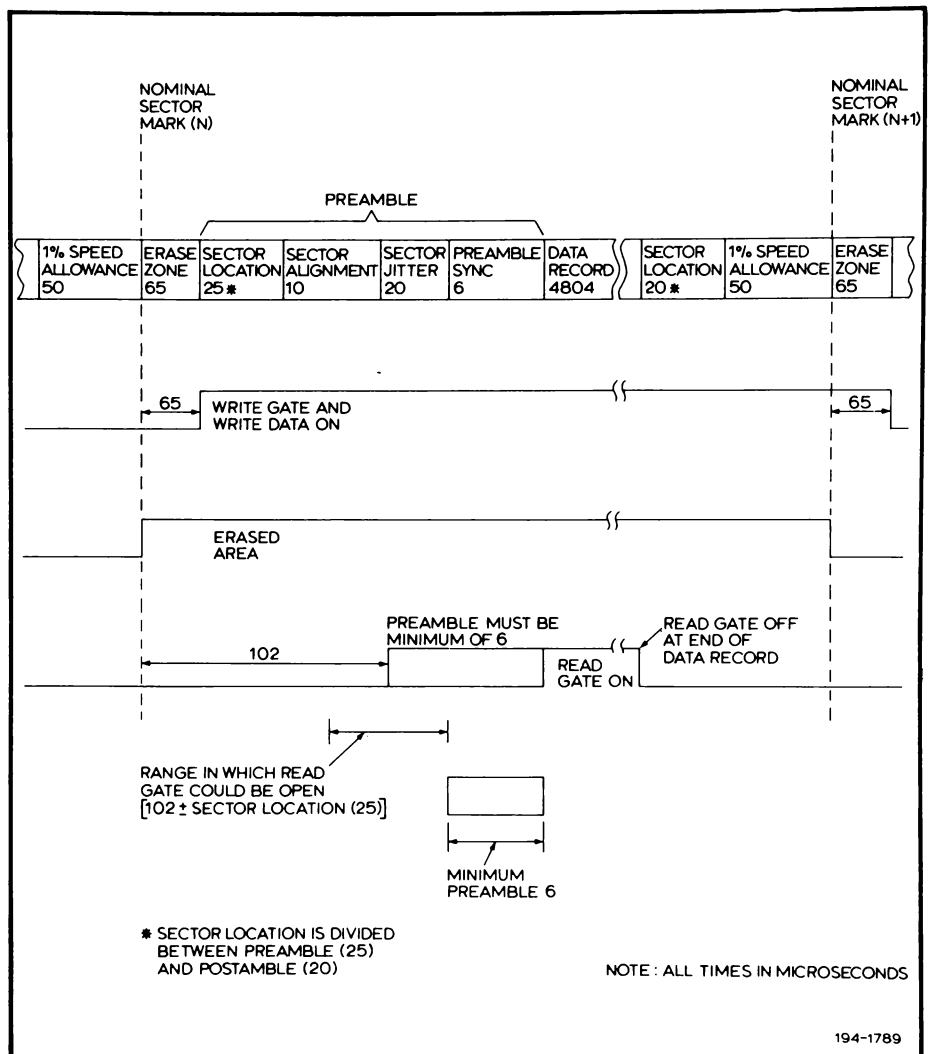

FIGURE 4.7 DATA FORMAT

4.8 CONTROL

4.8.1 Power-on condition

The +5 volts for the disc drive is derived from the supplied +15 volts (see the J8 circuit diagram, chapter 8). The regulating circuit uses a 4,3 volt zener diode as a voltage reference, and a 6,2 volt zener protects against overvoltage if the circuit should malfunction. The series-pass transistor is located on the heatsink.

The externally-supplied voltages (+15 and -15 volts dc) are monitored by circuits on board J8. If either voltage falls more than 10% below its rated value, a voltage-error signal is generated. If the voltage-error signal is long enough it causes the write-check indicator to light and a write-check signal to be generated. Voltage-error from J8 generates load/run reset and start-up reset on J9. Voltage-error is also routed to J10 to the write-check line and then back to J8 to the write-check indicator driver circuit.

The 100 kHz crystal located on J8 starts oscillating when power is supplied and 100 kHz square-wave pulses are provided to the two-phase clock-generator on board J3 (used in the spindle-speed control circuit).

The 100 kHz square-wave pulses are also divided by two by the flipflop on J9 and these derived 50 kHz pulses are used in the speed-control circuits. The 50 kHz pulses are also sent to the interface for pseudo-sector marks, and in addition, are used as input to the triangle-waveform generator on the J8 board, which drives the head-position transducer.

4.8.2 Initial power-on (power-up reset)

When power is first applied to the drive a voltage-error signal is generated on board J8. Since a voltage-error signal, when the drive is operating, will unload the heads, retract the head carriage, stop the spindle and leave the drive ready for further commands, this signal now holds the drive in safe condition during the initial application of power.

Voltage-error lo to board J9 causes a 70 millisecond power-up reset, producing a load/run-reset hi pulse (see also section 4.8.3) and start-up-reset lo pulse.

The load/run-reset hi pulse causes the following on J9:

- (a) Sets write-protect FF (into protect condition)
- (b) Resets motor-drive-delay FF
- (c) Resets index-delay FF
- (d) Sets start-up FF (this holds index-delay FF reset during start-up)
- (e) Sets head-load FF

- (f) Resets high-speed FF
- (g) Sets index/clock synchronizing FF
- (h) Zeros the binary counters
- (j) Resets speed-OK FF

The load/run-reset hi pulse also goes to J2 and J10 where it causes the following:

- (k) Initiates a power-up restore operation (J2)
(See section 4.8.4)
- (m) Resets write-check FF (J10)

The start-up-reset lo pulse goes to J8 where it makes servohold lo to allow a restore operation, and generates initial-reset lo (see restore section 4.8.4), to force the difference-address counter to zero.

The door-unlock solenoid is energized to allow the door to be opened, only under the following conditions:

- (n) The heads are unloaded and the head carriage is at (about) cylinder-000 (the carriage-interlock switch is closed)
- (p) Spindle rotation has stopped
- (q) The load/run switch is in the LOAD position
- (r) The head-in-motion line from J2 is hi, indicating that the carriage is stationary

4.8.3 Load/run reset

The load/run-reset signal is generated by one of the following:

- (a) Initial power-on (see section 4.8.2)
- (b) Detection of a voltage error (see section 4.8.2)
- (c) The operator setting the load/run switch to RUN to start the drive

When the load/run switch is in the LOAD position and the drive is in the power-on condition, the following applies:

- (d) The spindle drive motor is not turning
- (e) The disc-cartridge-loading door is not locked
- (f) The voltage levels at the points shown in figure 4.8 are: X at +5 volts, Y at 0 volts, Z at +5 volts (see also the J9 circuit diagram)

When the load/run switch is set to RUN (with disc cartridge loaded and the drive in the power-on condition) the following occurs:

- (g) The spindle-drive motor is connected across the +15 volt and -15 volt supplies: the spindle starts to turn
- (h) The disc-cartridge-loading door is locked
- (j) The load/run-reset signal is generated to cause a restore operation. Figure 4.8 shows how load/run-reset hi is produced: when the load/run switch is set to RUN, X goes to 0 volts, Y goes to 5 volts and, provided start-up reset is hi, Z goes to 0 volts in a time governed by capacitor C

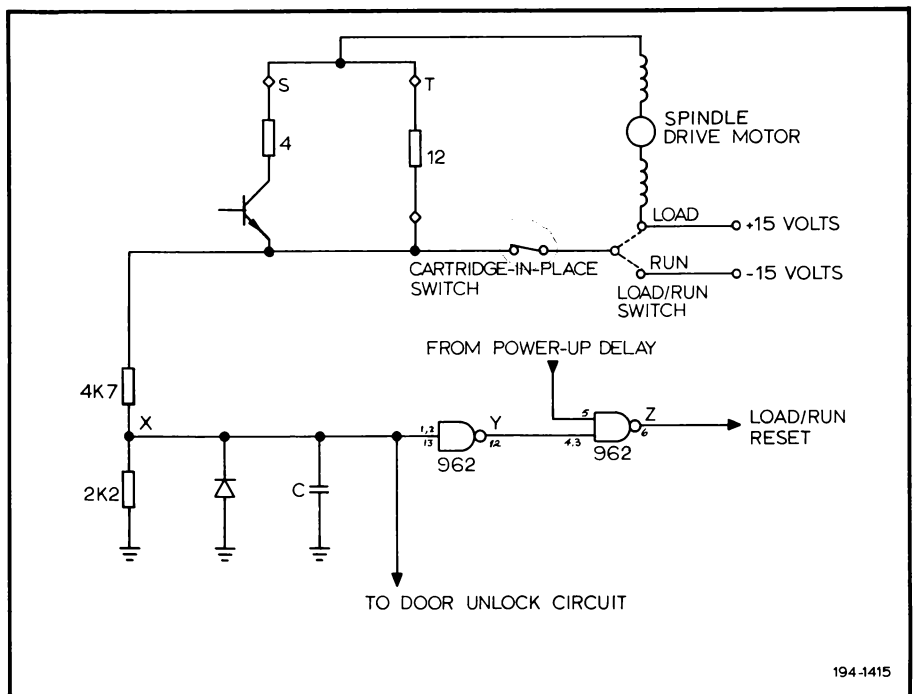

FIGURE 4.8 LOAD/RUN CIRCUIT, SIMPLIFIED

4.8.4 Restore operation

A restore operation is initiated by one of the following:

- (a) Power-up reset
- (b) Rising or falling edge of load/run reset
- (c) From the interface (restore-line lo with strobe-line lo makes initiate-restore lo)

Restore is initiated by load/run reset changing logic level or initiate-restore going lo to cause the restore one-shot (16 ms) to fire (servohold is made lo by start-up-reset lo)

The restore one-shot output's going lo, first resets the address-error FF then resets the seek-incomplete FF. Restore FF1 and restore FF2 are set. The low-going edge also resets the seek FF and inhibits ready-for-address and the ready-to-seek/read/write line. Reverse-and-first-speed increment is set lo.

The Q output of restore FF1 goes hi, is inverted and restore-FF1-Q lo goes to J3. This will be referred to later.

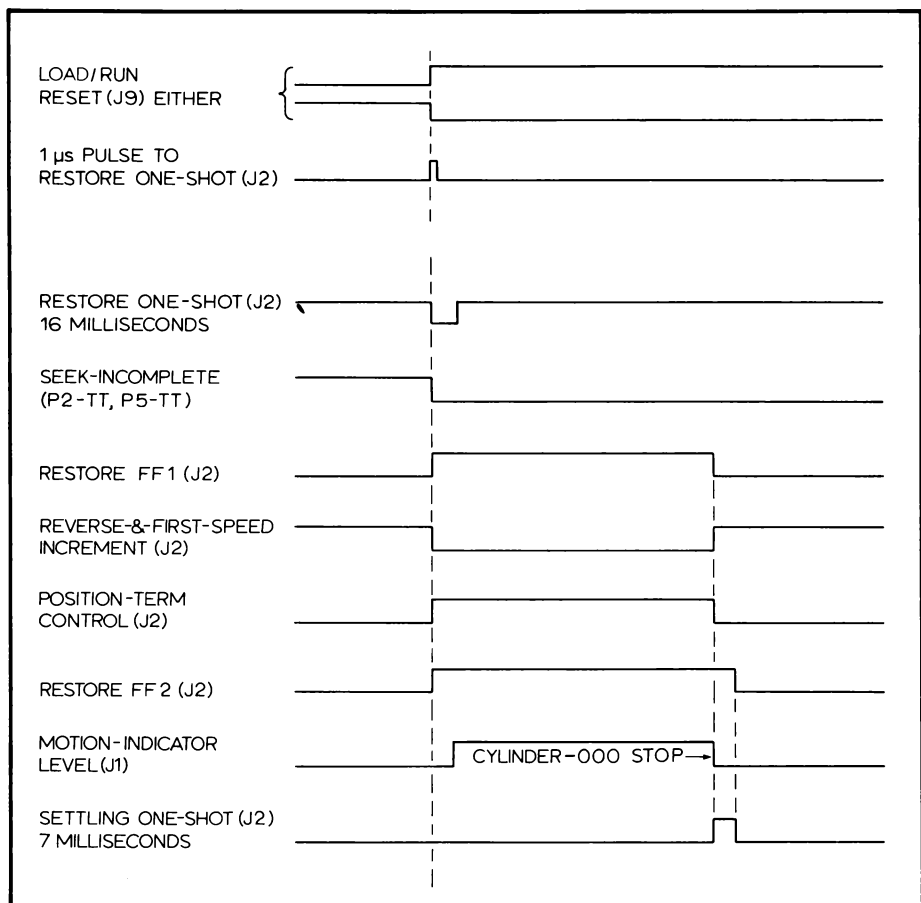

FIGURE 4.9 RESTORE TIMING

The \bar{Q} output of restore FF1 goes lo with the following effect:

- (d) Reverse-and-first-speed increment goes lo
- (e) The output of forward/reverse FF is inhibited, position-term control is lost, advancing of the difference-address counter is inhibited and the 2nd, 3rd and 4th speed increments are inhibited
- (f) Seek FF is inhibited

The \bar{Q} output of restore FF1 also goes lo to restore FF2. The Q output of restore FF2 goes hi and, as the carriage is now in motion, this has no effect; the \bar{Q} output goes lo and, as the carriage is moving and the seek FF is reset, this has no effect.

When restore FF1 is set, restore-FF1- \bar{Q} lo goes to J3 where it is gated to provide load-address-register hi and strobe-difference-counter hi. The load-address-register hi clocks the address register, and the address gates are enabled by the sequence-FF1 \bar{Q} output, so that the zero address on the interface track-address lines is clocked into the address register and gated to the subtractor. The all-zero output from the subtractor is strobed into the difference-address-counter; the difference-address-counter advance is inhibited during a restore operation, so the address register and difference-address-counter are forced to cylinder 000.

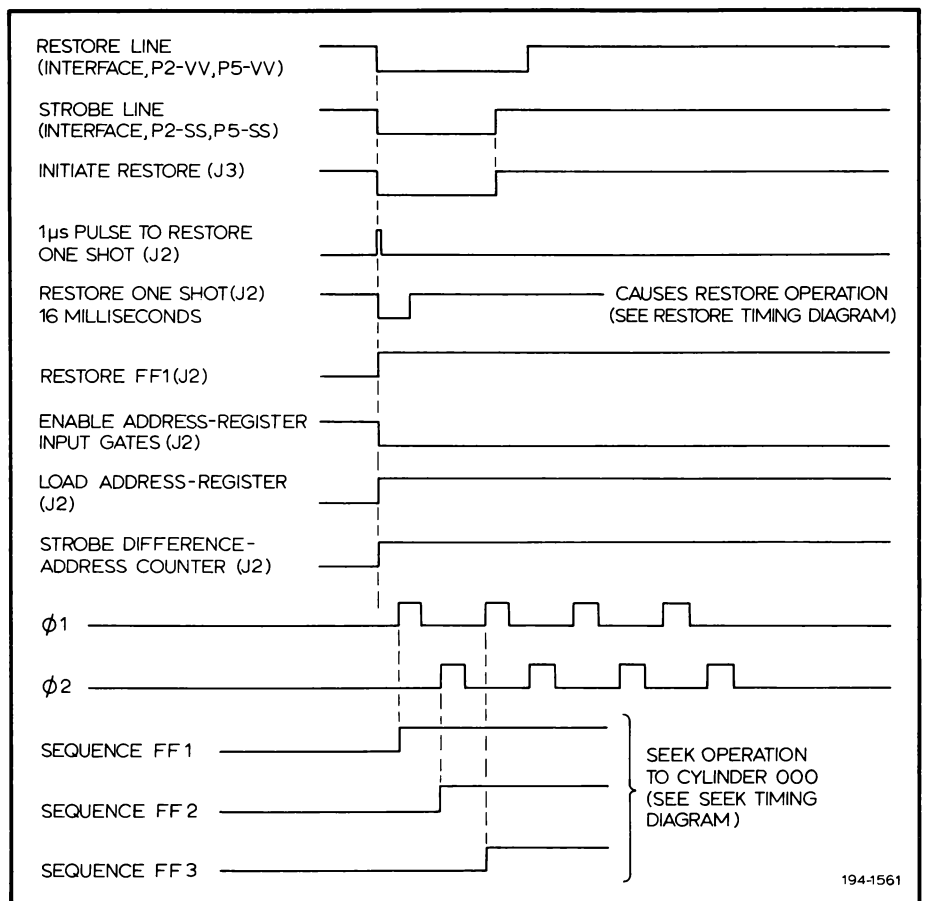

FIGURE 4.10 RESTORE (CALLED BY EXTERNAL EQUIPMENT) TIMING

The heads reverse at first-speed increment until the cylinder-000 stop is detected. No-motion hi (TP6 on J2) is gated with restore-FF2-Q to reset restore FF1. Restore-FF1-Q turns on position-term-control to fire the settling one-shot. At the end of the 7 millisecond period, the settling one-shot clocks and resets restore FF2, thus completing the restore operation.

When restore is sent from the external equipment the sequencing logic on J3 is used. Restore-line lo and strobe-line lo make initiate restore go lo to start the restore operation described above and to set the sequencing logic in operation.

4.8.5 Start-up and speed-control

Before start-up, the series 30 must have the power applied and the disc cartridge properly loaded (the model 33F starts up on receipt of power).

The sequence is started by setting the load/run switch to RUN, and is as follows:

- (a) The load/run-reset line initiates restore
- (b) Power is applied to the spindle-drive motor
- (c) The disc-cartridge-loading door is locked
- (d) The index pulses are counted
- (e) The high-speed FF is set
- (f) The high-speed FF is reset, the heads load
- (g) The spindle comes under servo speed-control
- (h) The interface lines are enabled

See timing diagram, figure 4.11; flowchart, figure 4.12;
J9 circuit diagram.

The load/run-reset line goes lo when the load/run switch is set to RUN, and causes a restore operation (see section 4.8.3).

The spindle-drive-motor circuit is completed: power goes to the spindle-drive motor through the 15 ohm resistor located between terminals U and T on the power-driver board.

A spindle-rotation sensing-circuit on J9 keeps the door of the drive locked whenever the voltage across the spindle motor is 1 volt or more. Pin 11 of F13 on J9 goes lo, so pin 8 goes hi and transistors K13, B11 and B13 turn off and the door-unlock solenoid is de-energized. This condition exists when power is applied to the motor through the load/run switch, or when the motor, acting as a generator, slows to a stop in the load condition.

As the spindle starts turning, the sector marks and index marks are detected and amplified. The spindle shortly reaches sufficient speed for the index/sector separator circuit to separate the index mark from the sector marks.

When the index mark follows the adjacent sector mark within the 1 millisecond period of the index-separation one-shot (fired by the sector-mark pulse), an index-mark pulse is gated from F46 pin 3 (see the J9 circuit diagram).

Sector mark pulses are directed, as hi-going pulses, to the binary counters. The pulses are gated through E57, with start-up-FF reset output hi, to the counters.

After counting 128 sector-mark pulses, pin 11 of F68 binary counter goes hi: this output is gated from D46 pin 8, with the next sector-mark pulse and start-up reset-output, to set the high-speed FF.

Setting the high-speed FF causes the following:

- (j) The \bar{Q} output disenables D68 which then stops sector-mark pulses from going to the binary counters: index-mark pulses are now counted instead
- (k) The Q output goes to the motor-drive-delay FF, which is clocked and set by the next sector pulse

The Q output of the motor-drive-delay FF is gated through E46 with voltage-error hi to turn on transistors K9, B30 and B31; this connects a 4 ohm resistor (between terminals S and R) in parallel with the 15 ohm resistor (between T and U) to allow high current to the spindle-drive motor. The spindle now accelerates towards 1800 rev/min.

Index pulses are counted until the binary counters reach 1024. At this count, pin 8 of counter E68 goes hi and resets the start-up FF; the index-delay FF is no longer held reset and the speed-control circuits begin to operate.

The binary counters start to count 50 kHz pulses: 100 kHz pulses, supplied from the crystal oscillator on J8, are divided by two on J9 and gated to the counters.

Since the count was 1024 when the start-up FF was reset, the counter output is greater than 2048 (E68, pin 11 hi) at the next index pulse. At this next index pulse, the index-delay FF is set. (The index pulse may occur at a random time with respect to the 50 kHz pulses, so cannot be used directly to strobe the counters.) The following 50 kHz pulse clocks and resets the index/clock synchronizing FF, generating the strobe-counter-decode pulse. At this time, because of the high counter state, (E24 pin 2 and E68 pin 11 are hi), the strobe-counter-decode pulse does not affect either the high-speed FF or head-load FF. The next 100 kHz pulse, with strobe-counter-decode pulse, resets the binary counters and the index-delay FF. The next 50 kHz pulse, with index-delay FF reset, sets the index/clock synchronizing FF.

50 kHz pulses are again counted, until the next index pulse. When the index pulse occurs, the strobe-counter-decode pulse is again generated, and, as the drive speed is well above normal, the count is less than 1999 (E24 pin 2 is lo): the high-speed FF and head-load FF are now reset.

High-speed FF Q output goes low, resetting motor-drive-delay FF to switch off the high current to the spindle-drive motor. Head-load FF \bar{Q} output goes hi to prime the speed-OK FF and fire the head-load one-shot (700 milliseconds). E46 pin 4 goes lo, turning on transistors K17, B18 and B22 on the power-driver board to connect +15 volts, -15 volts across the head-load solenoid and load the heads. The Q output of the head-load FF makes E46 pins 10 and 11 hi to turn on transistor B37 and maintain a circuit between +15 volts and +5 volts across the head-load solenoid: this keeps the heads loaded at the end of the head-load one-shot firing period.

The spindle speed is now falling. The counters continue to count the 50 kHz pulses between index pulses, and each index pulse resets the counters to zero.

When the spindle speed has fallen sufficiently for E24 pin 2 to go hi (count greater than 1999) the high-speed FF is again set. The high-speed FF Q output is gated with strobe-counter decode and head-load FF \bar{Q} output by B57: pin 6 of B57 goes lo and sets the speed-OK FF to generate spindle-speed OK (provided the head-load one-shot 700 millisecond period has ended).

Spindle-speed OK is used for the following:

- (l) Lights the ready indicator on the drive control panel (through J8)
- (m) With select and read/write enable, is gated on J10 to enable the data channel input gates
- (n) With select, is gated on J10 to provide ready status at the interface

Speed control is effected by checking the number of 50 kHz pulses counted from one index pulse to the next, and turning on or off the high current to the spindle-drive motor as required. The counter output is decoded to produce a signal that is hi for a count greater than 1999 (spindle-speed should be 1500 rev/min, this gives 2000 of the 50 kHz pulses for each revolution). At index time the high-speed FF is set if the greater-than-1999 signal is hi, and reset if the signal is lo. The following sector-pulse makes the motor-drive-delay FF the same state as the high-speed FF, and this turns on or off the high current to the spindle-drive motor.

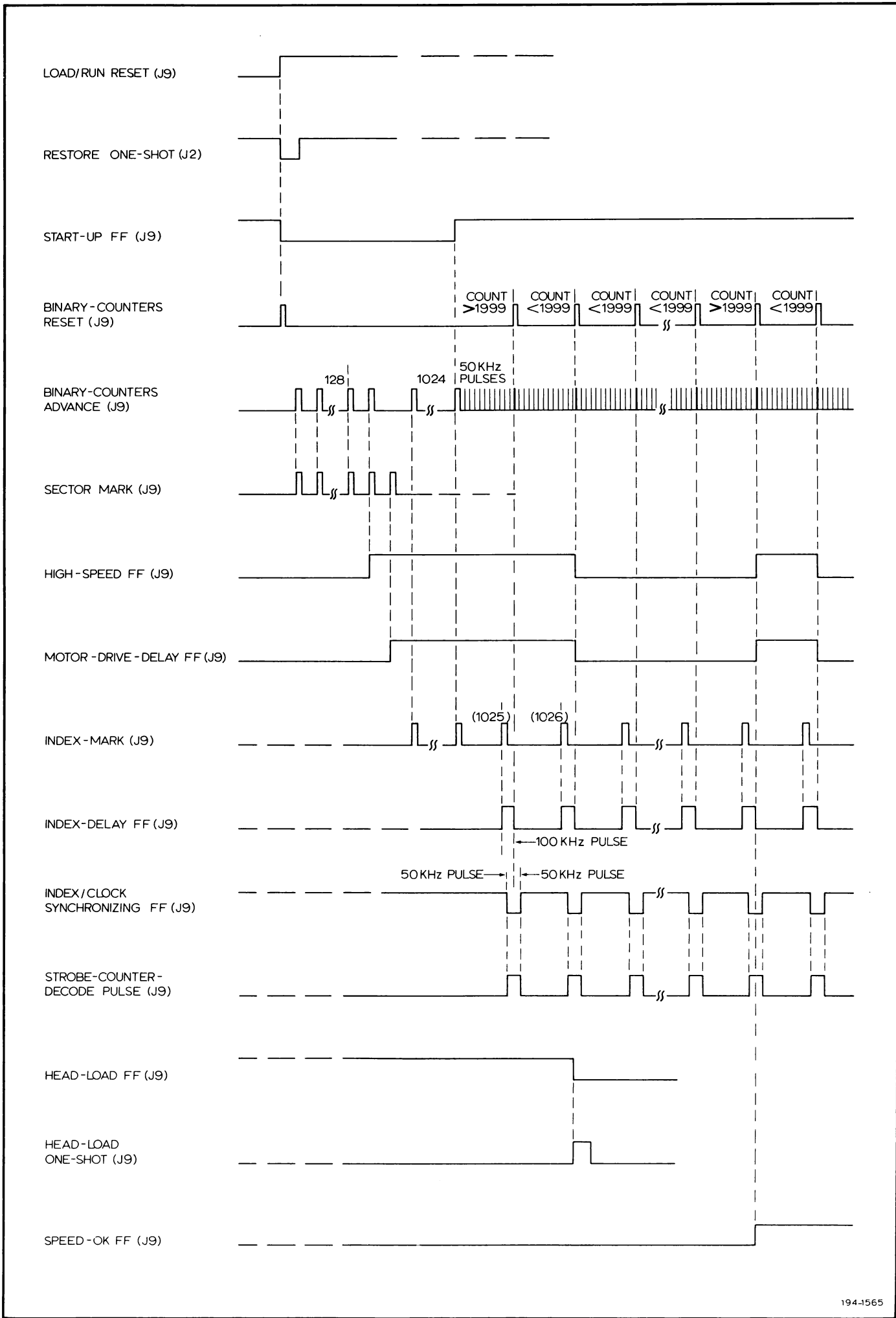

194-1565

FIGURE 4.11 START-UP TIMING

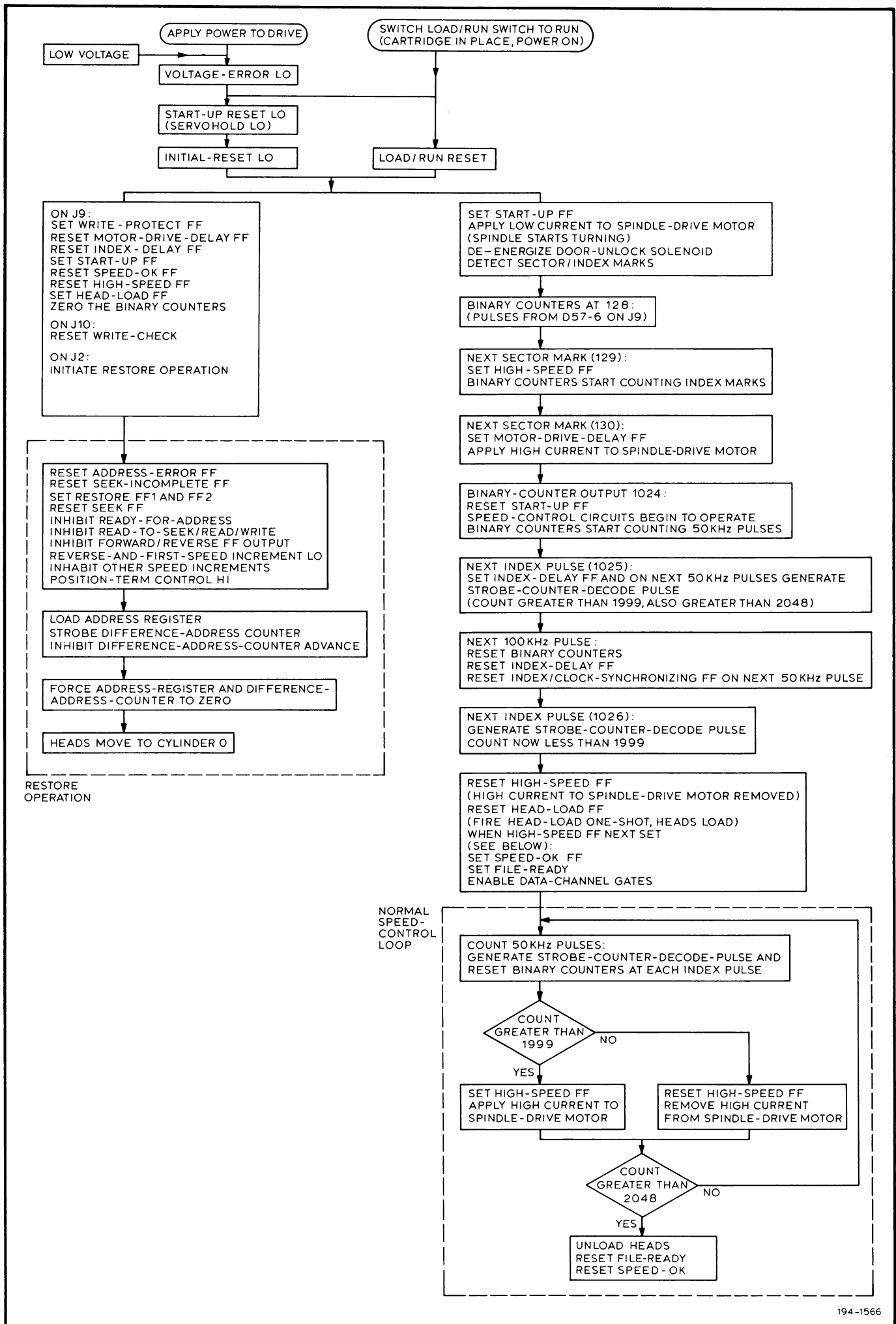

FIGURE 4.12 START-UP FLOWCHART

If the drive-speed slows sufficiently for 2048 50 kHz clock pulses to be counted, the head-load FF is set by the strobe-counter-decode pulse and the heads are unloaded, the speed-OK FF is reset and the ready signal goes hi.

If a voltage error occurs during normal speed control a reset is generated: this causes the whole start-up sequence to be carried out and sets write protect (see figure 4.13).

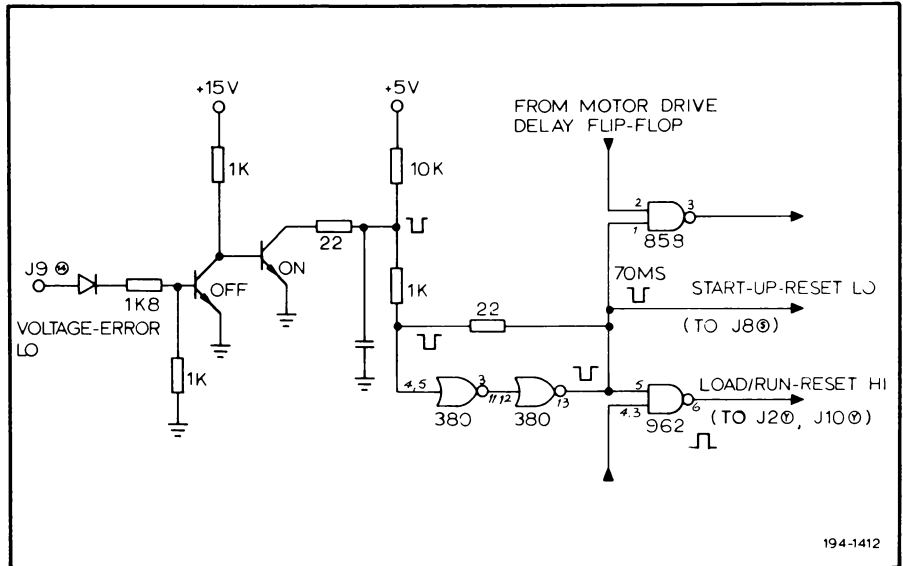

FIGURE 4.13 PRODUCTION OF START-UP RESET AND LOAD/RUN RESET

4. 8. 6 Carriage-velocity control

Carriage velocity and positioning are achieved by an electronic servo system. The source of reference and feedback voltage is the position transducer.

The transducer consists of two discs (see figure 4.15). A voltage applied to the track on the upper disc induces a voltage in the tracks of the lower disc: induced-voltage level and polarity depend on the alignment of the two sets of tracks. When the two tracks are in phase (see position 1, figure 4.15) flux linkage is maximum; as the upper disc turns through positions 2, 3 and 4, flux linkage goes minimum, maximum (but opposite polarity), then minimum. Outputs A and B are offset 90° to provide two out-of-phase position signals.

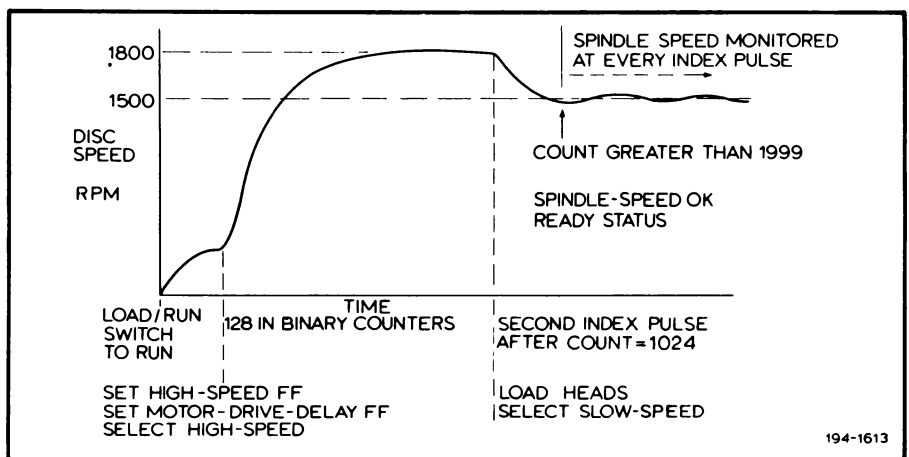

FIGURE 4.14 START-UP, SIMPLIFIED SPINDLE-SPEED/TIME DIAGRAM

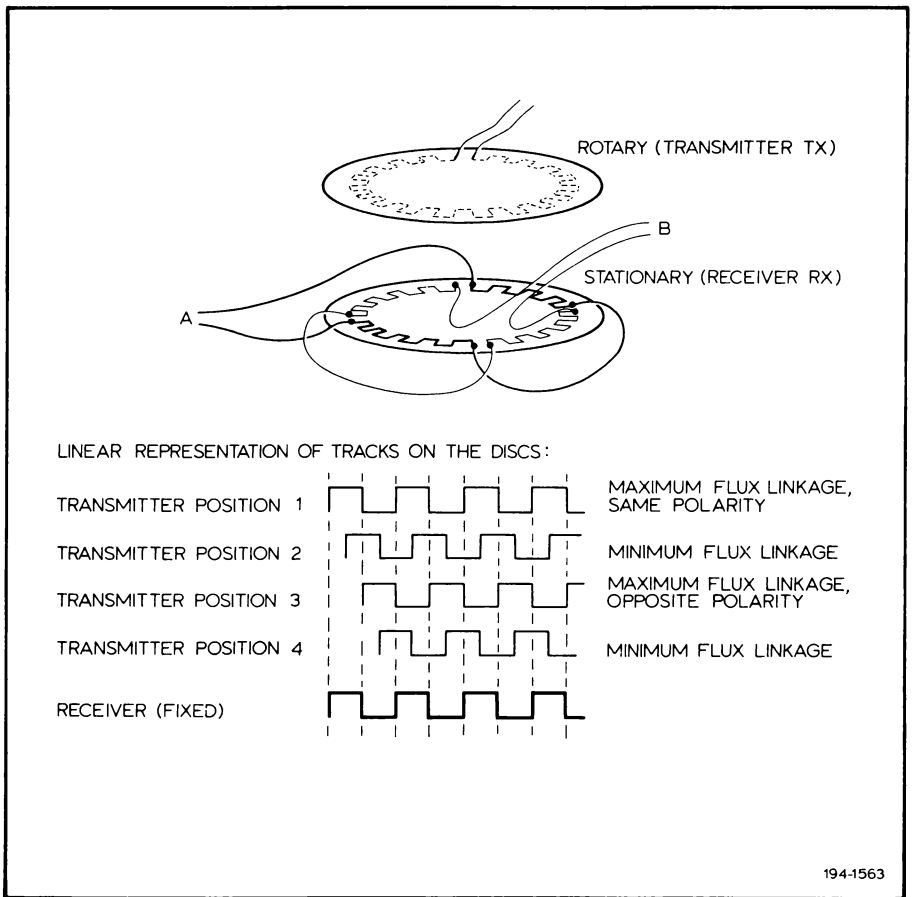
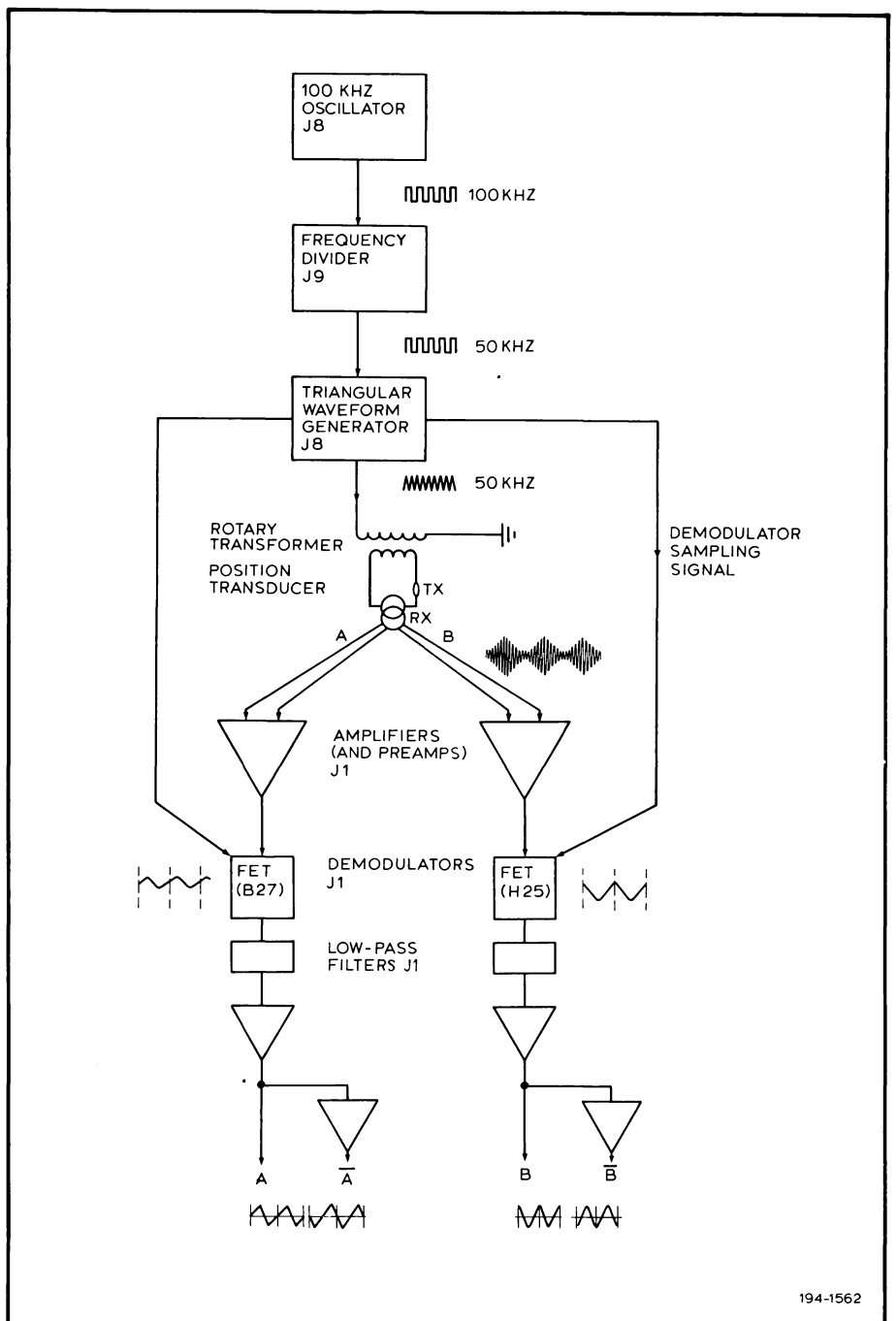

FIGURE 4.15 SIMPLIFIED PRINCIPLE OF POSITION TRANSDUCER

The transducer is fed with a 50 kHz triangular waveform as a carrier, and develops a modulation on the 50 kHz waveform, as shown in figure 4.16, which after demodulation results in the position-signals A and B and the inverted signals \bar{A} and \bar{B} shown in figure 4.16, constant velocity assumed (see the J1 circuit diagram, chapter 8).



194-1562

FIGURE 4. 16 POSITION-TRANSDUCER SIGNALS, BLOCK DIAGRAM

These four signals are differentiated by CR networks to produce A' \bar{A}' B' \bar{B}' which are fed to a summing point through four commutator FETs. The four differentiated waveforms are shown in figure 4. 17 and have an amplitude that is proportional to carriage velocity, regardless of direction of movement.

The commutating signals C and D are derived by summing and squaring the A and B signals, using schmitt triggers. A and B produce C, A and \bar{B} produce D. The commutation is equivalent to a phase-sensitive, four-phase rectification so that the net current into the summing point is dc current proportional to the velocity, plus a ripple current. This velocity feedback is E in figure 4. 17 where:

$$E = A' \cdot (\bar{C} \cdot D) + B' \cdot (C \cdot D) + \bar{A}' \cdot (C \cdot \bar{D}) + B' \cdot (\bar{C} \cdot \bar{D})$$

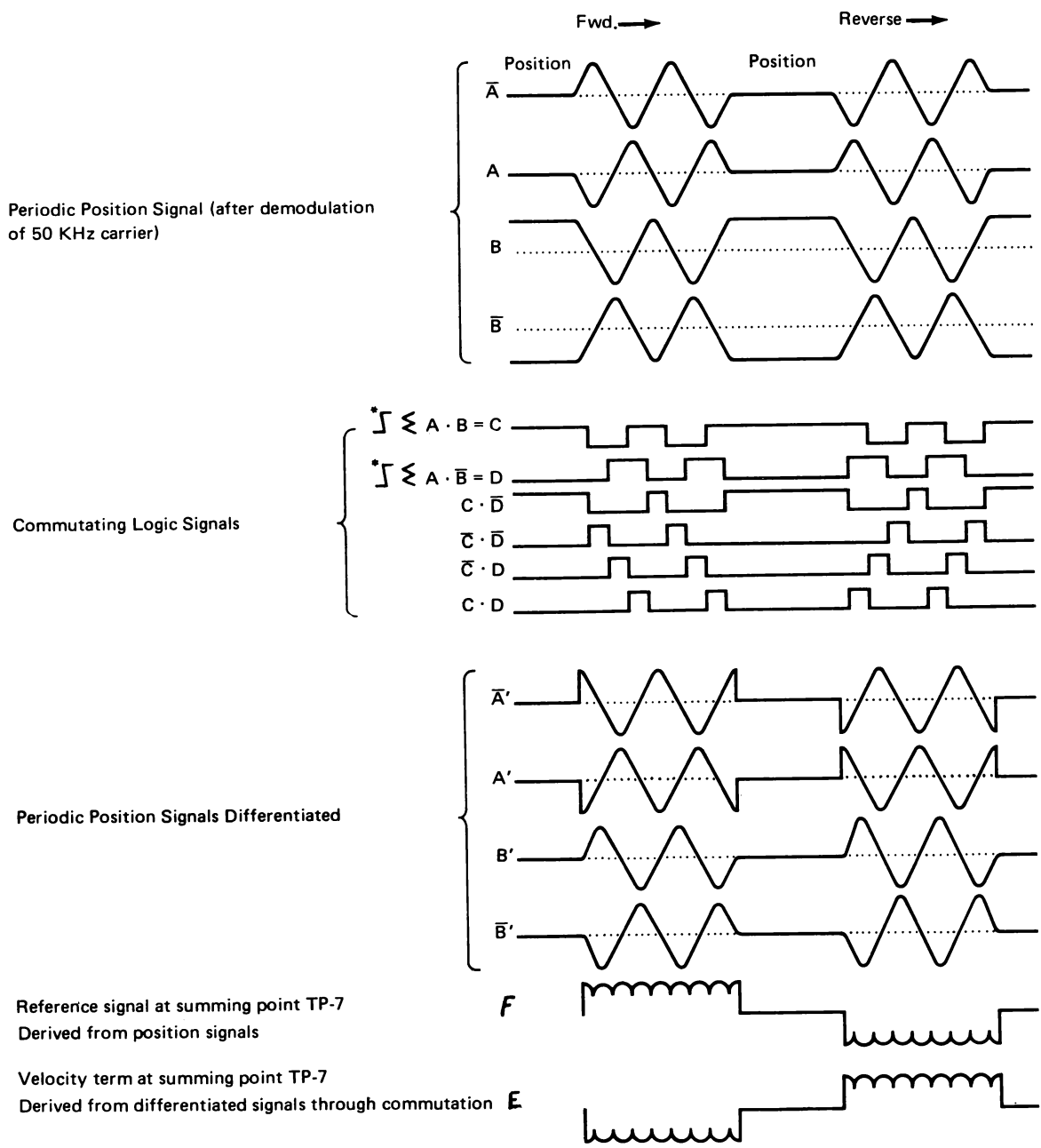

*the $\int \sum$ symbol designates a summing and squaring function

FIGURE 4.17 CARRIAGE-POSITION SIGNALS

The error due to ripple current is removed by constructing a velocity reference term F with an equal ripple content. This reference is derived from the position signals and is therefore independent of velocity.

When carrying out a seek operation the position-term control FET is switched off and, depending on direction, either the two forward-control FETs are switched on or the reverse-control FET is switched on. The velocity of the carriage is controlled by the speed-increment terms which are gated into the summing-point through three FETs (second-, third-, fourth-speed-increment FETs). These FETs are directly controlled by the output of the difference-address counter. The first-speed-increment has maximum attenuation and is active whenever a direction FET is on. The second-, third-, and fourth-speed-increment FETs and their associated series resistors are in parallel with the first-speed-increment FET and resistor, so that when they are on, they decrease the attenuation of the reference voltage, allowing higher carriage-velocity. Thus, if the differentiated position-waveform (at TP3 on J1) is monitored during a long seek the waveform shown in figure 4.18 is observed.

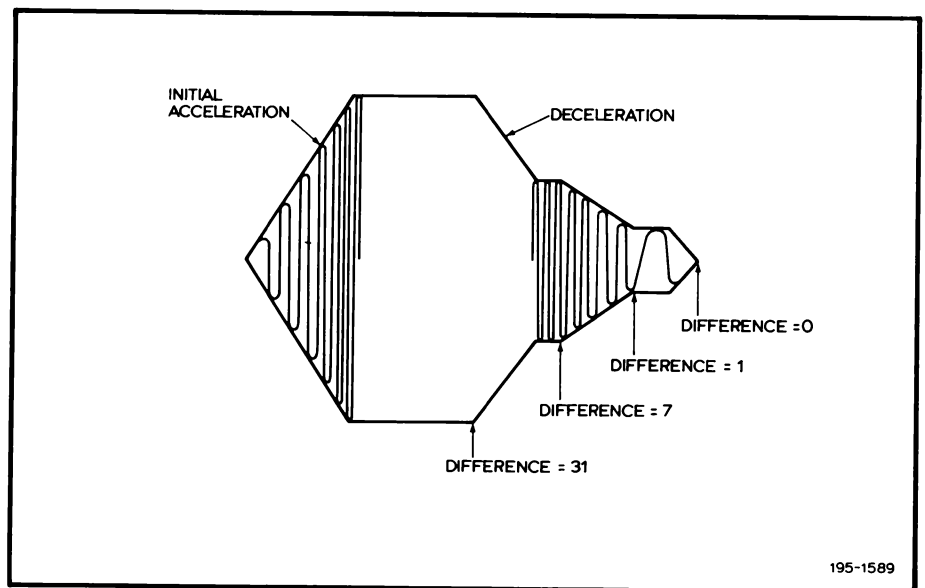

FIGURE 4.18 DIFFERENTIATED WAVEFORM (J1, TP3)

Each time a cylinder centreline is passed, servo-control-levels \bar{C} and D are coincident and this advances the difference-address counter by one.

Until the difference-address counter is advanced to 255 the servo imposes constant-velocity control on the positioner with four discrete velocities depending on the number of cylinders still to be travelled.

The difference = 0 condition (difference counter equal to 255) occurs at $3/8$ of a track still to go. At this time the position-term control FET is switched on. The inputs to the servo are now the velocity-feedback-term \bar{A}' and the position-signal \bar{A} . The servo now behaves as a standard positioning-servo: the servo locks on to the null on the position envelope. If, owing to vibration or other cause, the positioner is deflected from its true cylinder position, the position-signal A becomes non-zero, which creates a force which returns it to its null.

The motion-indicator level, at pins 14 and R of J1 goes lo only when the positioner has been stationary for the preceding 30 milliseconds. This signal is used to detect motion, or the lack of motion, during a seek or restore operation.

4.8.7 Seek operation

Refer to figures 4.19 and 4.20 and the J1, J2 and J3 circuit diagrams.

The sequence is as follows:

- (a) Start seek
- (b) Set sequence FF1
- (c) Set sequence FF2
- (d) Head movement
- (e) Set sequence FF3
- (f) Advance difference-address-counter
- (g) Stop seek
- (h) If necessary, set seek-incomplete FF

At the beginning of a seek operation the address register (on J3) contains the address of the present head-location. The new address, in absolute form, is on the interface lines. An interface strobe-pulse initiates the seek sequence.

100 kHz square-wave clock pulses are fed into a two-phase generator to produce $\emptyset 1$ and $\emptyset 2$ pulses, which are used to sequence the address and seek functions.

Sequence FF1, on J3, is set by the first $\emptyset 1$ pulse after the start of the strobe, and enables the address-register input gates. The new address is checked for validity: any address less than or equal to 202 is considered valid. The new address is compared with the present address, contained in the address register, and the results of the comparison are present at the output of the subtractor. A carry from the subtractor indicates forward motion.

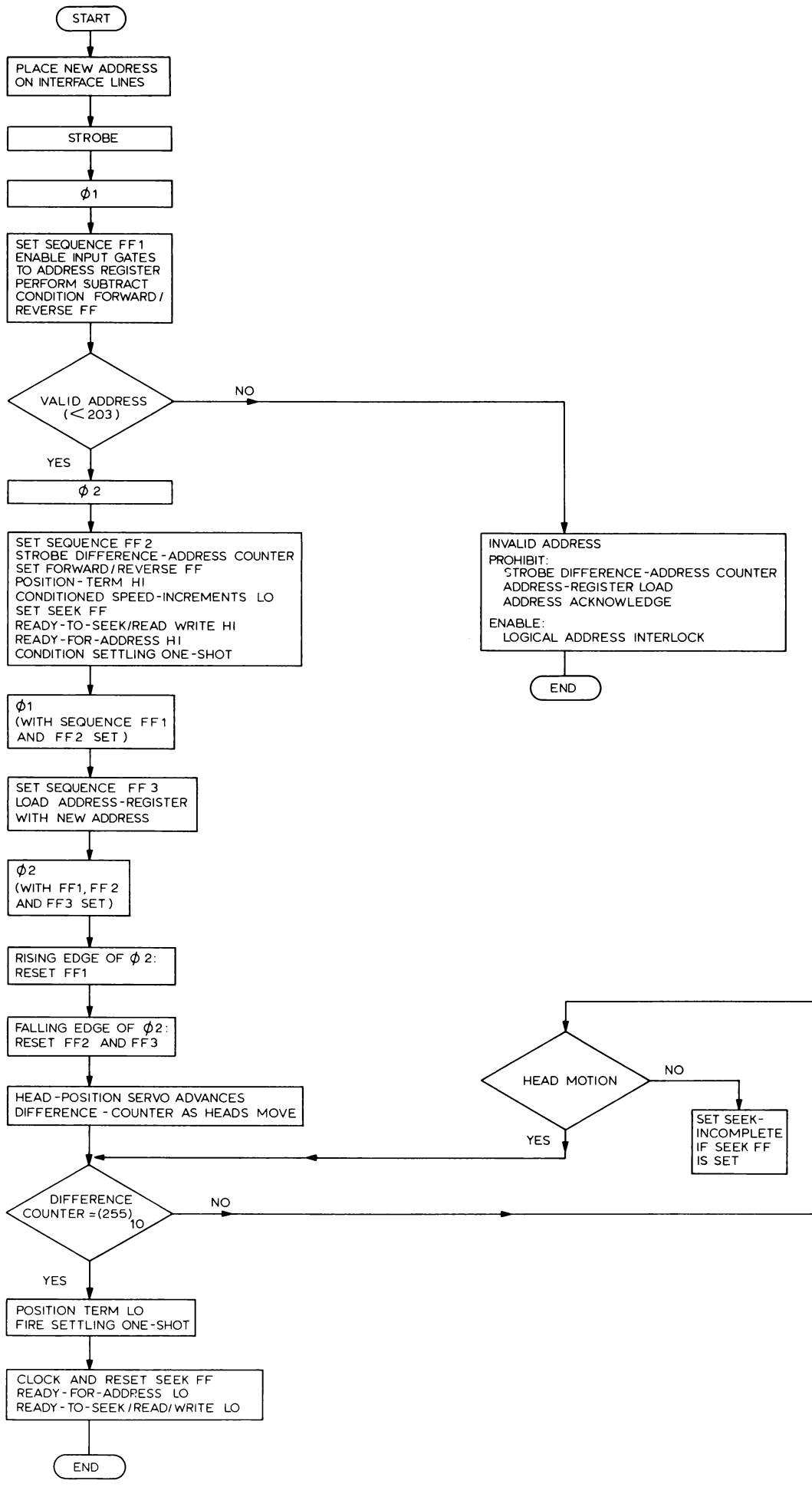
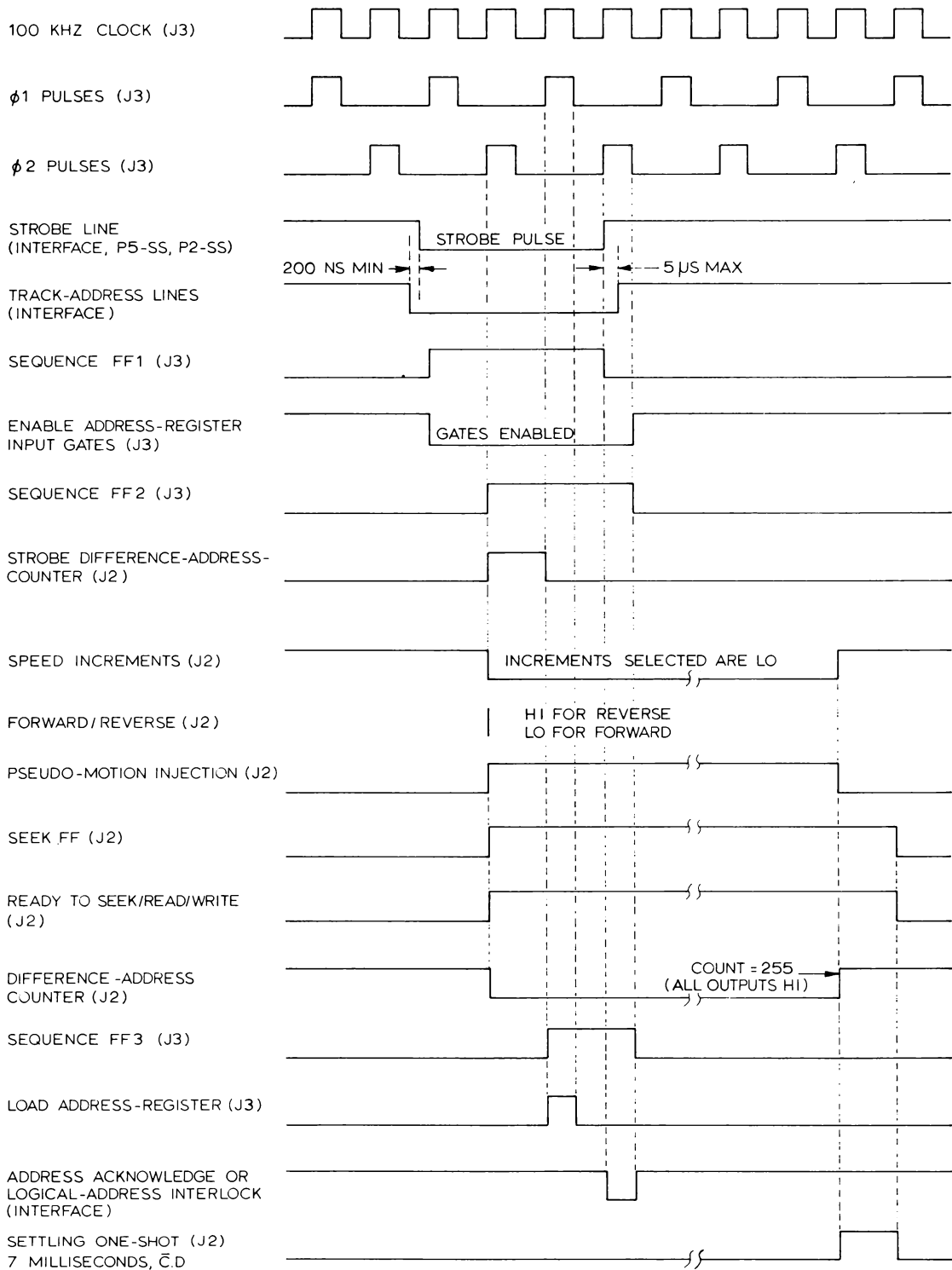

FIGURE 4.19 SEEK-OPERATION, FLOWCHART



194-1402

FIGURE 4.20 SEEK-OPERATION, TIMING

Sequence FF2 on J3, is set by the first $\emptyset 2$ pulse after FF1 is set, and causes a strobe of the difference-address counter. With a change in cylinder address, the position term goes hi and any other conditioned speed-increments go lo. The difference-address-counter strobe also sets the forward/reverse FF on J2, which causes the head carriage to move in the required direction under control of the servo circuits.

Loss of the position term enables head movement and pseudo-motion injection. The seek FF is set with position-term hi and motion, as long as restore FF1 is reset. The seek FF makes the ready-for-address and the ready-to-seek/read/write lines hi.

Sequence FF3 is set with $\emptyset 1$ following the setting of FF2, and loads the address register with the new address. The next $\emptyset 2$ pulse resets FF1, enables the address-acknowledge interface-line (or logical-address interlock if track address is greater than 202). FF2 and FF3 are reset at the fall of this $\emptyset 2$.

When the difference-address counter is at less than 255, the servo causes the head carriage to move at the correct velocity and, through the commutating logic, provides servo-logic control-level \bar{C} and servo-logic control-level D. These logic levels cause the difference-address counter to advance by one each time the heads cross a cylinder centreline. Provided position term control is hi and a restore is not in operation, the counter advances by one each time servo-logic control-levels \bar{C} and D are coincident.

As the difference-address counter advances, its changing outputs switch off the speed increments. When the carriage has 32 cylinders still to travel, fourth speed increment turns off; at 8 cylinders, third speed increment turns off; at 2 cylinders, second speed increment turns off. When the difference-address counter has advanced to 255 (all outputs hi) the position term is made lo, pseudo-motion-injection lo, head-in-motion hi, and the settling one-shot (7 milliseconds) is triggered. The settling-one-shot pulse clocks the seek FF and resets it. This makes the ready-to-seek/read/write line and ready-for-address line lo (provided a restore is not in operation), thus completing the seek operation.

If the seek FF does not become reset and the motion-indicator level from J1 goes lo, provided a restore is not in operation, the seek-incomplete FF is set and seek-incomplete is sent across the interface. Seek-incomplete can be reset only by a restore operation.

4.9 READ/WRITE OPERATION

4.9.1 Head selection

Head selection is based on a three-level principle with one head always selected. For reading, the centre-tap of the selected head is about +1 volt (write-gate hi). For writing, the centre-tap of the selected head is at about +14 volts (write-gate lo). The unselected head is at about -1 volt.

4.9.2 Write operation

The incoming data and clock pulses are fed to the write FF so that data and clock pulses become head-current transitions. This requires head-in-motion hi, selected hi and spindle-speed-OK hi.

The Q and \bar{Q} outputs of the write FF are fed through separate drivers to the read/write winding of both heads. Write current flows in only the head that has its select driver at +14 volts.

In a high-density drive, count-stage-128 lo (from the address register) causes an increased write current when the heads are beyond cylinder 128.

4.9.3 Erase operation

When the erase gate is lo, through the erase-gate interface line (or, if the erase-gate interface line is not fitted, the 10 ohm resistor to the write-gate line) the erase driver allows current to flow through the erase coils of the head that is selected for write operation.

4.9.4 Read operation

The output from the selected head-winding is amplified and clipped. Pulses are generated on both transitions of the clipped signal; these pulses have a width of 100 ± 50 nanoseconds, and are separated into data and clock pulses.

4.9.5 Data separation

In a standard-density drive, the leading edge of the first transition that is read triggers the data-separation one-shot. For a transfer rate of 781 kHz, this one-shot is set (the data-separation FF Q output goes hi) at 900 nanoseconds (970 nanoseconds with 720 kHz).

The data-separation FF is set on the trailing edge of this first read pulse and reset on the trailing edge of the one-shot pulse. The result is that the data gate at TP5 on J10 starts at the trailing edge of a clock pulse and extends for 70% of the bit-cell time. Any pulse occurring during this data-gate-on time produces a lo pulse, at F26 pin 6, which is transmitted to the interface as read data. The remaining pulses produce lo pulses, at F26 pin 3, which are transmitted as clock pulses.

In a high-density drive, data separation and timing are accomplished by using two one-shots, a long and a short, and a ones-trigger FF. These additional circuits provide a data gate at TP5 which is shorter if the previous bit-cell contained a data-bit one. The shorter data-gate allows for any pulse shifting.

4.9.6 Write check

Write-check lo and file-ready hi are presented to the interface when any of the following conditions are present:

- (a) Voltage supplied is down to a nominal 13.5 volts
- (b) Write-current without write-gate lo
- (c) Write-gate lo and no write-current
- (d) Write-current through both heads
- (e) Erase-current without erase-gate lo
- (f) Erase-gate lo and no erase-current
- (g) Erase-current through both heads

A load/run reset is required to reset the write-check FF. All functions are disabled while the write-check FF is set. (A voltage-down condition causes a write-check indication only for the duration of the low-voltage condition, the write-check FF is not set).

4.9.7 Write protect

All write functions are disabled when write-protect is lo. On initial start-up the drive comes up in the write-protected state. The write-protect switch, on the control panel is the only means of clearing the protect state. The operator can place the drive in a protected state by switching the load/run switch from RUN to LOAD and back to RUN. If the interface has write-protect-input and write-protect-status lines, the external equipment can place a drive in the protected state with the write-protect-input line.

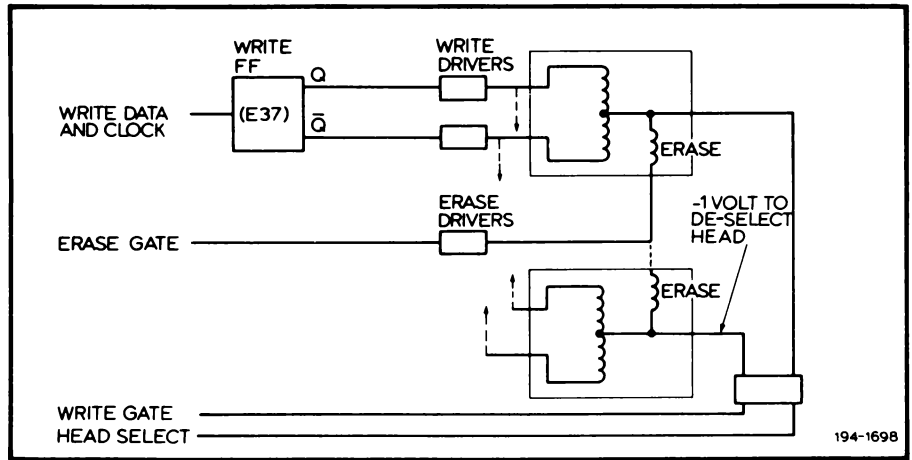

FIGURE 4.21 WRITE OPERATION, BLOCK DIAGRAM

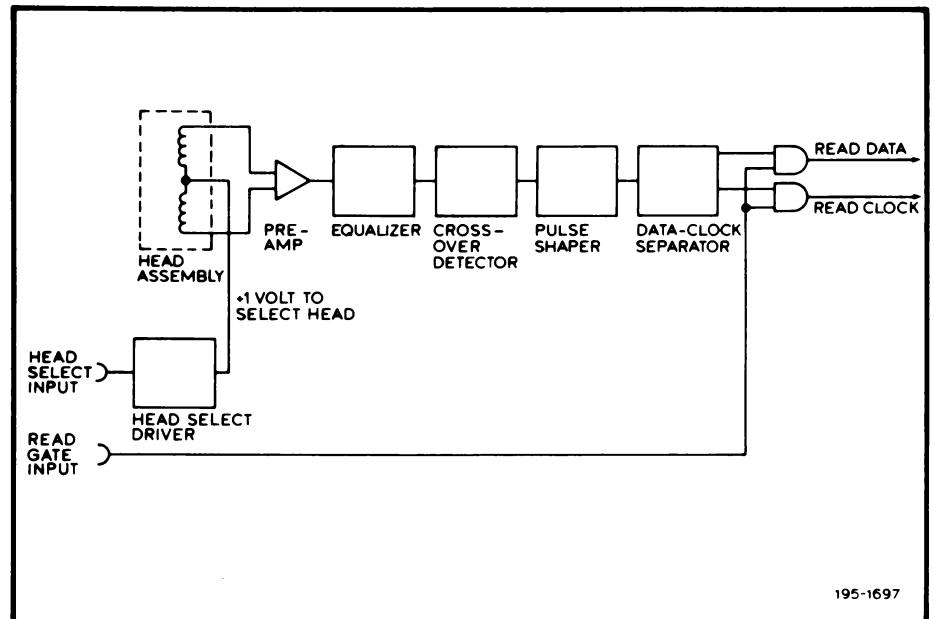

FIGURE 4.22 READ OPERATION, BLOCK DIAGRAM

5.1 LIST OF CONTENTS

page	section	title
5.1	5.1	LIST OF CONTENTS
5.2	5.2	GENERAL
5.2	5.2.1	Changing the disc cartridge of a model 33F
5.2	5.2.2	Exerciser
5.2	5.2.3	CE cartridges
5.3	5.2.4	Cautions
5.3	5.3	PREVENTIVE MAINTENANCE
5.3	5.3.1	Cleaning the heads
5.3	5.3.2	Renewing the air filter
5.4	5.4	MAINTENANCE REQUIREMENTS
5.4	5.4.1	Preventive maintenance kit
5.4	5.4.2	Corrective maintenance items
5.5	5.4.3	Parts-support location
5.5	5.5	ADJUSTMENT AND REPLACEMENT
5.5	5.5.1	Removing a circuit board
5.6	5.5.2	Removing the motherboard
5.8	5.5.3	Removing the cartridge receiver
5.8	5.5.4	The sector transducer
5.9	5.5.5	The head-positioner assembly
5.20	5.5.6	Removing the spindle assembly
5.20	5.5.7	Door-lock assembly

TABLE 5.1

5.2 GENERAL

This chapter includes preventive maintenance and replacement procedures, with details of tools and test-equipment required in the correct use of a series 30 disc drive.

Field maintenance consists of on-line diagnosis, off-line repair, off-line checkout and adjustment then on-line verification of performance. The drive is taken off-line by disconnecting the power and signal cables.

Do not cut power by removing the power cables. Switch off power at the external equipment. All power must be removed before either the power cables or signal cable is disconnected.

5.2.1 Changing the disc cartridge of a model 33F

The disc cartridge on the model 33F is not normally changed by the operator.

The procedure for replacing the disc cartridge on the model 33F is as follows.

- (a) Make sure all power is removed from the drive
- (b) Ensure that the disc has stopped turning by allowing 30 seconds to elapse and then remove the top cover
- (c) Ensure that the heads are fully retracted (at cylinder 000)
- (d) Open the front panel
- (e) Remove the cartridge
- (f) Insert replacement cartridge and close the front panel
- (g) Refit the top cover

5.2.2 Exerciser

The head-positioning exerciser has the control switches necessary to perform basic seek and restore operations. (A test terminator is required when using this exerciser).

5.2.3 CE cartridges

A CE cartridge has two prerecorded tracks on each side of its disc. Standard and high density CE cartridges are available. The high-density cartridge is similar to the standard version but is run eccentrically and has different track numbering. The tracks are numbered as in table 5.2.

type of CE cartridge	sector index timing	head alignment
standard density	track 095	track 100
high density	track 100	track 105

TABLE 5.2

When the standard-density CE cartridge is used, read/write head alignment is accomplished when equal amplitudes are present in the signal read from track 100 by the tunnel-erase coils (see figure 5.8).

On the high-density cartridge, read/write head alignment is accomplished when equal nul amplitudes are present in the signal read from track 105 by the read/write coils (see figure 5.8).

The CE cartridge is also used to check the sector transducer position. The transducer is adjusted to obtain a time delay of 30 ± 5 microseconds between the negative-going edge of the index pulse and the isolated pulse preceding the data burst. These are recorded on track 095 of the standard-density cartridge or track 100 of the high-density cartridge.

5.2.4 Cautions

A head adaptor tool is available for head alignment on standard-density cartridges only; this enables direct reading through the erase coil.

- (a) Do not allow writing to occur on the CE cartridge
- (b) The electronic detenting of the series 30 holds the head carriage. Do not attempt to move the head location when power is applied until the servo is released
- (c) To gain access to the motherboard, pull the drive out from its rack to its fullest extent (in the case of rack-mounted drives), remove the top cover and release the four screws securing the motherboard. Raise the motherboard to its servicing position by the grip at the centre of the board. Before releasing the grip, ensure that the board is locked in its servicing position by the hand-operated linkage. Similar precautions should be taken when the board is returned to its normal operating position. Do not leave the securing screws loose or data errors will result

5.3 PREVENTIVE MAINTENANCE

When the series 30 is operating in a normal office environment on a one-shift basis, preventive maintenance procedures are to be performed at 1000-operating-hour intervals. An abnormally dirty environment, high number of cartridge-loading operations, or the initializing of a large number of new cartridges may make necessary increased preventive maintenance. The spindle motor and head positioner brushes do not require preventive-maintenance action and should not be inspected. Table 5.3 indicates the areas that should receive preventive maintenance and the actions to be performed.

item	action
read/write heads	clean and inspect for scratches and build-up of oxide
carriage rail	clean and inspect. Apply two drops of oil on each of the two wicks if their colour is white
spindle assembly	clean and inspect the magnetic ring: magnetic particles may be removed by using adhesive tape
base plate and covers	clean and inspect
air filter	renew

FIGURE 5.3

5.3.1 Cleaning the heads

Clean the heads with an approved cleaning fluid, [see sub-section 5.4.1(a)], using a lint-free wiper to remove any alcohol residue. Take care not to handle the recording surfaces of the heads.

5.3.2 Renewing the air filter

Disconnect all cables from the disc drive and pull the drive out from the rack to its fullest extent. If the drive is a table-top model, turn it upside-down.

- (a) Loosen the two filter securing screws and lift out the filter element
- (b) Install a new element, making sure that its orientation agrees with the airflow-direction arrow shown on the filter
- (c) Tighten the filter retaining screws

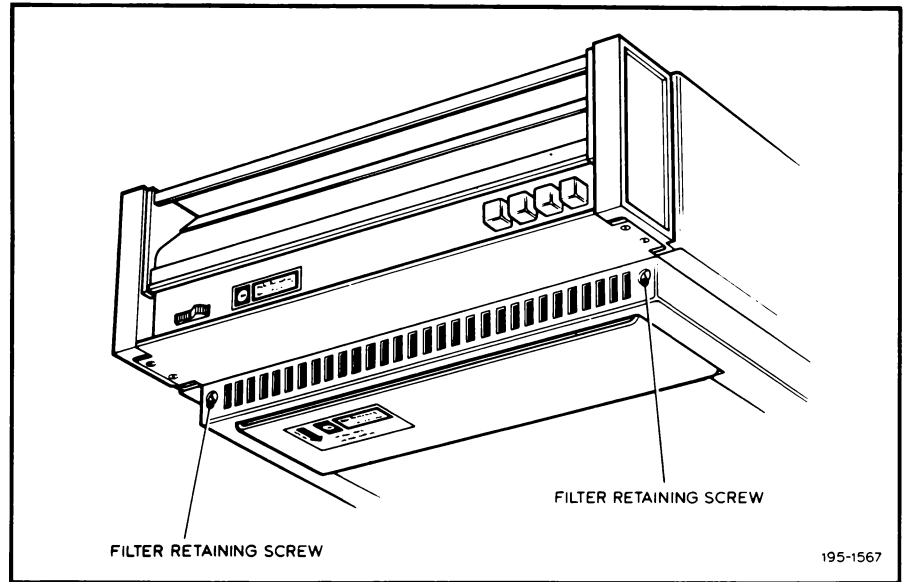

FIGURE 5. 1 AIR FILTER LOCATION

5. 4 MAINTENANCE REQUIREMENTS

5. 4. 1 Preventive maintenance kit

The following three sections list spare parts and equipment representing the three levels of a recommended spare parts for supporting the series 30.

The following items should be available for servicing the series 30 on a scheduled basis:

- (a) Approved cleaning fluids:
 - (i) Isopropyl alcohol solution (made from 91% reagent grade isopropyl alcohol mixed with 9% distilled or deionized water by volume)
 - (ii) Arclone P
- (b) Lint-free cloth
- (c) Syringe oiler
- (d) Touch-up paint
- (e) Air filter, part number 15170

5. 4. 2 Corrective maintenance items

The following sub-sections contain all the sub-assemblies, tools and test equipment that are normally required to repair the series 30:

- (a) One of each plug-in circuit board
- (b) Head-positioning exerciser (and terminator)
- (c) CE disc-cartridge (standard-density: part number TD276 or high-density: part number TD277)
- (d) One upper and one lower read/write head
- (e) Head cable, part number 11114

- (f) Circuit-board retainers, left and right
- (g) Power transistors:
 - (i) MJE2955, part number 10114
 - (ii) MJE3055, part number 10115
 - (iii) MPSU61, part number 10110
 - (iv) MPSU51, part number 10111
- (h) Lamps , part number 10545
- (j) Extender board, part number 11042
- (k) Oscilloscope
- (m) Long-blade screwdriver
- (n) Philips screwdriver
- (p) Cylinder-0 deflection tools, part number 15171 and 15172
- (q) Head adaptor, part number TD5803 (if standard-density)
- (r) Torque-wrench set, part number 99001
- (s) Head-adjusting tool, part number TD10289
- (t) Adhesive, part number 70226

5.4.3 Parts-support location

Parts-support location is the level of spare parts that is recommended for the self-sufficient customer who has a large number of series 30 drives and prefers to supply parts-support through his own facilities:

- (a) Increased quantities of those items referred to in sections 5.4.1 and 5.4.2
- (b) Spindle assembly
- (c) Head-positioner assembly
- (d) Motherboard and heatsink assembly
- (e) Cartridge-receiver assembly
- (f) Door-lock assembly

5.5 ADJUSTMENT AND REPLACEMENT

The electronics assembly consists of plug-in circuit boards, motherboard and heatsink assembly (with power-driver and servo-driver). There are no potentiometers or adjustments in the electronics assembly.

5.5.1 Removing a circuit board

The plug-in circuit boards are held in position by a spring-loaded retainer. To remove a board (make sure the power is off), raise the retainer to no further than 20 mm (0.8 inch) above the circuit board. Do not raise it too high or the rear tip can drop too far and be bent.

Each circuit board is keyed so that it will fit only in the correct location. Insert the boards carefully to avoid damage.

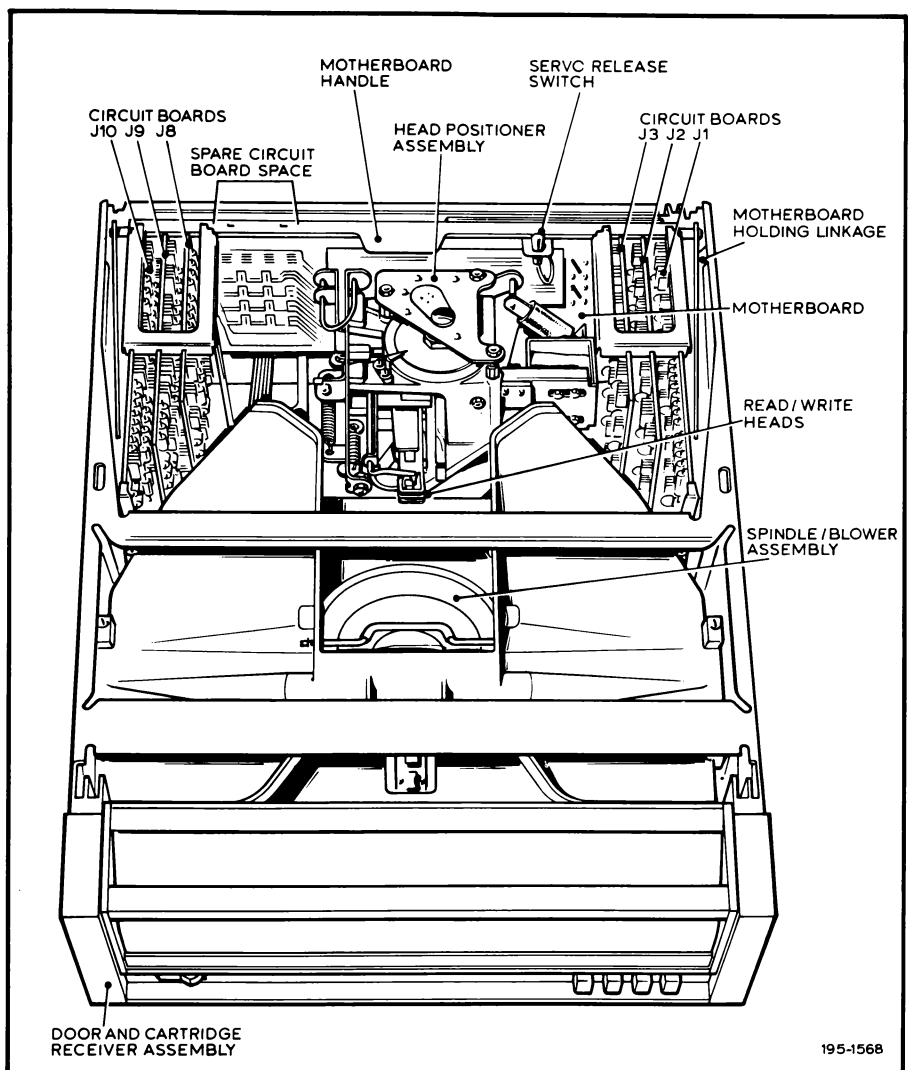

FIGURE 5.2 INTERNAL COMPONENTS OF THE DISC DRIVE

The extender board is not keyed: it must fit all locations. Always check that the circuit boards are fitted in the correct location when using the extender board.

5.5.2 Removing the motherboard

The motherboard and heatsink assembly is removed as a single unit.

- (a) Remove all printed-circuit boards
- (b) Remove the two sets of twisted-pair wires (black/yellow, black/white) that connect the motherboard to the head-positioner transducer, at the transducer-end of the wires
- (c) Remove the two head-positioner-motor wires: white wire at motherboard, yellow wire at servo-driver board (mounted on heatsink)
- (d) Remove the flat-cable connector located on the power-driver board (heatsink), below the circuit-board J9 position
- (e) If the assembly is to be removed from the drive, remove the rear bottom cover to gain access to release P7, which is held by one pan-head screw
- (f) Remove the read/write-head-lead plug from circuit-board J10 (A-80)

PROCEDURE

1. WITH THE DOOR CLOSED (VIEW A) ADJUST THE CARTRIDGE RECEIVER ASSY. SO THAT THE FOLLOWING CRITERIA ARE MET AND TIGHTEN SCREWS (W).
 - 1.1 DISTANCE FROM SPINDLE (C) TO CARTRIDGE STOP POSTS (T) IS AS SHOWN.
 - 1.2 DIMEN. (BB) & (CC) ARE EQUAL WITHIN .015.
 - 1.3 DIMEN. U & V ARE EQUAL WITHIN .030.
2. WITH DOOR CLOSED (VIEW B), WITHOUT CARTRIDGE, CARTRIDGE DOOR ACTUATOR (H) SHALL CLEAR UPPER HEAD (HH) BY CLEARANCE SHOWN
3. OPEN DOOR SLOWLY (VIEW C) UNTIL CARTRIDGE RECEIVER IS AT ITS HIGHEST POINT OF TRAVEL & ADJUST ECCENTRIC (A) SO THAT CLEARANCE TO SUB FRAME (E) IS AS SHOWN & TIGHTEN SCREWS.
4. WITH DOOR FULLY OPEN (VIEW C), SLOWLY INSERT CARTRIDGE (C) & CHECK FOR CLEARANCE BETWEEN CARTRIDGE (C) & CARTRIDGE DOOR ACTUATOR (H) AS SHOWN. IF CLEARANCE IS INSUFFICIENT FORM DOOR ACTUATOR (H) AT POINT OF CONTACT WITH RECEIVER AT (J).
5. CLEARANCE (R) & (P) (VIEW A) SHOULD BE .030 MINIMUM. ADJUST BY LOOSENING SCREWS (S).
6. INSERT CARTRIDGE & SLOWLY CLOSE DOOR. CARTRIDGE SHOULD SEAT DOWN COMPLETELY & IF PUSHED FROM FRONT TO REAR & SIDE TO SIDE A SMALL AMOUNT OF PLAY SHOULD BE FELT. IF NOT RECHECK CHECK STEPS 1.1, 1.2 & 1.3.
7. WITH CARTRIDGE INSTALLED & DOOR CLOSED (VIEW B) ADJUST CANTILEVER SPRING (Y) TO EQUALIZE DIMENSION (DD) & (EE). ALSO CENTRALIZE OVER ACTUATOR (Z) (VIEW A) & TIGHTEN SCREWS.
8. WITH CARTRIDGE INSTALLED & DOOR CLOSED (VIEW B) CLEARANCE (FF) SHOULD EXIST BETWEEN CANTILEVER SPRING (Y) & ACTUATOR (Z). CARTRIDGE DOOR SHOULD ALSO CLOSE UPON REMOVAL. IF EITHER IS INCORRECT, TWIST ACTUATOR SLIGHTLY AND RECHECK ABOVE.
9. WITH CARTRIDGE INSTALLED & DOOR CLOSED (VIEW A) CHECK FOR .015 MINIMUM CLEARANCE BETWEEN THE CARTRIDGE CONE & THE DISK HUB (NOT SHOWN - INSIDE CARTRIDGE) BY DEPRESSING THE CARTRIDGE DOOR AT POINT (AA). IF THE CLEARANCE IS INSUFFICIENT RECHECK STEPS 7 & 8, AND CHECK FOR WARPED CARTRIDGE RECEIVER OR DAMAGED OR DEFECTIVE CARTRIDGE.
10. WITH CARTRIDGE INSTALLED & DOOR CLOSED, (VIEW B), CENTRALIZE SWITCH BLADE (K) IN HOLE IN CARTRIDGE RECEIVER BASE (N) & TIGHTEN SCREWS (M).
11. WITH CARTRIDGE INSTALLED, DOOR CLOSED, (VIEW B), & BLADE (K) HELD DOWN, CLEARANCE SHOWN SHOULD EXIST TO CARTRIDGE. TO ADJUST ROTATE SWITCH (L) AND TIGHTEN SCRFW (GG).
12. ADJUST HEIGHT OF CARTRIDGE DOOR ACTUATOR (H) TO DIMENSION SHOWN IN VIEW B (BROKEN LINES) BY TURNING NUTS (KK) KEEPING TOP HORIZONTAL. LOCK WITH NUTS (J).

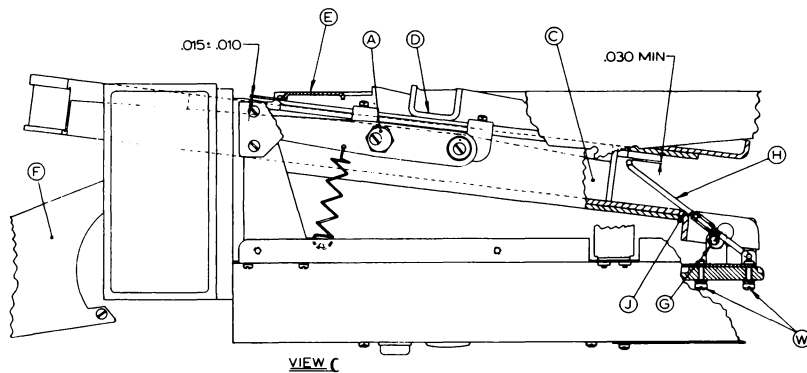
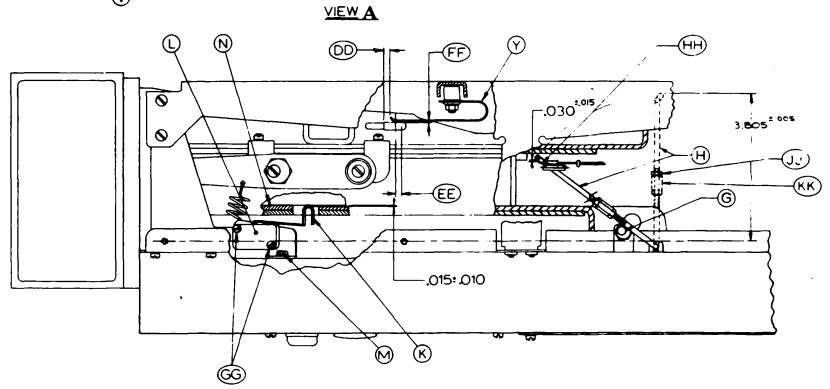
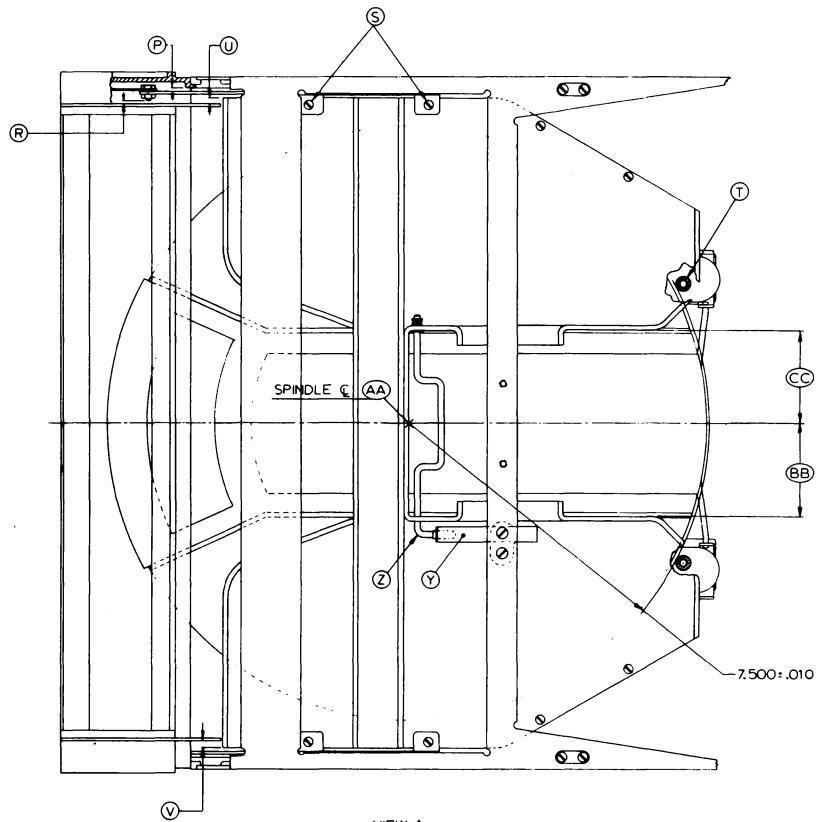

NOTES

1. THE PURPOSE OF THE VIEWS ON THIS SHEET IS TO AID IN THE DESCRIPTION OF THESE ADJUSTMENTS, THEREFORE MANY PARTS HAVE BEEN OMITTED.

FIGURE 5.3 CARTRIDGE RECEIVER AND BASE ADJUSTMENTS

- (g) Remove the eight pan-head screws holding the bottom of the heatsink to the shadow box (base of the drive). There are two screws on each side and four on the rear of the heatsink
- (h) Remove the four screws holding the heatsink to the H-frame (two screws on each side). The motherboard and heatsink assembly is now unsupported and may be lifted out and placed flat behind the series 30
- (j) To completely remove the motherboard and heatsink, remove the screw holding the groundstrap between the heatsink and the head positioner, at the heatsink-end of the groundstrap (black wire)
- (k) If the motherboard and heatsink are to be separated, remove the power cable from between the motherboard and heatsink by removing the cover on the rear of the motherboard, the rod interconnecting the motherboard, pivot arms (held on by pan-head screws and circlips), the power plug (P1) and the cable connections on the motherboard. Slide the motherboard out of the heatsink
- (m) Refit by reversing the above procedure
- (n) No adjustments are required

5. 5. 3 Removing the cartridge receiver

- (a) Remove the six screws holding the H-frame to the base frame and remove the H-frame
- (b) Remove the two screws, indicated as A and D in figure 5. 3, on each side of the cartridge receiver assembly
- (c) Remove the four screws, indicated as W in figure 5. 3, holding the front of the cartridge receiver to the main base assembly. There are two screws on each side of receiver; the rear bottom cover must be removed to gain access to these screws
- (d) Remove screw, located under receiver on left-hand side of drive, securing receiver earth braid to base
- (e) Open the door, remove the cartridge receiver
- (f) Refit by reversing the above procedure
- (g) Carry out the cartridge-receiver and base adjustment procedure provided in figure 5. 3

5. 5. 4 The sector transducer

5. 5. 4. 1 Removing the sector transducer

- (a) Remove the cartridge receiver (see section 5. 5. 3) to expose the sector transducer
- (b) Disconnect the two cable wires at the sector transducer
- (c) Remove the two screws holding the transducer to the base assembly and remove the transducer; the air filter must be removed to gain access to the two screws (see section 5. 3. 2)
- (d) Refit by reversing the above procedure. Locate the transducer so that the front edge of the transducer magnet to the centreline of the dowel pins is $15,037 \pm 0,076$ millimetres (0.592 ± 0.003 inch) and the base of the transducer to the base of the drive is $32,664 \pm 0,457$ millimetres (1.286 ± 0.018 inch). Carry out the transducer adjustments detailed in section 5. 5. 4. 2.

5.5.4.2 Adjusting the sector transducer

The head positioner, read/write head, cartridge receiver and base adjustments are assumed to be correct.

- (a) Select heads by stopping drive and connecting appropriate head to lower (outside) head socket on side of positioner assembly

control	setting
timebase	5 ms/cm
deflexion sensitivity	2 V/cm
trigger	ext -ve

TABLE 5.4

- (b) Set up oscilloscope as shown in table 5.4
- (c) Trigger an oscilloscope from the leading edge of the index mark. This is the negative-going edge of the pulse at TP6 of circuit board J9
- (d) Position the read/write heads over prerecorded track 095. On a high-density drive use track 100
- (e) Observe the signal from TP2 on J10. Note the isolated pulse followed by a burst of pulses
- (f) Adjust the sector transducer by means of screw M (see figure 5.7, view D) to position the first peak of the isolated pulse 30 microseconds after the beginning of the sweep. This first peak may be positive or negative going. Increase the sweep rate to 5 microseconds per division for maximum resolution. Access to screw M is obtained by inserting a long-shank $\frac{1}{4}$ -inch tip screwdriver through the hole located on the right-hand side of the drive. With the interface connector removed, the lower head is selected; the upper head is selected by grounding pin 5 of J10. The above adjustment sets the relationship of the selected head to the index and sector-mark pulses
- (g) Alternately select each of the two heads, and adjust the sector transducer to locate the isolated pulse (first peak) symmetrically around the 30 microsecond point. Their separation must remain less than 10 microseconds. The adjustment screw is self-locking

5.5.5 The head-positioner assembly

5.5.5.1 Removing the head-positioner assembly

- (a) Remove the read/write-head-lead plug at circuit board J10, the two sets of twisted-pair wires at the positioner transducer, the two positioner-motor wires (white on motherboard, yellow on heatsink) and P8 (located at primary of rotary transformer)
- (b) Remove the three bolts holding the head positioner to the main base frame (the rear bottom cover must be removed to obtain access to these bolts)
- (c) With the motherboard in the service position the head positioner can be removed
- (d) Refit by reversing the above procedure
- (e) See figure 5.6 for adjustments within the head positioner; these adjustments are not normally performed in the field and are included for reference only

5.5.5.2 Adjusting the cylinder pointer

- (f) See figure 5.5 for head-positioner-to-base and head-positioner mechanical-alignment
- (a) Install tool 15172 in either head position on the head carriage, butted against the back plate (see figure 5.5)
- (b) Place tool 15171 on the spindle cone with its flat portion adjacent to face* (figure 5.5) on tool 15172
- (c) Move the carriage to its most rearward position until tool 15172 is butted against or is near as possible to the round part of tool 15171
- (d) Adjust the carriage stop eccentric (K on figure 5.7) until it is just inhibiting carriage movement. Tighten locknut (L on figure 5.7) to a torque of 4 newton-metres (36 pound-inches)
- (e) Adjust the cylinder indicator pointer to cylinder 000

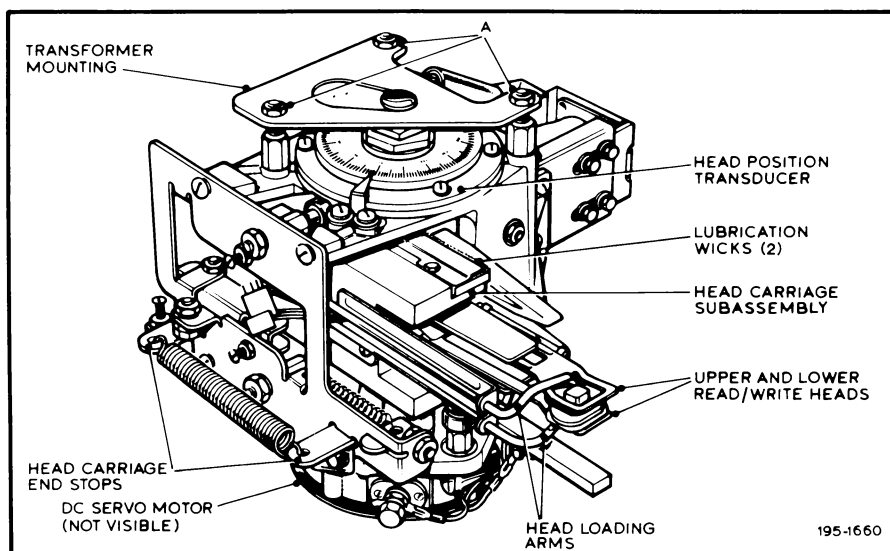

FIGURE 5.4 HEAD POSITIONER ASSEMBLY

5.5.5.3 Adjusting the head-positioner transducer

- (a) Set up an oscilloscope as shown in table 5.5

control	setting
timebase	5 ms/cm
deflexion sensitivity	5 V/cm
trigger	free run
input	dc coupled

TABLE 5.5

- (b) Connect the oscilloscope to TP1 of circuit-board J1 and allow automatic sweep
- (c) With power applied and the servo-release switch depressed, manually move the rotary disc of the position transducer backwards and forwards
- (d) A sine-wave signal with an amplitude of 15 volts peak-to-peak should appear on the oscilloscope. If necessary, loosen the upper nuts A (shown on figure 5.4) and rotate the transformer mounting until 15 volts peak-to-peak is observed

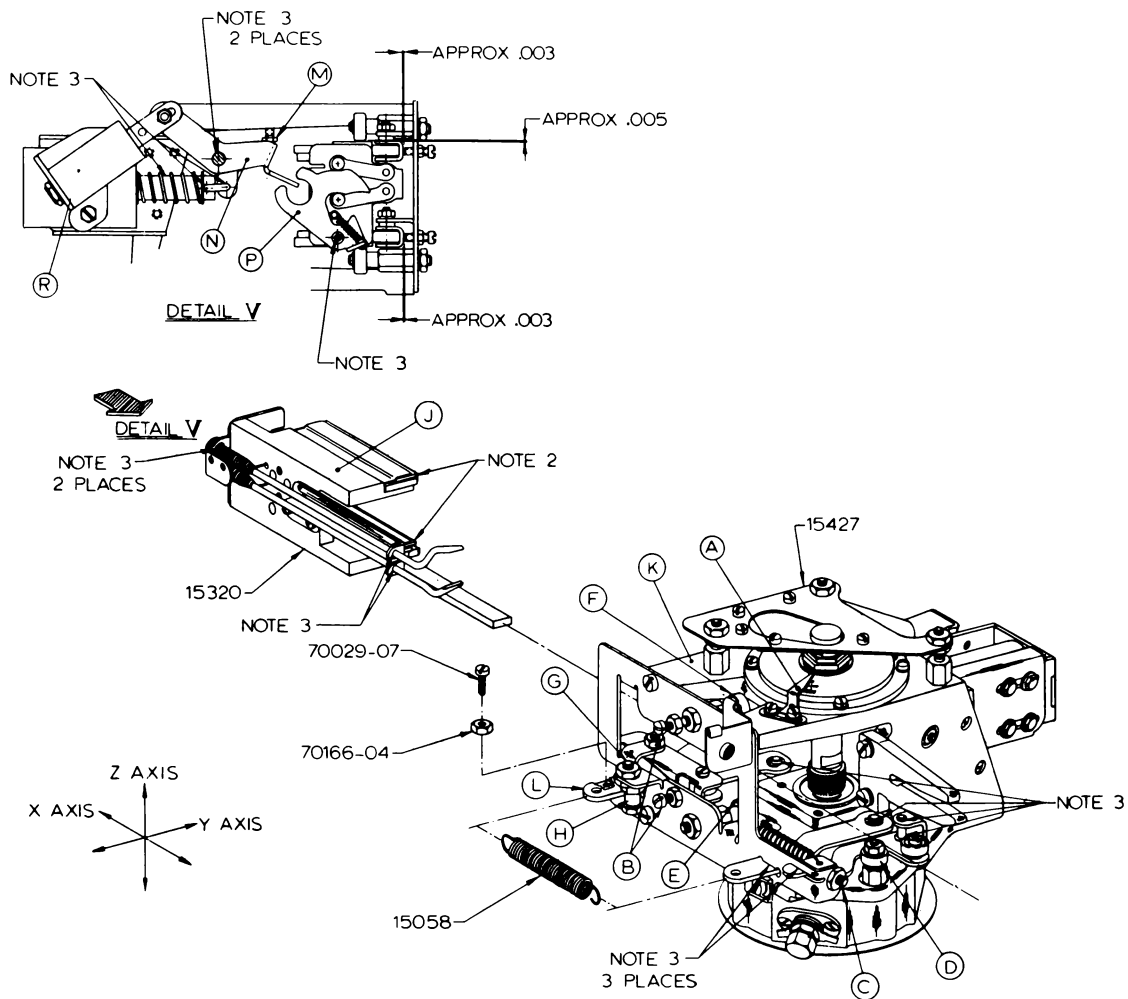

PROCEDURE

1. APPROXIMATELY CENTER POINTER (A) AND TIGHTEN SCREWS - NOTE 1.
2. LOOSEN NUT AND SCREW (B) SUFFICIENTLY TO ALLOW ASSY OF CARRIAGE 15320.
3. LOOSEN NUT AND TURN SCREW (C) SUFFICIENTLY TO ALLOW ASSY OF CARRIAGE 15320.
4. APPROXIMATELY CENTER ROLLER (D) ABOUT "AXIS X" AND TIGHTEN NUT - NOTE 1.
5. APPROXIMATELY CENTER ROLLER (E) ABOUT "AXIS X" AND TIGHTEN NUT - NOTE 1.
6. RAISE ROLLER (F) SUFFICIENTLY TO ALLOW ASSY OF CARRIAGE 15320.
7. APPROXIMATELY CENTER ECCENTRIC (G) ABOUT "Y AXIS" AND TIGHTEN NUT - NOTE 1.
8. APPROXIMATELY CENTER ECCENTRIC (H) ABOUT "Y AXIS" AND TIGHTEN NUT - NOTE 1.
9. INSTALL CARRIAGE SO THAT THE FOLLOWING CRITERIA ARE MET:
 - 9.1 SURFACE (J) IS PARALLEL TO SURFACE (K) WITHIN .010.
 - 9.2 WITH ARM (L) TIGHT AGAINST ECCENTRIC (H) AND THE CARRIAGE ASSEMBLY AT THE EXTREME LEFT POSITION AGAINST ARM (L) POINTER (A) IS POINTING AT CYLINDER INDICATION ZERO ± 4 CYLINDERS.
10. INSTALL 15058, 70029-07 AND 70166-04 WITH 70029-07 AS HIGH AS POSSIBLE.
11. ADJUST ROLLER (F) TO ADJUSTMENT SHOWN IN DETAIL V AND TIGHTEN NUT - NOTE 1.
12. ADJUST SCREW (B) TO ADJUSTMENT SHOWN IN DETAIL V AND TIGHTEN NUT - NOTE 1.
13. ADJUST SCREW (M) SO THAT BAIL (N) IS APPROXIMATELY CENTERED IN CAM (P) - NOTE 1.
14. ADJUST DASHPOT (R) SO THAT PISTON DOESN'T BOTTOM IN CYLINDER - NOTE 1.

NOTES:

1. THIS ADJUSTMENT IS TEMPORARY AND WILL BE READJUSTED AT FINAL ASSY.
2. SATURATE FELT WITH OIL 70243, SQUEEZE LIGHTLY AND REMOVE EXCESS.
3. LUBRICATE WITH ONE DROP OF 70243 OIL.

FIGURE 5.6 HEAD POSITIONER, INTERNAL ADJUSTMENTS

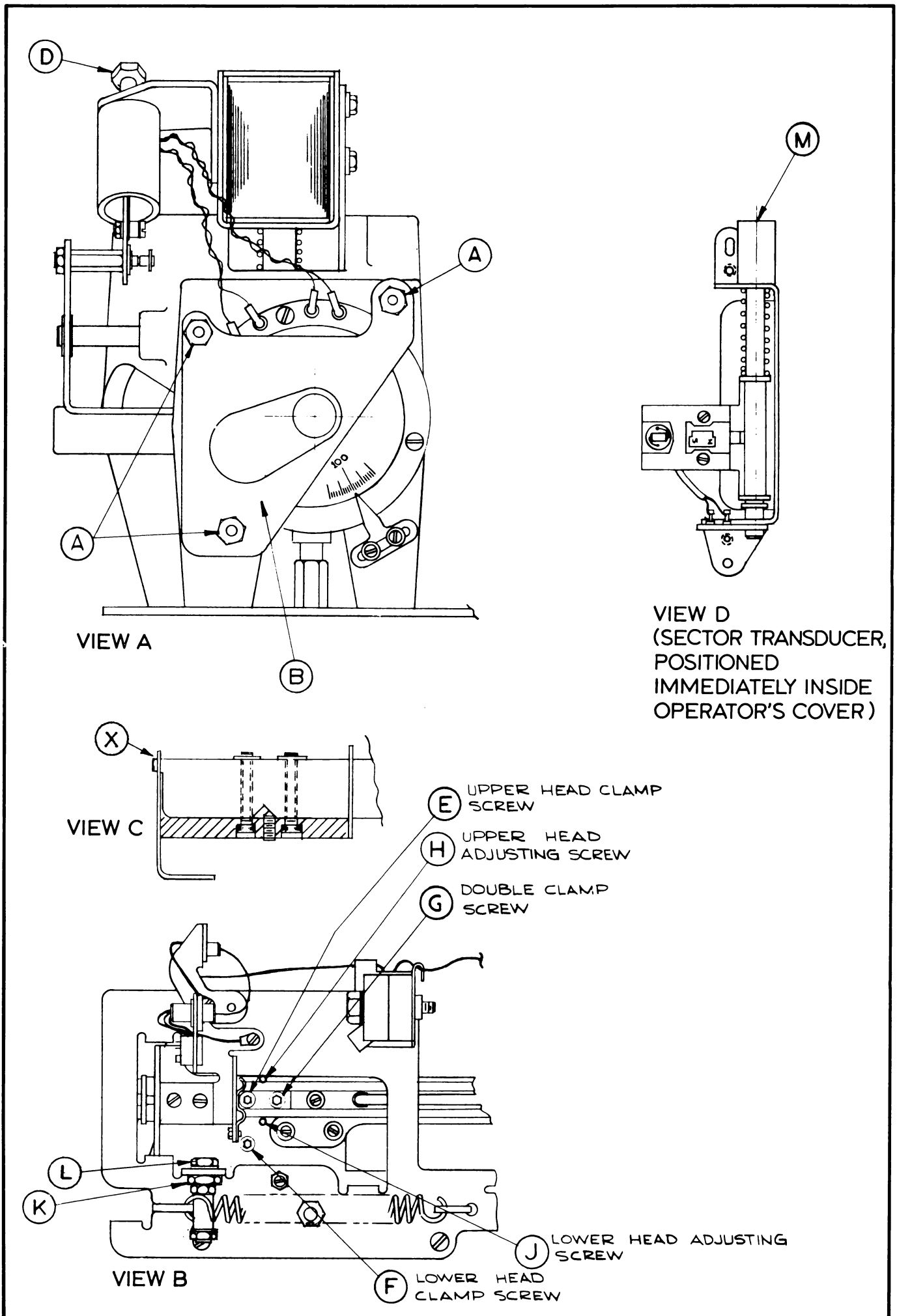

VIEW D
(SECTOR TRANSDUCER,
POSITIONED
IMMEDIATELY INSIDE
OPERATOR'S COVER)

FIGURE 5.7 HEAD POSITIONER TO BASE ADJUSTMENTS, REFERENCE DRAWING

- (e) Connect the oscilloscope to TP2 of circuit board J1 and allow automatic sweep
- (f) While rotating the position transducer as in sub-section (b), observe the sine-wave: it should have the same amplitude (± 1 volt) as that observed at TP1
- (g) The rotary transformer gap is set by adjustment nuts below the transformer mounting plate. As a rough guide, the transformer gap will be about right when the top securing nuts are flush with their studs
- (h) The position-transducer gap is set to 0,127 millimetres (0.005 inch) by shims on the positioner motor shaft

5.5.5.4 Removing the read/write heads

- (a) Loosen the cable clamp holding the two head-plug cables. The motherboard must be in the servicing position to gain access from the rear of the drive
- (b) Unplug the head-plug (the upper head is the inner connector)
- (c) Loosen the double clamp screw (indicated by G on figure 5.7) and the required head-clamp screw. Do not loosen the clamp screw more than half a turn
- (d) Pull the loosened head towards the spindle until it is clear (do not touch the recording surface of the head)
- (e) To refit a head, insert it into the head carriage. Make sure that the head bracket is installed in the clamps and is fully inserted into the plate on the rear of the head carriage
- (f) Apply 0,18 newton-metres (26 ounce-inches) of torque to the head-clamp screws
- (g) Proceed with the adjustments detailed in section 5.5.5.5.

5.5.5.5 Adjusting the read/write heads

- (a) Disconnect the power supply from the drive, remove the interface connectors and fit a terminator to the interface socket
- (b) If an extender board without head-lead sockets is available, the procedure is:
 - (i) Standard-density drive: fit the J10 board into the extender board in the J10 position, insert the head adaptor TD5803 between the head-lead plug and the head-lead socket on board J10
 - (ii) High-density drive: sub-section (b)(i) is not necessary
- (c) If an extension board that has head-lead sockets is available the procedure is:
 - (i) Standard-density drive: fit board J10 into the extender board in the J10 position, connect the lead from the extender board in place of the head-lead plug on J10, connect the head-lead plug to the standard-density head-alignment socket on the extender board

HIGH DENSITY

STANDARD DENSITY

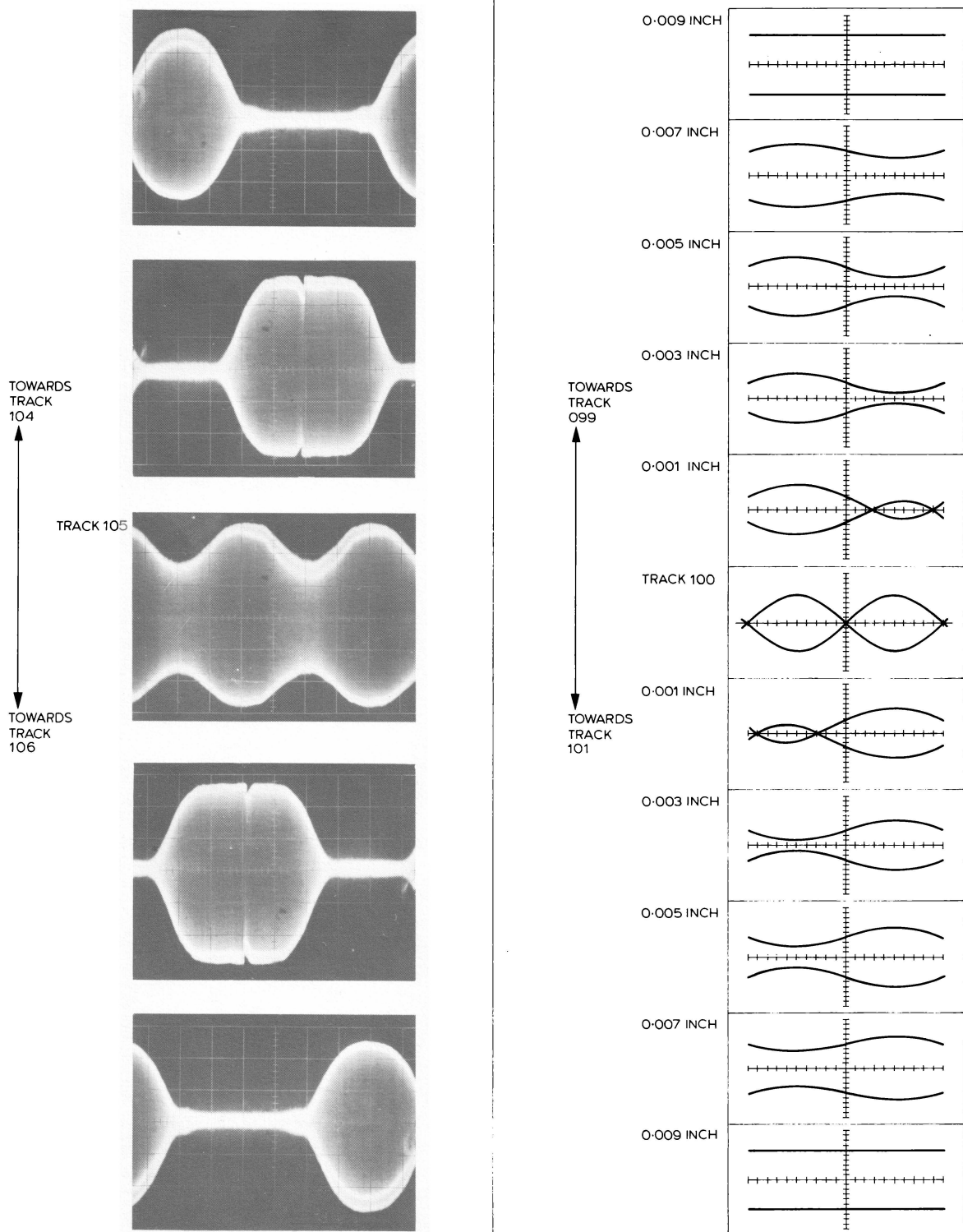

194-1733

FIGURE 5.8 HEAD ADJUSTMENT, OSCILLOSCOPE DISPLAYS

- (ii) High-density drive: proceed as sub-section (c)(i) but connect the head-lead plug to the high-density head-alignment socket on the extender board
- (d) Refit the power connector and load the appropriate CE cartridge
- (e) Allow the drive to run for 30 minutes, for temperature stabilization
- (f) Position the head carriage at cylinder 100 (use cylinder 105 with a high-density drive)
- (g) Set up an oscilloscope as shown in table 5.6

control	setting for standard-density drive	setting for high-density drive
timebase	10 ms/cm	5 ms/cm
deflexion sensitivity	10 mV/cm	1 V/cm
trigger	ext -ve	ext -ve

TABLE 5.6

- (h) Trigger an oscilloscope with the leading-edge of the index mark (this is the negative going edge of the pulse at TP6 of circuit board J9)
- (j) Monitor TP2 of J10 to check the alignment on both heads. With the interface connector removed the lower head is selected; the upper head is selected by grounding pin 5 of J10. A correctly-aligned head will correspond with figure 5.8. For a standard-density drive, a good crossover is required and successive lobes (L) in the signal should not differ by more than 20% peak-to-peak: if necessary adjust the head position until the lobes are of equal amplitude. For a high-density drive, successive nuls in the signal should not differ in separation (D) by more than 20%: if necessary adjust until equal
- (k) If a head needs adjusting, slightly slacken the double-clamp screw, G in figure 5.7 (there is no need to slacken the single-clamp screw, E or F) since this is at a lower torque; if a head has just been refitted, there is no need to slacken G since it is not yet fully tightened [see sub-section 5.5.5.4(f)]
- (m) Using the head-adjusting tool (TD10289), move the selected head by turning the appropriate adjusting setscrew (see figure 5.7). The head can be adjusted forwards only (when a head is installed in its rearmost position the head is about five cylinders too far back, at about cylinder 095)
- (n) As the head moves forward the leading erase-winding reads part of the eccentric recording. The head is correctly adjusted when an equal part of the eccentrically-recorded track is read by each erase winding (see figure 5.8). (With a high-density drive, the read/write winding reads between two eccentric tracks.) Take great care when adjusting the head forwards: do not allow the tang on the end of the head support arm to disengage from the slot in which it is located (X in figure 5.7)

- (p) If the head is adjusted too far forward, unscrew the setscrew; switch to the load condition, remove the CE cartridge, loosen both clamps that secure the selected head, and manually push the head towards the rear of the drive. Tighten the single-clamp screw to its normal torque of 0,18 newton-metres (26 ounce-inches) and repeat the adjusting procedure until the oscilloscope display is correct
 - (q) When the head is correctly adjusted, apply a torque of 0,56 newton-metres (80 ounce-inches) to the double-clamp screw, (G in figure 5.7), and a torque of 0,18 newton-metres (26 ounce-inches) to the single-clamp screw
 - (r) Recheck head setting on oscilloscope
- 5.5.5.6 Adjusting the cylinder-000 stop
- (a) Before adjusting the cylinder-000 stop, check that the cylinder-pointer adjustment is correct (see section 5.5.5.2)
 - (b) Set up oscilloscope as shown in table 5.7

control	setting
deflexion sensitivity	5 V/cm
trigger	ext
input	dc coupled

TABLE 5.7

- (c) Connect the vertical amplifier of the oscilloscope to TP2 of J1, and the horizontal amplifier input to TP1 of J1
- (d) Hold down the servo-release switch (located at the top of the motherboard, to the left of J3) and manually turn the head positioner. The oscilloscope trace should be a lissajous figure of circular form as shown in figure 5.9 (since the almost-sinusoidal input-signals to the vertical and horizontal deflexion plates of the oscilloscope are of equal gain and frequency and 90° out of phase, they trace an approximate circle when allowed to pass through a full cycle)
- (e) Manually turn the head positioner fully-clockwise to retract the head carriage as far as possible and release the servo-release button. The cylinder pointer should indicate cylinder-000. Using the horizontal position knob on the oscilloscope, centre the dot on the top part of the oscilloscope Y-axis [see figure 5.9, (position 1)]
- (f) Hold down the servo-release button. With slight pressure, force the head positioner against its crash stop. The oscilloscope trace should move round the circle and stop just before position 2 of figure 5.9. (Some oscilloscopes will show this trace moving clockwise around the circle instead of counter-clockwise. To check, touch the X-plate lead on the +5 volt rail: if the oscilloscope trace moves to the right, the adjustment pattern should be the same as in figure 5.9.) If the trace moves to the left the lissajous figure will be reversed left to right
- (g) Slacken the locknut, L in figure 5.7, using a 3/8-inch AF spanner, and adjust the eccentric K, using a 7/16-inch AF spanner, until the requirement of sub-section (e) is achieved

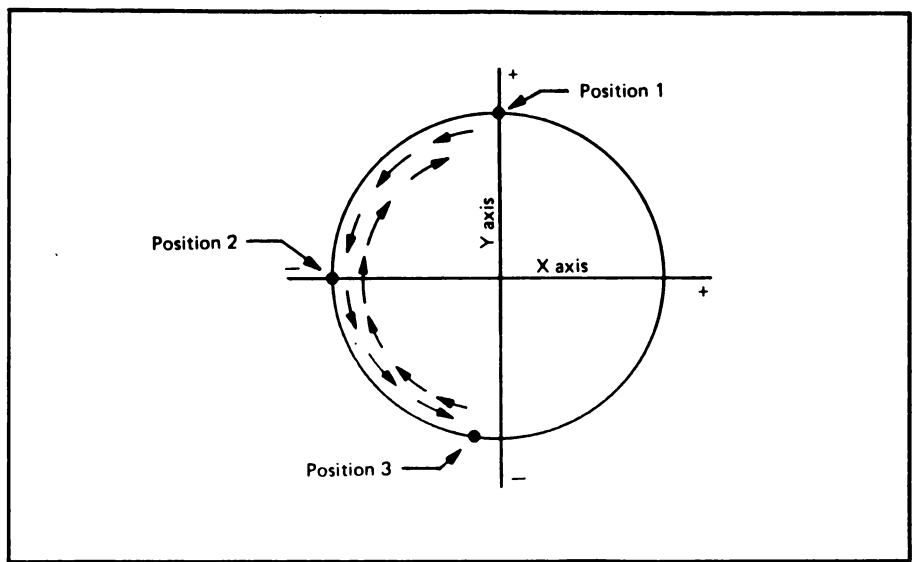

FIGURE 5.9 CYLINDER-000 STOP-ADJUSTMENT PATTERN

5.5.5.7 Adjusting the head-load dashpot

- (h) Release the servo-release button. The dot should return to the Y-axis position of sub-section (d)
- (j) Transfer the load/run switch from LOAD to RUN and back to LOAD, several times. The trace should swing a maximum arc of $145^{\circ} \pm 35^{\circ}$ from the top Y-axis position to an equivalent position on the negative part of the Y-axis, travelling in a counter-clockwise direction (see figure 5.9, position 3). If it exceeds 180° , repeat the procedure from sub-section (c)
- (a) Load a disc cartridge that has information written on cylinder-000, start the drive and allow a complete start-up cycle
- (b) Set up an oscilloscope as shown in table 5.8

control	setting
timebase	2 V/cm
deflexion sensitivity	20 ms/div
trigger	ext +ve

TABLE 5.8

- (c) Trigger an oscilloscope from the leading edge of head-load-pick signal. This is a positive-going edge at pin W of circuit board J9
- (d) Connect the vertical input of the oscilloscope to TP2 of J10
- (e) Trigger the head-load one-shot by momentarily grounding the set input of the head-load FF, (TP5 of J9)
- (f) Observe the read data and clock signal on the oscilloscope. The signal appears when the heads are loaded
- (g) Repeat sub-sections (d) and (e), turning screw D (figure 5.7, view A) until the data signal begins to appear 120 ± 10 milliseconds after the start of the sweep. Lock screw D with a drop of adhesive (part number 70226) when the adjustment is completed

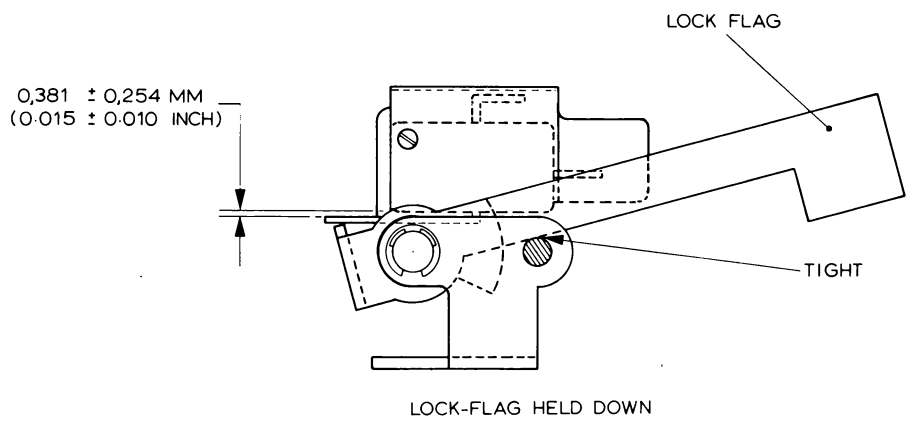
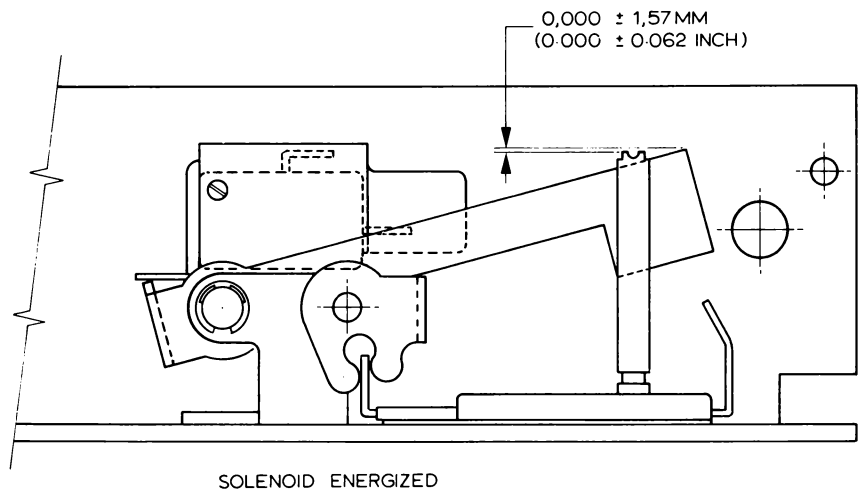

194-1288

FIGURE 5.11 DOOR-LOCK MECHANISM

5.5.6 Removing the spindle assembly

- (a) Remove the cartridge-receiver assembly (see section 5.5.3) and sector transducer (see section 5.5.4.1)
- (b) Remove the spindle-motor leads from the filter board (the front bottom cover must be removed to gain access to the filter board and bolts holding spindle assembly)
- (c) Remove the three bolts holding the spindle assembly to the base frame and remove the spindle assembly
- (d) Refit by reversing the above procedure
- (e) Adjust the head positioner assembly and read/write head adjustments, (see sections 5.5.5.2 to 5.5.5.6)
- (f) Adjust the cartridge receiver (see figure 5.3)
- (g) Adjust the sector transducer (see section 5.5.4.2)

5.5.7 Door-lock assembly

- (a) Remove the lamps from the front panel (pull-out type lamps)
- (b) With the door open, remove the two bolts holding the front trim-piece to the frame assembly
- (c) Raise the front trim-piece slightly and pivot it towards the open door. This action allows the trim-piece to drop down between the door and frame
- (d) Removal of front trim provides access to the bolts holding the trim-piece above the door-lock solenoid. Remove this trim-piece also
- (e) Disassemble as required
- (f) Reassemble by reversing the above procedure
- (g) Adjust the assembly (see figure 5.10). Particular attention to the adjustments affecting switch-transfer is required. If the switch transfers too early the lock flag will bounce: if transfer is not accomplished the door-lock solenoid will heat up when energized

6.1 LIST OF CONTENTS

The information for this section is not yet available and will be issued at a later date.

7.1 LIST OF CONTENTS

page	section	description
7.1	7.1	CONTENTS
7.2	7.2	GENERAL
7.3	7.3	PART NUMBERS

TABLE 7.1

page	figure	description
7.7	7.1	GENERAL ASSEMBLY
7.9	7.2	BASEPLATE
7.10	7.3	HEAD-POSITIONER HOUSING
7.12	7.4	HEAD-POSITIONER CARRIAGE
7.13	7.5	FRONT PANEL AND DOOR
7.15	7.6	MOTHERBOARD
7.16	7.7	HEATSINK
7.17	7.8	DISC-CARTRIDGE RECEIVER
7.18	7.9	SECTOR TRANSDUCER
7.19	7.10	FILTER BOARD

TABLE 7.2

7.2 GENERAL

The purpose of this chapter is to identify and locate the various component parts of the series 30 disc drive and to provide part numbers for replacement and spare-parts ordering. A price list of the recommended spare-parts is available and will be provided on request. Pricing on each item shown in this section is also available upon request.

Maintenance items that are not illustrated are listed below:

- (a) Preventive-maintenance kit, 99000
 - (i) cleaning pads 22350001
 - (ii) syringe oiler 99000-02
 - (iii) bottle of oil 99000-07
 - (iv) light bulb 10545-00
 - (v) air filter 15170
 - (vi) carrying case 99000-06
 - (vii) cleaning fluid 08350040
- (b) Tools required for corrective maintenance:
 - (i) extender board 11040-01
 - (ii) CE cartridge;
standard-density TD277
high-density TD276
 - (iii) torque-wrench set 99001
 - (iv) head-adjusting tool TD10289
 - (v) carriage-alignment cone 15171
carriage-alignment bar 15172
- (c) Optional tools for corrective maintenance:
 - (i) head-positioning exerciser 022
 - (ii) test terminator 021

See item 90 for components supplied with slide mounting kit.

Series 30 disc drives are shipped in a reusable carton. This carton is part number 15488.

7.3 PART NUMBERS

item	part number	quantity	description
1	11062-00	1	heatsink and motherboard assembly (see figures 7.6 and 7.7 for additional details). Specify serial number of drive and options installed
2	15395	1	shadow-box assembly
3	15434-01	1	baseplate assembly (see figure 7.2 for additional details)
4	15481-01	1	front panel and door assembly. See figure 7.5 for additional details
5	15342-00	1	P7 connector bracket
6	15226	2	gasket, printed-circuit board
7	10535-11	1	cable clamp 1/8 inch
8	10535-12	5	cable clamp 1/4 inch
9	10537-00	6	D-washer
10	70031-08	10	screw number 8-32
11	70168-08	14	lock washer number 8
12	70030-04	40	screw number 6-32
13	70168-06	40	lock washer number 6
14	70029-04	5	screw number 4-40
15	70168-04	7	lock washer number 4
16	70029-07	2	screw number 4-40
17	70169-04	2	washer number 4
18	70166-04	2	nut number 4-40
19	15283	2	snap button plug
20	70244	3	nut 5/16-18

TABLE 7.3 (continues)

item	part number	quantity	description
21	70168-14	3	lock washer 5/16
22	10513	2	quick-disconnect terminal
23	10538	1	tie wrap
24	70039-04	10	machine screw number 6-32
25	15221	1	retainer, pcb
26	15194	4	spring
27	15189	4	spring cover
28	Not used	-	location for additional pcb
29	Not used	-	location for additional pcb
30	Not used	-	location for additional pcb
31	Not used	-	location for additional pcb
32	11085	1	pcb J8 (see note 1)
33	11071	1	pcb J9 (see note 1)
34	11113	1	pcb J10 (see note 1); use 11082 for high-density
35	15185	1	Retainer, pcb
36	11026	1	pcb J3 (see note 1)
37	11111	1	pcb J2 (see note 1)
38	11078	1	pcb J1 (see note 1)
39	15486	2	spacer, cartridge-closing
40	70039-12	2	flat-head screw 6-32
41	70169-06	2	plain washer 6
42	70166-06	2	nut 6-32
43	15487	1	spring, cartridge-closing
44	15414	1	shipping restraint
45	15277	1	H-frame
46	15404	1	cartridge-receiver assembly (see figure 7.8 for additional details)
47	15099	2	eccentric, cartridge-receiver
48	15095	2	bushing, cartridge-receiver
49	70031-10	4	screw 8-32
50	70169-08	4	washer 8

TABLE 7.3 (continues)

item	part number	quantity	description
51	25045	1	upper-head assembly, 1100 bpi (use part 25065 for 2200 bpi head)
52	25047	1	lower-head assembly, 1100 bpi (use part 25066 for 2200 bpi head)
53	15549	1	bottom rear cover, shadow box
54	15406	1	bottom front cover, plenum chamber
55	15245	2	spring, cartridge-receiver
56	15170	1	air filter
57	15295	1	reflector assembly
58	70030-06	4	screw 6-32
59	70066-04	2	undercut screw 6-32
60	10544-02	1	lens, red
61	10544-03	1	lens, orange
62	10544-04	1	lens, yellow
63	10544-09	1	lens, white
64	10544	4	lamp
65	15471	1	strip assembly, front trim; orange, logo (use part 15244-01 for orange, no logo; use part 15244-02 for unpainted, no logo)
66	15439	1	narrow indicator trim, write-protect (use part 15438 for power)
67	15546	1	top-cover assembly
68	15386	8	truss screw 8-32
69	15387	8	washer
70	15453	2	trim, window-support
71	15455	2	magnet, retainer-assembly
72	15476		screw
73	15383		trim, shadow box
74	11114	1	read/write-head cable-assembly (use 11061 with J10-11006)
75	15442	1	label, caution
76	15449	2	label, pcb-retainer
77	15445	1	label, serial-number
78	15428	1	head-positioner assembly (see figures 7.3, 7.4 for additional details)

TABLE 7.3 (continues)

item	part number	quantity	description
80	15415	1	sector transducer (see figure 7.9)
81	11048	1	filter board assembly (see figure 7.10)
82	70229	6	rubber feet
83	11116	1	motherboard assembly: order by part number, specify options installed and serial-number of drive when ordering replacement (see figure 7.6 for additional details)
84	11050	1	heatsink assembly: specify serial-number of drive when ordering replacement (see figure 7.7)
85	not used	-	not used
86	not used	-	not used
87	not used	-	not used
88	not used	-	not used
89	not used	-	not used
90	not shown		slide-mounting kit, includes:
	15376	2	slides
	700168-10	8	screw number 10-32 x 5/16
	70168-10	8	lock washer number 10
	70169-10	8	flat washer number 10
	70005-08	4	philips truss-head screw number 10-32 x 1/2
	15558	4	brackets
	70031-06	8	screw number 8-32 x 3/8
	70166-08	8	nut number 8-32
	70168-08	8	lock washer number 8
	70169-08	8	flat washer number 8
91	15488	1	shipping container (not shown)
92	15587	1	shipping restraint

TABLE 7.3 (CONCLUDED)

Note
Specify options and serial-number of drive when ordering replacements. Each pcb is marked with an assembly-number and option-code, if applicable. The two suffix-numbers designate option-code. Early production pcb have part-numbers that differ from those listed above and may not be compatible with present-level drives.

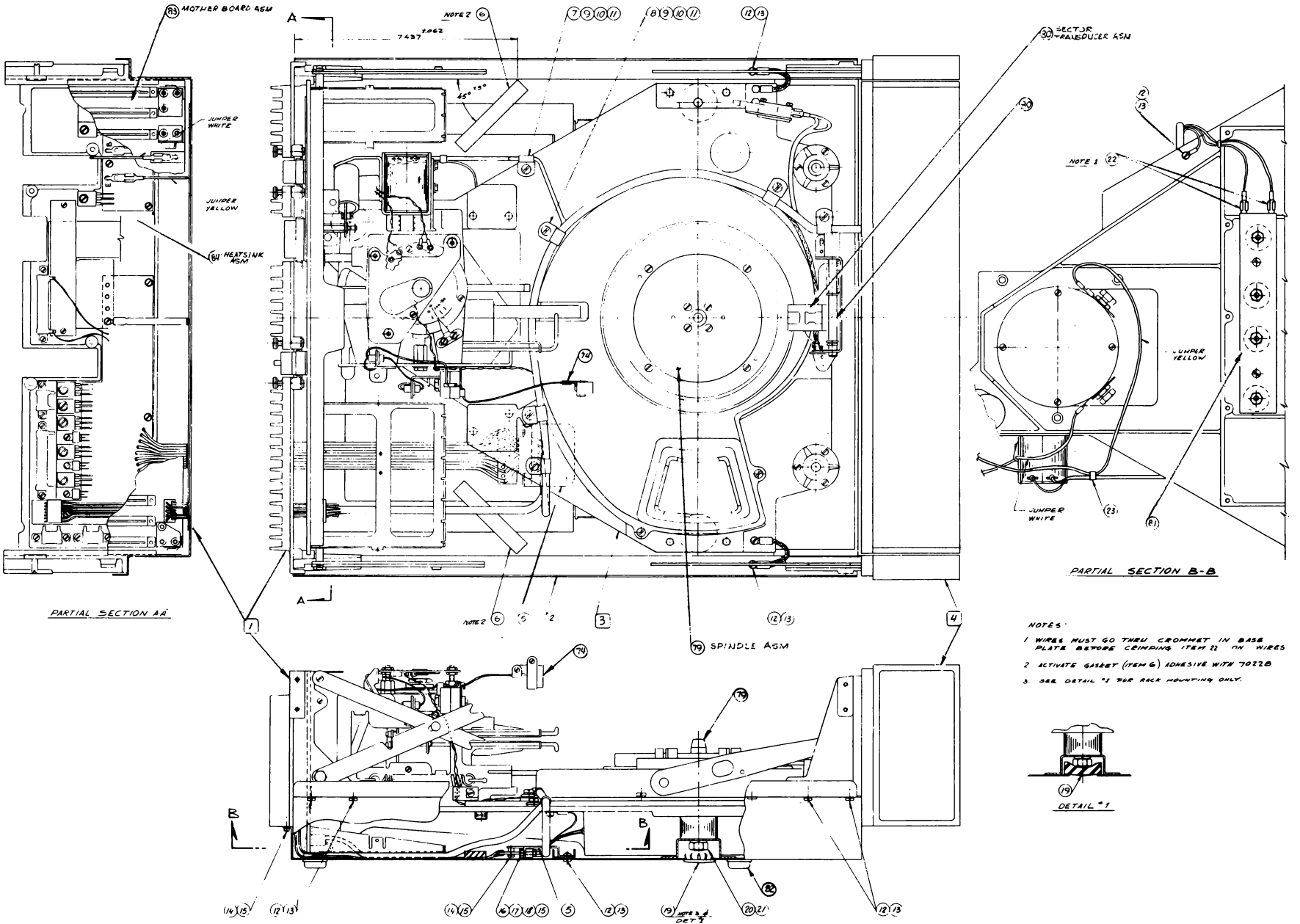

- NOTES:
- 1 WIRES MUST GO THRU CROMMET IN BASE PLATE BEFORE CRIMPING (ITEM 22) ON WIRES
 - 2 ACTIVATE GASKET (ITEM 6) ADHESIVE WITH 7022B
 - 3 SEE DETAIL *1 FOR RACK MOUNTING ONLY.

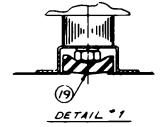

FIGURE 7.1 (2 of 2) GENERAL ASSEMBLY

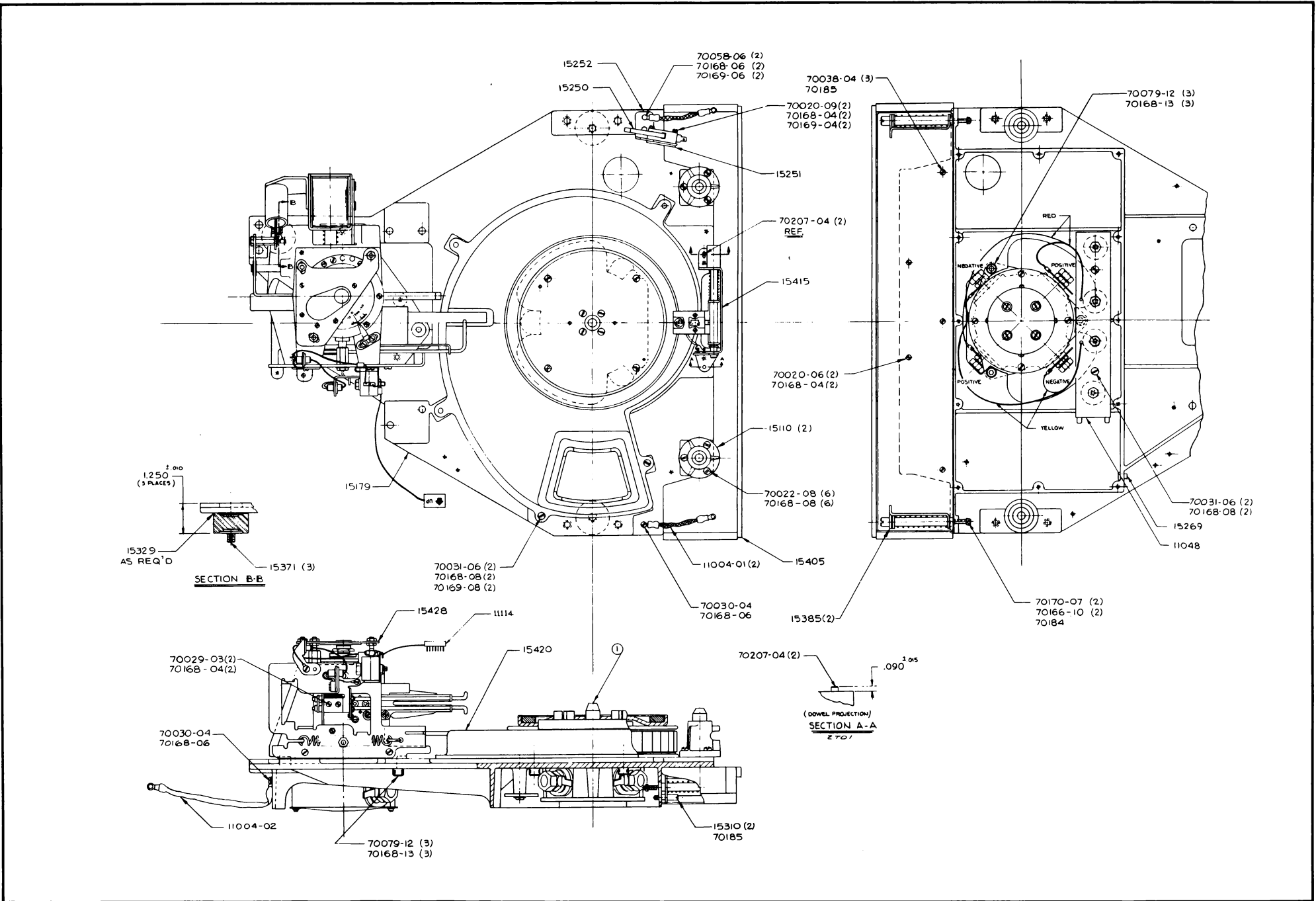

FIGURE 7.2 BASEPLATE ASSEMBLY

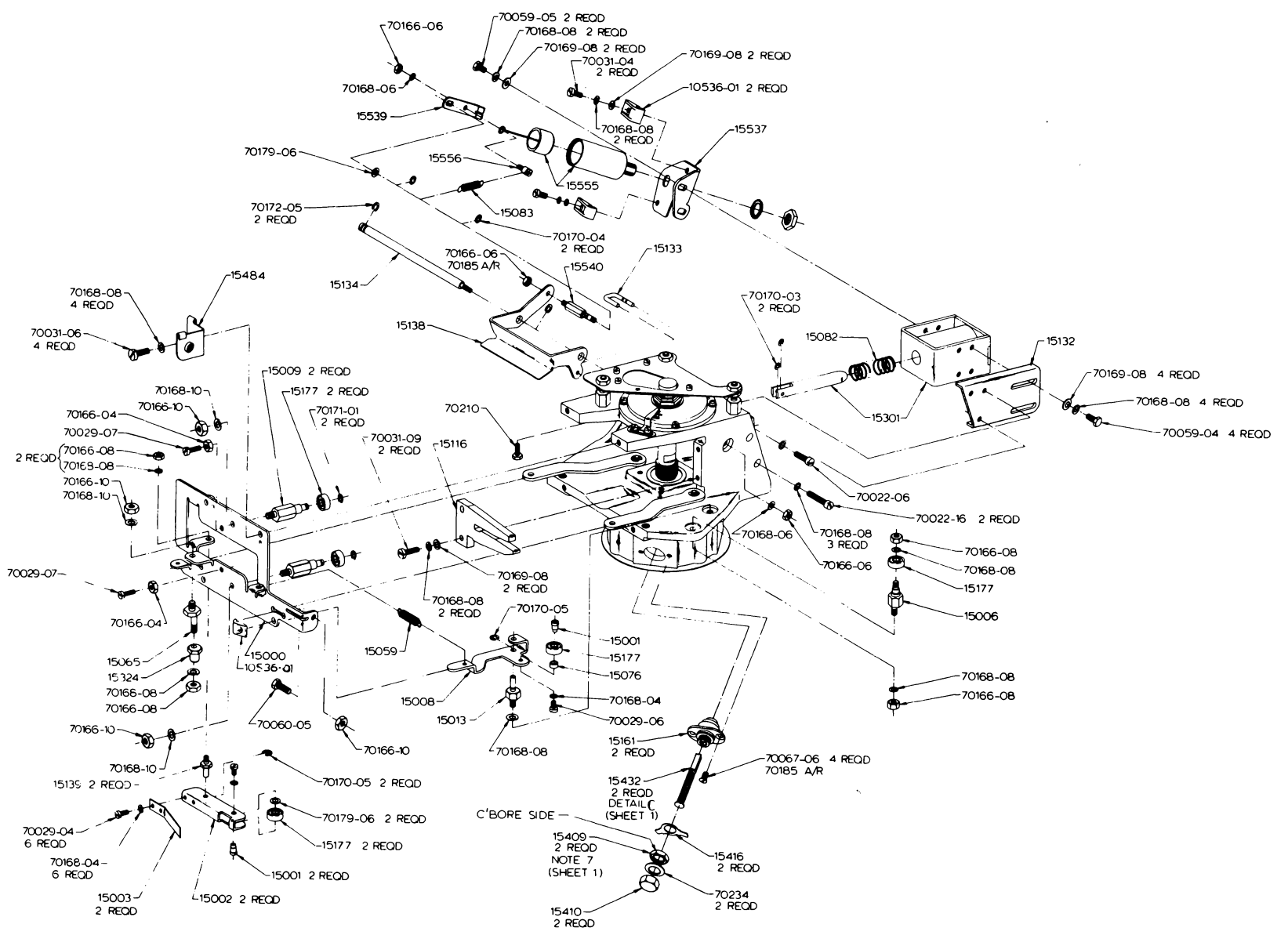

FIGURE 7.3 (1 of 2) HEAD-POSITIONER HOUSING

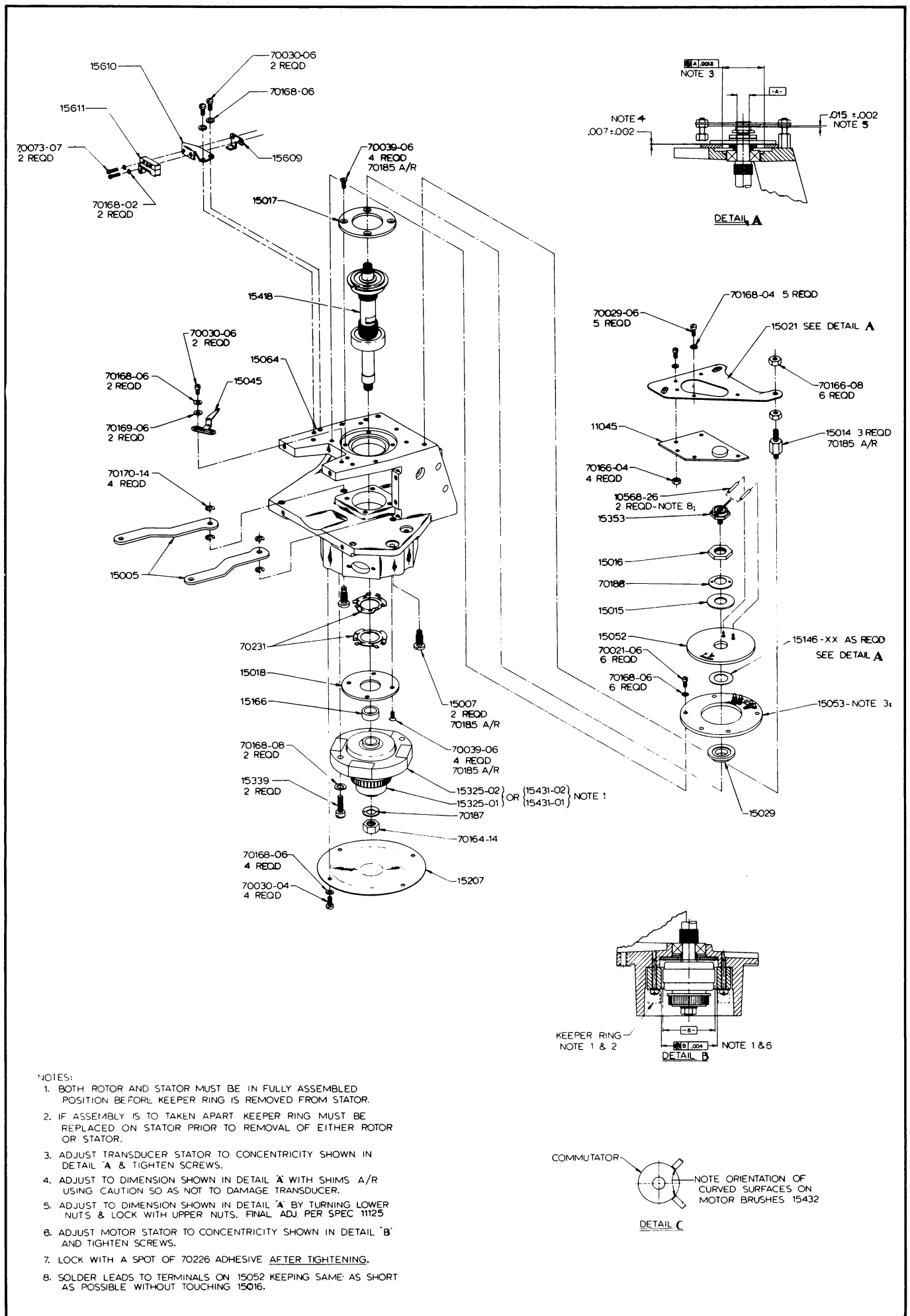
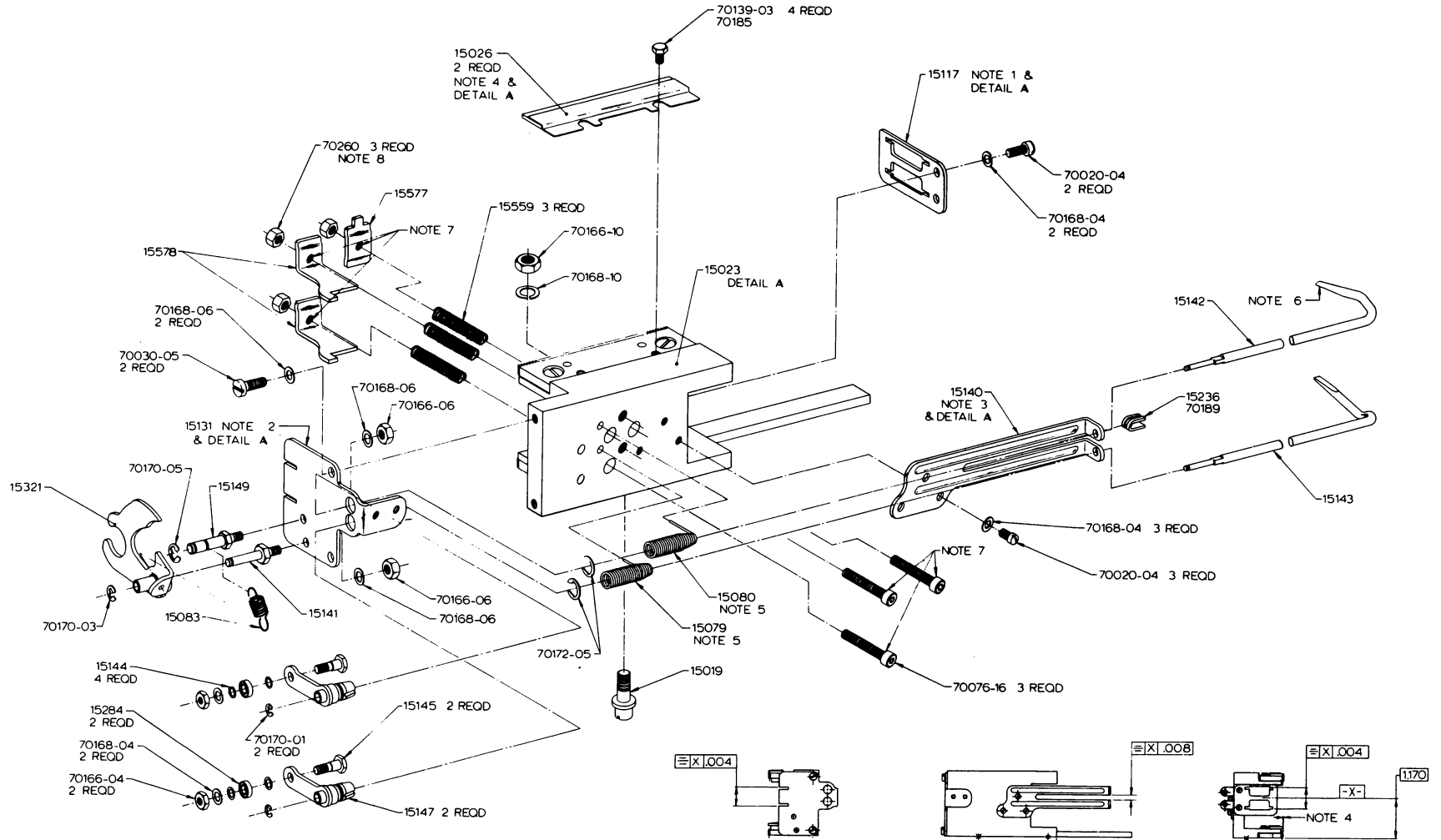

FIGURE 7.3 (2 of 2) HEAD-POSITIONER HOUSING

FIGURE 7.4 HEAD-POSITIONER CARRIAGE



NOTES:

1. ADJUST 15117 PER DETAIL "A" AND TIGHTEN SCREWS.
2. ADJUST 15131 PER DETAIL "A" AND TIGHTEN SCREWS.
3. ADJUST 15140 PER DETAIL "A" AND TIGHTEN SCREWS.
4. ALIGN RACK LUBRICATORS SO THAT LUBRICATORS ARE FLUSH WITH TIPS OF RACK TEETH WITHIN $\pm .010$ AND TIGHTEN SCREWS.
5. TORSION SPRINGS ARE TO BE WOUND UP TWO REVOLUTIONS WHEN ASSEMBLED
6. FORCE AT ENDS OF 15142 & 3 IS 275 ± 25 GRAMS.
7. LUBRICATE WITH A DROP OF 70243 LUBRICANT.
8. NUT 70260 SHALL BE FLUSH WITH END OF SCREW 70076-16 & LOCKED WITH 70258 ADHESIVE.

FIGURE 7.5 (1 of 2) FRONT PANEL AND DOOR

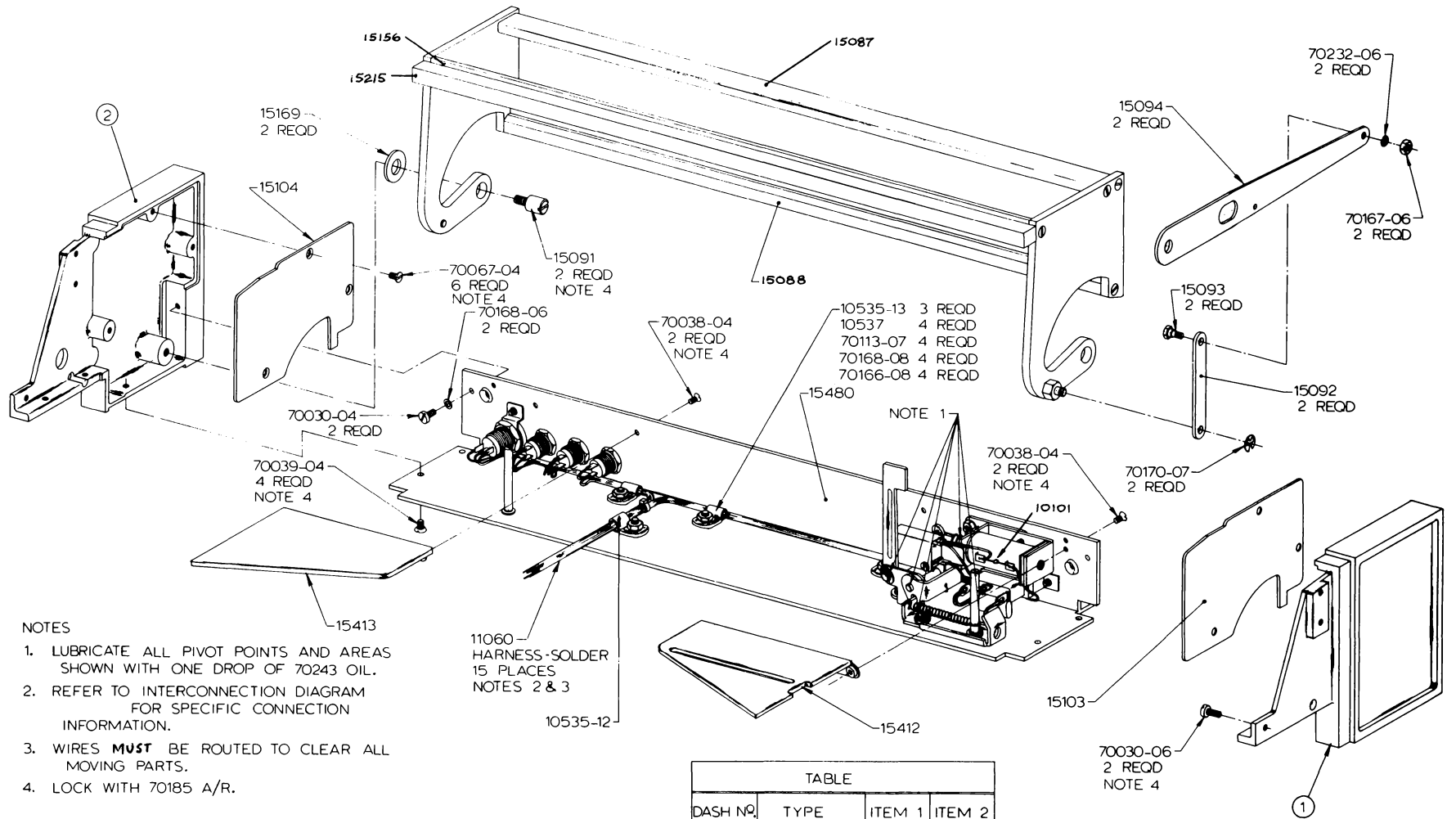
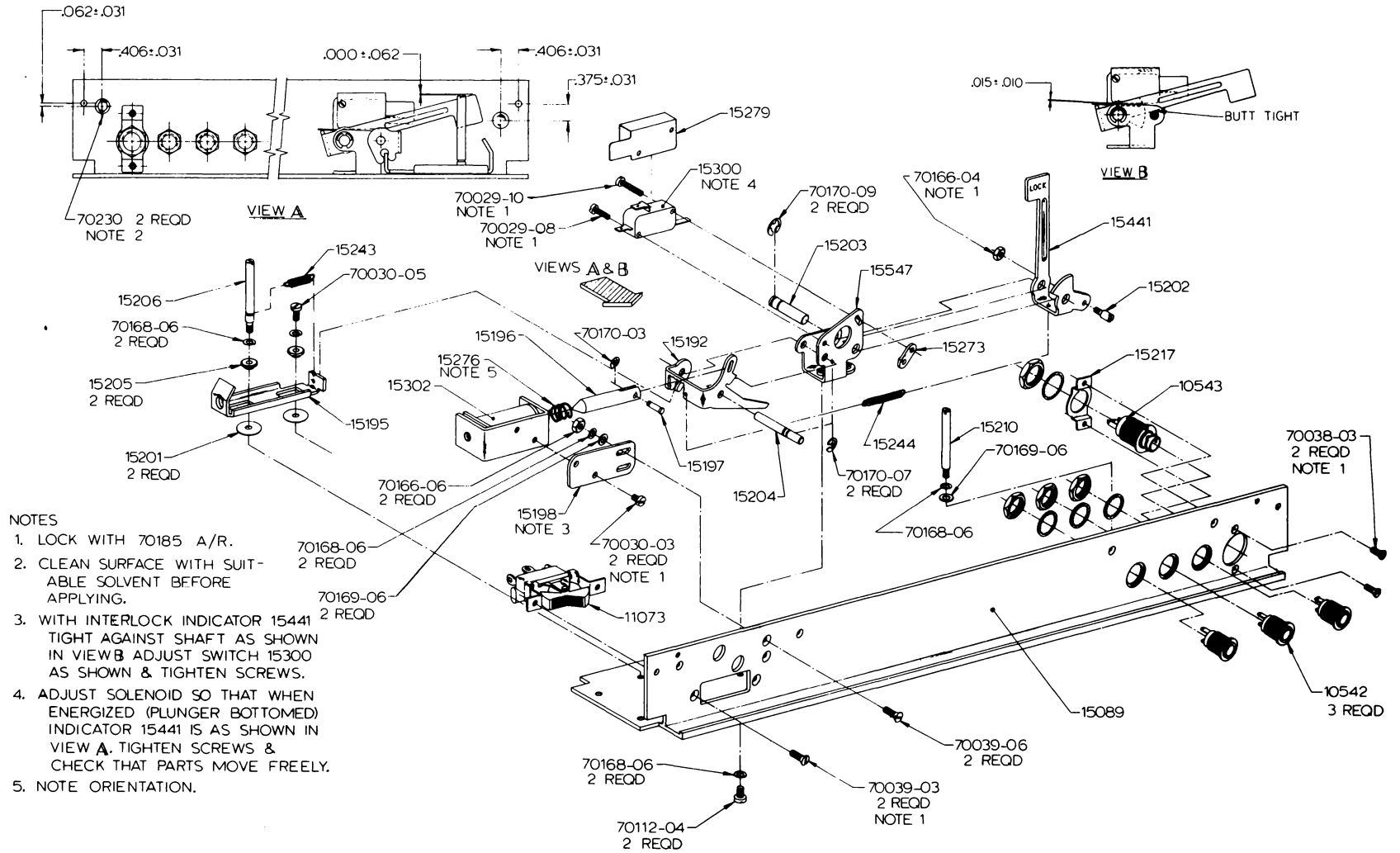
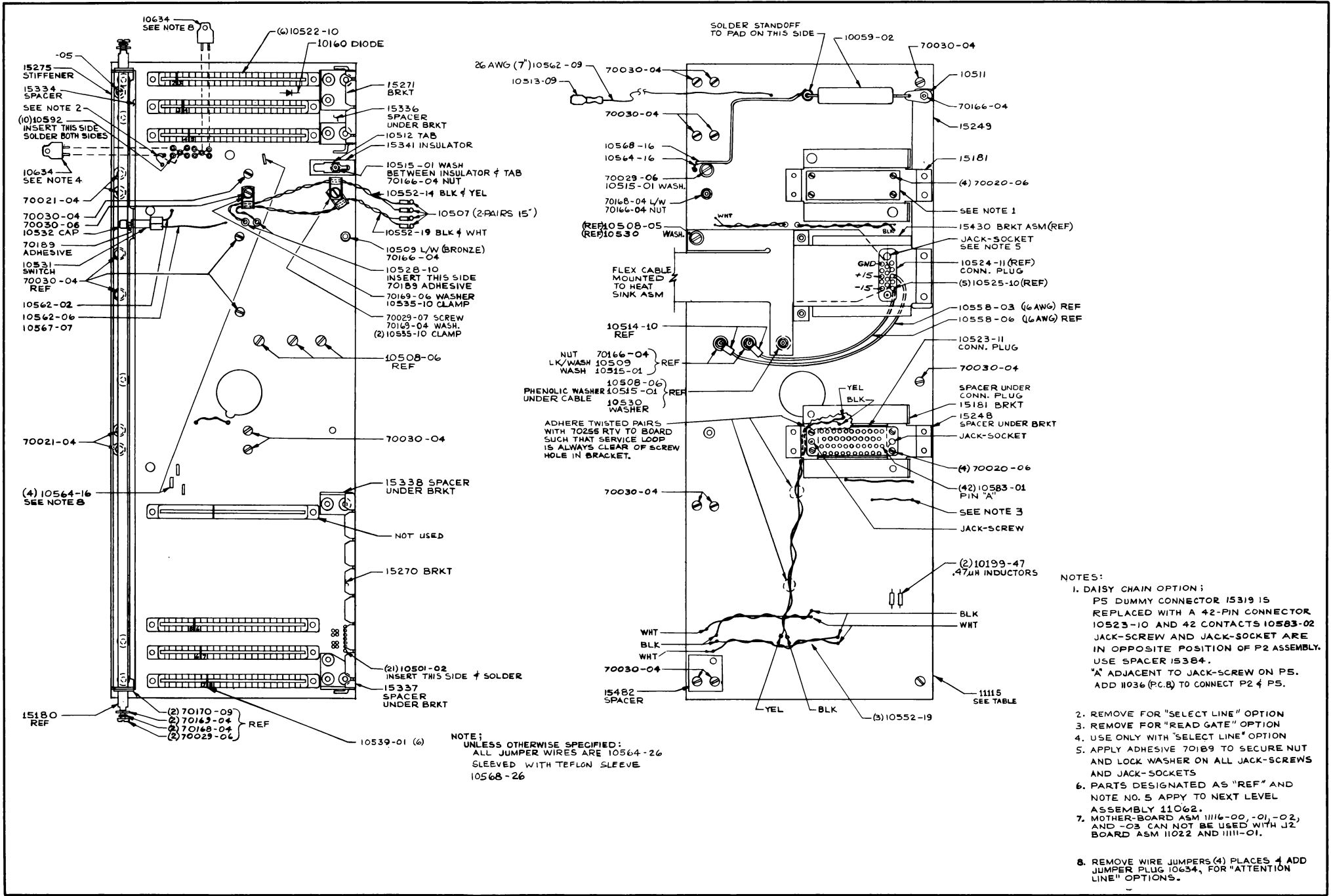

FIGURE 7.5 (2 of 2) FRONT PANEL AND DOOR



- NOTES
1. LOCK WITH 70185 A/R.
 2. CLEAN SURFACE WITH SUITABLE SOLVENT BEFORE APPLYING.
 3. WITH INTERLOCK INDICATOR 15441 TIGHT AGAINST SHAFT AS SHOWN IN VIEW B ADJUST SWITCH 15300 AS SHOWN & TIGHTEN SCREWS.
 4. ADJUST SOLENOID SO THAT WHEN ENERGIZED (PLUNGER BOTTOMED) INDICATOR 15441 IS AS SHOWN IN VIEW A. TIGHTEN SCREWS & CHECK THAT PARTS MOVE FREELY.
 5. NOTE ORIENTATION.

FIGURE 7.6 MOTHERBOARD



NOTE;
UNLESS OTHERWISE SPECIFIED:
ALL JUMPER WIRES ARE 10564-26
SLEEVED WITH TEFLON SLEEVE
10568-26

- NOTES:
1. DAISY CHAIN OPTION;
P5 DUMMY CONNECTOR 15319 IS
REPLACED WITH A 42-PIN CONNECTOR
10523-10 AND 42 CONTACTS 10583-02
JACK-SCREW AND JACK-SOCKET ARE
IN OPPOSITE POSITION OF P2 ASSEMBLY.
USE SPACER 15384.
A ADJACENT TO JACK-SCREW ON P5.
ADD 1036 (PC.B) TO CONNECT P2 & P5.
 2. REMOVE FOR "SELECT LINE" OPTION
 3. REMOVE FOR "READ GATE" OPTION
 4. USE ONLY WITH "SELECT LINE" OPTION
 5. APPLY ADHESIVE 70189 TO SECURE NUT
AND LOCK WASHER ON ALL JACK-SCREWS
AND JACK-SOCKETS
 6. PARTS DESIGNATED AS "REF" AND
NOTE NO. 5 APPLY TO NEXT LEVEL
ASSEMBLY 11062.
 7. MOTHER-BOARD ASM 11116-00, -01, -02,
AND -03 CAN NOT BE USED WITH J2
BOARD ASM 11022 AND 11111-01.
 8. REMOVE WIRE JUMPERS (4) PLACES 4
AD JUMPER PLUG 10634, FOR "ATTENTION
LINE" OPTIONS.

FIGURE 7.7 HEATSINK

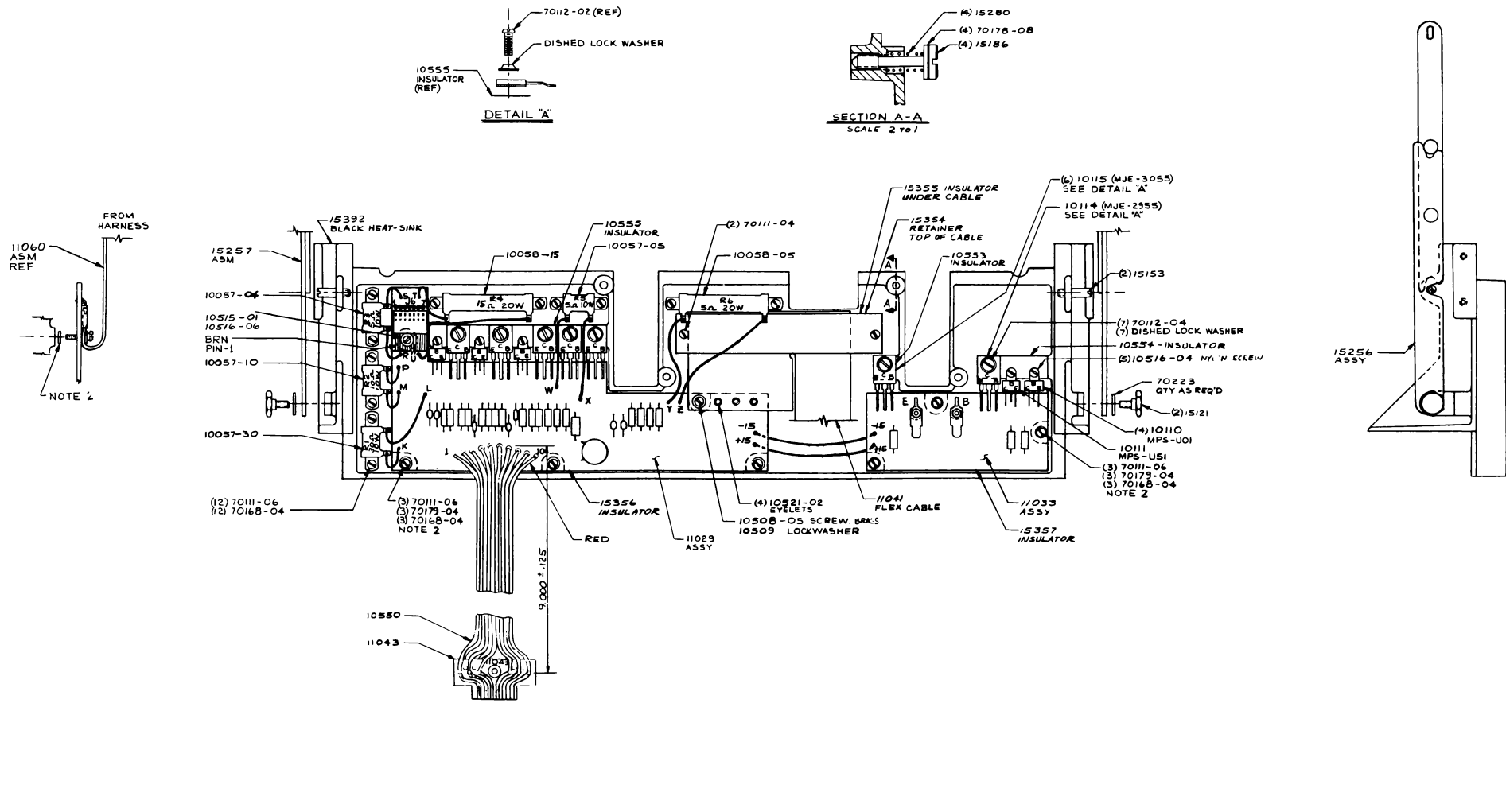

- NOTES
1. APPLY 10569 BETWEEN INSULATOR AND TRANSISTOR, AND BETWEEN INSULATOR AND HEAT-SINK
 2. APPLY ADHESIVE (20189) TO WASHER 10515-02 ONTO HEAT SINK

WIRE		CHART		
FROM	TO	COLOR	AWG	PART NO.
R1	K	BLK	20	10540-00
R1	L	WHT		-09
R2	M	RED		-02
R2	P	WHT		-03
R3	R	WHT		-09
R3	S	WHT		-09
R4	T	WHT		-09
R4	U	WHT		-09
R5	V	WHT		-09
R5	X	WHT		-09
R6	Y	WHT		-09
R6	Z	RED	20	10540-02
-15	-15	BLU	16	10558-04
+15	+15	RED	16	10558-02

FIGURE 7.8 DISC-CARTRIDGE RECEIVER

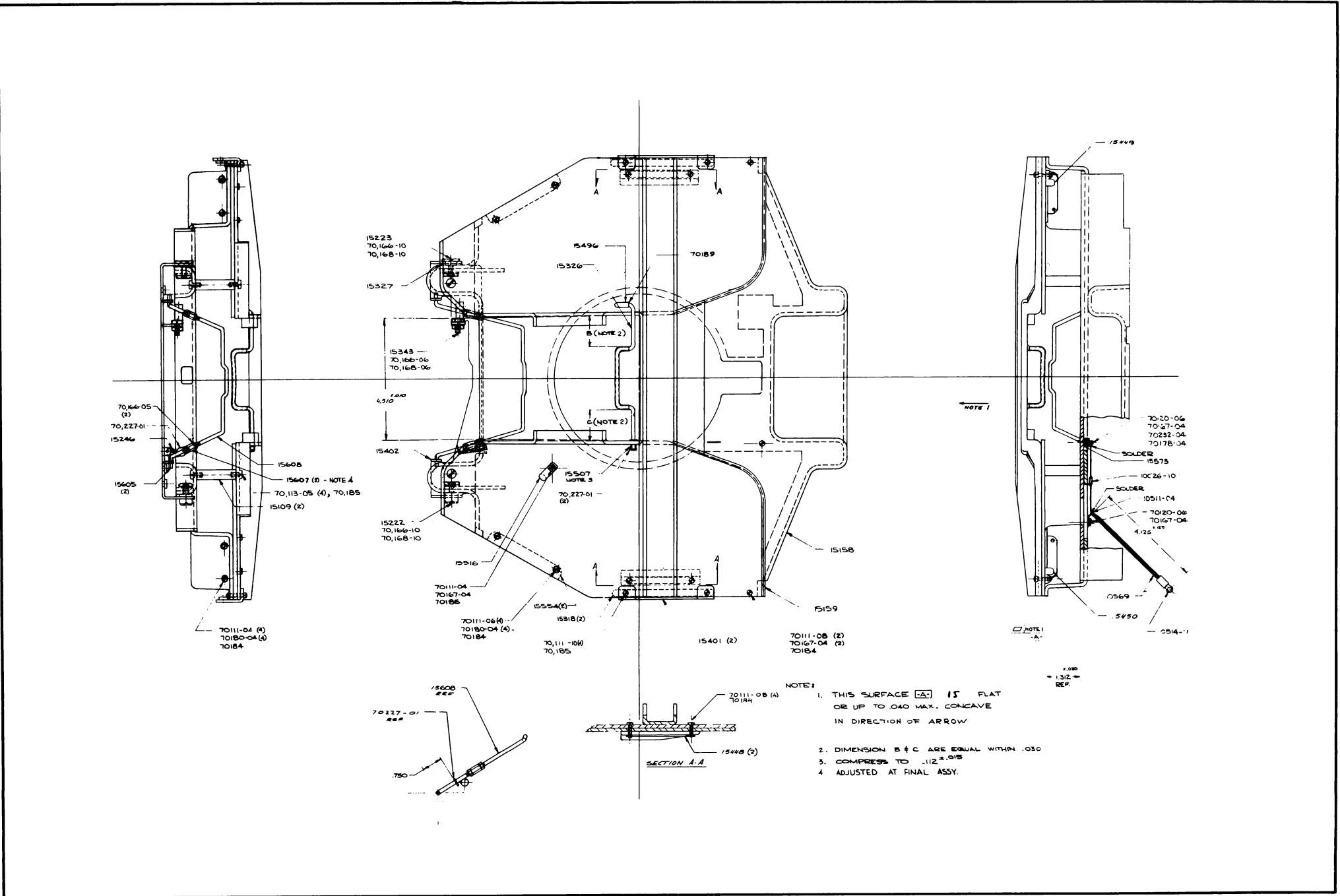

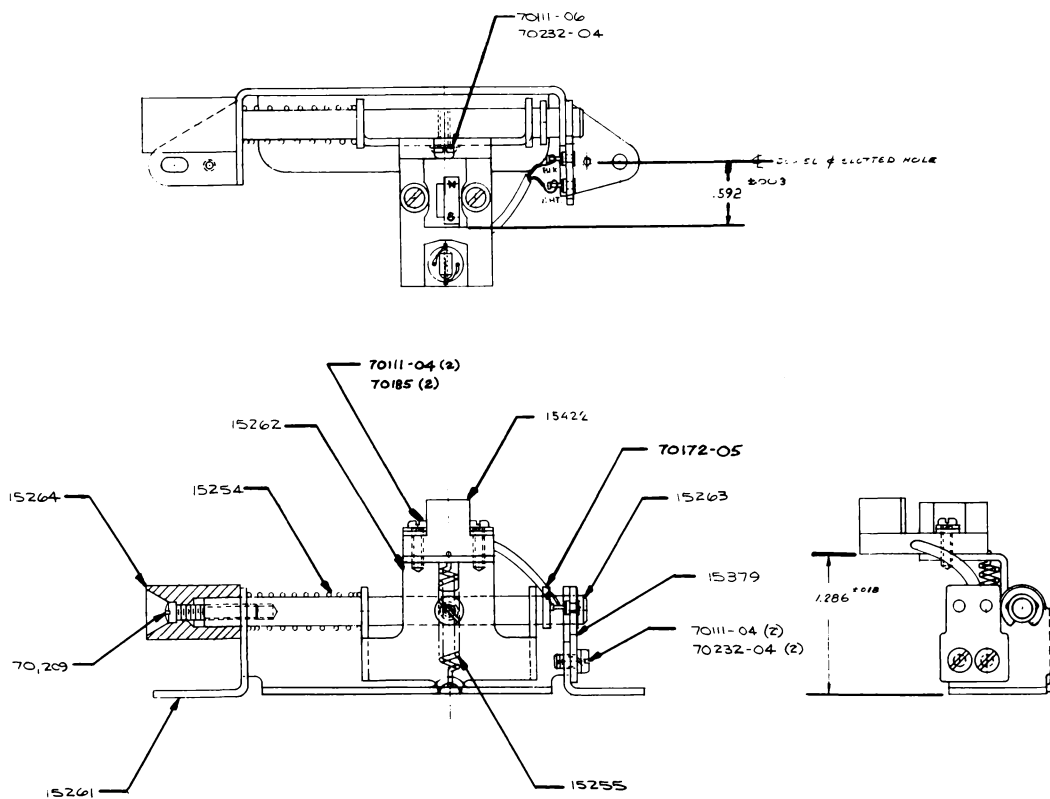
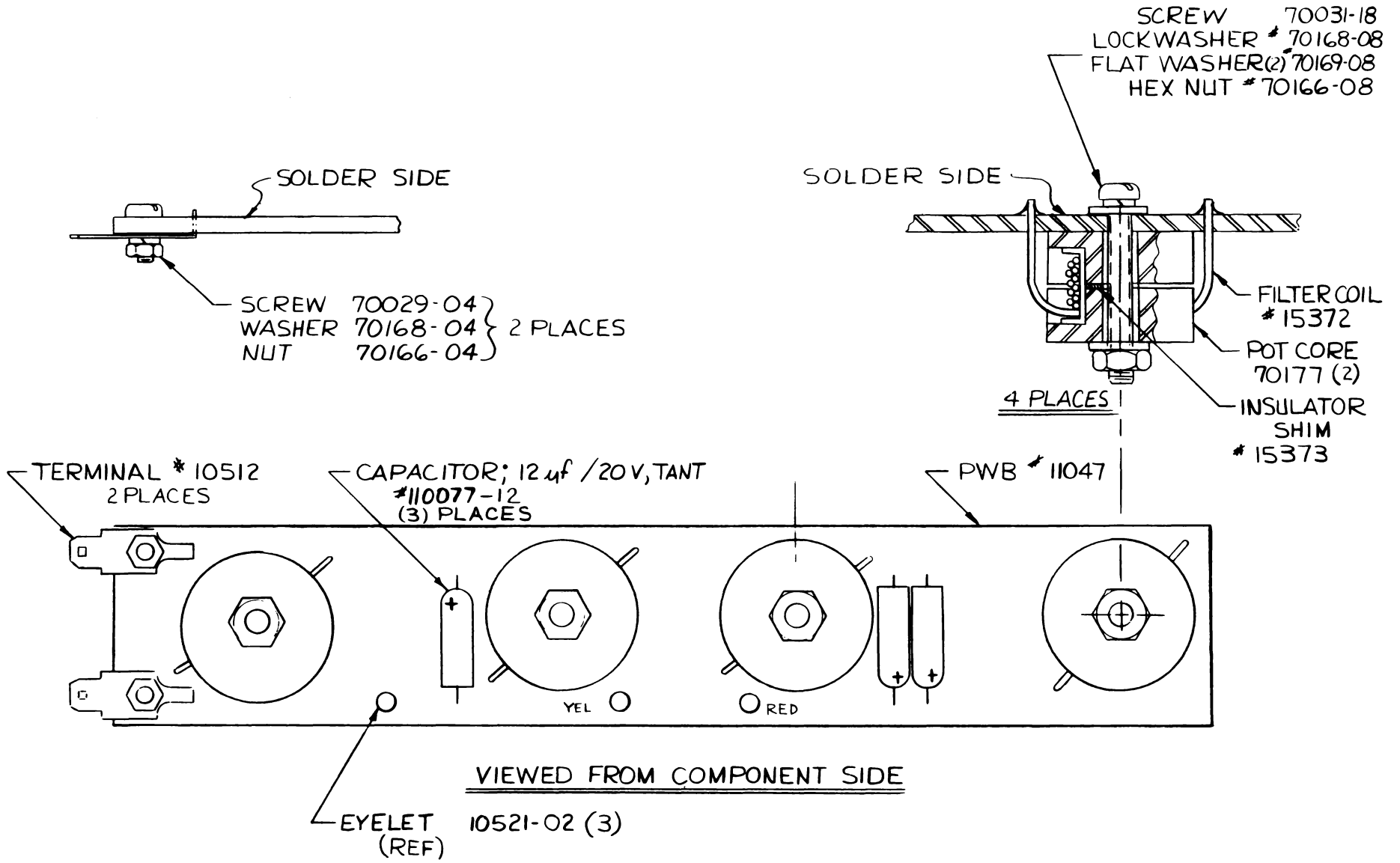

FIGURE 7.9 SECTOR TRANSDUCER

FIGURE 7.10 FILTER BOARD



8.1 LIST OF CONTENTS

page	figure	title
8.1	-	LIST OF CONTENTS
8.2	8.1	INTERCONNECTIONS (BASED ON 11116, REVISION-LEVEL H)
8.5	8.2	SERVO, J1 (BASED ON 11078, REVISION-LEVEL G/107)
8.8	8.3	SEEK LOGIC, J2 (BASED ON 11111, REVISION-LEVEL F/103)
8.10	8.4	ADDRESSING LOGIC, J3 (BASED ON 11026, REVISION-LEVEL J/101)
8.12	8.5	LOGIC, J8 (BASED ON 11085, REVISION-LEVEL G/104)
8.14	8.6	START-UP, J9 (BASED ON 11071, REVISION-LEVEL J/108)
8.16	8.7	STANDARD-DENSITY DATA, J10 (BASED ON 11113, REVISION-LEVEL G/104)
8.18	8.8	HIGH-DENSITY DATA, J10 (BASED ON 11082, REVISION-LEVEL S/107)
8.20	8.9	POWER DRIVERS (BASED ON 11030, REVISION-LEVEL A)

TABLE 8.1

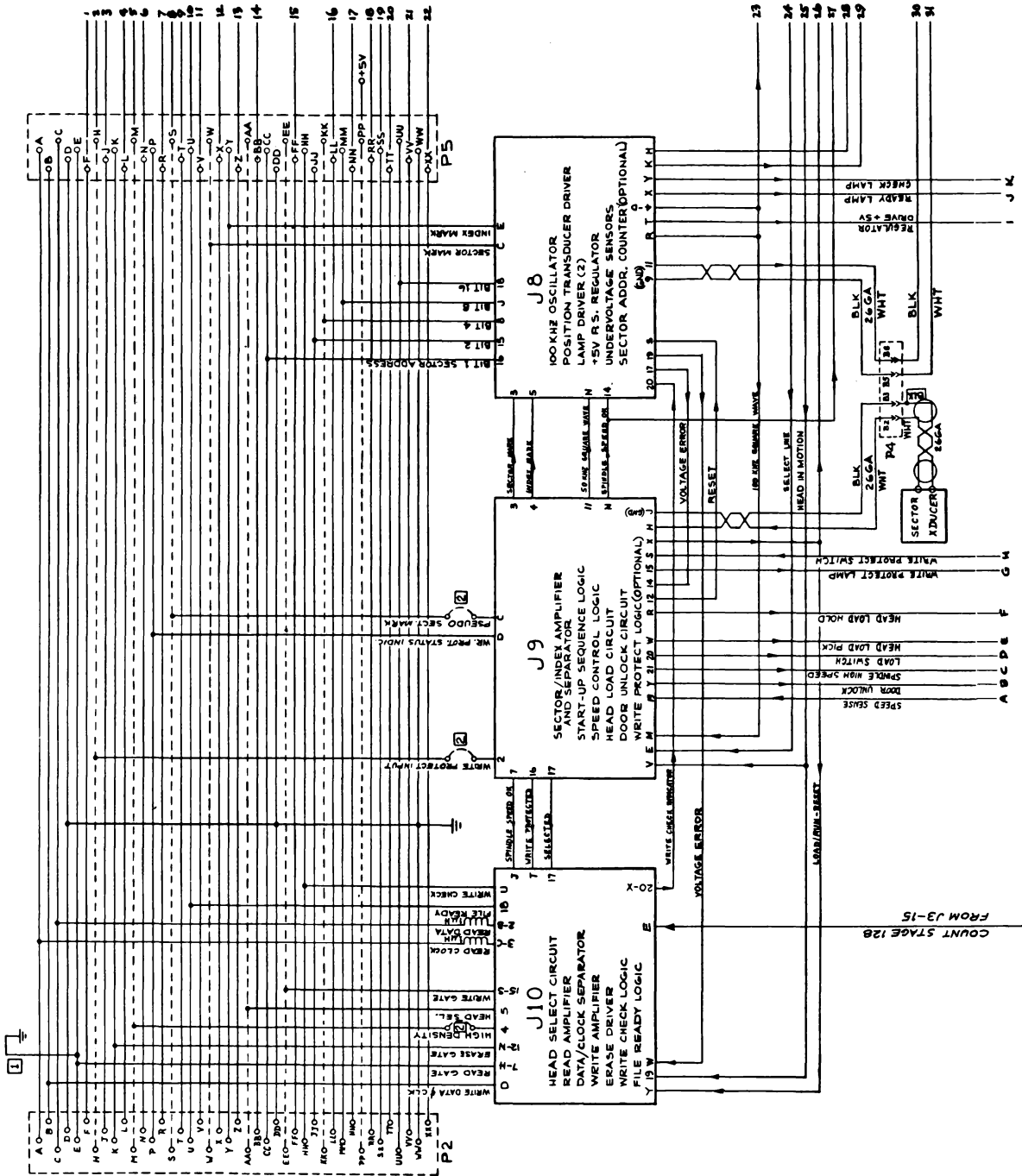

FIGURE 8.1 INTERCONNECTIONS WITHIN SERIES 30 (sheet 1 of 3)
SCHEMATIC #11116 REVISION H

FIGURE 8.1 INTERCONNECTIONS WITHIN MODEL 31 (sheet 2 of 3)
SCHEMATIC #11116 REVISION H

SEE SHEET 1 OF 3

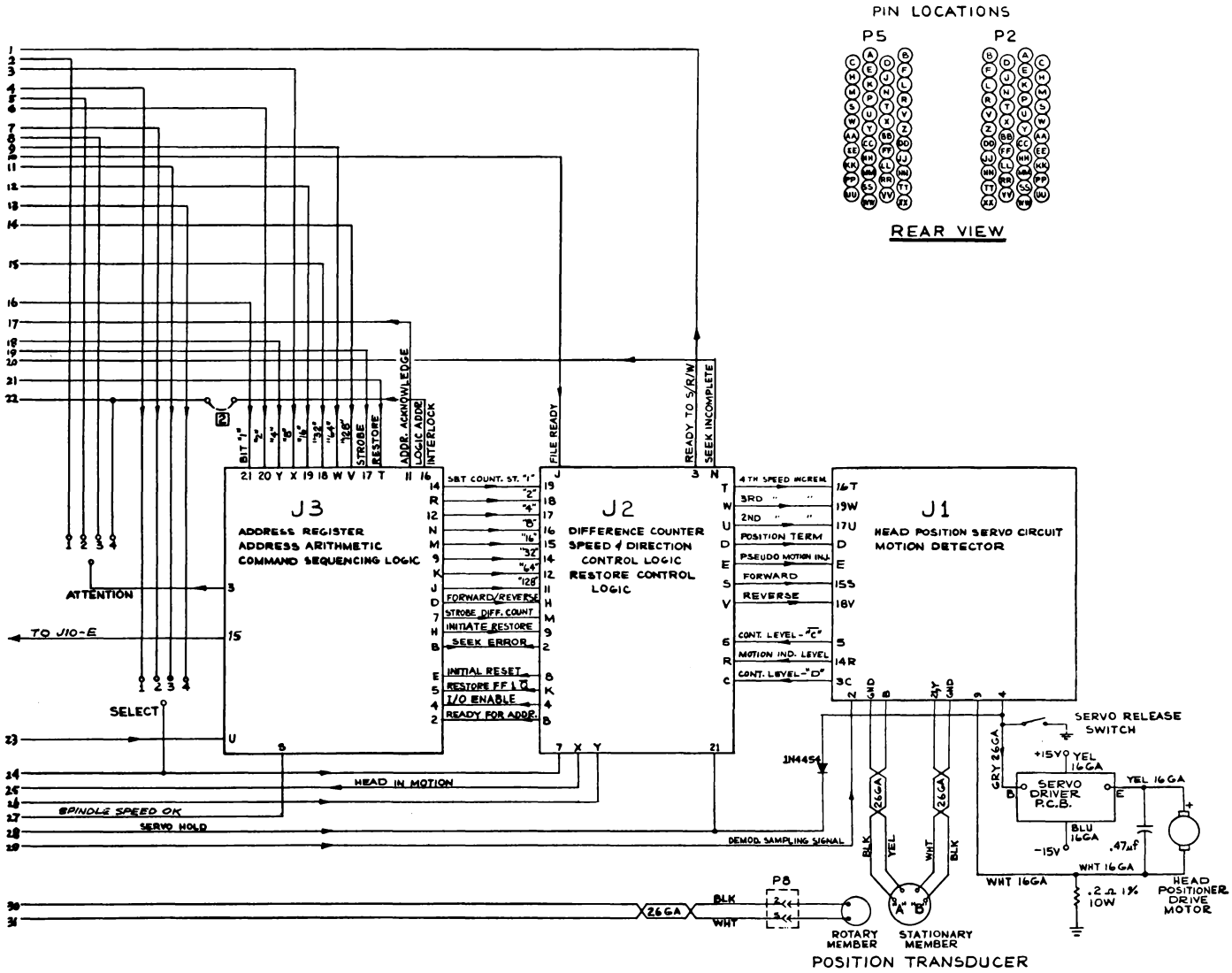

FIGURE 8.1 INTERCONNECTIONS WITHIN SERIES 30 (sheet 3 of 3)
SCHEMATIC #11116 REVISION H

- NOTES:
- 1.1 FOR "READ GATE" OPTION JUMPER WIRE MARKED [1] IS OMITTED
 - 1.2 FOR "ATTENTION LINE" OPTIONS, JUMPER WIRES MARKED [2] ARE REMOVED.
 - 1.3 INTERCONNECTIONS INDICATED BY DOTTED LINES BETWEEN P2 AND P5 ARE ON THE JUMPER P.C.B. 11036
 - 1.4 FOR "WRITE PROTECT" OPTION, JUMPER WIRE MARKED [3] IS OMITTED, AND "POWER" LABEL ON FRONT PANEL IS REPLACED BY "WRITE PROTECT".

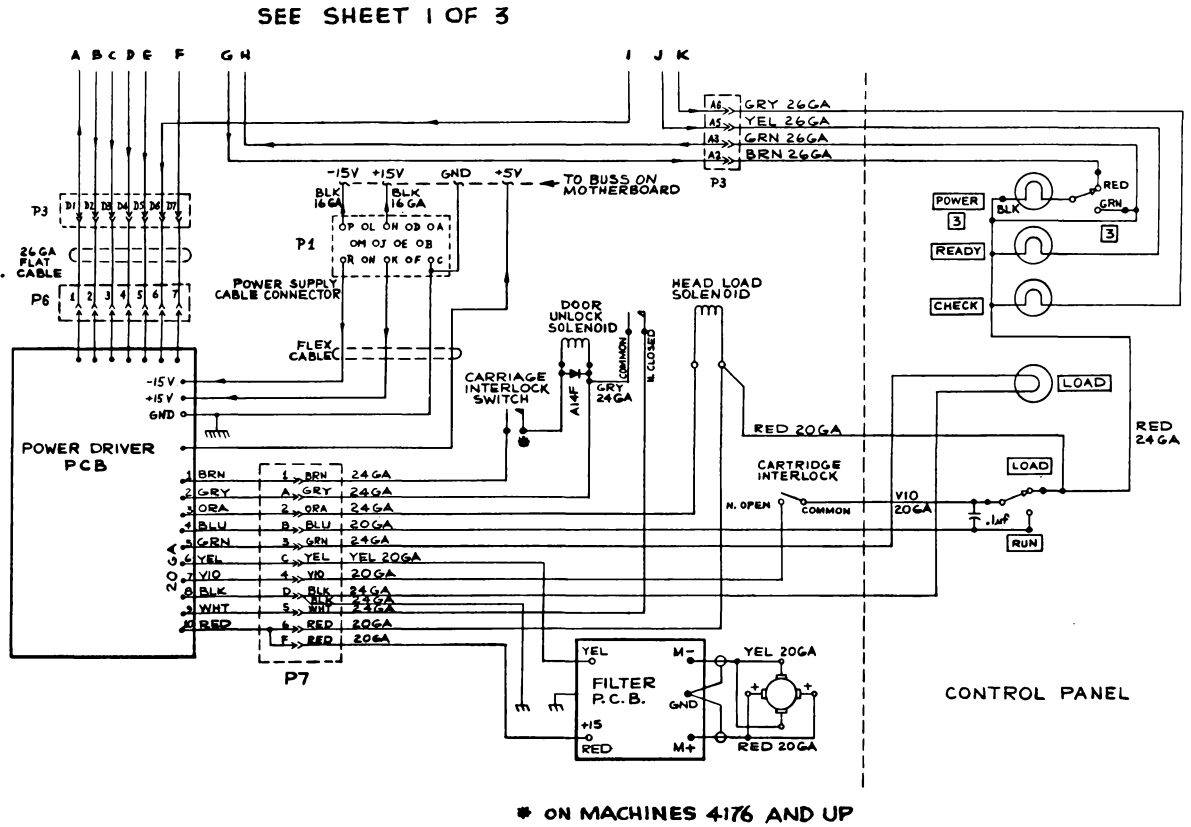
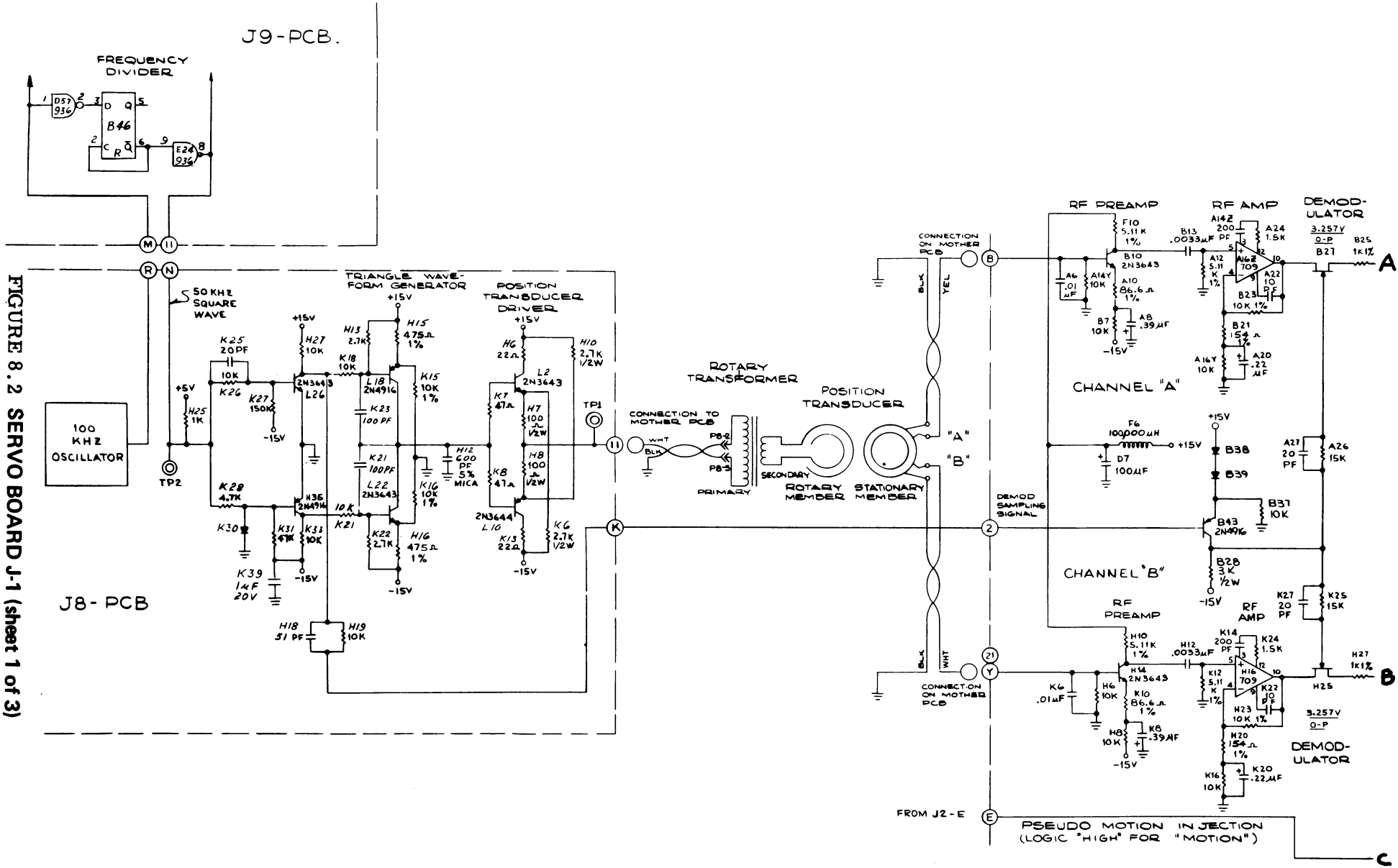

FIGURE 8.2 SERVO BOARD J-1 (sheet 1 of 3)
SCHEMATIC #11078 REVISION G/107



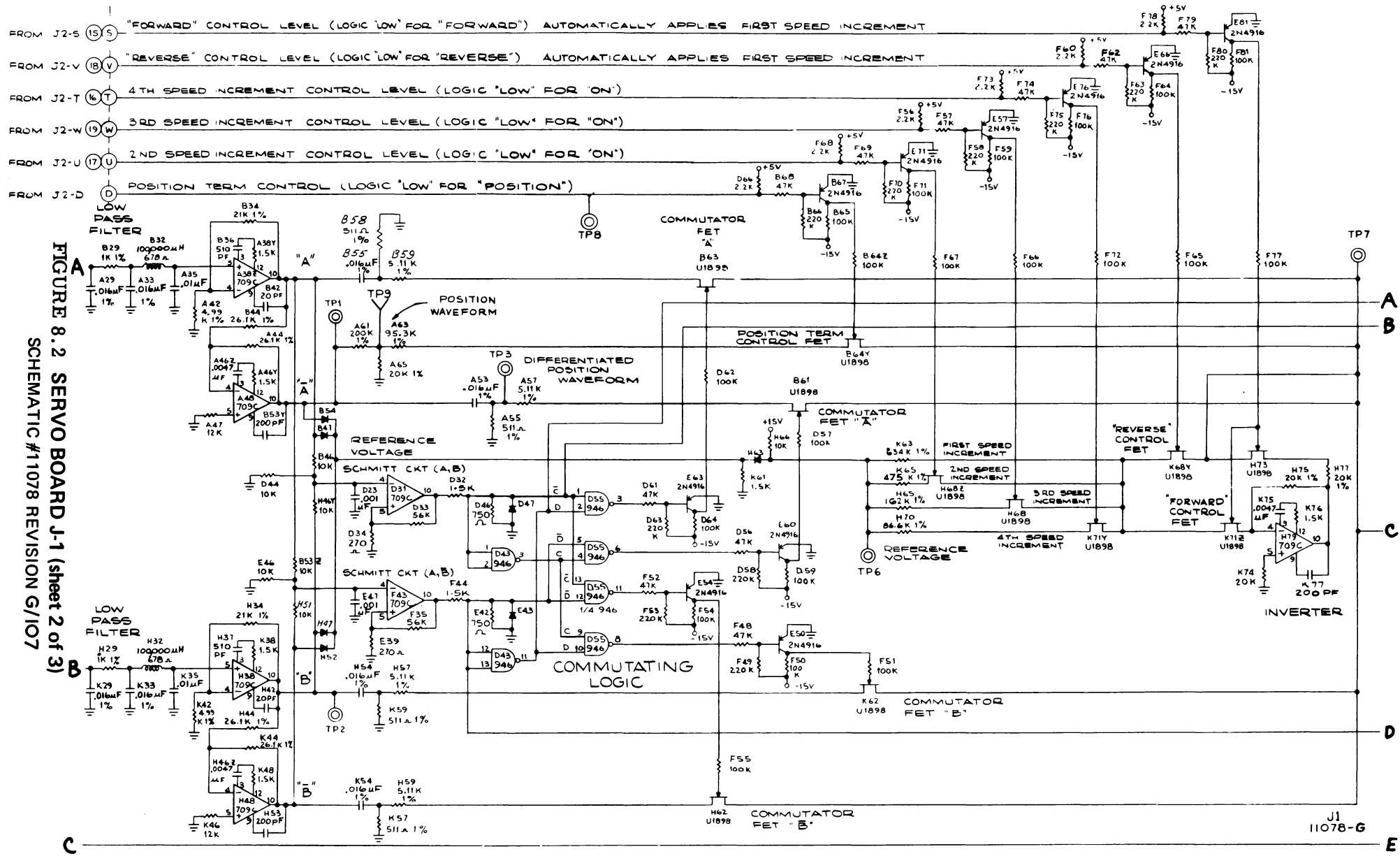
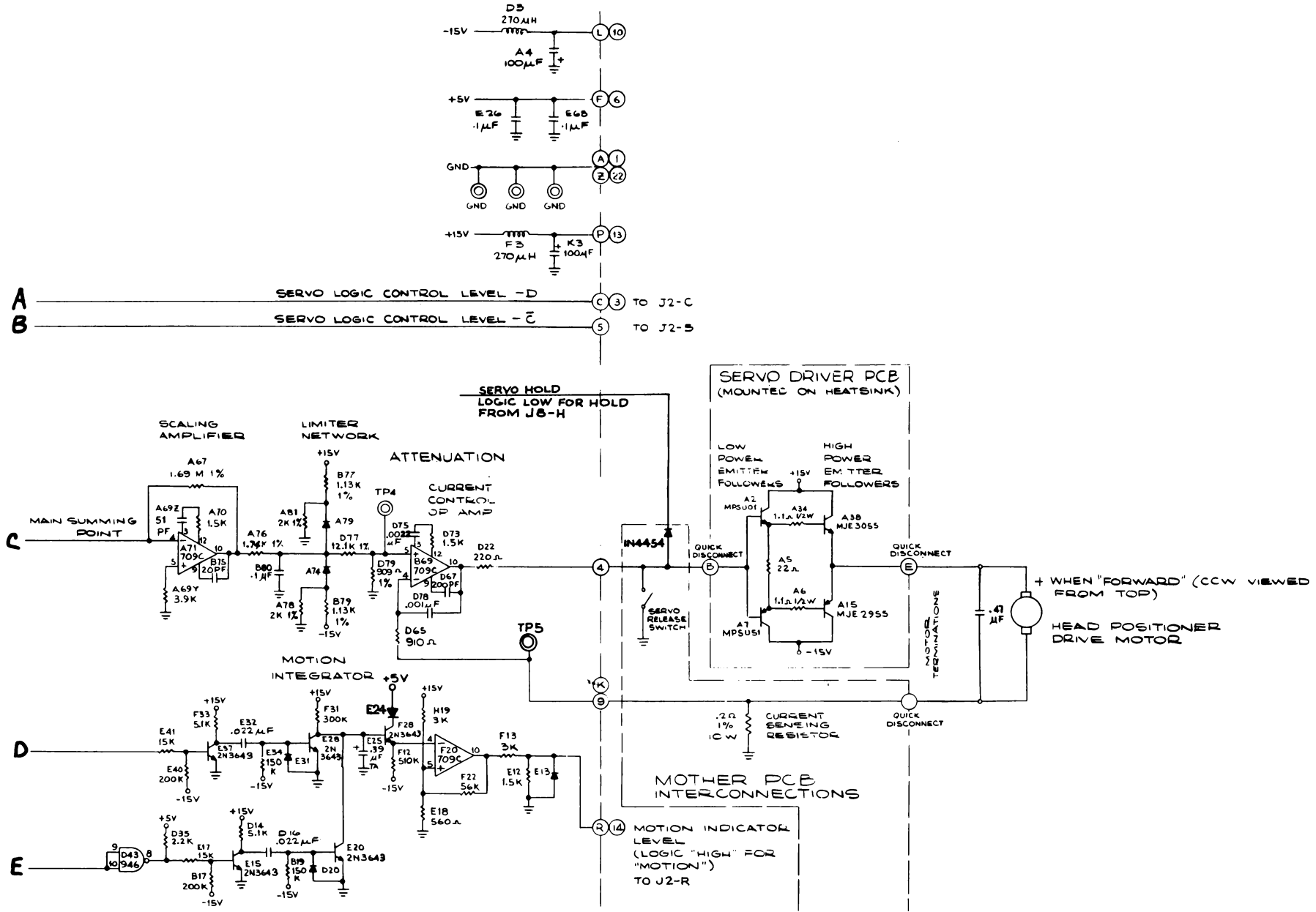

FIGURE 8.2 SERVO BOARD J-1 (sheet 2 of 3)
SCHEMATIC #11078 REVISION G/107

FIGURE 8.2 SERVO BOARD J-1 (sheet 3 of 3)
SCHEMATIC #11078 REVISION G/107



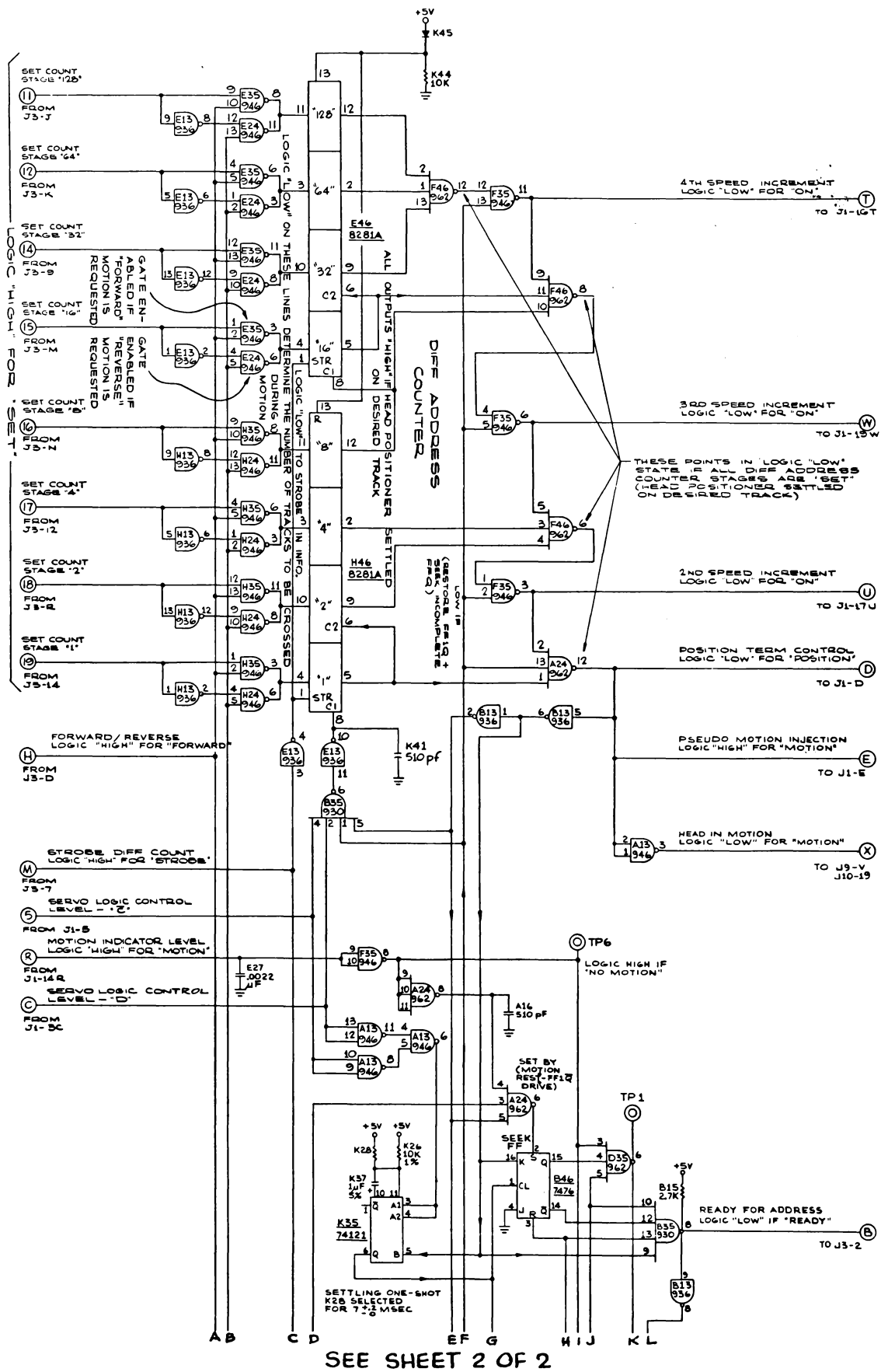

FIGURE 8.3 SEEK FUNCTIONS J-2 (sheet 1 of 2)
SCHEMATIC #11111 REVISION F/IO3

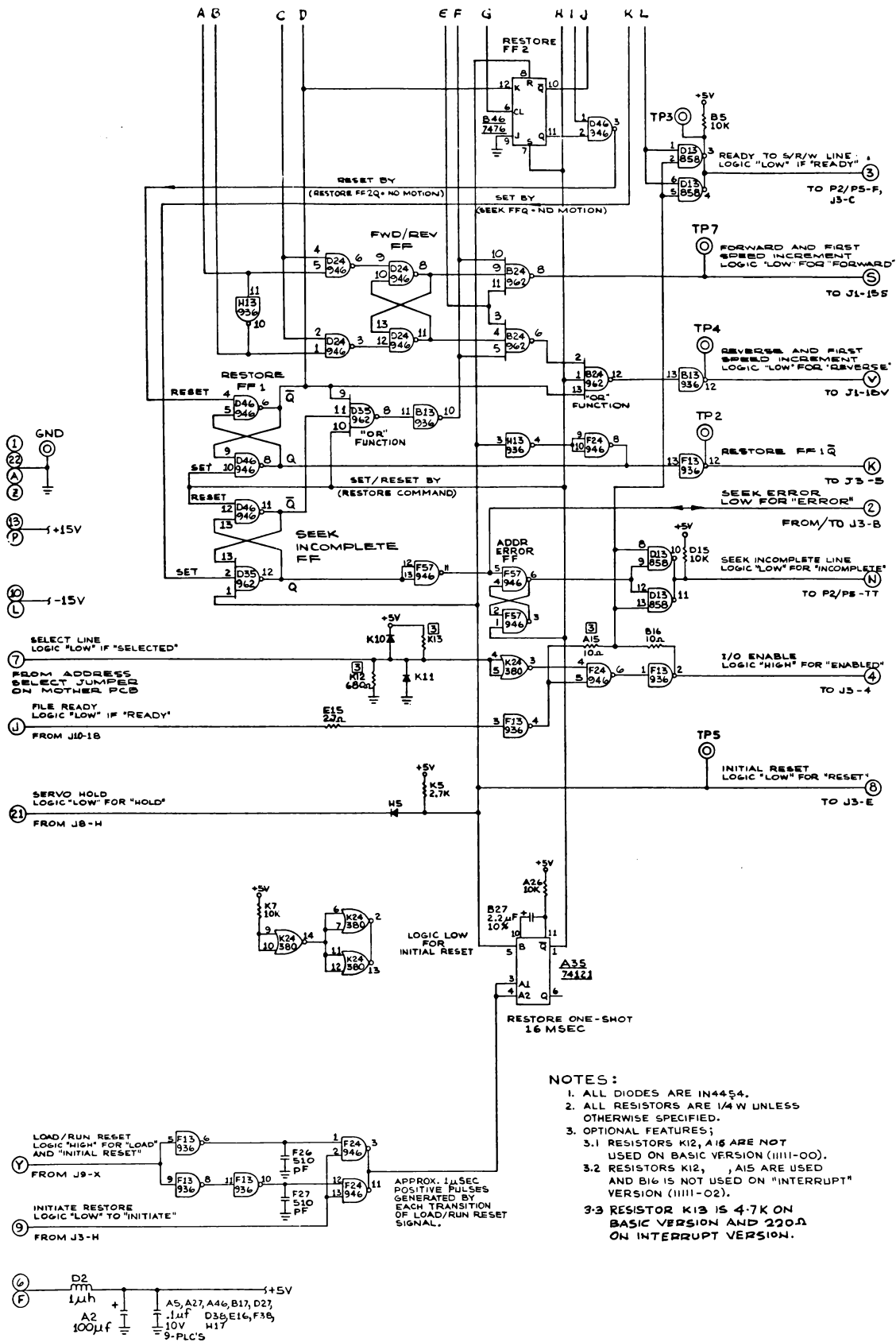

FIGURE 8.3 SEEK FUNCTIONS J-2 (sheet 2 of 2)
SCHEMATIC #11111 REVISION F/IO3

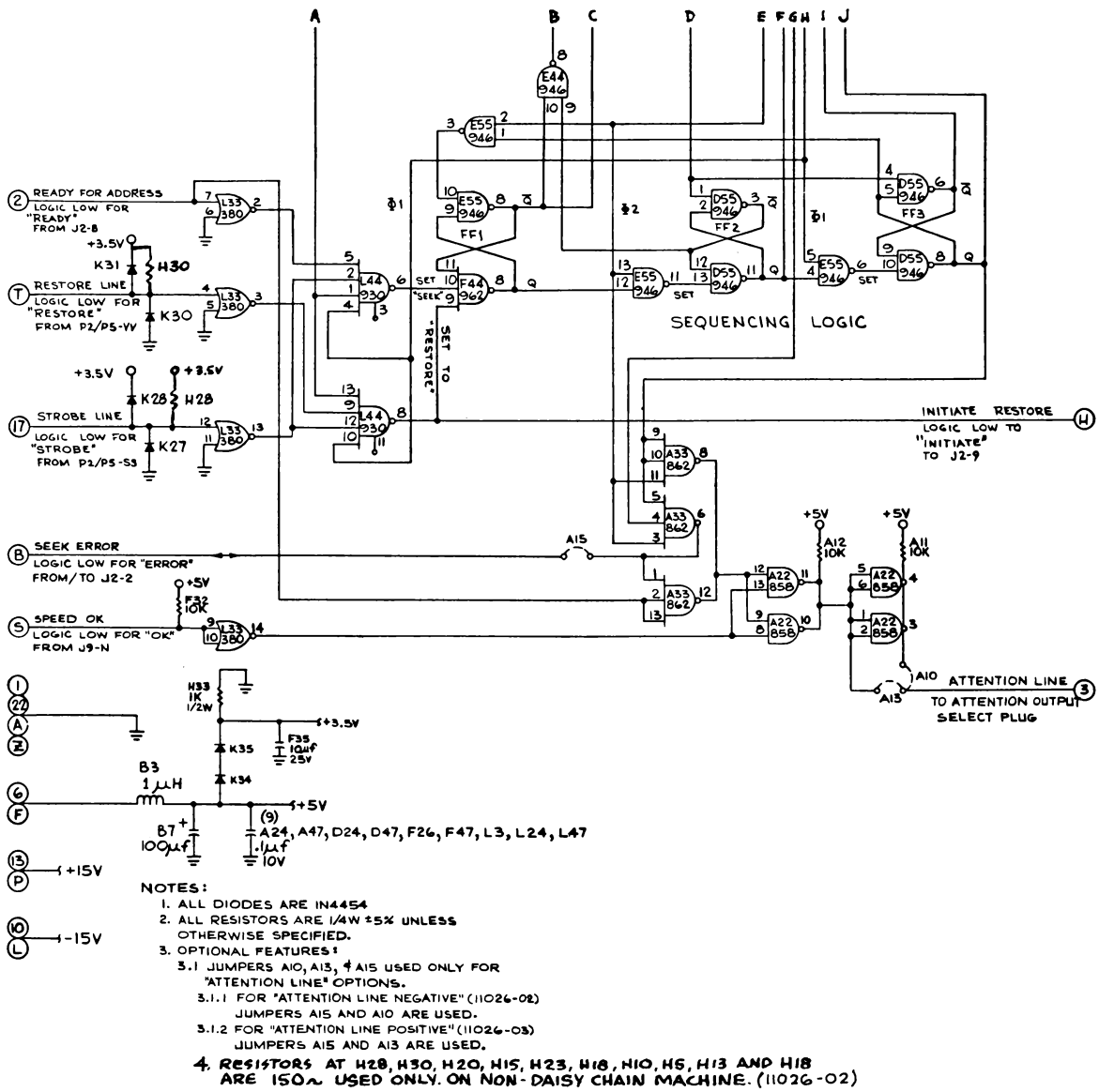

FIGURE 8.4 ADDRESSING FUNCTIONS J-3 (sheet 2 of 2)
SCHEMATIC #11026 REVISION J/101

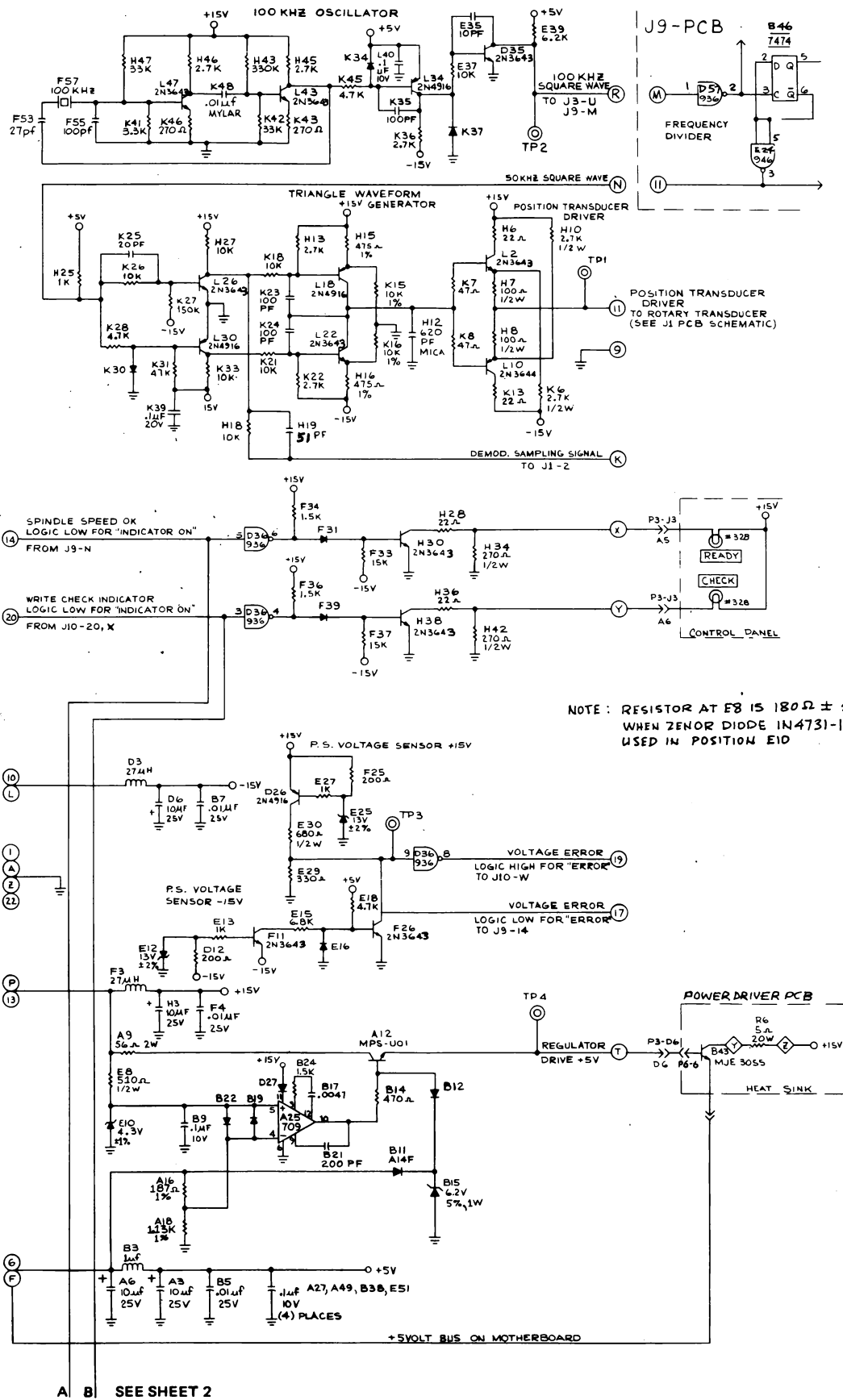

FIGURE 8.5 LOGIC DRAWING J-8 (Sheet 1 of 2)
 SCHEMATIC # 11085 REVISION G/104

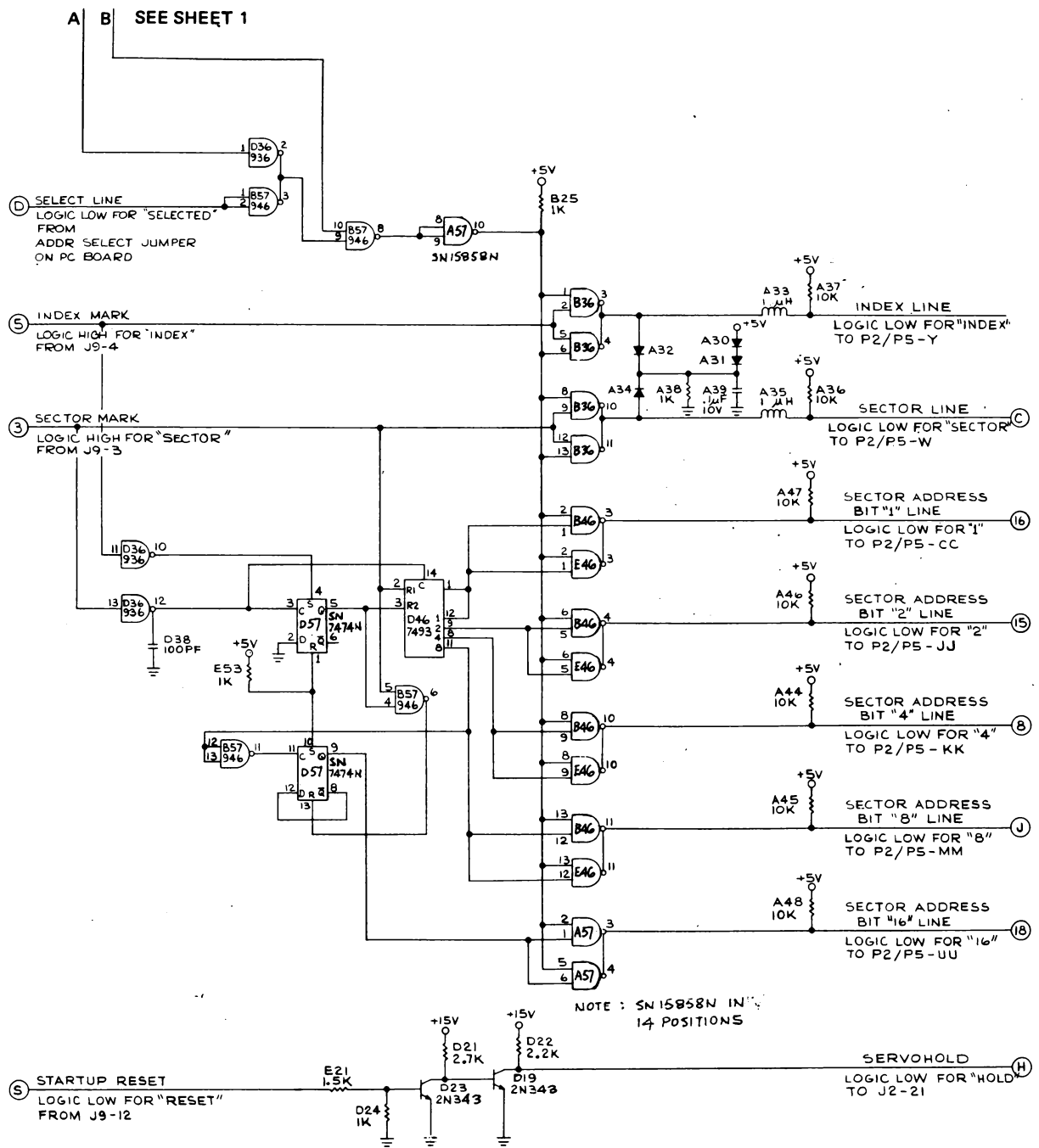
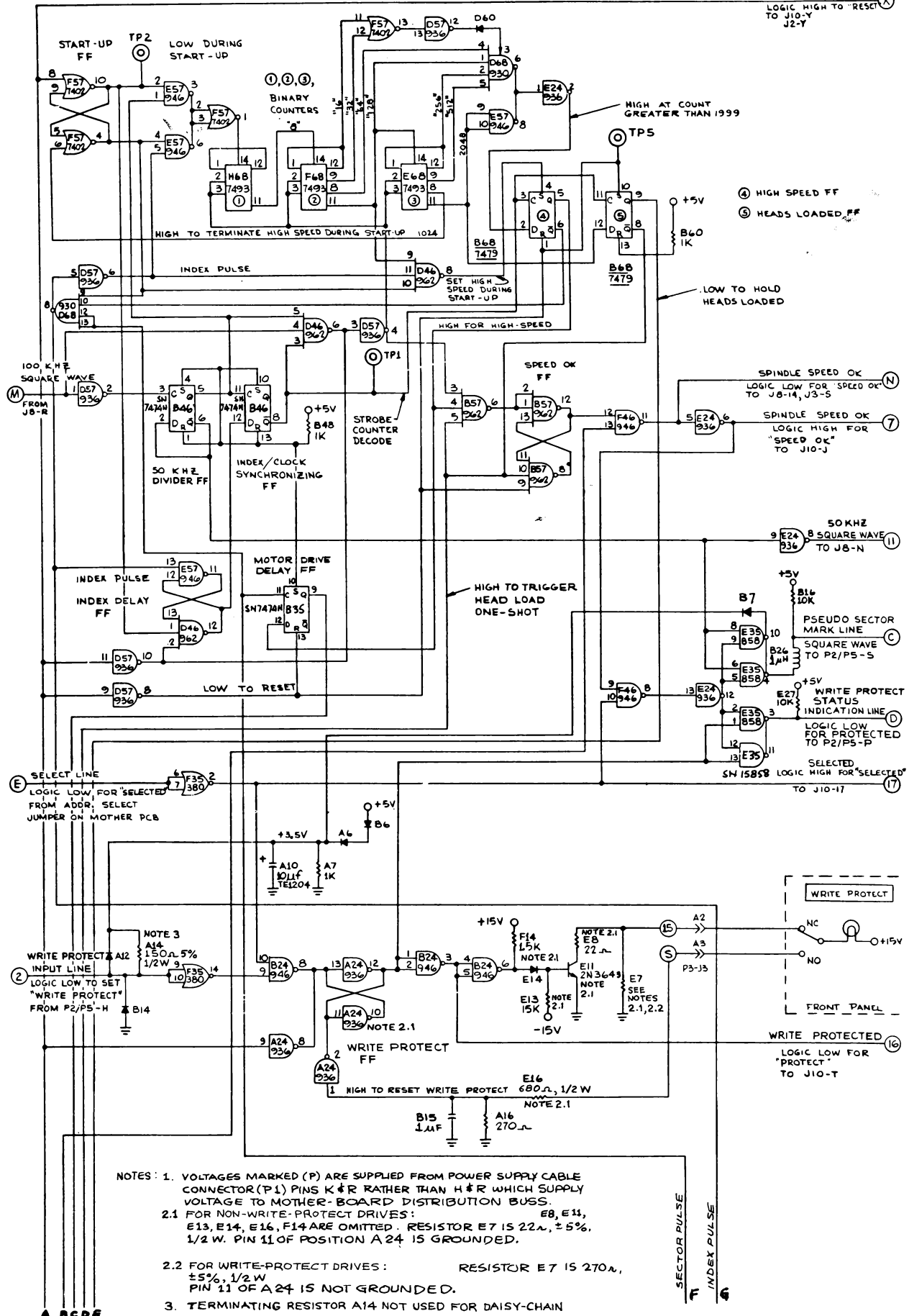

FIGURE 8.5 LOGIC DRAWING J-8 (sheet 2 of 2)
SCHEMATIC # 11085 REVISION G/IO4



NOTES: 1. VOLTAGES MARKED (P) ARE SUPPLIED FROM POWER SUPPLY CABLE CONNECTOR (P1) PINS K & R RATHER THAN H & R WHICH SUPPLY VOLTAGE TO MOTHER-BOARD DISTRIBUTION BUSS.
 2.1 FOR NON-WRITE-PROTECT DRIVES: E8, E11, E13, E14, E16, F14 ARE OMITTED. RESISTOR E7 IS 22Ω, ± 5%, 1/2 W. PIN 11 OF POSITION A 24 IS GROUNDDED.
 2.2 FOR WRITE-PROTECT DRIVES: RESISTOR E7 IS 270Ω, ± 5%, 1/2 W. PIN 11 OF A 24 IS NOT GROUNDDED.
 3. TERMINATING RESISTOR A14 NOT USED FOR DAISY-CHAIN

SEE SHEET 2 OF 2

SEE SHEET 2 OF 2

FIGURE 8.6 START-UP AND LOGIC J-9 (sheet 1 of 2) SCHEMATIC #11071 REVISION J/108

FIGURE 8.7 STANDARD DENSITY DATA CARD (sheet 1 of 2)
SCHEMATIC #11113 REVISION G/104

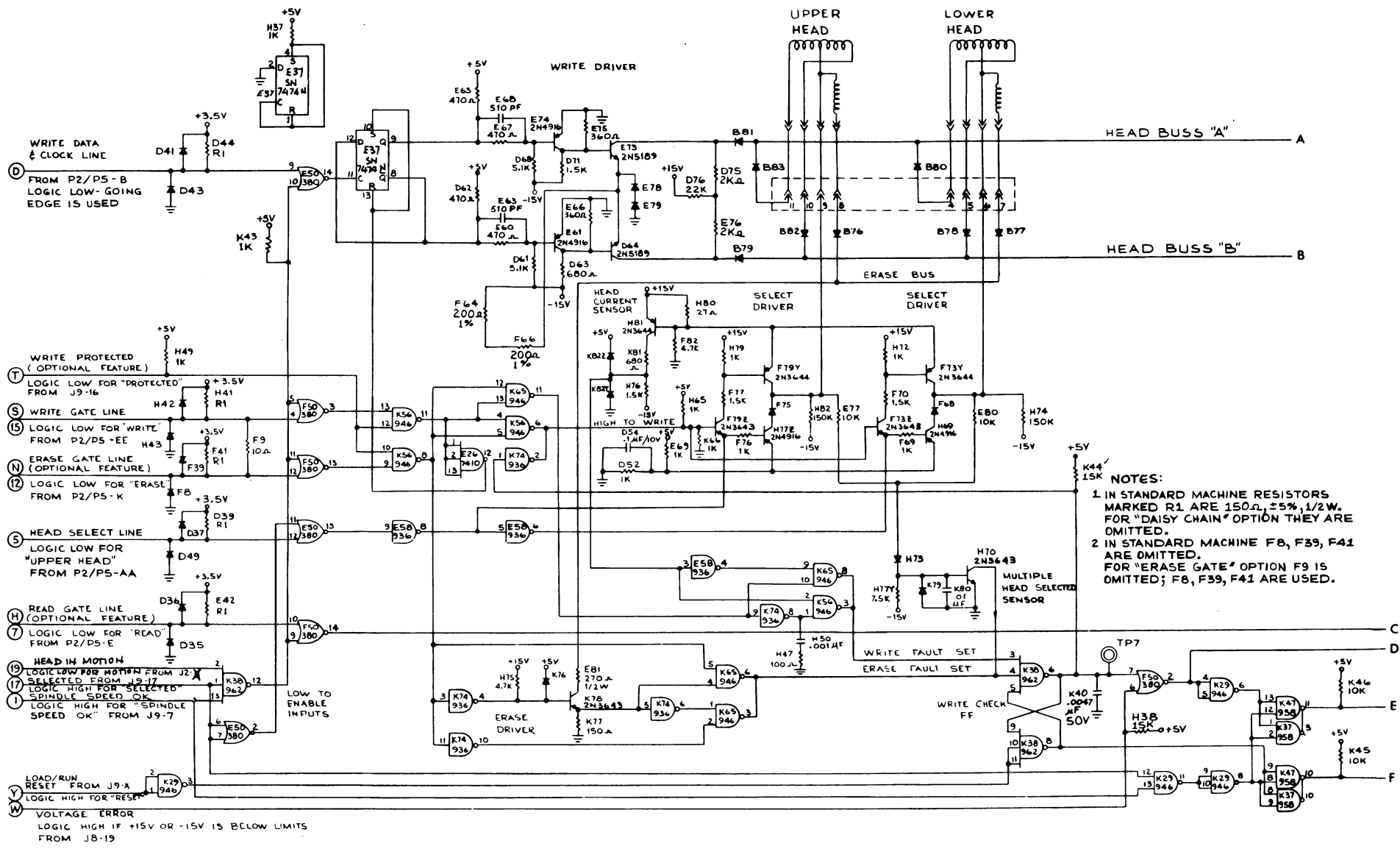

- NOTES:
- 1 IN STANDARD MACHINE RESISTORS MARKED R1 ARE 150Ω, ±5%, 1/2W. FOR "DAISY CHAIN" OPTION THEY ARE OMITTED.
 - 2 IN STANDARD MACHINE F8, F39, F41 ARE OMITTED. FOR "ERASE GATE" OPTION F9 IS OMITTED; F8, F39, F41 ARE USED.

FIGURE 8.7 STANDARD DENSITY DATA CARD J-10 (sheet 2 of 2)
SCHEMATIC #11113 REVISION G/104

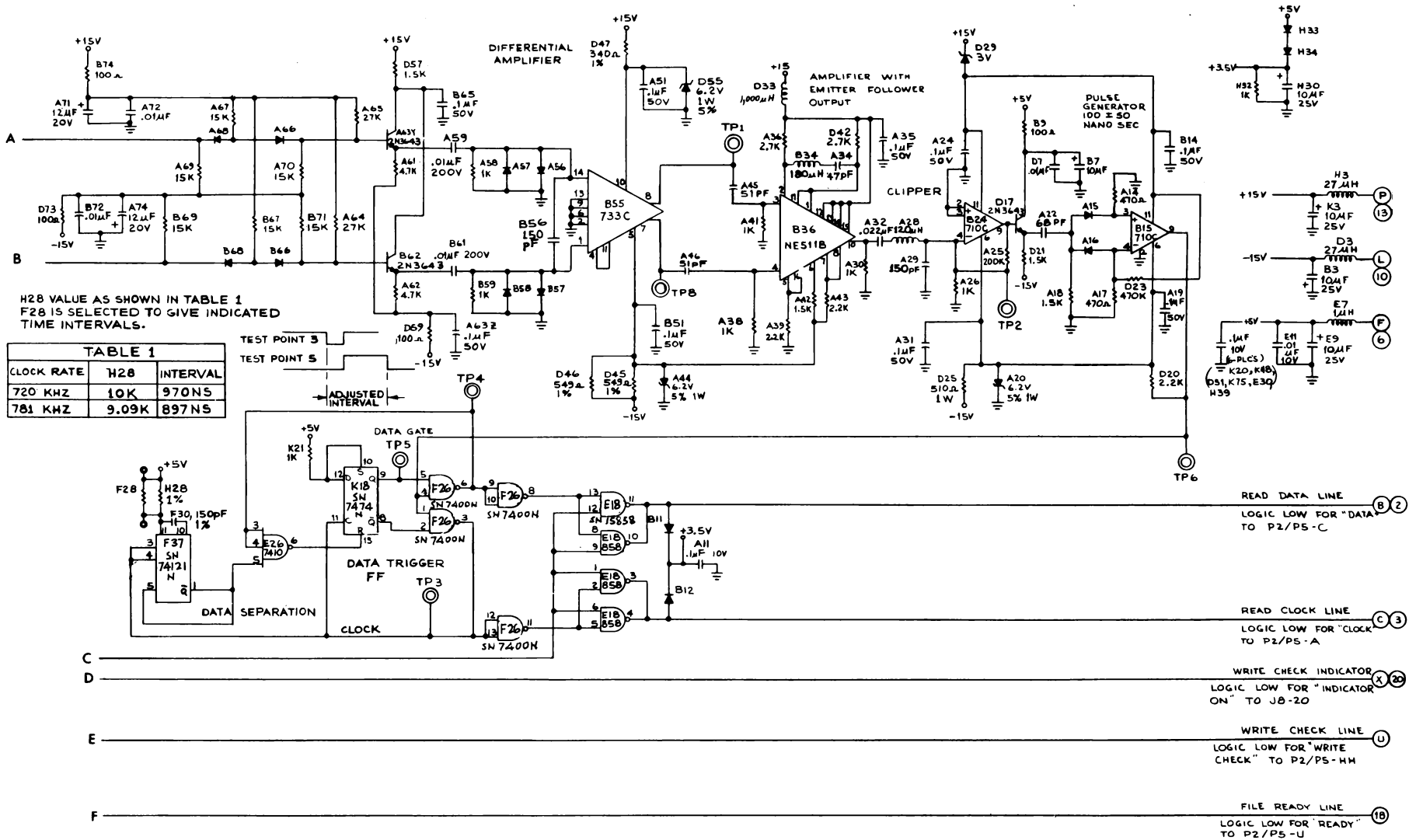
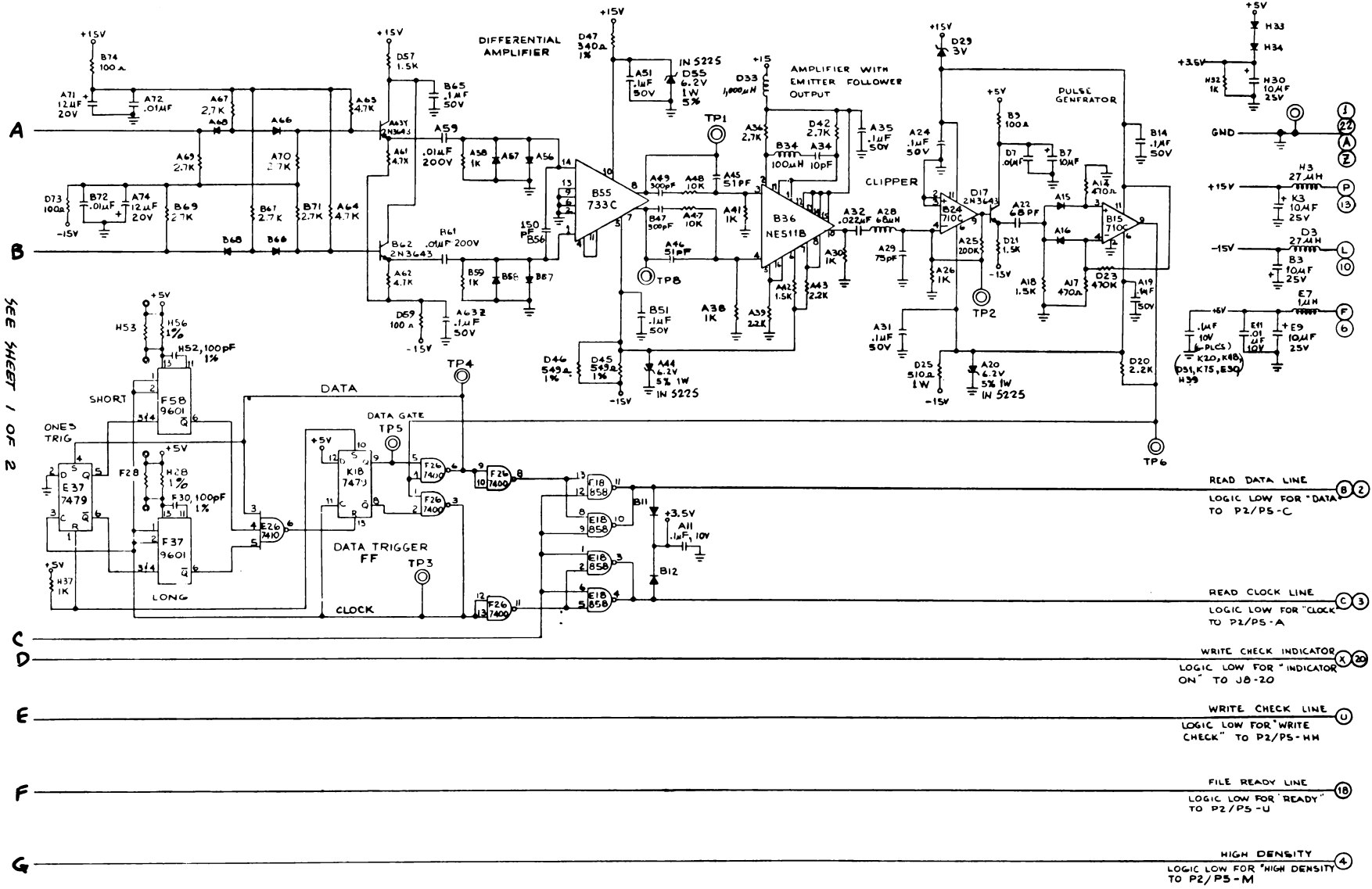

FIGURE 8.8 HIGH DENSITY DATA CARD J-10 (sheet 2 of 2)
SCHEMATIC #11082 REVISION S/107



SEE SHEET 1 OF 2

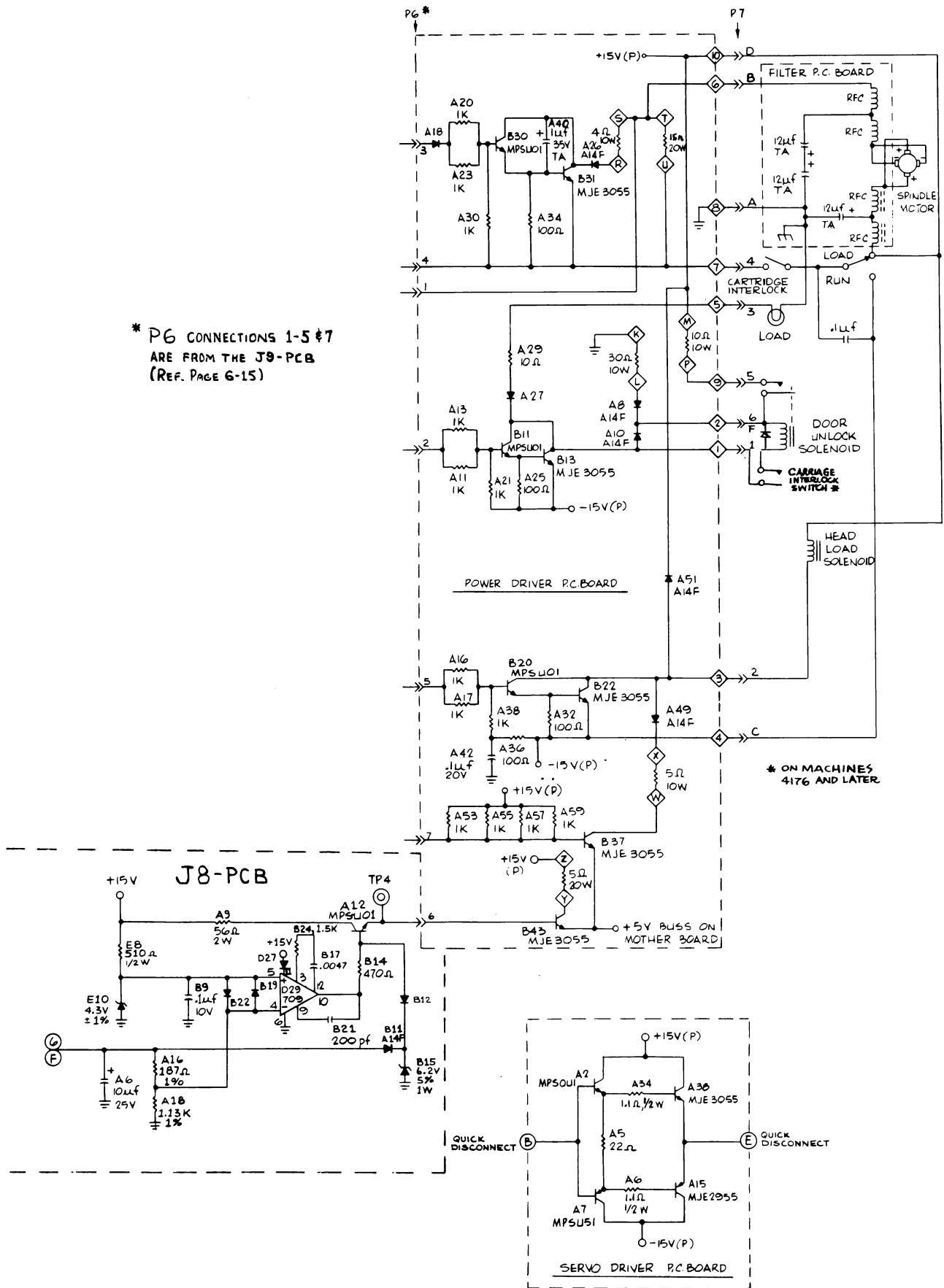

FIGURE 8.9 POWER DRIVERS
SCHEMATIC # 11030 REVISION A

8.2 REVISION LEVELS OF PRINTED CIRCUIT BOARDS

Table 8.2 shows the revision history of the Printed Circuit Boards (PCB) used in the exchangeable disc drive, series 30. A recent change in DRI administration requires that a PCB is now assembled in accordance with a Revision Level Schedule (RLS); the issue of the RLS is written on the PCB in white ink after assembly. Prior to use of the RLS system, a PCB was marked with the issue level of the schematic to which it conformed. The table shows both schematic issue and RLS to permit comparison of printed circuit boards in the drive with circuit diagrams in the technical manual. An asterisk (*) is shown against the issue of each schematic shown in issue D of the technical manual.

PCB	Part No	Schematic issue	RLS issue	Diablo equivalent	Affects Field Engineering	Comment
J1	11078	108	010.02	-	No	-
		107 *	-	G	No	-
		106	-	G	No	-
		105	-	G	No	-
		104	-	G	-	-
J2	11111	104	010.02	-	No	-
		103 *	-	F	-	-
J3	11026	102	010.02	-	No	-
		101 *	-	J	-	-
J8	11085	106	020	-	No	Diode B11 was A14F, now 1N4001
		105	010.02	-	No	-
		104 *	-	G	Yes	Transistor at 12 positions were 2N3641 now 2N3643
		103	-	-	No	-
		102	-	F	Yes	Capacitor H19 was 20pf, now 51pf; to improve DEMOD signal
		101	-	F	-	-
J9	11071	112	025.01	-	Yes	Diode H15 was A14F, now 1N4001
		111	10.02	-	No	-
		110	025	-	Yes	Operational amplifier at D17 was 709C, now 709D. Resistor at D9 was 56 ohm, now 75 ohm. Change overcomes spurious index pulses or failure to enter high speed mode.
		109	10.01	-	No	-

PCB	Part No	Schematic issue	RLS issue	Diablo equivalent	Affects Field Engineering	Comment
		108 *	-	-	Yes	Capacitor at K30 was 10uf, now 100uf. Change extends delay time to front door opening
		107		J	No	-
		106	-	-	No	-
		105	-	-	No	-
J10	11082-14	108	020	-	No	-
		107 *	-	-	Yes	Zener diodes at A20, A44 and D55 now 1N5225 were 6.2V 5% 1W Diodes locations changed E78 and E39 were E70 and F39 respectively.
		106	-	-	No	-
		105	-	-	Yes	New head plug connected introduced. Obsolete head plug and resistors D39, D44, E42, H41, A54 and A55 removed.
		104	-	-	Yes	Resistor B67 was 15K, now 2.7K
		103	-	S	-	-

9.1 LIST OF CONTENTS

page	section	title
9.1	9.1	LIST OF CONTENTS
9.2	9.2	INTRODUCTION
9.2	9.2.1	Operating specification
9.2	9.2.1.1	Input power requirements
9.2	9.2.1.2	Output
9.3	9.2.1.3	Protection
9.3	9.2.2	Physical characteristics
9.3	9.3	INSTALLATION
9.3	9.3.1	Unpacking
9.3	9.3.2	Mounting
9.3	9.3.3	Input ac
9.4	9.3.4	Output dc
9.4	9.3.5	DC power cables
9.4	9.3.6	Operating and storage temperatures
9.4	9.4	DESCRIPTION
9.7	9.4.1	Input ac
9.7	9.4.2	Heatsink assembly and series-pass transistors
9.7	9.4.3	Voltage regulation
9.7	9.4.4	Current limiting
9.7	9.4.5	Overvoltage protection
9.8	9.4.6	Reverse-polarity protection
9.8	9.5	MAINTENANCE
9.8	9.5.1	Recommended spare parts
9.8	9.6	ILLUSTRATED PARTS LIST
9.8	9.6.1	Notes on use of illustrated parts list
9.8	9.6.2	Schedule of parts lists

TABLE 9.1

9.2 INTRODUCTION

The model 029 power supply has been designed for use with series 30 disc drives. One model 029 provides the power requirements of one model 33 or two model 31 disc drives.

The power supply is supplied for use from a 210 to 240 volt ac supply. Details on adaption of the power supply for use from a 105 to 120 volt ac supply are given in section 9.3.3

Output of the model 029 is +15 and -15 volts dc. Combined noise and ripple on either output voltage does not exceed 10 millivolts peak-to-peak with nominal operating conditions. Both output voltages will remain within 300 millivolts of their respective values for the worst-case combination of the variables listed in table 9.2. The power supply has an allowable line frequency range of 47 to 63 Hz.

parameter	variation
temperature	0° to 55° centigrade
input voltage	±10%
line frequency	47 to 63 Hz
load	
+15 volt dc	0 to 14,5 amps
-15 volt dc	0 to 12 amps

TABLE 9.2

Overvoltage protection is provided to become effective if the output voltage should reach 17 ± 1 volt dc. Current limiting is at a nominal 18 amps. Each output is equipped with a fuse to protect the wiring should the limiting circuits fail to function. The input-voltage line is also fused.

9.2.1 Operating specification

9.2.1.1 Input power requirements

voltages (single phase ac)	210 to 240 volts or 105 to 120 volts (adjustable transformer windings)
line regulation	±10% of nominal value
line frequency	47 to 63 Hz

TABLE 9.3

9.2.1.2 Output

nominal output	+15 and -15 volts dc
ripple voltage	10 millivolts peak to peak maximum
current range	0 to 14,5 amps on +15 volts dc 0 to 12,0 amps on -15 volts dc

TABLE 9.4

9.2.1.3 Protection

Input lines	5 amp fuse with 210 to 240 volts 7 amp fuse with 105 to 120 volts
output dc	15 amp fuse for +15 volts 15 amp fuse for -15 volts
reverse polarity	output clamped to less than 0,8 volt
current limiting	nominal 18 amps for +15 volts nominal 18 amps for -15 volts

TABLE 9.5

9.2.2 Physical characteristics

width	203 mm (8 inches)
depth	432 mm (17 inches)
height	83 mm (3.25 inches)
weight	11,5 kg (25 pounds)

TABLE 9.6

9.3 INSTALLATION

The model 029 power supply unit may be mounted in a 19-inch rack or can be used as a bench supply. When mounted in a rack cabinet, the power supply should be supported on slide rails to provide servicing access. No additional cooling is required when the model 029 is rack mounted.

9.3.1 Unpacking

Use normal care while opening the reusable shipping container. Optional dc power cables and rack-mounting hardware are packaged separately.

9.3.2 Mounting

Rack-mounting hardware, which is adaptable for one or two model 029 power supplies, is available.

Option 044, rack-mounting hardware, may be ordered with the model 029 for convenient installation in a standard 19 inch cabinet. Option 044 supplies all the hardware needed for slide-mounting the model 029. A nominal 83 millimetres (3.25 inches) of cabinet height is required. The slides provided are designed for a minimum cabinet depth of 572 millimetres (22.5 inches) and a maximum cabinet depth of 762 millimetres (30 inches). A front panel is not supplied with option 044.

9.3.3 Input ac

The model 029 is supplied for use from a 210 to 240 volt ac supply. If the power supply is required to operate from a 105 to 120 volt ac supply, the primary taps must be changed as follows.

- (a) Remove the two screws at the dc-output end of the cover. Loosen the hexagon-head screw on each side of the cover and the two screws on the ac-end of the cover. Remove the top cover of the power supply
- (b) Observe the layout board mounted on the transformer. There are two primary windings, both are marked with the same notation. Note the ac-line fuse mounted on the printed-circuit board at the ac-end of the model 029
- (c) For operation from a 210 to 240 volts-ac supply, the two primary windings are connected in series and the input line is protected with a 5-amp fuse

For operation from a 105 to 120 volts-ac supply, connect the two primary windings in parallel, remove the 5 amp fuse and fit a fuse of 7 amp rating

If neither of the two ac-input lines is grounded, as is commonly found where one phase of a three-phase system is used as the ac input, two fuses must be used.

To add the second fuse, cut the wire link, which is located immediately below the left-hand fuse holder, and place the same value fuse in each holder. Mark the label on the power supply to indicate that the second fuse must be removed, and the wire link replaced, before using a single-phase system with one line grounded.

9.3.4 Output dc

Output-dc voltage is available from terminals located on the top of the power supply at the opposite end from the ac input. There are two +15 volt-dc connectors and a ground on one side of the power supply, and two -15 volt-dc connectors and a ground on the other side of the power supply. The voltage and ground connexions are clearly marked. The ground connexions are linked.

Each dc-voltage output has its own 15 amp fuse. These fuses are located on the heatsink assembly.

9.3.5 DC power cables

A 1,27 metre (5 feet)-long dc power cable, designed for use with the series 30 disc drive, is available as option 032. This cable has five lugs at one end, for attachment to the power supply, and a 14-pin MRAC winchester plug at the other end.

9.3.6 Operating and storage temperatures

operating ambient	0° to 55° centigrade
storage	-55° to +85° centigrade

TABLE 9.7

9.4 DESCRIPTION

Sections 9.4.2 to 9.4.7 contain circuit descriptions of the features within the power supply. Reference should be made to the block diagram (figure 9.2) and the circuit diagram (figure 9.3).

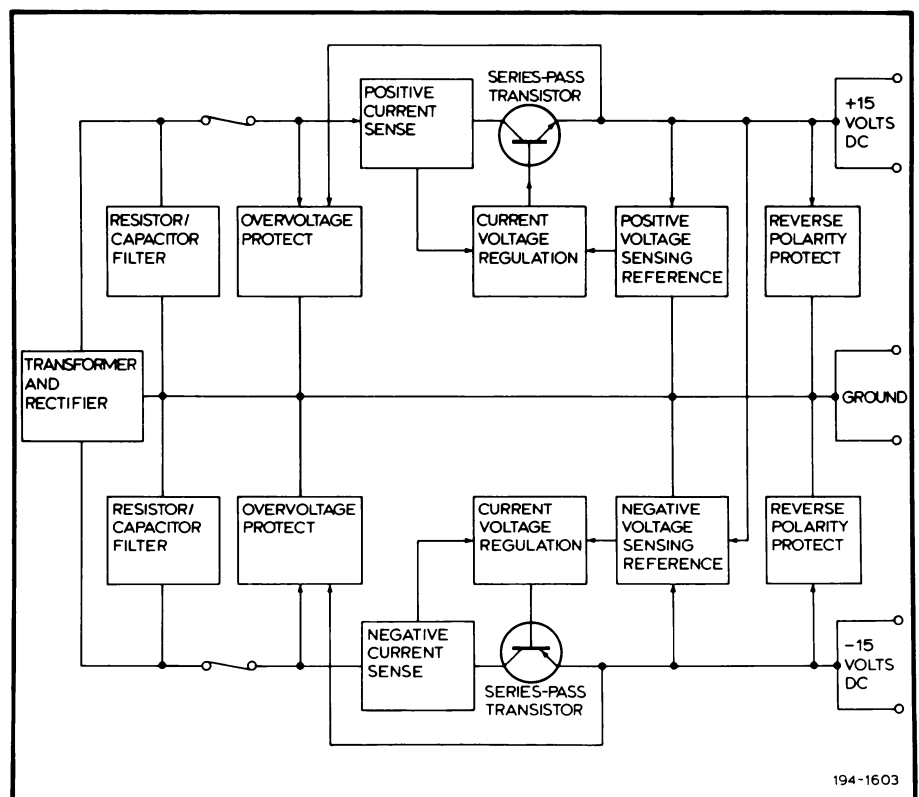
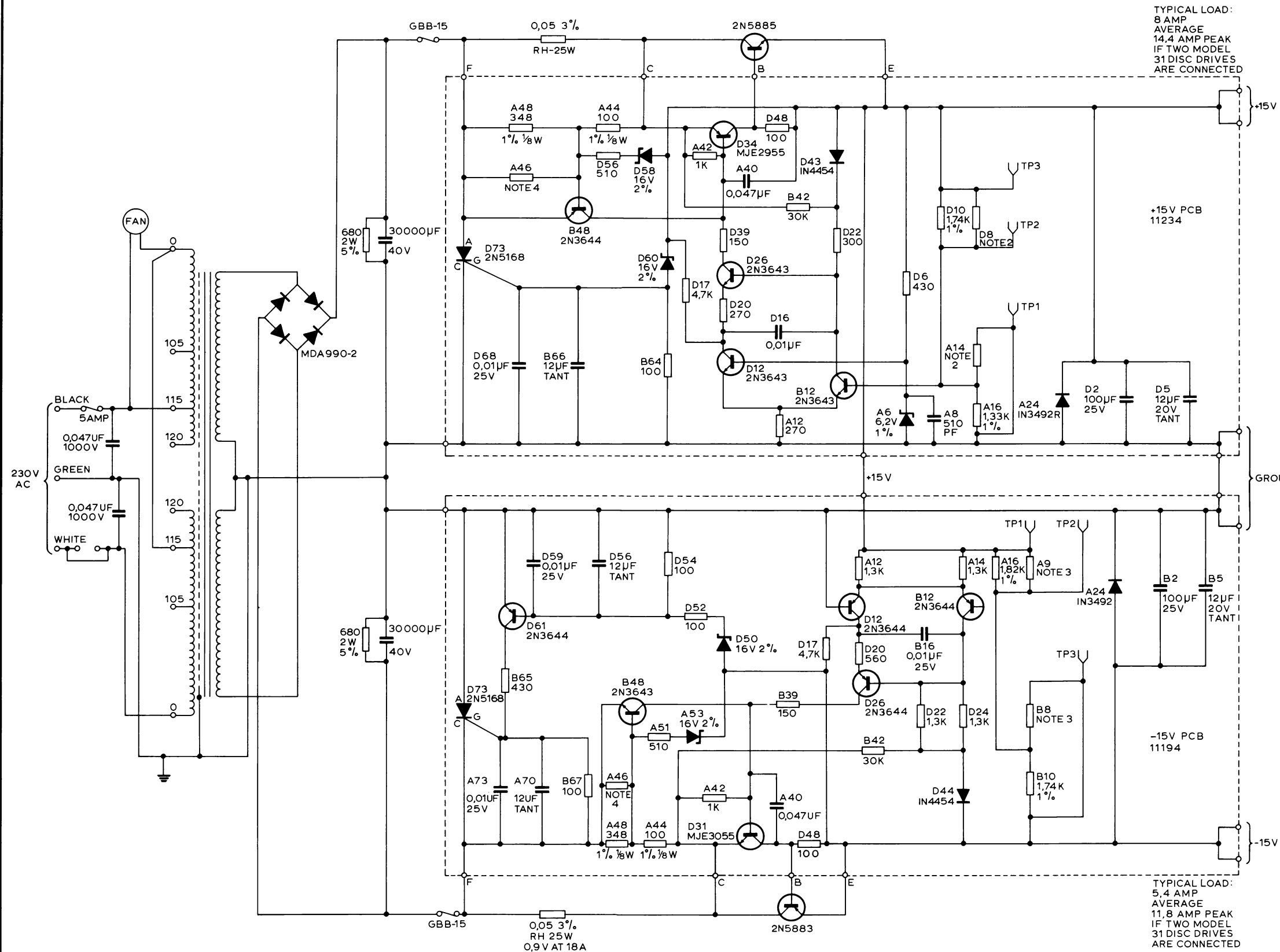

FIGURE 9.2 BLOCK DIAGRAM OF MODEL 029 POWER SUPPLY UNIT



9.4.1 Input ac

AC line voltage is applied to the transformer's appropriate primary windings from the terminals on the input printed-circuit board.

The secondary of the transformer connects to the MDA990-2 full-wave bridge rectifier. The output of the rectifier is filtered by a resistor/capacitor network to provide unregulated 15 volts dc to the remaining circuitry.

9.4.2 Heatsink assembly and series-pass transistors

The heatsink assembly contains the series-pass transistors. The base-current drive of these transistors is adjusted by the regulation circuits to maintain an evenly-regulated output.

9.4.3 Voltage regulation

The +15 volt-dc regulation circuit uses a 6,2 volt zener diode for an internal voltage reference. This diode is located at A6 of the positive-voltage printed-circuit board. This reference voltage is tied to the base of the transistor at D12. The emitter of D12 is tied to the emitter of a transistor at B12. This arrangement allows the potential at the collector of D12 to change by electronically controlling the current flow through B12.

The +15 volt dc output voltage is scaled through a voltage divider consisting of resistors at D10 and A16. The voltage at the junction of these two resistors has been trimmed at the factory to give the correct current flow through B12 to provide an output of $15 \pm 0,06$ volts.

If the output voltage of the power supply drops below +15 volts the potential at the base of B12 will also drop, causing its current flow to decrease. This will cause the transistor at D26 and the transistor at D34 to allow a decrease in current flow. This causes the base potential of the series pass transistor to increase, which returns the output voltage to its nominal 15 volts.

If the output voltage from the power supply rises above +15 volts the potential at the base of B12 will increase. This will cause D26 and D34 to increase in conduction. The increased conduction will cause the base potential of the series pass transistor to decrease which will return the output voltage to its nominal 15 volts.

9.4.4 Current limiting

A 0,05 ohm, 25 watt, current-sensing resistor is in the collector circuit of each series pass transistor. If current flow through the series pass transistor should reach a nominal 18 amps, the voltage drop across this current-sensing resistor will cause a control transistor at B48 to increase conduction. This increased conduction will shut-off an MJE transistor (D34 in the positive circuit and D31 in the negative circuit). When the MJE transistor is shut-off the series pass transistor will also be shut off. The output voltage is dropped to a low potential and will remain there until the cause of the overcurrent condition is removed.

9.4.5 Overvoltage protection

Overvoltage protection circuits are used to ensure that the output voltage level will not injure the load if the power-supply circuits should malfunction.

In the positive supply a zener diode at D60 will conduct if the output voltage exceeds a nominal 16,5 volts. The SCR at D73 will be turned on causing the 15 amp fuse to break thereby disabling the power supply.

If the 16 volt zener diode at D50 in the negative supply conducts, it will cause the transistor at D61 also to conduct. This will cause the SCR at D73 to conduct and the 15 amp fuse to break thereby disabling the power supply.

9.4.6 Reverse-polarity protection

If a voltage of an opposite polarity is connected to either the positive or negative output of the power supply it will be tied to ground through a diode at A24.

9.5 MAINTENANCE

The model 029 consists of four main components; the transformer assembly, the rectifier, the heatsink assembly with attached electronics, and the covers. Illustrations of these components are at the end of this chapter.

The model 029 will require maintenance only in the event of failure, scheduled maintenance is unnecessary.

9.5.1 Recommended spare parts

The list of components in table 9.8 are the items recommended for supporting the model 029. No special tools or test equipment are required.

description	part number
fuse GBB 15 amp	10602-15
fuse 250V 5 amp	16000018
transistor MJE 3055	10115
transistor MJE 2955	49650052
transistor 2N3643	49400066
transistor 2N3644	49650049
transistor 2N5883	10116-01
transistor 2N5885	10116-02
diode 1N3492R	10161-02
bridge rectifier	10162-01
SCR 2N5168	10163-01

TABLE 9.8

9.6 ILLUSTRATED PARTS LIST

9.6.1 Notes on use of illustrated parts list

(a) An illustration item number must be prefixed by its respective figure number to obtain the figure and item number shown in the parts list. For example: item number 3 in figure 1-1 will appear as 1-1-3 in the parts list

(b)  This arrow indicates an illustrated assembly

9.6.2 Schedule of parts lists

page	figure	title
9.9	1	MODEL 029 POWER SUPPLY UNIT
9.11	1-1	HEATSINK ASSEMBLY
9.13	1-2	PCB ASSEMBLY, AC INPUT
9.15	1-3	TRANSFORMER ASSEMBLY
9.17	2	RACK MOUNTING HARDWARE

TABLE 9.1

MODEL 029 POWER SUPPLY UNIT

figure and item number	quantity per assembly	part or stock number	supplementary information
1	1 REF	11200	Model 029 power supply
1-1	1	11195	Heatsink assembly
1-2	1	11191	PCB assembly AC input
1-3	1	11216	Transformer assembly
1-4	1	11201	Chassis
1-5	1	11202	Cover, top
1-6	1	11218	Clamp
1-7	1	10162	Rectifier, bridge
1-8	3	10514-11	Terminal
1-9	A/R	10549	Thermal compound 120
1-10	1 or 2*	1600018	Fuse, 5 amp 250V OR
	1 or 2*	10604-02	Fuse, 7 amp 125V
1-11	1	10607-01	Cable
1-12	1	10608-01	Grommet
1-13	2	10618-01	Bracket, right angle
1-14	1	10630	Label, serial number
1-15	1	15550	Insulator, cover
1-16	11	70029-05	Screw, 4-40 x 5/16 inch pan hd
1-17	2	70029-08	Screw, 4-40 x 1/2 inch pan hd
1-18	4	70030-08	Screw, 6-32 x 1/2 inch pan hd
1-19	8	70031-05	Screw, 8-32 x 5/16 inch
1-20	1	70038-11	Screw, 4-40
1-21	1	70041-10	Screw, 8-32 x 5/8 inch csk hd
1-22	2	70057-03	Screw, 4-40 x 3/16 inch hex hd
1-23	5	70166-04	Nut, 4-40 hex
1-24	7	70166-08	Nut, 6-32 hex
1-25	12	70168-04	Washer, lock 4
1-26	7	70168-06	Washer, lock 6
1-27	8	70168-08	Washer, lock 8
1-28	16	70169-04	Washer, flat 4
1-29	5	70169-06	Washer, flat 6
1-30	A/R	70190	Adhesive, 3M EC1792

* See section 9.3.3

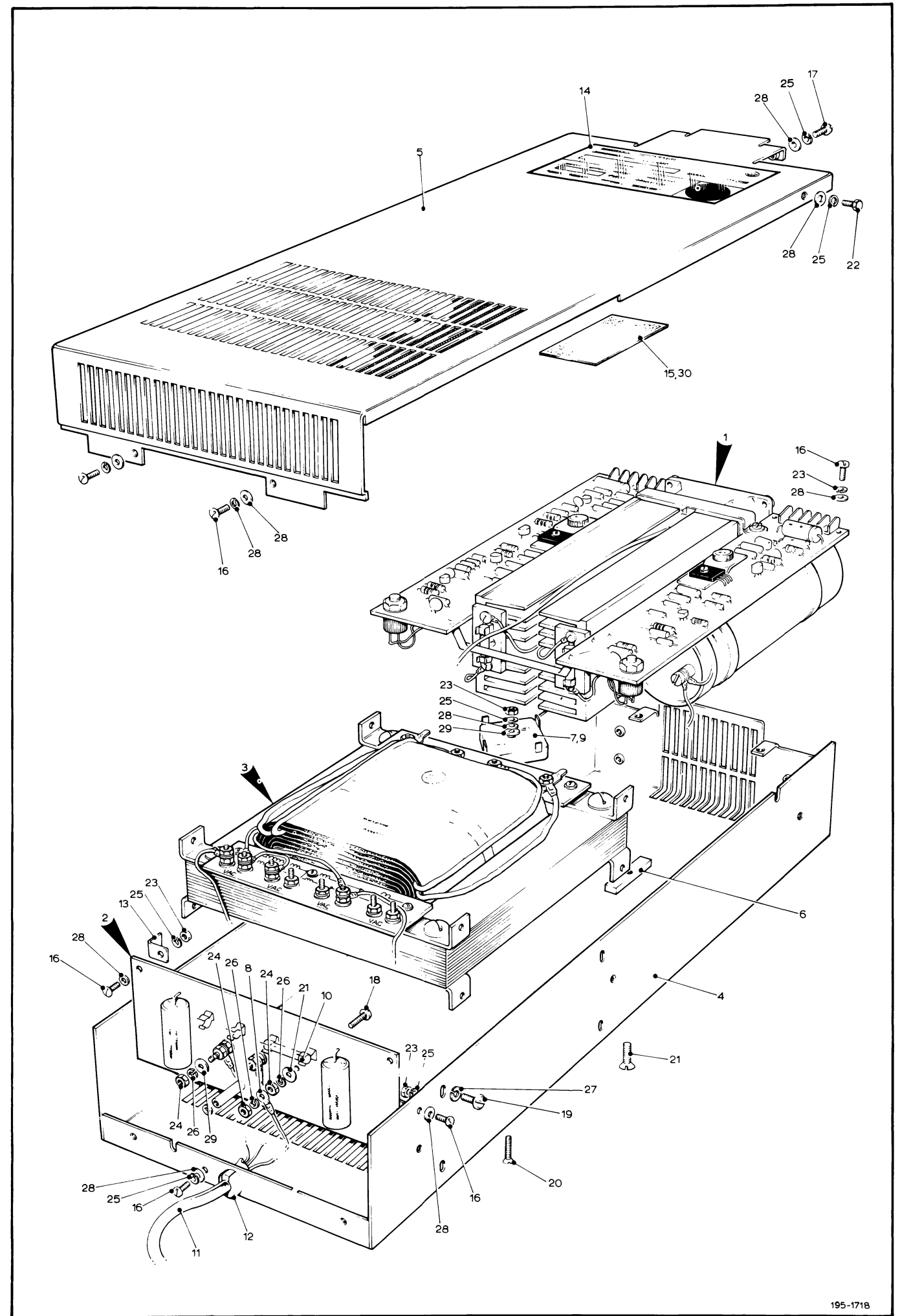
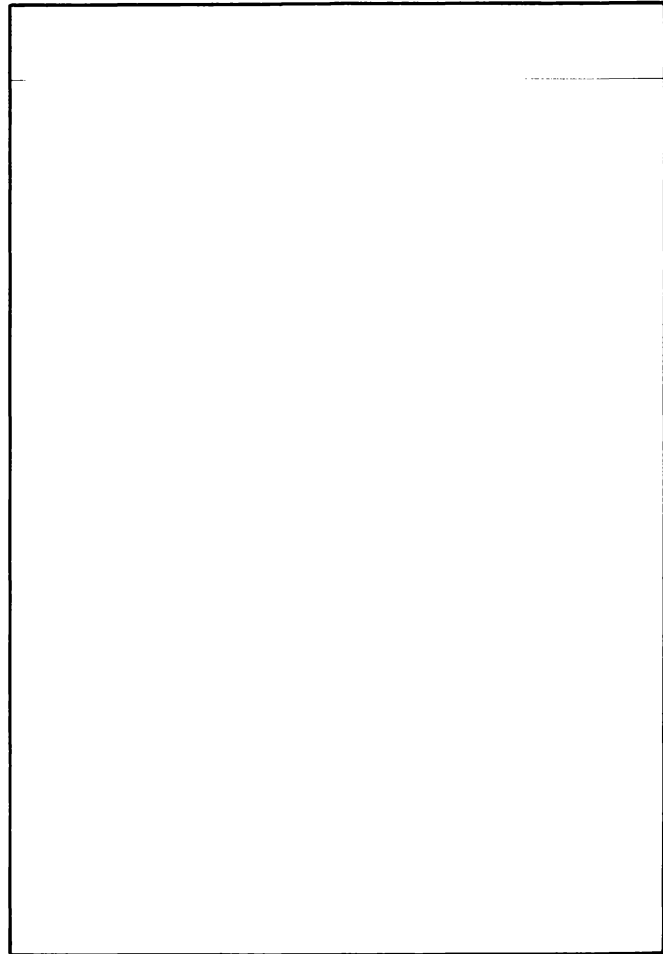

MODEL 029 POWER SUPPLY UNIT

FIGURE 1

HEATSINK ASSEMBLY

figure and item number	quantity per assembly	part or stock number	supplementary information
1-1	1 REF	11195	Heatsink assembly
1-1-1	1	11194	PCB assembly -15 V DC
1-1-2	1	11234	PCB assembly +15 V DC
1-1-3	1	11196	Heatsink, right-hand) (viewed
1-1-4	1	11197	Heatsink, left-hand) from fan)
1-1-5	4	11199	Strap, capacitor
1-1-6	2	11208	Pivot
1-1-7	4	11210	Pad, rubber
1-1-8	2	11232	PCB, transistor socket
1-1-9	1	11235	Strap, ground
1-1-10	2	10052-68	Resistor, 680 ohm 5% 2W
1-1-11	2	10060-05	Resistor, 0,05 ohm 25W
1-1-12	2		Capacitor 30 000uF 40V
1-1-13	1	10116-01	Transistor, 2N5883 -15V
1-1-14	1	10116-02	Transistor, 2N5885 +15V
1-1-15	4	10514-11	Terminal, lug No. 6
1-1-16	14	10514-12	Terminal, lug No. 10
1-1-17	4	10528-11	Bush
1-1-18	4	10528-12	Bush
1-1-19	2	10548-11	Terminal, crimped No. 4
1-1-20	A/R	10549	Thermal compound 120
1-1-21	A/R	10561-03	Wire, 24 red
1-1-22	A/R	10562-02	Wire, 26 black
1-1-23	A/R	10563-02	Wire, 14 AWG black
1-1-24	A/R	10563-03	Wire, 14 AWG red
1-1-25	A/R	10563-05	Wire, 14 AWG yellow
1-1-26	A/R	10563-06	Wire, 14 AWG blue
1-1-27	A/R	10567-31	Tubing, shrink 1/4 inch
1-1-28	A/R	10567-43	Tubing, shrink
1-1-29	A/R	10569-02	Wire, braid 1/4 inch
1-1-30	2	10601	Block, fuse KAW 4512
1-1-31	2	10602-15	Fuse, GBB 15 amp
1-1-32	4	10603-02	Spacer, hexagonal
1-1-33	1	10611-01	Fan, Pamotor 8500
1-1-34	2	10612-01	Insulator, transistor T03
1-1-35	4	10613-11	Receptacle, tab
1-1-36	18	70029-05	Screw, 6-32 x 5/16 inch csk hd
1-1-37	4	70030-14	Screw, 6-32 x 7/8 inch
1-1-38	2	70038-05	Screw, 6-32 x 5/16 inch csk hd
1-1-39	2	70166-04	Nut, 6-32 hex
1-1-40	18	70168-04	Washer, lock No. 4
1-1-41	8	70168-06	Washer, flat No. 6
1-1-42	14	70169-04	Washer, flat No. 4
1-1-43	8	70169-06	Washer, flat No. 6
1-1-44	A/R	70189	Adhesive, loctite 404
1-1-45	2	70227-02	Ring, retainer

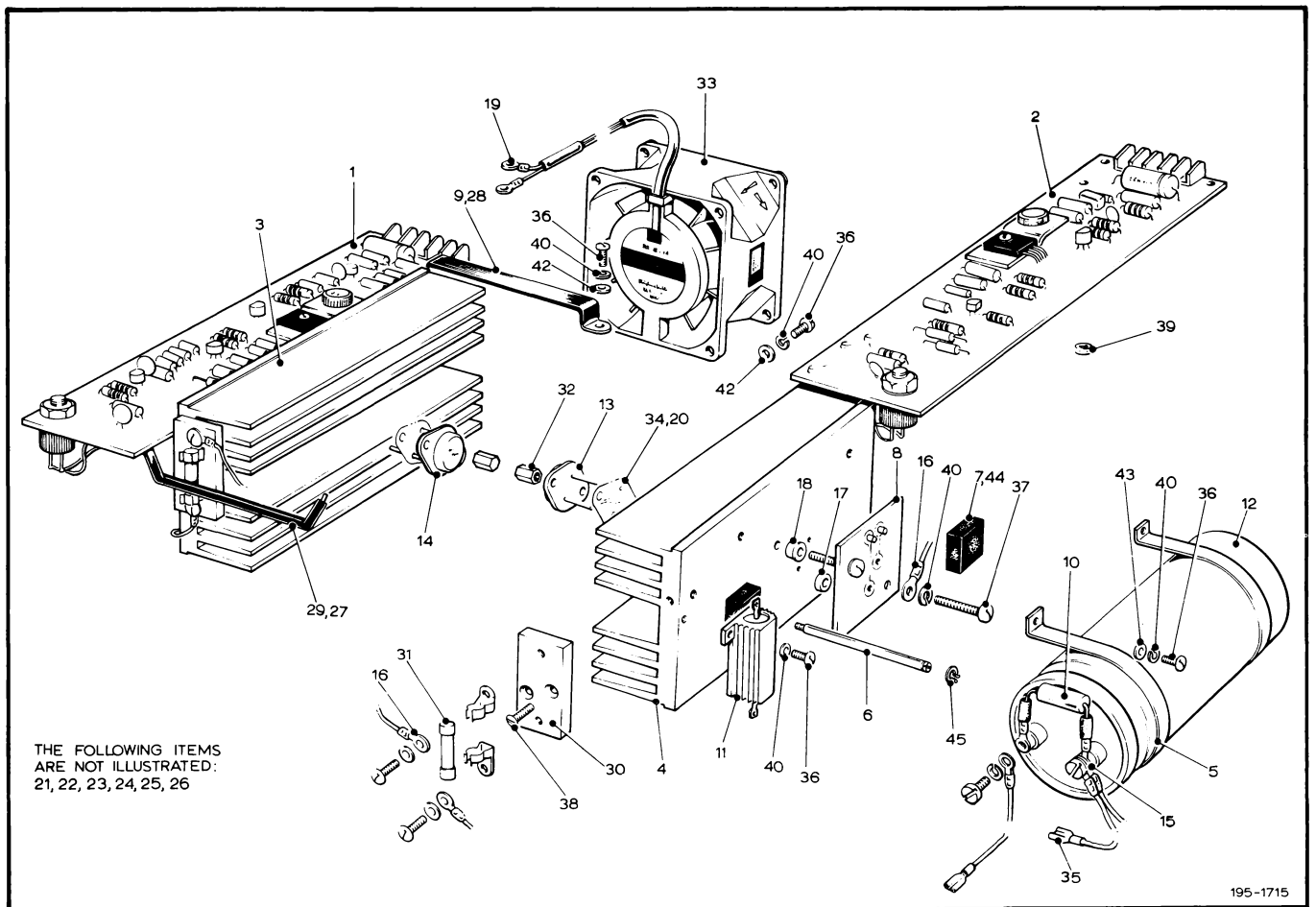
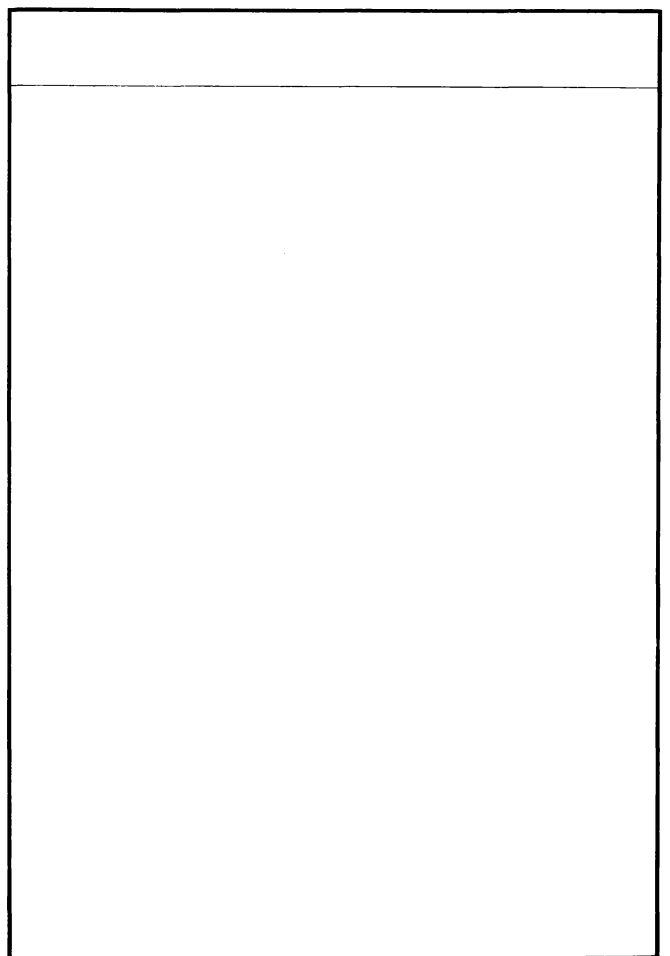

HEATSINK ASSEMBLY

FIGURE 1-1

PCB ASSEMBLY, AC INPUT

figure and item number	quantity per assembly	part or stock number	supplementary information
1-2	1 REF	11191	PCB assembly, AC input
1-2-1	1	11190	PCB, AC input
1-2-2	2		Capacitor, 0.047uF 1000V
1-2-3	4	10605	Clip, fuse

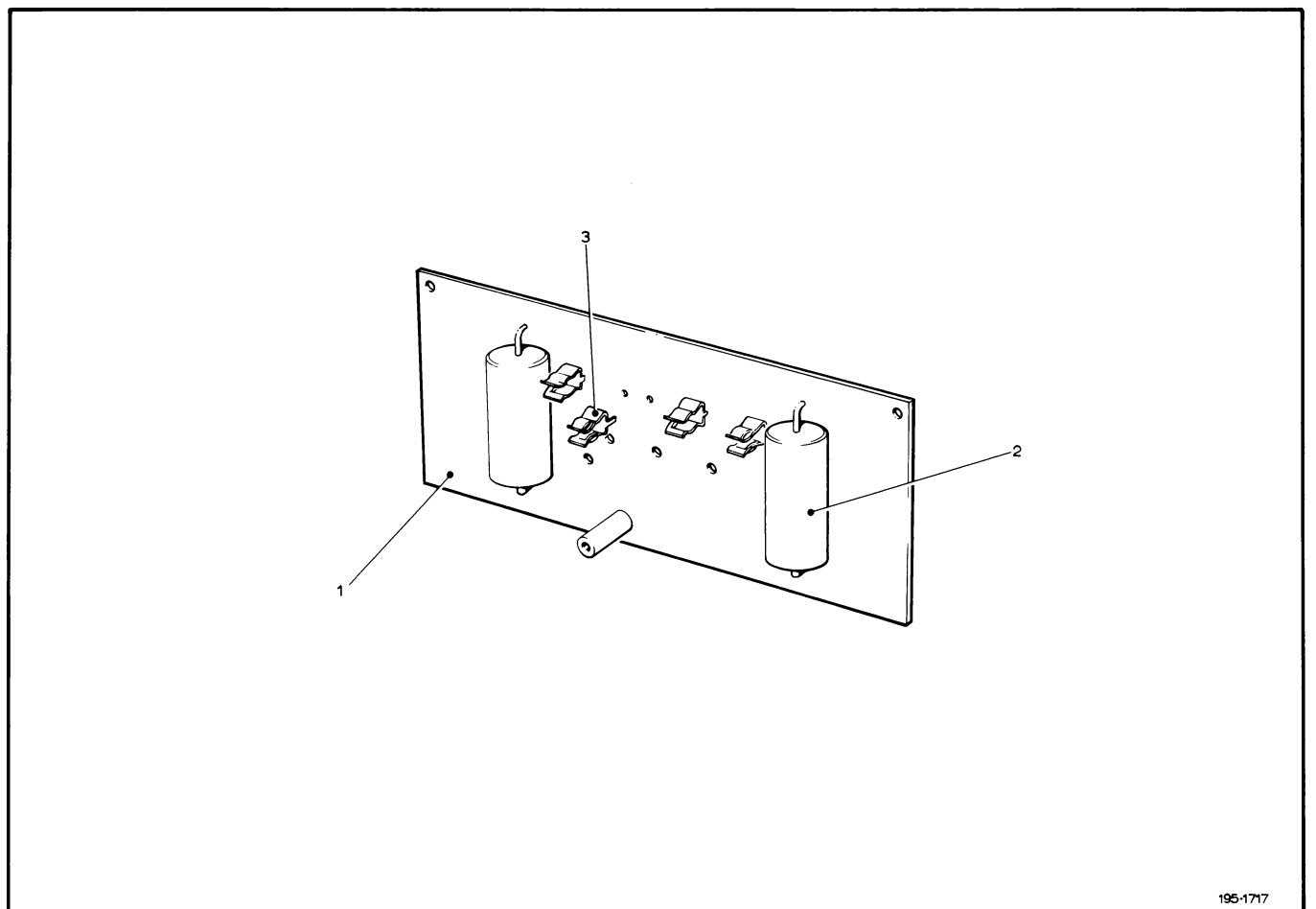
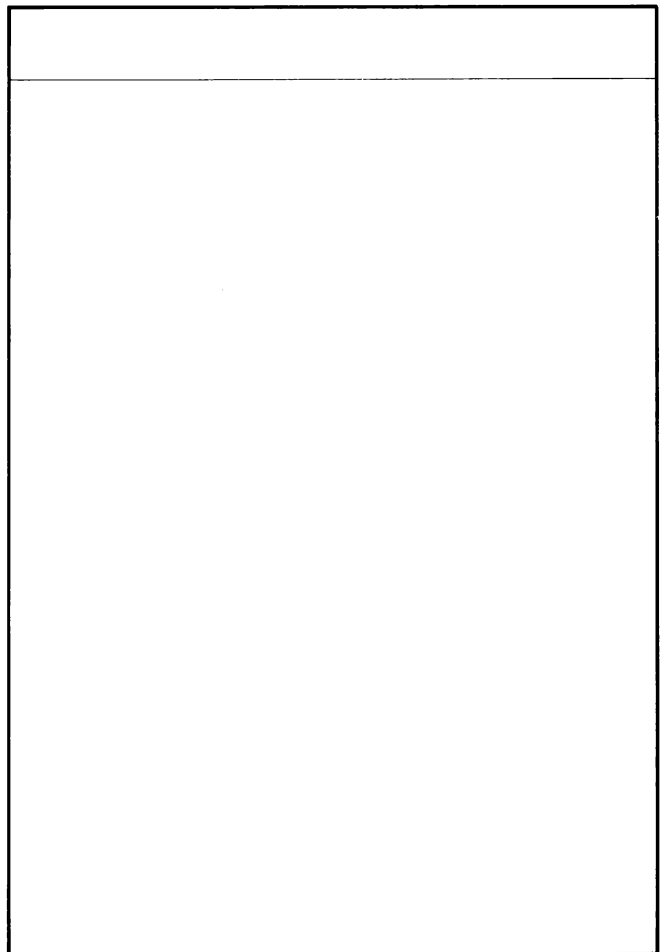

195-1717

PCB ASSEMBLY, AC INPUT

FIGURE 1-2

TRANSFORMER ASSEMBLY

figure and item number	quantity per assembly	part or stock number	supplementary information
1-3	1 REF	11216	Transformer assembly
1-3-1	1	11205	Transformer, 18V 16A
1-3-2	1	11212	Terminal board, primary
1-3-3	1	11213	Terminal board, secondary
1-3-4	2	10512-01	Terminal, lug 14/16 AWG
1-3-5	11	10514-11	Terminal, lug No. 6
1-3-6	2	10515-02	Washer, flat No. 6
1-3-7	A/R	10560-01	Wire, 20 white
1-3-8	A/R	10560-02	Wire, 20 black
1-3-9	A/R	10563-01	Wire, 14 AWG white
1-3-10	A/R	10563-02	Wire, 14 AWG black
1-3-11	A/R	10564-18	Wire, bus 18 AWG
1-3-12	A/R	10567-31	Tubing, shrink 1/4 inch
1-3-13	A/R	10569-02	Wire, braid 1/4 inch
1-3-14	2	10613-11	Resceptacle, tab
1-3-15	4	10631-11	Terminal, lug 14/16
1-3-16	1	11004-03	Braid assembly 4.375 inch long
1-3-17	1	11004-04	Braid assembly 10.75 inch long
1-3-18	6	70029-05	Screw 4-40 x 5/16 in pan head
1-3-19	8	70029-08	Screw, 4-40 x 3/8 inch pan head
1-3-20	4	70030-08	Screw, 6-32 x 1/2 inch pan head
1-3-21	6	70166-06	Nut, hex 6-32
1-3-22	12	70166-04	Nut, 4-40
1-3-23	18	70168-04	Washer, lock No. 4
1-3-24	6	70168-06	Washer, lock No. 6
1-3-25	14	70169-04	Washer, flat No. 4
1-3-26	2	70169-06	Washer, flat No. 6
1-3-27	A/R	70255	Sealer/adhesive RTV.

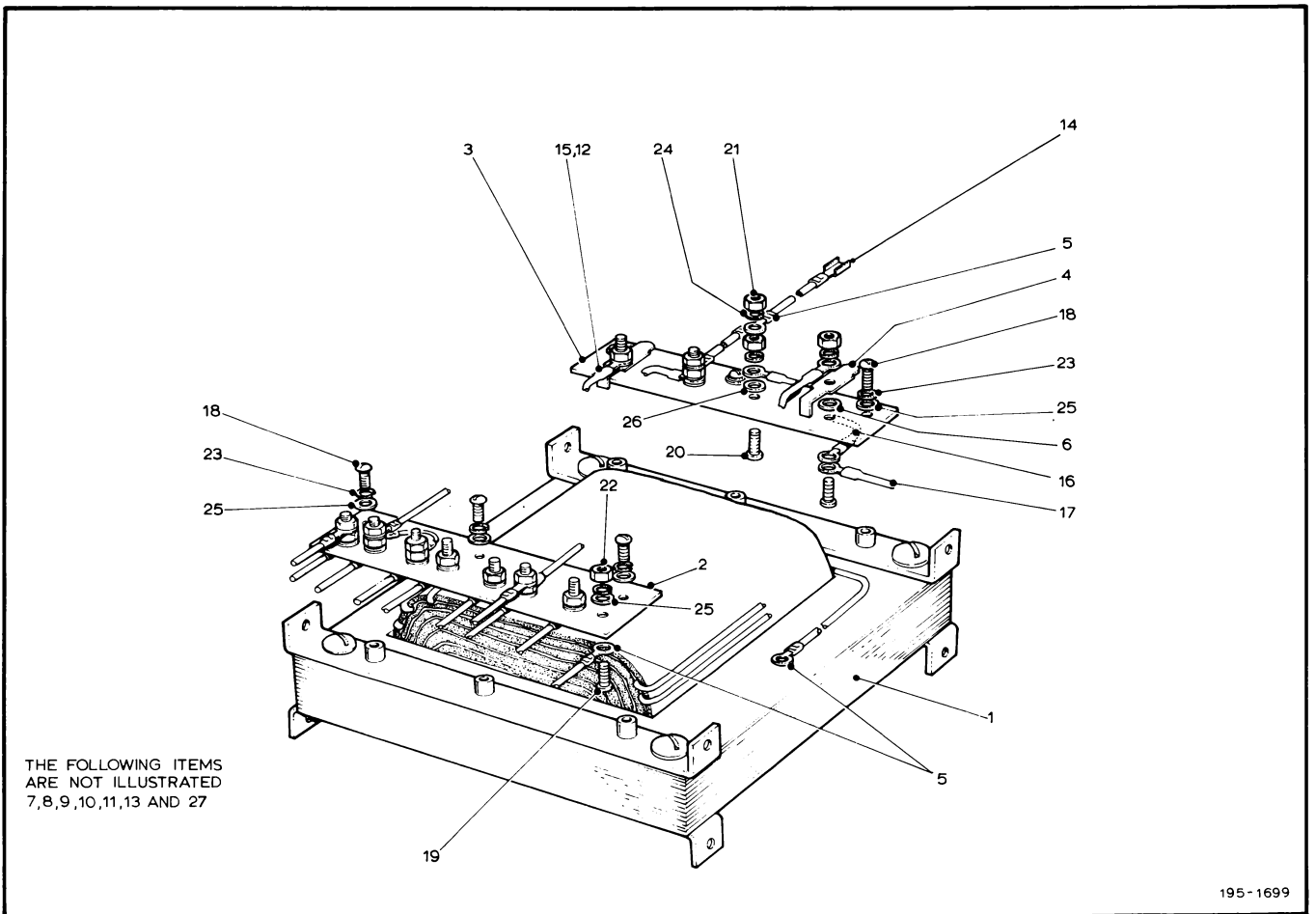
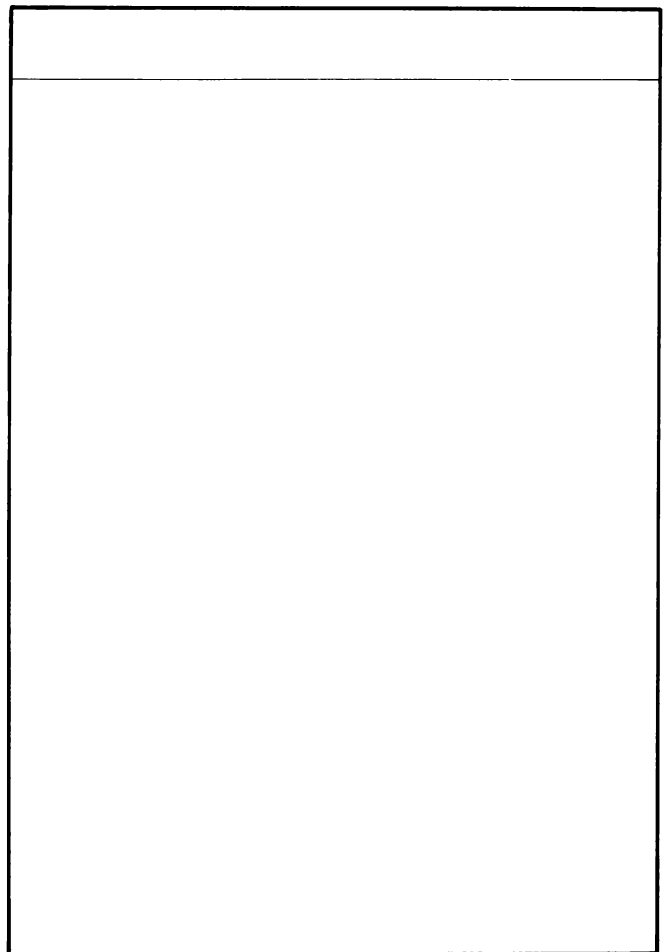

195-1699

TRANSFORMER ASSEMBLY

FIGURE 1-3

RACK MOUNTING HARDWARE

figure and item number	quantity per assembly	part or stock number	supplementary information
2	1 REF	11215	rack mounting kit, option 044
2-1	1 set	10615-01	slides
2-2	1	11206	support
2-3	2	11207	plate, end
2-4	2	11222	extender, slide
2-5	18	70031-06	screw, 8-32 x 3/8 inch pan hd
2-6	18	70168-08	washer, lock No 8
2-7	18	70169-08	washer, flat No 8

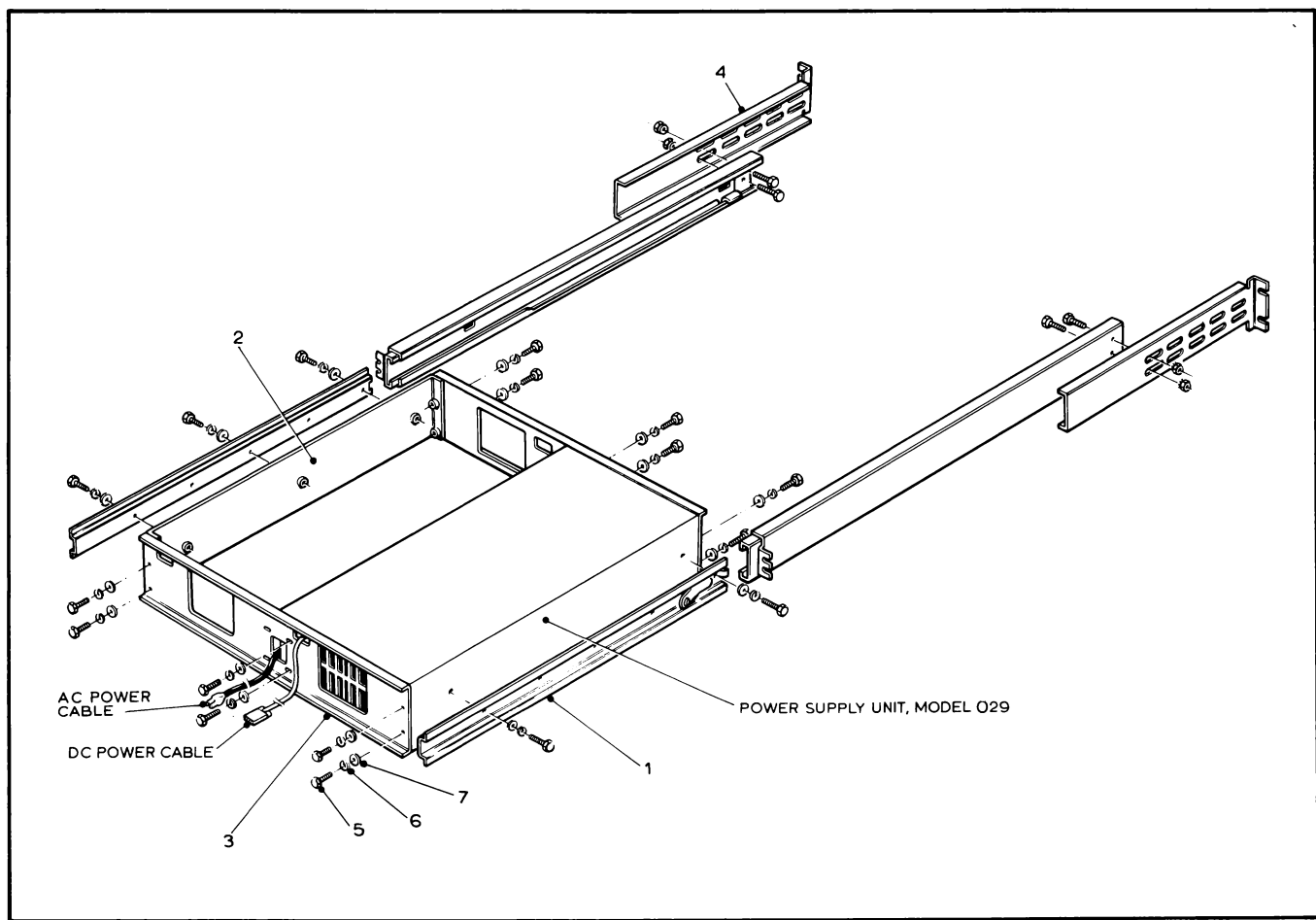
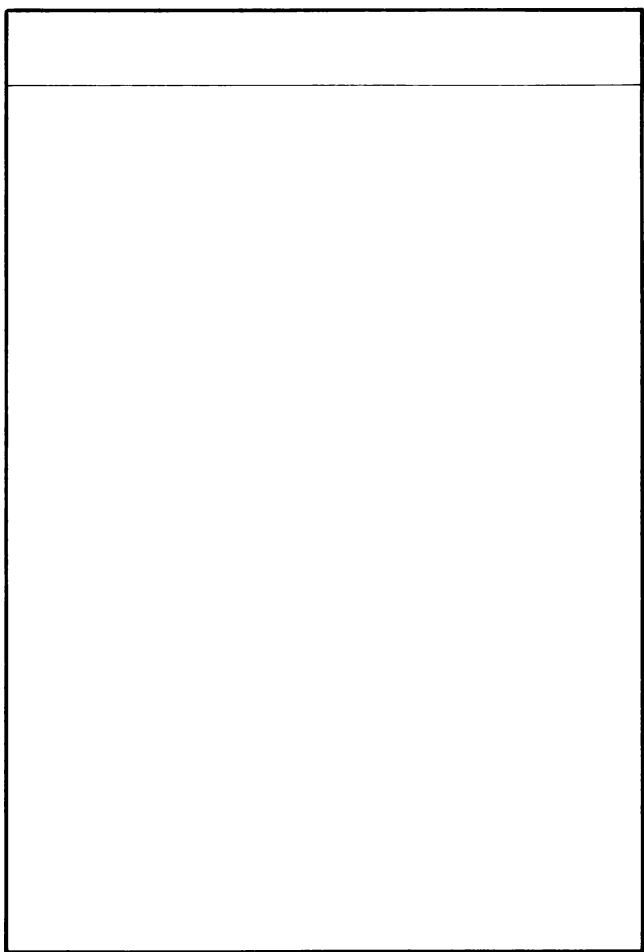

RACK MOUNTING HARDWARE

FIGURE 2



Supplementary information to technical manual document reference 30/issue E.

The information in this user notice is provisional. It will, after checking, be incorporated in a future amendment to the manual.

Figure 5.8 Head adjustment, oscilloscope displays

Delete existing illustration. Insert: "For revised illustration see user notice number 30 001"

Section 5.5.5.5 Adjusting the read/write heads

Delete the existing text. Insert: "For revised text see user notice number 30 001"

Revised text:

- (a) Remove power to the drive by interrupting the ac supply to the power supply. Remove interface connectors and fit a terminator to the interface socket.
- (b) For standard density drives only, fit head adaptor TD5083 between the head-lead plug and the head-lead socket of board J10.
- (c) Restore power and load the CE cartridge (part numbers TD277 and TD276 for 1100 and 2200 bpi respectively).
- (d) Allow the drive to run for 30 minutes for temperature stabilization
- (e) Position the head carriage at cylinder 100 (use cylinder 105 with a high-density drive).
- (f) Set up an oscilloscope as shown in table 5.6.

control	setting for standard-density drive	setting for high-density drive
timebase	10 ms/cm	5 ms/cm
deflexion sensitivity	10 mV/cm	1 V/cm
trigger	ext -ve	ext -ve

TABLE 5.6

HIGH DENSITY

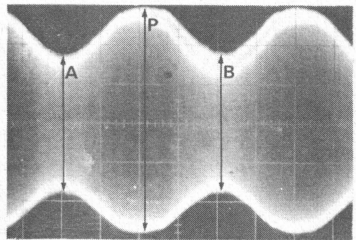
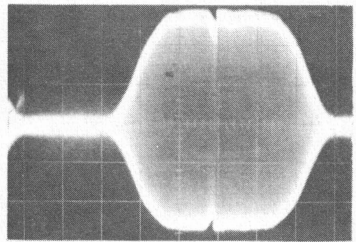
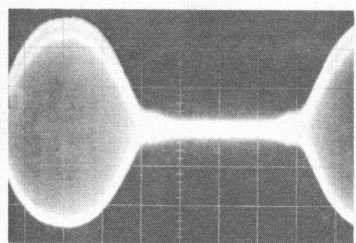

TRACK 105

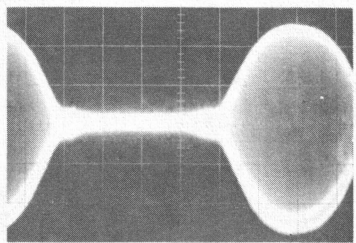
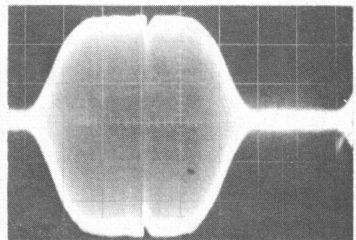

TOWARD TRACK 104

TOWARD TRACK 106

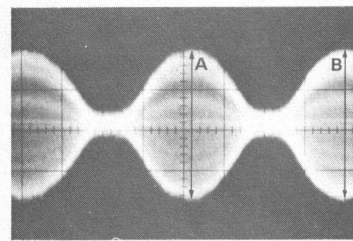
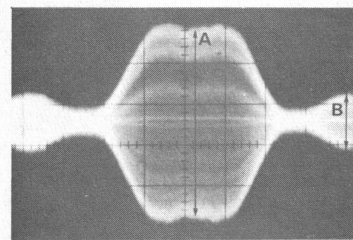
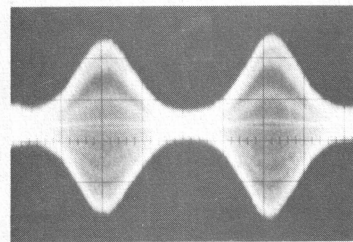
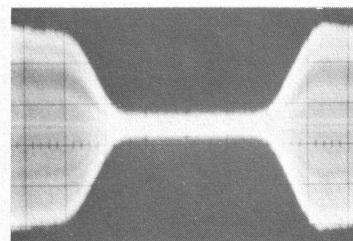

TRACK 100

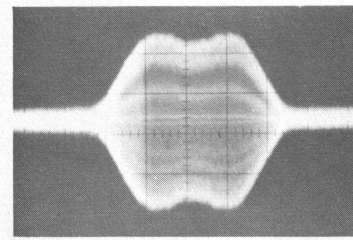
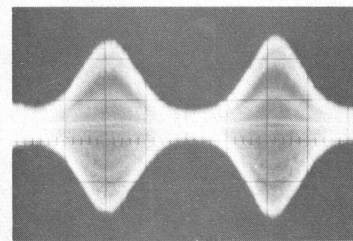
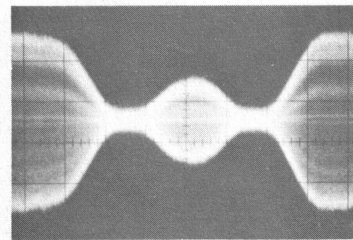

TOWARD TRACK 099

TOWARD TRACK 101

FIGURE 5.8 HEAD ADJUSTMENT, OSCILLOSCOPE DISPLAYS

- (g) Trigger an oscilloscope from the leading-edge of the index mark (this is the negative-going edge of the pulse at TP6 of the circuit board J9).
- (h) Monitor TP2 of J10 to check the alignment on both heads. With the interface connector removed the lower head is selected; the upper head is selected by grounding pin 5 of J10. Head alignment is checked by comparing the difference between successive lobes which, for a perfectly aligned head, corresponds with figure 5.8 (equal size of lobes).

Since all CE packs are slightly different from each other within tolerable limits, the extreme sensitivity of the head-alignment measuring technique will produce different results with different packs, and slight variations with the same pack. Actual differences in terms of head displacement are negligible. Owing to different head configurations, results for standard density drives will be different from those for high density ones. Thermal variations will also affect results. All these variations have been allowed for in the design and data interchangeability is assured provided the unit meets the following requirements.

High density drives are checked using the nulls of the oscilloscope trace. Resetting is unnecessary if nulls do not differ by more than 30% using the equation $\frac{A-B}{p} \times 100$.

If necessary, adjust until they are equal. See subsection (j).

Standard density drives are set using the peaks of the oscilloscope trace. Resetting is not necessary until successive peaks vary by more than 50% using the equation $\frac{A-B}{A+B} \times 100$.

However, owing to differences in the configurations between high and standard density heads, and the normal CE pack variations, the shape of the waveform alters when the peak amplitudes differ by more than 30% and the lobes may become indeterminate.

For this reason the following recommendation is made.

If the peak amplitude variation is seen to be within 30% then no adjustment should be made. If the lobes are indeterminate then the heads may be adjusted at the users discretion. This should only be carried out if there is some evidence of data incompatibility between the subject drive and other series 30 units.

It should be borne in mind that units newly delivered from Data Recording will have been set up by factory technicians using the CE packs which have been specially selected to be close to the centre line of the normal spread of such packs. It is therefore highly unlikely that new drives will require any adjustment to the head setting, though lobe discrepancies will probably be observable as indicated above.

- (j) If a head needs adjusting, slacken the three head clamp screws E, F and G and push heads against back of carriage. Retighten screws E and F to about 0,14 newton-metres (20 ounce-inches).
- (k) Using the head-adjusting tool (TD10289) move the selected head forward by screwing the tool against the head at points H or J (see figure 5.7). The head can be adjusted forwards only.
- (m) Heads are set using the erase windings for the standard density drive. The read/write winding is used for the high density drive. Either type is correctly adjusted when directly over the effective centre of the single eccentrically recorded track. Take care when adjusting heads; do not allow the tang on the end of the head support arm to disengage from the slot in which it is located (X in figure 5.7).
- (n) If the head is adjusted too far forward, unscrew the setscrew; switch to the load condition, remove the CE cartridge, loosen both clamps that secure the selected head, and manually push the head towards the rear of the drive. Do not push on the actual head pad or its mounting gimbals - use part of the rigid mounting hardware. Tighten the single-clamp screw to a torque of 0,18 newton-metres (26 ounce-inches) and repeat the adjusting procedure until the oscilloscope display is correct.
- (p) When the head is correctly adjusted, apply a torque of 0,56 newton-metres (80 ounce inches) to the double-clamp screw (G in figure 5.7). Tighten single-clamp screws (E and F) to the same torque.
- (q) Recheck head setting on oscilloscope.

Section 5.5.5.6
Adjusting the
cylinder 000 stop

Delete sections (f) to (j). Insert the following:

- (f) To check direction of trace, touch the X-plate lead on the +5 volt rail. If the trace moves to the right, the adjustment pattern will be the same as in figure 5.9. If the trace moves to the left the lissajous figure will be reversed left to right.

- (g) Check mechanical setting of backstop by pushing the head positioner lightly against its crash stop with the servo-release button depressed and ensure that the trace rests between positions 1 and 2 (see figure 5.9).
- (h) Check that, when load/run switch is operated several times, the trace swings a maximum arc of between 45° and 180° . (Locknut L should be tightened to 4 newton-metres (36 pound-inches).
- (j) If resetting is necessary, slacken locknut L (figure 5.7) and adjust eccentric so that condition in subsection (h) is $145^{\circ} \pm 20^{\circ}$. Check that condition in subsection (g) is still satisfied. Note that drift over the range defined in subsections (g) and (h) is permissible.

Section 5.5.6
Removing the
spindle assembly

Add in bracketed clause of subsection (e): "and subsection 5.5.5.1 (f)"



Approved for design authority:

Date: 4 June 7A



This user notice gives details of changes in the types of indicators and switch/indicators used on the front panel of the series 30 exchangeable disc drive.

This information will be incorporated in a future amendment to the technical manual.

1 REASON FOR CHANGE AND NEW PART NUMBERS

Supply difficulties have caused alternative sourcing of the indicator assembly, the switch/indicator assembly and their lenses, listed in table 1. The descriptions of the items affected remain unchanged but the items from the alternative source have the part numbers listed in column three of the table.

description	old type part number	new type part number
indicator assembly	10542	70683
switch/indicator assembly	10543	70682
lens, white	10544-09	70684-01
lens, yellow	10544-04	70684-02
lens, orange	10544-03	70684-03
lens, red	10544-02	70684-04
lens, green	10544-05	70684-05

TABLE 1

2 DRIVES AFFECTED

Drives manufactured after September 1974 may be fitted with the new-type indicator or switch/indicator assemblies.

3 RECOGNITION OF NEW ASSEMBLIES

When fitted into a drive a new-type assembly may be recognised by the raised edges on the left and right-hand sides of the lens, as shown in figure 1. All faces of the old type lens are flat and smooth. There are differences also in the part of the lens that accepts the filament lamp.

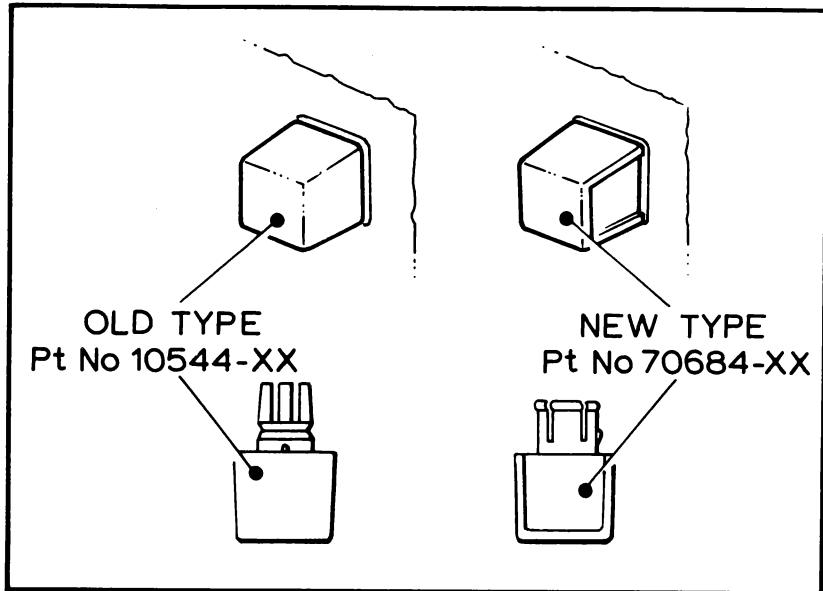

FIGURE 1 DIFFERENCES BETWEEN OLD AND NEW TYPE LENSES

4 COMPATIBILITY

The lenses of both the old and new-type assemblies accept the same filament lamp, part number 10545-00, but the lenses of one type are not compatible with indicators or switch/indicators of the other type. So if a replacement lens is required for an old type assembly, and a spare old-type lens is not available, a complete new assembly of lens plus indicator or switch/indicator must be substituted. The new-type assembly is a direct replacement for the old-type.

NOTE: A filament lamp is not included in an assembly.

5 DOCUMENTATION, FILING INSTRUCTIONS

File this user notice in chapter 7 of the series 30 technical manual, facing sheet 2 of figure 7.5.

Approved:

Tom Richardson

Date:

11/11/74.