

ECMA

EUROPEAN COMPUTER MANUFACTURERS ASSOCIATION

STANDARD ECMA-62

DATA INTERCHANGE ON 12,7 mm 9-TRACK MAGNETIC TAPE

32 ftpmm – NRZ1 – 32 cpmm
126 ftpmm – Phase Encoding – 63 cpmm
356 ftpmm – NRZ1 – 246 cpmm GCR

2nd Edition – March 1985

Free copies of this document are available from ECMA,
European Computer Manufacturers Association
114 Rue du Rhône – 1204 Geneva (Switzerland)

ECMA

EUROPEAN COMPUTER MANUFACTURERS ASSOCIATION

STANDARD ECMA-62

DATA INTERCHANGE ON 12,7 mm 9-TRACK MAGNETIC TAPE

32 ftpmm – NRZ1 – 32 cpmm

126 ftpmm – Phase Encoding – 63 cpmm

356 ftpmm – NRZ1 – 246 cpmm GCR

2nd Edition – March 1985

BRIEF HISTORY

In November 1967 ECMA issued a first standard for data interchange on 12,7 mm, 9-track magnetic tapes. This Standard ECMA-12 specified the NRZ1 method at the physical recording density of 32 ftpmm. In 1971 a second standard, ECMA-36, specifying phase encoding at 126 ftpmm, was issued.

In 1975 TC17, the ECMA Technical Committee for magnetic tape, started work on high density tapes using group coded recording. A complete standard was drafted and contributed to ISO/TC97/SC11 which adopted it as basic text for the future international standard ISO 5652. TC17 also contributed a complete text for the revision of ISO 1864, the international standard for unrecorded tapes. Whilst in ISO each of these subjects is described in a specific standard, TC17 decided to issue a single standard for 12,7 mm, 9-track magnetic tapes specifying the unrecorded tape, the reel, the track layout, the data representation, three alternative recording methods and appendices.

This 2nd Edition of Standard ECMA-62 is fully compatible with the latest editions of international standards ISO 1863, ISO 1864, ISO 3788 and ISO 5652.

Adopted by the General Assembly of ECMA on Dec. 14, 1984.

TABLE OF CONTENTS

	<u>Page</u>
SECTION I - GENERAL	
1. SCOPE AND CONFORMANCE	1
1.1 Scope	1
1.2 Conformance	1
2. REFERENCES	1
3. DEFINITIONS	1
3.1 Magnetic Tape	1
3.2 Reference Tape	1
3.3 Secondary Reference Tape	1
3.4 Signal Amplitude Reference Tape	2
3.5 Typical Field	2
3.6 Reference Field	2
3.7 Standard Reference Amplitude	2
3.8 Reference Edge	2
3.9 In Contact	2
3.10 Track	2
3.11 Row	2
3.12 Skew	2
3.13 Position of Flux Transition	3
3.14 Physical Recording Density	3
3.15 Data Density	3
SECTION II - UNRECORDED TAPE	
4. ENVIRONMENT	4
4.1 Testing Environment	4
4.2 Operating Environment	4
4.3 Storage Environment	4
4.4 Transportation	4
5. CHARACTERISTICS OF TAPE	5
5.1 Material	5
5.2 Width	5
5.3 Total Thickness of Tape	5
5.4 Base Material Thickness	5
5.5 Magnetic Coating Thickness	5
5.6 Length	5
5.7 E Value	5
5.8 Elastoplastic Properties	5
5.9 Longitudinal Curvature	5
5.10 Tape Wind	6
5.11 Magnetic Properties	6
5.12 Test Density	6
5.13 Recording Current	6
5.14 Average Signal Amplitude	6
5.15 Ease of Erasure	7
5.16 Test for Missing Pulses and Extra Pulses	7
5.17 Reflective Markers	8

TABLE OF CONTENTS (cont'd)

	<u>Page</u>
5.18 Cupping	9
5.19 Opacity	9
5.20 Resistance	9
5.21 Reflectivity	9
5.22 Dynamic Frictional Characteristics	9
 SECTION III - REEL	
6. REEL	12
6.1 Description	12
6.2 Construction	12
6.3 Designation	12
6.4 Dimensions	12
6.5 Moment of Inertia	15
6.6 Rigidity of the Hub	15
6.7 Identification of Ownership	15
6.8 Manufacturer's Reel Identification	15
6.9 Interchange Label	15
6.10 Write-enable Ring	15
 SECTION IV - TRACK LAYOUT AND DATA REPRESENTATION	
7. TRACKS	19
7.1 Number of Tracks	19
7.2 Track Identification	19
7.3 Track Positions	19
7.4 Track Width	19
8. DATA REPRESENTATION	19
 SECTION V - 32 ftpmm - NRZ1 - 32 cpmm	
9.1 Method of Recording	21
9.2 Physical Recording Density	21
9.3 Nominal Flux Transition Spacing	21
9.4 Average Flux Transition Spacing	21
9.5 Skew	21
9.6 Write Quality Check	21
9.7 Signal Amplitude	22
9.8 Erasure	22
9.9 Format of the Tape	22
9.10 Quality of Recording for Data Interchange	24
9.11 Erasure of ID Bursts	24
 SECTION VI - 126 ftpmm - Phase Encoding - 63 cpmm	
10.1 Method of Recording	25
10.2 Physical Recording Density	25
10.3 Average Bit Flux Transition Spacing	25
10.4 Instantaneous Flux Transition Spacing	25
10.5 Skew	26
10.6 Signal Amplitude	26
10.7 Erasure	26

TABLE OF CONTENTS (cont'd)

	<u>Page</u>
10.8 Format of the Tape	27
10.9 Quality of Recording for Data Interchange	28
SECTION VII - 356 ftpmm - NRZ1 - 246 cpmm GCR	
11.1 Method of Recording	29
11.2 Physical Recording Density	29
11.3 Average Flux Transition Spacing	29
11.4 Instantaneous Flux Transition Spacing	29
11.5 Skew	30
11.6 Signal Amplitude	30
11.7 Erasure	31
11.8 Data Formatting	31
11.9 Recording of Data Bytes on Tape	37
11.10 Control Sub-Groups	37
11.11 Storage Block	38
11.12 Tape Format	40
11.13 Interchange Criteria	41
SECTION VIII - APPENDICES	
APPENDIX A - TRANSPORTATION	43
APPENDIX B - COMMENTS ON REELS	45
APPENDIX C - CYCLIC REDUNDANCY CHECK CHARACTER	46
APPENDIX D - DETERMINATION OF THE ERASE MAGNETIC FIELD DIRECTION	48
APPENDIX E - PROCEDURE AND INSTRUMENTATION FOR MEASURING FLUX TRANSITION SPACING	49
APPENDIX F - PROCEDURE AND EQUIPMENT FOR MEASURING FLUX TRANSITION SPACING	57
APPENDIX G - DIFFERENCES BETWEEN THE FIRST EDITION OF ECMA-62 AND THIS SECOND EDITION	61

SECTION I

SCOPE AND CONFORMANCE

REFERENCES

DEFINITIONS

ENVIRONMENT

1. SCOPE AND CONFORMANCE

1.1 Scope

This Standard ECMA-62 specifies the physical and magnetic characteristics of 12,7 mm, 9-track magnetic tape with reel, to enable interchangeability of such tapes. It also provides a format and three recording methods, thus allowing together with Standard ECMA-13 for Magnetic Tape Labelling full data interchange by means of such magnetic tapes. The three methods defined in this Standard are:

- NRZ1 at the physical recording density of 32 ftpmm, yielding a data density of 32 cpmm,
- Phase Encoding at the physical recording density of 126 ftpmm, yielding a data density of 63 cpmm,
- NRZ1 at the physical recording density of 356 ftpmm, yielding a data density of 246 cpmm when Group Coded Recording is used.

1.2 Conformance

A magnetic tape is conforming to this Standard if it satisfies all the requirements of Sections I to IV and all those of one of Sections V to VII.

2. REFERENCES

- ECMA-6 : 7-Bit Input/Output Coded Character Set
- ECMA-13 : Magnetic Tape Labelling and File Structure for Information Interchange
- ECMA-35 : Extensions of the 7-Bit Coded Character Set
- ECMA-43 : 8-Bit Coded Character Set
- ECMA-56 : Self-Loading Cartridges for 12,7 mm Wide Magnetic Tapes

3. DEFINITIONS

For the purpose of this Standard, the following definitions apply:

3.1 Magnetic Tape

Tape which will accept and retain the magnetic signals intended for input, output and storage purposes on computers and associated equipment.

3.2 Reference Tape

A tape which has been selected for given properties for use in calibration.

3.3 Secondary Reference Tape

A tape intended for routing calibrating purposes, whose performance is known and stated in relation to that of a reference tape.

3.4 Signal Amplitude Reference Tape

A reference tape selected as a standard for signal amplitude.

NOTE 1

A Signal Amplitude Reference Tape has been established at the US National Bureau of Standards (NBS) for the physical recording densities 32 ftpmm and 126 ftpmm. Secondary Signal Amplitude Reference Tapes are available from NBS under the part number SRM 3200. A further Signal Amplitude Reference Tape has been established at the NBS for the physical recording density 356 ftpmm. Secondary Signal Amplitude Reference Tapes are available from NBS under the part number SRM 6250.

3.5 Typical Field

The minimum recording field which, when applied to a magnetic tape causes a signal output equal to 95% of the maximum signal amplitude at the specified physical recording density.

3.6 Reference Field

The Reference Field is the typical field of the Signal Amplitude Reference Tape at the specified physical recording density.

3.7 Standard Reference Amplitude

The average peak-to-peak signal amplitude derived from the Signal Amplitude Reference Tape on the NBS measurement system, or equivalent, under the recording conditions specified in 5.13.

3.8 Reference Edge

The edge further from an observer, when the tape is lying flat with the magnetic surface uppermost and the direction of movement for recording is from left to right.

3.9 In Contact

An operating condition in which the magnetic surface of a tape is in contact with a magnetic head.

3.10 Track

A longitudinal area on a tape along which a series of magnetic signals may be recorded.

3.11 Row

Nine transversely related locations (one in each track) in which bits are recorded.

3.12 Skew

Within a row, the maximum displacement of any location from any other location measured as the distance between two perpendiculars to the Reference Edge through said locations.

3.13 Position of Flux Transition

That point which exhibits the maximum free-space flux density normal to the tape surface.

3.14 Physical Recording Density

The number of recorded flux transitions per unit length of track (ftpmm).

3.15 Data Density

The number of data characters stored per unit length of tape (cpmm).

4. ENVIRONMENT

The conditions specified below refer to the ambient conditions in the test or computer room and not to those within the tape equipment.

4.1 Testing Environment

Test and measurements made on the tape to check requirements of this Standard shall be carried out under following conditions:

Temperature : 23 °C ± 2 °C

RH : 40% to 60%

Conditioning before testing : 24 hours

4.2 Operating Environment

Tapes used for data interchange shall be operated under the following conditions:

Temperature : 16 °C to 32 °C

RH : 20% to 80%

Wet bulb temperature : not greater than 27 °C

Conditioning before operating : If a tape has been exposed during storage and/or transportation to conditions outside the above values, it should be conditioned for a period of at least 12 hours, preferably 24 hours.

Operation near the same extremes of both temperature and relative humidity may result in degraded performance.

4.3 Storage Environment

4.3.1 Unrecorded tape

Temperature : 5 °C to 48 °C

RH : 20% to 80%

Wet bulb temperature : not to exceed 27 °C

4.3.2 Recorded tape

Temperature : 5 °C to 32 °C

RH : 20% to 80%

Wet bulb temperature : not to exceed 26 °C

If the temperature of 32 °C is exceeded, performance may be affected.

4.4 Transportation

Recommendations for transportation appear in Appendix A.

5. CHARACTERISTICS OF TAPE

5.1 Material

The tape shall consist of a base material (oriented polyethylene terephthalate film or its equivalent) coated on one side with a strong yet flexible layer of ferromagnetic material dispersed in a suitable binder. If the tape is also coated on the rear surface, the coating shall be non-ferromagnetic.

5.2 Width

The width of the tape shall be 12,7 mm $\begin{matrix} + 0,0 \text{ mm} \\ - 0,1 \text{ mm} \end{matrix}$

5.3 Total Thickness of Tape

The total thickness of the tape, at any point, shall be 0,048 mm \pm 0,008 mm.

5.4 Base Material Thickness

The thickness of the base material, including the rear surface coating, if present, shall be 0,038 mm nominal.

5.5 Magnetic Coating Thickness

The magnetic coating thickness shall not exceed 0,015 mm.

5.6 Length

The normal minimum length of tape shall be 732 mm splice-free. If the length of tape is less than 732 mm, the actual length shall be stated. Maximum tape length is limited by thickness, E value (see 5.7), moment of inertia and reel dimensions.

5.7 E Value

The E value shall be the radial distance by which the reel flanges extend beyond the outermost layer of a tape which has been wound at a tension of 2 N to 3,6 N on the specified reel. The minimum E value shall be 3,2 mm.

When used with a self-loading cartridge (Standard ECMA-56), the E value shall satisfy:

$$6,3 \text{ mm} \leq E \leq 15,9 \text{ mm}.$$

5.8 Elastoplastic Properties

The elastoplastic properties of the tape shall be such that when the tape is subjected to a tension of 30 N for a period of 3 min. under any combination of temperature and relative humidity within the ranges of 10 °C to 50 °C and 20% to 80% relative humidity, the permanent elongation measured with negligible tension after a second 3 min. interval is less than 1,0%.

5.9 Longitudinal Curvature

There shall be a minimum radius of curvature for the edge of the tape, defined and tested by allowing a 1 m length of the

tape to unroll and assume its natural curvature on a flat surface. The minimum radius shall be 33 m if measured over an arc of a circle, this corresponds to a deviation of 3,8 mm from a 1 m cord.

5.10 Tape Wind

Tape shall be wound, with its magnetic surface toward the reel hub, in a clockwise direction; i.e. when the reel is viewed from the front (see Fig. 2), the loose end of the tape hangs from the right side of the reel. Tape shall be wound with a constant tension in the range of 2 N to 3,6 N.

5.11 Magnetic Properties

The magnetic properties of the tape are not defined here by B-H loops or similar parameters, but are defined by the testing procedures given in 5.13 to 5.16.

5.12 Test Density

For the purpose of testing tape in accordance with this Standard, the physical recording density shall be 32, 126 or 356 ftpmm. The flux transitions shall be uniformly spaced. The flux transition spacing and the track configuration shall conform to Section IV and clauses 9.3, 9.4, 10.3, 10.4 and 11.3, 11.4 as appropriate.

5.13 Recording Current

The ratio k between the recording current (I_r) and the current required to produce the Reference Field (I_f) at various physical recording densities shall be as follows:

Physical recording density	$k = \frac{I_r}{I_f}$
For 32 ftpmm	2,0 to 2,2
For 126 ftpmm	1,75 to 1,85
For 356 ftpmm	1,35 to 1,45

For the physical recording densities of 32 ftpmm and 126 ftpmm, the Typical Field of the tape under test shall be within $\pm 20\%$ of the Reference Field; for the physical recording density of 356 ftpmm it shall be within $\pm 15\%$ of this Reference Field.

5.14 Average Signal Amplitude

The average signal amplitude shall be the average value of the peak-to-peak output voltage over at least 76 mm of a tape that has been recorded under the conditions of 5.13 on all tracks.

When played back on a system, each channel of which has been calibrated by means of a Signal Amplitude Reference Tape, the average signal amplitude shall be within $\pm 10\%$ of the Standard Reference Amplitude at 32 ftpmm within -10% to $+25\%$ at 126 ftpmm and within $\pm 40\%$ at 356 ftpmm.

This test shall be conducted on the read-while-write pass for both tapes and in accordance with instructions issued with the Signal Amplitude Reference Tape.

NOTE 2

It has been observed that the average signal amplitude level at 356 ftpmm can vary along the length of tape. This effect is termed "tilt". Results indicate that a variation of 20% can be expected. The effect of such variations is included in the specified tolerance on average signal amplitudes.

5.15 Ease of erasure

The field for erasure shall be a longitudinal steady field of 79 500 A/m and be reasonably uniform such as that in the middle of a solenoid.

- 5.15.1 When a tape has been recorded at 32 ftpmm and then passed through an erasure field the remaining Average Signal Amplitude shall not exceed 4% of the Standard Reference Amplitude at 126 ftpmm.
- 5.15.2 When a tape has been recorded at 32 ftpmm or 126 ftpmm and passed through an erasure field, the remaining Average Signal Amplitude shall not exceed 4% of the Standard Reference Amplitude at 356 ftpmm.

5.16 Test for Missing Pulses and Extra Pulses

These tests shall be carried out in the In Contact condition and over the entire tested area, which shall extend from 0,2 m before the BOT reflective marker to 3,0 m beyond the EOT reflective marker (see Fig. 1).

When performing the tests in 5.16.1 and 5.16.2, the output or resultant signal must be measured on the same relative pass for both the Signal Amplitude Reference Tape and the tape under test, i.e. either read-while-write or read-on-first-pass-after-write. The Standard Reference Amplitude shall be measured at the appropriate density.

5.16.1 Missing Pulses

When a tape has been recorded on all tracks, with a 32 ftpmm signal, as defined in 5.12 and 5.13, and is played back on a system each channel of which has been calibrated as in 5.14, any signal from any track, when measured base-to-peak which is less than 50% of half the Standard Reference Amplitude shall be a missing pulse. At 126 ftpmm a missing pulse shall be any pair of consecutive output pulses from any track the peak-to-peak amplitude of which is less than 35% of the Standard Reference Amplitude. At 356 ftpmm any signal from any track, when measured base-to-peak, the amplitude of which is less than 35% of half the Standard Reference Amplitude shall be a missing pulse.

5.16.2 Extra Pulses

Following DC-erasure of the tape on the machine used for conducting the missing pulse test as described in 5.16.1, any signal from any track when measured base-to-peak which exceeds 10% of half the Standard Reference Amplitude shall be an extra pulse.

5.16.3 Allowable number of missing pulses and extra pulses

The allowable number of missing pulses and of extra pulses is not specified by this Standard, but is a matter for agreement between purchaser and supplier.

NOTE 3

It is considered impractical to specify this number for several reasons including:

- a) the performance of test equipment for magnetic tape is not uniform but depends on such things as tape tension, head design and the method of guidance employed;*
- b) different machines and systems of programming vary in their ability to tolerate missing and extra pulses on tapes.*

5.17 Reflective markers

Each reel of tape shall be furnished with two photo-reflective markers, each consisting of, or equivalent to, a transparent plastic base with a metallic (for example vaporized aluminium) coating between the base and a thin layer of low cold flow thermal setting adhesive.

Reflective markers shall be placed on the side of the tape which does not carry the magnetic surface, and they shall be on opposite edges of the tape with the beginning-of-tape reflective marker (BOT) on the reference edge.

The width of the markers shall be $4,8 \text{ mm} \pm 0,5 \text{ mm}$.

The length of the markers shall be $28 \text{ mm} \pm 5 \text{ mm}$.

The thickness of the markers, measured after their application to the tape, shall be not greater than $0,020 \text{ mm}$.

The beginning-of-tape reflective marker (BOT) shall be placed $4,8 \text{ m} \pm 0,6 \text{ m}$ from the beginning of the tape and the end-of-tape marker (EOT) shall be placed $7,6 \pm_{0,0}^{1,5} \text{ m}$ from the end of the tape.

The distance from the outer edge of a marker to the adjacent edge of the tape shall be $0,8 \text{ mm}$ maximum and the marker shall not protrude beyond the edge of the tape.

The marker shall be free of wrinkles and excessive adhesive. The surface of the reflective markers shall be non-conductive.

NOTE 4

It is desirable to employ the thinnest markers which perform satisfactorily to minimize the distortion of layers of tape adjacent to them.

5.18 Cupping

Cupping is the departure across the width of tape from a flat surface. The maximum cupping of a 6,35 mm long length of tape shall not exceed 0,25 mm when placed concave side down on a smooth flat surface. The time between cutting and the measurement should be 1 h.

5.19 Opacity

Opacity is a characteristic which limits the amount of transmission of light through the tape. The opacity of tape shall not be less than 95% over the range of wavelength from 0,4 μm to 1,5 μm .

5.20 Resistance

The electrical resistance of a square area of the magnetic surface of any size shall be within the range $5 \cdot 10^5$ Ohm/square to $5 \cdot 10^8$ Ohm, measured between electrodes placed along two opposite sides of the square, using a voltage of $500 \text{ V} \pm 10 \text{ V}$.

5.21 Reflectivity

5.21.1 Marker reflectivity

The photo-reflective marker shall have a reflectivity of at least 90% compared to a reference standard, at an angle of incidence of light of 60° and over the range of wavelengths from 0,4 μm to 1,5 μm .

NOTE 5

The reference standard should be constructed from a piece of aluminium Al-MgSiCu (see ISO 209) with a flat face dimension of 30 mm by 5 mm with a surface roughness R_a (arithmetical mean deviation) between 0,008 μm and 0,016 μm (see ISO 468). The standard should be resurfaced periodically to prevent a reflectivity shift due to oxidation.

5.21.2 Rear surface reflectivity

The rear surface of the tape shall have a reflectivity not exceeding 30% of that of the reference standard when measured under the conditions specified in 5.21.1.

5.22 Dynamic frictional characteristics

The force specified in 5.22.1.1, 5.22.2.1, 5.22.3.1 and 5.22.4.1 shall be the sum of the forces exerted by the 65 g mass and the dynamic friction.

5.22.1 Oxide coating to brass and chrome

5.22.1.1 Requirement

The force shall be a maximum of 1,28 N.

5.22.1.2 Procedure

The sample shall be pulled at 50 mm per minute over a brass (chrome) cylinder (90 degree wrap) of diameter

25 mm with a 65 g mass on the other end of the tape. The force versus time (or force versus distance) shall be plotted. Particular attention should be given to keeping the samples clean and maintaining the brass (chrome) cylinder finish (0,13 um to 0,26 um peak-to-peak).

5.22.2 Oxide coating to back surface

5.22.2.1 Requirement

The force shall be a minimum of 0,78 N.

5.22.2.2 Procedure

The oxide-coated surface of the sample shall be pulled at 50 mm per minute over a cylinder (90-degree wrap) of diameter 25 mm covered with one layer of the same tape, back surface up. A 65 g mass shall be suspended on the free end of the tape. The force versus time (or force versus distance) shall be plotted.

5.22.3 Tape back surface to stainless steel

5.22.3.1 Requirement

The force shall be a maximum of 0,83 N.

5.22.3.2 Procedure

The sample shall be pulled at 50 mm per minute over a stainless steel cylinder (90-degree wrap) of diameter 25 mm with a 65 g mass on the other end of the tape. The force versus time (or force versus distance) shall be plotted. Particular attention should be given to keeping the samples clean and maintaining the stainless steel cylinder finish (0,13 um to 0,26 um peak-to-peak).

5.22.4 Rubber to tape back surface

5.22.4.1 Requirement

The force shall be a minimum of 0,78 N.

5.22.4.2 Procedure

The sample shall be pulled at 50 mm per minute over a rubber-coated cylinder (90-degree wrap) with a 65 g mass on the other end of the tape.

The cylinder construction shall consist of a stainless steel inner cylinder 25 mm in diameter and 18 mm in length (a centre core convenient for mounting is optional) to which a 5 mm coating of rubber is vulcanized. This rubber shall be type BG830, in accordance with ASTM D 2000.

The force versus time (or force versus distance) shall be plotted.

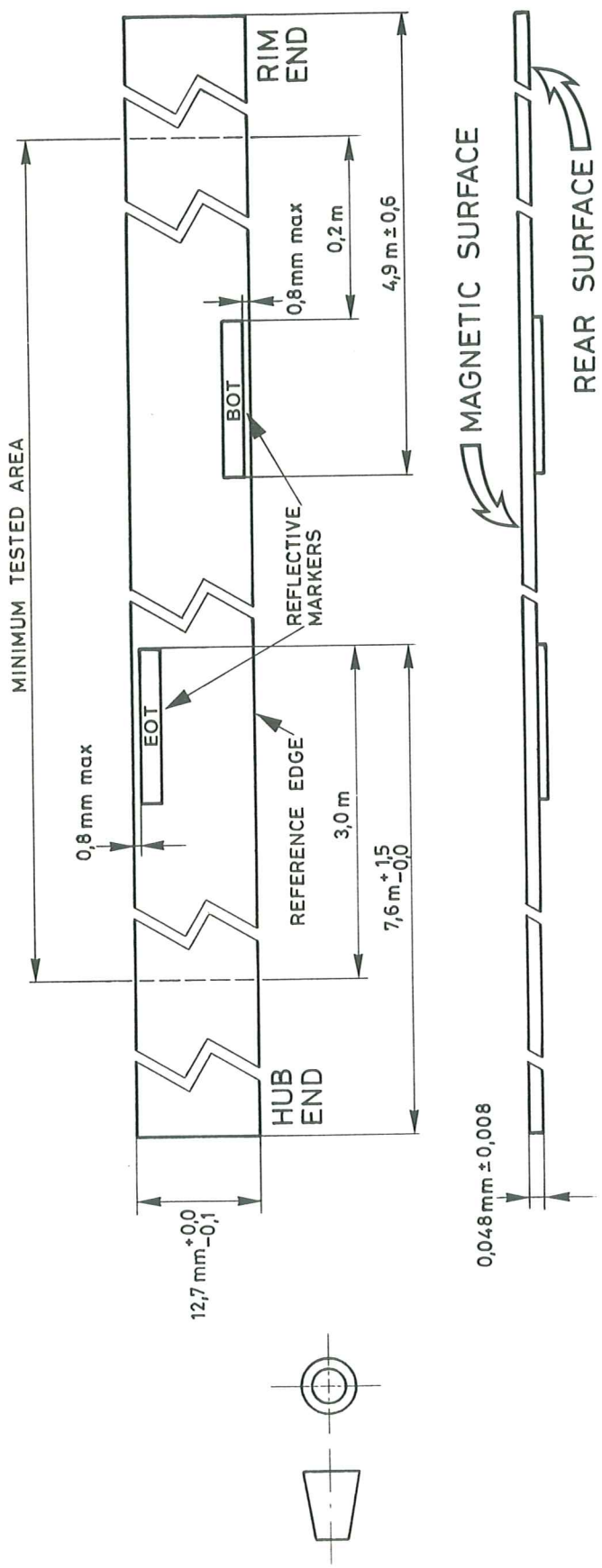

FIG. 1

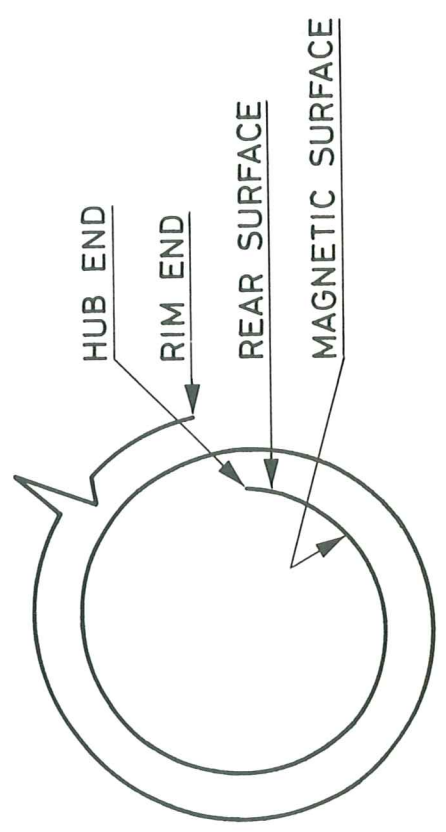

FIG. 2

SECTION III

CHARACTERISTICS OF THE REEL

6. REEL

6.1 Description

In Fig. 3, a reel according to this Standard is shown for illustrative purposes. The reel shall comprise a hub and two flanges. The front flange shall exhibit a circular groove for a write-enable ring. All dimensions and tolerances specified apply both to empty reels and reels wound with tape.

6.2 Construction

6.2.1 Cross-section

Reels shall be constructed such, that any cross-section taken through the central axis of the reel conforms to the cross-section shown in the drawing except where taken so as to pass through the relieved portion of the write-enable ring groove. The section shall, in this case, conform to this cross-section with appropriate deviations permitted at the ring groove relief as illustrated in section Z-Z of Fig. 3.

6.2.2 Symmetry of reel

Reels shall not be symmetrical, the flanges differing from each other as to the presence or absence of the write-enable ring, which shall be adjacent to the mounting pedestal for correct machine operation.

6.2.3 Hub and flanges

Hub and flanges need not be integral, but may be separate parts at the manufacturer's option as long as no relative movement between parts can occur and all requirements of this Standard are met.

6.2.4 Outside surface of flanges

Bosses, ribs, or raised designs are permitted on the outside surface of the flanges, provided that they do not extend beyond the cross-hatched envelope of the cross-section shown in Fig. 3.

6.3 Designation

The reel specified by this Standard shall be designated by:
Size 27.

6.4 Dimensions

6.4.1 Reference surface

The axial dimensions are referred to a reference surface U.

This reference surface U shall be used for reel mounting. It is a circular surface defined by diameters A and D on the rear flange (see 6.4.2 and 6.4.5.1).

6.4.2 Inside diameter of the hub

The inside diameter A of the hub shall be

$$A = 93,68 \text{ mm } \begin{matrix} + 0,13 \text{ mm} \\ - 0,08 \text{ mm} \end{matrix}$$

6.4.3 Overall diameter of the flanges

The overall diameter B of the flanges shall be

$$B = 266,70 \text{ mm } \begin{matrix} + 0,25 \text{ mm} \\ - 0,75 \text{ mm} \end{matrix}$$

6.4.4 Outside diameter of the hub

The outside diameter C of the hub shall be

$$C = 130,18 \text{ mm}$$

The tolerance on this dimension shall be

In ranges N : $\pm 0,20 \text{ mm}$

In range W : $\pm 0,13 \text{ mm}$

6.4.5 Dimensions of the groove for the write-enable ring

6.4.5.1 The inside diameter D of the groove shall be

$$D = 98,42 \text{ mm } \pm 0,13 \text{ mm}$$

6.4.5.2 The outside diameter E of the groove shall be

$$E = 111,46 \text{ mm } \pm 0,13 \text{ mm}$$

6.4.5.3 The angle α of the wall of the groove with the axis of the reel shall be

$$\alpha = 4^{\circ} \pm 15'$$

6.4.5.4 The depth F of the groove shall be

$$F = 6,35 \text{ mm } \begin{matrix} + 0,25 \text{ mm} \\ - 0,00 \text{ mm} \end{matrix}$$

6.4.5.5 The radius H of the tab for facilitating removal of the write-enable ring shall be

$$H = 19,05 \text{ mm } \pm 0,38 \text{ mm}$$

when measured at the distance R which shall be

$$R = 42,60 \text{ mm } \pm 0,25 \text{ mm}$$

The depth P of the tab shall be

$$P = 0,90 \text{ mm max.}$$

The angle β of the chamfer of the tab shall be

$$\beta = 45^{\circ} \pm 15'$$

6.4.6 Distances of the flange surfaces from the reference surface

Thickness of the flange portion of the reels may be varied, but shall fall entirely within the cross-hatched envelopes defined by dimensions J_f , J_r , K_f , K_r and M.

6.4.6.1 The distance J_f of the inside surface of the front flange from the reference surface U shall be

$$J_f = 15,80 \text{ mm } \begin{matrix} + 0,64 \text{ mm} \\ - 0,13 \text{ mm} \end{matrix}$$

6.4.6.2 The distance J_r of the inside surface of the rear flange from the reference surface U shall be

$$J_r = 2,46 \text{ mm } \begin{matrix} + 0,13 \text{ mm} \\ - 0,64 \text{ mm} \end{matrix}$$

6.4.6.3 The distance K_f of the outside surface of the front flange from the reference surface U shall be

$$K_f = 21,54 \text{ mm max.}$$

6.4.6.4 The distance K_r of the outside surface of the rear flange from the reference surface U shall be

$$K_r = 2,03 \text{ mm max.}$$

6.4.7 Relieved area of the front flange

6.4.7.1 The diameter L of the relieved area of the front flange shall be

$$L = 104,78 \text{ mm min.}$$

6.4.7.2 The distance M of the bottom surface of the relieved area from the reference surface U shall be

$$M = 18,24 \text{ mm } \pm 0,13 \text{ mm}$$

6.4.8 Relieved area of the outer surface of the flanges

6.4.8.1 At their outer rim, the outside surfaces of the flanges shall be relieved over a length T of

$$T = 4,00 \text{ mm min.}$$

6.4.8.2 The distance S_f of the surface of the front flange within this relieved area from the reference surface U shall be

$$S_f = 12,12 \text{ mm max.}$$

6.4.8.3 The distance S_r of the surface of the rear flange within this relieved area from the reference surface U shall be

$$S_r = 0,76 \text{ mm max.}$$

6.4.8.4 The edges of the flanges shall be rounded and have the following radii:

$$\begin{aligned} \text{inner edges: } R_i &= 0,89 \text{ mm min.} \\ \text{outer edges: } R_o &= 0,38 \text{ mm min.} \end{aligned}$$

6.4.9 Relations between dimensions

6.4.9.1 Relation between dimensions A and C

The outside cylindrical surface of the hub shall be concentric with the bore of the hub within 0,50 mm

total indicator reading (TIR).

6.4.9.2 Relation between dimension C and the reference surface U

Within ranges N, the perpendicularity of the outside cylindrical surface and the reference surface U shall be within

0,100 mm

Within range W, it shall be within

0,065 mm

The nominal length of ranges N shall be

$N = 1,5 \text{ mm}$

6.5 Moment of Inertia

The moment of inertia of the tape and reel combined shall not exceed $10,3 \text{ g.m}^2$. In general, this will require a reel whose moment of inertia does not exceed $2,71 \text{ g.m}^2$.

6.6 Rigidity of the Hub

Dimension A shall not be reduced to less than 93,60 mm when the reel is fully loaded with tape wound at a constant tension of 3,6 N.

6.7 Identification of Ownership

An identification area shall be provided on the front flange of the reel for ownership identification.

6.8 Manufacturer's Reel Identification

The manufacturer's identification may be placed on the reel.

6.9 Interchange Label

A labelling area or card holder may be provided on the front flange. Suitable labels shall be used for marking the contents of the reel of tape. Adhesive labels, if employed, shall be of a type which leave no residue when removed. The use of pencil or similar erasable marking is not allowed.

6.10 Write-enable Ring

6.10.1 Top surface

When installed in the write-enable ring groove, the top surface of the write-enable ring shall not protrude above the reel mounting surface (U).

6.10.2 Tab

All write-enable rings shall have a tab to facilitate removal from the groove.

6.10.3 Construction

Dimensions and materials used shall be such that the write-enable ring may be inserted and removed with reasonable effort and remain inserted during normal use. Furthermore, the ring shall be constructed so as not to interfere with normal tape transport performance.

	Nominal	Tolerance
A	93,68	+ 0,13 - 0,08
B	266,70	+ 0,25 - 0,75
C	130,18	(N) \pm 0,20 (W) \pm 0,13
D	98,42	\pm 0,13
E	111,46	\pm 0,13
F	6,35	+ 0,25 - 0,00
H	19,05	\pm 0,38
J _f	15,80	+ 0,64 - 0,13
J _r	2,46	+ 0,13 - 0,64
K _f	21,54	maximum
K _r	2,03	maximum
L	104,78	minimum
M	18,24	\pm 0,13
N	1,5	\pm 0,13
P	0,43	maximum
R	42,60	\pm 0,25
α	4°	\pm 15'
β	45°	
R _o	0,38	minimum
R _i	0,89	minimum
S _r	0,76	maximum
S _f	19,12	maximum
T	4,00	minimum

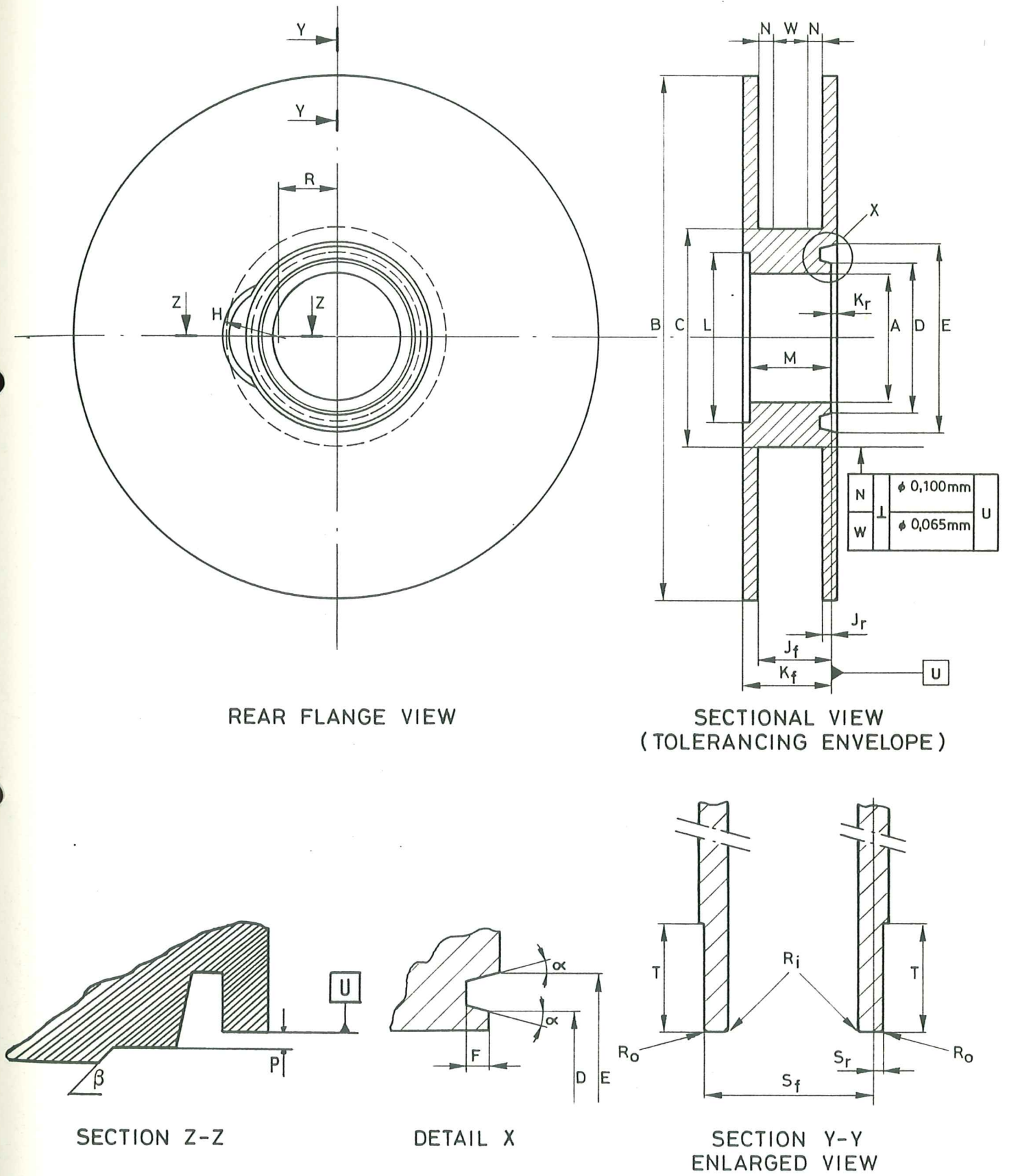

FIG. 3

SECTION IV

TRACK LAYOUT AND DATA REPRESENTATION

7. TRACKS

7.1 Number of Tracks

There shall be 9 tracks.

7.2 Track Identification

Tracks shall be numbered consecutively beginning at the Reference Edge with track #1.

7.3 Track Positions

The distance from the centrelines of the tracks to the Reference Edge shall be :

- Track #1 : 0,74 mm \pm 0,08 mm
- Track #2 : 2,13 mm \pm 0,08 mm
- Track #3 : 3,53 mm \pm 0,08 mm
- Track #4 : 4,93 mm \pm 0,08 mm
- Track #5 : 6,32 mm \pm 0,08 mm
- Track #6 : 7,72 mm \pm 0,08 mm
- Track #7 : 9,12 mm \pm 0,08 mm
- Track #8 : 10,52 mm \pm 0,08 mm
- Track #9 : 11,91 mm \pm 0,08 mm

7.4 Track Width

The width of a written track shall be :

1,09 mm min.

8. DATA REPRESENTATION

The characters shall be represented by means of the ECMA 7-bit coded character set (Standard ECMA-6) or the ECMA 8-bit coded character set (Standard ECMA-43) or, where required, of another extension of the 7-bit coded character set (Standard ECMA-35).

The bit-to-track allocation shall be as follows :

7-bit coded characters

Binary weight	2 ⁰	2 ¹	2 ²	2 ³	2 ⁴	2 ⁵	2 ⁶	-	-
Bit designation	b ₁	b ₂	b ₃	b ₄	b ₅	b ₆	b ₇	-	P
Track #	2	8	1	9	3	5	6	7	4

Track # 7 shall always be recorded with bit ZERO.

8-bit coded characters

Binary weight	2^0	2^1	2^2	2^3	2^4	2^5	2^6	2^7	-
Bit designation	b_1	b_2	b_3	b_4	b_5	b_6	b_7	b_8	P
Track #	2	8	1	9	3	5	6	7	4

Bit P in track # 4 shall be the parity bit. The parity shall be odd.

NOTE 6

When Group Coded Recording (Section VII) is used, this data representation applies to the preparation of the data prior to recording. Due to the very nature of Group Coded Recording the bits recorded on the tape are to be considered as binary digits only and not as representing the bits of the coded character sets of Standards ECMA-6 and ECMA-43.

SECTION V

32 ftpmm - NRZ1 - 32 cpmm

9.1 Method of Recording

The "non return to zero mark" (NRZ1) method of recording shall be used where a ONE is represented by a change of direction of longitudinal magnetization.

9.2 Physical Recording Density

The nominal density shall be designated by 32 ftpmm. The actual density shall be 31,5 ftpmm.

9.3 Nominal Flux Transition Spacing

The nominal flux transition spacing shall be 31,75 um.

9.4 Average Flux Transition Spacing

The average flux transition spacing shall be within $\pm 3\%$ of the nominal flux transition spacing. This average shall be measured over a minimum of $1,2 \cdot 10^5$ successive flux transitions, at the extremes of operating conditions, by reading a continuously and evenly recorded tape at 31,5 ftpmm in phase in all tracks.

9.5 Skew

The skew shall be less than 3,81 um. This condition must be satisfied for both flux transition polarities. The value of static recorded skew is the maximum static deviation within a row.

9.6 Write Quality Check

During the writing of an interchange tape, the write-check operation will determine bit timing (converted to apparent length) and signal amplitude.

NOTE 7

On equipment that is not capable of reading during the write-pass, bit timing and signal amplitude may be checked on the first-read-pass.

9.6.1 Bit timing (converted to apparent length)

To determine bit timing, from leading edge to leading edge, the following conditions must be considered together :

- a) the timing between the first detected bit of successive rows shall be greater than a design centre value which shall exceed 22,9 um;
- b) the timing between the first detected bit and the last detected bit of a row shall be less than a design centre value which shall not exceed 10,8 um;
- c) there shall be a minimum apparent space between any bits of successive rows of 11,2 um.

9.6.2 Signal amplitude

The signal amplitude shall be such that when the tape is interchanged the requirements of 9.7 are complied with.

9.7 Signal Amplitude

9.7.1 Standard Reference Amplitude

The Standard Reference Amplitude is the average peak-to-peak signal amplitude derived from the Signal Amplitude Reference Tape on the qualified measurement system at the nominal density of 32 ftpmm and the recording current $I_r = k.I_f$.

The signal amplitude shall be averaged over a minimum of 4000 flux transitions and shall be measured on the read-whilest-write-pass.

The reference current I_f is the current producing the Reference Field (see 5.13).

9.7.2 Average signal amplitude

9.7.2.1 The average peak-to-peak signal amplitude of an interchange tape shall not deviate by more than +15%, -30% from the Standard Reference Amplitude.

9.7.2.2 Averaging shall be done over a minimum of 4000 flux transitions, which for the interchange tape may be segmented into blocks. Averaging shall be done on the first-read-pass after interchange.

9.7.3 Maximum signal amplitude

No tape when interchanged shall contain flux transitions the base-to-peak signal amplitude of which exceeds 120% of half the Standard Reference Amplitude in the first-read-pass after interchange.

9.7.4 Minimum signal amplitude

No tape when interchanged shall contain flux transisions the base-to-peak signal amplitude of which is less than 35% of half the Standard Reference Amplitude in the first-read-pass after interchange.

9.8 Eraseure

9.8.1 When erased, the rim end of the erased area of the tape shall be magnetized so that it is a North-seeking pole (see Appendix D).

9.8.2 The full width of the tape shall be DC erased in the direction specified in clause 9.8.1.

9.8.3 The tape shall be erased so that all signals, including NRZ1 at 32 ftpmm and 356 ftpmm and phase encoding at 126 ftpmm are less than 4% of the Standard Reference Amplitude at 32 ftpmm.

9.9 Format of the Tape

9.9.1 Block structure

All blocks shall consist of a data portion followed by a Cyclic Redundancy Check character (CRC) and a Longitudinal Redundancy Check character (LRC).

9.9.2 Length of the data portion

The data portion of a block shall consist of at least 18 characters and at most of 2048 characters.

9.9.3 Cyclic Redundancy Check character (CRC)

The Cyclic Redundancy Check character, CRC, shall be hardware-generated by shifting serially the relevant bits as specified in Appendix C through a 9-bit shift register described by the generator polynomial:

$$x^9 + x^6 + x^5 + x^4 + x^3 + 1$$

9.9.4 Longitudinal Redundancy Check character (LRC)

The Longitudinal Redundancy Check character, LRC, shall have a ONE in all tracks in which the longitudinal count is otherwise odd, else a ZERO.

9.9.5 Gaps

9.9.5.1 Initial gap

Between the hub end of the BOT marker and the first recorded character of the first block there shall be a gap with a length of 76 mm minimum and 7,6 m maximum. It shall be erased according to 9.8.

9.9.5.2 Inter-block gap

The length of inter-block gaps shall be:

- nominal : 15 mm
- minimum : 12,7 mm
- maximum : 7,6 m

This gap shall be erased according to 9.8. The actual gap length depends on the number of consecutive erase instructions.

9.9.5.3 CRC gap

There shall be a gap of 0,127 mm \pm 0,013 mm between the last recorded data character and the CRC.

9.9.5.4 LRC gap

There shall be a gap of 0,127 mm \pm 0,013 mm between the CRC and the LRC characters.

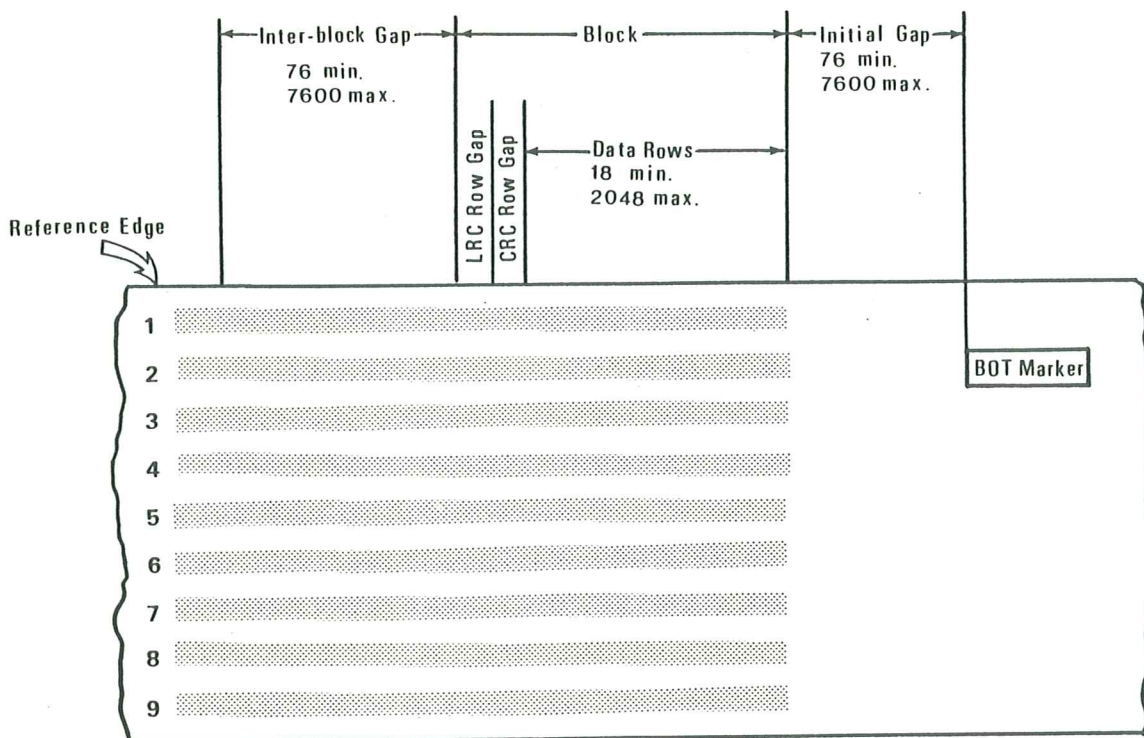

9.9.6 Tape Mark

The Tape Mark shall be a control block comprising:

- a row with ONES in tracks #2, #3 and #8 and erasure in tracks #1, #4, #5, #6, #7 and #9,
- a CRC gap,
- a CRC character containing only ZEROs,
- an LCR gap,
- an LCR character.

A Tape Mark shall be separated from blocks by an inter-block gap.

The use of Tape Mark is specified in Standard ECMA-13.

9.10 Quality of Recording for Data Interchange

Tape shall not be employed for data interchange where the number of gaps which have been elongated due to erase instructions exceed two in number or 0,5% of the total number of blocks written, whichever is the larger.

No parity errors are permissible in data to be interchanged.

9.11 Erasure of ID Bursts

The use of tapes, previously recorded at 126 ftpmm or 356 ftpmm for recording at 32 ftpmm presents a difficulty in that the 126 ftpmm and 356 ftpmm identification bursts extend from a minimum of 43 mm before the trailing edge of the BOT marker. To ensure proper working of the 32 ftpmm system, it is necessary for the burst to be erased, either by the system itself or by bulk erasure.

SECTION VI

126 ftpmm - Phase Encoding - 63 cpmm

10.1 Method of Recording

The recording method shall be phase encoding, described as follows: A ONE bit is a flux transition to the polarity of the inter-block gap, when reading in the forward direction. A ZERO bit is a flux transition to the polarity opposite to that of the inter-block gap, when reading in the forward direction.

Additional flux transition shall be written at the nominal mid-point between bit flux transitions, as defined, if required to establish the proper polarity for the succeeding bits. These flux transitions shall be called phase flux transitions.

10.2 Physical Recording Density

The density of recording shall be 126 ftpmm.

10.3 Average Bit Flux Transition Spacing

The nominal bit flux transition spacing shall be 15,87 μm .

10.3.1 Long-term average (static) bit flux transition spacing shall be within $\pm 4\%$ of the nominal spacing. This average shall be measured over a minimum of $5 \cdot 10^5$ successive bit flux transitions.

10.3.2 Short-term average (dynamic) bit flux transition spacing, when referred to a particular bit flux transition spacing, is the average of that bit flux transition spacing and the preceding three bit flux transition spacings. The short-term average bit flux transition spacing shall be within $\pm 10\%$ of the long-term average bit flux transition spacing. In addition, the short-term average bit flux transition spacing shall change at a rate not greater than 0,5% per bit flux transition.

10.4 Instantaneous Flux Transition Spacing

The instantaneous spacing between flux transitions may be influenced by the reading and writing process, the bit sequence recorded (pulse crowding effects) and other factors.

To determine the instantaneous spacing between any two flux transitions, the following five conditions must all be satisfied.

10.4.1 The spacing between successive bit flux transitions without an intervening phase flux transition shall be between 85% and 108% of the corresponding short-term average bit flux transition spacing.

10.4.2 The spacing between successive bit flux transitions with an intervening phase flux transition shall be between 93% and 112% of the corresponding short-term average bit flux transition spacing.

10.4.3 The spacing between a bit flux transition and any adjacent phase flux transition shall be between 44% and 62% of the corresponding short-term average bit flux transition spacing.

10.4.4 The average distance between actual bit flux transitions in a sequence of flux transitions of 63 per mm and the predicted position of those bit flux transitions relative to flux transitions of 126 per mm preceding or succeeding the sequence shall not exceed $\pm 6\%$ of the corresponding short-term average bit flux transition spacing.

10.4.5 The equipment used for recording tapes at 126 ftpmm and the magnetic tape to be used for interchange shall fulfil the requirements of 10.4.1 to 10.4.4 when tested under the conditions specified in the reference read chain (see Appendix E).

10.5 Skew

The skew shall be less than 15,87 μm .

10.6 Signal Amplitude

10.6.1 Standard Reference Amplitude

The Standard Reference Amplitude is the average peak-to-peak signal amplitude derived from the Signal Amplitude Reference Tape on the qualified measurement system at the density of 126 ftpmm and the recording current $I_r = k \cdot I_f$.

The signal amplitude shall be averaged over a minimum of 4000 flux transitions and shall be measured on the read-whilst-write-pass.

The reference current I_f is the current producing the Reference Field (see 5.13).

10.6.2 Average signal amplitude

10.6.2.1 The average peak-to-peak signal amplitude of the interchanged tape at 126 ftpmm shall not deviate by more than +50%, -35% from the Standard Reference Amplitude.

10.6.2.2 The average peak-to-peak signal amplitude at 63 ftpmm shall be less than 3 times the Standard Reference Signal Amplitude.

10.6.2.3 Averaging shall be done over a minimum of 4000 flux transitions, which for the interchange tape may be segmented into blocks. Averaging shall be done on the first-read-pass after interchange.

10.6.3 Minimum signal amplitude

No tape when interchanged shall contain flux transitions the base-to-peak signal amplitude of which is less than 20% of half the Standard Reference Amplitude.

10.7 Erasure

10.7.1 When erased, the rim end of the erased area of the tape shall be magnetized so that it is a North-seeking pole (see Appendix D).

10.7.2 The full width of the tape shall be DC erased in the direction specified in clause 10.7.1.

10.7.3 The tape shall be erased so that all signals, including NRZ1 at 32 ftpmm and 356 ftpmm and phase encoding at 126 ftpmm, are less than 4% of the Standard Reference Amplitude at 126 ftpmm.

10.8 Format of the Tape

10.8.1 Identification burst

The phase-encoding recording method shall be identified by a burst of recording at the BOT marker. This burst shall consist of 63 ftpmm on track #4 and erasure on all other tracks. The identification burst shall begin at least 43 mm before the hub end of the BOT marker and continue past the hub end of the BOT marker, but shall end at least 12,7 mm before the first block.

10.8.2 Block structure

All blocks shall consist of a preamble, a data portion and a postamble.

10.8.3 Preamble

The preamble, preceding the data portion of a block, shall consist of 40 rows containing only ZEROs followed by one row containing only ONES.

10.8.4 Length of the data portion

The data portion of a block shall consist of at least 18 characters and at most 2048 characters.

10.8.5 Postamble

The postamble, following the data portion, shall consist of one row containing only ONES followed by 40 rows containing only ZEROs.

10.8.6 Gaps

10.8.6.1 Initial gap

Between the hub end of the BOT marker and the first recorded character of the preamble of the first block there shall be a gap with a length of 76 mm minimum and 7,6 m maximum. This gap shall be erased according to 10.7 with the exception of the Identification Burst.

10.8.6.2 Inter-block gap

The length of the inter-block gaps shall be:

- nominal : 15 mm
- minimum : 12,7 mm
- maximum : 7,6 m

This gap should be erased according to 10.7. The actual gap length depends upon the number of consecutive erase instructions.

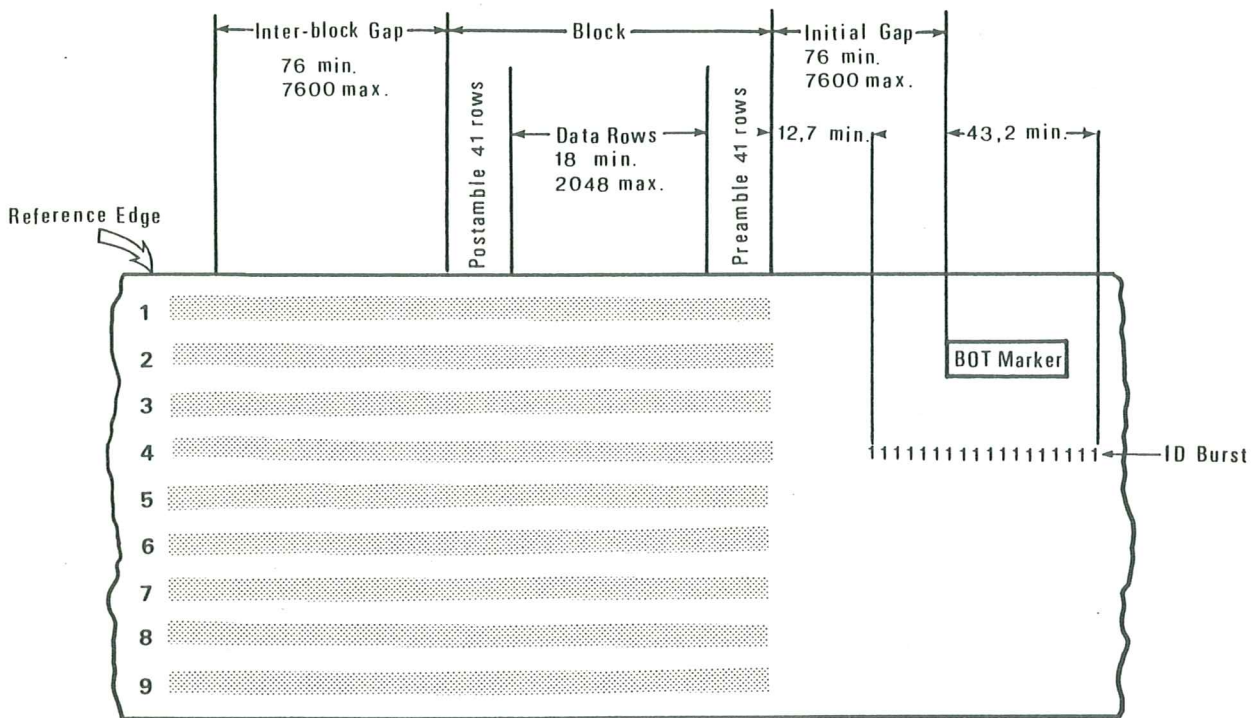

10.8.7 Tape Mark

The Tape Mark shall be a control block characterized by:

- DC-erasure in tracks #3, #6 and #9,
- by bit pattern (1111 ...), over 64 to 256 transitions in tracks #2, #5 and #8,
- tracks #1, #4 and #7, in any combination, may be DC-erased or recorded in the manner stated for tracks #2, #5 and #8. All eight possible combinations shall be considered as a Tape Mark.

A Tape Mark shall be separated from blocks by an Inter-block gap.

The use of Tape Mark is specified in Standard ECMA-13.

10.9 Quality of Recording for Data Interchange

Tapes shall not be employed for data interchange where the number of gaps which have been elongated due to erase instructions

either : exceeds 2 when total number of blocks written is less than or equal to 400,

or : is greater than 0,5% of the total number of blocks written in any other case.

No permanent parity errors are permissible in the data to be interchanged.

SECTION VII

356 ftpmm - NRZ1 - 246 cpmm GCR

11.1 Method of Recording

The "non return to zero mark" (NRZ1) method of recording shall be used where a ONE is represented by a change of direction of longitudinal magnetization.

11.2 Physical Recording Density

The nominal physical recording density shall be 356 ftpmm. Other physical recording densities used hereafter for specific measurements shall be:

- 178 ftpmm
- 119 ftpmm

11.3 Average Flux Transition Spacing

For the following measurements the density is 178 ftpmm. The nominal flux transition spacing at this density shall be 5,618 μm .

11.3.1 The long term average (static) flux transition spacing shall be within $\pm 4\%$ of the nominal spacing. This average shall be measured over a minimum of $5 \cdot 10^5$ successive flux transitions.

11.3.2 The short term average (dynamic) flux transition spacing, when referred to a particular flux transition spacing, is the average of that flux transition spacing and the preceding flux transition spacing. The short term average flux transition spacing shall be within $\pm 6\%$ of the long term average flux transition spacing.

In addition the rate of change of the short term average flux transition spacing shall not exceed 0,26% per flux transition spacing (see Appendix G).

11.4 Instantaneous Flux Transition Spacing

The instantaneous spacing between flux transitions may be influenced by the reading and writing processes, the pattern recorded (pulse crowding effects) and other factors.

Instantaneous spacings between flux transitions shall meet the following conditions, when tested on the Reference Read Chain (see Appendix F).

11.4.1 At the nominal maximum density of 356 ftpmm the spacing d_1 between successive flux transitions shall be between 48% and 52% of the corresponding short term average flux transition spacing determined at 178 ftpmm.

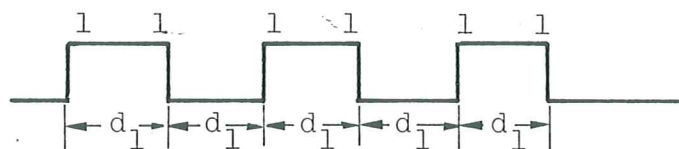

11.4.2 In a sequence of flux transitions defined by bit pattern 1110011100 the centre flux transition of each group of 3 ONEs is called reference flux transition. The average displacement of the spacing of the flux transitions on either side of a reference transition, from that reference transition, shall be not more than $\pm 28\%$ from the average spacing of flux transitions at 356 ftpmm.

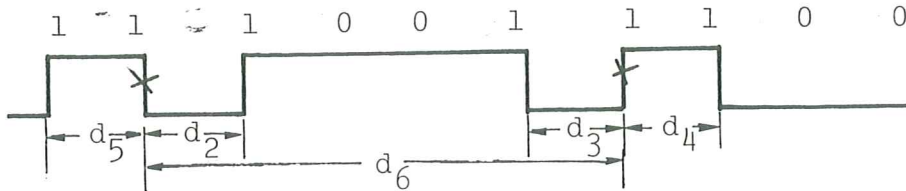

x denotes a reference flux transition

$$1,28 d_1 \geq \text{average } d_5 \geq 0,72 d_1$$

$$1,28 d_1 \geq \text{average } d_2 \geq 0,72 d_1$$

$$1,28 d_1 \geq \text{average } d_3 \geq 0,72 d_1$$

$$1,28 d_1 \geq \text{average } d_4 \geq 0,72 d_1$$

The tolerances of long term average spacing and short term average spacing (6.3.1 and 6.3.2) are included in this deviation.

The average spacing d_6 between consecutive reference flux transitions in a sequence defined by bit pattern 1110011100 and the calculated spacing $5 d_1$ of six flux transitions at the nominal maximum density of 356 ftpmm shall not differ by more than 6% of d_1 .

$$5,06 d_1 \geq \text{average } d_6 \geq 4,94 d_1$$

11.5 Skew

No flux transition shall be displaced by more than 16,86 μm from any other flux transition in the same row. This displacement shall be measured as the distance between perpendiculars to the reference edge through the said flux transitions.

11.6 Signal Amplitude

11.6.1 Standard Reference Amplitude

The Standard Reference Amplitude is the average peak-to-peak signal amplitude derived from the Signal Amplitude Reference Tape on the qualified measurement system at the density of 356 ftpmm and the recording current

$$I_r = k \cdot I_f.$$

The signal amplitude shall be averaged over a minimum of 4000 flux transitions and shall be measured on the Read-Whilst-Write pass.

The reference current I_f is the current producing the Reference Field.

11.6.2 Average signal amplitude

- 11.6.2.1 The average peak-to-peak signal amplitude of the interchanged tape at 356 ftpmm shall not deviate by more than $\pm 50\%$ from the Standard Reference Amplitude.
- 11.6.2.2 The average peak-to-peak signal amplitude at 119 ftpmm shall be less than 5 times the Standard Reference Signal Amplitude.
- 11.6.2.3 Averaging shall be done over a minimum of 4000 flux transitions, which for the interchange tape may be segmented into blocks. Averaging shall be done on the First-Read pass after interchange.

11.6.3 Minimum signal amplitude

A tape to be interchanged shall contain no flux transition in more than one track since the last MARK 1 control subgroup, the base-to-peak amplitude of which is less than 15% of half the Standard Reference Amplitude.

11.7 Erasure

- 11.7.1 When erased, the rim end of the erased area of the tape shall be magnetized so that it is a North-seeking pole (see Appendix D).
- 11.7.2 The full width of the tape shall be DC erased in the direction specified in clause 11.7.1.
- 11.7.3 The tape shall be erased so that all signals, including NRZ1 at 32 ftpmm and 356 ftpmm and phase encoding at 126 ftpmm, are less than 4% of the Standard Reference Amplitude at 356 ftpmm.

11.8 Data Formatting

Prior to recording the data shall be arranged in groups completed with computed check characters (11.8.4). These data groups shall be in turn arranged in a given sequence together with groups of control characters. The so arranged data and control character groups shall then be recorded on the tape according to a specific coding scheme.

11.8.1 Data groups

- A Data Group shall be a group of 8 bytes comprising :
- in position # 1 to # 7, seven data bytes,
 - in position # 8, and ECC character.

11.8.2 Residual Group

- A Residual Group shall be a group of 8 bytes comprising :
- in position # 1 to # 6, the remaining data bytes, if any;
 - positions # 1 to # 6 not occupied by a data byte, shall be filled with a padding character (byte (00));
 - in position # 7, an Auxiliary CRC character;
 - in position # 8, an ECC character.

11.8.3 CRC Group

After the Residual Group a CRC Group shall be formed comprising :

- in position # 1: byte (00) with odd parity if the number of preceding Data Groups is even, or the CRC character if the number of preceding Data Groups is odd,
- in position # 2 to # 6, the CRC character,
- in position # 7, the Residual character,
- in position # 8, the ECC character.

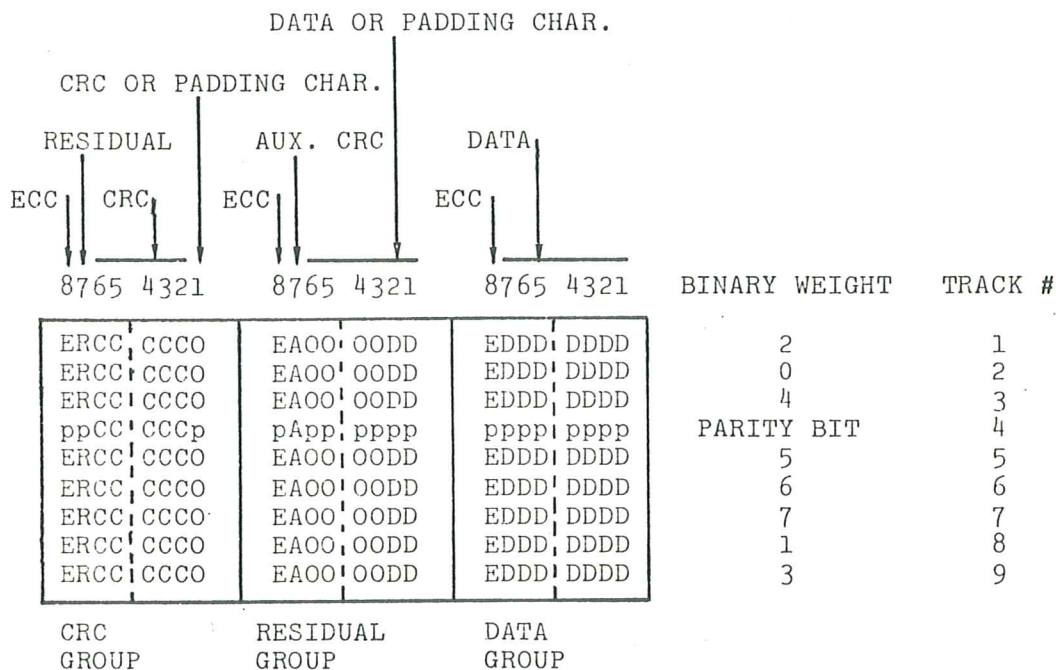

11.8.4 Check Characters

11.8.4.1 ECC character

The ECC character shall be calculated separately for each group (Data Group, Residual Group and CRC Group). In each case 7 polynomials D₁ to D₇ shall be formed, the coefficients of which shall be the 8 bits of each byte in positions # 1 to # 7. The coefficients of polynomial D₁ shall be the bits in position # 1, those of polynomial D₂ shall be the bits in position # 2, etc. The parity bit in track # 4 shall not be part of the ECC character generation.

These bits shall be allocated to the polynomials as follows :

BIT FROM TRACK #	IS COEFFICIENT OF
7	x^0
1	x^1
8	x^2
5	x^3
2	x^4
9	x^5
6	x^6
3	x^7
-	-

The ECC character shall be obtained from the coefficients of polynomial E computed as follows :

$$E = \sum (x^i D_j) \pmod{G}$$

where:

$i = 7$ to 1

$j = 1$ to 7

$G = x^0 + x^3 + x^4 + x^5 + x^8$

All arithmetic operations shall be (mod 2).

The bits of the ECC character shall be the coefficients of the resulting polynomial:

IN TRACK #	THE COEFFICIENT OF
1	x^1
2	x^4
3	x^7
4	P
5	x^3
6	x^6
7	x^0
8	x^2
9	x^5

In track # 4 an odd parity bit P shall be inserted.

11.8.4.2 Auxiliary CRC character

The Auxiliary CRC character shall be calculated from the data bytes only, considered as 9-bit bytes by inclusion of their parity bit P. Polynomials M_j shall be formed the coefficients of which shall be the bits in each data byte.

The coefficients of polynomial M_1 shall be the bits of the byte in position # 1 of the 1st Data Group, those of polynomial M_2 shall be the bits of the byte in position # 2, etc., up to M_n for n data bytes.

These bits shall be allocated to the polynomials as follows:

BIT FROM TRACK #	IS COEFFICIENT OF
1	x^0
5	x^1
8	x^2
4	x^3
2	x^4
6	x^5
3	x^6
7	x^7
9	x^8

The Auxiliary CRC character shall be obtained as follows :
An asymmetrical polynomial N shall be computed :

$$N = \sum (x^i M_j) \pmod{H}$$

where:

$$\begin{aligned} i &= n \text{ to } 1 \\ j &= 1 \text{ to } n \\ H &= x^0 + x^2 + x^6 + x^9 \end{aligned}$$

All arithmetic operations shall be (mod 2).

A polynomial $(x^0 + x^1 + x^6 + x^7 + x^8)$ shall be combined by means of an exclusive OR operation with N in the corresponding bit positions. The coefficients of the resulting polynomial shall be the bits of the Auxiliary CRC character according to the following allocation :

IN TRACK #	THE COEFFICIENT OF
1	x^0
2	x^4
3	x^6
4	x^3
5	x^1
6	x^5
7	x^7
8	x^2
9	x^8

The Auxiliary CRC character shall have odd parity. If the Auxiliary CRC character obtained has even parity, the bit in track # 4 shall be inverted to obtain odd parity.

11.8.4.3 CRC Character

The CRC character shall be calculated from all the previous characters (data, padding characters, auxiliary CRC, and of the padding character, if any, in position # 1 of the CRC group) considered as 9-bit bytes by inclusion of their parity bit, but excluding all ECC characters in position # 8 of the Data Groups and of the Residual Group. Polynomials M_j shall be formed, the coefficients of which are the bits in each byte. The coefficients of polynomial M_1 shall be the bits of the byte in position # 1 of the 1st Data Group, those of polynomial M_2 shall be the bits of the byte in position # 2, etc., up to M_n for the n characters to be considered.

These bits shall be allocated to the polynomials as follows :

BIT FROM TRACK #	IS COEFFICIENT OF
4	x^0
7	x^1
6	x^2
5	x^3
3	x^4
9	x^5
1	x^6
8	x^7
2	x^8

The CRC character shall be obtained as follows. A polynomial C shall be computed :

$$C = \sum (x^i M_j) \pmod{K}$$

where:

$$\begin{aligned}
 i &= n \text{ to } 1 \\
 j &= 1 \text{ to } n \\
 K &= x^0 + x^3 + x^4 + x^5 + x^6 + x^9
 \end{aligned}$$

All arithmetic operations shall be (mod 2).

A polynomial $(x^0 + x^1 + x^2 + x^4 + x^6 + x^7 + x^8)$ shall be combined by means of an exclusive OR operation with C in the corresponding bit positions. The coefficient of the resulting polynomial shall be the bits of the CRC character according to the following allocation:

IN TRACK #	THE COEFFICIENT OF
1	x^6
2	x^8
3	x^4
4	x^0
5	x^3
6	x^2
7	x^1
8	x^7
9	x^5

11.8.4.4 Residual Character

The Residual Character shall be obtained from the number n of data bytes.

$$R_1 = n \pmod{7}$$

$$R_2 = n-1 \pmod{32}$$

With R_1 and R_2 expressed in binary notation, the bits of the Residual Character shall be :

$$R_1 = \text{bits } 0 \ 1 \ 2$$

$$R_2 = \text{bits } 3 \ 4 \ 5 \ 6 \ 7$$

These bits shall be allocated to tracks as follows :

BIT	IN TRACK #
0	5
1	6
2	7
3	2
4	8
5	1
6	9
7	3

In track # 4 an odd parity bit shall be inserted.

11.9 RECORDING OF DATA BYTES ON TAPE

The data prepared as described above shall be recorded on the tape as follows:

Each 4 consecutive positions on each track shall be translated according to the following table and recorded on the tape as 5 consecutive bits.

0000	→	11001
0001	→	11011
0010	→	10010
0011	→	10011
0100	→	11101
0101	→	10101
0110	→	10110
0111	→	10111
1000	→	11010
1001	→	01001
1010	→	01010
1011	→	01011
1100	→	11110
1101	→	01101
1110	→	01110
1111	→	01111

After recording, the different fields on the tape are called:

Data Storage Group

Residual Storage Group

CRC Storage Group

A row of 9 recorded bits across the tape is called a Storage row

A block of data is called a Storage block.

11.10 CONTROL SUB-GROUPS

With the exception of TERM 2, a control sub-group shall be a group of five positions having the same bit pattern in each track. There shall be 8 different control sub-groups.

11.10.1 Terminator Control Sub-groups (TERM)

A TERM 1 shall be a (10101) control sub-group. It shall be placed at the BOT end of each block.

A TERM 2 shall be a (1010X) control sub-group, where X represents a bit which restores for each track the magnetic remanence to the erase state (5.15). It shall be placed at the EOT end of each block.

11.10.2 Second Control Sub-groups (SEC)

A SEC 1 shall be a (01111) control sub-group. It shall be placed at the BOT end of each block.

A SEC 2 shall be a (11110) control sub-group. It shall be placed at the EOT end of each block.

11.10.3 Synchronization Control Sub-group (SYNC)

A SYNC shall be a (11111) control sub-group.

11.10.4 MARK 1 Control Sub-group

A MARK 1 shall be a (00111) control sub-group.

11.10.5 MARK 2 Control Sub-group

A MARK 2 shall be a (11100) control sub-group.

11.10.6 END MARK Sub-group

An END MARK shall be a (11111) control sub-group. It has the same pattern as a SYNC sub-group, but not the same function.

11.11 STORAGE BLOCK

11.11.1 Data Portion

The data portion of a Storage Block shall be at least 18 data bytes and at most 8192 data bytes. Blocks comprising more than 8192 data bytes can be used only by specific agreement between the interchanging parties.

11.11.2 Structure of a Block

The structure of a block shall depend on the number of Data Storage groups. The general structure shall be:

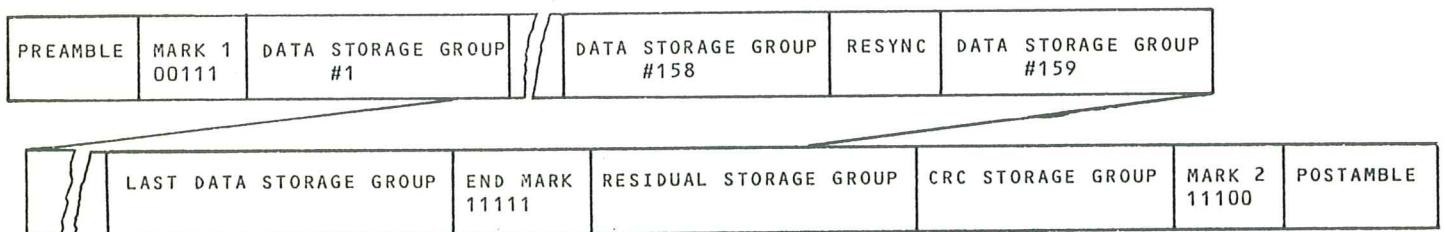

11.11.2.1 Preamble

The structure of the Preamble shall be:

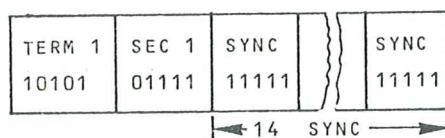

11.11.2.2 Mark 1

A Mark 1 control sub-group shall follow the Preamble.

11.11.2.3 Re-synchronization Burst (RESYNC)

The structure of a RESYNC Burst shall be:

MARK 2	SYNC	SYNC	MARK 1
11100	11111	11111	00111

11.11.2.4 Number N of Data Storage Groups

$N \leq 158$

In this case the last Data Storage Group is followed by an END MARK control sub-group preceding the Residual Storage Group and there is no RESYNC Burst.

$N > 158$

In this case a RESYNC Burst is inserted after every 158 Data Storage Groups and an END MARK control sub-group is inserted after the last Data Storage Group. However, if N is a multiple of 158, there is no RESYNC Burst after the last Data Storage Group but only an END MARK control sub-group.

NOTE 8

When a RESYNC Burst is present, a MARK 1 and a MARK 2 control sub-group are bracketing all sequences of 158 Data Storage Groups.

11.11.2.5 Residual Storage Group and CRC Storage Group

The Residual Storage Group and the CRC Storage Group shall follow the END MARK inserted after the last Data Storage Group.

11.11.2.6 MARK 2

A MARK 2 control sub-group shall follow the CRC Storage Group and precede the Postamble.

11.11.2.7 Postamble

The structure of the Postamble shall be:

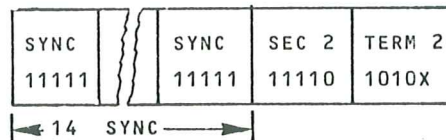

11.11.3 Inter-block gap

Between storage blocks there shall be an Inter-block gap:

Nominal length : 7,6 mm

Minimum length : 7,1 mm

Maximum length : 4,6 m

The tape shall be erased in these gaps according to 11.7.

11.11.4 Elongated interblock gap

An elongated interblock gap shall be a gap which has been elongated due to an erase instruction.

11.11.5 Maximum Data Density

Due to the insertion of an ECC character after each 7th data byte, to the 4-bit to 5-bit conversion and to the RESYNC Burst after each 158th Data Storage group, the maximum density of recorded data is necessarily less than the maximum physical recording density of 356 per mm.

$$356 \cdot \frac{7}{8} \cdot \frac{4}{5} \cdot \frac{158}{160} = 246 \text{ characters stored per mm.}$$

11.12 TAPE FORMAT

The beginning of the tape before the first Preamble shall present four typical areas defined hereafter.

11.12.1 Density Identification Area (ID Burst)

The ID Burst shall be an area characterized by bit pattern (100100100...) in track # 6, i.e. by a density of 119 ftpmm \pm 12 ftpmm and by erasure in all other tracks. It shall begin at least 43 mm before the trailing edge of the BOT marker and continue past this edge.

11.12.2 Gap G1

The ID Burst shall be followed by an undefined gap G1 of at most 86,36 mm.

11.12.3 Automatic Read Amplification Area (ARA Area)

The ARA Area shall comprise an ARA Level Burst followed by an ARA identification burst.

11.12.3.1 ARA Level Burst

The ARA Level Burst which follows gap G1 shall be characterized by bit pattern (1111...) recorded in all tracks, i.e. by a density of 356 ftpmm. It shall begin at least 38 mm and at most 109 mm after the leading edge of the BOT marker. It shall end at least 241 mm and at most 292 mm after this edge. Accordingly its minimum length is 132 mm and its maximum length is 254 mm.

11.12.3.2 Automatic Read Amplification Identification (ARA ID Burst)

The last part of the ARA Area shall be the ARA ID Burst of 50 mm \pm 10 mm. It shall be characterized by:

- erasure in tracks #1, #4 and #7,
- recording of bit pattern (1111..) in all other tracks.

A length of at least 6,35 mm shall be error-free in all tracks (see 11.13.3).

11.12.4 Gap G2

Between the end of the ARA ID Burst and the first Storage Block there shall be a gap G2 of the same length as an Interblock gap.

11.12.5 Tape Mark

The Tape Mark shall be a control block characterized by:

- erasure in tracks #3, #6 and #9,
- bit pattern (1111...) over 250 to 400 transitions in all other tracks.

A Tape Mark shall be separated from blocks by an Interblock gap.

The use of Tape Mark is specified in Standard ECMA-13.

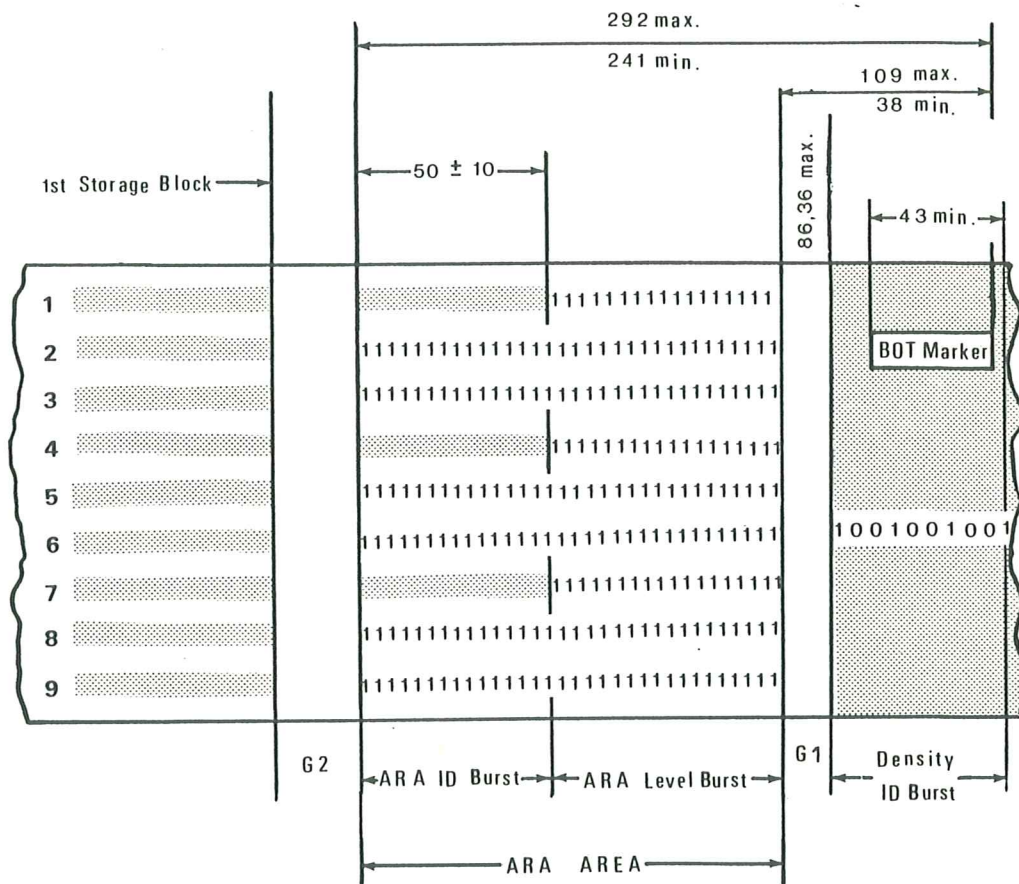

11.13 INTERCHANGE CRITERIA

11.13.1 Definitions

11.13.1.1 Single error

A single error shall occur on a track when missing pulse (see 5.16.1) or an extra pulse (see 5.16.2) is detected on this track.

11.13.1.2 Error-free track

A track shall be error-free when it presents no single error.

11.13.2 Correctable errors

In a tape offered for interchange there shall not be, between a MARK 1 Sub-group and MARK 2 Sub-group, more than two tracks in which errors occur.

11.13.3 Acceptable criteria

Tapes with errors in excess of the requirement of 11.13.2 do not conform with this Standard. However, they may be acceptable for interchange between parties after agreement between those parties.

SECTION VIII

APPENDICES

- A : Transportation
- B : Comments on Reels (Sec. III)
- C : CRC Register (Sec. V)
- D : Determination of the Erase Magnetic Field Direction (Sec. V, VI, VII)
- E : Procedure and Instrumentation for Measuring Flux Transition Spacing (Sec. VI)
- F : Procedure and Instrumentation for Measuring Flux Transition Spacing (Sec. VII)
- G : Differences between this 2nd Edition and the 1st Edition dated January 1980

APPENDIX A

TRANSPORTATION

A.1 Environment

It is recommended that during transportation the tapes are kept within the following conditions:

Temperature : 5 °C to 32 °C

RH : 20% to 80%

A.2 Hazards

Transportation of data bearing magnetic tape involves three basic potential hazards:

- A.2.1 Impact loads and vibrations: which could cause damage to the reel, or movement within the tape pack, with consequential loss of wind tension.

Recommendation

- A.2.1.1 The free end of the tape should be secured to prevent any tendency to unwind.
- A.2.1.2 The use of a rigid container free from dust or other extraneous matter.
- A.2.1.3 The container(s) to be fitted into a rigid box containing adequate shock-absorbant material.
- A.2.1.4 The final box must have clean interior and a lid construction that provides sufficient sealing to prevent the ingress of dirt and water.
- A.2.1.5 The orientation of the reels within the final box should be such that their axes are horizontal.
- A.2.1.6 The final box should be clearly marked to indicate its correct orientation.

- A.2.2 Extremes of temperature and humidity: which could set up stresses within the body of the tape.

Recommendation

- A.2.2.1 Extreme changes in temperature and humidity should be avoided wherever possible.

A.2.2.2 Whenever a tape is received it should be conditioned in the operating environment for a period of at least 12 hours, depending upon the type of transportation used.

A.2.3 Effects of straymagnetic fields: which would possibly cause corruption of data.

Recommendation

A nominal spacing of not less than 80 mm should exist between the magnetic tape reel and the outer surface of the final container in which case it is considered that the risk of corruption will be negligible.

APPENDIX B

COMMENTS ON REELS

The reels defined in former standards dealing with 12,7 mm, 9-track magnetic tapes (ECMA-12, ECMA-36) differ in certain aspects from the reels defined in this Standard. These are:

- i) $B = 266,70 \text{ mm} \pm 0,51 \text{ mm}$
- ii) R_i and R_o were not specified.
- iii) The maximum distance K_f (equal to $[M + K_f]$ in ECMA-12 and ECMA-36) between the front flange outside surface and the mounting surface was 21,54 mm at all points and did not need to be reduced to 19,12 mm over the distance T as now specified by S_f .
- iv) The maximum distance K_r between the rear flange outside surface and the mounting surface was 2,03 mm at all points and did not need to be reduced to 0,76 mm over the distance T as now specified by S_r .

The new requirements are to enable self-loading cartridges to be used and are within the requirements of the former standards. Reels according to these standards cannot be used together with self-loading cartridges.

APPENDIX C

CYCLIC REDUNDANCY CHECK CHARACTER

C.1 Generation

Consider the contents of a 9-position register to be C_1 to C_9 with the following track assignments:

Register position	C_1	C_2	C_3	C_4	C_5	C_6	C_7	C_8	C_9
Track #	4	7	6	5	3	9	1	8	2

The CRC character shall be derived as follows:

- i) all data rows in the block are added to the CRC register without carry (exclusive OR);
- ii) between additions, the CRC register is shifted by one position: C_1 to C_2 etc., and C_9 to C_1 ;
- iii) if shifting will cause C_1 to contain ONE, then the bits being shifted into positions C_4 , C_5 , C_6 and C_7 are inverted;
- iv) after the bits of last data character have been added, if shifting will cause C_1 to become ONE, then the CRC register is shifted once more in accordance with i) and iii);
- v) to write the CRC character on tape, the contents of all positions except C_4 and C_6 are inverted. The parity of the CRC character will be odd if the number of data characters within the block is even, and even if the number of data characters within the block is odd. The CRC character may contain only ZEROS, in which case the number of data characters is odd.

C.2 CRC Register

When reading, the CRC register is controlled as it was for writing until the last data character has been added and the final shift made. The CRC character on tape is then added to the register.

To test for an error, the register is read out inverting all positions except C_4 and C_6 . If the masked output of any position is a ONE, an error has been detected.

To determine whether the errors occurred in a single track, and if so, which, an error pattern (EP) must be generated. This pattern must then be compared with the error indicating pattern in the CRC register.

Consider the contents of a 9-position EP register to be E_1 to E_9 corresponding to C_1 to C_9 of the CRC register. The error pattern may be constructed as follows:

- a) whenever a character parity error is detected for a data character or for the CRC character, a ONE is added without carry to E_9 (exclusive OR);
- b) between the reading of characters, the EP register is shifted by one position: E_1 to E_2 etc., and E_9 to E_1 ;
- c) if shifting will cause E_1 to contain ONE, then the bits being shifted into positions E_4 , E_5 , E_6 and E_7 are inverted.

To determine the track in error, a series of comparisons is made between the contents of the EP register and the CRC register. The CRC register, read out through the mask which inverts all positions except C_4 and C_6 is compared with the EP register.

The first comparison is direct: E_1 to C_1 , E_2 to C_2 , etc. If all positions match, the error was in the track associated with C_9 (track # 2).

The CRC register is then shifted once, according to ii) and iii) above between each comparison. This is continued until a match is obtained or until a maximum of nine comparisons (eight shifts) have been made. The track in error corresponds to C_9 through C_1 for a match on the first through ninth comparison respectively.

There are two conditions for the final contents of the CRC register for which an uncorrectable error has been detected and for which an incorrect track-in-error indication will be obtained if comparisons are made. These are as follows:

- a) C_1 to C_9 contain ZEROs
- b) C_4 to C_6 contain ZEROs, all other positions containing ONES (the read-out mask).

If a track-in-error indication is obtained, the error block may be re-read. The output of the track in error is then inverted whenever the parity of a character is incorrect.

APPENDIX D

DETERMINATION OF THE ERASE MAGNETIC FIELD DIRECTION

The beginning of a correctly erased tape must exhibit a North-seeking pole. When the point of a compass needle which normally indicates North is placed in close proximity to the rim end of a correctly erased tape, the needle will be deflected away from the tape.

A section of the erased area of the tape shall be cut in such a way that the end toward the rim end of the tape is identifiable. This end of the cut section is brought as close as possible to the compass needle and the presence or absence of deflection of the needle away from the tape is determined.

APPENDIX E

PROCEDURE AND INSTRUMENTATION FOR MEASURING FLUX TRANSITION SPACING

E.1 FORMAT

The equipment used for recording tapes (see tape transport E.2.1) at a data density of 63 cpmm shall record on the magnetic tape to be used for interchange using the format described in the following six sub-clauses.

E.1.1 Worst case patterns

<u>Test pattern #</u>	<u>Test pattern</u>
1.	11111111
2.	00000000
3.	11110000
4.	00001111
5.	00010000
6.	11101111
7.	00010111
8.	11101000
9.	11001100
10.	10101010
11.	10101111
12.	11110101
13.	01010000
14.	00001010

These test patterns are to be used in the following sequence:
1,1,1,3,2,2,2,4,6,3,4,4,6,6,3,5,5,5,7,8,7,8,7,8,9,9,9,10,10,10,12,11,14,13.

This sequence is to be repeated 3 times to constitute each tape block.

E.1.2 Writing

The tape shall be written in any start-stop mode of operation compatible with system operation.

E.1.3 Block format

Two block formats shall be generated. Each block format shall be repeated 800 times together with interblock gaps. All tracks shall be recorded simultaneously, each to meet the format specified as follows:

E.1.3.1 Format A

E.1.3.1.1 Each of tracks #1, #2, #4, #6, #8 and #9 shall contain preamble, the 102 8-bit test patterns defined in E.1.1, and postamble.

E.1.3.1.2 Track #5 shall contain the preamble, 816 ONEs, and postamble. This track is written to provide a record of speed variations.

E.1.3.1.3 Each of tracks #3 and #7 shall contain preamble, the sequence of test pattern #1 followed by test pattern #2 to be recorded 51 times, and postamble. These tracks are written to provide a means for locating any test pattern in a block defined in E.1.3.1.1.

E.1.3.2 Format B

E.1.3.2.1 Each of tracks #1, #3, #5, #7, #8 and #9 shall contain preamble, the 102 8-bit test patterns defined in E.1.1 and postamble.

E.1.3.2.2 Track #4 shall contain the preamble, 816 ONEs and postamble. This track is written to provide a record of speed variations.

E.1.3.2.3 Each of tracks #2 and #6 shall contain preamble, the sequence of test pattern #1 followed by test pattern #2 to be recorded 51 times, and postamble. These tracks are written to provide a means for locating any test pattern in a block defined in E.1.3.2.1.

NOTE - On using the formats described in E.1.3.1 and E.1.3.2, odd parity is preserved in each row on recorded tape.

E.2 INSTRUMENTATION

E.2.1 Tape transport

E.2.1.1 Nominal tape speeds shall be between 0,380 m/s to 0,480 m/s $\pm 1\%$, constant speed.

E.2.1.2 The start-stop mode is not used; therefore, start-stop parameters are irrelevant.

E.2.2 Read chain

E.2.2.1 Read head

NOTE - The length of gap is defined as the dimension parallel to the tape movement.

E.2.2.1.1 Voltage output parameters are irrelevant.

E.2.2.1.2 The head mechanical dimensions should be such as to meet the requirement of Section IV of the Standard. The length of the physical read gap shall be less than 2,8 μm but greater than 1,9 μm .

E.2.2.1.3 Transfer function

E.2.2.1.3.1 Test

Test the amplitude and phase response relative to the magnetic field induced by a wire placed at right angles to the length of the gap. The position of the wire shall be such as to maximize the head output. The current in the wire shall be constant at all frequencies of the test.

E.2.2.1.3.2 Specification

In the frequency range of 6 kHz to 45 kHz, the amplitude frequency characteristic shall be within 1 dB from a + 6 dB per octave line.

E.2.2.2 Impedance match

Head to amplifier: The loading effect of the input impedance of the amplifier shall not cause the head output to change by more than + 0 dB, -0,1 dB in the range of frequencies from 0 kHz to 200 kHz.

E.2.2.3 Amplifier-differentiator

E.2.2.3.1 The frequency response of the amplifier alone shall be flat within a total variation of 0,1 dB in the frequency range of 1 kHz to 100 kHz, and not more than 3 dB down at 30 Hz and 1 MHz.

E.2.2.3.2 The frequency limiting lumped components within the amplifier-differentiator shall be designed to produce the following transfer functions. ¹⁾

E.2.2.3.2.1 Function for a 475 mm/s drive:

$$H(S) = \frac{AS}{(s + 1,0 \times 10^6)(s^2 + 1,59 \times 10^6 s + 1,2 \times 10^{12})}$$

where

A is the gain to be adjusted to produce 2 V peak-to-peak output at 126 ftpmm.

in the numerator, s produces differentiation;

in the denominator the poles are designed for 3-pole Bessel filter with a -3 dB frequency of 120 kHz and a constant delay of 2,32 us with less than 1% deviation in the frequency range from 0 kHz to 90 kHz.

E.2.2.3.2.2 Function for a 380 mm/s drive:

$$H(S) = \frac{AS}{(s + 6,61 \times 10^5)(s^2 + 1,04 \times 10^6 s + 5,25 \times 10^{11})}$$

where

A is the gain to be adjusted to produce 2 V peak-to-peak output at 126 ftpmm

in the numerator, s produces differentiation:

in the denominator the poles are designated for a 3-pole Bessel filter with a -3 dB frequency of 80 kHz and a constant delay of 3,48 us, with less than 1% deviation in the frequency range from 0 kHz to 60 kHz.

¹⁾ The symbol S represents the complex frequency variable arising in the Laplace Transform. The symbol ρ is also often used.

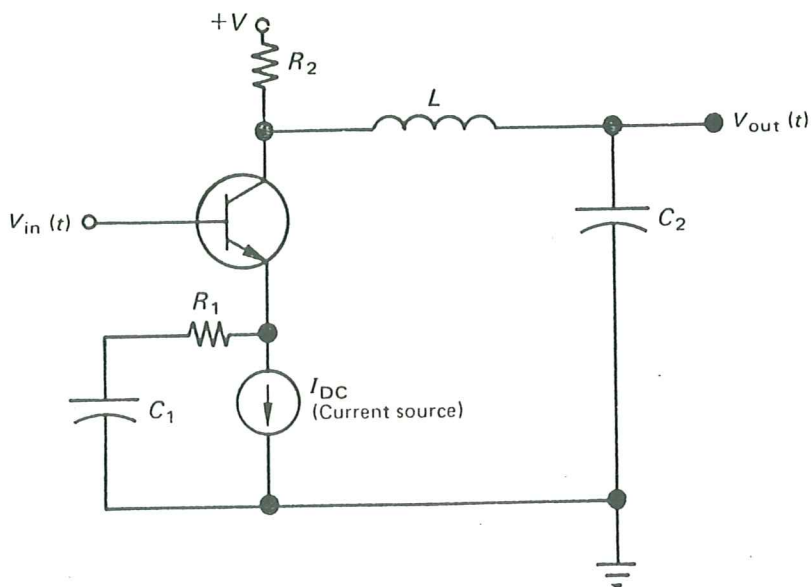

FIGURE E.1 - Example of amplifier-differentiator

E.2.2.3.3 Generalized equation for a 3-pole filter with differentiation (see figure E.1).

$$\frac{V_{out}(s)}{V_{in}(s)} = \frac{As}{(s+a)(s^2+bs+c)}$$

where

$$V_{out}(s) = L[V_{out}(t)]$$

$$V_{in}(s) = L[V_{in}(t)]$$

Solution to the equation:

$$A = R_2/R_1LC_2$$

$$a = 1/R_1C_1$$

$$b = R_2/L$$

$$c = 1/LC_2$$

On selecting the gain A, the value of one of the passive components in the above circuit, and the proper values for a, b, and c from either E.2.2.3.2.1 or E.2.2.3.2.2, the solution for the other passive components is determinate. The bias current "IDC" is selected for convenience and does not affect the transfer function.

E.2.2.4 Amplifier-limiter

The gain of the limiter shall be such as to produce at the output a minimum slope of 0,025 V/ns with a 30 kHz, 2 V peak-to-peak sinewave. With the same input, the limiter shall introduce less than a 20 ns asymmetry.

E.2.2.5 Overall response head gap to output of amplifier-limiter

E.2.2.5.1 Equipment required

A sinewave generator able to generate frequencies in the range of 5 kHz to 50 kHz. The harmonic distortion content of the generator's sinewave output shall be such as to produce less than 1% harmonic distortion of the sinewave at the output of the amplifier-differentiator.

A time-interval counter able to measure 5 us with a resolution of 10 ns.

NOTE - The required resolution may be obtained by any convenient means: for example, an average of 100 or more independent measurements, each of 100 ns resolution, may be used.

E.2.2.5.2 Equipment Setup

The setup of the equipment is as shown in figure E.2.

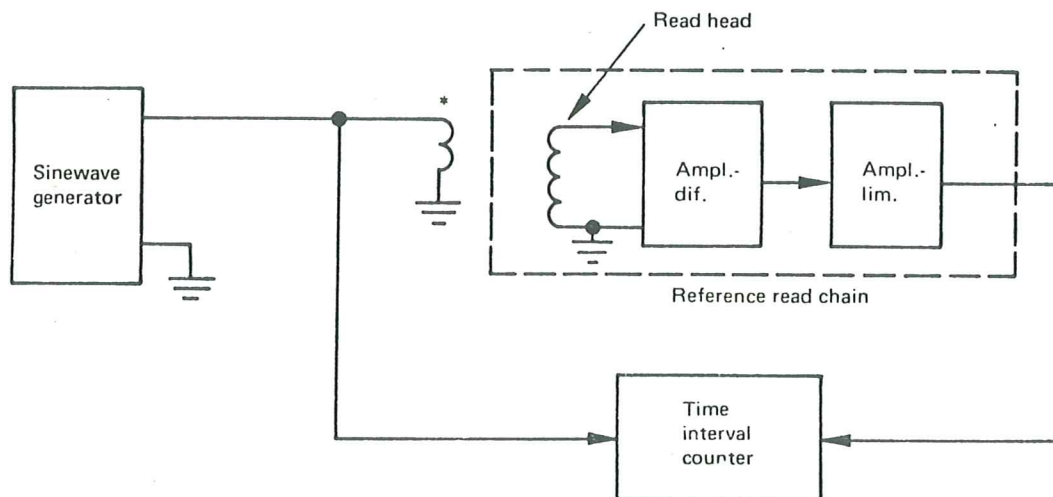

* Wire placed at right angles to the length of the gap as defined in § 2.2.1.3.1.

FIGURE E.2 - Calibration equipment setup

E.2.2.5.3 Experiment Description

With the generator output set to give 2 V peak-to-peak at the output amplifier-differentiator at each test frequency, vary the frequency of the generator from 6 kHz to 45 kHz. At each test frequency, measure the time displacement between the positive zero crossover of the current sinewave flowing through the gap wire and the positive transition at the output of the amplifier-limiter.

E.2.2.5.4 Specification for the calibration of the read chain

E.2.2.5.4.1 For the filter in E.2.2.3.2.1 at 475 mm/s the time delay between the positive zero crossover of the current sinewave flowing through the gap-wire and the positive transition at the output of the amplifier-limiter shall not vary by more than $\pm 400 \times \frac{7500}{f}$ ns*,

where f is the test frequency, with respect to the time delay measured at 15 kHz, in the range of frequencies from 7,5 kHz to 45 kHz.

E.2.2.5.4.2 For the filter in E.2.2.3.2.2 at 380 mm/s the time delay between the positive zero crossover of the current sinewave flowing through the gap-wire and the positive transition at the output of the amplifier-limiter shall not vary by more than $\pm 500 \times \frac{6000}{f}$ ns**,

where f is the test frequency, with respect to the time delay measured at 12 kHz, in the range of frequencies from 6 kHz to 36 kHz.

* This value is equivalent to ± 1 degree at 7,5 kHz.

** This value is equivalent to ± 1 degree at 6 kHz.

E.3 PROCEDURE FOR MEASURING FLUX TRANSITION SPACING

E.3.1 Equipment required

E.3.1.1 The tape generated meeting the conditions specified in E.1.

E.3.1.2 The tape drive and 3 read chains as specified in E.2.

E.3.1.3 Time-measuring equipment suitable for measuring the time between flux transitions.

E.3.2 A possible method of measurement

E.3.2.1 Assumptions

For the purposes of this equipment, the time-measuring equipment shall be a triple-trace oscilloscope, and the tape format shall be as specified in E.1.3.1.

E.3.2.2 Setup

Arrange the equipment as shown in figure E.3.

E.3.2.2.1 The flux transition spacings shall be measured as the time between the transitions present at the output of the amplifier-limiter of track # 4.

E.3.2.2.2 The short-term average bit flux transition spacing as defined in clause 10.3.2 of the Standard shall be measured at the output of the amplifier-limiter of track # 5 simultaneously with the measurement on E.3.2.2.1.

E.3.2.2.3 Track # 3 is a track written in such a way as to provide a means for locating the test pattern to be analysed in E.3.2.2.1.

E.3.2.3 Measurement

E.3.2.3.1 Data

Figure E.4 shows a picture of the oscilloscope as it might look when analysing the fourth pattern (test pattern # 3) as specified in the sequence in E.1.1.

E.3.2.3.2 Measurements

Measure the time for A, B₁, B₂, C₁, C₂, C₃ and C₄ on track #4, and T_A, T_B, T_{C_{1,2}} and T_{C_{3,4}} on track # 5.

E.3.2.3.3 Requirements

As specified in clause 10.4 of the Standard, the patterns in figure E.4 shall meet all of the following requirements:

$$85 \leq \frac{A}{\frac{T_A}{4}} \times 100 = \frac{400 A}{T_A} \leq 108$$

$$93 \leq \frac{400 B_1}{T_B} \text{ and } \frac{400 B_2}{T_B} \leq 112$$

$$44 \leq \frac{400 C_1}{T_{C_{1,2}}} \text{ and } \frac{400 C_2}{T_{C_{1,2}}} \text{ and } \frac{400 C_3}{T_{C_{3,4}}} \text{ and } \frac{400 C_4}{T_{C_{3,4}}} \leq 62$$

E.3.2.4 Requirements

The measurement sequence specified in E.3.2.3 shall be repeated on every data pattern recorded on the tape. Each and every data pattern shall meet the requirements of clause 10.4 of the Standard.

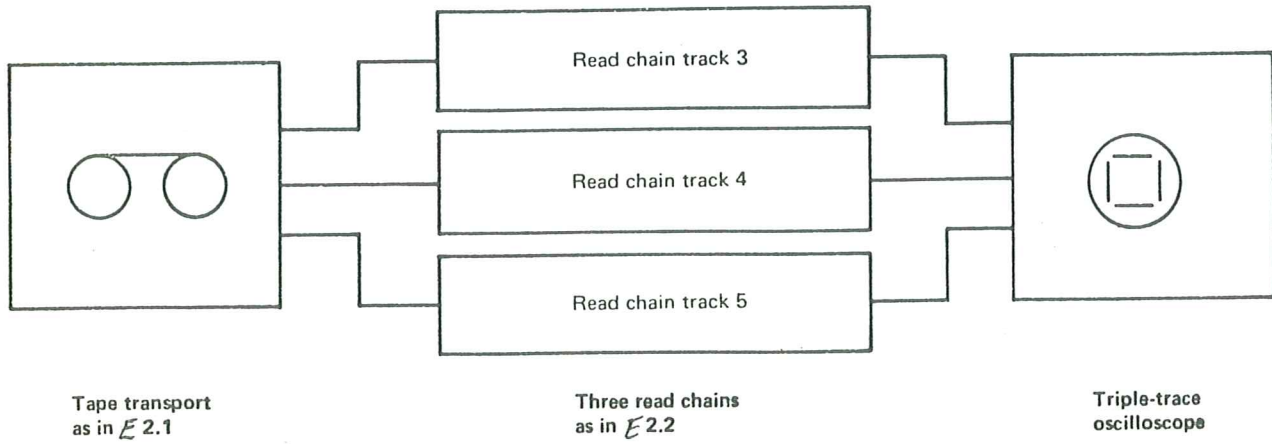

FIGURE E.3 - Measurement equipment setup

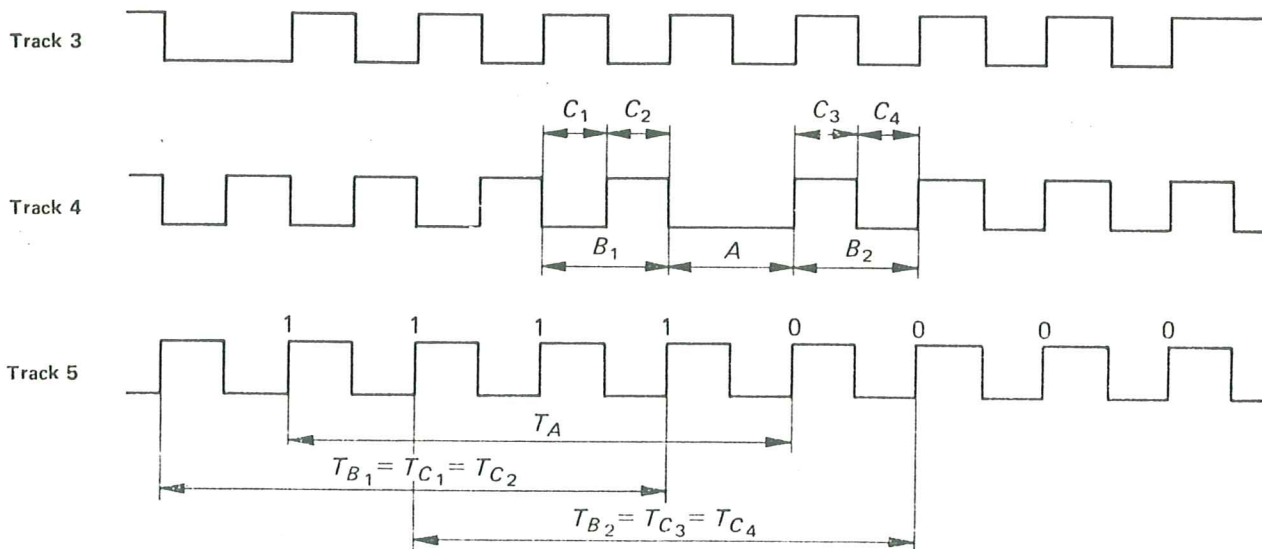

FIGURE E.4 - Test pattern display

APPENDIX F

PROCEDURE AND EQUIPMENT FOR MEASURING FLUX
TRANSITION SPACING

F.1 GENERAL

The equipment normally used for recording interchange tapes (tape transport) at 245 cpmm shall be used for recording the tape under test.

The tape shall be written in any start-stop mode of operation compatible with system operation.

The full length of tape of 732 m shall be recorded with the following test patterns.

Track #	Test Pattern
9	1 0 0 1 1 1 0 0 1 1
8	1 1 0 0 1 1 1 0 0 1
7	1 0 0 1 1 1 0 0 1 1
6	1 1 0 0 1 1 1 0 0 1
5	1 0 1 0 1 0 1 0 1 0
4	1 1 0 0 1 1 1 0 0 1
3	1 0 0 1 1 1 0 0 1 1
2	1 1 0 0 1 1 1 0 0 1
1	0 1 0 0 1 1 0 1 1 0

The tape under test shall be read through the instrumentation chain.

Measurement samples shall be made once on each block for a minimum of 100 blocks.

Average measurements associated with 11.4.1 of the Standard shall be made in the stable part of the preamble that is closest to the data. At this point the density is 356 ftpmm.

F.2 READ EQUIPMENT

F.2.1 Tape Transport

The tape speed shall be 1,52 m/s \pm 1%. As the start/stop mode is not used, start/stop parameters are irrelevant.

F.2.2 Head

There are no absolute output voltage requirements. However, the output voltage shall be sufficient to avoid problems due to a low signal-to-noise ratio.

The gap shall be less than 1,143 um.

The transfer function of the head shall be such that:

- The amplitude and phase response relative to the magnetic field induced can be tested by means of a wire placed parallel and adjacent to the gap. The position of the wire must be such as to maximize the head output.
- In the frequency range of 27 kHz to 540 kHz, the magnitude characteristic shall be within 1 dB from a +6 dB/octave line.

The loading effect of the input impedance of the amplifier-differentiator shall not cause the head output to change by more than +0 dB, -0,1 dB in the frequency range from dc to 540 kHz.

F.2.3 Amplifier-Differentiator

The frequency response of the amplifier without the frequency-limiting lumped components shall be flat within +0 dB, -1 dB in the frequency range from 13,5 kHz to 1,08 MHz.

The frequency-limiting lumped components within the amplifier-differentiator shall be designed to produce the following transfer function:

$$H(S) = \frac{A \cdot S}{\left(\frac{S}{\omega_0}\right)^3 + 6\left(\frac{S}{\omega_0}\right)^2 + 15\frac{S}{\omega_0} + 15}$$

A is the gain to be adjusted to produce at the output of the amplifier-limiter the specified rise and fall times. In the numerator, S produces differentiation. In the denominator, the poles are designed for a 3-pole Bessel filter. At 1,52 m/s, $\omega_0 = 2 \pi 540$ krad/s.

F.2.4 Amplifier-Limiter

The gain of the amplifier-limiter together with the head and amplifier-differentiator shall be such as to produce the waveform shown below.

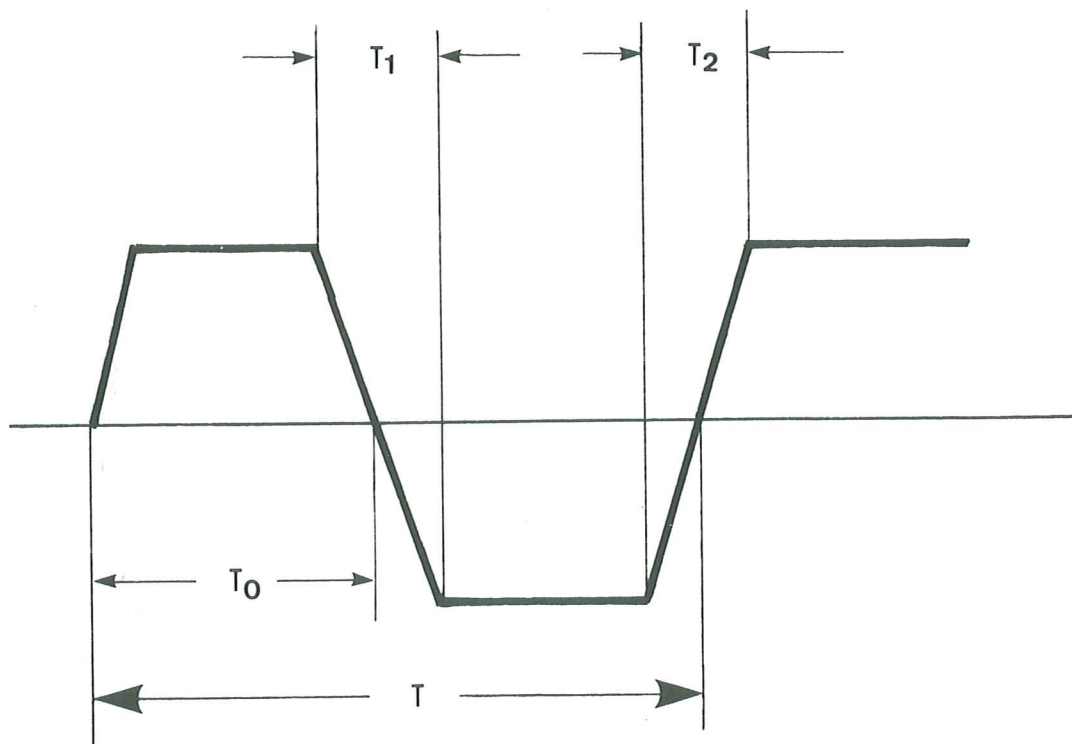

where:

T is the period equal to 3,6865 μ s (356 ftpmm at 1,52 m/s)

T_0 is the transition time and lies within the range of 0,4975 T to 0,5025 T

T_1 and T_2 are the rise and fall times and have a maximum value of 18 ns.

F.2.5 Sinewave Generator

The sinewave generator shall be able to generate frequencies in the range from 27 kHz to 540 kHz. The harmonic distortion content of the generator's sinewave output shall be less than 1% at the output of the amplifier-differentiator.

F.2.6 Time Interval Counter

The time interval counter shall be able to measure 10 μ s with at least 5 ns resolution.

F.3 PROCEDURE AND CALIBRATION

F.3.1 Procedure

The generator's amplitude output is set so as to produce a signal at the head equivalent to that observed when reading a tape recorded at 356 ftpmm. With this amplitude setting the frequency is varied from 27 kHz to 540 kHz. At each test frequency the time displacement between the positive zero crossover of the current sinewave flowing

through the gap wire and the positive transition at the output of the amplifier-limiter is measured.

F.3.2 Calibration of the Read Chain

The time delay between the positive zero crossover of the current sinewave flowing through the gap wire and the positive transition at the output of the amplifier-limiter shall not vary more than

$$\pm \left(\frac{100 \cdot 27000}{f} \right) \text{ ns} = \pm \frac{1}{f} \cdot 2,7 \text{ ms}$$

with respect to the time delay measured at 27 kHz. The test frequency f shall be in the range of 27 kHz to 540 kHz.

The value $(1/f \cdot 2,7)$ ms is equivalent to 1^0 .

F.4 SET-UP

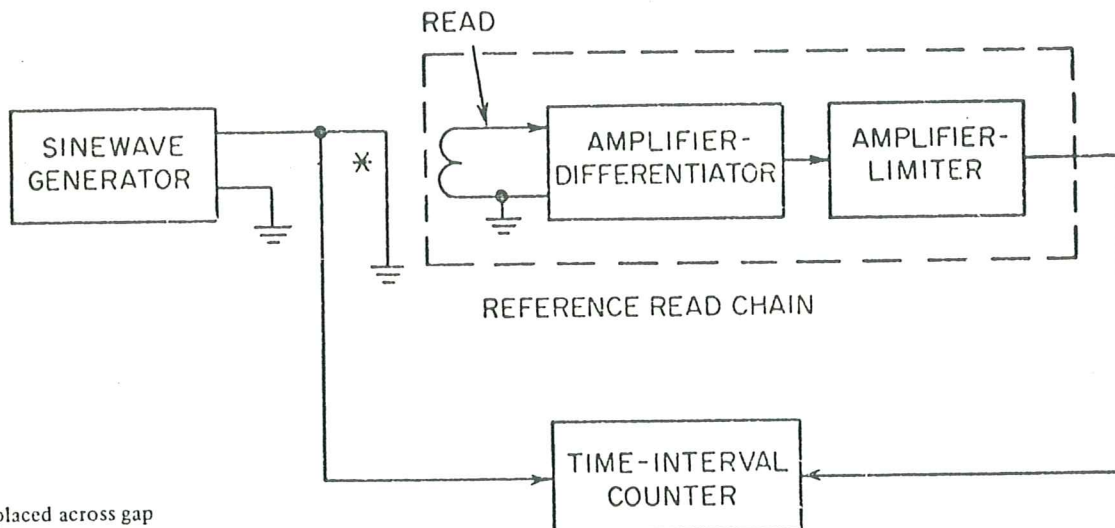

*Wire placed across gap

APPENDIX G

DIFFERENCES BETWEEN THE FIRST EDITION OF ECMA-62
AND THIS SECOND EDITION

G.1 GENERAL

With the adoption of the revision of ISO 1864 and the final approval of ISO 1863, ISO 3788 and ISO 5652, it has been found necessary to amend ECMA-62 accordingly.

G.2 ENVIRONMENT

G.2.1 Operating Environment

The wet bulb temperature is now 27 °C (instead of 26 °C). a note of caution has been added.

G.2.2 Storage Environment

The wet bulb temperatures are now 27 °C and 26 °C (instead of 26 °C and 25 °C respectively).

G.3 MATERIAL

A sentence covering tapes with a coating on the rear surface has been added.

G.4 RECORDING CURRENT AND AVERAGE SIGNAL AMPLITUDE

The maximum value of the ratio k for the density of 356 ftpmm has been reduced to 1,45 (from 1,5). The Average Signal Amplitude at this density must be within ± 40% of the Standard Reference Amplitude (instead of - 30% and + 25%). A note of caution concerning "tilt" has been added.

G.5 REAR SURFACE REFLECTIVITY

This value has been raised from 25% to 30%.

G.6 DYNAMIC FRICTIONAL CHARACTERISTICS

This clause is new.

G.7 REEL CHARACTERISTICS

The text has been edited instead of referring to a table.

New value

T = 4,00 mm min.

New parameters

$P = 0,90 \text{ mm max.}$

$\beta = 45^{\circ} \pm 15'$

New figure

Section Z-Z

G.8 SECTION V

A figure summarizing the tape format has been added.

G.9 SECTION VI

A figure summarizing the tape format has been added.

G.10 SECTION VII

G.10.1 Skew

New definition.

G.10.2 ARA Area

Wording adapted to that of ISO 5652.

G.10.3 Correctable errors

Wording adapted to that of ISO 5652.

