

M2351A/AF  
**Mini-Disk Drive**  
**Customer Engineering Manual**

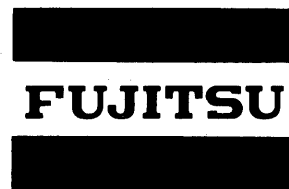

REVISION RECORD		
Edition	Date Published	Revised contents
A	Mar. 1, 1981	First Edition
B	Aug. 10, 1982	Second Edition
C	Jan., 1983	Third Edition
D	Apr., 1983	Fourth Edition
D1	Aug., 1983	Fifth Edition
E	Mar., 1984	1-1, 1-17, 2-8, 3-8, 3-19, 7-15, 8-6, 8-7 - 16, 13-6, 13-7, 17-12, 17-21, 17-27, 17-30, 17-33, 17-36, 17-38, 17-39, 17-43, 17-45, 17-48, 17-49, 17-68, 17-75 - 17-81, 17-83, 17-88, 17-90, 17-91
E1	Dec., 1984	Sixth Edition
Specification No.: B03P-4655-0001A		

Address comments concerning this manual to:  
**FUJITSU LIMITED**  
 International Marketing,  
 6-1 Marunouchi 2-chome, Chiyoda-ku, Tokyo 100, Japan  
 TEL: 03-216-3211  
 TLX: J22833  
 Cable: "FUJITSULIMITED TOKYO"  
 or  
**FUJITSU AMERICA INC.**  
 3055 Orchard Drive, San Jose, California 95134-2107, U.S.A.  
 TEL: (408) 946-8777  
 TWX: 910-338-2193  
 FAX: (408) 945-1318  
 or  
**FUJITSU EUROPE LIMITED**  
 54 Jermyn Street, London SW1Y 6NQ, ENGLAND  
 TEL: 01-493-1138  
 TEX: 263871 FT ERP G  
 or  
**FUJITSU ELEKTRONIK GmbH**  
 Sonnenstraße 29 8000 München 2, F.R. GERMANY  
 TEL: (089) 592891 - 5 (FAX TEL: (089) 592895)  
 TLX: 5213994 FEG D

The contents of this manual is subject to change without prior notice.

© Copyright 1984 by Fujitsu Limited.  
 Printed in U.S.A.



LIST OF EFFECTIVE PAGES

PAGE	REV	PAGE	REV	PAGE	REV	PAGE	REV	PAGE	REV	PAGE	REV
Cover		3-14	E1	6-3	E1	8-10	E	10-13	C	13-26	D1
Blank	—	3-15	E1	6-4	E1	8-11	E	10-14	B	14-1	E1
i	E1	3-16	B	6-5	C	8-12	E	10-15	B	14-2	E1
Blank	—	3-17	B1	6-6	C	8-13	E	10-16	B	14-3	B
iii	E1	3-18	B	6-7	E1	8-14	E	10-17	C	14-4	B
iv	E1	3-19	E	Blank	—	8-15	E	10-18	C	14-5	B
v	D	3-20	E1	7-1	B	8-16	E	11-1	E1	14-6	B
Blank	—	3-21	C	7-2	B	8-17	B	11-2	E1	14-7	B
vi	D	3-22	B1	7-3	E1	8-18	B	11-3	E	14-8	E1
vii	D	4-1	E1	7-4	B1	8-19	B1	11-4	E	14-9	C
viii	E1	4-2	B	7-5	B	8-20	B1	11-5	B	14-10	E
Blank	—	4-3	E1	7-6	B	9-1	B	11-6	B	14-11	E
1-1	E1	4-4	B	7-7	B	9-2	B	11-7	C	14-12	B
1-2	E1	4-5	E1	7-8	B	9-3	B	11-8	C	14-13	C
1-3	E1	4-6	E1	7-9	E1	9-4	B	11-9	B	14-14	B
1-4	D1	5-1	E1	7-10	B	9-5	B	11-10	B	14-15	B
1-5	E1	5-2	E1	7-11	E1	9-6	E1	11-11	B	14-16	B
1-6	B	5-3	E1	7-12	B	9-7	E1	Blank	—	14-17	B
1-7	C	5-4	B	7-13	E1	9-8	B	12-1	E1	14-18	B
1-8	B1	5-5	B	7-14	E1	9-9	B	12-2	E1	14-19	B
1-9	E1	5-6	E1	7-15	E	9-10	B	12-3	E1	14-20	C
1-10	C	5-7	B	7-16	B	9-11	B	12-4	E1	15-1	B
1-11	D	5-8	B	7-17	B	9-12	E1	12-5	B	15-2	B1
1-12	B	5-9	B	7-18	B	9-13	B	12-6	B	15-3	B1
1-13	E1	5-10	E1	7-19	B	9-14	B	12-7	B	15-4	B
1-14	B1	5-11	B	7-20	B	9-15	E1	Blank	—	15-5	B
1-15	E1	5-12	B	7-21	E1	9-16	B	13-1	D	15-6	E1
1-16	E1	5-13	B	7-22	B	9-17	B	13-2	E1	15-7	E1
1-17	E	5-14	B	7-23	B	9-18	E	13-3	E1	15-8	E1
Blank	—	5-15	B	7-24	B	9-19	B	13-4	E1	15-9	E
2-1	E1	5-16	B	7-25	B	9-20	B	13-5	E1	15-10	E
2-2	D	5-17	E1	7-26	B	9-21	B	13-6	E1	15-11	E
2-3	E1	5-18	E1	7-27	E1	9-22	B	13-7	E1	15-12	E1
2-4	E1	5-19	E1	7-28	B	9-23	B	13-8	D	15-13	E1
2-5	E1	5-20	B	7-29	B	9-24	E1	13-9	E1	15-14	E
2-6	E1	5-21	E1	7-30	B	9-25	B	13-10	E1	15-15	E1
2-7	D	5-22	D	7-31	B	9-26	E1	13-11	E	15-16	E
2-8	E	5-23	D	7-32	B	9-27	B	13-12	E1	15-17	B
3-1	E1	5-24	B	7-33	B	Blank	—	13-13	E1	15-18	B
3-2	E1	5-25	E1	7-34	B	10-1	B	13-14	E1	15-19	B
3-3	E1	5-26	C	7-35	B	10-2	E	13-15	D	15-20	B
3-4	E1	5-27	D1	7-36	B	10-3	B	13-16	D	15-21	B
3-5	E1	5-28	E1	8-1	B1	10-4	B	13-17	B	15-22	B
3-6	E1	5-29	D1	8-2	B	10-5	B	13-18	E1	15-23	B
3-7	E1	5-30	D	8-3	B	10-6	C	13-19	E1	15-24	B
3-8	E	5-31	E1	8-4	B	10-7	C	13-20	E1	15-25	B
3-9	E1	5-32	E1	8-5	B	10-8	E	13-21	D	Blank	—
3-10	E1	5-33	D	8-6	E	10-9	B	13-22	B	16-1	B
3-11	E1	5-34	D1	8-7	E	10-10	E1	13-23	B	16-2	B
3-12	E1	6-1	E1	8-8	E	10-11	B	13-24	B	16-3	C
3-13	E1	6-2	E1	8-9	E	10-12	C	13-25	B	16-4	C

**LIST OF EFFECTIVE PAGES**

PAGE	REV	PAGE	REV	PAGE	REV	PAGE	REV	PAGE	REV
16-5	B	16-37	C	17-25	B	17-57	B	17-89	B
16-6	B	16-38	C	17-26	B	17-58	B	17-90	E
16-7	B	16-39	C	17-27	E	17-59	B	17-91	E
16-8	B	16-40	C	17-28	B	17-60	C	17-92	B
16-9	B	16-41	C	17-29	B	17-61	C	17-93	B
16-10	B	16-42	C	17-30	E	17-62	B	17-94	B
16-11	B	16-43	C	17-31	C	17-63	B	17-95	B
16-12	B	16-44	C	17-32	B	17-64	B	17-96	B
16-13	B	17-1	B1	17-33	E	17-65	B	17-97	B
16-14	B	17-2	B	17-34	C	17-66	B	17-98	B
16-15	B	17-3	B	17-35	B	17-67	B	17-99	B
16-16	B	17-4	B	17-36	E	17-68	E	17-100	B
16-17	B	17-5	C	17-37	B	17-69	C	17-101	B
16-18	B	17-6	B	17-38	E	17-70	B	17-102	B
16-19	B	17-7	B	17-39	E	17-71	B	17-103	B
16-20	B	17-8	B	17-40	B	17-72	B	17-104	E1
16-21	B	17-9	C	17-41	B	17-73	B	17-105	B
16-22	B	17-10	B	17-42	B	17-74	B	Blank	—
16-23	B	17-11	D	17-43	E1	17-75	E		
16-24	B	17-12	E	17-44	E1	17-76	E		
16-25	B	17-13	B	17-45	E	17-77	E		
16-26	B	17-14	B	17-46	E1	17-78	E		
16-27	C	17-15	B	17-47	E1	17-79	E		
16-28	E1	17-16	B	17-48	E	17-80	E		
16-29	C	17-17	B	17-49	E	17-81	E		
16-30	C	17-18	B	17-50	B	17-82	B		
16-31	C	17-19	B	17-51	B	17-83	E		
16-32	C	17-20	B	17-52	B	17-84	E1		
16-33	C	17-21	E	17-53	B	17-85	B		
16-34	C	17-22	B	17-54	B	17-86	B		
16-35	C	17-23	B	17-55	B	17-87	B		
16-36	C	17-24	B	17-56	C	17-88	E		

Note 1: A revision of each page except "A" is indicated by the Revision Letter with the specification number of this manual in the bottom of the page.

Note 2: A bar by the page number in this page indicates pagination rather than content has changed.

\* 17-75 thru 17-105 have page number changes and/or revision changes.

## INTRODUCTION

This manual is for customer engineers who handle the new Mini-Disk Drive M2351A/AF. It describes how to operate, handle and maintain the drive.

This manual consists of the following seventeen chapters.

Chapter 1	GENERAL INFORMATION
Chapter 2	INSTALLATION
Chapter 3	OPERATION AND CHECKOUT
Chapter 4	SYSTEM INSTALLATION
Chapter 5	MECHANICAL ASSEMBLIES
Chapter 6	DATA FORMAT
Chapter 7	INTERFACE
Chapter 8	LOGIC CIRCUIT
Chapter 9	SERVO CIRCUIT
Chapter 10	READ/WRITE CIRCUIT
Chapter 11	VFO CIRCUIT
Chapter 12	DC POWER SUPPLY UNIT
Chapter 13	MAINTENANCE
Chapter 14	ELECTRICAL TEST AND ADJUSTMENT
Chapter 15	TROUBLE SHOOTING
Chapter 16	DESCRIPTION OF ICs
Chapter 17	SCHEMATICS

## Table of Contents

CHAPTER 1	GENERAL INFORMATION .....	1-1
1.1	GENERAL DESCRIPTION .....	1-1
1.2	FEATURES .....	1-2
1.3	PERFORMANCE SPECIFICATIONS .....	1-5
1.4	ENVIRONMENTAL SPECIFICATIONS .....	1-7
1.5	POWER SPECIFICATIONS .....	1-8
1.6	CABLE AND CONNECTOR SPECIFICATIONS .....	1-9
1.7	OPTIONS .....	1-11
1.8	SPARE PARTS .....	1-13
1.9	MAINTENANCE TOOLS AND EQUIPMENT .....	1-15
1.10	RELIABILITY AND SERVICE GOALS .....	1-16
CHAPTER 2	INSTALLATION .....	2-1
2.1	STORAGE .....	2-1
2.2	UNPACKING .....	2-1
2.3	ROTARY ACTUATOR UNLOCKING/LOCKING .....	2-5
2.4	SLIDE/MOUNTING INSTRUCTIONS .....	2-7
CHAPTER 3	OPERATION AND CHECKOUT .....	3-1
3.1	DC POWER SUPPLY UNIT .....	3-1
3.2	INTERFACE PCBs .....	3-3
3.3	LOGIC PCB ----- (C168-5123-0980#U) .....	3-6
3.4	SECTOR COUNT .....	3-8
3.5	OPERATOR PANEL .....	3-17
3.6	INDICATOR UNIT ----- HGAMU (B16B-7830-0010A#U) .....	3-19
3.7	STANDALONE CHECK .....	3-22
CHAPTER 4	SYSTEM INSTALLATION .....	4-1
4.1	CONTROL CABLE ("A" CABLE) .....	4-1
4.2	READ/WRITE CABLE ("B" CABLE) .....	4-2
4.3	SYSTEM GROUNDING .....	4-3
CHAPTER 5	MECHANICAL ASSEMBLIES .....	5-1
5.1	CONSTRUCTION OF THE DRIVE .....	5-1
5.2	DISK ENCLOSURE (DE) .....	5-4
5.3	ROTARY ACTUATOR .....	5-7
5.4	SPINDLE MOTOR .....	5-10
5.5	MAGNETIC HEAD AND DISK .....	5-14
5.6	COOLING SYSTEM .....	5-18
5.6.1	Cooling system of old version .....	5-18
5.6.2	Cooling system of new version .....	5-19
5.7	ASSEMBLY DRAWINGS .....	5-20
5.7.1	Old version (M2351A: ~ #1898) .....	5-21
5.7.2	New version (M2351A: #1899 ~,, M2351AF: #1 ~) .....	5-28
CHAPTER 6	DATA FORMAT .....	6-1
6.1	FORMAT .....	6-1
6.2	TRACK EFFICIENCY .....	6-3
6.3	MEDIA SPECIFICATIONS .....	6-4

CHAPTER 7	INTERFACE .....	7-1
7.1	SIGNAL TRANSMISSION DRIVER/RECEIVER .....	7-1
7.2	PIN ASSIGNMENT OF INTERFACE CONNECTORS .....	7-4
7.3	A-CABLE INPUT SIGNALS .....	7-5
7.4	A-CABLE OUTPUT SIGNALS .....	7-12
7.5	B-CABLE INPUT SIGNALS .....	7-20
7.6	B-CABLE OUTPUT SIGNALS .....	7-21
7.7	TIME SPECIFICATIONS .....	7-23
CHAPTER 8	LOGIC CIRCUIT .....	8-1
8.1	BLOCK DIAGRAM .....	8-1
8.2	DE SEQUENCE .....	8-2
8.3	SELECTION .....	8-5
8.4	OUTLINE OF ACCESS CONTROL .....	8-6
8.5	SEQUENCE RTZ .....	8-7
8.6	SYSTEM RTZ/MANUAL RTZ .....	8-10
8.7	SEEK .....	8-14
8.8	OFFSET .....	8-17
8.9	FAULT AND ERROR DETECTION .....	8-19
CHAPTER 9	SERVO CIRCUIT .....	9-1
9.1	DATA AND SERVO ZONE .....	9-1
9.2	SERVO FORMAT .....	9-3
9.3	SEEK CONTROL OPERATION .....	9-7
9.4	REZERO CONTROL OPERATION .....	9-9
9.5	SERVO BLOCK DIAGRAM .....	9-11
CHAPTER 10	READ WRITE CIRCUIT .....	10-1
10.1	WRITE CIRCUIT .....	10-1
10.2	READ CIRCUIT .....	10-6
10.3	ERROR DETECTING CIRCUIT .....	10-12
10.4	DE INTERFACE .....	10-16
CHAPTER 11	VFO CIRCUIT .....	11-1
11.1	MFM MODULATOR AND WRITE COMPENSATION CIRCUIT .....	11-1
11.2	VFO AND MFM DEMODULATOR CIRCUIT .....	11-5
11.3	PRINCIPLE OF SYNCHRONIZATION AND DEMODULATION .....	11-7
11.4	VFO CONTROL .....	11-9
CHAPTER 12	DC POWER SUPPLY UNIT .....	12-1
12.1	INPUT REQUIREMENT .....	12-2
12.2	OUTPUT CONDITIONS .....	12-2
12.3	ALARM DETECTIONS .....	12-4
12.4	CONTROL OF SPINDLE MOTOR .....	12-5
12.5	OPERATION .....	12-7



CHAPTER 13	MAINTENANCE AND PARTS REPLACEMENT .....	13-1
13.1	GENERAL PRECAUTIONS .....	13-1
13.2	DE REPLACEMENT .....	13-4
13.2.1	DE replacement of old version .....	13-4
13.2.2	DE replacement of New version .....	13-6
13.3	FRONT PANEL AND OPERATOR PANEL .....	13-8
13.4	AIR FILTER .....	13-11
13.5	LINE BLOWER (Refer to Figure 13.4-1) .....	13-14
13.5.1	Old version (Refer to Figure 13.4-1 (a)) .....	13-14
13.5.2	New version (Refer to Figure 13.4-1 (b)) .....	13-14
13.6	BACK PANEL (BQGMU) .....	13-15
13.7	HOUR METER .....	13-17
13.8	DUAL CHANNEL OPTION .....	13-20
13.9	DC POWER SUPPLY UNIT .....	13-23
13.10	POWER CABLE .....	13-25
13.11	POWER AMPLIFIER (TVKMU) (Refer to Figure 13.11-1) .....	13-26
CHAPTER 14	ELECTRICAL TEST AND ADJUSTMENT .....	14-1
14.1	GUIDE TO PCBs AND LOGIC DIAGRAMS (SCHEMATICS) .....	14-1
14.2	ADJUSTMENT OF SERVO CIRCUIT .....	14-4
14.3	ADJUSTMENT OF READ/WRITE CIRCUIT .....	14-15
14.4	ADJUSTMENT OF VFO CIRCUIT .....	14-19
CHAPTER 15	TROUBLE SHOOTING .....	15-1
15.1	INTRODUCTION .....	15-1
15.2	ERROR STATE .....	15-2
15.3	TROUBLE SHOOTING SYMBOL .....	15-4
15.4	TROUBLE SHOOTING FLOW CHART .....	15-5
CHAPTER 16	DESCRIPTION OF ICs .....	16-1
16.1	INTRODUCTION .....	16-1
16.2	INTERCHANGEABILITY .....	16-2
16.3	DETAIL OF ICs .....	16-5
CHAPTER 17	SCHEMATICS .....	17-1
17.1	SCHEMATICS/DRAWINGS .....	17-1
17.2	ABBREVIATIONS .....	17-94

## CHAPTER 1 GENERAL INFORMATION

### 1.1 GENERAL DESCRIPTION

The M2351 Disk Drive is a compact state-of-the-art moving head disk drive with a storage capacity of up to 474 megabytes (unformatted) in a very compact package. It uses Winchester type heads and platters, allowing higher recording density, data transfer rate, and greater reliability, while offering a faster access time. The media is non-removable. This drive is appropriate for large capacity, high speed data storage in an online and/or batch system.

Model M2351A is of the Non-Fixed-Head type, and model M2351AF is of the Fixed-Head type with an unformatted fixed-head capacity of 1.69 megabytes to further improve the system throughput.

Higher cost/performance and improved reliability can be achieved in computer systems that utilize M2351 disk drives.

The drive is designed to meet the following standards:

1. UL478 Electronic Data Processing Unit and Systems.
2. CSA C22.2 No. 154-1975 Data Processing Equipment.

Note: 'Early version' denotes M2351A (- #1898) and 'Current version' denotes M2351A (#1899-). Regarding the M2351AF, all drives are 'Current version'.

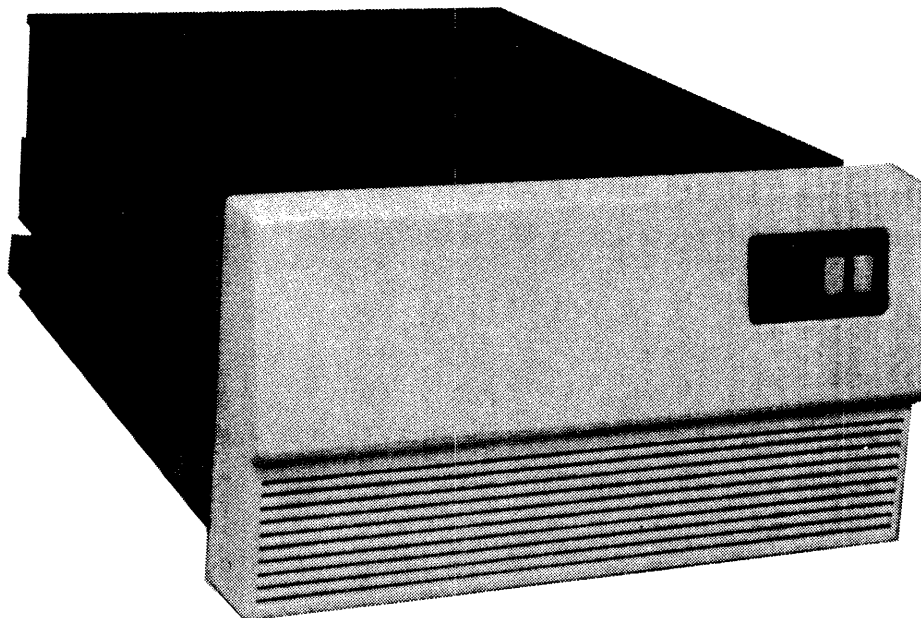

Fig. 1.1-1 External View of M2351A/AF

## 1.2 FEATURES

### (1) Large Capacity and High Performance

- 474 megabytes of unformatted data can be stored on six disks.
- The M2351 disk drive provides exceedingly high performance characteristics such as 1.859 megabytes per second data transfer, 18 milliseconds average access time, and 7.58 milliseconds average latency time.

### (2) Compact Size

The disk drive is a compact unit containing Disk Enclosure (DE), DC power supply and circuit boards, is designed for mounting in a standard 19-inch rack.

### (3) High Reliability

The disk enclosure includes a rotary actuator, a direct-drive spindle motor, the magnetic heads, disks and carriage. A completely sealed self-contained airflow system is used within the DE to assure a clean environment for low-flying heads, thus ensuring very high reliability.

### (4) High Serviceability

- The drive is modular in construction. All major subassemblies are easily removed/replaced in the field.
- Serviceability is further improved by diagnostic information provided on the maintenance-aid display and/or sense information provided by the interface signals.

### (5) Maintenance-free

The M2351 disk drive requires substantially reduced maintenance because of the completely sealed DE, a direct-drive DC Spindle motor and highly reliable printed circuit boards.

### (6) Other Features

- High recording density with state-of-the-art technology  
A recording density of more than  $10^7$  bits per square inch is achieved with the advanced head and disk.

- Low power consumption

Less than 0.62 KVA is required despite the large storage capacity.

- Fixed-head model

The M2351AF has a fixed-head area of 1.69 megabytes (unformatted) capacity. The data in this area can be accessed without positioning time delay but with only latency time delay, thus providing high system throughput.

- Dual channel feature

This option permits two controllers to access the same disk drive, allowing the drive to be shared by two systems.

- Modified SMD Interface

The interface between the controller and the disk drive is modified from the standard SMD interface to provide higher track capacity and higher maintainability.

The following are the major modified items.

- (1) Data Transfer rate
- (2) Track capacity
- (3) Timing of Read/Write operation
- (4) Addition of Tag 4 and Tag 5

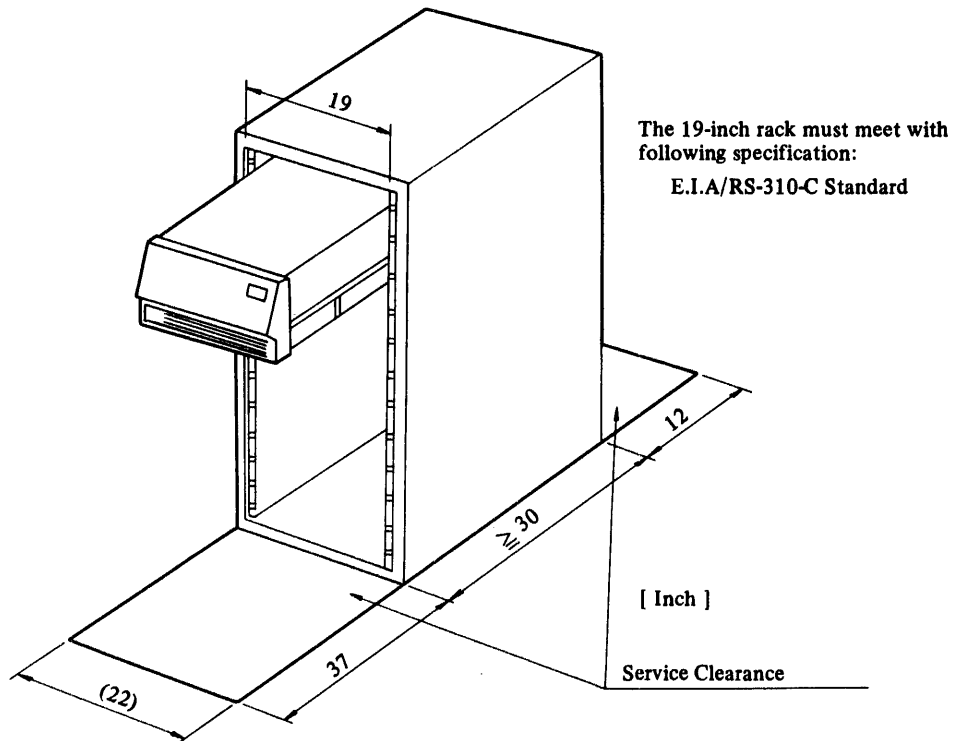
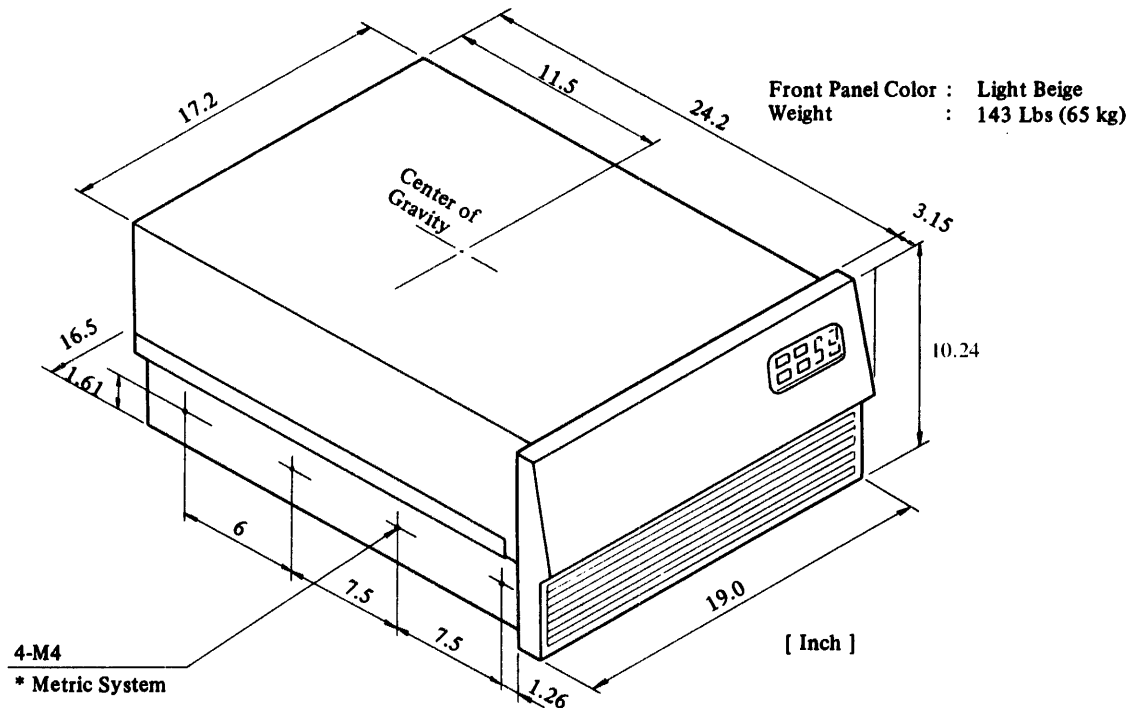

Fig. 1.1-2 Physical Dimensions

1.3 PERFORMANCE SPECIFICATIONS

Table 1.3-1 Specifications of M2351A/AF

Capacity	/Drive (MB)	474.2 (Unformatted)
	/Track (KB)	28.160 (Unformatted)
Configuration of Disks and Heads		<p>Fixed heads</p> <p>6 } Data heads</p> <p>5 } Data heads</p> <p>4 } Data heads</p> <p>3 } Data heads</p> <p>2 } Data heads</p> <p>1 } Servo head</p>
Fixed Head (M2351AF Only)	Tracks	60 (3 Cylinders)
	Capacity (MB)	1.69 (Unformatted)
Rotational Speed (RPM)		3,961
Latency (ms)		7.5
Disk	Diameter (Inch)	10.5
	Number	6
Heads	/Drive	20 + 1 (Servo)
	/Surface	2
Cylinders		842
Data Transfer Rate (MB/sec)		1.859
Positioning Time (ms)	Maximum	35
	Average	18
	Minimum	5.5
Track Density (TPI)		880
Bit Density (BPI)		12,800
Data Coding	on interface	NRZ
	on disk surface	MFM

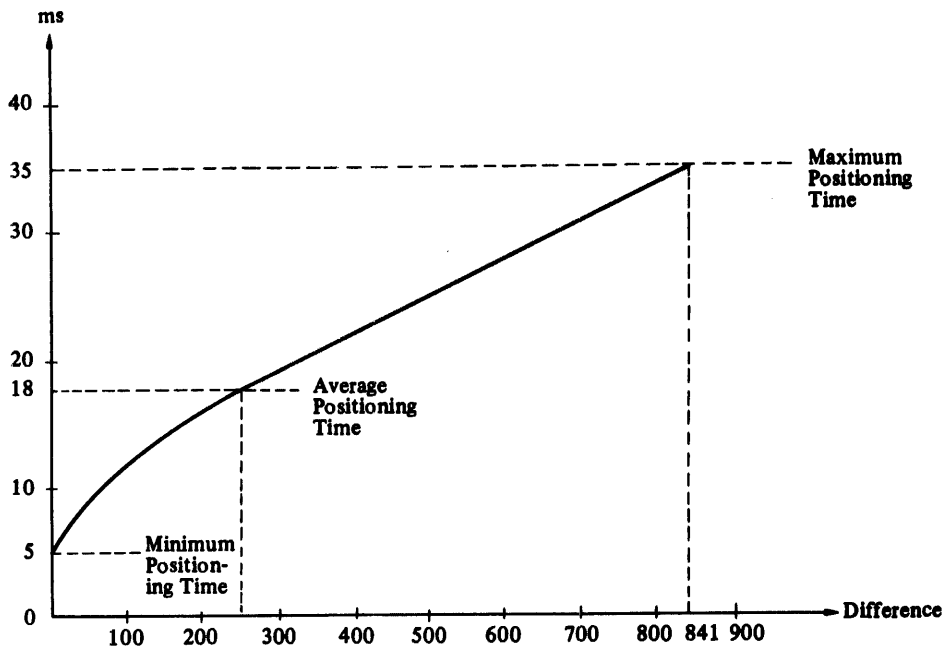

Fig. 1.3-1 Positioning Time vs. Difference

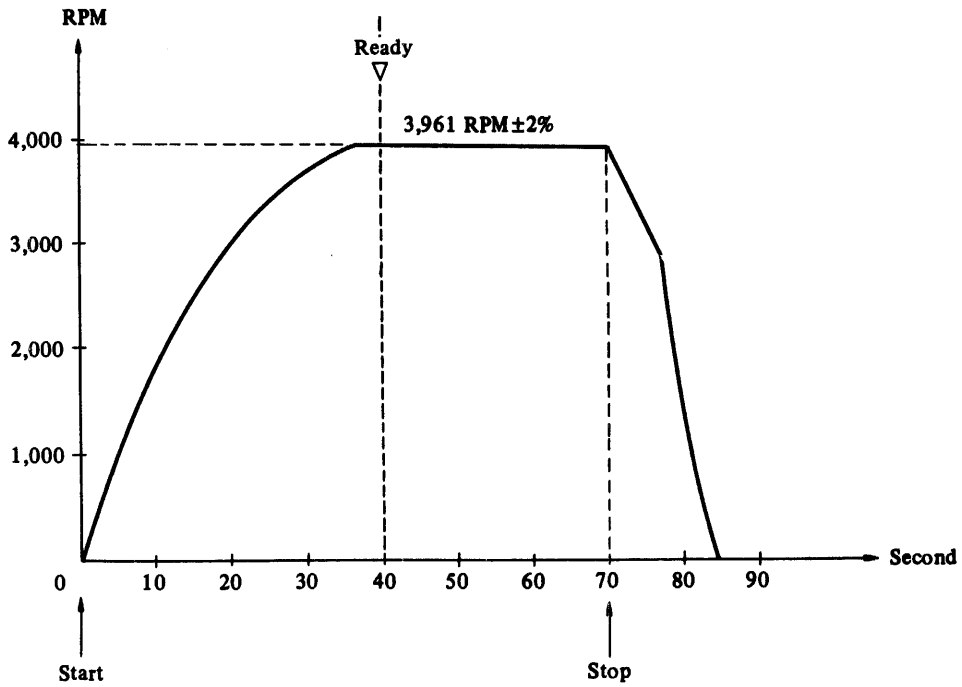

Fig. 1.3-2 Spindle Start/Stop Time

1.4 ENVIRONMENTAL SPECIFICATIONS

Table 1.4-1 Environmental Requirements

Environment	Storage or transmit in packaged form		On Site Non-Operating	Operating Office Environment
	Within 24 Hours	More than 24 Hours		
Temperature*	-40°F ~ 140°F (-40°C ~ 60°C) Max change 36°F/Hour (20°C/Hour)	23°F ~ 140°F (-5°C ~ 60°C) Max change 18°F/Hour (10°C/Hour)	23°F ~ 140°F (-5°C ~ 60°C) Max change 18°F/Hour (10°C/Hour)	50°F ~ 104°F (10°C ~ 40°C) Max change 18°F/Hour (10°C/Hour)
Humidity	5% ~ 95% RH Non-condensing		20% ~ 80% RH Max change 10%/Hour Non-condensing	
Vibration	3G (When locked for shipment)		0.2G (10Hz ~ 500Hz)	0.2G (5Hz ~ 50Hz) 1G (50Hz ~ 500Hz)
Shock	5G (Max. 30 ms)		3G (Max. 10ms)	2G (Max. 10ms)
Altitude	40,000 FT (12,000 m)		10,000 FT (3,000 m)	
Dust	0.168 mg/m <sup>3</sup> (Stearic Acid Standard)			
Air flow	—			2.5 m <sup>3</sup> /min.
Acoustic	—			60 dBA

\* °C =  $\frac{5}{9}(\text{°F}-32)$



1.5 POWER SPECIFICATIONS

Table 1.5-1 Power Requirements (Typical Values)

Voltage (Vac±10%)	Frequency (Hz±2Hz)	Current (Aac)		Power Consumption (KVA)	Heat Dissipation	
		Starting*	Running		(K•Cal/ Hour)	BTU/ Hour
100	50/60		5.7/5.4	0.57/0.54	460/420	1,800/1,600
120	60	5.3	4.6	0.55	430	1,700
220	50		2.8	0.62	510	2,000
240	50		2.6	0.62	510	2,000

\* Worst case transient with a maximum of 40 amps for less than 1/2 cycle of input AC Power.  
Refer to Figure 1.5-1.

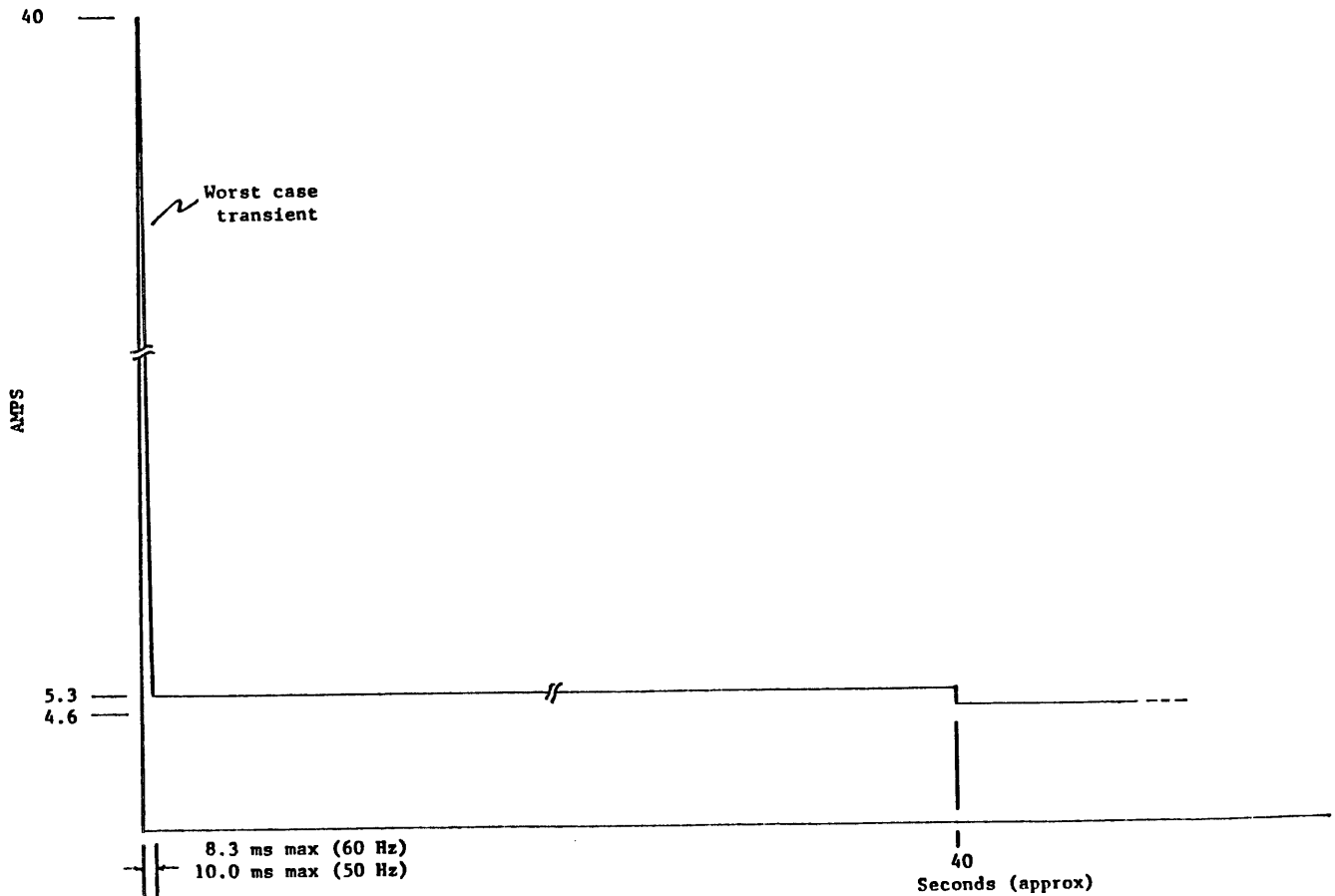

Fig. 1.5-1 AC START/RUN CURRENT CURVE M2351A

1.6 CABLE AND CONNECTOR SPECIFICATIONS

Table 1.6-1 Cables and Connectors

	Cable		Connector (Supplier)	
	Specification	Supplier	Drive Side	Cable Side
A-Cable (60-Pin)	Zo = 100±10Ω 28 AWG 7 Strands 100 FT. Max.	SPECTRA STRIP 455-248-60	FUJITSU FCN-704P060-AU/L	FUJITSU FCN-707J060-AU/B
			3M 3472-2303	3M 3334-6010
B-Cable (26-Pin)	Zo = 100±10Ω 28 AWG 7 Strands 50 FT. Max.	ANSLEY 174-26	FUJITSU FCN-705P026-AU/L	FUJITSU FCN-707J026-AU/B
			3M 3429-1303	3M 3399-6010
Power Cable A	See Figure 1.6-1			
Power Cable B	See Figure 1.6-2			
Power Cable C ~ D	See Figure 1.6-3			

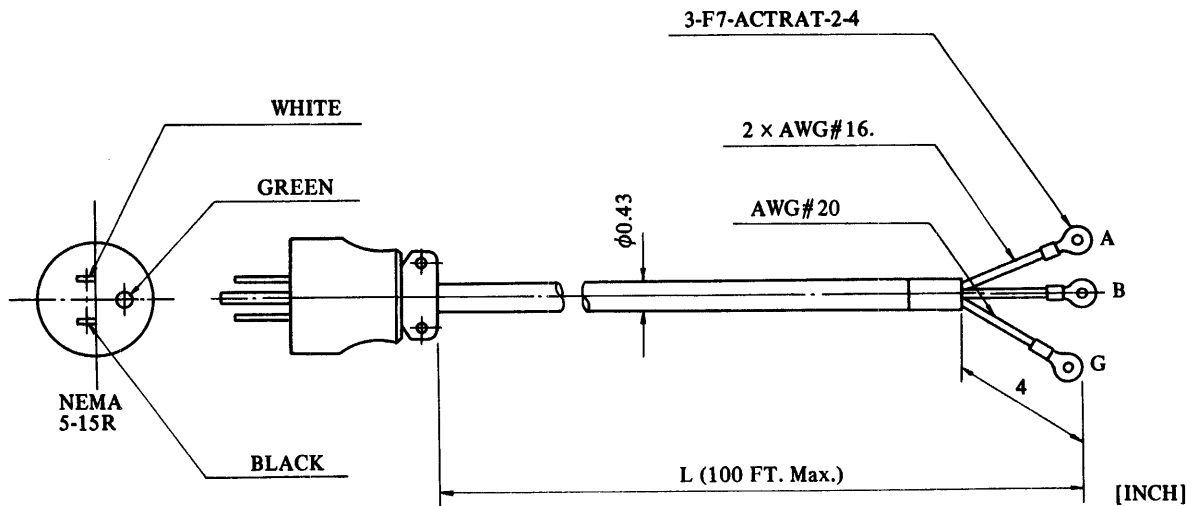

Fig. 1.6-1 Power Cable A

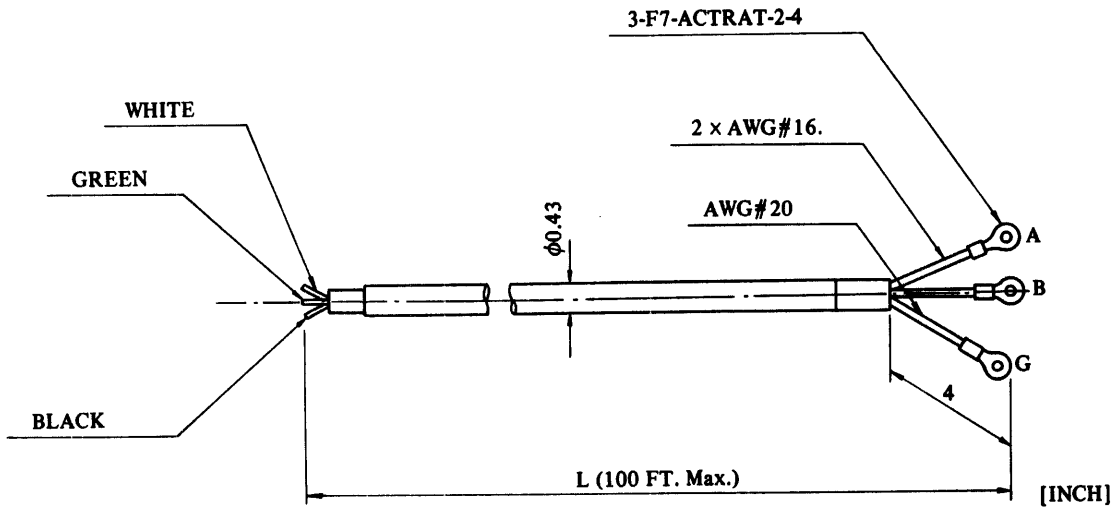

Fig. 1.6-2 Power Cable B

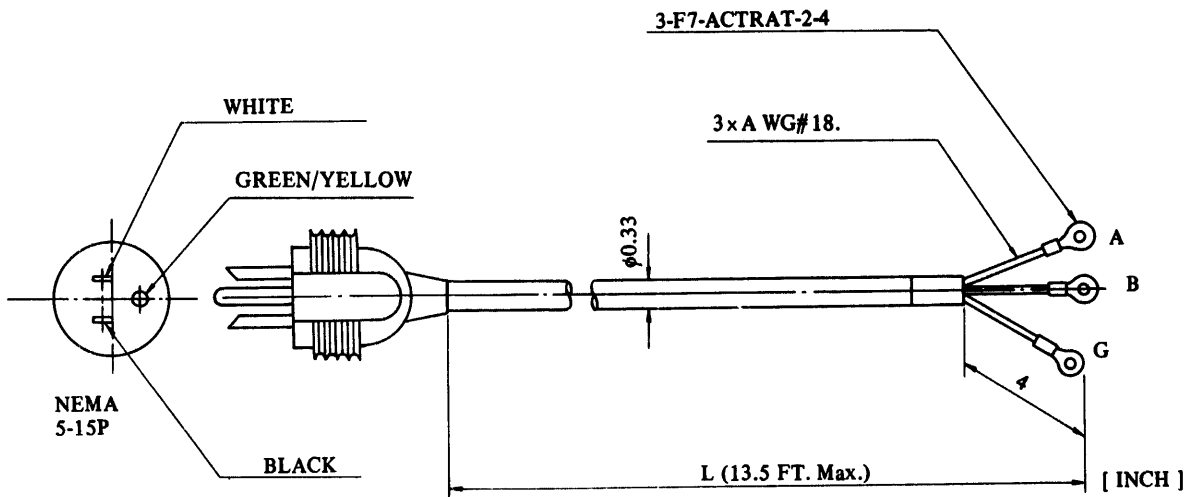

Fig. 1.6-3 Power Cable C ~ D

1.7 OPTIONS

Table 1.7-1 Option List

No.	Name	Specification	Remark	
1	A-Cable	B660-1065-T006A	Non-shield	Cable length can be specified from 0.5 m to 30 m in 0.5 m increments
2		B660-1954-T904A	Shield	
3	B-Cable	B660-1065-T008A	Non-shield	Cable length can be specified from 0.5 m to 15 m in 0.5 m increments
4		B660-1954-T903A	Shield	
5	Power Cable A (UL only)	B660-1055-T027A	Cable length can be specified from 1 m to 30 m in 0.5 m increments. (100/120 Vac only)	
6	Power Cable B (UL, CSA)	B660-0620-T387A	Cable length can be specified from 1 m to 30 m in 0.5 m increments. (220/240 Vac only)	
7	Power Cable C (UL, CSA)	B660-1055-T033A	L = 2.5 m, (100/120 Vac only)	
8	Power Cable D (UL, CSA)	B660-1055-T034A	L = 3.5 m, (100/120 Vac only)	
9	Power Cable E (UL, CSA)	B660-1055-T035A	L = 4.5 m, (100/120 Vac only)	
10	Line Terminator (TCAMU)	B16B-4870-0010A#U	Note that two line terminators are required in dual channel system.	
11	Dual Channel Option	B03B-4655-0100A		
12	Slide Guide Option	B030-4655-V100A		
13	Front Panel Option	B210-1435-X012A		
14	Operator Panel Assembly	N860-3346-T001		
15	Hour Meter	B61L-0140-0011A #10000	10,000 hours	

Note that the Fixed-Head is not an option but a model change from the Non Fixed-Head drive.

Non Fixed-Head Drive; M2351A (B03B-4655-B002A)

Fixed Head Drive ; M2351AF (B03B-4655-B003A)

When M2351A or M2351AF is ordered alone, it does not include the front panel, operator panel, etc. listed in Table 1.7-1.

A-, B- and Power Cable A, B length must be specified by adding comment behind the cable specification.

Example: B660-1065-T006A #10.5 m (A-Cable, 10.5 meters)

1.8 SPARE PARTS

Table 1.8-1 Recommended Spare Parts List

No.	Name	Specification	Quantity		MTBF (K-hours)			Remarks	
			A	AF					
1	DE Assembly	B030-4610-T005A	1	-	60			Non-fixed heads type	M2351A (#1~#1898)
	DE Assembly	B030-4610-T007A	1	-	60				M2351A (#1899~)
2	DE Assembly	B030-4610-T006A	-	1	60			Fixed heads type	-
	DE Assembly	B030-4610-T008A	-	1	60				M2351AF (#1~)
3	DC Power Supply	B14L-5105-0073A	1	1	200				
4	Line Blower	B90L-1200-0101A	1	1	400	-	-		
5	Operator Panel Assembly	N860-3346-T001	1	1	400				
6	PCB TVHMU	B16B-8130-0010A#U	1	1	360			Power Amplifier	M2351A (#1~#1898) M2351AF ( - )
	PCB TVKMU	B16B-8800-0010A#U	1	1	360				M2351A (#1899~) M2351AF (#1~)
7	PCB RFJAU	C16B-5500-0990#U	1	1	220				Read Amplifier
8	PCB SVIAU	C16B-5501-0010#U	1	1	180				Servo Circuit
9	PCB 512398	C16B-5123-0980#U	1	1	420				Logic Circuit
10	PCB DQEMU	B16B-8140-0010A#U	1	1	500				Interface Circuit
11	PCB HGAMU	B16B-7830-0010A#U	1	1	1660				Indicator Unit
12	PCB BQGMU	B16B-8160-0010A#U	1	1	1440				Back Panel
13	PCB DQFMU	B16B-8150-0010A#U	(1)	(1)	400				Interface Circuit (Dual Channel Option)
14	Air Filter	B90L-0400-0303A	1	1	-	-	-		
15	Fuse	C60L-0020-0001 #MP05	1	1	-	-	-		Used in DC Power Supply (0.5 A)

Notes: MTBF; Mean Time Between Failures (K•hours)

1.9 MAINTENANCE TOOLS AND EQUIPMENT

Table 1.9-1 Maintenance Tools and Equipment

No.	Tools and Equipment	Specification	Remark
1	Extension Cable	B660-1060-T072A#L510R0	20 pins
2	Extension Cable	B660-1060-T074A#L510R0	50 pins (2 required)
3	Extension Unit	C960-0030-T029	
4	Extractor	C960-0300-T001	One required
5	Oscilloscope	TEKTRONIX 475, or equivalent	
6	Oscilloscope Probe (X10)	TEKTRONIX P6053B or equivalent	
7	Digital Multimeter		
8	Screwdriver	#2 Phillips	
9	Hexagonal Wrenches	6 MM	Metric system
10			
11			
12			
13			



## 1.10 RELIABILITY AND SERVICE GOALS

### (1) MTBF

MTBF is defined as follows.

$MTBF = \text{operating time} / \text{the number of failures encountered.}$

Operating time is the total time duration during which the power is ON except during maintenance work. Failure is defined as a malfunction that requires either repairs, adjustments, or replacement. Mishandling by the operator, power failure, control unit trouble, cable trouble and trouble due to improper environmental conditions are not included.

The MTBF or M2351A/M2351AF is more than 20,000 hours estimated value after an initial period of 200 hours.

### (2) MTTR

MTTR is the average time a trained service mechanic should take to diagnose and repair the failure. The M2351A/M2351AF are designed for an MTTR of 30 minutes or less.

### (3) Preventive Maintenance Time

The front panel air filter should be cleaned or replaced at one year intervals, or as required.

### (4) Component Life

M2351A/M2351AF need not be overhauled for the five first years.

### (5) Power Loss

If AC power to the unit is lost, data stored in the disk is preserved. However, if the power failure occurs during a WRITE operation, that data is not guaranteed.

(6) Read Error

Prior to determination of the read error rate, the data must be verified as correctly written and all identified media defects must be deallocated or skipped.

- Recoverable Error Rate .....  $10 \times 10^{-11}$

While reading  $10^{11}$  bits of data, less than 10 read errors would be encountered which are recoverable in 4 retries without using the ECC functions and the offset operation.

- Unrecoverable Error Rate ...  $10 \times 10^{-14}$

While reading  $10^{14}$  bits of data, less than 10 read errors would be encountered which are unrecoverable in 5 retries without using the ECC function.

Retry routine; after 4 times of re-reading with and without offset, RTZ must be performed.

(7) Seek Error Rate .....  $1 \times 10^{-7}$

(8) Quality Standards of Media at Shipment (Summary)

- The number of defects per DE shall not exceed 500.

- The number of defective tracks per DE shall not exceed 30.

(A track containing two or more defects is defined as a defective track.)

- Head 0 and 1 at cylinder 0 should be perfect tracks.

Refer to Chapter 6.3 for detail.



## CHAPTER 2 INSTALLATION

### 2.1 STORAGE

When the drive is stored for a prolonged period, avoid locations where the environment is extreme. Stored units should be properly packed and can be stored stacked vertically, two high. When the temperature difference between storage (or shipping) and the unpacking environment exceeds 20°C (36°F), the unit should be allowed to remain in packaged form for more than 3 hours to avoid condensation when unpacking.

### 2.2 UNPACKING

- (1) The M2351 is shipped in a carton surrounded by shock absorber as shown in Figure 2.2-1. (Note: the shipping carton is intended to be reuseable.) To unpack the unit, first the carton flaps to the left and right and then take out the unit. Do not grasp the front panel or cover of the unit to lift - use the sub-frame at the bottom to avoid the possibility of sub-assembly damage. Take care to move the unit carefully to avoid abrupt impact or shock.
- (2) After unpacking the drive, check for scratches or dents. Remove the cover, (Figure 2.2-2) and visually inspect inside the drive as follows:
  - (a) Check for loose or missing parts, or foreign matter.
  - (b) Check that the PCB's are properly seated in the correct positions.
  - (c) Check that all connectors are secure and no cable chafing damage has occurred.

After inspection, (prior to operating the drive), unlock the rotary actuator and secure in the unlocked position. (Refer to Figure 2.3-1) And then, lift the card cage vertically rotate over the side. Remove the vibration preventive block under the DE housing.

#### (3) Packing

Prior to packing the drive, insure that the rotary actuator locking mechanism is secured in the locking position, (Refer to Figure 2.3-1) and the vibration preventive block properly inserted under the DE housing (Refer to Figure 2.2-2). When reshipping the drive, place it in a polyethelene bag and repack it in the Original carton with shock absorbers. (Refer to Figure 2.2-1)

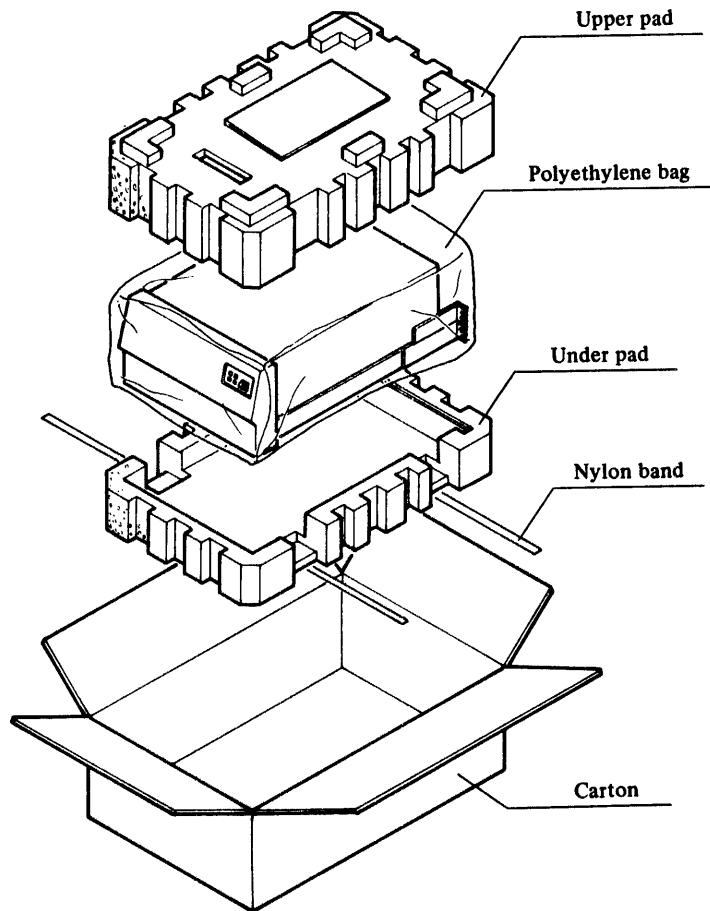

(a) Inner packaging

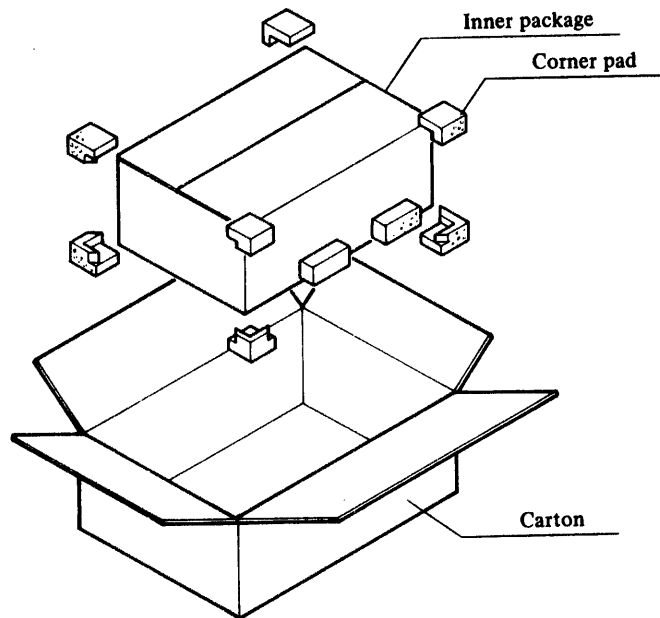

(b) Outer packaging

Figure 2.2-1 Exterior View and Construction of Carton

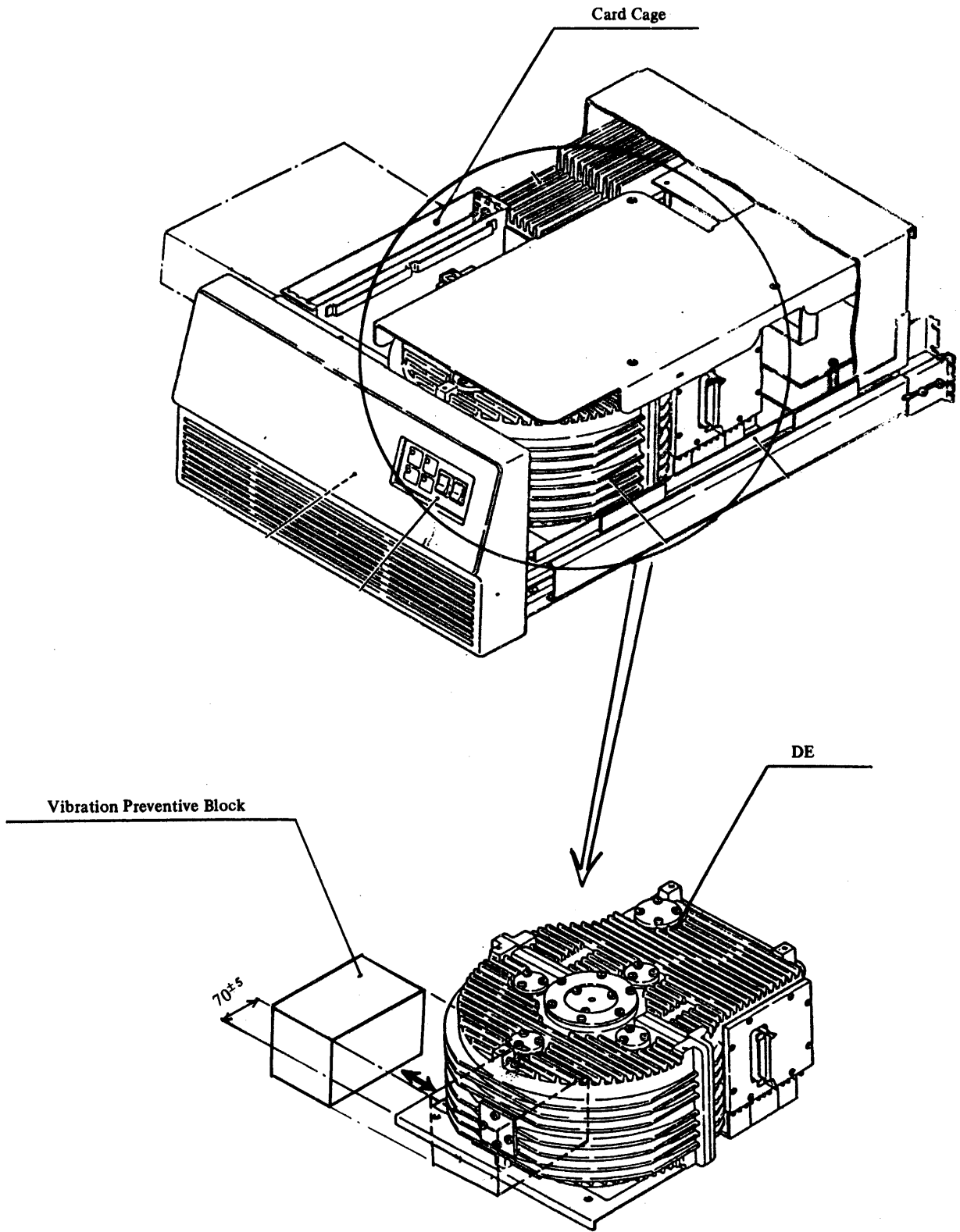

(a) Early version

Figure 2.2-2 Cover Removal

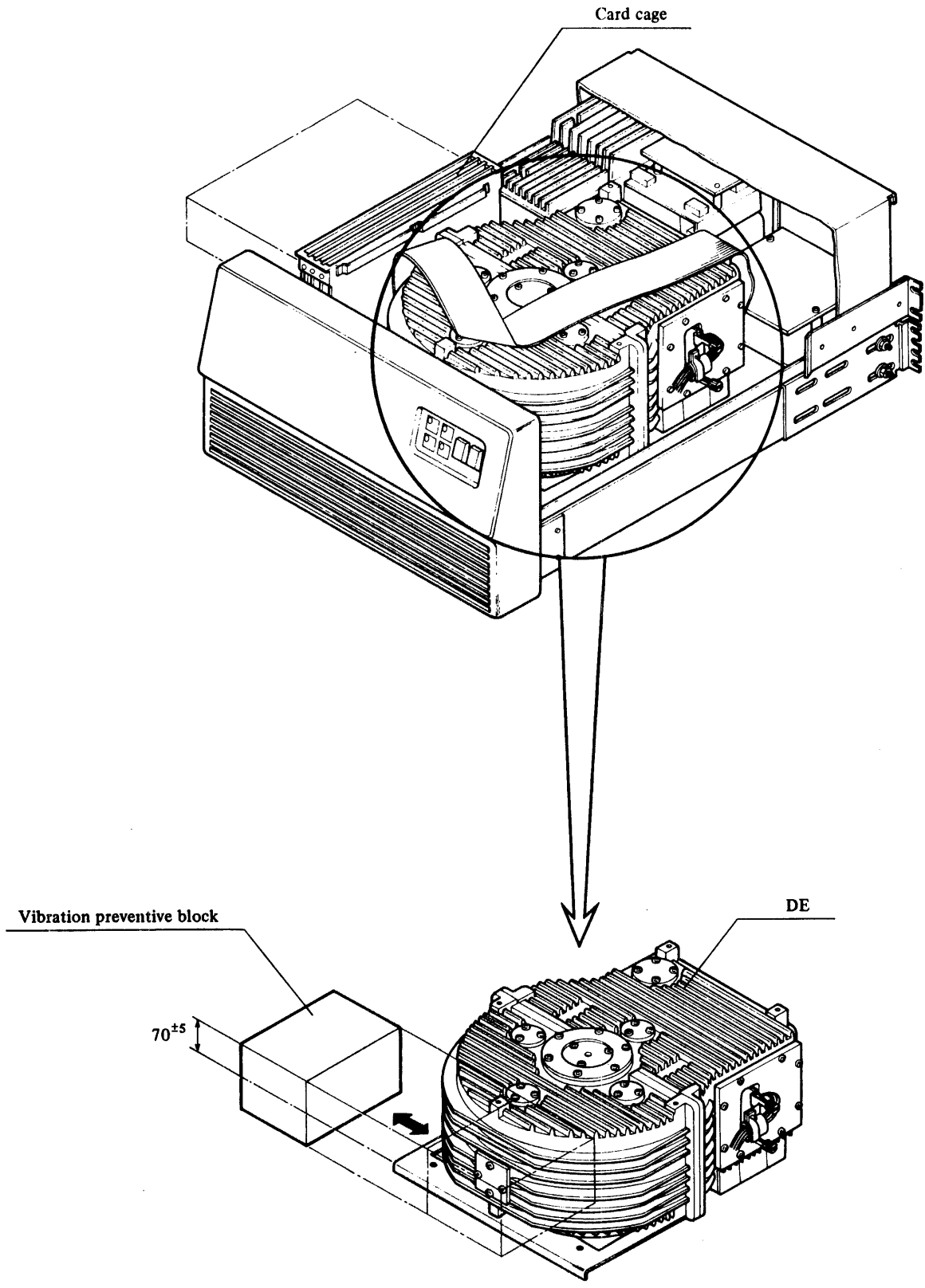

(b) Current version

Figure 2.2-2 - Continued

## 2.3 ROTARY ACTUATOR UNLOCKING/LOCKING

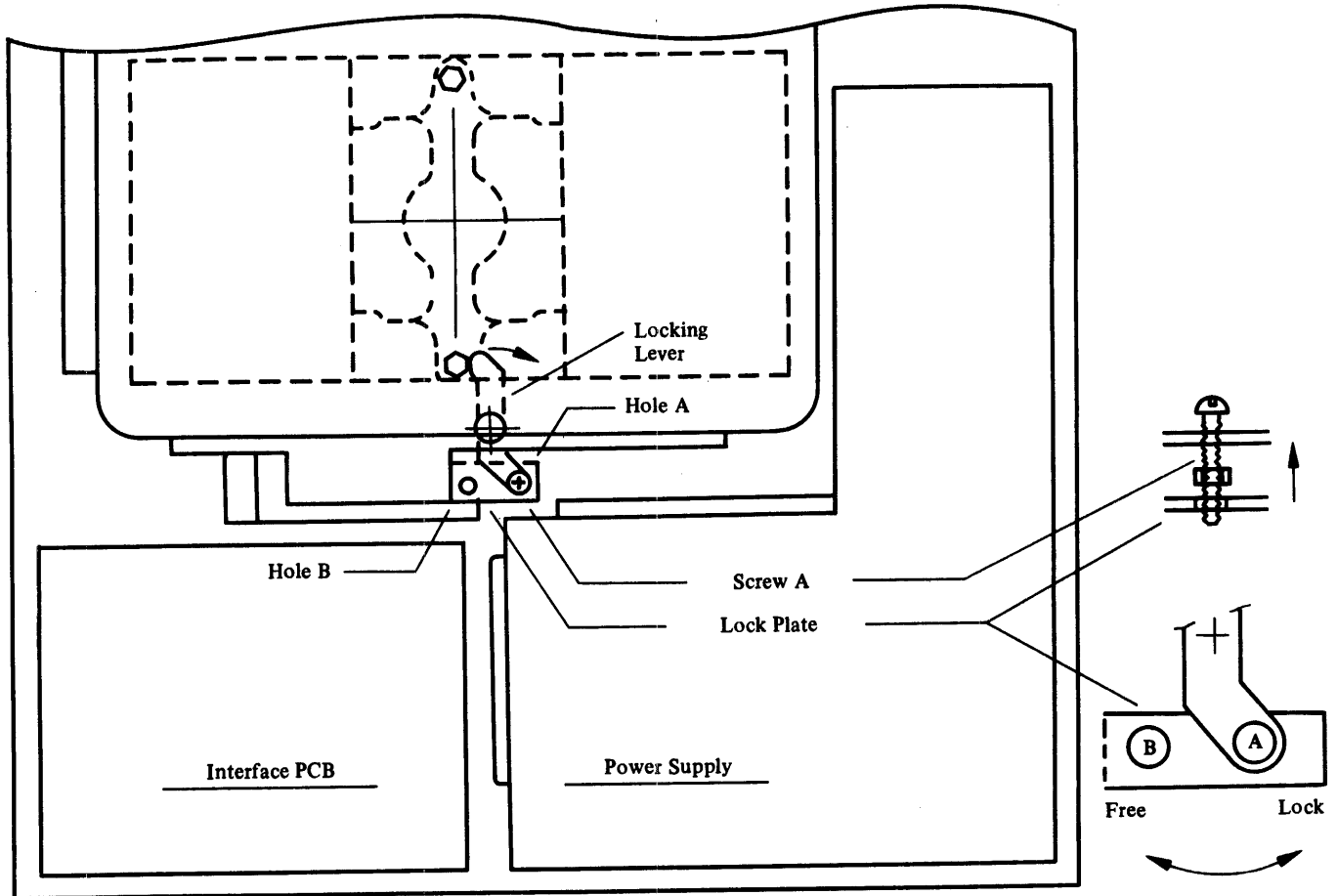

Figure 2.3-1 Rotary Actuator Unlocking/Locking  
(Top View)

This mechanism can be readily viewed from the rear of the drive by looking over the Interface PCB.

### (1) Unlocking

Loosen Screw A (by means of a phillips screwdriver, 8 inches or longer), sufficiently to free the screw tip from the hole in the Lock Plate. With the screwdriver, rotate the Locking Lever to the Unlocked position (Hole B), and secure in that position by gently tightening Screw A. (Refer to Figure 2.3-1)



## (2) Locking

Loosen Screw A (by means of a phillips screwdriver, 8 inches or longer), sufficiently to free the screw tip from the hole in the Lock Plate. With the screwdriver, rotate the Locking Lever to the Locked position (Hole A), and secure in that position by gently tightening Screw A. (Refer to Figure 2.3-1)

## 2.4 SLIDE/MOUNTING INSTRUCTIONS

The drive can be slide-mounted in a standard 19-inch rack or built into a system cabinet. Installation procedures follow, and are illustrated in Figure 2.4-1.

### (1) Slide Rail Installation and Mounting

- a. Extend the slide guide and release from slide rail.
- b. Install the slide guide (as shown) in the 19-inch rack or cabinet.
- c. With both the slide guides installed and extended, lift the drive (with slide rails already attached) onto the extended guides. Be sure the rail is correctly seated and latched in the guide.

NOTE: The drive weight approximately 143 lbs (65 kg), and requires at least two people to install.

### (2) Drive Removal

- a. Fully extend the drive from the rack. Release the latching mechanism and, with a lifting-forward motion, lift the drive off the slide guides.

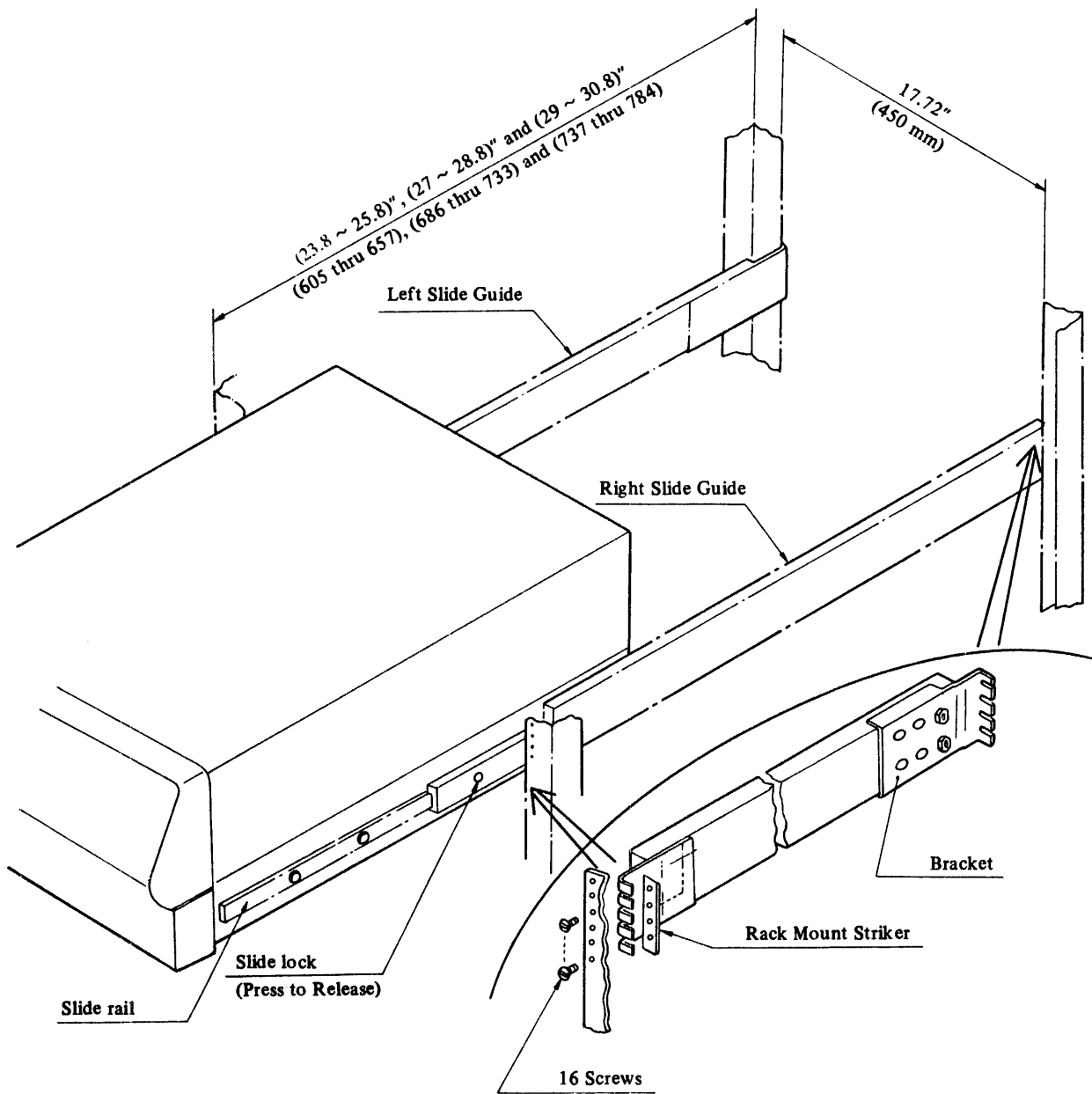

Figure 2.4-1 Rack Mount Installation

## CHAPTER 3 OPERATION AND CHECKOUT

### 3.1 DC POWER SUPPLY UNIT

Control panel of the DC power supply unit is shown in Figure 3.1-1.

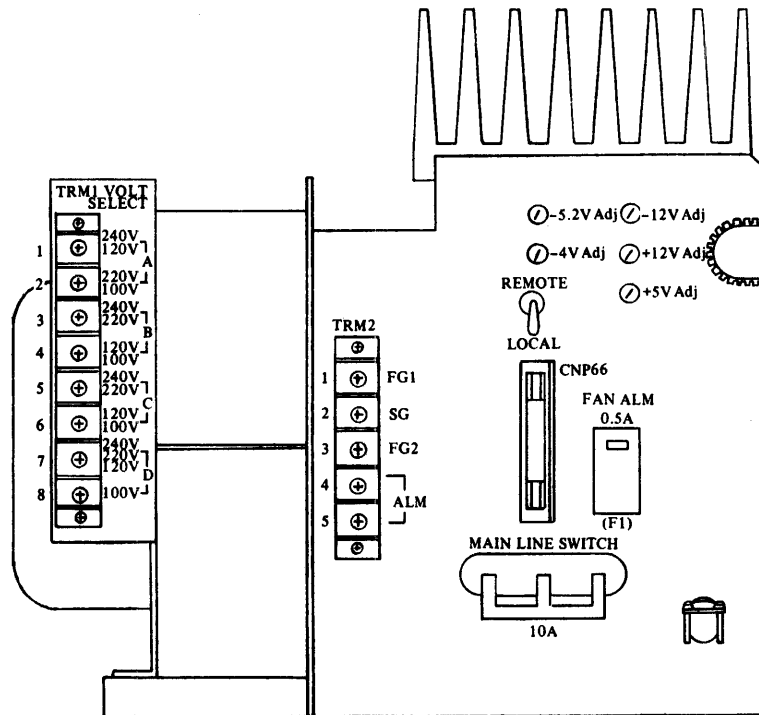

Figure 3.1-1 Control Panel of DC Power Supply Unit

#### (1) Main Line Switch (Non-Fuse Breaker)

Supplies AC power to the unit. If any of following failures occurs, the breaker is tripped.

- Over current in the AC input
- Over current or voltage in the DC output
- Fan (Line-Blower) Alarm
- Over Temperature of the heat sink or of the transformer in the DC power supply unit.

#### (2) Fan ALM (Fuse)

Indicates failure of the line-blower.

#### (3) Remote/Local (Switch)

When this is set to Remote, the spindle motor starts/stops rotating in accordance

with the commands (Power Sequence Pick/Hold) issued from the controller in conjunction with the operator panel start switch. When set to Local, rotation is controlled solely by the Start switch on the operator panel.

(4) TRM 1 (Terminal)

The taps on this terminal must be changed in accordance with the voltage and frequency of AC input power, as shown in Table 3.1-1

Table 3.1-1 Tap Number to be shortened

Vac (Hz)	Tap Number	
	(A) - (B)	(C) - (D)
100 (50/60)	2 - 4	6 - 8
120 (60)	1 - 4	6 - 7
200	2 - 3	5 - 8
220 (50)	2 - 3	5 - 7
240 (50)	1 - 3	5 - 7

(5) TRM 2 (Terminal)

- FG1 ..... Frame Ground
- SG ..... Signal Ground
- FG2 ..... Frame Ground with a 510 kΩ resistor
- ALM ..... Alarm Output (not used)

The Frame Ground and Signal Ground are completely isolated in the drive, and they are provided as FG1/FG2 and SG on this terminal.

As shown in Figure 3.1-2, FG1 is a frame ground itself, but FG2 is a frame ground to which a 510 kΩ resistor is provided in DC Power Supply.

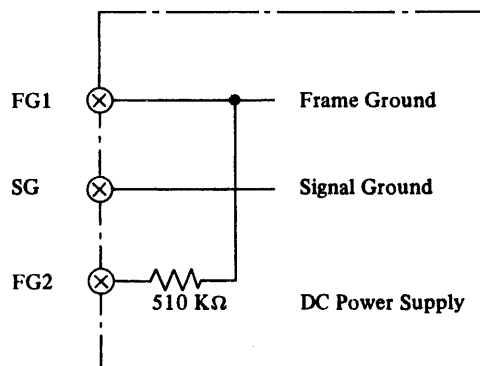

Figure 3.1-2 FG1/FG2 and SG

At the time of shipment, SG and FG2 are connected with a shorting plate.

Refer to Chapter 4.3 on the operation.

(6) Volt ADJ (Variable Resistors)

Although adjustment should not be required, variable resistors are provided to adjust the -5.2, -4, ±12, -5 Vdc output voltages within the tolerance specified, if necessary.

3.2 INTERFACE PCBs

(1) INTERFACE PCB - DQEMU (B16B-8140-0010A#U)

Drive logical address 0 to 7 can be set with three positions of the switch in binary code as shown in Table 3.2-1.

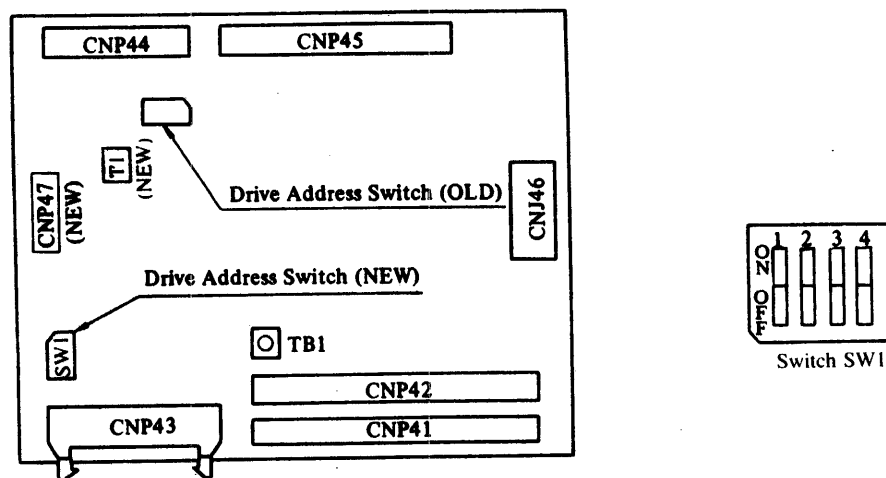

Figure 3.2-1 Drive Address Switch

Table 3.2-1 Drive Addressing

Drive Address	Switch Position			
	1	2	3	4
0	OFF	OFF	OFF	Not Used
1	ON	OFF	OFF	
2	OFF	ON	OFF	
3	ON	ON	OFF	
4	OFF	OFF	ON	
5	ON	OFF	ON	
6	OFF	ON	ON	
7	ON	ON	ON	

Interface Configuration Jumper (T1)

In normal dual port operation, a Priority Select on one port will cause the B Cable Interface on the alternate port to be disabled. Also, a Seek-End response is given for Reserve (Select) and Reserve (Select) Release commands.

Jumper T1 provides the means to inhibit the disabling of the alternate port's B Cable Interface in response to a Priority Select. (See also - Table 3.2-3 for DQFMU, Jumpers T1, T2 & T3)

Table 3.2-2 DQEMU Interface Configuration

Jumper #	Pin Numbers	Option
T1	01-02*	Disable B cable with Priority Select
(Port A)	02-03	Inhibit disabling B cable with Priority Select

\* Jumper position for normal dual port operation

(2) DUAL CHANNEL INTERFACE PCB ----- DQFMU (B16B-8150-0010A/U)

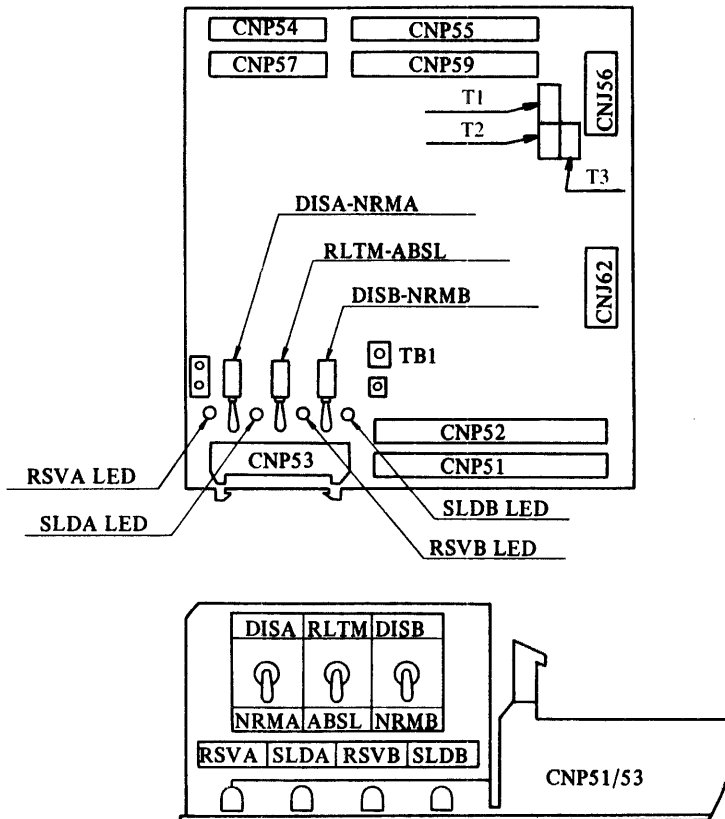

Figure 3.2-2 Switches and Indicators

LEDs

- (1) RSVA (Channel A Reserved) – Orange  
Indicates that the drive is reserved by A-channel.
- (2) SLDA (Channel A Selected) – Green  
Indicates that the drive is selected by A-channel.
- (3) RSVB (Channel B Reserved) – Orange  
Indicates that the drive is reserved by B-channel.
- (4) SLDB (Channel B Selected) – Green  
Indicates that the drive is selected by B-channel.

Switches

- (1) DISA – NRMA (Disable A – Normal A)  
Disconnects or connects the interface signals of A-channel.
- (2) RLTM – ABSL (Release Timer – Absolute)  
When the switch is at RLTM side, reserved status will be released 500 ms after Unit Select Command if the Release Command has not already been issued. When the switch is at ABSL side, reserved status can be released only by the Release Command.
- (3) DISB – NRMB (Disable B – Normal B)  
Disconnects or connects the interface signals of B-channel.

Interface Configuration Jumpers (T1, T2, T3)

In normal dual port operation, a Priority Select on one port will cause the B Cable Interface on the alternate port to be disabled. Also, a Seek-end response is given for Reserve (Select) and Reserve (Select) Release commands.

Jumpers T1 and T2 provide a means to inhibit the Seek-end response to Reserve (Select) and Reserve (Select) Release commands.

Jumper T3 provides the means to inhibit the disabling of the alternate port's B Cable Interface in response to a Priority Select.

Table 3.2-3 DQFMU Interface Configuration

Jumper #	Pin Numbers	Option
T1 (Port A)	01-02*	Seek-End response for Reserve/Release command.
	02-03	Inhibit Seek-End response for Reserve/Release command.
T2 (Port B)	01-02*	Seek-End response for reserve/release command.
	02-03	Inhibit Seek-End response for reserve/release command.
T3 (Port B)	01-02*	Disable B cable with Priority Select
	02-03	Inhibit disabling B cable with Priority Select

\* Jumper position for normal dual-port operation.



3.3 LOGIC PCB ----- (C16B-5123-0980#U)

Jumper pins (SH09) and jumper plugs for setting sector count and changing inter-  
face requirements are provided.

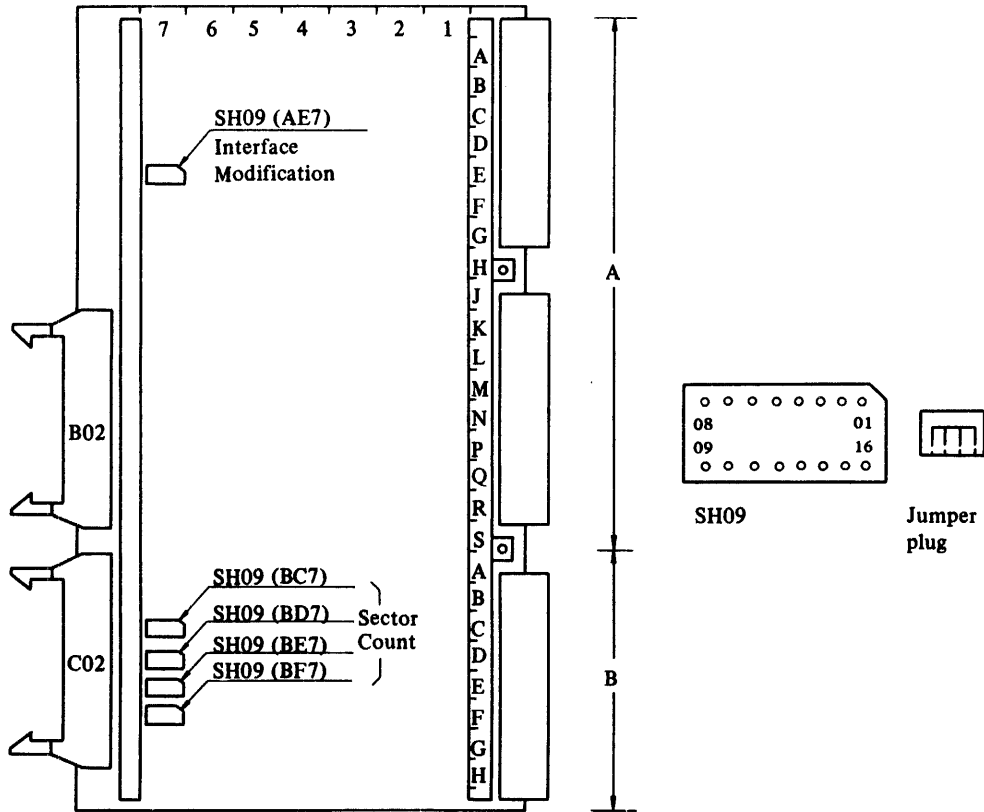

( ) indicates location of jumper pins on the PCB.

Figure 3.3-1 Sector Count and Interface Selection

Removal of the Logic PCB is required to set the sector count or change the interface options. This is accomplished with the extractor tools provided with the drive (refer to Table 1.9-1, item 4) as shown below.

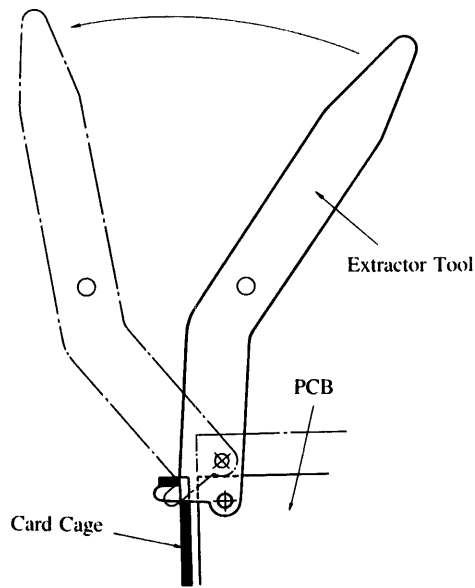

Figure 3.3-2 PCB Removal

(1) Interface Configuration

The interface can be reconfigured by shorting the appropriate pins (Logic PCB, Location AE 7) with jumper plugs, as shown below.

Table 3.3-1 Interface Selection

Item	Pin number to be shortened	Default mode	Function
Incorporate * TAG4, 5 Status Capability	03 - 02	x	Enable
	03 - 04		Disable
Operation of Seek End status	06 - 05		Seek End is not issued after Offset Command is reset.
	06 - 07	x	Seek End is issued after Offset Command is reset.
Response of Unit Ready	10 - 09	x	Unit Ready is issued even if the drive is in a fault condition.
	10 - 11		Unit Ready is not issued when the drive is in a fault condition.

\* (Note) It is recommended that tag 4 & 5 be disabled if the disk controller does not use the option.

### 3.4 SECTOR COUNT

The number of bytes per sector in Fixed Sector Format is determined by the location of jumper plugs according to the following table and example.

Example; 9 Sectors/Track

$$\text{Bytes/Sector} = \frac{\text{Bytes/Track}}{\text{Sectors/Track}} = \frac{28,160}{9} = 3,128.89$$

If the above calculation results in a remainder, round it up to the next integer, i.e.,

$$\text{Bytes/Sector} = 3,129$$

Set this figure minus one with jumper plugs to allow the Byte Counter to start counting from zero.

$$3,129-1 = 3,128 = \underbrace{2,048}_{\text{BE7}} + \underbrace{1,024}_{\text{BD7}} + \underbrace{32}_{\text{BC7}} + \underbrace{16}_{\text{BC7}} + \underbrace{8}_{\text{BC7}}$$

Therefore, jumper plugs should be placed on pins 13 - 12 and 10 - 9 of BE7, pins 06 - 05 and 03 - 02 of BD7, and pins 13 - 12 of BC7. However, those pins representing byte-count value not appearing in the calculation must also be jumpered (the complementary position).

In this case, the number of bytes in the last sector is calculated as follows.

$$28,160 - (8 \times 3,129) = 3,128$$

Namely, the last sector is one byte shorter than the others.

Table 3.4-1 Setting of Sector Count

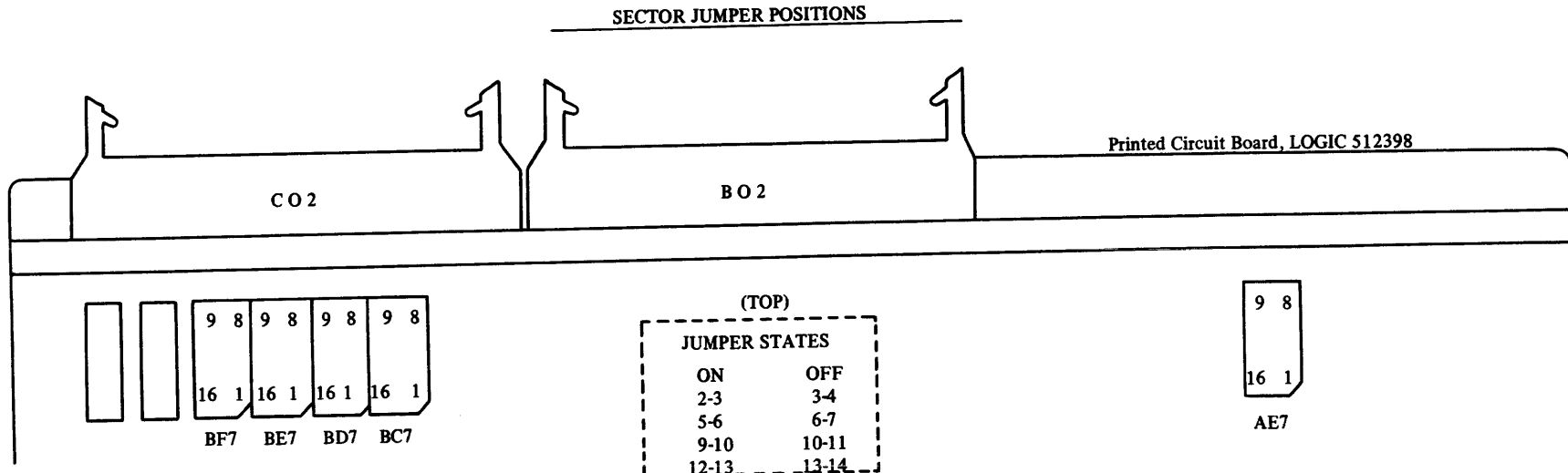

Sector Count	Location BC7				Location BD7				Location BE7				Location BF7				Bytes Per Sect/Last Sect
	(2 <sup>n</sup> )	1	2	4	8	16	32	64	128	256	512	1024	2048	4096	8192	16384	
1	2-3	5-6	9-10	12-13	2-3	5-6	9-10	12-13	2-3	6-7	9-10	12-13	3-4	5-6	9-10	13-14	28160
2	2-3	5-6	9-10	12-13	2-3	5-6	9-10	12-13	3-4	5-6	9-10	13-14	2-3	5-6	10-11	13-14	14080
3	3-4	5-6	10-11	12-13	3-4	5-6	10-11	12-13	3-4	6-7	9-10	13-14	3-4	5-6	10-11	13-14	9387/9386
4	2-3	5-6	9-10	12-13	2-3	5-6	9-10	13-14	2-3	5-6	10-11	12-13	2-3	6-7	10-11	13-14	7040
5	2-3	5-6	9-10	12-13	2-3	5-6	9-10	12-13	2-3	6-7	9-10	13-14	2-3	6-7	10-11	13-14	5632
6	2-3	6-7	9-10	13-14	2-3	6-7	9-10	13-14	3-4	5-6	10-11	13-14	2-3	6-7	10-11	13-14	4694/4690
7	3-4	5-6	9-10	13-14	2-3	5-6	10-11	12-13	2-3	5-6	9-10	12-13	3-4	6-7	10-11	13-14	4023/4022
8	2-3	5-6	9-10	12-13	2-3	5-6	10-11	12-13	2-3	6-7	9-10	12-13	3-4	6-7	10-11	13-14	3520
9	3-4	6-7	10-11	12-13	2-3	5-6	10-11	13-14	3-4	6-7	9-10	12-13	3-4	6-7	10-11	13-14	3129/3128

B03P-4655-0001A...E1

Sector Count	Location BC7				Location BD7				Location BE7				Location BF7				Bytes Per Sect/Last Sect
	(2 <sup>n</sup> )	1	2	4	8	16	32	64	128	256	512	1024	2048	4096	8192	16384	
10	2-3	5-6	9-10	12-13	2-3	5-6	9-10	12-13	3-4	5-6	10-11	12-13	3-4	6-7	10-11	13-14	2816
11	2-3	5-6	9-10	12-13	2-3	5-6	9-10	12-13	2-3	6-7	10-11	12-13	3-4	6-7	10-11	13-14	2560
12	3-4	5-6	10-11	12-13	3-4	5-6	10-11	13-14	2-3	6-7	10-11	12-13	3-4	6-7	10-11	13-14	2347/2343
13	3-4	5-6	9-10	13-14	2-3	5-6	9-10	13-14	3-4	6-7	10-11	12-13	3-4	6-7	10-11	13-14	2167/2156
14	2-3	5-6	10-11	12-13	2-3	6-7	9-10	12-13	2-3	5-6	9-10	13-14	3-4	6-7	10-11	13-14	2012/2004
15	2-3	6-7	9-10	13-14	2-3	6-7	9-10	13-14	2-3	5-6	9-10	13-14	3-4	6-7	10-11	13-14	1878/1868
16	2-3	5-6	9-10	12-13	2-3	6-7	9-10	12-13	3-4	5-6	9-10	13-14	3-4	6-7	10-11	13-14	1760
17	3-4	6-7	10-11	12-13	2-3	5-6	9-10	13-14	3-4	5-6	9-10	13-14	3-4	6-7	10-11	13-14	1657/1648
18	3-4	6-7	9-10	12-13	2-3	6-7	10-11	13-14	3-4	5-6	9-10	13-14	3-4	6-7	10-11	13-14	1565/1555
19	3-4	5-6	10-11	12-13	3-4	6-7	9-10	12-13	2-3	6-7	9-10	13-14	3-4	6-7	10-11	13-14	1483/1466
20	2-3	5-6	9-10	12-13	2-3	5-6	9-10	13-14	2-3	6-7	9-10	13-14	3-4	6-7	10-11	13-14	1408
21	3-4	6-7	9-10	12-13	2-3	5-6	10-11	13-14	2-3	6-7	9-10	13-14	3-4	6-7	10-11	13-14	1341/1340
22	2-3	5-6	9-10	12-13	2-3	5-6	9-10	12-13	3-4	6-7	9-10	13-14	3-4	6-7	10-11	13-14	1280
23	3-4	6-7	10-11	12-13	3-4	6-7	9-10	12-13	3-4	6-7	9-10	13-14	3-4	6-7	10-11	13-14	1225/1210
24	2-3	6-7	9-10	13-14	2-3	6-7	10-11	12-13	3-4	6-7	9-10	13-14	3-4	6-7	10-11	13-14	1174/1158
25	3-4	5-6	9-10	13-14	3-4	5-6	9-10	13-14	3-4	6-7	9-10	13-14	3-4	6-7	10-11	13-14	1127/1112
26	2-3	5-6	10-11	12-13	2-3	5-6	10-11	13-14	3-4	6-7	9-10	13-14	3-4	6-7	10-11	13-14	1084/1060
27	3-4	5-6	10-11	13-14	2-3	6-7	10-11	13-14	3-4	6-7	9-10	13-14	3-4	6-7	10-11	13-14	1043/1042
28	2-3	6-7	9-10	12-13	3-4	5-6	9-10	12-13	2-3	5-6	10-11	13-14	3-4	6-7	10-11	13-14	1006/998
29	2-3	5-6	10-11	12-13	3-4	6-7	9-10	12-13	2-3	5-6	10-11	13-14	3-4	6-7	10-11	13-14	972/944
30	3-4	5-6	10-11	12-13	3-4	5-6	10-11	12-13	2-3	5-6	10-11	13-14	3-4	6-7	10-11	13-14	939/929
31	3-4	6-7	9-10	12-13	3-4	6-7	10-11	12-13	2-3	5-6	10-11	13-14	3-4	6-7	10-11	13-14	909/890
32	2-3	5-6	9-10	12-13	3-4	5-6	9-10	13-14	2-3	5-6	10-11	13-14	3-4	6-7	10-11	13-14	880

Sector Count	Location BC7				Location BD7				Location BE7				Location BF7				Bytes Per Sect/Last Sect
	(2 <sup>n</sup> )	1	2	4	8	16	32	64	128	256	512	1024	2048	4096	8192	16384	
33	2-3	6-7	9-10	13-14	2-3	6-7	9-10	13-14	2-3	5-6	10-11	13-14	3-4	6-7	10-11	13-14	854/832
34	3-4	6-7	9-10	12-13	2-3	5-6	10-11	13-14	2-3	5-6	10-11	13-14	3-4	6-7	10-11	13-14	829/803
35	3-4	6-7	9-10	13-14	3-4	5-6	10-11	13-14	2-3	5-6	10-11	13-14	3-4	6-7	10-11	13-14	805/790
36	3-4	5-6	9-10	12-13	3-4	6-7	10-11	13-14	2-3	5-6	10-11	13-14	3-4	6-7	10-11	13-14	783/755
37	2-3	6-7	10-11	12-13	2-3	5-6	9-10	12-13	3-4	5-6	10-11	13-14	3-4	6-7	10-11	13-14	762/728
38	2-3	6-7	9-10	13-14	3-4	5-6	9-10	12-13	3-4	5-6	10-11	13-14	3-4	6-7	10-11	13-14	742/706
39	3-4	5-6	10-11	13-14	2-3	6-7	9-10	12-13	3-4	5-6	10-11	13-14	3-4	6-7	10-11	13-14	723/686
40	2-3	5-6	9-10	12-13	2-3	5-6	10-11	12-13	3-4	5-6	10-11	13-14	3-4	6-7	10-11	13-14	704
41	3-4	5-6	9-10	12-13	3-4	5-6	10-11	12-13	3-4	5-6	10-11	13-14	3-4	6-7	10-11	13-14	687/680
42	3-4	5-6	9-10	12-13	2-3	6-7	10-11	12-13	3-4	5-6	10-11	13-14	3-4	6-7	10-11	13-14	671/649
43	3-4	5-6	9-10	12-13	3-4	6-7	10-11	12-13	3-4	5-6	10-11	13-14	3-4	6-7	10-11	13-14	655/650
44	2-3	5-6	9-10	12-13	2-3	5-6	9-10	13-14	3-4	5-6	10-11	13-14	3-4	6-7	10-11	13-14	640
45	2-3	6-7	10-11	13-14	2-3	5-6	9-10	13-14	3-4	5-6	10-11	13-14	3-4	6-7	10-11	13-14	626/616
46	3-4	6-7	9-10	13-14	3-4	5-6	9-10	13-14	3-4	5-6	10-11	13-14	3-4	6-7	10-11	13-14	613/575
47	2-3	5-6	9-10	13-14	2-3	6-7	9-10	13-14	3-4	5-6	10-11	13-14	3-4	6-7	10-11	13-14	600/560
48	3-4	5-6	10-11	12-13	3-4	6-7	9-10	13-14	3-4	5-6	10-11	13-14	3-4	6-7	10-11	13-14	587/571
49	3-4	5-6	9-10	12-13	2-3	5-6	10-11	13-14	3-4	5-6	10-11	13-14	3-4	6-7	10-11	13-14	575/560
50	2-3	5-6	10-11	13-14	2-3	5-6	10-11	13-14	3-4	5-6	10-11	13-14	3-4	6-7	10-11	13-14	564/524
51	3-4	6-7	10-11	12-13	3-4	5-6	10-11	13-14	3-4	5-6	10-11	13-14	3-4	6-7	10-11	13-14	553/510
52	2-3	6-7	9-10	12-13	2-3	6-7	10-11	13-14	3-4	5-6	10-11	13-14	3-4	6-7	10-11	13-14	542/518
53	2-3	5-6	10-11	13-14	2-3	6-7	10-11	13-14	3-4	5-6	10-11	13-14	3-4	6-7	10-11	13-14	532/496
54	2-3	6-7	10-11	12-13	3-4	6-7	10-11	13-14	3-4	5-6	10-11	13-14	3-4	6-7	10-11	13-14	522/494
55	2-3	5-6	9-10	12-13	2-3	5-6	9-10	12-13	2-3	6-7	10-11	13-14	3-4	6-7	10-11	13-14	512

B03P-4655-0001A...E1

Sector Count	Location BC7				Location BD7				Location BE7				Location BF7				Bytes Per Sect/Last Sect
	(2 <sup>B</sup> ) 1	2	4	8	16	32	64	128	256	512	1024	2048	4096	8192	16384	spare	
56	3-4	5-6	9-10	13-14	2-3	5-6	9-10	12-13	2-3	6-7	10-11	13-14	3-4	6-7	10-11	13-14	503/495
57	3-4	5-6	9-10	12-13	3-4	5-6	9-10	12-13	2-3	6-7	10-11	13-14	3-4	6-7	10-11	13-14	495/440
58	2-3	6-7	9-10	13-14	3-4	5-6	9-10	12-13	2-3	6-7	10-11	13-14	3-4	6-7	10-11	13-14	486/458
59	2-3	6-7	9-10	12-13	2-3	6-7	9-10	12-13	2-3	6-7	10-11	13-14	3-4	6-7	10-11	13-14	478/436
60	2-3	6-7	9-10	13-14	2-3	6-7	9-10	12-13	2-3	6-7	10-11	13-14	3-4	6-7	10-11	13-14	470/430
61	2-3	6-7	9-10	12-13	3-4	6-7	9-10	12-13	2-3	6-7	10-11	13-14	3-4	6-7	10-11	13-14	462/440
62	3-4	5-6	9-10	13-14	3-4	6-7	9-10	12-13	2-3	6-7	10-11	13-14	3-4	6-7	10-11	13-14	455/405
63	3-4	5-6	9-10	12-13	2-3	5-6	10-11	12-13	2-3	6-7	10-11	13-14	3-4	6-7	10-11	13-14	447/446
64	2-3	5-6	9-10	13-14	2-3	5-6	10-11	12-13	2-3	6-7	10-11	13-14	3-4	6-7	10-11	13-14	440
65	2-3	6-7	10-11	13-14	2-3	5-6	10-11	12-13	2-3	6-7	10-11	13-14	3-4	6-7	10-11	13-14	434/384
66	3-4	5-6	10-11	12-13	3-4	5-6	10-11	12-13	2-3	6-7	10-11	13-14	3-4	6-7	10-11	13-14	427/405
67	3-4	6-7	9-10	13-14	3-4	5-6	10-11	12-13	2-3	6-7	10-11	13-14	3-4	6-7	10-11	13-14	421/374
68	3-4	5-6	9-10	12-13	2-3	6-7	10-11	12-13	2-3	6-7	10-11	13-14	3-4	6-7	10-11	13-14	415/355
69	3-4	6-7	10-11	12-13	2-3	6-7	10-11	12-13	2-3	6-7	10-11	13-14	3-4	6-7	10-11	13-14	409/348
70	3-4	5-6	10-11	13-14	2-3	6-7	10-11	12-13	2-3	6-7	10-11	13-14	3-4	6-7	10-11	13-14	403/353
71	3-4	6-7	9-10	12-13	3-4	6-7	10-11	12-13	2-3	6-7	10-11	13-14	3-4	6-7	10-11	13-14	397/370
72	2-3	5-6	9-10	13-14	3-4	6-7	10-11	12-13	2-3	6-7	10-11	13-14	3-4	6-7	10-11	13-14	392/328
73	2-3	6-7	10-11	13-14	3-4	6-7	10-11	12-13	2-3	6-7	10-11	13-14	3-4	6-7	10-11	13-14	386/368
74	3-4	6-7	9-10	12-13	2-3	5-6	9-10	13-14	2-3	6-7	10-11	13-14	3-4	6-7	10-11	13-14	381/347
75	2-3	5-6	9-10	13-14	2-3	5-6	9-10	13-14	2-3	6-7	10-11	13-14	3-4	6-7	10-11	13-14	376/336
76	3-4	5-6	10-11	13-14	2-3	5-6	9-10	13-14	2-3	6-7	10-11	13-14	3-4	6-7	10-11	13-14	371/335
77	2-3	6-7	9-10	12-13	3-4	5-6	9-10	13-14	2-3	6-7	10-11	13-14	3-4	6-7	10-11	13-14	366/344
78	2-3	6-7	10-11	12-13	3-4	5-6	9-10	13-14	2-3	6-7	10-11	13-14	3-4	6-7	10-11	13-14	362/286

Sector Count	Location BC7				Location BD7				Location BE7				Location BF7				Bytes Per Sect/Last Sect
	(2 <sup>n</sup> ) 1	2	4	8	16	32	64	128	256	512	1024	2048	4096	8192	16384	spare	
79	3-4	6-7	9-10	13-14	3-4	5-6	9-10	13-14	2-3	6-7	10-11	13-14	3-4	6-7	10-11	13-14	357/314
80	2-3	5-6	9-10	12-13	2-3	6-7	9-10	13-14	2-3	6-7	10-11	13-14	3-4	6-7	10-11	13-14	352
81	2-3	5-6	10-11	12-13	2-3	6-7	9-10	13-14	2-3	6-7	10-11	13-14	3-4	6-7	10-11	13-14	348/320
82	2-3	5-6	9-10	13-14	2-3	6-7	9-10	13-14	2-3	6-7	10-11	13-14	3-4	6-7	10-11	13-14	344/296
83	2-3	5-6	10-11	13-14	2-3	6-7	9-10	13-14	2-3	6-7	10-11	13-14	3-4	6-7	10-11	13-14	340/280
84	2-3	5-6	9-10	12-13	3-4	6-7	9-10	13-14	2-3	6-7	10-11	13-14	3-4	6-7	10-11	13-14	336/272
85	2-3	5-6	10-11	12-13	3-4	6-7	9-10	13-14	2-3	6-7	10-11	13-14	3-4	6-7	10-11	13-14	332/272
86	2-3	5-6	9-10	13-14	3-4	6-7	9-10	13-14	2-3	6-7	10-11	13-14	3-4	6-7	10-11	13-14	328/280
87	2-3	5-6	10-11	13-14	3-4	6-7	9-10	13-14	2-3	6-7	10-11	13-14	3-4	6-7	10-11	13-14	324/296
88	2-3	5-6	9-10	12-13	2-3	5-6	10-11	13-14	2-3	6-7	10-11	13-14	3-4	6-7	10-11	13-14	320
89	3-4	6-7	9-10	12-13	2-3	5-6	10-11	13-14	2-3	6-7	10-11	13-14	3-4	6-7	10-11	13-14	317/264
90	3-4	6-7	10-11	12-13	2-3	5-6	10-11	13-14	2-3	6-7	10-11	13-14	3-4	6-7	10-11	13-14	313/303
91	2-3	6-7	9-10	13-14	2-3	5-6	10-11	13-14	2-3	6-7	10-11	13-14	3-4	6-7	10-11	13-14	310/260
92	3-4	5-6	10-11	13-14	2-3	5-6	10-11	13-14	2-3	6-7	10-11	13-14	3-4	6-7	10-11	13-14	307/223
93	3-4	5-6	9-10	12-13	3-4	5-6	10-11	13-14	2-3	6-7	10-11	13-14	3-4	6-7	10-11	13-14	303/284
94	2-3	5-6	10-11	12-13	3-4	5-6	10-11	13-14	2-3	6-7	10-11	13-14	3-4	6-7	10-11	13-14	300/260
95	3-4	6-7	10-11	12-13	3-4	5-6	10-11	13-14	2-3	6-7	10-11	13-14	3-4	6-7	10-11	13-14	297/242
96	2-3	6-7	9-10	13-14	3-4	5-6	10-11	13-14	2-3	6-7	10-11	13-14	3-4	6-7	10-11	13-14	294/230
97	3-4	5-6	10-11	13-14	3-4	5-6	10-11	13-14	2-3	6-7	10-11	13-14	3-4	6-7	10-11	13-14	291/224
98	2-3	5-6	9-10	12-13	2-3	6-7	10-11	13-14	2-3	6-7	10-11	13-14	3-4	6-7	10-11	13-14	288/224
99	3-4	6-7	9-10	12-13	2-3	6-7	10-11	13-14	2-3	6-7	10-11	13-14	3-4	6-7	10-11	13-14	285/230
100	2-3	6-7	10-11	12-13	2-3	6-7	10-11	13-14	2-3	6-7	10-11	13-14	3-4	6-7	10-11	13-14	282/242
101	3-4	5-6	9-10	13-14	2-3	6-7	10-11	13-14	2-3	6-7	10-11	13-14	3-4	6-7	10-11	13-14	279/260

B03P-4655-0001A...E1



Sector Count	Location BC7				Location BD7				Location BE7				Location BF7				Bytes Per Sect/Last Sect
	(2 <sup>n</sup> ) 1	2	4	8	16	32	64	128	256	512	1024	2048	4096	8192	16384	spare	
102	3-4	6-7	9-10	13-14	2-3	6-7	10-11	13-14	2-3	6-7	10-11	13-14	3-4	6-7	10-11	13-14	277/183
103	2-3	6-7	10-11	13-14	2-3	6-7	10-11	13-14	2-3	6-7	10-11	13-14	3-4	6-7	10-11	13-14	274/212
104	3-4	5-6	9-10	12-13	3-4	6-7	10-11	13-14	2-3	6-7	10-11	13-14	3-4	6-7	10-11	13-14	271/247
105	3-4	6-7	9-10	12-13	3-4	6-7	10-11	13-14	2-3	6-7	10-11	13-14	3-4	6-7	10-11	13-14	269/184
106	2-3	6-7	10-11	12-13	3-4	6-7	10-11	13-14	2-3	6-7	10-11	13-14	3-4	6-7	10-11	13-14	266/230
107	2-3	5-6	9-10	13-14	3-4	6-7	10-11	13-14	2-3	6-7	10-11	13-14	3-4	6-7	10-11	13-14	264/176
108	3-4	6-7	9-10	13-14	3-4	6-7	10-11	13-14	2-3	6-7	10-11	13-14	3-4	6-7	10-11	13-14	261/233
109	3-4	5-6	10-11	13-14	3-4	6-7	10-11	13-14	2-3	6-7	10-11	13-14	3-4	6-7	10-11	13-14	259/188
110	2-3	5-6	9-10	12-13	2-3	5-6	9-10	12-13	3-4	6-7	10-11	13-14	3-4	6-7	10-11	13-14	256
111	2-3	6-7	9-10	12-13	2-3	5-6	9-10	12-13	3-4	6-7	10-11	13-14	3-4	6-7	10-11	13-14	254/220
112	2-3	5-6	10-11	12-13	2-3	5-6	9-10	12-13	3-4	6-7	10-11	13-14	3-4	6-7	10-11	13-14	252/188
113	2-3	6-7	10-11	12-13	2-3	5-6	9-10	12-13	3-4	6-7	10-11	13-14	3-4	6-7	10-11	13-14	250/160
114	2-3	5-6	9-10	13-14	2-3	5-6	9-10	12-13	3-4	6-7	10-11	13-14	3-4	6-7	10-11	13-14	248/136
115	3-4	6-7	9-10	13-14	2-3	5-6	9-10	12-13	3-4	6-7	10-11	13-14	3-4	6-7	10-11	13-14	245/230
116	3-4	5-6	10-11	13-14	2-3	5-6	9-10	12-13	3-4	6-7	10-11	13-14	3-4	6-7	10-11	13-14	243/215
117	3-4	6-7	10-11	13-14	2-3	5-6	9-10	12-13	3-4	6-7	10-11	13-14	3-4	6-7	10-11	13-14	241/204
118	3-4	5-6	9-10	12-13	3-4	5-6	9-10	12-13	3-4	6-7	10-11	13-14	3-4	6-7	10-11	13-14	239/197
119	3-4	6-7	9-10	12-13	3-4	5-6	9-10	12-13	3-4	6-7	10-11	13-14	3-4	6-7	10-11	13-14	237/194
120	3-4	5-6	10-11	12-13	3-4	5-6	9-10	12-13	3-4	6-7	10-11	13-14	3-4	6-7	10-11	13-14	235/195
121	3-4	6-7	10-11	12-13	3-4	5-6	9-10	12-13	3-4	6-7	10-11	13-14	3-4	6-7	10-11	13-14	233/200
122	3-4	5-6	9-10	13-14	3-4	5-6	9-10	12-13	3-4	6-7	10-11	13-14	3-4	6-7	10-11	13-14	231/209
123	3-4	6-7	9-10	13-14	3-4	5-6	9-10	12-13	3-4	6-7	10-11	13-14	3-4	6-7	10-11	13-14	229/222
124	2-3	5-6	10-11	13-14	3-4	5-6	9-10	12-13	3-4	6-7	10-11	13-14	3-4	6-7	10-11	13-14	228/116

Sector Count	Location BC7				Location BD7				Location BE7				Location BF7				Bytes Per Sect/Last Sect
	(2 <sup>n</sup> )	1	2	4	8	16	32	64	128	256	512	1024	2048	4096	8192	16384	
125	2-3	6-7	10-11	13-14	3-4	5-6	9-10	12-13	3-4	6-7	10-11	13-14	3-4	6-7	10-11	13-14	226/136
126	2-3	5-6	9-10	12-13	2-3	6-7	9-10	12-13	3-4	6-7	10-11	13-14	3-4	6-7	10-11	13-14	224/160
127	2-3	6-7	9-10	12-13	2-3	6-7	9-10	12-13	3-4	6-7	10-11	13-14	3-4	6-7	10-11	13-14	222/188
128	2-3	5-6	10-11	12-13	2-3	6-7	9-10	12-13	3-4	6-7	10-11	13-14	3-4	6-7	10-11	13-14	220

One of the following interface cable configurations must be chosen depending on the feature of the controller. (Note; Dual Channel Feature is optional.)

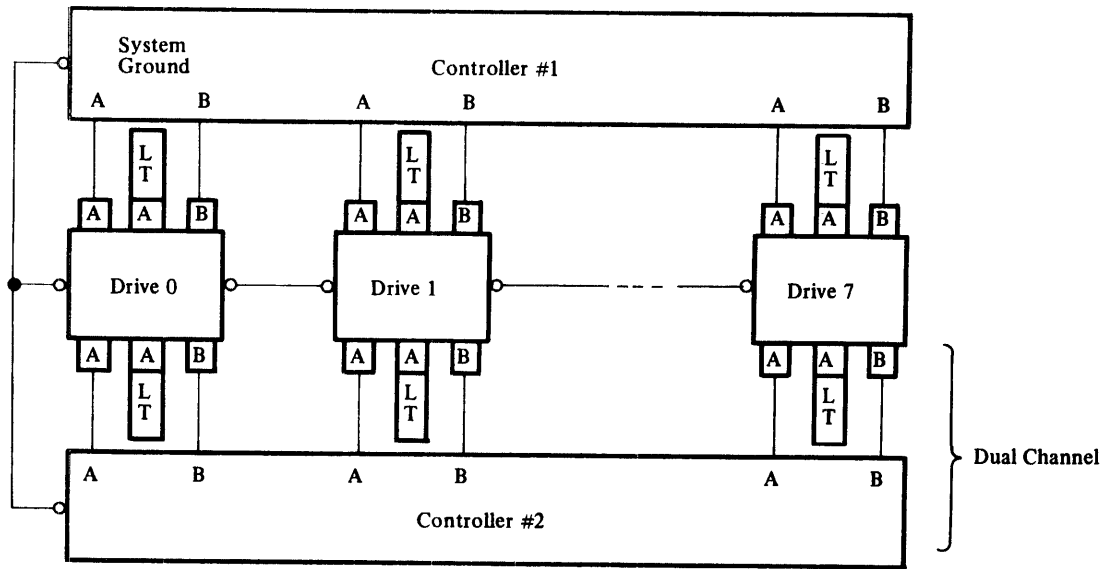

Note that Line Terminators (LT) are required in each drive in a radial cable configuration.

Figure 3.5-1 Radial Cable Configuration

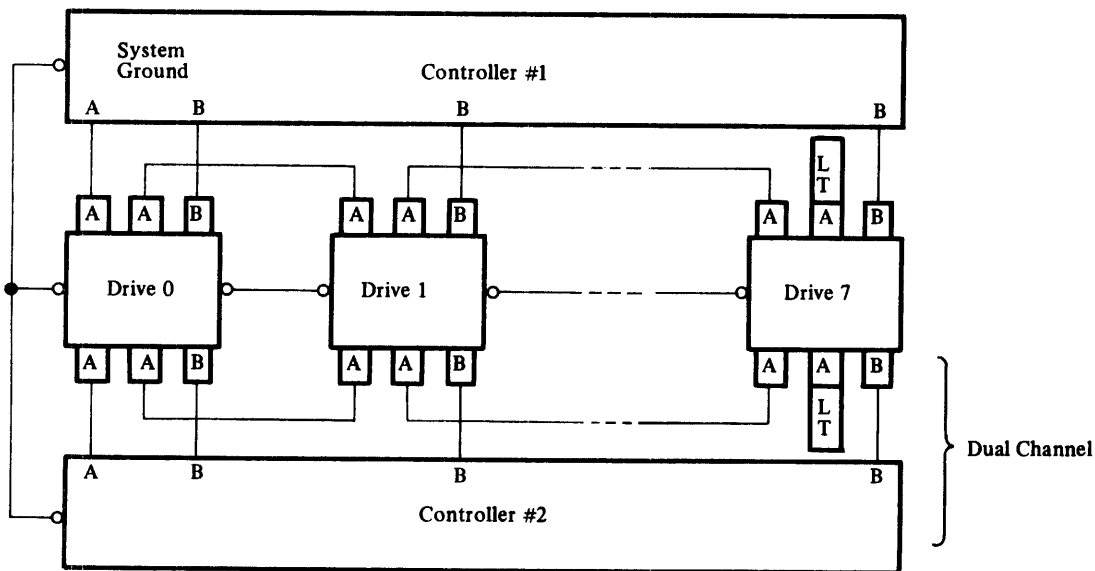

Note that a Line Terminator (LT) is required in the last drive in a daisy-chain cable configuration.

Figure 3.5-2 Daisy-Chain Cable Configuration

### 3.5 OPERATOR PANEL

Switches and indicators on the operator panel are shown in Figure 3.5-1.

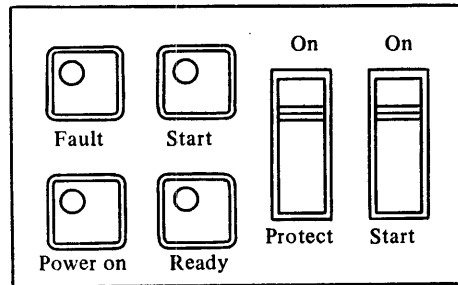

Figure 3.5-1 Operator Panel

#### (1) Start-On (Switch)

When the Remote/Local switch on the control panel of DC power supply unit is set to Local, this switch enables rotation of the spindle motor. The heads start Initial Seek operation and stop on the cylinder zero, approximately 40 seconds later, lighting the Ready lamp. The spindle motor stops rotating approximately 15 seconds after the switch is set to off position.

When the Remote/Local switch is set to Remote, the spindle motor starts and stops rotating in accordance with the Power Sequence Pick/Hold commands issued from the controller if the Start switch is On.

#### (2) Protect-On (Switch)

Inhibits Write operation. If a write command is issued from the controller while the switch is On, the Fault and Control Check conditions will be returned to the controller. Note: The function of the Protect Switch can only occur with the selection of the drive. If the drive is selected prior to the switch being turned on, it must be deselected, then reselected to enable File Protect.

#### (3) Start (LED)

Indicates that the spindle is rotating.

#### (4) Ready (LED)

Indicates that the spindle has reached the rated speed and no fault condition exists in the drive. It goes off when the heads are seeking to the desired cylinder.

(5) Fault (LED and Switch)

Indicates a Fault condition (i.e., R/W check status) or a Seek Error.  
Depressing the indicator switch clears this condition.

(6) Power On

Indicates that the DC power supply unit is on.

### 3.6 INDICATOR UNIT ----- HGAMU (B16B-7830-0010A#U)

These switches and indicators are provided for aiding maintenance, and are shown in Figure 3.6-1.

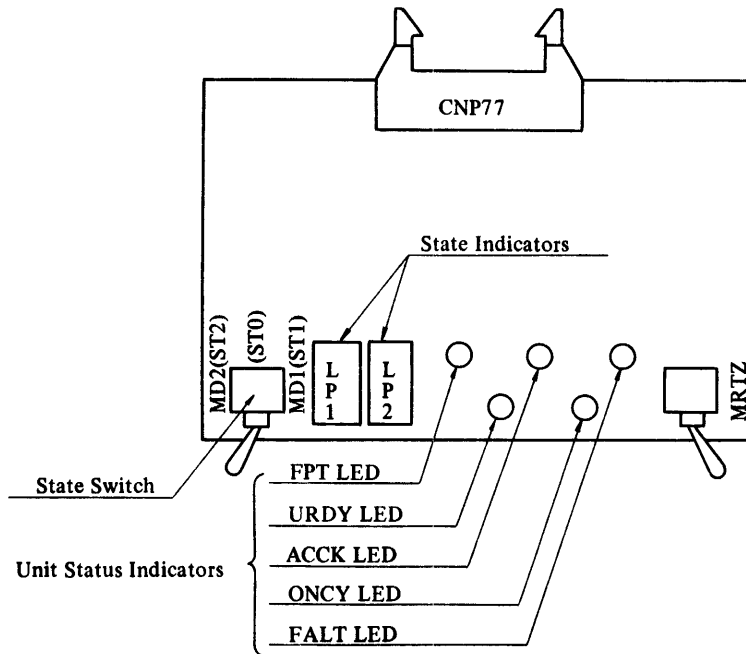

Figure 3.6-1 Switches and Indicators

#### (1) Unit Status Indicators (LEDs)

Indicate Unit Status as shown in Table 3.6-1. These statuses are also issued to the controller as States 0 to 4 when both Tag 4 and 5 are false if this feature is utilized.

Refer to item (2-1) ~ (2-5) in Section 7.4 for detailed descriptions of each state.

Table 3.6-1 Unit Status Indicators

Name of LED	Color of LED	Content
URDY	Green	Unit Ready
ONCY	Green	On Cylinder
ACCK	Red	Seek Error (Access Check)
FALT	Red	Fault
FPT	Yellow	Write Protected (File Protect)

(2) State Switch and State Indicators (Toggle Switch and 7-Segment LEDs)

Two 7-segment LEDs indicate detailed drive states as shown in Table 3.6-2 in accordance with the position of the State Switch.

Table 3.6-2 Status and State

State Switch Position		Left (MD 2)	Center (MD 0)	Right (MD1)
LED	STATE	DE Sequence State	Write/Read Check State	Access State
	Bit			
LP1	1	DE Sequence Latch 1	Index Check	DE Sequence Check
	2	DE Sequence Latch 2	Control Check	Access Timeout Check
	4	DE Sequence Latch 4	Multi Head Check	Over Shoot Check
	8	Hall Alarm	Head Short Check	Rezero Mode Latch
LP2	1	Motor At Speed	Write Current on Read Check	Servo Latch
	2	Inhibit DE Seq. Recycle	Write Transition Check	Linear Mode Latch
	4	Unit Ready	Delta I Write Check	Control Latch
	8	Access Busy	Servo Off-Track	Wait Latch

DE Sequence Stage (MD 2)

DE Sequence 1, 2 and 4

Indicates Start/Stop status sequence of the DE. Details are described in item (5-1) of Section 7.4.

Hall Alarm

Indicates that all output signals from the hall-elements used to detect the pole position of the rotor in the spindle motor are high or low level simultaneously.

#### Motor At Speed

Indicates that the spindle motor is rotating at 3,961 RPM  $\pm 2\%$ .

#### Inhibit DE Sequence Recycle

Indicates that Run State Good goes false while the DE Sequence Latch is in State 7. Stop sequence of the DE may be inhibited hereafter. Switching off the drive power or pushing the Start switch to Off position clears this state.

#### Unit Ready

Indicates that the drive has reached the rated rotational speed and heads are positioned on track.

#### Access Busy

Indicates that the heads are in motion, i.e., heads are performing Seek, RTZ or Offset operation.

#### Write/Read Check State (MD 0)

Refer to item (4) in Section 7.4.

#### Access State (MD 1)

Refer to item (5) in Section 7.4.

#### (3) MRTZ (Manual RTZ) Switch

The head performs RTZ operation when this maintenance-aid switch is pressed.



### 3.7 STANDALONE CHECK

After the preceding Sections 3.1 through 3.6 have been applied as required (3.1, in particular), a basic standalone check of drive operation can be made. The rotary actuator must be unlocked (refer to Section 2.3). Proceed with the check as follows:

- (1) With the circuit breaker and Start switch OFF, plug in the AC line cord.
- (2) Turn the circuit breaker ON. The Power on LED on the operator panel should light. The blower motor starts.
- (3) Press the Start switch on the operator panel to ON. The Start LED on the operator panel should light. The DC motor will begin to rotate. Approximately 40 seconds later, the Ready LED on the operator panel should light, and the green On Cylinder and Unit Ready LEDs on the Indicator PCB should light.
- (4) Depress the MRTZ switch on the Indicator PCB and note that the drive executes a RTZ operation. The On Cylinder and Unit Ready LEDs should blink during the carriage motion and remain On when locked on Cylinder 0.

This basic check has significance for initial Power On, Heads Load, Lock-on and RTZ capabilities.

4.1 CONTROL CABLE ("A" CABLE)

A description of the Control cable signals and Pin assignments will be found in Chapter 7.2.

"A" Cables may be installed radially or daisy-chained. Connect the "A" cable from the controller output port to the Interface PCB (DQEMU) or Dual channel PCB (DQFMU), (CNP 41 or 51), as shown in Figure 4.1-1. Note that Pin 1 is to the right when facing the rear of the drive.

In a daisy-chain configuration, the "A" cable will be continued by connecting another cable from the Terminator header, (CNP 42 or 52), to the next drives input (CNP 41 or 51).

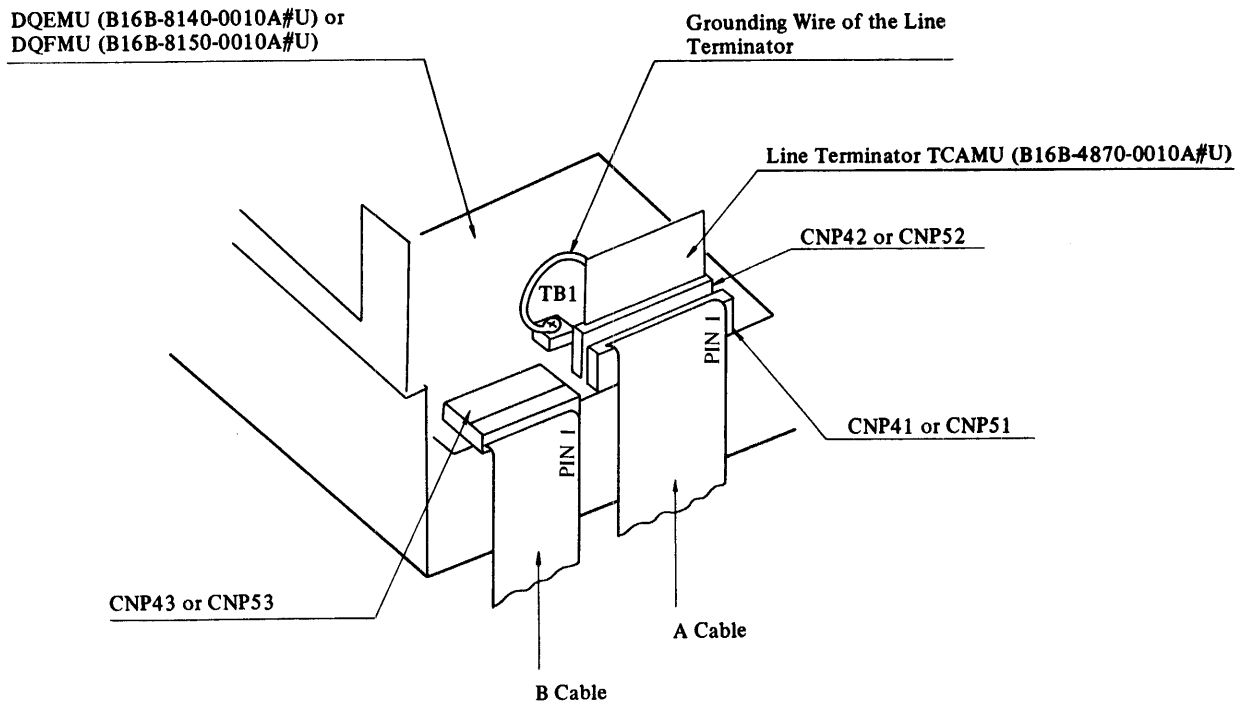

Fig. 4.1-1 Cable Connection

## 4.2 READ/WRITE CABLE ("B" CABLE)

A description of the Read/Write cable signals and Pin assignments will be found in Chapter 7.2.

"B" cables are always installed radially from the controller. Connect the "B" cable from the controller output port to the Interface PCB (DQEMU) or Dual Channel PCB (DQFMU), (CNP 43 or 53), as shown in Figure 4.1-1. Note that Pin 1 is to the right when facing the rear of the drive.

### 4.3 SYSTEM GROUNDING

#### (1) Definitions of SG, FG1 and FG2.

SG is Signal ground or DC ground and is isolated from AC ground within the drive.

FG1 is Frame ground or AC ground and is a direct short to chassis.

FG2 is a high impedance AC ground, connected to FG1 through a 510 Kohm resistor.

For shipment, SG is connected to FG2 with the shorting plate, as shown in Figure 4.3-1.

#### (2) Grounding Methods

It is always recommended that drives be grounded, and it is required if cable lengths longer than 10 ft. are used or if the drives are connected in the daisy-chain configuration. All grounding should be done with flat braided wire, preferably covered with a jacket or tubing. Note: Proper grounding is important for the operation of the drive.

Grounding methods vary with site and system integration design, and are commonly derived in a trial-and-error fashion. However, four approaches are offered in order of preference:

- (a) Connect SG to FG1 with the shorting plate. Connect a flat braid wire from SG to controller ground. If daisy-chained, daisy-chain the braid from SG to SG as shown in Figure 4.3-3.
- (b) Leave SG connected to FG2 (shipping configuration) and connect a flat braid wire to controller ground. If daisy-chained, daisy-chain the braid from SG to SG as shown in Figure 4.3-2.
- (c) Remove the shorting plate, isolating SG and FG grounds. Connect a flat braid wire from SG to controller ground (preferably DC ground). In this case, the braided wire must be covered to prevent accidental shorting to chassis (AC ground).
- (d) Leaving the same arrangement as in (c) above, connect another covered, braided wire from FG1 to controller chassis (AC ground).

(3) AC Considerations

- (a) The controller should always be solidly connected to earth ground. The drives and the system are then grounded through the controller.  
(Controller AC-DC isolation is a function of design, and is assumed to be common in the four approaches described in (2) above.)
- (b) It is always recommended that the drive, controller and CPU share a common AC branch circuit.

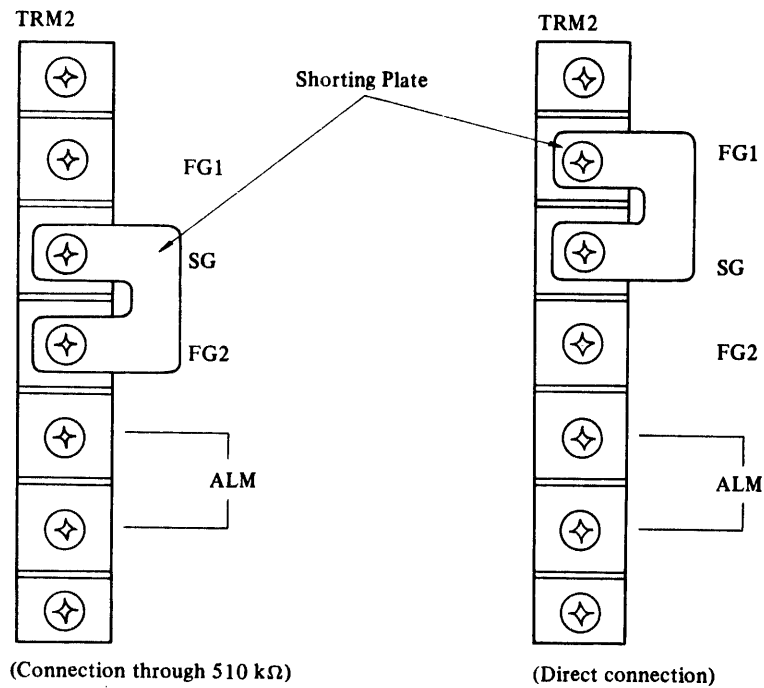

Fig. 4.3-1 Connection of FG and SG

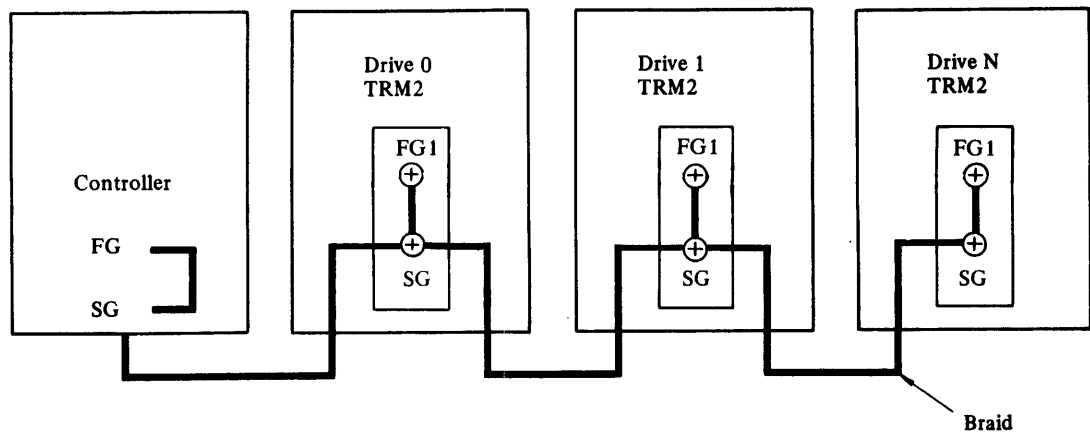

Fig. 4.3-2 SG/FG1 Common

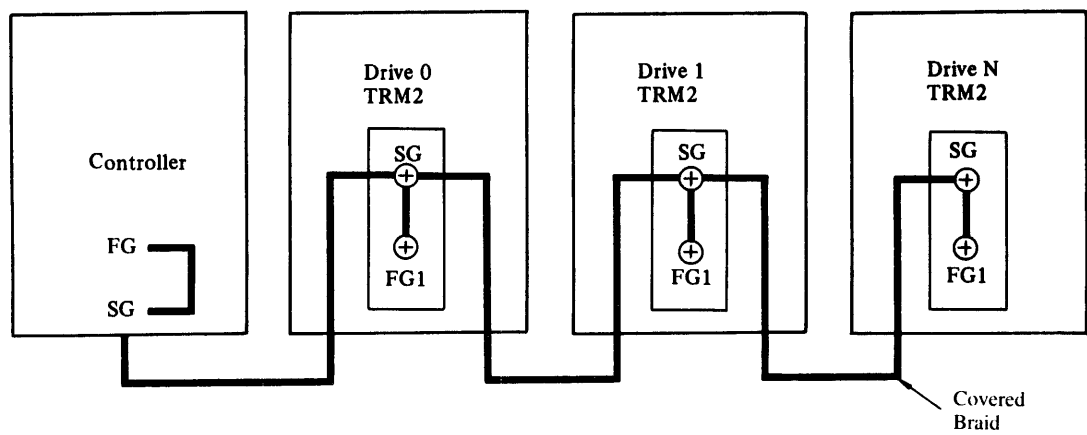

Fig. 4.3-3 SG/HI Z FG2 Common

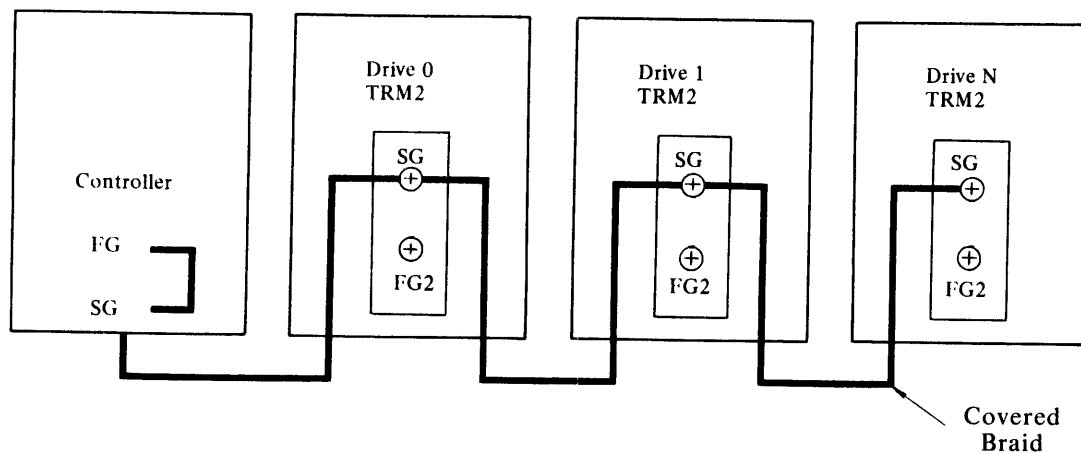

Fig. 4.3-4 SG/FG Isolated

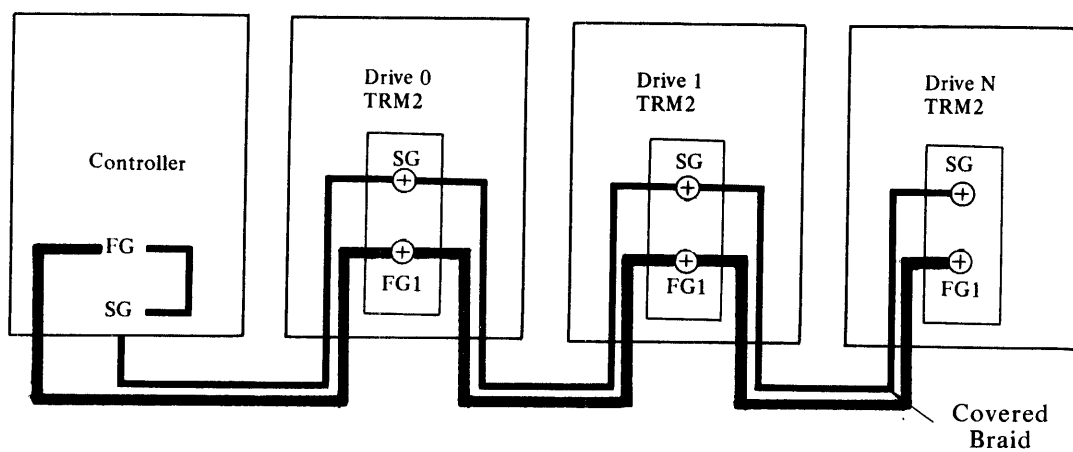

Fig. 4.3-5 SG/FG Isolated - Separate AC Ground

## CHAPTER 5 MECHANICAL ASSEMBLIES

### 5.1 CONSTRUCTION OF THE DRIVE

The overall construction is shown in Figure 5.1-1. The DE is supported horizontally at three points with rubber mounts for vibration and shock absorption. A shock sensor is provided on the DE to monitor for excess shock against the DE during shipping and handling. The rotary actuator is secured by a mechanical lock to prevent damage to the heads and disks during transportation. No mechanical lock is required for the spindle motor.

The Power Amplifier (TVHMU; B16B-8130-0010A#U or TVKMU; B16B-8800-0010A#U) which drives both spindle motor and rotary actuator is mounted horizontally above the DE (Old Version) or vertically behind the front panel (New Version).

Logic PCB (C16B-5123-0980#U), Servo Circuit (SVIAU; C16B-5501-0010#U) and Read/Write Circuit (RFJAU; C16B-5500-0990#U) are inserted in a card cage located at the side of the DE. This card cage can be pulled up and turned 90 degrees for access to the back panel (BQGMU; B16B-8160-0010A#U).

Indicator unit (HGAMU; B16B-7830-0010A#U) is attached on top of the DC Power Supply, located at the rear of the drive. Five LEDs and two 7-segment LED displays provide the status of the drive.

The interface PCBs are also located at the rear of the drive. When the sub-system is single channel, an interface PCB (DQEMU; B16B-8140-0010A#U) is placed in the lower position. When the sub-system is dual channel, an additional interface PCB (DQFMU; B16B-8150-0010A#U) must be placed in the upper position.

The entire drive is cooled by a line blower located at the front of the drive.



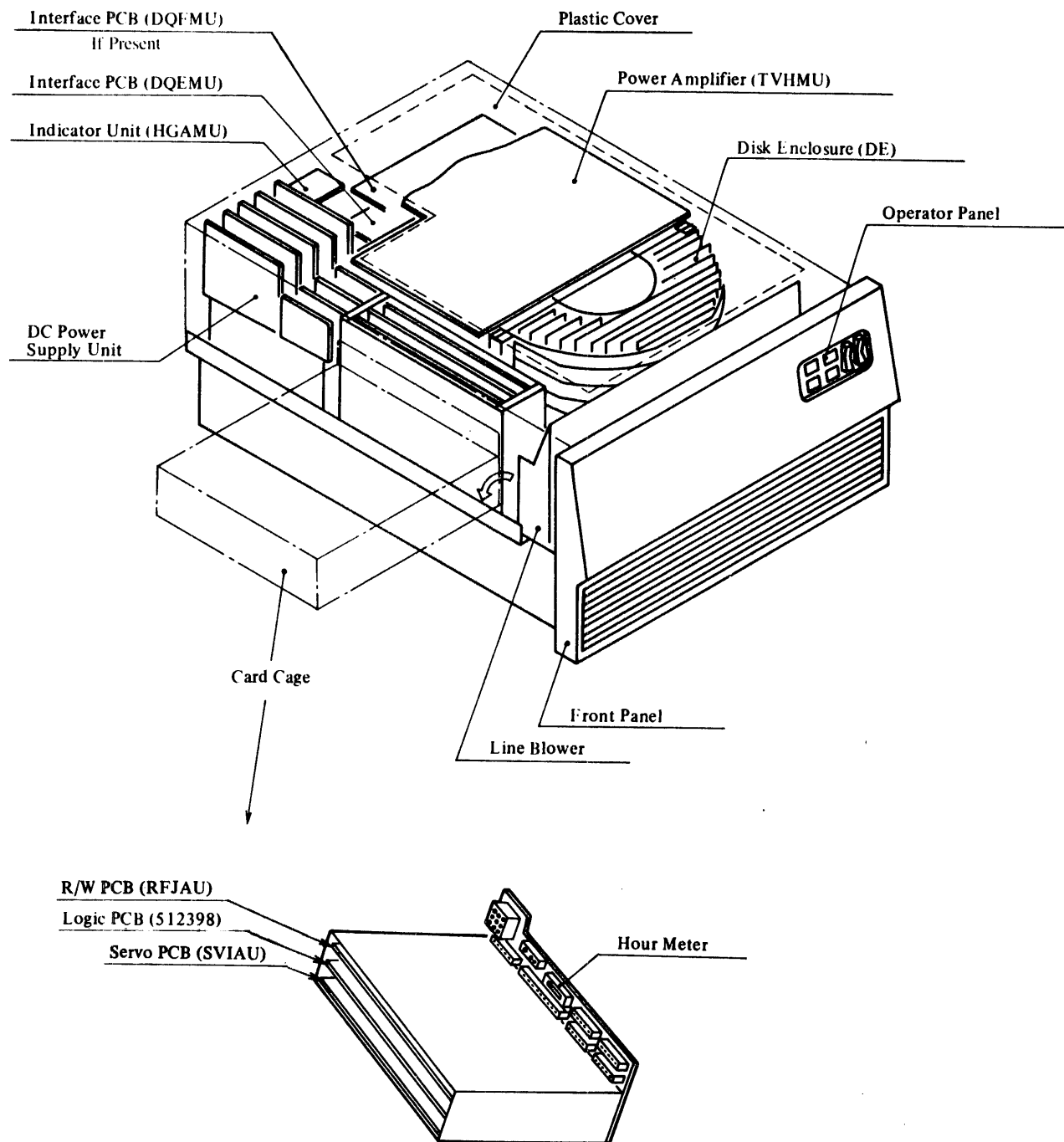

(a) Old version

Figure 5.1-1 Construction of the Drive

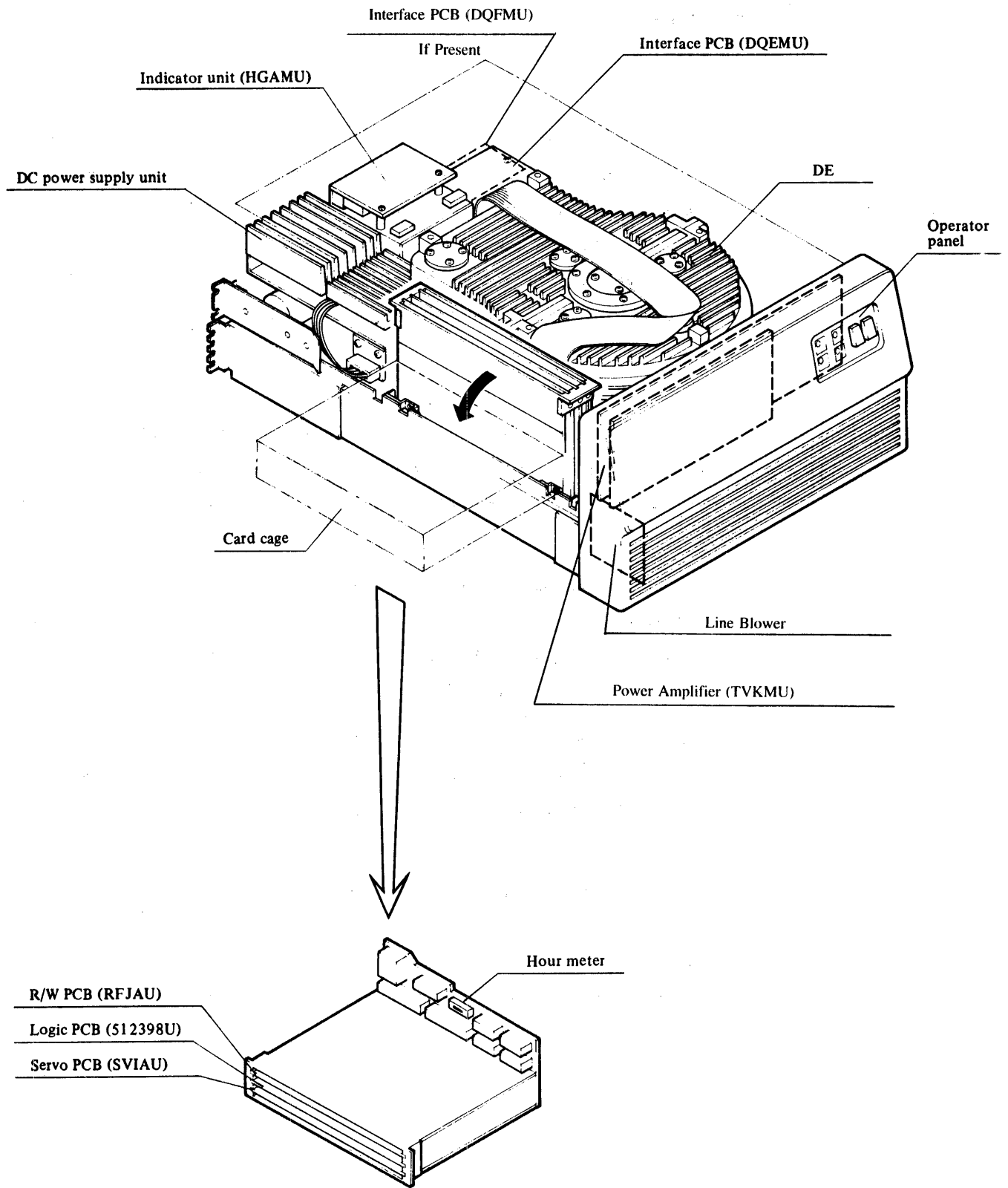

(b) New version

Figure 5.1-1 - Continued

## 5.2 DISK ENCLOSURE (DE)

### (1) Design Concept

The mechanical configuration of the DE shown in Figure 5.2-1 and 5.2-2 was designed to provide a compact, low power consumption, and maintenance-free file with enhanced performance. It features six 10.5 inch diameter disks and a rotary actuator with the fast average positioning time of 18 msec. The rotary actuator is completely balanced statically and dynamically by using a pair of moving coils, thereby avoiding undesired vibration that prolongs settling time.

### (2) Spindle and Base Casting

The primary function of the spindle is to maintain precise and constant rotation of the assembled disks. The accuracy of rotation involves concentricity, precision, thermal and dynamic stability; all of which become more stringent as the track spacing gets tighter.

The dual-supported spindle construction reduces this problem. In this design, the supporting casting is divided into two pieces in a plane parallel to the spindle axis, with one of the divided pieces substantially retaining the rotating bearings. Thus, precise concentricity can be maintained.

With regard to the base casting, it is important to keep the relative dimension between the spindle and rotary actuator very rigid, especially in a dynamic mode. This has been given critical attention as track spacing and access time become smaller and shorter.

In the present drive, the rotary actuator is designed so that the rotating axis is pivoted at both ends, similar to the spindle. A pair of arms are extended from the spindle bearing part to the pivoting element of the rotary actuator. This technique, combined with the high rigidity of the actuator, provides resonant-free seek operation.

B03P-4655-0001A...B

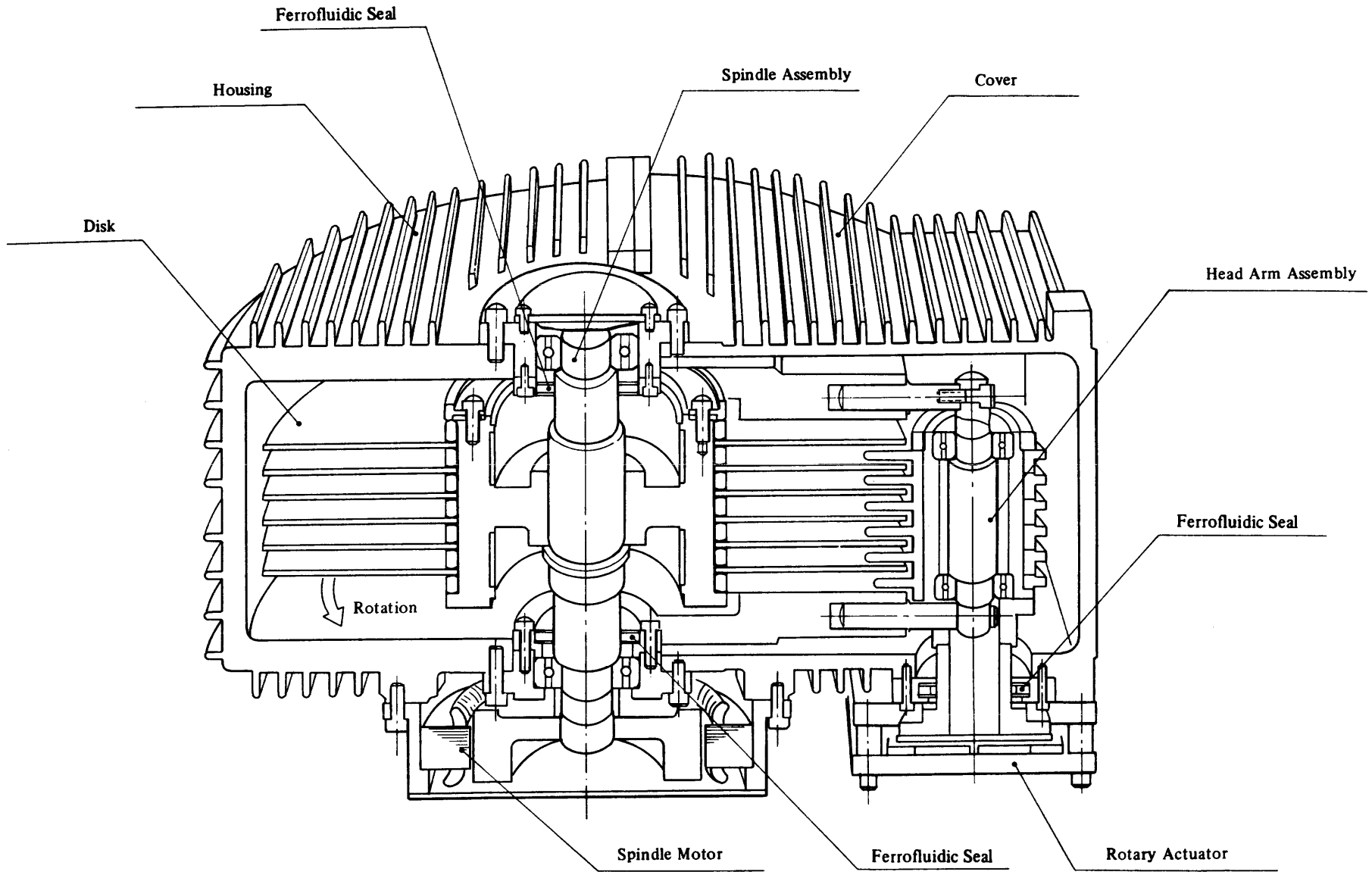

Figure 5.2-2 Cross Sectional View of the DE

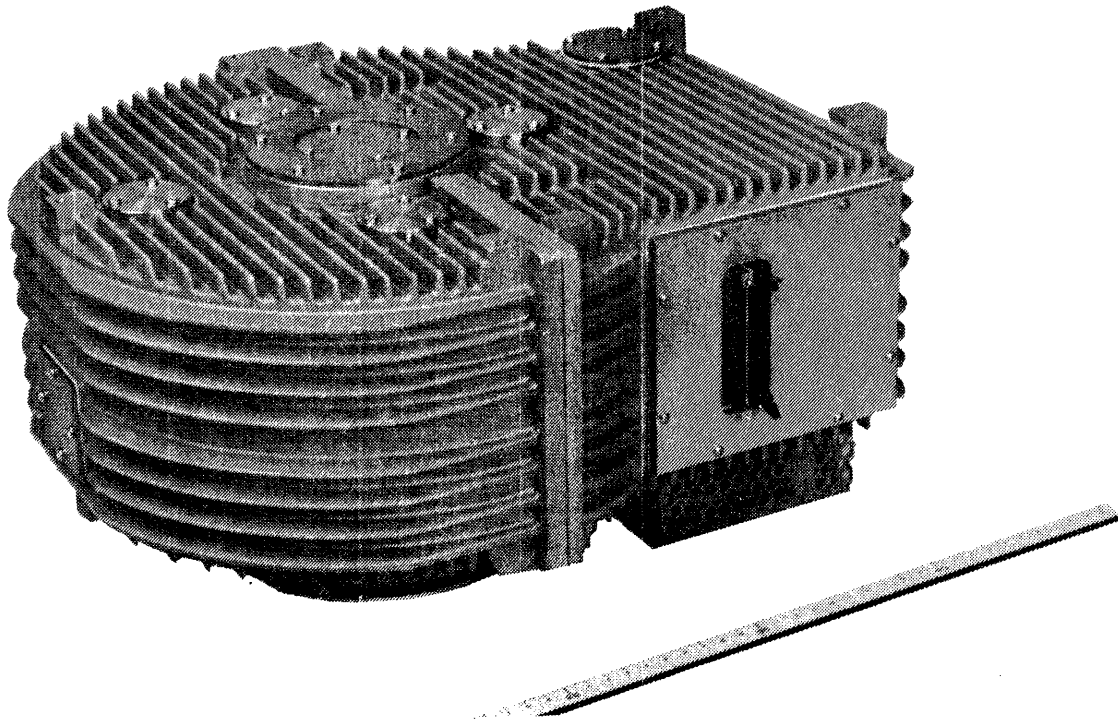

Figure 5.2-1 Overview of the DE

### (3) Air System

The fundamental and important function of the air system is to maintain an ultra-clean environment within the space of the DE to minimize the possibility of head-disk interference. In this DE, A new type of self circulating air system is provided. Features of the system are its simplicity and maintenance-free operation. Air flows through the disk spacings from the center to outside of the disks by the pressure difference between them, induced by the rotation of disks. An absolute filter, whose efficiency is 99.97 percent above 0.3  $\mu\text{m}$  particle size dust, is attached within the spindle hub and is rotating with the disks. Particle count goes very nearly zero in a few minutes from the start of rotation. Ferrofluidic seals are adopted to complete the elimination of air contamination. To enhance the cooling efficiency, the housing is made entirely of aluminum casting with a high heat conductivity, and many fins formed around it. Air circulation is completely symmetrical in the disk stacking direction, and air flow

is well intermingled at the inside of disk hub for uniform and efficient cooling around the read/write heads along with the servo head.

### 5.3 ROTARY ACTUATOR

The drive shaft of the head-arm assembly in the DE is coupled directly to a bobbin supporting base to be driven by the rotary actuator outside the DE. Ferrofluidic seal is utilized to separate inside and outside the DE. Two coil-bobbins are attached to the bobbin supporting base, and two magnetic circuits are provided to supply torque to the coil bobbins, moving the head-arm assembly to the desired cylinder within a short access time.

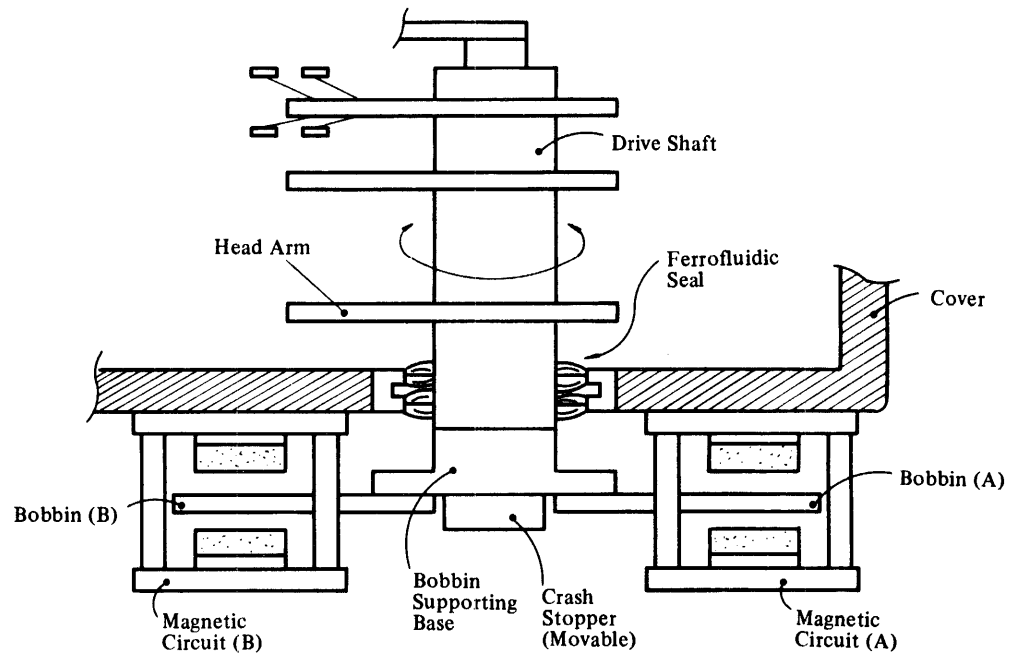

Figure 5.3-1 Construction of the Actuator

(1) Magnetic Circuit

The pair of magnetic circuits are constructed symmetrically as shown in Figure 5.3-2. Each circuit incorporates four permanent magnets (rare earth magnets) with two magnetic gaps in between. Each magnetic gap contains a uniformly spread magnetic field. The coil bobbin is inserted in it and generates torque proportional to the current in the coil and the intensity of the magnetic field. This torque is sufficient to move the head-arm assembly at the specified speed.

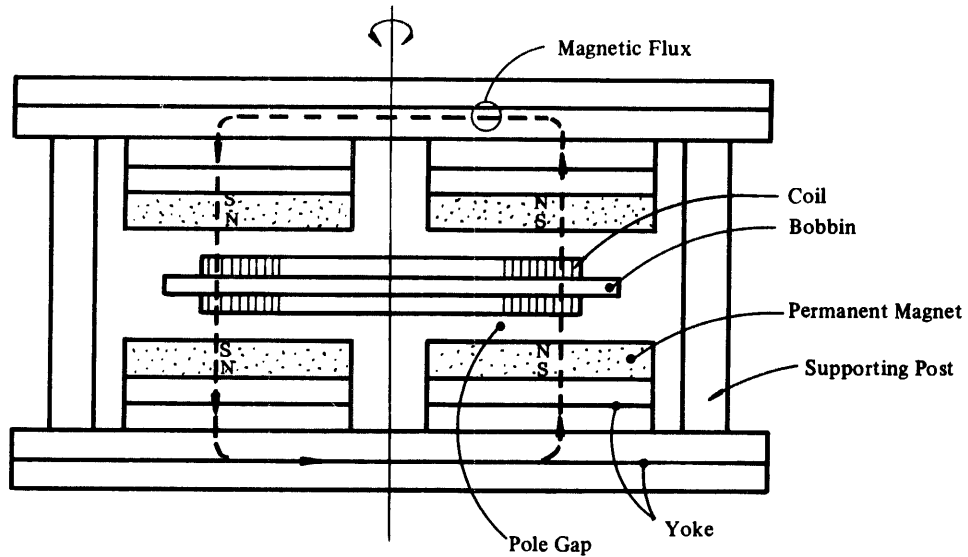

Figure 5.3-2 Magnetic Circuit

## (2) Drive Coil

The two coil bobbins are identical. A pair of flat copper wire coils are attached on the front and rear side of each coil bobbin. The four coils are then connected in series to generate torque in the same direction due to the current flowing in each coil.

## (3) Crash Stopper

The crash stopper consists of a moving part attached to the bobbin supporting base and fixed parts on the DE. It determines the movable range of the head-arm assembly, and provides safe deceleration in the event of an uncontrolled seek.

## (4) Major Specifications

- Force coefficient : 0.11 (kg-m/A)
- Movable section inertia :  $24 \times 10^{-4}$  (kg-m<sup>2</sup>)
- Coil resistance : 10 ( $\Omega$ ) (20°)
- Moving angle : 0.208 (rad)
- Magnetic circuit weight : 2.4 (kg)

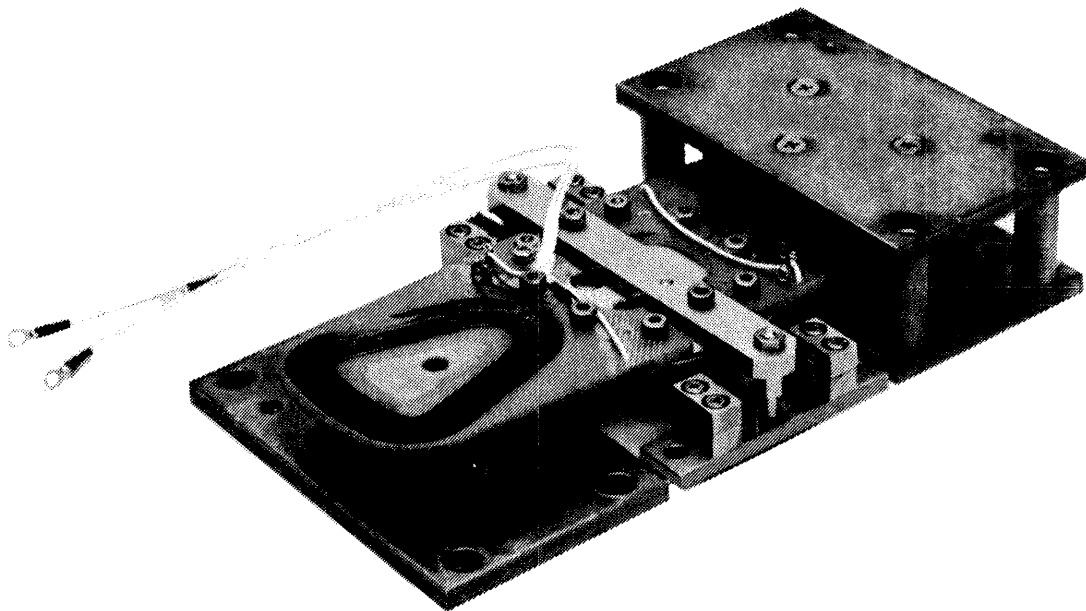

Figure 5.3-3 Outer view of Rotary Actuator



## 5.4 SPINDLE MOTOR

### (1) Features

By adopting the brushless DC spindle motor and connecting the motor directly to the spindle shaft, the following are realized.

- The device becomes compact.
- Pulley and belts are unnecessary, therefore, no maintenance is required.
- Accuracy of rotational speed is improved.
- Vibration is reduced.
- Dynamic braking replaces mechanical brake

### (2) Construction

Construction of the motor is shown in Figure 5.4-1. The rotor poles generate torque by the revolving magnetic field, and are connected directly to a single shaft to which magnetic disks are attached.

The stator winding generates the above mentioned revolving magnetic field by successively switching the current in it.

The rotor pole position detector determines the switching time of the current in the stator winding by detecting the position of rotor poles. The stator winding and rotor pole position detector are fixed in the motor housing, which is fixed on the DE base.

(3) Specification

Table 5.4-1 Specifications

Output	P	W	120
Rated torque	T	kg-cm	2.7
Rated revolution	N	rpm	3,961
Rated Current	I	A	4.0
Induced voltage constant	$K_e$	mV/rpm, O/P/phase	8.2
Winding resistance	$R_a$	$\Omega$ /phase at 20°C	1.12
Winding inductance	$L_a$	mH/phase	1.7
Winding phase number			3
Number of poles and pole pairs	2P		4
Position sensor		DN6839 Matsushita Electric	

The rated values are 3-phase, half drive (for 120° conduction)

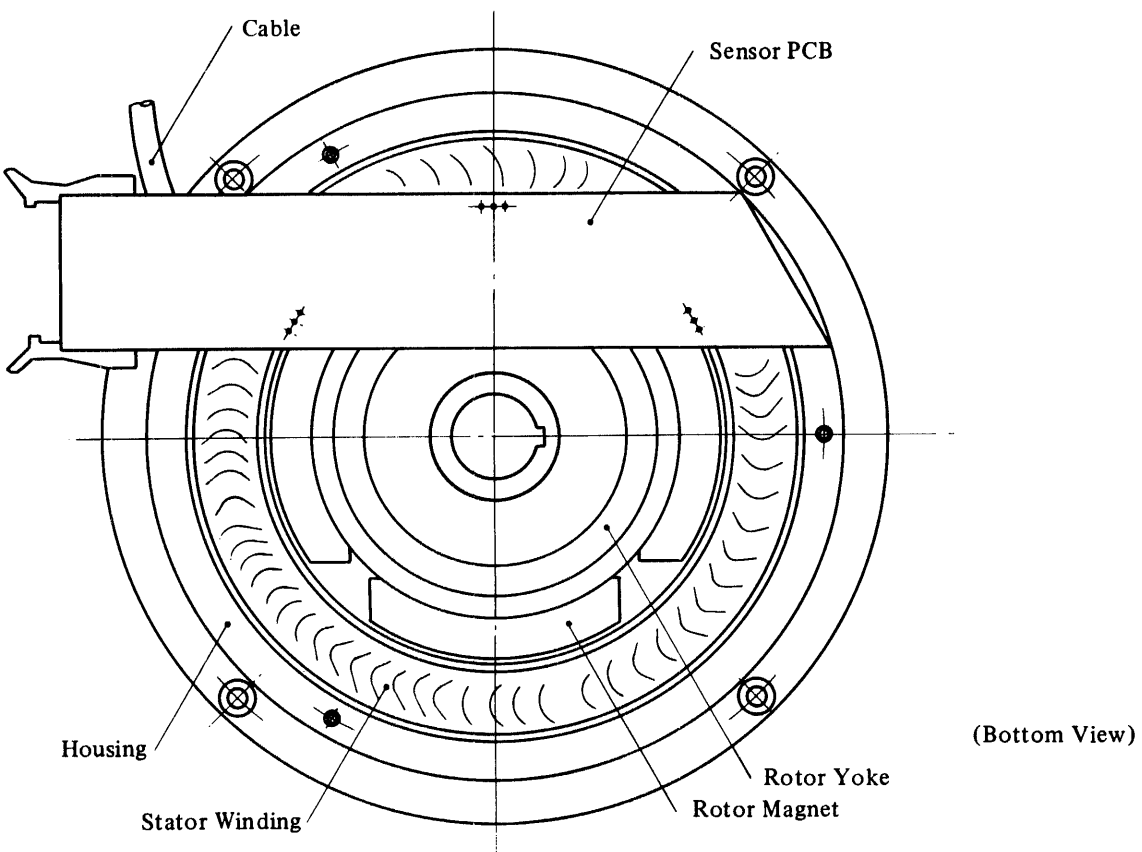
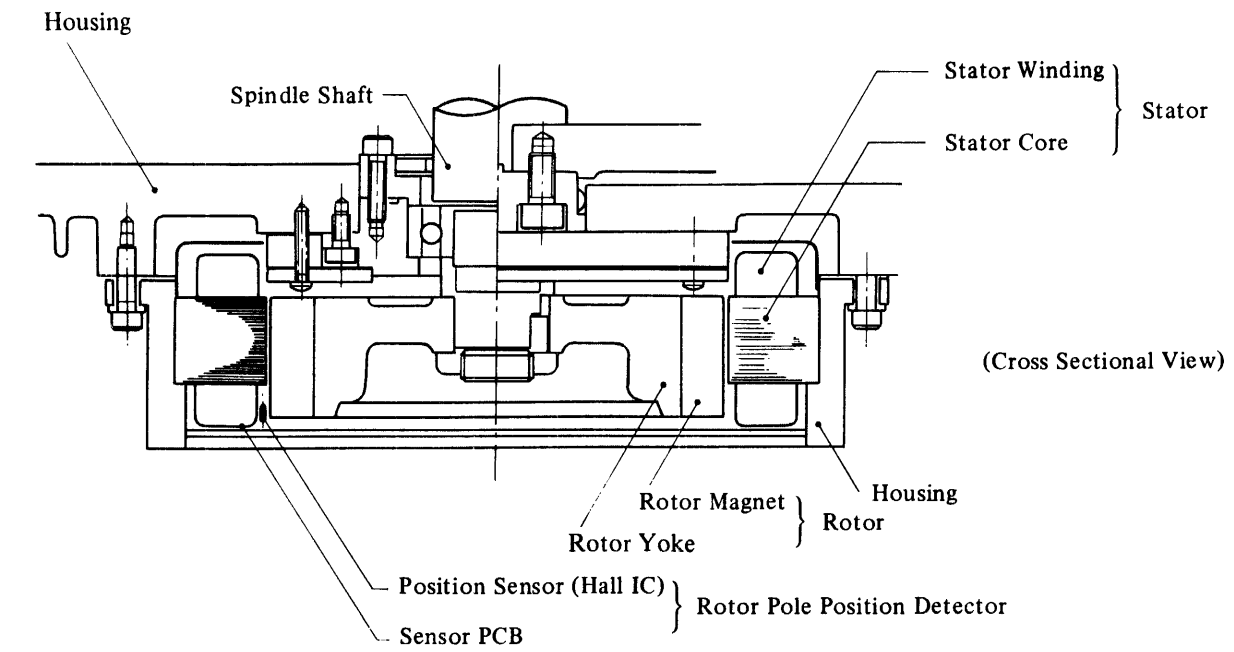

Figure 5.4-1 Construction of the Spindle Motor

(4) Principle of Operation

The brushless DC motor is made by replacing brushes and commutators of the ordinary DC motor with a rotor pole position detector and a semiconductor drive circuit. The schematic circuit of the 3-phase half-wave drive used is shown in Figure 5.4-2. The various waveforms when the DC motor is rotating in the regular direction are shown in Figure 5.4-3. Consequently, in an actual drive, the rotational force is obtained by energizing the windings in the order of C'-C → B'-B → A'-A.

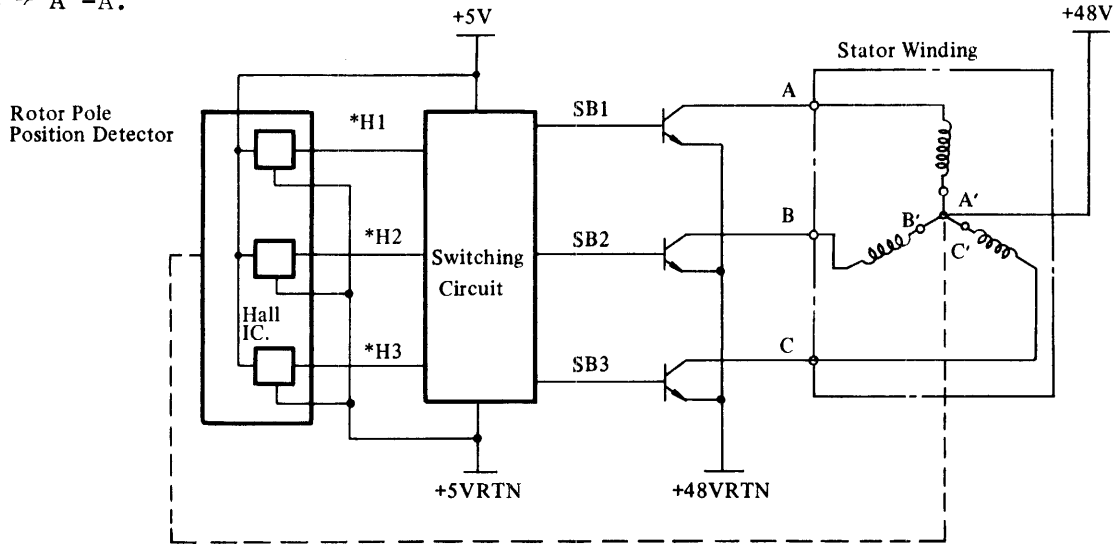

Figure 5.4-2 Schematic Diagram of the Drive Circuit

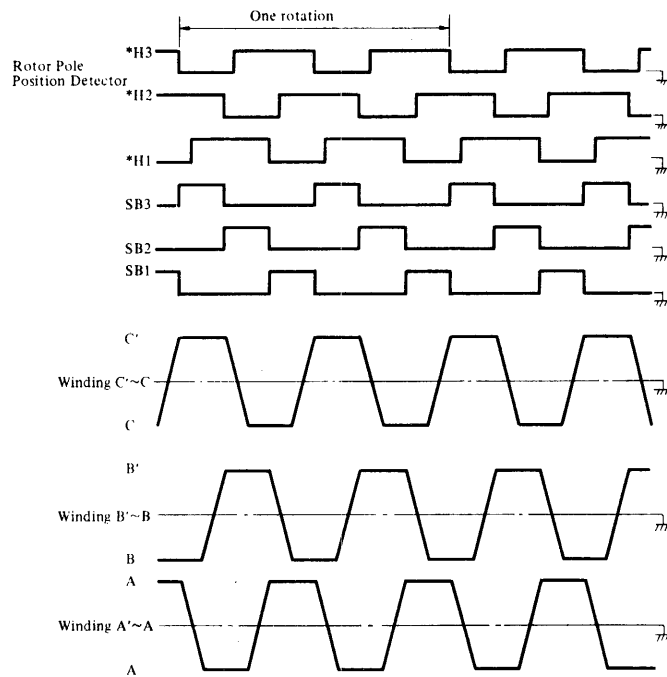

Figure 5.4-3 DC Motor Waveforms

## 5.5 MAGNETIC HEAD AND DISK

### (1) Magnetic Head

To obtain a high recording density, advanced Winchester type CSS (Contact Start and Stop) heads are used for both moving and fixed heads. While the disks are not rotating, the heads rest on the disk surfaces in contact, but when the rotation starts, the heads begin to float over the disk surfaces. After the disks reach the specified rotational speed, the heads maintain the flying height with the balanced force of each load spring and the air-bearing between disk surfaces and the head sliders.

Therefore, to prevent wear caused by contact-start/stop, and to achieve minimum but stable flying height, the head is loaded slightly and its slider rails are tapered.

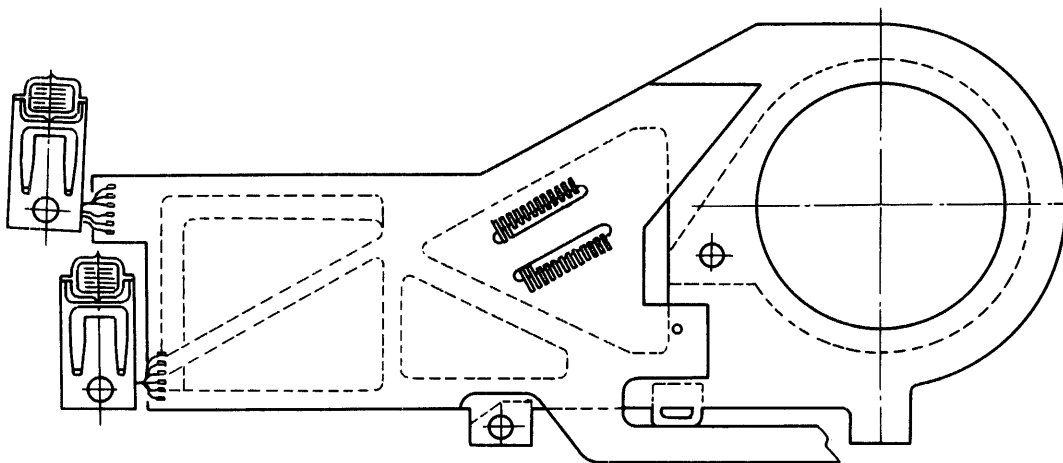

Figure 5.5-1 Moving Head Arm Assembly

There are two kinds of heads, i.e., moving head and fixed head. Both heads have a similar construction, but the moving head has only one Read/Write core whereas fixed head has four Read/Write cores, as shown in Figures 5.5-2 and 5.5-3 respectively. To increase the output voltage at high recording density, the core is made from Mn-Zn instead of Ni-Zn which is the commonly used material.

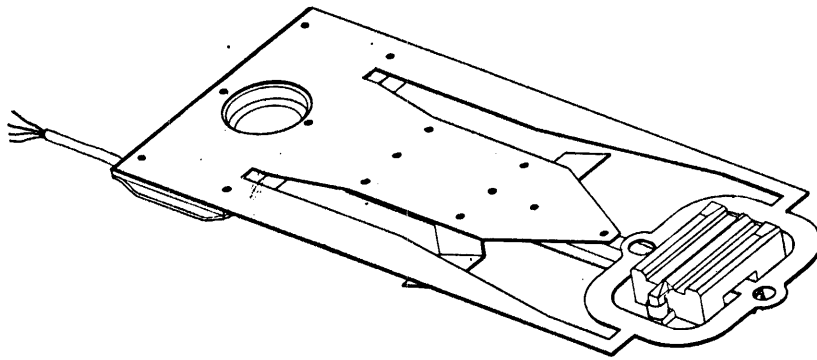

Figure 5.5-2 Moving Head

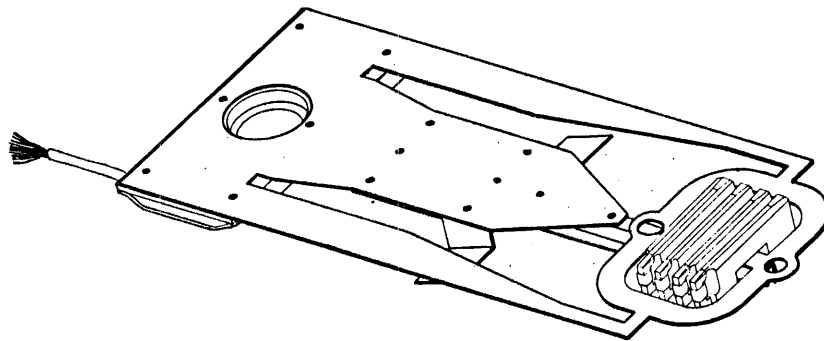

Figure 5.5-3 Fixed Head

(2) Disk

A magnetic disk has a diameter of 10.5 inches (268 mm) and is made of aluminum on which magnetic material is coated. Special coating is provided on the surface of this magnetic material in order to prevent wear caused by repeated contact-start/stop operations.

(3) Fixed Heads Block

Fixed heads are located at the top surface of the disks in the DE of M2351AF. Fifteen sliders having four cores each are attached to a fixed head block. Thus, there are 60 fixed head tracks in all, and are allocated to Cylinder 896 to 898 and Head 0 to 19 respectively.

A PCB with ICs (fifteen head pre-amplifiers and two decoders) is also attached to the block. Input and Output signals are transferred through a flat cable. The construction of the Fixed Head Block and address of each head are shown in Table 5.5-1 and Figure 5.5-4.

Table 5.5-1 Slider No. Vs. Cylinder/Head Address

Slider No.	Address		Slider No.	Address		Slider No.	Address	
	CYL	HD		CYL	HD		CYL	HD
1	897	08 ~ 11	6	896	08 ~ 11	11	898	00 ~ 03
2	897	04 ~ 07	7	896	12 ~ 15	12	898	04 ~ 07
3	897	00 ~ 03	8	896	16 ~ 19	13	898	08 ~ 11
4	896	00 ~ 03	9	897	12 ~ 15	14	898	12 ~ 15
5	896	04 ~ 07	10	897	16 ~ 19	15	898	16 ~ 19

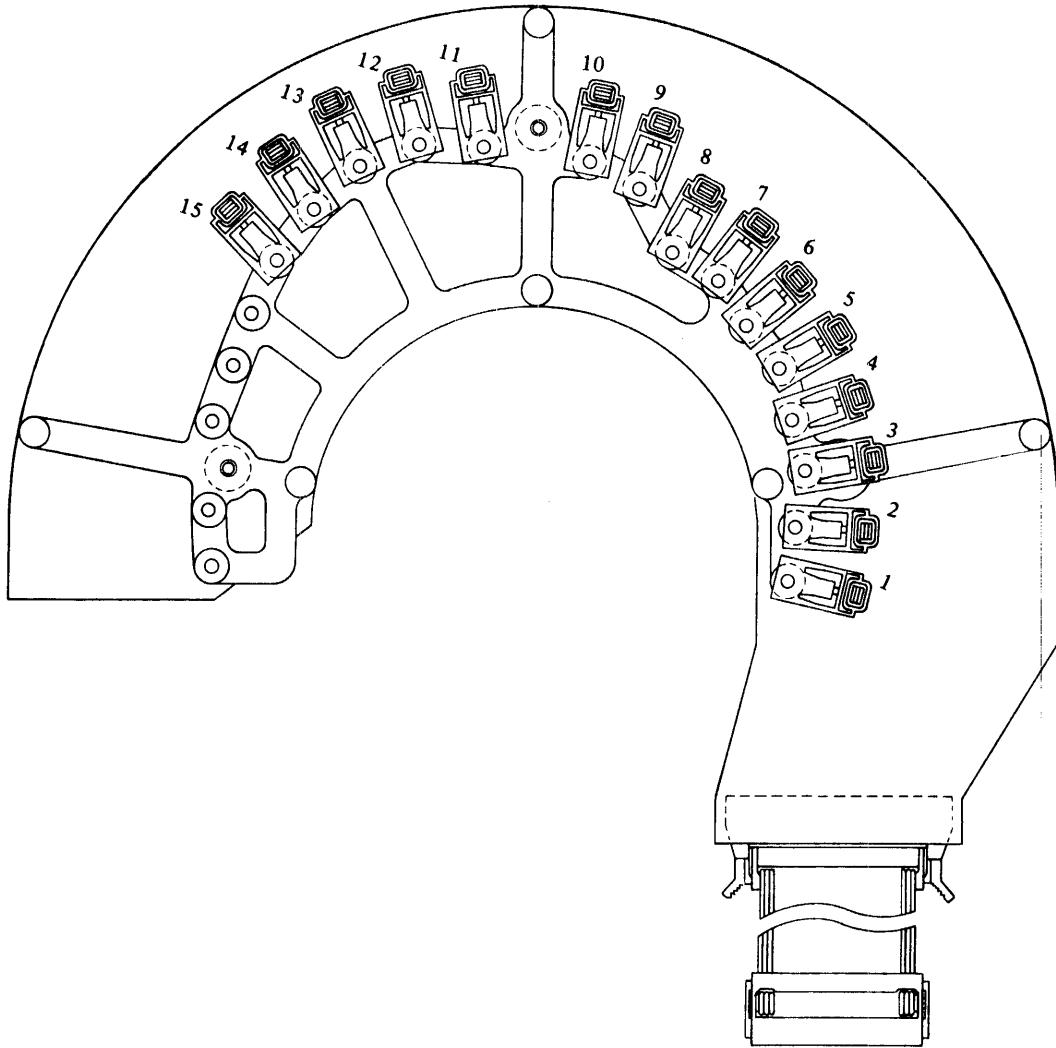

Numbers written in the figure denote the slider numbers.

Figure 5.5-4 Fixed Head Block



## 5.6 COOLING SYSTEM

### 5.6.1 Cooling system of early version

The drive is cooled by a centralized cooling system using a line blower. The air is sucked in through the cooling hole of the front panel, passes through air filter, the line blower and the air duct, and is blown uniformly over the entire DE, card cage power amplifier, and interface PCBs. The air which passes over the card cage cools the DC power supply and the air which passes over the DE and the power amplifier cools interface PCBs, and is discharged.

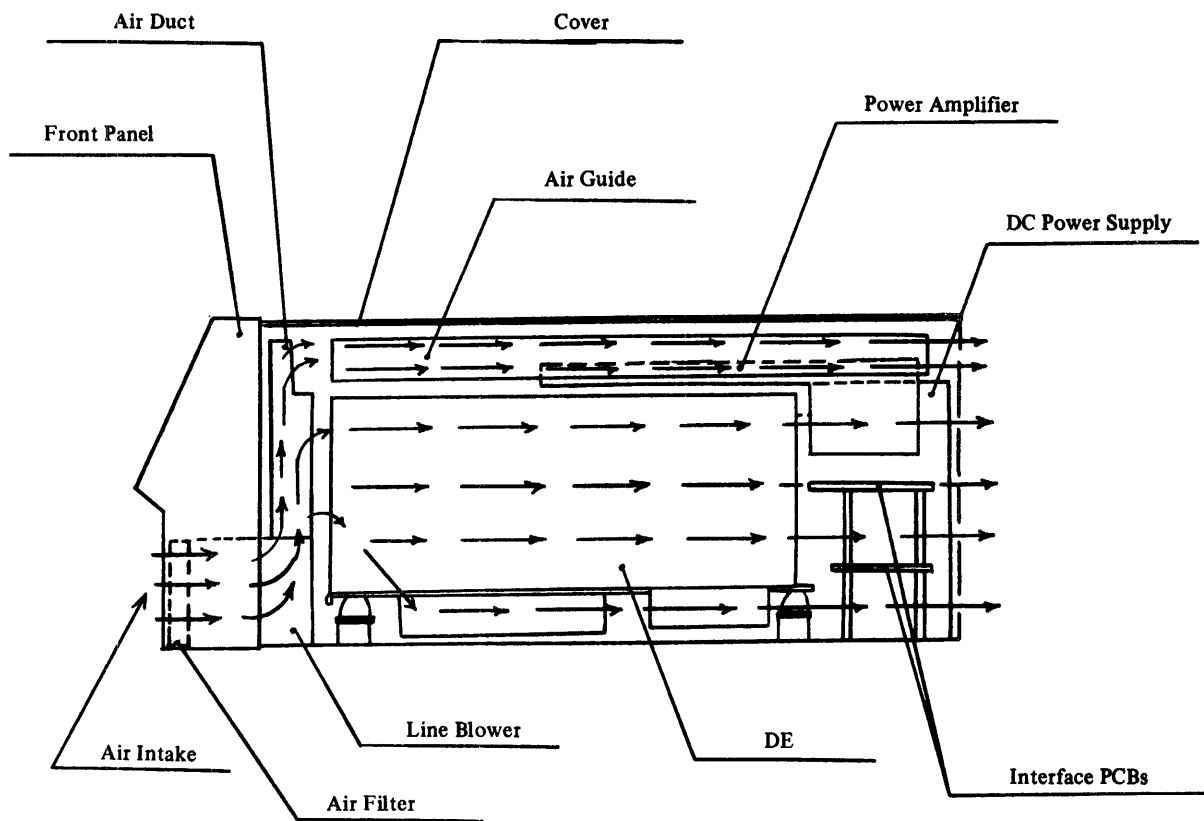

Figure 5.6-1 Air-Flow

### 5.6.2 Cooling system of current version

The drive is cooled by a centralized cooling system using a line blower. The air is sucked in through the cooling slot of the front panel, passes through air filter, the line blower and Power amplifier, and is blown uniformly over the entire DE, card cage, and interface PCBs. The air which passes over the card cage cools the DC power supply and the air which passes over the DE cools interface PCBs, and is discharged.

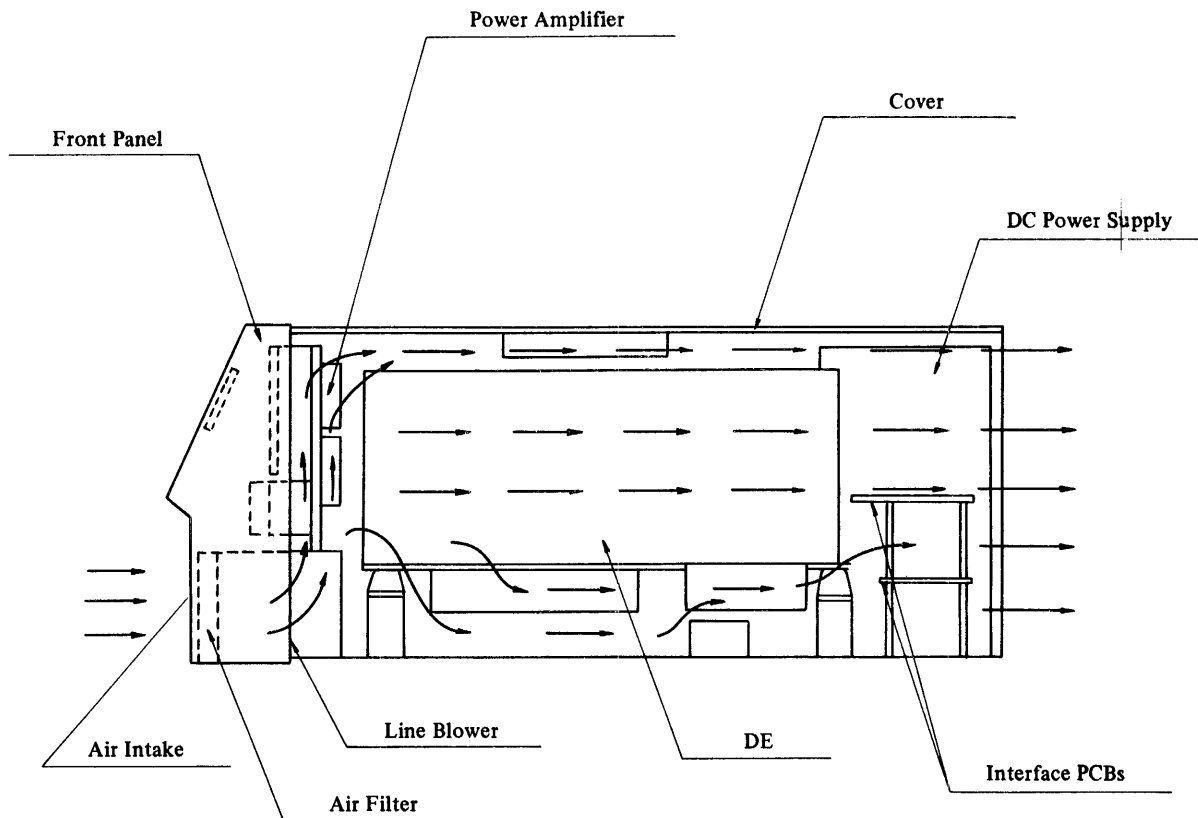

Figure 5.6-2 Air-Flow

## 5.7 ASSEMBLY DRAWINGS

The following drawings illustrate different levels of assembly in the disk drive. Each breakdown is followed by a corresponding table containing an Index No., Quantity, Composition (component parts of the larger assembly), Part Number and Description.

5.7.1 Early version (M2351A:~ #1898)

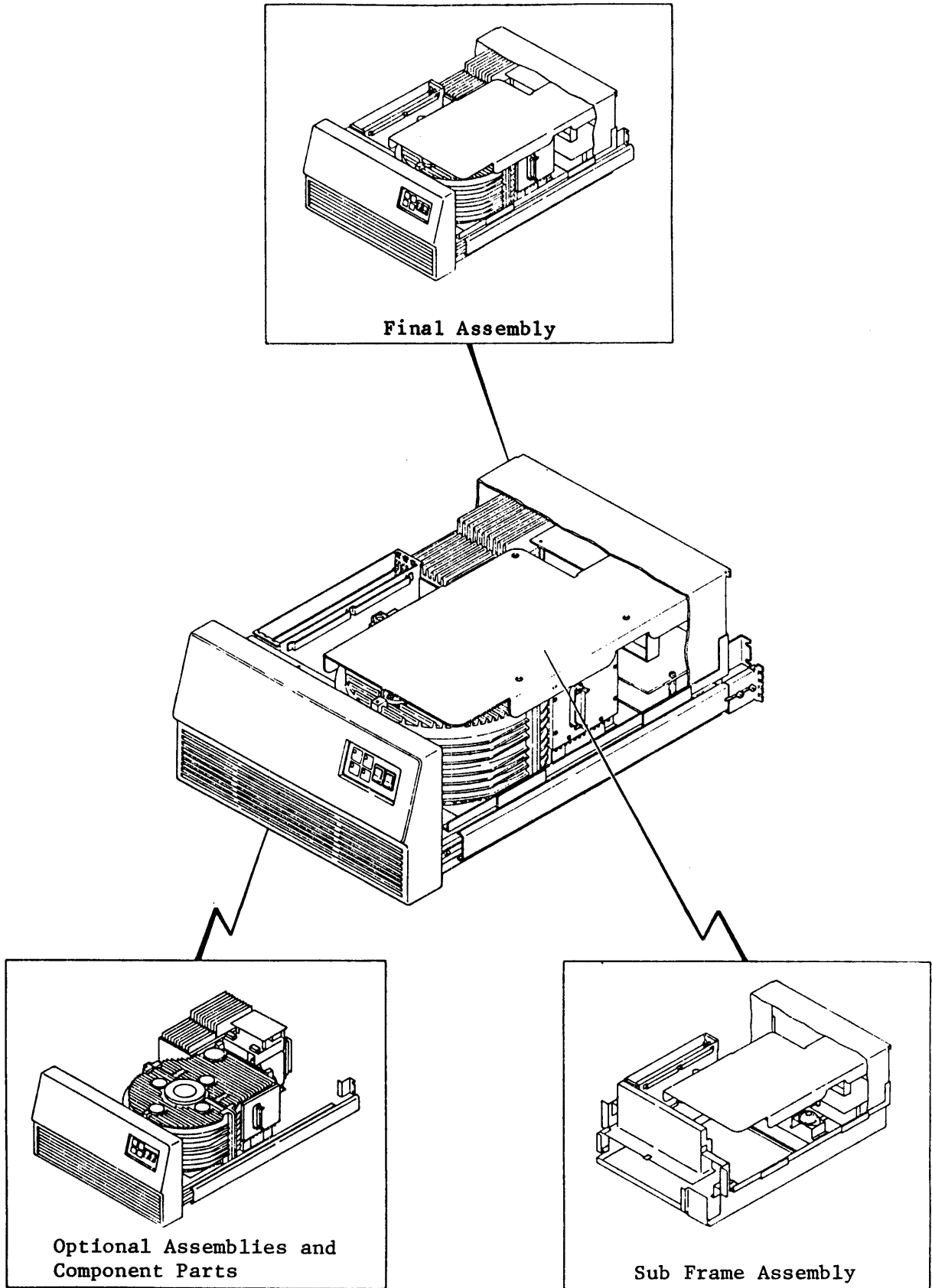

Figure 5.7-1 Visual Index Mini-Disk Drive

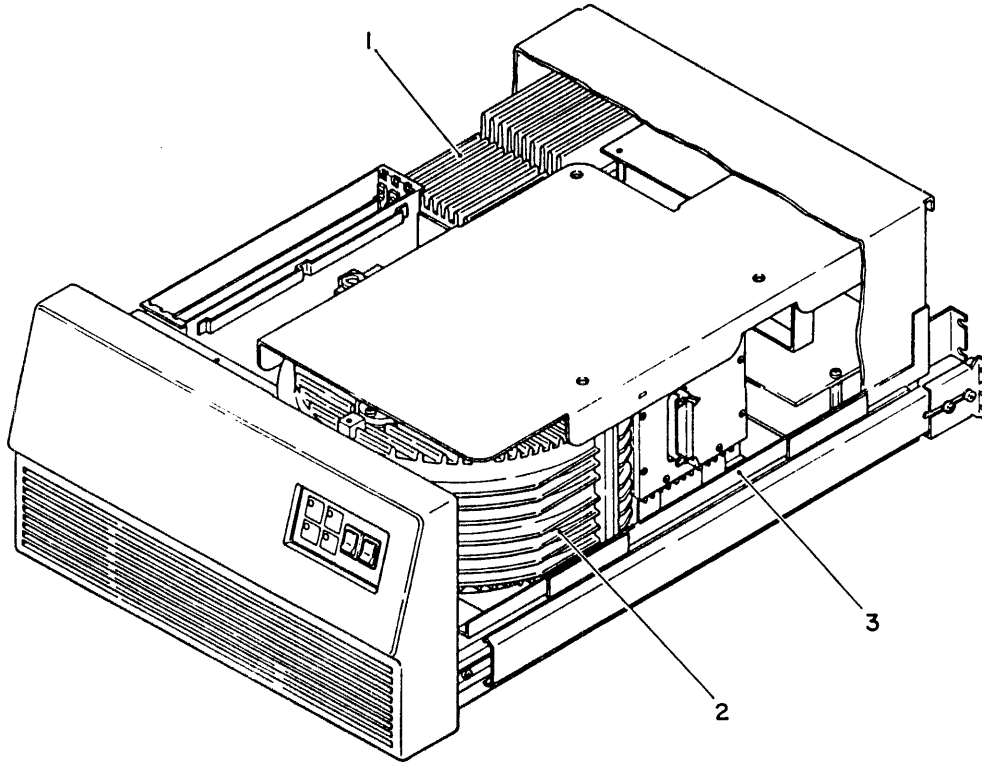

Figure 5.7-2

Table 5.7-1

Index No.	Composition & Quantity						Part Number	Description
	1						B03B-4655-B002A	M2351A Mini-Disk Drive
	1						B03B-4655-B003A	M2351AF Mini-Disk Drive
1		1					B14L-5105-0073A	DC Power Supply
2		1					B030-4610-T005A	DE Assembly (Non-Fixed Heads Type)
2		1					B030-4610-T006A	DE Assembly (Fixed Heads Type)
3		1					B210-1435-T001A	Sub-Frame Assembly

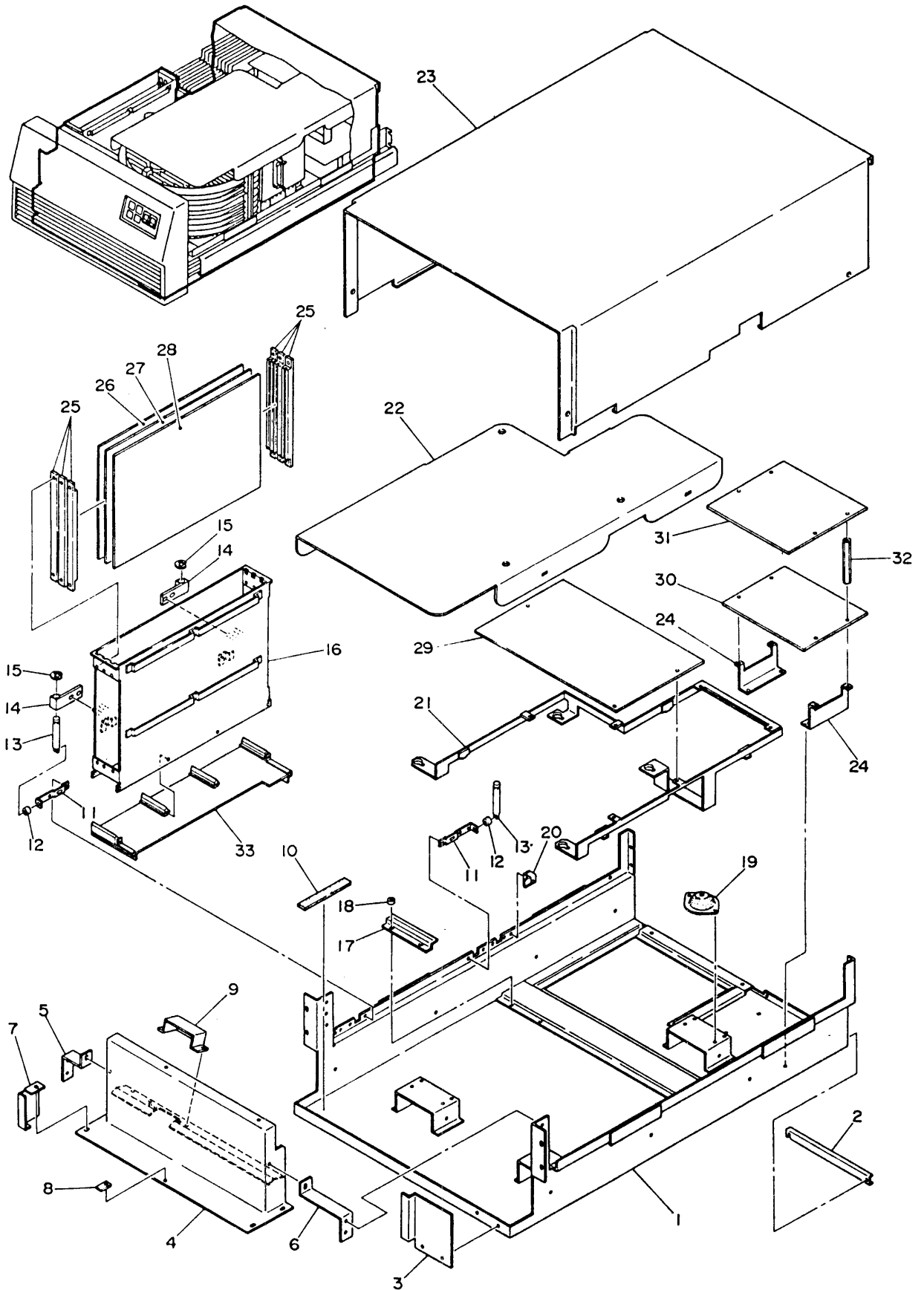

Figure 5.7-3 Sub-Frame Assembly

Table 5.7-2 Sub-Frame Assembly

Index No.	Composition & Quantity						Part Number	Description
	1							
	1						B210-1435-T001A	Sub-Frame Assy
1		1					B210-1435-W001A	Sub-Frame
2		1					B210-1435-X068A	Cable Pad
-		2					F6-SBD-4×16S-M-NI1A	Screw
3		1					B210-1435-X037A	Plate
-		2					F6-SSA-3×5S-M-NI1A	Screw
4		1					B210-1435-X017A	Duct
-		6					F6-SBD-4×6S-M-NI1A	Screw
5		1					B210-1435-X039A	Plate
6		1					B210-1435-X040A	Plate
-		4					F6-SSA-3×5S-M-NI1A	Screw
7		1					B210-1435-X070A	Guide
8		1					B210-1435-X071A	Plate
-		1					F6-SBD-4×6S-M-NI1A	Screw
9		1					B210-1435-X042A	Cover
-		2					F6-SBD-2.5×6S-M-NI1A	Screw
10		2					B210-1435-X018A	Rubber Plate
11		2					B210-1435-X056A	Plate
-		6					F6-SSA-3×6S-M-NI1A	Screw
12		2					B210-1435-X057A	Spacer
-		2					F6-SBD-4×16S-M-NI1A	Screw
-		2					F6-N1-4S	Nut
-		2					F6-SPK-4×4S	Spacer
13		2					B210-1435-X055A	Shaft
14		2					B210-1435-X058A	Bearing
-		4					F6-N1-4S	Nut
-		4					F6-WB-4S	Washer
-		4					F6-WM-4S	Washer
15		2					F6-ER-6	Retaining Ring
16		1					B210-1435-W045A	Gate Cover
-		2					F6-SBD-4×10S-M-NI1A	Screw
-		4					F6-SBD-4×6S-M-NI1A	Screw
17		1					B210-1435-X053A	Stopper

Table 5.7-2 - continued

Index No.	Composition & Quantity						Part Number	Description
18		1					B210-1435-X057A	Spacer
-		2					F6-SBD-4×6S-M-NI1A	Screw
19		3					B30L-1150-0003A	Damper
-		6					F6-SBD-4×6S-M-NI1A	Screw
20		1					B210-1435-X054A	Plate
-		2					F6-SSA-3×6S-M-NI1A	Screw
21		1					B210-1435-W048A	Frame
22		1					B210-1435-X074A	Cover
23		1					B210-1435-X024A	Cover
24		2					B210-1435-X049A	Plate
-		4					F6-SSA-3×6S-M-NI1A	Screw
-		3					F6-BA-8×12-M-ZN1A	Bolt (for DE Assembly)
-		2					F6-SBD-4×6S-M-NI1A	Screw (for DC Power Supply)
-		8					F6-SBD-4×6S-M-NI1A	Screw (for Slide Guide)
25	6						C980-3010-X031	Card Guide
26	1						C16B-5510-0010#U	Servo Circuit
27	1						C16B-5123-0980#U	Logic Circuit
28	1						C16B-5500-0990#U	Read Amplifier
29	1						B16-8130-0010A#U	Power Amplifier
30	1						B16-8140-0010A#U	Interface Circuit
-	1						B03B-4655-0100A	Dual Channel (Option)
31		1					B16B-8150-0010A#U	Interface Circuit
32		4					F6-KKB1-3×70	Stud
33	1						B16B-8160-0010A#U	Back Panel



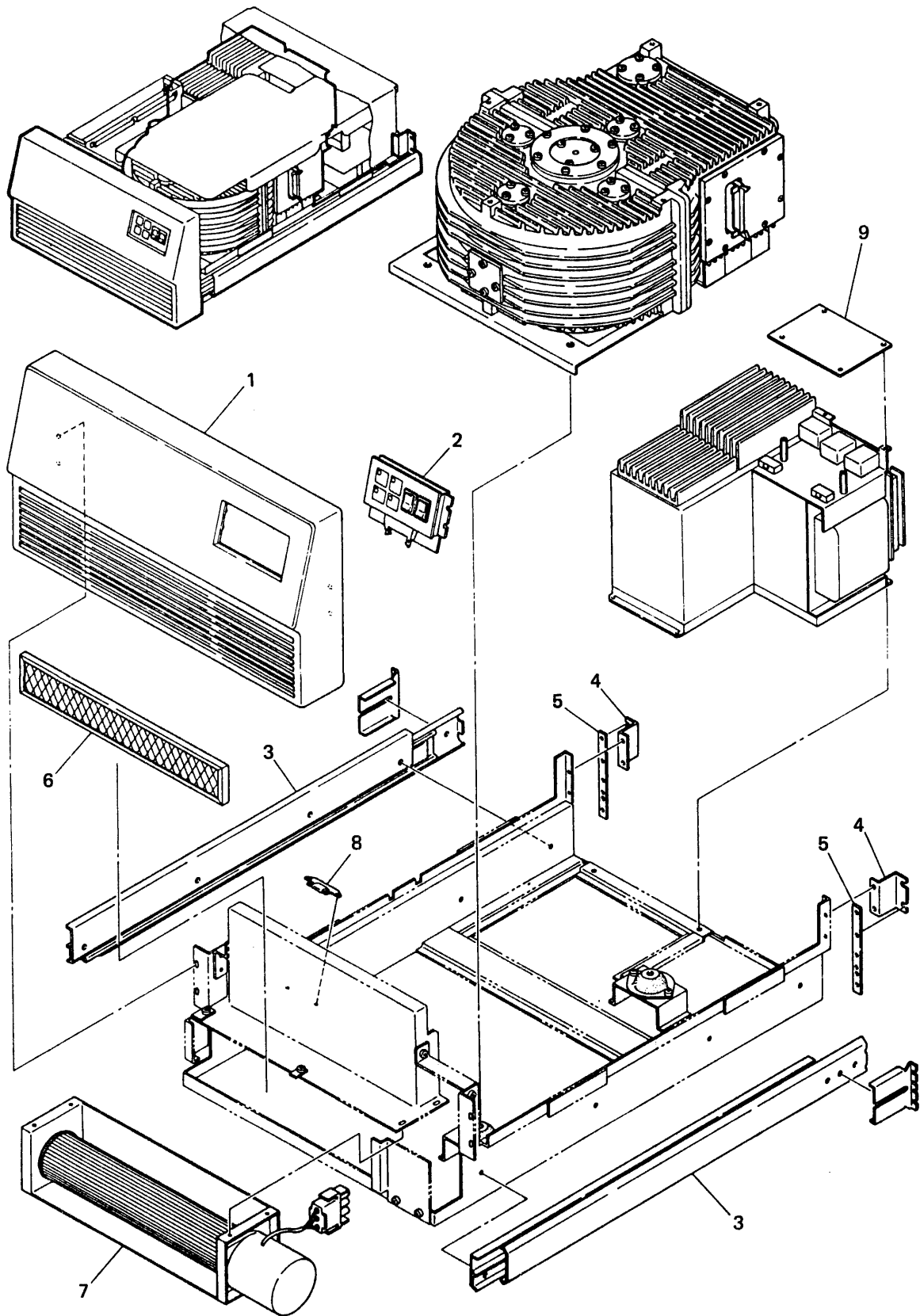

Figure 5.7-4 Optional Assemblies and Component Parts

Table 5.7-3 Optional Assemblies and Component Parts

Index No.	Composition & Quantity						Part Number	Description
1	1						B250-2150-X163A	Front Panel
2	1						N860-3346-T001	Operator Panel
	1						B030-4655-V100A	Slide Guide
3		1					B27L-0230-0010A	Slide Guide } (Option)
4		2					B210-1435-X902A	Metal Fitting
5		4					B210-1435-X903A	Plate
-		20					F6-SW2NA-5×10S	Screw with Washer
6	1						B90L-0400-0303A	Air Filter
7	1						B90L-1200-0101A	Line Blower
8	1						B57L-0040-0003A	Fan Alarm
9	1						B16B-7830-0010A#U	Indicator Unit

5.7.2 CURRENT VERSION (M2351A: #1899-, M2351AF: #1-)

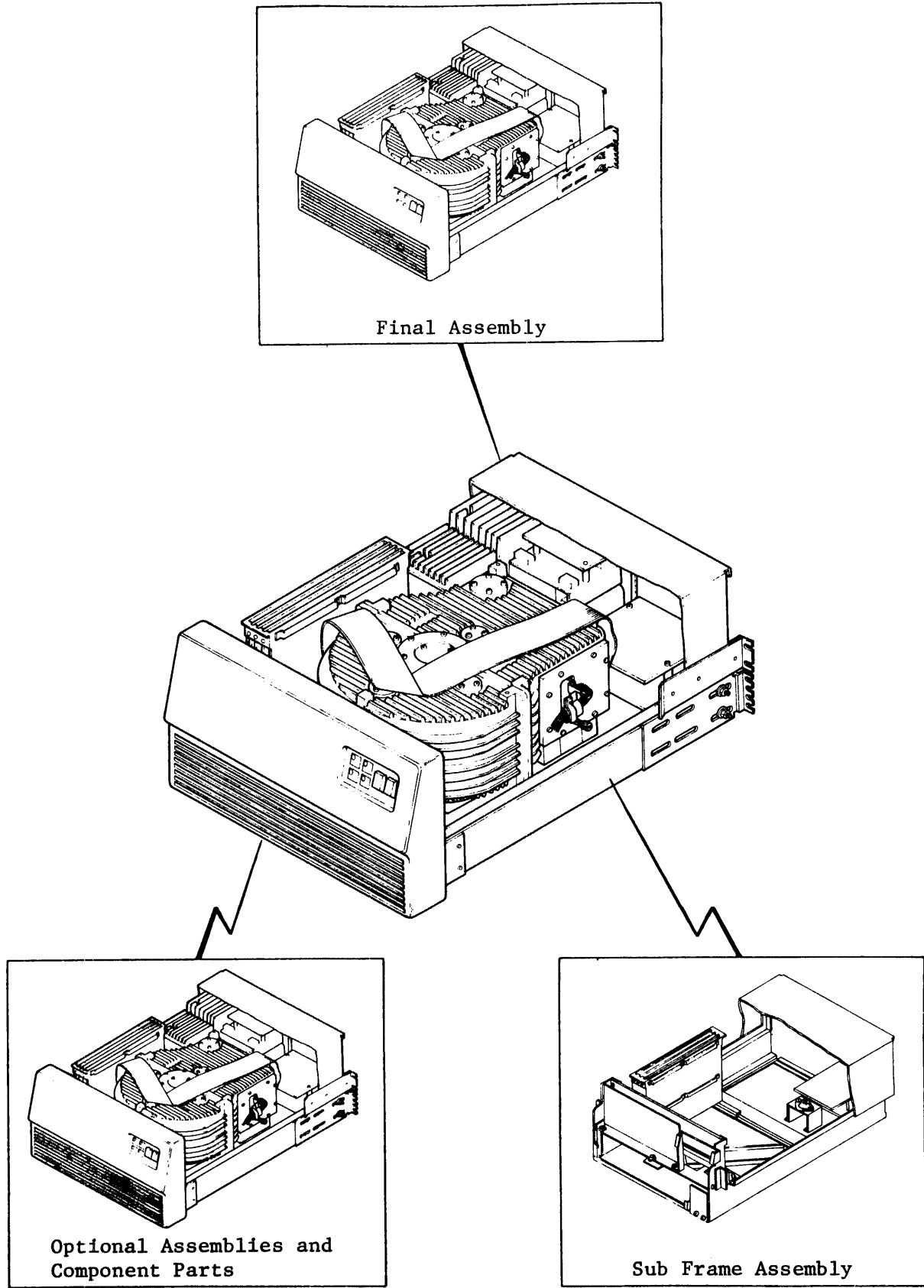

Figure 5.7-5 Visual Index Mini-Disk Drive

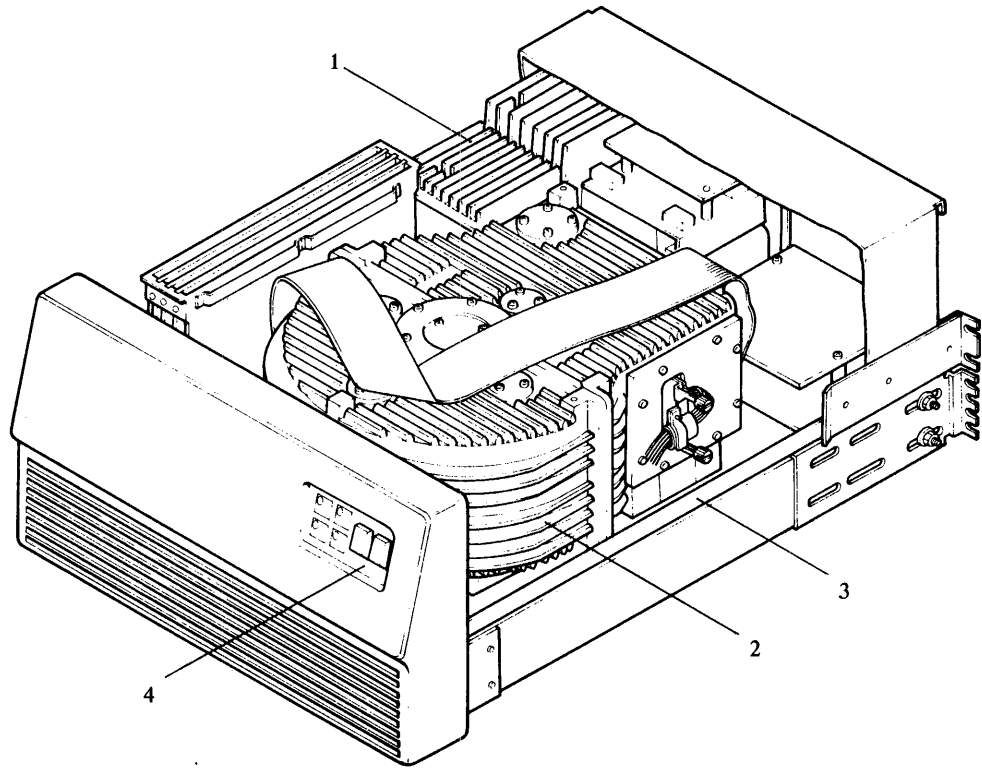

Figure 5.7

Table 5.7-4

Index No.	Composition & Quantity							Specifications	Description
	1							B03B-4655-B002A	M2351A Mini-Disk Drive
	1							B03B-4655-B003A	M2351AF Mini-Disk Drive
1	1							B14L-5105-0073A	DC Power Supply
2	1							B030-4610-T007A	DE Assembly (Non-Fixed Heads Type)
2	1							B030-4610-T008A	DE Assembly (Fixed Heads Type)
3	1							B210-1435-T002A	Sub-Frame Assembly
4	1							N860-3346-T001	Operator Panel

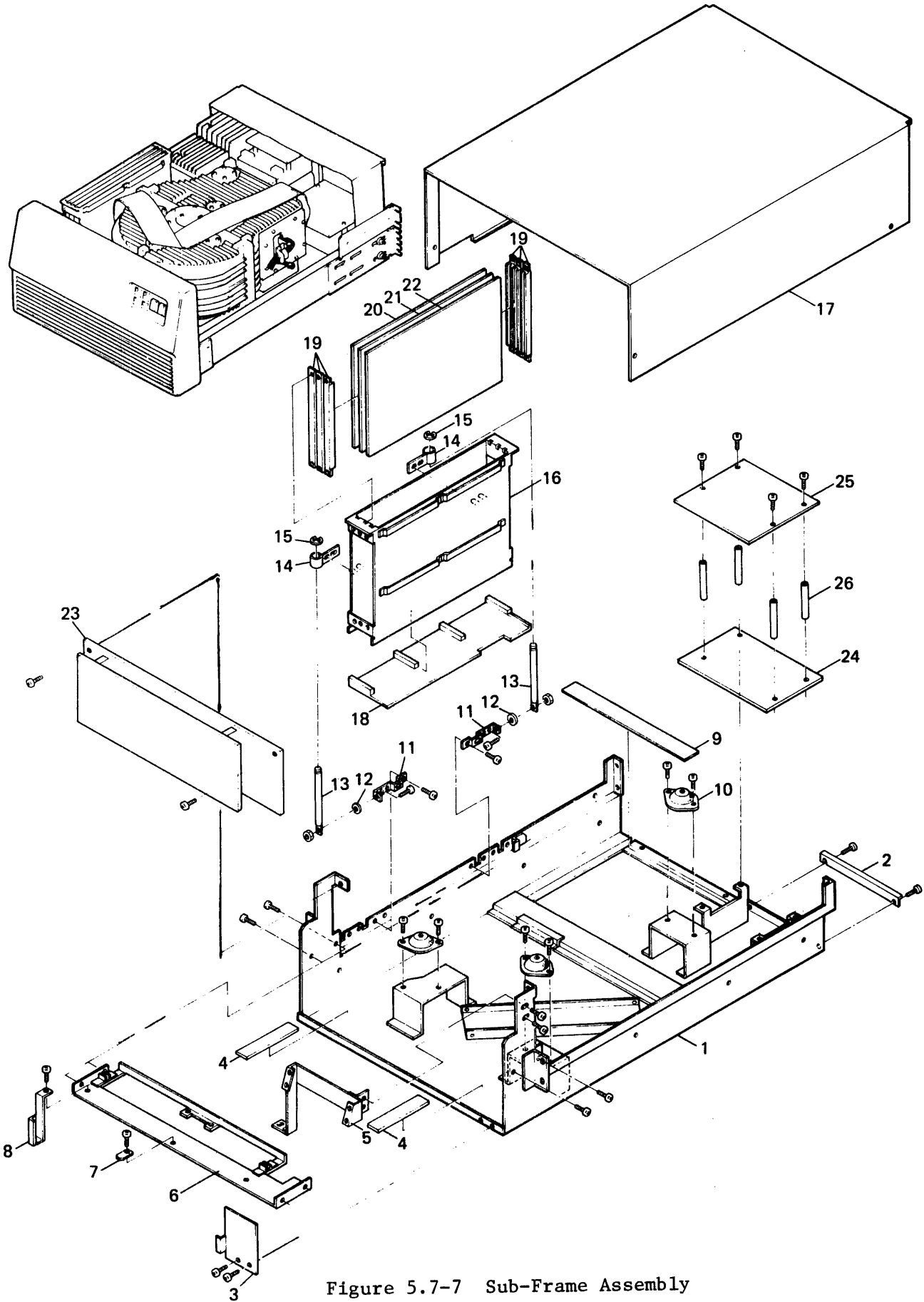

Figure 5.7-7 Sub-Frame Assembly

Table 5.7-5 Sub-Frame Assembly

Index No.	Composition & Quantity						Specifications	Description
	1						B210-1435-T002A	Sub-Frame Unit
1		1					B210-1435-W101A	Sub-Frame Assy
2		1					B210-1435-X068A	Cable Pad
-		2					F6-SW2NA-4×20S	Screw
3		1					B210-1435-X912A	Guide (right side)
-		2					F6-SSA-3×5S-M-N11A	Screw
4		2					B210-1435-X112A	Rubber Plate
5		1					B210-1435-W115A	Bracket
-		4					F6-SW2NA-4×8S	Screw
6		1					B210-1435-W110A	Plate
-		4					F6-SSA-3×6S-M-N11A	Screw
7		1					B210-1435-X071A	Plate
-		1					F6-SW2NA-4×8S	Screw
8		1					B210-1435-X911A	Guide (left side)
-		1					F6-SW2NA-4×8S	Screw
9		1					B210-1435-X122A	Packing
10		3					B30L-1150-0003A	Damper
		1					B210-1435-W055A	Hinge Assy (left side)
		1					B210-1435-W056A	Hinge Assy (right side)
11			1				B210-1435-X056A	Plate
12			1				B210-1435-X057A	Spacer
-			1				F6-SBD-4×16S-M-N11A	Screw
-			1				F6-N1-4S	Nut
-			1				F6-SPK-4×4S	Spacer
13			1				B210-1435-X055A	Shaft
14			1				B210-1435-X058A	Plate
15			1				F6-ER-6	Retaining Ring
16		1					B210-1435-W045A	Gate Cover
-		4					F6-N1-4S	Nut
-		4					F6-WB-4S	Washer
-		4					F6-WM-4S	Washer

Table 5.7-5 - continued

Index No.	Composition & Quantity						Specifications	Description
17		1					B210-1435-W120G	Cover
-		2					F6-SSA-3×6S-M-N11A	Screw
-		2					F6-SW2NA-4×8S	Screw
18	1						B16B-8160-0010A#U	Back Panel PCB (BQGMU)
19	6						C980-3010-X031	Card Guide
20	1						C16B-5501-0010#U	Servo PCB (SVIAU)
21	1						C16B-5123-0980#U	Logic PCB (512398U)
22	1						C16B-5500-0990#U	R/W PCB (RFJAU)
23	1						B16B-8800-0010A#U	Power Amplifier PCB (TVKMU)
24	1						B16B-8140-0010A#U	Interface PCB (DQEMU)
	1						B03B-4655-0100A	Dual Channel Option
25		1					B16B-8150-0010A#U	Interface PCB (DQFMU)
26		4					F6-KKB1-3×70	Stud

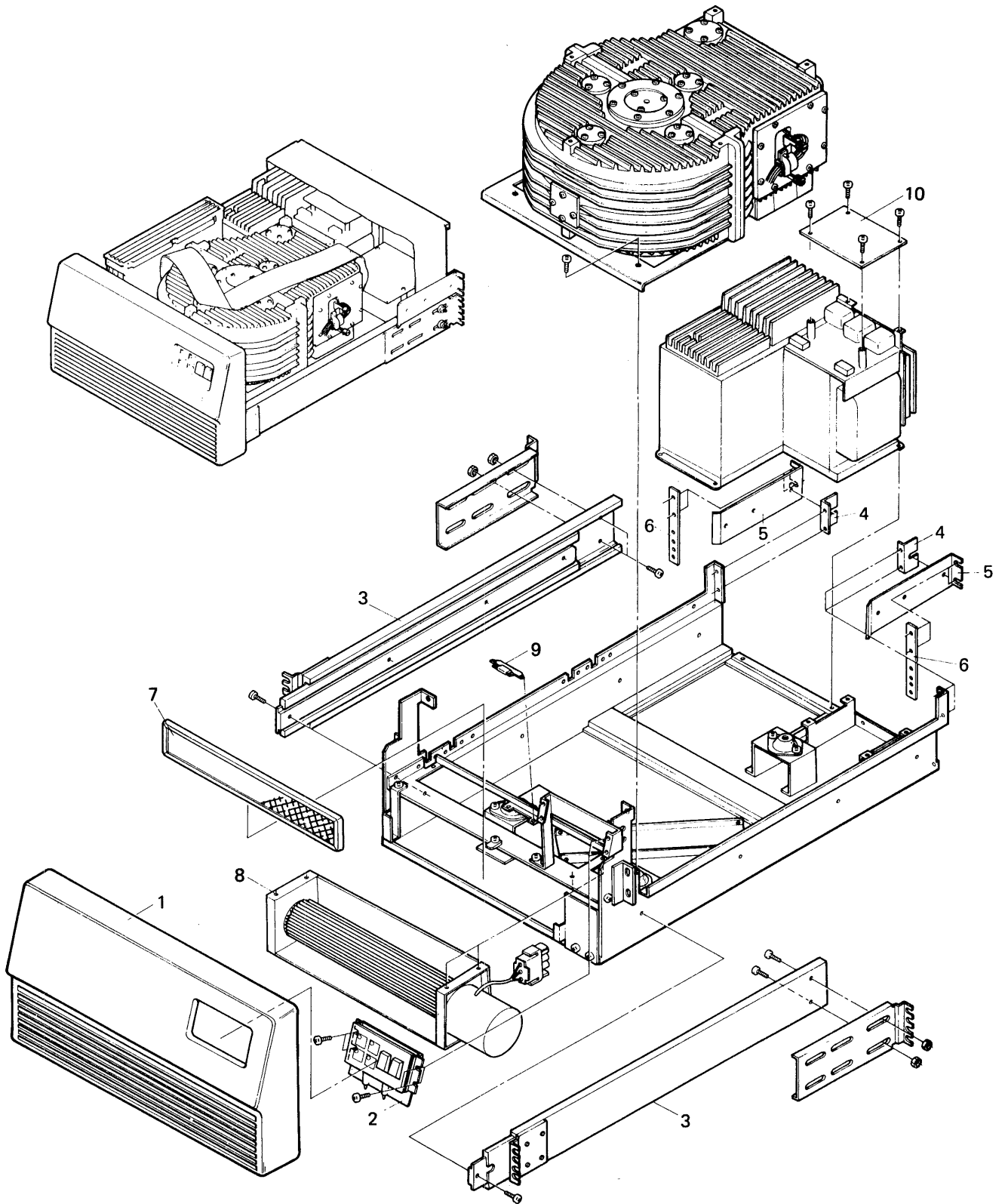

Figure 5.7-8 Optional Assemblies and Component Parts



Table 5.7-8 Optional Assemblies and Component Parts

Index No.	Composition & Quantity						Specifications	Description
1	1						B210-1435-X012A	Front Panel
2	1						N860-3346-T001	Operator Panel
	1						B030-4655-V100A	Slide Guide Assy
3		1					B27L-0230-0010A	Slide Guide } (Option)
4		2					B210-1435-X908A	Metal Fitting
5		2					B210-1435-X909A	Guide Plate
6		4					B210-1435-X903A	Plate
-		20					F6-SW2NA-5×10S	Screw
7	1						B90L-0400-0303A	Air Filter
8	1						B90L-1200-0101A	Line Blower
9	1						B57L-0040-0003A	Fan Alarm
10	1						B16B-7830-0010A#U	Indicator PCB (HGAMU)

CHAPTER 6 DATA FORMAT

The M2351A/AF can be used with two different formats, i.e., Variable Sector Format and Fixed Sector Format, as determined by the controller. The former contains a 3-Byte DC erased area called an Address Mark (AM) prior to each Address Area (AA) indicating the beginning of a record. Therefore, Data Area (DA) with different lengths in a track can be written or read. On the other hand, every record must have the same data area length (governed by sector length) in the Fixed Sector Format.

6.1 FORMAT

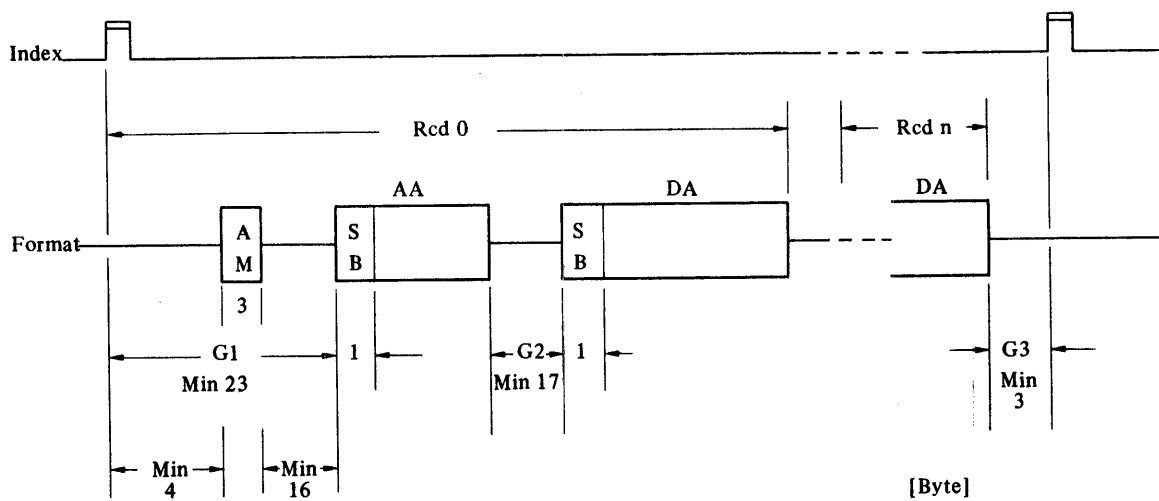

Figure 6.1-1 Variable Sector Format

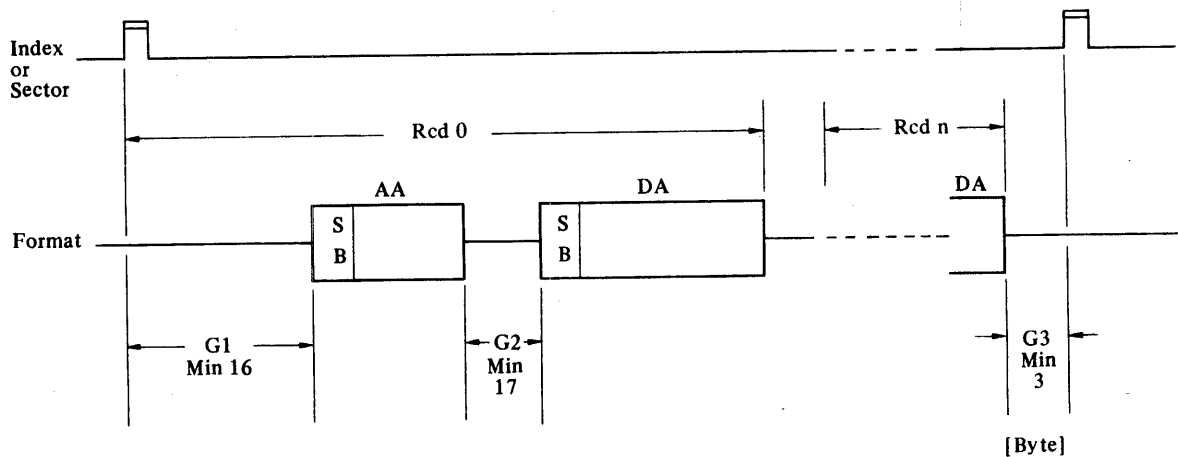

Figure 6.1-2 Fixed Sector Format

## Description of Format Parameters

### - G1, G2, G3 (Gap 1, 2 and 3)

Gaps between adjacent areas. They must be filled with all '0''s.

### - SB (Sync Byte Pattern)

Indicates the beginning of Address or Data Area.

The pattern for both areas can be varied but the recommended pattern is  $(19)_{16}$  or  $(0E)_{16}$ .

### - AA (Address Area)

The Address Area should contain the following information:

- Flag Byte to indicate various conditions of the track or sector, i.e., Primary/Alternate track/Sector, Good/Bad track/Sector
- Logical Drive Address
- Cylinder Address
- Head Address
- Sector Address or Record Number
- CRC to check whether the address area information has been read correctly or ECC to correct the address area information when a data error has been detected.

### - DA (Data Area)

The area where data should be recorded. CRC or ECC should be added. CRC or ECC fields for the data area must be included in the count of bytes selected for the DA.

## 6.2 TRACK EFFICIENCY

Table 6.2-1 shows examples of calculated results of track efficiency in Variable and Fixed Sector Formats. The following assumptions are made for this calculation.

- . The length of Address Area including the SB is 8 Bytes.
- . All gap lengths used are the shortest in Figures 6.1-1 and 6.1-2.
- . The length of the data area is determined using the formula.

$$\begin{aligned} \text{Data Area} &= \text{SB} + \text{DL (Data Length)} + \text{CRC (2 Bytes)} \\ &= 1 + \text{DL} + 2 = \text{DL} + 3 \text{ (Bytes)} \end{aligned}$$

$$\text{Efficiency} = \frac{\text{DL} \times (\text{Sector/Track})}{28,160 \text{ (Bytes/Track)}} \times 100 \text{ (\%)}$$

Table 6.2-1 Track Efficiency

	DL(B)	256	512	1,024	2,048
Variable Sector Format	Sector/Track	90	49	26	13
	Efficiency (%)	81.8	89.0	94.5	94.5
Fixed Sector Format	Sector/Track	92	50	26	13
	Efficiency (%)	83.6	90.9	94.5	94.5

### 6.3 MEDIA SPECIFICATIONS

The quality of all tracks are checked, and location and length of media flaws which may affect the reliability of stored data are recorded in the Header Areas of all tracks before the shipment of a drive from the factory.

By using this media defect information to trigger techniques such as sector/track deallocation or skip displacement, recording data over known media flaws can be avoided.

#### (1) Definition of Track Quality

Every track is classified into three grades dependent on number of defects on a track. They are:

Perfect track : A track containing no defects

Good track : A track containing one defect

Defective track: A track containing two or more defects, or a track containing flaws which may contribute to missing AM or false AM.

If the track is defective, the high order bit of the first cylinder byte in the Header Area is set to one. (Ref. Figure 6.3-1)

Here, defect is defined as media flaws grouped by the maximum flaw length of 64 bytes. 65 bytes of media flaws are treated as two defects, as an example.

#### (2) Quality Standards of Media at Shipment

- The number of defects per DE $\leq$ 500
- The number of defective tracks per DE $\leq$ 30
- Head 0 and 1 at cylinder 0 are perfect tracks
- There is at least one perfect track and no defective tracks at cylinder 841
- All tracks in fixed-heads area are not defective
- If there is a defect in the region of bytes 14-55 after the index mark, there is no defect in the region of bytes 69-164.
- If there is a defect in the region of bytes 56-104 after the index mark, there is no defect in the region of bytes 14-55 and 116-164.

A DE which does not meet these standards is rejected at its shipment.

### (3) Header Format

The Header format is divided into two parts. The first part of the format is a Fixed Sector Format, and the second part is a Variable Sector Format. The Fixed Sector Format information is normally included in the first 56 bytes following the index mark. The Variable Sector Format information consists of 49 bytes and normally follows the Fixed Sector information.

Following are rules for the defect recording:

- The position of a defect is listed in bytes (Hex.) after the index mark, +/- 1 byte.
- The length of a defect is in bits (Hex.) +/- 1 bit.
- Unused defect locations are all zeros.
- Every track is recorded with this defect format whether defects exist or not.
- More than one defect on a track causes the track to be flagged as a defective track. The first four media defects on the track are logged.

Figure 6.3-1 shows the format when there are no defects in the first 105 bytes after the index mark.

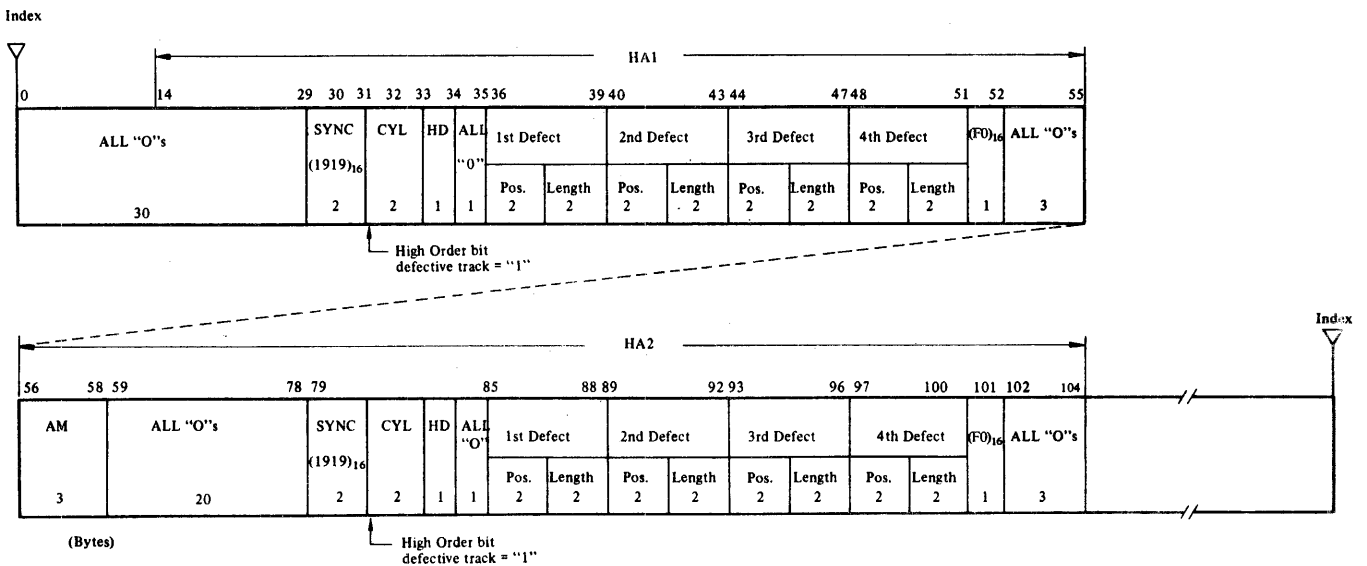

Figure 6.3-1 Format 1

If the beginning of a defect is located in the region of bytes 14 - 55, 60 bytes of zeros are added to Gap 1. Figure 6.3-2 shows an example of this format.

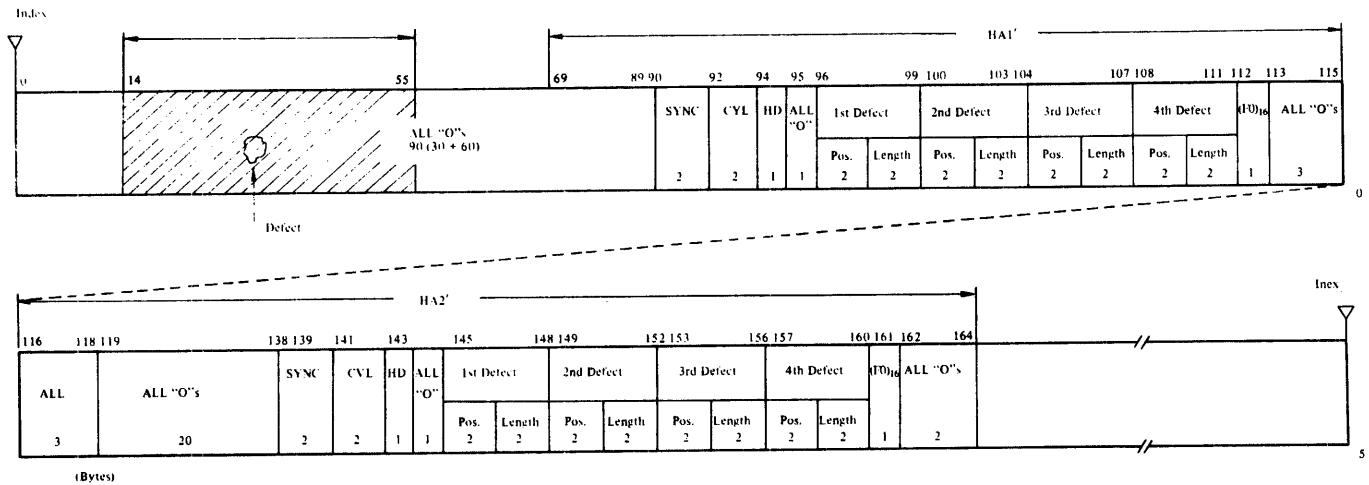

Figure 6.3-2 Format 2

If a defect is located in the region of bytes 56 - 104, the gap before the address mark is increased to 60 bytes. Figure 6.3-3 shows an example of this format.

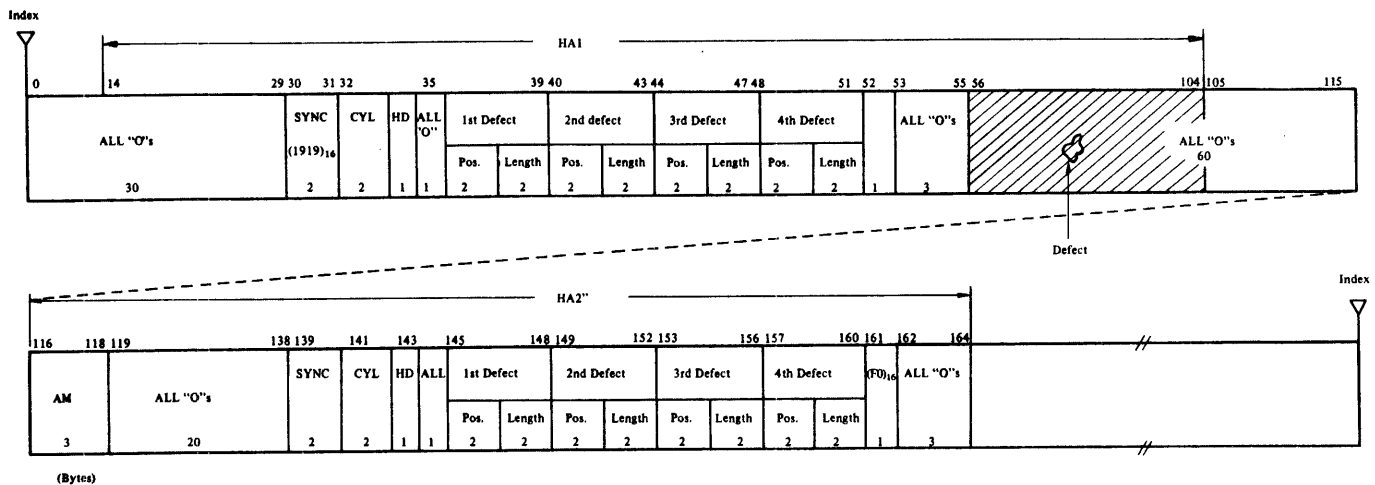

Figure 6.3-3 Format 3

In Figure 6.3-2 and 6.3-3, it is guaranteed that there are no defects in the regions where HA1 and HA2 are newly relocated due to a defect.

(4) Inspection Data Sheet

The location and length of media flaws are recorded in Header Areas as described in (3), as well as printed out on a sheet which is attached to each drive.

The contents of this sheet are listed below.

- Date (Year: Month: Day)
  - Drive type (M2351A/M2351AF)
  - Serial number of drive
  - DE type (Non-fixed/Fixed head type)
  - Serial number of DE
  - Information about flaws
    - Cylinder address
    - Head address
    - Location of flaws in bytes afer index mark
    - Length of flaws in bits
  - Defective track address (Cylinder/Head address)
  - Every perfect head address at cylinder 841
- 'Refer to printout below'

MEDIA DEFECT LIST

Date 9/19/84

Model: M2351A#R Serial No.: 15991 De Type: Non De Serial No.: PN46W6T27

NO.	CYLINDER	HEAD	POS/BYTES	LEN/BITS	
1	0001( 1)	09( 9)	3DC2(15810)	0003( 3)	0000
2	0002( 2)	0A(10)	3278(12920)	0009( 9)	0000
3	0003( 3)	0A(10)	3277(12919)	0011( 17)	0000
4	0004( 4)	04( 4)	269A( 9882)	0002( 2)	0000
5	0006( 6)	0C(12)	5D90(23952)	0005( 5)	0000
6	0006( 6)	0E(14)	3418(13336)	0002( 2)	0000
7	0006( 6)	10(16)	59F4(23028)	0002( 2)	0000
8	000A( 10)	10(16)	019C( 412)	0003( 3)	0000
9	0011( 17)	11(17)	38A4(14500)	0002( 2)	0000
10	0013( 19)	10(16)	32A4(12964)	0003( 3)	0000
11	0014( 20)	10(16)	587C(22652)	0005( 5)	0000
12	0017( 23)	09( 9)	32AD(12973)	0002( 2)	0000
13	0017( 23)	0F(15)	518F(20879)	0002( 2)	0000
14	0019( 25)	03( 3)	1C1B( 7195)	0003( 3)	0000
15	0019( 25)	0A(10)	6A13(27155)	0003( 3)	0000
16	0020( 32)	11(17)	34FB(13563)	0003( 3)	0000
17	0022( 34)	10(16)	5B76(23414)	0002( 2)	0000
18	0028( 40)	10(16)	1C91( 7313)	0003( 3)	0000
19	002A( 42)	11(17)	1D98( 7576)	0002( 2)	0000
20	002D( 45)	12(18)	4E60(20064)	0004( 4)	0000
21	0030( 48)	03( 3)	51A7(20903)	0006( 6)	0000
22	0034( 52)	0C(12)	1A10( 6672)	0002( 2)	0000
23	0038( 56)	0C(12)	420E(16910)	0003( 3)	0000
24	0039( 57)	03(03)	1157( 4439)	0002( 2)	0000
25	003A( 58)	0C(12)	48FD(18685)	0002( 2)	0000





CHAPTER 7 INTERFACE

This chapter describes the physical and logical specifications of interface signals between the M2351A/AF and any controller.

7.1 SIGNAL TRANSMISSION DRIVER/RECEIVER

SN75110 Drivers and SN75107/108 Receivers are used to provide a terminated and balanced transmission system.

(1) A-Cable

All signals except Open Cable Detect and Power Sequence Pick/Hold signals must be terminated both in the drive and the controller as shown in Figure 7.1-1.

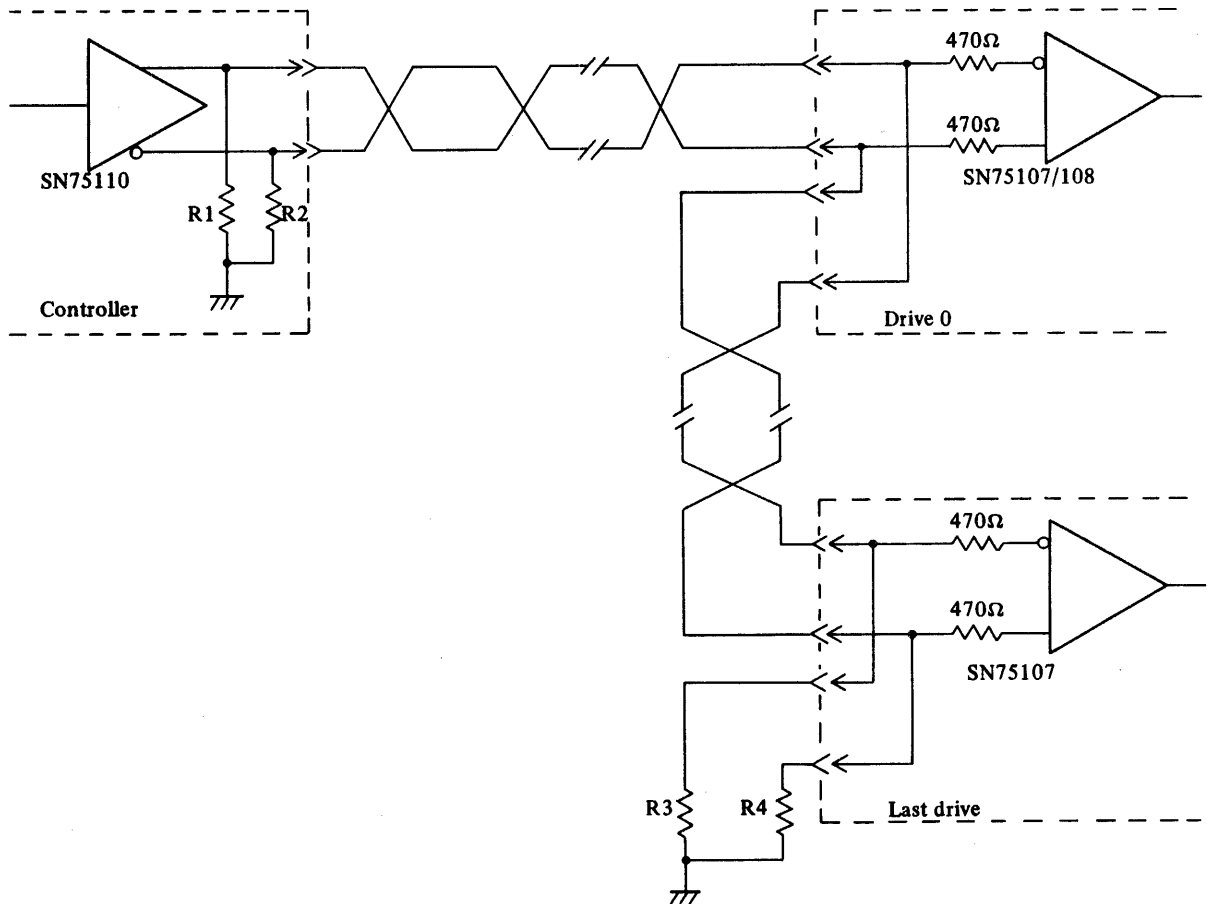

- Note; (1) Line terminators are located in the drive and the controller. R1 to R4; 56 Ohms±10%.1/10W.
- (2) The maximum cable length is 100 FT (30 m).

Fig. 7.1-1 Balanced Transmission of A-Cable

For the Open Cable Detect signal, two drivers of SN75110 would be required in parallel without termination to increase the drive current in the interface cable as shown in Figure 7.1-2.

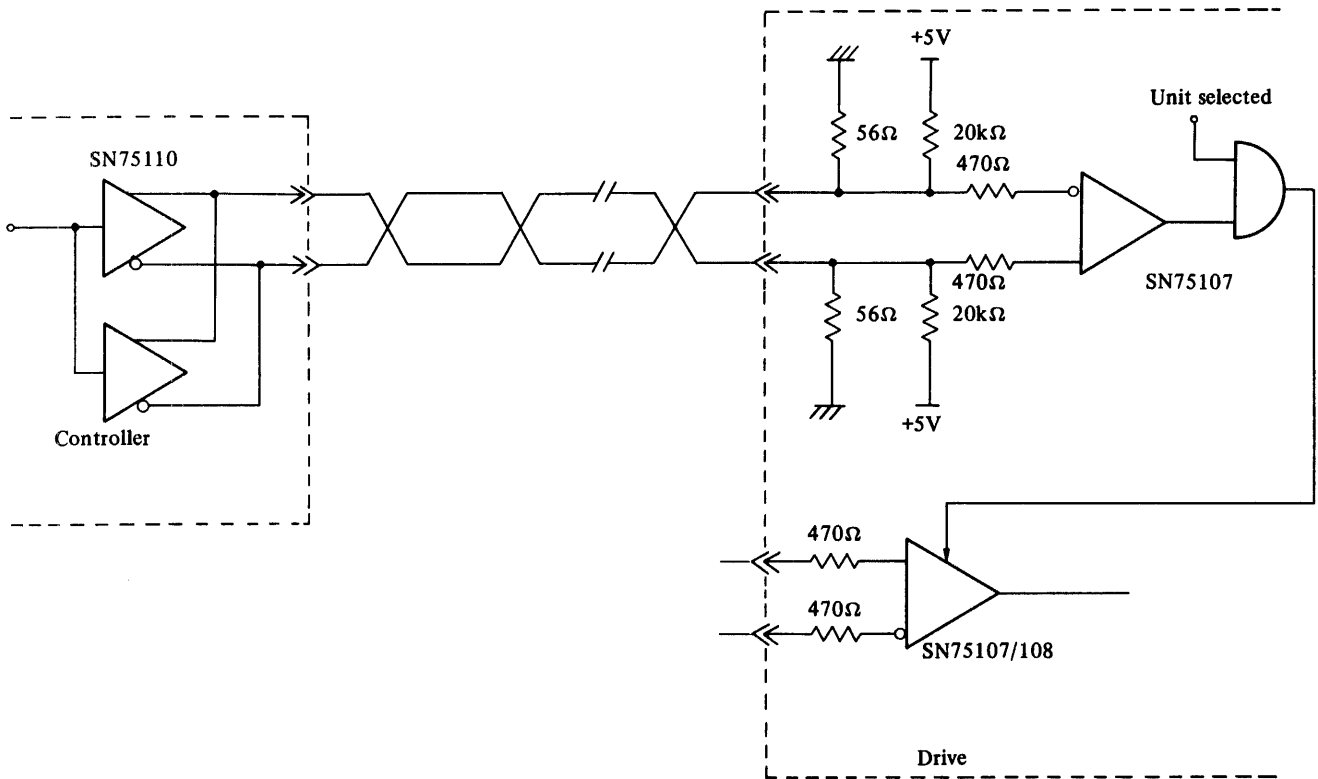

Fig. 7.1-2 Open Cable Detect

Power Sequence Pick and Hold must be set to ground in the controller.

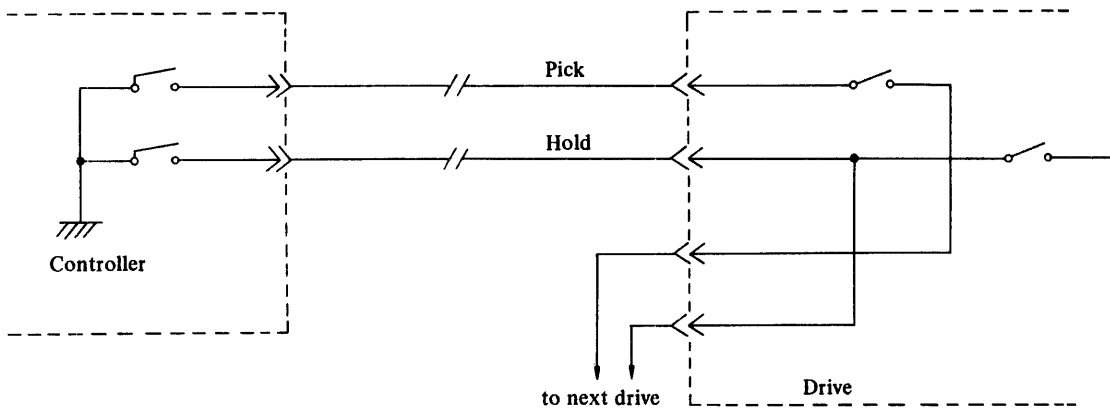
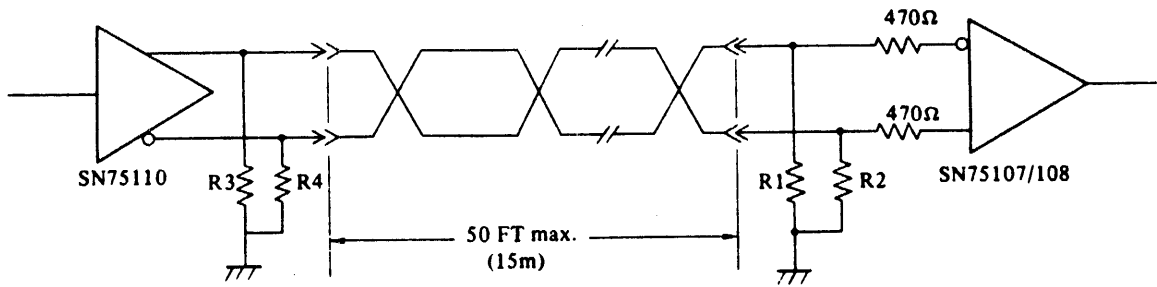

Fig. 7.1-3 Power Sequence Pick/Hold

(2) B-Cable



Note; (1) Line terminators are located in the drive and the controller. R1 to R4; 82 Ohms $\pm$ 5%.1/10W.

Fig. 7.1-4 Balanced Transmission of B-Cable

(3) Input/Output Characteristics of Driver/Receiver

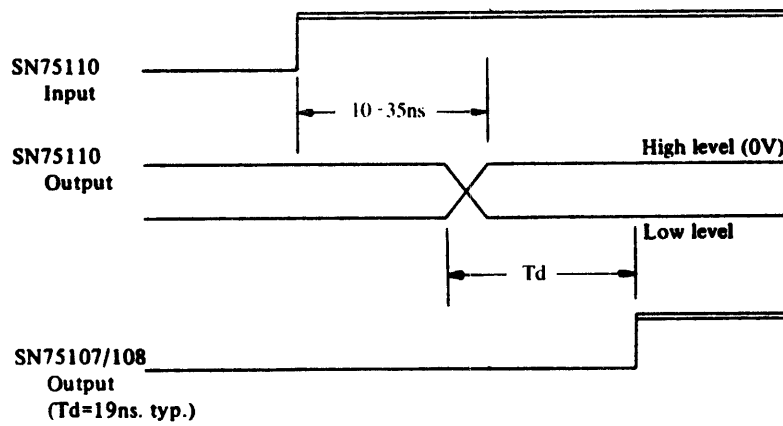

Typical output level of SN75110

	A-cable	B-cable
High level	0V	
Low level	-0.33V	-0.49V

Fig. 7.1-5 Input/Output Characteristics

7.2 PIN ASSIGNMENT OF INTERFACE CONNECTORS

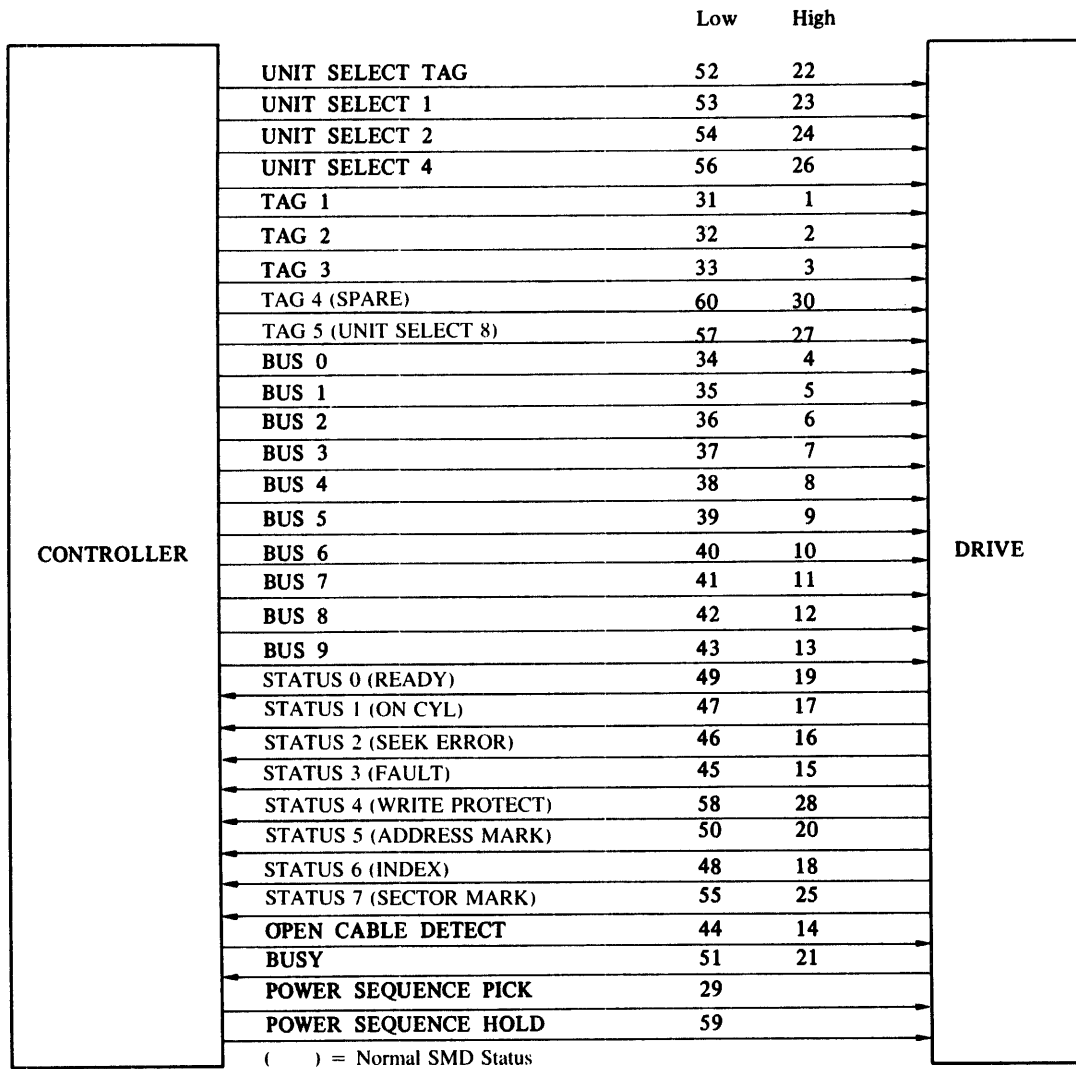

Fig. 7.2-1 A-Cable

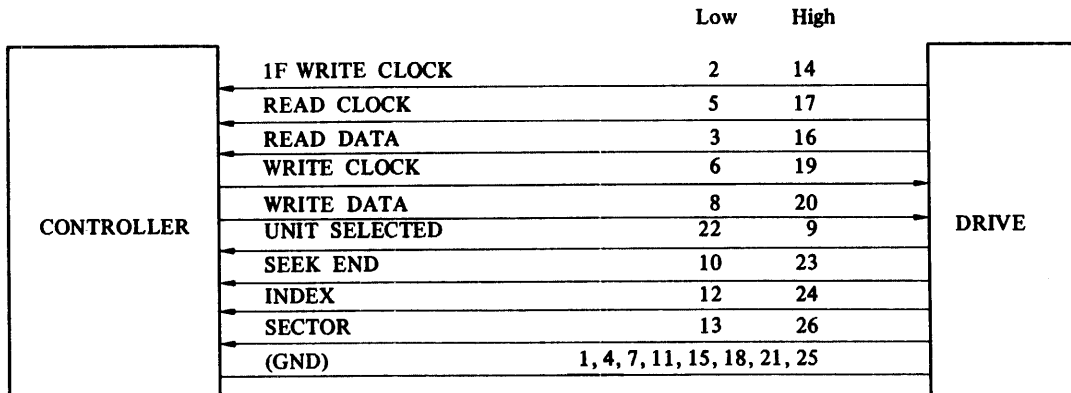

Fig. 7.2-2 B-Cable

### 7.3 A-CABLE INPUT SIGNALS

#### (1) Unit Select Tag

This signal gates Unit Select 1, 2 and 4 to select the drive. Refer to timing of Unit Select (Figure 7.7-1 if dual channel option is not installed, or Figure 7.7-23 if dual channel option is installed). Elaboration of the dual channel select operation follows.

Suppose that the dual channel option is installed and the drive has been reserved by Unit Select command from channel-A, the drive is not selectable from channel-B until a Release command will be issued from channel-A or the internal 500 ms timer times out. However, Priority Select from channel-B can interrupt the reserved status at any time. (Refer to Figure 7.7-23)

On the other hand, if the dual channel option is installed and the drive has been reserved by a Priority Select command from channel-A, channel-B cannot reserve the drive with Unit Select or Priority Select command until a Release command from channel-A is issued. (Refer to Figure 7.7-24)

#### (2) Unit Select 1, 2 and 4

These three signals are binary-coded to select the drive and are validated by the leading edge of Unit Select Tag. The logical number of the drive (0 through 7) is selectable by means of a switch located on the PCB (DQEMU; B16B-8140-0010A#U).

Table 7.3-1 Tag/Bus

Bus	Tag 1	Tag 2	Tag 3	(With Unit Select Tag)
	Cylinder Address	Head Address	Control Select	
0	1	1	Write Gate	-
1	2	2	Read Gate	-
2	4	4	Servo Offset Plus	-
3	8	8	Servo Offset Minus	-
4	16	16	Fault Clear	-
5	32	-	AM Enable	-
6	64	-	RTZ	-
7	128	-	-	-
8	256	-	-	-
9	512	-	Release*	Priority Select*

\* Dual Channel only.

(3) Cylinder Address (Tag 1)

The cylinder address is set by Tag 1 and Bus 0 to 9. Throughout Tag 1, the Bus must be stable. Refer to Figures 7.7-2 and -3.

The drive must be On Cylinder prior to Tag 1. When the Bus content is equal to or more than 896 for the drive with fixed heads, the Fixed Head area is selected. When the Fixed Head area is selected, no physical movement of the heads is performed in the drive.

Fixed Head and Movable Head Addresses are specified as follows. (Storage capacity shown is unformatted). Refer to Figure 7.3-1.

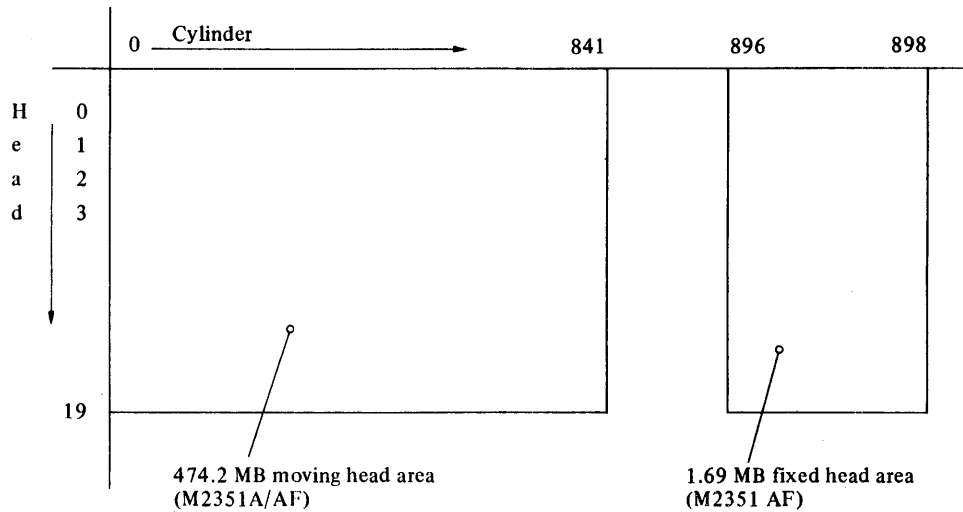

Fig. 7.3-1 Mapping

Detection of Over Cylinder;

Table 7.3-2 shows responses from the drive when illegal cylinder address is issued from the controller.

Table 7.3-2 Responses for Over Cylinder

Drive \ CYL.	842 ~ 895	896 ~ 898	899 ~
M2351A	Seek End and Seek Error		
M2351AF	Seek End and Seek Error	(No response)	

(4) Head Address (Tag 2)

The head address is set by Tag 2 and Bus 0 to 4. Throughout Tag 2, Bus 0 to 4 must be stable. Refer to Figures 7.7-4, -5, -6, -7 and -8.

If the Head Address transferred from the controller is equal to or more than 20, no response is generated in the drive.



(5) Control Select (Tag 3)

Bus 0 to 9 gated by Tag 3 have a different meaning in each bit. All signals are defined as control signals.

(5-1) Write Gate (Bus 0)

Enables the write operation on the specified track. It is validated under the following conditions;

Unit Ready	-----	True
On Cylinder	-----	True
Seek Error	-----	False
Fault	-----	False
Open Cable Detect	---	True
File Protected	-----	False
Servo Offset	-----	False
Read Gate	-----	False

If Write Gate is turned on in cases other than the above mentioned conditions, Fault occurs and the Write operation is inhibited immediately. See Figures 7.7-4, -7, -20, -21 and -22.

(5-2) Read Gate (Bus 1)

Enables the Read operation on the specified track. It is validated under the following conditions;

Unit Ready	-----	True
On Cylinder	-----	True
Seek Error	-----	False
Fault	-----	False
Open Cable Detect	---	True
Write Gate	-----	False

See the Read Gate timing chart in Figures 7.7-4, -7, -21 and -22.

(5-3) Servo Offset Plus (Bus 2)

When this signal is true, the head is offset 100 micro-inches away from nominal On Cylinder position in the outer direction with the responses of Seek End and On Cylinder after 5 ms. Data cannot be written in the offset mode. An attempt to do so will result in the drive setting a fault indication. See Figure 7.7-9.

When Servo Offset Plus and Minus are sent simultaneously, Servo Offset Plus will be effective.

(5-4) Servo Offset Minus (Bus 3)

When this signal is true, the head is offset 100 micro-inches away from nominal On Cylinder position in the inner direction with the responses of Seek End and On Cylinder after 5 ms. Data cannot be written while in the offset mode. An attempt to do so will result in the drive setting a fault indication. See Figure 7.7-9.

(5-5) Fault Clear (Bus 4)

This signal clears the fault status i.e., Write/Read Check Status, however, if the cause of the Fault condition still exists, the status will not be cleared. See Figure 7.7-10.

(5-6) AM Enable (Bus 5)

AM Enable, in conjunction with Write Gate or Read Gate, is used in a Variable Sector Format. When AM Enable is true while Write Gate is true, an AM of three bytes (DC erase) is written on the track.

Refer to Figure 7.7-11.

When AM Enable is true while Read Gate is true, the read circuit searches an AM of three bytes (DC erased). When the AM is found, the drive will issue Address Mark Found to the controller.

See Figure 7.7-12.

(5-7) RTZ (Bus 6)

Wherever the movable heads are located, they return to cylinder zero and head zero when the RTZ signal is received. Also, the RTZ signal is functional in the fixed head area and resets Fixed Head Select latch. This signal clears the Seek Error.

Refer to Figure 7.7-13.

(5-8) Release (Bus 9); Dual Channel only

After the drive is reserved by Unit Select or Priority Select, Release command becomes valid at Tag 3 and Bus 9. Enabling this signal will release the reserved status in the drive, making alternate channel access possible after selection by the other channel. (Refer to Figures 7.7-23 and -24.)

If the drive has been reserved by Unit Select and the Release Timer Switch on the optional dual channel PCB (DQFMU; B16B-8150-0010A#U) is set to RLTM side, the drive will automatically release the reserved condition approximately 500 ms after the Unit Select command is issued.

(6) Priority Select (Bus 9 with Unit Select Tag and Unit Select 1, 2, 4)

By sending Priority Select (Bus 9) along with Unit Select Tag, Unit Select 1, 2, 4, a controller can select the drive even if it has been selected or reserved by the other channel, except when its own channel is disabled by the Disable switch or the drive is priority selected by the other channel.

With this command, the drive is set in the unconditionally reserved state with respect to that channel. Once it is unconditionally reserved, the control becomes exclusive, i.e., the other channel cannot access the drive until the drive is released from the controller which has reserved the drive. If the drive is unconditionally reserved, all the signals including Unit Selected, and Busy signals are inhibited with respect to the other channel. (Refer to Figure 7.7-24).

(7) Open Cable Detect (Channel Ready)

This signal is used to prevent damage of data caused by interface disturbances when the power to the controller is lost. Therefore, this signal must be stable when the controller is available, and must be disabled before logic levels decay on the interface when a power failure occurs in the controller.

Refer to Figure 7.7-14.

(8) Tag 4 and 5

Unit Status, Sector Status, Write/Read Check Status and Access Status can be sensed throughout Status 0- 7 lines with a combination of those two coded signals. Status 0 to 5 for Unit Status are always displayed by 5 LEDs and Status 0 to 7 for DE Sequence State, Write/Read Check State and Access State are also displayed by 7-segment LEDs on the PCB (HGAMU; B16B-7830-0010A#U) for maintenance aid.

See Table 7.4-1 for information about these Tags.

Note that Unit Status can be made available on the interface by shorting a circuit on the Logic PCB (C16B-5123-0980#U) with a shorting plug.

See Figure 7.7-15 for time specifications.

(9) Power Sequence Pick/Hold

Power Sequence is required when the Remote/Local switch on the power supply unit is set to Remote. In this mode, when the controller sets the Pick and Hold lines to ground, the first drive's spindle starts rotating if the start switch has been pressed. Approximately five seconds later the Pick signal is transferred to the next drive, and this is repeated until all drives are sequenced up. When both signals go false, the spindle stops rotating. If the mode switch on the power supply unit is set to Local, each Start Switch must be pressed manually to start the spindle rotating. Refer to Figure 7.7-16.

## 7.4 A-CABLE OUTPUT SIGNALS

### (1) Status 0 to 7

The Status 0 to 7 lines indicate status information determined by combinations of Tag 4 and Tag 5 signals. Information available is specified in Table 7.4-1.

Table 7.4-1 Status

Tag 4	False	True	False	True
Tag 5	False	False	True	True
Status	Unit Status	Sector Status	Write/Read Check Status	Access Status
0	Unit Ready	Sector 1	Index Check	DE Sequence Check
1	On Cylinder	Sector 2	Control Check	Access Time-Out Check
2	Seek Error	Sector 4	Multi Head Check	Over Shoot Check
3	Fault	Sector 8	Head Short Check	Rezero Mode Latch
4	Write Protected	Sector 16	Write Current on Read Check	Servo Latch
5	Address Mark Found	Sector 32	Write Transition Check	Linear Mode Latch
6	Index	Sector 64	Delta I Write Check	Control Latch
7	Sector	Sector 128	Servo Off-Track	Wait Latch

### (2) Unit Status

When both Tag 4 and 5 are False, Status 0 ~ 7 indicate the basic information required for the Seek, Read and Write operations.

(2-1) Unit Ready (Status 0)

When this signal is true and the drive is selected, this signal indicates that the drive has reached the rated speed. Note that when the drive is in fault condition, Unit Ready may or may not be issued depends on the position of a jumper plug as described in Table 3.3-1.

(2-2) On Cylinder (Status 1)

Indicates that the heads are located on the specified track. This signal goes false for approximately 5 ms at the beginning and at the end of the offset operation. For a zero Track Seek, On Cylinder will go false for max. 10 us.

(2-3) Seek Error (Status 2)

Indicates that a Seek Error has occurred. In this case, On Cylinder does not go true. The Seek Error is cleared when an RTZ (Tag 3 and Bus 6) is received or by pushing the Fault Clear Switch on the operator panel or maintenance-aid MRTZ Switch on the PCB (HGAMU; B16B-7830-0010A#U). The Seek Error status is defined as follows;

1. Seek or RTZ operation is not complete within the specified time.
2. Heads travel to a position outside the recording area.
3. An illegal cylinder address is issued to the drive.
4. Head overshoots to an unspecified cylinder address.
5. Seek command is received by the drive during the not On Cylinder status, when the heads are in motion, or during a Write/Read operation.

(2-4) Fault (Status 3)

Indicates that a fault condition for Write/Read operation exists in the drive. Fault conditions are described in the Write/Read Check status in detail.

If one of the Fault conditions occurs, writing is immediately inhibited and the Fault signal is issued to the controller.

The Fault status can be cleared by one of the following operations;

1. Fault Clear on Tag 3 and Bus 4
2. Fault Clear switch on the operator panel
3. Pushing on the maintenance-aid MRTZ Switch on the PCB  
(HGAMU; B16B-7830-0010A#U)
4. Switching off the power to the drive
5. Stopping rotation of the spindle motor

Fault Status turns on the check lamp on the operator panel as well as Maintenance Aid LED on the PCB.

#### (2-5) Write Protected (Status 4)

Indicates that the drive is in the write-protected mode. The write-protect function is enabled by the File Protect Switch on the operator panel, and becomes active while the drive is not selected. If the drive is selected and the write-protect-function is desired, the drive must be momentarily deselected.

#### (2-6) Address Mark Found (Status 5)

Address Mark Found is an 8-Byte pulse which is sent to the controller at least 2 Bytes after the recognition of a 3-Byte DC-erased area.

#### (2-7) Index (Status 6)

Index mark is derived from the servo information. It occurs once per revolution and is used for reference in Write/Read operation.

Refer to Figure 7.7-17 for the timing of Index and Sector.

#### (2-8) Sector (Status 7)

The Sector mark is also derived from the servo information. The number of sectors per revolution is selectable by 15 jumper plugs and is determined by counting Byte Clock. The jumper pins are located on the Logic PCB (C16B-5123-0980#U). Each pin represents a binary number minus 1 of Byte Clock to be counted in each sector.

#### (3) Sector Status (Status 0 ~ 7)

Indicates the current sector address from 1 to 255 in the drive. Refer to Figure 7.7-17 for timing of Sector Address.

#### (4) Write/Read Check Status

Indicates the fault status while in the Write or Read operation. When one of these conditions occurs in the drive, the Fault signal in the Unit Status is issued as a summary to the controller. It can be cleared by a Fault Clear Signal from the controller.

##### (4-1) Index Check (Status 0)

Indicates that the Index signal is not detected where it should be or was detected where it should not have been while performing Write/Read operations.

##### (4-2) Control Check (Status 1)

The following fault conditions cause Control Check.

1. Write and Read Gate are issued at the same time.
2. Write operation during offset mode.
3. Write Gate is issued in the write protect mode.

##### (4-3) Multi-Head Check (Status 2)

Indicates that two or more head ICs are selected simultaneously. (One DE has five head ICs and four heads are connected to one head IC.)

##### (4-4) Head Short Check (Status 3)

Indicates that abnormal current was sensed in the Write Select line during write operation.

##### (4-5) Write Current on Read Check (Status 4)

Indicates that write current was sensed during a read operation.

##### (4-6) Write Transition Check (Status 5)

Indicates that write current has not been switched for writing data. The detection is continued from byte-8 after Write Gate is true until the end of the Write operation.



(4-7) Delta I Write Check (Status 6)

Indicates that an abnormal write current was sensed in the inner head, outer head or fixed head.

(4-8) Servo Off-Track (Status 7)

Indicates the following fault conditions.

1. The head is  $\pm 100$  micro inches off the desired track during the Write/Read operation.
2. Write/Read Gate is received by the drive during not On Cylinder status, heads in motion or seek error.

(5) Access Status

Indicates access status of the head in Seek and RTZ operation. It also indicates start and stop sequence of the spindle motor.

(5-1) DE Sequence Check (Status 0)

Indicates that an abnormal start/stop sequence of the DE occurred in the drive. Latch 4, Latch 2, and Latch 1 of DE SEQ represent the various DE sequence status as shown in the following table:

Table 7.4-2 Contents of DE Sequence Latches

State No.	Latch 4	Latch 2	Latch 1	Status
0	0	0	0	Wait status
1	0	0	1	The START/STOP switch on the operator panel is set to START.
3	0	1	1	The spindle motor starts rotating.
2	0	1	0	Sequence Rezero starts approximately 40 seconds after State 3.
6	1	1	0	Sequence Rezero is completed and seek operation is possible.
7	1	1	1	DE Stop Sequence State results and the head begins to return to the home position. (Go Home)
5	1	0	1	Go Home operation is completed and the spindle motor stops rotating.
4	1	0	0	Approximately 40 seconds have passed since State 5. (Returns to State 0.)

One of the following errors occurred as DE Sequence State advanced:

1. Initial State Good (Motor At Speed and Hall Alarm are not present) does not result in State 1.
2. Run State Good (not Hall Alarm and Motor At Speed are sent out) cannot be obtained for approximately 40 seconds in State 3.
3. Run State Good goes off during State 6.

It cannot be cleared by the Fault Clear Switch on the operator panel or Fault Clear signal on the interface but only by stopping rotation of the spindle.

(5-2) Access Time-Out Check (Status 1)

During an RTZ or Seek operation, On Cylinder failed to appear within 250 ms  $\pm$ 30% after Access Start. It can be cleared by RTZ operation.

(5-3) Over-Shoot Check (Status 2)

Indicates the heads go past the desired track during Seek or RTZ operation or go into the Guard Band during a Seek operation.

It also indicates that the heads are moving at abnormal speed during RTZ operation.

Over-Shoot Check can be cleared by RTZ operation.

- (5-4) Rezero Mode Latch (Status 3)
- Servo Latch (Status 4)
- Linear Mode Latch (Status 5)
- Control Latch (Status 6)
- Wait Latch (Status 7)

These five latches observe the sequence of seek and RTZ operations. Whenever an error occurs during Seek or RTZ, the content of these latches are frozen at that time, so that they are beneficial for error analysis. They can be cleared by RTZ operation. The relationship between access state and the contents of latches is shown in Table 7.4-3.

Table 7.4-3 Access States

Rezero Mode Latch	Servo Latch	Linear Mode Latch	Control Latch	Wait Latch	State	Mode
0	0	0	0	1	Wait State	Reset
0	0	0	0	0	Start RTZ	RTZ
1	0	0	0	0	Move In	
1	0	0	1	0	Turn Around	
1	0	1	1	0	Move Out	
0	0	1	1	0	RTZ Linear Mode	
0	1	1	1	0	On Track	
0	1	0	1	0	Accelerate	Seek
0	1	0	0	0	Decelerate	
0	1	1	0	0	Seek Linear Mode	
0	1	1	1	0	On Track	

(6) Busy (Dual Channel only)

If the drive has been already reserved and/or selected, a Busy signal will be issued together with Unit Selected to the other channel attempting the select. Busy signal will remain true until Unit Select Tag is dropped or the Busy condition in the drive is released.

It is necessary to gate Busy signal by Unit Selected signal at the controller.

## 7.5 B-CABLE INPUT SIGNALS

### (1) Write Data

Carries NRZ data which is to be written on the disk surface and must be synchronized with Write Clock. Refer to Figure 7.7-18.

### (2) Write Clock

Write Clock is a return signal of the 1F Write Clock issued from the drive as shown in Figure 7.5-1, and must be synchronized with the NRZ Write Data. Refer to Figure 7.7-18.

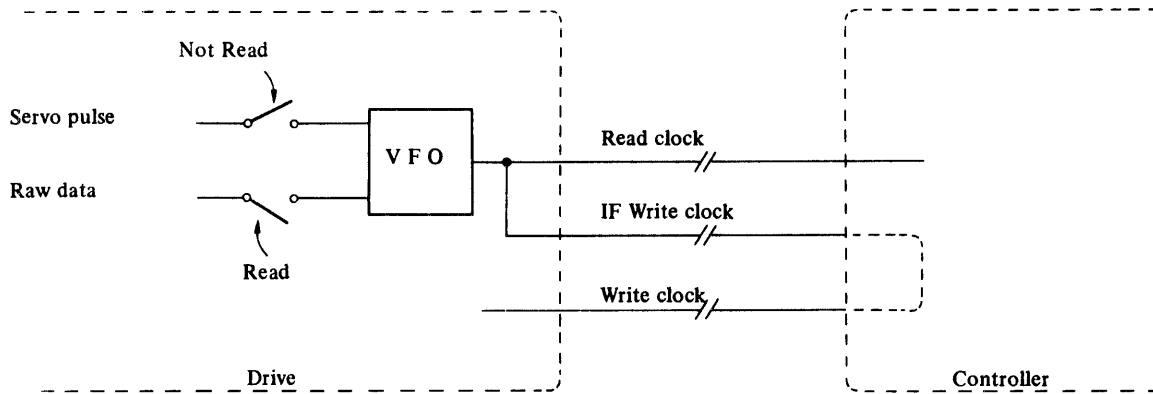

Fig. 7.5-1 Generation of Write/Read Clock

## 7.6 B-CABLE OUTPUT SIGNALS

### (1) 1F Write Clock

Used by the controller to synchronize Write Data and Write Clock. It is synchronized to the Servo Pulse while in the Write operation and to the Raw Data during in a Read operation. Refer to item (1) of Chapter 7.5 and Figure 7.7-18.

### (2) Read Data

Transmits the recovered data in the form of NRZ data synchronized with the Read Clock. Refer to Figure 7.7-19.

### (3) Read Clock

Transmits Read Clock which defines the beginning of a bit cell. The Read Data is synchronized with the Read Clock. Refer to Figure 7.7-19.

### (4) Unit Selected

When three Unit Select lines match with the logical address of the drive, and the leading edge of Unit Select Tag is received, the Unit Selected goes true and is issued to the controller. This signal activates all signals in the A-Cable. Refer to Figure 7.7-1.

### (5) Seek End

In a combination with On Cylinder or Seek Error, Seek End goes true after a Seek or RTZ, indicating that a Seek or RTZ operation has terminated. Seek End goes false for 5 ms at the beginning and end of an Offset operation in default mode. In the other mode, Seek End never goes false at resetting offset as described in Table 3.3-1.

For a Zero Track Seek, it will go false for max. 10  $\mu$ s. Note that Seek End and On Cylinder do not change when a fixed head is selected. Refer to Figures 7.6-2, -3, -6, -9 and -13.

In case of dual channel sub-system, Seek End is always true to the other channel (unselected channel). Suppose that channel-A attempts to select the drive which has already been selected by channel-B. When channel-B releases Selected and Reserve Condition, Seek End goes false for approximately 30  $\mu$ s for channel-A which has been waiting.

(6) Index

Same as Index signal in the A-Cable which is described in item (2-7) of Chapter 7.4. This signal is available with or without the dual channel feature.

(7) Sector

Same as Sector signal in the A-Cable which is described in item (2-8) of Chapter 7.4. This signal is available with or without the dual channel feature.

## 7.7 TIME SPECIFICATIONS

Timings are specified at the connector position of the drive. It is necessary for signal timings to consider both the delay time of the interface cable and the circuit of the controller.

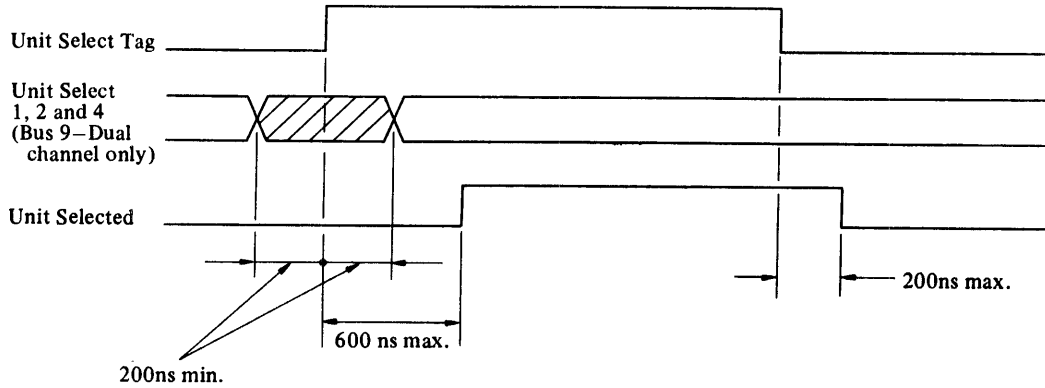
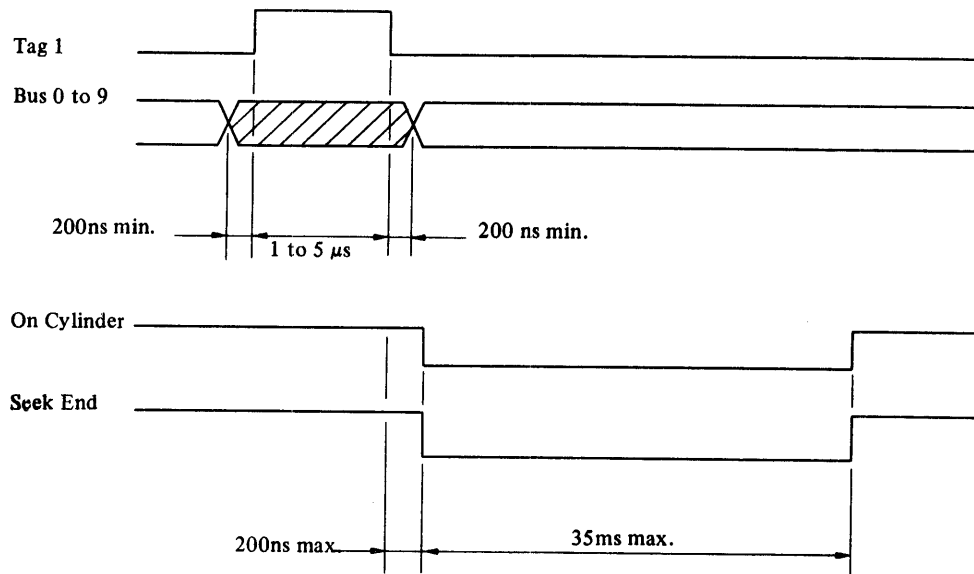

Fig. 7.7-1 Unit Select Timing



Note; The cylinder address must be less than 841 to select a movable head.

Fig. 7.7-2 Seek Timing



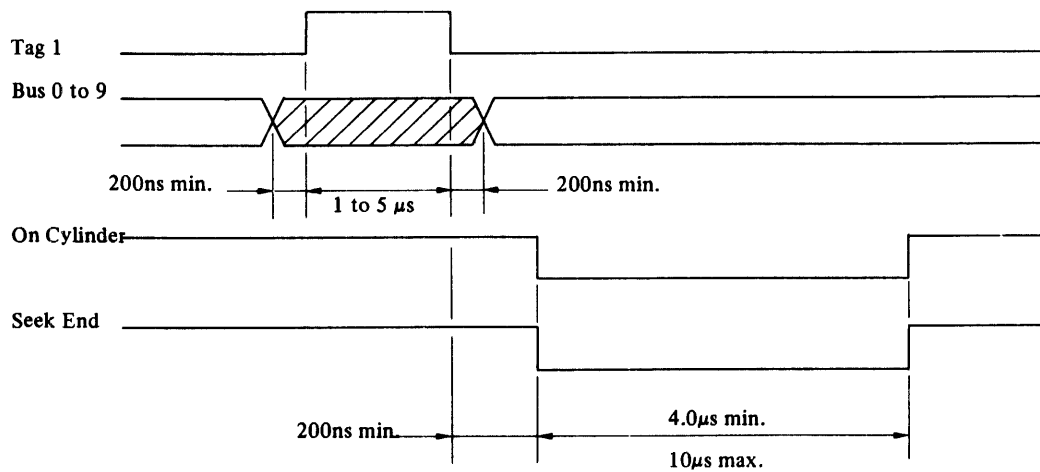

Fig. 7.7-3 Zero Track Seek Timing

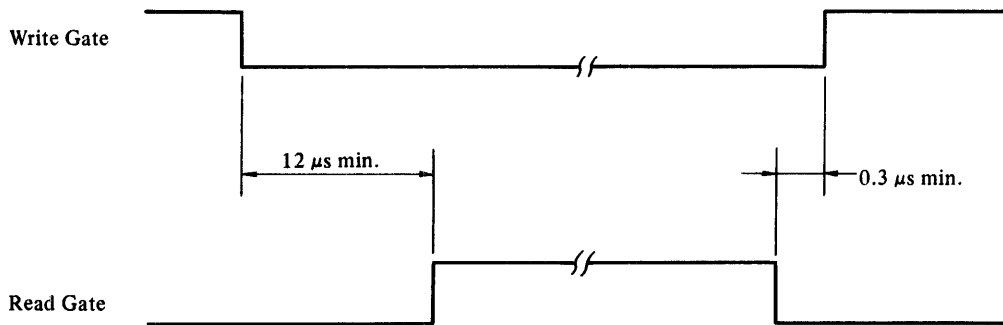
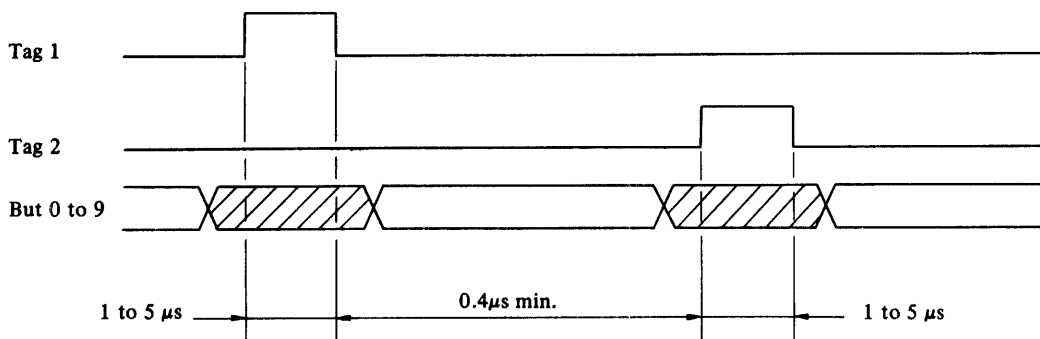
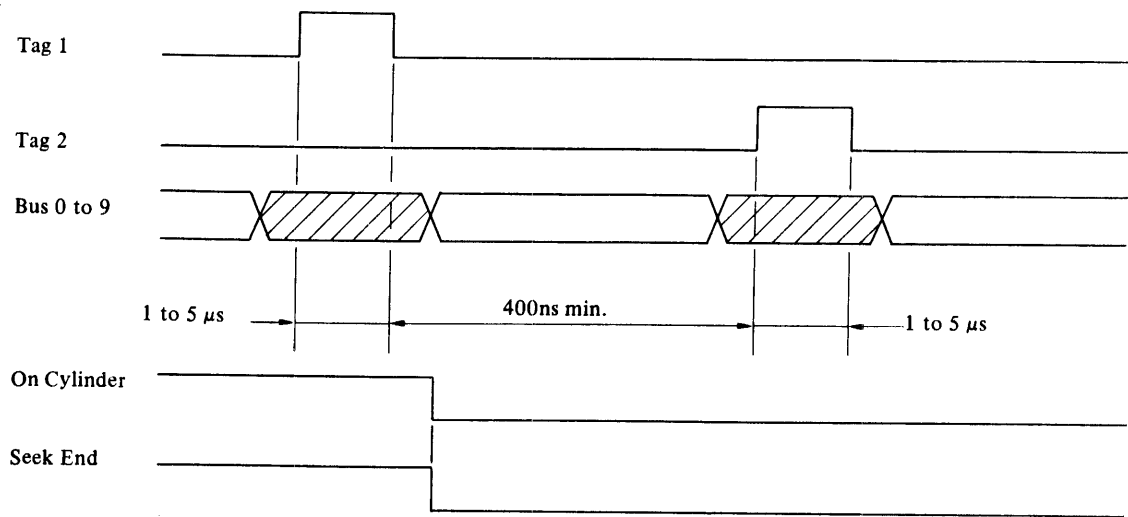

Fig. 7.7-4 Read after Write and Write after Read Timing



Note; When the cylinder address is more than or equal to 896, the cylinder address is defined as a fixed head area and the subsequent Tag 2 is defined as fixed head.

Fig. 7.7-5 Addressing for Fixed Head



Note; Tag 2 can be set during seek operation.

Fig. 7.7-6 Addressing for Movable Head

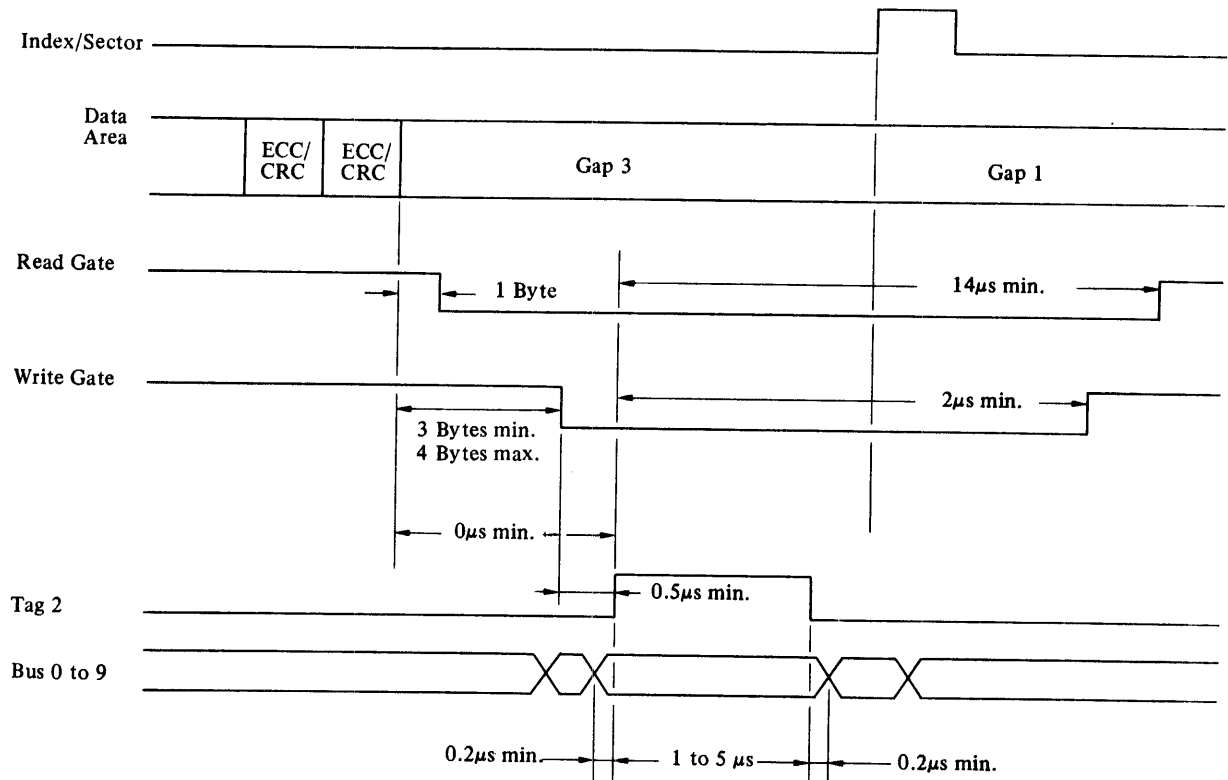

Figure 7.7-7 Head Address Change at the Last Gap

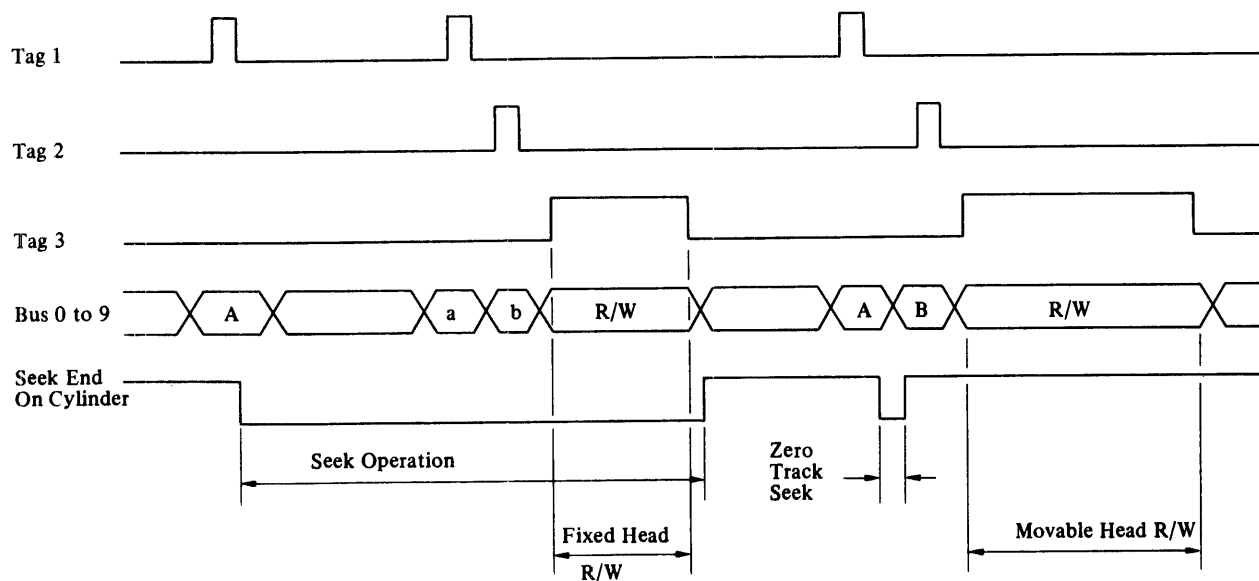
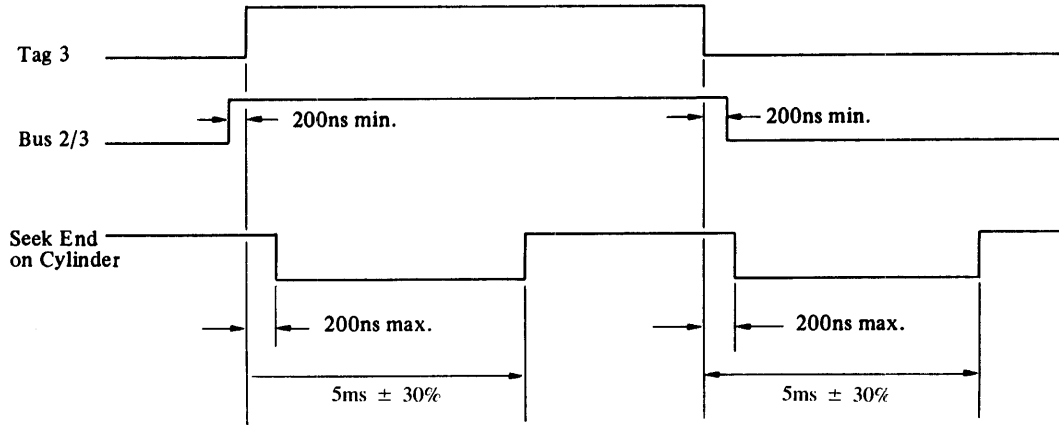

Fig. 7.7-8 Fixed Head Addressing During Seek

The normal sequence of this operation would be in the following order;

- (1) The controller issues Tag 1 (Cylinder Select) with the desired cylinder address (A) of the moving head. On Cylinder and Seek End will go false.
- (2) The controller accesses the desired fixed head area with the appropriate cylinder (896-898) (a) and head (b) select signals.
- (3) The controller can read or write on the fixed head area while the movable heads are in motion. Reading or writing in the fixed head area during the absence of On Cylinder and Seek End will not cause a Fault.
- (4) At the completion of the seek on the movable heads, On Cylinder and Seek End will go true.
- (5) After the write or read operation in the fixed head area, the controller must readdress the movable head by sending the appropriate cylinder select (A) (Zero Track Seek) and head select (B) signals. The cylinder select Tag 1 resets the fixed head mode.



Note that Seek End does not go false at offset-reset operation depending on the position of a jumper plug as described in Table 3.3-1.

Fig. 7.7-9 Offset Timing

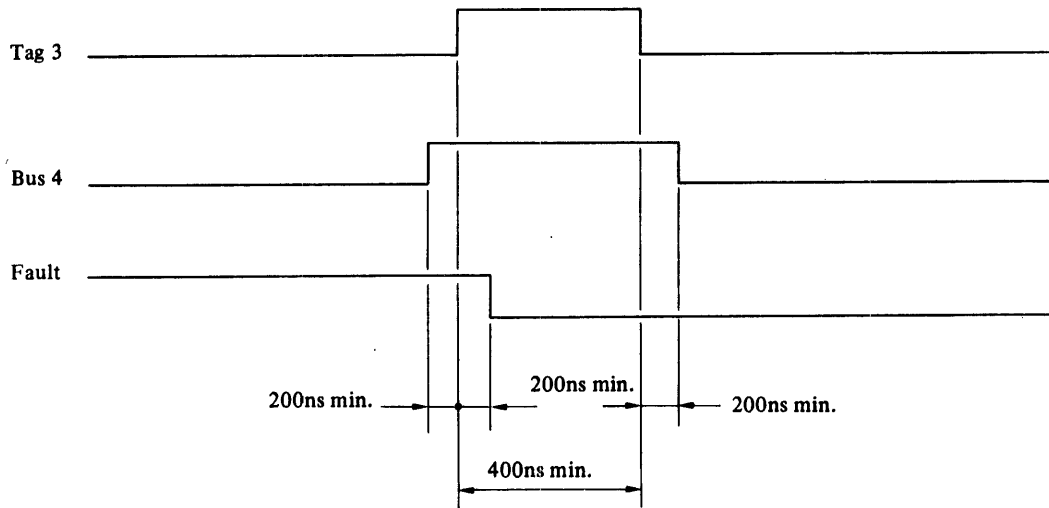

Fig. 7.7-10 Fault Clear Timing

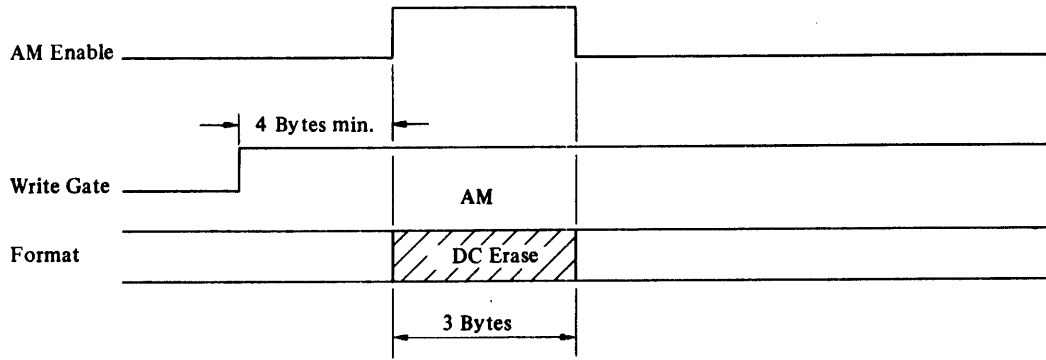

Fig. 7.7-11 AM Write

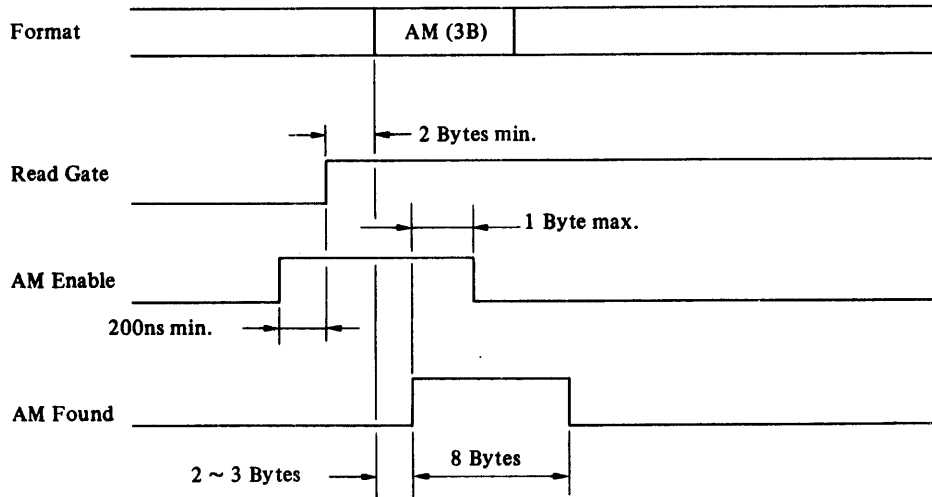
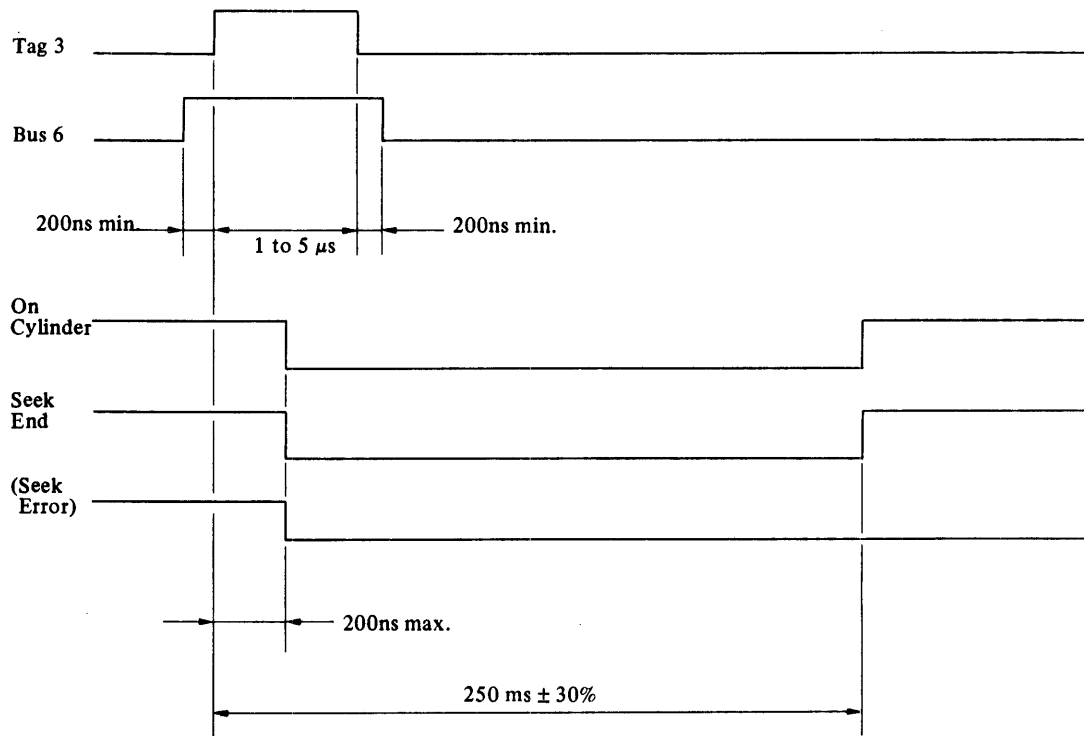
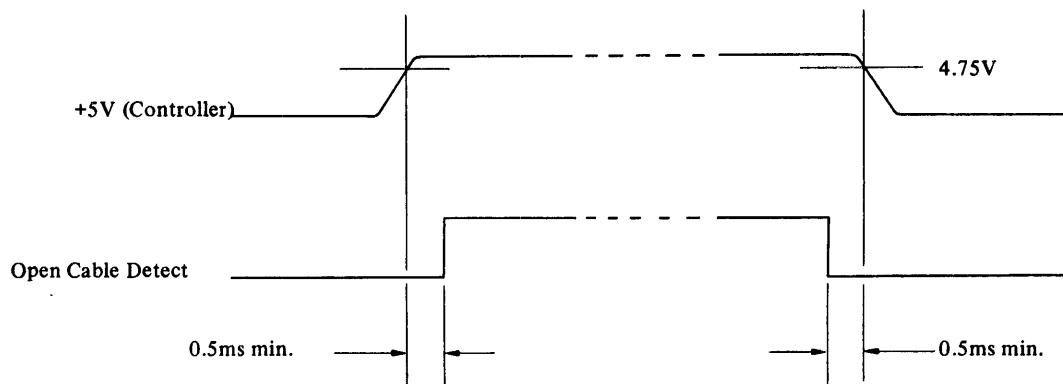

Fig. 7.7-12 AM Detection



Note; On Cylinder is not always set if Seek Error occurs.

Fig. 7.7-13 RTZ Timing



Note; Two Drivers of SN75110 would be required in parallel without termination to increase the drive current in the interface cable.

Fig. 7.7-14 Open Cable Detect Timing

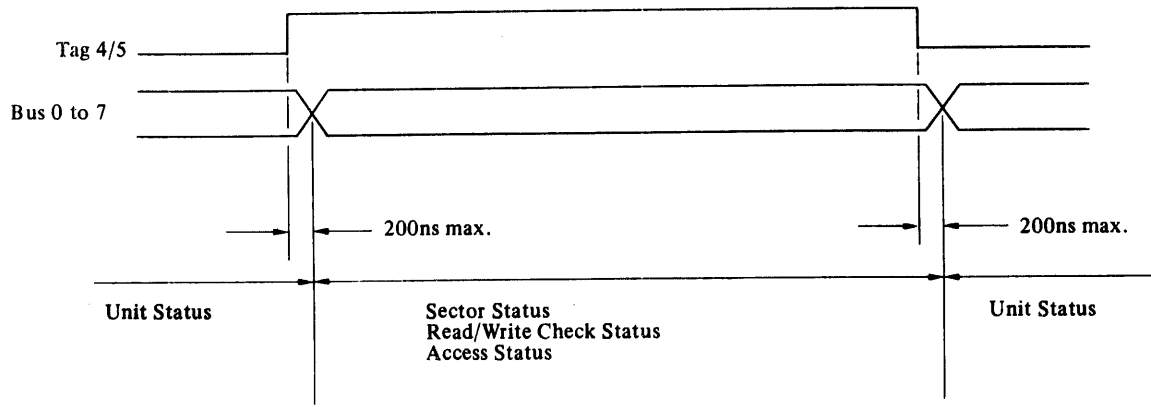

Fig. 7.7-15 Tag 4/5 Timing

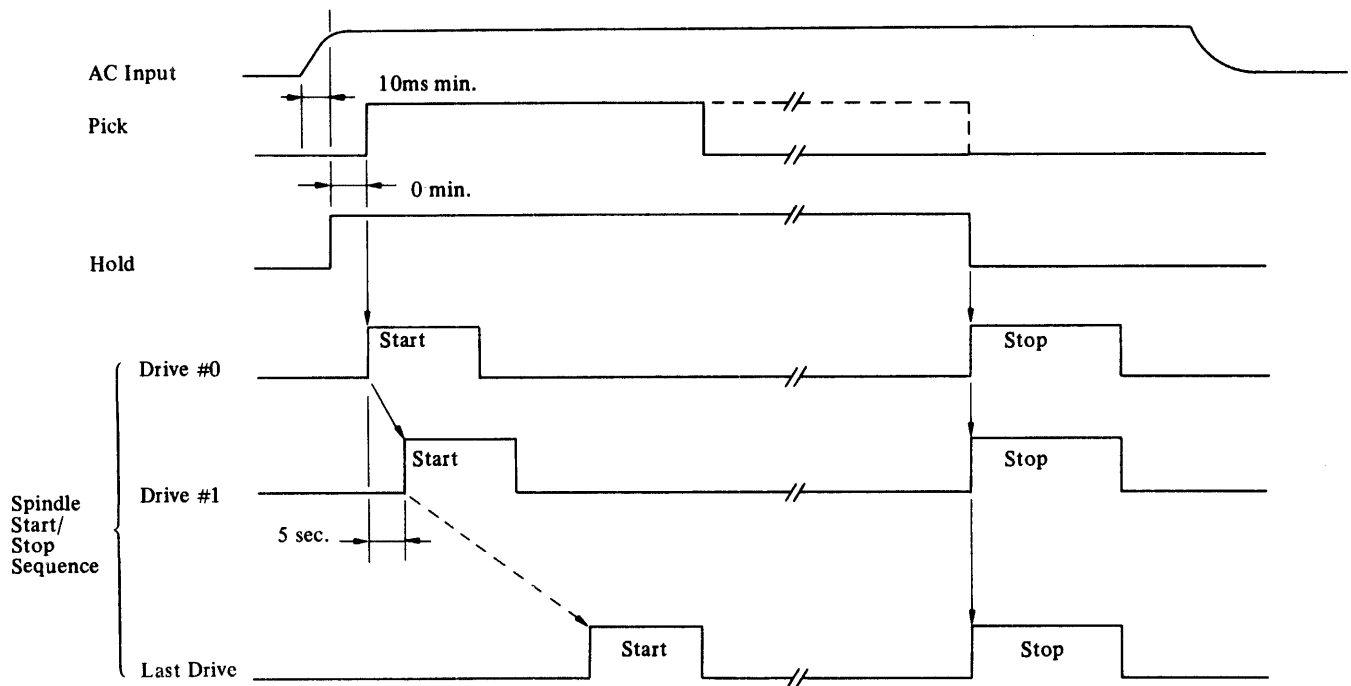

Fig. 7.7-16 Power Sequence Pick/Hold Timing

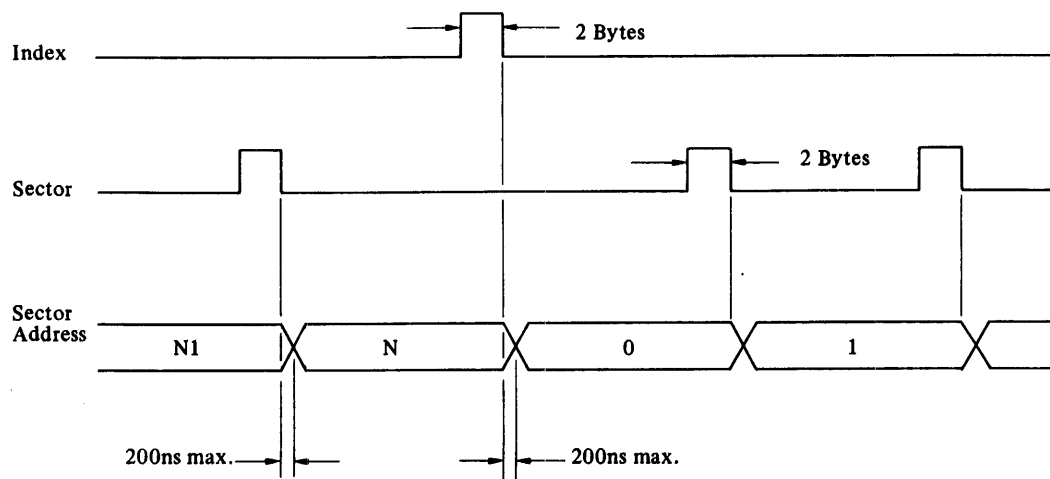
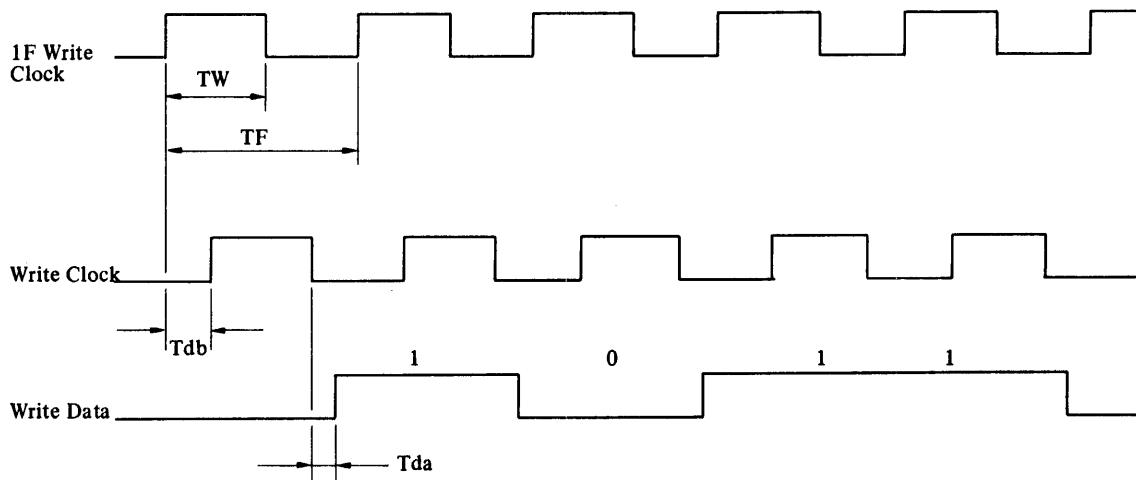

Fig. 7.7-17 Index and Sector Timing



$$\begin{aligned}
 TW &= TF/2 = 33.62 \pm 2 \text{ ns} \\
 TF &= 67.24 \pm 2 \text{ ns} \\
 Tdb &= \text{Continuous delay within 4 bits} \\
 Tda &= 0 \pm 15 \text{ ns}
 \end{aligned}$$

- Note; (1) Write Data and Write Clock timing shall be specified at the output connector of the controller.
- (2) The tolerance of TF includes the rotational speed tolerance and the jitter of servo signal.
- (3) NRZ Write Data issued from the controller is put in to the MFM-modulator and then written on the disk surface with write-compensation.

Fig. 7.7-18 Write Clock and Write Data Timing



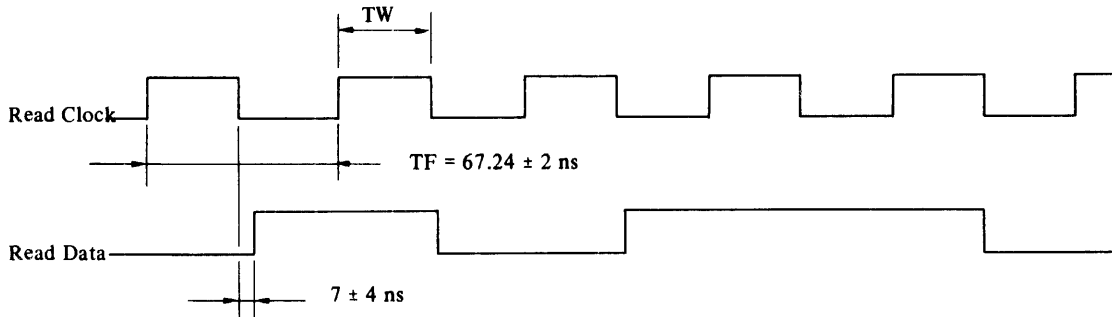

$$TW = TF/2 = 33.62 \pm 2 \text{ ns}$$

- Note; (1) Read Clock and Read Data timing shall be specified at the output connector of the drive.
- (2) Read Data signal should be clocked at the positive-going edge of Read Clock in the controller.

Fig. 7.7-19 Read Clock and Read Data Timing

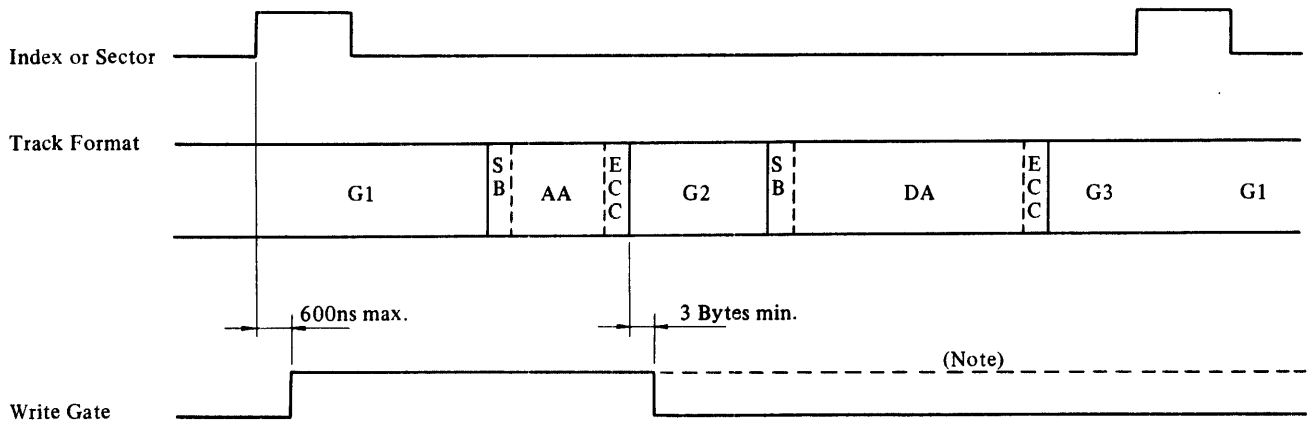

Note: Write Gate may be at high level.

Fig. 7.7-20 Format Write Timing

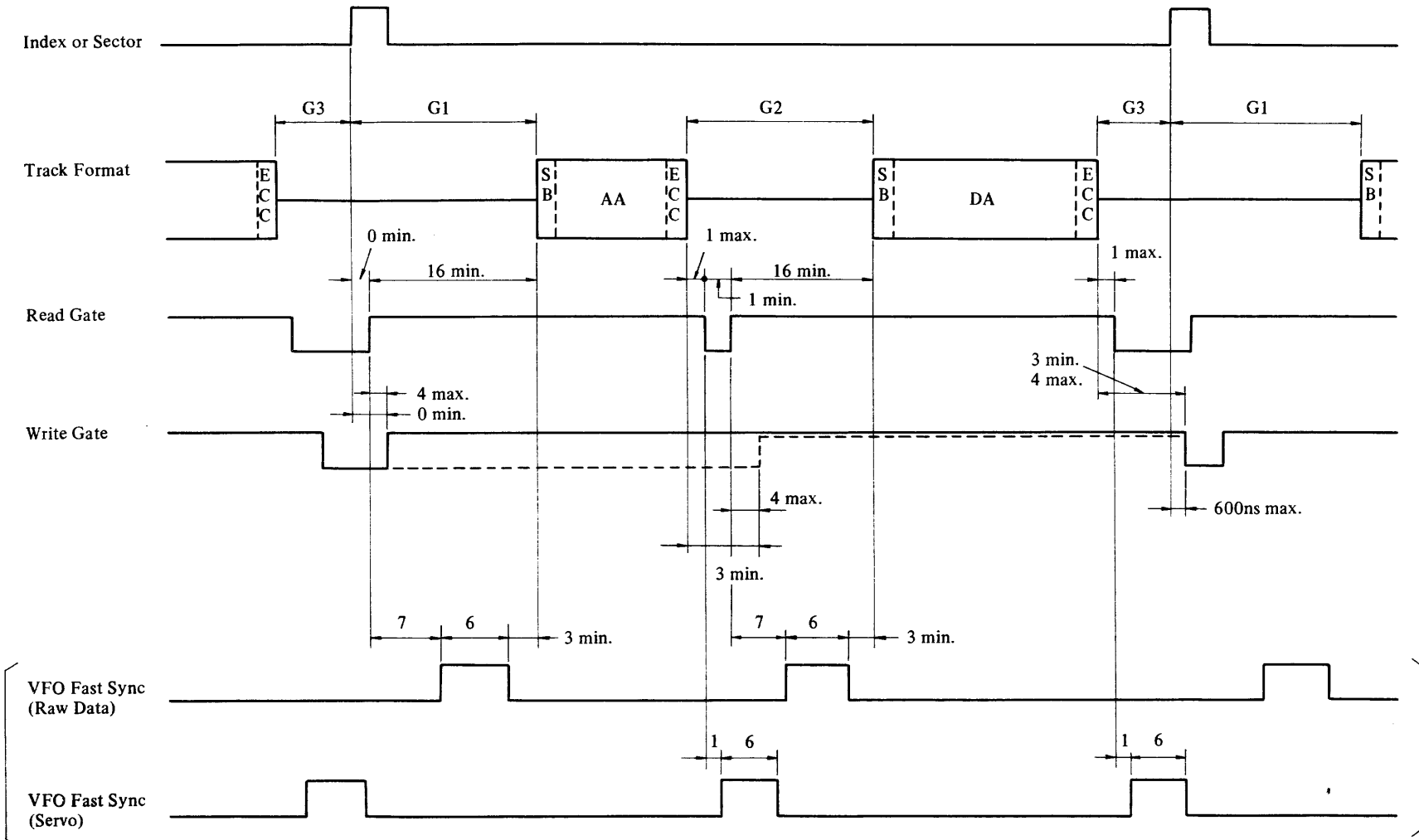

- \* Unit: Byte
- \* Not including head switching time, read-after-write and write-after-read transient time.
- \* VFO Fast Sync (Raw Data and Servo) are signals in the drive.

Fig. 7.7-21 Fixed Sector Format Timing

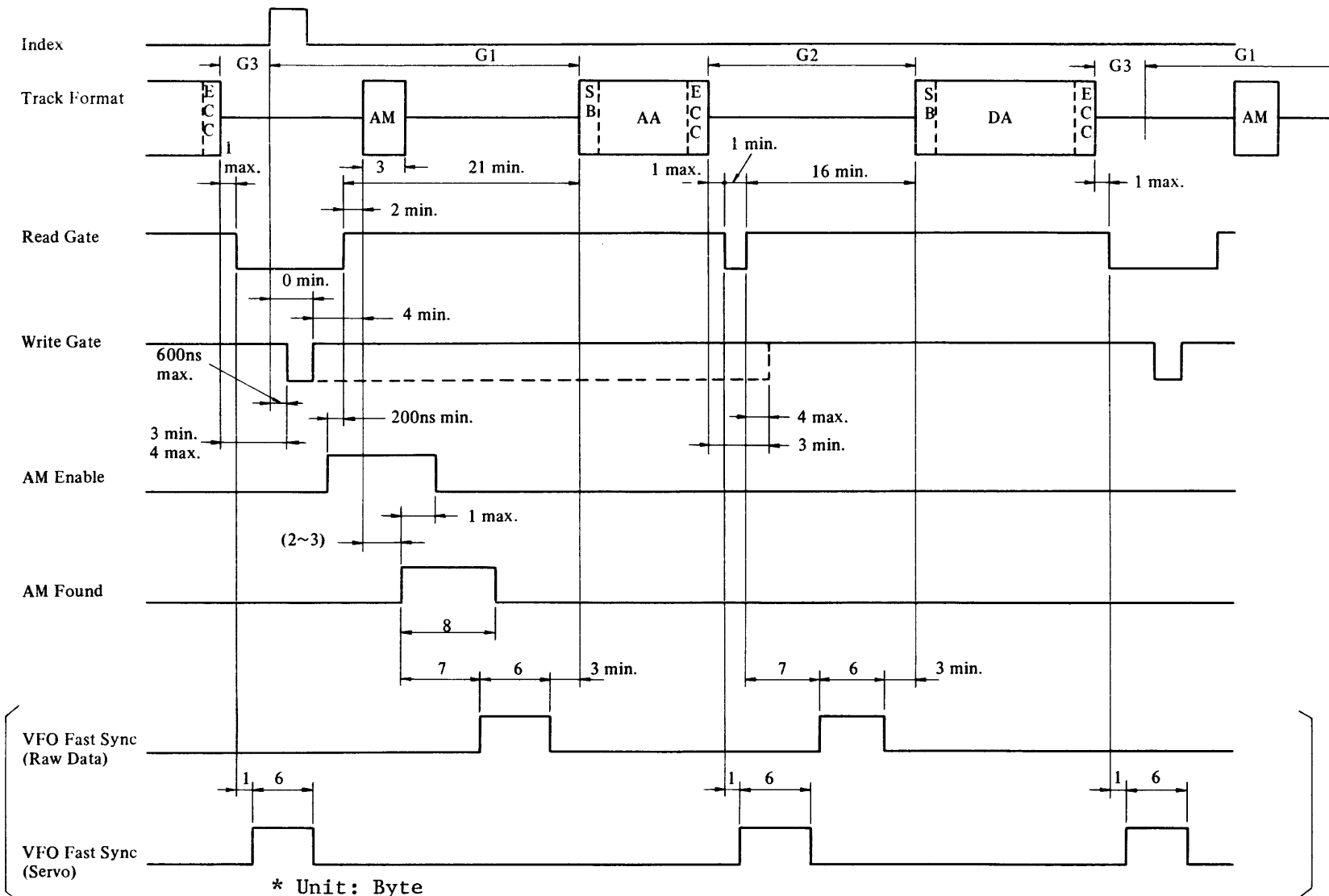

\* Unit: Byte  
 \* Not including head switching time, read-after-write and write-after-read transient time.  
 \* VFO Fast Sync (Raw Data and Servo) are signals in the drive.

Fig. 7.7-22 Variable Sector Format Timing

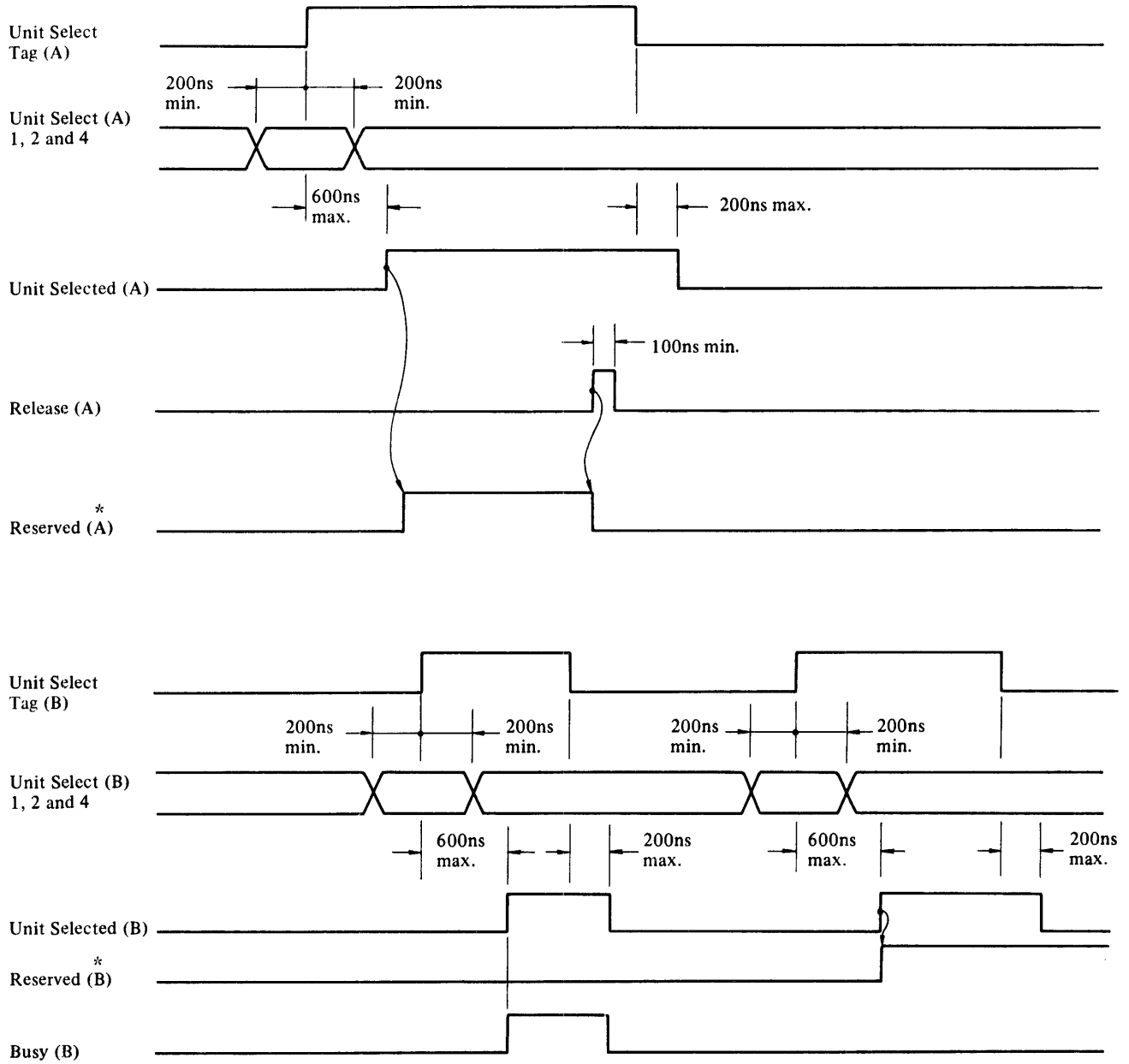

Note; Reserved (\*) is a signal within the drive.

Fig. 7.7-23 Unit Select Timing (Dual Channel Only)

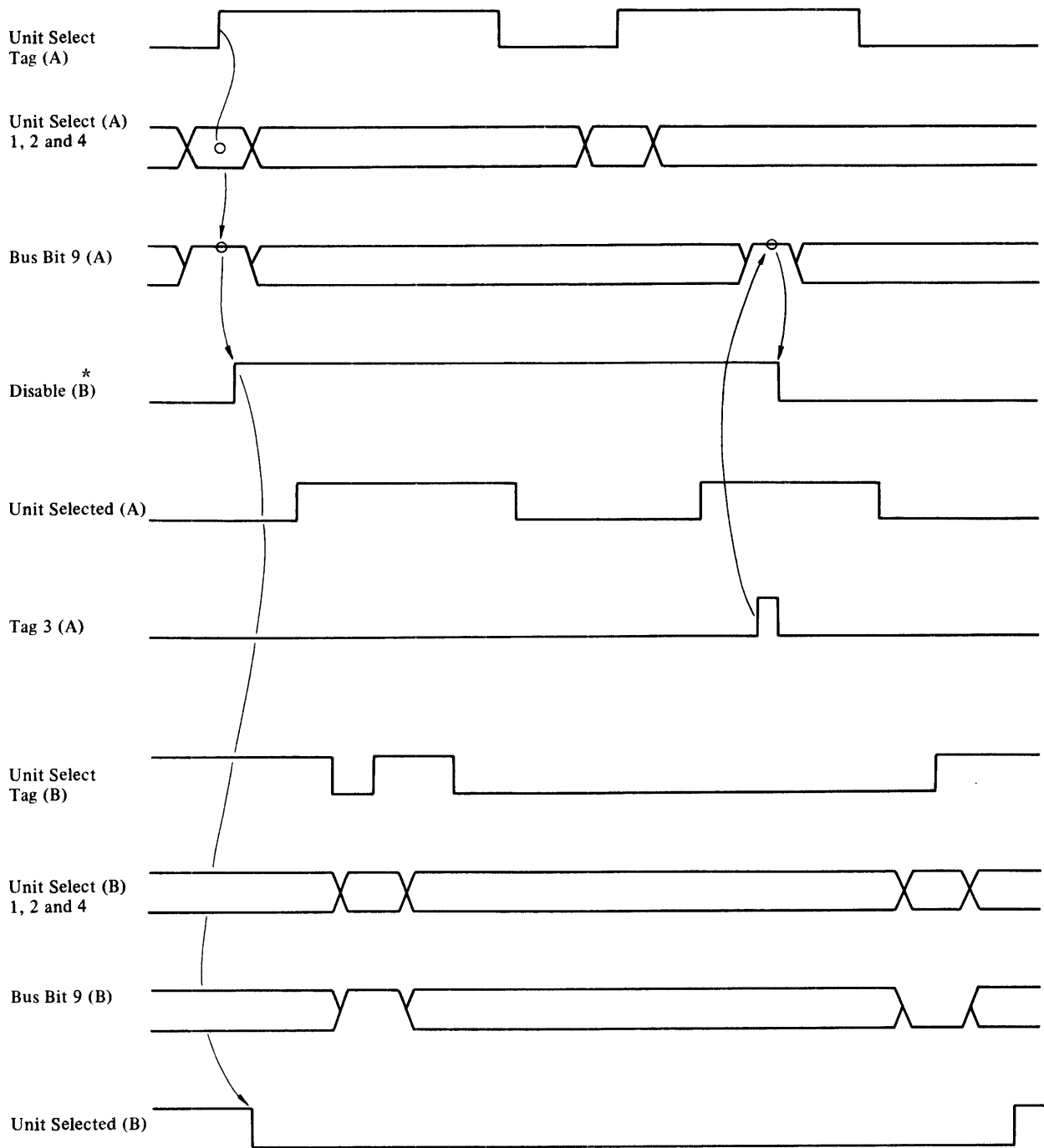

Note; (1) Disable (\*) is a signal within the drive.  
 (2) A sequence example of the above is as follows:  
 Channel B Select → Channel A Priority Select  
 → Channel B Priority Select Try → Channel  
 A Release → Channel B Select

Fig. 7.7-24 Priority Select Sequence (Dual Channel Only)

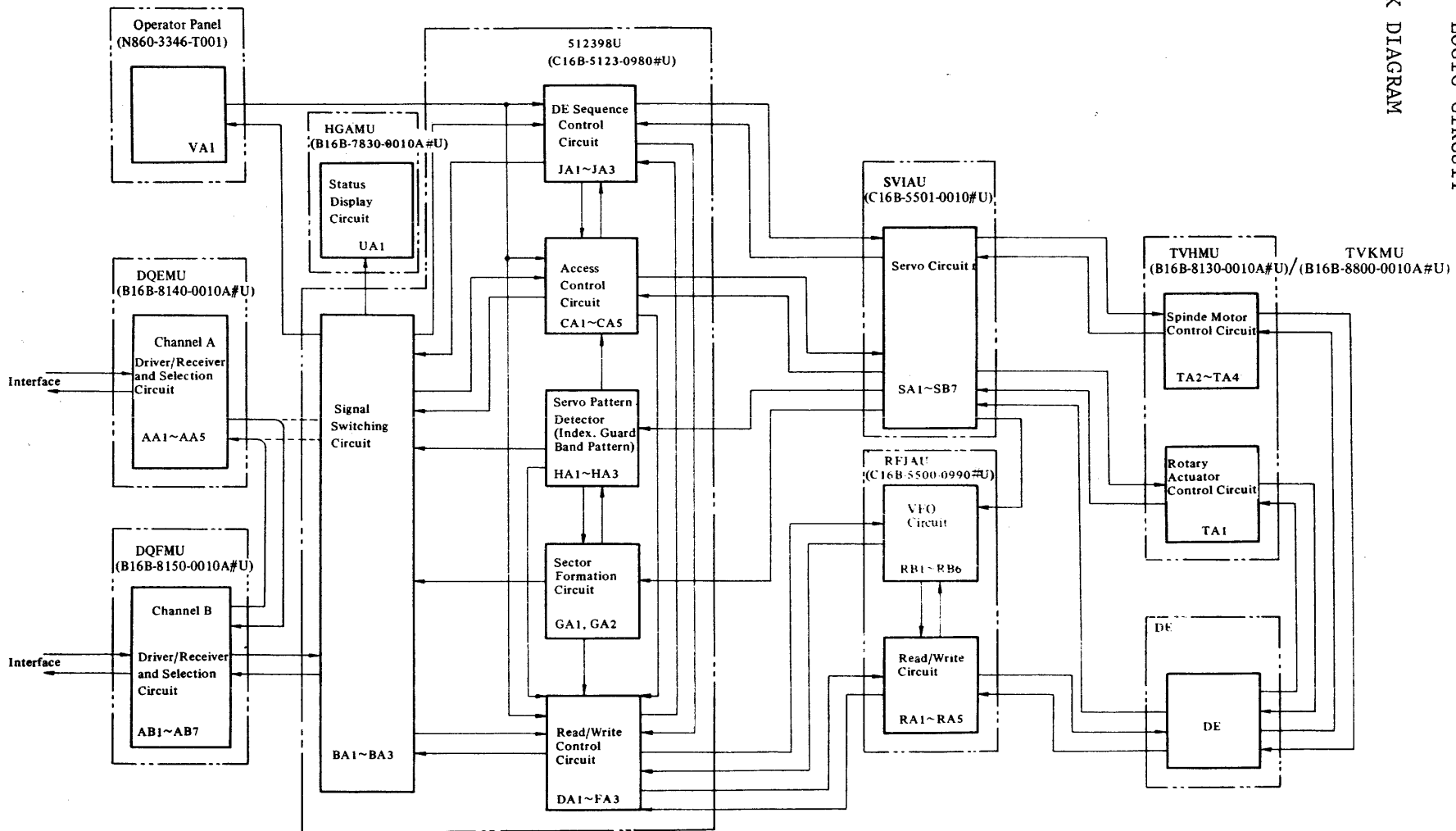

The number at the bottom of each box indicates the circuit diagram number in chapter 17.

Fig. 8.1-1 Drive Circuit Configuration Diagram (Included Dual Channel Option)

## 8.2 DE SEQUENCE

The drive can execute instructions (TAG1, TAG2, TAG3) sent from the controller after the START switch on the operator panel is set to ON, the disk comes up to the rated speed, the head is moved from the CSS area to cylinder 00 (hereafter called sequence RTZ), and the disk becomes ready. The operations performed between the moment the START switch is set to ON and the moment the drive becomes ready is called the DE Start Sequence. When the START switch is set to OFF, the drive stops the rotation of the disk after the head is moved to the CSS area. The operations performed between the moment the START switch is set to OFF and the moment the disk stops is called the DE Stop Sequence.

Each of these sequences is divided into several states (five states for the DE Start Sequence, and three states for the DE Stop Sequence), which are determined by decoding DE sequence latches 1, 2, and 4 (hereafter called DESQL1, DESQL2, and DESQL4) and are named states 0 to 7 (hereafter called ST0 ~ ST7). Figure 8.2-1 shows the states of a drive.

### DE Start Sequence and Its States

#### (1) State 0

When power is turned on, DESQL1, DESQL2, and DESQL4 are reset by the Initial Reset signal (PWRST).

#### (2) State 1

When the START switch on the operator panel is set to ON in state 0 (STARTS is set high), the start latch (STARTL) is set and DESQL1 is set. At this time, if the Initial Good signal is low [INSTG = Hall Alarm signal is low (\*HALRM) and Motor Speed signal is low (\*MTRSP)], the DE sequence check latch (DESQCKL) is set, DESQL1 is reset, and the operation returns to state 0. When the START switch is set to ON again (OFF → ON), DESQCKL is reset and the operation enters state 1.

#### (3) State 3

When the INSTG state occurs, DESQL1 and DESQL2 are set in this order and the operation enters state 3. When DESQL2 is set, the disk starts rotation. When the state 3 signal (ST3) goes high, the Start Timer signal (STTMR) is set high,

causing the timer to be started. If the Run State Good signal (RNSTG = \*HALRM\* MTRSP) remains low about 60 seconds after it has started (EN60S), DESQCKL and DESQL4 are set and the operation enters state 7.

(4) State 2

If RNSTG is high when EN25S is high in state 3, DESQL1 is reset and the operation enters state 2.

The state 2 signal (ST2) goes high, causing the sequence RTZ (SQRTZ) operation to be started.

(5) State 6

The interrupt signal (ACCOMP) generated upon completion of the SQRTZ operation sets DESQL4 and the operation enters state 6. In this state, the Unit Ready signal may be sent to the controller.

If one of the following conditions occur during state 6, DESQL1 is set and the operation enters state 7:

- 1 The START switch on the operator panel is set to OFF.
- 2 The MTRSP signal goes low.
- 3 The HALRM signal goes high.

DE Stop Sequence and Its States

(1) State 7

When the State 7 signal goes high, the ANGHM signal is set high, causing the head to start moving to the CSS area (GO HOME).

(2) State 5

The interrupt signal (GHCMP) generated upon completion of the Go Home operation resets DESQL2, and the operation enters state 5. The State 5 signal (ST5) causes the timer to be started.

(3) State 4

The EN11S signal generated upon completion of the timer operation resets DESQL1, and the operation enters state 4.

(4) State 0

The State 4 signal (ST4) resets DESQL4, and the operation enters state 0 to indicate the end of the DE Stop Sequence.



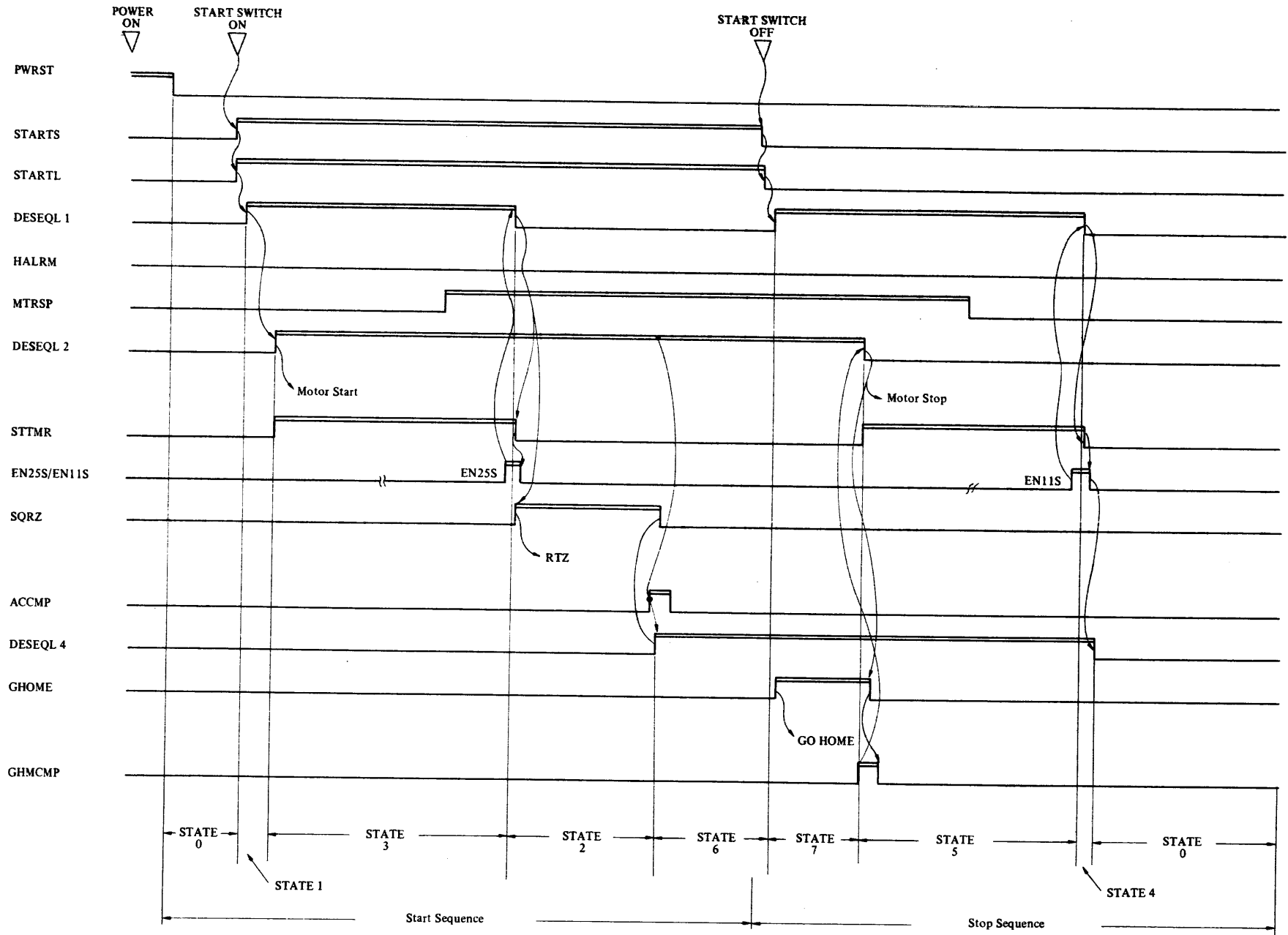

Figure 8.2-1 DE Start/Stop Sequence

### 8.3 SELECTION

The unit selection must be performed before instructions, such as Seek, Reed/Write, are sent from the controller.

When a drive receives Unit Select Tag (USLTG) and Unit Select 1, 2, 4 (USLCT1, USLCT2, and USLCT4), the drive compares it with its own address. The drive address is set by SW1 on the PCB, DQEMU. If the address sent from the controller matches the address of the drive when the Open Cable Detector (OCDTR) and Power Ready (PWRDY) signals are high, Select Latch (SLCTL) is set, Enable signal (ENABL) is generated, Unit Selected (SLCTD) is sent to the B-cable, and, at the same time, the driver/receiver for the A-cable are enabled for transmission.

While the drive is selected, instructions (Seek, RTZ, Read/Write, and others) may be received. The drive is released when one of USLTG, OCDTR, PWRDY goes low.

Figure 8.3-1 shows the unit selection sequence timing diagram.

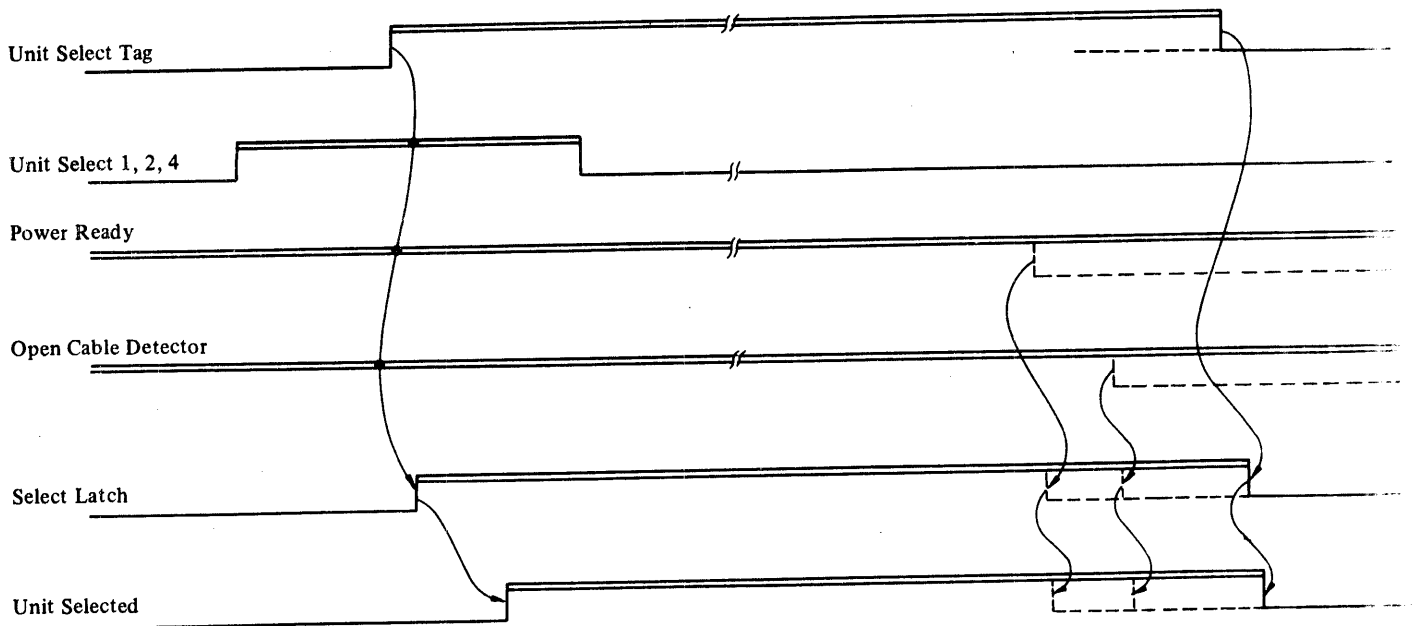

Figure 8.3-1 Unit Selection

## 8.4 OUTLINE OF ACCESS CONTROL

The access control circuit has five latches for controlling access operation. The operation modes and the outputs of the latches are as follows:

- (1) Sequence RTZ
- (2) System RTZ
- (3) Manual RTZ
- (4) Direct seek
- (5) Fine control

Table 8.4-1 Access Mode Latches

Operation Mode	REZERO MODE LATCH	SERVO LATCH	LINEAR MODE LATCH	CONTROL LATCH	WAIT LATCH	STATE NO.	Operation State
Reset	0	0	0	0	1	0 8	Wait State
RTZ Operation	0	0	0	0	0	0 0	Start RTZ
	1	0	0	0	0	8 0	Move In
	1	0	0	1	0	8 4	Turn Around
	1	0	1	1	0	8 6	Move Out
	0	0	1	1	0	0 6	RTZ Linear Mode
	0	1	1	1	0	0 7	On track
	Seek Operation	0	1	0	1	0	0 5
0		1	0	0	0	0 1	Decelerate
0		1	1	0	0	0 3	Seek Linear Mode
0		1	1	1	0	0 7	On track

## 8.5 SEQUENCE RTZ

In this mode, the head is moved from the CSS zone to cylinder 00 during the DE Start Sequence. Figure 8.5-1 shows the timing diagram.

### (1) State 08 (Wait state)

When Power On Reset goes high, Wait Latch (WAITL) is set high. Control Latch (CNTL), Linear Mode Latch (LNML), Servo Latch (SRVL), and Rezero Mode Latch (RZML) are low.

### (2) State 00 (Start RTZ)

When the State 2 (ST2) signal goes high in the DE Start Sequence, Sequence Rezero (SQRZ) and Any Rezero (ANYRZ) are set high and WAITL is set low.

### (3) State 80 (Move In)

When ANYRZ goes high, Start Rezero (STRZ) and Rezero Mode Latch (RZML) are set high. STRZ initializes the head address register and the cylinder address register. When RZML is set high, Rezero Mode (RZMOD) is set high and is sent to the servo control circuit.

At this time, the servo head is located at the innermost position of the CSS zone.

### (4) State 84 (Turn Around)

When guard band pattern 2 (GBP2) in the CSS zone is detected, Control Latch (CNTL) is set high and, at the same time, High Velocity Set (HVLST) and Move Out Gate (MVOTG) are set high and are sent to the servo control circuit. Upon reception of these signals, the servo control circuit moves the head from guard band pattern 2 (GBP2) to guard band pattern 1 (GBP1) at the REZERO High Speed.

### (5) State 86 (Move Out)

As the head is moved through the GBP2 zone in the outer direction, GBP1 is detected. Upon detection of GBP1, Linear Mode Latch (LNML) is set high and, at the same time, HVLST is set low.

From this moment, the head movement speed is reduced to the REZERO Low Speed, and the head is moved in the direction of cylinder 00 (outer direction).

At the end of the GBP1 zone is reached, Guard Band Latch (GRDBL) is set low and,

after that, the head speed is controlled by the Position Curve generated from the Position signal.

(6) State 06 (RTZ Linear mode)

When the head speed reaches the speed determined by the Position Curve, the servo control circuit sets End Decelerate (ENDDC) high and, then, RZML is set low.

When RZML goes low, the head is controlled in the Position Error Mode. If the head reaches within a specified distance from the center of cylinder 00 (On Track is high), the monostable multivibrator is activated. If On Track is high again at the end of the monostable multivibrator operation, Track Following Timer (TFTMR) is set high.

The operation mode controlled by Position Error is called Fine Control.

(7) State 07 (On Track)

If Valid Index (VLIX) goes high while TFTMR is high, Servo Latch (SRVL) is set high and Unit Ready, Seek End (SKEND), and On Cylinder (ONCYL) are sent to the controller.

If the sequence RTZ is unsuccessful, that is, if Overshoot Check (OVSCCK) or Time Out Check (TMOCK) is detected, Access Check (ACCK) is set high and the carriage is released. At this time, Unit Ready (UNRDY), Seek End (SKEND), and Seek Error are sent to the controller.

Over Shoot Check (OVSCCK) is set high when the head is moved at an abnormal speed during the RTZ operation (VG20I is set high if the speed exceeds 20 inches/second), or when Guard Band Pattern [Inner Guard Band Pattern (GBP2 and GBP1) or the Outer Guard Band Pattern (OGB)] is detected during the fine control, or when the head is not on the track and Track Crossing Pulse (TRXGP) is set high three or more times. Time Out Check (TMOCK) is set high if the operation is set high and the operation is not terminated within 250 ms.

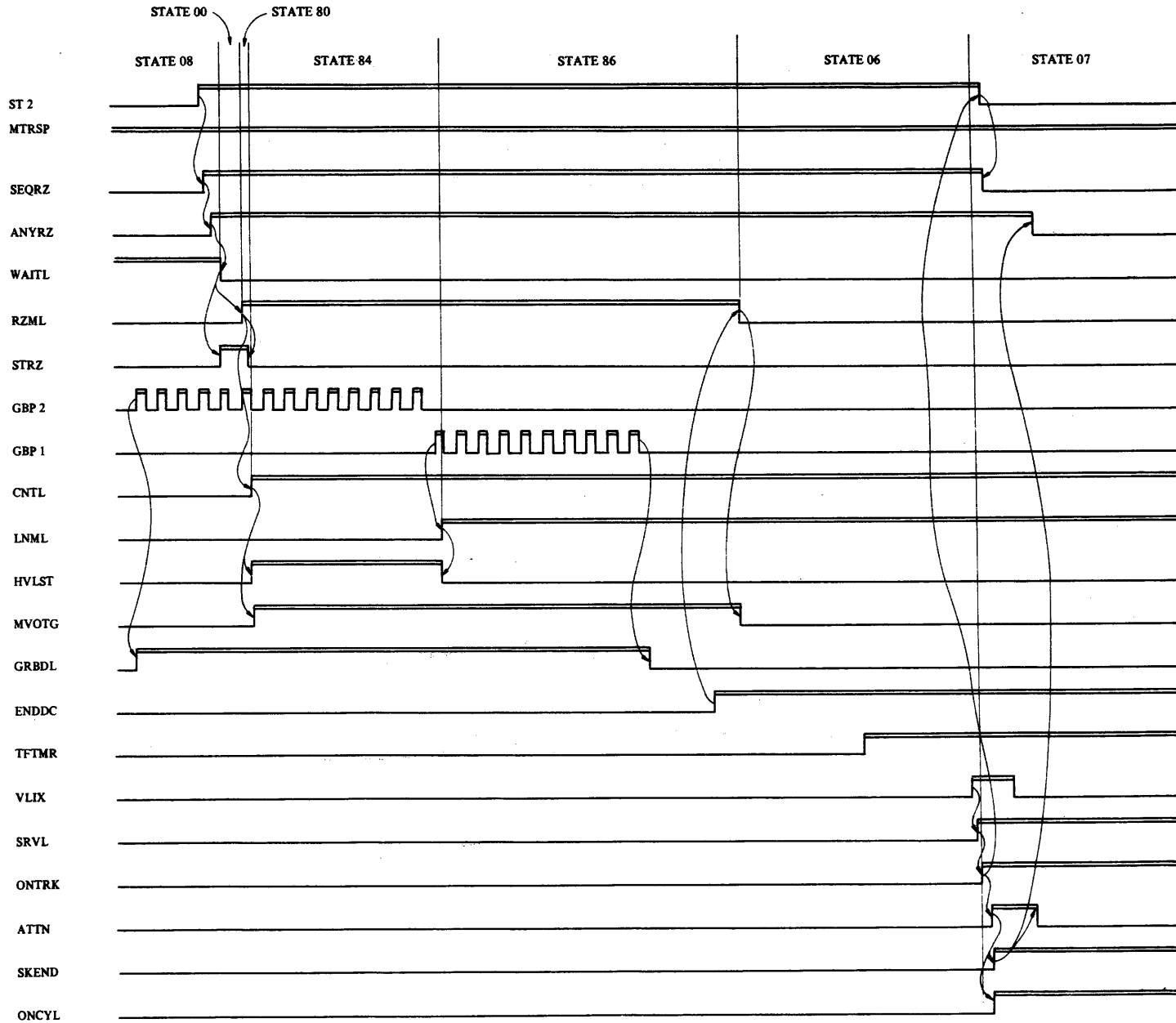

Figure 8.5-1 Sequence RTZ

## 8.6 SYSTEM RTZ/MANUAL RTZ

In the system RTZ (SYSRZ) and manual RTZ (MRTZL) modes, the head is moved to cylinder 00 regardless of the position at which the head is currently located. The system RTZ operation (SYSRZ) is started, upon receipt of Tag 3/bit 6 (RTZ) from the controller, when the drive is selected and is not performing the seek or RTZ operation or when a seek error occurs. The manual RTZ operation (MRTZL) is started by switch 2 (SW2) on the PCB, HGAMU, when the drive is not performing the seek, RTZ, offset, or read/write operation. Figures 8.6-1 and 8.6-2 show how SYSRZ and MRTZL are started, respectively. Figure 8.6-3 shows the sequence that is performed after RZML is set high.

### (1) State 08 (Wait state)

When SYSRZ or the MRTZL operation is performed, ANYRZ is set high. Then, WAITL is set high, and the access mode latches (RZML, SRVL, LNML, CNTL) and Seek Error (Access Check: ACCCK) are set low.

### (2) State 00 (Start RTZ)

When the SYSRZ operation is performed, the access mode latches are set low and, then, WAITL is set low.

When the MRTZL operation is performed, WAITL is set high while SW2 is high.

When SW2 goes low, WAITL is set low.

### (3) State 80 (Move In)

When WAITL is set low, STRZ and RZML are set high.

Before the head detects Guard Band Patterns 1 and 2 (GBP1 and GBP2), the carriage is moved in the inner direction at the RTZ High Speed. When the carriage passes cylinder 00 and GBP1 is detected, Guard Band Latch 1 is set high and the speed is reduced to the low speed.

If the head is on GBP1 at the start of this state, the carriage is moved at the low speed from the beginning.

### (4) State 84 (Turn Around)

When the head passes GBP1 and detects GBP2, CNTL is set high and, at the same time, HVLST and MVOTG are set high. In this case, the head is moved at the high speed to the outer direction.

(5) State 86 (Move Out)

Same as that of sequence RTZ.

(6) State 06 (Rezero Linear Mode)

Same as that of sequence RTZ.

(7) State 07 (On Track)

Same as that of sequence RTZ.

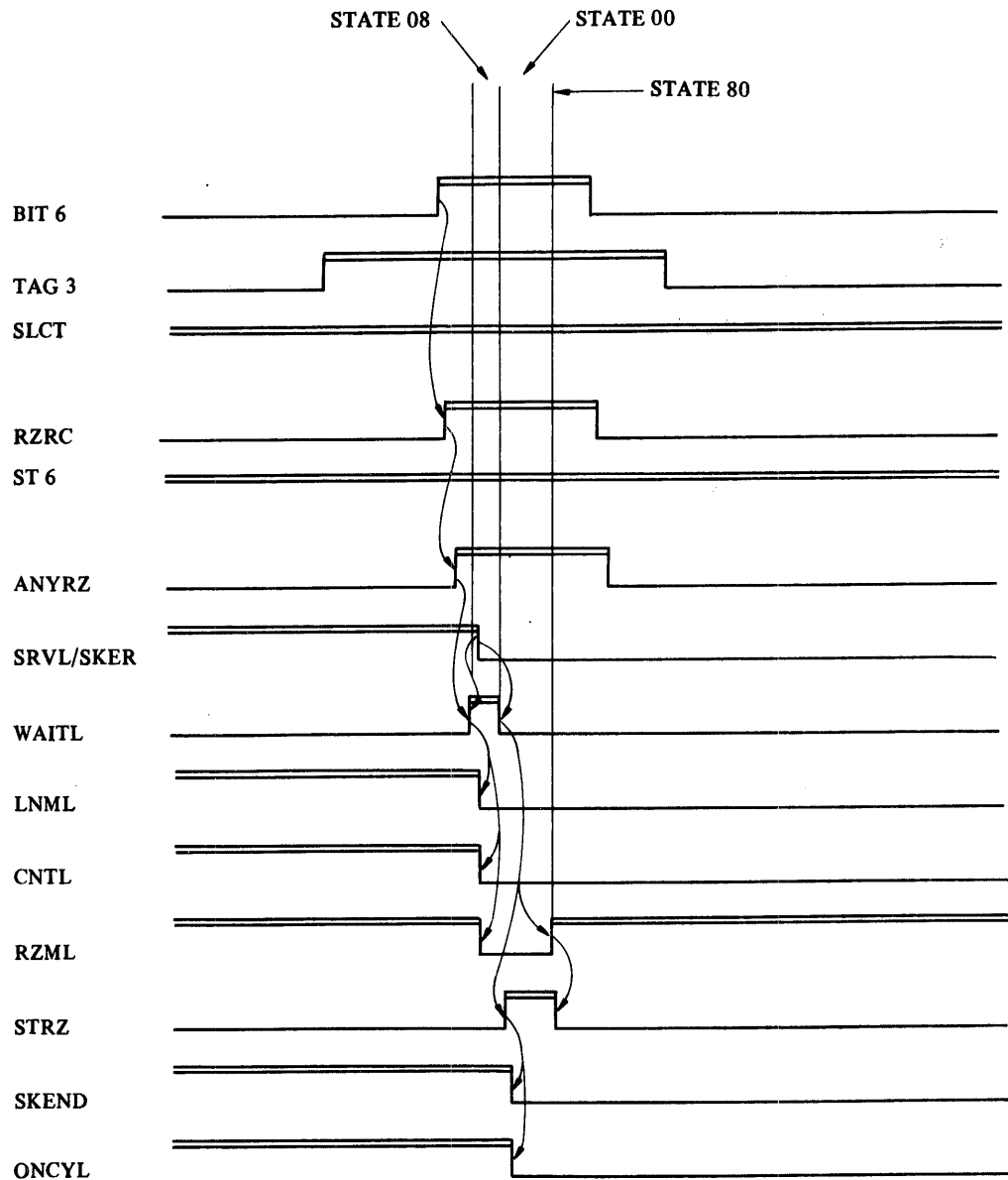

Figure 8.6-1 System RTZ Sequence



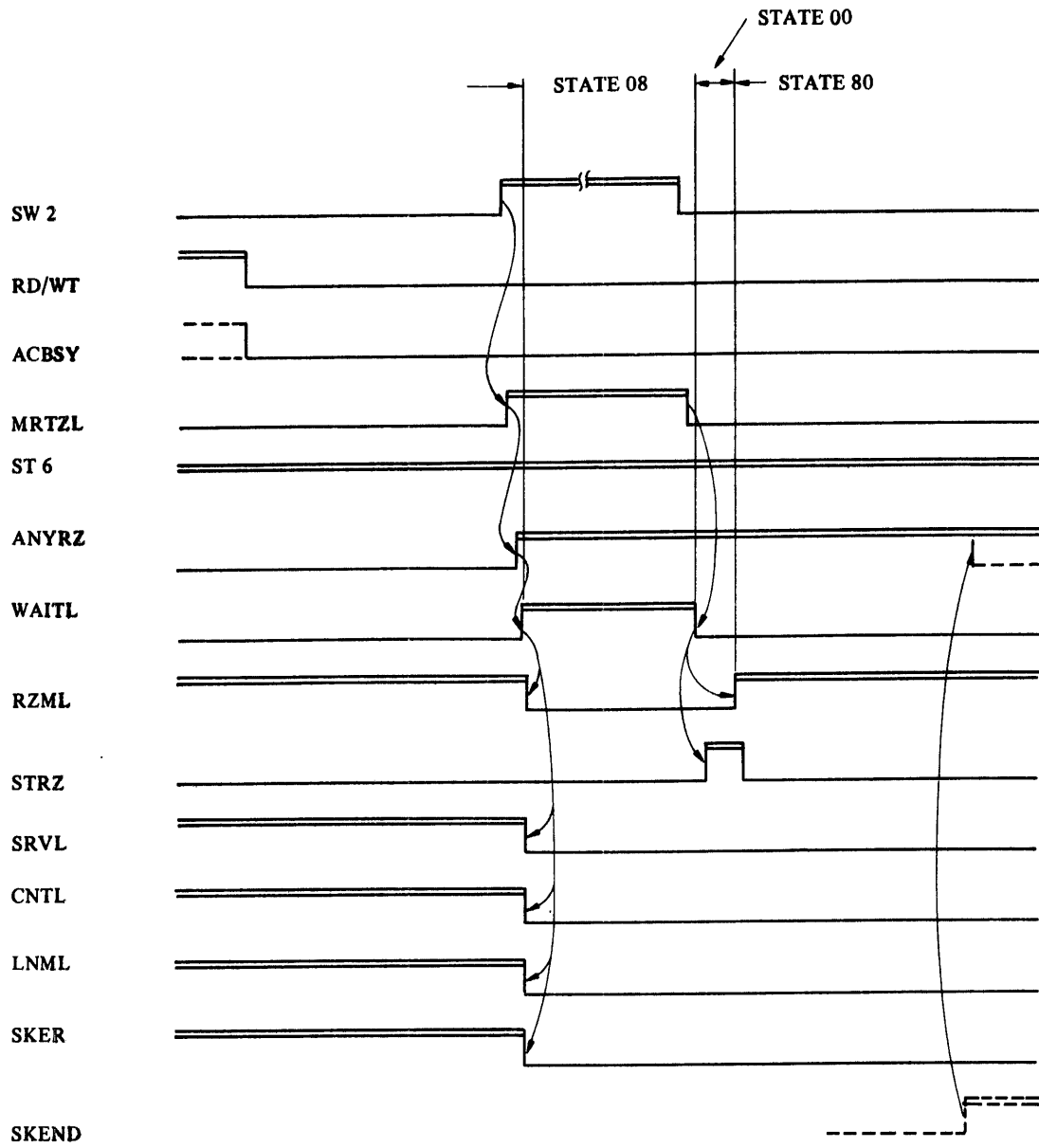

Figure 8.6-2 Manual RTZ Sequence

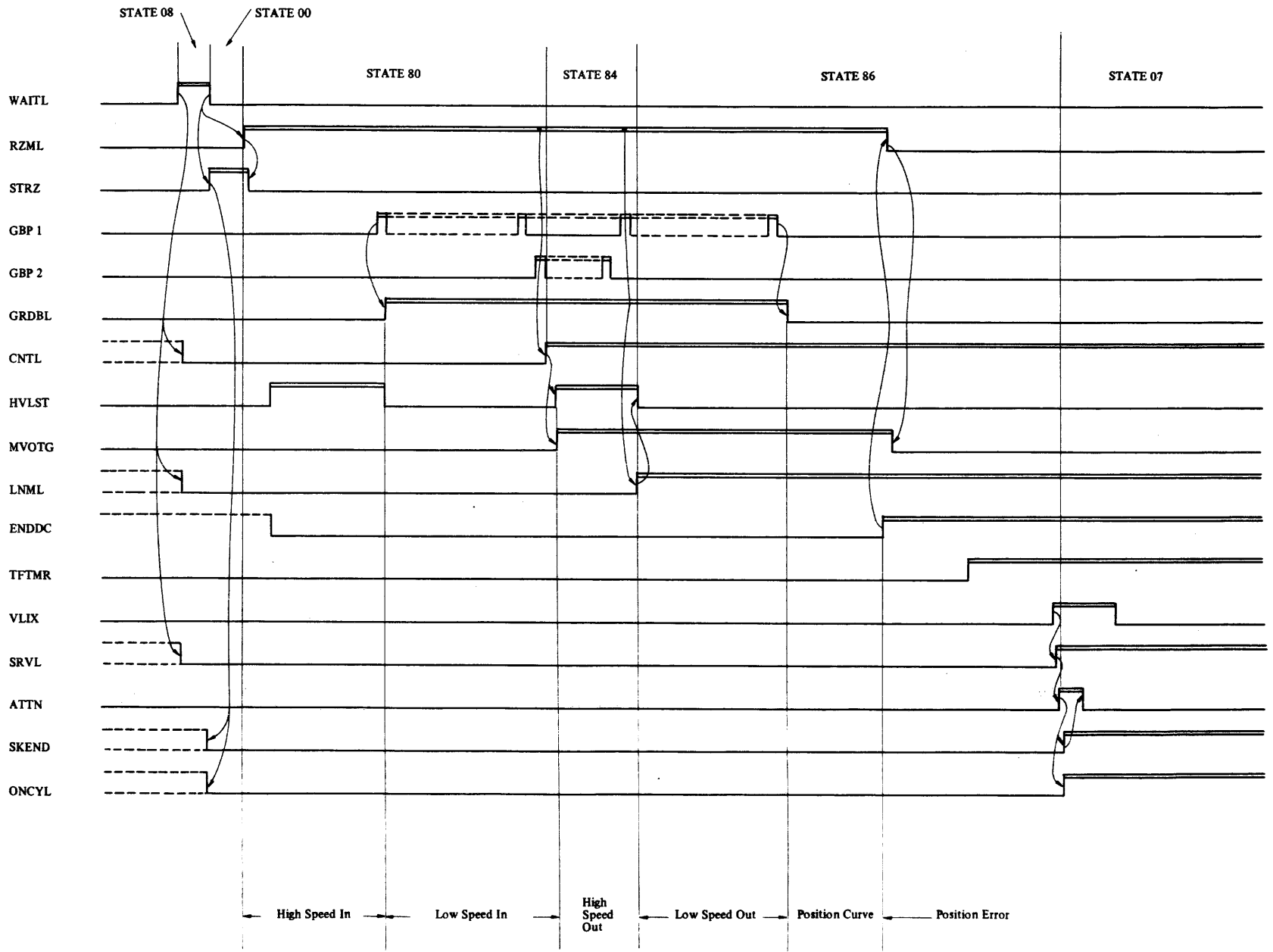

Figure 8.6-3 System/Manual RTZ Sequence (Continued)

## 8.7 SEEK

The head is moved to the cylinder specified by TAG1/bits 0 - 9 sent from the controller. Figure 8.7-1 shows the timing diagram.

### (1) State 05 (Accelerate)

When TAG1 goes high, the contents of bits 0 to 9 are set in the new cylinder address register (NCAR). The address of the cylinder on which the head is currently located is stored in the present cylinder address register (PCAR). The difference between the address stored in the NCAR and that in the PCAR is calculated and is output in the binary code (D1 - D128). If the difference is 144 or greater ( $NCAR - PCAR > 144$ ), D1 - D128 is set to a value of all 1 bits and is sent to the servo control circuit. The servo control circuit forms the desired speed curve according to the value indicated by D1 - D128.

If the value indicated by the NCAR is greater than that indicated by the PCAR, Move Out Gate (MVOTG) is set high to cause the head to be moved in the outer direction; conversely, if the value indicated by the NCAR is smaller than that indicated by the PCAR, MVOTG is set low to cause the head to be moved in the inner direction.

Then, when TAG1 goes low, Set CAR Off Pulse (SCAROFF) is set high, SKEND, ONCYL, TFTMR, and LNML are set low, and Access Mode (ACCMD) is set high.

The servo control circuit moves the head according to the desired speed curve and generates Track Crossing Pulse (TRXGP) whenever the head crosses a cylinder. TRXGP is sent to the PCAR to increment the register when the head is moved in the outer direction, or to decrement the register when the head is moved in the inner direction. Thus, the output of the difference counter (D1 - D128) is decremented by one at a time.

### (2) State 01 (Decelerate)

If the head is moved at a speed higher than that indicated by the desired speed curve, the servo control circuit generates End Accelerate (ENDAC) and sets CNTL low. The speed of the head is then reduced so that the head is moved according to the desired speed curve.

### (3) State 03 (Seek Linear Mode)

When the head detects On Cylinder at the desired cylinder (NCAR=PCAR), the servo control circuit generates End Decelerate (ENDDC) and, at the same time, starts the 2.5 ms-timer and sets LNML high. Then, the operation mode of the head is changed from the position curve control mode to the position error control mode.

### (4) State 07 (On Track)

If the head is on the desired track when the operation of the 2.5 ms-timer is ended, TFMTR is set high. CNTL is set high and, at the same time, SKEND and ONCYL are set high. This means that the seek operation is terminated. When a no-motion seek command is issued from the controller, the 5  $\mu$ s-timer is activated and, at the completion of the timer, SKEND and ONCYL are set high.

If an illegal cylinder address is sent (a value greater than 842 for M2351A, or a value between 842 and 895 for M2351AF, SKER and SKEND are set high after about 5  $\mu$ s. If the seek operation is not terminated normally, that is, if the seek operation is not terminated within 250 ms (TMOCK), or if the Inner or Outer Guard Band are detected during the seek operation, or if TRXGP is detected three times or more after the head is reached to the desired cylinder (OVSK), SKER and SKEND are set high.

When SKER is set high, the head is released.

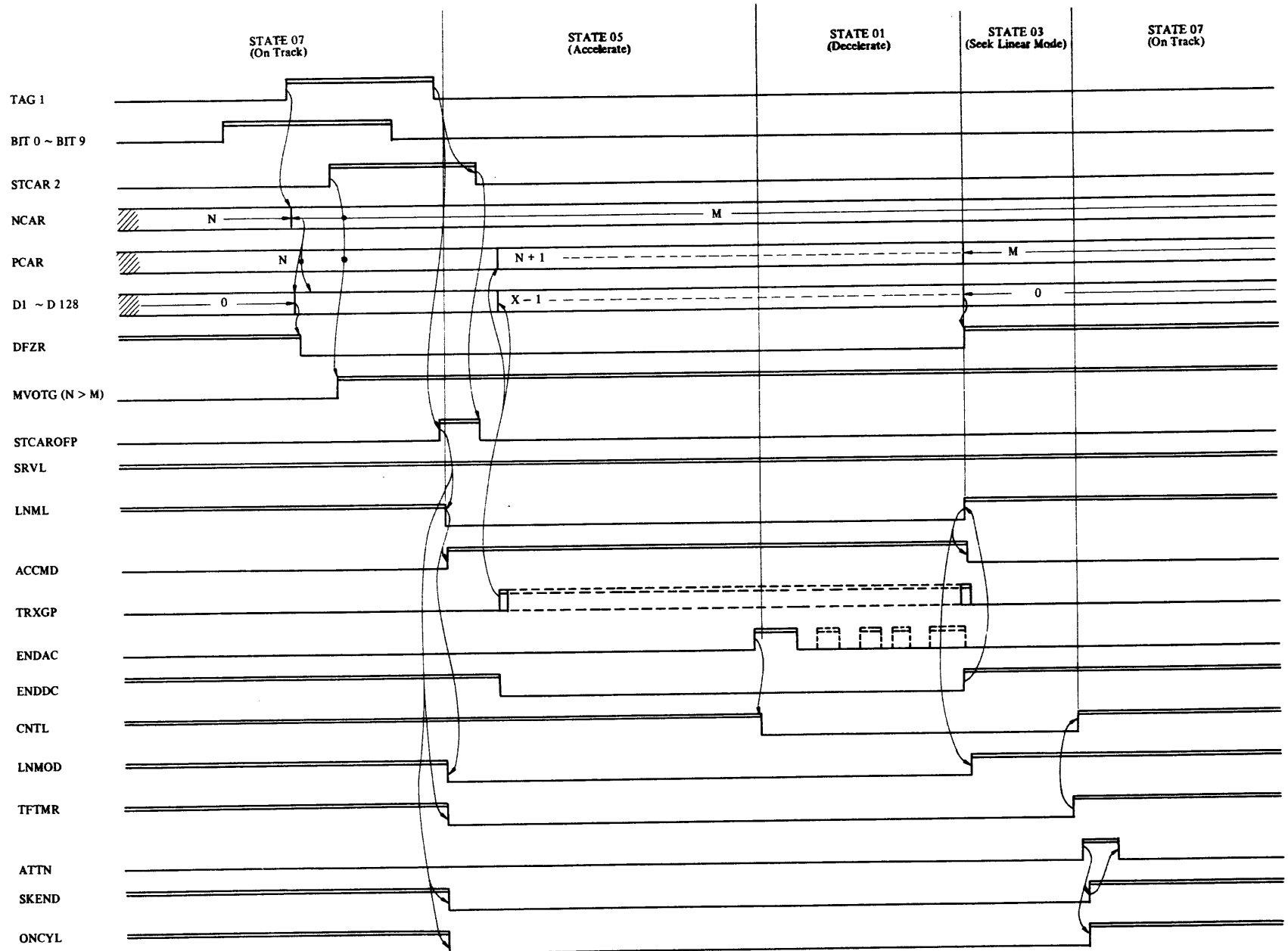

Figure 8.7-1 Seek Sequence

## 8.8 OFFSET

The head being at the center of a track (On Track) is moved 100 $\mu$  inches in the direction specified by bit 2 or 3 of TAG3 sent from the controller. The fine control method is used in this operation mode. Figure 8.8-1 shows the timing diagram.

While the drive is selected (SLCT), Offset Plus (OFSTP) is set high when bit 2 of TAG3 is set to 1 by the controller and, at the same time, Offset Out (OFSOT) is set high. If the drive is not in the abnormal condition (ABN) at this time, Offset Active (OFACT) is set high and, at the same time, Difference 16 (GD16) is set high. Then, the servo control circuit moves the head in the outer direction; i.e., the servo control circuit starts the offset operation and moves the head to the location 100 $\mu$  inches outward of the on-track position. This operation is terminated within 5 ms.

When OFACT goes high, Offset Active Pulse (OFACP) is set high and the 5 ms-timer is started (M5MS). At the same time, Seek End (SKEND) and On Cylinder (ONCYL) are set low. SKEND and ONCYL are set high when the timer operation is terminated.

When bit 3 of TAG3 is set to 1, Offset Minus (OFSTM) is set high and, by holding OFSOT low, the head is moved in the inner direction.

When bit 2 or bit 3 of TAG3 is set to 0 and OFSTP, OFSTM, OFSTA, and GD16 are set low, the head is returned to the on-track position. This operation is terminated within 5 ms.

When OFACT goes low, OFACP is set high, the 5 ms-timer (M5MS) is started and, at the same time, SKEND and ONCYL are set low. When M5MS goes low, SKEND is set high and, if the head is at the on-track position, ONCYL is set high.

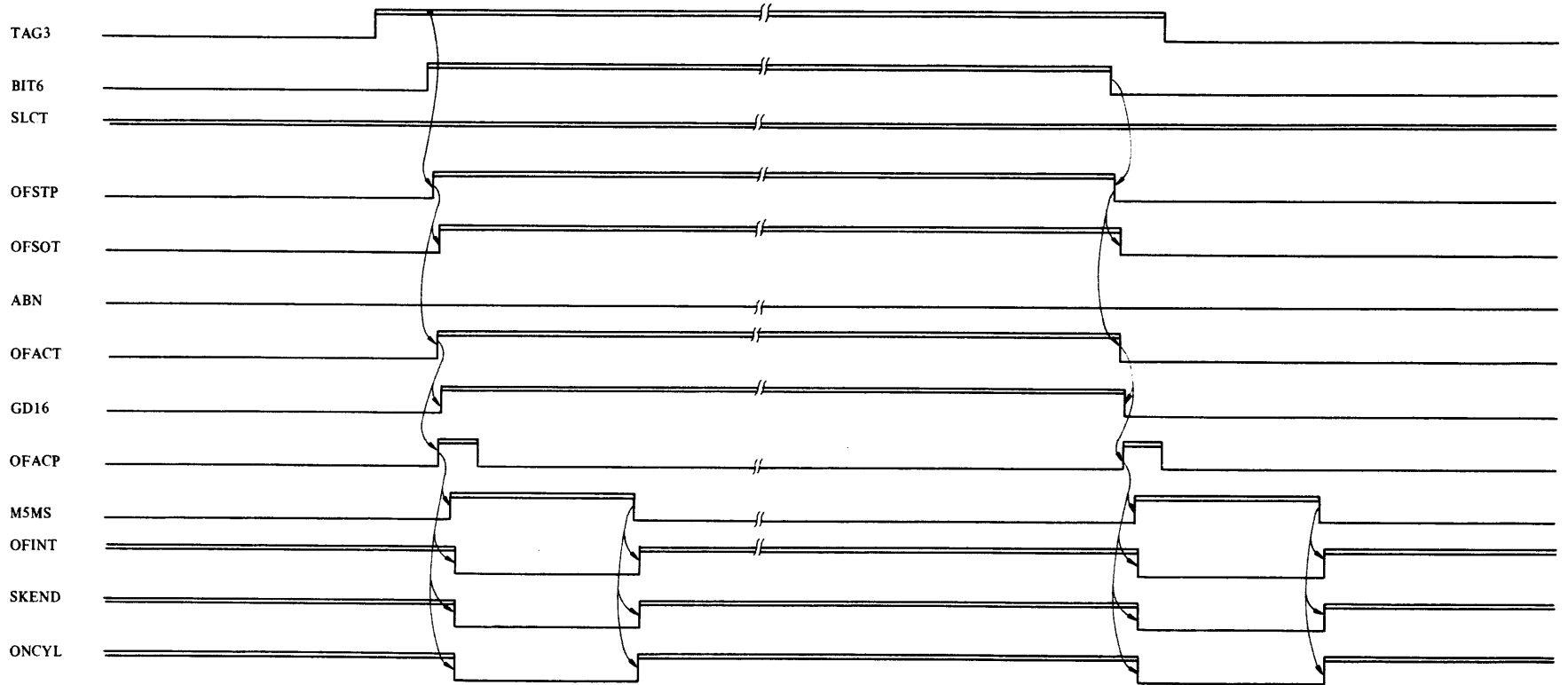

Figure 8.8-1 Offset Sequence

## 8.9 FAULT AND ERROR DETECTION

Faults and errors detected in the drive are displayed by the maintenance - aid LEDs on the indicator unit (HGAMU; B16B-7830-0010A#U) and reported to the controller through the interface lines.

### (1) Fault Register

If the following errors occur, the Fault register will be set and Fault line will be enabled.

Table 8.9-1 Write/Read Check Conditions

No.	Write/Read Check State	Conditions	MD 0	LP
1	Index Check	$(RG+WG) \cdot IDXCK$	Bit 1	LP1
2	Control Check	$RG \cdot WG$ $OFACT \cdot WG$ $RONLY \cdot WG$	Bit 2	
3	Multi-Head Check	$(RG+WG) \cdot MCPSL$	Bit 4	
4	Head Short Check	$(RG+WG) \cdot HDSHT$	Bit 8	
5	Write Current On Read Check	$RG \cdot MUSFV$	Bit 1	LP2
6	Write Transition Check	$WG \cdot \overline{AMCTL} \cdot MUSFV$	Bit 2	
7	Delta I Write Check	$WG \cdot DIECK$	Bit 4	
8	Servo Off-Track	$WG \cdot \overline{RWCAP} \cdot (\overline{URDY} + \overline{TFTMR} + ACCK)$ $RG \cdot \overline{EQUAL}$	Bit 8	

These fault status can be cleared by one of the followings;

- ① Depressing the Fault Clear switch on the operator panel
- ② Fault Clear signal sent from the controller

### (2) Seek Check Latch

If seek error occurs in the drive, the error will set Seek Check Latch, enabling Seek Error to the controller, and light the maintenance-aid LED.



Table 8.9-2 Seek Error Fault Conditions

No.	Access State	Conditions	MD 1	LP
1	Access Timeout Check	Timeout in direct or RTZ seek	Bit 2	LP1
2	Over Shoot Check	Any Guard Band in direct seek, or Over track-crossing pulse in settling	Bit 4	

The following explains the servo format and how the head positioning control circuit operates:

The seek control operation and the rezero seek control operation are outlined first, followed by the function of each component of the head positioning control circuit, and the spindle motor control method.

9.1 DATA AND SERVO ZONE

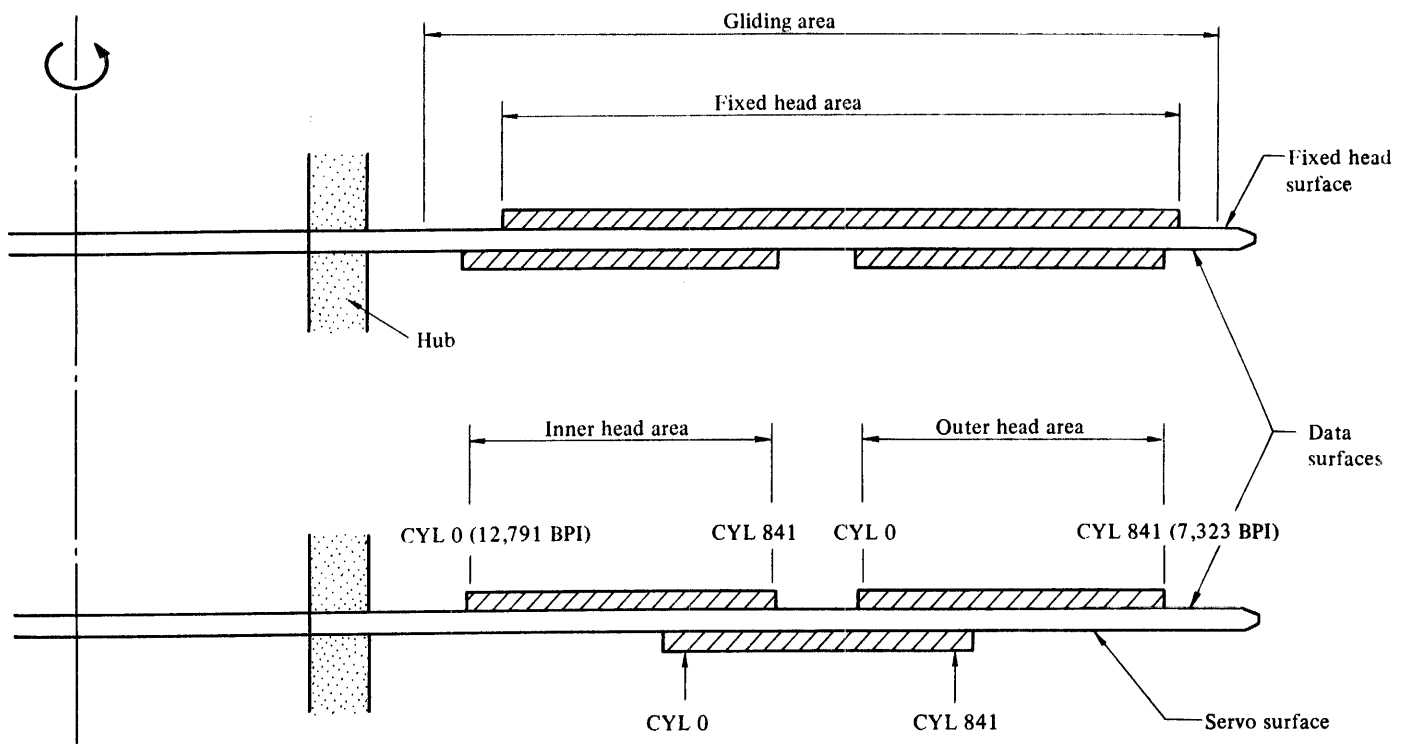

Figure 9.1-1 Data and Servo Area Locations

Though the rotational angle of arm assemblies is constant for all tracks ( $2.27 \times 10^{-4}$  radians per track), the track pitch for the servo, inner, and outer R/W heads varies as shown in Figure 9.1-2 depending on the mechanical arrangement of the head-arm and the cores.

The track width of the inner R/W head is made wider than that of the outer R/W head to avoid decrease of time margin for the read operation.

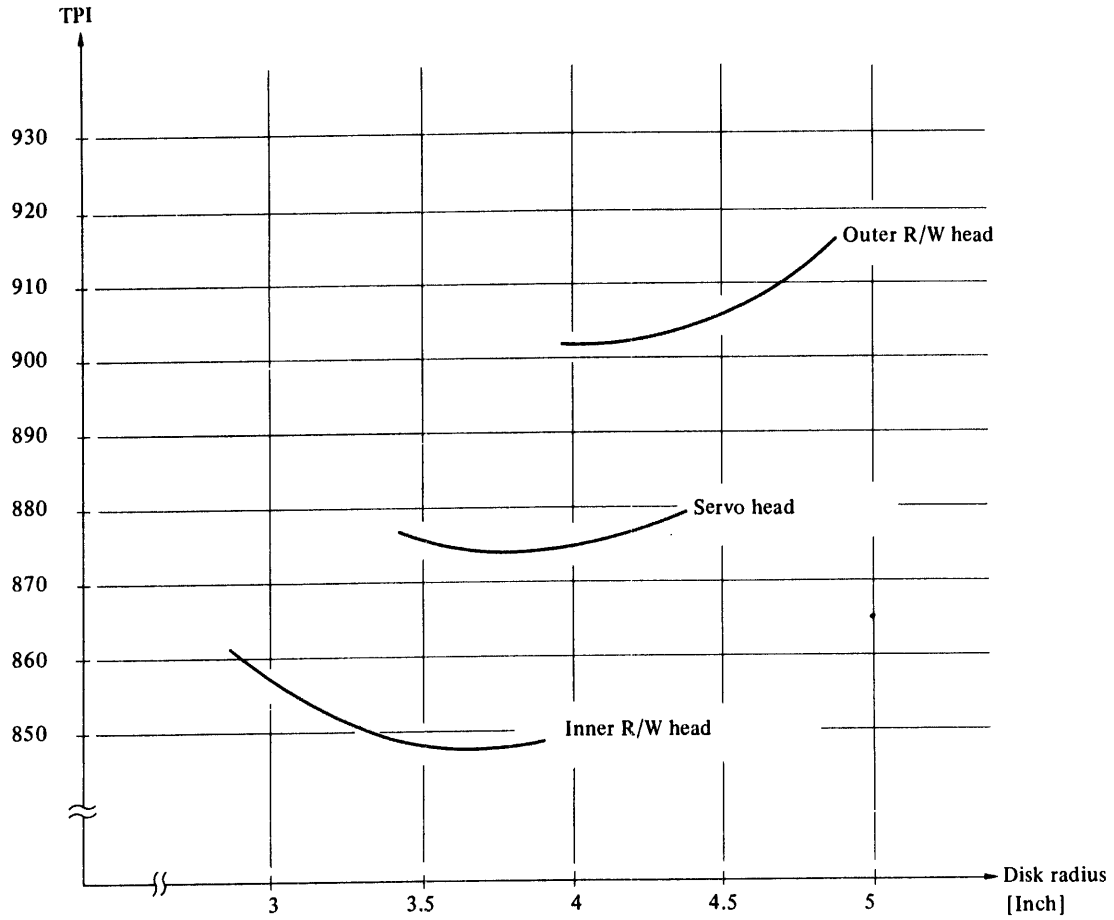

Figure 9.1-2 Track Pitch

## 9.2 SERVO FORMAT

The two-phase composite servo signal is pre-recorded on the bottom servo surface. This signal is read by the servo head, and the index signal, sector count clock signal, read/write PLO signal, and two types of position signals, 90 degrees out of phase with each other, are generated. The two-phase servo signal makes the effective track width of the servo signal ( $29\mu\text{m}$ ), one-half of the actual track width ( $58\mu\text{m}$ ).

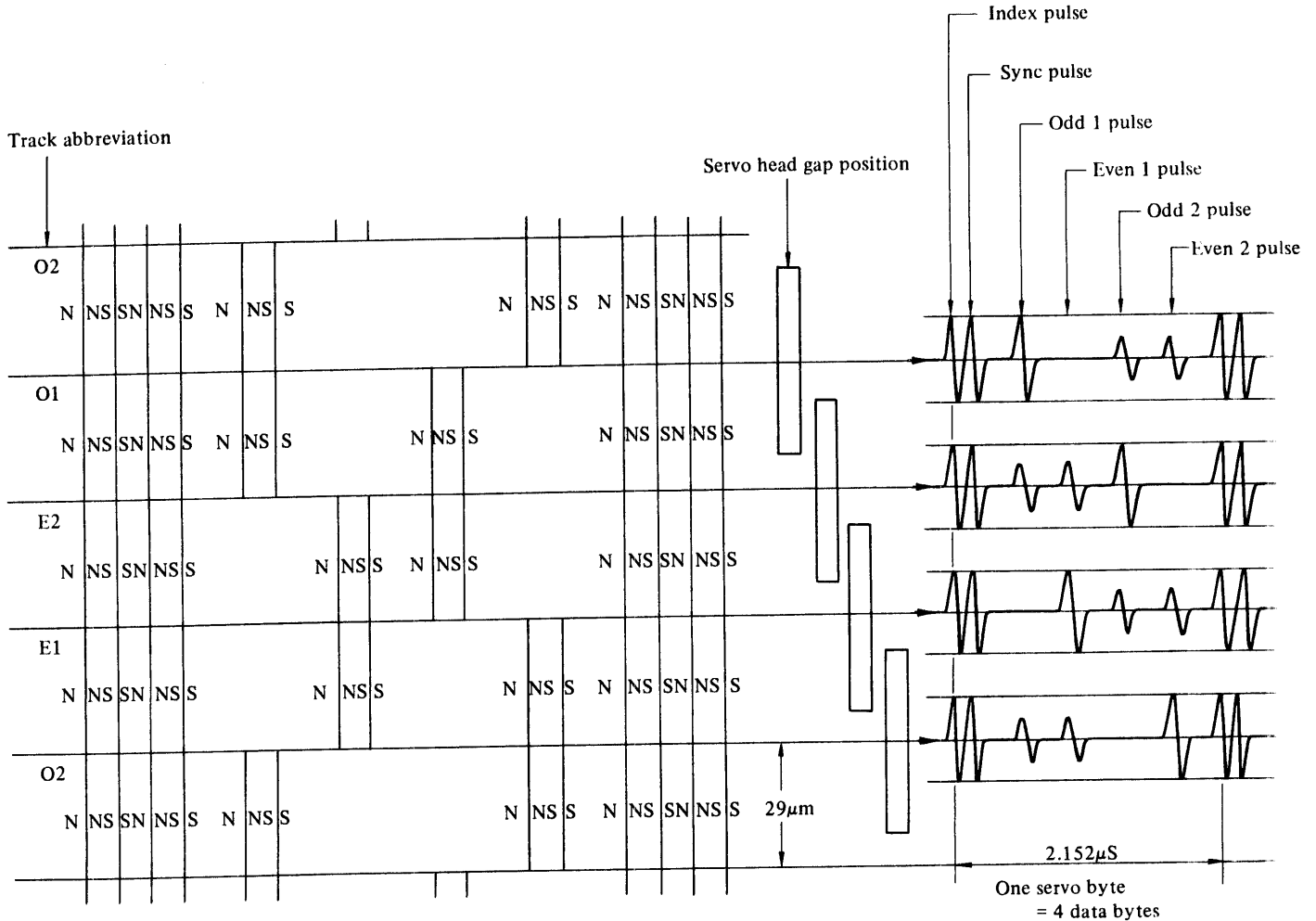

Figure 9.2-1 Magnetized Pattern of Two-phase Servo Signal and Read Signal

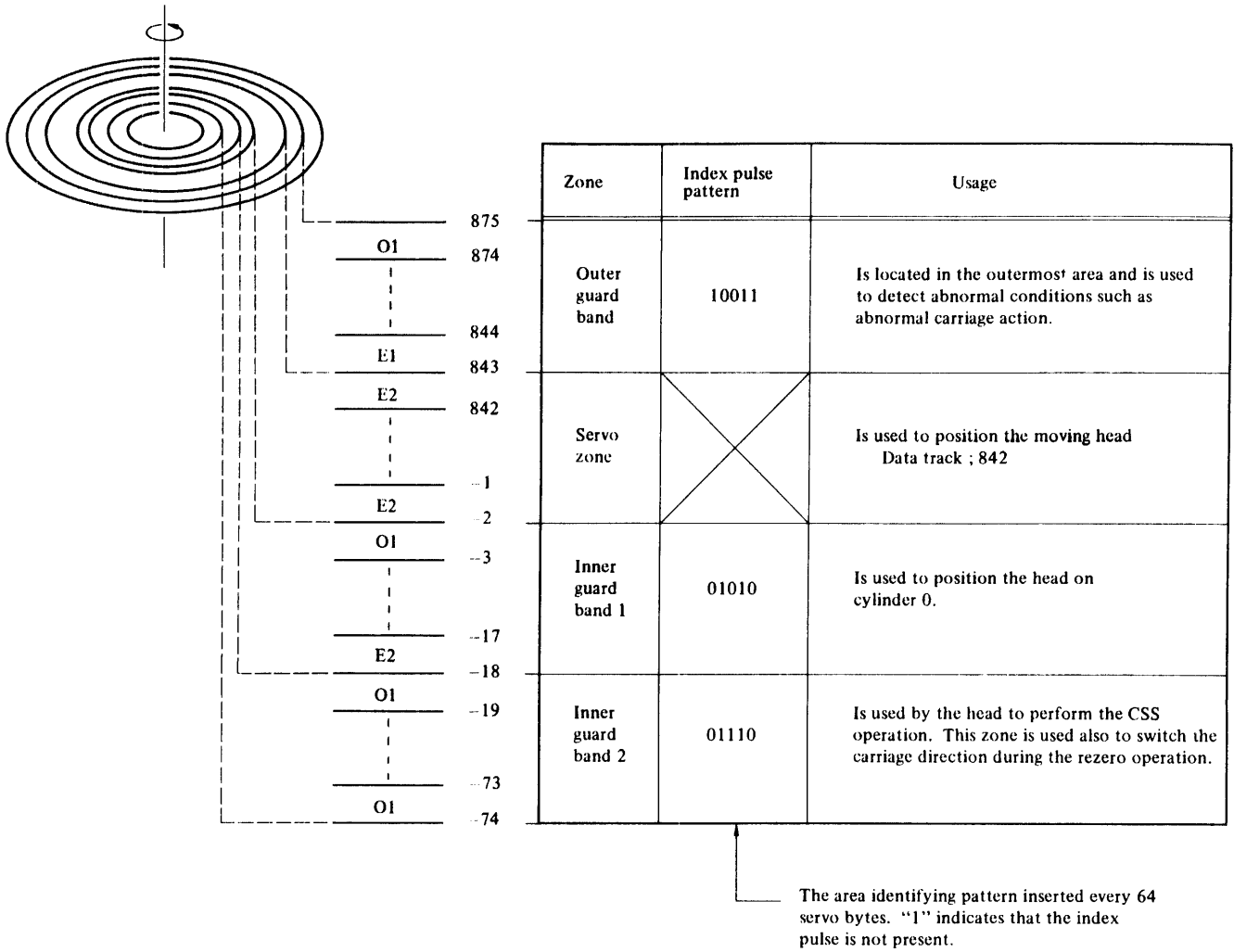

Figure 9.2-2 Zone Allocation on Servo Surface

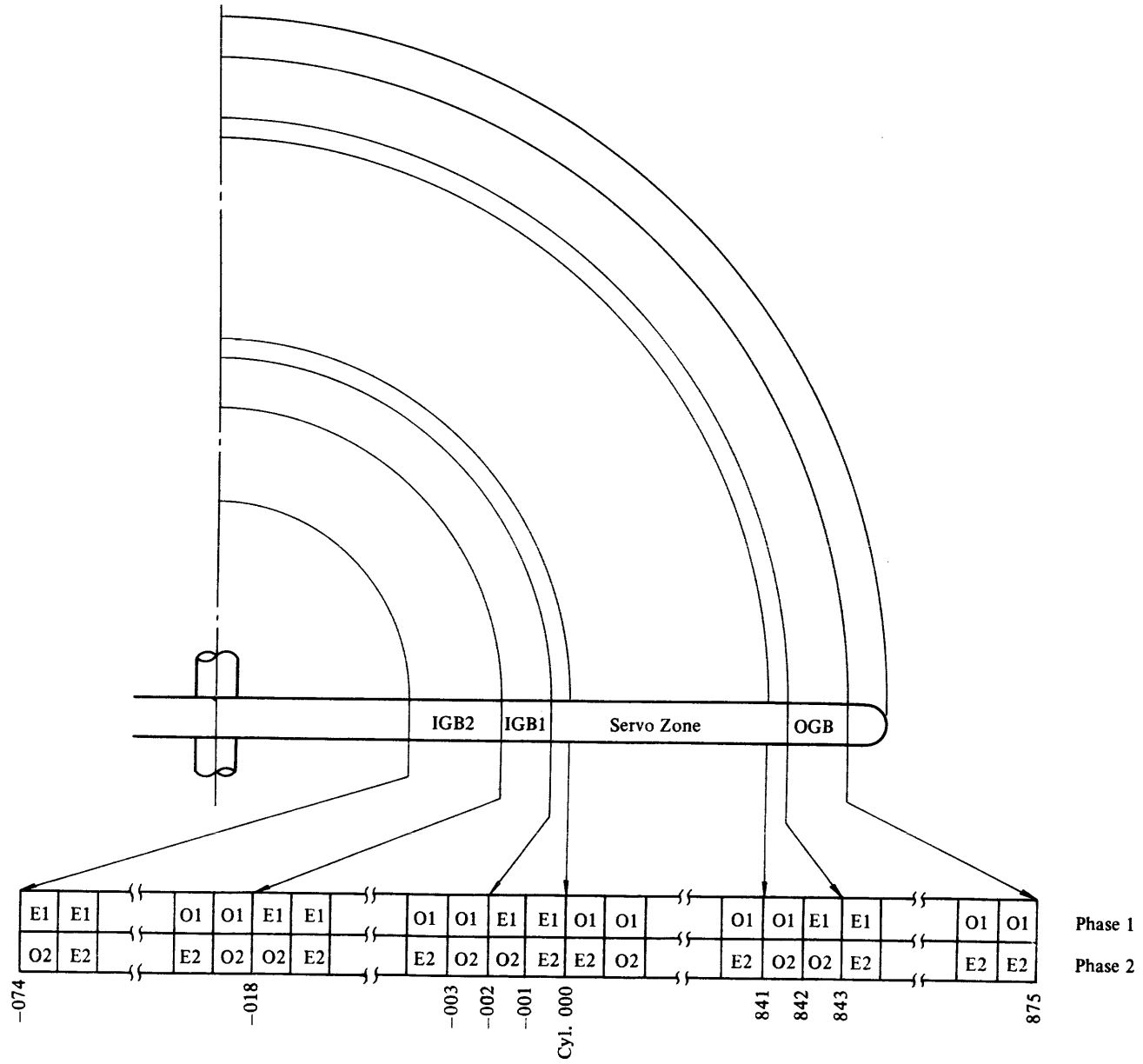
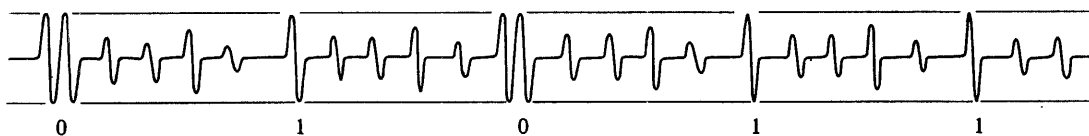

Figure 9.2-3 Servo Track Configuration

## Index pulse pattern

Each area is identified by the index pulse (0: present, 1: absent) preceding the sync pulse. The valid index pattern, detected once per rotation, indicates the physical starting point. Inner Guard Band 1 and 2 and the Outer Guard Band are written every 64 servo bytes; this means that there are 110 locations at which these patterns are written. However, if any of the 110 locations coincides with the location at which the valid pattern is written, the valid index pattern is effective.



Valid index pattern

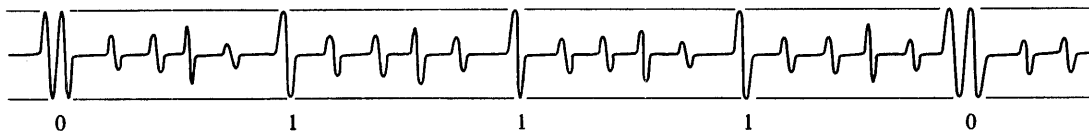

Inner Guard Band 2 pattern

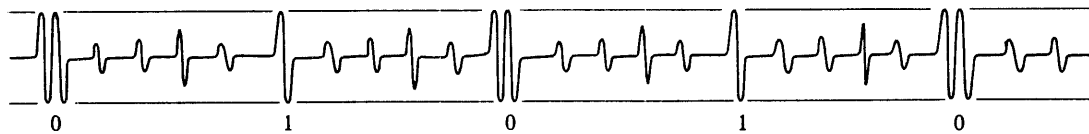

Inner Guard Band 1 pattern

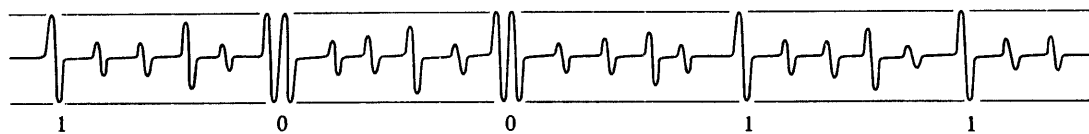

Outer Guard Band pattern

Figure 9.2-4 Index Pulse Pattern

### 9.3 SEEK CONTROL OPERATION

The seek control operation is classified roughly into the coarse control operation and fine control operation.

#### (1) Coarse control operation

The coarse control operation is performed to move the head to the desired cylinder position. That is, the head is moved with a speed feedback loop at a high speed by comparing the target speed, derived from the position difference between the desired position sent from the logic circuit and the actual position, with the actual speed derived from the position signal read from the servo surface with the servo head.

The speed is decreased as the position difference is reduced and, when the head reaches near the neighborhood of the desired cylinder, the speed becomes very slow.

#### (2) Fine control operation

When the head approaches the desired cylinder and the difference between the desired position and the current position is within the specified range (on track), the coarse control operation is switched to the fine control operation. During the fine control operation, the position signal is fed back to ensure that the head is always on the desired cylinder notwithstanding mechanical vibration and temperature change.

The speed signal is used as the damping factor. The signal generated by integrating the position signal is also used to increase stiffness.



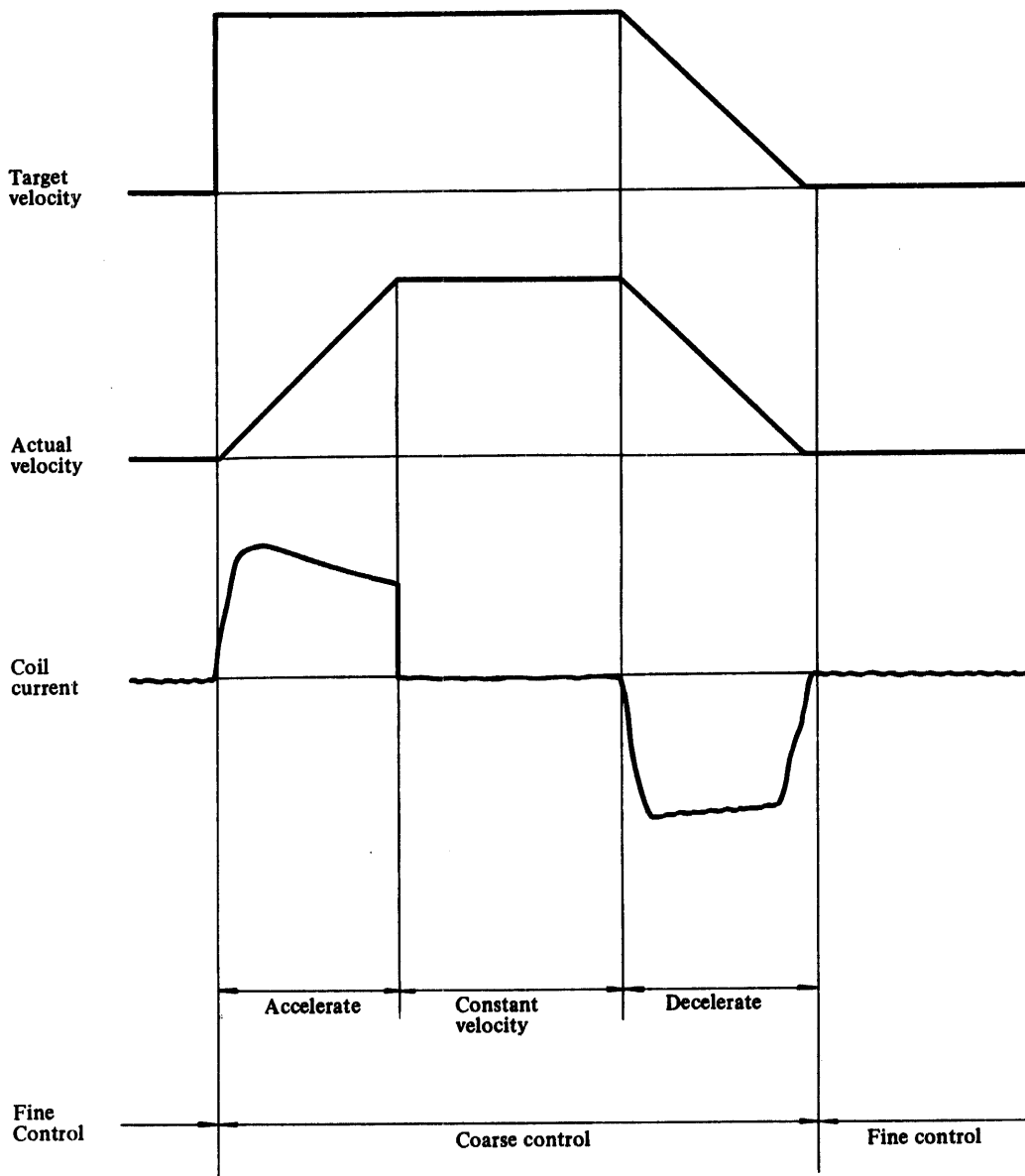

Figure 9.3-1 Seek Control

#### 9.4 REZERO CONTROL OPERATION

The head is returned to the reference cylinder (cylinder 0). The rezero seek operation is classified into the coarse control operation and the fine control operation as with the seek control operation; however, unlike the seek control operation, the target speed is determined by the signal generated by the reference voltage. The following explains how the rezero seek operation is performed, assuming that the head is not in the Inner Guard Band.

(1) High Speed In (HSPIN)

The head is moved in the inner direction about 8 inches per second until Inner Guard Band 1 (IGB1) is detected.

(2) Low Speed In (LSPIN)

The head is moved in the inner direction at about 2.5 inches per second between the moment when IGB1 is detected in the neighborhood of cylinder-2 (minus 2) and the moment when Inner Guard Band 2 (IGB2) is detected.

(3) High Speed Out (HSPOT)

The direction in which the head is to be moved is inverted, and the head is moved in the outer direction at about 3.5 inches per second between the moment when IGB2 is detected in the neighborhood of cylinder-18 (minus 18) and the moment when IGB1 is detected.

(4) Low Speed Out (LSPOT)

The head is moved in the outer direction at about 0.8 inches per second after being returned to IGB1.

(5) Rezero Out (RZOUT)

When the head enters the servo zone from IGB1 after it travels in the neighborhood of cylinders-2 (minus 2), the head is moved to cylinder 0 with the target speed signal generated from the position signal.

(6) Fine control

After On Track is detected when the head is in the neighborhood of cylinder 0, the Position control is performed in the same manner as the seek control operation.

The rezero operation is performed from (2) if the head is to be returned from IGB1, or from (3) if the head is to be returned from IGB2; after that, the same control method is performed until the head is positioned on cylinder 0.

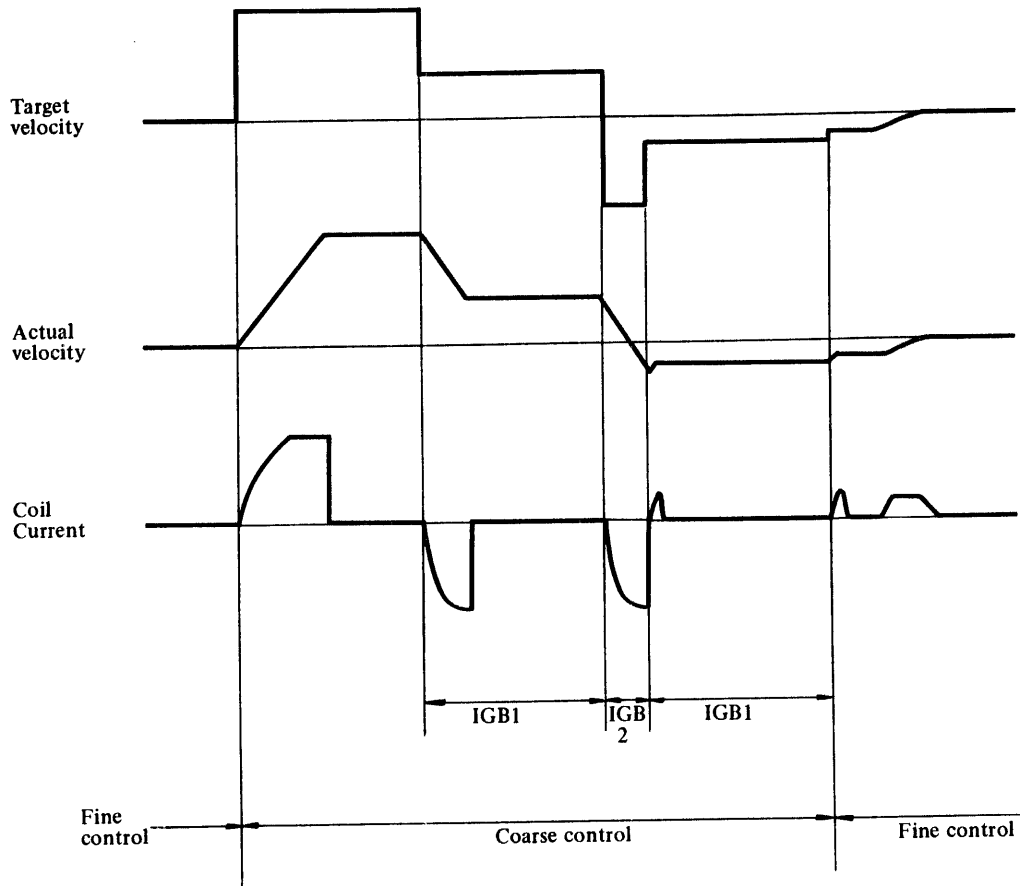
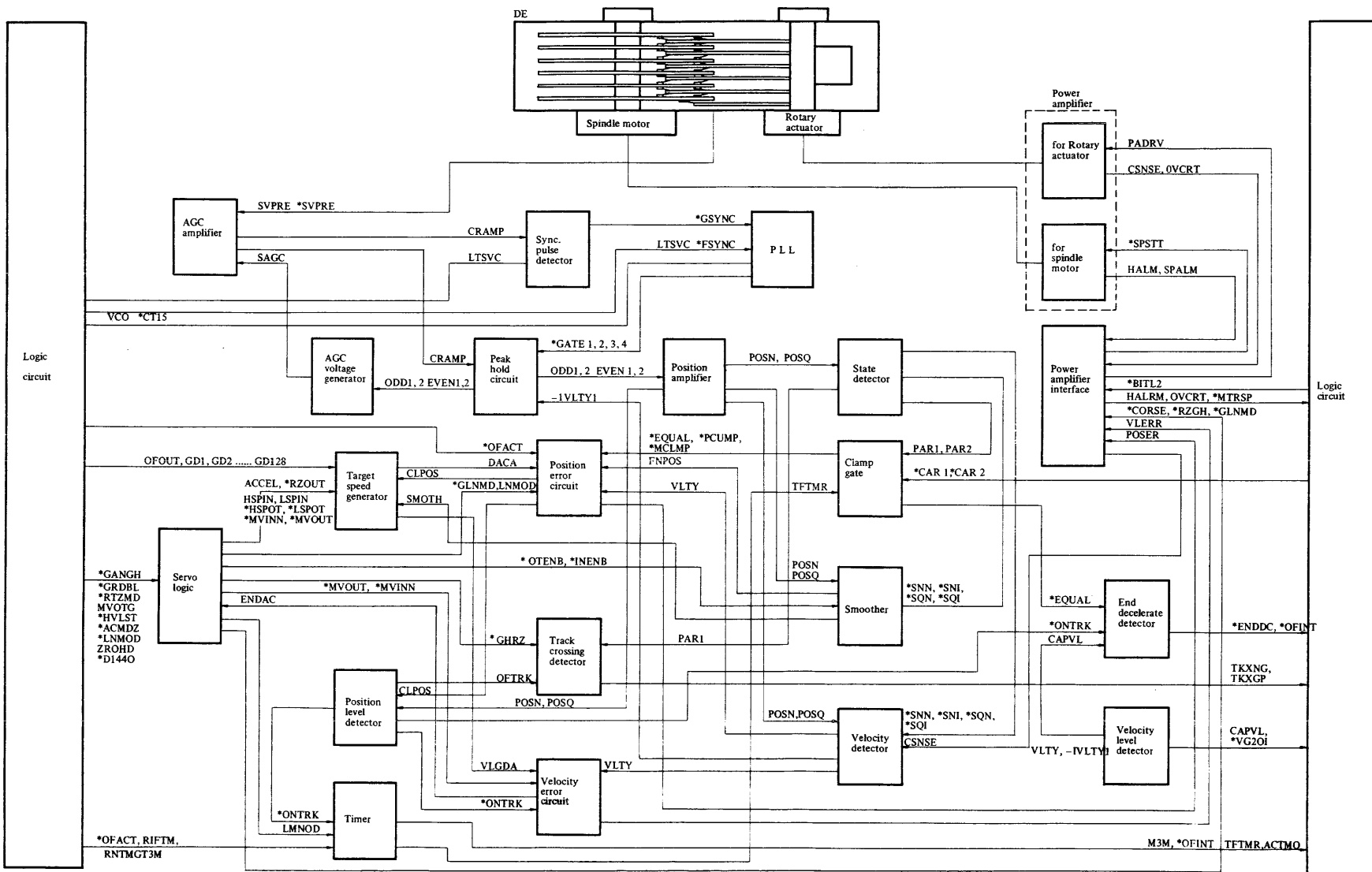

Figure 9.4-1 Rezero Control



B03P-4655-0001A...B

Figure 9.5-1 Servo Block Diagram

(1) AGC amplifier

The AGC amplifier amplifies the output signal from the servo head (SVPRE and \*SVPRE) to generate the carrier amplifier signal (CRAMP). The amplifier gain is controlled by the output (SAGC) of the AGC voltage generating circuit to compensate for level fluctuation on the servo surface.

(2) Peak hold circuit

The peak hold circuit receives gate signals (\*GATE1 - 4) from PLL to sample ODD1, EVEN1, ODD2, and EVEN2 pulse from the output of an AGC amplifier (CRAMP). This circuit uses the output (-1 VLT1) from the speed detect circuit in order to vary the discharge time constant of the sampling circuit according to the head travelling speed.

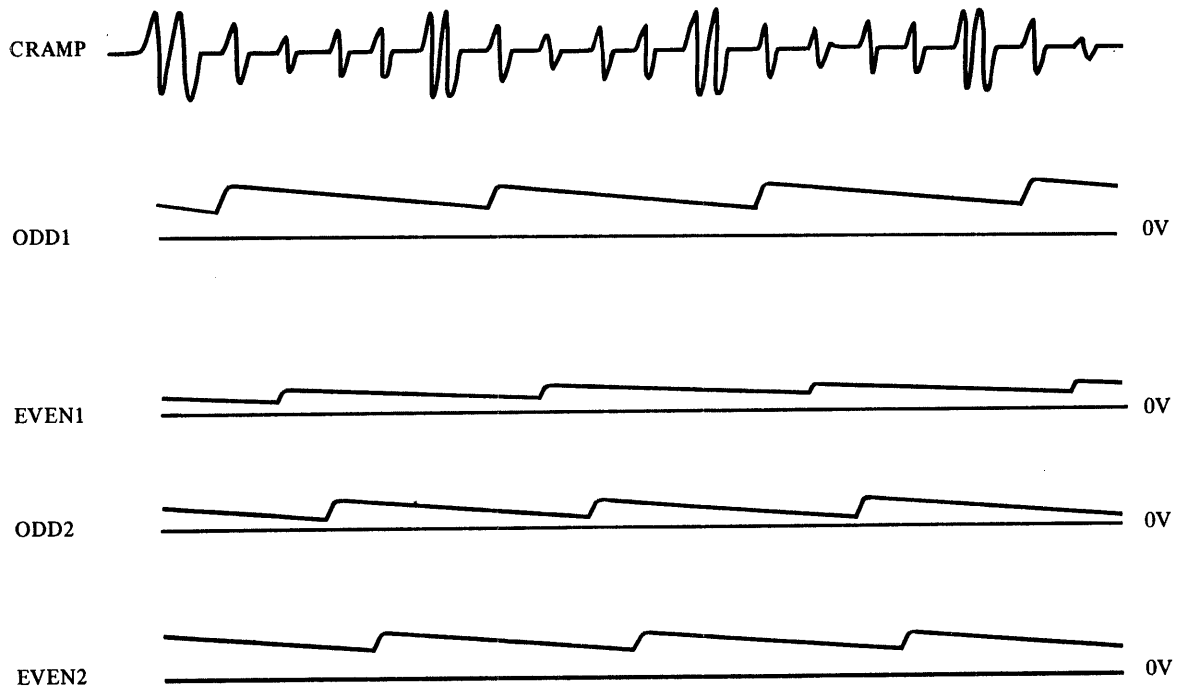

Figure 9.5-2 Peak Hold Circuit

(3) AGC voltage generator

This circuit generates the AGC amplifier gain control signal SAGC by means of ODD1, EVEN1, ODD2, and EVEN2 which are generated by the peak hold circuit. If the output voltage of the servo head falls due to variations in the level of the signal read from the medium, the amplitude of the carrier amplifier output decreases and the output voltage of the peak hold circuit falls, lowering the SAGC voltage. When the control voltage SAGC of the AGC amplifier falls, the gain is increased to compensate for the drop in the output voltage level of the servo head. Conversely, when the output voltage rises, it is compensated for in the same manner.

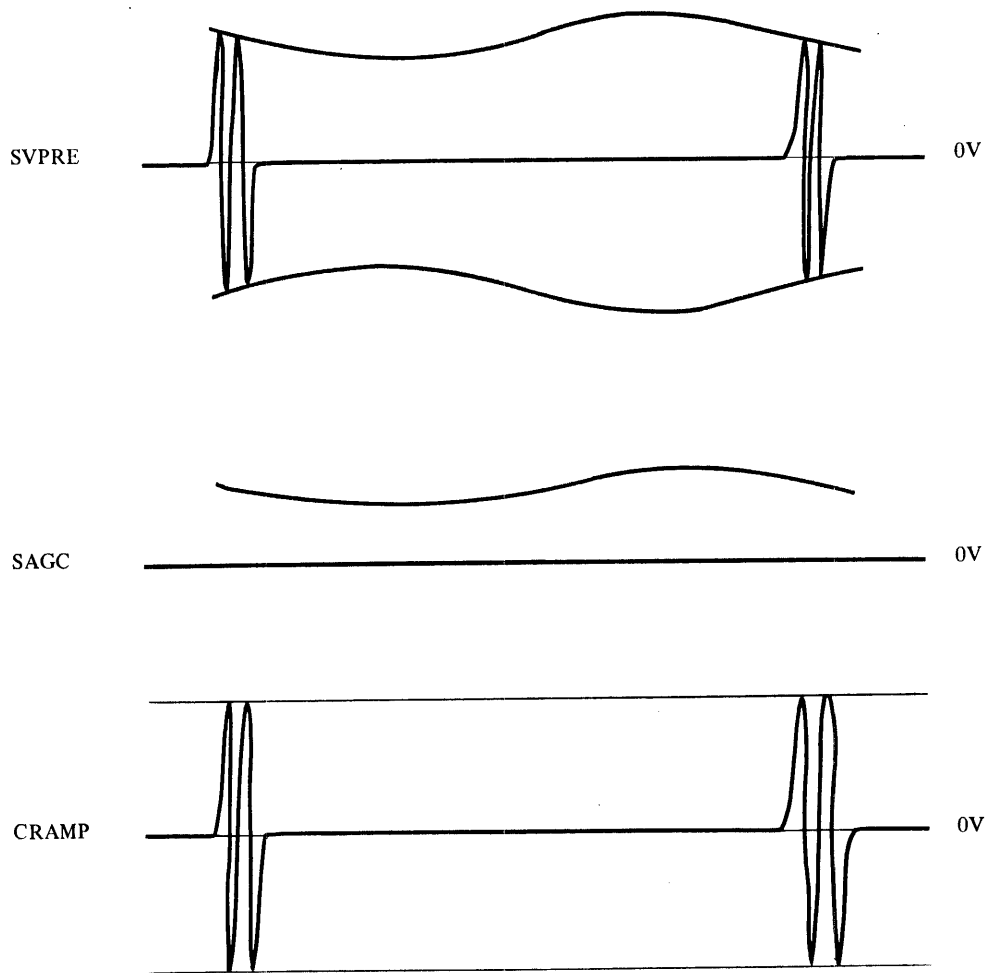

Figure 9.5-3 Function of AGC

(4) Sync pulse detector

The gated sync pulse signal (\*GSYNC) is generated using the signal generated by slicing the carrier amplifier signal (CRAMP). \*GSYNC is absent at the locations where the index pulses in the valid index pattern and the Guard Band patterns are written. This signal is used for the VCO and logic circuits to detect patterns.

\*GSYNC is generated by ANDing TP4 and the LTSVC signal generated by the logic circuit.

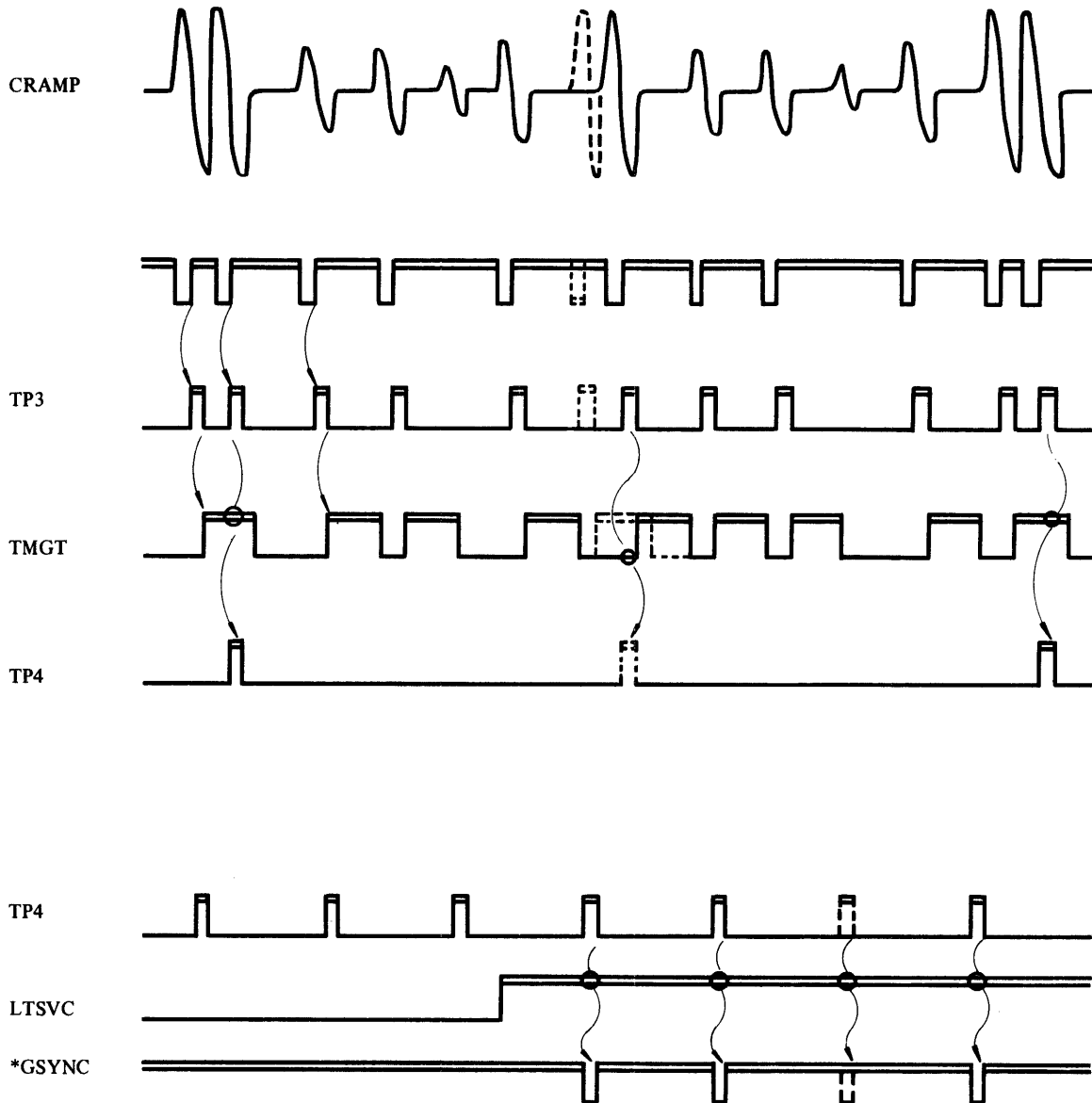

Figure 9.5-4 Detection of Sync Pulse

## (5) PLL

The PLL circuit, consisting of the phase detector, charge pump, VCO, counter, and decoder, generates gate signals used to sample ODD1, ODD2, EVEN1, and EVEN2 of the carrier amplifier. Even in the area where the index pulse is absent, the circuit generates gate signals.

### - Phase detector

This circuit detects the difference in phase between \*CT7, generated by VCO which divides \*GSYNC by 16, and \*GSYNC. It outputs \*INC or \*DEC according to a shift in phase.

### - Charge pump

The charge pump raises or lowers the PLO analog (PLOAN) voltage depending on the signal from the phase detector (\*INC/\*DEC). The output voltage of PLOAN is when the disk is rotating at the specified constant speed.

### - VCO, counter, and decoder

The VCO converts the DC voltages to the pulse oscillation frequency. The PLOAN voltage is proportional to the oscillation frequency. When the disk is rotating at the specified speed, the oscillating frequency of the VCO is 7.44 MHz, 16 times as high as the frequency of \*GSYNC. The output of the VCO is sent to the logic circuit and counted by the four-bit binary counter. The output of the counter is decoded and \*CT7 is sent to the phase detector and \*GATE1 - \*GATE4 to the peak hold circuit. \*CT15 is sent to the logic circuit to detect the valid index pattern and Guard Band Patterns.

## (6) Position amplifier

The position amplifier generates POSN by the difference between ODD1 and EVEN1, and POSQ by the difference between ODD2 and EVEN2. These two position signals are 90 degrees out of phase with each other.



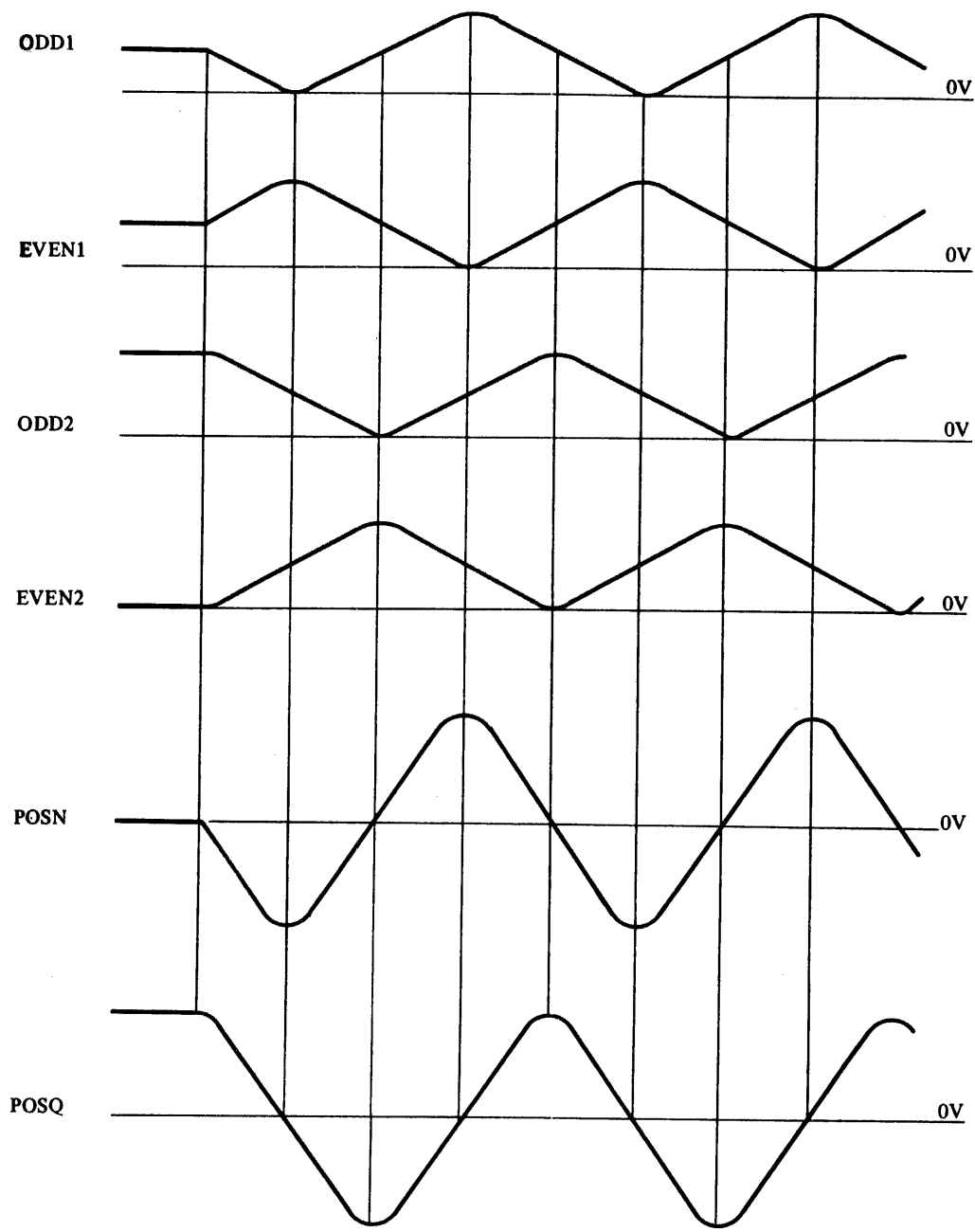

Figure 9.5-5 Position Signals

(7) State detector

The state detect circuit detects the low-order two bits of the present head position by two position signals, POSN and POSQ.

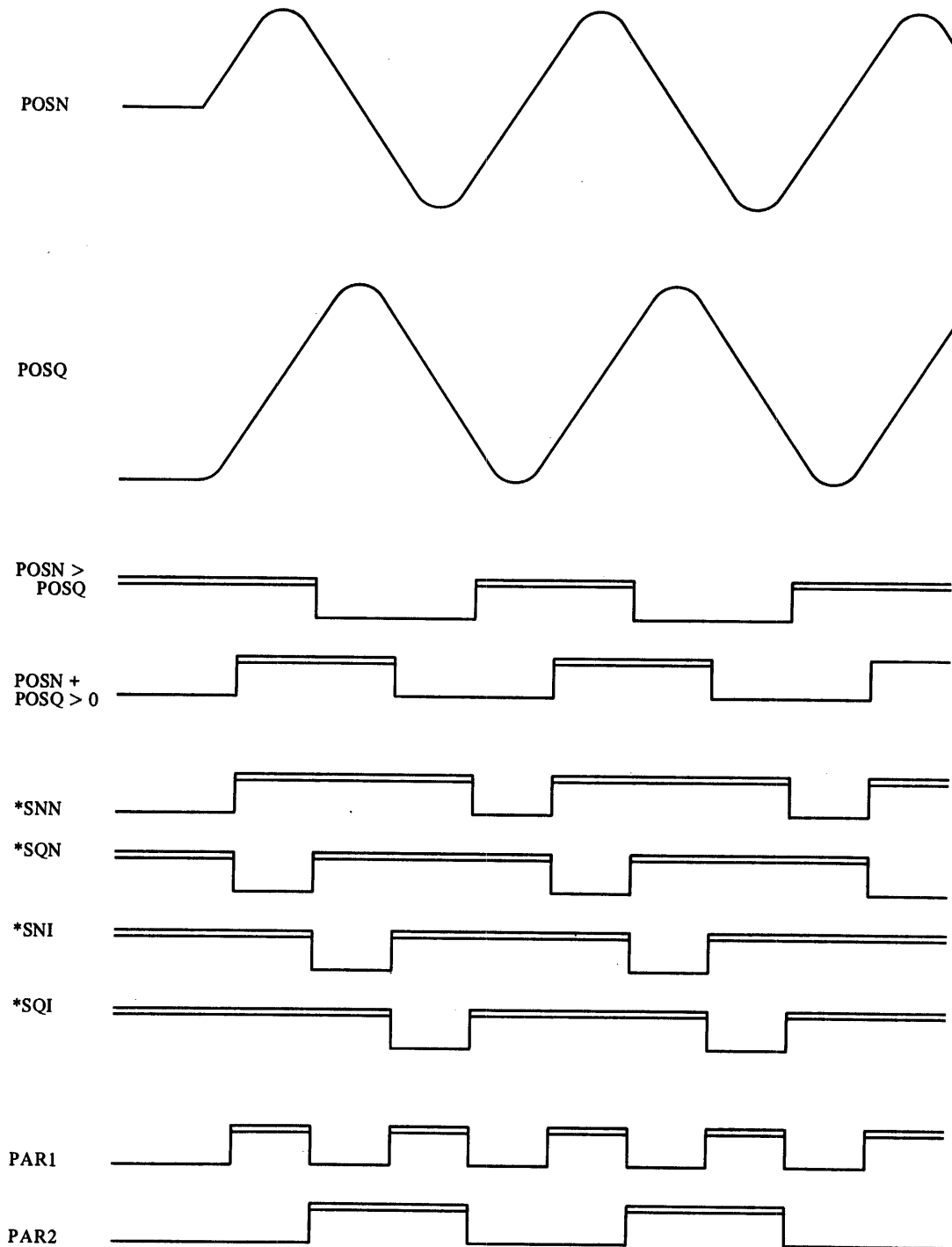

Figure 9.5-6 State of Position Signals

(8) Smoother

The position signal (FNPOS) for fine control is generated by selecting POSN or POSQ by means of \*SNN, \*SNI, \*SQN, and \*SQI generated from the state detect circuit. Switching the polarity of FNPOS according to the carriage movement direction, the interpolation signal (SMOTH) is generated for smoothing the stair step signal from the DA converter.

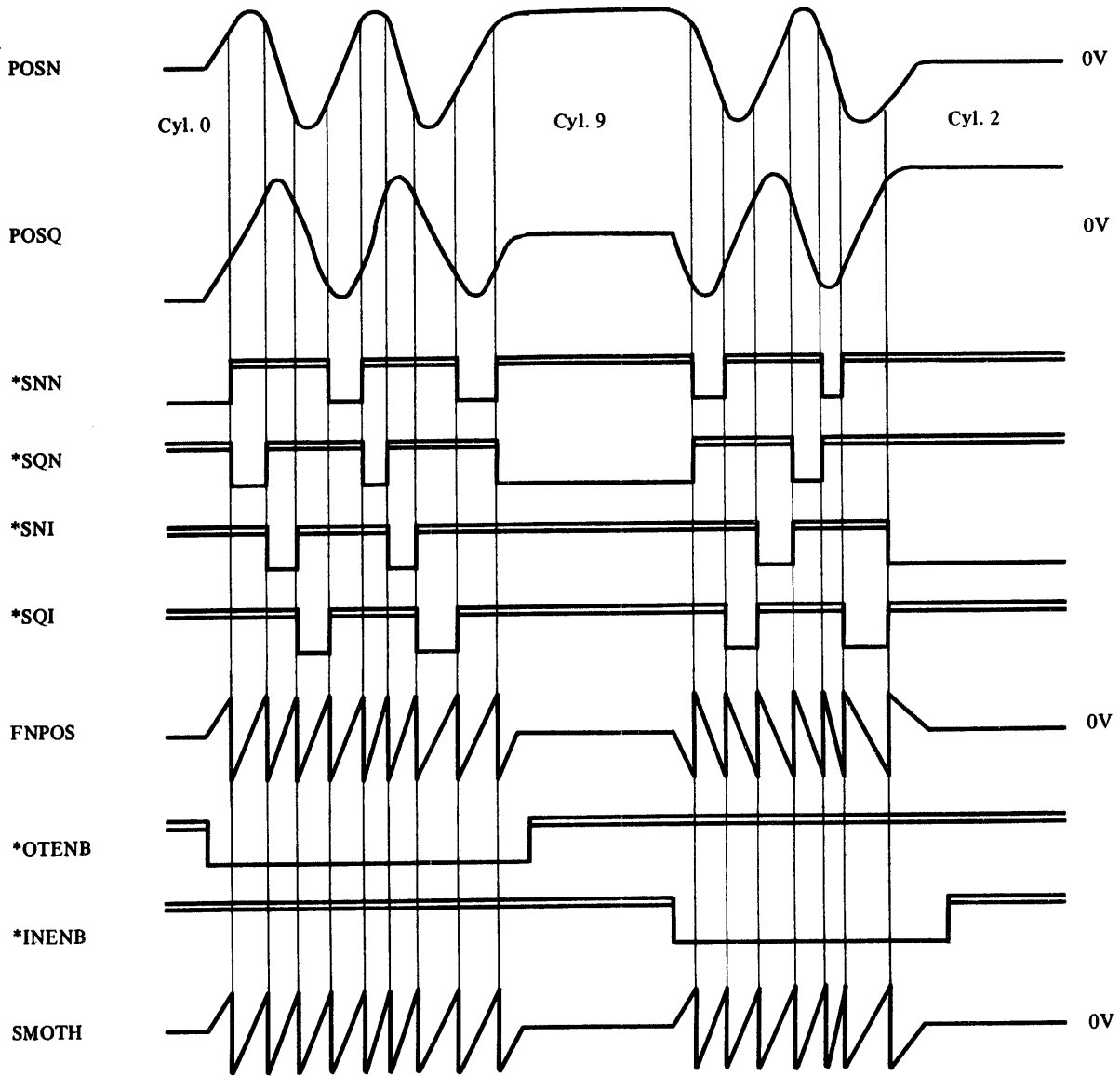

Figure 9.5-7 Output Signal of Smoother

(9) Clamp gate

The clamp gate holds the position signal at the specified level when the signal voltage is higher or lower than the specified level in order to extend the distance over which the head can be controlled. It generates \*EQUAL, \*PCLMP, and \*MCLMP by comparing the low-order two bits of the desired position sent from the logic circuit with the low-order two bits of the present head position sent from the state detect circuit.

(10) Position error circuit

The position error circuit generates the position signal (CLPOS) for position control by means of FNPOS generated from the smoother circuit and \*EQUAL, \*PCLMP, and \*MCLMP signals sent from the clamp gate circuit. It then combines CLPOS and the velocity signal (VLTY) to generate the position error signal (POSER), the error signal for fine control. At offset operation, this circuit combines the output (DACA) from the DA converter with the position signal. Figure 9.5-8 shows how the clamp circuit works when the head is moved from cylinder 0 to cylinder 9 (\*CAR1=0, \*CAR2=1).

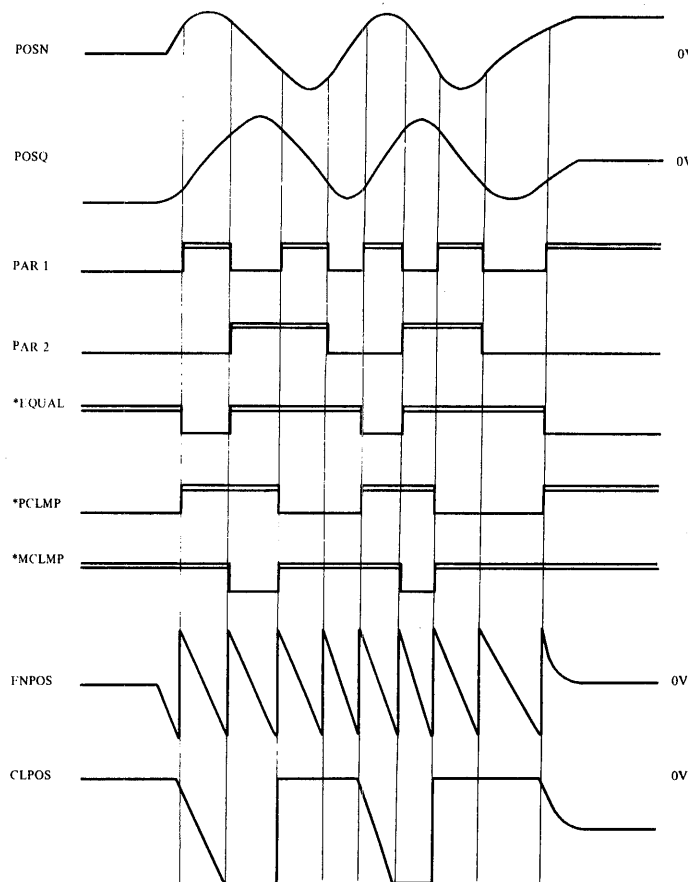

Figure 9.5-8 Clamped Position Signal

(11) Track crossing detector

The track crossing detect circuit generates the track crossing signal (TKXNG) by means of PAR1 sent from the state detect circuit and OFTRK sent from the position level detect circuit. The track crossing pulse (TKXGP) used to decrement the difference counter is generated on the rising edge of TKXNG. At rezero operation, \*GHRZ is activated to prevent TDXGP from being generated.

(12) Position level detector

The position level detect circuit generates the off-track signal (OFTRK) by slicing the position signal (POSN, POSQ) and also generates the on-track signal (\*ONTRK) by slicing the clamped position signal (CLPOS) output from the position error circuit. OFTRK is used in the circuit which generates the track crossing pulse for decrementing the difference counter in the logic circuit. \*ONTRK is used to generate switching signal (\*ENDDC) which changes the control method from the coarse control to the fine control, the signal (ENDAC) which indicates the end of carriage acceleration, and the signal (TFTMR) which indicates, after the control is switched to the fine control, that the head is positioned properly.

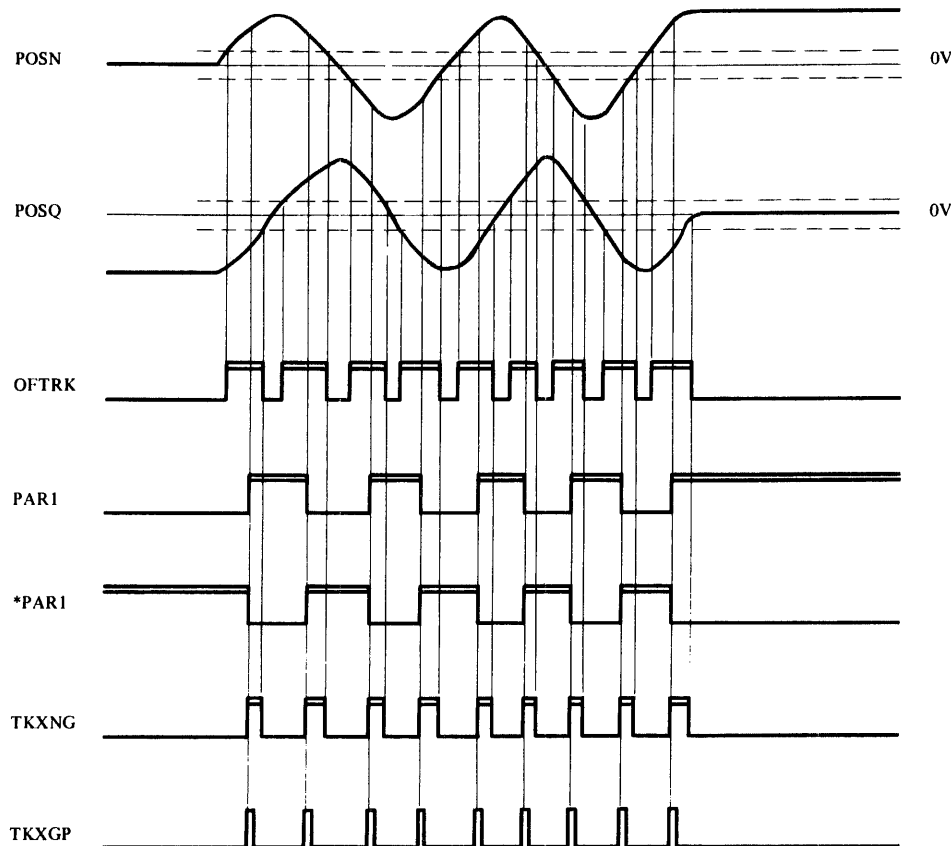

Figure 9.5-9 Position Level Detector

### (13) Target speed generator

The target speed generator, consisting of the DA converter, nonlinear circuit, and switching circuit, determines the carriage traveling speed at seek or rezero operation.

#### - DA converter

The DA converter converts the digital positional difference (held to 144 when the number of remaining cylinders is not less than 144) stored in the difference register (the number of cylinders over which the carriage is to be moved is set and is decremented whenever the track crossing pulse is detected) to the analog stair step waveform which decreases as the carriage approaches the desired cylinder. The DA converter is also used in converting the offset amount (3-bit digital amount) to the corresponding analog voltage at offset operation.

#### - Non-linear circuit

The nonlinear circuit combines the stair step signal sent from the DA converter with the signal sent from the smoother to smooth the waveform and, at the same time, generates the deceleration curve which is optimum from viewpoints of decelerating current and the access time. In addition, it applies the output from the charge-discharge circuit, which is controlled by the acceleration signal (ACCEL), to prevent excessive accelerating force from being applied to the carriage.

#### - Switching circuit

The switching circuit selects the target velocity for seek operation, and rezero operation generated based on the reference voltage by means of various logic signals generated by the servo logic circuit.

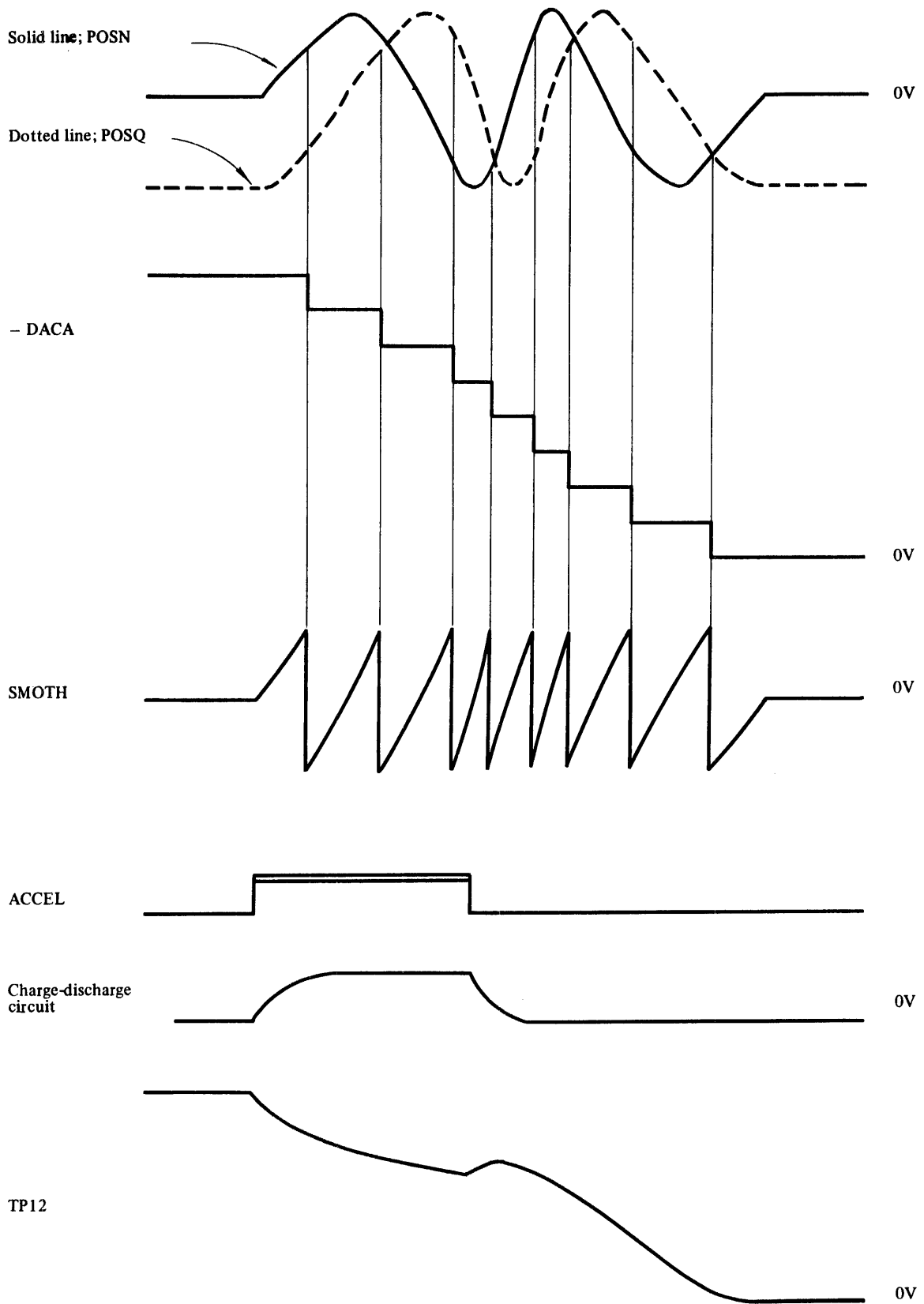

Figure 9.5-10 Target Speed

Figure 9.5-11 is the timing chart of the signals at the rezero operation:

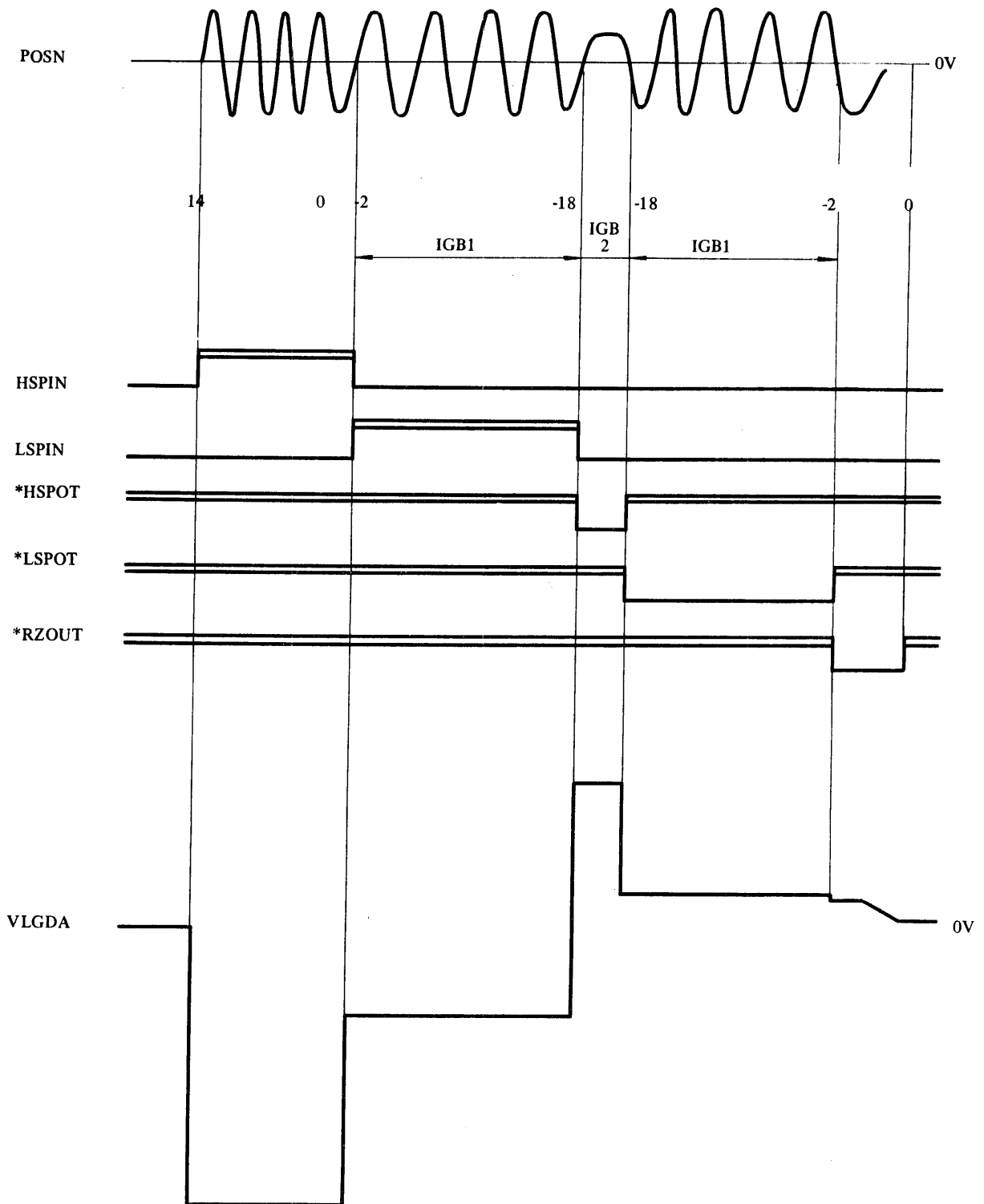

Figure 9.5-11 Signals in Rezero Operation



(14) Velocity detector

The velocity detect circuit generates the velocity signal by composing the differentiated value of the position signal (POSN and POSQ) for the linear portion with the integrated value of the coil current (CSNSE) in the rotary actuator. The output of the state detect circuit is used to select the linear portion of the position signal.

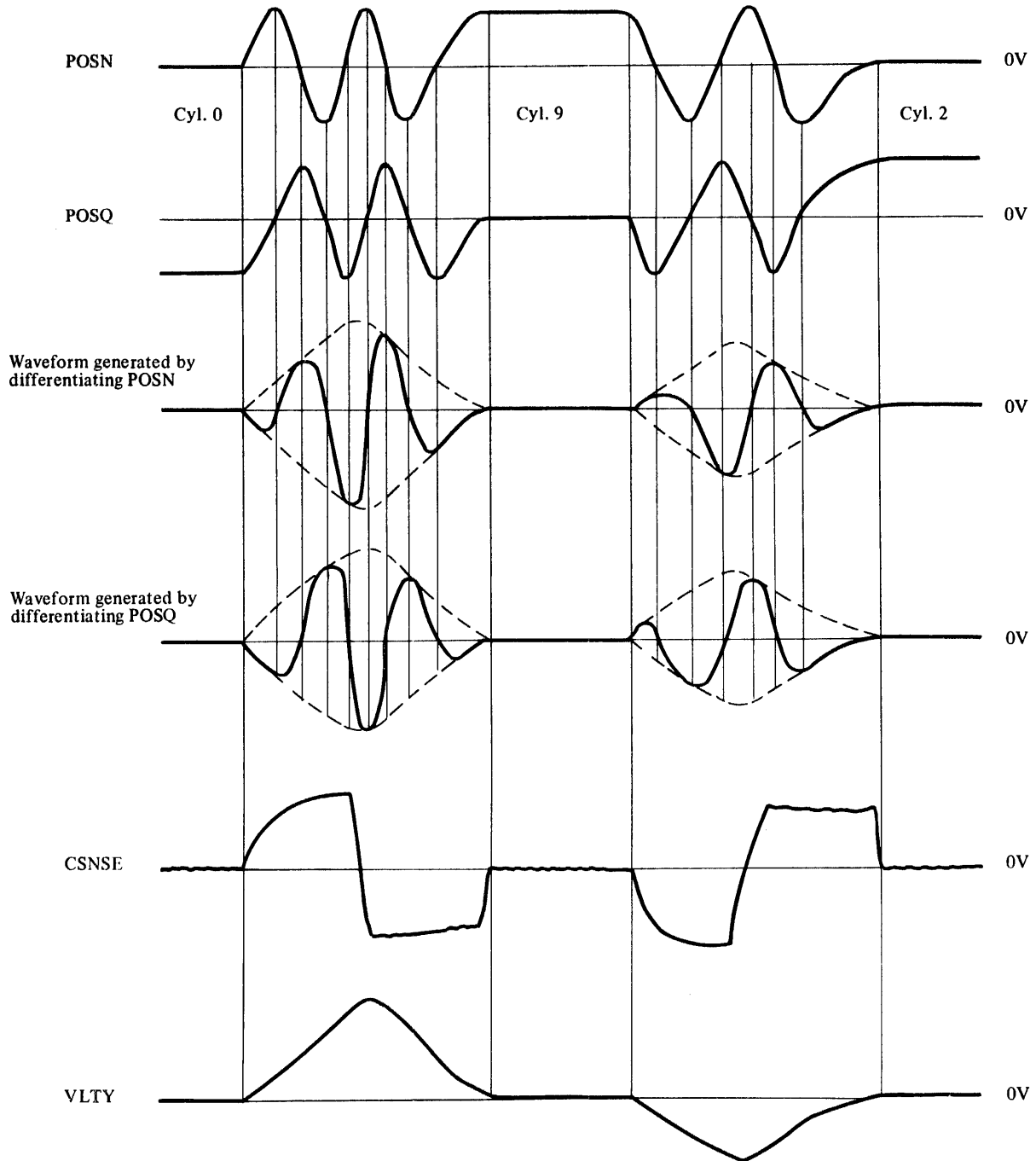

Figure 9.5-12 Velocity

(15) Velocity level detector

The velocity level detect circuit slices the velocity signal (VLTY) and sends CAPVL and \*VG20I signal to the logic circuit. CAPVL, which indicates the carriage velocity is lower than the specified value, is used to prevent the rezero operation from being started while the carriage is being moved at high speed and also used to provide switching moment from coarse control to fine control. \*VG20I, which indicates the carriage velocity is too high during the rezero operation, is used to monitor the access mechanism.

(16) Velocity error circuit

The velocity error circuit generates the velocity error signal (VLERR) which indicates a difference between the target velocity signal VLGDA and the actual velocity signal VLTY. It also generates, by slicing VLERR, the end accelerate signal (ENDAC) which indicates the end of acceleration.

(17) End decelarate detector

The end decelarate detect circuit generates the end decelerate signal (\*ENDDC) which indicates switching of the control mode from the coarse control to the fine control. That is, the circuit generates \*ENDDC after the specified time has elapsed from the moment \*ONTRK goes low and \*EQUAL is low. At this time, CAPVL is used to indicate that the velocity is lower than the specified velocity.

(18) Timer

The timer is used to generate the track following timer signal (TFTMR) which informs the logic circuit that the access operation has been completed normally after the specified time period from the moment the control mode had been switched to the fine control or, it sends the access timeout signal (ACTMO), which indicates that the operation has not been completed within the specified time period after the start of movement. It also provides the time setting signal (M3M, \*OFINT) to be used during an offset operation.

(19) Reference voltage generator

The reference voltage generator generates -4V and +6V reference DC voltages to be supplied to the head IC on the servo head assembly. They are also used as reference voltages for various level detect circuits and the desired velocity level during a rezero operation.

## (20) Servo logic

The servo logic generates various signals used in coarse control and fine control based on the control logic signals sent from the logic circuit.

## (21) Power amplifier interface

This is the interface between the power amplifier for driving the rotary actuator and spindle motor and the servo circuit. When the coarse control operation is performed, the interface selects VLERR by means of \*CORSE. When the fine control is performed, the interface selects POSER by means of \*GLNMD. One of these signal is sent to the power amplifier as the power amplifier drive signal (PADRV). When the rezero operation is performed, the amplifier gain of PADRV is reduced to avoid the excessive acceleration force to be applied to the carriage and the head. In addition, a DC bias circuit is provided to prevent the head from moving away from the CSS area when the spindle motor rotation is lower than the specified rotational speed (3,961 rpm -2%). The interface for the power amplifier of the rotary actuator includes the current sense signal (CSNSE) which is proportional to the current in the drive coil and the overcurrent signal (OVCRT) which indicates an excessive current flows. The interface for the power amplifier of the spindle motor includes the spindle start signal (\*SPSTT) which indicates the start/stop of the motor, the speed alarm signal (SPALM) which indicates that the rotational speed is not in the range of 3961 rpm  $\pm$  2%, and the hall alarm signal (HALM) which indicates an abnormal condition of the hall-effect element used for monitoring the spindle motor rotation.

## (22) Power amplifier for rotary actuator

This amplifier provides drive coil current proportional to PADRV sent through the power amplifier interface and sends CSNSE to the servo circuit upon detection of coil current. In addition, it sets OVCRT high to indicate an abnormal condition when current of 5A or more flows for 0.7 seconds or longer.

## (23) Power amplifier for spindle motor

This amplifier controls the spindle motor so that it rotates at the specified speed (3961 rpm) when the spindle start signal (\*SPSTT) is "0". The rotational speed is checked by the output of three hall-effect elements which are equipped in the motor. The rotational speed is compared with the specified speed each time the disk rotates; if the speed is lower than 3961 rpm, the amplifier provides current and, if the speed is higher than 3961 rpm, current does not flow, allowing

the disks to be rotated by the force of inertia. The speed alarm signal (SPALM) is changed from "1" to "0" when the rotational speed comes up to 3961 rpm, and changed to "1" again when the rotational speed is not within the specified range. The rotational speed monitor circuit is reset when the disk is restarted. The following diagram shows the outputs of the hall-effect elements.

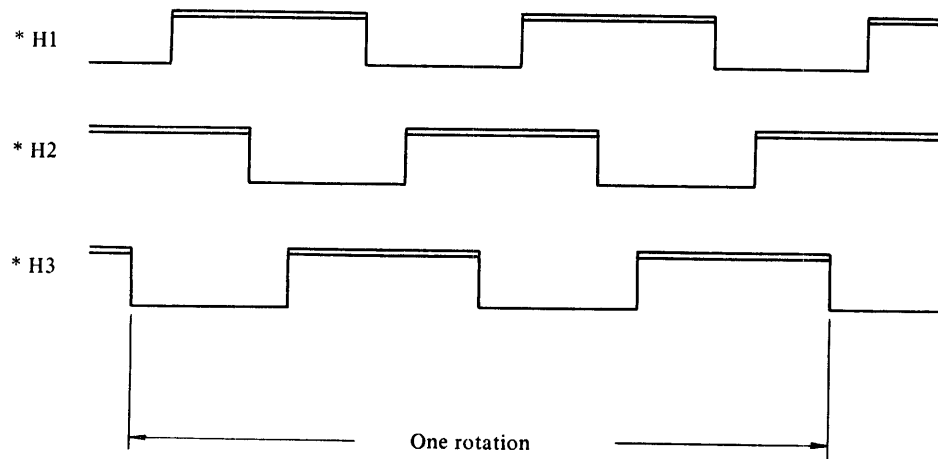

Figure 9.5-13 Outputs of Hall-Effect Elements



10.1 WRITE CIRCUIT

When a write command is issued from the controller after head selection, Write Data and Write Clock signals are sent to the drive. Through the MFM modulator and write compensation circuit, Write Data in NRZ code is converted into WDATA in MFM code.

The block diagram of Read/Write circuit is shown in Figure 10.1-1, and the block diagram of circuits in the DE is shown in Figure 10.1-2.

(1) Head Select - Movable Heads

Movable heads are selected by Head Address Register outputs (\*HAR1 through \*HAR16). \*HAR4, \*HAR8 and \*HAR16 are also decoded and used as Chip Select signals (\*CHP0 ~ \*CHP4).

One of the 5 head ICs on the head arm assemblies is selected according to the Chip Select signals.

The low-order two bits of Head Address Register (\*HAR1 and \*HAR2) are converted from TTL to ECL level and used as Head Select signals to select one of the 4 heads.

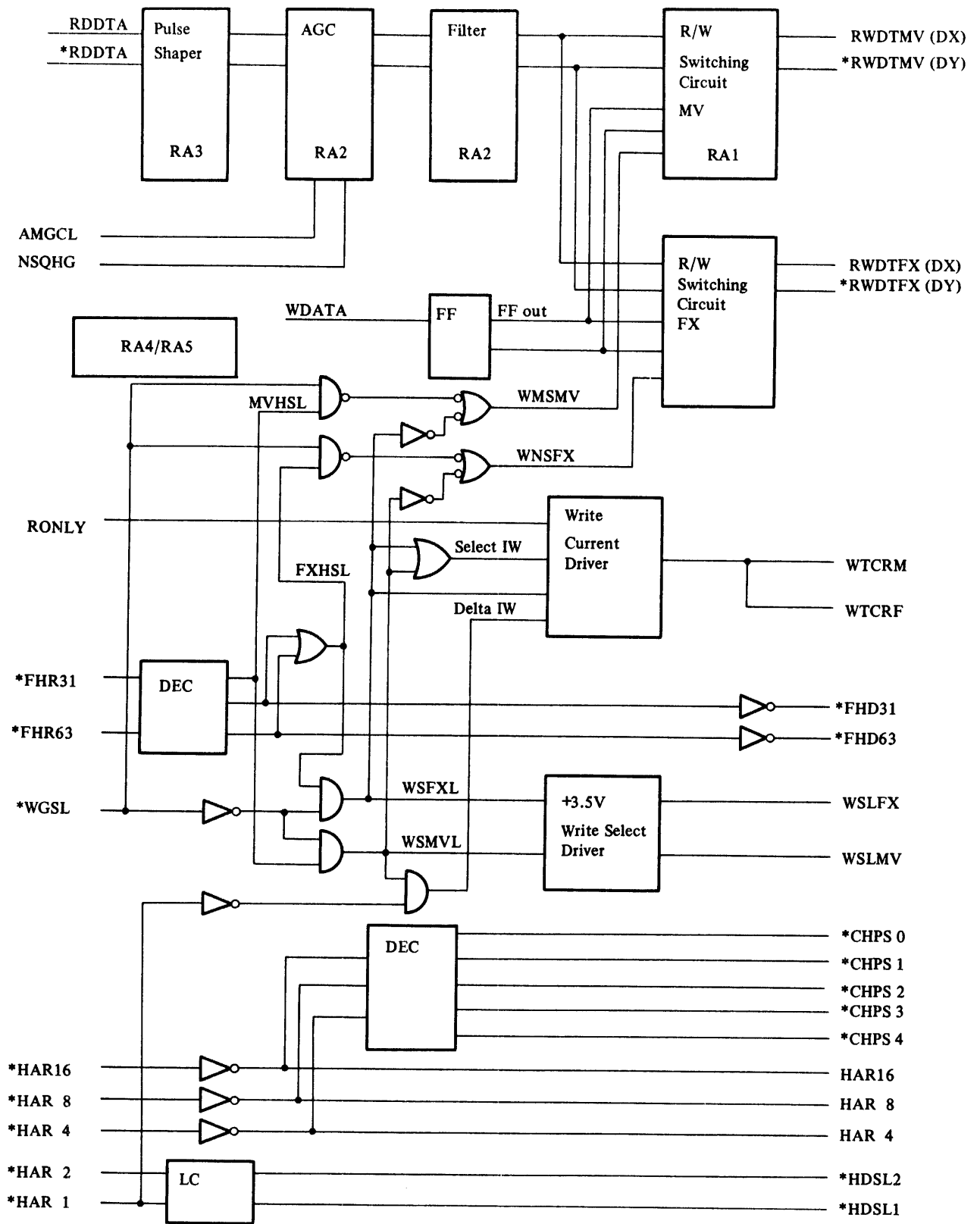

Fig. 10.1-1 Read/Write Circuit Block Diagram

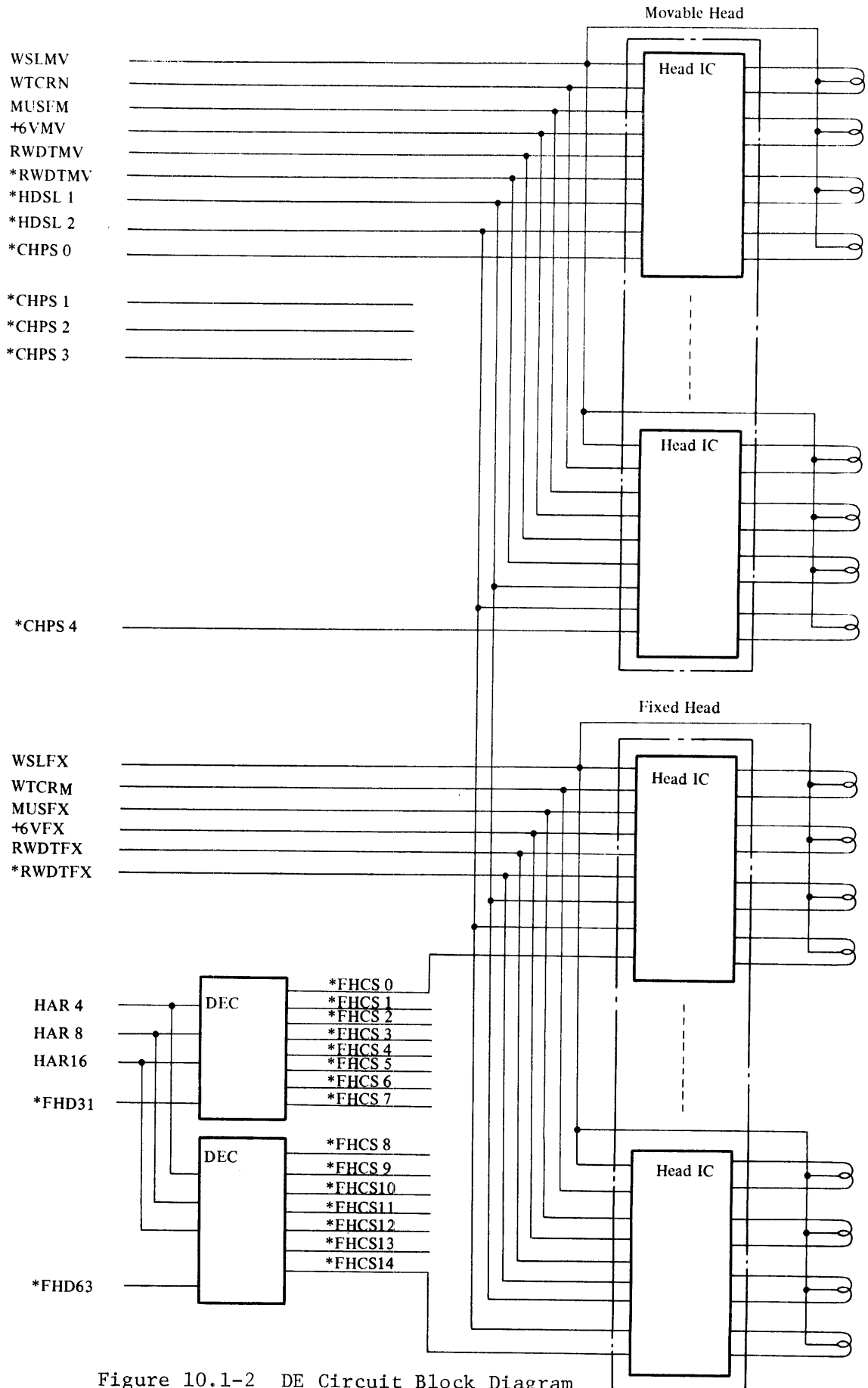

Figure 10.1-2 DE Circuit Block Diagram



## (2) Head Select - Fixed Heads

Fixed heads are selected by Fixed Head Register outputs (\*FHR31 and \*FHR63) and Head Address Register outputs (\*HAR4, \*HAR8 and \*HAR16). \*HAR4, \*HAR8 and \*HAR16 are inverted and, in conjunction with \*FHR31 and \*FHR63, are sent to two decoders in the DE. These decoders provide Fixed Head Chip Select signals (\*FHCS0 through \*FHCS14) to select one of the 15 fixed head ICs which are mounted on the PCB in the DE. \*HDSL1 and \*HDSL2 then select one of the four cores in the fixed head.

## (3) Write Select

Write Select Fixed Head (WSLFX) and Write Select Movable Head (WSLMV) signals are constant-voltage +3.5 volts in the active state and are connected to the head center taps during a write operation. Write Gate Select (\*WGSL) is low during a write operation, enabling Write Select Movable Head (\*WSLMV) and Write Select Fixed Head (\*WSLFX). Depending on the mode selected (fixed or movable), the +3.5 volt Write Select drive (WSLFX or WSLMV) is sent to the respective heads in the DE.

## (4) Write Current Source

The write current driver is a constant-current power source which supplies write current to the head. The write current varies depending on the signals Select IW, \*WSLFX and Delta IW as follows:

Odd number movable head: (Inner movable head)	20 mA
Even number movable head: (Outer movable head)	25 mA
Fixed head 0 ~ Fixed head 31:	40 mA
Fixed head 32 ~ Fixed head 59:	45 mA

The write current driver is disabled by Read Only signal (RONLY).

## (5) Write Data

Write data (WDATA) is sent out from the MFM modulator and the write compensation circuit in the VFO. The flip-flop is clocked by the positive-going edge of the WDATA signal, and its output is sent to two (bidirectional) Read/Write switching circuit. The write data is switched to the DX, DY inputs to the DE if either \*WSLFX (fixed) or \*WSLMV (movable) is active.

The DX, DY signals from the respective switching circuit drives the Head IC as Write Data. A timing chart of the Read/Write flip-flop circuit is shown in Figure 10.1-3.

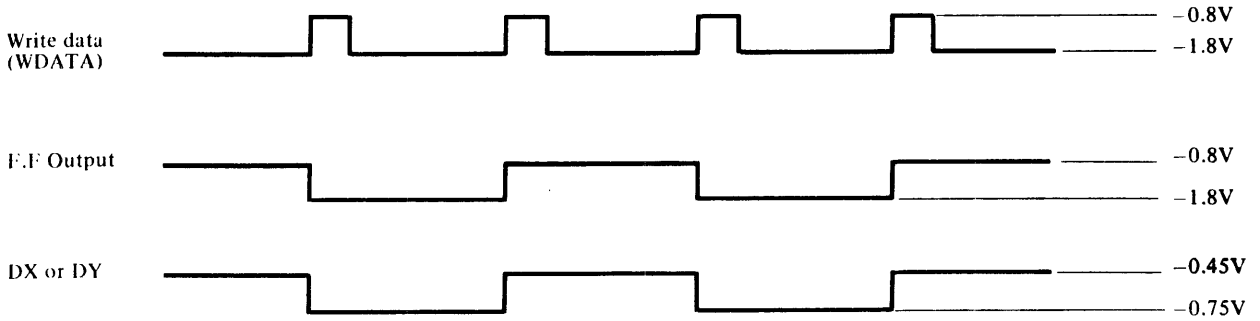

Fig. 10.1-3 Read/Write Flip-Flop Timing Chart

## 10.2 READ CIRCUIT

When a read command (Tag 3, Bus 1) is issued by the controller, Read Gate signal becomes active and the read operation is initiated. The Read/Write circuit block diagram is shown in Figure 10.1-1.

### (1) Read/Write Switching Circuit

The read circuit is enabled anytime Write Mode Select Movable Head (WMSMV) and Write Mode Select Fixed Head (WMSFX) signals are inactive. The DX, DY signals from the Head IC output are applied to the Read/Write switching circuit IC (MB4316), amplified and sent to a low pass filter circuit. The block diagram is shown in Figure 10.2-1.

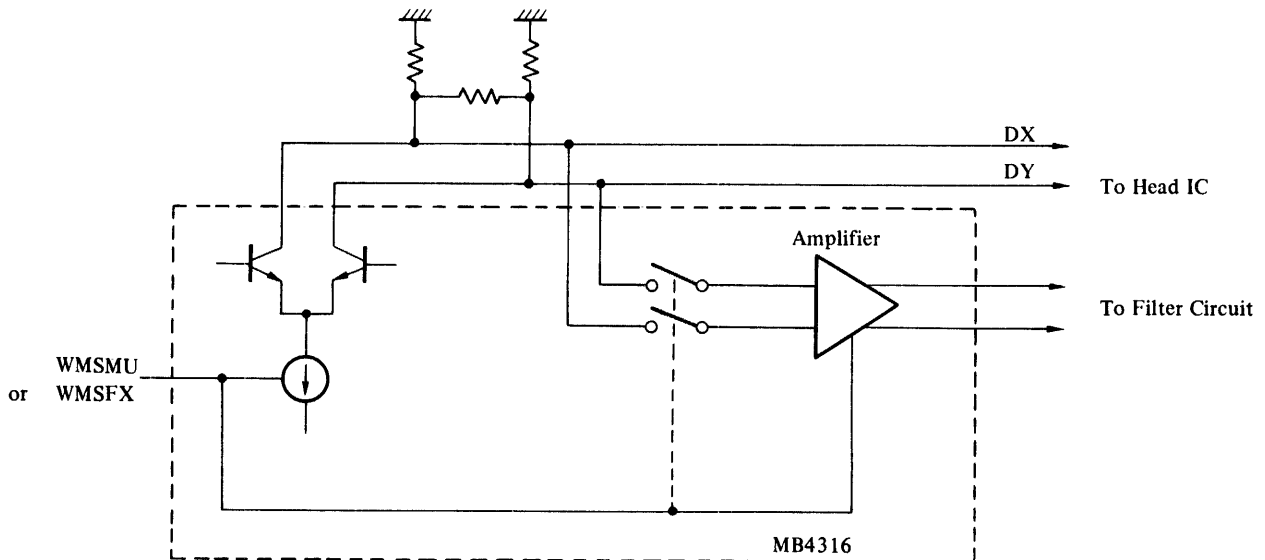

Fig. 10.2-1 Read Write Switching Circuit

### (2) Low Pass Filter Circuit (LPF)

The purpose of the low pass filter is to attenuate high-frequency noise. The filter is a Butterworth, with a cut-off frequency of approximately 14 MHz.

### (3) AGC Circuit

The AGC loop consists of an AGC amplifier IC (MB4303) and a level sensor IC (MB4311). The LPF output signal is applied to the AGC amplifier, and sent to the level sensor IC. Here, it is further amplified (about 10 times) before being applied to the level sensor and charge pump (LSCP) circuit and out to a pulse shaper circuit.

The LSCP circuit compares the peak of AC voltage of the AGC output signal with the DC reference voltage 1 (RFV1) and 2 (RFV2). If the voltage of the AGC output signal is lower than the voltage of the RFV1 signal, the LSCP discharges the capacitor 1 (C1) and the voltage VAGC decreases. The decreasing VAGC causes the AGC Amplifier to increase amplitude (gain). The AGC output signal is amplified about 2.6 volts peak to peak. Figure 10.2-2 is a block diagram of the AGC loop circuit.

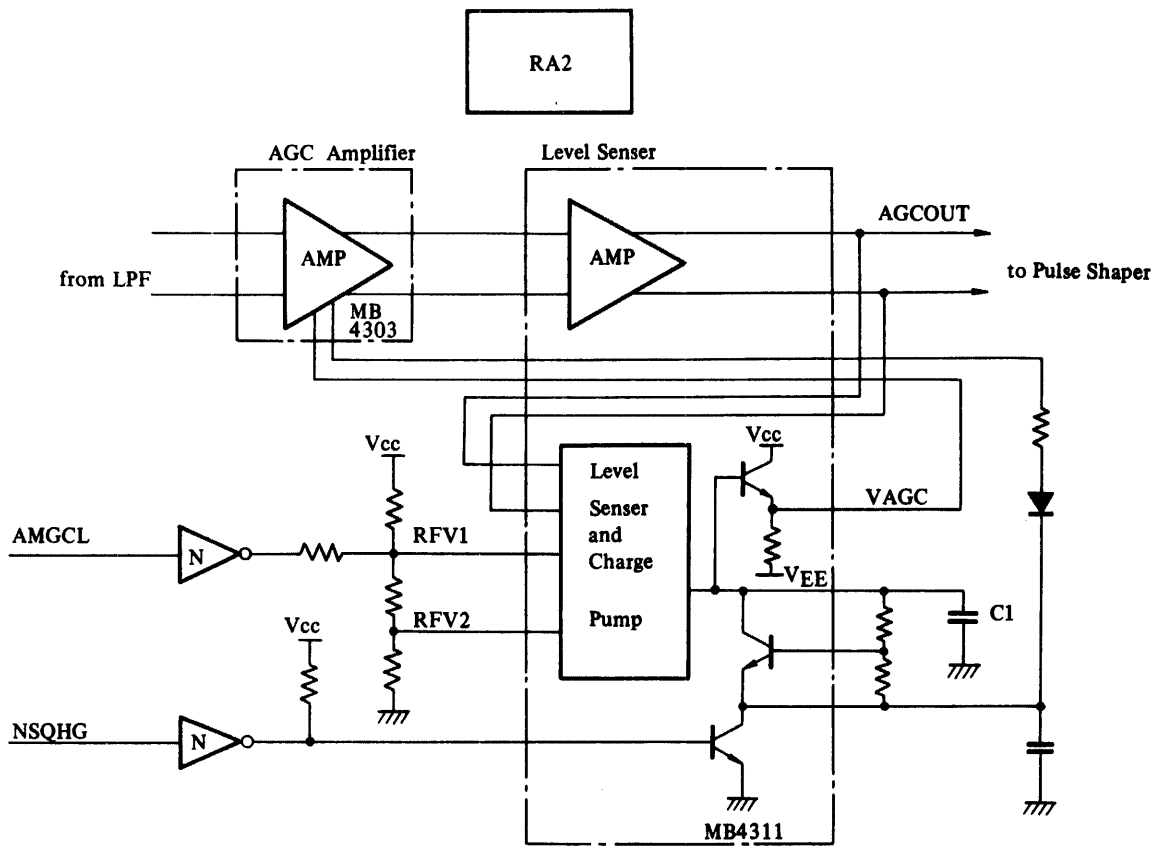

Fig. 10.2-2 AGC Loop Circuit

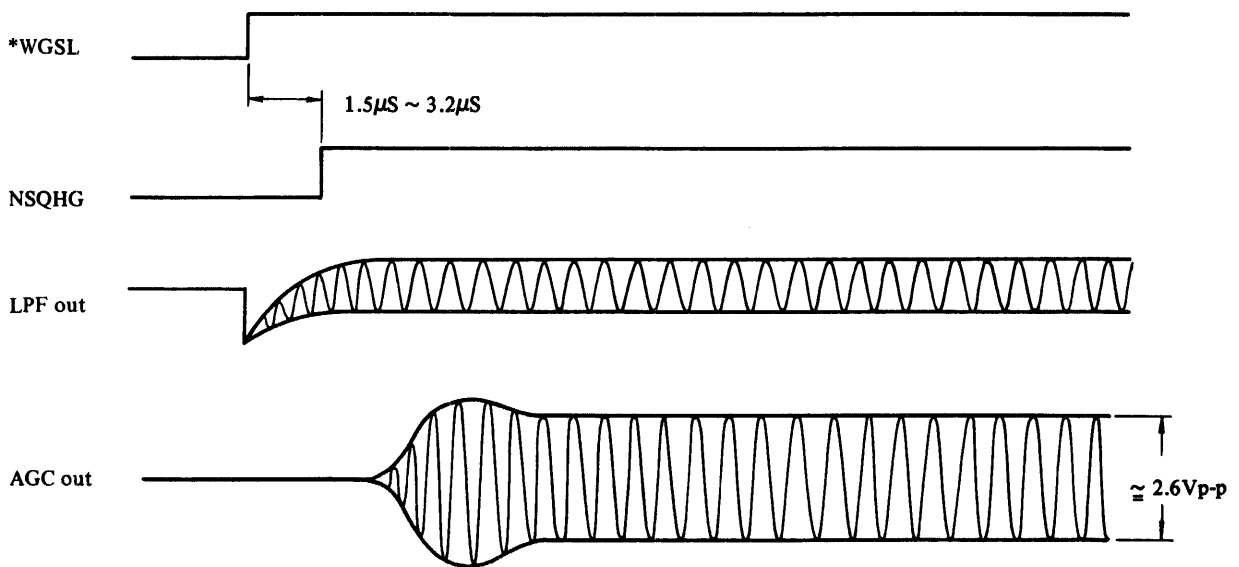

Fig. 10.2-3 AGC Squelch Function

When Write Gate Select signal (\*WGSL) is deactivated, the read circuit is activated. However, a read transient caused by the DC unbalance of the read pre-amplifier will occur. Therefore, Not Squelch Gate signal (NSQHG) is enabled about 2  $\mu$ sec after the Write Gate Select signal (\*WGSL) goes high.

The NSQHG signal suppresses this read transient. The AGC squelch function is shown in Figure 10.2-3.

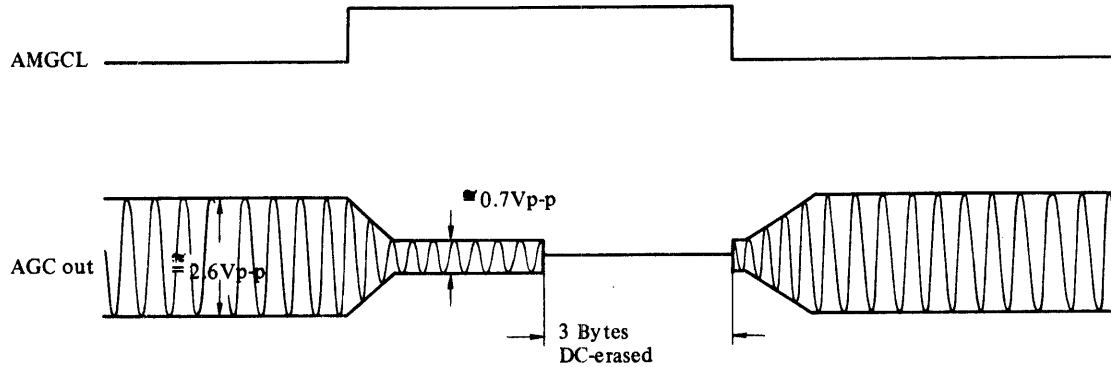

Fig. 10.2-4 AM Search Function

In the variable sector format mode, the address mark (AM), which is a three-bytes DC-erased area, is used for detecting the beginning of a sector. When the controller issues an AM read command, AM Gate Control signal (AMGCL) goes high and decreases the DC voltage of RFV1.

This suppresses the gain of the AGC circuit to avoid false AM detection caused by external noise or media noise in the DC-erased area.

The AM search function is shown in Figure 10.2-4.

(4) Pulse Shaper Circuit (Analog-to-digital converter)

The analog-to-digital converter or pulse shaper has two fundamental circuit; a differentiator which differentiates the AGC output signal and then converts the peaks (flux transition) into zero-crossing signals; and, an integrator which AC-slices the AGC output signal (floating slice) and then generates data window pulse signals.

The block diagram is shown in Figure 10.2-5 and the timing chart in Figure 10.2-6.

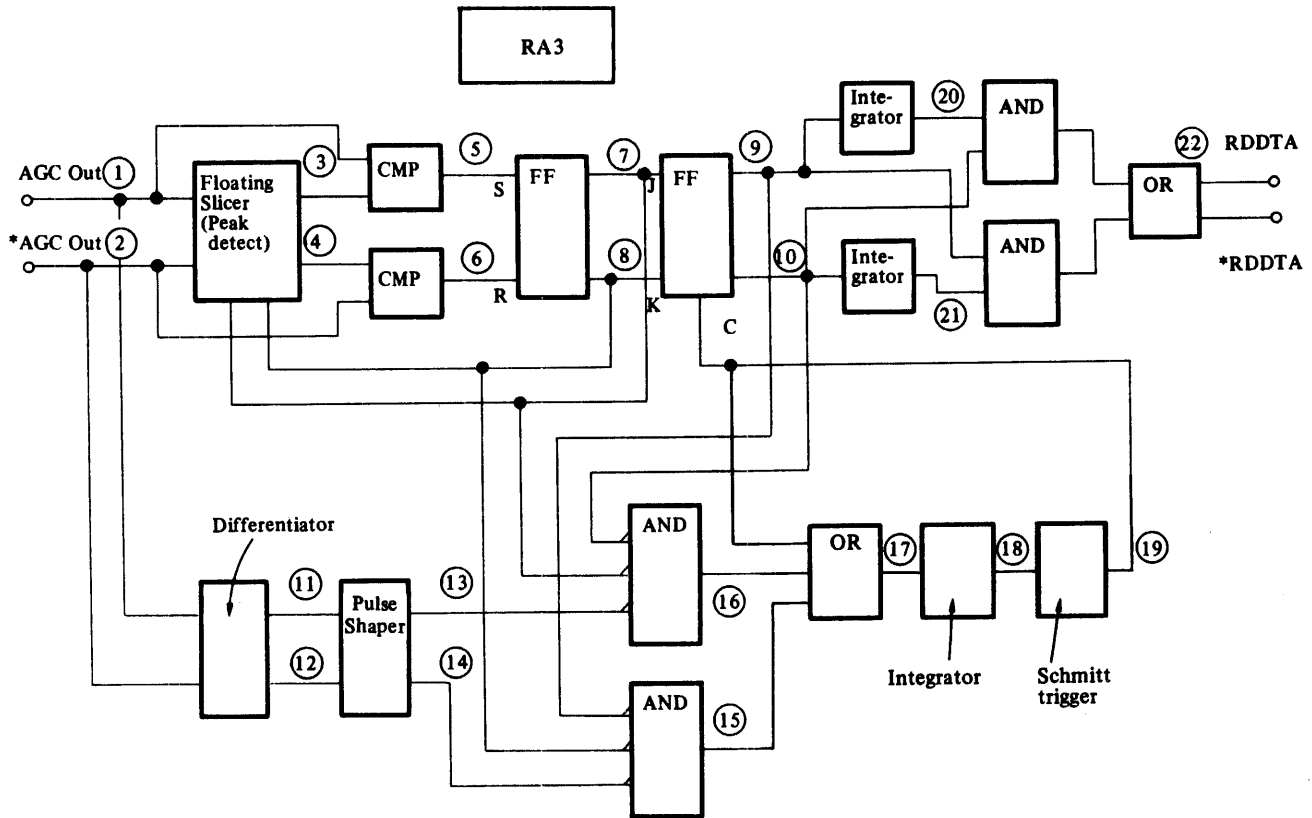

Fig. 10.2-5 Pulse Shaper Circuit Block Diagram

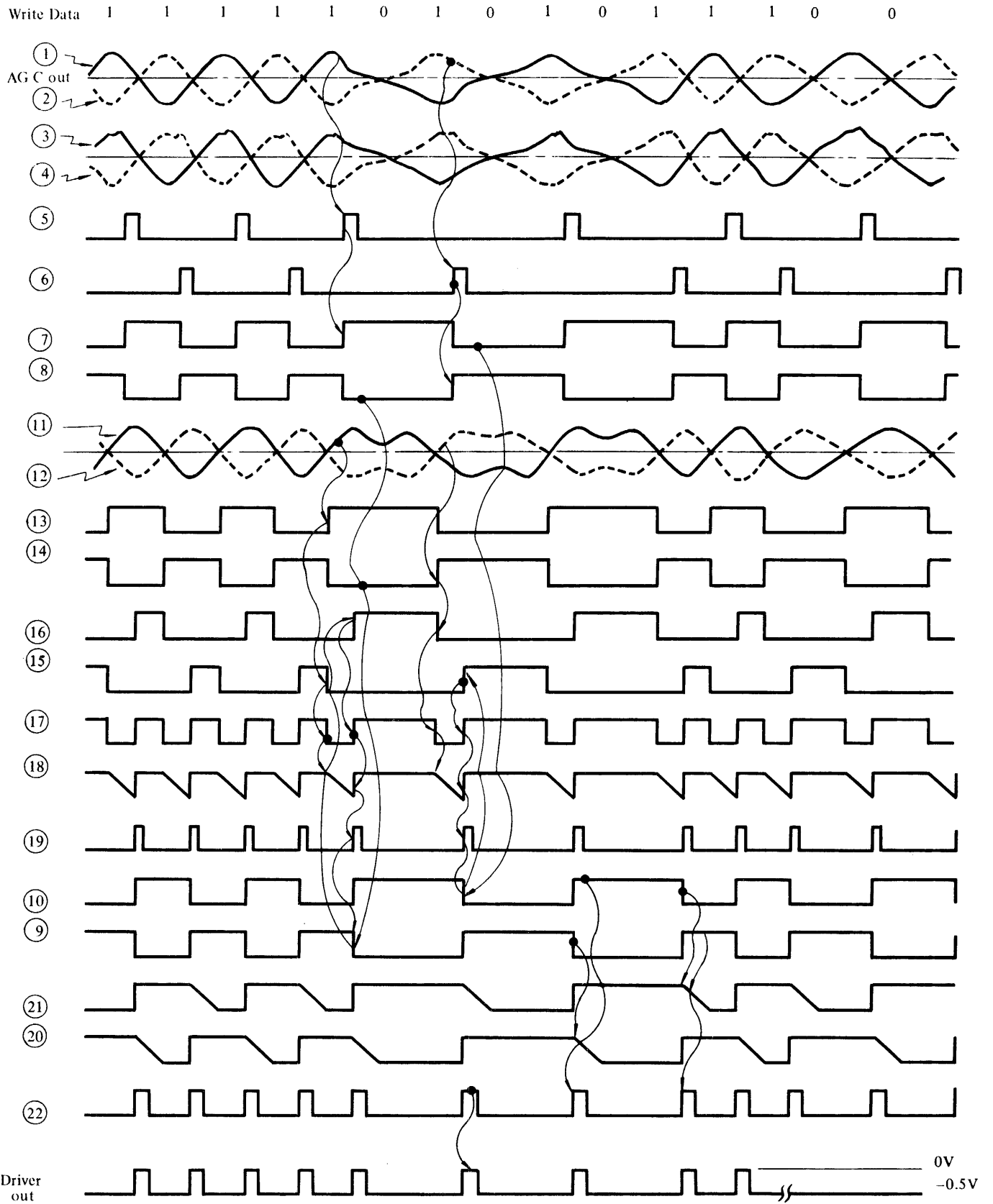

Fig. 10.2-6 Pulse Shaper Circuit Timing Chart



### 10.3 ERROR DETECTING CIRCUIT

The Read/Write circuit has the following error detecting circuits:

#### (1) Head Short Check

This circuit detects any abnormal current flowing in Write Select Line during Write operations. The block diagram is shown in Figure 10.3-1.

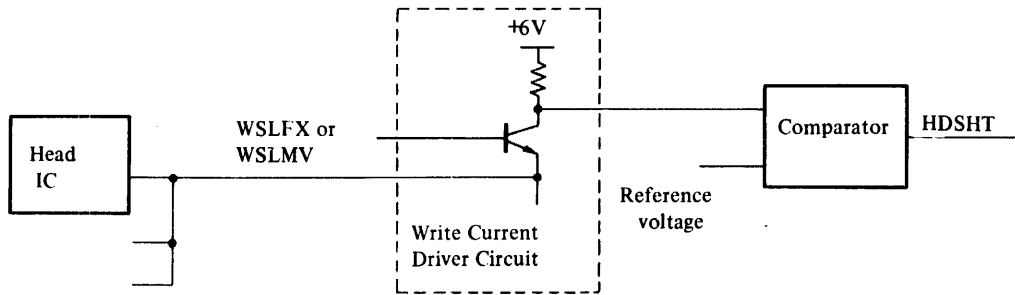

Fig. 10.3-1 Head Short Check Block Diagram

#### (2) Multi Head Check

This circuit detects that two or more head ICs have been selected. The block diagram is shown in Figure 10.3-2.

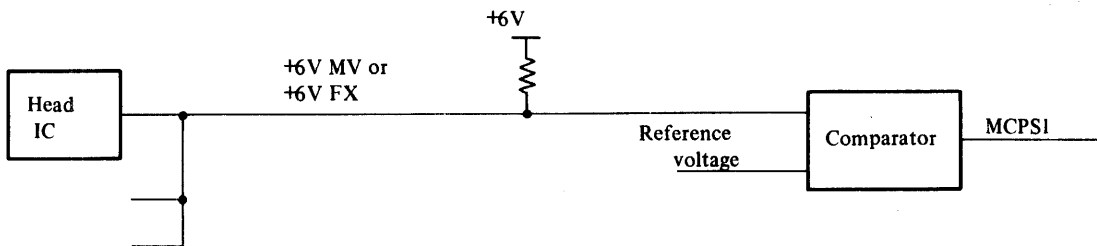

Fig. 10.3-2 Multi Head Check Block Diagram

(3) Delta I Write Check

This circuit checks for normal write-current supplied to the Head IC and Head. The write-current source contains three circuits; Main IW circuit, Delta IW1 circuit and Delta IW2 circuit.

If an even number movable head is selected, for example, Select I write (SLIW) and Gated I Write 1 (GDIW1) signals are enabled. Then Main IW circuit and Delta IW1 circuit are activated and supply about 25 mA of write-current.

But, in this case, if the Delta IW1 circuit is not active, the detector senses this and Delta I Write Check signal goes high.

The block diagram is shown in Figure 10.3-3.

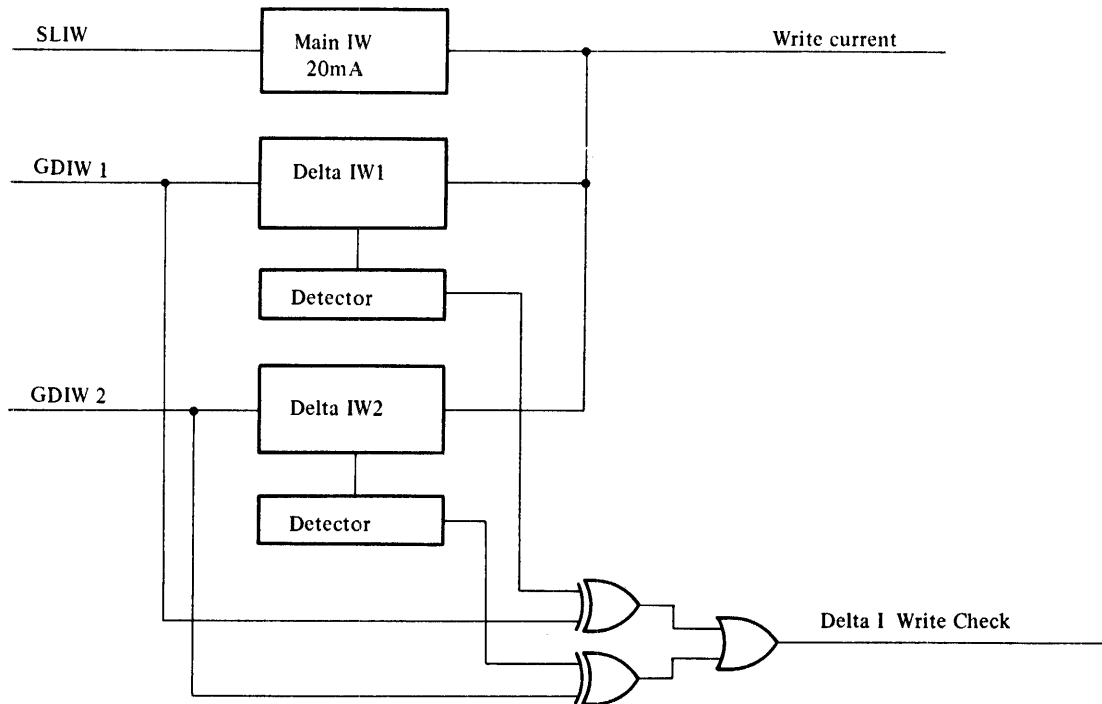

Fig. 10.3-3 Delta I Write Check Block Diagram

(4) Write Transition Check

During a write operation, the write-current in a data head coil flows in alternate directions according to the write data pulse train.

If this write-current transition is not performed, the Mars Unsafe Fixed Head or Movable Head (MUSFX, MUSMV) signal goes high and the FF will set the Write Transition Check signal to high about 12 bytes after the leading edge of the Write Gate.

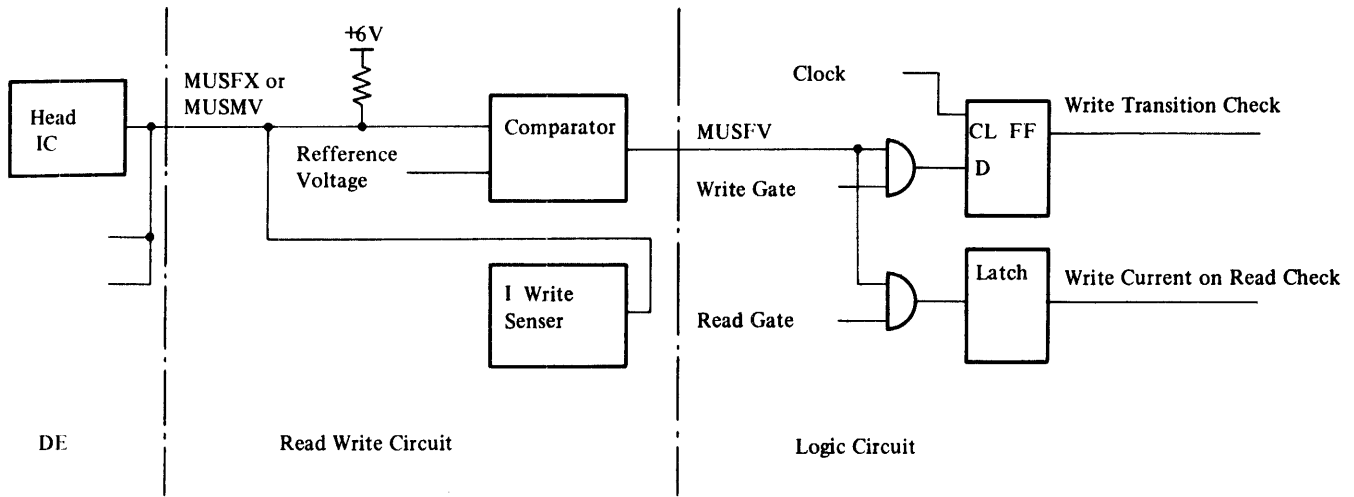

Fig. 10.3-4 Write Transition Check and Write Current on Read Check Block Diagram

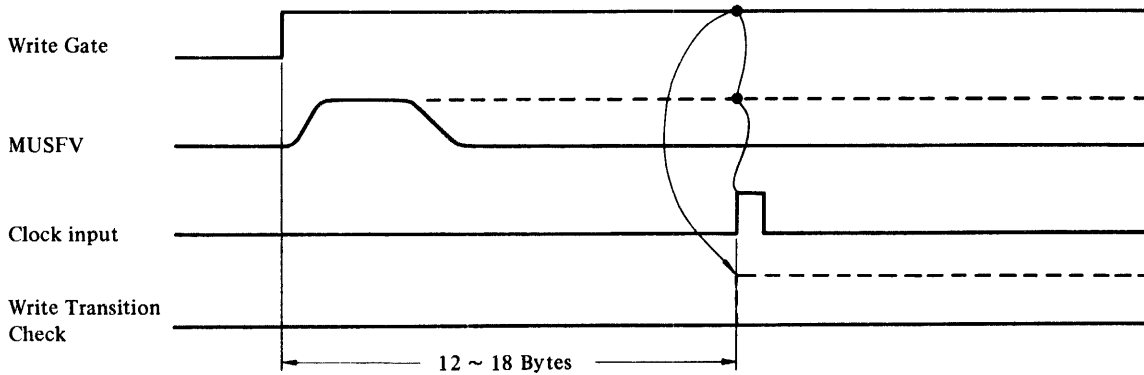

Fig. 10.3-5 Write Transition Check Timing Chart

The write transition check block diagram is shown in Figure 10.3-4 and timing chart in Figure 10.3-5.

(5) Write Current on Read Check

This circuit detects any write current during a not write operation. The block diagram is shown in Figure 10.3-4.

10.4 DE INTERFACE

The interfaces between the DE (Disk Enclosure) and the printed circuit board are shown in Table 10.4-1. The DE circuit block diagram is shown in Figure 10.1-2.

Table 10.4-1 DE Interface

Signal Name	Level		DE Connector	Pin No.
	Select	Non-Select		
*CHPS 0	0 ~ +0.4V	≅6V	CND	03
" 1	"	"	"	05
" 2	"	"	"	07
" 3	"	"	"	09
" 4	"	"	"	11
*HDSL 1	ECL Low	ECL High	"	36
" 2	"	"	"	38
HAR 4	"	"	"	17
" 8	"	"	"	15
" 16	"	"	"	13
*FHD 31	"	"	"	23
" 63	"	"	"	21
*FHFB	0V	Open	"	01
WTCRM	Special	Special	CNE	09
WTCRF	"	"	"	10
WSLMV	+3.5V 0.3V	0V 0.1V	CND	28
WSLFX	"	"	"	30
MUSFM	Special	Special	"	32
MUSFX	"	"	"	34
+6VMV	*	*	"	25
+6VFX	*	*	"	26
+5VFX	*	*	CNE	19
-4VDE	*	*	"	13,14,15
RWDTMV	Special	Special	"	06
*RWDTMV	"	"	"	05
RWDTFX	"	"	"	01
*RWDTFX	"	"	"	02

## Description of signals

### (1) \*CHIP SEL 0 ~ 4

CHIP SEL is the signal which selects one of the 5 movable head ICs. Two or more movable head ICs must not be selected simultaneously. Simultaneously selecting two or more movable head ICs causes Multi Head error.

### (2) \*HDSL 1 and 2

Each HEAD IC has 4 read/write channels. These signals are used to select one of the four heads connected to each channel.

### (3) \*HAR 4, 8, and 16

These signals are used to select a fixed head. These signals are used in conjunction with the \*FHD31 and \*FHD63 signals to generate the 15 Chip Select signals in the fixed head block.

### (4) \*FHD31 and 63

See the above.

### (5) \*FHFB

This signal is clamped to 0 V when the Fixed Head block is installed in the DE.

### (6) WTCRM, WTCRF

This is the line through which the write current is supplied to the head.

### (7) WSLMV, WSLFX

These signals are the write gate signals for the head IC and head center tap voltage.

### (8) MUSFM, MUSFX

These signals are used to detect the transient during write operations. These signals also detect the fact that Write current is flowing during read operations.

(9) +6VMV, +6VFX

These are the DC voltages to be supplied to the head IC. If no head IC is selected, there is no load current. If a head IC is selected, the load current for one head IC is constant. When the load current exceeds the specified value for one head IC, Multi Head Check occurs.

(10) (\*)RWDTMV, (\*)RWDTFX

The write data is sent to DE during a write operation, and the read data is sent from the DE during a read operation.

The VFO circuit consists of Switching Gate, Time-margin Measurement Monostable multivibrator (TMM), Reference Monostable multivibrator, Latch, Phase Comparator and Charge Pump, Low Pass Filter, Voltage Controlled Oscillator, MFM Demodulator, MFM Modulator and Write Compensator, as shown in Figure 11.1-1.

### 11.1 MFM MODULATOR AND WRITE COMPENSATION CIRCUIT

When the bit density (BPI) is high on a disk surface, and a read operation is performed, peak shift phenomenon appears. A bit span tends to widen the narrow part of the bit spacing because of mutual magnetic interference of the bits.

When such a phenomenon appears, reading of the data will deviate from the correct bit spacing, causing data errors. The write compensation circuit measures the peak shift direction and amount that will occur during the read operation, and generates pre-shifted write data in the opposite direction. Figure 11.1-2 shows the block diagram of the MFM Modulator and Write Compensation Circuit, and Figure 11.1-3 shows the timing chart.

The NRZ Write Data (WRDT) sent from the controller is clocked by the positive-going edge of the WTCL, and then the WTDT is synchronized with the internal VFO write clock by a Sync Decision Window circuit at the negative-going edge of the Write Gate Select (\*WGSL).

The NRZ write data, synchronized with the internal write clock, is applied to a four-bit shift register. Each output of the four-bit shift register is applied to a MFM Modulator and Write Compensation circuit, and then converted into a modified frequency modulated and pre-shifted data pulse train, according to the truth table as shown in Table 11.1-1.

The pre-shift timing of write compensation is defined by 2F Early 1 (2FE1), 2F Early 2 (2FE2), 2F On-time (2FOT) and 2F Late (2FLT) clock signals.



Tabl 11.1-1 MFM Modulator and Write Compensation Truth Table

Shift Register Status				MFM & Write Comp. Data							
				Data Bit				Clock Bit			
SR0	SR1	SR2	SR3	EY1	EY2	OT	LT	EY1	EY2	OT	LT
0	1	1	*	1	0	0	0	0	0	0	0
0	1	0	*	0	1	0	0	0	0	0	0
1	1	1	*	0	0	1	0	0	0	0	0
1	1	0	*	0	0	0	1	0	0	0	0
1	0	0	0	0	0	0	0	1	0	0	0
1	0	0	1	0	0	0	0	0	1	0	0
0	0	0	0	0	0	0	0	0	0	1	0
0	0	0	1	0	0	0	0	0	0	0	1

\* = Don't Care

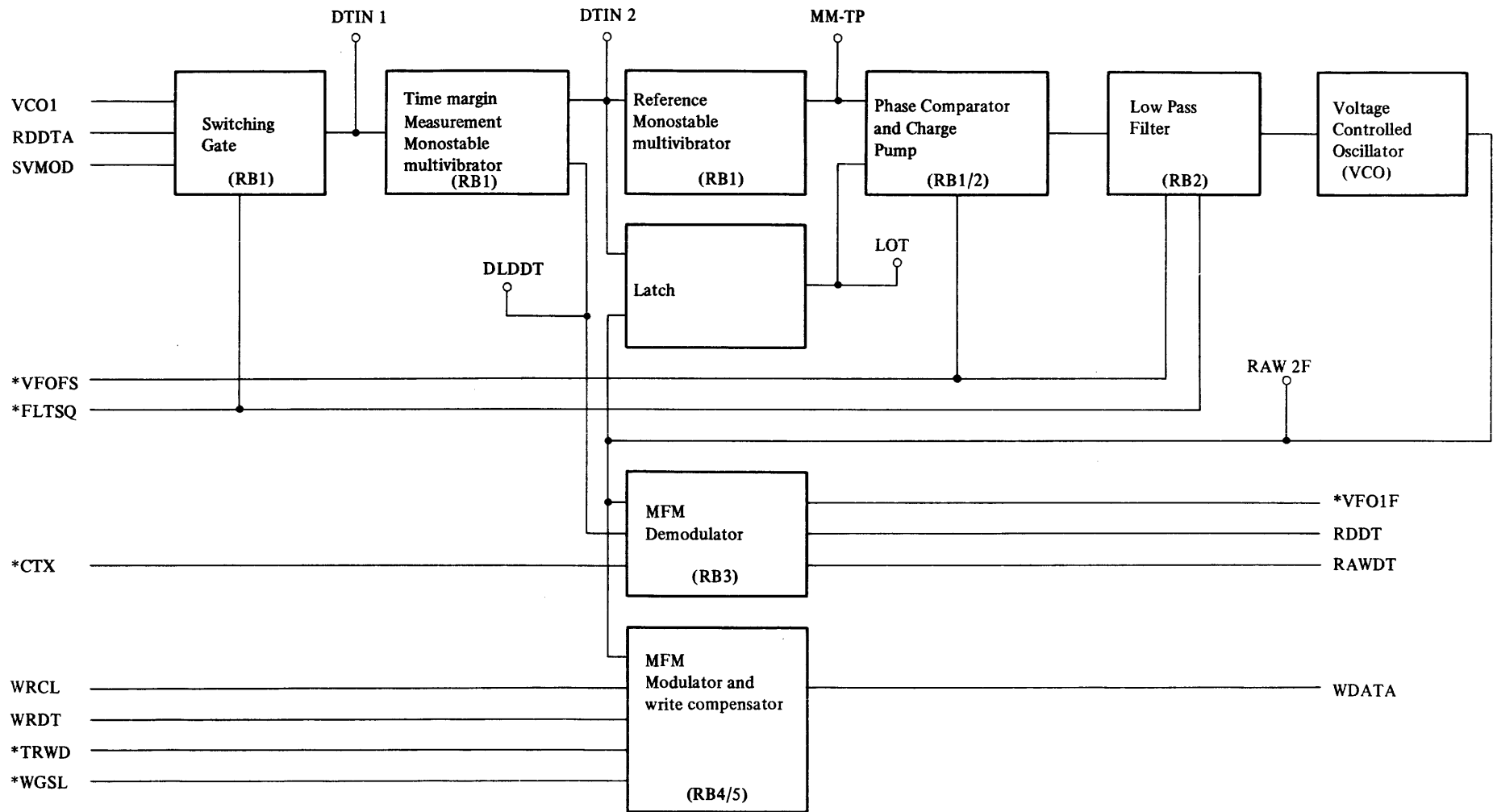

Fig. 11.1-1 VFO Block Diagram

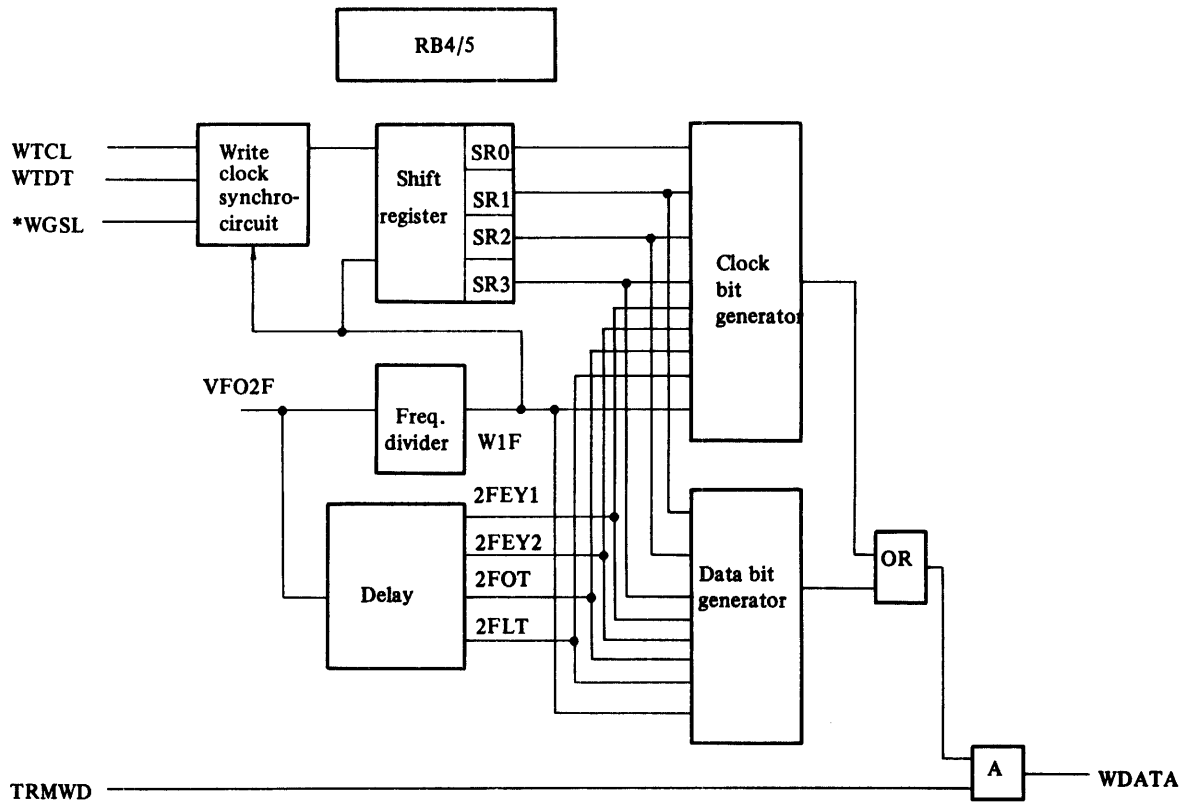

Fig. 11.1-2 MFM Modulator and Write Compensator Block Diagram

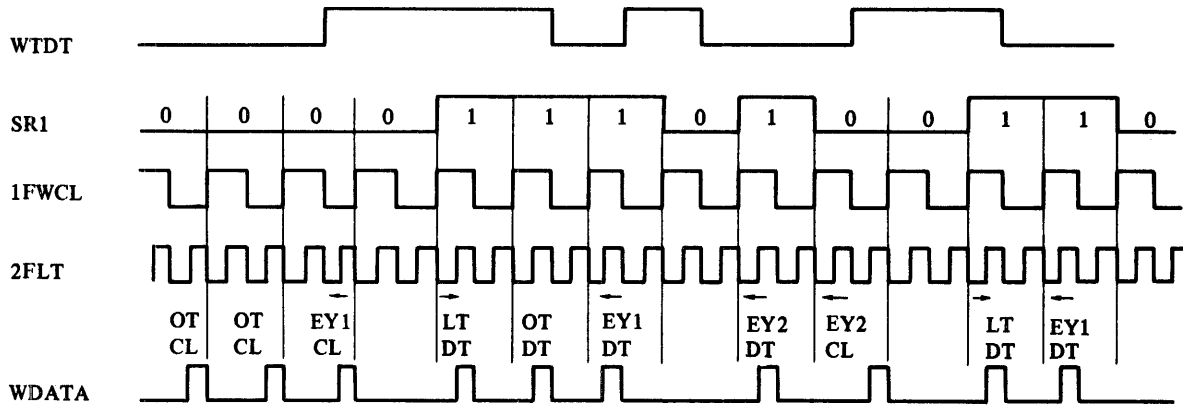

Fig. 11.1-3 MFM Modulator and Write Compensator Timing Chart

## 11.2 VFO AND MFM DEMODULATOR CIRCUIT

The Variable Frequency Oscillator (VFO) circuit synchronizes with a VCO1 signal from the servo track during a Not-Read operation, and with the Raw Data (RDDTA) signal from the data track during a Read operation. The block diagram of the VFO circuit is shown in Figure 11.1-1.

### (1) Switching Gate

The Switching Gate controls the VFO input. During an initial seek operation or a RTZ operation, this circuit inhibits an input data into the VFO circuit by enabling the Filter Squelch (\*FLTSQ).

This causes the VCO to oscillate at the free-running frequency. During a Not-Read operation, the VCO1 is applied to the VFO circuit by enabling the Servo Mode (SVMOD).

During a Read operation, the RDDTA is applied by disabling the SVMOD. The Switching Gate output, Data Input 1 (DTIN1), is applied to the Time-margin Measurement Monostable multivibrator (TMM) circuit.

### (2) Time-margin Measurement Monostable multivibrator (TMM)

The TMM circuit issues a Data Input 2 (DTIN2) to the Phase Comparator and the Latch, and it also issues a Delayed Data (DLDDT) to the MFM Demodulator. The timing relation between DTIN2 and DLDDT is adjusted by potentiometer RV6 and it determines the time-margin of read data.

### (3) Reference Monostable multivibrator

The positive-going edge of the DTIN2 triggers the Reference Monostable multivibrator, which issues 14 nsec Reference Pulse to the Phase Comparator and Charge Pump.

### (4) Latch

The positive going edge of the DTIN2 sets the Latch and the negative going edge of the RAW2F reset it.

The Latch issues Latch Output (LOT) to the Phase Comparator and Charge Dump circuit.

(5) Phase Comparator and Charge Pump

The Phase Comparator and Charge Pump circuit issues Decrease Frequency (DECFR) when the VFO input signal is leading, and an Increase Frequency (INCFR) when the VFO input signal is late, comparing the phase between DTIN2 and RAW2F.

The Charge Pump circuit, a constant-current driver, charges or discharges the capacitor in the Low Pass Filter circuit by INCFR or DECFR.

(6) Low Pass Filter

The Charge Pump output signal is applied to Low Pass Filter circuit which attenuate a high-frequency noise.

During an initial seek operation or a RTZ operation, the FLTSQ clamps the Charge Pump output to 0V to recalibrate the VFO function. During an initial data read operation, the VFO Fast Synchronization (\*VFOFS) is issued to the VFO circuit.

This increases the loop gain of the VFO circuit to widen the pull-in range and shorten the pull-in time for synchronization with input data.

The output of the Low Pass Filter is the control voltage signal (VCX).

(7) Voltage Controlled Oscillator (VCO)

The VCO circuit is controlled by the VCX.

The VCO output signal (RAW2F) frequency increases when the VCX goes high, and decreases when the VCX goes low.

(8) MFM Demodulator

The MFM Demodulator circuit generates NRZ Read Data (RDDT) and VFO1F Clock (VFO1F) from MFM Read Data.

The MFM Demodulator circuit is controlled by RAW2F, Delayed Data (DLDDT) and Count X (\*CTX) during the read operation.

### 11.3 PRINCIPLE OF SYNCHRONIZATION AND DEMODULATION

MFM Demodulator circuit block diagram is shown in Figure 11.3-1 and timing chart is shown in Figure 11.3-2. During a read operation, the RDDTA is applied to the VFO circuit by disabling the SVMOD signal.

The TMM circuit generates two output signals, the DTIN2 and the DLDDT, by triggering two monostable multivibrators at the positive going edge of the RDDTA.

The positive-going edge of the DTIN2 triggers the Reference Monostable multivibrator. The Reference Monostable multivibrator output signal (MM-TP) has a pulse width about 14 nsec, and the VFO circuit operates to synchronize the negative-going edge of the MM-TP with the positive going-edge of the RAW2F.

The 2F Main Clock (\*2FMCL) is derived from the RAW2F delayed by a delay line. The delay line supplies 2F Early 1, 2F Early 2, 2F On time and 2F Late clock signals which are used in the MFM Modulator and Write Compensation circuit.

The positive-going edge of the \*2FMCL clocks two Flip-Flops (FF1 and FF2). The FF1 and FF2 circuits divide the frequency of the \*RAW2F in two, and then the divided signals are used for the Pre-data Window (PRWD) and Data Window (DTWD).

The DLDDT can trigger FF3 to generate Separated Data (SPD) if the DTWD keeps high when the DLDDT goes high.

The FF3 is reset by Reset Pulse A (RSPA) when CTX is in active and is reset by Reset Pulse B (RSPB) when CTX is active.

The CTX can be activated only in a Gap and the SPD in a Gap must be read only logical zero, but if FF3 generates logical one signal as SPD during CTX is high, the RSPB is issued from AND Gate and force to change the phase of PRWD and DTWD 180 degrees. This causes the SPD to read all zeros.

The DTWD clocks the FF5 circuit relative to the PRRD and generates NRZ Read Data (RDDTA) synchronized with the VFO1F clock. The FF5 output signal (RDDT) is held reset until Read Data Gate (\*RDDGT) goes low.

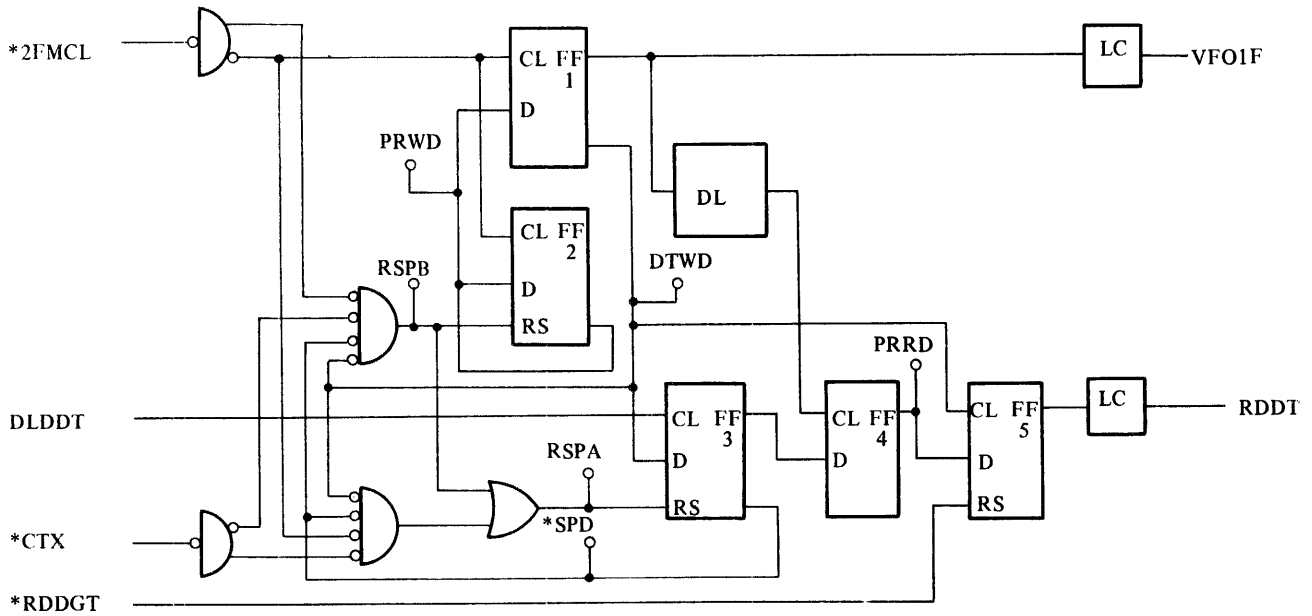

Fig. 11.3-1 MFM Demodulator Circuit Block Diagram

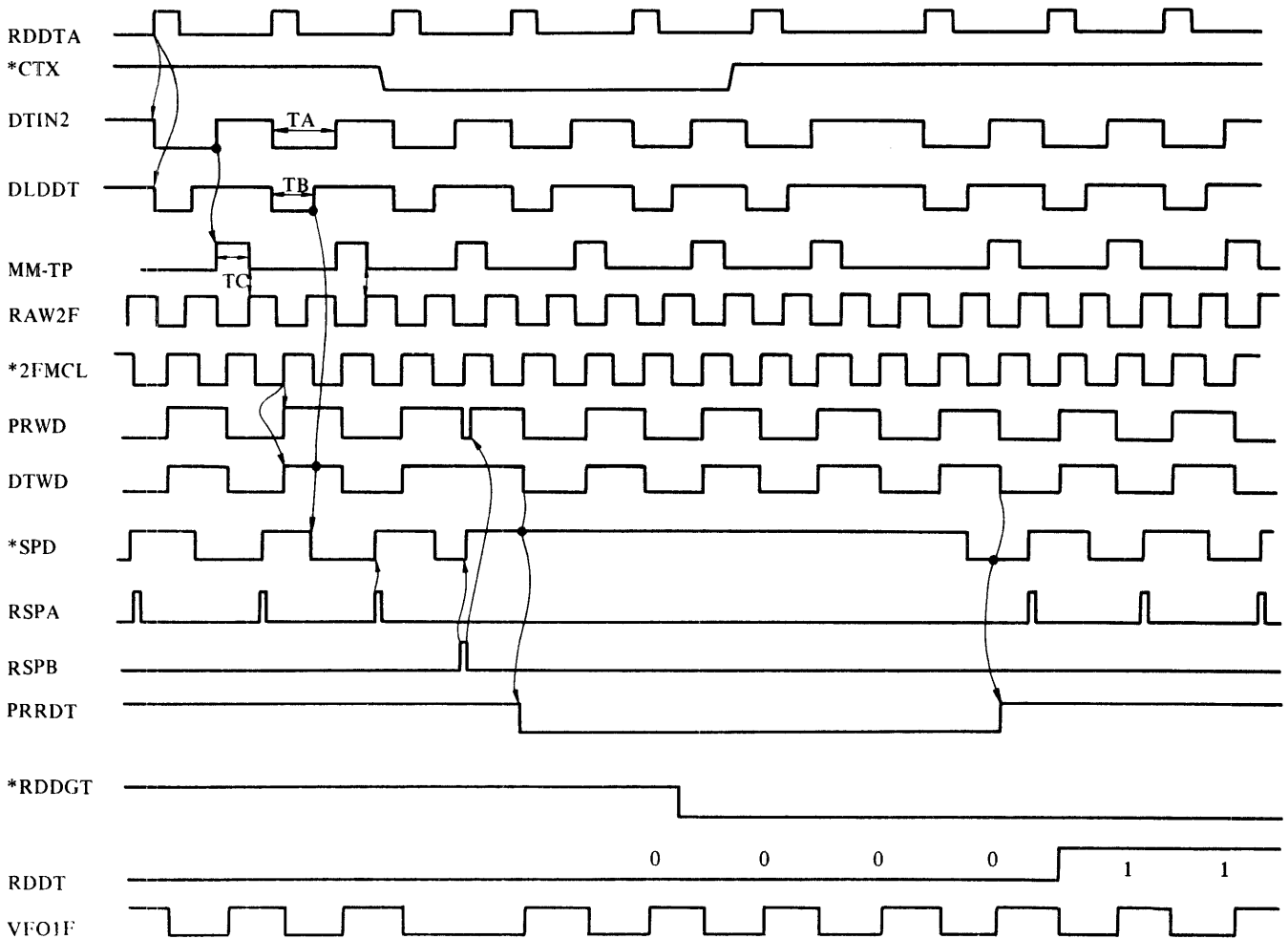

Fig. 11.3-2 MFM Demodulator Circuit Timing Chart

## 11.4 VFO CONTROL

### (1) Initial VFO Control

The VFO control circuit controls the input of the VFO circuit.

In a start up sequence, the initial seek completion sets a Servo Latch (SRVL), and then sets the Filter Squelch (\*FLTSQ) to enable the synchronization of the VFO circuit.

The leading edge of the SRVL triggers the initial VFO fast sync circuit, which issues 15-byte pulse of the \*VFOFS followed by a 1-byte pulse of the \*CTX.

The negative-going edge of \*VFOFS sets the Servo Mode Latch (SVMOD), which is applied to the VFO circuit, selecting the VCO1 as the VFO input data.

The timing chart of an initial VFO control is shown in Figure 11.4-1.

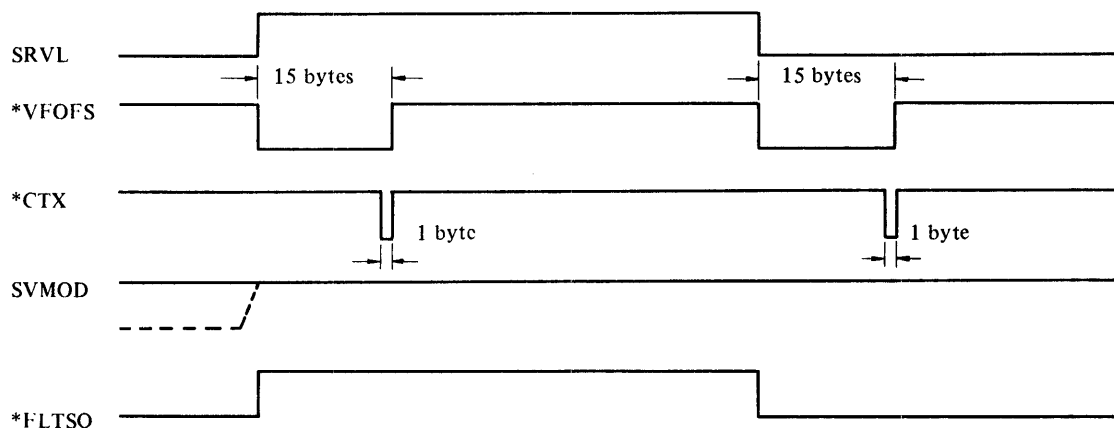

Fig. 11.4-1 Initial VFO Control Timing Chart

### (2) VFO Control in Fixed Sector Format

When executing a Read/Write operation, the VFO control circuit generates \*VFOFS, SVMOD and \*CTX signals triggered by negative and positive-going edges of the Read Gate Control signal (RGC).

The positive-going edge of RGC clocks the VFO control counter circuit to issue a 6-byte pulse of the \*VFOFS 7 bytes after the negative going edge of the RGC.

The negative going edge of the \*VFOFS sets the SVMOD. The RGC must be held low at least 1 byte or more in a read operation.



The VFO control in Fixed Sector Format timing chart is shown in Figure 11.4-2.

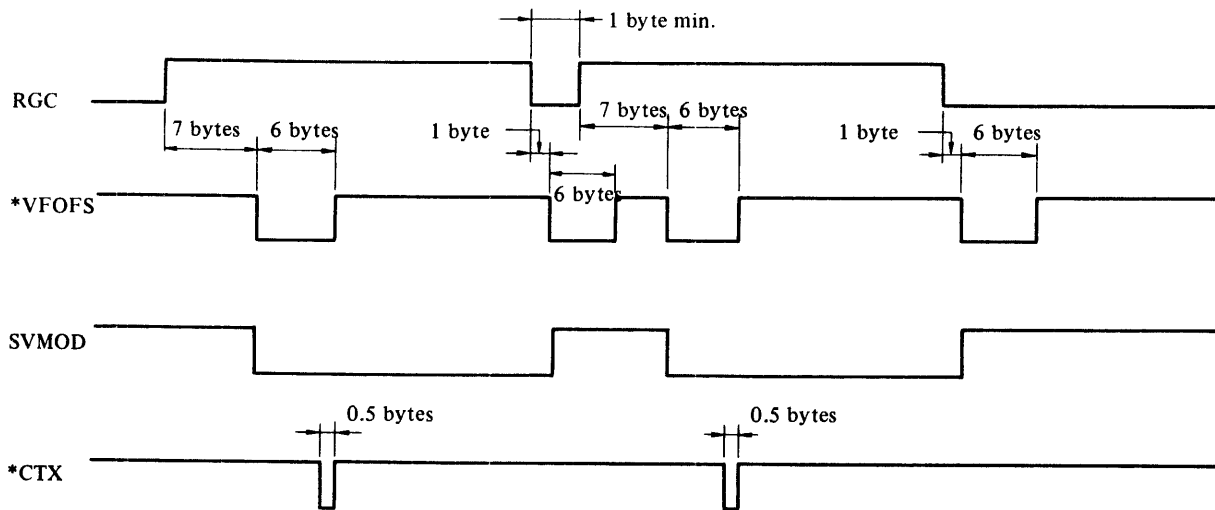

Fig. 11.4-2 VFO Control in Fixed Sector Format Timing Chart

(3) VFO Control in Variable Sector Format

In Variable Sector Format, the controller issues AM Search to the drive. The drive circuit searches for an AM and, when found, issues AM Found (AMFD) with an 8-byte pulse to the controller.

The leading edge of the AMFD triggers the VFO control counter circuit to issue a 6-byte pulse of the \*VFOFS 7 bytes after the leading edge of the AMFD.

The remaining operation of the VFO control circuit is the same as that of the Fixed Sector Format.

The VFO control in Variable Sector Format timing chart is shown in Figure 11.4-3.

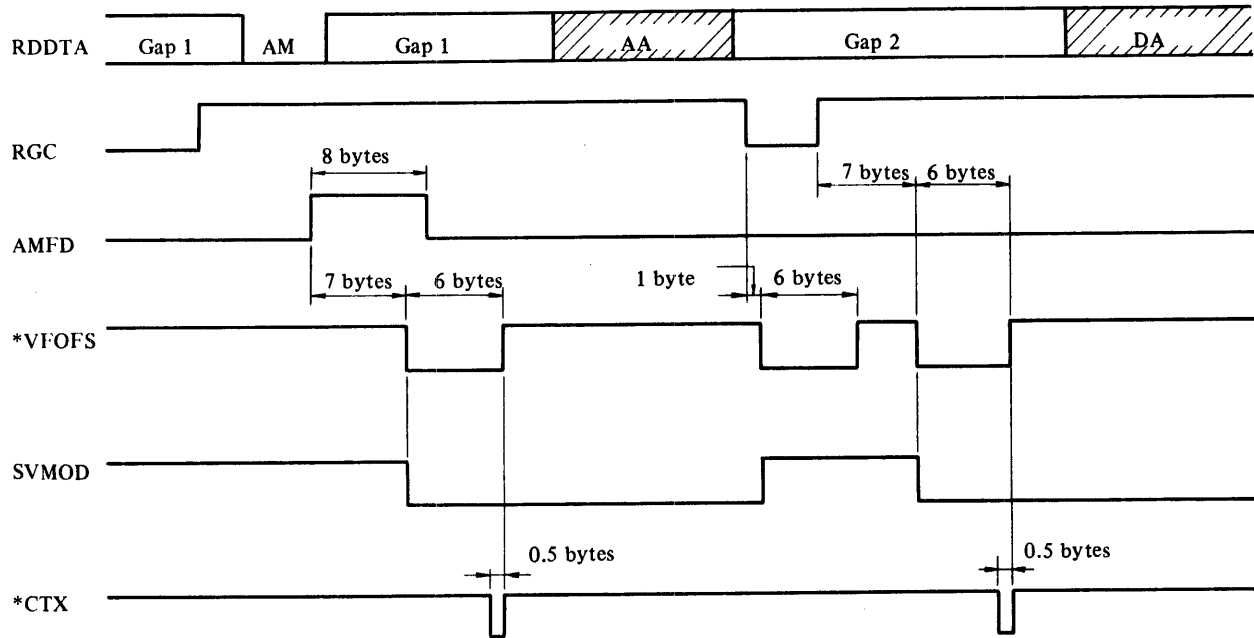

Fig. 11.4-3 VFO Control in Variable Sector Format Timing Chart



## CHAPTER 12 DC POWER SUPPLY UNIT

The DC Power Supply Unit receives input from a Single Phase AC power source and provides all voltages necessary for drive operation.

Reconfiguration for different input voltages is accomplished by changing the connections of the terminals located on the control panel of the unit. (Refer to Figure 2.2-1). The unit accepts 50Hz or 60Hz input frequency.

The power supply utilizes a multi-purpose 3 pole circuit breaker as the Main Line Switch. Two poles of this switch are used conventionally for primary power interrupt. One of these poles provides a contact closure for remote sensing of a tripped breaker. (TRM2 taps 4 and 5) The third pole is used for over-current protections of the 48 VDC supplied to the spindle and voice coil motors. It also has a trip coil which is used in the DC over-current/voltage and over-heat detection circuits noted in Table 12.3-1.

A sequence control circuit is incorporated. It remotely controls the start/stop operations of the spindle motor with the Pick and Hold signals in the interface cable.

The DC Power Supply Unit does not have a fan for cooling. It is cooled by the airflow from the line blower which cools the entire drive. When the Main Line Switch is turned on, AC power is supplied to this line blower.

## 12.1 INPUT REQUIREMENT

Input requirements of the DC power supply are those listed for the drive itself.  
(Refer to Table 1.5-1)

The drive is shipped with a power supply cable installed. Strain relief is provided by a cable clamp on the power supply control panel. Refer to Section 1.6.

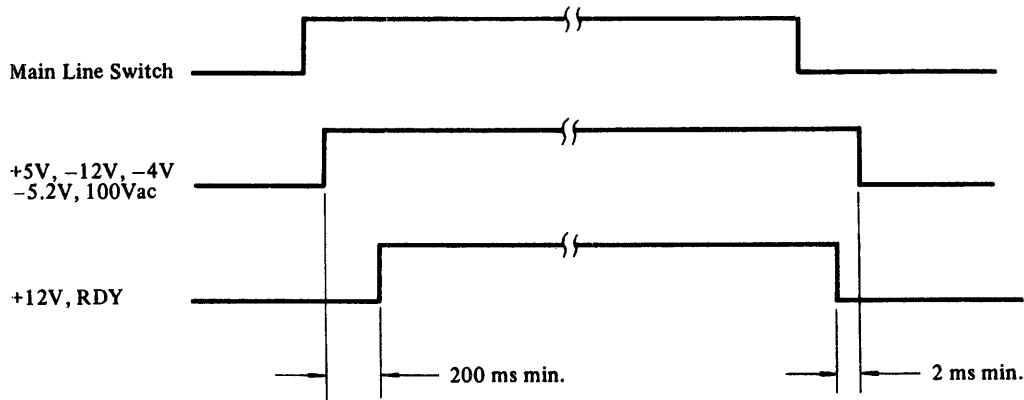

Figure 12.2-1 Output Sequence

## 12.2 OUTPUT CONDITIONS

Output conditions will be found in Table 12.2-1.

Table 12.2-1 Output Conditions

Voltage		Protection		Current	Variable Range (%)	Usage
Vdc	Tolerance %	Over-Voltage	Over-Current	Adc		
+5	±4	With	With	4 ~ 5	±5	PCBs
+12	±4	Without	With	0.3 ~ 1.0	±5	
-12	±4	Without	With	0.3 ~ 0.5	±5	
-4	±4	Without	With	0.2 ~ 1.3	±5	
-5.2	±4	Without	With	3.0 ~ 6.0	±5	
+48	+20 -11	Without	With	3.3 ~ 5.3 (Peak; 9.6)		Rotary Actuator Spindle Motor
(100Vac)	+13 -15	Without	Without	(0.8 Aac)		Line Blower

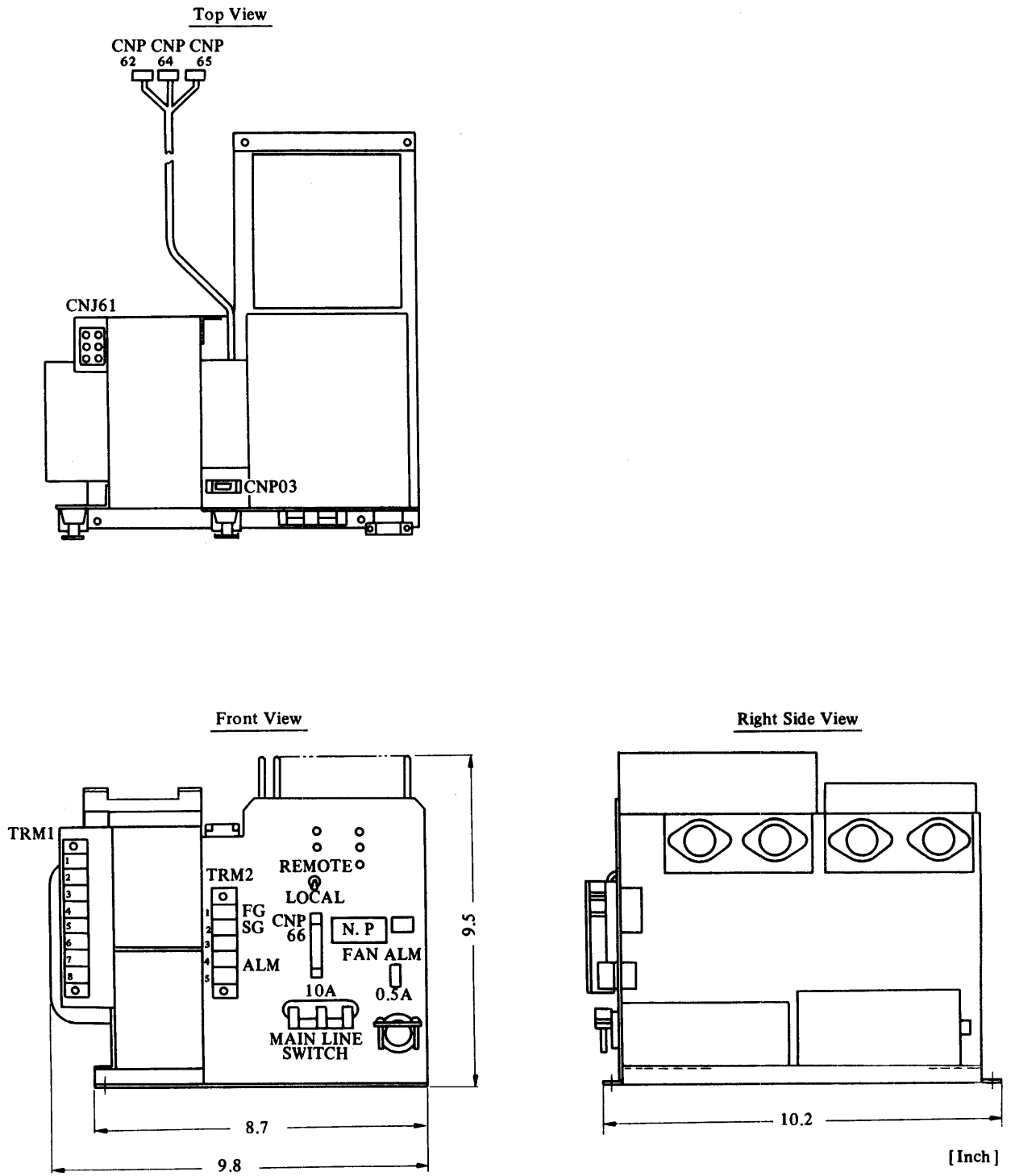

Figure 12.1-1 DC Power Supply Unit

### 12.3 ALARMS

The causes of various alarms and the indications when they occur are listed in Table 12.3-1.

Table 12.3-1 Alarm Indications

Alarm	Cause	Indication		(Note)
		Main Line Sw.	Fan Alm Fuse	
Power Alarm	Over-current of AC input	Tripped	X	
	Over-current/voltage of DC output			
	Overheat of transformer (139°C)			A thermal fuse embedded in the transformer blows out.
	Overheat of heat-sink (90°C)			
Fan Alarm	Stoppage of line blower		Blown	

## 12.4 CONTROL OF SPINDLE MOTOR

The start/stop operations of the spindle motor are under control of sequence circuit in DC power supply unit. It is described in Figure 12.4-1 and 12.4-2.

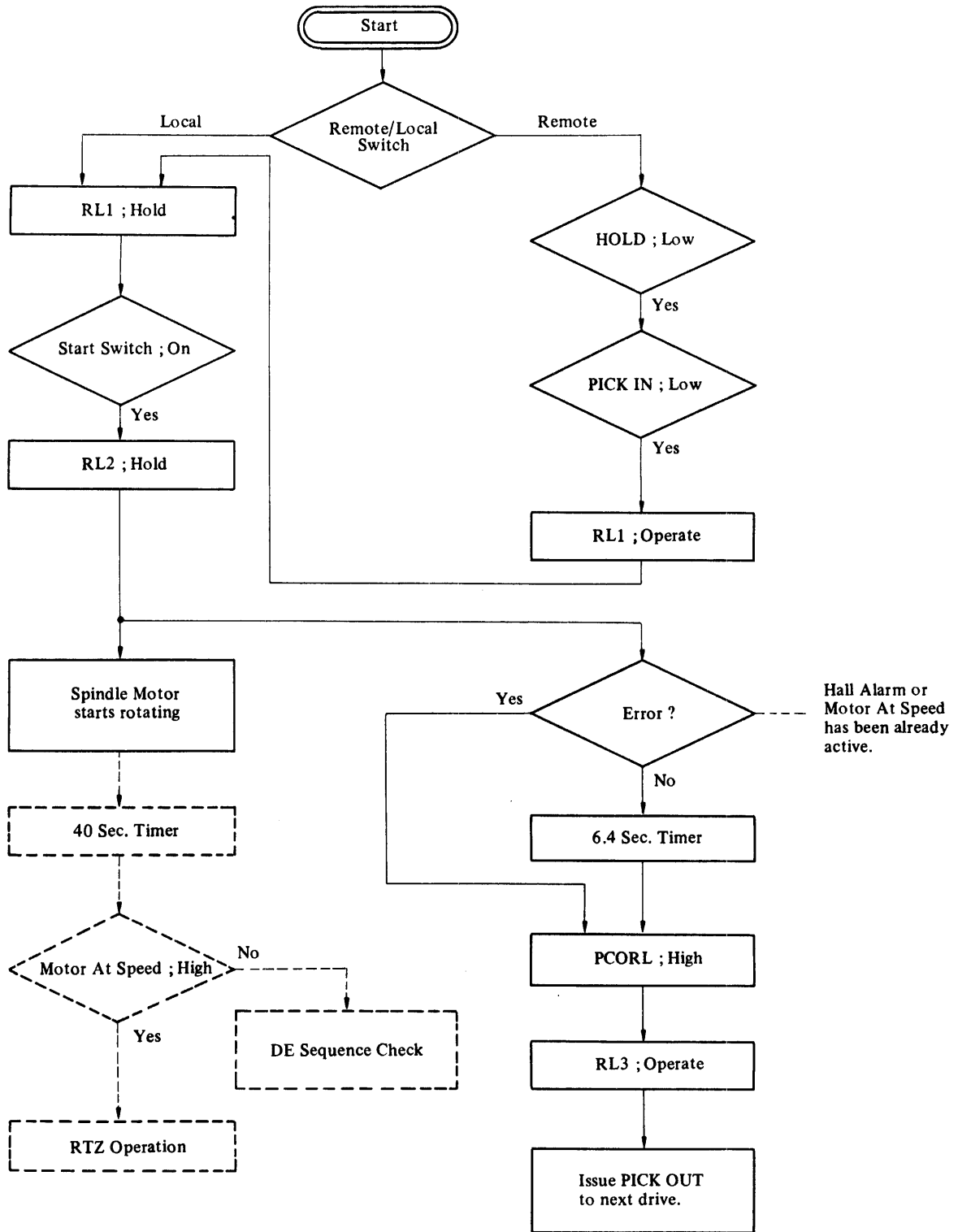

Figure 12.4-1 Flow Chart of Spindle Motor Control



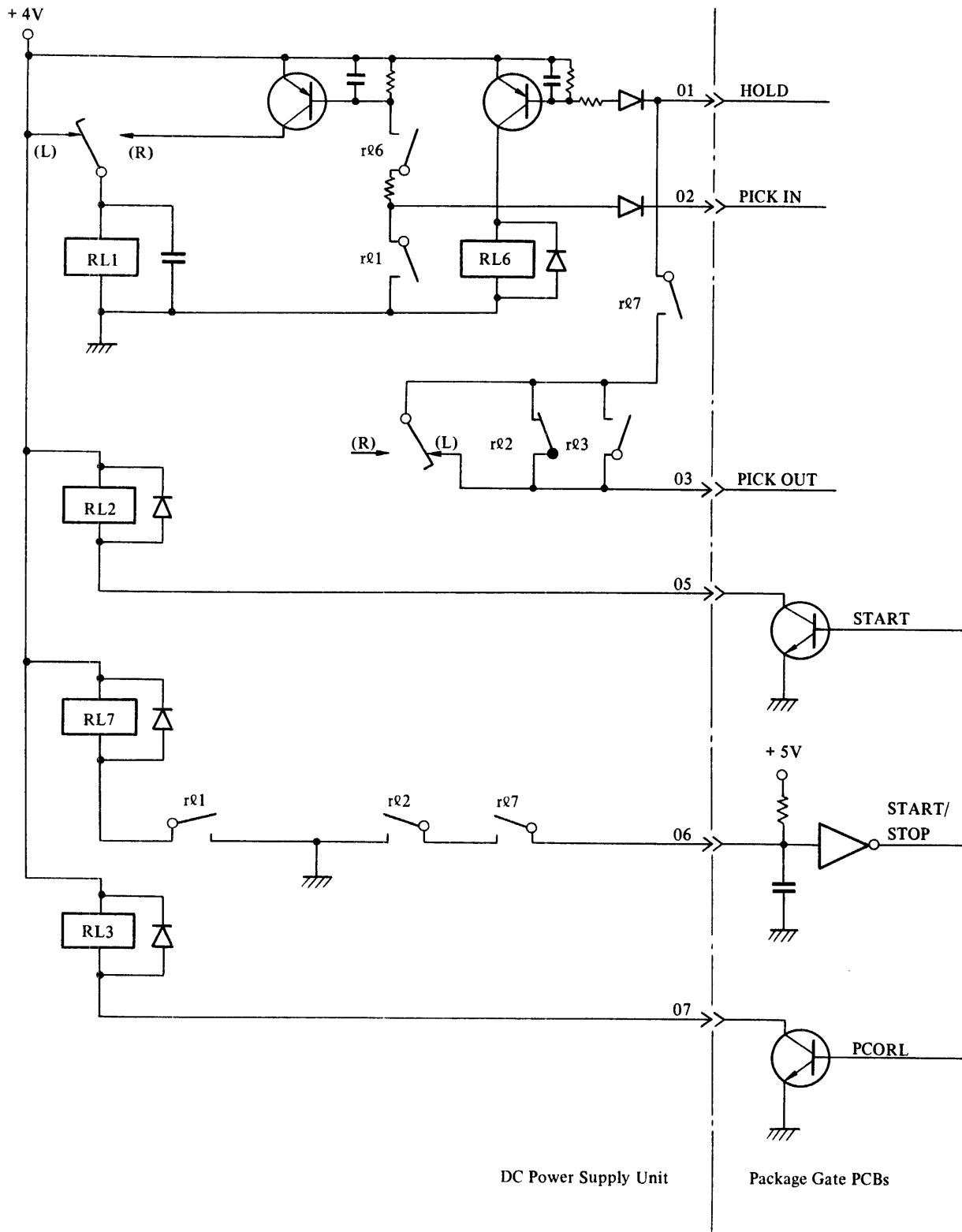

Figure 12.4-2 Spindle Motor Control Circuit

A functional block diagram will be found in Figure 12.5-1.

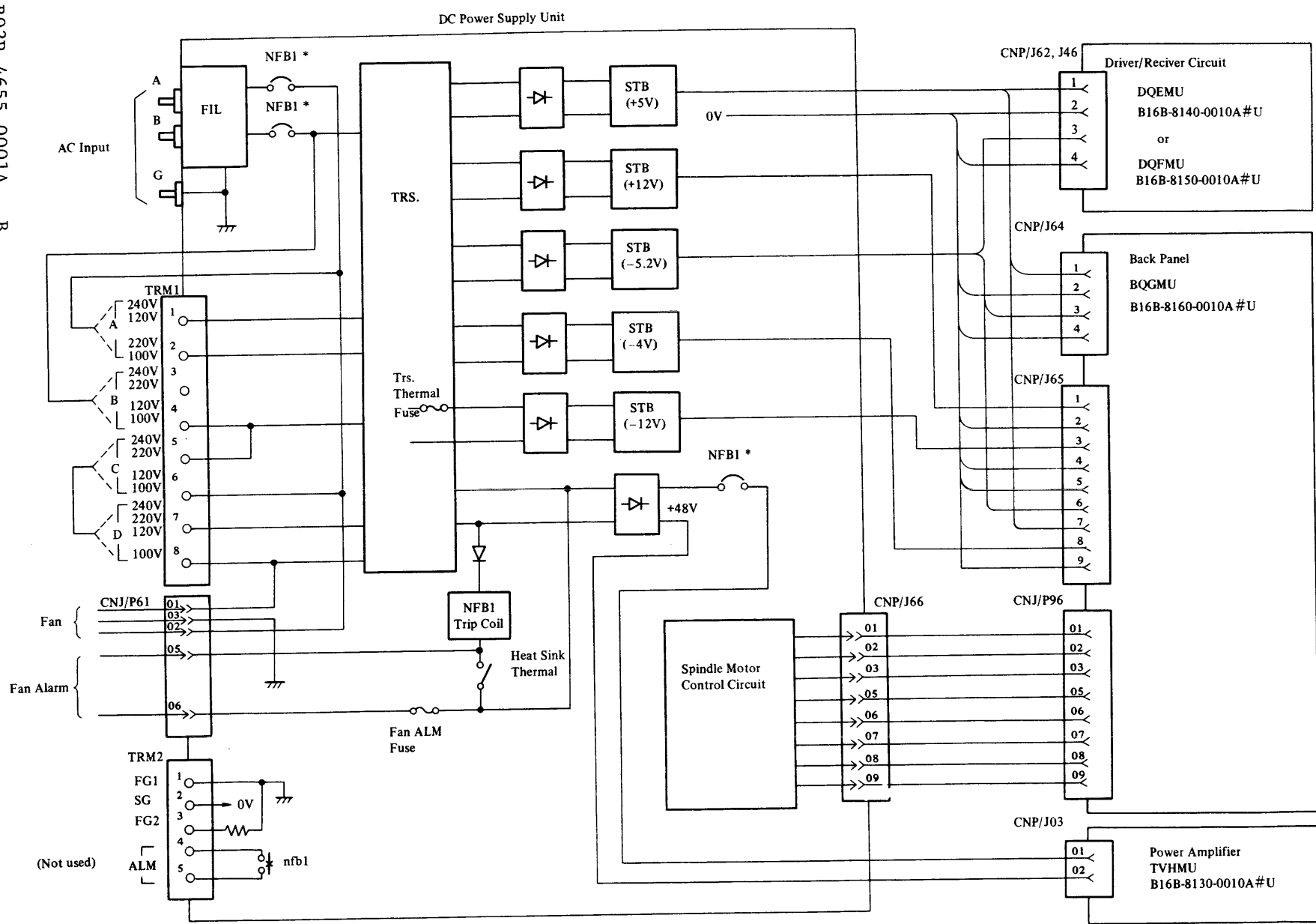

Figure 12.5-1 Functional Block Diagram of the DC Power Supply Unit



## CHAPTER 13 MAINTENANCE AND PARTS REPLACEMENT

This chapter covers the maintenance of the drive, namely, general precautions and replacement procedures (including options).

### 13.1 GENERAL PRECAUTIONS

#### (1) Power ON/OFF

- Check the operating condition of the drive before turning the power on or off.
- Before turning the power on after the maintenance has been finished, check that all parts are properly Re-assembled.

#### (2) Removing/Installing connectors

- Always turn the power off before removing or inserting connectors.
- Verify all connectors are inserted correctly.

#### (3) Replacement

- Use screwdrivers, wrenches and other tools suitable for the screws and bolts to be installed or removed.
- Do not leave removed screws in the drive.
- Tighten all screws with proper torque.

#### (4) Others

- Use test equipment which is calibrated correctly.
- Always record the trouble-shooting data for later reference.

#### (5) Replacement of Mechanical Parts

Prior to the replacement of mechanical parts, fully extend the drive and remove the cover. The cover is held by 4 screws. Always lock the rotary actuator when replacing mechanical parts.

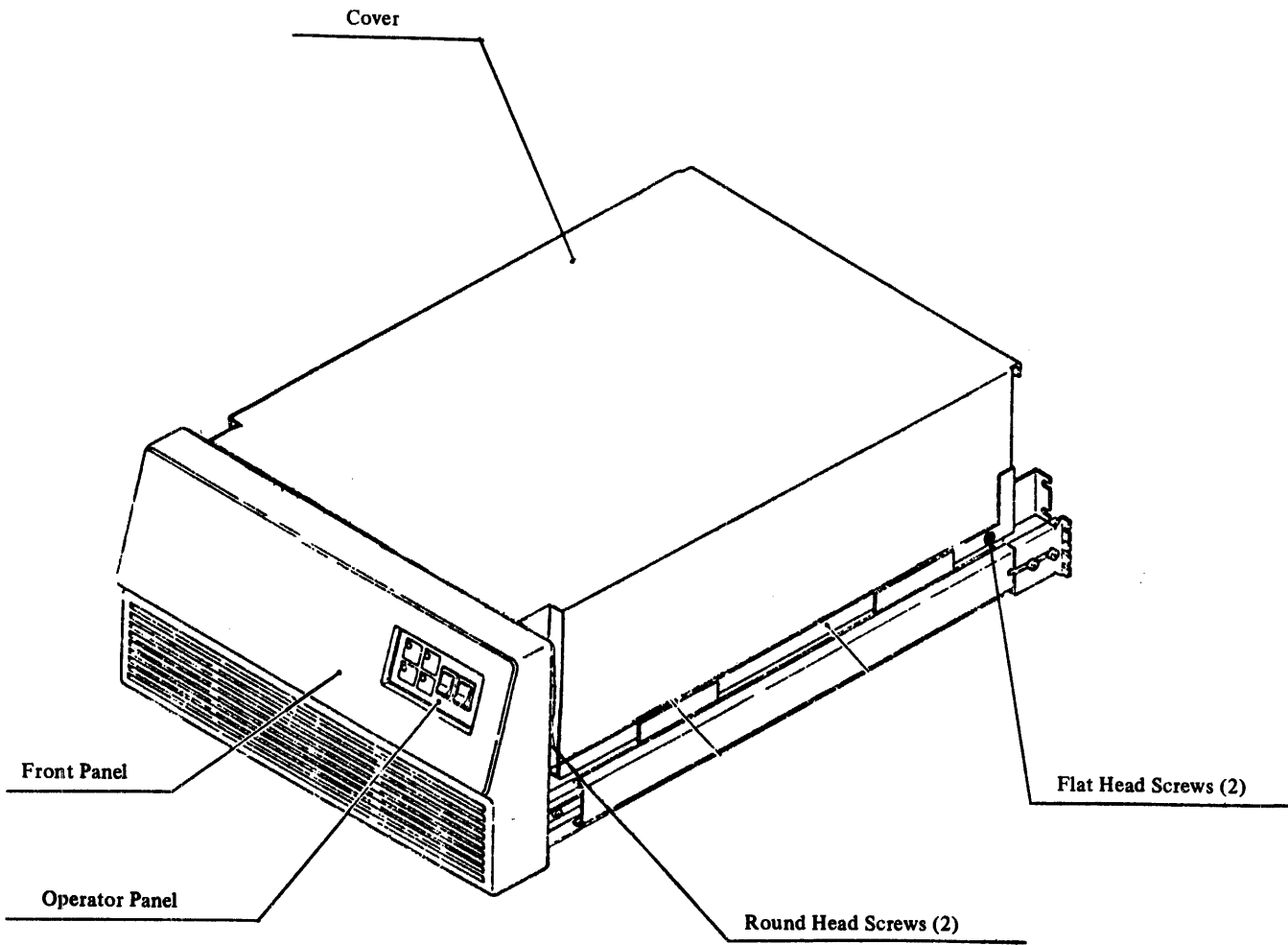

(a) Early version

Figure 13.1-1 Exterior View of M2351 DKU

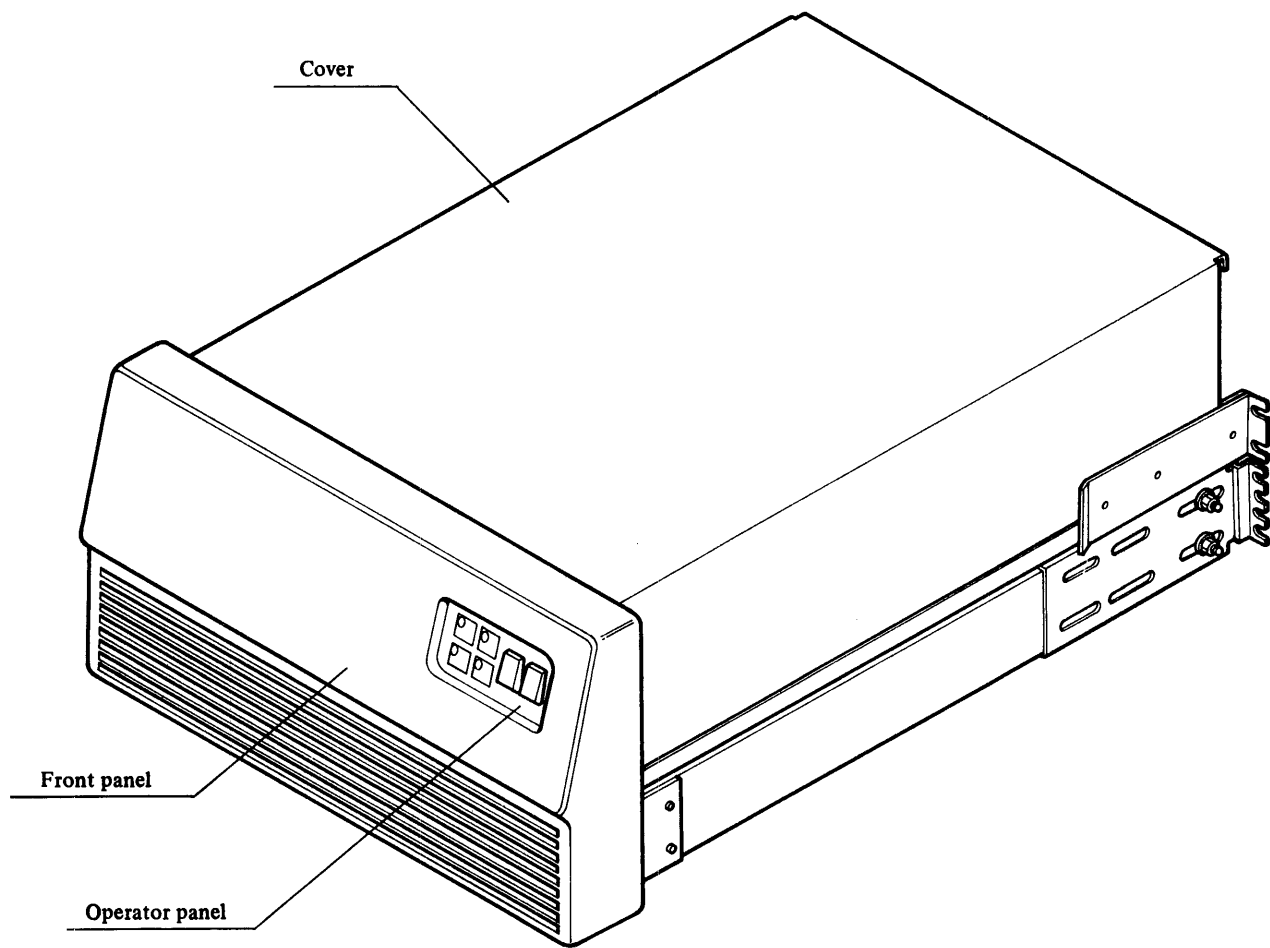

(b) Current version

Figure 13.1-1 - Continued

## 13.2 DE REPLACEMENT

### 13.2.1 DE replacement of old version

#### (1) REMOVAL

1. Lock the rotary actuator. (Refer to 2.3)
2. Remove the Plastic Cover.
3. Disconnect CNJ01, CNJ02, CNJ03, CNP504 and CNP505 from the TVHMU PCB.
4. Remove the 6 screws (Refer to Figure 13.2-1 ~~A~~) holding the TVHMU PCB and remove the entire TVHMU PCB.
5. Remove the 4 screws (Refer to Figure 13.2-1 ~~A~~) holding the TVHMU mounting bracket.
6. If it's a single port drive, remove CNP44 and CNP45 cables to clear the DE area.
7. If the Dual Channel option is installed, remove CNJ56, CNJ62, CNP54, CNP55, CNP57 and CNP59 from DQFMU PCB. (Refer to 13.8-(2))
8. Remove the DQFMU PCB by removing 4 screws and locate cables so as to clear the DE area. (Refer to 13.8-(2))
9. Remove CNJ506 and CNJ508 from the side of the DE.
10. Remove the three hexagon socket-head bolts (Refer to Figure 13.2-1,\*) from the shock mounts.
11. Carefully lift the DE from the drive. Three cables will come out with the DE. Use care because the DE weighs approximately 58 lb, (25kg).

#### (2) INSTALLATION

1. To install a DE, be sure the three cables (CNJ502, CNJ504 and CNJ505) are attached/connected and held to the sides of the DE.
2. Gently Lower the DE on the shock mounts, taking care to watch the area all around the DE so cables aren't pinched.
3. Follow, in reverse order, the instructions for removal.

Note: The three hexagon socket-head bolts must be tighten at the torque of about 120 kg.cm.

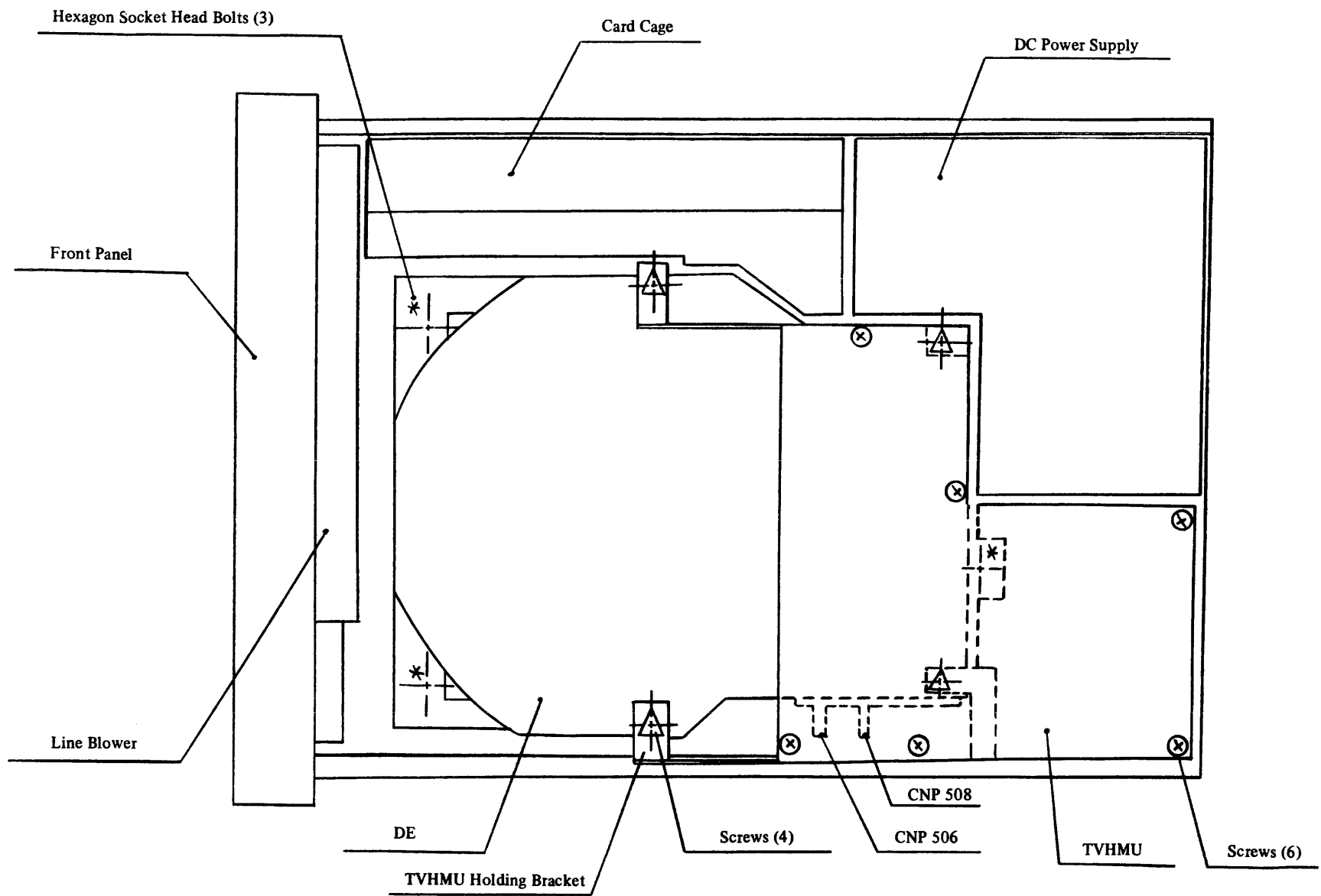

Figure 13.2-1 DE Replacement (Top View) . . . . Early version



### 13.2.2 DE replacement of New version

#### (1) REMOVAL

1. Lock the rotary actuator. (Refer to 2.3)
2. Remove the cover by removing two screws.
3. Disconnect CNJ02, CNP504 and CNP505 from the TVKMU PCB.
4. Remove the screw (Refer to Figure 13.2-1) and the wire.
5. If it's a single port drive, remove CNP45 cable to clear the DE area.
6. If the Dual Channel option is installed, remove CNJ56, CNJ62, CNP54, CNP55, CNP57 and CNP59 from DQFMU PCB. (Refer to 13.8-(2))
7. Remove the DQFMU PCB by removing 4 screws and locate cables so as to clear the DE area. (Refer to 13.8-(2))
8. Remove CNJ506 and CNJ508 from the side of the DE.
9. Remove the three hexagon socket-head bolts (Refer to Figure 13.2-1, \*) from the shock mounts.
10. Carefully lift the DE from the drive. Three cables will come out with the DE. Use care because the DE weighs approximately 58 lb, (25 kg).

#### (2) INSTALLATION

1. To install a DE, be sure the cable (CNJ502, are attached/connected and held to the sides of the DE.
2. Gently Lower the DE on the shock mounts, taking care to watch the area all around the DE so cables aren't pinched.
3. Follow, in reverse order, the instructions for removal.

Note: The three hexagon socket-head bolts must be tighten at the torque of about 120 kg·cm.

4. Make dynamic adjustments of Servo Circuit Refer 14.2-(3).

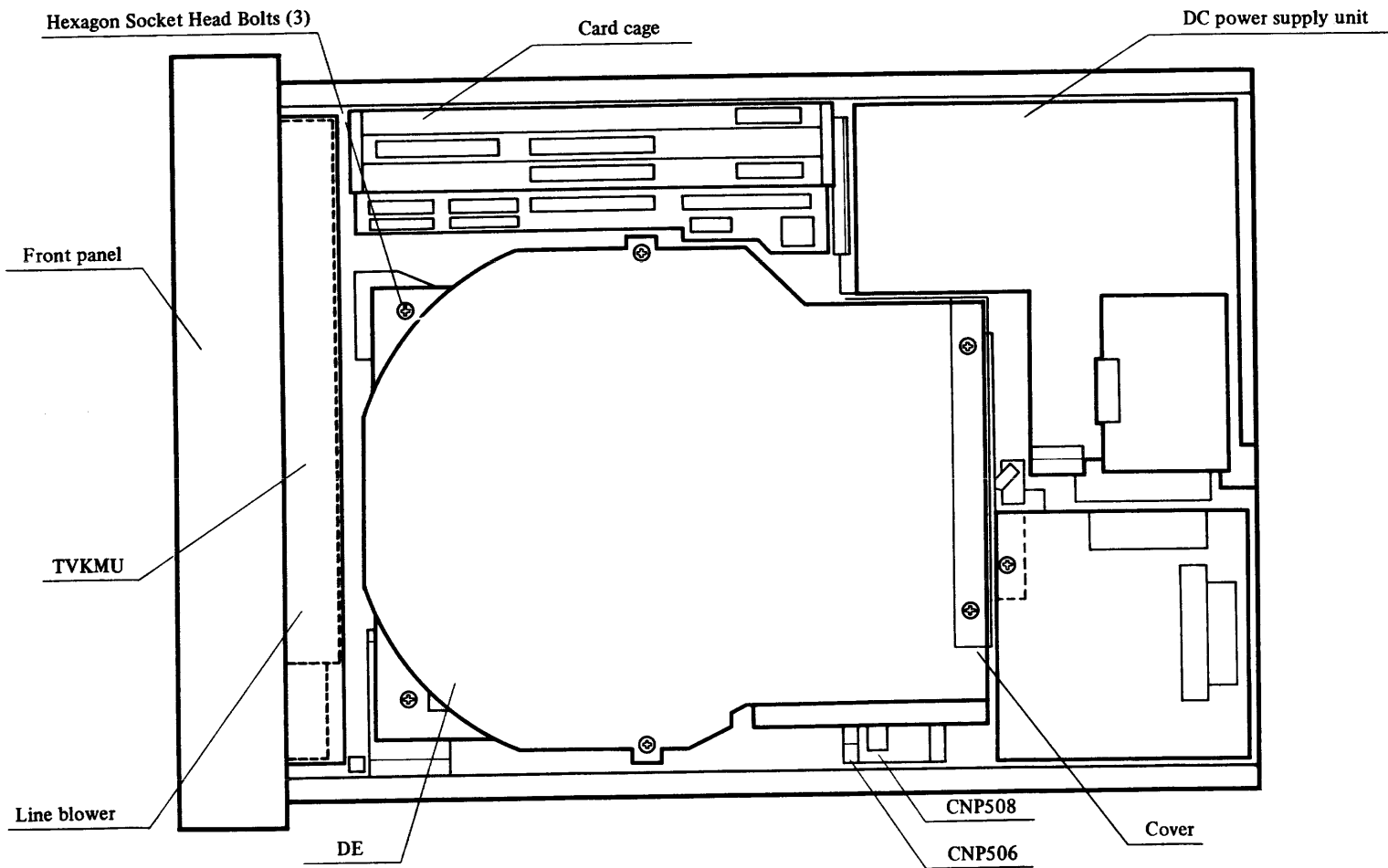

Figure 13.2-2 DE Replacement (Top View) . . . . Current version

### 13.3 FRONT PANEL AND OPERATOR PANEL

#### (1) Removal

1. Remove the 4 screws holding the front panel to the frame.
2. Remove CNP83 from the Operator Panel PCB, and remove the 4 screws holding the Operator Panel to the bracket.

#### (2) Installation

1. Follow, in reverse order the procedure for removal.

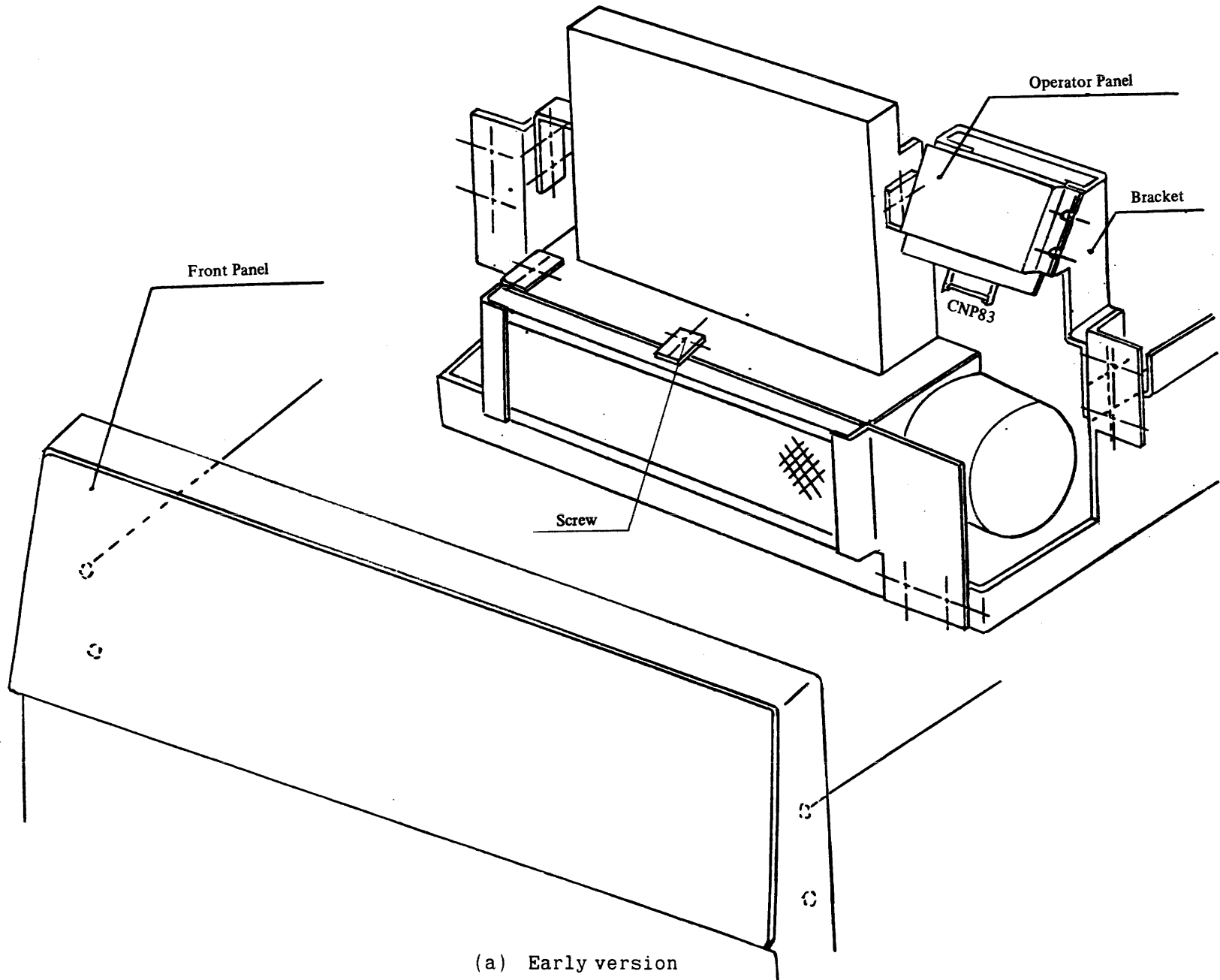

(a) Early version

Figure 13.3-1 Front Panel and Operator Panel Removal

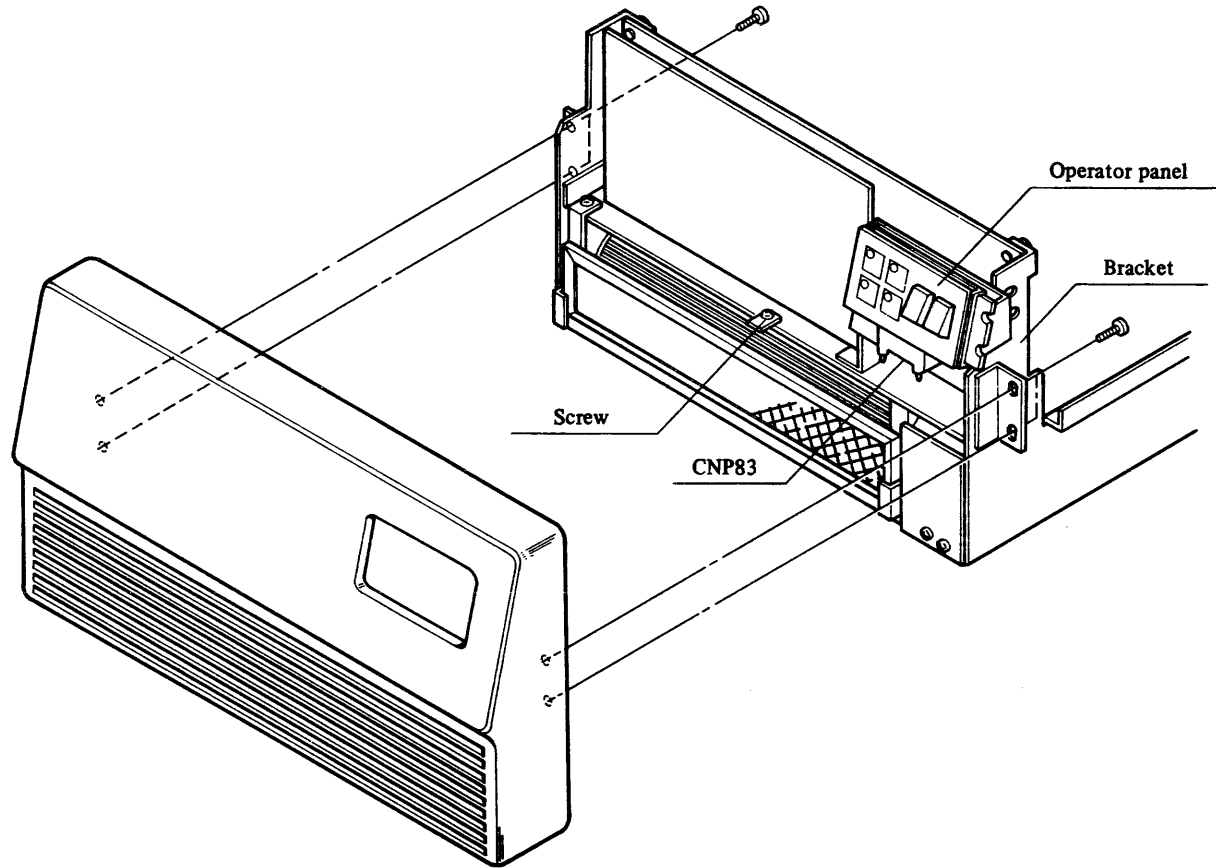

(b) Current version

Figure 13.3-1 - Continued

## 13.4 AIR FILTER

### (1) Removal

1. Remove the front panel. (Refer to 13.3-(1))
2. Loosen a screw and rotate the plate.
3. Remove the Air Filter by pulling it in directions of arrow in Figure 13.4-1.

### (2) Installation

1. Insert the Air Filter in front of the Line Blower.
2. Rotate the plate to upper position of the Air Filter and fasten the screw.
3. Install the front Panel (Refer to 13.3-(2))

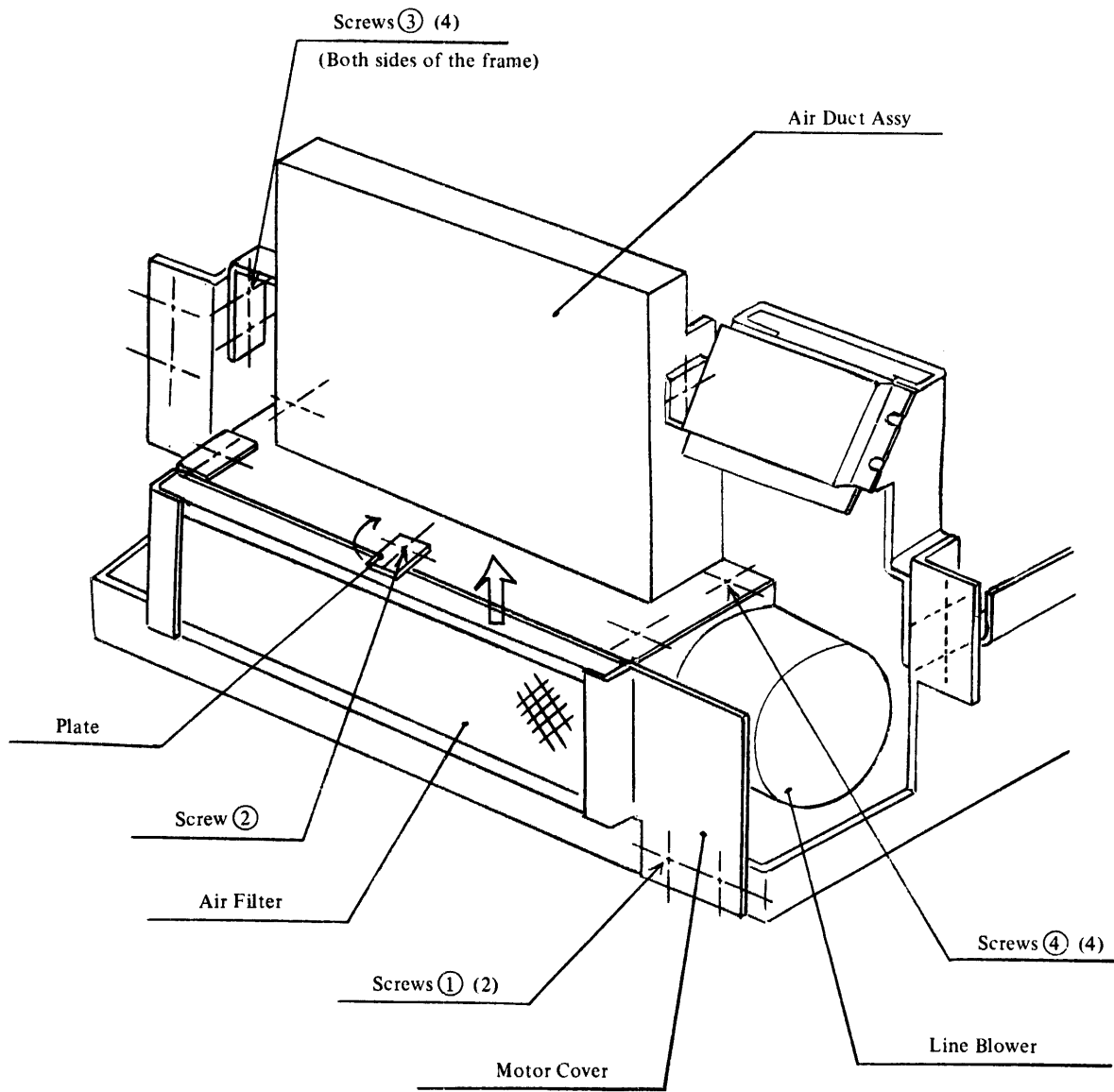

(a) Early version

Figure 13.4-1 Air Filter and Line Blower Replacement

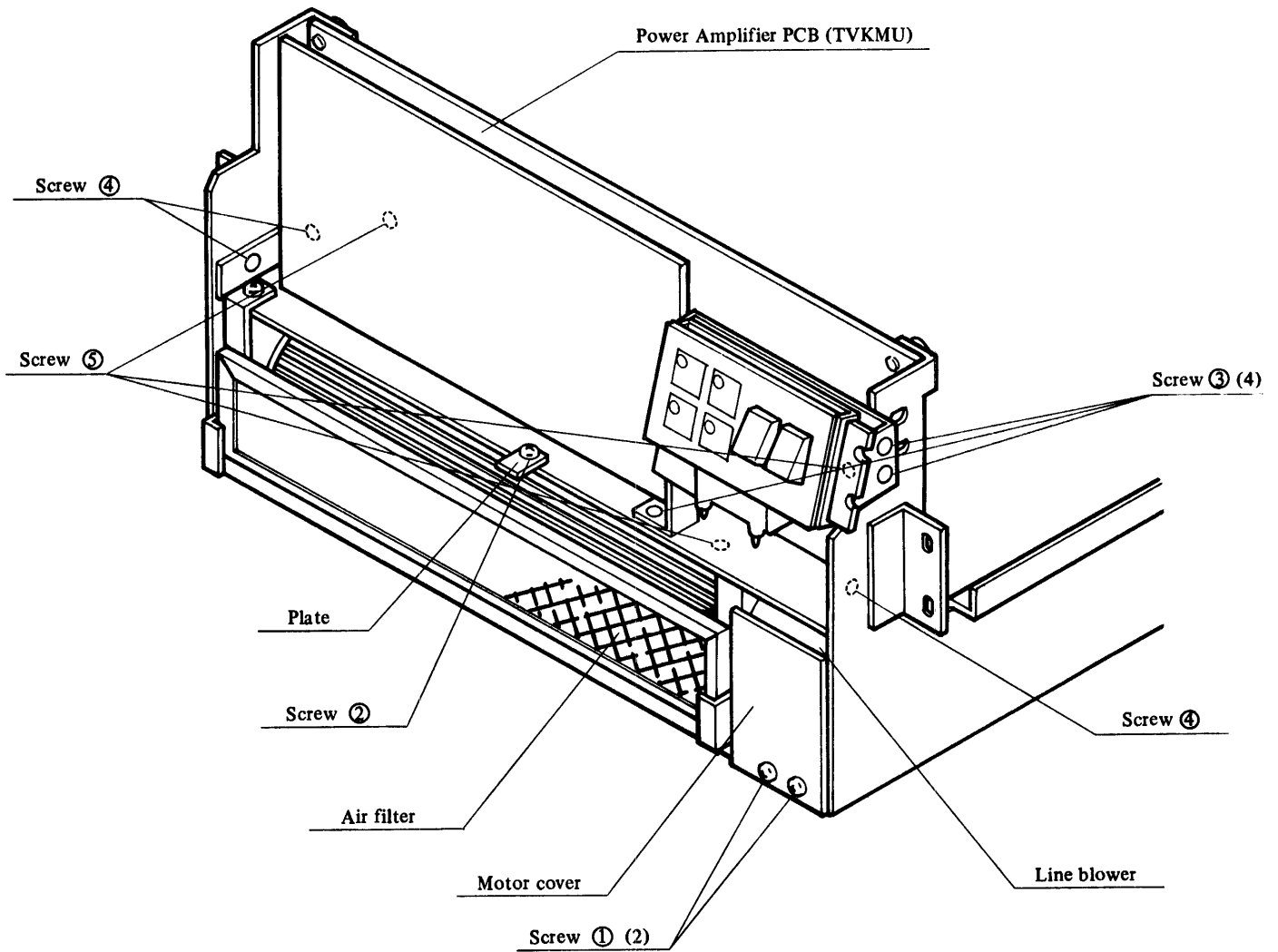

(b) Current version

Figure 13.4-1 - continued



## 13.5 LINE BLOWER

### 13.5.1 Early version (Refer to Figure 13.4-1 (a))

#### (1) Removal

1. Remove the front Panel (Refer to 13.3-(1)).
2. Remove the 2 screws (①) holding the motor cover and remove this cover.
3. Rotate the screw (②) and remove the air filter.
4. Remove the 4 screws (③).
5. Disconnect the motor plug, CNP71. Remove the 4 screw (④) and lift the air duct assy slightly, and remove the line blower forward.

#### (2) Installation

1. Follow, in reverse order, the procedure for line blower removal.

### 13.5.2 Current version (Refer to Figure 13.4-1 (b))

#### (1) Removal

1. Remove the front Panel (Refer to 13.3-(1)).
2. Remove the 2 screws (①) holding the motor cover and remove this cover.
3. Rotate the screw (②) and remove the air filter.
4. Remove the 4 screws (③), holding the operator panel bracket and remove this panel assy.
5. Remove the TVKMU pulling out two fastening latches.
6. Remove the 4 screws (④).
7. Disconnect the motor plug, CNP71. Remove the 4 screw (⑤) and remove the line blower forward.

#### (2) Installation

1. Follow, in reverse order, the procedure for line blower removal.

## 13.6 BACK PANEL (BQGMU)

### (1) Removal

1. Remove the PCBs from the card cage.
2. Remove screws (2) and then, lift the card cage vertically.  
Rotate over the side and remove all connectors (9) to back panel.
3. Remove nuts (4) washers (8) (Refer to Figure 13.6-1).
4. Remove the card cage and 7 screws (7).
5. Remove the back panel.

### (2) Installation

1. Follow, in reverse order, the procedure for back panel removal.

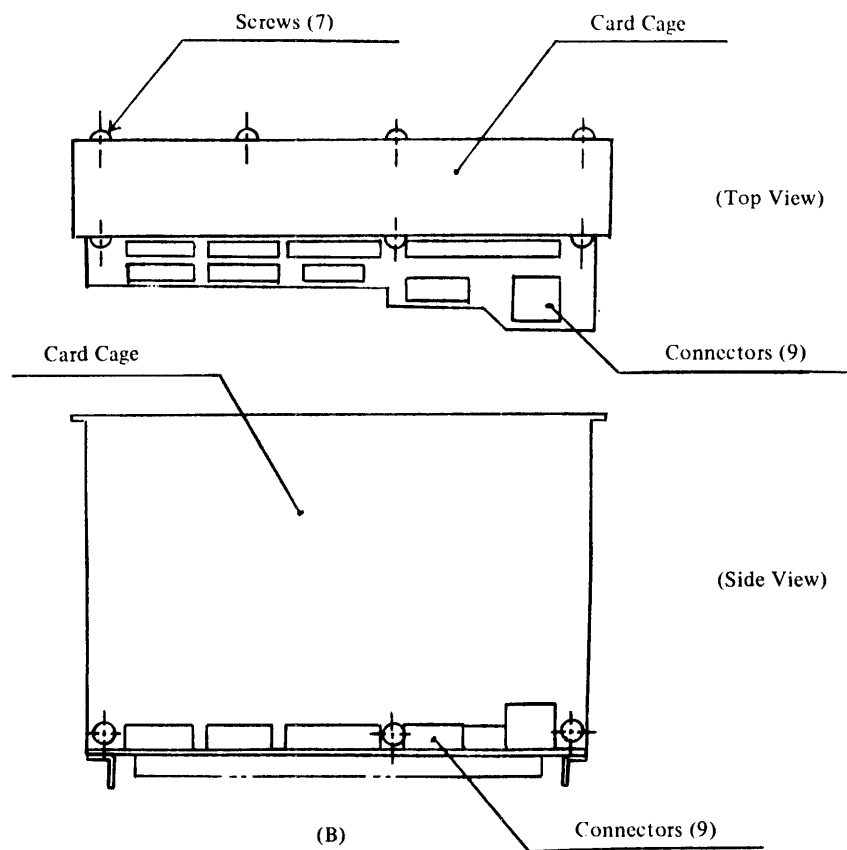
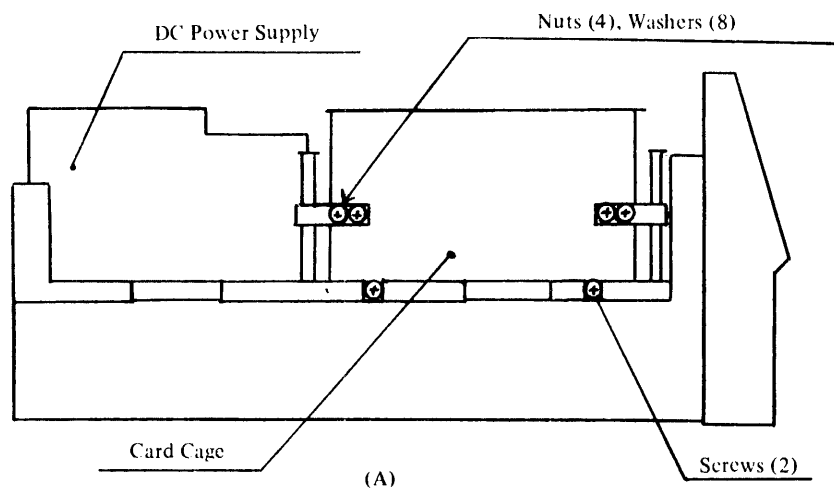

Figure 13.6-1 Back Panel Replacement

## 13.7 HOUR METER

### (1) Installation

1. Remove 2 binder-head screws holding the card cage.
2. Lift the card cage vertically and rotate over the side.
3. Install the Hour Meter in the connector, as indicated in Figure 13.7-1.

Note: The arrow of the hour meter must be the same direction of the socket, and then if the indicator will fully change red, pull out this indicator and plug in again reversely.

### (2) Removal

Follow, in reverse order, the instructions for installation.

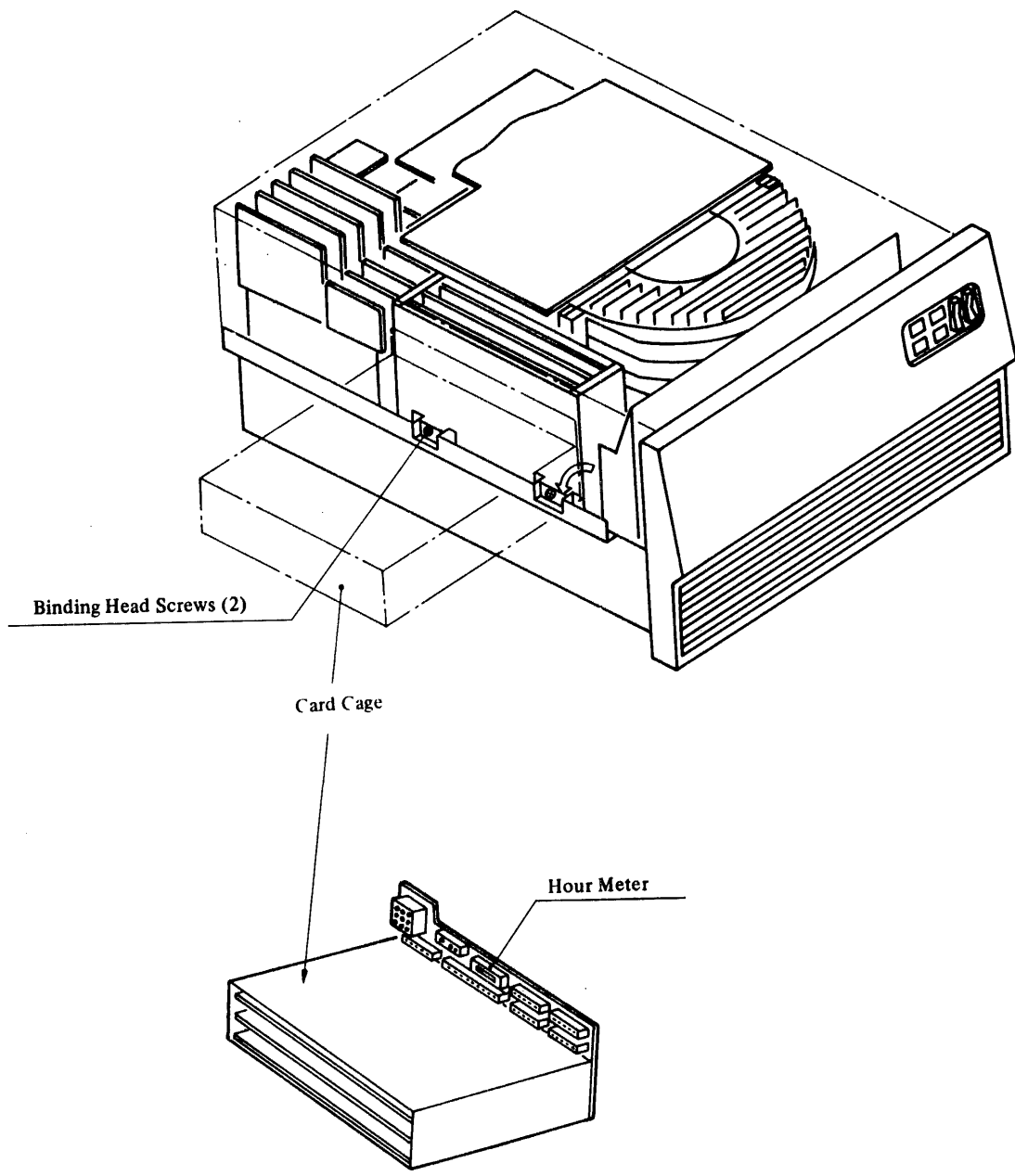

(a) Early version

Figure 13.7-1 Installation of Hour Meter

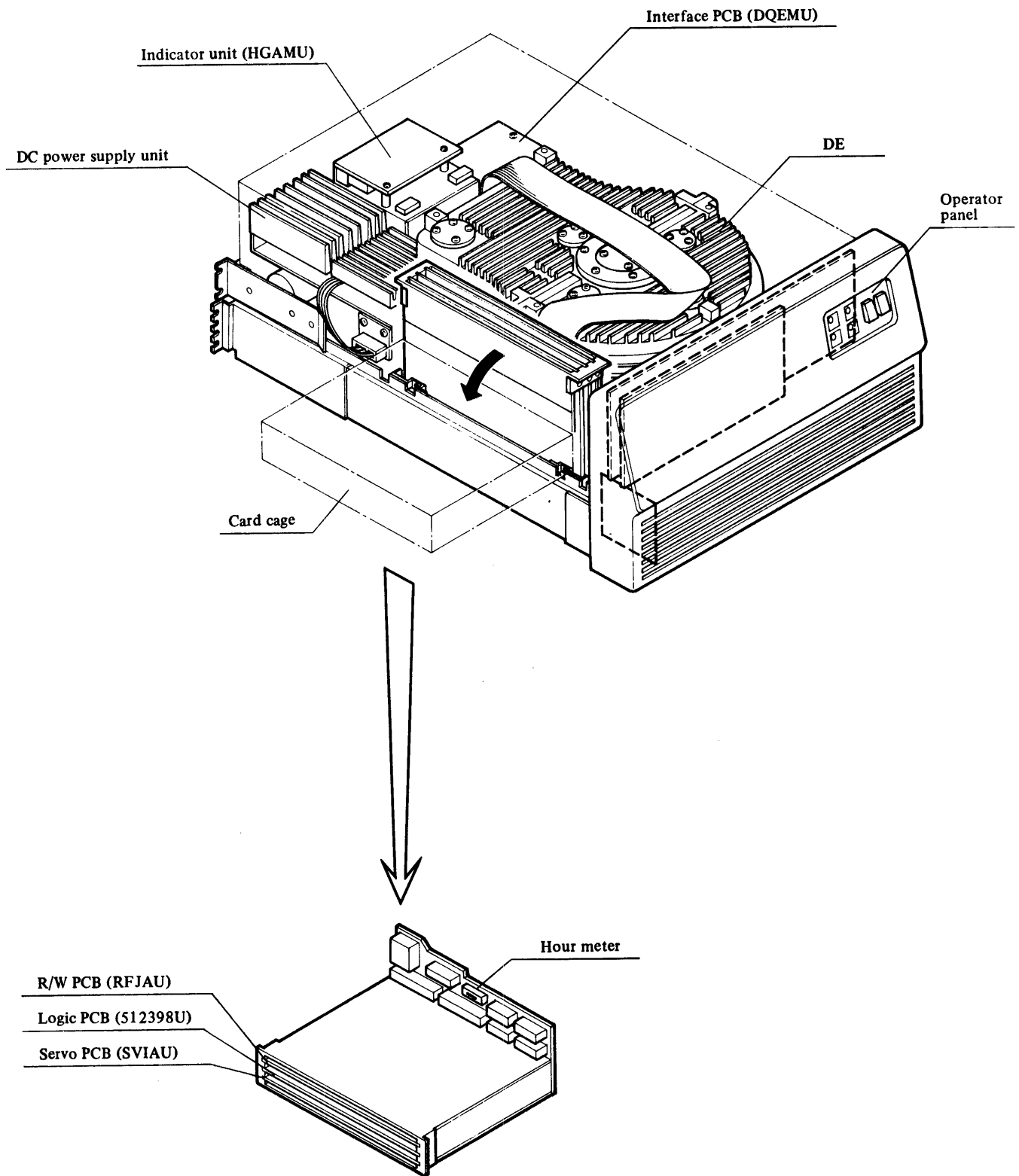

(b) Current version

Figure 13.7-1 - Continued

## 13.8 DUAL CHANNEL OPTION

### (1) Installation

1. Remove the TVHMU PCB. (Refer to 13.2-(1)) (Early version only)
2. If standoffs are not already in place on interface PCB (DQEMU), remove the 4 screws holding DQEMU and install 4 standoffs.
3. Disconnect CNP44, CNP45 and CNP62/46 cables.
4. Connect jumper cables (between the interface and dual channel PCBs) in the headers on the interface PCB (DQEMU).
5. Install dual channel PCB (DQFMU) on the 4 standoffs and secure with 4 screws.
6. Connect the other end of the jumper cables from DQEMU to CNP54, CNP55 and CNJ62 of the DQFMU PCB.
7. Connect cables CNP44, CNP45 and CNP62/46 to CNP57, CNP59 and CNJ56.
8. Install the TVHMU PCB (Refer to 13.2-(2)) (Early version only)

### (2) Removal

Follow, in reverse order, the instructions for installation.

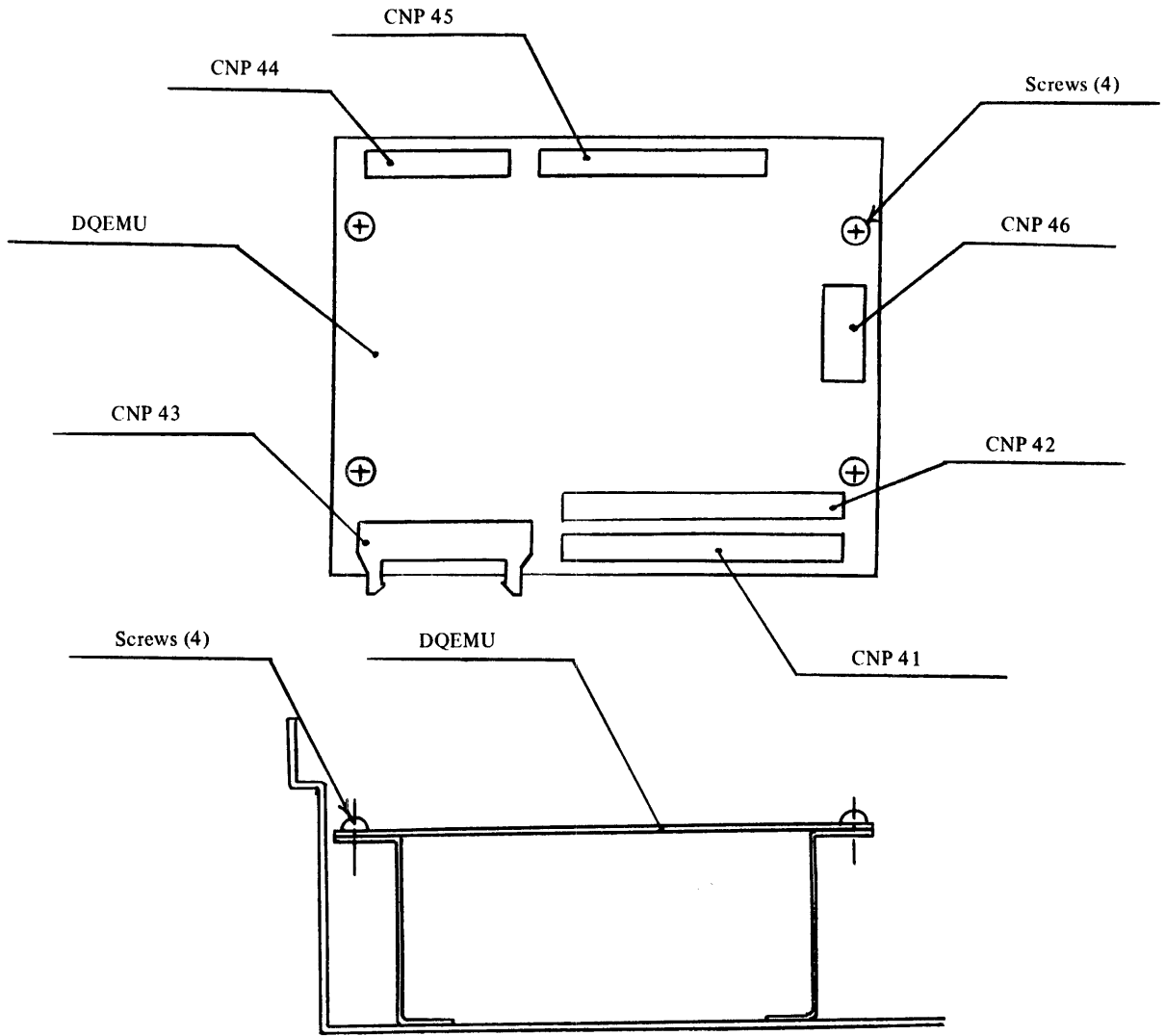

Figure 13.8-1 Installation of Dual Channel Option



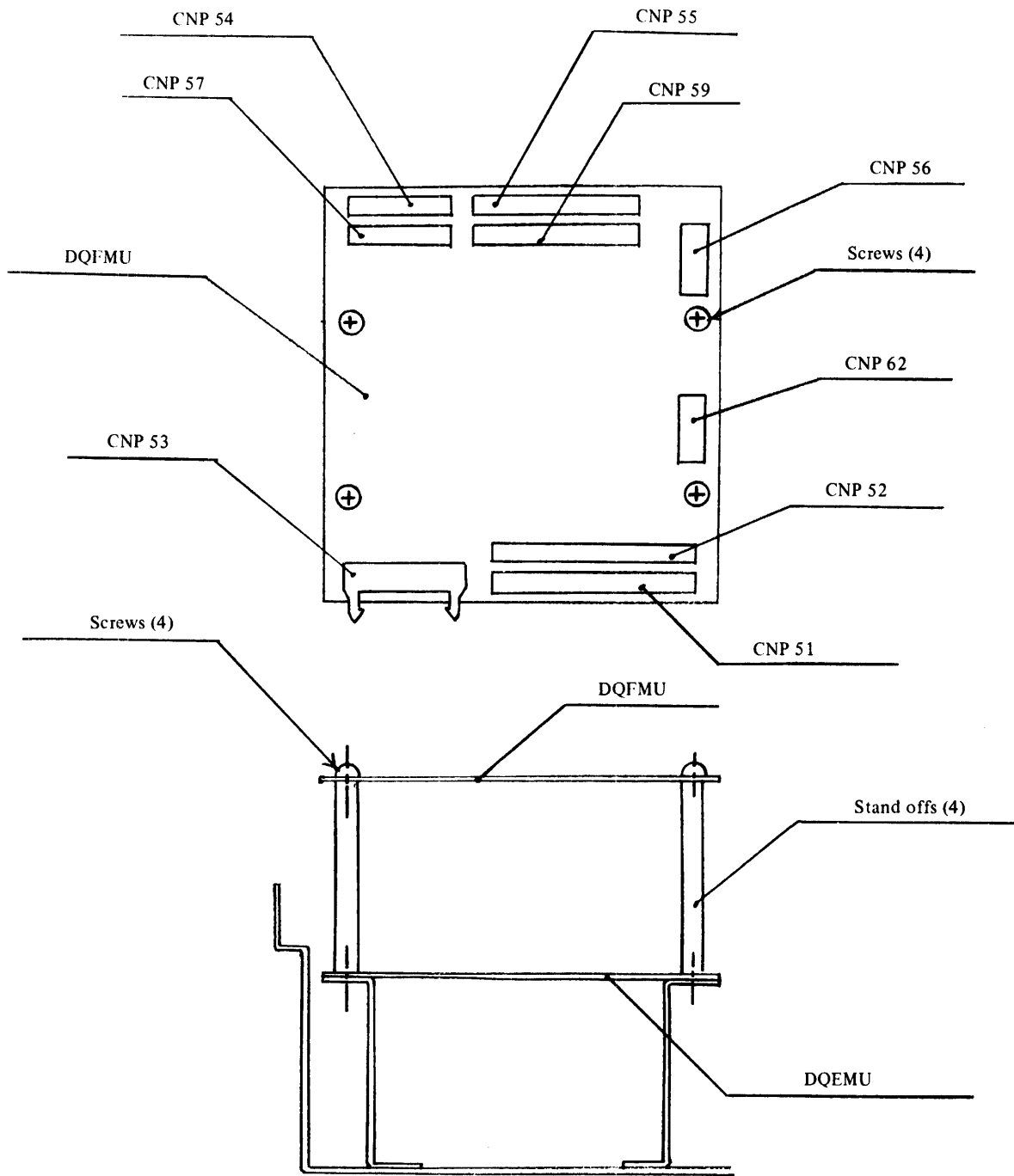

Figure 13.8-2 Installation of Dual Channel Option

## 13.9 DC POWER SUPPLY UNIT

### (1) Removal

1. Remove the PCB (HGAMU).
2. Remove connectors (CNP03, CNP61, CNP62, CNP64, CNP65, CNJ66) that go out from the power supply unit.
3. Remove the screws (2) which hold the power supply unit to the frame of the drive.
4. Carefully slide the power supply unit back and remove.
5. Remove the input AC power cable. (Refer to 13.10)

### (2) Installation

Follow, in reverse order, the procedure for DC power supply removal.

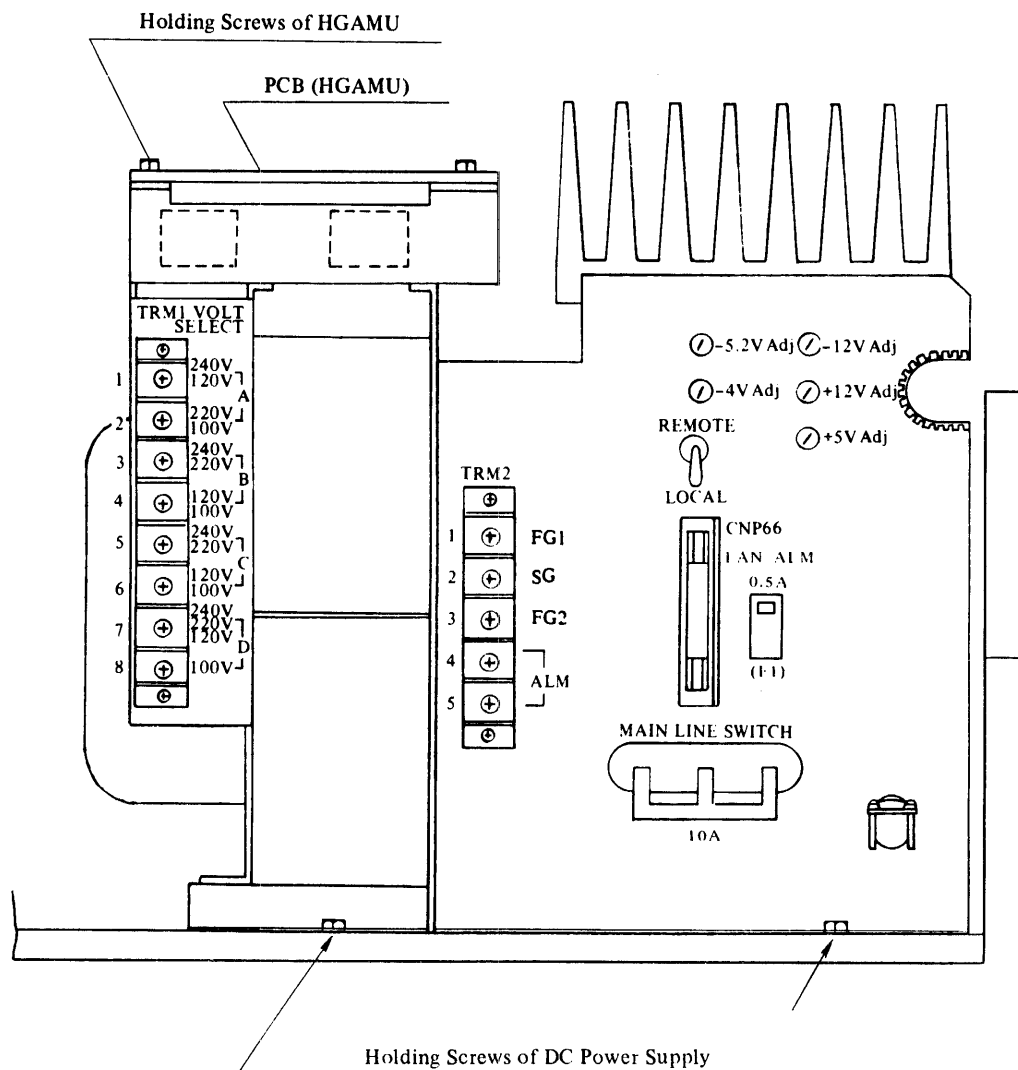

Figure 13.9-1

(3) Adjustment of DC Voltages

Check the DC voltages at the check pins of Back Panel (BQGMU) using digital multimeter. The check pins' configuration is shown in Figure 13.9-2. If a DC voltage is out of the acceptable range of Table 13.9-1, readjust the corresponding RV shown in Figure 13.9-1.

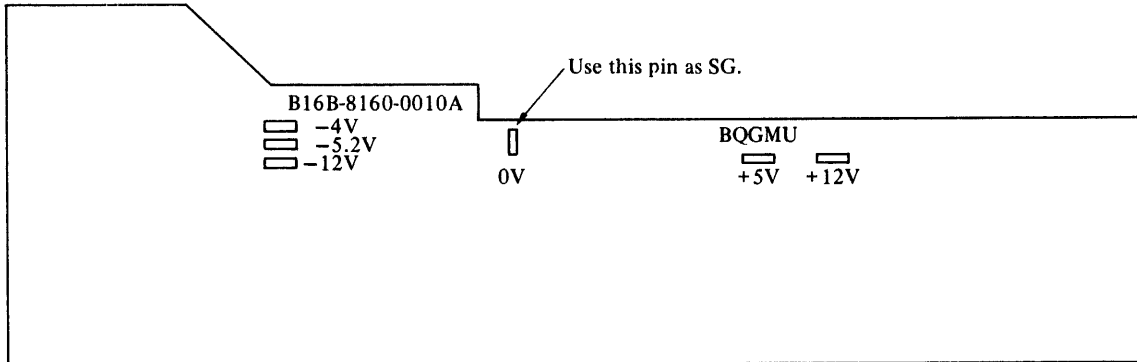

Figure 13.9-2 Top View of Back Panel

Table 13.9-1 Acceptable Range of DC Voltages

DC Voltage	Acceptable Range
+12 V	11.4 ~ 12.6 V
+5 V	4.75 ~ 5.25 V
-4 V	-3.8 ~ -4.2 V
-5.2 V	-4.94 ~ -5.46 V
-12 V	-11.4 ~ -12.6 V

## 13.10 POWER CABLE

CAUTION: Check to be certain that the AC cable is not plugged in.

### (1) Removal

1. Remove the DC power supply (Refer to 13.9).
2. Remove the side cover by loosening 4 screws as shown in Figure 13.10-1.
3. Loosen cable clamp.
4. Remove terminals A and B (AC power) and terminal G (ground).
5. Remove the AC cable.

### (2) Installation

1. Follow, in reverse order, the procedure for power cable removal.

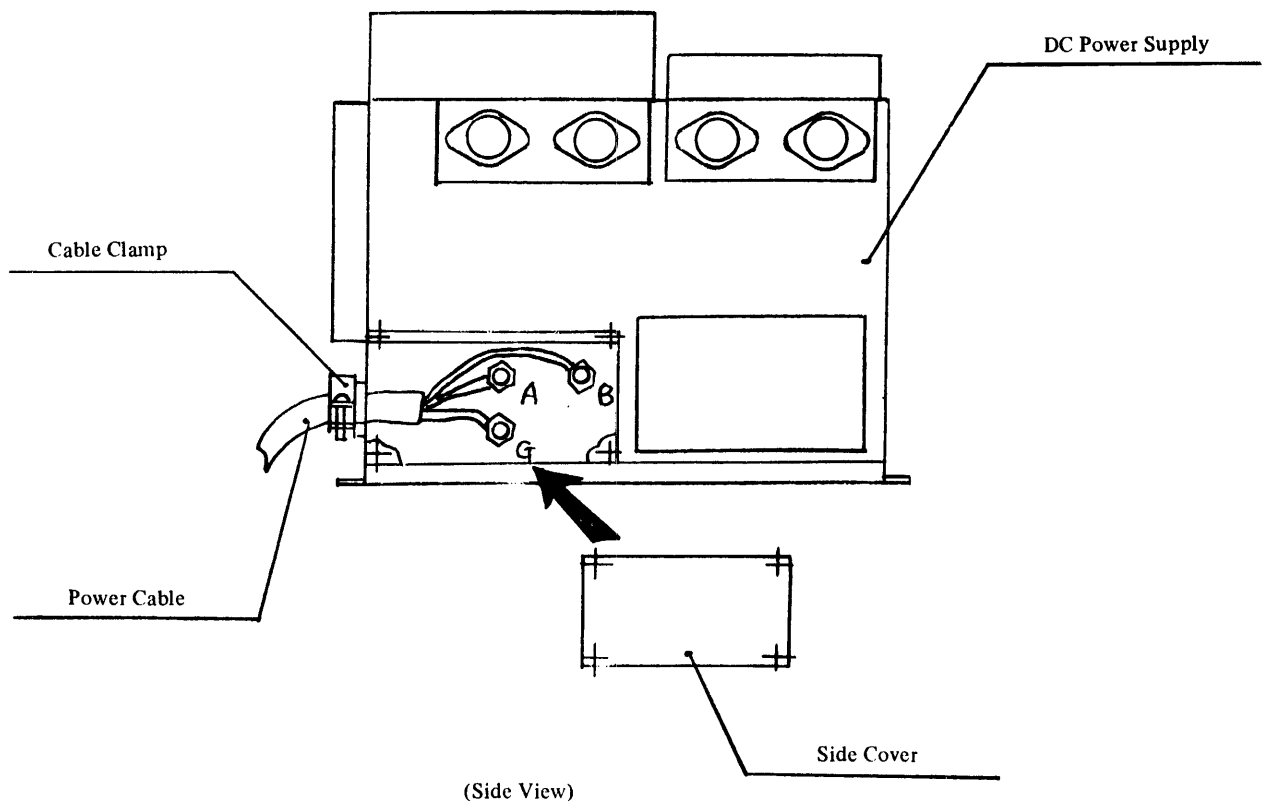

Figure 13.10-1 Installation of a Power Cable

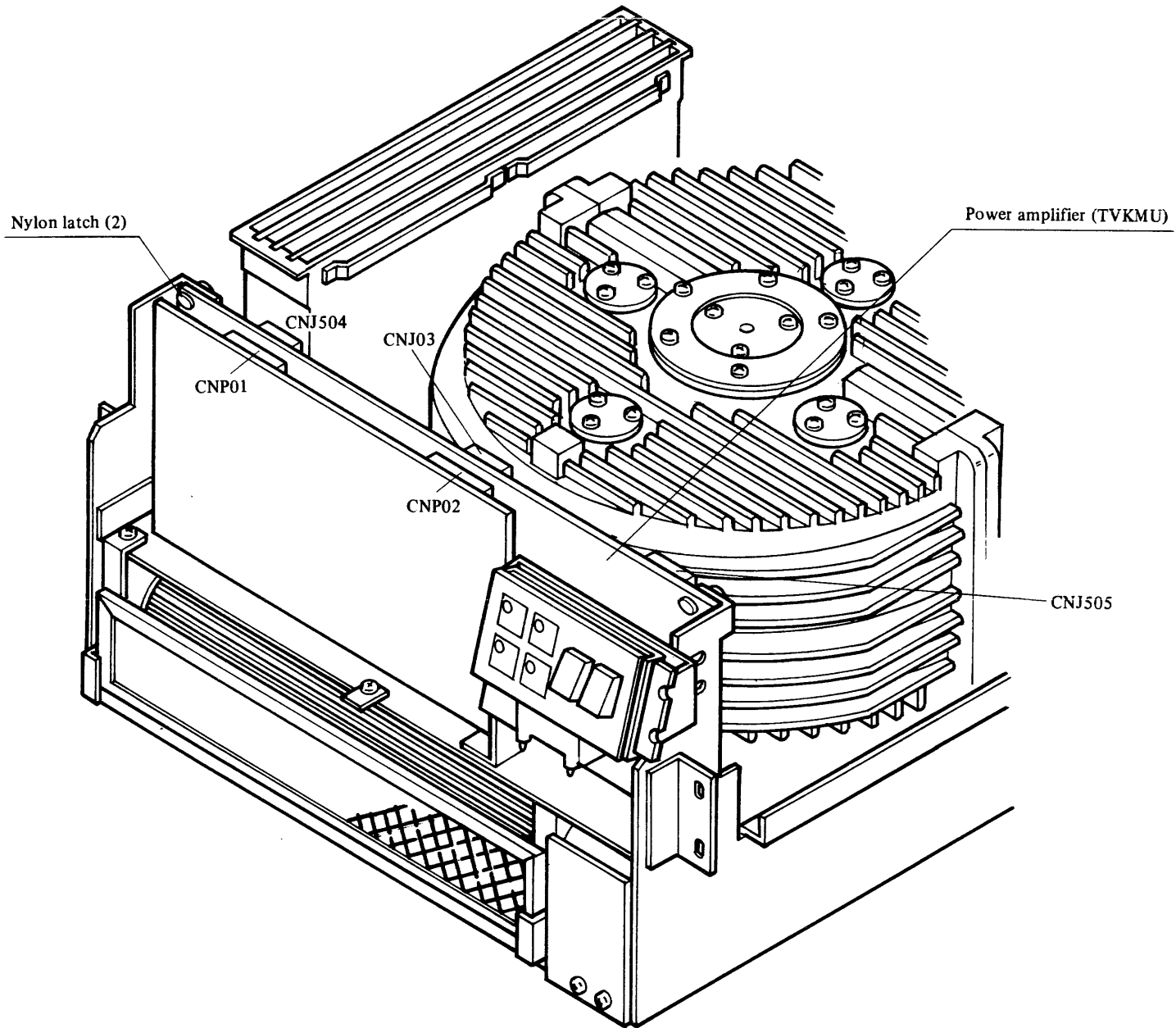

Figure 13.11-1 Power amplifier replacement

14.1 GUIDE TO PCBs AND LOGIC DIAGRAMS (SCHEMATICS)

Circuit diagrams contain input and output signal names (mnemonics), coordinate locations of ICs, input origins, destination coordinates of output signals, IC pin numbers and IC types. Figure 14.1-1 shows how to read circuit diagrams.

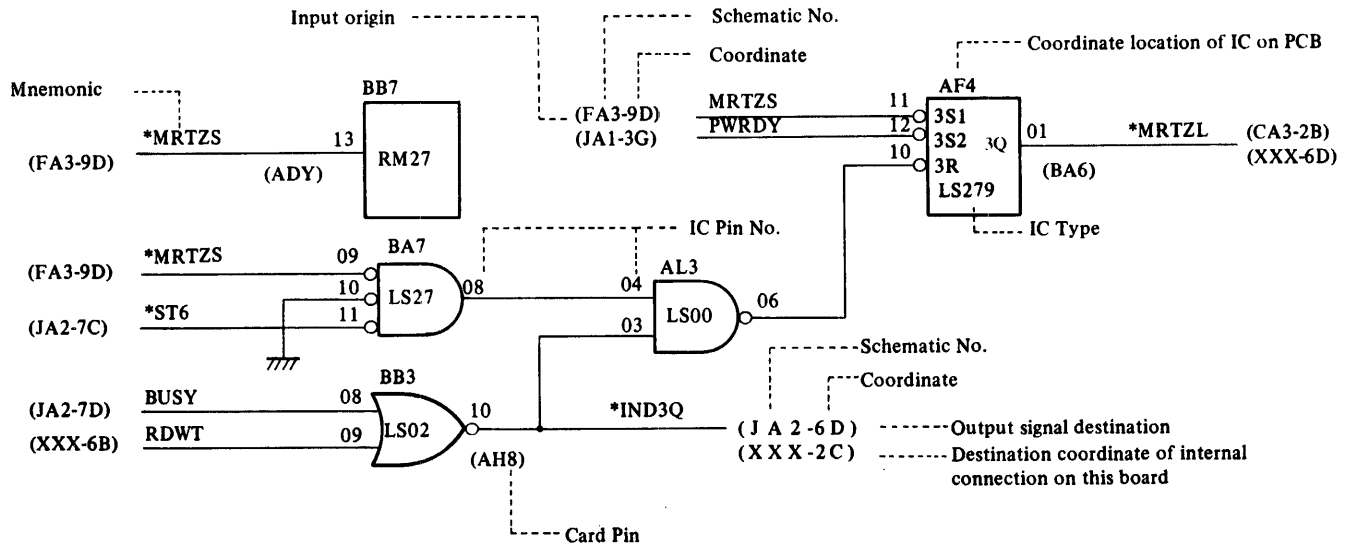

Figure 14.1-1 Logic Symbols

Figure 14.1-2 shows the IC location of PCB 512398.

Figure 14.1-3 shows the pin numbering of PCB.

Figure 14.1-4 shows the pin numbering of Back Panel.

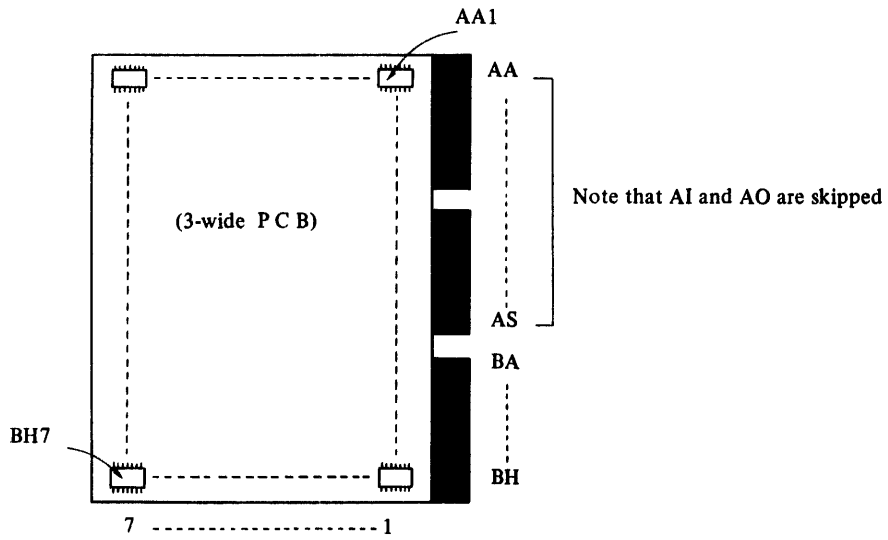

Figure 14.1-2 IC Location

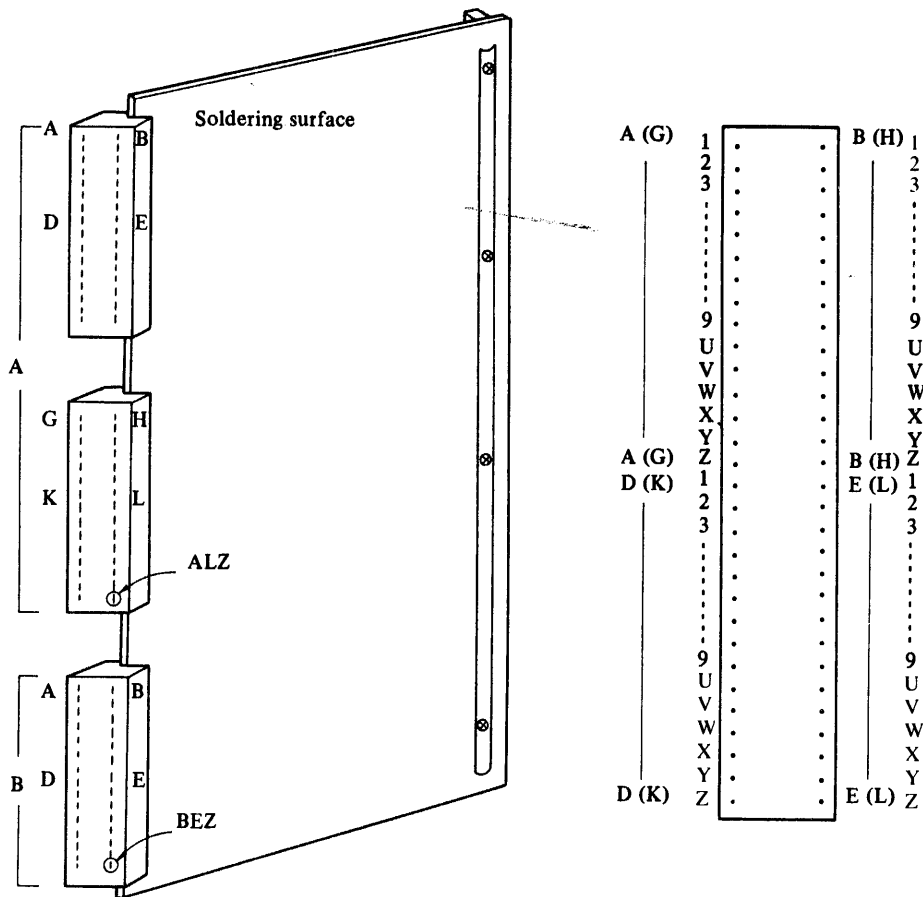

Figure 14.1-3 PCB Pin Numbering

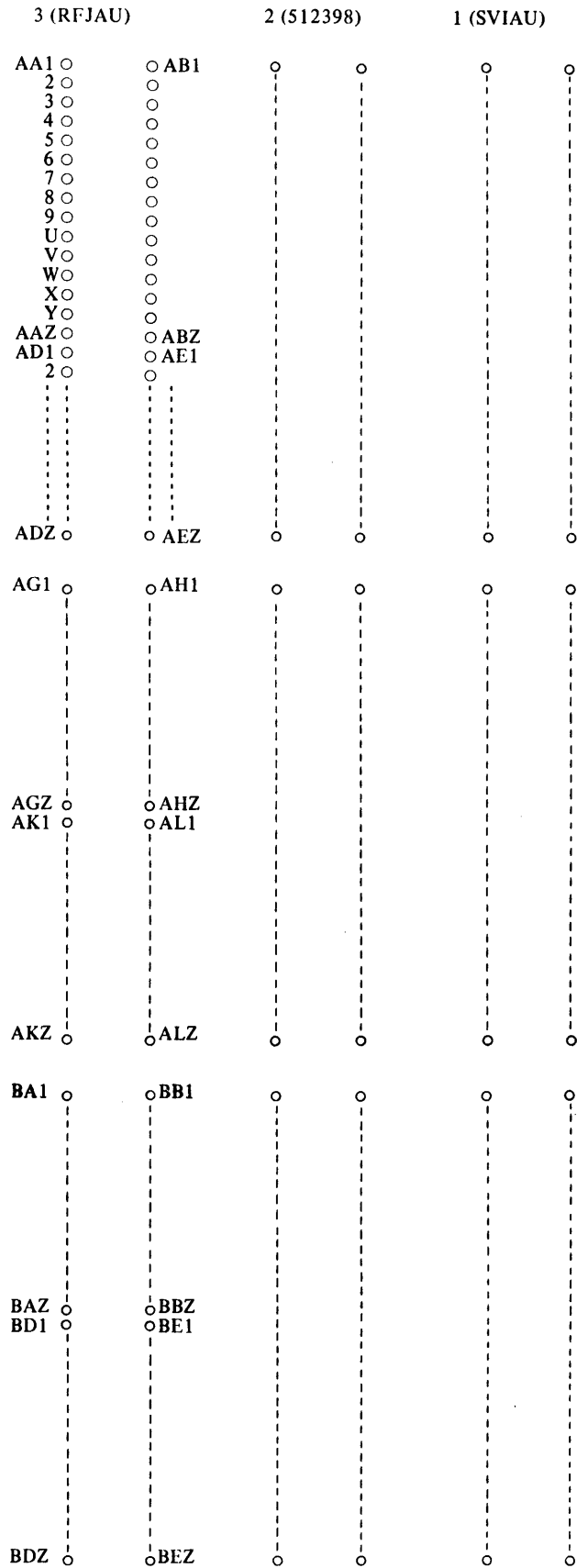

Figure 14.1-4 Back Panel Pin Numbering (Bottom View)



## 14.2 ADJUSTMENT OF SERVO CIRCUIT

### (1) Introduction

The following flow chart shows how to adjust and test the servo circuit.

If none of variable resistors have been adjusted, both "Static Adjustment" and "Dynamic Adjustment" are necessary. After changing the DE or PCB SVIAU, only "Dynamic Adjustment" is needed, that is, RVs 1, 2, 3, 10 and 13 are needed to be adjusted.

Prior to the "Static Adjustment", stop the spindle, power off and pull out connector CNP504 (Output cable of Power Amplifier to the rotary actuator).

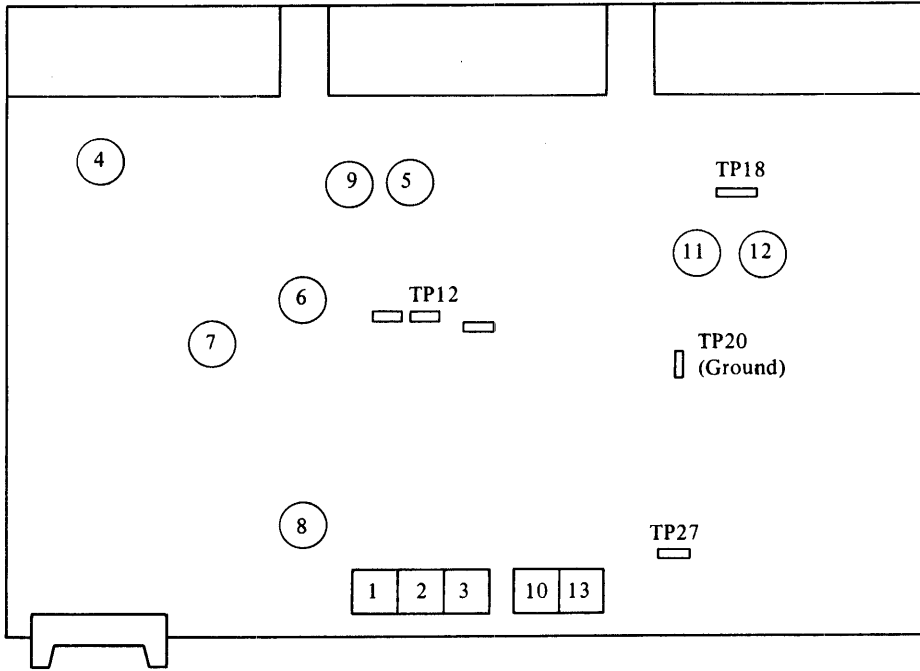

Figure 14.2-1 RVs and TPs on PCB SVIAU/01

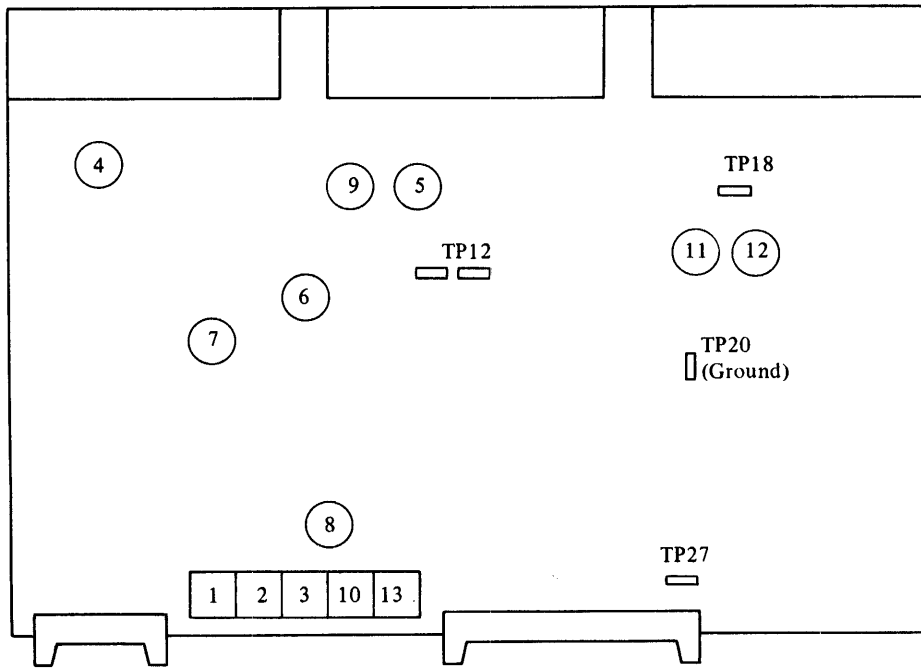

Figure 14.2-2 RVs and TPs on PCB SVIAU/02

Table 14.2-1 Function of RVs

RV No.	Function/Adjustment	Sealed <sup>*</sup>
1	AGC Amplifier gain	No
2	Over - shooting	No
3	Access time	No
4	-4V	Yes
5	Offset voltage of the desired velocity curve	Yes
6	VCO free - running frequency	Yes
7	Timer - Gate pulse width	Yes
8	Sync. - Gate timing	Yes
9	D/A Converter gain	Yes
10	Velocity offset	No
11	Access Time Out pulse width	Yes
12	Track Following Timer pulse width	Yes
13	Settling in Fine Control	No

\* Do not touch the sealed RVs unless adjustments are required.

(2) STATIC ADJUSTMENT

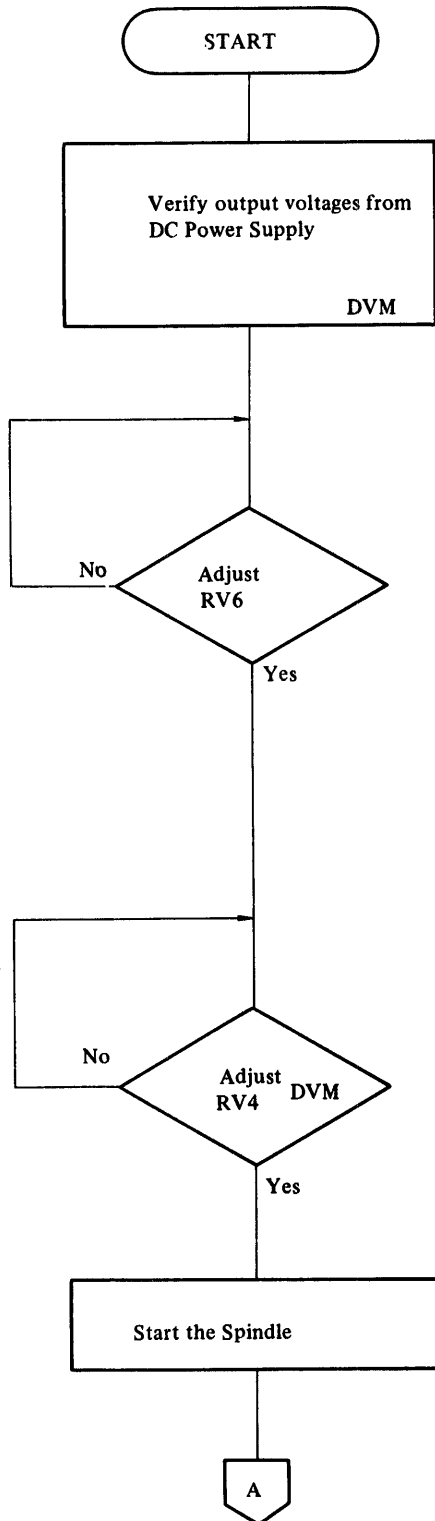

The card cage must be opened (lifted and rotated 90°) to expose the Back Panel.

+12V; CP.AA1  
 +5V; CP.AAZ  
 -5.2V; CP.ABZ  
 -12V; CP.AEZ  
 (Ground; CP.AD2)

VCO Free-Running frequency  
 Connect CP.AEW to ADW (Ground)

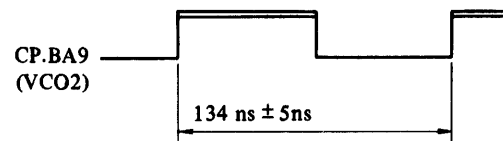

After the adjustment, disconnect CP.AEW from Ground.

CP.AA6; -4V ± 0.1V  
 CP.AA5; +6V ± 0.1V  
 (Ground; CP.AD2)

Turn on the Start/Stop switch on the operator panel and check that the spindle is rotating.

Figure 14.2-3 Static Adjustment of Servo Circuit (Sheet 1 of 5)

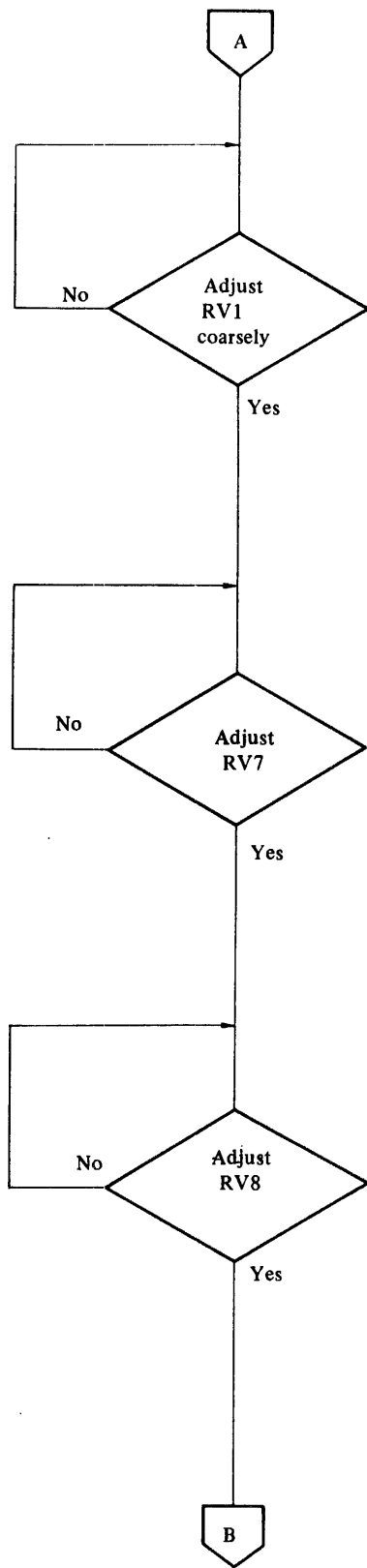

CP. AA4 (CRAMP)

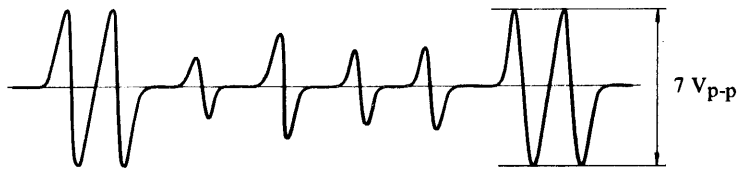

CP. AD5 (TMGT)

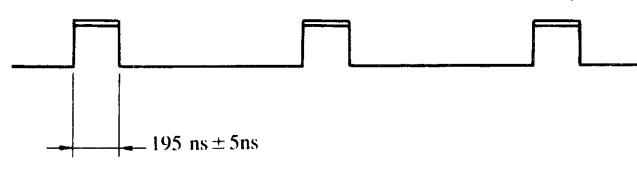

Sync. Gate timing diagram  
PCB 512398 CP.AH2 (\*GSYNC)  
and CP.AE7 (SYNCG)

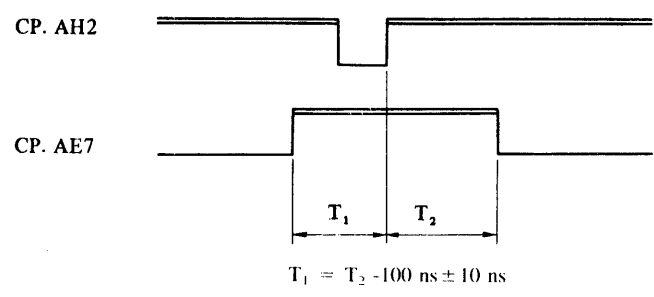
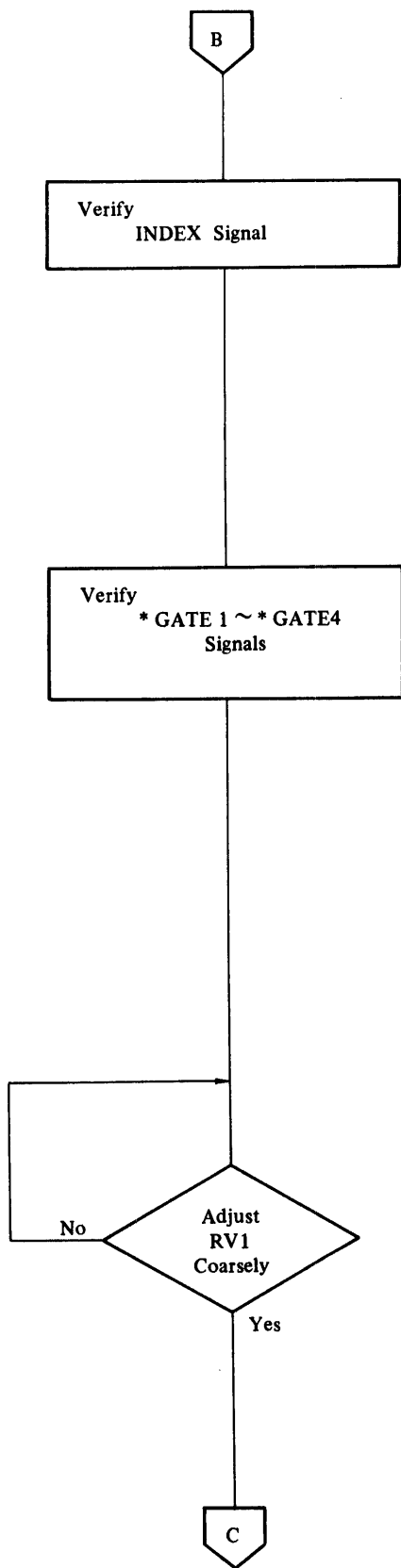
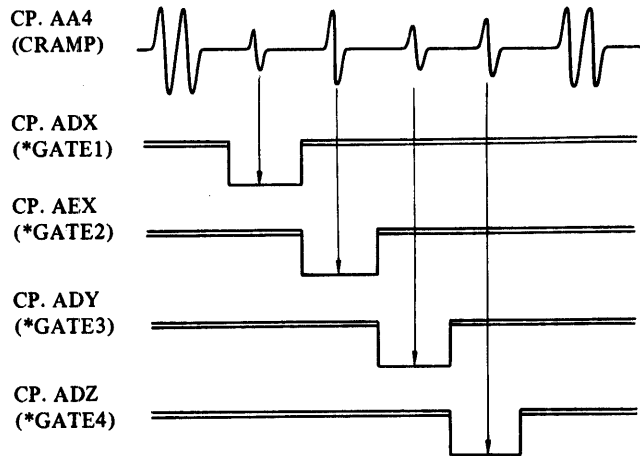
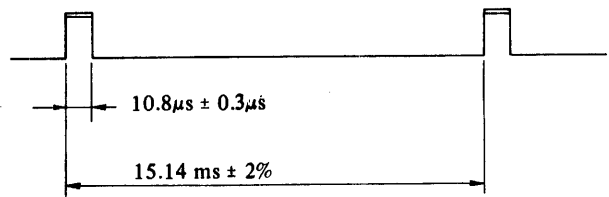

Figure 14.2-3 Static Adjustment of Servo Circuit (Sheet 2 of 5)



PCB512398 CP. AA8



Push the bobbin of rotary actuator slowly with your hand.

CP. ABW (POSN)  
CP. AAV (POSQ)

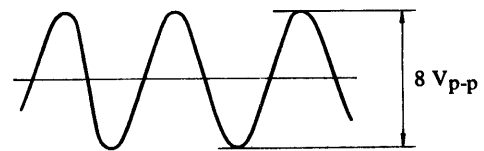
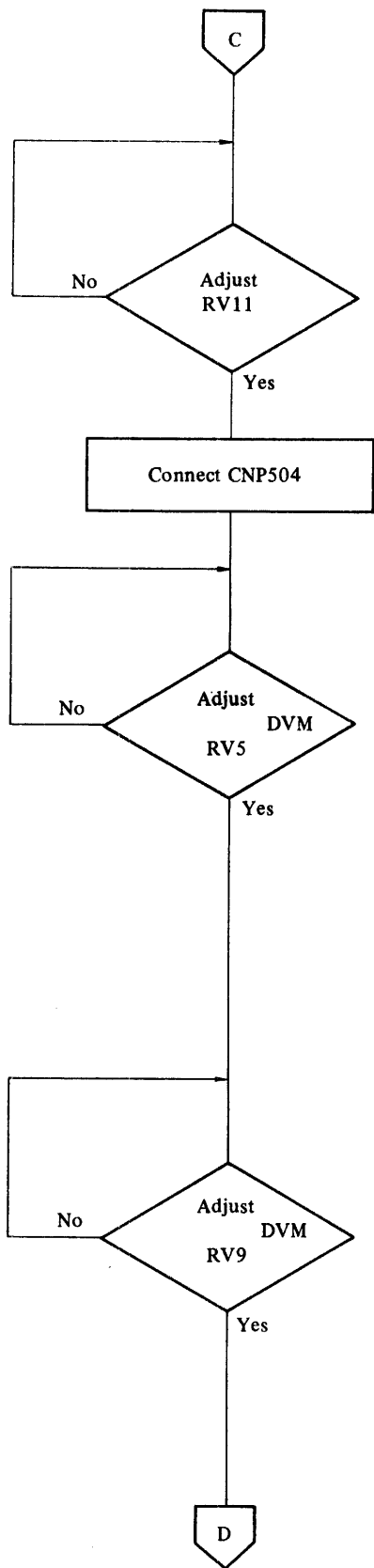
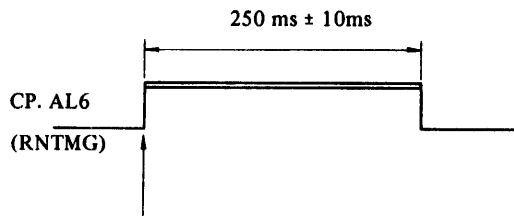

Figure 14.2-3 Static Adjustment of Servo Circuit (Sheet 3 of 5)



Access Time Out



Turn on the MRTZ switch on the PCB HGAMU.

Connect the output cable of Power Amp. to the Rotary actuator.

Offset voltage of the desired velocity curve

TP12, CP.AB3; 0V ±10mV (FG)

When GD1 ~ GD128 are all inactive.

Digital to analog converter gain

TP12, CP.AB3; +6V ±0.1V (FG)

When the difference register contains a value greater than 144.

Figure 14.2-3 Static Adjustment of Servo Circuit (Sheet 4 of 5)

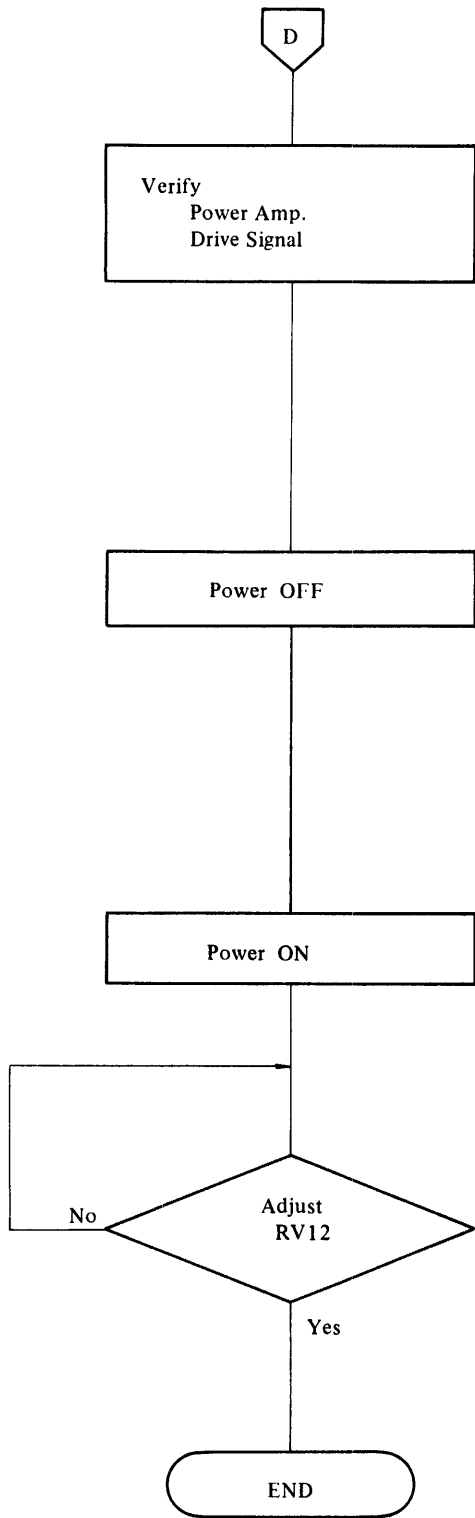

Turn on the MRTZ switch on the PCB HGAMU.

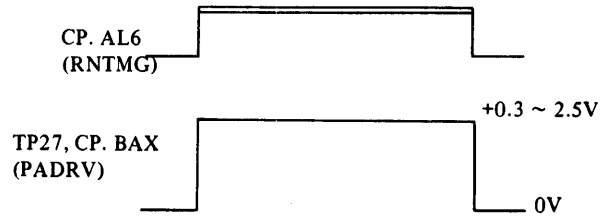

Turn on the MRTZ switch on the PCB HGAMU.

Track following Timer pulse width

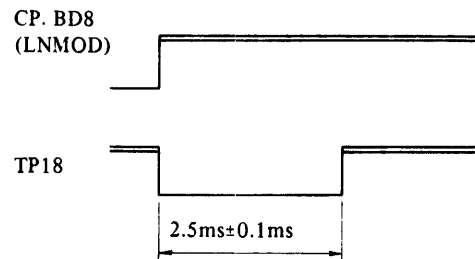

Adjust RV3 by trial and error until the READY lamp light after RTZ operation.

Figure 14.2-3 Static Adjustment of Servo Circuit (Sheet 5 of 5)



(3) DYNAMIC ADJUSTMENT

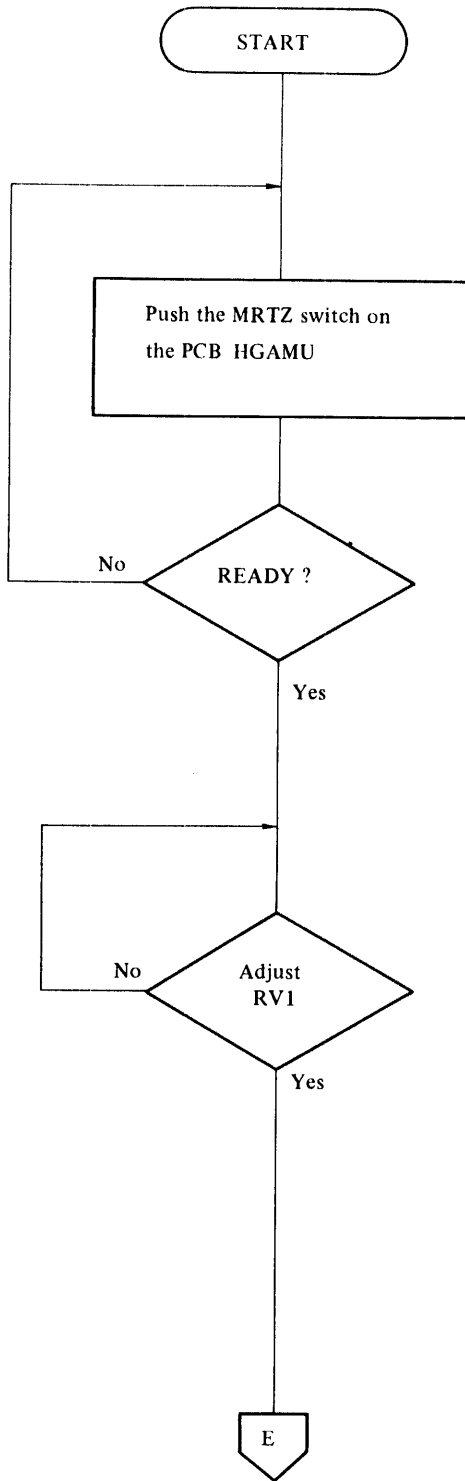

Adjust RV3 by trial and error until the READY lamp on the operator panel light after RTZ operation.

Performing RTZ operation from cylinder 841 repetitively, adjust RV1 as follows.

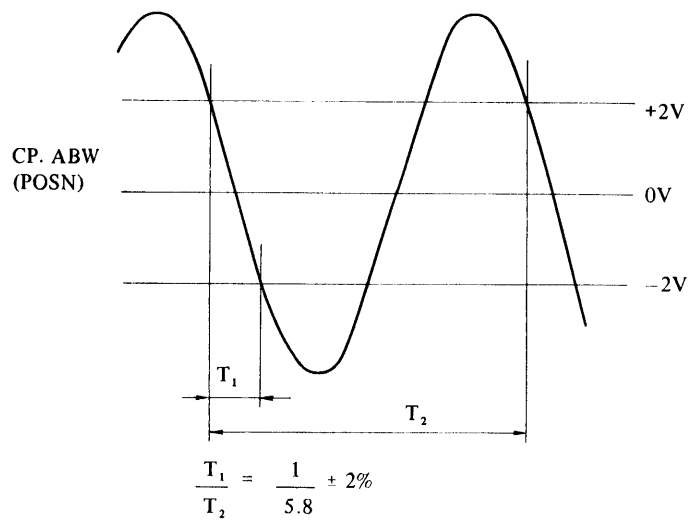

Figure 14.2-4 Dynamic Adjustment of Servo Circuit (Sheet 1 of 3)

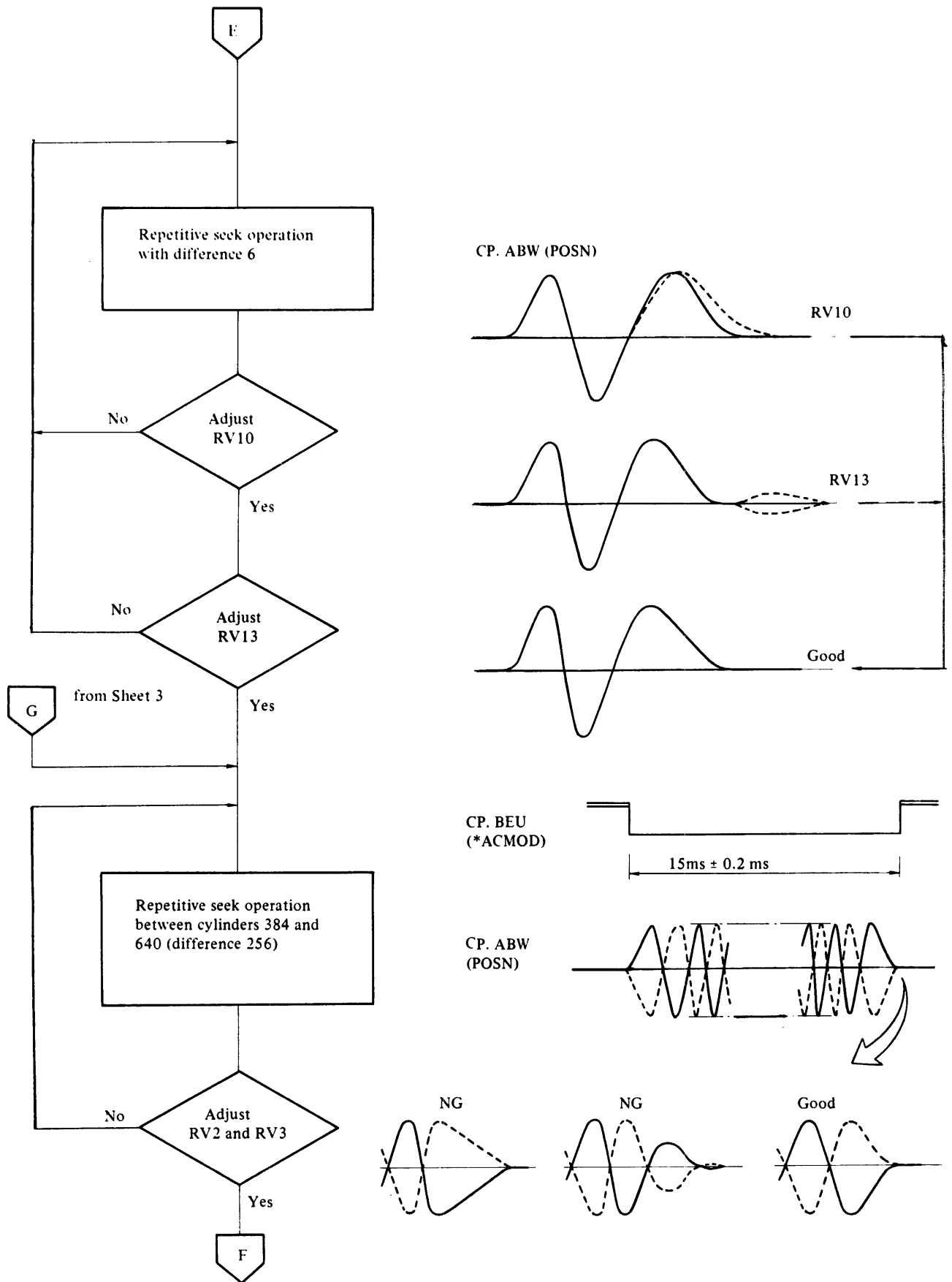
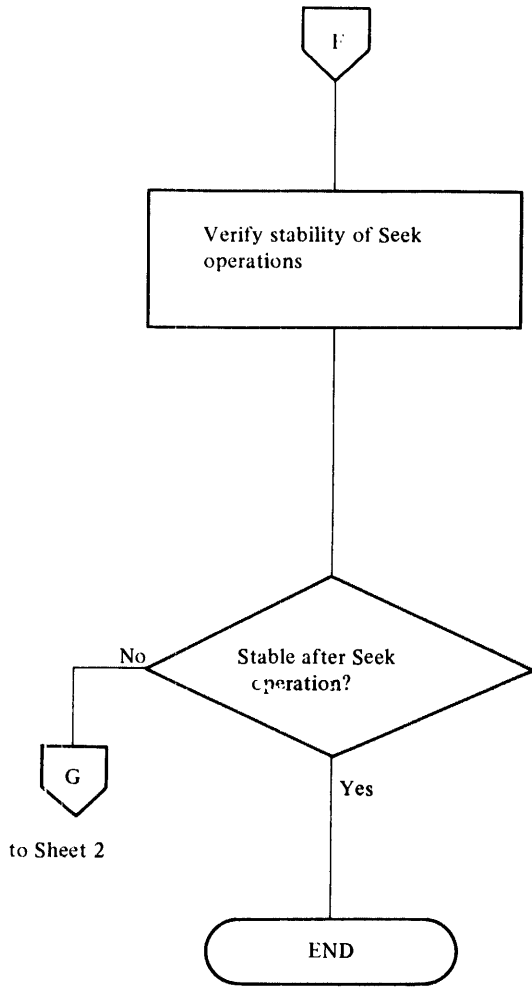

Figure 14.2-4 Dynamic Adjustment of Servo Circuit (Sheet 2 of 3)



Verify stability and vibration while performing seek operations by varying seek distance and time interval.

CP.AL3 (FNPOS)

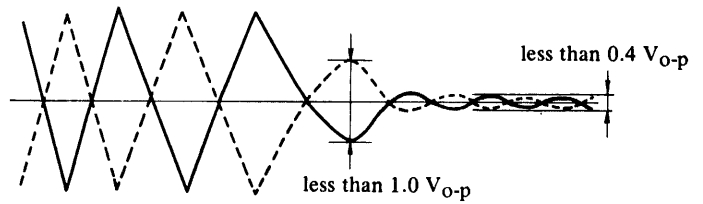

Figure 14.2-4 Dynamic Adjustment of Servo Circuit (Sheet 3 of 3)

### 14.3 ADJUSTMENT OF READ/WRITE CIRCUIT

The following describes how to adjust and test the Read/Write circuit in case none of variable resistors have been adjusted.

The card cage must be opened (lifted and rotated 90°) to expose the Back Panel.

PCB RFJAU must be inserted in Extender Unit.

Refer to Table 14.3-1 and Figure 14.3-1 for monitor point and location.

Table 14.3-1 Variable Resistors in Read/Write Circuit

Item	RV No.	Test point	Specification
-5.2V (DC Voltage)	RV1	AB2 (or W3)	-5.2V±0.2V
+6V (DC Voltage)	RV5	W15	+6V±0.2V
Balance of Read Signal	RV2	W7 W8 (ADX) (AEX)	Refer to (1)
Write Current	RV3	W1 W2	Refer to (2)
Jitter of Read Signal	RV4	W49	Refer to (3)

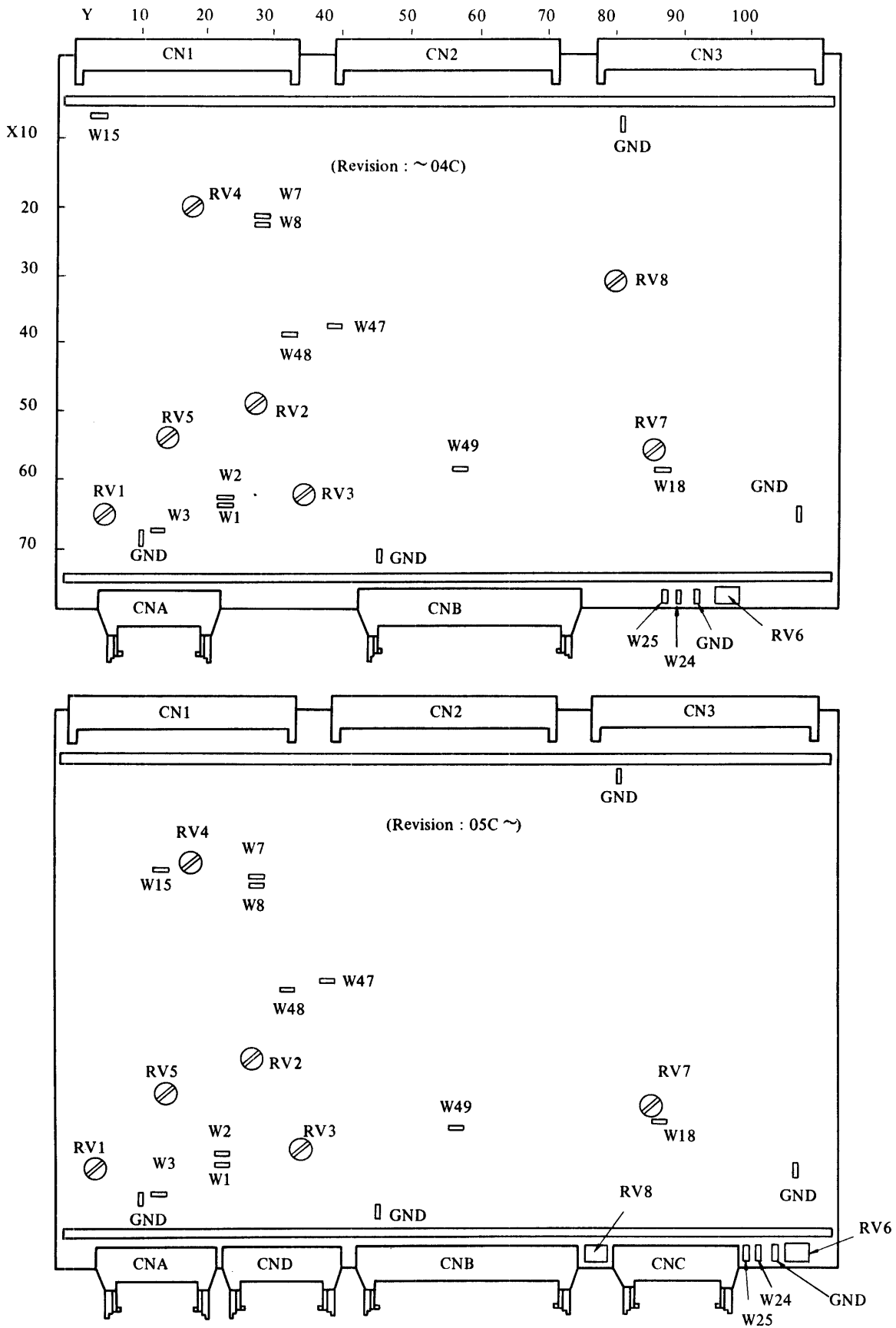

Figure 14.3-1 Variable Resistors on PCB RFJAU

(1) Balance of Read Signal (RV2)

Read the data recorded in Variable Sector Format on Cylinder 00 and Head 01, and adjust RV2 so that the read signal matches Figure 14.3-2.

If the data is recorded in Sector Format, the AMGCL signal is clamped low and the Differential Output continues  $2.6 V_{p-p} \pm 10\%$ .

Verify that, this balanced waveform is maintained on Cylinder 256, 512 and 841 for Head 00 and 01.

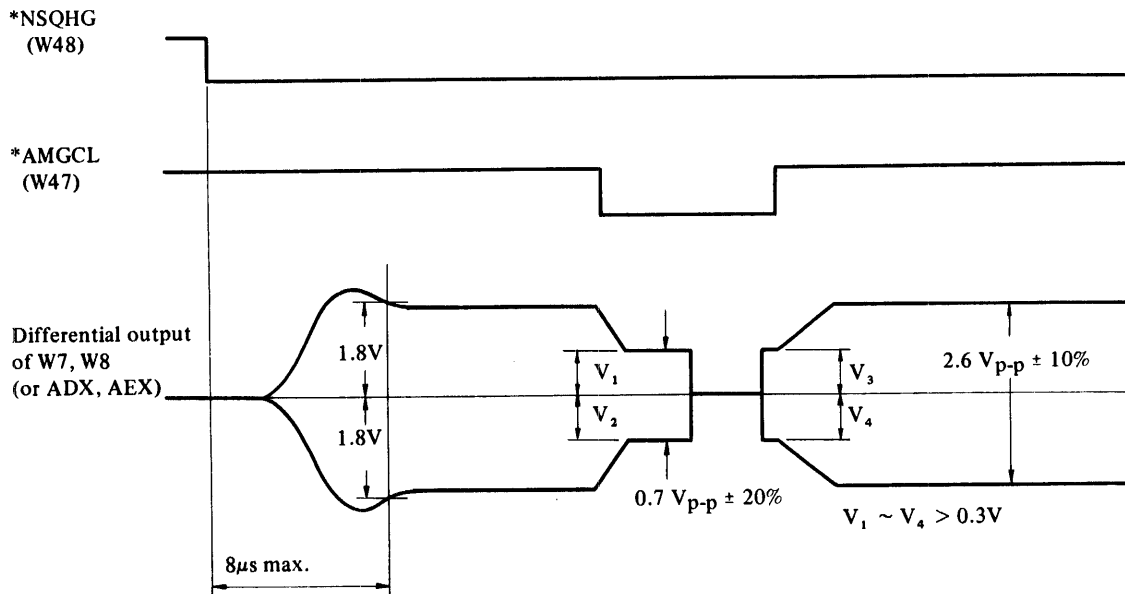

Figure 14.3-2 Balance of Read Signal

(2) Write current (RV3)

Adjust RV3 so that the differential output voltage  $V_5$  (W1 and W2) is  $400 \text{ mV} \pm 20 \text{ mV}$  while writing any data on Cylinder 00 Head 01 (Refer to Figure 14.3-3). Verify that, the voltage is  $500 \text{ mV} \pm 50 \text{ mV}$  on Cylinder 00 Head 00.

For Fixed Head Option, verify that the voltage is  $800 \text{ mV} \pm 80 \text{ mV}$  at Cylinder 896 Head 00 and is  $900 \text{ mV} \pm 100 \text{ mV}$  at Cylinder 897 Head 00 while writing any data.

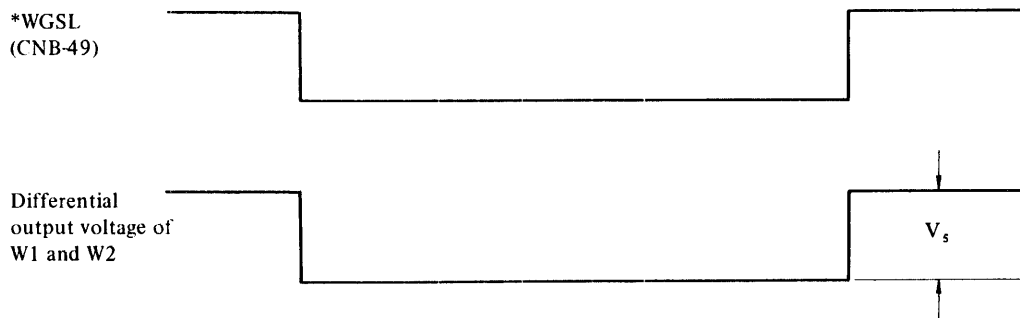

Figure 14.3-3 Write Current Adjustment

(3) Jitter of Read Signal (RV4)

Read the data pattern of "AAAA --- AA", recorded on Cylinder 00 and Head 00.

Adjust RV4 to minimize the jitter at the negative-going edge of the pulses as shown in Figure 14.3-4.

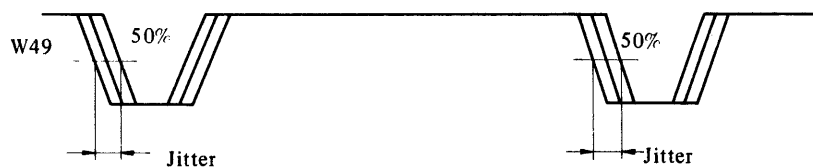

Figure 14.3-4 Jitter of Read Signal Adjustment

#### 14.4 ADJUSTMENT OF VFO CIRCUIT

The following describes how to adjust and test the VFO (Modulator and Demodulator) circuit (PCB RFJAU) in case none of variable resistors have been adjusted. Refer to Table 14.4-1 and Figure 14.3-1 for monitor point and location.

Table 14.4-1 Variable Resistors in VFO Circuit

Item	RV No.	Test point	Specification
VCO Free-running Frequency	RV8	BA9 (or W24)	Refer to (1)
Reference Pulse Width	RV7	W18	Refer to (2)
Phase Adjustment	RV6	W24 W25	Refer to (3)

##### (1) VCO Free-running Frequency (RV8)

Connect CNB-24 (Connector B, Pin 24) to ground, and adjust RV8 so that the pulse period or frequency of BA9 or W24 matches Figure 14.4-1.

Disconnect the cable between CNB-24 and ground after adjust or confirm the item.

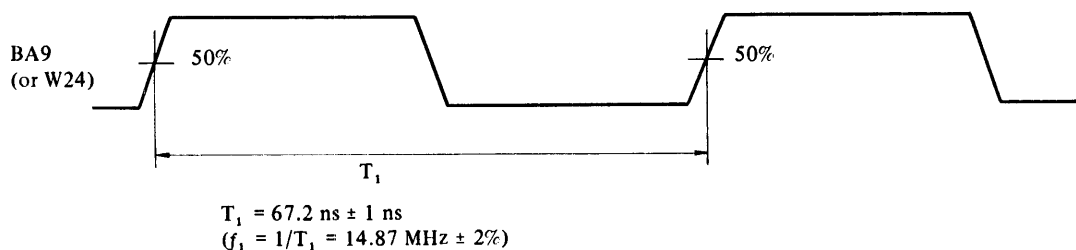

Figure 14.4-1 VCO Free-running Frequency Adjustment



(2) Reference Pulse width (RV7)

Read or write any data, and adjust RV7 so that the pulse width of W18 matches Figure 14.4-2.

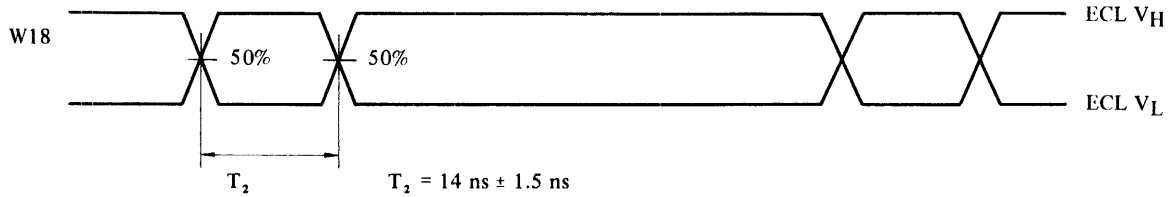

Figure 14.4-2 Reference Pulse width Adjustment

(3) Phase adjustment (RV6)

Read the data pattern of "FF...FF", and adjust RV6 so that the phase between W24 and W25 matches Figure 14.4-3.

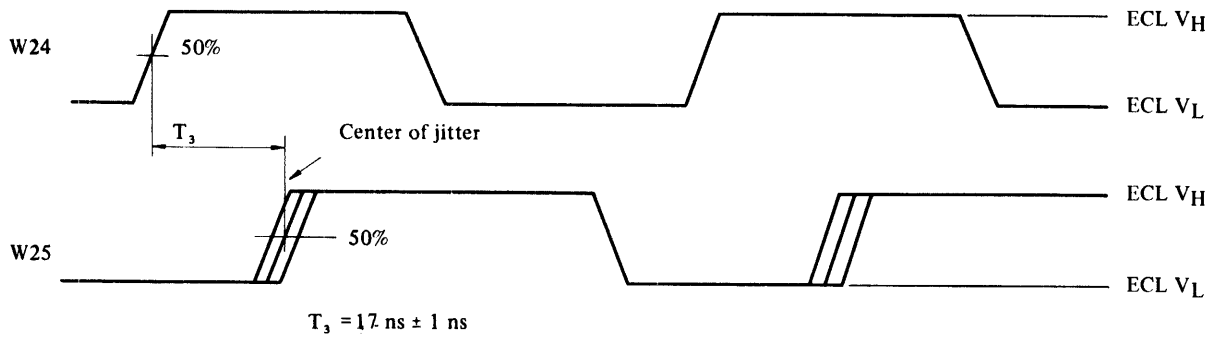

Figure 14.4-1 Phase Adjustment

## CHAPTER 15 TROUBLE SHOOTING

### 15.1 INTRODUCTION

This section contains trouble shooting flow charts according to the error status on the disk unit and control unit.

It is recommended that before any operations, maintenance personnel read carefully Chapter 12 Maintenance and fully understand the details of the procedures and tools required.

Inspect the following items before applying power to the unit.

- (1) Ensure that the AC line conditions satisfy the unit's requirements.
- (2) If the control unit does not utilize Pick/Hold power sequencing lines, select "Local" mode on the power supply unit.
- (3) Verify all connectors are inserted correctly.
- (4) If the unit is in daisy chain with another unit, make sure that the last unit has a line terminator (LTN) installed.
- (5) Verify that the rotary actuator is unlocked.
- (6) Ensure that the logical unit number (LUN) is selected properly and is assigned to only one unit.
- (7) In case of Hard sector mode (fixed sector length), ensure that the correct sector count is set on the PCB 512398.
- (8) Ensure that Tag 4/5, seek end status and response of unit ready are set correctly according to the system configuration.
- (9) Ensure that all PCB assemblies are firmly seated.

## 15.2 ERROR STATE

The disk unit and the control unit will issue the following statuses.

Table 15.2-1 Error Status

NOT READY	Not Ready status indicates disk drive is not ready
FAULT	Fault status indicates a fault condition has occurred in the unit
SEEK ERROR	Seek Error status indicates a seek error has occurred in seek operation
READ ERROR	Read Error status indicates a data error has occurred in read operation
AM MISSING	AM Missing status indicates that AM (Address Mark) has not found in read operation

Maintenance Personnel can see the unit status and error state on the Indicator Unit (HGAMU) and the Operator Panel. Refer to Section 3.7 for detailed unit status and error state, and how to know the error state by unit state indicators (colored LEDs), state indicators (7-segment LEDs) and state switch (Toggle Switch) mounted on the Indicator PCB.

The troubleshooting guide, Table 15.2-2, will help in locating a faulty sub-assembly. Use of the guide is as follows:

- (1) The Fault or Access Check LED must be lit, or the Unit Ready LED must be out. (These LED's are located on the Indicator PCA, HGAMU.) If none of these conditions exist, the drive is not in a fault state and the guide will be of no value.
- (2) The error status as defined by the LED's will be either Not Ready, Fault, or Seek Error (left side of Table 15.2-2).
- (3) Continuing to the right, the LED's also define the only valid switch position to observe the 7-Segment readouts (LP1 and LP2).
- (4) The hexadecimal number displayed is represented binarily in the guide. Thus, if the Fault LED is lit, switch position 0 is selected, and "04" is displayed, you have a Delta I Write Check.
- (5) The flow-charts for all Fault-type errors begin with Figure 15.4-2, as shown in the last column on the right. Looking at the starting points at the top of the pages, Delta I Write Check is found on Sheet 3 of 4.

Table 15.2-2 Error State





Error Status	Indicator Unit (HGAMU)							Indicators on the Operator Panel			Error State	Figure	
	Unit State Indicator (LEDs)			State Indicator Lamp				Fault	Power on	Ready			
	URDY	ACCK	FALT	State Switch	Lamp 1		Lamp 2						
					Bit 1 2 4 8	Bit 1 2 4 8							
Not Ready	Off	-	-	-	- - - -	- - - -	00	-	Off	Off	Power Alarm Hall Alarm DE Sequence Check	Not Ready	15.4-1
	Off	-	-	2	- - - 1	- - - -	80	-	-	Off			
	Off	-	-	1	- - - -	1 - - -	01	-	-	Off			
Fault	-	-	On	0	1 - - -	- - - -	10	On	-	-	Index Check	15.4-2	
	-	-	On	0	- 1 - -	- - - -	20	On	-	-	Control Check		
	-	-	On	0	- - 1 -	- - - -	40	On	-	-	Multi Head Check		
	-	-	On	0	- - - 1	- - - -	80	On	-	-	Head Short Check		
	-	-	On	0	- - - -	1 - - -	01	On	-	-	Write Current On Read Check		
	-	-	On	0	- - - -	- 1 - -	02	On	-	-	Write Transition Check		
	-	-	On	0	- - - -	- - 1 -	04	On	-	-	Delta I Write Check		
	-	-	On	0	- - - -	- - - 1	08	On	-	-	Servo Off-Track		
Seek error	-	On	-	1	- 1 - -	- - - -	20	-	-	-	Access Timeout Check	15.4-3	
	-	On	-	1	- - 1 -	- - - -	40	-	-	-	Over Shoot Check		
Read error	-	-	-	-	- - - -	- - - -	00	-	-	-	Read Error	15.4-4	
AM Missing	-	-	-	-	- - - -	- - - -	00	-	-	-	AM Missing	15.4-5	

### 15.3 TROUBLE SHOOTING SYMBOL

The trouble shooting flow charts contain the procedures to pursue trouble causes starting from error status information.

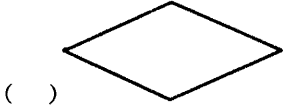
The following conventions are provided to aid understanding the symbols used in the trouble shooting flow charts as shown in Table 15.3-1

Table 15.3-1 Symbol of Flow Chart

Symbol	Description
	<p>Terminal. Starting point of the trouble.</p>
	<p>Decision, go ahead according with YES or NO. (Reference test point.)</p>
	<p>Connector, go ahead same-numbered symbol in the same sheet.</p>
	<p>Connector, go ahead same-numbered symbol in another sheet.</p>
	<p>Process.</p>

## 15.4 TROUBLE SHOOTING FLOW CHART

In this paragraph, the following charts are provided.

Figure 15.4-1 Not Ready

Figure 15.4-2 Fault

Figure 15.4-3 Seek Error

Figure 15.4-4 Read Error

Figure 15.4-5 AM Missing (for only Soft Sector Mode)

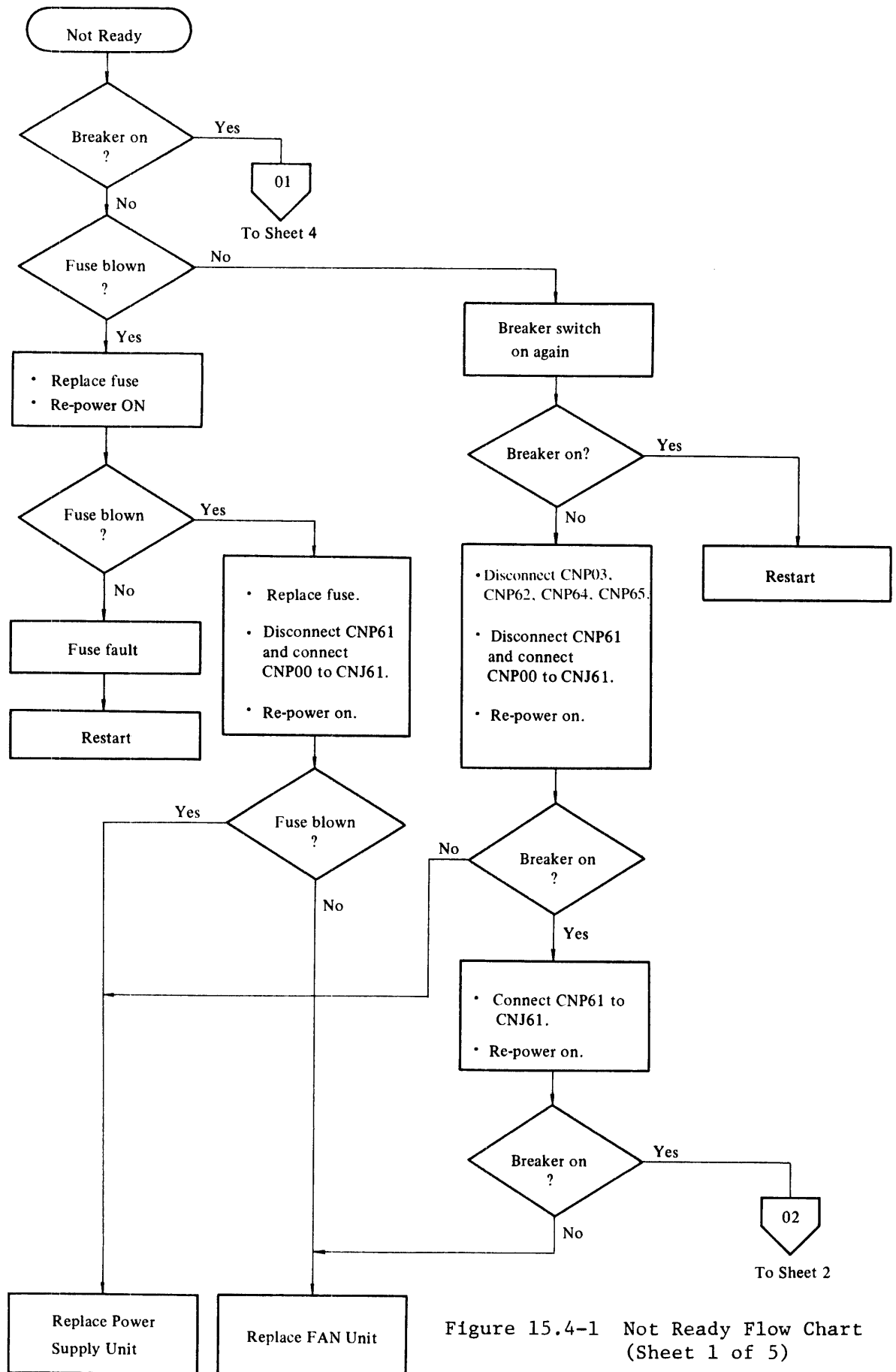

Figure 15.4-1 Not Ready Flow Chart (Sheet 1 of 5)

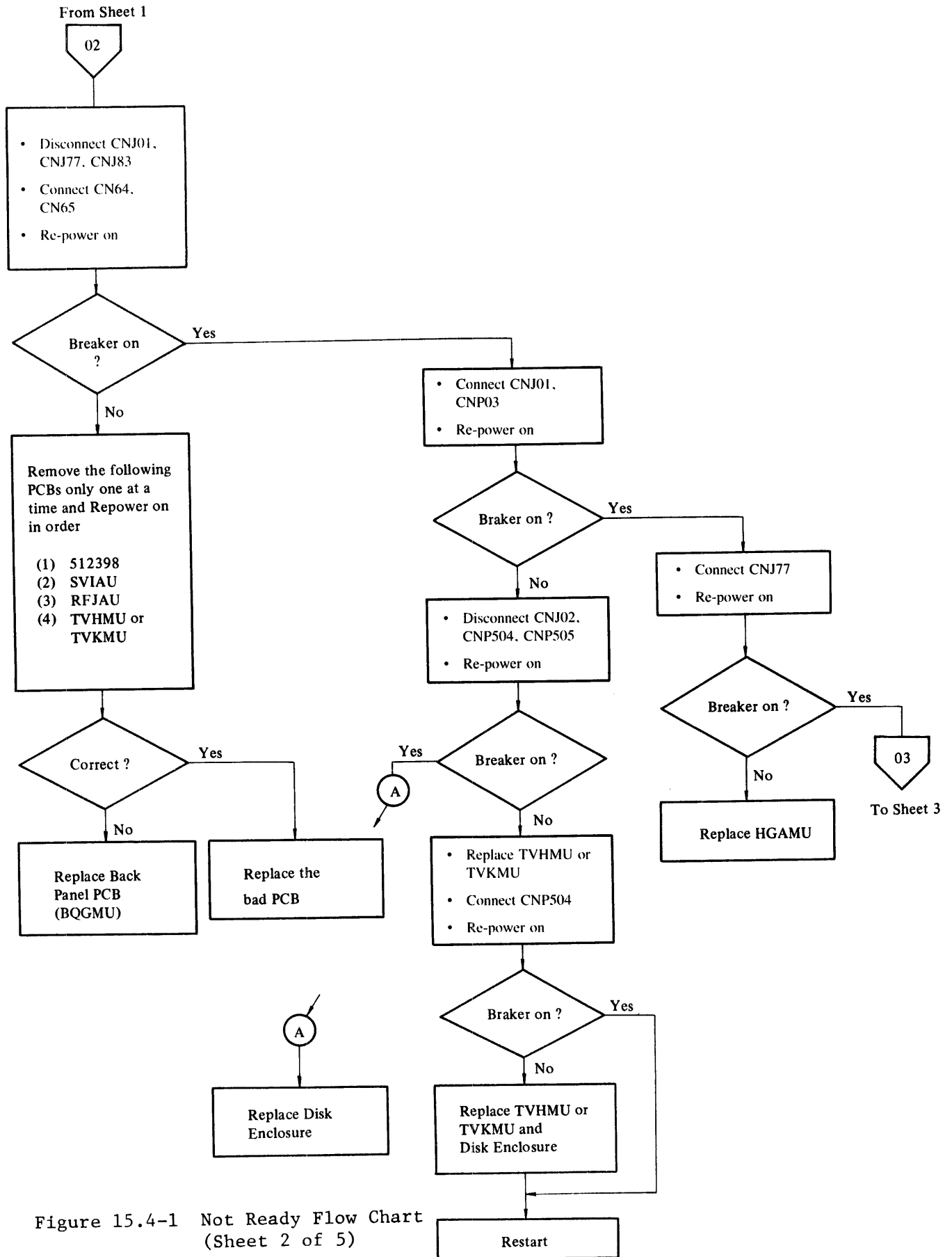

Figure 15.4-1 Not Ready Flow Chart  
(Sheet 2 of 5)



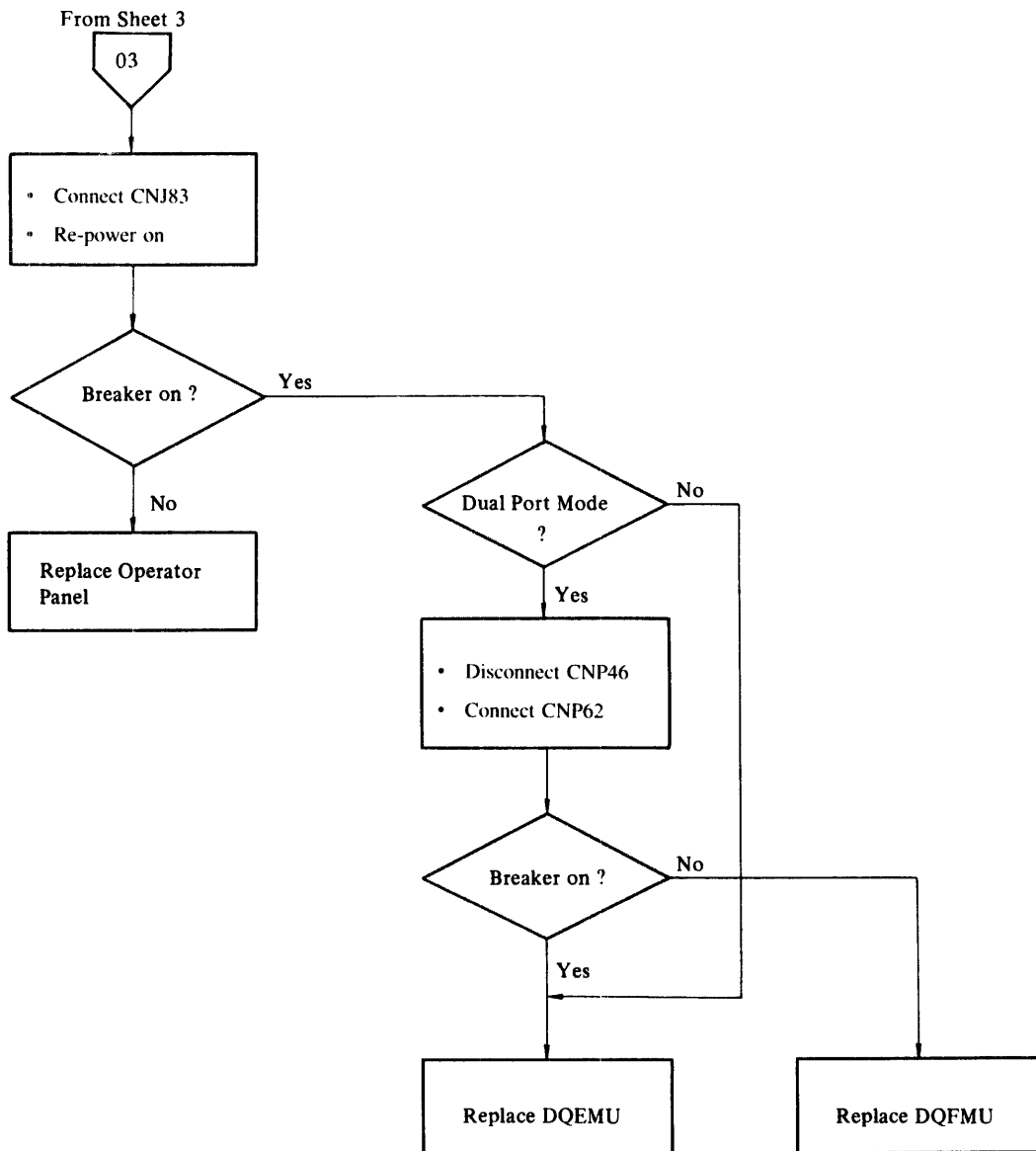

Figure 15.4-1 Not Ready Flow Chart  
(Sheet 3 of 5)

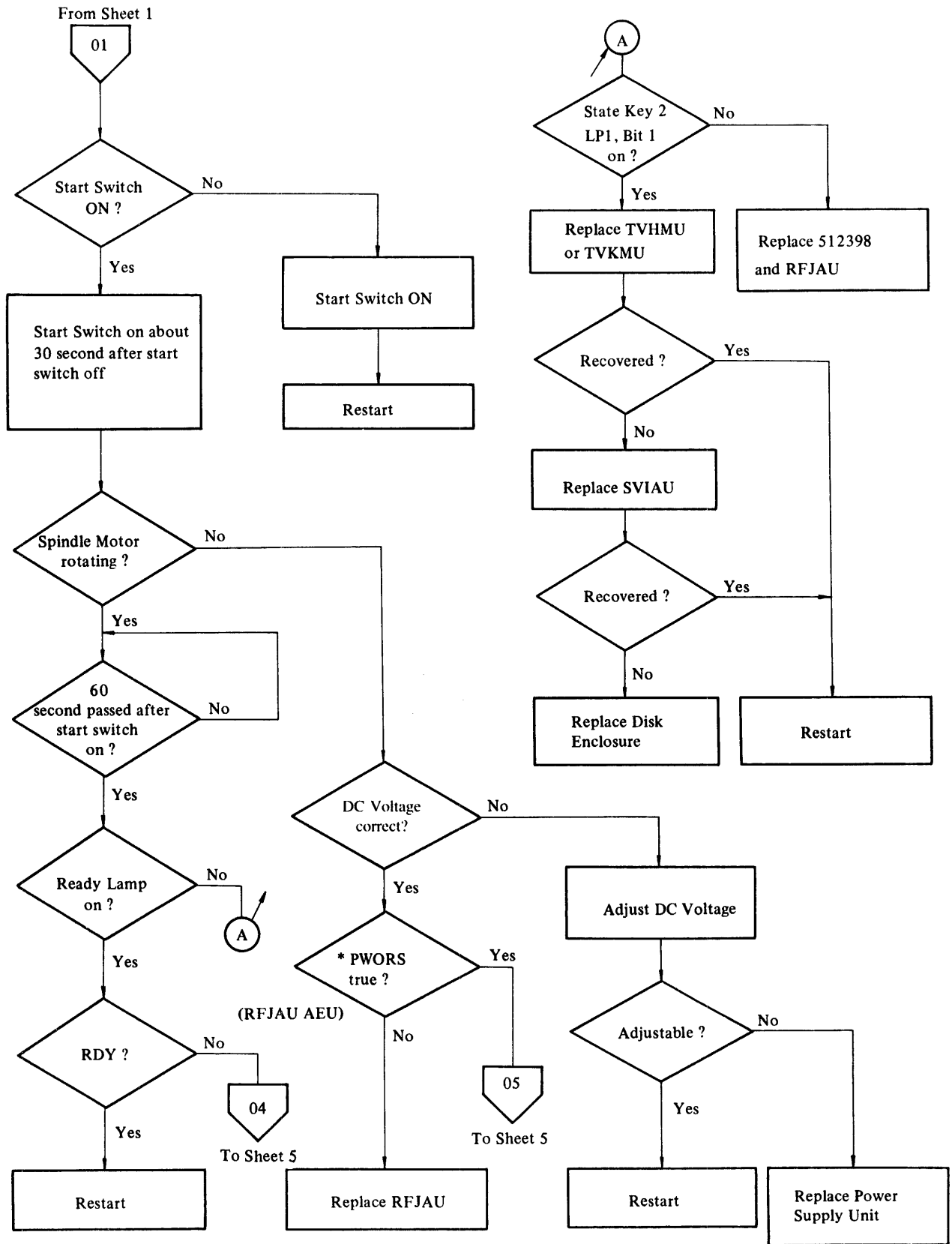

Figure 15.4-1 Not Ready Flow Chart  
(Sheet 4 of 5)

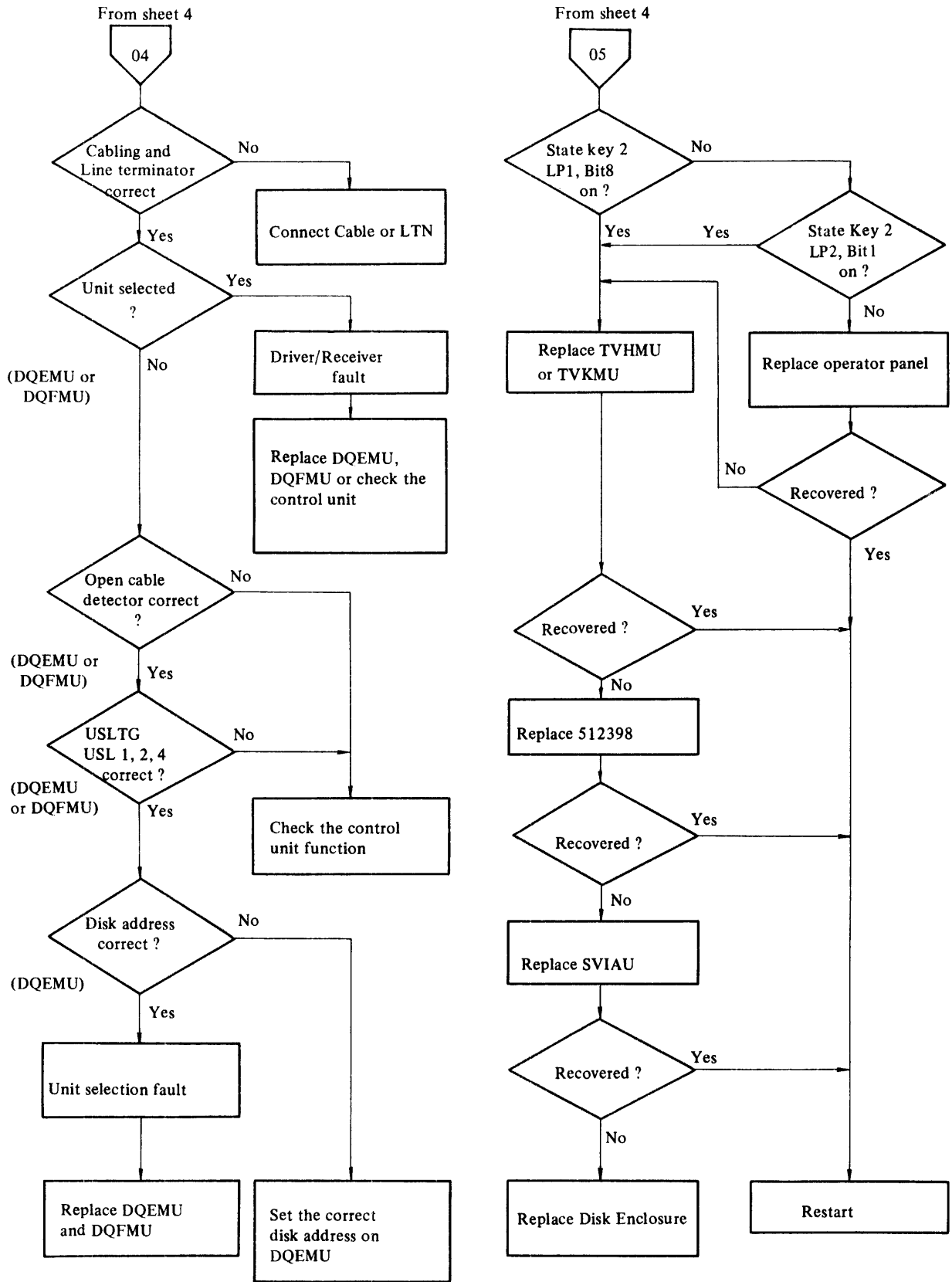

Figure 15.4-1 Not Ready Flow Chart (Sheet 5 of 5)

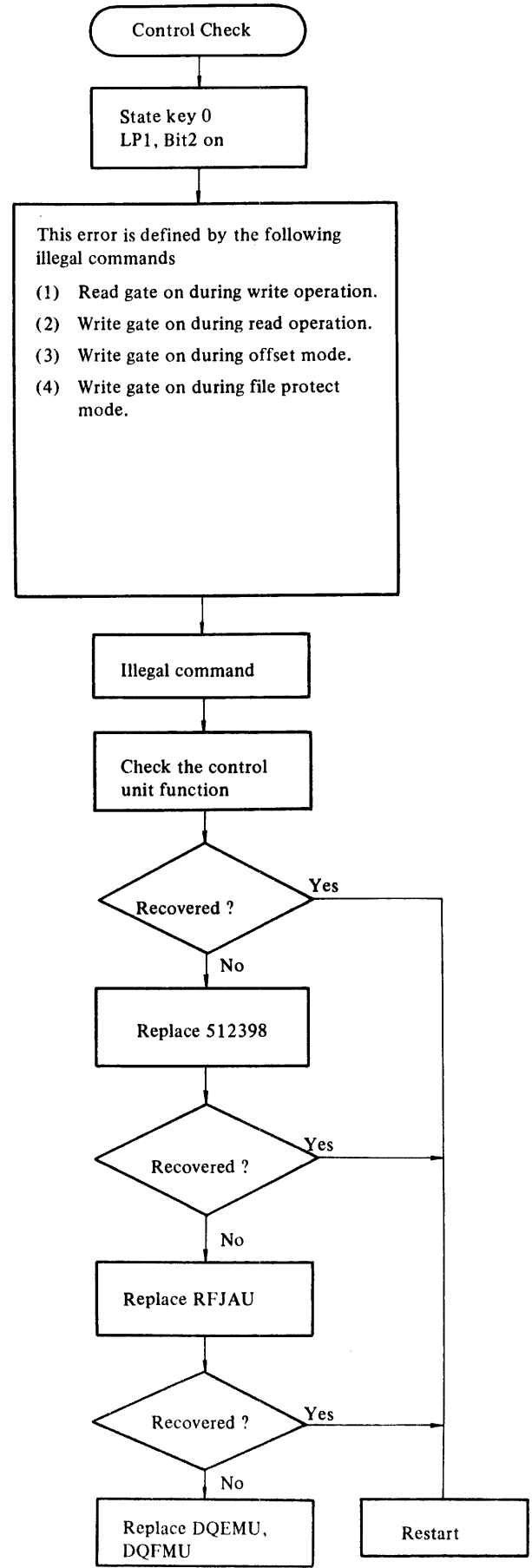
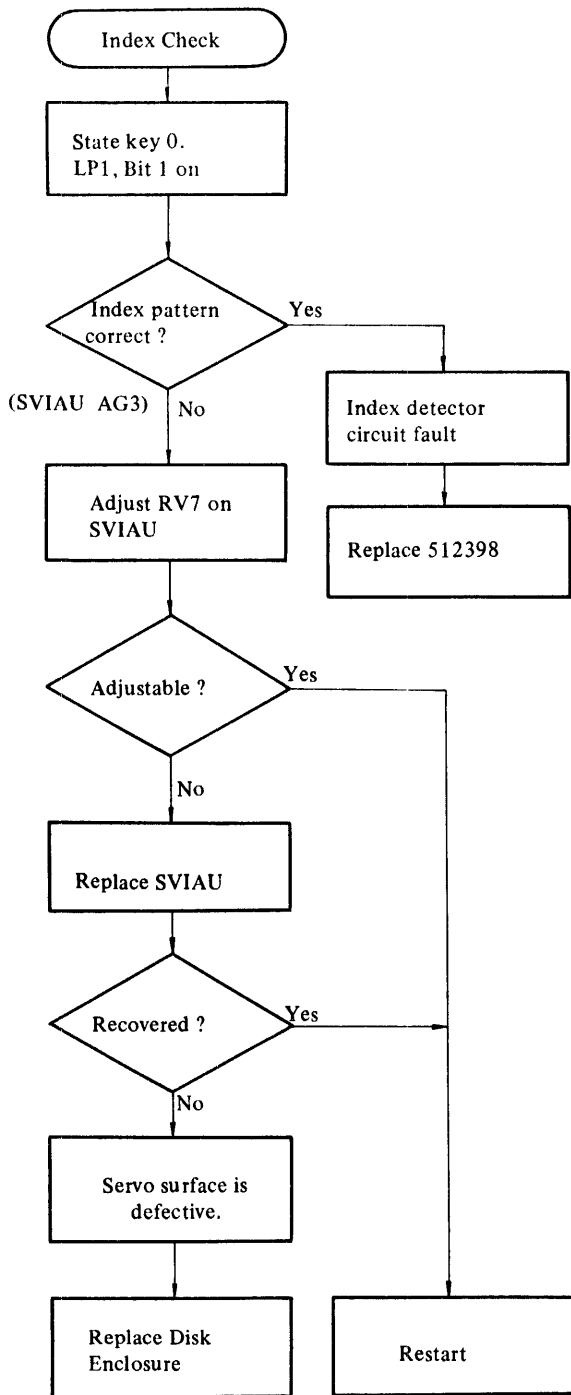

Figure 15.4-2 Fault Flow Chart (Sheet 1 of 4)

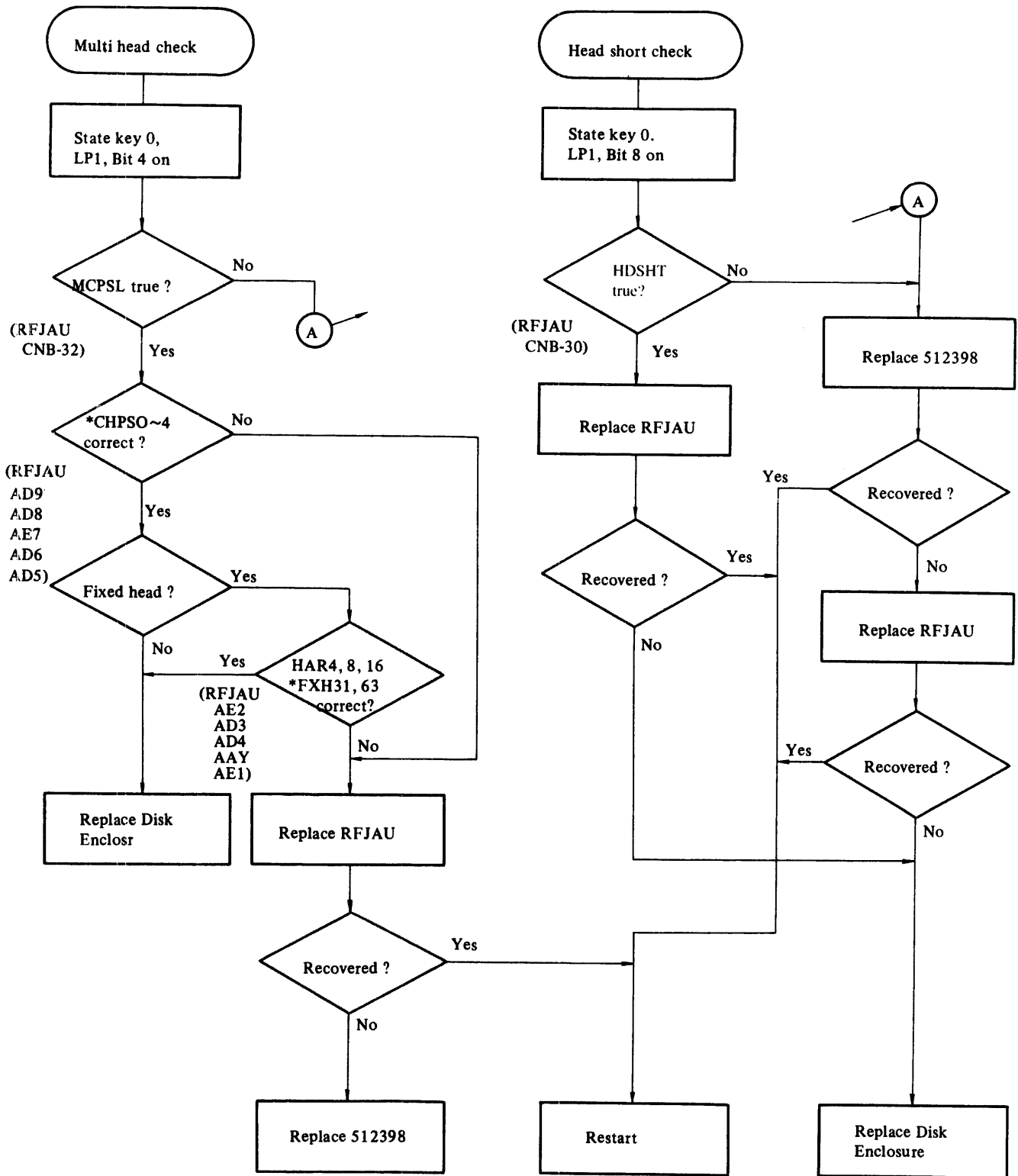

Figure 15.4-2 Fault Flow Chart (Sheet 2 of 4)

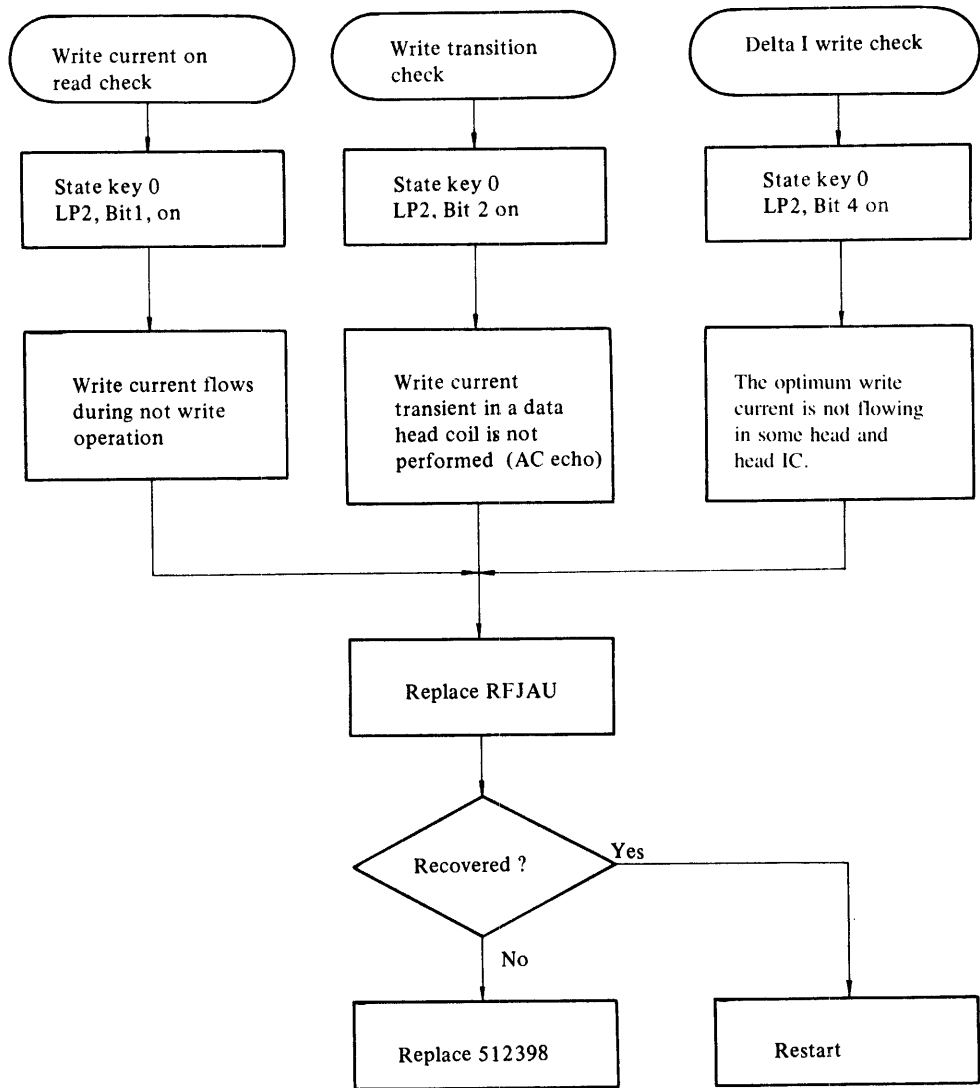

Figure 15.4-2 Fault Flow Chart (Sheet 3 of 4)

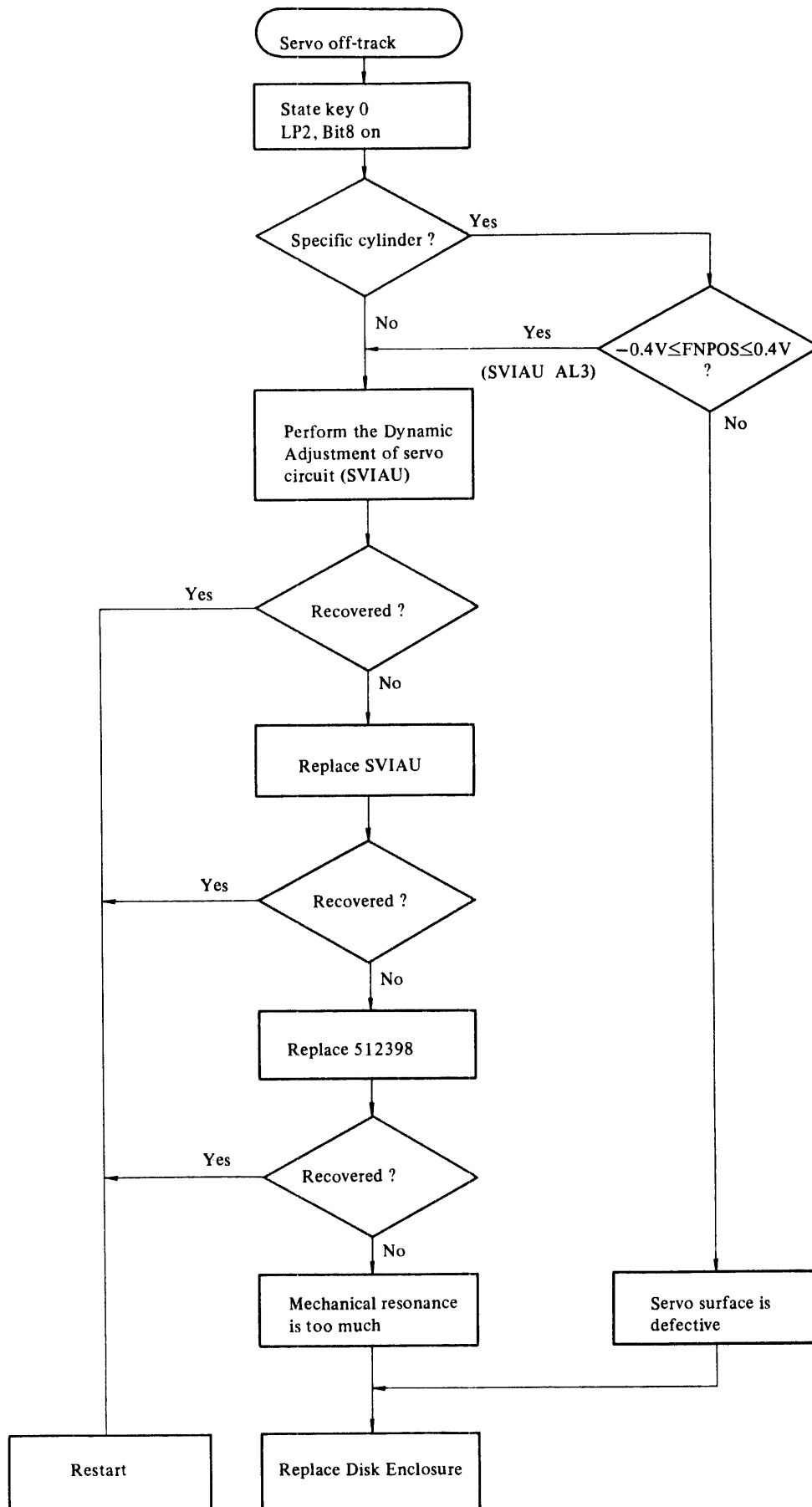

Figure 15.4-2 Fault Flow Chart (Sheet 4 of 4)

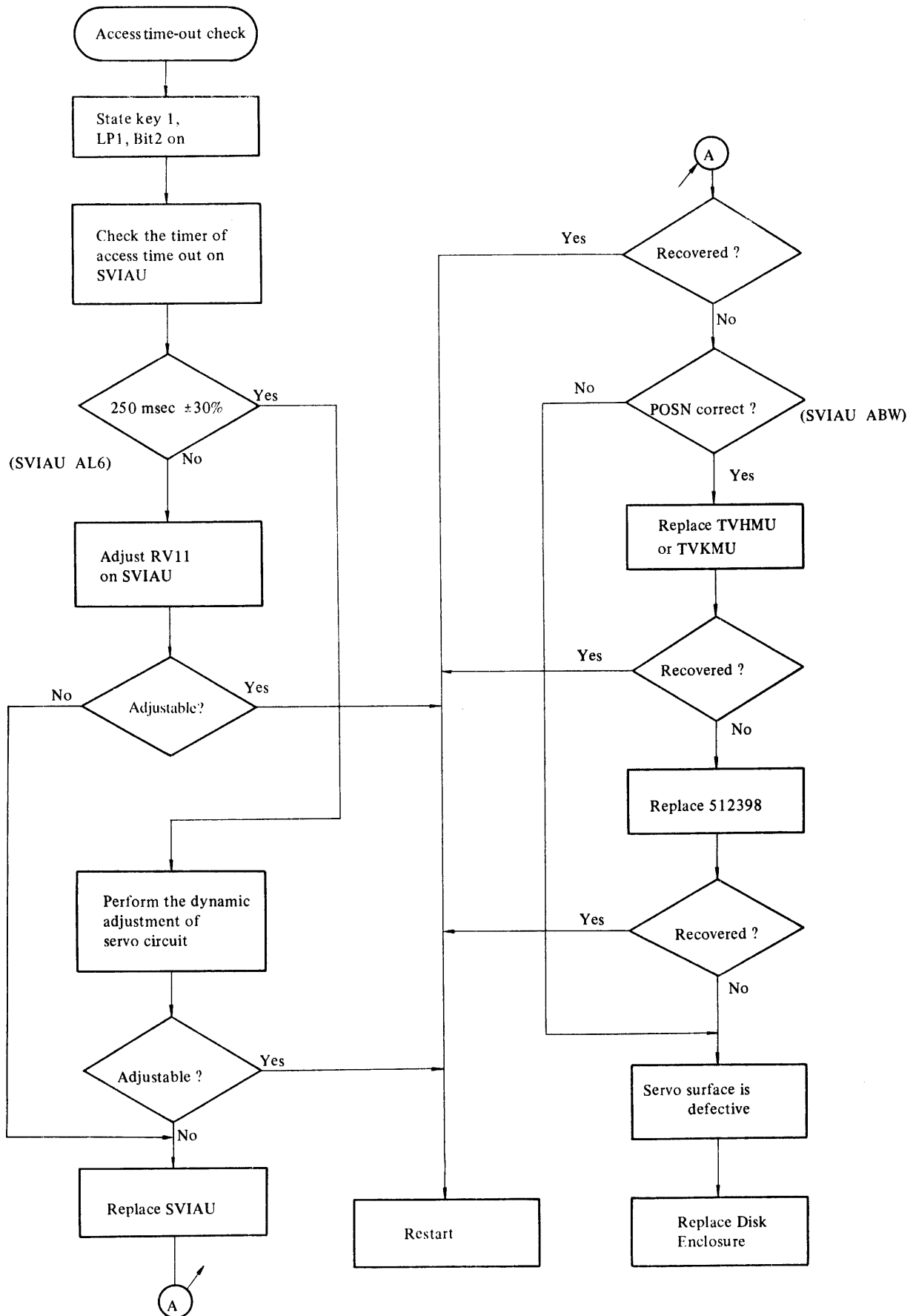

Figure 15.4-3 Seek Error Flow Chart (Sheet 1 of 2)



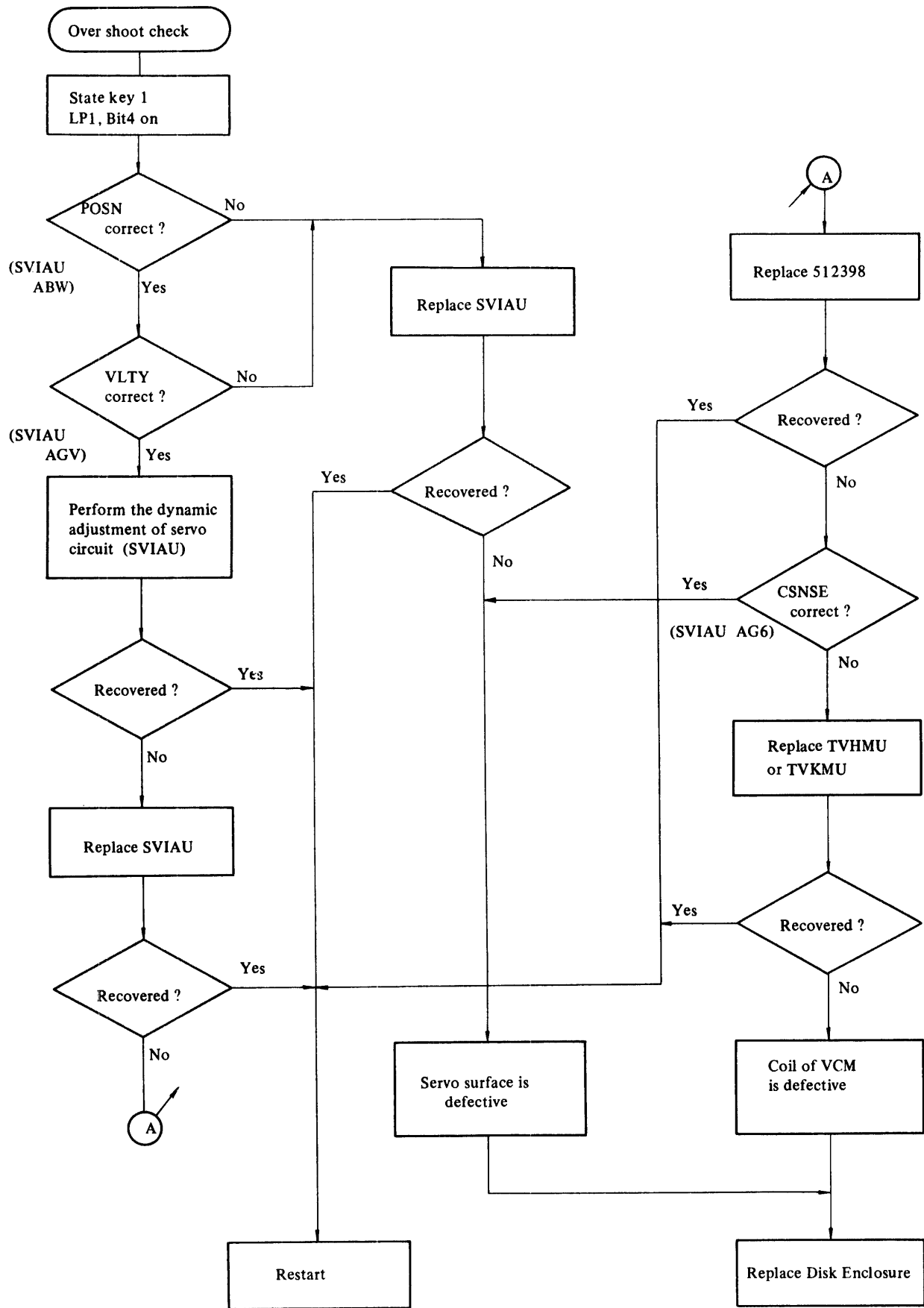
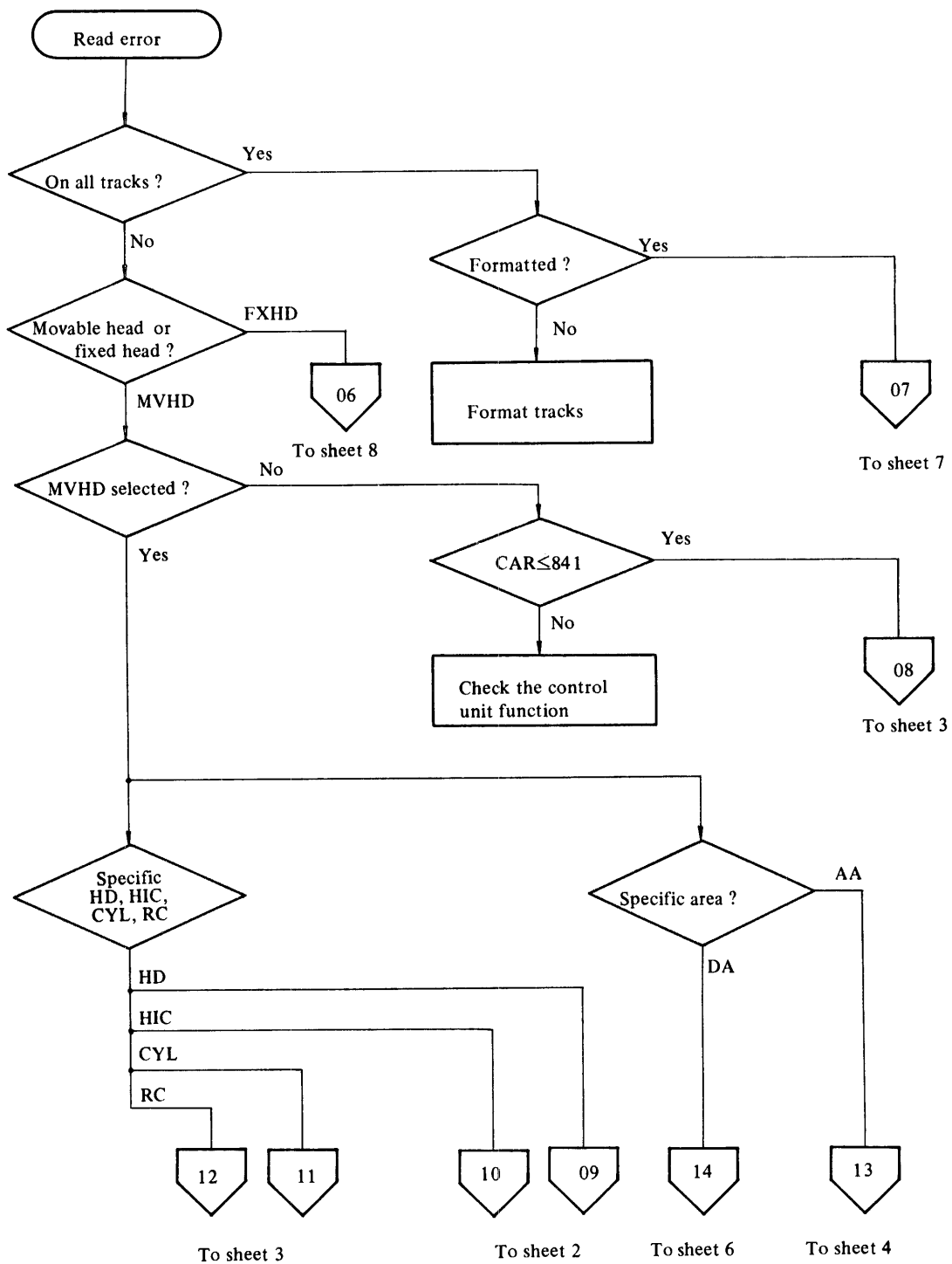

Figure 15.4-3 Seek Error Flow Chart (Sheet 2 of 2)



Note : AA is address area  
 DA is data area  
 HD is head  
 HIC is head IC (or chip)  
 CYL is cylinder  
 RC is record

Figure 15.4-4 Read Error Flow Chart (Sheet 1 of 8)

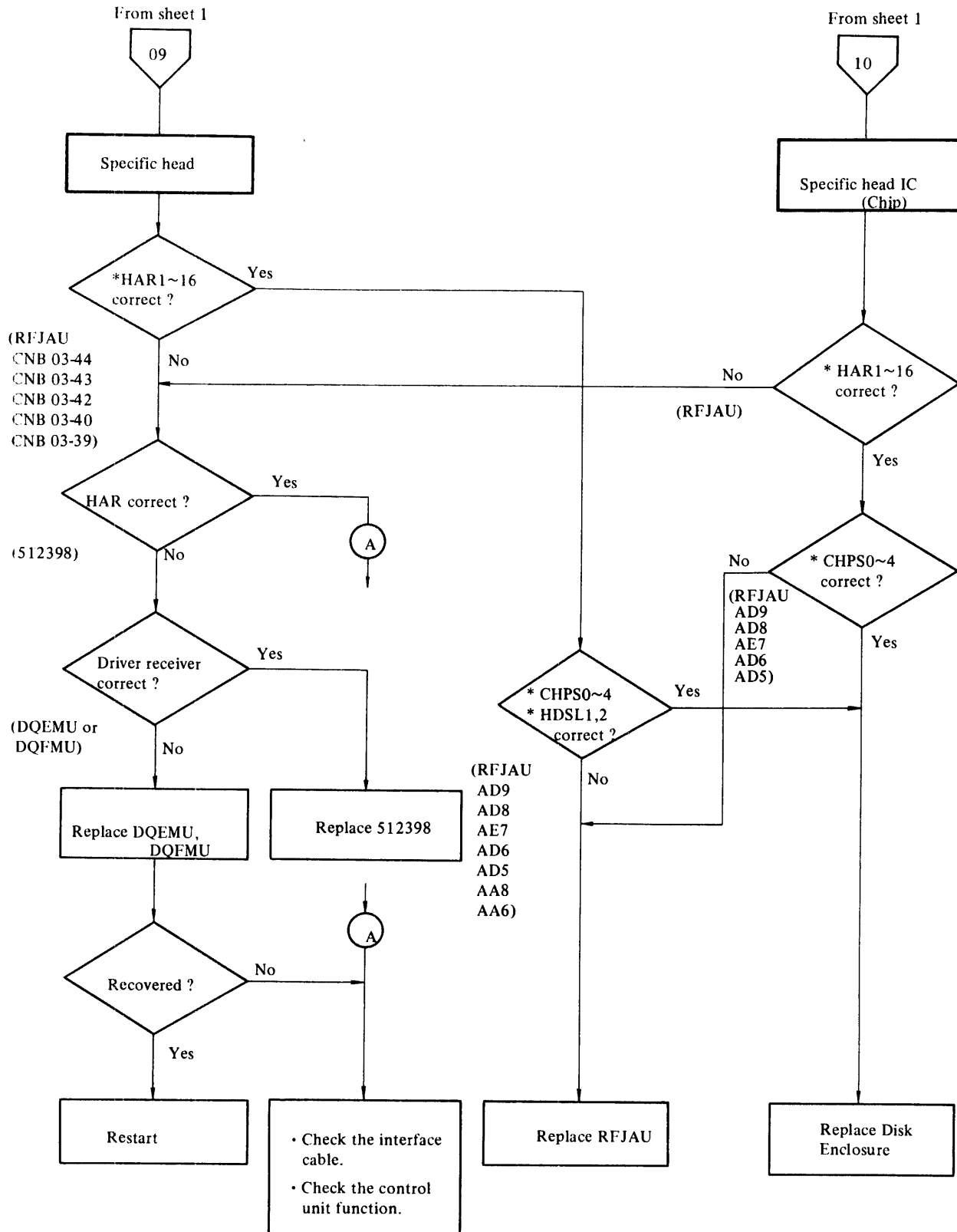

Figure 15.4-4 Read Error Flow Chart (Sheet 2 of 8)

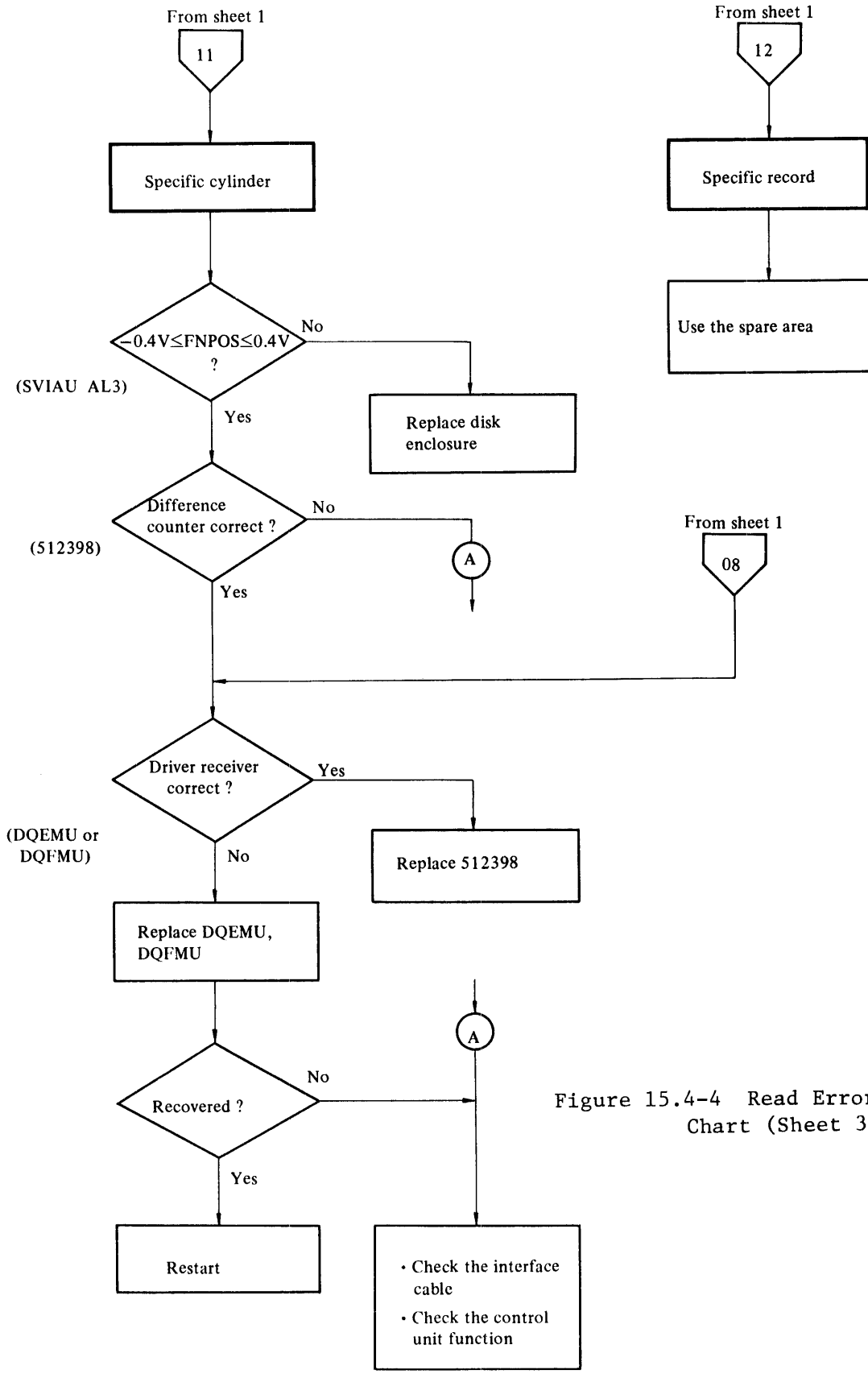

Figure 15.4-4 Read Error Flow Chart (Sheet 3 of 8)

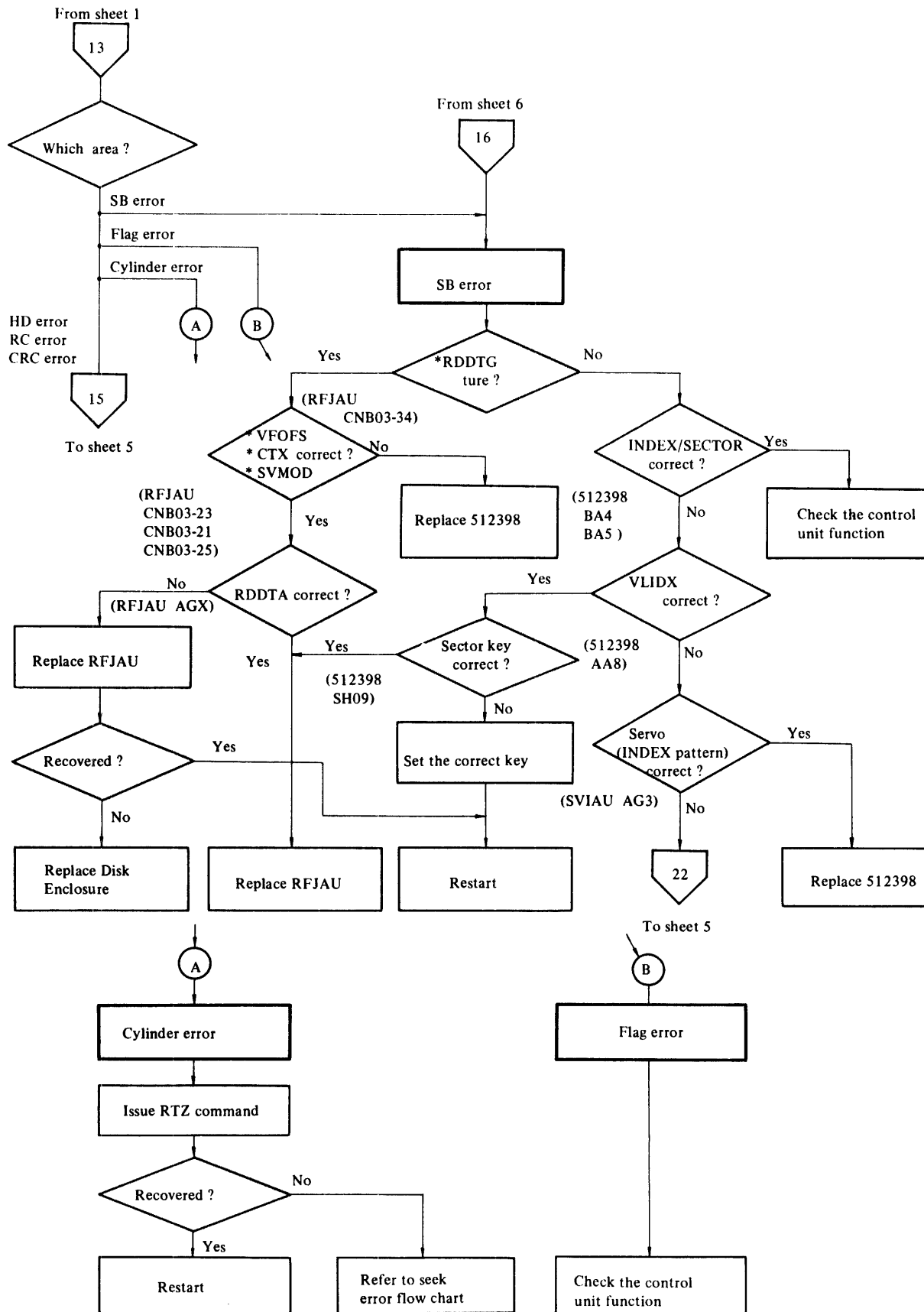

Figure 15.4-4 Read Error Flow Chart (Sheet 4 of 8)

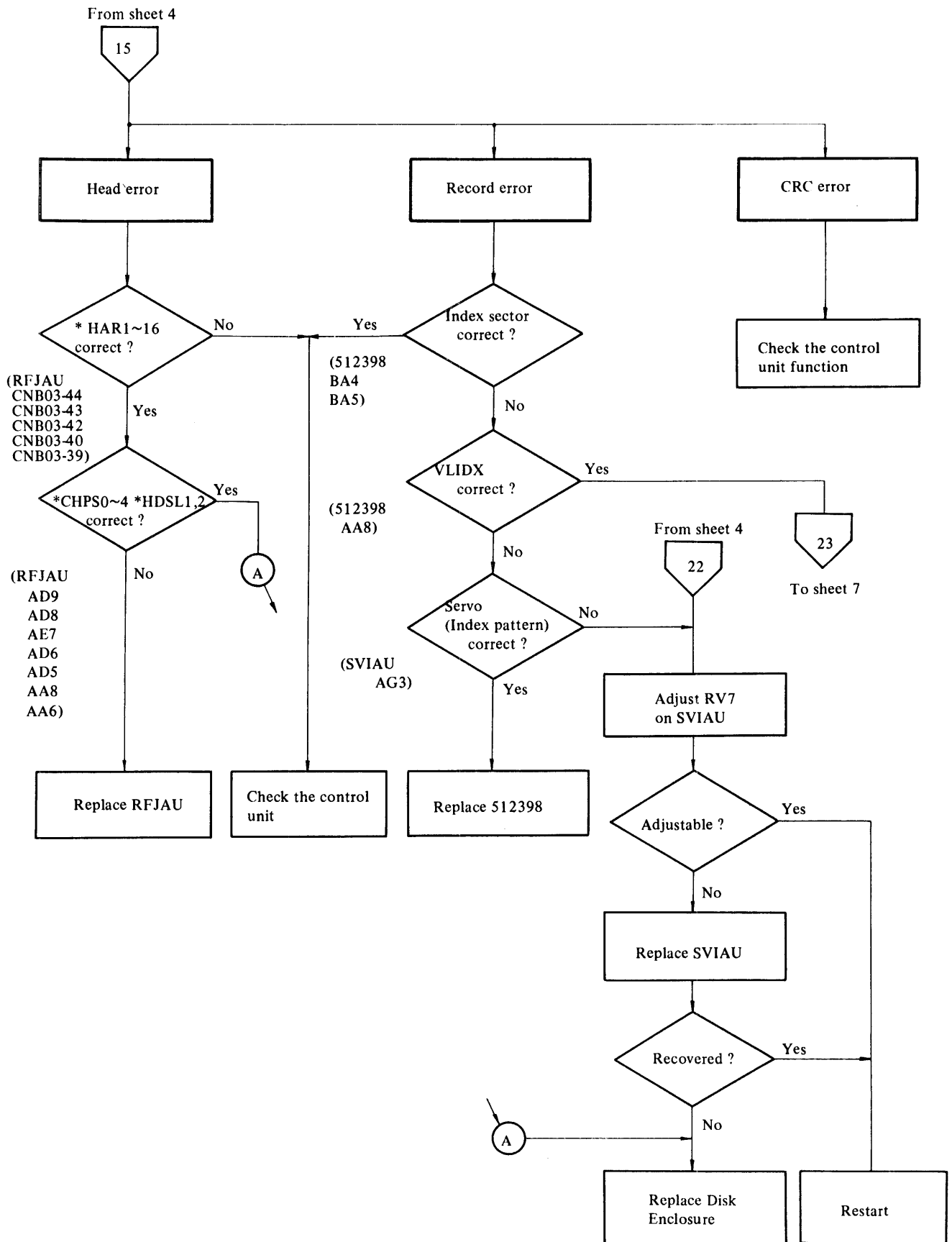

Figure 15.4-4 Read Error Flow Chart (Sheet 5 of 8)

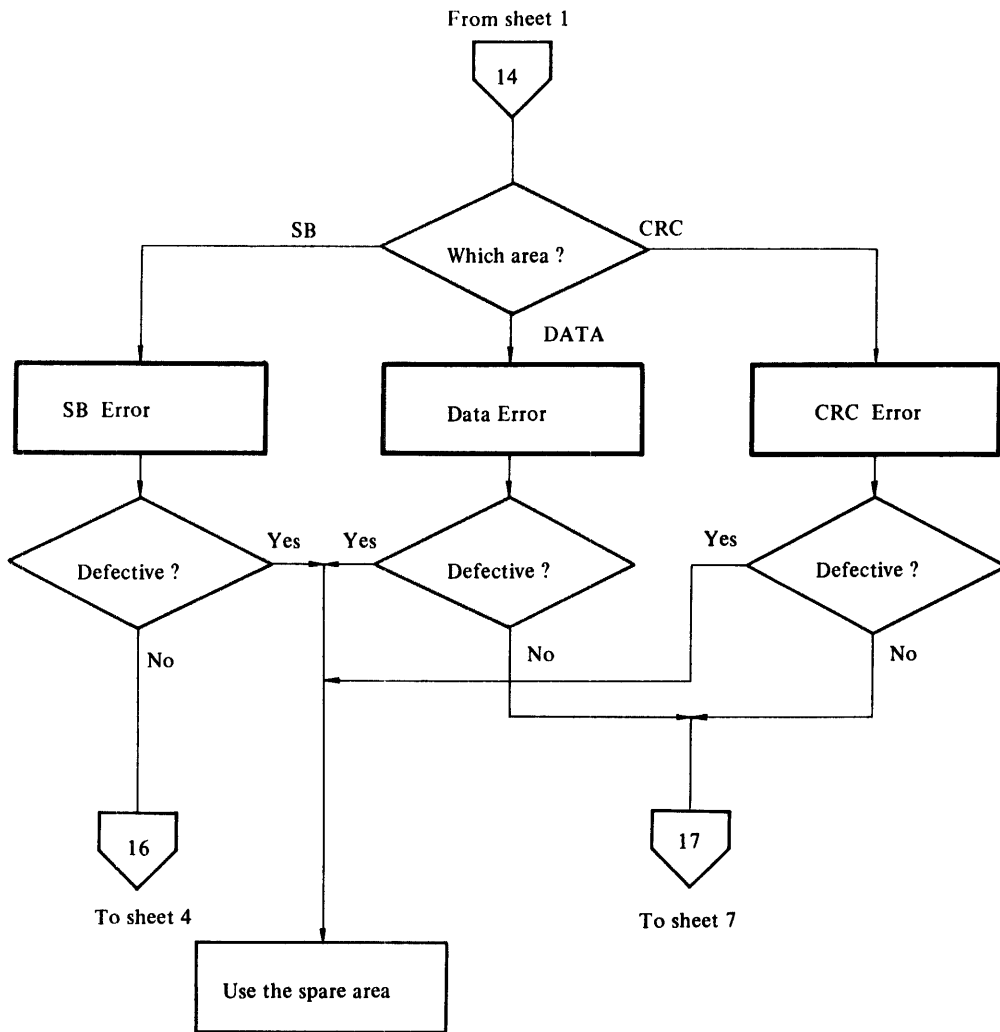

Figure 15.4-4 Read Error Flow Chart (Sheet 6 of 8)

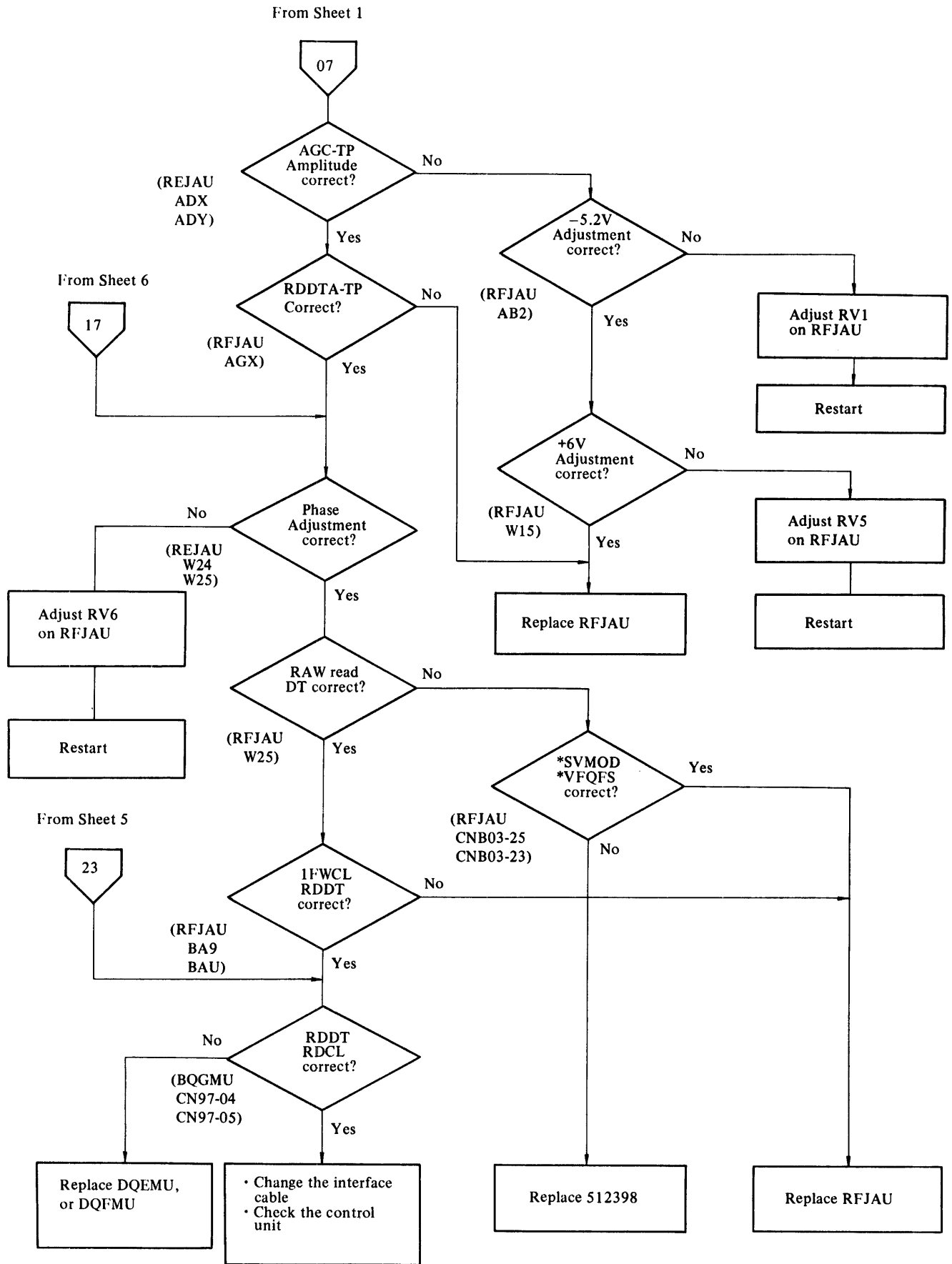

Figure 15.4-4 Read Error Flow Chart (Sheet 7 of 8)



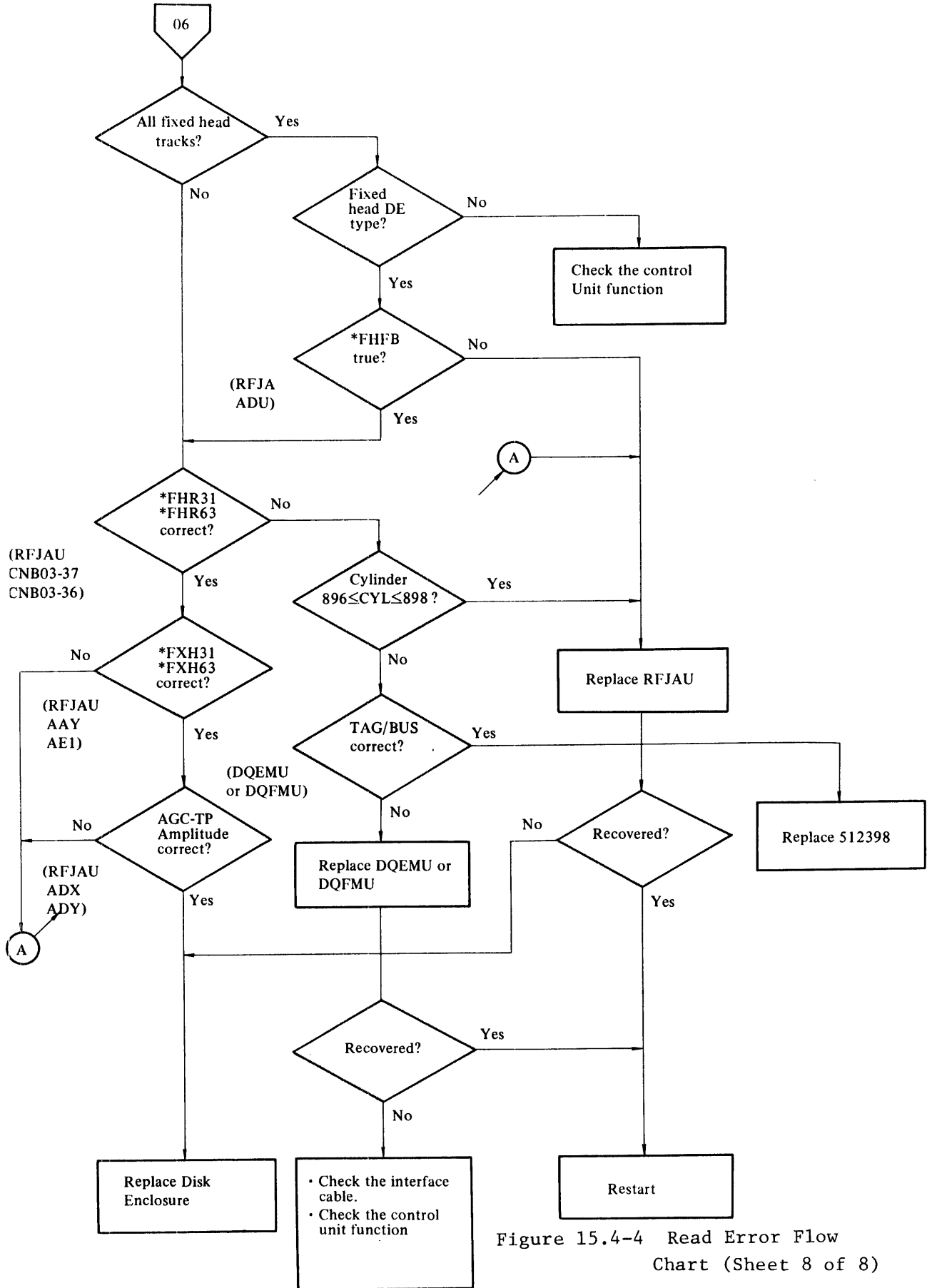

Figure 15.4-4 Read Error Flow Chart (Sheet 8 of 8)

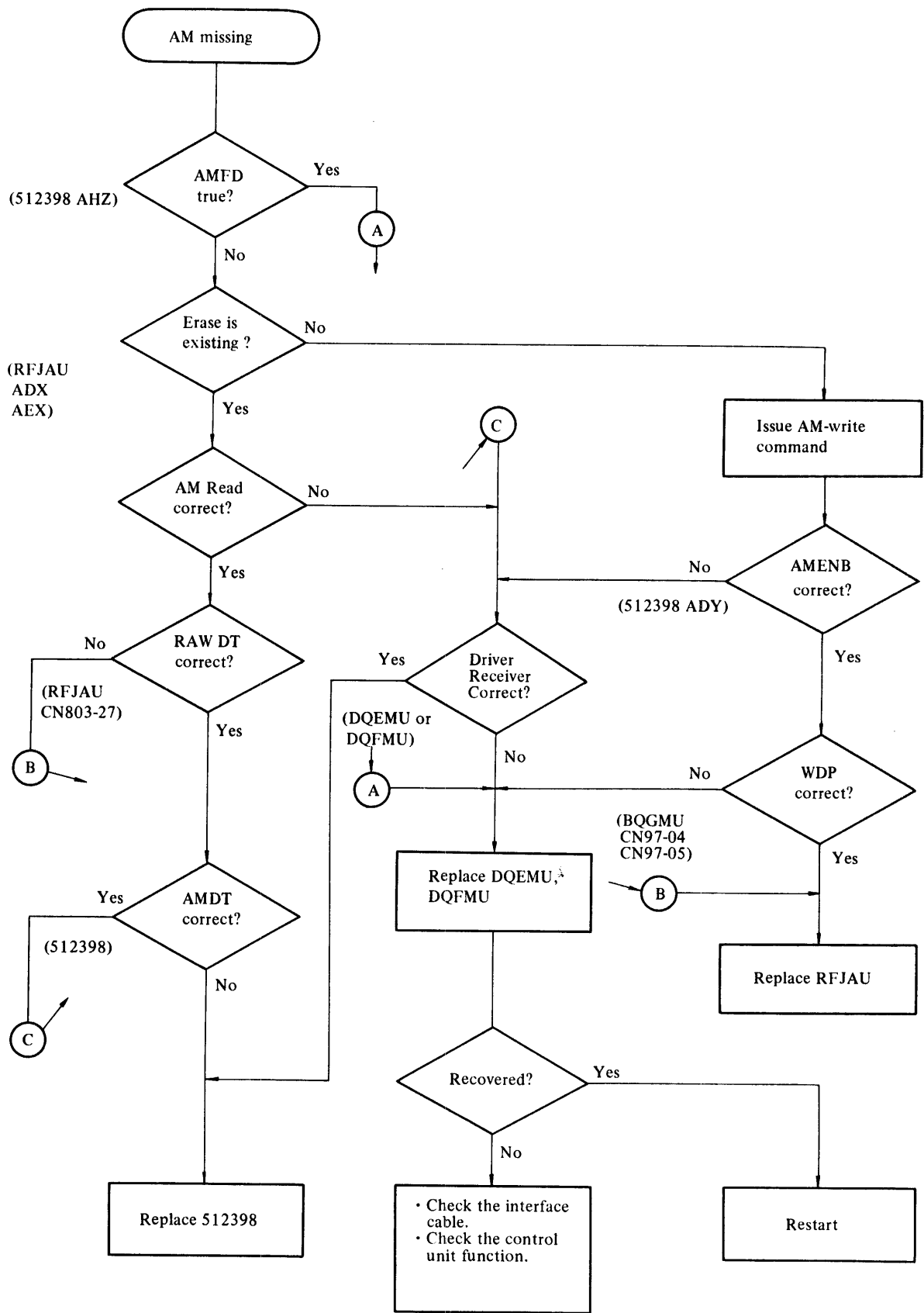

Figure 15.4-5 AM Missing Flow Chart (Sheet 1 of 1)



## 16.1 INTRODUCTION

This section describes the functions and interchangeability of TTL, ECL and Linear ICs used in the drive.

The specifications of input and output voltage level for each kind of IC are listed in Table 16.1-1.

Table 16.1-1 Input/Output Level

	Input (V)		Output (V)	
	High	Low	High	Low
TTL Medium Speed	5.5 ~ 2.0	0.8 ~ -0.5	5.25 ~ 2.4	0.4 ~ 0
TTL Schottkey	5.5 ~ 2.0	0.8 ~ -0.3	5.25 ~ 2.7	0.5 ~ 0
TTL Low Power Schottkey	5.5 ~ 2.0	0.8 ~ -0.3	5.25 ~ 2.7	0.4 ~ 0
ECL	-0.81 ~ -1.105	-1.475 ~ -1.85	-0.81 ~ -0.98	-1.63 ~ -1.85

Logical "1" and "0" correspond to high and low level respectively for input or output of each kind of IC.

16.2 INTERCHANGEABILITY

(1) TTL (SSI/MSI)

FUJITSU		Direct Replacement	Function	Ref. No.
Type No.	Marking			
MB74LS00M	LS00	SN74LS00N	Quad 2-Input NAND	1
MB74LS01M	LS01	SN74LS01N	Quad 2-Input NAND . Open Collector	2
MB74LS02M	LS02	SN74LS02N	Quad 2-Input NOR	3
MB74LS04M	LS04	SN74LS04N	Hex Inverter	5
MB74LS05M	LS05	SN74LS05N	Hex Inverter . Open Collector	6
MB74LS08M	LS08	SN74LS08N	Quad 2-Input AND	8
MB74LS10M	LS10	SN74LS10N	Triple 3-Input NAND	9
MB74LS11M	LS11	SN74LS11N	Triple 3-Input AND	10
MB74LS20M	LS20	SN74LS20N	Dual 4-Input NAND	11
MB74LS21M	LS21	SN74LS21N	Dual 4-Input AND	12
MB74LS27M	LS27	SN74LS27N	Triple 3-Input NOR	13
MB74LS32M	LS32	SN74LS32N	Quad 2-Input OR	14
MB74LS37M	LS37	SN74LS37N	Quad 2-Input NAND Buffer	1
MB74LS42M	LS42	SN74LS42N	BCD to Decimal Decoder	16
MB74LS74AM	LS74	SN74LS74N	Dual D-Type Flip-Flop	17
MB74LS85M	LS85	SN74LS85N	4-bit Magnitude Comparator	18
MB74LS86M	LS86	SN74LS86N	Quad 2-Input EOR	19
MB74LS107M	LS107	SN74LS107N	Dual J-K Flip-Flop	20
MB74LS153M	LS153	SN74LS153N	Dual 4 to 1 Data Selector/Multiplexer	21
MB74LS155M	LS155	SN74LS155N	Dual 2 to 4 Decoder	22
MB74LS161AM	LS161	SN74LS161N	4-bit Binary Counter	23
MB74LS164M	LS164	SN74LS164N	8-bit Shift Register	24
MB74LS175M	LS175	SN74LS175N	Quad D-Type Flip-Flop	15
MB74LS191M	LS191	SN74LS191N	4-bit Up/Down Counter	25
(None)	LS279	SN74LS279N	Quad R-S Latch	26
MB74LS283M	LS283	SN74LS283N	4-bit Full Adder	27
(None)	LS123	SN74LS123	Dual Monostable	28
(None)	LS221	SN74LS221	Dual Monostable	29
MB400M	LA01	SN7400N	Quad 2-Input NAND	1
MB418M	LA18	SN7404N	Hex Inverter	5
MB463M	463	SN7438N	Quad 2-Input NAND . Open Collector	30
MB434M	434	SN75451BP	Dual 2-Input AND Buffer	31
MB435M	435	SN7437N	Quad 2-Input NAND Buffer	32
MB439M	439	SN75450BN	Dual 2-Input AND Buffer	33
MB440M	440	SN74123N	Dual Monostable	28
MB443M	LA23	SN74145N	BCD to Decimal Decoder	34
(None)	LX32	SN7406	Hex Inverter	7
(None)	LX26	SN74157	Quad D-Type Flip-Flop	15
(None)	LX34	SN74193	4-bit Binary Up/Down Counter	35
(None)	LX27	SN74221	Dual Monostable	29
(None)	LX16	SN75452	Dual NAND Driver	36
MB74S00M	S00	SN74S00N	Quad 2-Input NAND	1
MB74S03M	S03	SN74S03N	Quad 2-Input NAND . Open Collector	4
MB74S04M	S04	SN74S04N	Hex Inverter	5
MB74S11M	S11	SN74S11N	Triple 3-Input AND	10
(None)	S112	SN74S112N	Dual J-K Flip-Flop	37
(None)	S153	SN74S153N	Dual 4 to 1 Data Selector /Multiplexer	21
(None)	75107A	SN75107AN	Dual Receiver	38
(None)	75108A	SN75108AN	Dual Receiver	38
(None)	75110	SN75110A	Dual Dreiver	39

Note: Direct replacements are ICs of TEXAS INSTRUMENTS INCORPORATED.

## (2) TTL (Bipolar 500-Gate Master Slice LSI)

FUJITSU		Direct Replacement	Function	Ref. No.
Type No.	Marking			
MB15139C	15139	(None)	Access Control	40
MB15140C	15140	(None)	HDA Sequencer	41

Note: All ICs are FUJITSU original.

## (3) TTL (Bipolar 200-Gate Master Slice LSI)

FUJITSU		Direct Replacement	Function	Ref. No.
Type No.	Marking			
MB14601M	14601	(None)	Linear Motor Control	42
MB14613M	14613	(None)	Servo Pattern Detector	43

Note: All ICs are FUJITSU original.

## (4) ECL 10K

FUJITSU		Direct Replacement	Function	Ref. No.
Type No.	Marking			
MB10101C	101	MC10101L	Quad 2-Input OR/NOR	44
MB10102C	102	MC10102L	Quad 2-Input NOR	45
MB10105C	105	MC10105L	Triple 2-3-2 OR/NOR	46
MB10106C	106	MC10106L	Triple 4-3-3 NOR	47
MB10109C	109	MC10109L	Dual 4-5 Input OR/NOR	48
MB10116C	116	MC10116L	Triple Line Receiver	49
MB10124C	124	MC10124L	Quad TTL to ECL Translator	50
MB10125C	125	MC10125L	Quad ECL to TTL Translator	51
MB10131C	131	MC10131L	Dual D-Type Flip-Flop	52
MB10135C	135	MC10135L	Dual J-K Flip-Flop	53
(None)	(None)	HD103107	Voltage Controlled Oscillator	54

Note: MC is MOTOROLA Semiconductor Products Inc..

HD is Hitachi, Ltd..

## (5) Analog Master-Slice LSI

FUJITSU		Direct Replacement	Function	Ref. No.
Type No.	Marking			
MB4306C	A4306	(None)	Voltage Controlled Oscillator A	55
MB4311C	A4311	(None)	Level Senser	56
MB4313C	A4303	(None)	AGC Amp.	57
MB4316C	A4316	(None)	Read/Write Bus Switch C	58
MB4319C	A4319	(None)	Peak Hold	59
MB4112	A4112	SSI105	Disk Head IC (Fixed Head)	60
MB4113	A4113	(None)	Disk Head IC (Movable Head)	60

Note: SSI is Silicon Systems Inc..

## (6) Analog IC

FUJITSU		Direct Replacement	Function	Ref. No.
Type No.	Marking			
MB4002M	A4002		High Speed Differential Comparator	61
MB3607M	A1458	MC1458	Dual Operational Amplifier	62
MB3501M	A733	$\mu$ A733DM	Differential Video Amplifier	63
MB5365AM	Q5365M		NPN Dual Transistors	64
(None)	A142	$\mu$ PC142A	Negative Voltage Regulator	65
(None)	A741	$\mu$ PC151C	Frequency Compensated Op. Amp.	66
(None)	A318	$\mu$ PC159A	High Speed Wide Band Op. Amp.	67
(None)	A311	$\mu$ PC271C	Voltage Comparator	68
(None)	A610	$\mu$ PC610D	10-Bit D/A Converter	69
(None)	Q049AX	$\mu$ PA49A	PNP Dual Transistors	70
(None)	A201	DG201BK	Quad Analog Switches	71
(None)	A555M	M51841P	Timing Circuit	72
(None)	A1590	MC1590G	AGC Amplifier	73

Note: MC is MOTOROLA Semiconductor Products Inc..

$\mu$ A is Fairchild Camera and Instrument Corporation.

$\mu$ PC and  $\mu$ PA are NIPPON Electric Co., Ltd..

DG is Siliconix Incorporated.

M is Mitsubishi Electric Co., Ltd..

## (7) Memory IC

FUJITSU		Direct Replacement	Function	Ref. No.
Type No.	Marking			
MB7055C	7055	(None)	1024 $\times$ 8 (8192) Bit PROM	74

### 16.3 DETAIL OF ICs

- (1) MB74LS00M (SN74LS00N)  
 MB400M (SN7400N)  
 MB74S00M (SN74S00N)  
 MB74LS37M (SN74LS37N)

QUADRUPLE 2-INPUT  
 POSITIVE-NAND GATES

positive logic:  $Y = \overline{AB}$

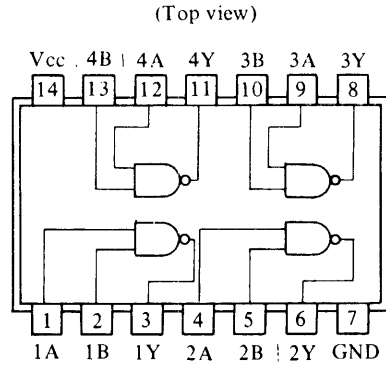

- (2) MB74LS01M (SN74LS01N)

QUADRUPLE 2-INPUT  
 POSITIVE-NAND GATES  
 WITH OPEN-COLLECTOR OUTPUTS

positive logic:  $Y = \overline{AB}$

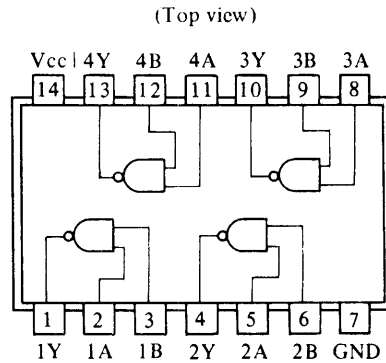

- (3) MB74LS02M (SN74LS02N)

QUADRUPLE 2-INPUT  
 POSITIVE-NOR GATES

positive logic:  $Y = \overline{A+B}$

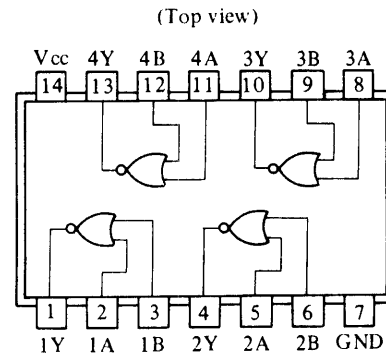

- (4) MB74S03M (SN74S03N)

QUADRUPLE 2-INPUT  
 POSITIVE-NAND GATES  
 WITH OPEN-COLLECTOR OUTPUTS

positive logic:  $Y = \overline{AB}$

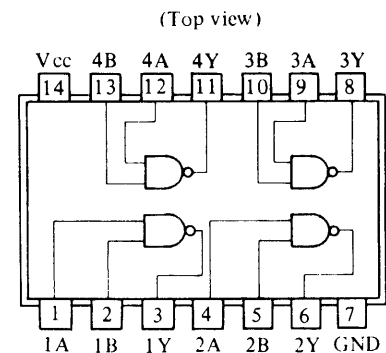



- (5) MB74LS04M (SN74LS04N)  
 MB418M (SN7404N)  
 MB74S04M (SN74S04N)

HEX INVERTERS

positive logic:

$$Y = \bar{A}$$

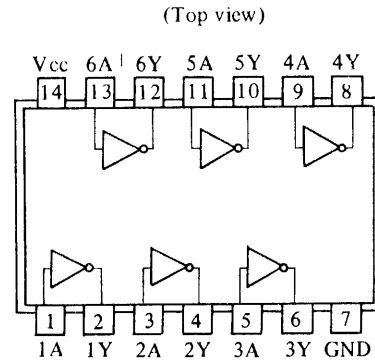

- (6) MB74LS05M (SN74LS05N)

HEX INVERTERS  
 WITH OPEN-COLLECTOR OUTPUTS

positive logic:

$$Y = \bar{A}$$

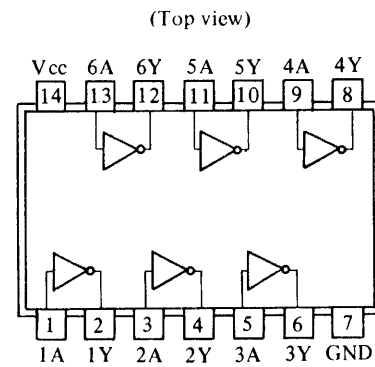

- (7) SN7406

HEX INVERTER BUFFERS/DRIVERS  
 WITH OPEN-COLLECTOR  
 HIGH-VOLTAGE OUTPUTS

positive logic:

$$Y = \bar{A}$$

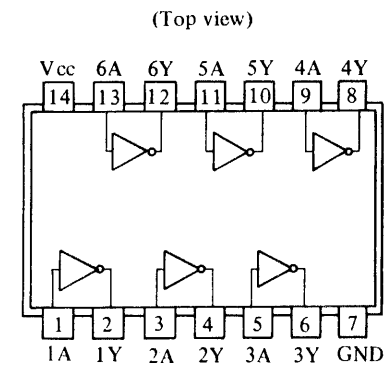

- (8) MB74LS08M (SN74LS08N)

QUADRUPLE 2-INPUT  
 POSITIVE-AND GATES

positive logic:

$$Y = AB$$

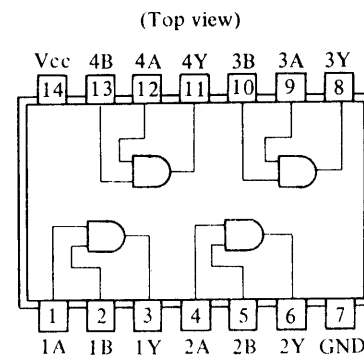

(9) MB74LS10M (SN74LS10N)

TRIPLE 3-INPUT  
POSITIVE-NAND GATES

positive logic:  
 $Y = \overline{ABC}$

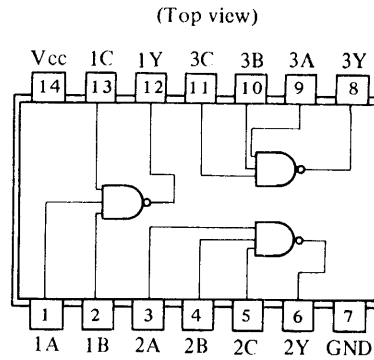

(10) MB74LS11M (SN74LS11N)  
SN74LS11N

TRIPLE 3-INPUT  
POSITIVE-AND GATES

positive logic:  
 $Y = ABC$

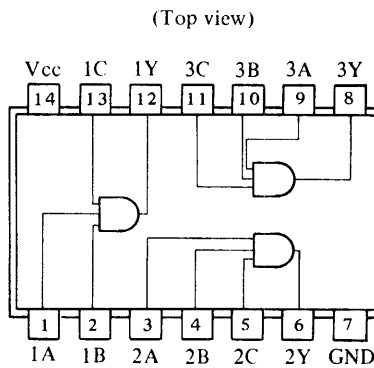

(11) MB74LS20M (SN74LS20N)

DUAL 4-INPUT  
POSITIVE-NAND GATES

positive logic:  
 $Y = \overline{ABCD}$

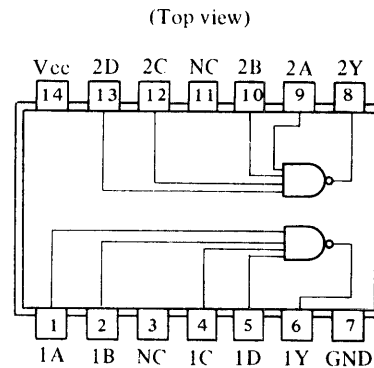

(12) MB74LS21M (SN74LS21N)

DUAL 4-INPUT  
POSITIVE-AND GATES

positive logic:  
 $Y = ABCD$

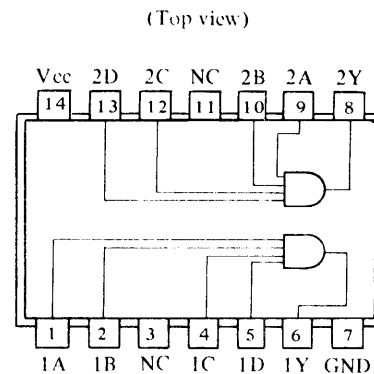

(13) MB74LS27M (SN74LS27N)

TRIPLE 3-INPUT  
POSITIVE-NOR GATES

Positive logic:  
 $Y = \overline{A+B+C}$

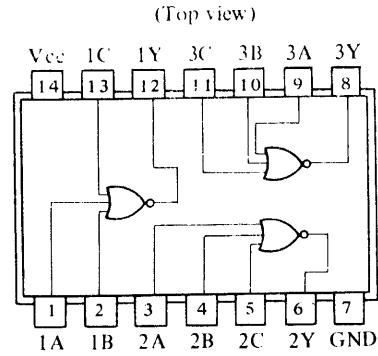

(14) MB74LS32M (SN74LS32N)

QUADRUPLE 2-INPUT  
POSITIVE-OR GATES

positive logic:  
 $Y = A+B$

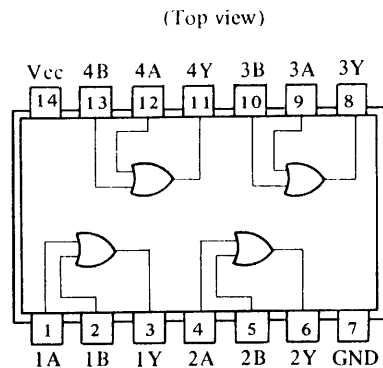

(15) SN74175

QUADRUPLE D-TYPE FLIP-FLOPS

Positive logic;

FUNCTION TABLE  
(EACH FLIP-FLOP)

INPUT			OYTPUTS	
CLEAR	CLOCK	D	Q	Q <sup>↑</sup>
L	X	X	L	H
H	↑	H	H	L
H	↑	L	L	H
H	L	X	Q <sub>0</sub>	$\overline{Q_0}$

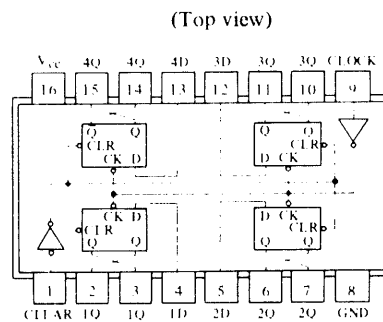

H = High level (steady state)

L = low level (steady state)

X = irrelevant

↑ = transition from low to high level

Q<sub>0</sub> = the level of Q before the indicated steady-state input conditions were established.

(16) MB74LS42M (SN74LS42N)  
BCD TO DECIMAL DECODER

Positive logic;

FUNCTION TABLE

No.	BCD INPUT				DECIMAL OUTPUT										
	D	C	B	A	0	1	2	3	4	5	6	7	8	9	
0	L	L	L	L	L	H	H	H	H	H	H	H	H	H	H
1	L	L	L	H	H	L	H	H	H	H	H	H	H	H	H
2	L	L	H	L	H	H	L	H	H	H	H	H	H	H	H
3	L	L	H	H	H	H	H	L	H	H	H	H	H	H	H
4	L	H	L	L	H	H	H	H	L	H	H	H	H	H	H
5	L	H	L	H	H	H	H	H	H	L	H	H	H	H	H
6	L	H	H	L	H	H	H	H	H	H	L	H	H	H	H
7	L	H	H	H	H	H	H	H	H	H	H	L	H	H	H
8	H	L	L	L	H	H	H	H	H	H	H	H	L	H	H
9	H	L	L	H	H	H	H	H	H	H	H	H	H	L	H
INVALID	H	L	H	L	H	H	H	H	H	H	H	H	H	H	H
	H	L	H	H	H	H	H	H	H	H	H	H	H	H	H
	H	H	L	L	H	H	H	H	H	H	H	H	H	H	H
	H	H	L	H	H	H	H	H	H	H	H	H	H	H	H
	H	H	H	L	H	H	H	H	H	H	H	H	H	H	H
	H	H	H	H	H	H	H	H	H	H	H	H	H	H	H

H = high level      L = low level

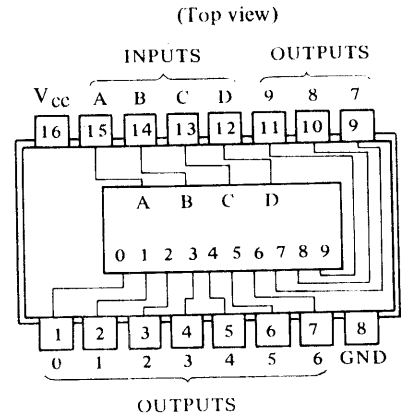

(17) MB74LS74AM (SN74LS74N)  
DUAL D-TYPE POSITIVE-EDGE-TRIGGERED FLIP-FLOPS WITH PRESET AND CLEAR

Positive logic;

FUNCTION TABLE

INPUTS				OUTPUTS	
PRESET	CLEAR	CLOCK	D	Q	$\bar{Q}$
L	H	X	X	H	L
H	L	X	X	L	H
L	L	X	X	H*	H*
H	H	↑	H	H	L
H	H	↑	L	L	H
H	H	L	X	Q <sub>0</sub>	$\bar{Q}_0$

\* This configuration is nonstable; that is, it will not persist when preset and clear inputs return to their inactive (high) level.

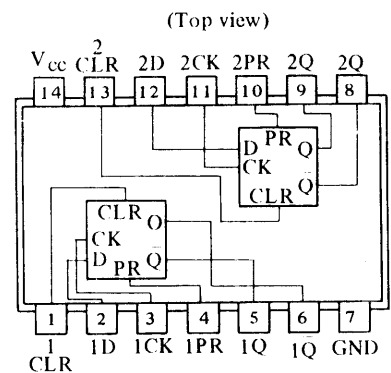

(18) MB74LS85M (SN74LS85N)

4-BIT MAGNITUDE COMPARATOR

These four-bit magnitude comparators perform comparison of straight binary and straight BCD (8-4-2-1) codes. Three fully decoded decisions about two 4-bit words (A, B) are made and are externally available at three outputs. These devices are fully expandable to any number of bits without external gates. Words of greater length may be compared by connecting comparators in cascade. The A>B, A<B, and A=B output of a stage handling less-significant bits are connected to the corresponding A>B, A<B, and A=B inputs of the next stage handling more-significant bits.

Positive logic;

FUNCTION TABLES

COMPARING INPUTS				CASCADING INPUTS			OUTPUTS		
A3, B3	A2, B2	A1, B1	A0, B0	A>B	A<B	A=B	A>B	A<B	A=B
A3>B3	X	X	X	X	X	X	H	L	L
A3<B3	X	X	X	X	X	X	L	H	L
A3=B3	A2>B2	X	X	X	X	X	H	L	L
A3=B3	A2<B2	X	X	X	X	X	L	H	L
A3=B3	A2=B2	A1>B1	X	X	X	X	H	L	L
A3=B3	A2=B2	A1<B1	X	X	X	X	L	H	L
A3=B3	A2=B2	A1=B1	A0>B0	X	X	X	H	L	L
A3=B3	A2=B2	A1=B1	A0<B0	X	X	X	L	H	L
A3=B3	A2=B2	A1=B1	A0=B0	H	L	L	H	L	L
A3=B3	A2=B2	A1=B1	A0=B0	L	H	L	L	H	L
A3=B3	A2=B2	A1=B1	A0=B0	L	L	H	L	L	H
A3=B3	A2=B2	A1=B1	A0=B0	X	X	H	L	L	L
A3=B3	A2=B2	A1=B1	A0=B0	H	H	L	L	L	L
A3=B3	A2=B2	A1=B1	A0=B0	L	L	L	H	H	L

H = high level L = low level X = irrelevant

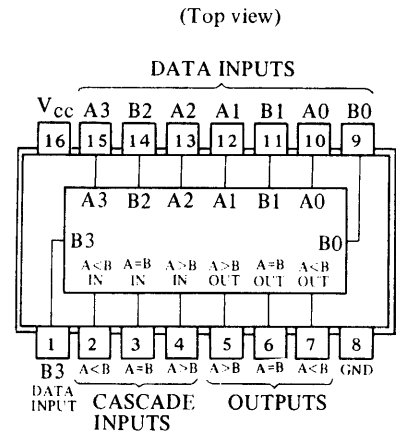

(19) MB74LS86M (SN74LS86M)

QUADRUPLE 2-INPUT EXCLUSIVE-OR GATES

Positive logic:  $Y = A + B = \overline{AB} + \overline{A\overline{B}}$

FUNCTION TABLE

INPUTS		OUTPUT
A	B	Y
L	L	L
L	H	H
H	L	H
H	H	L

H = high level, L = low level

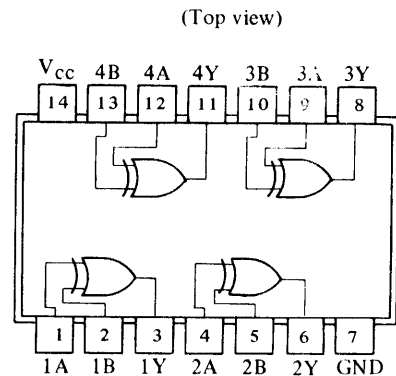

(20) MB74LS107M (SN74LS107N)  
 DUAL J-K FLIP-FLOPS WITH CLEAR

positive logic;

FUNCTION TABLE

INPUTS				OUTPUTS	
CLEAR	CLOCK	J	K	Q	$\bar{Q}$
L	X	X	X	L	H
H	--	L	L	$Q_0$	$\bar{Q}_0$
H	--	H	L	H	L
H	--	L	H	L	H
H	--	H	H	TOGLE	

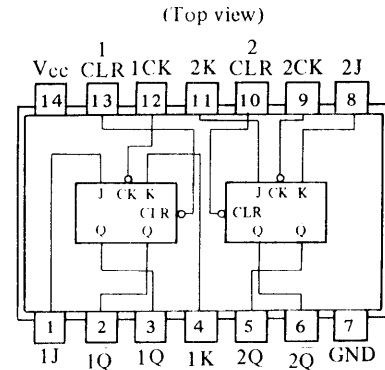

(21) MB74LS153N (SN74LS153N)  
 S153  
 QUAL 4-LINE-TO-1-LINE DATA SELECTORS/MULTIPLEXERS

- Permits Multiplexing from N lines to 1 line
- Performs Parallel-to-Serial Conversion
- Strobe (Enable) Line Provided for Cascading (N lines to n lines)

Each of these monolithic, data selectors/multiplexers contains inverters and drivers to supply fully complementary, on-chip, binary decoding data selection to the AND-OR-invert gates. Separate strobe inputs are provided for each of the two four-line sections.

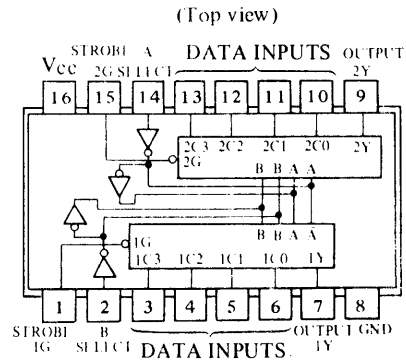

functional block diagram

positive logic;

FUNCTION TABLE

SELECT INPUTS		DATA INPUTS				STROBE	OUTPUT
B	A	C0	C1	C2	C3	G	Y
X	X	X	X	X	X	H	L
L	L	L	X	X	X	L	L
L	L	H	X	X	X	L	H
L	H	X	L	X	X	L	L
L	H	X	H	X	X	L	H
H	L	X	X	L	X	L	L
H	L	X	X	H	X	L	H
H	H	X	X	X	L	L	L
H	H	X	X	X	H	L	H

Select inputs A and B are common to both sections.

H=high level, L=low level, X=irrelevant

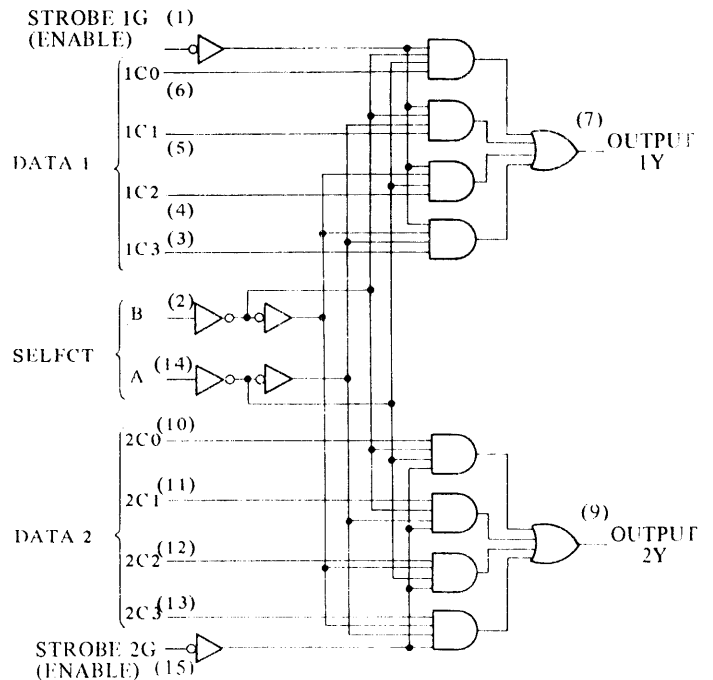

(22) MB74LS155M (SN74LS155N)

DUAL 2-LINE-TO-4-LINE DECODERS/DEMULTIPLEXERS

This monolithic transistor-transistor-logic (TTL) circuit features dual 1-line-to-4-line demultiplexers with individual strobes and common binary-address inputs in a single 16-pin package. When both sections are enabled by the strobes, the common binary-address inputs sequentially select and route associated input data to the appropriate output of each section. The individual strobes permit activating or inhibiting each of the 4-bit sections as desired. Data applied to input 10 is inverted at its outputs and data applied at 2C is not inverted through its outputs. The inverter following the 1C data input permits use as 3-to-8-line decoder or 1-to-8-line demultiplexer without external gating. Input clamping diodes are provided on all of these circuits to minimize transmission-line effects and simplify system design.

Positive logic;

FUNCTION TABLES  
2-LINE-TO-4-LINE DECODER  
OR 1-LINE-TO-4-LINE DEMULTIPLEXER

INPUTS				OUTPUTS			
SELECT	STROBE	DATA		1Y0	1Y1	1Y2	1Y3
B	A	1G	1C				
X	X	H	X	H	H	H	H
L	L	L	H	L	H	H	H
L	H	L	H	H	L	H	H
H	L	L	H	H	H	L	H
H	H	L	H	H	H	H	L
X	X	X	L	H	H	H	H

INPUTS				OUTPUTS			
SELECT	STROBE	DATA		2Y0	2Y1	2Y2	2Y3
B	A	2G	2C				
X	X	H	X	H	H	H	H
L	L	L	L	L	H	H	H
L	H	L	L	H	L	H	H
H	L	L	L	H	H	L	H
H	H	L	L	H	H	H	L
X	X	X	H	H	H	H	H

FUNCTION TABLE  
3-LINE-TO-8-LINE DECODER  
OR 1-LINE-TO-8-LINE DEMULTIPLEXER

INPUTS				OUTPUTS							
SELECT	STROBE	OR DATA		(0)	(1)	(2)	(3)	(4)	(5)	(6)	(7)
C†	B	A	G	2Y0	2Y1	2Y2	2Y3	1Y0	1Y1	1Y2	1Y3
X	X	X	H	H	H	H	H	H	H	H	H
L	L	L	L	L	H	H	H	H	H	H	H
L	L	H	L	H	L	H	H	H	H	H	H
L	H	L	L	H	H	L	H	H	H	H	H
L	H	H	L	H	H	H	L	H	H	H	H
H	L	L	L	H	H	H	H	L	H	H	H
H	L	H	L	H	H	H	H	H	L	H	H
H	H	L	L	H	H	H	H	H	H	L	H
H	H	H	L	H	H	H	H	H	H	H	L

C = inputs 1C and 2C connected together, G = inputs 1G and 2G connected together  
H = high level, L = low level, X = irrelevant

(Top view)

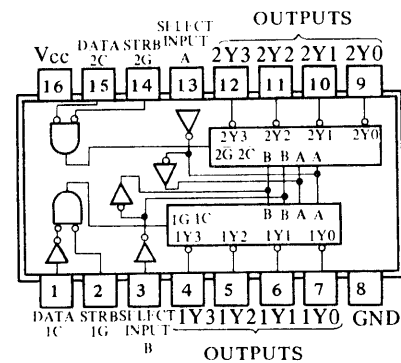

functional block diagram and logic

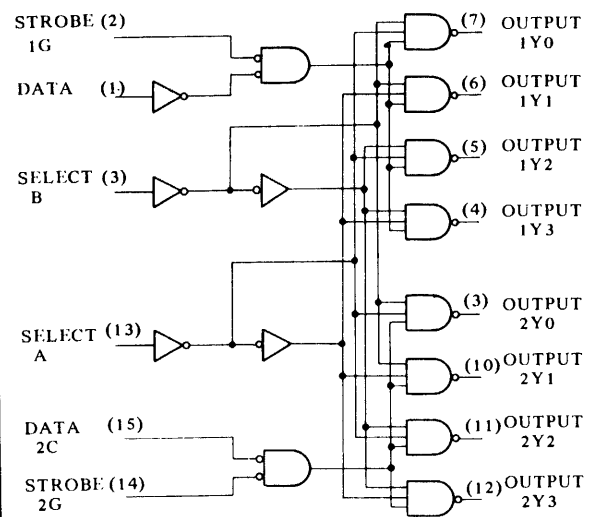

(23) MB74LS161A (SN74LS161N)

SYNCHRONOUS 4-BIT BINARY COUNTERSWITCH DIRECT CLEAR

This synchronous, presetable counters features an internal carry look-ahead for application in high-speed counting designs. Synchronous operation is provided by having all flip-flops clocked simultaneously so that the outputs coincident with each other when so instructed by the count-enable inputs and internal gating. This mode of operation eliminates the output counting spikes that are normally associated with asynchronous (ripple clock) counters. A buffered clock input triggers the four flip-flops on the rising (positive-going) edge of the clock input waveform.

The counter is fully programmable; that is, the outputs may be preset to either level. As presetting is synchronous, setting up a low level at the load input disables the counter and causes the outputs to agree with the setup data after the next clock pulse regardless of the levels of the enable inputs. The clear function is asynchronous and a low level at the clear input sets all four of the flip-flop outputs low regardless of the levels of clock, load, or enable inputs.

The carry look-ahead circuitry provides for cascading counters for n-bit synchronous applications without additional gating. Instrumental in accomplishing this function are two count-enable inputs and a ripple carry output. Both count-enable inputs (P and T) must be high to count, and input T is fed forward to enable the ripple carry output. The ripple carry output thus enabled will produce a high-level output pulse with a duration approximately equal to the high-level portion of the  $Q_A$  output. This high-level overflow ripple carry pulse can be used to enable successive cascaded stages. High-to-low-level transitions at the enable P or T inputs are allowed regardless of the level of the clock input.

It features a fully independent clock circuit. Changes at control inputs (enable P or T, or clear) that will modify the operating mode have no effect until clocking occurs. The function of the counter (whether enabled, disabled, loading or counting) will be dictated solely by the conditions meeting the stable setup and hold times.

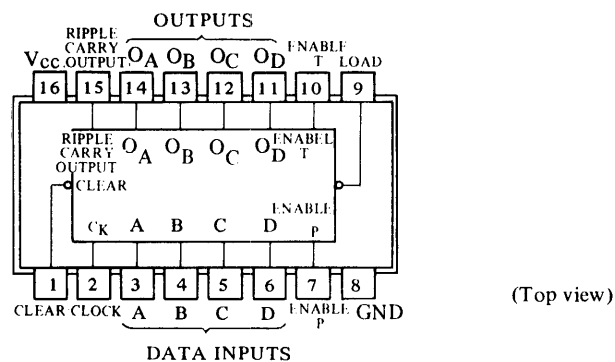



(24) MB74LS164M (SN74LS164N)

8-BIT PARALLEL-OUT SERIAL SHIFT REGISTERS

These 8-bit shift registers feature gated serial inputs and an asynchronous clear. The gated serial inputs (A and B) permit complete control over incoming data as a low at either (or both) input(s) inhibits entry of the new data and resets the first flip-flop to the low level at the next clock pulse. A high-level input enables the other input which will then determine the state of the first flip-flop. Data at the serial inputs may be changed while the clock is high or low, but only information meeting the setup requirements will be entered. Clocking occurs on the low-to-high-level transition of the clock input. All inputs are diode-clamped to minimize transmission-line effects.

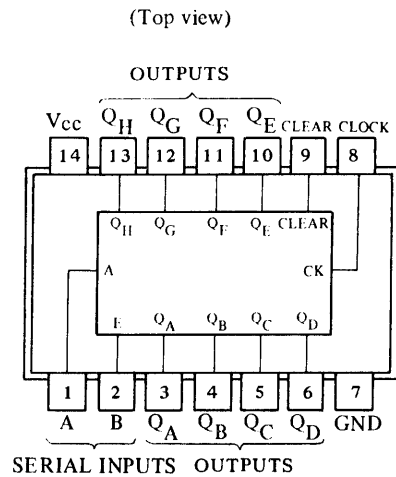

positive logic;

FUNCTION TABLE

INPUTS				OUTPUTS		
CLEAR	CLOCK	A	B	QA	QB... QH	
L	X	X	X	L	L	L
H	L	X	X	QA0	QB0	QH0
H	↑	H	H	H	QAn	QGn
H	↑	L	X	L	QAn	QGn
H	↑	X	L	L	QAn	QGn

H = high level (steady state), L = low level (steady state)

X = irrelevant (any input, including transitions)

↑ = transition from low to high level

QA0, QB0, QH0 = the level of QA, QB, or QH, respectively, before the indicated steady-state input conditions were established

QAn, QGn = the level of QA or QG before the most-recent ↑ transition of the clock; indicates a one-bit shift

typical clear, shift, and clear sequences

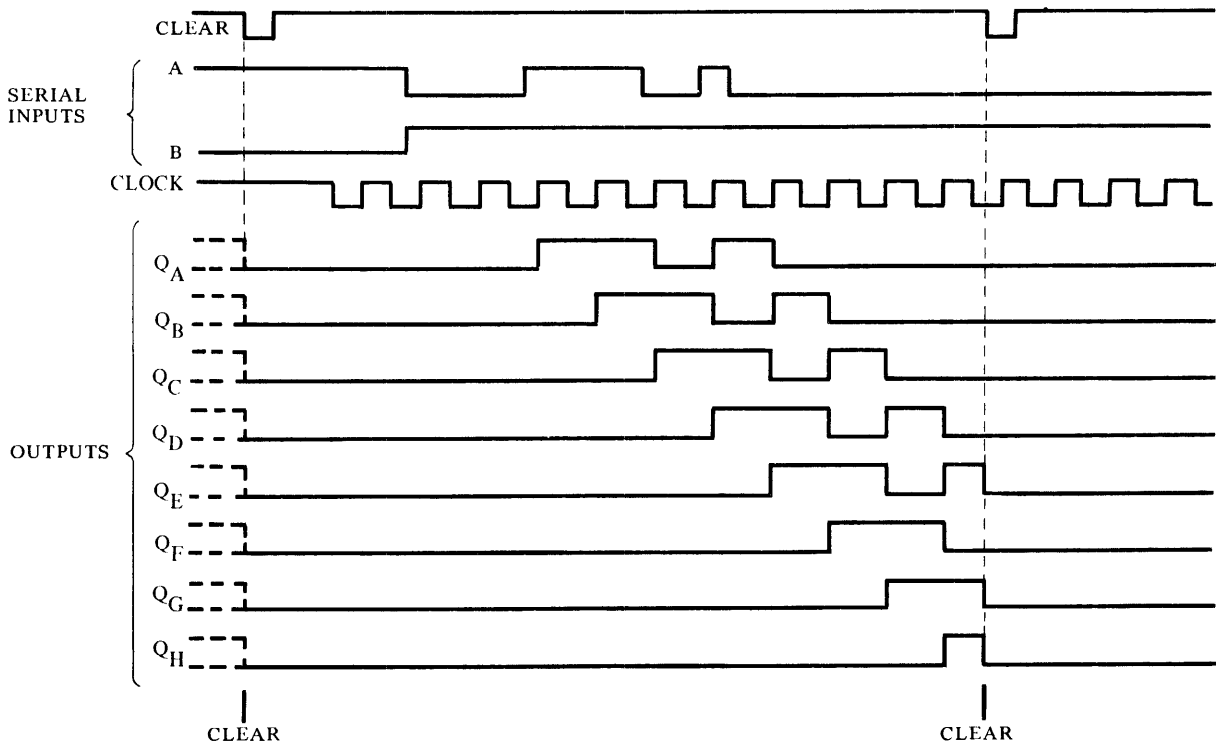

functional block diagram

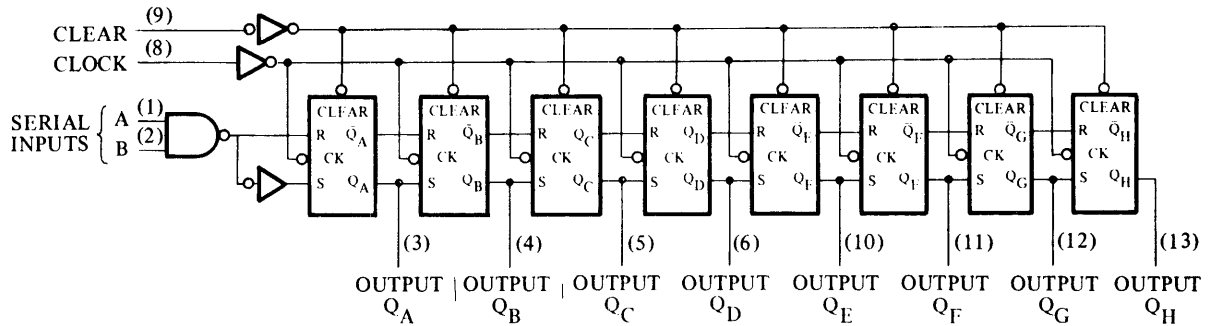

(25) MB74LS191M (SN74LS191N)  
 SYNCHRONOUS 4-BIT UP/DOWN COUNTER

The LS191 is synchronous, reversible up/down counter having a complexity of 58 equivalent gates. Synchronous operation is provided by having all flipflops clocked simultaneously so that the outputs change coincident with each other when so instructed by the steering logic. This mode of operation eliminates the output counting spikes normally associated with asynchronous (ripple clock) counters.

The outputs of the four master-slave flip-flops are triggered on a low-to-high-level transition of the clock input if the enable input is low. A high at the enable input inhibits counting. Level changes at the enable input should be made only when the clock input is high. The direction of the count is determined by the level of the down/up input. When low, the counter counts up and when high, it counts down. Level changes at the down/up input should be made only when the clock input is high.

These counters are fully programmable; that is, the outputs may be preset to either level by placing a low on the load input and entering the desired data at the data inputs. The output will change to agree with the data inputs independently of the level of the clock input. This feature allows the counters to be used as modulo-N dividers simply modifying the count length with the preset inputs.

The clock, down/up, and load inputs are buffered to lower the drive requirement which significantly reduces the number of clock drivers, etc., required for long parallel words.

Two outputs have been made available to perform the cascading function: ripple clock and maximum/minimum count. The latter output produces a high-level output pulse with a duration approximately equal to one complete cycle of the clock when the counter overflows or underflows. The ripple clock output produces a low-level output pulse equal in width to the low-level portion of the clock input when an overflow or underflow condition exists. The counters can be easily cascaded by feeding the ripple clock output to the enable input of the succeeding counter if parallel clocking is used, or to the clock input if parallel enabling is used. The maximum/minimum count output can be used to accomplish look ahead for high-speed operation.

positive logic:

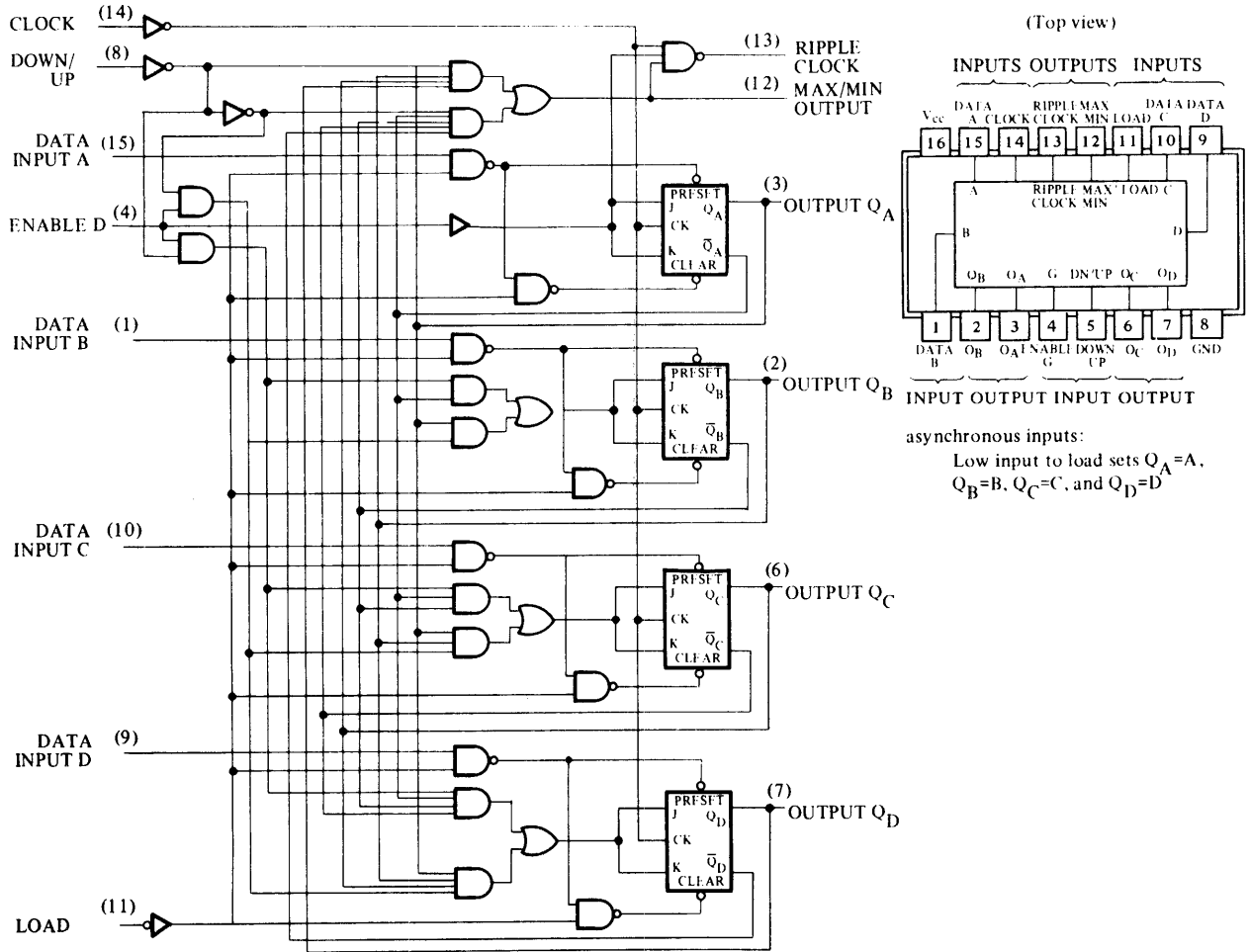

(26) SN74LS279N  
QUAD  $\overline{S}$ - $\overline{R}$  LATCHES

DIODE-CLAMPED INPUTS  
TOTEM-POLE OUTPUTS

FUNCTION TABLE

INPUTS		OUTPUT
$\overline{S}$	$\overline{R}$	Q
H	J	Q <sub>0</sub>
L	H	H
H	L	L
L	L	*

H = high level

L = low level

Q<sub>0</sub> = the level of Q before the indicated input conditions were established.

\* This output level is pseudo stable, that is, it may not persist when the  $\overline{S}$  and  $\overline{R}$  inputs return to their inactive (high) level.

For latches with double  $\overline{S}$  input.

H = both  $\overline{S}$  input high

L = one or both  $\overline{S}$  inputs low

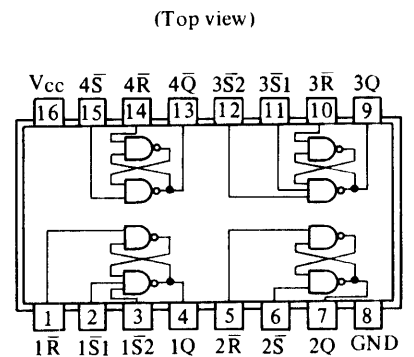

(27) MB74LS283M (LN74LS283M)

4-BIT BINARY FULL ADDER

This full adder performs the addition of two 4-bit binary words. The sum ( $\Sigma$ ) outputs are provided for each bit and the resultant carry ( $C_4$ ) is obtained from the fourth bit. These address feature full internal look-ahead across all four bits generating the carry term in ten nano-seconds typically. This capability provides the system designer with partial look-ahead performance at the economy and reduced package count of a ripple-carry implementation.

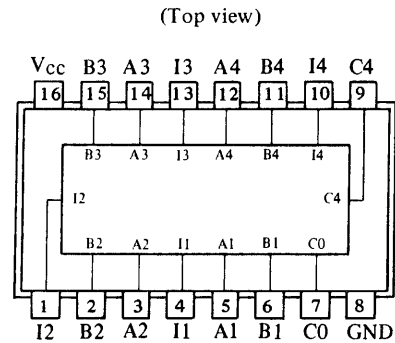

The adder logic, including the carry, is implemented in its true form. End around carry can be accomplished without the need for logic or level inversion.

positive logic;

FUNCTION TABLE

INPUT				OUTPUT					
				WHEN CO-L			WHEN CO-H		
A1	B1	A2	B2	$\Sigma 1$	$\Sigma 2$	C2	$\Sigma 1$	$\Sigma 2$	C2
A3	B3	A4	B4	$\Sigma 3$	$\Sigma 4$	C4	$\Sigma 3$	$\Sigma 4$	C4
L	L	L	L	L	L	L	H	L	L
H	L	L	L	H	L	L	L	H	L
L	H	L	L	H	L	L	L	H	L
H	H	L	L	L	H	L	H	H	L
L	L	H	L	L	H	L	H	H	L
H	L	H	L	H	H	L	L	L	H
L	H	H	L	H	H	L	L	L	H
H	H	H	L	L	L	H	H	L	H
L	L	L	H	L	H	L	H	H	L
H	L	L	H	H	H	L	L	L	H
L	H	L	H	H	H	L	L	L	H
H	H	L	H	L	L	H	H	L	H
L	L	H	H	L	L	H	H	L	H
H	L	H	H	H	L	H	L	H	H
L	H	H	H	H	L	H	L	H	H
H	H	H	H	L	H	H	H	H	H

H = high level, L = low level

NOTE: Input conditions at A1, B1, A2, B2, and C0 are used to determine outputs  $\Sigma 1$  and  $\Sigma 2$  and the value of the internal carry C2. The values at C2, A3, B3, A4, and B4 are then used to determine outputs  $\Sigma 3$ ,  $\Sigma 4$ , and C4.

(28) MB440M (SN74123)  
 SN74LS123N

DUAL RETRIGGERABLE MONOSTABLE MULTIVIBRATORS

This monolithic TTL retriggerable monostable multivibrator features d-c triggering from gated low-level-active (A) and high-level-active (B) inputs, and also provides overriding direct clear inputs. The retrigger capability simplifies the generation of output pulses of extremely long duration. By triggering the input before the output pulse terminated, the output pulse may be extended. The overriding clear capability permits any output pulse to be terminated at a predetermined time independently of the timing components R and C. The output pulse is primarily a function of the external capacitor and resistor.

For Cext 1000pF, the output pulse width (tw) is defined as:

$$t_w = 0.32R_t C_{ext} \left( 1 + \frac{0.7}{R_t} \right)$$

tw : ns

Rt : kohms

Cext : pF

FUNCTION TABLE

INPUTS			OUTPUTS	
CLEAR	A	B	Q	$\bar{Q}$
L	X	X	L	H
X	H	X	L	H
X	X	L	L	H
H	L	↑	⌊	⌋
H	↓	H	⌊	⌋
↑	L	H	⌊	⌋

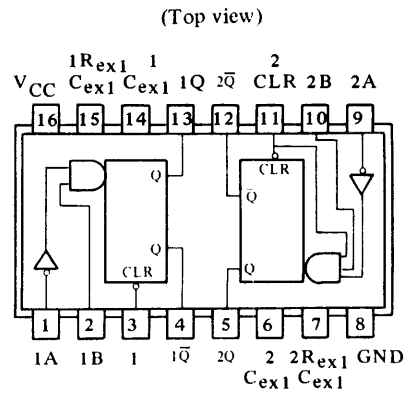

(29) SN74LS221N  
SN74221N

DUAL MONOSTABLE MULTIVIBRATORS

The SN74LS221N and SN74221N are monolithic dual multivibrators. Each multivibrator features a negative-transition-triggered input and a positive-transition-triggered input either of which can be used as an inhibit input.

Pulse triggering occurs at a particular voltage level and is not directly related to the transition time of the input pulse. Schmitt-trigger input circuitry (TTL hysteresis) for B input allows jitter-free triggering from inputs with transition rates as slow as 1 volt/second, providing the circuit with excellent noise immunity of typically 1.2 volts. A high immunity to Vcc noise of typically 1.5 volts is also provided by internal latching circuitry.

FUNCTION TABLE  
(EACH MONOSTABLE)

INPUTS			OUTPUTS	
CLEAR	A	B	Q	$\bar{Q}$
L	X	X	L	H
X	H	X	L	H
X	X	L	L	H
H	L	0		
H	↓	H		
H	↑	L		

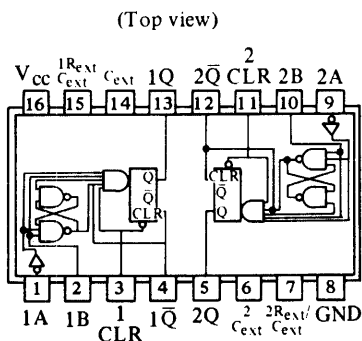

Positive logic: Low input to clear resets Q low and  $\bar{Q}$  high regardless of d-c levels at A or B inputs.

The output pulse width (tw) defined as:

$$tw = 0.7R_{ext}C_{ext}$$

tw ; ns,  $r_{ext}$  : kohms,  $C_{ext}$  : pf

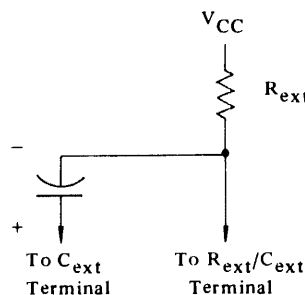

TIMING COMPONENT CONNECTIONS

(30) MB463M (SN7438N)

QUADRUPLE 2-INPUT  
 POSITIVE-NAND BUFFERS  
 WITH OPEN-COLLECTOR OUTPUTS

positive logic:  $Y = \overline{AB}$

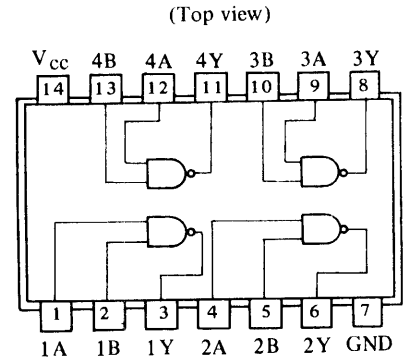

(31) MB434M (SN75451BP)

DUAL PERIPHERAL POSITIVE-AND DRIVERS

positive logic:  $Y = AB$

FUNCTION TABLE  
 (EACH DRIVER)

A	B	Y
L	L	L (on state)
L	H	L (on state)
H	L	L (on stage)
H	H	H (off state)

H=high level, L=low level

(Top view)

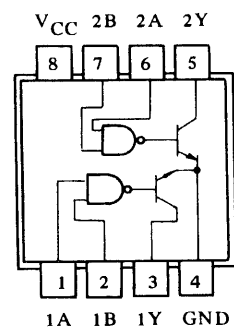

(32) MB435M (SN7437N)

QUADRUPLE 2-INPUT  
 POSITIVE-NAND BUFFERS

positive logic:  $Y = \overline{AB}$

(Top view)

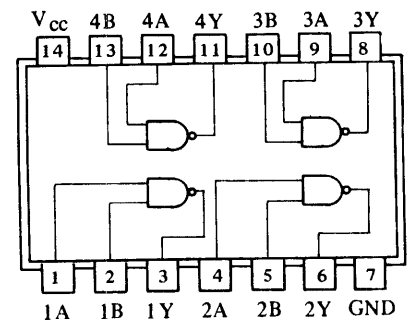

(33) MB439M (SN75450BN)

DUAL PERIPHERAL POSITIVE-AND DRIVERS

positive logic:

$Y = \overline{AG}$  (gate only)

$C = AG$  (gate and transistor)

(Top view)

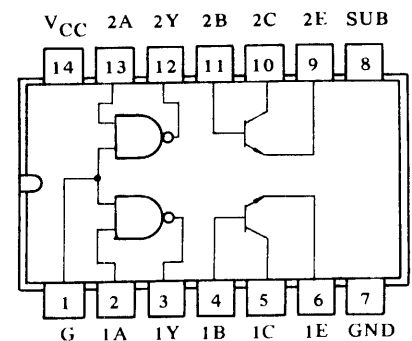



(34) MB443M (SN74145N)

BCD-TO-DECIMAL DECODERS/DRIVERS

This monolithic BCD-to-decimal decoder/drivers consists of eight inverters and ten four-input NAND gates. The inverters are connected in pairs to make BCD input data available for decoding by the NAND gates. Full decoding of valid BCD input logic ensures that all outputs remain off for all invalid binary input conditions. These decoders feature high-performance, n-p-n output transistors designed for use as indicator/relay drivers or as open-collector logic-circuit drivers. Each of the high-breakdown output transistors (15 volts) will sink up to 80 milliamperes of current. Inputs and outputs are entirely compatible for use with TTL or DTL logic circuits, and the outputs are compatible for interfacing with most MOS integrated circuits.

(Top view)

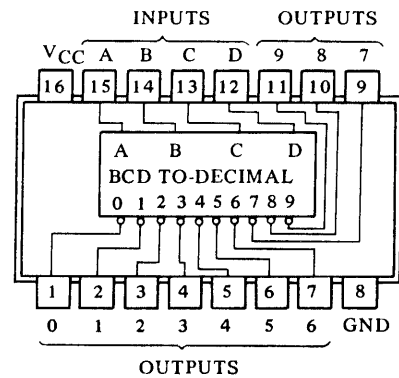

Positive logic

FUNCTION TABLE

No.	INPUTS				OUTPUTS										
	D	C	B	A	0	1	2	3	4	5	6	7	8	9	
0	L	L	L	L	L	H	H	H	H	H	H	H	H	H	H
1	L	L	L	H	H	L	H	H	H	H	H	H	H	H	H
2	L	L	H	L	H	H	L	H	H	H	H	H	H	H	H
3	L	L	H	H	H	H	H	L	H	H	H	H	H	H	H
4	L	H	L	L	H	H	H	H	L	H	H	H	H	H	H
5	L	H	L	H	H	H	H	H	H	L	H	H	H	H	H
6	L	H	H	L	H	H	H	H	H	H	L	H	H	H	H
7	L	H	H	H	H	H	H	H	H	H	H	L	H	H	H
8	H	L	L	L	H	H	H	H	H	H	H	H	L	H	H
9	H	L	L	H	H	H	H	H	H	H	H	H	H	L	H
INVALID	H	L	H	L	H	H	H	H	H	H	H	H	H	H	H
	H	L	H	H	H	H	H	H	H	H	H	H	H	H	H
	H	H	L	L	H	H	H	H	H	H	H	H	H	H	H
	H	H	L	H	H	H	H	H	H	H	H	H	H	H	H
	H	H	H	L	H	H	H	H	H	H	H	H	H	H	H
	H	H	H	H	H	H	H	H	H	H	H	H	H	H	H

H = high level (off),  
L = low level (on)

functional block diagram

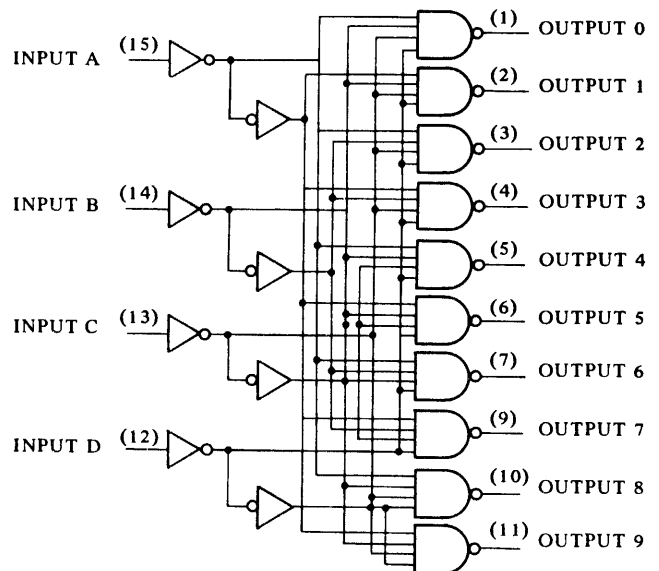

(35) SN74193

SYNCHRONOUS 4-BIT BINARY UP/DOWN COUNTERS (DUAL CLOCK WITH CLEAR)

Synchronous operation is provided by having all flip-flops clocked simultaneously so that the outputs change coincidentally with each other when so instructed by the steering logic. This mode of operation eliminates the output counting spikes which are normally associated with asynchronous (ripple-clock) counters.

The outputs of the four master-slave flip-flops are triggered by a low-to-high-level transition of either count (clock) input. The direction of counting is determined by which count input is pulsed while the other count input is high.

All four counters are fully programmable; that is, each output may be preset to either level by entering the desired data at the data inputs while the load input is low. The output will change to agree with the data inputs independently of the count pulses. This feature allows the counters to be used as modulo-N dividers by simply modifying the count length with the preset inputs.

A clear input has been provided which forces all outputs to the low level when a high level is applied. The clear function is independent of the count and load inputs. The clear, count, and load inputs are buffered to lower the drive requirements. This reduces the number of clock drivers, etc., required for long words.

These counters were designed to be cascaded without the need for external circuitry. Both borrow and carry outputs are available to cascade both the up- and down-counting functions. The borrow output produces a pulse equal in width to the count-down input when the counter underflows. Similarly, the carry output produces a pulse equal in width to the count-up input when an overflow condition exists. The counters can then be easily cascaded by feeding the borrow and carry outputs to the count-down and count-up inputs respectively of the succeeding counter.

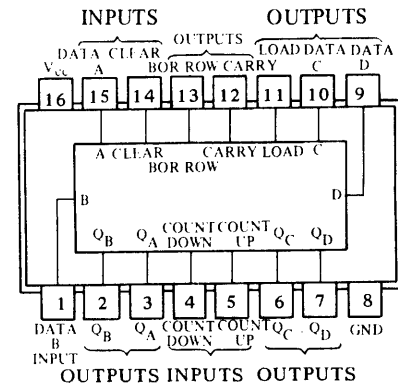

(Top view)

logic: Low input to load sets  $Q_A = A$ ,  
 $Q_B = B$ ,  $Q_C = C$ , and  $Q_D = D$

(36) SN75452

DUAL PERIPHERAL POSITIVE-NAND DRIVERS

positive logic:  $Y = \overline{AB}$

FUNCTION TABLE  
(EACH DRIVER)

A	B	
L	L	H (off state)
L	H	H (off state)
H	L	H (off state)
H	H	L (on state)

H = high level, L = low level

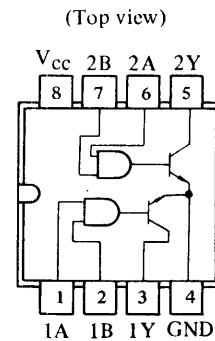

(37) SN74S112N

DUAL J-K ENGATEVE-EDGE-TRIGGERED FLIP-FLOPS WITH PRESET AND CLEAR

positive logic;

FUNCTION TABLE

INPUTS					OUTPUTS	
PRESET	CLEAR	CLOCK	J	K	Q	$\overline{Q}$
L	L	X	X	X	H	L
H	L	X	X	X	L	H
L	L	X	X	X	H*	H*
H	H	↓	L	L	Q <sub>0</sub>	Q <sub>0</sub>
H	H	↓	H	L	H	L
H	H	↓	L	H	L	H
H	H	↓	H	H	TOGGLE	
H	H	H	X	X	Q <sub>0</sub>	Q <sub>0</sub>

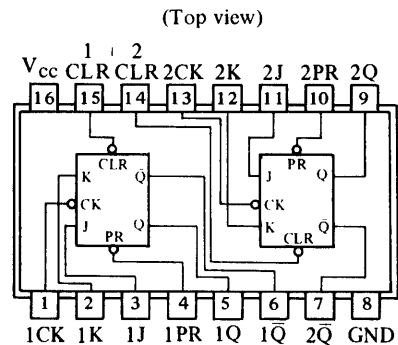

(38) SN75107AN  
 SN75108AN

DUAL LINE RECEIVERS

The 107A, and 108A line receivers are TTL-compatible dual circuits intended for use in high-speed data-transmission systems. They are designed to detect low-level differential signals in the presence of common-mode noise and variations of temperature and supplies. Dc specifications reflect worst-case conditions of temperature, supply voltages, and input voltages.

These receivers feature independent channels with common voltage supply and ground terminals. The 107A features TTL-compatible active pull-up (totem-pole) outputs. The 108A is also TTL-compatible, but features an open-collector output configuration that permits the wired-AND logic connection with similar outputs. This permits a level of logic to be implemented without extra delay.

The input common-mode voltage range is  $\pm 3$  volts. This is adequate for application in most systems. In systems with requirements for greater common-mode voltage range, input attenuators may be used to decrease the noise to an acceptable level at the receiver-input terminals.

The receivers feature individual strobe inputs for each channel and a strobe input common to both channels for logic versatility. The strobe inputs are tested to guarantee 400 millivolts of dc noise margin when interfaced with Series 54/74 TTL.

The circuits feature high input impedance and low input currents, which induce very little loading on the transmission line. This makes these devices especially useful in party-line systems. The excellent input sensitivity is particularly important when data is to be detected at the end of a long transmission line and the amplitude of the data has deteriorated due to cable losses. These line receivers are designed to detect input signals of 25 millivolts (or greater) amplitude and convert the polarity of the signal into appropriate TTL-compatible output logic levels.

FUNCTION TABLE

DIFFERENTIAL INPUTS A-B	STROBES		OUTPUT Y
	G	S	
$V_{ID} > 25mV$	X	X	H
$-25mV < V_{ID} < 25mV$	X	L	H
	L	X	H
$V_{ID} < -25mV$	H	H	INDETERMINATE
	X	L	H
	L	X	H
	H	H	L

H = high level, L = low level,  
 X = irrelevant

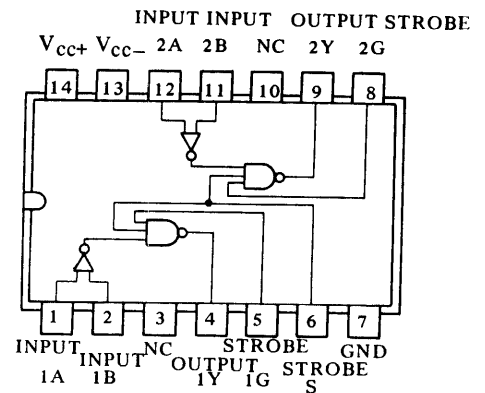

NC--No internal connection

(Top view)

(39) SN75110A

DUAL LINE DRIVERS

These drivers feature independent channels with common voltage supply and ground terminals. The driver circuits feature a constant output current that is switched to either of two output terminals by the appropriate logic levels at the input terminals. The output current can be switched off (inhibited) by low logic levels on the inhibit inputs. The output current is nominally 12 milliamperes.

The inhibit feature is provided so the circuits can be used in party-line or data-bus applications. Astrobe or inhibitor, common to both drivers, is included for increased driver-logic versatility. The output current in the inhibited mode,  $I_{O(off)}$ , is specified so that minimum line loading is induced when the driver is used in a party-line system with other drivers. The output impedance of the driver in the inhibited mode is very high—the output impedance of a transistor biased to cutoff.

The driver outputs have a common-mode voltage range of -3 volts to 10 volts, allowing common-mode voltage on the line without affecting driver performance.

FUNCTION TABLE

LOGIC INPUTS		INHIBITOR INPUTS		OUTPUTS	
A	B	C	D	Y	Z
X	X	L	X	OFF	OFF
X	X	X	L	OFF	OFF
L	X	H	H	ON	OFF
X	L	H	H	ON	OFF
H	H	H	H	OFF	ON

H = high level, L = low level,  
X = irrelevant

(40) MB15139C

ACCESS CONTROL

This Bipolar 500-Gate LSI has features to control and check the rezero and seek operation of disk drive.

Package; 64-pin RIT

Pin-  
+5V; 47, 61  
0V; 40, 54

(Top view)

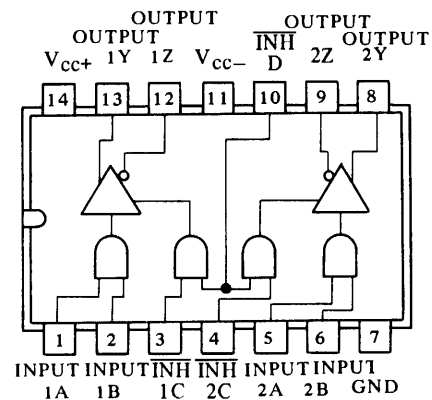

(Bottom view)

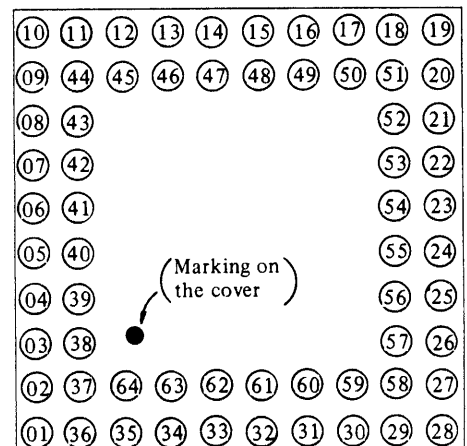

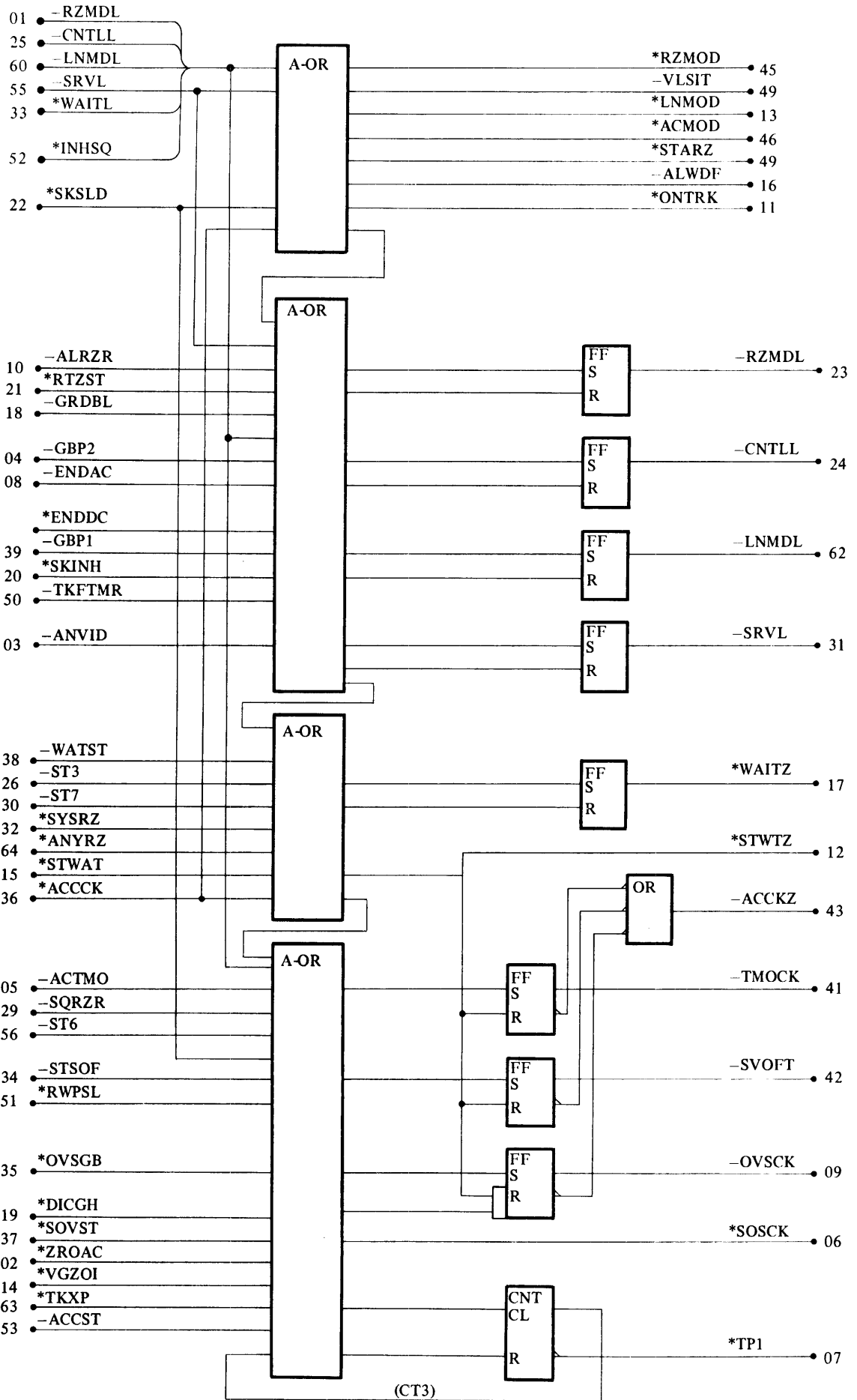

(41) MB15140C  
HDA SEQUENCER

This Bipolar 500-Gate LSI has the following functions when used in the disk drive.

- Sequence control of spindle motor
- Generation of machine status information

Package ; 64-pin, RIT

functional block diagram

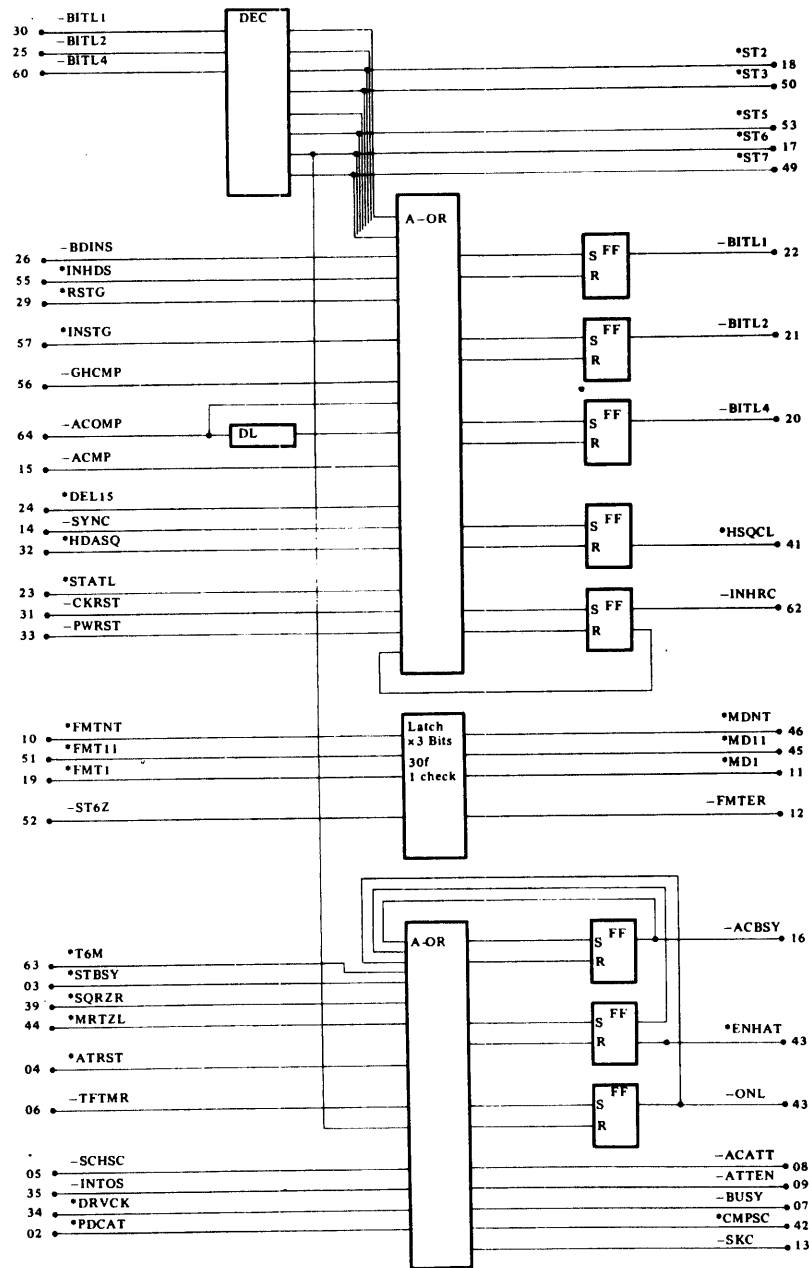

(42) MB14601C

LINEAR MOTOR CONTROL

This Bipolar 200-Gate LSI generates gating signals to sense both the position signal and the velocity signal. The position logic portion in the IC forms a PLL circuit in conjunction with a VCO. The velocity logic portion contains a polarity check circuit and a gate signal generator for velocity signal demodulation.

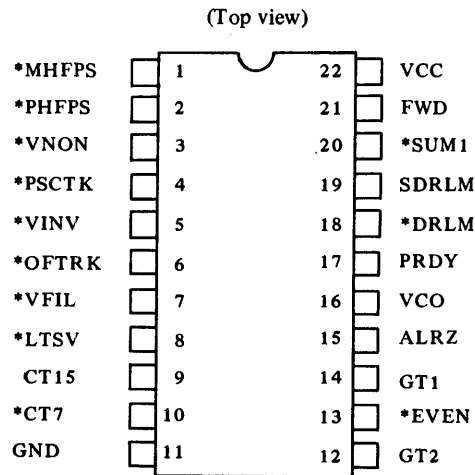

functional block diagram

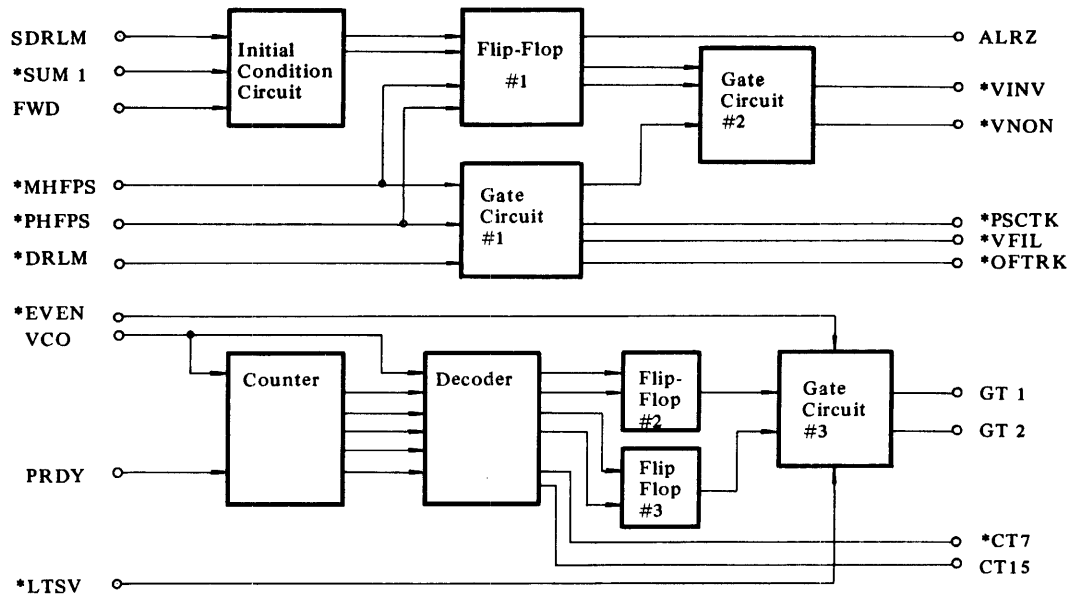



(43) MBI4613C

Servo Pattern Detector

This circuit identifies the Servo Patterns and detects guard band 1, guard band 2, index and the outer guard band.

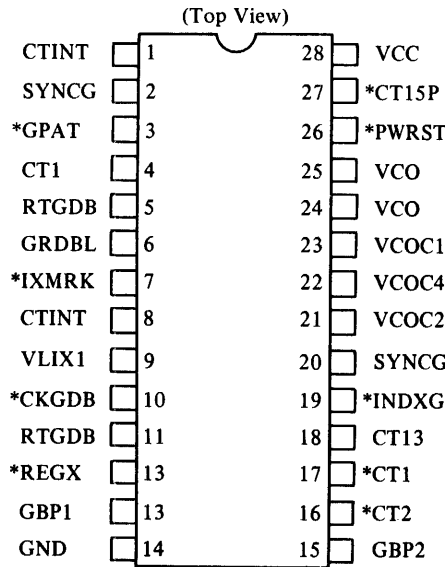

functional block diagram

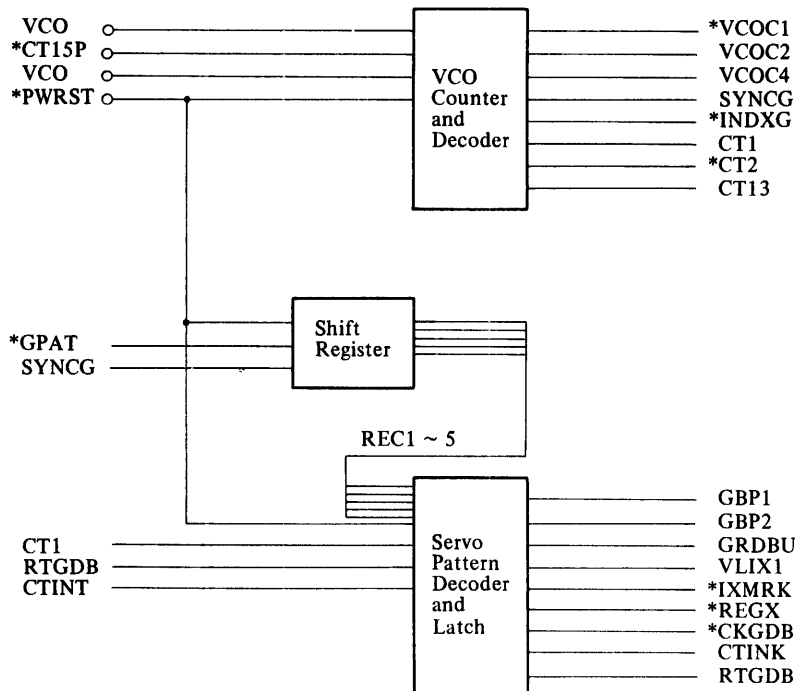

(44) MB10101C (MC10101)  
 QUAD 2-INPUT OR/NOR GATES

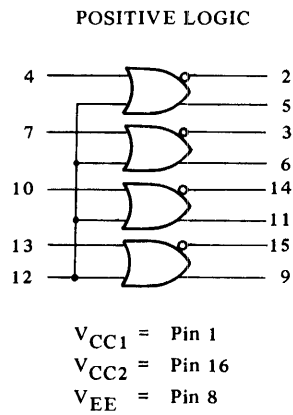

(45) MB10102C (MC10102)  
 QUAD 2-INPUT NOR GATES

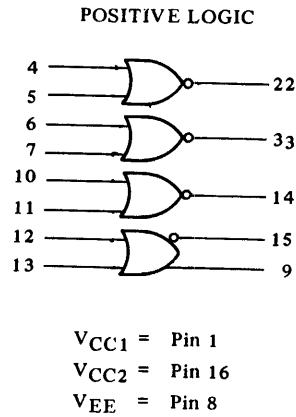

(46) MB10105C (MC10105)  
 TRIPLE 2-3-2 INPUT OR/NOR GATES

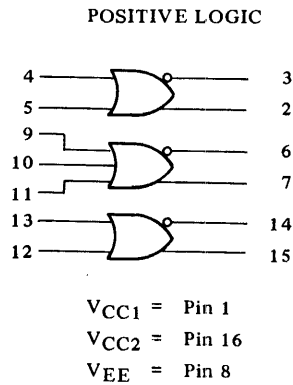

(47) MB10106C (MC10106)

TRIPLE 4-3-3 NOR GATES

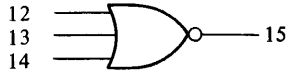
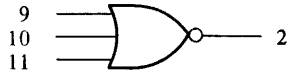
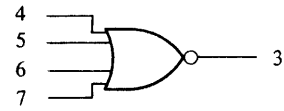

$V_{CC1}$  = Pin 1  
 $V_{CC2}$  = Pin 16  
 $V_{EE}$  = Pin 8

(48) MB10109 (MC10109)

DUAL 4-5 INPUT OR/NOR GATES

POSITIVE LOGIC

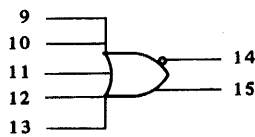
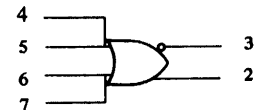

$V_{CC1}$  = Pin 1  
 $V_{CC2}$  = Pin 16  
 $V_{EE}$  = Pin 8

(49) MB10116 (MC10116)

TRIPLE LINE RECEIVERS

The MC10116 is a triple differential amplifier designed for use in sensing differential signals over long lines. The base bias supply ( $V_{BB}$ ) is made available at pin 11 to make the device useful as a Schmitt trigger, or in other applications where a stable reference voltage is necessary.

Active current sources provide the MC10116 with excellent common mode noise rejection. If any amplifier in a package is not used, one input of that amplifier must be connected to  $V_{BB}$  (pin 11) to prevent upsetting the current source bias network.

Complementary outputs are provided to allow driving twisted pair lines, to enable cascading of several amplifiers in a chain, or simply to provide complement outputs of the input function.

POSITIVE LOGIC

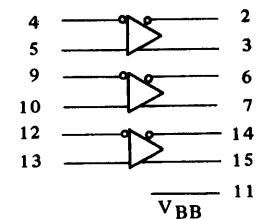

$V_{CC1}$  = Pin 1  
 $V_{CC2}$  = Pin 16  
 $V_{EE}$  = Pin 8

(50) MB10124 (MC10124)

QUAD MTTL TO MECL TRANSLATORS

The MC10124 is a quad translator for interfacing data and control signals between a saturated logic section and the MECL section of digital systems. The MC10124 has MTTL compatible inputs, and MECL complementary open-emitter outputs that allow use as an inverting/non-inverting translator or as a differential line driver. When the common strobe input is at the low logic level, it forces all true outputs to a MECL low logic state and all inverting outputs to a MECL high logic state.

Power supply requirements are ground, +5.0 Volts, and -5.2 Volts. Propagation delay of the MC10124 is typically 3.5 ns. The dc levels are standard or Schottky TTL in MECL 10,000 out.

An advantage of this device is that MTTL level information can be transmitted differentially, via balanced twisted pair lines, to the MECL equipment, where the signal can be received by the MC10115 or MC10116 differential line receivers. The MC10124 is useful in computers, instrumentation, peripheral controllers, test equipment, and digital communications systems.

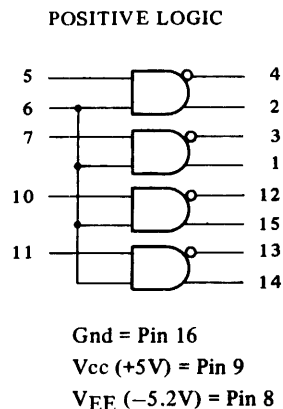

(51) MB10124 (MC10125)

QUAD MECL TO MTTL TRANSLATORS

The MC10125 is a quad translator for interfacing data and control signals between the MECL section and saturated logic sections of digital systems. The MC10125 incorporates differential inputs and Schottky MTTL "totem pole" outputs. Differential inputs allow for use as an inverting/non-inverting translator or as a differential line receiver. The  $V_{BB}$  reference voltage is available on pin 1 for use in single-ended input biasing. The outputs of the MC10125 go to a low logic level whenever the inputs are left floating.

Power supply requirements are ground, +5.0 Volts and 05.2 Volts. Propagation delay of the MC10125 is typically 4.5 ns. The MC10125 has fanout of 10 MTTL loads. The dc levels are MECL 10,000 in and Schottky TTL, or MTTL out. This device has an input common mode noise rejection of  $\pm 1.0$  Volt.

An advantage of this device is that MECL level information can be received, via balanced twisted pair lines, in the MTTL equipment. This isolates the MECL logic from the noisy MTTL environment. This device is useful in computers, instrumentation, peripheral controllers, test equipment and digital communications systems.

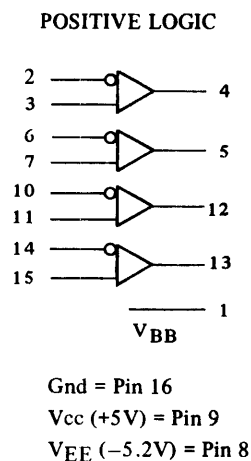

## DUAL D-TYPE MASTER-SLAVE FLIP-FLOPS

The MC10131 is a dual master-slave type D flip-flop. Asynchronous Set (S) and Reset (R) override Clock ( $C_C$ ) and Clock Enable ( $C_E$ ) input. Each flip-flop may be clocked Separately by holding the common clock in the low state and using the enable inputs for the clocking function. If the common clock is to be used to clock the flip-flop, the Clock Enable inputs must be in the low state. In this case, the enable inputs perform the function of controlling the common clock.

The output states of the flip-flop change on the positive transition of the clock. A change in the information present at the data (D) input will not affect the output information at any other time due to master-slave construction.

Input pulldown resistors eliminate the need to tie unused inputs to  $V_{EE}$ . Output rise and fall times have been optimized to provide relaxation of system design and layout criteria.

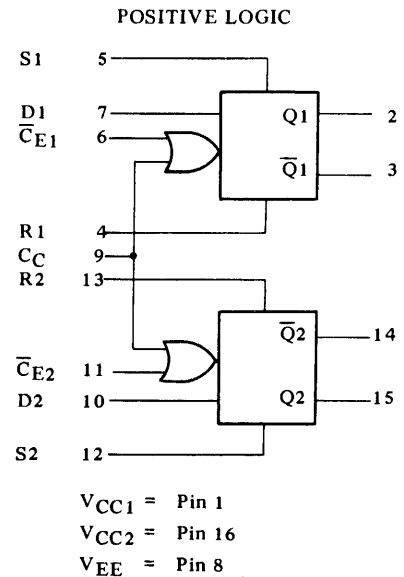

RS TRUTH TABLE

R	S	$Q_{n+1}$
L	L	$Q_n$
L	H	H
H	L	L
H	H	N.D.

N.D. = Not Defined

CLOCKED TRUTH TABLE

C	D	$Q_{n+1}$
L	$\phi$	$Q_n$
H	L	L
H	H	H

$\phi$  = Don't Care

$$C = \bar{C}_E + C_C$$

A clock H is a clock transition from a low to a high state.

(53) MB10135C (MC10135)

DUAL J-K MASTER-SLAVE FLIP-FLOPS

The MC10135 is a dual master-slave dc coupled J-K flip-flop. Asynchronous set (S) and reset (R) are provided. The set and reset inputs override the clock.

A common clock is provided with separate  $\bar{J}$   $\bar{K}$  inputs. When the clock is static, the  $\bar{J}$   $\bar{K}$  inputs do not affect the output.

The output states of the flip-flop change on the positive transition of the clock.

Input pulldown resistors eliminate the need to tie unused inputs to  $V_{EE}$ . Output rise and fall times have been optimized to provide relaxation of system design and layout criteria.

R-S TRUTH TABLE

R	S	$Q_{n+1}$
L	H	H
H	L	L
H	H	N.D.

N.D. = Not Defined

CLOCK J-K TRUTH TABLE

J	K	$Q_{n+1}$
H	L	$Q_n$
L	H	H
H	H	$Q_n$

Output states change on positive transition of clock for J-K input condition present.

POSITIVE LOGIC

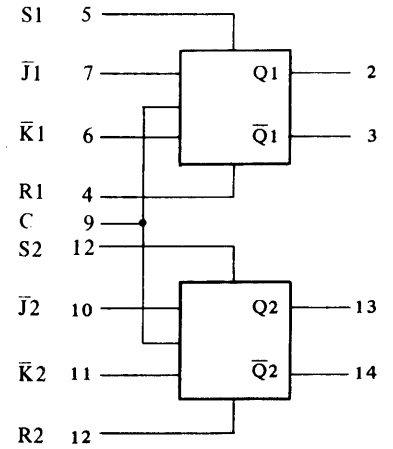

$V_{CC1}$  = Pin 1  
 $V_{CC2}$  = Pin 16  
 $V_{EE}$  = Pin 8

(54) HD103107

VOLTAGE CONTROLLED OSCILLATOR

Typical Gain; 5 MHz/mA

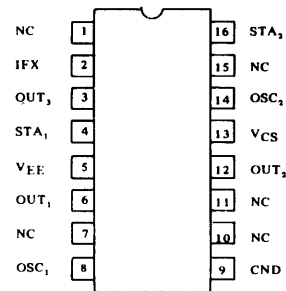
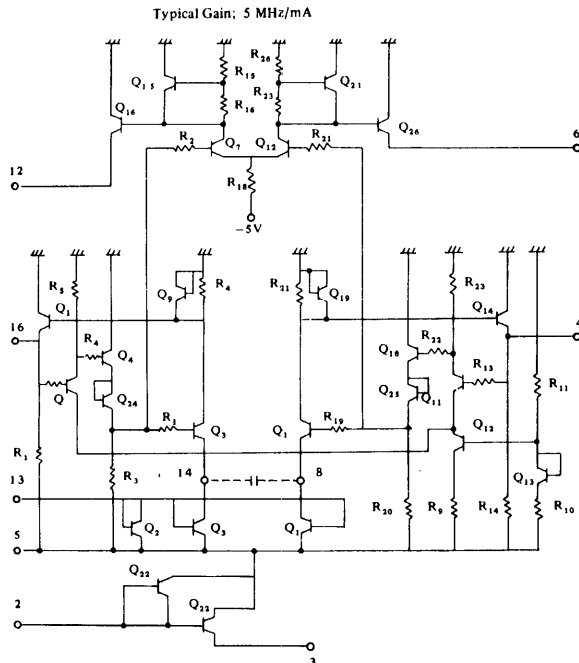

Functional block diagram

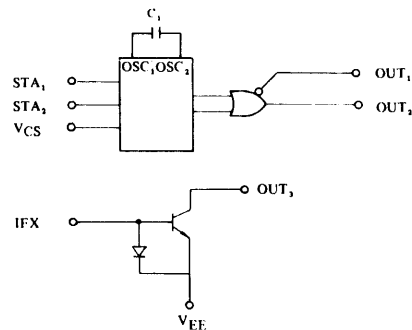

(55) MB4306C

VOLTAGE CONTROLLED OSCILLATOR

The MB4306C is mainly used as an oscillator with its oscillating frequency synchronous with the rotational speed of the disks. The output clock signal is used to modulate and demodulate the write and read data. The circuit consists of two portions, one is oscillator whose output frequency varies with the input control voltage level, and the other is a monostable multi-vibrator which is generally used in demodulating the read data.

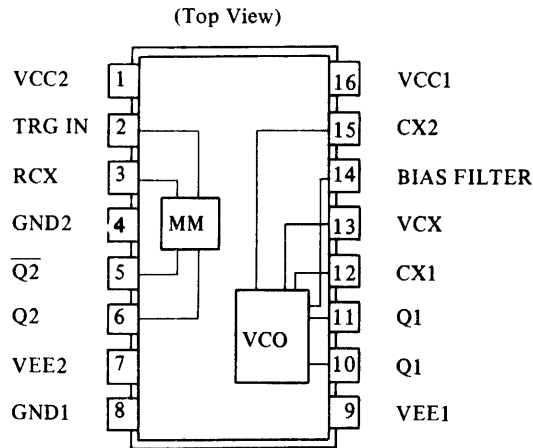

(56) MB4311C

LEVEL SENSOR

The MB4311C is used in conjunction with the MB4303C (AGC Amplifier) to keep the read out signal derived from a magnetic head at a constant level. It also contains an amplifier with a gain of 10.

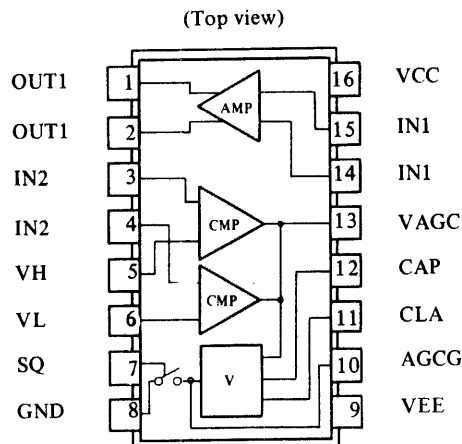

(57) MB4303C

AGC AMPLIFIER

The MB4303C is used in conjunction with the MB4311C (Level Sensor) to keep the read out signal derived from a magnetic head at a constant level. It also contains an amplifier.

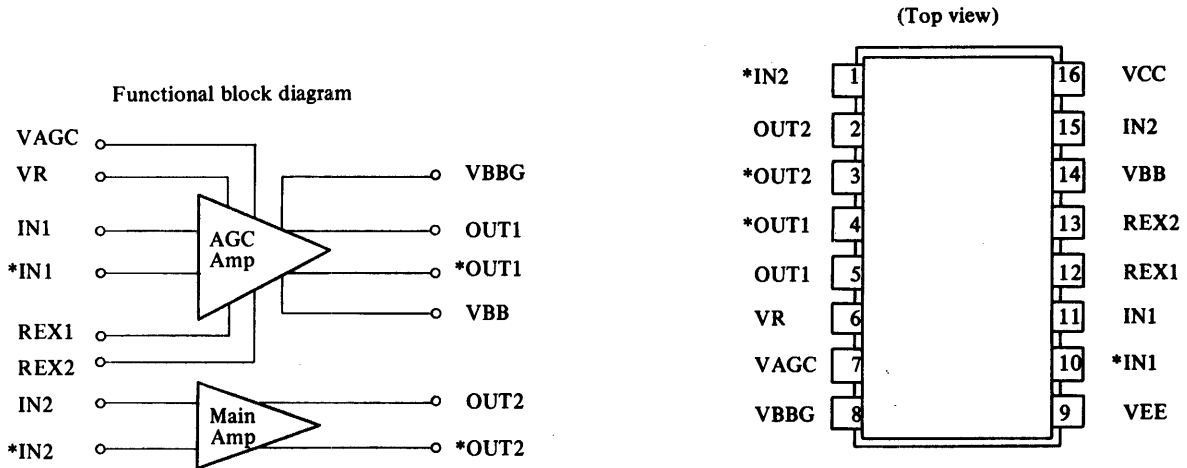

(58) MB4316C

READ/WRITE BUS SWITCH C

The MB4316C contains a driver and a receiver circuit to transmit write/read data to/from the Head IC. It also generates the write-current which flows in a magnetic head during a write operation.

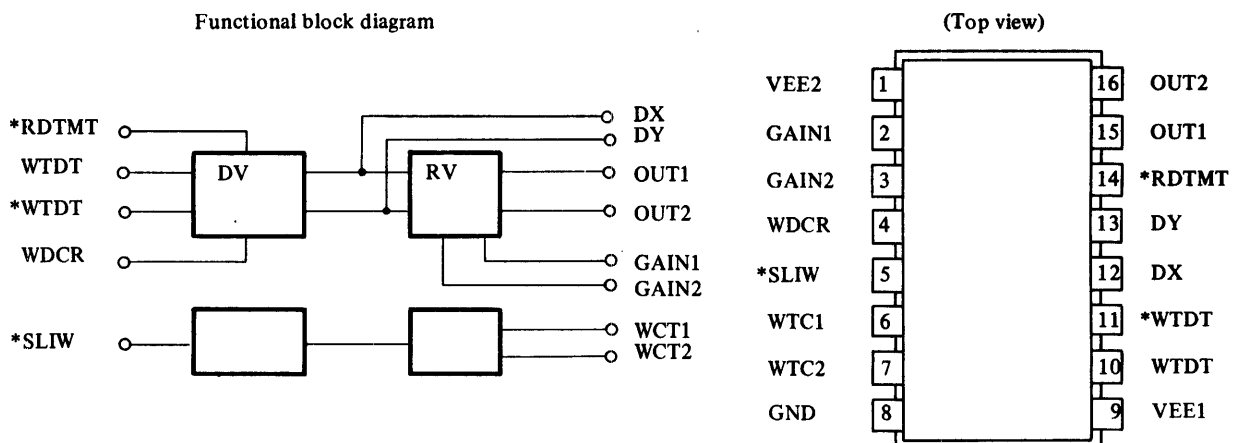



(59) MB4319C  
PEAK HOLD

The MB4319C is used in the position sensing circuit of the disk drive. The peak-voltage of raw-servo signal is hold for demodulating inot the position signal.

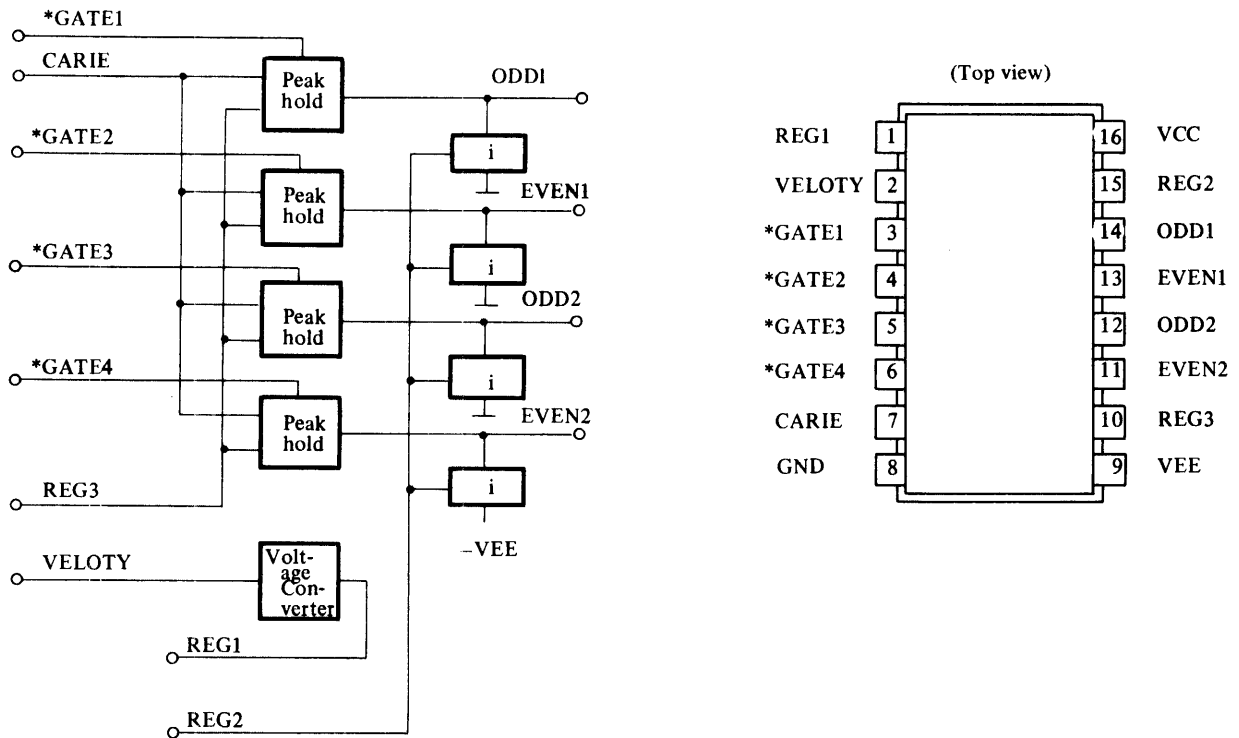

(60) MB4112 (SS1105)  
MB4113  
DISK HEAD IC (FIXED/MOVABLE)

The MB4112 and MB4113 are analog LSIs for Fixed-Head and Movable-Head respectively used in the disk drive. The MB4112 has lower amplifier gain depending on characteristics of magnetic head. Both can control up to four heads and contain the following circuits.

- Read amplifier
- Write amplifier
- RAS circuit
- Head select circuit

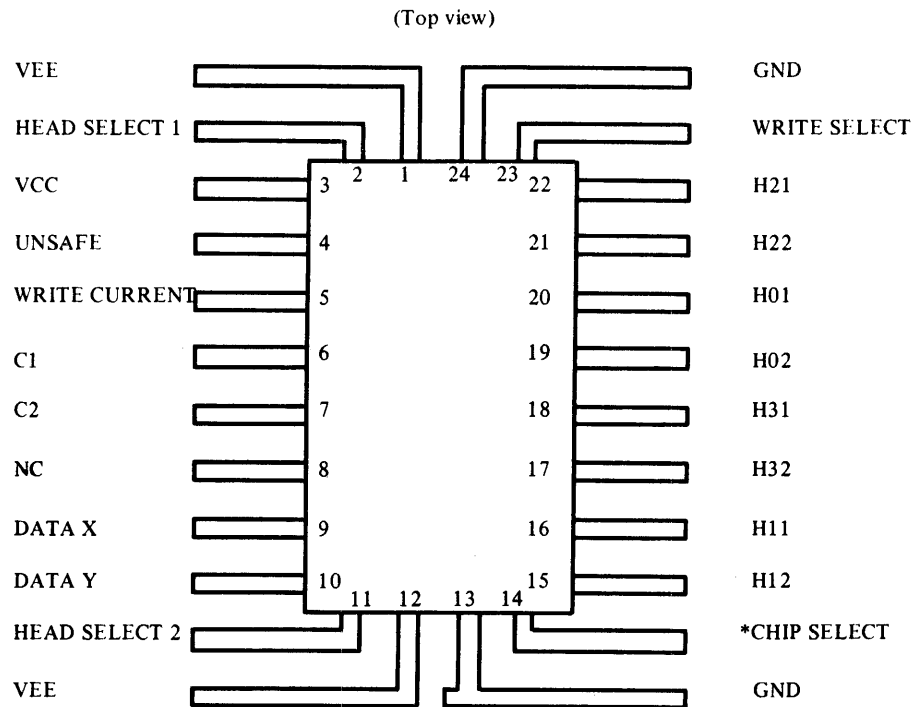

(61) MB4002M

HIGH SPEED DIFFERENTIAL COMPARATOR

The MB4002M is a Differential Voltage Comparator intended for applications requiring high accuracy and fast response times. The device is useful as a variable threshold Schmitt trigger, a pulse height discriminator, a voltage comparator in high-speed A/D converters, a memory sense amplifier or a high noise immunity line receiver. The output of the comparator is compatible with all integrated logic forms.

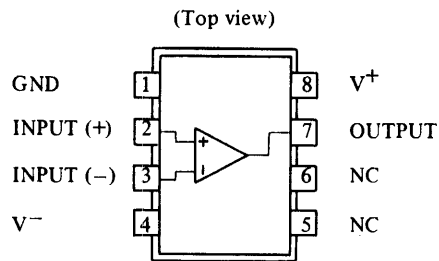

(62) MB3607M ( $\mu$ pC251C, MC1458C)  
 DUAL OPERATIONAL AMPLIFIERS

The MB3607M is designed for use as a summing amplifier integrator, or amplifier with operating characteristics as a function of the external feed-back components.

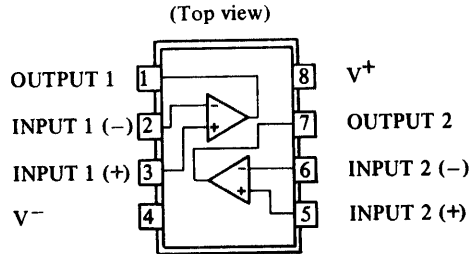

(63) MB3501M ( $\mu$ A733DM)  
 DIFFERENTIAL VIDEO AMPLIFIER

The MB3510M is a monolithic tow-stage Differential Input and Output Video Amplifier.

Internal series-shunt feedback is used to obtain wide bandwidth, low phase distortion, and excellent gain stability. Emitter follower outputs enable the device to drive capacitive loads and all stages are current-source biased to obtain high power supply and common mode rejection ratios. It offers fixed gains of 10, 100 or 400 without external components, and adjustable gains from 10 to 400 by the use of a single external resistor. No external frequency compensation components are required for any gain option. The device is particularly useful in magnetic tape or disc file systems using phase or NRZ encoding and in high speed film or plate wire memories. Other applications include general purpose video and pulse amplifiers where wide bandwidth, low phase shift, and excellent gain stability are required.

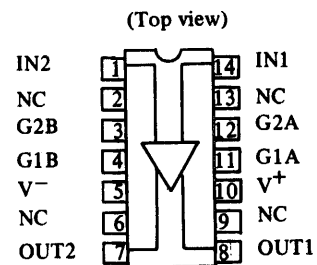

(64) MB5365M  
 NPN DUAL TRANSISTORS

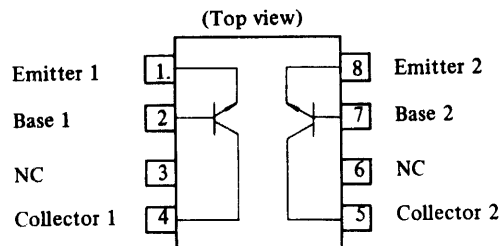

(65)  $\mu$ PC142A

NEGATIVE VOLTAGE REGULATOR

The  $\mu$ PC142A is a precision negative voltage regulator, consisting of temperature-compensated reference constant current source and a differential error amplifier with emitter follower input. The output voltage is adjustable from  $-0.035V$  to  $030V$ . In addition, an external pass transistor enhances output current capability up to  $10A$ . The current limiting circuit is incorporated and the limiting current is externally adjustable. The applications include negative voltage supply for operational amplifiers.

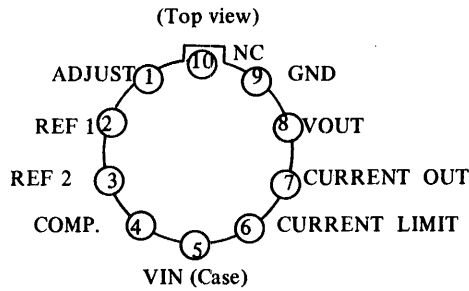

(66)  $\mu$ PC151C

FREQUENCY COMPENSATED OPERATIONAL AMPLIFIER

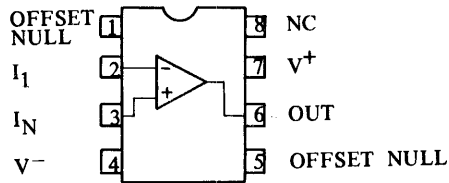

(67)  $\mu$ PC159A

HIGH SPEED WIDE BAND OPERATIONAL AMPLIFIER

(top view)

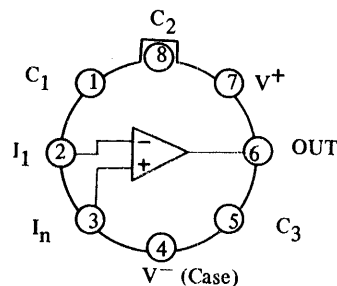

(68)  $\mu$ PC271C

VOLTAGE COMPARATOR

This is a single high-speed voltage comparator. This device is designed to operate from a wide range of power supply voltage, including  $\pm 15V$  supplies for operational amplifiers and +5 supplies for logic systems. The output level is compatible with most DTL, TTL, and MOS circuits. This comparator is capable of driving Lamps or relays and switching voltage up to 50V at 50mA. All inputs and outputs can be isolated from system ground. The output can drive loads referenced to ground,  $V_{cc+}$ ,  $V_{cc-}$ . Offset balancing and strobe capability are available and the output can be wire-OR connected. If the strobe input is low, the output will be in the off state regardless of the differential input.

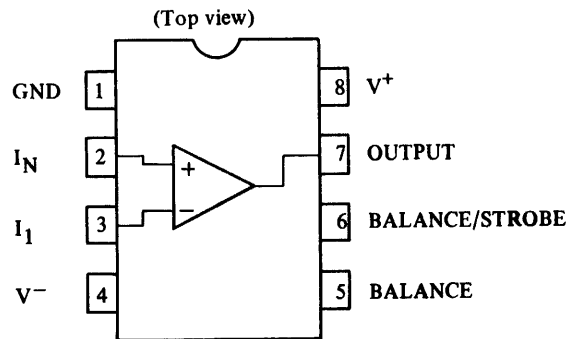

(69)  $\mu$ PC610D

10-BIT D/A CONVERTER

The  $\mu$ PC610D is a complete 10 bit plus sign D/A convertor. All elements of a complete sign/magnitude DAC are included—precision voltage reference, current steering logic, current sources, R-2R resistor network, logic controlled polarity switch and high speed internally compensated output of amp. The wide power supply range, low power consumption, choice of full scale output voltages and sign/magnitude coding assure utility in a wide range of applications.

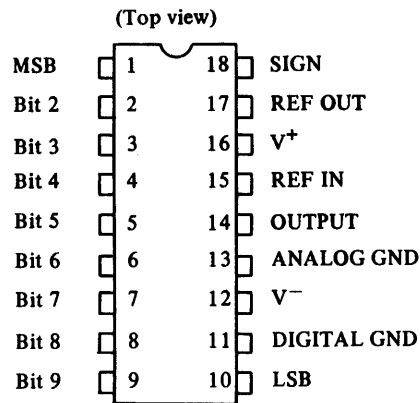

(70)  $\mu$ PA49A

PNP DUAL TRANSISTORS

- $I_C = -50 \text{ mA}$
- $f_T = 250 \text{ MHz}$
- $P_c = 300 \text{ mW/UNIT}$

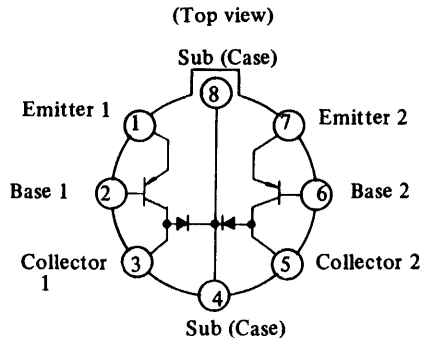

(71) DG201BK

QUAD ANALOG SWITCHES

The DG201 is a 4-channel single pole signal throw analog switch which employs CUOS technology to insure low and nearly constant ON resistance over the entire analog signal range. The switch will conduct current in either direction with no fooset voltage in the ON condition, and block voltages up to 30V peak-to-peak in the OFF condition. The )N-OFF state of each switch is controlled by a driver. With a logic "0" at the input to the driver (0V to 0.8V) the switch will be ON, and a logic "1" (214V to 15V) will turn the switch OFF. Switch action is break-before-make.

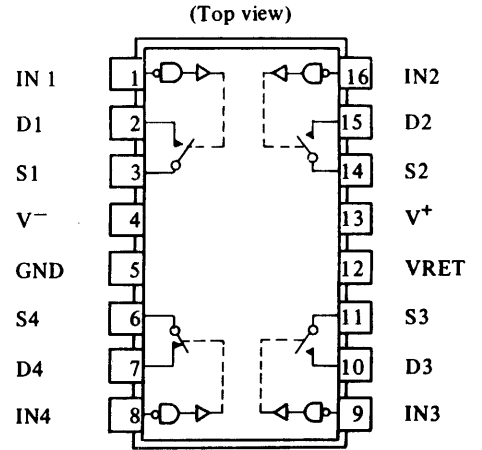

LOGIC	SWITCH
0	ON
1	OFF

(72) M51841P

TIMING CIRCUIT

This monolithic timing circuit is a highly stable controller capable of producing accurate time delays, or oscillation. Additional terminals are provided for triggering or resetting if desired. In the time delay mode of operation, the time is precisely controlled by one external resistor and capacitor. For astable operation as an oscillator, the free running frequency and the duty cycle are both accurately controlled with two external resistors and one capacitor. The circuit may be triggered and reset on falling waveforms, and the output structure can source or sink up to 200 mA or drive M TTL circuits.

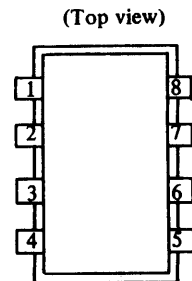

functional block diagram

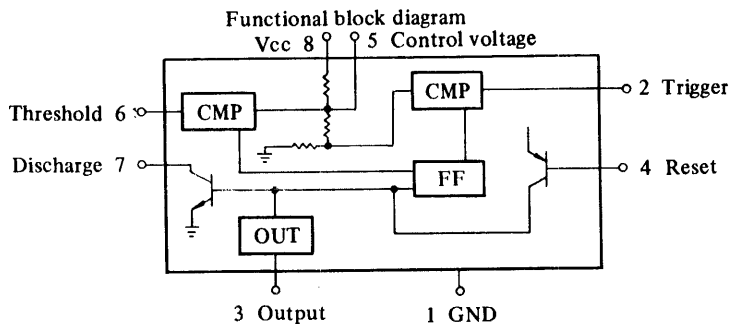

(73) MC1590G  
AGC AMPLIFIER

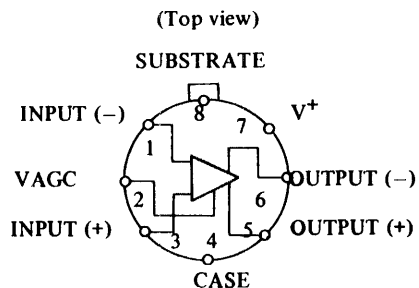

(74) MB7055C  
8192-BIT PROGRAMMABLE READ ONLY MEMORY

The MB7055C is a 1024 × 8 bit bipolar programmable read only memory

A0 ~ A9 ; Address input  
Out1 ~ Out8; Data Output  
CE1 CE2 ; Chip enable  
Vcc ; +5V

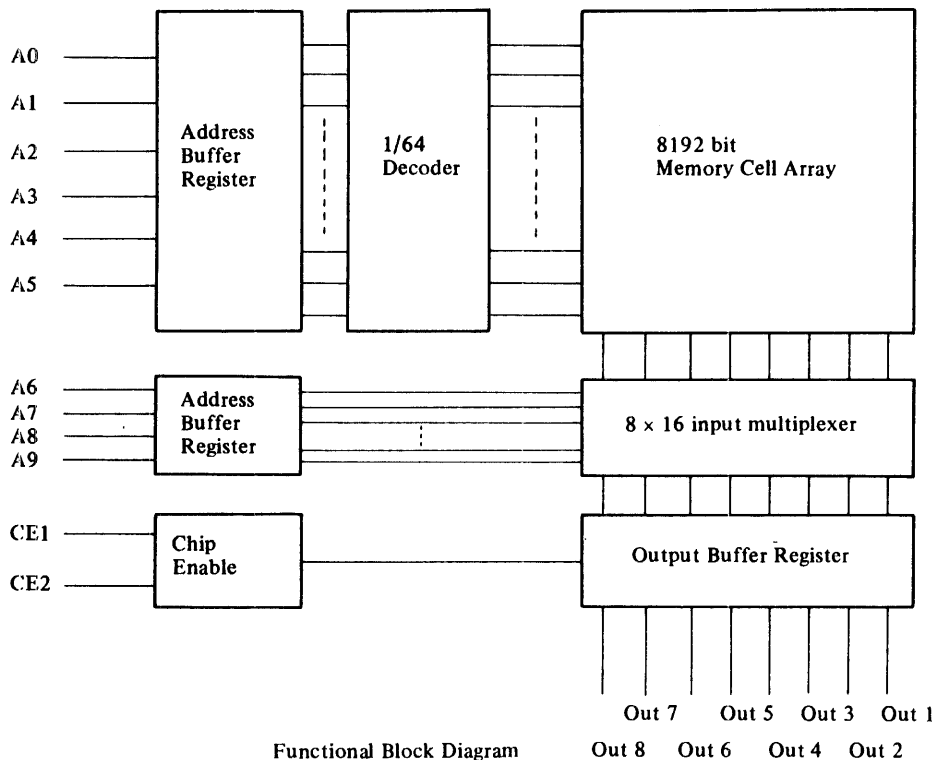
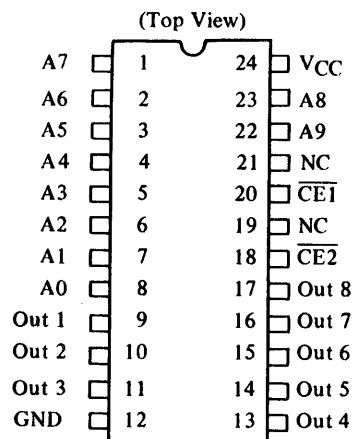

	1	2	3	4	5	6	7	8	9	X	Y	Z
A												
B												
C												
D												
E												
F												
G												
H												
I												
J												
K												
L												
M												
N												
P												
Q												

	1	2	3	4	5	6	7	8	9	X	Y	Z
A												
B												
C												
D												
E												
F												
G												
H												
I												
J												
K												
L												
M												
N												
P												
Q												

SHEET	ABBR	T I T L E
001		Schematics/Drawings List
002	AA1	CR,A Interface Circuit Diagram (1)
003	AA2	CR,A Interface Circuit Diagram (2)
004	AA3	CR,A Interface Circuit Diagram (3)
005	AA4	CR,A Interface Circuit Diagram (4)
006	AA5	CR,A Interface Circuit Diagram (5)
007	AB1	CR,B Interface Circuit Diagram (1)
008	AB2	CR,B Interface Circuit Diagram (2)
009	AB3	CR,B Interface Circuit Diagram (3)
010	AB4	CR,B Interface Circuit Diagram (4)
011	AB5	CR,B Interface Circuit Diagram (5)
012	AB6	CR,B Interface Circuit Diagram (6)
013	AB7	CR,B Interface Circuit Diagram (7)
014	BA1	Interface Circuit Diagram (1)
015	BA2	Interface Circuit Diagram (2)
016	BA3	Interface Circuit Diagram (3)
017	CA1	Access Control Circuit Diagram (1)
018	CA2	Access Control Circuit Diagram (2)
019	CA3	Access Control Circuit Diagram (3)
020	CA4	Access Control Circuit Diagram (4)
021	CA5	Access Control Circuit Diagram (5)
022	DA1	Read Address Register Circuit Diagram
023	EA1	R/W Control Circuit Diagram (1)
024	EA2	R/W Control Circuit Diagram (2)
025	FA1	VFO Control Circuit Diagram (1)
026	FA2	VFO Control Circuit Diagram (2)
027	FA3	VFO Control Circuit Diagram (3)
028	GA1	Sector Control Circuit Diagram (1)
029	GA2	Sector Control Circuit Diagram (2)
030	HA1	Servo Pattern Detector Circuit Diagram (1)

SHEET	ABBR	T I T L E
031	HA2	Servo Pattern Detector Circuit Diagram (2)
032	HA3	Servo Pattern Detector Circuit Diagram (3)
033	JA1	DE Sequencer Circuit Diagram (1)
034	JA2	DE Sequencer Circuit Diagram (2)
035	JA3	DE Sequencer Circuit Diagram (3)
036	KA1	Servo Circuit Diagram
037	LA1	Read Amplifier Circuit Diagram
038	MA1	Internal Connection Circuit Diagram (1)
039	MA2	Internal Connection Circuit Diagram (2)
040	MA3	Internal Connection Circuit Diagram (3)
041	MA4	Internal Connection Circuit Diagram (4)
042	MA5	Internal Connection Circuit Diagram (5)
043	MA6	Internal Connection Circuit Diagram (6)
044	MA7	Internal Connection Circuit Diagram (7)
045	MA8	Internal Connection Circuit Diagram (8)
046	MB1	Internal Cable Connection Diagram (1)
047	MB2	Internal Cable Connection Diagram (2)
048	PA1	Power Unit Circuit Diagram (1)
049	PA2	Power Unit Circuit Diagram (2)
050	RA1	Read Amplifier Circuit Diagram (1)
051	RA2	Read Amplifier Circuit Diagram (2)
052	RA3	Read Amplifier Circuit Diagram (3)
053	RA4	Read Amplifier Circuit Diagram (4)
054	RA5	Read Amplifier Circuit Diagram (5)
055	RB1	Variable Freq. Osc. Circuit Diagram (1)
056	RB2	Variable Freq. Osc. Circuit Diagram (2)
057	RB3	Variable Freq. Osc. Circuit Diagram (3)
058	RB4	Variable Freq. Osc. Circuit Diagram (4)
059	RB5	Variable Freq. Osc. Circuit Diagram (5)
060	RB6	Variable Freq. Osc. Circuit Diagram (6)

SHEET	ABBR	T I T L E
061	SA1	Position Sensing Circuit Diagram (1)
062	SA2	Position Sensing Circuit Diagram (2)
063	SA3	Position Sensing Circuit Diagram (3)
064	SB1	Servo Control Circuit Diagram (1)
065	SB2	Servo Control Circuit Diagram (2)
066	SB3	Servo Control Circuit Diagram (3)
067	SB4	Servo Control Circuit Diagram (4)
068	SB5	Servo Control Circuit Diagram (5)
069	SB6	Servo Control Circuit Diagram (6)
070	SB7	Servo Control Circuit Diagram (7)
071	TA1	Power Amplifier Circuit Diagram (1)
072	TA2	Power Amplifier Circuit Diagram (2)
073	TA3	Power Amplifier Circuit Diagram (3)
074	TA4	Power Amplifier Circuit Diagram (4)
075	UA1	Indicator Circuit Diagram
076	VA1	Operator Panel Circuit Diagram
077	--	Logic Circuit S12390U Mounting Diagram
078	--	Read Amplifier RFJAU Mounting Diagram
079	--	Servo Circuit SVIAU Mounting Diagram
080	--	Indicator Circuit HGAMU Mounting Diagram
081	--	Indicator Circuit HGAMU Mounting Diagram
082	--	Power Amplifier TVPMU Mounting Diagram
083	--	Driver Receiver DQEMU Mounting Diagram
084	--	Driver Receiver DQPMU Mounting Diagram

SHEET	ABBR	T I T L E
		Schematics/Drawings List

REV.	DATE	DESCRIPTION
1		
2		
3		
4		
5		

**FUJITSU LIMITED** 201/



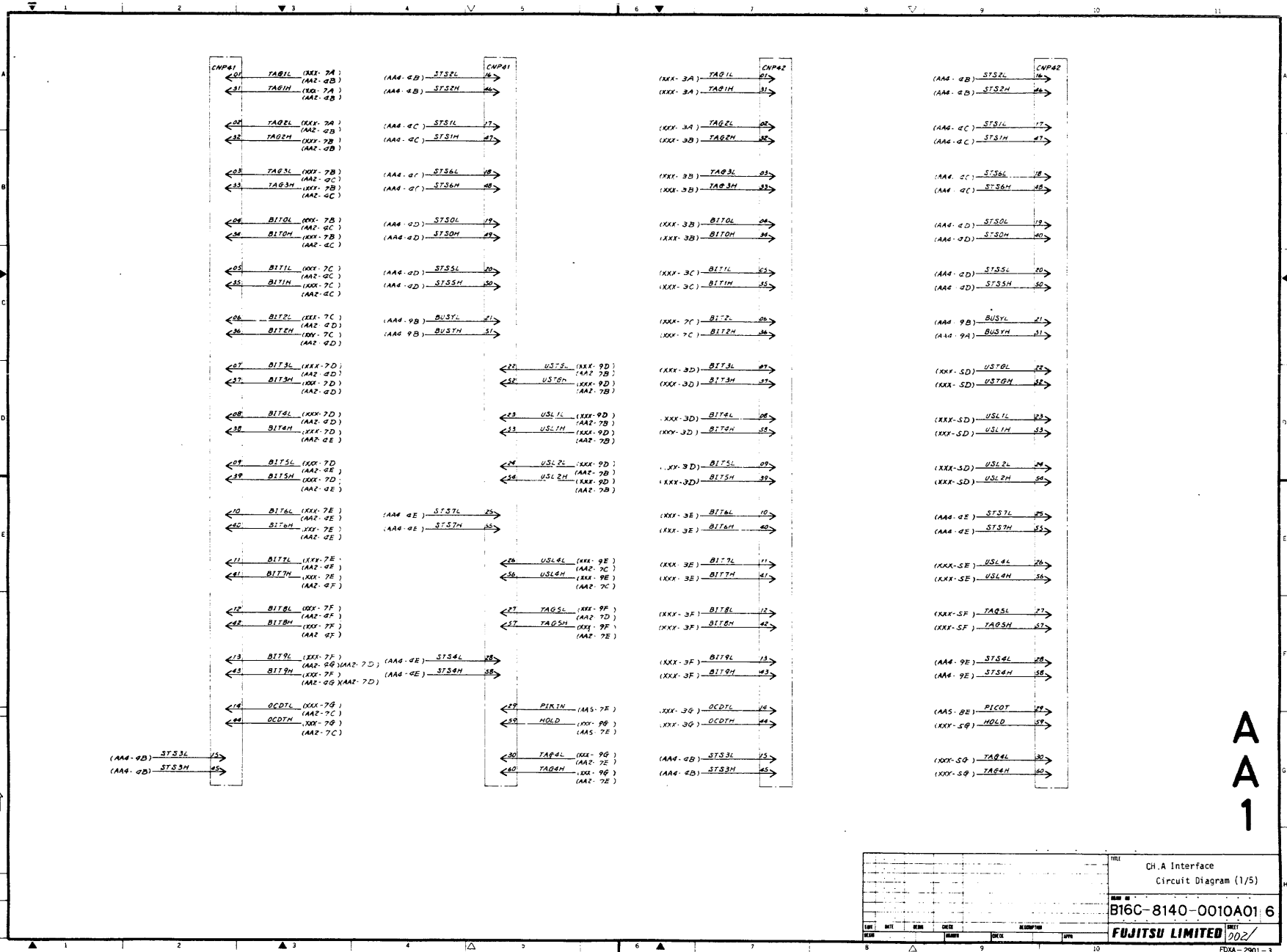

TITLE						CH. A Interface	
Circuit Diagram (1/5)							
DRAWN BY						B16C-8140-0010A01 6	
CHECKED BY						FUJITSU LIMITED	
DATE	REV.	BY	DATE	BY	REVISION	DATE	BY

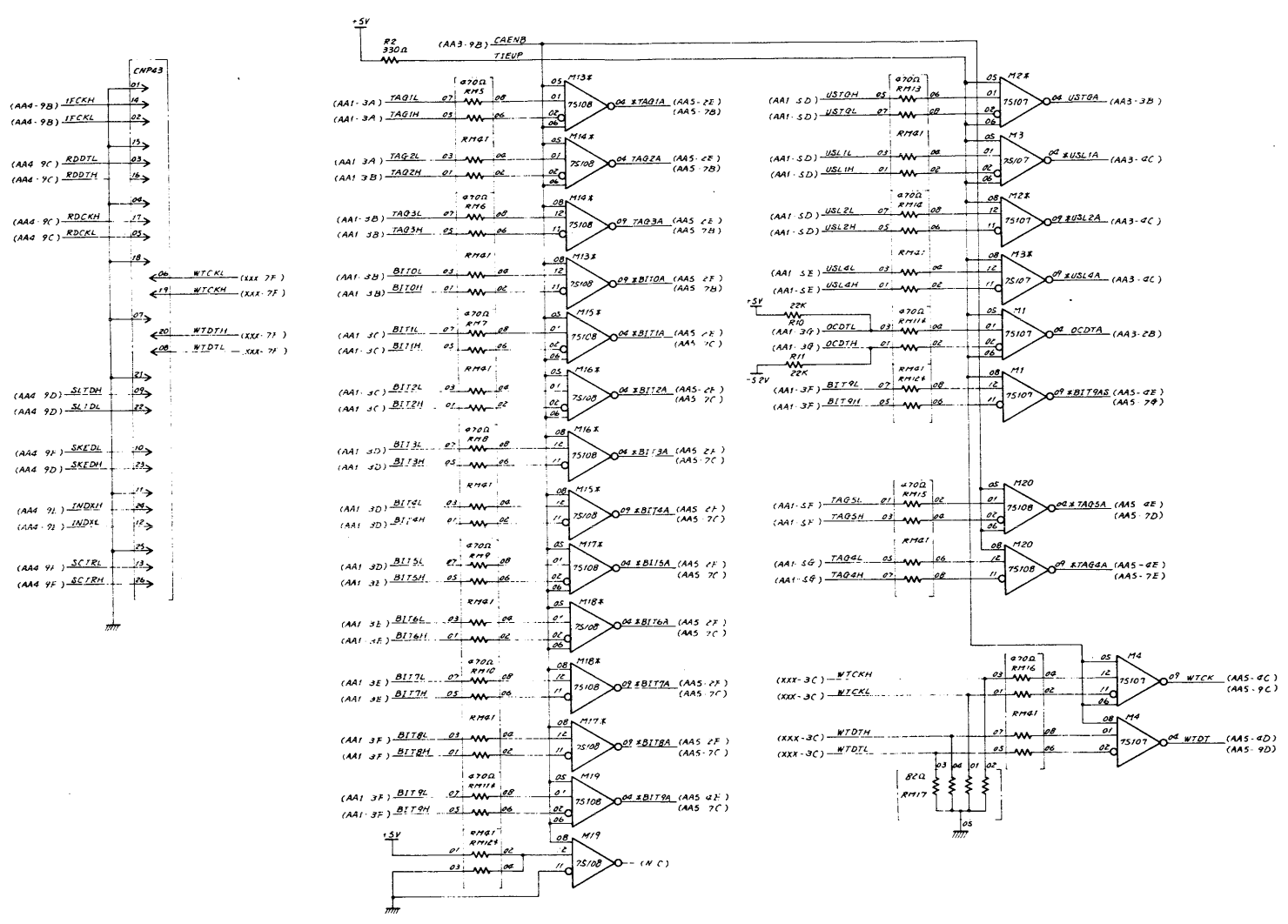

AA2

CH.A Interface Circuit Diagram (2/5)	
B16C-8140-0010A01.6	
FUJITSU LIMITED	

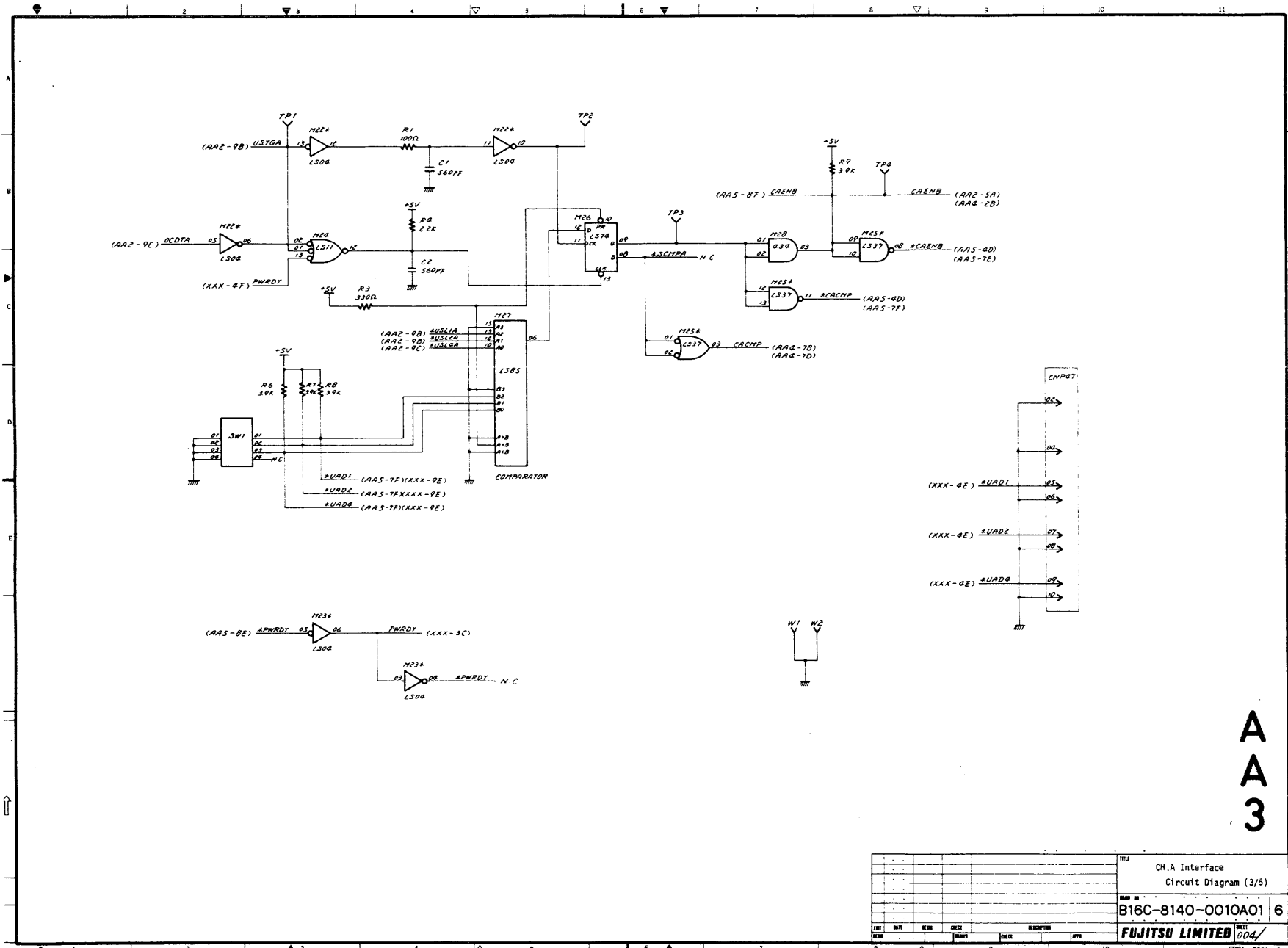

A  
A  
3

TITLE						CH.A Interface					
						Circuit Diagram (3/5)					
PART NO.						B16C-8140-0010A01   6					
REV.						004/					
DES.	CHK.	APP.	DES.	CHK.	APP.	DES.	CHK.	APP.	DES.	CHK.	APP.

FUJITSU LIMITED

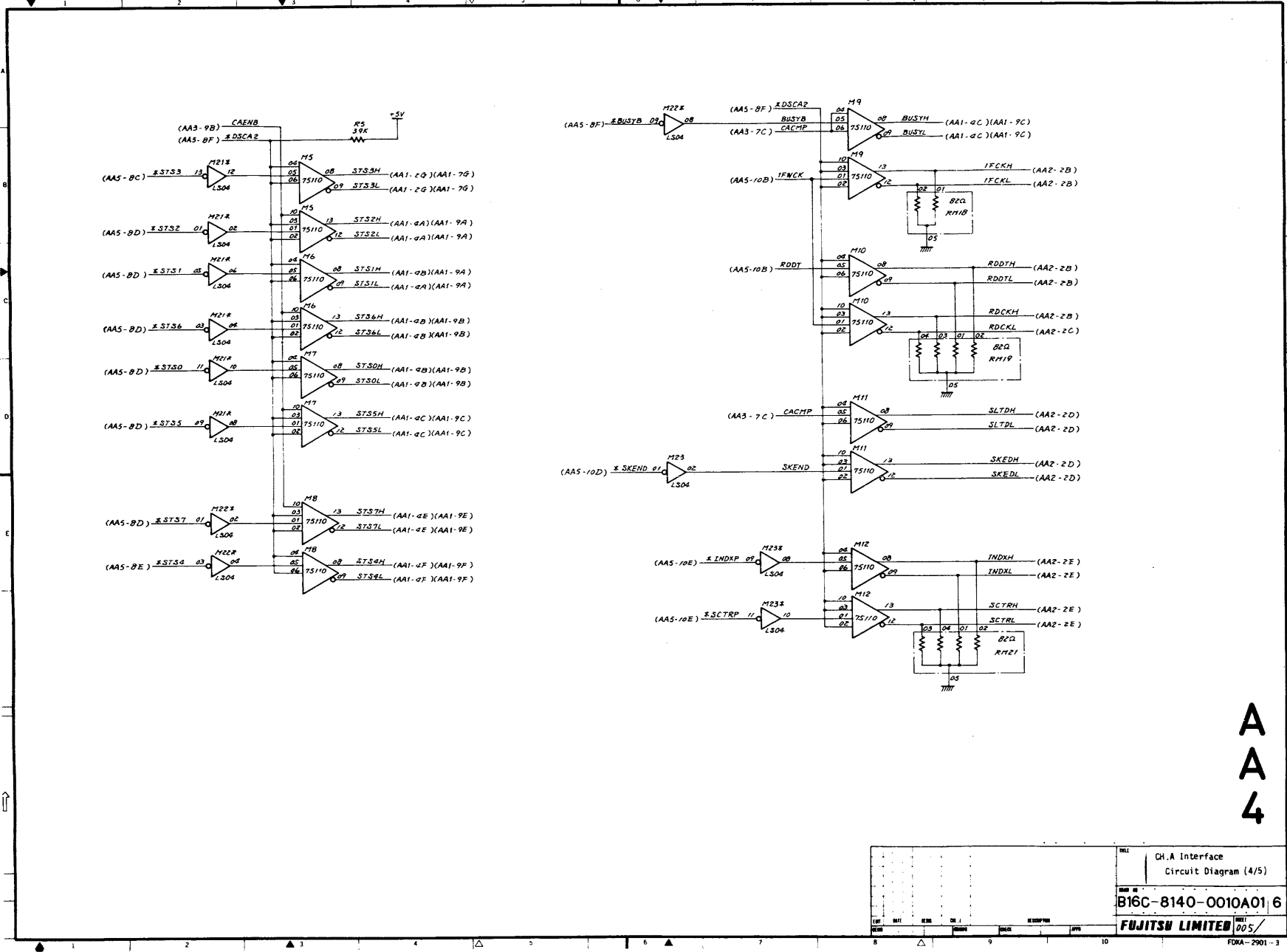

AA4

TITLE		CH.A Interface	
CIRCUIT		Circuit Diagram (4/5)	
DRAWN BY		B16C-8140-0010A01 6	
CHECKED BY		FUJITSU LIMITED	
DATE	REV.	QTY.	UNIT
			005

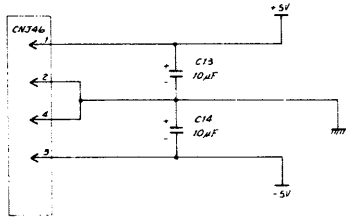

(XXX-10B)	IFWCK	06	LTN
(XXX-10B)	RDDT	03	
(XXX-10F)	WDT	14	
(XXX-10F)	WTCK	03	RH27
(XXX-10F)	WTRND	07	
(XXX-10F)	WTRDT	03	RH3
(XXX-10F)	WTRDP	04	
(XXX-10F)	WTRTP	12	
(XXX-10F)	WTRND	03	

(AA2-6B)	STAG1A	03	LTN
(AA2-6B)	STAG2A	03	
(AA2-6B)	STAG3A	03	
(AA2-6C)	EBIT0A	07	RH27
(AA2-6C)	EBIT1A	07	
(AA2-6C)	EBIT2A	07	
(AA2-6D)	EBIT3A	07	RH1
(AA2-6D)	EBIT4A	07	
(AA2-6E)	EBIT5A	07	
(AA2-6E)	EBIT6A	07	
(AA2-6F)	EBIT7A	07	
(AA2-6F)	EBIT8A	07	

(AA2-6F)	EBIT9A	07	LTN
(AA2-9E)	STAG2A	03	
(AA2-9E)	STAG3A	03	
(XXX-9C)	ESTS3	18	RH27
(XXX-9D)	ESTS7	12	
(XXX-9D)	ESTS6	03	RH2
(XXX-9D)	ESTS0	12	
(XXX-9D)	ESTS1	04	
(XXX-9D)	ESTS2	04	
(XXX-9E)	ESTS4	04	
(XXX-9F)	EWTRD	00	

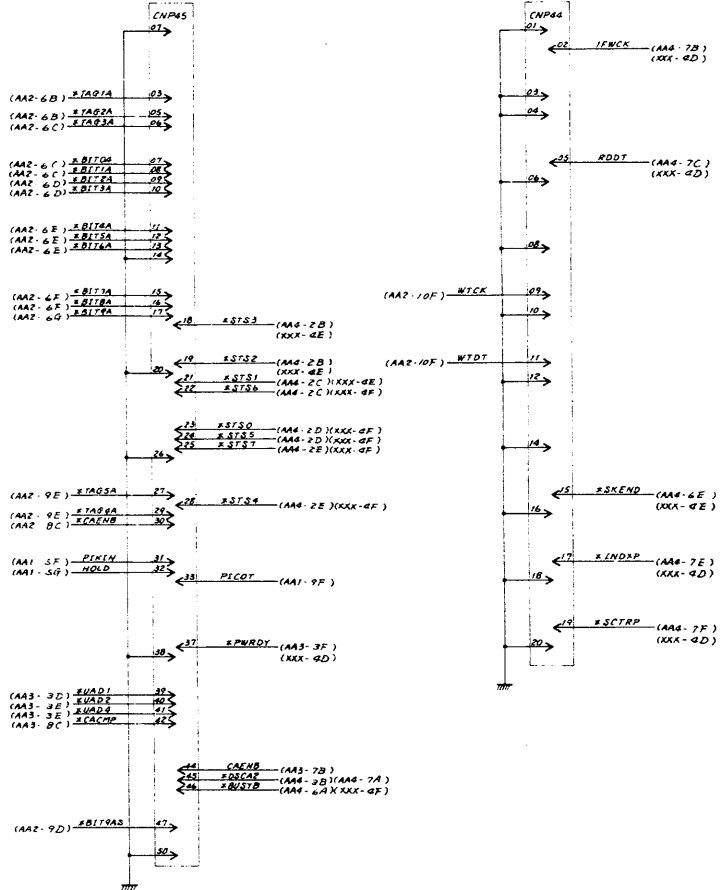

AA5

INTL	
CH.A Interface	
Circuit Diagram (5/5)	
PART NO.	
B16C-8140-0010A01 6	
FUJITSU LIMITED	
006/	

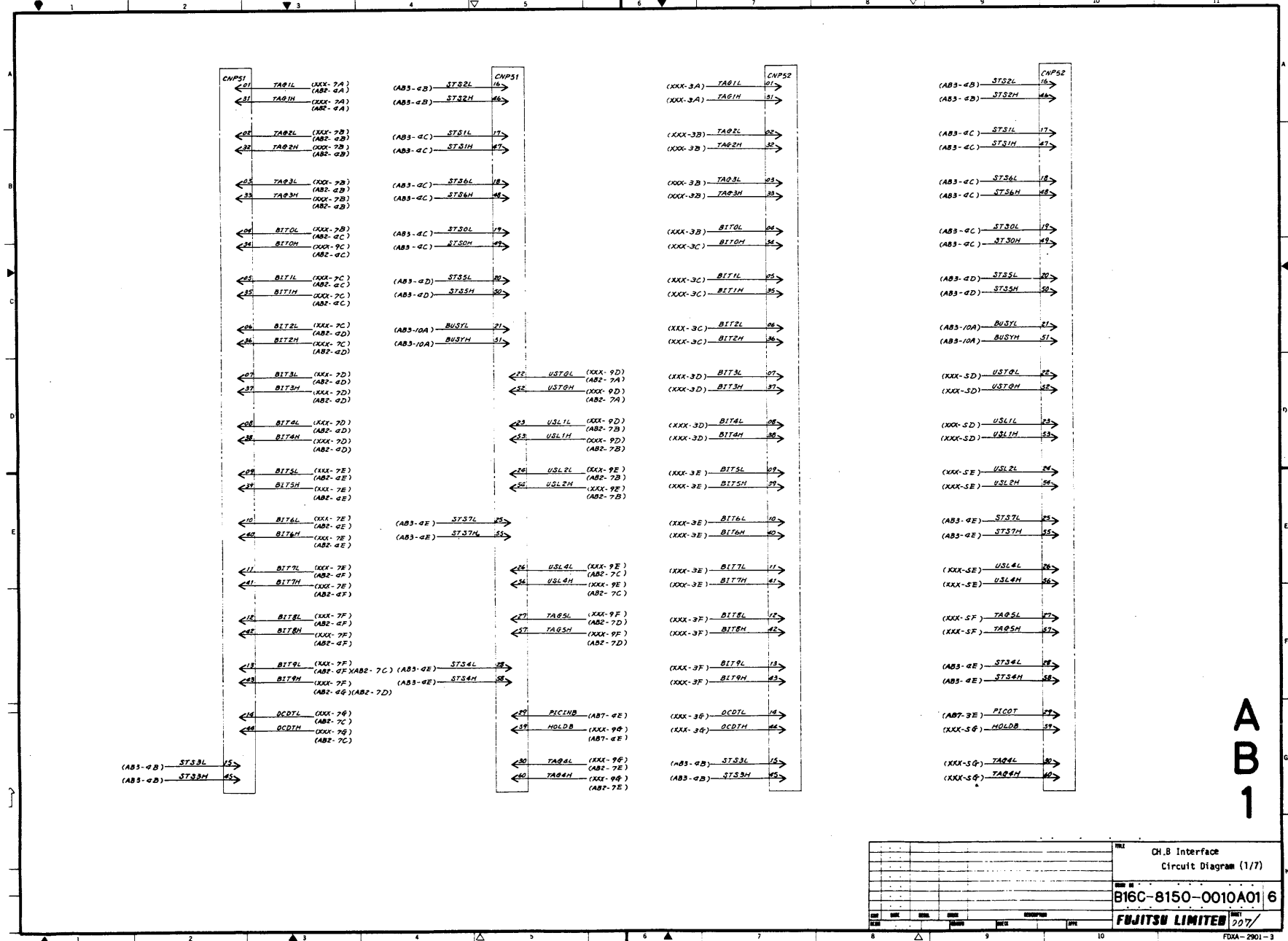

		CH.B Interface	
		Circuit Diagram (1/7)	
		B16C-8150-0010A01 6	
		FUJITSU LIMITED	
		207/	

A  
B  
1

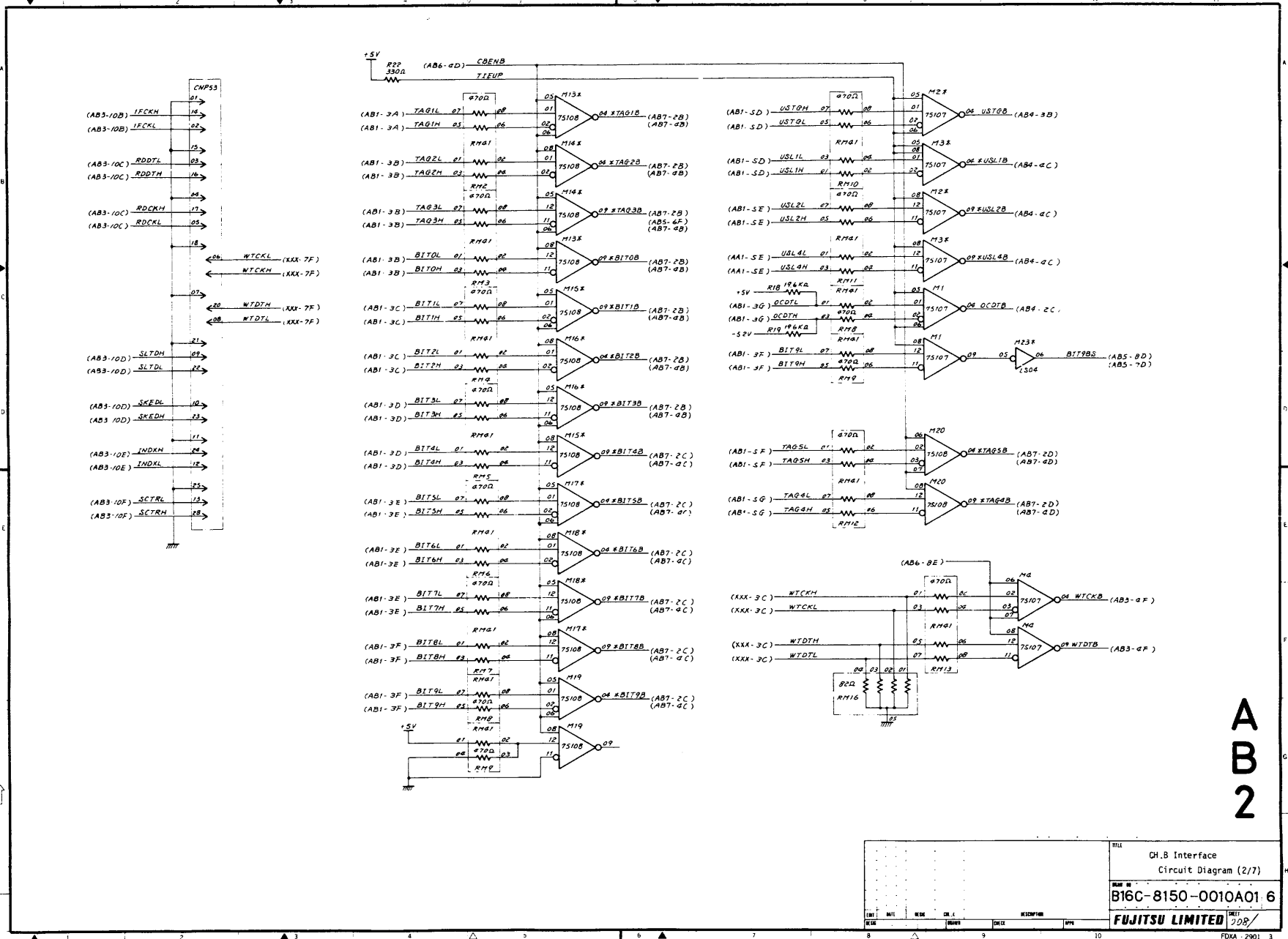

AB2

TITLE		Ch.B Interface	
Circuit Diagram (2/7)			
PART NO.		B16C-8150-0010A01.6	
REV.	DATE	DESIGNER	CHKD.
FUJITSU LIMITED		DRAWN	

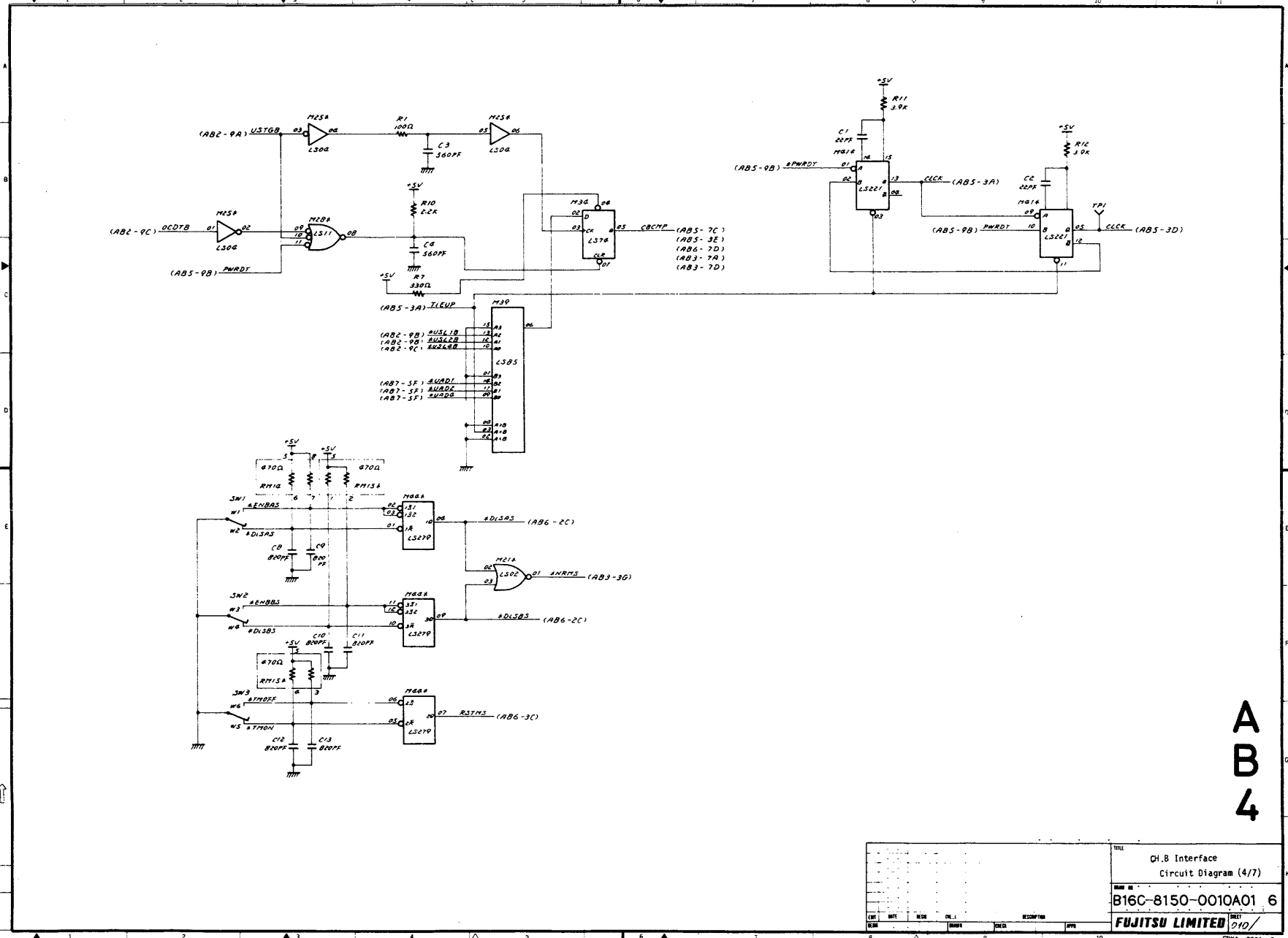

AB4

TITLE		CH.B Interface	
Circuit Diagram (4/7)			
PART NO.		B16C-8150-0010A01 6	
FABRICATION		FUJITSU LIMITED	
DATE		2/10/	
DRAWN			
CHECKED			
APPROVED			
REVISION			





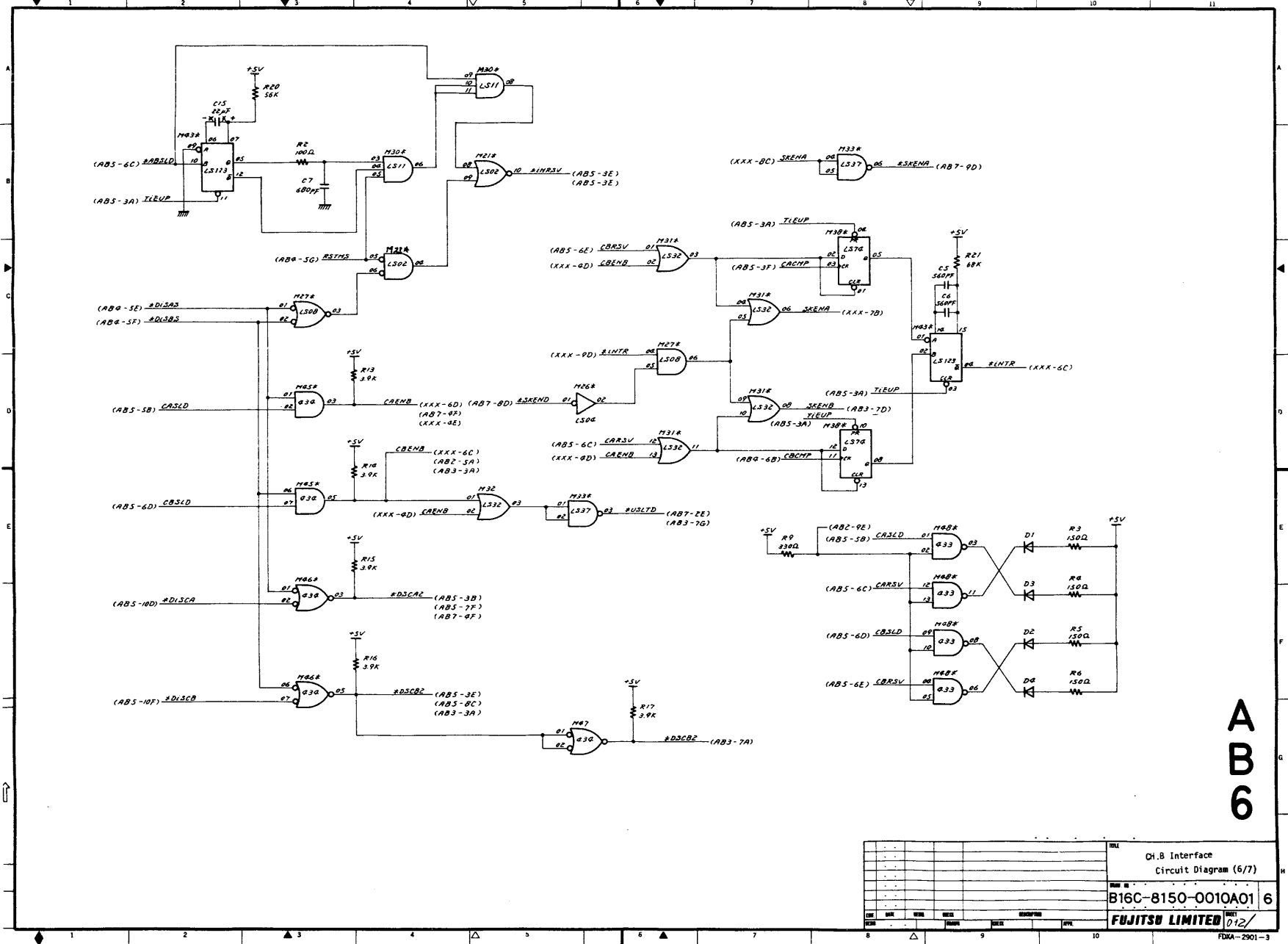

# AB6

					TITLE Ch.B Interface Circuit Diagram (6/7)	
					PART NO. <b>B16C-8150-0010A01</b>	
					QTY <b>6</b>	
					MANUFACTURER <b>FUJITSU LIMITED</b>	
					DATE <b>012/</b>	
					FILE NO. <b>FDXA-2901-3</b>	

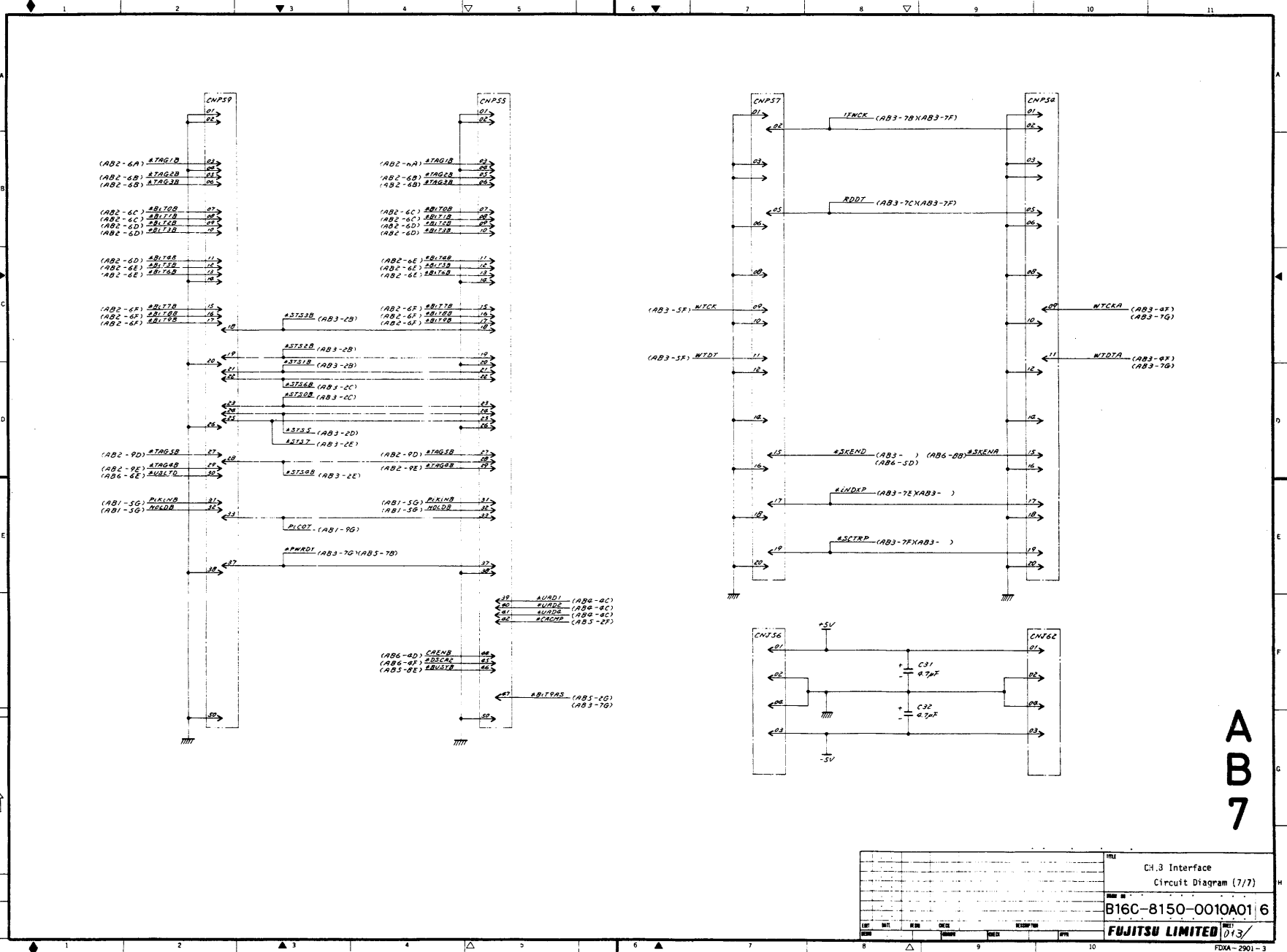

AB7

Ch.3 Interface Circuit Diagram (7/7)									
B16C-8150-0010A01 6									
FUJITSU LIMITED									
FDXA-2901-3									

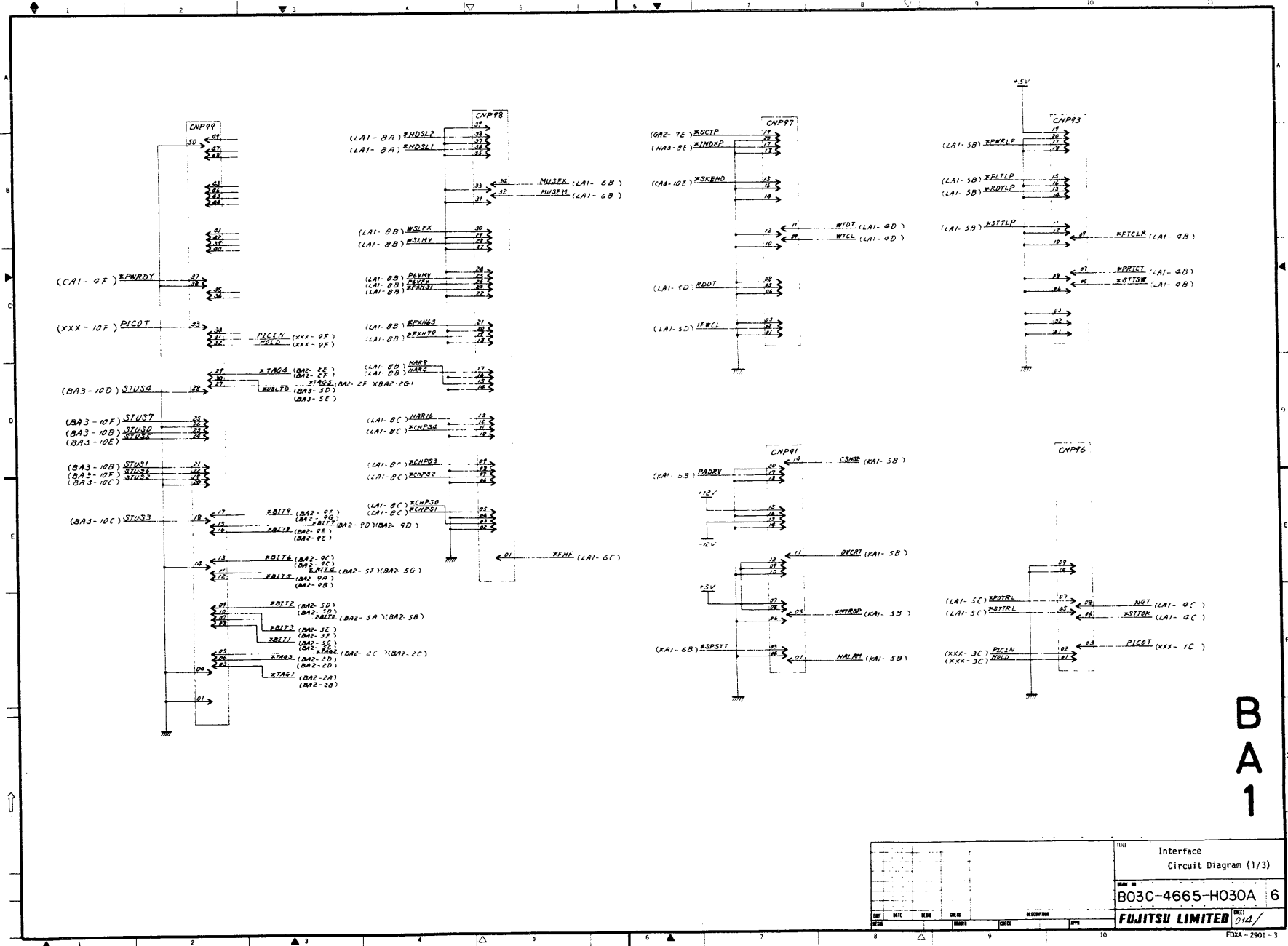

B  
A  
1

TITLE					Interface Circuit Diagram (1/3)				
PART NO.					B03C-4665-H030A				
REV.					6				
DATE					014/				
DRAWN					FUJITSU LIMITED				
CHECK					FDXA-2901-3				
REVISION									
APP'D.									

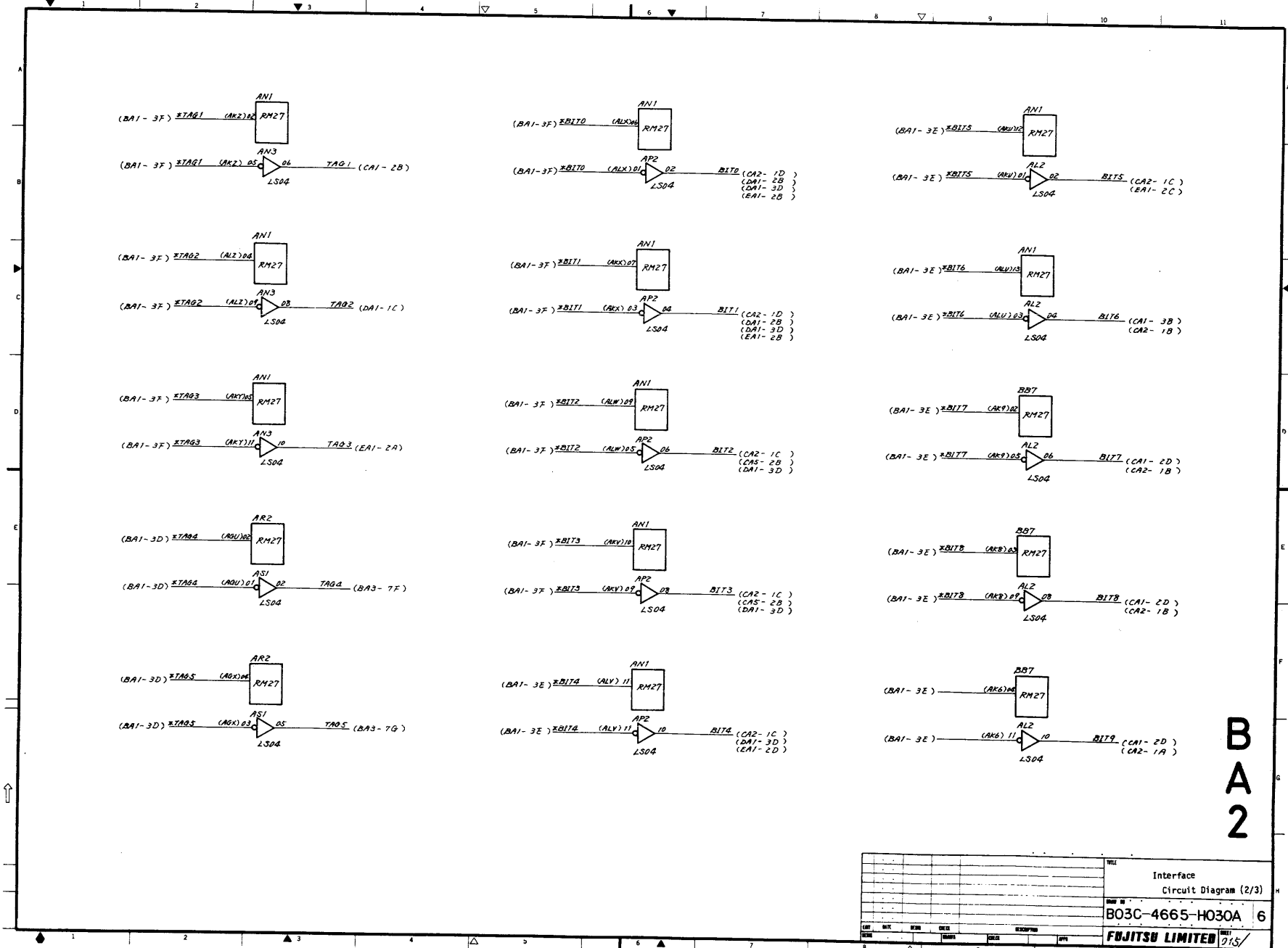

B  
A  
2

Interface		Circuit Diagram (2/3)	
B03C-4665-H030A		6	
FUJITSU LIMITED		7/15	

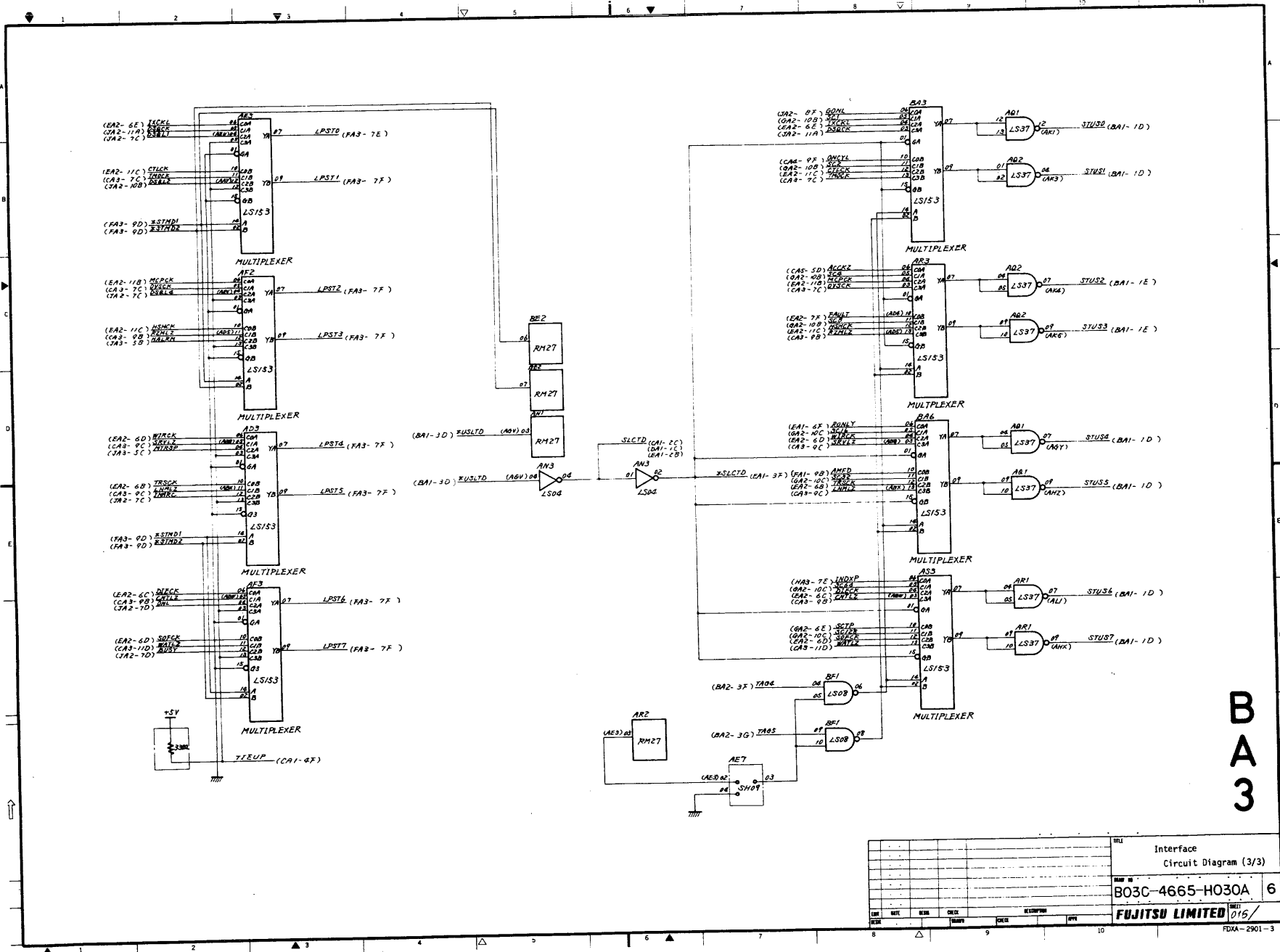

Interface Circuit Diagram (3/3)					
B03C-4665-H030A					6
FUJITSU LIMITED					
REV	DATE	BY	CHK	DESCRIPTION	APP

B  
A  
3

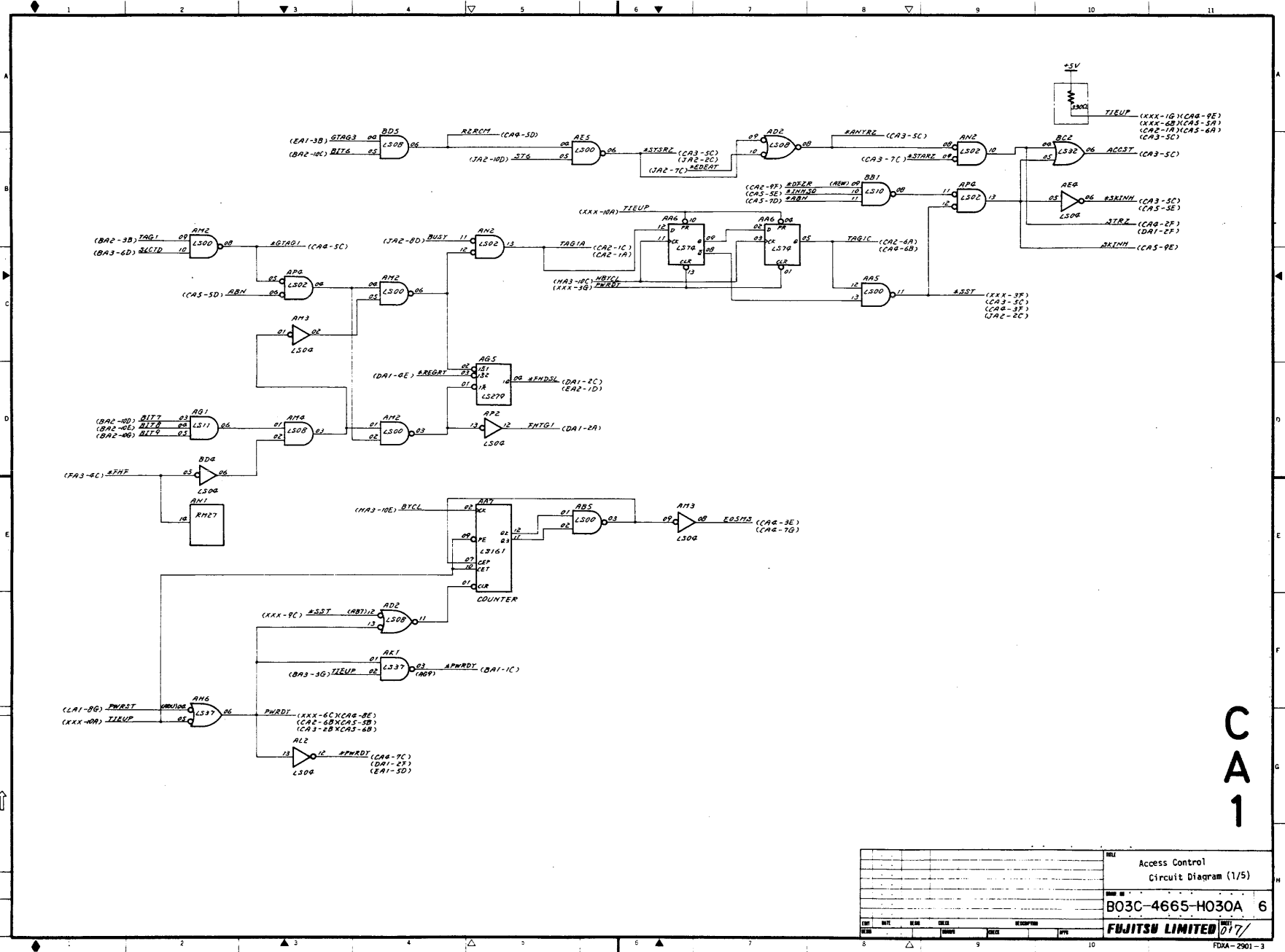

CA1

					Access Control Circuit Diagram (1/5)	
					B03C-4665-H030A 6	
					FUJITSU LIMITED	
					FDXA-2901-3	

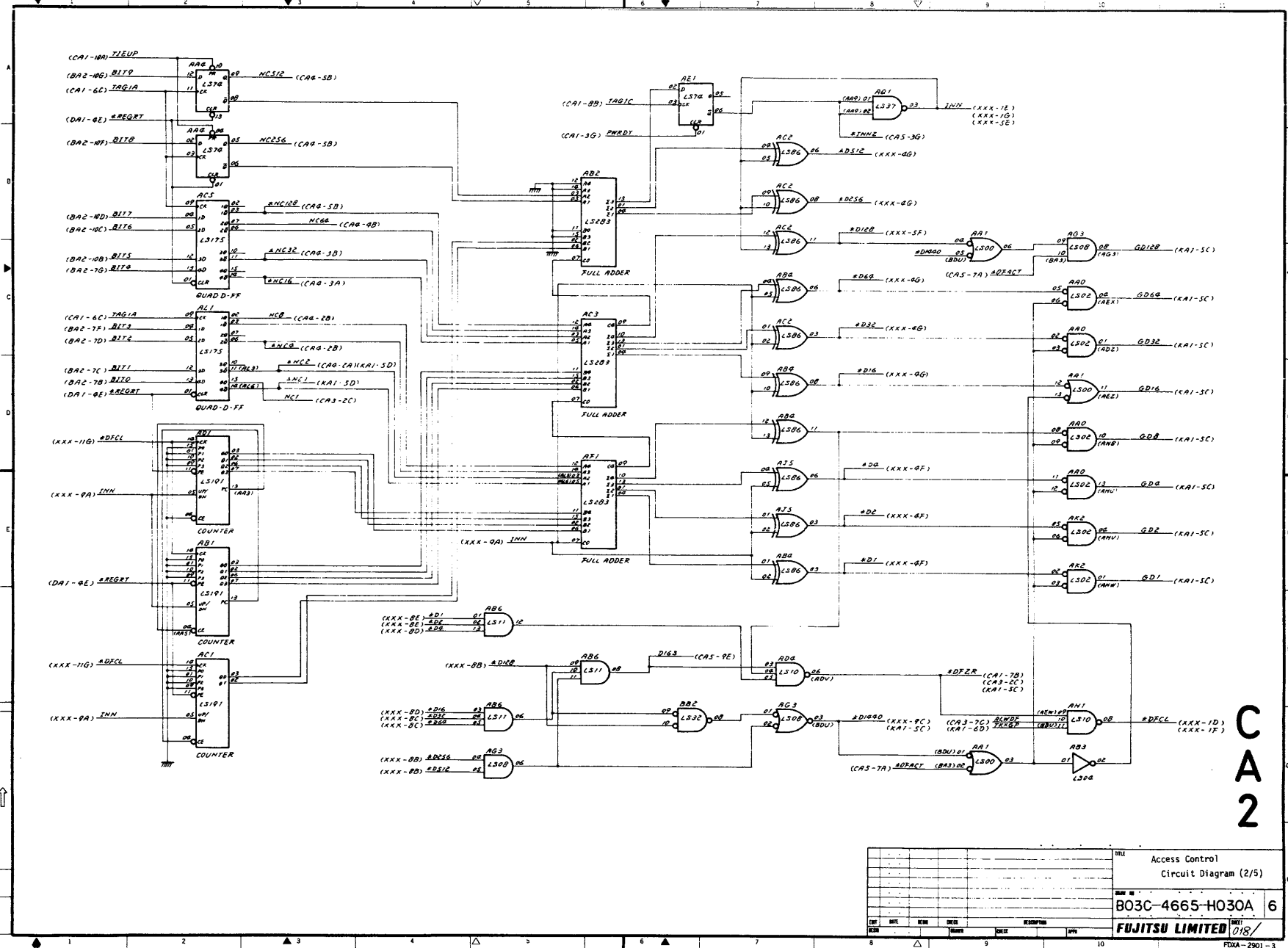

# CA2

Access Control						Circuit Diagram (2/5)	
B03C-4665-H030A						6	
DATE	REVISION	CHECK	DESIGN	DATE	DESCRIPTION	DRAWN BY: 018/	
						FUJITSU LIMITED	





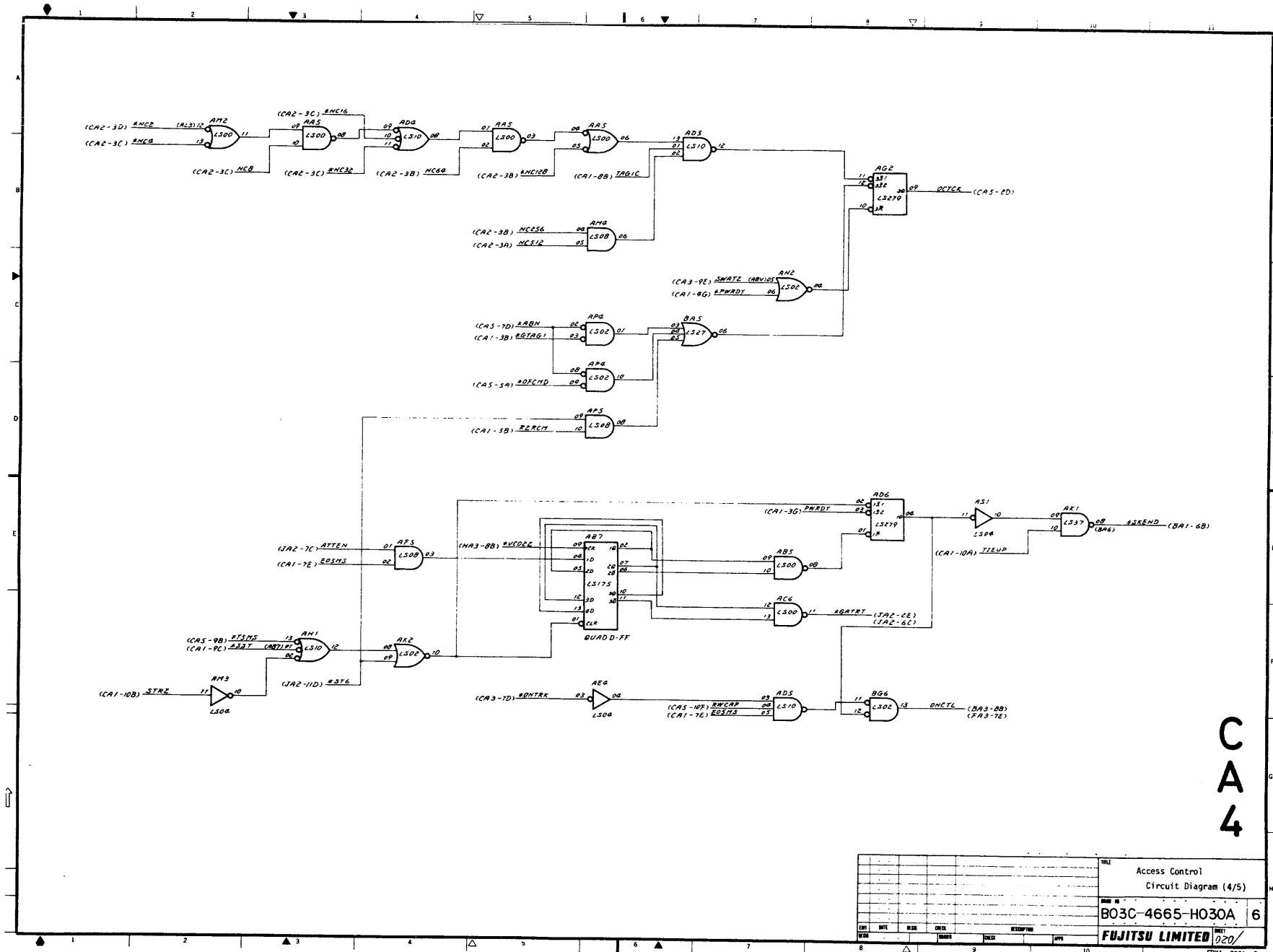

CA4

TITLE					Access Control				
					Circuit Diagram (4/5)				
NO. IN					B03C-4665-H030A				
					6				
REV.	DATE	REVISION	DESIGN	DATE	REV.	DATE	REVISION	DESIGN	DATE
					FUJITSU LIMITED				
					020				

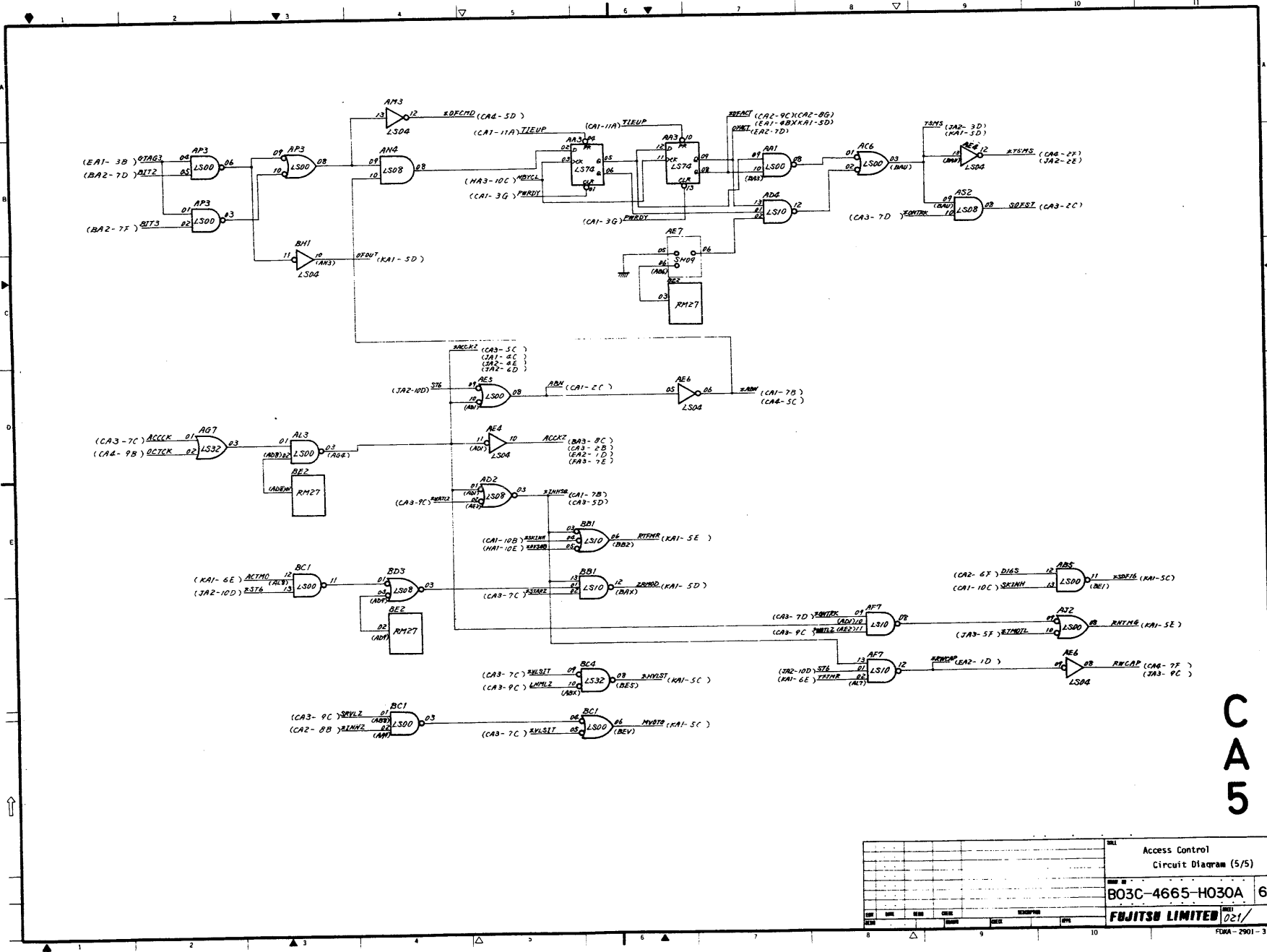

Access Control		Circuit Diagram (5/5)	
B03C-4665-H030A		6	
FUJITSU LIMITED		021	

CA5

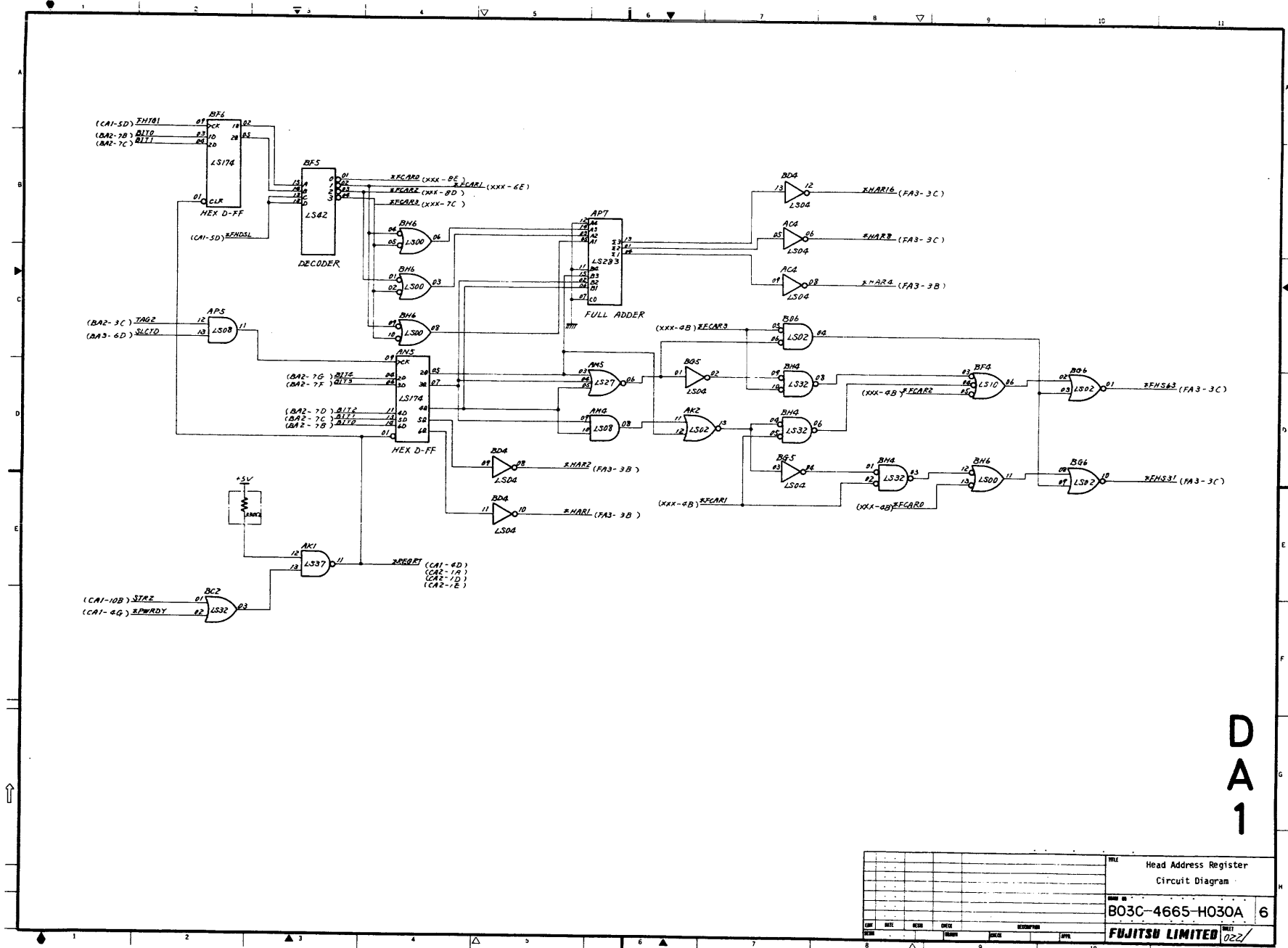

DA1

TITLE		Head Address Register	
CIRCUIT		Circuit Diagram	
NO.	REV.	DATE	BY
001			
PART NO.		B03C-4665-H030A 6	
MANUFACTURER		FUJITSU LIMITED	
DRAWN		022/	

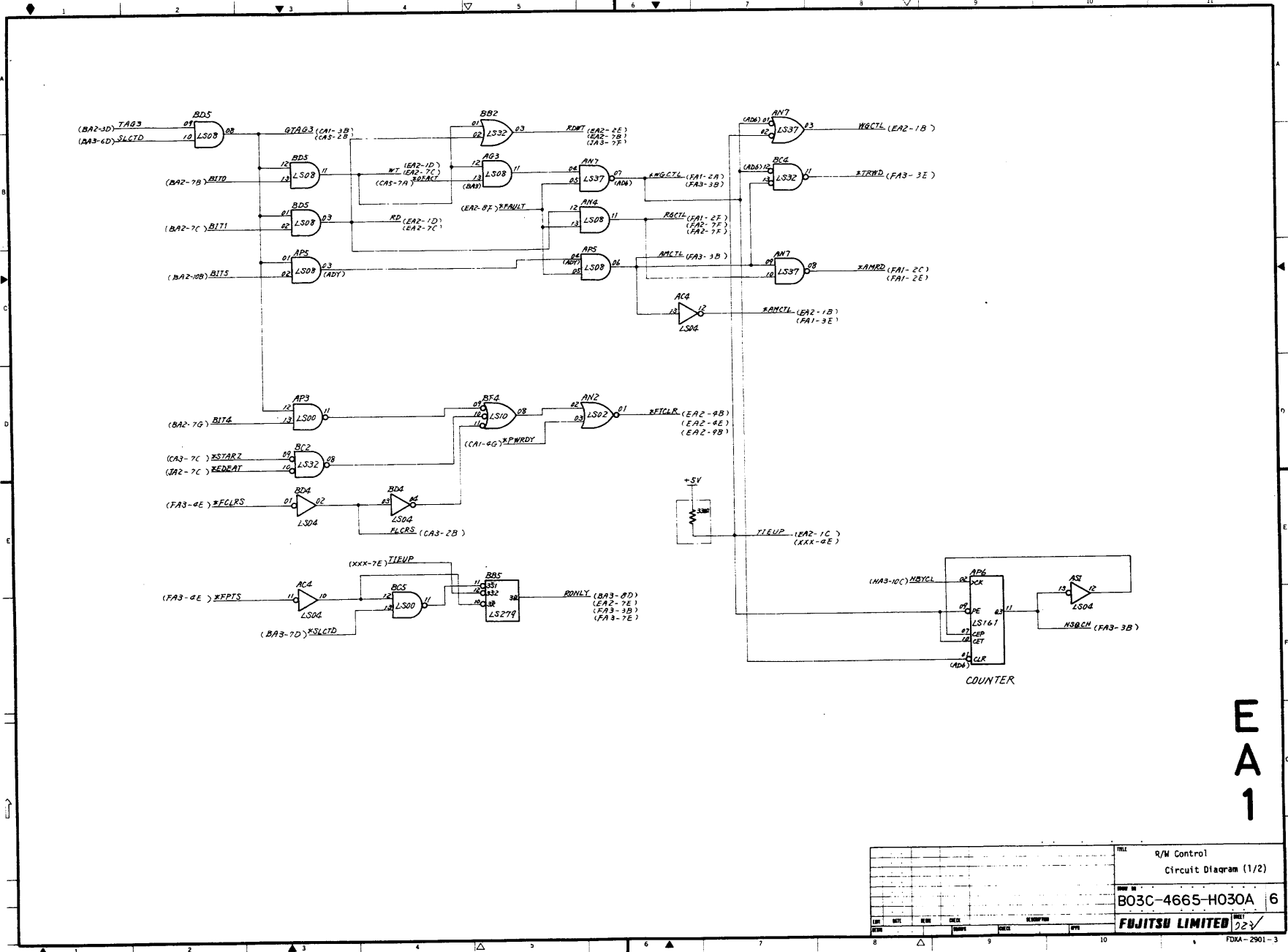

								TITLE		R/M Control	
										Circuit Diagram (1/2)	
								DRAWN BY		B03C-4665-H030A	
										6	
DATE	REV	BY	CHK	APP	DESCRIPTION	QTY		FUJITSU LIMITED		REV 023	

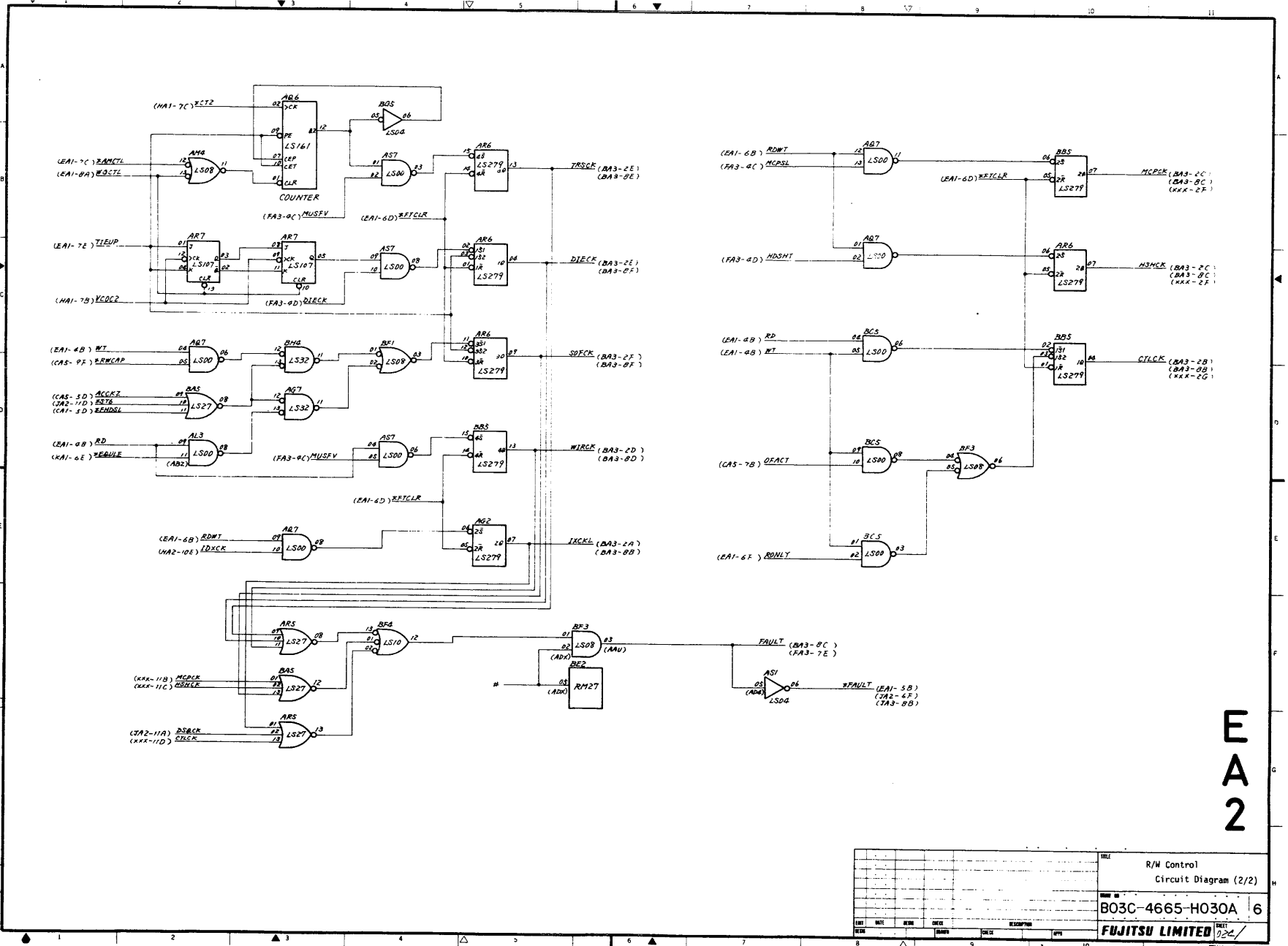

TITLE				R/M Control
Circuit Diagram (2/2)				
PART NO.				B03C-4665-H030A 6
FABRICATION				FUJITSU LIMITED
DATE	REV.	BY	CHKD.	APP.

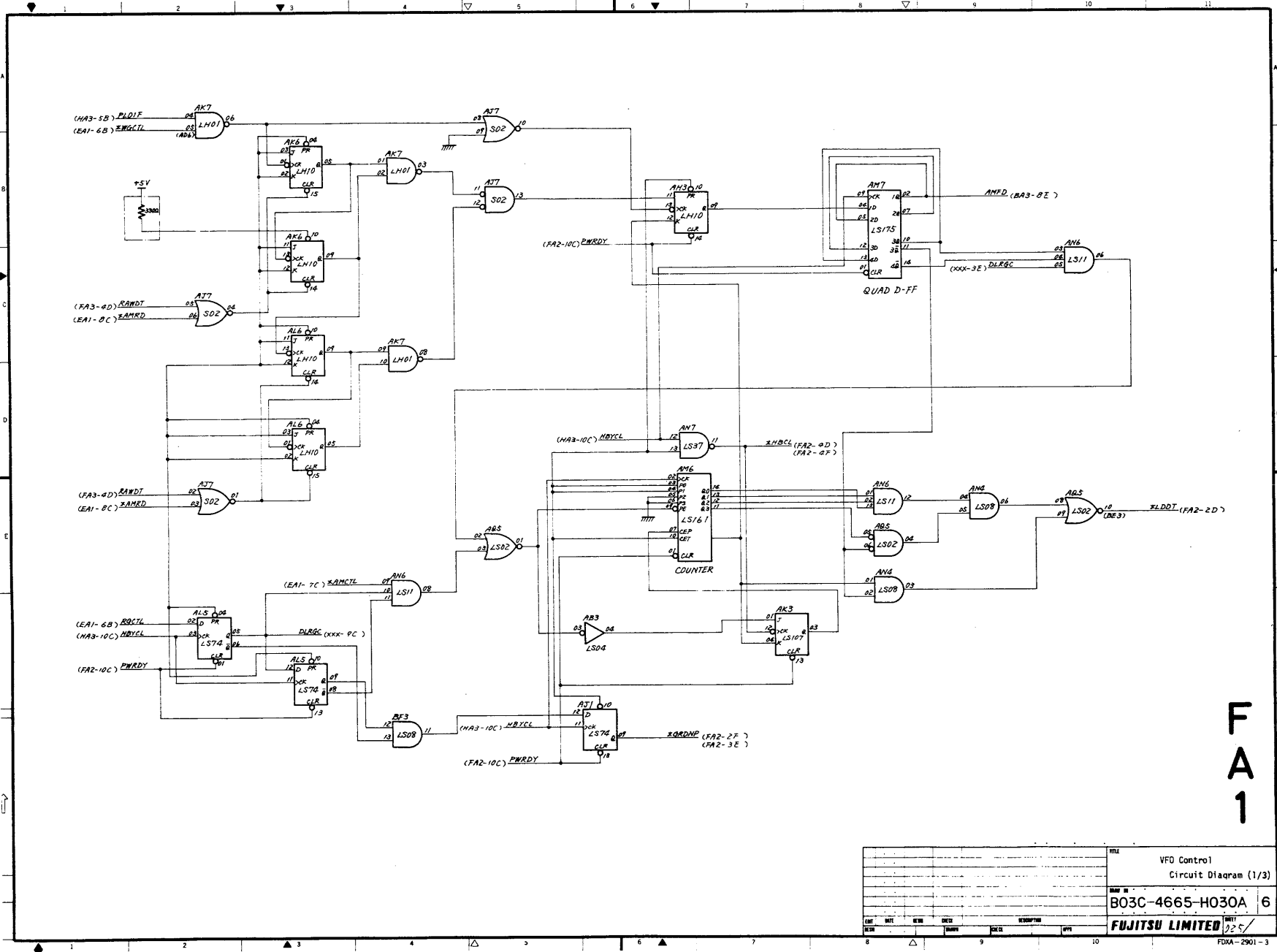

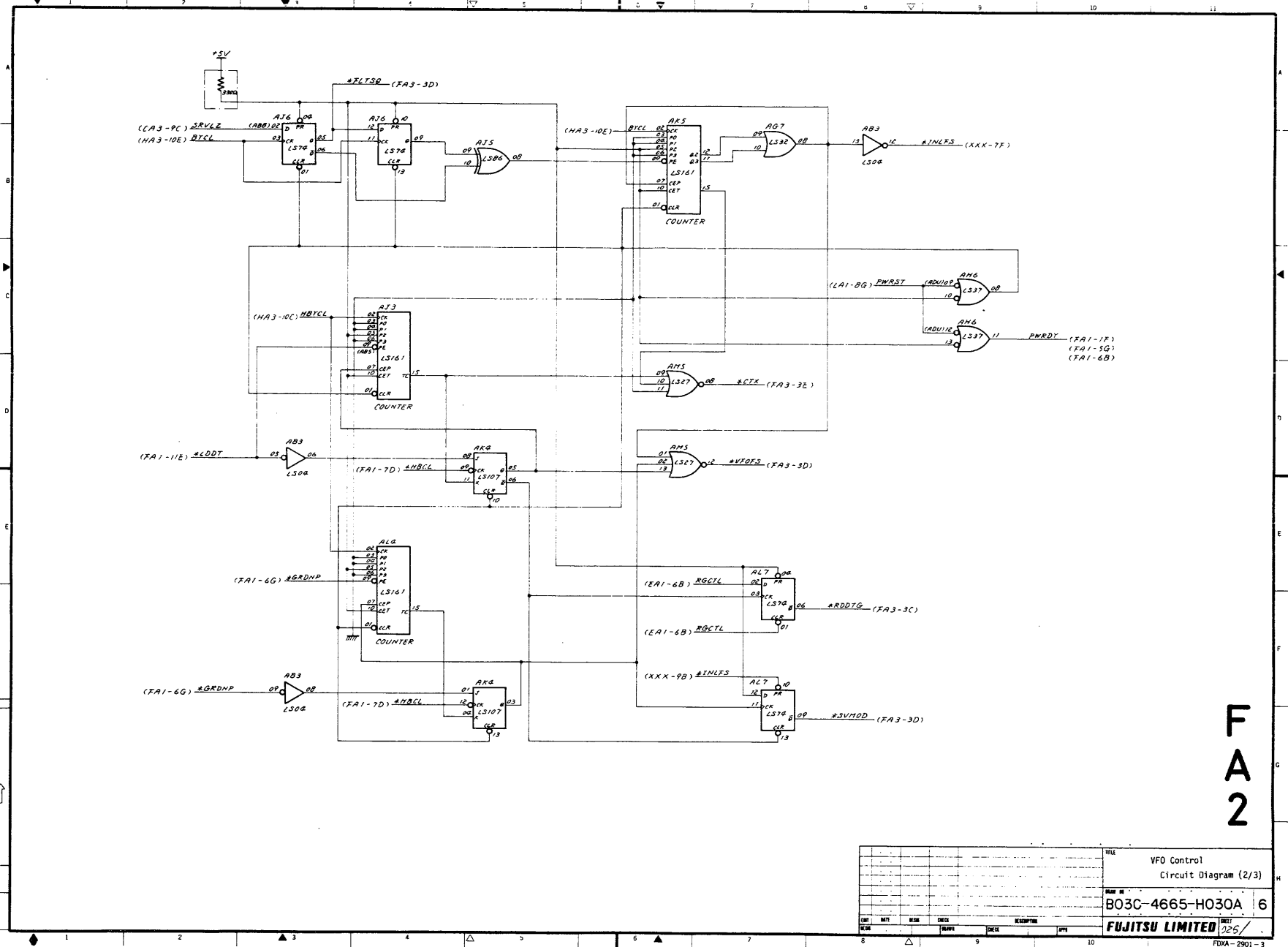

FA2

REV				DATE		EXPLANATION		BY		DATE	
TITLE								VFO Control			
Circuit Diagram (2/3)											
PART NO.								B03C-4665-H030A			
								6			
FUJITSU LIMITED											



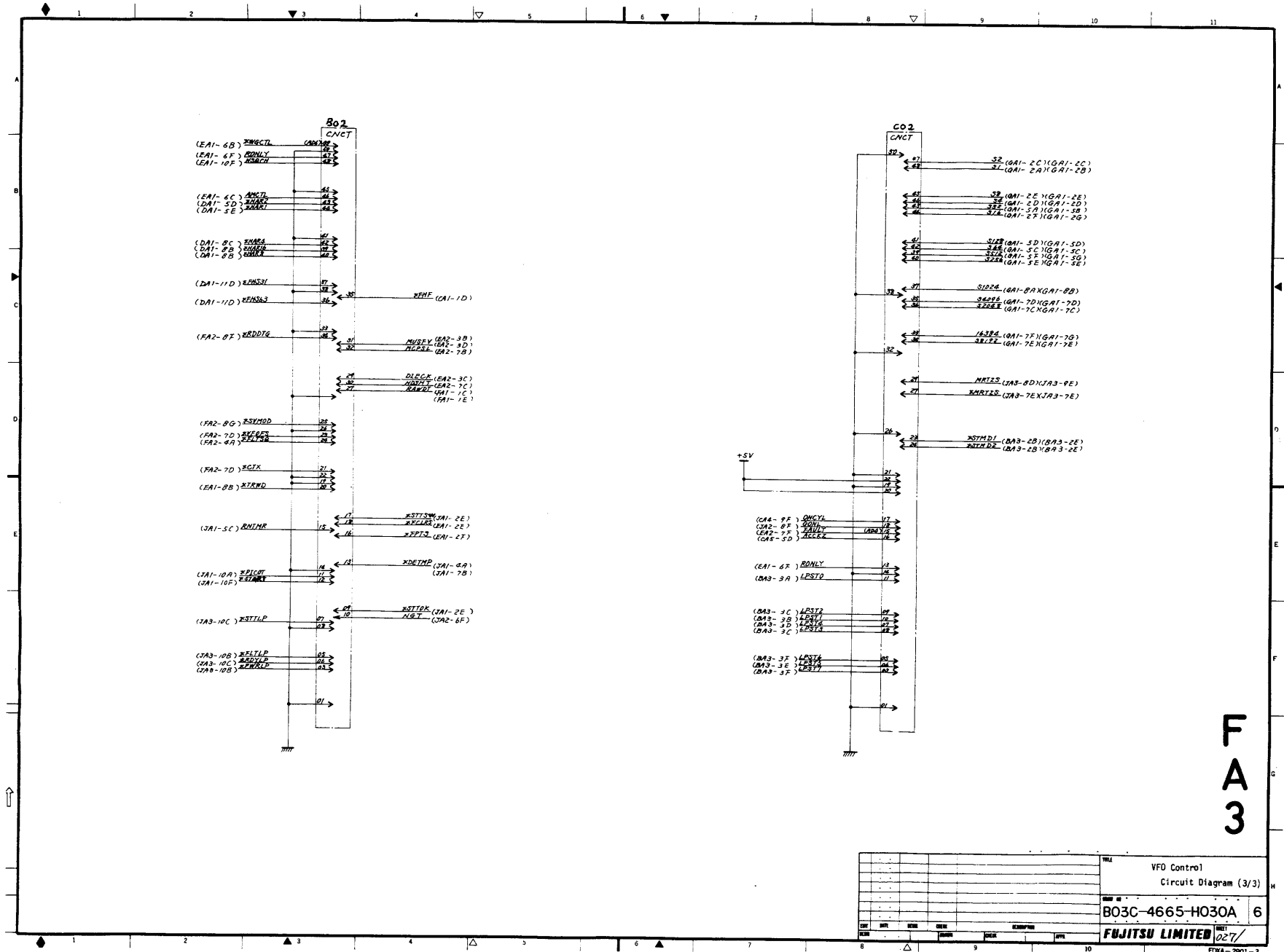

FA3

VFD Control		Circuit Diagram (3/3)	
B03C-4665-H030A		6	
FUJITSU LIMITED		0277	

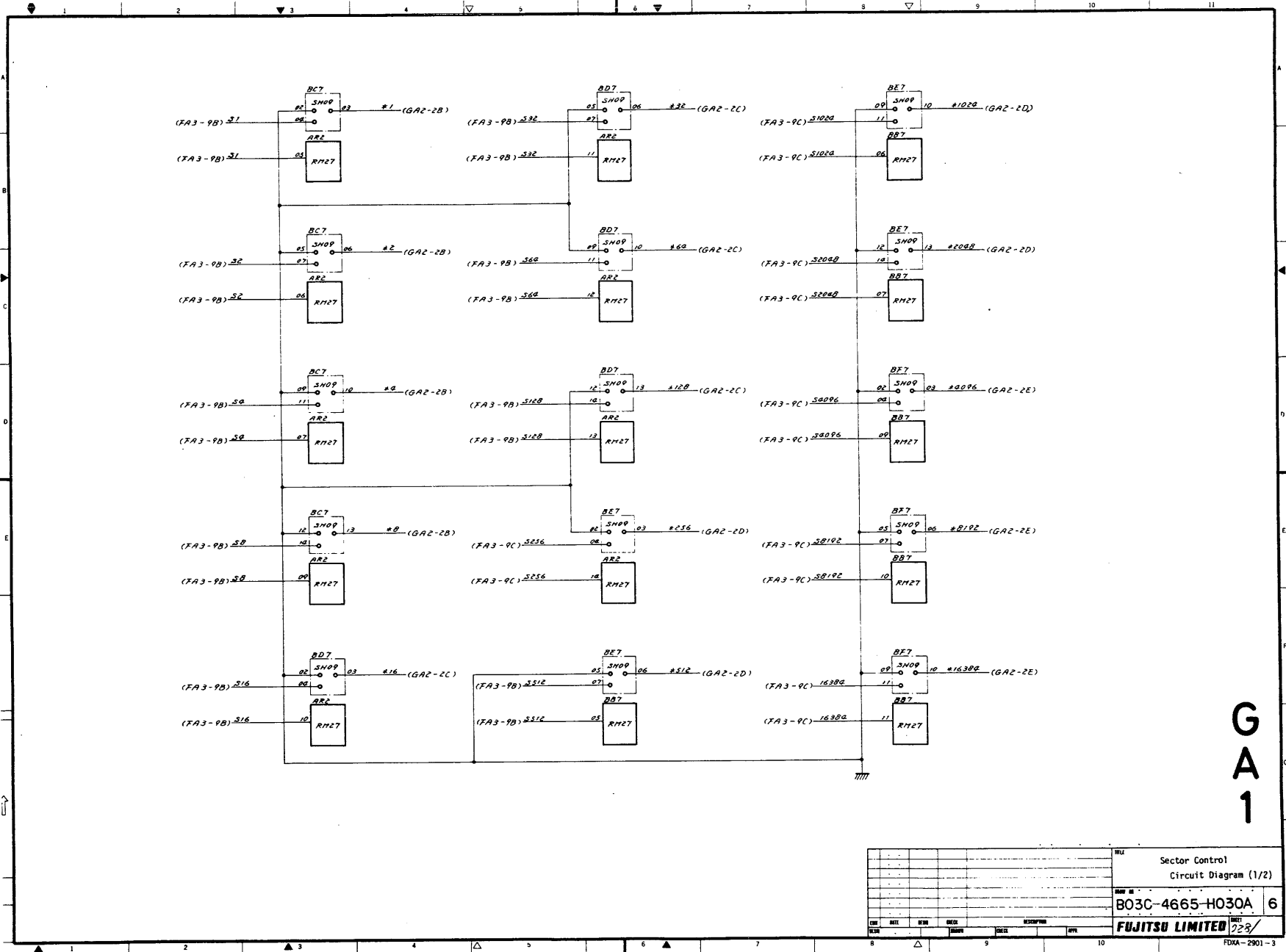

G  
A  
1

					Sector Control Circuit Diagram (1/2)	
					B03C-4665-H030A 6	
					FUJITSU LIMITED	
REV	DATE	BY	CHKD	REVISION		



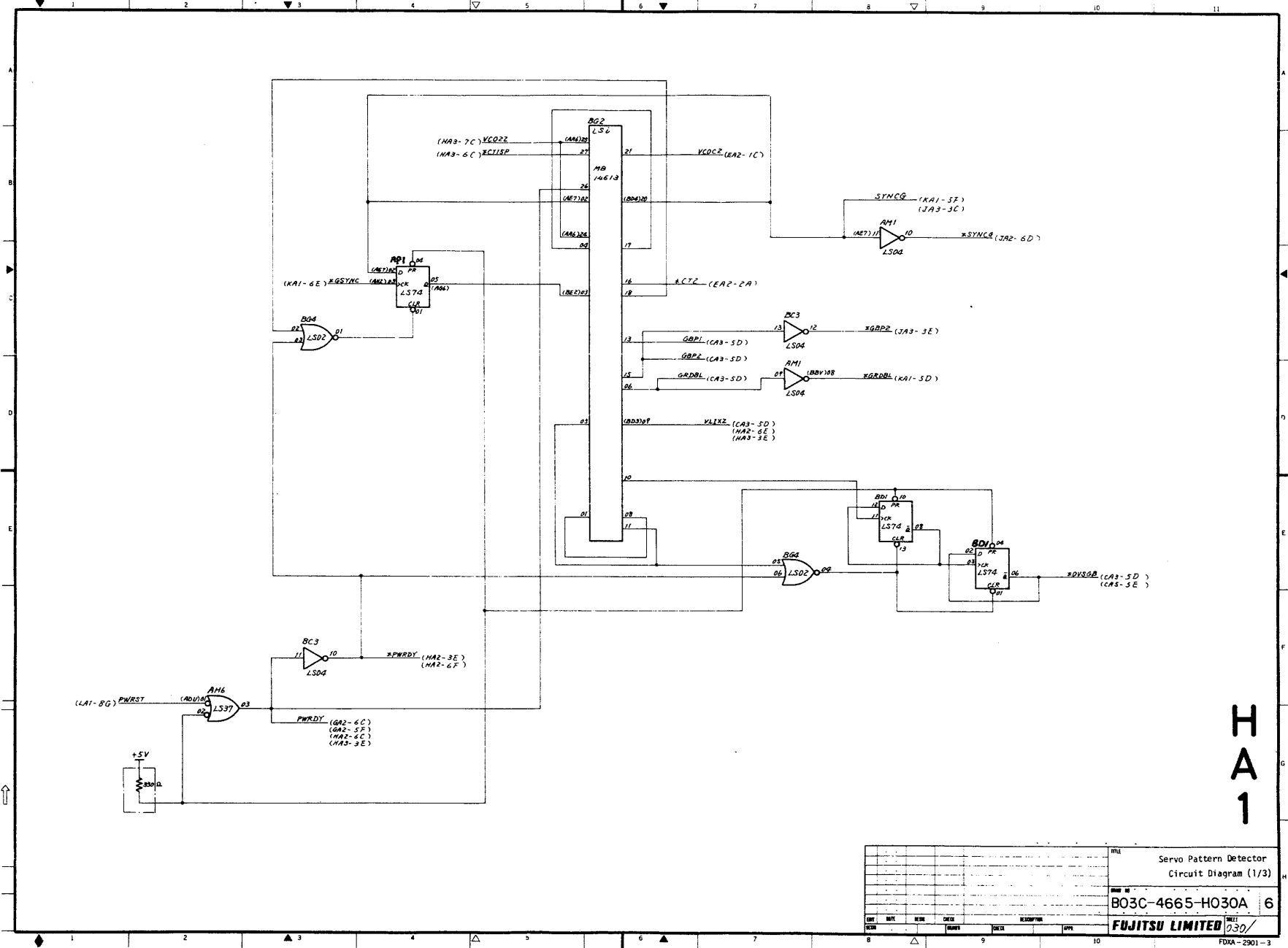

H  
A  
1

						TITLE Servo Pattern Detector Circuit Diagram (1/3)	
						PART NO. B03C-4655-H030A 6	
						FUJITSU LIMITED 230/	
REV.	DATE	BY	CHECK	APPROV.	REVISION	DATE	APPV.

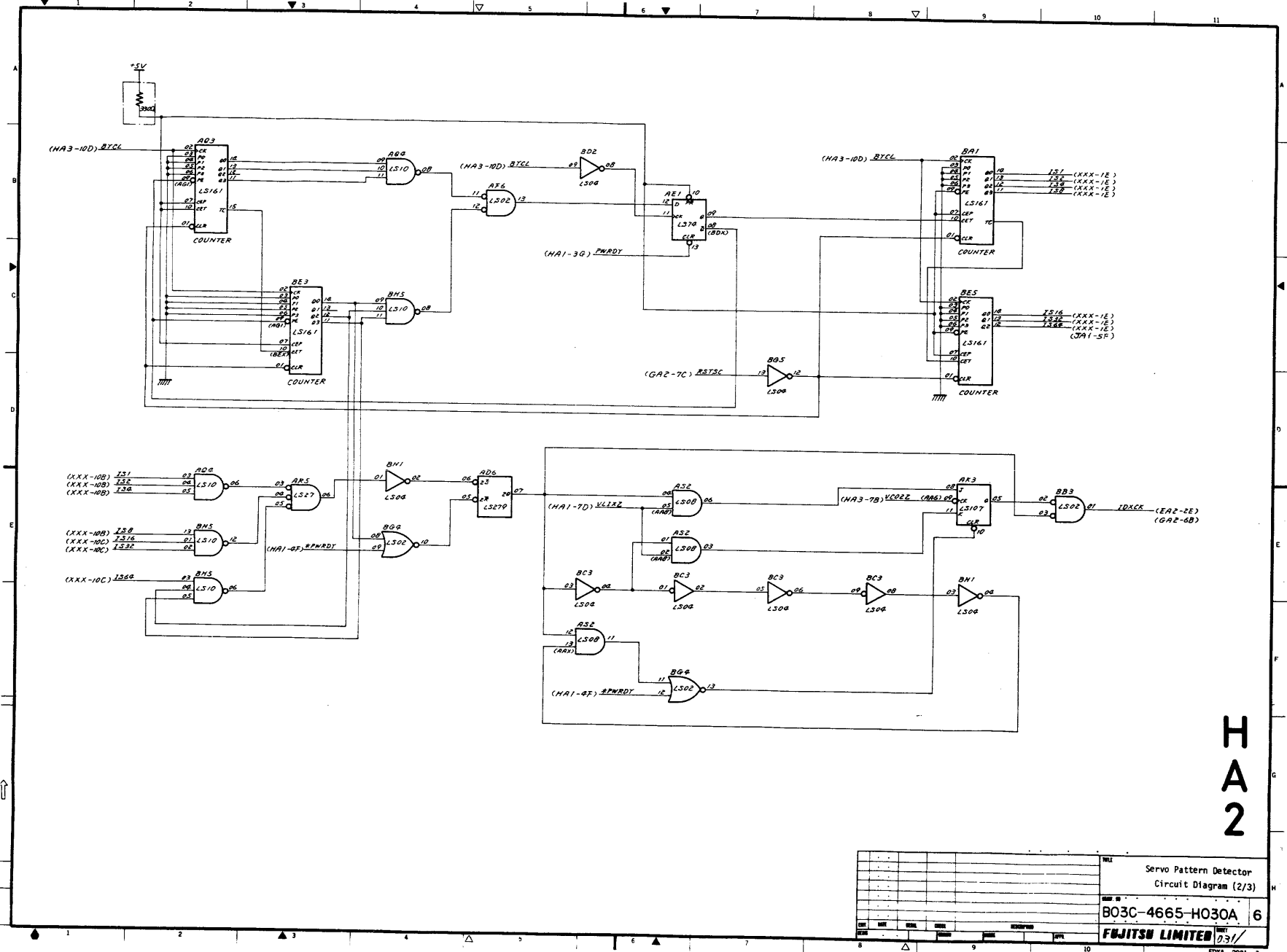

Rev. No.						PART	
Date						Servo Pattern Detector	
Drawn						Circuit Diagram (2/3)	
Checked						B03C-4665-H030A 6	
Approved						FUJITSU LIMITED	
Spec.						731	
Scale						FDNA-2901-3	

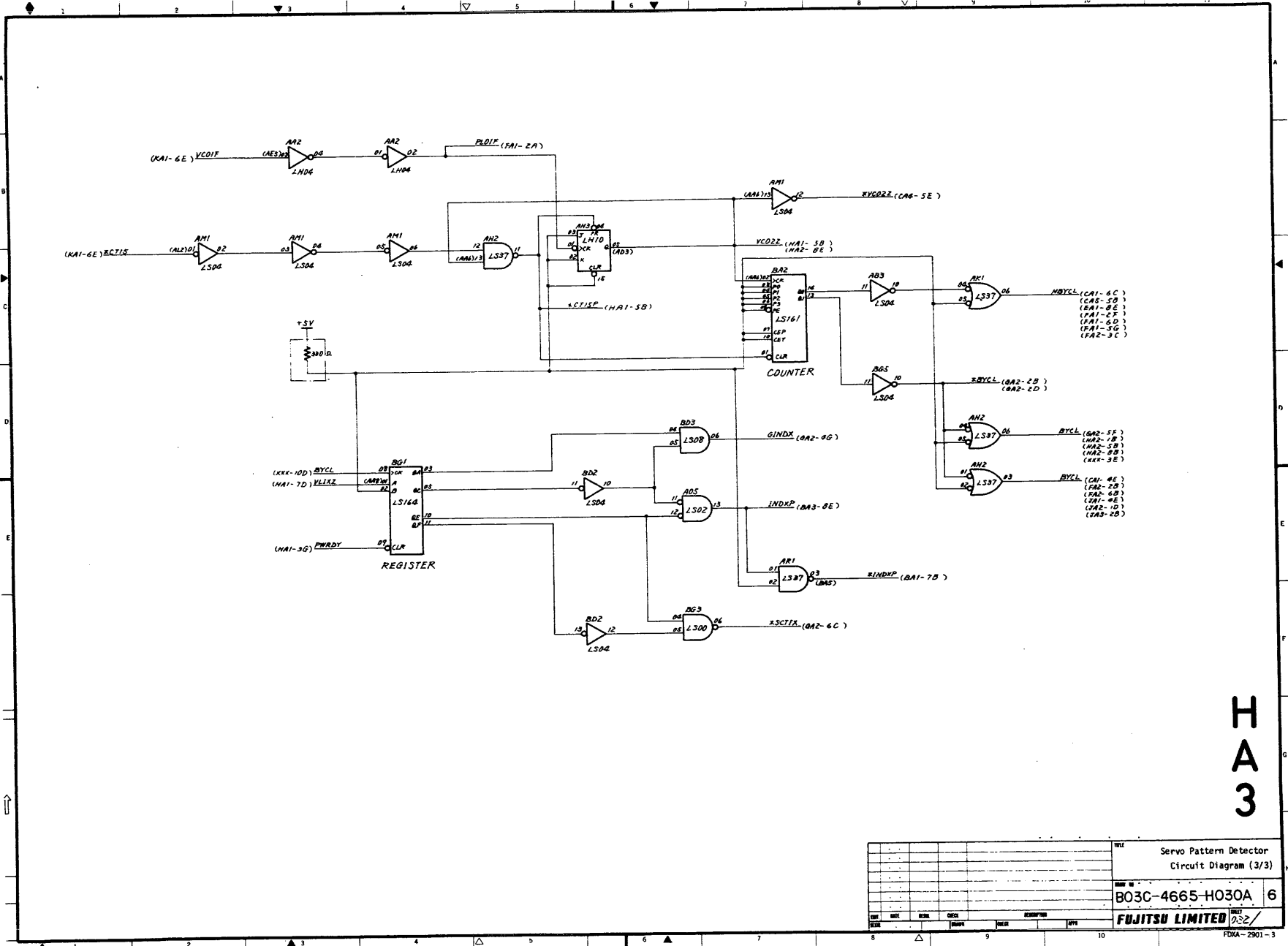

H  
A  
3

REV						DATE		BY		CHKD		APP		TITLE	
														Servo Pattern Detector Circuit Diagram (3/3)	
														B03C-4655-H030A 6	
														FUJITSU LIMITED	
														FDXA-2901-3	

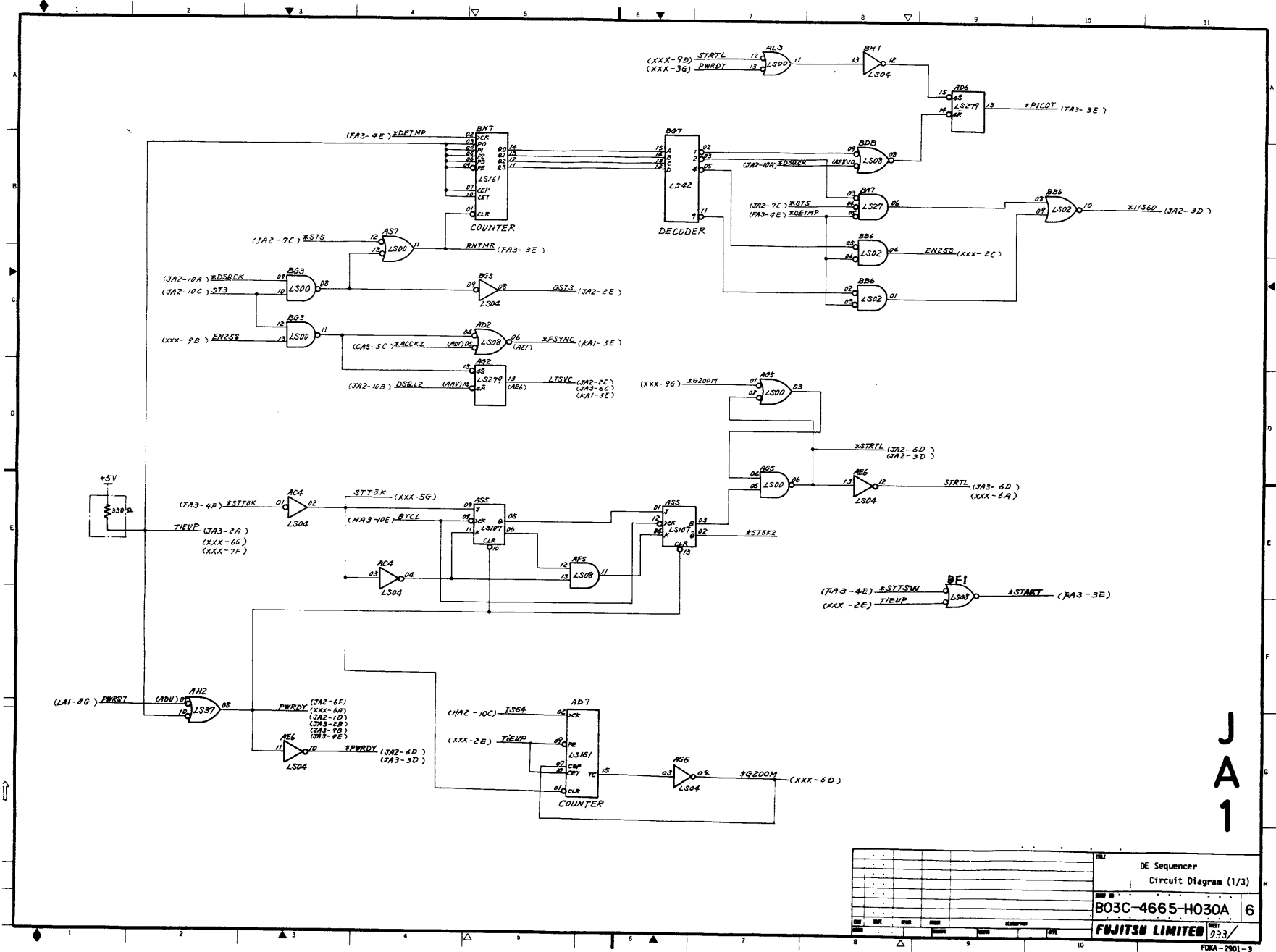

J  
A  
1

DE Sequencer Circuit Diagram (1/3)	
B03C-4655-H030A 6	
FUJITSU LIMITED	
REV 733/	
FORM-2901-3	







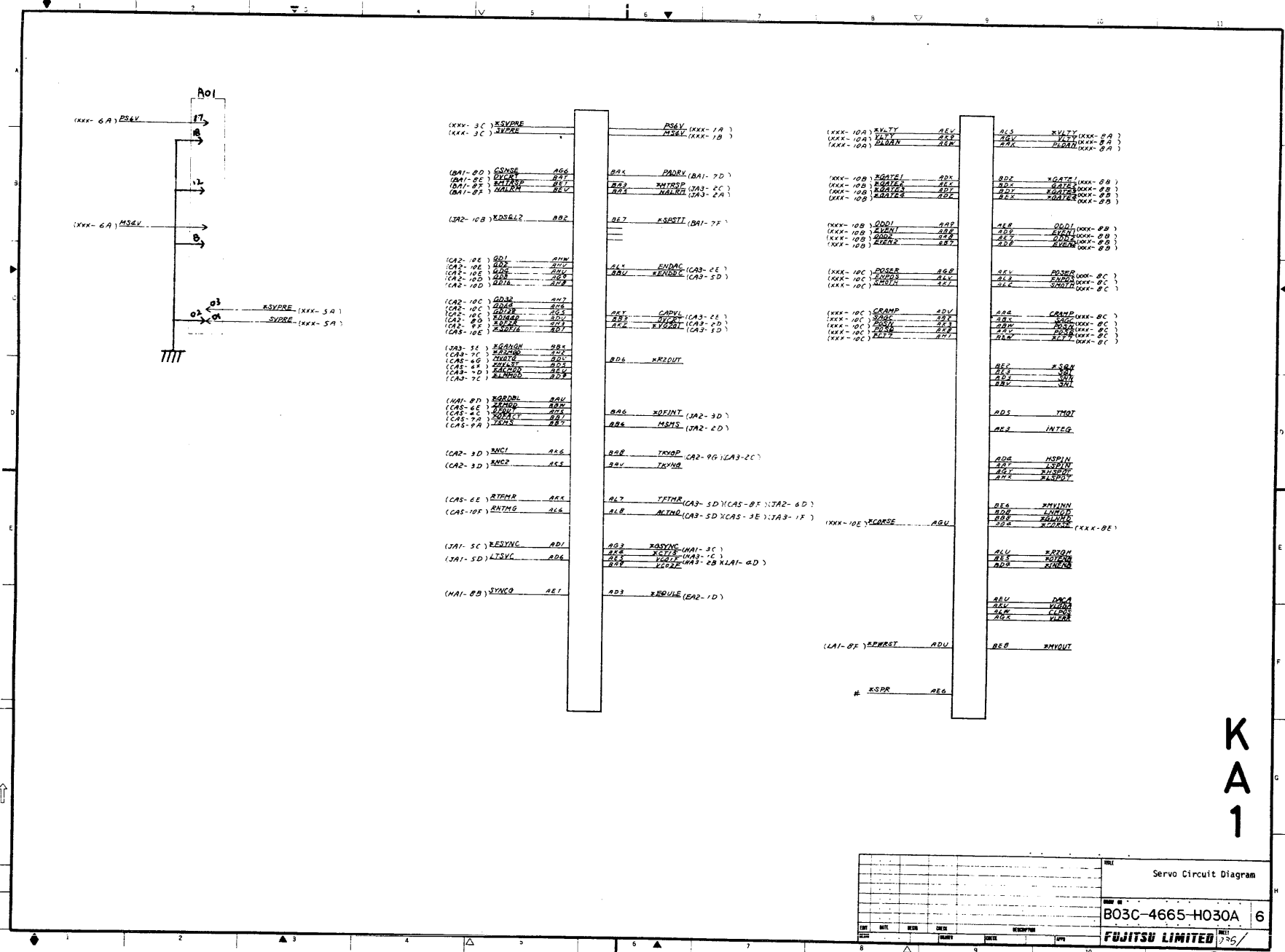

B03P-4655-0001A...E

K A 1

						SERVO	
						Servo Circuit Diagram	
						B03C-4665-H030A 6	
						FUJITSU LIMITED	
REV	DATE	BY	CHKD	APPD	REVISION		

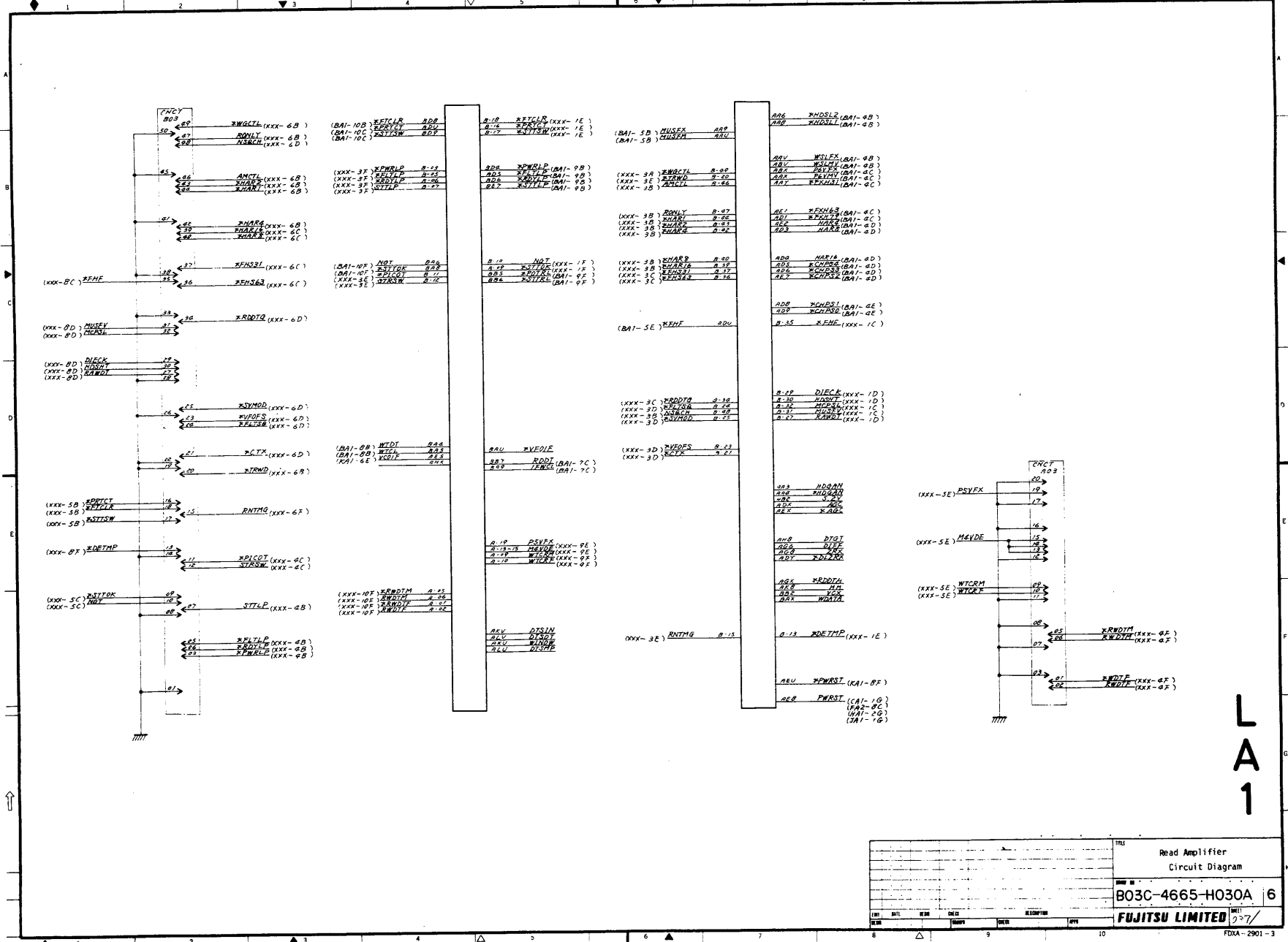

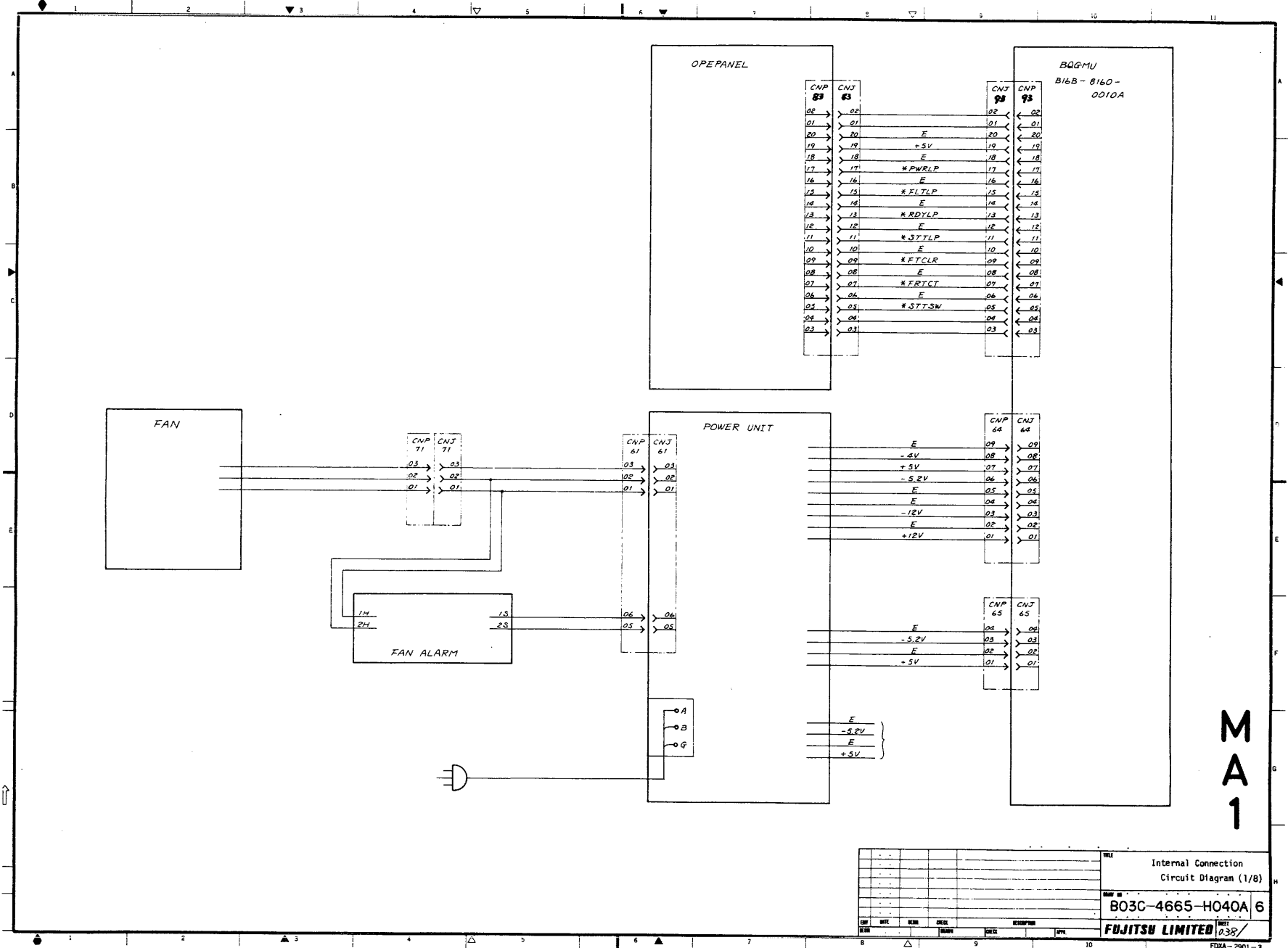

Internal Connection  
Circuit Diagram (1/8)  
B03C-4665-H040A 6  
FUJITSU LIMITED

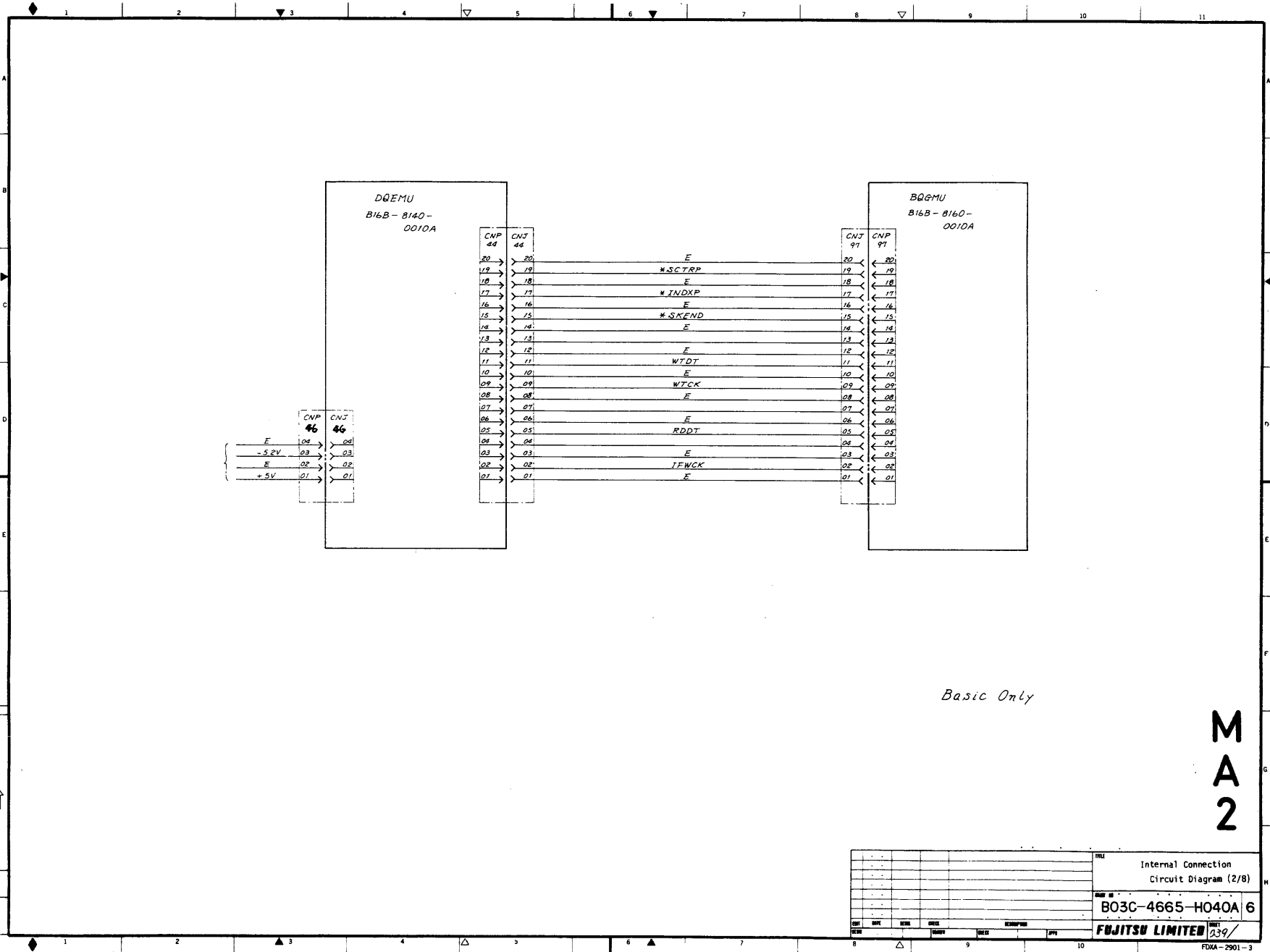

Basic Only

M  
A  
2

						TITLE Internal Connection Circuit Diagram (2/8)	
						PART NO. B03C-4665-H040A 6	
						MANUFACTURER FUJITSU LIMITED	
REV	DATE	BY	CHKD	APPD	DATE	DRAWN 039/	

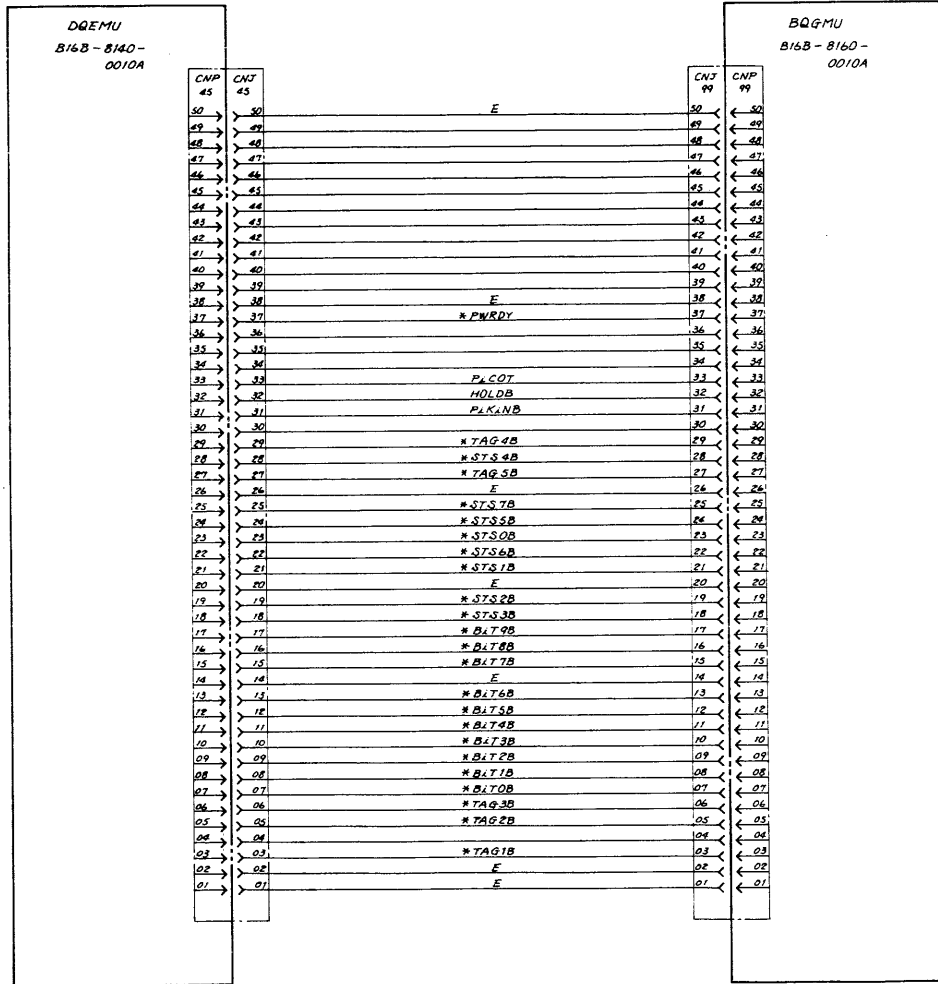

Basic Only

M  
A  
3

				Internal Connection Circuit Diagram (3/8)			
				B03C-4655-H040A 6			
				FUJITSU LIMITED 040/			
				FDXA-2501-3			

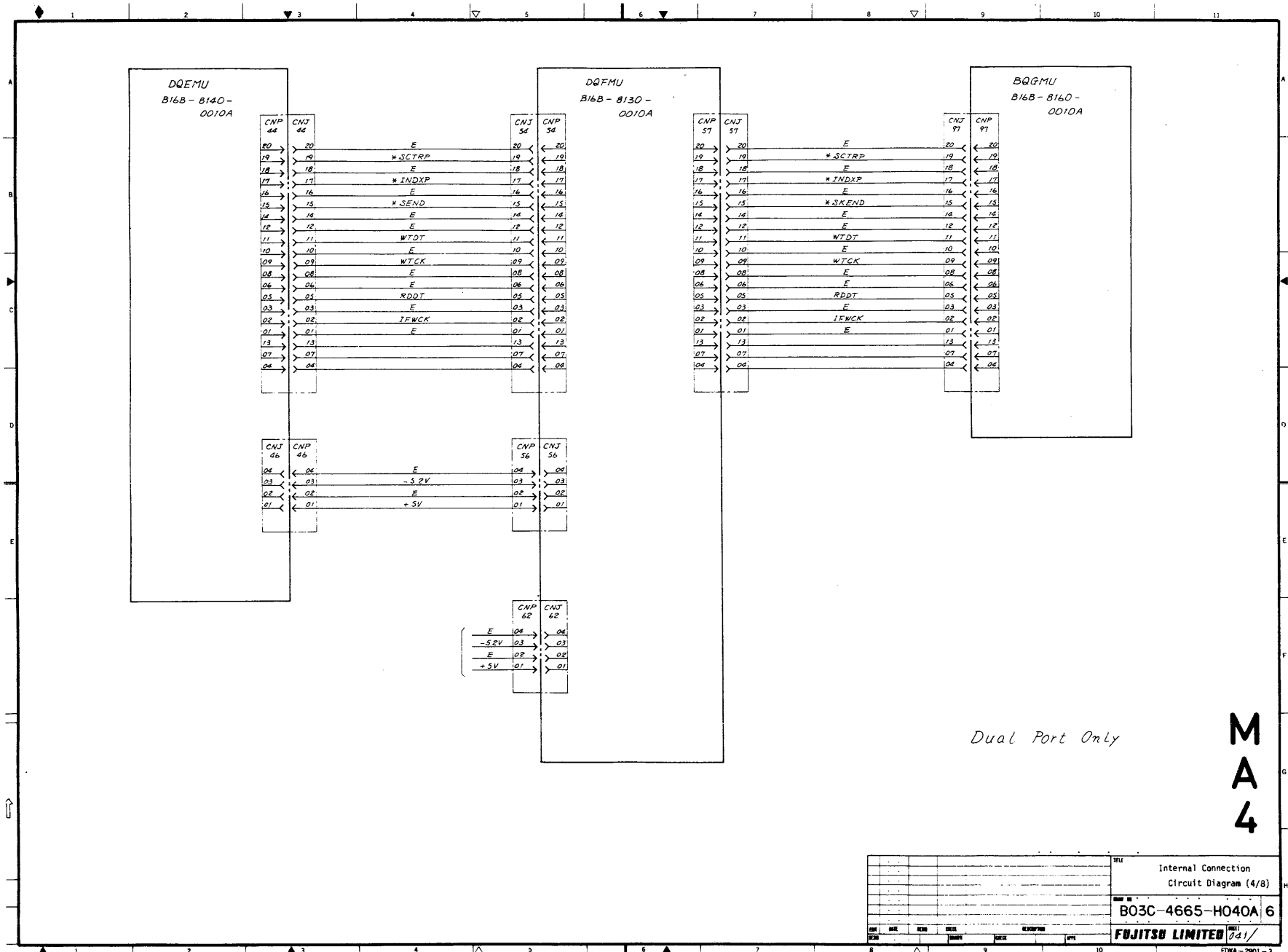

M  
A  
4

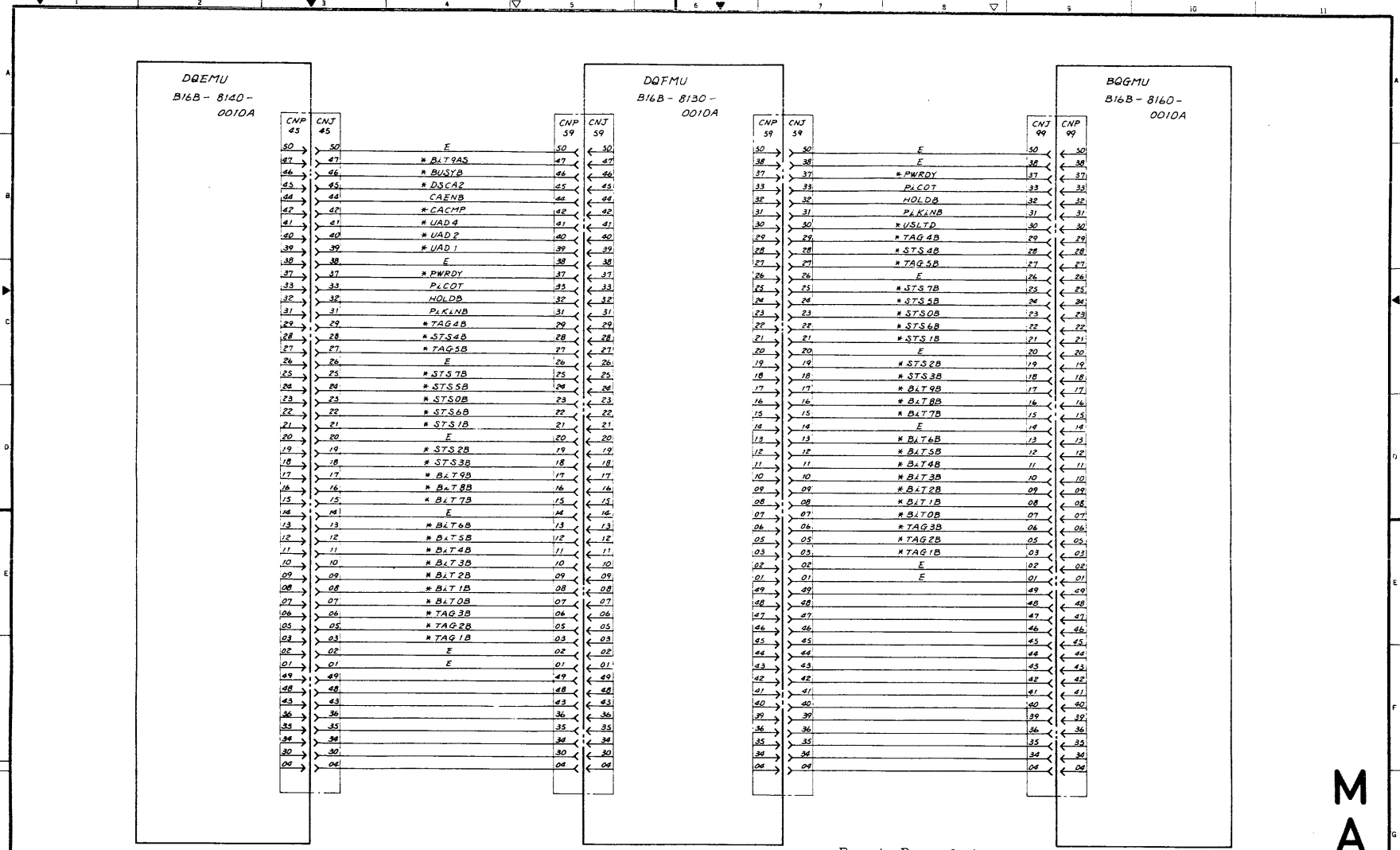

Dual Port Only

M  
A  
5

Internal Connection		Circuit Diagram (5/8)	
B03C-4665-H040A 6		042/	
FUJITSU LIMITED		042/	



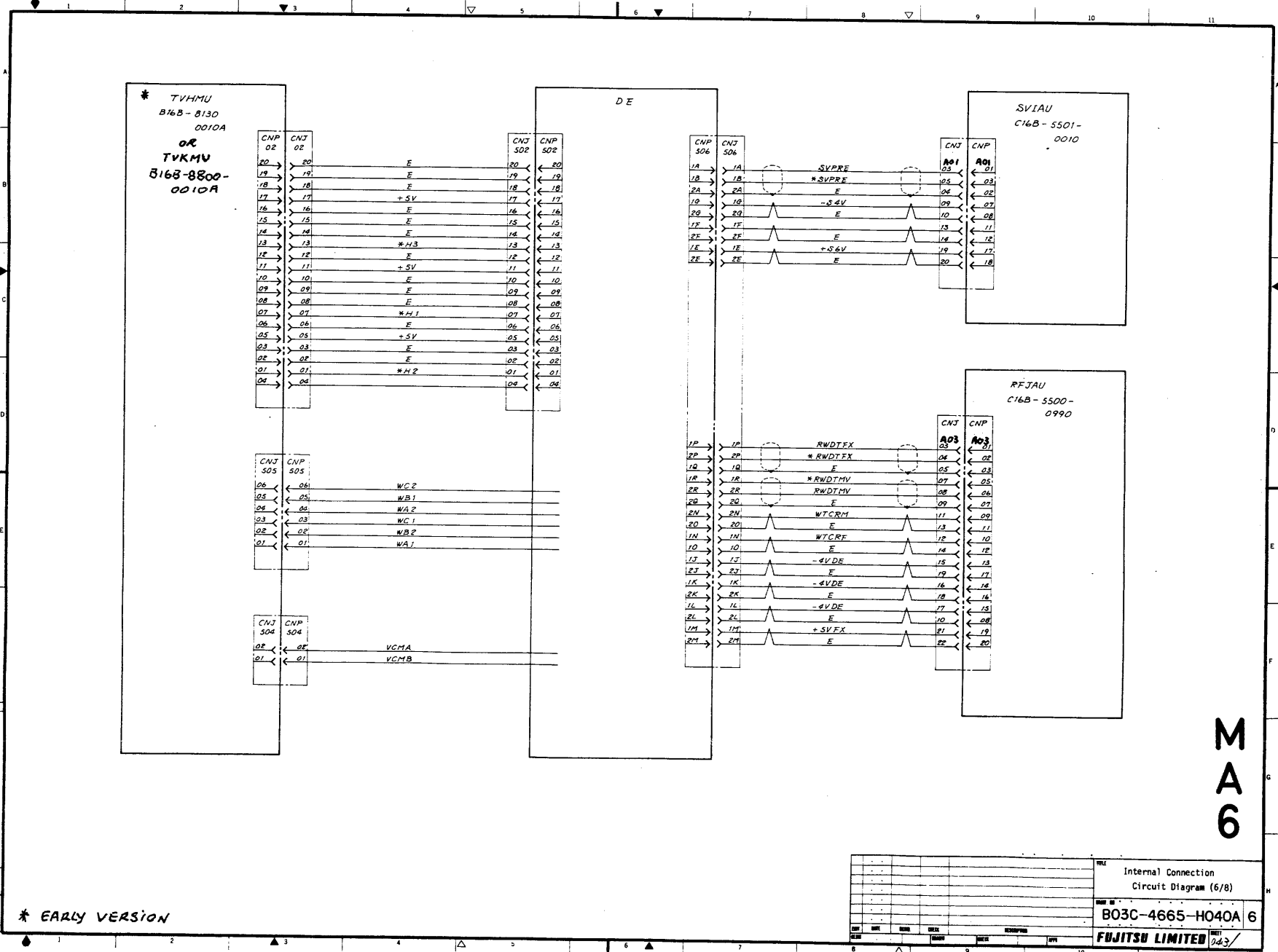

\* EARLY VERSION

Internal Connection Circuit Diagram (6/8)					
B03C-4665-H040A 6					
FUJITSU LIMITED					

M A 6

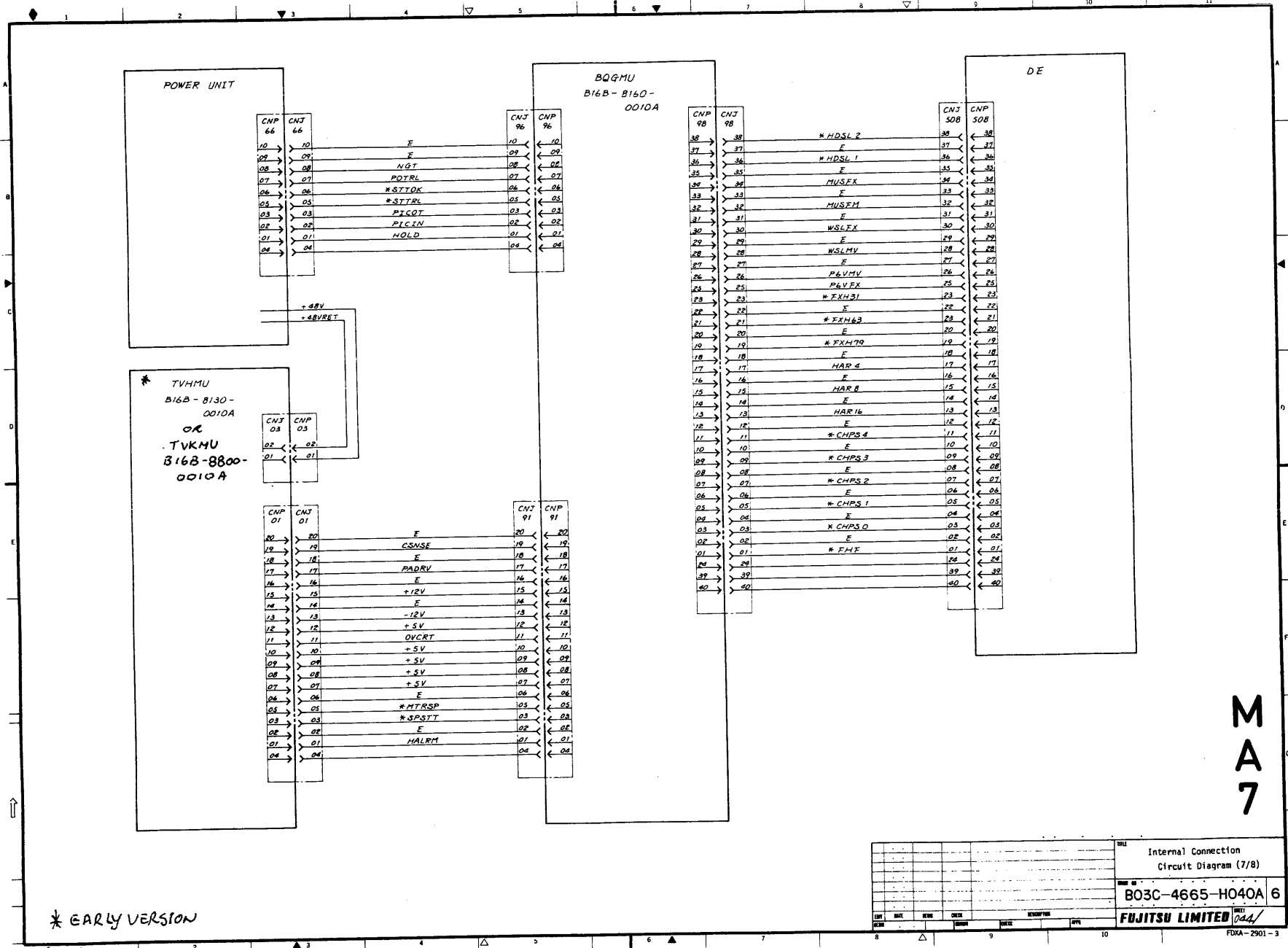

\* EARLY VERSION

Internal Connection Circuit Diagram (7/8)			
B03C-4655-H040A 6			
FUJITSU LIMITED			

MA7

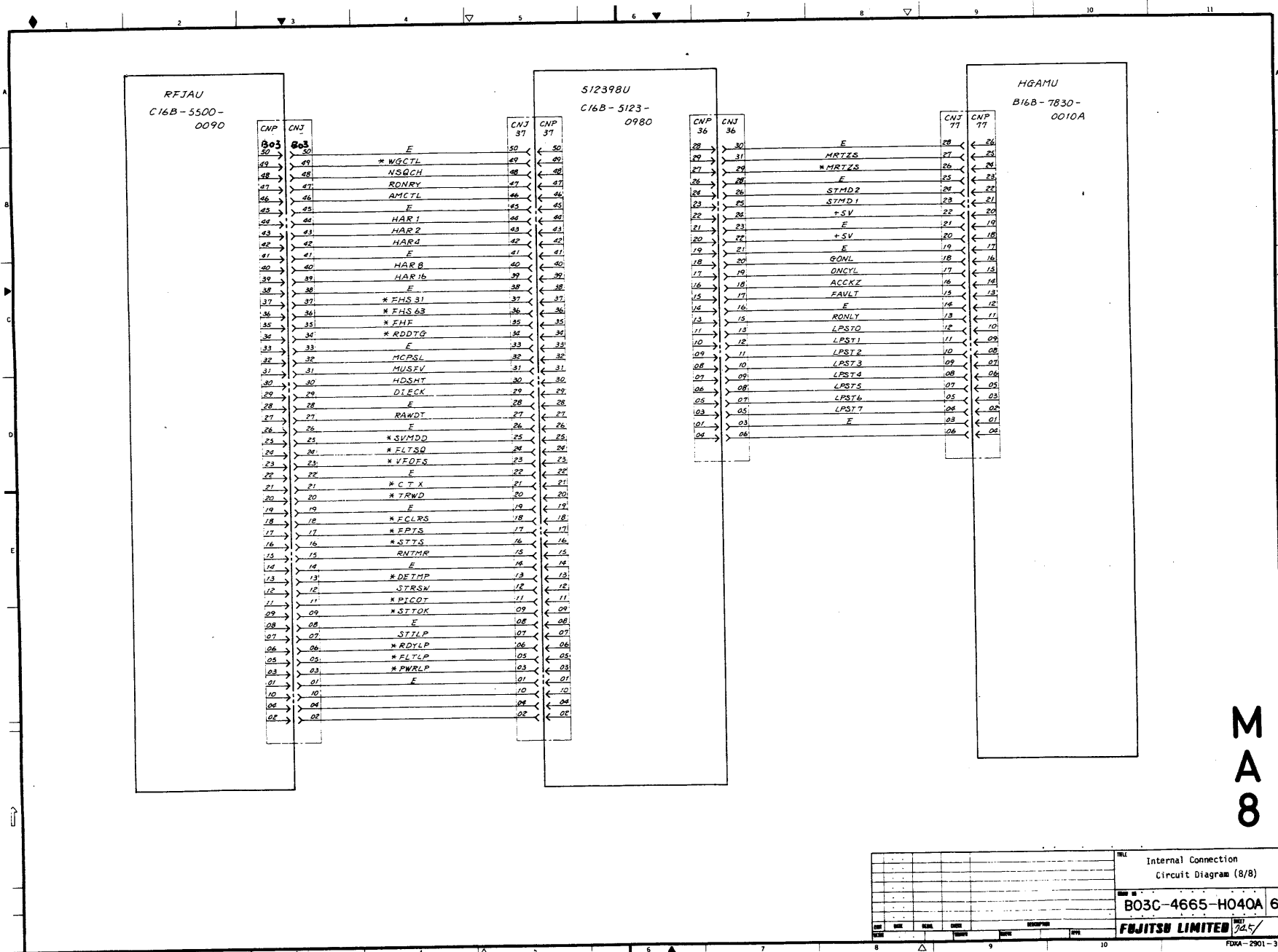

M  
A  
8

TITLE				Internal Connection			
				Circuit Diagram (8/8)			
PART NO.				B03C-4665-H040A 6			
DATE				7/25/75			
DRAWN				FUJITSU LIMITED			
CHECKED				REV. 1			
APPROVED				FDMA-2901-3			

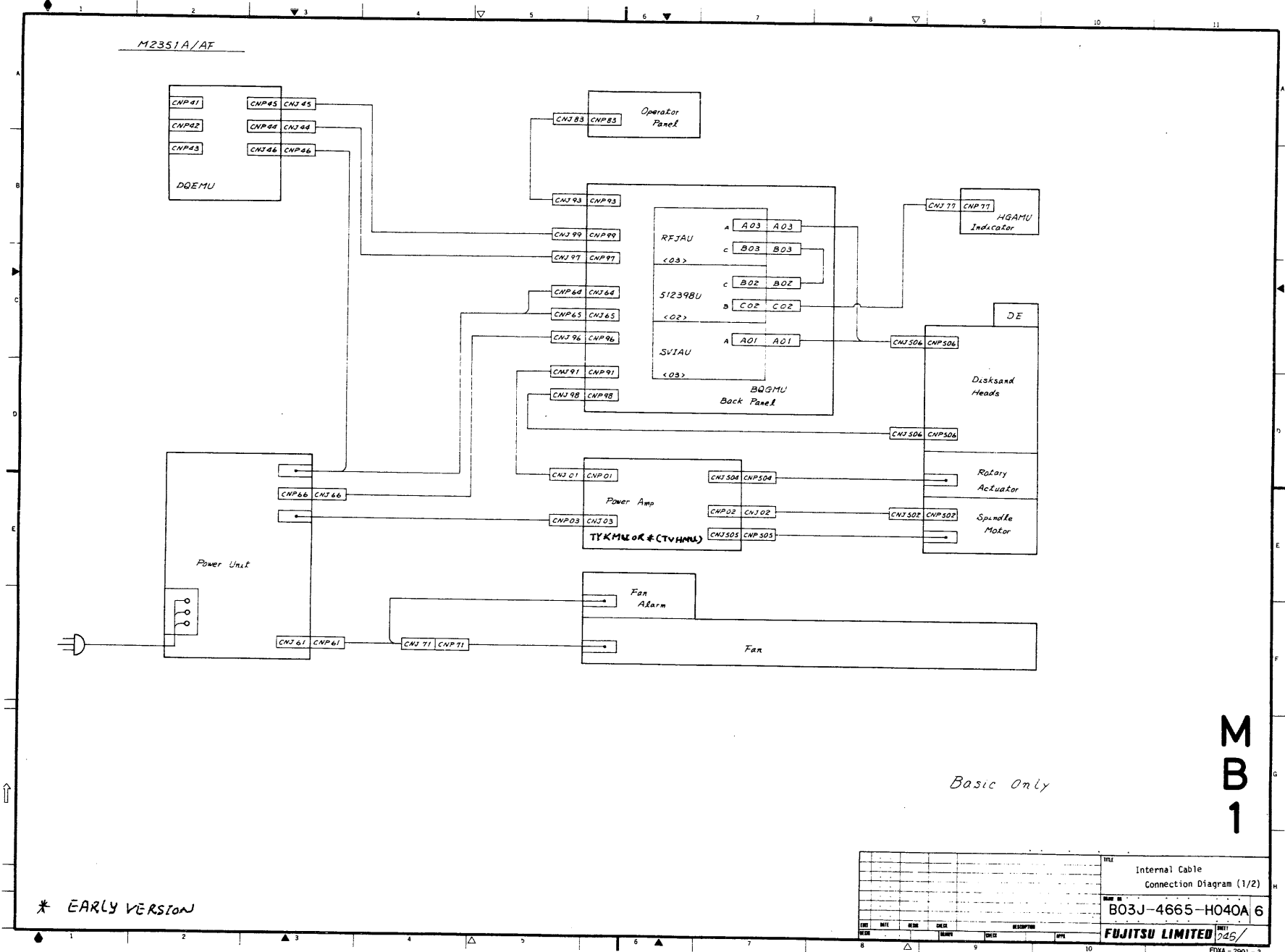

Internal Cable Connection Diagram (1/2)							
B03J-4655-H040A 6							
FUJITSU LIMITED							
REV	DATE	BY	CHK	DATE	BY	CHK	DATE

M B 1

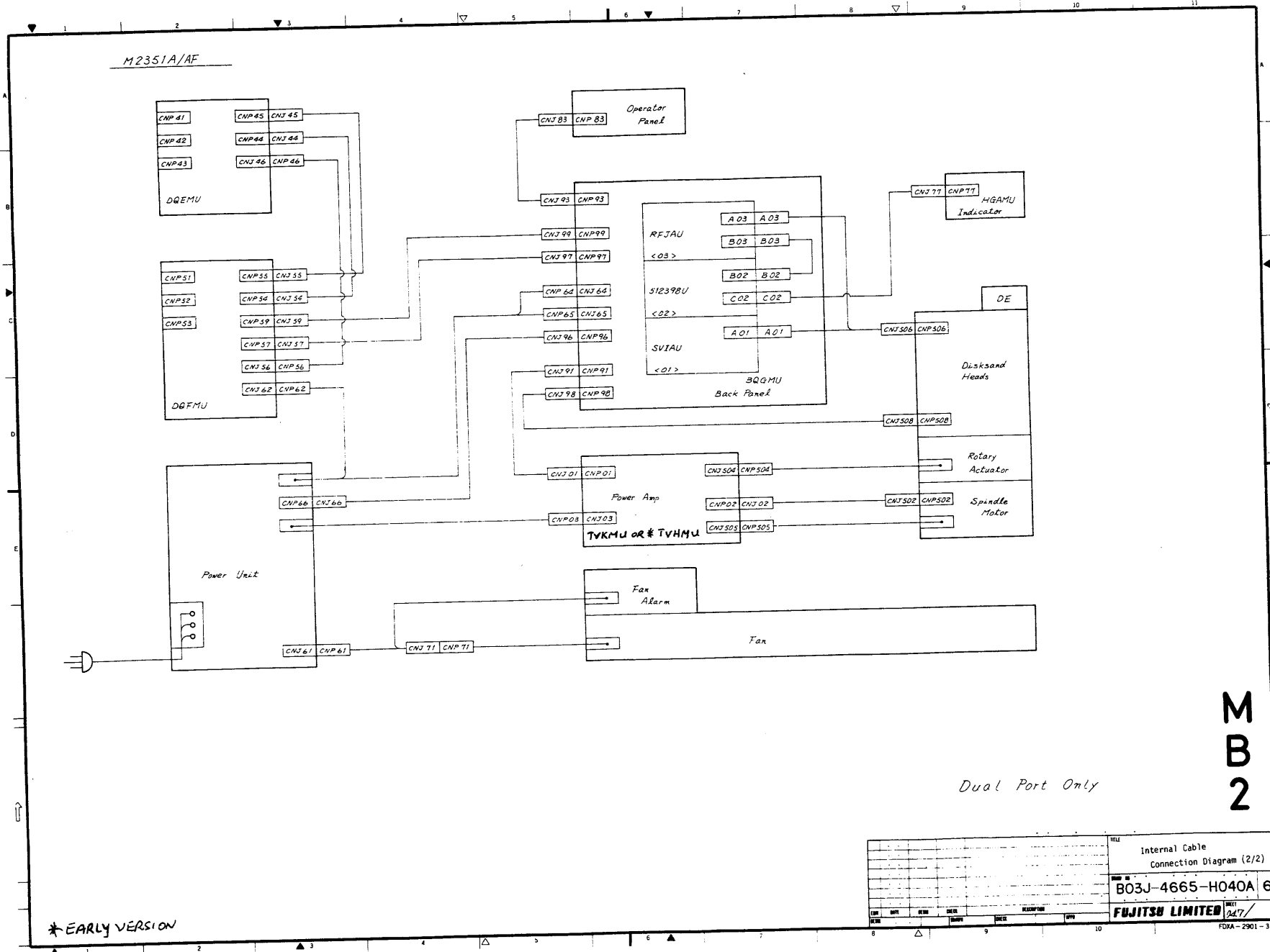

\*EARLY VERSION

Dual Port Only

**M  
B  
2**

Internal Cable Connection Diagram (2/2)	
B03J-4665-H040A 6	
FUJITSU LIMITED	

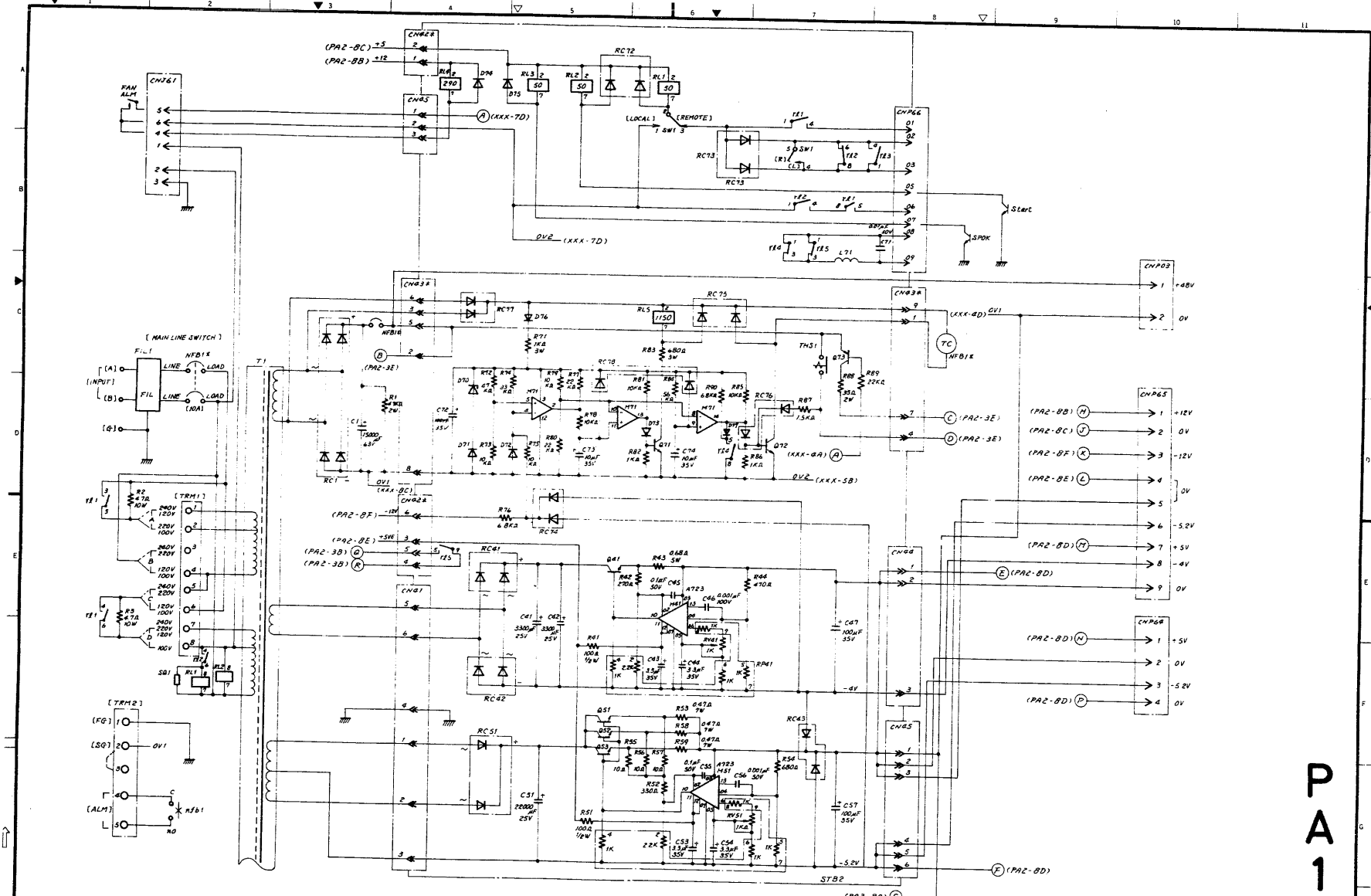

# PA 1

TITLE		Power Unit
CIRCUIT		Circuit Diagram (1/2)
PART NO.		B14C-5105-0073A/01 6
MANUFACTURER		FUJITSU LIMITED

B03P-4655-0001A...E

17-49

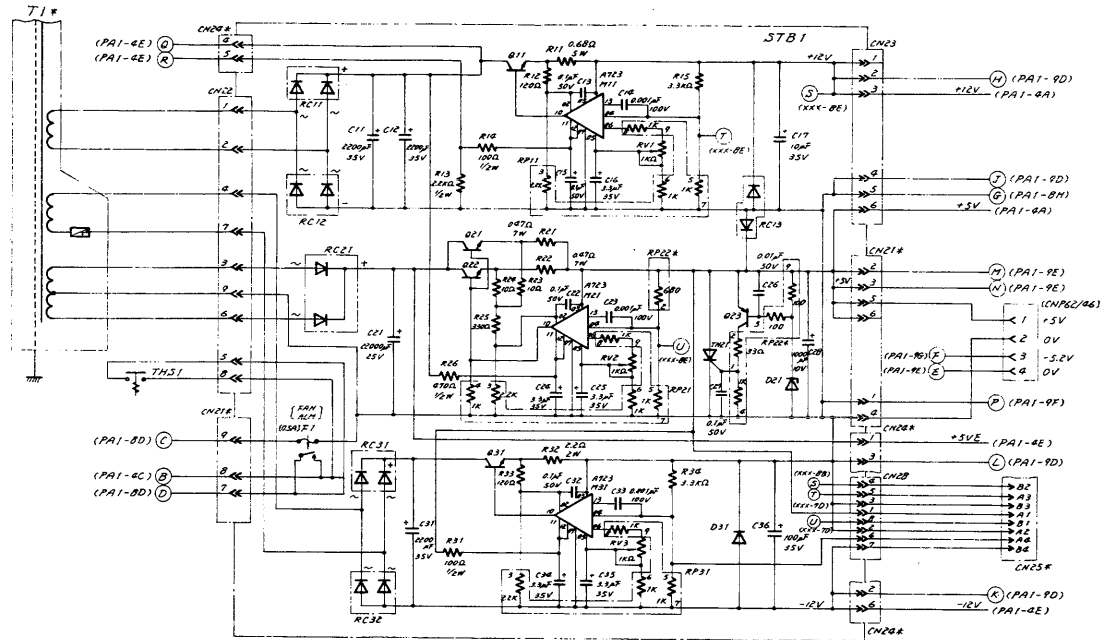

P  
A  
2

TITLE						POWER UNIT
CIRCUIT DIAGRAM (2/2)						
PART NUMBER						B14C-5105-0073A/01 6
DESIGNED BY						FUJITSU LIMITED
CHECKED BY						CHY
DATE						
DRAWN BY						
APPROVED BY						
REVISION						
FOXA-2901-3						

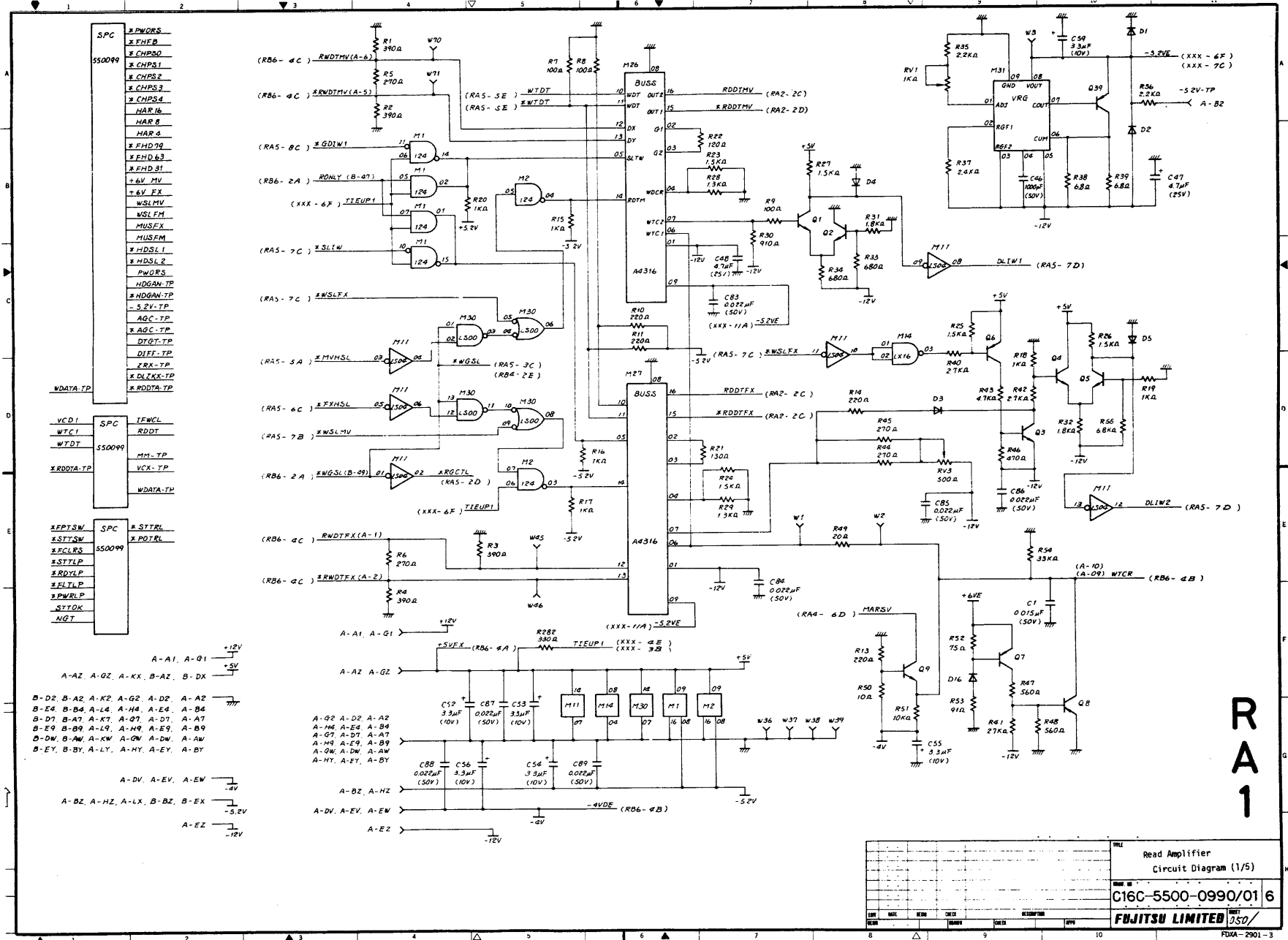

RA 1



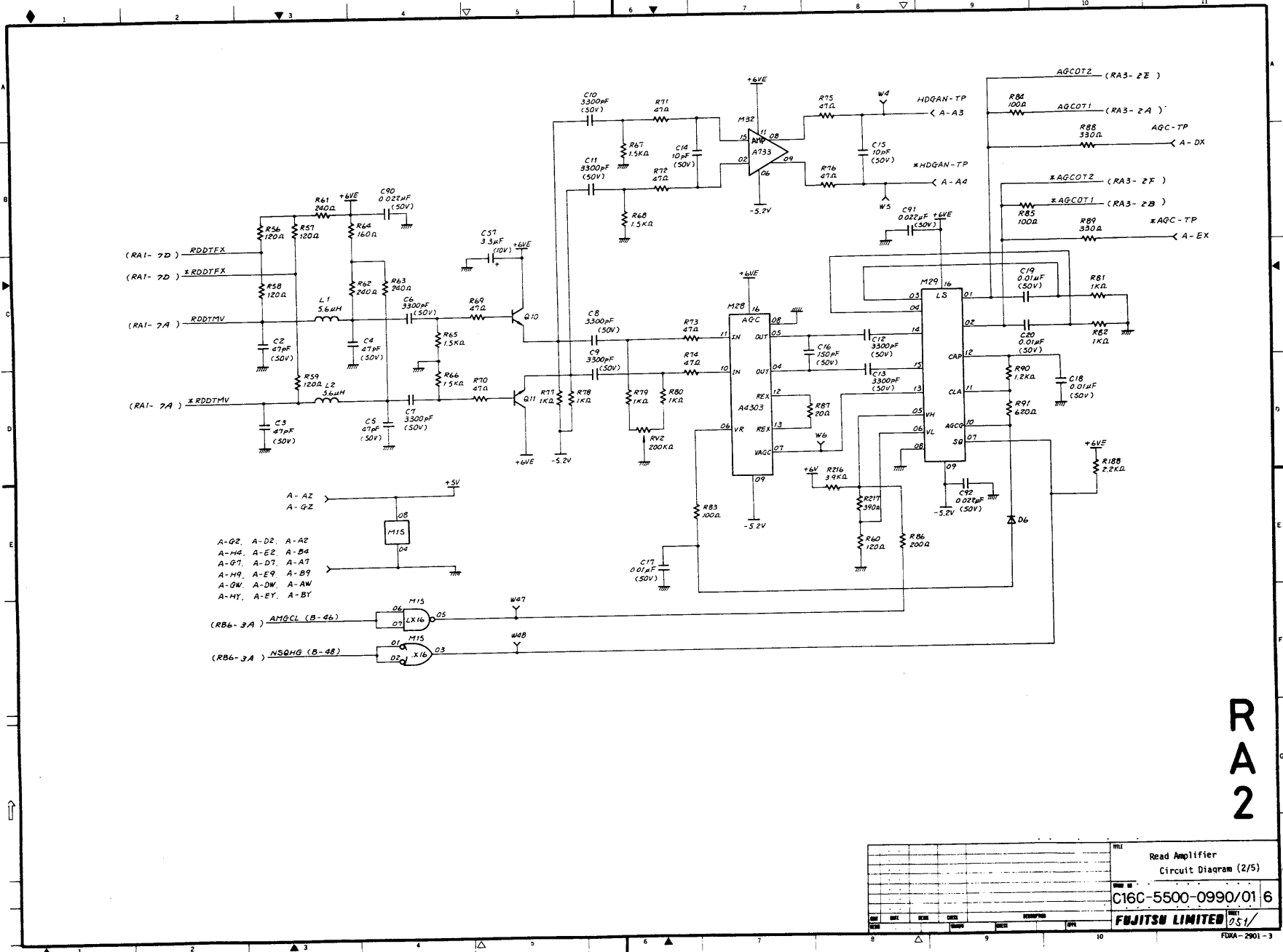

RA2

Read Amplifier	
Circuit Diagram (2/5)	
C16C-5500-0990/01 6	
FUJITSU LIMITED	



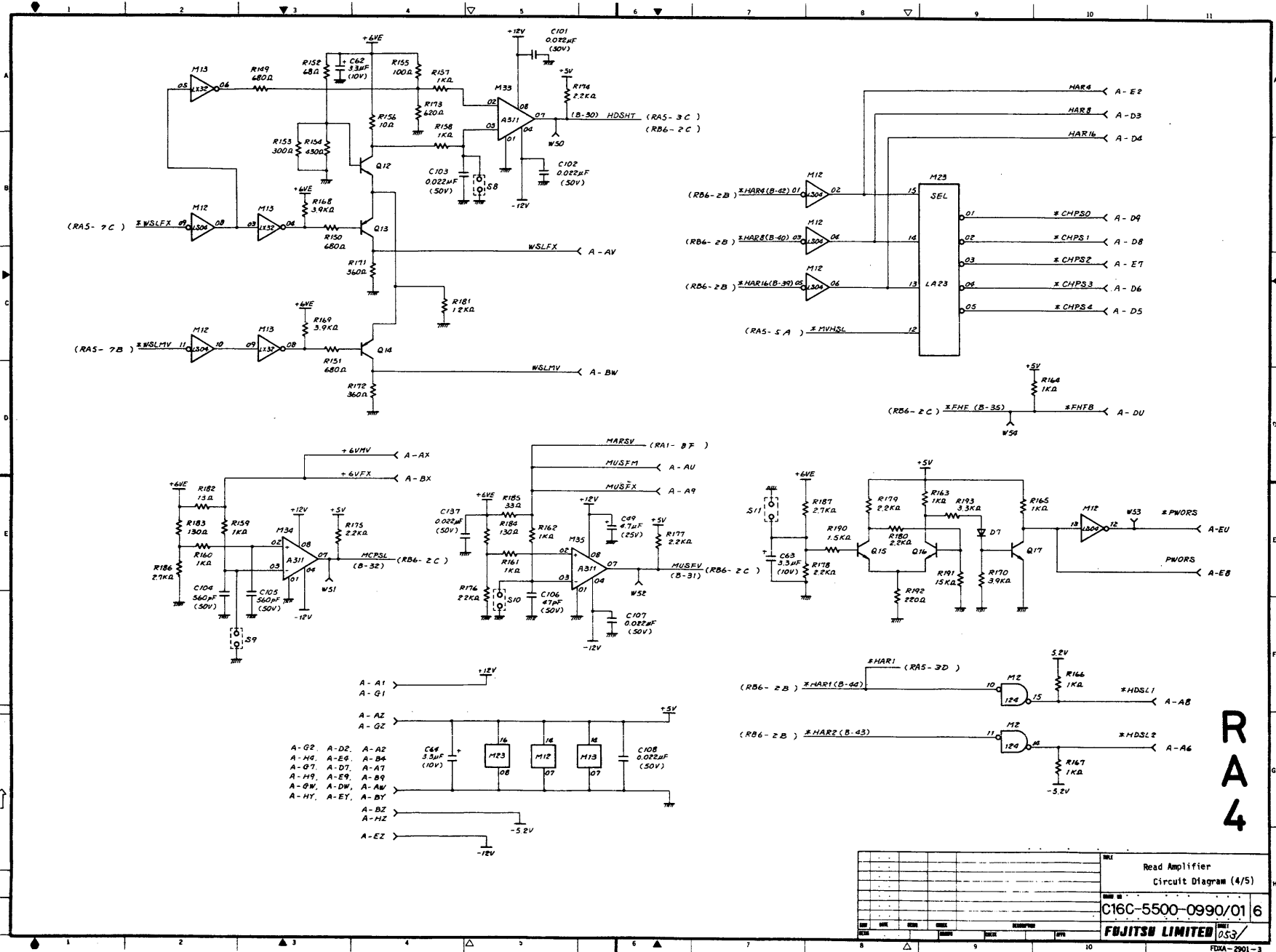

RA4

Read Amplifier	
Circuit Diagram (4/5)	
C16C-5500-0990/01 6	
FUJITSU LIMITED	

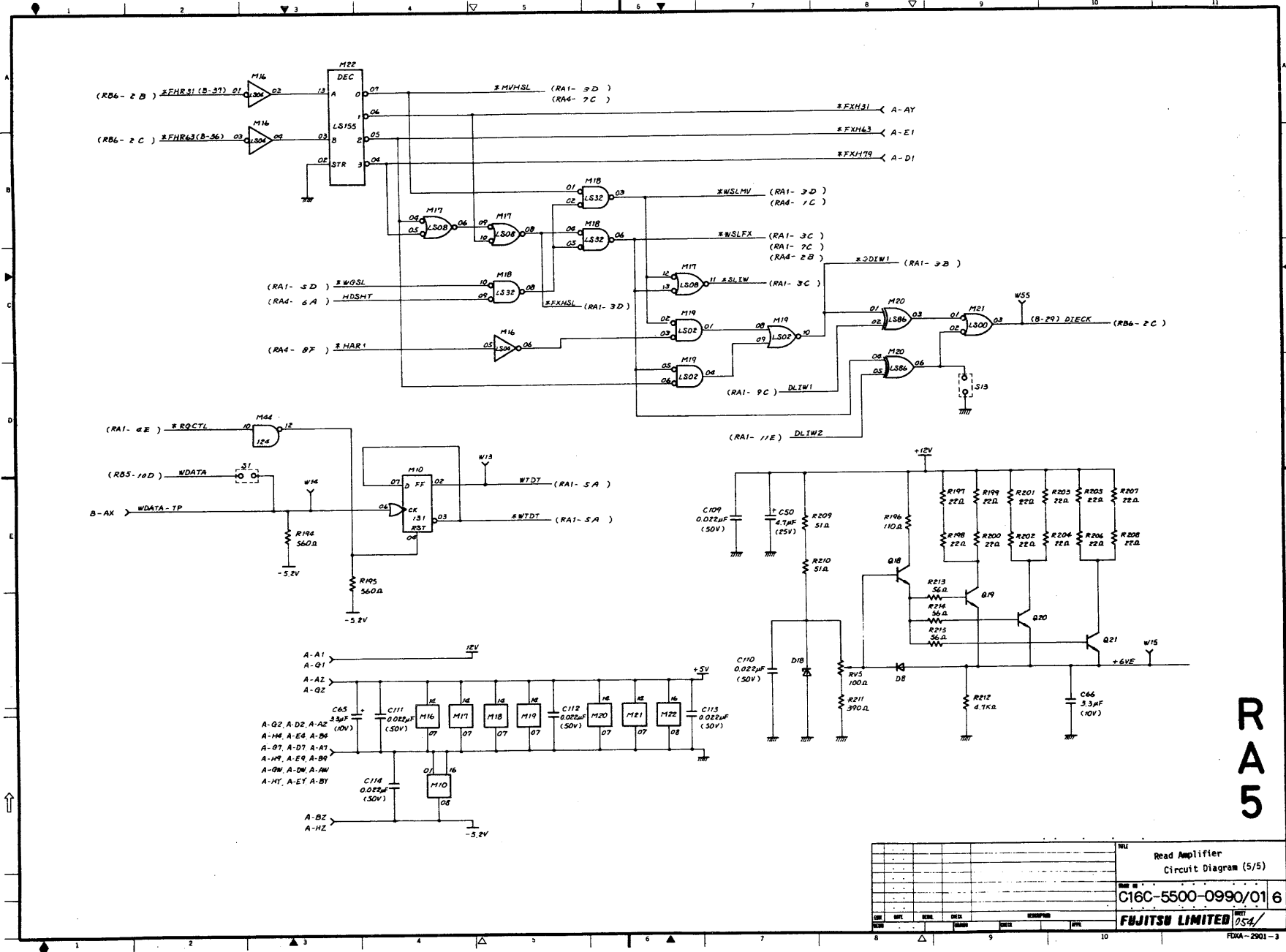

RA5

MIL		Read Amplifier	
		Circuit Diagram (5/5)	
C16C-5500-0990/01 6			
FUJITSU LIMITED		054	

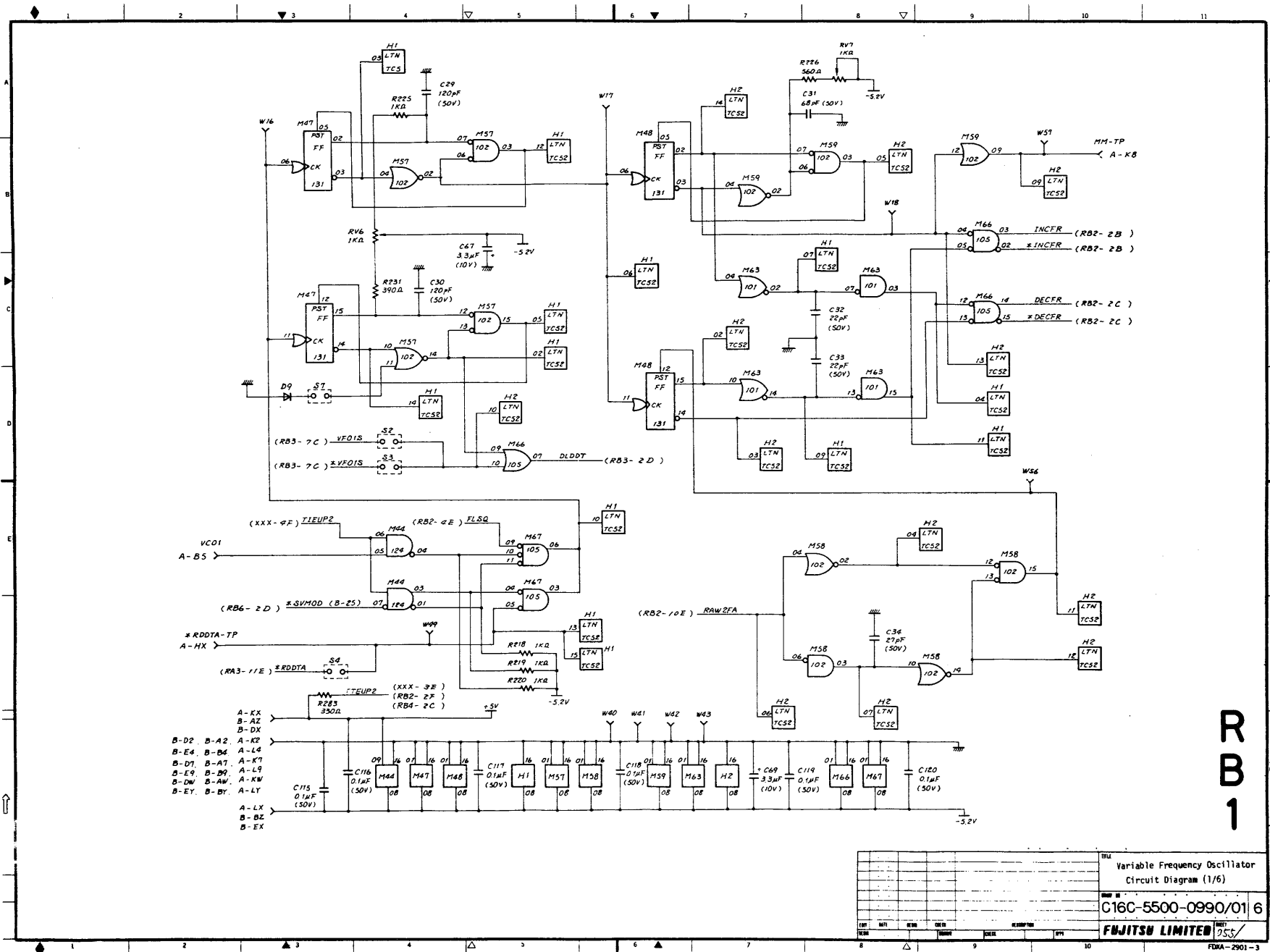

Variable Frequency Oscillator Circuit Diagram (1/6)	
C16C-5500-0990/01 6	
FUJITSU LIMITED	

RR-1

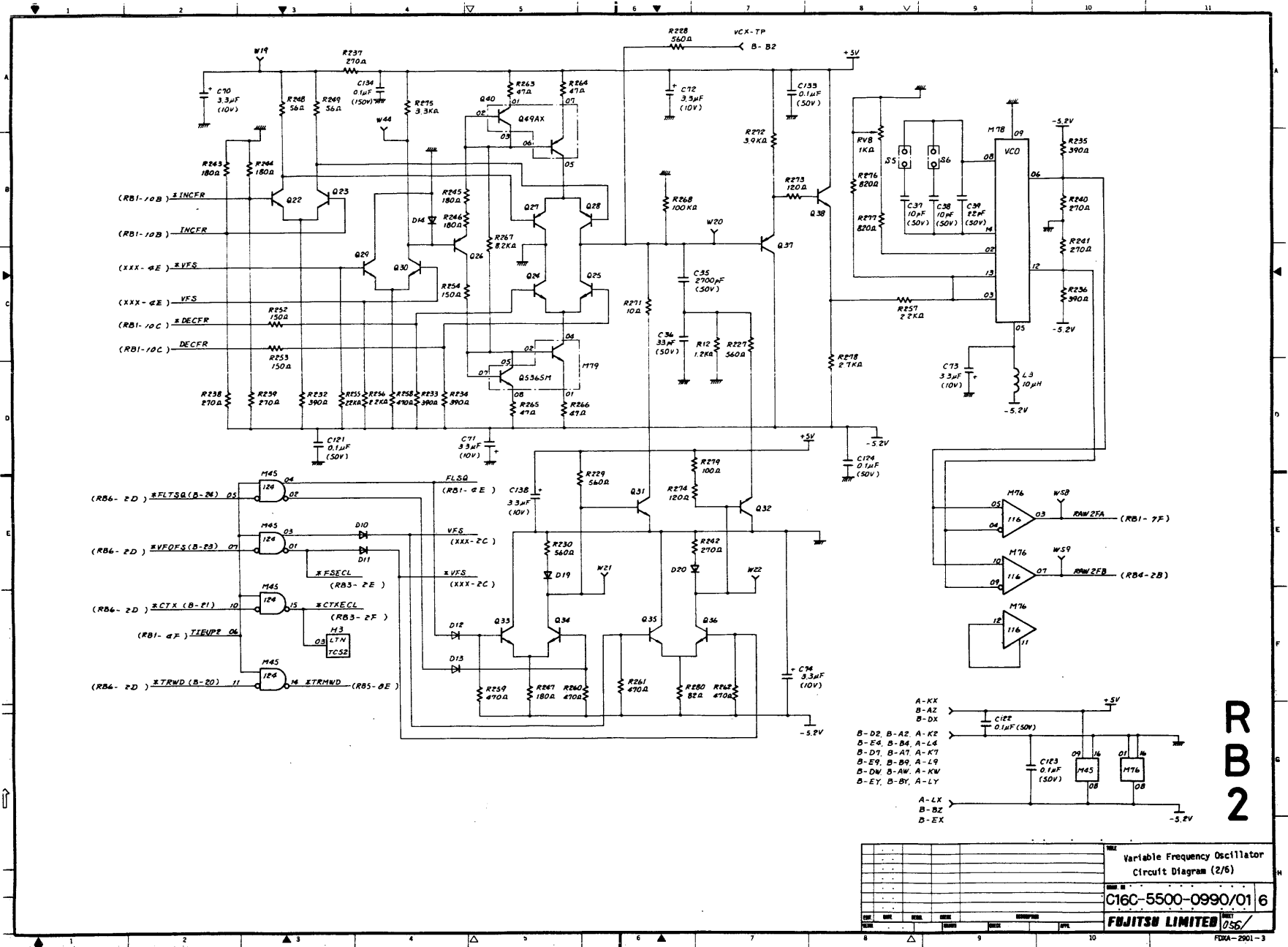

- A-KX
- B-AZ
- B-DX
- B-D2 B-A2 A-K2
- B-E4 B-B4 A-L4
- B-D7 B-AT A-K7
- B-E9 B-B9 A-L9
- B-DW B-AW A-KW
- B-EY B-BY A-LY
- A-LX
- B-BZ
- B-EX

	Variable Frequency Oscillator Circuit Diagram (2/6)
	C16C-5500-0990/01 6
	FUJITSU LIMITED 055/

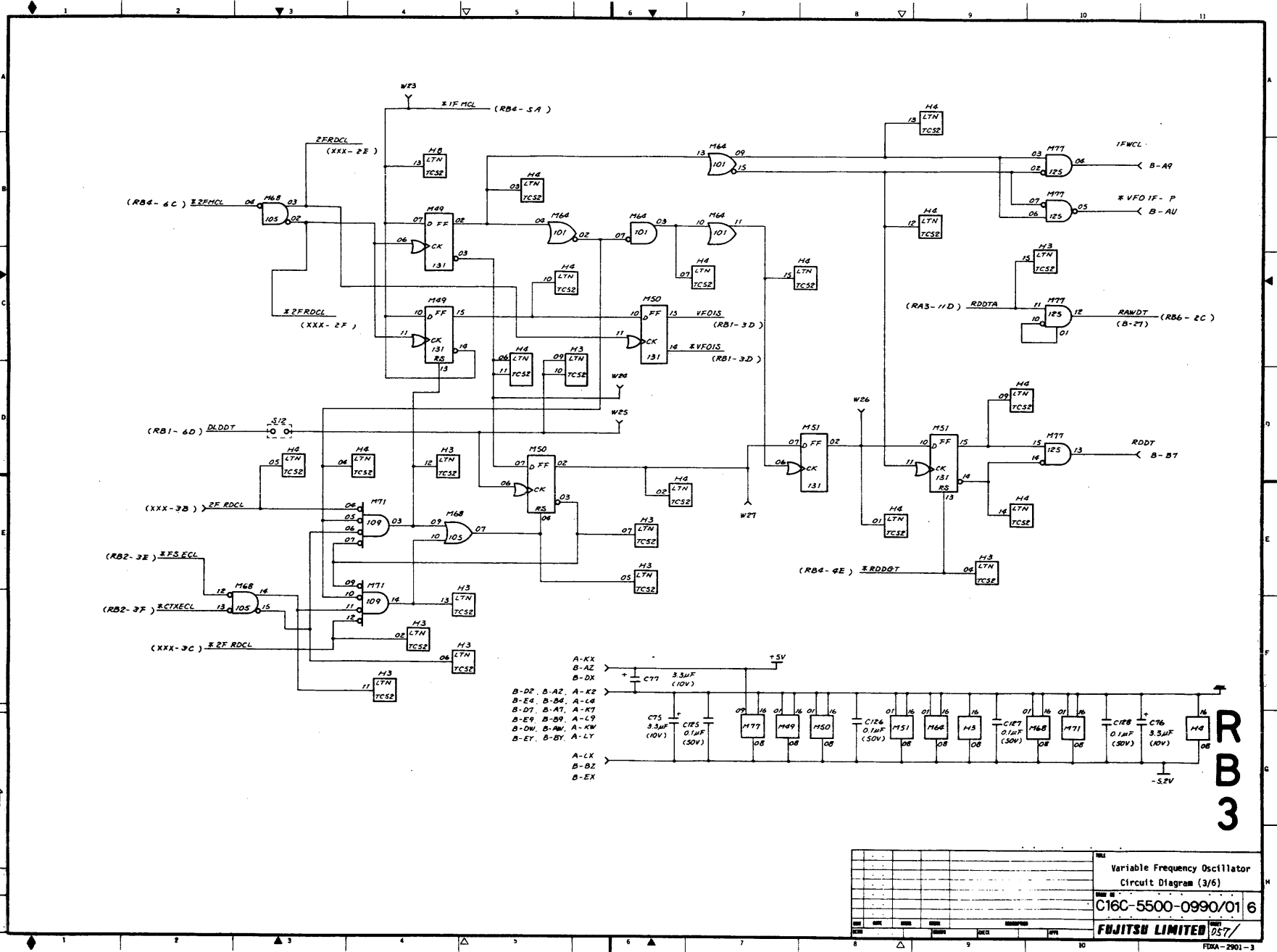

Variable Frequency Oscillator	
Circuit Diagram (3/6)	
C16C-5500-0990/01 6	
FUJITSU LIMITED	

R3

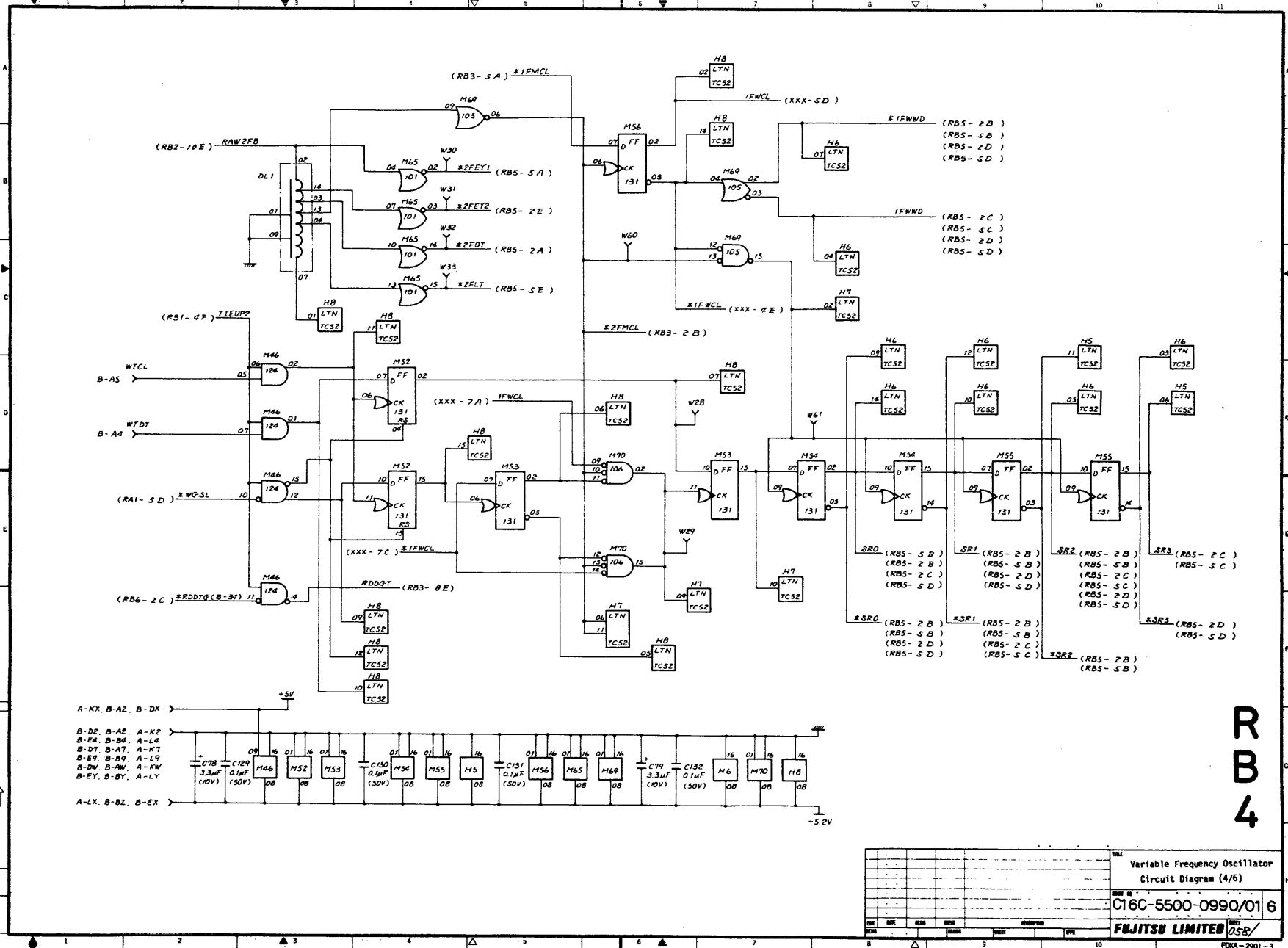

- A-KX, B-AZ, B-DX
- B-DZ, B-AZ, A-KZ
- B-EA, B-B4, A-L4
- B-DT, B-A7, A-K7
- B-EY, B-B9, A-L9
- B-DV, B-OW, A-LV
- B-EY, B-BY, A-LY
- A-CX, B-BZ, B-EX

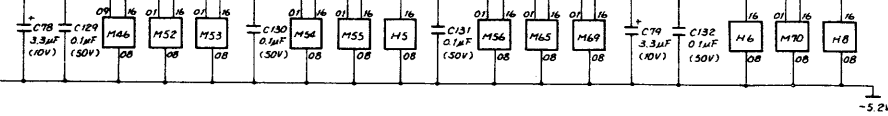

Variable Frequency Oscillator Circuit Diagram (4/6)	
C16C-5500-0990/01 6	
FUJITSU LIMITED	

RB4



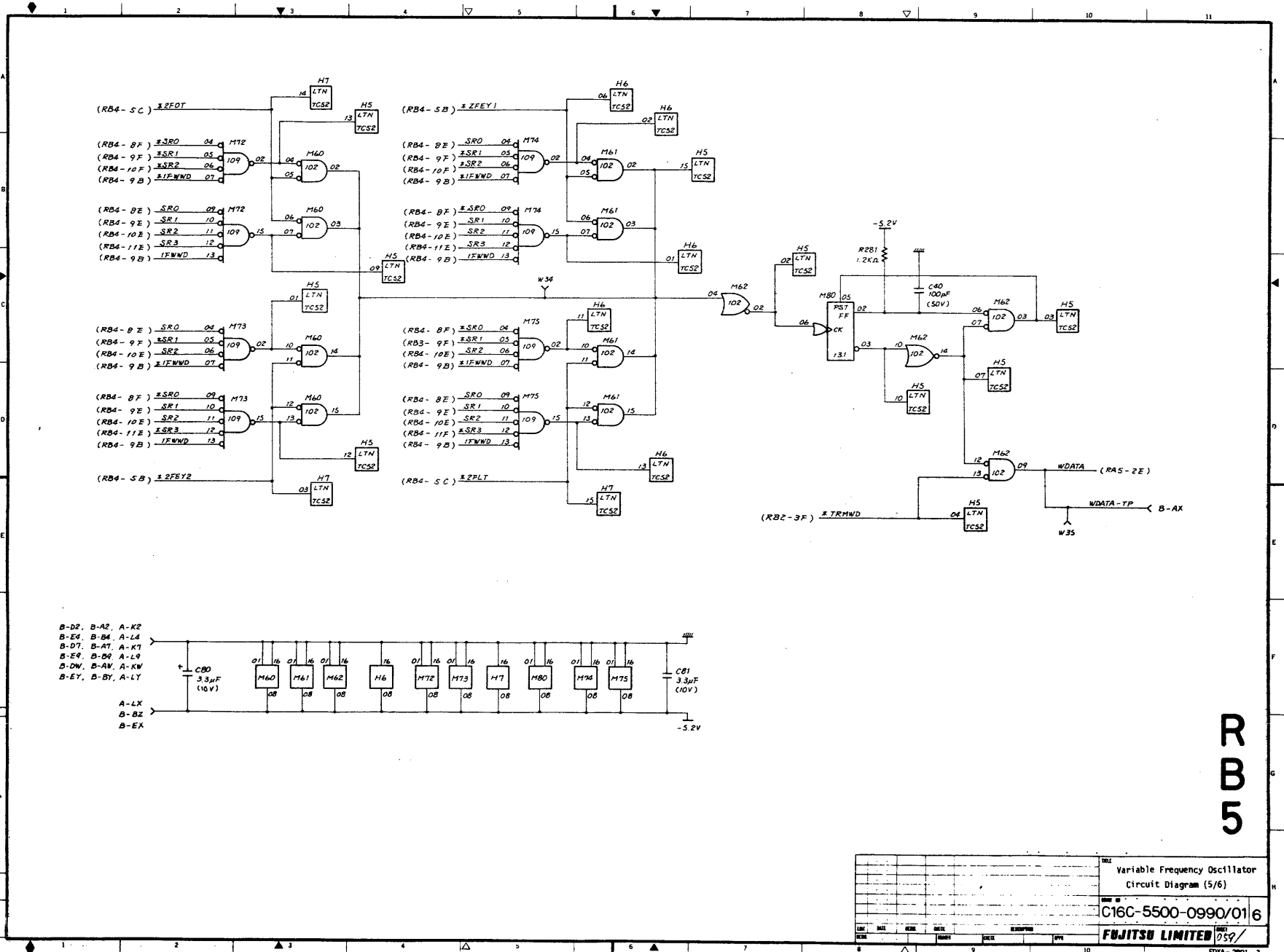

R5B

REV						Variable Frequency Oscillator Circuit Diagram (5/6)	
DATE						C16C-5500-0990/016	
DRAWN						FUJITSU LIMITED	
CHECKED						029/	
APPROVED						FDMA-2901-3	

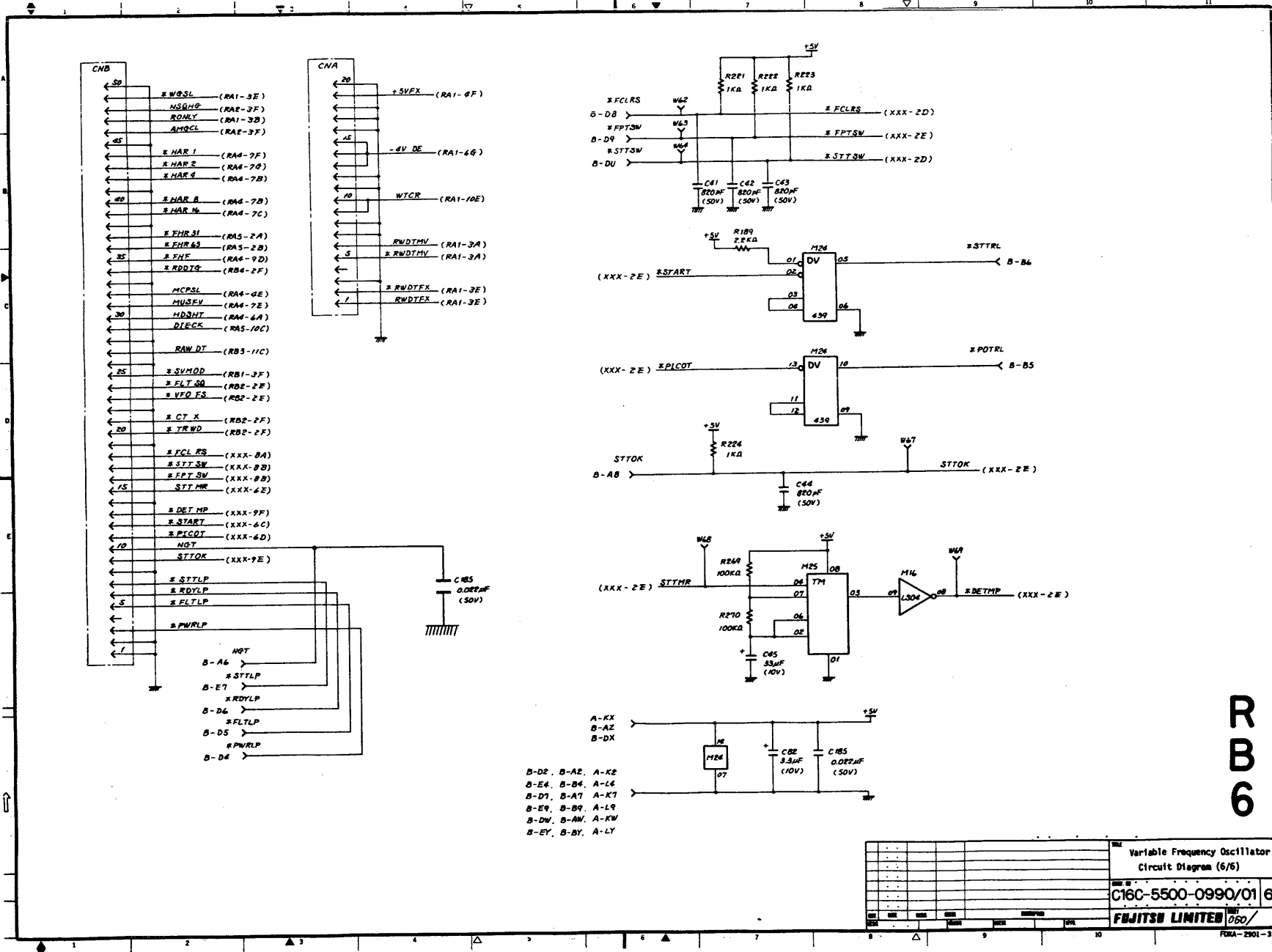

**R66**

Variable Frequency Oscillator Circuit Diagram (6/6)	
C16C-5500-0990/01 6	
FUJITSU LIMITED	

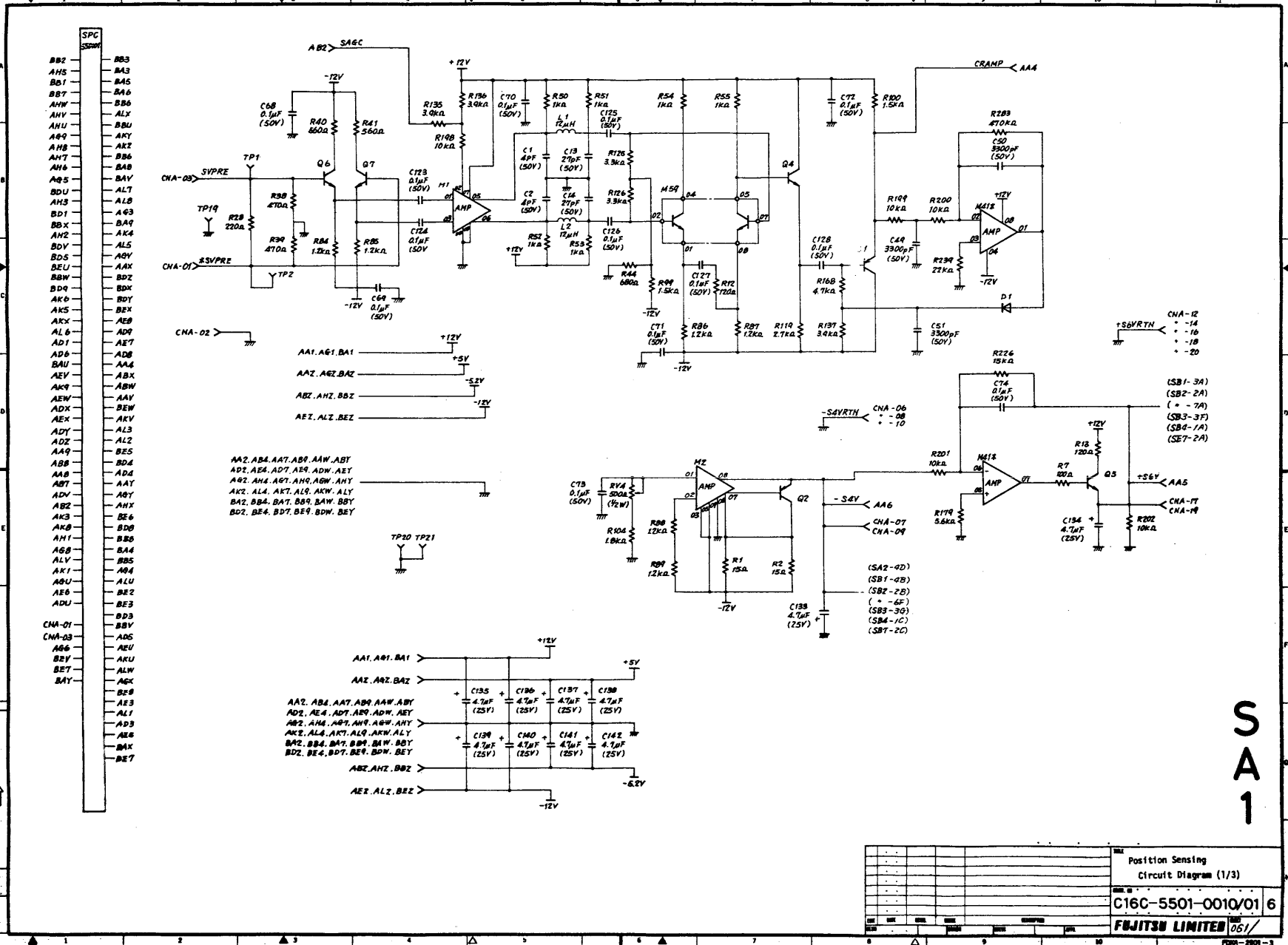

SA1

Position Sensing	
Circuit Diagram (1/3)	
C16C-5501-0010/01 6	
FUJITSU LIMITED 05/	

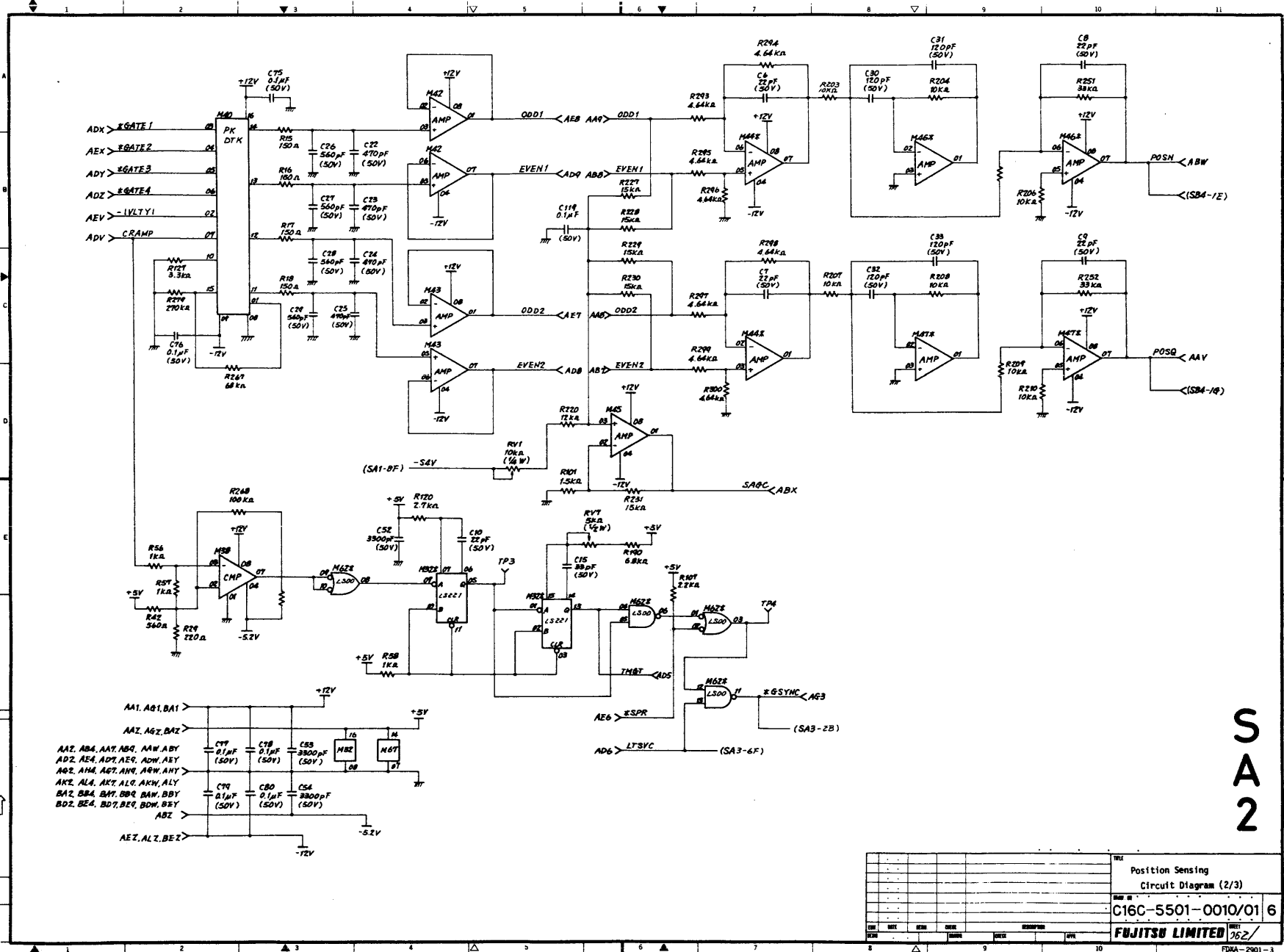

S  
A  
2



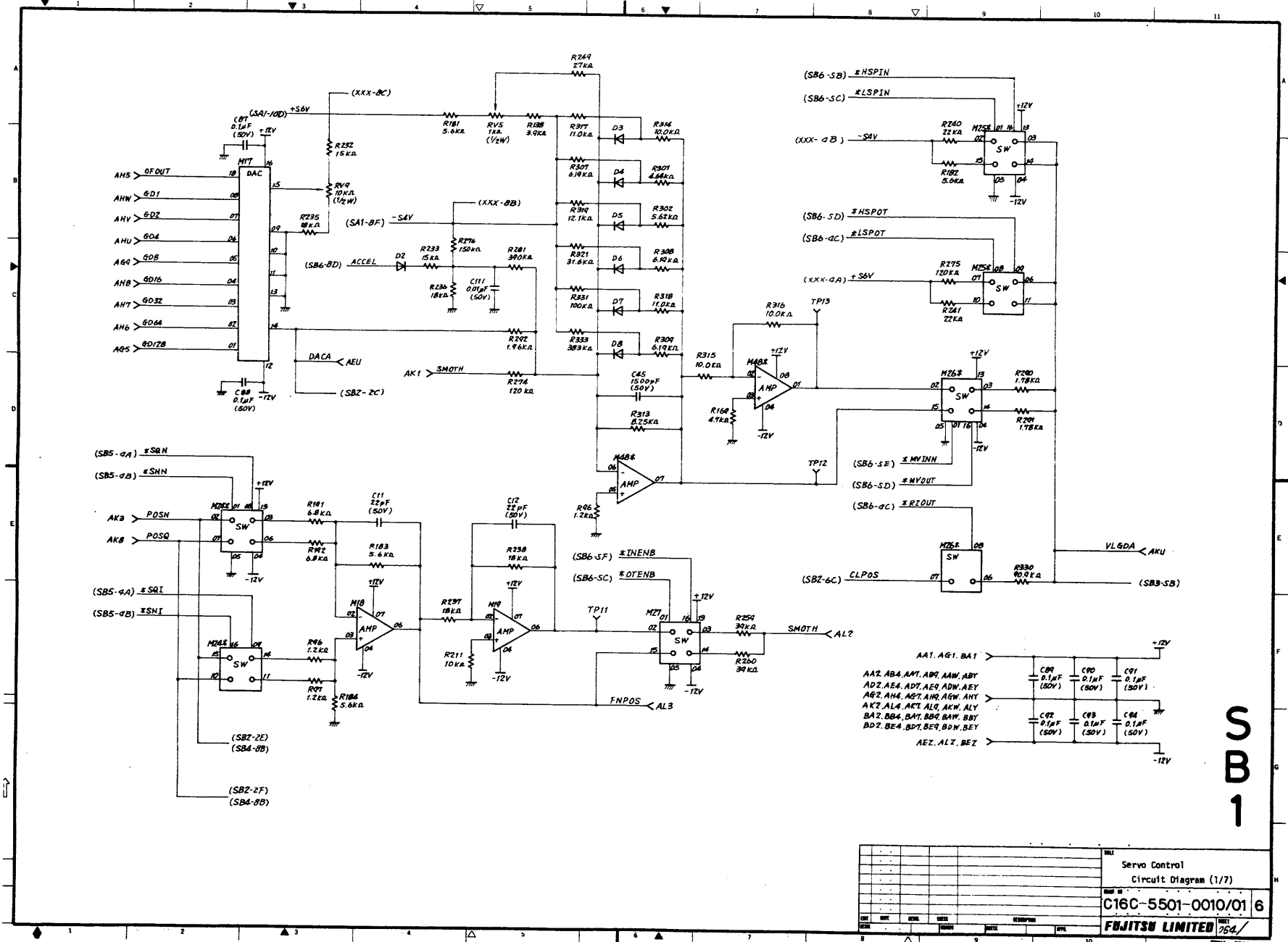

S  
B  
1

TITLE		Servo Control	
Circuit Diagram (1/7)			
DRAWN BY		6	
CHECKED BY		C16C-5501-0010/01	
DATE		FUJITSU LIMITED	
REV.		754	
APPROVED BY		FDXA-2901-3	







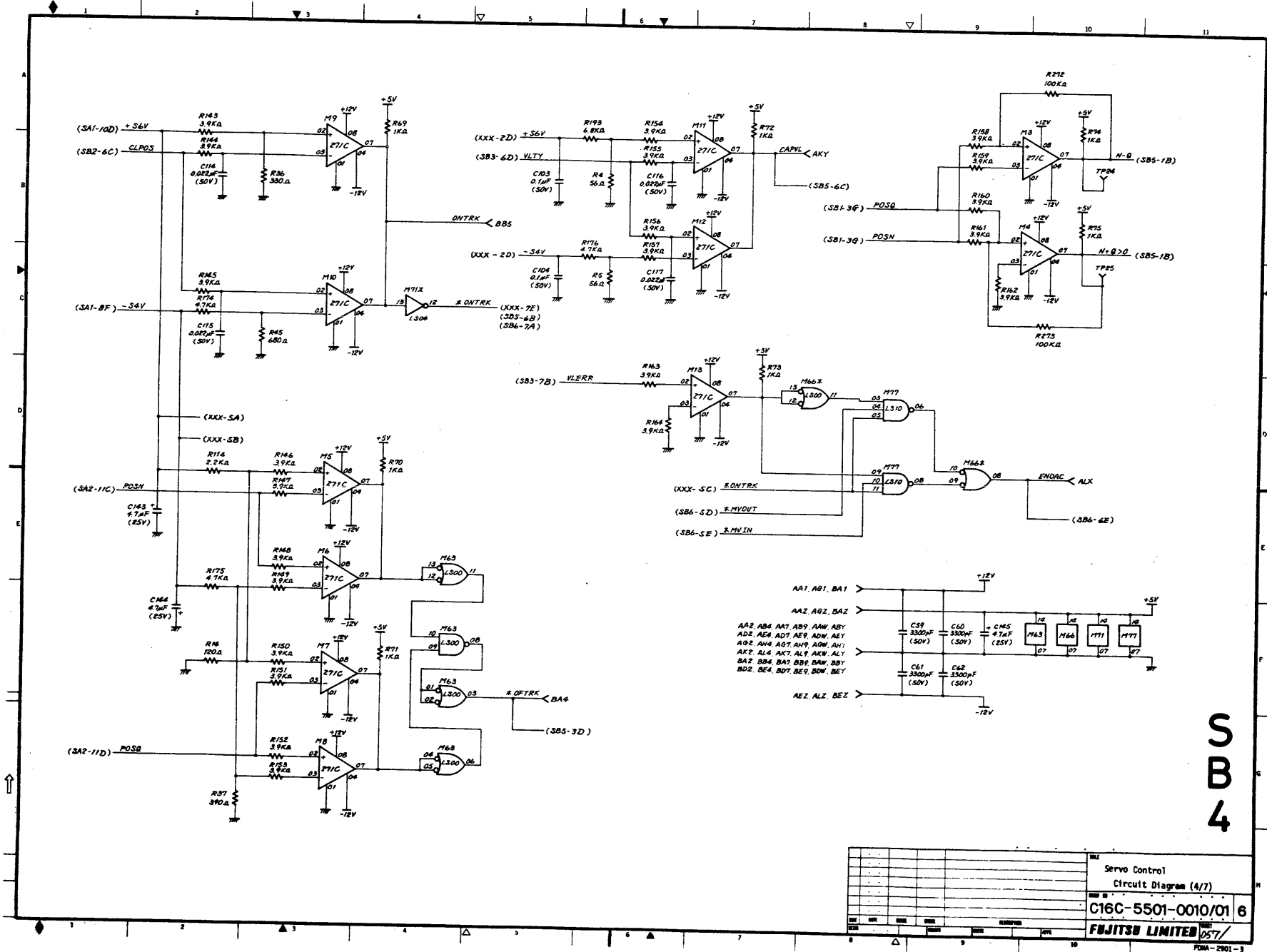

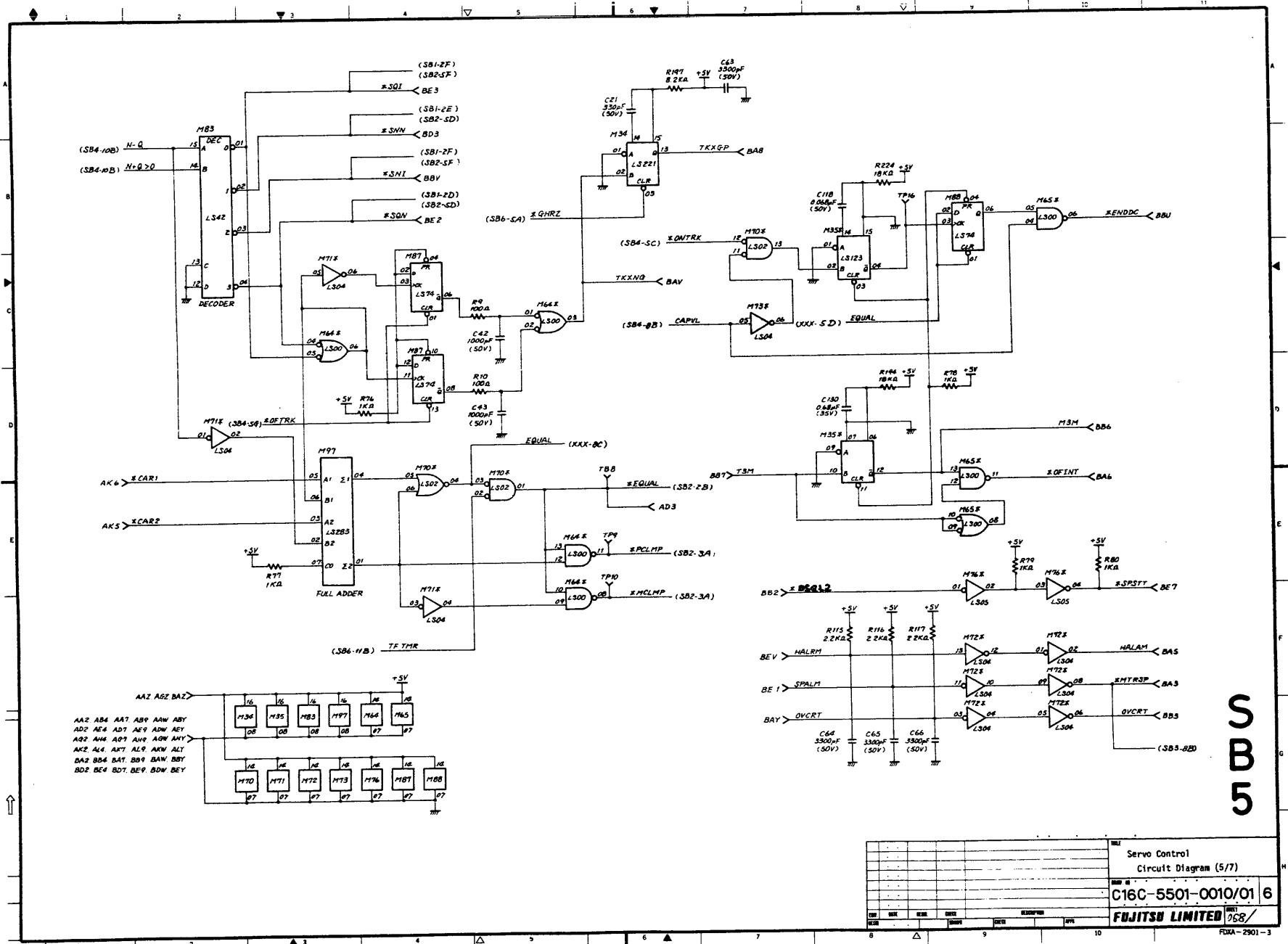

SBS

Servo Control	
Circuit Diagram (5/7)	
C16C-5501-0010/01 6	
FUJITSU LIMITED	

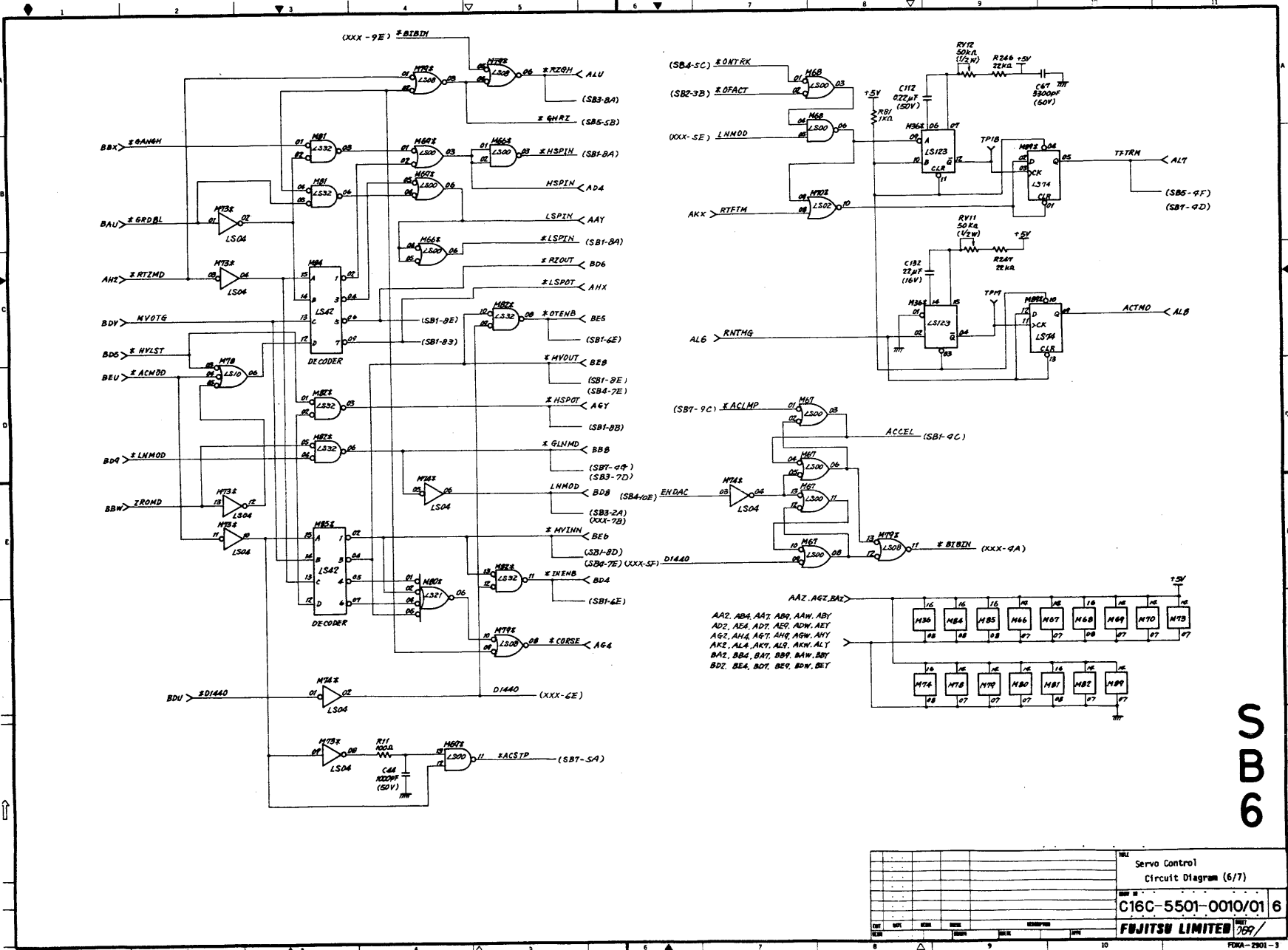

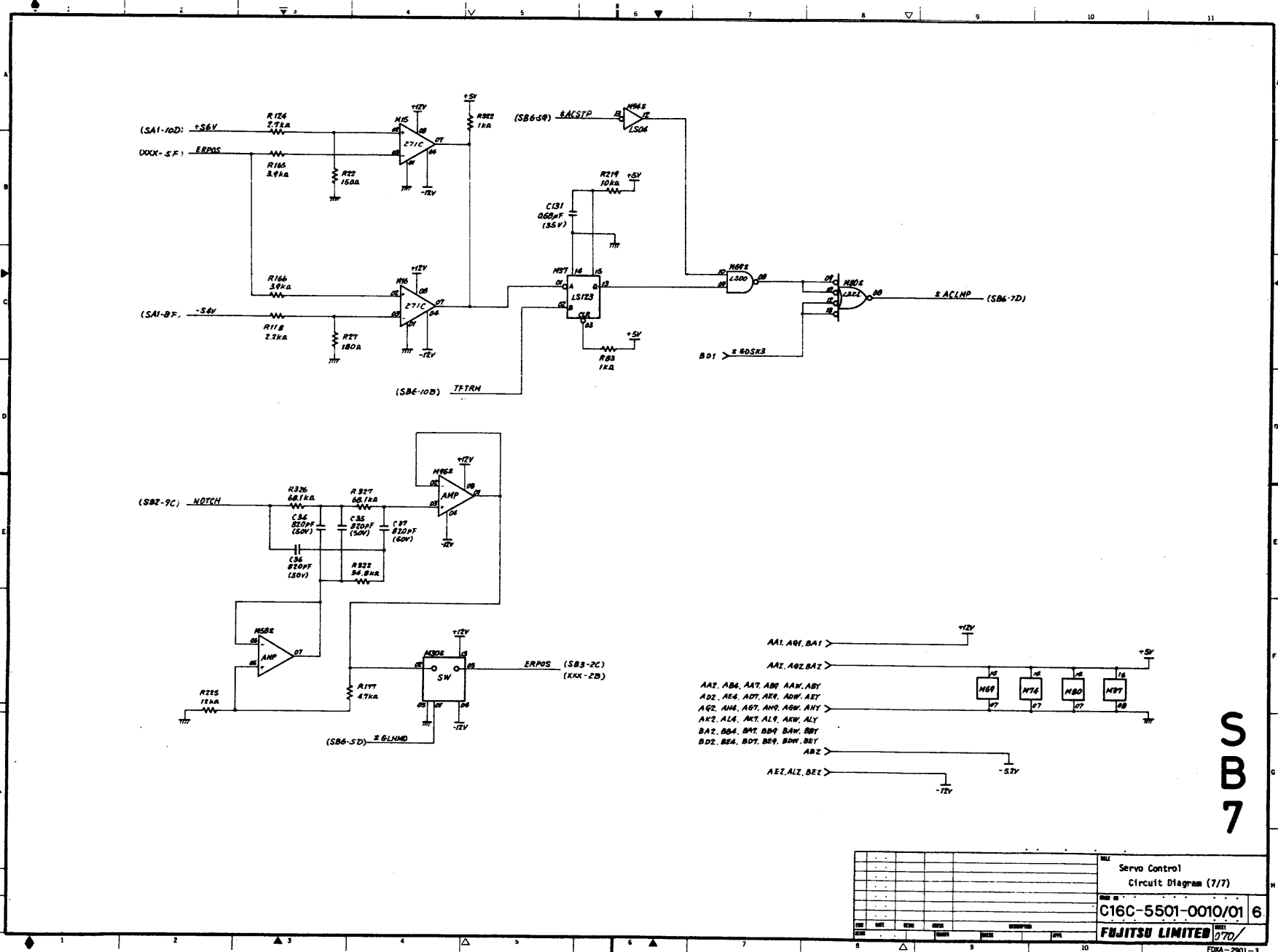

S  
B  
7

SERVO CONTROL			
Circuit Diagram (7/7)			
C16C-5501-0010/01 6			
FUJITSU LIMITED			
FDXA-2901-3			

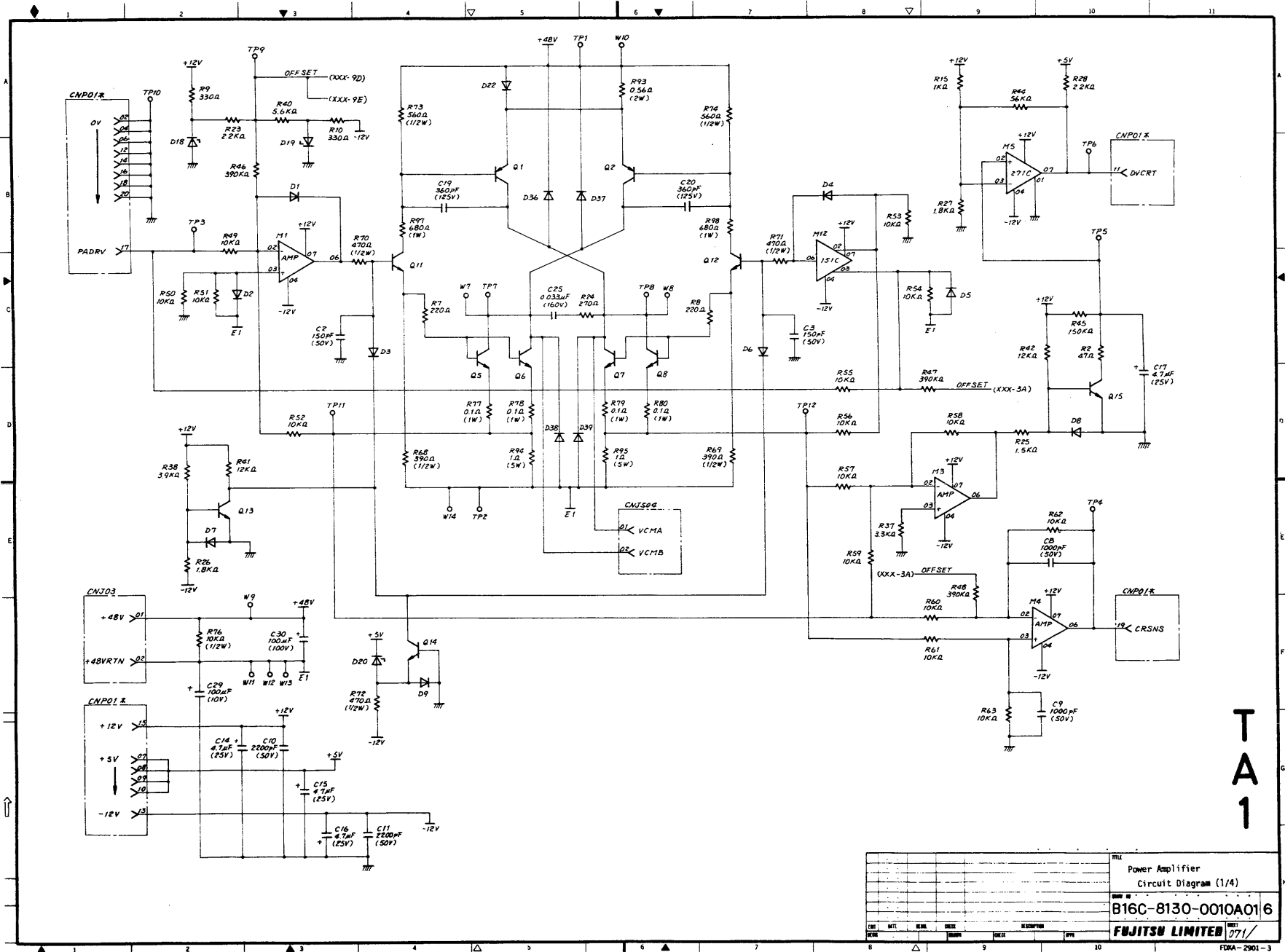

T  
A  
1

REV		DATE		BY		CHKD		APP		MATERIALS		DESCRIPTION		QTY	
Power Amplifier Circuit Diagram (1/4)														B16C-8130-0010A016	
FUJITSU LIMITED														271/	

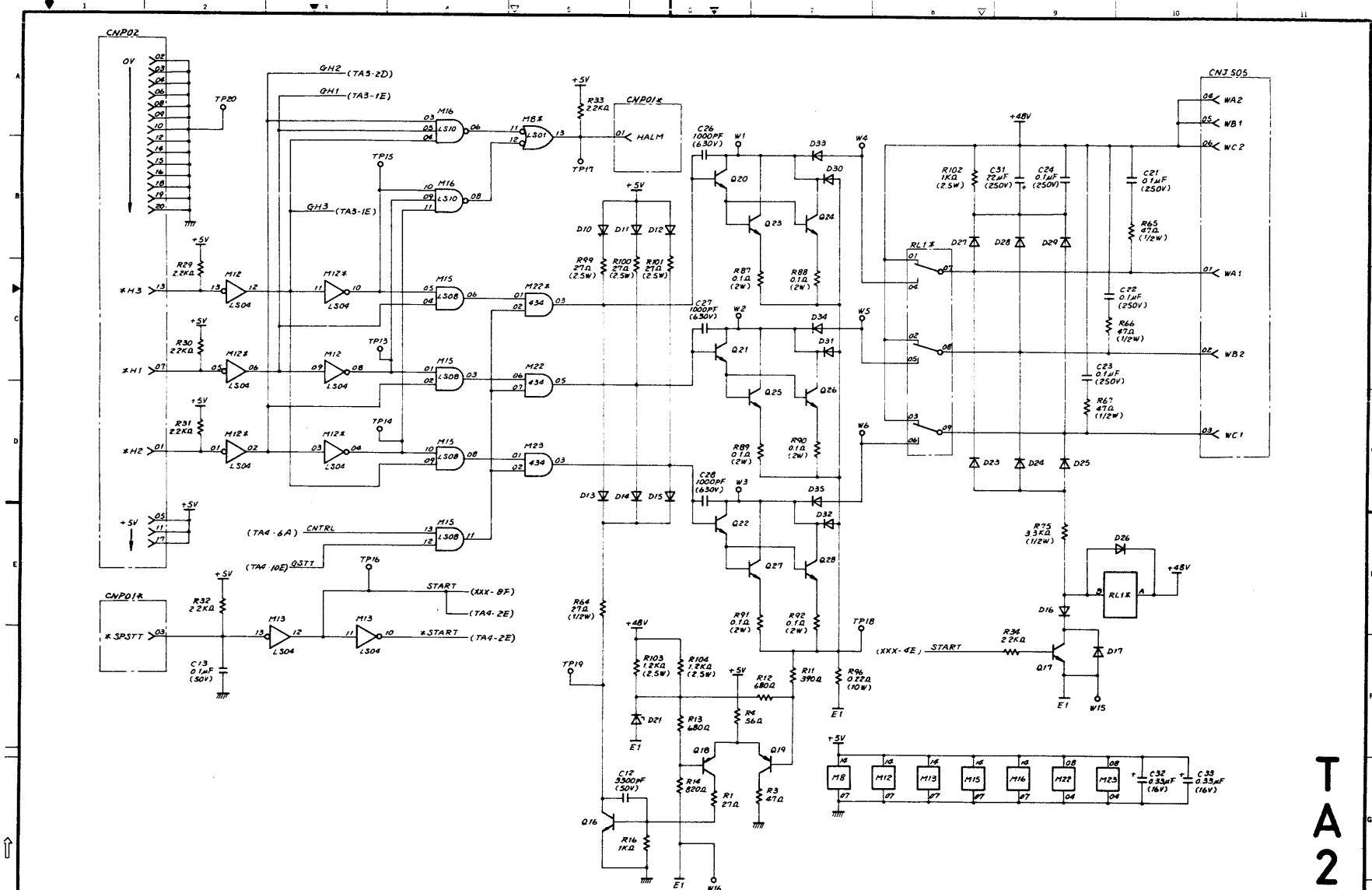

TA2

REV		DATE		BY		CHKD		APP'D		TITLE	
											Power Amplifier
											Circuit Diagram (2/4)
											B16C-8130-0010A016
											FUJITSU LIMITED

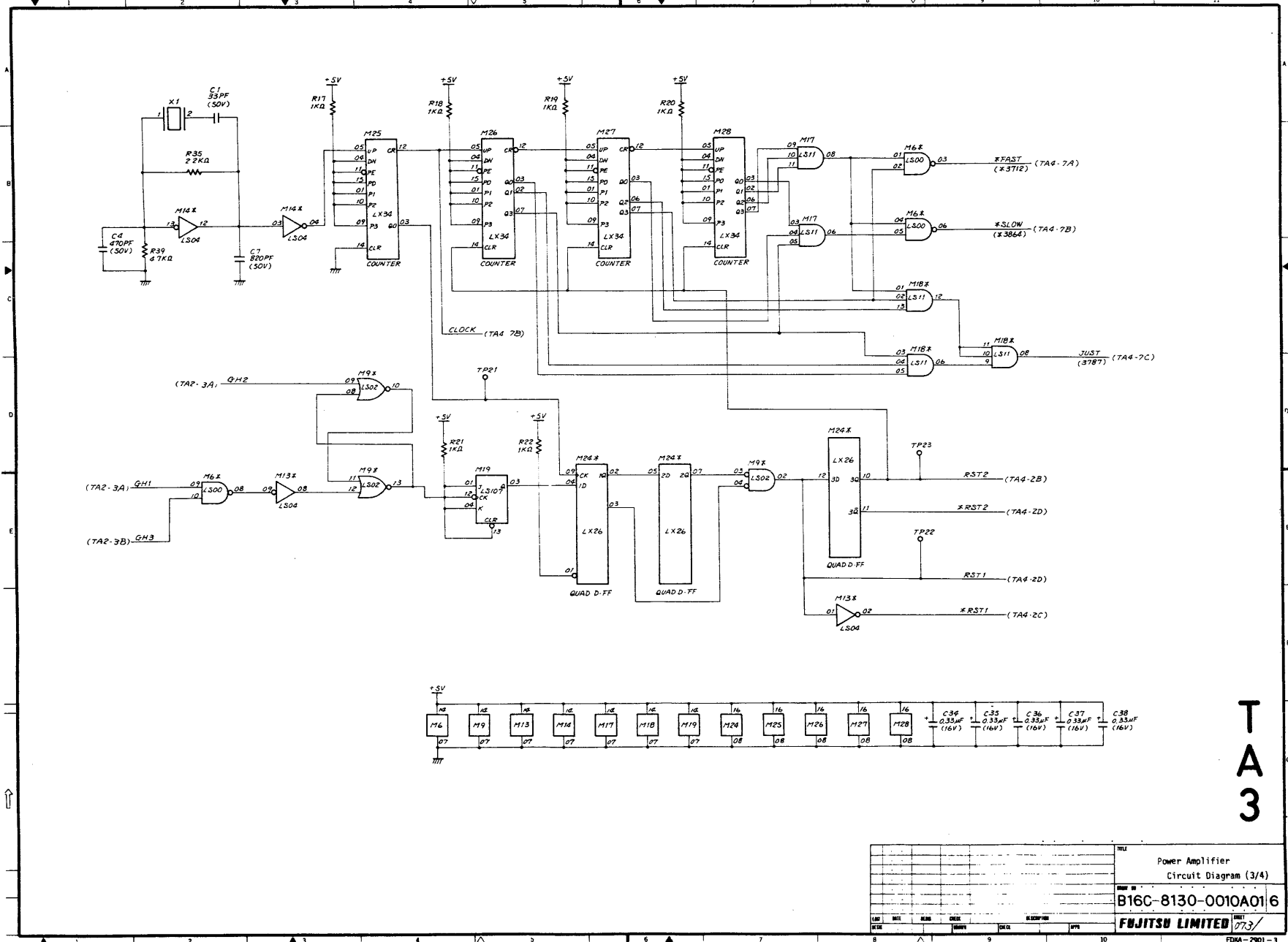

TA3

TUJ						Power Amplifier	
						Circuit Diagram (3/4)	
						B16C-8130-0010A016	
FUJITSU LIMITED						073/	

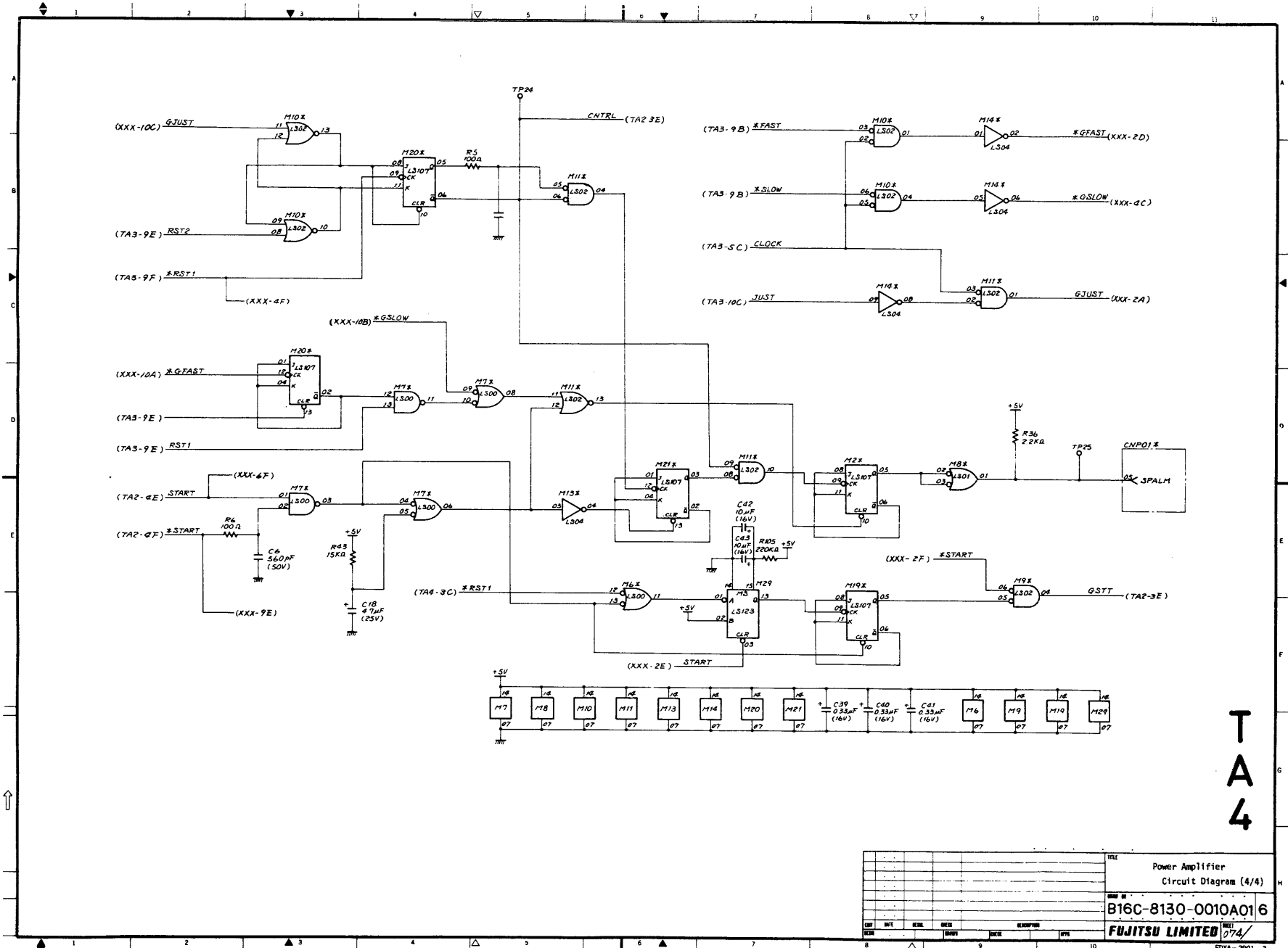

T  
A  
4

TITLE						Power Amplifier					
						Circuit Diagram (4/4)					
DRAWN BY						B16C-8130-0010A016					
CHKD BY						FUJITSU LIMITED					
DATE						074					
REV						FDXA-2901-3					



B03P-4655-0001A...E

17-75

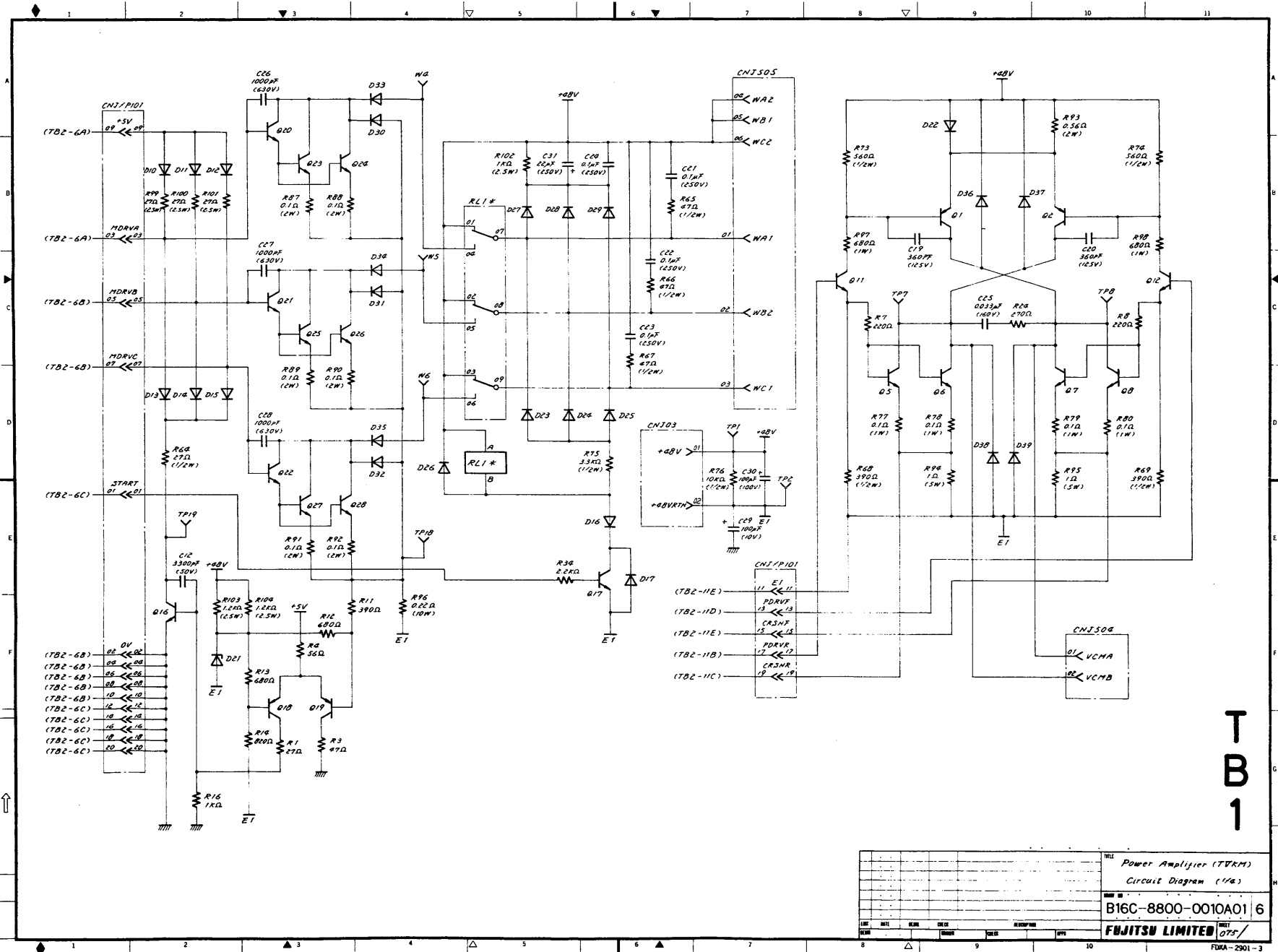

T  
B  
1

TITLE						Power Amplifier (TWRM)
CIRCUIT DIAGRAM (1/2)						
PART NO.						B16C-8800-0010A01 6
DESIGNER	CHKD	DATE	REV	BY	DATE	
FUJITSU LIMITED						OTS
FORM NO. 2901-3						

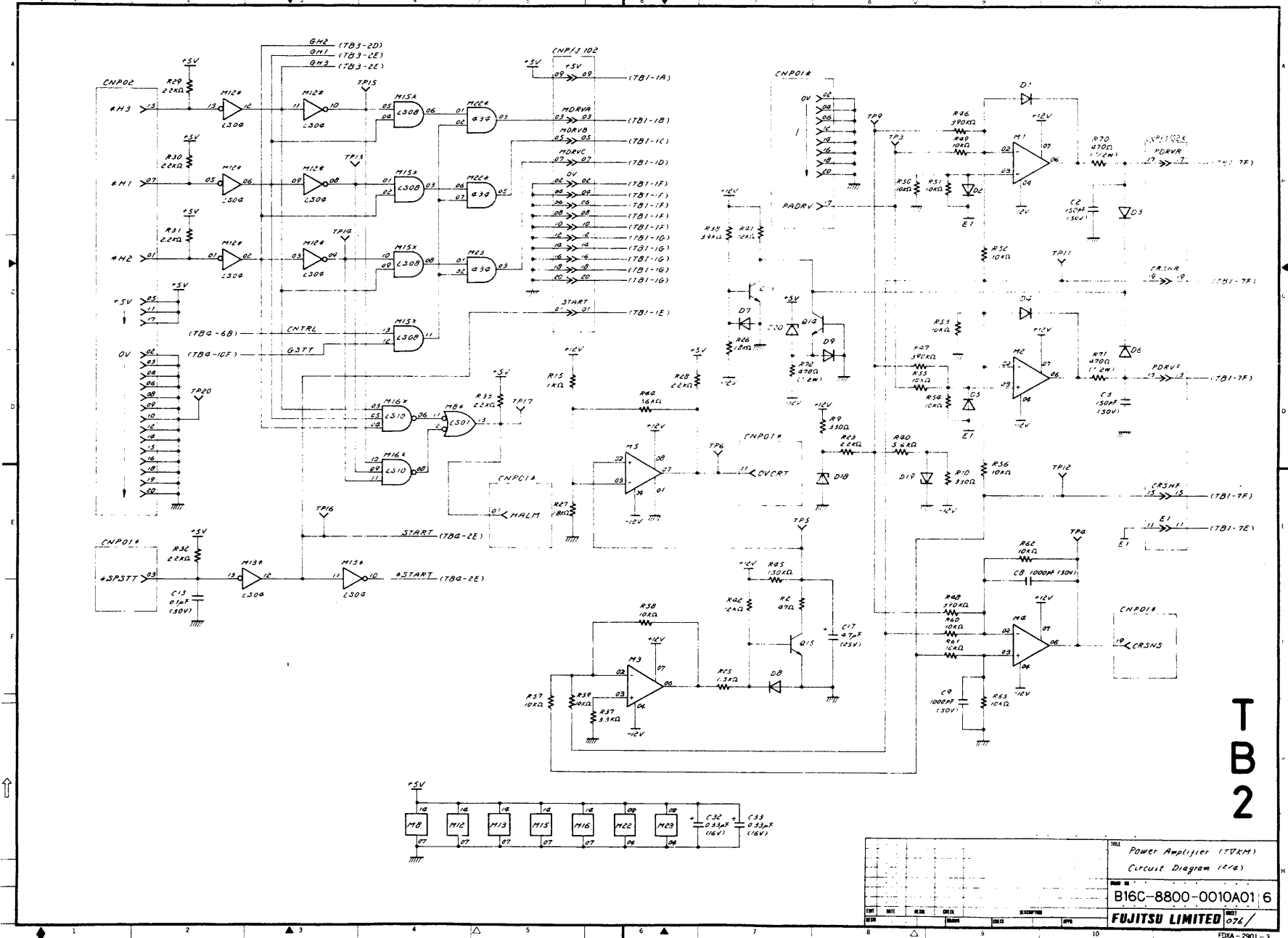

T B 2

TITLE		Power Amplifier (TVM)
CIRCUIT DIAGRAM (P/A)		
PART NO.		B16C-8800-0010A01 6
DRAWN		
CHECKED		
APPROVED		
DATE		
BY		
FOR		
REVISION		
DATE		
BY		
FOR		

FUJITSU LIMITED  
 076/

B03P-4655-0001A...E

17-77

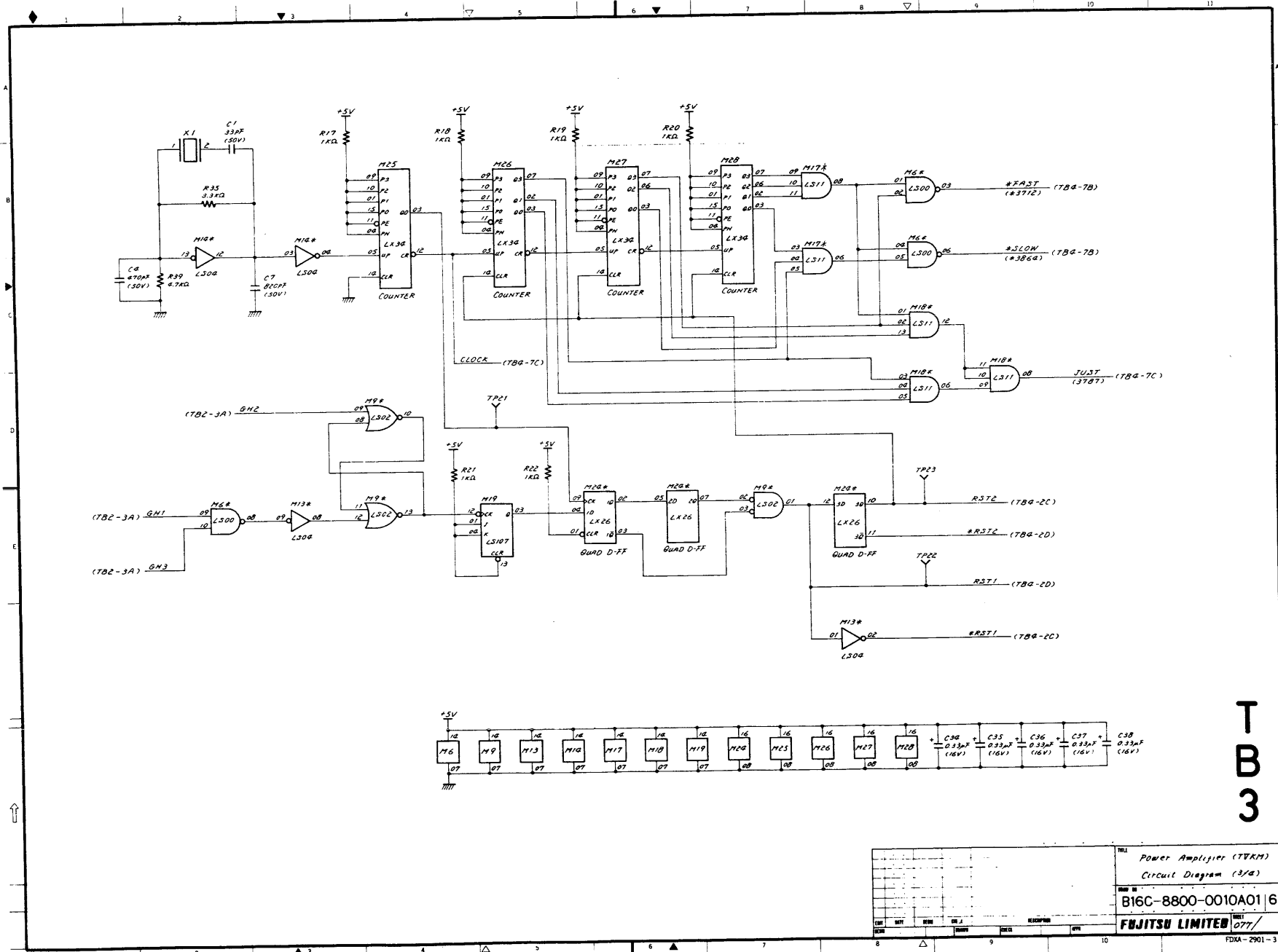



B03P-4655-0001A...E

17-79

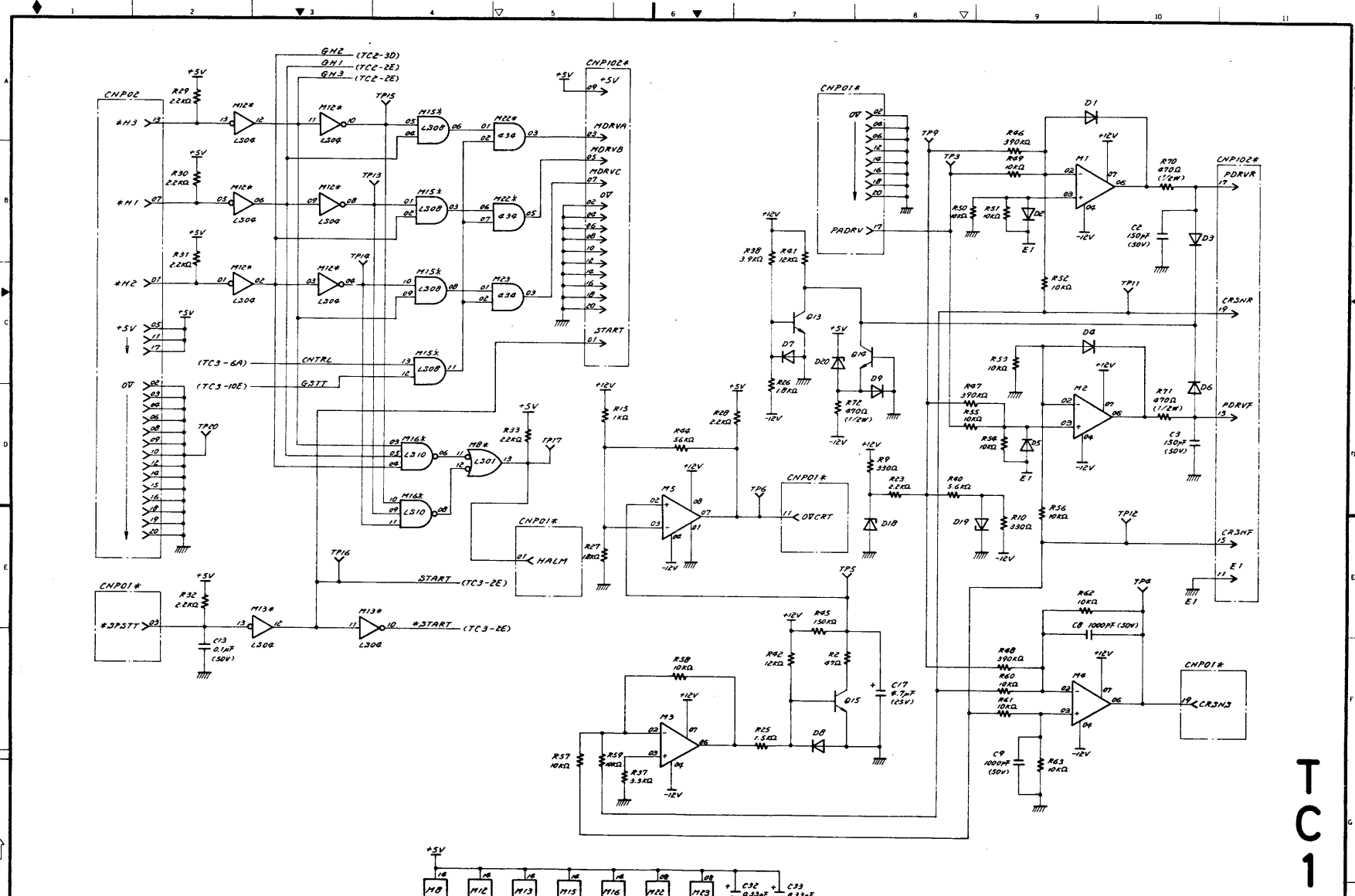

T C 1

Power Amplifier (TFLM)	
Circuit Diagram (1/3)	
B16C-8810-0010A01 6	
FUJITSU LIMITED	

FDA-2901-3



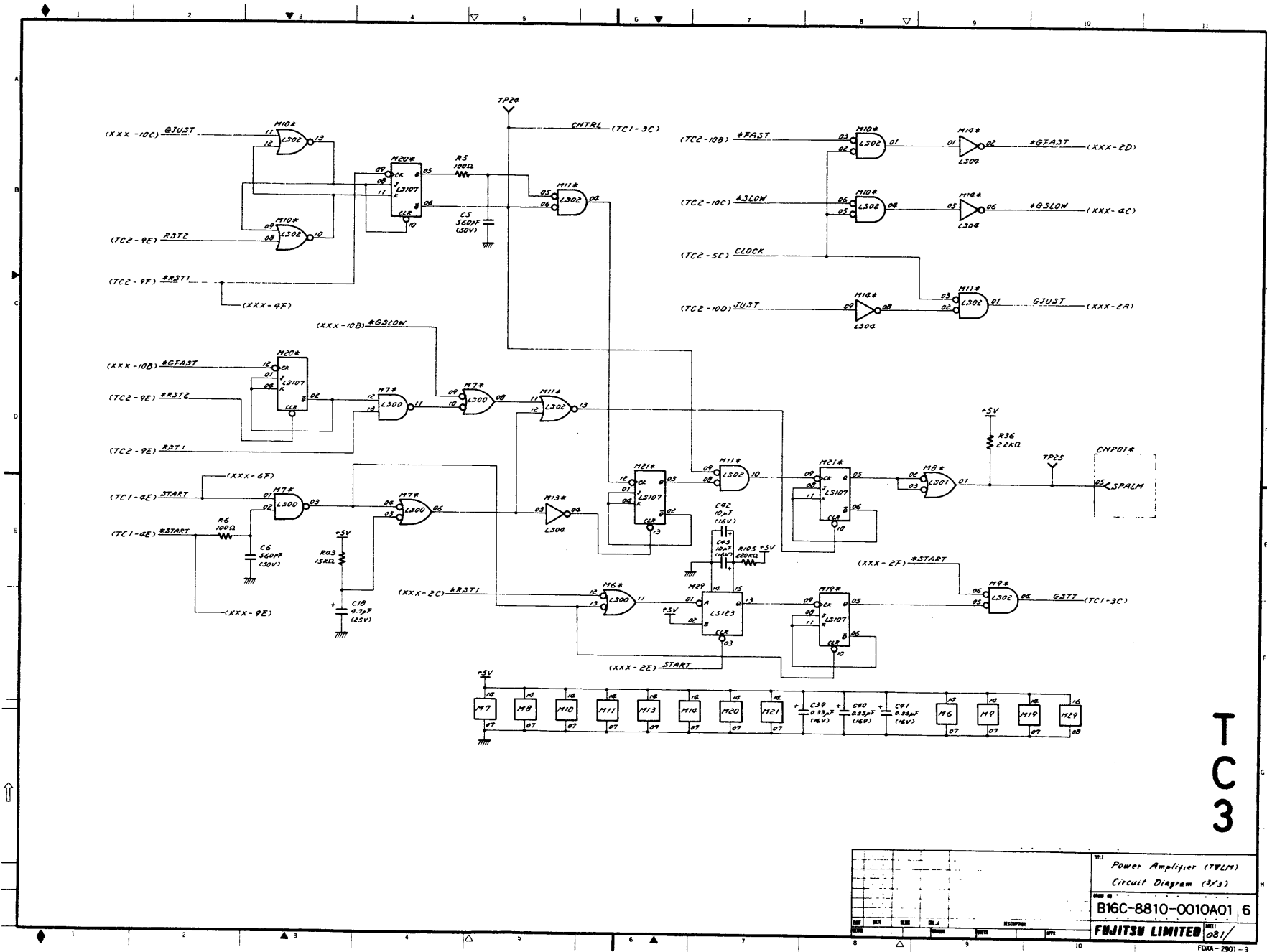

TCC3

Power Amplifier (TWLM) Circuit Diagram (1/3)	
B16C-8810-0010A01 6	
FUJITSU LIMITED	

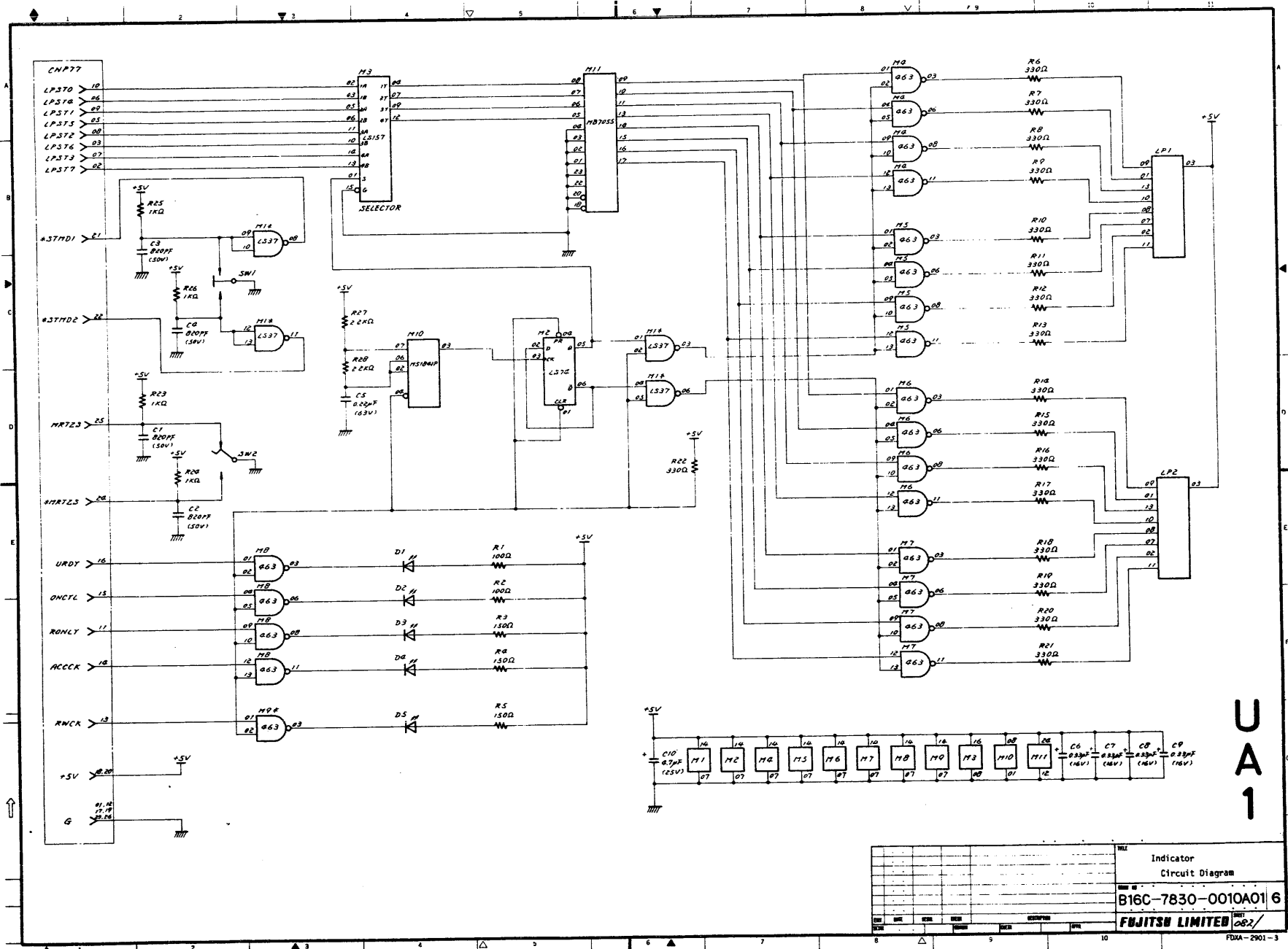

U  
A  
1

Indicator Circuit Diagram					
B16C-7830-0010A016					
FUJITSU LIMITED					



B03P-4655-0001A...E

17-83

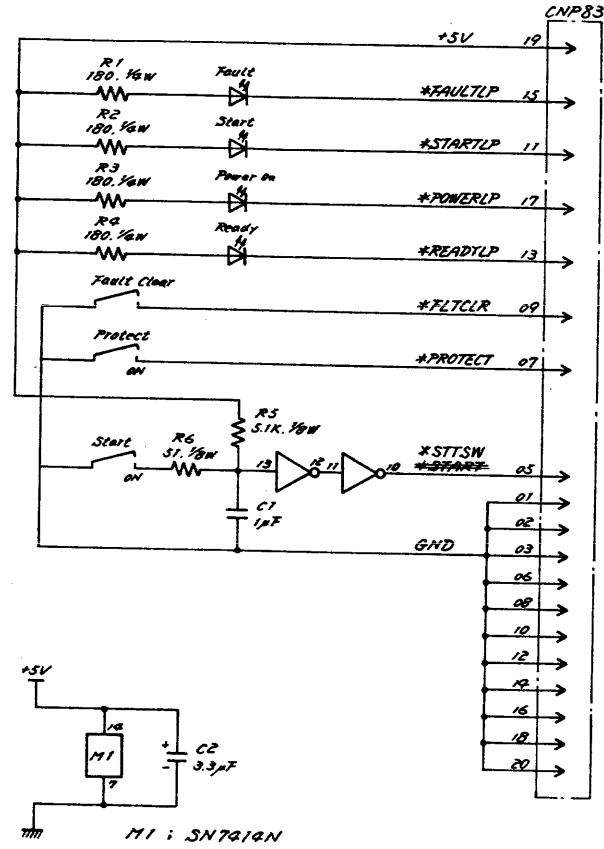

V  
A  
1

				TITLE	
				Operator Panel	
				Circuit Diagram	
				DRAW NO	
				N86C-3346-0001A 6	
REV	DATE	BY	CHKD	DESCRIPTION	APP
FUJITSU LIMITED				SHEET 083/	

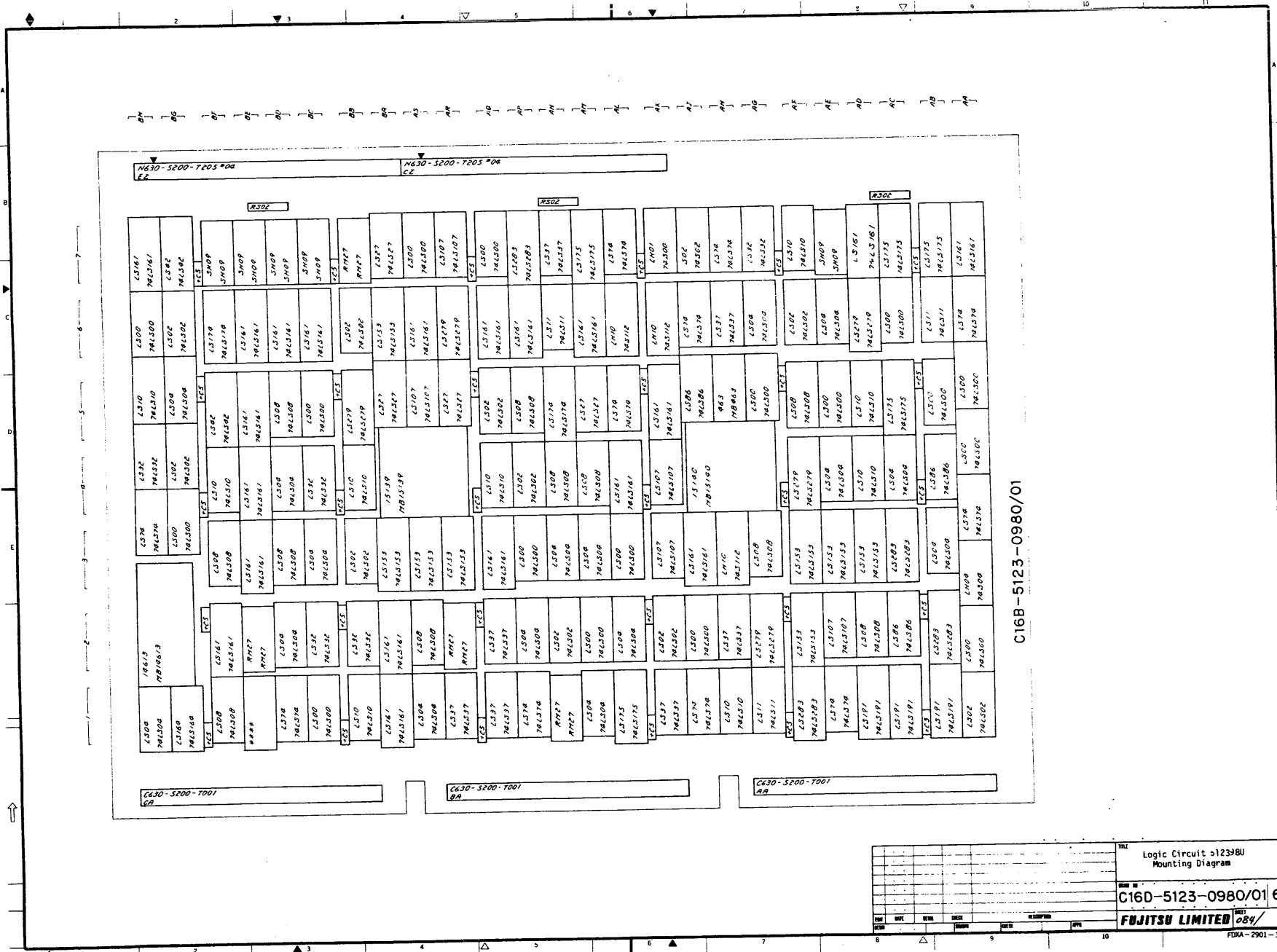

10/0860-1215-B1C

Logic Circuit 51238U Mounting Diagram									
C160-5123-0980/016									
FUJITSU LIMITED									
REV	DATE	BY	CHK	APPROV	DATE	BY	DATE	BY	DATE

B03P-4655-0001A...B

17-85

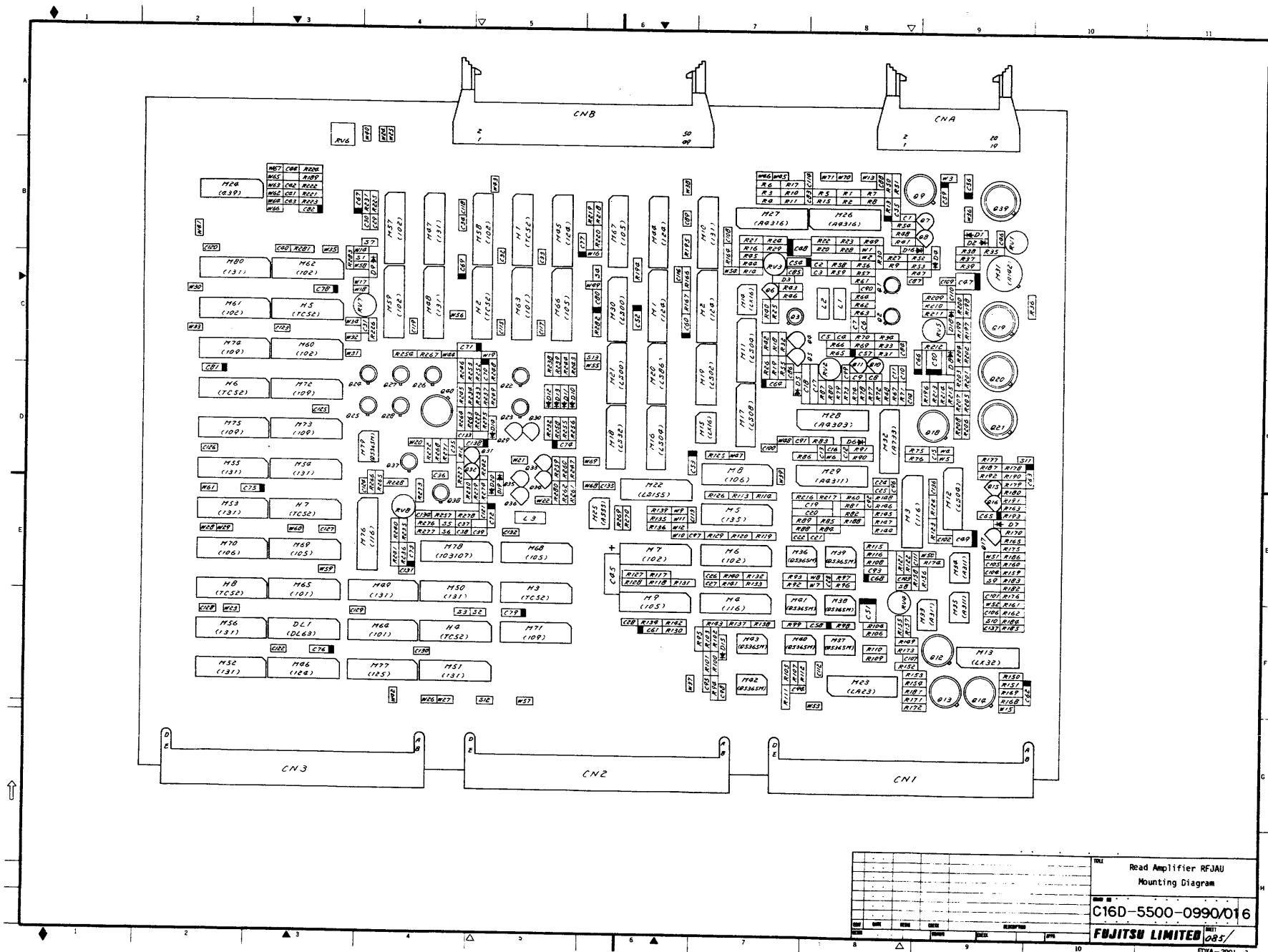

Read Amplifier RFJAU Mounting Diagram			
C16D-5500-0990/016			
FUJITSU LIMITED			
FDXA-2901-3			

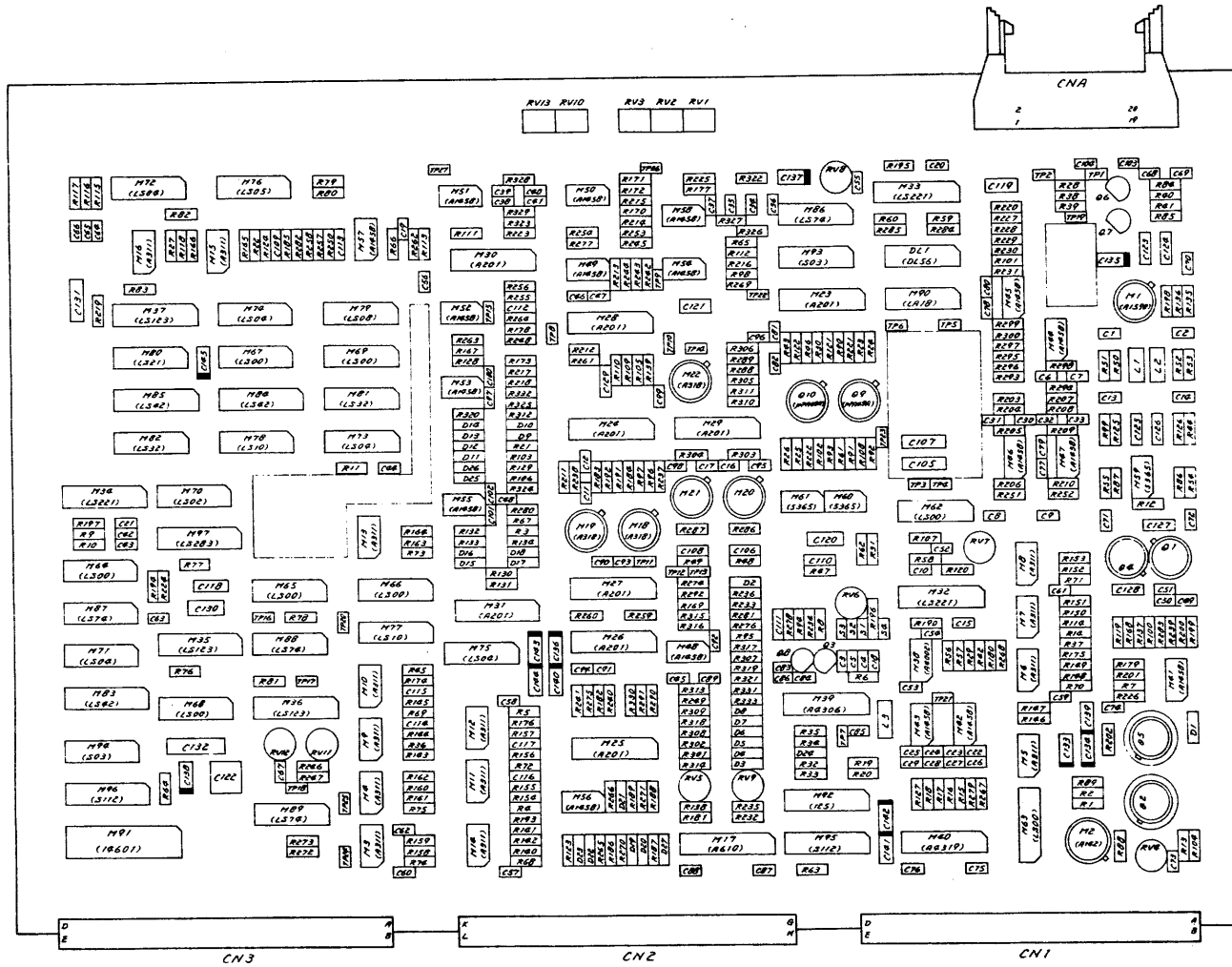

Servo Circuit SV1AU	
Mounting Diagram	
C16D-5501-0010/01 6	
FUJITSU LIMITED 084/	

B03P-4655-0001A...B

I7-87

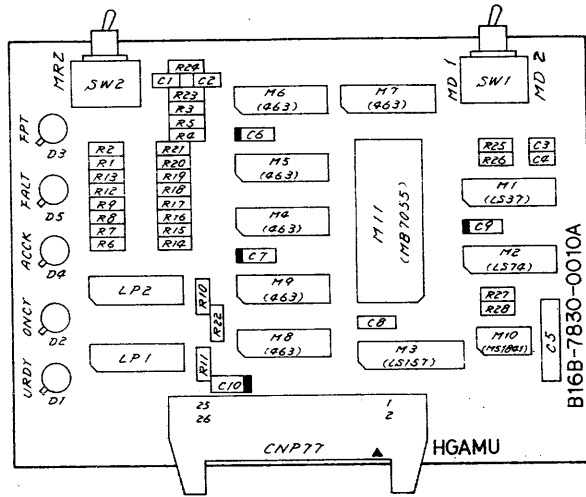

B16B-7830-0010A

					TITLE		Indicator Circuit HGAMU Mounting Diagram	
					DRAWN BY		B16D-7830-0010A01 6	
					CHECKED BY		FUJITSU LIMITED	
					DATE		SHEET 087/	
					REVISION		APPV	



B03P-4655-0001A...B

17-89

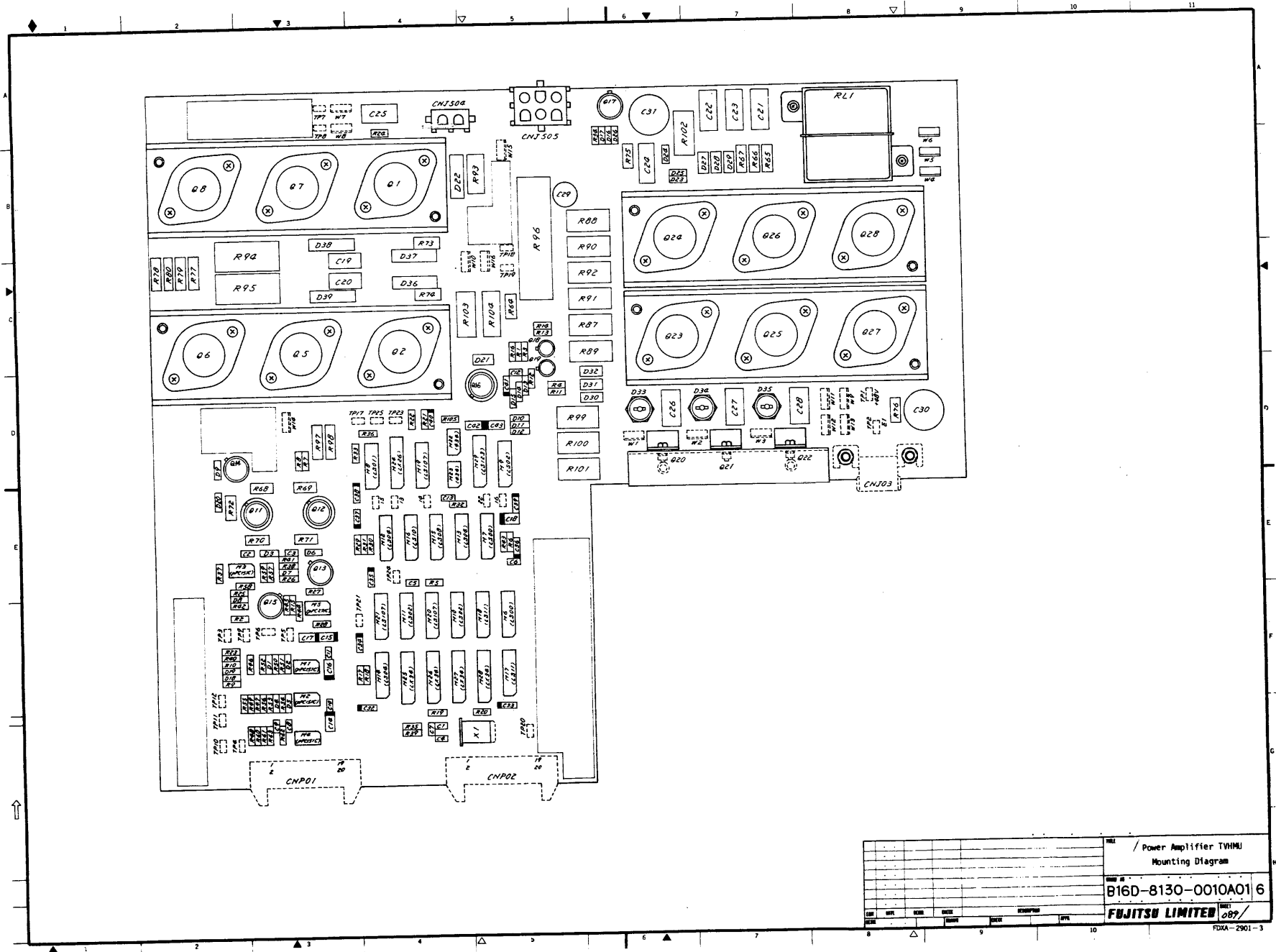

/ Power Amplifier TWHMJ	
Mounting Diagram	
B16D-8130-0010A01 6	
FUJITSU LIMITED	
FDXA-2901-3	

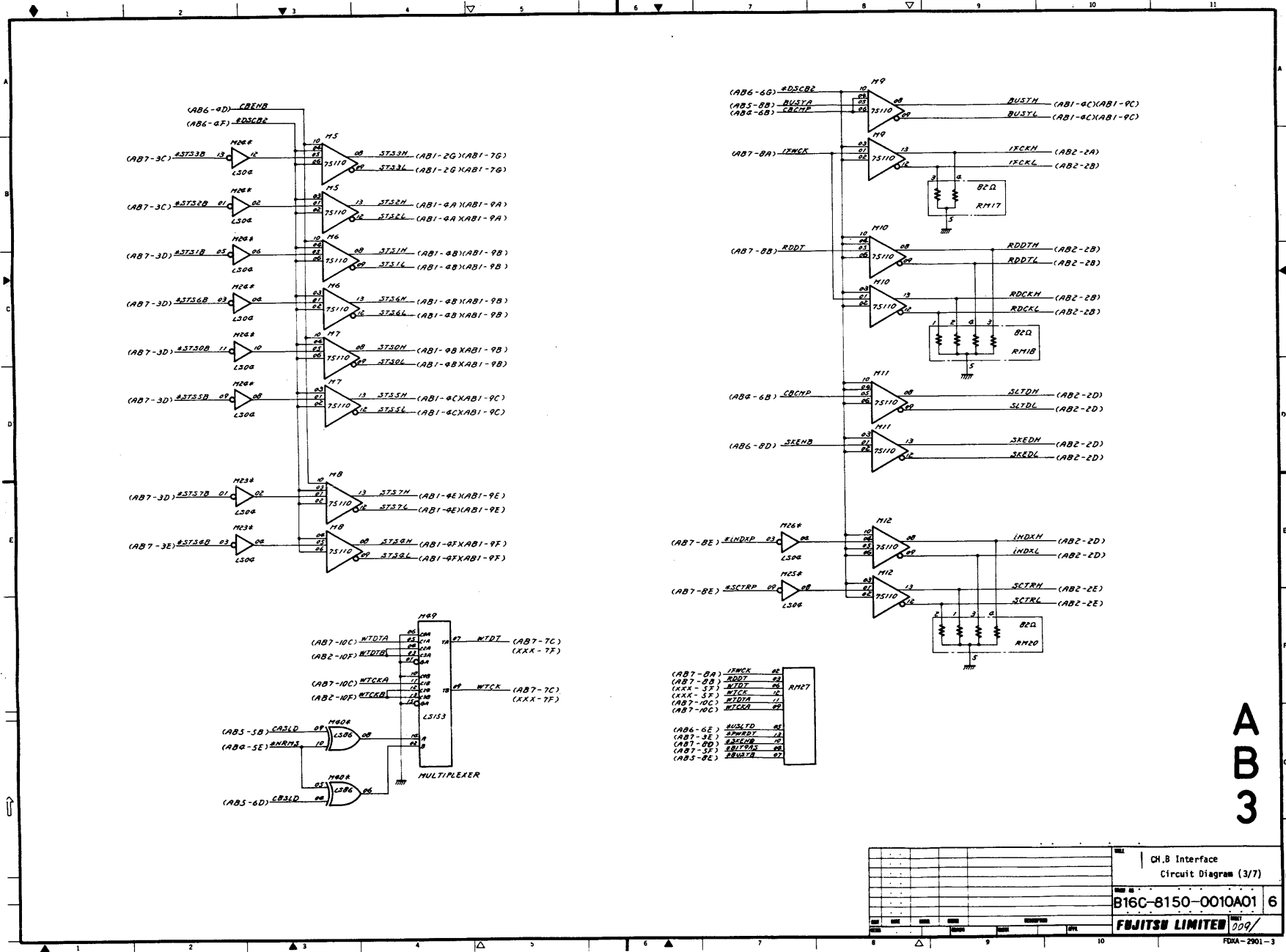

- (A7-0A) JFCK 02
- (A7-0B) RDDT 02
- (XXX-5F) JFCK 02
- (XXX-5F) RDDT 02
- (A7-10C) WDTA 11
- (A7-10C) WDTB 11
- (A7-10C) WDTA 11
- (A7-10C) WDTB 11
- (A6-6E) RUSH 02
- (A7-3E) RDDT 02
- (A7-0B) RDDT 02
- (A7-3E) RDDT 02
- (A7-3E) RDDT 02
- (A7-3E) RDDT 02

**AB3**

CH. B Interface	
Circuit Diagram (3/7)	
B16C-8150-0010A01 6	
FUJITSU LIMITED 009/	



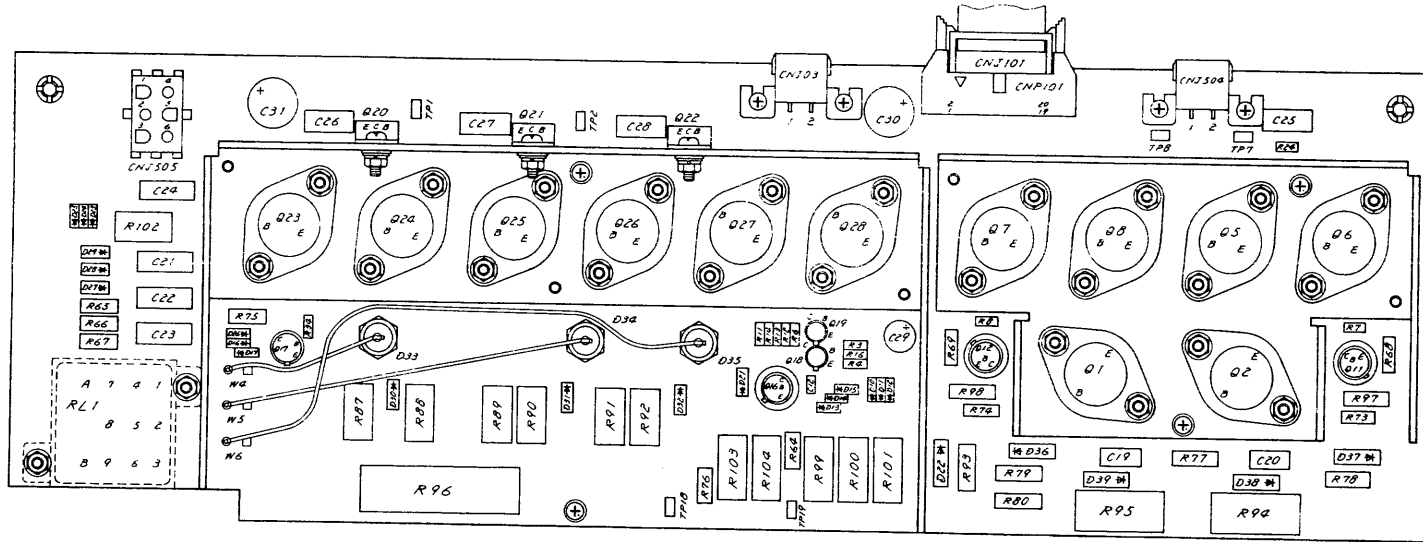
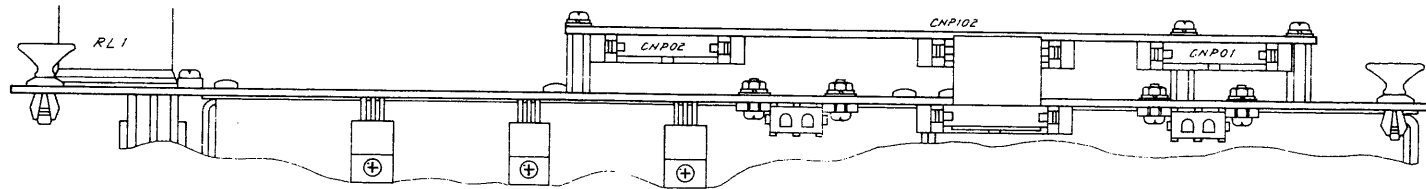

No.	Q11, Q12, Q16	CN107 - 916P10
2	Q20 - Q22	- 916P107
3	W4 - W6	- 251P1
4	TP1, TP2, TP7, TP8, TP9, TP10	- 351P1
5	Q1, Q2, Q3, Q4, Q5, Q6	- 916P103

					Power Amplifier (TXAM)	
					B16D-8800-0010A03 6	
					FUJITSU LIMITED	
					090/	
					FIXA-2901-3	

B03P-4655-0001A...E

I7-91

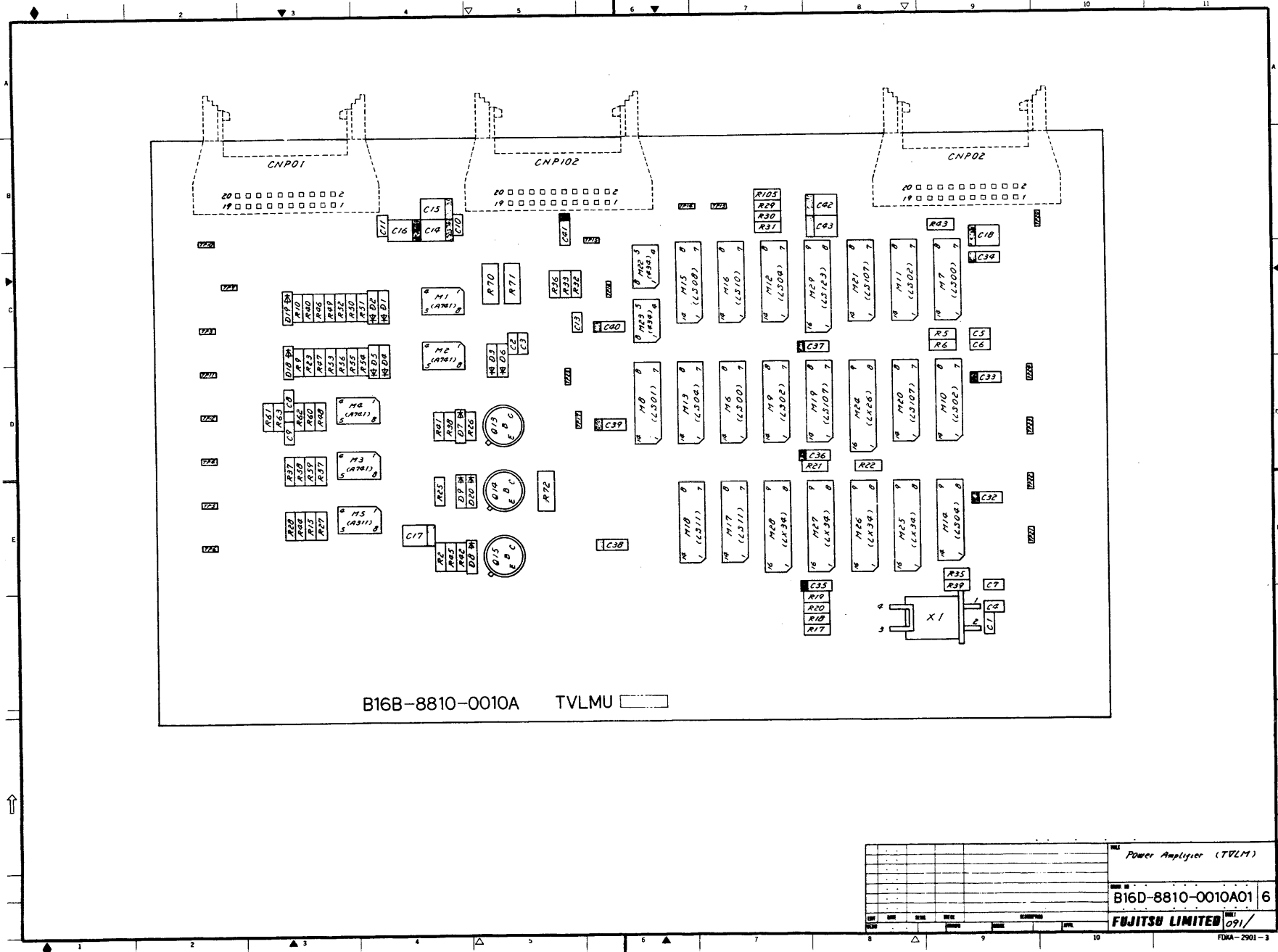

B16B-8810-0010A TVLMU

Power Amplifier (TVLM)	
B16D-8810-0010A01 6	
FUJITSU LIMITED 091/	

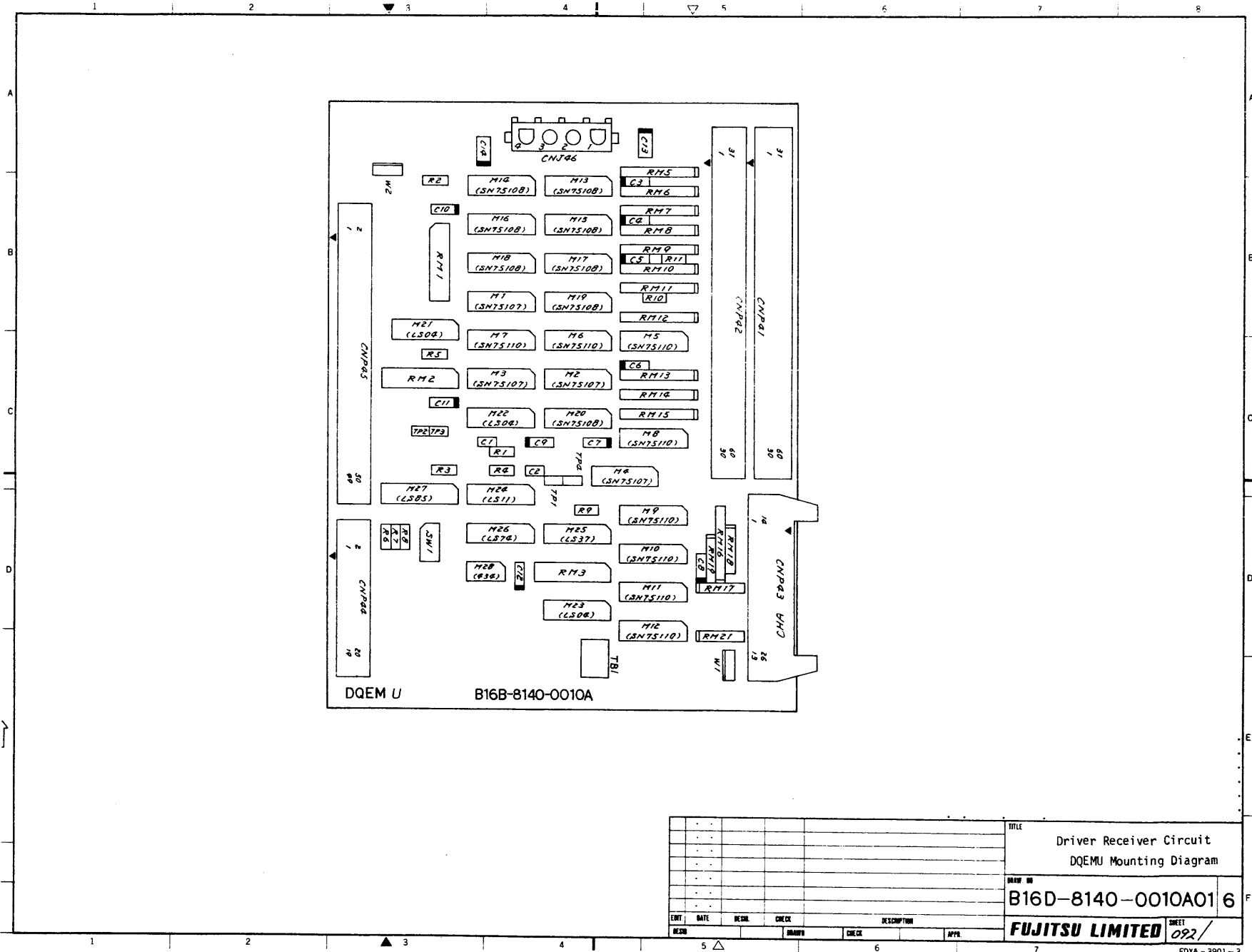

					TITLE	
					Driver Receiver Circuit	
					DQEMU Mounting Diagram	
					DRAWING NO.	
					B16D-8140-0010A01 6	
ENT	DATE	REVIS	CHECK	DESCRIPTION		
RECD					FUJITSU LIMITED SHEET 092/	

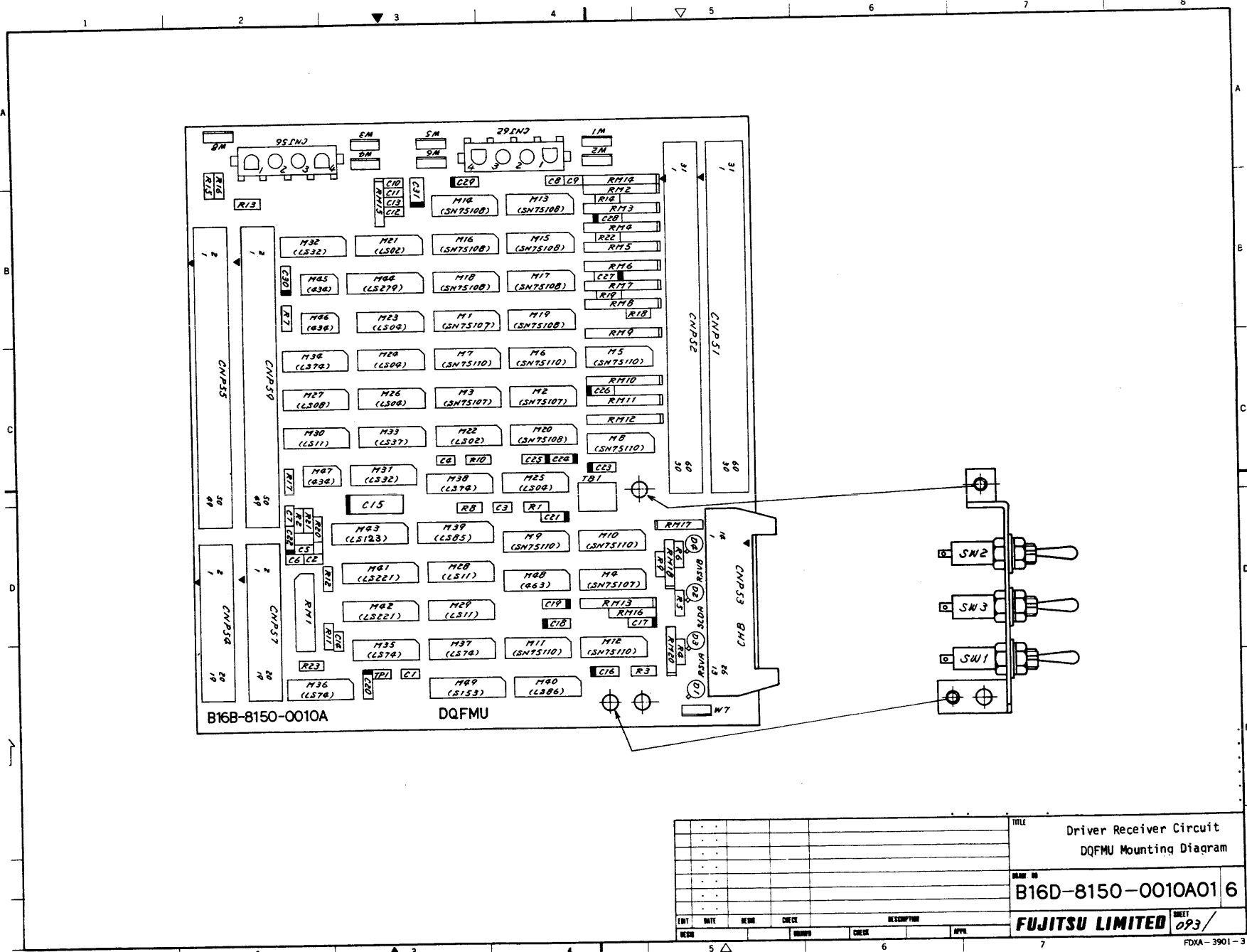

B03P-4655-0001A...B

17-93

						TITLE Driver Receiver Circuit DQFMU Mounting Diagram	
						DRAWING NO. B16D-8150-0010A01 6	
ENT	DATE	REVISION	CHECK	DESCRIPTION	APPROVAL	SHEET 093/	
						FDXA-3901-3	

17.2 ABBREVIATIONS

A	Abbreviation	Full Name
	ABN	Abnormal
	ABSLD	A/B Channel Selected
	ACCCK	Access Check
	ACCEL	Acceleration
	ACCST	Access Start
	ACLMP	Acceleration Clamp
	ACMOD	Access Mode
	ACSTP	Access Start Pulse
	ACTMO	Access Time Out
	AGC	Automatic Gain Control
	AGC-TP	Automatic Gain Control - Test Point
	AGCOT1 ~ AGCOT2	Automatic Gain Control Output 1 ~ 2
	ALWDF	Allow Difference
	AMCTL	Address Mark Control
	AMENB	Address Mark Enable
	AMFD	Address Mark Found
	AMFD3	Address Mark Found 3
	AMGCL	Address Mark Gate Control
	AMRD	Address Mark Read
	AM8BT	Address Mark Round 8-Byte
	ANYRZ	Any Rezero
	ATTEN	Attention
B	BDINS BIBIH BIBIN BITL2 BITO ~ BIT9 BITOA ~ BIT9A BITOB ~ BIT9B BITOH ~ BIT9H BITOL ~ BIT9L BIT9AS BIT9BS BIT9S BTC1 ~ BTC8 BUSY BUSYA/BUSYB BUSYH/BUSYL BYCL	Bad Initial Status Bibration Inhibit " " " Bit Latch 2 Bit 0 ~ 9 Bit 0 ~ 9 (Channel-A) Bit 0 ~ 9 (Channel-B) Bit 0 ~ 9 High Bit 0 ~ 9 Low Bit 9 (Channel-A Priority Select) Bit 9 (Channel-B Priority Select) Bit 9 (Priority Select) Bit Counter 1 ~ 8 Busy Busy (Channel-A/B) Busy High/Low Byte Clock

	Abbreviation	Full Name
C	CACMP CAENB CAPVL CARSV CAR1 ~ CAR2 CASLD CBCMP CBENB CBRSV CBSLD CHPS0 ~ CHPS4 CKGDB CLCK CLOCK CLPOS CL1 ~ CL219 CNCT CNTRL CORSE CRAMP CRSNS CSNSE CTINT CTLCK CTX CTXECL CT1 ~ CT15 CT15P	Channel-A Compare Channel-A Enable Capture Velocity Channel-A Reserved Cylinder Address Register 1 ~ 2 Channel-A Selected Channel-B Compare Channel-B Enable Channel-B Reserved Channel-B Selected Chip Select 0 ~ 4 Check Guard Band Clock Clock Clamped Position Clock Counter 1 ~ 219 Connect Control Coarse Carrier Amp Current Sense Current Sense Counter Initialize Control Check Count X Signal Count X ECL Level Count 1 ~ Count 15 Count 15 Pulse
D	DACA DAMFD DECFR DETMP DFCL DFGT1 ~ DFGT2 DFZR DIECK DIFF DIFF-TP DISAS DISBS DISCA DISCB DLDAM DLDDT DLIW1 ~ DLIW2 DLIXW	Digital to Analog Converter A Delayed Address Mark Found Decrease Frequency DE Timer Pulse Difference Clock Difference Gate 1 ~ 2 Difference Zero Delta I Write Check Differentiator Differentiator - Test Point Disable Channel-A Switch Disable Channel-B Switch Disable Channel-A Disable Channel-B Delayed Address Mark Delayed Data Delta I Write 1 ~ 2 Delayed Index Window

	Abbreviation	Full Name
D	DLMSP DLRGC DLZRX DLZRX-TP DSCA/DSCB DSCA2 DSCB2 DSQCK DSQL1 ~ DSQL4 DTFSC DTFSP DTGT DTGT-TP D1 ~ D512 D1440 D16S	Delayed Moter at Speed Delayed Read Gate Control Delayed Zero Cross Data Delayed Zero Cross Data - Test Point Disable Channel-A/B Disable Channel-A2 Disable Channel-B2 DE Sequence Check DE Sequence Latch 1 ~ 4 Data Fast Sync. Data Fast Sync. Pulse Data Gate Data Gate - Test Point Difference 1 ~ 512 Difference 144 Over Difference 16 or Smaller
E	EDEAT ENBAS ENBBS ENDAC ENDDC EN11S ~ EN60S EQUAL EQULE ERPOS EVEN1 ~ 2 E05MS E5MS	Enable DE Attention Enable Channel-A Switch Enable Channel-B Switch End Accelerate End Decelerate End 11 Seconds ~ End 60 Seconds Equal Equal Error Position Even 1 ~ 2 End 5 Micro-Seconds End 5 Milli-Seconds
F	FAST FAULT FCARO ~ FCAR3 FCLRC FCLRS FG FHDSL FHF FHR31 ~ FHR63 FHS31 ~ FHS95	Fast Fault Fix Cylinder Address Register 0 ~ 3 Fault Clear Command Fault Clear Switch Function Generator Fixed Head Select Fixed Head Feature Fixed Head Register 31 ~ 63 Fixed Head Select 31 ~ 95

	Abbreviation	Full Name
F	FHTG1 FLCLR FLCRS FLSQ FLTLP FLTSQ FNPOS FNVEL FPT FPTSW FSECL FSYNC FTCLR FXHSL	Fixed Heat Tag 1 Fault Clear Fault Clear Switch Filter Squelch Fault Lamp Filter Squelch Fine Position Fine Velocity File Protect Switch File Protect Switch Fast Synchronization ECL Fast Synchronization Fault Clear Fixed Head Select
G	GANGH GATE1 ~ GATE4 GATRT GBP1 ~ GBP2 GDIW1 GDSK3 GD1 ~ GD128 GENAC GFAST GHCMP GHRZ GH1 ~ GH3 GINDX GJUST GLNMD GONL GPAT GRDBL GRDNP GSLOW GSTT GST3 GSYNC GTAG1 ~ GTAG5 GTKXP G1440	Gated Any Go Home Gate 1 ~ Gate 4 Gate Attention Reset Guard Band Pattern 1 ~ 2 Gated I Write 1 Gated Difference Seek 3 Gated Difference 1 ~ 128 Gated End Accelerate Gated Fast Go Home Complete Go Home or Rezero Gated Hall Element 1 ~ 3 Gated Index Gated Just Gated Linear Mode Gated On Line Gated Pattern Guard Band Latch Gated Read Down Pulse Gated Slow Gated Start Gated State 3 Gated Synchronous Pulse Gated Tag 1 ~ 5 Gated Track Crossing Pulse Gated Difference 144 Over



	Abbreviation	Full Name
H	HALRM HARI ~ HAR16 HAL ~ HA16 HBYCL HDGAN HDGAN-TP HDSHT HDSL1 ~ HDSL2 HOLD HOLDB HSHCK HSPIN HSPOT HVLST H1 ~ H3	Hall Alarm Head Address Register 1 ~ 16 Head Address 1 ~ 16 Half Byte Clock Head Gain Head Gain-Test Point Head Short Head Select 1 ~ 2 Hold Hold Channel-B Head Short Check High Speed In High Speed Out High Velocity Set Hall Element 1 ~ 3
I	IDXCK IHRSV IHTAG INCFR INDSQ INDXG INDXH/INDXL INDXP INENB INHRC INHSQ INLFS INN INSTG INTEG IS1 ~ IS128 IXCKG IXCKL IXMRK IXW	Index Check Inhibit Reserve Inhibit Tags 4 and 5 Increase Frequency Inhibit DE Sequence Index Gate Index High/Low Index Pulse Inner Enable Inhibit Recycle Inhibit Sequencer Initial Fast Sync Inner Initial State Good Integrated Position Index Sector Counter 1 ~ 128 Index Check Gate Index Check Latch Index Mark Index Window
J	JUST	Just

	Abbreviation	Full Name
L	LDBYT LDDT LNML LNMOD LPST0 ~ LPST7 LSPIN LSPOT LTSVC	Load Byte Load Data Linear Mode Latch Linear Mode Lamp Status 0 ~ 7 Low Speed In Low Speed Out Lock to Servo Clock
M	MARSV MCLMP MCPCK MCPSL MLEVL MM MM-TP MRTZL MRTZS MS4V MTRSP MUSFM MUSFV MUSFX MVHSL MVINN MVOTG MVOU M12V M25M M3M M4VDE M5MS	MARS Voltage Minus Clamp Multi Chip Check Multi Chip Select Minus Level Mono-Stable Multivibrator Mono-stable Multivibrator - Test Point Manual Rezero Latch Manual Rezero Switch -4V Motor at Speed MARS Unsafe Movable Head MARS Unsafe Voltage MARS Unsafe Fixed Head Movable Head Select Move Inner Move Out Gate Move Outer -12V Mono-Stable 2.5 Milli-Second Mono-Stable 3 Milli-Second -4V DE Mono-Stable 5 Milli-Second
N	N-Q N+Q>0 NC1 ~ NC512 NGT NOTCH NRMS NSQCH NSQHG	Normal Minus Quadrature Normal Plus Quadrature Greater Than Zero New Cylinder Address Register 1 ~ 512 Noise Gate Notch Filter Normal Switch Not Squelch Not Squelch Gate

	Abbreviation	Full Name
O	OCDTA/OCDTB OCDTH/OCDTL OCTCK ODD1 ~ 2 OFACT OFCMD OFSET OFINT OFOUT OFTRK ONCYL ONL ONTRK OSC OTENB OVCRT OVCY OVSK OVSGB	Open Cable Detect Channel-A/B Open Cable Detect High/Low Over Cylinder and Control Check Odd 1 ~ 2 Offset Active Offset Command Offset Offset Interrupt Offset Out Off Track On Cylinder On Line On Track Oscillator Out Enable Over Current Over Cylinder Over-Shoot Check Over-Shoot Guard Band
P	PADRV PCLMP PC1 ~ PC512 PICIN PICINB PICOT PLEVEL PLOAN PLO1F POSER POSN POSQ POTRL PRTCT PS6V PWORS PWRDY PWRLP PWRST P12V P5V P5VFX P6VMV	Power Amp. Drive Plus Clamp Physical Cylinder Address Register 1 ~ 512 Pic-In Pic-In Channel-B Pic-Out Plus Level PLO Analog PLO 1F Position Error Position Normal Position Quadrature Pick Out Relay Protect +6V Power On Reset Power Ready Power Lamp Power On Reset +12V +5V +5V for Fixed Heads +6V for Movable Heads

R	Abbreviation	Full Name
	RAWDT	Raw Read Data
	RAW2FA/RAW2FB	Raw 2F A/B
	RD	Read
	RDCKH/RDCKL	Read Clock High/Low
	RDDGT	Read Data Gate
	RDDT	Read Data
	RDDTA	Read Data
	RDDTA-TP	Read Data - Test Point
	RDDTFX	Read Data Fixed Head
	RDDTG	Read Data Gate
	RDDTH/RDDTL	Read Data High/Low
	RDDTMV	Read Data Movable Head
	RDWT	Read/Write
	RDYLP	Ready Lamp
	REGRT	Register Reset
	RGCTL	Read Gate Control
	RGDNP	Read Gate Down Pulse
	RGUPP	Read Gate Up Pulse
	RNTMG	Run Timer Gate
	RNTMR	Run Timer
	RONLY	Read Only
	RRSVA/RRSVB	Reset Reserve Channel A/B
	RSKEN	Reset Seek End
	RSSCT	Reset Index Sector Counter
	RST	Reset
	RSTMS	Release Timer Switch
	RSTSC	Reset Sector Counter
	RST1 ~ 2	Reset 1 ~ 2
	RTBTC	Reset Bit Counter
	RTFTM	Reset Track Following Timer
	RTGDB	Reset Guard Band
	RTZMD	Rezero Mode
	RWCAP	Read/Write Capable
	RWDTF	Read/Write Data for Movable Head
	RWDTFX	Read/Write Data for Fixed Head
	RWDTM	Read/Write Data for Movable Head
	RWDTMV	Read/Write Data for Movable Head
	RZGH	Rezero or Go Home
	RZML	Rezero Mode Latch
	RZMOD	Rezero Mode
	RZOUT	Rezero Out
	RZRCM	Rezero Command
	RZRST	Rezero Start

S	Abbreviation	Full Name
	SAGC	Servo AGC
	SCMPA/SCMPB	Selecte Compare Channel-A/B
	SCTCL	Sector Clock
	SCTLX	Sector Index
	SCTP	Sector Pulse
	SCTRH/SCTRL	Sector High/Low
	SCTRP	Sector Pulse
	SC1 ~ SC128	Sector Counter 1 ~ 128
	SDF16	Seek Difference 16
	SHORT	Short
	SKEDA/SKEDB	Seek End Channel-A/B
	SKEDH/SKEDL	Seek End High/Low
	SKENA/SKENB	Seek End Channel-A/B
	SKEND	Seek End
	SKINH	Seek Inhibit
	SLCTD	Selected
	SLIW	Select I Write
	SLOW	Slow
	SLTDH/SLTDL	Selected High/Low
	SMOTH	Smoother
	SNI	Select Normal Invert
	SNN	Select Normal Non-Invert
	SOFCK	Servo Offtrack Check
	SOFST	Set Servo Offset
	SOSCK	Set Over-Shoot Check
	SPALM	Speed Alarm
	SPR	Spare
	SPSTT	Spindle Start
	SQI	Select Quadrature Invert
	SQN	Select Quadrature Non-Invert
	SQRZR	Sequence Rezero
	SRVL	Servo Latch
	SRO ~ SR3	Shift Register 0 ~ 3
	SST	Seek Start
	START	Start
	STMD1 ~ 2	Status Mode 1 ~ 2
	STRSW	Start Switch
	STRTL	Start Latch
	STRZ	Start Rezero
	STSOF	Set Servo Offtrack Check
	STS0 ~ STS7	Status 0 ~ 7
	STSOB ~ STS7B	Status 0 ~ 7 Channel B
	STSOH ~ STS7H	Status 0 ~ 7 High
	STSOL ~ STS7L	Status 0 ~ 7 Low
	STTLP	Start Lamp
	STTMR	Start Timer
	STTOK	Start OK
	STTRL	Start Relay
	STTSW	Start Switch
	STUSO	Status 0
	STWAT	Set Wait
	SVLVL	Servo Level

	Abbreviation	Full Name
S	SVM DG SVM DP SVM OD SVO FT SVP RE SYN CG SYS RZ S1 ~ S16384	Servo Mode Gate Servo Mode Pulse Servo Mode Servo Off-Track Servo Pre-Amp. Sync. Gate System Rezero Sector Switch 1 ~ 16384
T	TAG1 ~ TAG5 TAG1A ~ TAG5A TAG1B ~ TAG5B TAG1C TAG1H ~ TAG5H TAG1L ~ TAG5L TFTMR TIEDN TIEUP TIEUP1 ~ 2 TKXGP TKXNG TMGT TMOCK TMOFF TMON TMOTL TMOUT TRMWD TRSCK TRWD T3M T5MS	Tag 1 ~ 5 Tag 1 ~ 5 Channel-A Tag 1 ~ 5 Channel-B Tag 1 C Tag 1 ~ 5 High Tag 1 ~ 5 Low Track Following Timer Tie-Down Tie-Up Tie-Up 1 ~ 2 Track Crossing Pulse Track Crossing Timer Gate Time Out Check Timer Off Timer On Time Out Latch Time Out Transmit Write Data Transition Check Transmit Write Data Trigger 3 Milli-Second Trigger 5 Milli-Second
U	UAD1 ~ UAD4 USLTD USL1A ~ USL4A USL1B ~ USL4B USL1H ~ USL4H USL1L ~ USL4L USTGA/USTGB USTGH/USTGL	Unit Address 1 ~ 4 Unit Selected Unit Select Bit 1 ~ 4 Channel-A Unit Select Bit 1 ~ 4 Channel-B Unit Select Bit 1 ~ 4 High Unit Select Bit 1 ~ 4 Low Unit Select Tag Channel A/B Unit Select Tag High/Low

	Abbreviation	Full Name
V	VCMA/VCMB VCOC1 ~ VCOC4 VC01F/VC02F VCX VCX-TP VC01/VC02 VFOFS VFO1F VFO1S VFS VG20I VLERR VLGDA VLIX1 VLSIT VLTU	Voice Coil Motor A/B VCO Counter 1 ~ 4 VCO 1F/2F Voltage Control Signal Voltage Control Signal - Test Point Voltage Controlled Oscillator 1/2 VFO Fast Sync VFO 1F VFO 1 Shifted Clock VFO Fast Velocity Greater Than 20 Inch/Sec Velocity Error Velocity Guide Valid Index 1 Velocity Velocity
W	WATL WATST WDATA WDATA-TP WGCTL WGSL WIRCK WSLFX WSLMV WT WTCA/WTCB WTCK WTCKA/WTCKB WTCKH/WTCKL WTCL WTCR WTCRF WTCRM WTDI WDTA/WDTB WTDTH/WDTL	Wait Latch Wait Set Write Data Write Data - Test Point Write Gate Control Write Gate Selected Write Current On Read Check Write Select Fixed Head Write Select Movable Head Write Write Clock Channel-A/B Write Clock Write Clock Channel-A/B Write Clock High/Low Write Clock Write Current Write Current Fixed Head Write Current Movable Head Write Data Write Data Channel-A/B Write Data High/Low

	Abbreviation	Full Name
Z	ZRACM ZRMOD ZRX ZRX-TP 1 ~ 16384 1FCKH/1FCKL 1FMCL 1FWCK 1FWCL 1FWWD 11S60 2FEY1/2FEY2 2FLT 2FMCL 2FOT 2FRDCL	Difference Zero Access Mode Zero Mode Zero Cross Data Zero Cross - Test Point Sector Switch Input 1 ~ 16384 1F Write Clock High/Low 1F Main Clock 1F Write Clock 1F Write Clock 1F Write Clock 1F Write Window 11 Second or 60 Second 2F Early Clock 1/2 2F Late Clock 2F Main Clock 2F On Time Clock 2F Read Clock
	-S4V -S4VRTN - VLTY  -4VDE -5.2V-TP -5.2VE +S6V +S6VRTN +48VRTN +5VFX +6VE +6VFX +6VMV	Servo -4 Volt Servo -4 Volt Return Negated Absolute Velocity -4 Volt to DE -5.2 Volt - Test Point -5.2 Volt Servo +6 Volt Servo +6 Volt Return +48 Volt Return +5 Volt to Fixed Head +6 Volt +6 Volt to Fixed Head +6 Volt to Movable Head







Fold



No Postage  
Necessary  
If Mailed  
in the  
United States

**BUSINESS REPLY MAIL**

First Class

Permit # 7446

San Jose

Postage will be paid by Addressee

**FUJITSU AMERICA, INC.**  
**Storage Products Division**  
**Technical Support Dept.**  
**3055 Orchard Dr.**  
**San Jose, CA 95134**

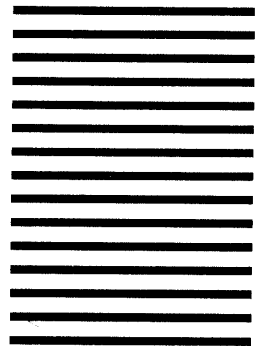

Fold