

M2301B/M2302B

**Microdisk Drives  
CE Manual**



REVISION RECORD		
REVISION	DATE	DESCRIPTION
A	6-24-80	First Edition
B	2-10-81	Manual updated on pages 3-14, 3-15, 3-16 and 3-17 and editorial changes.
C	4-30-81	Manual updated with editorial changes.
SPECIFICATION NO.: B03P-4605-0003A		

REVISION LETTERS I, O, Q, U AND X ARE NOT USED

Date; Month, Day, Year

© Copyright 1980  
by Fujitsu Limited.  
Printed in the U.S.A.

Address comments concerning this manual to:

FUJITSU LIMITED

Computer Systems Marketing,

North America and QEM,

6-1 Marunouchi 2-chome, Chiyoda-ku, Tokyo 100, Japan

TEL : 03-216-3211

TLX : J22833

Cable : "FUJITSULIMITED TOKYO"

or

FUJITSU AMERICA INC.

2945 Oakmead Village Court, Santa Clara, California 95051, U.S.A.

TEL : (408) 727-4300

TLX : 171182

TWX : 910-338-0047



**LIST OF EFFECTIVE PAGES**

PAGE	REV	PAGE	REV	PAGE	REV
Cover	—	4-6	C	6-1	C
i	C	4-7	B	6-2	C
Blank	—	4-8	C	6-3	C
iii	C	4-9	C	6-4	C
Blank	—	4-10	C	6-5	C
v	B	4-11	C	Blank	—
Blank	—	4-12	C	S-7	A
vii	C	4-13	C	Blank	B
viii	C	4-14	C	7-1	C
ix	C	4-15	C	Blank	—
x	C	4-16	C	S-8	A
xi	B	4-17	C	Blank	—
xii	C	4-18	C	8-1	A
S-1	A	4-19	C	8-2	A
Blank	—	4-20	C	8-3	B
1-1	C	4-21	C	8-4	C
1-2	B	4-22	B	8-5	C
1-3	C	4-23	B	8-6	C
1-4	C	4-24	B	8-7	C
1-5	B	4-25	C	Blank	—
1-6	C	4-26	B	S-9	A
1-7	B	4-27	C	Blank	—
1-8	B	4-28	C	9-1	C
S-2	A	4-29	B	9-2	B
Blank	—	4-30	A	9-3	B
2-1	C	4-31	A	9-4	B
Blank	—	4-32	B	9-5	C
S-3	A	4-33	B	Blank	—
Blank	—	4-34	C	S-10	A
3-1	C	4-35	C	Blank	—
3-2	B	4-36	C	10-1	B
3-3	C	4-37	B	10-2	B
3-4	C	4-38	C	10-3	B
3-5	C	4-39	B	10-4	B
3-6	C	4-40	C	10-5	B
3-7	C	4-41	C	10-6	B
3-8	C	4-42	C	10-7	B
3-9	C	4-43	C	10-8	B
3-10	C	4-44	C	10-9	C
3-11	C	4-45	B	10-10	B
3-12	B	4-46	A	10-11	B
3-13	C	4-47	A	10-12	C
3-14	C	4-48	C	10-13	B
3-15	C	4-49	A	10-14	C
3-16	C	4-50	B	10-15	B
3-17	B	4-51	B	Blank	—
Blank	—	Blank	—	Cover	—
S-4	A	S-5	A		
Blank	—	Blank	—		
4-1	C	5-1	C		
4-2	B	5-2	C		
4-3	C	5-3	C		
4-4	C	Blank	—		
4-5	B	S-6	A		
		Blank	—		

Note 1. A revision of each page is indicated by the Revision Letter with the specification number of this manual in the bottom of the page.

Note 2. A bar by the page number in this page indicates pagination rather than content has changed.



# Preface

This manual is for customer engineers who handle M2301B/M2302B MICRO-DISK DRIVES. It describes how to operate, handle and maintain the equipment.

This manual consists of the following ten sections.

- Section 1:** General Description
- Section 2:** Operation
- Section 3:** Installation and Checkout
- Section 4:** Theory of Operation
- Section 5:** Troubleshooting
- Section 6:** Maintenance
- Section 7:** Spare Parts
- Section 8:** IC Detail
- Section 9:** Parts List
- Section 10:** Schematics

Fujitsu Ltd.



# Table of Contents

	Page
<b>1. GENERAL DESCRIPTION</b>	1-1
<b>1.1 GENERAL</b>	1-1
1.1.1 General	1-1
1.1.2 Features	1-1
<b>1.2 SPECIFICATIONS</b>	1-2
1.2.1 Environmental Condition of Installation Site	1-2
1.2.2 Power Source Specifications	1-3
1.2.3 Performance	1-6
1.2.4 Reliability	1-7
<b>1.3 EXTERNAL APPEARANCE</b>	1-8
<b>2. OPERATION</b>	2-1
<b>2.1 GENERAL</b>	2-1
<b>2.2 POWER ON/OFF SEQUENCE</b>	2-1
<b>3. INSTALLATION AND CHECKOUT</b>	3-1
<b>3.1 GENERAL</b>	3-1
<b>3.2 UNPACKING</b>	3-1
<b>3.3 VISUAL INSPECTION</b>	3-1
<b>3.4 MOUNTING</b>	3-3
3.4.1 Installation in Locker	3-3
3.4.2 Securing for Transportation	3-4
3.4.3 Service Area	3-5
<b>3.5 CABLES</b>	3-6
3.5.1 Cable and Connector Specifications	3-6
3.5.2 Cable Connections	3-7
<b>3.6 SWITCH ARRANGEMENT</b>	3-9
3.6.1 Drive Select (Device Number Selection)	3-9
3.6.2 Seek Complete	3-9
3.6.3 Sector/Byte Clock	3-10
3.6.4 Sector During the Generation of Index	3-10
3.6.5 Write/Read Data, Write/PLO Clock	3-11
3.6.6 Assigning the Number of Sectors	3-11
3.6.7 Delay SKC	3-13
3.6.8 Controlling the Basic Drive Select Signals	3-14
3.6.9 Timing Margin Measurement Switch	3-14
3.6.10 Input Negative Voltage Selection	3-14
3.6.11 Timing Specification Selection	3-15
3.6.12 Media Error	3-16
<b>4. THEORY OF OPERATION</b>	4-1
<b>4.1 GENERAL</b>	4-1
<b>4.2 OPERATION OF MECHANICAL PORTION</b>	4-1
4.2.1 Disk Enclosure	4-1
4.2.2 Spindle	4-2
4.2.3 Carriage Assembly	4-3
4.2.4 Air Circulation in DE	4-4
<b>4.3 MAGNETIC HEADS AND RECORDING MEDIA</b>	4-5
4.3.1 Magnetic Heads	4-5
4.3.2 Recording Media (Magnetic Disk)	4-6
4.3.3 Head and Surface Configuration	4-6



	Page
4.3.4 Clock Track Format .....	4-6
4.4 FORMAT .....	4-8
4.4.1 General .....	4-8
4.4.2 Track Format .....	4-8
4.4.3 Detail of The Format .....	4-8
4.5 INTERFACE .....	4-9
4.5.1 General .....	4-9
4.5.2 Type and Name of Signal Lines .....	4-10
4.5.3 Signal Lines .....	4-11
4.5.4 Timing Specifications .....	4-14
4.5.5 Format Timing Specifications .....	4-16
4.5.6 Driver/Receiver .....	4-17
4.5.7 Pin Assignment in Connectors .....	4-17
4.6 ELECTRIC CIRCUIT OPERATION .....	4-18
4.6.1 Block Diagram .....	4-18
4.6.2 Start/Stop Circuit .....	4-18
4.6.3 DC Spindle Motor Driving Circuit .....	4-21
4.6.4 DC Spindle Motor Controller .....	4-21
4.6.5 Unit Select Operation .....	4-21
4.6.6 SEEK Control .....	4-27
4.6.7 Stepper Driving Circuit .....	4-35
4.6.8 Index and Sector Generation Circuit .....	4-39
4.6.9 Read/Write Circuit .....	4-42
5. TROUBLESHOOTING .....	5-1
6. MAINTENANCE .....	6-1
6.1 GENERAL .....	6-1
6.2 CHECK OF THE CONTROL CIRCUIT .....	6-1
6.2.1 General .....	6-1
6.2.2 Confirming the Switch Settings .....	6-1
6.2.3 Check of Standard Frequency Oscillator .....	6-1
6.2.4 Check of Clock Signal .....	6-2
6.2.5 Inspection of PLO Circuit .....	6-2
6.2.6 Check of Index and Sector .....	6-3
6.2.7 Inspection of VFO Circuit .....	6-3
6.2.8 Observation of the Read Waveform .....	6-4
6.2.9 Check of the Settling Waveform after Seeking .....	6-5
7. SPARE PARTS .....	7-1
8. IC DETAIL .....	8-1
8.1 OUTLINE .....	8-1
8.2 LOGIC CONVENTION AND SYMBOLOGY .....	8-1
8.2.1 TTL Logic .....	8-1
8.2.2 ECL Logic .....	8-3
8.2.3 Logic Symbology .....	8-3
8.3 IC CROSS REFERENCE GUIDE .....	8-4
8.4 IC INTERCHANGEABILITY .....	8-6
8.4.1 TTL IC Interchangeability .....	8-6
8.4.2 ECL .....	8-7
8.4.3 LINEAR IC .....	8-7
8.4.4 C MOS .....	8-7
8.4.5 FUJITSU ANALOG MASTER SLICE IC .....	8-7

	Page
9. PARTS LIST .....	9-1
9.1 INTRODUCTION .....	9-1
9.2 ASSEMBLY DRAWINGS .....	9-1
9.3 LIST .....	9-1
9.2.1 Index Number .....	9-1
9.2.2 Composition & Quantity .....	9-1
9.2.3 Specification .....	9-1
9.2.4 Description .....	9-1
10. SCHEMATICS .....	10-1

# Illustrations

FIGURE		Page
1.1	External Appearance .....	1-8
3.1	Exterior View and Construction of Carton .....	3-2
3.2	Installation in Locker .....	3-3
3.3	Shipping Restraint .....	3-4
3.4	Securing the Unit .....	3-4
3.5	Maintenance Access on the Unit .....	3-5
3.6	Connection of One Unit .....	3-7
3.7	Connection of 2 to 4 Units .....	3-7
3.8	Device Selecting Switch .....	3-9
3.9	SEEK COMPLETE Switch .....	3-9
3.10	SECTOR/BYTE CLOCK .....	3-10
3.11	SECTOR during the Generation of INDEX .....	3-10
3.12	W/R DATA and W/PLO CLOCK .....	3-11
3.13	Method of Assigning the Number of Sectors .....	3-13
3.14	DELAY SKC .....	3-13
3.15	Drive Selection Control .....	3-14
3.16	Time Margin Measurement Switch .....	3-14
4.1	Appearance of the Unit .....	4-1
4.2	Spindle .....	4-2
4.3	Carriage Assembly .....	4-3
4.4	Air Circulation Inside the DE .....	4-4
4.5	Read/Write Head .....	4-5
4.6	Structure of Head Slider .....	4-5
4.7	Clock Signal Waveform/Index Pattern Waveform .....	4-7
4.8	Block Diagram .....	4-19
4.9	Start/Stop Circuit Block Diagram .....	4-20
4.10	DC Spindle Motor Driving Circuit Block Diagram .....	4-22
4.11	DC Spindle Motor Driving Circuit Timing Chart .....	4-23
4.12	DC Spindle Motor Control Block Diagram .....	4-24
4.13	DC Spindle Motor Control Timing Chart (1) .....	4-25
4.13	DC Spindle Motor Control Timing Chart (2) .....	4-26
4.14	SEEK Control Block Diagram .....	4-28
4.15	SEEK Control Flow Chart .....	4-29
4.16	CONTROLLED STEP Mode Timing Chart .....	4-30
4.17	SLAVE STEP Mode Timing Chart .....	4-31
4.18	Speed Up/Slow Down Step Rate .....	4-32
4.19	RTZ Mode Timing Chart .....	4-33
4.20	SEEK COMPLETE Response Timing Chart .....	4-34
4.21	Stepper Driving Circuit Block Diagram .....	4-36
4.22	Stepper Driving Circuit Timing Chart (Page 1 of 2) .....	4-37
4.22	Stepper Driving Circuit Timing Chart (Page 2 of 2) .....	4-38
4.23	INDEX and SECTOR Generation Circuit Block Diagram .....	4-40
4.24	INDEX and SECTOR Generation Circuit Timing Chart (When a Sector Length is 300 bytes) .....	4-41
4.25	Write Circuit Block Diagram .....	4-44
4.26	Correlation between NRZ and MFM .....	4-45
4.27	Read Circuit Block Diagram .....	4-46
4.28	Read Circuit Waveform .....	4-47
4.29	VFO Circuit Block Diagram .....	4-49

<b>FIGURE</b>	<b>Page</b>
<b>4.30</b> VFO Circuit Phase Comparator Timing Chart .....	4-50
<b>4.31</b> Data Demodulation Circuit .....	4-51
<b>8.1</b> TTL Medium/High Speed IC Level .....	8-1
<b>8.2</b> TTL Super High Speed IC Level .....	8-2
<b>8.3</b> Low Power Schottky Level .....	8-2
<b>8.4</b> ECL Logic Level .....	8-3
<b>9.1</b> MICRO-DISK DRIVE .....	9-2
<b>9.2</b> MICRO-DISK DRIVE .....	9-4

# Tables

TABLE	Page
1.1 Performance .....	1-6
3.1 Cable and Connector Specifications .....	3-6
3.2 Device Number Selection .....	3-9
3.3 SECTOR/BYTE CLOCK .....	3-10
3.4 SECTOR during the Generation of INDEX .....	3-10
3.5 W/R DATA and W/PLO CLOCK .....	3-11
3.6 Sector Counter Byte Table .....	3-11
3.7 Method of Assigning the Number of Sectors .....	3-12
3.8 DELAY SKC .....	3-13
3.9 Drive Selection Control .....	3-14
7.1 Spare Parts List .....	7-1
9.1 MICRO-DISK DRIVE .....	9-3
9.2 MICRO-DISK DRIVE .....	9-5

Section 1  
**General Description**

# 1. GENERAL DESCRIPTION

## 1.1 GENERAL

### 1.1.1 General

The M2301B/M2302B micro-disk drives are high performance disk drives with unformatted storage capacity of 11.7MB and 23.4MB respectively.

The unit consists of contact start-stop type heads and media, a unique head positioning band actuator, air filter, and a DC motor and other parts to drive the disks. All these are contained within a sealed cover. And outside the cover there is a printed circuit board with the following functions: read-write, driver receiver and sequence logic. In addition there is an external head pre-amplifier board.

The unit is remarkably compact, highly reliable and inexpensive. It was designed to be the same size as an 8 inch floppy disk drive. The unit can also be connected in daisy chain configuration of up to 4 units. Its data format is of a fixed length and together with its easy-to-handle interface, has simplified system design.

### 1.1.2 Features

(1) Compact

Since the disks are 200mm in outer diameter and are driven by a DC motor directly connected to the spindle, the device is extremely compact in size. The unit measures 217mm (8.5 in) in width, 111mm (4.4 in) in height and 356mm (14.0 in) in length.

(2) Economical

The positioning mechanism of the drive is a stepping motor which uses a steel band and a viscous damper. This has made the unit less expensive.

(3) High Reliability

The heads, disks, and the positioner are within the disk enclosure and are protected by a plastic cover. In the disk enclosure, there is a breathing filter and a recirculation filter to keep the air clean, thus ensuring reliability.

(4) Preventive maintenance is unnecessary.

(5) DC Power

Because a built-in DC motor is used, the unit does not have to be modified to suit line frequencies (50Hz/60Hz) or input power voltages (110, 115, 220, 240V).

(6) Physical Size

The unit is the same size as an 8 inch floppy disk. Therefore, when replacing a floppy disk, the locker need not be changed.

(7) Mounting Plane

The unit can be installed in its locker either vertically on either edge or horizontally on either edge. This allows easier installation and flexible system design.

(8) Low Power Consumption

Very low power demand (seeking 60W, non seek 50W) permits it to be used in a wide range of environmental temperature (5°C to 45°C) without a cooling fan.

(9) Audible Noise

The unit's low noise output, approx. 55dB (A-scale weighting) even during seeking makes it ideal for office use.

- (10) **Vibration**  
Vibration is not transmitted to external parts because the unit is fitted to the locker with vibration isolating rubber mounts.

## 1.2 SPECIFICATIONS

### 1.2.1 Environmental Condition of Installation Site

- |  |   |
|--|---|
| (1) <b>Temperature</b>                       |   |
| Operating                                    | 5 to 45°C (41° to 113°F)  |
| Non-operating                                | -40 to 60°C (-40° to 140°F)   |
| Gradient                                     | Less than 15°C/H  |
| (2) <b>Humidity</b>                          |   |
| Operating                                    | 20% to 80% RH (Moisture must not condense.)   |
| Non-operating                                | 5% to 95% RH  |
| (3) <b>Vibration</b>                         |   |
| Operating                                    | Less than 0.2G (3 to 60Hz) (except resonance)<br>Both ways 2 minutes x 30 cycle (sine wave) |
| Non-operating (power OFF after installation) | Less than 0.4G (3 to 60Hz)<br>Both ways 2 minutes x 30 cycle (sine wave)                    |
| During storage or transportation             | Less than 3G  |
| (4) <b>Shock</b>                             |   |
| Operating                                    | Less than 2G (maximum 10ms)   |
| Non-operating                                | Less than 3G (maximum 10ms)   |
| During storage or transportation             | Less than 5G (maximum 30ms)   |
| (5) <b>Altitude</b>                          |   |
| Operating                                    | Less than 3,000m (10,000 ft)  |
| Non-operating                                | Less than 12,000m (40,000 ft)   |



## 1.2.2 Power Source Specifications

### (1) Consumption Current

Voltage	Peak Current	Steady Current
+5V $\pm$ 5%	6.0A max	4.1A
-5V $\pm$ 5% or -7V $\sim$ -16V	0.5A max	0.5A
+24V $\pm$ 10%	6.0A max (Pulse) 4.5A (10 sec*)	1.6A

The voltage value above is the voltage at the power input terminal of the unit. Steady current is the current at AVERAGE SEEK + LATENCY TIME + 1 revolution READ or WRITE.

\* Start-up time.

### (2) Current Wave Form

#### (a) +24V current wave form

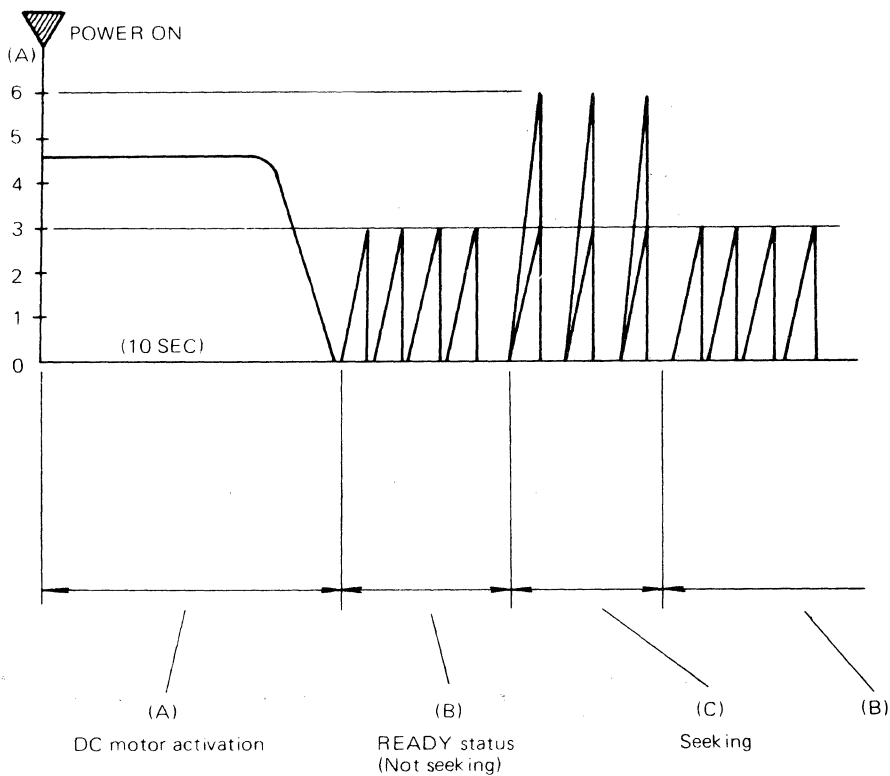

Magnified wave of (B) part

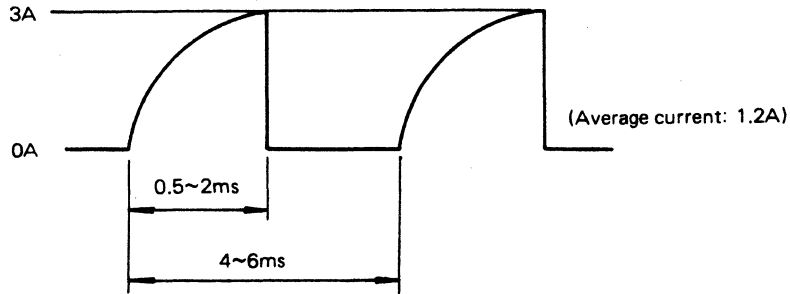

Magnified wave of (C) part

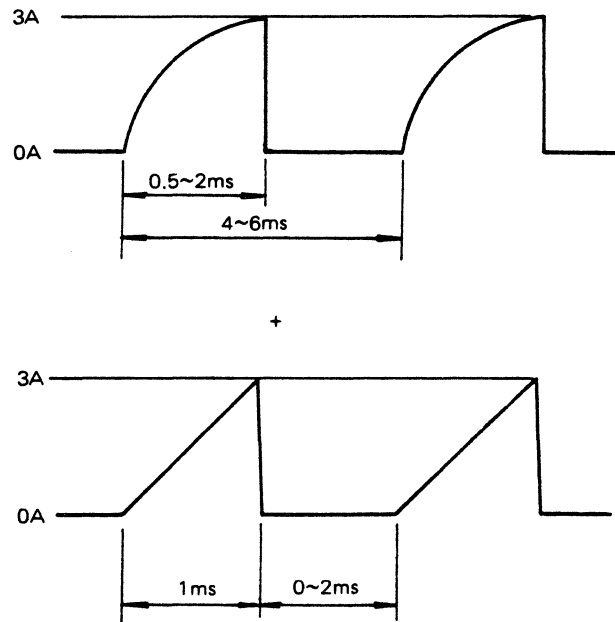

**Note:** The wave form of (C) is determined by the current flow timing of the spindle motor and the stepper motor. When current flows simultaneously in both motors, a peak of 6 A results.

(b) +5V current wave shape

The +5V current, at the time of seeking, forms the following switching current wave form.

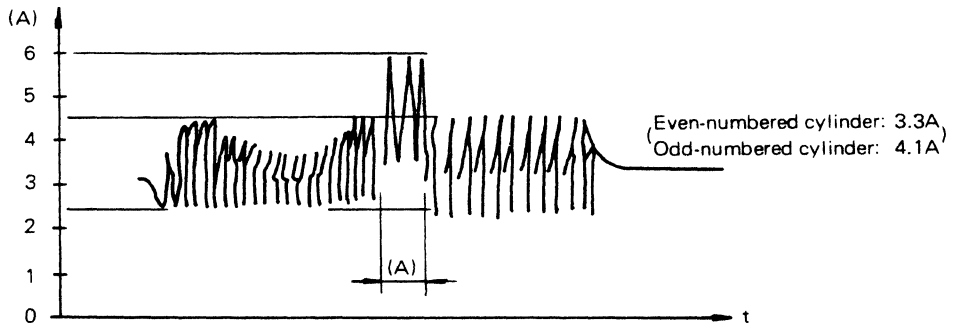

Magnified wave of (A) part

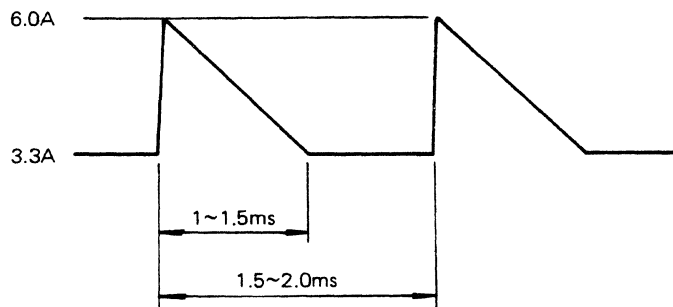

Note: The 6A peak current of the (A) part is present 3 or 4 times in one seek.

### 1.2.3 Performance

Table 1.1 Performance

Spec.	Model	Micro Disk Drive	
		M2301	M2302
Total storage capacity			
Unformat	(MB)	11.71	23.42
* Format	(MB)	9.99	19.98
Storage capacity/track			
Unformat	(B)	12,000 <sup>+32</sup> <sub>-0</sub>	
* Format	(B)	10,240	
Number of disks		2	4
Number of heads (for R/W)		4	8
Number of heads (CLOCK)		1	
Number of cylinders		244	
Number of tracks/cylinder		4	8
Number of sectors		Variable Hard	
Recording density	(BPI)	6100	
Track density	(TPI)	195	
Transfer rate	(KB/S)	593	
Rotational speed	(rpm)	2964	
Average latency time	(ms)	10.1	
Encoding method		MFM	
Positioning time			
Min	(ms)	30	
Ave	(ms)	70	
Max	(ms)	140	
Start/Stop Time	(sec)	25/25	

\* Format based on 40 sectors/track.

## 1.2.4 Reliability

### (1) MTBF

MTBF is defined as follows.

MTBF = operating time/the number of equipment failures

Operating time is the entire time at which the power is ON except during maintenance work. Failure of the unit means trouble that requires, either repairs, adjustments, or a replacement. Mishandling by the operator, power failure, control unit problems, cable problems and failure due to unsuitable environment are not included.

The MTBF of the M2301/M2302 shall exceed 10,000 hours (engineering specification).

### (2) MTTR

MTTR is the average time a well-trained service technician should take to diagnose and correct a failure to the sub-assembly level. The M2301/M2302 is designed for a MTTR of 30 minutes or less.

### (3) Component Life

The M2301/M2302 need not be overhauled for the first five years.

### (4) Power Loss

Integrity of the data on the disk is guaranteed against all forms of abnormal DC power loss. However, if the power failure occurs during a WRITE operation, the data is not guaranteed.

### (5) Error Rate

An error detected during initialization, and processed to be replaced by a spare record is not included in the error rate.

#### (a) Recoverable Error Rate

An error which is recoverable with one try of the RETRY command should not exceed once per  $10^{10}$  bits read.

#### (b) Non Recoverable Error Rate

Errors that cannot be recovered within 16 retries are included in the MTBF.

#### (c) Positioning Error Rate

The rate of positioning errors recoverable by one retry is one error or less per  $10^6$  seeks.

#### (d) Media Error

i) No error will be found at H0 and H1 in cylinder 000.

ii) The following shows the number of defective spots in the M2301/M2302.

M2301B . . . . . Less than 10

M2302B . . . . . Less than 20

### 1.3 EXTERNAL APPEARENCE

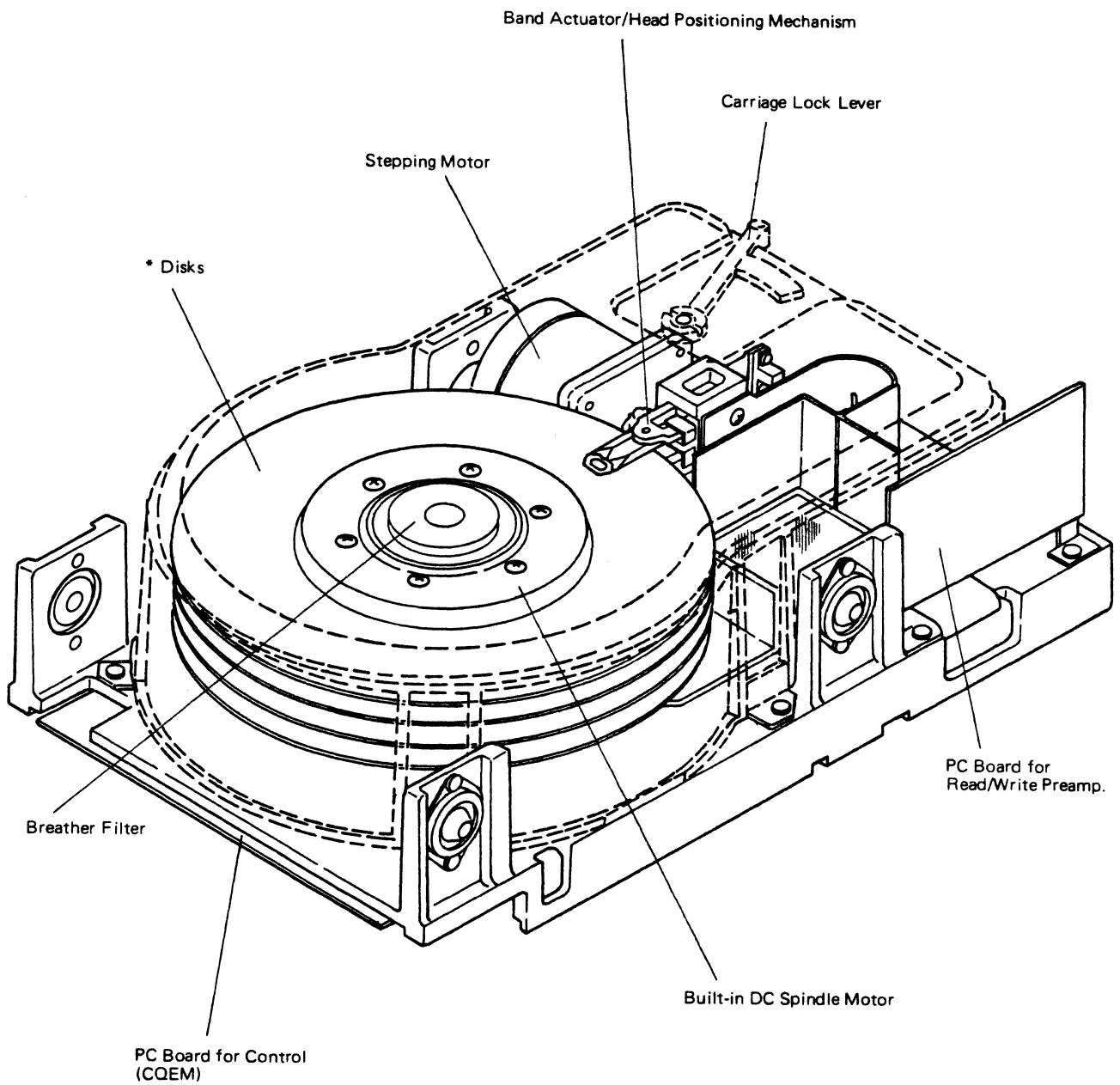

**\*Note: M2301B contains two disks.  
M2302B contains four disks.**

**Fig. 1.1 External Appearance**

Section 2  
**Operation**

## 2. OPERATION

### 2.1 GENERAL

Power-on/off for the unit is described in this section.

### 2.2 POWER ON/OFF SEQUENCE

The M2301B/M2302B micro disk drive has no power ON/OFF switch of its own. Therefore, power ON/OFF for the micro disk drive is performed by the power ON/OFF function of the system.

If the write gate signal coming from the controller is kept OFF in advance to a power-on or power-off, a sequence of the power source (+24V, +5V, -5V/-7V to -16V) of the device is unnecessary. That is, the stored data is not destroyed and mechanical and electric errors do not occur. In order to keep the write gate signal OFF during a power-ON/OFF transition, the power source of the controller and the device must adhere to the following sequence.

#### (1) Basic Sequence

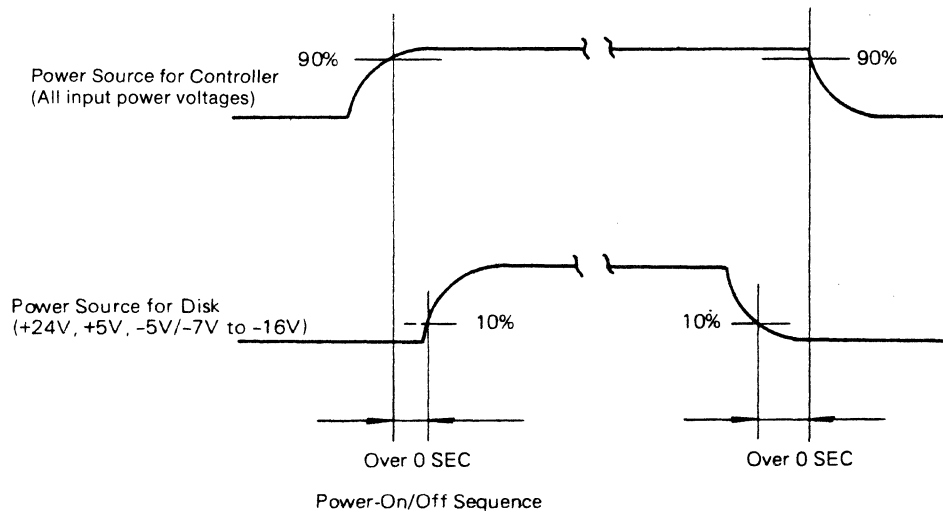

- (2) By detecting the +5V voltage level in the drives the write gate signal is inhibited and power sequencing is unnecessary if the +5V power source for the drive is supplied from the +5V power source for the controller, and the interface signal from the controller is determined only by the +5V power source for the controller.



Section 3  
**Installation and Checkout**

### **3. INSTALLATION AND CHECKOUT**

#### **3.1 GENERAL**

Unpacking, installation, cable connections, configuration settings, how to install the unit into the system, etc., are described in this section.

This unit is packed so as to withstand the shocks of long distance transportation. When the difference in the storage (or shipping) environment and the unpacking environment exceeds 20°C(36°F), the carton should be allowed to stand at the unpacking site for approximately 3 hours prior to unpacking in order to avoid condensation.

#### **3.2 UNPACKING**

The device is wrapped in a polyethylene bag, and enclosed in a inner case and outer box. An exterior view of the carton is shown in Fig. 3.1.

- (1) Place the unit (Note: Do not turn disk drive upside-down) near the installation area.
- (2) Remove the adhesive tape on the box and open it.
- (3) Remove the upper inner case and pull the unit out by grasping the base of the unit.
- (4) Store packing material for possible future use.

#### **3.3 VISUAL INSPECTION**

After unpacking, check the following.

- (1) There should be no crack, rust etc. that mar its appearance and integrity.
- (2) All parts should be firmly fixed and there should be no loose screws, etc.
- (3) The carriage lock (shipping restraint) should be in tact with no abnormalities.
- (4) The duplicate media defect label should be correct.

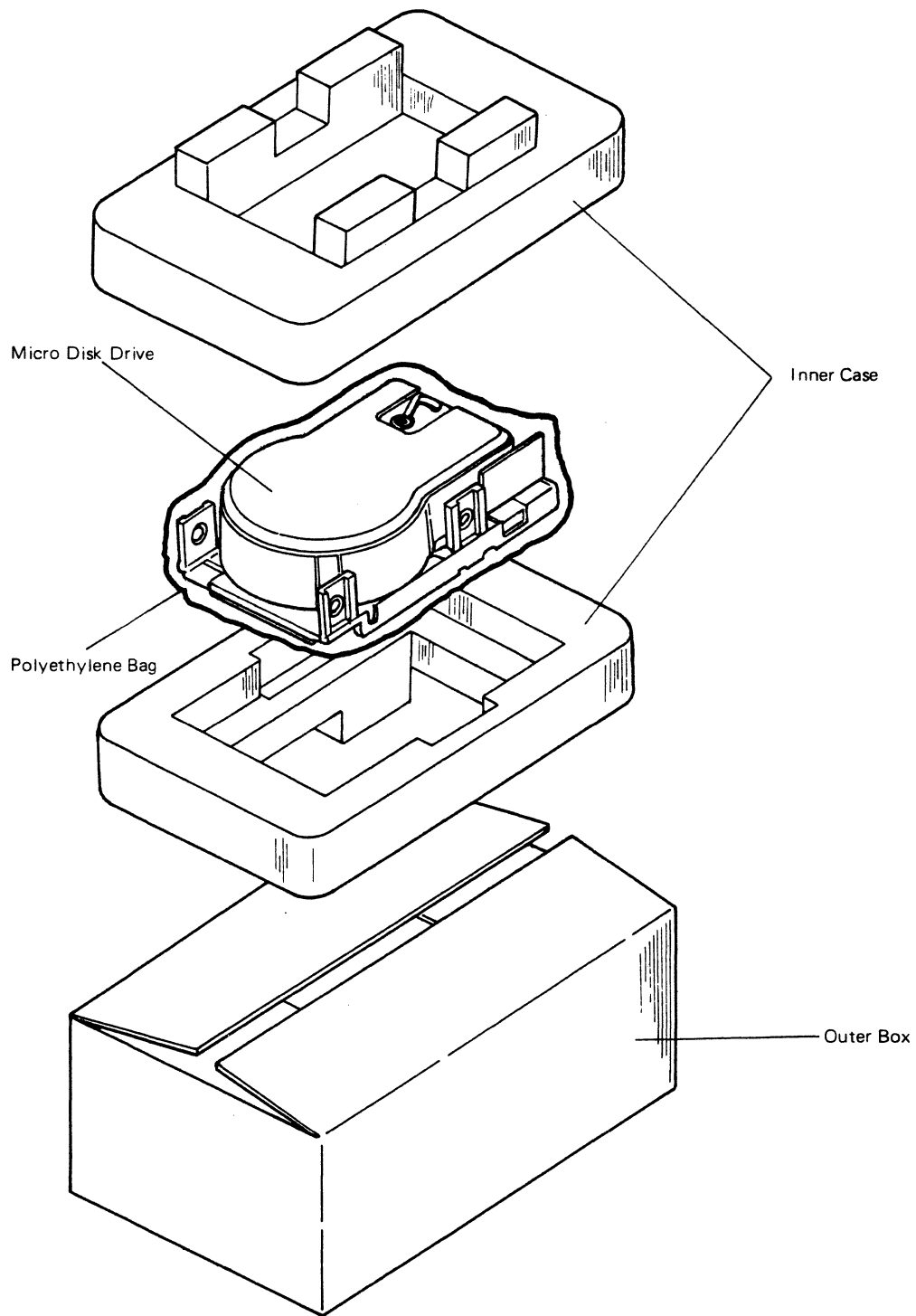

**Fig. 3.1 Exterior View and Construction of Carton**

### 3.4 MOUNTING

#### 3.4.1 Installation in Locker

The accompanying diagram shows how to install the drive according to the dimensions and the structure of the frame. (Dimensions are in millimeters)

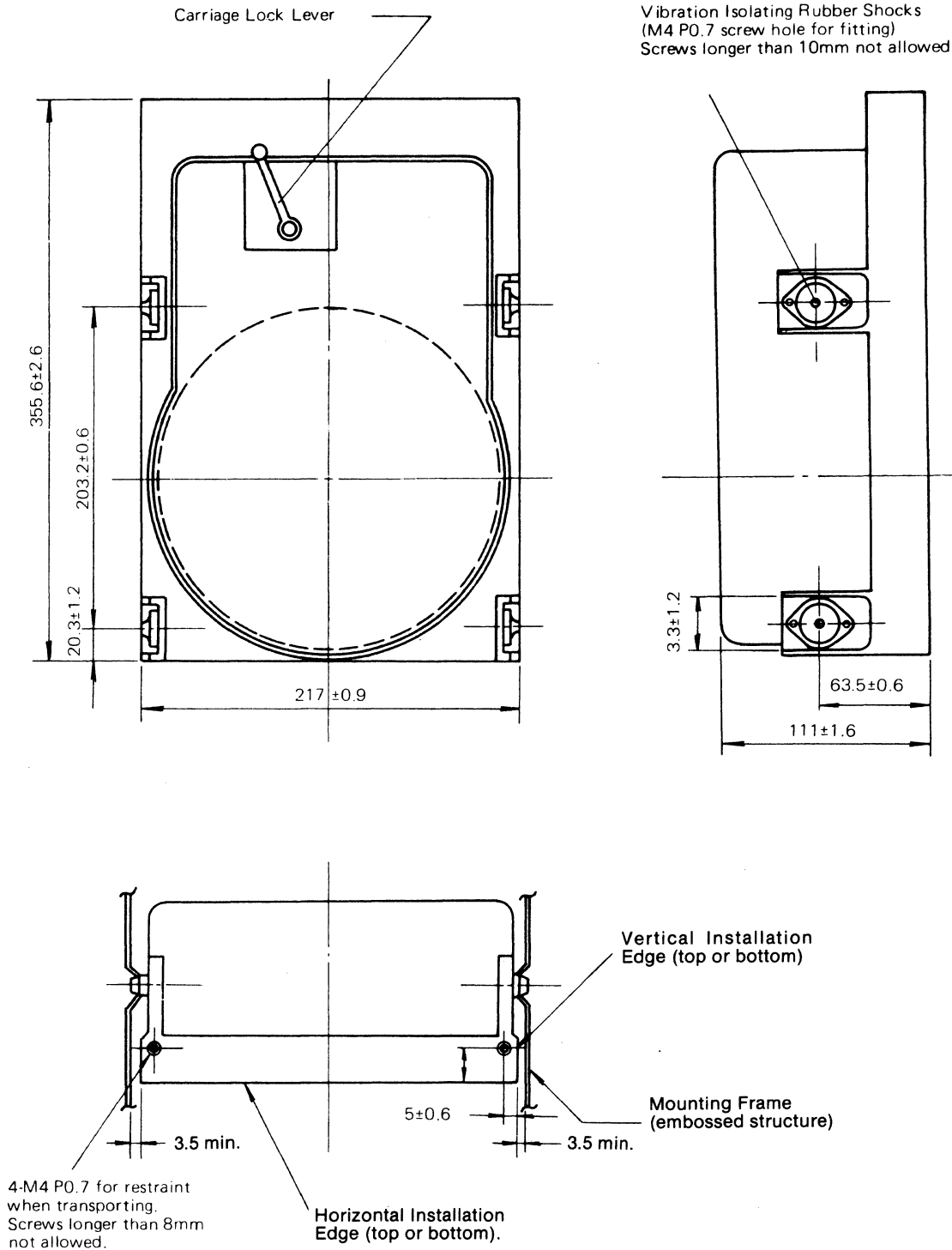

Fig. 3.2 Installation in Locker

### 3.4.2. Securing for Transportation

If the unit is installed in the locker during transportation, in order to prevent damage, set the carriage lock lever to LOCK.

**CAUTION:** Before placing the carriage restraint in the LOCK position, insure that the heads are at Track 0. Do NOT use the carriage restraint to position the heads.

#### (1) Fixing Carriage

Pull up the lock lever, rotate it in the direction of the arrow and fix the carriage (LOCK) or release it (FREE).

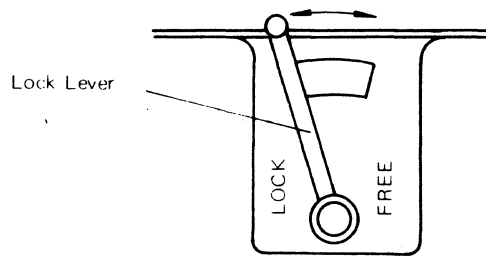

**Fig. 3.3 Shipping Restraint**

#### (2) Securing the Unit

Secure the unit to the mounting frame using the screw holes that are provided, when transporting the unit.

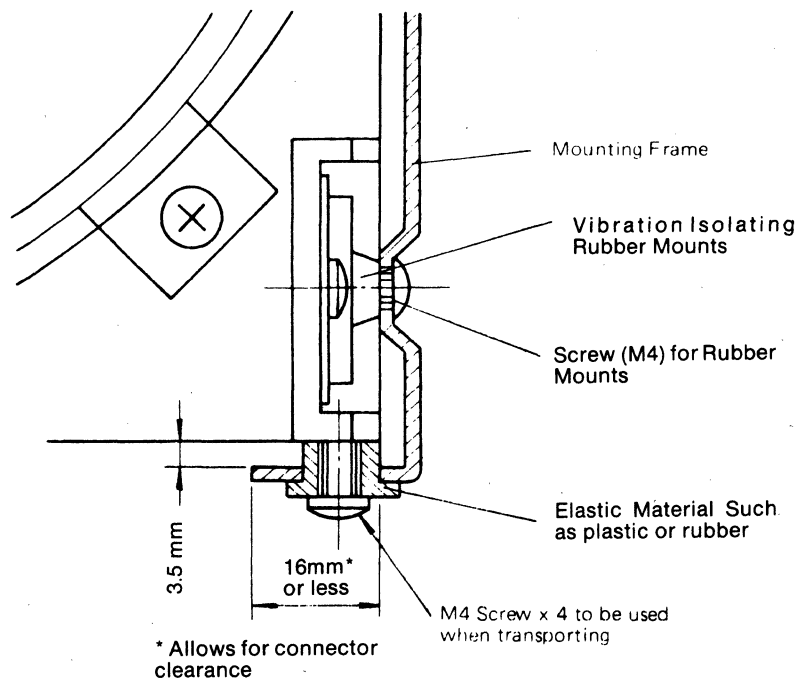

**Fig. 3.4 Securing the Unit**

### 3.4.3 Service Area

Maintenance, securing for transportation, cable connection, are accessed as shown below. When determining the service area and where to install the locker, make sure that there is enough room for maintenance work.

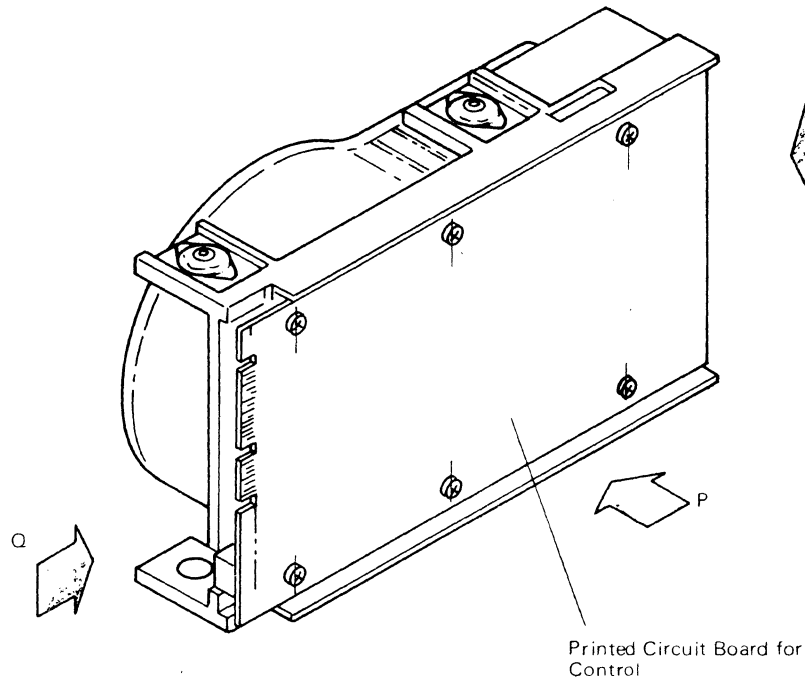

P side: Maintenance operations on PCB.

Q side: Cable connections.

Installation and removal of the securing screws when transporting.

R side: Accessing the carriage lock lever to secure the carriage.

Installation and removal of the securing screws when transporting.

Bad track label and a name-plate

**Fig. 3.5 Maintenance Access on the Unit**

### 3.5 CABLE

#### 3.5.1 Cable and Connector Specification

Table 3.1 shows specifications recommended for cables and connectors.

**Table 3.1 Cable and Connector Specification**

Connector	Name	Type	Maker
A cable (50P)	Cable side connector	FCN-767J050-AU/1 or 88373-1 or 3415-0001	Fujitsu AMP 3M
	Device side card edge	—	—
	Cable	455-248-50 or 171-50	Spectrastrip Ansley
B cable (20P)	Cable side connector	FCN-767J020-AU/1 or 88373-6 or 3461-0001	Fujitsu AMP 3M
	Device side card edge	—	—
	Cable	455-248-20 or 171-20	Spectrastrip Ansley
Power cable	Cable side connector	1-480270-0	AMP
	Device side connector	1-380999-0	AMP
	Contact	60619-1	AMP
	Cable	AWG14 (+5V, RTN) AWG16(+24V, RTN) AWG20 (-5V/-7V to -16V, RTN)	—

### 3.5.2 Cable Connection

#### (1) Connection of One Unit

Fig. 3.6 is an example of only one unit connected to the controller. The unit is also operable when both Cable A and Cable B are connected at the same time.

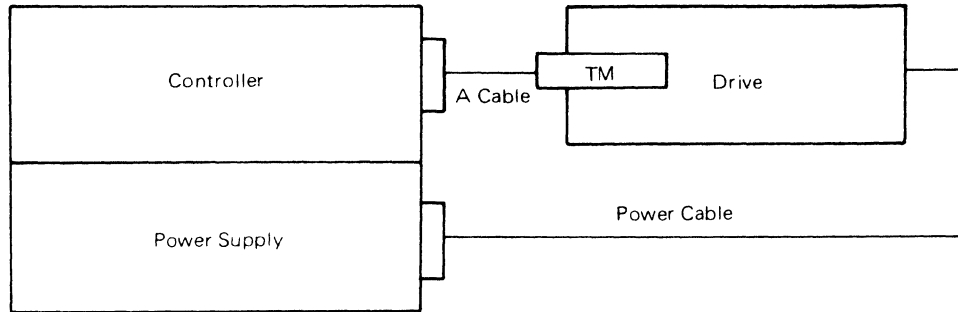

Fig. 3.6 Connection of One Unit

#### (2) Connection of 2 to 4 Units

When 2 to 4 units are connected, cable A (control signal) is daisy chained, and cables B (R/W signal) are connected in radial.

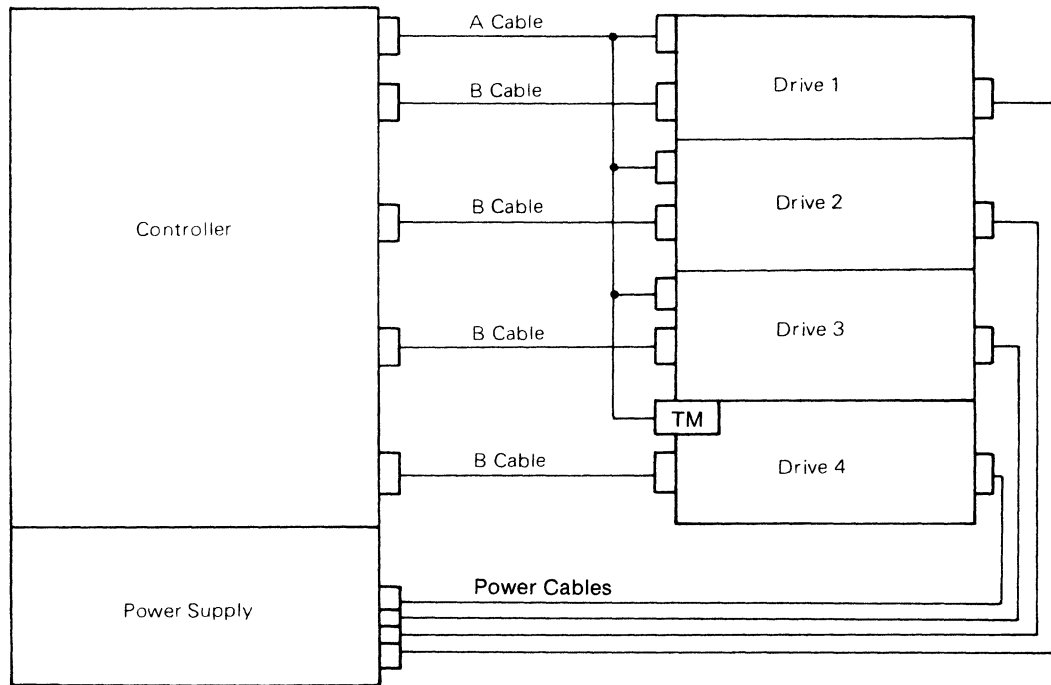

Fig. 3.7 Connection of 2 to 4 Units



### (3) Caution in Connecting the Cable

In order to reduce the influence of external electrical noise and the like, the following should be noted.

- (a) The power cable and the interface cable should not be in the same plane.
- (b) If the power is supplied from the system, a voltage drop would occur in the DC cable, so that each voltage must be set while measuring at the input terminal entry of the unit.
- (c) If the unit is installed in a system, and or if it is installed in the 19 inch rack, firmly connect an SG ground to the hole which is provided in the casting so as to reduce the influence of external noise.  
A screw hole (M4 P0.7) is provided in the casting for DC ground as shown below. Use an M4 screw less than 8mm in length.
- (d) The +5V RTN and -5V/-7~-16V RTN are tied together on the control PCB. The +24V RTN is isolated on the drive because of inductive feedback from the stepper motor. All returns should therefore be tied together at the power supply.

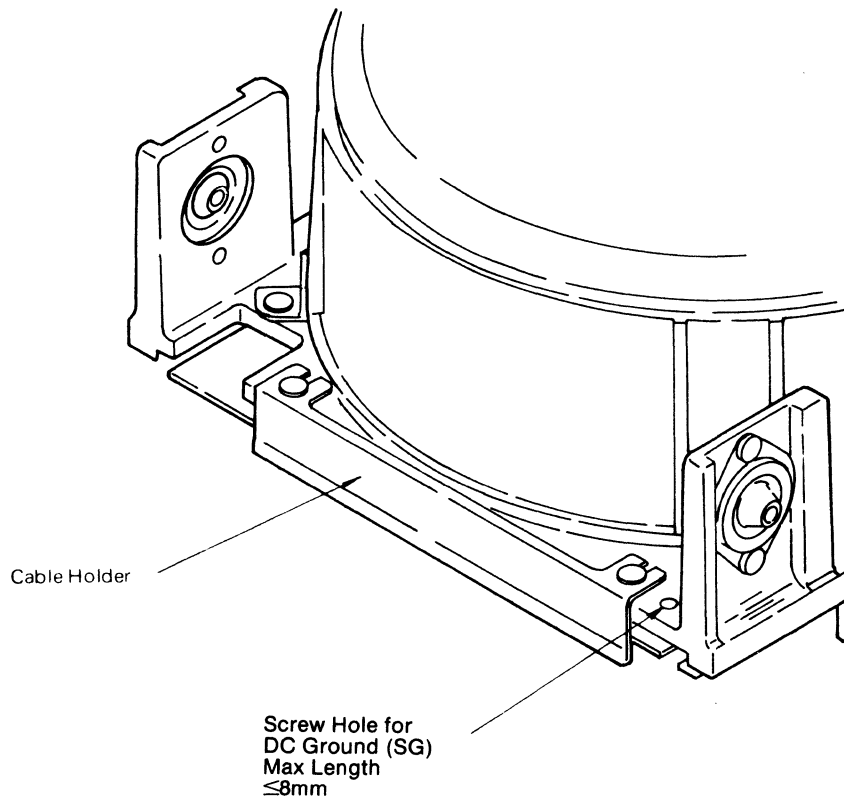

### 3.6 SWITCH ARRANGEMENT

The functions and assignment procedures of the different switches on the circuit board of the M2301/2302 are described below.

#### 3.6.1 Drive Select (Device Number Selection)

The drive select switch is used to select one logical unit number up to a maximum of 4 devices. Of the 4 switches, you are to turn ON one relevant switch while turning OFF the other 3. The device number selection procedures are shown in Table 3.2 and Fig. 3.8

**Table 3.2 Device Number Selection**

Device Number	SW3 Switch			
	Key 8	Key 7	Key 6	Key 5
1	○	×	×	×
2	×	○	×	×
3	×	×	○	×
4	×	×	×	○

○: ON  
 ×: OFF

SW3 (Mounting Location B6)

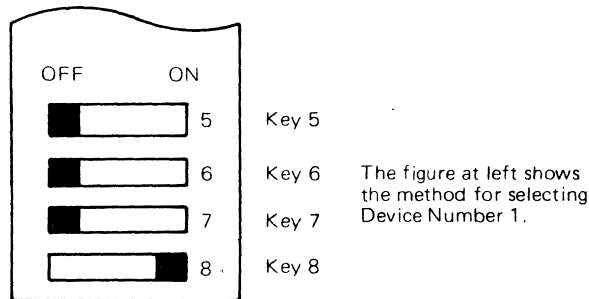

**Fig. 3.8 Device Selecting Switch**

#### 3.6.2 Seek Complete

When sending the SEEK COMPLETE onto the A cable of the interface, turn ON Key 4 of SW3.

However, at this point, be sure not to leave DRIVE SELECT Key 4 in the ON status (See Fig. 3.9).

SW3 (Mounting Location B6)

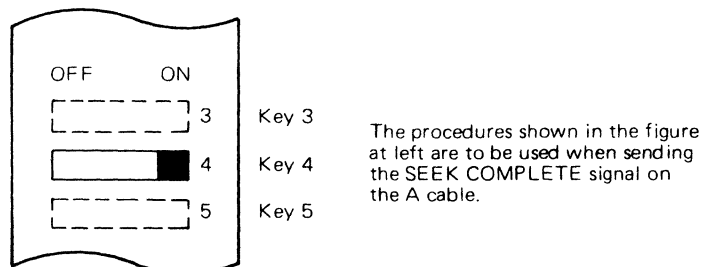

**Fig. 3.9 SEEK COMPLETE Switch**

### 3.6.3 Sector/Byte Clock

This switch is used to select either SECTOR pulses or BYTE CLOCK onto the interface cable. The switch assignment procedures are shown in Table 3.3 and Fig. 3.10 below.

Table 3.3 SECTOR/BYTE CLOCK

Signal Name	SW2 Switch	
	Key 3	Key 2
SECTOR	○	X
BYTE CLOCK	X	○

○: ON  
X: OFF

SW2 (Mounting Location T4)

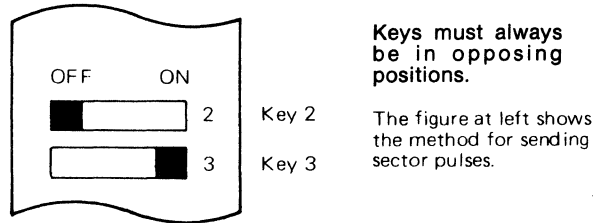

Fig. 3.10 SECTOR/BYTE CLOCK

### 3.6.4 Sector During the Generation of Index

This is used to select whether or not to send the sector mark generated during the same times as Index onto the interface. The switch selection procedures are shown in Table 3.4 and Fig. 3.11.

Table 3.4 SECTOR during the Generation of INDEX

Selection Content	SW2
	Key 1
Send the SECTOR.	X
Do not send the SECTOR.	○

○: ON  
X: OFF

SW2 (Mounting Location T4)

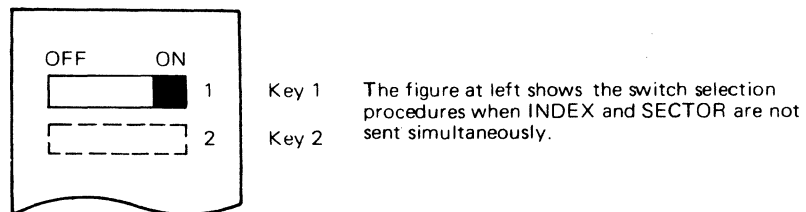

Fig. 3.11 SECTOR during the Generation of INDEX

### 3.6.5 Write/Read Data, Write/PLO Clock

The method for sending WRITE/READ DATA and WRITE/PLO CLOCK signals onto the A cable of the interface is shown in Table 3.5 and Fig. 3.12

**Table 3.5 W/R DATA and W/PLO CLOCK**

Signal Name	Assigned Switch SW4
±WRITE DATA	Key 7, Key 8 ON
±READ DATA	Key 1, Key 2 ON
±WRITE CLOCK	Key 5, Key 6 ON
±PLO CLOCK	Key 3, Key 4 ON

SW4 (Mounting Location B5)

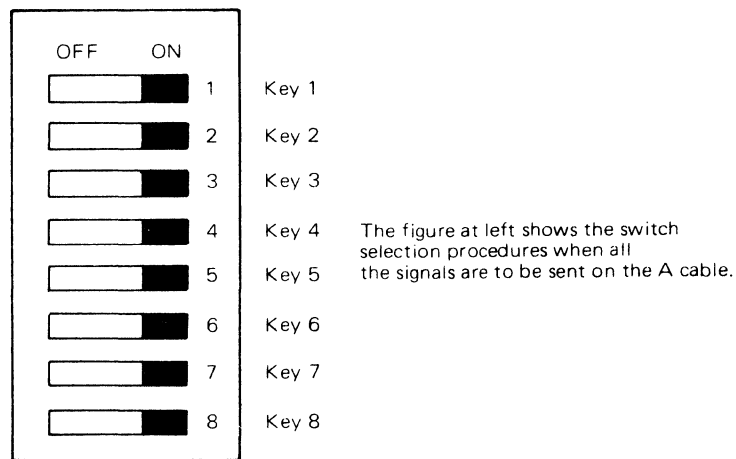

**Fig. 3.12 W/R DATA and W/PLO CLOCK**

### 3.6.6 Assigning the Number of Sectors

The number of sectors can be assigned by using a combination of the SW1 and SW2 switch keys. Each key of the respective switch corresponds to binary powers of the byte count ( $2^0$  to  $2^{11}$  bytes). See Table 3.6.

**Table 3.6 Sector Counter Byte Table**

SW1	No. of Bytes	SW2	No. of Bytes
Key 8	1	Key 8	256
Key 7	2	Key 7	512
Key 6	4	Key 6	1024
Key 5	8	Key 5	2048
Key 4	16		
Key 3	32		
Key 2	64		
Key 1	128		

The method of assigning the number of sectors is shown in Table 3.7 and Fig. 3.13, where the LAST SECTOR indicates the number of excess bytes. This also indicates that only the last sector becomes longer because of excess bytes.

Table 3.7 Method of Assigning the Number of Sectors

SECTORS	SW1								SW2				BYTES/ SECTOR	LAST SECTOR
	8	7	6	5	4	3	2	1	8	7	6	5		
2	1	1	1	1	1	1	1	1	1	1	1	1	4095	+3810 <sup>-32</sup> <sub>0</sub>
3	0	0	0	0	0	1	0	1	1	1	1	1	4000	0 "
4	0	0	0	1	1	1	0	1	1	1	0	1	3000	0 "
5	0	0	0	0	0	1	1	0	1	0	0	1	2400	0 "
6	0	0	0	0	1	0	1	1	1	1	1	0	2000	0 "
7	0	1	0	0	1	1	0	1	0	1	1	0	1714	+2 "
8	0	0	1	1	1	0	1	1	1	0	1	0	1500	0 "
9	1	0	1	0	1	1	0	0	1	0	1	0	1333	+3 "
10	0	0	0	0	1	1	0	1	0	0	1	0	1200	0 "
11	0	1	0	0	0	0	1	0	0	0	1	0	1090	+10 "
12	0	0	0	1	0	1	1	1	1	1	0	0	1000	0 "
13	1	1	0	1	1	0	0	1	1	1	0	0	923	+1 "
14	1	0	0	1	1	0	1	0	1	1	0	0	857	+2 "
15	0	0	0	0	0	1	0	0	1	1	0	0	800	0 "
16	0	1	1	1	0	1	1	1	0	1	0	0	750	0 "
17	1	0	0	0	0	0	1	1	0	1	0	0	705	+15 "
18	0	1	0	1	1	0	0	1	0	1	0	0	666	+12 "
19	1	1	1	0	1	1	1	0	0	1	0	0	631	+11 "
20	0	0	0	1	1	0	1	0	0	1	0	0	600	0 "
21	1	1	0	1	1	1	0	0	0	1	0	0	571	+9 "
22	1	0	0	0	0	1	0	0	0	1	0	0	545	+10 "
23	1	0	0	1	0	0	0	0	0	1	0	0	521	+17 "
24	0	0	1	0	1	1	1	1	1	0	0	0	500	0 "
25	0	0	0	0	0	1	1	1	1	1	0	0	480	0 "
26	1	0	1	1	0	0	1	1	1	0	0	0	461	+14 "
27	0	0	1	1	1	1	0	1	1	0	0	0	444	+12 "
28	0	0	1	1	0	1	0	1	1	0	0	0	428	+16 "
29	1	0	1	1	1	0	0	1	1	0	0	0	413	+23 "
30	0	0	0	0	1	0	0	1	1	0	0	0	400	0 "
31	1	1	0	0	0	0	0	1	1	0	0	0	387	+3 "
32	0	0	0	1	1	1	1	0	1	0	0	0	375	0 "
33	1	1	0	1	0	1	1	0	1	0	0	0	363	+21 "
34	0	0	0	0	0	1	1	0	1	0	0	0	352	+32 "
35	0	1	1	0	1	0	1	0	1	0	0	0	342	+30 "
36	1	1	0	1	0	0	1	0	1	0	0	0	333	+12 "
37	0	0	1	0	0	0	1	0	1	0	0	0	324	+12 "
38	1	1	0	1	1	1	0	0	1	0	0	0	315	+30 "
39	1	1	0	0	1	1	0	0	1	0	0	0	307	+27 "
40	0	0	1	1	0	1	0	0	1	0	0	0	300	0 "
50	0	0	0	0	1	1	1	1	0	0	0	0	240	0 "
60	0	0	0	1	0	0	1	1	0	0	0	0	200	0 "
70	1	1	0	1	0	1	0	1	0	0	0	0	171	+30 "
80	0	1	1	0	1	0	0	1	0	0	0	0	150	0 "
90	1	0	1	0	0	0	0	1	0	0	0	0	133	+30 "
100	0	0	0	1	1	1	1	0	0	0	0	0	120	0 "
110	1	0	1	1	0	1	1	0	0	0	0	0	109	+10 "
120	0	0	1	0	0	1	1	0	0	0	0	0	100	0 "
130	0	0	1	1	1	1	1	0	0	0	0	0	92	+40 "

"0" indicates the OFF and "1" the ON status.

**SW1 (Mounting Location T5)**

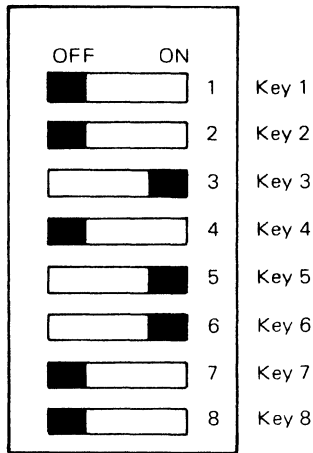

**SW2 (Mounting Location T4)**

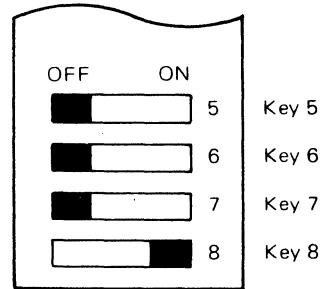

The figure indicates the switch selection procedures for 40 sectors.

**Fig. 3.13 Method of Assigning the Number of Sectors**

**3.6.7 Delay SKC**

This is used to select whether or not to include settling time (Signal name: SEKC) when SEEK COMPLETE (Signal name: SKC) is sent to the interface. The switch assignment procedure is shown in Table 3.8 and Fig. 3.14.

**Table 3.8 DELAY SKC**

Signal Name	SW3
	Key 1
SEKC	○
SKC	X

○: ON  
X: OFF

**SW3 (Mounting Location B6)**

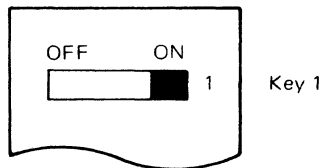

The figure at left shows the switch assignment procedures when sending the SEKC signal which includes setting time delay provided by the drive.

**Fig. 3.14 DELAY SKC**

### 3.6.8 Controlling the Basic Select Signals

Even when the relevant drives are not selected, the four basic signals (INDEX, DRIVE READY, SECTOR/BYTE CLOCK and SEEK COMPLETE) can be sent to the interface cables (both A and B). The method of sending these signals is shown in Table 3.9 and fig. 3.15.

Table 3.9 Drive Selection Control

Cable A	SW3	Cable B	SW3
	Key 2		Key 3
Gate	○	Gate	○
Does not gate	X	Does not gate	X

○: ON  
X: OFF

SW3 (Mounting Location B6)

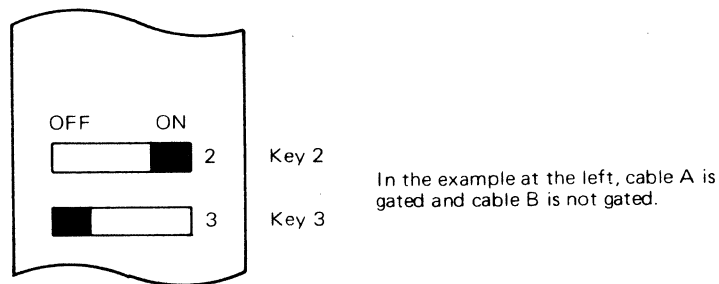

Fig. 3.15 Drive Selection Control

### 3.6.9 Time Margin Measurement Switch

This is a switch for measuring time margins. Set this switch to OFF only when measuring margins.

SW2 (Mounting Location T4)

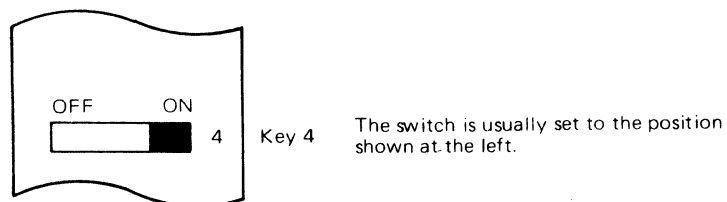
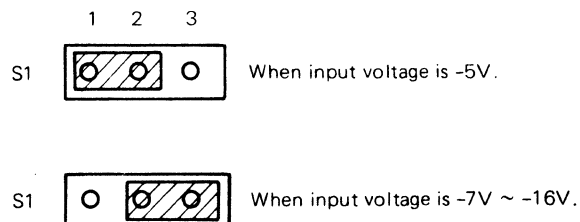

Fig. 3.16 Time Margin Measurement Switch

### 3.6.10 Input Negative Voltage Selection

The drive requires -5V input but has the capability of regulating higher negative voltage (-7V to -16V) into the required one (-5V). Such voltage value selection configurations are described below.



### 3.6.11 Timing Specification Selection

The drive utilizes jumpers to provide SA4000 interface compatibility.

#### (1) PLO Clock and Read Data



(for SA4000 Controller)

#### S2 (Mounting Location C3)

#### (2) Direction and Step Pulse

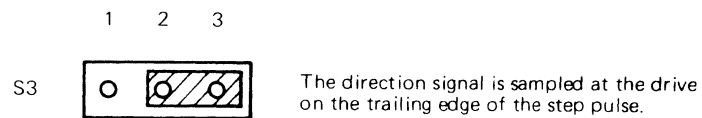
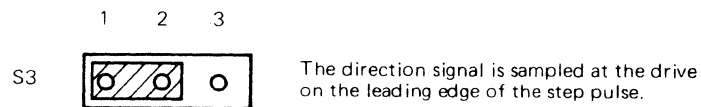

(for SA4000 Controller)

#### S3 (Mounting Location $\bar{E}1$ )



### 3.6.12 Media Error

#### (1) MEDIA ERROR DISPLAY METHOD

A defective area of the M2301/M2302 media is located with reference to the Physical Index by the number of bytes from the Physical Index. The Physical Index represents the Index Pattern Division recorded on the clock track. The relationships of the Physical Index and Interface Index/Sector are as shown below.

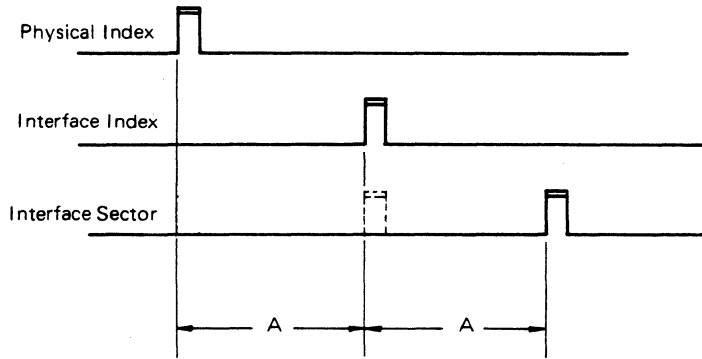

A: This represents the number of bytes of one sector.

#### (2) RELATION of the DEFECTIVE AREA DISPLAY VALUE and the DEFECTIVE SECTOR

The defective sector number can be calculated from the defective area display value by using the following formula.

$$\text{Defective sector number} = \left[ \frac{X}{A} \right] - 1$$

Note 1: X : Defective position display value

A : Number of bytes of one sector

[ ] : This indicates that all the numbers after the decimal point are to be omitted.

For example, [2.3] = 2

1 : Compensates for the difference between Physical and Interface Index.

Note 2: The sector next to the index is assumed to be the 0 sector.

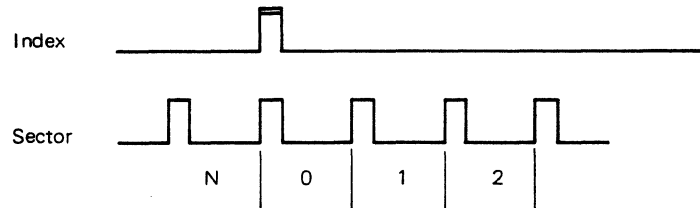

The following 2 examples indicate how the defective sector number can be calculated.

[Example 1]  $X = 800$   
 $A = 300$   
Defective sector number =  $\left[ \frac{800}{300} \right] - 1$   
 $= 2 - 1$   
 $= 1$   
1 sector is defective.

[Example 2]  $X = 200$   
 $A = 300$   
Defective sector number =  $\left[ \frac{200}{300} \right] - 1$   
 $= 0 - 1$   
 $= 1$   
N (last) sector is defective.

Section 4  
**Theory of Operation**

## 4. THEORY OF OPERATION

### 4.1 GENERAL

This section consists of three parts. The first concerns major assemblies of the device. The second takes up the magnetic head and magnetic disk. These are part of the disk enclosure, however, they are explained below because they are closely related to the electric control portion. The last describes electric control such as interface, R/W, etc.

### 4.2 OPERATION OF MECHANICAL PORTION

#### 4.2.1 Disk Enclosure

In the disk enclosure (DE), disks, spindle, actuator, heads, etc., are protected by a sealed plastic cover. Each of these parts can be seen through the plastic cover. The disk enclosure is sealed at the factory after assembly, and must not be opened in the field.

The head preamplifier (PCB) is installed outside the plastic cover and is an individual maintenance part.

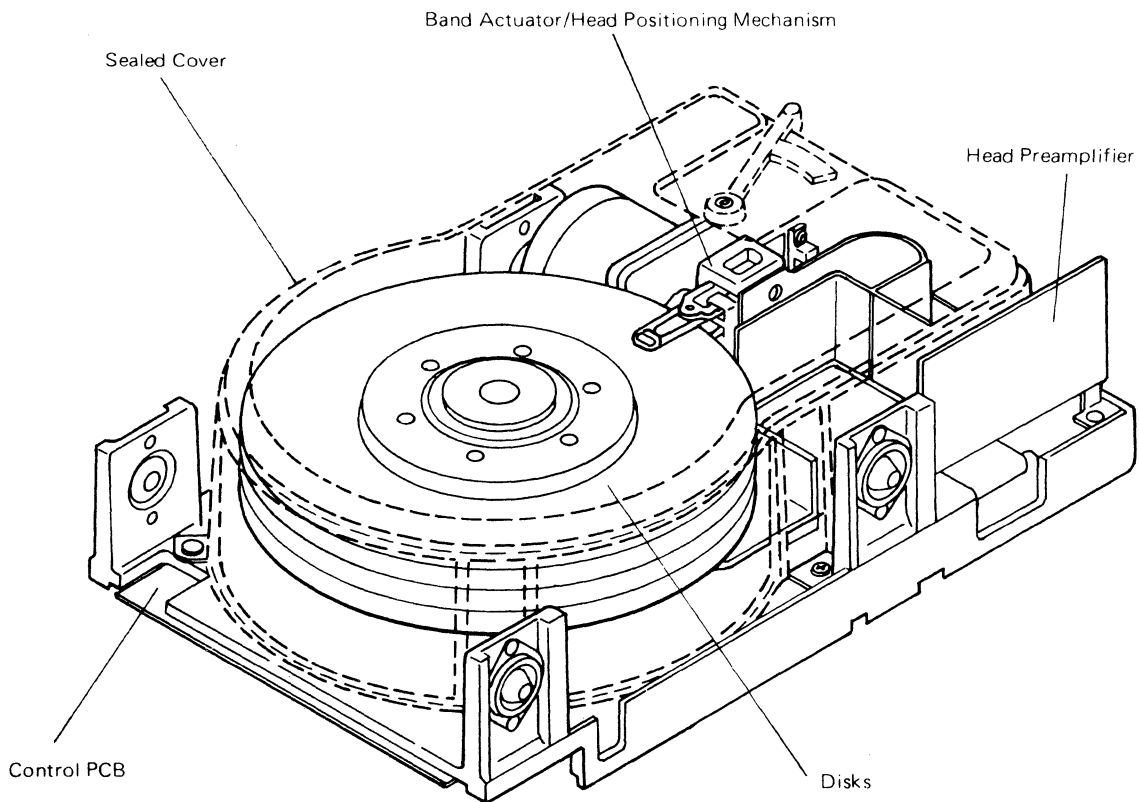

Fig. 4.1 Appearance of the Unit

#### 4.2.2 Spindle

The disk spindle is fixed to the base of the DE from the top side. The base is sealed to prevent the intrusion of air through the bearings. At the top of the spindle is a hub, to which recording media are fitted. A DC motor is set concentrically with the spindle to drive the disks. The spindle is grounded to the DE through an anti-static brush.

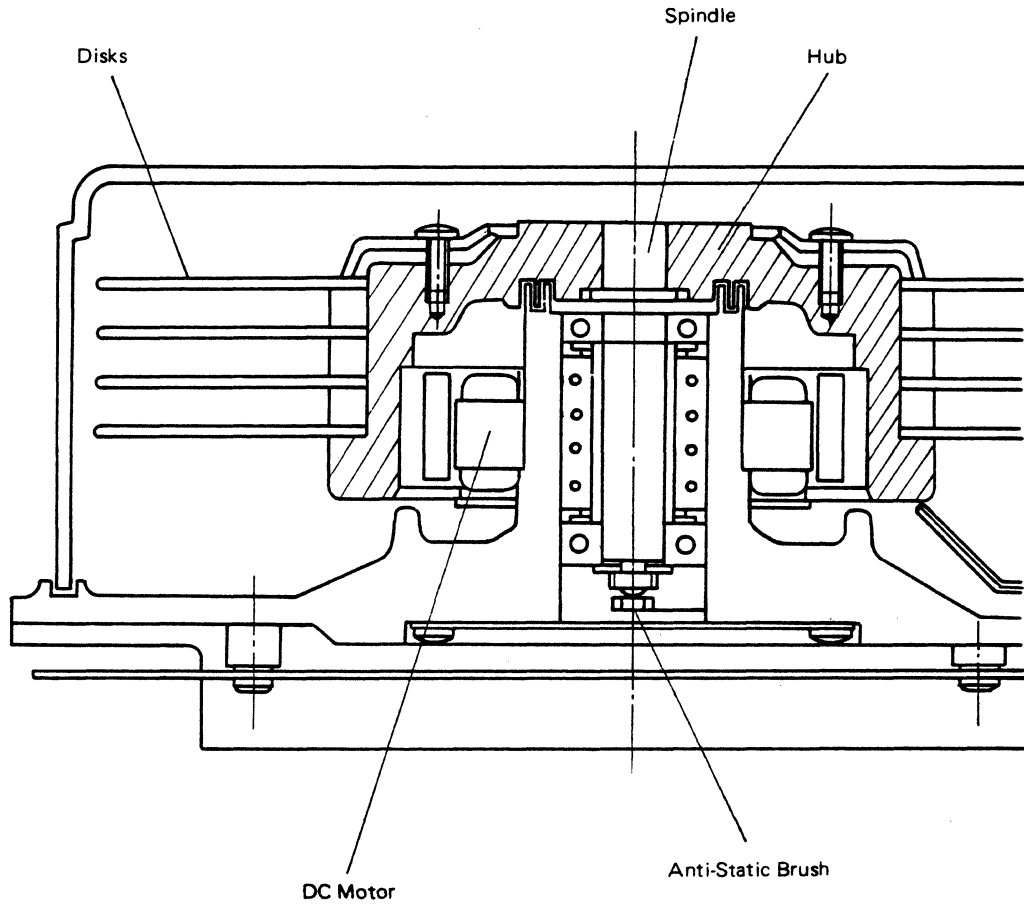

Fig. 4.2 Spindle

### 4.2.3 Carriage Assembly

Carriage assembly consists of a four-phase stepping motor, band actuator, viscous damper, and carriage with linear bearings. The assembly is controlled by a special driving circuit which achieves an average positioning time of 70ms. In addition to high speed, the structure of the assembly gives increased reliability.

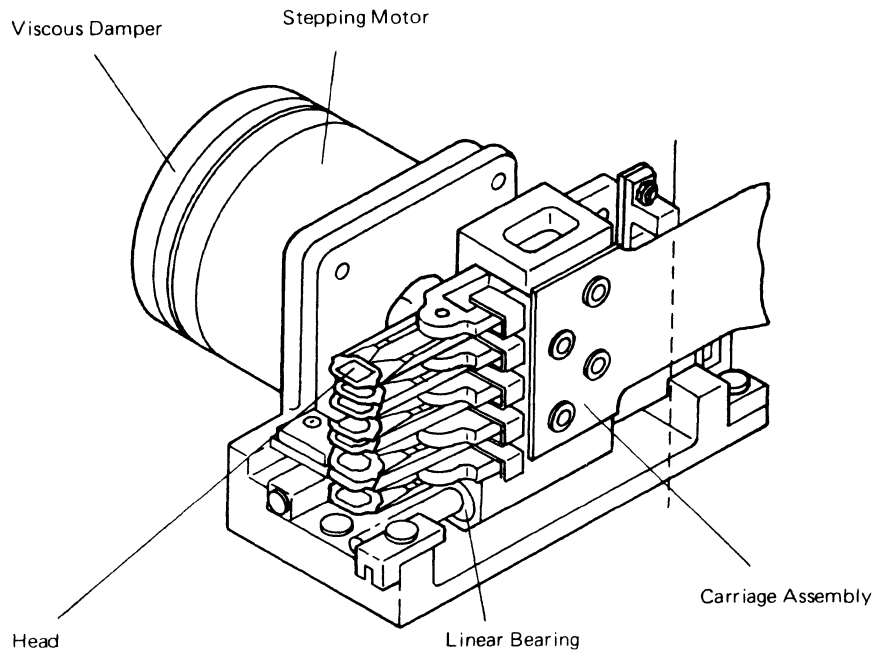

Fig. 4.3 Carriage Assembly

If the disks do not rotate, the heads rest on the disk surface. Therefore, during maintenance or when transporting the drive, the carriage must be locked to protect the heads.

#### 4.2.4 Air Circulation in DE

The unit is provided with CSS heads which have a flying height of about 0.45 microns. Therefore, a small dust-particle could cause a head crash. For this reason the DE is perfectly sealed. There are two filters. One for breathing, the other one is for recirculation to keep the air inside the DE clean.

The filter for breathing serves:

- (1) To prevent suction near the spindle when it starts rotating.
- (2) To prevent the intrusion of dust into the DE, when the air pressure inside of the DE decreases due to the difference in temperature between the inside of the DE and the atmosphere.

The recirculation filter is fitted inside of the pipe which forms a closed loop in the DE. When suction occurs by virtue of the rotation of the spindle, the air in the DE circulates through the closed loop. Thus the air circulates continuously whenever the spindle is rotating to keep it clean.

These two filters can eliminate 99.97% of contaminates with a particle size larger than 0.3 micron.

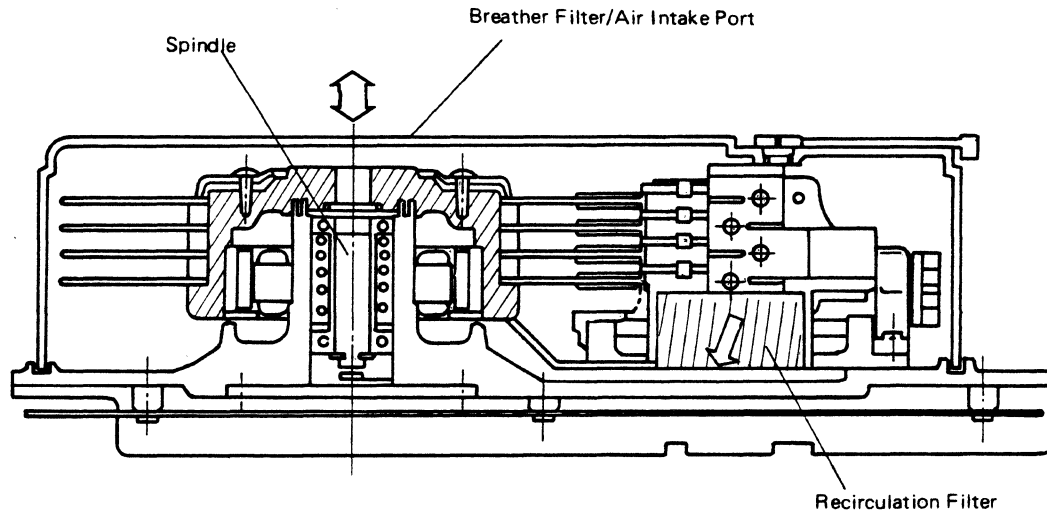

Fig. 4.4 Air Circulation Inside the DE

## 4.3 MAGNETIC HEADS AND RECORDING MEDIA

### 4.3.1 Magnetic Heads

To accomplish high density recording, CONTACT START/STOP (CSS) flying heads are employed. The heads fly on the surface air flow generated by the rotating disk. The CSS system differs from the conventional ramp load system in that the heads are always over the recording media and rest on the disk surface when the disk is not rotating.

Therefore, the head and disk make contact, and the wear caused by this contact must be minimized. For this reason, the CSS type head is lightly loaded and the surface pressure is reduced by using a tapered flat slider such as that shown in Fig. 4.6. The slider has 3 rails. The air intake end of the slider is tapered to obtain flying force by means of the air flow over the disk surface. Reads and writes are performed by a ferrite core at the rear of the head, the minimum flying height position.

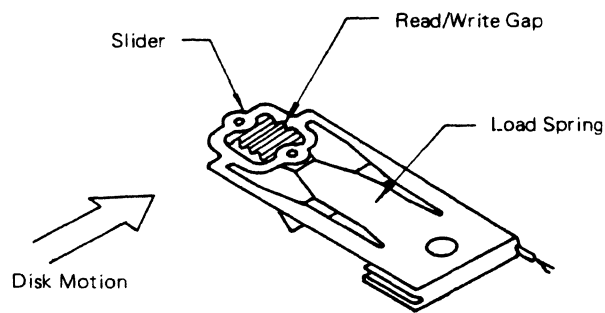

Fig. 4.5 Read/Write Head

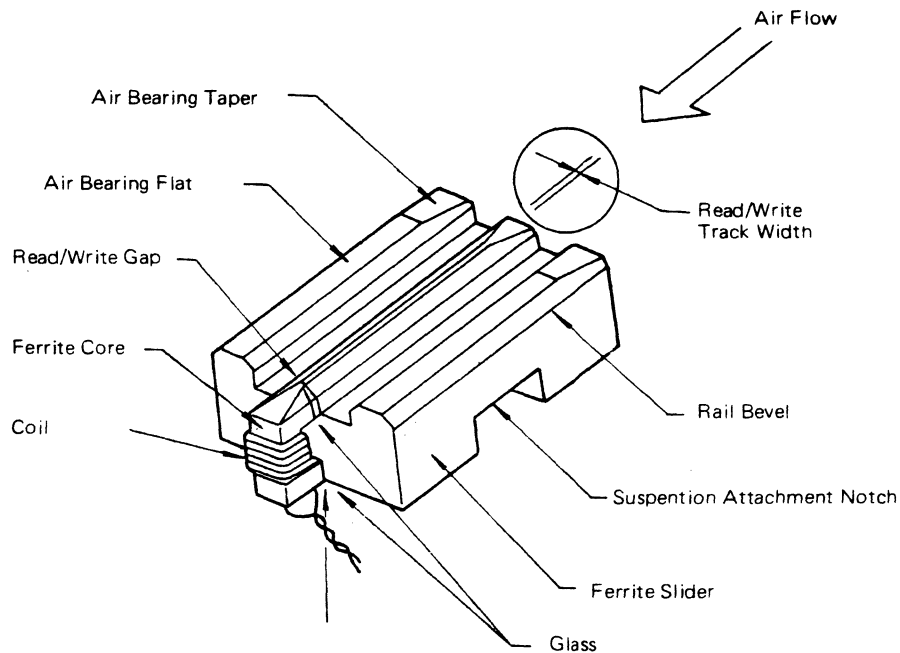

Fig. 4.6 Structure of Head Slider



#### 4.3.2 Recording Media (Magnetic Disk)

A magnetic disk is made of an aluminum substrait on which magnetic material is coated, measures 200mm (8 inches) in diameter, and 2mm in thickness. It is used to store data. Because of the CSS characteristic of the drive, the media surface is lubricated with a special lubrication in order to prevent wear. Up to four disks are installed for a maximum storage capacity of 23.4M bytes.

The index information is stored in the outer circumference (beyond the data field) on the under side of the lowest disk.

#### 4.3.3 Head and Surface Configuration

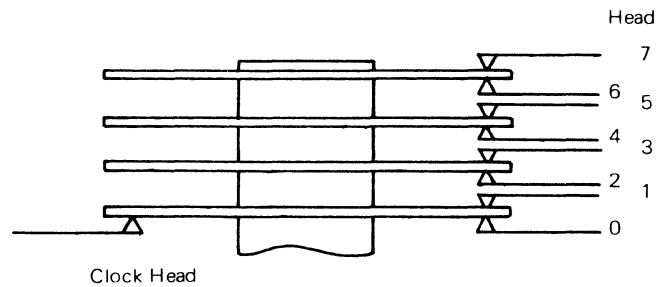

#### 4.3.4 Clock Track Format

As was described in 4.3.2, the clock track is the outermost track on the bottom surface. It contains  $12,000 \pm 3\%$  data intervals for generating clock signals as well as one index pattern.

Fig. 4.7 shows the clock signal waveform and index pattern waveform.

(1) Clock Signal Waveform

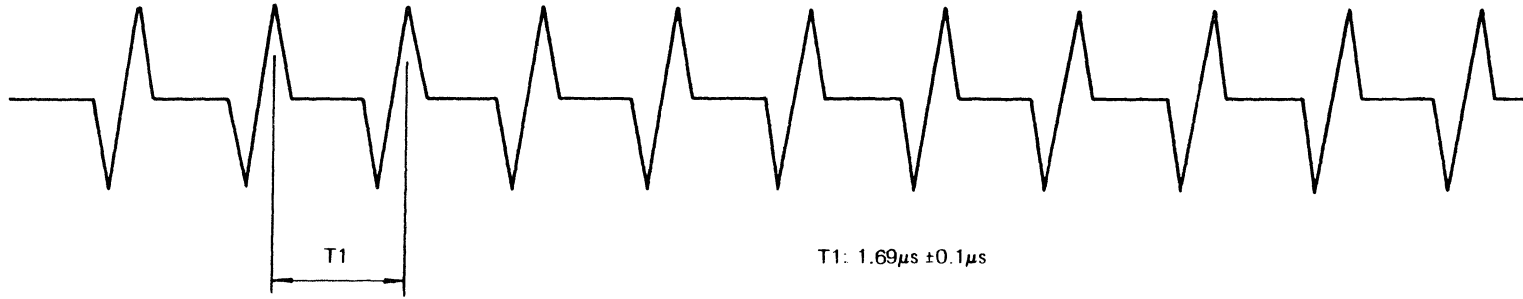

(2) Index Pattern Waveform

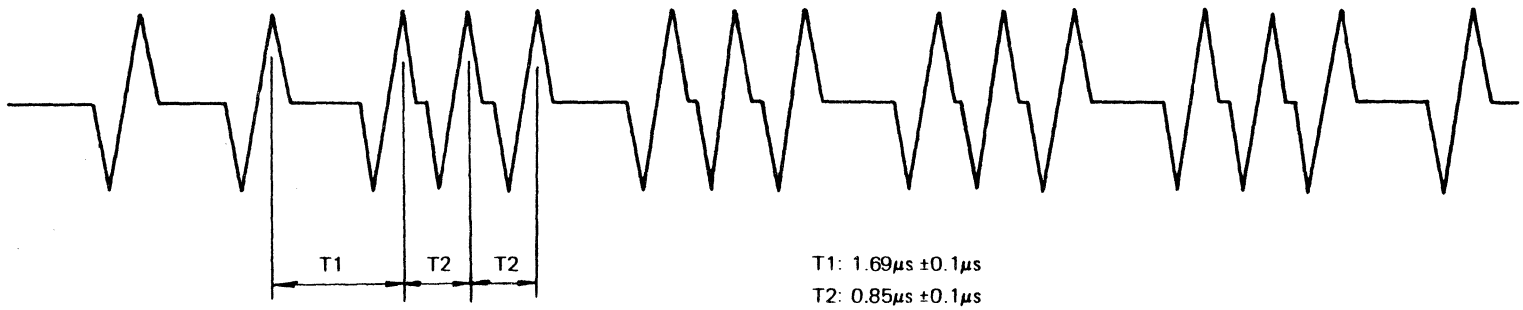

Fig. 4.7 Clock Signal Waveform/Index Pattern Waveform

## 4.4 FORMAT

### 4.4.1 General

A sector (or record) is used to allocate addresses. Each sector has an address area (AA) which ensure that the correct sector is located, and a data area (DA) in which data is stored.

The index and sector signals are used to inform the controller of the beginning of a track and sector. The sector format is determined by the control unit. On the other hand, the device must be set to generate the desired fixed length sector format by means of switches.

A fixed length format of 40 sectors is described as an example in this section.

### 4.4.2 Track Format

Example of a format of 40 sectors.

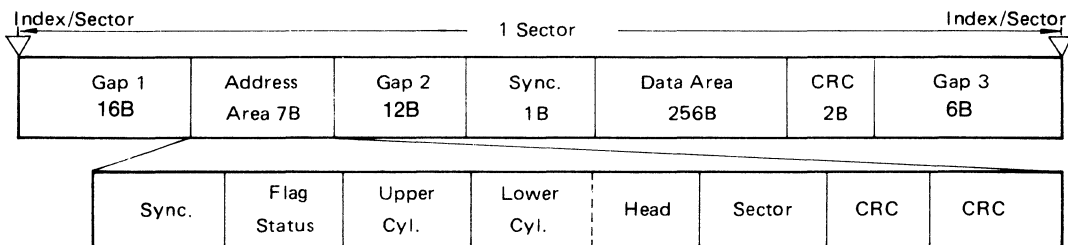

Note: (1) The format shown here is only an example and the construction of an optimum format compatible to the system is possible.

(2) A different SYNC BYTE pattern between the address area and the data area is permissible. A recommended pattern is "0E" and "09" (Hex.) respectively.

### 4.4.3 Detail of The Format

(1) GAP 1

The gap allows for displacement of the head, circuit tolerances, and write to read transient after write operation under worst case conditions. The gap must be a minimum of 16 bytes, in which all "0"s are written.

(2) SYNC BYTE

This shows the starting point of the address area.  
A recommended pattern is "0E" (Hex.).

(3) FLAG STATUS/LOGICAL UNIT

This shows the status of each sector (record).  
Normal record, spare record, or replacement record may be indicated here. However, its meaning is defined by the control unit.

(4) UPPER CYLINDER ADDRESS/LOWER CYLINDER ADDRESS (MSB/LSB)

This indicates the cylinder address on the track.

(5) HEAD ADDRESS

This indicates the head address on the track.

(6) SECTOR ADDRESS

This indicates the sector (record) address on the track.

(7) CRC (CYCLIC REDUNDANCY CHECK)

This is the area which checks whether the data was correctly read.

- (8) GAP 2  
This is an area where a write splice would occur when the data area of the sector was updated. Since the read circuit may be reactivated after the write splice area, all "0" must be written in this 12 or more Byte area. The read circuit requires an all "0"s area to synchronize read circuits.
- (9) SYNC BYTE  
Indicates the beginning of the data area.
- (10) DATA AREA  
This is the area where data is written and read.
- (11) CRC  
See (7)
- (12) GAP 3  
This pad time is required by the control unit. All "0"s are written in this 6 Byte area.

## 4.5 INTERFACE

### 4.5.1 General

Logical and physical conditions for the reception/transmission of signals in the interface of M2301/M2302 micro disk drive are described in this chapter.

- (1) Connection  
There are two connectors for external connection on this unit. These are called "A" and "B" connectors. The cables connected to these are called cable "A" and cable "B". "A" cables may be connected in daisy chain. When this configuration is utilized, the terminator must be removed from all but the last drive. See Fig. 3.7. The "B" cable is connected in a radial fashion. Therefore, the control unit, requires "B" cables and connectors in proportion to the number of drives connected.
- (2) Timing Specification  
The timing specifications for signals are referenced at the connector position of the unit. Consequently, with regard to the signal timing from the unit, time lag of the cable, and time lag due to the number of circuit stages in the control unit must be considered.
- (3) Interface Transmission Level  
There are two types of interface drivers and receivers used. For the high frequency signal lines, balanced line differential devices are used. These lines are indicated by "(1 pair)" in the diagrams below. The control and select lines are TTL level and 0 volt is active or true.

## 4.5.2 Type and Name of Signal Lines

### (1) A Cable Signal Lines

Controller Side		Drive Side	
(3)	HEAD SELECT 0 ~ 2	INDEX	(1)
		READY	(1)
(4)	DRIVE SELECT 1 ~ 4		
(1)	DIRECTION	SECTOR/BYTE CLOCK	(1)
(1)	STEP	WRITE FAULT	(1)
(1)	FAULT CLEAR	TRACK 0	(1)
(1)	WRITE GATE		
		(SEEK COMPLETE)	(1)*
(1)	READ GATE		
* (1 pair)	WRITE DATA	READ DATA	(1 pair)*
* (1 pair)	WRITE CLOCK	PLO CLOCK	(1 pair)*
12 line + 2 pairs		6 line + 2 pairs	

\* This signal line is connected by a switch setting on the PCB.

### (2) B Cable Signal Lines

		INDEX	(1)
		READY	(1)
		SECTOR/BYTE CLOCK	(1)
		SEEK COMPLETE	(1)
(1 pair)	WRITE DATA	READ DATA	(1 pair)
(1 pair)	WRITE CLOCK	PLO CLOCK	(1 pair)
2 pairs		4 line + 2 pairs	

### 4.5.3 Signal Lines

#### (1) Input Signals

(a) HEAD SELECT 0 ~ 2

These binary coded signal lines select one of eight data heads positioned in the disk drive. However, the M2301 has only 4 data heads.

(b) DRIVE SELECT 1 ~ 4

These signal lines enable the input/output signals of the disk drive having a matching logical unit number. Each line selects one drive. The signal line of DRIVE SELECT 4 can be changed to the SEEK COMPLETE signal by a switch setting on the PCB.

(c) DIRECTION

This indicates the seek direction of the data heads when STEP PULSES are sent to the disk drive. When this signal is TRUE, it causes a seek in the inner direction. And if this signal is FALSE, this causes a seek in the outer direction (Toward track 0).

(d) STEP

This signal triggers the carriage to move the data heads one track in the direction indicated by the DIRECTION signal. The following three step modes are provided.

i) Controlled Step Mode

If the step pulse rate is 1kHz or less, the drive performs a seek one track in response to one STEP pulse from the controller.

ii) Slave Step Mode

If the step pulse rate is more than 3kHz but less than 3MHz the drive does not perform SEEK individually in response to each STEP signal from the controller, but rather starts the seek operation after receiving all STEP pulses from the controller. The drive will then move the heads at high speed to the desired track according to an ideal velocity curve stored in ROM.

When the SEEK operation is finished, the drive responds by sending the SEEK COMPLETE signal.

Note: STEP RATE of 1kHz to 3kHz is prohibited.

iii) Return to Zero Mode

When the drive has received more than 255 step pulses in the slave step mode, it performs a SEEK at normal speed to TRACK 0.

(e) FAULT CLEAR

This signal line resets the write fault latch. The width of the pulse must be greater than 100ns.

(f) WRITE GATE

This signal line gates write current to the selected data head.

(g) READ GATE

This signal line gates read data from the selected data head to the data separator. Separated READ DATA and READ CLOCK are then provided to the interface. READ GATE is valid when 10.0 $\mu$ s (6-byte) have elapsed after READ GATE is active.

(h) **WRITE DATA (Balanced Transmission)**  
This is the write data signal in NRZ format.  
The signal is sent out by the controller using balanced line transmission levels.  
The **WRITE DATA** signal must be synchronized by the trailing edge of **WRITE CLOCK**. **WRITE DATA** may be input to either the A or B cable depending on the switch setting on the PCB.

(i) **WRITE CLOCK (Balanced Transmission)**  
This is the **WRITE CLOCK** signal from the controller synchronized with **WRITE DATA**. **WRITE CLOCK** may be input to either the A or B cable dependings on the switch setting on the PCB. This signal is derived from the PLO Clock generated in the drive and sent to the controller.

(2) **Output Signals**

(a) **Index**  
This pulse is sent out at the rate of once per revolution of the disks. The width of a pulse is  $1.7\mu\text{s}$ . This signal is available to both the A and B cables.

(b) **Ready**  
This signal indicates that the drive is selected and the disks are rotating at the correct speed. (The PLO circuit synchronizes with the speed of the disk). This signal is available to both the A and B cables.

(c) **SECTOR (BYTE CLOCK)**  
Either **SECTOR Pulses** or **BYTE CLOCK** is available through the selection of a switch on the PCB on the drive. This signal is available to both the A and B cables.

i) **BYTE CLOCK**  
This is a pulse which occurs  $12,000^{+32}_0$  times on the track. The width of pulse is  $0.84\mu\text{s}$ .

ii) **SECTOR PULSE**  
The number of **SECTOR** pulses which occur per revolution of the disks is switch selectable. The pulse is generated by counting the number of bytes within one sector. One sector may contain a maximum of 4,095 bytes. The width of this pulse is  $1.7\mu\text{s}$ .

(d) **TRACK 0**  
This indicates that the data heads are at Track 0.

(e) **WRITE FAULT**  
This indicates that one of the following fault conditions occurred during **WRITE**. The **WRITE FAULT** is retained until it is reset by a **FAULT CLEAR** pulse.

- i) **WRITE GATE** is sent out when the drive is not **READY**.
- ii) **WRITE GATE** and **READ GATE** are sent at the same time.
- iii) **WRITE GATE** is sent when more than one head is selected.
- iv) **WRITE GATE** is sent when **SKC** (seek complete) is false.
- v) During **WRITE**, a normal write current does not flow to the data head.

(f) **READ DATA (Balanced Transmission)**  
These lines transmit the recovered data in the form of NRZ data synchronized with PLO clock. The **READ DATA** becomes valid 6 Bytes after the leading edge of **READ GATE**. **READ DATA** is available to both the A and B cables when enabled by a switch on the PCB.

- (g) **PLO CLOCK (Balanced Transmission)**  
This pulse is sent out every other bit. When READ GATE is false, the PLO CLOCK is synchronized with the pulse read from the clock track. When READ GATE is true, the PLO is synchronized with the READ DATA from the data head. The controller uses the PLO CLOCK during a write operation as WRITE CLOCK. PLO CLOCK is available to both the A and B cables when enabled by a switch on the PCB. This pulse is jumper selectable to provide a normal or inverted triggering.
  
- (h) **SEEK COMPLETE**  
The SEEK COMPLETE signal indicates that the selected data head in the drive is positioned over the required track. This signal may contain the settling time for the seek operation. A READ/WRITE operation is legal the instant this signal turns TRUE. This signal is available to both the A and B cables, however, in case of CNA it is enabled by a switch key on the PCB.



## 4.5.4 Timing Specification

### (1) SEEK Timing

#### CONTROLLED STEP MODE

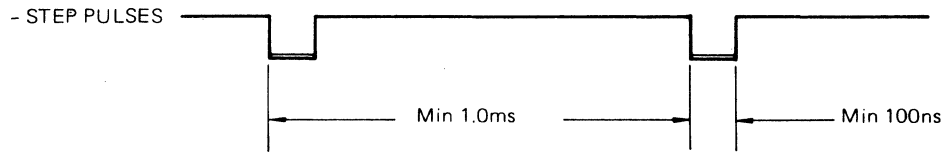

#### SLAVE STEP MODE

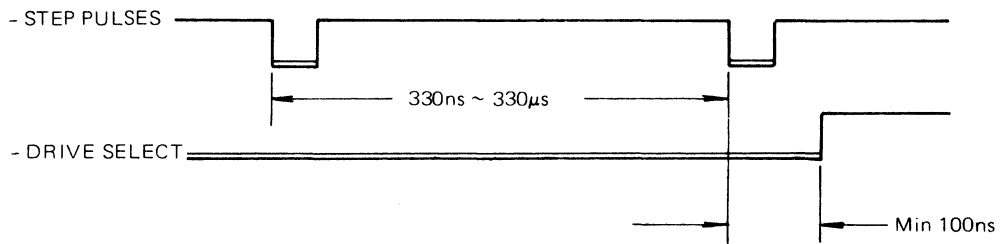

#### (i) S3 on PCA: 1-2 short

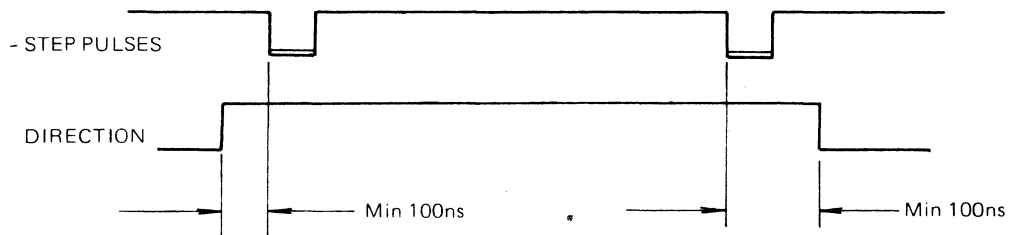

#### (ii) S3 on PCA: 2-3 short

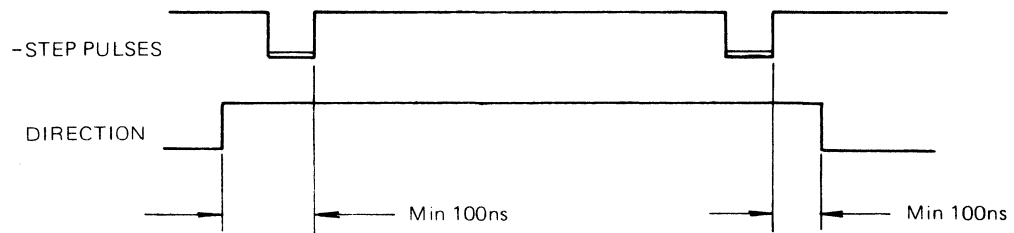

(2) WRITE/READ DATA Timing  
 WRITE DATA, WRITE CLOCK

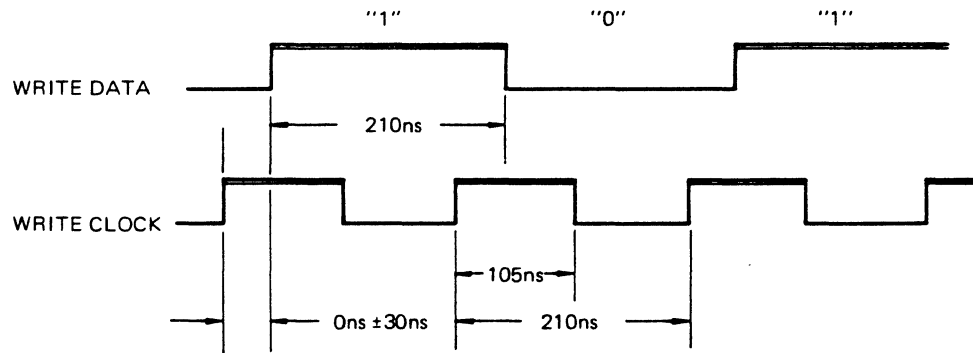

READ DATA, PLO CLOCK

(i) S2 on PCA: 1-2 short

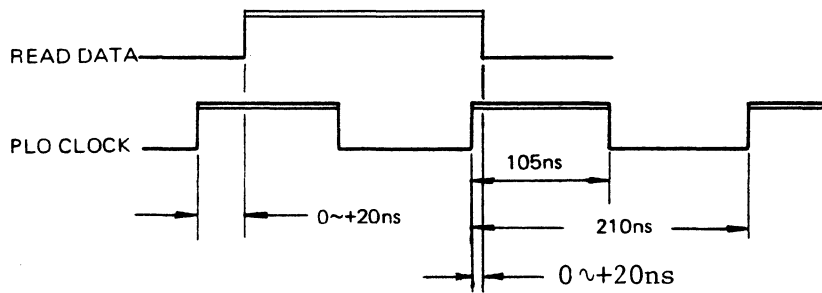

(ii) S2 on PCA: 2-3 short

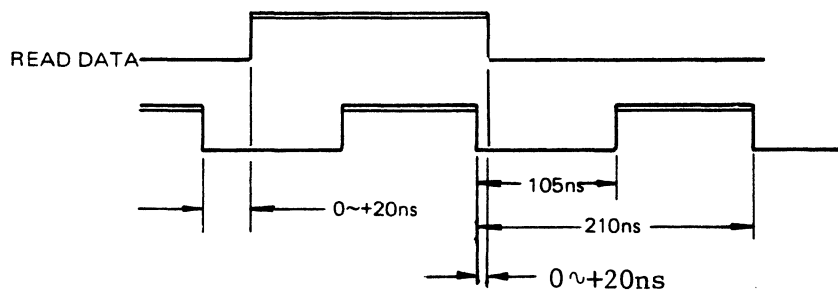

### 4.5.5 Format Timing Specification

#### (1) Format Write

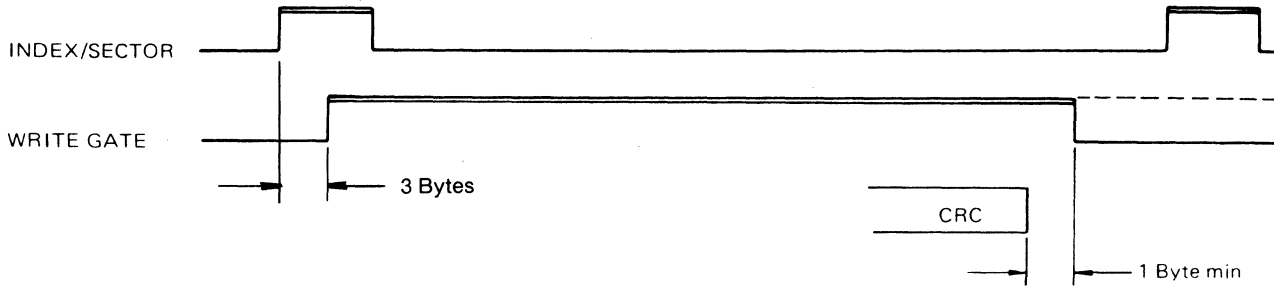

#### (2) Data Write

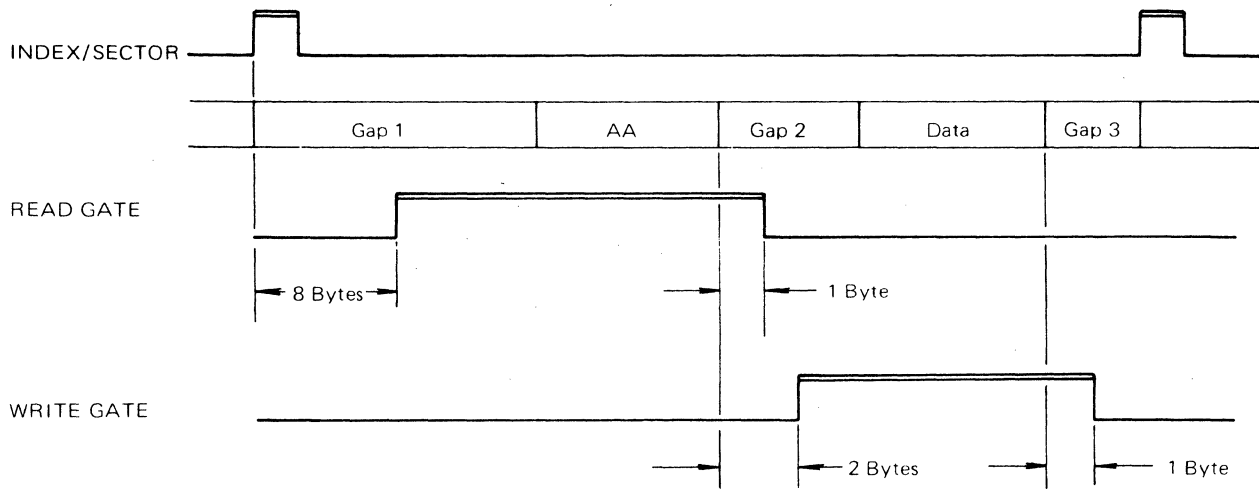

#### (3) Data Read

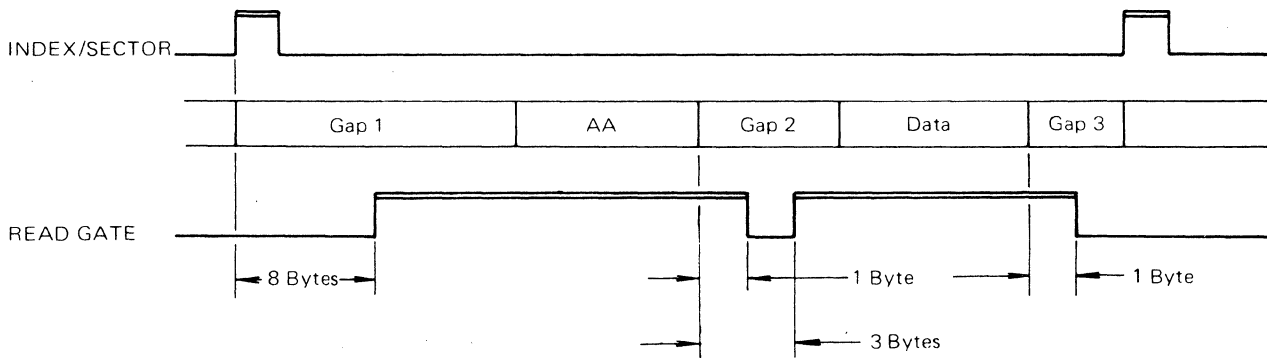

#### 4.5.6 Driver/Receiver

Both types of Driver/Receivers used on the drive are shown in the following diagram. The maximum cable length specification includes all cables from the controller to the last drive when the A cable is daisy chained.

Control signal (TTL)

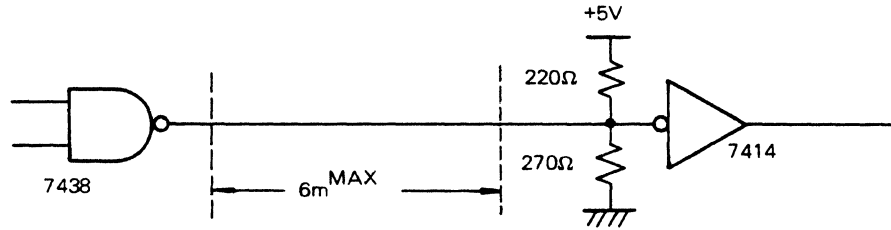

R/W signal (Balanced Transmission)

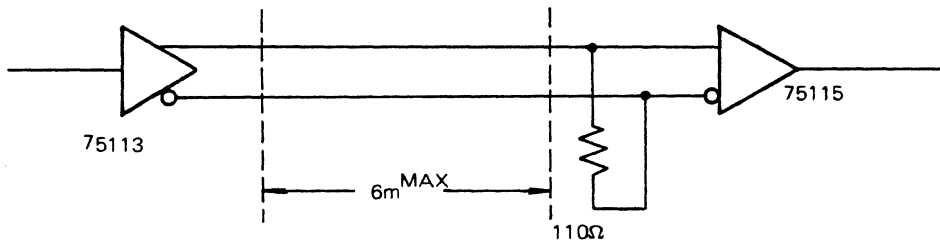

Driver/Receiver

#### 4.5.7. Pin Assignment in Connectors

CNA

1	GND	2	-HEAD SELECT 0
3	"	4	" 1
5	"	6	" 2
7	"	8	SPARE
9	"	10	-INDEX
11	"	12	-READY
13	"	14	-SECTOR/BYTE CLOCK
15	"	16	-DRIVE SELECT 1
17	"	18	" 2
19	"	20	" 3
21	"	22	" 4
23	"	24	-DIRECTION
25	"	26	-STEP
27	"	28	-FAULT CLEAR
29	"	30	-WRITE GATE
31	"	32	-TRACK 0
33	"	34	-WRITE FAULT
35	"	36	-READ GATE
37	"	38	GND
39	+WRITE DATA	40	-WRITE DATA

### CNA (continued)

41	GND	42	-WRITE CLOCK
43	+WRITE CLOCK	44	GND
45	+PLO CLOCK	46	-PLO CLOCK
47	GND	48	+READ DATA
49	-READ DATA	50	GND

Key slot: Between 8P and 10P.

### CNB

1	-INDEX	2	GND
3	-READY	4	"
5	-SECTOR/BYTE CLOCK	6	"
7	-SEEK COMPLETE	8	"
9	+WRITE DATA	10	-WRITE DATA
11	GND	12	+WRITE CLOCK
13	-WRITE CLOCK	14	GND
15	+PLO CLOCK	16	-PLO CLOCK
17	GND	18	+READ DATA
19	-READ DATA	20	GND

Key slot: Between 8P and 10P.

### CNC

1	+24V	2	+24V RTN
3	-5V/-7~-16V RTN	4	-5V/-7~-16V
5	+5V	6	+5V RTN

## 4.6 ELECTRIC CIRCUIT OPERATION

### 4.6.1 Block Diagram

The block diagram for the electric circuit is shown in Fig. 4.8.

### 4.6.2 Start/Stop Circuit

When all DC voltages are applied to the unit, the brake relay is opened and the driving circuit of the DC spindle motor is enabled, thus turning the disks. The speed of the spindle motor is monitored by an internal timer. When the disks are rotating at the correct speed, the stepping motor is energized, and the SEEK COMPLETE and the READY signals are sent to the interface. When the power is turned off, the brake relay is closed, and the DC motor is connected to the brake resistor from the driving circuit. This brakes the DC motor and the disk comes to a complete stop in about 25 seconds.

When power is applied to the circuit, the position of the data head is not guaranteed to be track 0. Therefore, if the track 0 signal is false on the interface, the controller must return the data heads to track 0 in order to initialize the Cylinder Address Control.

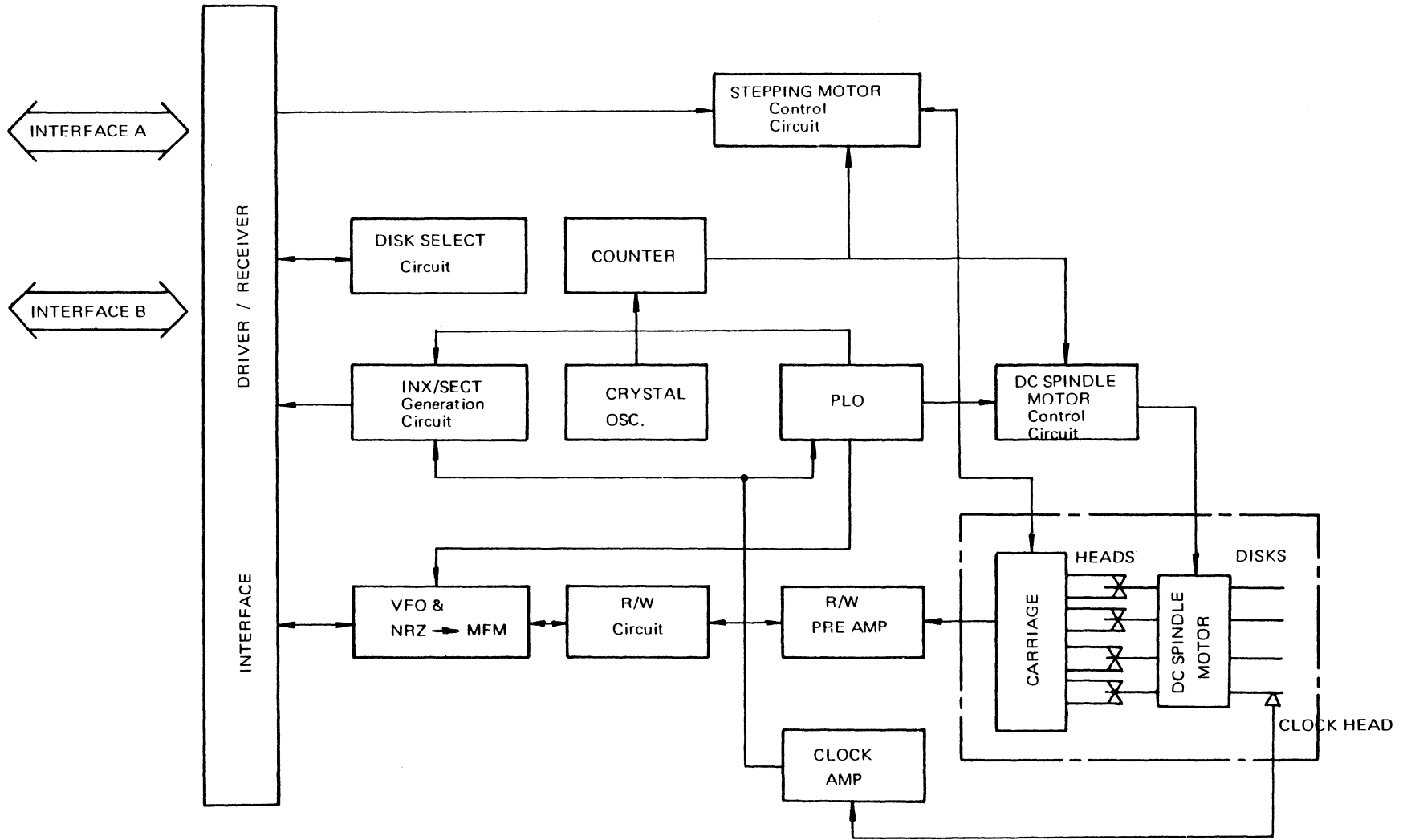

Fig. 4.8 Block Diagram

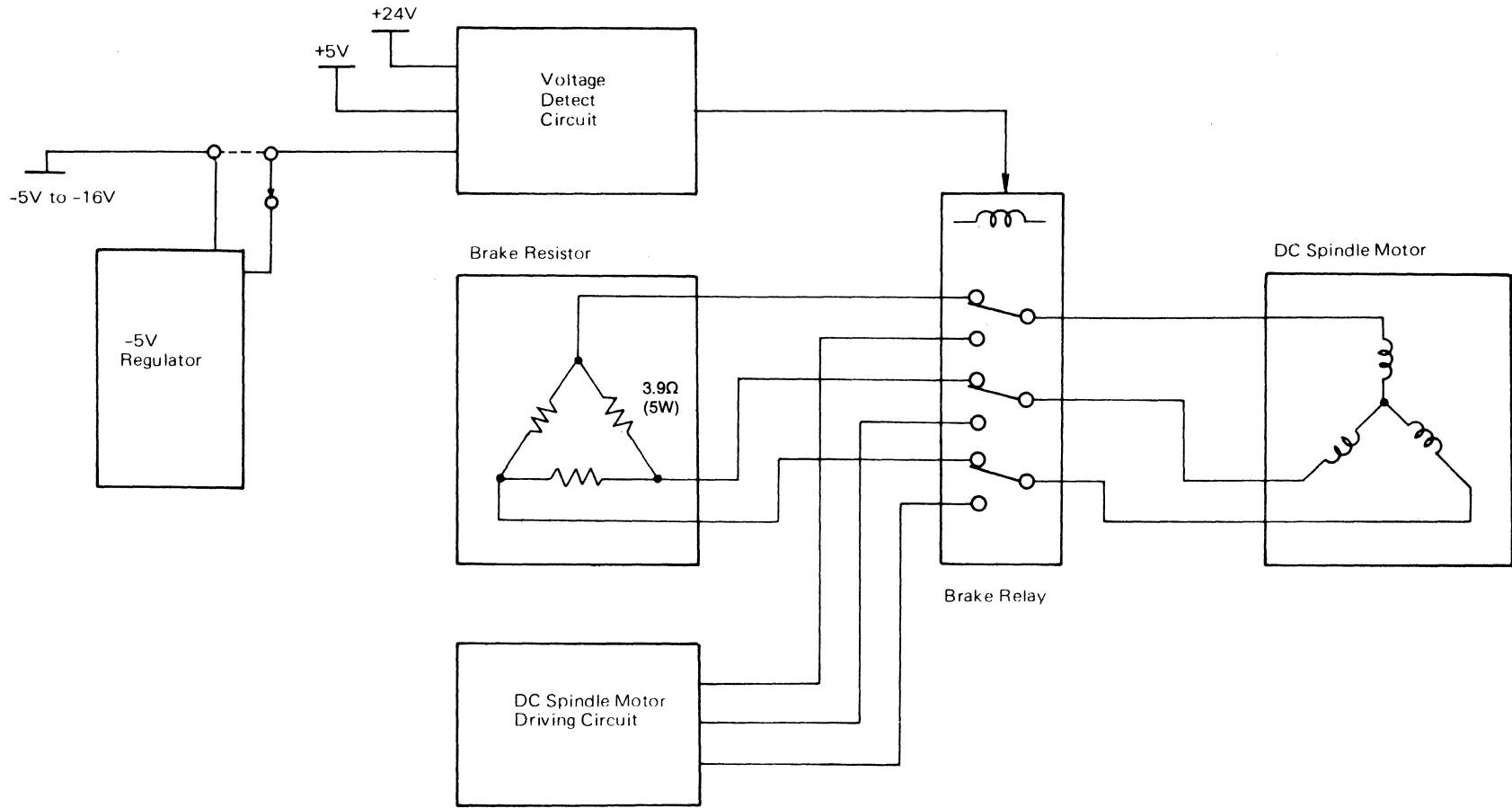

Fig. 4.9 Start/Stop Circuit Block Diagram

#### **4.6.3 DC Spindle Motor Driving Circuit**

The integral DC spindle motor consists of 4-poles with a 3-phase outer rotor. The detection of the rotation angle is conducted by three hall-effect elements fitted into the motor.

The motor driving circuit controls the coil current of the motor by sensing the three pairs of output signals from the hall-effect elements. The driving circuit also serves to detect the coil current of the motor in order to regulate the current required during start-up, and if the value exceeds specification, the circuit turns off the coil current. Fig. 4.10 shows the block diagram of the DC spindle motor driving circuit. Fig. 4.11 shows the timing chart.

#### **4.6.4 DC Spindle Motor Controller**

The DC spindle motor controller controls the rotational speed so that it falls within the range 2964 rpm  $\pm$ 2% by comparing the reference frequency of signals generated by the internal oscillator with the frequency of clock signals from the clock head on the lower disk.

Fig. 4.12 shows the block diagram of the DC spindle motor controller, and Fig. 4.13 shows the timing chart.

#### **4.6.5 Unit Select Operation**

The unit may be configured as logical unit number 1, 2, 3 or 4 by setting the proper switch keys on the PCB. The select operation enables the interface of the drive with the logical unit designated by the controller. The drive is selected when the logical unit number compares with the drive select 1 to 4 signals from the controller. Refer to Section 3.6.1 for the setting procedure.



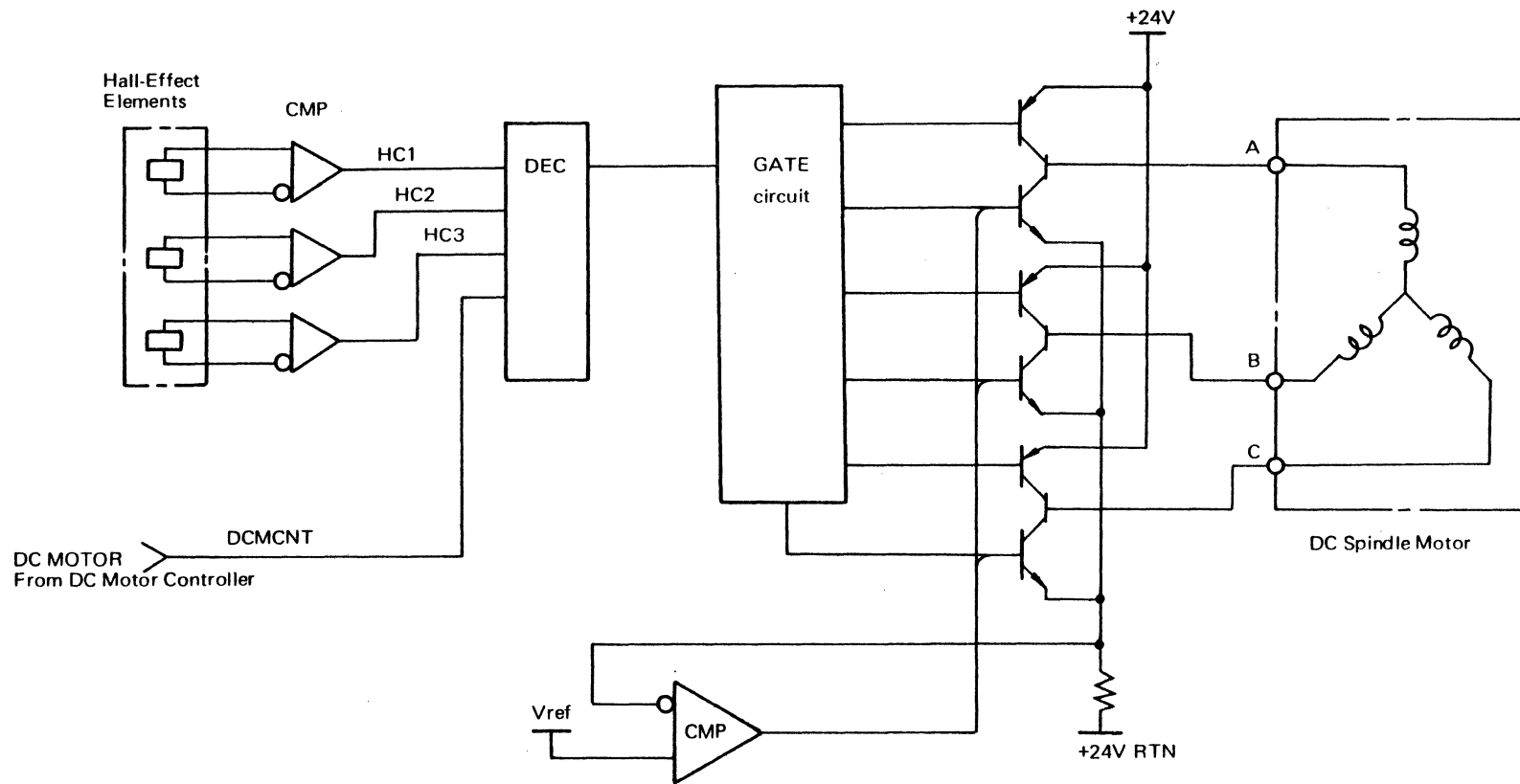

Note: DCMCNT is the signal which controls the speed of the DC spindle motor.  
 When DCMCNT is logical "1", it blocks current to the motor.  
 When DCMCNT is logical "0", it permits the current to flow.

Fig. 4.10 DC Spindle Motor Driving Circuit Block Diagram

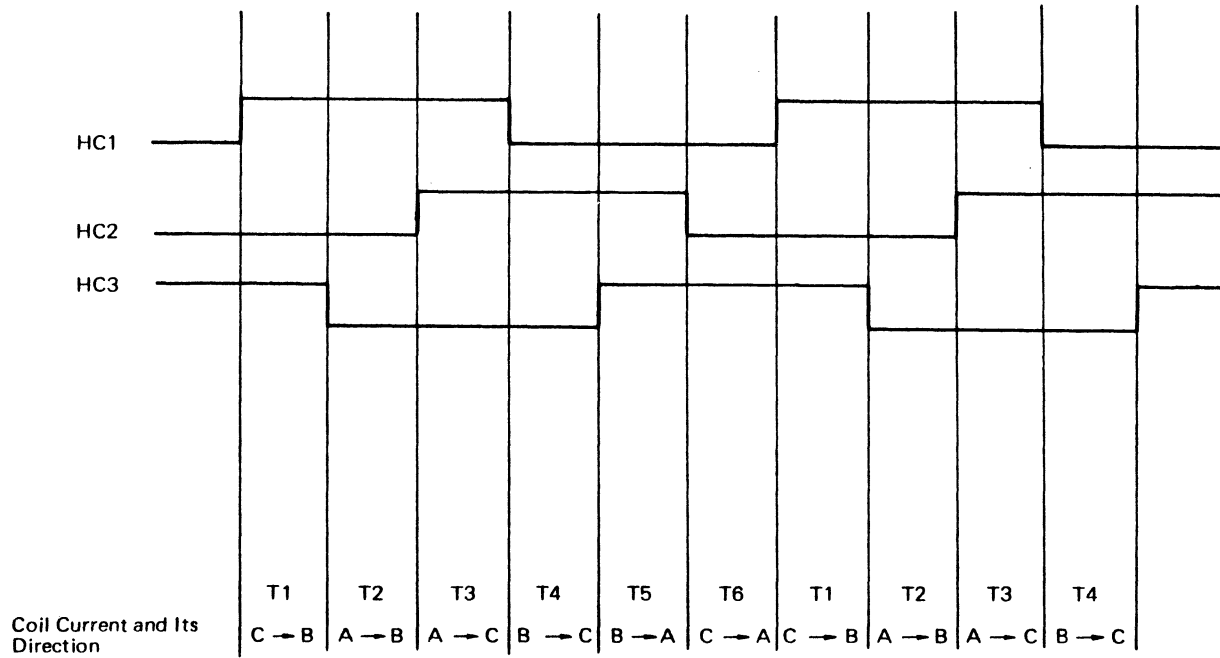

Fig. 4.11 DC Spindle Motor Driving Circuit Timing Chart

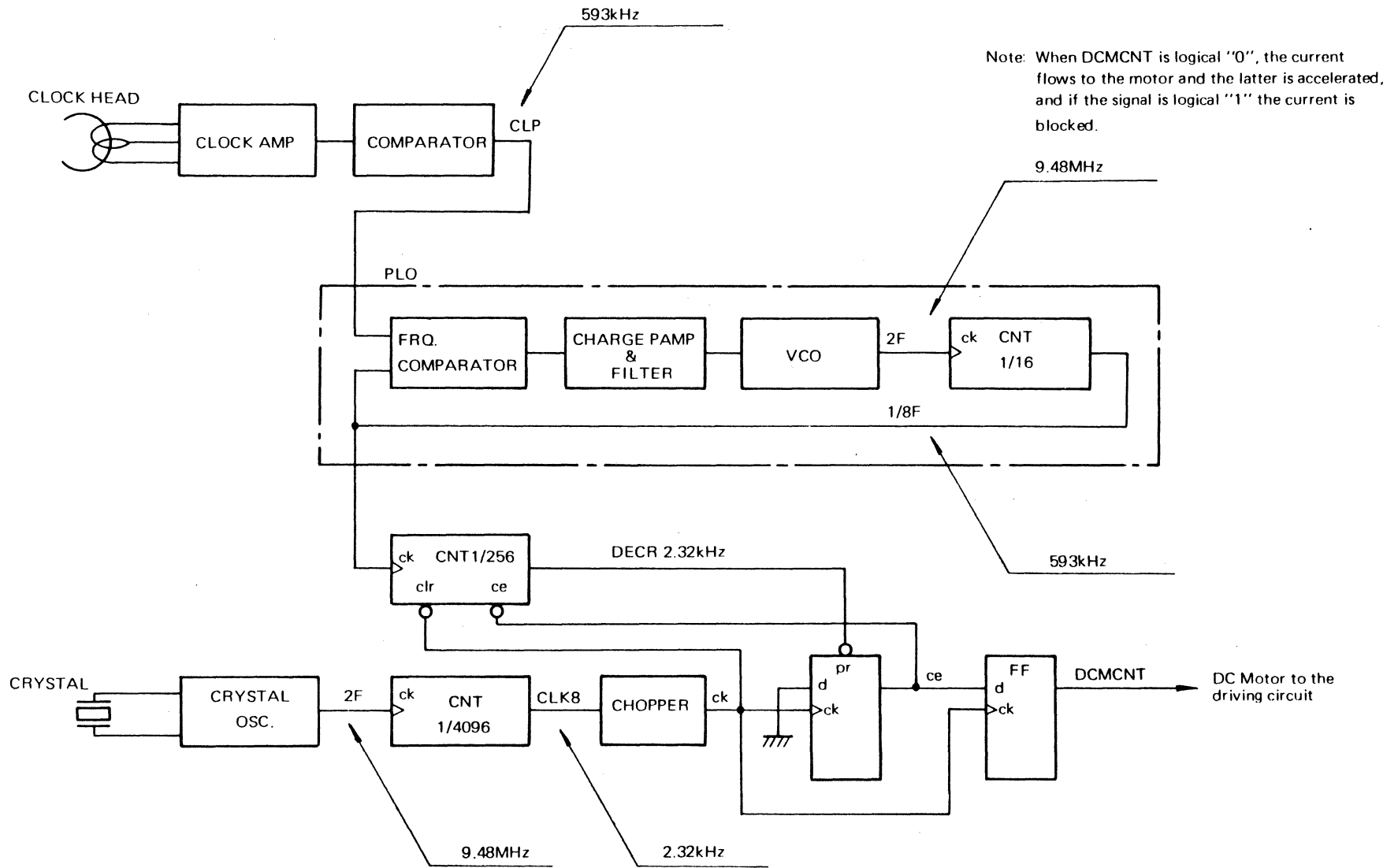
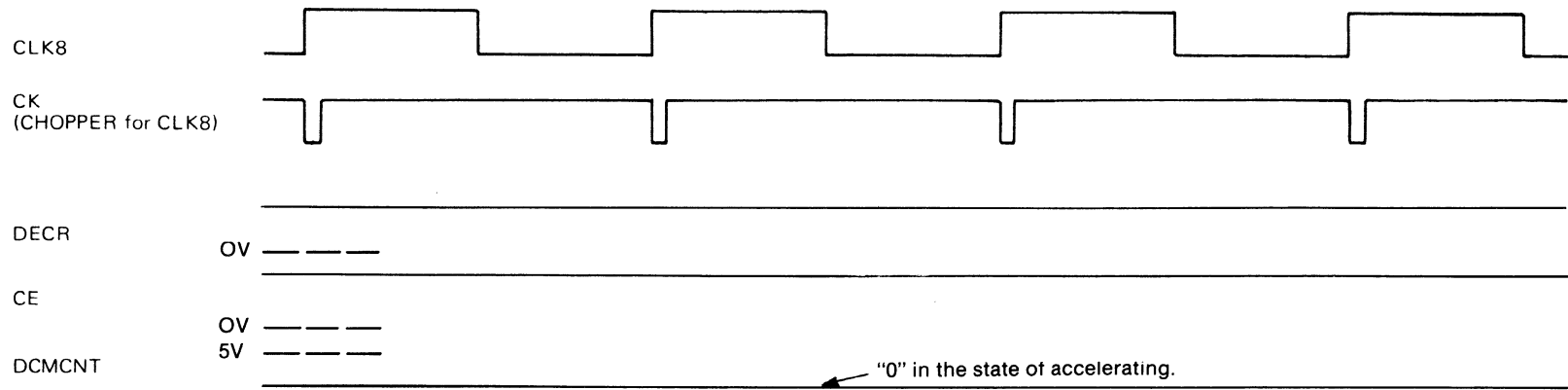

Fig. 4.12 DC Spindle Motor Control Block Diagram

(1) During Acceleration (when motor is rotating slowly) DCMCNT is "0".



(2) During Deceleration (when the motor is rotating fast) DCMCNT is "1".

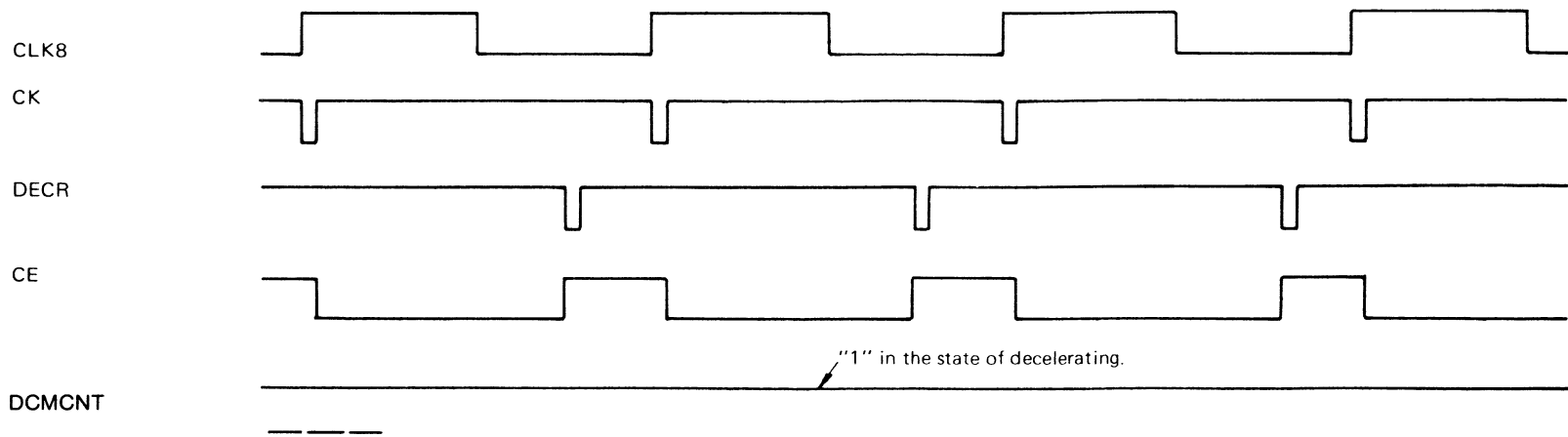

Fig. 4.13 DC Spindle Motor Control Timing Chart (1)

(3) Under Control (the speed of rotation is controlled to the 2964 rpm  $\pm$ 2%).

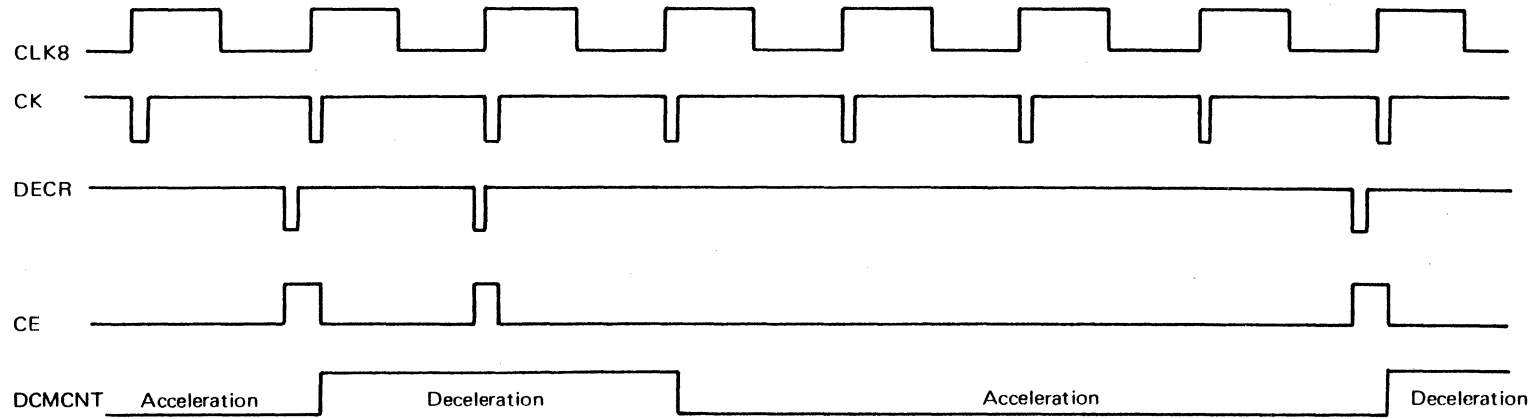

Fig. 4.13 DC Spindle Motor Control Timing Chart (2)

#### 4.6.6 SEEK Control

(1) General

There are two modes of operation for the head, positioning stepper motor: controlled step mode and slave step mode. The seek control circuit monitors the frequency of the step pulse transmitted from the controller to the drive, and if the input frequency is less than 1kHz, the controlled step mode is automatically selected. If the input frequency is over 3kHz, the slave step mode is automatically selected. However both the step rates of 1kHz to 3kHz and over 3MHz are prohibited.

When 255 or more step pulses are received in slave mode, the drive will automatically return the heads to track 0. This operation is called RETURN TO ZERO (RTZ). Fig. 4.14 shows the block diagram of seek control. Fig. 4.15 shows the flowchart.

(2) Controlled Step Mode

In this mode, the stepper motor performs a SEEK directly controlled and synchronized with the step pulse sent from the controller. The direction of the seek is controlled by the DIRECTION line from the controller. Fig. 4.16 shows the timing chart of controlled step mode.

(3) Slave Step Mode

In this mode, the seek is performed by step pulses generated by the speed up/slow down circuit within the drive. After receiving and storing all step pulses in the 3kHz to 3MHz range, coming from the controller, the seek is controlled automatically by the drive in order to complete the operation in the least amount of time.

The step rate of the speed up/slow down circuit is stored in ROM which is accessed in the Slave Step mode according to the value of the seek counter and the difference counter. The pulse train is formed depending on the data read out from ROM. Fig. 4.17 shows the timing chart. Fig. 4.18 shows the step rate of speed up/slow down.

(4) RTZ Mode

When more than 255 step pulses in slave step mode are received from the controller, the internal difference counter is kept at 255 and at the same time, RTZ LATCH is set. After all the step pulses from the controller are received, the SEEK is performed in the outer direction until the TRACK 0 indication is received by the speed up/slow down circuit. The step rate of the speed up/slow down circuit, in this case, is determined by the data from ROM accessed by the RTZ LATCH bit. In the RTZ mode, the regular step rate is 500 pps. Fig. 4.19 shows the timing chart.

(5) SEEK COMPLETE

The SEEK COMPLETE signal indicates to the controller that a seek operation has been completed. The unit can be set to use the SEKC signal which includes the positioner settling time after seek or the SKC signal which does not include the settling time.

SKC responds instantly when the last step pulse to the stepper driving circuit is issued. SEKC responds after about 30ms time lag from when the settling timer is triggered by the leading edge of SKC. Refer to item 3.6.6 for the setting method of switches. Fig. 4.20 shows the timing chart of the SEEK COMPLETE response.

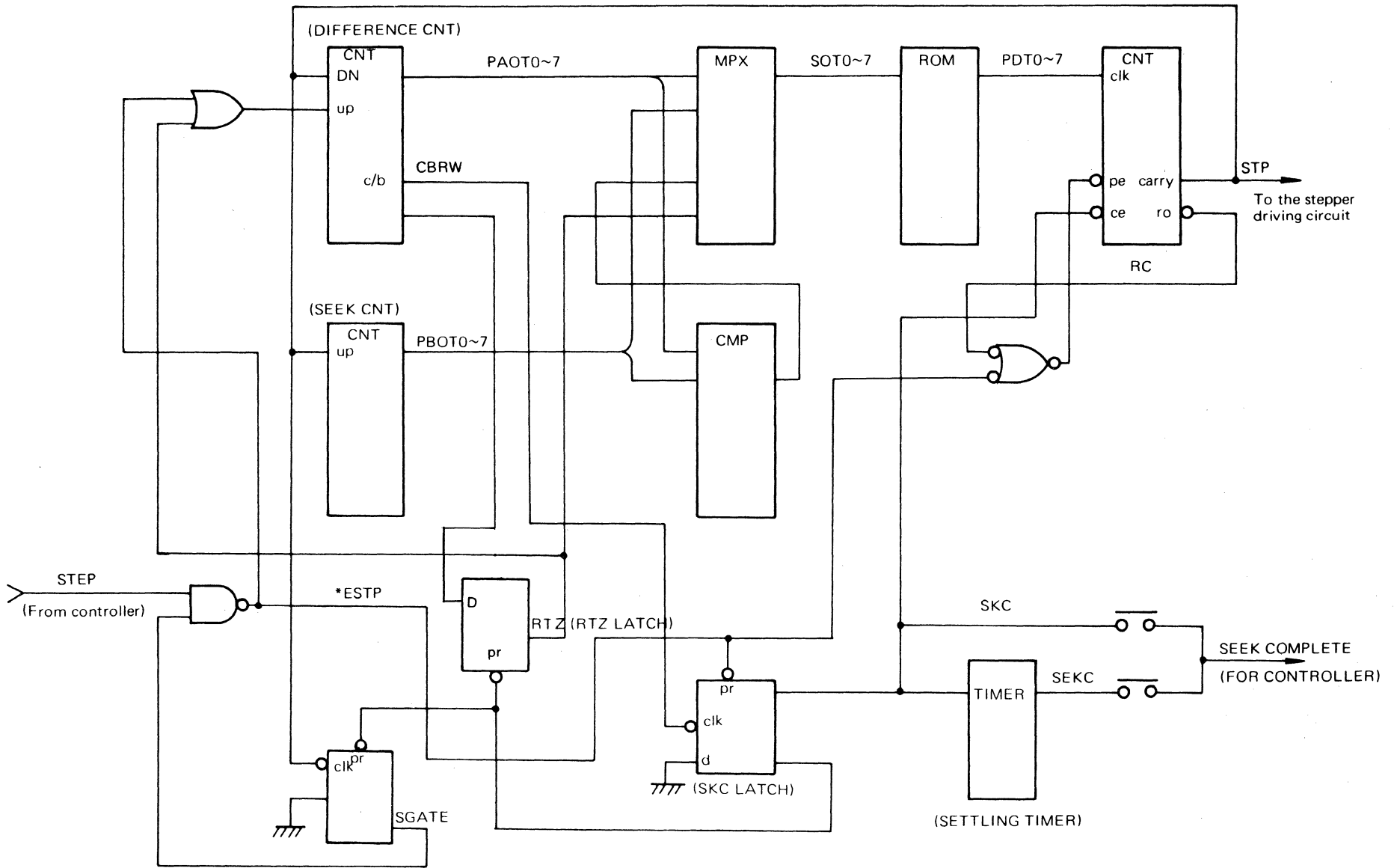
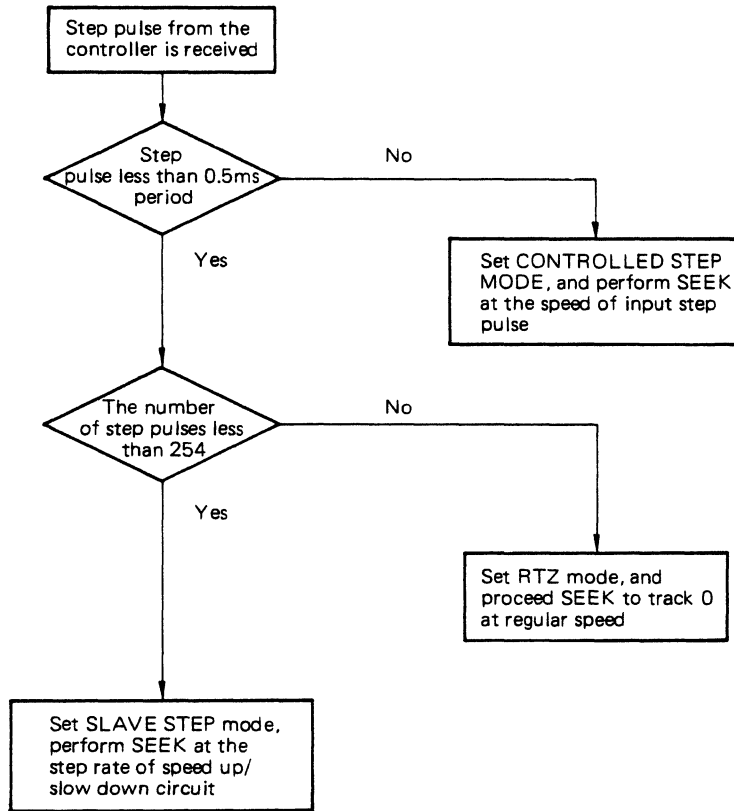

Fig. 4.14 SEEK Control Block Diagram



**Fig. 4.15 SEEK Control Flow Chart**



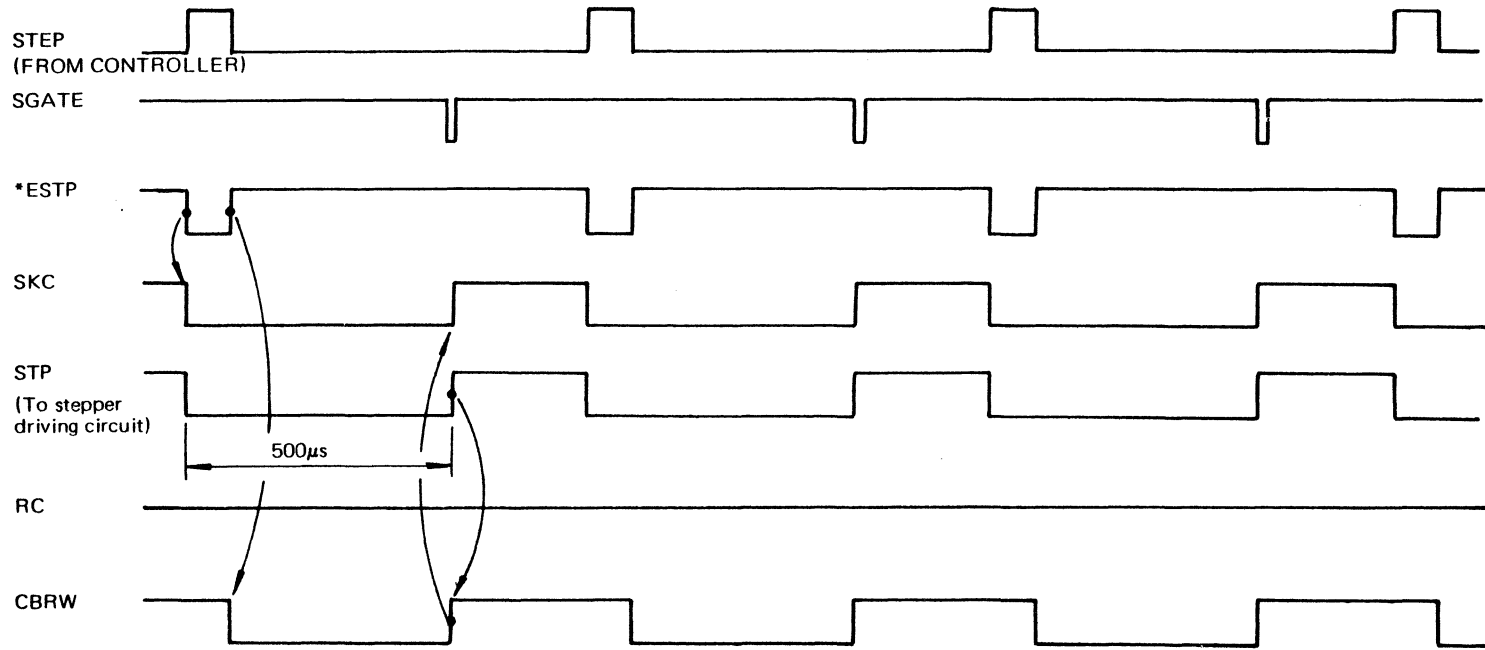

Fig. 4.16 CONTROLLED STEP Mode Timing Chart

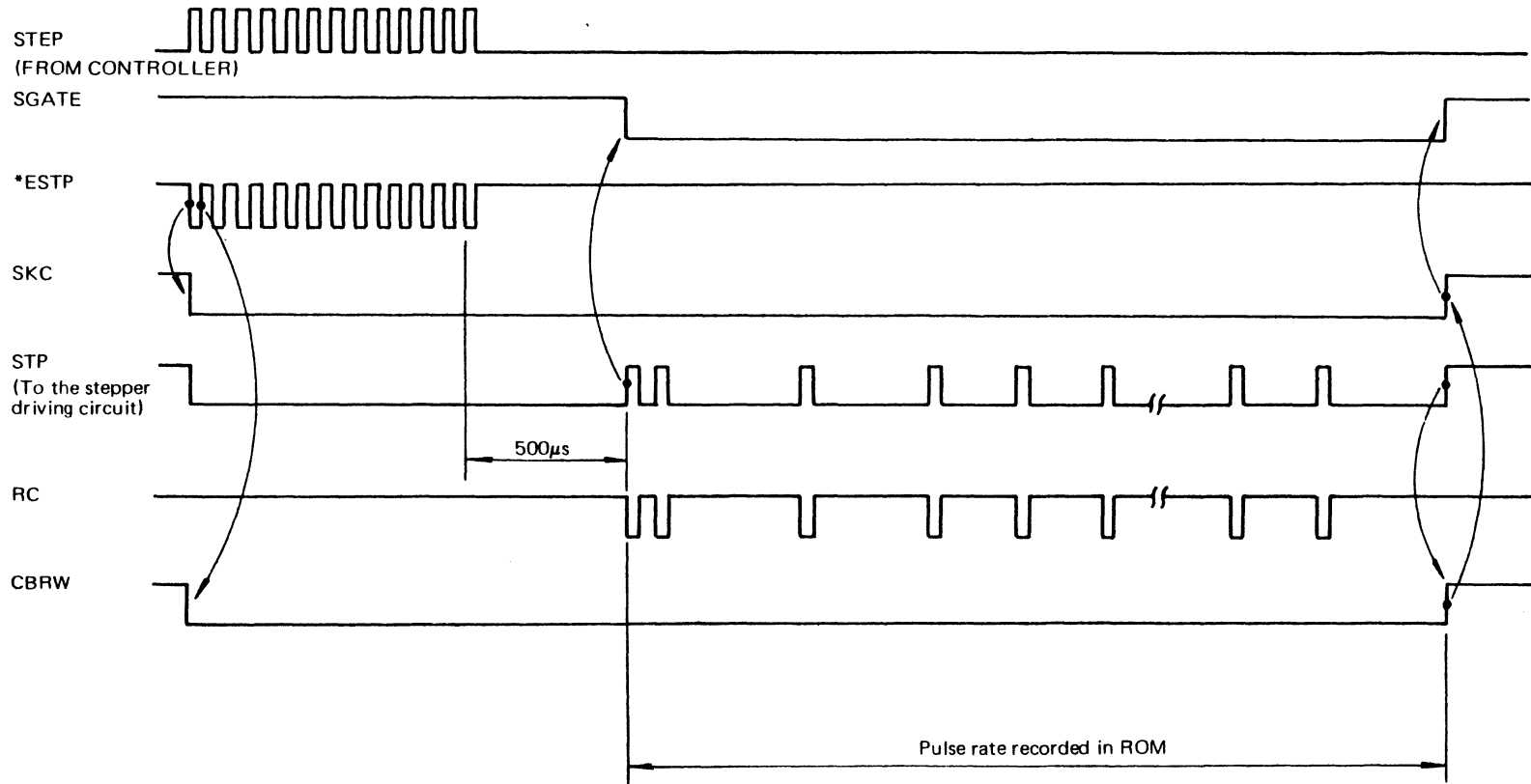

Fig. 4.17 SLAVE STEP Mode Timing Chart

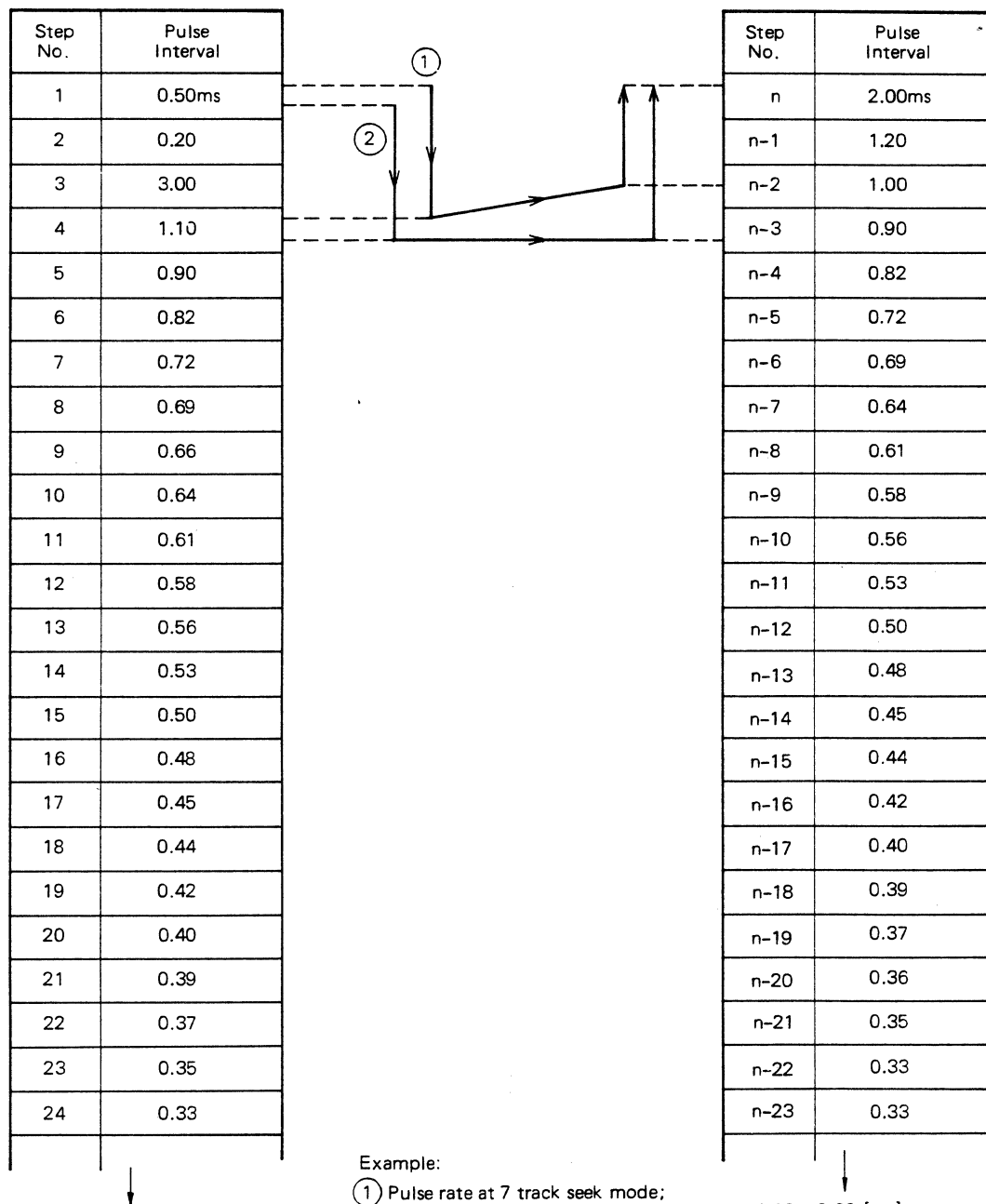
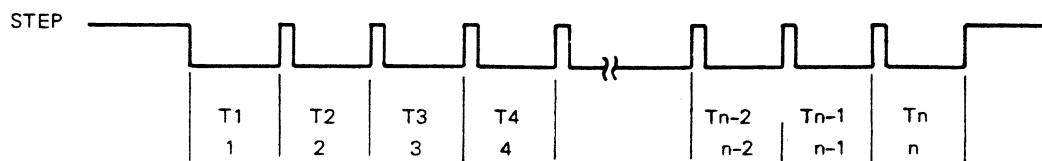

Fig. 4.18 Speed Up/Slow Down Step Rate

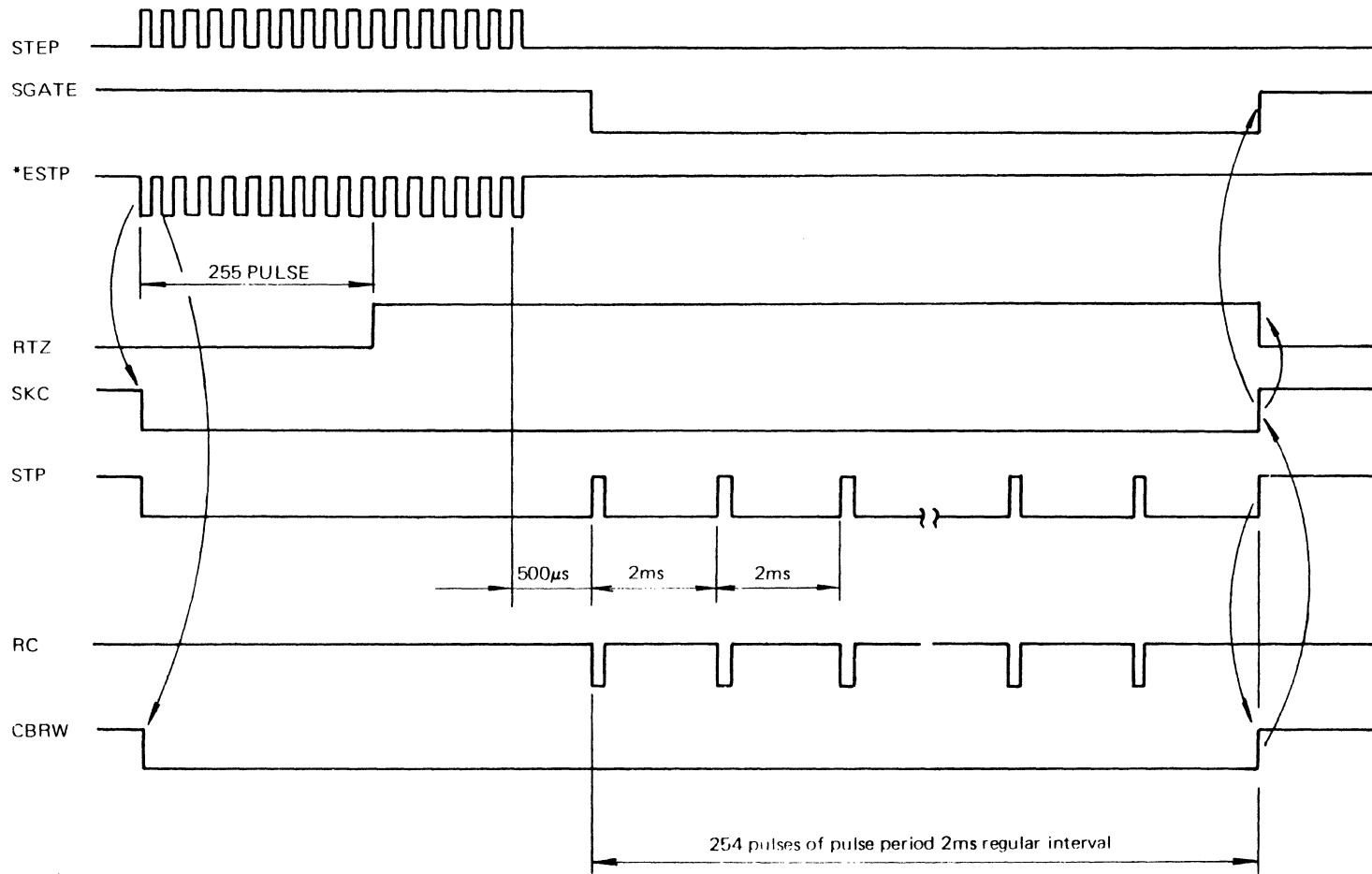
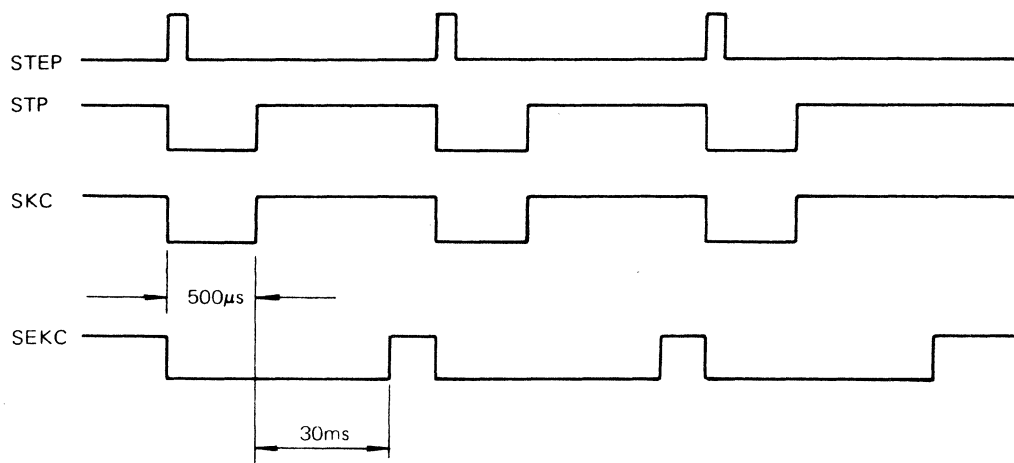

Fig. 4.19 RTZ Mode Timing Chart

(1) Response at the Time of CONTROLLED STEP Mode

(a) When the input step pulse period is more than 30ms.



(b) When the input step pulse period is less than 30ms.

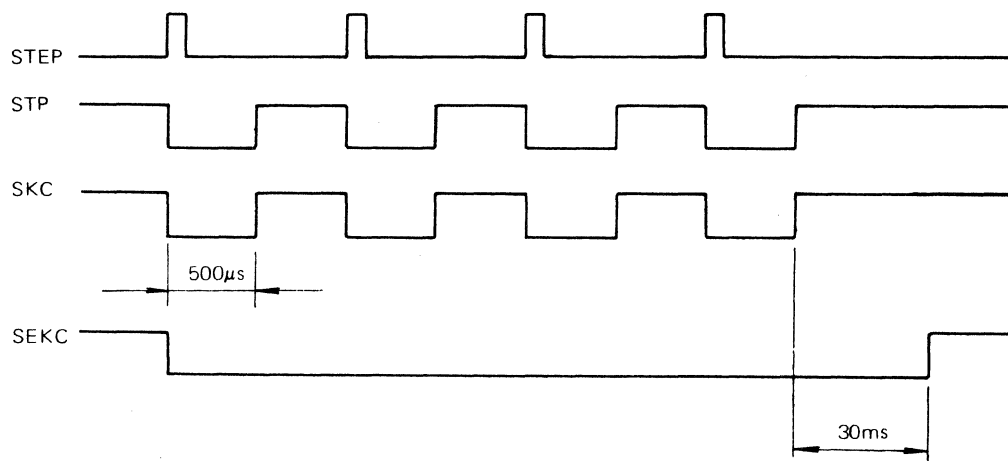

(2) Response at the Time of SLAVE STEP Mode

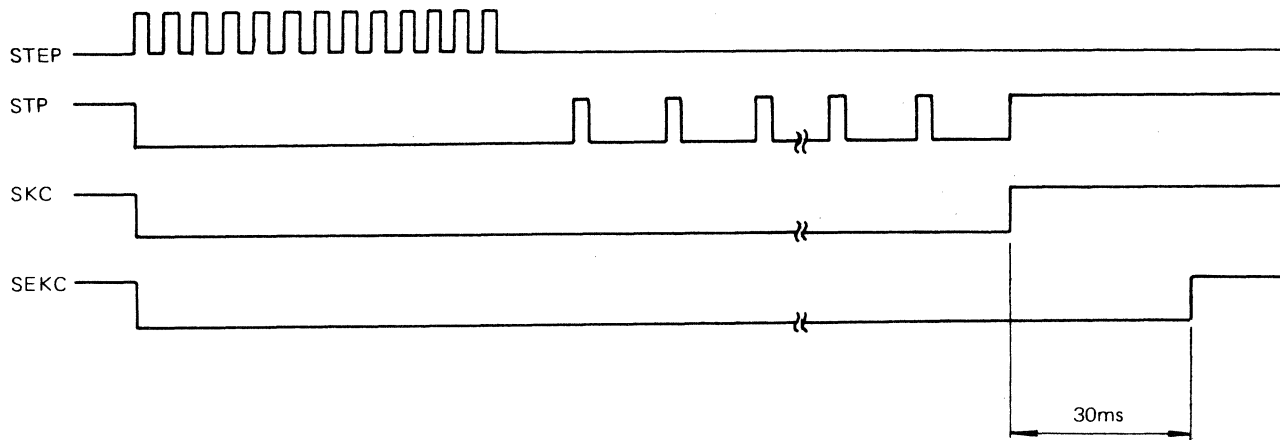

Fig. 4.20 SEEK COMPLETE Response Timing Chart

#### 4.6.7 Stepper Driving Circuit

The four phase stepping motor is used to position the data heads, and the stepper driving circuit is the circuit for driving the stepping motor. For stepper motor rotation, the 1 - 2 phase magnetization system is employed. The magnetizing phase control circuit controls the winding of the stepping motor to be magnetized and the timing of its magnetization by means of step pulse STP and DIRECTION coming from the seek control circuit. The stepper driving system requires two types of magnetization voltage, +24V and +5V. Switching occurs between these two voltages in order to maximize performance during the power-on, seeking, and settling operations.

##### (1) At Power-On

At Power-On, only the spindle motor is energized; the stepper motor is kept in the deenergized state for about 13 seconds by GATES. After this time, the spindle motor has reached the prescribed RPM's. The stepper motor is then energized for about 30ms with +24V/+5V of switching voltage and then it is fed with a magnetization voltage of +5V in order to generate a holding torque.

##### (2) During SEEK

During the SEEK operation, when magnetization starts, a voltage of +24V is fed for about 1ms to the phase of the stepping motor to be magnetized, and after that a voltage of +5V is fed to the phase until the magnetization of that phase is switched to the other phase.

##### (3) During Settling

During settling time, which starts after the SEEK operation has completed, and lasts for about 30ms, the stepping motor is magnetized by a switching voltage of +24V/+5V. The switching rate is changed depending on whether only one phase is magnetized or two phases are magnetized at the time of SEEK completion.

And after the settling is completed, the hold torque of the stepping motor is created by using +5V. Fig. 4.21 shows block diagram of the driving circuit. Fig. 4.22 shows the timing chart.

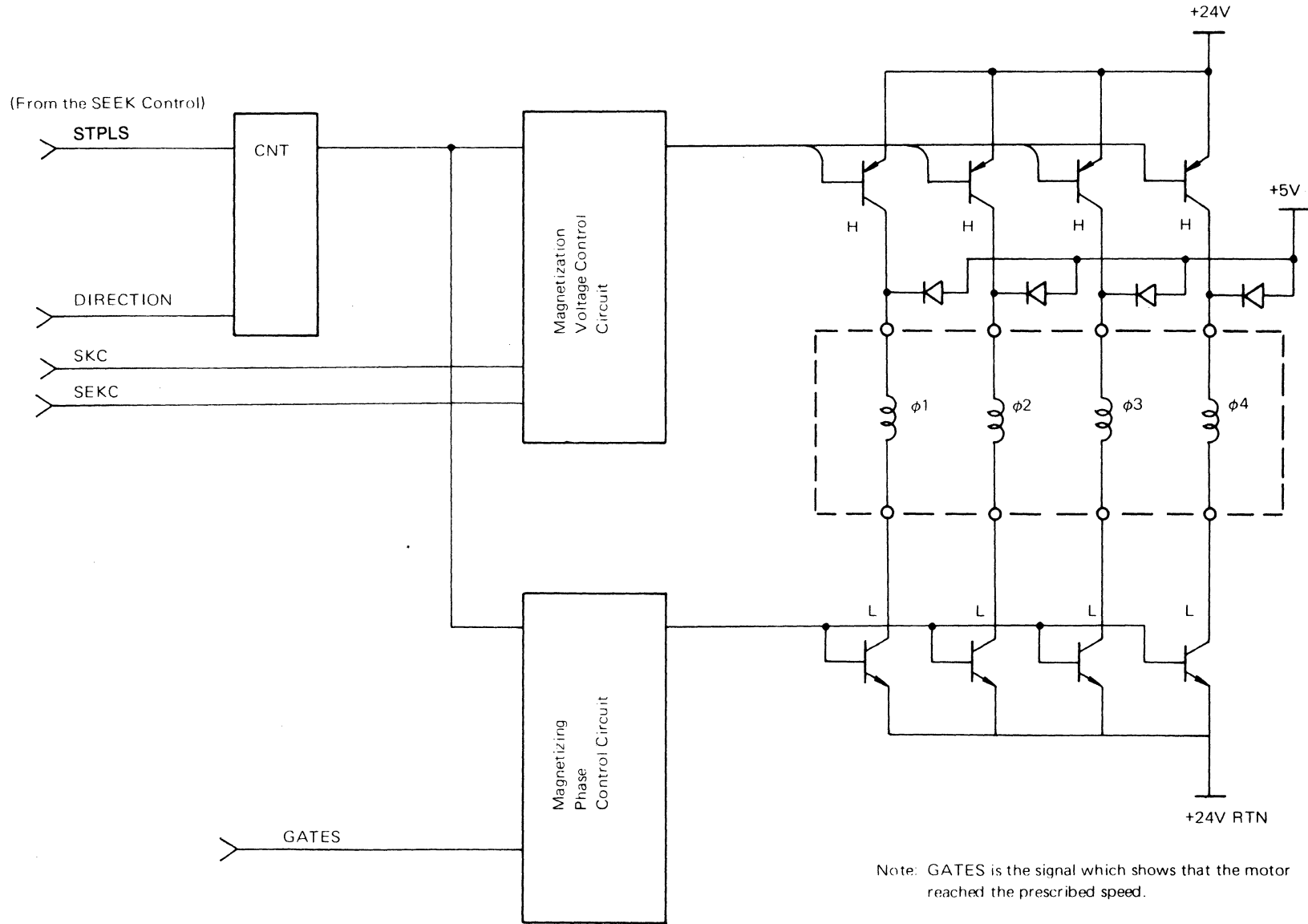
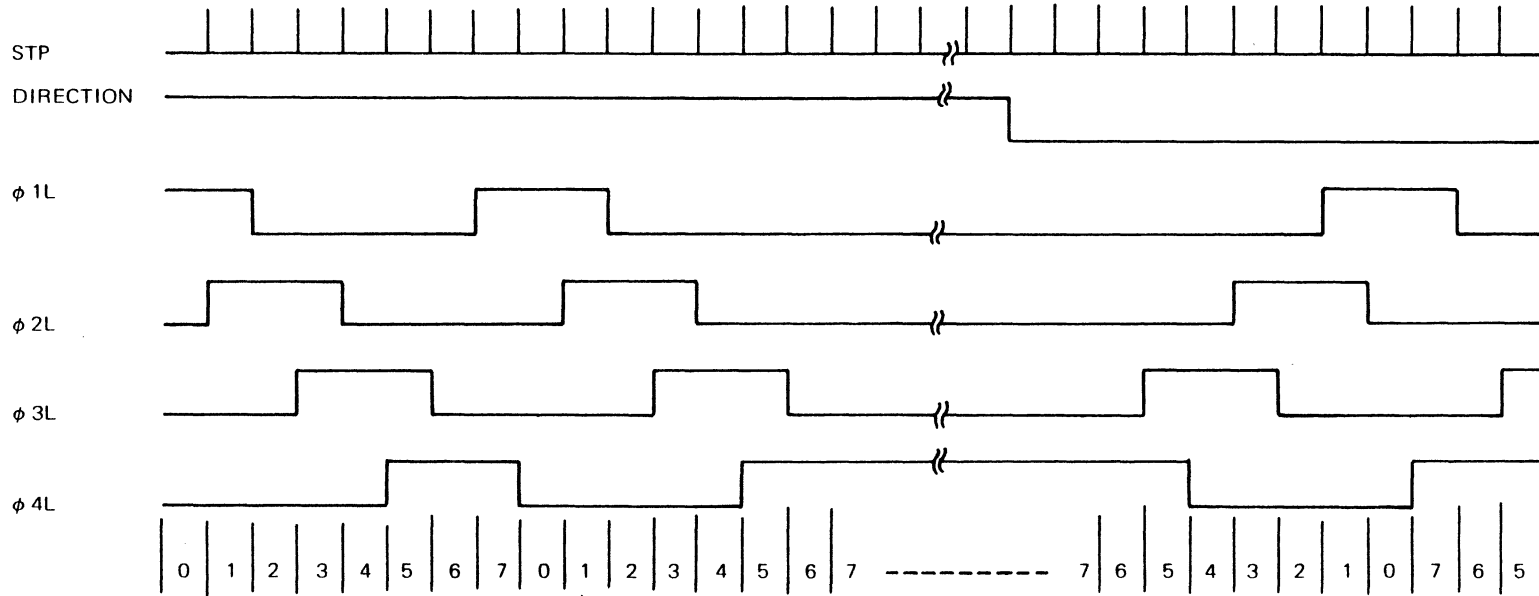

Fig. 4.21 Stepper Driving Circuit Block Diagram

(1) Magnetizing Phase Control Circuit



(2) Magnetization Voltage Control Circuit

(a) At the Time of Power-On

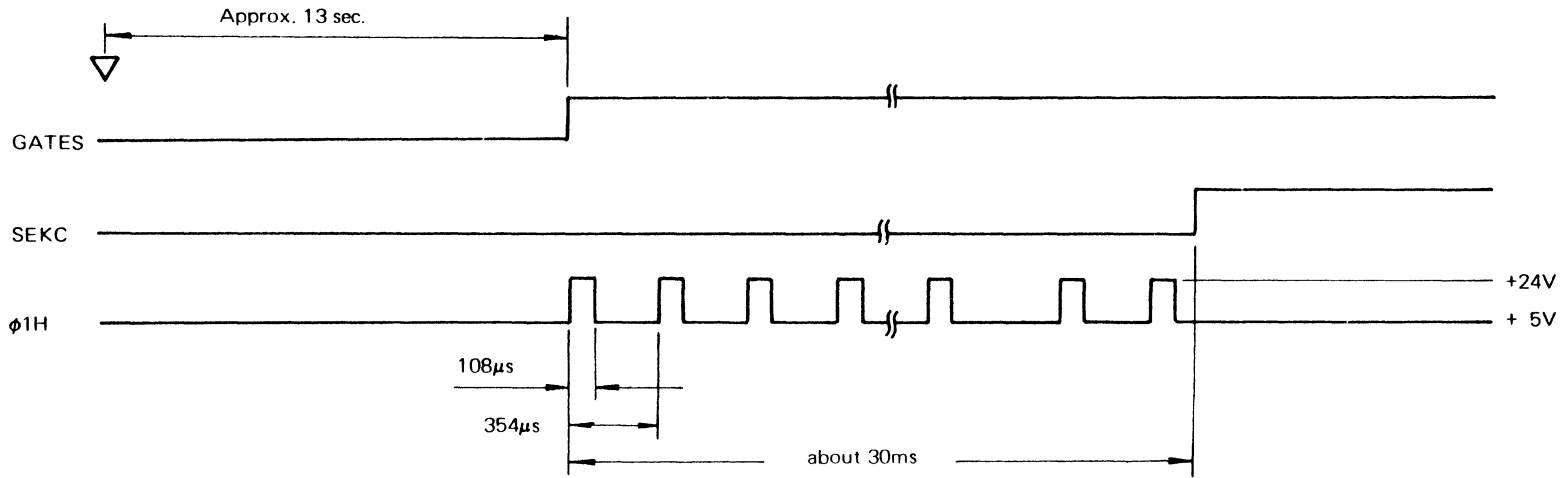

Fig. 4.22 Stepper Driving Circuit Timing Chart (Page 1 of 2)



(b) During Seeking and Settling

T3: 1 phase magnetized stopping time 324 $\mu$ s  
2 phase magnetized stopping time 1,728 $\mu$ s

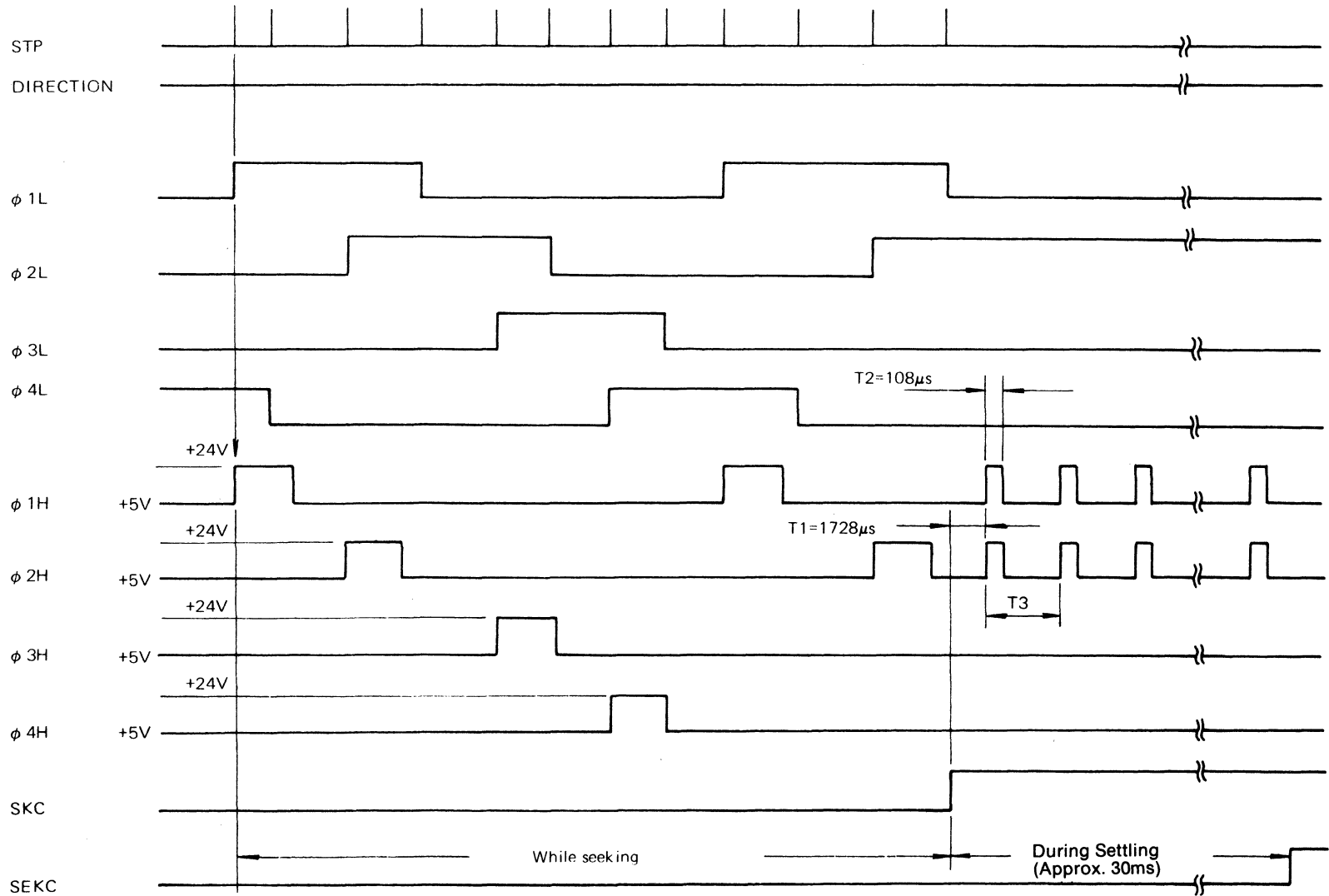

Fig. 4.22 Stepper Driving Circuit Timing Chart (Page 2 of 2)

#### 4.6.8 Index and Sector Generation Circuit

On the clock track, there is one index pattern and  $12,000 \pm \frac{32}{0}$  byte clocks stored. Sector pulses are generated by the byte counter. This counter is preset by each index or the sector pulse to the value set by switches and counts the byte clock (1/8F) from the PLO clock which is synchronized to the clock signal coming from the clock track. The length of a sector is determined by the setting of the switches on the PCB.

For example, for a sector length of 300 bytes, the data preset input of the byte counter is set to  $(4,095 - 300) = 3,795$  by switch setting, and loaded to 3,795 by the physical index which comes from the index pattern on the clock track. Then the byte counter is incremented by the byte clock (1/8F). When the number of bytes reaches 4,095, a CARRY of one byte width is sent out, which becomes sector pulse, and at the same time, the byte counter is preset to 3,795. Forty sector pulses per one revolution are generated (12,000 divided by 300 equals 40).

Since the number of bytes stored on one track is  $12,000 \pm \frac{32}{0}$  bytes, if the sector length is set to 300 bytes, the last sector is lengthened by  $\pm \frac{32}{0}$  bytes.

Refer to 3.6.6 for switch setting method to set sector length. Fig. 4.23 shows a block diagram of the INDEX and SECTOR generation circuit. Fig. 4.24 show the timing chart.

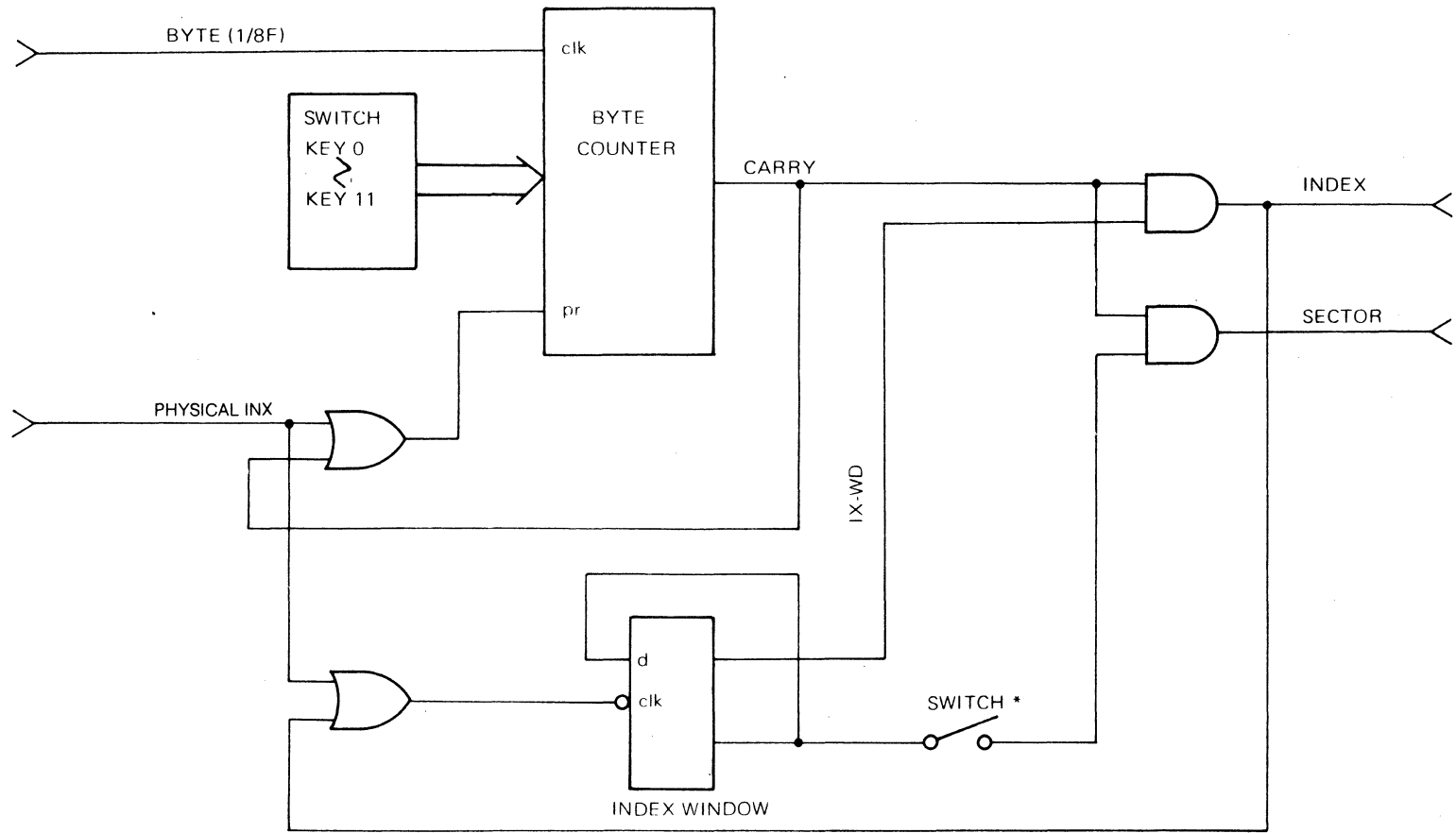

\* Note: This switch determines if the sector pulse is sent during index pulse time. When closed, the sector pulse is masked at INDEX.

Fig. 4.23 INDEX and SECTOR Generation Circuit Block Diagram

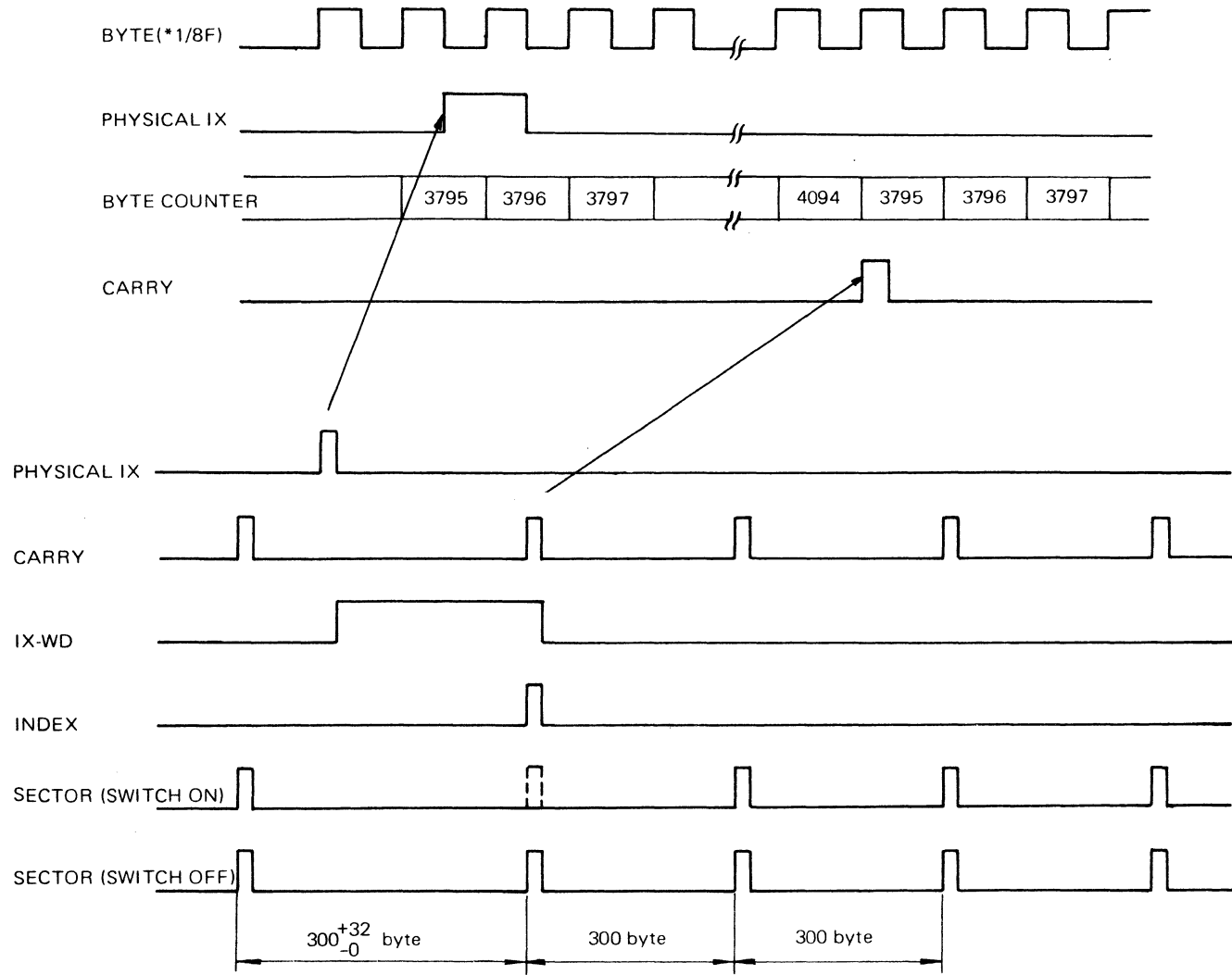

Fig. 4.24 INDEX and SECTOR Generation Circuit Timing Chart (when a Sector Length is 300 bytes)

#### 4.6.9 Read/Write Circuit

(1) General

This circuit consists of the head select circuit, write circuit, read circuit, and VFO circuit.

(2) Head Select Circuit

This is the circuit which selects the designated data head from 4 heads in the M2301, and from 8 heads in the M2302 in response to the head select signal (HEAD SELECT 0 to 2) from the controller. A head is selected when +12V is applied. When a head is not selected, 0V is applied.

(3) Write Circuit

The block diagram of the write circuit is shown in Fig. 4.25.

(a) NRZ to MFM Encoding Circuit

The MFM recording method is used to write data on the disks. The encoding circuit converts NRZ data from the controller. The output of this encoding circuit is called Write Data Pulse (WDP) and is sent to the Write Driver circuit. Fig. 4.26 shows the correlation between NRZ and MFM.

(b) Write Amplifier

This is the circuit which supplies the write current to the data head. The WRITE GATE signal, a write instruction from the controller, causes the circuit to be turned on and off. If an error is detected by the write fault detection circuit or the power loss detection circuit, the write amplifier circuit is unconditionally turned off.

(c) Write Drive

This is the circuit which switches the write current to the data head according to WDP. The circuit receives the current from the write amplifier and the MFM write data pulse from the encoding circuit.

(d) Write Fault Detection Circuit and Fault Latch

This is the circuit which detects the occurrence of an error during the write operation. If any of the following conditions occur, the circuit sets up the FAULT LATCH and transmits the WRITE FAULT to the controller. The circuit also sets up the detail of an error and holds it until the FAULT CLEAR is received from the controller. The detail of an error can be observed on test points on the PCB.

Error Status	The Check Terminal Set by Fault Latch
Both WRITE GATE and READ GATE come at the same time.	RGF
WRITE GATE comes when more than one head is selected.	MLT
During the WRITE operation, abnormal current flows through the data head.	UNS
The WRITE GATE signal comes when SEEK COMPLETE is false.	SEK
The WRITE GATE signal comes when the unit is not READY	FRY

(e) **Power Loss Detection Circuit**

At the time of power-on/off, and when an instantaneous power-failure occurs, an abnormal current could flow through the data head due to turbulence in the logic circuit, and could cause the data on the disk to be destroyed. For this reason, the power loss detection circuit monitors the DC power level so as to clamp the power source of the WRITE AMP very quickly in the event of a power drop, thus preventing an influx of abnormal current to the data head.

(4) **Read Circuit**

Figure 4.27 shows the block diagram of the read circuit.

(a) **Head Preamplifier**

During a read, the input to the head preamplifier is the head output created by induced voltage generated by the difference in magnetic flux on the disk. The head output signal is amplified about 160 times.

(b) **Main Amplifier**

The main amplifier amplifies the output voltage of the head preamplifier about 25 times.

(c) **Filter**

The filter eliminates high frequency noise from the read signal amplified by the head preamplifier and main amplifier. The type of filter whose delay time is always constant is employed so as to prevent giving a peak shift to the read signal. High area cut off frequency is about 4MHz.

(d) **Differentiator**

The read signal after passing the filter shows flux change at its peak. The differentiator is the circuit which modulates the read signal so that its flux change point comes to a zero crossing point. The differentiator formed by the RC is employed.

(e) **Pulse Shaper**

This is the circuit which detects the zero crossing point of the differential wave form in analog differentiated by the differentiator and modulates it to logic level. The output of the pulse shaper is the logical ECL level.

(f) **Shoulder Noise Rejection Circuit**

The read waveform from the head has a so called shoulder as shown in Fig. 4.28. When this waveform is differentiated, the part of this shoulder approximates to the zero cross line, and after the output of pulse shaper, a noise pulse would overlap on it due to external noise.

The shoulder noise rejection circuit identifies signal pulse and noise pulse by the width of the pulse and eliminates the noise pulse which has less width than the regular pulse. The output level of this circuit is also CML level.

(g) **Level Converter and Differentiating Circuit**

In this part, RAW DATA is formed which becomes a regular pulse width from the leading edge and trailing edge of the output of shoulder noise rejection circuit. And it also converts the ECL level to the TTL level. Fig. 4.28 shows each part of the waveform created by the read circuit.

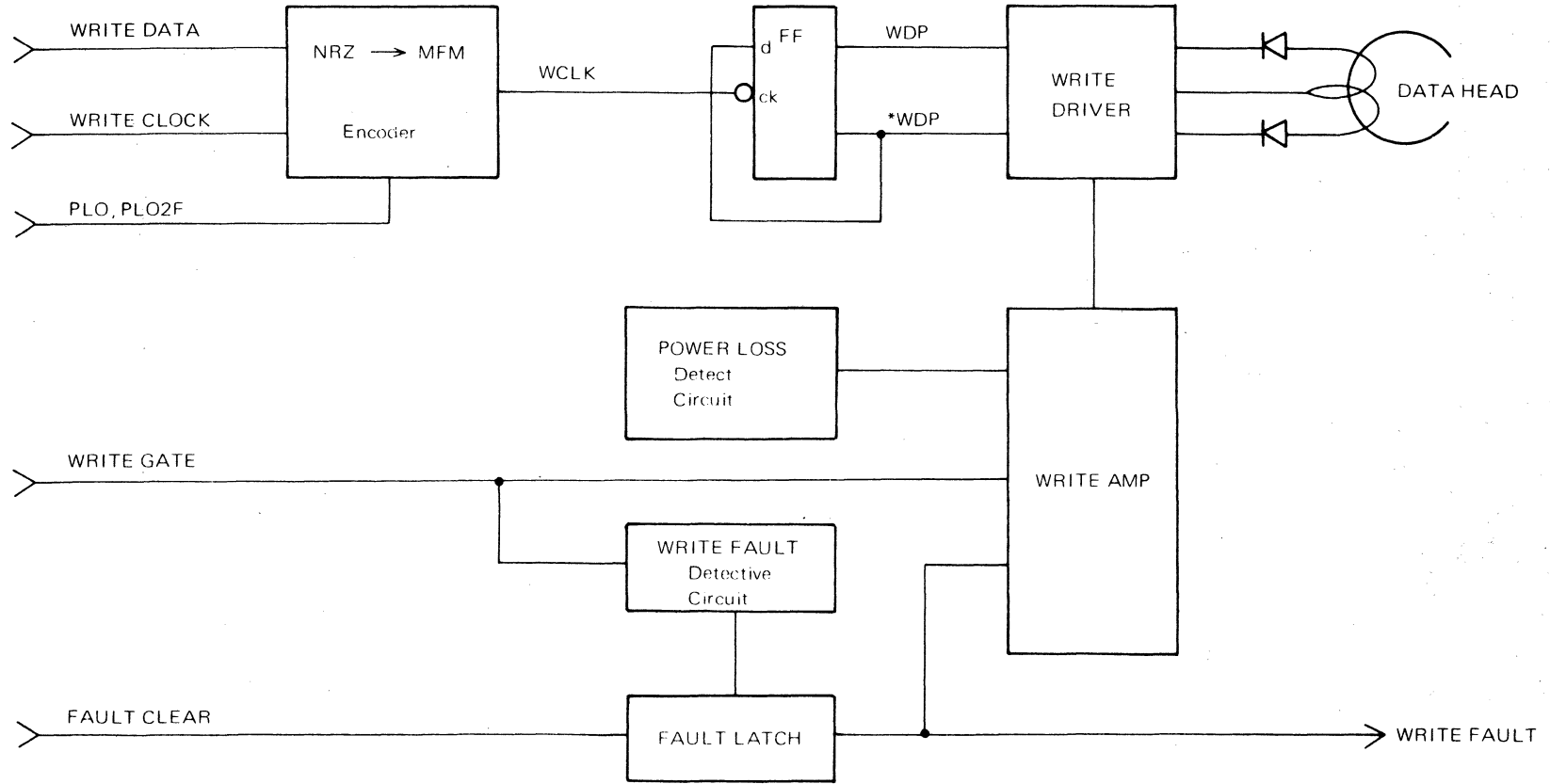
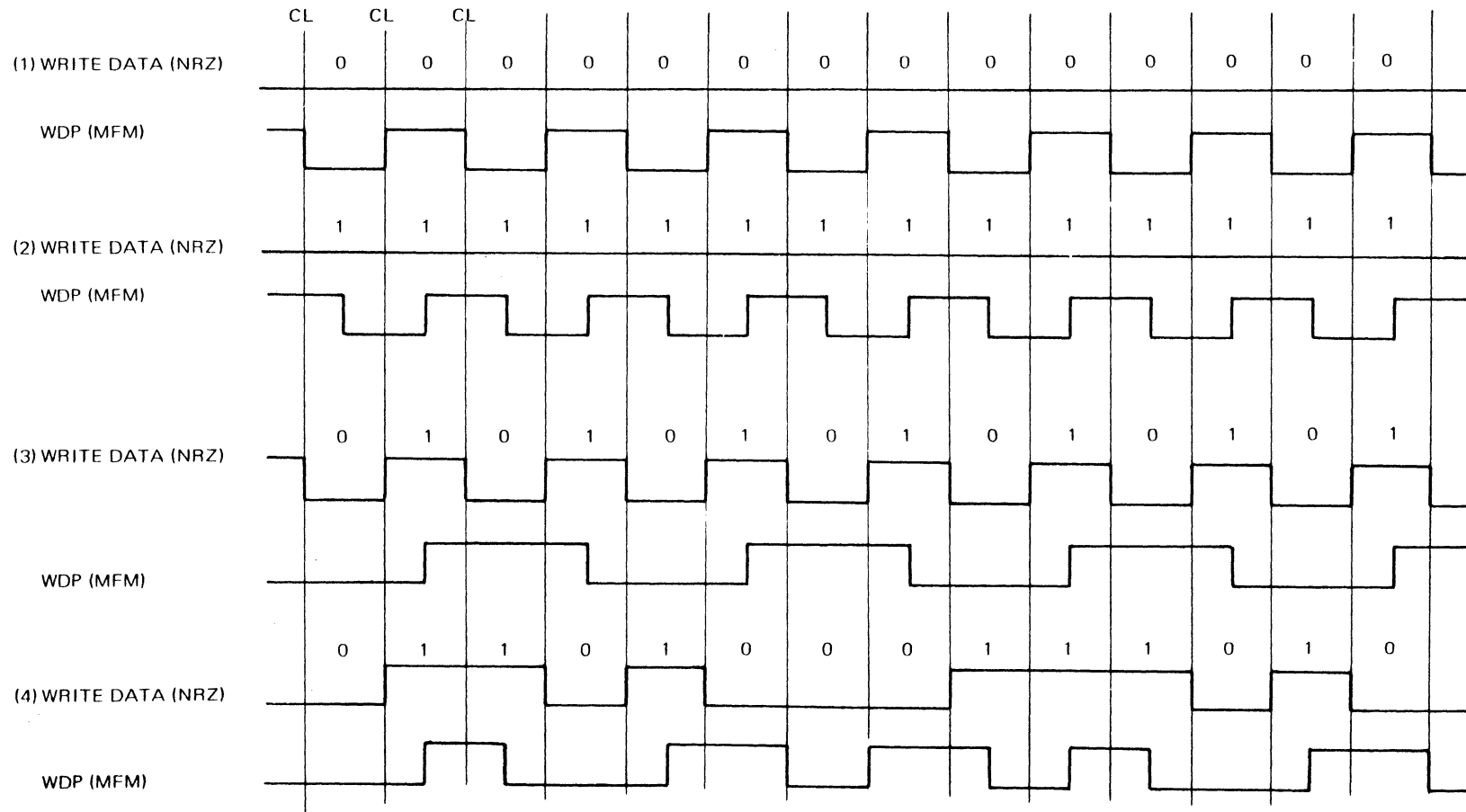

Fig. 4.25 Write Circuit Block Diagram



MFM Recording Rules:

1. There is a flux transition for each "1" data bit.
2. There is a flux transition between each pair of "0" data bits.
3. There is no transition between "01" or "10" data bit patterns.

Fig. 4.26 Correlation between NRZ and MFM



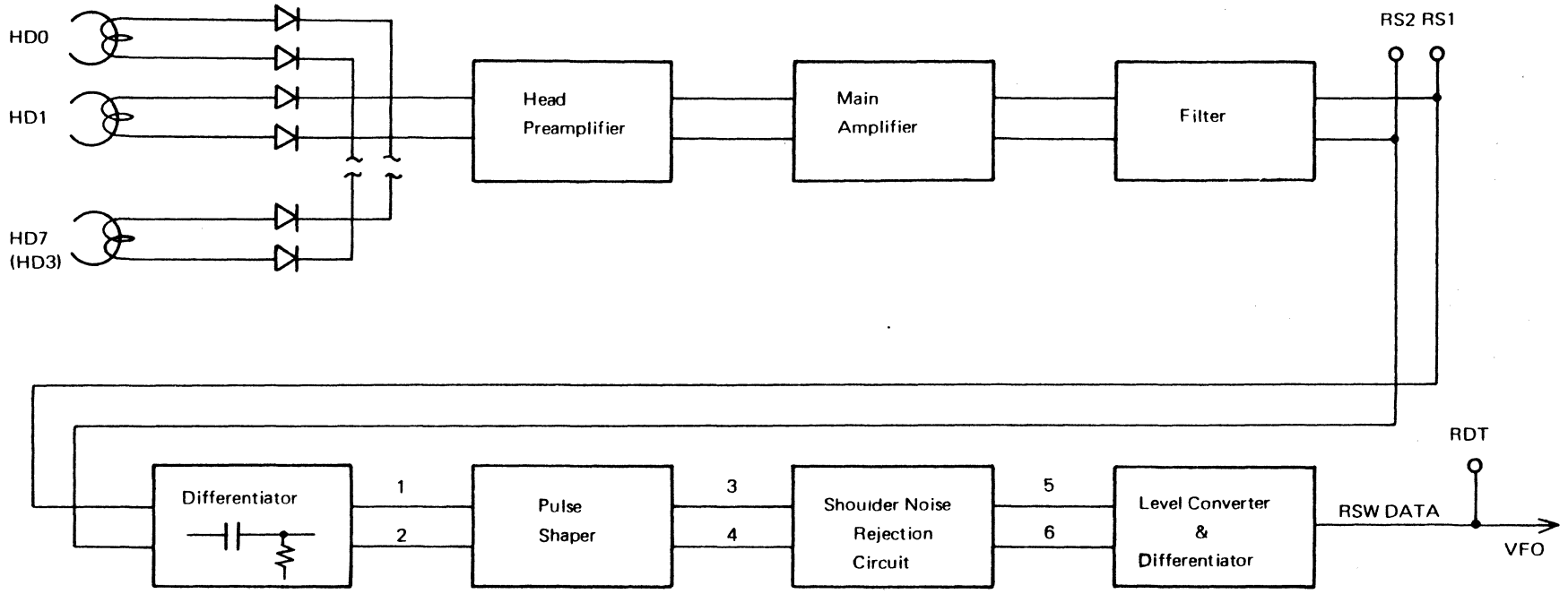

Fig. 4.27 Read Circuit Block Diagram

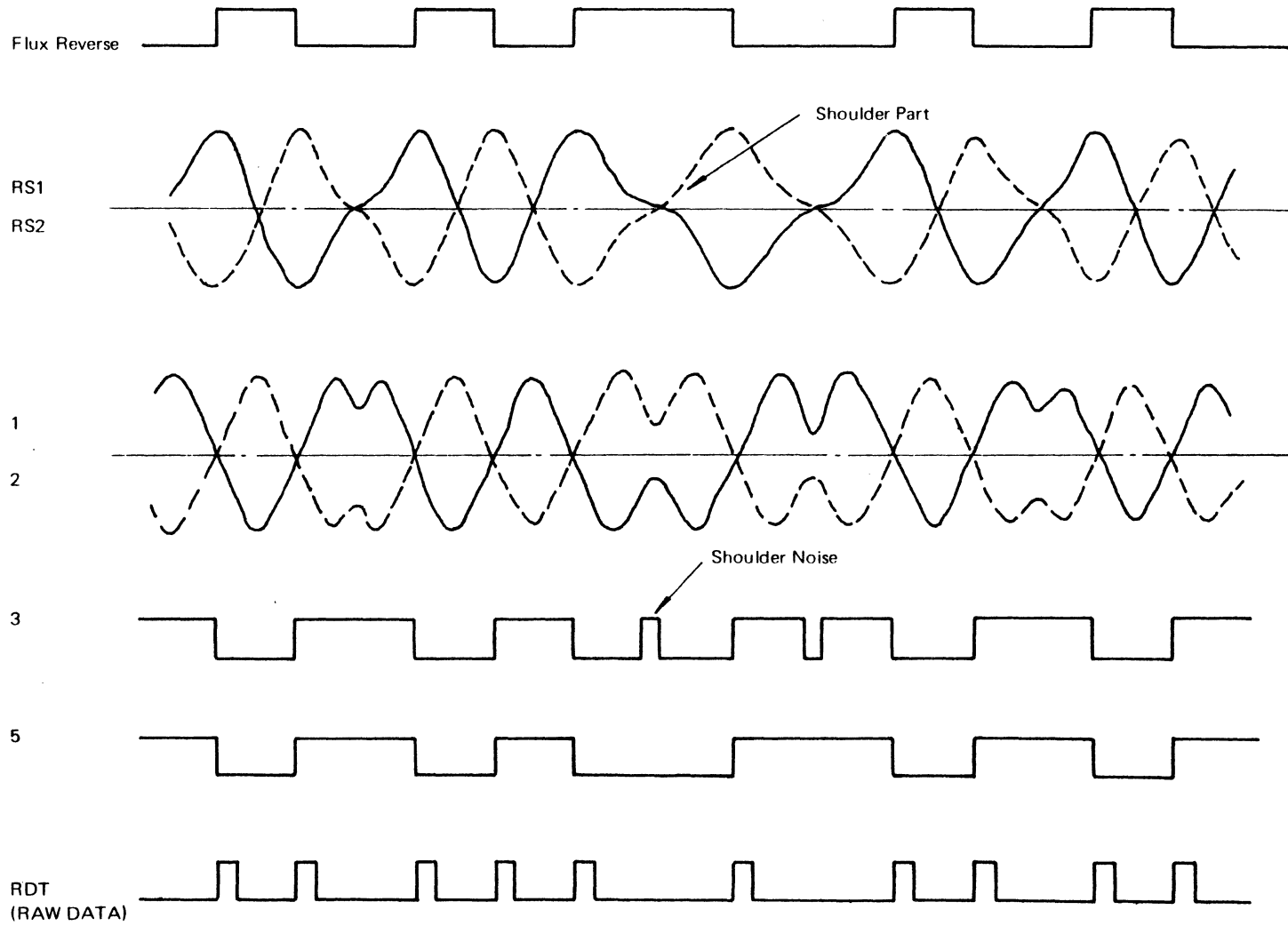

Fig. 4.28 Read Circuit Waveform

(5) VFO Circuit

The VFO circuit is a PLL (PHASE LOCKED LOOP) circuit which synchronizes to PLO2F clock during READ GATE OFF, and to read data pulse RAW DATA (RDT) during READ GATE ON. The VFO circuit demodulates the read data to NRZ using the VFO2F clock synchronized to MFM's RAW DATA during the READ operation.

A voltage control oscillator (VCO) in the VFO circuit temporarily stops oscillation at the time of READ GATE ON/OFF, so as to shorten VFO's synchronization time when the VFO locks to RDT (READ GATE ON) or PLO2F (READ GATE OFF). The VCO is oscillated so that the demodulated data is all "0"s when the READ GATE is on, because the READ GATE signal rises in the gap area where only "0"s were written.

The block diagram of the VFO circuit is shown in Fig. 4.29, the timing chart of the phase comparator in the VFO circuit in Fig. 4.30, and the timing chart of the data demodulation circuit in Fig. 4.31.

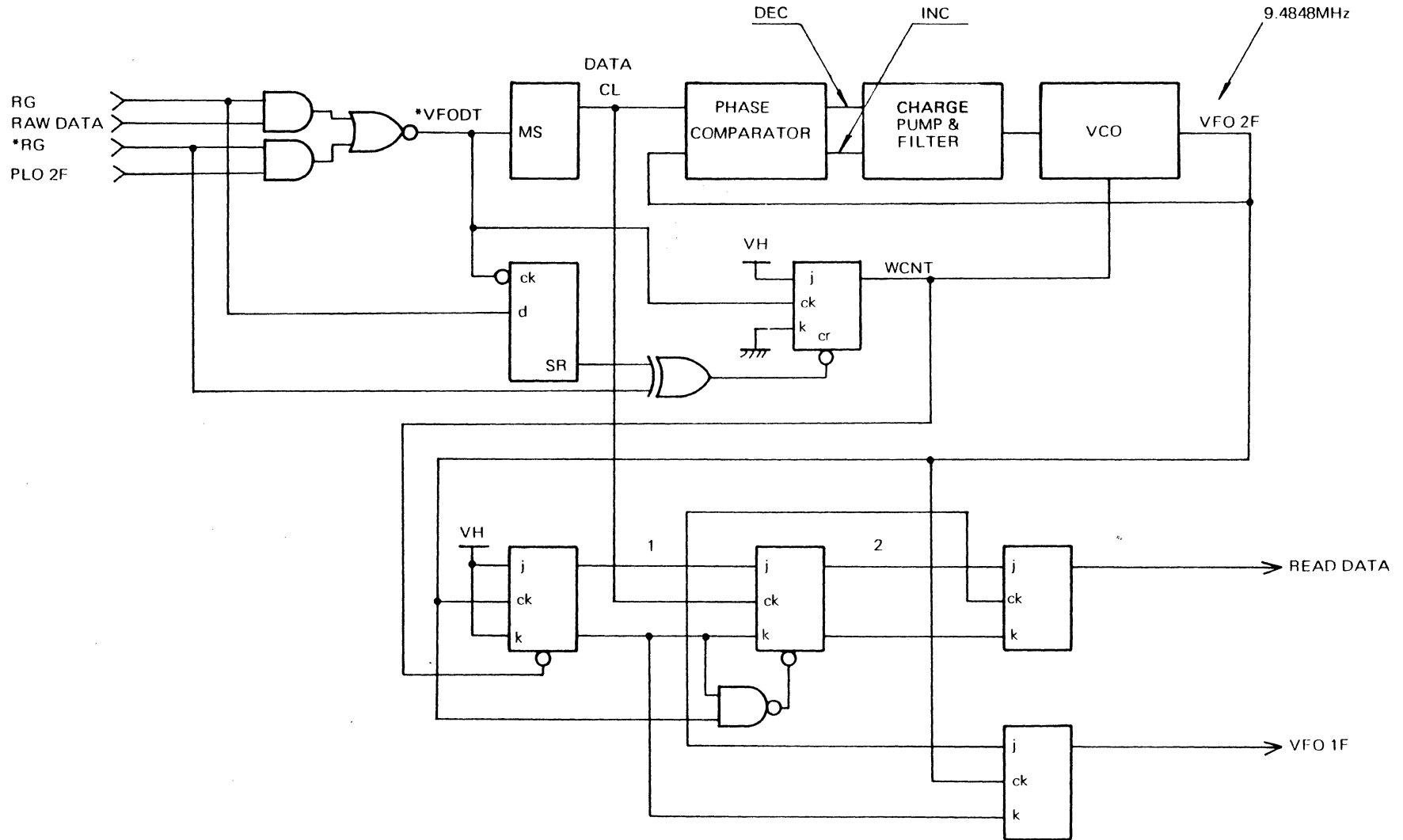

Fig. 4.29 VFO Circuit Block Diagram

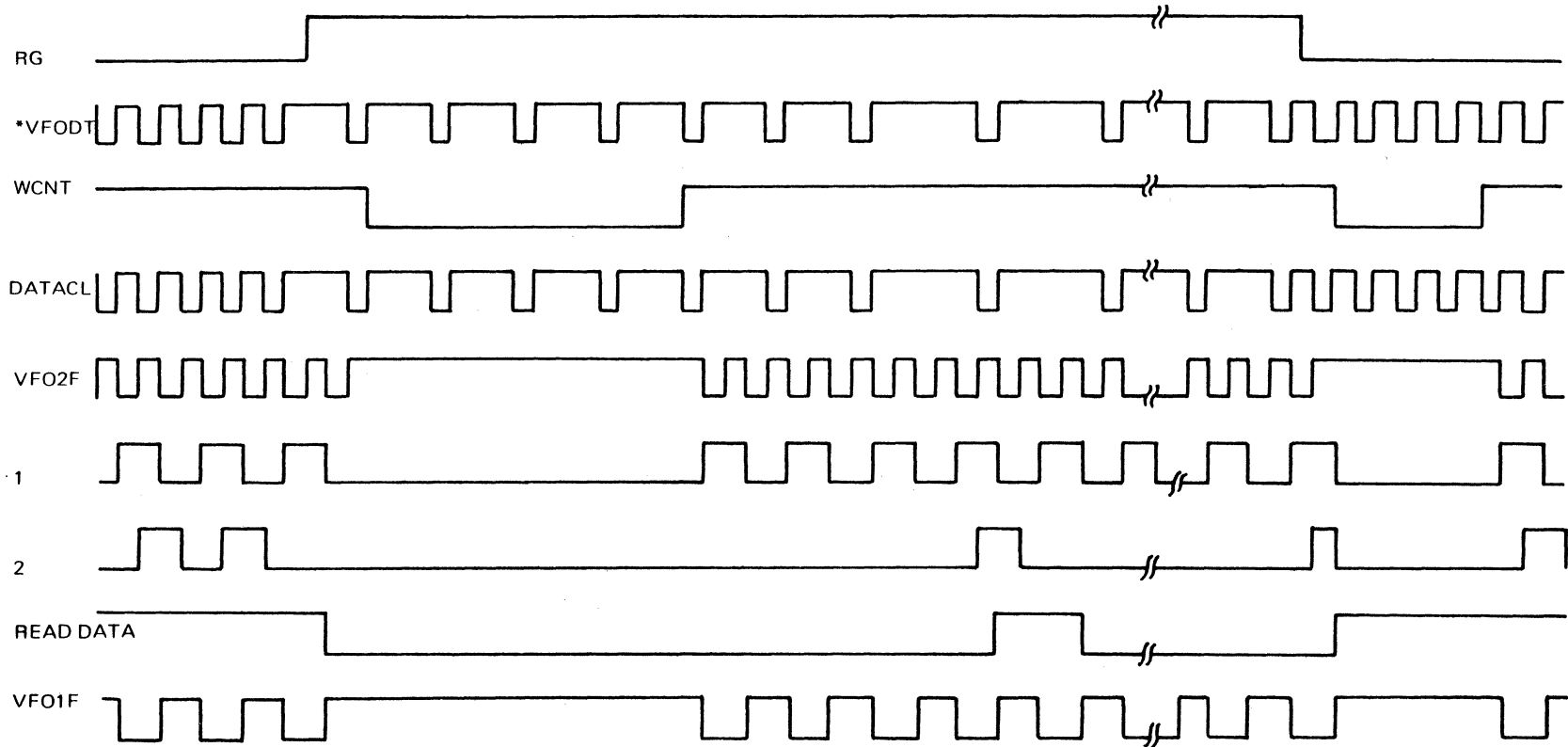
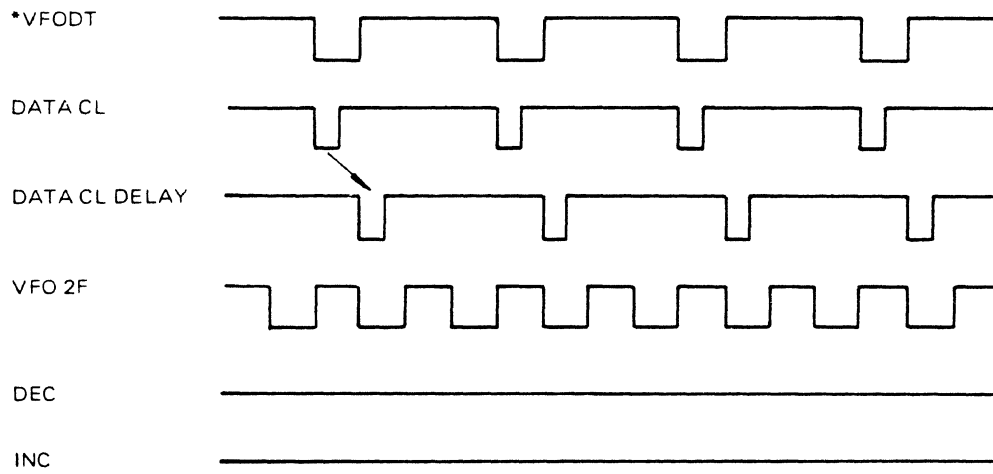
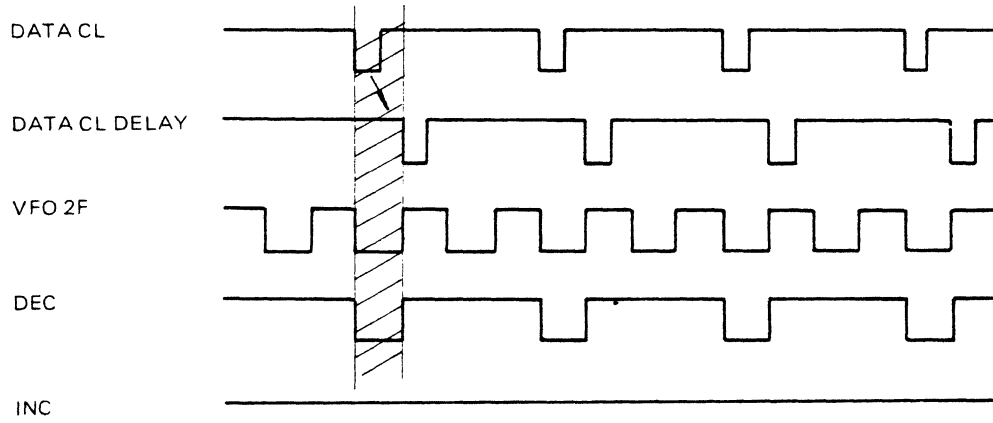

Fig. 4.30 VFO Circuit Phase Comparator Timing Chart

(1) In the Same Phase



(2) VFO Phase Advances



(3) VFO Phase Delays

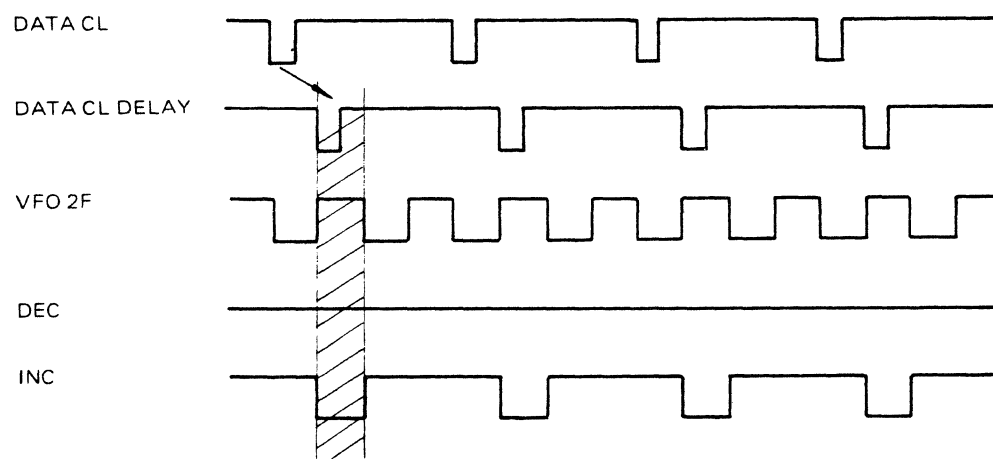
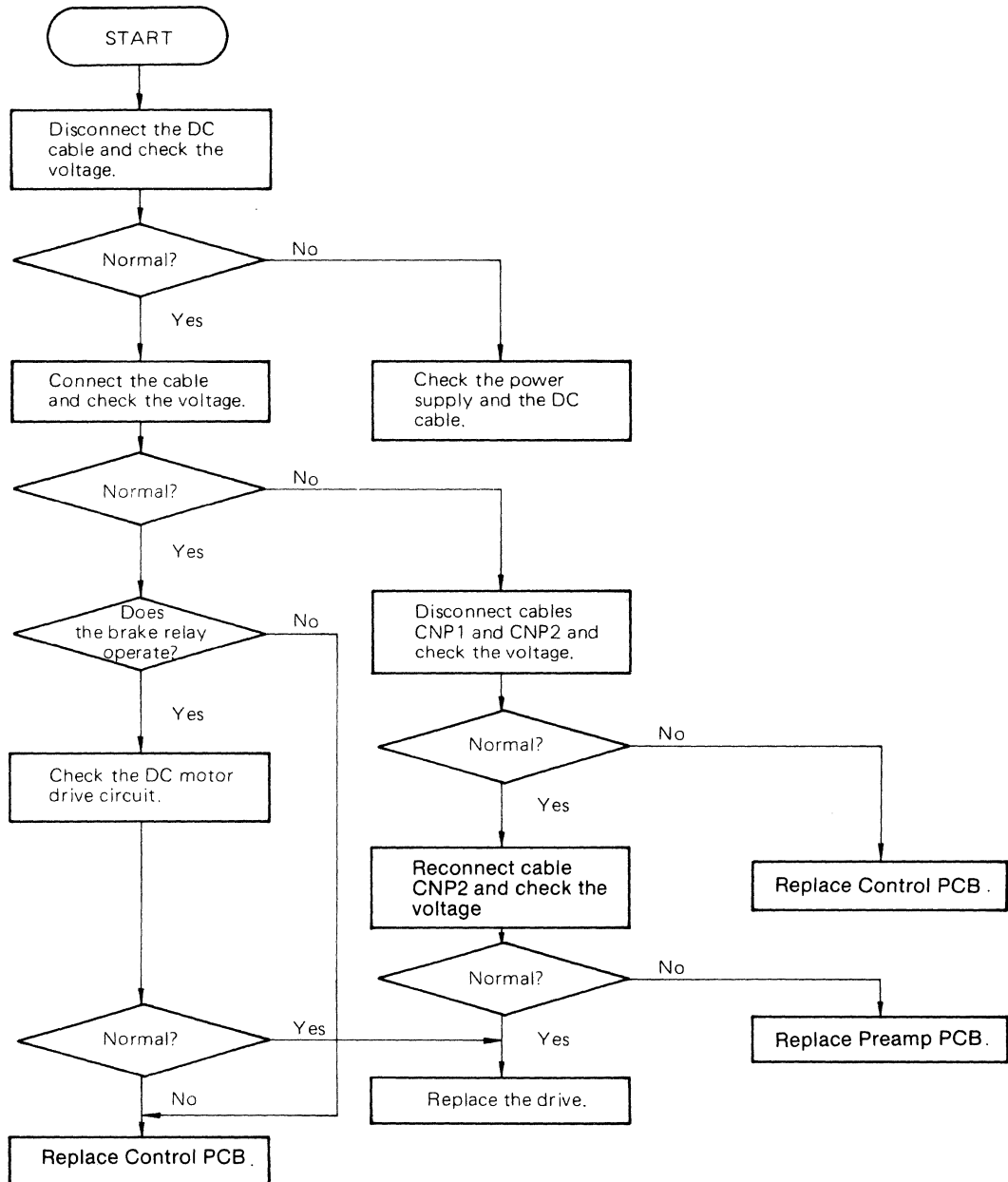

Fig. 4.31 Data Demodulation Circuit

Section 5  
**Troubleshooting**

## 5. TROUBLESHOOTING

FAULT 1 The disk does not rotate.





## FAULT 2 Not Ready

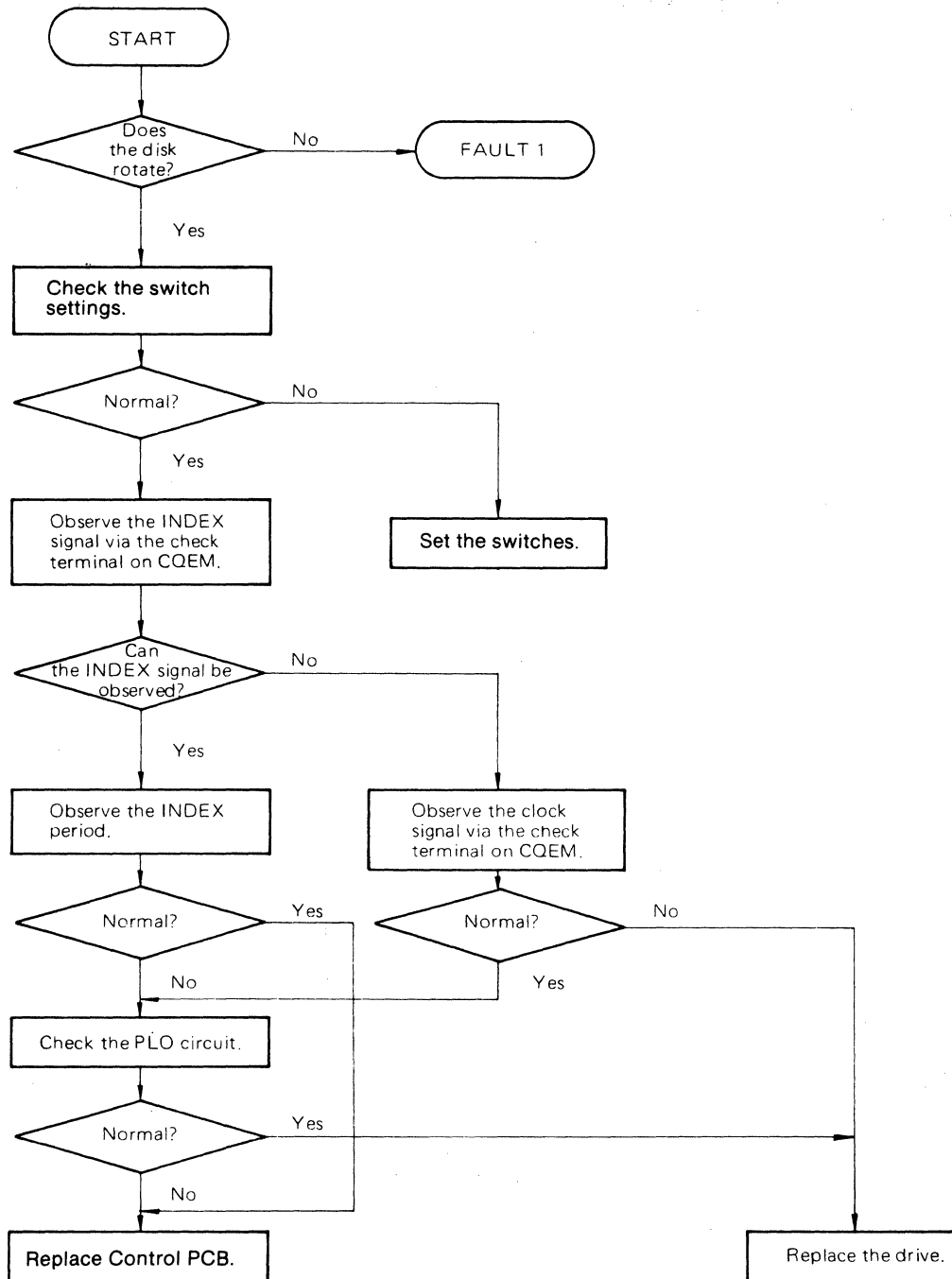

### FAULT 3 Read Error

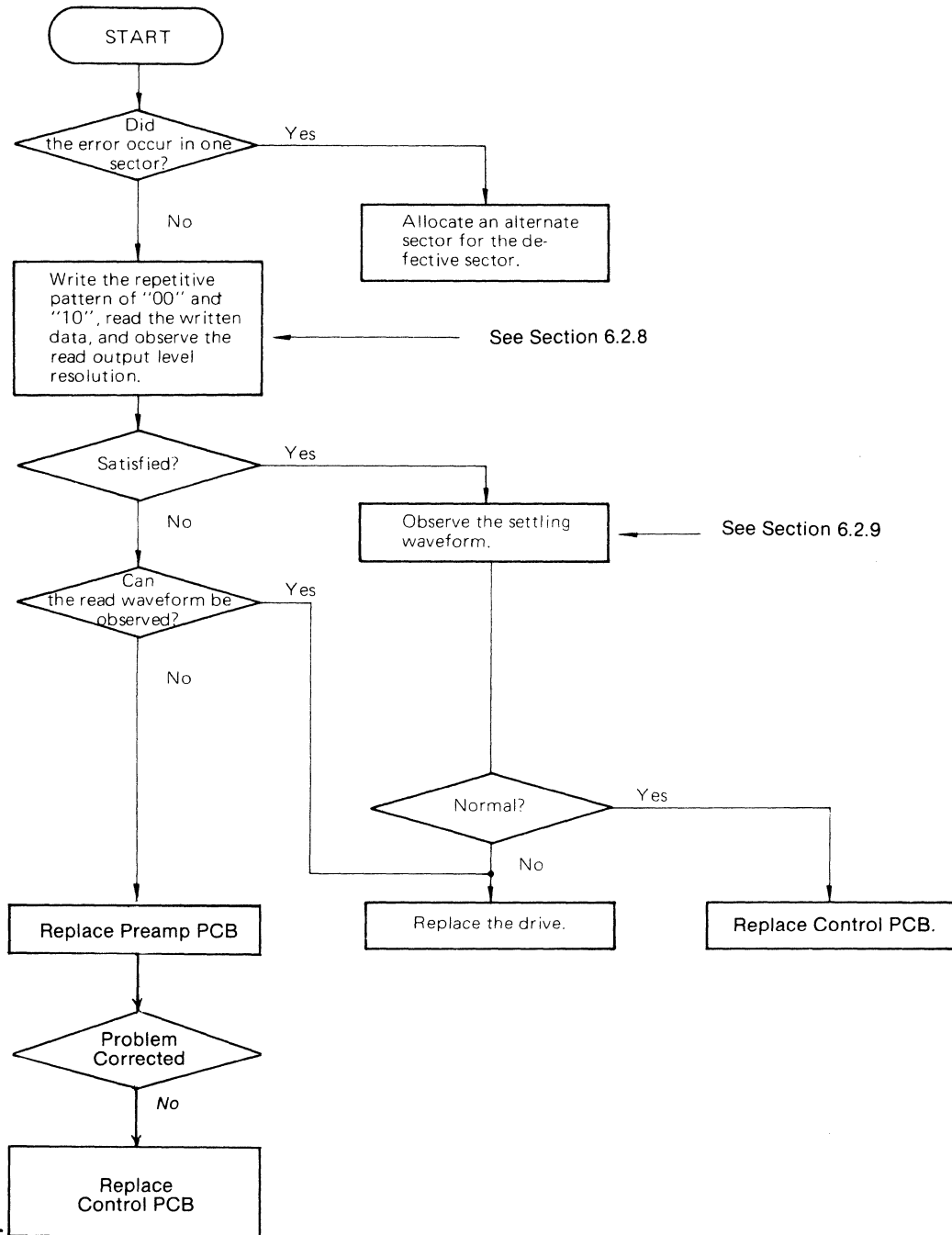

Section 6  
**Maintenance**

## 6. MAINTENANCE

### 6.1 GENERAL

The unit needs no preventive maintenance. The parts required for maintenance are only the two printed circuit assemblies. This section describes verification of the control circuits on the printed circuit assembly and the replacement operation of the printed circuit assembly.

**CAUTION:** Under no circumstances should the disk enclosure be opened unless in a clean room. Likewise, the retaining clamps for the DE plastic cover must not be loosened.

### 6.2 CHECKS OF THE CONTROL CIRCUIT

#### 6.2.1 General

In this device there are no parts which need adjustment such as variable resistors. Only setting of the switches on the printed circuit assembly for a variety of functions is required. Accordingly, this section deals with how to removed the defective PCB's when a failure occurs, and how to check the control circuits if a failure is suspected.

#### 6.2.2 Confirming the Switch Settings

There are switches (SW1 to SW4 and S1 to S3) on the Control E (CQEM) PCB assembly which can be set to perform a variety of functions. Careful attention should be given to setting the switches in accordance with item 3.6, Switch Setting procedure, particularly in the voltage setting of S1 (-5V/-7V to -16V) before power is applied.

#### 6.2.3 Check of Standard Frequency Oscillator

Observe the check terminal "OSC" on the Control E (CQEM) PCB, and confirm that the waveform is as follows.

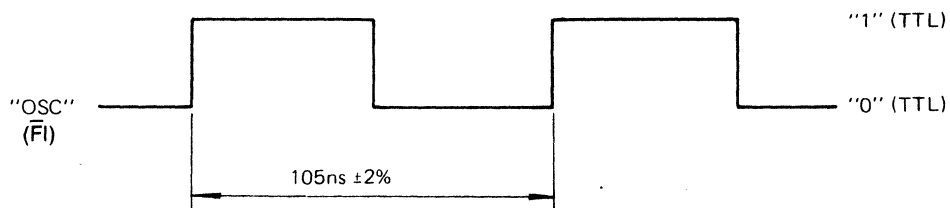

### 6.2.4 Check of Clock Signal

In the ready status, that is, when the disk rotation is up to speed, observe the check terminals "CLS" and "CLP" and confirm that the waveforms are as follows.

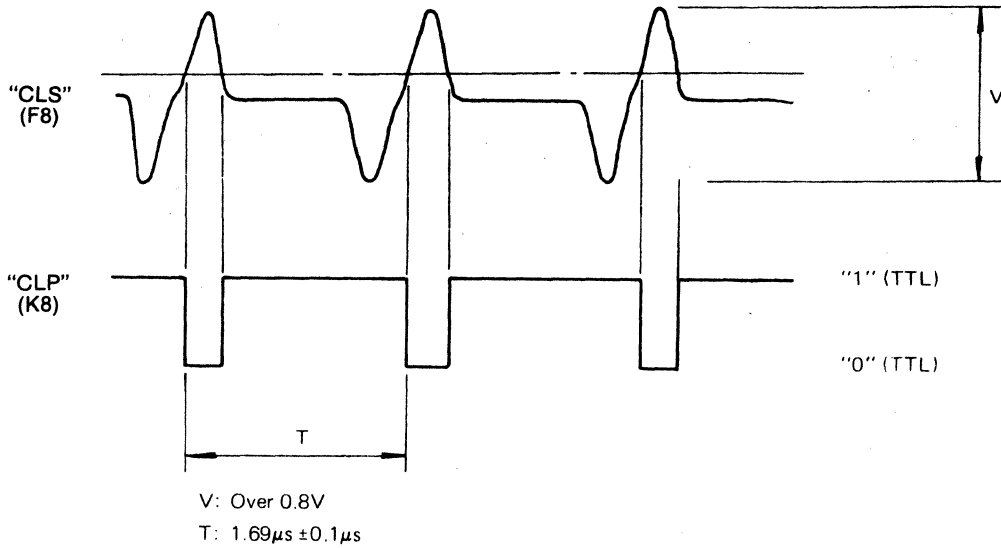

### 6.2.5 Inspection of PLO Circuit

In the ready status, observe check terminals "P2F" and "1/8" of the Control E (CQEM) PCB and confirm that their waveforms are as follows.

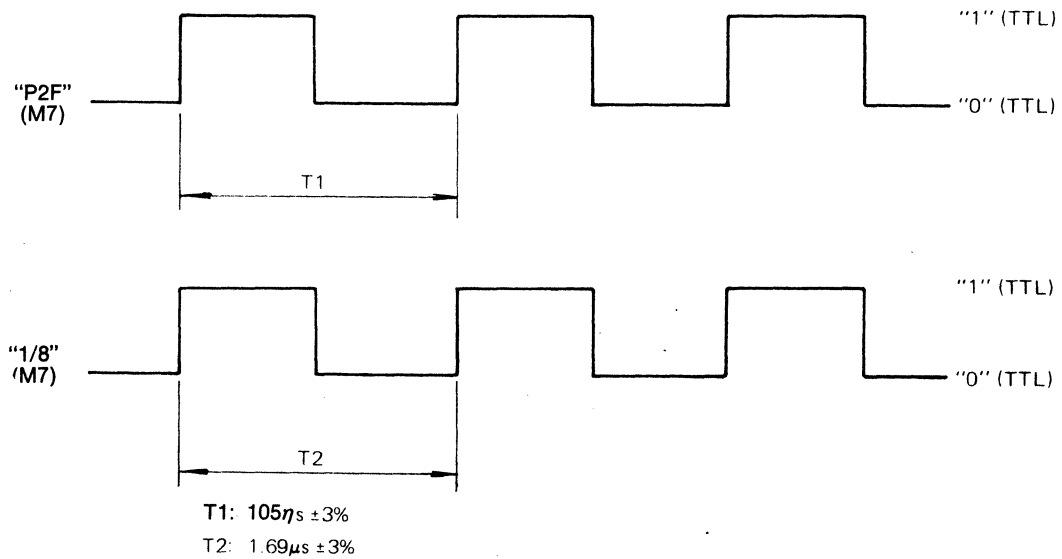

### 6.2.6 Check of Index and Sector

In the ready status, observe check terminals "INX" and "SEC" on the Control E (CQEM) PCB, and confirm that their waveforms are as follows.

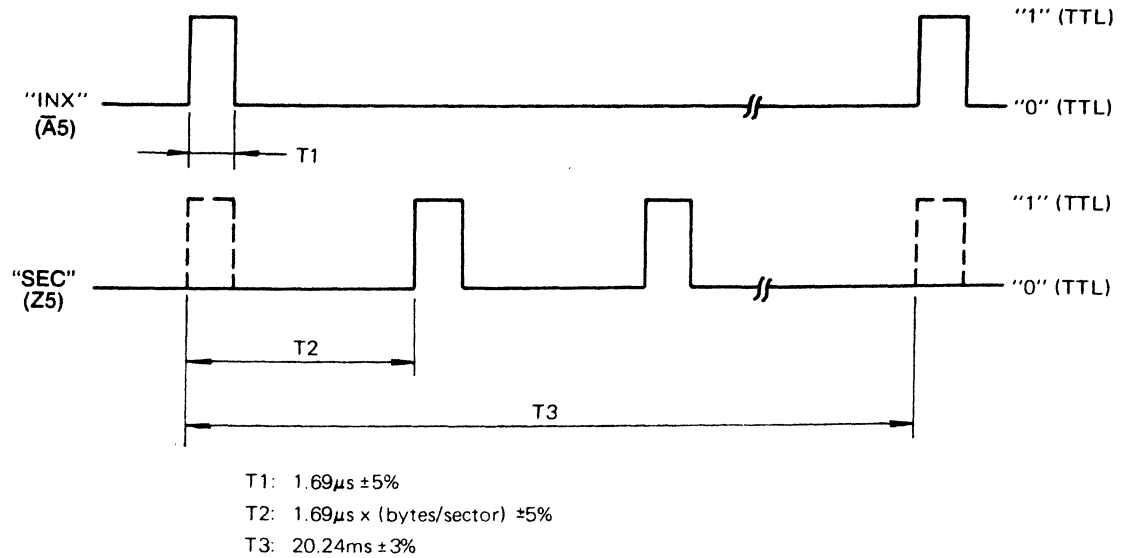

### 6.2.7 Inspection of VFO Circuit

#### (1) Confirmation of Frequency

In the ready status, and yet not read status, observe the check terminal "V2F" on the Control E (CQEM) PCB, and confirm that the waveform is as follows.

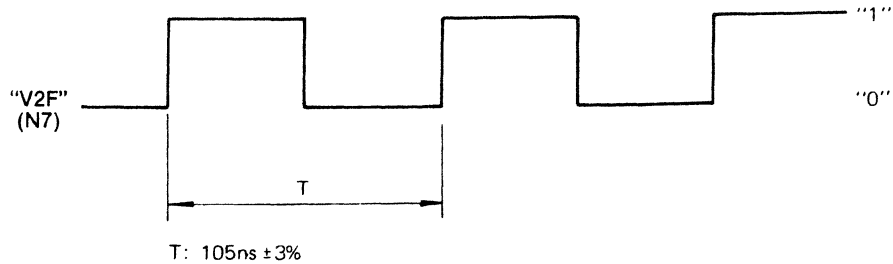

#### (2) Confirmation of Control Voltage

During power-on and during the read operation, observe the check terminal "VCT" and confirm that the waveform is as follows.

### During Power-On

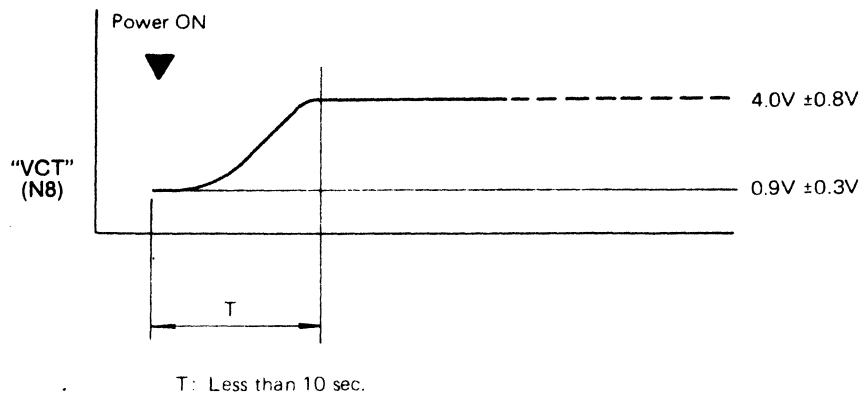

### During the beginning of the read operation

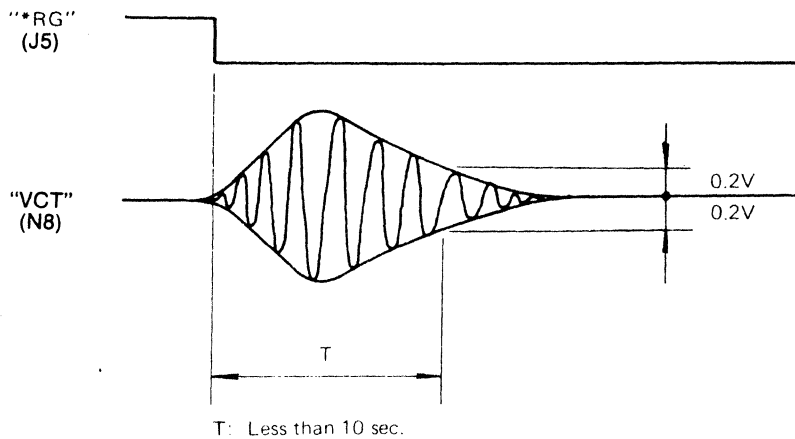

### 6.2.8 Observation of the Read Waveform

Write the repetitive data pattern "00" then "10", and using the differential mode, observe the output level on the check terminals "RS1" and "RS2" on the Control E (CQEM) PCB. Confirm that they satisfy the following standards in every cylinder and data head. In general, the read output level and resolution ratio at cylinder 243 are the most critical.

#### "00" Read Waveform

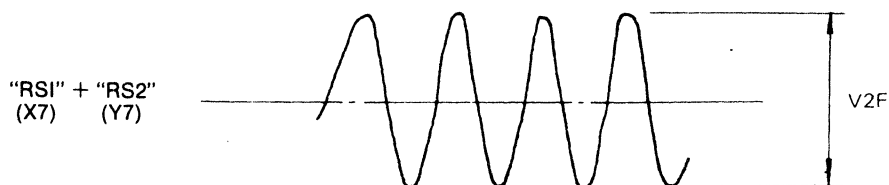

## "10" Read Waveform

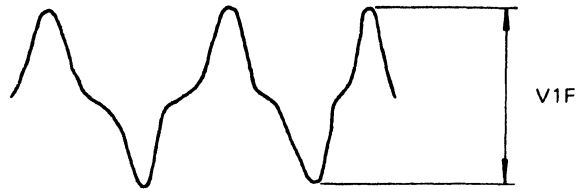

Read output level  $V2F > 3.0V$   
Resolution ratio  $(V2F/V1F) \times 100 > 55\%$

Note: Differential observation mode:

Use both channels of the oscilloscope. Connect one channel to "RS1" and the other to "RS2". Set one of the two channels to invert and add mode and observe. Make sure to connect ground lines to the two probes, and then connect the grounds to the 0V terminal on the PCB assembly, near "RS1" and "RS2".

### 6.2.9 Check of the Settling Waveform after Seeking

Perform an alternate seek operation between two cylinders. Observe the read waveform after seek completion at the check terminal "RS1" on the Control E (CQEM) PCB. Confirm that it satisfies the following standards.

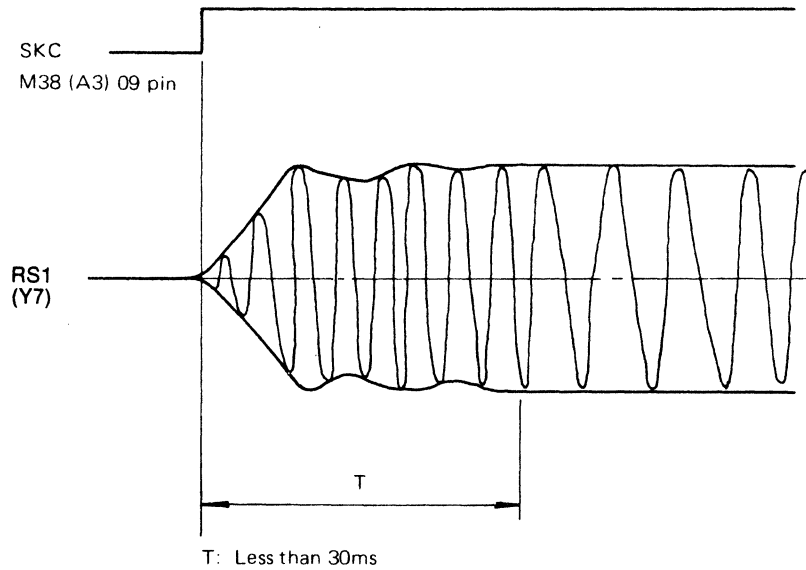



Section 7  
**Spare Parts**

## 7. SPARE PARTS

Table 7.1 shows parts which are replaceable in the field.

**Table 7.1 Spare Parts List**

<b>Item</b>	<b>Designation</b>	<b>Specification</b>	<b>Number/Unit</b>
1	Control E (CQEM) PCB Assembly	B16B-6840-0030A	1
2	Head preamplifier (HPZM) PCB Assembly	B16B-6990-0020A	1

Section 8  
**IC Detail**

## 8. IC DETAIL

### 8.1 OUTLINE

This section describes functions of TTL, ECL, Linear IC's and Fujitsu Analog Master Slice IC's.

### 8.2 LOGIC CONVENTION AND SYMBOLOGY

#### 8.2.1 TTL Logic

M2301/M2302 micro disk drives use +5V transistor – transistor – logic. TTL logic is defined in terms of standard POSITIVE LOGIC using the following definitions:

High Voltage = Logical "1"

Low Voltage = Logical "0"

The input/output logic levels of TTL are defined as follows:

#### (1) TTL Medium/High Speed IC

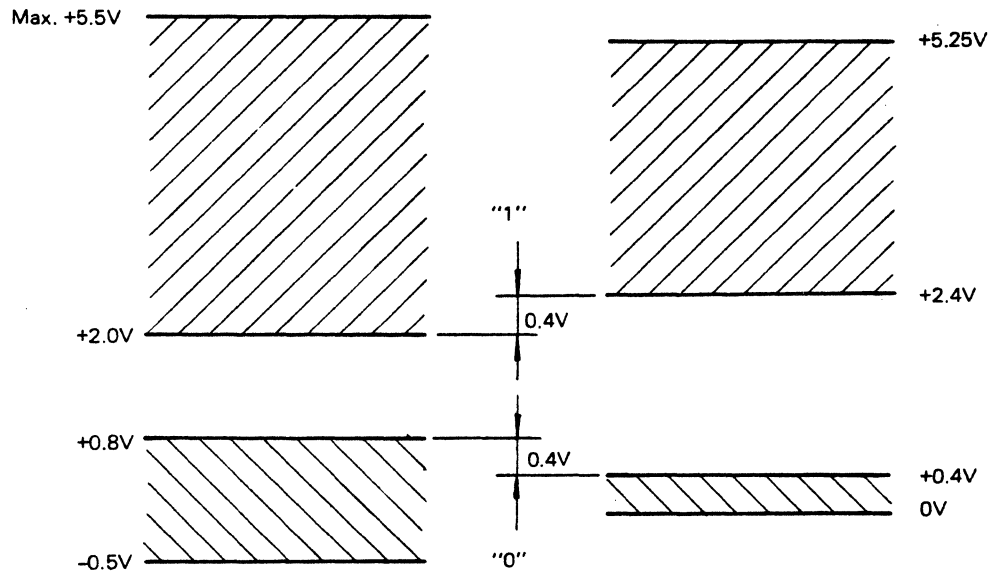

Fig. 8.1 TTL Medium/High Speed IC Level

(2) TTL Super High Speed IC

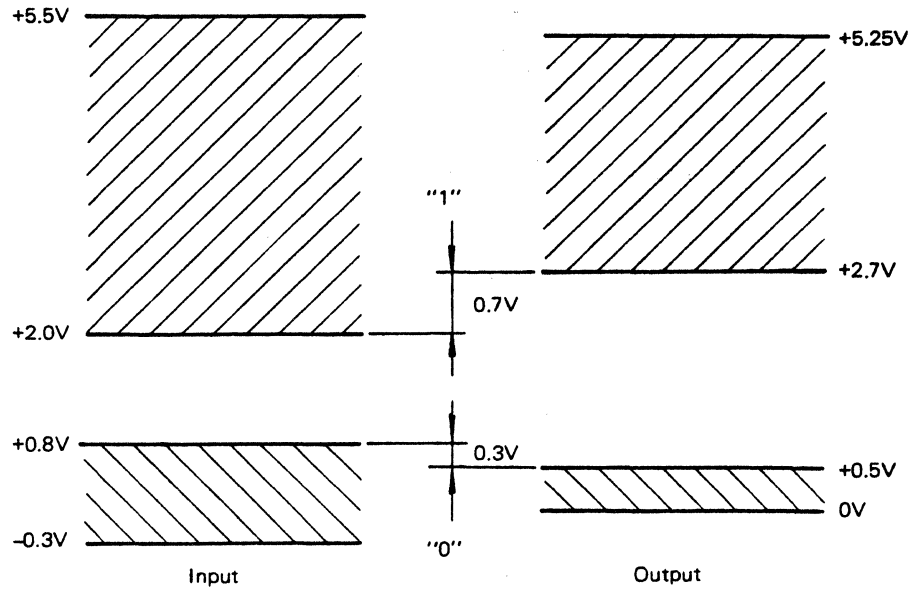

Fig. 8.2 TTL Super High Speed IC Level

(3) Low Power Schottky

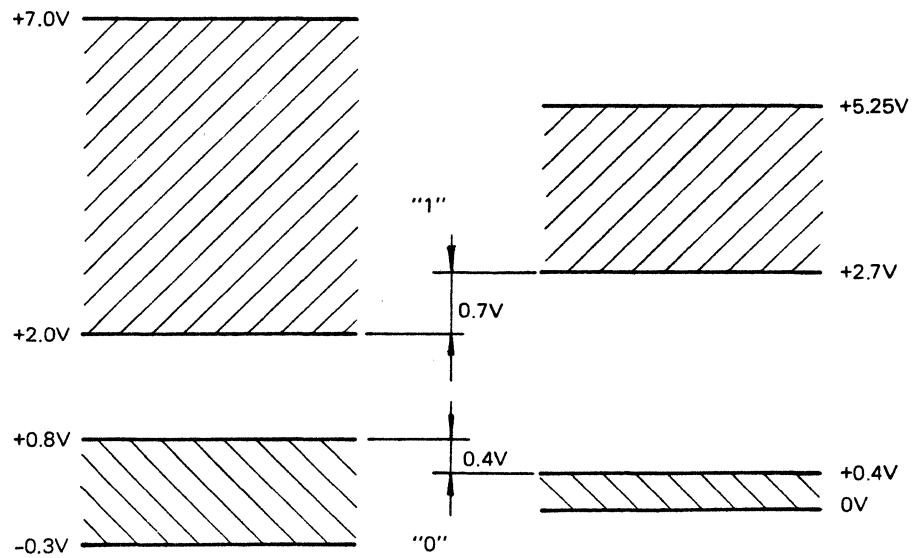

Fig. 8.3 Low Power Schottky Level

### 8.2.2 ECL Logic

The unit uses ECL (Emitter-Coupled-Logic). The ECL logic is defined as POSITIVE LOGIC used for the diffinition as follows.

High Voltage = Logical "1"

Low Voltage = Logical "0"

The input/output logic levels of ECL are defined as follows.

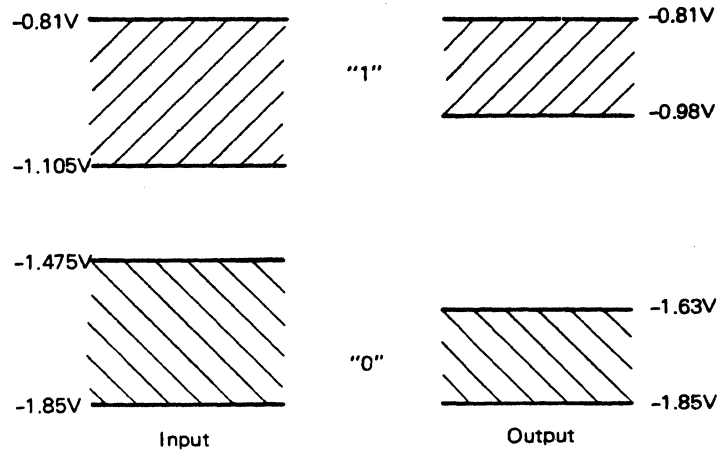
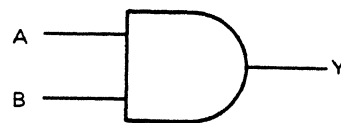

Fig. 8.4 ECL Logic Level

### 8.2.3 Logic Symbology

The following conventions are provided to aid in understanding the symbology used in this manual.

#### (1) TTL



The diagram shows AND gate.

$$Y = A \cdot B$$

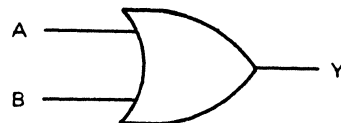

The diagram shows OR gate.

$$Y = A + B$$



A circle placed on any input line or on the output line indicates that logical "0" is the significant state.

The absence of a circle indicates logical "1" is the significant state.

(2) ECL

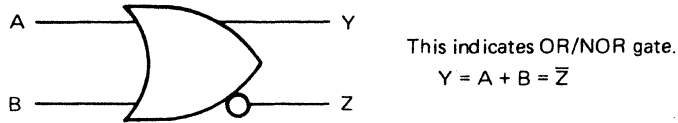
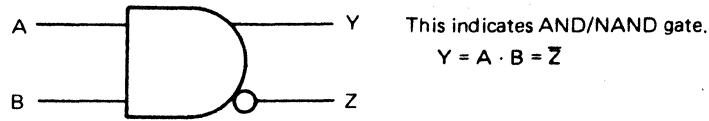

○ This symbol has the same meaning as in TTL

(3) All logic symbols on each logic diagram are identified by a sequential numbering and element type code.

For example:

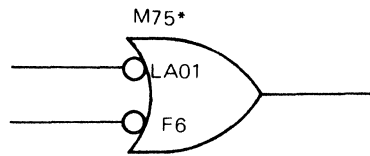

M75\*: Sequential part number of each parts list.  
 LA01: Abbreviation of the element code name.  
 F6: Physical installation position of an element on the printed circuit assembly.

8.3 IC CROSS REFERENCE GUIDE

(1) MB4301C Differential Amp.

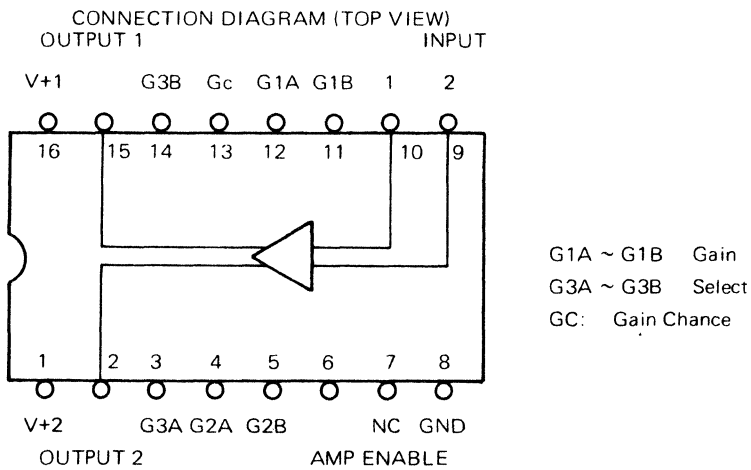

The MB4301C amplifies the signal read out from the magnetic head, and is provided with the gain exchange function and the read gate function.

(2) MB4302C Head Selection Circuit

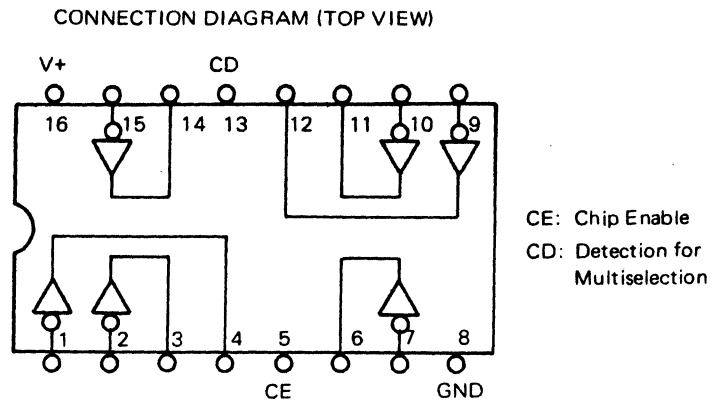

The MB4302C is used in the circuit which selects one head from plural heads, and is provided with the sensor part to detect multiple head section.

(3) MB4305C Write Amp.

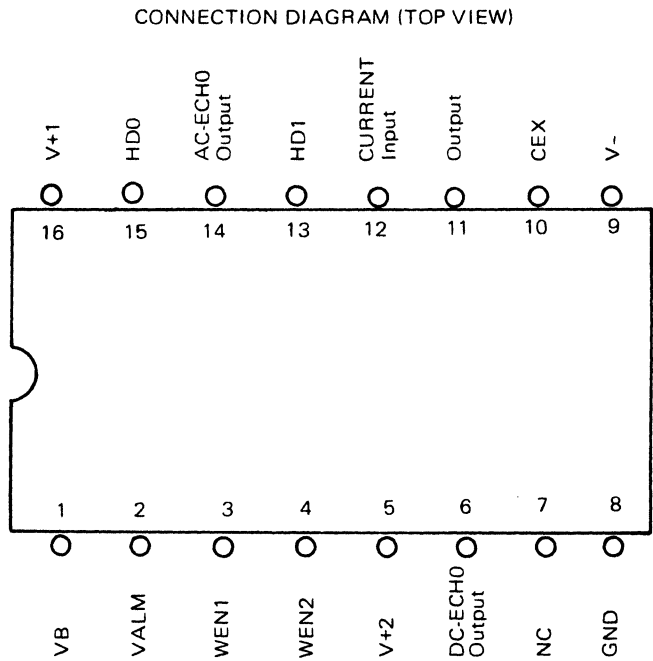

The MB4305C has a constant current source circuit to supply a write current for writing to the magnetic head, and DC-ECHO function to detect operation of constant current.



## 8.4 IC INTERCHANGEABILITY

### 8.4.1 TTL IC Interchangeability

FUJITSU		DIRECT REPLACEMENT	FUNCTION
TYPE NO.	MARKING		
MB74LS00M	LS00	SN74SL00N	QUAD 2 NAND
MB74LS02M	LS02	SN74SL02N	QUAD 2 NOR
MB74LS04M	LS04	SN74SL04N	FEH INVERTER
MB74LS08M	LS08	SN74LS08N	QUAD 2 AND
MB74LS10M	LS10	SN74LS10N	TRIPLE 3 NAND
MB74LS30M	LS30	SN74LS30N	8 OR
MB74LS32M	LS32	SN74LS32N	8 NAND
MB74LS42M	LS42	SN74LS42N	BCB TO DECIMAL DECORDER
MB74LS54M	LS54	SN74LS54N	4 AND-OR INVERTER
MN74LS74M	LS74	SN74LS74N	DUAL D EDGE TRIGGER F,F
MB74LS85M	LS85	SN74LS85N	4 BIT COMPARATOR
MB74LS86M	LS86	SN74LS86N	QUAD 2 EX-OR
MB74LS157M	LS157	SN74LS157N	QUAD 2-1 MULTIPLEXER
MB74LS161M	LS161	SN74LS161N	4 BIT BINARY COUNTER
MB74LS174M	LS174	SN74LS174N	HEX D F, F
MB74LS191M	LS191	SN74LS191N	4 BIT UP/DOWN COUNTER
MB74LS194M	LS194	SN74LS194N	4 BIT SHIFT REGISTER
MB418M	LA18	SN7404N	HEX INVERTER
MB450M	LA30	SN74161N	4 BIT BINARY COUNTER
MB74S00M	LH00	SN74S00N	QUAD 2 NAND
MB74S04M	LH04	SN74S04N	HEX INVERTER
MB74S08M	S08	SN74S08N	QUAD 2 AND
MB74S51M	LH06	SN74S51M	DUAL 2 AND-OR INVERTER
C76L-0650-0112	LH10	SN74S112N	DUAL J-K, F, F
C76L-0080-0020	LX16	SN75452BP	DUAL 2 NAND PERIPHERAL DV
C76L-0080-0020	LX20	SN7414N	HEX SCHMITT INVERTER
C76L-0080-0032	LX32	SN7432N	QUAD 2 OR
C76L-0080-0221	LX27	SN74221N	DUAL SCHMITT MONOSTABLE
C76L-0080-0193	LX34	SN74193N	4 BIT UP/DOWN COUNTER
MB420M	420	SN7474N	DUAL D F, F
MB427M	427	SN75113N	3 STATE DUAL LINE DV
MB428M	428	SN75115N	DUAL LINE DV
MB433M	433	SN7438N	QUAD 2 NAND BUFFER
MB434M	434	SN75451BP	DUAL PERIPHERAL 2 AND DV
MB440M	440	—	DUAL RETRIGGER MONOSTABLE
MB456M	456	SN74191N	4 BIT UP/DOWN COUNTER
CG24103A	DV18	—	OSCILLATOR
C76L-0700-0503	75108A	SN75108AN	DIFF DUAL LINE RV

### 8.4.2 ECL

FUJITSU		DIRECT REPLACEMENT	FUNCTION
TYPE NO.	MARKING		
MB10115C	115	MC10115L	QUAD RECEIVER
MB10116C	116	MC10116L	TRIPLE RECEIVER
MB10131C	131	MC10131L	DUAL D M-S F, F
MB10124C	124	MC10124L	DUAL TTL TO ECL

### 8.4.3 LINEAR IC

C76L-0400-0033	A339	$\mu$ PC117C	COMPARATOR
C76L-0130-0002	A331	$\mu$ PC271C	COMPARATOR
MB3501M	A733	—	AMP
MB4001M	A710	—	COMPARATOR

### 8.4.4 C MOS

MB84040BM	4040	MC14040BCP	12 BIT BINARY COUNTER
MB84020BM	4020	MC14020BCP	14 BIT BINARY COUNTER
MB7052C	7052	—	P ROM

### 8.4.5 FUJITSU ANALOG MASTER SLICE IC

MB4301C	A4301	—	AMP
MB4302C	A4302	—	HEAD SELECT
MB4305C	A4305	—	AMP

Section 9  
**Parts List**

## 9. PARTS LIST

### 9.1 INTRODUCTION

This section contains the assembly diagrams for the major subassemblies. Each diagram is accompanied by a parts list referencing parts within the subassembly. The list contains the part number, quantity used and description of each part. The diagrams will, therefore, be useful in determining the position and sequence of each part during assembly and maintenance operations.

### 9.2 ASSEMBLY DRAWINGS

Each drawing is an exploded view of a subassembly with each discrete part illustrated. Each part is labeled with a number which corresponds to a number in the Index Number column of the parts list.

NOTE: The parts that cannot be disassembled in the usual maintenance environment are not illustrated discretely, but rather are illustrated in their assembled state.

### 9.3 LIST

The quantity of parts, the name of parts and the specification (part number) are entered corresponding to the number of the illustration.

#### 9.3.1 Index Number

A number is assigned to each part in the illustration. The number corresponds to the Index Number. But in case the Index Number is given for every part of the assembly, the Index Number, will be blank next to the Assembly Part Number.

#### 9.3.2 Composition and Quantity

This portion of the table reflects the relationship of the parts and their respective quantities within a subassembly. A number in the left column of this section designates an assembly. Each column to the right reflects stages of disassembly.

#### 9.3.3 Specification

Specifications of parts (Drawing Number) are represented.

#### 9.3.4 Description

Name of the part (in Japanese and English), maker of parts and applicable machine etc. are entered.

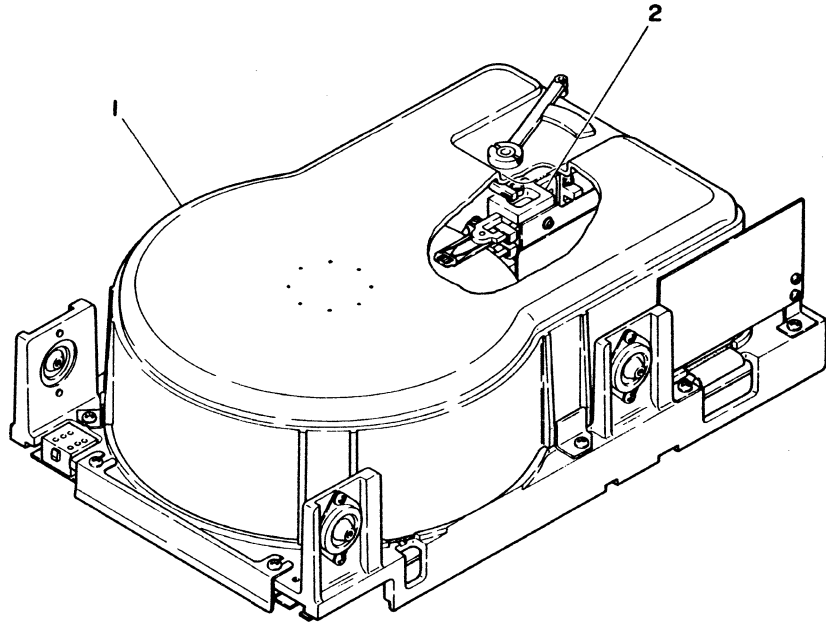

Fig. 9.1 MICRO-DISK DRIVE

INDEX NO.	COMPOSITION & QUANTITY					SPECIFICATION	DESCRIPTION	CHARACTER	REMARK	REVISION
	1					B030-4600-T001A	マイクロディスクソータ Micro-Disk Drive		M2301	
	1					B030-4600-T002A	マイクロディスクソータ Micro-Disk Drive		M2302	
1	1					B030-4600-T001A	マイクロディスク Micro-Disk Drive		M2301	
1	1					B030-4600-T002A	マイクロディスク Micro-Disk Drive		M2302	
2		1				B030-4600-W018A	キャリッジミタテ Carriage Assembly		M2301	
2		1				B030-4600-W019A	キャリッジミタテ Carriage Assembly		M2302	

Table 9.1 MICRO-DISK DRIVE

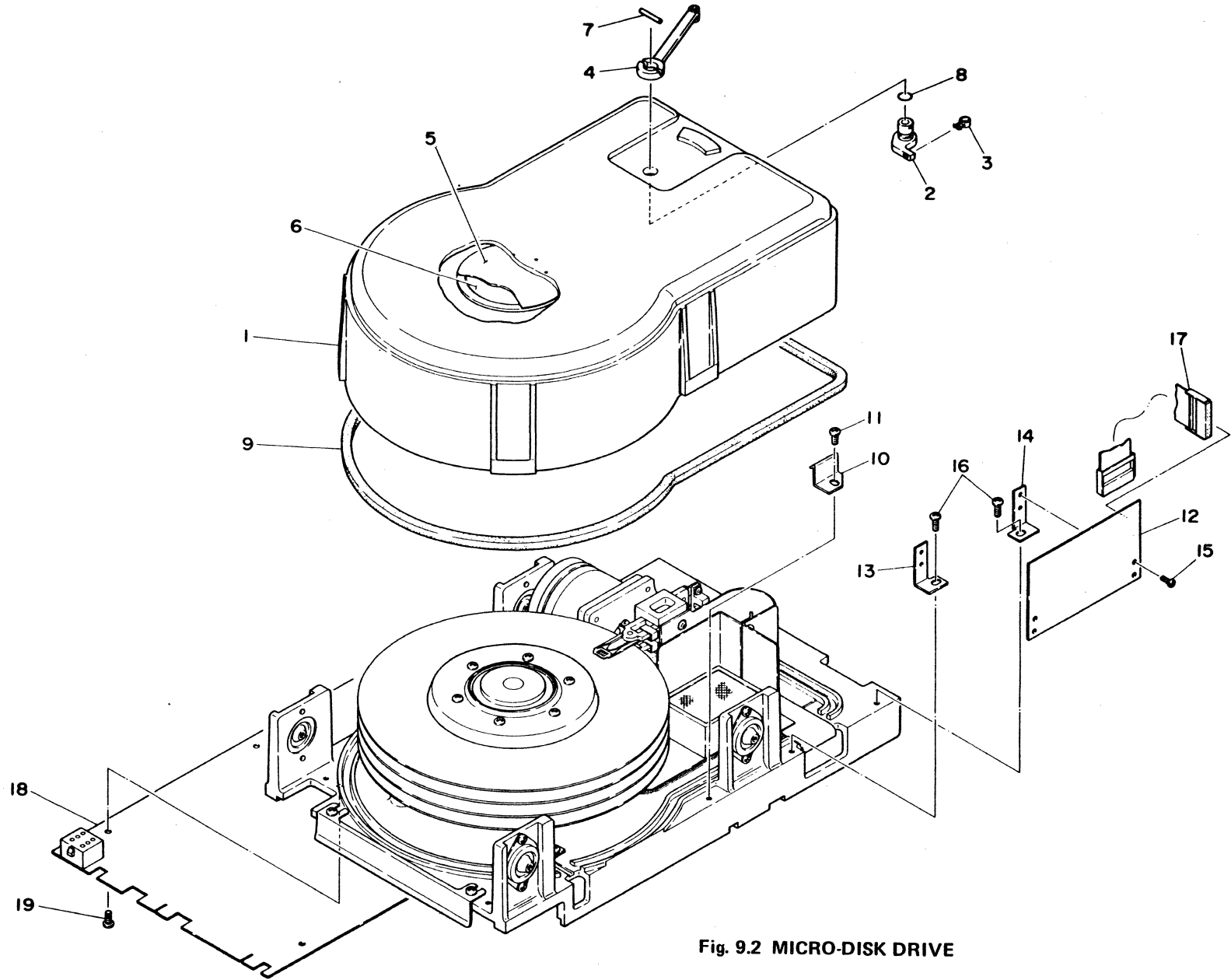

Fig. 9.2 MICRO-DISK DRIVE

INDEX NO.	COMPOSITION & QUANTITY	SPECIFICATION	DESCRIPTION	CHARACTER	REMARK	REVISION
1	1	B030-4600-T001A	マイクロディスク Micro-Disk Drive		M2301	
1	1	B030-4600-T002A	マイクロディスク Micro Disk Drive		M2302	
	1	B030-4600-W016A	カバー-カンセイ Cover Assy.			
1	1	B030-1600-X078A	カバー Cover			
2	1	B030-1600-X079A	ロックジク Lock Shaft			
3	1	B030-1600-X098A	ストップ Stopper			
4	1	B030-1600-X080A	レバー Lever			
5	1	B030-1600-X081A	フィルタ Filter			
6	1	B030-1600-X082A	フタ Plate			
7	1	F6-PS-16×16S	ピン Pin			
8	1	JB-OR1A-P7	リング Ring			
9	1	B030-4600-X045A	パッキン Gasket			
10	4	B030-4600-X046A	イタ Plate			
11	4	F6-SBD-4×8S	コネジ Screw			
12	1	B16B-6990-0020A	ヘッドプリアンプ Head Pre-Amplifier PCB			
13	1	B030-4600-X050A	イタ Plate			
14	1	B030-4600-X051A	イタ Plate			
15	4	F6-SBD-3×5S	コネジ Screw			
16	2	F6-SBD-4×6S	コネジ Screw			
17	1	B660-1160-T007A	アダプタケーブル Adapter Cable			
18	1	B16B-6840-0030A	コントロール Control PCB			
19	6	F6-SBD-4×6S	コネジ Screw			

Table 9.2 MICRO-DISK DRIVE



Section 10  
**Schematics**

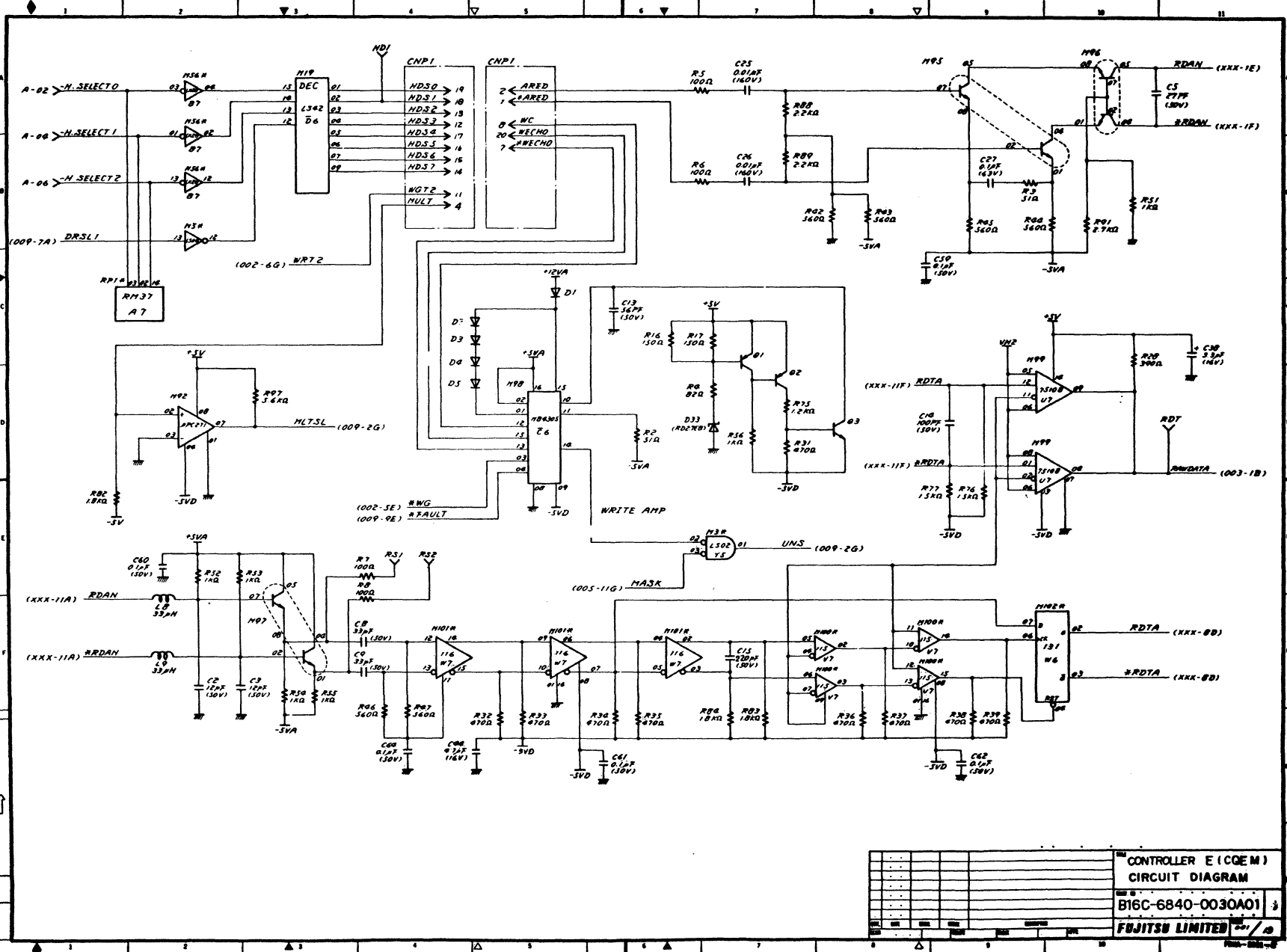

CONTROLLER E (COEM)  
 CIRCUIT DIAGRAM  
 B16C-6840-0030A01  
 FUJITSU LIMITED

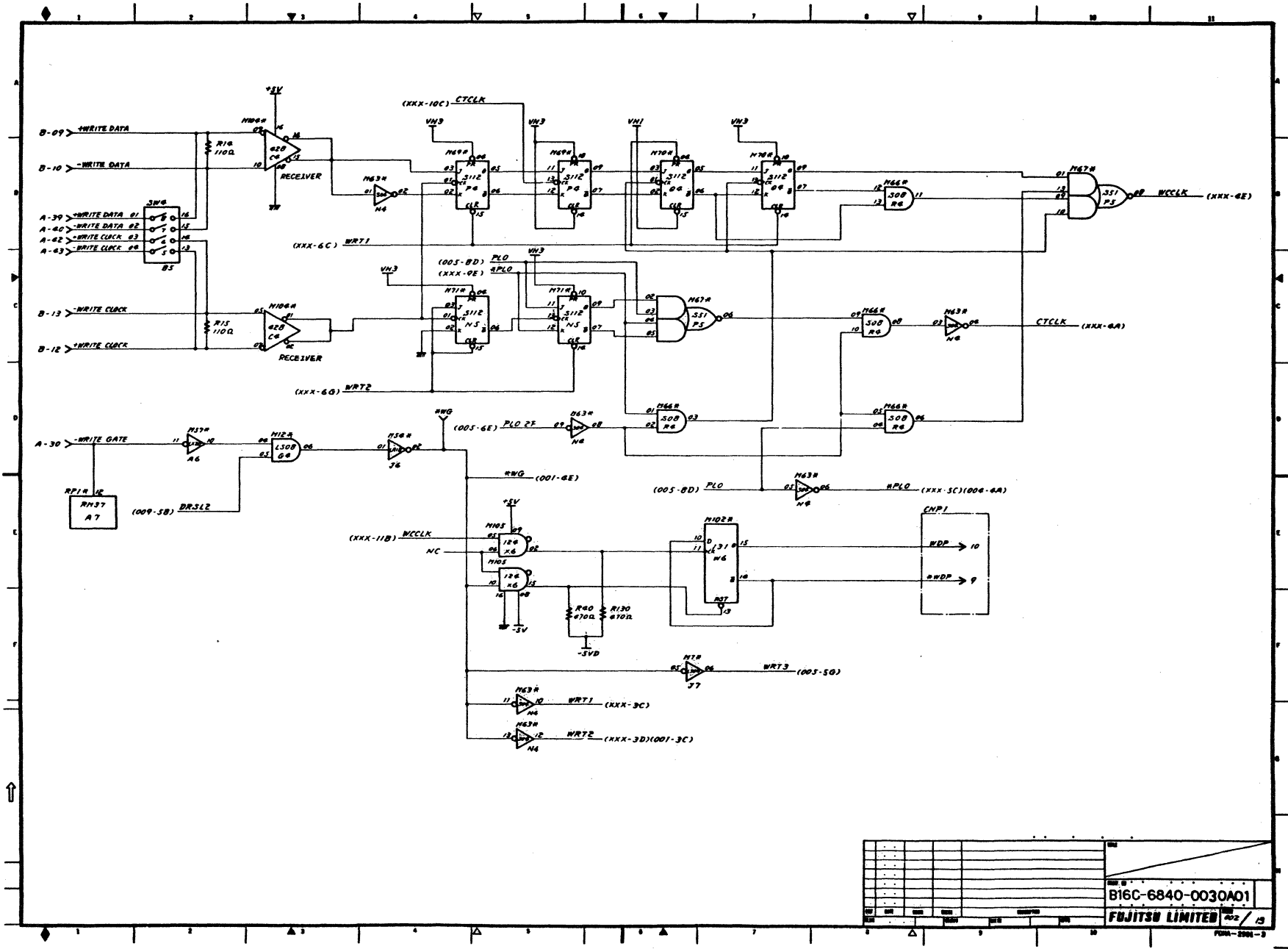

B16C-6840-0030A01

FUJITSU LIMITED

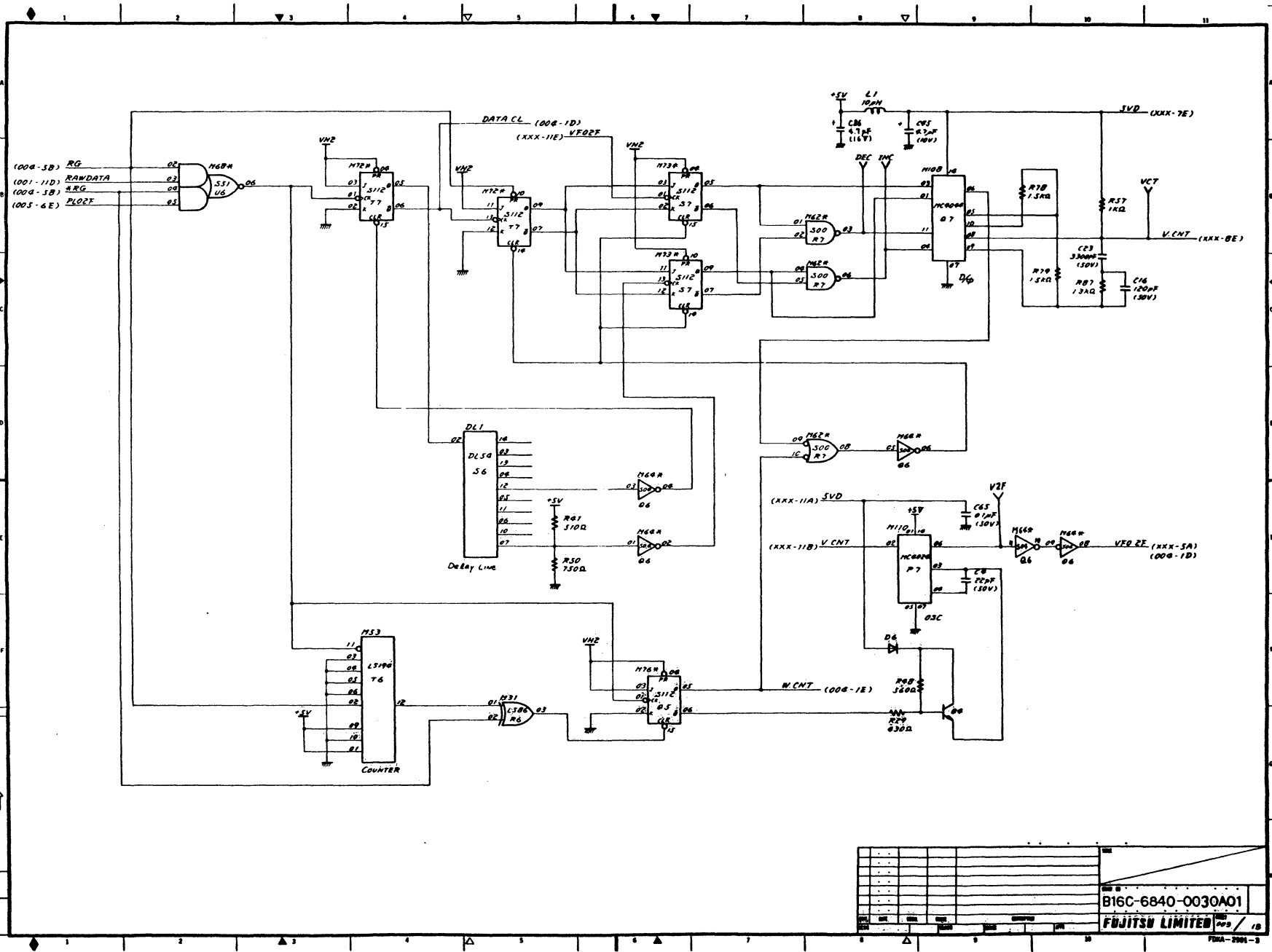

REV	1	DATE	11/70	BY	...
REV	2	DATE	...	BY	...
REV	3	DATE	...	BY	...
REV	4	DATE	...	BY	...
REV	5	DATE	...	BY	...
REV	6	DATE	...	BY	...
REV	7	DATE	...	BY	...
REV	8	DATE	...	BY	...
REV	9	DATE	...	BY	...
REV	10	DATE	...	BY	...
REV	11	DATE	...	BY	...
REV	12	DATE	...	BY	...
REV	13	DATE	...	BY	...
REV	14	DATE	...	BY	...
REV	15	DATE	...	BY	...
REV	16	DATE	...	BY	...
REV	17	DATE	...	BY	...
REV	18	DATE	...	BY	...
REV	19	DATE	...	BY	...
REV	20	DATE	...	BY	...
REV	21	DATE	...	BY	...
REV	22	DATE	...	BY	...
REV	23	DATE	...	BY	...
REV	24	DATE	...	BY	...
REV	25	DATE	...	BY	...
REV	26	DATE	...	BY	...
REV	27	DATE	...	BY	...
REV	28	DATE	...	BY	...
REV	29	DATE	...	BY	...
REV	30	DATE	...	BY	...

B16C-6840-0030A01  
FUJITSU LIMITED

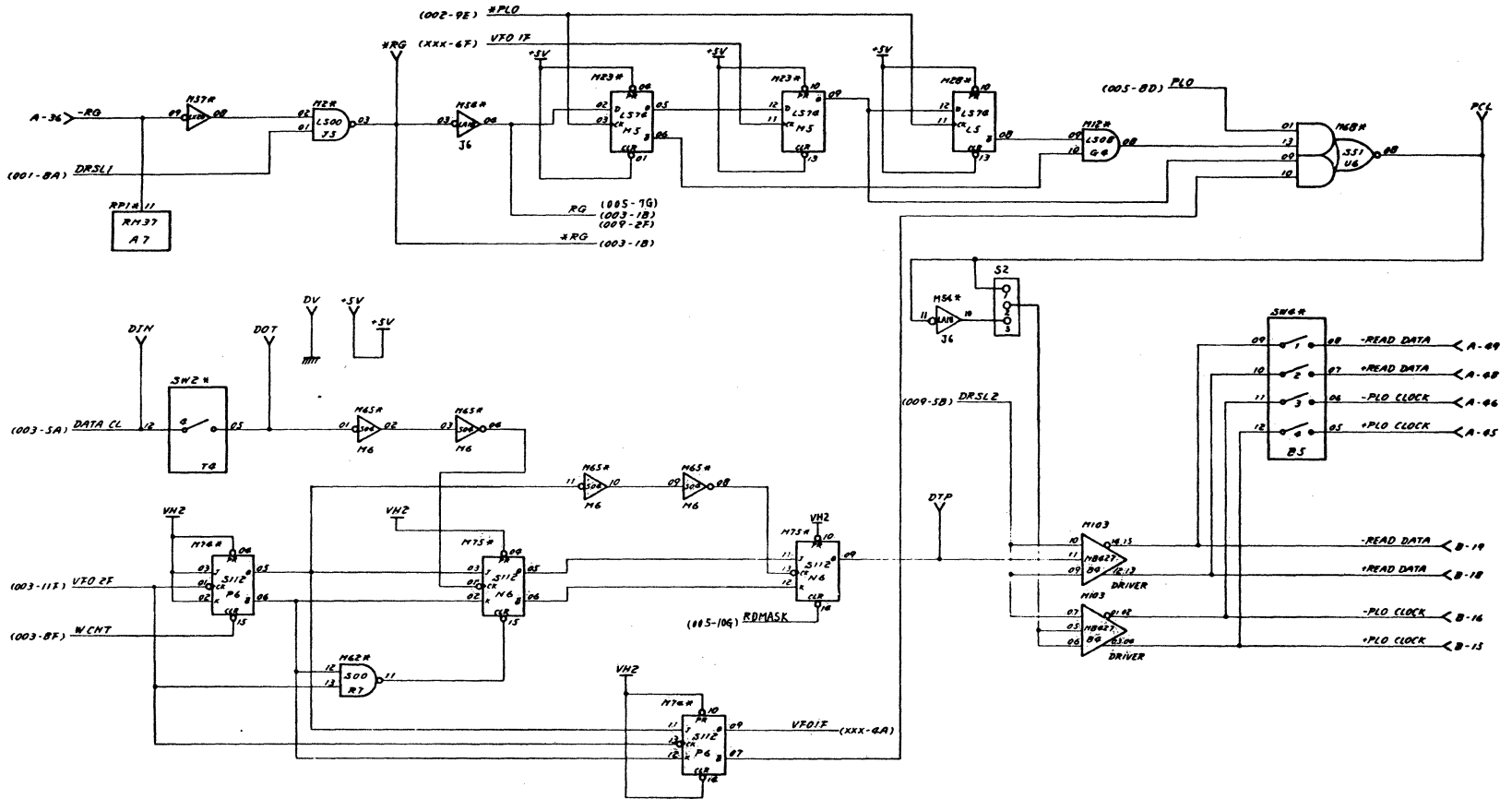

B03P-4605-0003A .... B

REV				REV				REV			
B16C-6840-0030A01											
<b>FUJITSU LIMITED</b>											

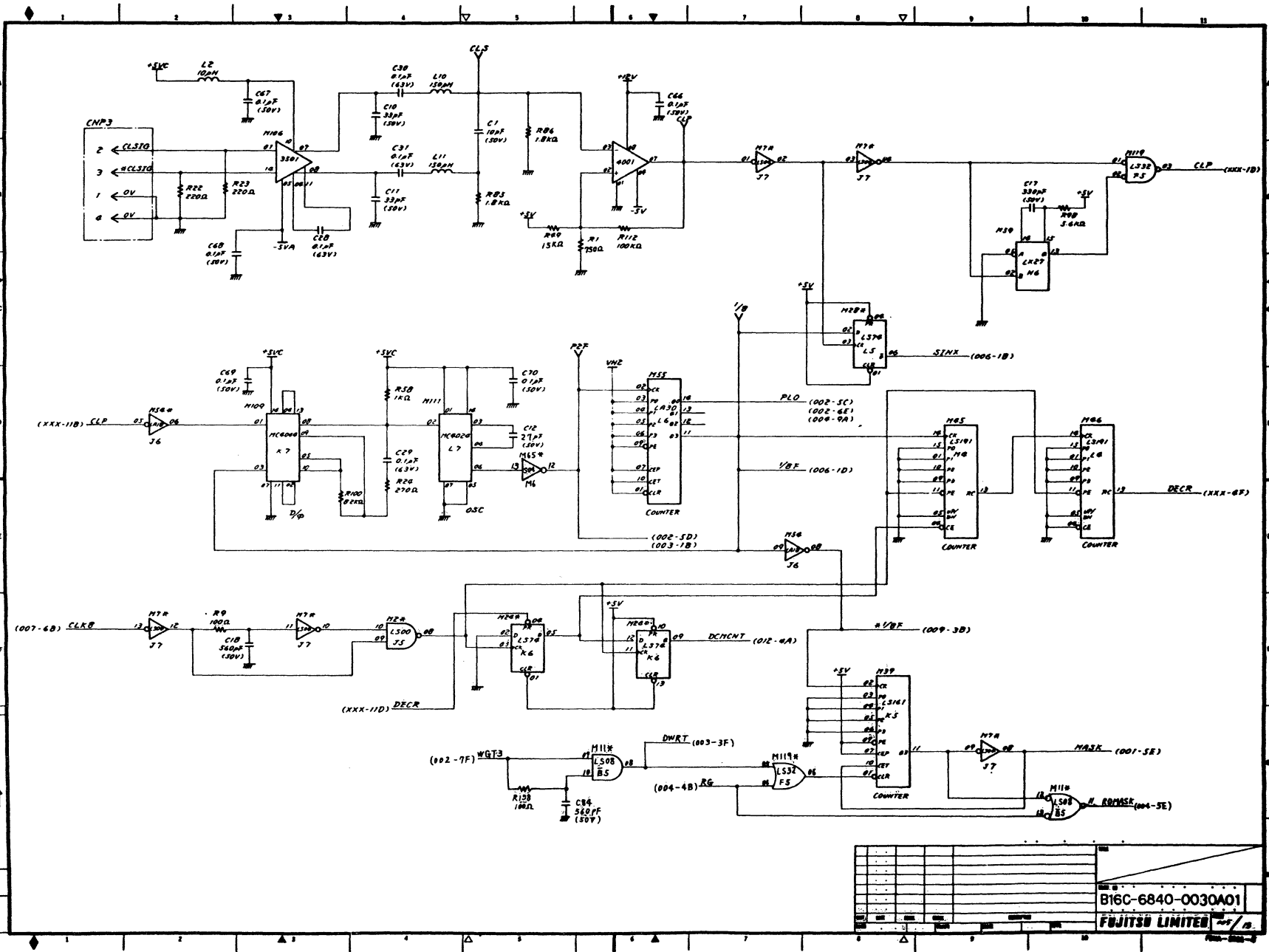

B16C-6840-0030A01

FUJITSU LIMITED

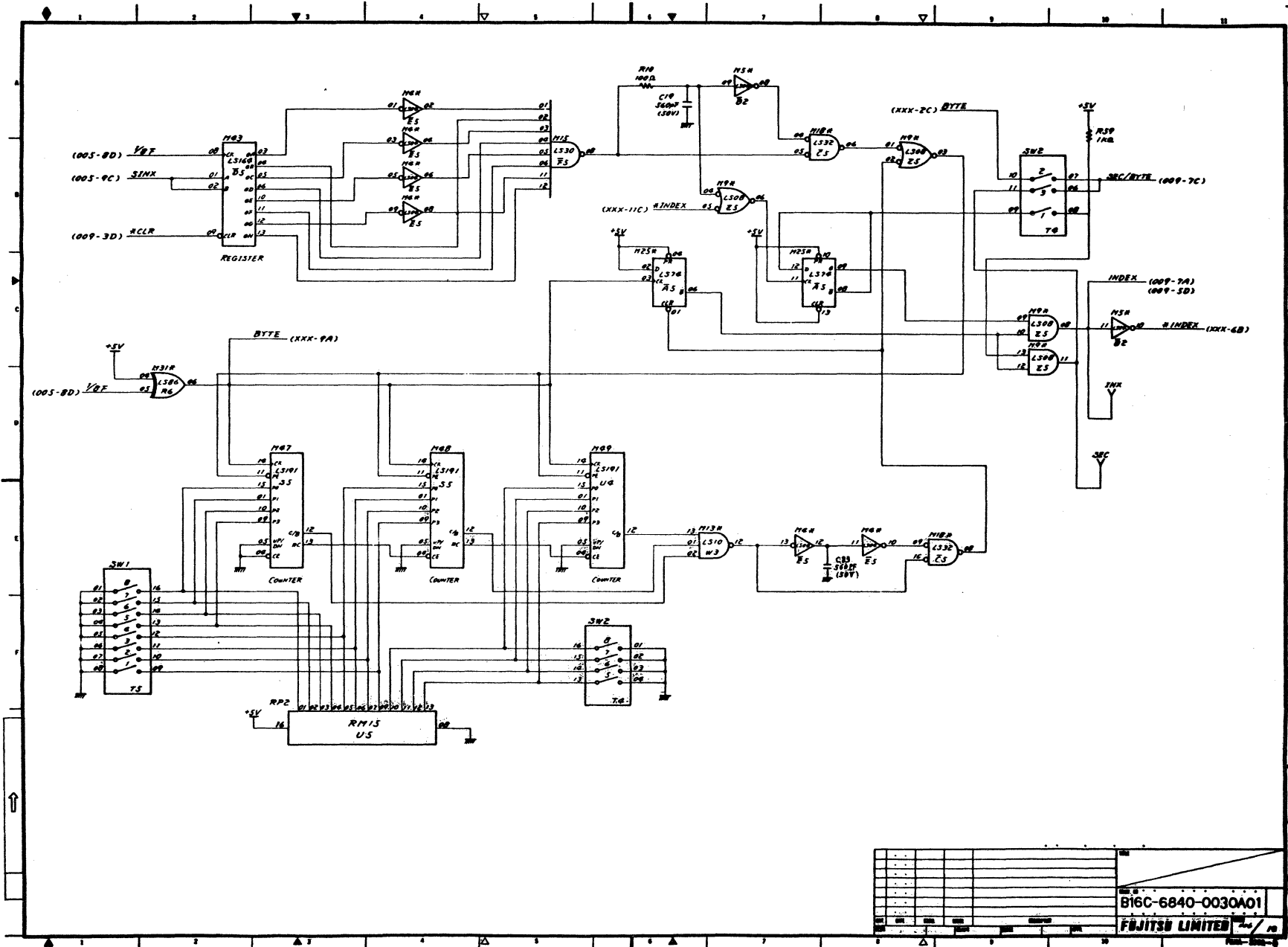

B16C-6840-0030A01  
 FUJITSU LIMITED

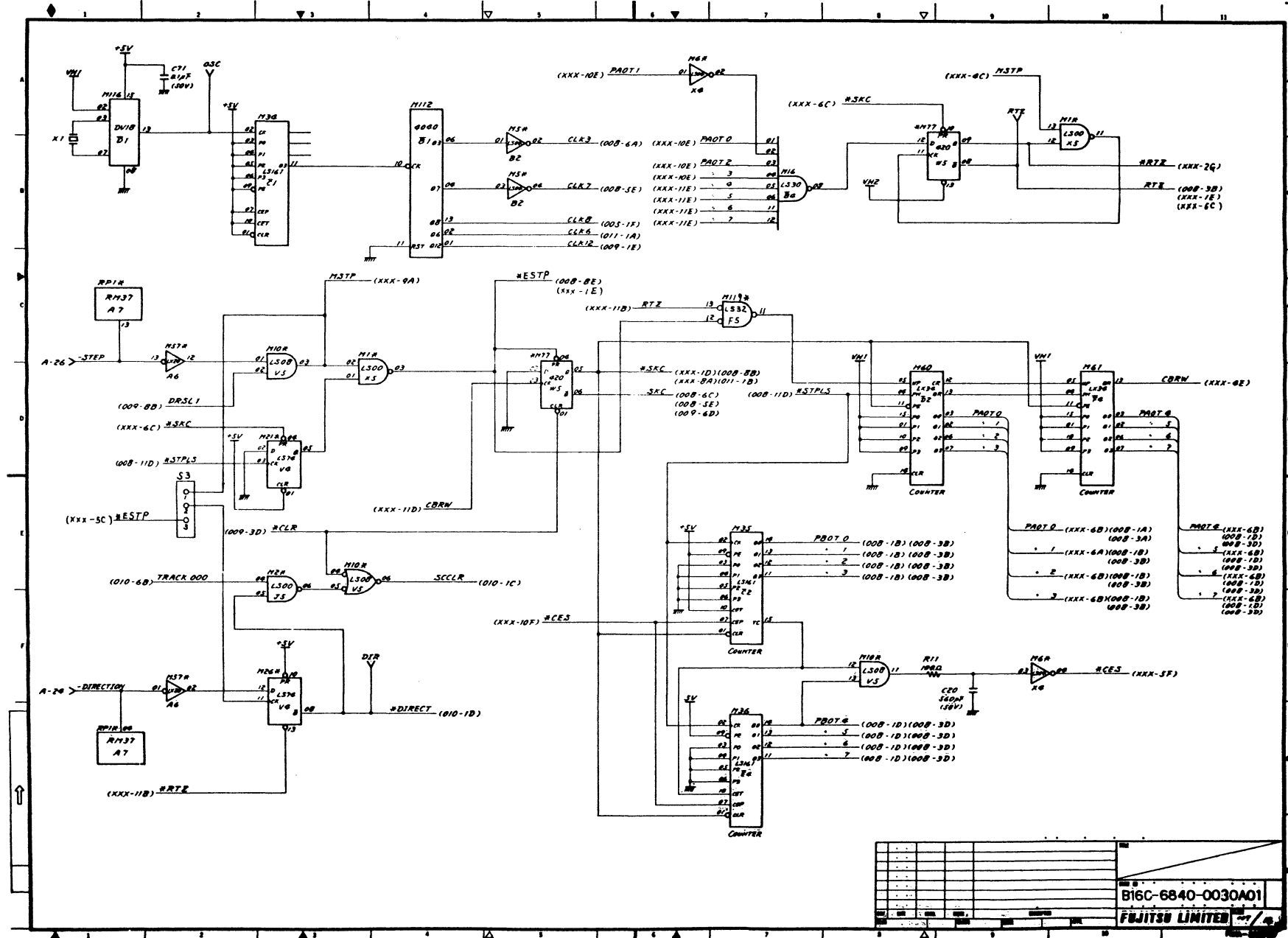

B16C-6840-0030A01	
FUJITSU LIMITED	



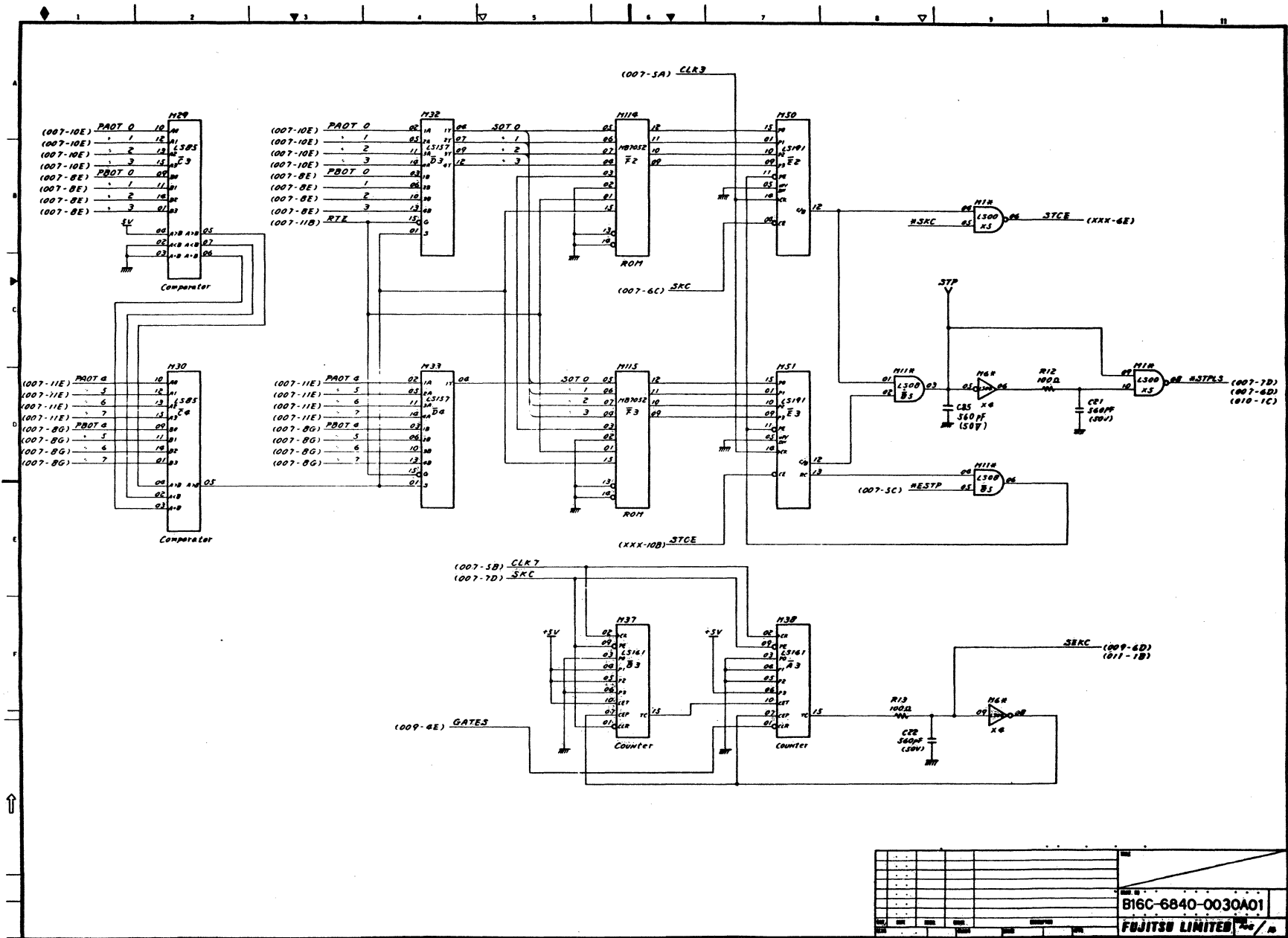

B16C-6840-0030A01	
FUJITSU LIMITED	

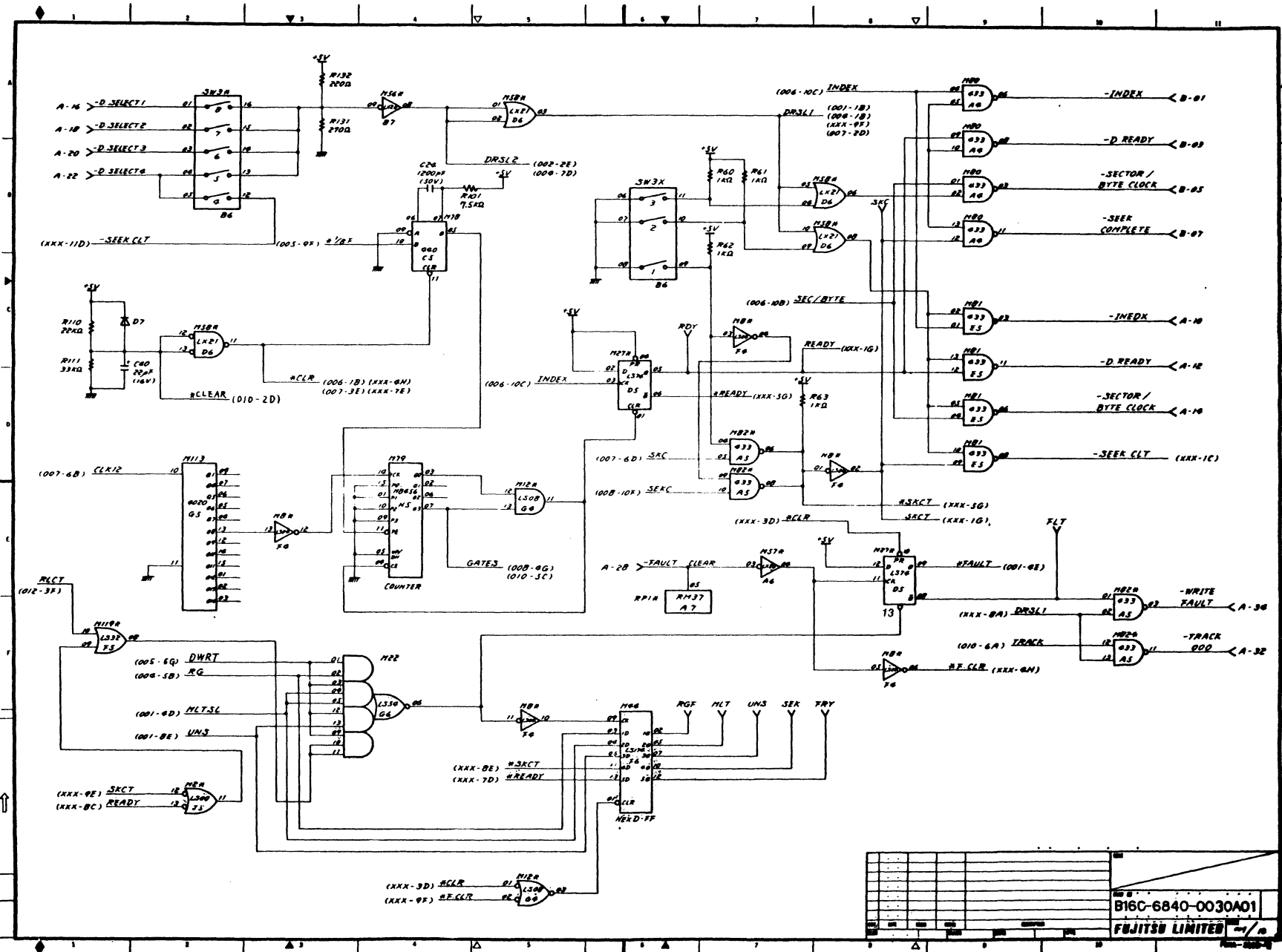

B16C-6840-0030A01  
 FUJITSU LIMITED

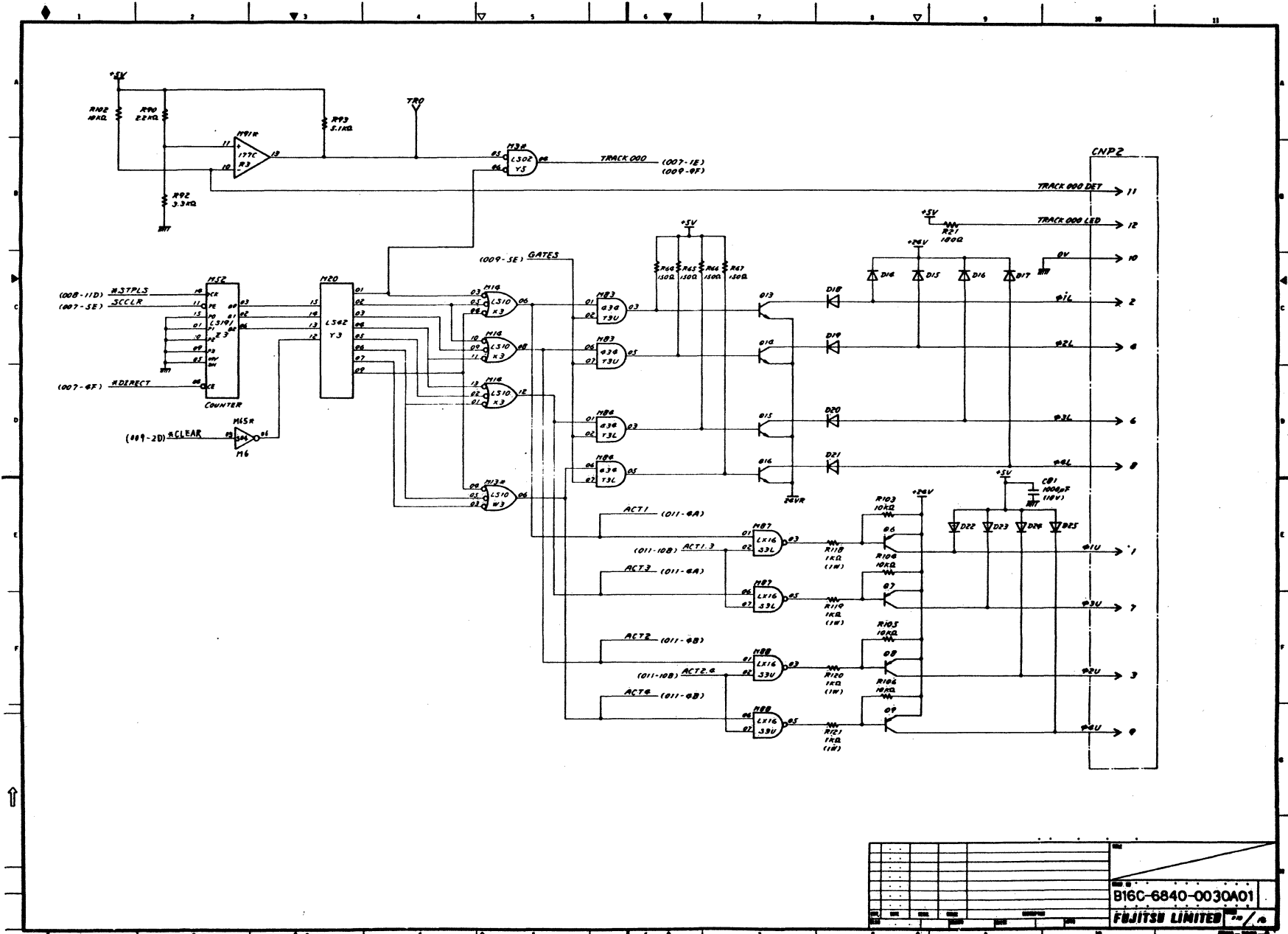

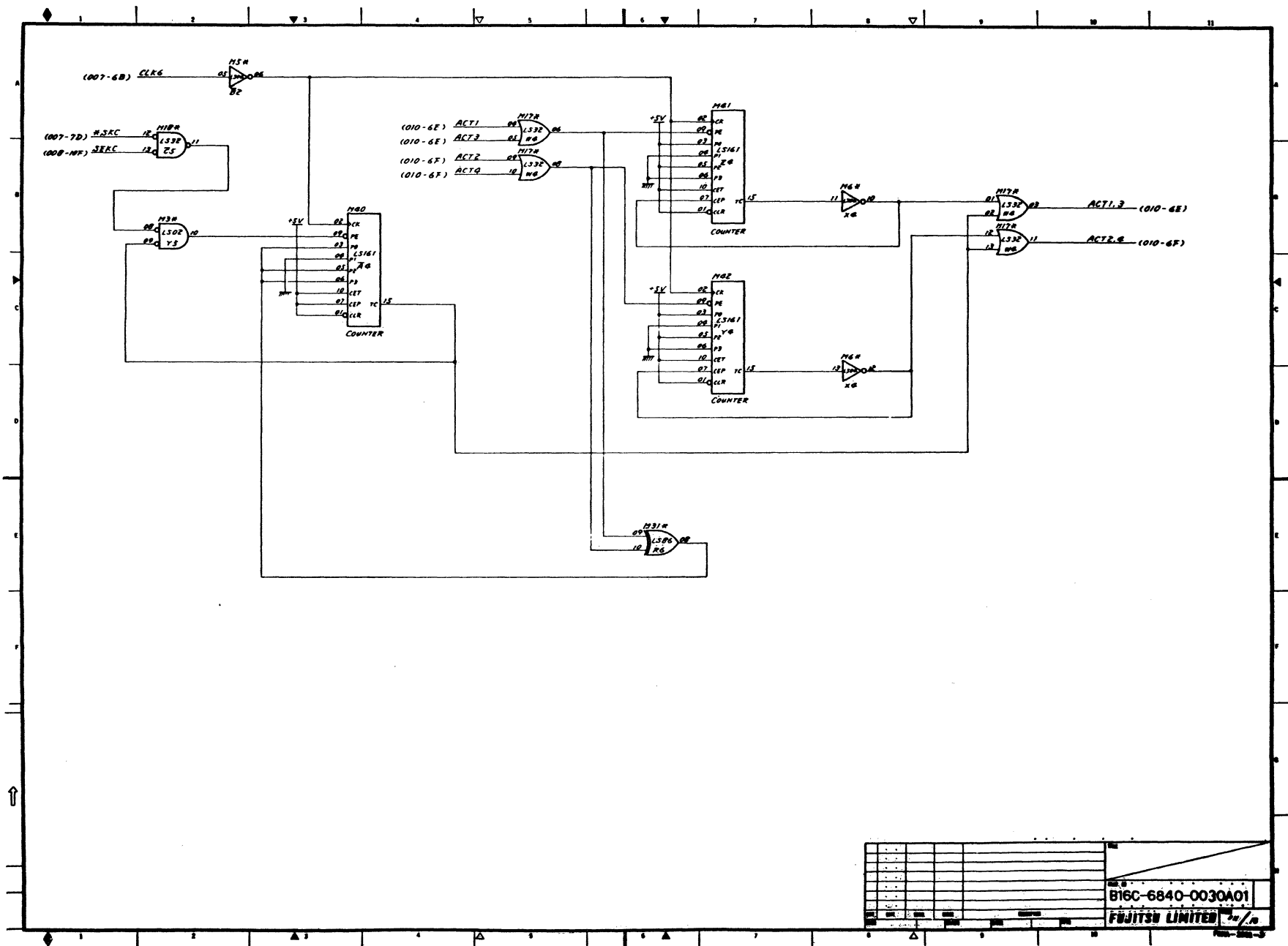

B16C-6840-0030A01  
FUJITSU LIMITED



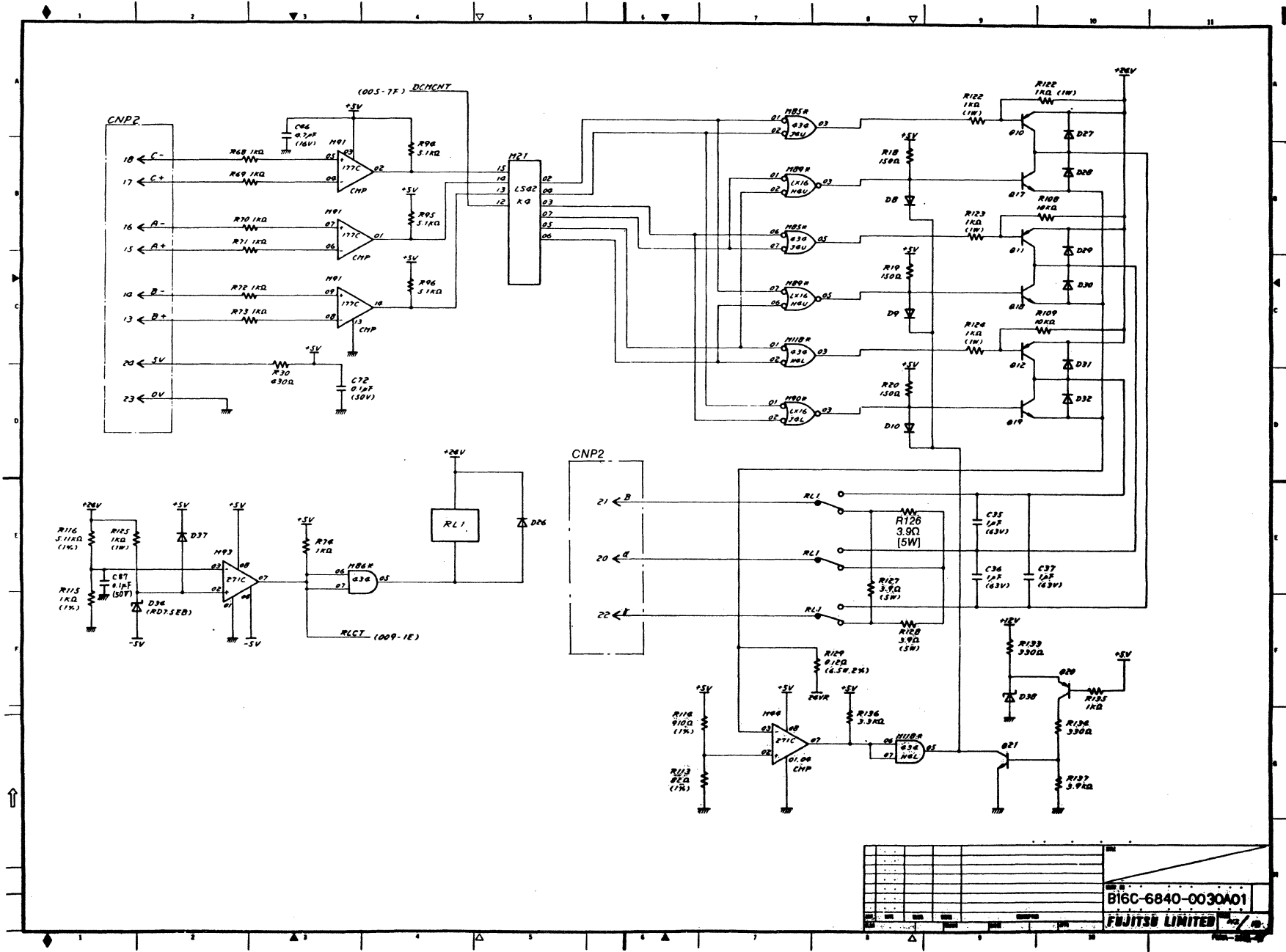

B16C-6840-0030A01  
**FUJITSU LIMITED**

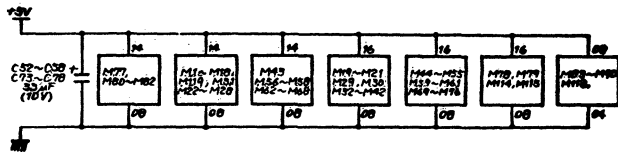
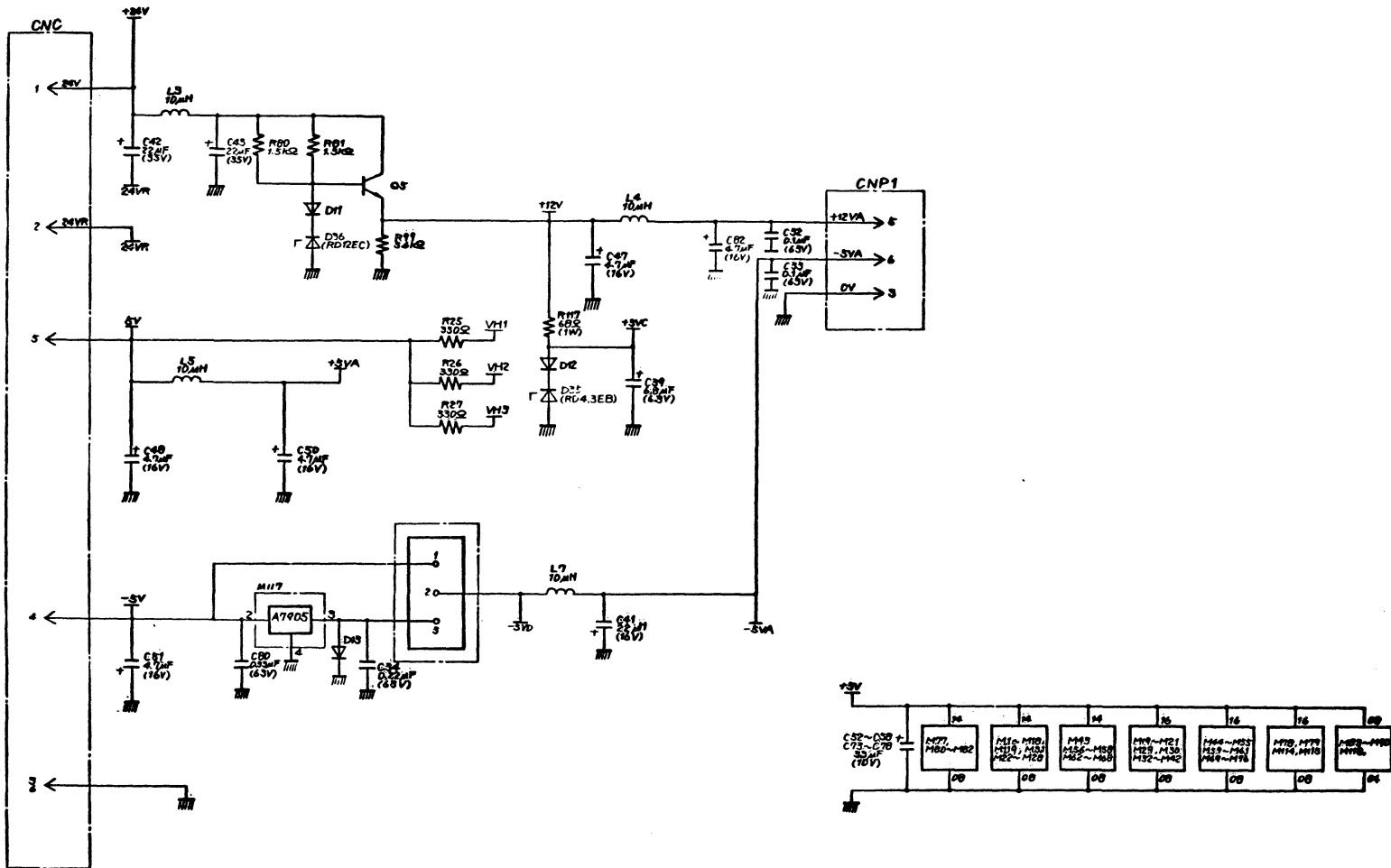

B16C-6840-0030A01  
FUJITSU LIMITED

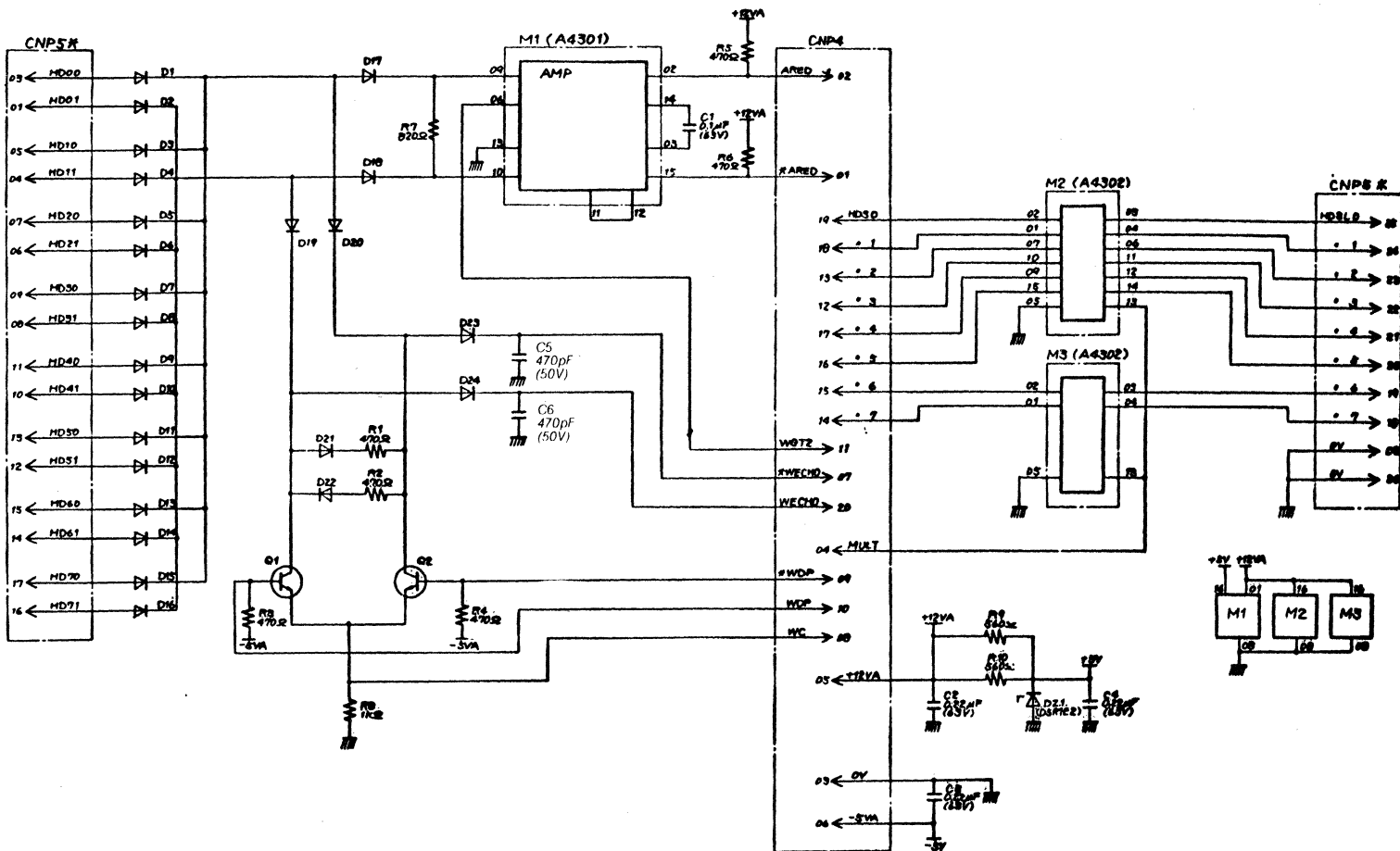

BIGC-6840-0030A01  
FUJITSU LIMITED



HEAD PRE-AMP ZHPZM	
CIRCUIT DIAGRAM	
B16C-6990-0020A01	
FUJITSU LIMITED	

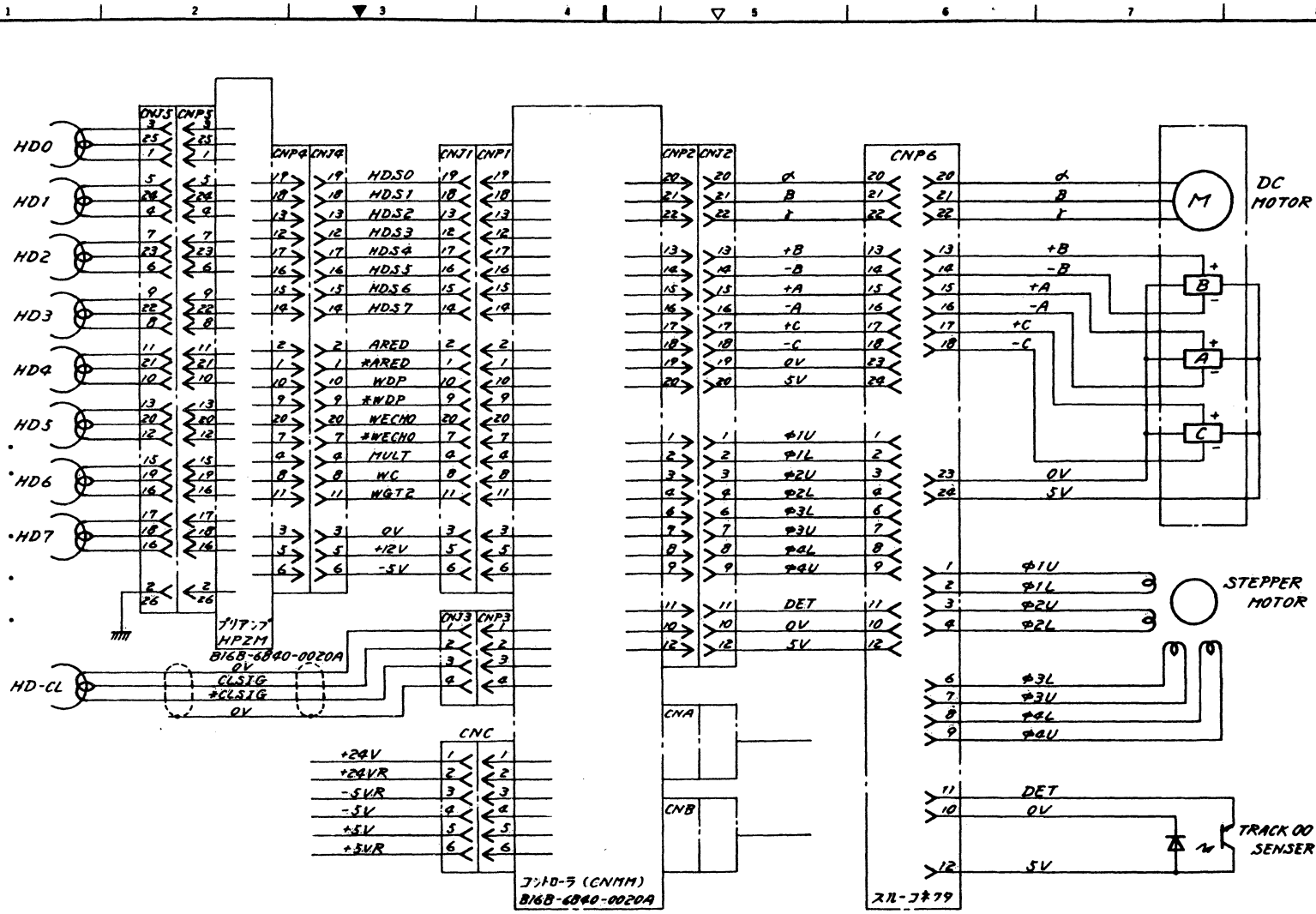

REV	DATE	BY	CHK	APP	REVISION

MODEL  
**M2301/M2302 MDD**  
 Circuit Diagram  
 PLAN NO  
**B03C-4600-0001A**  
**FUJITSU LIMITED**