

GA27-2739-3

**Systems**

**An Introduction to the  
IBM 3270 Information  
Display System**

**IBM**

## Preface

This publication provides customer executives, installation managers and planners, and IBM marketing representatives with planning information about the IBM 3270 Information Display System. The 3270 display system is composed of the following units:

- 3271 Control Unit, Models 1 and 2
- 3272 Control Unit, Models 1 and 2
- 3275 Display Station, Models 1 and 2
- 3277 Display Station, Models 1 and 2
- 3284 Printer, Models 1, 2, and 3
- 3286 Printer, Models 1 and 2

The 3270 display system is offered with the following programming support:

- BTAM under DOS and OS (MFT, MVT, and VS)
- DIDOCS and SDS under OS
- VIDEO/370 under DOS and OS (MFT and MVT)
- DATA/360 under DOS and OS (MFT and MVT)

This book is divided into ten chapters. Chapter 1 provides an introduction to the 3270 display system, highlighting the most important aspects of the product. Chapter 2 is concerned with configuring applications-oriented display systems and also describes the many

special features available to expand performance. Appendixes A and B support this chapter by providing a configurator and a features list, respectively. Chapter 3 highlights the functional capabilities of the display system. A reader who is concerned with the detailed operation of these capabilities will find them described in depth in Appendix C. Chapter 4 discusses types of applications that can be served by the 3270 display system. Chapter 5 describes highlights of the programming support, and Chapter 6 cites programming considerations for converting from an IBM 2260/2848 or an IBM 2265/2845 display system to a 3270 display system. Chapters 7 through 10 provide descriptions of human factors considerations, installation planning, reliability and availability, and performance considerations, respectively.

The book assumes that a reader has a basic understanding of display systems and their relationship to a central processor. Someone reading those chapters related to programming is expected to have an understanding of an operating system and applications-related display system programming support. Chapter 5, Programming Support, and Chapter 8, Installation Planning, provide references to other IBM documentation for additional information on their respective subjects.

A more-detailed description of the 3270 Information Display System may be found in *IBM 3270 Information Display System Component Description*, GA27-2749.

*Fourth Edition (October 1972)*

This is a major revision of GA27-2739-2. Descriptions of the following special features are included: Dial, IBM 600/1200-bps Line Adapter, IBM 600/1200-bps Line Adapter with Auto Answer, Switched Network Backup capability, and 4800/7200-bps Transmission Speed. Minor changes have been made throughout the text. All changes or additions to the text and illustrations are indicated by a vertical line to the left of the change.

Copies of this and other IBM publications can be obtained through IBM branch offices.

Text for this publication has been prepared with the IBM SELECTRIC ® Composer.

A form is provided at the back of this publication for reader's comments. If the form has been removed, comments may be addressed to: IBM Systems Development Division, Product Publications, Dept. 520, Neighborhood Road, Kingston, N.Y. 12401

©Copyright International Business Machines Corporation, 1971, 1972

<b>Chapter 1 Introduction</b> . . . . .	1-1	Cursor Positioning Controls . . . . .	3-4
Configurations and Features . . . . .	1-1	Editing Controls . . . . .	3-4
Functional Capabilities . . . . .	1-1	Program Function and Program Access Keys . . . . .	3-4
Applications, Programming Support, Conversion . . . . .	1-1	Numeric Lock Feature . . . . .	3-4
Reliability and Availability . . . . .	1-2	Shift Keys . . . . .	3-4
Human Factors and Installation Planning . . . . .	1-3	Duplicate (DUP) Key . . . . .	3-4
<b>Chapter 2 Display System Units and Features</b> . . . . .	2-1	Erasing Controls . . . . .	3-5
Introduction . . . . .	2-1	Audible Alarm . . . . .	3-5
Example Display System Configurations . . . . .	2-1	Security Enhancements . . . . .	3-5
Features . . . . .	2-3	Key Lock . . . . .	3-5
Specify Features . . . . .	2-4	Operator Identification Card Reader . . . . .	3-5
Power . . . . .	2-4	Non-Display Keying Mode . . . . .	3-5
ASCII Transmission Code . . . . .	2-4	<b>Chapter 4 Applications</b> . . . . .	4-1
ASCII Character Generator . . . . .	2-4	Application Types . . . . .	4-1
Monospace Character Generator . . . . .	2-4	Inquiry . . . . .	4-1
Pin Platen Feed . . . . .	2-4	Simple Inquiry . . . . .	4-1
Special Features . . . . .	2-5	Complex Inquiry . . . . .	4-1
Device Adapter . . . . .	2-5	Inquiry with File Update . . . . .	4-1
1200-bps Transmission Speed . . . . .	2-5	Conversational Inquiry . . . . .	4-1
4800/7200-bps Transmission Speed . . . . .	2-5	Conversational Inquiry with File Update . . . . .	4-2
Dial . . . . .	2-5	Data Entry . . . . .	4-2
IBM 600/1200-bps Line Adapter . . . . .	2-5	Source File Update . . . . .	4-2
IBM 600/1200-bps Line Adapter with Auto Answer . . . . .	2-5	Online Key Entry . . . . .	4-2
Keyboards . . . . .	2-5	System Operator's Console . . . . .	4-2
Keyboard Numeric Lock . . . . .	2-5	Display Operator Console . . . . .	4-2
Selector Pen . . . . .	2-5	Output-Only Display Console . . . . .	4-2
Audible Alarm . . . . .	2-5	Advantages of Display Systems . . . . .	4-3
Key Lock . . . . .	2-5	Advantages of the 3270 Display System . . . . .	4-3
Printer Adapter . . . . .	2-6	Application Highlights of a 3270 Display System . . . . .	4-3
Operator Identification Card Reader . . . . .	2-6	<b>Chapter 5 Programming Support</b> . . . . .	5-1
<b>Chapter 3 Functional Capabilities</b> . . . . .	3-1	Introduction . . . . .	5-1
Introduction . . . . .	3-1	Telecommunications Access Methods . . . . .	5-1
Functional Control Capability . . . . .	3-1	BTAM Under DOS or OS . . . . .	5-1
Operator Control Capabilities . . . . .	3-1	Functions and Organization . . . . .	5-1
Functional Control Capability . . . . .	3-1	Environment . . . . .	5-1
Format Control by Data Field . . . . .	3-1	The 3270 Display System and BTAM Under	
Character Addressing . . . . .	3-2	DOS or OS . . . . .	5-1
Null Suppression . . . . .	3-2	Functions and Use . . . . .	5-2
BSC Line Control . . . . .	3-2	3270 Display System Capabilities Supported . . . . .	5-2
Channel Interface Speeds . . . . .	3-2	3270 Display System Devices Supported . . . . .	5-2
Communication Line Speeds . . . . .	3-2	Environment . . . . .	5-2
Protected Data Image Format . . . . .	3-2	TCAM Under OS . . . . .	5-2
Select . . . . .	3-2	Functions and Organization . . . . .	5-2
Read Modified . . . . .	3-2	Environment . . . . .	5-3
Copy . . . . .	3-2	3270 Display System and OS TCAM . . . . .	5-3
Erase Unprotected . . . . .	3-2	Display Console Support . . . . .	5-3
Short Read . . . . .	3-2	Functions . . . . .	5-3
Repeat Characters . . . . .	3-3	Basic Display Console Support . . . . .	5-3
Program Tab . . . . .	3-3	New Console Support Functions . . . . .	5-3
Selector Pen . . . . .	3-3	Advantages and Limitations . . . . .	5-4
Remote General Poll . . . . .	3-3	Environment . . . . .	5-5
Dial Feature . . . . .	3-3	System Requirements . . . . .	5-5
IBM 600/1200-bps Line Adapter . . . . .	3-4	Devices Supported . . . . .	5-5
IBM 600/1200-bps Line Adapter with Auto Answer . . . . .	3-4	DIDOCs Storage Requirements . . . . .	5-5
Operator Control Capability . . . . .	3-4	Status Display Support Storage Requirements . . . . .	5-6
Keyboard Options . . . . .	3-4	Physical Characteristics of 3270 Display	
Keyboard Functions . . . . .	3-4	Stations Used as Display Consoles . . . . .	5-6

Screen Format for the 3277 Display Station, Model 2 . . . . .	5-6	Message Editing . . . . .	6-4
Line Format for the 3277 Display Station, Model 2 . . . . .	5-6	Display Operator Considerations . . . . .	6-4
Screen and Line Format for the 3277 Display Station, Model 1 . . . . .	5-8	Display Operator Reorientation . . . . .	6-4
System Procedures . . . . .	5-8	Screen Format Example . . . . .	6-4
System Generation . . . . .	5-8	2260 Display Station - Step 1 . . . . .	6-5
Operating Procedures . . . . .	5-8	2260 Display Station - Step 2 . . . . .	6-5
VIDEO/370 . . . . .	5-9	3277 Display Station - Step 1 . . . . .	6-5
Background . . . . .	5-9	3277 Display Station - Step 2 . . . . .	6-5
VIDEO/370 Overview . . . . .	5-9	3277 Display Station - Step 3 . . . . .	6-6
VIDEO/370 Features and Attributes . . . . .	5-11	Estimating the Conversion Effort . . . . .	6-6
Data Editing and Attribute Specification . . . . .	5-11	Conversion Segmentation . . . . .	6-6
Keystroke Reduction . . . . .	5-11	Conversion Aids . . . . .	6-6
Easy Error Correction . . . . .	5-11	Conclusion . . . . .	6-6
Data Security . . . . .	5-11	<b>Chapter 7 Human Factors</b> . . . . .	7-1
Operator and Production Statistics . . . . .	5-12	Display Image . . . . .	7-1
Flexibility . . . . .	5-12	Keyboards . . . . .	7-1
Checkpoint/Restart . . . . .	5-12	Finger Positioning . . . . .	7-1
Improved Method of Data Entry . . . . .	5-12	Keyboard Design . . . . .	7-2
Operation . . . . .	5-12	Typamatic Operation . . . . .	7-2
Entry Mode . . . . .	5-12	Ease of Operation . . . . .	7-2
Verification Mode . . . . .	5-13	Operator Controls . . . . .	7-2
Correction Mode . . . . .	5-13	Indicators . . . . .	7-2
Scan Mode . . . . .	5-13	<b>Chapter 8 Installation Planning Data</b> . . . . .	8-1
Other Command Functions . . . . .	5-13	Physical Characteristics . . . . .	8-1
Environment . . . . .	5-14	Cables . . . . .	8-1
Software . . . . .	5-14	<b>Chapter 9 Reliability, Serviceability, and Availability</b> . . . . .	9-1
Hardware . . . . .	5-14	<b>Chapter 10 Performance Considerations</b> . . . . .	10-1
Storage Requirements . . . . .	5-15	Basic Configuration Differences . . . . .	10-1
Installation Considerations . . . . .	5-15	Display Systems Attached Locally . . . . .	10-1
Access Method Requirements . . . . .	5-16	Display Systems Attached Remotely . . . . .	10-3
DATA/360 . . . . .	5-16	<b>Appendix A Configurator</b> . . . . .	A-1
Features . . . . .	5-16	<b>Appendix B Features List and World Trade Keyboards</b> . . . . .	B-1
Command Functions . . . . .	5-16	<b>Appendix C Functional Capabilities (Detailed)</b> . . . . .	C-1
Environment . . . . .	5-17	Basic Functions . . . . .	C-1
Software . . . . .	5-17	Unformatted and Formatted Display Images . . . . .	C-1
Utility Programs . . . . .	5-17	Formatting a Display Image on the 3275 or 3277 Display Station . . . . .	C-1
Hardware . . . . .	5-17	Formatting a Printout from the 3284 and 3286 Printer, Models 1 and 2 . . . . .	C-1
Storage Requirements . . . . .	5-17	Operator Capabilities . . . . .	C-3
Information Management System (IMS) . . . . .	5-17	Keyboard Functions . . . . .	C-3
Customer Information Control System (CICS) . . . . .	5-17	Positioning the Cursor . . . . .	C-3
Interactive Query Facility (IQF) . . . . .	5-17	Inputting Data . . . . .	C-5
Time Sharing Option (TSO) . . . . .	5-18	Insert Mode and Delete . . . . .	C-5
<b>Chapter 6 Conversion</b> . . . . .	6-1	Program Function and Program Attention Keys . . . . .	C-5
Introduction . . . . .	6-1	Numeric Lock Operation . . . . .	C-6
BTAM Data Stream Conversion Macro . . . . .	6-1	Duplicate and Field Mark Keys . . . . .	C-6
Assumptions . . . . .	6-1	Erase Keys . . . . .	C-6
Steps in Conversion . . . . .	6-1	Test Request . . . . .	C-6
Application Program Structure and Modification . . . . .	6-2	<b>Glossary</b> . . . . .	G-1
Summary . . . . .	6-2	<b>Index</b> . . . . .	X-1
Configuration Considerations . . . . .	6-2		
3270 and 2260/2848 Display System Functional Differences . . . . .	6-3		
Line Control . . . . .	6-3		
Data Stream . . . . .	6-3		
Commands and Control Characters . . . . .	6-3		
Device Conversion . . . . .	6-3		
Output Considerations . . . . .	6-4		
Input Considerations . . . . .	6-4		

## Illustrations

	Frontispiece A 3270 Information Display System (Design Model) . . . . .	viii		
1-1	3277 Display Station, Model 1 (Design Model) . . . . .	1-2	6-1	IBM 3277/3275 Display . . . . . 5-11
1-2	3277 Display Station, Model 2 (Design Model) . . . . .	1-3	6-2	2260 (Step 1) . . . . . 6-5
2-1	Locally Attached 3270 Display System . . . . .	2-2	6-3	2260 (Step 2) . . . . . 6-5
2-2	Remotely Attached 3270 Display System . . . . .	2-3	6-4	3277 (Step 1) . . . . . 6-5
2-3	3275 Display Station with 3284 Printer, Model 3 (Design Model) . . . . .	2-4	6-5	3277 (Step 2) . . . . . 6-5
2-4	Typewriter Keyboard (EBCDIC) . . . . .	2-6	7-1	3277 (Step 3) . . . . . 6-6
2-5	Operator Console Keyboard . . . . .	2-6	10-1	Examples of Monocase Characters Formed with 7 x 9 Dot Pattern . . . . . 7-1
2-6	Data Entry Keyboard . . . . .	2-6	10-2	Information Path Comparison . . . . . 10-1
2-7	Selector Pen in Use . . . . .	2-7	A-1	Comparison of Local and Remote Response Times . . . . . 10-2
2-8	Key Lock Feature Installed on a 3277 Display Station . . . . .	2-7	A-2	3270 Display System - Local . . . . . A-1
3-1	3275 Display Station with Dial Feature Installed (Design Model) . . . . .	3-3	A-3	3270 Display System - Remote . . . . . A-2
4-1	Displays Appearing during Sample Accounting Procedure (Display 1 of 3) . . . . .	4-5	B-1	3275 Display Station . . . . . A-3
4-2	Displays Appearing during Sample Accounting Procedure (Display 2 of 3) . . . . .	4-6	B-2	United Kingdom Keyboards . . . . . B-3
4-3	Displays Appearing during Sample Accounting Procedure (Display 3 of 3) . . . . .	4-6	B-3	French Keyboards . . . . . B-4
5-1	Screen Formats for 3277 Display Station, Model 2 . . . . .	5-7	B-4	German Keyboards . . . . . B-5
5-2	Overview of VIDEO/370 . . . . .	5-10	C-1	Italian Keyboards . . . . . B-6
5-3	Sample Payroll Record Format As Seen on		C-2	Information Exchange between a Central Processing System and a Display System . . . . . C-2
			C-3	Display Station Buffer and Display Image Character Position Relationship . . . . . C-3
			C-4	Examples of Display Image Fields . . . . . C-3
			C-5	Printer Buffer and Printout Character Position Relationship . . . . . C-4
				Example of a Display Image Showing a Cursor . . . . . C-5

## Tables

5-1	A Summary of Display Devices and Features That Are Serviced by DIDOCS and SDS . . . . .	5-5		
5-2	DCM Main Storage Requirements . . . . .	5-6	6-3	Comparable 2260/2848, 2265/2845, and 3270 Display System Configurations . . . . . 6-3
5-3	Storage Estimates for VIDEO/370 . . . . .	5-15	8-1	3270 Display System Maximum and Fixed Length Cables . . . . . 8-1
6-1	3270 Display System Configurations . . . . .	6-2	B-1	Features List . . . . . B-1
6-2	2260/2848 and 2265/2845 Display System Configurations . . . . .	6-2		

## | Abbreviations

ASCII	American National Standard Code for Information Interchange	JCL	job control language
bps	bits per second	MCS	multiple console support
BSC	binary synchronous communications	MFT	multiprogramming with a fixed number of tasks
BTAM	Basic Telecommunications Access Method	MVT	multiprogramming with a variable number of tasks
CICS	Customer Information Control System	OLT	online test
CPU	central processing unit	OS	Operating System
CRT	cathode-ray tube	PFK	program function key
DCM	display control module	RFT	request for test
DIDOCS	Device Independent Display Operator Console Support	SDS	Status Display Support
DOS	Disk Operating System	TCAM	Telecommunications Access Method
EBCDIC	Extended Binary-Coded-Decimal Interchange Code	TCU	transmission control unit
IMS	Information Management System	TPTC	Teleprocessing Test Center
IQF	Interactive Query Facility	TSO	Time Sharing Option
		VS	virtual storage





**Frontispiece. A 3270 Information Display System (Design Model)**



The IBM 3270 Information Display System is a new family of display products that can significantly reduce total display system cost through:

- Configuration and feature flexibility.
- Advanced hardware, programming, and operator capabilities.
- Increased reliability and availability.

The 3270 display system can be tailored to meet the needs of all alphanumeric display applications. It sets a new standard for display system price/performance by offering improved response times and transaction rates based on increased transmission and operator efficiency. In addition, the 3270 display system is easy to operate and well suited to an office environment.

### CONFIGURATION AND FEATURES

The 3270 display system has outstanding configuration flexibility:

- It can be a standalone unit, a small cluster, or a large cluster (of up to 32 units).
- It can include 480-character display stations (Figure 1-1) or large-capacity 1920-character display stations (Figure 1-2) or both.
- It can also include printers (40 or 66 characters per second).
- It can be attached locally (directly to the channel) or remotely (through communications facilities).
- It allows more display stations to be attached to each communications line and is compatible with other BSC devices.

The 3270 display system also has exceptional feature flexibility:

- It offers typewriter, data entry, and operator console keyboards and a selector pen.
- It provides local data transfer rates of up to 650,000 characters per second and remote line speeds of up to 7200 bits per second (using a MODEM such as the IBM 3875 High-Speed MODEM).
- It includes data security enhancement features, such as a key lock, an operator identification card reader, and the ability to enter data without it being displayed.

For details about configurations and features, see Chapter 2.

### FUNCTIONAL CAPABILITIES

The advanced capabilities of the 3270 display system include:

- Hardware capabilities for data compaction (which reduces the number of characters that have to be transmitted) to improve response time by increasing transmission efficiency.
- Programming capabilities for screen formatting and operator capabilities for screen editing to improve transaction rates by increasing operator efficiency.

Chapter 3 describes functional capabilities of the 3270 display system; performance considerations are described in Chapter 10.

### APPLICATIONS, PROGRAMMING SUPPORT, CONVERSION

The 3270 display system is designed for the whole range of alphanumeric display applications, including simple, interactive, or complex inquiry applications, data or order entry applications, and system console applications. Chapter 4 contains a survey of applications and a description of advantages and highlights of the 3270 display system in relation to these applications.

Programming support for the 3270 display system includes:

- General-purpose Basic Telecommunications Access Method (BTAM), under both the Disk Operating System and the Operating System.
- Telecommunications Access Method (TCAM) under the Operating System.
- Display console (DIDOCs) and status display (SDS) under the System/360 Operating System for using the local 3270 display system as a system console to control a system and to present status displays.
- VIDEO/370, under both the Operating System and the Disk Operating System, on either System/360 or System/370, for using the 3277/3275 display for data entry and verification in local and remote environments.
- DATA/360, under both the Operating System and the Disk Operating System, on either System/360 or System/370, for using the 3277 in 2260 mode for data entry and verification.

- Information Management System (IMS), under the Operating System, on either System/360 or System/370, for using the 3270 Information Display System for data base or data communication applications.
- Interactive Query Facility (IQF) for IMS, under both the Disk Operating System and the Operating System, for using the 3270 system for terminal-oriented query applications.
- Customer Information Control System (CICS), under both the Disk Operating System and Operating System, for using the 3270 Information Display System for data base or data communication and applications.
- Time Sharing Option (TSO) under the Operating System, under both System/360 and System/370, for terminal-oriented time-sharing applications.

Chapter 5 discusses the programming support.

For information about converting from IBM 2260/2848 or IBM 2265/2845 display systems to 3270 display systems, see Chapter 6.

#### RELIABILITY AND AVAILABILITY

The 3270 display system provides customers with much higher reliability and availability:

- The latest solid-state components ensure extremely reliable character generation and image control and regeneration.
- The decentralized design, which places more circuitry in the display station and less in the control unit, minimizes the failure of one unit from affecting the availability of the rest of the display system.



Figure 1-1. 3277 Display Station, Model 1 (Design Model)

Chapter 9 gives more information on reliability and availability.

#### **HUMAN FACTORS AND INSTALLATION PLANNING**

The 3270 display system has been carefully designed with human factors and installation planning considerations in mind:

- The display image is of a high quality in terms of clarity, stability, and brightness.

- The display stations are easy to operate: features such as movable keyboards with layouts familiar to typists, data entry operators, or system operators contribute to maximum operator efficiency with minimum retraining.
- The display systems are easy to install in a normal office or computer room environment: the units are comparatively small in size and light in weight and do not require air conditioning.

For details about human factors and installation planning, see Chapters 7 and 8, respectively.



Figure 1-2. 3277 Display Station, Model 2 (Design Model)



## Chapter 2. Display System Units and Features

### INTRODUCTION

The 3270 family of display system products was described in the previous chapter as being flexible. Flexibility includes the ability to configure a variety of display systems from one basic group of IBM units:

#### 3271 Control Unit

- Model 1 - 480 character buffer capacity.
- Model 2 - 1920 character buffer capacity.
- Attaches to a System/360 or System/370 via data sets and any of the following: an IBM 2701 Data Adapter Unit, an IBM 2703 Transmission Control Unit, an Integrated Communications Adapter, or an IBM 3705 Communications Controller.
- Attaches to System/3 Model 10 via a System/3 Binary Synchronous Communications Adapter.

#### 3272 Control Unit

- Model 1 - 480 character buffer capacity.
- Model 2 - 1920 character buffer capacity.
- Attaches to a System/360 or System/370 via a selector, multiplexer, or block multiplexer channel.

#### 3275 Display Station

- Model 1 - 480 character display image.
- Model 2 - 1920 character display image.
- A stand-alone unit that attaches to a System/360 or System/370, via data sets or data access arrangements and any of the following: an IBM 2701, an IBM 2703, an Integrated Communications Adapter, or an IBM 3705 Communications Controller.
- Attaches to System/3 Model 10 via a System/3 Binary Synchronous Communications Adapter.

#### 3277 Display Station

- Model 1 - 480 character display image.
- Model 2 - 1920 character display image.
- Attaches to a 3271 or a 3272 control unit.

#### 3284 Printer

- Model 1 - 480 character buffer capacity with a 40-cps printout rate.
- Model 1 attaches to a 3271 or a 3272 control unit, model 1 or 2.

- Model 2 - 1920 character buffer capacity with a 40-cps printout rate.
- Model 2 attaches to a 3271 or a 3272 control unit, model 2.
- Model 3 - no buffer is provided; the printout rate is 40 cps.
- Model 3 attaches to a 3275 display station, model 1 or 2.

#### 3286 Printer

- Model 1 - 480 character buffer capacity with a 66-cps printout rate.
- Model 1 attaches to a 3271 or a 3272 control unit, model 1 or 2.
- Model 2 - 1920 character buffer capacity with a 66-cps printout rate.
- Model 2 attaches to a 3271 or a 3272 control unit, model 2.

A 3270 display system, configured from the list of units just introduced, can be one that fits the needs of most applications. The flexibility of configuring the display system is further enhanced by the number of IBM systems with which it can be operated. Among the systems that can operate with 3270 display systems are:

System/360 Models 25, 30, 40, 50, 65, 67\*, 75, 85, and 195.

System/370 Models 135, 145, 155, 158, 165, and 168.  
System/3 Model 10.

The following text describes how to configure a local or a remote 3270 display system.

### EXAMPLE DISPLAY SYSTEM CONFIGURATIONS

The 3272 control unit, model 1, can direct the operation of up to 32 attached:

- 3277 display stations, model 1.
- 3284 printers, model 1.
- 3286 printers, model 1.

The 3272 control unit, model 2, can direct the operation of up to 32 attached:

- 3277 display stations, model 1 or 2.

\*The System/360 Operating System (OS) will support attachment in 65 mode only.

- 3284 printers, model 1 or 2.
- 3286 printers, model 1 or 2.

At least one display station with a keyboard must be attached to any control unit (Figure 2-1). Local (direct) attachment of a control unit to a System/360 or System/370 is through a selector, multiplexer, or block multiplexer channel; the control unit attaches via one of the eight control unit positions on the channel interface. The channel provides the control unit with data that is to be displayed and with control information that is needed to direct the operation of the display station or printer controller that may be attached to the control unit. Buffer storage in the devices (display station or printer) stores digitally coded data from the control unit for display or printing. The buffer permits simultaneous display image presentation and message composition from a keyboard at each display station.

Locally attached control units can be positioned up to 200 feet from the system channel, depending upon system and channel configuration. Each attached device can operate up to 2000 feet from a control unit, allowing computer access from a display operator's normal working area. Sharing of the control unit by several devices results in economical configurations.

The 3270 display system is remotely attached to System/360 or System/370 via a 3271 control unit model 1 or 2 (Figure 2-2). Remote attachment to System/3 requires a System/3 Binary Synchronous Communications Adapter. Remote attachment differs from local attachment in the medium through which the control unit and system channel communicate. In a local configuration, the control unit is cabled directly to the system channel. In a remote

configuration, a transmission control unit (TCU) is cabled locally to the system channel. The TCU relays display data and control information from the system channel to the control unit in a binary synchronous communications (BSC) multipoint data link mode of operation via MODEMS and common carrier leased voice grade channels or the customer's own equivalent communication facilities (telephone lines, microwave transmission, or satellite). The 3271 operates in half-duplex mode on either half-duplex or duplex facilities.

Switched-network backup capability is available when using an IBM 3872 or 3875 MODEM. Switched-network capability provides a dial communications system to replace a failing leased-line network. Installation of the switched-network backup feature ensures minimum interruption of data transfer when a failure or an excessively high error rate occurs on a leased line. In addition, backup capability offers a diagnostic tool for isolating a malfunction either to terminal equipment or to the common carrier. Transmission speeds of 1200 or 2400 bps are available using the IBM 3872 MODEM; speeds of 1800 or 3600 bps may be obtained using the IBM 3875 MODEM. Switched-network backup operation is initiated by the terminal operator using a dial telephone. When, for example, excessive trouble is experienced with a leased line, the terminal operator places a call to the 2701 (or equivalent unit) at a specified time and establishes a connection for operation.

A stand-alone remote display system, the 3275 display station, model 1 or 2, provides added convenience for locations requiring a single display device. The 3275 display station does not require a control unit to communicate and is therefore more economical than a control unit with a single 3277 display station attached. The 3275 display station unit can be expanded by attaching a 3284 printer,

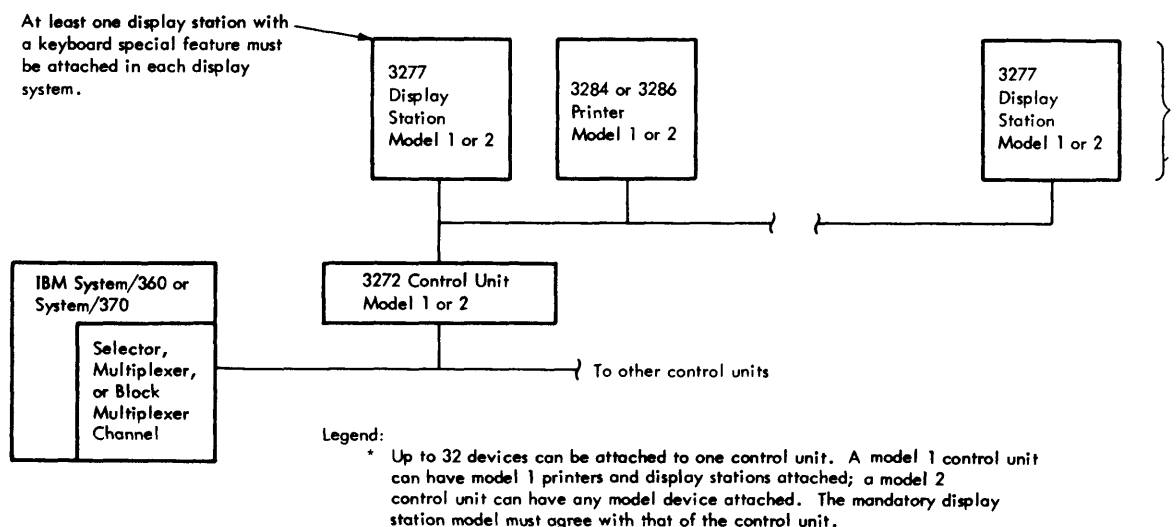

Figure 2-1. Locally Attached 3270 Display System

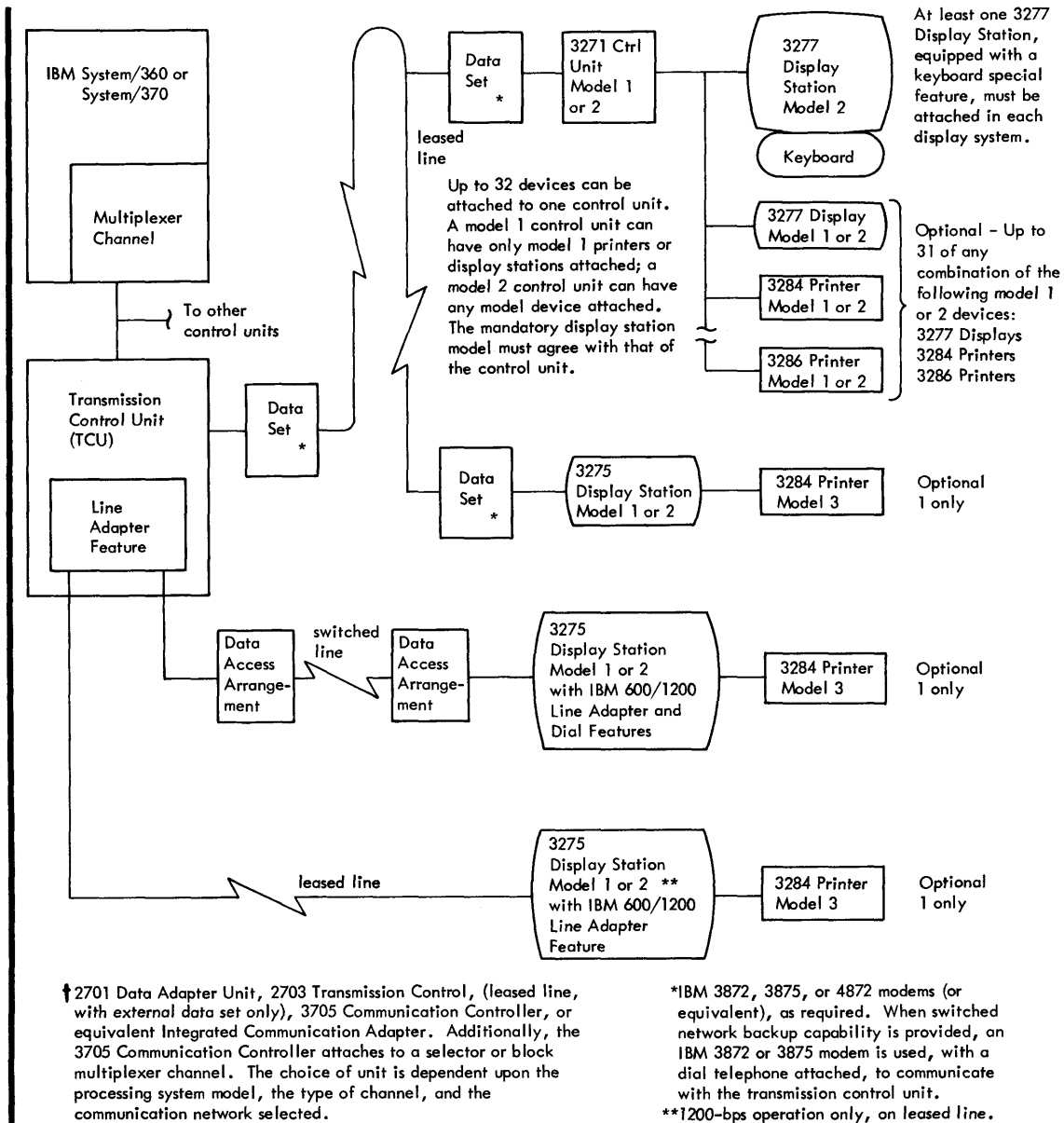

Figure 2-2. Remotely Attached 3270 Display System

model 3 (Figure 2-3), to provide a paper copy of computer messages. The 3275 display station can be attached (dropped) to the same remote communication line as other 3270 display systems and other IBM products that use the BSC mode of operation.

## FEATURES

Many features are available for installation on 3270 display system units. The features are described below, and a three-page display system configurator is provided in Appendix A.

Features are categorized as Specify or Special. A Specify (standard) feature is one that must be chosen (at no extra cost) to make a display system functional. A special feature is one that involves extra costs but is not required to make the display system functional; this feature will improve performance, provide additional operational capability, or permit expansion of the display system.

Appendix B lists all features, Specify and Special, now available.

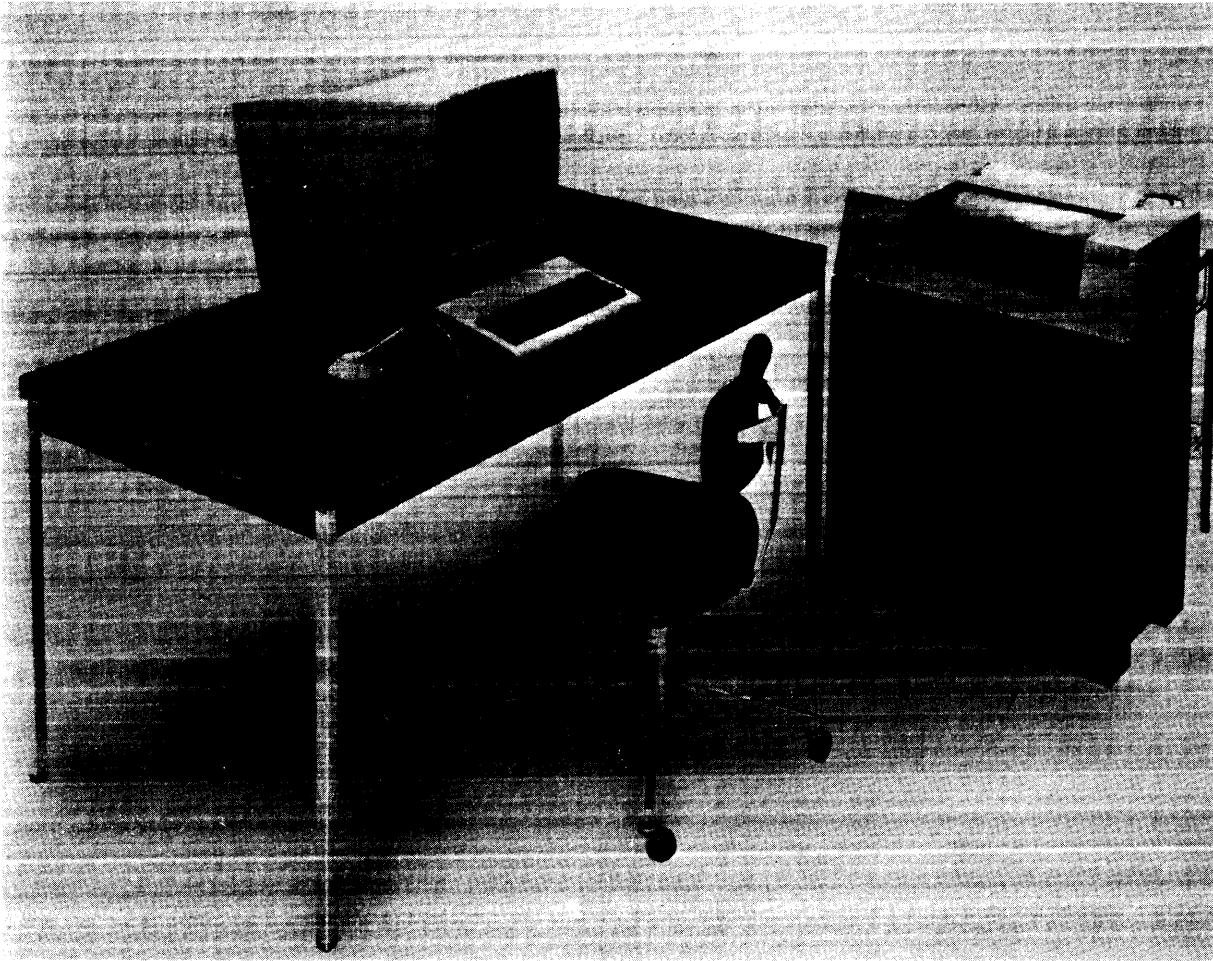

Figure 2-3. 3275 Display Station with 3284 Printer, Model 3 (Design Model)

### **Specify Features**

#### *Power*

Display stations and printers in the United States all operate with 115V, 60Hz power; control units, however, operate from any one of three different power sources. All units available through the IBM World Trade Corporation can operate from one of several different power sources.

#### *ASCII Transmission Code*

This feature allows the display station to be attached to central processing systems that communicate in ASCII code. (ASCII, American National Standard Code for Information Interchange, X3.4-1968.)

#### *ASCII Character Generator*

An ASCII character generator feature is required for each unit that will display or print the ASCII character set.

#### *Monocase Character Generator*

Monocase character generators are designed in American English, United Kingdom English, and German. The French and Italian monocase character generators are identical with the American English character generator.

#### *Pin Platen Feed*

This feature is applicable to the 3284 and 3286 printers and allows a choice of 120, 126, or 132 print positions.



## Special Features

### Device Adapter

Every control unit has one built-in device adapter. This adapter provides a control unit with the facilities necessary to communicate with, and service up to, four devices (display stations or printers). Since each control unit can operate with up to 32 devices, up to 7 device adapters can be added to a basic control unit.

### 1200-bps Transmission Speed

The 3271 control units and 3275 display stations can communicate with a central processing unit from a remote location via communication facilities at speeds of 1200, 2000\*, 2400\*, 4800 or 7200 bps.

At other than 600/1200-bps rates, the data set must provide the necessary clocking. At the 600- and 1200-bps transmission rate, clocking is not provided by the data set. When this situation exists, a 1200-bps transmission speed feature is required to provide the needed clocking.

### 4800/7200-bps Transmission Speed

Installing this feature in a 3271 control unit or a 3275 display station permits operation with communication facilities at speeds of 4800 or 7200 bps.

### Dial

This feature enables the 3275 operator to establish communication by dialing the telephone number(s) of the processor(s) serving the display station. Similarly, the operator at the remotely located processor(s) may dial the 3275. The dial feature employs switched telephone network lines (instead of permanently attached leased lines). Either EBCDIC or ASCII transmission code may be used, as specified. The BSC point-to-point contention line discipline is employed.

### IBM 600/1200-bps Line Adapter

The IBM 600/1200-bps line adapter is a low-cost telephone line adapter which provides an electrical interface for attaching the 3275 equipped with the dial feature to common-carrier switched-network lines. A line adapter feature is also available for attachment to the 3275, allowing 1200-bps operation over leased lines. The line adapter is placed within the 3275. In this environment, the 2701 TCU must contain the IBM line adapter and switched line features. Data access arrangements attach the line adapters to the phone lines.

### IBM 600/1200-bps Line Adapter with Auto Answer

If desired, automatic answering capability may be obtained with 3275 units equipped with the dial feature by

\*2000 and 2400-bps are base machine transmission rates. 2000-bps is not available to World Trade Customers.

requesting the IBM 600/1200-bps line adapter with auto answer feature. Auto answer allows the line adapter to respond automatically to a ring signal.

### Keyboards (Figures 2-4, 2-5, 2-6)

Numerous keyboard features are available. Variations between keyboards include 78- and 66-key versions: operator console, data entry, typewriter EBCDIC, and typewriter ASCII layouts and several different languages (American English, United Kingdom English, French, German, and Italian). Refer to Appendix B for a list of keyboard features.

Basic display operator needs are fulfilled by the 66-key keyboard. The 78-key keyboard provides expanded operator-to-program message flexibility with 12 additional application program defined keys.

The operator console key layout, which is the same as an IBM 1052 Model 7 keyboard, is available only as a 78-key keyboard. The data entry key layout, which is similar to the keyboard on the IBM 24, 26, 29, 129, and 59 keypunch equipment, is available only as a 66-key keyboard.

### Keyboard Numeric Lock

This feature is used in conjunction with a keyboard to provide a means of alerting the operator to a keying mistake. During a numeric operation, this feature inhibits keyboard input operations whenever the operator attempts to enter alphabetic data without purposely overriding the feature. Once inhibited, keyboard input operations can be resumed only after the operator presses the RESET key at the keyboard. Although this feature is available for all keyboards, its primary application is in a data entry environment where large quantities of numeric data are being entered into the system.

### Selector Pen (Figure 2-7)

This feature provides a light-sensitive pen with which an operator can identify a portion of a displayed message for entry into the data processing system.

### Audible Alarm

The audible alarm feature can be installed on any display station. This feature causes a short audible tone to be sounded whenever an operator enters a character in the next-to-last position of the display image or whenever the tone is called for under program control.

### Key Lock (Figure 2-8)

This feature provides key-operated control over communication with the program. With the key off, only a cursor will appear on the display image, the unit will be unavailable to the program, and the display operator will be unable to input messages to the program.

**Printer Adapter**

This feature provides a 3275 display station with control circuitry and cable connection outlets to permit attachment of a 3284 printer, model 3.

**Operator Identification Card Reader**

This feature provides a card reader unit to permit an operator to identify himself to a program. Specially designed magnetic stripe credit cards can be read by the card reader.

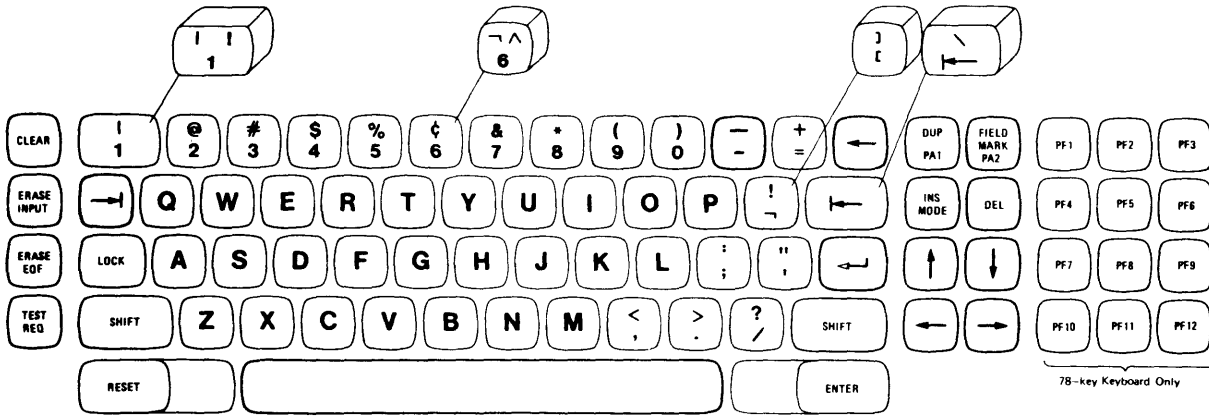

Figure 2-4. Typewriter Keyboard (EBCDIC) – The ASCII typewriter keyboard has four different keys, shown in above keyboard.

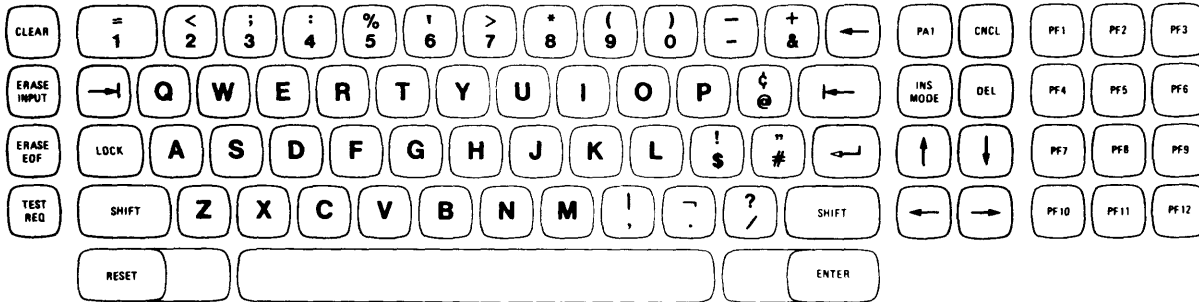

Figure 2-5. Operator Console Keyboard

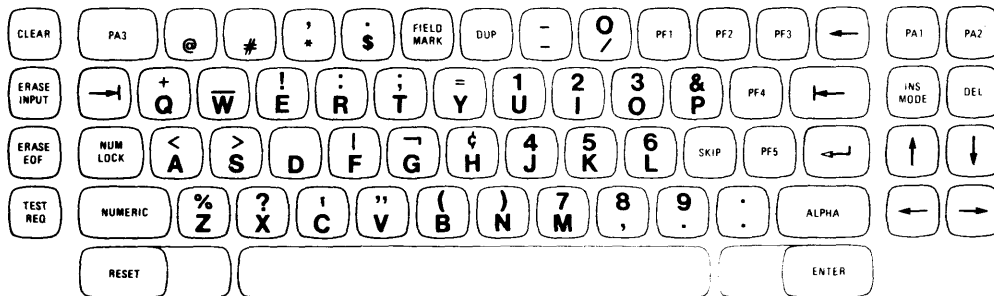

Figure 2-6. Data Entry Keyboard

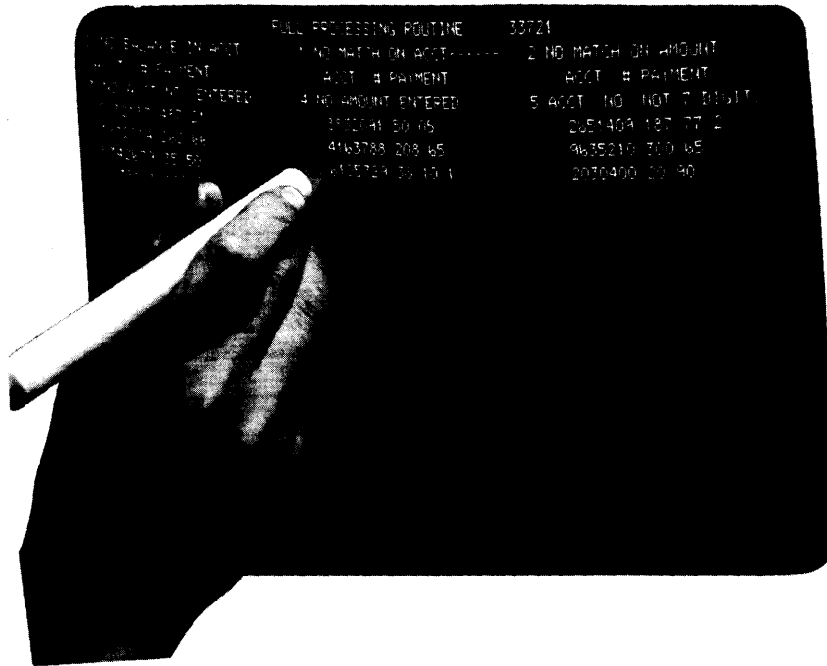

Figure 2-7. Selector Pen in Use

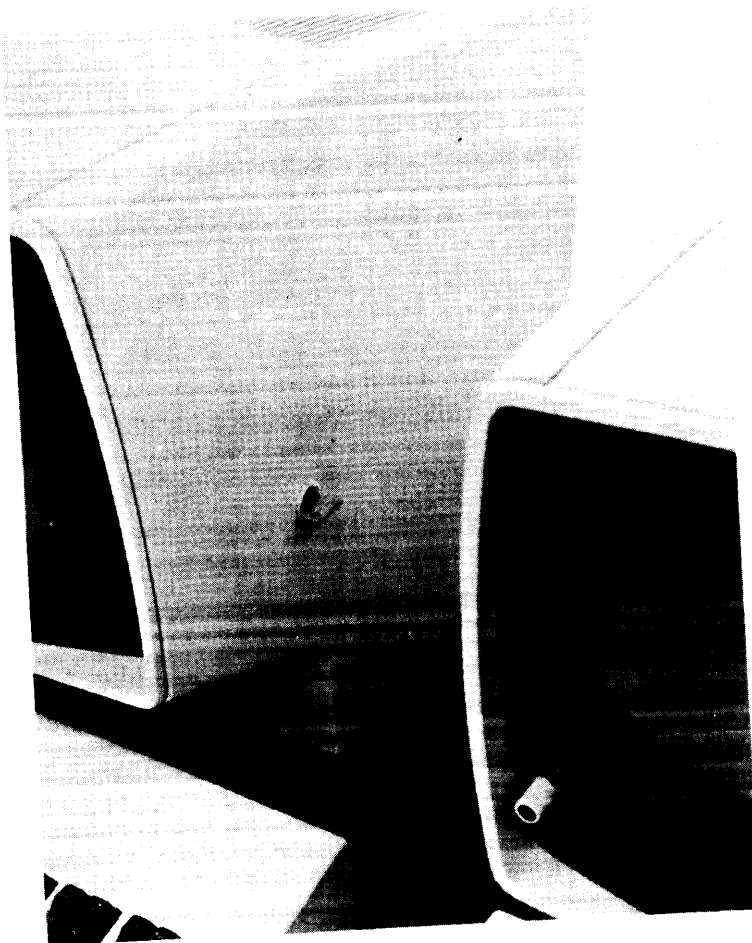

Figure 2-8. Key Lock Feature Installed on a 3277 Display Station



### INTRODUCTION

The IBM 3270 Information Display System introduces a new dimension to display systems design: functional control capability. Design and evaluation of the IBM 2260 Display System led to the conclusion that the total cost of a system can be significantly reduced by minimizing:

- Communication line facilities.
- Transmission control facilities.
- CPU overhead.
- Channel utilization.

To reduce system costs associated with these items, numerous hardware and programming features that together provide functional control capability have been incorporated in the 3270 display system.

#### Functional Control Capability

The functional control capability of the 3270 display system consists of the following features:

- Format control by data field.
- Addressing or updating, or both, of any character position of the display image.
- Null suppression.
- BSC line control.
- Channel interface data rates up to 650,000 characters per second.
- Communication line transmission speeds up to 4800 bps.
- Protected data image format.
- Select.
- Read modified data.
- Copy.
- Erase unprotected.
- Short read.
- Repeat characters.
- Program tab.
- Remote general poll.
- Dial
- IBM 600/1200-bps Line Adapter.
- IBM 600/1200-bps Line Adapter with Auto Answer.

To use this new functional control capability effectively, the system designer must consider: the display image

formats, transaction design, communication facilities, operator wait times, operator costs, channel loading, number of CPU interrupts, number of TP messages, and application program design. He can do this best by selecting a typical transaction and evaluating the effects of functional control capability on system costs and performance. This evaluation, coupled with an evaluation of operator control capabilities, system configuration considerations, physical considerations, and installation planning considerations, will determine the best ratio between cost and performance for a display system.

#### Operator Control Capabilities

The 3270 display system also provides operator control capabilities that allow maximum operator efficiency with a minimum of retraining. The advantages of card punch and typewriter keyboard designs have been incorporated into the 3270 data entry and typewriter keyboard options.

The highlights of the functional capabilities of the 3270 display system are described below. For a more detailed, hardware-oriented discussion of functional capabilities, see Appendix C.

### FUNCTIONAL CONTROL CAPABILITY

#### Format Control by Data Field

The 3270 display system provides program control by data field. Each data field is established when a field attribute control code is written in the first position of the field. The field attribute control code, which is written by the program, utilizes a single nondisplayed character position and serves as a visual separation between successive fields. A field may be started at any character position of the image. The characteristics controlled by the attribute control code include:

- Protected (fixed format).
- Unprotected (variable input data).
- Brightness (off/normal/bright).
- Alphameric input.
- Numeric input (auto shift).
- Auto lock.
- Auto skip.
- Selector pen detectable.
- Tab stop.

### **Character Addressing**

Addressing facilities are provided by the 3270 display system to allow starting a program write at any character position of the image. The write address can be set any number of times during an image write or update, or both. This allows selective writes to various noncontiguous areas of the image. This facility also allows the modification of single or multiple field attribute control characters as well as data characters.

### **Null Suppression**

To minimize message lengths while providing maximum length input fields, 3270 display system data fields can be erased to null codes under operator or program control. As an operator keys input data into a field, data codes replace null codes, leaving null codes in any unkeyed positions of the field. When a read modified message is sent to the CPU, null codes are not transmitted as part of the message. This facility eliminates the transmission of nonmeaningful codes from unused positions of a field.

### **BSC Line Control**

The IBM BSC line control design provides maximum transmission reliability, requires significantly less transmission control overhead, and provides more comprehensive data checking.

### **Channel Interface Speeds**

Data transfer rates of 10,000 to 650,000 characters per second are provided to allow operation at the speed of the channel to reduce response time and CPU loading by allowing faster completion of a transaction. This capability allows highly efficient local display systems to be developed and removes the restrictions imposed by the data rate (2560 characters per second) of the IBM 2260.

### **Communication Line Speeds**

The capability to transmit data at speeds of up to 7200 bps on a C2 conditioned line provides a significant performance advantage over slower transmission data rates. In many instances, higher line speeds will significantly reduce the number of communications lines required to support remote display systems and greatly reduce response times.

### **Protected Data Image Format**

The protected data image format capability allows a format that contains field labels, instructions, and field control information to be written to a display station once and reused any number of times with variable input or output data. For file inquiry, a protected data image format can be written to the display station once, allowing subsequent transmission of only the variable data records. Similarly, a protected data image format can be written to a display

station once and can be used many times for repetitive key entry input transactions.

### **Select**

Display systems directly attached to a channel require a buffer load delay to prepare to execute a write operation. A select operation is provided to allow a selector or block multiplexer channel to be released for other use during this delay time.

### **Read Modified**

A read modified operation capability is provided that transfers only operator-modified data fields with null codes suppressed. This operation reduces the message size by including essential data only, thus minimizing communication line and channel loading.

### **Copy**

A copy operation capability is used on remote 3270 systems to control the interchange of buffer information between devices attached to the same control unit. For example, any display station image can be printed out at any printer by means of a copy operation. On a copy operation the device buffer transfer is concluded within the 3270 display system, thus total message transmission to the 3270 is significantly reduced. Because the internal 3270 operating rate is far greater than the remote transmission rates, substantially shorter response times can be maintained. An additional example, showing the value of the copy operation, is the case where one basic display image format is frequently used at several display stations in the 3270 display system. The image format need be transmitted to a device on the 3270 display system only once; thereafter, a copy operation can be used to copy the image format from one device buffer to another.

### **Erase Unprotected**

An erase unprotected operation capability is provided that erases all unprotected data fields to null codes and positions the cursor in the first unprotected field of the image. This operation eliminates the buffer load delay that is associated with a normal write operation.

### **Short Read**

To allow an operator to communicate with the program without transmitting unprotected data fields to the CPU, program access (PA) keys have been provided. Pressing one of these keys causes a short read operation that restricts the information transmitted to that required to identify which of the keys caused the attention. This eliminates the transmission of nonmeaningful data to the CPU, thereby minimizing communication line and channel loading.

### Repeat Characters

To minimize the number of data characters that must be transmitted to a display station, capability is provided to cause the display hardware to repeatedly write a specified character code from the current write address position into all positions up to a specified address. By the use of this facility, four control bytes transmitted to the display system can cause up to 480 identical character codes to be written to the display station.

### Program Tab

To minimize the length of a message transmitted to a display station, capability is provided that will automatically write successive data fields into successive unprotected data fields that were previously defined by an image format. This eliminates the requirement to transmit control characters to specify the starting address of noncontiguous data, reducing the number of control characters required.

### Selector Pen

The 3270 display system offers a new concept in light pen design. Previously, light pens required a heavy CPU interrupt loading, and the response characteristics of remote display systems prevented their practical use on a remotely attached display system. The 3270 selector pen provides new capability for handling transactions in the display system hardware, thereby providing a minimum of CPU interrupts and response times of less than 0.4 second

for selector pens attached to both local and remote display systems.

### Remote General Poll

Provisions are made in the control unit hardware to allow the program, with a general poll instruction, to interrogate all devices attached to the control unit with just one request. This results in greatly reduced polling overhead and minimizes communication line loading.

### Dial Feature

This special feature attaches a 3275 display station to a computer system via a common-carrier switched telephone network and the IBM 600/1200-bps line adapter (or equivalent MODEM). Permanently attached leased-network lines are not required for dial feature attachment; thus, network operating costs are reduced, and system flexibility is added in some communication environments. Clocking is obtained from the 3275, which must be equipped with the 600/1200-bps transmission speed capability (provided as part of the dial feature). EBCDIC or ASCII transmission codes may be used. The BSC point-to-point contention line discipline is employed.

The dial feature provides a DISCONNECT toggle switch (shown in Figure 3-1) to terminate a call. A 3275 equipped with the dial feature may be attached to the telephone network through an external MODEM or via a MODEM mounted within the 3275 and called the IBM 600/1200-bps line adapter.



Figure 3-1. 3275 Display Station with Dial Feature Installed (Design Model)

### **IBM 600/1200-bps Line Adapter**

The IBM 600/1200-bps line adapter is a low-cost MODEM placed within the 3275 and 2701 or 3705 units. It operates at 600 or 1200 bps (determined concurrently by the 3275 BIT RATE switch and the selected 2701 unit). The line adapter provides an electrical interface between a 3275 display station and common-carrier leased telephone lines or, when the dial feature is selected, between a 3275 and a switched telephone network. With dial capability present, the line adapters are attached to the telephone lines by data access arrangements, which are required coupling devices available from the telephone company. The line adapter operates at 600 or 1200 bps on switched telephone lines and at 1200 bps on leased lines.

The IBM 600/1200-bps line adapter may be obtained with automatic answering capability.

### **IBM 600/1200-bps Line Adapter with Auto Answer**

The IBM 600/1200-bps line adapter with auto answer feature is applicable to the 3275 using the dial feature. The auto answer portion of the line adapter provides the 3275 with the capability of automatically answering incoming calls from the central processor, without operator assistance. If a call has been answered, and if at any time data or control information is not received or transmitted by the 3275 within 20 seconds, the 3275 automatically disconnects (hangs up). This timeout prevents the 3275 from tying up the line upon receiving an erroneous phone call.

## **OPERATOR CONTROL CAPABILITIES**

The 3270 display system provides numerous operator control capabilities to maximize operator efficiency and minimize operator training costs.

### **Keyboard Options**

Four keyboard options are provided to allow a display system to be tailored to the requirements of each application. Similar keyboards are interchangeable and may be used with any of the 3270 display stations. The following keyboard options are offered:

1. Typewriter keyboard.
2. Typewriter keyboard with 12 program function keys.
3. Data entry keyboard.
4. Operator console keyboard with 12 program function keys.

### **Keyboard Functions**

#### *Cursor Positioning Controls*

Several cursor controls are provided to permit rapid positioning of the cursor to any character position on the

display image. Included in these cursor controls are:

- UP (↑), DOWN (↓), LEFT (←), and RIGHT (→) keys
- BACKSPACE (←) key
- TAB (→|) or SKIP and BACKTAB (←) keys
- NEW LINE (↵) key

#### *Editing Controls*

Two keys, INS MODE and DEL, enable a display operator to perform unique editing functions. The INS MODE key allows characters to be inserted into a field, while all characters following the point of insertion are shifted to the right. The DEL key has an opposite function: characters can be deleted from a field, while all characters on the same line and following the point of deletion are shifted left.

#### *Program Function and Program Access Keys*

Program function (PF) keys allow any input data on the screen to be transmitted to the program together with a code that identifies which program function key was pressed. Program access (PA) keys allow a code to be transmitted to the program to identify which key was pressed, but no input data from the screen is transmitted to the program.

#### *Numeric Lock Feature*

This feature provides a means of alerting the display operator to certain keying errors. With a data entry keyboard, when the cursor is positioned within a numeric input field the display station automatically upshifts the keyboard. With the numeric lock feature, the keyboard is electrically locked if any key other than the numerals 0 through 9, minus (-), period (.), or duplicate (DUP) is pressed.

#### *Shift Keys*

All typewriter and operator console keyboards are provided with the standard typewriter shift keys: SHIFT and LOCK. These keys function exactly like typewriter shift keys to allow access to upshift characters. Data entry keyboards are provided with the ALPHA (alphameric) and NUMERIC shift keys. The ALPHA shift key is used to override a numeric (input) field definition and the numeric lock special feature to purposely input alphameric data into a numeric field. The NUMERIC shift key also overrides the numeric field definition and numeric lock condition to permit upshift character entry for other characters.

#### *Duplicate (DUP) Key*

This key allows a unique code, which is displayed as an asterisk (\*), to be inputted to the program, while the cursor is advanced automatically to the next input field. The DUP



code is typically interpreted by the program to mean duplicate this field from the previous record.

#### ***Erasing Controls***

The CLEAR, ERASE EOF, and ERASE INPUT keys provide erasing functions by setting to null codes any character positions on the display image that are affected by the key operation. If the operator must erase the entire display image and the image format, the CLEAR key is used. The ERASE EOF key is used when the display operator inputs data into part of a field and wants the rest of the field erased. The ERASE INPUT key is used to erase all input fields on the display image.

#### **Audible Alarm**

This special feature can be used by the application program to alert the display operator for any application. Additionally, the alarm sounds whenever the operator inputs a data character into the next to last character of the display image.

#### **Security Enhancements**

##### ***Key Lock***

This special feature provides a display operator with a key that can be used to disable the display station whenever it is

to be left unattended. The unit is enabled when the proper key is inserted in the lock and turned to the "on" position.

#### ***Operator Identification Card Reader***

This feature is provided to enter system user identification. This capability enhances the (programmed) control of operator access to data and an audit of operator actions. Additionally, this feature may be used to enter any sequence of characters (pre-recorded on a card) for other purposes, such as transaction control, account control, and billing.

Credit cards having an encoded magnetic stripe can be read by the card reader. The magnetic stripe containing numeric and control information is on the back of the card. Magnetic stripe credit cards may be ordered with up to 40 numeric characters, including control characters, or they may be obtained pre-recorded and pre-embossed with a maximum of 16 numeric characters.

#### ***Non-Display Keying Mode***

This unique mode of operation permits program definition of fields so they will accept data entered from the keyboard without displaying the data on the screen.



Display stations can be used advantageously in many data-processing applications. The three general categories of applications for display stations are:

- Inquiry
- Data entry
- System operator's console

The material under "Application Types" discusses these categories in terms of application types that are found throughout the data-processing industry. The distinctive characteristics and the business uses of each type of application are discussed, and the features that make the 3270 display system well suited for each application type are listed.

## APPLICATION TYPES

### Inquiry

A display station that is used with an inquiry application allows the operator to have rapid access to the central computer file. Five types of inquiry applications are described below.

#### *Simple Inquiry*

In a simple inquiry application, there is a small input message, for example, a name or an account number. The output message is short (for example, "yes" or "no"), predictable within a narrow range of possibilities, and required quickly. This is a repetitive operation.

A credit house uses a simple inquiry application to determine whether a charge customer should be allowed to make additional charge purchases. Usually, the person who needs the information has telephoned the request to the credit house and waits for the reply.

The 3277 display station, attached locally or remotely, can be used in a simple inquiry application. The efficiency of data transmission between the system and the operator makes the 3270 display system desirable in this type of application because of the high volume of requests and the necessity for rapid retrieval of information.

#### *Complex Inquiry*

In a complex inquiry application, the input message is small (up to 100 characters). The output message is large (an entire screen or several screens of data) and often contains historical or status information.

This type of application is used by insurance companies to get policy information about policyholders. A credit house uses a complex inquiry application when getting a complete credit history of a person who is trying to establish credit.

The editing tools of the 3270 display system and its ability to transmit data efficiently are advantageous in a complex inquiry application. The 3277 display station, model 2, is useful because large amounts of output data can be displayed.

#### *Inquiry with File Update*

In an inquiry with file update application, the input message is again about 100 characters, and the output message can be several screens of data. Part of the displayed record is modified by the display operator after the output message has been viewed. A customer service application is a specialized form of the inquiry with file update application.

State and local governments (for example, departments of tax and welfare) use inquiry with file update applications to review and change official records. This application is also used by a credit house to record credit payments and by an insurance company to make policy changes.

The 3277 display station, model 1 or model 2, can be used, depending on the amount of data output from the processing program. The terminals can be attached locally or remotely. Formatting and editing tools are useful for applications that move data into specific areas or that modify input data. The 3284 or 3286 printer can be used to get a printed copy of the latest records.

#### *Conversational Inquiry*

In a conversational application, a progression of input and output messages leads up to a completed transaction. The output message often determines the next input message; for example, an output message that contains a series of items from which the operator must make a selection is the basis of the next input message.

A catalog order house uses conversational applications. In this use, an order might be entered in the following sequence:

INPUT MESSAGE, AN	
ORDER NUMBER	54763D
OUTPUT MESSAGE	Size (S, M, L)
INPUT MESSAGE	S
OUTPUT MESSAGE	Color (BLK, GRN, OR)
INPUT MESSAGE	GRN
OUTPUT MESSAGE	quantity
INPUT MESSAGE	15

Simulation programming, problem solving, and modeling are specialized versions of a conversational application.

The 3277 display station and 3284 or 3286 printer can be used in a conversational application. Editing and formatting tools aid the operator when messages consist of fill-in-the blanks and other formatted forms. Modified-data-only and null suppression for transmission efficiency aid message flow.

#### *Conversational Inquiry with File Update*

In an inquiry application that combines conversational and file update, many input and output message steps complete one transaction that initiates other processing transactions (for example, production and warehouse control, shipping, and receiving), which are not necessarily done on the display. These other processing transactions are applications that are used by distributors, manufacturers, and service order businesses.

The 3270 display system is a compatible family of general-purpose products that have been designed to solve a wide range of customer application problems. This application can use the 3277 display station, attached locally or remotely, in combination with the 3284 or 3286 printer for printed output.

#### **Data Entry**

A display used for a data entry application can replace conventional keypunch equipment. Two types of data entry applications are described below.

#### *Source File Update*

In a source file update application, the first step is some type of inquiry to get access to the data that must be modified. Next, the transaction is processed, and the data in the working file is updated immediately.

A state department of motor vehicles uses this type of application to update the large central files on drivers and vehicles as information is sent in from local offices. Remotely configured display stations of the 3270 display system can be used at local offices to provide input to the central office. The 3277 display station, attached locally at the computing installation, can be used for direct input to the computing file. Formatting and editing features aid the operator in making corrections and entering data in predefined formats.

#### *Online Key Entry*

In an online key entry application, records are batched and are entered into an intermediate file that is online, usually on disk. This file is rapidly available to the processing program. The online key entry procedure is used to copy large amounts of data and is designed for high productivity and efficiency. The aim is to eliminate from the computing

installation clerical functions that are not essential to data-processing activity (for example, receiving a job and scheduling it for keypunching and handling cards and tapes).

Payroll and inventory control are applications in which large amounts of data are entered into a computing system for separate processing by the application program.

The 3270 display system can be used for online key entry. The editing tools help the operator verify that input data is correct. Formatted fields and protected data make the operation more productive because input need not be in a character-oriented stream. Remotely attached displays can be used (even though an online key entry application is directed toward high volume) because the devices have high data-transmission efficiency.

#### **System Operator's Console**

A display station that is used as a system operator's console is used in place of conventional typewriter consoles. The display console can hold many system messages and can display them faster than a typewriter console. Two types of system operator's console applications are discussed below; either application might be useful to any computing installation. Programming support available for these applications is described under "Display Console Support" in Chapter 5.

#### *Display Operator Console*

In a display operator console application, the system operator uses the display station to control the operation of the system by entering data into the system and receiving it from the system.

The 3277 display station, model 2, displays large amounts of data. Messages can be separated into different areas on the screen, depending on the type of message that is being displayed. For example, status displays and warnings can be displayed in their own predefined areas. A keyboard is used with the display so that the operator can enter commands and other data. The program function keys and the selector pen can be used to enter predefined commands.

#### *Output-Only Display Console*

In an output-only application, the display console can be used for status displays or operator messages, but it cannot be used to enter data into the system. Display consoles used in this type of application monitor system activity. They can be used in areas away from the central processing unit, for example, in the tape and disk libraries. Also, they can be available at several locations in the computing installation as backup for the display operator console. As no data is entered from the device, a keyboard is not necessary. Since the messages are small, the 3277 display

station, model 1, can be used in an output-only display console application.

### ADVANTAGES OF DISPLAY SYSTEMS

Many installations must answer questions concerning the status of an account or check the disposition of an order while someone waits on the telephone or in the office; also, there may be a high volume of requests for information. When a display station is used, the person waiting can be given fast service. Furthermore, the information is obtained directly from the computer file, thereby avoiding unnecessary clerical operations.

Because display stations can be connected remotely to the computer by means of telephone lines, they can be far from the central file. There can be many people at many locations using the system at the same time. The users at one location can have rapid response to input, even though the files are maintained at a central location that is distant.

An operator of a display station is probably familiar with several parts of the device because the parts are similar to common objects. For example, the keyboard that is used to enter data is similar to a typewriter keyboard, and the output is displayed on a TV-like screen. The display operator can treat the displayed information as if it were in a book; he can turn the pages of the file, looking at one page at a time, making additions and corrections to the data in the format displayed on the screen, checking each page for accuracy, and extracting information he needs.

### ADVANTAGES OF THE 3270 DISPLAY SYSTEM

The 3270 display system is well suited to the types of applications that are listed above. Some of the specific benefits offered by the system follow.

The display operator can enter data in free form. For example, he types in the name and account number of a customer's file; then he types in an order that consists of part number, quantity, price, and special instructions. The sequence of items in the entry is important, but the location of the items on the screen is not. The data could be entered on one or two lines, or each item could be entered on one line.

The display operator can also enter data in formatted form. For example, in typing in a sell-stock order, he would type data opposite the following labels:

ACCOUNT NUMBER:  
STOCK IDENTIFIER:  
QUANTITY:  
SELLING PRICE:

After the operation, the screen would show:

ACCOUNT NUMBER: 7246  
STOCK IDENTIFIER: ABC  
QUANTITY: 50 SHARES  
SELLING PRICE: 5-1/2

There are aids to help the display operator manipulate data that is to be entered in formatted form.

- He is prevented from entering data into a protected field. In an application where he must enter certain items (renewal date of driver's license, amount to be paid, and change of address), but where he cannot modify other items (driver's license number), he is prevented from doing so. He can skip over a protected field by pressing the SKIP key or the TAB key.

He can change unprotected alphanumeric data; he must use special keys to change numeric-only data. He can erase the screen, a field, or characters in a field, and can use the two edit keys (INSERT MODE and DELETE) to correct data. Characters to be corrected are located easily, because the cursor can be moved rapidly in any one of four directions.

- The display station can present selected data items at a brighter intensity than other data on the screen. Intensified data can be distinguished easily. This ability would be useful in an application in which exceptions must be apparent. For example, in a credit authorization application in which the customer's balance cannot be greater than a specified amount, the balance and the limit would be intensified, and the operator could easily compare them.
- The display operator can enter data in fields that are programmed to prevent data from being displayed or printed out. This benefits applications where there are security restrictions on some part of files. In such a use, the operator must enter a special password or identification for access to the data. This identification can be entered in nondisplay fields to prevent unauthorized acquisition of the identification.

### APPLICATION HIGHLIGHTS OF A 3270 DISPLAY SYSTEM

This section describes how a 3270 display system can be used in an application. The description is simplified to emphasize the role of the display station.

A vending company sells goods and services to companies and sends its customers monthly bills. The company's accounting department is automated and uses the IBM 3277 display station, model 2, that has the optional data entry keyboard layout, numeric lock, selector pen, dual-display brightness, and audible alarm. The account-processing procedure is as follows.

A tally of goods and services is computed, and the bill that is sent is in the format:

DATE/OLD AMOUNT/LAST PAYMENT/CHARGES/  
NEW TOTAL

All bills are sent out on the fifteenth of the month. Customers may make full or partial payment; payment is

requested within 30 days. When payment is made, the customer returns part of the bill, which shows:

CUSTOMER'S NAME  
ACCOUNT NUMBER (SEVEN DIGITS)  
VENDOR'S BILLING AMOUNT  
PAYMENT AMOUNT

Every day, the vending company's accounting department receives payments and the returned part of the bill and sorts them alphabetically in the batches: A-E, E-J, K-O, P-T, and U-Z. One accounting department employee handles the entire accounting procedure for one batch. Each batch is divided for full-payment processing (vendor's billing amount and payment amount are equal) and other-amount processing.

Two service representatives are in direct contact with customers and must have immediate access to the latest records to take care of customers' problems. These two employees use 3277 display stations, model 2, that have the 66-key data entry EBCDIC keyboard. The display stations make the latest version of the accounts quickly available to the representatives for customers who usually discuss problems over the telephone. The 5 user-interpretable keys on the keyboard have been given special meanings to help the representatives get customer data. For example, one key is used to have the application program move the display forward to the next part of the data file, and one key is used to move the display backward to the previous part of the data file.

The accounting department employee takes one of the two sets of payments in his alphabetical batch and, using the selector pen, selects from the instructions that are first presented on the display station the name of the processing routine he will use, either FULL or OTHER. Then, instructions for the operator to follow when entering payment data are displayed on the first four lines of the screen.

When processing under the FULL payment routine, the accounting department employee types, in two predefined fields, the account number and payment amount for a customer. He can type in data for three customers on one line and up to 20 lines on each display. A maximum of 60 accounts can be entered at once.

The following aids help the employee enter data quickly:

1. The data entry keyboard layout allows all typing to be done with the right hand, leaving the left hand free to turn payment vouchers.
2. The numeric lock and program-controlled, numeric-only field definition prevent the employee from entering alphabetic data accidentally.
3. One space is skipped automatically, under program control, after the account number has been typed in. This saves a typing stroke between account number and amount.

4. The SKIP key allows the operator to skip over unused spaces in the amount field to the next account number field. The operator is freed from keeping track of how many numbers were entered for the amount and how many spaces are left in the field.

After all data has been entered, the employee presses the ENTER key, and only the information that was entered is sent to the computer. The FULL payment routine checks each account number and amount to ensure that (1) an account number and amount have been entered (for example, that no field is blank because the operator pressed the SKIP key twice), (2) the account number has seven digits and matches an account number in the balance-due file, and (3) the payment matches the amount in the balance-due file. If any of these checks fails, an error code describing the error is displayed in brighter intensity next to the incorrect entry. With the full screen of data that was entered still in view, the operator can go back through the bills and locate the data for entries that must be corrected.

Corrections are easily made by positioning the cursor at the error and typing the correction over the error or by using the text-editing control keys. Corrections are displayed immediately. The operator again presses the ENTER key, and, if no additional errors have been made, the transactions are applied to the customer's accounts. Data transmission is efficient, because only modified data is transmitted, null characters are not transmitted, and the screen can hold up to 1920 characters. The instruction lines are left on the screen, but the data entered by the display operator is cleared so that new entries can be made.

Processing of customers' accounts under the OTHER payment routine is as follows. The employee types in the account number and amount in the preplanned layout. The routine checks all data to ensure that the account number is valid (that is, seven digits and amount have been entered) and that it matches a number in the balance-due file. Errors are noted, and corrections are made in the same way as when processing under FULL. When a match of account numbers is found, the program deducts the payment from the amount due and computes the new balance. If an overpayment is made, the amount of credit is noted for the next bill.

Refer to Figures 4-1 through 4-3 to see what the operator sees as this accounting procedure is being followed.

The application program, which the FULL and OTHER processing routines are part of, performs other accounting work. It totals each day's payments that were applied to the customers' accounts and prepares a bank deposit voucher, which is printed out on a 3286 printer; it also checks the payments-due file at the end of the billing cycle for accounts that were not paid.

When a customer calls in for account information, he is referred to the service representative who handles his file.

The service representative types in the account number on the keyboard of the display. The system retrieves the account file and presents the most recent transactions on the screen. The representative can cause data from earlier transactions to be displayed. This use of the display system

by the vendor helps the company maintain close contact with its customers. Quick handling of problems gives customers confidence in the vendor's ability to provide the offered goods and services.

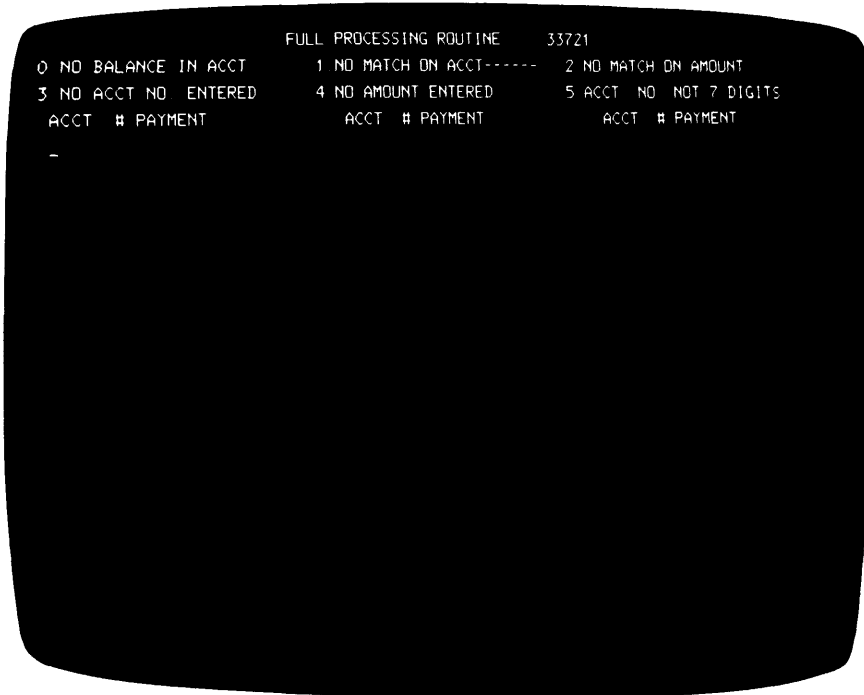

This display appears after the operator has selected the routine that will process a batch of transactions. The first four lines on the screen contain the name of the processing routine (FULL), error codes returned by the system if the information that has been typed in is incorrect, and column headings to help the operator type in data.

Figure 4-1. Displays Appearing during Sample Accounting Procedure (Display 1 of 3)

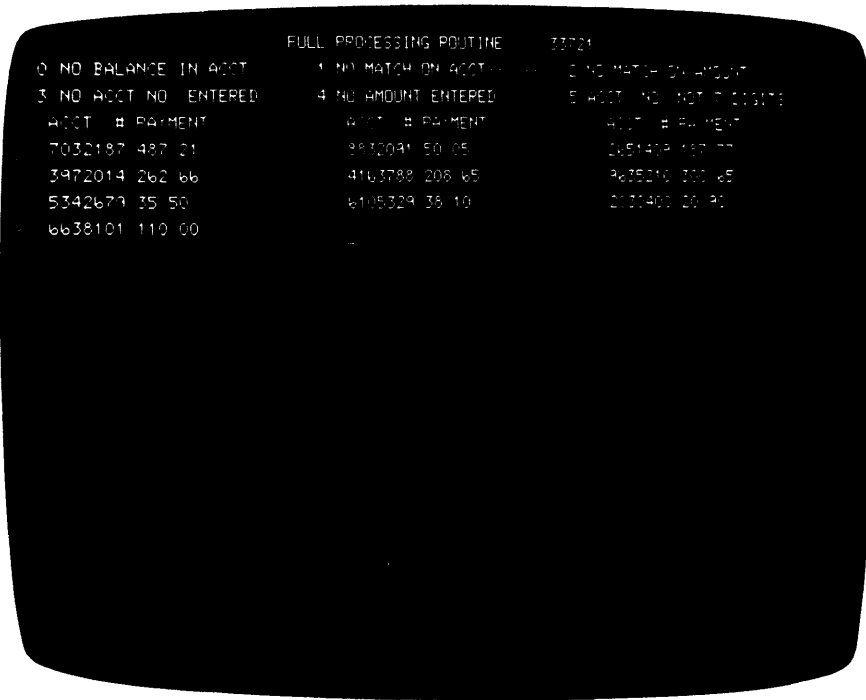

The operator sees this display as data is being typed in. The next entry can be made at the cursor.

Figure 4-2. Displays Appearing during Sample Accounting Procedure (Display 2 of 3)

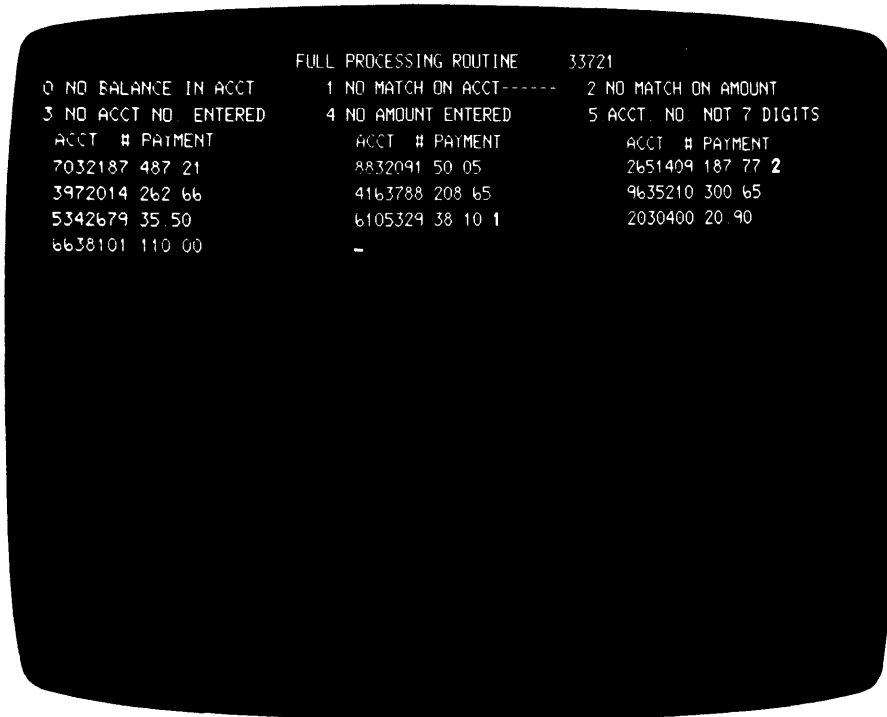

If errors are found, a code is displayed next to the data that is incorrect. The error code is in a brighter intensity than the data that has been typed in. Error codes appear on lines 5 and 7.

Figure 4-3. Displays Appearing during Sample Accounting Procedure (Display 3 of 3)



## INTRODUCTION

This chapter describes the programming available for the 3270 display system, including telecommunications support (BTAM under DOS and OS and TCAM under OS), display console support (DIDOCS and SDS under OS), and VIDEO/370 (under OS and DOS), DATA/360 (under OS and DOS), IMS, CICS, IQF, and TSO.

Telecommunications support for the 3270 display system is provided by the Basic Telecommunications Access Method (BTAM) under the Disk Operating System and the Operating System and the Telecommunications Access Method (TCAM) under the Operating System.

Display console support for local 3270 displays and printers used as operator's consoles is available through Device Independent Display Operator Console Support (DIDOCS) and Status Display Support (SDS) under the Operating System. DIDOCS provides uniform services for all display operator's consoles on MFT, MVT, and VS systems. Status Display Support extends existing system status display services to improve the way information is presented to the operator. Local 3270 display and printer support is comparable to the DIDOCS and SDS support for other devices.

BTAM under DOS or OS, TCAM under OS, DIDOCS, and SDS are supplied without additional charge to users of IBM data processing systems.

VIDEO/370 is a program product that allows OS or DOS users to enter and verify data at local or remote 3277/3275 displays.

DATA/360 is a program product that allows OS or DOS users to enter and verify data at 3277 displays.

IMS allows OS users to use the 3270 system for data base and data communication applications.

IQF is a terminal-oriented query application program that uses the 3270 system under either DOS or OS.

CICS uses the 3270 system under DOS or OS for data base or data communication application.

TSO, an OS option, uses the 3270 system for terminal-oriented time-sharing applications.

## TELECOMMUNICATIONS ACCESS METHODS

The Basic Telecommunications Access Method (BTAM) is used to control the transfer of data between main storage and local or remote terminals. BTAM provides the application program with macro instructions for using the capabilities of the devices supported. BTAM supports binary synchronous, as well as start-stop, communication.

For a detailed description of BTAM under the System/360 Disk Operating System, see *IBM System/360 Disk Operating System: Basic Telecommunications Access Method*, GC30-5001; for BTAM under the operating system with MFT or MVT, see *IBM System/360 Operating System: Basic Telecommunications Access Method*, GC30-2004; for BTAM under VS, see *OS/VS BTAM*, GC27-6980.

The Operating System Telecommunications Access Method (OS TCAM) supports the IBM 3270 Information Display System in either local or remote applications. TCAM is used to control data transfer between main storage and local or remote display stations.

For a description of OS TCAM, see *OS TCAM Concepts and Facilities*, GC30-2022.

## BTAM Under DOS or OS

### Functions and Organization

The primary functions of BTAM under the Disk Operating System or the Operating System are channel program generation and, optionally, buffer management and 2260-3270 basic data stream translation (see Chapter 6).

When the application program (also called the problem program) is assembled, BTAM macro instructions are expanded into (1) BTAM routines; (2) inline instructions, including linkages to executable BTAM routines; and (3) control blocks and tables defining lines, terminals, and options to be used. During execution, the application program communicates with DOS/BTAM or OS/BTAM through BTAM macro instructions and BTAM control blocks and tables in order to request such telecommunications services as preparing lines for use, performing data transmission, and managing buffers.

### Environment

BTAM operates under control of the Disk Operating System or the MFT, MVT, or VS versions of the System/360 Operating System.

BTAM under DOS or OS can be used in telecommunications systems that contain many different control units and devices, including those that make up the 3270 display system.

### The 3270 Display System and BTAM Under DOS or OS

BTAM under DOS or OS supports the control units, displays, and printers that make up the 3270 display system. DOS/BTAM support for the local 3277 display stations is comparable to DOS/BTAM support for the local

2260. DOS/BTAM and OS/BTAM support for the remote 3277 and 3275 display stations is part of BTAM support for nonswitched multipoint lines that use binary synchronous communication (BSC). Support for the local or remote 3270 display stations or both can be included among the DOS/BTAM or OS/BTAM routines and channel programs.

#### *Functions and Use*

BTAM under DOS or OS supports the 3270 display system by:

- Generating channel programs.
- Translating data streams for 2260 processing routine.
- Starting I/O operations.
- Handling attentions.
- Handling line interrupts.
- Performing error recovery procedures, posting, and counting errors.
- Converting data streams for 2260 processing routines (see Chapter 6).

For local 3270 display systems, capabilities of the display system are used through the “optype” operand of the DOS/BTAM or OS/BTAM READ and WRITE macro instructions. For remote 3270 display systems, a combination of DOS/BTAM or OS/BTAM READ and WRITE macro instructions for BSC and device control characters included in the data to be transmitted provides access to the display system capabilities.

#### *3270 Display System Capabilities Supported*

BTAM under DOS or OS supports the following capabilities of the 3270 display system:

- Write data to display or printer buffer.
- Erase buffer and write data.
- Erase all unprotected fields in buffer.
- Read data from buffer.
- Read buffer from specified location.
- Read modified fields from buffer.
- Read modified fields from buffer from specified location.

#### *3270 Display System Devices Supported*

BTAM under DOS or OS supports the following 3270 display system devices:

- 3277 display station, model 1, attached to a 3272 control unit, model 1 or 2, or a 3271 control unit, model 1 or 2.

- 3277 display station, model 2, attached to a 3272 control unit, model 2, or a 3271 control unit, model 2.
- 3275 display station, model 1 or 2.
- 3284 printer, model 1, 2, or 3.
- 3286 printer, model 1 or 2.

#### *Environment*

BTAM under DOS operates in any System/360 or System/370 processor that has at least 32K bytes of main storage. BTAM under OS requires a System/360 or System/370 processor that has at least the minimum main storage requirement for MFT, MVT, or VS.

In addition to the minimum requirement of 5K bytes for BTAM under DOS, main storage requirements are:

1. Approximately 3K bytes for support of the local 3270 display system.
2. Approximately 7K bytes for support of multipoint lines using BSC, which includes support for the remote 3270 display system.

For BTAM under OS, main storage requirements are:

1. Approximately 5K bytes for support of the local 3270 display system.
2. Approximately 9K bytes for support of the remote 3270 display system.
3. Approximately 11K bytes for support of both the local and remote 3270 display systems.

#### **TCAM Under OS**

##### *Functions and Organization*

TCAM under OS controls the transfer of messages between TCAM and application programs, and provides a high-level message control language. TCAM macro instructions can be used to construct a message control program that controls messages between remote stations and between remote stations and application programs.

The data set definition and control information macro instructions are used to specify the installation's equipment configuration and the buffers necessary for message processing. Functional macro instructions are used to select TCAM logic modules that route messages, edit messages, and check for message errors. TCAM can be tailored to application requirements through selection of the appropriate macro instructions and operands.

A teleprocessing control system created with the TCAM message control language can:

- Establish contact and control messages between the computer and local or remote display stations.
- Delete and insert line control characters automatically.

- Assign, use, and free buffers as required during execution.
- Edit incoming and outgoing messages.
- Forward messages to display stations and application programs.
- Provide message error handling.
- Maintain statistics about message traffic.

#### *Environment*

TCAM operates under control of the Operating System. OS TCAM can be used in telecommunication systems that include the IBM 3270 Information Display System.

#### **3270 Display System and OS TCAM**

OS TCAM supports the 3270 display stations, control units, and printers. The support includes the following features:

- Device scheduling under control of a TCAM message control program provides either general or specific polling, dynamically selectable with TCAM operator control.
- The TCAM SCREEN macro extension allows the user to select the command to be executed when writing to a display.
- The TCAM online test capability for the 3270 enables concurrent diagnostic testing on one control unit while other control units on the line continue operations.
- TCAM provides error-handling, recording, and user notification of asynchronous errors.
- TCAM application programs may be written without concern for local or remote attachment of the 3270 display stations that are supported.

3270 support requires 2K additional bytes for the TCAM message control program. TCAM message handlers must also be coded to process the 3270 data and control blocks.

#### **DISPLAY CONSOLE SUPPORT**

Display consoles are operator's consoles that present the operator's message traffic on the screen of a display instead of printing it on paper. Device Independent Display Operator Console Support (DIDOCS), which is a programming service under multiple console support (MCS), provides uniform services for all display consoles on MFT, MVT, and VS2 systems. Status Display Support (SDS) improves the existing system status display services under MFT, MVT, and VS2. Extensions to DIDOCS and SDS provide services for 3270 display stations and printers and also provide several new functions applicable to all devices serviced by the support.

#### **Functions**

##### *Basic Display Console Support*

DIDOCS provides the linkage between displays and the system to make the displays usable as operator consoles. In conjunction with multiple console support, DIDOCS provides processing and routing of messages from the operating system and problem programs to the consoles, presentation of the messages within the appropriate area of the console screen, and processing of information entered through the console by the operator. The support is device-independent in that it services all devices in a similar manner; on the other hand, it takes advantage of features that are peculiar to a particular console (for example, selector pens and audible alarms).

The additions to DIDOCS for the 3270 display system extend this basic console support to include locally attached 3270 display stations and printers. The 3277 display station, model 2, is made available as a full-capability console or as an output-only console, and the 3277 display station, model 1, is made available as an output-only console. Output-only consoles can be used to display system messages but cannot be used to enter information into the system.

DIDOCS is also extended to include the 3284 and 3286 printers, models 1 and 2, as hard-copy consoles (output-only consoles that produce typed pages instead of screen displays).

Status Display Support is designed to improve system status display services for display and nondisplay consoles. Status displays are formatted, multiple-line displays of system information written to the operator's console in response to certain operands of the DISPLAY and MONITOR commands. The operator uses status displays to monitor system activity and to determine the status of various system devices.

##### *New Console Support Functions*

At the same time that display console support is extended to include the local 3270 display stations and printers, new functions are added to DIDOCS and to existing system status display services to increase the general efficiency of all display consoles.

The new DIDOCS functions are in four areas.

*Programmed Function Keyboard Command Entry.* The programmed function keyboard (PFK) is made available for rapid entry of operator commands. One or more commands may be associated with each PFK key after initial program load, and the operator can enter commands by pressing the appropriate key or keys.

*Selector Pen Command Entry.* This service is related to the PFK service described above. Commands are again associated with PFK key numbers after initial program

load, but command entry is accomplished by positioning a selector pen over key numbers displayed on the screen. This feature is available on all display consoles equipped with a selector pen (except the 3277 display station, model 1); a program function keyboard is not required.

**Transient Display Control Modules.** Display control modules (DCMs) can require large amounts of main storage in a system with many display consoles. The transient DCM service added to DIDOCS allows several consoles to be grouped together during system generation, so that one area of main storage may be assigned to the group.

While the system is operating, DIDOCS moves the display control module associated with each console into this main-storage area as it is needed. By means of this feature, the main storage required by a group of consoles can be reduced to just slightly more than the main storage formerly required by a single console (see "Storage Requirements").

**Pageable DCM Support.** Under VS, transient DCMs are replaced by pageable DCMs. Pageable DCMs reside in virtual storage whenever they are not needed; when they are needed, they are brought into real storage by the VS paging facility.

**Output-Only Mode of Operation.** The 2260 display console, the 3277 display station, model 2, and the 3277 display station, model 1, can be put in the output-only mode of operation during system generation or after initial program load. An output-only console can be used to display operator messages but cannot be used to enter information into the system. Removing the input function from a console adds several lines to the message area on the screen (see "Physical Features") and provides a separate display screen that might be used for special purposes, such as presentation of status displays.

The 3277 display station, model 2, and the 2260 display console operate in either the input/output or output-only mode. If they are designated for input/output operation during system generation, they can be varied to output-only mode by the operator. The 3277 display station, model 1, operates only in the output-only mode and can only receive general message traffic; it cannot be designated to receive status displays.

The primary purpose of Status Display Support is to improve system status display services by enhancing the way information is presented to the operator. These improvements are in three areas.

**Contiguous Status Displays.** The system WTO macro facility (the WTO macro is used to write the lines of the status display to the operator's console) is extended to allow presentation of status displays in contiguous, multiple-line format. This eliminates interleaving of other operator messages with the lines of the status display.

**Display Area Designation.** A means of separating status displays from normal message traffic and routing them to separate consoles is provided. The operator (or the system programmer during system generation) can designate blocks of lines in the screen's message area as "display areas" for presentation of status displays. The system assigns an alphabetic identifier to the designated display areas and also assigns a numerical identifier to each console in the system. The operator can use these identifiers to specify the precise console and display area in which a status display is to be presented.

**Time-Interval-Updated Display.** The operator's ability to monitor system activity is enhanced by the addition of time interval updating of the active jobs displays. The A operand of the MONITOR command requests the active jobs display (the same display that is requested by the DISPLAY A command), but also requests that the system update the display each time a pre-set time interval elapses. The time interval can be adjusted by the operator according to his requirements.

#### **Advantages and Limitations**

The advantages of the display console are speed, efficiency, and clear presentation of information.

The system can fill a display screen with information almost instantly, expediting the presentation of information to the operator.

Certain display consoles (Table 5-1) allow present command entry by selector pen or PFK. This form of entry, which enables the operator to enter several commands with one action (positioning a selector pen or pressing a PFK key), is faster than command entry on typewriter consoles and is not subject to typing errors.

Display consoles present different types of information in separate areas of the display screen (see "Physical Features"). Also, the operator may designate a number of contiguous lines of the message area for status displays. When a status display is not present, these lines are used for system message output. When a status display is involved, the information overlays the system messages in the area. When the status information is removed from the screen, the overlaid messages are restored. If the status display contains more lines of information than can be presented in the predefined area, it is dynamically segmented, and the operator can frame through the information.

The operator can classify items as special messages about the console, warning messages, status displays, or general message traffic simply by their location on the screen. Display consoles keep the operator advised of messages requiring action. Unless the operator specifically deletes action messages, they remain on the screen, marked with an asterisk for easy identification. The system also marks messages for which action has been taken and deletes them automatically when the screen becomes full (if the operator

Table 5-1. A Summary of Display Devices and Features That Are Serviced by DIDOCS and SDS

Feature Device	Input/ Output	Output- Only	Selector Pen Message Deletion*	Selector Pen Command Entry*	PFK Command Entry*	Audible Alarm*	Inten- sified Warning Line
2250 Models 1 and 3	Yes	No	Yes	Yes	Yes	Yes	No
2260 Display Console	Yes	Yes	No	No	No	No	No
Model 85, Model 165, and Model 168 Operator Consoles	Yes	No	No	No	No	Yes	No
Model 91 and Model 195 Operator Consoles	Yes	No	Yes	Yes	Yes	Yes	No
3277 Display Station, Model 2 and the Model 158 console	Yes	Yes	Yes	Yes	Yes	Yes	Yes
3277 Display Station, Model 1	No	Yes	No	No	No	No	Yes

\*When the required equipment is attached.

has requested automatic deletion). The operator may also control message deletion himself.

In the output-only mode, the display console can provide an effective system monitoring device separate from the main operator console (in a tape or disk library, for example). Most output-only consoles may be designated to receive either general messages or status displays; the 3277 display station, model 1, can be used as an output-only console, but it cannot receive status displays.

A console designated for status displays might be set up close to the master console to provide the operator with system status information in a convenient location, but away from the normal messages. This arrangement would help the operator by making the status displays easier to read. It could also increase system throughput by freeing space on the master console screen for other messages.

System monitoring with display consoles may also take advantage of the time-interval updating of the display of active jobs. The MONITOR A command can be used to provide the operator with information about the jobs active in the system; the system keeps the information current by updating the display according to a preset time interval.

The 3270 display stations (and other display devices), designated as operator's consoles during system generation, are still available for other display applications. The VARY command is used to reconfigure the consoles for these purposes.

Display consoles involve some limitations and restrictions. They require more control modules and more main storage than typewriter consoles, although this can be eased through the use of transient DCMs (see "Storage

Requirements"). The display console screen also requires close operator attention, particularly because of the message deletion requirements, although automatic message deletion and the audible alarm can help in these areas (see "Operating Procedures" and Table 5-1).

## Environment

### System Requirements

The support (DIDOCS) required to operate the 3270 display stations as display consoles can be used with any central processor in which the MFT, MVT, or VS2 versions of the Operating System operate. In order to use display consoles, multiple console support (MCS) must be included in the system. Status Display Support is an integral part of Operating System with MFT, MVT, and VS.

### Devices Supported

Table 5-1 contains a summary of the display consoles that are supported by DIDOCS and the special features of each.

### DIDOCS Storage Requirements

The processing modules of DIDOCS operate from the SVC transient area (unless the user specifies otherwise). They will require no additional resident storage in the system. The display control modules (DCMs), which support display consoles, are control blocks that require varying amounts of main storage, depending on the type of console they are supporting. The DCM main-storage requirement

for each type of console is provided in Table 5-2 (K equals 1024 bytes of main storage).

Table 5-2. DCM Main Storage Requirements

Console	Storage Required
2250, Models 1 and 3	5.0K
2260, Model 1	1.5K
Display Console for Models 85, 165, and 168	3.5K
Display Console for Model 91 and Model 195	5.0K
3277 Display Station, Model 2 and Model 158 Console	3.0K
3277 Display Station, Model 1	1.1K

If the transient display control module feature is not used, separate main-storage areas must be assigned to each console in the system. The total amount of main storage required to support the system consoles therefore equals the sum of the storage requirements for each console plus 36 bytes for each console. For example, a system with a Model 85 display console, a 2260 display console, and a 3277 display station, model 2, needs 8300 (3.5K+1.5K+3.0K+108) bytes of main storage for display consoles.

**Transient Display Control Modules.** The transient DCM feature allows DCMs to reside in auxiliary storage and to occupy main storage only when they are used. The system assigns to a group of consoles enough main storage to service the console with the largest individual storage requirement (Table 5-2) plus 8 bytes. The system also requires 50 bytes of main storage for each console in the group and 384 bytes of main storage for the access method (BTAM) that is used to transfer the DCMs between auxiliary storage and main storage. If the three consoles used in the example above were assigned to a transient DCM area, the system would require about 4K (3.5K+8+150+384) bytes of main storage.

**Pageable DCM Support.** Under pageable DCM support (VS only), the DCMs for each active console reside in virtual storage. When the system requires the DCM for a console, the DCM is "paged" into real storage. When it is no longer required, it is "paged" out of real storage and returns to virtual storage.

**PFK Command Entry.** The system requires no more than 150 bytes of main storage for each PFK associated with commands. The size of the storage utilization block is not affected by PFK support.

#### Status Display Support Storage Requirements

Status Display Support requires only a minimal increase in the storage required for the Master Scheduler and

Communications Task resident areas. The amount is variable according to the system options that are specified (MFT, MVT, MCS, Non-MCS), but the maximum is not more than 1200 bytes. The system also required some main storage to keep track of time-interval-updated displays, display areas, and console information. The maximum requirement is approximately 100 bytes of main storage for time-interval-updated displays, 32 bytes for each display area, and 30 bytes for each console in the system. The user cannot alter the storage requirements; the system automatically includes the required storage according to the options that are specified.

An increased amount of Write-to-Operator message buffers may be required by systems using display areas and time-interval-updated status displays. The number of buffers required varies according to the number of display areas defined and the number of display areas to be used for time-interval-updated displays.

#### Physical Characteristics of 3270 Display Stations Used as Display Consoles

The device-independent feature of DIDOCS maintains a high degree of similarity among all display consoles. Operators already familiar with other display consoles will find that the 3277 display stations follow the same general format for physical presentation of information. Operators accustomed to typewriter consoles should find the display presentation clear and easy to read.

#### Screen Format for the 3277 Display Station, Model 2

The appearance of the display screen for the 3277 display station, model 2, in the input/output and output-only modes, is shown in Figure 5-1. In the input/output mode of operation, the 24 lines of the screen are used as follows:

- Message area – 19 lines for messages.
- PFK display line – one line for display of PFK numbers (for selection using the selector pen).
- Instruction line – one line for display of error or operating instruction messages relating to control of the console.
- Entry area – two lines for entering commands.
- Warning line – one line for warning messages (intensified).

In the output-only mode, the message area is expanded to 23 lines.

#### Line Format for the 3277 Display Station, Model 2

The lines on the 3277 display station, model 2, are 80 character positions in length. Message area lines have system indicators in the first two positions, which appear blank on the screen. Positions 3 and 4 contain the message line number. Positions 5 and 6 may be blank or may contain

INPUT/OUTPUT  
MODE

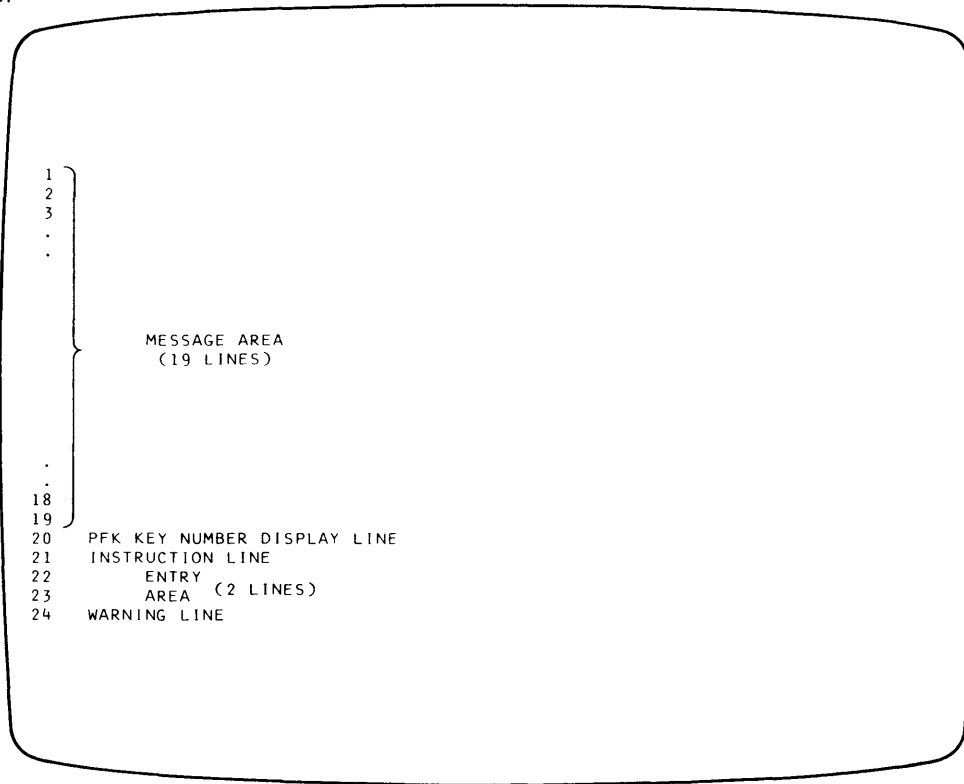

OUTPUT-ONLY  
MODE

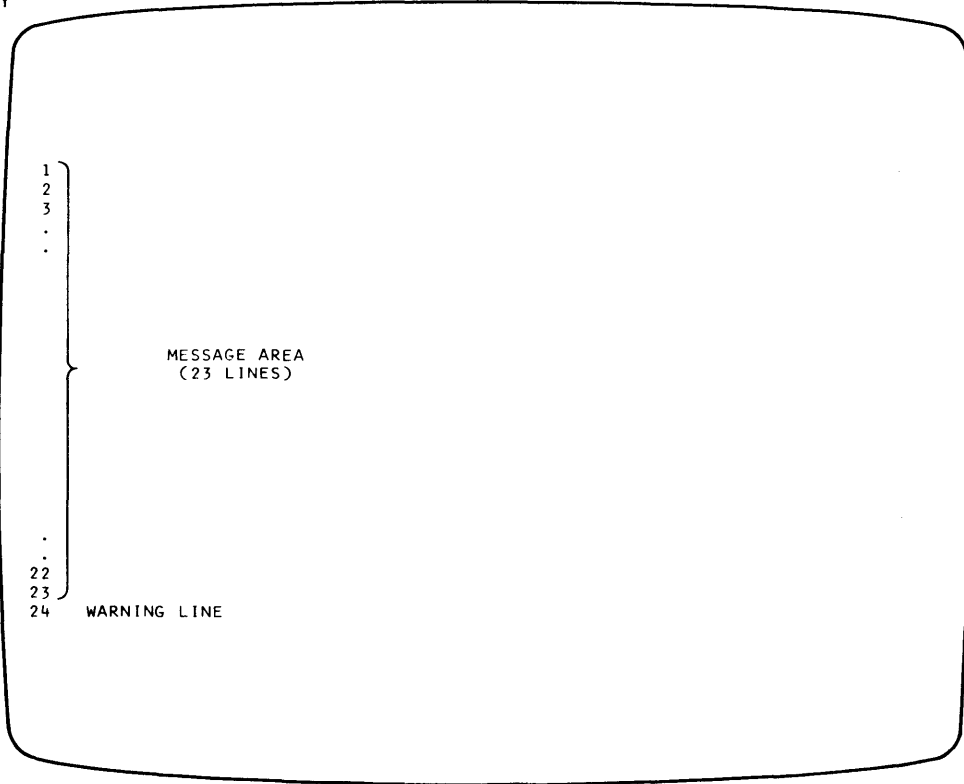

Note: These diagrams indicate how the display-screen lines are used in the two modes of operation; the labels shown do not appear on the screen.

Figure 5-1. Screen Formats for 3277 Display Station, Model 2

indicators noting that action is required or has been taken. The message text is contained in positions 7–78. Messages longer than one line are divided at a blank space or comma after the 71st character position; if no comma or blank is found, the message is written to character position 78. The message is continued at position 7 of the next line.

Entry area lines have a blank in the first screen position; positions 2–80 are used for command entry.

In the output-only mode, lines 1–23 are in the format used for the message area, and the warning line is intensified.

### *Screen and Line Format for the 3277 Display Station, Model 1*

The 3277 display station, model 1, has an 11-line message area and one warning line. Each 40-character line has an asterisk in position 1 when an action is required; otherwise, position 1 is blank. Message text is contained in positions 2–40 of the first 11 lines. Messages longer than one line are continued at character position three of the following line. (Messages longer than two lines are continued on the third line.) Warning messages are printed in positions 1–39 of the warning line; position 40, which contains system information, appears blank on the screen. The warning line is intensified.

### **System Procedures**

Certain specifications must be made during system generation in order to establish the 3270 display consoles in the system. The operator may change these basic specifications after initial program load to arrange the consoles in what he finds to be their most useful configuration. This section outlines the specifications required during system generation and introduces the basic procedures involved in operating display consoles. Detailed information about system generation is contained in *IBM System/360 Operating System: System Generation*, GC28-6554 and *OS/VS System Generation Reference*, GC26-3791; display console operating procedures are fully explained in *IBM System/360 Operating System: Operators Guide for Display Consoles*, GC27-6949 and *Operator's Library: OS/VS Display Consoles*, GC38-0260.

### *System Generation*

Specification is required in the following areas:

- **Multiple Console Support:** This option under the SCHEDULR macro instruction is required to use display consoles.
- **Console Designation:** Each console must be specified under the SCHEDULR or SECONSLE macro instruction. This specification, combined with the multiple console support specification, provides the basic DIDOCS services for the console.

- **Output-Only Consoles:** Operands of the SECONSLE macro instruction allow specification of output-only consoles.
- **Transient Display Control Modules (MFT and MVT only):** This service is selected by means of the OPSTRAN operand of the SCHEDULR and SECONSLE macro instructions. If transient DCMs are used, the DCM library must be included in the system by means of the DCMLIB macro instruction.
- **PFK Command Entry:** This feature is selected by means of the PFK operand of the SCHEDULR and SECONSLE macro instructions. PFK keys may be associated with commands by the operator after initial program load.
- **Selector Pen Command Entry:** This function is also selected by means of the PFK operand of the SCHEDULR and SECONSLE macro instructions. Key numbers may be associated with commands by the operator after initial program load.
- **Hard-Copy Consoles:** The 3284 and 3286 printers may be designated as hard-copy consoles by means of the SECONSLE macro instruction.
- **Display Areas:** Display areas may be specified by means of the A operand of the SCHEDULR and SECONSLE macro instructions. Display areas may also be specified by the operator after initial program load.

### *Operating Procedures*

The new operator or the operator trained on typewriter consoles should have little difficulty learning to work with display consoles. The procedures the operator is required to perform may involve altering the operating modes of the consoles or controlling the system.

*Altering Console Configurations.* The basic configuration of consoles is set during system generation. The operator should be aware of this original configuration and of the capabilities of each console in the system. He should know, for example, which consoles have been designated for input/output mode of operation and which have been designated for output-only operation. He can use the DISPLAY and CONTROL commands to keep informed of the configurations, and he may make alterations in the following areas:

- **Mode of Operation:** The VARY command can be used to make a display console available for other display applications; the CONTROL command can be used to change a console from input/output mode of operation to output-only mode (for either general messages or status displays) or from output-only to input/output.
- **Message Area Use:** The entire message area of a console screen may be used for messages, status displays, or a



combination of both. By means of the CONTROL command, the operator may define areas of a console screen for presentation of status displays. Several of these display areas can be defined in one message area.

- **PFK Definitions:** If PFK support is requested during system generation, the operator can use the CONTROL command to associate commands with the PFK keys. PFK commands can be redefined by the operator at any time after initial program load.

*Controlling the System with Display Consoles.* During normal system operation, the operator:

1. Enters commands (1) by typing the command and pressing the ENTER key, (2) by typing the command and selecting the word ENTER from the display screen with the selector pen, (3) by pressing a PFK key, or (4) by selecting a displayed PFK number with the selector pen.
2. Requests status displays by means of the DISPLAY command. The operator can request a display for his console or he can use the console to request a display for presentation on another console.
3. Deletes messages. If a display console screen becomes full, the operator must delete nonaction messages and messages for which required action has been taken. The operator deletes messages by using the CONTROL command, by positioning the cursor and pressing the ENTER key, or by using the selector pen. When messages are waiting for screen space, a message appears in the warning line.
4. Replies to Write-to-Operator-with-Reply messages, using the same procedure as for command entry.

Several display console features assist the operator in performing these procedures:

- The CONTROL command enables the operator to request automatic deletion of nonaction messages and messages for which required action has been taken.
- The DISPLAY command enables the operator to request a display of the commands associated with the PFK keys allocated to his console.
- Routing defaults for status displays can be established, so that the operator need not specify console and display area identifiers each time a display is requested.
- Some consoles have an audible alarm that sounds when an action message is displayed, when a message-waiting warning appears, or when an error is made in entering a CONTROL command.

## VIDEO/370

### Background

In recent years the cost of data entry has risen considerably. Faster computers and printers have been

handicapped by the inefficiency of transcriptive data entry (which requires source document handling, the recording and transcribing of data by keypunching, card handling, and card transport).

Distributive data entry, by means of online graphic display units with keyboards for direct entry of data to a computing system, offers numerous advantages over the transcriptive method:

1. Data may be entered at, or closer to, its point of origin rather than in a centralized keypunch shop.
2. Card handling and transport are eliminated.
3. Data may be entered directly from source documents.
4. Turnaround time between source document and residence of data in the computing system is greatly reduced.

### VIDEO/370 Overview

VIDEO/370 (Visual Data Entry Online) is a program product designed to provide an easy and direct method for distributive or conventional data entry, using IBM 3277/3275 displays in local and remote environments to produce input for application programs. An overview of VIDEO/370 appears in Figure 5-2. The customer designs the format (A) for the display screen image and application record and defines characteristics for data fields that are checked for errors. If errors are detected in data entry, the operator (B) is able to dynamically correct them. Error-free data is stored on disk (C) for subsequent retrieval (D) and use by the customer's application program (E). Statistics concerning operator production (F) are generated and formatted by the statistics program (G).

VIDEO/370 is an improved method of data entry because:

- VIDEO/370 allows data entry by a simple "fill-in-the-blanks" manner, through customer-formatted screen images.
- VIDEO/370 allows installation of local or remote displays, in single units or clusters, with as many terminals and control units as the computing system can support.
- VIDEO/370 provides highly efficient use of storage through its modular, open-ended design.
- Detailed statistics may be produced regarding operator performance and efficiency.
- VIDEO/370 is easy to learn, and minimal operator training is required.
- Input and output formats are flexible and are designed by the customer.
- Costs are reduced due to data editing, early error-detection, and increased operator productivity.
- Diagnostic system messages allow dynamic error-correction by the operator.

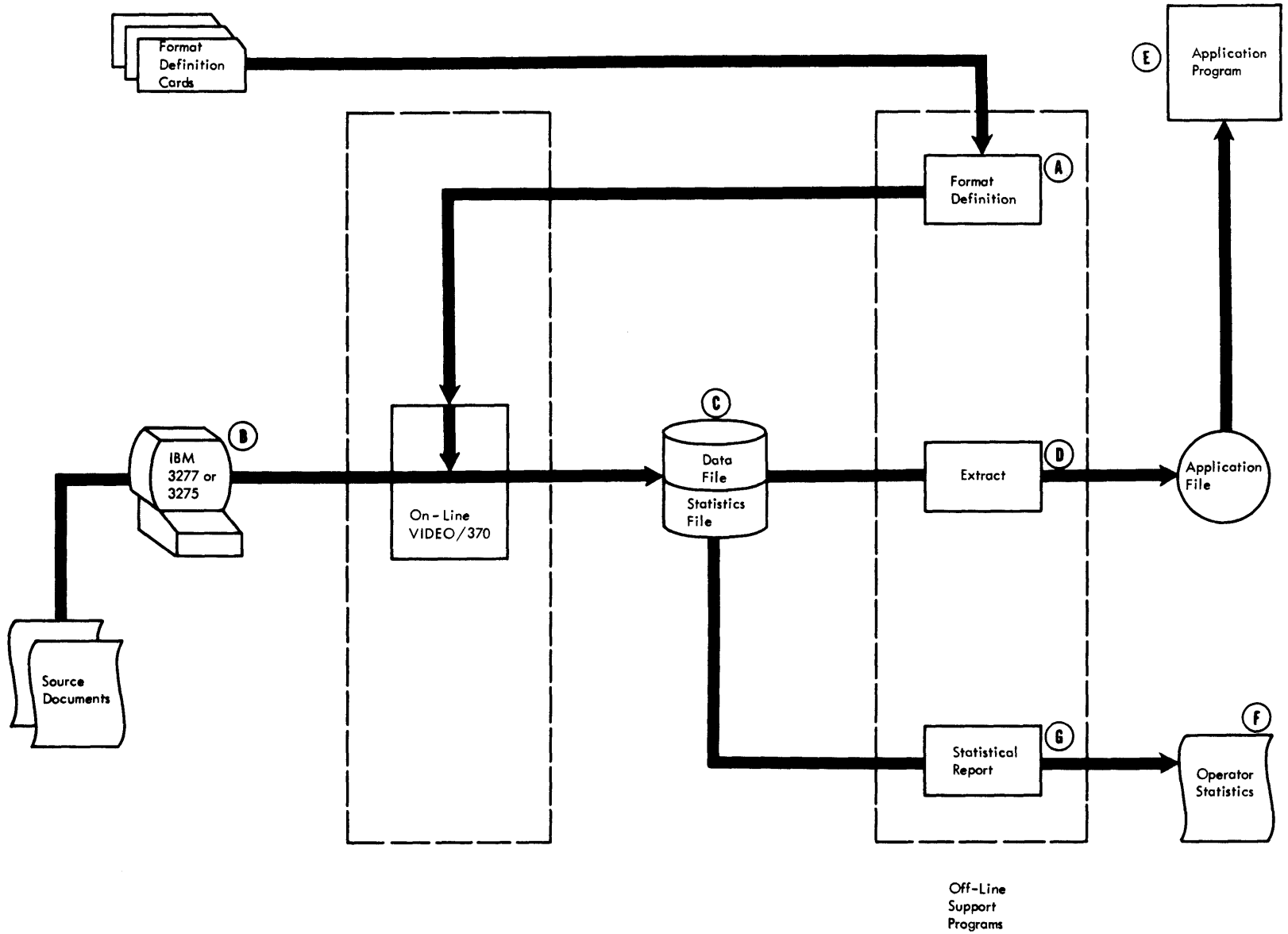

Figure 5-2. Overview of VIDEO/370

VIDEO/370 displays formats that enable an operator to enter source data at the IBM 3277/3275 keyboard directly from source documents and without regard for conventional application record formats. The formats may include field names and instructions so that personnel may use the formats to enter data by filling in the blank areas. For example, a VIDEO/370 display of a customer-designed payroll record format might appear in the format shown in Figure 5-3.

As the operator enters data at the keyboard, the data is displayed within the format on the screen. The data entered on the screen constitutes an operator input record, which is stored on disk for later conversion into the application record format required by the application program.

### VIDEO/370 Features and Attributes

VIDEO/370 provides most basic punching and verifying functions, plus the following additional features:

#### Data Editing and Attribute Specification

VIDEO/370 provides internal editing facilities to ensure the accuracy of operator input data by checking whether all data entered in a field corresponds to that field's format definition. Editing is provided for the following field specifications:

(Field types)

- Alphanumeric (any EBCDIC characters)
- Numeric (period, minus, dup, 0-9)
- Hexadecimal (0-9, A-F)
- Signed (positive or negative integers)
- Left and right zero insertion
- Left and right blank insertion
- Self-check Modulus 10
- Self-check Modulus 11

The power shift feature allows specification of automatic lock-up for the shift key for a particular field. Input field length and position characteristics are specified by the customer.

One special editing feature is the use of "balance" fields. Up to four numeric counters can be designated for the accumulation of numeric data for comparison with a predefined total. Any number of numeric fields within a record, or over several records, may be specified as balance fields or total fields. A balance field is added to the contents of a counter, and a total field is compared with the contents of a counter. If the comparison is not equal, the operator is notified and allowed to correct the error. If the fields are equal, the counter is set to zero, and accumulation starts again. In Figure 5-3, for example, the NET (pay) and TOTAL (deduction) fields could be designated as balance fields and added into the same counter for a comparison with the GROSS field (the corresponding total field). VIDEO/370 then makes a

comparison for each payroll record as it is entered. In addition, the GROSS field could be added to another counter for all the records that are entered to accumulate a total company payroll. Individual fields may have multiple definitions; that is, a field may be added to more than one balance field and also serve as a total.

The format designer could also provide specialized editing by defining a program to be used with a format. In such a case, this program would be given control after each record was entered and error-checked but before its storage in the file.

#### Keystroke Reduction

VIDEO/370 enables screen image formats to be defined with automatic duplication fields and automatic skipping between fields. Fields may also be designated as verification or nonverification fields, to reduce the number of keystrokes during verification operations. In addition, constant data may be designated in the format definition as part of the application record so that the operator need not enter such information in the source data.

#### Easy Error Correction

If the operator detects an error while entering data, he may backspace and correct the error. Also, when an error condition is detected by VIDEO/370, the keyboard is locked to notify the operator, an error message is displayed, and the fields in error are intensified. The IBM 3277/3275 is programmed to automatically skip the nonerror fields.

#### Data Security

VIDEO/370 provides three methods of improving data security at the display terminal. First, the installation can



Figure 5-3. Sample Payroll Record Format As Seen on IBM 3277/3275 Display

assign identification numbers to authorized VIDEO/370 operators. Second, the installation can restrict an operator's access to one or more modes of operation. Third, the operator can assign an "access code" to a batch of data; this data cannot subsequently be retrieved without this code.

#### *Operator and Production Statistics*

VIDEO/370 has programs that generate and format statistical information, for any specified work period, on operations performed at the IBM 3277/3275 displays. These statistics may appear as five types of reports:

- Operator reports, which provide statistics on all entry and verification operations. One report breaks the statistics down by operator names and includes keystroke counts, elapsed time, number of records and errors, names of formats, and the balance fields for the batch. The second report includes accumulated keystroke count, error count, record count, and elapsed time for all operators.
- Format statistics reports, which provide information to help the installation evaluate its formats. One report breaks down error counts, by field, for each format. The second report lists, by format name, the operator who used the format, the error count, and the number of records entered.
- Production report, which summarizes jobs, keystrokes, time, and records for the period of activity.
- Batch status report, which lists the status of batch jobs that are still active, that is, those entered or verified batches that have not yet been extracted and those that have been saved or suspended.
- Message report, which lists the message codes, a description of the messages, and the total number of times each message was issued.

#### *Flexibility*

VIDEO/370 can be tailored to fit each customer's application. The IBM 3277/3275 terminals can be used in any combination, for either entry or verification to balance the workload. Any number of terminals, assigned to either type of application, can be utilized. A verification operation does not have to follow an entry operation within a time limit.

Formats may be defined by the installation to allow input of the data in its source data forms and to allow output that meets the application program requirements. During data entry, the operator can make any number of format changes. The number of records per batch is limited only by the space available on disk. The number of fields per record and the record length are limited only by the physical limits of the display device and the size of the

computing system. Multiple application records may be built from one operator input record. Up to 10,000 batches can be stored in each of the user data files, and as many as 99 user data files can be installed, but only one is required.

VIDEO/370 utilizes the flexibility of the IBM 3277/3275 displays. Function keys can be used to enter certain operator commands to minimize keystrokes. When an editing error is detected, the error fields are intensified, and the cursor is positioned at the first error. Incorrect fields are unprotected, while all other fields are temporarily protected so that the TAB key automatically moves the cursor to the next incorrect field.

#### *Checkpoint/Restart*

VIDEO/370 will checkpoint the system at intervals specified by the customer. Thus, if the system fails, terminal operators can resume from the point at which the last checkpoint was taken.

#### *Improved Method of Data Entry*

With VIDEO/370, data entry is improved because of increased throughput and source editing. Remote displays can be located where the source data is generated to avoid the time and expense of transporting the data to a central system. VIDEO/370 formats can be defined to accommodate source data so that clerical personnel can enter data directly at the display, rather than transferring the data to a separate form to be keypunched. Greater system efficiency results from higher input rates, lower error rates, and the elimination of cards, card-to-tape or disk operations, and card handling costs.

#### **Operation**

The VIDEO/370 command system facilitates data entry and error-correction. Function keys on the display and command abbreviations speed command-entry.

To begin VIDEO/370 operations at an IBM 3277/3275 display, the operator enters the ON command with an operator ID.

The operator then chooses a mode of operation: entry, verification, correction, or scan. Each of these modes is established by entering a command with the name of the operation.

#### *Entry Mode*

For data entry, the operator issues the ENTER command. After this command is entered, instructions on the display allow the operator to enter any of the following: a name for the batch to be entered, an authorization code (if required by the installation for the batch), a data file number on which the batch data is to be stored, a sequence number to be associated with the batch, and up to four format names to be associated with the function keys.

VIDEO/370 then obtains storage for the batch and creates a unique batch number to be used for future reference to the batch. The installation determines the initial batch size; however, an overflow mechanism allows any number of records to be entered in a batch (within the limitation of available auxiliary storage).

The operator may either specify the first format to be used or allow VIDEO/370 to supply one defaulted from the batch name. When the operator is ready to enter data, this operator input record format, initialized for input data, is displayed on the screen. After the data is entered, the operator presses the ENTER key, and VIDEO/370 transfers the input data to a specified data file. The display screen is then cleared, and the same record format, reinitialized, is automatically displayed for the next record.

#### *Verification Mode*

To verify a batch of previously entered data, the operator enters the VERIFY command. Instructions on the display request entry of the batch name, the authorization code (if one was used to enter the data), and up to four format names (which may be associated with function keys), if desired. The display screen is then initialized with the first format selected by the operator. The operator can enter data for all fields, but only those fields that were defined for verification operations in the format definition are used for comparison during the verification.

When an error is detected, the operator is notified, and copies of the original data and the verification data are alternately displayed on the screen until the error is corrected. When the error is corrected, VIDEO/370 replaces the erroneous data with the correct data. This procedure eliminates the extra steps normally required when an erroneous record must be returned to a card punch and rekeyed.

#### *Correction Mode*

If the operator is unable to correctly enter a record he may mark the record for later examination. Correction mode is established with the CORRECT command to make the necessary corrections. The operator selects a previously entered batch, and the marked records are displayed one at a time. The operator may delete the records, re-mark them, or correct them.

#### *Scan Mode*

The SCAN command establishes scan mode, allowing the operator to display records from any previously entered batch and alter them using the command language. Records may be inserted, marked, revised, or deleted at any point within the batch.

#### *Other Command Functions*

In addition to the mode commands described previously, the following special function operator commands are available:

*FORMAT SELECT:* At any time during data entry, the operator may select a different format, either by entering the FORMAT SELECT command or by use of a function key. The next record will be entered under control of the new format, without interrupting the flow of data.

*MARK:* If illegible, incorrect, or incomplete source data records are encountered during data entry, the operator may enter these records and mark them for later correction by issuing the MARK command. Marked records can then be modified or deleted later, in correction mode, which automatically pages to marked records.

*AUTO DUP CHANGE:* This command, or the appropriate function key, allows the operator to make changes in a field that has been specified for automatic duplication.

*SAVE/RESTORE:* These two commands are used when entry or verification operations must be interrupted. The SAVE command automatically stores the current data and all relevant batch status information needed to resume work on the batch at a later time. The RESTORE command, used in conjunction with ENTER or VERIFY to establish mode, allows resumption of the interrupted operation. It formats the display screen with the last operator input record that was successfully entered or verified and displays with it the batch name, the format name, and the record number. After this information is displayed for review, VIDEO/370 formats the display screen, ready for the next operator input record.

*INSERT/DELETE:* These two commands enable the operator to insert or delete records at any point in a batch. INSERT instructs VIDEO/370 to insert the currently displayed record, which the operator just entered, in the position after the previously displayed record in the batch. INSERT may be used to enter a record that was omitted or to add new records. DELETE removes the displayed record from the batch.

*CANCEL:* The CANCEL command causes the data entered in the current mode to be lost. In entry mode, all data is lost. In verification mode, the batch status reverts to that of an unverified batch.

*UPDATE:* The update facility enables the operator to modify previously entered records. For example, if the operator wishes to review a record while entering data, he may page back to it and then update it, if necessary.

**PAGEF/PAGEB:** These commands allow the operator to move forward or backward by a single record or by several records within a batch. For example, an operator who is viewing the first record of a batch and wants to view the fourth may enter PAGEF,03 to page forward three records. Function keys may be used for rapid single-record paging.

**RETURN:** The RETURN command allows the operator to return to the record that was displayed when the first paging request was issued.

**ACCEPT:** This command is used for error correction during the verification procedure. When the correct record is displayed, the operator enters the ACCEPT command, and that record is entered in the batch.

**RETRY:** This command causes all data in the input fields on the display to be erased. The format remains, and the operator can enter a new record.

**END:** This command causes the current mode of operation to be ended. The terminal is then available for the next operation.

**TERMINATE:** This command begins the VIDEO/370 timed-shutdown procedure. The operator who issues the command, with the correct installation-defined password, must sign off. All other displays operating under VIDEO/370 receive a message requesting that they sign off. After an interval (specified by the installation), the outstanding operations of any terminals that do not respond are saved.

**OFF:** The operator completes a mode of operation with the END, SAVE, or CANCEL command. To end all VIDEO/370 operations at the IBM 3277/3275 display, the operator enters the OFF command.

The VIDEO/370 operator has four additional commands that provide special assistance:

**FORMAT DISPLAY:** This command allows the operator to view any format that has been defined for the VIDEO/370 system. The format is displayed as a representation of its characteristics: field types, length, positions, and editing features (such as balance fields or Modulus 10 fields).

**STATUS:** Upon receipt of this command, VIDEO/370 displays all the information about the designated batch: the name, the number of records entered or verified, the number of suspended records, the names of predefined formats, the values of balance fields, the mode of operation, and the current record number.

**HELP:** This command may be entered by the operator in response to an operator message that is issued by VIDEO/370. It displays the message ID associated with the displayed message so that the operator can refer to documentation about the message.

**ROUTE:** This command allows the operator to communicate with the system operator's console. One line (64

characters) is written to the operator's console each time this command is issued. ROUTE can be issued without interrupting VIDEO/370 operations.

## Environment

### Software

VIDEO/370 executes under the Operating System or Disk Operating System, utilizing both local and remote IBM 3277/3275 display units in a BTAM environment. VIDEO/370 is started by job control language (JCL) statements. There are three VIDEO/370 support programs, which are offline and initiated by standard JCL for background processing:

- Format Definition Program, for which input cards are defined by the installation to describe each format that will be used for entry of data. Formats are stored in a format file on disk, for reuse and quick access.
- Extract Program, which moves data from the VIDEO/370 file to an application data set. This program may be run at the same time as online VIDEO/370. It supports fixed, variable, blocked, or unblocked output record formats for the customer's sequential output data set. One or more batches may be combined to produce output data. Data is converted to the record format required by the application program. During extraction, sequence numbers can be added to the records, and records can be arranged in any desired output format, including several application records for each operator input record. The extract program provides for an exit to a customer program associated with the format. If used, the customer program is entered before each record is written into the application file.
- Statistical Report Program, which compiles information during any specified work period to provide comprehensive statistics on operator performance at all the IBM 3277/3275 displays. These statistics enable the installation to evaluate its format usage, operator performance, and system efficiency and to identify operational problems. The statistics provided by this program can be printed in five different types of statistical reports.

### Hardware

VIDEO/370 can be used under OS with System/360 Model 40, System/370 Model 135, or larger processors and under DOS with System/360 Model 30, System/370 Model 135, or larger processors. VIDEO/370 can be used with the IBM 3277/3275 Model 1 or Model 2 display devices, with either typewriter or data entry keyboards.

### Storage Requirements

To operate VIDEO/370 under OS requires a minimum machine size of 128K bytes in an MFT system and 256K bytes in an MVT system. DOS requires a minimum of 64K bytes. For planning purposes, the approximate storage figures given in Table 5-3 may be used.

VIDEO/370 allows the customer to select only those options required for his installation, so, in many cases, the VIDEO/370 storage required for a particular customer may fall between the minimum and all-options figures. The main storage required for each terminal is keyed to customer requirements (the figures given assume a typical customer environment), based on the options selected by the customer and the nature of the input. VIDEO/370 allows the sharing of buffers between terminals, so the cost for each terminal for a given installation may be less than stated in Table 5-3. For example, an additional terminal could be added to VIDEO/370 for 620 additional bytes. If the BTAM On-Line Test program is included, extra storage is required.

VIDEO/370 uses the IBM 2311, 2314, 2319, or 3330 disk drive for secondary storage in DOS and any direct-access device supported by BSAM and BDAM in OS for its programs and data entered by the operators. The secondary storage necessary for VIDEO/370 programs depends on the options chosen and the values chosen for the installation variables. A typical 10-terminal system with no options uses no more than 100K bytes of secondary storage for programs. Additional secondary storage required depends on:

- The number of operators.
- The frequency of data extraction.

- The amount of data and size of data records in the batch.
- The number and size of formats.
- The statistics file (optional).

Additional primary and secondary storage depends on the number and size of the customer's exit programs.

### Installation Considerations

The IBM 3277/3275 display terminals used for VIDEO/370 are part of a teleprocessing network controlled by VIDEO/370 using BTAM.

VIDEO/370 provides two methods by which the installation may tailor its system. The first is by selecting any combination of optional features, such as commands or editing options. The second is by defining specific terminal configurations, data set allocation, buffer size, record size, batch size, and frequency of checkpoints.

The VIDEO/370 installation material is distributed on tape with the JCL (except where customer information is required) to perform the installation. A set of macro instructions designed to assemble certain VIDEO/370 options and control information is included in the material. The installation chooses the optional features it wants by selecting the proper operands for these macro instructions. A basic VIDEO/370 system includes six operator commands: ON, OFF, ENTER, FORMAT SELECT, AD (auto dup change), and END. The installation must assemble and link-edit the modules with the preassembled modules in the installation package.

A pre-format program, which is included in the VIDEO/370 package, pre-formats all the VIDEO/370 data

Table 5-3. Storage Estimates for VIDEO/370

	Typical Storage Size for Minimum VIDEO/370 System				Typical Storage Size for VIDEO/370 with All Described Options			
	Program Storage	Each Terminal	Each Control Unit	Each Line	Program Storage	Each Terminal	Each Control Unit	Each Line
OS local	38010	782	510	---	60689	875	510	---
OS remote	46558	763	25	350	69285	860	25	350
OS local & remote	50195	**	**	**	72922	**	**	88
DOS local	40721	775	340	---	63493	850	340	---
DOS remote	49631	775	25	275*	72673	850	25	275*
DOS local & remote	54353	**	**	**	77395	**	**	**

\*320 for first line to be defined.

\*\*This figure should be calculated on the basis of local or remote.

files and batch entry files. It must be run at the time of installation, before the online VIDEO/370 program is started.

Sample programs and input are also included, along with a sample format, a sample customer's exit, and sample input cards for the extract program. The material is designed to help the installation check the VIDEO/370 system and provide a guide for further design.

#### *Access Method Requirements*

VIDEO/370 requires the use of BDAM, BSAM (DAM and SAM in DOS), and BTAM.

#### **DATA/360**

DATA/360 is a program product that allows OS and DOS users to enter and verify data from local IBM 3277 Model 1 display stations in 2260 mode. Data is entered in fields on the screen, and correct data is sent directly to a disk-storage device. Card-handling is eliminated. Any errors in entry and verification are displayed to the operator for correction. Entered data can be extracted from disk (by a utility program) for use by application programs.

#### **Features**

DATA/360 performs most of the functions of the IBM 29 Card Punch and the IBM 59 Card Verifier. These functions include manual and automatic duplication, manual and automatic skip, left- and right-padding with zeros or blanks, verification of selected fields, and automatic duplication override. Any two numeric fields may be used for balancing. If editing errors (e.g., numeric data in an alphabetic field) occur during either entry or verification, the keyboard is locked. The record is displayed with X's over the incorrect fields, and the record can be corrected or entirely rekeyed.

Up to 117 characters may be entered for each record. A record format may contain as many as 24 fields in OS, or 16 fields in DOS, with editing specifications for each field. A collection of related records is called a batch; a document consists of up to 200 related batches. The records of each document can be edited under as many as seven formats, or three formats in DOS, each with its own unique editing characteristics, plus an unedited format. The number of documents is limited only by the amount of available disk-storage space. Formats may be displayed at any time to show field names, length, and editing specifications.

To each field entered under a format a set of editing specifications is applied during editing. A signed numeric field can be specified for balancing, verification, or automatic duplication. A field may be of fixed or variable length. A variable-length field may be justified to the left or right, with zero or blank padding; balance fields may only be padded with zeros. In addition, data can be transferred

after editing to a user-written application program for custom processing.

The DATA/360 checkpoint/restart facility allows an operator to resume an interrupted batch with a minimum of rekeying.

#### **Command Functions**

DATA/360 commands allow extensive operator control and flexibility.

The primary commands request entry or exit from a mode of operation and allow the operator to perform the following functions:

- Sign on with two initials as identification.
- Request a batch assignment for data entry.
- Ask to verify a particular batch.
- Reverify a previously verified record.
- Cancel the batch currently in progress.
- Save the current batch on the master file to allow later resumption of processing.
- Restart a saved batch.
- Page through a batch during or after entry or verification, to display individual records.
- Display document formats.
- Return to the status that existed before the paging or displaying procedure was initiated.
- Display the status of the operator's display station, including the current document name, the assigned batch number, the operator's identification, the maximum number of records that may be entered, the current number of records entered, the format being used, and the current mode of operation.
- End the current batch.
- Terminate DATA/360.

The secondary DATA/360 commands extend the functions of the primary commands. In response to an editing error, the operator may rekey an entire record or may correct part of the record. One secondary command displays the next six fields of a displayed format. During paging, secondary commands allow the operator to page forward or backward, by one record or (in OS) by a specified number of records. The operator can also insert or delete records while paging. During verification, the operator can use secondary commands to accept the original record or the verification record, to delete the original record, or to rekey the verification record.

Entry of a series of special characters allows the operator to change data in automatic duplication fields or to select a different format.



## Environment

### Software

DATA/360 operates under either the Operating System (MFT or MVT) or the Disk Operating System. The program is written in Assembler Language and incorporates ISAM, SAM, and BTAM for DOS. OS incorporates BDAM, GAM, and QSAM. A sort/merge program is required for the operator and production statistics utility program.

### Utility Programs

DATA/360 has five support programs that are executed offline:

- File load: specifies editing formats and batch sizes, to create and define new files.
- Extract: moves data from the master file to a sequential output file on cards, tape, disk, or at the printer; generates a report of the current status of batches in the master file. Extract allows fields to be arranged in a different sequence from that entered and may be run while data is being entered or verified.
- File transfer: copies active data into a newly loaded master file from a previously active file.
- Analyze: shows the status and content of each batch on the master file.
- Operator and production statistics: provides daily or monthly summaries of operator performance, production, documents, production rates, editing and verification errors, error codes, log details, and system activity.

### Hardware

DATA/360 can be used on any System/370; on a System/360 Model 40G, or larger, processor for OS; or on a System/360 Model 30F, or larger, processor for DOS. Up to four control units and a maximum of 128 display stations can be supported.

Because the IBM 3277 Model 1 display station operates in 2260 mode, function keys are not supported, fields may not be protected, and dual intensity is not supported.

Records are entered online to IBM 2311, 2314, 2319, or 3330 direct-access storage devices.

### Storage Requirements

DATA/360 under OS requires approximately 36K (including access method modules) for the online program and 1300 bytes for each display station. Each utility program requires approximately 26K of storage.

DATA/360 under DOS requires approximately 28K (including access method modules) for the online program

and 714 bytes for each display station, assuming a configuration of 20 display stations and two control units. Each utility program requires approximately 22K of storage.

## INFORMATION MANAGEMENT SYSTEM (IMS)

The IMS Version 2 is a program product that uses OS/BTAM to allow IMS applications to operate on the IBM 3270 Information Display System. The 3270 is supported for local and remote applications. Remote display stations require non-switched lines.

For Version 2, applications that run on the 2260 require no change if the input message clearly identifies the format of the next output message. Otherwise a function call to IMS/360 must be inserted in the application program to provide the necessary formatting information before the message is transmitted to the display station.

The format language utility allows the installation to define its message formats and their associated screen image formats. In addition, the format language allows transmission of a message between a logical terminal and an application program without concern for device characteristics.

Storage estimate information is available in *IMS/360 General Information Manual*, GH20-0765.

## CUSTOMER INFORMATION CONTROL SYSTEM (CICS)

The CICS, including CICS/OS Standard Version 2, CICS/DOS Standard, and CICS/DOS Entry, uses the 3270 display station in both local and remote environments. CICS provides an interface between the operating system, access methods, and application programs, to allow display station interaction with a data base.

Version 2 includes time management facilities, support for binary synchronous dial-up, PL/I support for CICS/DOS systems, and expanded data base control items (such as file browsing and dynamic file open or close).

## INTERACTIVE QUERY FACILITY (IQF)

The IQF under IMS/360 Version 2 is a program product designed to provide spontaneous online information. The simple IQF language is easily learned and allows non-programmers to request information from the IMS/360 data bases. The language can be customized with synonyms and null words to suit particular needs.

Queries are easily prepared, and the online response allows quick followup in response to previous answers without leaving the display station.

## TIME SHARING OPTION (TSO)

The TSO of the Operating System can use the IBM 3275 or 3277 display station in both local and remote configurations. TSO application programs may use optional features of the display station as follows:

- The TSO command system uses typewriter mode support for the 3270. The external characteristics of this support are similar to those of TSO/TCAM 2260/2265 support, as described in *TSO Terminals Manual*, GC28-6762.
- The selector pen, program function keys, operator identification card reader, and screen format flexibility

can be supported in user-written TSO command processors and TSO application programs using the TGET or TPUT ASIS terminal macro instructions. The 3270 printers are not supported.

- Screen image intensification is used to differentiate output generated by the system (brighter intensity) from user input (normal intensity). Information entered as a password is not displayed.

The TSO message control program requires approximately 1.5K extra bytes to support the 3270 display system. The TSO message handler requires additions to process 3270 data and control blocks.

### INTRODUCTION

As previous chapters of this publication have indicated, the 3270 display system provides more functional capabilities and has greater flexibility than the 2260/2848 and 2265/2845 display systems. Therefore, many advantages can be realized by replacing 2260 or 2265 display stations with 3270 display stations. Among the advantages are improvements in:

- Transmission efficiency - because of higher local and remote transmission speeds and data compaction features.
- Operator efficiency - because of cursor controls and editing features.
- Simplicity of operation - because of formatting features.

Advantages such as the many possible configurations, the optional features, and the other added functional capabilities also contribute to the superiority of the 3270 display system.

This chapter is based on the assumption that, for expediency, some customers will at first want to use the 3270 display station in the same way as the 2260 display station is used in existing applications. These customers will enjoy the above-mentioned advantages of the 3270 display system, but the impact on their current application programs will be minimal. They can then take advantage of the added functional capabilities and flexibility of the 3270 display system at their own convenience. This chapter is intended primarily for customers who want to replace 2260 or 2265 display stations with 3270 display stations as quickly as possible and who choose not to take immediate advantage of all the added capabilities of the 3270 display system. For such customers, screen formats and display operator procedures for the 3270 display station should remain as much like existing formats and procedures for the 2260 or 2265 display station as possible.

Customers who require more functional capabilities than the 2260/2848 or 2265/2845 display system possesses should consider redesigning and rewriting for the 3270 display system parts or all of their existing application programs. To help them redesign and rewrite, manuals that describe the levels of programming support for the added capabilities of the 3270 display system will be available. To use the full potential of the 3270 display system, these customers are encouraged to complete this step as quickly as possible. All new applications should be developed with the features of the 3270 display system in mind.

### BTAM Data Stream Conversion Macro

A BTAM macro instruction is available to provide basic translation of the output data stream of 2260 processing routines for the 3270 and to reformat the incoming 3270 data stream so that it can be used by the 2260 processing routines.

### Assumptions

For a typical installation, the following assumptions can be made about converting from a 2260/2848 display system to a 3270 display system:

- As little reprogramming as possible is to be done. Therefore, changes should be confined to as few routines as possible. The BTAM conversion macro instruction will be used.
- The conversion process will occur in steps. Therefore, during the conversion period, 2260 display stations and 3270 display stations will operate simultaneously for most applications. Since simultaneous operation may degrade performance, conversion to 3270 display stations should be completed quickly.
- It may or may not be necessary to change from one access method to another (GAM to BTAM, for example). If the access method must be changed, access method planning guides will be available.
- It should not be necessary to change from one operating system to another (DOS to OS, for example). (If a change is necessary, operating system planning guides will be available.)

### Steps in Conversion

If a change of access method is required, it should be done first. During this step, the 2260 display stations and the application program should, for the most part, remain unchanged.

If a change of access method is not required, the first step should be to replace the 2260/2848 display system with a 3270 display system and to use the 3270 display stations like 2260 display stations; that is, in a simple, unformatted, typewriter-like mode of operation. After this step is complete, uses and requirements for functional capabilities not available to the application program with the 2260 display station (but now available with the 3270 display station) will probably become apparent. The next step is to reprogram the applications, as time permits, to

take advantage of the additional capabilities of the 3270 display system.

### Application Program Structure and Modification

The typical structure of an application program consists of terminal control routines and processing routines. The terminal control routines, which are a distinct part of the application program, are normally responsible for all device communication or terminal I/O operations. In many cases, all display-device dependencies are handled within the terminal control part, so that these dependencies are transparent to the processing routines. Therefore, in converting the application program, it is the terminal control routines that should be examined for modifications, including use of the BTAM data stream conversion macro instruction to minimize or eliminate changes to the 2260 processing routines. In many cases, modifications to the terminal control routines will cause differences in screen format and input procedures that will be apparent to the display operator.

### Summary

The programming changes necessary to replace 2260/2848 display systems with 3270 display systems and to use 3270 display stations like 2260 display stations are usually confined to a few parts of the application program. Redesign of application program logic should be minimal. Slight changes in the orientation of display operators will be required. Customers using program products for their applications should be the least affected.

Customers should approach replacement of the 2260/2848 display system with the 3270 display system in a logical, step-by-step procedure. The remainder of this chapter is intended to help do so.

### CONFIGURATION CONSIDERATIONS

Table 6-1 is a general summary of configurations of the 3270 display system; Table 6-2 is a summary for the 2260/2848 and 2265/2845 display systems. Table 6-3 summarizes comparable 2260/2848, 2265/2848, and 3270 display system configurations.

There are two different screen sizes of 3270 display stations. The 3277 and 3275 display stations, model 2, have a screen that displays 24 80-character lines. The 3277 and 3275 display stations, model 1, have a screen that displays 12 40-character lines. The 2260 model 1 and 2260 model 2 display stations have the same screen size; screen capacity depends upon the control unit to which these display stations are attached. The 2260 model 1 displays 12 80-character lines when attached to a 2848 model 3. The 2260 model 2 displays 12 40-character lines when attached to a 2848 model 2 or 22, and it displays 6 40-character lines when attached to a 2848 model 1 or 21.

Table 6-1. 3270 Display System Configurations

Control Unit	Display Station or Printer	Number of Devices on Control Unit	Capacity of Display Station (in Characters)
3272 Model 1	3277 Model 1	1-32	480
	3284 Model 1	0-31	-
3272 Model 2	3277 Model 2	1-32	1920
	3286 Model 2	0-31	-
3271 Model 1	3277 Model 1	1-32	480
	3284 Model 1	0-31	-
3271 Model 2	3277 Model 2	1-32	1920
	3286 Model 2	0-31	-
-	3275 Model 1	1	480
	3284 Model 3	0-1	-
-	3275 Model 2	1	1920
	3284 Model 3	0-1	-

Table 6-2. 2260/2848 and 2265/2845 Display System Configurations

Control Unit	Display Station or Printer	Number of Devices on Control Unit	Capacity of Display Station (in Characters)
2848 Model 1	2260 Model 2	1-24	240
	1053 Model 4	0-1	-
2848 Model 2	2260 Model 2	1-16	480
	1053 Model 4	0-1	-
2848 Model 3	2260 Model 1	1-8	960
	1053 Model 4	0-1	-
2848 Model 21	2260 Model 2	1-24	240
	1053 Model 4	0-1	-
2848 Model 22	2260 Model 2	1-16	480
	1053 Model 4	0-1	-
2845	2265 Model 1	1	960
	1053 Model 4	0-1	-

Table 6-3. Comparable 2260/2848, 2265/2845, and 3270 Display System Configurations

Current 2848 or 2845 Control Unit	Current 2260 or 2265 Display Station or 1053 Printer	Comparable 3270 Display Station or Printer	Comparable 3270 Control Units
2848 Model 1	2260 Model 2	3277 Model 1	3272 Model 1
	1053 Model 4	3284 Model 1	3271 Model 1
2848 Model 2	2260 Model 2	3277 Model 1	3272 Model 1
	1053 Model 4	3284 Model 1	3271 Model 1
2848 Model 3	2260 Model 1	3277 Model 2	3272 Model 2
	1053 Model 4	3286 Model 2	3271 Model 2
2848 Model 21	2260 Model 2	3277 Model 1	3272 Model 1
	1053 Model 4	3284 Model 1	3271 Model 1
2848 Model 22	2260 Model 2	3277 Model 1	3272 Model 1
	1053 Model 4	3284 Model 1	3271 Model 1
2845	2265 Model 1	3275 Model 2 3275 Model 1	—
	1053 Model 4	3284 Model 3	

For local and remote groups and for remote standalone, there are 3270 display stations. The 3277 display stations, models 1 and 2, are attached to the 3272 control units, models 1 and 2, to form local groups. They are attached to the 3271 control units, models 1 and 2, to form remote groups. The 3275 model 1 and model 2 are remote standalone control unit/display stations. There are 2260 display stations for local groups and remote groups. The 2260 model 1 is attached to the 2848 model 3 to form local or remote groups. The 2260 model 2 is attached to the 2848 model 1, 2, 21, or 22 to form local or remote groups.

For a more detailed description of 3270 display system configuration considerations, see Chapter 2. For more detailed 2260/2848 or 2265/2845 display system configuration considerations, see *IBM System/360 Component Description: IBM 2260 Display Station - IBM 2848 Display Control, GA27-2700*, or *IBM System/360 Component Description: 2265 Display Station Model 1 - 2845 Display Control, GA27-2731*.

## 3270 AND 2260/2848 DISPLAY SYSTEM FUNCTIONAL DIFFERENCES

Some of the major functional differences between the 3270 and the 2260/2848 display systems are noted below. For details on these and other functional differences, compare information in the relevant chapters of the manuals mentioned above.

### Line Control

Using BTAM support under DOS or OS, differences between the binary synchronous communication line control used for a 3270 display station and the start/stop line control used for a 2260 display station will be apparent to the application program.

### Data Stream

Using BTAM support under DOS or OS, differences between a data stream for a 3270 display station and a data stream for a 2260 display station will be apparent to the application program. The 3270 display system has additional buffer and display control information embedded in the data stream.

### Commands and Control Characters

Through various control characters and orders in the output data stream, the 3270 display system Write command can be used to perform the same functions as the 2260 Write DS Buffer, Write DS Line Address, and Write 1053 Buffer Commands. The 3270 Write command can also be used to perform the same functions as the 2260 Erase DS Buffer command. The 3270 Read Buffer command can be used to perform the same functions as the 2260 Read Full DS Buffer command.

The start manual input and new line control characters are unique to the 2260 display station. Because these control characters are essential to the operation of the commands, the 2260 Read DS Manual Input and Short Read Manual Input commands have no directly equivalent 3270 display system commands.

## DEVICE CONVERSION

Assuming that access method conversion was unnecessary or has been made, there are several ways of introducing 3270 display system devices into the system without completely rewriting application programs. A simple, 2260-like mode of operating the 3270 display station is suggested below. The changes described are merely an example of the impact of conversion on an existing 2260 application program. Each application program must be

examined to determine the exact changes that apply. After new line control is established, some editing is needed to convert input and output data streams. The changes suggested below should affect only the I/O module or modules of the application program and will have little impact on the display operator.

#### **Output Considerations**

On output, the message text is scanned, and the following substitutions and additions are performed:

- The start manual input (Start MI) character is replaced by a field separator for an unprotected field.
- A cursor positioning (IC) code is inserted in the first position following the field separator that replaces the Start MI character.
- New line (NL) characters are replaced by start field (SF) sequences placed in the last character positions of the lines for unprotected fields (if the NL character may be entered as data). The first text character following the NL character should be forced to the next line in all cases by using a set buffer address (SBA) sequence.

#### **Input Considerations**

On input, the message text is scanned, and the following substitutions and deletions are performed:

- All device control through the first set buffer address (SBA) sequence is deleted, and the message is compacted.
- Each subsequent SBA sequence is deleted, an NL character is substituted (if the NL character may be entered as data), and the message is compacted.

#### **Message Editing**

On both output and input, message editing must be done within the application program. One technique for finding the locations that require editing is the use of the Translate-and-Test instruction. The required editing routine should be straightforward if the application program has used Write DS Line Address commands. If the program has used Write DS Buffer commands (so that current cursor position may not be known), but NL characters have not been used, the editing routine remains straightforward. Output conversion is also simple if the data stream is constructed of defined constants with variable areas referenced by symbols; if this is not the case, output conversion may be more complex.

#### **Display Operator Considerations**

In conjunction with the changes indicated above, the display operator performs the following operations when entering data:

- Enters data at the cursor location.

- Presses the ERASE EOF key to clear the rest of the field to nulls.
- Presses the ENTER key.

The operator's actions remain essentially unchanged except for the additional requirement of pressing the ERASE EOF key. For most modes of operation, this presents no problem. Even though the "fill-in-the blanks" approach is potentially more difficult, the ERASE EOF key can be used for each field, thus simplifying the total operation. Caution should be exercised if the entire screen has been defined as one field.

#### **Display Operator Reorientation**

When using the 3270 display station, the display operator no longer sees the start manual input, new line, and end of message symbols that appear on the 2260 display station.

For a 2260 display station and a 2260 application program, the display operator enters data in a field (if necessary) and presses the NEW LINE key to move to the next field. After this data has been entered, the operator presses the ENTER key. For a 3270 display station and a modified 2260 application program with a data-stream editing routine, the operator enters data in a field (by overwriting either data or blanks) and presses the ERASE EOF and TAB keys to place the cursor in the first character position of the next unprotected field. If no data is required for a field, the operator enters a "no data" character that is recognized by the editing routine.

Unlike the 2260 display station, for which the new line character serves to end a field for input, the 3270 display station sends the total field (including spaces, but excluding nulls). To allow the message processing routines to scan input correctly and to reduce the logic required in the editing routine, the input data length should always equal the length of the data entered. The operator presses the ERASE EOF key after entering data in a field to guarantee that no other data (such as spaces used to fill out the fields, instead of nulls) is transmitted.

#### **SCREEN FORMAT EXAMPLE**

With the device-conversion considerations discussed above in mind, a simple example of the step-by-step transition sequence is described below. To illustrate this sequence from the programmer's and the display operator's points of view, both the screen formats and the input and output data streams are shown.

The screen format example chosen is representative of several different operating modes used in transaction processing, including conversation, data selection, free form, sequence key, and code link.

### 2260 Display Station - Step 1

When the display is initially written (by means of the Write DS Line Address command), it appears as shown in Figure 6-1. The data stream for this display format is:

2260 Output (command in selection sequence remote)

[STX] 

Lineno	TEXT	Start MI
--------	------	----------

 [ETX]

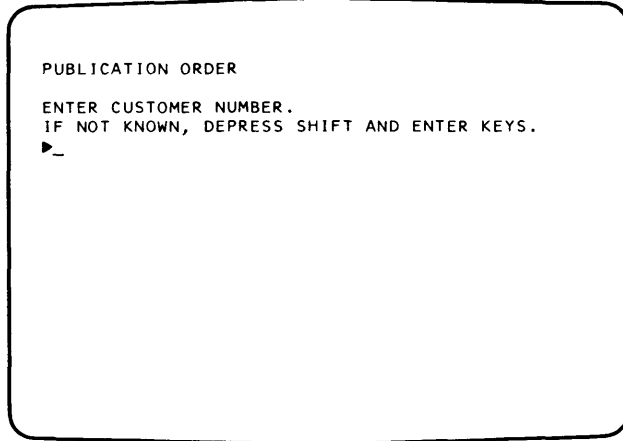

Figure 6-1. 2260 (Step 1)

### 2260 Display Station - Step 2

After the display operator types a response, the display appears as shown in Figure 6-2. The data stream is:

2260 Input

[STX DVC] 

1 2 3 4 5 - 6 7
-----------------

 [ETX]

Note that the new line character is not used in this example. The required editing is somewhat simplified, since the new line character does not have to be compensated for.

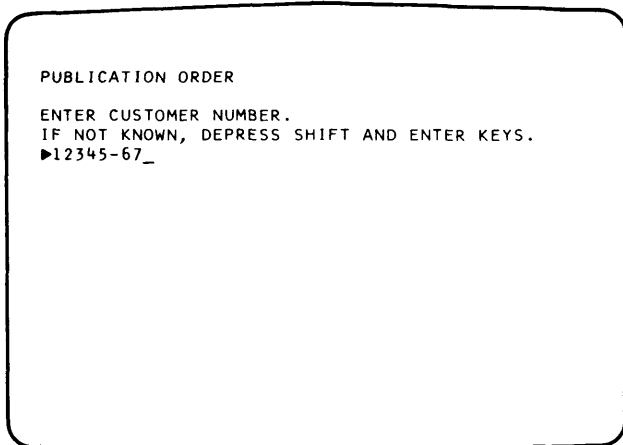

Figure 6-2. 2260 (Step 2)

### 3277 Display Station - Step 1

After the 2260 output data stream has been edited for the 3277 display station, and the display is initially written, it appears as shown in Figure 6-3. The data stream for this display format is:

3277 Output (command specified by ESC CMD sequence remote)

[STX ESC CMD] 

Control Code	SBA seq	SF seq	TEXT
--------------	---------	--------	------

SF seq	IC
--------	----

 [ETX]

Note both the change in text written to the display station and the deletion of the Start MI symbol which has been replaced by a "blank" character. The required changes have been made by the editing routine in the application program. The operator needs to press only the ENTER key (rather than the SHIFT and ENTER keys).

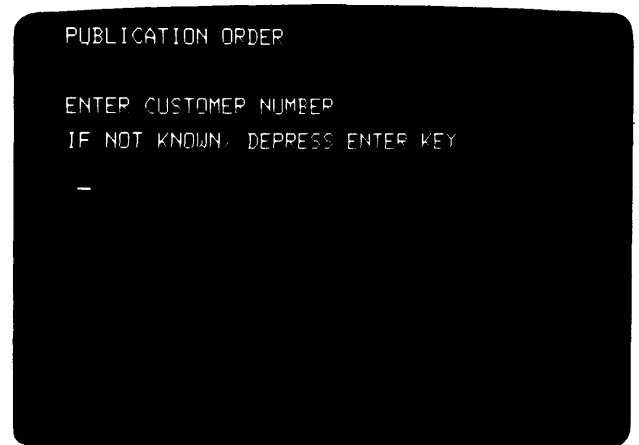

Figure 6-3. 3277 (Step 1)

### 3277 Display Station - Step 2

After the display operator types in the data requested, the display appears as shown in Figure 6-4.

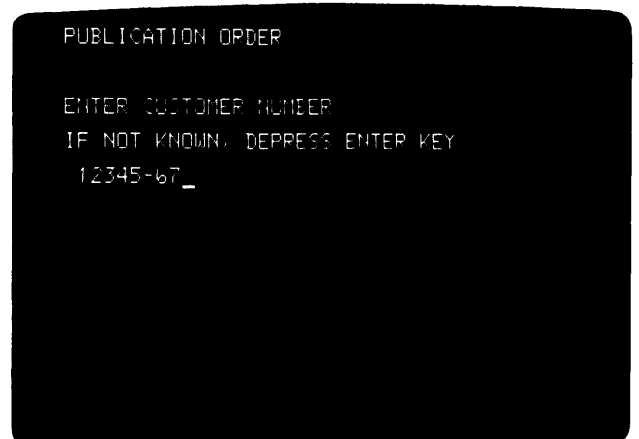
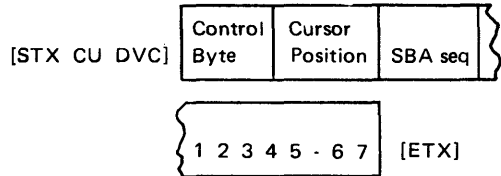

Figure 6-4. 3277 (Step 2)

### 3277 Display Station - Step 3

After the display operator presses the ERASE EOF and ENTER keys, the display appears as shown in Figure 6-5. The data stream is:

3277 Input



Note that, as compared with the 2260 data streams, additional characters are required in the 3277 data streams preceding and following the text on output and preceding the text on input. Space for the additional characters must be provided by the editing routine in the application program, possibly through expanded input/output work or buffer areas.

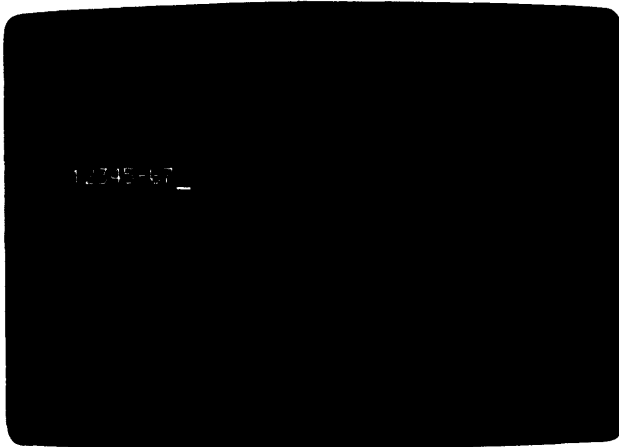

Figure 6-5. 3277 (Step 3)

### ESTIMATING THE CONVERSION EFFORT

There is no general “cookbook” for conversion. Every installation has its own special conversion considerations, depending on its particular applications. To gauge the magnitude of a particular conversion effort, these considerations, together with any factors unique to the installation, must be thoroughly understood.

#### Conversion Segmentation

Typically, key segments of the conversion process can be distinguished, and estimates of the effort involved in each segment can be developed. For example, converting an application program can be segmented as follows:

1. Operating system conversion (if applicable).
2. Access method conversion (if applicable).
3. Minimal modification of application program (to use the 3270 display station in a “2260-like” mode of operation).
4. Maximum modification (redesign and rewrite) of application program (to use additional functional capabilities of the 3270 display system).
5. Reorientation of display operator to new displays and new operations.

#### Conversion Aids

Planning guides, which can aid in developing estimates, will be available for the first two items listed above. For all items, in addition to documentation, other resources (such as SE services) are available. The list of items is merely intended as a general guideline for assembling the information needed to develop a conversion plan.

### CONCLUSION

After the customer has assessed the impact of conversion on his particular applications, a reasonable estimate of the total conversion effort can be assembled. Based on this estimate, the installation can determine the method and schedule for replacing its 2260/2848 display systems with 3270 display systems.



Primary emphasis has been given to the relationship of the equipment to the operator during the development of the IBM 3270 Information Display System. Factors considered include: operator comfort, glare, image legibility, keyboard design, operator efficiency, and operator training costs. This chapter discusses many of these considerations.

### DISPLAY IMAGE

All information displayed on the CRT screen must be regenerated periodically for retention of the image. This generation is accomplished automatically by the circuitry in each unit. The speed at which the display image is reproduced is called the "refresh" rate, and, if the displayed image is not refreshed often enough, it can flicker and become difficult to read. The 3270 display system has been designed to refresh the image approximately 50 times per second, creating an easy-to-read display under nominal office conditions.

All characters displayed on the CRT are formed by a pattern of small dots of light on a 7 x 9 dot matrix.

All font designs have been specifically developed for the displays on which they are to appear. Each character has been designed and tested for maximum legibility and minimum ambiguity with similar-appearing symbols. The operator will find the displayed information easily, rapidly, and accurately readable.

Figure 7-1 shows some characters formed with the 7 x 9 dot pattern. A cursor is shown under the E character.

Glare on the face of the CRT from overhead lighting has been minimized by means of the cover design and proper positioning of the CRT. Selecting this approach to control glare in lieu of an anti-glare treatment on the CRT surface prevents degradation of image clarity. Brightness and contrast of the image with the background are other areas of importance. The brightness is operator-adjustable over a range from an unilluminated screen to full character brightness. Added to this, the green CRT phosphor, in conjunction with a neutral density filter which has been incorporated in the CRT, provides excellent character color and contrast within the normal range of room illumination.

### KEYBOARDS

The keyboard is connected to the display station by a 2½-foot cable that allows the operator to place the keyboard in the most comfortable and convenient position. Selection of furniture for use with the 3270 should provide

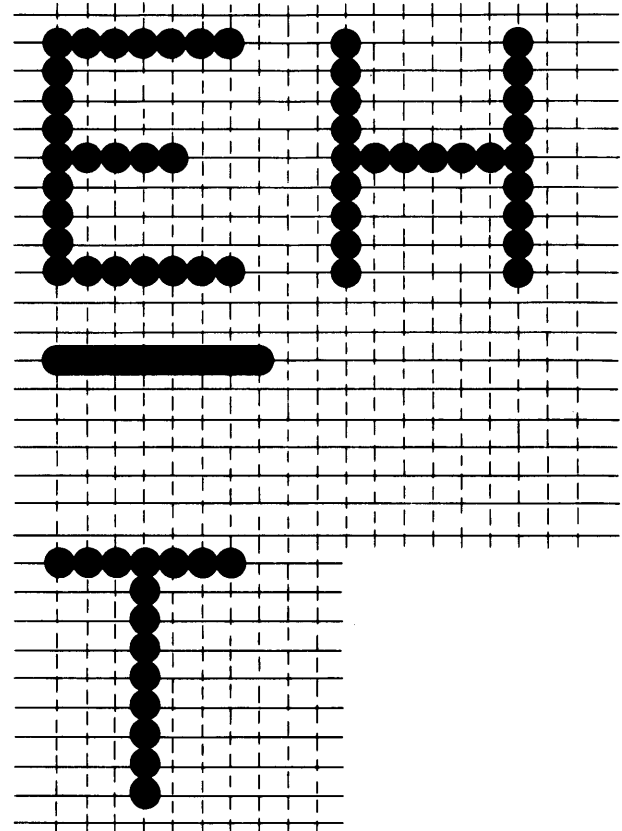

Figure 7-1. Examples of Monospace Characters Formed with 7 x 9 Dot Pattern

a supporting surface for the keyboard that is 26 inches above the floor; this will place the home row keys at the optimum operating height from the floor. A dimension of up to 29 inches may be allowed for lower keying throughput requirements. The angle of surface of the keyboard has been carefully selected to provide maximum comfort and efficiency.

### Finger Positioning

So they can be easily found by touch, a deeper than normal depression is provided on those keys that establish the home row position for all keyboards. In the case of the typewriter and operator console keyboards, the two keys selected are those for the index fingers (F and J). On the data entry keyboard, the middle three keys in the numeric row are more deeply dished (4, 5, 6). This ability to identify the proper home row keys improves throughput and reduces error rates.

## Keyboard Design

The keyboard design has been developed to provide an uncomplicated keyboard layout. This allows an operator to adapt easily and to feel comfortable during operation of the display station.

The keyboard has been divided into three key groups: data keys, special control keys, and erase keys.

The typewriter keyboards retain the basic key layout found on a common office typewriter. Special function keys, such as ENTER and cursor control keys, have been placed where they can be readily reached from the home row of keys. Little training will be required for an operator who is able to type on a typewriter.

Data entry keyboards use the same conventional key layout for alphabetic characters that is used on typewriter keyboards. However, the numeric keys and certain function keys are patterned after the IBM 29. The numeric keys are placed in the same configuration that is found on IBM keypunches, allowing one-hand operation.

Data, special cursor control, and function keys are placed so that they may be operated smoothly from the home row position during a single-hand operation. Keypunch operators will have little difficulty in rapidly adapting to this keyboard.

Operator console keyboard layouts are identical with the keyboard layout of the IBM 1052 Model 7 that is presently used with IBM System/360. Here again, the cursor control and special program alert keys have been positioned where they can be used conveniently.

## Typamatic Operation

All keyboards in the 3270 system have some typamatic keys, that is, keys that repeat their function as long as they are held down. On the typewriter and operator console keyboards, the TAB, SPACE, HYPHEN/UNDERSCORE, NEW LINE, BACKSPACE, and cursor control keys have this function. On the data entry keyboard, the TAB, SPACE, NEW LINE, SKIP, BACKSPACE, and cursor control keys are typamatic.

## Ease of Operation

All keyboards in the 3270 display system operate swiftly, quietly, and have an electrical lock. Data can be inputted from the keyboard at a rate of up to 25 characters per second. Each depression of a key generates an audible reply that signals the operator that the data has been entered into the display station buffer. The lack of an audible reply signifies that the keyboard input is inhibited. In addition, an indication on the display alerts the operator to the fact that the keyboard is electrically locked.

## OPERATOR CONTROLS

All 3270 display stations have the combination OFF-PUSH and contrast control located on the front of the unit. Pulling this control out turns the unit on; pushing in turns it off. When the control is pulled out, the stem of the switch will show red, indicating that the display station is on. Image brightness and dual brightness character contrast can be changed by the operator at any time.

The key lock feature, if installed, is another operator control. This feature provides a key that can be used to control program access to or from a display station (refer to Security Enhancements, Chapter 3); the key receptacle is located on the right side of the unit cover.

## INDICATORS

Three indicators are found on all 3277 display stations. These indicators provide the operator with a visual indication of the operational status of the entire display system and particularly that of her own unit. All indicators are located to the right on the CRT screen in a vertical row and are clearly visible. The labels that describe each indicator are located to the right of the CRT screen, parallel with the associated indicator.

3275 display stations have five additional indicators located in line with those described above. 3275 indicators are not located on the CRT screen. Their function is to provide information on the status of the remote communication facilities.

## Chapter 8. Installation Planning Data

The physical characteristics and environmental requirements of 3270 units allow a display system installation to be placed in a normal office or computer room environment with a minimum amount of special arrangements. This chapter describes, in general, the reasons why a 3270 display system is easily installed. For more detailed information, contact an IBM installation planning representative or refer to one of the following publications:

1. *IBM System/360 Installation Manual - Physical Planning*, Form GC22-6820
2. *IBM System/360 Installation Manual - Physical Planning, IBM World Trade 50-Hertz Requirements*, Form GC19-0001
3. *IBM System/370 Installation Manual - Physical Planning*, Form GC22-7004
4. *IBM System/370 Installation Manual - Physical Planning, IBM World Trade 50-Hertz Requirements*, Form GC19-0004

### PHYSICAL CHARACTERISTICS

The 3270 display system units are attractively packaged, of small size, and of light weight. Control units and printers are similar in appearance and occupy a volume of space equivalent to that of a standard two-drawer office file cabinet. Access to service these units is gained by means of a removable front cover. Service access to display stations is gained by means of removable side, top and back, and lower front covers.

Approximate unit weights vary from 120 pounds for a printer, downward to 95 pounds for a control unit, 95 to 65 pounds for various display station models, and 20 pounds for a keyboard.

### CABLES

A single coaxial cable connects each 3277 display station or 3284 and 3286 printer in the display system to its control unit. This cable is not included with the unit; up to 2000 feet of cabling can be installed. Each device attached to a control unit requires its own cable; therefore, if a control unit has 16 display stations and 8 printers in a configuration, 24 output cables leave this unit. A power control cable (EPO) and a data signal cable are used in local configurations to communicate with the system channel. These two cables vary in length; depending upon the central processing system configuration, 150 feet is the maximum length of the power cable, and 200 feet is the maximum

length of the data signal cable. Remote configurations use only one additional control unit cable, which is the connection to the communication data set.

Display stations, in addition to having a cable for connection to the control unit, have other cables that connect to their attached features; that is, selector pen, card reader, or keyboard. 3275 display stations may also accept one additional cable to attach a 3284 printer, model 3. Table 8-1 lists maximum cable lengths and indicates fixed length cables.

Table 8-1. 3270 Display System Maximum and Fixed Length Cables

From	To	Length (feet)
3271/2 Control Unit	Display station	2000
3271/2 Control Unit	Printer	2000
3272 Control Unit	Channel (power control) <sup>1</sup>	150
3272 Control Unit	Channel (data signals) <sup>1</sup>	Channel dependent
3271 Control Unit or 3275 Display Station	Data set <sup>2,3</sup> or data access arrangement <sup>4</sup>	40
3275/7 Display Station	Keyboard	2½*
3275/7 Display Station	Selector light pen	2*
3275/7 Display Station	Card reader	2½*
3275 Display Station	Printer	10*

\* - Fixed length

1 - Local configurations only

2 - Remote configurations only, employing a 3275 display station without the IBM 600/1200-bps Line Adapter feature installed, or employing a 3271 control unit.

3 - A cable is needed for each of the following feature groups:

- |  |   |  |
|--|---|--|
| <ul style="list-style-type: none"> <li>a. 3275 with external data set</li> <li>b. 3275 with the IBM 600/1200-bps Line Adapter</li> <li>c. 3275 using Dial and IBM 600/1200-bps Line Adapter with Auto Answer feature.</li> </ul> | } | <p>The 3275 operates via leased lines or with Dial feature installed via switched lines.</p> |
|--|---|--|

4 - A data access arrangement is required when using the IBM 600/1200-bps Line Adapter to connect a 3275 equipped with the Dial feature to a switched telephone network.

Customers who presently use an IBM 2260/2848 display system can convert to a 3270 display system without replacing the 2848-to-2260 coaxial signal cable. The cables used in the installed display system can easily be adapted for use on the 3270 display system.



With the growth of online data processing, the availability of a central processing system and attached devices becomes an essential factor in computer operations. The 3270 display system has been provided with many facilities to achieve a high degree of reliability, serviceability, and availability.

Decentralized packaging of critical hardware components highlights the engineering features that make the 3270 more reliable and easier to service. Earlier display systems were designed with central storage buffer and central controls packaged in the control unit. In the 3270 display system, each unit is provided with a separate buffer character generator and separate keyboard controls that are packaged in the device. Thus, the number of components in the control unit is significantly reduced, resulting in a substantial improvement in subsystem reliability. Further, decentralization results in a lower-cost control unit; this permits a customer with a critical application to configure a display system with two control units at a minimal cost increase. With two control units included in a configuration, failure of a critical component in one unit disables only a portion of the display system.

Serviceability improvements include:

- Built-in recovery and retry circuits.
- A maintenance approach based on online and offline test procedures.
- IBM FE Teleprocessing Test Center support for the IBM customer engineer.

Unit reliability is improved through the use of a more-reliable and more-densely-packed circuit technology. This improvement reduces the frequency of service calls. Additionally, 3270 control units have the capability to retry any data transfer to a device which fails. The application program is not alerted to a failure unless the retry also fails. Parity check circuits are incorporated at many points within the control units and devices.

Access method programming error-recovery procedures provide additional improvements important to the system operation to supplement the hardware provisions.

Service is also made easier by the interchangeability of similar 3270 units. This factor is particularly useful when a keyboard or selector pen problem is being investigated.

The general maintenance approach begins with providing the customer as much information as possible so that he can determine the operational status of the equipment before calling the customer engineer (CE). When the CE

arrives, the customer's description of the problem will aid in directing fault-isolation activities. In some cases the customer's awareness will allow rapid system restoration by directing the CE to the geographic location where the failure exists. The CE will replace failing sections of a unit, called field-repairable units (FRU) rather than repairing them.

Online maintenance capability is stressed as the starting point of all 3270 maintenance activity. Customers are encouraged to learn the operational status of the equipment. Online tests available for customer use are the request-for-test (RFT) facilities. RFT capability under the Basic Telecommunications Access Method (BTAM) programming support allows a limited number of test messages to be requested and run concurrently with the customer's application program. These messages generate predetermined patterns for 3270 display stations and printers. The tests are performed from a display station according to a procedure initiated by the device operator; this procedure requires depressing the TEST REQ key. Under the Telecommunications Access Method (TCAM), the requested test pattern may be sent to the display station that originated the request, to a different display station, or to a buffered printer.

Units may be reassigned to different partitions to aid problem-determination and fault-isolation. This capability is applicable to local display systems employing the Basic Telecommunications Access Method (BTAM) under the System/360 Disk Operating System (DOS) or the System/360 Operating System (OS); or it may apply to a system using the Telecommunications Access Method (TCAM) under OS. The access method and operating systems allow the failing unit to be removed from the applicable partition for corrective maintenance.

The customer can initiate an offline printer test which will exercise the mechanical parts of the printer and approximately 80 to 85 percent of the electronic logic (to demonstrate operational status).

RFT online tests are useful problem determination tools because they provide considerable information about system operation. For example, the successful reception of an online test is valuable as follows:

1. It verifies that the operating system and the BTAM program are executing in the computer.
2. It verifies continuity of the data transmission path from the requesting device to the computer and from the computer to the device being tested.

To aid customers and operating personnel in reporting equipment problems, in running RFTs, and in gaining an overall operational knowledge of the 3270, the following publications are made available: The *IBM 3270 Information Display System Problem Determination Guide*, GA27-2750, and the *Operator's Guide for IBM 3270 Information Display Systems*, GA27-2742. The Operator's Guide describes manual operation of the 3270 system display station, the operator identification card reader, the selector pen, and the printer. The functions of all keys and controls are explained. When a trouble is first noted, the operator should follow instructions given in the Operator's Guide to determine whether the problem was caused by incorrect operating procedure or by an equipment failure. The operator is instructed to check that the power cord is plugged into the power receptacle and then repeat and verify the operating procedure used when the failure occurred. The Problem Determination Guide is an aid for reporting trouble symptoms accurately and completely. Specific trouble-isolating procedures are given. The guide also contains procedures for initiating RFTs from a display station and instructions for reporting unit configuration data, (information which tells the CE the relationship of a unit to other system units).

If the customer at a remote terminal is not certain that a failure has occurred at the terminal location, he should contact the CE at the CPU location to determine whether a CE should be sent to service the terminal.

The CE's efforts to locate and repair a failing unit are usually based on the customer's description of the trouble.

Both online and offline test procedures are available to the CE, as described in the FE Troubleshooting manuals. In general, the CE begins by trying to simulate the customer's failing program, using manual offline test procedures.

In local configurations, the CE may decide to run RFTs to confirm customer-reported symptoms, or he may run on line test (OLT)\* diagnostic programs at the main computer site. There are five OLT categories: functional checks, which isolate failures to units within a system; keyboard checks, which test keyboards attached to a display station; operator identification card reader checks, to verify card reader operation; test patterns, to check for correct display station operation; and card calling routines, which specify failing circuit cards within a control unit.

In remote configurations, simulated operation is made possible at the 3271 control unit and at the 3275 display stations by using test equipment which functions without the main computer and the common carrier network. The IBM CE is further supported by a Test Specialist and Test Programs at the IBM FE Teleprocessing Test Center (TPTC). This support is provided to further minimize service time for remote 3270 display system problems. By connecting the configuration to the TPTC via common carrier lines and a data set, the CE has access to the diagnostic programs without using the customer's CPU. These programs are the regular 3270 remote OLTs that can be executed from the TPTC.

---

\*The OLT program resides in the library of the customer's operating system.

Evaluation of the performance of a 3270 display system is affected by several factors that significantly influence the results. The principal influence is the type of configuration. A display system configured for local (direct) attachment to a system channel will generally provide a response time of 1 second or less for typical transactions. The larger part of this 1-second response period is utilized for processing and file operations within the central processor. A display system configured for remote attachment (by means of communication facilities) to a system channel will generally require more than 1 second to respond to operator inquiries. The added time for a remote operation is caused by the data transmission rates of the communication facilities and is significantly influenced by the number of display stations attached to the same communication line.

Other factors that influence performance are largely dependent upon the application, for example, typical message length, message format, system channel loading, and transaction interaction time.

Because of the many possible display system configurations and the wide variety of applications, it is not practical to provide simple timing formulas, graphs, or performance data that expresses, in exact terms, the system performance capabilities. The data presented in this chapter represents reasonable approximations of 3270 display system performance for a few general applications; and it should be understood that many factors could cause variations in the results.

**BASIC CONFIGURATION DIFFERENCES**

The reason for a difference in operator response times between a locally attached and a remotely attached display system becomes apparent when the total information transfer path of each configuration is considered (Figure 10-1). Depending upon the line speed, 1200, 2400, 4800, or 7200 bps, the 100, 300, 600, or 900 character-per-second data-transfer rate, respectively, is the fundamental factor limiting response time and the number of display stations that can be supported on a single communication line.

Plotting local and remote response times with various numbers of displays in the display system produces a relationship such as that shown in Figure 10-2. The transactions evaluated in Figure 10-2 consist of a 40-character input message and an 800-character output message from the program. The average time between transactions (interval between enter operations) for this case is 30 seconds.

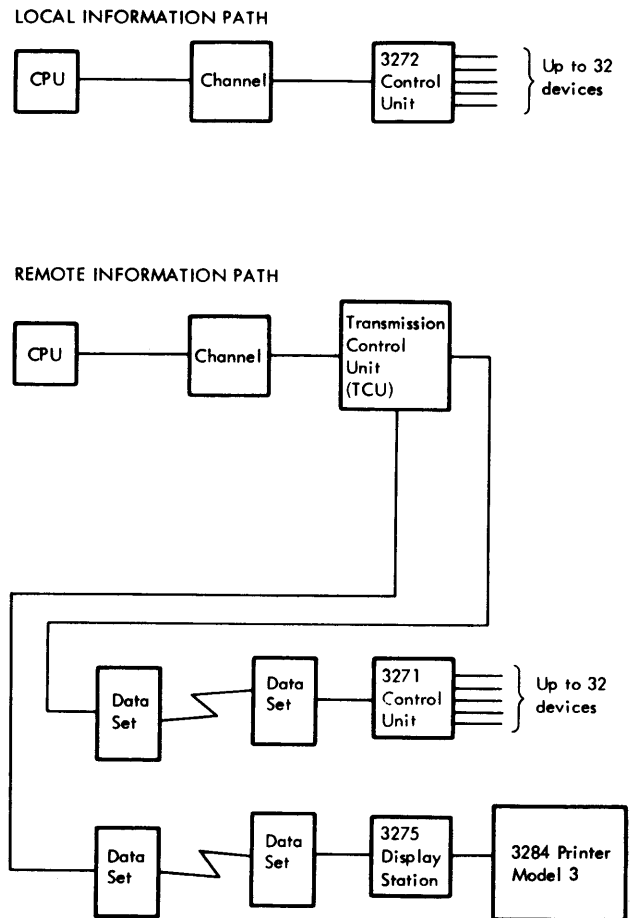

Figure 10-1. Information Path Comparison

**DISPLAY SYSTEMS ATTACHED LOCALLY**

Locally attached display systems service operator inquiries fast enough to virtually eliminate operator idle-time between the transmission and reception of messages. A local display system that is attached to a heavily loaded system channel may experience response times greater than 1 second because of heavy channel activity. To help rectify this situation, the display system is provided with the ability to prepare for an anticipated system channel instruction without being operationally connected to the system channel. The Select command (Chapter 3) initiates a device to control unit buffer transfer operation that requires up to 70 ms. Upon completion of the buffer load

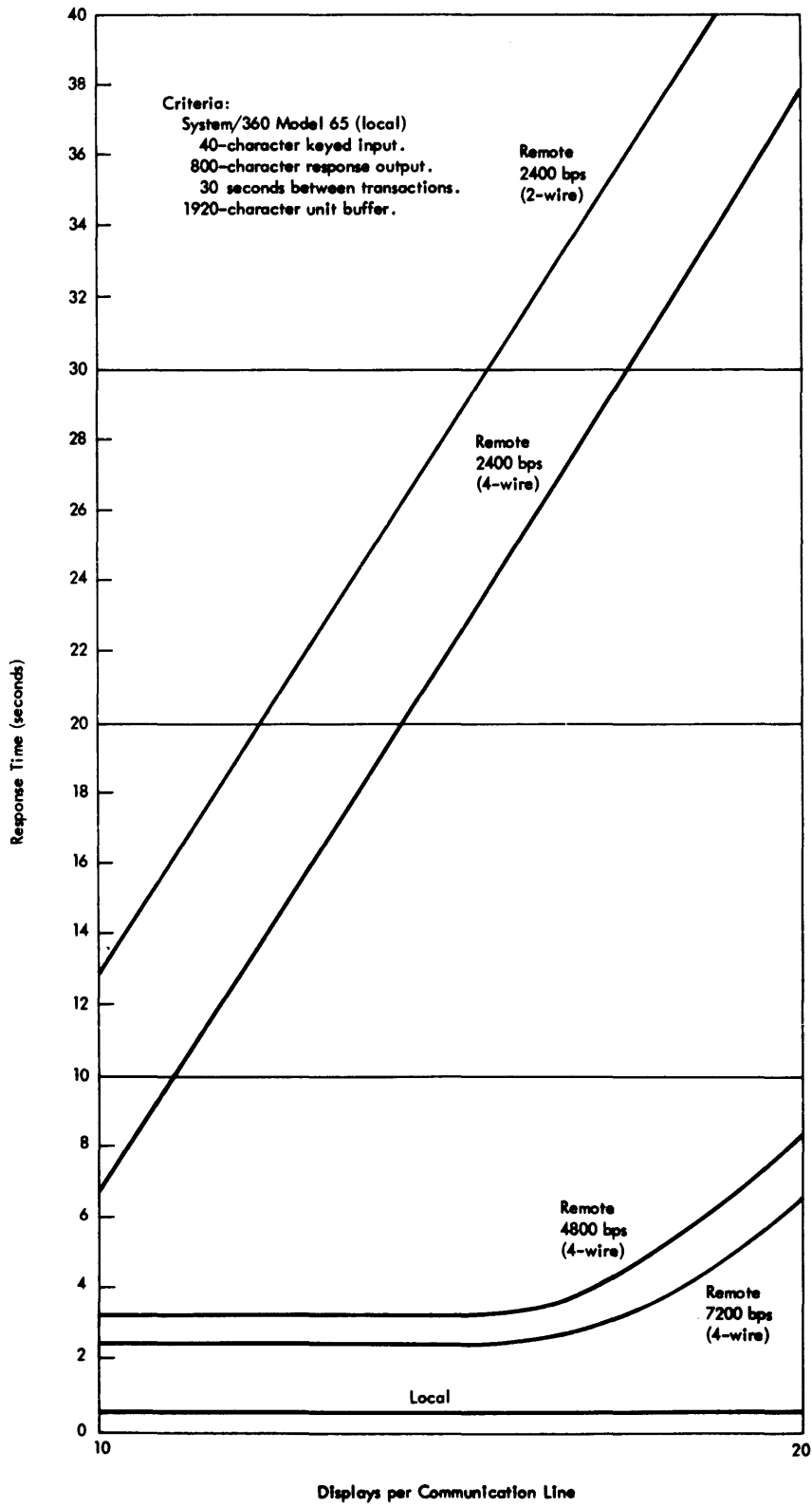

Figure 10-2. Comparison of Local and Remote Response Times



operation, the subsequent program operation is executed with data transfer rates of 14,000 to 650,000 characters per second, depending upon channel characteristics. The select operation is most advantageous when used with a block multiplexer channel.

#### **DISPLAY SYSTEMS ATTACHED REMOTELY**

The design of remote display systems must satisfy three important factors: (1) operator idle-time while waiting for a system response, (2) the workload (messages per unit time) to be processed, and (3) the cost of the communication facilities. Proper use of the built-in functional control capabilities of the 3270 display system can lead to a significant reduction in the amount of information transmitted per transaction and, consequently, can decrease the transmission load of the communication facility. While also reducing the time an operator waits for a system response, the decrease in utilization allows more displays to share a communications line and may lower the total cost of the required communications network.

The importance of careful remote display system planning to incorporate the advantages offered in the 3270 display system cannot be overemphasized. Significant reductions in communications line cost can be realized if the advantages of data compaction are fully employed. Contact your IBM representative for additional information.

A wide variety of representative applications have been analyzed with the Systems Performance and Design

Evaluation Simulator. Directed at performance estimation on a total system basis, this simulator accounts for all hardware characteristics of the 3270, the operational sequences of the BSC line control discipline, data set request-to-send/clear-to-send delays, characteristics of the TCAM access method, and all pertinent application program timings associated with operator-initiated transactions. Charts A through E present average operator wait times (response times) as a function of the number of displays (often in cluster sizes) sharing a single line. The data set characteristics are based upon the IBM 3872, the IBM 4872, and the IBM 3875 MODEMS for the 2400-bps, 4800-bps, and 7200-bps networks respectively. All other criteria are outlined on each chart.

The time between transactions represents the time required for an operator to prepare a message (think time plus key-in time) following receipt of the previous response from the system. Average response time is defined as the elapsed time between depression of an ENTER key and the appearance of the first character of the system response on the display screen.

Charts A through E are provided for general information and should be interpreted only within the context of their underlying assumptions. It should also be recognized that many points on the curves represent excessively high system response times because of an unreasonable load on the communications line. In reality, such a system would not be configured; the results are presented only for completeness.

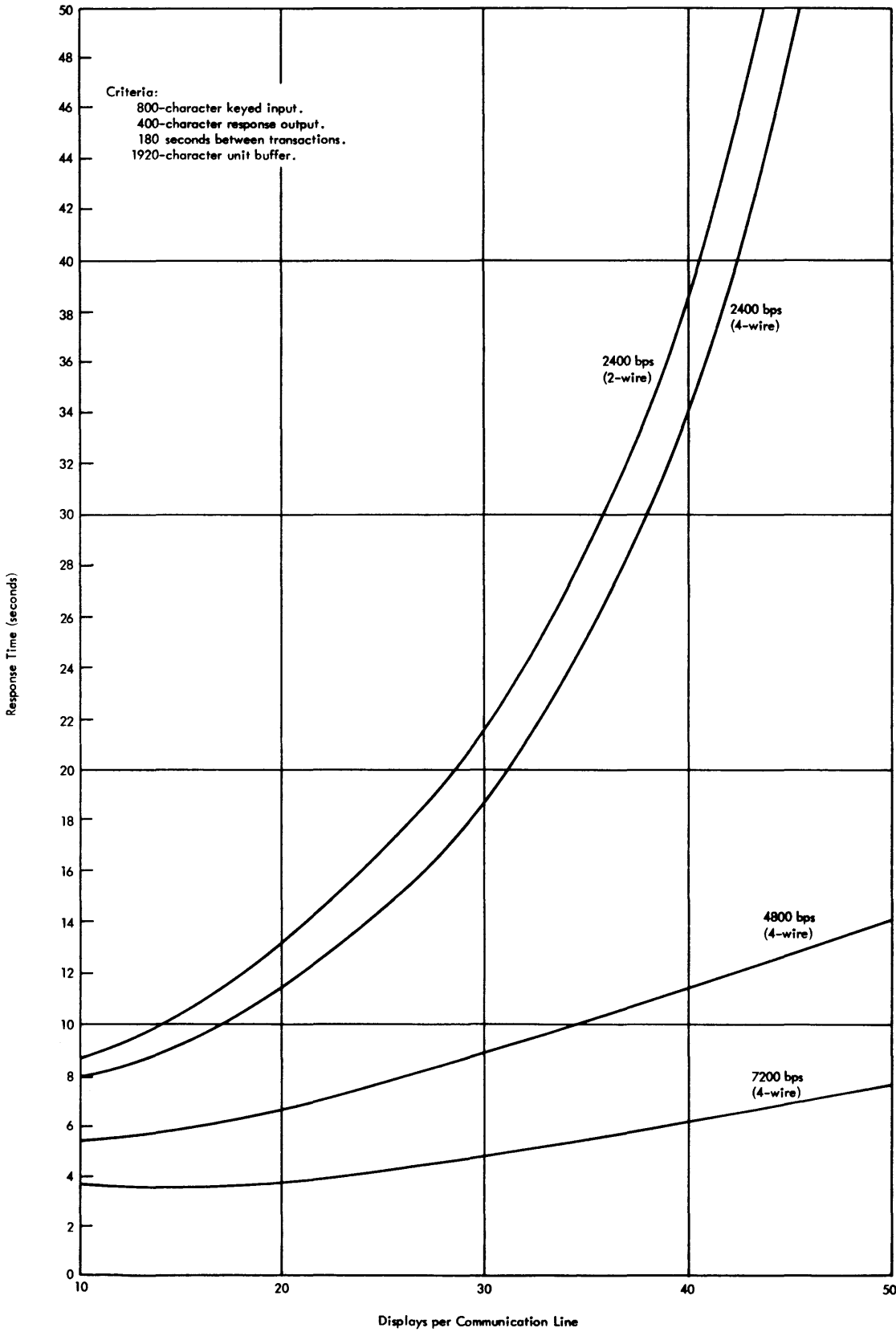

CHART A

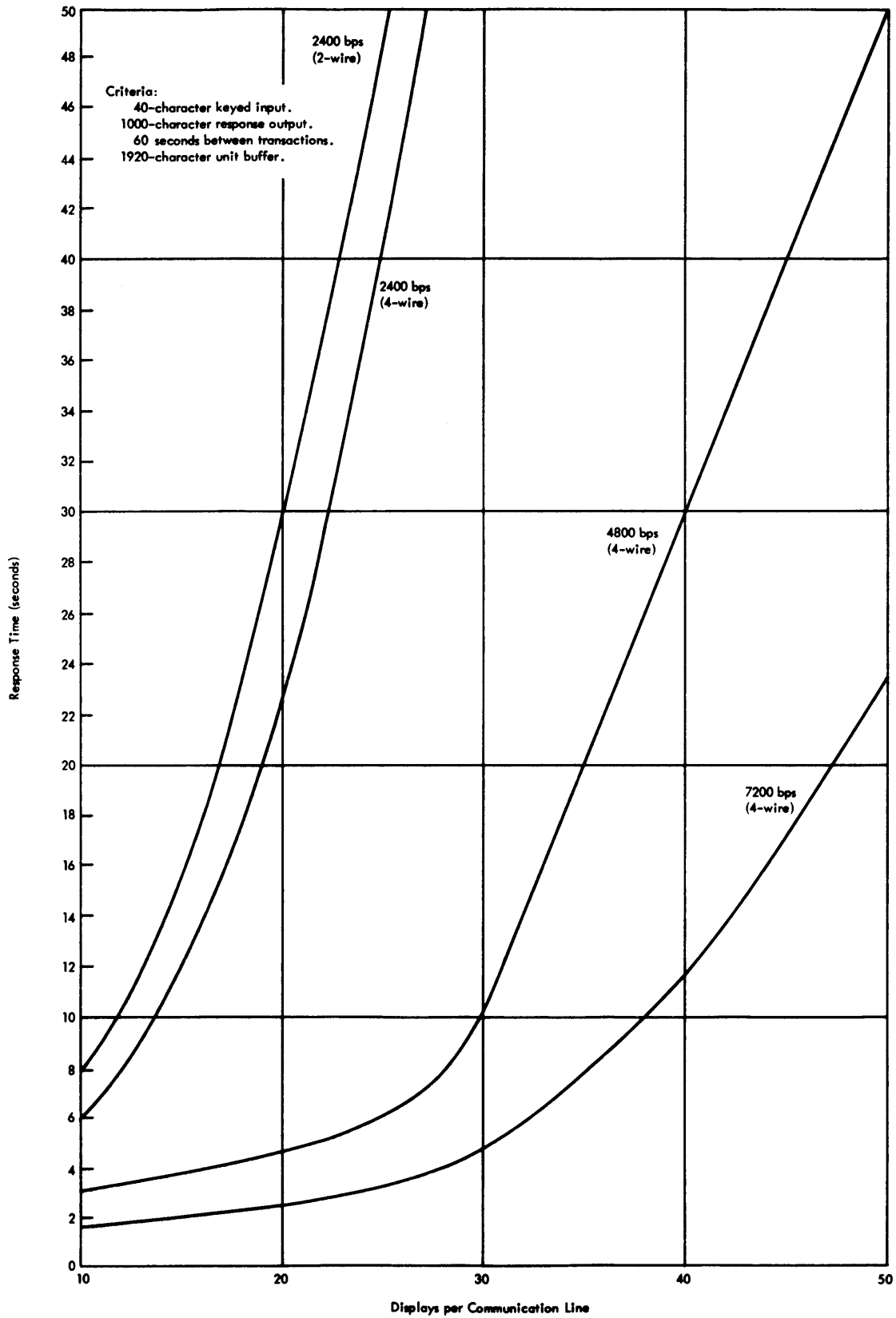

CHART B

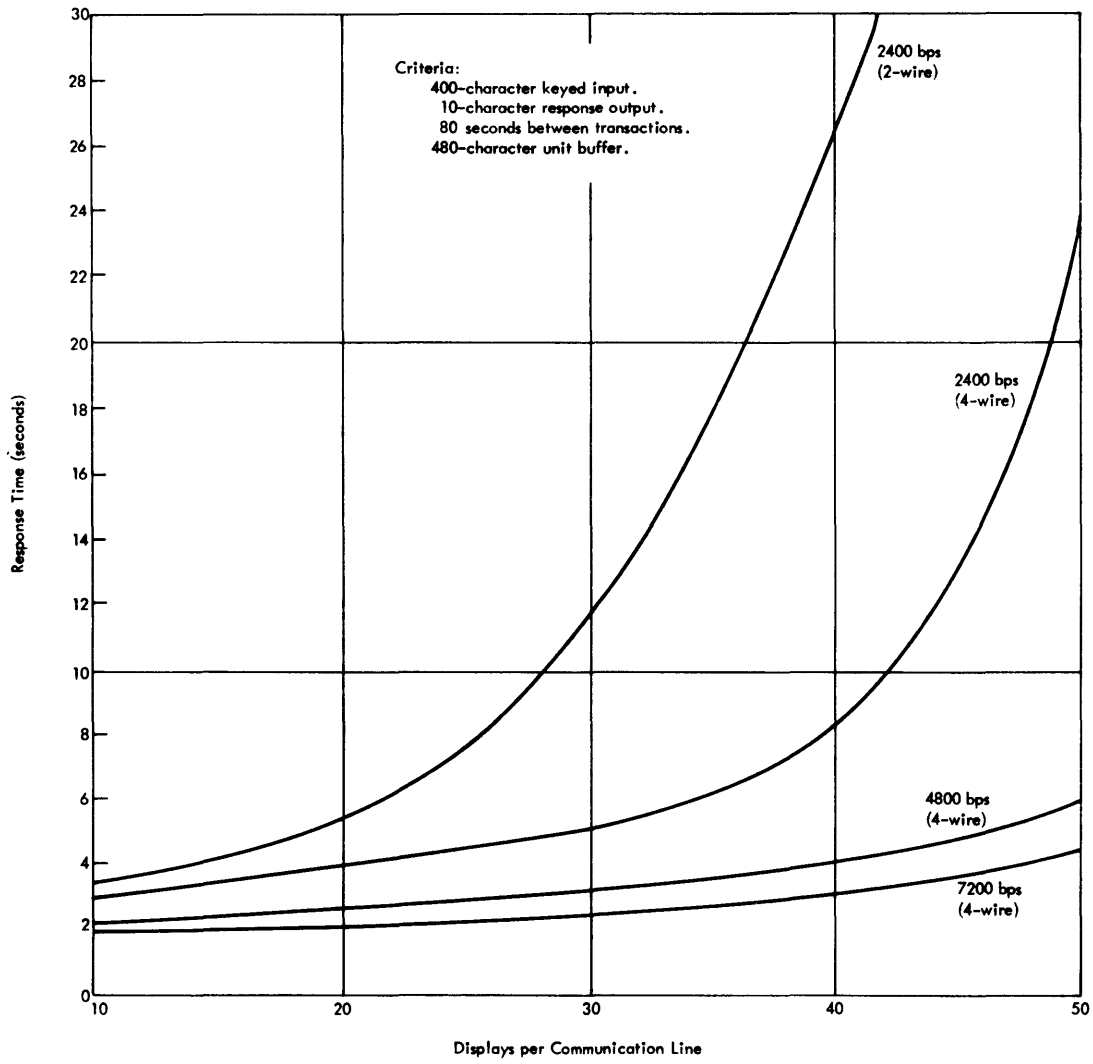

CHART C

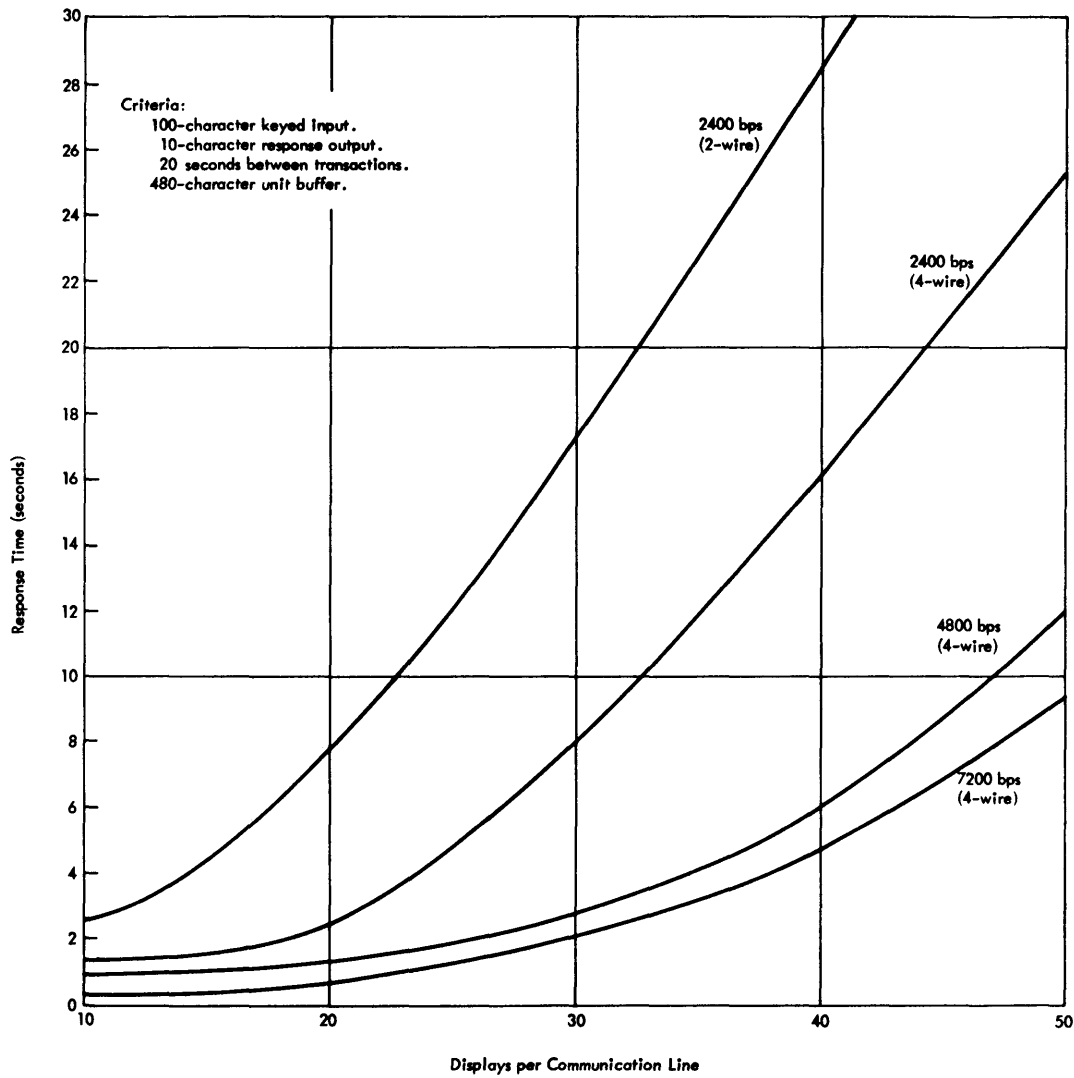

CHART D

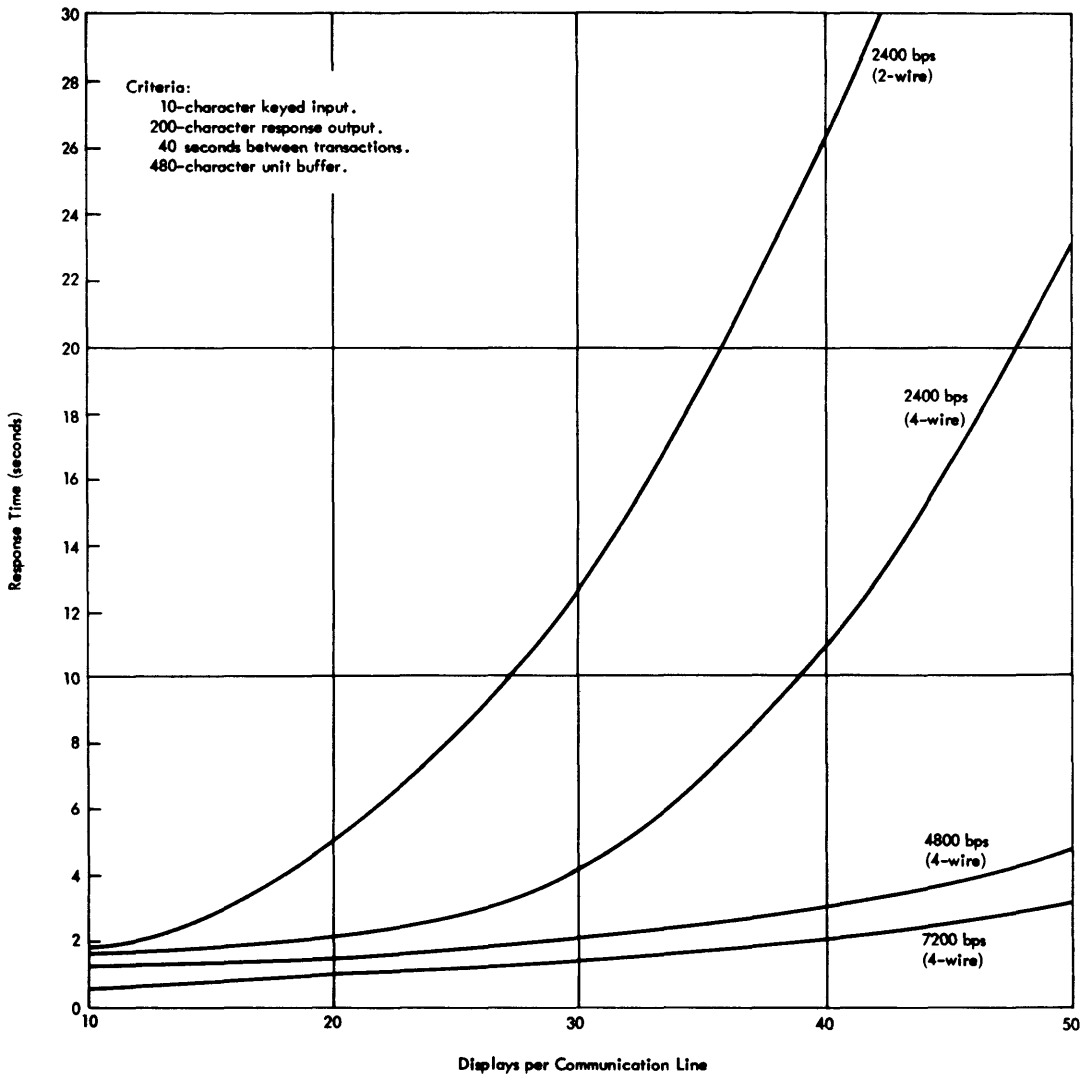

CHART E

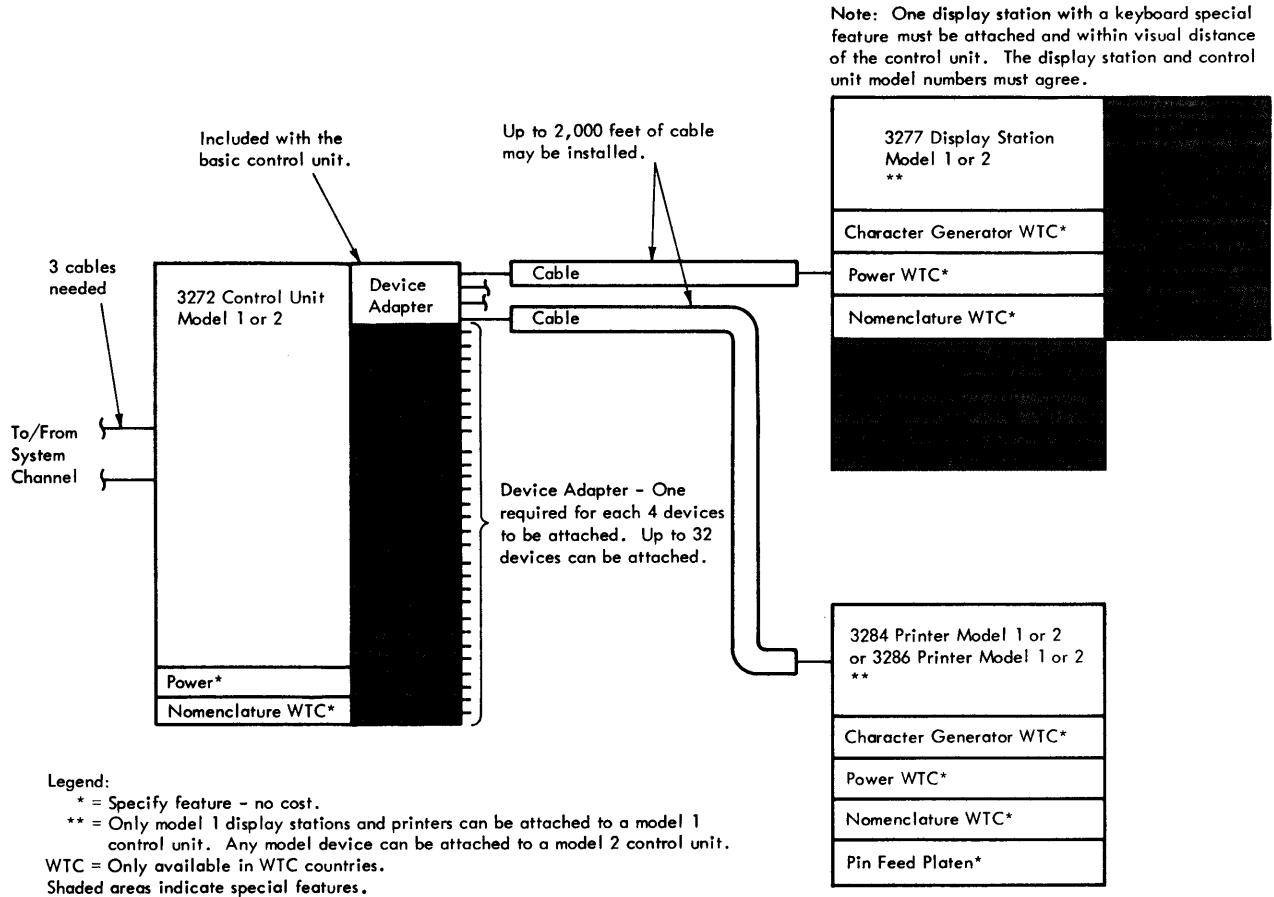

Figure A-1. 3270 Display System - Local

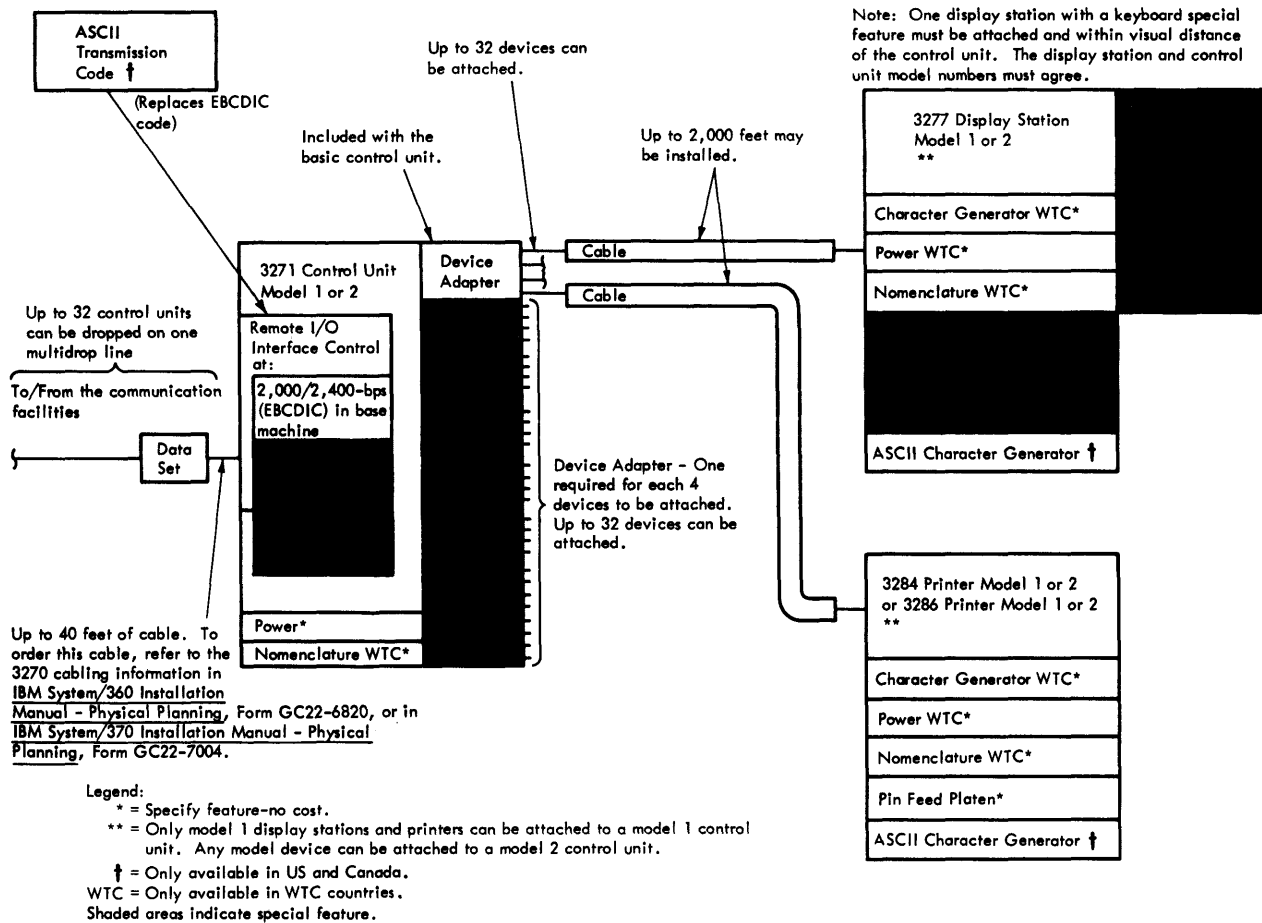

Figure A-2. 3270 Display System - Remote



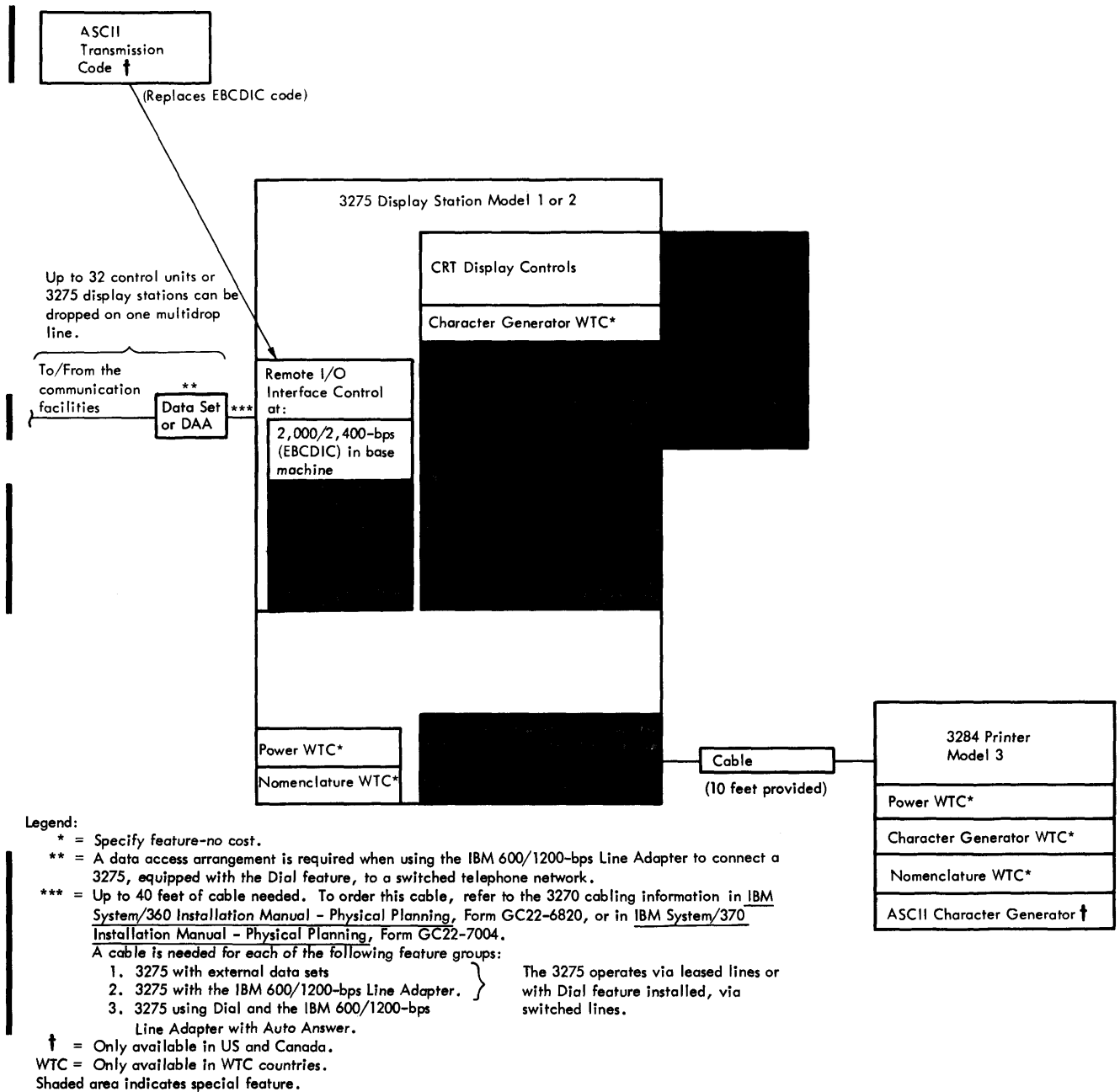

Figure A-3. 3275 Display Station



## Appendix B. Features List and World Trade Keyboards

Table B-1. Features List

Feature Name	3272 CU	3271 CU	3275 DS	3277 DS	3284 P	3286 P
US Power 115V ± 10% - 60 Hz	S	S	S	S	S	S
US Power 208V ± 10% - 60 Hz	S	S				
US Power 230V ± 10% - 60 Hz	S	S				
Pin Feed Platen, 120 Print Positions*					S	S
Pin Feed Platen, 126 Print Positions*					S	S
Pin Feed Platen, 132 Print Positions*					S	S
ASCII Transmission Code		S	S			
ASCII Character Generator - Character Set A			S	S	S	S
ASCII Character Generator - Character Set B			S	S	S	S
Device Adapter*	O	O				
66-Key US EBCDIC Typewriter Keyboard*			O	O		
78-Key US EBCDIC Typewriter Keyboard*			O	O		
66-Key US EBCDIC Data Entry Keyboard*			O	O		
78-Key US Operator Console Keyboard*			O	O		
66-Key US ASCII Typewriter Keyboard			O	O		
78-Key US ASCII Typewriter Keyboard			O	O		
Selector Pen*			O	O		
Printer Adapter*			O			
Operator Identification Card Reader*			O	O		
1,200-bps Transmission Speed*		O	O			
4800/7200-bps Transmission Speed*		O	O			
Audible Alarm*			O	O		
Dial*			O			
Key Lock*			O	O		
600/1200-bps Line Adapter*			O			
600/1200-bps Line Adapter, with Auto Answer			O			
Numeric Lock*			O	O		

**Legend:**

S - Specify Features

O - Special Features

\* - Features available to World Trade and US customers.

Table B-1. Features List (cont)

Feature Name	3272 CU	3271 CU	3275 DS	3277 DS	3284 P	3286 P
World Trade Power 100V ± 10% - 60 Hz**	S	S	S	S	S	S
World Trade Power 100V ± 10% - 50 Hz**	S	S	S	S	S	S
World Trade Power 110V ± 10% - 50 Hz**	S	S	S	S	S	S
World Trade Power 123.5V ± 10% - 50 Hz**	S	S	S	S	S	S
World Trade Power 200V ± 10% - 50 Hz**	S	S				
World Trade Power 200V ± 10% - 60 Hz**	S	S				
World Trade Power 220V ± 10% - 50 Hz**	S	S	S	S	S	S
World Trade Power 235V ± 10% - 50 Hz**	S	S	S	S	S	S
66-Key United Kingdom Typewriter Keyboard**			O	O		
78-Key United Kingdom Typewriter Keyboard**			O	O		
66-Key United Kingdom Data Entry Keyboard**			O	O		
66-Key French Typewriter Keyboard***, **			O	O		
78-Key French Typewriter Keyboard***, **			O	O		
66-Key French Data Entry Keyboard***, **			O	O		
66-Key German Typewriter Keyboard**			O	O		
78-Key German Typewriter Keyboard**			O	O		
66-Key German Data Entry Keyboard**			O	O		
66-Key Italian Typewriter Keyboard***, **			O	O		
78-Key Italian Typewriter Keyboard***, **			O	O		
66-Key Italian Data Entry Keyboard***, **			O	O		
American English Character Generator*			S	S	S	S
United Kingdom Character Generator**			S	S	S	S
German Character Generator**			S	S	S	S
English Nomenclature*	S	S	S	S	S	S
French Nomenclature**	S	S	S	S	S	S
German Nomenclature**	S	S	S	S	S	S
Italian Nomenclature**	S	S	S	S	S	S
Spanish Nomenclature**	S	S	S	S	S	S
Japanese Nomenclature**	S	S	S	S	S	S

Legend:

S - Specify Features

O - Special Features

\* - Features available to World Trade and US customers.

\*\* - Features available to World Trade customers only.

\*\*\* - Display Stations attaching to French or Italian keyboards require the American English Character Generator.

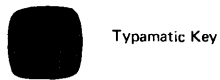

Data Entry Keyboard



Typewriter Keyboard

Figure B-1. United Kingdom Keyboards



**Data Entry Keyboard**

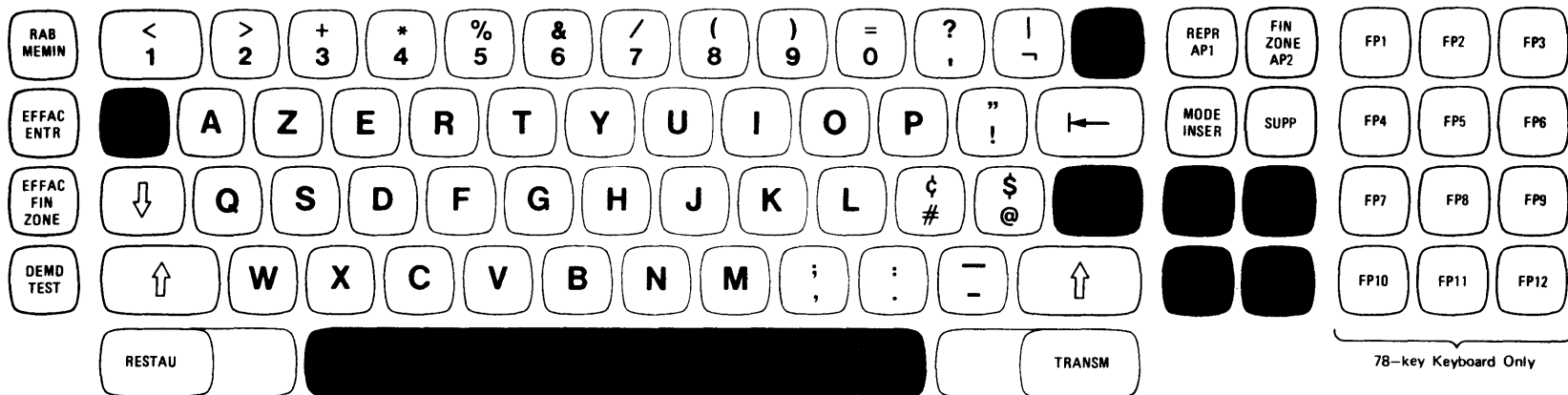

**Typewriter Keyboard**

Figure B-2. French Keyboards



Typamatic Key

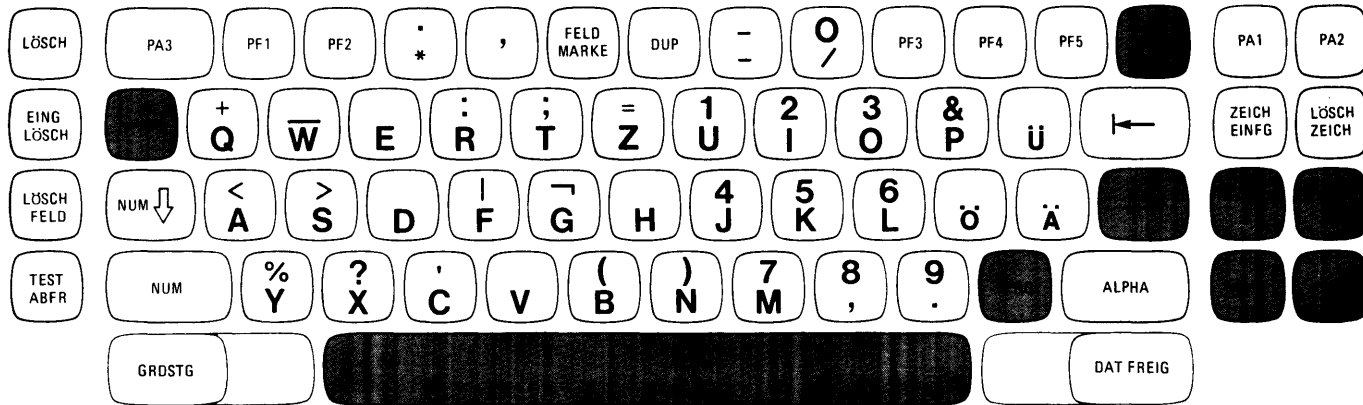

Data Entry Keyboard



Typewriter Keyboard

Figure B-3. German Keyboards

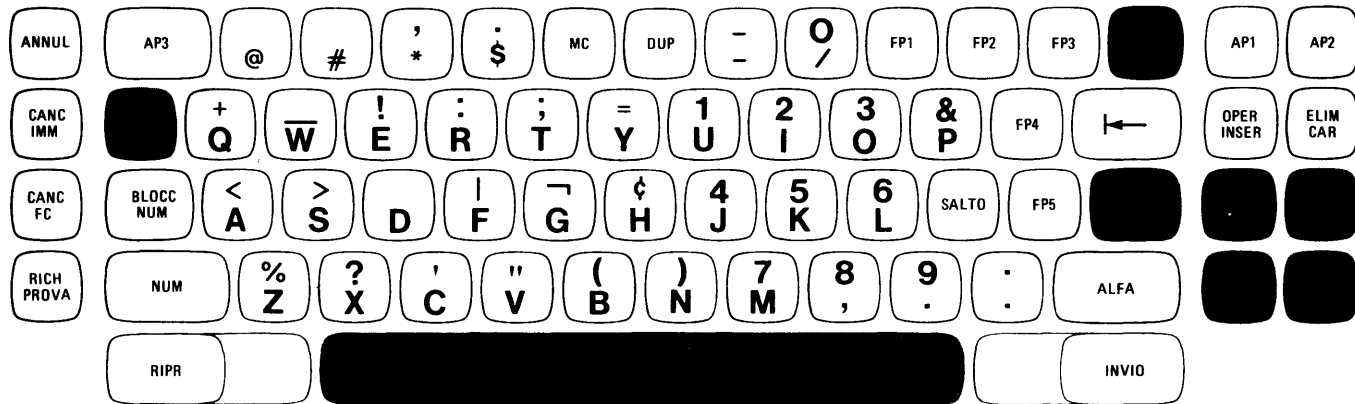

**Data Entry Keyboard**

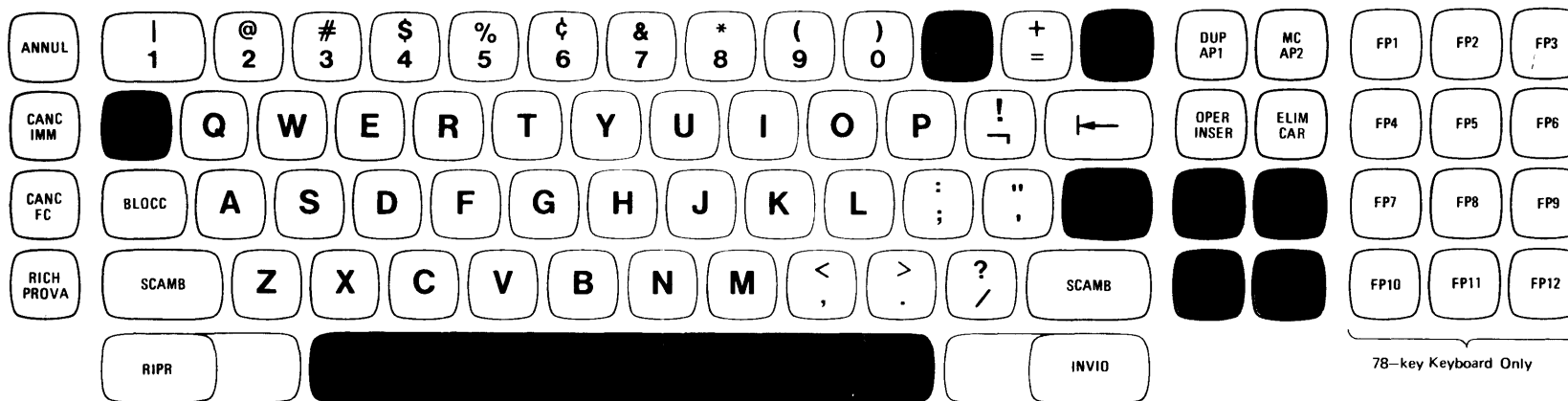

**Typewriter Keyboard**

Figure B-4. Italian Keyboards



## Appendix C. Functional Capabilities (Detailed)

Display system operations in response to program commands depend on the functional capabilities of the display system hardware, the facilities available to the display operator, and the means of communication between the system channel and the display system. The following paragraphs describe some of the basic or built-in capabilities of the display system hardware and some of the optional feature capabilities and relate them to the programmed operations and the operator's needs.

### BASIC FUNCTIONS

Each unit in the display system (except the 3284 printer, model 3) is provided with a buffer to store display or print data (Figure C-1). Model 1 unit buffers are capable of storing 480 characters; model 2 unit buffers, 1920 characters. Display data, print data, or control data that is sent from the system channel to a 3277 display station or a 3284 or 3286 printer is received and formatted at a control unit buffer and is then transferred to the device buffer. Conversely, display or print data that originates at a device is first sent to the control unit buffer, is prepared for transmission, and is then sent to the system.

Display data that is stored in a display station buffer is presented to the operator on a CRT screen in the form of alphameric characters and symbols. The display image on a 480-character unit is presented on 12 horizontal lines of 40 characters each. The display image on a 1920-character unit consists of 80 characters on each of 24 horizontal lines. Printed data appears in the same alphameric characters and symbols that appear on a display image. Printout line length can be program-defined up to 132 characters per line, depending upon the needs of the application.

### Unformatted and Formatted Display Images

An application program can communicate with a display operator using one of two basic methods. In one method, the display screen is left unformatted, similar to the IBM 2260. The display operator uses the screen in a free-form manner. In the second method, the display image is completely or partially formatted by the application program. This method helps define the operator's tasks and provides capabilities that assist in performing the tasks.

### Formatting a Display Image on the 3275 or 3277 Display Station

Since all 3270 display stations employ a fixed relationship between each buffer storage location and its related character position on the display image (Figure C-2), a program can load a display station buffer with many combinations of control and data characters to present to the operator a display image that exactly fits the application.

To illustrate the flexibility available in 3270 display image formatting, consider the display image shown in Figure C-3. The visible characters represent display data stored by the program in the unit buffer; character positions indicated by dotted squares represent buffer locations where attribute control code information is stored; and dotted characters represent display data that is defined by the program as not displayable, that is, not visible to the operator. Attribute control code stored in a unit buffer is not displayed; data characters may or may not be displayed, depending upon program definition.

A field starts at an attribute control code and extends through succeeding locations up to the next attribute control code. Eight fields are shown in Figure C-3. Attribute control codes, in addition to defining the start of a field, define the following field characteristics:

- Protected (from modification by a display operator) or unprotected (available for the operator to modify or to input data). The unprotected definition classifies a field as an input field.
- Alphameric (an input field in which an operator can enter alphabetic, numeric, or symbol character data) or numeric (implementing certain data entry functions such as auto shift and numeric lock).
- Character brightness (off, normal, bright).
- Selectable or not selectable (by means of the selector pen).
- Tab stop positions (first position of input fields).

### Formatting a Printout from the 3284 and 3286 Printer, Models 1 and 2

Printouts can be formatted in the same manner as a display image. Fields can be defined as printable or not printable.

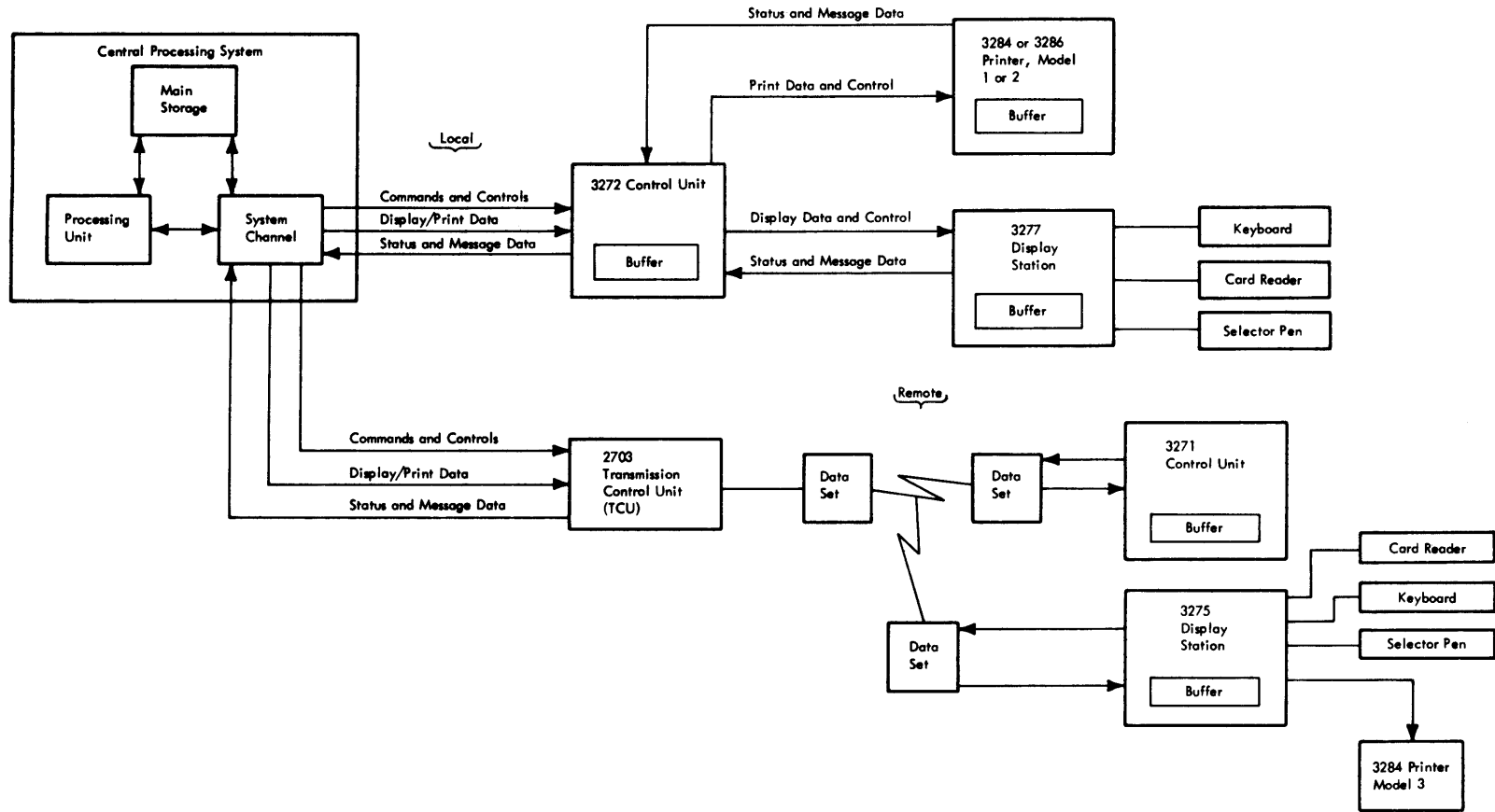

Figure C-1. Information Exchange between a Central Processing System and a Display System

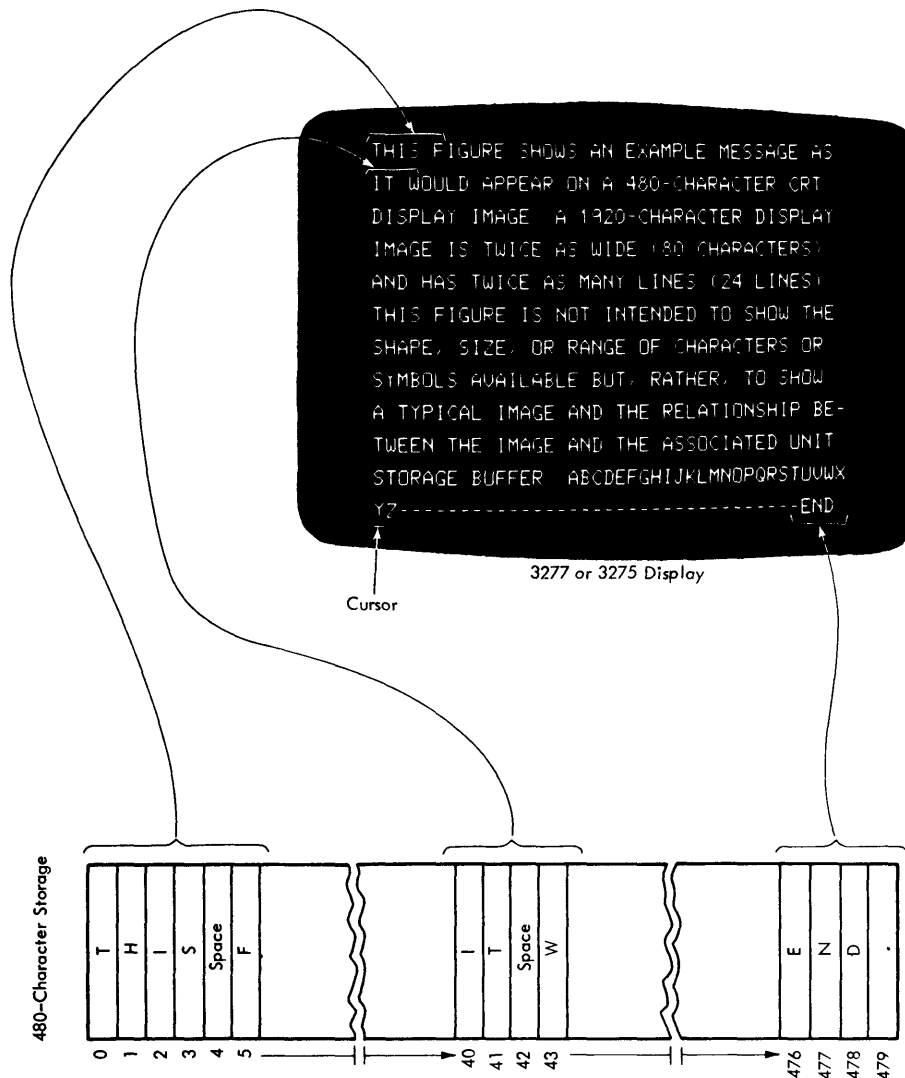

Figure C-2. Display Station Buffer and Display Image Character Position Relationship

```

[ ]NAME : [ ]JOHN B DOE
[ ]SALARY [ ]12525
[ ]JOB TITLE : [ ]WRITER
[ ]PHONE # : [ ]383-7628
  
```

Figure C-3. Examples of Display Image Fields

Attribute control codes are not printed and appear as a space. Printouts are started under program control. A new-line or end-of-message control code can be stored in the 3284 or 3286 printer or in the 3275 display station buffer to format a printout. The relationship between the 3284 or 3286 printer or 3275 display station buffer and a printout is shown in Figure C-4.

### OPERATOR CAPABILITIES

This section provides information on the operation and application of display stations and their associated special features. No distinction is made between 3277 and 3275 display stations, since each unit has the same capabilities. Additionally, no distinction is made between various keyboard special features, unless they are pertinent to the topic being discussed.

### Keyboard Functions

#### Positioning the Cursor

An underscore-like marker (Figure C-5), called a cursor, is visible on the display image. The cursor appears under the character position where a display operator can input a data character. Several keyboard controls are provided to permit

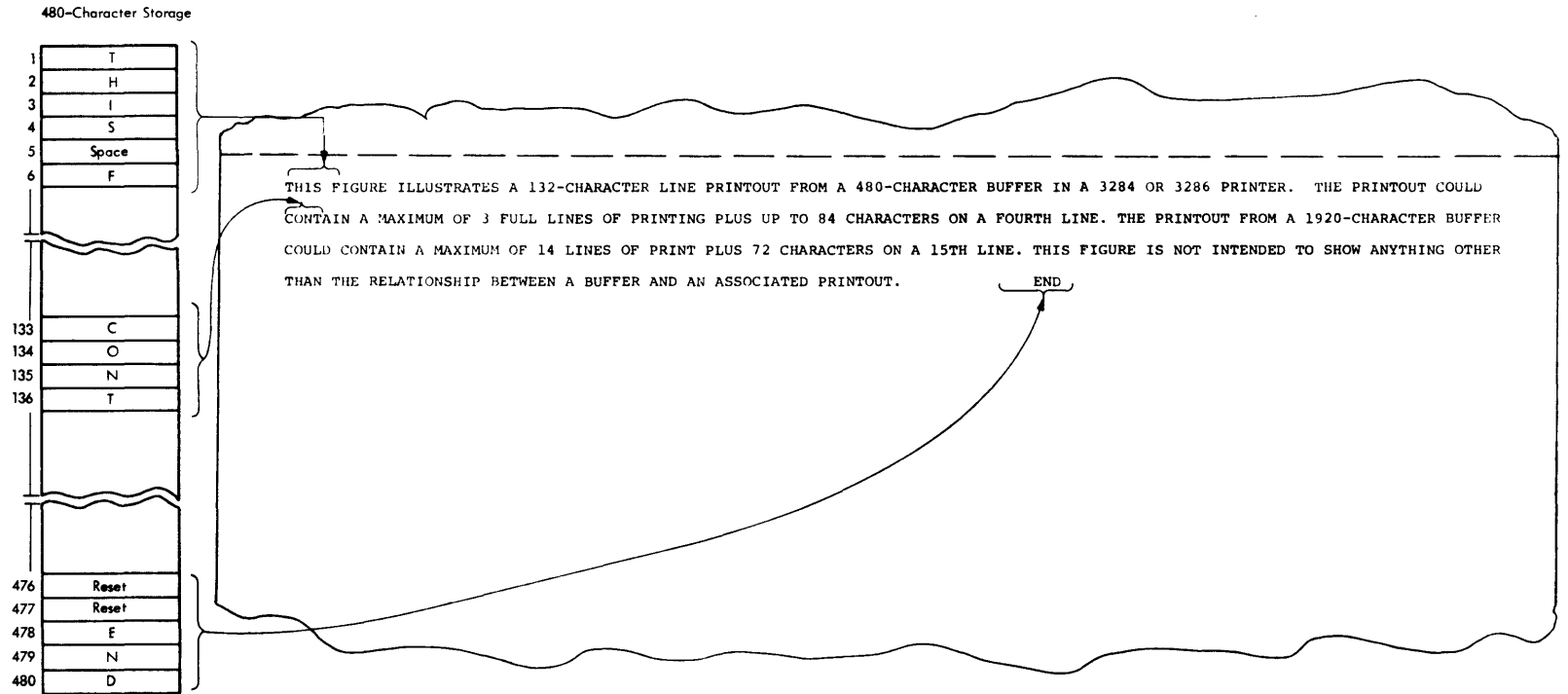

Figure C-4. Printer Buffer and Printout Character Position Relationship

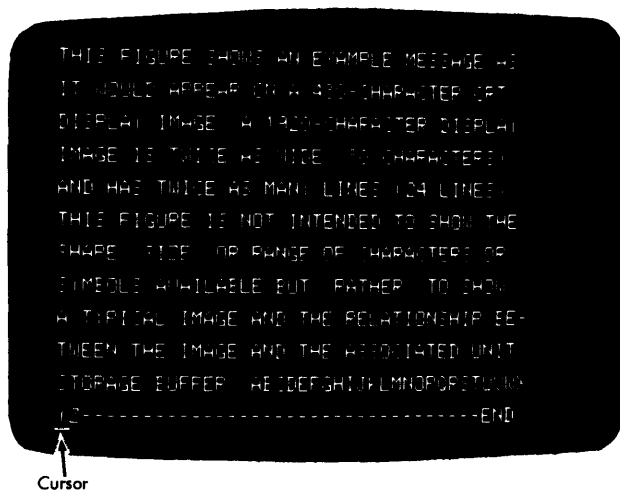

Figure C-5. Example of a Display Image Showing a Cursor

rapid positioning of the cursor to any character position on the display image. Included in these cursor controls are the UP (↑), DOWN (↓), LEFT (←), and RIGHT (→) keys. These keys are used to move the cursor either one character step to the left or right or one line step up or down. If the key is held depressed, cursor movement continues step by step until the key is released.

The BACKSPACE (←) key is also used for cursor control. This key functions exactly as the LEFT key, except that movement of the cursor is restricted to one character position per key depression.

The TAB (→) and BACKTAB (←) keys function much like the RIGHT and LEFT keys except that they cause cursor movement that is related to program-defined input fields rather than successive display image character positions. For example, when the TAB key is depressed while the operator is working on a formatted display image, the cursor does not stop until it reaches the first character location of the next input field encountered in the cursor movement. The BACKTAB key functions in the same manner as the TAB key except that cursor movement is to the left. If either of these keys is depressed when no input field has been defined, the cursor will scan the complete display image once and then be repositioned to the upper left corner of the display image

*Note:* Data entry keyboards are provided with a SKIP key. This key works the same as the TAB key; it is provided to maintain the efficiency of data entry applications.

The NEW LINE key (↵) functions as the TAB key except that the cursor moves to the start of the next lower line before beginning a search for an input field.

### Inputting Data

Before inputting data, the cursor is positioned to the desired location on the display image. The display operator can depress any alphanumeric key. The character associated with the key appears on the display image in the character position marked by the cursor, and the cursor moves one character position to the right. If the display operator attempts to key data into a control character position or a protected field, or to key alphabetic or symbol data into a numeric field (see "Numeric Lock Operation", below), the keyboard will electrically lock, no audible feedback will be provided, and the INPUT INHIBITED indicator (located on the front of the display station) will light. The RESET key allows the display operator to recover from the electrical lock condition.

### Insert Mode and Delete

Two keyboard keys, INS MODE and DEL, enable a display operator to perform unique text-editing functions. To illustrate the DEL key function, assume the display operator has completed an input message and discovers the name "JONES" was mistakenly inputted as "JONNES". To correct this mistake, the operator positions the cursor under either N in the name and depresses the DEL key. The N over the cursor will disappear and all characters to the right of the character position occupied by the N, within the same field and on the same line, will shift one character position to the left.

The INS MODE key function is comparable to that of the DEL key except that characters are inserted into a field and field characters shift to the right. For example, consider a situation where the display operator has neglected to key a word into the field. If "NOW IS TIME" was inputted, and "NOW IS THE TIME" is correct, the display operator must position the cursor under the T in "TIME" to prepare to insert "THE". Once the cursor is positioned, the INS MODE key is depressed. This causes the INSERT MODE indicator on the front of the display station to light. The display operator then keys T, H, E, and SPACE. Once the T is inputted, the message changes to "NOW IS TTIME". The inputted T appears in the cursor position, and the word TIME, plus all other characters to the right in the field, shift to the right one character position. The cursor also shifts to the right with the T in "TIME". Provisions have been made to avoid discarding meaningful data characters.

### Program Function and Program Access Keys

Twelve program function keys (PF1–PF12) are provided on some keyboard options. Two or three program access keys (PA1–PA3) are provided as standard equipment. These keys, when depressed, provide a uniquely coded input to the application program.

### *Numeric Lock Operation*

The numeric lock special feature provides a means of alerting a display operator to certain keying errors. Although this special feature may be installed on any style keyboard, its primary purpose is to support data entry applications.

Whenever the cursor moves under a character position within a numeric input field, the display station upshifts the data entry keyboard. Without the numeric lock special feature, the display operator can input any upshift character into the field. With the numeric lock feature, the keyboard is electrically locked if any character other than minus (-), period (.), the numerals 0 through 9, or the DUP (duplicate) key is keyed.

### *Duplicate and Field Mark Keys*

These keys, when depressed, cause a (\*) and a (;), respectively, to appear on the display image. The application program, however, defines the unique codes inputted by these keys. Thus, the duplicate and field mark functions, common to IBM keypunch applications, may be duplicated by the application program.

### *Erase Keys*

Erase keys reset character positions on the display image. The CLEAR key resets the buffer to nulls, moves the cursor to the upper left corner of the screen, and alerts the program that this action has been taken. The ERASE EOF key is used by the display operator to reset the remainder of a field which has been modified. The ERASE INPUT key is used to reset all input fields on the display image and to reposition the cursor to the first character position of the first input field on the display image.

### **Test Request**

An online test (OLT) program is available to help determine the source of display system troubles. A TEST REQ key is provided on each keyboard to permit initiation of the OLT program. Diagnostic tests included in the program can be individually initiated or the entire program of tests can be initiated by inputting the proper test request message from the keyboard and depressing the TEST REQ key. Documentation will be provided to allow a customer to initiate the test request message and to help him interpret the test results.

**access method:** A technique for moving data between main storage and an input/output device.

**alphameric field:** A field that may contain any alphabetic, numeric, or special character that is available on any of the 3270 keyboards.

**alphameric keyboard:** A typewriter-like keyboard used to enter letters, numbers, and special characters into a display station buffer; also used to perform special functions (such as backspacing) and to produce special control signals.

**application program:** A program written by a user that applies to his own work.

**ASCII (American National Standard Code for Information Interchange X3.4-1968):** A standard code consisting of control characters and graphic characters; used for information interchange between data processing and communication systems and associated equipment.

**attention:** An I/O interruption signal generated by a display station, usually as the result of an action taken by the operator of the device.

**attribute:** A characteristic of a display field. The attributes of a display field include: protected or unprotected; numeric only or alphameric input control; displayed, nondisplayed, display intensified; selector pen detectable or nondetectable; and modified or not modified.

**attribute character:** A code that defines the attributes of the display field that follows. An attribute character is the first character in a display field but is not a displayable character.

**buffer:** The hardware portion of a display station, control unit, or buffered printer in which display or print data is stored.

**buffer address:** The address of a location in the buffer at which one character can be stored.

**channel interface:** The communication link between the channel unit and its attached control units, consisting of shared control and data lines.

**character addressing:** The process of gaining access to any character position in the buffer by using an address.

**character generator:** A hardware unit (contained in 3275 and 3277 display stations) that converts the digital code for a character into signals that cause the cathode-ray tube electron beam to create the character on the screen.

**character position:** A location on the screen at which one character can be displayed; also, an addressed location in the buffer at which one character can be stored.

**clocking:** Time base control signals within the 3271 control unit, 3275 display station, or associated data sets; regulate the bit rate of information transfer between a computer system and a remotely attached 3270 display system.

**command:** An instruction that directs a control unit or device to perform an operation or a set of operations.

**control character:** A character used in conjunction with a Write command to specify that a control unit is to perform a particular operation.

**cursor:** A unique symbol (an underscore) that identifies a character position in a screen display, usually the character position at which the next character entered from the keyboard will be displayed.

**data-entry keyboard:** A standard typewriter keyboard on which the numeric keys are grouped in a format similar to the numeric keys on a card punch keyboard (to facilitate entry of numeric data). Other features include (1) automatic upshift of the keyboard when the cursor enters a numeric-only display field and (2) automatic prevention of entry of nonnumeric characters into a numeric-only display field when the special Numeric Lock feature is installed.

**data stream:** All data transmitted through a channel in a single read or write operation to display station or printer.

**detectable:** An attribute of a display field; determines whether the field can be sensed by the selector pen.

**display field:** A group of consecutive characters (in the buffer) that starts with an attribute character (defining the characteristics of the field) and contains one or more alphameric characters. The field continues to, but does not include, the next attribute character.

**display operator:** A person who uses the keyboard or selector pen to perform operations at a display station.

**EBCDIC:** Extended Binary Coded Decimal Interchange Code.

**end of message:** A character in the data stream transmitted to a printer; marks the end of the data to be printed.

**field:** See display field.

**formatted display:** A screen display in which a display field (or fields) has been defined as a result of storing at least one attribute character in the display buffer.

**hardware:** Refers to the electronic circuits (within the units of the 3270 system) that perform various data transfer and control functions.

**input field:** An unprotected field in which data can be entered, modified, or erased by any keyboard action.

**intensified display:** An attribute of a display field that causes data in that field to be displayed at a brighter level than other data displayed on the screen.

**MODEM (also called data set):** A coupling device providing signal conversion functions required for transfer of information between a remote display system and telephone lines and, also, between telephone lines and computer equipment.

**new line:** A code sent to a printer; causes the printer to begin printing subsequent characters on a new line.

**null character:** An all-zero character that occupies a position in the storage buffer and is displayed as a blank.

**null suppression:** In reading the contents of the buffer for a display or printer, the bypassing of all null characters in order to reduce the amount of data to be transmitted or printed.

**order code:** A code that may be included in the write data stream transmitted for a display station or printer; provides additional formatting or definition of the write data.

**polling:** A technique by which terminals sharing a communication line are periodically interrogated to determine whether the terminals require service.

**program access (PA) keys:** Allow a code to be transmitted to the program to identify which key was pressed, but no input data from the screen is transmitted to the program.

**program function keys:** Allow input data on the display screen to be transmitted to the program together with a code that identifies which program key was depressed.

**protected field:** A display field for which the display operator cannot use the keyboard to enter, modify, or erase data.

**read-modified operation:** An operation in which only those display fields that are operator-modified with null codes suppressed are transferred.

**selector pen:** A pen-like instrument which may be attached to the display station as a special feature. When pointed at a detectable portion of an image and then activated, the selector pen senses the presence of light at a display field and identifies that portion of the displayed message for entry into the data processing system.

**selector pen attention:** An interruption generated when a selector pen detect occurs on a display field that has a null or space designator character. The attention concludes the selector pen operation.

**time sharing:** Refers to the interleaved use of the operating time of a device.

**unformatted display:** A screen display in which no attribute character (and, therefore, no display field) has been defined; the attributes of the displayed data are controlled by the hardware of the display device.

**unprotected field:** A display field for which the display station operator can use the keyboard to enter, modify, or erase data.

**wraparound:** The continuation of an operation (for example, a read operation or a cursor movement operation) from the last character position in a buffer to the first character position in the buffer.



- Access Methods (*see* BTAM and TCAM)
- Applications:
  - Advantages of Display Systems in 4-3
  - Advantages of 3270 Display System in 4-3
  - Categories of 4-1
  - Data Entry:
    - DATA/360 5-8
    - VIDEO/370 5-9
    - Online Key Entry 4-2
    - Source File Update 4-2
  - Highlights of 3270 Display System in 4-3
  - Inquiry:
    - Complex 4-1
    - Conversational 4-1
    - Conversational with File Update 4-2
    - Simple 4-1
    - With File Update 4-1
  - System Operator's Console (*see also* DIDOCS and SDS):
    - Display Operator Console 4-2
    - Output-only Display Console 4-2
  - Types of 4-1
- ASCII Features:
  - Character Generator 2-4, A-1, A-2, B-1, B-2
  - Transmission Code 2-4
- Audible Alarm Feature, 2-5, 3-4
- Availability (*see also* Reliability; Serviceability):
  - Decentralization for 9-1
  - Highlights of 1-2
  - OLT Programs for 9-1, C-6
- BSC Line Control 3-2
- BTAM (Basic Telecommunications Access Method):
  - Support for 3270 Display System:
    - Capabilities Supported 5-2
    - Devices Supported 5-2
    - Functions and Use 5-2
    - Main Storage Requirements 5-2
    - Processor Requirements 5-2
  - Under DOS or OS:
    - Environment 5-1
    - Functions and Organization 5-1
- Card Reader 2-6, 3-4
- Channel Interface Speeds 1-1, 3-1, 3-2, 10-3
- Character Addressing 3-2
- Character Generator Feature 2-4
- Charts, Performance 10-2, 10-4 to 10-8
- Communication Line Speeds 3-2
- Configurations:
  - Description 2-1
  - Highlights of 1-1
  - Local Attachment 2-2 (Fig. 2-1)
  - Remote Attachment 2-2, 2-3 (Fig. 2-2)
- Configurator A-1, A-2, A-3
- Conversion:
  - Aids for 6-6
  - Application Program Modification for 6-2
  - Application Program Structure for 6-2
  - Assumptions for 6-1
  - BTAM Macro Instruction for 6-1
  - Comparable 2260 and 2265 Configurations for 6-3
  - Configuration Considerations for 6-2
  - Estimating Effort for 6-6
  - Functional Differences of 3270 from 2260:
    - Commands and Control Characters 6-3
    - Data Stream 6-3
    - Line Control 6-3
  - Of Devices:
    - Display Operator Considerations 6-4
    - Display Operator Reorientation 6-4
    - Input Considerations 6-4
    - Message Editing 6-4
    - Output Considerations 6-3
    - Screen Format Example of 6-4
    - Segmenting Effort for 6-6
    - Steps in 6-1
  - Copy 3-2
  - Cursor Positioning Controls 3-4
  - Customer Information Control System (CICS) 5-17
  - Data Access Arrangement 2-1, 2-5
  - DATA/360:
    - Access Methods 5-17
    - Commands:
      - Primary 5-16
      - Secondary 5-16
    - Editing Features 5-16
    - Formats 5-16
    - Hardware Requirements 5-17
    - Storage Requirements 5-17
    - Utility Programs:
      - Analyze 5-17
      - Extract 5-17
      - File Load 5-17
      - File Transfer 5-17
      - Operator and Production Statistics 5-17
  - Data Entry Applications (*see* Applications, Data Entry)
  - Delete C-5
  - Device Adapter Feature 2-5
  - Dial Feature 2-5, 3-3
  - DIDOCS (Device Independent Display Operator Console Support):
    - Advantages and Limitations 5-4
    - Devices Supported 5-5
    - Functions:
      - Basic Display Console Support 5-3
      - New Display Console Support 5-3
    - Main Storage Requirements 5-6
    - Physical Characteristics of 3270 Display Consoles 5-6
    - System Procedures:
      - Operating Procedures 5-8
      - System Generation 5-8
    - System Requirements 5-5
  - Display Console Support (*see* DIDOCS and SDS)
  - Display Image 7-1
  - Display System:
    - Configurations 2-1
    - Configurator A-1, A-2, A-3
    - Features 2-3
    - Features List B-1, B-2

- Local Attachment of 2-1, 2-2 (Fig. 2-1)
- Remote Attachment of 2-2, 2-3 (Fig. 2-2)
- Units 2-1
- DOS (*see* Programming Support, Under DOS)
- DOS/BTAM (*see* BTAM, Under DOS or OS)
- DUP (Duplicate) Key 3-4, C-6
- Editing Controls 3-4
- Environmental Requirements (*see* Installation Planning Data, Environmental Requirements)
- Erase Keys C-1
- Erase Unprotected 3-2
- Erasing Controls 3-5
- Features:
  - Highlights of 1-1
  - Special:
    - Audible Alarm 2-5
    - Device Adapter 2-5
    - Dial 2-5
    - IBM 600/1200-bps Line Adapter 2-4
    - IBM 600/1200-bps Line Adapter with Auto Answer 2-4
    - Keyboard Numeric Lock 2-5
    - Keyboards 2-5, 2-6, (Figs. 2-4, 2-5, 2-6)
    - Operator Identification Card Reader 2-6, 3-5
    - Printer Adapter 2-6
    - Security Key Lock 2-5, 2-7 (Fig. 2-8)
    - Selector Pen 2-5, 2-7 (Fig. 2-7)
    - 1200-bps Transmission Speed 2-5
    - 4800/7200-bps Transmission Speed 2-5
  - Specify:
    - ASCII Character Generator 2-4
    - ASCII Transmission Code 2-4
    - Character Generator 2-4
    - Pin Platen Feed 2-4
    - Power 2-4
  - List B-1, B-2
- Field Mark Key C-6
- Format Control 3-1
- Formatted Display Image C-1
- Formatting:
  - Display Image C-1
  - Printout C-1
- Functional Capabilities:
  - Basic Functions C-1
  - Description of 3-1
  - Detailed C-1
  - Highlights of 1-1
  - Operator Capabilities C-3
- Functional Control Capabilities:
  - BSC Line Control 3-2
  - Channel Interface Speeds 3-2
  - Character Addressing 3-2
  - Communication Line Speeds 3-2
  - Copy 3-2
  - Dial Feature 3-2
  - Erase Unprotected 3-2
  - Format Control 3-1
  - IBM 600/1200-bps Line Adapter 3-4
  - IBM 600/1200-bps Line Adapter with Auto Answer 3-4
  - Null Suppression 3-2
  - Program Tab 3-3
  - Protected Data 3-2
  - Read Modified 3-2
  - Remote General Poll 3-3
  - Repeat Characters 3-3
  - Select 3-2
  - Selector Pen 3-3
  - Short Read 3-2
  - 4800/7200-bps Transmission Speed 2-5
  - General Poll 3-3
  - Human Factors:
    - Display Image 7-1
    - Highlights of 1-3
    - Indicators 7-2
    - Keyboards:
      - Ease of Operation 7-2
      - Finger Positioning 7-1
      - Keyboard Design 7-2
      - Typamatic Operation 7-2
    - Operator Controls 7-2
  - IBM FE Teleprocessing Test Center 9-1
  - IBM 600/1200-bps Line Adapter Feature 2-5, 3-4
  - IBM 600/1200-bps Line Adapter with Auto Answer Feature 2-5, 3-4
  - Identification Card Reader 2-6, 3-5
  - Indicators 7-2
  - Information Management System (IMS) 5-17
  - Inputting Data C-5
  - Inquiry Applications (*see* Applications, Inquiry)
  - Insert Mode C-5
  - Installation Planning Data:
    - Cables:
      - Adapting 2260/2848 8-1
      - For Local Attachment 8-1
      - For Remote Attachment 8-1
    - Environmental Requirements 8-1
    - Highlights of 1-3
    - Installation Manuals for 8-1
    - Physical Characteristics:
      - Size 8-1
      - Weight 8-1
  - Image, Display (*see* Display Image)
  - Integrated Communications Adapter 2-1, 2-3
  - Interactive Query Facility (IQF) 5-17
  - Key Lock Feature 2-5, 2-7 (Fig. 2-8), 3-5
  - Keyboards:
    - Features 2-5
    - Functions:
      - Cursor Positioning Controls 3-4, C-3
      - Delete C-5
      - Duplicate Key C-6
      - Editing Controls 3-4
      - Erase Keys C-6
      - Erasing Controls 3-5
      - Field Mark Key C-6
      - Inputting Data C-5
      - Insert Mode C-5
      - Numeric Lock 3-4, C-6
      - Positioning the Cursor 3-4, C-3
      - Program Access Keys C-5
      - Program Function Keys 3-4, C-5
      - Shift Keys 3-4
  - Human Factors:
    - Design 7-2
    - Ease of Operation 7-2

- Finger Positioning 7-1
- Typamatic Operation 7-2
- Illustrations:
  - Data Entry 2-6 (Fig. 2-6)
  - Operator Console 2-6 (Fig. 2-5)
  - Typewriter 2-6 (Fig. 2-4)
  - Numeric Lock Feature 2-5
- Maintenance Approach 9-1
- Non-Display Keying Mode 3-5, C-1
- Null Suppression 3-2
- Numeric Lock 2-5, 3-4, C-6
- OLT Programs 9-1, C-6
- Operator Capabilities C-3
- Operator Control Capabilities:
  - Audible Alarm 3-5
  - Keyboard Functions 3-4
  - Keyboard Options 3-4
  - Key Lock 3-5
- Operator Controls 7-2
- Operator Identification Card Reader 2-6, 3-5
- OS (*see* Programming Support, Under OS)
- OS BTAM (*see* BTAM, Under DOS or OS)
- OS TCAM (*see* TCAM, Under OS)
- Pageable DCM Support 5-4, 5-6
- Performance Considerations:
  - Charts 10-2, 10-4 to 10-8
  - Display Systems Attached Locally 10-1
  - Display Systems Attached Remotely 10-3
- Physical Characteristics (*see* Installation Planning Data, Physical Characteristics)
- Positioning the Cursor C-3
- Power Feature 2-4
- Printer Adapter Feature 2-6
- Program Access Keys 3-4, C-5
- Program Function Keys 3-4, C-5
- Program Tab 3-3
- Programming Support (*see also* BTAM, VIDEO/370, DIDOCS, and SDS):
  - BTAM 5-1
  - DIDOCS 5-3
  - Introduction to 5-1
  - SDS 5-2
  - TCAM 5-2
  - Under DOS 5-1
  - Under OS 5-1
- Protected Data 3-2
- Read Modified 3-2
- Reliability (*see also* Availability and Serviceability):
  - Circuit Technology for 9-1
  - Decentralization for 9-1
  - Highlights of 1-2
- Remote Polling 3-3
- Repeat Characters 3-3
- SDS (Status Display Support):
  - Advantages and Limitations 5-4
  - Devices Supported 5-5
  - Functions:
    - Basic Display Console Support 5-3
    - New Display Console Support 5-3
- Main Storage Requirements 5-6
- Physical Characteristics of 3270 Display Consoles 5-6
- System Procedures:
  - Operating Procedures 5-8
  - System Generation 5-8
  - System Requirements, 5-5
- Security Enhancements:
  - Key Lock 3-5
  - Non-Display Keying Mode 3-5
  - Operator Identification Card Reader 3-5
  - Select 3-2
  - Selector Pen Feature 2-5, 2-7 (Fig. 2-7), 3-3
- Serviceability (*see also* Availability and Reliability):
  - OLT Programs for 9-1, C-6
  - Recovery and Retry Circuits for 9-1
  - Test Center Support for 9-1
- Shift Keys 3-4
- Short Read 3-2
- Specify Features (*see* Features)
- Switched Network Backup Capability 2-2
- System Operator's Console Applications (*see* Applications, System Operator's Console)
- System/360 Disk Operating System (*see* Programming Support, Under DOS)
- System/360 Operating System (*see* Programming Support, Under OS)
- 7 x 9 Dot Matrix 7-1
- TCAM (Telecommunications Access Method):
  - Support for 3270 Display System:
    - Features 5-3
    - Requirements 5-3
  - Under OS:
    - Environment 5-3
    - Functions and Organization 5-2
- Telecommunications Access Methods (*see* BTAM and TCAM)
- Test Request C-6
- Time Sharing Option (TSO) 5-18
- Transmission Speed Feature:
  - 1200-bps 2-5
  - 4800/7200-bps 2-5
- Typamatic Operation 7-2
- 1200-bps Transmission Speed 2-5
- 2260/2848 Display System:
  - Configurations of 6-2
  - Conversion to 3270 (*see* Conversion)
  - Functional Differences from 3270 6-3
- 2265/2845 Display System:
  - Configurations of 6-2
  - Conversion to 3270 (*see* Conversion)
- 3270 Display System:
  - Access Method Support for 5-1
  - Advantages over 2260 or 2265 6-1
  - Application Advantages of 4-3
  - Application Highlights of 4-3
  - Applications of 4-1
  - Availability 9-1
  - Basic Functions C-1
  - Configurations 2-1
  - Conversion to 6-1
  - Data Paths 10-1 (Fig. 10-1)
  - Display Console Support for 5-3
  - Features 2-3
  - Functional Control Capabilities 3-1

**Highlights:**

- Applications 1-1
- Configurations 1-1
- Features 1-1
- Functional Capabilities 1-1
- Human Factors 1-3
- Installation Planning 1-3
- Programming Support 1-1
- Reliability and Availability 1-2
- Installation Planning Data 8-1
- Operator Capabilities C-3
- Operator Control Capabilities 3-1, 3-4
- Performance 10-1
- Programming Support 5-1
- Reliability 9-1
- Serviceability 9-1
- Unit Description 2-1

Unformatted Display Image C-1

**VIDEO/370:**

- Access Methods 5-16
- Automatic Duplication 5-13
- Checkpoint/Restart 5-12
- Commands 5-13

- Data Editing 5-11
- Data Security 5-12
- Error Correction 5-12
- Fields:
  - Balance 5-11
  - Total 5-11
- Format Definition 5-12
- Format Selection 5-13
- Function Keys 5-13, 5-14
- Hardware 5-14
- Modes:
  - Correction 5-13
  - Entry 5-12
  - Scan 5-13
  - Verification 5-13
- Operation 5-12
- Software 5-14
- Statistics Reports 5-12
- Storage Estimates 5-15
- Support Programs:
  - Extract 5-14
  - Format Definition 5-14
  - Statistical Report 5-14
- Tailoring 5-12, 5-15

World Trade Keyboards B3 through B-6

## READER'S COMMENT FORM

An Introduction to the IBM 3270 Information Display System

GA27-2739-3

Your comments about this publication may be helpful to us. If you wish to comment, please use the space provided below, giving specific page and paragraph references.

Please do not use this form to ask technical questions about the system or equipment or to make requests for copies of publications; this only delays the response. Instead, make such inquiries or requests to your IBM representative or to the IBM Branch Office serving your locality.

Reply requested

Yes

No

Name \_\_\_\_\_

Job Title \_\_\_\_\_

Address \_\_\_\_\_

\_\_\_\_\_ Zip \_\_\_\_\_

**Your comments, please . . .**

Your comments, together with your answer to the questions on the back of this form will help us produce better publications for your use. Your comments will be carefully reviewed by the persons responsible for writing and publishing this material. All comments and suggestions become the property of IBM.

Cut or Fold Along Line

Fold

Fold

First Class  
Permit 40  
Armonk  
New York

**Business Reply Mail**  
No postage stamp necessary if mailed in the U.S.A.

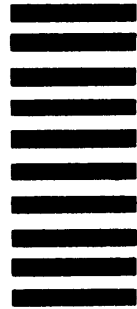

Postage will be paid by:

International Business Machines Corporation  
Department 520  
Neighborhood Road  
Kingston, New York 12401

Fold

Fold

Introduction to 3270 Information Display System Printed in U.S.A. GA27-2739-3



**International Business Machines Corporation**  
Data Processing Division  
1133 Westchester Avenue, White Plains, New York 10604  
(U.S.A. only)

**IBM World Trade Corporation**  
821 United Nations Plaza, New York, New York 10017  
(International)