

GA23-0065-6

File No. S360/S370/S3/4300/8100-09

IBM 3270
Information Display System

3274 Control Unit
Customizing Guide

Systems

Configuration Support D

Validation Number 34

Models 31 and 51
with 192K of Storage
(Feature 3650)

Models 41 and 61

IBM

GA23-0065-6
File No. S360/S370/S3/4300/8100-09

**IBM 3270
Information Display System**

**3274 Control Unit
Customizing Guide**

Systems

Configuration Support D

Validation Number 34

**Models 31 and 51
with 192K of Storage
(Feature 3650)**

Models 41 and 61

The IBM logo, consisting of the letters 'IBM' in a bold, sans-serif font, with each letter formed by eight horizontal bars of varying lengths, creating a striped effect.

Federal Communications Commission (FCC) Statement

Warning: This equipment generates, uses, and can radiate radio frequency energy and if not installed and used in accordance with the instruction manual, may cause interference to radio communications. It has been tested and found to comply with the limits for a Class A computing device pursuant to Subpart J of Part 15 of FCC Rules, which are designed to provide reasonable protection against such interference when operated in a commercial environment. Operation of this equipment in a residential area is likely to cause interference in which case the user at his own expense will be required to take whatever measures may be required to correct the interference.

IBM Statement

This warning is also applicable to all attaching units produced for use in the U.S.A. that have been manufactured after December 31, 1980. A notice of compliance has been affixed within the customer access area of all affected units.

Seventh Edition (September 1985)

This revision obsoletes GA23-0065-5. Changes or additions to the text and illustrations are indicated by a vertical line to the left of the change.

This publication is for planning only. Changes are made periodically to the information herein; before using this publication in connection with the operation of IBM systems or equipment, consult your IBM sales representative or the latest *IBM System/360 Bibliography*, GC20-0360, or *IBM System/370 and 4300 Processors Bibliography*, GC20-0001, for the editions that are applicable and current.

References in this publication to IBM products, programs, or services do not imply that IBM intends to make these available in all countries in which IBM operates. Any reference to an IBM program product in this publication is not intended to state or imply that only IBM's program product may be used. Any functionally equivalent program may be used instead.

Publications are not stocked at the address given below. Requests for IBM publications should be made to your IBM representative or to the IBM branch office serving your locality.

A form for readers' comments is provided at the back of this publication. If the form has been removed, address comments to IBM Corporation, Department 52Q, Neighborhood Road, Kingston, N.Y., U.S.A. 12401. IBM may use or distribute whatever information you supply in any way it believes appropriate without incurring any obligation to you.

Preface

This guide is written for customer personnel who are responsible for planning the installation of the IBM 3274 Control Unit with Configuration Support D only.

Organization of Manual

This guide has 6 chapters and 10 appendixes:

- Chapter 1, “Introduction to Customizing,” describes the customizing operation and how and by whom the 3274 customizing procedure is performed.
- Chapter 2, “Preparing to Customize,” describes the sequence numbers used in the 3274 customizing procedure. These sequence numbers are associated with functions and features of the 3274 and guide you through the customizing procedure. They are grouped by 3274 model.
- Chapter 3, “Initial Customizing Procedure,” explains how to perform the initial customizing of the 3274.
- Chapter 4, “Modification Procedure,” explains how to modify a 3274 configuration without performing the entire customizing procedure.
- Chapter 5, “Backup Diskette Generation Procedures,” explains how to generate a backup (duplicate) system or load diskette. You can use this procedure to create a duplicate of your system or load diskette.
- Chapter 6, “Update-Diskette Installation Procedures,” explains how to install an update-diskette package on your customized 3274.
- Appendix A, “Printer Authorization Matrix,” describes the printer authorization matrix, how to define it, and a quick method of updating it. You will need to refer to this appendix if you wish to use this function.
- Appendix B, “Port Host Address Assignment (User-Controlled),” explains how to assign host addresses to 3274 ports using sequence numbers 116, 117, and 118.
- Appendix C, “Subsystem Verification Procedure,” describes a procedure for verifying the 3274 subsystem after initial microcode load (IML) is performed.
- Appendix D, “Color Convergence Procedure,” describes a procedure for converging the color patterns on the 3279 Color Display Station during customizing.

- Appendix E, “Planning for 3274 Model 31C Modem Address Switch Settings,” tells you how to set the Modem Address switches if you have a 3274 Model 31C with an integrated modem.
- Appendix F, “Planning for 3274 Model 51C and 61C Switch Settings,” tells you how to set the Transmit Level, Line Speed, or Modem Address switches if you have a 3274 Model 51C. This appendix also tells you how to set the Line Speed switches if you have a 3274 Model 61C.
- Appendix G, “Response Time Monitor Customizing Information,” briefly describes the RTM function and provides background information needed to answer the two customizing questions for RTM, sequence numbers 127 and 128.
- Appendix H, “Alert Function Customizing Information (Sequence Number 220),” briefly describes the alert function and provides background information needed to answer the customizing question for alert, sequence number 220.
- Appendix I, “X.25 Customizing Information (Sequence Number 332),” tells you how to customize remote models of the 3274 Control Unit for the X.25 interface.
- Appendix J, “Keyboard Layouts for Sequence Numbers 136, 138, 139, and 166,” contains the keyboard diagrams referred to in Chapter 3 for these sequence numbers.

A list of abbreviations used in this manual and an index follow Appendix J.

Related Publications

For detailed information about the functions and features of the 3270 Information Display System units, see the latest editions of:

- *IBM 3270 Information Display System: Introduction*, GA27-2739, which describes the 3270 hardware units and capabilities, lists programming support, and suggests typical applications.
- *IBM 3270 Information Display System: 3274 Control Unit Description and Programmer’s Guide*, GA23-0061, which provides system level information regarding the functional and programming characteristics of the 3274 Control Unit and attached terminals.
- *IBM 3270 Information Display System: 3274 Control Unit Site Planning and Preparation Guide*, GA23-0064, which provides 3274-specific planning information, including predelivery planning and cabling.
- *IBM 3270 Information Display System: Installation Manual—Physical Planning*, GA27-2787, which provides physical planning information for the 3270 units, including floor planning, electrical and environmental requirements, cabling, and machine specifications and descriptions.

- *IBM 3270 Information Display System: Character Set Reference*, GA27-2837, which illustrates keyboard layouts and character set codes available with the 3270 display system both in the United States and in World Trade countries.
- *IBM 3270 Personal Computer Introduction and Preinstallation Planning*, GA23-0179, which provides information for evaluating and planning the installation of the IBM 3270 Personal Computer and planning the customization of the IBM 3274 Control Unit.
- *IBM 3179-G Color Graphics Display Station Description*, GA18-2261, which provides introductory and programming information.
- *IBM 3290 Information Panel: Description and Reference*, GA23-0021, which provides introductory and programming information.

See the *IBM 3270 Information Display System: Library User's Guide*, GA23-0058, for a list of 3270 Information Display System manuals.

Contents

Chapter 1. Introduction to Customizing	1-1
Distributed Function Terminals	1-2
3290 Compatibility with the Host	1-3
Subsystem Verification	1-3
IBM 3270 Personal Computer Compatibility with the 3274	1-3
3274 Model 31C, 51C, and 61C Switch Settings	1-3
Configuration Support	1-4
Preparation for Customizing	1-4
Local Copy Utility Routine	1-7
Chapter 2. Preparing to Customize	2-1
3274 Models 31A and 41A	2-3
001: Keyboard and Customizing Guide Validation	2-3
011: Patch Request	2-3
021: Printer Authorization Matrix	2-3
022: Printer Authorization Matrix Definition	2-4
031: Number of RPQ Diskettes Required	2-4
032: Request RPQ Parameter List	2-4
111: Number of Category B Terminals (Model 31A Only)	2-4
112: Number of Category A Terminals	2-5
113: Extended Function Store	2-6
114: IBM 3270 Personal Computer Attachment	2-7
115: Entry Assist Function	2-7
116: User-Controlled Port Assignment Request	2-8
117: Port Assignment Specification Table	2-8
118: Port Address Table	2-8
121: Keyboard Language/Character Set I/O Interface Code	2-9
125: Miscellaneous Feature Options	2-10
127: Response Time Monitor (RTM) Definition	2-11
128: RTM Boundaries and Interface Specification	2-11
136: Modifiable Keyboard Layout Selection – Unmodified Layouts	2-12
137: Modifiable Keyboard Selection – Modified Layouts	2-12
138: Modifiable Keypad Selection – Unmodified Layout	2-13
139: 3290 Keypad Selection	2-13
141: Magnetic Character Set	2-14
151: 3274 Model Designation	2-14
160: Extended Data Stream	2-14
161: Color Convergence	2-15
165: Decompression	2-15
166: Attribute Select Keyboard	2-15
170: Distributed Function Terminals	2-16
173: Distributed Function Terminal (DFT) Options	2-16
175: 3290 Password	2-18
201: SNA Local Channel Control Unit Address	2-18
213: Between Bracket Printer Sharing	2-18
215: Physical Unit Identification (PUID)	2-18
220: Alert Function	2-18
900: Entry Acceptance	2-19

999: Specification Panel	2-19
3274 Models 31C, 41C, 51C, and 61C	2-21
001: Keyboard and Customizing Guide Validation	2-21
011: Patch Request	2-21
021: Printer Authorization Matrix	2-23
022: Printer Authorization Matrix Definition	2-23
031: Number of RPQ Diskettes Required	2-23
032: Request RPQ Parameter List	2-23
111: Number of Category B Terminals (Models 31C and 51C Only)	2-24
112: Number of Category A Terminals	2-24
113: Extended Function Store	2-26
114: IBM 3270 Personal Computer Attachment	2-27
115: Entry Assist Function	2-27
116: User-Controlled Port Assignment Request	2-27
117: Port Assignment Specification Table	2-28
118: Port Address Table	2-28
121: Keyboard Language/Character Set I/O Interface Code	2-28
125: Miscellaneous Feature Options	2-30
127: Response Time Monitor (RTM) Definition	2-31
128: RTM Boundaries and Interface Specification	2-32
136: Modifiable Keyboard Layout Selection — Unmodified Layouts	2-32
137: Modifiable Keyboard Selection — Modified Layouts	2-32
138: Modifiable Keypad Selection — Unmodified Layouts	2-33
139: 3290 Keypad Selection	2-33
141: Magnetic Character Set	2-34
151: 3274 Model Designation	2-34
160: Extended Data Stream	2-34
161: Color Convergence	2-35
165: Decompression	2-35
166: Attribute Select Keyboard	2-35
170: Distributed Function Terminals	2-36
173: Distributed Function Terminal (DFT) Options	2-36
175: 3290 Password	2-38
176: BSC Enhanced Communication Option (Distributed Function Terminals)	2-38
213: Between Bracket Printer Sharing (SDLC Only)	2-39
215: Physical Unit Identification (PUID) (SDLC Only)	2-39
220: Alert Function (SNA Only)	2-39
301: Control Unit Number (BSC Only)	2-39
302: SDLC Control Unit Address/X.25 Secondary Station Address	2-40
305: BSC Printer Polling	2-41
310: Modem Connection	2-41
311: Modem Wrap (External Modems Only)	2-41
313: NRZI (SDLC Only) or NRZ Encoding	2-41
313: Internal or External Clocking (BSC Only)	2-42
314: Multipoint or Point-to-Point Network	2-42
317: Switched Network Backup (SNBU)	2-42
318: Normal or Half-Speed Transmission	2-42
331: BSC/SDLC/X.25 Protocol	2-43
332: X.25 Customization Panel	2-43
342: Request-to-Send (RTS) Control (2-Wire or 4-Wire)	2-43
343: Communication Interface Options	2-44
345: Answer Tone (World Trade External Switched Network Modems Only)	2-45

347: High-Speed Data Rate (Loop Attachment Only; Models 51C and 61C Only)	2-45
351: HPCA (SDLC Only) or CCA Adapter	2-45
352: Encrypt/Decrypt (SDLC Only)	2-45
360: X.21 Switched Retry (SDLC Only)	2-45
361: X.21 Switched Retry Timing (SDLC Only)	2-45
362: X.21 Switched Options (SDLC Only)	2-46
900: Entry Acceptance	2-46
999: Specification Panel	2-47
3274 Models 31D and 41D	2-49
001: Keyboard and Customizing Guide Validation	2-49
011: Patch Request	2-49
021: Printer Authorization Matrix	2-49
022: Printer Authorization Matrix Definition	2-50
031: Number of RPQ Diskettes Required	2-50
032: Request RPQ Parameter List	2-50
111: Number of Category B Terminals	2-50
112: Number of Category A Terminals	2-51
113: Extended Function Store	2-52
114: IBM 3270 Personal Computer Attachment	2-53
115: Entry Assist Function	2-53
116: User-Controlled Port Assignment Request	2-54
117: Port Assignment Specification Table	2-54
118: Port Address Table	2-54
121: Keyboard Language/Character Set I/O Interface Code	2-55
125: Miscellaneous Feature Options	2-56
127: Response Time Monitor (RTM) Definition	2-57
128: RTM Boundaries and Interface Specification	2-57
136: Modifiable Keyboard Layout Selection — Unmodified Layouts	2-58
137: Modifiable Keyboard Selection — Modified Layouts	2-58
138: Modifiable Keypad Selection — Unmodified Layout	2-59
139: 3290 Keypad Selection	2-59
141: Magnetic Character Set	2-60
151: 3274 Model Designation	2-60
160: Extended Data Stream	2-60
161: Color Convergence	2-61
165: Decompression	2-61
166: Attribute Select Keyboard	2-61
170: Distributed Function Terminals	2-62
173: Distributed Function Terminal (DFT) Options	2-62
175: 3290 Password	2-64
900: Entry Acceptance	2-64
999: Specification Panel	2-64

Chapter 3. Initial Customizing Procedure 3-1

Chapter 4. Modification Procedure 4-1

Chapter 5. Backup Diskette Generation Procedures 5-1

Backup System Diskette Generation Procedure 5-1

Backup Load Diskette Generation Procedure 5-2

Chapter 6. Update-Diskette Installation Procedures 6-1

RPQ Update-Diskette Installation 6-1

Language Update-Diskette Installation	6-1
Feature, System, and Load Update-Diskette Installation	6-2
Procedure for Updating with New Feature and New System Diskettes	6-2
Procedure for Updating with a New Load Diskette Only	6-4
Appendix A. Printer Authorization Matrix	A-1
Description	A-1
Printer Modes	A-1
Printer Class Structure	A-2
Source Device Lists	A-3
Matrix Structure	A-3
Defining the Printer Authorization Matrix during Customizing	A-5
Appendix B. Port Host Address Assignment (User-Controlled)	B-1
Guidelines	B-1
Multiple Interactive Screens Feature	B-1
Procedures 1 and 2	B-2
Conserving Channel Addresses	B-2
Printer Authorization Matrix	B-3
Sequence Numbers 117 and 118	B-3
Procedure 1 (116=1)	B-3
Sequence of Operations	B-3
Category B Terminals	B-4
Examples – Procedure 1	B-10
Procedure 2 (116=2)	B-22
Sequence of Operations	B-22
Port Assignment Operator Procedure (Sequence Number 117)	B-29
Appendix C. Subsystem Verification Procedure	C-1
Appendix D. Color Convergence Procedure	D-1
Operator Instructions	D-1
Convergence Procedure	D-1
Error Conditions	D-3
Appendix E. Planning for 3274 Model 31C Modem Address Switch Settings	E-1
Modem Address Switches (Integrated Modems Only)	E-1
Instructions for Setting 3274 Model 31C Modem Address Switches	E-2
Appendix F. Planning for 3274 Model 51C and 61C Switch Settings	F-1
Transmit Level Switches (1200 BPS Integrated Modem, U.S. and Canada Only)	F-1
Instructions for Setting 3274 Model 51C Transmit Level Switches (U.S. and Canada Only)	F-3
Loop Data Speed Switches (Loop Adapter Feature Only)	F-5
Instructions for Setting 3274 Model 51C and 61C Loop Data Speed Switches	F-6
Modem Address Switches (Integrated Modems with Speeds Greater Than 1200 BPS Only)	F-8
Instructions for Setting 3274 Model 51C Modem Address Switches	F-9

Appendix G. Response Time Monitor (RTM) Customizing Information G-1

RTM Requirements G-1
Host Interface G-1
RTM Description G-2
 Sequence Number 127 G-2
 Sequence Number 128 G-4

Appendix H. Alert Function Customizing Information (Sequence Number 220) H-1

Operator-Generated Alert Message H-1

Appendix I. X.25 Customizing Information (Sequence Number 332) I-1

X.25 – A Brief Description I-1
Customizing the 3274 I-2
Sequence Number 332: X.25 Customization Panel I-3
X.25 Customizing Questions I-4
 400 Network Type I-4
 401 Circuit Type (I/O) I-4
 402 Logical Channel Identifier I-5
 403 Logical Link Control I-5
 410 Host DTE Address (HNAD) I-5
 411 3274 DTE Address I-5
 420 Incoming Call Options I-6
 421 Outgoing Call Options I-7
 430 Negotiated Packet Size (NPKT) I-8
 431 Packet Sequence Numbering I-8
 432 Negotiated Window Size (NWND) I-8
 433 K-Maximum Out I-9
 434 Nonstandard Default Packet Size (DPKT) I-9
 435 Nonstandard Default Window Size (DWND) I-9
 440 Throughput Class Negotiation (TCLS) I-10
 441 Closed User Group (CUG) I-10
 442 Recognized Private Operating Agency (RPOA) I-11
 443 X.25 Keyboard Support Options I-11
 450 Link Level Transmit Timeout I-13
 451 Number of Retries I-13
 452 Connection Identifier Password (CID) I-13

Appendix J. Keyboard Layouts for Sequence Numbers 136, 138, 139, and 166 J-1

List of Abbreviations X-1

Index X-3

Figures

- 1-1. Configuration Information Needed 1-8
- 2-1. 3274 Model 31A Category A and B Terminal Quantity Relationships 2-7
- 2-2. 3274 Model 31A and 41A Keyboard Language and Character Set I/O Interface Code 2-9
- 2-3. Default Values 2-22
- 2-4. 3274 Model 31C and 51C Category A and B Terminal Quantity Relationships 2-26
- 2-5. 3274 Model 31C, 41C, 51C, and 61C Keyboard Language and Character Set I/O Interface Code 2-29
- 2-6. Chart of BSC Polling Address and Control Unit Number Conversion 2-40
- 2-7. Communication Interface Options (Sequence Number 343) 2-44
- 2-8. 3274 Model 31D Category A and B Terminal Quantity Relationships 2-53
- 2-9. 3274 Model 31D and 41D Keyboard Language and Character Set I/O Interface Code 2-55
- 3-1. Valid Key Positions during Customizing 3-11
- 3-2. Valid Key Positions during Customizing When Japanese Katakana and Japanese English Keyboards Are Used 3-12
- 3-3. Inserting a Diskette into the 3274 Control Unit during Customizing 3-13
- 3-4. Operator Codes during Customizing 3-16
- 3-5. Steady 8 4 2 1 Indicator Codes during Customizing Only 3-20
- 3-6. Flashing 8 4 2 1 Indicator Codes during Customizing Only 3-21
- 3-7. 8 4 2 1 Indicator Codes during IML That May Result from an Incorrect Customizing Procedure 3-22
- 4-1. Valid Key Positions during Modification Procedure 4-9
- 4-2. Valid Key Positions during Modification Procedure When Japanese Katakana and Japanese English Keyboards Are Used 4-10
- 4-3. Inserting a Diskette into the 3274 Control Unit during Modification 4-11
- 4-4. Operator Codes during Modification Procedure 4-14
- 4-5. Steady 8 4 2 1 Indicator Codes during Modification Procedure Only 4-18
- 4-6. Flashing 8 4 2 1 Indicator Codes during Modification Procedure Only 4-19
- 4-7. 8 4 2 1 Indicator Codes during IML That May Result from an Incorrect Modification Procedure 4-20
- 5-1. Valid Key Positions during Backup Diskette Generation 5-11
- 5-2. Valid Key Positions during Backup Diskette Generation When Japanese Katakana and Japanese English Keyboards Are Used 5-12
- 5-3. Inserting a Diskette into the 3274 Control Unit during Backup Diskette Generation 5-13
- 5-4. Operator Codes during Backup-Diskette Generation 5-16
- 5-5. Steady 8 4 2 1 Indicator Codes during Backup-Diskette Generation Only 5-20
- 5-6. Flashing 8 4 2 1 Indicator Codes during Backup-Diskette Generation Only 5-21

- 5-7. 8 4 2 1 Indicator Codes during IML That May Result from
Incorrect Backup-Diskette Generation 5-22
- 6-1. Steady 8 4 2 1 Indicator Error Codes during Update-Diskette
Procedure 6-5
- 6-2. Flashing 8 4 2 1 Indicator Error Codes during Update-Diskette
Procedure 6-5
- A-1. Example of a Printer Authorization Matrix A-4
- A-2. Example of a Completed Printer Authorization Matrix Form A-6
- A-3. Example of a Printer Authorization Matrix Worksheet (Models 31A,
31C, 31D, 41A, 41C, and 41D) A-7
- A-4. Sample Printer Authorization Matrix Worksheet (Models 31A, 31C,
31D, 41A, 41C, and 41D) A-8
- A-5. Sample Printer Authorization Matrix Worksheet (Models 51C and
61C) A-9
- B-1. Port Assignment Specification Table (Procedure 1, CS-D/Releases
60–63) B-5
- B-2. Port Assignment Specification Table (Procedure 1, CS-D/Release
64) B-6
- B-3. Port Address Table with Multiple Interactive Screens (Procedure 1,
CS-D/Releases 60–63) B-7
- B-4. Port Address Table with Multiple Interactive Screens (Procedure 1,
CS-D/Release 64) B-8
- B-5. Port Address Table with Category B Terminals (Procedure 1,
CS-D/Releases 60–63) B-9
- B-6. Port Address Table with Category B Terminals (Procedure 1,
CS-D/Release 64) B-10
- B-7. Example 1 (Procedure 1) Configuration B-12
- B-8. Port Assignment Specification Table and Port Address Table for
Example 1 (Procedure 1, CS-D/Releases 60–63) B-13
- B-9. Port Assignment Specification Table and Port Address Table for
Example 1 (Procedure 1, CS-D/Release 64) B-14
- B-10. Example 2 (Procedure 1) Configuration Showing Assigned
Addresses B-16
- B-11. Port Assignment Specification Table and Port Address Table for
Example 2 (Procedure 1, CS-D/Releases 60–63) B-17
- B-12. Port Assignment Specification Table and Port Address Table for
Example 2 (Procedure 1, CS-D/Release 64) B-18
- B-13. Example of Host View of Multiple Interactive Screen Addressing
(Example 2, Procedure 1) B-19
- B-14. Port Assignment Specification Table and Port Address Table for
Example 3 (Procedure 1, CS-D/Releases 60–63) B-20
- B-15. Port Assignment Specification Table and Port Address Table for
Example 3 (Procedure 1, CS-D/Release 64) B-21
- B-16. Port Assignment Specification Table (Procedure 2, CS-D/Release
64) B-23
- B-17. Port Assignment Specification Table and Port Address Table
(Procedure 2, CS-D/Release 64) B-24
- B-18. Incorrect Address Specifications B-25
- D-1. Examples of Unconverged and Converged Display Screens D-2
- E-1. Conversion of BSC and SDLC Control Unit Addresses to
Binary-Equivalent Modem Address Switch Settings on 3274 Model
31C E-1
- E-2. Example of 3274 Model 31C Modem Address Switch Settings E-2
- F-1. 3274 Model 51C Transmit Level Switches F-2
- F-2. Loop Data Speed Switch Settings F-5

- F-3. Conversion of BSC Control Unit Address and SDLC Control Unit Address to Binary-Equivalent Modem Address Switch Settings on 3274 Model 51C F-8
- F-4. Example of 3274 Model 51C Modem Address Switch Settings F-8
- G-1. Counters and Boundaries G-7
- I-1. Sequence Number 332 Panel I-3
- J-1. Modifiable Keyboards (English - U.S.) J-2
- J-2. Modifiable Keypads (English - U.S.) J-4
- J-3. 3290 Keypads J-5
- J-4. Attribute Select Keyboard (English - U.S.) J-6

Summary of Changes

Seventh Edition (September 1985)

- Customizing information has been added for the IBM 3179-G Color Graphics Display Station.
- “Appendix B. Port Host Address Assignment (User-Controlled)” has been enhanced with updated examples and editorial clarifications.
- Minor technical corrections and editorial clarifications have been made throughout the publication.

Sixth Edition (November 1984)

- A new port address assignment capability enables reconfiguration of a terminal cluster (especially the addition of distributed function terminals) with minimal rework required at the host system. See sequence number 116 (in Chapter 2) and Appendix B.
- A local copy utility routine has been added. Copies of customization panels can now be requested via the Print key. See Chapter 1.
- A 3290 field intensify option has been added to sequence number 173. See Chapter 2.
- Minor technical corrections and editorial changes have been made throughout the publication.

Fifth Edition (August 1984)

- Changes from the fourth edition are indicated by a revision bar to the left of the change.
- A new chapter, “Chapter 6. Update-Diskette Installation Procedures,” has been added. This information was in Appendix J.
- “Appendix J. Keyboard Layouts” contains illustrations of the keyboard types referred to in the customizing questions.
- Model designations in Chapter 2 are now indicated by a tab on each page. The running-head model designations have been deleted.
- Technical corrections and clarifications have been made in Chapters 1 through 5 and in Appendixes A, C, and D.

Chapter 1. Introduction to Customizing

Once installation of your 3274 Control Unit is completed as shown in the appropriate "Setup Instructions," and the device cables are connected, you are ready to configure your system of displays and printers. The 3274 Control Unit permits you, the user, to specify the configuration in which your 3274 operates; that is, you customize your 3274 subsystem. The configuration information is stored on a diskette mounted inside the 3274 and enables the 3274 to control all the terminals attached to it. This diskette, delivered with the 3274, also contains microcode to direct control unit functions and perform diagnostic routines to test the 3274 prior to operation. But, before this diskette can function in your system, you must customize it by writing your configuration information on it.

Briefly, you perform customizing by typing in the system parameters at a 3178, 3179, 3180, 3278, or a 3279 attached to port A0 of the 3274. If a 3179 is used, it must be operating in 3279-emulation mode. If a 3180 is used, it must be operating in 3278-emulation mode. As a result of this procedure, a unique configuration table is written on the diskette. If 3290 Information Panels or 3179-G Color Graphics Display Stations are being used with the 3274, the configuration table is written onto a *load* diskette. If no 3290s or 3179-Gs are being used, the configuration table is written onto a *system* diskette. In daily operations, the operator inserts this customized diskette in the 3274 and presses the on/off switch to the on position, or, if this switch is already on, presses the IML pushbutton. This action causes the 3274 to execute the diagnostic routines stored on the diskette. Upon successful completion of these tests, the 3274 is loaded with the configuration that was stored on the diskette by the customizing procedure. System operation can now begin.

There are various occasions when it will be necessary to customize your system or load diskette(s):

- When you initially customize your diskette (as described above).
- When you wish to duplicate your diskette. (This new diskette is referred to as a *backup* diskette.)
- When you wish to generate a second diskette to be used for a different purpose; for example, you may choose to have one diskette to operate in binary synchronous communication (BSC) mode and another to operate in Synchronous Data Link Control/systems network architecture (SDLC/SNA) mode.
- When you need to recustomize your diskette because you have changed your configuration. This includes adding or removing features such as Encrypt/Decrypt or terminal adapters.

Customizing a 3274 Control Unit usually involves a planner and someone responsible for the actual customizing operation. The planner identifies and compiles the configuration information needed for each 3274 and gives it to the person responsible for customizing the 3274. This person is prompted by a series of sequence numbers displayed in the form of three digits. The responses to these sequence numbers are alphanumeric characters. The display station used for this operation must be attached to port A0 of the 3274. The display station should also be near the 3274 during customizing, because certain indicators must be observed on the 3274. (If you are using a 3279 Color Display Station, a color convergence procedure may have to be performed before customizing. The color convergence procedure is described in Appendix D.)

In general, the person who customizes the system or load diskette uses a *language* diskette and a *feature* diskette in conjunction with the customizing procedure. The language diskette is used to customize the system diskette for languages other than English (U.S.), Canadian (French), and Canadian (Bilingual) (all are extended binary-coded decimal interchange code [EBCDIC]), and American National Standard Code for Information Interchange (ASCII) (U.S.).¹ The language diskette is also used to run the precustomizing Keyboard Definition Utility. Refer to *Keyboard Definition Utility User's Guide*, GA23-0187, for more information. The feature diskette is used to customize the system or load diskette for all other cluster parameters. The detailed customizing procedures explain when to insert the required diskettes and direct the person customizing the 3274 to enter the configuration information into the 3274 through a display station attached to port A0 of the 3274.

To simplify the customizing task, it is recommended that the planner compile the configuration information and supply it to the person responsible for performing the customizing procedure. Included in Chapter 2 are descriptions of the parameters to be entered and instructions for completing the Initial Customizing Procedure Form (in Chapter 3). A form should be completed for each 3274 ordered before delivery of the unit. In addition, configuration information should be copied on the *IBM 3274 Control Unit Configuration Data Card (Configuration Support: D)*, GA23-0114 (shipped with the 3274), and stored in the 3274.

Distributed Function Terminals

The phrase *distributed function terminals* is used in this publication. The terminals in this category are:

IBM 3179-G Color Graphics Display Station

IBM 3270 Personal Computer

IBM 3290 Information Panel

IBM 5550 3270/Personal Computer

¹ ASCII is available in the United States only.

3290 Compatibility with the Host

If any 3290 Information Panels are included in the subsystem, check to see whether setup level 3 changes are required to make the 3290s compatible with their definition at the host. If so, after customizing is completed and an initial microcode load (IML) of the system performed, it may be necessary to set the control unit offline before switching on the 3290. Otherwise, errors may occur when the host attempts to communicate with the 3290.

Subsystem Verification

After customizing is completed, all devices are attached to the 3274, and an IML of the subsystem has been performed, it should be verified that the control unit can reach all attached devices. This can be done by means of the Subsystem Verification Procedure in Appendix C. This procedure allows the operator to:

- Verify the number of Type A and B devices configured
- Determine whether a device is powered on or off
- Determine whether a device has been disabled as a result of a device error.

This procedure should be given to the person responsible for performing the customizing procedure.

IBM 3270 Personal Computer Compatibility with the 3274

If any IBM 3270 Personal Computers are included in the subsystem, obtain a copy of the Information Worksheet that is used for customizing the IBM 3270 Personal Computer system diskette. Make sure that the information on this worksheet agrees with the responses given to the sequence numbers during 3274 customizing. Refer to *IBM 3270 Personal Computer Introduction and Preinstallation Planning*, GA23-0179, for more information.

3274 Model 31C, 51C, and 61C Switch Settings

It may be necessary to set various switches on the 3274 Models 31C, 51C, and 61C prior to operation. Information needed to set these switches is given in Appendix E for Model 31C and in Appendix F for Models 51C and 61C. Instructions for the person who will do the customizing are also included in these appendixes.

Configuration Support

Configuration Support D includes support for the following functions:

- All Category A Terminals and their functions/features
- All Category B Terminals and their functions/features
- 3270 Personal Computer Attachment
- X.21 Switched Network
- Extended Color on attached terminals
- Extended Highlighting on attached terminals
- Integrated Modems
- ASCII
- APL/Text Control
- 3289 Text Print Control
- Host Loadable Printer Authorization Matrix
- Between Bracket Printer Sharing
- SCS Printer Support
- Magnetic Reader Control
- Color Convergence
- Structured Field and Attribute Processing
- Programmed Symbols
- Decompression of Programmed Symbols load data
- Copy (Print Key Function)
- Solicitation of summary maintenance statistics
- Pacing of inbound message traffic
- Automatic session recovery in both single- and multidomain networks
- Host notification of changes in attached terminal power on/off status
- BSC Text Blocking
- BSC Transparency
- Entry Assist
- Response Time Monitor
- Alert function (Models 41A, 41C/SNA, and 61C/SNA)
- X.25 data transmission services (Models 41C and 61C with 256K)
- 3180 Model 1 display station scrolling support
- Keyboard Definition Utility for the 3179 and 3180 Model 1
- 4250 printer attachment (Models 41A and 41D only)

Some functions are either available on all models or not applicable.

When new function or maintenance enhancements are added to a configuration support, IBM sends its customers, at their request, an update diskette. The *Update-Diskette Installation Procedures* are in Chapter 6.

Preparation for Customizing

To prepare for customizing, it is recommended that the planner:

1. Use the sequence-number descriptions in Chapter 2 as a guide to determine what configuration information is needed for each 3274 model. Figure 1-1 and the sequence-number descriptions identify the information sources.

2. Using Figure 1-1 as a guide and the sequence-number descriptions in Chapter 2, compile the needed information for each 3274 and fill in the Initial Customizing Procedure Form in Chapter 3.

Note: The sequence-number descriptions in Chapter 2 are grouped by 3274 model, as follows: A Models, C Models, D Models.

3. Identify each diskette. A label in the upper right corner of the diskette identifies the diskette type by name, IBM part number, configuration support release number, and validation number. The IBM part numbers are:

Feature diskette	6016490
System diskette	6016492
Language diskette	6016571
Load diskette	6062858

Note: The validation number identifies the level of Customizing Guide that can be used to customize the system diskette. The validation number is increased when new or changed sequence numbers and responses are included in a new release of microcode. The validation number of the Customizing Guide (and thus the customizing procedure) must be equal to or greater than the validation number printed on the diskette labels. Do not use a Customizing Guide with a validation number that is lower than the validation number printed on the diskette labels.

In addition, you may wish to write a unique designation of your own on the label; for example, you could specifically identify the diskette as to configuration and 3274 Control Unit in which it is to be customized and used.

4. Enter the following information on the Initial Customizing Procedure Form in Chapter 3:

- a. The type of keyboard (typewriter or data entry) to be used by the operator during customizing.

Note: If using a 76- or 88-key Japanese English or Japanese Katakana keyboard, specify the number of keys and the keyboard type.

- b. In step 1, the identification of each diskette to be used.
- c. In step 7, the response to sequence number 031. This is the number (0, 1, 2, or 3) of RPQ diskettes to be used. If your response to sequence number 031 is not 0, you will have to enter a response to sequence number 032. See "032 (Request RPQ Parameter List)" in Chapter 2.
- d. In steps 8, 10, 11, and 12, the responses to be keyed in by the operator, using as a guide the information in Chapter 2 that applies to the model to be customized. Do the steps that apply to your configuration.

5. Fill out the additional forms that will be needed for this customization:
 - Printer Authorization Matrix Form (end of Chapter 3)
 - Port Assignment Entry Form and Port Address Table (Appendix B)
 - RTM Boundaries and Interface Form (Appendix G)
 - X.25 Customization Response Form (Appendix I).

6. Make a package of these items to give to the operator who will customize the 3274:
 - A copy of the keyboard layout showing the valid keys for the keyboard the operator will use (Figures 3-1 and 3-2, in Chapter 3)
 - Customizing Forms
 - The completed Initial Customizing Procedure Form
 - A copy of the *IBM 3274 Control Unit Configuration Data Card (Configuration Support: D)*, GA23-0114
 - The completed Printer Authorization Matrix Form, if necessary (end of Chapter 3)
 - The completed Port Assignment Entry Form, if necessary (Appendix B)
 - The completed RTM Boundaries and Interface Form, if necessary (Appendix G)
 - The completed X.25 Customization Response Form, if necessary (Appendix I)
 - Procedures
 - The 3274 Diskette Insertion Procedure for the model being customized (Figure 3-3, in Chapter 3)
 - The Color Convergence Procedure, if necessary (Appendix D)
 - RPQ parameter list instructions supplied with the RPQ, if necessary
 - The Subsystem Verification Procedure (Appendix C)
 - Instructions for setting Model 31C switches, if necessary (Appendix E)
 - Instructions for setting Model 51C or 61C switches, if necessary (Appendix F)

- Code Charts
 - The Operator Codes Chart (Figure 3-4, in Chapter 3)
 - The “8 4 2 1 Indicator Codes” charts (Figures 3-5 through 3-7)
- Diskettes
 - Feature and system diskettes
 - Language diskette, if necessary
 - Load diskette, if necessary
 - RPQ diskette(s), if necessary

If convenient, the planner at the central or host-system location can prepare the Initial Customizing Procedure Forms for several 3274s at other locations and forward the forms to each location.

Local Copy Utility Routine

A local copy utility routine is included in the customization program so that you can make a copy of the customization panel currently displayed. Pressing the Print key at the display station attached to port 0 initiates the copy operation.

The local copy utility routine functions as follows:

- The first printer to be powered on after IML is the local copy utility routine printer. The printer may be on any port (other than port 0).
- The printer assignment cannot be changed with the Print-ID key.
- The printer assignment can be changed by powering off the current printer and powering on another printer.
- The printer assignment symbol is displayed in the operator information area (OIA) of the display, as are any other appropriate symbols.
- A second copy request issued while the printer is busy with a previous request is queued. A third copy request causes the operator retry symbol to be displayed in the operator information area.
- Pressing the Device Cancel key cancels a queued copy request.

Sequence Number	Function	31A, 41A ¹	31C, 41C ¹	51C, 61C ¹	31D, 41D ¹	Notes	Response Definition
001	Keyboard validation	X	X	X	X	1	—
011	Patch request	X	X	X	X	1	—
021	Printer authorization matrix	X	X	X	X	2	0=No 1=Yes
022	Printer authorization matrix definition	X	X	X	X	1	See Chapter 2 and Appendix A.
031	Number of RPO diskettes required	X	X	X	X	3	0=Not required 1=One diskette required 2=Two diskettes required 3=Three diskettes required
032	Request RPO parameter list	X	X	X	X	4	0=No 1=Yes
111	Number of Category B terminals	X	X	X	X	—	See Chapter 2.
112	Number of Category A terminals	X	X	X	X	—	See Chapter 2.
113	Extended function store	X	X	X	X	3	See Chapter 2.
114	IBM 3270 Personal Computer Attachment	X	X	X	X	—	0=No 1=Yes
115	Entry Assist Function	X	X	X	X	—	0=No 1=Yes
116	User-controlled port assignment request	X	X	X	X	—	0=No 1=Program-assigned addresses, 2=User-assigned addresses
117	Port assignment specification table	X	X	X	X	—	See Chapter 2.
118	Port address table	X	X	X	X	—	See Chapter 2.
121	Keyboard language/character set I/O interface code	X	X	X	X	3	See Chapter 2.
125	Miscellaneous feature options	X	X	X	X	2	See Chapter 2.
127	RTM definition	X	X	X	X	—	See Chapter 2.
128	RTM boundaries and interface specification	X	X	X	X	—	See Chapter 2 and Appendix G.
136	Modifiable keyboard selection—unmodified	X	X	X	X	—	See Chapter 2.
137	Modifiable keyboard selection—modified	X	X	X	X	8	See Chapter 2.
138	Modifiable keypad selection—unmodified	X	X	X	X	—	See Chapter 2.
139	3290 keypad selection	X	X	X	X	—	See Chapter 2.
141	Magnetic character set	X	X	X	X	3	A=No B=Numeric (3277-compatible) C=Alphanumeric (auto entry for non-display data) D=Alphanumeric (auto entry for all data)
151	3274 model designation	X	X	X	X	3	Enter model number.
160	Extended data stream	X	X	X	X	3	0=No 1=Yes
161	Color convergence	X	X	X	X	3	0=No 1=Yes
165	Decompression	X	X	X	X	3	0=No 1=Yes
166	Attribute Select keyboard	X	X	X	X	—	A=None B=Without numeric lock C=With numeric lock
170	Distributed function terminals	X	X	X	X	—	See Chapter 2.

Figure 1-1 (Part 1 of 3). Configuration Information Needed

Sequence Number	Function	31A, 41A ¹	31C, 41C ¹	51C, 61C ¹	31D, 41D ¹	Notes	Response Definition
173	DFT options	X	X	X	X	—	See Chapter 2.
175	3290 Password	X	X	X	X	—	See Chapter 2.
176	BSC enhanced communication option (distributed function terminals)	—	X	X	—	2	0=No 1=Yes
201	SNA local channel control unit address	X	—	—	—	2	See Chapter 2.
213	Between bracket printer sharing	X	X	X	—	2	0=No 1=Yes
215	Physical unit identification (PUID)	X	X	X	—	2	See Chapter 2.
220	Alert (SNA only)	X	X	X	—	—	See Chapter 2 and Appendix H.
301	Control unit number (BSC only)	—	X	X	—	2	See Chapter 2.
302	SDLC control unit address/ X.25 secondary station address	—	X	X	—	2	See Chapter 2.
305	BSC printer polling	—	X	X	—	5	0=No 1=Yes
310	Modem connection	—	X	X	—	3	See Chapter 2.
311	Modem wrap (external modems only)	—	X	X	—	3	0=Not possible 1=Possible
313	NRZI (SDLC only) or NRZ encoding	—	X	X	—	3,6	0=NRZ 1=NRZI
313	Internal or external clocking (BSC only)	—	X	X	—	5	0=External 1=Internal
314	Multipoint or point-to-point network	—	X	X	—	3,6	0=Multipoint 1=Point-to-point
317	Switched network backup (SNBU)	—	X	X	—	3,6	See Chapter 2.
318	Normal or half-speed transmission	—	X	X	—	3,6	0=Normal 1=Half
331	BSC/SDLC/X.25 protocol	—	X	X	—	3,6	0=BSC 1=SDLC 2=X.25
332	X.25 customization panel	—	X	X	—	3	See Chapter 2 and Appendix I.
342	Request-to-Send (RTS) control (2-wire or 4-wire)	—	X	X	—	3,6	See Chapter 2.
343	Communication interface options	—	X	X	—	3,6	See Chapter 2.
345	Answer tone (World Trade external switched network modems only)	—	—	X	—	—	0=Transmit Answer Tone Required 1=Transmit Answer Tone Not Required
347	High-speed data rate (loop attachment only; Models 51C and 61C only)	—	—	X	—	—	0=Data rate less than 38.4K 1=Data rate 38.4
351	HPCA (SDLC only) or CCA adapter	—	X	X	—	3,6	0=CCA 1=HPCA
352	Encrypt/decrypt (SDLC only)	—	X	X	—	3	0=No 1=Yes
360	X.21 Switched retry (SDLC only)	—	—	X	—	—	00=X.21 Switched Not Used XX=Number of retries Minimum=00
361	X.21 Switched retry timing (SDLC only)	—	—	X	—	—	00=X.21 Switched Not Used XX=Number of seconds between retries, must be from 01 to 20.

Figure 1-1 (Part 2 of 3). Configuration Information Needed

Sequence Number	Function	31A, 41A ¹	31C, 41C ¹	51C, 61C ¹	31D, 41D ¹	Notes	Response Definition
362	X.21 Switched options	-	-	X	-	-	See Chapter 2.
400	Network type	-	X	X	-	7	00=CCITT 02=UKPASS or TELENET
401	Circuit type (I/O)	-	X	X	-	7	1=PVC 2=Incoming SVC 3=Outgoing SVC 4=Two-way SVC
402	Logical channel identifier	-	X	X	-	7	See Appendix I.
403	Logical link control	-	X	X	-	7	0=PSH 1=QLLC
410	Host DTE address (HNAD)	-	X	X	-	7	See Appendix I.
411	3274 DTE address	-	X	X	-	7	See Appendix I.
420	Incoming call options	-	X	X	-	7	See Appendix I.
421	Outgoing call options	-	X	X	-	7	See Appendix I.
430	Negotiated packet size (NPKT)	-	X	X	-	7	0=64-byte packet 1=128-byte packet 2=256-byte packet 3=512-byte packet
431	Packet sequence numbering	-	X	X	-	7	0=Modulo 8 1=Modulo 128
432	Negotiated window size (NWND)	-	X	X	-	7	See Appendix I.
433	K-maximum out	-	X	X	-	7	See Appendix I.
434	Nonstandard default packet size (DPKT)	-	X	X	-	7	0=64-byte packet 1=128-byte packet 2=256-byte packet 3=512-byte packet
435	Nonstandard default window size (DWND)	-	X	X	-	7	See Appendix I.
440	Throughput class negotiation (TCLS)	-	X	X	-	7	See Appendix I.
441	Closed user group (CUG)	-	X	X	-	7	See Appendix I.
442	Recognized private operating agency (RPOA)	-	X	X	-	7	See Appendix I.
443	X.25 keyboard support options	-	X	X	-	7	See Appendix I.
450	Link level transmit timeout	-	X	X	-	7	See Appendix I.
451	Number of retries	-	X	X	-	7	See Appendix I.
452	Connection identifier password (CID)	-	X	X	-	7	See Appendix I.
900	Entry acceptance	X	X	X	X	1	See Chapter 2.
901	Printer authorization matrix acceptance	X	X	X	X	1	See Appendix A.
904	Response time monitor acceptance	X	X	X	X	-	See Appendix G.
906	Port assignment acceptance	X	X	X	X	-	See Appendix B.
907	Port assignment specification acceptance	X	X	X	X	-	See Appendix B.
908	X.25 acceptance	-	X	X	-	-	See Appendix I.
999	Specification panel	X	X	X	X	1	See Chapters 2 and 3.

¹ An X in the model column indicates needed information; a dash indicates not applicable.

Notes:

1. Information is already identified on the Initial Customizing Procedure Form.
2. Obtain information from the system programmer.
3. Obtain information from equipment orders placed with IBM, with the common carrier, and (if necessary) with the modem manufacturer.
4. An RPO Parameter List is required by certain RPOs. Specific information is supplied with the RPO.
5. Models 31C, 41C, 51C, and 61C BSC only.
6. This parameter must be compatible with the host-system communication controller and/or the modem.
7. Obtain information from your X.25 network subscription.
8. Obtain information from Keyboard Definition Utility User's Guide, GA23-0187.

Figure 1-1 (Part 3 of 3). Configuration Information Needed

Chapter 2. Preparing to Customize

This chapter supplies the information the planner needs to fill in the Initial Customizing Procedure Form in Chapter 3. The sequence numbers for customizing the 3274 Control Unit are grouped by model under three headings:

- 3274 Models 31A and 41A
- 3274 Models 31C, 41C, 51C, and 61C
- 3274 Models 31D and 41D.

Select the heading that includes the model to be customized, and write the replies on the Initial Customizing Procedure Form in Chapter 3. The sequence numbers are listed here and on the form, left to right, top to bottom, in numeric order.

The terminals currently in the *distributed function terminal* category are the IBM 3179-G Color Graphics Display Station, the IBM 3270 Personal Computer, the IBM 3290 Information Panel, and the IBM 5550 3270/Personal Computer.

3274 Models 31A and 41A

Use the following sequence numbers and instructions in conjunction with the Initial Customizing Procedure Form in Chapter 3 to customize 3274 Model 31A with a 2-sided diskette drive and Model 41A.

001: Keyboard and Customizing Guide Validation

The response required for this sequence number is '1234567890ABCDEF' followed by a space and the validation number that is printed on the front cover of this book and on the first page of the Initial Customizing Procedure Form. The first part of the response verifies that the keyboard being used for customizing is operating properly. The last part (the validation number) is used to check that the level of this customizing guide is equal to or greater than the level of the feature and system diskettes. This check ensures that the sequence numbers and their responses are compatible with the diskettes you are customizing.

Note: If a data entry keypunch layout keyboard is used, the New Line key is pressed when ENTER is specified. Also, the PF10 key is pressed when RESET is required; the PF8 key is pressed when New Line is required. See Figures 3-1 and 3-2 (in Chapter 3) for the valid key positions and for the differences just noted. Be sure to specify the keyboard type on the Initial Customizing Procedure Form.

011: Patch Request

The response required for this sequence number is already entered on the form in step 5. The IBM service representative may use this sequence number to make a diskette patch request.

021: Printer Authorization Matrix

Enter a 1 in step 6 on the Initial Customizing Procedure Form if a matrix is to be defined, thereby causing sequence number 022 to be displayed. The matrix defined in sequence number 022 will remain in effect each time a 3274 IML is performed.

Enter a 0 if any of the following conditions applies:

- The printer authorization matrix is to be entered only by a host application program.
- All printers are to be used in system mode, and local copy operations are not desired.
- No printers are to be attached to the system.

022: Printer Authorization Matrix Definition

The printer authorization matrix is defined in sequence number 022. See Appendix A for detailed information on responding to sequence number 022.

Fill in the appropriate spaces on the Printer Authorization Matrix Form with a definition for each printer in your configuration, and attach it to the Initial Customizing Procedure Form. The definitions may be entered in any sequence and in any group; for example, you may enter definitions anywhere in groups 1, 2, and 3 of the form, skip groups 4 and 5, and continue at group 6.

Once a printer authorization matrix has been defined, sequence number 021 is no longer displayed when a customized 3274 Control Unit is being updated. Instead, the defined matrix is displayed. If the entire matrix is deleted, sequence number 021 is again displayed during each updating procedure until a new matrix is defined. Any time the initial customizing procedure is performed, the sequence number 021 is displayed and the printer authorization matrix must be redefined if it is still required.

031: Number of RPQ Diskettes Required

Enter the number of RPQ diskettes required (0, 1, 2, or 3) in step 7 of the Initial Customizing Procedure Form.

032: Request RPQ Parameter List

Enter a 1 if you require the RPQ parameter list; enter a 0 if not. If you enter a 1 here, sequence number 033 (RPQ Parameters) is displayed, with *F*s for parameter information. If you enter a 0, sequence number 033 is not displayed.

Note: An RPQ parameter list is required by certain RPQs. Specific information about this list, sequence number 033 format, and implementation is supplied with the RPQ.

111: Number of Category B Terminals (Model 31A Only)

Enter a 2-digit number (00 to 16; when necessary, use a leading zero, as 04) to specify the number of Category B terminals that can be attached to your 3274. (The actual number you have attached at any given time may be smaller than this number.) See sequence number 112 for a description of category types.

Notes:

1. *If you intend to assign port host addresses (your response to sequence number 116 is 2), your response to 111 must be 00.*
2. *If you intend to select the ports to which the control unit will assign addresses (your response to sequence number 116 is 1), see Procedure 1 (116=1) in Appendix B for a possible limitation on the number of Category B terminals that can be addressed.*

Model 31A with Distributed Function Terminals: Category B terminals cannot be attached.

112: Number of Category A Terminals

Enter a 2-digit number (08 to 32) to specify the number of Category A terminals that can be attached to your 3274. (The actual number you have attached at any given time may be smaller than this number.) See Note 1 below.

The 3274 customization program will use your response to assign port addresses automatically. No choice of ports or of addresses to be assigned is allowed. Addresses run sequentially, and each port is assigned an address, including unused ports.

If you want control of the port address assignment process, respond to this sequence number with 00 and see sequence number 116. User control of port host address assignment is explained in Appendix B.

Notes:

1. *If you are going to have distributed function terminals with the multiple interactive screen feature attached to your 3274, you must respond with 00 to this sequence number and use the user-controlled port assignment procedure (sequence numbers 116, 117, and 118) to assign ports and addresses.*
2. *A 2-digit number must be entered. If necessary, use a leading zero; for example, to specify 8, enter 08.*
3. *Category A terminals are:*

*IBM Personal Computer XT/370
IBM 3270 Personal Computer
IBM 3270 Personal Computer AT, AT/G, and AT/GX*
IBM 5550 3270/Personal Computer
3178 Models C1, C2, C3, and C4
3179
3179-G Models G1 and G2
3180 Model 1
3230 Model 2
3262 Models 3 and 13*

*Requires Configuration Support D, Release 61 or higher.

3268 Models 2 and 2C
 3278 Models 1, 2, 3, 4, and 5
 3278 Models 1–5 with IBM 3270 Personal Computer Attachment
 3279, all models except 2C
 3287 Models 1 and 2 with 3274/3276 Attachment (feature 8331)
 3287 Models 1C and 2C
 3289 Models 1 and 2
 3290 Information Panel
 4245 Models D12 and D20
 4250 Model 1
 5210 Models G01 and G02
 6580 Displaywriter System

Category B terminals are:

3277 Models 1 and 2
 3284 Models 1 and 2
 3286 Models 1 and 2
 3287 Models 1 and 2 with 3271/3272 Attachment (feature 8330)
 3288 Model 2

4. Specify the number of Category A terminals in multiples of 8 (maximum of 32) and the number of Category B terminals in multiples of 4 (maximum of 16), unless the sum of the two categories exceeds 32.

If the sum of the two categories exceeds 32:

- a. For Category B terminals, specify the actual number of Category B terminals (sequence number 111).
- b. For Category A terminals, specify the difference between 32 and the number of Category B terminals (sequence number 111).

Example: 13 Category B terminals and 17 Category A terminals would be specified as 13 and 19, respectively. Figure 2-1 shows the relationship and the ways to specify the various Category A and B terminal quantities. Note that, when Category A terminal adapters are added or removed, the host-recognized address of port B0 changes.

113: Extended Function Store

Models 31A and 41A: Enter DA if no Extended Function Store feature is installed. Enter DC if the Extended Function Store type D5 (feature 3660) is installed.

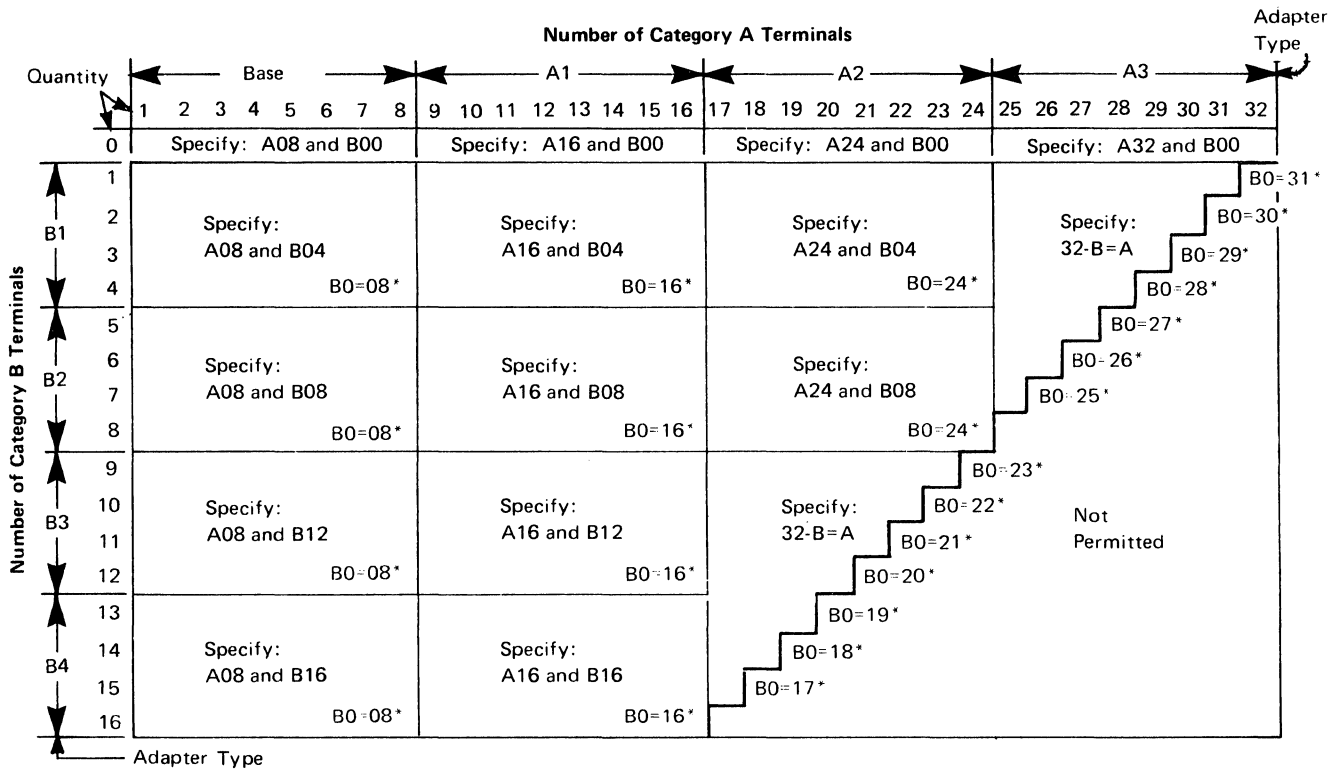

*The host-recognized port addresses are sequential, with the first Category A port (port A0) always being address 0 (with the exception of SNA, which is always 02). The first Category B port (port B0) is always the next sequential address after the last Category A port.

Figure 2-1. 3274 Model 31A Category A and B Terminal Quantity Relationships

114: IBM 3270 Personal Computer Attachment

Enter a 1 if an IBM 3270 Personal Computer Attachment will be attached to a 3278 Display Station connected to your 3274; enter a 0 if not.

Note: If you answer 114 with a 1, you must answer sequence number 160 (Extended Data Stream) with a 1.

115: Entry Assist Function

Enter a 0 if you do not want the Entry Assist function installed; enter a 1 if you do. There is no need to customize for Entry Assist if you plan to use it *only* on 3179-G Color Graphics Display Stations and 3290 Information Panels.

Note: Entry Assist is not supported with all languages; see sequence number 121.

116: User-Controlled Port Assignment Request

If you are going to assign ports and addresses, see Appendix B for the procedures to use and for explanations of sequence numbers 117 and 118. Appendix B will also aid you in selecting a response (other than 0) to this sequence number.

The amount of user control over port selection and host address assignment varies between the Release 60–63 levels of Configuration Support D (Validation Numbers 30–33) and the Release 64 level (Validation Number 34). Following are the possible responses to sequence number 116 for CS-D/Releases 60–63 and CS-D/Release 64.

CS-D/Releases 60–63

Enter a 0 if you have no distributed function terminals attached and do not want control of port selection and address assignment. (Your response to 112 must be nonzero.)

Enter a 1 if you want to select the ports and to define the number of addresses to be assigned to the ports. Addresses will be assigned automatically. (Your response to 112 must be zero.)

CS-D/Release 64

Enter a 0 if you have no distributed function terminals attached and do not want control of port selection and address assignment. (Your response to 112 must be nonzero.)

Enter a 1 if you want to select the ports and to define the number of addresses to be assigned to the ports. Addresses will be assigned automatically. (Your response to 112 must be zero.)

Enter a 2 if you want to select the ports to which addresses will be assigned and to specify the exact addresses to be assigned. (Your response to sequence numbers 111 and 112 must be zero.)

117: Port Assignment Specification Table

This table is displayed after the specification panel is accepted and if sequence number 116 is answered with other than a 0. See Appendix B for details.

118: Port Address Table

This table appears after sequence number 117 is completed. See Appendix B for details.

121: Keyboard Language/Character Set I/O Interface Code

Enter a 2-digit number (01 and 03 to 32) from Figure 2-2 specifying the keyboard language and character set I/O interface code being used. A 2-digit number must be entered. If necessary, use a leading zero; for example, to specify 7, enter 07.

Sequence Number 121 Response	Keyboard Language	Character Set I/O Interface Code
01	English (U.S.) EBCDIC	English (U.S.) EBCDIC
03	Austrian/German	Austrian/German
04	Belgian	Belgian
05 ¹	Brazilian	Brazilian
06 ^{1, 2, 3}	Canadian (French)	Canadian (French)
07	Danish	Danish/Norwegian
08 ^{1, 2, 3, 4}	Danish	Danish/Norwegian (Alternate)
09 ²	Finnish	Finnish/Swedish
10 ^{1, 2, 3, 4}	Finnish	Finnish/Swedish (Alternate)
11 ^{1, 3}	French (QWERTY)	French
12 ^{1, 2, 3}	French (AZERTY)	French
13 ^{1, 2, 3, 4}	Austrian/German	Austrian/German (Alternate)
14 ¹	International	International
15	Italian	Italian
16 ¹	Japanese (English)	Japanese (English)
17 ³	Japanese (Katakana)	Japanese (Katakana)
19	Spanish	Spanish
20 ^{1, 2, 3, 4}	Spanish	Spanish (Alternate)
21	Spanish-speaking	Spanish-speaking
22	English (U.K.)	English (U.K.)
23	Norwegian	Danish/Norwegian
24	Swedish	Finnish/Swedish
25 ¹	EBCDIC (WT)	English (U.S.)
26 ^{1, 2, 3, 4}	Norwegian	Danish/Norwegian (Alternate)
27 ^{1, 2, 3, 4}	Swedish	Finnish/Swedish (Alternate)
28	Portuguese	Portuguese
29	Canadian (Bilingual)	Canadian (Bilingual)
30	French AZERTY (105-character)	French AZERTY (105-character)
31	Swiss German	Swiss French/Swiss German
32	Swiss French	Swiss French/Swiss German

Notes:

- Keyboard layouts and character set I/O interface code information are given in *IBM 3270 Information Display System: Character Set Reference, GA27-2837*.
- An alternative character set I/O Interface code should be selected only when compatibility with the 3271/3272/3275 data base is required. To facilitate later migration, all systems should be upgraded to the latest support 3270 level.

¹ Not valid for 3179-G.

² Not valid for 3290.

³ The Entry Assist function is not supported with these languages.

⁴ Not supported with Extended Data Stream (160=1).

Figure 2-2. 3274 Model 31A and 41A Keyboard Language and Character Set I/O Interface Code

125: Miscellaneous Feature Options

Each of the eight digits in this response must be specified as either 1, meaning *yes*, or 0, meaning *no*.

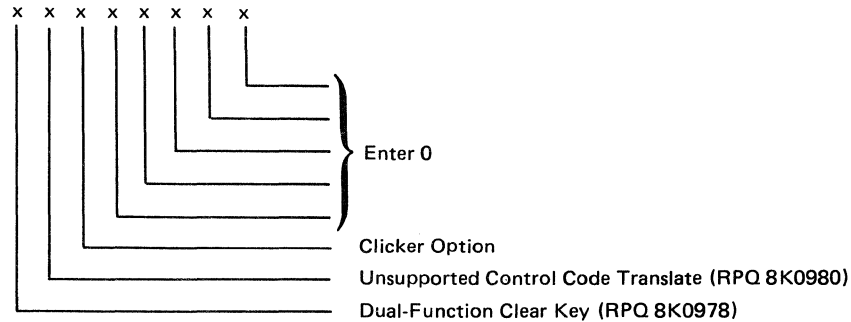

Dual-Function Clear Key (Functionally Equivalent to RPQ 8K0978 on Configuration Support C)

Specifying this bit as a 1 changes the operation of the Clear key so that it no longer puts a 3278 or 3180 Display Station, a 3279 Color Display Station, or a 3179-G Color Graphics Display Station into the default screen size mode.

Unsupported Control Code Translate (Functionally Equivalent to RPQ 8K0980 on Configuration Support C)

Specifying this bit as a 1 translates the following interface codes into a hyphen character code (EBCDIC X'60'):

01 through 04, 06, 07, 09, 0A, 0B, 0E, 0F, 10, 14, 16, 17, 18, 1A, 1B, 1F, 20 through 27, 2A, 2B, 2D, 2E, 2F, 30 through 3B, 3D, 3F, and FF.

During READ operations, the hyphen character code is returned to the host instead of the original code.

Specifying this bit as a 0 causes the 3274 to reject the above interface codes and to display a PROG 470 in the operator information area of all display stations.

Clicker Option

0 = Keyboard clicker is turned off when the display station is powered on.

1 = Keyboard clicker is turned on when the display station is powered on.

Default = 1.

127: Response Time Monitor (RTM) Definition

A two-digit response is required. Both digits must be either zero or a nonzero value as follows:

First Digit:

- 0 = RTM support not wanted.
- 1 = RTM without host support. The RTM log and Last Transaction Time Indicator are displayed and reset on port 0* only.
- 2 = RTM without host support. The RTM log and Last Transaction Time Indicator are displayed and reset on all ports.*
- 3 = RTM with host support. The RTM log and Last Transaction Time Indicator are not displayable on any port.*
- 4 = RTM with host support. The RTM log and Last Transaction Time Indicator are displayable on port 0* only.
- 5 = RTM with host support. The RTM log and Last Transaction Time Indicator are displayable on all ports.*

*All terminals can display the Last Transaction Time Indicator, but only non-distributed-function terminals can display the RTM log.

Second Digit:

- 0 = RTM support not wanted.
- 1 = End response time measurement when the first character is displayed on screen.
- 2 = End response time measurement when the keyboard again becomes usable.
- 3 = End response time measurement when a Change Direction (CD) or End Bracket (EB) indication is received. (A CD in conjunction with a Read command will not stop the timer.)

Response time measurement starts with recognition by the control unit of an inbound AID request, for example, by pressing the ENTER key. The response to the second digit defines the end of the measurement.

Nonzero responses to sequence number 127 cause sequence number 128, RTM Boundaries and Interface Specification, to be displayed later in the customization sequence.

See Appendix G for more details concerning RTM.

128: RTM Boundaries and Interface Specification

This sequence number (a panel) is displayed after the specification panel and, if applicable, 116 and 117 are accepted *and* only if the response to sequence number 127 is nonzero. See Appendix G for details.

Note: The following three sequence numbers, 136, 137, and 138, apply only if the 3274 has display stations with modifiable keyboards (such as the 3179 Color Display Station and the 3180 Display Station Model 1) attached, and if these devices are to be operated in native mode (that is, not in 3278-emulation mode).

136: Modifiable Keyboard Layout Selection – Unmodified Layouts

For modifiable keyboards, keyboard translate tables supporting Typewriter-, APL-, and Data Entry-style keyboard layouts are provided (on the language diskette). For examples of these layouts, see Figure J-1 in Appendix J. The response to sequence number 136 selects these layouts in unmodified form. (If you have modified these layouts, using the Keyboard Definition Utility, see sequence number 137.)

You respond to sequence number 136 with a 3-digit entry, each digit position having meaning as follows:

First digit = Typewriter Keyboard layout
Second digit = APL Keyboard layout
Third digit = Data Entry Keyboard layout

Entering a 1 in the appropriate digit position (in place of the 0 displayed) indicates that you want that layout configured into the system; a 0 indicates that the layout is not wanted.

Any combination of 1's and 0's is allowed.

There is a restriction that the total number of unmodified and modified keyboard layouts selected (sequence numbers 136 and 137) cannot exceed four. Therefore, if all three unmodified keyboard layouts are configured, only one modified keyboard layout can be selected in sequence number 137.

137: Modifiable Keyboard Selection – Modified Layouts

This sequence number can be answered only if the Keyboard Definition Utility was used prior to customizing to define one to four unique keyboard layouts by making modifications to the layouts provided. Each modified layout consists of a keyboard/keypad combination that is assigned an ID (A, B, C, or D). A modified keyboard layout cannot be selected unless it was defined. How to define modifiable keyboard layouts is described in the *Keyboard Definition Utility User's Guide*, GA23-0187.

The four 0's displayed represent the four modified keyboard IDs A, B, C, and D. Select the modified keyboard layout(s) to be configured into the system by entering a 1 in place of the 0.

First digit = Keyboard ID A
 Second digit = Keyboard ID B
 Third digit = Keyboard ID C
 Fourth digit = Keyboard ID D

The total number of keyboard layouts selected in sequence numbers 136 and 137 cannot exceed four.

138: Modifiable Keypad Selection — Unmodified Layout

The response to this sequence number specifies the type of keypad to be used with the modifiable keyboard layout(s) selected in sequence number 136. For examples of these layouts, see Figure J-2 in Appendix J. Only one of the following may be selected:

0 = Default Keypad (National Language Numeric)
 1 = Data Entry Keypad
 2 = PF Keys Keypad

The response consists of one character: 0, 1, or 2. (0, the default selection, is displayed.)

Although up to three types of unmodified keyboard layouts may be selected in sequence number 136, the one keypad layout selected here will be used with all those keyboard layouts. If a keyboard layout is not selected in sequence number 136 (response 0 0 0), a keypad layout cannot be selected.

139: 3290 Keypad Selection

Enter a 0 if you have no 3290 Information Panels. If you have a 3290, enter one of the following to specify the type of keypad you will be using on your 3290 Information Panel:

0 = No keypad or the default keypad (National Language Numeric Keypad).
 1 = 24-key numeric keypad.
 2 = 25-key numeric keypad (, on key 4).
 3 = 25-key numeric keypad (. on key 4).
 4–6 = Reserved.
 7 = Program Function Keypad.

For examples of these keypads, see Figure J-3 in Appendix J.

Note: If a nonzero response is specified for this sequence number, you must specify a 1 for sequence number 170.

141: Magnetic Character Set

Enter 0 if you have no 3290 Information Panels. If you have a 3290, enter one of the following to specify the magnetic character set installed:

- A = None
- B = Numeric (3277-compatible)
- C = Alphanumeric (auto entry for secure data only)
- D = Alphanumeric (auto entry for all data)

151: 3274 Model Designation

Enter the 3274 model type (31A or 41A).

160: Extended Data Stream

Enter a 1 if you are using any of the following items; enter a 0 if not:

- An IBM 3270 Personal Computer Attachment
- APL (To use APL on a distributed function terminal, you do not need to customize with a 1 response.)
- Structured Field and Attribute Processing (SFAP) (To use structured fields on a distributed function terminal, you do not need to customize with a 1 response.)

Required for the use of the Write Structured Field command or of the Set Attribute, Start Field Extended, or Modify Field order.

- LU Type 1 SNA character string (SCS)
Supports extended color, extended highlighting (underscore), and Programmed Symbols (PS) on LU Type 1 printers with feature 9661 (if you wish more than the basic SCS support provided by feature 9660), 3262 Line Printers, and 3289 Line Printers.
- Programmed Symbols (PS) (feature 5781, 5782, or 5783) (To use programmed symbols on a distributed function terminal, you do not need to customize with a 1 response.)
- 3230 Model 2
- 3262 Models 3 and 13
- 3268 Model 2
- 3278 or 3287 with Extended Character Set Adapter (feature 3610)
- 3279, all models
- 4250 Model 1

Note: If you respond to this sequence number with a 1, you must not respond to sequence number 121 with 08, 10, 13, 20, 26, or 27.

161: Color Convergence

Enter a 0 if either:

- In U.S. and Canada only, **all** the 3279 Color Display Stations attached have model numbers ending in -1 (for example, S2A-1)

or:

- No 3279 Color Display Stations are attached.

Enter a 1 if any other 3279 Color Display Stations are attached.

165: Decompression

Enter a 1 if you want to send compressed PS data; otherwise, enter a 0. For a distributed function terminal, you do not need to customize with a 1 response.

Notes:

1. *If you respond to this sequence number with a 1, you must respond to sequence number 160 with a 1.*
2. *Decompressing data on a channel-attached 3274 could degrade performance.*

166: Attribute Select Keyboard

For examples of the attribute select keyboards, see Figure J-4.

Enter one of the following to specify whether an attribute select typewriter keyboard (feature 4651), an attribute select typewriter/APL keyboard (feature 4652), or a typewriter overlay keyboard (feature 4640) is being used:

A = None of these keyboards is being used.

B = One or more of these keyboards are being used, but you do not wish to use the numeric lock function on *any* of them.

C = One or more of these keyboards are being used, and you wish to use the numeric lock function on *all* of them.

Note: If you respond to this sequence number with B or C, you must respond to sequence number 160 with a 1.

170: Distributed Function Terminals

- 0 = No distributed function terminals are attached.
- 1 = Distributed function terminals that require a load diskette will be attached; or a combination of distributed function terminals that require a load diskette and those that do not require a load diskette will be attached.
- 2 = Only distributed function terminals that *do not* require a load diskette will be attached.

Note: If your response is 0 or 2, respond to sequence numbers 139, 173, and 175 with 0's.

173: Distributed Function Terminal (DFT) Options

Except for the Intensify Option (bits 5 and 6), which calls for a 2-digit response, you enter a single-digit response (0 or 1) in the appropriate position to disable (0) or enable (1) the DFT options listed below. See the explanation for bits 5 and 6 for the possible 2-digit responses for the Intensify Option.

If you do not have a 3179-G Color Graphics Display Station or a 3290 Information Panel, disable all the options and enter a 0 in the reserved bit positions.

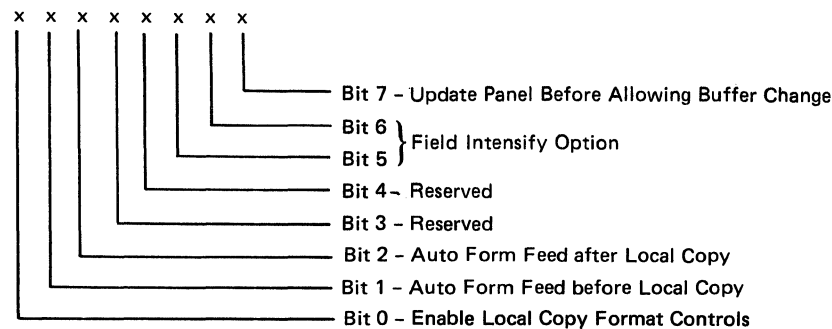

Bit 0: Enable Local Copy Format Controls (3179-G and 3290)

The 3179-G and the 3290 generate an SCS data stream to perform a local copy operation to a printer. If the printer does not have Save/Restore Format capability and is operated in shared mode, that is, if a local copy operation is permitted between brackets of an LU-1 session, there is a possibility that the local copy operation will destroy the format controls established by the host program. Proper use of this bit will help alleviate the contention situation for establishing format controls. When the printer supports Save/Restore Format, this option has no effect: the 3179-G and the 3290 will send format controls.

When bit 0 is set to 0, the 3179-G and the 3290 will not send format controls to a printer that lacks Save/Restore Format capability. The 0 setting is the default and is applicable to those operating environments where the host

program does not reestablish format controls with each Begin Bracket. Note that the format of the local copy output depends on the format controls established by the operator and/or host program.

When bit 0 is set to 1, the 3179-G and the 3290 will send format controls to the printer even though the printer lacks Save/Restore Format capability. This will enable the local copy output to duplicate, as closely as possible, the character image being copied from the 3179-G and 3290. The 1 setting is applicable to those operating environments where the printer is not shared and/or the host program reestablishes format controls with each Begin Bracket.

Bit 1: Automatic Form Feed before Local Copy (3179-G and 3290)

Specify bit 1 as a 1 if you want to generate an automatic form feed before a local copy operation is performed.

Specify bit 1 as a 0 if you do not want to generate an automatic form feed before a local copy operation is performed.

Bit 2: Automatic Form Feed after Local Copy (3179-G and 3290)

Specify bit 2 as a 1 if you want to generate an automatic form feed after a local copy operation is performed.

Specify bit 2 as a 0 if you do not want to generate an automatic form feed after a local copy operation is performed.

Bits 3 and 4: Reserved

Specify 0.

Bits 5 and 6: Field Intensify Option (3290 Only)

When bits 5 and 6 are set to 00 or 11, the 3290 *will* underscore all fields carrying the field intensify attribute.

When bits 5 and 6 are set to 01, the 3290 *will not* underscore or display in reverse video the fields carrying the field intensify attribute.

When bits 5 and 6 are set to 10, the 3290 *will* display in reverse video the fields carrying the field intensify attribute.

Bit 7: Update Panel Before Allowing Buffer Change (3290 Only)

When bit 7 is set to 0, the 3290 will suspend panel updating to process a host transmission. Under high-data-rate conditions, messages sent by the host and placed in the display buffer may get overlaid with new data before being displayed on the panel.

When bit 7 is set to 1, all display buffer contents must be displayed on the panel before new data can be placed in the display buffer. It is recommended that bit 7 be set to 1 when 3290s are being used as system consoles or other applications where potentially high message rates are possible and the user is required to visually interpret all data sent by the host.

175: 3290 Password

Enter the 6-digit password to allow permanent changes to the 3290 logical terminal definition table with setup level 3.

201: SNA Local Channel Control Unit Address

Enter the 2-character hexadecimal control unit address; this information can be obtained from the system programmer at the host system location. The host system recognizes this address as the input/output (I/O) address.

213: Between Bracket Printer Sharing

Enter a 1 if Between Bracket Printer Sharing is allowed; enter a 0 if it is not.

215: Physical Unit Identification (PUID)

The physical unit identification (PUID) is a 5-character code that identifies the control unit to the host in response to an SDLC XID command.

If the PUID is not used, enter 00000 for this sequence number in step 8 on the Initial Customizing Procedure Form.

If the PUID is used, each control unit in a network should be assigned a unique PUID. The PUID must be obtained from the system programmer and entered as the response to this sequence number in step 12 on the Initial Customizing Procedure Form. (Only characters 0 through 9 and A through F are valid.)

220: Alert Function

Enter a 0, 1, 2, or 3 as follows:

0 = No alert function wanted.

1 = Alert function without operator-generated alert message capability.

2 = Alert function with operator-generated alert message capability from port 0 only.*

3 = Alert function with operator-generated alert message capability from all ports.*

*Operator-generated alert messages cannot be issued from a 3277 or a distributed function terminal.

Refer to Appendix H for more information concerning alert.

900: Entry Acceptance

Sequence number 900, which appears as part of the sequence number 999 display, prompts the operator to enter a 1 if, after the entries are verified, all the responses are entered correctly. If incorrect responses are detected by the 3274, the 1 is automatically changed back to a 0 by the 3274, an operator code is displayed for the incorrect information, and incorrect entries are intensified.

999: Specification Panel

Sequence number 999 displays all sequence numbers except 001, 011, 021, 031, and 032. When sequence number 999 appears during the first initial customizing, default values are shown. The customizer uses the sequence number 999 panel to key in the desired customizing specifications. These specifications remain in effect until recustomizing occurs. See step 12 of the Initial Customizing Procedure Form, in Chapter 3, for an example of the use of sequence number 999.

3274 Models 31C, 41C, 51C, and 61C

Use the following sequence numbers and instructions in conjunction with the Initial Customizing Procedure Form in Chapter 3 to customize 3274 Models 31C and 51C with 2-sided diskette drives and Models 41C and 61C.

When a C model is being customized, some sequence numbers may be defaulted. Many of these defaulted responses are determined by the response given to sequence number 343 (Communication Interface Options). Figure 2-3 shows those default values. This figure does not list all the sequence numbers that may be necessary to customize a 3274 C model. Use this section of the chapter (C models) to decide on the proper responses to sequence numbers not satisfied by the figure.

Find your response to sequence number 343 at the top of Figure 2-3. The default values are given in the shaded blocks in the column for that response. The sequence numbers are listed in the left column of the chart. Use the values in the shaded blocks as the responses to the sequence numbers in step 12 of the Initial Customizing Procedure Form. Blank blocks indicate that you should use the sequence number explanations for the C models to decide on the proper response.

001: Keyboard and Customizing Guide Validation

The response required for this sequence number is '1234567890ABCDEF' followed by a space and the validation number that is printed on the front cover of this book and on the first page of the Initial Customizing Procedure Form. The first part of the response verifies that the keyboard being used for customizing is operating properly. The last part (the validation number) is used to check that the level of this customizing guide is equal to or greater than the level of the feature and system diskettes. This check ensures that the sequence numbers and their responses are compatible with the diskettes you are customizing.

Note: If a data entry keypunch layout keyboard is used, the New Line key is pressed when ENTER is specified. Also, the PF10 key is pressed when RESET is required; the PF8 key is pressed when New Line is required. See Figures 3-1 and 3-2 (in Chapter 3) for the valid key positions and for the differences just noted. Be sure to specify the keyboard type on the Initial Customizing Procedure Form.

011: Patch Request

The response required for this sequence number is already entered on the form in step 5. The service representative may use this sequence number to make a diskette patch request.

Response to Sequence Number 343

C Models

Sequence Number	00	01	02	03	04	05	06	07	08	09	10	11	← 343 Response
301			00	00	00		00	00			00		
305			0	0	0		0	0			0		
310	0	0	0	0		0	0	0	0	0	0	0	
311		0	0	0		0	0	0	0	0	0	0	
313			0	0		1	1	1	1	1	0		
314		0	0	0	0		0	0			0		
317		0	0	0	0	0	0	0			0	0	
318		0	0	0	0	0	0	0	0	0	0	0	
331			1	1 or 2	1		1	1			1		
342		0	0	0	0		0	0			0	1	
345	1	1	1	0		1	1	1	1	1	1	1	
347	0	0	0	0	0	0	0	0	0	0		0	
351				1		0	0	0	0	0	1		
352											0		
360	00	00	00		00	00	00	00	00	00	00	00	
361	00	00	00		00	00	00	00	00	00	00	00	
362	← 00000000 →				← 00000000 →								

Figure 2-3. Default Values

021: Printer Authorization Matrix

Enter a 1 in step 6 on the Initial Customizing Procedure Form if a matrix is to be defined, thereby causing sequence number 022 to be displayed. This matrix will be established for each 3274 IML.

Enter a 0 if any of the following conditions applies:

- The printer authorization matrix is to be entered only by a host application program.
- All printers are to be used in system mode, and local-copy operations are not desired.
- No printers are to be attached to the system.

022: Printer Authorization Matrix Definition

The printer authorization matrix is defined in sequence number 022. See Appendix A for detailed information on responses to sequence number 022.

Fill in the appropriate spaces on the Printer Authorization Matrix Form with a definition for each printer in your configuration, and attach it to the Initial Customizing Procedure Form. The definitions may be entered in any sequence and in any group; for example, you may enter definitions anywhere in groups 1, 2, and 3 of the form, skip groups 4 and 5, and continue at group 6.

Once a printer authorization matrix has been defined, sequence number 021 is no longer displayed when a customized 3274 Control Unit is being updated. Instead, the defined matrix is displayed. If the entire matrix is deleted, sequence number 021 is again displayed during each updating procedure until a new matrix is defined. Any time the initial customizing procedure is performed, the sequence number 021 is displayed and the printer authorization matrix must be redefined if it is still required.

031: Number of RPQ Diskettes Required

Enter the number of RPQ diskettes required (0, 1, 2, or 3) in step 7 on the Initial Customizing Procedure Form.

032: Request RPQ Parameter List

Enter a 1 if you require the RPQ parameter list; enter a 0 if not. If you enter a 1 here, sequence number 033 (RPQ Parameters) is displayed, with *F*s for parameter information. If you enter a 0, sequence number 033 is not displayed.

Note: An RPQ parameter list is required by certain RPQs. Specific information about this list, sequence number 033 format, and implementation is supplied with the RPQ.

111: Number of Category B Terminals (Models 31C and 51C Only)

Model 31C: Enter a 2-digit number (00 to 16; when necessary, use a leading zero, as 04) to specify the number of Category B terminals that can be attached to your 3274. (The actual number you have attached at any given time may be smaller than this number.) See sequence number 112 for a description of category types.

Model 51C: If Category B terminals are to be used, enter 04 in response to this sequence number. Note that a Model 51C with the loop adapter (feature 4850) does not allow Category B terminals to be attached.

Notes:

1. *If you intend to assign port host addresses (your response to sequence number 116 is 2), your response to 111 must be 00.*
2. *If you intend to select the ports to which the control unit will assign addresses (your response to sequence number 116 is 1), see Procedure 1(116=1) in Appendix B for a possible limitation on the number of Category B terminals that can be addressed.*

Model 31C or 51C with Distributed Function Terminals: Category B terminals cannot be attached.

112: Number of Category A Terminals

Models 31C and 41C: Enter a 2-digit number (08 to 32) specifying the number of Category A terminals that can be attached to your 3274. (The actual number you have attached at any given time may be smaller than this number.) See Note 1 below.

Model 51C: Enter 08 in response to this sequence number. See Note 1 below.

Model 61C: Enter 08 or 16 in response to this sequence number. See Note 1 below.

The 3274 customization program will use your response to assign port addresses automatically. No choice of ports or of addresses to be assigned is allowed. Addresses run sequentially, and each port is assigned an address, including unused ports.

If you want control of the port address assignment process, respond to this sequence number with 00 and see sequence number 116. User control of port host address assignment is explained in Appendix B.

Notes:

1. *If you are going to have distributed function terminals with the multiple interactive screen feature attached to your 3274, you must respond with 00 to this sequence number and use the user-controlled port assignment procedure (sequence numbers 116, 117, and 118) to assign port and addresses.*
2. *A 2-digit number must be entered. If necessary, use a leading zero; for example, to specify 8, enter 08.*
3. *Category A terminals are:*

*IBM Personal Computer XT/370
IBM 3270 Personal Computer
IBM 3270 Personal Computer AT, AT/G, and AT/GX*
IBM 5550 3270/Personal Computer
3178 Models C1, C2, C3, and C4
3179
3179-G Models G1 and G2
3180 Model 1
3230 Model 2
3262 Models 3 and 13
3268 Models 2 and 2C
3278 Models 1, 2, 3, 4, and 5
3278 Models 1–5 with IBM 3270 Personal Computer Attachment
3279, all models except 2C
3287 Models 1 and 2 with 3274/3276 Attachment (feature 8331)
3287 Models 1C and 2C
3289 Models 1 and 2
3290 Information Panel
4245 Models D12 and D20
5210 Models G01 and G02
6580 Displaywriter System*

**Requires Configuration Support D, Release 61 or higher.*

Category B terminals are:

*3277 Models 1 and 2
3284 Models 1 and 2
3286 Models 1 and 2
3287 Models 1 and 2 with 3271/3272 Attachment (feature 8330)
3288 Model 2*

4. *Specify the number of Category A terminals in multiples of 8 (maximum of 32) and the number of Category B terminals in multiples of 4 (maximum of 16), unless the sum of the two categories exceeds 32.*

If the sum of the two categories exceeds 32:

- a. *For Category B terminals, specify the actual number of Category B terminals (sequence number 111).*

- Enter DA if your 3274 has Extended Function Store Types D2 (feature 3632) and C1 (feature 3650), or Types D4 (feature 1800) and C1 (feature 3650).

If you are using X.25 protocol (331 = 2):

- Enter DC if your 3274 has the Extended Function Store Types D4 (feature 1800) and two C1s (feature 3650), or D2 (feature 3632), two C1s (feature 3650), and feature 1802.
- Enter CC if your 3274 has the Extended Function Store Types D1 (feature 3630), D3 (feature 3631), two C1s (feature 3650), and feature 1802.

114: IBM 3270 Personal Computer Attachment

Enter a 1 if an IBM 3270 Personal Computer Attachment will be attached to a 3278 Display Station connected to your 3274; enter a 0 if not.

Note: If you answer 114 with a 1, you must answer sequence number 160 (Extended Data Stream) with a 1.

115: Entry Assist Function

Enter a 0 if you do not want the Entry Assist function installed; enter a 1 if you do. There is no need to customize for Entry Assist if you plan to use it only on 3179-G Color Graphics Display Stations and 3290 Information Panels.

Note: Entry Assist is not supported with all languages; see sequence number 121.

116: User-Controlled Port Assignment Request

If you are going to assign ports and addresses, see Appendix B for the procedures to use and for explanations of sequence numbers 117 and 118. Appendix B will also aid you in selecting a response (other than 0) to this sequence number.

The amount of user control over port selection and host address assignment varies between the Release 60–63 levels of Configuration Support D (Validation Numbers 30–33) and the Release 64 level (Validation Number 34). Following are the possible responses to sequence number 116 for CS-D/Releases 60–63 and CS-D/Release 64.

CS-D/Releases 60 – 63

Enter a 0 if you have no distributed function terminals attached and do not want control of port selection and address assignment. (Your response to 112 must be nonzero.)

Enter a 1 if you want to select the ports and to define the number of addresses to be assigned to the ports. Addresses will be assigned automatically. (Your response to 112 must be zero.)

CS-D/Release 64

Enter a 0 if you have no distributed function terminals attached and do not want control of port selection and address assignment. (Your response to 112 must be nonzero.)

Enter a 1 if you want to select the ports and to define the number of addresses to be assigned to the ports. Addresses will be assigned automatically. (Your response to 112 must be zero.)

Enter a 2 if you want to select the ports to which addresses will be assigned and to specify the exact addresses to be assigned. (Your response to sequence numbers 111 and 112 must be zero.)

117: Port Assignment Specification Table

This table is displayed after the specification panel is accepted and if sequence number 116 is answered with other than a 0. See Appendix B for details.

118: Port Address Table

This table appears after sequence number 117 is completed. See Appendix B for details.

121: Keyboard Language/Character Set I/O Interface Code

Enter a 2-digit number (01 to 32) from Figure 2-5 specifying the keyboard language and character set I/O interface code being used. A 2-digit number must be entered. If necessary, use a leading zero; for example, to specify 7, enter 07.

Sequence Number 121 Response	Keyboard Language	Character Set I/O Interface Code
01	English (U.S.) EBCDIC	English (U.S.) EBCDIC
02 ^{1, 2, 3, 4}	English (U.S.) ASCII	English (U.S.) ASCII
03	Austrian/German	Austrian/German
04	Belgian	Belgian
05 ⁴	Brazilian	Brazilian
06 ^{1, 2, 4}	Canadian (French)	Canadian (French)
07	Danish	Danish/Norwegian
08 ^{1, 2, 3, 4}	Danish	Danish/Norwegian (Alternate)
09 ¹	Finnish	Finnish/Swedish
10 ^{1, 2, 3, 4}	Finnish	Finnish/Swedish (Alternate)
11 ^{2, 4}	French (QWERTY)	French
12 ^{1, 2, 4}	French (AZERTY)	French
13 ^{1, 2, 3, 4}	Austrian/German	Austrian/German (Alternate)
14 ⁴	International	International
15	Italian	Italian
16 ⁴	Japanese (English)	Japanese (English)
17 ²	Japanese (Katakana)	Japanese (Katakana)
19	Spanish	Spanish
20 ^{1, 2, 3, 4}	Spanish	Spanish (Alternate)
21	Spanish-speaking	Spanish-speaking
22	English (U.K.)	English (U.K.)
23	Norwegian	Danish/Norwegian
24	Swedish	Finnish/Swedish
25 ⁴	EBCDIC (WT)	English (U.S.)
26 ^{1, 2, 3, 4}	Norwegian	Danish/Norwegian (Alternate)
27 ^{1, 2, 3, 4}	Swedish	Finnish/Swedish (Alternate)
28	Portuguese	Portuguese
29	Canadian (Bilingual)	Canadian (Bilingual)
30	French AZERTY (105-character)	French AZERTY (105-character)
31	Swiss German	Swiss French/Swiss German
32	Swiss French	Swiss French/Swiss German

Notes:

1. Keyboard layouts and character set I/O interface code information are given in *IBM 3270 Information Display System: Character Set Reference, GA27-2837*.
2. All character set I/O interface codes are EBCDIC except English (U.S.) ASCII.
3. An alternative character set I/O Interface code should be selected only when compatibility with the 3271/3272/3275 data base is required. To facilitate later migration, all systems should be upgraded to the latest support 3270 level.

¹ Not valid for 3290.

² The Entry Assist function is not supported with these languages.

³ Not supported with Extended Data Stream (160=1).

⁴ Not valid for 3179-G.

Figure 2-5. 3274 Model 31C, 41C, 51C, and 61C Keyboard Language and Character Set I/O Interface Code

125: Miscellaneous Feature Options

Each of the eight digits in this response must be specified as either 1, meaning *yes*, or 0, meaning *no*.

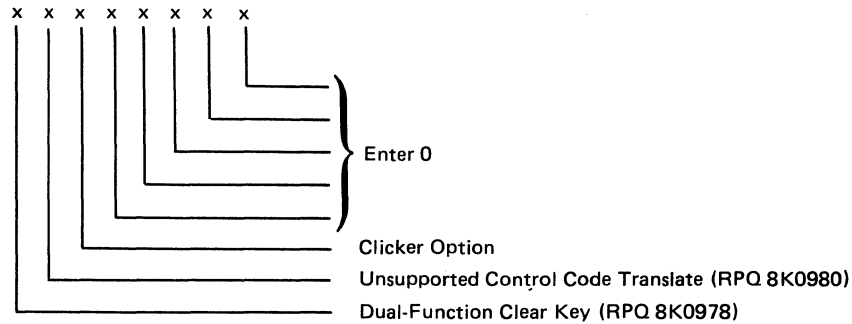

Dual-Function Clear Key (Functionally Equivalent to RPQ 8K0978 on Configuration Support C)

Specifying this bit as a 1 changes the operation of the Clear key so that it no longer puts a 3278 or 3180 Display Station, a 3279 Color Display Station, or a 3179-G Color Graphics Display Station into the default screen size mode.

Unsupported Control Code Translate (Functionally Equivalent to RPQ 8K0980 on Configuration Support C)

Specifying this bit as a 1 translates the following interface codes into a hyphen character code (EBCDIC X'60'):

01 through 04, 06, 07, 09, 0A, 0B, 0E, 0F, 10, 14, 16, 17, 18, 1A, 1B, 1F, 20 through 27, 2A, 2B, 2D, 2E, 2F, 30 through 3B, 3D, 3F, and FF.

During READ operations, the hyphen character code is returned to the host instead of the original code.

Specifying this bit as a 0 causes the 3274 to reject the above interface codes and to display a PROG 470 in the operator information area of all display stations.

Clicker Option

0 = Keyboard clicker is turned off when the display station is powered on.

1 = Keyboard clicker is turned on when the display station is powered on.

Default = 1.

127: Response Time Monitor (RTM) Definition

A two-digit response is required. Both digits must be either zero or a nonzero value as follows:

First Digit:

- 0 = RTM support not wanted.
- 1 = RTM without host support. The RTM log and Last Transaction Time Indicator are displayed and reset on port 0* only.
- 2 = RTM without host support. The RTM log and Last Transaction Time Indicator are displayed and reset on all ports.*
- 3 = RTM with host support. The RTM log and Last Transaction Time Indicator are not displayable on any port.*
- 4 = RTM with host support. The RTM log and Last Transaction Time Indicator are displayable on port 0* only.
- 5 = RTM with host support. The RTM log and Last Transaction Time Indicator are displayable on all ports.*

*All terminals can display the Last Transaction Time Indicator, but only non-distributed-function terminals can display the RTM log.

Note: Responses 3, 4, and 5 are applicable to SNA systems only.

Second Digit:

- 0 = RTM support not wanted.
- 1 = End response time measurement when the first character is displayed on screen.
- 2 = End response time measurement when the keyboard again becomes usable.
- 3 = End response time measurement when a Change Direction (CD) or End Bracket (EB) indication is received. (A CD in conjunction with a Read command will not stop the timer.)

Note: Response 3 is applicable to SNA systems only.

Response time measurement starts with recognition by the control unit of an inbound AID request, for example, by pressing the ENTER key. The second digit responses define the end of the measurement.

Nonzero responses to sequence number 127 cause sequence number 128, RTM Boundaries and Interface Specification, to be displayed later in the customization sequence.

See Appendix G for more details concerning RTM.

128: RTM Boundaries and Interface Specification

This sequence number (a panel) is displayed after the specification panel and, if applicable, 116 and 117 are accepted *and* only if the response to sequence number 127 is nonzero. See Appendix G for details.

Note: The following three sequence numbers, 136, 137, and 138, apply only if the 3274 has display stations with modifiable keyboards (such as the 3179 Color Display Station and the 3180 Display Station Model 1) attached, and if these devices are to be operated in native mode (that is, not in 3278-emulation mode).

136: Modifiable Keyboard Layout Selection – Unmodified Layouts

For modifiable keyboards, keyboard translate tables supporting Typewriter-, APL-, and Data Entry-style keyboard layouts are provided (on the language diskette). For examples of these layouts, see Figure J-1 in Appendix J. The response to sequence number 136 selects these layouts in unmodified form. (If you have modified these layouts, using the Keyboard Definition Utility, see sequence number 137.)

You respond to sequence number 136 with a 3-digit entry, each digit position having meaning as follows:

First digit = Typewriter Keyboard layout
Second digit = APL Keyboard layout
Third digit = Data Entry Keyboard layout

Entering a 1 in the appropriate digit position (in place of the 0 displayed) indicates that you want that layout configured into the system; a 0 indicates that the layout is not wanted.

Any combination of 1's and 0's is allowed.

There is a restriction that the total number of unmodified and modified keyboard layouts selected (sequence numbers 136 and 137) cannot exceed four. Therefore, if all three unmodified keyboard layouts are configured, only one modified keyboard layout can be selected in sequence number 137.

137: Modifiable Keyboard Selection – Modified Layouts

This sequence number can be answered only if the Keyboard Definition Utility was used prior to customizing to define one to four unique keyboard layouts by making modifications to the layouts provided. Each modified layout consists of a keyboard/keypad combination that is assigned an ID (A, B, C, or D). A modified keyboard layout cannot be selected unless it was defined. How to define modifiable keyboard layouts is described in the *Keyboard Definition Utility User's Guide*, GA23-0187.

The four 0's displayed represent the four modified keyboard IDs A, B, C, and D. Select the modified keyboard layouts to be configured into the system by entering a 1 in place of the 0.

First digit = Keyboard ID A
Second digit = Keyboard ID B
Third digit = Keyboard ID C
Fourth digit = Keyboard ID D

The total number of keyboard layouts selected in sequence numbers 136 and 137 cannot exceed four.

138: Modifiable Keypad Selection — Unmodified Layouts

The response to this sequence number specifies the type of keypad to be used with the modifiable keyboard layout(s) selected in sequence number 136. For examples of the layouts, see Figure J-2 in Appendix J. Only one of the following may be selected:

0 = Default Keypad (National Language Numeric)
1 = Data Entry Keypad
2 = PF Keys Keypad

The response consists of one character: 0, 1, or 2. (0, the default selection, is displayed.)

Although up to three types of unmodified keyboard layouts may be selected in sequence number 136, the one keypad type selected here will be used with all those keyboard layouts. If a keyboard layout is not selected in sequence number 136 (response 0 0 0), a keypad type cannot be selected.

139: 3290 Keypad Selection

Enter a 0 if you have *no* 3290 Information Panels. If you have a 3290, enter one of the following to specify the type of keypad you will be using on your 3290 Information Panel:

0 = No keypad or the default keypad (National Language Numeric Keypad).
1 = 24-key numeric keypad.
2 = 25-key numeric keypad (, on key 4).
3 = 25-key numeric keypad (. on key 4).
4-6 = Reserved.
7 = Program Function Keypad.

For examples of these keypads, see Figure J-3 in Appendix J.

Note: If a nonzero response is specified for this sequence number, you must specify a 1 for sequence number 170.

141: Magnetic Character Set

Enter one of the following to specify the magnetic character set installed:

A = None

B = Numeric (3277-compatible)

C = Alphanumeric (auto entry for secure data only)

D = Alphanumeric (auto entry for all data)

151: 3274 Model Designation

Enter the 3274 model type (31C, 41C, 51C, or 61C).

160: Extended Data Stream

Enter a 1 if you are using any of the following items; enter a 0 if not:

- An IBM 3270 Personal Computer Attachment
- APL (To use APL on a distributed function terminal, you do not need to customize with a 1 response.)
- Structured Field and Attribute Processing (SFAP) (To use structured fields on a distributed function terminal, you do not need to customize with a 1 response.)

Required for the use of the Write Structured Field command or of the Set Attribute, Start Field Extended, or Modify Field order.

- LU Type 1 SNA character string (SCS)
Supports extended color, extended highlighting (underscore), and Programmed Symbols (PS) on LU Type 1 printers with feature 9661 (if you wish more than the basic SCS support provided by feature 9660), 3262 Line Printers, and 3289 Line Printers.
- Programmed Symbols (PS) (feature 5781, 5782, or 5783) (To use programmed symbols on a distributed function terminal, you do not need to customize with a 1 response.)
- 3230 Model 2
- 3262 Models 3 and 13
- 3268 Model 2
- 3278 or 3287 with Extended Character Set Adapter (feature 3610)
- 3279, all models

Note: If you respond to this sequence number with a 1, you must not respond to sequence number 121 with 08, 10, 13, 20, 26, or 27.

161: Color Convergence

Enter a 0 if either:

- In U.S. and Canada only, all the 3279 Color Display Stations attached have model numbers ending in -1 (for example, S2A-1)

or:

- No 3279 Color Display Stations are attached.

Enter a 1 if any other 3279 Color Display Stations are attached.

165: Decompression

Enter a 1 if you want to send compressed PS data; otherwise, enter a 0. For a distributed function terminal, you do not need to customize with a 1 response.

Note: If you respond to this sequence number with 1, you must respond to sequence number 160 with 1.

166: Attribute Select Keyboard

For examples of the attribute select keyboards, see Figure J-4.

Enter one of the following to specify whether an attribute select typewriter keyboard (feature 4651), an attribute select typewriter/APL keyboard (feature 4652), or a typewriter overlay keyboard (feature 4640) is being used:

A = None of these keyboards is being used.

B = One or more of these keyboards are being used, but you do not wish to use the numeric lock function on *any* of them.

C = One or more of these keyboards are being used, and you wish to use the numeric lock function on *all* of them.

Note: If you respond to this sequence number with B or C, you must respond to sequence number 160 with a 1.

170: Distributed Function Terminals

- 0 = No distributed function terminals are attached.
- 1 = Distributed function terminals that require a load diskette will be attached; *or* a combination of distributed function terminals that require a load diskette and those that do not require a load diskette will be attached.
- 2 = Only distributed function terminals that *do not* require a load diskette will be attached.

Note: If your response is 0 or 2, respond to sequence numbers 139, 173, and 175 with 0's.

173: Distributed Function Terminal (DFT) Options

Except for the Intensify Option (bits 5 and 6), which calls for a 2-digit response, you enter a single-digit response (0 or 1) in the appropriate position to disable (0) or enable (1) the DFT options listed below. See the explanation for bits 5 and 6 for the possible 2-digit responses for the Intensify Option.

If you do not have a 3179-G Color Graphics Display Station or a 3290 Information Panel, disable all the options and enter a 0 in the reserved bit positions.

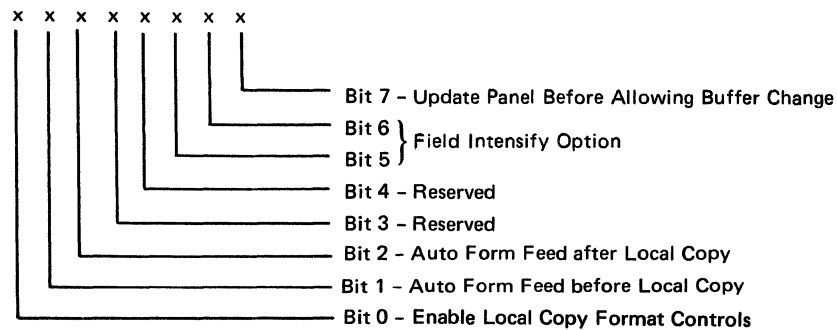

Bit 0: Enable Local Copy Format Controls (3179-G and 3290)

The 3179-G and the 3290 generate an SCS data stream to perform a local copy operation to a printer. If the printer does not have Save/Restore Format capability and is operated in shared mode, that is, if a local copy operation is permitted between brackets of an LU-1 session, there is a possibility that the local copy operation will destroy the format controls established by the host program. Proper use of this bit will help alleviate the contention situation for establishing format controls. When the printer supports Save/Restore Format, this option has no effect: the 3179-G and the 3290 will send format controls.

When bit 0 is set to 0, the 3179-G and the 3290 will not send format controls to a printer that lacks Save/Restore Format capability. The 0 setting is the default and is applicable to those operating environments where the host

program does not reestablish format controls with each Begin Bracket. Note that the format of the local copy output depends on the format controls established by the operator and/or host program.

When bit 0 is set to 1, the 3179-G and the 3290 will send format controls to the printer even though the printer lacks Save/Restore Format capability. This will enable the local copy output to duplicate, as closely as possible, the character image that is being copied from the 3179-G and the 3290. The 1 setting is applicable to those operating environments where the printer is not shared and/or the host program reestablishes format controls with each Begin Bracket.

Bit 1: Automatic Form Feed before Local Copy (3179-G and 3290)

Specify bit 1 as a 1 if you want to generate an automatic form feed before a local copy operation is performed.

Specify bit 1 as a 0 if you do not want to generate an automatic form feed before a local copy operation is performed.

Bit 2: Automatic Form Feed after Local Copy (3179-G and 3290)

Specify bit 2 as a 1 if you want to generate an automatic form feed after a local copy operation is performed.

Specify bit 2 as a 0 if you do not want to generate an automatic form feed after a local copy operation is performed.

Bits 3 and 4: Reserved

Specify 0.

Bits 5 and 6: Field Intensify Options (3290 Only)

When bits 5 and 6 are set to 00 or 11, the 3290 *will* underscore all fields carrying the field intensify attribute.

When bits 5 and 6 are set to 01, the 3290 *will not* underscore or display in reverse video the fields carrying the field intensify attribute.

When bits 5 and 6 are set to 10, the 3290 *will* display in reverse video the fields carrying the field intensify attribute.

Bit 7: Update Panel Before Allowing Buffer Change (3290 Only)

When bit 7 is set to 0, the 3290 will suspend panel updating to process a host transmission. Under high-data-rate conditions, messages sent by the host and placed in the display buffer may get overlaid with new data before being displayed on the panel.

When bit 7 is set to 1, all display buffer contents must be displayed on the panel before new data can be placed in the display buffer. It is recommended that bit 7 be set to 1 when 3290s are being used as system consoles or other applications where potentially high message rates are possible and the user is required to visually interpret all data sent by the host.

175: 3290 Password

Enter the 6-digit password to allow permanent changes to the 3290 logical terminal definition table using setup level 3.

176: BSC Enhanced Communication Option (Distributed Function Terminals)

Specify a 1 if all the following conditions exist:

- You have distributed function terminals attached.
- Your system is capable of handling enhanced BSC protocols in response to outbound transmissions of wait before transmit positive acknowledgment (BSC WACK).
- You use any of the following IBM program products, which support BSC WACK:
 - ACF/NCP Version 1, Release 2 and higher (CICS/VS and IMS/VS using VTAM or TCAM and ACF/NCP are supported.)
 - ACF/VTAM Version 2, Release 1 and higher (4321/4331 Communication Adapter*)
 - ACF/VTAME
 - CICS/VS Version 1, Release 6 and higher using BTAM
 - VM/370 SP, Release 3 and higher.

*Terminals attached through communication controllers are supported in the ACF/NCP releases indicated above.

Specify a 0 if any of the following conditions exists:

- You do not have distributed function terminals attached.
- Your system is not capable of handling BSC WACK.
- You use IMS/VS with BTAM.
- You use TCAM or ACF/TCAM with 370X EP.

You must ensure that the program products being used are at compatible levels and support the required display functions.

213: Between Bracket Printer Sharing (SDLC Only)

Enter a 1 if Between Bracket Printer Sharing is allowed; enter a 0 if not.

215: Physical Unit Identification (PUID) (SDLC Only)

The physical unit identification (PUID) is a 5-character code that identifies the control unit to the host in response to an SDLC XID command. It is required if the 3274 is to be used on a switched data link.

If the PUID is not used, enter 00000 for this sequence number on the Initial Customizing Procedure Form.

If the PUID is used, each control unit in a network should be assigned a unique PUID. The PUID must be obtained from the system programmer and entered as the response to this sequence number on the Initial Customizing Procedure Form. (Only characters 0 through 9 and A through F are valid.)

220: Alert Function (SNA Only)

Enter a 0, 1, 2, or 3 as follows:

- 0 = No alert function wanted.
- 1 = Alert function without operator-generated alert message capability.
- 2 = Alert function with operator-generated alert message capability from port 0 only.*
- 3 = Alert function with operator-generated alert message capability from all ports.*

*Operator-generated alert messages cannot be issued from a 3277 or a distributed function terminal.

Refer to Appendix H for more information concerning alert.

301: Control Unit Number (BSC Only)

Enter the 2-digit decimal control unit number. Obtain the polling address (in hexadecimal) for this control unit from the system programmer at the host system site. Use Figure 2-6 to convert this address to the decimal control unit number.

Notes:

1. *Because it is standard practice to send the address twice, the system programmer may give you a "double address," for example, 4040. You would use only the first two digits, that is, 40.*
2. *If your 3274 has an integrated modem feature (5640, 5740, 5840, or 5842) installed, see Appendix E for proper setting of the Modem Address switches.*

302: SDLC Control Unit Address/X.25 Secondary Station Address

If you are using SDLC protocol, enter the 2-character hexadecimal SDLC control unit address. The system programmer at the host system location can give you this information. The host system, if using NCP, specifies this address in the 3704/3705 PU macro. For loop operation, this address must match the loop adapter station address.

If you are using X.25 protocol, enter the 2-character hexadecimal secondary address. This information should be available from your X.25 subscription information, or from the system programmer at the host system location.

Note: If your 3274 has an integrated modem feature (5640, 5740, 5840, or 5842) installed, see Appendix E for proper setting of the Modem Address switches.

BSC Hexadecimal Polling Address		Control Unit Number (Sequence Number 301 Response)
EBCDIC	ASCII	
40	20	00
C1	41	01
C2	42	02
C3	43	03
C4	44	04
C5	45	05
C6	46	06
C7	47	07
C8	48	08
C9	49	09
4A	5B	10
4B	2E	11
4C	3C	12
4D	28	13
4E	2B	14
4F	21	15
50	26	16
D1	4A	17
D2	4B	18
D3	4C	19
D4	4D	20
D5	4E	21
D6	4F	22
D7	50	23
D8	51	24
D9	52	25
5A	5D	26
5B	24	27
5C	2A	28
5D	29	29
5E	3B	30
5F	5E	31

Example: If the EBCDIC hexadecimal BSC polling address is 4E, the value to be entered is 14. If the ASCII hexadecimal BSC polling address is 4E, the value to be entered is 21.

Figure 2-6. Chart of BSC Polling Address and Control Unit Number Conversion

305: BSC Printer Polling

Reply with a 1 if the host uses specific polling and printers are not defined in the host polling list. Reply with a 0 if the host uses general polling.

310: Modem Connection

Enter a 1 if the 3274 is connected via the CCITT 108.1 interface operating in connect-data-set-to-line (CDSTL) mode.

Enter a 0 if the 3274 is:

- Operating on a nonswitched line
- Operating on a switched line in the U.S. or in Canada
- Operating in data terminal ready/data set ready (DTR/DSR) mode in countries other than Canada
- Connected via the CCITT V.35 interface.

311: Modem Wrap (External Modems Only)

Enter a 1 if the modem is capable of a DTE-initiated automatic wrap test; enter a 0 if not. (In this case, the DTE is the 3274 Control Unit. The wrap test is initiated by the test [DTE] control signal option via pin 18 from the 3274 Control Unit.)

If an IBM 3863, 3864, 3865, 3872, 3874, or 3875 modem is used, enter a 1 if the test (DTE) control signal option was activated at the time of modem installation.

Wrap Feature: Determine whether the modem permits data to be wrapped under control of the 3274 Control Unit or whether the modem has a switch to control the wrap function. If the modem has the wrap capability and wrapping can be controlled from the 3274 Control Unit, this method is recommended.

If you are unable to determine that your modem has the wrap option activated, enter a 0. Note, however, that this may require you to recustomize at a later date if you determine that the modem does have the wrap option activated and you wish to use the wrap capability.

313: NRZI (SDLC Only) or NRZ Encoding

Enter a 1 if nonreturn to zero inverted (NRZI) encoding is used; enter a 0 if nonreturn to zero (NRZ) encoding is used. (This parameter must be compatible with the host system communication controller and/or the modem.)

313: Internal or External Clocking (BSC Only)

Enter a 1 if feature 6301 is installed; otherwise, enter a 0.

Note: For external modems operating at 1200 bps with 3274 feature 6301 (business machine clock) installed, you must enter 1.

314: Multipoint or Point-to-Point Network

Enter a 1 if the 3274 is part of a point-to-point network; enter a 0 if it is part of a multipoint network.¹

Note: If the 3274 is attached to an IBM 3865 Modem Model 2, or if the 3274 has integrated modem feature 5842 installed, you must enter a 0.

317: Switched Network Backup (SNBU)

If your modem does not have SNBU capability, if you do not wish to use SNBU, or if you are using the CCITT V.35 Interface feature (1550), enter a 0 in response to this sequence number.

2-Wire SNBU:

If your modem has SNBU capability and you wish to use this capability, you should customize a second diskette, using the modification procedure in Chapter 4. When customizing the second diskette, enter 1 in response to this sequence number¹ if your modem is a 3872, 3874, 3875, or a 1200-bps integrated modem; enter a 0 in all other cases.

4-Wire SNBU:

If the 3274 is attached to an IBM 3863, 3864, or 3865 modem with the 4-wire SNBU feature, enter a 0.

Note: A switched network attachment to some original equipment manufacturer (OEM) equipment requires the use of a protective device. This might have to be ordered from an OEM communication equipment supplier and installed separately.

318: Normal or Half-Speed Transmission

Enter a 1 if half-speed transmission operation is desired. Enter a 0 if the modem does not have half-speed transmission capability, if full-speed transmission capability is desired, or if you are using the CCITT V.35 Interface feature (1550).

¹ This parameter must be compatible with the host system communication controller and/or the modem.

Note: If the modem has half-speed transmission capability, determine whether this capability can be controlled externally by the 3274 or by a switch on the modem. If the capability can be controlled by a switch on the modem, it is recommended that a 0 be entered and that the switch be used. (This parameter must be compatible with the host system communication controller and/or the modem.)

If features 5640, 5740, 5840, and 5842 are installed, the operating speed is controlled by the host modem. Enter a 0 in response to this sequence number.

If the 3274 controls the operation speed, to have the capability to operate in either full-speed or half-speed mode, two system diskettes may be generated (as described in Chapter 5), one for full-speed operation and one for half-speed operation. To switch modes, select the other system diskette and perform IML procedures. Ensure that diskettes are appropriately labeled.

331: BSC/SDLC/X.25 Protocol

Enter a 1 if SDLC protocol is used; enter a 0 if BSC protocol is used. (This parameter must be compatible with the host system communication controller.)

Enter a 2 if X.25 (HDLC) protocol is used.

If the response to sequence number 331 is 2, sequence number 332 (a panel) will be displayed after all the sequence numbers on the sequence number 999 panel have been answered.

332: X.25 Customization Panel

See Appendix I for details about the sequence number 332 panel.

342: Request-to-Send (RTS) Control (2-Wire or 4-Wire)

SDLC:

2-Wire: Enter a 0.

4-Wire: Enter a 1.

Notes:

- 1. If you are using the CCITT V.35 Interface feature (1550), enter a 1.*
- 2. Entering a 1 here and in response to sequence number 314 will provide a permanent RTS.*
- 3. If you enter a 0 in response to this sequence number, you must also enter a 0 in response to sequence number 314.*

BSC:

2-Wire: Enter a 0.

4-Wire: If your host modems use the NEW SYNC feature, enter a 0. If you desire RTS from selection to end of transmission (EOT), enter a 1. (Be aware that entering a 1 may cause communication errors if your host modems use the NEW SYNC feature. If in doubt, enter a 0.)

Notes:

1. If you are using the CCITT V.35 Interface feature (1550), enter a 1.
2. If you enter a 0 in response to this sequence number, you must also enter a 0 in response to sequence number 314.

343: Communication Interface Options

Choose the communication interface you are using from the Interface and Feature Number columns in Figure 2-7, and enter the corresponding response to this sequence number.

Interface	Feature Number	Response	Applicable Model
CCITT V.35 Interface	1550	00	31C, 41C, 51C, 61C
Digital Data Service (DDS) Adapter	5650, 5651	01	31C, 41C, 51C, 61C
External Modem Interface (Nonswitched)	3701	00	31C, 41C, 51C, 61C
External Modem Interface (Switched)	3701	04	51C, 61C
Integrated Modem with Speeds Greater Than 1200 bps	5640, 5740, 5840, 5842	11	31C, 51C
Loop Attachment	4850	10	51C, 61C
X.21 Switched	5656	03	51C, 61C
X.21 Nonswitched	5655	02	31C, 41C, 51C, 61C
X.25 with CCITT V.35 Interface	1550	00	31C, 41C, 51C, 61C
X.25 with External Modem Interface (Nonswitched)	3701	00	31C, 41C, 51C, 61C
X.25 with X.21 Nonswitched	5655	03	31C, 41C, 51C, 61C
1200-bps Integrated Modem (Nonswitched)	5500	05	51C
1200-bps Integrated Modem (Switched) with Auto Answer	5501	06	51C
1200-bps Integrated Modem (Switched) with Manual Answer	5502	07	51C
1200-bps Integrated Modem with SNBU and Auto Answer	5508	09	51C
1200-bps Integrated Modem with SNBU and Manual Answer	5507	08	51C

Figure 2-7. Communication Interface Options (Sequence Number 343)

345: Answer Tone (World Trade External Switched Network Modems Only)

Enter a 1 if your external switched network modem does not require the 3274 transmit answer tone; otherwise, enter a 0.

347: High-Speed Data Rate (Loop Attachment Only; Models 51C and 61C Only)

Enter a 1 if your loop attachment data rate is 38.4 kb. Enter a 0 if it is less than 38.4 kb. This answer depends on the loop speed selected. (See Appendix F for additional information.) If you respond to this sequence number with 1, you must respond to sequence numbers 331 and 351 with 1.

351: HPCA (SDLC Only) or CCA Adapter

Enter a 1 if the HPCA Adapter feature (6303) is installed. Enter a 0 if the CCA Adapter feature (6301 or 6302) is installed.

352: Encrypt/Decrypt (SDLC Only)

Enter a 1 if the Encrypt/Decrypt feature (3680) is installed; enter a 0 if it is not.

360: X.21 Switched Retry (SDLC Only)

Enter 00 if you are not using the X.21 Switched feature. If you are using this feature, enter the number of times that an incoming or outgoing call will be retried after the initial attempt is unsuccessful. The maximum number of retries allowed is 99. Enter 00 if retry will not be used.

Note: A 2-digit number must be entered. If necessary, use a leading zero; for example, to specify 3, enter 03.

361: X.21 Switched Retry Timing (SDLC Only)

Enter 00 if you are not using the X.21 Switched feature. If you are using this feature, enter the number of seconds between the retries specified in sequence number 360. This can be from 01 to 20 seconds. Enter 00 if retry will not be used.

Note: A 2-digit number must be entered. If necessary, use a leading zero; for example, to specify 3, enter 03.

362: X.21 Switched Options (SDLC Only)

Enter 00000000 if you are not using the X.21 Switched feature. If you are using this feature, the response to this sequence number defines what X.21 options can be used on the terminals attached to all Category A ports except port A0. The conditions for port A0 are described following the diagram. Each of the eight digits in this response must be specified as either 1, meaning *yes*, or 0, meaning *no*. Each digit allows or disallows one of the options.

Digit

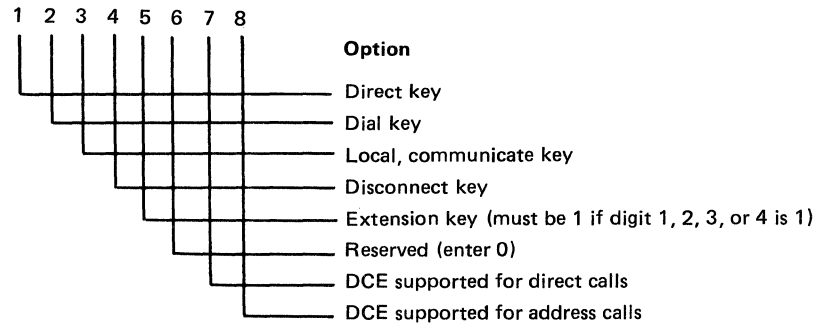

Note: If the X.21 Switched feature is being used, either digit 7 or digit 8 must be specified as 1, depending on which data circuit-terminating equipment (DCE) support is used.

Port A0 access to the X.21 options is determined as follows. Except for the Direct and Dial keys (digits 1 and 2), port A0 always has access to all the X.21 options. Access to Direct and to Dial depends on the status of the DCE for direct calls (digit 7) and for address calls (digit 8). If direct calls are supported (digit 7 specified as 1), the Direct key is supported on port A0. If address calls are supported (digit 8 specified as 1), the Dial key is supported on port A0. If both digits 7 and 8 are specified as 1, both the Direct and Dial keys are supported on port A0.

Example: 00011001 indicates that the Disconnect key (digit 4 specified as 1) and the Extension key (digit 5 specified as 1) can be used on all Category A terminals attached to the 3274. All Category A terminals support the DCE for address calls (digit 8 specified as 1). Since the Extension key allows access to all other X.21 keys, it must be specified if the other keys are to be used. Regardless of the response to this sequence number, the terminal attached to port A0 always has access to all the X.21 options.

900: Entry Acceptance

Sequence number 900, which appears as part of the sequence number 999 display, prompts the operator to enter a 1 if, after the entries are verified, all the responses are entered correctly. If the 3274 detects incorrect responses, it automatically changes the 1 back to a 0, an operator code is displayed for the incorrect information, and incorrect entries are intensified.

999: Specification Panel

Sequence number 999 displays all sequence numbers except 001, 011, 021, 031, and 032. When sequence number 999 appears during the first initial customizing, default values are shown. The customizer uses the sequence number 999 panel to key in the desired customizing specifications. These specifications remain in effect until recustomizing occurs. See step 12 of the Initial Customizing Procedure Form, in Chapter 3, for an example of the use of sequence number 999.

3274 Models 31D and 41D

Use the following sequence numbers and instructions in conjunction with the Initial Customizing Procedure Form in Chapter 3 to customize 3274 Model 31D with 2-sided diskette drives and Model 41D.

001: Keyboard and Customizing Guide Validation

The response required for this sequence number is '1234567890ABCDEF' followed by a space and the validation number that is printed on the front cover of this book and on the first page of the Initial Customizing Procedure Form. The first part of the response verifies that the keyboard being used for customizing is operating properly. The last part (the validation number) is used to check that the level of this customizing guide is equal to or greater than the level of the feature and system diskettes. This check ensures that the sequence numbers and their responses are compatible with the diskettes you are customizing.

Note: If a data entry keypunch layout keyboard is used, the New Line key is pressed when ENTER is specified. The PF10 key is pressed when RESET is required; the PF8 key is pressed when New Line is required. See Figures 3-1 and 3-2 (in Chapter 3) for the valid key positions and for the differences just noted. Be sure to specify the keyboard type on the Initial Customizing Procedure Form.

011: Patch Request

The response required for this sequence number is already entered on the form in step 5. The service representative may use this sequence number to make a diskette patch request.

021: Printer Authorization Matrix

Enter a 1 in step 6 on the Initial Customizing Procedure Form if a matrix is to be defined, thereby causing sequence number 022 to be displayed. This matrix will be established for each 3274 IML.

Enter a 0 if any of the following conditions applies:

- The printer authorization matrix is to be entered only by a host application program.
- All printers are to be used in system mode, and local-copy operations are not desired.
- No printers are to be attached to the system.

022: Printer Authorization Matrix Definition

The printer authorization matrix is defined in sequence number 022. See Appendix A for detailed information on responding to sequence number 022.

Fill in the appropriate spaces on the Printer Authorization Matrix Form with a definition for each printer in your configuration, and attach it to the Initial Customizing Procedure Form. The definitions may be entered in any sequence and in any group; for example, you may enter definitions anywhere in groups 1, 2, and 3 of the form, skip groups 4 and 5, and continue at group 6.

Once a printer authorization matrix has been defined, sequence number 021 is no longer displayed when a customized 3274 Control Unit is being updated. Instead, the defined matrix is displayed. If the entire matrix is deleted, sequence number 021 is again displayed during each updating procedure until a new matrix is defined. Any time the initial customizing procedure is performed, the sequence number 021 is displayed and the printer authorization matrix must be redefined if it is still required.

031: Number of RPQ Diskettes Required

Enter the number of RPQ diskettes required (0, 1, 2, or 3) in step 7 on the Initial Customizing Procedure Form.

032: Request RPQ Parameter List

Enter a 1 if you require the RPQ parameter list; enter a 0 if not. If you enter a 1 here, sequence number 033 (RPQ Parameters) is displayed, with *F*s for parameter information. If you enter a 0, sequence number 033 is not displayed.

Note: An RPQ parameter list is required by certain RPQs. Specific information about this list, sequence number 033 format, and implementation is supplied with the RPQ.

111: Number of Category B Terminals

Enter a 2-digit number (00 to 16; when necessary, use a leading zero, as 04) to specify the number of Category B terminals that can be attached to your 3274. (The actual number you have attached at any given time may be smaller than this number.) See sequence number 112 for a description of category types.

Notes:

1. *If you intend to assign port host addresses (your response to sequence number 116 is 2), your response to 111 must be 00.*
2. *If you intend to select the ports to which the control unit will assign addresses (your response to sequence number 116 is 1), see Procedure 1 (116=1) in Appendix B for a possible limitation on the number of Category B terminals that can be addressed.*

Model 31D with Distributed Function Terminals: Category B terminals cannot be attached.

112: Number of Category A Terminals

Enter a 2-digit number (08 to 32) to specify the number of Category A terminals that can be attached to your 3274. (The actual number you have attached at any given time may be smaller than this number.) See Note 1 below.

The 3274 customization program will use your response to assign port addresses automatically. No choice of ports or of addresses to be assigned is allowed. Addresses run sequentially, and each port is assigned an address, including unused ports.

If you want control of the port address assignment process, respond to this sequence number with 00 and see sequence number 116. User control of port host address assignment is explained in Appendix B.

Notes:

1. *If you are going to have distributed function terminals with the multiple interactive screen feature attached to your 3274, you must respond with 00 to this sequence number and use the user-controlled port assignment procedure (sequence numbers 116, 117, and 118) to assign ports and addresses.*
2. *A 2-digit number must be entered. If necessary, use a leading zero; for example, to specify 8, enter 08.*
3. *Category A terminals are:*

*IBM Personal Computer XT/370
IBM 3270 Personal Computer
IBM 3270 Personal Computer AT, AT/G, and AT/GX*
IBM 5550 3270/Personal Computer
3178 Models C1, C2, C3, and C4
3179
3179-G Models G1 and G2
3180 Model 1
3230 Model 2*

*Requires Configuration Support D, Release 61 or higher.

3262 Models 3 and 13
3268 Models 2 and 2C
3278 Models 1, 2, 3, 4, and 5
3278 Models 1–5 with IBM 3270 Personal Computer Attachment
3279, all models except 2C
3287 Models 1 and 2 with 3274/3276 Attachment (feature 8331)
3287 Models 1C and 2C
3289 Models 1 and 2
3290 Information Panel
4245 Models D12 and D20
4250 Model 1
5210 Models G01 and G02
6580 Displaywriter System

Category B terminals are:

3277 Models 1 and 2
3284 Models 1 and 2
3286 Models 1 and 2
3287 Models 1 and 2 with 3271/3272 Attachment (feature 8330)
3288 Model 2

4. *Specify the number of Category A terminals in multiples of 8 (maximum of 32) and the number of Category B terminals in multiples of 4 (maximum of 16), unless the sum of the two categories exceeds 32.*

If the sum of the two categories exceeds 32:

- a. *For Category B terminals, specify the actual number of Category B terminals (sequence number 111).*
- b. *For Category A terminals, specify the difference between 32 and the number of Category B terminals (sequence number 111).*

Example: 13 Category B terminals and 17 Category A terminals would be specified as 13 and 19, respectively. Figure 2-8 shows the relationship and the ways to specify the various Category A and B terminal quantities. Note that, when Category A terminal adapters are added or removed, the host-recognized address of port B0 changes.

113: Extended Function Store

Models 31D and 41D: Enter DA if no Extended Function Store feature is installed. Enter DC if the Extended Function Store Type D5 (feature 3660) is installed.

Quantity	Number of Category A Terminals																																Adapter Type	
	Base								A1								A2								A3									
	1	2	3	4	5	6	7	8	9	10	11	12	13	14	15	16	17	18	19	20	21	22	23	24	25	26	27	28	29	30	31	32		
	Specify: A08 and B00								Specify: A16 and B00								Specify: A24 and B00								Specify: A32 and B00									
Number of Category B Terminals	1																									Specify: 32-B=A								B0=31*
	2	Specify: A08 and B04								Specify: A16 and B04								Specify: A24 and B04																B0=30*
	3																																	B0=29*
	4																																	B0=28*
	5																																	B0=27*
	6	Specify: A08 and B08								Specify: A16 and B08								Specify: A24 and B08																B0=26*
	7																																	B0=25*
	8																																	B0=24*
	9																																	B0=23*
	10	Specify: A08 and B12								Specify: A16 and B12								Specify: 32-B=A								Not Permitted								B0=22*
	11																																	B0=21*
	12																																	B0=20*
	13																																	B0=19*
	14	Specify: A08 and B16								Specify: A16 and B16																								B0=18*
	15																																	B0=17*
	16																																	B0=16*

* The host-recognized port addresses are sequential, with the first Category A port (port A0) always being address 0 (with the exception of SNA, which is always 02). The first Category B port (port B0) is always the next sequential address after the last Category A port.

Figure 2-8. 3274 Model 31D Category A and B Terminal Quantity Relationships

114: IBM 3270 Personal Computer Attachment

Enter a 1 if an IBM 3270 Personal Computer Attachment will be attached to a 3278 Display Station connected to your 3274; enter a 0 if not.

Note: If you answer 114 with a 1, you must answer sequence number 160 (Extended Data Stream) with a 1.

115: Entry Assist Function

Enter a 0 if you do not want the Entry Assist function installed; enter a 1 if you do. There is no need to customize for Entry Assist if you plan to use it only on 3179-G Color Graphics Display Stations and 3290 Information Panels.

Note: Entry Assist is not supported with all languages; see sequence number 121.

116: User-Controlled Port Assignment Request

If you are going to assign ports and addresses, see Appendix B for the procedures to use and for explanations of sequence numbers 117 and 118. Appendix B will also aid you in selecting a response (other than 0) to this sequence number.

The amount of user control over port selection and host address assignment varies between the Release 60–63 levels of Configuration Support D (Validation Numbers 30–33) and the Release 64 level (Validation Number 34). Following are the possible responses to sequence number 116 for CS-D/Releases 60–63 and CS-D/Release 64.

CS-D/Releases 60–63

Enter a 0 if you have no distributed function terminals attached and do not want control of port selection and address assignment. (Your response to 112 must be nonzero.)

Enter a 1 if you want to select the ports and to define the number of addresses to be assigned to the ports. Addresses will be assigned automatically. (Your response to 112 must be zero.)

CS-D/Release 64

Enter a 0 if you have no distributed function terminals attached and do not want control of port selection and address assignment. (Your response to 112 must be nonzero.)

Enter a 1 if you want to select the ports and to define the number of addresses to be assigned to the ports. Addresses will be assigned automatically. (Your response to 112 must be zero.)

Enter a 2 if you want to select the ports to which addresses will be assigned and to specify the exact addresses to be assigned. (Your response to sequence numbers 111 and 112 must be zero.)

117: Port Assignment Specification Table

This table is displayed after the specification panel is accepted and if sequence number 116 is answered with other than a 0. See Appendix B for details.

118: Port Address Table

This table appears after sequence number 117 is completed. See Appendix B for details.

121: Keyboard Language/Character Set I/O Interface Code

Enter a 2-digit number (01 and 03 to 32) from Figure 2-9 specifying the keyboard language and character set I/O interface code being used. A 2-digit number must be entered. If necessary, use a leading zero; for example, to specify 7, enter 07.

Sequence Number 121 Response	Keyboard Language	Character Set I/O Interface Code
01	English (U.S.) EBCDIC	English (U.S.) EBCDIC
03	Austrian/German	Austrian/German
04	Belgian	Belgian
05 ¹	Brazilian	Brazilian
06 ^{1, 2, 3}	Canadian (French)	Canadian (French)
07	Danish	Danish/Norwegian
08 ^{1, 2, 3, 4}	Danish	Danish/Norwegian (Alternate)
09 ²	Finnish	Finnish/Swedish
10 ^{1, 2, 3, 4}	Finnish	Finnish/Swedish (Alternate)
11 ^{1, 3}	French (QWERTY)	French
12 ^{1, 2, 3}	French (AZERTY)	French
13 ^{1, 2, 3, 4}	Austrian/German	Austrian/German (Alternate)
14 ¹	International	International
15	Italian	Italian
16 ¹	Japanese (English)	Japanese (English)
17 ³	Japanese (Katakana)	Japanese (Katakana)
19	Spanish	Spanish
20 ^{1, 2, 3, 4}	Spanish	Spanish (Alternate)
21	Spanish-speaking	Spanish-speaking
22	English (U.K.)	English (U.K.)
23	Norwegian	Danish/Norwegian
24	Swedish	Finnish/Swedish
25 ¹	EBCDIC (WT)	English (U.S.)
26 ^{1, 2, 3, 4}	Norwegian	Danish/Norwegian (Alternate)
27 ^{1, 2, 3, 4}	Swedish	Finnish/Swedish (Alternate)
28	Portuguese	Portuguese
29	Canadian (Bilingual)	Canadian (Bilingual)
30	French AZERTY (105-character)	French AZERTY (105-character)
31	Swiss German	Swiss French/Swiss German
32	Swiss French	Swiss French/Swiss German

Notes:

- Keyboard layouts and character set I/O interface code information are given in *IBM 3270 Information Display System: Character Set Reference, GA27-2837*.
- All character set I/O interface codes are EBCDIC except English (U.S.) ASCII.
- An alternative character set I/O Interface code should be selected only when compatibility with the 3271/3272/3275 data base is required. To facilitate later migration, all systems should be upgraded to the latest support 3270 level.

¹ Not supported for 3179-G.

² Not valid for 3290.

³ The Entry Assist function not supported with these languages for 3274.

⁴ Not supported with Extended Data Stream (160=1).

Figure 2-9. 3274 Model 31D and 41D Keyboard Language and Character Set I/O Interface Code

125: Miscellaneous Feature Options

Each of the eight digits in this response must be specified as either 1, meaning *yes*, or 0, meaning *no*.

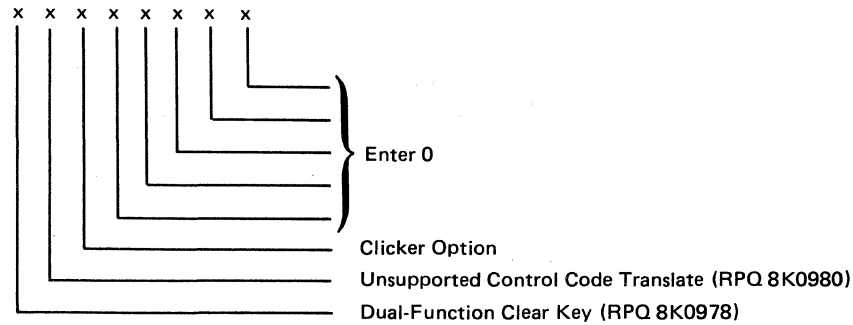

Dual-Function Clear Key (Functionally Equivalent to RPQ 8K0978 on Configuration Support C)

Specifying this bit as a 1 changes the operation of the Clear key so that it no longer puts a 3278 or 3180 Display Station, a 3279 Color Display Station, or a 3179-G Color Graphics Display Station into the default screen size mode.

Unsupported Control Code Translate (Functionally Equivalent to RPQ 8K0980 on Configuration Support C)

Specifying this bit as a 1 translates the following interface codes into a hyphen character code (EBCDIC X'60'):

01 through 04, 06, 07, 09, 0A, 0B, 0E, 0F, 10, 14, 16, 17, 18, 1A, 1B, 1F, 20 through 27, 2A, 2B, 2D, 2E, 2F, 30 through 3B, 3D, 3F, and FF.

During READ operations, the hyphen character code is returned to the host instead of the original code.

Specifying this bit as a 0 causes the 3274 to reject the above interface codes and to display a PROG 470 in the operator information area of all display stations.

Clicker Option

0 = Keyboard clicker is turned off when the display station is powered on.

1 = Keyboard clicker is turned on when the display station is powered on.

Default = 1.

127: Response Time Monitor (RTM) Definition

A two-digit response is required. Both digits must be either zero or a nonzero value as follows:

First Digit:

- 0 = RTM support not wanted.
- 1 = RTM without host support. The RTM log and Last Transaction Time Indicator are displayed and reset on port 0* only.
- 2 = RTM without host support. The RTM log and Last Transaction Time Indicator are displayed and reset on all ports.*

*All terminals can display the Last Transaction Time Indicator, but only non-distributed-function terminals can display the RTM log.

Second Digit:

- 0 = RTM support not wanted.
- 1 = End response time measurement when the first character is displayed on screen.
- 2 = End response time measurement when the keyboard again becomes usable.

Response time measurement starts with recognition by the control unit of an inbound AID request, for example, by pressing the ENTER key. The second digit responses define the end of measurement.

Nonzero responses to sequence number 127 cause sequence number 128, RTM Boundaries and Interface Specification, to be displayed later in the customization sequence.

See Appendix G for more details concerning RTM.

128: RTM Boundaries and Interface Specification

This sequence number (a panel) is displayed after the specification panel and, if applicable, 116 and 117 are accepted *and* only if the response to sequence number 127 is nonzero. See Appendix G for details.

Note: The following three sequence numbers, 136, 137, and 138, apply only if the 3274 has display stations with modifiable keyboards (such as the 3179 Color Display Station and the 3180 Display Station Model 1) attached, and if these devices are to be operated in native mode (that is, not in 3278-emulation mode).

136: Modifiable Keyboard Layout Selection — Unmodified Layouts

For modifiable keyboards, keyboard translate tables supporting Typewriter-, APL-, and Data Entry-style keyboard layouts are provided (on the language diskette). For examples of these layouts, see Figure J-1 in Appendix J. The response to sequence number 136 selects these layouts in unmodified form. (If you have modified these layouts, using the Keyboard Definition Utility, see sequence number 137.)

You respond to sequence number 136 with a 3-digit entry, each digit position having meaning as follows:

First digit = Typewriter Keyboard layout
Second digit = APL Keyboard layout
Third digit = Data Entry Keyboard layout

Entering a 1 in the appropriate digit position (in place of the 0 displayed) indicates that you want that layout configured into the system; a 0 indicates that the layout is not wanted.

Any combination of 1's and 0's is allowed.

There is a restriction that the total number of unmodified and modified keyboard layouts selected (sequence numbers 136 and 137) cannot exceed four. Therefore, if all three unmodified keyboard layouts are configured, only one modified keyboard layout can be selected in sequence number 137.

137: Modifiable Keyboard Selection — Modified Layouts

This sequence number can be answered only if the Keyboard Definition Utility was used prior to customizing to define one to four unique keyboard layouts by making modifications to the layouts provided. Each modified layout consists of a keyboard/keypad combination that is assigned an ID (A, B, C, or D). A modified keyboard layout cannot be selected unless it was defined. How to define modifiable keyboard layouts is described in the *Keyboard Definition Utility User's Guide*, GA23-0187.

The four 0's displayed represent the four modified keyboard IDs A, B, C, and D. Select the modified keyboard layouts to be configured into the system by entering 1's in the corresponding digits.

- First digit = Keyboard ID A
- Second digit = Keyboard ID B
- Third digit = Keyboard ID C
- Fourth digit = Keyboard ID D

The total number of keyboard layouts selected in sequence numbers 136 and 137 cannot exceed four.

138: Modifiable Keypad Selection — Unmodified Layout

The response to this sequence number specifies the type of keypad to be used with the modifiable keyboard layout(s) selected in sequence number 136. For examples of these layouts, see Figure J-2 in Appendix J. Only one of the following may be selected:

- 0 = Default Keypad (National Language Numeric)
- 1 = Data Entry Keypad
- 2 = PF Keys Keypad

The response consists of one character: 0, 1, or 2. (0, the default selection, is displayed.)

Although up to three types of unmodified keyboard layouts may be selected in sequence number 136, the one keypad layout selected here will be used with all those keyboard layouts. If a keyboard layout is not selected in sequence number 136 (response 0 0 0), a keypad layout cannot be selected.

139: 3290 Keypad Selection

Enter 0 if you have no 3290 Information Panel. If you have a 3290, enter one of the following to specify the type of keypad you will be using on your 3290 Information Panel:

- 0 = No keypad or the default keypad (National Language Numeric Keypad).
- 1 = 24-key numeric keypad.
- 2 = 25-key numeric keypad (, on key 4).
- 3 = 25-key numeric keypad (. on key 4).
- 4 – 6 = Reserved.
- 7 = Program Function Keypad.

For examples of these keypads, see Figure J-3 in Appendix J.

Note: If a nonzero response is specified for this sequence number, you must specify a 1 for sequence number 170.

141: Magnetic Character Set

Enter one of the following to specify the magnetic character set installed:

A = None

B = Numeric (3277-compatible)

C = Alphanumeric (auto entry for secure data only)

D = Alphanumeric (auto entry for all data)

151: 3274 Model Designation

Enter the 3274 model type (31D or 41D).

160: Extended Data Stream

Enter a 1 if you are using any of the following items; enter a 0 if not:

- An IBM 3270 Personal Computer Attachment
- APL (To use APL on a distributed function terminal, you do not need to customize with a 1 response.)
- Structured Field and Attribute Processing (SFAP) (To use structured fields on a distributed function terminal, you do not need to customize with a 1 response.)

Required for the use of the Write Structured Field command or of the Set Attribute, Start Field Extended, or Modify Field order.

- Programmed Symbols (PS) (feature 5781, 5782, or 5783) (To use programmed symbols on a distributed function terminal, you do not need to customize with a 1 response.)
- 3230 Model 2
- 3262 Models 3 and 13
- 3268 Model 2
- 3278 or 3287 with Extended Character Set Adapter (feature 3610)
- 3279, all models
- 4250 Model 1

Note: If you respond to this sequence number with a 1, you must not respond to sequence number 121 with 08, 10, 13, 20, 26, or 27.

161: Color Convergence

Enter a 0 if either:

- In U.S. and Canada only, **all** the 3279 Color Display Stations attached have model numbers ending in -1 (for example, S2A-1)

or:

- No 3279 Color Display Stations are attached.

Enter a 1 if any other 3279 Color Display Stations are attached.

165: Decompression

Enter a 1 if you want to send compressed PS data; otherwise, enter a 0. For a distributed function terminal, you do not need to customize with a 1 response.

Notes:

1. *If you respond to this sequence number with 1, you must respond to sequence number 160 with 1.*
2. *Decompressing data on a channel-attached 3274 could degrade performance.*

166: Attribute Select Keyboard

For examples of the attribute select keyboards, see Figure J-4.

Enter one of the following to specify whether an attribute select typewriter keyboard (feature 4651), an attribute select typewriter/APL keyboard (feature 4652), or a typewriter overlay keyboard (feature 4640) is being used:

A = None of these keyboards is being used.

B = One or more of these keyboards are being used, but you do not wish to use the numeric lock function on *any* of them.

C = One or more of these keyboards are being used, and you wish to use the numeric lock function on *all* of them.

Note: If you respond to this sequence number with B or C, you must respond to sequence number 160 with a 1.

170: Distributed Function Terminals

- 0 = No distributed function terminals are attached.
- 1 = Distributed function terminals that require a load diskette will be attached; *or* a combination of distributed function terminals that require a load diskette and those that do not require a load diskette will be attached.
- 2 = Only distributed function terminals that *do not* require a load diskette will be attached.

Note: If your response is 0 or 2, respond to sequence numbers 139, 173, and 175 with 0's.

173: Distributed Function Terminal (DFT) Options

Except for the Intensify Option (bits 5 and 6), which calls for a 2-digit response, you enter a single-digit response (0 or 1) in the appropriate position to disable (0) or enable (1) the DFT options listed below. See the explanation for bits 5 and 6 for the possible 2-digit responses for the Intensify Option.

If you do not have a 3179-G Color Graphics Display Station or a 3290 Information Panel, disable all the options and enter a 0 in the reserved bit positions.

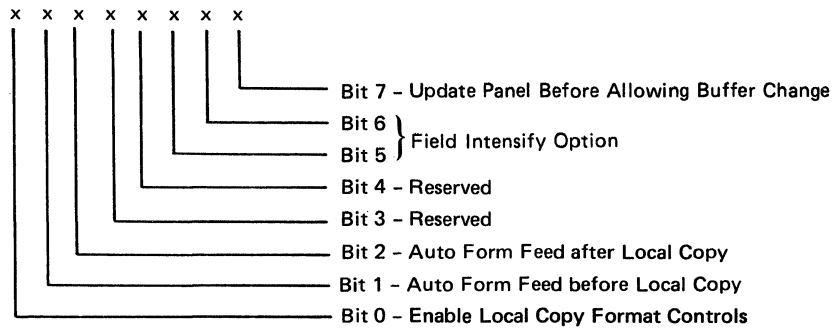

Bit 0: Enable Local Copy Format Controls (3179-G and 3290)

The 3179-G and the 3290 Information Panel generate an SCS data stream to perform a local copy operation to a printer. If the printer does not have Save/Restore Format capability and is operated in shared mode, that is, if a local copy operation is permitted between brackets of an LU-1 session, there is a possibility that the local copy operation will destroy the format controls established by the host program. Proper use of this bit will help alleviate the contention situation for establishing format controls. When the printer supports Save/Restore Format, this option has no effect: the 3179-G and the 3290 will send format controls.

When bit 0 is set to 0, the 3179-G and the 3290 will not send format controls to a printer that lacks Save/Restore Format capability. The 0 setting is the default and is applicable to those operating environments where the host

program does not reestablish format controls with each Begin Bracket. Note that the format of the local copy output depends on the format controls established by the operator and/or host program.

When bit 0 is set to 1, the 3179-G and the 3290 will send format controls to the printer even though the printer lacks Save/Restore Format capability. This will enable the local copy output to duplicate, as closely as possible, the character image that is being copied from the 3179-G and the 3290. The 1 setting is applicable to those operating environments where the printer is not shared and/or the host program reestablishes format controls with each Begin Bracket.

Bit 1: Automatic Form Feed before Local Copy

Specify bit 1 as a 1 if you want to generate an automatic form feed before a local copy operation is performed.

Specify bit 1 as a 0 if you do not want to generate an automatic form feed before a local copy operation is performed.

Bit 2: Automatic Form Feed after Local Copy

Specify bit 2 as a 1 if you want to generate an automatic form feed after a local copy operation is performed.

Specify bit 2 as a 0 if you do not want to generate an automatic form feed after a local copy operation is performed.

Bits 3 and 4: Reserved

Specify 0.

Bits 5 and 6: Field Intensify Option

When bits 5 and 6 are set to 00 or 11, the 3290 *will* underscore all fields carrying the field intensify attribute.

When bits 5 and 6 are set to 01, the 3290 *will not* underscore or display in reverse video the fields carrying the field intensify attribute.

When bits 5 and 6 are set to 10, the 3290 *will* display in reverse video the fields carrying the field intensify attribute.

Bit 7: Update Panel Before Allowing Buffer Change

When bit 7 is set to 0, the 3290 will suspend panel updating to process a host transmission. Under high-data-rate conditions, messages sent by the host and placed in the display buffer may get overlaid with new data before being displayed on the panel.

When bit 7 is set to 1, all display buffer contents must be displayed on the panel before new data can be placed in the display buffer. It is recommended that bit 7 be set to 1 when 3290s are being used as system consoles or other applications where potentially high message rates are possible and the user is required to visually interpret all data sent by the host.

175: 3290 Password

Enter the 6-digit password to allow permanent changes to the 3290 logical terminal definition table with setup level 3.

900: Entry Acceptance

Sequence number 900, which appears as part of the sequence number 999 display, prompts the operator to enter a 1 if, after the entries are verified, all the responses are entered correctly. If incorrect responses are detected by the 3274, the 1 is automatically changed back to a 0 by the 3274, an operator code is displayed for the incorrect information, and incorrect entries are intensified.

999: Specification Panel

Sequence number 999 displays all sequence numbers except 001, 011, 021, 031, and 032. When sequence number 999 appears during the first initial customizing, default values are shown. The customizer uses the sequence number 999 panel to key in the desired customizing specifications. These specifications remain in effect until recustomizing occurs. See step 12 of the Initial Customizing Procedure Form, in Chapter 3, for an example of the use of sequence number 999.

Chapter 3. Initial Customizing Procedure

This chapter contains a recommended Initial Customizing Procedure Form. This form should be used the first time the 3274 Control Unit is customized. Once the 3274 is successfully customized, if changes are required or desired, the Modification Procedure Form might be useful. See Chapter 4 for specifics.

When initial customizing is completed, the information on the Initial Customizing Procedure Form should be copied onto the *IBM 3274 Control Unit Configuration Data Card (Configuration Support: D)*, GA23-0114, supplied with the 3274. The card should be stored, for future reference, in the diskette storage area of the 3274.

The planner should enter the following information on the Initial Customizing Procedure Form:

1. Enter the type of keyboard (typewriter or data entry) to be used by the operator.

Note: If using a 76- or 88-key Japanese English or Japanese Katakana keyboard, specify the number of keys and the keyboard type.

2. In step 1, enter the identification of each diskette to be used.
3. In step 7, enter the response to sequence number 031 (Number of RPQ Diskettes Required). If you have no RPQ diskettes, the response is 0. If your response to sequence number 031 is not 0, you will have to enter a response to sequence number 032. See "032 (Request RPQ Parameter List)" in Chapter 2.
4. In step 8, enter the response to sequence number 151 (3274 Model Designation).
5. In step 10, enter (if required) the response to sequence number 331 (BSC/SDLC/X.25 Protocol).
6. In step 11, enter (if required) the response to sequence number 343 (Communication Interface Options).
7. Step 12 refers to a layout of the required responses for sequence number 999. Blank layout forms immediately follow the last step of this procedure. Fill in the 999 layout that applies to the system for which you are customizing. All sequence numbers must have a response written in. Attach the completed 999 layout to this procedure.
8. If your response to sequence number 116 is 1, you must fill in the forms given in Appendix B and attach them to this procedure.

9. If your response to sequence number 127 is nonzero, fill in the form for sequence number 128 given in Appendix G, and attach it to this procedure.
10. If your response to sequence number 331 is 2 (for X.25), fill in the form for sequence number 332 (a panel), found in Appendix I. Attach the completed form to this procedure.

In addition to the Initial Customizing Procedure Form, this chapter contains other forms, diagrams, and informational charts that can be used during customization; attach them to the procedure form if desired:

- Required responses for sequence number 999. Fill in the 999 layout that applies to the system being customized.
- Keyboard diagrams showing the valid key positions for the keyboard attached to port A0 during customizing (Figures 3-1 and 3-2).
- Diagrams showing how to insert a diskette properly into the various 3274 models (Figure 3-3).
- A chart giving the meanings of, and recommended actions for, the operator codes that may appear on the display station during customizing (Figure 3-4).
- Charts giving the meanings of, and recommended actions for, the 8 4 2 1 indicator codes that appear on the 3274 control panel during customizing (Figures 3-5 and 3-6).
- A chart giving the meanings of, and recommended actions for, the 8 4 2 1 indicator codes that could appear on the 3274 control panel during IML because of improper customizing (Figure 3-7).
- A Printer Authorization Matrix Form to be used with sequence number 022 in Chapter 2.
- A copy of the *IBM 3274 Control Unit Configuration Data Card (Configuration Support: D)*, GA23-0114.

The following may also be required for proper customizing of your 3274; attach the applicable items to the Initial Customizing Procedure Form:

- User-controlled Port Assignment Procedure (Appendix B)
- Subsystem Verification Procedure (Appendix C)
- Color Convergence Procedure (Appendix D)
- 3274 Model 31C Modem Address Switch Settings (Appendix E)
- 3274 Model 51C and 61C Switch Settings (Appendix F)
- RTM Sequence Number 128 Responses (Appendix G)
- X.25 Sequence Number 332 Responses (Appendix I).

All the applicable information above and the completed Initial Customizing Procedure Form should be given to the operator who is to perform the customizing procedure at the display station.

Review this entire form before starting the customizing procedure. Display station operating procedures are described in the *Operator's Guide* for the display station to be used in customizing.

This procedure configures the 3274 Control Unit. *If you do not get the expected result in any step, start over at step 1. If you still do not get the expected result, report the problem.*

There are four indicators, labeled 8 4 2 1, on the 3274 control panel. The meanings of the 8 4 2 1 indicator codes are shown in Figures 3-5 and 3-6. If an error occurs during this procedure, the 8 4 2 1 indicator code may help you locate the cause. Within this form, an on indicator is called a 1, an off indicator a 0 (zero).

Example: 8 4 2 1
 * * 0 * = 1101

3274 Control Panel

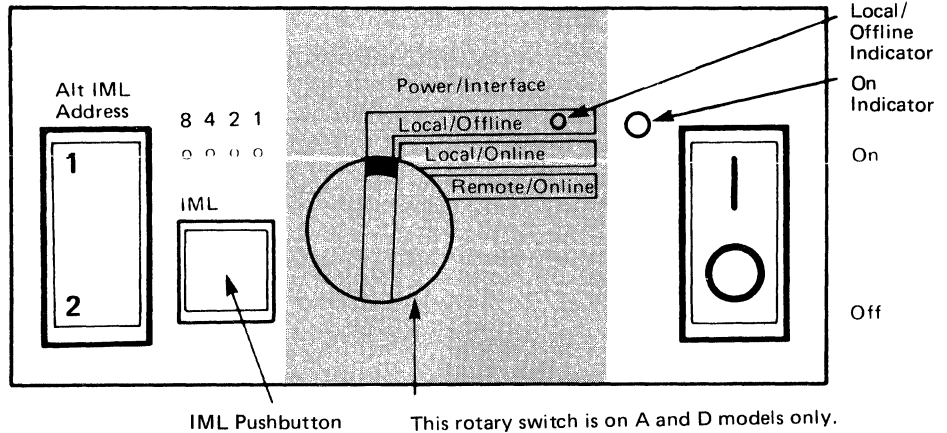

Type of keyboard to be used: _____

Note: See Figure 3-1 or 3-2 before continuing.

1. Obtain the:

- Feature diskette _____
 - System diskette _____
 - Language diskette (if applicable) _____
 - Load diskette (if applicable) _____
 - RPO diskette(s) (if applicable) 1. _____
 - 2. _____
 - 3. _____
- } These diskettes were delivered with the 3274.

2. Ensure that the 3274 Control Unit and the display station have power switched on. The display station must have a keyboard and must be attached to port A0 of the 3274.

If you are using a 3299 Terminal Multiplexer, ensure that:

- a. A display station (other than a distributed function terminal or a 3277) is connected to the 0–7 port adapter on the 3274.
- b. The port adapter switch is in the display position (up) (factory-installed port adapter), or the shorting cap is connected (field-installed port adapter). See the diagram on the port adapter panel on the 3274.

Note: When customizing 3274 A or D models, do not set the On/Off switch to the Off position unless the rotary switch on the control panel is in the Local/Offline position and the Local/Offline indicator is on. The Power/Interface switch must be in the Local/Offline position, and the Local/Offline indicator must be on.

3. Insert the *feature* diskette (Figure 3-3), and press the IML push-button for a moment. Within 1 minute, the 8 4 2 1 indicator code should be 0001. If you are using a 3279 Color Display Station that is designed to be converged, refer to Appendix D for the convergence procedure.

Power on a printer if you want the local copy function.

4. Look for a 3-digit sequence number in the upper left corner of the screen. The first one is 011. Beneath the sequence number are Xs, which you replace by typing in the response to sequence number 001 (below). If the response you enter is acceptable, a new sequence number is displayed. If the response is unacceptable, a 2-digit operator code is displayed in the upper, center portion of the screen. See Figure 3-4 for the meaning of this code.

If you are using a display station with a modifiable keyboard, the display station must be operating in 3278 emulation mode. If it is not (that is, if it is in native mode), the number 212 appears in the operator information area of the display station when the first key stroke is attempted, and customizing cannot proceed.

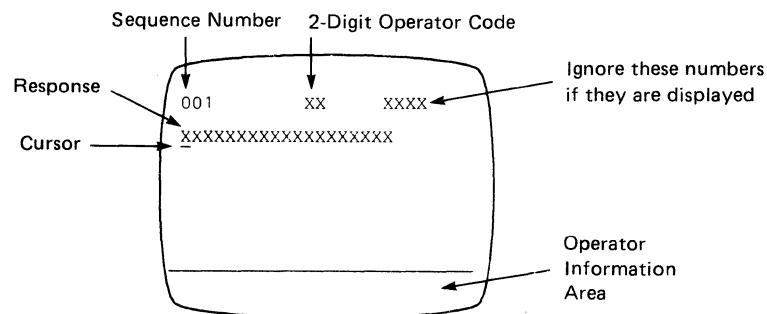

Note: If a 76- or 88-key Japanese English or Japanese Katakana keyboard is used, press the key circled in Figure 3-2 before proceeding. The keyboard will be locked for about 10 seconds. When the keyboard unlocks, continue.

- a. Type in the following characters in response to sequence number 011:
1234567890ABCDEF
- b. Press the spacebar once.
- c. Type in the 2-digit validation number printed on the first page of this form.
- d. Press ENTER.

Note: Use only the cursor move keys or the tab key to reposition the cursor.

5. A 0 is displayed in response to sequence number 011: Do not change this response. Press ENTER.
6. If you have *not* been given a Printer Authorization Matrix Form, press ENTER in response to sequence number 021. If you have been given the Printer Authorization Matrix Form, type in a 1 and press ENTER; then follow the instructions on the form.
7. Type in the number of RPO diskettes_____being used in response to sequence number 031. Press ENTER.

Note: If you respond to sequence number 031 with a 1, 2, or 3, sequence number 032 is displayed. If you have been given specific RPO parameter instructions, follow those instructions. If not, press ENTER.
8. Type in_____in response to sequence number 151. Press ENTER.
9. If your response in step 8 was 31A, 31D, 41A, or 41D, go to step 12. If not, go to step 10.
10. Type in_____in response to sequence number 331. Press ENTER.
11. Type in_____in response to sequence number 343. Press ENTER.
12. Sequence number 999 is now displayed, showing the remaining sequence numbers that are required to configure your 3274. A layout similar to the one shown on the display screen is attached to this form. The attached layout has the necessary responses written in. Type in the response indicated for each sequence number. Do *not* press ENTER until you are told in step 14.

All response positions on the display screen *must* be filled in. Do not blank out any positions. If positions are left blank on the attached layout, follow your local problem recovery procedure.

If any of the responses indicated on the attached layout are already displayed, you may skip over them by using the cursor move or tab keys.

13. After the last response is entered, check the entries. You may correct entries by moving the cursor to the entry to be changed and entering the correct response. Do not try to change the sequence number itself.
14. When all the entries are correct, move the cursor to the 0 after sequence number 900, change the 0 to a 1, and press ENTER. If all the entries are acceptable, the screen is cleared. If any entry is unacceptable, the entry to sequence number 900 is changed back to 0 and the unacceptable response is intensified. (With the 3279, intensified characters are white and red instead of blue and green.) The 2-digit operator code in the upper, center portion of the screen refers to the greatest sequence number with its response intensified. (Figure 3-4 gives the meanings of these codes.) Repeat step 13 and this step. If there are still unacceptable entries, report the problem.

If no more panels are displayed on your screen, go to step 15. These responses to sequence number 999 may now bring other panels to your screen:

- a. If your response to sequence number 116 was 1 or 2, sequence number 117 (a panel) is displayed. Enter the responses from the Port Assignment Entry Form attached to this form.

Sequence number 118 (a panel) follows right after number 117 and provides visual verification that the entries made in 117 have been accepted.

- b. If your response to sequence number 127 was *not* two zeros (0 0), sequence number 128 (a panel) is displayed. Enter the responses from the Sequence Number 128 Procedure Form attached to this form.
- c. If your response to sequence number 331 was 2, sequence number 332 (a panel) is displayed. Enter the responses from the X.25 Customization Response Form attached to this form.

15. Within 2 minutes, the 8 4 2 1 indicator code on the 3274 Control Unit should be flashing one of the following (1100, 1101, or 1011):

1100 — Replace the feature diskette with the *RPQ* diskette. *Do not press the IML pushbutton.* (If you do press the IML pushbutton, go back to step 3.) After the *RPQ* diskette is inserted, the code will change to 0111 within 30 seconds. If additional *RPQ* diskettes are required or if you inserted a diskette that is not an *RPQ* diskette, the indicator code will again flash 1100. Repeat the procedure for each additional *RPQ* diskette. *At no time should you press the IML pushbutton.* When the *RPQ* diskette procedure is completed, the indicator code should be flashing 1110. Reinsert the *feature* diskette. *Do not press the IML pushbutton.* Within 2 minutes, the 8 4 2 1 indicator code will flash 1011 or 1101. Follow the instructions associated with the code.

1101 – Replace the feature diskette with the *language* diskette. *Do not press the IML pushbutton.* (If you do press the IML pushbutton, go back to step 3.) Within 30 seconds, the indicator code will change to 0111 and then to flashing 1011 within 1 minute. When the indicator code is flashing 1011, replace the language diskette with the *system* diskette. *Do not press the IML pushbutton.* Within 1 minute, the 8 4 2 1 indicator code will change to a steady 1000. Within 15 minutes, the 8 4 2 1 indicator code will change to one of the following:

Note: If errors occur during this 15-minute period, a flashing 8 4 2 1 indicator code will appear. Figures 3-5 and 3-6 may help you locate the cause.

0011 – Replace the system diskette with the *load* diskette. *Do not press the IML pushbutton.* (If you do press the IML pushbutton, go back to step 3.) Within 5 minutes, the 8 4 2 1 indicator code will change to 1111 (all lights on), indicating that customizing is successfully completed.

1111 – Customizing is successfully completed. Go to step 16.

1011 – Replace the feature diskette with the *system* diskette. *Do not press the IML pushbutton.* (If you do press the IML pushbutton, go back to step 3.) Within 1 minute, the 8 4 2 1 indicator code will change to a steady 1000. Within 15 minutes, the 8 4 2 1 indicator code will change to one of the following:

Note: If errors occur during this 15-minute period, a flashing 8 4 2 1 indicator code will appear. Figures 3-5 and 3-6 may help you locate the cause.

0011 – Replace the system diskette with the *load* diskette. *Do not press the IML pushbutton.* (If you do press the IML pushbutton, go back to step 3.) Within 5 minutes, the 8 4 2 1 indicator code will change to 1111 (all lights on), indicating that customizing is successfully completed.

1111 – Customizing is successfully completed. Go to step 16.

Note: If you used a load diskette in this procedure, that load diskette should be used for step 18. Otherwise, the system diskette should be used.

16. Make sure that the 3274 is attached to the appropriate communication facility.

17. If you are using a 3299 Terminal Multiplexer:
 - a. Attach the cable leading to the 3299 to the 0-7 port adapter on the 3274.
 - b. Put the port adapter switch on the 3274 in the 3299 position (down) (factory-installed port adapter) or remove the shorting-cap (field-installed port adapter). (See the diagram on the port adapter panel.)
18. Press the *IML* pushbutton. During the IML operation, errors may occur because of improper customizing. The 8 4 2 1 indicator codes caused by these errors are shown in Figure 3-7.

If, after the IML operation is initiated, the X  symbol appears for more than 1 minute with no communication reminders in the display station's operator information area, contact your host system operator to ensure that the 3274 Control Unit is being polled.

19. It is suggested that you copy the configuration information from this form on the *IBM 3274 Control Unit Configuration Data Card (Configuration Support: D)*, GA23-0114, supplied with the 3274 Control Unit. Store the card, for future reference, in the diskette storage area of the 3274 that you are customizing for.
20. If a Subsystem Verification Procedure has been given to you, perform that procedure.
21. If you have been given instructions for setting 3274 Model 31C, 51C, or 61C switches, follow those instructions.

3274 A Models – 999 Sequence Number Layout

Note: Use leading zeros to have a 1-digit response fill a 2-digit box.

999

111 – <input type="text"/>	112 – <input type="text"/>	113 – <input type="text"/>	114 – <input type="text"/>	115 – <input type="text"/>	116 – <input type="text"/>
121 – <input type="text"/>	125 – <input type="text"/>		127 – <input type="text"/>		
136 – <input type="text"/>		137 – <input type="text"/>		138 – <input type="text"/>	139 – <input type="text"/>
141 – <input type="text"/>		151 – <input type="text"/>			
160 – <input type="text"/>	161 – <input type="text"/>	165 – <input type="text"/>	166 – <input type="text"/>		
170 – <input type="text"/>	173 – <input type="text"/>		175 – <input type="text"/>		
201 – <input type="text"/>	213 – <input type="text"/>	215 – <input type="text"/>		220 – <input type="text"/>	
					900 – 0

3274 C Models (BSC) – 999 Sequence Number Layout

Note: Use leading zeros to have a 1-digit response fill a 2-digit box.

999

111 – <input type="text"/>	112 – <input type="text"/>	113 – <input type="text"/>	114 – <input type="text"/>	115 – <input type="text"/>	116 – <input type="text"/>
121 – <input type="text"/>	125 – <input type="text"/>		127 – <input type="text"/>		
136 – <input type="text"/>		137 – <input type="text"/>		138 – <input type="text"/>	139 – <input type="text"/>
141 – <input type="text"/>		151 – <input type="text"/>			
160 – <input type="text"/>	161 – <input type="text"/>	165 – <input type="text"/>	166 – <input type="text"/>		
170 – <input type="text"/>	173 – <input type="text"/>		175 – <input type="text"/>		176 – <input type="text"/>
301 – <input type="text"/>		305 – <input type="text"/>			
310 – <input type="text"/>	311 – <input type="text"/>	313 – <input type="text"/>	314 – <input type="text"/>	317 – <input type="text"/>	318 – <input type="text"/>
331 – <input type="text"/>	342 – <input type="text"/>	343 – <input type="text"/>	345 – <input type="text"/>		
					900 – 0

3274 C Models (SDLC) – 999 Sequence Number Layout

Note: Use leading zeros to have a 1-digit response fill a 2-digit box.

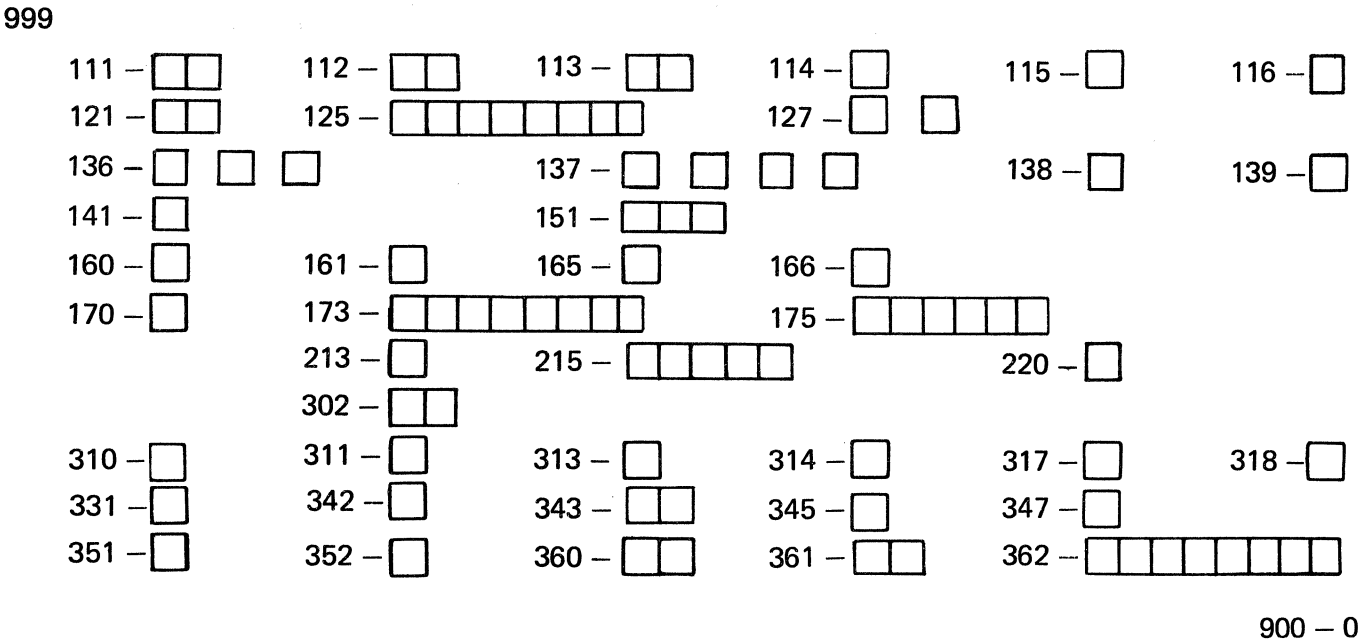

3274 C Models (X.25) – 999 Sequence Number Layout

Note: Use leading zeros to have a 1-digit response fill a 2-digit box.

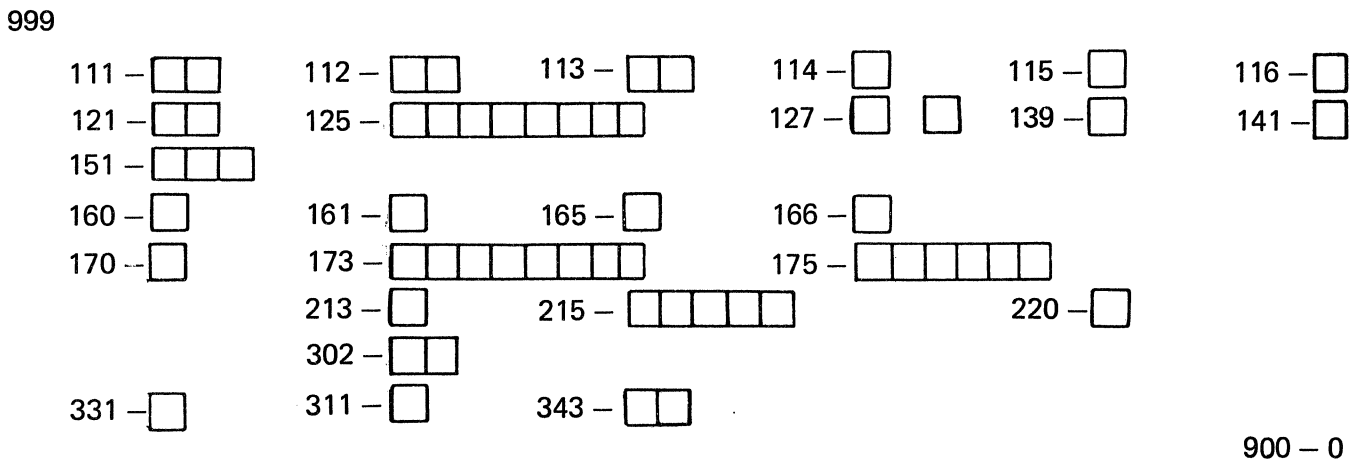

3274 D Models – 999 Sequence Number Layout

Note: Use leading zeros to have a 1-digit response fill a 2-digit box.

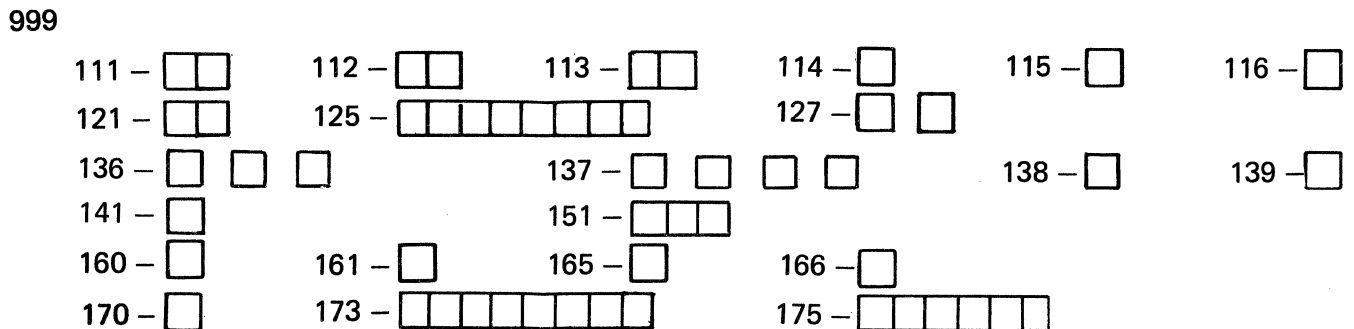

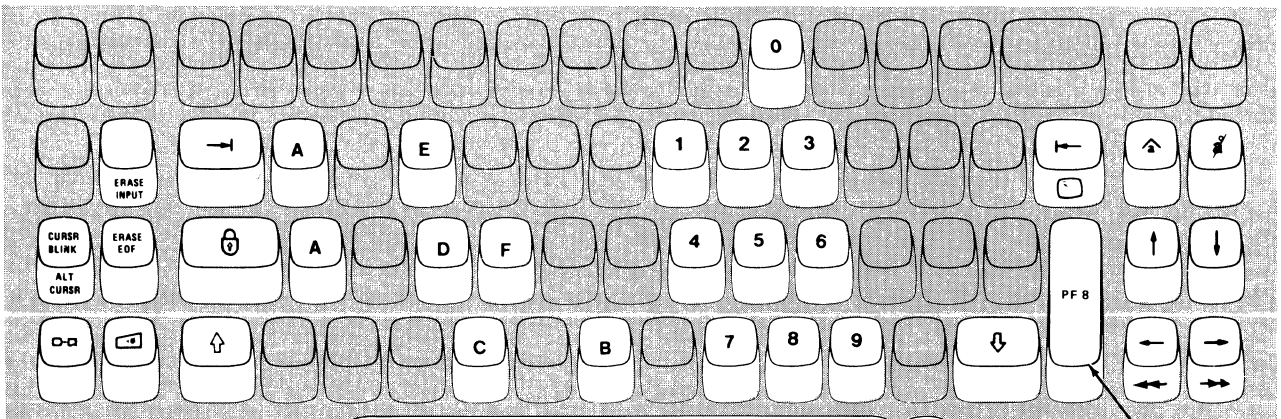
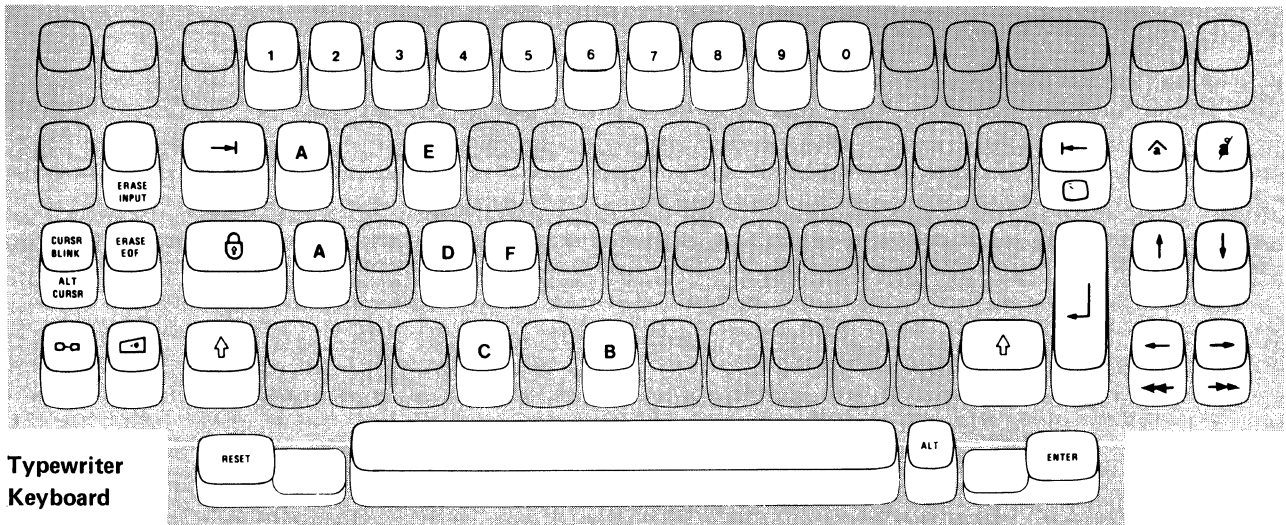

Data Entry Key Punch Keyboard

When ENTER is specified, press the New Line key.
 When RESET is required, press the PF 10 key.

When New Line is required, press the PF 8 key.

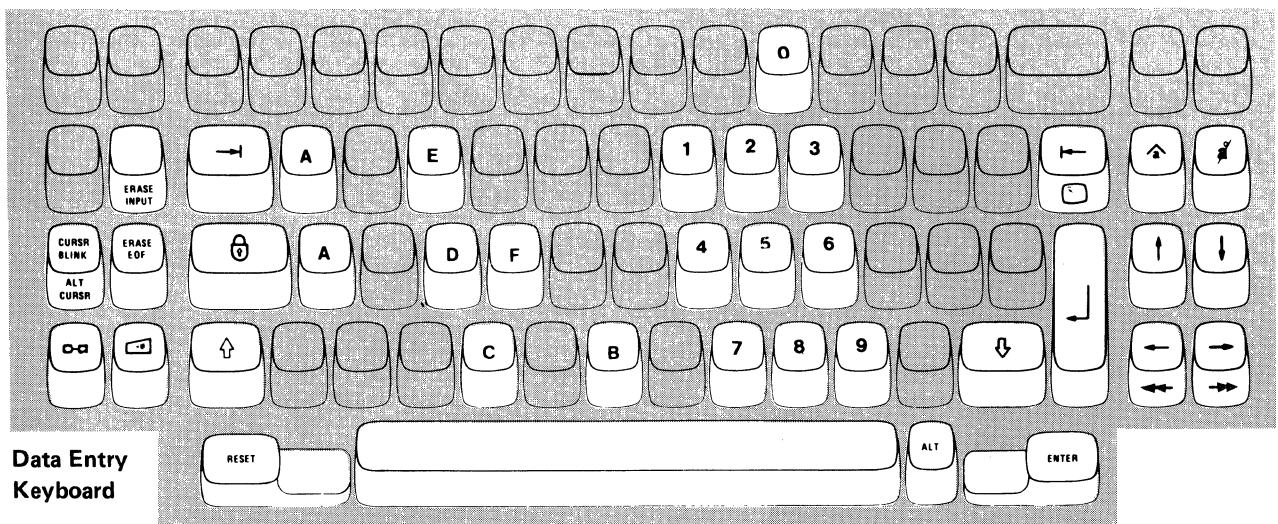

Note: During customizing, only certain key positions are valid. Use only those key positions shown above.

Figure 3-1. Valid Key Positions during Customizing

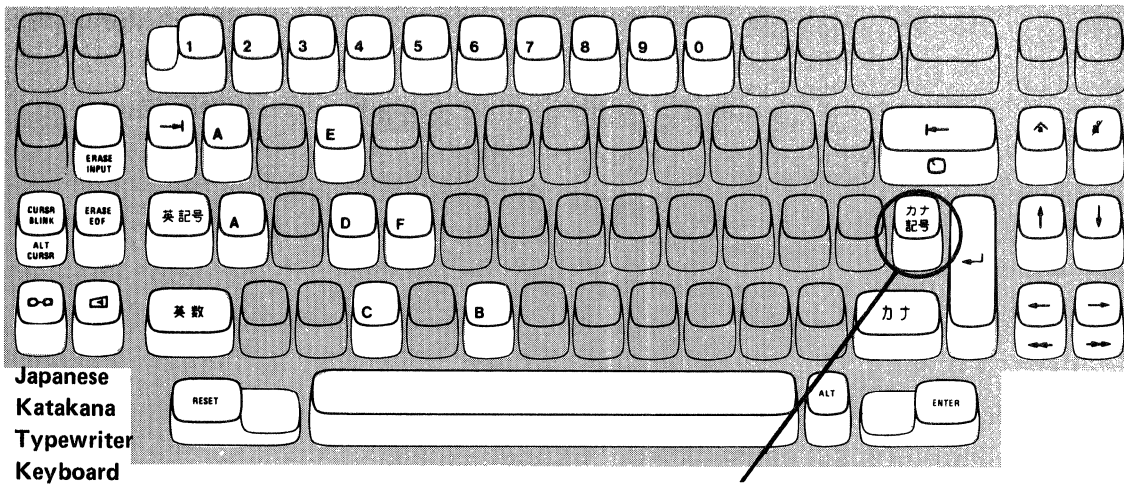

Japanese
Katakana
Typewriter
Keyboard

Press this key when sequence number 001 appears in the upper-left corner of the screen.

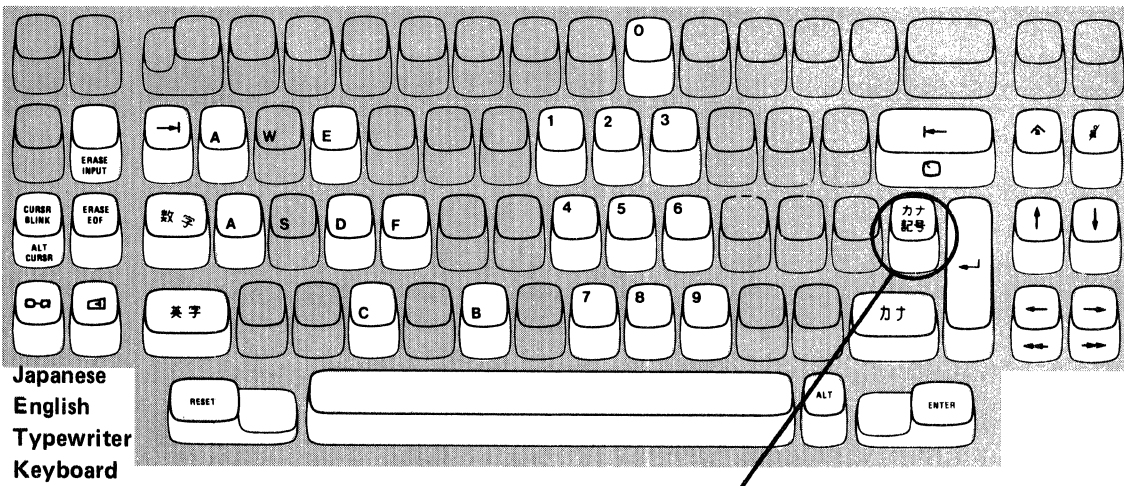

Japanese
English
Typewriter
Keyboard

Press this key when sequence number 001 appears in the upper-left corner of the screen.

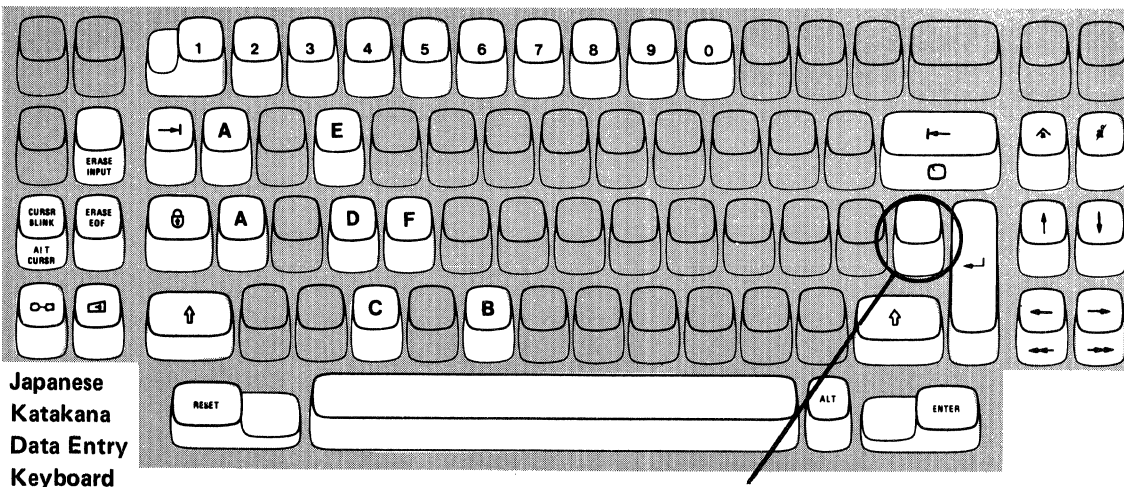

Japanese
Katakana
Data Entry
Keyboard

Press this key when sequence number 001 appears in the upper-left corner of the screen.

Note: These diagrams show the valid keys for both the 76- and 88-key keyboards. The PF keys on the right side of the 88-key keyboards are not valid during this procedure and therefore not shown.

Figure 3-2. Valid Key Positions during Customizing When Japanese Katakana and Japanese English Keyboards Are Used

3274 Diskette Insertion Procedure (Models 31A, 31C, and 31D)

1. Open the customer access door, and locate the diskette reader enclosure.

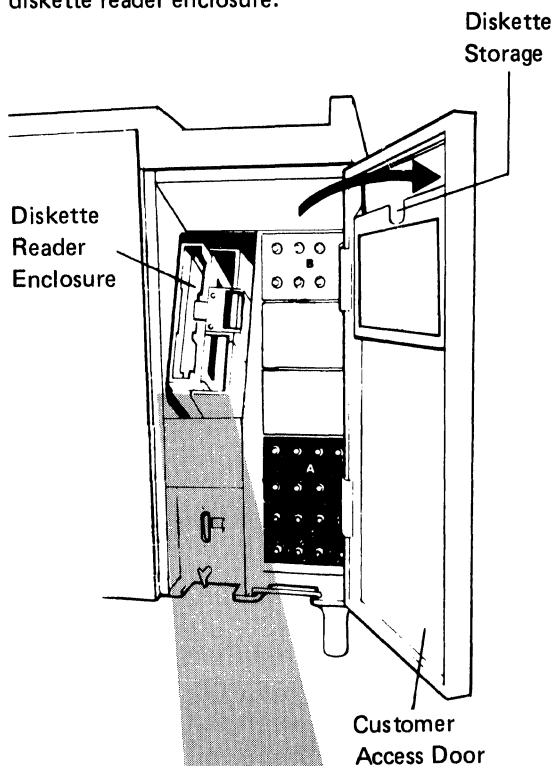

3. Remove the diskette to be used with the 3274 from its gray protective envelope, and insert it squarely into the enclosure. Note that the diskette label position is to the right.

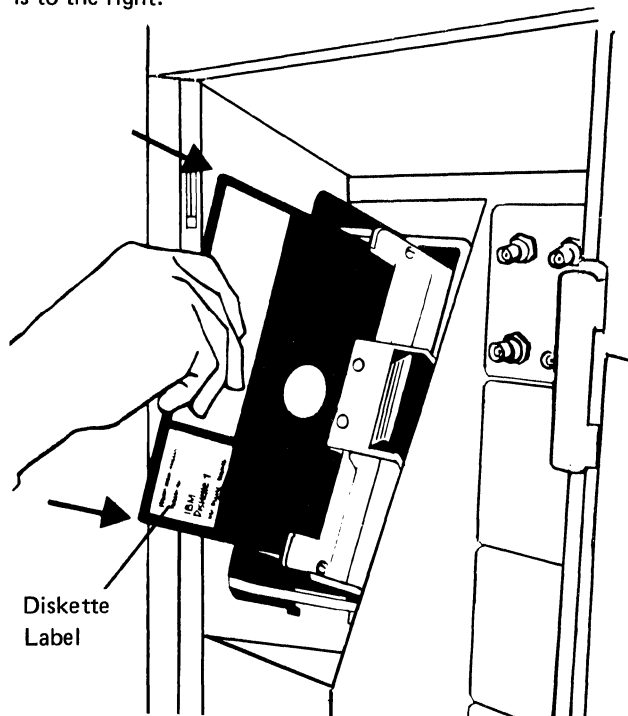

2. Open the diskette reader enclosure door by pressing the latch to the right.

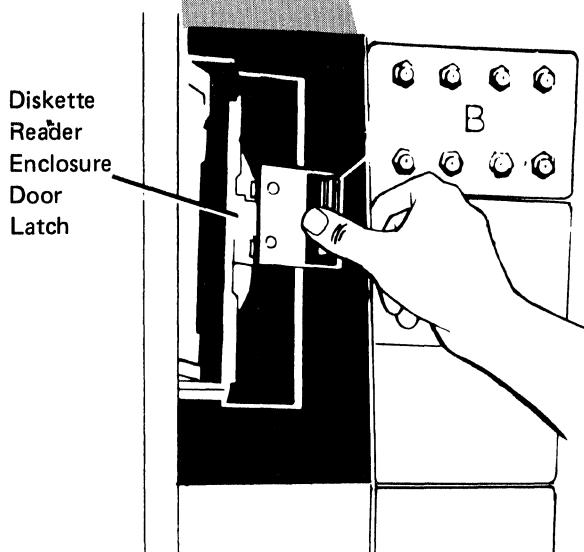

4. Close the diskette reader enclosure door by pushing the door to the left until it latches (clicks).

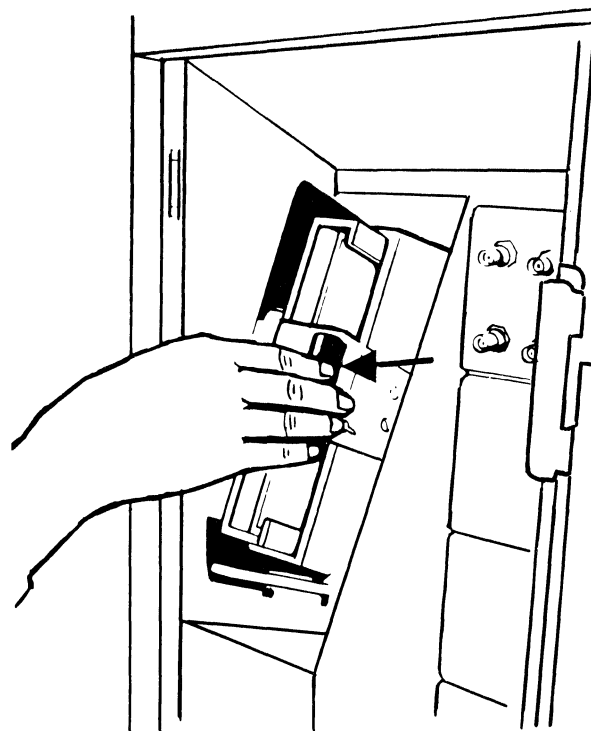
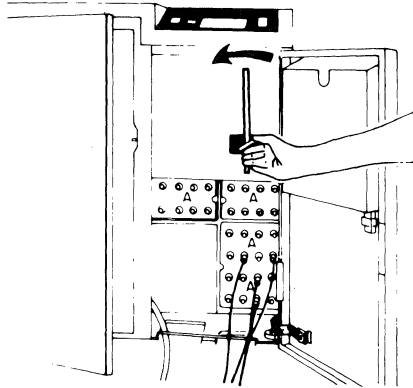

Figure 3-3 (Part 1 of 3). Inserting a Diskette into the 3274 Control Unit during Customizing

3274 Diskette Insertion Procedure (Models 41A, 41C, and 41D)

1. Open the diskette reader enclosure by turning the operator lever counterclockwise to the vertical position.



3. Close the diskette reader enclosure by turning the operator lever clockwise to the horizontal position.

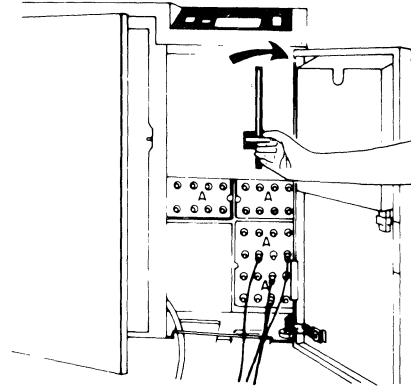

2. Remove one of the diskettes shipped with the 3274 from its gray protective envelope, the 3274 from its gray protective envelope, and insert it squarely into the enclosure, with the label facing left (as shown below).

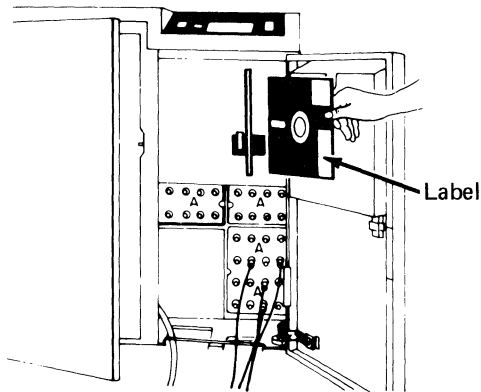

4. Close the customer access door.

Figure 3-3 (Part 2 of 3). Inserting a Diskette into the 3274 Control Unit during Customizing

3274 Diskette Insertion Procedure (Models 51C and 61C)

1. Open the diskette reader by turning the lever counterclockwise to the vertical position.

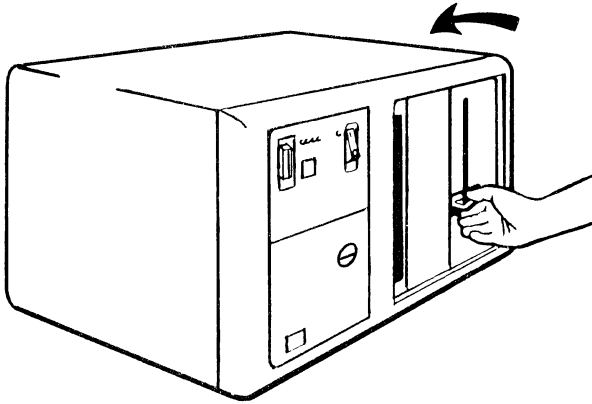

2. Remove the diskette to be used with the 3274 from its gray protective envelope, and insert it squarely into the enclosure. Note that the diskette label position is on your left.

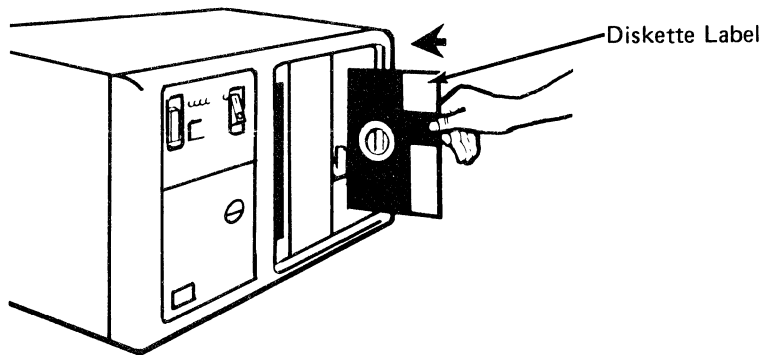

3. Close the diskette reader by turning the lever to the horizontal position.

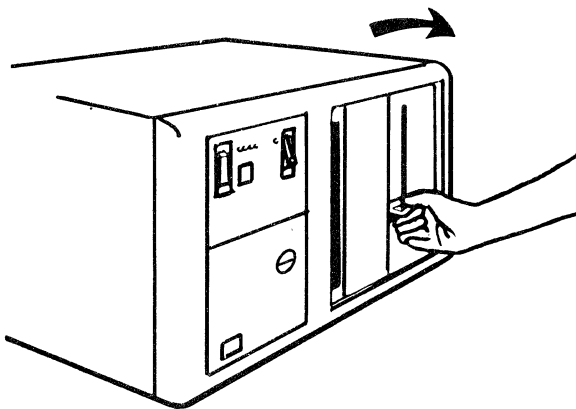

Figure 3-3 (Part 3 of 3). Inserting a Diskette into the 3274 Control Unit during Customizing

Code	Meaning	Action
01	One or more of the first 10 characters are incorrect.	Enter the correct response.
02	One or more of the 11th to 17th characters, including the space, are incorrect.	Enter the correct response.
03	<ol style="list-style-type: none"> One of the last two characters you entered in response to sequence number 001 is incorrect, or The diskette release level is not the same as the documentation level. 	<ol style="list-style-type: none"> Enter the correct response. Restart after matching diskette and documentation levels.
11 ¹	You entered an invalid response (too many characters, value too high or too low, wrong character, etc.).	Enter the correct response.
12	You entered an incorrect 3274 model designation in response to sequence number 151.	Enter the correct response.
13 ¹	Your response has not enough characters.	Enter the correct response.
14 ¹	The numeric total of the responses you entered for sequence numbers 111 (Number of Category B Terminals) and 112 (Number of Category A Terminals) is greater than 32 (Models 31 and 41), 12 (Model 51C), or 16 (Model 61C).	Enter the correct responses.
19	You cannot answer 901=2 during an initial customization or if any patches are being made during this session.	Answer 1 to sequence number 901.
21 ¹	You made an unacceptable change during the modify sequence (number 999).	Recheck the entries, and correct them.
22	In 121 you specified a language (121=02 (ASCII)) that is not compatible with the A or D control unit model specified in 151.	Verify and enter the correct response.
23	One or more of your responses are not compatible with the response to sequence number 331 (BSC, SDLC, or X.25).	Verify and enter the correct responses.
25	You have less storage than indicated in your response to sequence number 113.	Verify and enter the correct response.
26	You do not have enough storage to support all the features you have selected.	Report the problem and verify that the storage specified in response to sequence number 113 is correct.
27 ¹	<ol style="list-style-type: none"> You specified the Portuguese (Alternate) language (121=18). This is not allowed with your configuration. You specified Extended Data Stream (160=1) and a language that is not allowed with the Extended Data Stream (121=02, 08, 10, 13, 20, 26, or 27). You specified a language that is not allowed with a distributed function terminal (121=02, 06, 08, 09, 10, 12, 13, 20, 26, or 27). Entry Assist has been specified (sequence number 115=1) with a language that does not support Entry Assist (sequence number 121=02, 06, 08, 10, 11, 12, 13, 17, 20, 26, or 27). You specified a language (121=02, 05, 06, 08, 10, 11, 12, 13, 14, 16, 20, 25, 26, or 27) that is not allowed with the keyboards (typewriter or APL) selected in sequence number 136. You specified a language (121=02 through 16, 19, 20, 22 through 28, 30, 31, or 32) that is not allowed with the data entry keyboard selected in sequence number 136. You specified a language (121=02, 05, 06, 08, 10, 11, 12, 13, 14, 16, 17, 20, 25, 26, or 27) that is not allowed with modified keyboards (sequence number 137). 	<ol style="list-style-type: none"> Specify Portuguese (121=28). 2-7. Verify and enter the correct response.
28 ¹	Your responses to sequence numbers 113 (Extended Function Store) and 151 (3274 Model Designation) are incompatible.	Verify and enter the correct response.
33 ¹	Zero has been specified in sequence number 170, but you specified nonzero responses to sequence number 139, 173, 175, or 176.	Specify either 1 to sequence number 170 or 0's to sequence numbers 139, 173, 175, and 176.
34 ¹	You specified a Category B device in response to sequence number 111, but you specified a distributed function terminal in sequence number 170. Category B devices are not allowed with distributed function terminals.	Verify and enter the correct responses.

Figure 3-4 (Part 1 of 4). Operator Codes during Customizing

Code	Meaning	Action																																													
35 ¹	<p>Your responses to sequence numbers 151, 331, and 343 are incompatible. Compatible responses are:</p> <table border="1"> <thead> <tr> <th colspan="3">Sequence Number</th> </tr> <tr> <th>331</th> <th>151</th> <th>343</th> </tr> </thead> <tbody> <tr> <td>0, 1, or 2</td> <td>31C, 41C, 51C, 61C</td> <td>00</td> </tr> <tr> <td>0, 1, or 2</td> <td>31C, 41C, 51C, 61C</td> <td>01</td> </tr> <tr> <td>1</td> <td>31C, 41C, 51C, 61C</td> <td>02</td> </tr> <tr> <td>1</td> <td>51C, 61C</td> <td>03</td> </tr> <tr> <td>2</td> <td>31C, 41C, 51C, 61C</td> <td>03</td> </tr> <tr> <td>1</td> <td>51C, 61C</td> <td>04</td> </tr> <tr> <td>0 or 1</td> <td>51C</td> <td>05</td> </tr> <tr> <td>1</td> <td>51C</td> <td>06</td> </tr> <tr> <td>1</td> <td>51C</td> <td>07</td> </tr> <tr> <td>0 or 1</td> <td>51C</td> <td>08</td> </tr> <tr> <td>0 or 1</td> <td>51C</td> <td>09</td> </tr> <tr> <td>1</td> <td>51C, 61C</td> <td>10</td> </tr> <tr> <td>0 or 1</td> <td>31C, 51C</td> <td>11</td> </tr> </tbody> </table>	Sequence Number			331	151	343	0, 1, or 2	31C, 41C, 51C, 61C	00	0, 1, or 2	31C, 41C, 51C, 61C	01	1	31C, 41C, 51C, 61C	02	1	51C, 61C	03	2	31C, 41C, 51C, 61C	03	1	51C, 61C	04	0 or 1	51C	05	1	51C	06	1	51C	07	0 or 1	51C	08	0 or 1	51C	09	1	51C, 61C	10	0 or 1	31C, 51C	11	Verify and enter the correct responses.
Sequence Number																																															
331	151	343																																													
0, 1, or 2	31C, 41C, 51C, 61C	00																																													
0, 1, or 2	31C, 41C, 51C, 61C	01																																													
1	31C, 41C, 51C, 61C	02																																													
1	51C, 61C	03																																													
2	31C, 41C, 51C, 61C	03																																													
1	51C, 61C	04																																													
0 or 1	51C	05																																													
1	51C	06																																													
1	51C	07																																													
0 or 1	51C	08																																													
0 or 1	51C	09																																													
1	51C, 61C	10																																													
0 or 1	31C, 51C	11																																													
36 ¹	You have specified a nonzero response for sequence number 139, but a zero response for sequence number 170. 170 must be a 1 for 139 to be nonzero.	Verify the responses to sequence numbers 139 and 170; then enter the correct response(s).																																													
37 ¹	<ol style="list-style-type: none"> You specified Decompression (165=1), but did not specify EDS (160=1). You specified Attribute Select Keyboard (166=B or C), but did not specify EDS (160=1). You specified that you are using an IBM 3270 Personal Computer Attachment (114=1), but did not specify EDS (160=1). 	<ol style="list-style-type: none"> Verify and enter the correct responses. Verify and enter the correct responses. Verify and enter the correct response. 																																													
38 ¹	<ol style="list-style-type: none"> When 136 is 0, 138 must also be 0. Sequence number 136 must be configured for at least one keyboard for a keypad to be selected in 138. The numeric total of keyboards selected in sequence numbers 136 and 137 is greater than four. 	<ol style="list-style-type: none"> Verify the responses to 136 and 138, then enter the correct responses. Check which keyboards are needed and select no more than four total. 																																													
41 ²	The X.25 network type (400) is invalid.	Check the network type values and enter a valid response to 400.																																													
42 ²	The incoming call options (420) response included "Validate Host DTE Address," but the address was not entered in response to 410.	Either respond to 410 with the host address or do not include "Validate Host DTE Address" in response to 420.																																													
43 ²	<ol style="list-style-type: none"> The circuit type (401) chosen requires a host address (410). The outgoing call options chosen included "Validate 3274 DTE Address," but the address was not entered in response to 411. The response to 421 was invalid. 	<ol style="list-style-type: none"> Either change the response to 401 or provide a host DTE address (410). Either respond to 411 with 3274 address or do not include "Validate 3274 DTE Address" in response to 421. Check 421 and enter a valid response. 																																													
44 ²	Negotiated window size (432) or nonstandard window size (435) conflicts with packet sequence numbering (431).	If 431 equals 0, then 432/435 must equal 01–07 (two digits). If 431 equals 1, then 432/435 must equal 01–11 (two digits).																																													
45 ²	The circuit type (401) is invalid.	Check the circuit type values and correct the response.																																													
46 ²	An invalid X.25 keyboard support (443) was selected.	Check the X.25 keyboard support and correct the response.																																													

Figure 3-4 (Part 2 of 4). Operator Codes during Customizing

Code	Meaning	Action
47 ²	No CID password was initialized (452), but a CID is required for call options (420 and/or 421).	Either change the call options to remove the CID requirement or enter the CID password (452).
50 ³	<ol style="list-style-type: none"> (CS-D/Releases 60–63) Your response to sequence number 112 is incompatible with your response to sequence number 116. When 112 is nonzero, 116 must be zero; when 112 is zero, 116 must be nonzero. (CS-D/Release 64) Your response to sequence number 111 (111=nonzero) is incompatible with your response to sequence number 116 (116=2). When 116 is 2, 111 must be zero. (CS-D/Release 64) Your response to sequence number 112 is incompatible with your response to sequence number 116. When 112 is nonzero, 116 must be zero; when 112 is zero, 116 must be nonzero. 	<ol style="list-style-type: none"> If you are <i>not</i> controlling port addressing, make a nonzero response to 112. If you are controlling port addressing, respond to 112 with a zero, and to 116 with a 1. Make your response to 111 a zero. If you are <i>not</i> controlling port addressing, make a nonzero response to 112. If you are controlling port addressing, make the response to 112 a 0, and the response to 116 a 1 or a 2.
51 ³	<p>You are trying to use a port that is not available.</p> <p>Model 41X or 31X — The highest Category A port specified plus the number of Category B devices specified (sequence number 111) exceeds the number of allowed devices.</p> <p>Model 51C — You may use ports A00 through A07 only.</p> <p>Model 61C — You may use ports A00 through A15 only.</p>	<p>Change the responses to sequence number 117 so that they are compatible with the model you are using.</p> <p>or</p> <p>Change the 0 after 906 to an A, and press ENTER. Enter the proper response to sequence number 111 or 151.</p>
52 ³	<p>You have assigned too many addresses to a port.</p> <p>If sequence number 170 equals 0, you can assign 0 or 1 addresses only.</p> <p>If sequence number 170 equals 1, you can assign 0 through 5 addresses.</p>	Change the 0 after 906 to an A, and press ENTER. Verify your response to sequence number 170, and correct your port assignments.
53 ³	<p>You have assigned more than the number of system addresses allowed.</p> <p>For SNA protocol, you are allowed a total of 128 addresses.</p> <p>For non-SNA protocol, you are allowed a total of 32 addresses.</p>	Recalculate your port assignments so that they fall within the limits set, and then correct your port assignments. The LT=nnn field in sequence numbers 117 and 118 indicates the total number of addresses currently specified (in decimal).
54 ³	You have not assigned an address to port A00.	Assign an address to port A00.
55 ³	You have left a blank between assigned addresses on some port. Address assignments must be contiguous, for example, P, S1, S2, . . .	Shift the assigned addresses or fill in the blank.
56 ³	Either an out-of-range or a nondecimal address was specified. Valid ranges are 2 to 129 for SNA, 0 to 31 for non-SNA.	Correct the address(es) in error.
57 ³	You have assigned duplicate addresses.	Correct the address assignments in error.

Figure 3-4 (Part 3 of 4). Operator Codes during Customizing

Code	Meaning	Action
60 ⁴	Both response fields for sequence number 127 must be either zero or nonzero.	Enter a zero or nonzero response in both fields.
61 ⁴	Your first digit response to sequence number 127 was a 3, 4, or 5 and system communication is non-SNA, and/or your second digit response to sequence number 127 was 3 and system communication is non-SNA. This is not allowed.	Verify and enter the correct response.
62 ⁴	An invalid time boundary is specified in sequence number 128. The maximum time allowed is 27:18.3. The seconds field must not exceed 59.	Enter time values in the permitted range.
63 ⁴	Field B1 in sequence number 128 cannot be specified as 00:00.0.	Verify and enter the correct response.
64 ⁴	Entries for fields B1 through B4 in sequence number 128 are not in ascending order.	Verify and enter the correct response.
65 ⁴	A time boundary value of 00:00.0 is embedded between two nonzero values in sequence number 128. This is not allowed.	Enter an appropriate nonzero value.
66 ⁴	A nonzero boundary value follows a maximum boundary value (27:18.3) in sequence number 128. Only a zero boundary value (00:00.0) can follow the maximum.	Correct your boundary value sequence.
99	Your entries are acceptable, but the entry for sequence number 900, 901, 904, 906, 907, or 908 has not been changed to a 1.	Change the 900, 901, 904, 906, 907, or 908 entry to a 1.

¹ If any entry is unacceptable, the entry for sequence number 900 is changed back to 0 (zero), and the unacceptable value is intensified.

² If any entry is unacceptable, the entry for sequence number 908 is changed back to 0 (zero), and the unacceptable value is intensified.

³ If any entry is unacceptable, the entry for sequence number 906 is changed back to 0 (zero), and the unacceptable value is intensified.

⁴ If any entry is unacceptable, the entry for sequence number 904 is changed back to 0 (zero), and the unacceptable value is intensified.

Figure 3-4 (Part 4 of 4). Operator Codes during Customizing

Steady Code	Diskette Mounted	Meaning	Action
0001	Feature	Customizing being performed	None.
0010	Any (indication lasts for 3 minutes or more)	Diskette improperly inserted or an internal 3274 error	Insert diskette properly and retry.
0011	Feature	Customizing being performed	None.
0100	Feature	Patch, printer authorization matrix, or RPQ being performed	None.
0101	Feature	Configuration being performed	None.
0110	Feature	Modification being performed	None.
0111	Feature, language, or RPQ	Normal 3274 operation	None.
1000	System or load (customizing in process)	Normal 3274 operation	None.
1001	Any	Internal 3274 error	Retry. If the error recurs, follow your local procedure for problem recovery.
1010	Any	Internal 3274 error	Retry. If the error recurs, follow your local procedure for problem recovery.
1101	Any (customizing procedure in progress)	<ol style="list-style-type: none"> 1. IML pushbutton pressed while diskette is being changed, or 2. A bad or uncustomized system or load diskette is being used 	<ol style="list-style-type: none"> 1. Recustomize. Do not press the IML pushbutton unless instructed to do so. 2. Insert a good customized system or load diskette.
1111	System or load (IML not performed)	Customizing is completed	IML can be performed.

Figure 3-5. Steady 8 4 2 1 Indicator Codes during Customizing Only

Flashing Code ¹	Diskette Mounted	Meaning	Action
0000 0011	System	Load diskette request	Insert load diskette.
0000 1010	System	A diskette read error occurred.	Retry. If the error recurs, follow your local procedure for problem recovery.
	Load	A diskette read error occurred.	Attempt to perform Load Diskette Backup Procedure. If this fails, recustomize using the feature and system diskettes. If the error recurs, follow your local procedure for problem recovery.
0000 1011	Any	System diskette request	Insert system diskette.
0000 1100	Any	RPQ diskette request	Insert RPQ diskette.
0000 1101	Any	Language diskette request	Insert language diskette.
0000 1110	Any	Feature diskette request	Insert feature diskette.
0100 0010	System or Load	Configuration on system or load diskette being used for update-diskette procedure is not compatible with this 3274.	Use a system or load diskette with a compatible configuration.
	Language	Language number (sequence number 121) does not match the language number used in the Keyboard Definition Utility pre-customizing procedure.	Make sure language number is the same as used in the Keyboard Definition Utility. Refer to GA23-0187.
1000 0001	System or Load	Uncustomized system diskette being used during update procedure.	Use customized system diskette.
	Language	The keyboard IDs specified in sequence number 137 are not defined on the diskette.	Use the <i>Keyboard Definition Utility</i> , GA23-0187, to define the required keyboard IDs.
1001 0110	Any	Wrong-level diskette being used	Use correct-level diskette.
1111 0001	Feature	On/Off switch or TEST key pressed instead of ENTER	Retry. If the error recurs, follow your local procedure for problem recovery.
	System	Internal 3274 error	Follow your local procedure for problem recovery.
1111 0010	Feature	3278 Model 2 or higher is not attached to port A0.	Attach 3278 Model 2, its equivalent, or higher to port A0. Retry customizing.
1111 0011	Feature	Insufficient storage in 3274. At least 192K required on 3274.	Follow your local procedure for problem recovery.
1111 0100	System	Internal 3274 error	Retry. If the error recurs, follow your local procedure for problem recovery.
1111 0101	System	Internal 3274 error	Retry. If the error recurs, follow your local procedure for problem recovery.
	Feature	On/Off switch of TEST key on the 3278 pressed instead of ENTER	
1111 0110	RPQ	Incompatible RPQs	Follow your local procedure for problem recovery.
	Feature	Internal 3274 error	
1111 0111	System	Internal 3274 error	Follow your local procedure for problem recovery.
1111 1000	System	Internal 3274 error	Follow your local procedure for problem recovery.
1111 1001	System, feature language, or RPQ	Internal 3274 error	Follow your local procedure for problem recovery.
1111 1010	System	Internal 3274 error	Follow your local procedure for problem recovery.
1111 1011	System	Internal 3274 error	Follow your local procedure for problem recovery.
1111 1100	Any	Diskette drive error or a bad diskette	Retry. If the error recurs, follow your local procedure for problem recovery.
1111 1101	System, feature, language or load	Diskette drive error or a bad diskette	Retry. If the error recurs, follow your local procedure for problem recovery.
1111 1110	System, feature, language or RPQ	Internal 3274 error	Retry. If the error recurs, follow your local procedure for problem recovery.

¹ These codes will flash alternately as shown, for example, 0000, 1011, 0000, 1011.

Figure 3-6. Flashing 8 4 2 1 Indicator Codes during Customizing Only

Steady Code	Flashing Code ¹	Diskette Mounted	Meaning	Action
—	0101 0000 ²	System or load	Internal 3274 error or wrong response to sequence number 113 during customizing procedure	Check response to sequence number 113, and retry. If the error recurs, follow your local procedure for problem recovery.
—	0110 0000 ²	System or load	Internal 3274 error or wrong response to sequence number 111, 112, 151, or 351 during customizing procedure	Check response to sequence number 111, 112, 151, or 351, and retry. If the error recurs, follow your local procedure for problem recovery.
—	0110 0001 ³	System or load	Address range switches inside Model D control unit set improperly	Check responses to sequence numbers 111, 112, 116, 117, and 118. If correct, have IBM CE check address range setting in control unit.
—	0111 0000 ²	System or load	1. Internal 3274 error, or 2. Wrong response to sequence number 311 or 343, or 3. The 3274 is not connected to the communication facility	1 and 2. Check responses to sequence numbers 311 and 343, and retry. 3. Connect the 3274 to the communication facility. If the error recurs, follow your local procedure for problem recovery.
—	1000 0000	System or load	Internal 3274 error or wrong response to sequence number 111 during customizing procedure	Check response to sequence number 111, and retry. If the error recurs, follow your local procedure for problem recovery.
—	1001 0000	System or load	Internal 3274 error or wrong response to sequence number 352 during customizing procedure	Check response to sequence number 352, and retry. If the error recurs, follow your local procedure for problem recovery.
—	1001 1010	System or load	Internal 3274 error or wrong response to sequence number 151 during customizing procedure	Check response to sequence number 151, and retry. If the error recurs, follow your local procedure for problem recovery.
—	1001 1110	System or load	Insufficient storage	Follow your local procedure for problem recovery.
—	1011 0000	System or load	Internal 3274 error or wrong response to sequence number 127 during customizing procedure	Check response to sequence number 127, and retry. If the error recurs, follow your local procedure for problem recovery.
1101	—	System or load	Uncustomized system diskette	Insert customized system diskette.
1110	—	System or load	Insufficient storage	Check response to sequence number 113, and retry. If the error recurs, follow your local procedure for problem recovery.

Note: These indicators may be caused by something other than incorrect customizing. Further aids can be found in the *IBM 3270 Information Display System: 3274 Control Unit Problem Determination Guide, GA27-2850*.

¹These codes will flash alternately as shown, for example, 0101, 0000, 0101, 0000, and so on.

²These codes may blink for 5 seconds, followed by a different steady code for 3 seconds.

³Models 31D and 41D only. These codes will alternate continuously as follows: left code blinks for 5 seconds, then right code is on steady for 3 seconds.

⁴Address range switches inside the 3274 D models are set to multiples of 4. When a distributed function terminal is attached and the Multiple Interactive Screen function is being used, the address range switches are set as follows:

- If the highest logical device address is a multiple of 4, the address range switches must be set to equal the device address; for example, 16, 20, or 28.
- If the highest logical device address is not a multiple of 4, the address range switches must be set to the next higher multiple of 4. For example, if the highest logical device address is 26, the address range switches must be set to 28.

Figure 3-7. 8 4 2 1 Indicator Codes during IML That May Result from an Incorrect Customizing Procedure

Printer Authorization Matrix Form

In response to sequence number 022, enter the characters (below) supplied by the planner in the appropriate groups on your display screen. If a group already is displayed as AA M XXXX YYYY YYYY, your entry will overwrite these characters. When you have completed all your entries, move the cursor to the 0 (zero) after sequence number 901 at the bottom of the screen, change the 0 to a 1, and press ENTER. Any entry that is not valid will be intensified at this time and the 1 you entered will change back to a 0. Correct the invalid entry, and return to 901. Again, change the 0 to a 1, and press ENTER. When all entries are valid, the printer authorization matrix display will be replaced by the next customizing sequence number. (If, at any time during this procedure, you wish to cancel any entries you have just made, change the 0 after the 901 to A and press ENTER.) Return to your original instructions.

To delete an entry, move the cursor (with the cursor-move keys or tab key) to the leftmost position of the entry (the Printer Port Address) and press the spacebar twice. The entire matrix, or as many entries as desired, can be deleted in this manner. After all changes have been made, press ENTER. All deleted entries will be displayed as AA M XXXX YYYY YYYY. When the matrix is satisfactorily defined, move the cursor to the 0 after sequence number 901, change the 0 to a 1, and press ENTER.

	Printer Port Address		Printer Mode	Printer Class Assignment				Source Device List							
	A	A	M	X	X	X	X	Y	Y	Y	Y	Y	Y	Y	Y
1)	-	-	-	-	-	-	-	-	-	-	-	-	-	-	-
2)	-	-	-	-	-	-	-	-	-	-	-	-	-	-	-
3)	-	-	-	-	-	-	-	-	-	-	-	-	-	-	-
4)	-	-	-	-	-	-	-	-	-	-	-	-	-	-	-
5)	-	-	-	-	-	-	-	-	-	-	-	-	-	-	-
6)	-	-	-	-	-	-	-	-	-	-	-	-	-	-	-
7)	-	-	-	-	-	-	-	-	-	-	-	-	-	-	-
8)	-	-	-	-	-	-	-	-	-	-	-	-	-	-	-
9)	-	-	-	-	-	-	-	-	-	-	-	-	-	-	-
10)	-	-	-	-	-	-	-	-	-	-	-	-	-	-	-
11)	-	-	-	-	-	-	-	-	-	-	-	-	-	-	-
12)	-	-	-	-	-	-	-	-	-	-	-	-	-	-	-
13)	-	-	-	-	-	-	-	-	-	-	-	-	-	-	-
14)	-	-	-	-	-	-	-	-	-	-	-	-	-	-	-
15)	-	-	-	-	-	-	-	-	-	-	-	-	-	-	-
16)	-	-	-	-	-	-	-	-	-	-	-	-	-	-	-

	Printer Port Address		Printer Mode	Printer Class Assignment				Source Device List							
	A	A	M	X	X	X	X	Y	Y	Y	Y	Y	Y	Y	Y
17)	-	-	-	-	-	-	-	-	-	-	-	-	-	-	-
18)	-	-	-	-	-	-	-	-	-	-	-	-	-	-	-
19)	-	-	-	-	-	-	-	-	-	-	-	-	-	-	-
20)	-	-	-	-	-	-	-	-	-	-	-	-	-	-	-
21)	-	-	-	-	-	-	-	-	-	-	-	-	-	-	-
22)	-	-	-	-	-	-	-	-	-	-	-	-	-	-	-
23)	-	-	-	-	-	-	-	-	-	-	-	-	-	-	-
24)	-	-	-	-	-	-	-	-	-	-	-	-	-	-	-
25)	-	-	-	-	-	-	-	-	-	-	-	-	-	-	-
26)	-	-	-	-	-	-	-	-	-	-	-	-	-	-	-
27)	-	-	-	-	-	-	-	-	-	-	-	-	-	-	-
28)	-	-	-	-	-	-	-	-	-	-	-	-	-	-	-
29)	-	-	-	-	-	-	-	-	-	-	-	-	-	-	-
30)	-	-	-	-	-	-	-	-	-	-	-	-	-	-	-
31)	-	-	-	-	-	-	-	-	-	-	-	-	-	-	-

IBM 3274 Control Unit Configuration Data Card (Configuration Support: D)

Form No. GA23-0114-4

Number	Meaning
001	Keyboard and Customizing Guide Validation
011	Patch Request
021	Printer Authorization Matrix
022	Printer Authorization Matrix Definition (See third panel)
031	Number of RPQ Diskettes Required
032	Request RPQ Parameter List
111	Number of Category B Terminals
112	Number of Category A Terminals
113	Extended Function Store
114	IBM 3270 Personal Computer Attachment
115	Entry Assist Function
116	User-Controlled Port Assignment Request
117	Port Assignment Specification Table
118	Port Address Table
121	Keyboard Language/Character Set I/O Interface Code
125	Miscellaneous Feature Options
127	Response Time Monitor (RTM) Definition
128	RTM Boundaries and Interface Specification
136	Modified Keyboard Layout Selection - Unmodified Layouts
137	Modified Keyboard Layout Selection - Modified Layouts
138	Modified Keypad Selection - Unmodified Layout
139	3290 Keypad Selection
141	Magnetic Character Set
151	3274 Model Designation
160	Extended Data Stream
161	Color Convergence
165	Decompression
166	Attribute Select Keyboard
170	Distributed Function Terminals
173	3290 Options
175	3290 Password
176	BSC Enhanced Communication Option
201	SNA Local Channel Control Unit Address
213	Between Bracket Printer Sharing
215	Physical Unit Identification
220	Alert Function
301	BSC Control Unit Number
302	SDLC Control Unit Address/X.25 Secondary Station Address
305	BSC Printer Polling
310	Modem Connection
311	Modem Wrap
313	Internal or External Clocking - NRZI or NRZ Encoding
314	Multipoint or Point-to-Point
317	Switched Network Backup (SNBU)
318	Normal or Half-Speed Transmission
331	BSC/SDLC/X.25 Protocol
332	X.25 Customization Panel

Number	Meaning
342	Request-to-Send (RTS) Control
343	Communication Interface Options
345	Answer Tone
347	High-Speed Data Rate
351	HPCA or CCA Adapter
352	Encrypt/Decrypt
360	X.21 Switched Retry
361	X.21 Switched Retry Timing
362	X.21 Switched Options
400	Network Type
401	Circuit Type (I/O)
402	Logical Channel Identifier
403	Logical Link Control
410	Host DTE Address (HNAD)
411	3274 DTE Address
420	Incoming Call Options
421	Outgoing Call Options
430	Negotiated Packet Size (NPKT)
431	Packet Sequence Numbering
432	Negotiated Window Size (NWND)
433	K-Maximum Out
434	Nonstandard Default Packet Size (DPKT)
435	Nonstandard Default Window Size (DWND)
440	Throughput Class Negotiation (TCLS)
441	Closed User Group (CUG)
442	Recognized Private Operating Agency (RPOA)
443	X.25 Keyboard Support Options
450	Link Level Transmit Timeout
451	Number of Retries
452	Connection Identifier Password (CID)

CE Data

SNA Local Channel CU Address	_____		
Master Terminal Operator Phone	_____		
Host CPU	_____		
Application Program	_____		
Remote TP Line	BSC	SDLC	X.25
Logical Line No.	_____	_____	_____
Logical LU ID	_____	_____	_____
Line Speed	_____	_____	_____
Host	_____	_____	_____
Application	_____	_____	_____
Diskette No.	_____	_____	_____

Chapter 4. Modification Procedure

The Modification Procedure Form is used to modify an existing 3274 configuration without performing the entire customizing procedure. The recommended form in this chapter should be used only after the 3274 Control Unit has been initially customized with the Initial Customizing Procedure Form in Chapter 3.

Note: Changes to any of the following sequence numbers will cause extensive configuration changes. It is recommended that the initial customizing procedure in Chapter 3 be used to change these sequence numbers and that the proper planning be performed before the changes are made.

151 – Model Designation

201 – Control Unit Address¹

301 – Control Unit Number¹

302 – SDLC Control Unit Address/X.25 Secondary Station Address¹

331 – BSC/SDLC/X.25 Protocol

343 – Communication Interface Options

After changes are made, be sure that the changes are recorded on the *IBM 3274 Control Unit Configuration Data Card (Configuration Support: D)*, GA23-0114, stored in the diskette storage area of the 3274.

The planner should enter the following information on the Modification Procedure Form:

1. Enter the type of keyboard (typewriter or data entry) to be used by the operator.

Note: If using a 76- or 88-key Japanese English or Japanese Katakana keyboard, specify the number of keys and keyboard type.

2. In step 1, enter the identification of each diskette to be used.
3. In step 9, enter the response to sequence number 031 (Number of RPQ Diskettes Required). If your response to sequence number 031 is not 0, you will have to enter a response to sequence number 032. See “032 (Request RPQ Parameter List)” in Chapter 2.
4. For step 10, give the operator the appropriate 999 sequence number layout (from Chapter 3). Enter only the changed responses.

¹ The modification procedure should not be used to change a 0 response to sequence number 201, 301, or 302.

5. If your response to sequence number 116 is 1 or 2, you must fill in the forms given in Appendix B and attach them to this procedure.
6. If your response to sequence number 127 is nonzero, fill in the form for sequence number 128, given in Appendix G, and attach it to this procedure.
7. If your response to sequence number 331 is 2 (for X.25), fill in the form for sequence number 332 (a panel), found in Appendix I. Attach the completed form to this procedure.

In addition to the Modification Procedure Form, this chapter contains diagrams, informational charts, and another form that can be used during modification. Attach them to the procedure form if desired.

- Keyboard diagrams showing the valid key positions for the keyboard attached to port A0 during customizing (Figures 4-1 and 4-2)
- Diagrams showing how to insert a diskette properly into the various 3274 models (Figure 4-3)
- A chart giving the meanings of, and recommended actions for, the operator codes that may appear on the display station during modification (Figure 4-4)
- Charts giving the meaning of, and recommended actions for, the 8 4 2 1 indicator codes that appear on the 3274 control panel during modification (Figures 4-5 and 4-6)
- A chart giving the meanings of, and recommended actions for, the 8 4 2 1 indicator codes that could appear on the 3274 control panel during IML because of improper modification (Figure 4-7)
- A Printer Authorization Matrix Form to be used with sequence number 022 in Chapter 2.

The following items may also be required for proper modification of your 3274. Attach the applicable items to the Modification Procedure Form:

- User-controlled Port Assignment Procedure (Appendix B)
- 3274 Model 31C Modem Address Switch Settings (Appendix E)
- 3274 Model 51C and 61C Switch Settings (Appendix F)
- Sequence Number 128 Procedure Form (Appendix G)
- X.25 Customization Response Form (Appendix I).

All the applicable information above and the completed Modification Procedure Form should be given to the operator who is to perform the modification procedure at the display station.

Review this entire form before starting the modification procedure. Display station operating procedures are described in the *Operator's Guide* for the display station to be used in customizing.

This procedure modifies an existing 3274 Control Unit configuration. *If you do not get the expected result in any step, start over at step 1. If you still do not get the expected result, report the problem.*

You can negate the modification procedure at any time *before step 11* by inserting the customized system or load diskette and pressing the IML pushbutton. This will return your system to its last customized level.

There are four indicators, labeled 8 4 2 1, on the 3274 control panel. The meanings of the 8 4 2 1 indicator codes are shown in Figures 4-5 and 4-6. If an error occurs during this procedure, the 8 4 2 1 indicator code may help you locate the cause. Within this form, an On indicator is called a 1, an Off indicator a 0 (zero).

Example: 8 4 2 1
 * * 0 * = 1101

3274 Control Panel

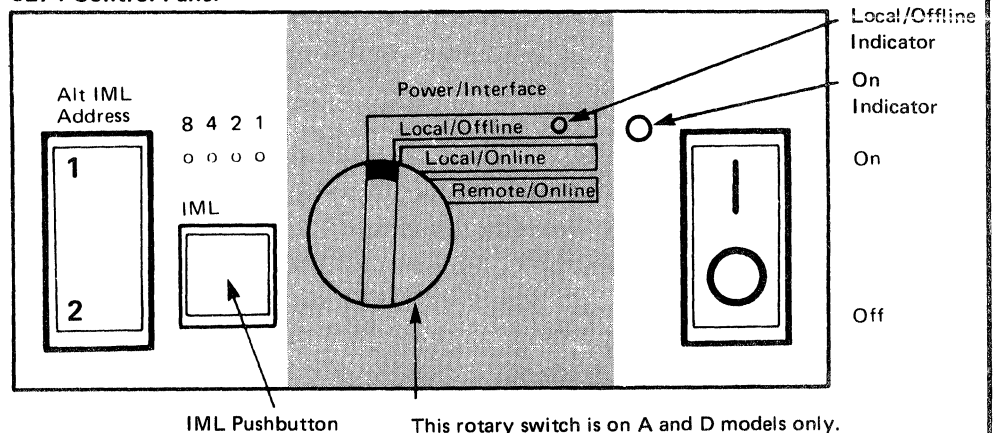

Type of keyboard to be used: _____

Note: See Figure 4-1 or 4-2 before continuing.

1. Obtain the:

- Feature diskette _____
 - Customized system diskette or load diskette _____
 - Backup diskette _____
 - Language diskette (if applicable) _____
 - RPQ diskette(s) (if applicable) _____
1. _____
 2. _____
 3. _____

2. Ensure that the 3274 Control Unit and the display station have power switched on. The display station must have a keyboard and must be attached to port A0 of the 3274.

If you are using a 3299 Terminal Multiplexer, ensure that:

- a. A display station (other than a distributed function terminal or a 3277) is connected to the 0–7 port adapter on the 3274.
- b. The port adapter switch is in the display position (up) (factory-installed port adapter), or the shorting cap is connected (field-installed port adapter). See the diagram on the port adapter panel on the 3274.

Note: When customizing 3274 A or D models, do not set the On/Off switch to the Off position unless the rotary switch on the control panel is in the Local/Offline position and the Local/Offline indicator is on. The Power/Interface rotary switch must be in the Local/Offline position, and the Local/Offline indicator must be on.

3. Insert the *feature* diskette (see Figure 4-3) and, holding the Alt IML Address switch in position 1, press and release the IML pushbutton; then release the Alt IML Address switch. Within 2 minutes, the 8 4 2 1 indicator code will be a flashing 0101.

Power on a printer if you want the local copy function.

4. If you have a customized load diskette, insert the customized load diskette; otherwise, insert the customized system diskette.

Within 1 minute, the 8 4 2 1 indicator code will be a flashing 1110.

5. Insert the *feature* diskette again. Within 1 minute, the 8 4 2 1 indicator code will be a steady 0001. If you are using a 3279 that is designed to be converged, refer to Appendix D for the convergence procedure.

6. Look for a 3-digit sequence number in the upper left corner of the screen. The first one is 001. Beneath the sequence number are Xs, which you replace by typing in the response to sequence number 001 (below). If the response you enter is acceptable, a new sequence number is displayed. If the response is unacceptable, a 2-digit operator code is displayed in the upper, center portion of the screen. See Figure 4-4 for the meaning of this code.

If you are using a display station with a modifiable keyboard, the display station must be operating in 3278 emulation mode. If it is not (that is, if it is in native mode), the number 212 appears in the operator information area of the display station when the first keystroke is attempted, and customizing cannot proceed.

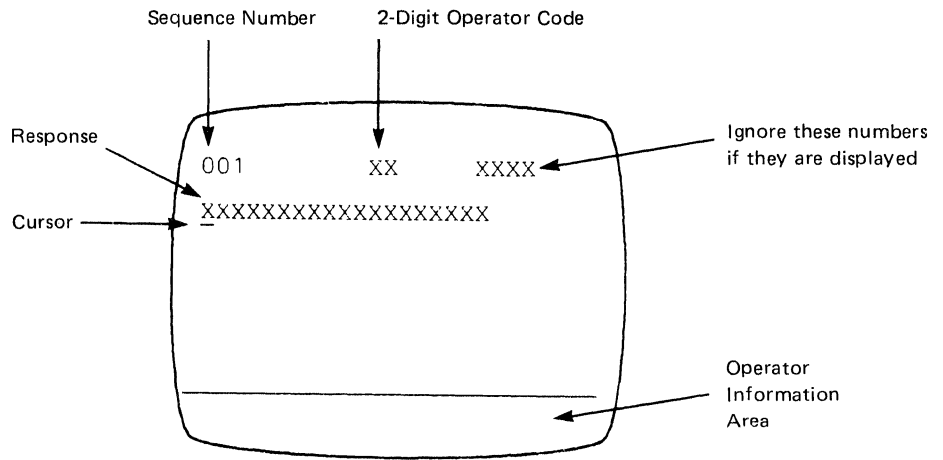

Note: If a 76- or 88-key Japanese English or Japanese Katakana keyboard is used, press the key circled in Figure 4-2 before proceeding. The keyboard will be locked for about 10 seconds. When the keyboard unlocks, continue.

a. Type in the following characters in response to sequence number 001:

1234567890ABCDEF

b. Press the spacebar once.

c. Type in the 2-digit validation number that is printed on the first page of this form.

d. Press ENTER.

Note: Use only the cursor move keys or the tab key to reposition the cursor during this procedure.

7. A 0 is displayed in response to sequence number 011. Do not change this response. Press ENTER.

8. At this time, either sequence number 021 is displayed (meaning that no printer authorization matrix has been defined) or the defined matrix is displayed.

If sequence number 021 is displayed and if you have not been given a Printer Authorization Matrix Form, press ENTER. If you have been given the Printer Authorization Matrix Form, type in a 1 and press ENTER; then follow the instructions on the form.

If the printer authorization matrix has been defined at a previous customization, it is displayed on the screen now. If you have no changes, move the cursor to the entry for 901 (located at the bottom of the screen), change the 0 to 1, and press ENTER. If you have changes to make to the matrix, follow the instructions on the Printer Authorization Matrix Form.

9. Type in the number of RPQ diskettes $\frac{\quad}{(0-3)}$ being used in response to sequence number 031. Press ENTER.

Note: If you respond to sequence number 031 with a 1, 2, or 3, sequence number 032 is displayed. If you have been given specific RPQ parameter instructions, follow those instructions. If not, press ENTER.

10. The entire 999 sequence number layout should now be displayed on the display screen. Change the responses to the sequence numbers as required. After all changes have been made, move the cursor to the entry for sequence number 900, change the 0 to a 1, and press ENTER. If all the entries are acceptable, the display screen is cleared. Go to step 11.

If any entry is unacceptable, the entry for sequence number 900 is changed back to a 0 and the unacceptable response is intensified. The operator code in the upper, center portion of the display refers to the greatest sequence number with its response intensified. (With the 3279, intensified characters are white and red instead of blue and green.) The meanings of the operator codes are shown in Figure 4-4. Check all responses that were changed, and correct any errors. Again, move the cursor to the entry for 900, change the 0 to a 1, and press ENTER. If errors recur, report the problem.

11. If no more panels are displayed on your screen, go to step 12. These responses to sequence number 999 may now bring other panels to your screen:

- a. If your response to sequence number 116 was a 1 or 2, sequence number 117 (a panel) is displayed. Enter the responses from the Port Assignment Entry Form attached to this form.

Sequence number 118 (a panel) follows right after number 117 and provides visual verification that the entries made in 117 have been accepted.

- b. If your response to sequence number 127 was *not* two zeros (0 0), sequence number 128 (a panel) is displayed. Enter the responses from the Sequence Number 128 Procedure Form.

- c. If your response to sequence number 331 was 2, sequence number 332 (a panel) is displayed. Enter the responses from the X.25 Customization Response Form.

12. Within 2 minutes, the 8 4 2 1 indicator code on the 3274 Control Unit should be flashing one of the following (1100, 1101, or 1011):

1100 — Replace the feature diskette with the *RPQ* diskette. *Do not press the IML pushbutton.* (If you do press the IML pushbutton, go back to step 3.) After the RPQ diskette is inserted, the code will change to 0111 within 30 seconds. If additional RPQ diskettes are required or if you inserted a diskette that is not an RPQ diskette, the indicator code will again flash 1100. Repeat the procedure for each additional RPQ diskette. *At no time should you press the IML pushbutton.* When the RPQ diskette procedure is completed, the indicator code should be flashing 1110. Reinsert the *feature* diskette. *Do not press the IML pushbutton.* Within 2 minutes, the 8 4 2 1 indicator code will flash 1011 or 1101. Follow the instructions associated with the code.

1101 — Replace the feature diskette with the *language* diskette. *Do not press the IML pushbutton.* (If you do press the IML pushbutton, go back to step 3.) Within 30 seconds, the indicator code will change to 0111 and then to flashing 1011 within 1 minute. When the indicator code is flashing 1011, replace the language diskette with the *system* diskette. *Do not press the IML pushbutton.* Within 1 minute, the 8 4 2 1 indicator code will change to a steady 1000. Within 15 minutes, the 8 4 2 1 indicator code will change to one of the following:

Note: If errors occur during this 15-minute period, a flashing 8 4 2 1 indicator code will appear. Figures 4-5 and 4-6 may help you locate the cause.

0011 — Replace the system diskette with the *load* diskette. *Do not press the IML pushbutton.* (If you do press the IML pushbutton, go back to step 3.) Within 5 minutes, the 8 4 2 1 indicator code will change to 1111 (all lights on), indicating that customizing is successfully completed.

1111 — Modification is successfully completed.

1011 — Replace the feature diskette with the *system* diskette. *Do not press the IML pushbutton.* (If you do press the IML pushbutton, go back to step 3.) Within 1 minute, the 8 4 2 1 indicator code will change to a steady 1000. Within 15 minutes, the 8 4 2 1 indicator code will change to one of the following:

Note: If errors occur during this 15-minute period, a flashing 8 4 2 1 indicator code will appear. Figures 4-5 and 4-6 may help you locate the cause.

0011 — Replace the system diskette with the *load* diskette. *Do not press the IML pushbutton.* (If you do press the IML pushbutton, go back to step 3.) Within 5 minutes, the 8 4 2 1 indicator code will change to 1111 (all lights on), indicating that customizing is successfully completed.

1111 — Modification is successfully completed.

13. If you are using a 3299 Terminal Multiplexer:

- a. Attach the cable leading to the 3299 to the 0-7 port adapter on the 3274.
- b. Put the port adapter switch on the 3274 in the 3299 position (down) (factory-installed port adapter), or remove the shorting cap (field-installed port adapter). (See the diagram on the port adapter.)

The modification procedure is completed. Record the changes made during this procedure on the *IBM 3274 Control Unit Configuration Data Card (Configuration Support: D)*, GA23-0114, stored in the diskette storage area of the 3274 that you are customizing for.

Be sure the 3274 is attached to the appropriate communication facility. An IML of the 3274 can be initiated. During IML, errors may occur because of improper modification. The 8 4 2 1 indicator codes caused by these errors are shown in Figure 4-7.

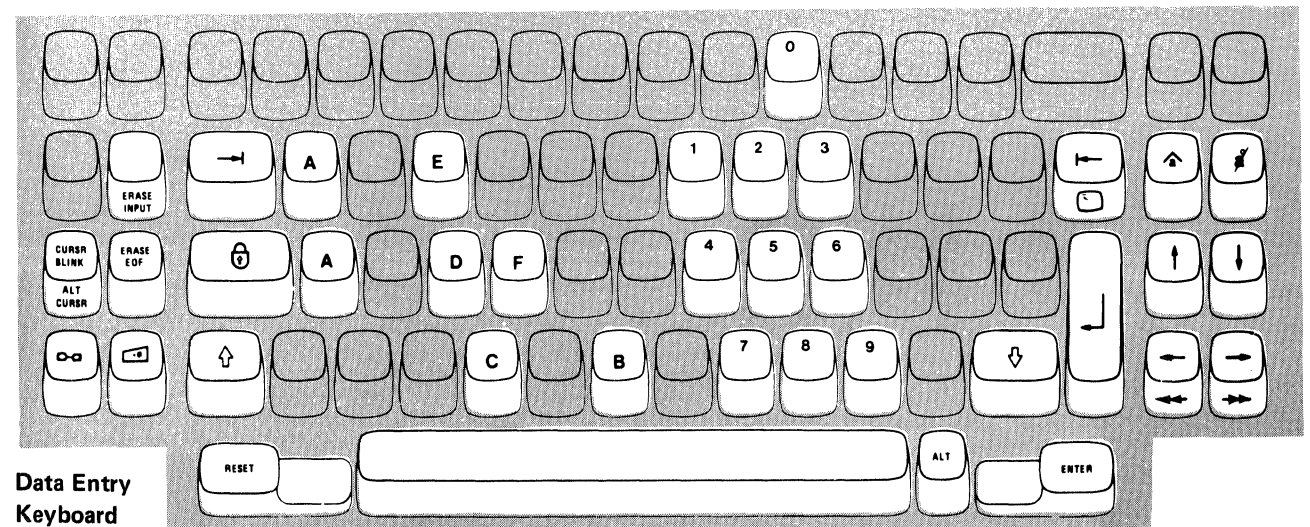
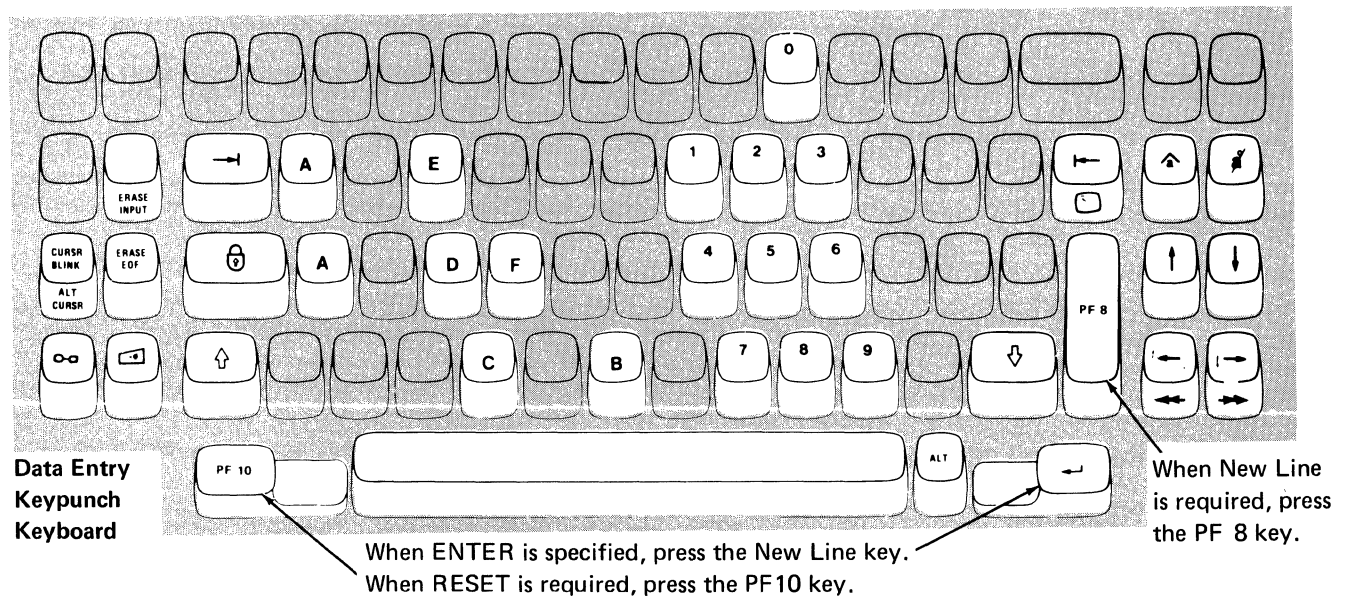
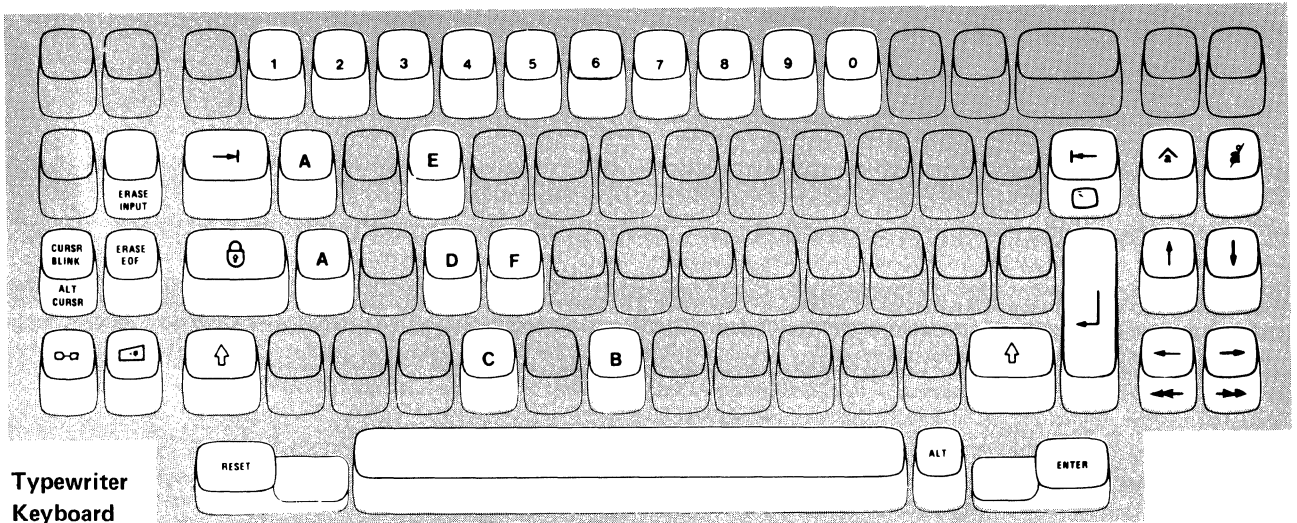

Note: During the modification procedure, only certain key positions are valid. Use only those key positions shown above.

Figure 4-1. Valid Key Positions during Modification Procedure

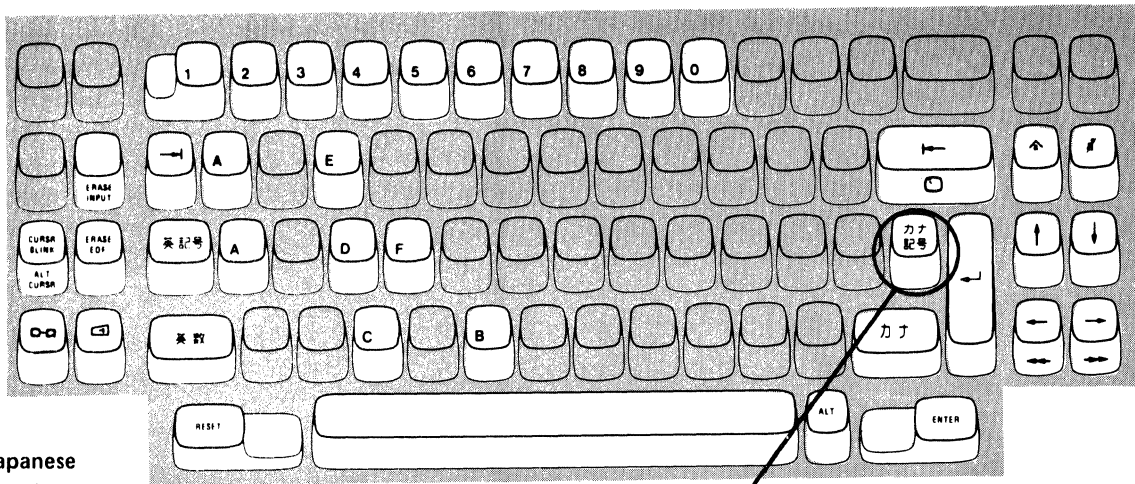

Japanese
Katakana
Typewriter
Keyboard

Press this key when sequence number 001 appears in the upper-left corner of the screen.

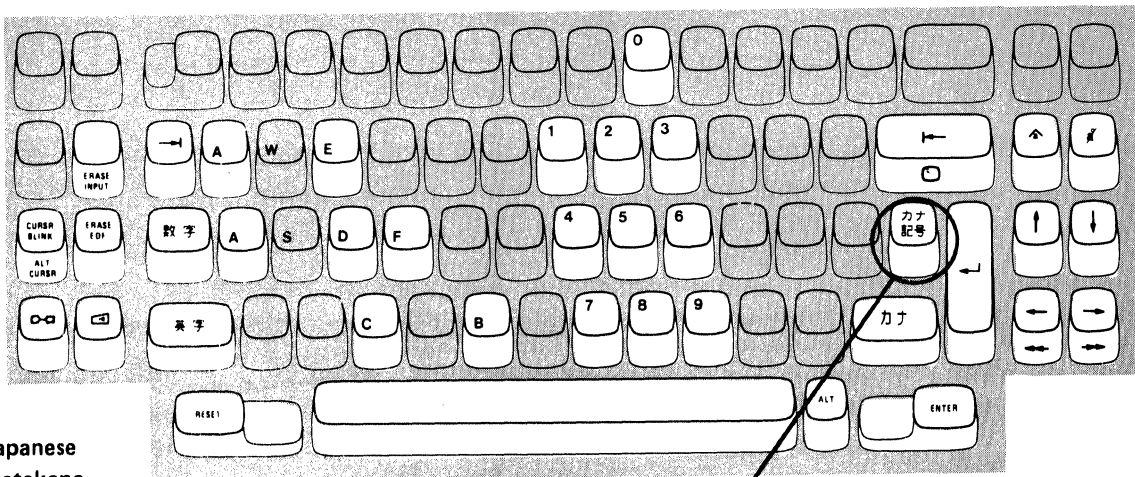

Japanese
Katakana
Data Entry
Keyboard

Press this key when sequence number 001 appears in the upper-left corner of the screen.

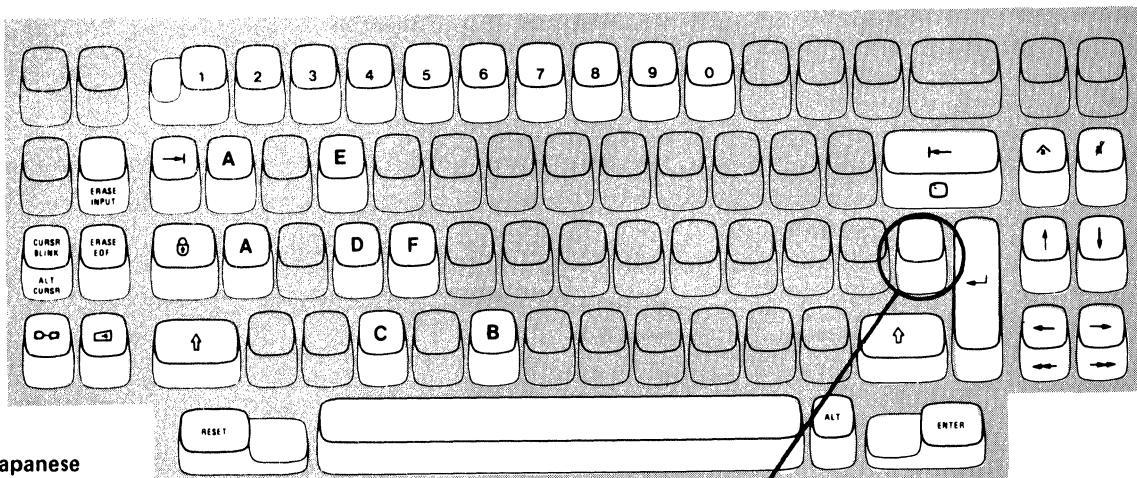

Japanese
English
Typewriter
Keyboard

Press this key when sequence number 001 appears in the upper-left corner of the screen.

Note: These diagrams show the valid keys for both the 76- and 88-key keyboards. The PF keys on the right side of the 88-key keyboards are not valid during this procedure and therefore not shown.

Figure 4-2. Valid Key Positions during Modification Procedure When Japanese Katakana and Japanese English Keyboards Are Used

3274 Diskette Insertion Procedure (Models 31A, 31C, and 31D)

1. Open the customer access door, and locate the diskette reader enclosure.

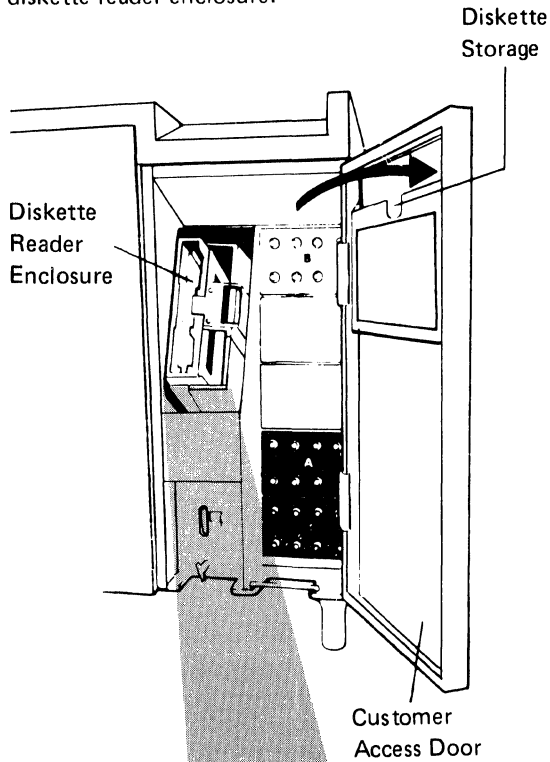

2. Open the diskette reader enclosure door by pressing the latch to the right.

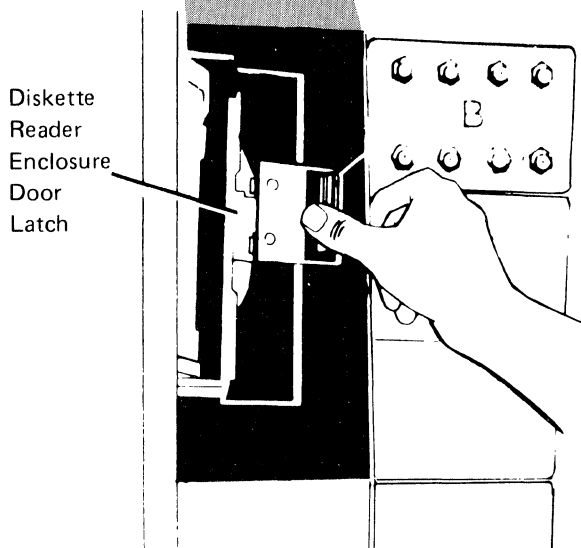

3. Remove the diskette to be used with the 3274 from its gray protective envelope, and insert it squarely into the enclosure. Note that the diskette label position is to the right.

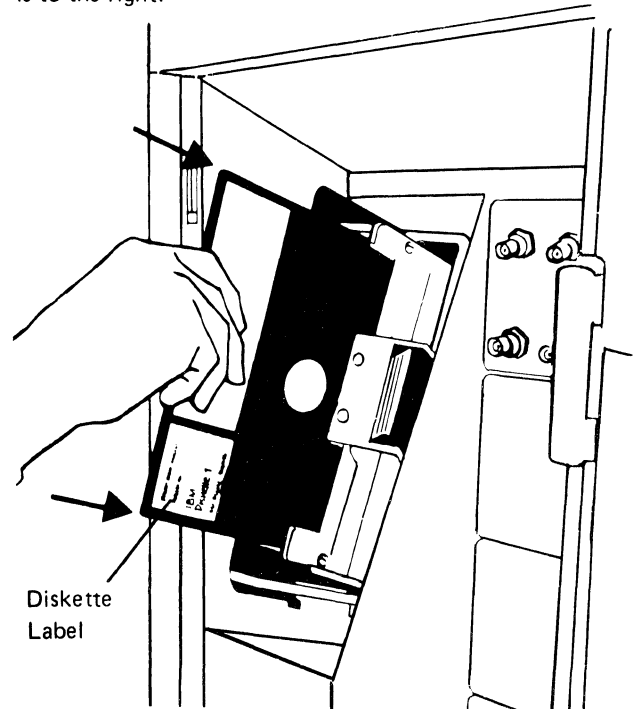

4. Close the diskette reader enclosure door by pushing the door to the left until it latches (clicks).

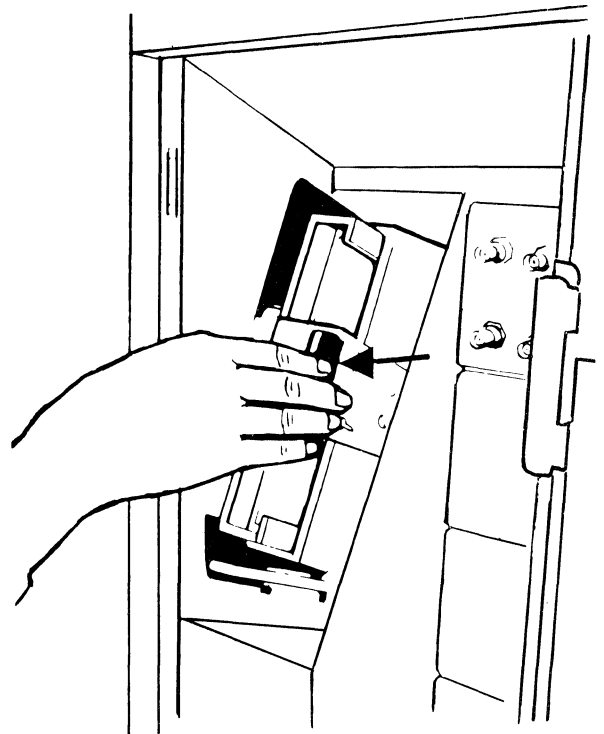
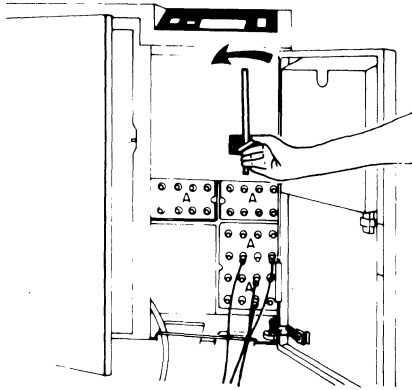

Figure 4-3 (Part 1 of 3). Inserting a Diskette into the 3274 Control Unit during Modification

3274 Diskette Insertion Procedure (Models 41A, 41C, and 41D)

1. Open the diskette reader enclosure by turning the operator lever counterclockwise to the vertical position.



3. Close the diskette reader enclosure by turning the operator lever clockwise to the horizontal position.

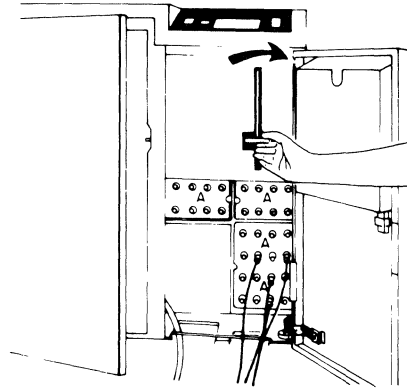

2. Remove one of the diskettes shipped with the 3274 from its gray protective envelope, and insert it squarely into the enclosure, with the label facing left (as shown below).

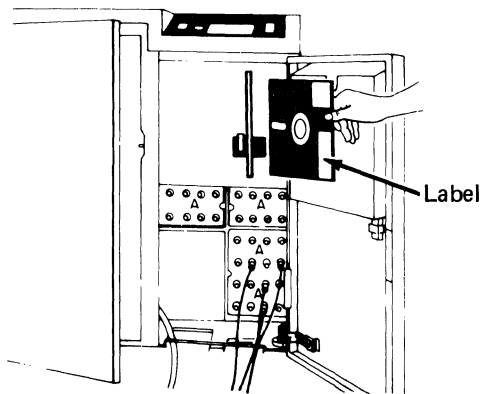

4. Close the customer access door.

Figure 4-3 (Part 2 of 3). Inserting a Diskette into the 3274 Control Unit during Modification

3274 Diskette Insertion Procedure (Models 51C and 61C)

1. Open the diskette reader by turning the lever counterclockwise to the vertical position.

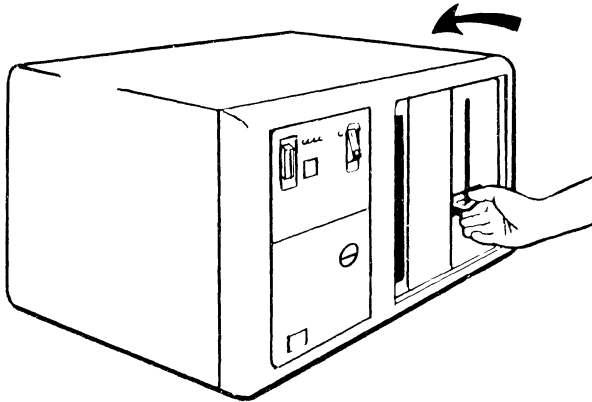

2. Remove the diskette to be used with the 3274 from its gray protective envelope, and insert it squarely into the enclosure. Note that the diskette label position is on your left.

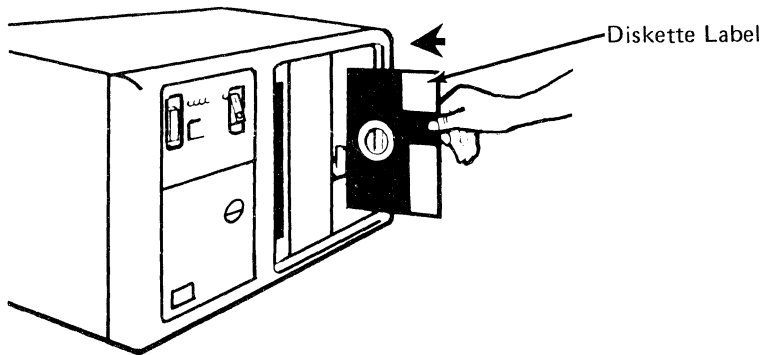

3. Close the diskette reader by turning the lever to the horizontal position.

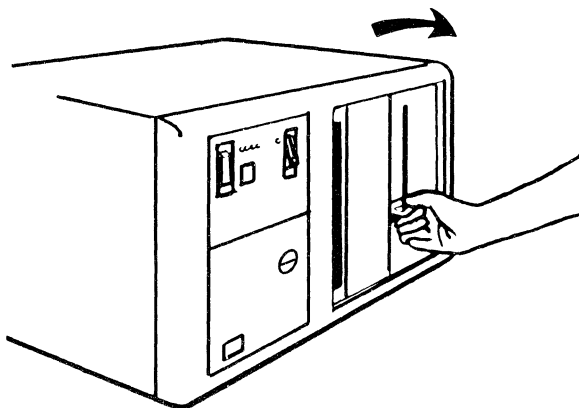

Figure 4-3 (Part 3 of 3). Inserting a Diskette into the 3274 Control Unit during Modification

Code	Meaning	Action
01	One or more of the first 10 characters are incorrect.	Enter the correct response.
02	One or more of the 11th to 17th characters, including the space, are incorrect.	Enter the correct response.
03	1. One of the last two characters you entered in response to sequence number 001 is incorrect, or 2. The diskette release level is not the same as the documentation level.	1. Enter the correct response. 2. Restart after matching diskette and documentation levels.
11 ¹	You entered an invalid response (too many characters, value too high or too low, wrong character, etc.).	Enter the correct response.
12	You entered an incorrect 3274 model designation in response to sequence number 151.	Enter the correct response.
13 ¹	Your response has not enough characters.	Enter the correct response.
14 ¹	The numeric total of the responses you entered for sequence numbers 111 (Number of Category B Terminals) and 112 (Number of Category A Terminals) is greater than 32 (Models 31 and 41), 12 (Model 51C), or 16 (Model 61C).	Enter the correct responses.
19	You cannot answer 901=2 during an initial customization or if any patches are being made during this session.	Answer 1 to sequence number 901.
21 ¹	You made an unacceptable change during the modify sequence (number 999).	Recheck the entries, and correct them.
22	In 121 you specified a language (121=02 (ASCII)) that is not compatible with the A or D control unit model specified in 151.	Verify and enter the correct response.
23	One or more of your responses are not compatible with the response to sequence number 331 (BSC, SDLC, or X.25).	Verify and enter the correct responses.
25	You have less storage than indicated in your response to sequence number 113.	Verify and enter the correct response.
26	You do not have enough storage to support all the features you have selected.	Report the problem and verify that the storage specified in response to sequence number 113 is correct.
27 ¹	1. You specified the Portuguese (Alternate) language (121=18). This is not allowed with your configuration. 2. You specified Extended Data Stream (160=1) and a language that is not allowed with the Extended Data Stream (121=02, 08, 10, 13, 20, 26, or 27). 3. You specified a language that is not allowed with a distributed function terminal (121=02, 06, 08, 09, 10, 12, 13, 20, 26, or 27). 4. Entry Assist has been specified (sequence number 115=1) with a language that does not support Entry Assist (sequence number 121=02, 06, 08, 10, 11, 12, 13, 17, 20, 26, or 27). 5. You specified a language (121=02, 05, 06, 08, 10, 11, 12, 13, 14, 16, 20, 25, 26, or 27) that is not allowed with the keyboards (typewriter or APL) selected in sequence number 136. 6. You specified a language (121=02 through 16, 19, 20, 22 through 28, 30, 31, or 32) that is not allowed with the data entry keyboard selected in sequence number 136. 7. You specified a language (121=02, 05, 06, 08, 10, 11, 12, 13, 14, 16, 17, 20, 25, 26, or 27) that is not allowed with modified keyboards (sequence number 137).	1. Specify Portuguese (121=28). 2-7. Verify and enter the correct response.
28 ¹	Your responses to sequence numbers 113 (Extended Function Store) and 151 (3274 Model Designation) are incompatible.	Verify and enter the correct response.
33 ¹	Zero has been specified in sequence number 170, but you specified nonzero responses to sequence number 139, 173, 175, or 176.	Specify either 1 to sequence number 170 or 0's to sequence numbers 139, 173, 175, and 176.
34 ¹	You specified a Category B device in response to sequence number 111, but you specified a distributed function terminal in sequence number 170. Category B devices are not allowed with distributed function terminals.	Verify and enter the correct responses.

Figure 4-4 (Part 1 of 4). Operator Codes during Modification Procedure

Code	Meaning	Action																																													
35 ¹	<p>Your responses to sequence numbers 151, 331, and 343 are incompatible. Compatible responses are:</p> <table border="1"> <thead> <tr> <th></th> <th colspan="2">Sequence Number</th> </tr> <tr> <th>331</th> <th>151</th> <th>343</th> </tr> </thead> <tbody> <tr> <td>0, 1, or 2</td> <td>31C, 41C, 51C, 61C</td> <td>00</td> </tr> <tr> <td>0, 1, or 2</td> <td>31C, 41C, 51C, 61C</td> <td>01</td> </tr> <tr> <td>1</td> <td>31C, 41C, 51C, 61C</td> <td>02</td> </tr> <tr> <td>1</td> <td>51C, 61C</td> <td>03</td> </tr> <tr> <td>2</td> <td>31C, 41C, 51C, 61C</td> <td>03</td> </tr> <tr> <td>1</td> <td>51C, 61C</td> <td>04</td> </tr> <tr> <td>0 or 1</td> <td>51C</td> <td>05</td> </tr> <tr> <td>1</td> <td>51C</td> <td>06</td> </tr> <tr> <td>1</td> <td>51C</td> <td>07</td> </tr> <tr> <td>0 or 1</td> <td>51C</td> <td>08</td> </tr> <tr> <td>0 or 1</td> <td>51C</td> <td>09</td> </tr> <tr> <td>1</td> <td>51C, 61C</td> <td>10</td> </tr> <tr> <td>0 or 1</td> <td>31C, 51C</td> <td>11</td> </tr> </tbody> </table>		Sequence Number		331	151	343	0, 1, or 2	31C, 41C, 51C, 61C	00	0, 1, or 2	31C, 41C, 51C, 61C	01	1	31C, 41C, 51C, 61C	02	1	51C, 61C	03	2	31C, 41C, 51C, 61C	03	1	51C, 61C	04	0 or 1	51C	05	1	51C	06	1	51C	07	0 or 1	51C	08	0 or 1	51C	09	1	51C, 61C	10	0 or 1	31C, 51C	11	Verify and enter the correct responses.
	Sequence Number																																														
331	151	343																																													
0, 1, or 2	31C, 41C, 51C, 61C	00																																													
0, 1, or 2	31C, 41C, 51C, 61C	01																																													
1	31C, 41C, 51C, 61C	02																																													
1	51C, 61C	03																																													
2	31C, 41C, 51C, 61C	03																																													
1	51C, 61C	04																																													
0 or 1	51C	05																																													
1	51C	06																																													
1	51C	07																																													
0 or 1	51C	08																																													
0 or 1	51C	09																																													
1	51C, 61C	10																																													
0 or 1	31C, 51C	11																																													
36 ¹	You have specified a nonzero response for sequence number 139, but a zero response for sequence number 170. 170 must be a 1 for 139 to be nonzero.	Verify the responses to sequence numbers 139 and 170; then enter the correct response(s).																																													
37 ¹	<ol style="list-style-type: none"> You specified Decompression (165=1), but did not specify EDS (160=1). You specified Attribute Select Keyboard (166=B or C), but did not specify EDS (160=1). You specified that you are using an IBM 3270 Personal Computer Attachment (114=1), but did not specify EDS (160=1). 	<ol style="list-style-type: none"> Verify and enter the correct responses. Verify and enter the correct responses. Verify and enter the correct response. 																																													
38 ¹	<ol style="list-style-type: none"> When 136 is 0, 138 must also be 0. Sequence number 136 must be configured for at least one keyboard for a keypad to be selected in 138. The numeric total of keyboards selected in sequence numbers 136 and 137 is greater than four. 	<ol style="list-style-type: none"> Verify the responses to 136 and 138, then enter the correct responses. Check which keyboards are needed and select no more than four total. 																																													
41 ²	The X.25 network type (400) is invalid.	Check the network type values and enter a valid response to 400.																																													
42 ²	The incoming call options (420) response included "Validate Host DTE Address," but the address was not entered in response to 410.	Either respond to 410 with the host address or do not include "Validate Host DTE Address" in response to 420.																																													
43 ²	<ol style="list-style-type: none"> The circuit type (401) chosen requires a host address (410). The outgoing call options chosen included "Validate 3274 DTE Address," but the address was not entered in response to 411. The response to 421 was invalid. 	<ol style="list-style-type: none"> Either change the response to 401 or provide a host DTE address (410). Either respond to 411 with 3274 address or do not include "Validate 3274 DTE Address" in response to 421. Check 421 and enter a valid response. 																																													
44 ²	Negotiated window size (432) or nonstandard window size (435) conflicts with packet sequence numbering (431).	If 431 equals 0, then 432/435 must equal 01–07 (two digits). If 431 equals 1, then 432/435 must equal 01–11 (two digits).																																													
45 ²	The circuit type (401) is invalid.	Check the circuit type values and correct the response.																																													
46 ²	An invalid X.25 keyboard support (443) was selected.	Check the X.25 keyboard support and correct the response.																																													

Figure 4-4 (Part 2 of 4). Operator Codes during Modification Procedure

Code	Meaning	Action
47 ²	No CID password was initialized (452), but a CID is required for call options (420 and/or 421).	Either change the call options to remove the CID requirement or enter the CID password (452).
50 ³	<ol style="list-style-type: none"> (CS-D/Releases 60–63) Your response to sequence number 112 is incompatible with your response to sequence number 116. When 112 is nonzero, 116 must be zero; when 112 is zero, 116 must be nonzero. (CSD-D/Release 64) Your response to sequence number 111 (111=nonzero) is incompatible with your response to sequence number 116 (116=2). When 116 is 2, 111 must be zero. (CS-D/Release 64) Your response to sequence number 112 is incompatible with your response to sequence number 116. When 112 is nonzero, 116 must be zero; when 112 is zero, 116 must be nonzero. 	<ol style="list-style-type: none"> If you are <i>not</i> controlling port addressing, make a nonzero response to 112. If you are controlling port addressing, respond to 112 with a zero, and to 116 with a 1. Make your response to 111 a zero. If you are <i>not</i> controlling port addressing, make a nonzero response to 112. If you are controlling port addressing, make the response to 112 a 0, and the response to 116 a 1 or a 2.
51 ³	<p>You are trying to use a port that is not available.</p> <p>Model 41X or 31X — The highest Category A port specified plus the number of Category B devices specified (sequence number 111) exceeds the number of allowed devices.</p> <p>Models 51C — You may use ports A00 through A07 only.</p> <p>Model 61C — You may use ports A00 through A15 only.</p>	<p>Change the responses to sequence number 117 so that they are compatible with the model you are using.</p> <p>or</p> <p>Change the 0 after 906 to an A, and press ENTER. Enter the proper response to sequence number 111 or 151.</p>
52 ³	<p>You have assigned too many addresses to a port.</p> <p>If sequence number 170 equals 0, you can assign 0 or 1 addresses only.</p> <p>If sequence number 170 equals 1, you can assign 0 through 5 addresses.</p>	Change the 0 after 906 to an A, and press ENTER. Verify your response to sequence number 170, and correct your port assignments.
53 ³	<p>You have assigned more than the number of system addresses allowed.</p> <p>For SNA protocol, you are allowed a total of 128 addresses.</p> <p>For non-SNA protocol, you are allowed a total of 32 addresses.</p>	Recalculate your port assignments so that they fall within the limits set, and then correct your port assignments. The LT=nnn field in sequence numbers 117 and 118 indicates the total number of addresses currently specified (in decimal).
54 ³	You have not assigned an address to port A00.	Assign an address to port A00.
55 ³	You have left a blank between assigned addresses on some port. Address assignments must be contiguous, for example, P, S1, S2, . . .	Shift the assigned addresses or fill in the blank.
56 ³	Either an out-of-range or a nondecimal address was specified. Valid ranges are 2 to 129 for SNA, 0 to 31 for non-SNA.	Correct the address(es) in error.
57 ³	You have assigned duplicate addresses.	Correct the address assignments in error.

Figure 4-4 (Part 3 of 4). Operator Codes during Modification Procedure

Code	Meaning	Action
60 ⁴	Both response fields for sequence number 127 must be either zero or nonzero.	Enter a zero or nonzero response in both fields.
61 ⁴	Your first digit response to sequence number 127 was a 3, 4, or 5 and system communication is non-SNA, and/or your second digit response to sequence number 127 was 3 and system communication is non-SNA. This is not allowed.	Verify and enter the correct response.
62 ⁴	An invalid time boundary is specified in sequence number 128. The maximum time allowed is 27:18.3. The seconds field must not exceed 59.	Enter time values in the permitted range.
63 ⁴	Field B1 in sequence number 128 cannot be specified as 00:00.0.	Verify and enter the correct response.
64 ⁴	Entries for fields B1 through B4 in sequence number 128 are not in ascending order.	Verify and enter the correct response.
65 ⁴	A time boundary value of 00:00.0 is embedded between two nonzero values in sequence number 128. This is not allowed.	Enter an appropriate nonzero value.
66 ⁴	A nonzero boundary value follows a maximum boundary value (27:18.3) in sequence number 128. Only a zero boundary value (00:00.0) can follow the maximum.	Correct your boundary value sequence.
99	Your entries are acceptable, but the entry for sequence number 900, 901, 904, 906, 907, or 908 has not been changed to a 1.	Change the 900, 901, 904, 906, 907, or 908 entry to a 1.

¹ If any entry is unacceptable, the entry for sequence number 900 is changed back to 0 (zero), and the unacceptable value is intensified.

² If any entry is unacceptable, the entry for sequence number 908 is changed back to 0 (zero), and the unacceptable value is intensified.

³ If any entry is unacceptable, the entry for sequence number 906 is changed back to 0 (zero), and the unacceptable value is intensified.

⁴ If any entry is unacceptable, the entry for sequence number 904 is changed back to 0 (zero), and the unacceptable value is intensified.

Figure 4-4 (Part 4 of 4). Operator Codes during Modification Procedure

Steady Code	Diskette Mounted	Meaning	Action
0001	Feature	Customizing being performed	None.
0010	Any (indication lasts for 3 minutes or more)	Diskette improperly inserted or an internal 3274 error	Insert diskette properly and retry.
0011	Feature	Customizing being performed	None.
0100	Feature	Patch, printer authorization matrix, or RPQ being performed	None.
0101	Feature	Configuration being performed	None.
0110	Feature	Modification being performed	None.
0111	Feature, language, or RPQ	Normal 3274 operation	None.
1000	System or load (customizing in process)	Normal 3274 operation	None.
1001	Any	Internal 3274 error	Retry. If the error recurs, follow your local procedure for problem recovery.
1010	Any	Internal 3274 error	Retry. If the error recurs, follow your local procedure for problem recovery.
1101	Any (customizing procedure in progress)	<ol style="list-style-type: none"> 1. IML pushbutton pressed while diskette is being changed, or 2. A bad or uncustomized system or load diskette is being used 	<ol style="list-style-type: none"> 1. Recustomize. Do not press the IML pushbutton unless instructed to do so. 2. Insert a good customized system or load diskette.
1111	System or load (IML not performed)	Customizing is completed	IML can be performed.

Figure 4-5. Steady 8 4 2 1 Indicator Codes during Modification Procedure Only

Flashing Code ¹	Diskette Mounted	Meaning	Action
0000 0011	System	Load diskette request	Insert load diskette.
0000 0101	Any	System or load diskette request	Insert system or load diskette (as appropriate).
0000 1010	System	A diskette read error occurred.	Retry. If the error recurs, follow your local procedure for problem recovery.
	Load	A diskette read error occurred.	Attempt to perform Load Diskette Backup Procedure. If this fails, recustomize using the feature and system diskettes. If the error recurs, follow your local procedure for problem recovery.
0000 1011	Any	System diskette request	Insert system diskette.
0000 1100	Any	RPQ diskette request	Insert RPQ diskette.
0000 1101	Any	Language diskette request	Insert language diskette.
0000 1110	Any	Feature diskette request	Insert feature diskette.
0100 0010	System or Load	Configuration on system or load diskette being used for update-diskette procedure is not compatible with this 3274.	Use a system or load diskette with a compatible configuration.
	Language	Language number (sequence number 121) does not match the language number used in the Keyboard Definition Utility pre-customizing procedure.	Make sure language number is the same as used in the Keyboard Definition Utility. Refer to GA23-0187.
1000 0001	System or Load	Uncustomized system diskette being used during update procedure.	Use customized system diskette.
	Language	The keyboard IDs specified in sequence number 137 are not defined on the diskette.	Use the <i>Keyboard Definition Utility</i> , GA23-0187, to define the required keyboard IDs.
1001 0110	Any	Wrong-level diskette being used	Use correct-level diskette.
1111 0001	Feature	On/Off switch or TEST key pressed instead of ENTER	Retry. If the error recurs, follow your local procedure for problem recovery.
	System	Internal 3274 error	Follow your local procedure for problem recovery.
1111 0010	Feature	3278 Model 2 or higher is not attached to port A0.	Attach 3278 Model 2, its equivalent, or higher to port A0. Retry customizing.
1111 0011	Feature	Insufficient storage in 3274. At least 192K required on 3274.	Follow your local procedure for problem recovery.
1111 0100	System	Internal 3274 error	Retry. If the error recurs, follow your local procedure for problem recovery.
1111 0101	System	Internal 3274 error	Retry. If the error recurs, follow your local procedure for problem recovery.
	Feature	On/Off switch of TEST key on the 3278 pressed instead of ENTER	
1111 0110	RPQ	Incompatible RPQs	Follow your local procedure for problem recovery.
	Feature	Internal 3274 error	
1111 0111	System	Internal 3274 error	Follow your local procedure for problem recovery.
1111 1000	System	Internal 3274 error	Follow your local procedure for problem recovery.
1111 1001	System, feature language, or RPQ	Internal 3274 error	Follow your local procedure for problem recovery.
1111 1010	System	Internal 3274 error	Follow your local procedure for problem recovery.
1111 1011	System	Internal 3274 error	Follow your local procedure for problem recovery.
1111 1100	Any	Diskette drive error or a bad diskette	Retry. If the error recurs, follow your local procedure for problem recovery.
1111 1101	System, feature, language or load	Diskette drive error or a bad diskette	Retry. If the error recurs, follow your local procedure for problem recovery.
1111 1110	System, feature, language or RPQ	Internal 3274 error	Retry. If the error recurs, follow your local procedure for problem recovery.

¹ These codes will flash alternately as shown, for example, 0000, 1011, 0000, 1011.

Figure 4-6. Flashing 8 4 2 1 Indicator Codes during Modification Procedure Only

Steady Code	Flashing Code ¹	Diskette Mounted	Meaning	Action
—	0101 0000 ²	System or load	Internal 3274 error or wrong response to sequence number 113 during customizing procedure	Check response to sequence number 113, and retry. If the error recurs, follow your local procedure for problem recovery.
—	0110 0000 ²	System or load	Internal 3274 error or wrong response to sequence number 111, 112, 151, or 351 during customizing procedure	Check response to sequence number 111, 112, 151, or 351, and retry. If the error recurs, follow your local procedure for problem recovery.
—	0110 0001 ³	System or load	Address range switches inside Model D control unit set improperly	Check responses to sequence numbers 111, 112, 116, 117, and 118. If correct, have IBM CE check address range setting in control unit.
—	0111 0000 ²	System or load	1. Internal 3274 error, or 2. Wrong response to sequence number 311 or 343, or 3. The 3274 is not connected to the communication facility	1 and 2. Check responses to sequence numbers 311 and 343, and retry. 3. Connect the 3274 to the communication facility. If the error recurs, follow your local procedure for problem recovery.
—	1000 0000	System or load	Internal 3274 error or wrong response to sequence number 111 during customizing procedure	Check response to sequence number 111, and retry. If the error recurs, follow your local procedure for problem recovery.
—	1001 0000	System or load	Internal 3274 error or wrong response to sequence number 352 during customizing procedure	Check response to sequence number 352, and retry. If the error recurs, follow your local procedure for problem recovery.
—	1001 1010	System or load	Internal 3274 error or wrong response to sequence number 151 during customizing procedure	Check response to sequence number 151, and retry. If the error recurs, follow your local procedure for problem recovery.
—	1001 1110	System or load	Insufficient storage	Follow your local procedure for problem recovery.
—	1011 0000	System or load	Internal 3274 error or wrong response to sequence number 127 during customizing procedure	Check response to sequence number 127, and retry. If the error recurs, follow your local procedure for problem recovery.
1101	—	System or load	Uncustomized system diskette	Insert customized system diskette.
1110	—	System or load	Insufficient storage	Check response to sequence number 113, and retry. If the error recurs, follow your local procedure for problem recovery.

Note: These indicators may be caused by something other than incorrect customizing. Further aids can be found in the *IBM 3270 Information Display System: 3274 Control Unit Problem Determination Guide*, GA27-2850.

¹These codes will flash alternately as shown, for example, 0101, 0000, 0101, 0000, and so on.

²These codes may blink for 5 seconds, followed by a different steady code for 3 seconds.

³Models 31D and 41D only. These codes will alternate continuously as follows: left code blinks for 5 seconds, then right code is on steady for 3 seconds.

⁴Address range switches inside the 3274 D models are set to multiples of 4. When a distributed function terminal is attached and the Multiple Interactive Screen function is being used, the address range switches are set as follows:

- If the highest logical device address is a multiple of 4, the address range switches must be set to equal the device address; for example, 16, 20, or 28.
- If the highest logical device address is not a multiple of 4, the address range switches must be set to the next higher multiple of 4. For example, if the highest logical device address is 26, the address range switches must be set to 28.

Figure 4-7. 8 4 2 1 Indicator Codes during IML That May Result from an Incorrect Modification Procedure

Printer Authorization Matrix Form (Modification Only)

In response to sequence number 022, enter the characters (below) supplied by the planner in the appropriate groups on your display screen. If a group is already displayed as AA M XXXX YYYY YYYY, your entry will overwrite these characters. To delete an entry, move the cursor to the leftmost position of the entry (the Printer Port Address) and press the spacebar twice. All deleted entries will be displayed as AA M XXXX YYYY YYYY after the ENTER key is pressed. After checking that all the entries in the matrix are correct, move the cursor to the 0 after the 901 at the bottom of the screen.

- Change the 0 to a 1 if the Printer Authorization Matrix is not the only update to the 3274 being made during this modification or if any RPO's are applied.
- Change the 0 to a 2 if this is a modification procedure and the Printer Authorization Matrix update is the only change being made.

Press ENTER. If unacceptable responses in the matrix are detected by the 3274, the 1 or 2 in the 901 field is automatically changed back to a 0, and the invalid entries are intensified. Correct the invalid entries, and again change the 901 response to a 1 or 2, and press ENTER.

If you responded to 901 with a 1 and all entries are valid, the printer authorization matrix display will be replaced by the next customizing sequence number. Return to your original instructions.

If you responded to 901 with a 2 and all entries are valid, the 3274 will clear the screen and go into printer authorization matrix writing mode. The indicators on the 3274 will flash a 0101. This means to insert a customized load or system diskette. This diskette can be at any release level and any configuration. 1000 is displayed on the indicators while the 3274 is writing the new printer authorization matrix onto the diskette and updating the configuration table. This takes about 8–10 seconds. When it is done, the indicators flash 0101 again. At this time you can copy the printer authorization matrix to another customized system or load diskette by inserting that diskette into the 3274. When you are finished writing the printer authorization matrix on the diskettes, remove the last diskette. The modification is finished, and the indicators are flashing 0101.

	Printer Port Address	Printer Mode	Printer Class Assignment	Source Device List
	A A	M	X X X X	Y Y Y Y Y Y Y Y
1)	- -	-	- - - -	- - - - - - - -
2)	- -	-	- - - -	- - - - - - - -
3)	- -	-	- - - -	- - - - - - - -
4)	- -	-	- - - -	- - - - - - - -
5)	- -	-	- - - -	- - - - - - - -
6)	- -	-	- - - -	- - - - - - - -

	Printer Port Address		Printer Mode	Printer Class Assignment				Source Device List							
	A	A	M	X	X	X	X	Y	Y	Y	Y	Y	Y	Y	Y
7)	-	-	-	-	-	-	-	-	-	-	-	-	-	-	-
8)	-	-	-	-	-	-	-	-	-	-	-	-	-	-	-
9)	-	-	-	-	-	-	-	-	-	-	-	-	-	-	-
10)	-	-	-	-	-	-	-	-	-	-	-	-	-	-	-
11)	-	-	-	-	-	-	-	-	-	-	-	-	-	-	-
12)	-	-	-	-	-	-	-	-	-	-	-	-	-	-	-
13)	-	-	-	-	-	-	-	-	-	-	-	-	-	-	-
14)	-	-	-	-	-	-	-	-	-	-	-	-	-	-	-
15)	-	-	-	-	-	-	-	-	-	-	-	-	-	-	-
16)	-	-	-	-	-	-	-	-	-	-	-	-	-	-	-
17)	-	-	-	-	-	-	-	-	-	-	-	-	-	-	-
18)	-	-	-	-	-	-	-	-	-	-	-	-	-	-	-
19)	-	-	-	-	-	-	-	-	-	-	-	-	-	-	-
20)	-	-	-	-	-	-	-	-	-	-	-	-	-	-	-
21)	-	-	-	-	-	-	-	-	-	-	-	-	-	-	-
22)	-	-	-	-	-	-	-	-	-	-	-	-	-	-	-
23)	-	-	-	-	-	-	-	-	-	-	-	-	-	-	-
24)	-	-	-	-	-	-	-	-	-	-	-	-	-	-	-
25)	-	-	-	-	-	-	-	-	-	-	-	-	-	-	-
26)	-	-	-	-	-	-	-	-	-	-	-	-	-	-	-
27)	-	-	-	-	-	-	-	-	-	-	-	-	-	-	-
28)	-	-	-	-	-	-	-	-	-	-	-	-	-	-	-
29)	-	-	-	-	-	-	-	-	-	-	-	-	-	-	-
30)	-	-	-	-	-	-	-	-	-	-	-	-	-	-	-
31)	-	-	-	-	-	-	-	-	-	-	-	-	-	-	-

Chapter 5. Backup Diskette Generation Procedures

Each 3274 Control Unit is shipped with two uncustomized system diskettes and (if you have 3179-G Color Graphics Display Stations or 3290 Information Panels attached) two uncustomized load diskettes. (The words *System Diskette* or *Load Diskette* are printed on the label.) You customize one of each of these diskettes by using the initial customizing procedure in Chapter 3. You can then use the duplicate diskette to make a copy of the one you customized. This duplicate diskette is called a *backup* diskette. It can be used if something goes wrong with, or if you misplace, the originally customized diskette.

You use one of the following procedures to create these backup diskettes:

- The Backup System Diskette Generation Procedure for customized system diskettes. Note that any IBM display station (except a distributed function terminal mode 3270 Personal Computer, a 3277, a 3179-G, or a 3290) *is* required for this procedure.
- The Backup Load Diskette Generation Procedure for customized load diskettes. Note that *no* display station is required for this procedure.

Backup System Diskette Generation Procedure

The planner should enter the following information on the Backup System Diskette Form:

1. The type of keyboard (typewriter or data entry) to be used by the operator.

Note: If using a 76- or 88-key Japanese English or Japanese Katakana keyboard, specify the number of keys and the keyboard type.

2. In step 1, the identification of each diskette to be used.
3. In step 9, the response to sequence number 031 (number of RPQ diskettes to be used). If your response to sequence number 031 is not 0, you will have to enter a response to sequence number 032. See “032 (Request RPQ Parameter List)” in Chapter 2.

The filled-in Backup System Diskette Form and the following information, included in this chapter, should be given to the operator who is to perform the backup system diskette generation.

- Keyboard diagrams showing the valid key positions for backup diskette generation (Figures 5-1 and 5-2)
- A diagram showing how to insert diskettes into the 3274 Control Unit (Figure 5-3)
- A chart giving the meanings of, and recommended actions for, the operator codes that may appear on the display station during backup diskette generation (Figure 5-4)
- Charts giving the meanings of, and recommended actions for, the 8 4 2 1 indicator codes that appear on the 3274 control panel during the backup diskette generation (Figures 5-5 and 5-6)
- A chart giving the meanings of, and recommended actions for, the 8 4 2 1 indicator codes that could appear on the 3274 control panel during IML as a result of improper backup diskette generation (Figure 5-7).

Backup Load Diskette Generation Procedure

The planner should enter the identification of each diskette in step 1 of the Backup Load Diskette Form. This form and the following information should be given to the operator who is to perform the backup load generation at the 3274 Control Unit:

- A diagram showing how to insert diskettes into the 3274 Control Unit (Figure 5-3)
- Charts giving the meanings of, and recommended actions for, the 8 4 2 1 indicator codes that appear on the 3274 control panel during the backup diskette generation (Figures 5-5 and 5-6)
- A chart giving the meanings of, and recommended actions for, the 8 4 2 1 indicator codes that could appear on the 3274 control panel during IML as a result of improper backup diskette generation (Figure 5-7).

Review this entire form before starting the procedure to create a backup system diskette. Display station operating procedures are described in the *Operator's Guide* for the display station to be used in customizing.

This procedure duplicates the existing system diskette. *If you do not get the expected result in any step, start over at step 1. If you still do not get the expected result, report the problem.*

There are four indicators, labeled 8 4 2 1, on the 3274 control panel. The meanings of the 8 4 2 1 indicator codes are shown in Figures 5-5 and 5-6. If an error occurs during this procedure, the 8 4 2 1 indicator code may help you locate the cause. Within this form, an On indicator is called a 1, an Off indicator a 0 (zero).

Example: 8 4 2 1
 * * 0 * = 1101

3274 Control Panel

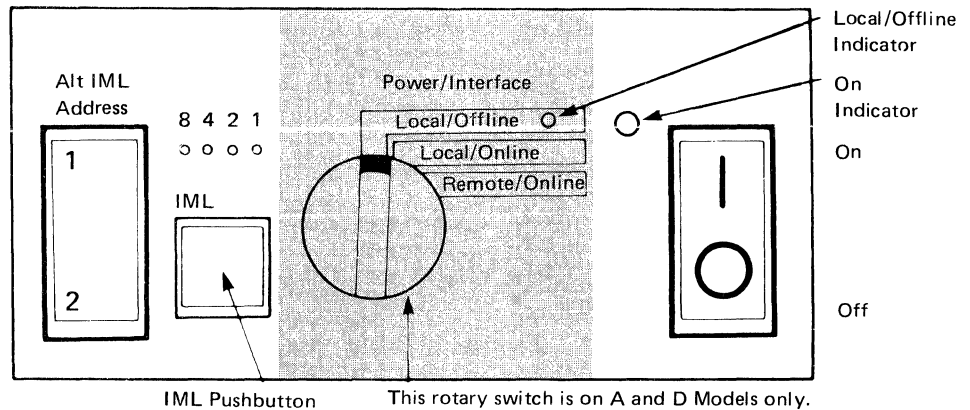

Type of keyboard to be used: Type writer

Note: See Figure 5-1 or 5-2 before continuing.

1. Obtain:

- Feature diskette _____ ✓
- Customized system diskette _____ ✓
- Backup system diskette (diskette to be customized) _____
- Language diskette (if applicable) _____
- RPO diskette(s) (if applicable) 1. _____
- 2. _____
- 3. _____

2. Ensure that the 3274 Control Unit and the display station have power switched on. The display station must have a keyboard and must be attached to port A0 of the 3274.

If you are using a 3299 Terminal Multiplexer, ensure that:

- a. A display station (other than a distributed function terminal or a 3277) is connected to the 0–7 port adapter on the 3274.
- b. The port adapter switch is in the display position (up) (factory-installed port adapter), or the shorting cap is connected (field-installed port adapter). See the diagram on the port adapter panel of the 3274.

Note: When customizing 3274 A or D models, do not set the On/Off switch to the Off position unless the rotary switch on the control panel is in the Local/Offline position and the Local/Offline indicator is lit. The Power/Interface switch must be in the Local/Offline position, and the Local/Offline indicator must be on.

3. Insert the *feature* diskette (see Figure 5-3) and, holding the Alt IML Address switch in position 1, press and release the IML pushbutton; then release the Alt IML Address switch. Within 2 minutes, the 8 4 2 1 indicator code will be a flashing 0101.

Power on a printer if you want the local copy function.

4. Insert the *customized system* diskette. Within 1 minute, the 8 4 2 1 indicator code will be a flashing 1110.
5. Insert the *feature* diskette again. Within 1 minute, the 8 4 2 1 indicator code will be a steady 0001. If you are using a 3279, refer to Appendix D for the convergence procedure.
6. Look for a 3-digit sequence number in the upper left corner of the screen. The first one is 001. Beneath the sequence number are Xs, which you replace by typing in the response to sequence number 001 (below). If the response you enter is acceptable, a new sequence number will be displayed. If the response is unacceptable, a 2-digit operator code will be displayed in the upper center portion of the screen. See Figure 5-4 for the meaning of this code.

If you are using a display station with a modifiable keyboard, the display station must be operating in 3278 emulation mode. If it is not (that is, if it is in native mode), the number 212 will appear in the operator information area of the display station when the first key stroke is attempted, and customizing cannot proceed.

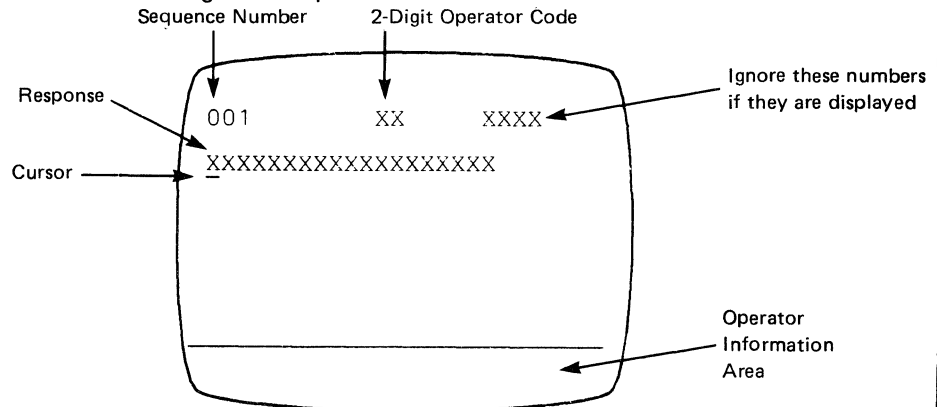

Note: If a 76- or 88-key Japanese English or Japanese Katakana keyboard is used, press the key circled in Figure 5-2 before proceeding. The keyboard will be locked for about 10 seconds. When the keyboard unlocks, continue.

- a. Type in the following character in response to sequence number 001:
1234567890ABCDEF
- b. Press the spacebar once.
- c. Type in the 2-digit validation number that is printed on the front page of this form.
- d. Press ENTER.

Note: Use only the cursor move keys or the tab key to reposition the cursor during this procedure.

7. A 0 is displayed in response to sequence number 011. Do not change this response. Press ENTER.
8. At this time, either sequence number 021 is displayed (meaning that no printer authorization matrix has been defined) or the defined matrix is displayed.

If sequence number 021 is displayed, type in a 0 (zero). Press ENTER. If the matrix is displayed, move the cursor to the 0 after sequence number 901 and change it to a 1. Press ENTER.

Note: Do not answer 901=2 here. If you answer 901=2 and press ENTER, go back to step 3 and start again.

9. Type in the number of RPO diskettes _____ being used in response to sequence number 031. Press ENTER. ⁽⁰⁻³⁾

Note: If you respond to sequence number 031 with a 1, 2, or 3, sequence number 032 is displayed. If you have been given specific RPO parameter instructions, follow those instructions. If not, press ENTER.

10. The entire 999 sequence number layout should now be displayed on the screen. Move the cursor to the 0 after sequence number 900, and change the 0 to a 1. Press ENTER.
11. If, in the sequence numbers displayed in step 10, your response to sequence number 116 was 0, go to step 18.
If your response to sequence number 116 was 1, sequence number 117 is displayed.
12. Move the cursor to the 0 after the 906 (bottom right of screen), change the 0 to a 1, and press ENTER.
Sequence number 118 is displayed.
13. Move the cursor to the 0 after the 907 (bottom right of screen), change the 0 to a 1, and press ENTER.
14. If, in the sequence numbers displayed in step 10, your response to sequence number 127 was zero, go to step 18.
If your response to sequence number 127 was nonzero, sequence number 128 is displayed.

15. Move the cursor to the 0 after the 904 (bottom right of screen), change the 0 to a 1, and press ENTER.
16. If, in the sequence numbers displayed in step 10, your response to sequence number 331 was 0 or 1, go to step 18.

If your response to sequence number 331 was 2, sequence number 332 (a panel) is displayed.
17. Move the cursor to the 0 after 908 (bottom right of screen). Change the 0 to a 1 and press ENTER.
18. Within 2 minutes, the 8 4 2 1 indicator code on the 3274 Control Unit should be flashing one of the following:
 - 1100— Replace the feature diskette with the *RPO* diskette. *Do not press the IML pushbutton.* (If you do press the IML pushbutton, go back to step 3.) After the RPO diskette is inserted, the code will change to 0111 within 30 seconds. If additional RPO diskettes are required or if you inserted a diskette that is not an RPO diskette, the indicator code will again flash 1100. Repeat the procedure for each additional RPO diskette. *At no time should you press the IML pushbutton.* When the RPO diskette procedure is completed, the indicator code should be flashing 1110. Reinsert the *feature* diskette. *Do not press the IML pushbutton.* Within 2 minutes, the 8 4 2 1 indicator code will flash 1011 or 1101. Follow the instructions associated with the code.
 - 1011— Replace the feature diskette with the *backup system* diskette. *Do not press the IML pushbutton.* (If you do, go back to step 3.) Within 1 minute, the indicator code will change to a 1000 and remain this way for approximately 15 minutes. Then the indicator code will change to 1111 (all lights on), indicating backup system diskette generation is successfully completed. If errors occur during this 15-minute period, a flashing 8 4 2 1 indicator code will appear. Figures 5-5 and 5-6 may help you locate the cause.
 - 1101— Replace the feature diskette with the *language* diskette. *Do not press the IML pushbutton.* (If you do press the IML pushbutton, go back to step 3.) Within 30 seconds, the indicator code will change to 0111 and then to flashing 1011 within 1 minute. When the indicator code is flashing 1011, replace the language diskette with the *backup system* diskette. *Do not press the IML pushbutton.* Within 1 minute, the indicator code will change to a 1000 and remain this way for approximately 15 minutes. Then the indicator code will change to 1111 (all lights on), indicating backup system diskette generation is successfully completed. If errors occur during this 15-minute period, a flashing 8 4 2 1 indicator code will appear. Figures 5-5 and 5-6 may help you locate the cause.

19. If you are using a 3299 Terminal Multiplexer:

- a. Attach the cable leading to the 3299 to the 0-7 port adapter on the 3274.
- b. Put the port adapter switch on the 3274 in the 3299 position (down) (factory-installed port adapter), or remove the shorting cap (field-installed port adapter). (See diagram on the port adapter panel.)

The newly created *backup* system diskette can now be used as well as the existing *customized* system diskette.

Be sure the 3274 is attached to the appropriate communication facility. The backup system diskette can now be used to initiate an IML of the 3274. During IML, errors may occur because of improper backup diskette creation. The 8 4 2 1 indicator codes caused by these errors are shown in Figure 5-7.

Review this entire form before starting the procedure to create a backup load diskette. Unit operating procedures are described in the *IBM 3274 Operator's Reference and Problem Determination Guide, GA27-2850*.

This procedure duplicates the existing load diskette. *If you do not get the expected result in any step, start over at step 1. If you still do not get the expected result, report the problem.*

There are four indicators, labeled 8 4 2 1, on the 3274 control panel. The meanings of the 8 4 2 1 indicator codes are shown in Figures 5-5 and 5-6. If an error occurs during this procedure, the 8 4 2 1 indicator code may help you locate the cause. Within this form, an On indicator is called a 1, an Off indicator a 0 (zero).

Example: 8 4 2 1
* * 0 * = 1101

3274 Control Panel

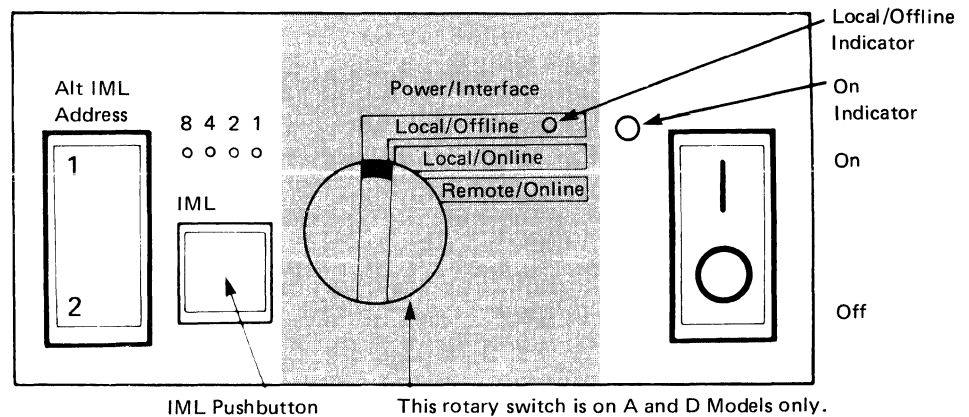

1. Obtain:

System diskette used to initially customize the load diskette (diskette to be duplicated)

Backup load diskette (diskette to be customized)

2. Ensure that the 3274 Control Unit has power switched on.

Note: When customizing a 3274 Model A or D, do not set the On/Off switch to the Off position unless the rotary switch on the control panel is in the Local/Offline position and the Local/Offline indicator is lit. The Power/Interface switch must be in the Local/Offline position and the Local/Offline indicator must be on.

3. Insert the *system* diskette (see Figure 5-3) and, holding the Alt IML Address switch in position 1, press and release the IML pushbutton; then release the Alt IML Address switch. Within 1 minute, the 8 4 2 1 indicator code will be flashing 0011.
4. Insert the *load* diskette. *Do not press IML.* Within 1 minute, the indicator code will change to a 1000 and remain this way for approximately 15 minutes. Then the indicator code will change to a solid 1111, indicating that backup load diskette generation has been successfully completed. If errors occur during this 15-minute period, a flashing 8 4 2 1 indicator code will appear. Figures 5-5 and 5-6 may help you locate the cause.

The newly created *backup* load diskette may now be used as well as the existing *customized* load diskette.

Be sure the 3274 is attached to the appropriate communication facility. The backup load diskette can now be used to initiate an IML of the 3274 Control Unit. During IML, errors may occur because of improper backup diskette creation. The 8 4 2 1 indicator codes caused by these errors are shown in Figure 5-7.

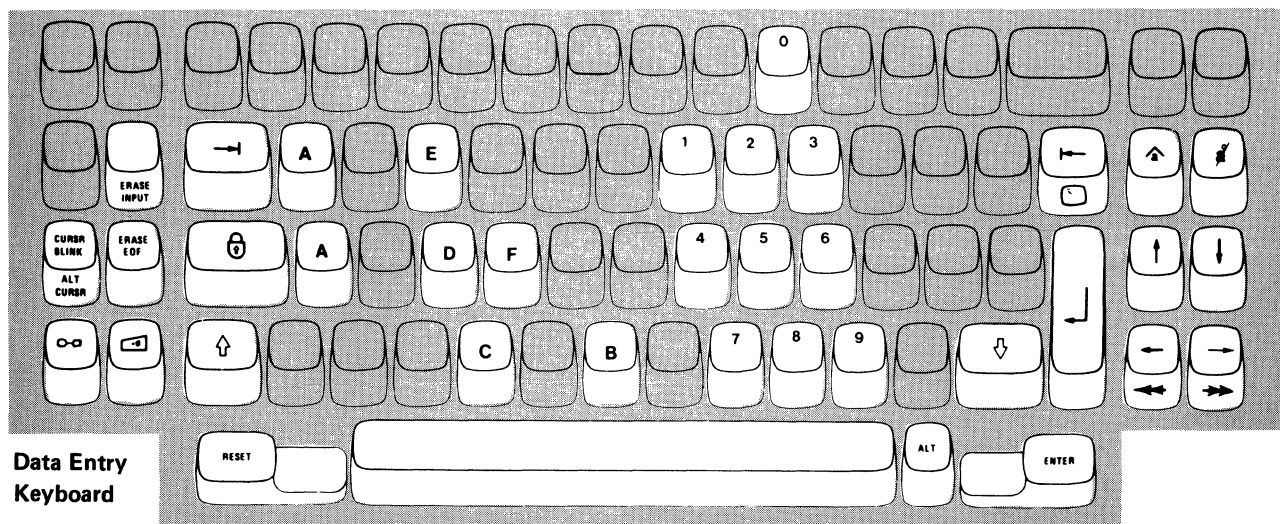
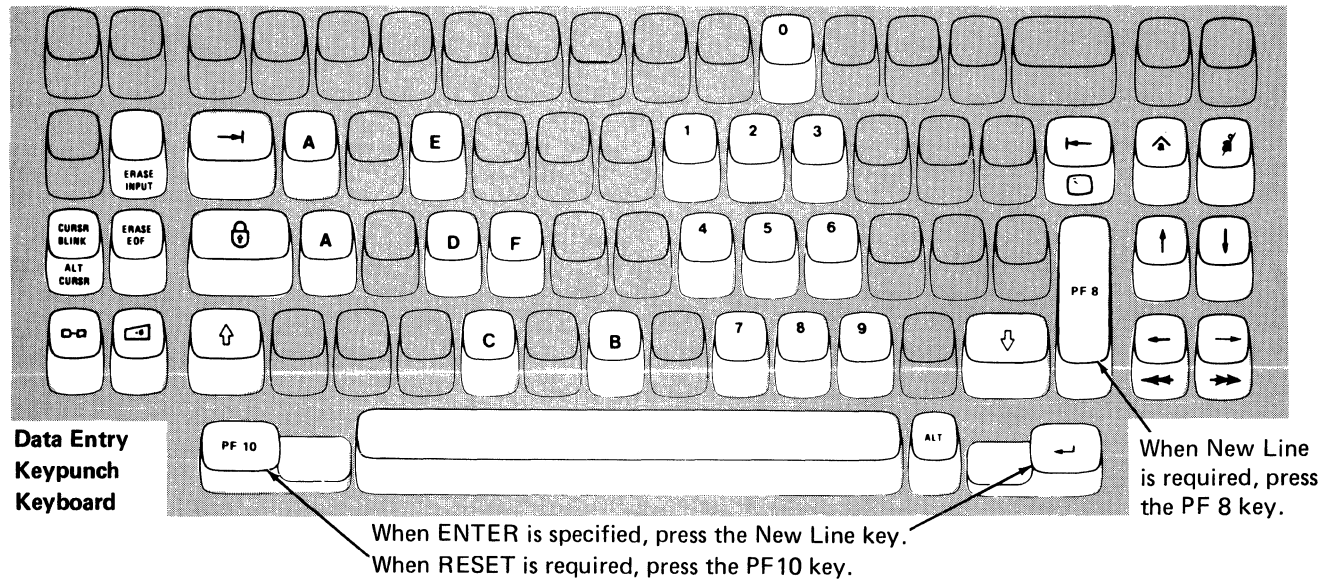
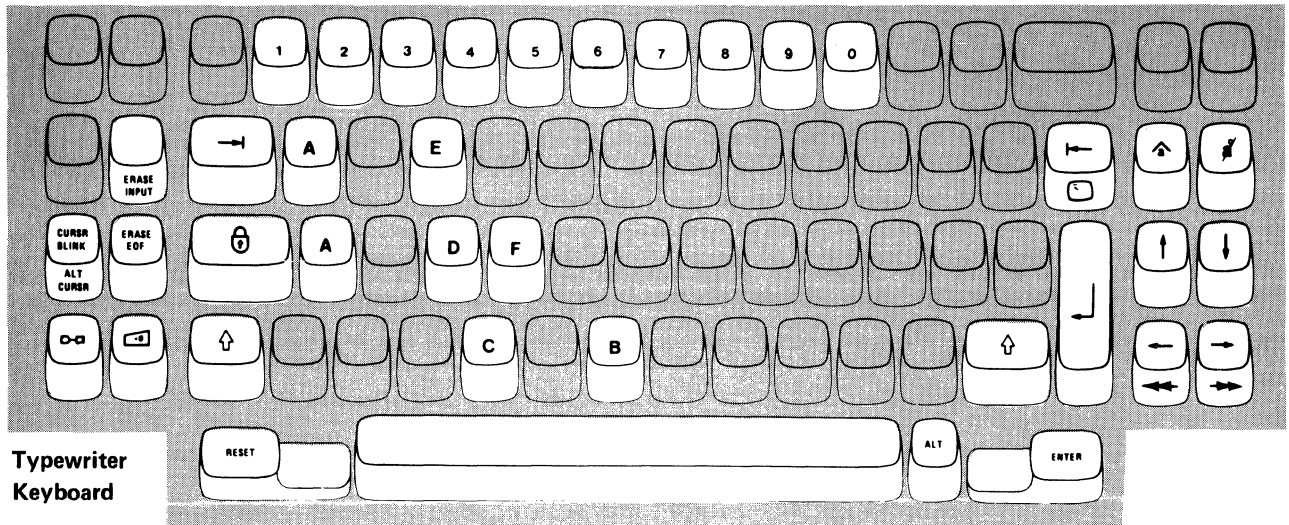

Note: During backup system diskette generation, only certain key positions are valid. Use only those key positions shown above.

Figure 5-1. Valid Key Positions during Backup Diskette Generation

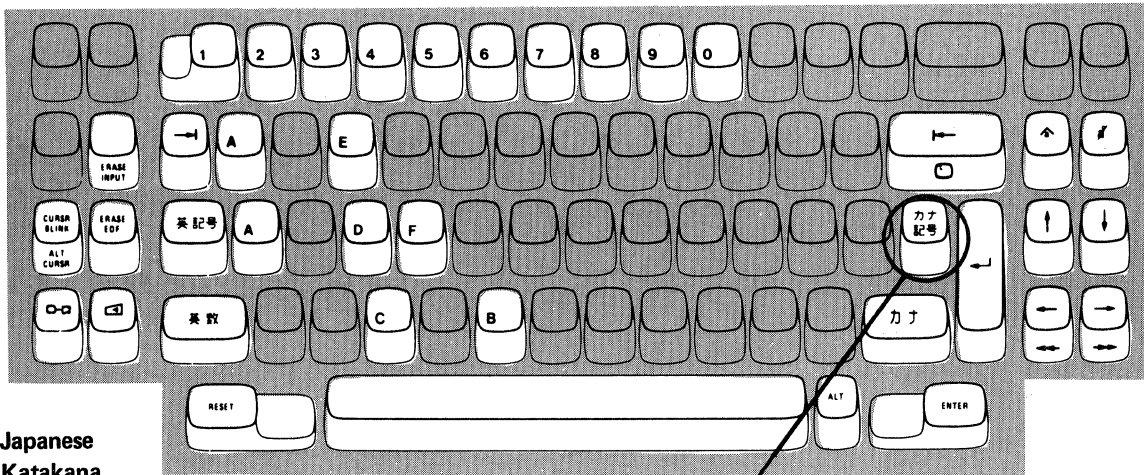

Japanese
Katakana
Typewriter
Keyboard

Press this key when sequence number 001 appears in the upper-left corner of the screen.

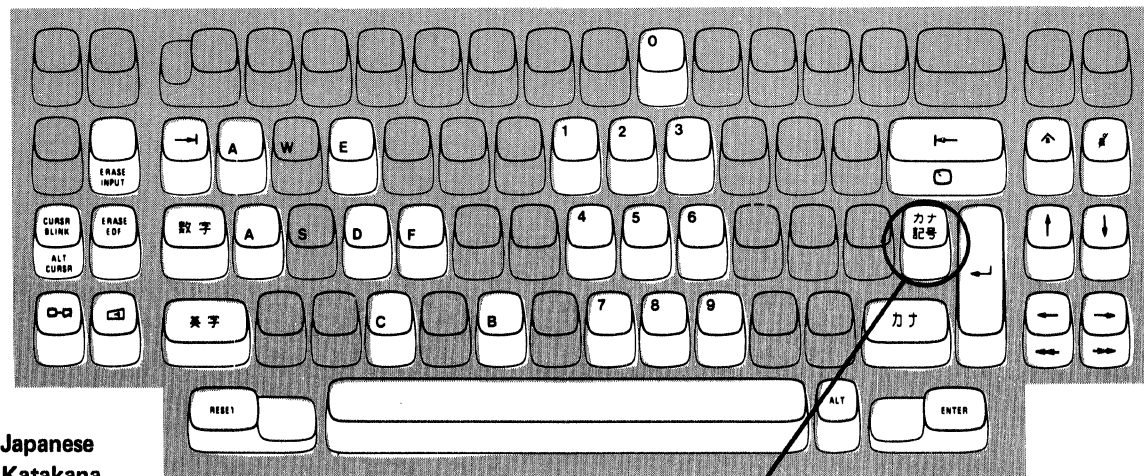

Japanese
Katakana
Data Entry
Keyboard

Press this key when sequence number 001 appears in the upper-left corner of the screen.

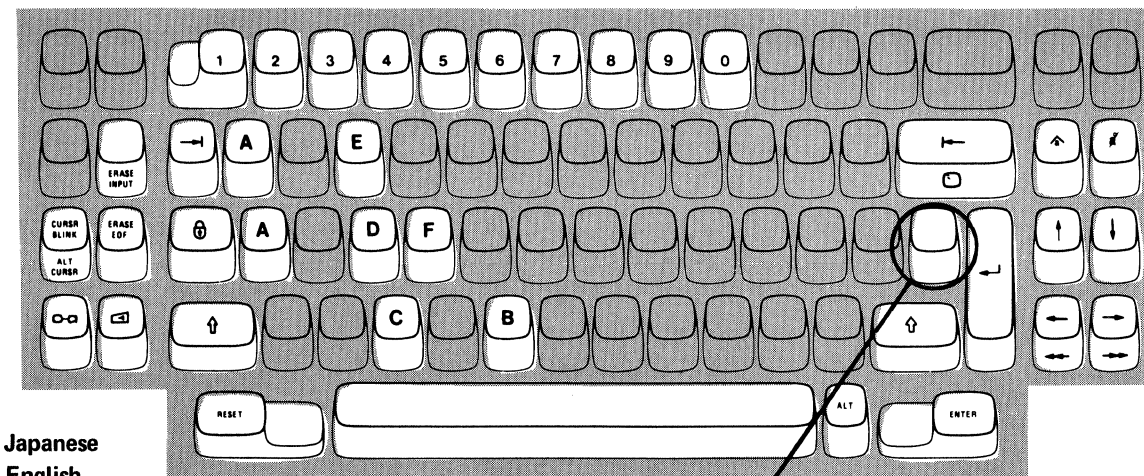

Japanese
English
Typewriter
Keyboard

Press this key when sequence number 001 appears in the upper-left corner of the screen.

Note: These drawings show the valid keys for both the 76- and 88-key keyboards. The PF keys on the right side of the 88-key keyboards are not valid during this procedure and therefore not shown.

Figure 5-2. Valid Key Positions during Backup Diskette Generation When Japanese Katakana and Japanese English Keyboards Are Used

3274 Diskette Insertion Procedure (Models 31A, 31C, and 31D)

1. Open the customer access door, and locate the diskette reader enclosure.

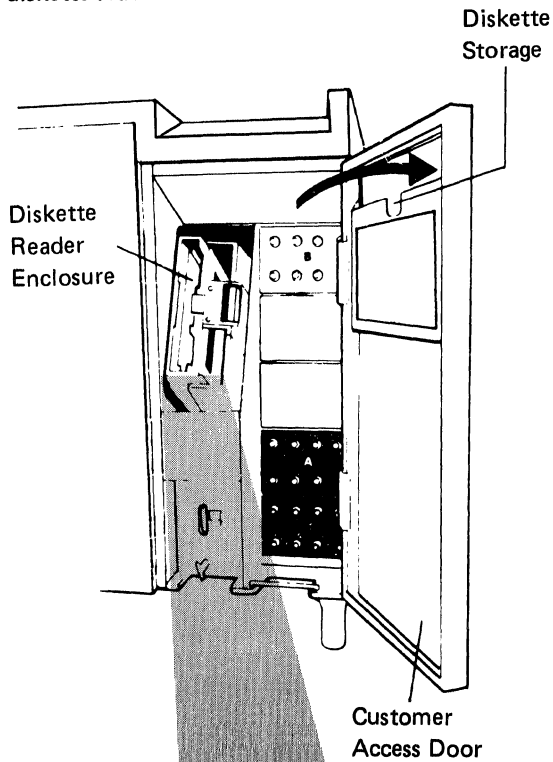

3. Remove the diskette to be used with the 3274 from its gray protective envelope, and insert the diskette squarely into the enclosure. Note that the diskette label position is to the right.

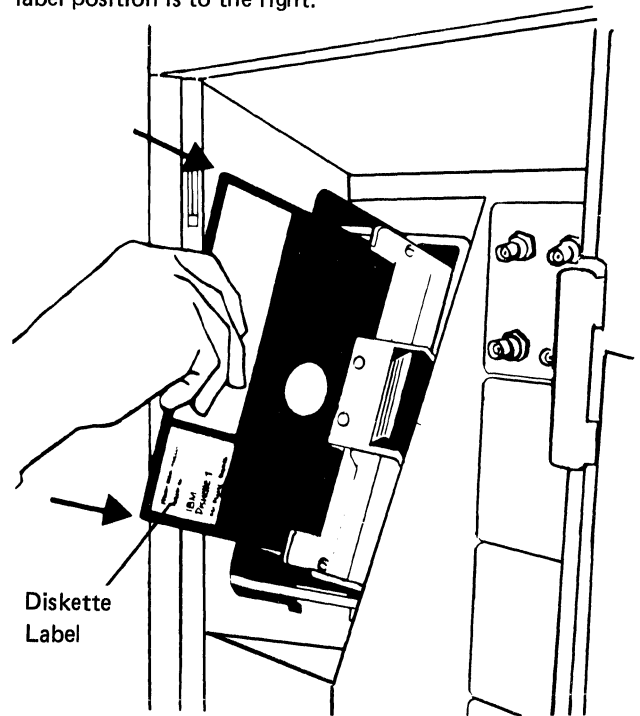

2. Open the diskette reader enclosure door by pressing the latch to the right.

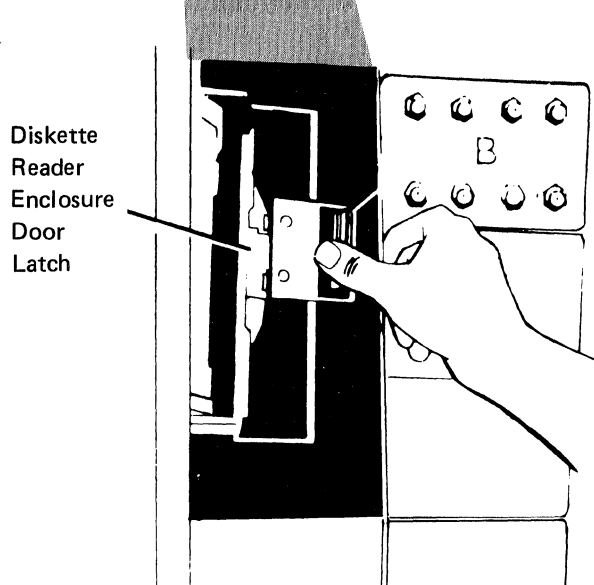

4. Close the diskette reader enclosure door by pushing the door to the left until it latches (clicks).

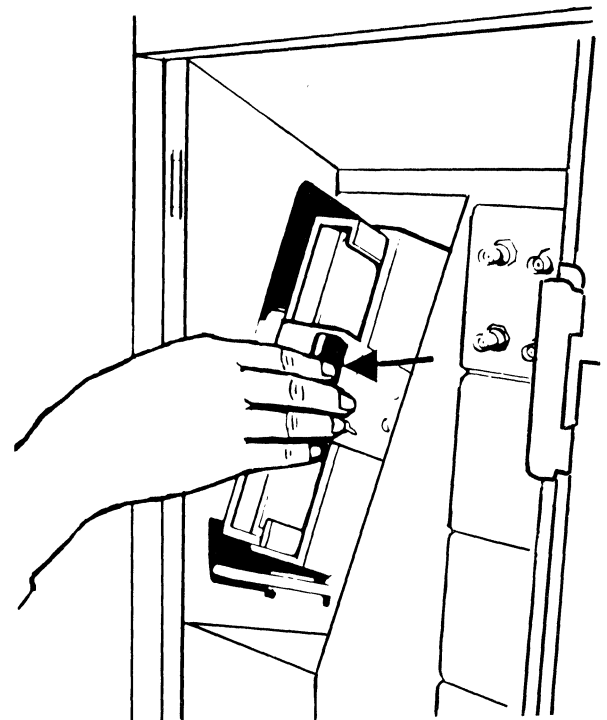
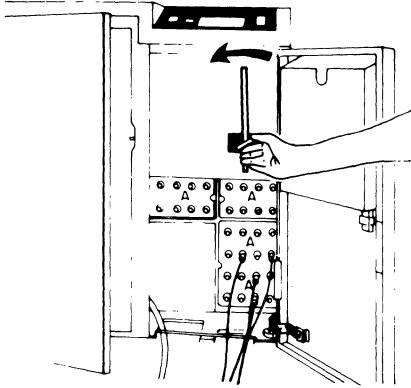

Figure 5-3 (Part 1 of 3). Inserting a Diskette into the 3274 Control Unit during Backup Diskette Generation

3274 Diskette Insertion Procedure (Models 41A, 41C, and 41D)

1. Open the diskette reader enclosure by turning the operator lever counterclockwise to the vertical position.



3. Close the diskette reader enclosure by turning the operator lever clockwise to the horizontal position.

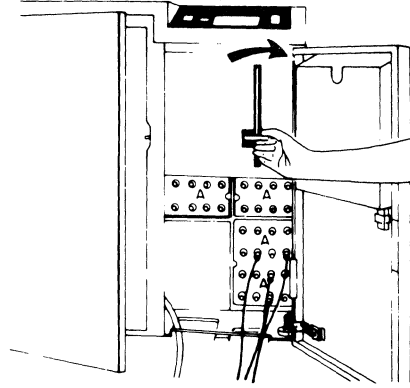

2. Remove one of the diskettes shipped with the 3274 from its gray protective envelope, and insert it squarely into the enclosure, with the label facing left (as shown below).

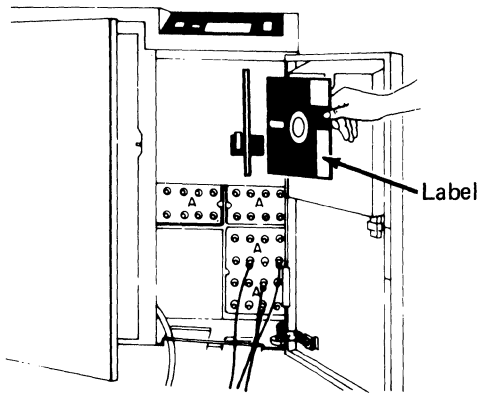

4. Close the customer access door.

Figure 5-3 (Part 2 of 3). Inserting a Diskette into the 3274 Control Unit during Backup Diskette Generation

3274 Diskette Insertion Procedure (Models 51C and 61C)

1. Open the diskette reader by turning the operator lever to the vertical position.

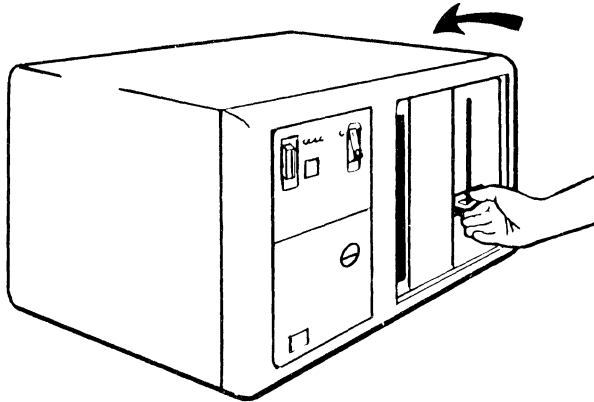

2. Remove the diskette to be used with the 3274 from its gray protective envelope, and insert the diskette squarely into the enclosure. Note that the diskette label position is on your left.

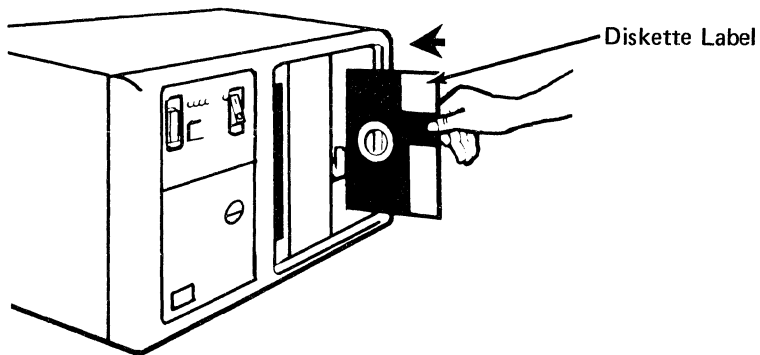

Close the diskette reader by turning the operator lever to the horizontal position.

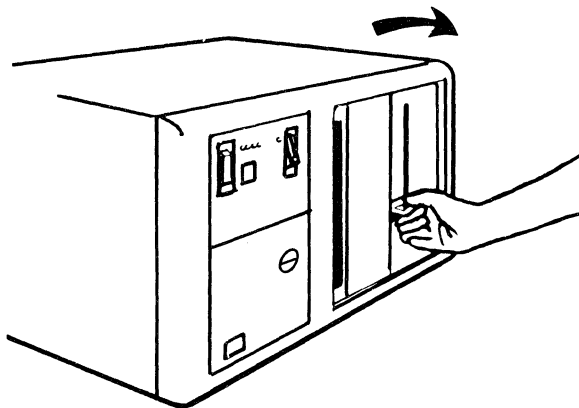

Figure 5-3 (Part 3 of 3). Inserting a Diskette into the 3274 Control Unit during Backup Diskette Generation

Code	Meaning	Action
01	One or more of the first 10 characters are incorrect.	Enter the correct response.
02	One or more of the 11th to 17th characters, including the space, are incorrect.	Enter the correct response.
03	1. One of the last two characters you entered in response to sequence number 001 is incorrect, or 2. The diskette release level is not the same as the documentation level.	1. Enter the correct response. 2. Restart after matching diskette and documentation levels.
11 ¹	You entered an invalid response (too many characters, value too high or too low, wrong character, etc.).	Enter the correct response.
12	You entered an incorrect 3274 model designation in response to sequence number 151.	Enter the correct response.
13 ¹	Your response has not enough characters.	Enter the correct response.
14 ¹	The numeric total of the responses you entered for sequence numbers 111 (Number of Category B Terminals) and 112 (Number of Category A Terminals) is greater than 32 (Models 31 and 41), 12 (Model 51C), or 16 (Model 61C).	Enter the correct responses.
19	You cannot answer 901=2 during an initial customization or if any patches are being made during this session.	Answer 1 to sequence number 901.
21 ¹	You made an unacceptable change during the modify sequence (number 999).	Recheck the entries, and correct them.
22	In 121 you specified a language (121=02 (ASCII)) that is not compatible with the A or D control unit model specified in 151.	Verify and enter the correct response.
23	One or more of your responses are not compatible with the response to sequence number 331 (BSC, SDLC, or X.25).	Verify and enter the correct responses.
25	You have less storage than indicated in your response to sequence number 113.	Verify and enter the correct response.
26	You do not have enough storage to support all the features you have selected.	Report the problem and verify that the storage specified in response to sequence number 113 is correct.
27 ¹	1. You specified the Portuguese (Alternate) language (121=18). This is not allowed with your configuration. 2. You specified Extended Data Stream (160=1) and a language that is not allowed with the Extended Data Stream (121=02, 08, 10, 13, 20, 26, or 27). 3. You specified a language that is not allowed with a distributed function terminal (121=02, 06, 08, 09, 10, 12, 13, 20, 26, or 27). 4. Entry Assist has been specified (sequence number 115=1) with a language that does not support Entry Assist (sequence number 121=02, 06, 08, 10, 11, 12, 13, 17, 20, 26, or 27). 5. You specified a language (121=02, 05, 06, 08, 10, 11, 12, 13, 14, 16, 20, 25, 26, or 27) that is not allowed with the keyboards (typewriter or APL) selected in sequence number 136. 6. You specified a language (121=02 through 16, 19, 20, 22 through 28, 30, 31, or 32) that is not allowed with the data entry keyboard selected in sequence number 136. 7. You specified a language (121=02, 05, 06, 08, 10, 11, 12, 13, 14, 16, 17, 20, 25, 26, or 27) that is not allowed with modified keyboards (sequence number 137).	1. Specify Portuguese (121=28). 2-7. Verify and enter the correct response.
28 ¹	Your responses to sequence numbers 113 (Extended Function Store) and 151 (3274 Model Designation) are incompatible.	Verify and enter the correct response.
33 ¹	Zero has been specified in sequence number 170, but you specified nonzero responses to sequence number 139, 173, 175, or 176.	Specify either 1 to sequence number 170 or 0's to sequence numbers 139, 173, 175, and 176.
34 ¹	You specified a Category B device in response to sequence number 111, but you specified a distributed function terminal in sequence number 170. Category B devices are not allowed with distributed function terminals.	Verify and enter the correct responses.

Figure 5-4 (Part 1 of 4). Operator Codes during Backup-Diskette Generation

Code	Meaning	Action																																													
35 ¹	<p>Your responses to sequence numbers 151, 331, and 343 are incompatible. Compatible responses are:</p> <table border="1"> <thead> <tr> <th></th> <th colspan="2">Sequence Number</th> </tr> <tr> <th>331</th> <th>151</th> <th>343</th> </tr> </thead> <tbody> <tr> <td>0, 1, or 2</td> <td>31C, 41C, 51C, 61C</td> <td>00</td> </tr> <tr> <td>0, 1, or 2</td> <td>31C, 41C, 51C, 61C</td> <td>01</td> </tr> <tr> <td>1</td> <td>31C, 41C, 51C, 61C</td> <td>02</td> </tr> <tr> <td>1</td> <td>51C, 61C</td> <td>03</td> </tr> <tr> <td>2</td> <td>31C, 41C, 51C, 61C</td> <td>03</td> </tr> <tr> <td>1</td> <td>51C, 61C</td> <td>04</td> </tr> <tr> <td>0 or 1</td> <td>51C</td> <td>05</td> </tr> <tr> <td>1</td> <td>51C</td> <td>06</td> </tr> <tr> <td>1</td> <td>51C</td> <td>07</td> </tr> <tr> <td>0 or 1</td> <td>51C</td> <td>08</td> </tr> <tr> <td>0 or 1</td> <td>51C</td> <td>09</td> </tr> <tr> <td>1</td> <td>51C, 61C</td> <td>10</td> </tr> <tr> <td>0 or 1</td> <td>31C, 51C</td> <td>11</td> </tr> </tbody> </table>		Sequence Number		331	151	343	0, 1, or 2	31C, 41C, 51C, 61C	00	0, 1, or 2	31C, 41C, 51C, 61C	01	1	31C, 41C, 51C, 61C	02	1	51C, 61C	03	2	31C, 41C, 51C, 61C	03	1	51C, 61C	04	0 or 1	51C	05	1	51C	06	1	51C	07	0 or 1	51C	08	0 or 1	51C	09	1	51C, 61C	10	0 or 1	31C, 51C	11	Verify and enter the correct responses.
	Sequence Number																																														
331	151	343																																													
0, 1, or 2	31C, 41C, 51C, 61C	00																																													
0, 1, or 2	31C, 41C, 51C, 61C	01																																													
1	31C, 41C, 51C, 61C	02																																													
1	51C, 61C	03																																													
2	31C, 41C, 51C, 61C	03																																													
1	51C, 61C	04																																													
0 or 1	51C	05																																													
1	51C	06																																													
1	51C	07																																													
0 or 1	51C	08																																													
0 or 1	51C	09																																													
1	51C, 61C	10																																													
0 or 1	31C, 51C	11																																													
36 ¹	You have specified a nonzero response for sequence number 139, but a zero response for sequence number 170. 170 must be a 1 for 139 to be nonzero.	Verify the responses to sequence numbers 139 and 170; then enter the correct response(s).																																													
37 ¹	<ol style="list-style-type: none"> You specified Decompression (165=1), but did not specify EDS (160=1). You specified Attribute Select Keyboard (166=B or C), but did not specify EDS (160=1). You specified that you are using an IBM 3270 Personal Computer Attachment (114=1), but did not specify EDS (160=1). 	<ol style="list-style-type: none"> Verify and enter the correct responses. Verify and enter the correct responses. Verify and enter the correct response. 																																													
38 ¹	<ol style="list-style-type: none"> When 136 is 0, 138 must also be 0. Sequence number 136 must be configured for at least one keyboard for a keypad to be selected in 138. The numeric total of keyboards selected in sequence numbers 136 and 137 is greater than four. 	<ol style="list-style-type: none"> Verify the responses to 136 and 138, then enter the correct responses. Check which keyboards are needed and select no more than four total. 																																													
41 ²	The X.25 network type (400) is invalid.	Check the network type values and enter a valid response to 400.																																													
42 ²	The incoming call options (420) response included "Validate Host DTE Address," but the address was not entered in response to 410.	Either respond to 410 with the host address or do not include "Validate Host DTE Address" in response to 420.																																													
43 ²	<ol style="list-style-type: none"> The circuit type (401) chosen requires a host address (410). The outgoing call options chosen included "Validate 3274 DTE Address," but the address was not entered in response to 411. The response to 421 was invalid. 	<ol style="list-style-type: none"> Either change the response to 401 or provide a host DTE address (410). Either respond to 411 with 3274 address or do not include "Validate 3274 DTE Address" in response to 421. Check 421 and enter a valid response. 																																													
44 ²	Negotiated window size (432) or nonstandard window size (435) conflicts with packet sequence numbering (431).	If 431 equals 0, then 432/435 must equal 01–07 (two digits). If 431 equals 1, then 432/435 must equal 01–11 (two digits).																																													
45 ²	The circuit type (401) is invalid.	Check the circuit type values and correct the response.																																													
46 ²	An invalid X.25 keyboard support (443) was selected.	Check the X.25 keyboard support and correct the response.																																													

Figure 5-4 (Part 2 of 4). Operator Codes during Backup-Diskette Generation

Code	Meaning	Action
47 ²	No CID password was initialized (452), but a CID is required for call options (420 and/or 421).	Either change the call options to remove the CID requirement or enter the CID password (452).
50 ³	<ol style="list-style-type: none"> (CS-D/Releases 60–63) Your response to sequence number 112 is incompatible with your response to sequence number 116. When 112 is nonzero, 116 must be zero; when 112 is zero, 116 must be nonzero. (CSD-D/Release 64) Your response to sequence number 111 (111=nonzero) is incompatible with your response to sequence number 116 (116=2). When 116 is 2, 111 must be zero. (CS-D/Release 64) Your response to sequence number 112 is incompatible with your response to sequence number 116. When 112 is nonzero, 116 must be zero; when 112 is zero, 116 must be nonzero. 	<ol style="list-style-type: none"> If you are <i>not</i> controlling port addressing, make a nonzero response to 112. If you are controlling port addressing, respond to 112 with a zero, and to 116 with a 1. Make your response to 111 a zero. If you are <i>not</i> controlling port addressing, make a nonzero response to 112. If you are controlling port addressing, make the response to 112 a 0, and the response to 116 a 1 or a 2.
51 ³	<p>You are trying to use a port that is not available.</p> <p>Model 41X or 31X The highest Category A port specified plus the number of Category B devices specified (sequence number 111) exceeds the number of allowed devices.</p> <p>Model 51C - You may use ports A00 through A07 only.</p> <p>Model 61C - You may use ports A00 through A15 only.</p>	<p>Change the responses to sequence number 117 so that they are compatible with the model you are using.</p> <p>or</p> <p>Change the 0 after 906 to an A, and press ENTER. Enter the proper response to sequence number 111 or 151.</p>
52 ³	<p>You have assigned too many addresses to a port.</p> <p>If sequence number 170 equals 0, you can assign 0 or 1 addresses only.</p> <p>If sequence number 170 equals 1, you can assign 0 through 5 addresses.</p>	Change the 0 after 906 to an A, and press ENTER. Verify your response to sequence number 170, and correct your port assignments.
53 ³	<p>You have assigned more than the number of system addresses allowed.</p> <p>For SNA protocol, you are allowed a total of 128 addresses.</p> <p>For non-SNA protocol, you are allowed a total of 32 addresses.</p>	Recalculate your port assignments to that they fall within the limits set, and then correct your port assignments. The LT=nnn field in sequence numbers 117 and 118 indicates the total number of addresses currently specified (in decimal).
54 ³	You have not assigned an address to port A00.	Assign an address to port A00.
55 ³	You have left a blank between assigned addresses on some port. Address assignments must be contiguous, for example, P, S1, S2, . . .	Shift the assigned addresses or fill in the blank.
56 ³	Either an out-of-range or a nondecimal address was specified. Valid ranges are 2 to 129 for SNA, 0 to 31 for non-SNA.	Correct the address(es) in error.
57 ³	You have assigned duplicate addresses.	Correct the address assignments in error.

Figure 5-4 (Part 3 of 4). Operator Codes during Backup-Diskette Generation

60 ⁴	Both response fields for sequence number 127 must be either zero or nonzero.	Enter a zero or nonzero response in both fields.
61 ⁴	Your first digit response to sequence number 127 was a 3, 4, or 5 and system communication is non-SNA, and/or your second digit response to sequence number 127 was 3 and system communication is non-SNA. This is not allowed.	Verify and enter the correct response.
62 ⁴	An invalid time boundary is specified in sequence number 128. The maximum time allowed is 27:18.3. The seconds field must not exceed 59.	Enter time values in the permitted range.
63 ⁴	Field B1 in sequence number 128 cannot be specified as 00:00.0.	Verify and enter the correct response.
64 ⁴	Entries for fields B1 through B4 in sequence number 128 are not in ascending order.	Verify and enter the correct response.
65 ⁴	A time boundary value of 00:00.0 is embedded between two nonzero values in sequence number 128. This is not allowed.	Enter an appropriate nonzero value.
66 ⁴	A nonzero boundary value follows a maximum boundary value (27:18.3) in sequence number 128. Only a zero boundary value (00:00.0) can follow the maximum.	Correct your boundary value sequence.
99	Your entries are acceptable, but the entry for sequence number 900, 901, 904, 906, 907, or 908 has not been changed to a 1.	Change the 900, 901, 904, 906, 907, or 908 entry to a 1.

¹ If any entry is unacceptable, the entry for sequence number 900 is changed back to 0 (zero), and the unacceptable value is intensified.

² If any entry is unacceptable, the entry for sequence number 908 is changed back to 0 (zero), and the unacceptable value is intensified.

³ If any entry is unacceptable, the entry for sequence number 906 is changed back to 0 (zero), and the unacceptable value is intensified.

⁴ If any entry is unacceptable, the entry for sequence number 904 is changed back to 0 (zero), and the unacceptable value is intensified.

Figure 5-4 (Part 4 of 4). Operator Codes during Backup-Diskette Generation

Steady Code	Diskette Mounted	Meaning	Action
0001	Feature	Customizing being performed	None.
0010	Any (indication lasts for 3 minutes or more)	Diskette improperly inserted or an internal 3274 error	Insert diskette properly and retry.
0011	Feature	Customizing being performed	None.
0100	Feature	Patch, printer authorization matrix, or RPQ being performed	None.
0101	Feature	Configuration being performed	None.
0110	Feature	Modification being performed	None.
0111	Feature, language, or RPQ	Normal 3274 operation	None.
1000	System or load (customizing in process)	Normal 3274 operation	None.
1001	Any	Internal 3274 error	Retry. If the error recurs, follow your local procedure for problem recovery.
1010	Any	Internal 3274 error	Retry. If the error recurs, follow your local procedure for problem recovery.
1101	Any (customizing procedure in progress)	<ol style="list-style-type: none"> 1. IML pushbutton pressed while diskette is being changed, or 2. A bad or uncustomized system or load diskette is being used 	<ol style="list-style-type: none"> 1. Recustomize. Do not press the IML pushbutton unless instructed to do so. 2. Insert a good customized system or load diskette.
1111	System or load (IML not performed)	Customizing is completed	IML can be performed.

Figure 5-5. Steady 8 4 2 1 Indicator Codes during Backup-Diskette Generation Only

Flashing Code ¹	Diskette Mounted	Meaning	Action
0000 0011	System	Load diskette request	Insert load diskette.
0000 0101	Any	System or load diskette request	Insert system or load diskette (as appropriate).
0000 1010	System	A diskette read error occurred.	Retry. If the error recurs, follow your local procedure for problem recovery.
	Load	A diskette read error occurred.	Attempt to perform Load Diskette Backup Procedure. If this fails, recustomize using the feature and system diskettes. If the error recurs, follow your local procedure for problem recovery.
0000 1011	Any	System diskette request	Insert system diskette.
0000 1100	Any	RPQ diskette request	Insert RPQ diskette.
0000 1101	Any	Language diskette request	Insert language diskette.
0000 1110	Any	Feature diskette request	Insert feature diskette.
0100 0010	System or Load	Configuration on system or load diskette being used for update-diskette procedure is not compatible with this 3274.	Use a system or load diskette with a compatible configuration.
	Language	Language number (sequence number 121) does not match the language number used in the Keyboard Definition Utility pre-customizing procedure.	Make sure language number is the same as used in the Keyboard Definition Utility. Refer to GA23-0187.
1000 0001	System or Load	Uncustomized system diskette being used during update procedure.	Use customized system diskette.
	Language	The keyboard IDs specified in sequence number 137 are not defined on the diskette.	Use the <i>Keyboard Definition Utility</i> , GA23-0187, to define the required keyboard IDs.
1001 0110	Any	Wrong-level diskette being used	Use correct-level diskette.
1111 0001	Feature	On/Off switch or TEST key pressed instead of ENTER	Retry. If the error recurs, follow your local procedure for problem recovery.
	System	Internal 3274 error	Follow your local procedure for problem recovery.
1111 0010	Feature	3278 Model 2 or higher is not attached to port A0.	Attach 3278 Model 2, its equivalent, or higher to port A0. Retry customizing.
1111 0011	Feature	Insufficient storage in 3274. At least 192K required on 3274.	Follow your local procedure for problem recovery.
1111 0100	System	Internal 3274 error	Retry. If the error recurs, follow your local procedure for problem recovery.
1111 0101	System	Internal 3274 error	Retry. If the error recurs, follow your local procedure for problem recovery.
	Feature	On/Off switch of TEST key on the 3278 pressed instead of ENTER	
1111 0110	RPQ	Incompatible RPQs	Follow your local procedure for problem recovery.
	Feature	Internal 3274 error	
1111 0111	System	Internal 3274 error	Follow your local procedure for problem recovery.
1111 1000	System	Internal 3274 error	Follow your local procedure for problem recovery.
1111 1001	System, feature language, or RPQ	Internal 3274 error	Follow your local procedure for problem recovery.
1111 1010	System	Internal 3274 error	Follow your local procedure for problem recovery.
1111 1011	System	Internal 3274 error	Follow your local procedure for problem recovery.
1111 1100	Any	Diskette drive error or a bad diskette	Retry. If the error recurs, follow your local procedure for problem recovery.
1111 1101	System, feature, language or load	Diskette drive error or a bad diskette	Retry. If the error recurs, follow your local procedure for problem recovery.
1111 1110	System, feature, language or RPQ	Internal 3274 error	Retry. If the error recurs, follow your local procedure for problem recovery.

¹These codes will flash alternately as shown, for example, 0000, 1011, 0000, 1011.

Figure 5-6. Flashing 8 4 2 1 Indicator Codes during Backup-Diskette Generation Only

Steady Code	Flashing Code ¹	Diskette Mounted	Meaning	Action
—	0101 0000 ²	System or load	Internal 3274 error or wrong response to sequence number 113 during customizing procedure	Check response to sequence number 113, and retry. If the error recurs, follow your local procedure for problem recovery.
—	0110 0000 ²	System or load	Internal 3274 error or wrong response to sequence number 111, 112, 151, or 351 during customizing procedure	Check response to sequence number 111, 112, 151, or 351, and retry. If the error recurs, follow your local procedure for problem recovery.
—	0110 0001 ³	System or load	Address range switches inside Model D control unit set improperly	Check responses to sequence numbers 111, 112, 116, 117, and 118. If correct, have IBM CE check address range setting in control unit.
—	0111 0000 ²	System or load	1. Internal 3274 error, or 2. Wrong response to sequence number 311 or 343, or 3. The 3274 is not connected to the communication facility	1 and 2. Check responses to sequence numbers 311 and 343, and retry. 3. Connect the 3274 to the communication facility. If the error recurs, follow your local procedure for problem recovery.
—	1000 0000	System or load	Internal 3274 error or wrong response to sequence number 111 during customizing procedure	Check response to sequence number 111, and retry. If the error recurs, follow your local procedure for problem recovery.
—	1001 0000	System or load	Internal 3274 error or wrong response to sequence number 352 during customizing procedure	Check response to sequence number 352, and retry. If the error recurs, follow your local procedure for problem recovery.
—	1001 1010	System or load	Internal 3274 error or wrong response to sequence number 151 during customizing procedure	Check response to sequence number 151, and retry. If the error recurs, follow your local procedure for problem recovery.
—	1001 1110	System or load	Insufficient storage	Follow your local procedure for problem recovery.
—	1011 0000	System or load	Internal 3274 error or wrong response to sequence number 127 during customizing procedure	Check response to sequence number 127, and retry. If the error recurs, follow your local procedure for problem recovery.
1101	—	System or load	Uncustomized system diskette	Insert customized system diskette.
1110	—	System or load	Insufficient storage	Check response to sequence number 113, and retry. If the error recurs, follow your local procedure for problem recovery.

Note: These indicators may be caused by something other than incorrect customizing. Further aids can be found in the *IBM 3270 Information Display System: 3274 Control Unit Problem Determination Guide*, GA27-2850.

¹These codes will flash alternately as shown, for example, 0101, 0000, 0101, 0000, and so on.

²These codes may blink for 5 seconds, followed by a different steady code for 3 seconds.

³Models 31D and 41D only. These codes will alternate continuously as follows: left code blinks for 5 seconds, then right code is on steady for 3 seconds.

⁴Address range switches inside the 3274 D models are set to multiples of 4. When a distributed function terminal is attached and the Multiple Interactive Screen function is being used, the address range switches are set as follows:

- If the highest logical device address is a multiple of 4, the address range switches must be set to equal the device address; for example, 16, 20, or 28.
- If the highest logical device address is not a multiple of 4, the address range switches must be set to the next higher multiple of 4. For example, if the highest logical device address is 26, the address range switches must be set to 28.

Figure 5-7. 8 4 2 1 Indicator Codes during IML That May Result from Incorrect Backup-Diskette Generation

Chapter 6. Update-Diskette Installation Procedures

If you have requested and received an update-diskette package from IBM, follow the procedures in this chapter to update your customized IBM 3274 Control Units.

The update-diskette package is for use only on previously customized 3274 Control Units and should not be used prior to initial customizing. It is recommended that each update-diskette package be installed on your 3274 Control Units as soon as possible after the package is received.

RPQ Update-Diskette Installation

If your 3274 has not been customized and you have received a new RPQ diskette, follow the Initial Customizing Procedure in Chapter 3.

If your 3274 has been customized and you have received only a new RPQ diskette (no new feature, system, or load diskettes), use the Modification Procedure in Chapter 4 to install the new RPQ diskette.

If your update-diskette package includes new feature, system, or load diskettes in addition to a new RPQ diskette, use the appropriate procedure in this chapter for your configuration support to install the update-diskette package.

Language Update-Diskette Installation

Notes:

- 1. Do not install the new language diskette unless the release level number on the new language diskette is greater than or equal to the release level number on your current (old) language diskette.*
- 2. If you have 3179 or 3180 display stations with modified keyboards attached and you install a new language diskette, you must redefine the 3179 or 3180 keyboards, using the new language diskette, before performing either the update diskette procedure or the customizing procedure. (The keyboard definition procedure is described in Keyboard Definition Utility User's Guide, GA23-0187.)*

If your 3274 has not been customized and you have received a new language diskette, follow the Initial Customizing Procedure in Chapter 3.

If your 3274 has been customized and you have received only a new language diskette (no new feature, system, or load diskettes), use the Modification Procedure in Chapter 4 to install the new language diskette.

If your update-diskette package includes new feature, system, or load diskettes in addition to a new language diskette, use the appropriate procedure in this chapter for your configuration support to install the update-diskette procedure.

Feature, System, and Load Update-Diskette Installation

The following procedures describe how to update Configuration Support D customized IBM 3274 Control Units using:

- New feature and system diskettes (no load diskette)
- New feature and system diskettes and a new load diskette
- New feature and system diskettes and the current load diskette
- A new load diskette and the current system diskette.

The procedures incorporate maintenance enhancements and/or new function into a 3274 Control Unit that has been previously customized to operate under Configuration Support D. You should contact the person responsible for customizing your 3274 before you execute any of these procedures.

If an error occurs during a procedure, either a steady or a flashing error code will be displayed by the 8 4 2 1 indicators. Figures 6-1 and 6-2 contain the meaning of these error codes and the corrective action you should take.

Procedure for Updating with New Feature and New System Diskettes

Note: You may use this procedure with no load diskette, with a current load diskette, or with a new load diskette. For updating the 3274 Control Unit with a new load diskette, use the "Procedure for Updating with a New Load Diskette Only," the last procedure in this chapter.

Do not install this update unless (1) your 3274 is customized with Configuration Support D, and (2) the release number on the new diskettes is higher than the release number on your current diskettes.

1. Obtain the following:
 - Current system diskette (primary or backup), load diskette (primary or backup, if applicable), language diskette (if applicable), and RPQ diskette(s) (if applicable).
 - New system diskette
 - New feature diskette
 - New language diskette (if applicable)
 - New load diskette (if applicable)
 - All RPQ diskettes (if any) included in the update package. If a diskette is included for a new RPQ, place it with the other RPQ diskettes. If a new RPQ diskette is provided for an existing RPQ, substitute it for the current RPQ diskette.

2. Ensure that the 3274 Control Unit has power on.

Note: On channel-attached 3274 Control Units, the rotary switch on the operator panel must be in the Local/Offline position, and the Local/Offline indicator must be lit.

3. Insert the new feature diskette.
4. While holding the Alt IML Address switch in position 2, press and release the IML pushbutton and then release the Alt IML Address switch. Within 2 minutes, the 8 4 2 1 indicators will display a flashing 0101 code.
5. Replace the feature diskette with the current system diskette (or the current load diskette, if applicable). *Do not press the IML pushbutton.* (If you do press the IML pushbutton, go back to step 3.) In approximately 20 seconds, the 8 4 2 1 indicators will display a flashing 1110 code.
6. Replace the system diskette (or load diskette) with the new feature diskette.
7. The following 8 4 2 1 indicator status codes define the next actions to take. After a diskette is inserted, wait approximately 2 minutes for the machine to complete its operation before reading the 8 4 2 1 indicators and taking the next action.

0000 – 0011	Insert the load diskette, current or new as applicable.
0000 – 1011	Insert the new system diskette.
0000 – 1100	Insert the RPQ diskette, current or new as applicable. (If you have more than one RPQ diskette to be processed, repeat this step as required.)
0000 – 1101	Insert the language diskette, current or new as applicable.
0000 – 1110	Insert the new feature diskette.
1111	The update procedure is completed, and you may perform normal startup (IML).

Note: If a load diskette is used in your 3274 installation, it should be used for all subsequent IMLing of the 3274 and you should not use the system diskette.

Procedure for Updating with a New Load Diskette Only

1. Obtain the following:
 - Current system diskette (used to initially customize the current load diskette)
 - New load diskette.
2. Ensure that the 3274 Control Unit has power on.

Note: On channel-attached 3274s the rotary switch on the operator panel must be in the Local/Offline position and the Local/Offline indicator must be lit.

3. Insert the current system diskette.
4. While holding the Alt IML Address switch in position 1, press and release the IML pushbutton and then release the Alt IML Address switch. Within 1 minute, the 8 4 2 1 indicators will display a flashing 0011 code.
5. Replace the current system diskette with the new load diskette. *Do not press the IML pushbutton.* (If you do press the IML pushbutton, go back to step 3.)
6. Within 5 minutes, the 8 4 2 1 indicators will display a solid 1 1 1 1 code, indicating that the update procedure has been successfully completed.
7. To generate a backup load diskette, repeat the procedure.

Note: For all subsequent IMLing of the 3274 Control Unit, you should use the new load diskette, not the system diskette.

Steady Code	Meaning	Action
0010	The diskette is improperly inserted or an internal 3274 error has occurred.	Insert the diskette properly and retry.
1001	An internal 3274 error has occurred.	Retry. If the error recurs, follow your local procedure for problem recovery.
1010	An internal 3274 error has occurred.	Retry. If the error recurs, follow your local procedure for problem recovery.
1101	Either the IML pushbutton was pressed at the wrong time or an uncustomized or bad diskette is being used.	Contact the person responsible for customizing the 3274 to ensure that the proper diskette is being used. Then perform the procedure again, pressing the IML pushbutton only when told to do so.

Figure 6-1. Steady 8 4 2 1 Indicator Error Codes during Update-Diskette Procedure

Flashing Code	Meaning	Action
0000-1010	A diskette read error occurred.	Retry. If the error recurs, follow your local procedure for problem recovery.
0100-0010	The configuration support of the system diskette or load diskette is not compatible with this 3274.	Terminate this procedure and follow your local procedure for problem recovery.
1000-0001	The system diskette or load diskette is not customized.	Use the proper customized diskette and retry from step 3. If the retry is not successful, follow your local procedure for problem recovery.
1001-0110	Wrong diskette (system, feature, load, RPQ, or language diskette).	Insert the correct diskette.
1111-0001	Either the On/Off switch or TEST key was pressed instead of the ENTER key or an internal 3274 error occurred.	Retry. If the error recurs, follow your local procedure for problem recovery.
1111-0010	A 3278 Model 2, its equivalent, or higher must be attached to port A0.	After attaching the proper model, retry the procedure.
1111-0011	Insufficient storage in 3274.	Follow your local procedure for problem recovery.
1111-0100	An internal 3274 error occurred.	Retry. If the error recurs, follow your local procedure for problem recovery.
1111-0101	Either the On/Off switch or TEST key was pressed instead of the ENTER key or an internal 3274 error occurred.	Retry. If the error recurs, follow your local procedure for problem recovery.
1111-0111	An internal 3274 error occurred.	Follow your local procedure for problem recovery.
1111-1000	An internal 3274 error occurred.	Follow your local procedure for problem recovery.
1111-1001	An internal 3274 error occurred.	Follow your local procedure for problem recovery.
1111-1010	An internal 3274 error occurred.	Follow your local procedure for problem recovery.
1111-1011	An internal 3274 error occurred.	Follow your local procedure for problem recovery.
1111-1100	Either a diskette drive error occurred or a bad diskette is being used.	Retry. If the error recurs, follow your local procedure for problem recovery.
1111-1101	Either a diskette drive error occurred or a bad diskette is being used.	Retry. If the error recurs, follow your local procedure for problem recovery.
1111-1110	An internal 3274 error occurred.	Retry. If the error recurs, follow your local procedure for problem recovery.

Figure 6-2. Flashing 8 4 2 1 Indicator Error Codes during Update-Diskette Procedure

Appendix A. Printer Authorization Matrix

Description

The 3274 printer authorization matrix is required for local-copy operations. Local copy between Category A terminals can be either host-initiated or Print-key-initiated; local copy between Category B terminals must be host-initiated. Local-copy operations cannot be performed between Category A and Category B terminals.

The printer authorization matrix is used to:

- Establish printer mode. A printer may be reserved for the exclusive use of either the host or the local-copy function. A third mode allows a sharing between these two functions.
- Assign print *Classes*. A print *Class* is a way of grouping printers for use by local copy. A local-copy request directed to a class is then serviced by one of the printers assigned to that group.
- Define source device lists. The source device list specifies which displays may use any given printer for local copy. Note that all displays for a printer must be attached to the same adapter type as the printer. For example, a Category A printer can have only Category A displays in its source device list.

If a printer authorization matrix is not loaded, the default condition for the control unit and its terminals is that all printers are in system mode, and local-copy operations are not possible except with the BSC Copy command.

Printer Modes

A printer may be in one of three modes, specified in the printer authorization matrix as *local*, *system*, or *shared* mode. Each printer on the 3274 defaults to system mode until a matrix is loaded. Printers that are specified as being in shared or local mode then become available for local copy use.

Local Mode

A printer in local mode may be used for local-copy functions regardless of host attachment or communication protocol. This means that displays within the cluster may contend for the use of printers but the host may not. The printer is not available for direct print operations from the host.

A local-copy operation involves the transfer of data from the display buffer to the printer buffer and the subsequent printing of that data. A local copy may be initiated by an operator using the Print key on a display station attached to a 3274 or by the host when the display is operating in SNA/SDLC.

System Mode

A printer in system mode is entirely under host (system) control. This is the default mode each printer assumes when no matrix has been defined. The printer cannot be used for operator-initiated local-copy requests; nor is it available for host-initiated copy operations when using SNA/SDLC. When operating with BSC discipline, however, the printer may honor a BSC Copy command when it is in system mode. The BSC Copy command, directed to the *to* device, specifies the *from* device as a command parameter and does not use the printer authorization matrix.

Shared Mode

In shared mode, both host-directed printing operations and local-copy operations are permitted on the same printer. When in system mode, the printer is protected from local copies; in local mode, the printer is protected from host-initiated operations. In shared mode, however, the subsystem does not guarantee this kind of integrity. When using a printer in shared mode, the user must assume responsibility for the integrity of his printed data by "installation rules" and proper programming practices.

In SNA/SDLC, a printer designated as being in shared mode in the printer authorization matrix may be used for local copy under the following conditions:

- When the printer is not in session with a primary logical unit (PLU) in the host
- When Between Bracket Printer Sharing (sequence number 213) has been specified in the customizing procedure and the printer is not in bracket state with the PLU in the host.

Printer Class Structure

The printer authorization matrix permits the assignment of a printer to a class. By the selection of a class containing multiple printers, improved copy throughput can be obtained. The definition of a class of printers is made by the customer and may be based on type, character subset, type of forms mounted, location, and so forth. In a particular installation class, for example, 72 may have been defined as referring to all printers with yellow paper. Thus, an operator may select an authorized printer on the basis of this characteristic rather than by address.

The printer authorization matrix allows a maximum of 16 printer classes to be defined in each subsystem. A display operator may select a printer by class by using the IDENT key (ALT key pressed) and typing in a number ranging from 70 through 85 corresponding to one of 16 classes. In any configuration, a single printer may be in one class, several classes, or none. Several printers may be members of a single class.

Source Device Lists

Each printer may be restricted as to which displays it may accept local copies from. Any given printer may be permitted to process copies from some, all, or none of the displays on the control unit. When a local copy is directed to a print class, the printer selected will be one that is authorized to accept copies from the requesting display. Not all printers assigned to a particular class may be authorized for the same subset of display terminals.

Matrix Structure

The 3274 printer authorization matrix defines how display stations (source devices) can use printers (destination devices) attached to the same control unit for the purpose of accepting a local-copy request.

The printer authorization matrix is structured as a two-dimensional array, with each printer in the cluster represented by a printer port address with the following format:

Printer Port Address	Mode	Class	Source Device List
----------------------	------	-------	--------------------

Printer port address is the first field of the descriptor. A decimal address from 01 to 31 for all models except Models 51C and 61C (01 to 07 for Model 51C and 01 to 15 for Model 61C) allows all printers to be attached to any port on the control unit, except port 0.

Note: If you intend to control port selection and host address assignment (sequence number 117 [Port Assignment Specification Table]; see Appendix B), be sure that the printer port assigned here is selected and given a host address in sequence number 117.

Mode defines the printer to be in system, local, or shared mode, where:

0 = System

1 = Local

2 = Shared

Class permits the grouping of printers into classes. This field is bit-coded, one bit for every 16 classes, so that a single printer may be in more than one class. Valid classes are designated 70 through 85 inclusive. Coding a 1 under the appropriate class permits the printer to accept copies from display stations selected by that class.

Defining the Printer Authorization Matrix during Customizing

Figure A-2 shows how the printer authorization matrix is filled out to define the matrix shown in Figure A-1. In Sequence A, the port addresses are shown in numeric sequence; however, this is not a requirement. The entries may be entered as shown in Sequence B, that is, in no particular sequence and not in consecutive groups. The following description refers only to Sequence A. The example of a worksheet in Figure A-3 shows how the numeric entries of Figure A-2 are derived. To fill out the worksheet for the printer attached to port with address 02 (Figure A-1), AA = 02. This printer is to operate in local mode, so $m = 1$. These numbers will later be transferred to the Printer Authorization Matrix Form. Figure A-4 shows a sample printer authorization matrix worksheet for 3274 Models 31A, 31C, 31D, 41A, 41C, and 41D. Figure A-5 shows a sample printer authorization matrix worksheet for Models 51C and 61C. Note that when specifying a printer authorization matrix for Models 51C and 61C, although 31 possible entries are displayed, only seven can be specified.

The X and Y entries are completed in two steps. In step 1, the binary values of X and Y are entered on the worksheet for the class and the source device list, respectively. In step 2, the binary values are converted to hexadecimal notation. The hexadecimal notations are later transferred to the Printer Authorization Matrix Form.

To continue with Figure A-1, no class (70 through 85) is defined for the printer attached to port 02, so XXXX = hex 0000. The source device list in Figure A-1 indicates (by a 1) that the display terminal attached to port 0 can copy to this printer. Therefore, a 1 is entered in the 0 column of the first Y (Figure A-3). No other displays can copy to this printer, so 0's (zeros) are entered in all remaining columns under the Ys. The binary 1000 under the first Y on the worksheet is converted to hex 8. Because all other X and Y entries are binary 0's, all remaining hex entries are 0's.

Printer Authorization Matrix Form

In response to sequence number 022, enter the characters (below) supplied by the planner in the appropriate groups on your display screen. If a group is already displayed as AA M XXXX YYYY YYYY, your entry will overwrite these characters. To delete an entry, move the cursor to the leftmost position of the entry (the Printer Port Address) and press the spacebar twice. All deleted entries will be displayed as AA M XXXX YYYY YYYY after the ENTER key is pressed. After checking that all the entries in the matrix are correct, move the cursor to the 0 after the 901 at the bottom of the screen.

- Change the 0 to a 1 if the Printer Authorization Matrix is not the only update to the 3274 being made during this modification or if any RPO's are applied.
- Change the 0 to a 2 if this is a modification procedure and the Printer Authorization Matrix update is the only change being made.

Press ENTER. If unacceptable responses in the matrix are detected by the 3274, the 1 or 2 in the 901 field is automatically changed back to a 0, and the invalid entries are intensified. Correct the invalid entries, and again change the 901 response to a 1 or 2, and press ENTER.

If you responded to 901 with a 1 and all entries are valid, the printer authorization matrix display will be replaced by the next customizing sequence number. Return to your original instructions.

If you responded to 901 with a 2 and all entries are valid, the 3274 will clear the screen and go into printer authorization matrix writing mode. The indicators on the 3274 will flash a 0101. This means to insert a customized load or system diskette. This diskette can be at any release level and any configuration. 1000 is displayed on the indicators while the 3274 is writing the new printer authorization matrix onto the diskette and updating the configuration table. This takes about 8–10 seconds. When it is done, the indicators flash 0101 again. At this time you can copy the printer authorization matrix to another customized system or load diskette by inserting that diskette into the 3274. When you are finished writing the printer authorization matrix on the diskettes, remove the last diskette. The modification is finished, and the indicators are flashing 0101.

	Printer Port Address	Printer Mode	Printer Class Assignment	Source Device List
	A A	M	X X X X	Y Y Y Y Y Y Y Y
Sequence A	1) 0 2	1	0 0 0 0	8 0 0 0 0 0 0 0
	2) 0 3	2	4 0 0 0	4 8 0 0 0 0 0 0
	3) 0 6	1	4 0 0 0	4 8 C 0 0 0 0 0
	4) 0 7	0	0 0 0 0	0 0 0 0 0 0 0 0
	5) - -	-	- - - -	- - - - - - - -
	6) - -	-	- - - -	- - - - - - - -
Sequence B	7) - -	-	- - - -	- - - - - - - -
	8) 0 3	2	4 0 0 0	4 8 0 0 0 0 0 0
	9) - -	-	- - - -	- - - - - - - -
	10) 0 6	1	4 0 0 0	4 8 C 0 0 0 0 0
	11) - -	-	- - - -	- - - - - - - -
	12) - -	-	- - - -	- - - - - - - -
	13) 0 7	0	0 0 0 0	0 0 0 0 0 0 0 0
	14) 0 2	1	0 0 0 0	8 0 0 0 0 0 0 0

Figure A-2. Example of a Completed Printer Authorization Matrix Form

Printer Port Address	Mode	Class				Source Device List									
		X	X	X	X	Y	Y	Y	Y	Y	Y	Y	Y	Y	
Class Number		70 71 72 73	74 75 76 77	78 79 80 81	82 83 84 85	0 1 2 3	4 5 6 7	8 9 10 11	12 13 14 15	16 17 18 19	20 21 22 23	24 25 26 27	28 29 30 31		
A A	M	X	X	X	X	Y	Y	Y	Y	Y	Y	Y	Y		
02	1	0	0	0	0	8	0	0	0	0	0	0	0		
		0000	0000	0000	0000	1000	0000	0000	0000	0000	0000	0000	0000		
03	2	4	0	0	0	4	8	0	0	0	0	0	0		
		0100	0000	0000	0000	0100	1000	0000	0000	0000	0000	0000	0000		
06	1	4	0	0	0	4	8	C	0	0	0	0	0		
		0100	0000	0000	0000	0100	1000	1100	0000	0000	0000	0000	0000		
07	0	0	0	0	0	0	0	0	0	0	0	0	0		
		0000	0000	0000	0000	0000	0000	0000	0000	0000	0000	0000	0000		
--	-	-	-	-	-	-	-	-	-	-	-	-	-		
		-	-	-	-	-	-	-	-	-	-	-	-		

Port Number
Hexadecimal Notation
Binary Value

Figure A-3. Example of a Printer Authorization Matrix Worksheet (Models 31A, 31C, 31D, 41A, 41C, and 41D)

Printer Port Address	Mode	Class				Source Device List			
		X 70 71 72 73	X 74 75 76 77	X 78 79 80 81	X 82 83 84 85	Y 0 1 2 3	Y 4 5 6 7	Y 8 9 10 11	Y 12 13 14 15
--	-	-	-	-	-	-	-	-	-
--	-	-	-	-	-	-	-	-	-
--	-	-	-	-	-	-	-	-	-
--	-	-	-	-	-	-	-	-	-
--	-	-	-	-	-	-	-	-	-
--	-	-	-	-	-	-	-	-	-
--	-	-	-	-	-	-	-	-	-
--	-	-	-	-	-	-	-	-	-
--	-	-	-	-	-	-	-	-	-
--	-	-	-	-	-	-	-	-	-

Enter this row on the Printer Authorization Matrix Form

Figure A-5. Sample Printer Authorization Matrix Worksheet (Models 51C and 61C)

Appendix B. Port Host Address Assignment (User-Controlled)

This appendix discusses two procedures for performing user-controlled port selection and address assignment. Procedure 1 allows you to select the port and to specify the number of addresses you want assigned to that port; Procedure 2 allows you to select the port and to specify the exact addresses you want assigned to that port. The addresses in Procedure 1 are assigned by the customization program. One or the other of the procedures must be used for host address assignment when distributed function terminals are attached to the control unit:

- Procedure 1 provides for port selection and definition of the number of addresses to be assigned to a port, and is used when sequence number 116 is answered with a 1. (Procedure 1 can be used when customizing with any release of Configuration Support D.)
- Procedure 2 provides for port selection and host address specification, and is used when sequence number 116 is answered with a 2. (Procedure 2 can be used only when customizing with Configuration Support D, Release 64.)

This appendix provides guidelines for host address assignment, descriptions of Procedures 1 and 2, with examples, and forms that can be filled in by the customization planner and given to the person who will perform the customization.

Guidelines

Following are some concepts and pointers concerning host address assignment.

Multiple Interactive Screens Feature

The Multiple Interactive Screens feature, available on distributed function terminals (DFTs) such as the 3290 Information Panel (not on 3179-G), enables the terminal to appear to the host system as a number of logical terminals, each with its own address, interacting independently (only one logical terminal can be active at any given moment) with a host system program. The 3274 allows the assigning of up to five addresses per port, a primary address and four secondary addresses, in support of the Multiple Interactive Screens feature on attached DFTs.

SNA protocol allows the assignment of up to 128 addresses; BSC or channel-attached protocol allows only 32 addresses. When planning for sequence number 117, the Port Assignment Specification Table, be sure you know which protocol is to be used and what your port host address assignment limitations are.

The formats in which the screens may be presented on the terminal's physical display surface are discussed in the description, reference, or user's guide publications associated with the terminal. This appendix deals only with assigning addresses to the logical terminals or screens, and with the association of those addresses with a 3274 control unit terminal port.

Procedures 1 and 2

Distributed function terminals supporting multiple interactive screens require that, at customization of the control unit, an address for each screen being supported be assigned to the port to which the DFT is attached. Both Procedure 1 and Procedure 2 satisfy this requirement.

Procedure 1 ($116=1$), by allowing the specification only of the number of host addresses to be assigned to the selected port, provides you with partial control of port selection and port host address assignment. The customization program assigns the actual addresses to the selected ports. The addresses are assigned in sequence (ascending order). All ports selected are assigned one address (the primary address) before the customization program starts to assign further addresses (the secondary addresses) to those ports that have been specified as requiring more than one host address. For example, if addresses 2 to 10 were assigned as primary addresses, address 11 would be the first secondary address assigned. This address assignment procedure makes Procedure 1 rather inflexible when the control unit is being reconfigured. Adding one terminal (not necessarily a DFT) will cause what had been a secondary address (11, for instance, in the example just cited) to become a primary address associated with a different port (and perhaps with a different device type as far as the host system is concerned), and the host system must totally rework its address tables.

Procedure 2 ($116=2$), by allowing the assignment of any valid address(es) to any port, provides you with full control over port selection and port host address assignment. This capability is especially useful when the control unit is being reconfigured with additional DFTs. For example, unused host addresses could be assigned to the new DFT screens, eliminating the need for the host system to do a total rework of its address tables.

Conserving Channel Addresses

Control of host address assignment is also useful in conserving channel addresses when configuring channel-attached control units (Models A and D). When the customizing program assigns ports and addresses, all ports are assigned addresses (up to the numbers specified in sequence numbers 111 and 112), including unused ports. All assigned addresses take up channel address space, even if they are not actually used. With user-control of address assignment, you select only the ports that will be used, thus saving address space.

Printer Authorization Matrix

If you are using a printer authorization matrix (either host-generated or locally generated through sequence number 022), be sure that the ports assigned to shared and system printers in the printer authorization matrix are also selected and assigned an address in the Port Assignment Specification Table (PAST), sequence number 117.

Sequence Numbers 117 and 118

In both Procedures 1 and 2 (Release 64 and beyond), sequence number 117 is a panel (PAST) that is displayed after the other customizing entries have been made (the 999 panel is complete). In Procedure 1, the PAST panel varies in format between CS-D/Releases 60–63 and CS-D/Release 64; the purpose, however, is the same in both procedures.

After you have completed input to sequence number 117 and your entries have been checked, sequence number 118 is displayed. This is a panel, the Port Address Table, and will also differ in format between CS-D/Releases 60–63 and CS-D/Release 64. The Port Address Table (panel 118) enables you to verify that the entries you made in the Port Assignment Specification Table (panel 117) have been incorporated into the control unit address tables. Entries are made in panel 117 in decimal; panel 118 then displays the entries in hexadecimal. Hexadecimal representation will be required in system generation at the host. It will also be useful to the IBM service representative in problem analysis. You cannot change any entries on panel 118 directly; panel 118 is for display only. You must return to panel 117 to make any changes. The changes will then be reflected in panel 118 when it is redisplayed. You may copy either panel 117 or 118, or both, for your records by using the local copy utility.

Procedure 1 (116 = 1)

Procedure 1 is used with all releases of Configuration Support D; however, the panels displayed for sequence numbers 117 and 118 vary between Releases 60–63 and Release 64. Each format is illustrated in the following text. Refer to the illustration appropriate to the CS-D release you are going to customize with.

Sequence of Operations

If you have responded to sequence number 112 with 00 and to sequence number 116 with a 1, complete the other customizing entries on the 999 panel, respond to 900 with a 1, and press ENTER. Sequence number 117, the Port Assignment Specification Table, is displayed. Figures B-1 and B-2 show the format of the table. C@ is the heading for all the port numbers. #IS is the heading for the row or column where you select the port by entering the number of addresses you want assigned to that port.

Port A00 is always selected and assigned one address automatically. You cannot assign more than one address to this port. All other ports are initially set to 0. Examples of port selection and address assignment are shown under the heading "Examples – Procedure 1." If you want to return to the 999 panel, enter an A after the 906 and press ENTER.

Once your Port Assignment Specification Table has been completed, verified, and accepted (906 = 1), sequence number 118, the Port Address Table, is displayed. Figures B-3 and B-4 show an example of the Port Address Table when distributed function terminals with multiple interactive screens are part of the 3274 configuration.

Category B Terminals

Figures B-5 and B-6 show the Port Address Table that is displayed when Category B terminals are part of the 3274 configuration. The address assigned by the control unit is displayed for each port.

Category B terminal addresses are assigned after all addresses for Category A ports are assigned. However, the number of Category B terminals that can be addressed depends on the highest Category A port to which an address was assigned. For example, you may have selected only three Category A ports, but, if the highest port selected was A31, any Category B terminal attachments that you indicated in sequence number 111 cannot be addressed. Use the following formula to determine whether all your Category B terminals can be addressed.

$$\begin{array}{r} \text{Highest Category A} \\ \text{Port Number} \\ \text{Selected} \end{array} + 1 + \begin{array}{r} \text{Response to Sequence} \\ \text{Number 111} \end{array} = 32$$

If the result of this calculation exceeds 32, some or all of your Category B terminals cannot be addressed. For example, if you responded to sequence number 111 with an 8 and your highest Category A port in sequence number 117 is A24, the calculation would go:

$$24 + 1 + 8 = 33$$

The result exceeds 32. You must either change your response to sequence number 111 to less than 8 (that is, reduce the number of Category B terminals to be attached) or, if possible, select a lower-numbered Category A port in sequence number 117.

117				NN				X...X LT=nnn
C@.	A00	A01	A02	A03	A04	A05	A06	A07
#IS.	1	0	0	0	0	0	0	0
C@.	A08	A09	A10	A11	A12	A13	A14	A15
#IS.	0	0	0	0	0	0	0	0
C@.	A16	A17	A18	A19	A20	A21	A22	A23
#IS.	0	0	0	0	0	0	0	0
C@.	A24	A25	A26	A27	A28	A29	A30	A31
#IS.	0	0	0	0	0	0	0	0
								906 - 0

Where:

C@ is the physical 3274 port.

#IS is the number of addresses you want to assign to the port. Port A00 has a fixed response of 1. (Distributed function terminals with multiple interactive screens cannot be attached to this port.) All other ports can be assigned 0 to 5 addresses if a distributed function terminal is attached, 0 or 1 address if a single-screen terminal is attached.

NN is the operator code that appears if an error is detected.

X...X is the field that displays the control unit address or the X.25 secondary station address as entered in response to sequence number 201, 301, or 302; the control unit model number specified in sequence number 151; and, if applicable, the communication mode, BSC or SDLC.

LT=nnn is the total number of addresses that have been specified.

906 is the response verification field. Once you have entered all your port assignments, change the 0 after 906 to a 1 and press ENTER. If your entries are syntactically correct, the Port Address Table will be displayed. If there are errors in your entries, an operator code will appear in the NN field, and your erroneous entries will be highlighted. If you want to return to the initial customizing screen, change the 0 after 906 to an A and press ENTER.

Figure B-1. Port Assignment Specification Table (Procedure 1, CS-D/Releases 60 - 63)

117														NN	116=1	X...X LT=nnn	
C@	#IS	P	S1	S2	S3	S4	C@	#IS	P	S1	S2	S3	S4				
A00:	1	—					A01:	0	—	—	—	—	—				
A02:	0	—	—	—	—	—	A03:	0	—	—	—	—	—				
A04:	0	—	—	—	—	—	A05:	0	—	—	—	—	—				
A06:	0	—	—	—	—	—	A07:	0	—	—	—	—	—				
A08:	0	—	—	—	—	—	A09:	0	—	—	—	—	—				
A10:	0	—	—	—	—	—	A11:	0	—	—	—	—	—				
A12:	0	—	—	—	—	—	A13:	0	—	—	—	—	—				
A14:	0	—	—	—	—	—	A15:	0	—	—	—	—	—				
A16:	0	—	—	—	—	—	A17:	0	—	—	—	—	—				
A18:	0	—	—	—	—	—	A19:	0	—	—	—	—	—				
A20:	0	—	—	—	—	—	A21:	0	—	—	—	—	—				
A22:	0	—	—	—	—	—	A23:	0	—	—	—	—	—				
A24:	0	—	—	—	—	—	A25:	0	—	—	—	—	—				
A26:	0	—	—	—	—	—	A27:	0	—	—	—	—	—				
A28:	0	—	—	—	—	—	A29:	0	—	—	—	—	—				
A30:	0	—	—	—	—	—	A31:	0	—	—	—	—	—				
C@:	B00	B01	B02	B03	B04	B05	B06	B07	B08	B09	B10	B11	B12	B13	B14	B15	
P:																	906=0

Where:

- C@** is the column that designates the physical 3274 port.
- #IS** is the column in which you specify, in decimal, the number of addresses you want assigned to the port. Port A00 has a fixed response of 1 (distributed function terminals with multiple interactive screens cannot be attached to this port). A zero (initial setting) indicates that the port is unused; no address(es) will be assigned to it. The 3274 allows up to five addresses (a primary and four secondary addresses) to be assigned. 0 to 5 are valid responses.
- P, S1, S2, S3, S4** (columns) are protected fields. However, if you press the ENTER key while filling in the #IS column, and there are no errors, the addresses already assigned to the ports are displayed, in decimal. If you have made an error, an error code will be displayed. When the sequence number 118 panel, the Port Assignment Table, is displayed, the primary and secondary addresses assigned by the 3274 customization program will appear in these columns, in hexadecimal.
- C@: B00 B01** (in the row headed P:) are protected fields. You cannot select Type B ports. Addresses are assigned by the customization program. These fields are displayed only if sequence number 111 has a nonzero response. These fields will show up in the 117 and 118 panels with the addresses assigned by the customization program.
- 116=1** is your response to sequence number 116.
- NN** is the operator error code that appears if an error is detected.
- X...X** displays the control unit address or the X.25 secondary station address as entered in response to sequence number 201, 301, or 302; the control unit model number specified in sequence number 151; and, if applicable, the communication mode, BSC or SDLC.
- LT=nnn** is the total number of addresses that have been assigned; initially, zero.
- 906=0** is the response verification field. Once you have selected your ports and indicated the number of addresses to be assigned, change the 0 to a 1 and press ENTER. If your entries are syntactically correct, the Port Address Table (sequence number 118) will be displayed. If there are errors in your entries, an operator code will appear in the NN field and your erroneous entries will be highlighted. If you want to return to the 999 customizing panel, change the 0 to an A and press ENTER.

Figure B-2. Port Assignment Specification Table (Procedure 1, CS-D/Release 64)

118								X. . .X LT=nnn
C@. .	A00	A01	A02	A03	A04	A05	A06	A07
#IS .	1	X	X	X	X	X	X	X
P@. .	YY	YY	YY	YY	YY	YY	YY	YY
S@. .		ZZ-ZZ	ZZ-ZZ	ZZ-ZZ	ZZ-ZZ	ZZ-ZZ	ZZ-ZZ	ZZ-ZZ
C@. .	A08	A09	A10	A11	A12	A13	A14	A15
#IS .	X	X	X	X	X	X	X	X
P@. .	YY	YY	YY	YY	YY	YY	YY	YY
S@. .	ZZ-ZZ	ZZ-ZZ	ZZ-ZZ	ZZ-ZZ	ZZ-ZZ	ZZ-ZZ	ZZ-ZZ	ZZ-ZZ
C@. .	A16	A17	A18	A19	A20	A21	A22	A23
#IS .	X	X	X	X	X	X	X	X
P@. .	YY	YY	YY	YY	YY	YY	YY	YY
S@. .	ZZ-ZZ	ZZ-ZZ	ZZ-ZZ	ZZ-ZZ	ZZ-ZZ	ZZ-ZZ	ZZ-ZZ	ZZ-ZZ
C@. .	A24	A25	A26	A27	A28	A29	A30	A31
#IS .	X	X	X	X	X	X	X	X
P@. .	YY	YY	YY	YY	YY	YY	YY	YY
S@. .	ZZ-ZZ	ZZ-ZZ	ZZ-ZZ	ZZ-ZZ	ZZ-ZZ	ZZ-ZZ	ZZ-ZZ	ZZ-ZZ
								907 - 0

Where:

C@ is the physical 3274 port.

#IS shows the number of devices (X) you assigned to the port in sequence number 117. Port A00 has a fixed response of 1. All other ports can be assigned 0 through 5 devices.

P@ is the primary address (YY), in hexadecimal, that is assigned to the device. Ranges for primary address values are as follows: A and C/SDLC units -- 02 to 21 hexadecimal; C/BSC units -- Actual BSC/EBCDIC or BSC/ASCII addresses, as appropriate; D units -- 00 to 1F hexadecimal.

S@ is the range of secondary addresses (ZZ-ZZ) assigned to the device. Ranges for secondary addresses are: A and C/SDLC units -- 04 to 81 hexadecimal; C/BSC units -- actual BSC/EBCDIC or BSC/ASCII addresses, as appropriate; D units -- 02 to 1F hexadecimal. The secondary addresses are shown as a starting and ending address. For example, if addresses 19, 1A, 1B, and 1C were assigned to a single port, line S@ would show 19-1C. This line would be filled in only if multiple interactive screens were specified during sequence number 117.

X. . .X displays the control unit ID; the control unit address or the X.25 secondary station address as entered in response to sequence number 201, 301, or 302; the control unit model number specified in sequence number 151; and, if applicable, the communication mode, BSC or SDLC.

LT=nnn is the total number of addresses that have been specified.

907 is the response verification field. If you are satisfied with the port addresses shown, change the 0 after 907 to a 1 and press ENTER. If you want to return to the Port Assignment Specification Table (sequence number 117), change the 0 after 907 to an A, press ENTER, and proceed as you would in sequence number 117.

Figure B-3. Port Address Table with Multiple Interactive Screens (Procedure 1, CS-D/Releases 60 - 63)

118							NN							116=1	X..X
															LT=nnn
C@	#IS	P	S1	S2	S3	S4	C@	#IS	P	S1	S2	S3	S4		
A00:	1	<u>YY</u>					A01:	X	<u>YY</u>	<u>ZZ</u>	<u>ZZ</u>	<u>ZZ</u>	<u>ZZ</u>		
A02:	X	<u>YY</u>	<u>ZZ</u>	<u>ZZ</u>	<u>ZZ</u>	<u>ZZ</u>	A03:	X	<u>YY</u>	<u>ZZ</u>	<u>ZZ</u>	<u>ZZ</u>	<u>ZZ</u>		
A04:	X	<u>YY</u>	<u>ZZ</u>	<u>ZZ</u>	<u>ZZ</u>	<u>ZZ</u>	A05:	X	<u>YY</u>	<u>ZZ</u>	<u>ZZ</u>	<u>ZZ</u>	<u>ZZ</u>		
A06:	X	<u>YY</u>	<u>ZZ</u>	<u>ZZ</u>	<u>ZZ</u>	<u>ZZ</u>	A07:	X	<u>YY</u>	<u>ZZ</u>	<u>ZZ</u>	<u>ZZ</u>	<u>ZZ</u>		
A08:	X	<u>YY</u>	<u>ZZ</u>	<u>ZZ</u>	<u>ZZ</u>	<u>ZZ</u>	A09:	X	<u>YY</u>	<u>ZZ</u>	<u>ZZ</u>	<u>ZZ</u>	<u>ZZ</u>		
A10:	X	<u>YY</u>	<u>ZZ</u>	<u>ZZ</u>	<u>ZZ</u>	<u>ZZ</u>	A11:	X	<u>YY</u>	<u>ZZ</u>	<u>ZZ</u>	<u>ZZ</u>	<u>ZZ</u>		
A12:	X	<u>YY</u>	<u>ZZ</u>	<u>ZZ</u>	<u>ZZ</u>	<u>ZZ</u>	A13:	X	<u>YY</u>	<u>ZZ</u>	<u>ZZ</u>	<u>ZZ</u>	<u>ZZ</u>		
A14:	X	<u>YY</u>	<u>ZZ</u>	<u>ZZ</u>	<u>ZZ</u>	<u>ZZ</u>	A15:	X	<u>YY</u>	<u>ZZ</u>	<u>ZZ</u>	<u>ZZ</u>	<u>ZZ</u>		
A16:	X	<u>YY</u>	<u>ZZ</u>	<u>ZZ</u>	<u>ZZ</u>	<u>ZZ</u>	A17:	X	<u>YY</u>	<u>ZZ</u>	<u>ZZ</u>	<u>ZZ</u>	<u>ZZ</u>		
A18:	X	<u>YY</u>	<u>ZZ</u>	<u>ZZ</u>	<u>ZZ</u>	<u>ZZ</u>	A19:	X	<u>YY</u>	<u>ZZ</u>	<u>ZZ</u>	<u>ZZ</u>	<u>ZZ</u>		
A20:	X	<u>YY</u>	<u>ZZ</u>	<u>ZZ</u>	<u>ZZ</u>	<u>ZZ</u>	A21:	X	<u>YY</u>	<u>ZZ</u>	<u>ZZ</u>	<u>ZZ</u>	<u>ZZ</u>		
A22:	X	<u>YY</u>	<u>ZZ</u>	<u>ZZ</u>	<u>ZZ</u>	<u>ZZ</u>	A23:	X	<u>YY</u>	<u>ZZ</u>	<u>ZZ</u>	<u>ZZ</u>	<u>ZZ</u>		
A24:	X	<u>YY</u>	<u>ZZ</u>	<u>ZZ</u>	<u>ZZ</u>	<u>ZZ</u>	A25:	X	<u>YY</u>	<u>ZZ</u>	<u>ZZ</u>	<u>ZZ</u>	<u>ZZ</u>		
A26:	X	<u>YY</u>	<u>ZZ</u>	<u>ZZ</u>	<u>ZZ</u>	<u>ZZ</u>	A27:	X	<u>YY</u>	<u>ZZ</u>	<u>ZZ</u>	<u>ZZ</u>	<u>ZZ</u>		
A28:	X	<u>YY</u>	<u>ZZ</u>	<u>ZZ</u>	<u>ZZ</u>	<u>ZZ</u>	A29:	X	<u>YY</u>	<u>ZZ</u>	<u>ZZ</u>	<u>ZZ</u>	<u>ZZ</u>		
A30:	X	<u>YY</u>	<u>ZZ</u>	<u>ZZ</u>	<u>ZZ</u>	<u>ZZ</u>	A31:	X	<u>YY</u>	<u>ZZ</u>	<u>ZZ</u>	<u>ZZ</u>	<u>ZZ</u>		

907=0

Where:

- C@** is the physical 3274 port.
- #IS** shows the number of addresses you specified for that port in sequence number 117. Port A00 has a fixed assignment of 1. Valid responses are 0 through 5. A zero indicates an unused port.
- P, S1, S2, S3, S4** (columns) are the primary (YY) and secondary (ZZ) address values, in hexadecimal, for the ports to which addresses have been assigned. Ranges for address values are:

- SNA protocol – 02 to 81 hexadecimal
- BSC protocol – actual EBCDIC or ASCII values, as appropriate
- Channel protocol (D units) – 00 to 1F hexadecimal

LT=nnn is the total number of addresses that have been assigned.

907=0 is the response verification field. If you are satisfied with the port selection and addresses shown, change the 0 to 1 and press ENTER. If you want to return to the Port Assignment Specification Table (sequence number 117), change the 0 to an A and press ENTER.

Figure B-4. Port Address Table with Multiple Interactive Screens (Procedure 1, CS-D/Release 64)

118																		X. . X LT=nnn
C@. .	A00	A01	A02	A03	A04	A05	A06	A07										
#IS .	1	X	X	X	X	X	X	X										
P@. .	YY	YY	YY	YY	YY	YY	YY	YY										
C@. .	A08	A09	A10	A11	A12	A13	A14	A15										
#IS .	X	X	X	X	X	X	X	X										
P@. .	YY	YY	YY	YY	YY	YY	YY	YY										
C@. .	A16	A17	A18	A19	A20	A21	A22	A23										
#IS .	X	X	X	X	X	X	X	X										
P@. .	YY	YY	YY	YY	YY	YY	YY	YY										
C@. .	A24	A25	A26	A27	A28	A29	A30	A31										
#IS .	X	X	X	X	X	X	X	X										
P@. .	YY	YY	YY	YY	YY	YY	YY	YY										
C@. .	B00	B01	B02	B03	B04	B05	B06	B07	B08	B09	B10	B11	B12	B13	B14	B15		
P@	YY	YY	YY	YY	YY	YY	YY	YY	YY	YY	YY	YY	YY	YY	YY	YY		
																		907 - 0

Where:

C@ is the physical 3274 port. Category B devices are shown only when sequence number 111 has a response greater than 0.

#IS shows the number of devices (X) you assigned to the port in sequence number 117. Because Category B devices are being used in this figure, you are allowed to specify only one device for each port.

P@ is the primary address (YY), in hexadecimal, that is assigned to the device.

X. . X displays the control unit address or the X.25 secondary station address as entered in response to sequence number 201, 301, or 302; the control unit model number specified in sequence number 151; and, if applicable, the communication mode, BSC or SDLC.

LT=nnn is the total number of addresses that have been specified.

907 is the response verification field. If you are satisfied with the port assignments shown, change the 0 after 907 to a 1 and press ENTER. If you want to return to the Port Assignment Specification Table (sequence number 117), change the 0 after 907 to an A, press ENTER, and proceed as you would in sequence number 117.

Figure B-5. Port Address Table with Category B Terminals (Procedure 1, CS-D/Releases 60-63)

118							116=1							X...X LT=nnn		
C@	#IS	P	S1	S2	S3	S4	C@	#IS	P	S1	S2	S3	S4			
A00:	1	YY					A01:	X	YY							
A02:	X	YY					A03:	X	YY							
A04:	X	YY					A05:	X	YY							
A06:	X	YY					A07:	X	YY							
A08:	X	YY					A09:	X	YY							
A10:	X	YY					A11:	X	YY							
A12:	X	YY					A13:	X	YY							
A14:	X	YY					A15:	X	YY							
A16:	X	YY					A17:	X	YY							
A18:	X	YY					A19:	X	YY							
A20:	X	YY					A21:	X	YY							
A22:	X	YY					A23:	X	YY							
A24:	0						A25:	0								
A26:	0						A27:	0								
A28:	0						A29:	0								
A30:	0						A31:	0								
C@:	B00	B01	B02	B03	B04	B05	B06	B07	B08	B09	B10	B11	B12	B13	B14	B15
P:	YY	YY	YY	YY	YY	YY	YY	YY								

907=0

Where:

- C@: B00 B01** are fields in which port assignments and primary addresses for Category B devices are shown only when the response to sequence number 111 is nonzero.
- #IS** shows that, since eight Category B devices are attached, only Category A ports A00 to A23 can be selected.
- P** is a column of primary address values (YY). Distributed function devices with multiple interactive screens and Category B devices cannot be attached to the same control unit; therefore, only primary addresses are assigned.

Figure B-6. Port Address Table with Category B Terminals (Procedure 1, CS-D/Release 64)

Examples – Procedure 1

The following examples show how different 3274 device configurations are specified with individual port assignment. The following conditions must always be met before port assignments can be made:

- The response to sequence number 112 must always be 00.
- The response to sequence number 116 must always be 1.
- All sequence numbers shown on the initial customizing or modification screen (whichever you are using) must have responses.
- The response to the 900 on the bottom right of the initial customizing or modification screen must be 1, and you must press ENTER.

Once you have completed the initial customizing or modification screen, as described above, the Port Assignment Specification Table (sequence number 117) is displayed. This is the point at which the following examples begin.

Example 1

This example shows the Port Assignment Specification Table entries and Port Address Table for a configuration that is spread between three different buildings using 16 devices and four 3299 Terminal Multiplexers. Figure B-7 gives a pictorial representation of the configuration. Figures B-8 and B-9 give the proper Port Assignment Specification Table entries, followed by the resultant Port Address Table.

The following information applies to this example:

- You are using a 3274 Model 41A with a 32-port capacity.
- The first 12 devices are attached to ports 00 through 11, thus using all but four of the 16 ports available on the first two 3299 Terminal Multiplexers.
- There are no 3290s using the Multiple Interactive Screens function.
- The 3274, two 3299s, and the first 12 devices are located in Building 1.
- Ports 16 through 23 are connected through a 3299 Terminal Multiplexer located in Building 2.
- Ports 16 and 17 have devices attached. Ports 18 through 23 are not used.
- Ports 24 through 31 are connected through another 3299 located in Building 3. Ports 24 and 25 have devices attached, and ports 26 through 31 are not used.

Figures B-8 and B-9 show how this configuration is specified with sequence number 117 and the resulting port addressing in sequence number 118.

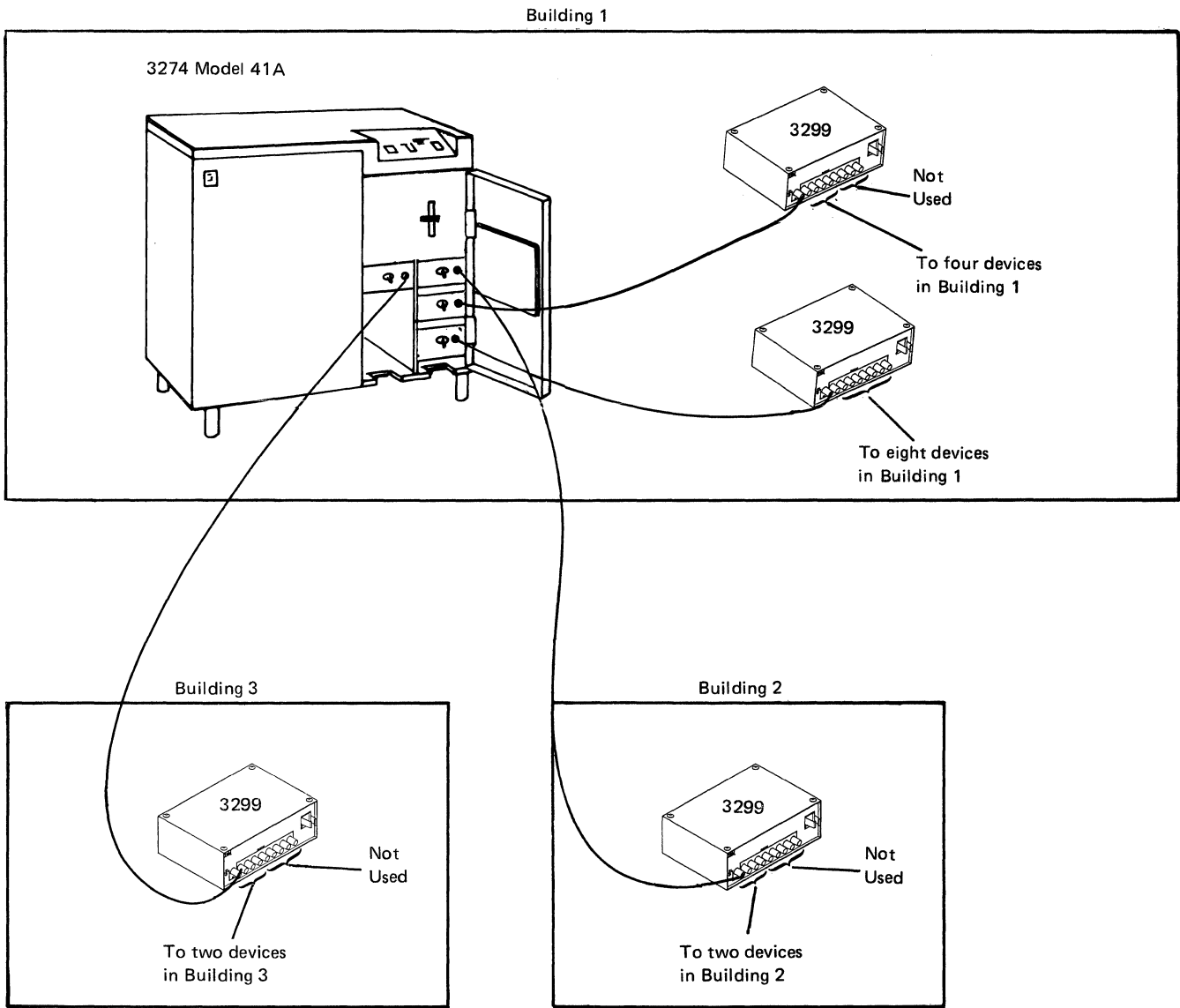

Figure B-7. Example 1 (Procedure 1) Configuration

117								08/41A LT=016
C@..	A00	A01	A02	A03	A04	A05	A06	A07
#IS.	1	1	1	1	1	1	1	1
C@..	A08	A09	A10	A11	A12	A13	A14	A15
#IS.	1	1	1	1	0	0	0	0
C@..	A16	A17	A18	A19	A20	A21	A22	A23
#IS.	1	1	0	0	0	0	0	0
C@..	A24	A25	A26	A27	A28	A29	A30	A31
#IS.	1	1	0	0	0	0	0	0
								906 - 1

118								08/41A LT=016
C@..	A00	A01	A02	A03	A04	A05	A06	A07
#IS.	1	1	1	1	1	1	1	1
P@..	02	03	04	05	06	07	08	09
C@..	A08	A09	A10	A11	A12	A13	A14	A15
#IS.	1	1	1	1	0	0	0	0
P@..	0A	0B	0C	0D				
C@..	A16	A17	A18	A19	A20	A21	A22	A23
#IS.	1	1	0	0	0	0	0	0
P@..	0E	0F						
C@..	A24	A25	A26	A27	A28	A29	A30	A31
#IS.	1	1	0	0	0	0	0	0
P@..	10	11						
								907 - 0

Figure B-8. Port Assignment Specification Table and Port Address Table for Example 1 (Procedure 1, CS-D/Releases 60-63)

117

116=1 08/41A
LT=001

C@	#IS	P	S1	S2	S3	S4	C@	#IS	P	S1	S2	S3	S4
A00:	1						A01:	1					
A02:	1						A03:	1					
A04:	1						A05:	1					
A06:	1						A07:	1					
A08:	1						A09:	1					
A10:	1						A11:	1					
A12:	0						A13:	0					
A14:	0						A15:	0					
A16:	1						A17:	1					
A18:	0						A19:	0					
A20:	0						A21:	0					
A22:	0						A23:	0					
A24:	1						A25:	1					
A26:	0						A27:	0					
A28:	0						A29:	0					
A30:	0						A31:	0					

906 - 0

The Port Assignment Specification Table after all #IS entries have been made.

117

99 116=1 08/41A
LT=016

C@	#IS	P	S1	S2	S3	S4	C@	#IS	P	S1	S2	S3	S4
A00:	1	002					A01:	1	003				
A02:	1	004					A03:	1	005				
A04:	1	006					A05:	1	007				
A06:	1	008					A07:	1	009				
A08:	1	010					A09:	1	011				
A10:	1	012					A11:	1	013				
A12:	0						A13:	0					
A14:	0						A15:	0					
A16:	1	014					A17:	1	015				
A18:	0						A19:	0					
A20:	0						A21:	0					
A22:	0						A23:	0					
A24:	1	016					A25:	1	017				
A26:	0						A27:	0					
A28:	0						A29:	0					
A30:	0						A31:	0					

906 - 0

The Port Assignment Specification Table after the ENTER key has been pressed (without changing the 906 response to 1). Note that the assigned addresses are displayed in decimal. The 99 indicates that your entries are acceptable but you have not changed the 906 entry to a 1.

118

116=1 08/41A
LT=016

C@	#IS	P	S1	S2	S3	S4	C@	#IS	P	S1	S2	S3	S4
A00:	1	02					A01:	1	03				
A02:	1	04					A03:	1	05				
A04:	1	06					A05:	1	07				
A06:	1	08					A07:	1	09				
A08:	1	0A					A09:	1	0B				
A10:	1	0C					A11:	1	0D				
A12:	0						A13:	0					
A14:	0						A15:	0					
A16:	1	0E					A17:	1	0F				
A18:	0						A19:	0					
A20:	0						A21:	0					
A22:	0						A23:	0					
A24:	1	10					A25:	1	11				
A26:	0						A27:	0					
A28:	0						A29:	0					
A30:	0						A31:	0					

907 - 0

The Port Address Table (information only) is displayed as a result of changing the 906 response in the Port Assignment Specification Table to 1 and pressing the ENTER key. Note that the assigned addresses are displayed in hexadecimal. Hexadecimal representation is required in system generation at the host. It may also be useful to the IBM service representative in problem analysis. Use the local copy utility to copy panel 117 or 118, or both, for your records.

Note: Changes can be made only in panel 117.

Figure B-9. Port Assignment Specification Table and Port Address Table for Example 1 (Procedure 1, CS-D/Release 64)

Example 2

In this example, a 3274 Model 61C is being used with SDLC, and two 3278 Display Stations and four 3290 Information Panels attached. The 3290s are each using a different multiple interactive screen configuration. Figure B-10 gives a pictorial representation of the configuration. Figures B-11 and B-12 give the proper Port Assignment Specification Table entries, followed by the resultant Port Address Table.

The following information applies to this example:

- Port 0 has a 3278 attached. A 3290 cannot be attached to this port. Address 02 is assigned to this port.
- Port 1 has a 5-screen 3290 multiple interactive screen configuration attached. The number 1 screen is addressed through port 1 as address 03. The addresses of screens 2 through 5 are logical devices and pick up where the primary addresses end – address 07 (port 5). Screens 2 through 5 are addressed as addresses 08 through 0B.
- Port 2 has a 2-screen 3290 multiple interactive screen configuration attached. Screen 1 is addressed through port 2 as address 04. Screen 2 is addressed as address 0C.
- Port 3 has a 4-screen 3290 multiple interactive screen configuration attached. Screen 1 is addressed through port 3 as address 05. Screens 2 through 4 are addressed as addresses 0D through 0F.
- Port 4 has a 3278 attached. This device is addressed through port 4 as address 06.
- Port 5 is the last port with a device physically attached to it. That device has a 3-screen 3290 multiple interactive screen configuration. Screen 1 is addressed through port 5 as address 07. Screens 2 and 3 are addressed as addresses 10 and 11.

Figure B-13 shows how the host would address the devices in this example when an SNA protocol is used.

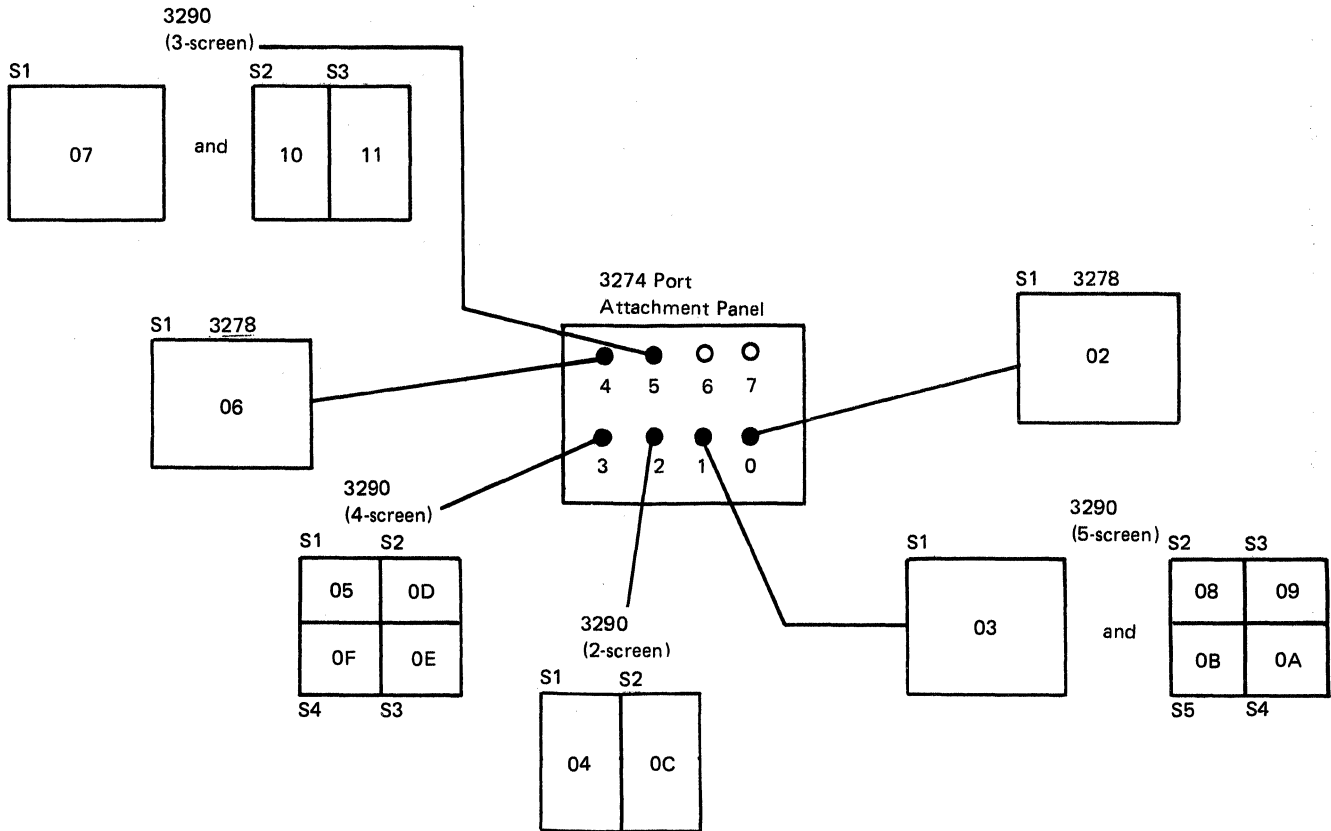

Note: Numbers within the screens indicate addresses.

● = Primary Terminal address (physical device attached)

Figure B-10. Example 2 (Procedure 1) Configuration Showing Assigned Addresses

117								07/61C/SDLC LT=016
C@..	A00	A01	A02	A03	A04	A05	A06	A07
#IS .	1	5	2	4	1	3	0	0
C@..	A08	A09	A10	A11	A12	A13	A14	A15
#IS .	0	0	0	0	0	0	0	0
C@..	A16	A17	A18	A19	A20	A21	A22	A23
#IS .	0	0	0	0	0	0	0	0
C@..	A24	A25	A26	A27	A28	A29	A30	A31
#IS .	0	0	0	0	0	0	0	0
								906 - 1

118								07/61C/SDLC LT=016
C@..	A00	A01	A02	A03	A04	A05	A06	A07
#IS .	1	5	2	4	1	3	0	0
P@..	02	03	04	05	06	07		
S@..		08-0B	0C	0D-0F		10-11		
C@..	A08	A09	A10	A11	A12	A13	A14	A15
#IS .	0	0	0	0	0	0	0	0
P@..								
S@..								
C@..	A16	A17	A18	A19	A20	A21	A22	A23
#IS .	0	0	0	0	0	0	0	0
P@..								
S@..								
C@..	A24	A25	A26	A27	A28	A29	A30	A31
#IS .	0	0	0	0	0	0	0	0
P@..								
S@..								
								907 - 0

Figure B-11. Port Assignment Specification Table and Port Address Table for Example 2 (Procedure 1, CS-D/Releases 60 - 63)

117								116=1 07/61C/SDLC LT=001							
C@	#IS	P	S1	S2	S3	S4		C@	#IS	P	S1	S2	S3	S4	
A00:	1							A01:	5						
A02:	2							A03:	4						
A04:	1							A05:	3						
A06:	0							A07:	0						
A08:	0							A09:	0						
A10:	0							A11:	0						
A12:	0							A13:	0						
A14:	0							A15:	0						
A16:	0							A17:	0						
A18:	0							A19:	0						
A20:	0							A21:	0						
A22:	0							A23:	0						
A24:	0							A25:	0						
A26:	0							A27:	0						
A28:	0							A29:	0						
A30:	0							A31:	0						

906 - 0

The Port Assignment Specification Table after all #IS entries have been made.

117								99 116=1 07/61C/SDLC LT=016							
C@	#IS	P	S1	S2	S3	S4		C@	#IS	P	S1	S2	S3	S4	
A00:	1	002						A01:	5	003	008	009	010	011	
A02:	2	004	012					A03:	4	005	013	014	015		
A04:	1	006						A05:	3	007	016	017			
A06:	0							A07:	0						
A08:	0							A09:	0						
A10:	0							A11:	0						
A12:	0							A13:	0						
A14:	0							A15:	0						
A16:	0							A17:	0						
A18:	0							A19:	0						
A20:	0							A21:	0						
A22:	0							A23:	0						
A24:	0							A25:	0						
A26:	0							A27:	0						
A28:	0							A29:	0						
A30:	0							A31:	0						

906 - 0

The Port Assignment Specification Table after the ENTER key has been pressed (without changing the 906 response to 1). Note that the assigned addresses are displayed in decimal. The 99 indicates that your entries are acceptable but you have not changed the 906 entry to a 1.

118								116=1 07/61C/SDLC LT=016							
C@	#IS	P	S1	S2	S3	S4		C@	#IS	P	S1	S2	S3	S4	
A00:	1	02						A01:	5	03	08	09	0A	0B	
A02:	2	04	0C					A03:	4	05	0D	0E	0F		
A04:	1	06						A05:	3	07	10	11			
A06:	0							A07:	0						
A08:	0							A09:	0						
A10:	0							A11:	0						
A12:	0							A13:	0						
A14:	0							A15:	0						
A16:	0							A17:	0						
A18:	0							A19:	0						
A20:	0							A21:	0						
A22:	0							A23:	0						
A24:	0							A25:	0						
A26:	0							A27:	0						
A28:	0							A29:	0						
A30:	0							A31:	0						

907 - 0

The Port Address Table (information only) is displayed as a result of changing the 906 response in the Port Assignment Specification Table to 1 and pressing the ENTER key. Note that the assigned addresses are displayed in hexadecimal. Hexadecimal representation is required in system generation at the host. It may also be useful to the IBM service representative in problem analysis. Use the local copy utility to copy panel 117 or 118, or both, for your records.
Note: Changes can be made only in panel 117.

Figure B-12. Port Assignment Specification Table and Port Address Table for Example 2 (Procedure 1, CS-D/Release 64)

Host View

3274 View

		Host Terminal Control Table		3274 Port
Physically Attached Devices	LU1	LU	LOCADDR=2, DLOGMOD=T3278M2	0
	LU2 ¹	LU	LOCADDR=3, DLOGMOD=T3290	1
	LU3 ²	LU	LOCADDR=4, DLOGMOD=T3290	2
	LU4 ³	LU	LOCADDR=5, DLOGMOD=T3290	3
3290 Secondary Terminal Address	LU5	LU	LOCADDR=6, DLOGMOD=3278M2	4
	LU6 ⁴	LU	LOCADDR=7, DLOGMOD=T3290	5
	LU7	LU	LOCADDR=8, DLOGMOD=T3278Mx	
	LU8	LU	LOCADDR=9, DLOGMOD=T3278Mx	
	LU9	LU	LOCADDR=10, DLOGMOD=T3278Mx	
	LU10	LU	LOCADDR=11, DLOGMOD=T3278Mx	
	LU11	LU	LOCADDR=12, DLOGMOD=T3278Mx	
	LU12	LU	LOCADDR=13, DLOGMOD=T3278Mx	
	LU13	LU	LOCADDR=14, DLOGMOD=T3278Mx	
	LU14	LU	LOCADDR=15, DLOGMOD=T3278Mx	
	LU15	LU	LOCADDR=16, DLOGMOD=T3278Mx	
	LU16	LU	LOCADDR=17, DLOGMOD=T3278Mx	

- ¹ Five-screen
- ² Two-screen
- ³ Four-screen
- ⁴ Three-screen

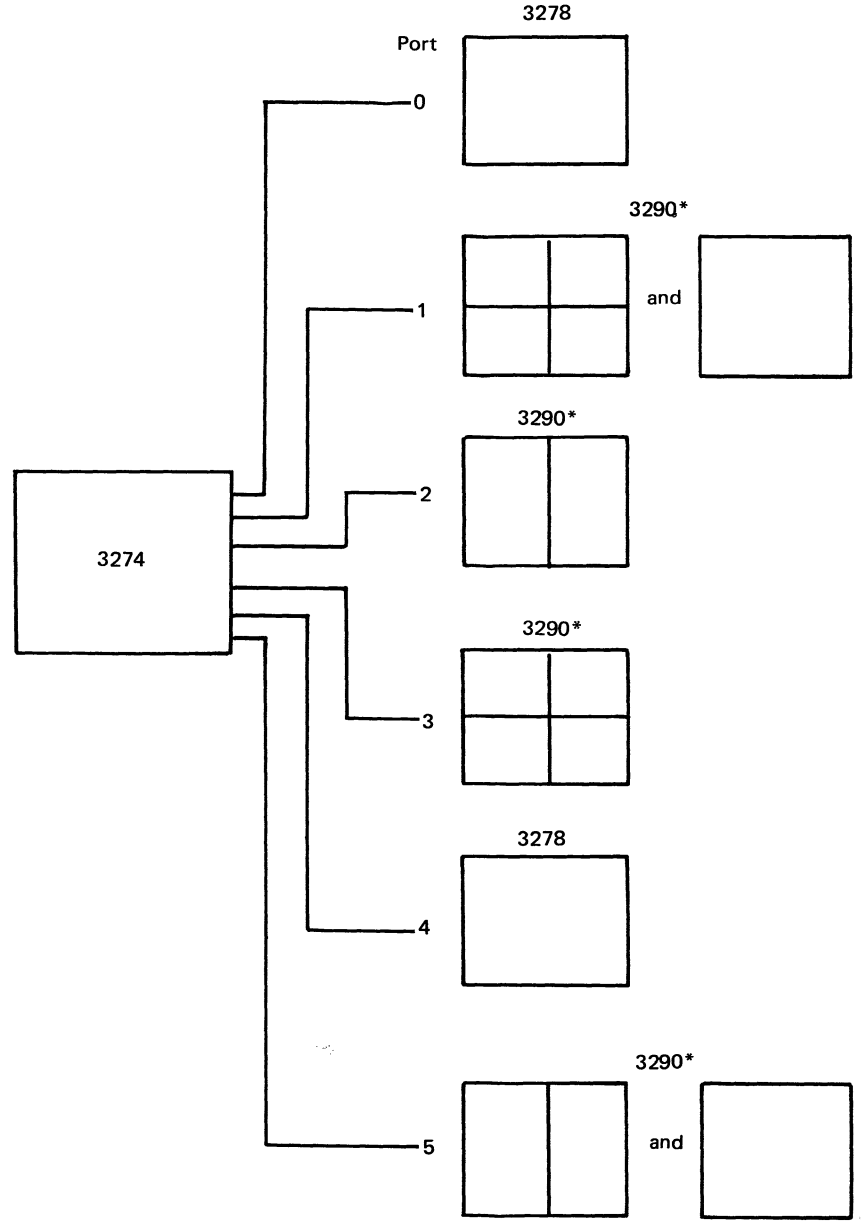

*With multiple interactive screen.

Figure B-13. Example of Host View of Multiple Interactive Screen Addressing (Example 2, Procedure 1)

Example 3

In this example, a 3274 Model 31C, with a double-sided diskette drive installed, is being used. Twenty-four 3278 Display Stations and two 3277 Display Stations are attached. Figures B-14 and B-15 give the specification used for the Category A devices (3278s) in sequence number 117. (Sequence number 112 was specified as 0.) (Note that ports A06, A07, A14, A15, A28, A29, A30, and A31 have no devices assigned.) Category B devices cannot be specified in sequence number 117, only in sequence number 111. In this example, sequence number 111 was specified as 2 before sequence number 117 was displayed.

117									4D/31C/BSC LT=26
C@..	A00	A01	A02	A03	A04	A05	A06	A07	
#IS.	1	1	1	1	1	1	0	0	
C@..	A08	A09	A10	A11	A12	A13	A14	A15	
#IS.	1	1	1	1	1	1	0	0	
C@..	A16	A17	A18	A19	A20	A21	A22	A23	
#IS.	1	1	1	1	1	1	1	1	
C@..	A24	A25	A26	A27	A28	A29	A30	A31	
#IS.	1	1	1	1	0	0	0	0	
									906 - 1

118									4D/31C/BSC LT=26
C@..	A00	A01	A02	A03	A04	A05	A06	A07	
#IS.	1	1	1	1	1	1	0	0	
P@..	40	C1	C2	C3	C4	C5			
C@..	A08	A09	A10	A11	A12	A13	A14	A15	
#IS.	1	1	1	1	1	1	0	0	
P@..	C6	C7	C8	C9	4A	4B			
C@..	A16	A17	A18	A19	A20	A21	A22	A23	
#IS.	1	1	1	1	1	1	1	1	
P@..	4C	4D	4E	4F	50	D1	D2	D3	
C@..	A24	A25	A26	A27	A28	A29	A30	A31	
#IS.	1	1	1	1	0	0	0	0	
P@..	D4	D5	D6	D7					
C@..	B00	B01							
P@..	D8	D9							
									907 - 0

Figure B-14. Port Assignment Specification Table and Port Address Table for Example 3 (Procedure 1, CS-D/Releases 60 - 63)

117

116=1 40/31C/BSC
LT=001

C@	#IS	P	S1	S2	S3	S4	C@	#IS	P	S1	S2	S3	S4
A00:	1						A01:	1					
A02:	1						A03:	1					
A04:	1						A05:	1					
A06:	0						A07:	0					
A08:	1						A09:	1					
A10:	1						A11:	1					
A12:	1						A13:	1					
A14:	0						A15:	0					
A16:	1						A17:	1					
A18:	1						A19:	1					
A20:	1						A21:	1					
A22:	1						A23:	1					
A24:	1						A25:	1					
A26:	1						A27:	1					
A28:	0						A29:	0					
A30:	0						A31:	0					

C@: B00 B01 B02 B03 B04 B05 B06 B07 B08 B09 B10 B11 B12 B13 B14 B15
P:

906 - 0

The Port Assignment Specification Table after all #IS entries have been made.

117

99

116=1 40/31C/BSC
LT=026

C@	#IS	P	S1	S2	S3	S4	C@	#IS	P	S1	S2	S3	S4
A00:	1	000					A01:	1	001				
A02:	1	002					A03:	1	003				
A04:	1	004					A05:	1	005				
A06:	0						A07:	0					
A08:	1	006					A09:	1	007				
A10:	1	008					A11:	1	009				
A12:	1	010					A13:	1	011				
A14:	0						A15:	0					
A16:	1	012					A17:	1	013				
A18:	1	014					A19:	1	015				
A20:	1	016					A21:	1	017				
A22:	1	018					A23:	1	019				
A24:	1	020					A25:	1	021				
A26:	1	022					A27:	1	023				
A28:	0						A29:	0					
A30:	0						A31:	0					

C@: B00 B01 B02 B03 B04 B05 B06 B07 B08 B09 B10 B11 B12 B13 B14 B15
P: 024 025

906 - 0

The Port Assignment Specification Table after the ENTER key has been pressed (without changing the 906 response to 1). Note that the assigned addresses are displayed in decimal. The 99 indicates that your entries are acceptable but you have not changed the 906 entry to a 1.

118

116=1 40/31C/BSC
LT=026

C@	#IS	P	S1	S2	S3	S4	C@	#IS	P	S1	S2	S3	S4
A00:	1	40					A01:	1	C1				
A02:	1	C2					A03:	1	C3				
A04:	1	C4					A05:	1	C5				
A06:	0						A07:	0					
A08:	1	C6					A09:	1	C7				
A10:	1	C8					A11:	1	C9				
A12:	1	4A					A13:	1	4B				
A14:	0						A15:	0					
A16:	1	4C					A17:	1	4D				
A18:	1	4E					A19:	1	4F				
A20:	1	50					A21:	1	D1				
A22:	1	D2					A23:	1	D3				
A24:	1	D4					A25:	1	D5				
A26:	1	D6					A27:	1	D7				
A28:	0						A29:	0					
A30:	0						A31:	0					

C@: B00 B01 B02 B03 B04 B05 B06 B07 B08 B09 B10 B11 B12 B13 B14 B15
P: D8 D9

907 - 0

The Port Address Table (information only) is displayed as a result of changing the 906 response in the Port Assignment Specification Table to 1 and pressing the ENTER key. Note that the assigned addresses are displayed in hexadecimal. Hexadecimal representation is required in system generation at the host. It may also be useful to the IBM service representative in problem analysis. Use the local copy utility to copy panel 117 or 118, or both, for your records.

Note: Changes can be made only in panel 117.

Figure B-15. Port Assignment Specification Table and Port Address Table for Example 3 (Procedure 1, CS-D/Release 64)

Procedure 2 (116 = 2)

You must be customizing with CS-D/Release 64 (Validation Number 34), and have responded to sequence number 116 with a 2, to use this procedure.

Sequence of Operations

If you have responded to sequence numbers 111 and 112 with 00 and to sequence number 116 with a 2, complete the other customizing entries on the 999 panel, respond to 900 with a 1, and press ENTER. Sequence number 117, the Port Assignment Specification Table, is displayed. Figure B-16 shows the format of the table and explains the fields.

Port A00 is always selected and must be assigned one address. You cannot assign more than one address to this port.

You enter, in decimal, in the P and S1 to S4 fields, the primary address and any secondary address(es) you want to assign to the port. The address fields can hold 3 digits:

- A single-digit address can be entered in any position; leading zeros are not required; spaces or nulls are not significant.
- A 2-digit address can be entered starting in the 1st or 2nd digit position. You cannot have a space or null between the digits of a 2-digit address.
- Entering a space causes the digit position underscore to disappear.
- To delete digits, enter spaces.

Pressing ENTER after you have finished specifying addresses causes the addresses to be displayed, with leading zeros where required. If you want to return to the 999 panel, enter an A after the 906 and press ENTER. Your responses are saved and will reappear upon return to the sequence number 117 panel. Once your Port Assignment Specification Table has been completed, verified, and accepted (906 = 1), panel 118, the Port Address Table, will be displayed.

Notes:

1. *If you are going to modify current address assignments, the previous address assignments will be displayed if:*
 - a. *You are going to use the same procedure, Procedure 1 or 2, that you did previously.*
 - b. *You are changing from Procedure 1 to Procedure 2.*
2. *If you change your method of address assignment from Procedure 2 to Procedure 1, the previous address assignments are lost.*

An example of the use of Procedure 2 is shown in Figure B-17. Note that the addresses assigned are not sequential, either from port to port or within the primary and secondary address string assigned to a specific port. Examples of incorrect address specification are shown in Figure B-18.

117							NN							116=2	X...X LT=000
C@	#IS	P	S1	S2	S3	S4	C@	#IS	P	S1	S2	S3	S4		
A00:	1	---					A01:		---	---	---	---	---		
A02:		---	---	---	---	---	A03:		---	---	---	---	---		
A04:		---	---	---	---	---	A05:		---	---	---	---	---		
A06:		---	---	---	---	---	A07:		---	---	---	---	---		
A08:		---	---	---	---	---	A09:		---	---	---	---	---		
A10:		---	---	---	---	---	A11:		---	---	---	---	---		
A12:		---	---	---	---	---	A13:		---	---	---	---	---		
A14:		---	---	---	---	---	A15:		---	---	---	---	---		
A16:		---	---	---	---	---	A17:		---	---	---	---	---		
A18:		---	---	---	---	---	A19:		---	---	---	---	---		
A20:		---	---	---	---	---	A21:		---	---	---	---	---		
A22:		---	---	---	---	---	A23:		---	---	---	---	---		
A24:		---	---	---	---	---	A25:		---	---	---	---	---		
A26:		---	---	---	---	---	A27:		---	---	---	---	---		
A28:		---	---	---	---	---	A29:		---	---	---	---	---		
A30:		---	---	---	---	---	A31:		---	---	---	---	---		
														906=0	

Where:

C@ designates the physical 3274 port.

#IS designates protected fields. When you press the ENTER key after specifying a primary address and any secondary addresses needed for the port, the number of addresses you have specified will appear in this column, if no errors are detected.

P1, S1, S2, S3, S4 are columns in which you must enter a primary address (P) for a port you have selected, and, if the terminal attached to that port is a distributed function terminal with the Multiple Interactive Screen feature, you can enter up to four secondary addresses to support the secondary screens or logical terminals associated with the primary terminal on the port.

116=2 is your response to sequence number 116.

NN is the operator error code that appears if an error is detected.

X...X displays the control unit address or the X.25 secondary station address as entered in response to sequence number 201, 301, or 302; the control unit model number specified in sequence number 151; and, if applicable, the communication mode, BSC or SDLC.

LT=nnn is the total number of addresses that have been assigned; initially, zero.

906=0 is the response verification field. Once you have selected your ports and entered the address(es) to be assigned to that port, change the 0 to a 1 and press ENTER; the Port Address Table (sequence number 118) will be displayed. If there are errors, an operator error code will appear in the NN field and your erroneous entries will be highlighted. If you want to return to the 999 customizing panel, change the 0 to an A and press ENTER.

Figure B-16. Port Assignment Specification Table (Procedure 2, CS-D/Release 64)

117							116=2 06/41A						
C@	#IS	P	S1	S2	S3	S4	C@	#IS	P	S1	S2	S3	S4
A00:	1	02					A01:						
A02:	3		4				A03:						
A04:							A05:						
A06:							A07:	13	011	10			
A08:							A09:						
A10:	5		06	9			A11:						
A12:							A13:						
A14:							A15:						
A16:	15						A17:						
A18:	12	8	07	16	14		A19:						
A20:							A21:						
A22:							A23:						
A24:							A25:						
A26:							A27:						
A28:							A29:						
A30:							A31:						

906 - 0

The Port Assignment Specification Table after all addresses have been entered.

117							99							116=2 06/41A							
C@	#IS	P	S1	S2	S3	S4	C@	#IS	P	S1	S2	S3	S4	C@	#IS	P	S1	S2	S3	S4	
A00:	1	002					A01:	0						A02:	2	003	004				
A02:	2	003	004				A03:	0						A04:	0						
A04:	0						A05:	0						A06:	0						
A06:	0						A07:	3	013	011	010			A08:	0						
A08:	0						A09:	0						A10:	3	005	006	009			
A10:	3	005	006	009			A11:	0						A12:	0						
A12:	0						A13:	0						A14:	0						
A14:	0						A15:	0						A16:	1	015					
A16:	1	015					A17:	0						A18:	5	012	008	007	016	014	
A18:	5	012	008	007	016	014	A19:	0						A20:	0						
A20:	0						A21:	0						A22:	0						
A22:	0						A23:	0						A24:	0						
A24:	0						A25:	0						A26:	0						
A26:	0						A27:	0						A28:	0						
A28:	0						A29:	0						A30:	0						
A30:	0						A31:	0													

906 - 0

The Port Assignment Specification Table after the ENTER key has been pressed (without changing the 906 response to 1). The assigned addresses are displayed in decimal. The 99 indicates that your entries are acceptable but you have not changed the 906 response to a 1.

118							116=2 06/41A						
C@	#IS	P	S1	S2	S3	S4	C@	#IS	P	S1	S2	S3	S4
A00:	1	02					A01:	0					
A02:	2	03	04				A03:	0					
A04:	0						A05:	0					
A06:	0						A07:	3	0D	0E	0A		
A08:	0						A09:	0					
A10:	3	05	06	09			A11:	0					
A12:	0						A13:	0					
A14:	0						A15:	0					
A16:	1	0F					A17:	0					
A18:	5	0C	08	07	10	0E	A19:	0					
A20:	0						A21:	0					
A22:	0						A23:	0					
A24:	0						A25:	0					
A26:	0						A27:	0					
A28:	0						A29:	0					
A30:	0						A31:	0					

907 - 0

The Port Address Table (for information only) is displayed as a result of changing the 906 response to a 1 and pressing the ENTER key. The assigned addresses are displayed in hexadecimal. Hexadecimal representation is required in system generation at the host. It may also be useful to the IBM service representative in problem analysis. Use the local copy utility to copy panel 117 or 118, or both, for your records.

Note: Changes can be made only in panel 117.

Where:

P, S1, S2, S3, S4 are columns in which the addresses are entered in decimal in the PAST panel (117) and displayed in hexadecimal in the Port Assignment Table (118).

Allowable address ranges are:

- 2 to 129 for SNA systems
- 0 to 31 for non-SNA systems

#IS indicates, for the ports being used, the number of addresses assigned to the port.

LT is the total number of addresses assigned, for this example, 15.

906, 907 are response verification fields. Entering a 1 after the 906 would cause the 118 panel to be displayed. Entering a 1 after the 907 would cause the next panel in the customization procedure to be displayed; entering an A would cause the 117 panel, and the responses you made, to be displayed again.

Figure B-17. Port Assignment Specification Table and Port Address Table (Procedure 2, CS-D/Release 64)

117							55							116=2 00/41A							LT=000
C@	#IS	P	S1	S2	S3	S4	C@	#IS	P	S1	S2	S3	S4								
A00:	1		016				A01:														
A02:							A03:														
A04:			014	015	010		A05:														
A06:							A07:														
A08:			021				A09:			18	22	28									
A10:							A11:														
A12:							A13:														
A14:			003				A15:														
A16:							A17:														
A18:							A19:														
A20:							A21:														
A22:							A23:														
A24:							A25:														
A26:							A27:														
A28:							A29:														
A30:							A31:														
														906 - 0							

A. Incorrect address specification: Address assignment must be contiguous, for example, P, S1, S2, A primary address, P, is always assigned. The 55 indicates a blank between assigned addresses on some port.

117							56							116=2 06/41A							LT=000
C@	#IS	P	S1	S2	S3	S4	C@	#IS	P	S1	S2	S3	S4								
A00:	1		002				A01:														
A02:			003	004			A03:														
A04:							A05:														
A06:			3	4			A07:			013	011	010									
A08:							A09:														
A10:			005	006	009		A11:														
A12:							A13:														
A14:							A15:														
A16:			015				A17:														
A18:			012	008	007	016	014	A19:													
A20:							A21:														
A22:							A23:														
A24:							A25:														
A26:							A27:														
A28:							A29:														
A30:							A31:														
														906 - 0							

B. Incorrect address specification: The 56 indicates a space or null between the digits of an address or that an out-of-range or nondecimal address was specified.

Figure B-18. Incorrect Address Specifications

Port Assignment Entry Form

117								
C@.	A00	A01	A02	A03	A04	A05	A06	A07
#IS.	1	-	-	-	-	-	-	-
C@.	A08	A09	A10	A11	A12	A13	A14	A15
#IS.	-	-	-	-	-	-	-	-
C@.	A16	A17	A18	A19	A20	A21	A22	A23
#IS.	-	-	-	-	-	-	-	-
C@.	A24	A25	A26	A27	A28	A29	A30	A31
#IS.	-	-	-	-	-	-	-	-
								906 - 1

Port Address Table Form

118																
C@.	A00	A01	A02	A03	A04	A05	A06	A07								
#IS.	1	-	-	-	-	-	-	-								
P@.																
S@.																
C@.	A08	A09	A10	A11	A12	A13	A14	A15								
#IS.	-	-	-	-	-	-	-	-								
P@.																
S@.																
C@.	A16	A17	A18	A19	A20	A21	A22	A23								
#IS.	-	-	-	-	-	-	-	-								
P@.																
S@.																
C@.	A24	A25	A26	A27	A28	A29	A30	A31								
#IS.	-	-	-	-	-	-	-	-								
P@.																
S@.																
C@.	B00	B01	B02	B03	B04	B05	B06	B07	B08	B09	B10	B11	B12	B13	B14	B15
P@.																

Port Assignment Entry Form / Port Address Table Form

Cā	#IS	P	S1	S2	S3	S4	Cā	#IS	P	S1	S2	S3	S4
A00:	1	___					A01:	___	___	___	___	___	___
A02:	___	___	___	___	___	___	A03:	___	___	___	___	___	___
A04:	___	___	___	___	___	___	A05:	___	___	___	___	___	___
A06:	___	___	___	___	___	___	A07:	___	___	___	___	___	___
A08:	___	___	___	___	___	___	A09:	___	___	___	___	___	___
A10:	___	___	___	___	___	___	A11:	___	___	___	___	___	___
A12:	___	___	___	___	___	___	A13:	___	___	___	___	___	___
A14:	___	___	___	___	___	___	A15:	___	___	___	___	___	___
A16:	___	___	___	___	___	___	A17:	___	___	___	___	___	___
A18:	___	___	___	___	___	___	A19:	___	___	___	___	___	___
A20:	___	___	___	___	___	___	A21:	___	___	___	___	___	___
A22:	___	___	___	___	___	___	A23:	___	___	___	___	___	___
A24:	___	___	___	___	___	___	A25:	___	___	___	___	___	___
A26:	___	___	___	___	___	___	A27:	___	___	___	___	___	___
A28:	___	___	___	___	___	___	A29:	___	___	___	___	___	___
A30:	___	___	___	___	___	___	A31:	___	___	___	___	___	___

Port Assignment Operator Procedure (Sequence Number 117)

These instructions are to be used with the Port Assignment Entry Form, which should have been filled in and attached by the person responsible for planning customizing. Before beginning this procedure, see that the following are attached:

- A filled-in Port Assignment Entry Form
- A Port Address Table Form that is not filled in
- A list of operator error codes.

If any of these items is not attached, or if the Port Assignment Entry Form is not filled in, do not proceed; follow your local problem recovery procedure.

If at any time during this procedure you do not get the expected result, start over at step 1. If you still do not get the expected result, follow your local problem recovery procedure.

1. Sequence number 117 should be on the display screen. If not, you are not at the point in customizing where this procedure is to be performed. Complete the steps on the Initial Customizing Procedure Form, and return to this procedure when sequence number 117 is displayed.
2. The attached Port Assignment Entry Form looks similar to sequence number 117 panel. Enter the values written on the attached form in the appropriate spaces in the 117 panel.
3. When all entries have been made, move the cursor to the 0 (zero) following the 906 entry (bottom right of display), change the 0 to a 1, and press ENTER.
4. If all your entries are acceptable, sequence number 117 will be cleared from the screen and sequence number 118 will be displayed. Go to step 5.

If any of your entries is unacceptable:

- a. The entry after 906 is changed back to a 0.
- b. The unacceptable entries are intensified. (With the 3279, intensified characters are white and red instead of blue and green.)
- c. A 2-digit operator code is displayed in the upper center of the display screen. Use the attached list of Operator Error Codes to find the cause of the error.
- d. Verify that all entries made in step 2 were as written on the form. Make any changes necessary, and perform step 3. If there are still unacceptable entries, follow your local problem recovery procedure.

5. Sequence number 118 shows you what addresses have been assigned. Use the attached Port Address Table Form to copy the information given in sequence number 118. The filled-in Port Address Table Form should be given to the person who is responsible for planning 3274 customizing.
6. The cursor is positioned at the 0 following the 907 entry (bottom right of the display screen). Change the 0 to a 1, and press ENTER.
7. Return to where you left off either in the Initial Customizing Procedure Form or in the Modification Procedure Form.

Appendix C. Subsystem Verification Procedure

This procedure verifies that the 3274 Control Unit can communicate with all its attached terminals (display stations and printers). It should be given to, and performed by, the person responsible for customizing the 3274.

This procedure can be performed only after the 3274 Control Unit has been successfully customized and an IML performed.

1. Ensure that all attached terminals and the 3274 are powered on.
2. Press the IML pushbutton. Various 8 4 2 1 patterns will appear. When IML is completed, all 8 4 2 1 indicators will be off.
3. While holding the ALT key down on the display station keyboard, press and release the TEST key and then release the ALT key.

The word TEST will appear on the bottom left of the display screen.

4. Enter /3, and press ENTER.

The first two lines of your display screen should resemble those shown in the diagram below. The actual format may vary, depending on how you replied to sequence numbers 111, 112, and 117 in the customizing procedure.

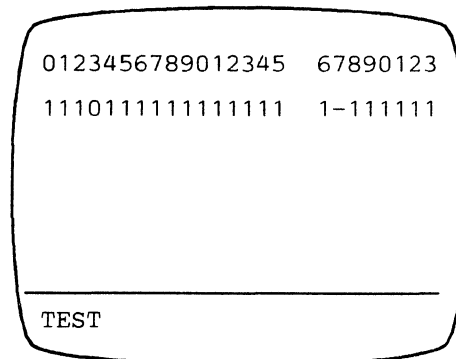

The first line represents the terminals configured for your 3274. Starting from the left, the 0 through 9 represent the Category A terminals attached to ports A0 through A9 on the 3274. The next characters (0 through 5) represent the Category A terminals attached to ports A10 through A15. The blank indicates that there are no more Category A terminals. The remaining characters on the first line (6 through 3) represent the Category B terminals attached to ports B0 through B7 on the 3274.

The second line represents the status of each terminal on line 1. A 1 indicates that the terminal is powered on and communicating with the 3274. A 0 indicates that the port represented is not communicating with a terminal; this is the case with the terminal attached to port A3 in the diagram. This could be caused by the following:

- a. The terminal connected to that port is powered off.
- b. No terminal is connected to that port.
- c. A problem exists within the terminal connected to that port.

When a 0 status is indicated, you should:

- a. Verify that a terminal is connected to the port. Do this by checking the port connectors on the 3274 (as shown in the following diagram) to see whether a wire is connected to the port.

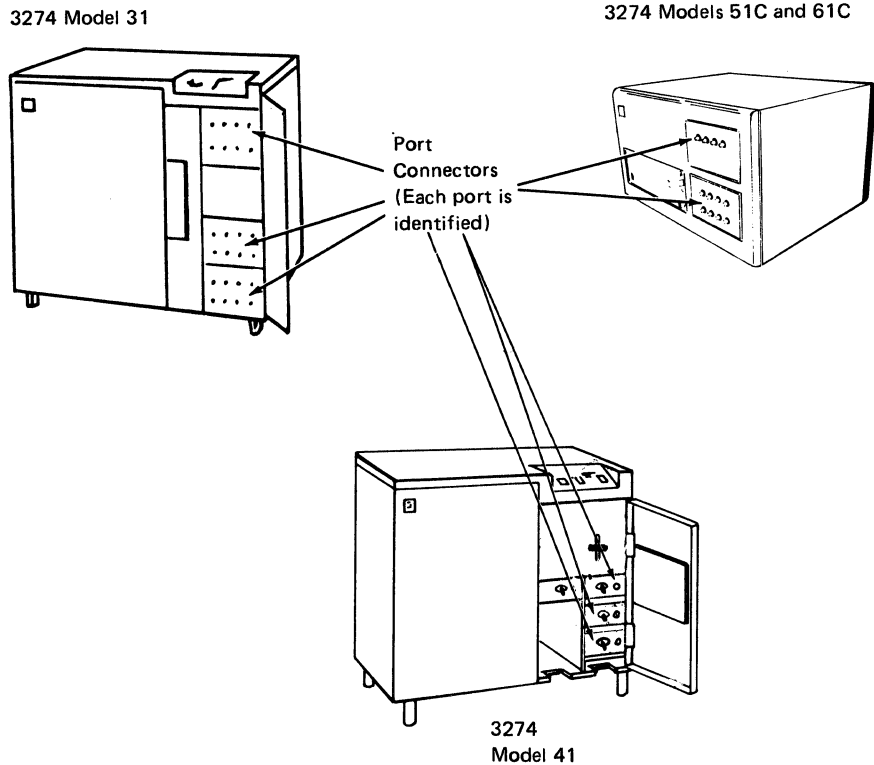

- b. If a coaxial cable is not connected, the 0 is not a problem indication.
- c. If a coaxial cable is connected, the terminal either is powered off, is not connected to the other end of the coaxial cable, or is not working properly. Follow your local procedures to correct the problem.

A dash (—) indicates that the 3274 was communicating with the terminal but, because of a problem within the terminal, no longer is. Follow your local procedures to correct the problem.

An X indicates that the port is unassigned. This will occur when individual port assignment (sequence number 116) is used.

Any other lines should be ignored. They contain information used by the IBM service representative for problem diagnosis.

5. To end this procedure: While holding the ALT key down on the display station keyboard, press and release the TEST key and then release the ALT key.

The word TEST will disappear from the bottom left of the display screen, and the screen will be cleared. If you are using a 3274 Model 31C, 51C, or 61C and have been given instructions for setting the Model 31C, 51C, or 61C switches, follow those instructions. Otherwise, proceed with your usual work.

Appendix D. Color Convergence Procedure

This procedure describes how to adjust the color convergence on a 3279 Color Display Station during 3274 customizing. It should be given to the person responsible for customizing the 3274.

Note: In the U.S. and in Canada, if you are using a 3279 whose model number ends in -1 (for example, S2A-1), this color convergence procedure cannot be performed.

Operator Instructions

When a 3274 is customized with a 3279 Color Display Station, a pattern similar to those shown in Figure D-1 will appear on the display screen after step 3 of the Initial Customizing Procedure Form is performed. The pattern allows you to adjust the convergence of the 3279 if needed. (*Convergence* means superimposing one set of lines on another so that only one set of lines is visible.) Allow a 10-minute warm-up period after the 3279 is switched on before deciding whether convergence is needed.

Figure D-1 shows examples of unconverged and converged display screens. An unconverged pattern will be multicolor; a converged pattern will appear as white lines. Take care when converging your 3279: improper convergence will make it difficult to tell the colors of characters on the outer edges of the display screen.

Convergence Procedure

Note: If your 3279 is properly converged, hold down the ALT key, press and release the TEST key, and return to step 4 of the Initial Customizing Procedure Form. If your 3279 is not properly converged, perform the following procedure.

1. Make sure that the center switch to the right of the display screen is in the lower (● ●) position.
2. Press the spacebar. A pattern will appear in the center of the display screen.
3. Use the cursor movement keys (<--, -->, |, and |) to move one set of lines until they converge with the other (color becomes yellow). The movement of the lines is very slight and may not be perceptible at first.
4. Press the spacebar again. A different color pattern will appear in the center of the screen.
5. Use the cursor movement keys to converge this pattern (color becomes pink).

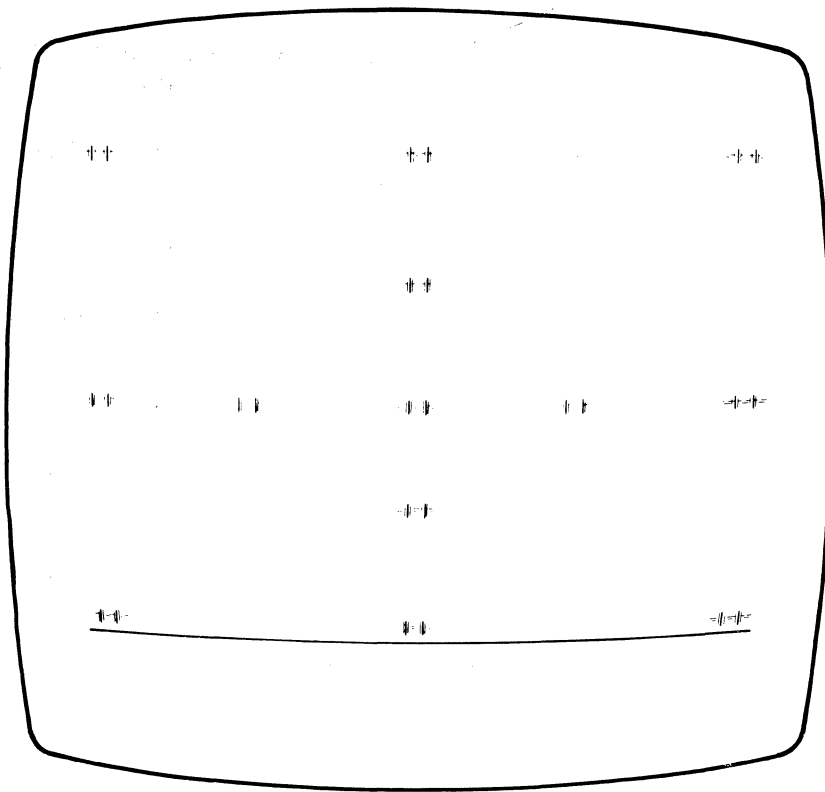

Unconverged

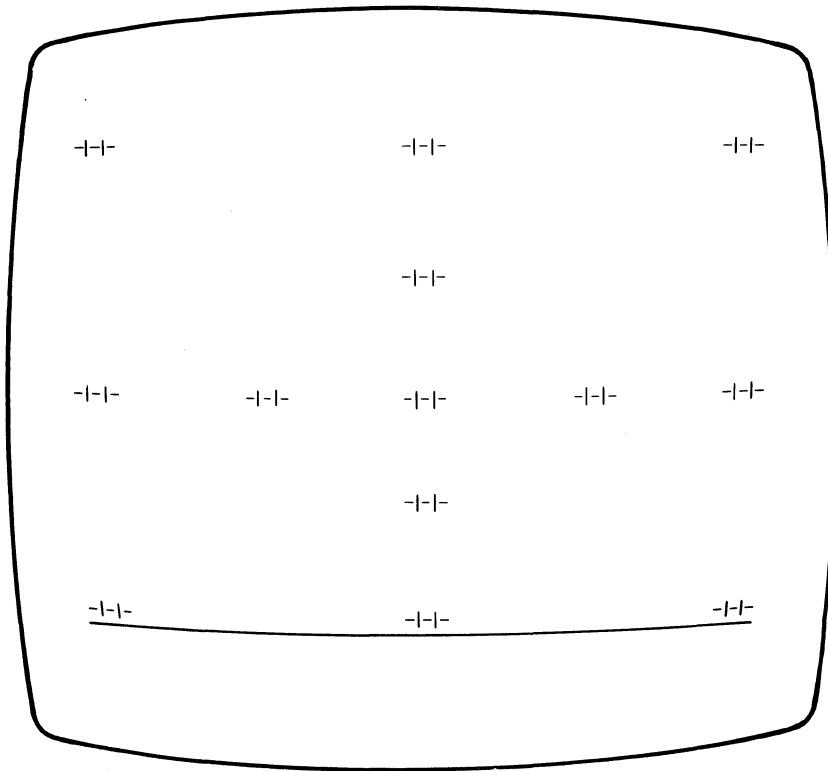

Converged

Figure D-1. Examples of Unconverged and Converged Display Screens

6. Press the R key. The pattern from step 2 will again appear in the center of the screen. Reconverge this pattern if necessary.
7. Press the spacebar twice. The pattern will appear in a different location of the display screen.
8. Use the cursor movement keys to converge the pattern.
9. Press the spacebar again. A different color pattern will appear in the same location.
10. Use the cursor movement keys to converge the pattern.
11. Press the R key. The pattern from step 6 will again appear on the display screen. Reconverge this pattern if necessary.
12. Repeat steps 7 through 11 (12 times) until all the patterns appear on the display screen at one time (as shown in Figure D-1).
13. When all the patterns are on the display screen at the same time, check that they are all converged properly. If any are not, repeat this procedure, starting at step 2.
14. When all the patterns are converged properly, hold down the ALT key, press and release the TEST key, and return to step 4 of the Initial Customizing Procedure Form.

Error Conditions

The following error indications may appear in the operator information area during the convergence procedure:

Indicator	Symptom	Action
228	Unable to converge pattern fully.	Change the battery.
229	Area of display screen above operator information area is all green.	Report the problem.

Appendix E. Planning for 3274 Model 31C Modem Address Switch Settings

Modem Address Switches (Integrated Modems Only)

The Modem Address switches are installed only on a 3274 Model 31C that has an integrated modem feature (5640, 5740, 5840, or 5842) installed. These switches are located behind a door on the control panel. They must be set to the binary equivalent of either your BSC control unit address (this is the hexadecimal polling address you obtained from the system programmer for your response to sequence number 301) or your SDLC control unit address (this is your response to sequence number 302). Failure to set the Modem Address switches properly will result in valid data operations of the 3274 but inability to execute the link problem determination aid (LPDA) function of the integrated modem.

Use Figure E-1 to convert your sequence number response to its binary equivalent. For example, if your response to sequence number 301 is 21, the eight Modem Address switches should be set as shown in Figure E-2.

Enter the Modem Address switch settings in step 2 of the instructions following Figure E-2. Give the completed instructions to the person who will customize the 3274.

Numeric Value	Modem Address Switch Settings			
0	Off	Off	Off	Off
1	Off	Off	Off	On
2	Off	Off	On	Off
3	Off	Off	On	On
4	Off	On	Off	Off
5	Off	On	Off	On
6	Off	On	On	Off
7	Off	On	On	On
8	On	Off	Off	Off
9	On	Off	Off	On
A	On	Off	On	Off
B	On	Off	On	On
C	On	On	Off	Off
D	On	On	Off	On
E	On	On	On	Off
F	On	On	On	On

Figure E-1. Conversion of BSC and SDLC Control Unit Addresses to Binary-Equivalent Modem Address Switch Settings on 3274 Model 31C

Response to Sequence Number 301	2				1			
Switch Number	1	2	3	4	5	6	7	8
Switch Setting	Off	Off	On	Off	Off	Off	Off	On

Figure E-2. Example of 3274 Model 31C Modem Address Switch Settings

Instructions for Setting 3274 Model 31C Modem Address Switches

1. Open the customer access area door on the control panel. Insert your finger into the recessed area to the left of the door. Pull the edge of the door toward you, and swing it to the right.

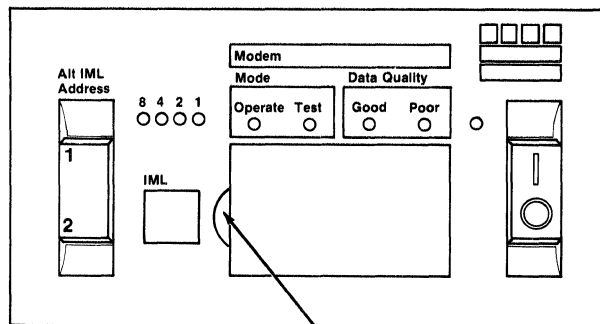

Insert finger in recess, and pull door to open.

2. Set the Modem Address switches on or off as indicated in the boxes below. Press the top of the switch for on; press the bottom of the switch for off.

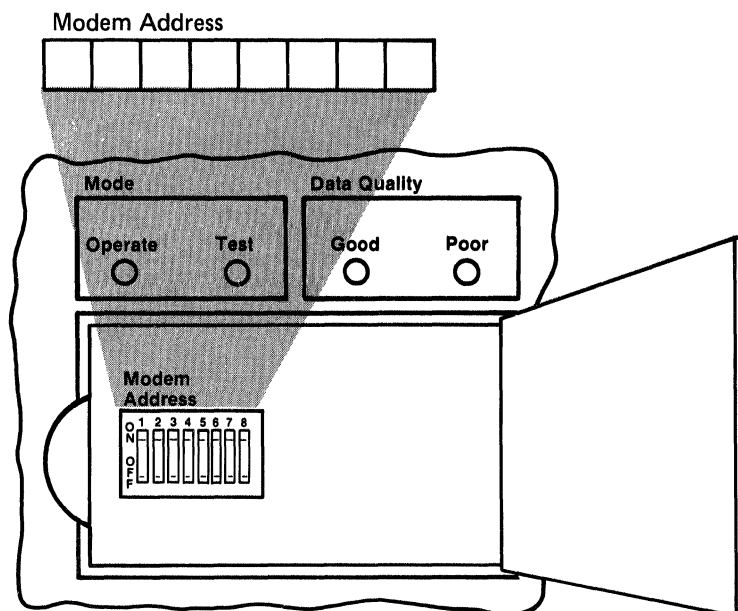

3. Close the customer access area door.

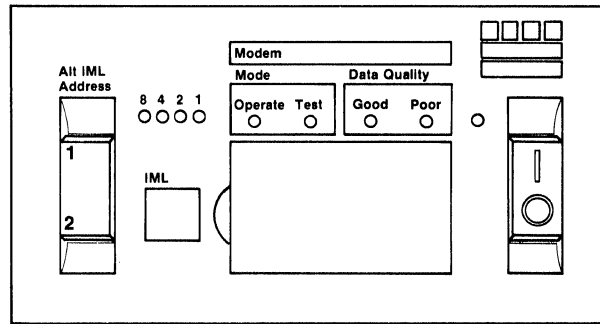

4. Your 3274 is now ready for use.

Appendix F. Planning for 3274 Model 51C and 61C Switch Settings

Note: Only the Loop Data Speed switches are applicable to a 3274 Model 61C.

Of the many switches that may be installed on a Model 51C operator panel, three switch groups require some planning: Transmit Level switches, Loop Data Speed switches, and Modem Address switches. The Transmit Level switches control the signal level between the Model 51C and the host. The Loop Data Speed switches control the data rate of the loop. The Modem Address switches determine the address that the host will use to communicate with the Model 51C.

Only one of these switch groups will be on your Model 51C. Transmit Level switches are installed on a Model 51C that attaches to a 1200-bps switched network (U.S. only). Loop Data Speed switches are installed on a Model 51C that attaches to an 8100 Information System or a 4331 Processor loop. Modem Address switches are installed on a Model 51C with a greater-than-1200-bps integrated modem that attaches to a nonswitched network.

The following descriptions tell you how to determine whether your Model 51C has any of these switches, how to determine the proper switch settings, and what information to pass on to the person who will customize your Model 51C.

Transmit Level Switches (1200 BPS Integrated Modem, U.S. and Canada Only)

The Transmit Level switches are installed only on a 3274 Model 51C Control Unit that has an integrated modem feature (5501, 5502, 5507, or 5508) that attaches to a switched network. These switches are used to match the Model 51C transmit level to the data coupler (type CDT, CBS, or FCC-certified equivalent) that is attached to the termination of the communication line. Consult the data coupler manufacturer's representative to determine the proper dBm¹ level for the data coupler. Use Figure F-1 to determine the correct setting of the Transmit Level switches for the dBm¹ level obtained from the manufacturer's representative; then enter this information in the instructions following the figure. Give the completed instructions to the person who will customize your Model 51C.

¹ Same as decibel (dB), but comparison is to an absolute value of power, 1 milliwatt.

dBm Level	Transmit Level Switches			
	-1dB	-2dB	-4dB	-8dB
0	OFF	OFF	OFF	OFF
-1	ON	OFF	OFF	OFF
-2	OFF	ON	OFF	OFF
-3	ON	ON	OFF	OFF
-4	OFF	OFF	ON	OFF
-5	ON	OFF	ON	OFF
-6	OFF	ON	ON	OFF
-7	ON	ON	ON	OFF
-8	OFF	OFF	OFF	ON
-9	ON	OFF	OFF	ON
-10	OFF	ON	OFF	ON
-11	ON	ON	OFF	ON
-12	OFF	OFF	ON	ON
-13	ON	OFF	ON	ON
-14	OFF	ON	ON	ON
-15	ON	ON	ON	ON

Figure F-1. 3274 Model 51C Transmit Level Switches

Instructions for Setting 3274 Model 51C Transmit Level Switches (U.S. and Canada Only)

1. Open the customer access area door on the bottom left of the Model 51C. To unlatch the door, turn the slotted screw head counterclockwise with a coin.

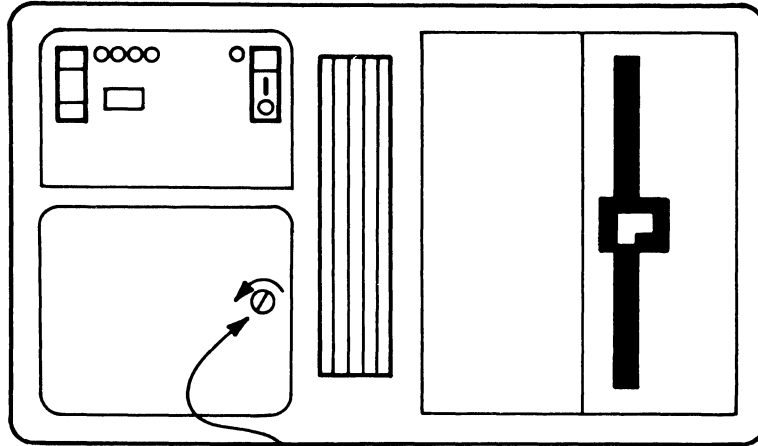

Slotted Screw Head
(Turn counterclockwise to open)

2. Set the Transmit Level switches on or off as indicated in the boxes below. Push the switch up for on and down for off.

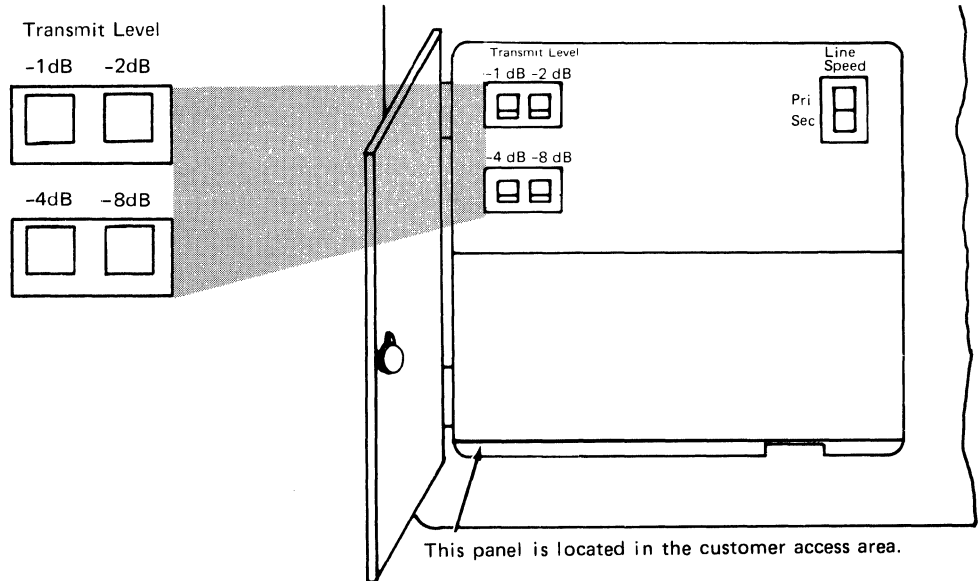

3. Close the customer access area door. Secure the latch by turning the slotted screw head clockwise with a coin.

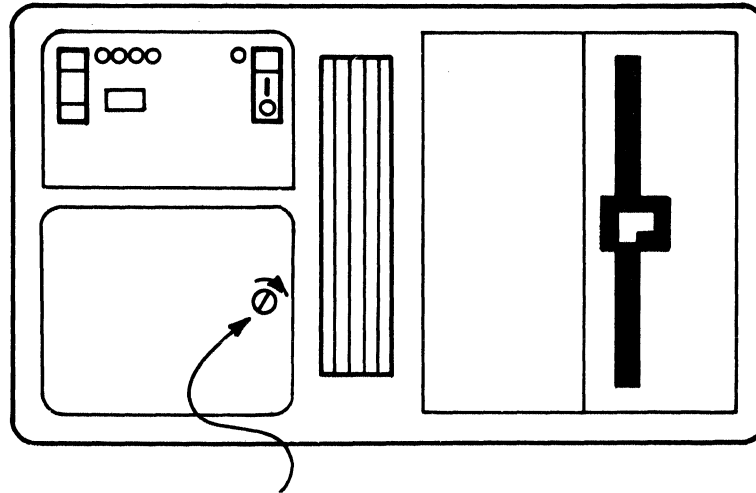

Slotted Screw Head (Turn clockwise to secure)

4. Your 3274 is now ready for use.

Loop Data Speed Switches (Loop Adapter Feature Only)

The Loop Data Speed switches are installed only on 3274 Model 51C and 61C Control Units that have the Loop Adapter feature (4850) to attach to a 4331 Processor or to an 8100 Information System loop. These switches are used to select the primary and secondary loop data speeds. If the loop operates at a carrier speed of 9600 bps, the operator can switch the loop data speed by using the Pri/Sec switch on the Model 51C or 61C operator panel. (If the loop operates at a carrier speed of 38,400 bps, the Sec [Secondary] position of the Pri/Sec switch should not be used.)

To determine the Loop Data Speed settings, first select the table in Figure F-2 for the loop carrier speed, either 9600 bps or 38,400 bps. Using this table, find the primary and secondary loop data speeds that your system is going to use. The switch settings are shown to the left of the loop data speeds you select. Fill in the switch settings on the instructions following Figure F-2. Give the completed instructions to the person who will customize your Model 51C or 61C.

For a loop carrier speed of 9600 bps, use the following table:

Loop Data Speed Switch Setting			Line Speed (bps)	
1	2	3	Pri	Sec
Off	Off	Off	9600	4800
Off	Off	On	9600	2400
Off	On	Off	4800	2400
On	Off	Off	2400	1200

For a loop carrier speed of 38,400 bps (direct-attached loop only), use the following table:

Loop Data Speed Switch Setting			Line Speed (bps)	
1	2	3	Pri	Sec
Off	Off	Off	38,400	*
On	Off	Off	9600	*

*Do not use.

Figure F-2. Loop Data Speed Switch Settings. (See sequence number 347 for additional information on changing loop speed selection.)

Instructions for Setting 3274 Model 51C and 61C Loop Data Speed Switches

1. Open the customer access area door on the bottom left of the Model 51C or 61C. To unlatch the door, turn the slotted screw head counterclockwise with a coin.

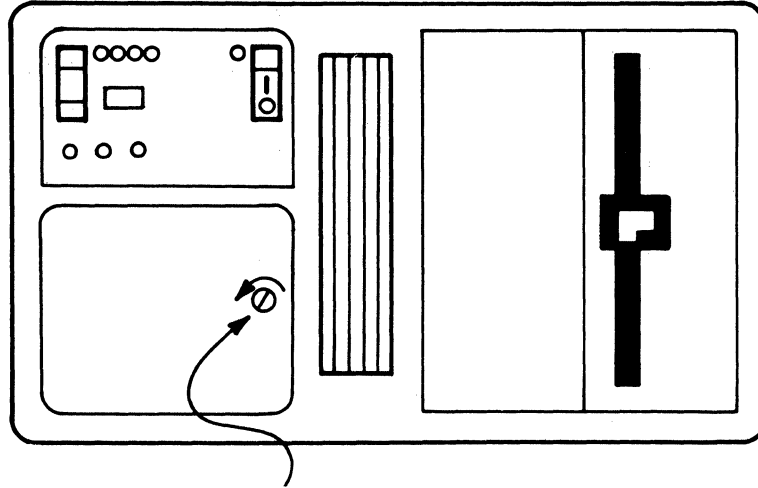

Slotted Screw Head
(Turn counterclockwise to open)

2. Set the Loop Data Speed switches on or off as indicated in the boxes below. Push the switch up for on and down for off.

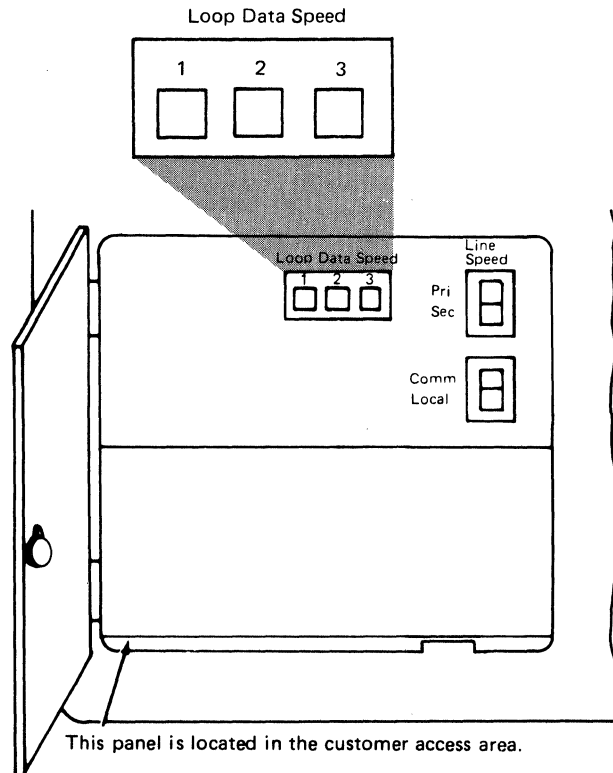

- 3. Close the customer access area door. Secure the latch by turning the slotted screw head clockwise with a coin.

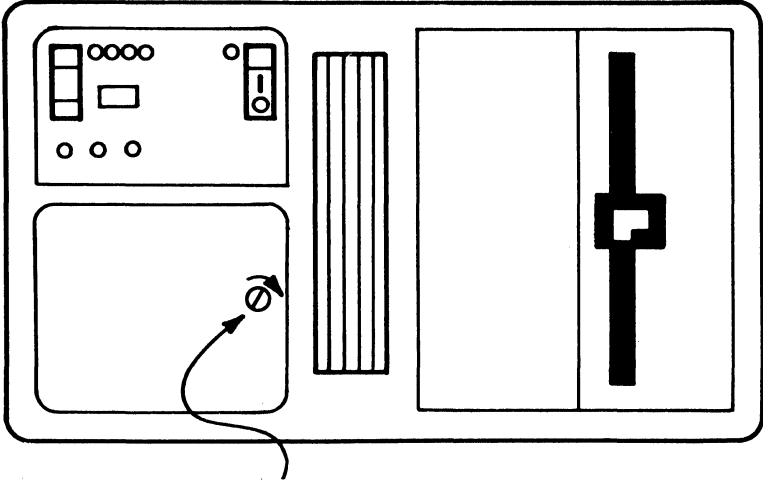

Slotted Screw Head (Turn clockwise to secure)

- 4. Your 3274 is now ready for use.

Modem Address Switches (Integrated Modems with Speeds Greater Than 1200 BPS Only)

The Modem Address switches are installed only on a 3274 Model 51C that has an integrated modem feature (5640, 5740, 5840, or 5842) installed. These switches are located behind a door on the control panel. These switches must be set to the binary equivalent of either your BSC control unit address (this is the hexadecimal polling address you obtained from the system programmer for your response to sequence number 301) or your SDLC control unit address (this is your response to sequence number 302). Failure to set the Modem Address switches properly will result in valid data operations of the 3274 but inability to execute the link problem determination aid (LPDA) function of the integrated modem.

Use Figure F-3 to convert your sequence number response to its binary equivalent. For example, if your response to sequence number 301 is 21, the eight Modem Address switches should be set as shown in Figure F-4.

Enter the Modem Address switch settings in step 2 of the instructions following Figure F-4. Give the completed instructions to the person who will customize the 3274.

Numeric Value	Modem Address Switch Settings			
0	Off	Off	Off	Off
1	Off	Off	Off	On
2	Off	Off	On	Off
3	Off	Off	On	On
4	Off	On	Off	Off
5	Off	On	Off	On
6	Off	On	On	Off
7	Off	On	On	On
8	On	Off	Off	Off
9	On	Off	Off	On
A	On	Off	On	Off
B	On	Off	On	On
C	On	On	Off	Off
D	On	On	Off	On
E	On	On	On	Off
F	On	On	On	On

Figure F-3. Conversion of BSC Control Unit Address and SDLC Control Unit Address to Binary-Equivalent Modem Address Switch Settings on 3274 Model 51C

Response to Sequence Number 301	2				1			
Switch Number	1	2	3	4	5	6	7	8
Switch Setting	Off	Off	On	Off	Off	Off	Off	On

Figure F-4. Example of 3274 Model 51C Modem Address Switch Settings

Instructions for Setting 3274 Model 51C Modem Address Switches

1. Open the customer access area door on the bottom left of the Model 51C. To unlatch the door, turn the slotted screw head counterclockwise with a coin.

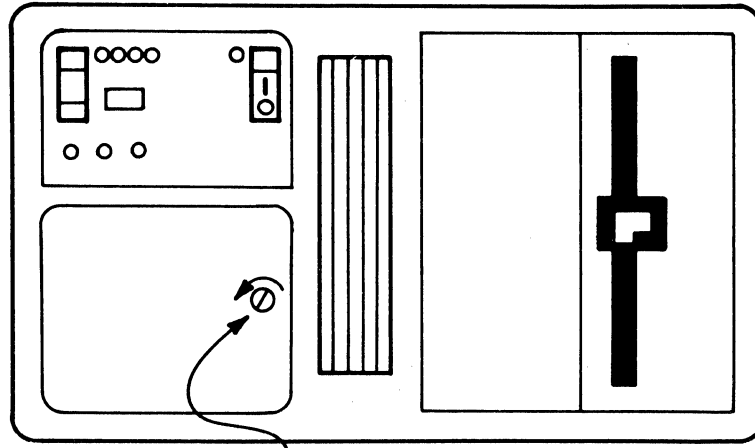

Slotted Screw Head
(Turn counterclockwise to open)

2. Set the Modem Address switches on or off as indicated in the boxes below. Press the top of the switch for on; press the bottom of the switch for off.

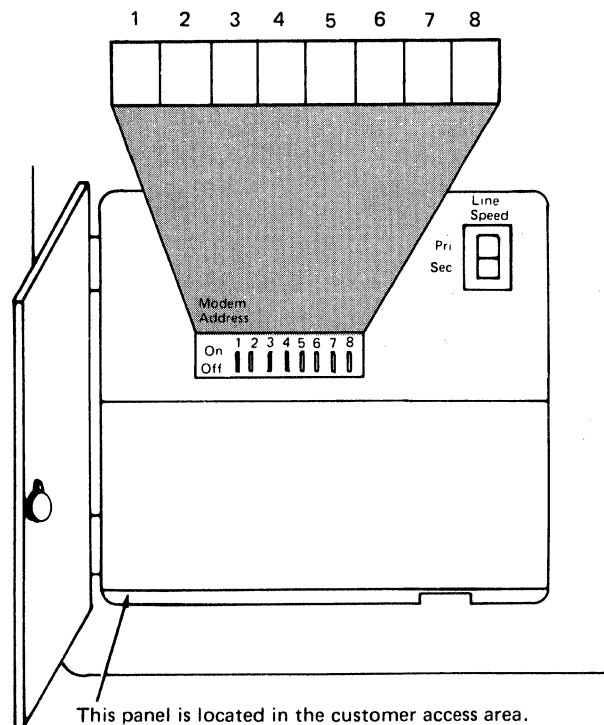

This panel is located in the customer access area.

3. Close the customer access area door. Secure the latch by turning the slotted screw head clockwise with a coin.

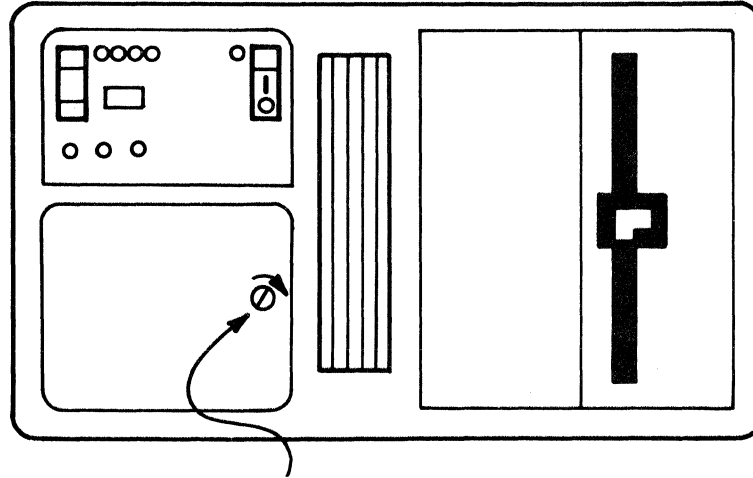

Slotted Screw Head (Turn clockwise to secure)

4. Your 3274 is now ready for use.

Appendix G. Response Time Monitor (RTM) Customizing Information

This appendix provides the background information needed to answer the customizing questions for the RTM function (sequence numbers 127 and 128). It also provides descriptions of sequence numbers 127 and 128.

More information about the RTM function is contained in the *3274 Control Unit Description and Programmer's Guide*, GA23-0061.

RTM Requirements

The RTM function is available on 3274 Models 41A, 41C, 41D, and 61C, and on 3274 Models 31A, 31C, 31D, and 51C when equipped with the appropriate Extended Function Store and Integrated Diskette Drive (two-sided diskette) features. Configuration Support D is required.

An RTM timer card (special feature 6101) must be installed in the control unit.

Display devices for which response times can be measured are the 6850 Displaywriter, the IBM 3270 Personal Computer, and the 3178, 3179, 3180, 3277, 3278, and 3279 display stations. Distributed function terminals such as the 3290 Information Panel are also supported through a special interface.

Host Interface

No specific host support is required; RTM has a host interface, however, for SNA communication. Host programming support (Network Logical Display Manager, Release 2) is available for the setting of RTM parameters from a host and for the collection and display of RTM information at a Network Communication Control Facility (NCCF) operator station.

No host programming is required to use the 3274 RTM function for 3270 subsystem display of response times.

For BSC and non-SNA local channels, no host interface is provided in RTM, and response time display is available only at the 3274 subsystem.

RTM Description

When the RTM function is customized (sequence numbers 127 and 128), you are specifying where the RTM data will be displayed (127), what will be timed (127), the status for the host interface (128), and the boundary values used in measuring the response times (128).

Sequence Number 127

The first digit response to sequence number 127 determines where data will be displayed.

Responses

Possible responses are:

- RTM is not configured.
- RTM is configured with *no* host support (SNA and non-SNA). On port 0 only, the operator is authorized to (1) display RTM log information in Test mode and (2) display the Last Transaction Time indicator. The authorized operator may also reset the RTM data via the A4/4 test.
- RTM is configured with *no* host support (SNA and non-SNA). On all ports, the operator is authorized to (1) display RTM log information in Test mode and (2) display the Last Transaction Time indicator. All operators may reset the RTM data via the A4/4 test.
- RTM is configured *with* host support (SNA only). No subsystem display of RTM log information or Last Transaction Time indicator is authorized.
- RTM is configured *with* host support (SNA only). On port 0 only, the operator is authorized to (1) display RTM log information in Test mode and (2) display the Last Transaction Time indicator.
- RTM is configured *with* host support (SNA only). On all ports, the operator is authorized to (1) display RTM log information in Test mode and (2) display the Last Transaction Time indicator.

Note: Authorization to display RTM log information given by the last three responses may be altered by the host at any time. These responses are applicable to SNA networks only.

What Will Be Timed

The second digit of the response to sequence number 127 determines what will be measured.

Response time is measured from recognition of the inbound AID request in the 3274 until the end of the transaction. The end-of-transaction parameter is defined for all terminals when the 3274 is customized. When the 3274 is attached via an SNA protocol, response time is measured on the LU-LU flow only; none is measured for the SSCP-LU session.

The end-of-transaction parameter may be defined as one of the following.

First Character: The measurement is terminated when the first character of the next outbound message is written to the terminal. Note that this character can be (1) Write, Erase/Write, or Erase/Write Alternate, (2) Erase All Unprotected, (3) Load Programmed Symbols, (4) Erase Reset, (5) Set Window Origin, (6) Activate Partition, (7) Create Partition, (8) Destroy Partition, (9) Reset Partition, or (10) BSC Copy. Note also that a Write with or without data terminates the RTM measurement. The foregoing are examples of outbound communication that could possibly be expected to modify the contents of the presentation space.

Keyboard Unlocked: For SNA devices, measurement is terminated when the next outbound operation (other than a read) to that terminal contains a Change Direction/End Bracket (CD/EB) or explicit or implicit keyboard restore (WCC = keyboard restore or EAU command).

In non-SNA:

- For terminals such as the 3278 or 3279 display stations, measurement is terminated:
 - On End of Transmission (EOT) for BSC. Exception: Upon receipt of a BSC Copy command, the measurement is terminated on the *from* device once the screen image has been stored in the control unit. At this point, the *from* device is available for the operator to use. The *to* device in the BSC Copy will still have the measurement terminated at EOT.
 - On End of Command Chain (when attached to a Model D control unit)
- For distributed function terminals, such as the 3290 Information Panel and the IBM 3270 Personal Computer, measurement is terminated upon receipt of a Terminate Chained Command Sequence (TCCS).

CD/EB: This definition is valid only in an SNA environment. The measurement is terminated upon receipt of a Change Direction (CD) or End Bracket (EB), which puts the terminal into a Send or Contention state, respectively. This is usually equivalent to a "time-to-last-character."

Notes:

1. *EB and CD received in an exception response request or in a definite response causes measurement to be terminated on LIC (last in chain).*
2. *CD in conjunction with a Read does not stop the timer.*

Sequence Number 128

When sequence number 127 is answered with a nonzero response, sequence number 128 (a panel) is displayed. One of two versions of the panel (Example A or Example B following) is displayed, depending on the first digit response to sequence number 127. The panel provides fields for specifying the time boundaries for the RTM counters (Example A) or a flag field for setting host interface status and fields for setting the time boundaries (Example B).

Example A

128	X...X
B1 - 00 : 01 . 0	
B2 - 00 : 02 . 0	
B3 - 00 : 05 . 0	
B4 - 00 : 10 . 0	

904 - 0

Example B

128

X...X

F1 - 00000000

B1 - 00 : 01 . 0

B2 - 00 : 02 . 0

B3 - 00 : 05 . 0

B4 - 00 : 10 . 0

904 - 0

The panel of Example B is not displayed unless the first digit response to sequence number 127 was a 3, 4, or 5.

The initial values shown in the F1 and B1 through B4 fields are the default values for those fields and will be present when the panel is first displayed.

The cursor is initially positioned as shown in each example.

Sequence number 128 fields and responses are as follows:

X...X is the model number field. This field is *not* defined during customization but will show the control unit address or X.25 secondary station address, the model number, and, if appropriate, the communication mode being used (SDLC, BSC, or X.25). The BSC, SDLC, or X.25 address is picked up from sequence number 301 or 302, as appropriate.

F1 is the host interface status field. If displayed, an 8-digit response is required. Valid digits are 0 and 1, which carry the following meaning:

A 0 turns off the function associated with the digit position.

A 1 turns on the function associated with the digit position.

The function and the digit position are related as follows:

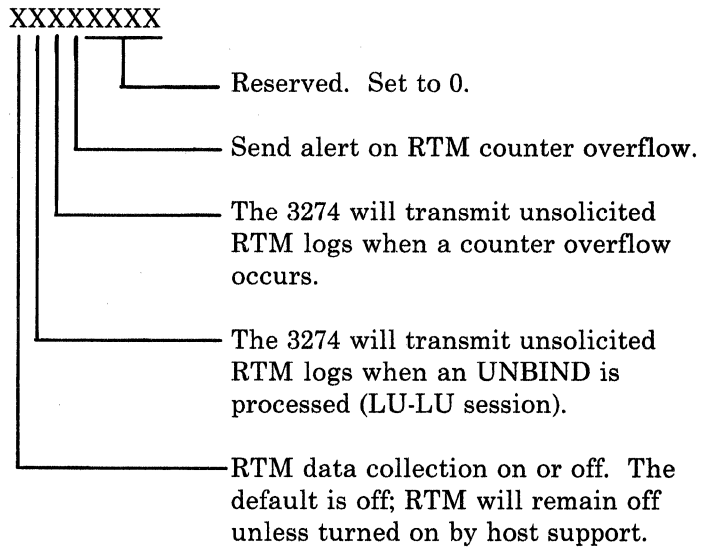

B1 – B4 are the fields used to specify the maximum time (the boundary) associated with each RTM counter. (See “Boundary Values” following.) Specification is in minutes, seconds, and tenths of a second; for example, 11 : 35 . 3 is 11 minutes and 35 and 3/10 seconds.

The rules for specifying boundaries are:

- One to four boundaries may be specified.
- One to four boundaries may be specified.
- The maximum allowable boundary is 27 : 18 . 3.
- The seconds field may not exceed 59 seconds.
- A zero entry (00 : 00 . 0) for field B1 is not allowed.
- Entries (B1 to B4) must ascend in value; any entries after the maximum value *must* be zero.
- A zero entry may not be embedded between two nonzero entries.

904 is the acceptance field. Change the zero to a one when you have completed your RTM specification.

Boundary Values (Sequence Number 128)

When the RTM feature support is customized in the 3274, a series of five counters (Figure G-1) is allocated for each configured device or logical terminal, representing intervals of time into which the various response times are mapped. During the customizing process, up to four counters may be set up by specifying the maximum times, or boundaries, associated with each. If a response time is less than or equal to a particular boundary, the counter associated with that boundary is incremented at the end of the transaction. If not, the next boundary value is checked. If the response time does not fit within any of the boundaries, then it is mapped into the fifth, or overflow, counter. Should any one of the four boundaries be specified as the maximum, the counter associated with that boundary becomes the overflow counter and subsequent counters are ignored. By specifying boundary values properly, a customer can obtain a distribution of his network responses for each logical terminal.

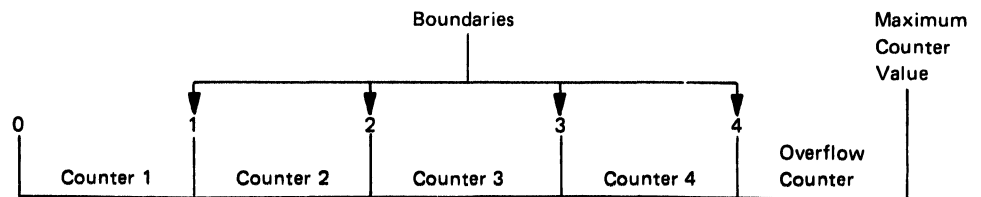

Figure G-1. Counters and Boundaries

Boundaries must be specified in order of increasing magnitude. The maximum boundary value is 27 minutes, 18.3 seconds. The maximum counter value is 65,535. The counter will not wrap around when this value is reached. If any of the boundaries is set to the maximum boundary value, the counter associated with it becomes the overflow counter. Customizing default boundaries are 1, 2, 5, and 10 seconds.

The total response time is also kept for each logical terminal. Each time a counter (including the overflow counter) is incremented, the corresponding transaction time is added to a total-time register for that device. By dividing this total time by the total number of transactions, the average response time may be calculated. This average response time is available only through the host application; it cannot be displayed on a device attached to the 3274.

Boundary Value Examples (Sequence Number 128)

The following examples illustrate a correct boundary specification and some of the incorrect specifications for which the operator error code is displayed at the top center of the sequence number 128 panel.

1. A correct specification.

B1 - 00 : 02 . 1
B2 - 00 : 03 . 2
B3 - 00 : 05 . 5
B4 - 00 : 07 . 7

The first counter will be incremented for each response time of 2.1 seconds or less.

The second counter will be incremented for each response time exceeding 2.1 seconds but less than or equal to 3.2 seconds.

The third counter will be incremented for each response time exceeding 3.2 seconds but less than or equal to 5.5 seconds.

The fourth counter will be incremented for each response time exceeding 5.5 seconds but less than or equal to 7.7 seconds.

The fifth counter (the overflow counter, no boundary specified) will be incremented for each response time exceeding 7.7 seconds.

2. Boundary values not in ascending order.

B1 - 00 : 02 . 0
B2 - 00 : 05 . 7
B3 - 00 : 04 . 5
B4 - 00 : 06 . 8

Operator error code 64 is displayed.

3. A zero entry for field B1 is not allowed.

B1 - 00 : 00 . 0
B2 - 00 : 00 . 1
B3 - 00 : 00 . 2
B4 - 00 : 00 . 3

Operator error code 63 is displayed.

4. Entries after the maximum boundary value allowed (27 : 18 . 3) must be zero.

B1 - 00 : 01 . 0
B2 - 27 : 18 . 3
B3 - 10 : 15 . 4
B4 - 20 : 10 . 5

Operator error code 66 is displayed.

5. The seconds field may not exceed 59.

B1 - 00 : 01 . 0
B2 - 00 : 10 . 0
B3 - 00 : 30 . 0
B4 - 00 : 61 . 0

Operator error code 62 is displayed.

Sequence Number 128 Procedures

The customization planner will have entered a check mark by the procedure to be followed.

Default values. Change the 0 after 904 to a 1 and press ENTER.

Procedure A. No host communication. Enter the values shown below in the B fields.

128

B1 - ___ : ___ . _

B2 - ___ : ___ . _

B3 - ___ : ___ . _

B4 - ___ : ___ . _

After entering the values shown, change the 0 after 904 to a 1 and press ENTER. If the entries are acceptable, the screen clears. If the entries are not acceptable, the incorrect entries are highlighted and an operator code is displayed at top center of the panel. See Figure 4-4.

Procedure B. Host Communication. Enter the values shown below in the F1 and B fields.

128

F1 - _____

B1 - ___ : ___ . _

B2 - ___ : ___ . _

B3 - ___ : ___ . _

B4 - ___ : ___ . _

After entering the values shown, change the 0 after 904 to a 1 and press ENTER. If the entries are acceptable, the screen clears. If the entries are not acceptable, the incorrect entries are highlighted and an operator code is displayed at top center of the panel. See Figure 4-4.

Appendix H. Alert Function Customizing Information (Sequence Number 220)

Alert is an SNA-only function and requires Configuration Support D on 3274 Models 41A, 41C, and 61C, and on 3274 Models 31A, 31C, and 51C. The 31 and 51 models require the Extended Function Store and Integrated Diskette Drive (two-sided diskette) features to operate with Configuration Support D.

The SSCP-PU session is used to send alert data to the host. The alert information flows through the Network Communication Control Facility (NCCF) to the Network Problem Determination Application Program (NPDA). NPDA maintains a data base of alert information based on filters currently in effect for devices throughout the network and allows users to perform problem determination and failure isolation.

The 3274 will attempt to send alert data for all errors that have not affected the integrity of the host adapter, the 3274 processor, control storage, or the control program itself. The 3274 sends alert data based on the NNN error codes generated by the 3274 control unit and attached devices, and the NPDA determines which alert data has significance.

NPDA Version 3, Release 1, is required at the host for use of the alert function.

Operator-Generated Alert Message

Among the possible responses to customizing question 220 are those indicating that operator-generated alert message capability is wanted. An operator-generated alert message is a skeleton message, called up by an operator and filled in with installation-specified information. To properly process an operator-generated alert message the Network Problem Determination Application at the host must have been set up to receive the message. See the *3274 Control Unit Description and Programmer's Guide*, GA23-0061, for the details of sending an operator-generated alert message.

Appendix I. X.25 Customizing Information (Sequence Number 332)

X.25 — A Brief Description

The X.25 adapter feature enables remote models (1C, 31C, 41C, 51C, and 61C) of the 3274 Control Unit to attach to host systems via an X.25 network, using SNA-defined protocols identical with existing 3274 SNA attachments. The International Telegraph and Telephone Consultative Committee (CCITT) Recommendation X.25 defines an interface between local data terminal equipment and data-circuit-terminating equipment to attach data terminal equipment to a packet-switched data network (PSDN). A packet-switched data network consists of switching nodes and high-speed transmission links between these nodes.

Users connect their data terminal equipment (DTE) to the data-circuit-terminating equipment (DCE) via a communication circuit. A DTE attached to a packet-switched data network can be a host processor, a cluster control unit, or a terminal that is sending and receiving data. The DCE is provided by the carrier and located near the DTE.

X.25 defines an interface between a user's DTE and the DCE in the packet network. When using X.25 protocols, the network includes:

- The 3274 Control Unit
- An operator at a 3178, 3278, 3279, or equivalent display station that is attached to the 3274 (distributed function terminals are not included)
- The X.25 network
- A network interface adapter, or equivalent
- A host CPU
- An access method, such as VTAM
- Host CPU application programs.

Packets are the basic information unit transmitted through a packet network. For transmission via the packet-switched data network, data is formatted into packets of fixed maximum length. Packet sizes range in the order of 64, 128, 256, and 512 bytes, depending on the particular packet network. Different packet networks implement different sizes of packets, but 128 bytes is the most common. In addition to data packets, various types of control packets (for example, a call request packet) can be sent between a DTE and an adjacent DCE.

A logical channel identifier in the packet header associates the packet with a permanent or switched virtual circuit, allowing the network to control the routing of the packet to the receiving DTE. The channel identifier (CID) is used as a shorthand address to obtain the complete DTE address. The data packets entering the DCE are routed over the internal packet network to a destination DCE, and the communication processors then route the data to the destination DTE.

For further description of the X.25 function, refer to *IBM 3270 Information Display System: X.25 Operation*, GA23-0178.

Customizing the 3274

To include X.25 support in Configuration Support D, the control unit must be a remote (C) model, with 256K of storage and a 2-sided diskette. Customizing the 3274 Control Unit for X.25 involves defining the packet formats and control procedures for the exchange of packets between the DTE and DCE. Control procedures include establishing and clearing calls, data transfer, flow control, and error recovery.

An X.25 network subscription can include many different facilities. To customize your 3274 Control Unit for X.25 support, you need a copy of your firm's X.25 network subscription, detailing which facilities your subscription includes. The 3274 supports these facilities and provides customizing questions for them:

- Closed user group
- Connection identifier
- Extended packet sequence numbering
- Flow control parameter negotiation (window and packet size)
- Nonstandard default window size
- Nonstandard default packet size
- One-way logical channel out
- One-way logical channel in
- Recognized private operating group selection
- Reverse charging
- Reverse charging acceptance
- Throughput class negotiation.

Customized values for certain X.25 facilities can be modified during the Dial procedure. To allow the values to be changed during the Dial procedure, for sequence number 443 you must set bit 5 equal to 0 ("display all fields").

A subscriber to an X.25 network will respond with a 2 to sequence number 331. This response will bring up the X.25 customization panel (sequence number 332), after the sequence number 999 specification panel is completed. This appendix explains how to enter your responses to the X.25 customization panel, which has 21 customizing questions.

Sequence Number 332: X.25 Customization Panel

Figure I-1 shows how the X.25 panel is first displayed, before any responses are entered. In the upper right-hand corner, your secondary station address will replace the two #s (for example, 01). Your 3274 Control Unit model designation (for example, 61C) will be displayed instead of the three Xs.

332				##/XXX/X25
400 - 00	401 - 4	402 - XXXX	403 - 1	
410 - NNNNNNNNNNNNNNNN			411 - NNNNNNNNNNNNNNNN	
420 - 00000000			421 - 00000000	
430 - 1	431 - 0	432 - 02	433 - 2	
434 - 1		435 - 02		
440 - 9	441 - NN	442 - NNNN	443 - 10100100	
450 - XXXX		451 - XX	452 - NNNNNNNN	
				908 - 0

Figure I-1. Sequence Number 332 Panel

Looking at the response fields, you will see that some are filled with Xs and Ns, and that default values are supplied for the rest:

X indicates that a response to this question is required.

N indicates that a response is not required. This question is a sequel to another question. Your response to the first question dictates whether this sequel needs to be answered. For example, if your response to question 401 (circuit type) is 1 (permanent virtual circuit), then no response is necessary for questions 410 and 411 (host and 3274 DTE address). If no response is necessary, the operator can just leave the Ns in the response field.

If **default values** are provided, you can override the default value with a different response during customization. If a default value is provided for a facility to which you do not subscribe, leave the default value unchanged.

At the end of this appendix, you will find the X.25 Customization Response Form and instructions for the person who will do the actual customizing at a display station. Enter the appropriate responses for your system on the X.25 Customization Response Form, and attach it to the Initial Customizing Procedure Form.

X.25 Customizing Questions

We suggest that you answer these questions first: 400, 401, 402, 403, 420, 421, 450, and 451. Then examine the remaining questions.

400 Network Type

This input field defines the network type supported. The default value is 00. If IBM has announced X.25 support for your country's network and it is not one of the networks specified below, use the default value:

- 00 = CCITT-recommended network with announced IBM support, not listed below (default)
- 02 = Connection is to United Kingdom Packet Switched Service (UKPSS)¹ or TELENET² networks.

401 Circuit Type (I/O)

This input field indicates the type of circuit the 3274 will operate on. The default value is 4. Refer to your subscription information for your response.

A permanent virtual circuit (PVC) gives users the appearance of an actual end-to-end connection, analogous to a point-to-point SDLC leased connection. It requires no call setup or clearing by the DTE.

¹ British Telecom

² General Telephone and Electronics (GTE) Telenet Communications Corporation

A switched virtual circuit (SVC) is a temporary logical connection between two DTEs, analogous to a point-to-point switched line.

- 1 = Permanent virtual circuit (PVC)
- 2 = Incoming call (from host) only (SVC)
- 3 = Outgoing call (to host) only (SVC)
- 4 = Two-way call (SVC) (default)

402 Logical Channel Identifier

The logical channel identifier for the circuit specified in 401 (Circuit Type) is included in the outgoing call request packet. Refer to your subscription information for your channel identifier.

Note: Some networks do not permit logical channel 0.

0000 – 4095 = Channel identifier for the circuit specified in 401

403 Logical Link Control

This input field defines whether qualified logical link control (QLLC) or physical service header (PSH) protocols are used. The default value is 1. QLLC is used by IBM products with integrated X.25 support. PSH support allows the 3274 to communicate with equipment attaching to the network via the network interface adapter box.

- 0 = PSH control
- 1 = QLLC control (default)

410 Host DTE Address (HNAD)

This field contains the host network DTE address. Enter 1 to 15 digits for your address. If your response to question 420 is 1XXXXXXX and question 401 is 2, then you must respond to this question. Otherwise, you may mark Ns (the default) in the field on the response form.

Note: If the response to this question does not fill the entire field, you may enter Ns or blanks wherever you have not entered an alphanumeric character.

411 3274 DTE Address

This field contains the local DTE address for the 3274. Enter 1 to 15 digits for your address. If your response to question 421 is 1XXXXXXX and question 401 is 3 or 4, then you must respond to this question. Otherwise, you may mark Ns (the default) in the field on the response form.

Note: If the response to this question does not fill the entire field, you may enter Ns or blanks wherever you have not entered an alphanumeric character.

420 Incoming Call Options

This 8-bit field must have either 0's or 1's entered for each bit. The bit settings allow the user to choose how to process fields in an incoming call. Many of the choices refer to optional facilities. Refer to your network subscription information before selecting the bit settings. The default field is all 0's. If question 401 equals 1 or 3, the response to this question must be 00000000.

Any values selected for incoming call options can be changed on a per-call basis during a Dial session if the X.25 keyboard support option specifies that all fields will be displayed on the Dial screen.

Bits	Bit Descriptions
0 1 2 3 4 5 6 7	
0	= Reserved.
0	= Do not accept packets that include throughput class negotiation.
1	= Negotiate throughput class.
0	= Do not validate CID on incoming calls.
1	= Validate CID on incoming calls.
0	= Do not accept packets that include the negotiated window size facility.
1	= Accept packets that include the negotiated window size facility.
0	= Do not accept packets that include the negotiated packet size facility.
1	= Accept packets that include the negotiated packet size facility.
00	= Do not accept calls with the reverse-charge facility included.
01	= Accept calls with the reverse-charge facility equal to the reverse charge requested.
10	= Accept calls with the reverse-charge facility <i>not</i> requested.
11	= Accept calls with the reverse-charge facility whether reverse charges are requested or not.
0	= Do not validate host (calling) DTE address.
1	= Validate host (calling) DTE address.

421 Outgoing Call Options

This 8-bit field must have either 0's or 1's entered for each bit. The bit settings allow the user to choose the fields to be included in an outgoing call. Many of the choices refer to optional facilities. Refer to your network subscription information before selecting the bit settings. The default field is all 0's. If question 401 equals 1 or 2, the response to this question must be 00000000.

Any values selected for outgoing call options can be changed on a per-call basis during a Dial session if the X.25 keyboard support option specifies that all fields be displayed on the Dial screen.

Bits	Bit Descriptions
0 1 2 3 4 5 6 7	
	= Reserved.
	0 = Do not include the throughput class facility in the call request packet.
	1 = Include the throughput class facility in the call request packet.
	0 = Do not include the CID in the call request packet.
	1 = Include the CID in the call request packet.
	0 = Do not include the negotiated window size facility field in the call request packet.
	1 = Include the negotiated window size facility field in the call request packet.
	0 = Do not include the negotiated packet size facility field in the call request packet.
	1 = Include the negotiated packet size facility field in the call request packet.
	00 = Do not include the reverse-charge facility in the call request packet.
	01 = Request reverse charge via the reverse-charge facility.
	10 = Request <i>no</i> reverse charge via the reverse-charge facility.
	11 = Invalid response.
	0 = Do not supply the 3274 (calling) DTE address in the call request packet.
	1 = Supply the 3274 (calling) DTE address in the call request packet.

430 Negotiated Packet Size (NPKT)

This field is used for the negotiated packet size facility. In 420 (Incoming Call Options), if bit 3 equals 1 (accept packets that include the negotiated packet size facility), this field sets the size limit to which the 3274 may negotiate. In 421 (Outgoing Call Options), if bit 3 equals 1 (include the negotiated packet size facility in the call request packet), this field serves as the requested value.

The default is 1 (128 bytes). Refer to your subscription information for information on the optional negotiated packet size facility.

Note: Although a packet size of 512 can be specified to match the network, the 3274 imposes an upper data limit of 256 for the path information unit size.

- 0 = 64-byte packet
- 1 = 128-byte packet (default)
- 2 = 256-byte packet
- 3 = 512-byte packet

431 Packet Sequence Numbering

This input field indicates whether the extended packet sequence numbering facility is to be used. Refer to your network subscription information for your response. The response to this question will influence your responses to questions 432 and 435. The default is 0 (modulo 8).

- 0 = Modulo 8 (default)
- 1 = Modulo 128

432 Negotiated Window Size (NWND)

This field is used for the negotiated window size facility. On 420 (Incoming Call Options), if bit 4 equals 1 (accept packets that include the negotiated window size facility), this sets the size limit to which the 3274 may negotiate. On 421 (Outgoing Call Options), if bit 4 equals 1 (include the negotiated window size facility field in the call request packet), this field indicates the requested value. Refer to your network subscription for your response. The default is 02.

- 01–07 = Range for modulo 8 (if 431 equals 0)
- 01–11 = Range for modulo 128 (if 431 equals 1)

433 K-Maximum Out

This field specifies the maximum number of link level I-frames that the 3274 transmits before waiting for an acknowledgment. Your network subscription information will indicate the correct response. The default is 2.

1–7 = Maximum number of link level I-frames (default = 2)

434 Nonstandard Default Packet Size (DPKT)

This field contains the packet size value to which you subscribed in your X.25 network agreement. The default is 1. This value is used to select the 3274 packet size when:

- In 421 (Outgoing Call Option), bit 3 equals 0 (*not* to include the negotiated packet size facility in the outgoing call packet), or
- An incoming call packet does *not* include the negotiated packet size facility.

This value can be entered by an operator on a per-call basis, overriding default or customized values.

Note: Although a packet size of 512 can be specified to match the network, the 3274 imposes an upper data limit of 256 for the path information unit size.

0 = 64-byte packet
1 = 128-byte packet (default)
2 = 256-byte packet
3 = 512-byte packet

435 Nonstandard Default Window Size (DWND)

This field contains the packet window size value subscribed to in your X.25 network agreement. This value is used to select the 3274 window size when:

- In 421 (Outgoing Call Option), bit 4 equals 0 (*not* to include the negotiated window size facility in the outgoing call packet), or
- An incoming call packet does *not* include the negotiated window size facility.

The default is 02. Refer to your network subscription for the value for this field.

01–07 = Range for modulo 8 (if 431 equals 0)
01–11 = Range for modulo 128 (if 431 equals 1)

440 Throughput Class Negotiation (TCLS)

Throughput class negotiation is a network facility that sets priority for packets. Refer to your network subscription information for the response to this question. The default is 9.

On 421 (Outgoing Call Options), if bit 6 equals 1 (include the throughput class negotiation facility in the call request packet), this field supplies the value. On 420 (Incoming Call Options), if bit 6 equals 1 (negotiate throughput class on an incoming call request packet), the 3274 accepts the request value if it is less than or equal to the customized value. If not, the customized value is returned.

- 3 = 75 bps
- 4 = 150 bps
- 5 = 300 bps
- 6 = 600 bps
- 7 = 1200 bps
- 8 = 2400 bps
- 9 = 4800 bps (default)
- A = 9600 bps
- B = 19,200 bps
- C = 48,000 bps

441 Closed User Group (CUG)

A response to this question is optional. Enter a value to be included in the closed user group facility in an outgoing call request packet. If the field is left with Ns, blanked or nulled, the closed user group facility is not included in the outgoing call request packet.

Consult your network subscription information for your response:

- 00–99 = Include closed user group facility in outgoing call request packet

Note: If the response is a number with less than two digits, use a leading zero. For example, if your response is 6, enter 06 on the response form. If there is no response to this question, enter two Ns on the response form.

This value can be entered by an operator on a per-call basis, overriding default or customized values.

442 Recognized Private Operating Agency (RPOA)

A response to this question is optional. Enter a value for the recognized private operating agency facility if this applies to your system. If the field is left with Ns, this facility is not included in the outgoing call request packet:

0000 – 9999 = Recognized private operating agency

Note: If the response is a number with less than four digits, use leading zeros. For example, if your response is 57, enter 0057 on the response form. If there is no response for this question, enter four Ns on the response form.

This value can be entered by an operator on a per-call basis, overriding default or customized values.

443 X.25 Keyboard Support Options

This field allows you to choose how to use X.25 Extension Mode keys. Keyboard support for initiating or terminating an X.25 communication is not available on distributed function terminals. The X.25 keys used in the Dial procedure are Extension, DIAL, LOCAL, COMM (Communicate), and DISC (Disconnect). For more information about the function of these keys during the Dial procedure, refer to *X.25 Operation*, GA23-0178.

To allow the operator to change customized values for certain X.25 facilities on a per-call basis, during the Dial procedure, set bit 5 equal to 0 (“display all fields”).

Typically, the device attached to port 0 has access to all the X.25 Switched function keys. During customization, however, the other keys may be assigned to all ports, or certain keys may be deleted.

The default values specified in the response field are 10100100.

Note: If PVC was the response to number 401 (response = 1), bits 0, 1, and 5 have no meaning and are ignored.

Bits

Bit Descriptions

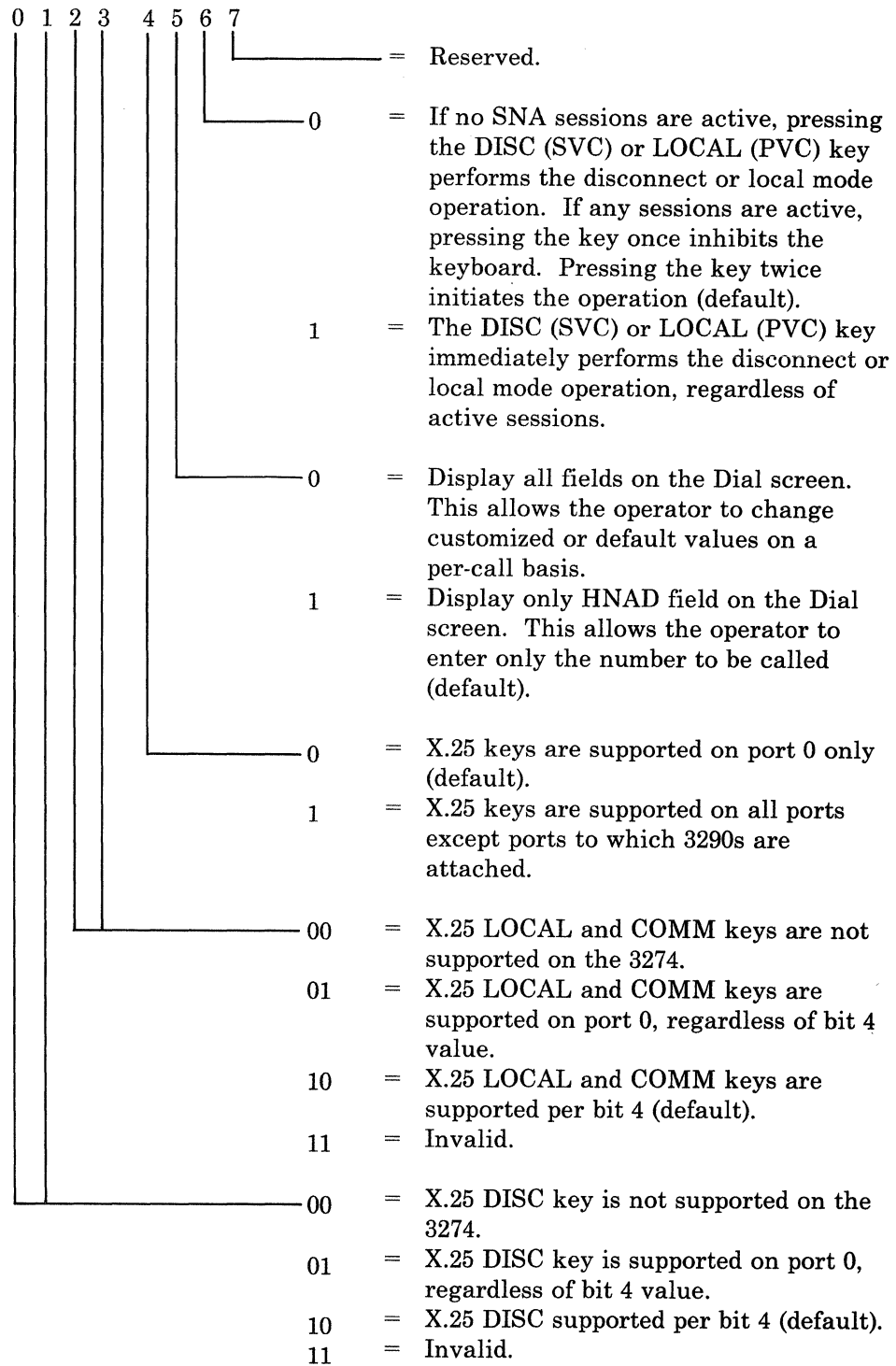

450 Link Level Transmit Timeout

This is the value (referred to as T_1 or Tp) specified in 0.1-second intervals and set to the value required by each individual network. Refer to your network subscription. The 3274 timer will be $\pm 20\%$ of the value specified. For values greater than 25.0 seconds (0250) input, the lower (tenths) digit is ignored. For example, 0277 is treated as 27 seconds:

0001 – 2540

451 Number of Retries

Set this value (referred to as Np or N_2) to the number of retries required by the individual network. Refer to your network subscription:

01 – 99

452 Connection Identifier Password (CID)

The connection identifier (CID) response is optional. On 420 (Incoming Call Options), if bit 5 equals 1 (validate the CID on incoming packets), this field is used for the validation. On 421 (Outgoing Call Options), if bit 5 equals 1 (include the CID in the call request packet), this input field supplies the CID.

This 8-character password can have numeric (0–9) and alphabetic (A–F) characters only.

Notes:

1. *If your password has fewer than 8 characters, enter Ns for the blanks on the response form.*
2. *The 3274 customizing procedure requires you to enter alphanumeric characters in this response. In the host SYSGEN procedure, however, you may be required to enter hexadecimal characters for the CID. (An example of this is the NPSI [NCP Packet Switching Interface] SYSGEN.) Check the appropriate system documentation to determine SYSGEN requirements.*

X.25 Customization Response Form

Operator:

This is how the X.25 panel looks when it is first displayed on your screen, before you enter any responses:

```
332                                     ##/XXX/X25
400 - 00                               401 - 4   402 - XXXX  403 - 1
410 - NNNNNNNNNNNNNNNNN              411 - NNNNNNNNNNNNNNNNN
420 - 00000000                        421 - 00000000
430 - 1                               431 - 0   432 - 02   433 - 2
434 - 1                               435 - 02
440 - 9                               441 - NN   442 - NNNN  443 - 10100100
450 - XXXX                            451 - XX   452 - NNNNNNNN
                                         908 - 0
```

In the upper right corner, your secondary station address (response to sequence number 302) replaces the two #s. Instead of the three Xs, your 3274 Control Unit model type, for example, 51C or 61C, (response to sequence number 151) is displayed. Some of the fields are filled with Xs and Ns; default values are supplied for the rest.

Here is the X.25 Customization Panel form with the responses your planner entered.

332				##/XXX/X25			
400 -	<input type="text"/>	401 -	<input type="text"/>	402 -	<input type="text"/>	403 -	<input type="text"/>
410 -	<input type="text"/>				411 -	<input type="text"/>	
420 -	<input type="text"/>				421 -	<input type="text"/>	
430 -	<input type="text"/>	431 -	<input type="text"/>	432 -	<input type="text"/>	433 -	<input type="text"/>
434 -	<input type="text"/>			435 -	<input type="text"/>		
440 -	<input type="text"/>	441 -	<input type="text"/>	442 -	<input type="text"/>	443 -	<input type="text"/>
450 -	<input type="text"/>			451 -	<input type="text"/>	452 -	<input type="text"/>

908-0

Before you begin to enter the responses that your planner has written down, read these instructions:

1. If any spaces are blank, ask your planner about them.
2. If your planner has marked Ns in any spaces, leave the Ns in the response field on the panel.
3. Note how the responses to these questions must be entered:

410, 411, and 452: The response to these questions may not fill the entire field. You may leave Ns wherever you have not entered an alphanumeric character. If you press EOF to clear the end of the field, a slash (/) will be displayed to mark the end of the original response field. Should you ever modify the response entered for this question, note that the slash (/) space is the last one in which a character may be entered.

441: If the response is a 1-digit number, use a leading zero (for example, 06 for 6). Blanks cannot be used. If there is no response to this question, leave the Ns unchanged.

442: If the response is a number with less than four digits, use leading zeros (for example, 0356 for 356). Blanks cannot be used. If there is no response to this question, leave the Ns unchanged.

After you have made all the entries and checked them, follow these steps:

1. Move the cursor to the 0 (zero) entry following the 908 at the bottom right of the display.
2. Change the 0 entry to a 1, and press ENTER.

If all your entries are acceptable, sequence number 332 is cleared from the screen. Return to step 16 in the Initial Customizing Procedure Form.

3. If any entry is invalid:
 - The entry after 908 is changed back to a 0.
 - The unacceptable entry is intensified. (With a 3279, intensified characters are white and red instead of blue and green.)
 - A 2-digit operator code is displayed in the upper center of the display screen. Use the attached list of Operator Error Codes to find the cause of the error.
 - Check that all the entries match those that were written on the form. Make any necessary changes.
 - Change the 0 entry after 908 to a 1, and press ENTER.

There may be several invalid entries. The error codes will help you correct them. If you are having a problem with an unacceptable entry that you cannot solve, follow your local problem recovery procedure.

- When all the entries are acceptable, sequence number 332 is cleared from the screen. Return to step 16 in the Initial Customizing Procedure Form.

Appendix J. Keyboard Layouts for Sequence Numbers 136, 138, 139, and 166

Sequence numbers 136, 138, 139, and 166 refer to the keyboard and keypad types that are shown in Figures J-1 through J-4. English (U.S.) is used as the keyboard/keypad language in these illustrations. For a complete description of all 3270 keyboard layouts, refer to the *IBM 3270 Information Display System: Character Set Reference*, GA27-2837.

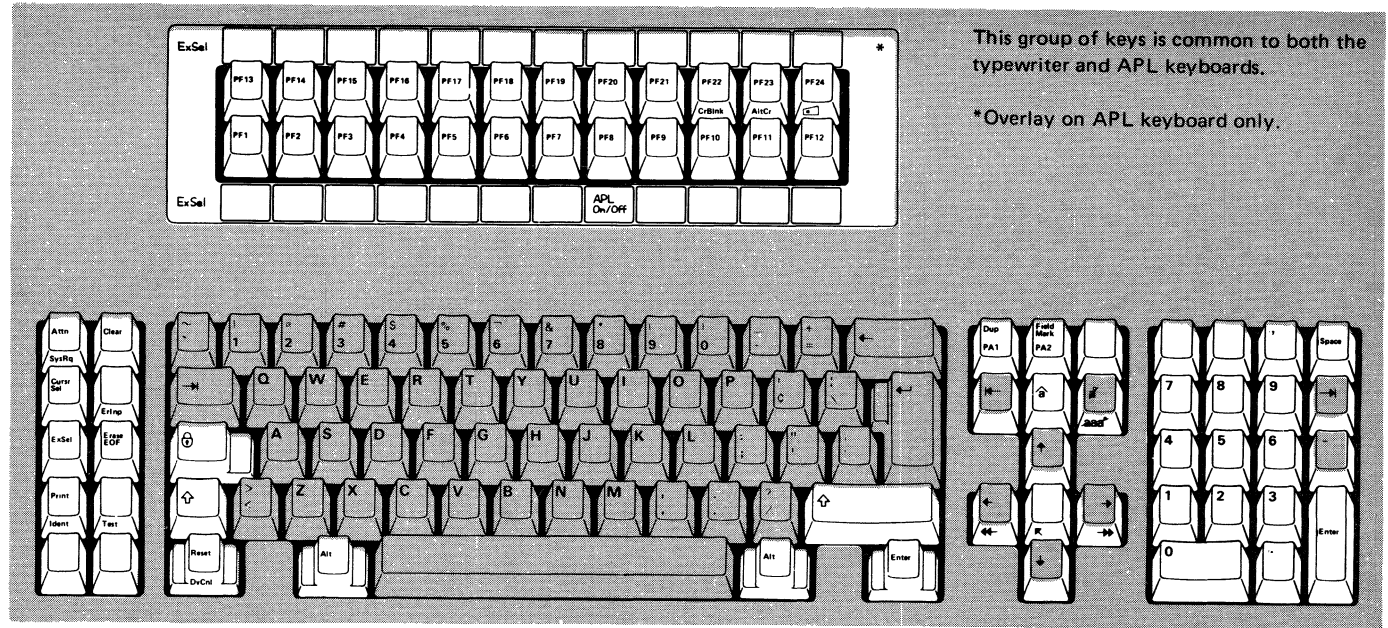

Example of Typewriter Keyboard

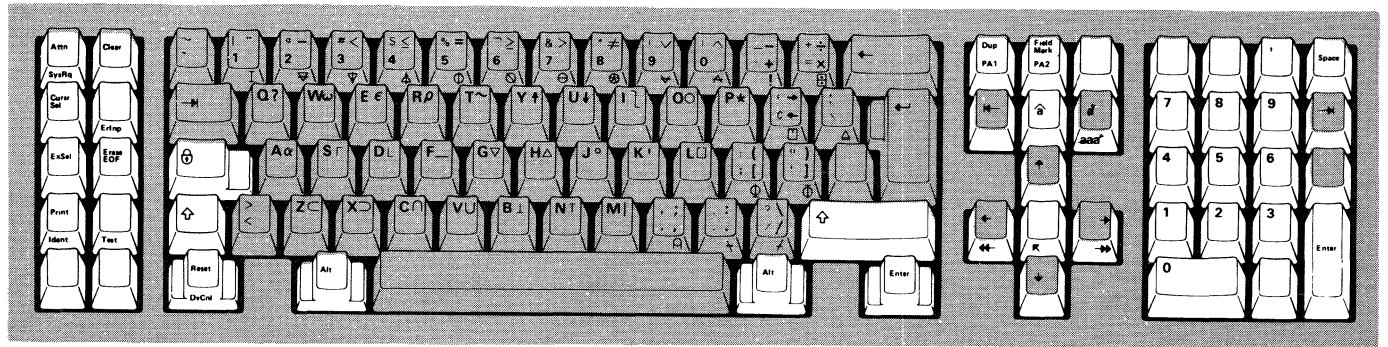

Example of APL Keyboard

Figure J-1 (Part 1 of 2). Modifiable Keyboards (English - U.S.)

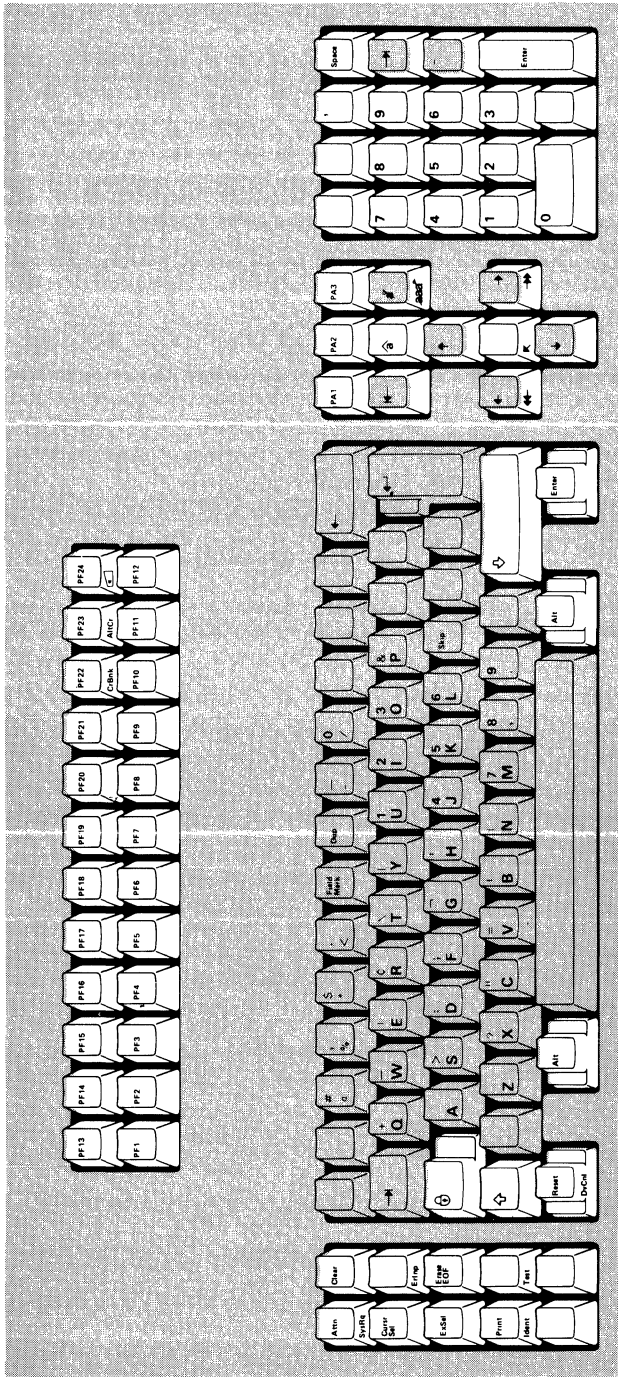

Example of Data Entry Keyboard

Figure J-1 (Part 2 of 2). Modifiable Keyboards (English - U.S.)

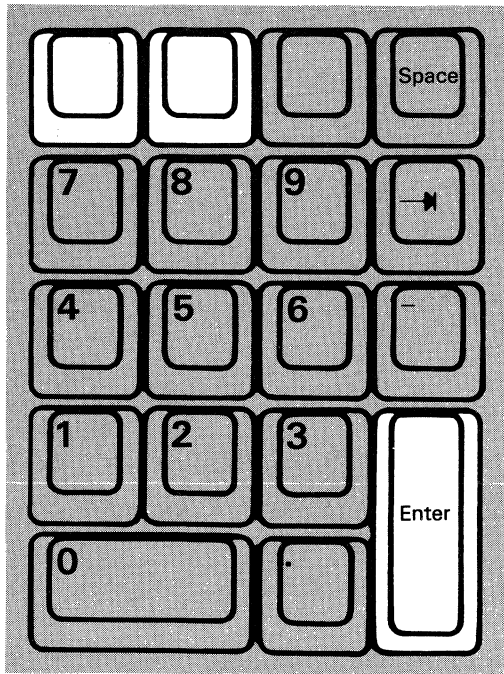

National Language Numeric

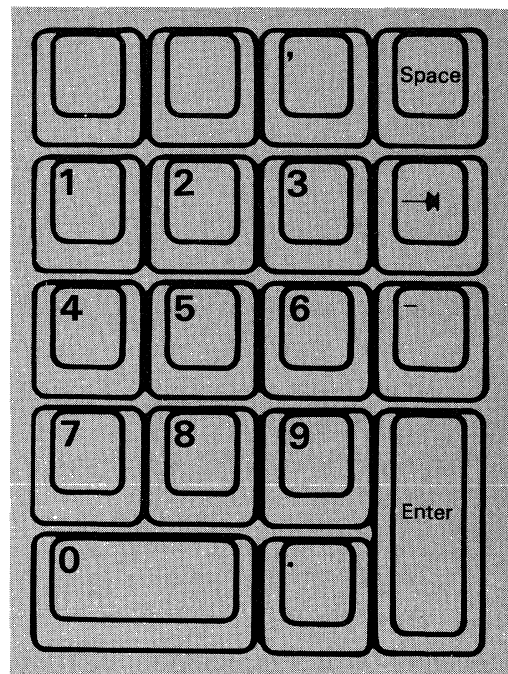

Data Entry

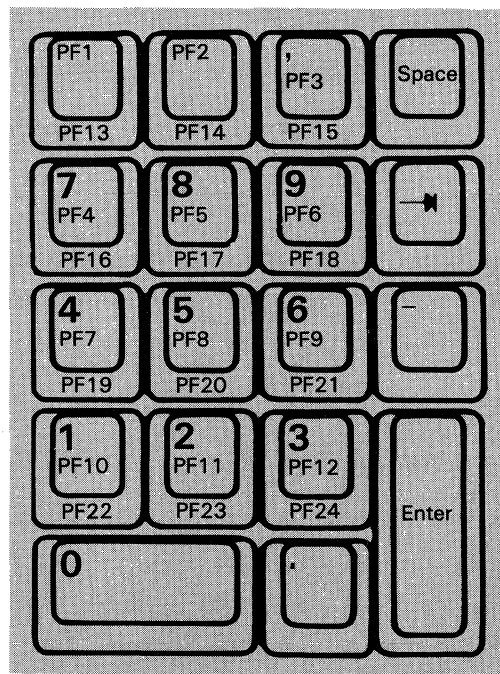

PF Keys

Figure J-2. Modifiable Keypads (English - U.S.)

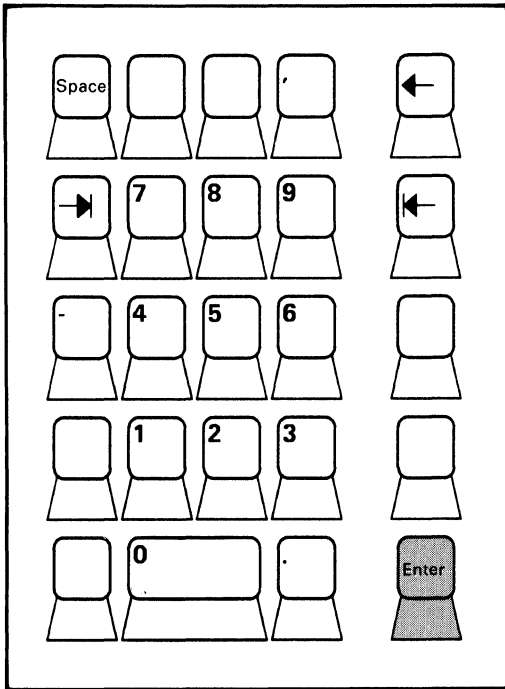

Numeric Keypad: U. S. and Canada

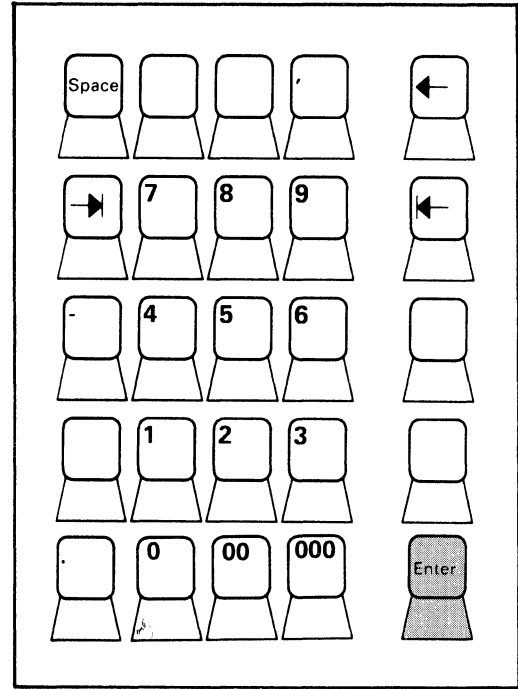

Numeric Keypad: World Trade Countries

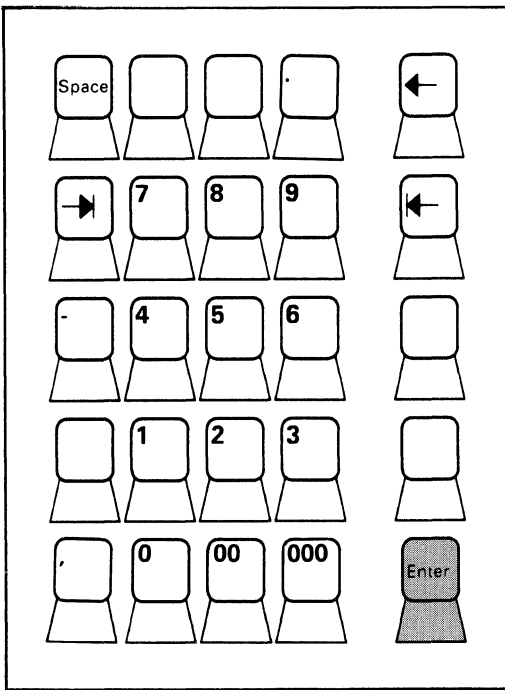

Numeric Keypad: World Trade Countries

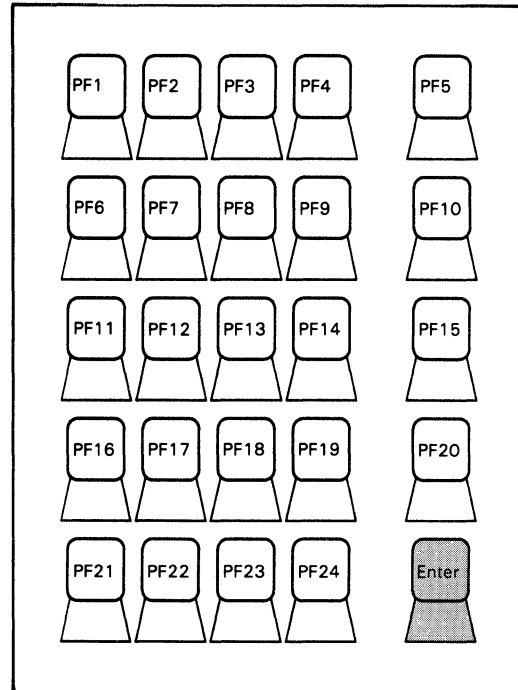

Program Function Keypad

Figure J-3. 3290 Keypads

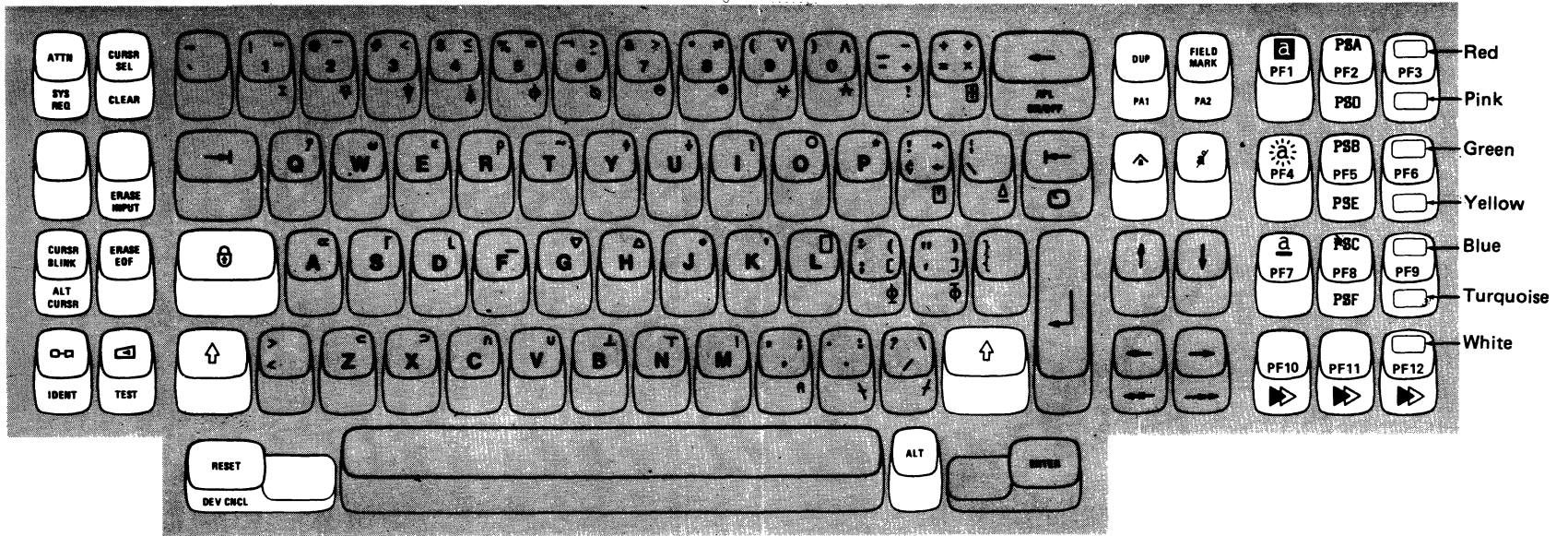

LEGEND:

 Repeat-action keys

Note: On 87-key and 88-key APL keyboards, program function keys are assigned PF1 through PF12 rather than PF13 through 24.

Attribute Select Typewriter/APL Keyboard

Figure J-4 (Part 2 of 3). Attribute Select Keyboard (English - U.S.)

List of Abbreviations

A/FE. Americas/Far East.

AID. Attention Identifier.

Alt. Alternate.

APL. A programming language.

ASCII. American National Standard Code for Information Interchange.

BPS. Bits per second.

BSC. Binary synchronous communication.

CCA. Common communication adapter.

CCITT. Consultative Committee on International Telephone and Telegraph.

CDSTL. Connect data set to line.

CID. Connection identifier.

CUG. Closed user group.

dB. Decibel.

DCC. Disconnect command chaining.

DCE. Data-circuit-terminating equipment.

DDS. Digital data service.

DFT. Distributed function terminal.

DPKT. Default packet size.

DSR. Data set ready.

DTE. Data terminal equipment.

DTR. Data terminal ready.

DWND. Default window size.

E/ME/A. Europe/Middle East/Africa.

EBCDIC. Extended binary-coded decimal interchange code.

EIA. Electronic Industries Association.

FCC. Federal Communications Commission.

HDLC. High-level data link control.

HNAD. Host network (DTE) address.

HPCA. High-performance communication adapter.

IML. Initial microcode load.

I/O. Input/output.

kb. Kilobyte.

LLC. Logical link control.

LPDA. Link problem determination aid.

LU. Logical unit.

MDT. Modified data tag.

NCP. Network Control Program.

NPKT. Negotiated packet size.

NRZ. Nonreturn to zero.

NRZI. Nonreturn to zero inverted.

NTT. Nippon Telegraph and Telephone.

NWND. Negotiated window size.

OEM. Original equipment manufacturer.

OLTEP. Online test executive program.

PF. Program function.

PLU. Primary logical unit.

PS. Programmed Symbols.

PSH. Physical services header.

PU. Physical unit.

PUID. Physical unit identification.

PVC. Permanent virtual circuit.

QLLC. Qualified logical link control.

RPOA. Recognized private operating agency.

RPQ. Request for price quotation.

RTM. Response time monitor.

RTS. Request to send.

SCS. SNA character string.

SDLC. Synchronous Data Link Control.

SFAP. Structured Field and Attribute Processing.

SNA. Systems network architecture.

SNBU. Switched network backup.

SSCP. System services control point.

SVC. Switched virtual circuit.

SYSGEN. System generation.

TCLS. Throughput class negotiation.

UCW. Unit control word.

UKPSS. United Kingdom Packet Switched Service.

U.S. United States.

WACK. Wait before transmit positive acknowledgment.

WT. World Trade.

Index

A

abbreviations, list of X-1
ACF/NCP 2-38
ACF/VTAM 2-38
ACF/VTAME 2-38
alert customizing H-1
answer tone (345) 2-45
attribute select keyboard (166) 2-15,
2-35, 2-61

B

backup diskette generation
load diskette 5-2
form 5-9
procedure 5-2
system diskette
form 5-3
procedure 5-1
between bracket printer
sharing (213) 2-18, 2-39
binary synchronous communication
(BSC) mode 1-1
boundary values G-6
BSC enhanced communication (176) 2-38
BSC mode 1-1
BSC printer polling (305) 2-41
BSC protocol (331) 2-43

C

category A terminals 2-5, 2-24, 2-51
category B terminals 2-4, 2-24, 2-50
CCA adapter (351) 2-45
channel identifier I-1
character set (121) 2-9, 2-28, 2-55
charts
IML 3-21, 4-19, 5-21
operator codes
backup diskette generation 5-16
customization 3-16
modification 4-14
valid key positions
backup diskette generation 5-11
customization 3-11
modification 4-9

8 4 2 1 indicators
backup diskette generation
flashing 5-21
steady 5-20
customizing
flashing 3-21
steady 3-20
modification
flashing 4-19
steady 4-18
CICS/VS 2-38
class A-1
Clear key 2-10, 2-30, 2-56
clicker option (125) 2-10, 2-30, 2-56
clocking (313) 2-41, 2-42
codes
IML 3-21, 4-19, 5-21
operator codes
backup diskette generation 5-16
customization 3-16
modification 4-14
8 4 2 1 indicators
backup diskette generation
flashing 5-21
steady 5-20
customizing
flashing 3-21
steady 3-20
modification
flashing 4-19
steady 4-18
color convergence
error conditions D-2
operator instructions D-1
procedure D-1
communication interface (343) 2-44
compressed PS data (see decompression)
configuration support
updating 1-4
control unit address (201) 2-18
control unit number (301) 2-39
customizing
alert H-1
initial customizing form 3-3
introduction to 1-1, 1-2
preparation for 1-5
printer authorization matrix
definition A-5
Response Time Monitor (RTM) G-1
X.25 I-1

D

data rate 2-42
 decompression (165) 2-15, 2-35, 2-61
 DFT options 2-16, 2-36, 2-62
 diskette insertion procedure
 31A, 31C, 31D 3-13, 4-11, 5-13
 41A, 41C, 41D 3-14, 4-12, 5-14
 51C, 61C 3-15, 4-13, 5-15
 diskette patch request 2-3, 2-21, 2-49
 diskettes
 backup 1-1, 5-1
 backup load 5-2, 5-9
 backup system 5-1, 5-3
 customized load 5-1
 customized system 5-1
 feature 1-2, 1-7
 generation 5-1
 IBM part numbers for 1-5
 language 1-2
 load 1-1
 RPQ 1-7, 2-4, 2-23, 2-50
 system 1-1
 uncustomized load 5-1
 uncustomized system 5-1
 distributed function terminal (DFT)
 options (173) 2-16, 2-36, 2-62
 distributed function terminals (170) 2-16, 2-36, 2-62
 definition 1-2, 2-1
 dual-function Clear key 2-10, 2-30, 2-55

E

encrypt/decrypt (352) 2-45
 entry acceptance (900) 2-19, 2-46, 2-64
 entry assist function (115) 2-7, 2-27, 2-53
 extended color 2-14, 2-34
 extended data stream (160) 2-14, 2-34, 2-60
 extended function store (113) 2-6, 2-26, 2-52
 extended highlighting 2-14, 2-34

F

feature diskette 1-2
 forms
 backup load diskette generation 5-9
 backup system diskette generation 5-3
 initial customizing procedure 3-1
 modification procedure 4-1
 port address table B-7, B-8
 port assignment entry B-1
 printer authorization matrix 3-23, 4-21
 RTM boundaries and interface 2-11, 2-32, 2-57

X.25 customization response I-15
 128 procedures G-6
 999 layout 3-9

H

half-speed transmission (318) 2-42
 high-speed data rate (347) 2-45
 host programming support G-1
 HPCA adapter (351) 2-45

I

IBM Personal Computer XT/370 2-5, 2-25, 2-51
 IBM 3270 Personal Computer 1-2
 IBM 3270 Personal Computer AT, AT/G, and
 AT/GX 2-5, 2-25, 2-51
 IBM 3270 Personal Computer
 Attachment (114) 2-7, 2-27, 2-53
 IBM 3274 Configuration Data Card 1-2
 IML pushbutton 1-1
 indicator codes (see codes)
 individual port addressing B-1
 individual port assignment
 request (116) 2-8, 2-27, 2-54
 Initial Customizing Procedure
 form 3-3

K

key positions, valid 3-11, 4-9, 5-11
 keyboard and customizing guide validation (001) 2-3, 2-21, 2-49
 keyboard definition utility 1-2, 2-12, 2-32, 2-58
 keyboard language (121) 2-9, 2-28, 2-55
 keyboards
 attribute select typewriter 2-15, 2-35, 2-61
 attribute select typewriter/APL 2-15, 2-35, 2-61
 data entry keypunch layout 2-3, 2-21, 2-49
 layouts (136, 138, 139, 166) J-1
 modifiable 2-12, 2-32, 2-58
 typewriter overlay 2-13, 2-33, 2-59
 keypad selection (139) 2-13, 2-33, 2-59

L

language, keyboard 2-9, 2-28, 2-55
 language diskette 1-2
 last transaction time indicator 2-11, 2-31, 2-57

- load diskette
 - backup generation 5-9
 - definition 1-1
- local copy operation A-1
- loop data speed switches F-5
 - setting F-6

M

- magnetic character set (141) 2-14, 2-34, 2-60
- miscellaneous features (125) 2-10, 2-30, 2-56
- modem address switches
 - Model 31C E-2
- modem connection (310) 2-41
- modem wrap (311) 2-41
- modes, printer A-1
- modifiable keyboard selection (136, 137) 2-12, 2-32, 2-58
- modifiable keypad selection (138) 2-13, 2-33, 2-59
- modification procedure
 - form 4-3
- multiple interactive screen feature B-1
- multipoint network (314) 2-42

N

- network
 - multipoint 2-42
 - point-to-point 2-42
- number of RPQ diskettes
 - required (031) 2-4, 2-23, 2-50

O

- operator codes (see codes)

P

- packet-switched data network (PSDN) I-1
- password (175) 2-18, 2-38, 2-64
- patch request (011) 2-3, 2-21, 2-49
- physical unit identification (215) 2-18, 2-39
- point-to-point network (314) 2-42
- polling address 2-41
- port address table (118) 2-8, 2-28, 2-54
 - form B-18
- port addressing B-1
- port assignment entry form B-27, B-28
- port assignment request 2-8, 2-27, 2-54

- port assignment specification
 - table (117) 2-8, 2-28, 2-54, B-5, B-6
- printer authorization matrix
 - definition (022) 2-23, 2-50
 - description A-1
 - matrix structure A-2
 - printer class structure A-2
 - printer modes A-1
 - source device lists A-2
 - form 3-26, 4-21
 - initial customizing 3-26
 - modification 4-21
- printer modes
 - local A-1
 - shared A-2
 - system A-1
- printer port address A-3
- printing, host-directed A-1
- procedures
 - backup load diskette generation 5-2
 - backup system diskette generation 5-1
 - color convergence D-1
 - initial customizing 3-1
 - modification 4-1
 - subsystem verification C-1
 - update-diskette installation 1-4, 3-1
 - 128 G-7
- programming support, host G-1

R

- request RPQ parameter
 - list (032) 2-4, 2-23, 2-50
- request-to-send (RTS) control (342) 2-43
- Response Time Monitor (RTM)
 - boundary and interface
 - specification (128) 2-11, 2-32, 2-57
 - boundary values G-5
 - customizing G-1
 - definition (127) 2-11, 2-31, 2-57
 - description G-1
 - form G-7
 - requirements G-1
- RPQ diskettes required (031) 2-23, 2-50
- RTM (see Response Time Monitor)

S

- SDLC/SNA mode 1-1
- sequence numbers
 - 001 keyboard and customizing guide
 - validation 2-3, 2-21, 2-49
 - 011 patch request 2-3, 2-21, 2-49
 - 021 printer authorization matrix 2-3, 2-23, 2-49

- 022 printer authorization matrix
 - definition 2-4, 2-23, 2-50
- 031 number of RPQ diskettes required 2-4, 2-23, 2-50
- 032 request RPQ parameter list 2-4, 2-23, 2-50
- 111 number of category B terminals 2-4, 2-24, 2-50
- 112 number of category A terminals 2-5, 2-24, 2-51
- 113 extended function store 2-6, 2-26, 2-52
- 114 IBM 3270 Personal Computer
 - Attachment 2-7, 2-27, 2-53
- 115 entry assist function 2-7, 2-27, 2-53
- 116 user-controlled port assignment
 - request 2-8, 2-27, 2-54
- 117 port assignment specification
 - table 2-8, 2-28, 2-54
- 118 port address table 2-8, 2-28, 2-54
- 121 keyboard language/character set
 - I/O interface code 2-9, 2-28, 2-55
- 125 miscellaneous feature options 2-10, 2-30, 2-56
- 127 response time monitor (RTM)
 - definition 2-11, 2-31, 2-57
- 128 RTM boundaries and interface
 - specification 2-11, 2-32, 2-57
- 136 modifiable keyboard
 - selection - unmodified 2-12, 2-32, 2-58
- 137 modifiable keyboard
 - selection - modified 2-12, 2-32, 2-58
- 138 modifiable keypad
 - selection - unmodified 2-13, 2-33, 2-59
- 139 3290 keypad selection 2-13, 2-33, 2-59
- 141 magnetic character set 2-14, 2-34, 2-60
- 151 3274 model designation 2-14, 2-34, 2-60
- 160 extended data stream 2-14, 2-34, 2-60
- 161 color convergence 2-15, 2-35, 2-61
- 165 decompression 2-15, 2-35, 2-61
- 166 attribute select keyboard 2-15, 2-35, 2-61
- 170 distributed function terminals 2-16, 2-36, 2-62
- 173 DFT options 2-16, 2-36, 2-62
- 175 3290 password 2-18, 2-38, 2-64
- 176 BSC enhanced communication
 - option 2-38
- 201 SNA local channel control unit
 - address 2-18
- 213 between bracket printer sharing 2-18, 2-39
- 215 physical unit identification 2-18, 2-39
- 220 alert function 2-18, 2-39
- 301 control unit number 2-39
- 302 SDLC control unit address/
 - X.25 secondary station address 2-40
- 305 BSC printer polling 2-41
- 310 modem connection 2-41
- 311 modem wrap 2-41
- 313
 - internal or external clocking 2-42
 - NRZI or NRZ encoding 2-41
- 314 multipoint or point-to-point
 - network 2-42
- 317 switched network backup 2-42
- 318 normal or half-speed transmission 2-42
- 331 BSC/SDLC/X.25 protocol 2-43
- 332 X.25 Customization Panel 2-43, I-2
- 342 request-to-send (RTS) control 2-43
- 343 communication interface options 2-44
- 345 answer tone 2-45
- 347 high-speed data rate 2-45
- 351 HPCA or CCA adapter 2-45
- 352 encrypt/decrypt 2-45
- 360 X.21 switched retry 2-45
- 361 X.21 switched retry timing 2-45
- 362 X.21 switched options 2-46
- 400 network type I-4
- 401 circuit type I-4
- 402 logical channel identifier I-5
- 403 logical link control I-5
- 410 host DTE address I-5
- 411 3274 DTE address I-5
- 420 incoming call options I-6
- 421 outgoing call options I-7
- 430 negotiated packet size I-9
- 431 packet sequence numbering I-8
- 432 negotiated window size I-8
- 433 K-maximum out I-8
- 434 nonstandard default packet size I-9
- 435 nonstandard default window size I-9
- 440 throughput class negotiation I-10
- 441 closed user group I-10
- 442 recognized private operating
 - agency I-11
- 443 X.25 keyboard support options I-11
- 450 link LVL transmit timeout I-13
- 451 number of retries I-13
- 452 CID password I-13
- 900 entry acceptance 2-19, 2-46, 2-64
- 999 specification panel 2-19, 2-47, 2-64
- SFAP 2-14, 2-34, 2-60
- SNA local channel control unit
 - address (201) 2-18
- source device lists A-3
- subsystem verification
 - introduction to I-3
 - procedure C-1
- switch settings
 - loop data speed F-6
 - modem address E-1
 - planning F-1
 - transmit level F-3
- switched network backup (SNBU)
 - (317) 2-42
- system diskette
 - backup generation 5-3
 - definition 1-1

T

tables
loop data speed switch settings F-5
modem address switch settings F-8
port address
category B devices B-4
multiple interactive screens B-1
port assignment specification B-5, B-22
transmit level switches F-2
TCAM 2-38
transmit level switches F-1

U

unsupported control code translate 2-8,
2-24, 2-44
update-diskette installation procedure 6-1
updating configuration support 1-1, 6-1

V

valid key positions 3-11, 4-9, 5-11
validation number 1-5
VM/370SP 2-38
VTAM 2-38

X

X.21 switched options (362) 2-46
X.21 switched retry (360) 2-45
X.21 switched retry timing (361) 2-45
X.25 Customization Panel (332) 2-43, I-3
X.25
CID password (452) I-13
circuit type (401) I-4
closed user group (441) I-10
customization response form I-15
customizing 2-43, I-2
description I-1
host DTE address (410) I-5
incoming call options (420) I-6
K-maximum out (433) I-9
keyboard support options (443) I-11
link level transmit timeout (450) I-13

logical channel identifier (402) I-5
logical link control (403) I-5
negotiated packet size (430) I-8
negotiated window size (432) I-8
network type (400) I-4
nonstandard default packet size (434) I-9
nonstandard default window size (435) I-9
number of retries (451) I-13
outgoing call options (421) I-7
packet sequence numbering (431) I-8
protocol (331) 2-43
recognized private operating
agency (442) I-11
secondary station address (302) 2-40
throughput class negotiation (440) I-10
3274 DTE address (411) I-5
X.25 customization response form I-15

Numerics

128 procedure form G-7

3178 Display Station 1-1
3179-G Color Graphics Display Station 1-2
3179-G Models G1 and G2 2-5, 2-25, 2-51
3180 Model 1 Display Station 2-5, 2-25, 2-51
3268 Models 2 and 2C 2-6, 2-25, 2-51
3270 Personal Computer 1-3
3270 Personal Computer Attachment 2-7, 2-27, 2-53
3274 Configuration Data Card 1-2, 3-25
3274 Control Unit C-1
3274 model designation (151) 2-14, 2-34, 2-60
3274 Models 31A and 41A 2-3
3274 Models 31C, 41C, 51C, 61C 2-21
3274 Models 31D and 41D 2-49
3278 Display Station I-1
3279 Color Display Station 1-1
3290 Information Panel 1-2
3290 keypad selection 2-13, 2-33, 2-59
3290 options (173) 2-16, 2-36, 2-62
3290 password 2-18, 2-38, 2-64
3299 Terminal Multiplexer 3-4, 4-4, 5-4

4245 Models D12 and D20 2-6, 2-25, 2-52
4250 Printer 2-5, 2-51

8 4 2 1 indicator codes (see codes)

999 layout form 3-9

**IBM 3270
Information Display System**

**READER'S
COMMENT
FORM**

**3274 Control Unit
Customizing Guide**

Configuration Support D

Order No. GA23-0065-6

This manual is part of a library that serves as a reference source for systems analysts, programmers, and operators of IBM systems. You may use this form to communicate your comments about this publication, its organization, or subject matter, with the understanding that IBM may use or distribute whatever information you supply in any way it believes appropriate without incurring any obligation to you. Your comments will be sent to the author's department for whatever review and action, if any, are deemed appropriate.

Note: *Copies of IBM publications are not stocked at the location to which this form is addressed. Please direct any requests for copies of publications, or for assistance in using your IBM system, to your IBM representative or to the IBM branch office serving your locality.*

How did you use this publication?

- | | |
|--|---|
| <input type="checkbox"/> As an introduction | <input type="checkbox"/> As a text (student) |
| <input type="checkbox"/> As a reference manual | <input type="checkbox"/> As a text (instructor) |
| <input type="checkbox"/> For another purpose (explain) _____ | |

Is there anything you especially like or dislike about the organization, presentation, or writing in this manual? Helpful comments include general usefulness of the book; possible additions, deletions, and clarifications; specific errors and omissions.

Page Number:

Comment:

What is your occupation? _____

Newsletter number of latest Technical Newsletter (if any) concerning this publication: _____

If you wish a reply, give your name and address: _____

IBM branch office serving you _____

Thank you for your cooperation. No postage stamp necessary if mailed in the U.S.A. (Elsewhere, an IBM office or representative will be happy to forward your comments or you may mail directly to the address in the Edition Notice on the back of the title page.)

Note: Staples can cause problems with automatic mail-sorting equipment. Please use pressure-sensitive or other gummed tape to seal this form.

Reader's Comment Form

Fold and Tape

Please Do Not Staple

Fold and Tape



NO POSTAGE
NECESSARY
IF MAILED
IN THE
UNITED STATES

BUSINESS REPLY MAIL
FIRST CLASS PERMIT NO. 40 ARMONK, N.Y.

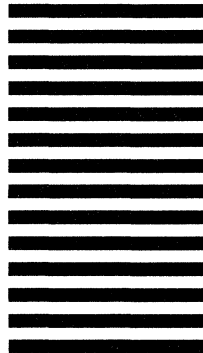

POSTAGE WILL BE PAID BY ADDRESSEE

International Business Machines Corporation
Department 52Q MS 458
Neighborhood Road
Kingston, New York 12401



Fold and Tape

Please Do Not Staple

Fold and Tape



**IBM 3270
Information Display System**

**READER'S
COMMENT
FORM**

**3274 Control Unit
Customizing Guide**

Configuration Support D

Order No. GA23-0065-6

This manual is part of a library that serves as a reference source for systems analysts, programmers, and operators of IBM systems. You may use this form to communicate your comments about this publication, its organization, or subject matter, with the understanding that IBM may use or distribute whatever information you supply in any way it believes appropriate without incurring any obligation to you. Your comments will be sent to the author's department for whatever review and action, if any, are deemed appropriate.

Note: *Copies of IBM publications are not stocked at the location to which this form is addressed. Please direct any requests for copies of publications, or for assistance in using your IBM system, to your IBM representative or to the IBM branch office serving your locality.*

How did you use this publication?

- | | |
|--|---|
| <input type="checkbox"/> As an introduction | <input type="checkbox"/> As a text (student) |
| <input type="checkbox"/> As a reference manual | <input type="checkbox"/> As a text (instructor) |
| <input type="checkbox"/> For another purpose (explain) _____ | |

Is there anything you especially like or dislike about the organization, presentation, or writing in this manual? Helpful comments include general usefulness of the book; possible additions, deletions, and clarifications; specific errors and omissions.

Page Number:

Comment:

What is your occupation? _____

Newsletter number of latest Technical Newsletter (if any) concerning this publication: _____

If you wish a reply, give your name and address: _____

IBM branch office serving you _____

Thank you for your cooperation. No postage stamp necessary if mailed in the U.S.A. (Elsewhere, an IBM office or representative will be happy to forward your comments or you may mail directly to the address in the Edition Notice on the back of the title page.)

Note: Staples can cause problems with automatic mail-sorting equipment. Please use pressure-sensitive or other gummed tape to seal this form.

Reader's Comment Form

Fold and Tape

Please Do Not Staple

Fold and Tape



NO POSTAGE
NECESSARY
IF MAILED
IN THE
UNITED STATES

BUSINESS REPLY MAIL
FIRST CLASS PERMIT NO. 40 ARMONK, N.Y.

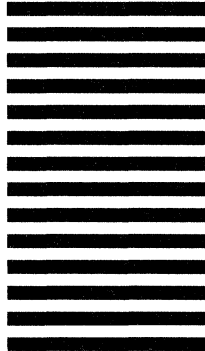

POSTAGE WILL BE PAID BY ADDRESSEE

International Business Machines Corporation
Department 52Q MS 458
Neighborhood Road
Kingston, New York 12401



Fold and Tape

Please Do Not Staple

Fold and Tape



GA23-0065-6

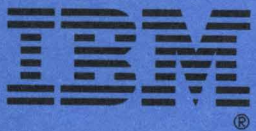

PRINTED IN U.S.A. GA23-0065-6