

IBM Maintenance Library

| | | | |
|------------------------|------------------------|------------------------|------------------------|
| 3803-2/ 3420 S/N | 3803-2/ 3420 S/N | 3803-2/ 3420 S/N | 3803-2/ 3420 S/N |
| MLM | MLM | MLM | MLM |
| PLAN | INTF | MAP | OPER |
| START | 07-000 | 16-000 | 40-000 |
| SENSE | CARR | 21-XXX | 58-XXX |
| MAP | 08-000 | | REF |
| 00-000 | MAP | | 75-001 |
| 1A-000 | 11-000 | | 85-XXX |
| 6A-XXX | 15-XXX | | INST |
| 1B-000 | | | 90-000 |
| 6B-XXX | | | INDEX |
| VOL. 1 | VOL. 2 | VOL. 3 | VOL. 4 |



3803-2/3420

Magnetic Tape Subsystem Maintenance Manual

3803-2/3420

| | | | | | | | | | |
|----------------------|------------------------|-------------------|--------------------|--|--|--|--|--|--|
| XD0005 Seq 1 of 2 | 2735739 Part Number | See EC History | 845958 1 Sep 79 | | | | | | |
|----------------------|------------------------|-------------------|--------------------|--|--|--|--|--|--|

SAFETY

PERSONAL

The importance of personal safety cannot be overemphasized. To ensure personal safety and the safety of co-workers, follow established safety practices and procedures at all times.

Look for and obey the DANGER notices found in the maintenance documentation. All CEs must be familiar with the general safety practices and the procedures for artificial respiration outlined in IBM Form 229-1264. For convenience, this form is duplicated to the right.

MACHINE

To protect machines from damage, turn off power before removing or inserting circuit cards of components. Do not leave internal machine areas needlessly exposed, avoid shorting panel pins when scoping, and handle machine parts carefully. In addition, look for and observe the CAUTION notices found in maintenance documentation.

A form for reader's comments is provided at the front of this publication. If the form has been removed, send your comments to the address below.

This manual was prepared by the IBM General Products Division, Department 21H, Boulder, Colorado 80302.

CE SAFETY PRACTICES

All Customer Engineers are expected to take every safety precaution possible and observe the following safety practices while maintaining IBM equipment:

1. You should not work alone under hazardous conditions or around equipment with dangerous voltage. Always advise your manager if you MUST work alone.
2. Remove all power, ac and dc, when removing or assembling major components, working in immediate areas of power supplies, performing mechanical inspection of power supplies, or installing changes in machine circuitry.
3. After turning off wall box power switch, lock it in the Off position or tag it with a "Do Not Operate" tag, Form 229-1266. Pull power supply cord whenever possible.
4. When it is absolutely necessary to work on equipment having exposed operating mechanical parts or exposed live electrical circuitry anywhere in the machine, observe the following precautions:
 - a. Another person familiar with power off controls must be in immediate vicinity.
 - b. Do not wear rings, wrist watches, chains, bracelets, or metal cuff links.
 - c. Use only insulated pliers and screwdrivers.
 - d. Keep one hand in pocket.
 - e. When using test instruments, be certain that controls are set correctly and that insulated probes of proper capacity are used.
 - f. Avoid contacting ground potential (metal floor strips, machine frames, etc.). Use suitable rubber mats, purchased locally if necessary.
5. Wear safety glasses when:
 - a. Using a hammer to drive pins, riveting, staking, etc.
 - b. Power or hand drilling, reaming, grinding, etc.
 - c. Using spring hooks, attaching springs.
 - d. Soldering, wire cutting, removing steel bands.
 - e. Cleaning parts with solvents, sprays, cleaners, chemicals, etc.
 - f. Performing any other work that may be hazardous to your eyes. **REMEMBER - THEY ARE YOUR EYES.**
6. Follow special safety instructions when performing specialized tasks, such as handling cathode ray tubes and extremely high voltages. These instructions are outlined in CEMs and the safety portion of the maintenance manuals.
7. Do not use solvents, chemicals, greases, or oils that have not been approved by IBM.
8. Avoid using tools or test equipment that have not been approved by IBM.
9. Replace worn or broken tools and test equipment.
10. Lift by standing or pushing up with stronger leg muscles - this takes strain off back muscles. Do not lift any equipment or parts weighing over 60 pounds.
11. After maintenance, restore all safety devices, such as guards, shields, signs, and grounding wires.
12. Each Customer Engineer is responsible to be certain that no action on his part renders products unsafe or exposes customer personnel to hazards.
13. Place removed machine covers in a safe out-of-the-way place where no one can trip over them.
14. Ensure that all machine covers are in place before returning machine to customer.
15. Always place CE tool kit away from walk areas where no one can trip over it, for example, under desk or table.

16. Avoid touching moving mechanical parts when lubricating, checking for play, etc.
17. When using stroboscope, do not touch ANYTHING - it may be moving.
18. Avoid wearing loose clothing that may be caught in machinery. Shirt sleeves must be left buttoned or rolled above the elbow.
19. Ties must be tucked in shirt or have a tie clasp (preferably nonconductive) approximately 3 inches from end. Tie chains are not recommended.
20. Before starting equipment, make certain fellow CEs and customer personnel are not in a hazardous position.
21. Maintain good housekeeping in area of machine while performing and after completing maintenance.

**Knowing safety rules is not enough.
An unsafe act will inevitably lead to an accident.
Use good judgment - eliminate unsafe acts.**

ARTIFICIAL RESPIRATION

General Considerations

1. Start Immediately - Seconds Count
Do not move victim unless absolutely necessary to remove from danger. Do not wait or look for help or stop to loosen clothing, warm the victim, or apply stimulants.
2. Check Mouth for Obstructions
Remove foreign objects. Pull tongue forward.
3. Loosen Clothing - Keep Victim Warm
Take care of these items after victim is breathing by himself or when help is available.
4. Remain in Position
After victim revives, be ready to resume respiration if necessary.
5. Call a Doctor
Have someone summon medical aid.
6. Don't Give Up
Continue without interruption until victim is breathing without help or is certainly dead.

Rescue Breathing for Adults

1. Place victim on his back immediately.
2. Clear throat of water, food, or foreign matter.
3. Tilt head back to open air passage.
4. Lift jaw up to keep tongue out of air passage.
5. Pinch nostrils to prevent air leakage when you blow.
6. Blow until you see chest rise.
7. Remove your lips and allow lungs to empty.
8. Listen for snoring and gurglings - signs of throat obstruction.
9. Repeat mouth to mouth breathing 10-20 times a minute. Continue rescue breathing until victim breathes for himself.



Thumb and finger positions



Final mouth-to-mouth position

3803-2/3420

| | | | | | | | | | |
|------------|-------------|---------|----------|--|--|--|--|--|--|
| XD0005 | 2735739 | See EC | 845958 | | | | | | |
| Seq 2 of 2 | Part Number | History | 1 Sep 79 | | | | | | |

GENERAL INFORMATION

07-000

The initial selection sequence is the communication between the channel and tape control that initiates an operation.

During initial selection, the tape control obtains initial status information that indicates the selected tape unit availability. If the tape unit response indicates it is available, the tape control activates lines that tell the tape unit to perform a specific command. In response to the command, the tape unit furnishes additional status information that indicates its ability to perform the specified command. If the tape unit is capable of performing the command, the tape control activates MOVE to the tape unit.

The communication between the tape control and tape unit is over the device interface lines.

Device Interface Lines

The device interface is composed of the following lines that perform the listed functions:

BUS OUT (nine lines): Transmits commands, amplitude sensing levels, write data, and sense byte identification to the tape unit.

MOVE tag: Initiates tape motion.

COMMAND tag: In conjunction with BUS OUT, initiates the execution of a command.

CONTROL tag: In conjunction with BUS OUT, initiates the execution of a control command.

CLOCK/METER OUT: Allows the tape unit usage meter to run.

BUS IN (nine lines): Transmits status, sense information, and read data to the tape control.

TACHOMETER IN/BUSY IN: When no tag is active, this line indicates that the tape unit is busy. When any OUT tag is active, this line carries the capstan tachometer pulses to the tape control.

INTERRUPT: This line signals the tape control that one of the following unusual conditions has occurred in the tape unit:

- Load check
- Loss of mechanical ready during a rewind
- Transition from Not Ready to Ready status occurred

- Transition from Ready to Not Ready status occurred while the MOVE tag was active.
- Beginning of tape (BOT) was sensed during a read backward operation.

Device Interface Lines

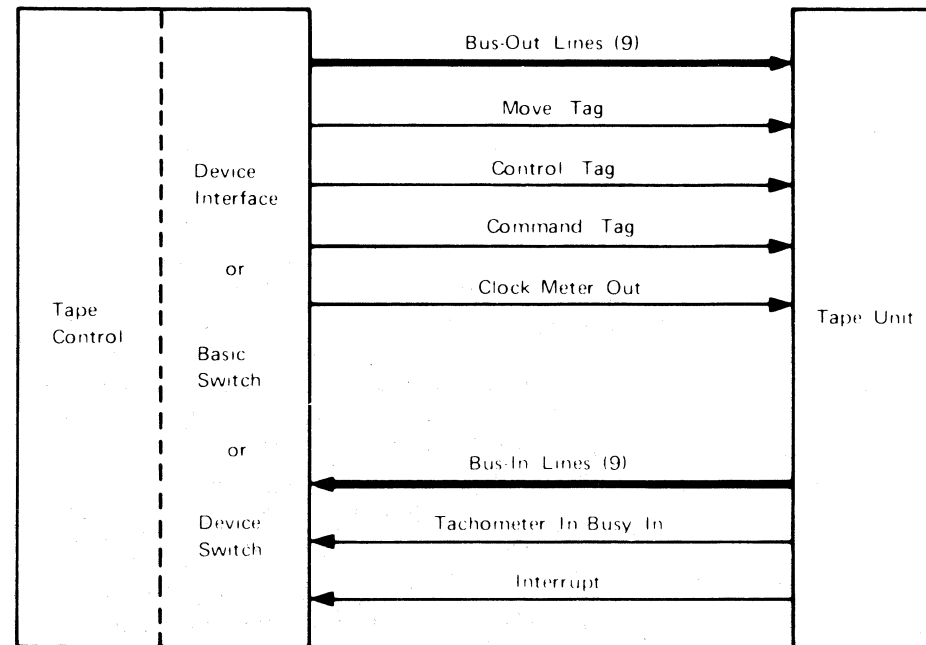

BUS OUT Lines

| BUS OUT Bit | COMMAND Tag Active | CONTROL Tag Active |
|-------------|--------------------------------------|--|
| 0 | Backward read | Rewind Unload |
| 1 | Forward read | Not used |
| 2 | Diagnostic (LWR) | (Model 4, 6, 8 only) Diagnostic (set high sense) |
| 3 | Pulse | NRZI or 6250 BPI mode |
| 4 | Write | (Model 4, 6, 8 only) Diagnostic (set low sense) |
| 5 | Set Extend Stop (Model 4, 6, 8 only) | Data security erase |
| 6 | Reset error latches | (Model 4, 6, 8 only) Erase Status |
| 7 | Not used | Rewind |

BUS IN Lines

| BUS IN Bit | COMMAND STATUS Byte | CONTROL STATUS Byte |
|------------|---|------------------------------------|
| 0 | Backward | Rewind Unload |
| 1 | Gap Control | Not used |
| 2 | Diagnostic mode | (Model 4, 6, 8 only) High Sense ON |
| 3 | (Model 4, 6, 8 only) Opposite direction | NRZI or 6250 BPI mode |
| 4 | Write status | (Model 4, 6, 8 only) Low sense ON |
| 5 | Extended Stop (Model 4, 6, 8 only) | Erase |
| 6 | Unit Check | (Model 4, 6, 8 only) |
| 7 | (Model 4, 6, 8 only) Positioning | Rewind |

3803-1,2,3/3420

| | | | | | | | | |
|------------|-------------|----------------|----------|--|--|--|--|--|
| XD0100 | 2735811 | See EC History | 845958 | | | | | |
| Seq 1 of 2 | Part Number | | 1 Sep 79 | | | | | |

© Copyright International Business Machines Corporation 1976, 1979

07-000

INITIATING TAPE MOTION

All commands that involve tape motion (except Rewind, Rewind Unload, and Data Security Erase), are performed in the following manner:

- The tape control activates the tape unit Forward/Backward latch to establish the proper direction before activating the Move tag.
- The tape control activates and deactivates the MOVE tag to start and stop tape motion. The MOVE tag becomes Move Command in the tape unit.

For Rewind, Rewind Unload, and Data Security Erase commands the tape unit controls the start and stop of the tape motion.

- The tape unit moves tape backwards to the beginning-of-tape (BOT) marker for a Rewind or Rewind Unload command.
- The tape unit moves tape forward to the end-of-tape (EOT) marker for a Data Security Erase command.

INTERMITTENT DROP READY PROBLEMS

Listed below are several cases of dropping READY problems, with most probable causes listed first. Examine the list and take any indicated action. If original failure still exists (Ready light off and tape still on reels) bits for sense byte 7 can be reliably scoped on ALD FT114.

1. **Vacuum Switches:** Defective vacuum switches usually show up with dropping READY problems. If sense byte 7 is available it can be helpful in determining which vacuum column caused the problem. A good test is to load the tape unit, make it ready and tap the vacuum switches with a screwdriver. This technique may cause the tape unit to drop READY. If one switch is more sensitive than the others, replace it. See ALD ZT011
2. **Fiber Optics:** Faulty or marginal fiber optics can cause loading problems, tape motion problems, and dropping ready. Check seating of fiber optic tubes at the light source. Check clearness of the lamp, and if questionable, see 08-620.

3. **Capstan Squaring:** If capstan squaring is out of adjustment it is indicated first by dropping READY (tape pulls out of left column, or bottoms in right column) when going into or coming out of a high speed rewind. Be sure to remove the photocell from the front of the capstan and clean the face of the tach (do not do this on Model 8), using a clean, dry lint-free cloth, before adjusting. See 08-130 (Model 3, 5, or 7) or 08-120 (Model 4, 6, 8) for adjustment procedure.
4. **Right Reel Slipping on Hub:** Slippage can easily be determined by loading a tape and turning the right reel until tape in the columns is above, then below the ports causing the right reel to drive.

Caution: Circuit damage or a blown Fuse (F12) may result if the reel is held for more than five or six seconds.

Hold the reel to keep the tape and hub from turning and observe the slippage. Tape Damage can occur if excessive pressure is put upon the Tape Reel Flange.

No slippage should occur. If slippage is observed go to 08-470 through 08-520.

5. **Reel Tachs:** Defective reel tachs can cause a tape unit to fail to enter high speed rewind and also cause dropping READY while in high speed rewind. Tachs with glazed surfaces will cause the tape to slip. If this condition is found, replace the Tach Assembly. Also check for binds in the bearings. If the tach wobbles it indicates a worn bearing. With an equal amount of tape on each reel, scope the tach outputs (ALD FT231) for plus pulses of similar frequency, duration and amplitude. Make sure the foam on the vacuum column door does not come in contact with the tachs when the door is closed.
6. **Reel Motor Boards:** Either one can cause intermittent problems. Check for cold flow solder joints, cracked land patterns, and loose or pushed in pins in the connectors. If boards are suspect, interchange them with boards of the same part number to isolate the failure. (ALD RM001).
7. **Door Interlock:** Machine vibration can cause a badly adjusted door interlock switch to open intermittently. Also check main machine door latch alignment.

8. **Damaged Tape:** Stretched or sliced tape will cause READY TO DROP. If failing tape has been retained, make one complete pass, using the field tester.
9. **Power Supply** Check for loose terminal connections. Ask operator if power check light has been blinking. (Power check circuit is not latched.)

3803-1,2,3/3420

| | | | | | | | | |
|------------|-------------|---------|----------|--|--|--|--|--|
| XD0100 | 2735811 | See EC | 845958 | | | | | |
| Seq 2 of 2 | Part Number | History | 1 Sep 79 | | | | | |

© Copyright International Business Machines Corporation 1976, 1979

ALPHABETIC REFERENCE LIST

A

Air Bearing (see D-Bearing, Right Rear Movable Guide and Retractor Removal/Replacement) 08-210
 Air Pressure Checks (see Pneumatic Pressure/Vacuum Checks) 08-400
 Altitude Vacuum Level Adjustment 08-420
 Amp Sensor Adjustment — NRZI Feature (Tape Unit Models 3, 5, 7) 08-300
 Amp Sensor Adjustment — PE Only (Tape Unit Models 3, 5, 7) 08-290
 Autocleaner Adjustment (Tape Unit Models 4, 6, 8) 08-382
 Autocleaner Operation (Tape Unit Models 4, 6, 8) 08-360
 Autocleaner Operational Check 08-380
 Autocleaner Removal/Replacement (Tape Unit Models 4, 6, 8) 08-370

B

Belt Adjustment (see Pneumatic Supply Belts, Pneumatic Supply Pulley Alignment)
 Belt-Adjusting Tool Procedure 08-440
 BOT/EOT Block Removal/Replacement 08-590
 BOT/EOT Voltage Checks and Adjustments 08-580

C

Capstan Assembly Removal (Non-90,000 Series Tape Units) 08-010, 08-020
 Capstan Assembly Removal (90,000 Series Tape Units) 08-010, 08-030
 Capstan Assembly Replacement (Non-90,000 Series Tape Units) 08-010, 08-040
 Capstan Assembly Replacement (90,000 Series Tape Units) 08-010, 08-050
 Capstan Cleaning, Glazed 08-700
 Capstan Dynamic Alignment (Non-90,000 Series Tape Units) 08-010, 08-150
 Capstan Dynamic Alignment (90,000 Series Tape Units) 08-010, 08-160
 Capstan Squaring (see Capstan Tachometer Check/Adjustment) 08-130, 08-120
 Capstan Static Alignment
 Capstan Assembly Having Round Support
 (Assembly Left in Tape Unit) 08-010, 08-070
 (Assembly Removed from Tape Unit) 08-010, 08-068
 Capstan Assembly Having Square Support With Zero Marks
 (Assembly Left in Tape Unit) 08-010, 08-066
 (Assembly Removed from Tape Unit) 08-010, 08-064
 Capstan Assembly Having Square Support Without Zero Marks
 (Assembly Removed from Tape Unit) 08-010, 08-062
 Non-90,000 Series Tape Units 08-010, 08-060
 Capstan Tachometer Check/Adjustment (Tape Unit Models 3, 5, 7) 08-130
 Capstan Tachometer Check/Adjustment (Tape Unit Models 4, 6, 8) 08-120
 Capstan Tachometer Cleaning 08-140

Capstan Tachometer Removal/Replacement (Tape Unit Models 3, 5, 7) 08-110
 Capstan Tachometer Removal/Replacement (Tape Unit Models 4 and 6) 08-090
 Capstan-To-Stubby Bar Clearance Adjustment 08-080
 Capstan Tracking 08-010
 Cartridge Motor Removal/Replacement 08-536
 Cartridge Restraint Pressure Check 08-535
 Cartridge Restraint Removal/Replacement 08-540
 Cleaner Blade Gauss Check and Degaussing 08-390
 Column Vacuum Level Check 08-400
 Cooling Fan Assembly Removal/Replacement 08-630

D

D-Bearing, Right Rear Movable Guide and Retractor Removal/Replacement (NRZI-Featured Tape Units) 08-210
 DC Power Supply Checks/Adjustments 08-570
 Degaussing (see Read/Write Head Degaussing or Cleaner Blade Gauss Check and Degaussing) 08-280, 08-390
 Dented Capstan Repair (see Field Repair of Dented Capstan) 08-020

E

Erase Head Checks 08-320
 Erase Head Removal/Replacement 08-250

F

Feedthrough Check 08-330
 Fiber Optic Bundle Removal/Replacement 08-610
 Fiber Optics Lamp (Removal, Replacement, and Cleaning) 08-620
 Field Repair of Dented Capstans 08-020
 Field Tester Accuracy Test 08-290, 08-310
 File-Protect Mechanism Check 08-340
 Forward-to-Backward Ratio (see Read Forward-to-Backward Ratio Test) 08-240

G

Glazed Capstan Cleaning 08-700
 Ground Check (see Tape Unit Ground Check) 08-600

H

Head-Mirror Stop Adjustment (Tape Unit Models 3, 5, 7) 08-350
 Head Resistance Check (see Read/Write Head Resistance Check) 08-280
 High-Speed Rewind Solenoid (Tape Unit Models 3, 5, 7) 08-405

3803-2/3420

| | | | | | | | |
|------------|-------------|---------|----------|--|--|--|--|
| XD0200 | 2735812 | See EC | 845958 | | | | |
| Seq 1 of 2 | Part Number | History | 1 Sep 79 | | | | |

ALPHABETIC REFERENCE LIST (Cont.)

L

Left Movable Guide and Retractor Removal/Replacement (NRZI-Featured Tape Units) 08-220
 Left Reel Hub and Motor Removal/Replacement/Adjustment 08-560
 Light Source (see Fiber Optics Lamp) 08-620
 Logic Panel Removal/Replacement (see 3420 or 3803 Logic Panel) 08-630

M

Mechanical Skew Check/Adjustment (NRZI-Featured Tape Units) 08-180
 Mechanical Skew Check/Adjustment (1600 and 6250 bpi Tape Units) 08-170
 Minireel Load Test 08-800

P

Photosensor (see Fiber Optics) 08-620
 Pneumatic Compressor Pulley Alignment (Type 1 Supply) 08-438
 Pneumatic Compressor Pulley Alignment (Type 2 Supply) 08-436
 Pneumatic Motor Large (Stepped) Pulley Alignment 08-434
 Pneumatic Pressure Level Adjustment (All Model Tape Units) 08-420
 Pneumatic Pressure/Vacuum Checks (Column, Regulator, Threading, Transfer Valve) 08-400, 08-405
 Pneumatic Supply Belts Replacement/Adjustment (All Supply Types) 08-440
 Pneumatic Supply Pulley Alignment (Type 3 Supply) 08-432
 Pneumatic Supply Stepped Pulley Replacement (All Types of Pneumatic Supplies) 08-430
 Pneumatic Vacuum Pump Pulley Adjustment 08-432
 Power Circuit Board (PCB) Removal/Replacement 08-575
 Power Supply (see DC Power Supply) 08-570
 Power Supply Printed Circuit Board Removal/Replacement (3803 Model 2 Only) 08-575
 Power Window Adjustment 08-640
 Power Window Glass Removal/Replacement 08-670
 Power Window, Rack, Limit Switch Adjustments 08-650
 Power Window Safety Bail Adjustment 08-040
 Power Window Safety-Bail Cable Removal/Replacement 08-660
 Pressure Checks (see Pneumatic Pressure/Vacuum Checks) 08-400

R

Read Amplitude Adjustment (Tape Unit Models 4, 6, 8) 08-310
 Read Electrical Skew Adjustment (NRZI-Featured Tape Units) 08-190
 Read Forward-to-Backward Ratio Test (Tape Unit Models 3, 5, 7) 08-240
 Read Forward-to-Backward Ratio Test (Tape Unit Models 4, 6, 8) 08-240
 Read/Write Head Card Removal/Replacement 08-260
 Read/Write Head Degaussing 08-280
 Read/Write Head Resistance Check (Tape Unit Models 4, 6, 8) 08-280
 Read/Write or Erase Head Removal/Replacement 08-250
 Reel (see Left Reel... or Right Reel...) 08-280
 Reel-Alignment Tool Modification 08-465
 Reel-Alignment Tool Preparation 08-460
 Reel-Alignment Tool Zeroing 08-465
 Reel Tachometer Removal/Replacement 08-550
 Regulator Air Pressure Check 08-400
 Right Reel Hub Individual Parts Replacement 08-490
 Right Reel Hub Removal 08-480
 Right Reel Hub Replacement/Adjustment 08-500
 Right Reel-Latch Rear Housing Pressure Test 08-520
 Right Reel-Latch Rear Housing Removal 08-470
 Right Reel-Latch Rear Housing Replacement 08-510
 Right Reel Motor Removal/Replacement 08-530

S

SAGC Checks (see 6250 SAGC Checks) 08-310
 Skew (see Mechanical Skew, Read Electrical Skew or Write Electrical Skew) 08-170, 08-180
 Stubby Bar Adjustment (see Capstan-to-Stubby Bar Clearance Adjustment) 08-080

T

Tachometer (see Capstan Tachometer or Reel Tachometer)
 Tape Guide Check for NRZI-Featured Tape Units 08-230
 Tape Guide Removal/Replacement
 (See D-Bearing, Right Rear Movable Guide and Retractor or
 Left Movable Guide and Retractor Removal/Replacement)
 Tape Tester (see Field Tester) 08-290
 Tape Unit Ground Check 08-600
 Threading Vacuum Check 08-400
 Transfer Valve Leakage Test 08-400

3803-2/3420

| | | | | | | | | |
|------------|-------------|---------|----------|--|--|--|--|--|
| XD0200 | 2735812 | See EC | 845958 | | | | | |
| Seq 2 of 2 | Part Number | History | 1 Sep 79 | | | | | |

CHECKS/ADJUSTMENTS/REMOVALS/REPLACEMENTS (CARR)

08-007

ALPHABETIC REFERENCE LIST (Cont'd)

V

Vacuum Balance 08-800
Vacuum Checks
 (See Pneumatic Pressure/Vacuum Checks, Vacuum Balance, Vacuum Column
 Switch Check or Column Vacuum Level Check)
Vacuum Column Door Glass Removal/Replacement 08-690
Vacuum Column Door Replacement and Adjustment 08-680
Vacuum Column Switch Check 08-450

W

Window (see Power Window)
Write Electrical Skew Adjustment (NRZI-Featured Tape Units) 08-200
Write Head Driver Card Plugging (Tape Unit Models 4, 6, 8) 08-270

Numeric

3420 Logic Panel Removal/Replacement 08-630
3803 Logic Panel Removal/Replacement 08-630
6250 SAGC Checks 08-310

3803-1,2,3/3420

| | | | | | | | | | |
|------------|-------------|---------|----------|--|--|--|--|--|--|
| XD0225 | 8492433 | See EC | 845958 | | | | | | |
| Seq 1 of 2 | Part Number | History | 1 Sep 79 | | | | | | |

08-007

NOTES:

08-008

3803-1,2,3/3420

| | | | | | | | | | |
|-----------------------------|-------------------------------|---------------------------|---------------------------|--|--|--|--|--|--|
| XD0225 Seq 2 of 2 | 8492433 Part Number | See EC History | 845958 1 Sep 79 | | | | | | |
|-----------------------------|-------------------------------|---------------------------|---------------------------|--|--|--|--|--|--|

© Copyright International Business Machines Corporation 1976, 1979

08-008

**CAPSTAN AND TRACKING CHECKS/
ADJUSTMENTS/REMOVALS/
REPLACEMENTS**

This section includes the capstan drive assembly (capstan and motor), the capstan tachometer, and all the other components that affect tape tracking. The read and write electrical skew adjustments (tape unit Models 3, 5, and 7) are also included because they **must** be rechecked after adjusting the mechanical skew.

Each procedure in this section has the following format:

- Procedure title
- Applicability:
 - tape unit serial number—90,000 Series* or non-90,000 Series
 - tape unit model
 - recording format—1600 bpi or 6250 bpi or NRZI-featured**
- Prerequisite procedures
- The procedure itself
- Subsequent procedure (if any)

*90,000 Series serial-numbered tape units are machines converted from 2420 tape units. These units have serial numbers of 90,000 to 99,999, 43,001 to 43,084, and 45,000 to 45,054. All other serial numbers are non-90,000 Series.

**NRZI-featured identifies a tape unit which is able to process data in either 7- or 9-track NRZI mode.

| | | | | | | | | |
|----------------------|------------------------|-------------------|--------------------|--|--|--|--|--|
| XD0250 Seq 1 of 2 | 4169707 Part Number | See EC History | 845958 1 Sep 79 | | | | | |
|----------------------|------------------------|-------------------|--------------------|--|--|--|--|--|

NOTES:

08-015

3803-2/3420

| | | | | | | | | | |
|-----------------------------|-------------------------------|---------------------------------|---------------------------|--|--|--|--|--|--|
| XD0250 Seq 2 of 2 | 4169707 Part Number | See EC History | 845958 1 Sep 79 | | | | | | |
|-----------------------------|-------------------------------|---------------------------------|---------------------------|--|--|--|--|--|--|

© Copyright International Business Machines Corporation 1976 1979

08-015

**CAPSTAN ASSEMBLY REMOVAL
(NON-90,000 SERIES TAPE UNITS)**

To retain an approximate capstan drive assembly alignment, do not turn the hollow adjusting sleeves when removing this assembly.

To remove the assembly:

1. Unload the tape unit and turn off tape unit power.
 2. Loosen the two upper stubby bar mounting screws and slide the bar down and to the right to increase capstan clearance. Tighten the screws temporarily.
 3. Disconnect the air hose(s) from the capstan motor and the left reel motor.
- Note:** The two wires inside the motor cooling port were used in manufacturing and should be ignored. Slip them back into the port so they do not interfere with your work.
4. Unplug the power cable from the capstan motor control board.
 5. Disconnect the tachometer cable.
 6. Remove the wedge holding the capstan fiber optic bundle in the light manifold and pull out the bundle.
 7. Remove the spring cluster load nut and spring cluster.
 8. Remove the capstan assembly from the rear, being careful not to snag any wires or damage the capstan or reference plate.

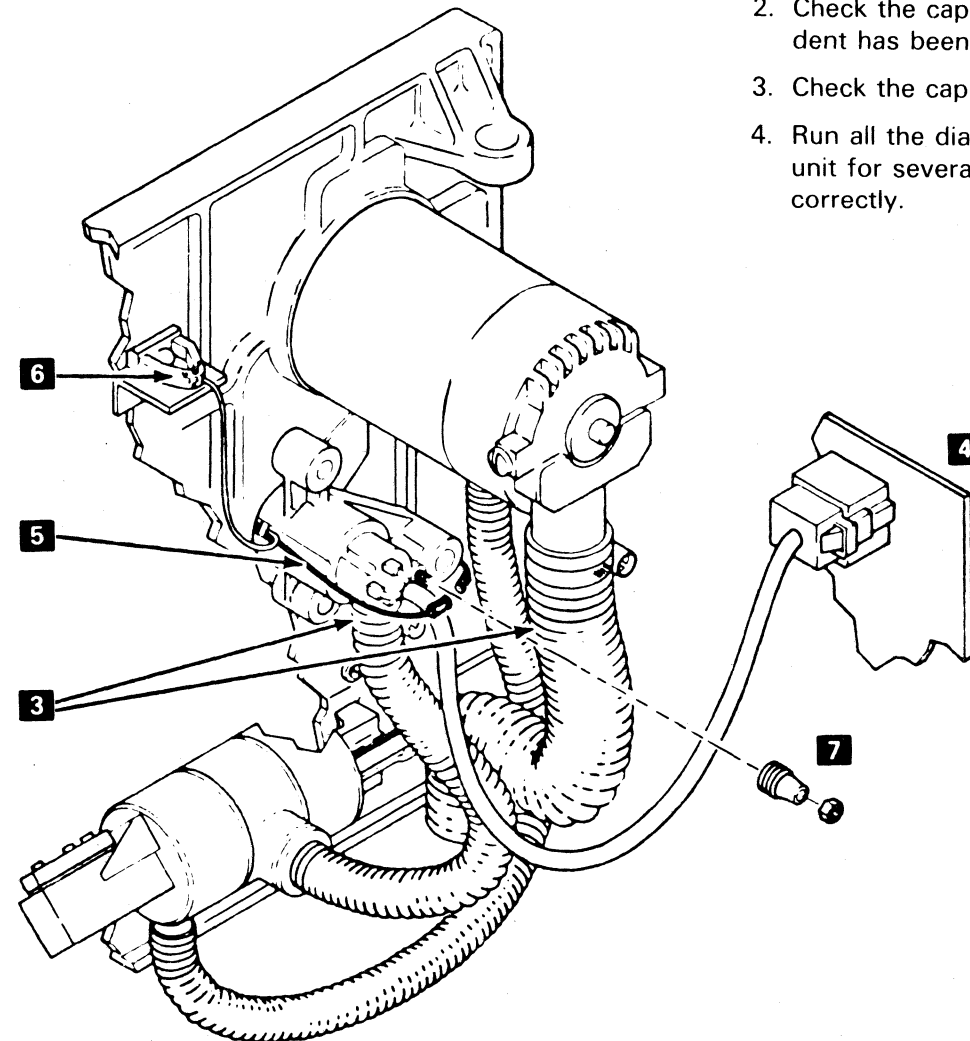

FIELD REPAIR OF DENTED CAPSTANS

Capstans may be dented if the protective capstan cover is not used by customer personnel during cleaning operations. These capstans can often be put back to correct operation by using the following procedure:

Note: This procedure is to be used as a temporary measure until the capstan motor can be replaced.

1. Use a spring hook (P/N 9900105 is recommended) to gently ease the dented section outward.
- Note:** Do not pull the section out beyond the normal plane of the capstan curvature.
2. Check the capstan for binds. If binds exist after the dent has been removed, replace the capstan.
 3. Check the capstan tracking.
 4. Run all the diagnostic routines. Monitor the tape unit for several days to ensure that it works correctly.

| | | | | | | | | |
|------------|-------------|---------|----------|--|--|--|--|--|
| XD0300 | 2735813 | See EC | 845958 | | | | | |
| Seq 1 of 2 | Part Number | History | 1 Sep 79 | | | | | |

**CAPSTAN ASSEMBLY REMOVAL
(90,000 SERIES TAPE UNITS)**

1. Unload the tape unit and turn off tape unit power.
2. Loosen the two upper stubby bar mounting screws and slide the bar down and to the right to increase capstan clearance. Tighten the screws temporarily.
3. Disconnect the air hose(s) from the capstan motor and the left reel motor.

Note: The two wires inside the motor cooling port were used in manufacturing and should be ignored. Put them back into the port so they do not interfere with your work.

4. Unplug the power cable from the capstan motor control board.

Note: If the tape unit has a square capstan support, remove the read/write head cards and cooling shroud to make removal of the capstan easier. See 08-260, "Read/Write Head Card Removal/Replacement."

5. Disconnect the tachometer cable.
6. Remove the wedge holding the capstan fiber optic bundle in the light manifold and pull out the bundle.
7. Remove the three nuts that hold the motor to the main casting. When removing these nuts, use a screwdriver to keep the slotted studs from turning and make sure the hollow adjusting sleeves do not turn.

Note: If a slotted stud is accidentally removed, replace it before proceeding. The studs act as guides and help prevent capstan and tachometer damage.

8. Remove the capstan assembly from the rear, being careful not to snag any wires or damage the capstan or reference plate.

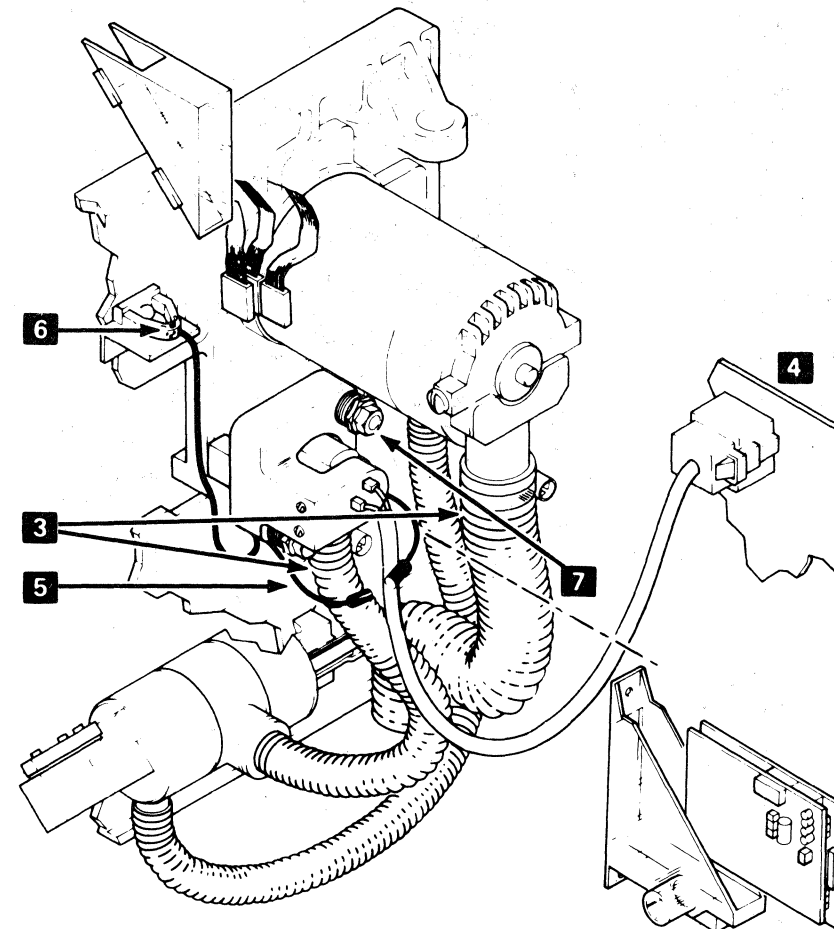

3803-1,2,3/3420

| | | | | | | | | |
|------------|-------------|---------|----------|--|--|--|--|--|
| XD0300 | 2735813 | See EC | 845958 | | | | | |
| Seq 2 of 2 | Part Number | History | 1 Sep 79 | | | | | |

© Copyright International Business Machines Corporation 1976, 1979

**CAPSTAN ASSEMBLY REPLACEMENT
(NON-90,000 SERIES TAPE UNITS)**

Note: Before installing the capstan assembly, inspect the capstan for damage.

Caution: Be careful not to damage the capstan wheel, reference plate, fiber optic bundle, or tachometer cable when installing the capstan drive assembly.

1. Slide the capstan assembly onto the threaded shaft extending from the rear of the casting.
2. Slide the spring cluster onto the threaded shaft.
3. Install the spring cluster load nut and tighten until the slack is removed, then tighten 4 to 4-1/4 turns more.
4. Insert the fiber optic bundle in the light manifold and install the holding wedge.
5. Connect the hose(s) to the capstan motor and the left reel motor.
6. Reconnect the tachometer cable.
7. Move the capstan power wires from the old motor to the new motor (not necessary for the Model 8 as the cable is wired internally). Check that the wires are plugged as before, then attach the power cable to the motor control board.
8. After replacing the capstan assembly, perform the following procedures:
 - a. Capstan Static Alignment, 08-060
 - b. Capstan-To-Stubby Bar Clearance Adjustment, 08-080
 - c. Capstan Tachometer Check/Adjustment, 08-0120 or 08-130
 - d. Capstan Dynamic Alignment, 08-150 or 08-160
 - e. Mechanical Skew Check/Adjustment, 08-170 or 08-180
 - f. On NRZI-featured tape units, Read Electrical Skew Adjustment, 08-190 and Write Electrical Skew Adjustment, 08-200

Note: See the capstan motor wiring chart if the wires are disconnected from the motor.

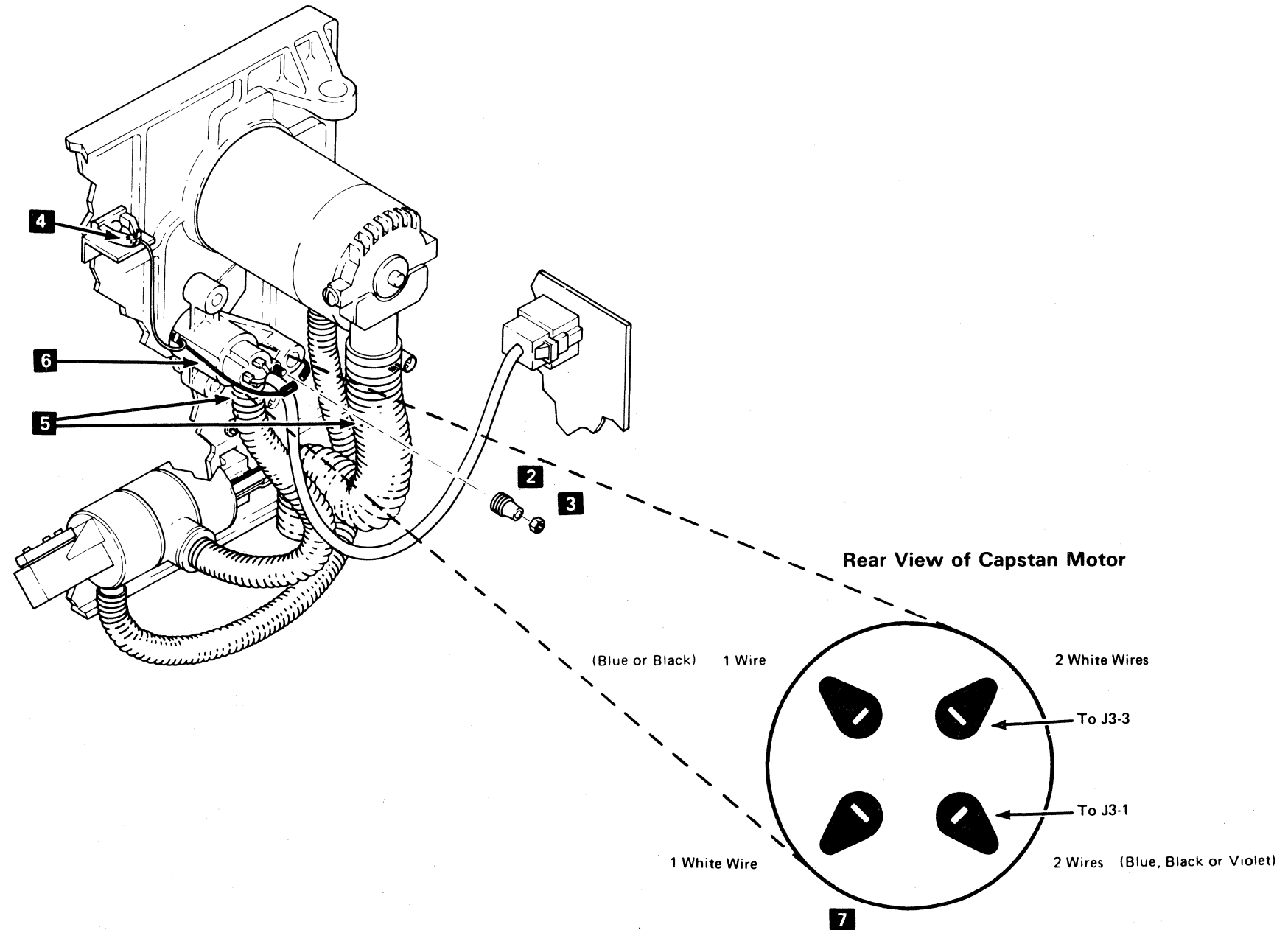

| | | | | | | | | |
|------------|-------------|---------|----------|--|--|--|--|--|
| XD0400 | 2735814 | See EC | 845958 | | | | | |
| Seq 1 of 2 | Part Number | History | 1 Sep 79 | | | | | |

**CAPSTAN ASSEMBLY REPLACEMENT
(90,000 SERIES TAPE UNITS)**

Note: Before installing the capstan assembly:

1. Inspect the capstan for damage.
2. See the Capstan Static Alignment procedure on 08-062 and perform the procedures on 08-062, 08-064, or 08-070.

Caution: Be careful not to damage the capstan wheel, reference plate, fiber optic bundle, or tachometer cable when installing the capstan assembly.

1. Insert the capstan assembly and partially tighten the three hex nuts.
 2. While tightening the three nuts, rotate the capstan wheel to make sure it does not bind against the reference plate or stubby bar. Tighten the nuts.
 3. Move the capstan power wires from the old motor to the new motor (not necessary for the Model 8 as the cable is wired internally). Check that the wires are plugged as before, then attach the cable to the motor control board.
 4. Connect the hose(s) to the capstan motor and the left reel motor.
 5. Reconnect the tachometer cable.
 6. Replace the fiber optic bundle in the light manifold.
- Note:** If the read/write head cooling shroud was removed, replace it. See 08-260, "Read/Write Head Card Removal/Replacement."
7. Perform the following procedures in the order listed:
 - a. Capstan Tachometer Check/Adjustment, 08-120 or 08-130
 - b. Capstan Dynamic Alignment, 08-160
 - c. Capstan-To-Stubby Bar Clearance Adjustment, 08-080
 - d. Mechanical Skew Check/Adjustment, 08-170 or 08-180

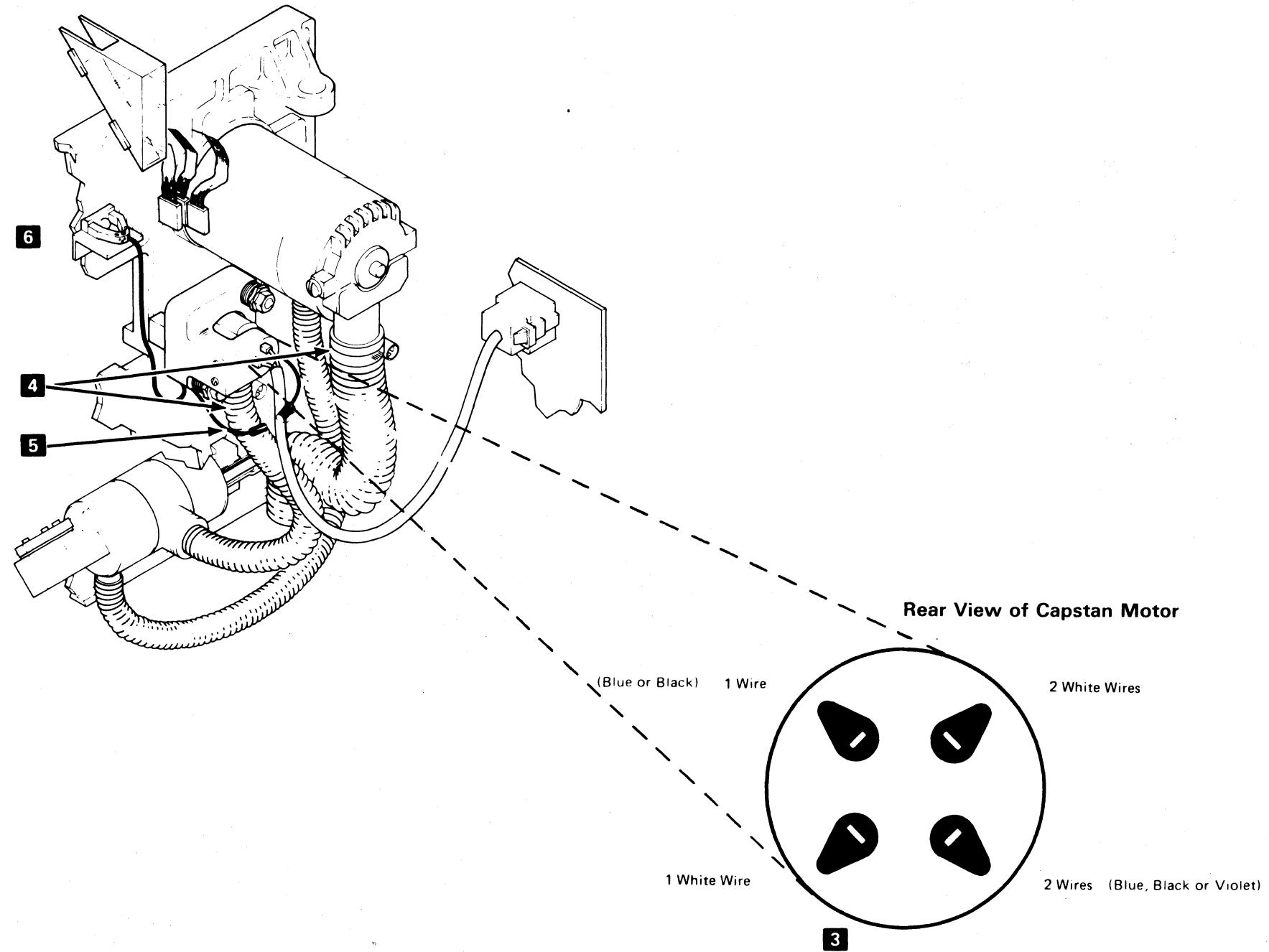

3803-1,2,3/3420

| | | | | | | | |
|------------|-------------|---------|----------|--|--|--|--|
| XD0400 | 2735814 | See EC | 845958 | | | | |
| Seq 2 of 2 | Part Number | History | 1 Sep 79 | | | | |

© Copyright International Business Machines Corporation 1976, 1979

CAPSTAN STATIC ALIGNMENT

Non-90,000 Series Tape Units

- 1 Loosen the spring cluster load nut three turns.
- 2 From the front, turn both adjusters counterclockwise until they touch the bottom in the threaded sleeve. Access is made through holes in the faceplate.
- 3 Turn each adjuster two full turns clockwise.
- 4 Tighten the spring cluster load nut until slack is removed; then tighten 4 to 4-1/4 turns more. If no slack is present, loosen the cluster load nut 1 until the slack is just noticeable, then retighten 4 to 4-1/4 turns.
- 5 Perform the Capstan-To-Stubby Bar Clearance Adjustment procedure on 08-080.
- 6 Check for $17/32 \pm 1/64$ inch (13.5 ± 0.4 mm) from the reference plate to the front edge of the capstan wheel.

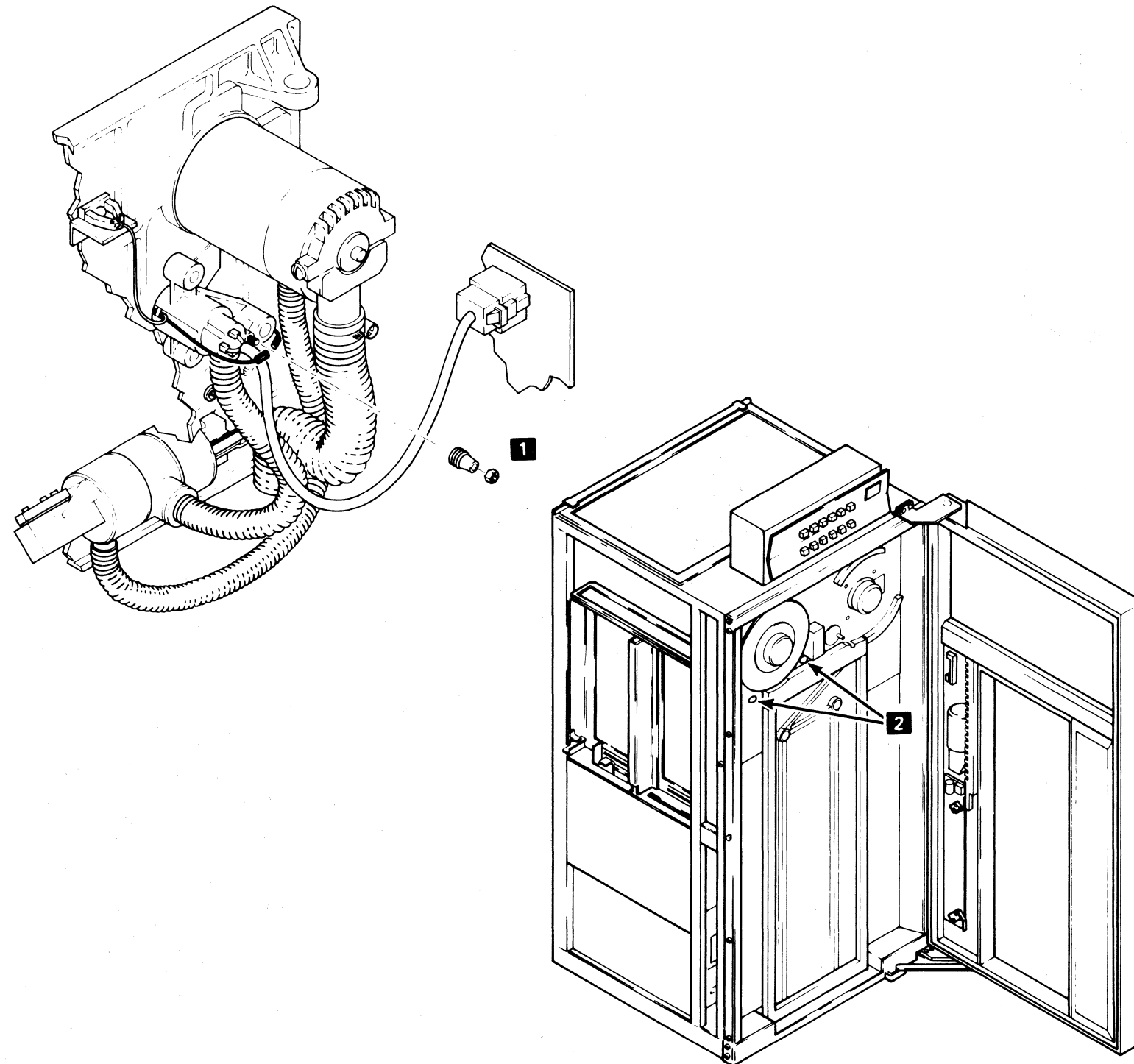

3803-1,2,3/3420

| | | | | | | | | |
|------------|-------------|---------|----------|--|--|--|--|--|
| XD0500 | 2735815 | See EC | 845958 | | | | | |
| Seq 1 of 2 | Part Number | History | 1 Sep 79 | | | | | |

CAPSTAN STATIC ALIGNMENT (Cont.)

Capstan Assembly Having Square Support Without Zero Marks (Assembly Removed From Tape Unit)

1. Remove the capstan assembly. See 08-030, "Capstan Assembly Removal."
2. Insert the capstan alignment tool, P/N 2515376, through the front of the motor casting.*
3. If necessary, rotate each hollow adjusting sleeve until the shoulder of the alignment tool is 0.004 to 0.005 inch (0.102 to 0.127 mm) from the casting surface for each sleeve.

4. Replace the capstan drive assembly. See 08-050, "Capstan Assembly Replacement."

Caution: Be very careful not to damage the capstan wheel, reference plate, fiber optic bundle, or tachometer cable when installing the capstan assembly.

- The front edge of the capstan should be $17/32 \pm 1/64$ inch (13.5 ± 0.4 mm) from the reference plate. If not, rotate the adjusting sleeves until this condition is met.

*If tool is not available, perform the procedure on 08-064, step 2.

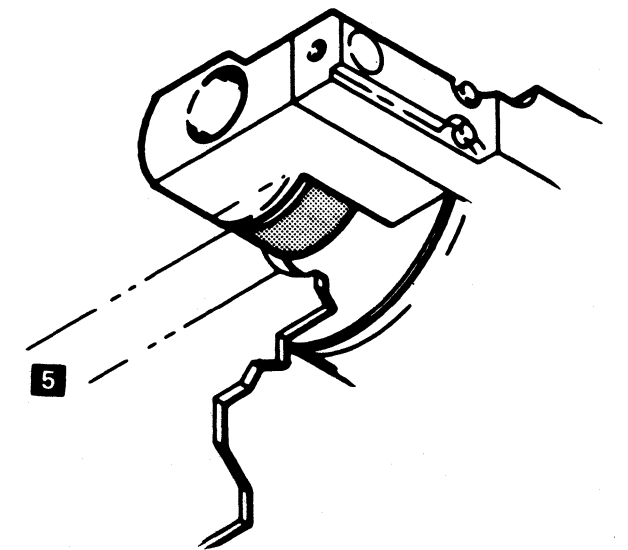
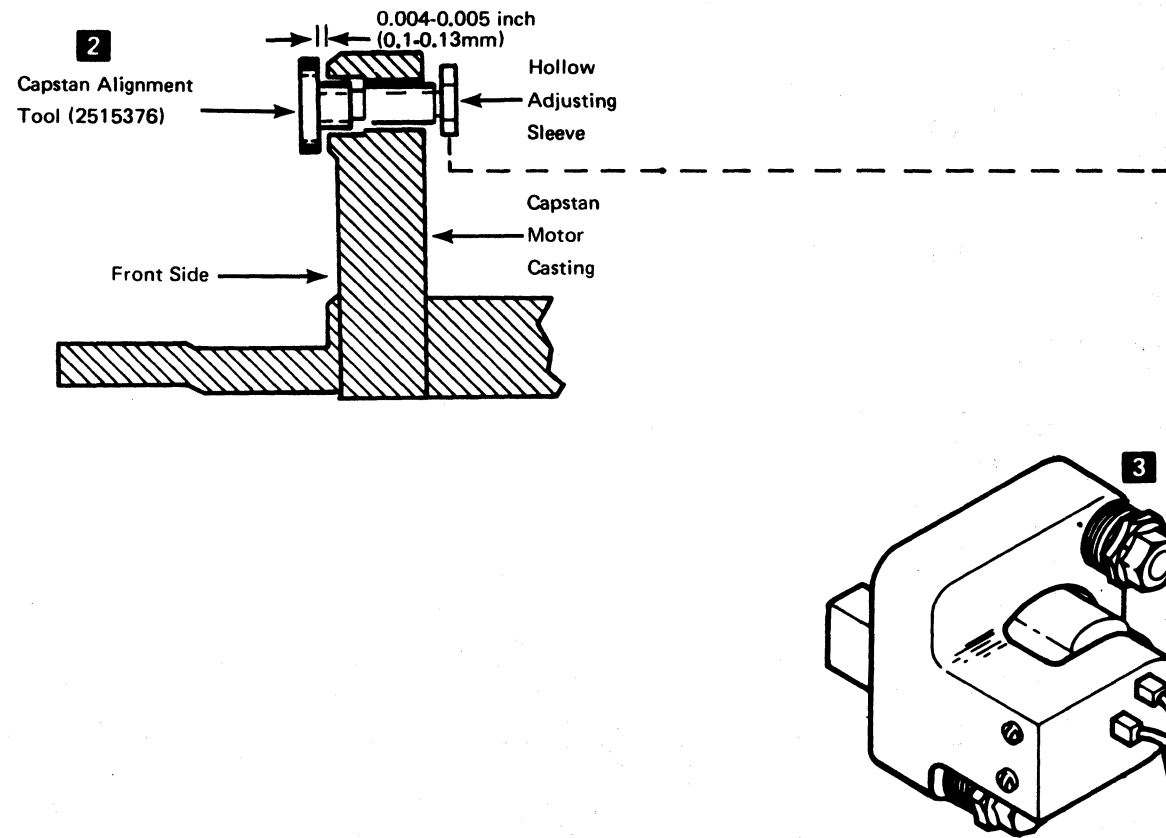

3803-1,2,3/3420

| | | | | | | | |
|------------|-------------|---------|----------|--|--|--|--|
| XD0500 | 2735815 | See EC | 845958 | | | | |
| Seq 2 of 2 | Part Number | History | 1 Sep 79 | | | | |

© Copyright International Business Machines Corporation 1976, 1979

CAPSTAN STATIC ALIGNMENT (Cont'd)

Capstan Assembly Having Square Support with Zero Marks
Support with Zero Marks
(Assembly Removed from Tape Unit)

If the capstan alignment tool, P/N 2515376, is available, use the procedure on 08-062. If the tool is not available, proceed as follows:

- 1 Remove the capstan assembly. See 08-030, "Capstan Assembly Removal."
 - 2 If necessary, rotate each sleeve until the zero marks align, and the sleeve tips are $13/32$ inch (10.3 mm) **A** from the end of the capstan motor casting. Use a steel scale, P/N 450158 or equivalent, to make this measurement.
 - 3 Replace the capstan assembly. See 08-050, "Capstan Assembly Replacement."
- Caution:** Be very careful not to damage the capstan wheel, reference plate, fiber optic bundle, or tachometer cable when installing the capstan assembly.
- 4 The front edge of the capstan should be $17/32 \pm 1/64$ inch (13.5 ± 0.4 mm) from the reference plate. If not, rotate all sleeves until this condition is met.

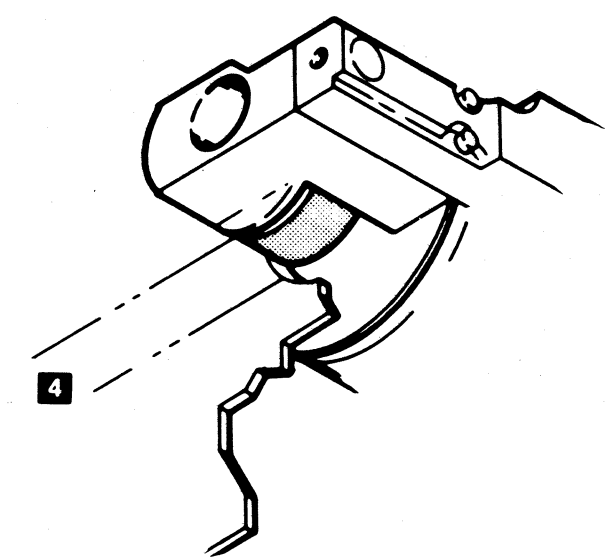
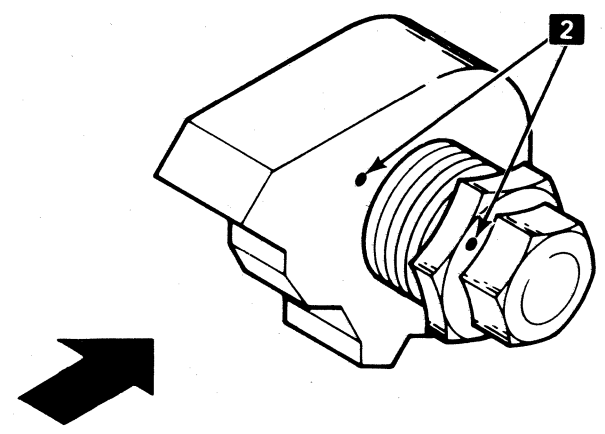
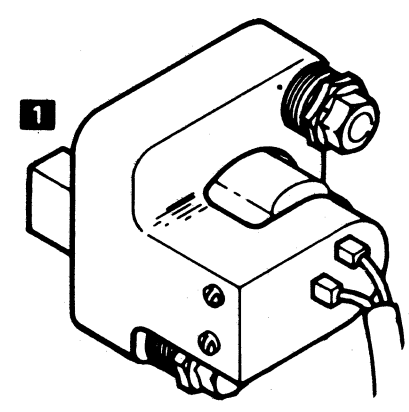
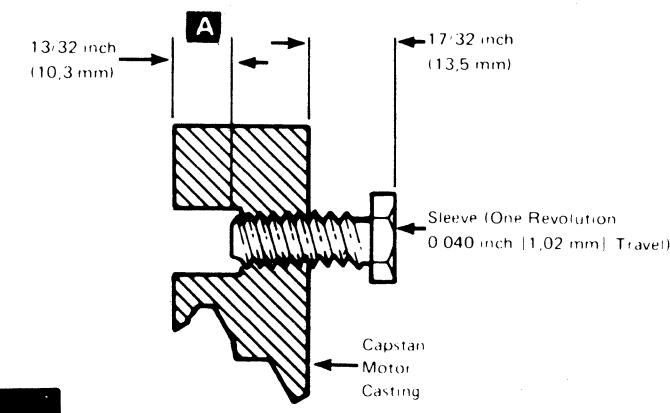

3803-1,2,3/3420

| | | | | | | | | |
|------------|-------------|----------------|----------|--|--|--|--|--|
| XD0600 | 2735816 | See EC History | 845958 | | | | | |
| Seq 1 of 2 | Part Number | | 1 Sep 79 | | | | | |

CAPSTAN STATIC ALIGNMENT (Cont'd)

Capstan Assembly Having Square Support with Zero Marks (Assembly Left in Tape Unit)

1. Check the zero mark on each sleeve for alignment with its corresponding casting mark.
2. If the zero marks are not aligned, turn the adjustable sleeves in the direction that requires the least rotation to align the sleeve and casting marks.

Note: If any sleeve requires more than 135 degrees of rotation, remove the capstan assembly and follow the procedure on 08-062 or 08-064.

3. When all the sleeves are aligned with their casting marks, measure from outside edge of each sleeve to the edge of the capstan casting. Each should measure $17/32 \pm 1/32$ inch (13.5 ± 0.8 mm) **A**; all should be within $1/32$ inch (0.8 mm) of each other. Use a steel scale, P/N 450158 or equivalent to make this measurement.
4. If the previous check is not within specifications, rotate each sleeve, where necessary, to meet this condition.

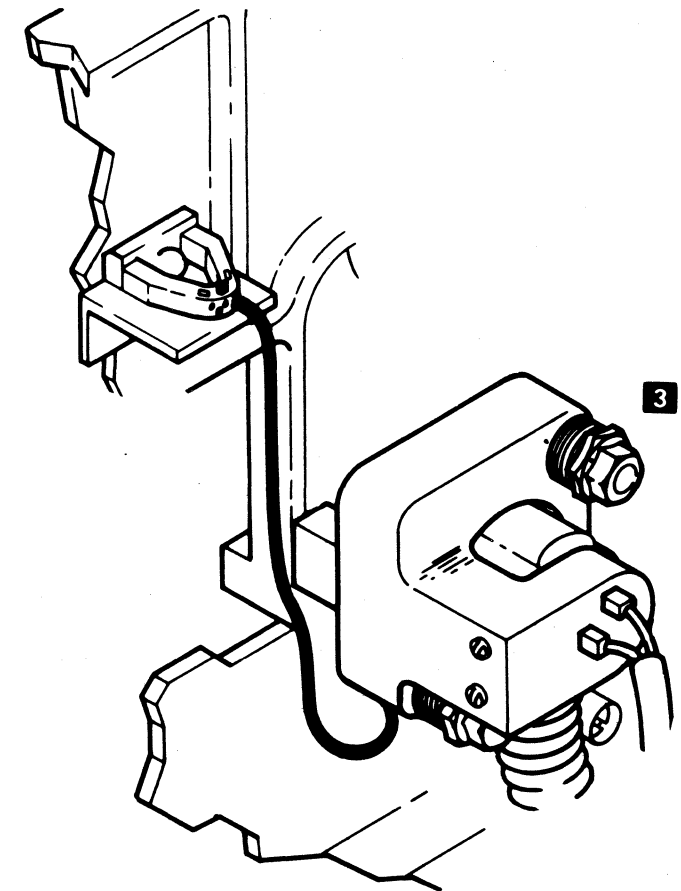
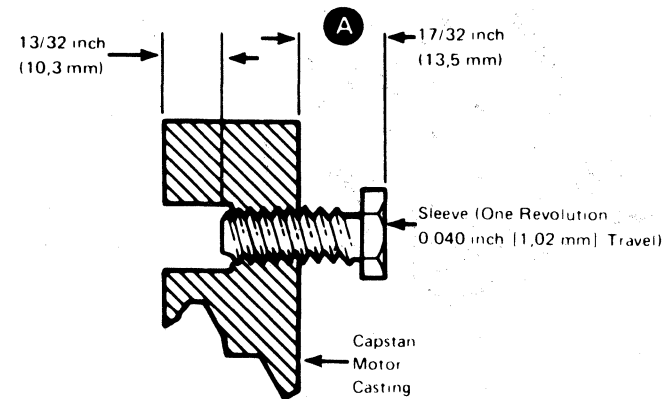
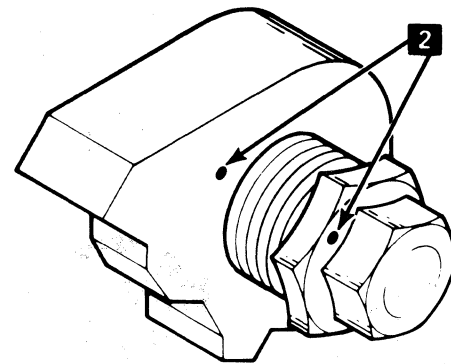

3803-1,2,3/3420

| | | | | | | | | |
|------------|-------------|---------|----------|--|--|--|--|--|
| XD0600 | 2735816 | See EC | 845958 | | | | | |
| Seq 2 of 2 | Part Number | History | 1 Sep 79 | | | | | |

© Copyright International Business Machines Corporation 1976, 1979

CAPSTAN STATIC ALIGNMENT (Cont'd)

Capstan Assembly Having Round Support
(Assembly Removed from Tape Unit)

Models 3, 4, 5, 6 and 7 (See Figure 1)

1. Remove the capstan assembly. See 08-020 or 08-030, "Capstan Assembly Removal."
2. Turn each sleeve until the zero marks align with the corresponding casting marks. When all the sleeves are aligned with their casting marks, measure from the sleeve tip to the end of the capstan motor casting. Each should measure $9/32 \pm 1/64$ inch (7.1 ± 0.4 mm). Use a steel scale, P/N 450158 or equivalent, to make this measurement.
3. Replace the capstan assembly. See 08-040 or 08-050, "Capstan Assembly Replacement."
4. The front edge of the capstan should be $17/32 \pm 1/64$ inch (13.5 ± 0.4 mm) from the reference plate. If not, rotate all the sleeves until this condition is met.

Model 8 (with Zero Marks, See Figure 2)

1. Remove the capstan assembly. See 08-020 or 08-030, "Capstan Assembly Removal."
2. Turn each sleeve until the zero marks align with the corresponding casting marks. When all the sleeves are aligned with their casting marks, measure from the sleeve tip to the end of the capstan motor casting. Each should measure $3/32 \pm 1/64$ inch (2.38 ± 0.4 mm). Use a steel scale, P/N 450158 or equivalent, to make this measurement.
3. Replace the capstan assembly. See 08-040 or 08-050, "Capstan Assembly Replacement."
4. The front edge of the capstan should be $17/32 \pm 1/64$ inch (13.5 ± 0.4 mm) from the reference plate. If not, rotate all the sleeves until this condition is met.

Model 8 (without Zero Marks, See Note on Figure 2)

1. Remove the capstan assembly. See 08-020 or 08-030, "Capstan Assembly Removal."
2. Turn each sleeve until all sleeves measure $3/32 \pm 1/64$ inch (2.38 ± 0.4 mm) from the sleeve tip to the end of the capstan motor casting. Use a steel scale, P/N 450158 or equivalent, to make this measurement.
3. Replace the capstan assembly. See 08-040 or 08-050, "Capstan Assembly Replacement."
4. The front edge of the capstan should be $17/32 \pm 1/64$ inch (13.5 ± 0.4 mm) from the reference plate. If not, rotate all the sleeves until this condition is met.

Figure 1.

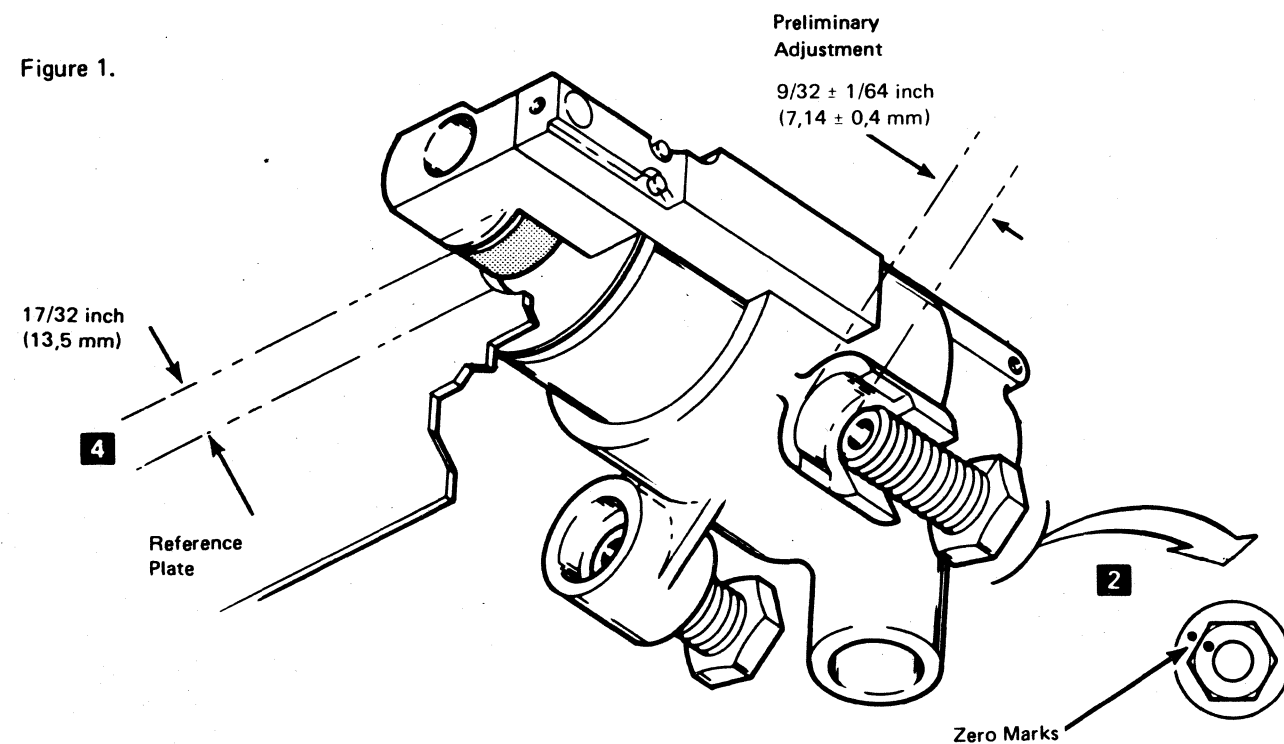
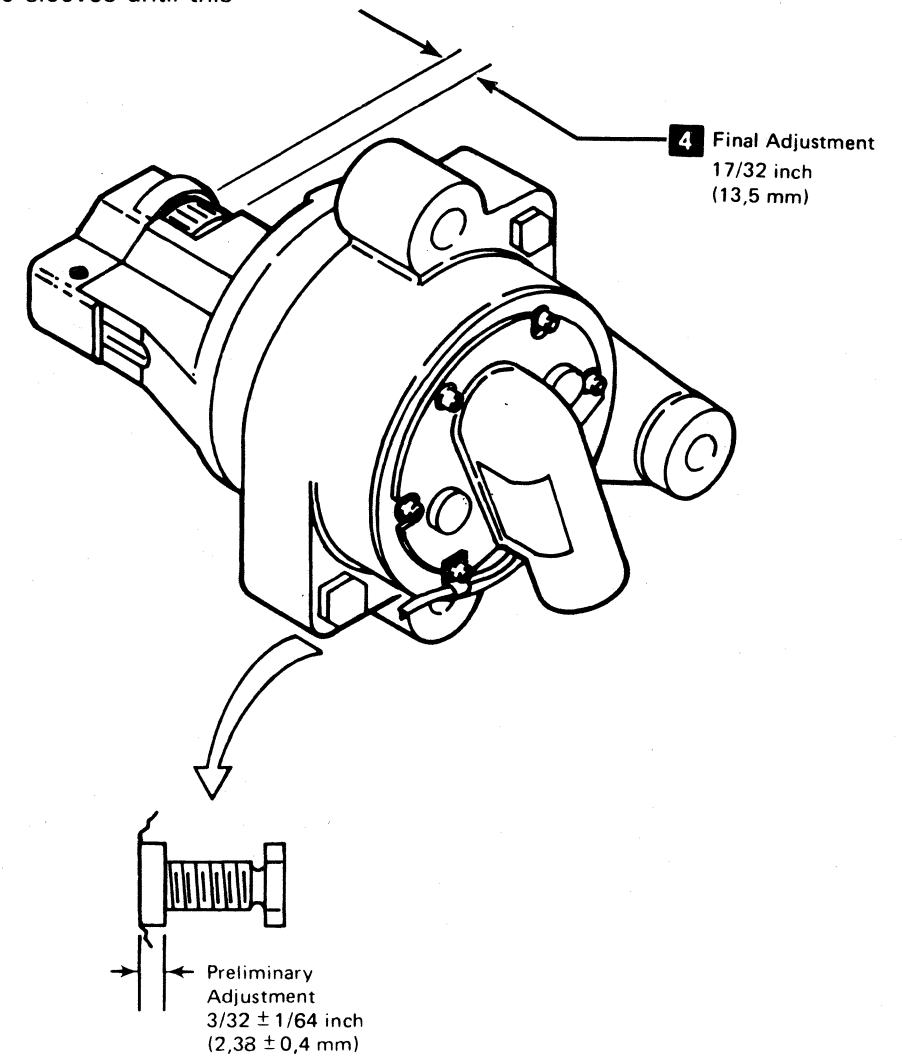

Figure 2.



3803-1,2,3/3420

| | | | | | | | | | |
|------------|-------------|---------|----------|--|--|--|--|--|--|
| XD0700 | 2735817 | See EC | 845958 | | | | | | |
| Seq 1 of 2 | Part Number | History | 1 Sep 79 | | | | | | |

CAPSTAN STATIC ALIGNMENT (Cont'd)

Capstan Assembly Having Round Support
(Assembly Left in Tape Unit)

Note: This procedure does not apply to tape unit Model 8 without the zero marks. For tape unit Model 8 without zero marks, use the procedure on 08-068.

- 1 Check the zero mark on each sleeve for alignment with its corresponding casting mark (loosen and partially unscrew the sleeve locking nut if a sleeve mark is obscured).
2. If the zero marks are not aligned, loosen the locking nut and turn the sleeve in the direction that requires the least rotation to align the sleeve and casting marks. **Note:** If any sleeve requires more than 135 degrees of rotation, remove the capstan assembly and follow the procedure on 08-068.
- 3 Check for $17/32 \pm 1/64$ inch (13.5 ± 0.4 mm) from the front surface of the reference plate to the front edge of the capstan. If this dimension is not met or you cannot see seven exposed threads on each sleeve, remove the capstan assembly and follow the procedure on 08-068.

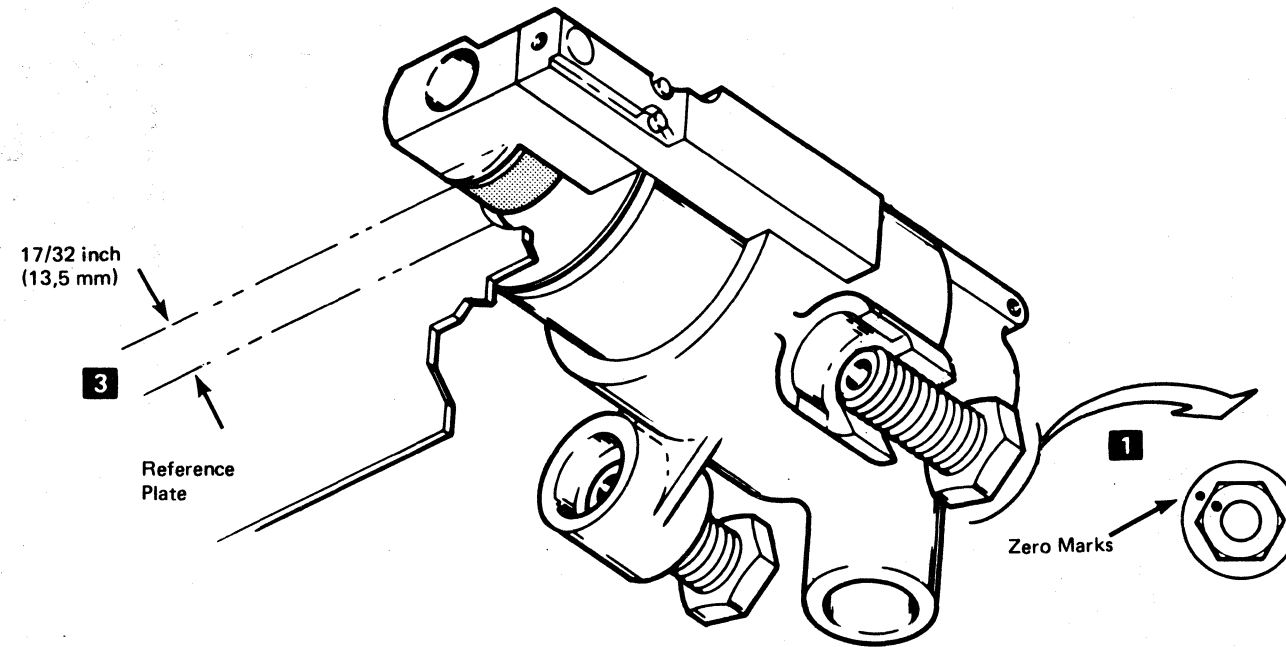

3803-1,2,3/3420

| | | | | | | | | | |
|------------|-------------|---------|----------|--|--|--|--|--|--|
| XD0700 | 2735817 | See EC | 845958 | | | | | | |
| Seq 2 of 2 | Part Number | History | 1 Sep 79 | | | | | | |

© Copyright International Business Machines Corporation 1976, 1979

**CAPSTAN-TO-STUBBY BAR CLEARANCE
ADJUSTMENT (TAPE UNIT MODELS
4, 6, 8)**

Caution: Do not use a metal feeler gauge or any metal object to measure the clearance. To avoid damage to the tape path surface, use a tab card, which is approximately 0.0065 inch (0.165 mm) thick, to make this check.

The capstan-to-upper stubby bar clearance must be 0.006 to 0.010 inch (0.15 to 0.25 mm) at both reference points **A** and **B** on the stubby bar, as shown. To adjust, loosen the two screws **C** in the upper stubby bar, position the bar to correct clearance and horizontal, then tighten the screws.

Note: Moving the stubby bar can affect the autocleaner adjustments. See 08-382.

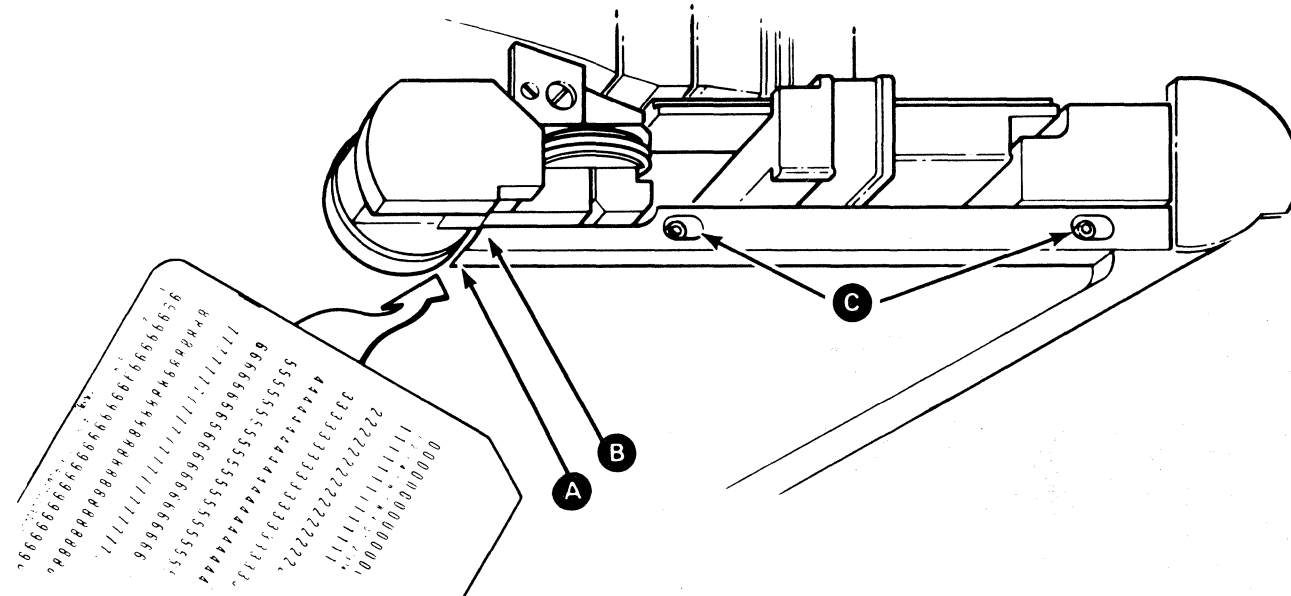

**CAPSTAN-TO-STUBBY BAR CLEARANCE
ADJUSTMENT (TAPE UNIT MODELS
3, 5, 7)**

Caution: To avoid damaging the smooth surface of the tape path, do not use a metal feeler gauge or any other hard object to measure the clearance. One data-processing card, approximately 0.0065 inch (0.165 mm) thick, can be used.

Check that the outside capstan diameter clears the radius of the upper stubby bar by 0.006 to 0.010 inch (0.15 to 0.25 mm) at **A** and **B**. The flip-down mirror must be centered between the capstan and the EOT/BOT block. Loosen the screws **C** on the stubby bar to adjust it.

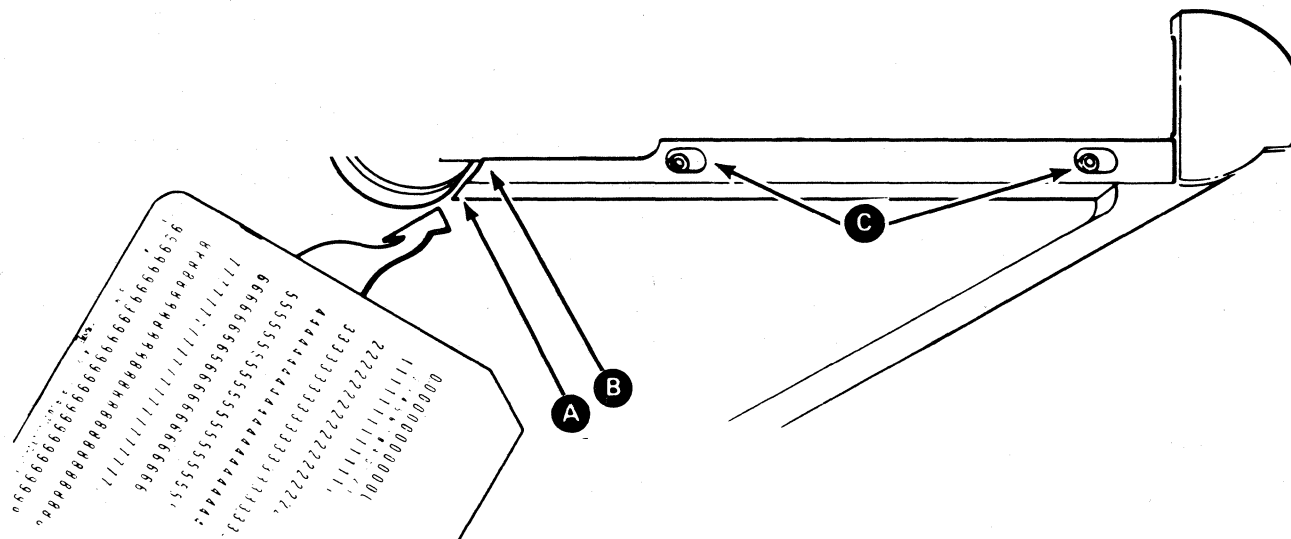

**CAPSTAN TACHOMETER
REMOVAL/REPLACEMENT
(TAPE UNIT MODELS 4 AND 6)**

1. Unplug the tachometer cable.
2. Remove the wedge and disconnect the fiber optic bundle from the light manifold.
3. Loosen the cable clamps at the front and rear of the capstan.
4. Loosen the protruding setscrew on top of the front motor support.
5. Carefully pull the tachometer and fiber optic bundle out of the supporting block.
6. Reverse the procedure to install the tachometer.
7. After installing the tachometer, perform the Capstan Tachometer Check/Adjustment procedure on 08-120.

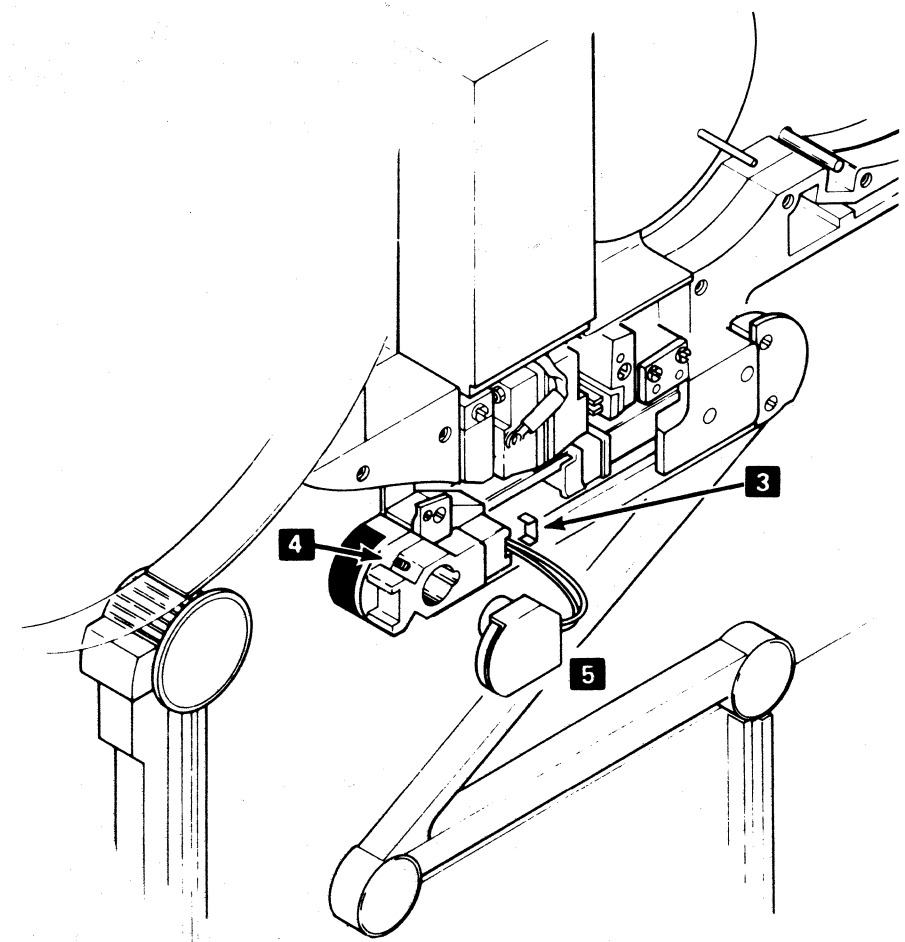
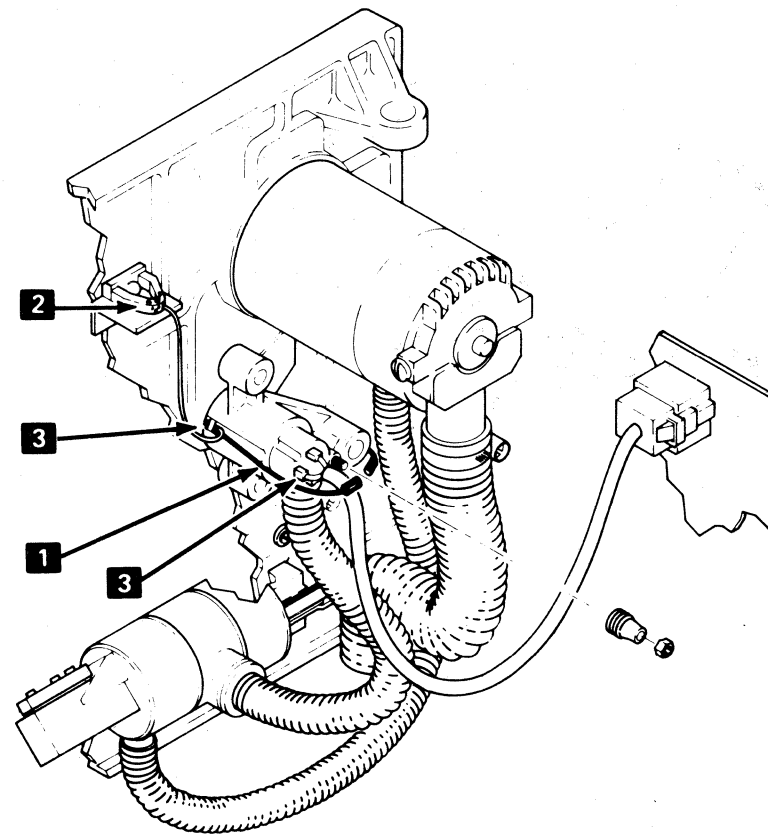

3803-1,2,3/3420

| | | | | | | | | | |
|------------|-------------|---------|----------|--|--|--|--|--|--|
| XD0800 | 2735818 | See EC | 845958 | | | | | | |
| Seq 2 of 2 | Part Number | History | 1 Sep 79 | | | | | | |

© Copyright International Business Machines Corporation 1976, 1979

NOTES:

08-100

3803-1.2.3/3420

| | | | | | | | | | |
|----------------------|------------------------|-------------------|--------------------|--|--|--|--|--|--|
| XD0900 Seq 1 of 2 | 2735819 Part Number | See EC History | 845958 1 Sep 79 | | | | | | |
|----------------------|------------------------|-------------------|--------------------|--|--|--|--|--|--|

© Copyright International Business Machines Corporation 1976, 1979

08-100

**CAPSTAN TACHOMETER
REMOVAL/REPLACEMENT
(TAPE UNIT MODELS 3, 5, 7)**

- 1 Unplug the tachometer cable.
- 2 Remove the wedge securing the tachometer fiber optic bundle to the light manifold; then remove the fiber optic bundle.
- 3 Loosen the cable clamps at the front and rear of the capstan. Remove the cable strap on the side of the motor.
- 4 Loosen the protruding set screw above the front motor support.
- 5 Carefully pull the tachometer and fiber optic bundle out of the supporting block.
- 6 Reverse the procedure to install the tachometer.
- 7 After installing the tachometer, perform the Capstan Tachometer Check/Adjustment procedure on 08-130.

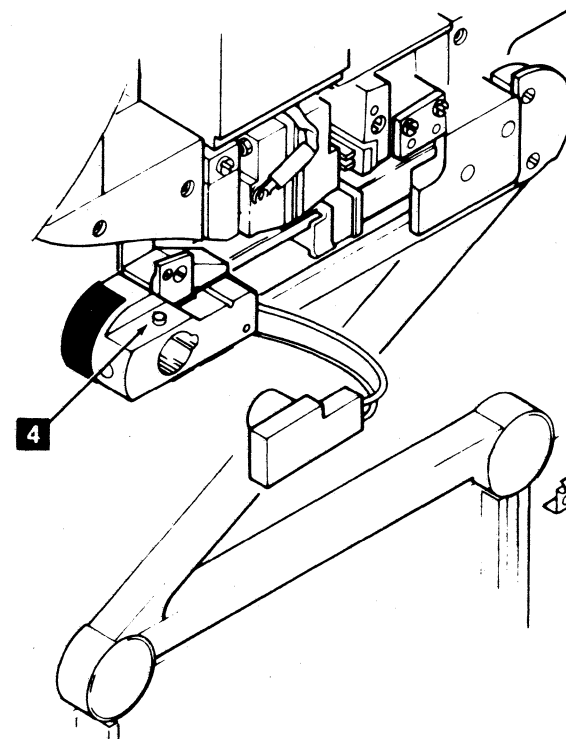
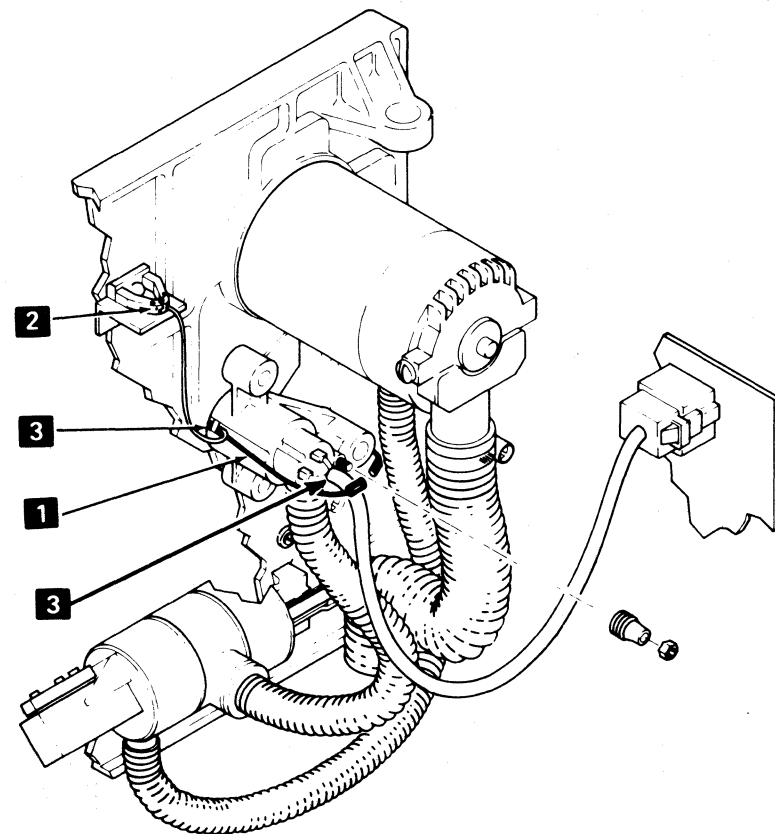

3803-1,2,3/3420

| | | | | | | | | | |
|------------|-------------|---------|----------|--|--|--|--|--|--|
| XD0900 | 2735819 | See EC | 845958 | | | | | | |
| Seq 2 of 2 | Part Number | History | 1 Sep 79 | | | | | | |

© Copyright International Business Machines Corporation 1976, 1979

**CAPSTAN TACHOMETER
CHECK/ADJUSTMENT
(TAPE UNIT MODELS 4, 6, 8)**

Follow the instructions in the sequence listed below:

Note: Model 8 — do not remove front cover.

1. Turn off tape unit power.

DANGER

Allow the lamp to cool before cleaning it.

2. Clean the fiber optic lamp (see 08-620).
3. Plug the capstan power cable into the test socket on the bottom of the capstan motor control board and turn on power.

If the fiber optic lamp has been off for more than 10 minutes, allow the fiber optic lamp to warm up for 20 to 30 minutes before continuing.

4. Display phase A and B on the oscilloscope as follows:
 - Display and sync plus on phase B (T-A1H2P04 test point) or pin B on the tachometer assembly.
 - Display phase A (T-A1H2J10 test point) or pin A on the tachometer assembly.
 - Invert phase A and put the scope switch in the ADD position. (2 usec/cm.)
 - With the scope in the uncalibrated mode, adjust the four state lengths so they span 10 cm on the scope face.
5. Total state length equals state length plus period variation. Total state length should exceed 1.2 cm for each of the four states.
6. If each of the four states exceed 1.2 cm, no adjustment is necessary. If not, do the following adjustments.
7. Connect the oscilloscope to phase A test point (T-A1H2J10) or pin A on the tachometer assembly and sync plus (set scope at 2 usec/cm). With the scope in the uncalibrated mode, adjust so that a full tach period spans 10 cm on the scope face.

8. Adjust potentiometer A and B on the tachometer circuit card on the front of the capstan motor so the average on-time (symmetry) is between 4.8 and 5.0 cm.

Repeat steps 7 and 8 for phase B using the phase B test point (T-A1H2P04) or pin B on the tachometer assembly.
9. Display both phases on the oscilloscope. Sync plus on phase B. Invert phase A and put the scope in the ADD position.
10. Total state length equals state length plus period variation. With symmetry set, as in steps 4 and 5, each total state length should exceed 1.2 cm for each of the four states.

If this limit cannot be obtained, clean or replace the tachometer. See 08-140, "Capstan Tachometer Cleaning;" 08-090 or 08-100, "Capstan Tachometer Removal/Replacement;" or 08-620, "Fiber Optics Lamp Removal/Replacement."
11. Direction sensing: Sync oscilloscope auto and check that -Backward Caps Motion (T-A1H2M12) is plus. This verifies the correct direction sensing.
12. Turn off tape unit power.
13. Return the capstan power plug to its normal operating position on the capstan motor control board.

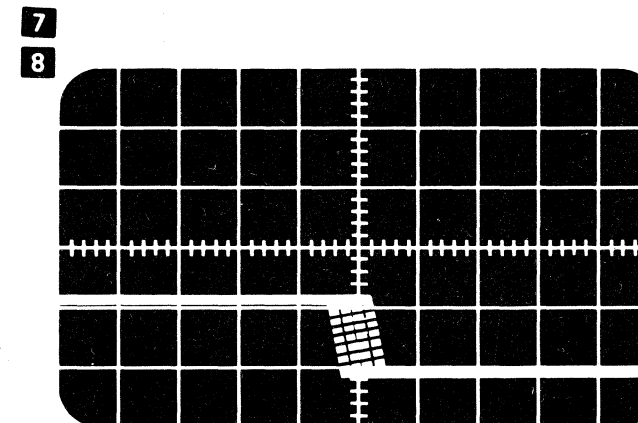
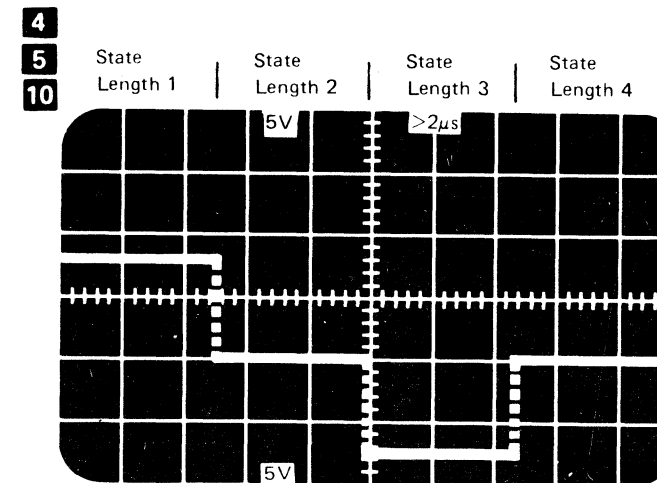

Model 8 Capstan

Note: If the waterfall is greater than 10%, remove the capstan tach and clean as instructed on 08-140.

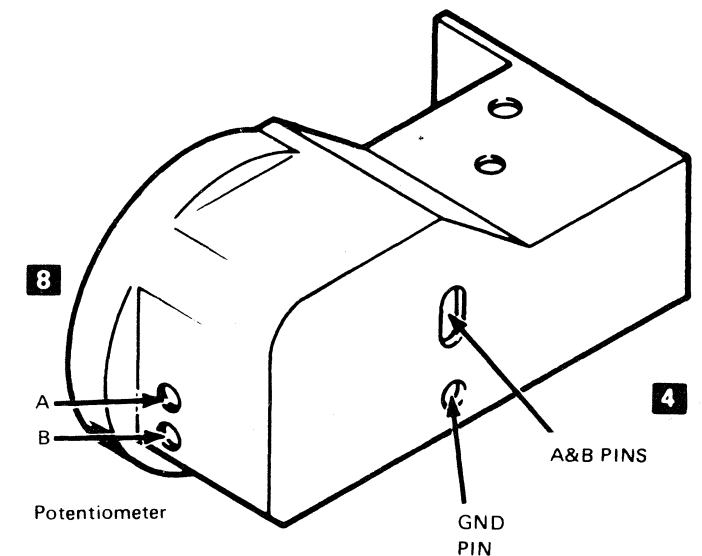

Models 4 and 6 Capstan

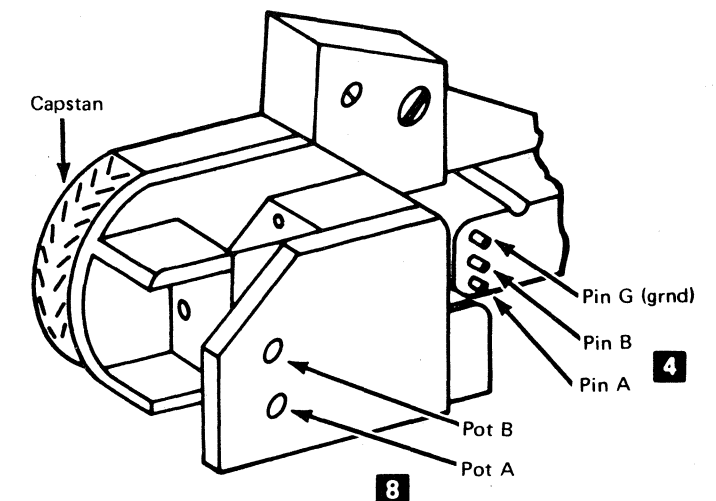

| | | | | | | | |
|------------|-------------|---------|----------|--|--|--|--|
| XD1000 | 2735820 | See EC | 845958 | | | | |
| Seq 1 of 2 | Part Number | History | 1 Sep 79 | | | | |

**CAPSTAN TACHOMETER
CHECK/ADJUSTMENT
(TAPE UNIT MODELS 3, 5, 7)**

If readjustment is necessary, do it at the normal tape unit operating temperature.

1. Unload the tape unit and turn off power.
2. Move the capstan motor plug to the test socket at the bottom of the capstan motor control board.
3. Remove the cover from the circuit card on the front of the capstan.
4. Turn on tape unit power.
5. Scope the capstan squaring pulses. Use test points on the tachometer assembly or A1G2G02. Sync positive on the tach pulses.
6. Adjust the scope so that one full tach period is displayed on 10 cm.

If the waveform is $\pm 10\%$ of 50/50 duration, the output is satisfactory and is not the cause of the problem. (Consider the center of the waterfall as the point of transition.) (See Figure 1 and Note.)

If the waveform is satisfactory, go to step 10; otherwise go to step 7.

7. Turn off tape unit power.

DANGER

Allow the lamp to cool before cleaning it.

8. Clean the fiber optic lamp. (See 08-620.)
9. Check the capstan fiber optics bundle for loose or broken parts.
10. Turn on tape unit power. Allow the fiber optic lamp to warm up for 20 to 30 minutes before continuing.
11. Adjust the potentiometer on the tachometer circuit card to obtain the waveform shown (+ during 40%, minus duration 60%). This setting allows for normal aging of components.
12. Turn off tape unit power and replace the capstan motor plug in the "normal" socket. Be sure to replace the circuit card cover.

If directed to this procedure by a MAP, return to that MAP.

Figure 1.

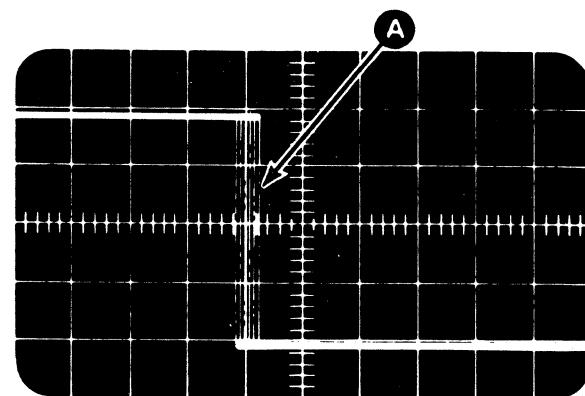

Note: If waterfall **A** is excessive, 10% of a full cycle or greater, remove the capstan tachometer and clean the tachometer disk and interrupter mask, following the procedure on 08-140.

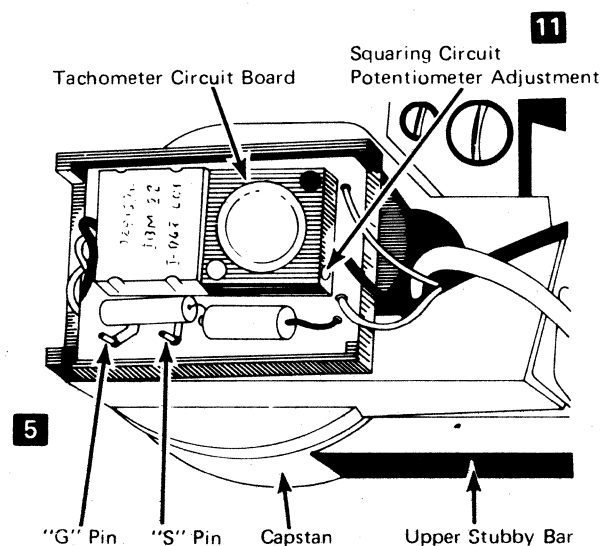

3803-1.2.3/3420

| | | | | | | | |
|------------|-------------|---------|----------|--|--|--|--|
| XD1000 | 2735820 | See EC | 845958 | | | | |
| Seq 2 of 2 | Part Number | History | 1 Sep 79 | | | | |

© Copyright International Business Machines Corporation 1976, 1979

CAPSTAN TACHOMETER CLEANING

If capstan operation cannot be adjusted to specified limits, clean the lamp (see 08-620), try the adjustment again, and then clean the tachometer disk and interrupter mask. These parts do not usually require cleaning.

Caution: If you damage the tachometer disk, you must replace the entire capstan motor assembly.

Remove the tachometer to clean:

1. On Models 3, 4, 5, 6, and 7, remove the tachometer by loosening the protruding setscrew **A** on the front support. Remove cable clamp **B** on the side of the motor and carefully slide the tachometer block out of support. On Model 8, remove three screws **C** fastening the front cover and carefully slide the cover forward and off.

2. Pressing lightly with a dry cotton swab, P/N 556944, clean the disk and interrupter mask.

Note: The interrupter mask is **not** cleaned on Model 8.

3. If this does not remove all the contaminants, slightly dampen the swab with tape cleaner. Making sure that the swab is touching only the disk surface, repeat step 2.

Caution: Do not use water.

4. Replace the tachometer by reversing the procedure in step 1.
5. Repeat the Capstan Tachometer Check/Adjustment procedure on 08-120 or 08-130.

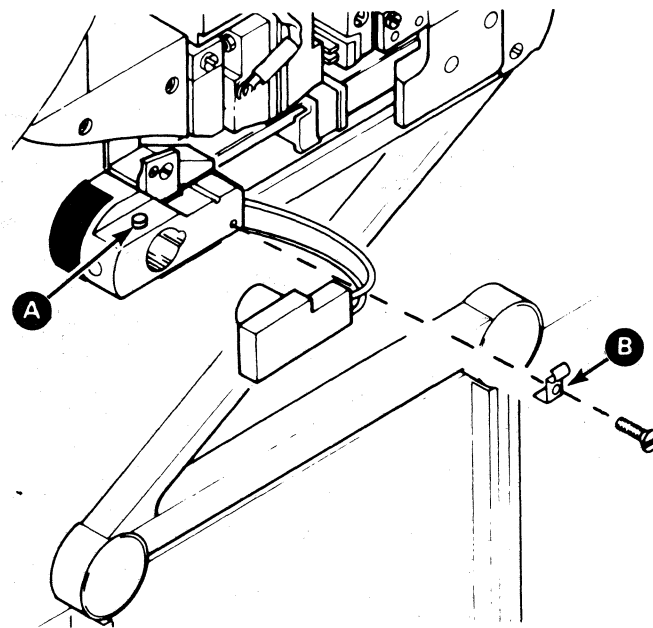

Model 3,5,7

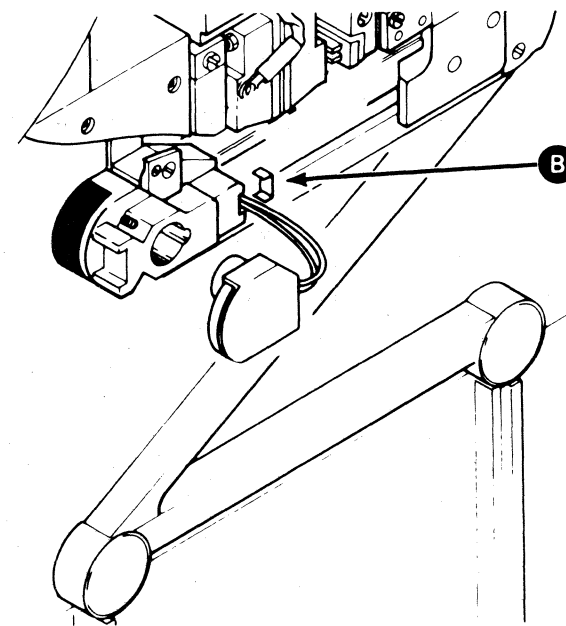

Model 4,6

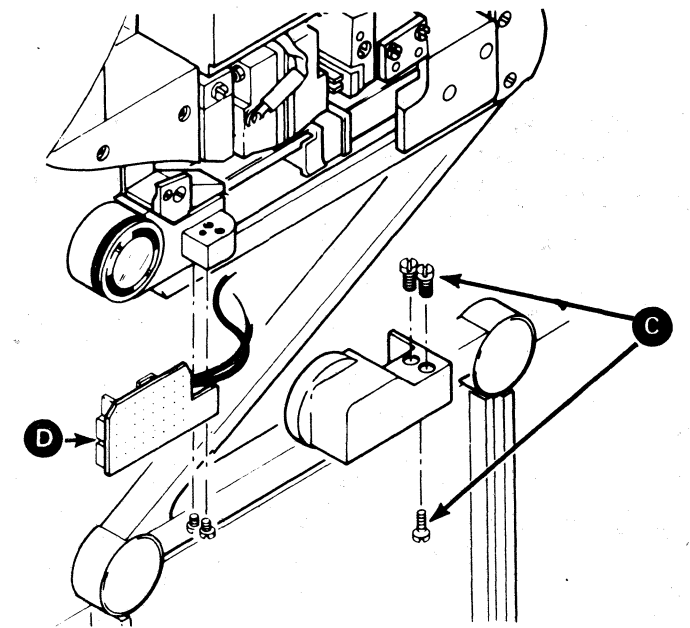

Model 8

Note: Tach block shown removed **D** for illustration only.

| | | | | | | | | |
|------------|-------------|---------|----------|--|--|--|--|--|
| XD1100 | 2735821 | See EC | 845958 | | | | | |
| Seq 1 of 2 | Part Number | History | 1 Sep 79 | | | | | |

**CAPSTAN DYNAMIC ALIGNMENT
(NON-90,000 SERIES TAPE UNITS)**

If the capstan assembly has been removed, perform the Capstan Static Alignment procedure on 08-060 before attempting the capstan dynamic alignment.

Note: Before starting the dynamic alignment, check the vacuum column door for correct sealing.

Look for tape in both stubby columns. If the tape is not in both columns, an air leak may be the problem caused by a misadjusted vacuum column door. See 08-680, "Vacuum Column Door Replacement and Adjustment."

Check tachometer operation. See 08-130, "Capstan Tachometer Check/Adjustment."

Do the following for dynamic alignment:

1. Switch the tape unit offline, using the switch on the tape unit logic gate.
2. Attach the 3420 field tester.
3. Mount an undamaged CE work tape.
4. Momentarily press LOAD REWIND.
5. When the right reel starts turning, press and hold LOAD REWIND until 20 to 30 feet (7.0 to 10.0 m) of tape is on the left reel.
6. Release LOAD REWIND and quickly press RESET to stop tape motion and loading.
7. Open the front door and the vacuum column door, and bypass the door interlock switch.

DANGER

Be extremely careful when the front door is open and the reels are turning to avoid personal injury.

8. For additional clearance, loosen the two retaining screws and slide the upper stubby bar away from the capstan, then retighten screws.

9. Remove the left threading channel.

Caution: Do not lose the two O-rings located behind the threading channel.

10. On NRZI-featured tape units, remove the small hose attached to the threading channel. Allow 3 to 5 inches (76 to 127 mm) of hose to extend beyond the reference plate. If the hose falls out of the reference plate, it may be necessary to remove the capstan motor to reinstall it.

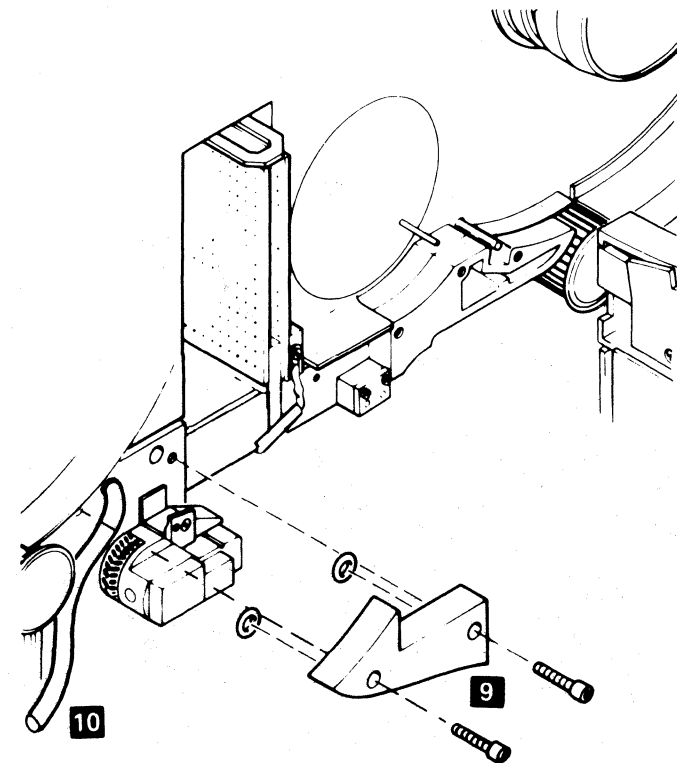

11. Remove the left threading plate on the vacuum column door so that you can observe the tape while making adjustments. Remove the rubber door spacer behind the threading plate, if necessary.

12. Remove the screws holding the front guide to the ramp and the large screw that holds the ramp to the reference plate. Remove the front guide.

Caution: Do not lose the spring behind the rear guide. (in NRZI-featured tape units only.)

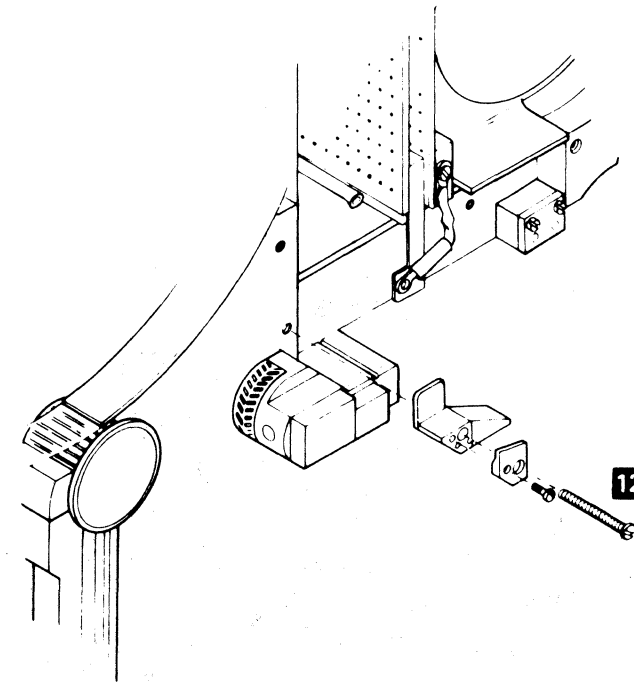

13. Use the long screw to fasten the ramp to the reference plate. Press down on the right side of the ramp for correct positioning.

14. On NRZI-featured tape units, retract the rear movable guide, using the retracting clip on the tape unit, P/N 2522983.

Note: The guide must retract completely behind the reference plate. Shape the retracting clip if necessary.

Caution: Do not allow the screw head to touch the tape. If necessary, fold a tab card several times and place it next to the screw head as shown (A) to prevent screw-head-to-ramp contact and damage to the reference plate.

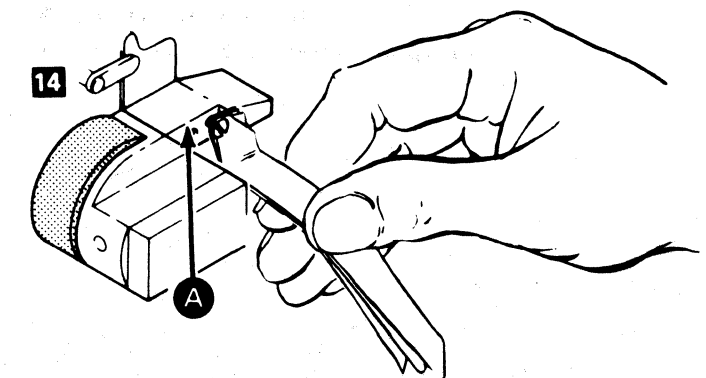

15. With the vacuum column door open, turn the left reel counterclockwise and the right reel clockwise until small tape loops form in both vacuum columns.
16. Close the vacuum column door.
17. Press LOAD REWIND and START.

3803-1,2,3/3420

| | | | | | | | | |
|------------|-------------|---------|----------|--|--|--|--|--|
| XD1100 | 2735821 | See EC | 845958 | | | | | |
| Seq 2 of 2 | Part Number | History | 1 Sep 79 | | | | | |

© Copyright International Business Machines Corporation 1976, 1979

**CAPSTAN DYNAMIC ALIGNMENT
(NON-90,000 SERIES TAPE UNITS) (Cont'd)**

To align the capstan, use a hex wrench, P/N 2523723, to turn the adjusters through the holes in the front of the tape unit **A**.

To check dynamic tracking at the left carbide guide:

18. Set the field tester to read forward.
19. With tape moving forward, turn the left adjuster **A** until the ramp surface **B** is just visible. Turn the adjuster clockwise to cause the tape to track toward the rear of the machine, or counterclockwise to cause the tape to track toward the front of the machine.

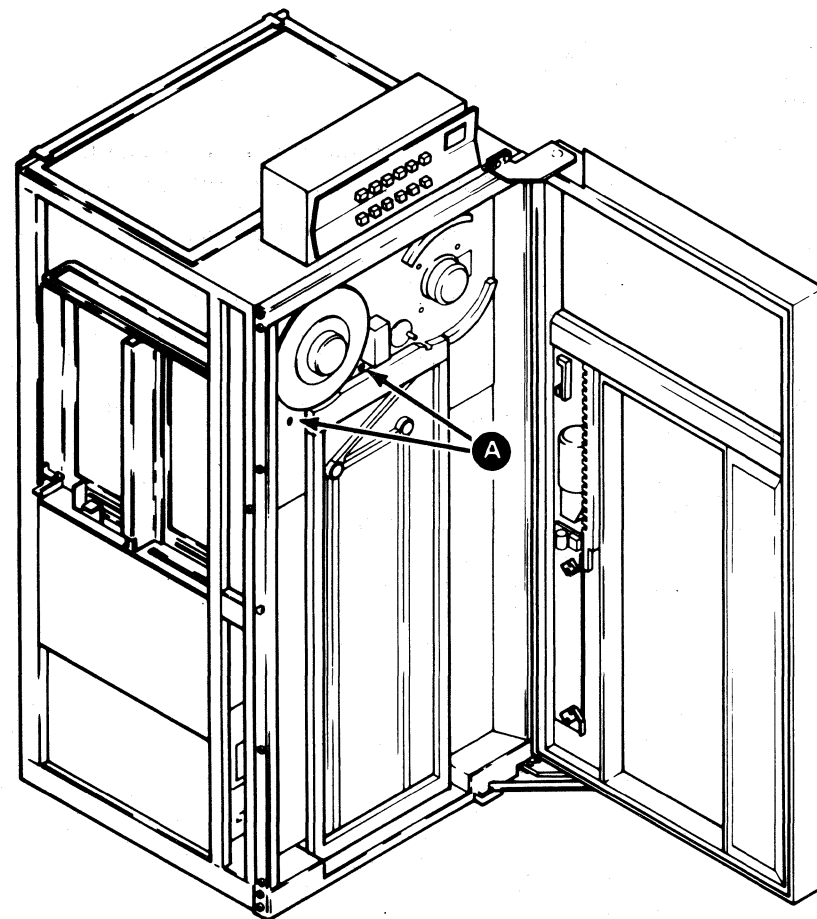

20. Set the field tester to read backward.
21. With tape moving backward, turn the upper adjuster to obtain a slight clearance **B**.
22. Set the field tester to read forward.
23. With tape moving forward, turn the left adjuster counterclockwise until the front edge of the tape rides exactly on the front edge of the ramp **C**.
24. Set the field tester to read backward.
25. With tape moving backward, turn the upper adjuster clockwise until the front edge of the tape rides exactly on the front edge of the ramp **C**.
26. Repeat steps 22 through 25 until the tape rides evenly on the ramp edge **C** when the tape is moving in either direction.
27. Turn both adjusters clockwise until the tape has a slight clearance **B** with the tape moving in either direction.

Note: A slight clearance at the reference plate and front of ramp **B** and no front-to-back movement indicates correct tracking. Verify that some capstan rubber is visible **D** at each edge of the tape.

When the rear movable guide is released **E**, the tape will track toward the front of machine. (Only NRZI-featured tape units have rear movable guides.) The tape may flutter slightly near the rear guide because of tape edge differences. Although a slight flutter at the rear guide can be allowed, a significant flutter at the rear guide or any flutter at the front guide requires further checking or adjustments or both.

28. Replace all parts previously removed. Ensure that the O-rings are in place behind the threading channel.
29. Perform the Capstan-To-Stubby Bar Clearance Adjustment procedure on 08-080. The autocleaner adjustment must then be checked. See 08-380.
30. On NRZI-featured tape units, perform the Mechanical Skew Check/Adjustment procedure on 08-180 and the Read Electrical Skew Adjustment procedure on 08-190. On other tape units, perform the Mechanical Skew Check/Adjustment procedure on 08-170.

Note: If the skew change (forward to backward) is more than that specified in the procedure on 08-170 or 08-180, recheck the mechanical skew.

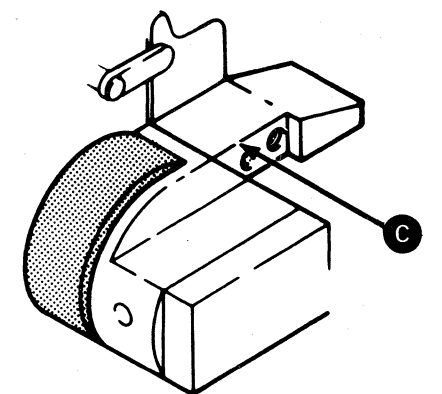
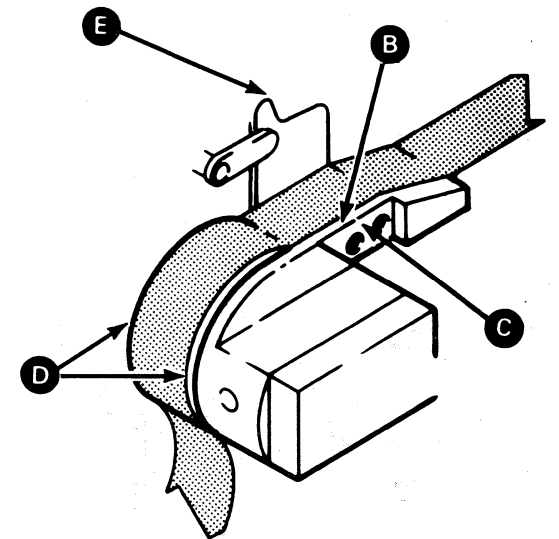

**CAPSTAN DYNAMIC ALIGNMENT
(90,000 SERIES TAPE UNITS)**

Note: If the static alignment was not done, check for 17/32 ± 1/64 inch (13.5 ± 0.4 mm) from the front surface of the reference plate to the front edge of the capstan. Before starting the dynamic alignment, check the vacuum door for correct sealing. Look for tape in both stubby columns, and if the tape is not in both columns, an air leak may be the problem. See 08-680, "Vacuum Column Door Replacement and Adjustment." Perform the Capstan Tachometer Check/Adjustment procedure on 08-120 or 08-130.

1. Switch tape unit offline.
2. Attach the 3420 field tester.
3. Load an undamaged CE work tape, set the field tester to read forward, and move the tape forward until the load-point sticker is past the BOT/EOT block.
4. Turn tape unit power off.
5. Remove the left threading channel and left threading plate on the vacuum column door so that you can observe the tape while making adjustments. Remove the rubber door spacer behind the threading plate, if necessary.

Caution: Do not lose the two O-rings located behind the threading channel.

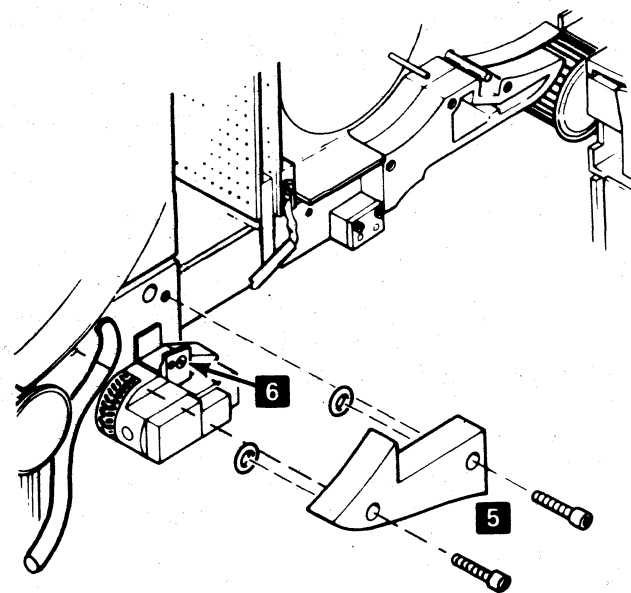

6. Remove one short and one long screw from the front of the carbide guide.
7. Remove the front carbide guide and threading ramp.
8. Use the long screw to fasten the threading ramp to the reference plate. Press down on the right side of the ramp for correct positioning. If a binder head screw is used, replace it with a flat-head screw to eliminate interference while setting the tracking, or place a folded tab card between the existing binder head screw and the ramp. A size 6 nut can also be used.

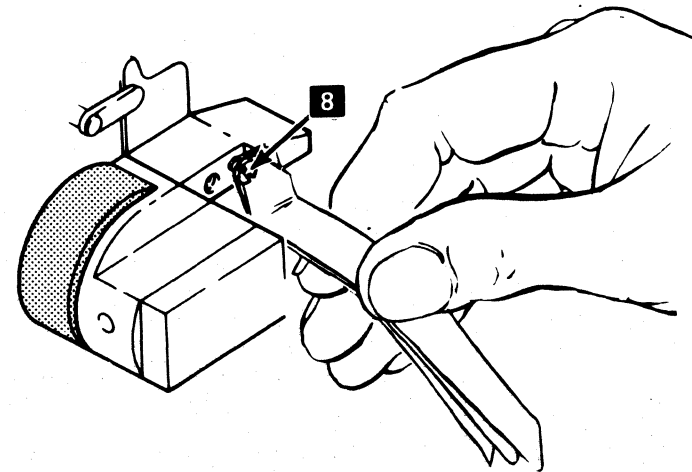

9. Loosen the two retaining screws and slide the upper stubby bar away from the capstan to obtain maximum clearance. Tighten the screws temporarily.
10. Clean the threading ramp and the left rear carbide guide. Use a brush, P/N 2513590.
11. With the vacuum column door open, turn the left reel counterclockwise and the right reel clockwise to form small tape loops in both columns.
12. Close the column door carefully, turn on tape unit power, and press LOAD REWIND and START to start a mid-tape load.
13. Set the field tester to read forward.
14. With tape moving forward, use a flashlight or service lamp and look for a slight gap between the rear edge of the tape and the rear carbide guide.

Note: For the remainder of this procedure, do not adjust sleeve 2. It was set during static alignment. Loosen all three locking nuts before making any adjustments.

15. If no gap is visible, turn adjustable sleeve 3 clockwise 1/8 turn (45 degrees). Repeat as necessary to obtain the gap.
16. If the gap is excessive, turn sleeve 3 counterclockwise until the gap is barely visible.
17. Use the field tester to move the tape in both directions. If tape tracking changes when tape motion is reversed, adjust sleeve 1 as follows:
 - a. If the tape rides toward the rear on a forward operation and toward the front on a backward operation, stop the tape motion and turn sleeve 1 clockwise a few degrees. Start the tape motion and recheck. Repeat this step until there is no visible variation.
 - b. If the tape rides toward the front on a forward operation, and toward the rear on a backward operation, stop the tape motion and turn sleeve 1 a few degrees counterclockwise. Start the tape motion and recheck. Repeat this step until there is no visible variation.
18. With tape moving forward, observe the gap between the tape edge and the rear carbide guide. Turn sleeve 3 counterclockwise until the gap just disappears.
19. Recheck the front-to-back movement (see step 17). Turning either sleeve 3 or sleeve 1 affects front-to-back movement.
20. Turn sleeve 3 an additional 1/24 turn (15 degrees) counterclockwise.
21. Observe the capstan from the top and bottom with the tape moving in both directions. Check that wrinkling or distortion of the tape does not occur.
22. If distortion occurs in one direction only, adjust sleeve 1. See step 17.
23. If distortion occurs in both directions, adjust sleeve 3 slightly clockwise.

Note: A slight clearance at the reference plate and front of ramp B and no front-to-back movement indicates correct tracking.

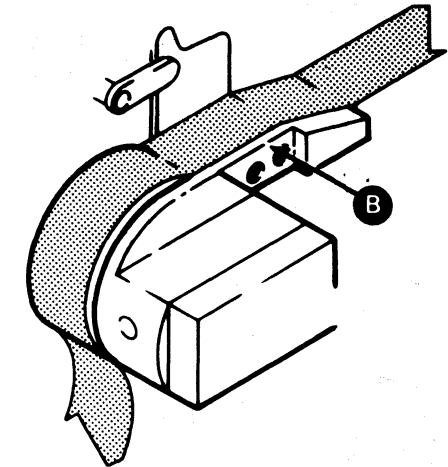

24. After adjustment, lightly tighten the three locking nuts and check the capstan for binds. When the capstan is free of binds, tighten all three locking nuts.

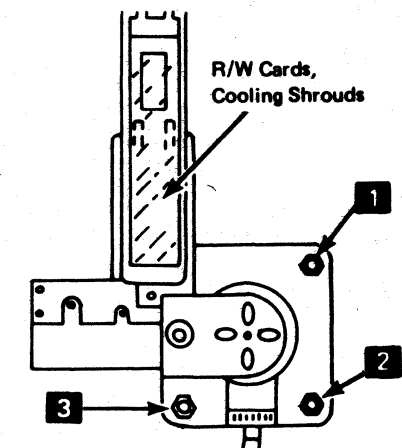

25. Unload the tape.
26. Replace all the parts previously removed. Ensure that the two O-rings are in position behind the threading channel.
27. Perform the Capstan-To-Stubby Bar Clearance Adjustment procedure on 08-080.
28. Perform the Mechanical Skew Check/Adjustment procedure on 08-170 or 08-180.
29. If this is a Model 4, 6 or 8, perform the Autocleaner Adjustment procedure on 08-382.

3803-1,2,3/3420

| | | | | | | | | | |
|------------|-------------|---------|----------|--|--|--|--|--|--|
| XD1200 | 2735822 | See EC | 845958 | | | | | | |
| Seq 2 of 2 | Part Number | History | 1 Sep 79 | | | | | | |

© Copyright International Business Machines Corporation 1976, 1979

**MECHANICAL SKEW
CHECK/ADJUSTMENT
(1600 AND 6250 BPI TAPE UNITS)**

Note: Go to 08-180 if the tape units are Model 3, 5 or 7 with the NRZI feature.

Mechanical Skew Check

If a tape skew problem is suspected, do the following maintenance check:

The read card test point locations are on the label inside the front read card cover (Models 3, 5, and 7), or on the rear read card cover (Models 4, 6, and 8). See the label on the logic gate for digital data test points.

For 6250 bpi tape units – do all the steps.

For 1600 bpi tape units – omit steps 3 through 5.

1. Switch the tape unit offline.
2. Attach the 3420 field tester.
3. Turn off tape unit power.
4. Attach a jumper from T-A1M2D06 to T-A1K2P02 (this sets the tape unit for 6250 bpi operation).
5. Turn on tape unit power.
6. Mount and load a master-skew tape, P/N 432640 or 432641.
7. Set the field tester to read forward continuously with the frequency switch set to 16.
8. With tape reading forward, set the scope for 2 usec/cm, 500 mV amplitude, and sync positive on the track 2 read signal. Use the left test point on the read card.
9. Using both probes, scope the digital output of tracks 4 and 5. Use the horizontal control to align the center of the waterfall for the leading track slightly off the vertical centerline on the scope face.
10. The forward mechanical skew (the time between centers of track 4 and 5 waterfalls when reading forward) should not exceed:

| TU Model | Forward or Backward Skew |
|----------|--------------------------|
| 3 or 4 | 1.3 usec |
| 5 or 6 | 0.8 usec |
| 7 or 8 | 0.5 usec |

11. Probe other tracks to verify that all the bits are in the same byte.
12. Set the field tester to read backward continuously.
13. Sync scope negative and check the digital outputs of tracks 4 and 5.
14. The backward mechanical skew (the time between centers of tracks 4 and 5 waterfalls when reading backward) should not exceed the specification in step 10.
15. Set the field tester to Alt Dir and check that the forward-to-backward mechanical skew is less than:

| TU Model | Fwd-to-Bkwd Skew |
|----------|------------------|
| 3 or 4 | 3.9 usec |
| 5 or 6 | 2.4 usec |
| 7 or 8 | 1.5 usec |

16. If the mechanical skew check procedure indicates that the skew is outside the given limits, go to the Mechanical Skew Adjustment procedure on this page.
17. If the mechanical skew check indicates that the skew is within the given limits, remove the jumper (step 4).

Mechanical Skew Adjustment

When the mechanical skew check procedure indicates that the skew is outside the given limits, or if you have replaced or adjusted components which affect skew (such as the read/write head or capstan assembly), make the following mechanical skew adjustment.

Note: Remove the cooling hose to the read/write card shroud for access to the skew-adjusting screw.

Caution: Inspect the tracking before adjusting the skew plate. See 08-150, "Capstan Dynamic Alignment," step 18, for tracking information.

1. See the Mechanical Skew Check procedure on this page up to step 7, to set up the tester.
 2. With tape reading forward, set the scope for 2 usec/cm, 500 mV amplitude, and sync positive on the track 2 read signal. Use the left test point on the read card.
 3. Using both probes, scope the digital outputs of tracks 4 and 5. Use the horizontal control to align the center of the waterfall for the leading track with the vertical centerline on the scope face.
- Caution: Do not attempt to loosen the lock nut on the adjusting screw.**

4. Turn the skew-adjusting screw (headless setscrew with the lock nut on the rear of the skew plate) until the centers of both waterfalls are aligned.
5. Scope other tracks to verify that all bits are in the same byte.
6. Set the field tester to read backward continuously.
7. Sync scope negative and check the digital outputs of tracks 4 and 5.
8. Do not adjust the head skew plate if the backward mechanical skew (the time between centers of tracks 4 and 5 waterfalls when reading backward) is less than:

| TU Model | Forward or Backward Skew |
|----------|--------------------------|
| 3 or 4 | 1.3 usec |
| 5 or 6 | 0.8 usec |
| 7 or 8 | 0.5 usec |

9. If the tape unit does not meet the specification in step 8, recheck the capstan dynamic alignment (08-150 or 08-160) and return to step 1 of the Mechanical Skew Adjustment procedure.
10. Set the field tester to Alt Dir and check that the forward-to-backward mechanical skew is less than:

| TU Model | Fwd-to-Bkwd Skew |
|----------|------------------|
| 3 or 4 | 3.9 usec |
| 5 or 6 | 2.4 usec |
| 7 or 8 | 1.5 usec |

11. Repeat steps 8 through 10 until the specification in step 10 is met.
12. Perform the Capstan-to-Stubby Bar Clearance Adjustment procedure on 08-080.

Caution: Attach the cooling hose to the read/write card shroud and remove the jumper installed.

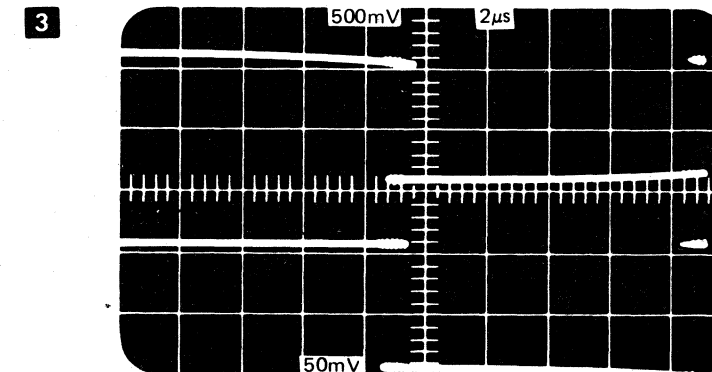
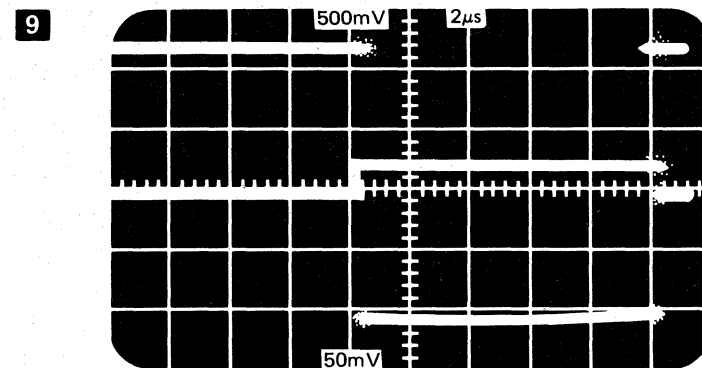

**MECHANICAL SKEW
CHECK/ADJUSTMENT
(NRZI-FEATURED TAPE UNITS)**

The read card test point locations are on the label inside the front read-amplifier cover. See the label on the logic gate for the digital data test points.

Note: The skew is adjusted while scoping digital data pulses, but since two such pulses are generated for every analog sine wave verify the adjustment by scoping the analog sine wave.

Prerequisite: Perform the Capstan Dynamic Alignment procedure on 08-150.

Note: Remove the cooling hose to the read/write card shroud for access to the skew-adjusting screw.

Initial preparations:

1. Attach the 3420 field tester.
2. Mount and load a master-skew tape, P/N 432640 or 432641.
3. Set the field tester to read forward continuously.
4. Set the frequency switch to 8 (800 bpi).

To set up the scope:

5. Sync scope positive on the track 2 read signal (9-track) or track 4 read signal (7-track). Use the left test point on the read card.
6. Scope the read card digital output for tracks 4 and 5 (9-track), or P and 7 (7-track). See the label to the left of the logic panel.

To adjust the skew:

Caution: Do not loosen the lock nut on the adjusting screw.

7. Adjust the head skew plate until the negative-transition waterfalls displayed in step 6 are aligned. The adjustment screw is found on the rear of the skew plate and is the headless setscrew with the lock nut.

To check the backward skew:

8. Set the tester to read backward continuously.
9. Sync scope negative and probe the points given in step 6.

10. The backward skew must not exceed:

| TU Model | Backward Skew |
|----------|---------------|
| 3 | 0.6 usec |
| 5 | 0.4 usec |
| 7 | 0.25 usec |

Note: If a different tape is used to check the skew from that used to set the skew, it is not necessary to adjust the head skew plate if the forward skew and the forward-to-backward skew meet the limits given:

| TU Model | Forward Skew | Fwd-to-Bkwd Skew |
|----------|--------------|------------------|
| 3 | 1.0 usec | 2.0 usec |
| 5 | 0.6 usec | 1.2 usec |
| 7 | 0.4 usec | 0.8 usec |

11. If the skew exceeds the limits, repeat the Capstan Dynamic Alignment procedure on 08-150.
12. If the skew is within the limits, adjust the head skew plate until the outside track signal either leads or lags the inside track signal by the same amount when going forward or backward. Track 4 is inside, track 5 is outside, on 9-track tape units. Track P is inside, track 7 is outside, on 7-track tape units.
13. At the completion of the mechanical skew adjustment in NRZI mode, ensure that the analog sine waves for all tracks coincide at the read-card test points (left side).
14. Check the capstan-to-stubby bar clearance. See 08-080, "Capstan To Stubby Bar Clearance Adjustment."
15. Check the read and write electrical skew. See 08-190, "Read Electrical Skew Adjustment" and 08-200, "Write Electrical Skew Adjustment."

Typical Scope Presentation of Skew

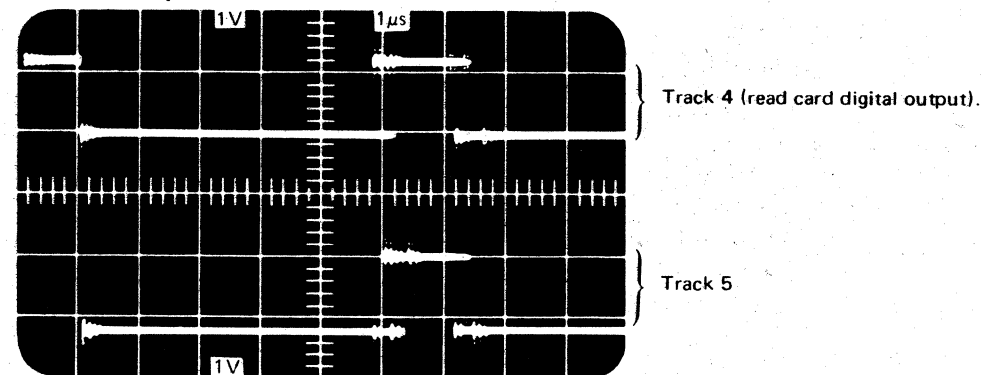

3803-1,2,3/3420

| | | | | | | | |
|------------|-------------|----------------|----------|--|--|--|--|
| XD1300 | 2735823 | See EC History | 845958 | | | | |
| Seq 2 of 2 | Part Number | | 1 Sep 79 | | | | |

© Copyright International Business Machines Corporation 1976, 1979

**READ ELECTRICAL SKEW ADJUSTMENT
(NRZI-FEATURED TAPE UNITS)**

Prerequisites: Perform the Mechanical Skew Check/Adjustment procedure on 08-180 and the Read/Write Head Degaussing procedure on 08-280.

Adjustment is not necessary if the forward and backward read skew is less than the following limits:

| TU Model | Read Skew (Fwd and Bkwd) |
|----------|--------------------------|
| 3 | 1.0 usec |
| 5 | 0.6 usec |
| 7 | 0.4 usec |

Initial Preparations:

1. Attach the field tester.
2. Load a master-skew tape, P/N 432641 or 432640.
3. Set the field tester to read forward continuously.
4. Set the frequency switch to 8 (800 bpi).

Determine the most lagging track:

5. Sync scope positive on the track 2 read signal (9-track) or track 4 read signal (7-track). Use the left test point on the read card.
6. With the channel A probe, scope the NRZI deskewed read data track P at A1M2. (See the label on the logic gate.)
7. With the channel B probe, determine which is the most lagging track. Look at the positive transition (leading edge) of each track signal. (Track 7 in the example.)
8. Adjust the most lagging track's pulse width to 1.0 usec by turning its potentiometer.

Set the skew:

9. Adjust each remaining track's pulse width until the negative transition (trailing edge) lines up with the trailing edge of the pulse adjusted in step 8.
10. Set the tester to read backward continuously.
11. Change the scope sync to negative.
12. Repeat steps 5 through 9 adjusting the backward potentiometer.
13. Check the write electrical skew. See 08-200, "Write Electrical Skew Adjustment."

BEFORE

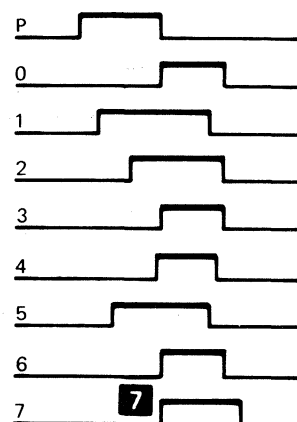

AFTER

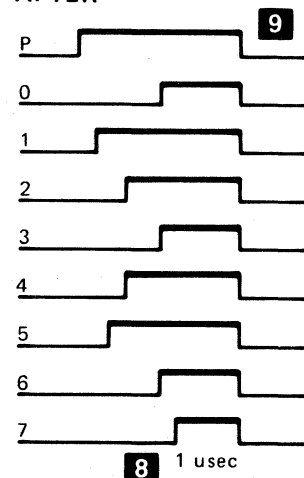

*Not present on 7 track machines

3803-1,2,3/3420

| | | | | | | | | |
|----------------------|------------------------|-------------------|--------------------|--|--|--|--|--|
| XD1400 Seq 1 of 2 | 2735824 Part Number | See EC History | 845958 1 Sep 79 | | | | | |
|----------------------|------------------------|-------------------|--------------------|--|--|--|--|--|

**WRITE ELECTRICAL SKEW ADJUSTMENT
(NRZI-FEATURED TAPE UNITS)**

Prerequisites: Perform the Mechanical Skew Check/Adjustment procedure on 08-180 and the Read Electrical Skew Adjustment procedure on 08-190.

Adjustment is not necessary if the forward and backward skew is within the following limits:

| TU Model | Write Skew (Fwd and Bkwd) |
|----------|---------------------------|
| 3 | 1.0 usec |
| 5 | 0.6 usec |
| 7 | 0.4 usec |

Initial preparations:

1. Attach the field tester.
2. Load a master signal-level tape, P/N 461108A or 432152A.
3. Set the field tester to write all ones.
4. Set the frequency switch to 8 (800 bpi).

Zero delays:

5. Sync negative and scope Bus Out P (A1K2D07) with the channel A probe.

6. With the channel B probe, scope each track's write deskew output (see the label on the logic gate) and adjust each track's write deskew pot until the negative transition occurs 1.0 usec after the negative transition on channel A.

Determine the most lagging track:

7. Sync positive on the read card test point of track 2 (9-track) or track 4 (7-track). Use the left test point.

8. Display track P at the NRZI read deskew test point and scope the remaining points (see the label on the logic gate). Look at the negative transition (trailing edge) to determine the most lagging track.

To adjust the skew:

9. Adjust each track's write deskew potentiometer until the negative transition (trailing edge) lines up with the negative transition of the most lagging track (step 8.)

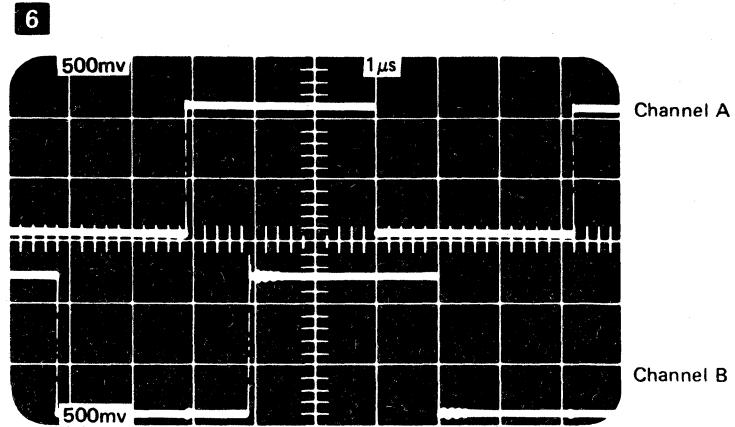

BEFORE

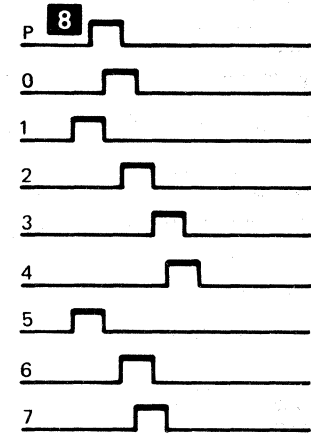

AFTER

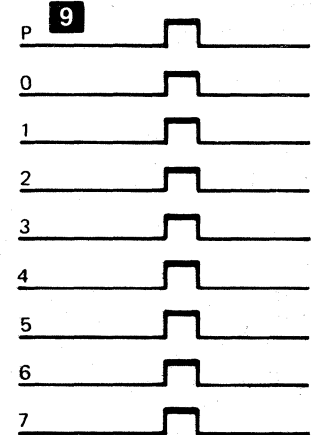

*Not present on 7 track machines

3803-1,2,3/3420

| | | | | | | | |
|----------------------|------------------------|-------------------|--------------------|--|--|--|--|
| XD1400 Seq 2 of 2 | 2735824 Part Number | See EC History | 845958 1 Sep 79 | | | | |
|----------------------|------------------------|-------------------|--------------------|--|--|--|--|

© Copyright International Business Machines Corporation 1976, 1979

**D-BEARING, RIGHT REAR MOVABLE
GUIDE
AND RETRACTOR
REMOVAL/REPLACEMENT —
(NRZI-FEATURED TAPE UNITS)**

To remove the guide:

- 1 Remove the two screws that hold the D-bearing to the front reference plate.
- 2 Remove the bearing.
- 3 Remove the single screw that holds the right rear movable guide to the retractor.

Caution: Do not lose any parts caused by the spring tension released by removing the screw.

To remove the retractor, continue as follows:

4. Disconnect the air-pressure hose from the retractor.
5. From the rear, remove the three screws that hold the retractor to the plenum cover and take out the retractor.
6. Reverse the procedure to replace the retractor and right rear movable guide.

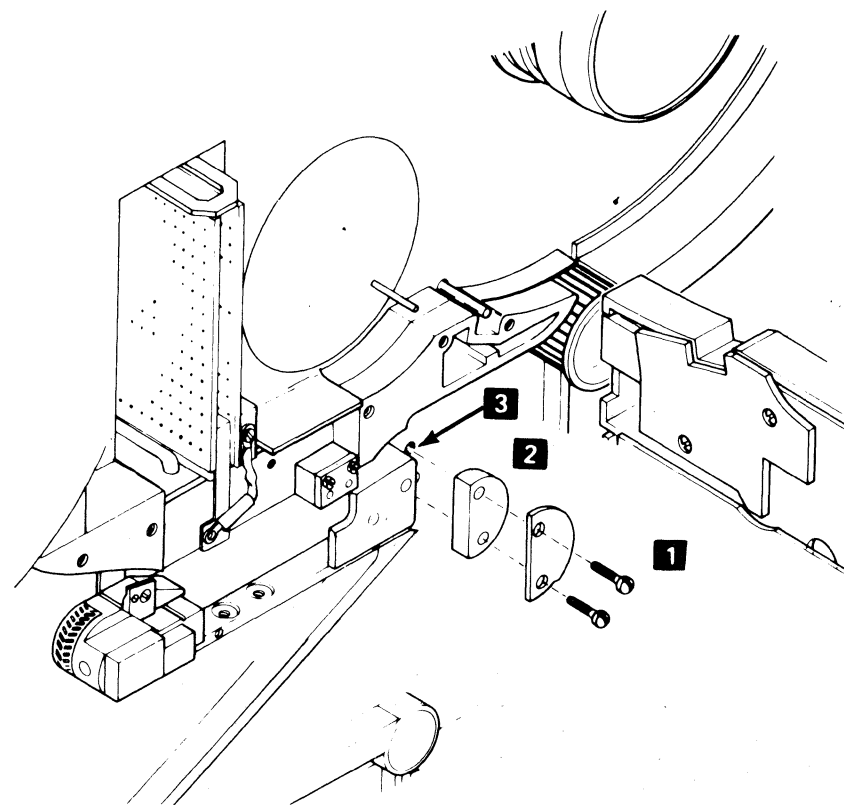

**LEFT MOVABLE GUIDE AND RETRACTOR
REMOVAL/REPLACEMENT
(NRZI-FEATURED TAPE UNITS)**

1 Remove the two screws that hold the left threading channel to the reference plate.

Note: *The retractor is built into the threading channel.*

2 **Caution:** Be careful not to lose the two small O-rings located behind the left threading channel.

Remove the left threading channel and disconnect the hose. Leave the hose protruding from the front of the machine through the hole in the casting.

3 Remove the large screw that holds the carbide tape guide assembly.

4. Remove the solid guide, movable rear guide, and spring.

5. Reverse the procedure to reassemble.

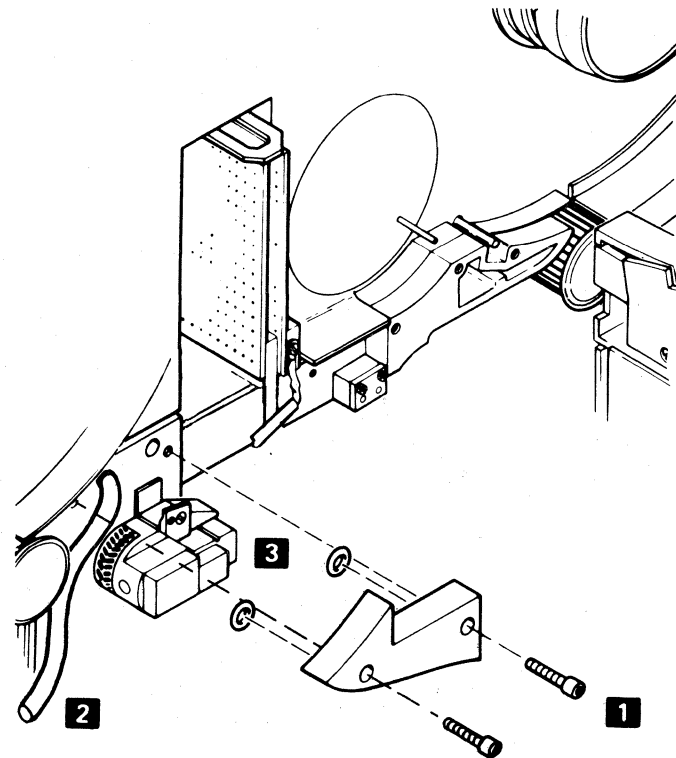

3803-1,2,3/3420

| | | | | | | | |
|------------|-------------|---------|----------|--|--|--|--|
| XD1500 | 2735825 | See EC | 845958 | | | | |
| Seq 2 of 2 | Part Number | History | 1 Sep 79 | | | | |

© Copyright International Business Machines Corporation 1976, 1979

TAPE GUIDE CHECK FOR NRZI-FEATURED TAPE UNITS

- 1** Remove the three screws that hold the right threading channel to the reference plate.
- 2** Clean the oxide deposits from the D-bearing, front flange, rear movable guide, and recessed area around the rear guide.
3. Inspect the flange and guide for wear and replace if the grooves are visible on their surfaces.
- 4** **Caution: Do not lose the two O-rings located behind the threading channel.**

Remove the left threading channel and disconnect the hose. Ensure that the hose does not slip back through the hole in the casting.

- 5** Clean the oxide deposits from the left front guide, left rear movable guide, and the recessed area around the rear guide.
6. Check that the right and left rear guides move freely.
- 7** Reinstall the threading channels. Ensure that the two O-rings are in position behind the left threading channel.

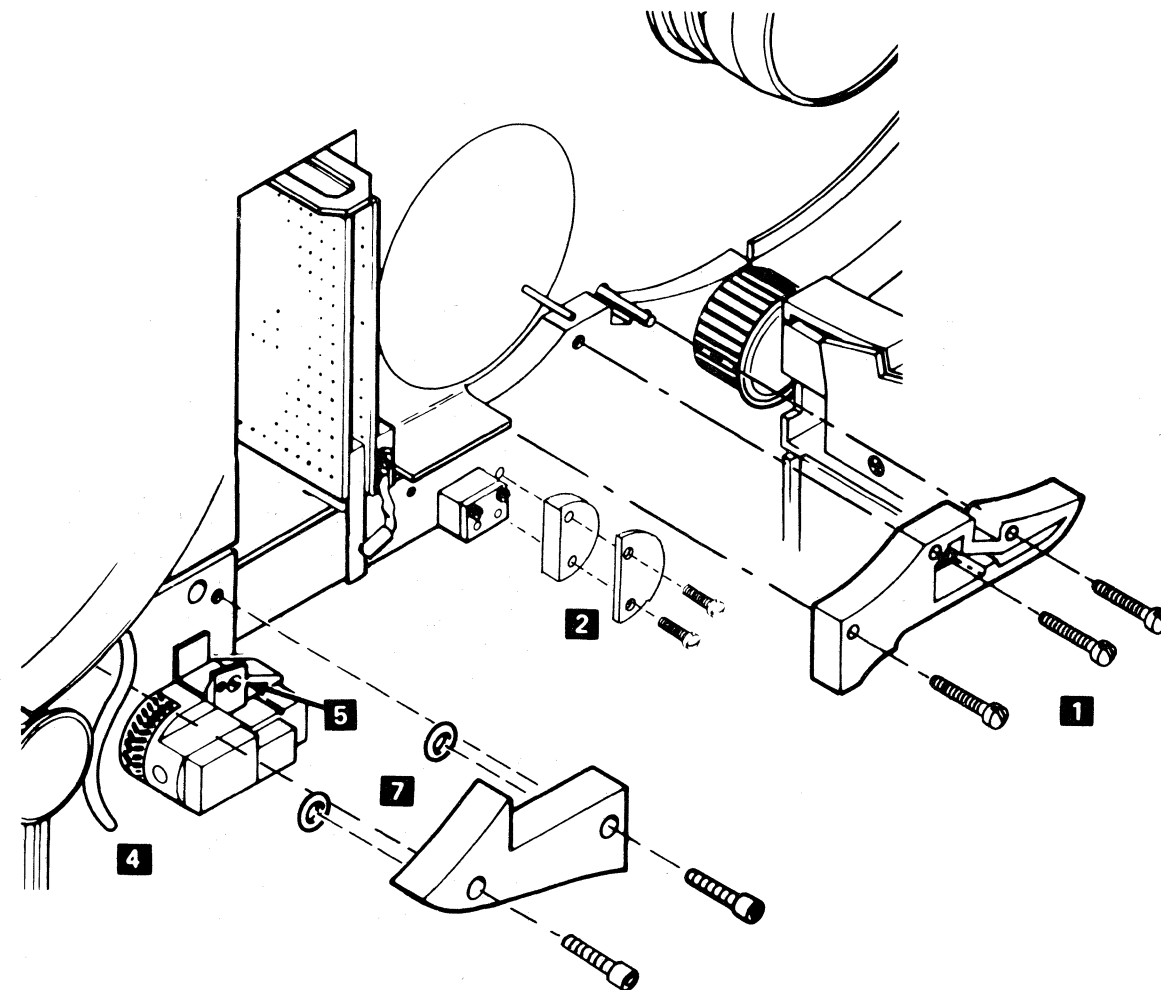

3803-1,2,3/3420

| | | | | | | | | |
|------------|-------------|---------|----------|--|--|--|--|--|
| XD1600 | 2735826 | See EC | 845958 | | | | | |
| Seq 1 of 2 | Part Number | History | 1 Sep 79 | | | | | |

READ FORWARD-TO-BACKWARD RATIO TEST (TAPE UNIT MODELS 4, 6, 8)

Use this test to determine if a read/write head needs replacement.

1. Degauss the head (08-280) and the cleaner blade (08-390).
2. Obtain a customer good-quality representative tape and write it at 6250 bpi on the unit being checked. You can write it from the 3803 or the field tester.
3. Make at least three full reel read passes with each tape after it is written.
4. Check read forward and backward amplitudes (all tracks) at read card test points.
5. If there is a read backward problem, and the amplitude in one direction is more than double the amplitude in the opposite direction on any one track, replace the read/write head. If you came from 5B-001 to perform this test, and the read/write head replacement is not required, return. If read/write head replacement is required, perform the removal/replacement procedure on 08-250, then return to 5B-001.
6. For field tester and tape control setup, see "Read Amplitude Adjustment" on 08-310.

Note: Verify that the tape is tracking correctly before any head replacement because of the above criteria.

READ FORWARD-TO-BACKWARD RATIO TEST (TAPE UNIT MODELS 3, 5, 7)

Use this test to determine if a read/write head needs replacement.

1. Degauss the head (08-280) and the cleaner blade (08-390).
2. Obtain a customer good-quality representative tape and write it at 1600 bpi on the unit being checked. You can write it from the 3803 or the field tester.
3. Make at least three full reel read passes with the tape after it is written.
4. Check read forward and backward amplitudes (all tracks) at read card test points.
5. If there is a read backward problem and the amplitude in the backward direction is less than that of the read forward direction by 50% on any one track, or 60% on the remaining tracks, the read/write head should be replaced. If entry was from 5A-000 and the read/write head replacement is not necessary, return to 5A-000 and continue.
6. For field tester and tape control setup, see "Amp Sensor Adjustment" on 08-290 or 08-300.

Note: Verify that the tape is tracking correctly before any head replacement because of the above criteria.

3803-1,2,3/3420

| | | | | | | | | |
|---------------|----------------|---------------|---------------|--|--|--|--|--|
| XD1600 | 2735826 | See EC | 845958 | | | | | |
| Seq 2 of 2 | Part Number | History | 1 Sep 79 | | | | | |

**READ/WRITE OR ERASE HEAD
REMOVAL/REPLACEMENT**

Before replacing the read/write head, perform the following to verify that replacement is necessary.

Phase Pointer Analysis

Many temporary write errors with MTE and not ENV errors can be caused by phase-shift problems. Use the following procedure to check for excessive phase pointers. Keep in mind that other tape-oriented problems can cause the phase pointers to look bad. Before changing a read/write head, ensure that none of the problems listed below exist. Occasional phase pointers might occur because of envelope fallout. Check the following:

1. Bad tape
2. Low vacuum
3. Dirty head
4. Incorrect voltages
5. Defective read or write cards
6. File-protect problems
7. Motion problems

Phase-shift scoping procedure (use a customer good-quality representative tape):

3803-2 Models 4, 6, 8

- a. Check the SAGC setup. See 08-310. The SAGC should set up in 14 or less steps.
- b. Loop write reliability test 3420R in 6250 bpi.
- c. Scope the phase pointers

| Logic | Card | Pins | |
|-------|------|---------------|--------|
| CD191 | Y1M2 | G12, J11, J12 | Zone 1 |
| CD291 | Y1L2 | G12, J11, J12 | Zone 2 |
| CD391 | Y1K2 | G12, J11, J12 | Zone 3 |

- d. Sync point
Stand-alone mode A1G3M12 - Mark 1 - ALD
BW191

3803-2 Models 3, 5, 7

- a. Ensure that the amp sensors are correctly set up. See 08-290.
- b. Loop write reliability test 3420L.
- c. Scope the phase pointers

| Logic | Card | Pins | |
|-------|------|---------------|--------|
| CD191 | Y1M2 | G12, J11, J12 | Zone 1 |
| CD291 | Y1L2 | G12, J11, J12 | Zone 2 |
| CD391 | Y1K2 | G12, J11, J12 | Zone 3 |

- d. Sync point
Stand-alone mode Y1H2P06 - All Ones

A sync will occur at the beginning and ending all-ones marker, but only the phase pointer between these pulses are valid.

To replace the read/write head:

1. Turn off tape unit power.
2. Remove the front read/write card cover by pulling it straight out.
3. Remove the two mounting screws, disconnect the hose, and remove the filler block (Models 4, 6, and 8), or the rewind plunger (Models 3, 5, and 7).
4. Unplug the read/write cards from the head. See 08-260, "Read/Write Head Card Removal/Replacement."
5. Remove the nylon screw that holds the erase head to the mounting plate. Carefully pull out the erase head without damaging the wires. Care must be taken not to damage the cable while unsoldering the leads.

Caution: When replacing the erase head, do not overtighten the nylon screw. It is not as strong as a metal screw. Ensure that the grey wire is connected to the top pin, and the yellow wire is connected to the bottom pin.

6. Remove the four screws from the mounting plate.

Note: The left two screws are hex-heads.

7. Carefully pull the head and mounting-plate assembly straight out. (If the locating pins bind, rock the assembly to loosen.)

Caution: Do not loosen or remove the eight skew-plate screws, as this causes the factory-set read/write head wrap angle to be changed.

8. Reverse the procedure to install a new head.

After installing a new head, do the following:

1. Degauss the head. See 08-280, "Read/Write Head Degaussing."
2. Verify the tape tracking by performing the Capstan Dynamic Alignment procedure on 08-150 or 08-160.
3. Adjust the amp sensors (Models 3, 5, and 7, see 08-290 or 08-300), or adjust the read amplitude (Models 4, 6, and 8, see 08-310).
4. Adjust the mechanical skew. See 08-170 (1600 and 6250 bpi tape units) or 08-180 (NRZI-featured tape units).
5. On NRZI-featured tape units, adjust the read and write electrical skew. See 08-190, "Read Electrical Skew Adjustment," and 08-200, "Write Electrical Skew Adjustment."

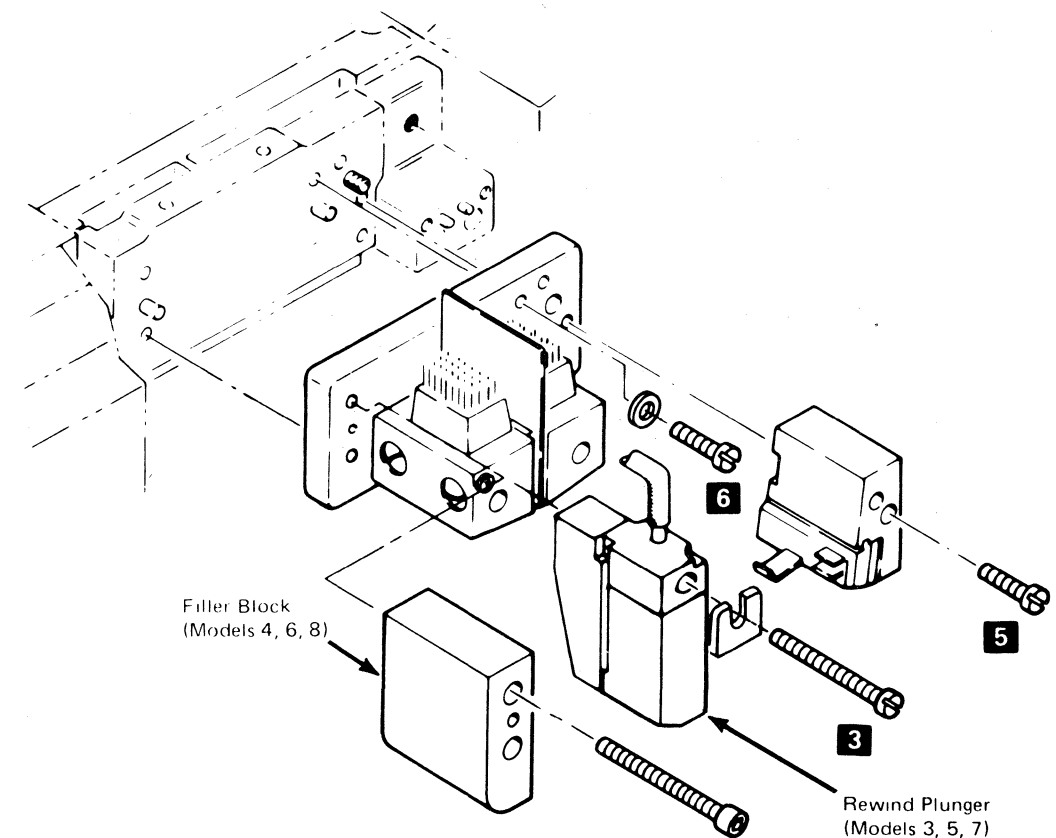

3803-1,2,3/3420

| | | | | | | | |
|------------|-------------|----------------|----------|--|--|--|--|
| XD1700 | 2735827 | See EC History | 845958 | | | | |
| Seq 1 of 2 | Part Number | | 1 Sep 79 | | | | |

**READ/WRITE HEAD CARD
REMOVAL/REPLACEMENT**

- 1 From the rear of the unit, unsnap the upper half of the read/write card cooling shroud.
- 2 From the rear of the unit, unplug the cable(s) from the top of the card being replaced. (Models 4, 6, and 8 have two cable plugs on the read card, Y and Z, and one on the write card J-3.) (Models 3, 5, and 7 have J3 and J1 cables only.)
- 3 From the front of the unit, remove the decorative head cover.
- 4 Disconnect the write card ground strap from the front of the read/write head.
- 5 Unplug the card while holding the socket with one hand, pull the front edge of the card straight up with your other hand, rocking gently to loosen.

Caution: Before removing the read card, shape the ground clip so it will clear the head plug pins.

- 6 From the rear of the unit, pull the card straight out until it clears the guides on the lower half of the cooling shroud.
- 7 To install a new card, reverse the procedure. Before changing the write head card, perform the Write Head Driver Card Plugging procedure on 08-270.

Caution: Plug the cables correctly. The rear cable Y has two heavy wires in addition to the ribbon cable and is identified by a label on EC 733222.

- 8 Before installing a new write head card on Model 4, 6, or 8, perform the Write Head Driver Card Plugging procedure on 08-270.
- 9 After installing a new read head card on Model 3, 5, or 7, perform the Amp Sensor Adjustment procedure on 08-290 or 08-300.
- 10 After installing a new read head card on Model 4, 6, or 8, perform the Read Amplitude Adjustment procedure on 08-310.
- 11 After installing a new write head card in any model, the verify amplitude or amp sensor adjustments on 08-290, 08-300, and 08-310.

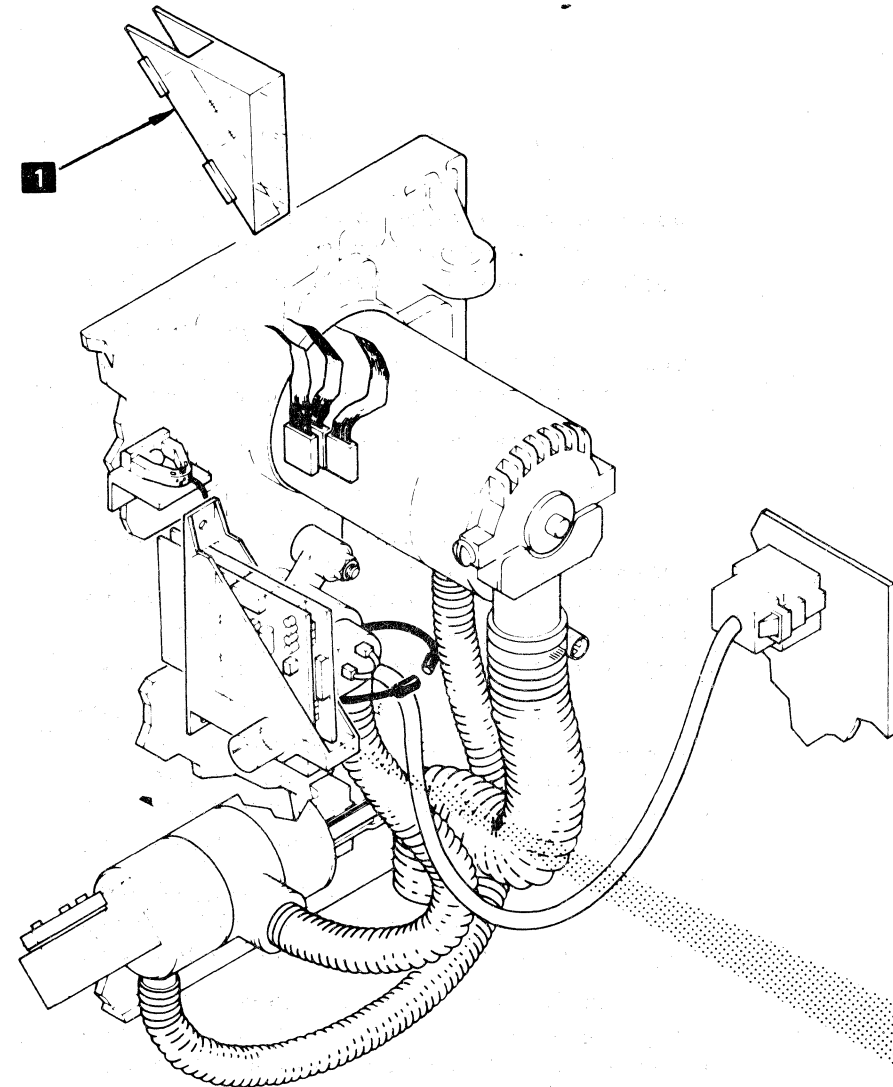

- 12 After replacing the write card, shape the ground strap in such a manner that the resultant forces are in a downward direction 4.
- 13 The cooling shroud reduces overheating of the read and write head cards. Ensure that the cooling shroud is reinstalled after working in this area.

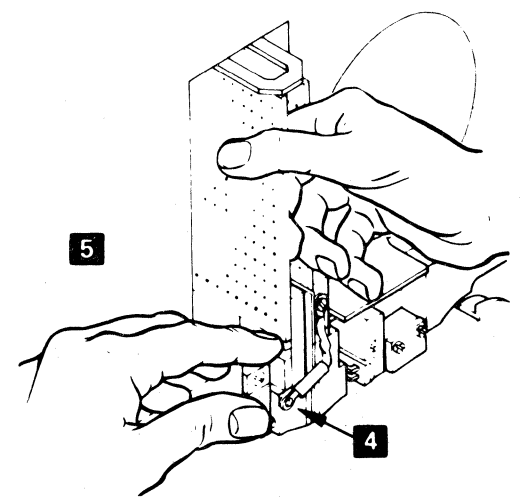
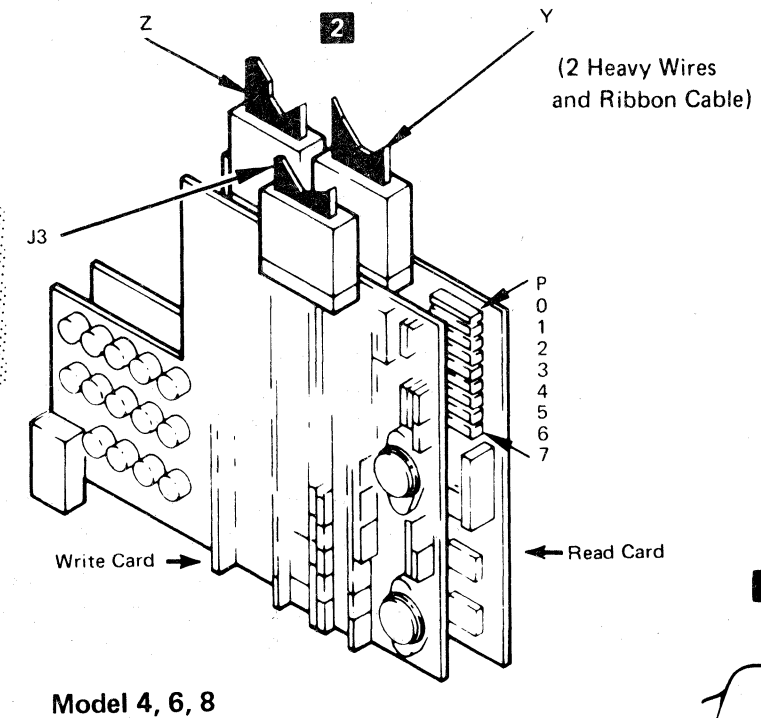
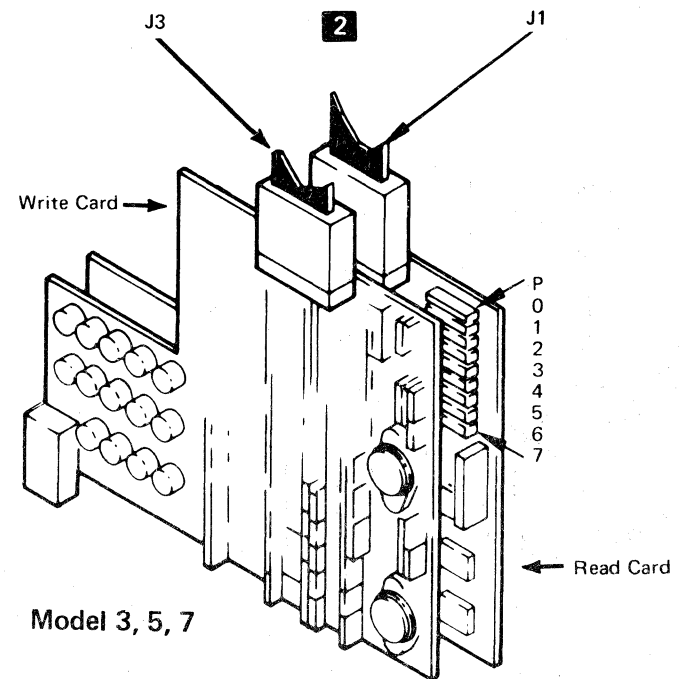

3803-1,2,3/3420

| | | | | | | | | | |
|------------|-------------|---------|----------|--|--|--|--|--|--|
| XD1700 | 2735827 | See EC | 845958 | | | | | | |
| Seq 2 of 2 | Part Number | History | 1 Sep 79 | | | | | | |

© Copyright International Business Machines Corporation 1976, 1979

**WRITE HEAD DRIVER CARD PLUGGING
(TAPE UNIT MODELS 4, 6, 8)**

The write head card is model-sensitive and must be plugged correctly.

When installing a new write head card, see the figure shown for correct plugging.

The write head card can be one of the four part numbers listed below:

| 3420 Model | Part Number |
|------------|-------------|
| 4, 6, 8 | 1845815 |
| 4, 6 | 1845792 |
| 8 | 1845799 |
| 4, 6, 8 | 1845791 |

Caution: If you use a write head card to troubleshoot another tape unit, ensure that the plugging is compatible with that tape unit.

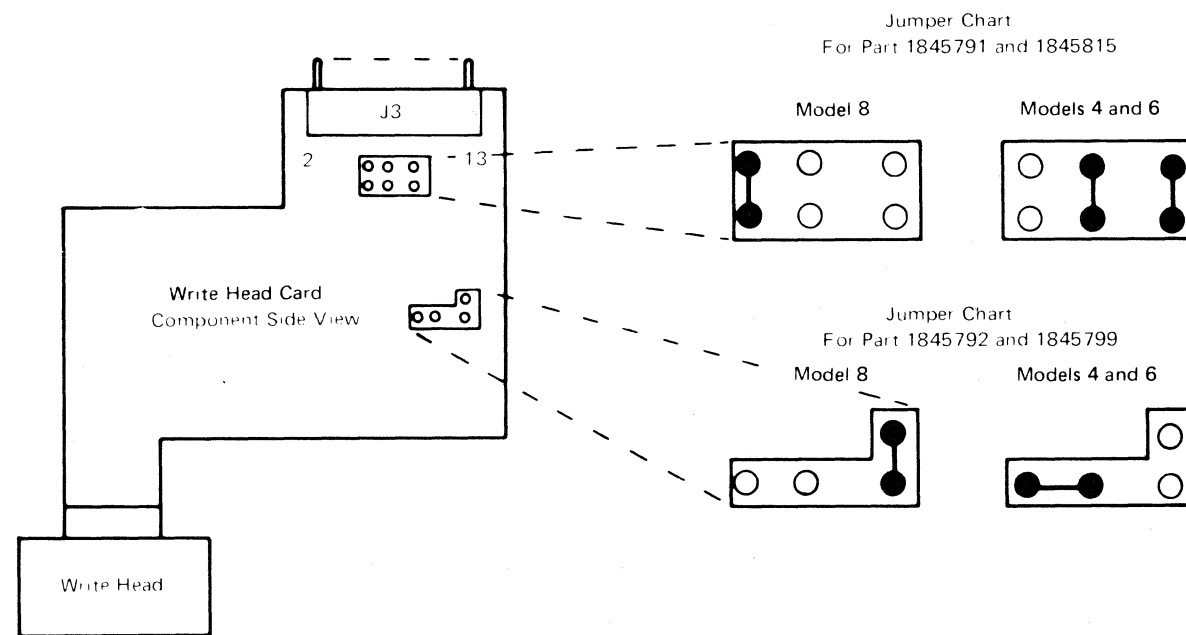

READ/WRITE HEAD DEGAUSSING

Caution: Do not use the degausser tool, P/N 451064, near any magnetic media because it erases information.

1. Unload the tape unit. Do not place the tape on top of the tape unit because the degausser will be too close.
2. Open the outer door and the vacuum column door. Plug the degausser into an ac outlet.
3. While the degausser is at least 1 foot (30.5 cm) away from the read/write head, press and hold the pushbutton and move the degausser slowly toward the head.
4. Hold the degausser against the front surface of the head for about 10 seconds.
5. Pull the degausser straight away from the head very slowly to a distance of at least 1 foot (30.5 cm) and release the pushbutton.
6. Check the electrical skew on NRZI-featured tape units. See 08-190 and 08-200.

Read/Write Head Resistance Check Procedure (Tape Unit Models 4, 6, 8)

1. Turn off tape unit power.
2. Remove the read/write card shroud. Disconnect the read/write cards from the head and slide them back even with the transport casting.
3. Use a calibrated Simpson* meter, not the CE tool bag meter. Measure the total resistance across each track of the head. Ignore the center tap of the coil. The normal reading on the write coil is 1.7 ohms; the reject point on the write coil is 5 ohms or greater. The normal resistance of a read coil is 3.6 ohms; the reject point on the read coil is 10 ohms or greater. Measure from the center tap to each side of the read and write coils. The resistance should be approximately equal.
4. Reinstall the read and write cards onto the head and reinstall the card shroud.
5. Degauss the read/write head using the procedure on this page.

*Trademark Simpson Electric Co.

3803-1,2,3/3420

| | | | | | | | | |
|------------|-------------|---------|----------|--|--|--|--|--|
| XD1800 | 2735828 | See EC | 845958 | | | | | |
| Seq 2 of 2 | Part Number | History | 1 Sep 79 | | | | | |

© Copyright International Business Machines Corporation 1976, 1979

**AMP SENSOR ADJUSTMENT — PE ONLY
(TAPE UNIT MODELS 3, 5, 7)**

Note: Ensure that the -4 Vdc supply is correctly adjusted before making this adjustment. See 08-570, "DC Power Supply Checks/Adjustments."

To adjust the amp sensors on a PE-only tape unit: Do steps 1 and 3 through 10 below if using the 3420 field tester; do steps 2 through 10 below if using the 3803 tape control.

1. Field tester only.
 - a. Switch the tape unit offline using the switch on the logic gate.
 - b. Attach the field tester, P/N 1765342.

Caution: Ensure that the tester's write frequency is within specifications. See Field Tester Accuracy Check on this page.

 - c. Load a master signal-level tape, P/N 432152A or 461108A.
 - d. Set the tester to write continuously, with the frequency switch set to 32.
 - e. Go to step 3.
2. 3803 tape control only.
 - a. Ensure that the tape control is offline.
 - b. Load a master signal-level tape, P/N 461108A or 432152A.
 - c. Put the tape control in ROS Stop mode for ALU2 with a compare register address of '21D' (3803 Model 2) or '2CB' (3803 Models 1 and 3). This prevents termination of the subsequent Write command.
 - d. Jumper T-A1N4D11 to T-A1N5D10 at the tape unit to rewind and unload the unit when Tape Indicate is sensed.
 - e. From the tape control, write a continuous pattern of all ones by jumpering A1R2J12 to ground.

Caution: Ensure that the data pattern is all ones and not a ripple pattern.

 - f. Go to step 3.

3. Plug an attenuator card, P/N 5861455, into the read card test socket. Insert the card with the components to the left.
4. Sync scope minus (internal) and display the read card digital data (T-A1N3) for the track you are adjusting. See the label on the tape unit logic gate for test points.

Note: If digital data does not exist, turn the read card potentiometer until a good solid signal is obtained, as shown in Figure B.
5. Using an uncalibrated (variable) horizontal sweep, adjust the scope so that one complete cycle is displayed, as shown in Figure B.
6. Locate the correct potentiometer on the read card for the track you are adjusting. See the label on the card cover.
7. Turn the potentiometer counterclockwise while observing the negative pulse until a dim trace exists, as shown in Figure A.
8. Then, turn the potentiometer slightly clockwise until you have a solid digital data pulse, as shown in Figure B.
9. Repeat steps 4 through 8 for each track.
10. Remove the attenuator card, field tester, and the jumpers if used.

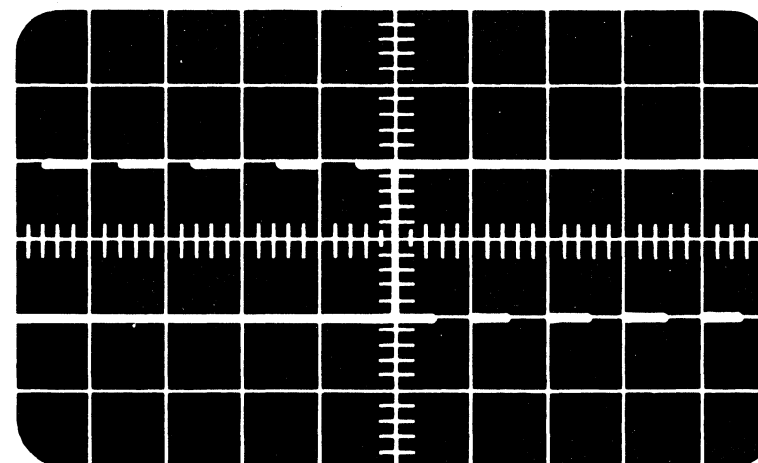

Figure A

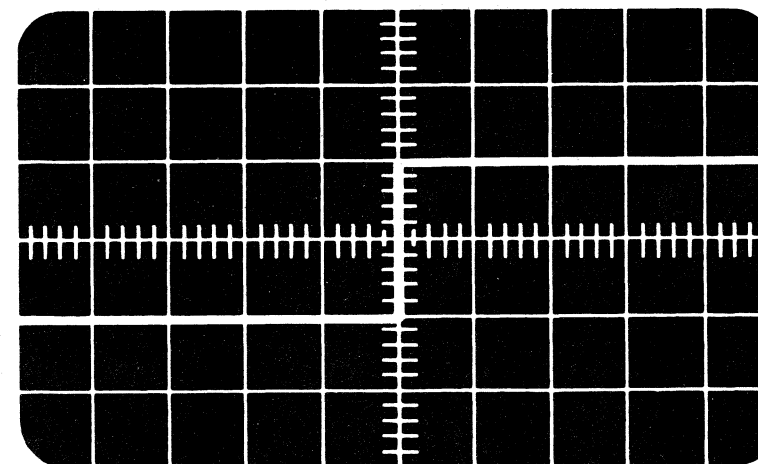
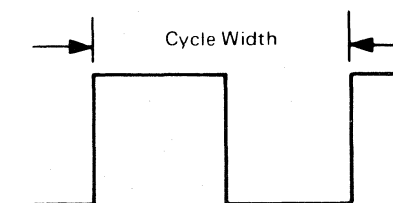

Figure B

FIELD TESTER ACCURACY CHECK

The amp sensors can be adjusted offline using the 3420 field tester, P/N 1765342, if the tester's write cycle width meets the specifications below:

| | PE | 7- or 9-Track NRZI |
|---------|-----------------|--------------------|
| Model 3 | 7.7 to 8.6 usec | 31.1 to 34.4 usec |
| Model 5 | 4.6 to 5.2 usec | 18.6 to 20.7 usec |
| Model 7 | 2.9 to 3.3 usec | 11.6 to 12.9 usec |



To determine tester accuracy:

1. Switch the tape unit offline using the switch on the logic gate.
2. Attach the field tester, P/N 1765342.
3. Load a master signal-level tape, P/N 432152A or 461108A.
4. Set the tester to write continuously with the frequency switch set to 32.
5. Sync scope plus (internal) and display T-A1K4G05 (tester Bus Out 2) and ensure that the cycle width is as shown for the tape unit model you are checking.

Note: If the frequency of the tester is not within specifications, and you wish to use it to adjust amp sensors, replace the tester card, P/N 8216712, and repeat steps 1-5 to ensure that the new card is within specifications.

3803-1,2,3/3420

| | | | | | | | |
|----------------------|------------------------|-------------------|--------------------|--|--|--|--|
| XD1900 Seq 1 of 2 | 2735829 Part Number | See EC History | 845958 1 Sep 79 | | | | |
|----------------------|------------------------|-------------------|--------------------|--|--|--|--|

AMP SENSOR ADJUSTMENT — NRZI FEATURE (TAPE UNIT MODELS 3, 5, 7)

Note: Ensure that the -4 Vdc supply is correct before making this adjustment. See 08-570, "DC Power Supply Checks/Adjustments."

To adjust the amp sensors on a NRZI-featured tape unit (7- or 9-track): Do step 1 and steps 3 through 10 below if using the 3420 field tester; do steps 2 through 10 below if using the 3803 tape control.

1. Field tester only.
 - a. Switch the tape unit offline using the switch on the logic gate.
 - b. Attach the field tester, P/N 1765342.
- Caution:** Ensure that the tester's write frequency is within specifications. See Field Tester Accuracy Check on this page.
- c. Load a master signal-level tape, P/N 432152A or 461108A.
- d. Set the tester to write continuously with the frequency switch set to 8.
- e. Go to step 3.
2. 3803 tape control only.
 - a. Ensure that the tape control is offline.
 - b. Load a master signal-level tape, P/N 461108A or 432152A.
 - c. Put the tape control in ROS Stop mode for ALU2 with a compare register address of '48D' (3803 Model 2) or '481' (3803 Models 1 and 3). This prevents termination of the subsequent Write command.
 - d. Jumper T-A1N4D11 to T-A1N5D10 at the tape unit to rewind and unload the tape unit when Tape Indicate is sensed.
 - e. From the tape control write (in NRZI mode, with a mode set of 'CB' for 9-track and '93' for 7-track) a continuous pattern of all ones by jumpering A1R2J12 to ground.
- Caution:** Ensure that the data pattern is all ones and not a ripple pattern.
- f. Go to step 3.

3. Remove the front head cover and plug an attenuator card into the read card test socket. For 9-track units (and 7-track units with EC 734949), use attenuator card, P/N 5861452; for 7-track units without EC 734949, use P/N 5861448, and ignore tracks 0 and 1. Insert the card with the components to the left.
4. Sync scope minus (internal) and display the read card digital data (T-A1N3) for the track you are adjusting. See the label on the tape unit logic gate for test points.

Note: If digital data does not exist, turn the appropriate read card potentiometer until a good solid signal is obtained, as shown in Figure A or B. See the label on the card cover.
5. Using an uncalibrated (variable) horizontal sweep, adjust the scope for a negative pulse width of 5 cm, as shown in Figure A.

Note: If a double trace at the positive transition is apparent, as shown in Figure B, use the outermost transition to obtain the 5 cm negative pulse width.
6. Locate the correct potentiometer on the read card for the track you are adjusting. See the label on the card cover.
7. Turn the potentiometer until the leading edge of the positive-transition waterfall starts 4 cm from the midpoint of the negative transition, as shown in Figure C.

Note: An occasional trace before 4 cm is acceptable when the adjustment is completed.
8. Repeat steps 4 through 7 for each track.
9. Remove the attenuator card, field tester, and the jumpers if used.

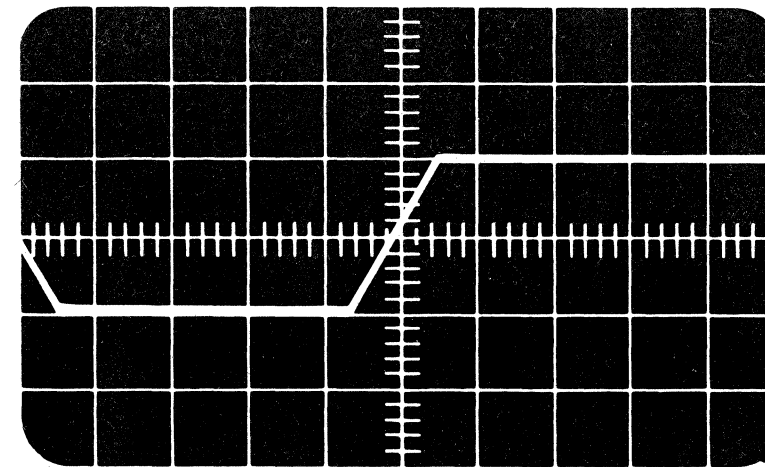

Figure A

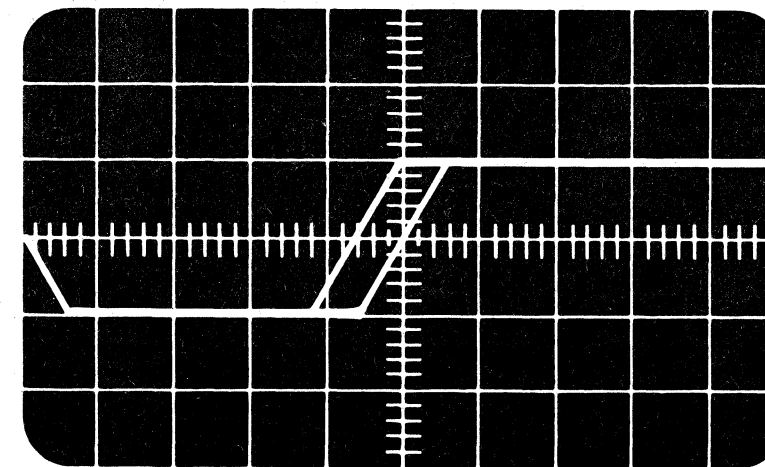

Figure B

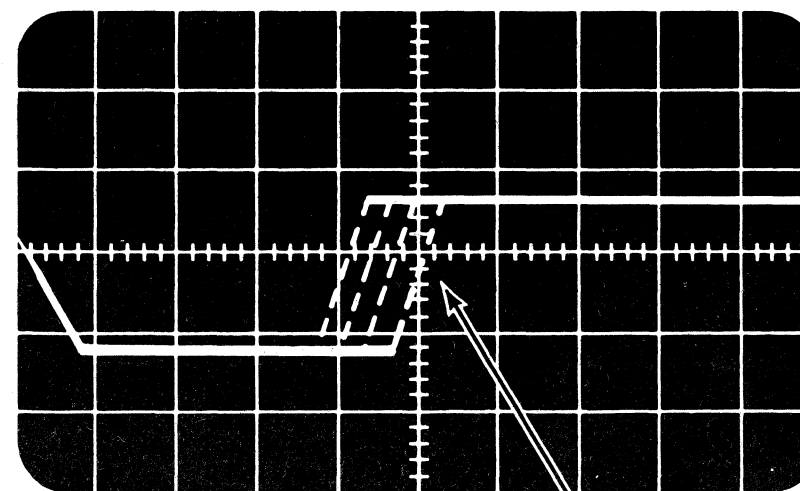

Figure C

Note: May not be visible.

FIELD TESTER ACCURACY CHECK

The amp sensors can be adjusted offline using the 3420 field tester, P/N 1765342, if the tester's write cycle width meets the specifications below:

| | PE | 7- or 9-Track NRZI |
|---------|-----------------|--------------------|
| Model 3 | 7.7 to 8.6 usec | 31.1 to 34.4 usec |
| Model 5 | 4.6 to 5.2 usec | 18.6 to 20.7 usec |
| Model 7 | 2.9 to 3.3 usec | 11.6 to 12.9 usec |

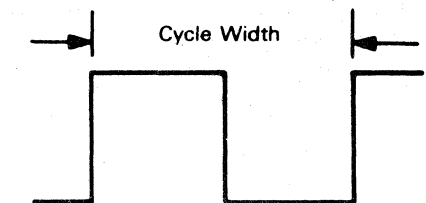

To determine tester accuracy:

1. Switch the tape unit offline using the switch on the logic gate.
2. Attach the field tester, P/N 1765342.
3. Load a master signal-level tape, P/N 432152A or 461108A.
4. Set the tester to write continuously, with the frequency switch set to 32.
5. Sync scope plus (internal) and display T-A1K4G05 (tester Bus Out 2) and ensure that the cycle width is as shown for the tape unit model you are checking.

Note: If the frequency of the tester is not within specifications, and you wish to use it to adjust amp sensors, replace the tester card, P/N 8216712, and repeat steps 1-5 to ensure that the new card is within specifications.

3803-1,2,3/3420

| | | | | | | | |
|------------|-------------|---------|----------|--|--|--|--|
| XD1900 | 2735829 | See EC | 845958 | | | | |
| Seq 2 of 2 | Part Number | History | 1 Sep 79 | | | | |

CARR — READ ADJUSTMENTS

READ AMPLITUDE ADJUSTMENT (TAPE UNIT MODELS 4, 6, 8)

1. Ensure that the -4 Vdc and +6 Vdc supplies are correctly adjusted before adjusting the read amplitudes. (See 08-570, "DC Power Supply Checks/Adjustments.")
2. Clean the read/write head and tape path before making adjustments.
3. Check the field tester accuracy.
4. Ensure that the density switch is set to the correct setting and that the tester has been converted to 6250 bpi.

READ AMPLITUDE ADJUSTMENT (6250 BPI ONLY)

1. Load a master signal-level tape on the tape unit to be tested. The tape must be at load point for this procedure to work.
2. If the TCU is not available, use the field tester for this adjustment. However, because the tester oscillator frequency varies, the read amplitudes should be rechecked using the TCU as soon as possible. If a field tester is being used, go to step 4.
3. Connect a jumper between ground and pin T-A1N3B04. Grounding T-A1N3B04 sets the threshold level and enables the adjusting pots. Set up the TCU in ROS Stop mode, ALU2 to Stop and Write Compare Register address to '6D2' (see CE panel operations on 12-010). Do a Write command with data of all ones (not ripple). Connect a jumper from T-A1N4D11 to T-A1N4D10 in the tape unit. This causes the tape unit to rewind after sensing the end-of-tape (EOT) marker. Go to step 5.
4. Connect a jumper from ground to T-A1N3B04. Set up the field tester to write forward continuously with the frequency switch set to 32.
5. Set up the scope to sync on a positive going signal and display the digital read signal at T-A1N3B07 (track 1). See Note 1.
6. Turn the potentiometer counterclockwise (for track 1) until the scope trace shows no digital data. Then turn the potentiometer clockwise until the scope picture looks like Figure 1. The square wave should

be a bright trace and the horizontal trace should be dim.

7. After making adjustments, ensure that the analog signal on each track is $2\text{ V} \pm .3\text{ V}$. Remove all the jumpers installed as per instructions in this procedure. Remove the field tester (if it was used).

READ AMPLITUDE ADJUSTMENT (1600/6250 BPI)

1. Load a master signal-level tape on the tape unit to be tested. The tape must be at load point for this procedure to work.
2. If the TCU is not available, use the field tester for this adjustment. However, because the tester oscillator frequency varies, the read amplitudes should be rechecked using the TCU as soon as possible. If a field tester is being used, go to step 4.
3. Connect a jumper from ground to A2R2J12 in the TCU to write continuously with all ones (not ripple). Perform the following sequence offline:

 CMND 1 C3X Mode Set
 CMND 2 01X Write
4. Connect a jumper from T-A1N4D11 to T-A1J2B02 to rewind and unload the tape after an EOT is sensed. Connect a jumper from ground to T-A1N3B04. Grounding T-A1N3B04 sets the threshold level and enables the adjusting pots. Set up the field tester to write forward continuously with the frequency switch set to 32. **Note:** Do not install jumper from T-A1M2D06 to T-A1K2P02 listed on the 3420 tape tester for this adjustment.
5. Set up the scope to sync on a positive going signal and display the digital read signal at the T-A1N3B07 socket cable. (See Note 2.)
6. Turn the potentiometer counterclockwise (for track 1) until the scope trace shows no digital data. Then turn the potentiometer clockwise until the scope picture looks like Figure 1. The square wave should be a bright trace and the horizontal trace should be dim.
7. Repeat step 6 for all tracks.

8. After making adjustments, ensure that the analog signal on each track is $2\text{ V} \pm .3\text{ V}$. Remove all the jumpers installed as per instructions in this procedure. Remove the field tester (if it was used) and verify that the adjustment is correct by running the OLT section 3420L using the same master output tape used during the adjustment of the amplitudes.

Running the OLT section 3420L at release 9 or later, will require the sense switches to be set. Refer to the OLT manual for switch setup instructions.

Figure 1. Read Amplitude Signal

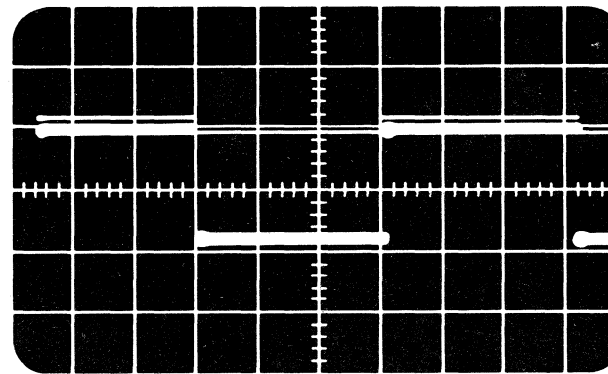

Notes:

1. Only the track 1 potentiometer (test point T-A1N3B07) is present on a 6250 bpi card.
2. Digital read signals for 1600 and 6250 bpi are:

| Track | Test Point | Track | Test Point |
|-------|------------|-------|------------|
| P | T-A1N3B05 | 4 | T-A1N3B10 |
| 0 | T-A1N3B06 | 5 | T-A1N3B11 |
| 1 | T-A1N3B07 | 6 | T-A1N3B12 |
| 2 | T-A1N3B08 | 7 | T-A1N3B13 |
| 3 | T-A1N3B09 | | |

Read Card Test Points

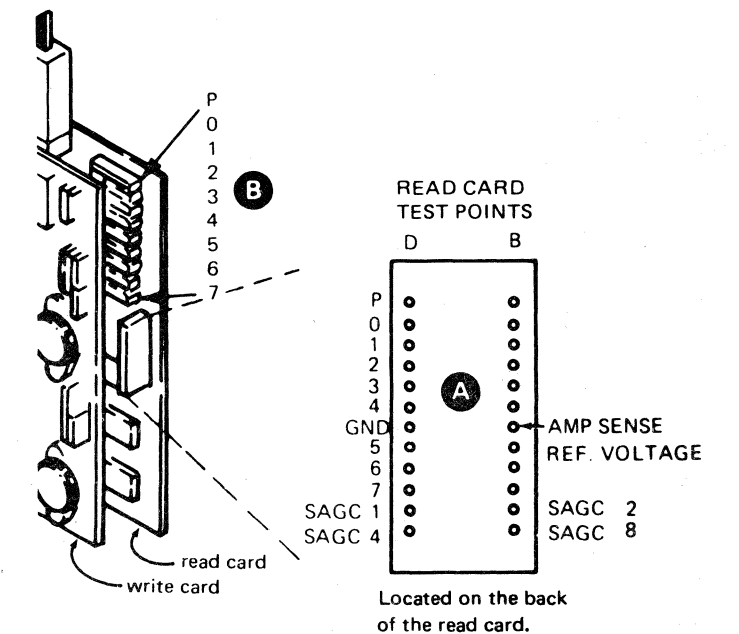

3803-1,2,3/3420

| | | | | | | | |
|------------|-------------|----------------|----------|--|--|--|--|
| XD2000 | 2735830 | See EC History | 845958 | | | | |
| Seq 1 of 2 | Part Number | | 1 Sep 79 | | | | |

6250 SAGC CHECKS

Set the 3420 field tester to write start/stop, and the frequency switch to 64. Install a jumper between T-A1M2D06 and T-A1K2P02. Sync scope minus on Move Command B at T-A1F2P12 and vary the go-up time to observe a full SAGC setup (set Dn/Bkwd all the way to rear of the tester) at the read card test points

Ⓐ. The SAGC setup must be completed in 14 or less steps on all tracks while writing. If the setup in any track exceeds 14 steps, check: (If the SAGC sets up in less than two steps, replace the read/write head)

1. Read head card
2. Vacuum level for low vacuum
3. Write head card
4. Read/write head
5. Capstan tracking

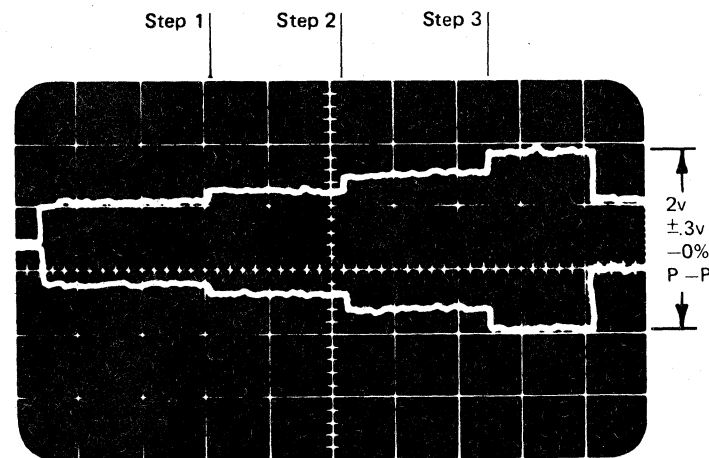

FIELD TESTER ACCURACY CHECK

The amp sensors can be adjusted offline using the 3420 field tester, P/N 1765342, if the tester's write cycle width meets the specifications below:

| PE | | 6250 | |
|-----------|-----------------|---------|----------------|
| Model 3-4 | 7.7 to 8.6 usec | Model 4 | 1350-1600 usec |
| Model 5-6 | 4.6 to 5.2 usec | Model 6 | 800-950 nsec |
| Model 7-8 | 2.9 to 3.3 usec | Model 8 | 500-600 nsec |

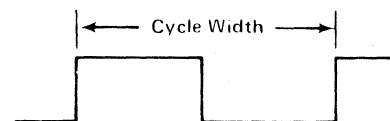

To determine tester accuracy:

1. Switch the tape unit offline using the switch on the logic gate.
2. Attach the field tester, P/N 1765342.
3. Load a master signal-level tape, P/N 432152A or 461108A.
4. Set the tester to write continuously, with the frequency switch set to 32 for 1600 bpi or 64 for 6250 bpi.
5. Sync scope plus (internal) and display T-A1K4G05 (tester Bus Out 2) and ensure that the cycle width is as shown for the tape unit model you are checking.

Note: If the frequency of the tester is not within specifications, and you wish to use it to adjust amp sensors, replace the tester card, P/N 8216712, and repeat steps 1-5 to ensure that the new card is within specifications.

3803-1,2,3/3420

| | | | | | | | | |
|----------------------|------------------------|-------------------|--------------------|--|--|--|--|--|
| XD2000 Seq 2 of 2 | 2735830 Part Number | See EC History | 845958 1 Sep 79 | | | | | |
|----------------------|------------------------|-------------------|--------------------|--|--|--|--|--|

NOTES:

08-316

3803-1,2,3/3420

| | | | | | | | | | |
|----------------------|------------------------|-------------------|--------------------|--|--|--|--|--|--|
| XD2050 Seq 1 of 2 | 8492597 Part Number | See EC History | 845958 1 Sep 79 | | | | | | |
|----------------------|------------------------|-------------------|--------------------|--|--|--|--|--|--|

08-316

ERASE HEAD CHECKS

Polarity Check (All Models)

1. The top pin of the erase head must read plus with respect to the bottom pin when writing.
- 2 If the erase head polarity is wrong, correct it by reversing the leads at the erase head.

Erasure Check (Tape Unit Models 4, 6,8)

Obtain an 800-bpi (NRZI) tape. If not available, use a 1600-bpi (PE) written tape, or you may use a CE work tape that has been written with a pattern of all ones.

1. Switch the tape unit offline and load the CE tape.
2. Install a jumper from T-A1K2P02 to T-A1M2D06, placing the tape unit in 6250 bpi.
3. Use the field tester to write all ones continuously. Set the frequency switch to 64. Set the tester switches to Write, Fwd, and Go, then to Reset and Start.
4. Immediately remove the jumper installed in step 2 (to prevent any further SAGC setups.) Scope the read card test points for tracks 4 and 5 (see the back of the read/write card cooling shroud for test point locations). Record the amplitude of the envelopes observed for both tracks.
5. Stop the tape unit. Change the field tester switch from Write to Read. Do not rewind.
6. Install a jumper from T-A1K2M10 to ground, which enables you to erase in read mode.
7. Reset the tape unit. Set the switches to Fwd and Go, then to Start.
8. Scope tracks 4 and 5 again and record the amplitude of the envelopes of these tracks.
9. If the amplitudes in step 8 are more than 4% of the amplitudes recorded in step 4, replace the erase head.
10. Remove the jumper installed in step 6 and unload the tape unit. Power the tape unit off, and power on again to reset the erase unit check latch.
11. Return the tape unit to the customer if the problem has been corrected.

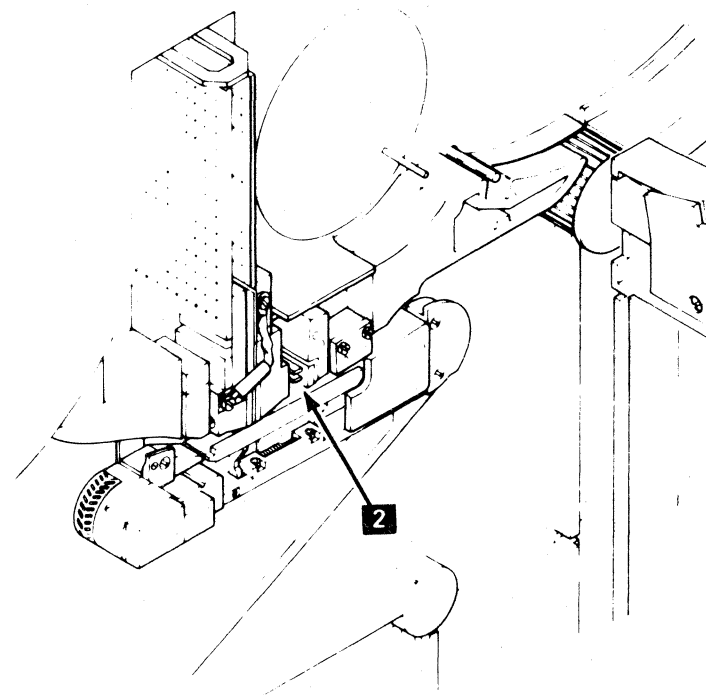

3803-1,2,3/3420

| | | | | | | | | | |
|----------------------|------------------------|-------------------|--------------------|--|--|--|--|--|--|
| XD2050 Seq 2 of 2 | 8492597 Part Number | See EC History | 845958 1 Sep 79 | | | | | | |
|----------------------|------------------------|-------------------|--------------------|--|--|--|--|--|--|

© Copyright International Business Machines Corporation 1976, 1979

FEEDTHROUGH CHECK

1. Switch the tape unit offline.
2. Attach the 3420 field tester, P/N 1765342.
3. Mount an undamaged CE work tape.
4. a. Models 3, 5, and 7 — Set the tester to write in Start/Stop mode. Set the frequency switch to 16. If the unit is NRZI-featured, set the frequency switch to 8.
- b. Models 4, 6, and 8 — Install a jumper from T-A1M2D06 to T-A1K2P02. Set the frequency switch to 64. Set the tester switches to Write, Fwd, and Go, then to Reset and Start. Change the switch to St/Stp.
5. Sync the scope negative on -Move tag at T-A1K4B12 (Models 3, 5, and 7) or T-A1K6B12 (Models 4, 6, and 8).
6. See the label on the inside of the front head card cover for Models 3, 5, and 7, or on the back of the read/write card cooling shroud for Models 4, 6, and 8, and scope the analog outputs for each track.

Note: The feedthrough signal precedes the record by 2.0 ms on Models 3 and 4; 1.2 ms on Models 5 and 6; and 750 usec on Models 7 and 8.

7. Replace the read/write head on a Model 3, 5 or 7 if the feedthrough **A** exceeds 10% **B** of the read signal. For a Model 4, 6 or 8 tape unit, set the amplitude of the first SAGC step to 4 cm. Replace the read/write head if the feedthrough **C** amplitude is greater than 0.6 cm (7% of the total read signal).
8. Remove jumper T-A1M2D06 to T-A1K2P02 installed in step 4b.

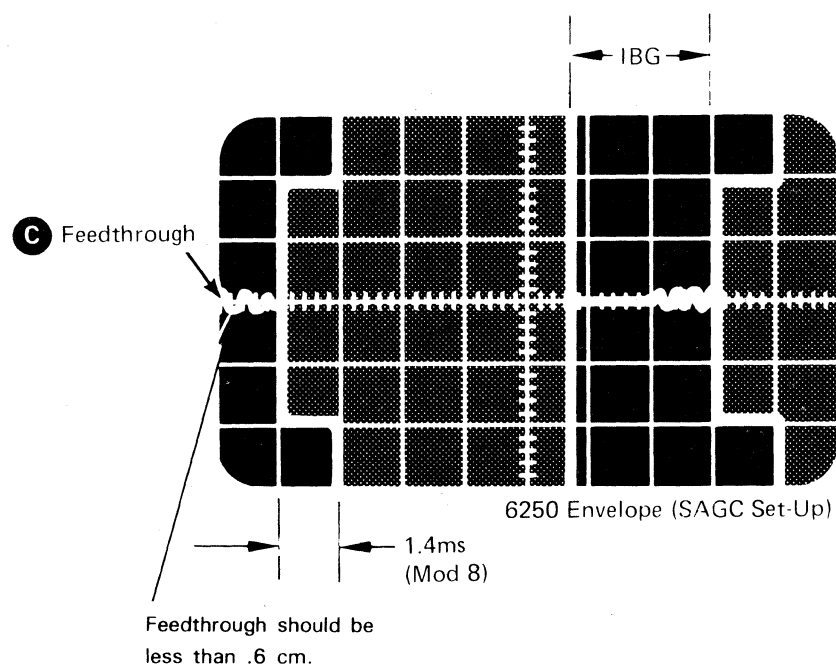
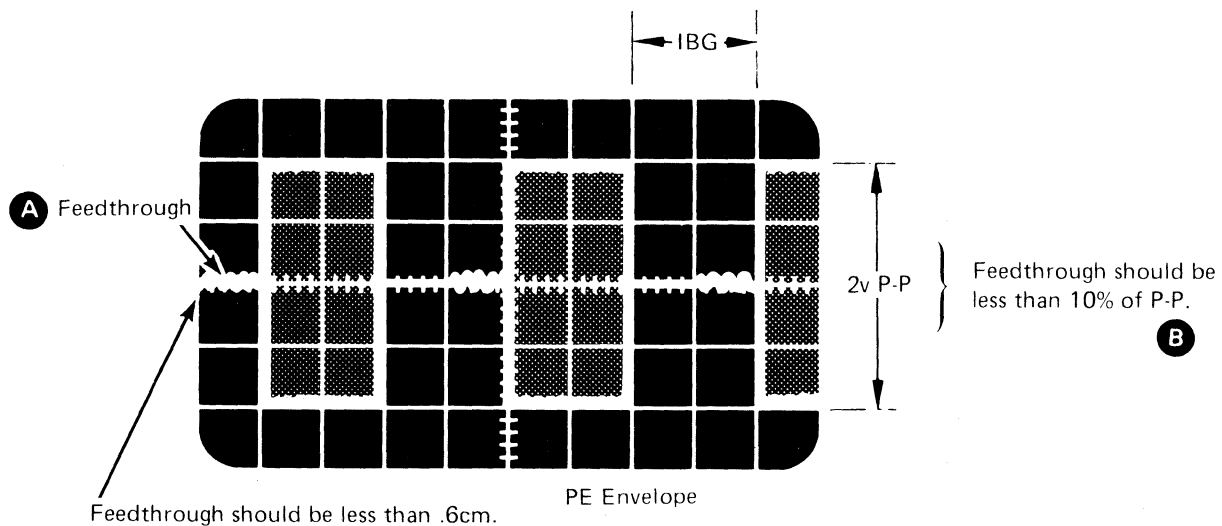

| | | | | | | | | |
|------------|-------------|---------|----------|--|--|--|--|--|
| XD2100 | 2735831 | See EC | 845958 | | | | | |
| Seq 1 of 2 | Part Number | History | 1 Sep 79 | | | | | |

FILE PROTECT MECHANISM CHECK

Do not lubricate any part of the file-protect mechanism. If the assembly does not operate correctly because the plunger is binding, replace as follows:

1. Remove the two file-protect mechanism mounting screws on the front of the unit.
2. Slide the assembly out the front.
3. Detach the two hoses from the rear of the assembly (see Note 1).
4. Reverse this procedure to install a new assembly (see Note 2).

After replacing the mechanism:

1. Check that the plunger extends $5/32 \pm 1/32$ inch (3.96 ± 0.8 mm) in front of the right-hub flange.
2. Check that the plunger retracts freely behind the hub flange.
 - a. Open the front door and pull out the door interlock.
 - b. Press RESET, then press and hold LOAD REWIND.
 - c. Push the file-protect plunger to the rear until the end of the plunger is approximately flush with the right reel hub flange. The plunger should then retract fully under control of the vacuum.

Note 1: Identify the hoses (mark) before removing them. Replace the hoses in the same location.

Note 2: It may be necessary to trim the end of the hoses to ensure that they have a good seal when reinstalling them.

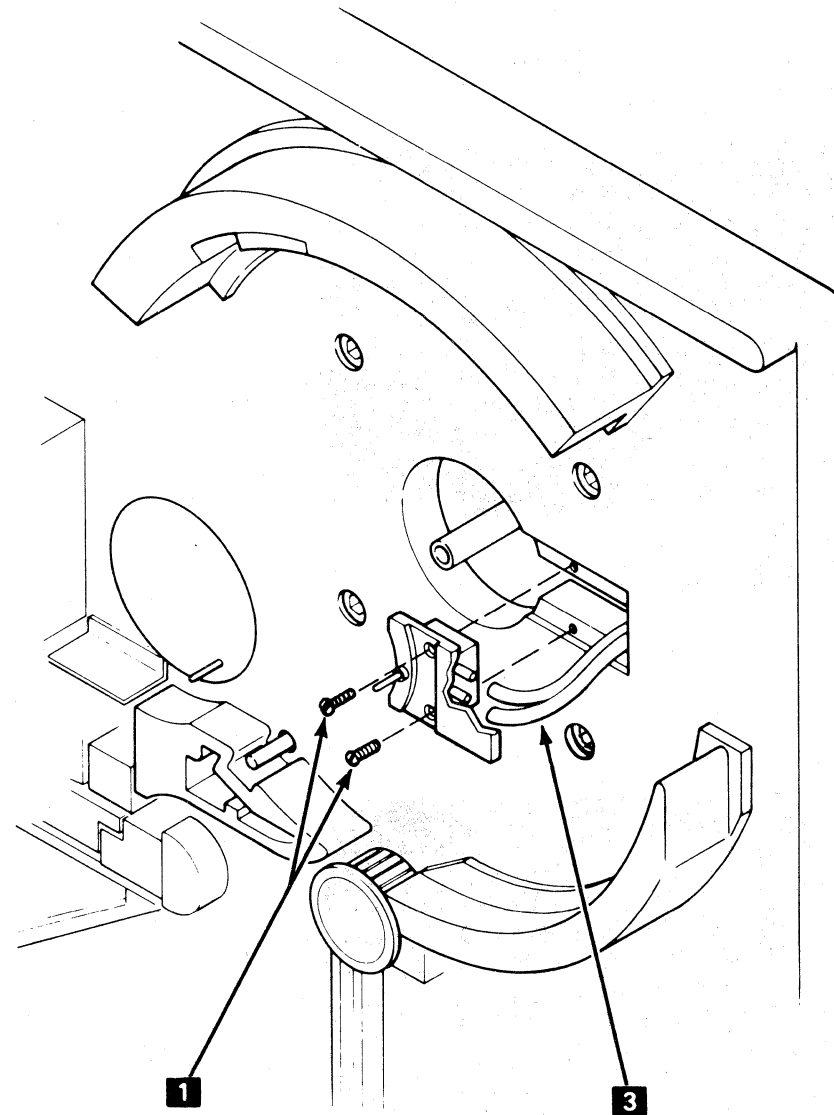

3803-1,2,3/3420

| | | | | | | | | |
|------------|-------------|---------|----------|--|--|--|--|--|
| XD2100 | 2735831 | See EC | 845958 | | | | | |
| Seq 2 of 2 | Part Number | History | 1 Sep 79 | | | | | |

© Copyright International Business Machines Corporation 1976, 1979

CARR — HEAD MIRROR

08-350

HEAD-MIRROR STOP ADJUSTMENT (TAPE UNIT MODELS 3, 5, 7)

Adjust the head-mirror stop: (1) if the tape catches on the reference plate when threading or (2) if the rewind plunger hits the mirror assembly during a high-speed rewind.

To adjust the head-mirror stop:

1. Turn off tape unit power.
2. Pivot mirror assembly downward to expose the stop screw.
3. Using a steel rule as a reference, adjust the stop screw behind the head mirror until the front edges of the mirror assembly, the cleaner block, and the left carbide tape guide are flush or within 0.010 inch (0.25 mm) of each other.

Note: Flex the steel rule without twisting to touch all surfaces.

Caution: Be careful not to let the mirror snap back into position until the screw is correctly adjusted.

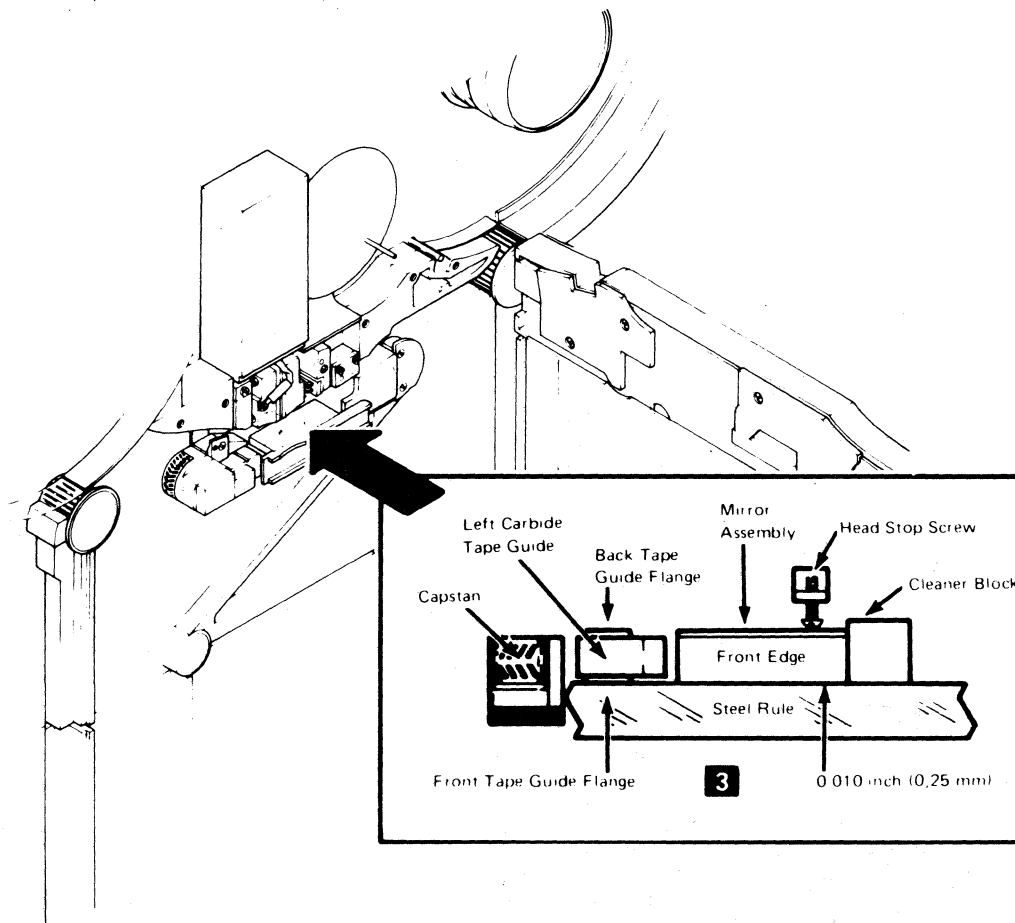

3803-1.2.3/3420

| | | | | | | | | | |
|------------|-------------|---------|----------|--|--|--|--|--|--|
| XD2200 | 2735832 | See EC | 845958 | | | | | | |
| Seq 1 of 2 | Part Number | History | 1 Sep 79 | | | | | | |

Copyright International Business Machines Corporation 1976-1979

08-350

**AUTOCLEANER OPERATION
(TAPE UNIT MODELS 4, 6, 8)**

The autocleaner protects the read/write head and cleans the tape by means of a cleaning ribbon positioned crosswise to the tape between the tape and the head. Tape is cleaned during:

1. High-speed rewind
2. Low-speed rewind
3. A thread/load operation
4. An unload operation

During tape cleaning operation, the autocleaner motor is energized and the cleaning ribbon moves across the tape at approximately 0.1 inch (2.5 mm) per minute.

During other operations, the cleaning ribbon is positioned to the right of the write gap.

In use, the autocleaner is self-adjusting. Initial adjustment is necessary only after replacement.

There is a cutout on the plastic cover over the erase head which enables you to see the white ribbon when the autocleaner is not activated.

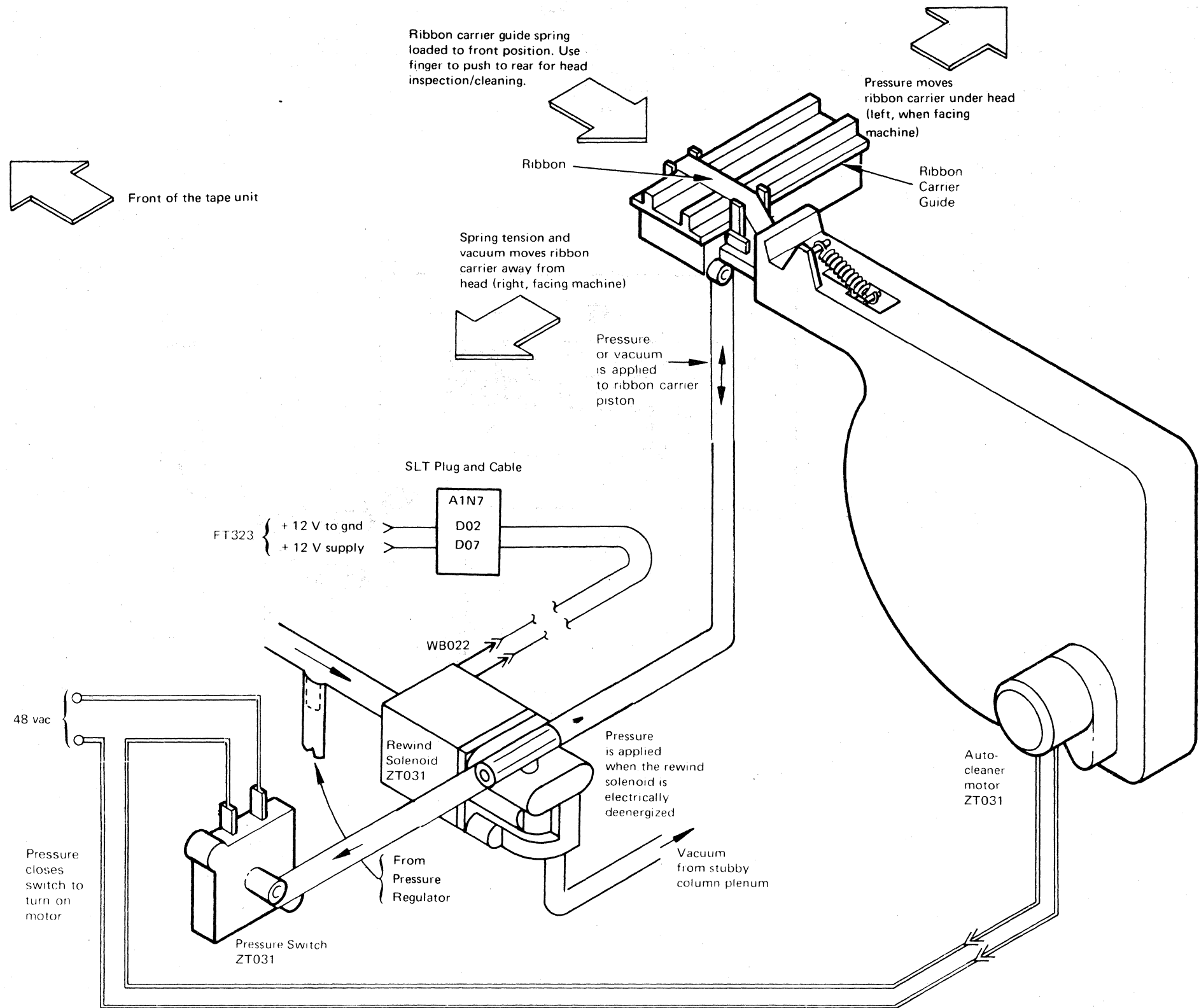

3803-1.2.3/3420

| | | | | | | | | | |
|------------|-------------|---------|----------|--|--|--|--|--|--|
| XD2200 | 2735832 | See EC | 845958 | | | | | | |
| Seq 2 of 2 | Part Number | History | 1 Sep 79 | | | | | | |

**AUTOCLEANER REMOVAL/REPLACEMENT
(TAPE UNIT MODELS 4, 6, 8)**

1. Unload the tape unit and turn off power.

From the front of tape unit:

Caution: Care must be taken when loosening screws to ensure that the head is not damaged.

2 Remove the two screws holding the autocleaner to the upper stubby bar. Gently lift the front of the autocleaner until the locators clear the countersunk holes.

From the rear of the tape unit:

3 Disconnect the autocleaner power connector.

4 Remove the two screws holding the adjustment plate to the autocleaner mounting bracket.

5. Gently slide the autocleaner to the rear of the machine. Do not disturb the fiber optic bundles or wires.

6. Reverse the above procedure to replace the autocleaner.

7. After replacing the autocleaner, perform the Autocleaner Adjustment procedure on 08-382.

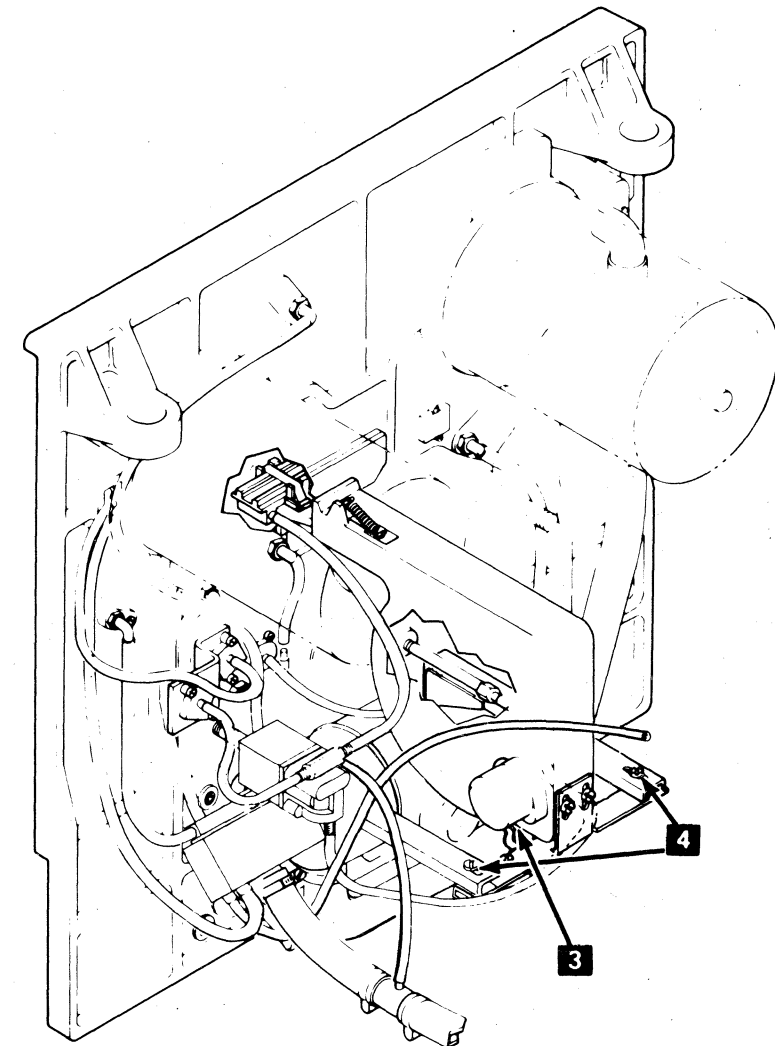
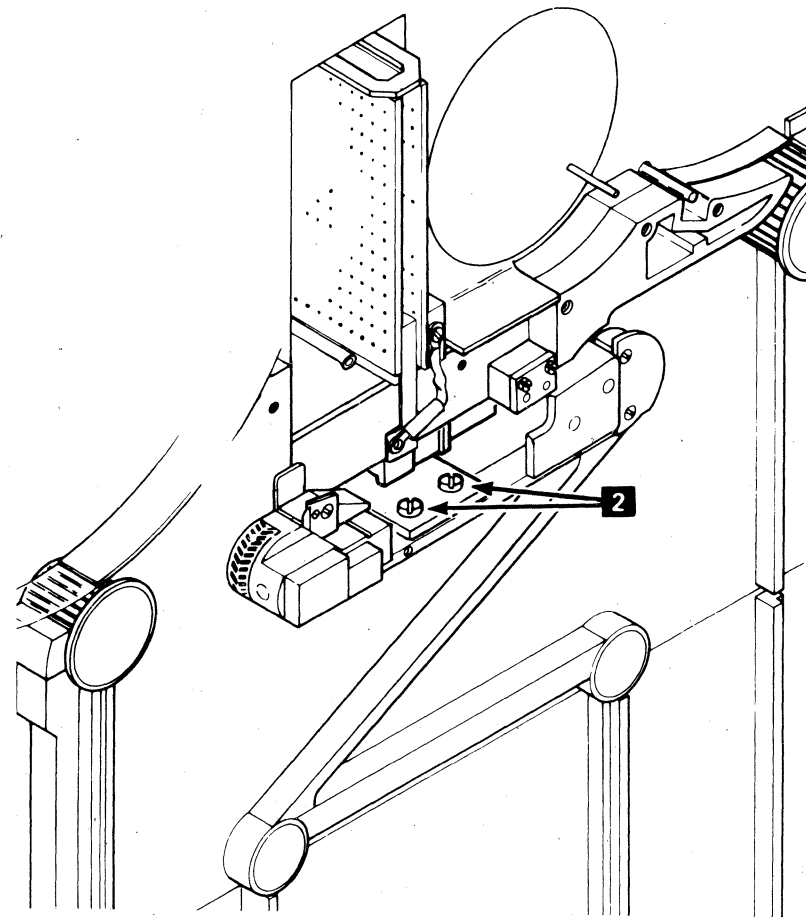

AUTOCLEANER OPERATIONAL CHECK

1. With the door interlock pulled out, no tape mounted, and the column door open, press LOAD REWIND and hold it down.

2. Place a piece of masking tape over the reels loaded port.

3. Use a tab card to block the light from the photosensor on the EOT/BOT.

4. This should cause the autocleaner to snap under the head and then return to its home position when the card is removed. See 08-360.

5. If the autocleaner fails to operate or is sluggish, proceed as follows:

6. Insert a tee between the output of the rewind solenoid valve and the hose to the autocleaner. Disconnect the rewind solenoid power plug.

Note: A temporary tee can be made by using a vacuum switch tee from one of the dual switch positions, and two small pieces of cleaner blade hose (P/N 1766567).

7. With a jumper between A1D4J09 and ground, hook the pressure/vacuum gauge to the tee. No less than 55 inches (1400 mm) pressure should be measured for a Model 4, or 65 inches (1650 mm) for a Model 6 or 8. If the pressure is good, inspect the autocleaner for the cause of the sluggish operation or replace the autocleaner.

8. If the pressure reading is bad, temporarily hook the tee to a new autocleaner. If a good reading is obtained, the first autocleaner is leaking. Check the screws on the front of the ribbon carrier. Replace the autocleaner if necessary. If a good reading is not obtained, check the pneumatic system. Remove the jumper A1D4J09 to ground.

9. Disconnect the rewind solenoid power plug. Then check that the autocleaner ribbon moves from the bottom to the top approximately 0.10 inch (2.54 mm) per minute by marking the tape and observing the direction while holding LOAD REWIND down.

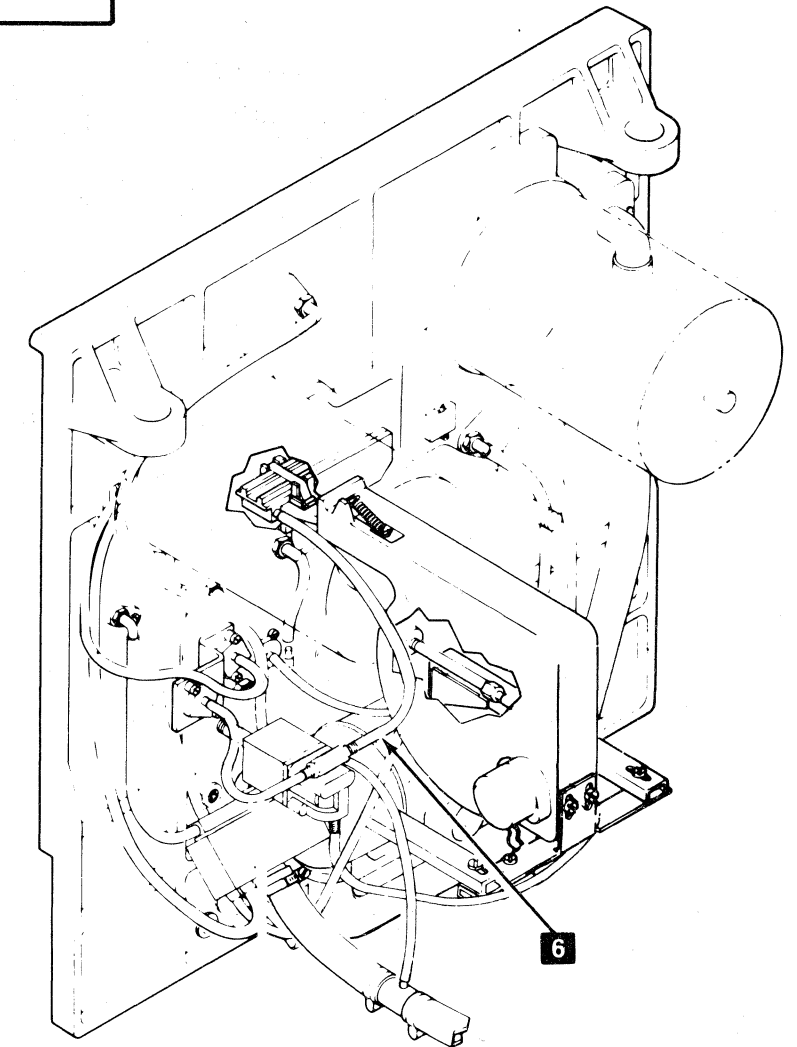
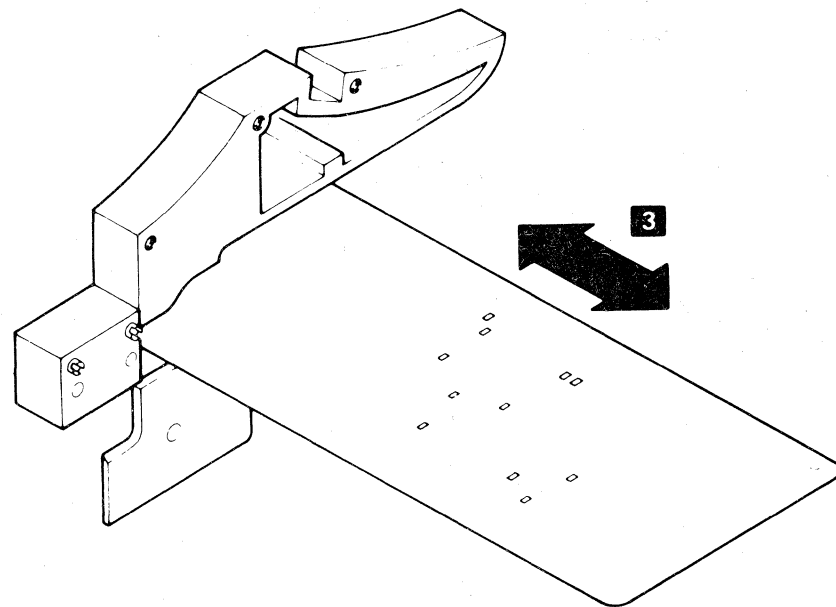
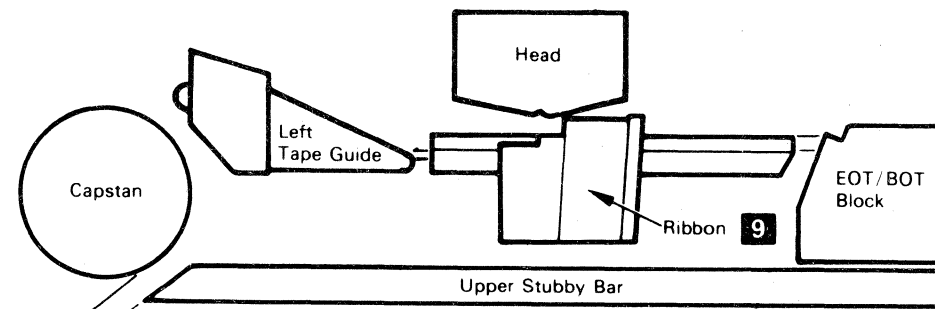
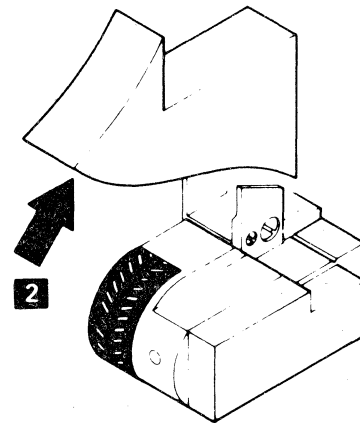

3803-1,2,3/3420

| | | | | | | | | | |
|------------|-------------|---------|----------|--|--|--|--|--|--|
| XD2300 | 2735833 | See EC | 845958 | | | | | | |
| Seq 2 of 2 | Part Number | History | 1 Sep 79 | | | | | | |

© Copyright International Business Machines Corporation 1976, 1979

**AUTOCLEANER ADJUSTMENT
(TAPE UNIT MODELS 4, 6, 8)**

See 08-080, "Capstan-To-Stubby Bar Clearance Adjustment before starting this procedure.

1. If required, take up the loose ribbon by turning counterclockwise the screw located at the rear of the autocleaner on the side opposite the motor.
2. Loosen the two adjustment screws at **A**. Position the screws to the center of their slots and tighten them.
3. Loosen the two adjustment screws at **B**.
4. Observe the autocleaner ribbon position relative to the read/write head surface. The left edge of the ribbon may just touch the head at point **D**. (Maximum clearance 0.015 inches (0.38 mm)). The ribbon should not touch any part of the head between point **D** and point **H**. (If the edge of the ribbon is folded, the ribbon position is too high). If the ribbon is too high, adjust bracket **E** toward the rear of the machine. If the ribbon is too low, adjust bracket **C** toward the front of the machine. To ease the adjustment:
 - a. Loosen screw **E** on one side, adjust bracket the desired amount, then tighten the screw.
 - b. Repeat for the other side, moving the bracket an equal amount.
 - c. Observe the autocleaner ribbon position. Repeat steps a, b, and c as required.
5. After the autocleaner ribbon has been correctly positioned, check that:
 - a. The left end of the autocleaner thread channel bed (glass bead) is 0.030 to 0.060 inch (0.76 to 1.52 mm) above the tape guide ramp edge. See the figure, point **E**.
 - b. The right end of the autocleaner thread channel bed (glass bead) is positioned below the top of the EOT/BOT block **F**, so that the autocleaner thread channel is approximately parallel with the upper stubby bar, point **G**.
6. If either step 5a or 5b is incorrect, loosen the screws at **A** and reposition the autocleaner assembly by tilting in the appropriate direction. Loosen and tighten the screws for each trial position.

7. Check to see that:
 - a. The autocleaner ribbon is correctly positioned.
 - b. The autocleaner arm retracts and extends freely.
 - c. The autocleaner ribbon actuates back and forth across the head freely. Verify by performing the Autocleaner Operational Check procedure on 08-380.
 - d. The magnetic tape leader threads through the channel freely by loading and unloading a reel of tape several times.

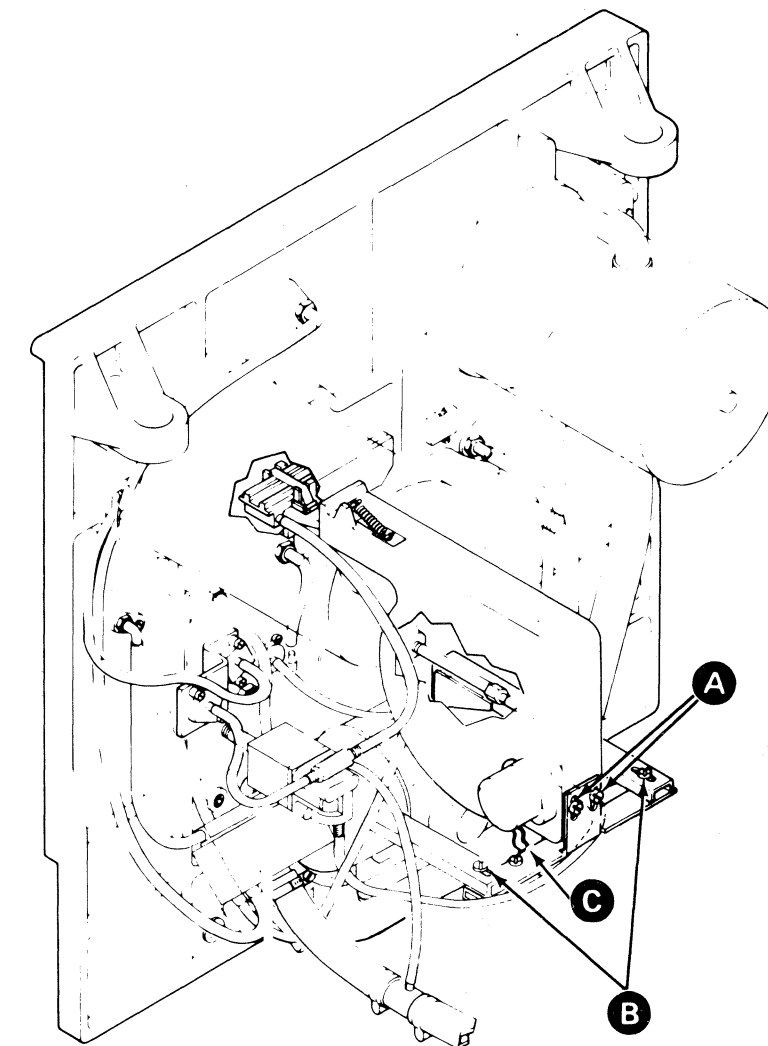
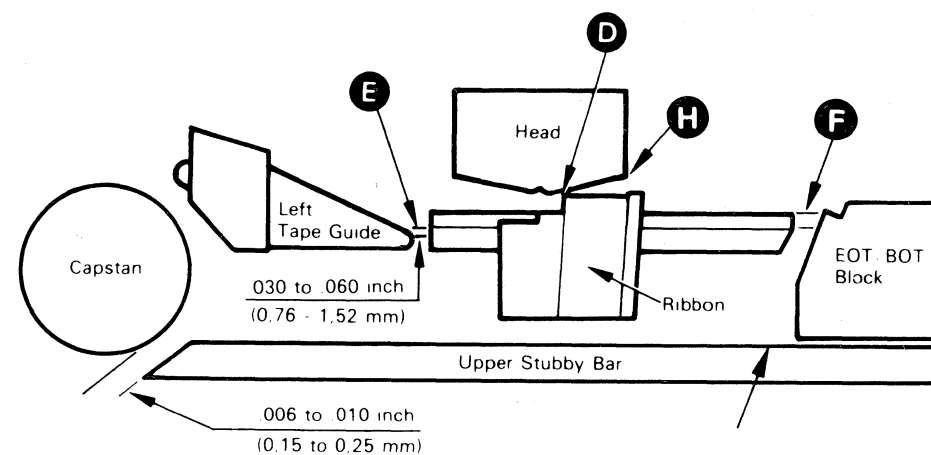

3803-1,2,3/3420

| | | | | | | | |
|------------|-------------|---------|----------|--|--|--|--|
| XD2350 | 2736042 | See EC | 845958 | | | | |
| Seq 1 of 2 | Part Number | History | 1 Sep 79 | | | | |

NOTES:

08-384

3803-1,2,3/3420

| | | | | | | | | | |
|----------------------|------------------------|-------------------|--------------------|--|--|--|--|--|--|
| XD2350 Seq 2 of 2 | 2736042 Part Number | See EC History | 845958 1 Sep 79 | | | | | | |
|----------------------|------------------------|-------------------|--------------------|--|--|--|--|--|--|

© Copyright International Business Machines Corporation 1976, 1979

08-384

CLEANER BLADE GAUSS CHECK AND DEGAUSSING

To check for a gaussed (magnetized) cleaner blade, proceed as follows:

1. Switch the tape unit offline.
2. Attach the field tester, P/N 1765342.
3. Load and make ready the tape unit with a good CE work tape.
4. Set the tester to write continuously, with the frequency switch set to 32 for PE, 8 for NRZI, or 64 for SAGC.
5. Probe the track analog signals at the read card test points and record the individual track amplitudes.
6. Set the tester to read tape backward to load point, and then to read tape forward.
7. With the tape reading forward, again probe and record the individual track analog amplitudes at the read card test points.
8. Compare both the write and read amplitudes recorded earlier.
 - a. If the read amplitude is at least 90% of the write amplitude, the cleaner blade is normal. Remove the field tester and place the tape unit online.
 - b. If the read amplitude is less than 90% of the write amplitude, the cleaner blade should be degaussed or replaced. **Note:** *If the cleaner blade is replaced, verify that the new cleaner blade is not gaussed.*
9. Remove the cleaner blade from the machine.

Caution: Do not use the degausser near customer tapes, disk packs, and so on, because data on these media may be destroyed.

10. Using the degausser, P/N 451064:
 - a. Hold the center of the degausser surface against the cleaner blade (surface of blade that touches the tape).
 - b. Turn on the degausser and hold it against the cleaner blade for a few seconds.
 - c. With the degausser still on, slowly withdraw the degausser straight away from the cleaner blade to a distance of approximately 1 foot.
11. Reinstall the cleaner blade on the tape unit.
12. Do the gauss check again before returning the tape unit to the customer.

Note: *If the degaussing was unsuccessful, replace the cleaner blade and ensure that the new blade is not gaussed.*

3803-1.2.3/3420

| | | | | | | | | |
|----------------------|------------------------|-------------------|--------------------|--|--|--|--|--|
| XD2400 Seq 1 of 2 | 2735834 Part Number | See EC History | 845958 1 Sep 79 | | | | | |
|----------------------|------------------------|-------------------|--------------------|--|--|--|--|--|

PNEUMATIC PRESSURE/VACUUM CHECKS

General Instructions

Observe the following:

- All pneumatic measurements and adjustments should be made only after allowing the unit to warm up for 15 minutes.
- To check pneumatic levels, consult the labels located on the transfer valve and its distribution manifold.
- Use a water manometer or a pressure/vacuum gauge, P/N 5495384, to make the following measurements. Use a pressure divider when needed to make this measurement. **Note:** Go to 80-010 for instructions.

Caution: Pressure in Models 6 and 8 and Model 7 NRZI-featured tape units exceeds 80 inches (2032 mm of water).

- Use a hose adapter, P/N 2512745, to connect the manometer hose to the smaller test point fittings.

Column Vacuum Level Check [Ⓐ]

With tape loaded in all columns, measure the column vacuum at the fitting on the tapered column plenum. See the label on the transfer valve for correct vacuum level. If the vacuum level is not within specifications, see 08-410, "Altitude Vacuum Level Adjustment."

Threading Vacuum Check [Ⓑ]

With the tape unit unloaded, ground pin T-A1N5B12 and measure the vacuum at the port indicated on the transfer valve label. The chart on this page shows the correct vacuum. If threading vacuum is not within specifications, see 08-410, "Altitude Vacuum Level Adjustment."

Transfer Valve Leakage Test

1. Cover the stubby column ports with masking tape. See Figure 1. Do not let the tape overlap the stubby bars.

2. Place an 8-inch piece of magnetic tape in the bottom of the right vacuum column to prevent vacuum from entering the column.
3. Cut a 12-inch piece of magnetic tape and lay it over the left reel tach just below the read/write head. Ensure that the tape loop is approximately in line with the bottom of the capstan. See Figure 1. Bypass the door interlock.
4. With no tape on the right reel, press LOAD REWIND. If the tape strip is pulled into the left column before load check occurs, there is sufficient leakage to cause intermittent problems and the transfer valve must be replaced. Repeat the test several times to ensure that the valve is bad.
5. Remove the masking tape from the stubby column ports and clean the area thoroughly with a cloth dampened with tape cleaner. Remove the magnetic tape from the right and left vacuum columns.

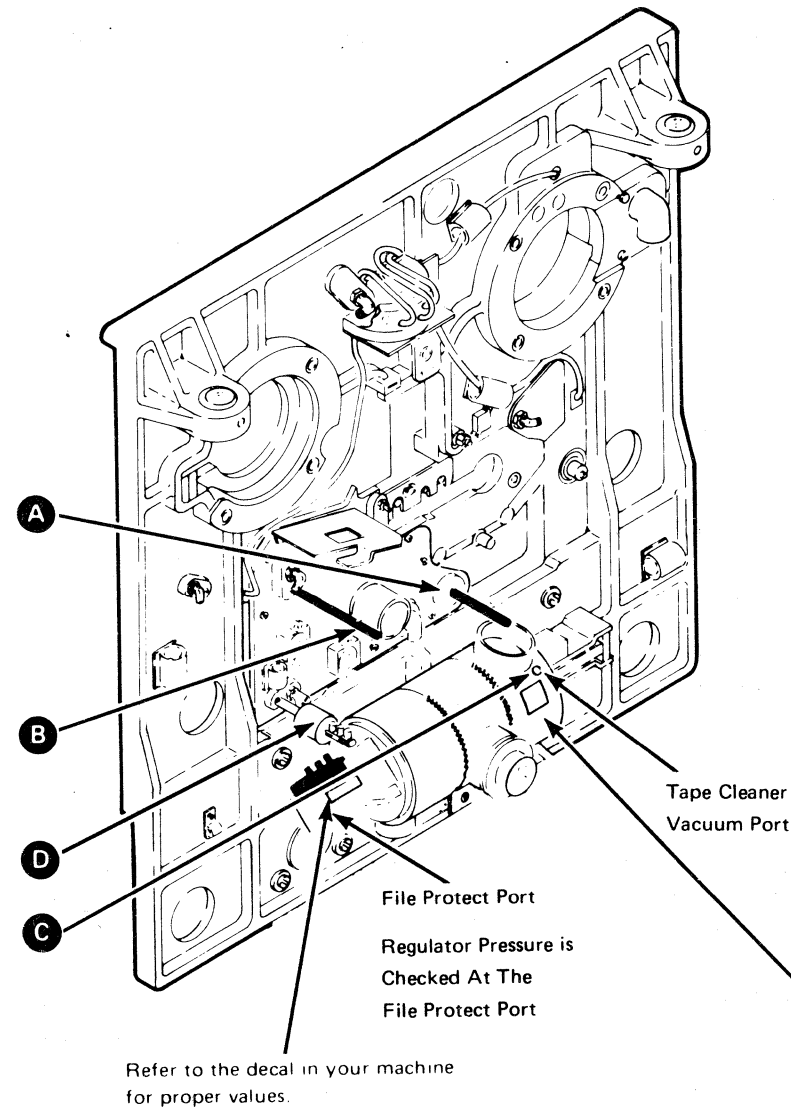
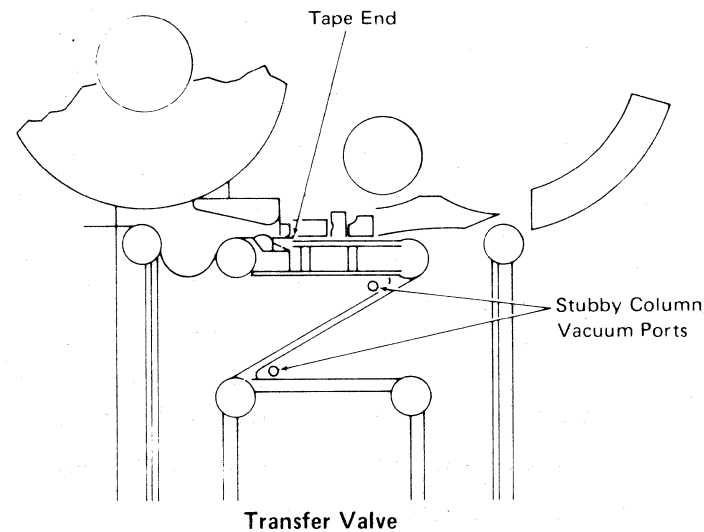

Column and Threading Vacuum Label.
(See chart of values for correct vacuum model levels.)

Note: If transfer valve is replaced, remove the decal from the old valve and place it on the new valve.

3803-1.2.3/3420

| | | | | | | | |
|----------------------|------------------------|-------------------|--------------------|--|--|--|--|
| XD2400 Seq 2 of 2 | 2735834 Part Number | See EC History | 845958 1 Sep 79 | | | | |
|----------------------|------------------------|-------------------|--------------------|--|--|--|--|

REGULATOR AIR PRESSURE CHECK

1. Tape Loaded Regulator Pressure

Install a write-enable ring on a tape reel. Mount and load this tape reel.

On earlier-level machines: Measure the regulator pressure at the port indicated on the distribution manifold. The chart on this page shows the correct pressure (see Note below).

On later-level machines: Remove the hose leading to the file-protect assembly and measure the regulator pressure at the output of the distribution manifold.

2. Thread Operation Regulator Pressure

To check the regulator pressure, ground pin T-A1N5B12 and measure the pressure at the port indicated on the distribution manifold. The chart on this page shows the correct pressure (see Note below).

3. Install jumper T-A1A5B13 to ground (Reel Hub Air Pressure switch). Remove the output hose from the reel latch manifold and connect the gauge to this point. A reading should be obtained of at least 63 on Model 4, and 77 on Models 6 and 8. (Check with the reel in motion.) If not, it indicates leaks in the latch. Usually this is caused by wear in the bearings, cam or bushing. See 08-510. Install hose again.

Note: If either regulator air pressure check is not within specifications, see 08-420, "Pneumatic Pressure Level Adjustment."

Vacuum Chart for All Models (in inches of water)

| Model | Column Vacuum Level | Threading Vacuum | Regulator Pressure |
|----------|---------------------|------------------|--------------------|
| 3 | 21 ±3 | 9 ±2 | 69 ±2 |
| 4 | 21 ±3 | 9 ±2 | 69 ±2 |
| 5 | 21 ±3 | 9 ±2 | 69 ±2 |
| 6 | 21 ±3 | 9 ±2 | 85 ±2 |
| 7 (PE) | 27 ±3 | 8 ±2 | See Note |
| 7 (NRZI) | 27 ±3 | 8 ±2 | 83 ±2 |
| 8 | 31 ±2 | 8 ±2 | 85 ±2 |

Note: For a unit with PE tape transport and without EC 736028, regulator pressure = 69 ±2 (black manifold).

For a unit with Pe tape transport and with EC 736028, regulator pressure = 85 ±2 (red manifold).

For a PE unit with NRZI transport, regulator pressure = 83 ±2 (grey manifold).

High-Speed Rewind Solenoid Check (Tape Unit Models 3, 5, 7)

Caution: Stay clear of the left reel as it will attempt to go into a high-speed rewind during this test.

1. Remove the tape from the tape unit.
2. Open the front door and bypass the door interlock.
3. Open the vacuum column door.
4. Manually move the high-speed rewind plunger to ensure that it is not sluggish. Replace the plunger if it does not move freely.
5. Jumper T-A1C2M02 (-Hi Speed Field ALD FT262) to ground.
6. Press LOAD REWIND.
7. After vacuum comes up and the left reel starts turning, the high-speed rewind plunger should fall sharply. This will occur just before load check. When vacuum falls, the plunger should go back to its normal position.
8. If the operation of the plunger is in question, compare the operation with that of a good tape unit.
9. Replace solenoid **Ⓧ** if the plunger operates sluggishly.
10. Remove the jumper.

| | | | | | | | | |
|----------------------|------------------------|-------------------|--------------------|--|--|--|--|--|
| XD2450 Seq 1 of 2 | 8492588 Part Number | See EC History | 845958 1 Sep 79 | | | | | |
|----------------------|------------------------|-------------------|--------------------|--|--|--|--|--|

NOTES:

08-406

3803-1,2,3/3420

| | | | | | | | | | |
|------------|-------------|---------|----------|--|--|--|--|--|--|
| XD2450 | 8492588 | See EC | 845958 | | | | | | |
| Seq 2 of 2 | Part Number | History | 1 Sep 79 | | | | | | |

© Copyright International Business Machines Corporation 1976, 1979

08-406

CARR — ALTITUDE VACUUM

08-410

ALTITUDE VACUUM LEVEL ADJUSTMENT

Figure 1.

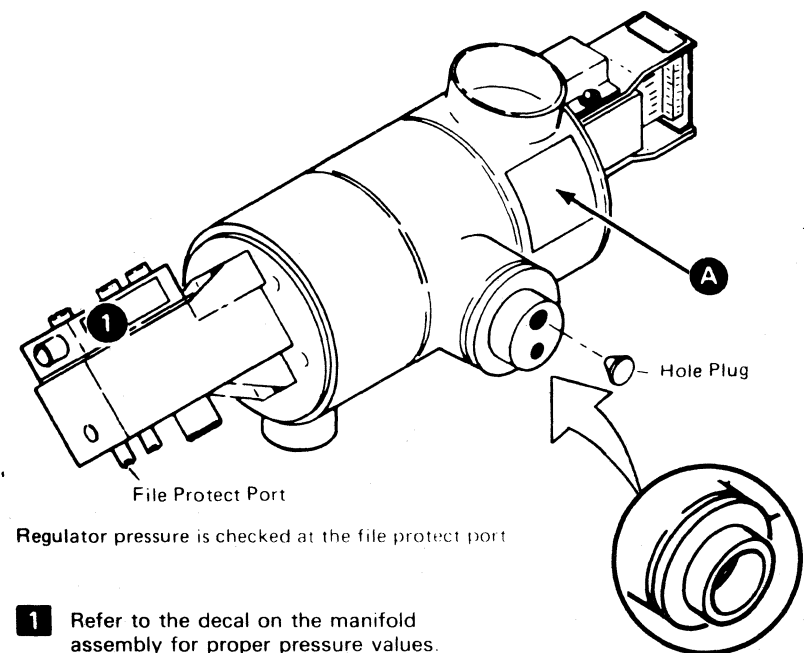

Model 8 transfer valve has an open end on the orifice leading to the capstan motor.

Measure the vacuum as shown on the transfer valve label **A**. (See Figure 1.) If incorrect, check the settings as follows:

| Altitude | Transfer Valve Plug | Pneumatic Supply Pulley Diameter |
|--------------------------------------|---|---|
| | Models 3, 4, 5, 6 and 7 Model 8* | All Models |
| | Remove the cooling hose leading to the capstan motor at the transfer valve. Determine which hole should be plugged. | Determine which diameter of pneumatic motor stepped pulley should be used B . (See Note 1 when changing the pulley diameter on Model 8.) |
| 0-2000 ft (0-610 m) See Note 2 | Small | Small |
| 2001-4000 ft (610-1219 m) | Large | Small |
| 4001-6000 ft (1219-1829 m) | Small | Large |
| above 6000 ft (1829 m) | Large | Large |

*The Model 8 has a restrictor **C**, P N 1765760, in the line between the pump and transfer valve (see Figure 3). The restrictor is adjusted for 31.5 inches (800 mm) of water. If 31.5 inches (800 mm) is unobtainable, adjust to the highest vacuum level between 29.0 and 31.5 inches (737 and 800 mm). If 29.0 inches (737 mm) is unobtainable, check for leaks, pinched hoses, or wrong pulley size.

- Measure the column vacuum (see 08-400).
- Loosen retaining screws **D**.
- Rotate the handle of the restrictor for adjustment **C**.
- Tighten retaining screws **D**.

Figure 2.

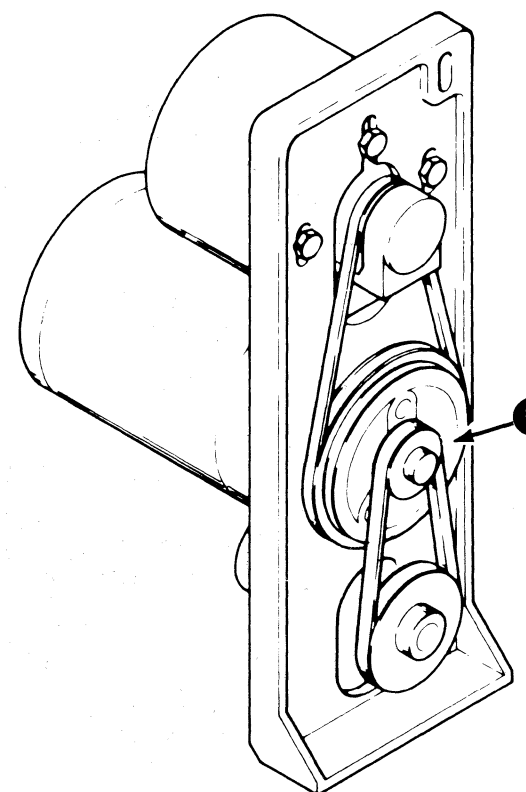

Note 1: The belt must be changed on Model 8 when changing the pulley diameter. The high-altitude belt is stored behind the pneumatic supply.

Note 2: Under extreme altitude (high barometric pressure at sea level), environmental (low-ambient temperature), and powerline conditions (10% line voltage variation), vacuum on the Model 4 and Model 6 tape units may be up to 2 inches (50.8 mm) higher than specified. This is a temporary condition and will not impair machine operation.

Figure 3.

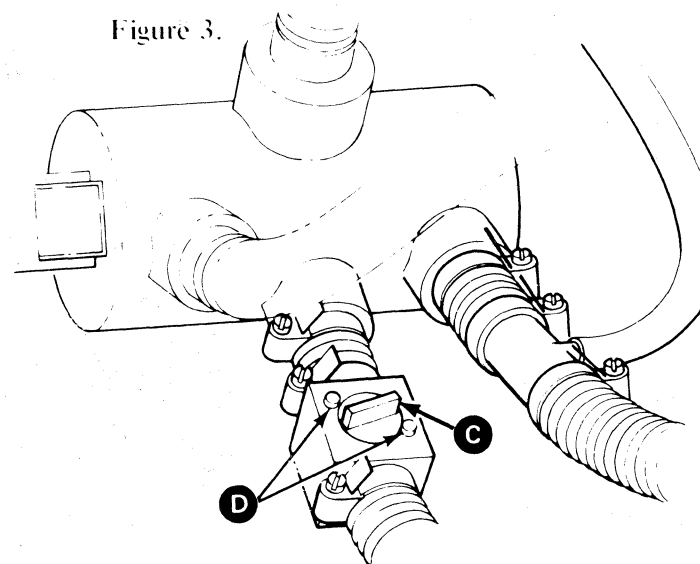

3803-1,2,3/3420

| | | | | | | | | |
|------------|-------------|---------|----------|--|--|--|--|--|
| XD2500 | 2735835 | See EC | 845958 | | | | | |
| Seq 1 of 2 | Part Number | History | 1 Sep 79 | | | | | |

© Copyright International Business Machines Corporation 1976, 1979

08-410

**PNEUMATIC PRESSURE LEVEL
ADJUSTMENT
(ALL MODEL TAPE UNITS)**

The pressure regulator is adjusted before shipment and should not require further adjustment in the field. If you suspect a pressure variation, check the pressure at the regulator test point on the distribution manifold **(A)**. If the level is not within the specifications listed in the chart on 08-400, check thoroughly for a kinked or leaking hose, a loose clamp or belt, or another faulty component in the pneumatic area.

Caution: If the regulator pressure is low, check for a dirty input filter to the pressure pump or leaking hose connections.

To adjust the regulator:

1. Pry the small plastic plug from the top center of the regulator **(B)**.
2. Insert a hex wrench in the adjustment port. Engage the adjustment screw inside the port.
3. To decrease the pressure, turn the wrench clockwise; to increase the pressure, turn the wrench counterclockwise.
4. Thread and load the tape unit and measure pressure again at the regulator test point. See 08-400, "Pneumatic Pressure/Vacuum Checks."
5. If correct, replace the plastic plug. If not, repeat steps 2, 3, and 4.

Note: The replacement regulator for Models 3, 4, 5, and 7 is P/N 2523048 and for Models 6 and 8 is P/N 1845566. Any new pressure regulator may require adjustment for the tape unit in which it is installed. Check the chart on 08-400 for the right setting.

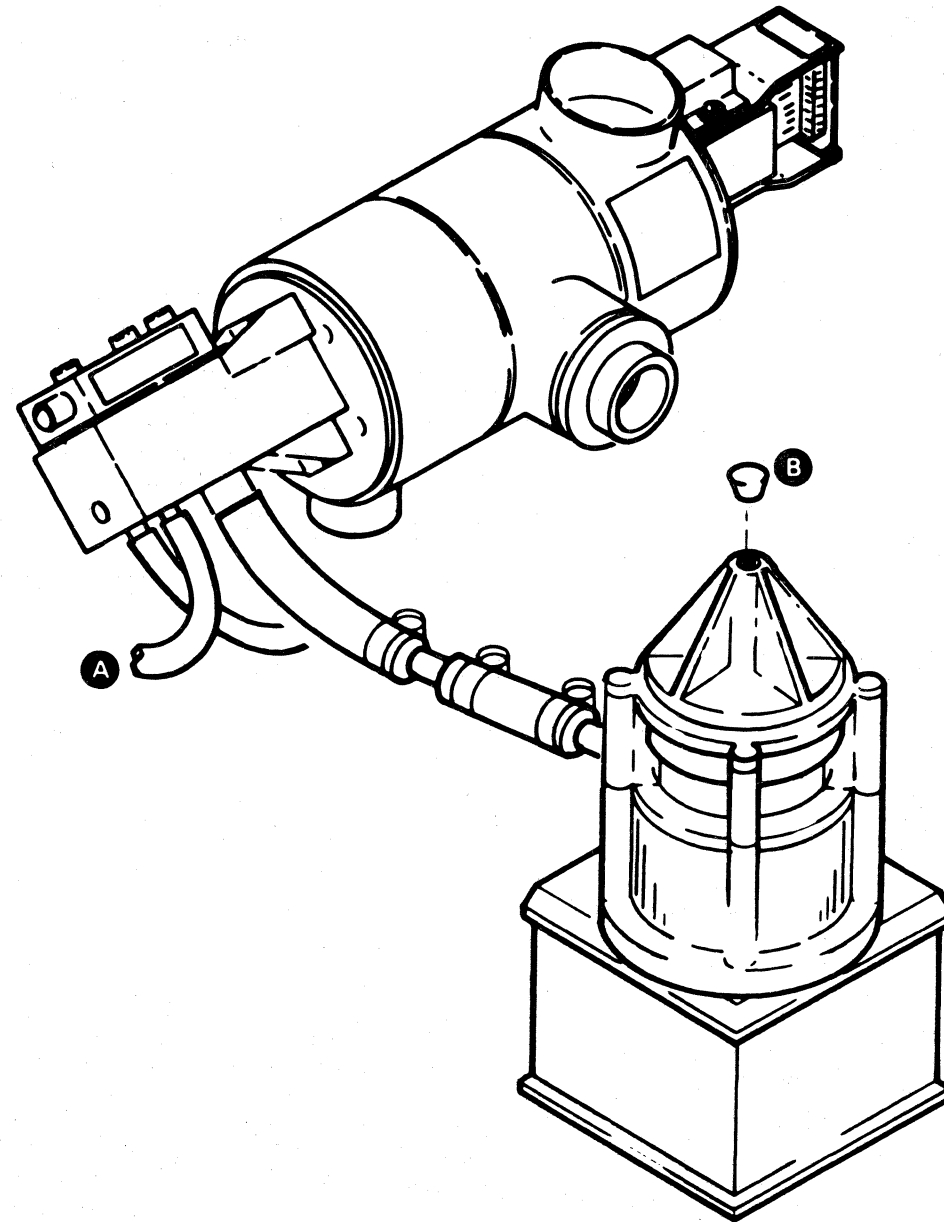

3803-1.2.3/3420

| | | | | | | | | |
|------------|-------------|---------|----------|--|--|--|--|--|
| XD2500 | 2735835 | See EC | 845958 | | | | | |
| Seq 2 of 2 | Part Number | History | 1 Sep 79 | | | | | |

© Copyright International Business Machines Corporation 1976, 1979

PNEUMATIC SUPPLY STEPPED PULLEY REPLACEMENT (ALL TYPES OF PNEUMATIC SUPPLIES)

To reverse or replace the motor stepped pulley:

1. Loosen the mounting bolts and move the pressure and vacuum pumps to loosen the pneumatic belts.
- Note:** Never roll the belts off the pulley as this will cause premature belt failure.
2. Remove the three screws that hold the pulley to the motor flange.
3. Reverse or replace the pulley.
4. Replace the screws and tighten to 75 ±5 inch-pounds (86.4 ±5.8 cm-kgf). See 08-460.
5. Adjust the belt tension. See 08-440, "Pneumatic Supply Belts Replacement/Adjustment."

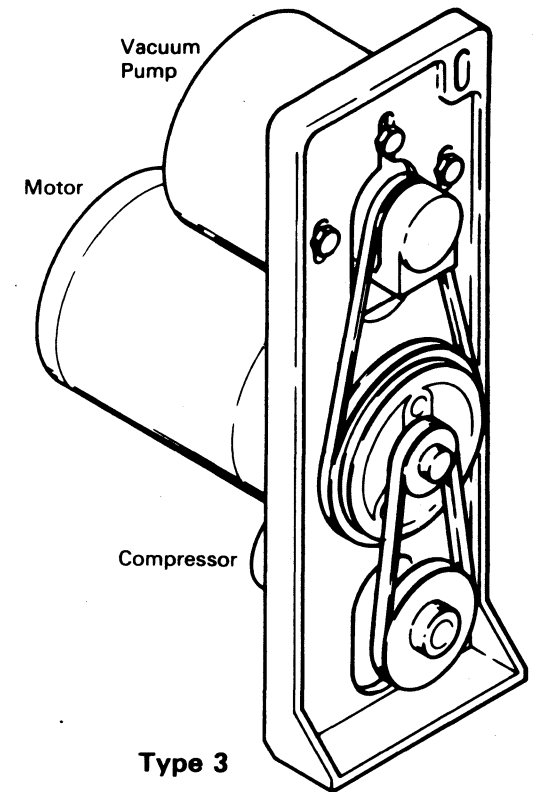
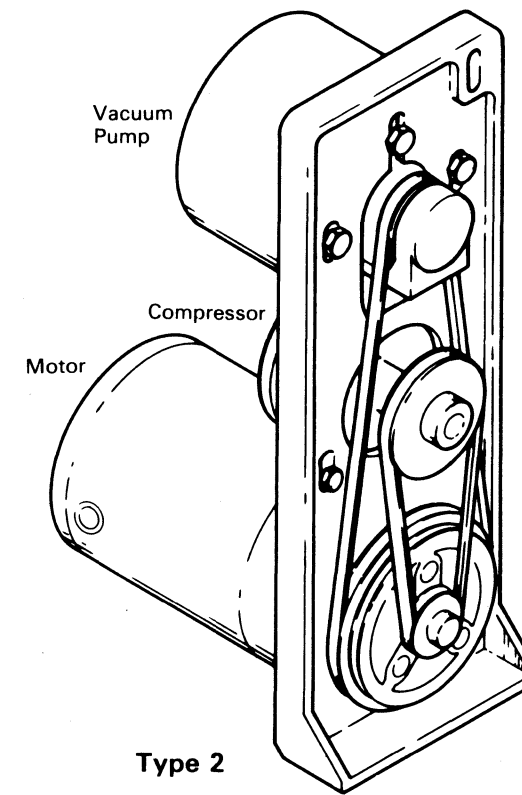
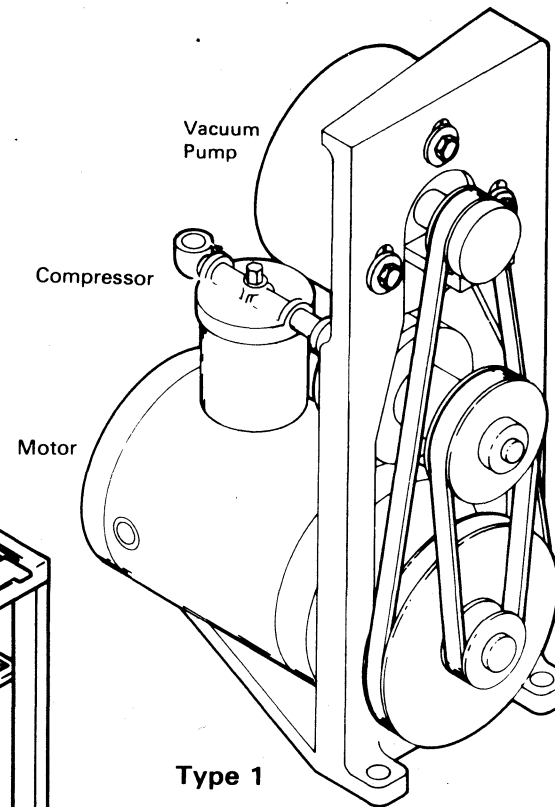
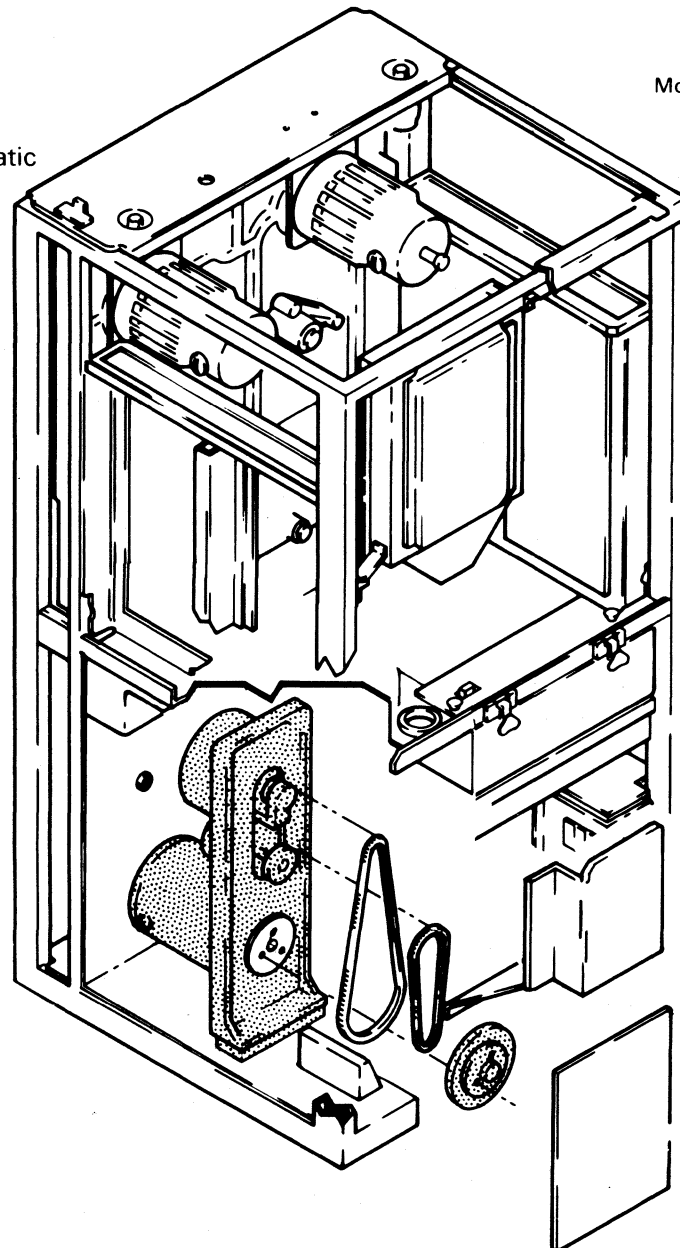

3803-1.2.3/3420

| | | | | | | | | | |
|------------|-------------|---------|----------|--|--|--|--|--|--|
| XD2600 | 2735836 | See EC | 845958 | | | | | | |
| Seq 1 of 2 | Part Number | History | 1 Sep 79 | | | | | | |

**PNEUMATIC SUPPLY PULLEY ALIGNMENT
(TYPE 3 SUPPLY)**

Note: The pulley alignment is fixed on Type 1 and 2 supplies.

Align the pulleys until the belts are parallel to the straight edge held on the outer face of each pulley. Align the pulleys in the following sequence.

Vacuum Pump Pulley Adjustment

1. Check the belt alignment between the vacuum pump pulley and the motor pulley.
2. If necessary, remove the drive motor pulley to expose the hub setscrews.
3. Adjust by moving the drive motor hub in or out on the shaft after loosening the setscrews.
4. Tighten the hub setscrews.
5. See 08-430 for the pulley replacement procedure.

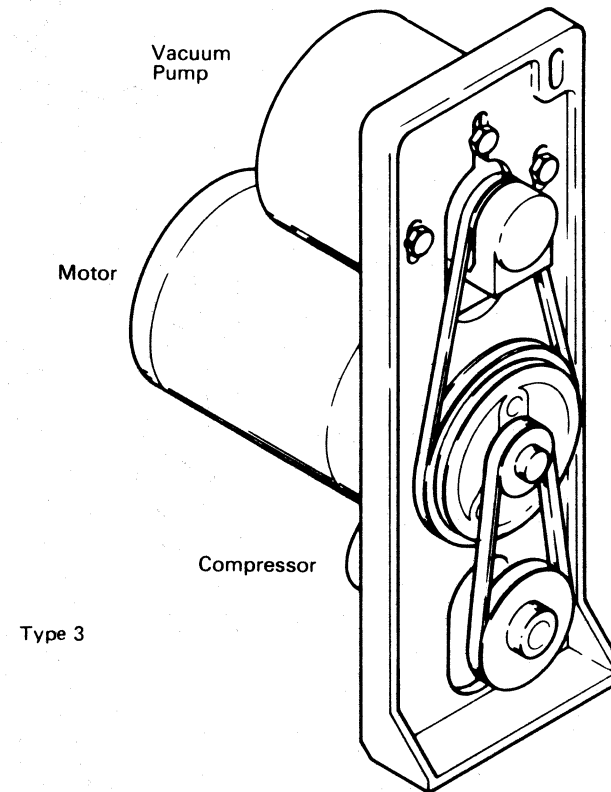

3803-1,2,3/3420

| | | | | | | | | |
|------------|-------------|---------|----------|--|--|--|--|--|
| XD2600 | 2735836 | See EC | 845958 | | | | | |
| Seq 2 of 2 | Part Number | History | 1 Sep 79 | | | | | |

© Copyright International Business Machines Corporation 1976, 1979

CARR — PNEUMATIC MOTOR

PNEUMATIC MOTOR LARGE
(STEPPED) PULLEY ALIGNMENT

1. Check the belt alignment between the large drive motor pulley and the compressor pulley.
2. To adjust, loosen mounting bolts **A**, **B**, and **C** holding the motor mount.
3. Slightly loosen mounting bolt **D** and use it as a pivot point.
4. Rotate the motor and mount around the pivot bolt until the pulley is parallel to the belt.
5. Tighten the mounting bolts.

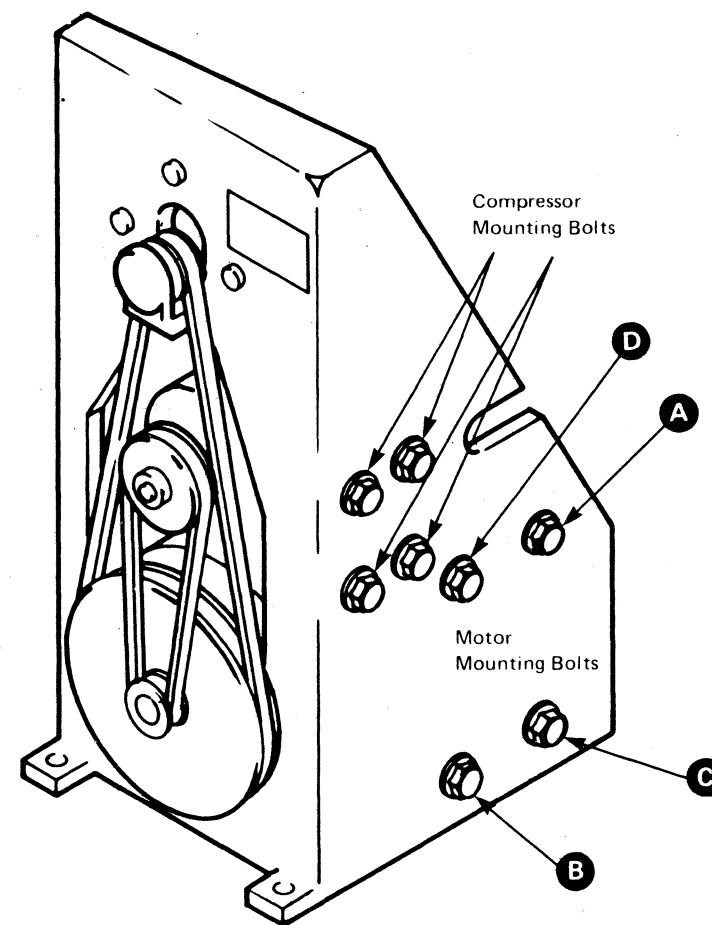
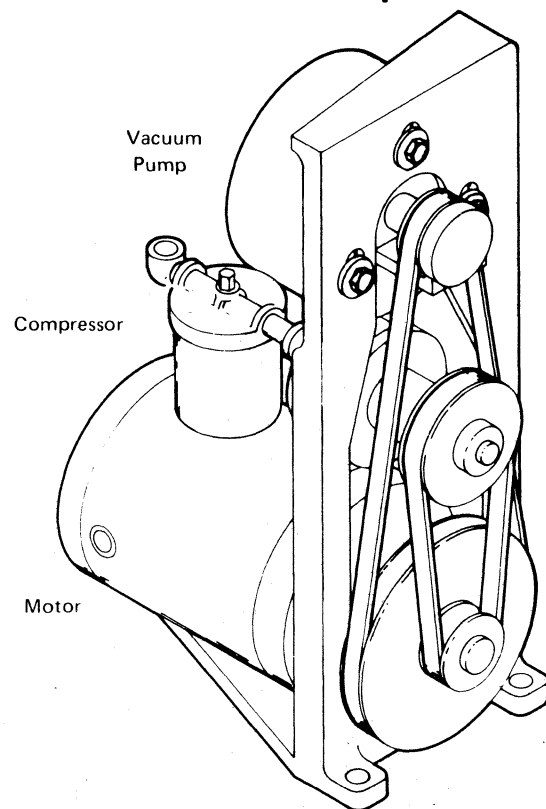

3803-1,2,3/3420

| | | | | | | | | |
|----------------------|------------------------|-------------------|--------------------|--|--|--|--|--|
| XD2700 Seq 1 of 2 | 2735837 Part Number | See EC History | 845958 1 Sep 79 | | | | | |
|----------------------|------------------------|-------------------|--------------------|--|--|--|--|--|

**PNEUMATIC COMPRESSOR PULLEY
ALIGNMENT
(TYPE 2 SUPPLY)**

1. Check the belt alignment between the small drive motor pulley and the compressor pulley.
- 2** Adjust by moving the compressor pulley in or out on the compressor shaft after loosening the pulley setscrews.
3. Tighten the setscrews.

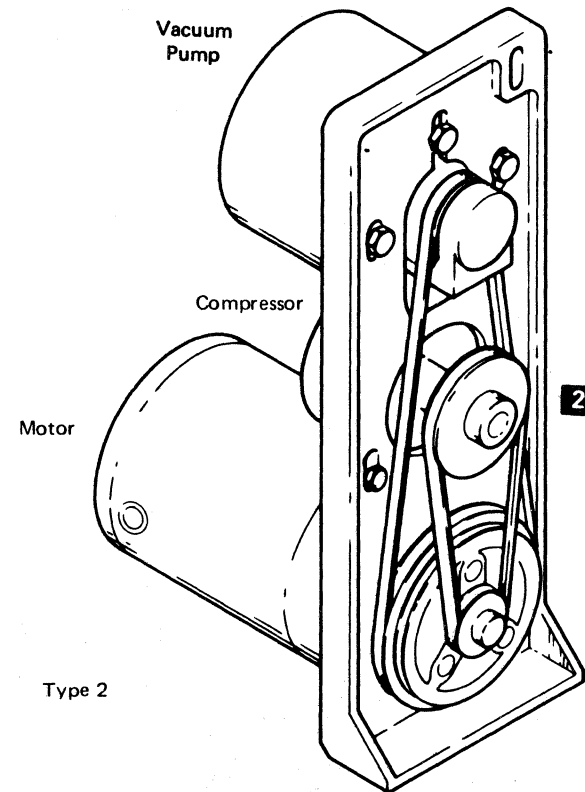

3803-1.2,3/3420

| | | | | | | | | | |
|------------|-------------|---------|----------|--|--|--|--|--|--|
| XD2700 | 2735837 | See EC | 845958 | | | | | | |
| Seq 2 of 2 | Part Number | History | 1 Sep 79 | | | | | | |

© Copyright International Business Machines Corporation 1976, 1979

CARR — COMPRESSOR PULLEY

08-438

PNEUMATIC COMPRESSOR PULLEY ALIGNMENT (TYPE 1 SUPPLY).

1. Check the belt alignment between the compressor pulley and the motor pulley.
2. Adjust by loosening mounting bolts **E**, **F**, and **G**.
3. Slightly loosen mounting bolt **H** and use it as a pivot point.
4. Rotate the compressor and mount around the pivot point until the pulley is parallel to the belt.
5. Tighten the mounting bolts.

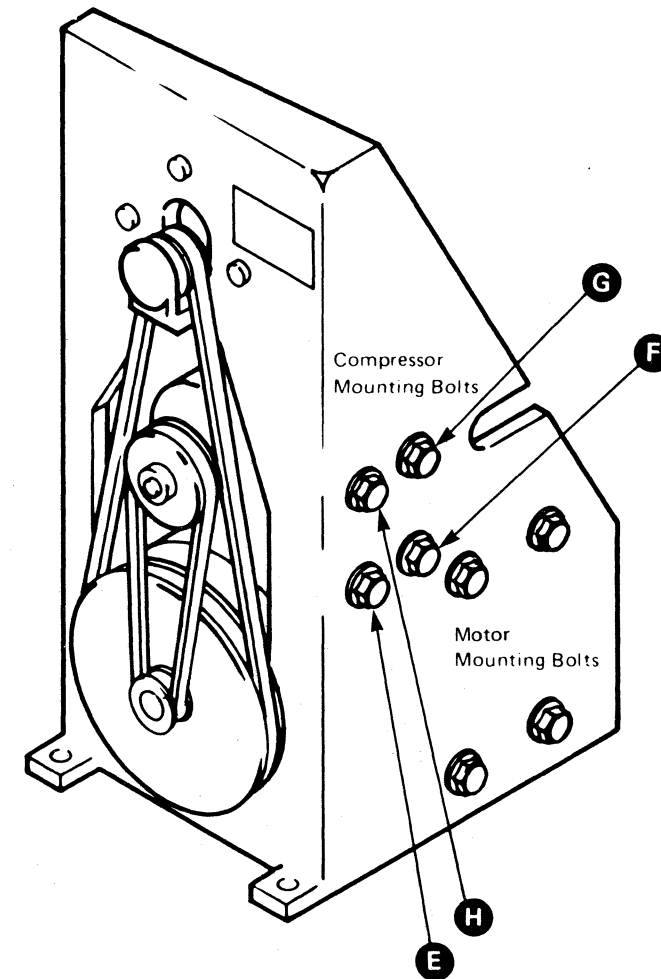
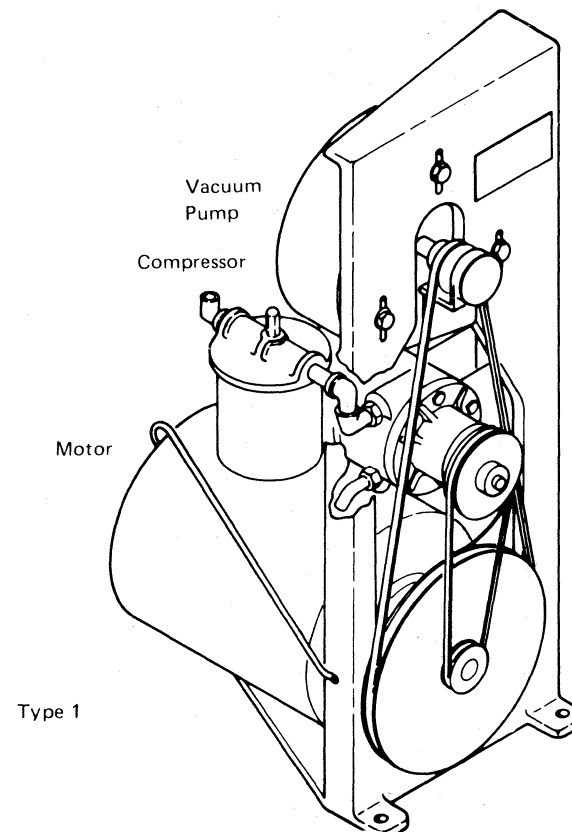

3803-1.2.3/3420

| | | | | | | | | | |
|------------|-------------|---------|----------|--|--|--|--|--|--|
| XD2800 | 2735838 | See EC | 845958 | | | | | | |
| Seq 1 of 2 | Part Number | History | 1 Sep 79 | | | | | | |

Copyright International Business Machines Corporation 1976, 1979

08-438

**PNEUMATIC SUPPLY BELTS
REPLACEMENT/
ADJUSTMENT (ALL SUPPLY TYPES)**

Caution: Do not roll the belts onto the pulleys under tension. Loosen the vacuum pump or pressure pump before installing the belts to avoid premature belt breakage.

Note: Adjusting one belt may affect tension of the other belt.

Before measuring the tension, rotate the pulleys by hand to seat the belts.

1. Loosen the three vacuum pump screws and move the vacuum pump up and down in its mounting slots to adjust the belt tension as follows (or use the new Belt-Adjusting Tool Procedure on this page):
 - a. If the tape unit has the motor at the bottom and a long belt, adjust for 0.30 inch \pm .02 inch (7.6 mm \pm .51 mm) deflection with 2 pounds (900 grams) force applied at the middle of the belt span.
 - b. If the tape unit has the motor in the middle and a short belt, adjust for 0.24 inch \pm .02 inch (6.1 mm \pm .51 mm) of deflection with 4 pounds (1800 grams) force applied at the middle of the belt span. Retighten the vacuum pump mounting screws.
2. Adjust the compressor belt tension by moving the compressor in its slots. Some pulley alignment may be lost, so a visual alignment check must be made at completion. See 08-432, "Pneumatic Supply Pulley Alignment." Adjust the tension for 0.24 \pm 0.030 inch (6.1 \pm 0.8 mm) of deflection with 4 pounds (1800 grams) force applied at the middle of the belt span. (Or use the new Belt-Adjusting Tool Procedure on this page.)

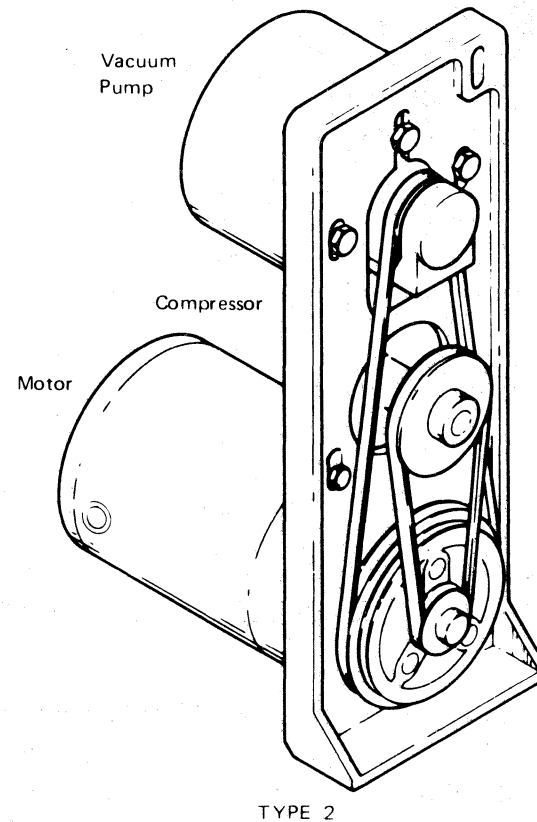
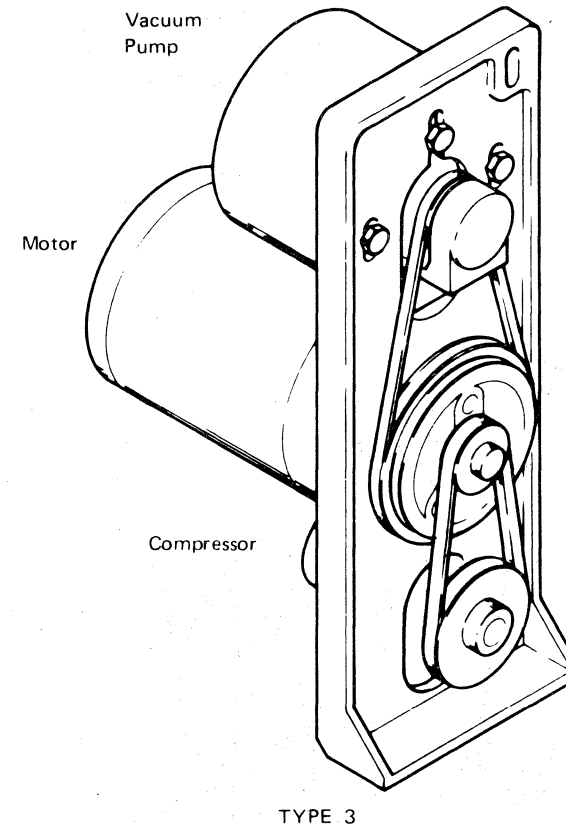
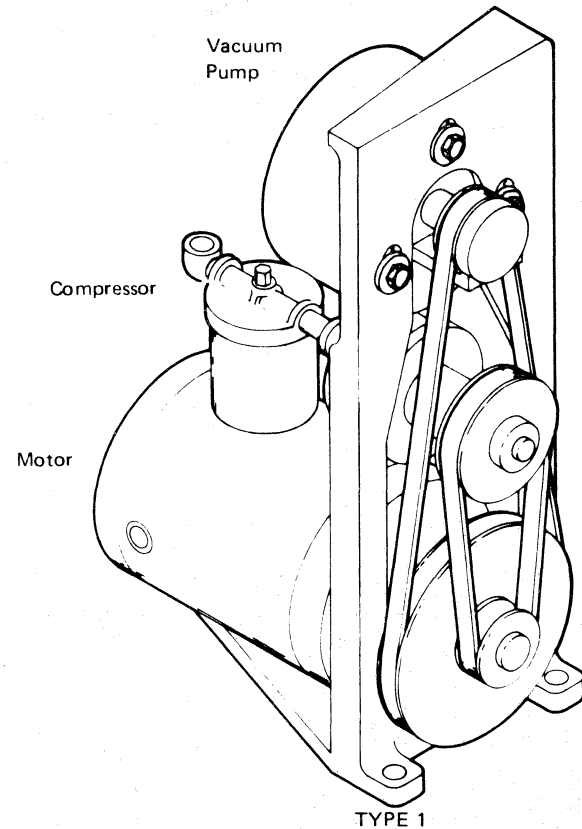

Belt-Adjusting Tool Procedure

If the belt-adjusting tool, P/N 4169639, is available, adjust all belts with this procedure.

1. Place the belt-adjusting tool on the belt midway between the pulleys, as shown in Figure 1. Hold the pulley to prevent movement.

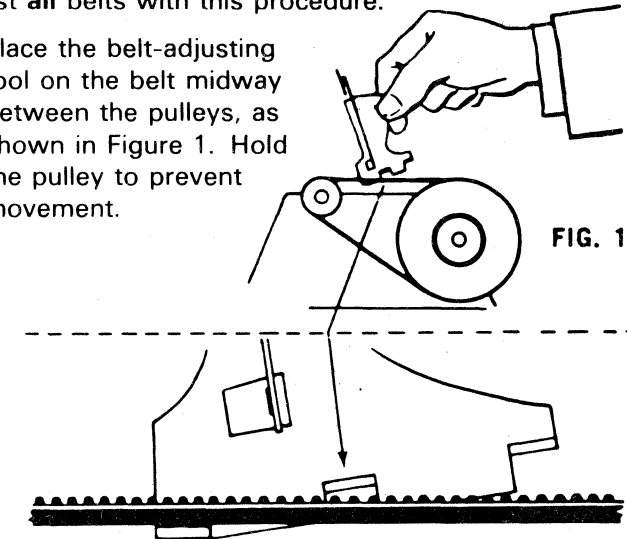

2. With the end of your fore-finger on the button on the top of the spring – pull the button around the top circumference of the belt-adjusting tool. See Figure 2.

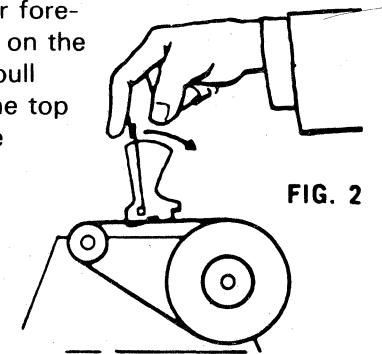

3. When the right-hand tab of the belt-adjusting tool just touches the top of the belt (see A in Figure 3), read the belt tension in pounds on the scale. (See B in Figure 3. Read at left of the spring.)

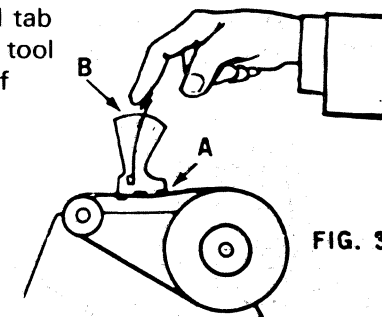

4. Set the tension to:
 - 18 to 25 pounds (8.2 to 11.3 kg) when adjusting existing belts.
 - 23 to 28 pounds (10.4 to 12.7 kg) when installing new belts.

3803-1,2,3/3420

| | | | | | | | | | |
|------------|-------------|---------|----------|--|--|--|--|--|--|
| XD2800 | 2735838 | See EC | 845958 | | | | | | |
| Seq 2 of 2 | Part Number | History | 1 Sep 79 | | | | | | |

© Copyright International Business Machines Corporation 1976, 1979

CARR — VACUUM COLUMN SWITCH

VACUUM COLUMN SWITCH CHECK

1. Unload the tape unit and turn off power.
2. Remove the vacuum switch cover panels.

Note: If EC 443893 is installed, the physical location of R1 and R2 vacuum switches could be reversed. Check the hoses to verify the correct switch position. Label the switches to avoid errors.

3. Insert a loop of tape long enough to reach the bottom in the failing vacuum column. Attach the two upper ends of the tape loop to the column, as shown, with transparent or masking tape. Ensure that the masking or transparent tape does not interfere with the vacuum column door seal.
4. Close the vacuum door.
5. Install a jumper between A1F4J09 Models 4, 6, 8 (A1E2J09 Models 3, 5, 7) to ground. This will activate the pneumatic supply.
6. Turn on tape unit power. The vacuum pump should run, and vacuum should be present in the columns.
7. Connect a voltmeter across the switch terminals to be tested. Attach the plus lead to the switch common.
8. Pull the tape until the loop is above the switch being tested. The switch should close as the loop moves above its sensing port causing a zero meter reading.
9. If the meter does not read zero, turn power off and replace the switch. Repeat the test.
10. If the meter still does not read zero, check the vacuum level. See 08-400, "Pneumatic Pressure/Vacuum Checks."
11. Remove the tape loop and clean away any remaining tape adhesive.
12. Be sure to remove the jumper installed in step 5.

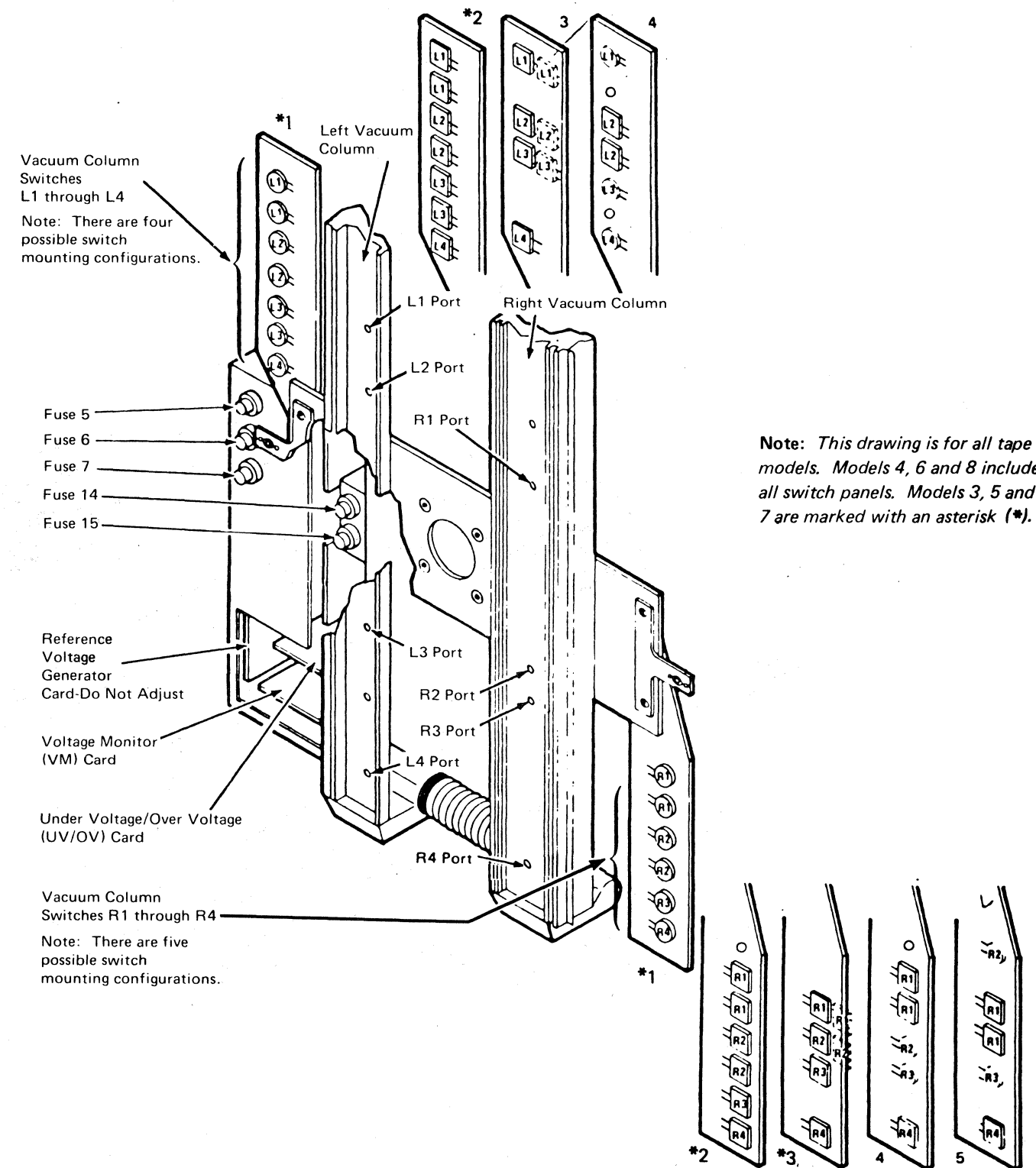
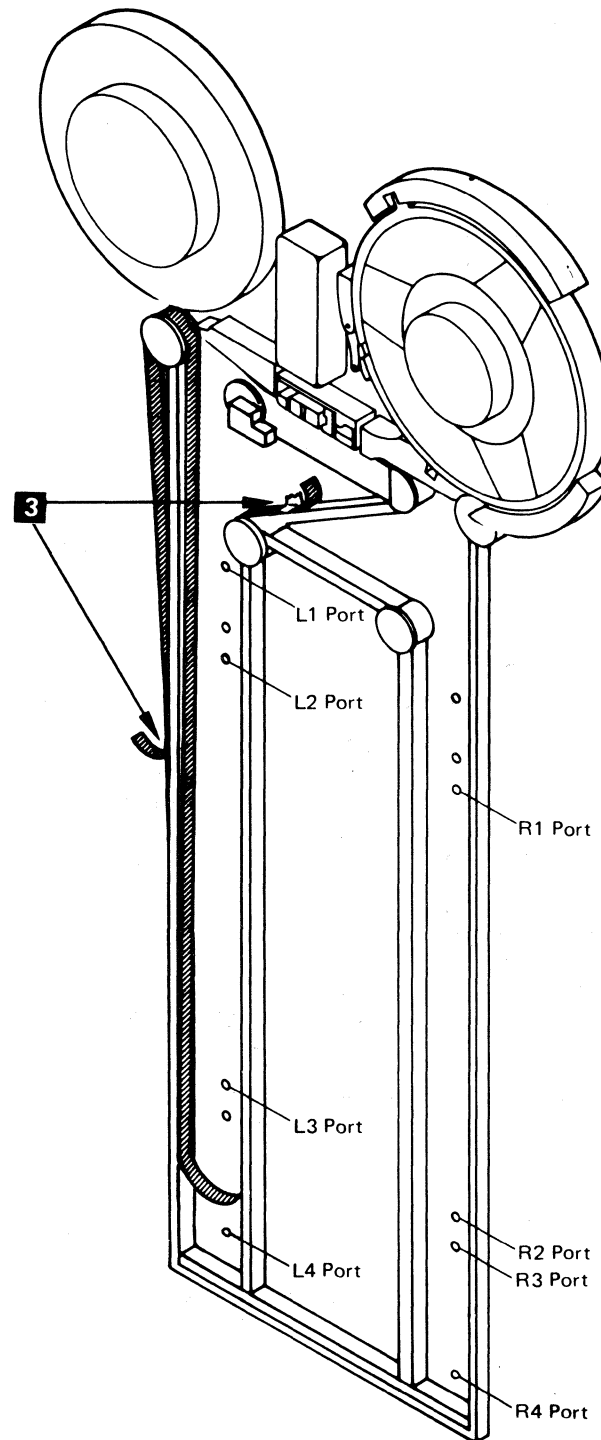

3803-1,2,3/3420

| | | | | | | | | | |
|------------|-------------|----------------|----------|--|--|--|--|--|--|
| XD2900 | 2735839 | See EC History | 845958 | | | | | | |
| Seq 1 of 2 | Part Number | | 1 Sep 79 | | | | | | |

REEL-ALIGNMENT TOOL PREPARATION

The reel-alignment tool kit, P/N 2515401, is used for reel area adjustments. Three parts — Allen wrench P/N 1766508, adapter P/N 1766510, and screw P/N 186925 — must be added to update the basic IBM 2420 tape unit tool kit for 3420 use. (See 08-465.)

Tool case P/N 2515394 is not shown

3420 Additional Tools

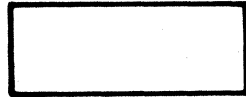

.030 inch (0,76 mm) Shim.
P/N 184625 (account item).

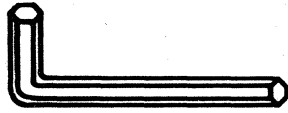

Hex wrench for reel hub.
P/N 1846252 (account item).

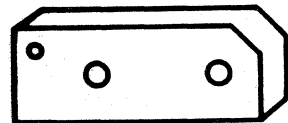

Mounting adapter bar.
P/N 1766510

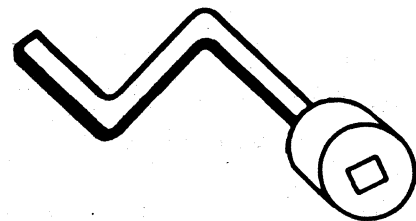

Offset Allen wrench P/N 1766508
DANGER: The wrench must be stamped with EC734455. Otherwise, discard it because of a safety problem.

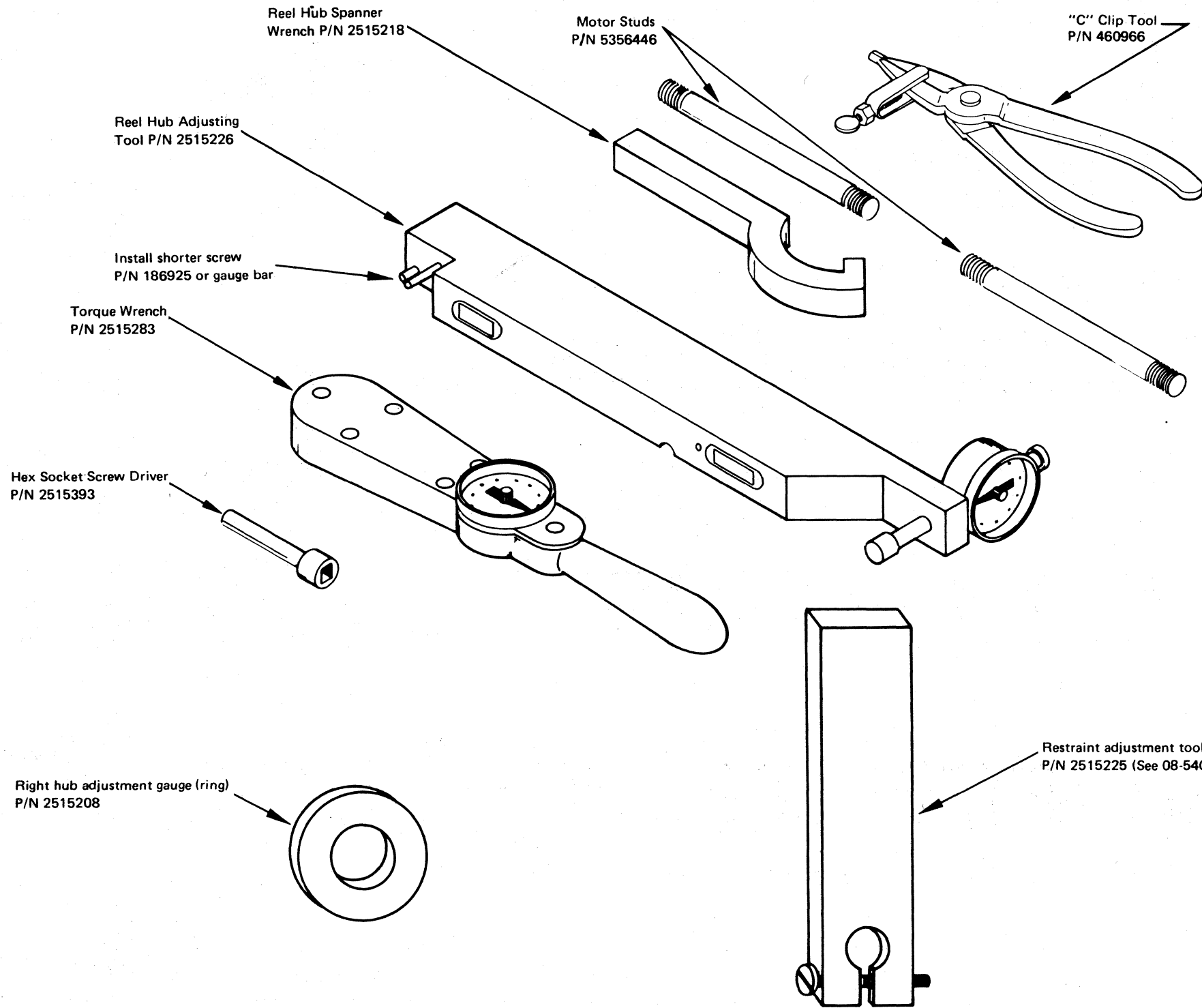

3803-1,2,3/3420

| | | | | | | | | | |
|------------|-------------|----------------|----------|--|--|--|--|--|--|
| XD2900 | 2735839 | See EC History | 845958 | | | | | | |
| Seq 2 of 2 | Part Number | | 1 Sep 79 | | | | | | |

CARR — REEL-ALIGNMENT TOOL

08-465

REEL-ALIGNMENT TOOL MODIFICATION

To modify the reel-alignment tool, P/N 2515226, for 3420 use:

1. Press the roll pin far enough to allow removal of the lower-left tool mounting screw **E**.
2. Replace the lower-left screw with screw, P/N 186925. This screw should only extend approximately 0.5 inch (12.7 mm) out of the tool.
3. Press the roll pin back to its normal position.

REEL-ALIGNMENT TOOL ZEROING

To ensure accurate reel alignment, the tool must be zeroed before use. The following procedure verifies the correct initial positioning of the dial indicator and its pointers.

Caution: The dial indicator is a delicate instrument and should be treated gently.

To zero the reel-alignment tool:

1. Loosen screw **A** and rotate the outer dial to position the markings as shown. Tighten screw **A**.
2. Turn sensing rod **B** to align the pointers as shown. This should allow a zero reading of both pointers, with a 90-degree movement of the large pointer when sensing rod **B** is depressed.
3. Extend the set-up spacers as shown by pulling out and rotating a 1/4 turn **C**.
4. Carefully place the tool against either vacuum column as shown. (The vacuum column is used as a reference surface.)
5. Loosen screw **C** and slide the gauge in the holder until both dial pointers read approximately zero.
6. Tighten screw **C**.

Caution: Tighten screw **C only enough to hold the gauge in position. Overtightening may damage the indicator.**

7. While still holding the tool against the vacuum column surface, rotate screw **D** to obtain a reading of **exactly** zero for both pointers.

8. Remove the tool from the vacuum column. The large pointer should move only about 90 degrees and both pointers should come to rest positioned approximately as shown **F**.

Note: Be very careful when handling and mounting the tool. The gauge's zero adjustment will be lost with rough handling.

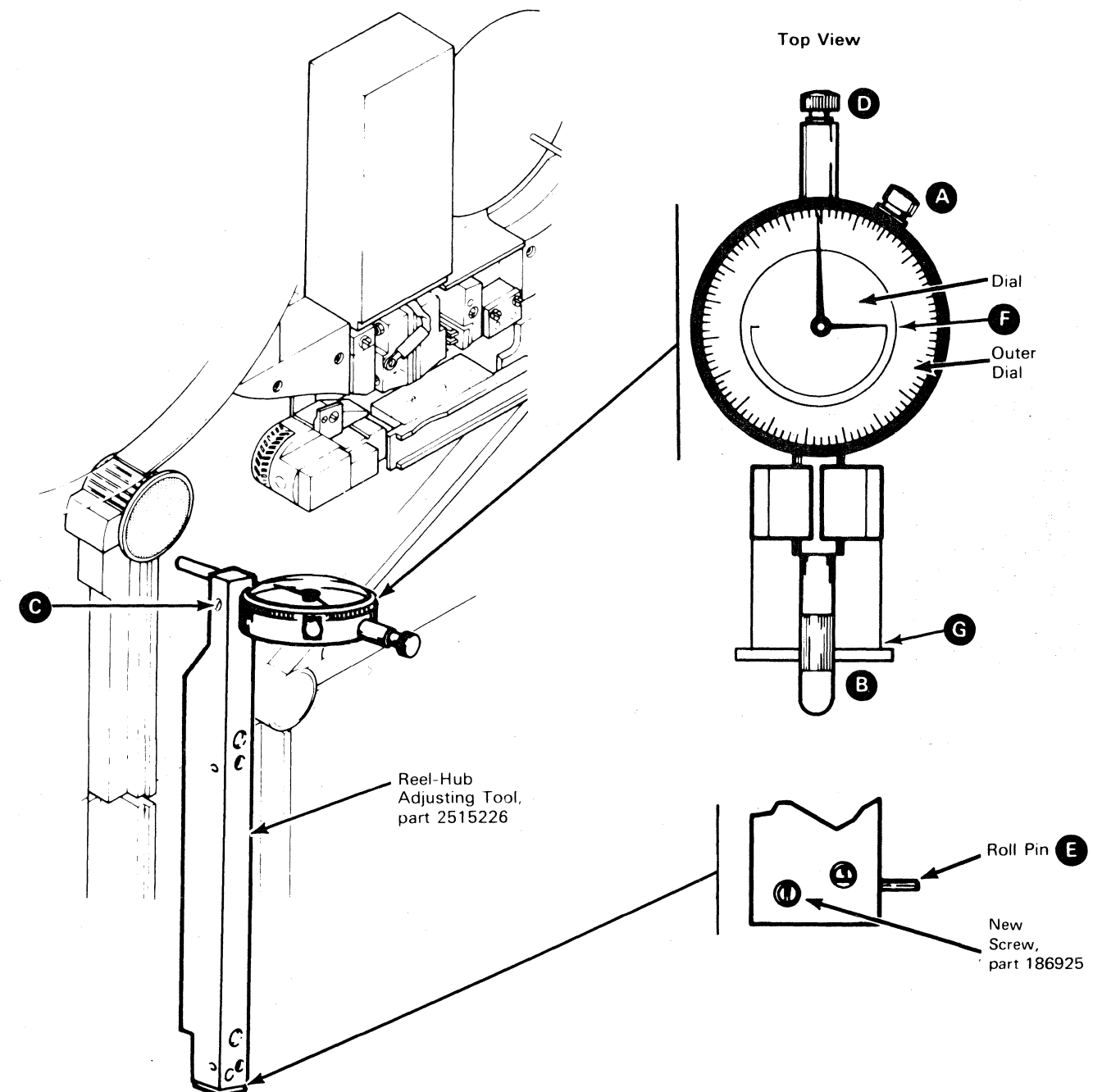

3803-1.2.3/3420

| | | | | | | | | |
|------------|-------------|---------|----------|--|--|--|--|--|
| XD3000 | 2735840 | See EC | 845958 | | | | | |
| Seq 1 of 2 | Part Number | History | 1 Sep 79 | | | | | |

© Copyright International Business Machines Corporation 1976, 1979

08-465

RIGHT REEL-LATCH REAR HOUSING REMOVAL

Note: This procedure is a prerequisite for removing the right reel hub and the right reel motor.

To remove the rear housing:

1. Remove the front decorative cover from the latch hub.
 2. Slip the adjustment shim, P/N 1846251, into the latch hub as shown.
- Caution:** This shim must be installed to prevent the camshaft from flying out of the hub when the rear housing is disassembled.
3. Disconnect the two air hoses from the rear housing.
 4. Remove the six cover mounting screws and the rear-housing cover. If necessary, carefully pry the bead of the diaphragm from the channel in the rear cover.
 5. To remove the piston assembly (including the diaphragm), loosen the setscrew on the clamping collar and slide the assembly off the shaft.

Caution: The piston assembly is under spring tension.

6. If only the piston assembly is being replaced, go to 08-510, "Right Reel-Latch Rear Housing Replacement," step 9. If only the diaphragm is being replaced, remove the four flat-head screws that fasten it to the piston assembly. Install the new diaphragm in the same position as the old one and insert and tighten the screws. Install the piston assembly. See 08-510, "Right Reel-Latch Rear Housing Replacement," step 9. If parts other than the piston assembly or the diaphragm are being replaced, continue with the next step.
 7. Slide the rear housing and spring off the reel shaft bushing.
 8. Slide the bushing off the end of the motor shaft.
 9. Remove the shim from the reel hub.
- Caution:** The camshaft is under spring tension — the shim is all that retains it.
10. Slide the camshaft and spring out of the reel hub.

11. Go to one of the following:
 - 08-480 "Right Reel Hub Removal"
 - 08-510 "Right Reel-Latch Rear Housing Replacement"
 - 08-530 "Right Reel Motor Removal/Replacement"

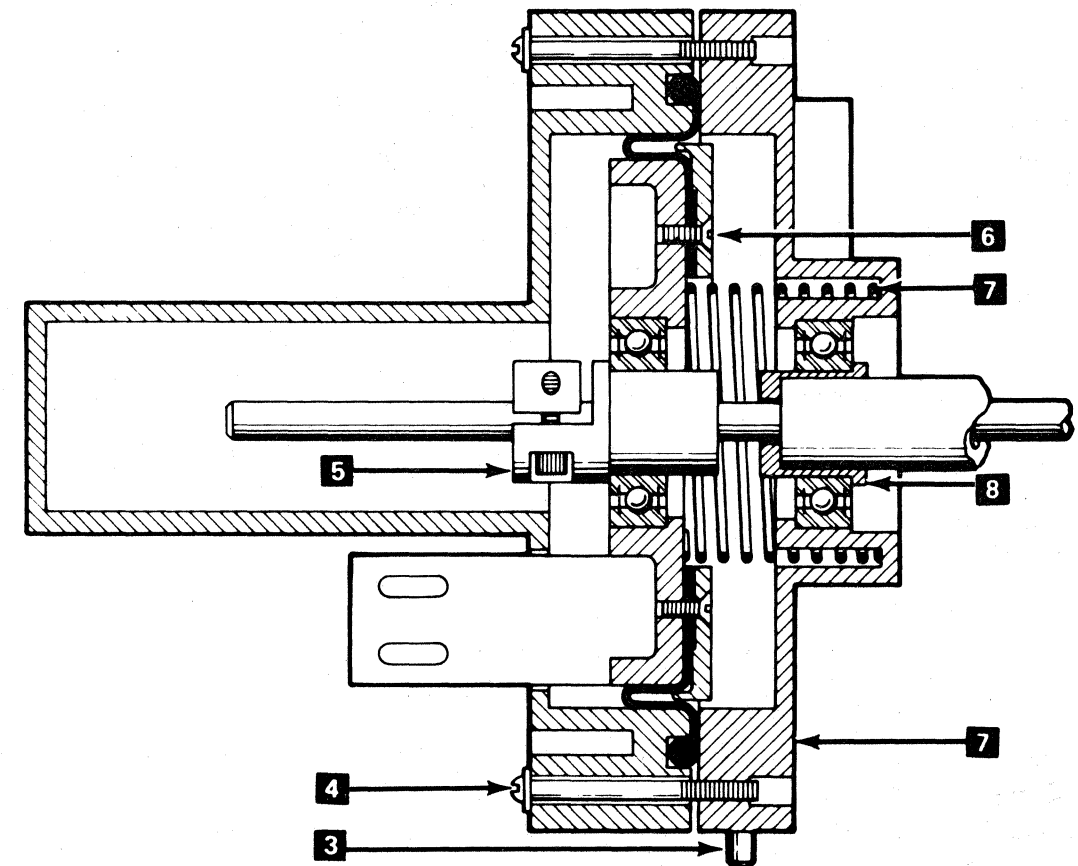
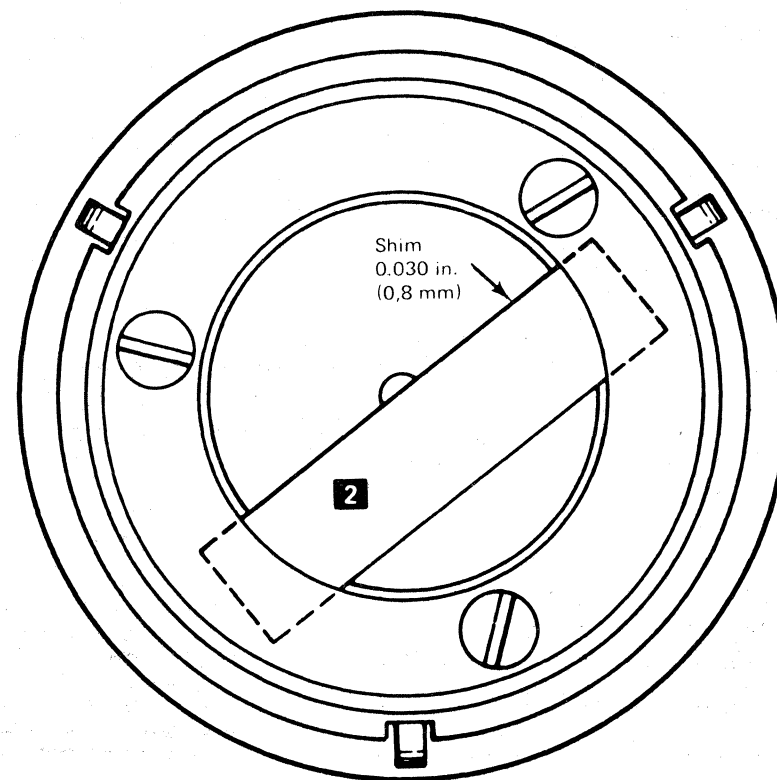

3803-1,2,3/3420

| | | | | | | | | |
|------------|-------------|---------|----------|--|--|--|--|--|
| XD3000 | 2735840 | See EC | 845958 | | | | | |
| Seq 2 of 2 | Part Number | History | 1 Sep 79 | | | | | |

© Copyright International Business Machines Corporation 1976, 1979

RIGHT REEL HUB REMOVAL

Note: The prerequisite for this procedure is 08-470, "Right Reel-Latch Rear Housing Removal."

To remove the hub:

- 1 Remove the two mounting screws from the file-protect plunger assembly and slide the assembly out of the front casting. Do not disconnect hoses **A**. Move the assembly out of the way.
- 2 Rotate the hub to allow access to the hub clamp screw through the file-protect assembly casting opening.
- 3 Loosen the clamp screw with a hex wrench, P/N 1846252, and slide the hub off the shaft.
- 4 Go to 08-500, "Right Reel Hub Replacement/Adjustment."

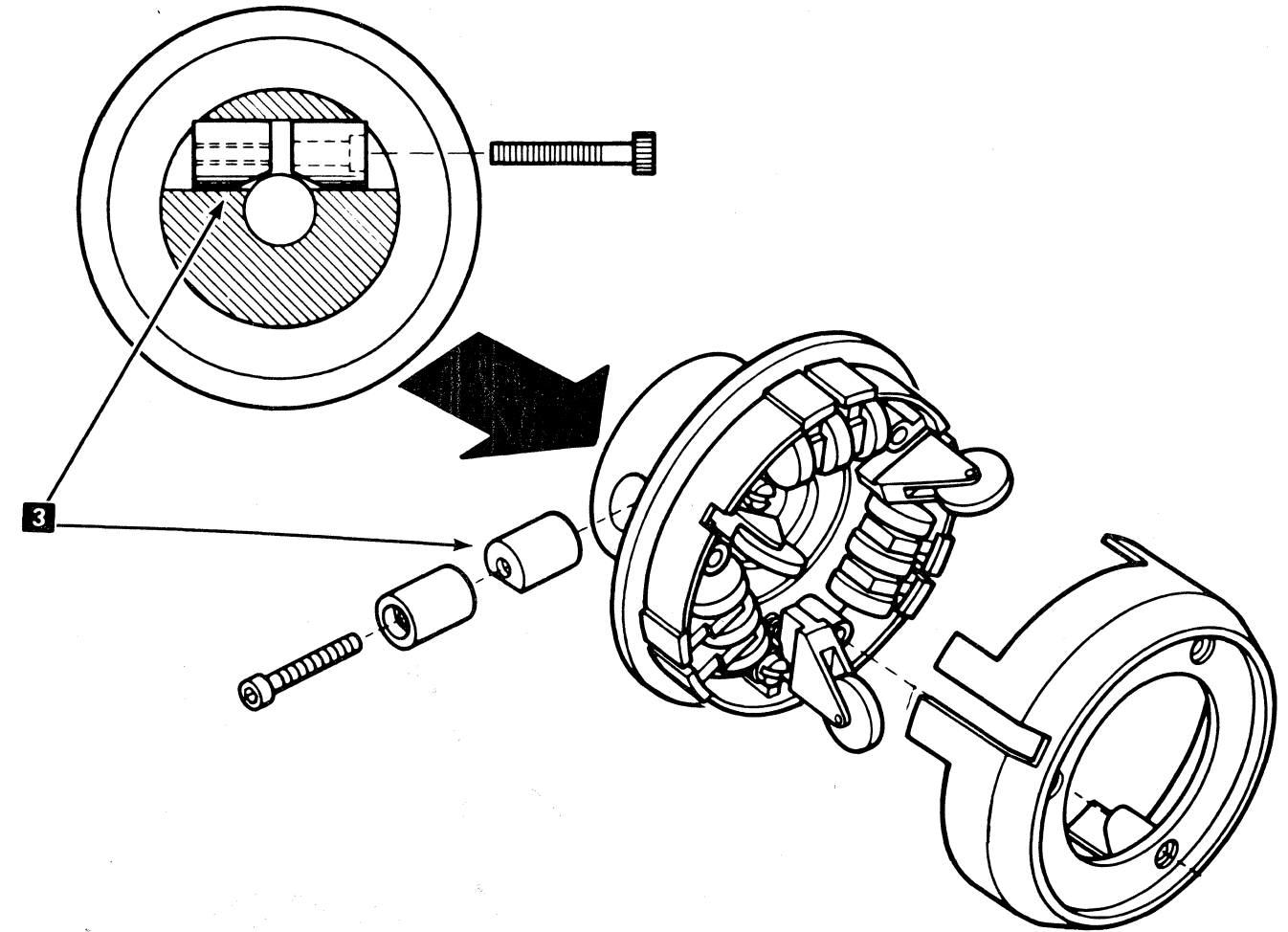
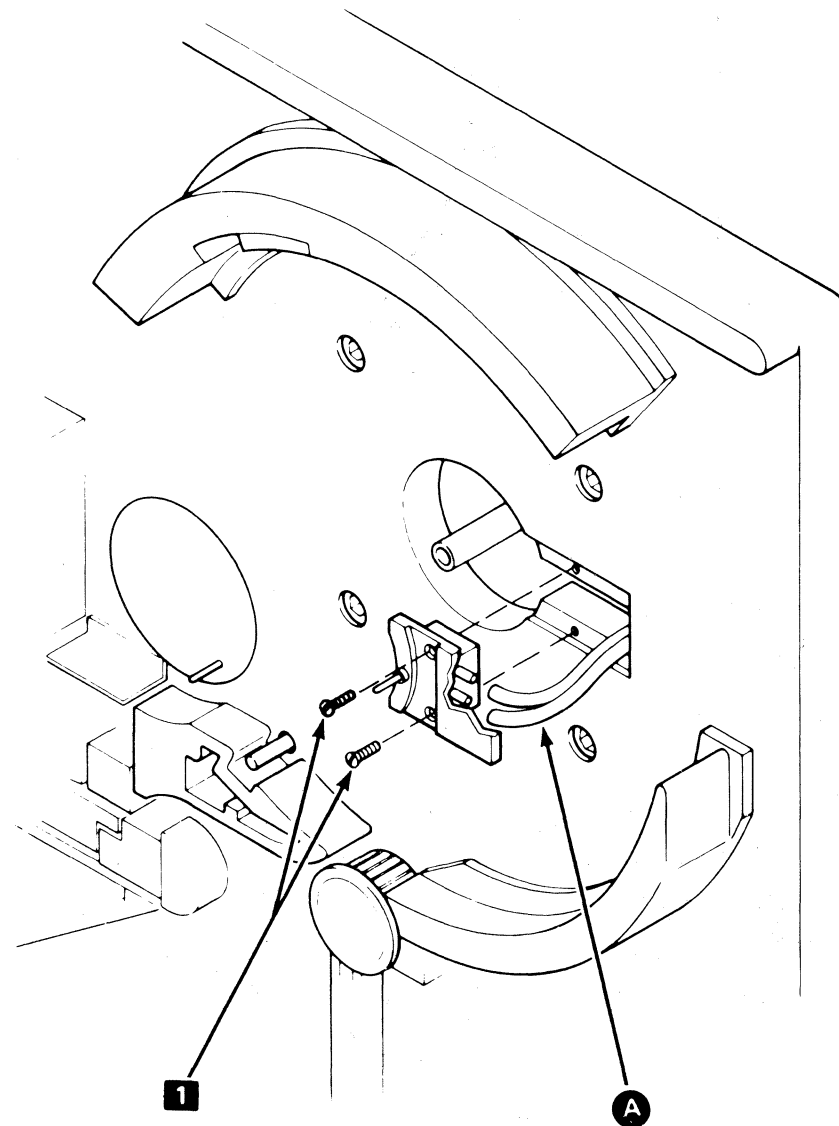

Note: Hub shown removed for illustration only.

3803-1,2,3/3420

| | | | | | | | |
|------------|-------------|---------|----------|--|--|--|--|
| XD3100 | 2735841 | See EC | 845958 | | | | |
| Seq 1 of 2 | Part Number | History | 1 Sep 79 | | | | |

RIGHT REEL HUB INDIVIDUAL PARTS REPLACEMENT

To replace the latch segments, friction pads, triple roller assemblies, or single roller assemblies (and their springs), proceed as follows:

- 1 Remove the hub decorative cover.
- 2 Remove the three hub cover mounting screws and the hub cover.
- 3 The friction pads and rollers can be replaced without removing the remaining screws. Carefully "strip" the pads to be replaced off the ends of the latch segments. Replace them carefully.
- 4 To replace the rollers and spring, the screws must be removed.

Caution: Take care not to lose the small compression springs located behind the single roller assemblies.

- 5 After replacing the parts, assemble the hub in the reverse order. The shorter screws must be replaced in the holes located clockwise from the single roller assemblies. As these screws are tightened, ensure that the springs under the single roller assemblies seat in their recesses in the hub.
- 6 Replace the hub cover and tighten the three mounting screws.
- 7 Check the operation of the hub by manually operating the cam assembly. Take care not to unseat the rear housing assembly from its antirotation screw on the back of the right reel motor.
- 8 Install the hub decorative cover, P/N 2523727.

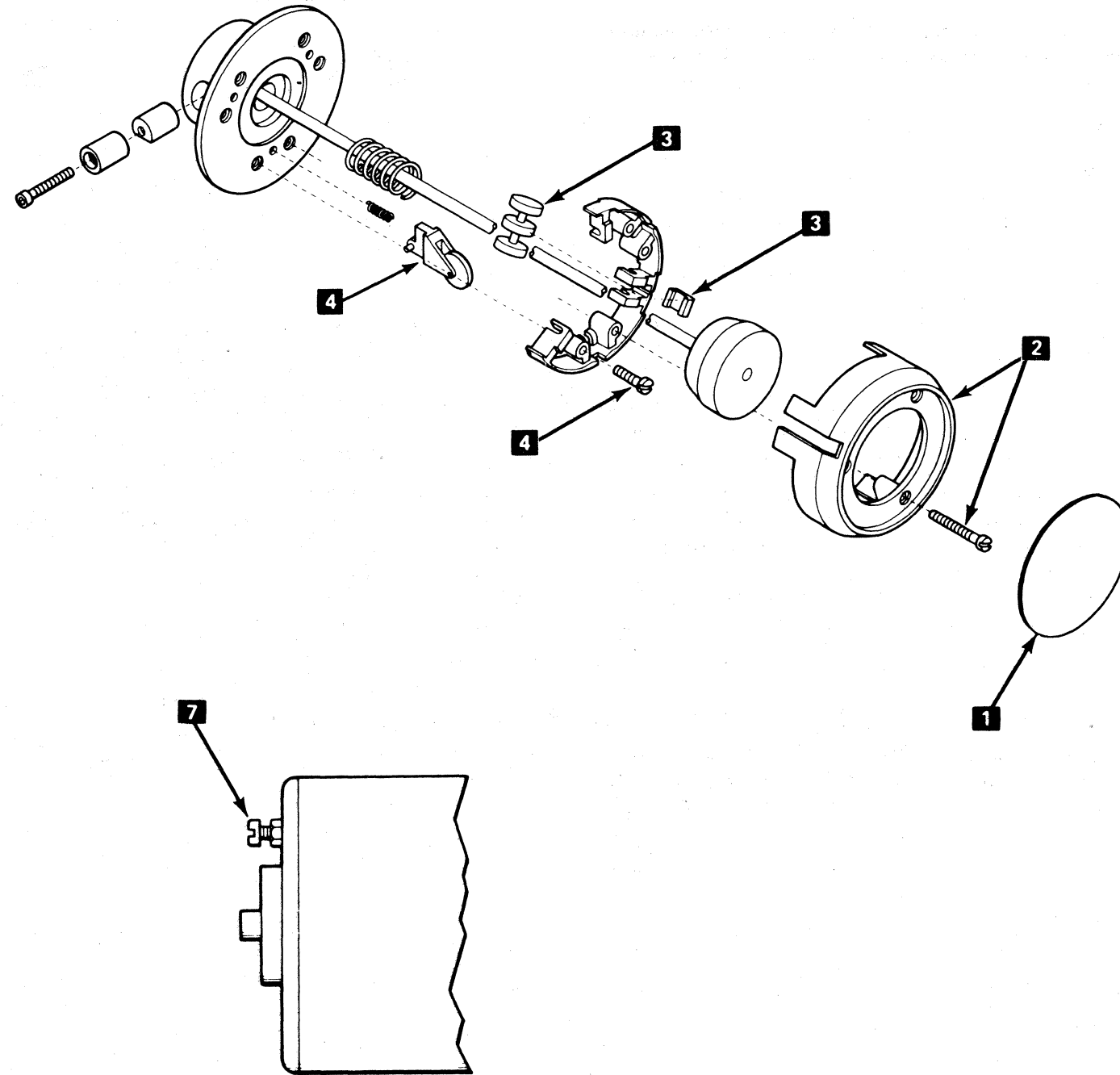

3803-1.2.3/3420

| | | | | | | | | | |
|------------|-------------|---------|----------|--|--|--|--|--|--|
| XD3100 | 2735841 | See EC | 845958 | | | | | | |
| Seq 2 of 2 | Part Number | History | 1 Sep 79 | | | | | | |

© Copyright International Business Machines Corporation 1976, 1979

CARR — REEL HUB

RIGHT REEL HUB REPLACEMENT/ADJUSTMENT

1. Zero the reel-alignment tool. See 08-465, "Reel-Alignment Tool Zeroing."
2. Remove the three right threading channel mounting screws and the threading channel.
3. Remove the decorative cover from the right air bearing.
4. Remove the two right air bearing mounting screws and bearing.
5. Remove the hub decorative cover, then the three hub cover mounting screws and the hub cover. If adjustment only, go to step 9.

6. Position the clamping keys in the hub assembly so that their bevels are aligned with the shaft hole.

Caution: Inspect the clamping screw to ensure that the screw threads are free of contamination or corrosive material. Replace as necessary.

7. Carefully slide the hub onto the reel shaft.
8. Tighten the clamp screw with a hex wrench, P/N 1846252, until the hub will **just slide** on the reel shaft. Position the hub so that the rubber-coated flange is approximately 0.125 inch (3.2 mm) behind the reference plate. Access to the clamp screw is through the casting opening of the file-protect assembly.
9. If not done before, remove the file-protect plunger assembly to gain access to the clamp screw. Loosen the clamp screw. Retract the set-up spacers on the reel-alignment tool, P/N 2515226, by rotating the spacers a 1/4 turn and allowing them to return to their recesses.

10. Fasten the reel-alignment tool to the reference plate with the screws located on the tool. Insert the upper mounting screw into the farthest right tapped hole used for mounting the right threading channel **A**. Insert the lower right mounting screw into the farthest right tapped hole used for mounting the air bearing **B**. This will position the dial indicator plunger above the rubber-coated flange of the hub.

11. Slide the hub on the shaft to obtain a zero indication, ± 0.002 inch (± 0.05 mm), on the dial indicator. This positions the hub 0.110 inch (2.79 mm) behind the reference plate.

12. Tighten the hub clamp screw with a hex wrench, P/N 1846252.

Caution: Care must be taken when tightening the screw to ensure that the wrench does not touch the machine casting. Torque until a slight twist is observed or felt in the small leg of the tool.

13. Maximum runout around the entire circumference of the hub should not exceed 0.002 inch (0.05 mm). If excessive runout is suspected, take readings at a number of places around the hub. Do this by loosening the alignment tool, rotating the hub to another position, tightening tool and taking another reading without disturbing the original gauge setting. All readings should be within 0.002 inch (0.05 mm) of each other. Runout cannot be adjusted. The hub must be replaced if runout is excessive.

14. Remove the reel-alignment tool.
15. Replace the right threading channel. Tighten the screws evenly.
16. Replace the right air bearing. Install a new decorative cover, P/N 2501719.
17. Replace the file-protect plunger assembly. Check that the plunger operates without binding. If it does not, see 08-340, "File-Protect Mechanism Check."
18. Replace the hub cover and its three screws.
19. Install the new right reel hub decorative cover.

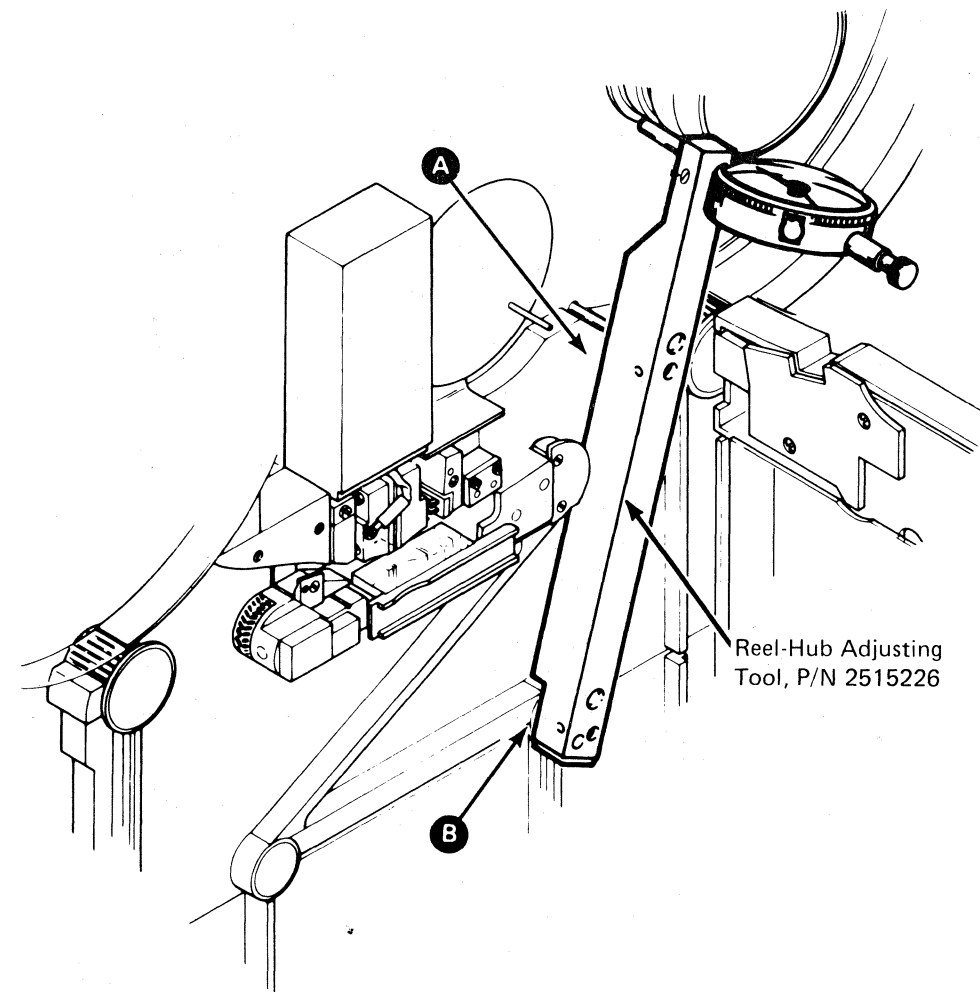
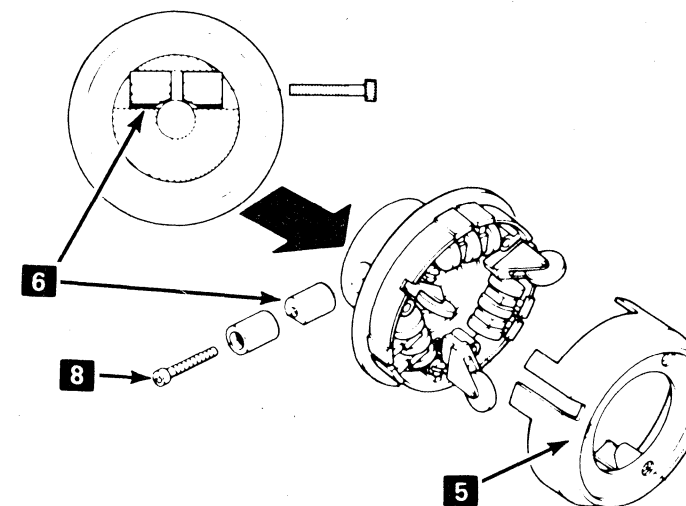

3803-1,2,3/3420

| | | | | | | | | |
|------------|-------------|---------|----------|--|--|--|--|--|
| XD3200 | 2735842 | See EC | 845958 | | | | | |
| Seq 1 of 2 | Part Number | History | 1 Sep 79 | | | | | |

© Copyright International Business Machines Corporation 1976, 1979

RIGHT REEL-LATCH REAR HOUSING REPLACEMENT

1. Slide the 1.19 inch (30.2 mm) diameter spring onto the camshaft.
2. Insert the camshaft assembly through the hub into the motor shaft. Ensure that the spring seats correctly in the hub recess.
3. Install the adjustment shim 0.030 inch (0.8 mm), P/N 1846251, as shown.

Note: This shim must be installed to retain the camshaft until the rear housing is installed. It also supplies the correct clearance adjustment for the cam.

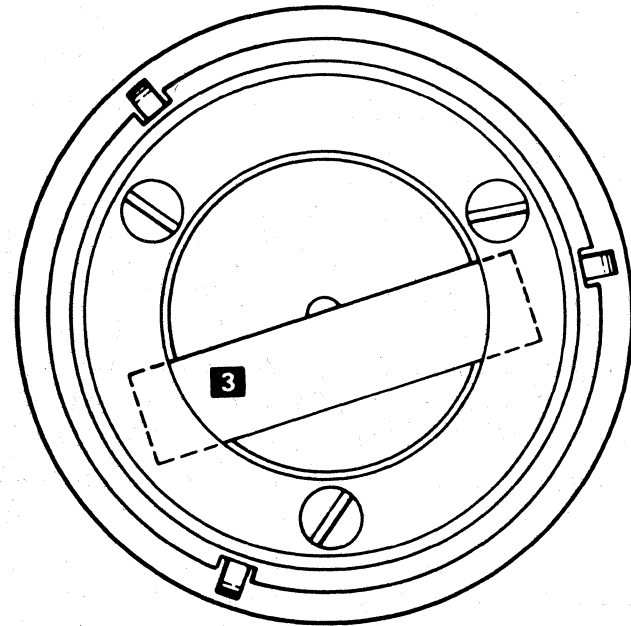

4. Ensure that the antirotation screw on the rear of the right reel motor is adjusted flush to 0.25 inch (6.4 mm) below the end of the reel motor shaft, as shown.

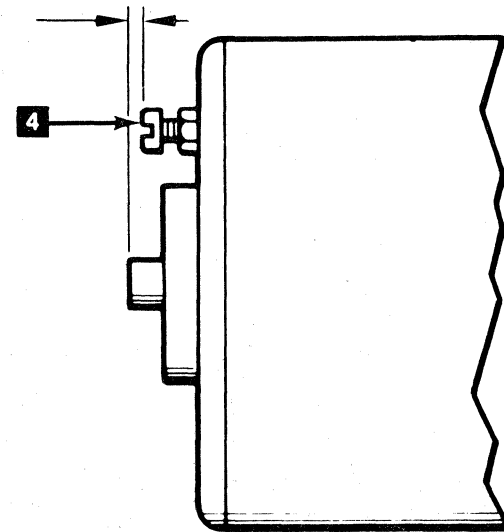

5. Install the bushing on the end of the reel motor shaft, as shown.
6. Install the rear housing over the bushing. Ensure that the antirotation screw enters the slot in the rear of the housing.
7. Insert the 1.75 inch (44.4 mm) diameter spring into the recess inside the rear housing, as shown.
8. Insert the clamping collar into the bearing of the piston assembly from the side with the guide extension.
9. Slide the clamping collar and piston assembly over the shaft.
10. Push against the spring pressure until the clamping collar touches the bushing installed in step 5. Hold the collar in this position and tighten the collar socket screw. The piston will return to a neutral position when pressure is removed from the collar.
11. Rotate the piston assembly to position the guide extension between the air connections on the rear housing.
12. Position the cover so that its slot is over the guide extension.
13. Ensure that the bead of the diaphragm fits into the cover channel.

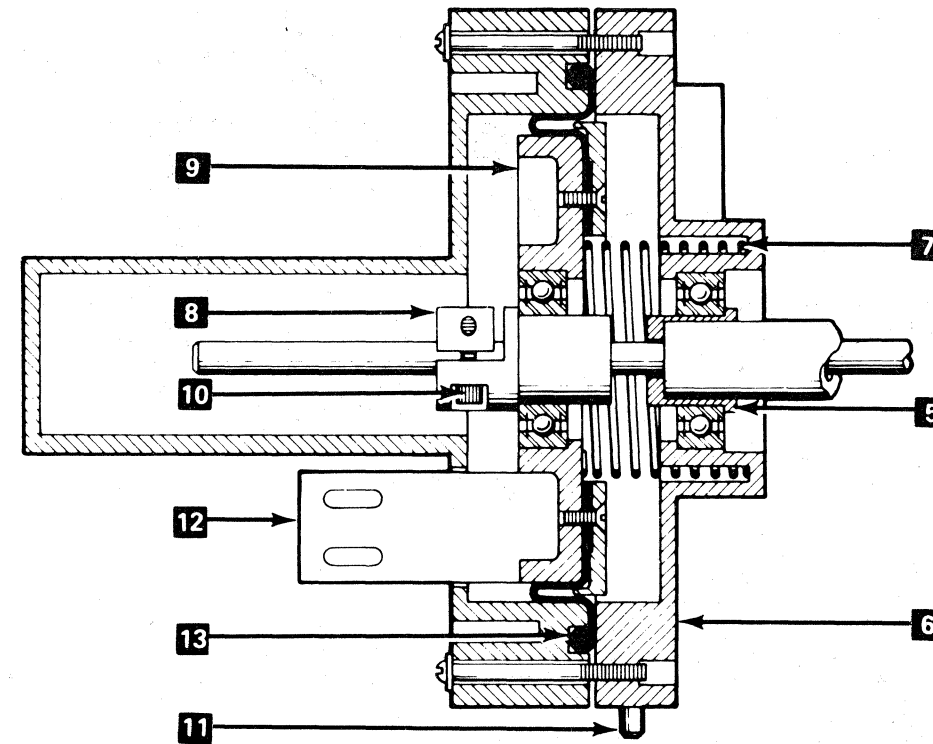

14. Insert and tighten the six cover mounting screws.
15. Place the two hoses onto the housing fittings.
16. Remove the shim from the hub.
17. Check for correct operation of the hub by manually operating the cam. Ensure you do not push the rear housing off the antirotation screw.
18. Install a new decorative cover, P/N 2523727, on the hub.

3803-1.2.3/3420

| | | | | | | | | | |
|------------|-------------|---------|----------|--|--|--|--|--|--|
| XD3200 | 2735842 | See EC | 845958 | | | | | | |
| Seq 2 of 2 | Part Number | History | 1 Sep 79 | | | | | | |

CARR — REEL LATCH

RIGHT REEL-LATCH REAR HOUSING PRESSURE TEST

To check the rear housing for leakage:

1. Load the tape unit with a CE work tape.
2. Jumper A-A5B13 to ground to bypass the pressure switch so that the vacuum and pressure stay up.
3. At the rear housing, disconnect the hose to the pressure sensing switch. This causes the tape unit to drop READY.
4. Attach a pressure/vacuum gauge, P/N 5495384, or a water manometer with a pressure divider to the same rear housing air connection.
5. With the tape loaded in the columns, minimum pressure should be:

| TU Model | Pressure—inches (mm) of water |
|-----------------|-------------------------------|
| 3 PE only | 64 (1626) |
| 3 NRZI-featured | 64 (1626) |
| 4 | 64 (1626) |
| 5 PE only | 64 (1626) |
| 5 NRZI-featured | 64 (1626) |
| 6 | 80 (2032) |
| 7 PE only | 64 (1626) |
| 7 NRZI-featured | 80 (2032) |
| 8 | 80 (2032) |

6. If the pressure is not correct, first check the pneumatic adjustment. See 08-420, "Pneumatic Pressure Level Adjustment." If the problem remains, replace the piston assembly (including the diaphragm). See 08-470, "Right Reel-Latch Rear Housing Removal." If the problem still remains, replace the rear housing. See 08-470, "Right Reel-Latch Rear Housing Removal" and 08-510, "Right Reel-Latch Rear Housing Replacement."
7. If the pressure is below 40 inches (1016 mm) of water on any model tape unit, and the monitoring circuits did not indicate a failure, replace the pressure sensing switch. If the failure is still not corrected, check the monitoring circuits.

8. Remove the jumper installed in step 2 and replace the hose removed in step 3.

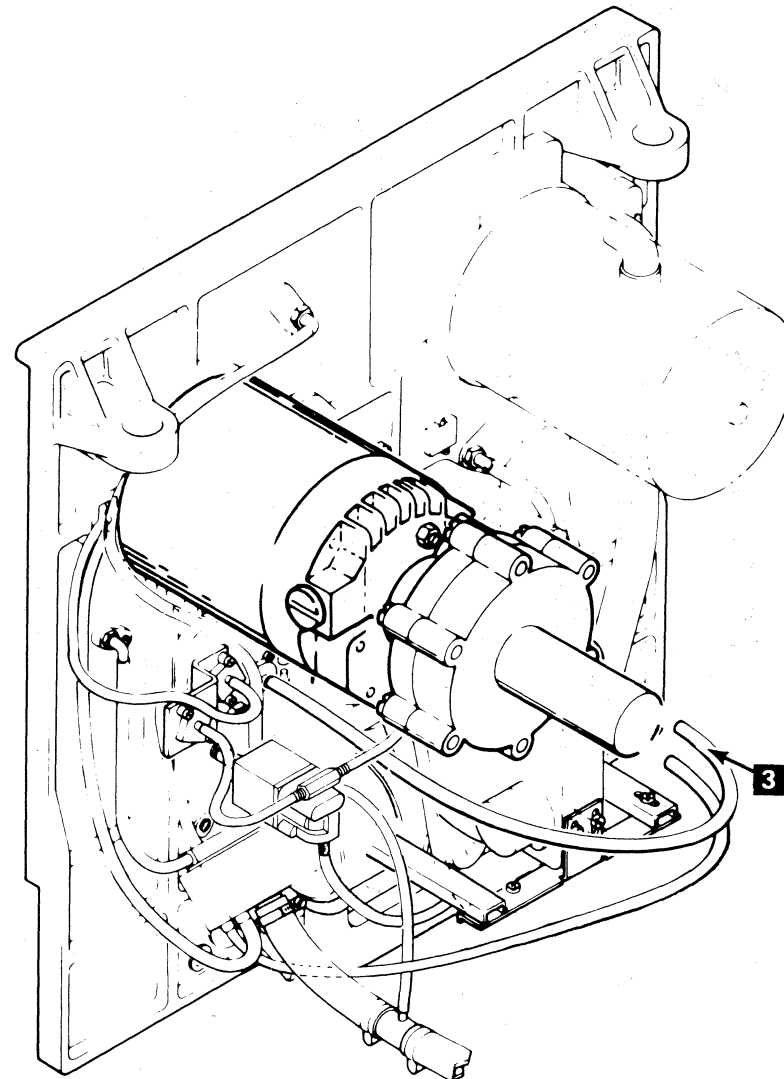

3803-1,2,3/3420

| | | | | | | | | |
|------------|-------------|---------|----------|--|--|--|--|--|
| XD3300 | 2735843 | See EC | 845958 | | | | | |
| Seq 1 of 2 | Part Number | History | 1 Sep 79 | | | | | |

**RIGHT REEL MOTOR
REMOVAL/REPLACEMENT**

1. Turn off tape unit power.
 2. Remove the rear housing. See 08-470, "Right Reel-Latch Rear Housing Removal."
 3. Disconnect the reel-motor power plug **B** from the motor control board. Next, unplug the paddle card **A** from the control board. Then, disconnect the input power plug **C** to the motor control board.
 4. Remove the reel motor control board.
 5. Disconnect the cooling hose from the motor.
 6. Remove the hub assembly. See 08-480, "Right Reel Hub Removal."
 7. Remove the two top motor mounting bolts and install two guide studs, P/N 5356446, in their place.
 8. Remove the two lower motor mounting bolts.
- Caution: The weight of the motor will not be supported when the motor clears the guide studs.**
9. Slide the motor out to the rear.
 10. Reverse the procedure to install a new motor.
 11. Replace the hub assembly. See 08-500, "Right Reel Hub Replacement/Adjustment."
 12. Replace the rear-housing assembly. See 08-510, "Right Reel-Latch Rear Housing Replacement."
 13. Test the housing pressure. See 08-520, "Right Reel-Latch Rear Housing Pressure Test."

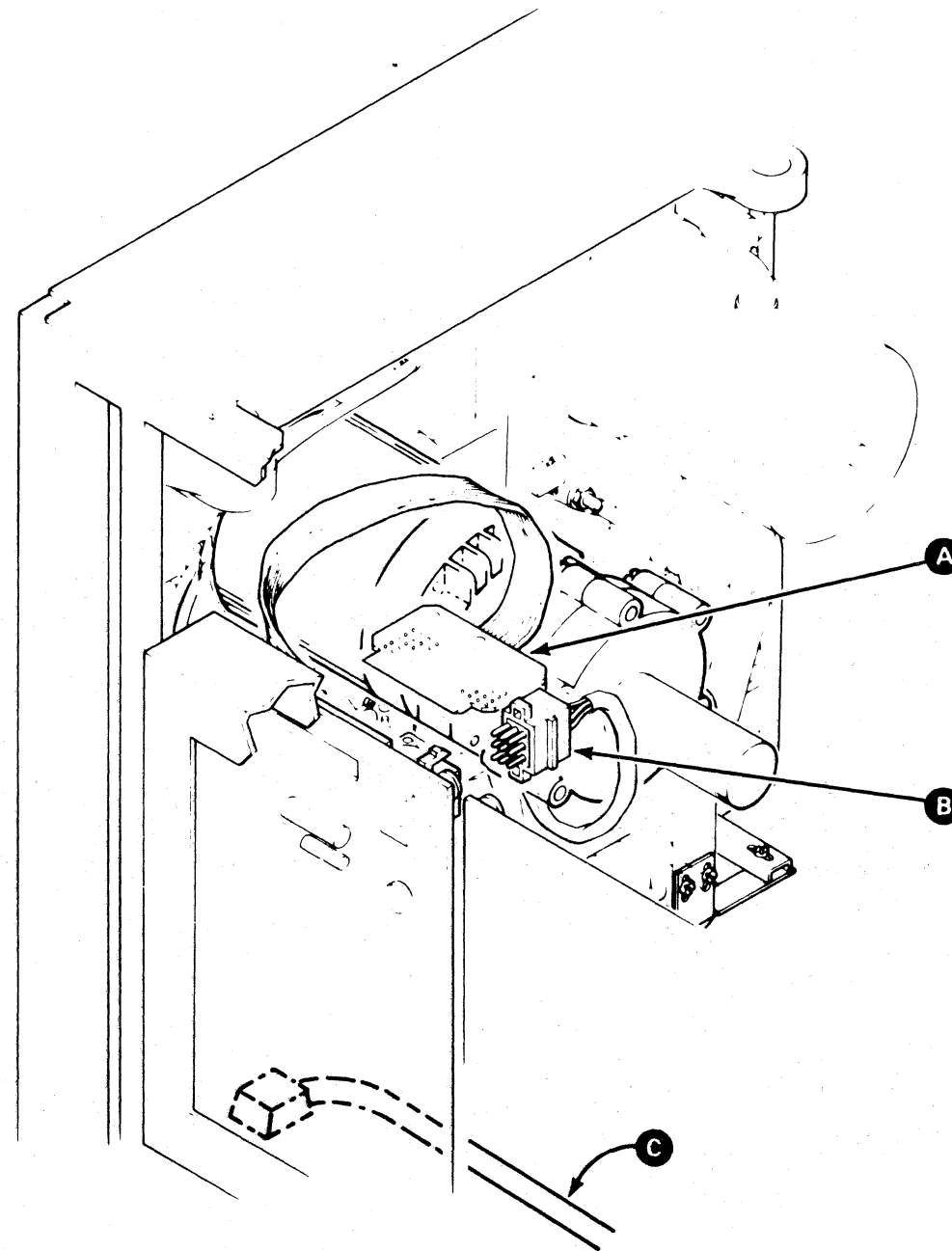

3803-1,2,3/3420

| | | | | | | | |
|------------|-------------|---------|----------|--|--|--|--|
| XD3300 | 2735843 | See EC | 845958 | | | | |
| Seq 2 of 2 | Part Number | History | 1 Sep 79 | | | | |

© Copyright International Business Machines Corporation 1976, 1979

CARTRIDGE MOTOR REPLACEMENT/ADJUSTMENT

Note: Adjustment only start at step 12.

1. Power off Tape Unit.
2. Open front door and remove screw holding cartridge opener cover, remove cover.
3. From rear of machine, remove the SMS card above cartridge motor assembly to gain better access.
4. Loosen the top 2 screws of cartridge motor, lift off SMS socket assembly. Remove the four cartridge motor leads noting their location (see Figure 1). Move assembly out of the way.
5. Remove the three screws from the motor assembly and rest the assembly on the transfer valve. Be careful not to put tension on the wires going to the micro-switch.
6. Mark the yellow and black wires so they can be easily replaced (see Figure 2). Unsolder yellow and black wires.
7. Remove the defective motor.
8. Rest the new motor on the transfer valve and resolder wires removed in step 6. See Figure 2.
9. Install new motor and loosely install screws.
10. Replace colored motor leads on the back of the SMS card connector (see Figure 1).
11. Install SMS socket assembly on top 2 screws.
12. Remove the right threading channel and cartridge opener cover if not removed.
13. Construct a template from a punch card (see Figure 3).
14. Tape the cartridge present plunger flush to the base plate (see Figure 4).
15. Move the locating pin on the cartridge motor counter-clockwise against the stop. This puts the motor in the fully closed position.
16. Position the template on the tape unit as shown in Figure 5.
17. Tape the template to the right threading channel on the bottom and to the base plate on the top.
18. Adjust the motor so the edge of the cartridge opening pin contacts the point made on the template with the other template point aligned as in Figure 5.

19. Tighten the motor assembly screws securely and recheck position.
20. Remove the template and all tape. Clean the tape unit thoroughly to insure no adhesive is left on the tape unit.
21. Install SMS card (if removed).
22. Replace cartridge opener cover.
23. Power up machine and check that the cartridge opener assembly properly opens and closes cartridges of the type used by the customer.

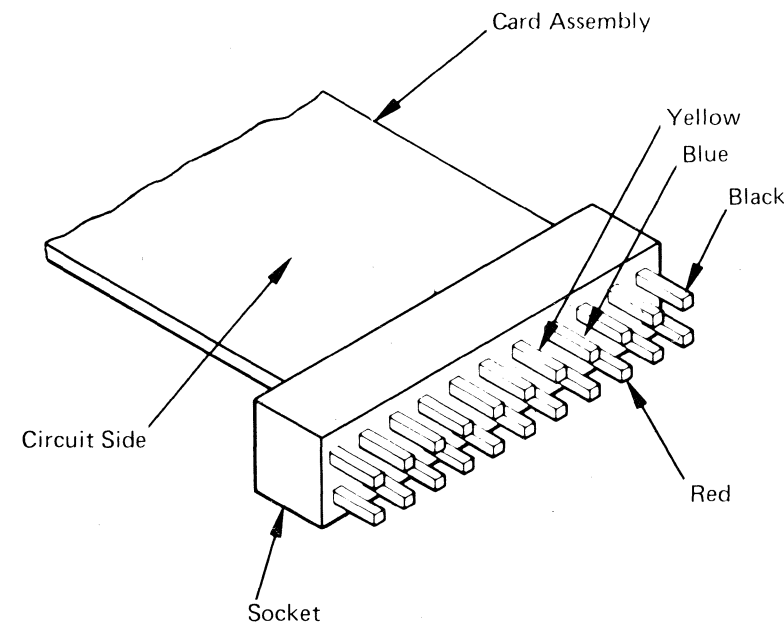

Figure 1.

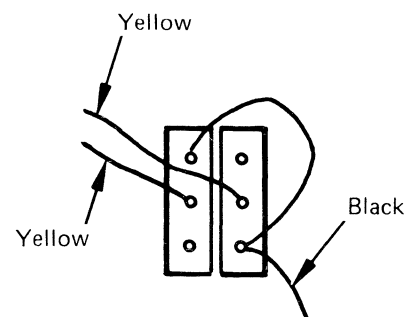

Figure 2.

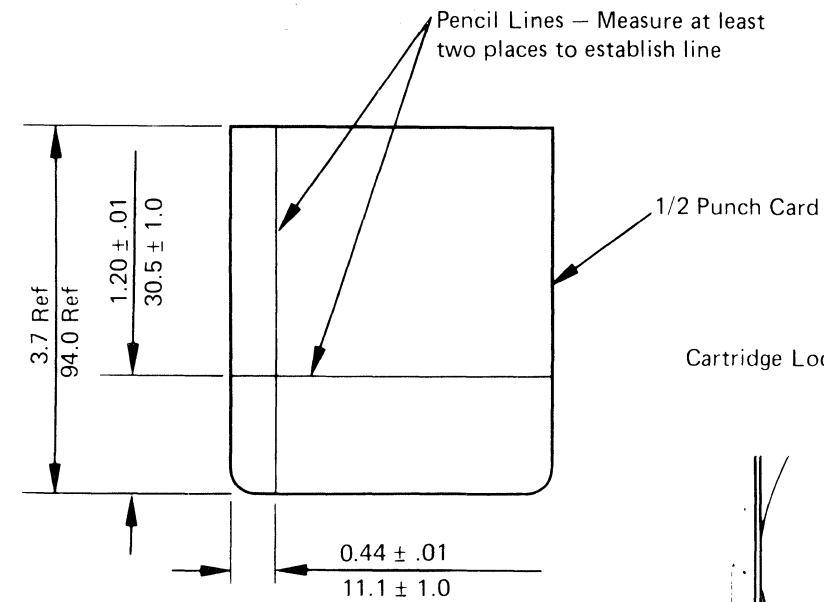

Figure 3.

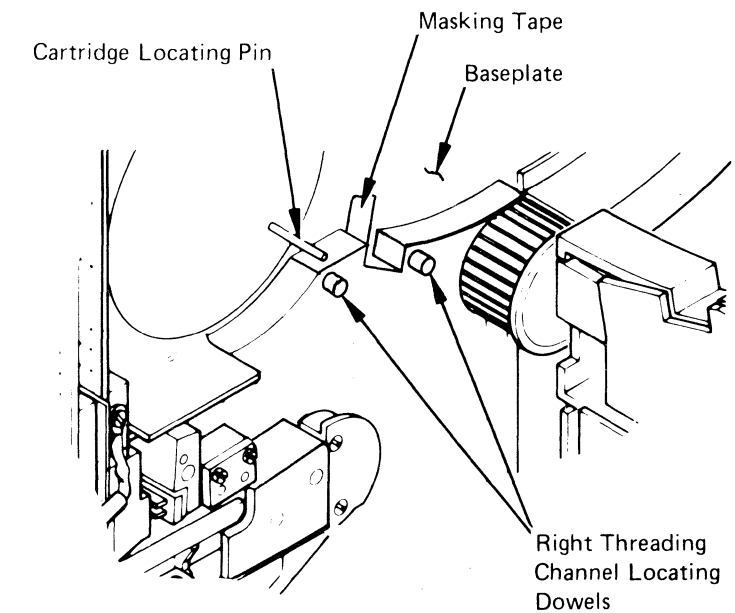

Figure 4.

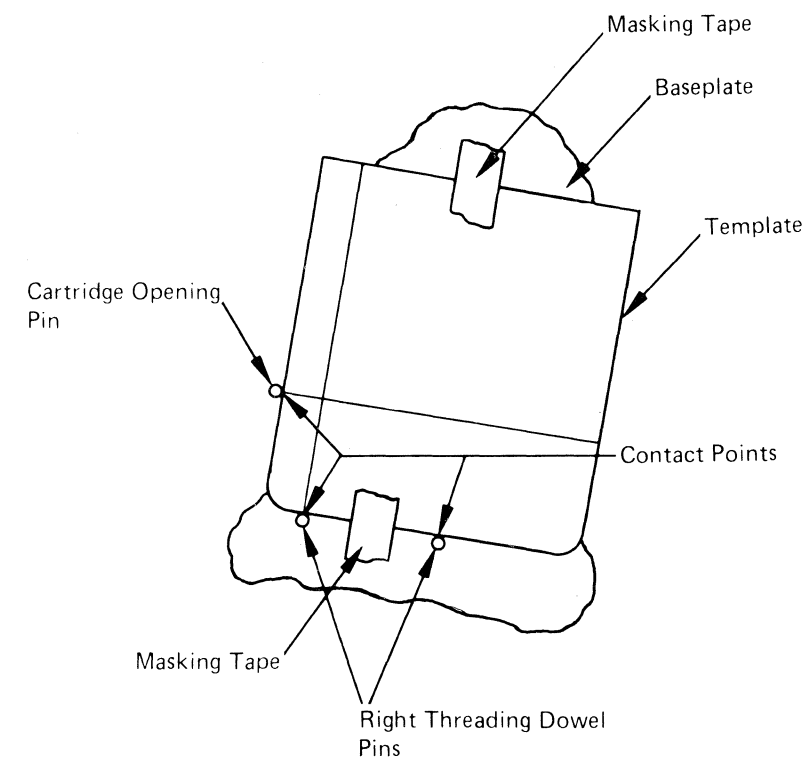

Figure 5.

3803-2/3420

| | | | | | | | |
|------------|-------------|---------|----------|--|--|--|--|
| XD3350 | 8492599 | See EC | 845958 | | | | |
| Seq 1 of 2 | Part Number | History | 1 Sep 79 | | | | |

CARTRIDGE RESTRAINT PRESSURE CHECK

08-536

All pneumatic measurements and adjustments should be made after allowing the tape unit a fifteen minute warm up period with tape loaded.

Use a water manometer or a pressure/vacuum gauge, P/N 5495384, to make the following measurement (see 80-010 for 3803-2 or 20-001 for 3803-1 subsystem).

1. Open power window door and bypass the door interlock.
2. Attach the manometer or pressure gauge hose to the upper restraint cartridge leakage tool.
3. Install the upper restraint cartridge leakage tool **A**. Tool will be held in place when cartridge motor goes to the cartridge open position.
4. Push RESET and LOAD REWIND. Pneumatics will come up and cartridge motor will open tool.
5. Pressure should be between 18-32 inches of water, if not check the list of probable causes below.
 - a. Regulator pressure incorrect (see 08-400).
 - b. Tool not properly seated against upper restraint port.
 - c. Loose or leaking hoses.
 - d. Upper restraint mounting screws loose or tightened in wrong sequence.
 - e. Defective transfer valve (see 04-400).
 - f. Defective upper restraint (see 08-540).
 - g. Upper restraint set screw loose or missing. This set screw does not exist on all models of upper restraint.
6. Push RESET and UNLOAD REWIND.
7. Remove tool and gauge or manometer.

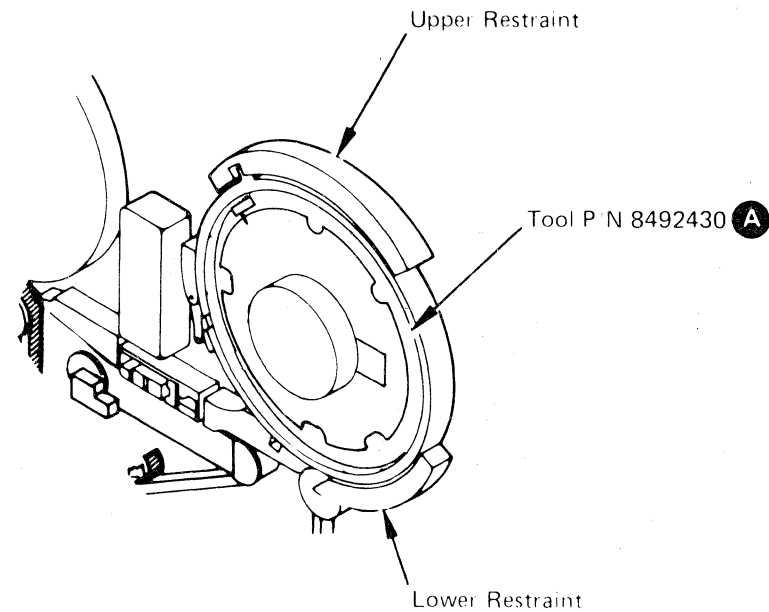

3803-2/3420

| | | | | | | | | | |
|------------|-------------|---------|----------|--|--|--|--|--|--|
| XD3350 | 8492599 | See EC | 845958 | | | | | | |
| Seq 2 of 2 | Part Number | History | 1 Sep 79 | | | | | | |

Copyright International Business Machines Corporation 1976 1979

08-536

CARR — CARTRIDGE RESTRAINT

08-540

CARTRIDGE RESTRAINT REMOVAL/REPLACEMENT (NON-90,000 SERIES TAPE UNITS)

The cartridge restraints are mounted on straight dowel pins through the casting to avoid alignment problems when removal or replacement is necessary.

Caution: When removing a restraint, note the order in which each screw is shimmed. The restraints are shimmed at the factory for the correct distance to the reel latch hub.

1. Remove the three retaining screws installed from the rear.

Note: The third screw used to mount the upper restraint is hidden behind the light manifold mounting bracket.

2. Install the restraint and place the shims in the same order in which they were removed.

Shim thickness is color-coded as follows:

| | |
|-------|-----------------------------------|
| Red | 0.002 inch (0.05 mm), P/N 2513186 |
| Green | 0.003 inch (0.07 mm), P/N 2513187 |
| Tan | 0.004 inch (0.10 mm), P/N 2513188 |
| Brown | 0.010 inch (2.5 mm), P/N 2513189 |

Replace any broken shim with a new one of the same thickness.

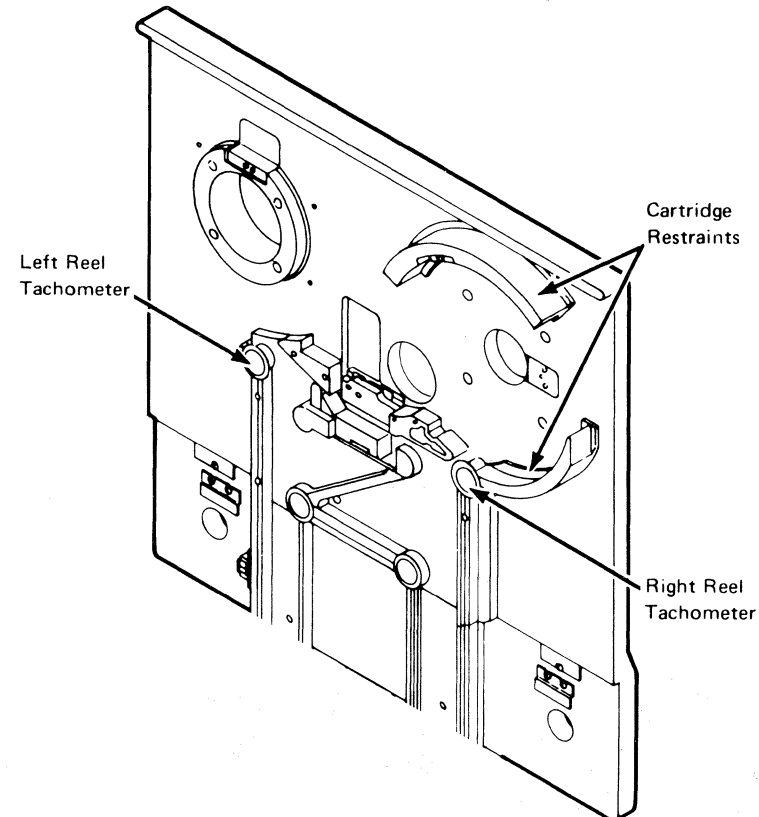

CARTRIDGE RESTRAINT REMOVAL/REPLACEMENT (90,000 SERIES TAPE UNITS)

Note: Reel-alignment tool kit, P/N 2515401, is required.

1. Remove the right reel latch. See 08-470, "Right Reel-Latch Rear Housing Removal."
2. Remove the right reel hub. See 08-480, "Right Reel Hub Removal."
3. Remove the three screws holding the restraint to be replaced.

Note: For access to the three screws holding the upper restraint, remove the top cover by loosening the four holding screws and removing three cable clamps.

4. Install the new restraint using the screws removed in step 3. Do not tighten the screws.
5. Fasten the restraint-adjusting tool, P/N 2515225, on the motor shaft **C**. Tool must not bind on surfaces **D** and **E**.

Caution: Press the rubber air seal when rotating the adjusting tool or the seal may be damaged. Do not allow the tool to rotate by its own weight until the clearance to both restraints is ensured.

6. Adjust upper and lower restraints so tool will turn 360° and clear by 0.000-0.010 inch (0-0.25mm) surfaces **A** and **B**.
7. Replace the top cover.
8. Install the right reel hub. See 08-500, "Right Reel Hub Replacement/Adjustment."
9. Install the right reel latch. See 08-510, "Right Reel-Latch Rear Housing Replacement."
10. Do the right reel-latch pressure check. See 08-520, "Right Reel-Latch Rear Housing Pressure Test."

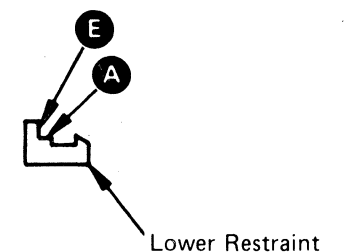
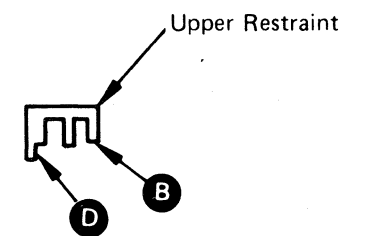
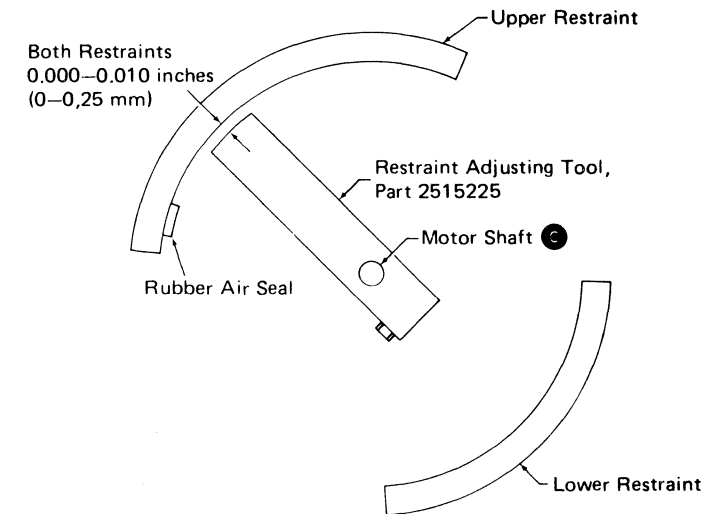

3803-2/3420

| | | | | | | | | |
|------------|-------------|---------|----------|--|--|--|--|--|
| XD3400 | 2735844 | See EC | 845958 | | | | | |
| Seq 1 of 2 | Part Number | History | 1 Sep 79 | | | | | |

© Copyright International Business Machines Corporation 1976, 1979

08-540

**LEFT REEL HUB AND MOTOR
REMOVAL/REPLACEMENT/ADJUSTMENT**

Note: Reel-alignment tool kit, P/N 2515401, is required. See 08-460.

To remove the left reel:

1. Turn off tape unit power.
2. Carefully remove the decorative disk from the front of the reel hub.
3. Remove the three screws that hold the reel to the hub and take off the reel.

Note: If the motor is replaced, the hub can remain mounted on the motor shaft during removal. The hub will be fastened to the shaft by either one or two screws. Torque the screws to the specifications shown in step 11f.

To remove the left reel motor, continue as follows:

4. Unplug the motor cable.
5. Disconnect the air duct from the bottom of the motor.
6. Unplug all the top paddle cards and connectors from the power boards on the side from which the motor is being removed.
7. Remove the two top motor mounting bolts and install two guide studs, P/N 5356446.
8. Remove the two lower motor mounting bolts.

Caution: The weight of the motor is not supported when the guide studs clear the main casting.

9. Slide the motor out to the rear.
10. To replace the left reel motor, reverse steps 4 through 9.

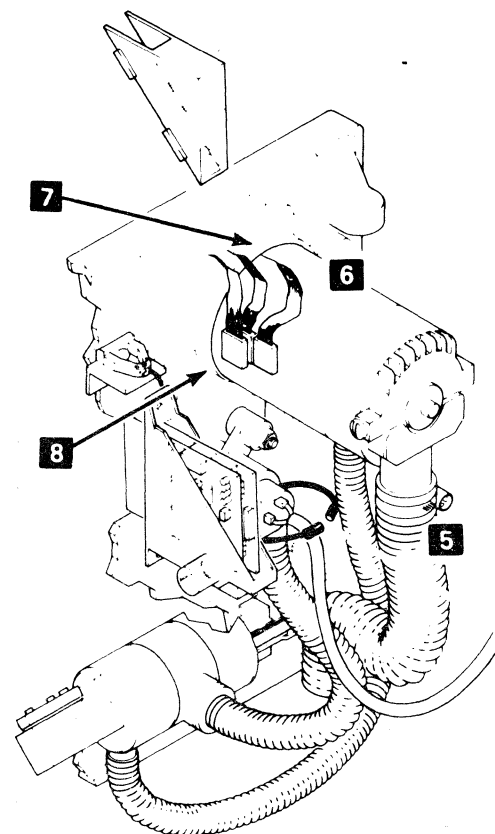

To adjust the hub:

11. If the hub is loose, adjust it as follows:
 - a. Remove the left reel tach (see 08-550) for reel-hub adjustment tool clearance.
 - b. Place the reel-hub adjusting tool, P/N 2515226, on a flat surface and set it to 0.100 inch (2.54 mm).
 - c. Place the tool on the reference plate so that the indicator tip touches the hub face.
 - d. Slide the hub in or out until the indicator reads 0.390 inch (9.91 mm). The desired 0.290-inch (7.37 mm) dimension is now set.
 - e. Install the hex tool and socket, P/N 1766508, on the torque wrench with the handle positioned exactly as shown in Figure B.
 - f. If the hub is fastened to the motor shaft by two screws, tighten the screws, in 10 inch-pound (11.5 cm-kgf) increments, to 108 inch-pounds (124.4 cm-kgf) torque. When the hub is fastened by only one screw, tighten it to 75 to 85 inch-pounds (86.4 to 97.9 cm-kgf) in 10 inch-pound increments.
 - g. Recheck the dimension and runout on the hub face. Adjust if necessary.
12. Install the reel, tightening the screws to 50 ±5 inch-pounds (57.6 ±5.7 cm-kgf).
13. Rotate the reel and check that it does not rub on the casting or on the radius-sense assembly.
14. Install a new decorative disk, P/N 2524134.
15. Replace the left reel tach (see 08-550).

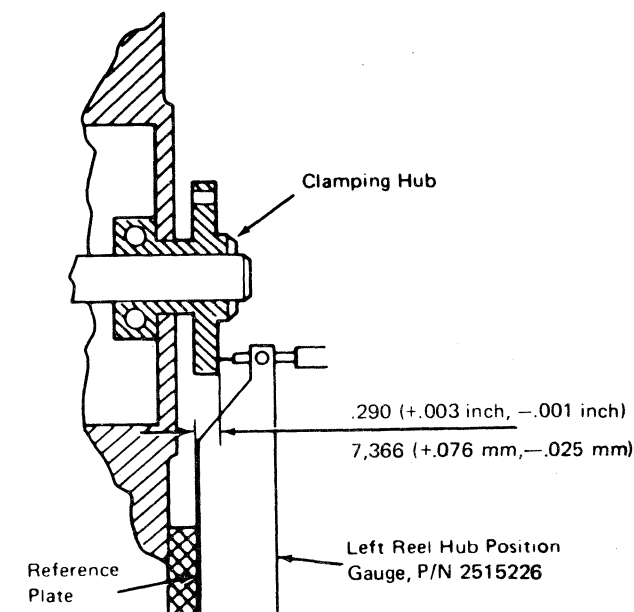

Figure A. Left Reel Setup

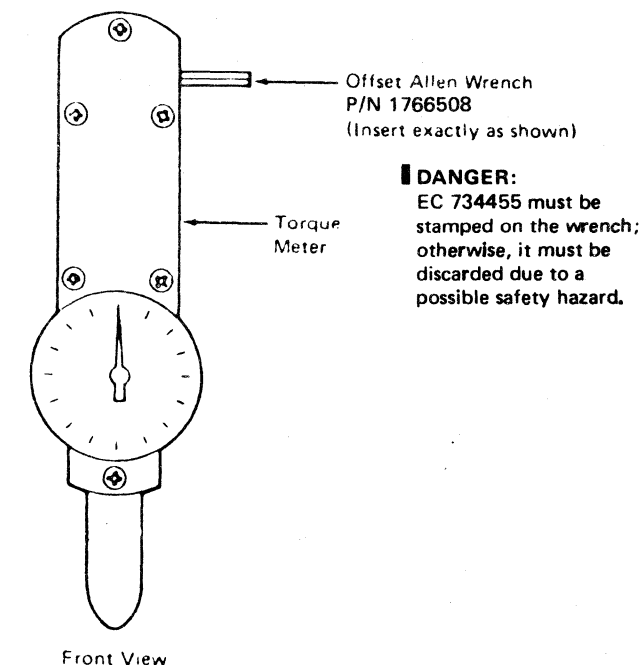

Figure B. Torque Meter

DC POWER SUPPLY CHECKS/ADJUSTMENTS

Check all dc power supplies for voltage tolerances listed. Adjust the associated regulator cards when necessary. (See 1A-002 or 1B-002 for terminal board locations.)

Caution: Use a digital voltmeter, P/Ns 453046, 453585, or equivalent, when making adjustments.

Notes:

1. Ensure that the tape unit is loaded, ready, and in write status before checking or adjusting the +6 V power supply. After a check or adjustment, measure the voltage at T-A1G2B11. If the voltage exceeds +6.24 V, check the fuse-protect circuits for resistance.
2. The maximum allowable ripple voltage is 24 mV peak-to-peak measured at the power supply.
3. The maximum allowable ripple for -4 V is 80 mV peak-to-peak and for +6 V it is 10 mV peak-to-peak.
4. If the -4v or +6v regulators are adjusted or replaced, check EOT/BOT, capstan squaring, amp sensor, or read amplitude adjustments to ensure the adjustments are still in spec.

3803 Model 1 Power Supply

| Power Supply Voltage | Test Point | Ground |
|---------------------------------|------------|----------|
| -4 V (± 0.01 V) See Note 3 | AA2T4B06 | AA2T4D08 |
| +6 V (± 0.01 V) See Note 3 | AB2R4B11 | AB2R4D08 |

3803 Model 2 Power Supply

| Power Supply Voltage | Test Point | Ground |
|---------------------------------|------------|---------|
| -4 V (± 0.01 V) See Note 3 | A2T4B06 | A2T4D08 |
| +6 V (± 0.01 V) See Note 3 | B2S4B11 | B2S4D08 |

3803 Model 3 Power Supply

| Power Supply Voltage | Test Point | Ground |
|---------------------------------|------------|----------|
| -4 V (± 0.01 V) See Note 3 | AA2T4B06 | AA2T4D08 |
| +6 V (± 0.01 V) See Note 3 | AB2T4B11 | AB2T4D08 |

Models 3, 5, and 7:

- a. If you have an unmodified power supply, check the voltages at the following test points:

| Power Supply Voltage | Test Point | Ground |
|--|------------|-----------|
| +6 V (± 0.05 V) See Notes 1 and 2 | T-A1G1E09 | T-A1G2D08 |
| -4.05 V (± 0.05 V) See Note 2 | T-A1N3D02 | T-A1N3D08 |
| -48 V (+7 V, -9 V) | TB1-9 | TB1-8 |
| +12 V (± 1 V) | TB2-1 | TB1-8 |
| -12 V (± 1 V) | TB2-5 | TB1-8 |
| +11 V (+2 V, -1.2 V) | TB3-12 | TB2-4 |

- b. If you have a modified power supply, check the voltages at the following test points:

| Power Supply Voltage | Test Point | Ground |
|--|------------|-----------|
| +6 V (± 0.05 V) See Notes 1 and 2 | T-A1G1E09 | T-A1G2D08 |
| +11 V (+2 V, -1.2 V) | TB2-1 | TB2-4 |
| -4.05 V (± 0.05 V) See Note 2 | T-A1N3D02 | T-A1N3D08 |
| -48 V (+7 V, -9 V) | TB1-9 | TB1-8 |
| ± 12 V (± 1 V) | TB3-1 | TB1-8 |
| -12 V (± 1 V) | TB3-5 | TB1-8 |
| +30 V (± 0.5 V)* | TB2-3 | TB1-8 |
| -12 V (± 1 V)* | TB2-2 | TB1-8 |
| +12 V (± 1 V)* | at Fuse 7 | TB1-8 |

*Used only for OV/UV sense.

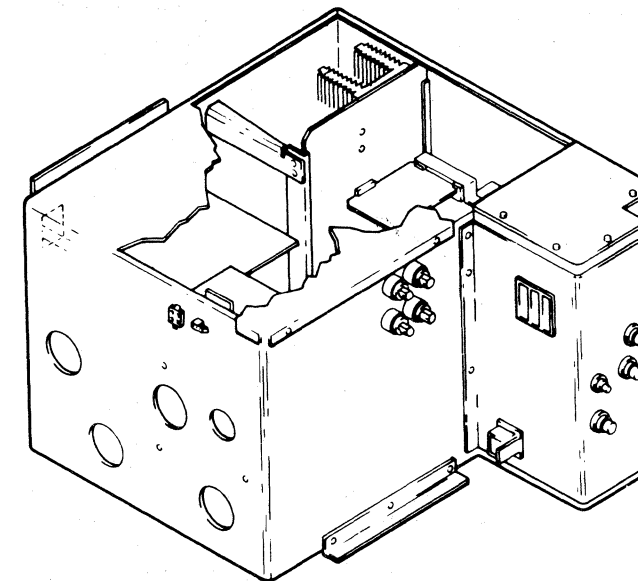

Basic Power Supply

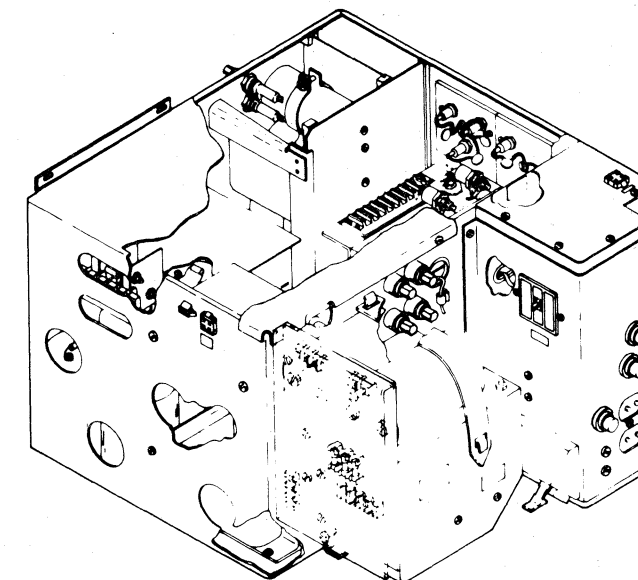

Modified Power Supply

Models 4, 6, and 8:

- a. If you have an unmodified power supply, check the voltages at the following test points:

| Power Supply Voltage | Test Point | Ground |
|------------------------------------|------------|-----------|
| +6 V (± 0.1 V) See Note 2 | T-A1G2B11 | T-A1G2D08 |
| -4.05 V (± 0.05 V) See Note 2 | T-A1H1C09 | T-A1G2D08 |
| -48 V (+9 V, -9.6 V) | TB1-9 | TB1-8 |
| +12 V (+1.4 V, -0.9 V) | TB2-1 | TB2-4 |
| -12 V (± 1.4 V) | TB2-5 | TB2-7 |
| +11 V (+1.7 V, -1.1 V) | TB3-12 | TB2-4 |

- b. If you have a modified power supply, check the voltages at the following test points:

| Power Supply Voltage | Test Point | Ground |
|------------------------------------|------------|-----------|
| +6 V (± 0.1 V) See Note 1 | T-A1G2B11 | T-A1G2D08 |
| +11 V (+1.7 V, -1.1 V) | TB2-1 | TB2-4 |
| -4.05 V (± 0.05 V) See Note 2 | T-A1H1C09 | T-A1G2D08 |
| -48 V (+9 V, -9.6 V) | TB1-9 | TB1-8 |
| +12 V (+1.4 V, -0.9 V) | TB3-1 | TB3-4 |
| -12 V (± 1.1 V) | TB3-5 | TB3-7 |

3803-1,2,3/3420

| | | | | | | | |
|----------------------|------------------------|-------------------|--------------------|--|--|--|--|
| XD3500 Seq 2 of 2 | 2735845 Part Number | See EC History | 845958 1 Sep 79 | | | | |
|----------------------|------------------------|-------------------|--------------------|--|--|--|--|

© Copyright International Business Machines Corporation 1976, 1979

CARR — TAPE CONTROL UNIT POWER CIRCUIT BOARD

08-575

POWER SUPPLY PRINTED CIRCUIT BOARD REMOVAL/REPLACEMENT (3803 MODEL 2 ONLY)

1. Remove all power from the tape control unit (TCU) by tripping main line CB1, and remove the power plug.
2. Remove the plastic cover from the power supplies.
3. Remove the regulator cards to prevent damage. Note their location for later replacement.
4. Remove all external cables and laminar bus connections from the power supply board to be removed (A1, A2, A3). Note their locations for later reassembly.
5. Remove the ground strap at the top of the power supply.
6. Remove the six screws **A** that fasten the printed circuit board to the three large capacitors behind the board. Note the location of each of the screws as some are slightly longer than the others. Also, note the cable dress position of the jumper wires on the A1 and A2 PCB. See Figure 1.

DANGER

Do not handle leaking capacitors with bare hands.

7. Inspect the capacitor screws for stripped threads and signs of heating. If any of the parts are questionable, replace them. See ALD YF037 for part numbers and locations.

DANGER

If jumpers (P/N 1766180) are omitted in the reassembly, the capacitors may explode.

8. To reassemble, perform steps 7 through 1 above. When installing the six screws in the capacitors, use a torque screwdriver (P/N 453570) to torque the screws to 18 ± 5 inch-pounds (20.74 ± 5.76 cm-kgf).
9. Perform the voltage checks on 08-570.

Figure 1. 3803 MODEL 2 -4V SUPPLY

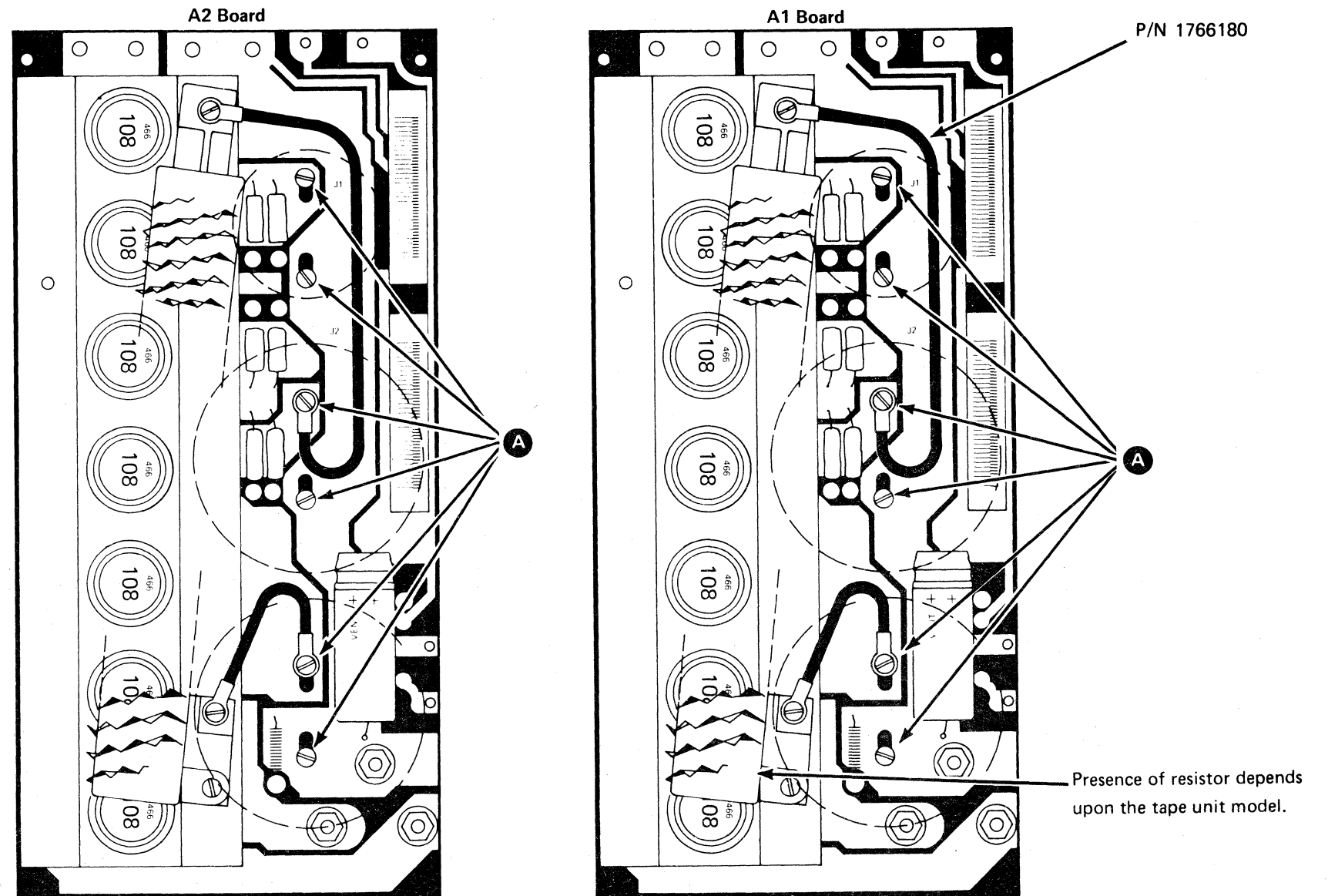

3803-1,2,3/3420

| | | | | | | | |
|------------|-------------|---------|----------|--|--|--|--|
| XD3550 | 4169703 | See EC | 845958 | | | | |
| Seq 1 of 2 | Part Number | History | 1 Sep 79 | | | | |

Copyright International Business Machines Corporation 1976, 1979

08-575

NOTES:

08-576

3803-2/3420

| | | | | | | | | | |
|----------------------|------------------------|-------------------|--------------------|--|--|--|--|--|--|
| XD3550 Seq 2 of 2 | 4169703 Part Number | See EC History | 845958 1 Sep 79 | | | | | | |
|----------------------|------------------------|-------------------|--------------------|--|--|--|--|--|--|

© Copyright International Business Machines Corporation 1976, 1979

08-576

CARR — BOT/EOT CHECKS

08-580

BOT/EOT VOLTAGE CHECKS AND ADJUSTMENTS

DANGER

Allow the lamp to cool before cleaning or inspecting it.

- 1 Turn off tape unit power. Clean the dust off the ends of the fiber optic bundle at the BOT/EOT block, the phototransistor lens, and the reflective mirror. Wipe with a lint-free cloth if necessary. (See 85-001.)
- 2 Clean the fiber optic lamp. Use a cloth lightly moistened with water. (See 08-620, "Fiber Optics Lamp Cleaning Procedure.") Inspect the inside of the fiber optic lamp for any sign of discoloration. Replace if necessary (see 08-620).
- 3 Turn on the tape unit power and allow the lamp to warm up for 20 to 30 minutes before continuing. Load a customer good-quality representative tape to ensure an average light reflectivity of the tape backing.

Note: If unable to load a tape because the BOT/EOT is out of adjustment, manually thread a tape and perform a mid-tape load. Press RESET before the load point.

- 4 Move the tape forward so that the BOT/EOT light spot falls on the tape surface and not the BOT marker.

Before making BOT/EOT adjustments, check the test points T-A1D2D11 (BOT) and T-A1D2B09 (EOT) for:

- 1.5 volts or less with the tape unit unloaded.
- 4.2 volts or greater with the tape unit loaded, and tape unit away from load point.

If voltages are not correct, continue with the steps below.

- 5 Measure the BOT voltage at T-A1D2D11.
- 6 Adjust the BOT pot on the lower portion of card T-A1D2 for 4.7 +0.1, -0 volts.
- 7 Measure the EOT voltage at T-A1D2B09.

Note: If a capacitor is mounted between T-A1D2B09 and ground, the capacitor may be removed during adjustment.

- 8 Adjust the EOT pot on the upper portion of card T-A1D2 for 4.7 +0.1, -0 volts.

- 9 Remove the tape from the BOT/EOT area so that the light falls on the reflective mirror.
- 10 Measure the BOT and EOT voltages again. The voltages should be 1.5 volts or less. Ensure that there is dc common to the BOT/EOT phototransistors by measuring 0 ohms between the center pin on the EOT/BOT block and any D08 pin on the logic panel. It may be necessary to remove the EOT/BOT block (see 08-590). If not, replace the BOT/EOT assembly (see ALD ZT031).
- 11 Perform the Capstan Tachometer Check/Adjustment procedure on 08-120 or 08-130.

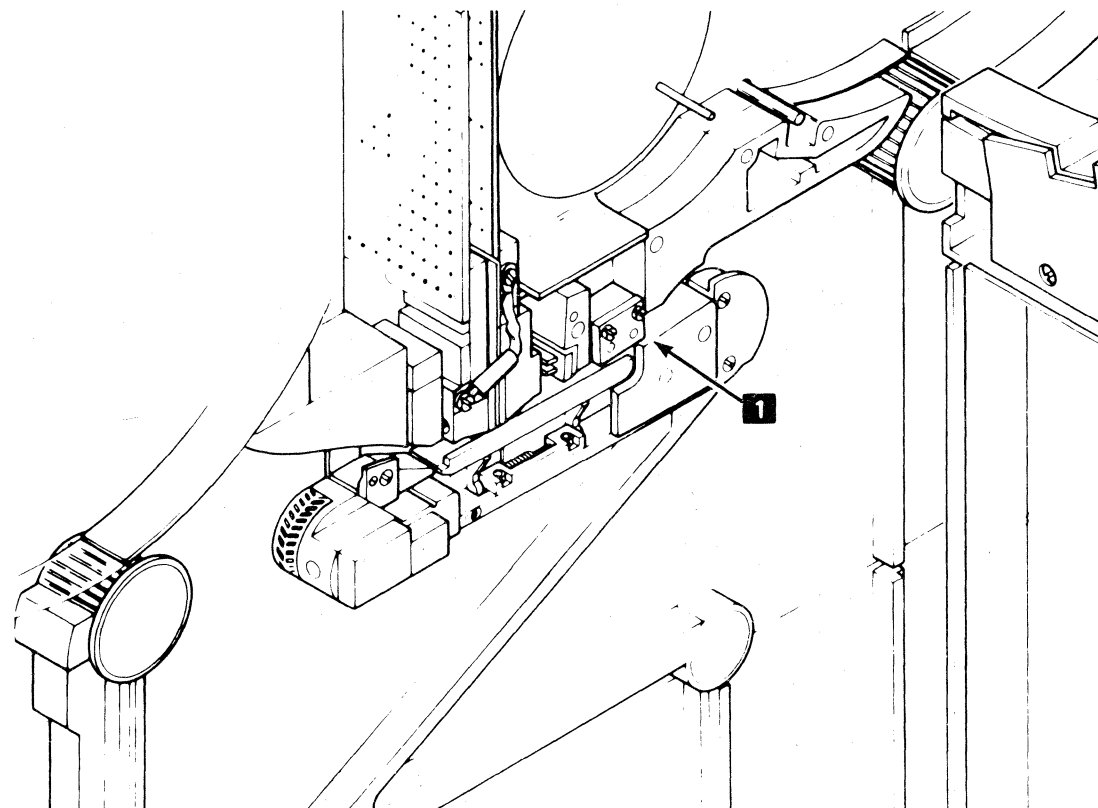

3803-1.2.3/3420

| | | | | | | | | | |
|------------|-------------|---------|----------|--|--|--|--|--|--|
| XD3600 | 2735846 | See EC | 845958 | | | | | | |
| Seq 1 of 2 | Part Number | History | 1 Sep 79 | | | | | | |

© Copyright International Business Machines Corporation 1976. 1979

08-580

**BOT/EOT BLOCK
REMOVAL/REPLACEMENT**

Removal:

1. Turn off tape unit power.
2. Pry the retaining wedge from the BOT/EOT fiber optic bundles at the manifold.
3. Push the bundles toward the BOT/EOT assembly to obtain sufficient slack.
- 4 Remove the two screws holding the assembly in place.
5. Pull the assembly out carefully.
6. If the fiber optic bundles are **not** being replaced, remove the screws which fasten the metal clips in place on the BOT/EOT assembly and remove the metal clips.
- 7 Turn the BOT/EOT assembly over. Unsolder the three wires (noting their position carefully to allow correct replacement), and remove the assembly, and fiber optic bundles if step 6 was omitted.

Replacement:

1. If the old fiber optic bundles are being used, blow dust off both ends (wipe with lint-free cloth if necessary) and install the clips which hold them to the BOT/EOT assembly.
2. Solder the wires to the assembly. Ensure that they are positioned as before.
3. Push the fiber optic bundles carefully back into the tape unit.
4. Attach the assembly with the two mounting screws.
5. Route the fiber optic bundles back to the manifold. Be careful to route them away from the autocleaner on Models 4, 6, and 8.
6. Insert the bundles into the light manifold and replace the retaining wedge.
7. Adjust the BOT/EOT voltages. See 08-580.

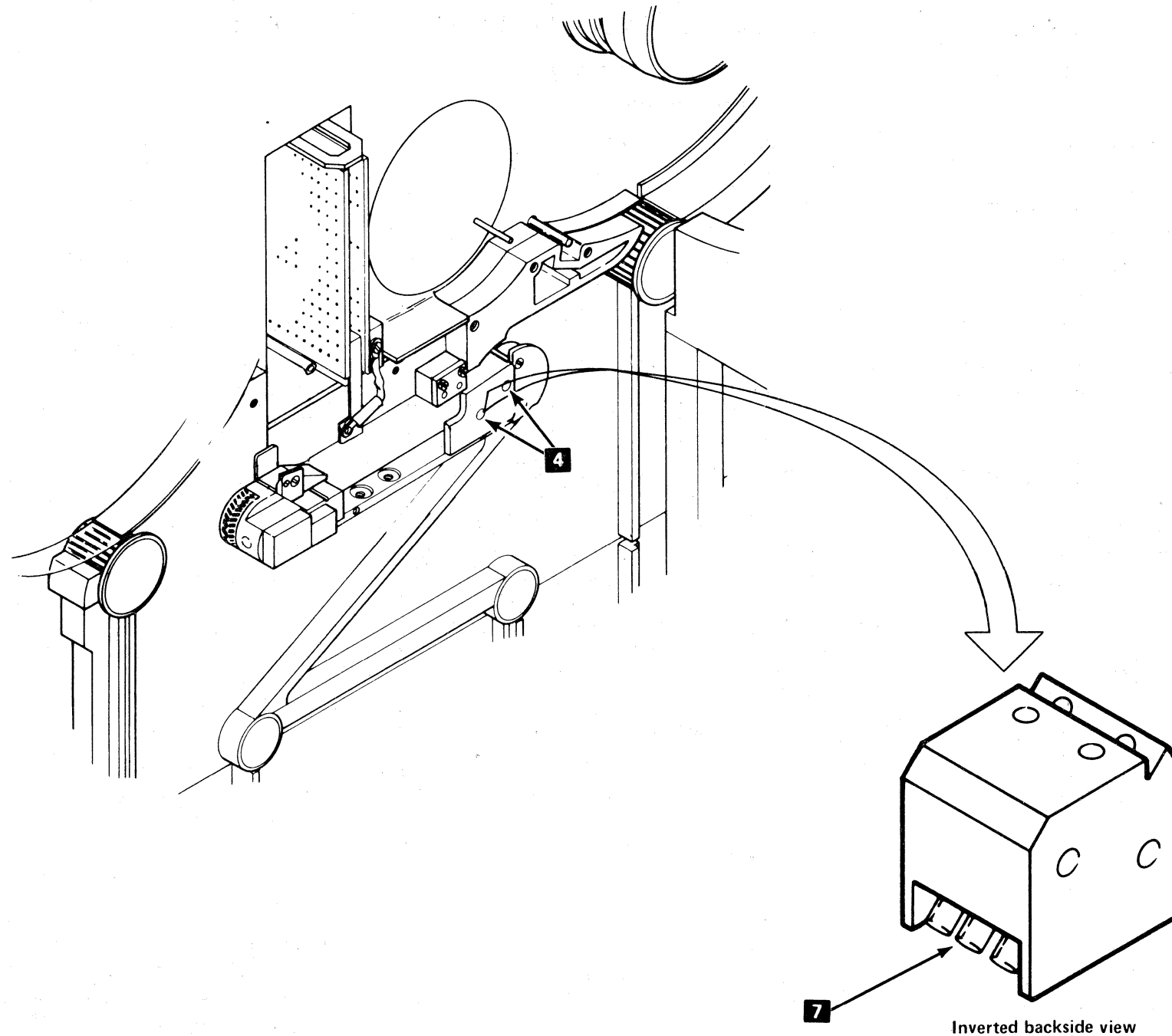

3803-1,2,3/3420

| | | | | | | | |
|------------|-------------|---------|----------|--|--|--|--|
| XD3600 | 2735846 | See EC | 845958 | | | | |
| Seq 2 of 2 | Part Number | History | 1 Sep 79 | | | | |

© Copyright International Business Machines Corporation 1976, 1979

CARR — TAPE UNIT GROUNDING

08-600

TAPE UNIT GROUND CHECK

1. Unload the tape unit and switch it offline and turn ac power off.
2. Disconnect the tape unit Power and Signal cables.
3. Unplug the cables at T-A1N2 and T-A1N4.
4. Check that the minimum resistance between the dc common and the frame ground is 10 megohms.

Caution: If you are using a "meggar" (megohm meter) which applies more than 250 volts to the circuit being tested, also disconnect the capstan tachometer signal cable and the capstan motor plug. On Models 4, 6, and 8, also disconnect read cables T-A1N3 and T-A1T4 and write cable T-A1T3.

3803-1,2,3/3420

| | | | | | | | | | |
|------------|-------------|---------|----------|--|--|--|--|--|--|
| XD3700 | 2735847 | See EC | 845958 | | | | | | |
| Seq 1 of 2 | Part Number | History | 1 Sep 79 | | | | | | |

© Copyright International Business Machines Corporation 1976, 1979

08-600

**FIBER OPTIC BUNDLE
REMOVAL/REPLACEMENT**

1. Pry the retaining wedge from the light manifold.
2. Pull the defective bundle out of the manifold.
3. Disconnect the other ends of the bundle by removing or loosening each retainer.
 - A The radius sense assembly uses the same type of wedge as the manifold.
 - B The reel tachometers use a nylon setscrew.
 - C The BOT/EOT assemblies use metal clips that are held in place by screws.
 - D The capstan tachometer uses a plastic taper pin on earlier parts. On later models the fiber optic bundle is not removable.
4. Reverse the procedure to install a new bundle.

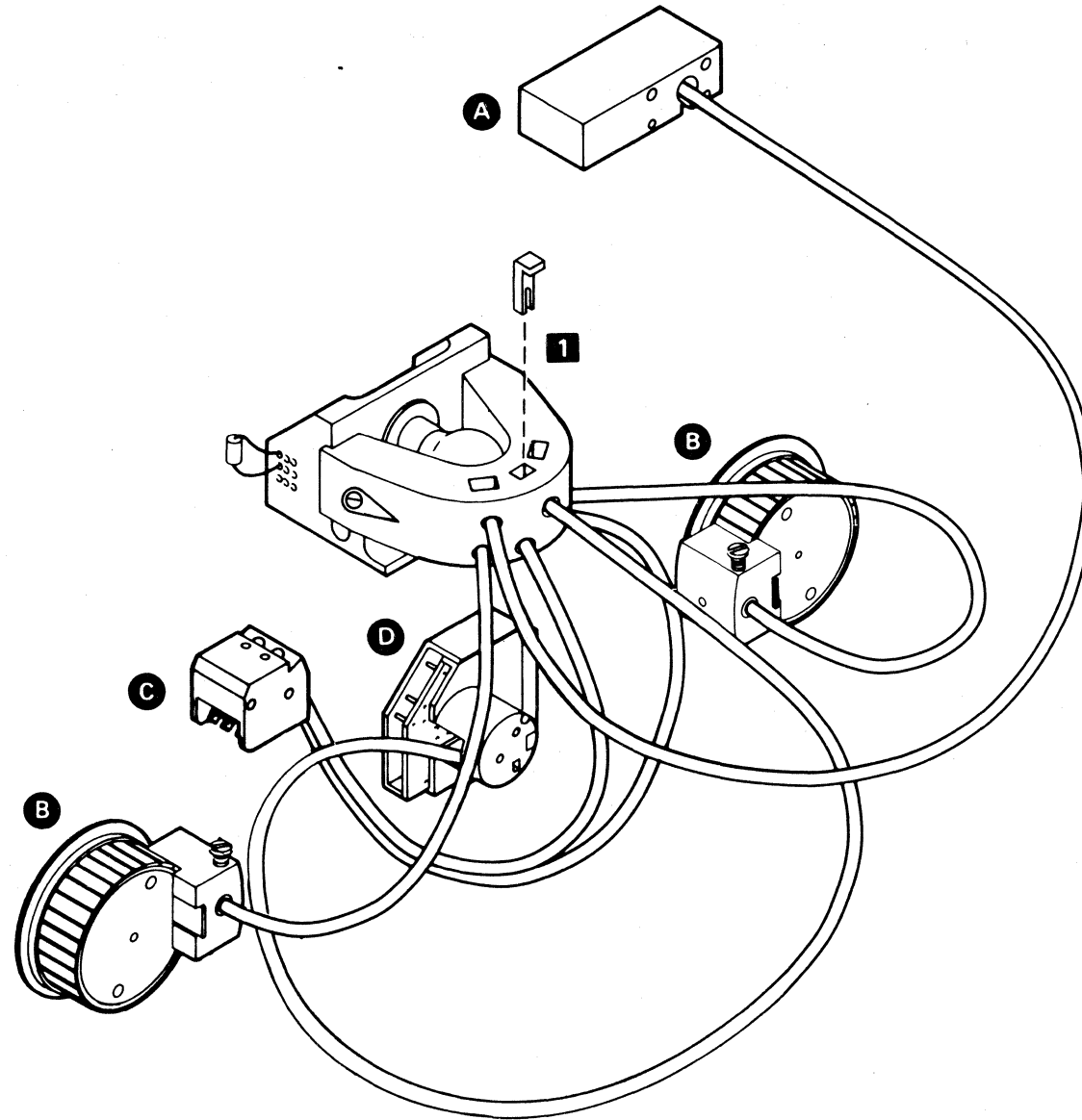

3803-1,2,3/3420

| | | | | | | | | |
|------------|-------------|---------|----------|--|--|--|--|--|
| XD3700 | 2735847 | See EC | 845958 | | | | | |
| Seq 2 of 2 | Part Number | History | 1 Sep 79 | | | | | |

© Copyright International Business Machines Corporation 1976, 1979

CARR — FIBER OPTICS

08-620

FIBER OPTICS LAMP REMOVAL/REPLACEMENT

1. Turn off tape unit power and allow the lamp to cool.
- 2 Remove the two screws that hold the light manifold to the front panel and carefully lower the manifold out of the way.
Caution: Do not pinch, kink, or stretch the fiber optic bundle.
- 3 Loosen the three flat-head screws that fasten the lamp base.
- 4 Rotate the lamp counterclockwise to remove it.
5. Reverse the procedure to install a new lamp. The lamp filament should be vertical to ensure correct operation.
6. Replace the light manifold.

Note: Power on the unit and allow at least 20 to 30 minutes warm-up time before doing step 7.

7. Perform the Capstan Tachometer Check/Adjustment procedure on 08-120 or 08-130 and the BOT/EOT Voltage and Adjustments procedure on 08-580.

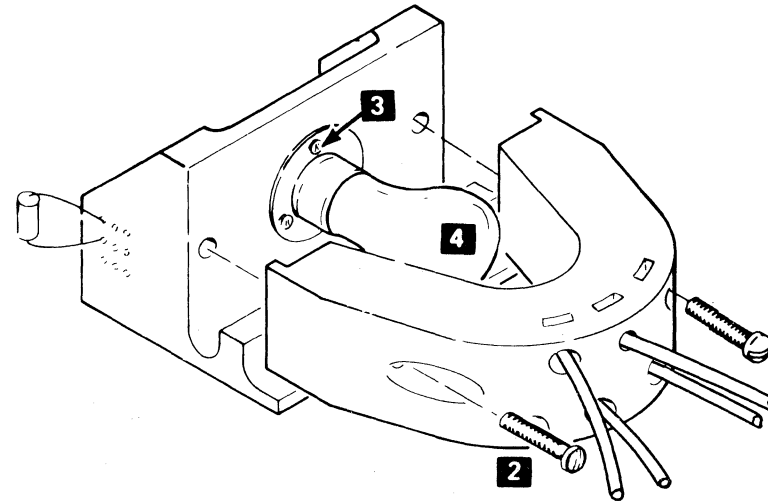

FIBER OPTICS LAMP CLEANING PROCEDURE

1. Turn off tape unit power.

DANGER

Allow the lamp to cool before inspecting or cleaning it.

2. Inspect the lamp. If any sign of discoloration is visible inside the lamp, replace it. (Most discoloration can only be seen with the lamp turned off.)
3. If replacement is not necessary, clean the lamp, using the following procedure:

Polish the lamp gently with a cloth lightly moistened with water.

DANGER

Do not twist the glass lamp out of its base.

4. Turn on power and inspect the lamp to verify that it is clear and free of smudges.
5. Perform the Capstan Tachometer Check/Adjustment procedure on 08-120 or 08-130 and the BOT/EOT Voltage Checks and Adjustments procedure on 08-580.

3803-1,2,3/3420

| | | | | | | | | | |
|------------|-------------|---------|----------|--|--|--|--|--|--|
| XD3800 | 2735848 | See EC | 845958 | | | | | | |
| Seq 1 of 2 | Part Number | History | 1 Sep 79 | | | | | | |

Copyright International Business Machines Corporation 1976-1979

08-620

**COOLING FAN ASSEMBLY
REMOVAL/REPLACEMENT**

1. Turn off tape unit power.
2. Disconnect the blower motor plug from the power supply.
3. Remove the air filter.
4. From the extreme rear of the blower assembly, unplug the cable that leads to the resistor frame.
5. Unlatch the two fasteners that hold the resistor frame and move the entire resistor assembly out of the way.
6. Unlatch the two fasteners on the rear vertical surface of the blower assembly.
7. Reach under the blower assembly and pull on the motor housing with one hand, while guiding the assembly out with the other hand.
8. After partially inserting a new assembly into its holder, push up from beneath the motor and lift the front end.
9. Push the assembly completely into place. Ensure that the front mounting lip slides over the front-edge frame.
10. Reverse steps 2 through 6 to complete the installation.

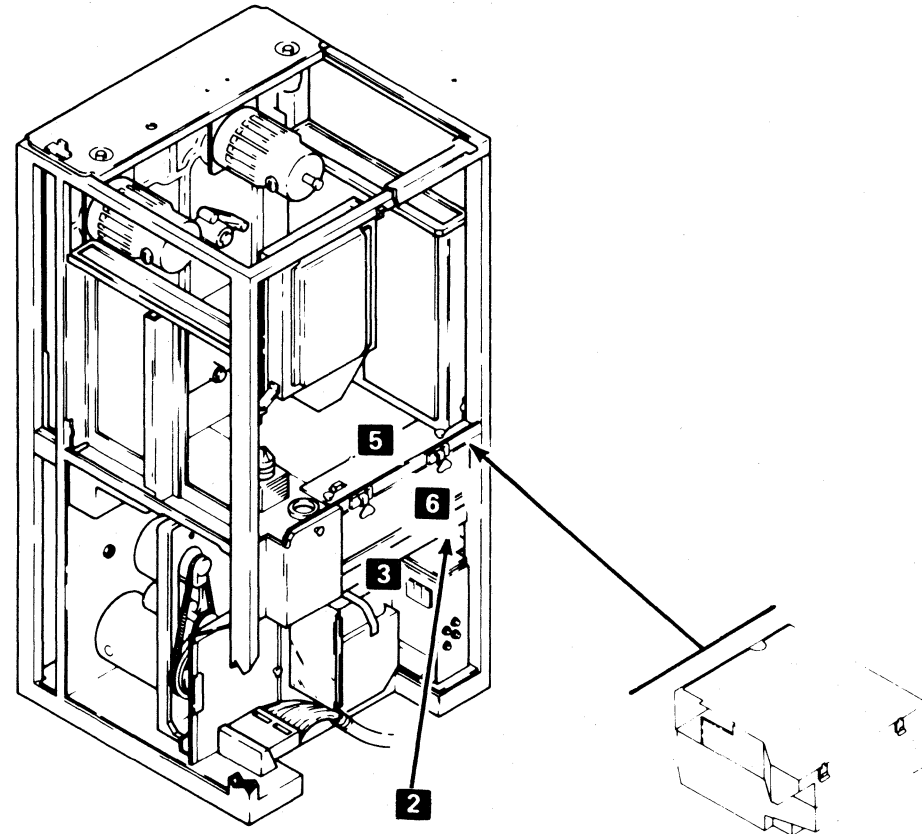

5. Place the old and the new panels side by side on a table with the A2 card location in the top left position. Transfer the cards from the old board to the new board one at a time.
6. Reverse steps 4 through 2 to install the new panel in the tape unit.
7. Check the machine history and ALD A6106 (2 of 2) for correct machine model jumper wires (Models 4, 6, and 8 only).
8. Test the tape unit and return it to the customer when it is checked out.

**3803 LOGIC PANEL
REMOVAL/REPLACEMENT**

1. Ensure that the subsystem is offline and the ac and dc power is turned off.
2. Remove the card cover and the cards from the panel. (Mark the cards for correct assembly in the new board later.)
3. Unplug all interpanel cables.
4. On the pin side of the panel, remove all the voltage jumper cables and mark their locations.
5. Remove the screws holding the panel to the gate. Carefully remove the panel.
6. Reverse steps 5 through 2 to install the new panel.
7. Check the machine history and ALD AA005 for correct machine feature jumper pins.
8. Test the subsystem and return it to the customer when it is checked out.

**3420 LOGIC PANEL
REMOVAL/REPLACEMENT**

1. Ensure that the tape unit is offline and the power is turned off.
2. Remove the card side panel cover and unplug all the cables on the card side of the logic panel. Ensure all cables are legibly marked.
3. Unplug all of the voltage jumpers on the pin side of the panel. (Mark these locations for assembly later.) Also, remove the resistor and capacitor if they are present. (Mark these locations also.)
4. Remove the screws fastening the panel and carefully remove the panel from the gate.

3803-1,2,3/3420

| | | | | | | | | |
|------------|-------------|---------|----------|--|--|--|--|--|
| XD3800 | 2735848 | See EC | 845958 | | | | | |
| Seq 2 of 2 | Part Number | History | 1 Sep 79 | | | | | |

© Copyright International Business Machines Corporation 1976, 1979

CARR — POWER WINDOW

08-640

POWER WINDOW ALIGNMENT

To align or adjust the power window:

- 1 Turn off tape unit power. Loosen the two screws at the bottom of the door (hinge side). Remove the cover.
- 2 Loosen the motor/gear box mounting screws and disengage the box from the gear rack. You can then manually move the glass up or down. Remember to engage gears before turning power back on.
3. Check that the top edge of the window is parallel to the frame surface.
4. If the window needs to be adjusted, lower the window and remove the two screws that hold the black plastic accent panel in place. On some tape units, the glass panel in the door must be removed to get to the accent panel screws. If glass removal is not required, go to step 5; otherwise do steps a through d below.
 - a. Remove the left roller tension spring.
 - b. Remove the screws and washers that hold the strips which fasten the top side and door latch side of the glass to the door.
 - c. Loosen the retaining strip on the door hinge side of the glass.
 - d. Slide the glass out.
5. To adjust the window, loosen the three screws and the two hex-head nuts on the window support.
6. Perform the Power Window, Rack, Limit Switch Adjustments procedure (08-650, step 3).
7. Perform steps 1 and 2 of the Power Window Safety-Bail Adjustment procedure on this page.

POWER WINDOW SAFETY BAIL ADJUSTMENT

This safety bail adjustment procedure is a continuation of the Power Window Alignment procedure on this page; the safety bail procedure explains how to replace many parts that were removed in the earlier procedure. Adjust as follows:

1. Move the safety bail switch and the actuator assembly as far right as possible without the switch closing. **A**
2. On all models, apply upward pressure (at the top-right side of the window) to the soft plastic strip through which the cable runs. (On models without the lower door glass, also apply pressure to the soft plastic strip at the top center of the bottom window.) The safety bail switch should close with a force of 5 pounds (2268 grams) or less, or a displacement of 0.44 inch (11.28 mm) or less. **B**
3. Replace the black accent panel.

Note: If removed, replace the door glass panel. Ensure that the beveled bottom edge of the glass is aligned with the beveled lower door frame member.

Install the top and side retaining strips and tighten the screws.

4. Reinstall the inner cover.

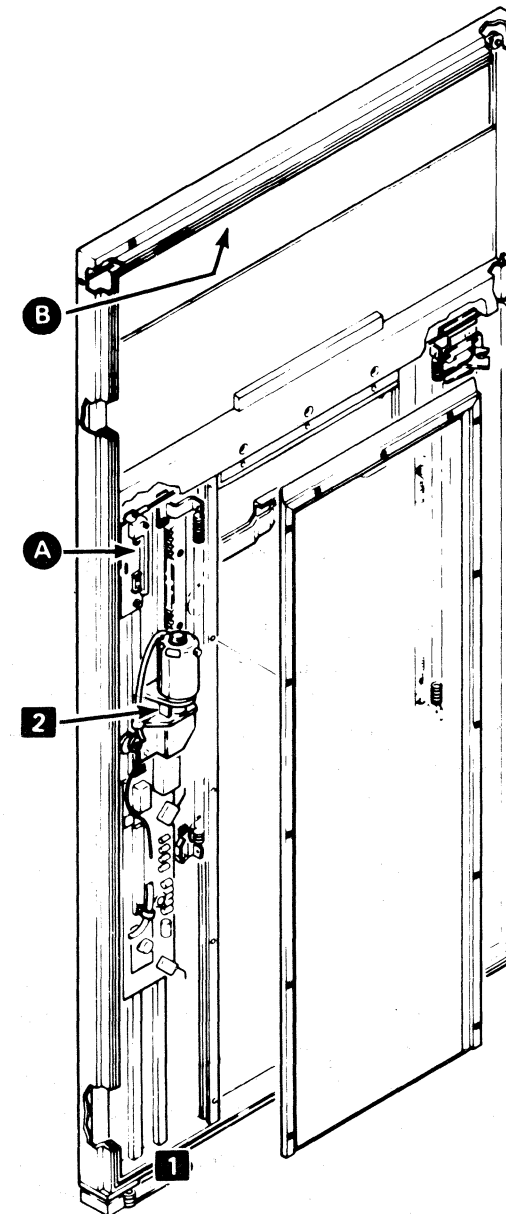

3803-2/3420

| | | | | | | | | | |
|------------|-------------|---------|-----------|--|--|--|--|--|--|
| XD3900 | 2735849 | See EC | 845958 | | | | | | |
| Seq 1 of 2 | Part Number | History | 1 Sep. 79 | | | | | | |

Copyright International Business Machines Corporation 1976, 1979

08-640

POWER WINDOW, RACK, LIMIT SWITCH ADJUSTMENTS (Without EC 443925)

1. Open the front door and remove the left cover to expose the window motor and gear rack.

DANGER
Power must be off.

2. Loosen the motor mounting screws and move the motor to disengage it from the gear rack. Move the window up and down by hand to verify that it has no heavy binds.

Caution: Do not lower the window below the top of the center horizontal frame member of the door.

3. Loosen the screws holding the gear rack, then retighten them when the rack is moved completely to the right and the limit switch actuator is centered.
4. Verify that both limit switches operate in each direction of window travel by manually lifting and lowering the window. Then remesh and adjust the motor gear to gear rack clearance. Carefully move the motor until the gear just bottoms. With the window down turn power on and check the gear mesh at the up position.
5. Under power, position or shape the upper limit switch so that the glass stops *just short* of its full upper travel. Adjust the lower limit switch so that the window stops just level with the center horizontal frame member.

6. While maintaining the step 5 adjustments, vary the position of the switch to ensure that the switch actuating arms have some over-travel remaining.

Caution: If the switch actuating arm is touching the switch body or some other object, shape the switch actuator arm and repeat the step 5 adjustment.

7. Perform the Power Window Safety Bail Adjustment procedure on 08-640.

POWER WINDOW, RACK, LIMIT SWITCH ADJUSTMENTS (With EC 443925)

1. Open the front door and remove the left cover to expose the window motor and gear rack.

DANGER
Power must be off.

2. Loosen the motor mounting screws and move the motor to disengage it from the gear rack. Move the window up and down by hand to verify that it has no heavy binds.

Caution: Do not lower the window below the top of the center horizontal frame member of the door. Before starting the window adjustment, adjust the upper and lower trip plates. Move the upper trip plate to its uppermost position and the lower trip plate to its lowermost position.

3. Loosen the screws holding the gear rack. Move the gear rack completely to the right and retighten the screws.
4. Move the window up by hand until the upper limit switch makes contact. Measure the distance to the top of the frame. If the distance is less than 0.25 inch (6.35 mm), shape the limit switch actuator arm until the distance is greater than 0.25 inch (6.35 mm). Move the flat trip plate down an amount equal to the difference between 0.25 inch and the distance between the window top and the top of the frame. The end result is to have the window 0.25 inch (6.35 mm) from the top frame when the upper limit switch makes contact. This allows the window to coast to a stop before hitting the upper door frame.

5. Carefully move the motor until the gear just bottoms. Hold the motor in position with one hand and try to move the window. If the window does not move, the gears are meshed correctly. Tighten the two motor mounting screws.

6. Turn power on and lower the window. Measure the distance from the top of the window to the center horizontal member of the door. If the window is below the center horizontal frame member, move the window up and shape the lower limit switch up. Lower the window and check the window position. Continue shaping the lower switch actuating arm up until the window top stops above the center horizontal frame member. Then move the trip plate until the window top is just slightly above the center horizontal frame member.

Caution: If the lower switch actuating arm is touching the switch body or any other object, shape the lower switch actuating arm up. Move the window down and check the window position, adjusting the trip plate as necessary with power off.

7. Move the window up. The window should close without hitting hard. If the window hits hard, move the flat trip plate down until the window lightly touches.

Caution: If the lower switch actuating arm is touching the switch body or any other object, shape the lower switch actuating arm up. Move the window down and check the window position, adjusting the trip plate as necessary with power off.

8. Perform the Power Window Safety Bail Adjustment procedure on 08-640.

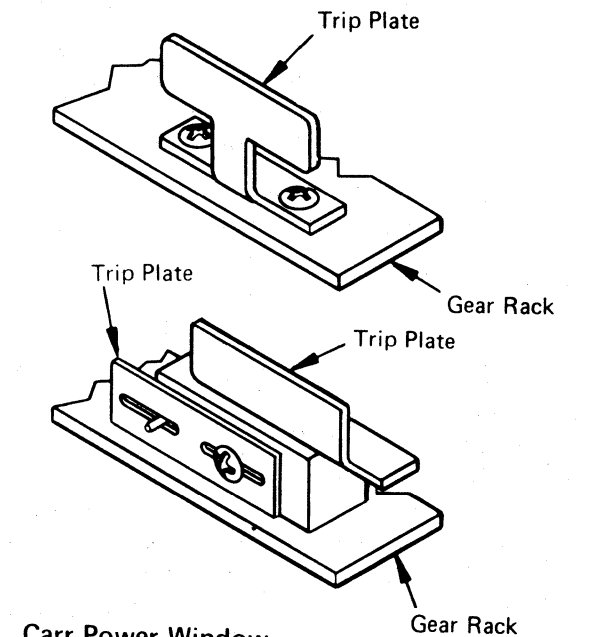

Carr Power Window

3803-1,2,3/3420

| | | | | | | | |
|------------|-------------|---------|----------|--|--|--|--|
| XD3900 | 2735849 | See EC | 845958 | | | | |
| Seq 2 of 2 | Part Number | History | 1 Sep 79 | | | | |

CARR — POWER WINDOW

08-660

POWER WINDOW SAFETY-BAIL CABLE REMOVAL/REPLACEMENT

To replace a power window safety-bail cable:

- 1 Remove the left and right door trim by loosening the setscrews beneath the outer edge of the rubber door seal. Hold back the rubber seal to expose the setscrews.
- 2 Remove the access cover to expose the window motor and gear rack by removing the two screws at the bottom.

If the cable is broken at its terminator:

1. Position or remove the bail actuator mounting bracket to provide cable slack.
2. Pull outward on the extruded rubber safety bail to expose the cable on the outside edge of the door.
3. Push the cable through the safety bail until enough cable is exposed on the other end to install the terminator.
4. Install the terminator and mount the actuator bracket.
5. Perform the Power Window Safety Bail Adjustment procedure on 08-640.
6. Replace the covers and trim.

If the break is not at the terminator:

1. Remove the left door access cover.
2. Disconnect the terminators and remove the broken cable.
3. Thread the new cable. Be careful not to fray the end.
4. Connect the terminators.
5. Perform the Power Window Safety Bail Adjustment procedure on 08-640.
6. Replace the covers and trim.

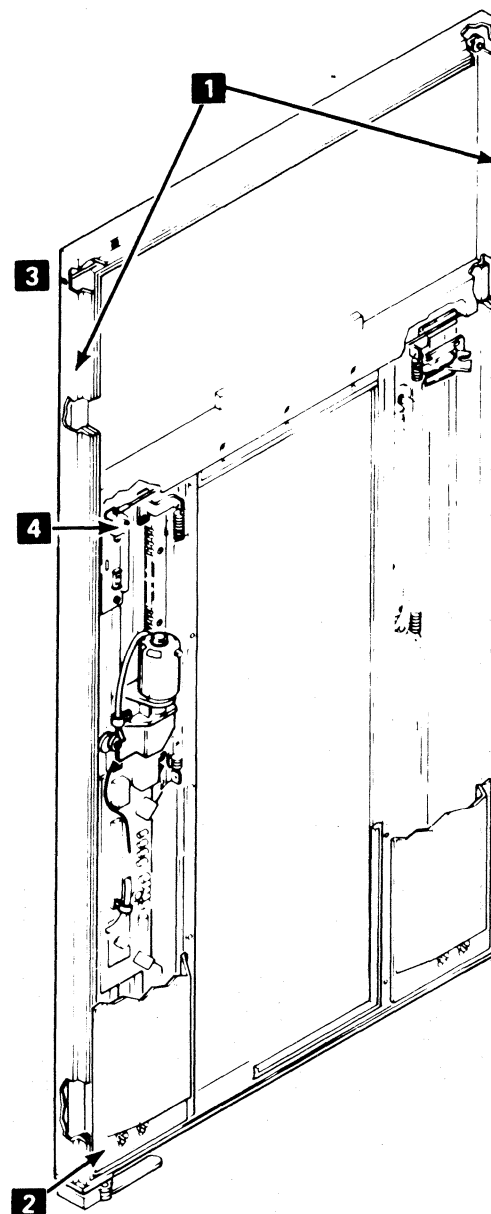

3803-1,2,3/3420

| | | | | | | | | | |
|------------|-------------|---------|----------|--|--|--|--|--|--|
| XD4000 | 2735850 | See EC | 845958 | | | | | | |
| Seq 1 of 2 | Part Number | History | 1 Sep 79 | | | | | | |

Copyright International Business Machines Corporation 1976, 1979

08-660

**POWER WINDOW GLASS REMOVAL/
REPLACEMENT**

DANGER

Before replacing the power window glass, tape both sides of the glass tightly to prevent pieces of glass from falling from the window. Protect your hands with gloves or other suitable covering, especially if you have to touch the broken edges of glass.

To replace the power window glass:

1. Remove the felt strip from both sides of the lower window channel.
2. Pry the decorative cover from the window assembly.
3. Lower the window enough to let you remove the black accent panel from the rear.

Note: On some tape units you must remove the bottom window to reach the accent-panel screws.

If so: Do steps 4a through 4d of the Power Window Alignment procedure on 08-640.

- 4 Support the glass with a rope or belt as shown. Remove three screws and two hex-head nuts from the window support.
5. Lower the window to where you earlier removed the felt strip and lift the glass out.
6. Replace the glass and reverse steps 1 through 5.

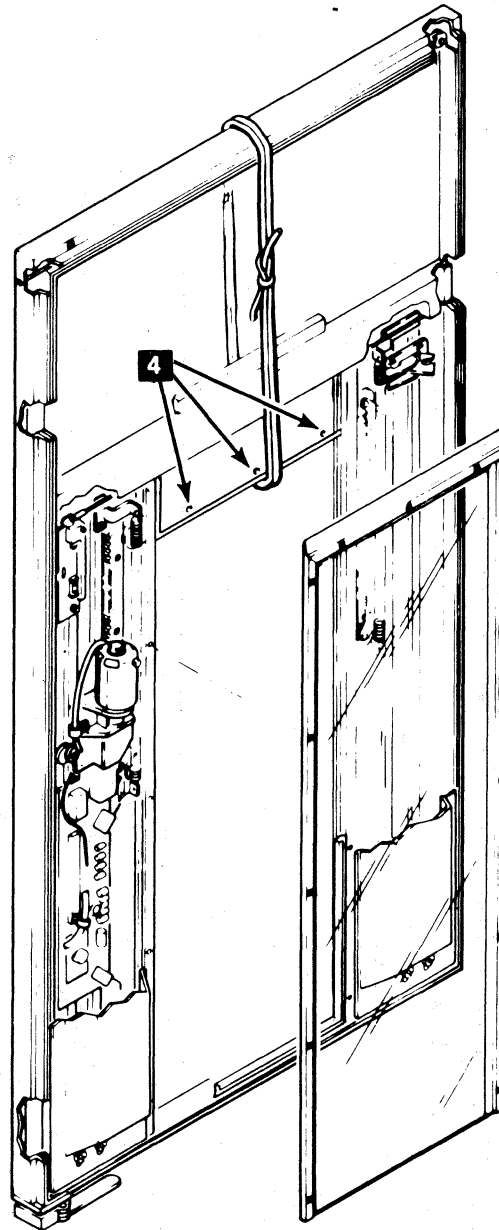

3803-1.2.3/3420

| | | | | | | | | |
|------------|-------------|---------|----------|--|--|--|--|--|
| XD4000 | 2735850 | See EC | 845958 | | | | | |
| Seq 2 of 2 | Part Number | History | 1 Sep 79 | | | | | |

© Copyright International Business Machines Corporation 1976, 1979

CARR — VACUUM COLUMN

08-680

VACUUM COLUMN DOOR REPLACEMENT AND ADJUSTMENT

DANGER

If the door is not a one-piece molded door, ensure that all door rails are tight at all four corners before proceeding.

To replace and adjust the vacuum column door:

- 1 Fasten the Z-bracket hinge to the vacuum column with five screws and washers.
- 2 Close the door and hold it tightly against the vacuum columns.
- 3 Adjust the door left or right by removing or adding shims **C** between the Z bracket and the column. When correctly adjusted, the notches **A** in the right threading channel and the float plate on the door overlap equally. Ensure that the Z bracket rests on the five screws **1**.
- 4 Adjust the door up or down so that the top of the notch float plate and the right threading channel are flush within ± 0.01 inch (0.25 mm). Open the vacuum column door and loosen the seven hinge mounting screws **B** on the Z bracket, and slide the door up or down within the slots.
- 5 With the five screws in the Z bracket loose and with the door latches loose, move the entire door in or out to obtain a tight glass-to-column fit under vacuum-up conditions.
- 6 Check that the latches pull the door toward the columns when the door is closed.
- 7 Tighten all the screws and recheck the adjustments.
- 8 Perform the checks on 08-690.

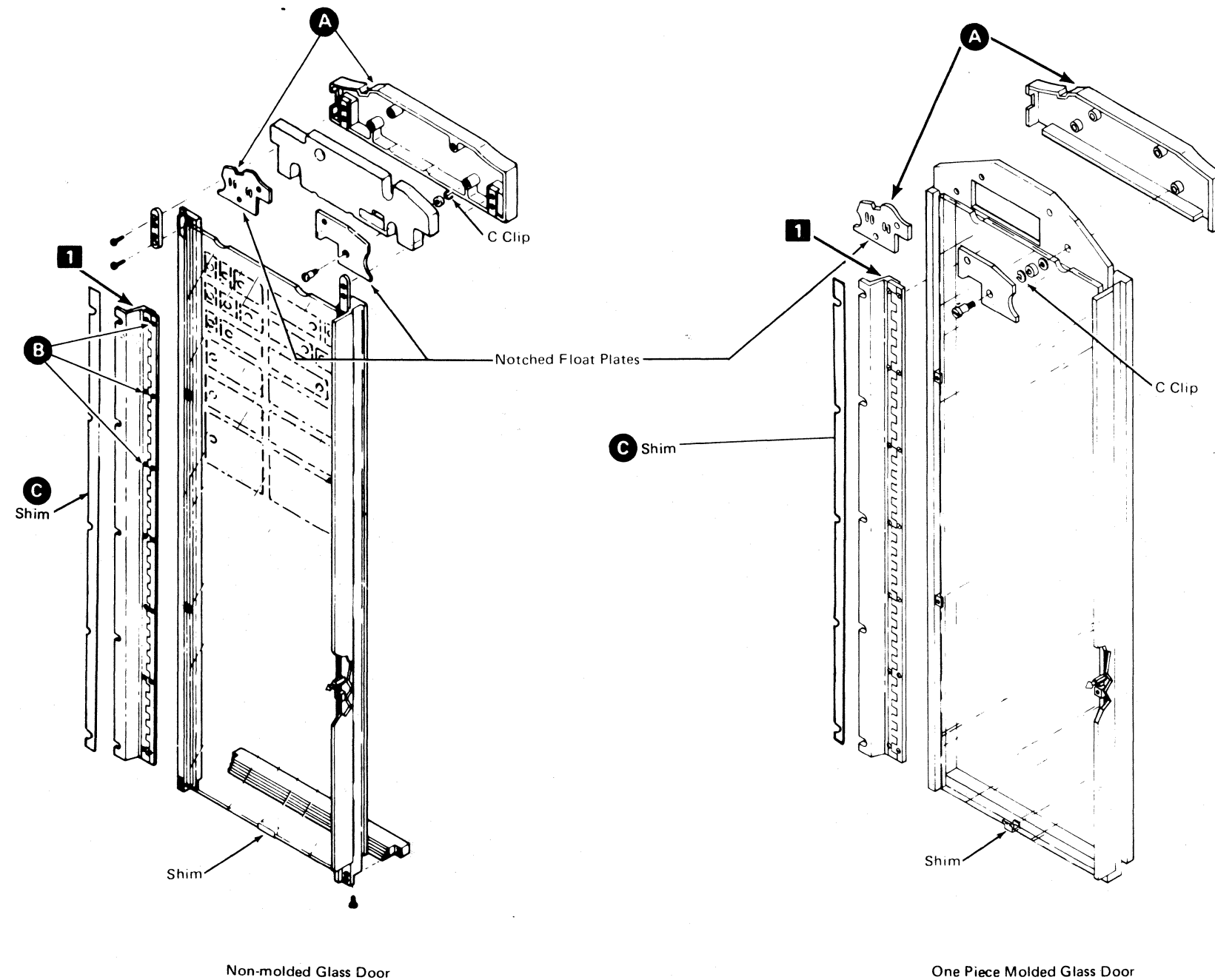

3803-1.2,3/3420

| | | | | | | | | | |
|------------|-------------|---------|----------|--|--|--|--|--|--|
| XD4100 | 2735851 | See EC | 845958 | | | | | | |
| Seq 1 of 2 | Part Number | History | 1 Sep 79 | | | | | | |

Copyright International Business Machines Corporation 1976, 1979

08-680

VACUUM COLUMN DOOR GLASS
REMOVAL/REPLACEMENT

DANGER

One CE should not attempt to replace the glass by himself. Before replacing the vacuum column door glass, tape both sides of the glass tightly to prevent pieces of glass from falling from the window. Protect your hands with gloves or other suitable covering, especially if you have to touch the broken edges of glass.

1. Open the door.
- 2 Loosen the screws and remove the clamps on the hinge side only. This will maintain the adjustment.
3. Slide the glass horizontally toward the hinge side until it clears the nonhinge side clamps.
4. After lifting out the glass, remove the shim package from its bottom edge.
- 5 Examine the new glass for a frosted section at a bottom corner. The frosted side is the flat side of the glass.
6. Install the glass so that the flat side touches the vacuum columns.

Note: Model 8 only install the door glass before installing the resonator. Double the tape back on the resonator before installing.

- 7 Using shims, adjust the glass up and down until its top edge is 0.015 to 0.030 inch (0.38 to 0.76 mm) below the bottom of the door float plate. Press on the center of the float plate and check for 0.015 inch (0.38 mm) clearance.

Note: Install the shim package in the center or the glass will bind and not seal correctly.

- 8 Ensure that the glass is firmly held by the nonhinge side clamps and reinstall the clamps on the hinge side. There should be 0.001 to 0.013 inch (0.025 to 0.33 mm) gap.

9. Perform the checks on 08-680.

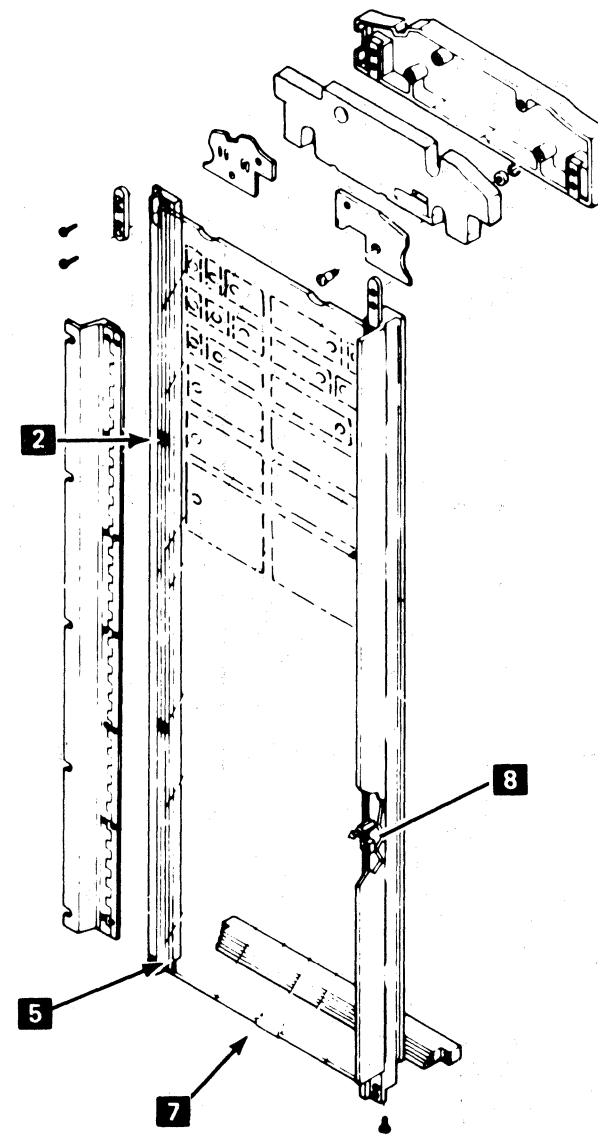

Non-molded Glass Door

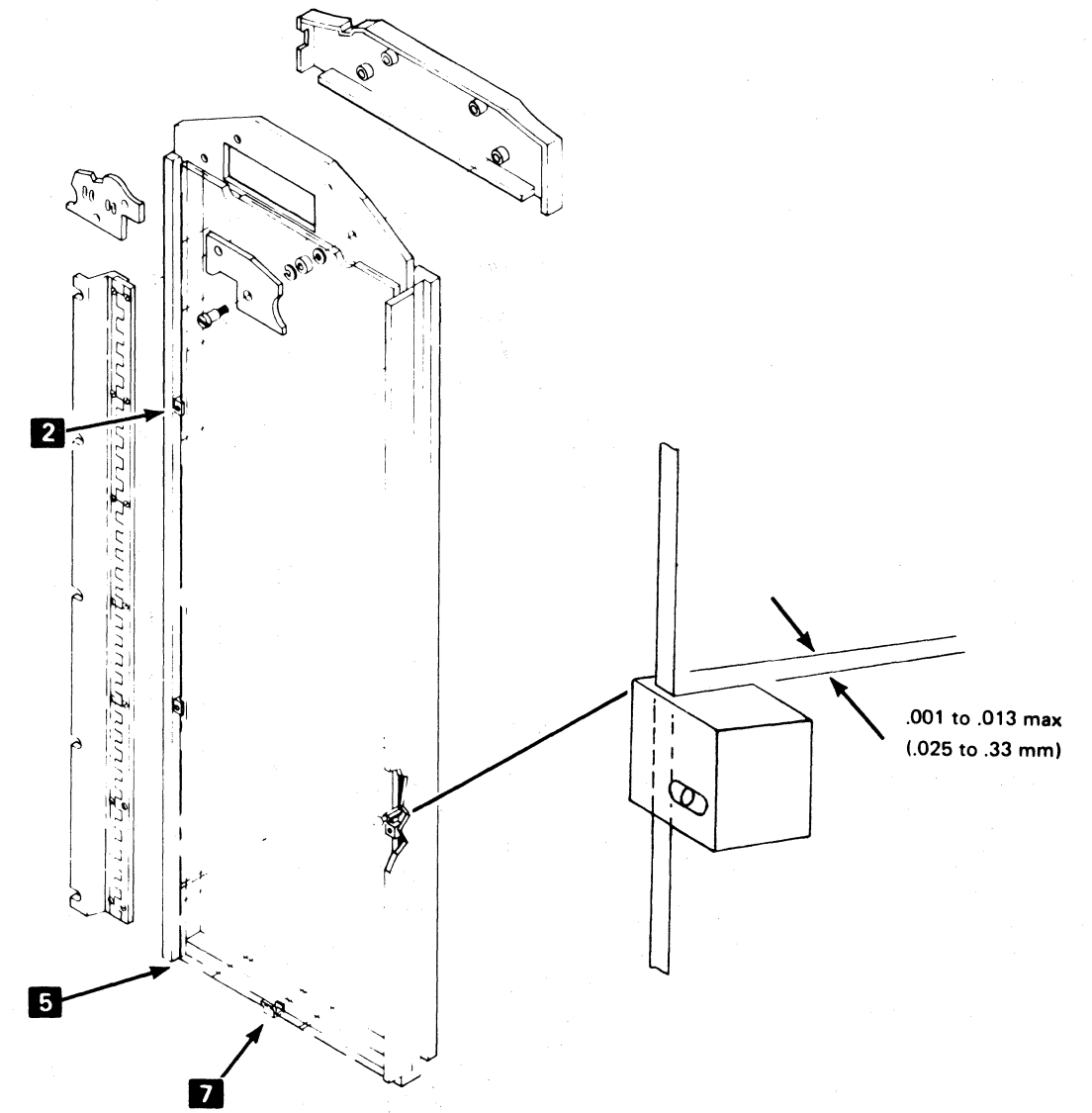

One Piece Molded Glass Door

3803-1,2,3/3420

| | | | | | | | | |
|------------|-------------|---------|----------|--|--|--|--|--|
| XD4100 | 2735851 | See EC | 845958 | | | | | |
| Seq 2 of 2 | Part Number | History | 1 Sep 79 | | | | | |

CARR — CAPSTAN CLEANING

08-700

GLAZED CAPSTAN CLEANING

This procedure is performed only if the glaze cannot be removed by normal cleaning (85-004).

Caution: This procedure, if not done correctly and with extreme care, can shorten the life of (or damage) the capstan. If the capstan edges are rounded or flat spots are created, tracking adjustments will not be possible.

Verify that this procedure is necessary:

1. Perform the Capstan Cleaning-Normal Procedure (see 85-004 if necessary).
2. Run the IBG and Creep measurement test. OLT T3420W determines the size of the interblock gaps. (0.301 inch (7.68 mm) is nominal for Models 4, 6, and 8, and 0.600 inch (15.24 mm) is nominal for Models 3, 5, and 7.)
3. Check the diagnostic printout for signs of slippage (gap sizes exceed the limits specified in the OLT).

If the tape is slipping, the Glazed Capstan Cleaning procedure is necessary. Proceed as follows:

1. Assemble an abrasive tool using 600-grit paper IBM P/N 460107 attached to a six-inch steel rule with double-back adhesive tape such as 3M Y-9122 or 4282*. You can also use rubber cement or printer carriage tape glue.
2. Remove the left threading channel. Place the steel rule with 600-grit paper **squarely** on the capstan and then **just** break the glaze on the capstan with the abrasive tool while rotating the capstan by hand.

The intent is not to remove the glaze with the tool but to break through the coating to allow the tape cleaning solution to soak under it.
3. Moisten cotton swabs with tape cleaner and scrub the capstan rubber thoroughly, until the capstan attains a dull rubber finish.
4. Follow up with a lint-free cloth moistened with tape cleaner to remove all traces of the cotton swab.
5. Verify the effectiveness of your cleaning by repeating the IBG and Creep measurement test (OLT T3420W)
6. The Capstan Dynamic Alignment procedure **must** now be performed. (see 08-150 or 08-160).

*Trademark of 3M Company.

3803-1,2,3/3420

| | | | | | | | | | |
|------------|-------------|---------|----------|--|--|--|--|--|--|
| XD4200 | 4169429 | See EC | 845958 | | | | | | |
| Seq 1 of 2 | Part Number | History | 1 Sep 79 | | | | | | |

© Copyright International Business Machines Corporation 1976, 1979

08-700

MINIREEL LOAD TEST

This procedure should be followed if minireels are used. The ability to load 2400-foot (731.52 m) reels and minireels interchangeably is directly affected by:

1. The vacuum column door seal.
2. The float plate-to-upper column seal.
3. The size of the orifice in the left lower manifold. (Remove the left side of the vacuum hose between the two columns to see the orifice.)
4. The adjustable plastic vacuum column vents located a few inches below the reel tachs.
5. The friction of the tape on the capstan as tape is lowered into both columns.

Any of these items affects the behavior of tape being pulled down into one column or the other. The force of the vacuum on the tape must be equalized between the two columns.

1. If the column door and float plate adjustments are correct, both seat flat against the 0.5 inch (12.7 mm) rails of the vacuum columns.
2. Three orifice sizes are available for the vacuum column manifold:

P/N 1766573 has a 0.750 inch (19.1 mm) orifice
 P/N 1848222 has a 0.625 inch (15.9 mm) orifice
 P/N 4416302 has a 0.870 inch (22.1 mm) orifice

The smaller the orifice, the smaller the vacuum force in the right-hand column.

3. Both left and right column vents, when opened, leak vacuum from their respective columns.

Perform the following steps:

1. Inspect the hose between the column manifolds and ensure that the manifold is tight.
2. Load a full 2400-foot (731.52 m) reel and watch for any tendency for it to pull into only one column.
3. Try loading each size of minireel available. Vary the column vent for the best possible loading characteristic.

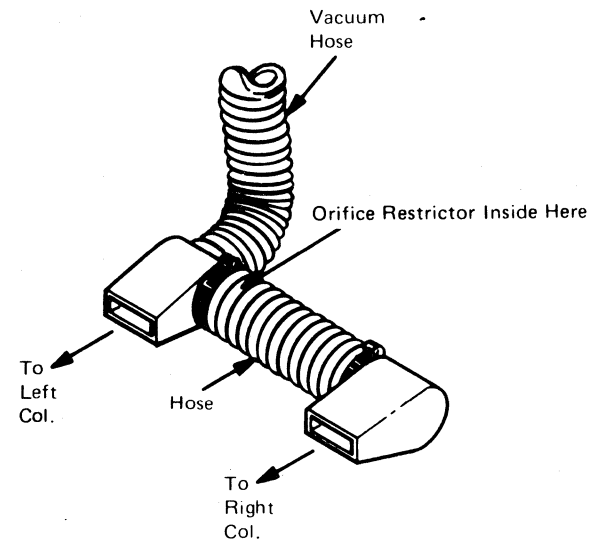

4. If reliable loading of both full and minireel tapes cannot be achieved, measure the orifice size with the 6-inch (152.4 mm) rule. Dumping in the left column indicates a need for a smaller orifice.
5. Replace the orifice and repeat steps 2 through 4.
6. If the adjustment cannot be made, ensure that both reels are attempting to lower the tape into the columns at the correct speed by comparison with an adjacent tape unit. Also check for a warped or cracked manifold.
7. You can connect the dial vacuum gauge to an unused column port to compare vacuum levels during loading. Remove an unused port cap to connect the gauge.

VACUUM BALANCE

The vacuum balance between the two columns is usually affected by the following three items:

1. A leak in the vacuum column door or the float plate area. Check the door and glass alignment (see 08-680 and 08-690). Also, check for broken or missing parts in the float plate area.
2. The size of the vent hole in the vacuum column. The vent is located on the upper outside edge of each vacuum column. If EC 734755 (ECA-041) is not installed, this hole will be approximately 0.5 inch (12.7 mm) in diameter or may not exist at all. If the EC is installed, the hole will contain an adjustable plastic vent (P/N 1846701) for varying the amount of air flow through the hole.

(The smaller the hole, the higher the initial vacuum will be in the columns.) Initial vacuum is the vacuum felt in the column when vacuum is first applied. After the tape has been loaded into both columns, the vacuum in both columns should be equalized.

3. The size of the orifice in the left vacuum column manifold assembly (P/N 2511687) may vary. The manifold may contain the small, medium, or large orifice mentioned above, or there may not be an orifice at all. (The larger the opening, the more initial vacuum is applied to the right column.) Knowing what affects the vacuum balance between the two columns should help resolve the load problem. For example, if the tape is dumping into the left column, it indicates that the left column has

too much initial vacuum when compared with the right column. First, check that item 1 is not the problem. Second, adjust the vacuum column vents (item 2) by decreasing the vacuum in the left column and increasing the vacuum in the right column. Third, if neither items 1 nor 2 solve the problem, increase the orifice opening (item 3) until a correct load occurs. When finished, check the loading of the minireels and the 2400-foot (731.52 m) reels. Ensure that both types of reels load correctly.

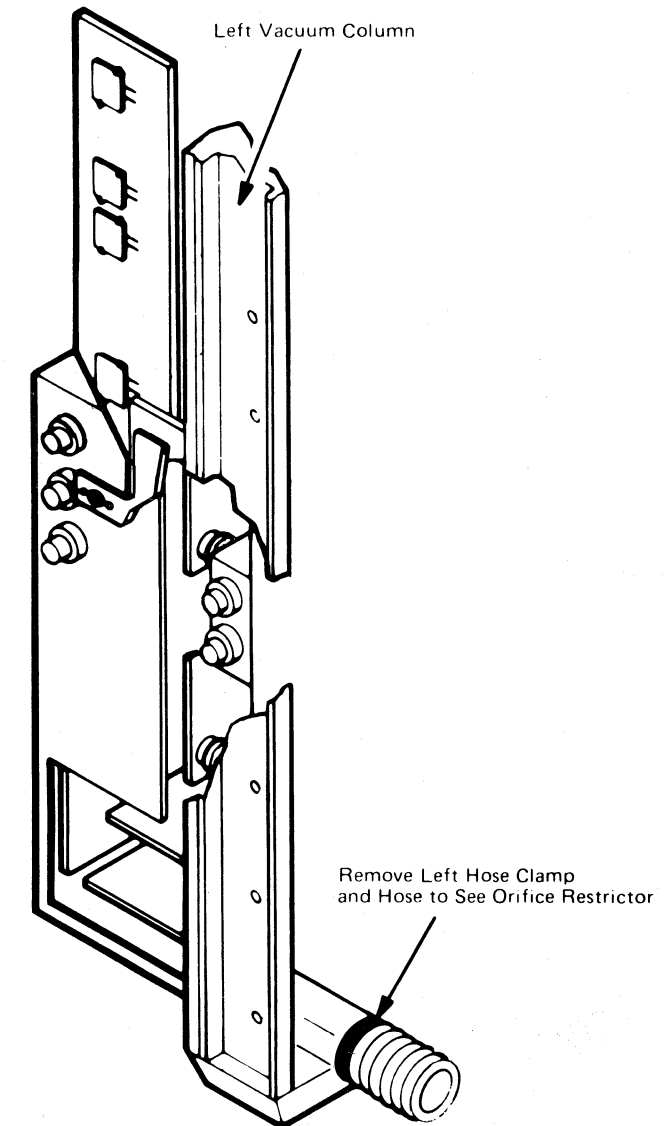

3803-1,2,3/3420

| | | | | | | | |
|------------|-------------|---------|----------|--|--|--|--|
| XD4200 | 4169429 | See EC | 845958 | | | | |
| Seq 2 of 2 | Part Number | History | 1 Sep 79 | | | | |

© Copyright International Business Machines Corporation 1976, 1979

TAPE CONTROL POWER SUPPLY

11-000

| From 00-010, Start 1, 13-000 | | |
|---|--|---|
| Before beginning, verify that the EPO cable is plugged into position J11 or J09, and that the Power On lamp is good. | | |
| Always start with Seq 1 and follow the procedure in sequence unless directed otherwise. Remember to END all problems or maintenance calls by going to MAP 00-030. | | |
| Seq | Condition/Instruction | Action |
| 1 | Is the power sequencing ok? | Go to Seq 25. |
| 2 | Move the AC switch to the UP (ON) position. Operate the Lamp Test switch on the CE panel. Do the lamps light? | If the power is on for all tape units, go to Seq 37; otherwise, go to Seq 4. |
| 3 | Are the power supply blowers operating? | Go to Seq 25. |
| 4 | Is CP17, CP1 tripped, or the customer main circuit protector tripped? | Reset the circuit protector and go to 00-030. |
| 5 | Is the power off on any tape unit powered from sockets J1 through J4? | Check CB1 on each tape unit. If it is tripped, reset it and go to 00-030. If not, go to Seq 14. |
| 6 | Is the power off on any tape unit powered from sockets J5 through J8? | Check CB1 on each tape unit. If it is tripped, reset it and go to 00-030. If not, go to Seq 8. |
| 7 | If not: | Go to Seq 37 on page 11-001. |
| 8 | The test points referred to in the following instructions are on the back of the ac printed circuit board. (See drawing.) Remove the cover below the four toggle switches. Measure from the test point specified below to test point 16. | |
| 9 | Is -24 Vdc present at test point 10? | Repair K8 (YF030) and go to 00-030. |
| 10 | Is -24 Vdc present at K3-16? | If -24 Vdc is present at K3-1, repair K3 (YF030) and go to 00-030; otherwise, go to Seq 14. |
| 11 | Is -24 Vdc present at test point 1. | Check CP19 on the ac board then terminals 1, 2, 3, and 4 (YF030) and go to 00-030. |
| 12 | Is -24 Vdc present at test point 4? | Repair or replace K2 (YF030) and go to 00-030. |
| 13 | If not: | Repair or replace J11-1 and J11-2 EPO contacts in the channel (YF030) and go to 00-030. |
| 14 | The test points referred to in the following instructions are on the back of the ac printed circuit board. (See drawing.) Remove the cover below the four toggle switches. Measure from the test point specified to test point 16. | |
| 15 | Is -24 Vdc present at test point 13? | Repair or replace K7 (YF030). |
| 16 | Is -24 Vdc missing at K1-10? | Go to Seq 11. |
| 17 | Is -24 Vdc present at K1-4? | Repair or replace K1 (YF030) and go to 00-030. |

| Seq | Condition/Instruction | Action |
|-----|--|---|
| 18 | Is -24 Vdc present at AC ON/OFF switch pin 2? | Replace the ac switch (YF030) and go to 00-030. |
| 19 | Is -24 Vdc present at test point 3? | Check power supply connectors and terminals for loose or bad connections and go to 00-030. |
| 20 | Is the REMOTE/LOCAL switch set to REMOTE? | Go to Seq 23. |
| 21 | Is -24 Vdc present at pin 2 of the LOCAL/REMOTE switch? | Repair the LOCAL/REMOTE switch (YF030) and go to 00-030. |
| 22 | If not: | Check EPO jumpers J11-2 to J11-1 or EPO control system and go to 00-030. |
| 23 | Is -24 Vdc missing at test point 2? | Repair EPO connector J11-5 which leads to the SYSTEM POWER ON contacts (YF030) and go to 00-030. |
| 24 | If not: | Repair EPO connector J11-6 which leads to the STEP CONTROL switch in the system (YF030) and go to 00-030. |
| 25 | Verify that the +6 Vdc and -4 Vdc power supply outputs are within the tolerances the tolerances given on pow To adjust, hold the DC RESET switch active, and use one of the digital voltmeters listed in 80-000. Check the voltages at the following points: +6 Vdc from A-B2R2M11 to Gnd A-B2R2D08, and the -4 Vdc from A-A2T4B06 to Gnd A-A2T4D08. Note: Make sure all terminal and capacitor screws are tight. Also check for improper solder connections on the power supply boards. The ripple specification for -4V is 80 mV peak-to-peak and for +6 V is 10 mV peak-to-peak. Measure at the power supply. | |
| 26 | Can the +6 and -4 voltages be adjusted within their tolerance? | Change J1 (YF031) on the +6 power supply. If this fixes the problem, return the tape unit to the customer. If it does not fix the problem, replace K4 (YF030) and go to 00-030. |
| 27 | If not: | Change and adjust the regulator that is out of tolerance. Go to Seq 28. |
| 28 | Is the voltage now in tolerance? | Go to 00-030. |

| Seq | Condition/Instruction | Action |
|-----|---|---|
| 29 | If not: | Remove the output leads from the bad power supply. For the +6 V supply, remove leads TB2-3 and TB2-4. For the -4 V supply, remove leads 6 and 7 from both -V supply and one end of the bypass resistor. Note: The bypass resistor (R-8) is the big resistor mounted on the A1 regulator assembly. Go to Seq 30. |
| 30 | Are the voltages within their tolerance? | You have an overload condition. Refer to ALD YA106 and go to 00-030. |
| 31 | Are the voltages within tolerance when the OV/UV card is removed? | Change the OV/UV card (YF031) and go to 00-030. This card is not field adjustable. |

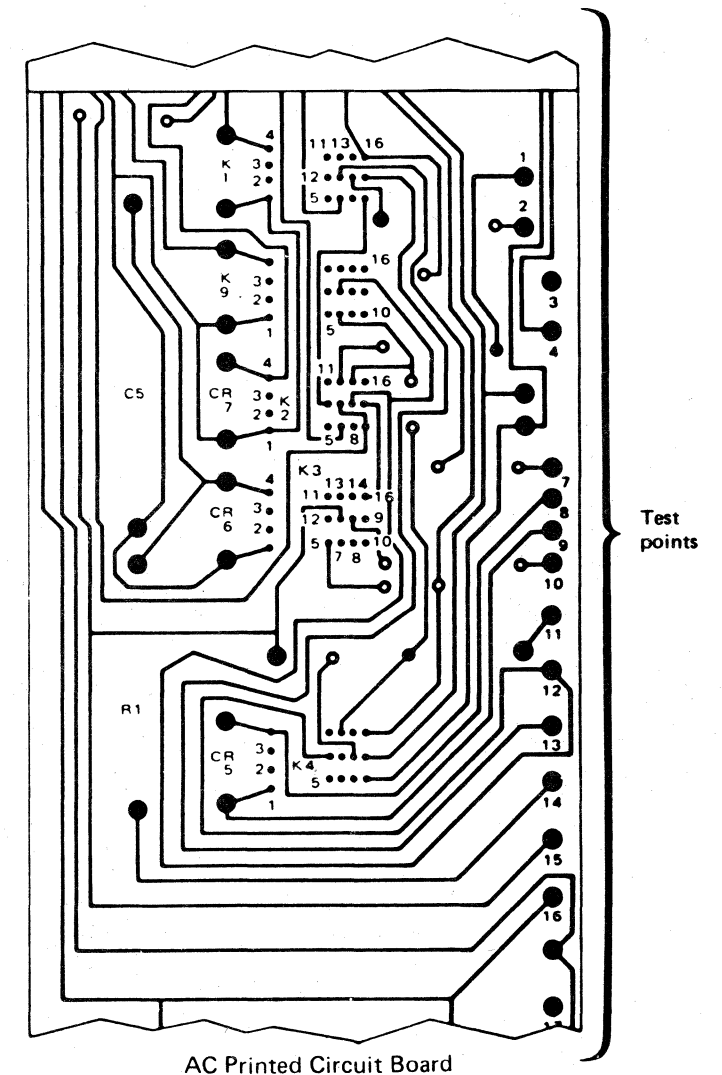

3803-2/3420

| | | | | | | | |
|----------------------|------------------------|-------------------|--------------------|--|--|--|--|
| XE0100 Seq 1 of 2 | 2735852 Part Number | See EC History | 845958 1 Sep 79 | | | | |
|----------------------|------------------------|-------------------|--------------------|--|--|--|--|

11-000

| Seq | Condition/Instruction | Action |
|-----|--|--|
| 32 | Check the input voltages. For the +6 V supply, you should have 11.4 Vac between leads TB1-5 and TB1-1 and between TB1-5 and TB1-3. For the -4 V supply, you should have 9.3 Vac between leads 3 and 2 and leads 3 and 1 (YF031). | |
| 33 | Is the measured input voltage for the +6 V supply 0 V or approximately 23 V? | Check for open connection between the secondary of T1 and the input to regulator assembly A3. See YF031. |
| 34 | Is the measured input voltage for the +4 V supply 0 V or approximately 18.6 V? | Check for open connection between the secondary of T1 and the inputs to regulator assemblies A1 and A2. See YF031. |
| 35 | Do both power supplies have incorrect input voltages? | Check the input capacitors for both power supplies (YF031) and go to 00-030. |
| 36 | If not: | 1. There is a poor connection between the heat sink and pin A of the 4 V regulator card. Add a jumper between the heat sink and pin A if you are unable to locate the cause of high resistance. 2. Change or repair the faulty power supply (YF031) and go to 00-030. If -4 V supply is defective, change both the A1 and A2 regulator assemblies. |
| 37 | Do the blowers operate while the DC RESET switch is held pressed? | If K4 is picked, go to Seq 39; otherwise, go to Seq 25. |
| 38 | If not: | Go to Seq 42. |
| 39 | Do the blowers stop operating when the DC RESET switch is released? | Repair or replace K4 (YF030) and go to 00-030. |
| 40 | Turn the ac switch off and then on. Do the blowers still fail to operate? | Repair or replace K3 (YF030) and go to 00-030. |
| 41 | If not: | Go to 00-030. |
| 42 | The test points referred to in the following instructions are on the back of the ac printed circuit board. Measure from the test point specified to test point 16. Is -24 Vdc present at test point 7? | Repair or replace K6 (YF030) and go to 00-030. |
| 43 | Is -24 Vdc present at K1-7? | Repair K1 (YF030) and go to 00-030. |
| 44 | Is -24 Vdc present at DC OFF switch pin 5? | Repair the DC OFF switch and go to 00-030. |

| Seq | Condition/Instruction | Action |
|-----|--|--|
| 45 | Is -24 Vdc present at the DC RESET switch pin 5? | Repair the DC RESET switch and go to 00-030. |
| 46 | Is -24 Vdc present at K2-6? | Repair or replace K2 (YF030) and go to 00-030. |
| 47 | If not: | Go to Seq 11. |

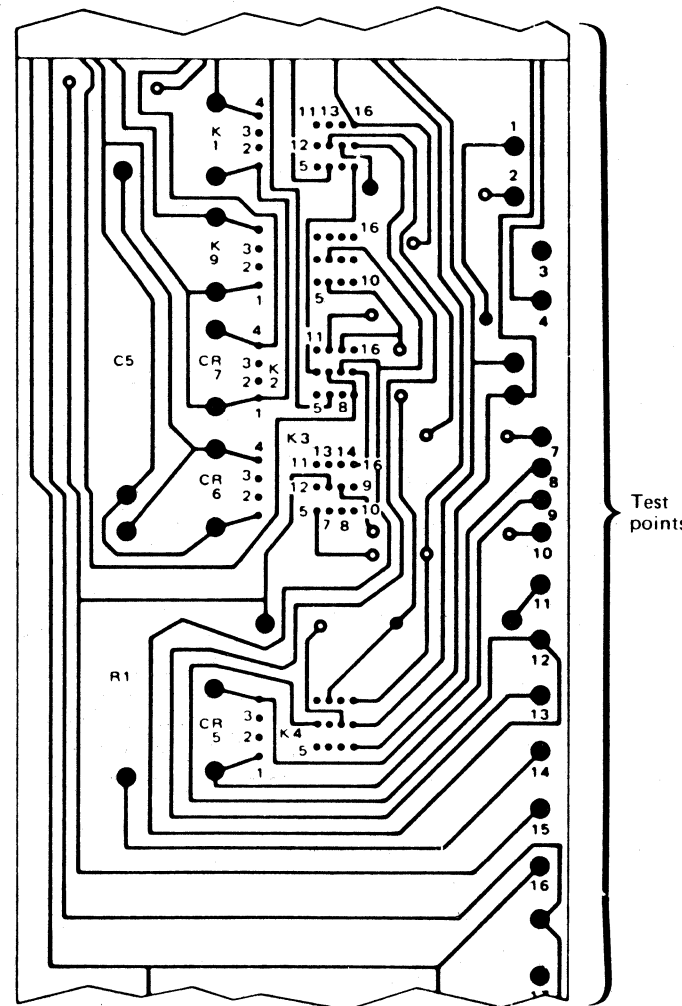

AC Printed Circuit Board

3803-2/3420

| | | | | | | | |
|---------------|----------------|-----------------------|---------------|--|--|--|--|
| XE0100 | 2735852 | See EC History | 845958 | | | | |
| Seq 2 of 2 | Part Number | | 1 Sep 79 | | | | |

OFFLINE DUPLICATION OF ONLINE FAILURES

12-000

| From: 13-000, 13-050 | | |
|--|--|---------------|
| <p>You have probably reached this MAP because:</p> <ol style="list-style-type: none"> 1. The CPU is unavailable for running OLTs. (If the problem is intermittent Read/Write, OLTs are required. See 00-010.) 2. You were sent here by another MAP. 3. The CE panel appears to be malfunctioning. (The CE panel description and switch operation is described on 75-001.) Note: If you have a 1x8 with address 8-F, change the address plugging to 0-7 before continuing. (See 90-130.) Return the address to 8-F before returning the unit to the customer. | | |
| <p>Always start with Seq 1 and follow the procedure in sequence unless directed otherwise. Remember to END all problems or maintenance calls by going to MAP 00-030.</p> | | |
| Seq | Condition/Instruction | Action |
| 1 | Do you need help operating the CE panel? | Go to 12-010. |
| 2 | Is the CE panel failing? | Go to 12-020. |
| 3 | <p>Try to duplicate the online failure from the CE panel. Perform ALU checkout.</p> <p>A. Take the tape control offline:</p> <p>Turn the Meter Enable switch(es) Off. (When all interrupts have been cleared, the Interface Disabled indicator should turn on.) If the indicator doesn't light, operate the Reset switch.</p> <p>Caution: Operating the RESET switch when the Interface Disable indicator is Off may cause a channel failure.</p> <p>B. Enable the CE panel:</p> <p>Turn on (raise) the Panel Enable switch. Set the ROS Mode switch to Norm. Operate the Set ROS Mode switch. The Panel Enable indicator should light.</p> <p>C. Set ROS Mode:</p> <p>Set the ROS Mode switch to Stop. Operate the Set ROS Mode switch.</p> <p>D. Select ALU1 and display ALU1 indicators:</p> <p>Turn on the Stop On Control Check and Stop On Data Flow Check switches. Set ALU1/ALU2 switch to ALU1. Set Display Select switch to IC.</p> <p>E. Operate the Reset switch to reset the tape control.</p> <p>Record any Control Check or Data Flow Check red lights and the IC address being displayed in the ROS address lights for ALU1. They should indicate hex '7FF'.</p> | |

| Seq | Condition/Instruction | Action |
|-----|--|---------------|
| | <p>F. Set the ALU1/ALU2 switch to ALU2. Record ALU2's IC address.</p> <p>G. Set ALU1/ALU2 switch to ALU2.</p> <p>H. Operate the Reset switch to reset the tape control. Record red lights and IC address for ALU2.</p> <p>I. Set the ALU1/ALU2 switch to ALU1. Record ALU1's IC address.</p> <p>Note: A Control Check stops only the selected ALU.</p> | |
| 4 | Did you get either a Control Check red light error or an IC address other than hex '7FF' in either ALU? | Go to 13-000. |
| 5 | <p>Power on Reset and ALU Checkout routines work normally. Test the tape unit operation.</p> <p>A. Set the following switches: ALU1/ALU2 switch to ALU1. Ripple/Wr Data switch to Ripple. Mple/Single switch to Mple. Stop On Control Check and Stop On Data Flow Check switches On. Note: ROS should still be in STOP Mode.</p> <p>B. Set the Compare Register to 20A: Set the Display Select switch to Cmpr Reg. Set the Data Entry Select switch to Cmpr Reg. Set the three Data Entry rotary switches to 20A, reading left to right. Operate the Set CE Cmpr switch. Verify that 20A is displayed in the indicators.</p> <p>C. Set the Command Chain, Data, and Byte Count into the CE Register: Set the Display Select switch to CE REG. Select the register to be loaded with the Data Entry Select switches. Dial the data to be entered into the three Data Entry switches. Load the register by operating the Set CE/Cmpr switch.</p> | |

| Seq | Condition/Instruction | Action | | | | | | | | | | | | | | | | | | | | | | | | | | | | | | |
|-------|--|---|----|---|---------------------------|---|--|----|----|----|----|--|---------------------|----|----|----|----|--|---------------------|----|----|----|----|--|-------------------------|----|----|----|----|--|---------------------------|--------------|
| 5 | <p>(continued)</p> <p>Cmdnd 1 = 07X Cmdnd 2 = 17X Cmdnd 3 = 8BX Cmdnd 4 = 01X Byte Cnt = 4D0 Write Data/ Go Down = FF0</p> <p>Install the LWR with gaps jumper from A1S2G08 to ground. (Allows LWR to terminate) X = the tape unit address 0 through F.</p> <p>Mount and load a CE work tape— Tape must be rewound to load point. Operate the Start switch.</p> | | | | | | | | | | | | | | | | | | | | | | | | | | | | | | | |
| 6 | Did any CE or Compare register fail to load? | Go to 12-020. | | | | | | | | | | | | | | | | | | | | | | | | | | | | | | |
| 7 | Set Display Select switch to IC. Did ALU1 stop at address of '301'? (IC address of '303' may appear in the ROS address indicators due to the lookahead circuit.) | A unit check condition has occurred and sense data is being saved. Go to Seq 14 and obtain the sense information. | | | | | | | | | | | | | | | | | | | | | | | | | | | | | | |
| 8 | Using the ALU1/ALU2 switch, select each ALU alternately. Reset the tape control and restart the command chain at least once with each ALU selected. Do you get any Control Check red lights? (A Control Check stops only the selected ALU.) | Go to 13-000 for interpretation of the error lights. | | | | | | | | | | | | | | | | | | | | | | | | | | | | | | |
| 9 | Did ALU1 display an IC address other than '7FF'? | Go to 13-000. | | | | | | | | | | | | | | | | | | | | | | | | | | | | | | |
| 10 | Is ALU1 idling at '7FF' but failing to start the command chain when the Command Controls Start switch is operated? | Go to 13-050. | | | | | | | | | | | | | | | | | | | | | | | | | | | | | | |
| 11 | <p>If the previous command chain will not fail, try the following:</p> <p>A. If the original failure was a P Compare or CRC problem, set the Ripple/Wr Data switch to Ripple and vary the byte count. These two errors are extremely data sensitive.</p> <p>B. Replace commands 1 through 4 with the following or try a combination based on the original failure:</p> <table border="1"> <tr> <td>Cmdnd</td> <td>1</td> <td>2</td> <td>3</td> <td>4</td> <td></td> </tr> <tr> <td>07</td> <td>02</td> <td>0C</td> <td>02</td> <td></td> <td>REW/RD/ RDBKD/RD</td> </tr> <tr> <td>07</td> <td>1F</td> <td>01</td> <td>27</td> <td></td> <td>REW/WTM/ WRT/BSB</td> </tr> <tr> <td>07</td> <td>C3</td> <td>01</td> <td>0C</td> <td></td> <td>REW/MS PE/ WRT/RDBKD</td> </tr> <tr> <td>07</td> <td>CB</td> <td>01</td> <td>0C</td> <td></td> <td>REW/MS NRZI/ WRT/RDBKD</td> </tr> </table> <p>Did the new command sequence fail?</p> | Cmdnd | 1 | 2 | 3 | 4 | | 07 | 02 | 0C | 02 | | REW/RD/ RDBKD/RD | 07 | 1F | 01 | 27 | | REW/WTM/ WRT/BSB | 07 | C3 | 01 | 0C | | REW/MS PE/ WRT/RDBKD | 07 | CB | 01 | 0C | | REW/MS NRZI/ WRT/RDBKD | Go to Seq 6. |
| Cmdnd | 1 | 2 | 3 | 4 | | | | | | | | | | | | | | | | | | | | | | | | | | | | |
| 07 | 02 | 0C | 02 | | REW/RD/ RDBKD/RD | | | | | | | | | | | | | | | | | | | | | | | | | | | |
| 07 | 1F | 01 | 27 | | REW/WTM/ WRT/BSB | | | | | | | | | | | | | | | | | | | | | | | | | | | |
| 07 | C3 | 01 | 0C | | REW/MS PE/ WRT/RDBKD | | | | | | | | | | | | | | | | | | | | | | | | | | | |
| 07 | CB | 01 | 0C | | REW/MS NRZI/ WRT/RDBKD | | | | | | | | | | | | | | | | | | | | | | | | | | | |

3803-2/3420

| | | | | | | | |
|------------|-------------|----------------|----------|--|--|--|--|
| XE0200 | 2735853 | See EC History | 845958 | | | | |
| Seq 1 of 2 | Part Number | | 1 Sep 79 | | | | |

12-000

OFFLINE DUPLICATION OF ONLINE FAILURES (Cont'd)

| Seq | Condition/Instruction | Action |
|-----|--|---|
| 12 | The failure is either extremely intermittent or cannot be created offline. Return to 00-010 and run OLTs if you have not found the problem. Is any sense data available from the OLT failure? | Go to 14-000. |
| 13 | If not: | Go to 18-020, 19-000, and 00-010 for ideas. |
| 14 | <p>Obtain Sense Data</p> <p>You should be stopped at ALU1 address '301' with a Data Flow Check Indicator On; however, the '301' failure may not light an indicator. Do not reset the tape control or the sense data will be lost.</p> <p>A. Set the Display Select switch to Cmpr Reg and verify that the Compare Register is still set to '20A'.</p> <p>B. Enter a Sense command into all four Command Registers. Set the Data Entry Select rotary switches to '04X'. Set the Display Select switch to CE Reg. Set the Data Entry Select switch to Cmnd 1, Cmnd 2, Cmnd 3, and Cmnd 4. Operate the Set CE/Cmpr switch for each position.</p> <p>C. Set the CE Panel switches: ALU1/ALU2 switch to ALU1. Display Select switch to IC. Stop On Control Check switch Off. Stop On Data Flow Check switch Off. Mple/Single switch to Single.</p> <p>D. Operate the Command Control Start switch.</p> <p>E. The indicators should be displaying an IC address of '20A'. Move the Display Select switch to Bus In. The indicators will now display Sense Byte 0.</p> <p>F. Move the Display Select switch back to IC and operate the Start or Step switch one time. Sense Byte 1 can now be displayed by setting the Display Select switch to Bus In.</p> <p>G. Obtain all 24 bytes of sense data by selecting IC, operating Start or Step once, then displaying Bus In. Do not operate Start or Step unless IC is selected.</p> | |

| Seq | Condition/Instruction | Action |
|-----|---|--|
| | <p>H. With the Mple/Single switch on Mple, ALU1 will go back to Idlescans (7FF) after the 24th sense byte is obtained.</p> <p>I. Contact bounce in the Start or Step switch may cause this routine to skip over several sense bytes. If this occurs, complete the routine to obtain remaining sense bytes, then go back to step D to get the sense bytes you skipped.</p> | |
| 15 | Have all 24 sense bytes been obtained? | Go to 14-000 and do a manual sense analysis. |
| 16 | If not: | Go to 00-030. |

3803-2/3420

| | | | | | | | | |
|----------------------|------------------------|-------------------|--------------------|--|--|--|--|--|
| XE0200 Seq 2 of 2 | 2735853 Part Number | See EC History | 845958 1 Sep 79 | | | | | |
|----------------------|------------------------|-------------------|--------------------|--|--|--|--|--|

CE PANEL OPERATION

12-010

CE PANEL OPERATION CONTENTS

For a description of each switch see 75-001.

1. CE Panel Notes
2. Enable the CE Panel
3. Online Stop on ALU Hardware Error (Control Check)
4. ALU "Babysitter" Using Cmpr Equal Lamp
5. Take the Tape Control Offline (Disable the Interface)
6. Reset the Tape Control Unit
7. Single Step Through a Microprogram (Loop on Routine)
8. Set IC to a ROS Address
9. Stop On Data Flow or Control Check Error
10. ROS Address compare, Stop or Sync
11. Restart On ALU Error or Address Compare
12. Cycle a Single ALU Instruction
13. Execute a Command Sequence to a Tape Unit
14. Ripple Data Pattern and Byte Count
15. Obtain 24 Sense Bytes
16. Display Local Storage Register (LSR) Contents
17. Display ROS Bits (ALU Instructions)
18. Display the Channel and Device Bus and Tags
19. Data Security Erase Procedure Offline

| Always start with Seq 1 and follow the procedure in sequence unless directed otherwise. Remember to END all problems or maintenance calls by going to MAP 00-030. | |
|--|---|
| Seq | Condition/Instruction |
| 1 | <p>CE Panel Notes</p> <p>A. Byte Count: Performing commands with the following values set in the Byte Count Register will result in the following size records being written:</p> <p style="margin-left: 40px;">'FF0' = 2 bytes '000' = 3 bytes '010' = 4 bytes '001' = 3+1024 bytes '042' = 7+2048 bytes</p> <p>B. Less than 24 bytes of Sense Data with the LWR jumper installed: If the sense operation ends before issuing all 24 bytes of sense, remove the LWR jumper from A1S2G08 to ground, which was installed in order to perform an LWR operation with gaps. The value set in the byte count register affects the number of bytes indirectly.</p> <p>C. Control Check errors on a Power-Up operation: If the CE panel has been left enabled and the Control Check Stop switch left on, you may encounter an error stop with Control Check red lights, due to uninitialized LSRs.</p> <p>D. Control Check Stop On switch without ROS Mode being set to STOP mode: The Control Check Stop On switch, by itself, will prevent the ALU HARDWARE ERROR trap to address 000, but will allow the ALUs to continue running.</p> <p>E. Control Check Stop On switch being left On prevents:</p> <ol style="list-style-type: none"> 1. The Address Compare Stop function. 2. The Set IC function. 3. The Address Compare Sync function. 4. The Restart/Compare function. 5. The Restart/Error function. <p>F. Loop-Write-Read (LWR): An LWR operation with a 3420 Model 4, 6, or 8 operates in 1600 bpi mode if the tape is at Load Point. To do an LWR at 6250 bpi, perform a write operation to move the tape off Load Point. All subsequent LWR operations will be performed in 6250 bpi mode.</p> <p>G. Data Flow Errors are Command Code sensitive Any change in the CE panel setup within a procedure can alter the error. Then the procedure does not apply.</p> |
| 2 | <p>Enable the CE Panel</p> <p>The CE Panel can be enabled at any time. Caution should be taken when the customer is running with the panel enabled—Control Check and Compare Stop functions are active in this status.</p> <ol style="list-style-type: none"> A. Raise the Panel Enable toggle switch. B. Verify that the Panel Enable lamp comes on. C. If Panel Enable lamp fails to come on, set the ROS Mode switch to the NORM position; then operate the Set ROS Mode toggle switch. (The latter switch is a spring-loaded, three-position switch. Operating it momentarily upward performs the Set ROS Mode function, operating it downward performs the Set CE/CMPR function.) |

| Seq | Condition/Instruction |
|-----|---|
| 3 | <p>Online Stop On ALU Hardware Error (Control Check)</p> <p>An ALU error (for example, D Bus Parity) can be caught online with the Control Check error light showing. Both ALUs are stopped, but only when the ALU selected by the ALU1/ALU2 switch turns on a red light. Therefore, if ALU1 is selected, and ALU2 has the error, a red light does not occur unless ALU1 later turns on its Microprogram Detected Error light or has a parity error due to a bad transfer from ALU2.</p> <ol style="list-style-type: none"> A. Enable the CE Panel as in Seq 2. B. Turn the Control Check Stop On switch On. C. Set the ROS Mode switch to Stop. D. Operate the Set ROS Mode switch. E. Select either ALU with the ALU1/ALU2 switch. F. After a failure occurs in the selected ALU, select the opposite ALU and wait for a failure. (ALU1 monitors ALU2, so try ALU1 first.) <p>The IC Address displayed is one past the failure.</p> <p>Caution: Trapping ALU errors online with the Control Check switch on can impact customer operations. Make use of the channel retry feature on System/370 CPUs. Place the CPU in hard-stop mode before activating the Control Check switch. Use the hard-stop mode that ignores recoverable storage errors. When the ALU stops; (1) obtain the required information from the CE panel, (2) turn off the Control Check switch, (3) switch the CPU to Process, and (4) start the CPU. This allows the channel retry hardware and software to recover. Recovery is only possible on intermittent ALU errors. Raise the Control Check Stop On switch first, before setting ROS Mode to Stop in order to prevent stopping on a Compare address.</p> |
| 4 | <p>ALU "Babysitter" Using the CMPR Equal Light</p> <p>To prove if a microprogram instruction is executed, either online or offline, use the following operation. If the exact sequence below is used, the setup can be done while the customer is running.</p> <ol style="list-style-type: none"> A. Enable the CE Panel (Seq 2). B. Leave the ROS in Normal mode. C. Enter the hex address of the instruction in the three data entry switches. D. Turn the Data Entry Select switch to Cmpr Reg. E. Turn the Display Select switch to Cmpr Reg. F. Operate the Set CE/Cmpr Switch. G. Select the proper ALU with the ALU1/ALU2 switch. H. Set the Display Select switch to IC. <p>The Cmpr Equal lamp lights each time the instruction is executed. To reset the light, just operate the Start or Step switch.</p> |
| 5 | <p>Take the Tape Control Offline (Disable the Interface)</p> <ol style="list-style-type: none"> A. Drop both Meter Enable switches (one switch if no TCS feature is installed). B. Observe the green INTFs Disabled lamp. <p>When all interrupts have been cleared by the channel, the interface will become disabled and turn on the lamp. If the channel or ALU is not free to run, operate the Reset switch.</p> <p>Caution: Reset without interface Disabled may hand or cause channel errors. Not disabling the interface when attached to a polling channel (such as a 2860) causes microprogram errors on the 3803.</p> |

3803-2/3420

| | | | | | | | | |
|------------|-------------|----------------|----------|--|--|--|--|--|
| XE0300 | 2735854 | See EC History | 845958 | | | | | |
| Seq 1 of 2 | Part Number | | 1 Sep 79 | | | | | |

12-010

| Seq | Condition/Instruction |
|-----|---|
| 6 | <p>Reset the Tape Control Unit</p> <p>A Reset can be initiated with the Reset/Start or Step switch.</p> <p>A. Enable the CE Panel (Seq 2). B. Operate the Reset switch.</p> <p>Caution: Disable the interface to prevent channel errors. Both ALUs will be trapped to address '000', then forced through the POR and ALU Checkout Routines.</p> |
| 7 | <p>Single Step Through a Microprogram Loop or Routine</p> <p>A. Find the initial starting point by entering the loop, stopping on a compare address (Seq 10), or setting IC (Seq 8). B. Enable the CE Panel (Seq. 2). C. Set the ROS Mode switch to Step. D. Operate the Set ROS Mode switch. E. Ensure that you are selecting the proper ALU with the ALU1/ALU2 switch. F. Each operation of the Start or Step switch will execute the instruction currently being displayed.</p> <p>The ROS Address displayed (with the Display Select switch set to IC), and the ROS Data Bits displayed (with the Display Select switch set to Hi or Low ROS) are for the next instruction to be executed.</p> |
| 8 | <p>Set IC to a ROS Address</p> <p>The Set IC function places the contents of the Compare Register into the Instruction Counter of the selected ALU.</p> <p>A. Set the desired Hex address into the Data Entry switches. B. Set Display Select and Data Entry Select switches to Cmpr Reg. C. Operate the Set CE/Cmpr switch. D. Set the ROS Mode switch to Set IC. E. Select the proper ALU with the ALU1/ALU2 switch. F. Operate the Set ROS Mode switch. (Control Check Stop On switch must be down.) G. Set the ROS Mode switch to the desired mode, and operate the Set ROS Mode switch. H. Operate Start or Step to restart ALU.</p> |
| 9 | <p>Stop on Data Flow or Control Check Error</p> <p>Control Check Stop: These errors are actually ALU hardware errors. See Seq 3 for the CE Panel setup and pertinent information. This function can be performed online or offline. The CE Panel need only be enabled.</p> <p>Data Flow Check Stop: This function is active only when offline. The CE Panel must be enabled, and the channel interface disabled.</p> <p>A. Enable the CE Panel (Seq 2). B. Disable the interface (Seq 5). C. Turn the Data Flow Check Stop switch on (up). D. Execute a command chain (Seq 13). E. The ROS Mode and ALU1/ALU2 switch positions are unimportant.</p> <p>The error will stop ALU1 at address '301' when an error occurs and maintain the failing sense bytes. See Seq 15 to obtain the sense bytes.</p> |

| Seq | Condition/Instruction |
|-----|--|
| 10 | <p>ROS Address Compare, Stop or Sync</p> <p>These functions are active either online or offline.</p> <p>A. Enable the CE Panel (Seq 2). B. Set the desired hex address into the Data Entry switches. C. Set the Display Select and Data Entry Select switches to Cmpr Reg. D. Operate the Set CE/Cmpr switch. E. Turn the Display Select switch to IC. F. Ensure that the Control Check Stop On switch is off (down). G. Select the proper ALU with the ALU1/ALU2 switch.</p> <p>The CE Panel setup is the same, at this point, for either stopping or syncing a scope on the address. The setting of the ROS Mode will determine the function.</p> <p>Stop On ROS Compare Set the ROS Mode switch to Stop and operate the Set ROS Mode switch. The selected ALU will stop when the IC address matches the Compare Register. The other ALU continues running. (The instruction at the compare address is not executed.)</p> <p>Sync On ROS Compare If the ROS Mode is left in Norm (ROS Mode switch to Norm, and Set ROS Mode switch operated), a Compare Equal line at A-A1U2U07 in the tape control will provide a 50 ns sync pulse when the selected ALU reaches the compare address. The pulse will occur prior to execution of the instruction. (The Cmpr Equal lamp will light.) (the Cmpr Equal lamp can be turned off at any time by operating the Start or Stop switch.)</p> |
| 11 | <p>Restart on ALU Error or Address Compare</p> <p>These functions are active either online or offline. If you are offline and desire to restart a command chain to a tape unit on an ALU error or compare address, add a jumper from General Reset to the CE Start latch (B2Q2S10 to A1T2G05).</p> <p>Restart on ALU Hardware Error: The restart (Trap to address '000' for General Reset) on error occurs after the failing instruction is executed.</p> <p>A. Enable the CE Panel. B. Turn the Control Check Stop On switch off. C. Select the ALU causing the error. D. Set the ROS Mode switch to Rst/Err. E. Operate the Set ROS Mode switch. F. Reset and start the failing operation.</p> <p>Restart on ALU Address Compare: The restart (Trap to address '000' for General Reset) on compare occurs before the instruction is executed.</p> <p>A. Enable the CE Panel. B. Turn the Control Check Stop On switch off. C. Select the desired ALU. D. Set the Display Select and Data Entry Select switches to Cmpr Reg. E. Set the desired hex address into the Data Entry switches. F. Operate the Set CE/Cmpr switch. G. Set the ROS Mode switch to Rst/Cmpr. H. Operate the Set ROS Mode switch. I. Start the operation.</p> |

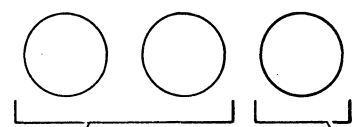
| Seq | Condition/Instruction | | | | | | | | | | | | | | | | | | |
|--------------------|---|---------------------|----------|------------|--------|----------|------------|--------|----------|------------|--------|----------|------------|------------|--------------------|---------------------|--------------------|--------------|--------------|
| 12 | <p>Cycle a Single ALU Instruction</p> <p>Not all functions are active on the cycle operation, but this can be a very useful operation when the failure occurs on a single instruction.</p> <p>A. Enable the CE Panel (Seq 2). B. Stop on ALU hardware error (Seq 9) or stop on the address one position past the instruction you wish to cycle (Seq 10). (You must have just executed the instruction you wish to cycle.) C. Ensure that the Control Check Stop On switch is off. D. Set the ROS Mode switch to Cycle. E. Operate the Set ROS Mode switch. F. Press the Start or Step switch.</p> | | | | | | | | | | | | | | | | | | |
| 13 | <p>Execute a Command Sequence to a Tape Unit</p> <p>The Channel Interface must be Disabled to activate the command controls.</p> <p>A. Enable the CE Panel (Seq 2). B. Disable the Channel Interface (Seq 5). C. Set the Display Select switch to CE Reg.</p> <p>The function of the Data Entry rotary switches are:</p> <div style="display: flex; justify-content: space-around; align-items: center;">  </div> <table style="width: 100%; border-collapse: collapse;"> <tr> <td style="width: 33%;">Cmnd 1</td> <td style="width: 33%;">OP Code*</td> <td style="width: 33%;">TU Address</td> </tr> <tr> <td>Cmnd 2</td> <td>OP Code*</td> <td>TU Address</td> </tr> <tr> <td>Cmnd 3</td> <td>OP Code*</td> <td>TU Address</td> </tr> <tr> <td>Cmnd 4</td> <td>OP Code*</td> <td>TU Address</td> </tr> <tr> <td>Byte Count</td> <td>00 to FF hex bytes</td> <td>(X) times 1024 byte</td> </tr> <tr> <td>Write Data/Go Down</td> <td>One byte hex</td> <td>Time in msec</td> </tr> </table> <p>*OP Code for example, 07=Rewind.</p> <p>D. Select the command, byte count, or write data to be entered with the Data Entry Switches. E. Set the desired value into the Data Entry Switches corresponding to the position selected in Step D. F. Operate the Set CE/Cmpr switch for each position selected, and the value in the Data Entry Switches. G. When all positions have been loaded, set the ROS Mode switch to Norm, operate the Set ROS Mode switch, then operate the Reset switch.</p> <p>When the Command control Start switch is operated, the tape unit selected will execute Command 1.</p> <p>H. Mple/Single Switch:</p> <ol style="list-style-type: none"> If set to Single, one command (the next sequential) will be executed, then the ALU will return to idle scans. If set to Mple, the four commands will be repeated until Stop is operated, Reset is operated, or until stopped by a data flow error (Data Flow Check Stop On switch up). <p>I. Ripple/Wr Data Switch:</p> <ol style="list-style-type: none"> If set to Wr Data, the character entered into the write data position will be repeated as many times as was specified by the byte count. If set to Ripple, a ripple pattern will be generated for all write operations rather than using the write data character (see Seq 14). | Cmnd 1 | OP Code* | TU Address | Cmnd 2 | OP Code* | TU Address | Cmnd 3 | OP Code* | TU Address | Cmnd 4 | OP Code* | TU Address | Byte Count | 00 to FF hex bytes | (X) times 1024 byte | Write Data/Go Down | One byte hex | Time in msec |
| Cmnd 1 | OP Code* | TU Address | | | | | | | | | | | | | | | | | |
| Cmnd 2 | OP Code* | TU Address | | | | | | | | | | | | | | | | | |
| Cmnd 3 | OP Code* | TU Address | | | | | | | | | | | | | | | | | |
| Cmnd 4 | OP Code* | TU Address | | | | | | | | | | | | | | | | | |
| Byte Count | 00 to FF hex bytes | (X) times 1024 byte | | | | | | | | | | | | | | | | | |
| Write Data/Go Down | One byte hex | Time in msec | | | | | | | | | | | | | | | | | |

3803-2/3420

| | | | | | | | |
|------------|-------------|----------------|----------|--|--|--|--|
| XE0300 | 2735854 | See EC History | 845958 | | | | |
| Seq 2 of 2 | Part Number | | 1 Sep 79 | | | | |

| Seq | Condition/Instruction | | | | | | | | | | | | | | | | | | | | | |
|------------|---|--|------------------------------|--------------|-------|---|-----------|-------|---|----------------|-------|---|-------------------------------|-------|------|--|-------|------|--|-------|------|--|
| 14 | <p>Ripple Data Pattern and Byte Count</p> <p>The ripple data pattern used for offline write operations (Ripple/Wr Data switch set to Ripple) is generated by a hardware counter. This same counter is used to determine the byte count.</p> <p>The counter steps as follows:</p> <p>Tape Op gates the comparison between the Byte Count Register and the counter. A byte count of FF0 entered from the CE panel writes two characters. Any other byte count writes three characters more than the number specified by the byte count.</p> <table border="1"> <thead> <tr> <th>Byte Count</th> <th>Number of Characters Written</th> <th>Data Written</th> </tr> </thead> <tbody> <tr> <td>'FF0'</td> <td>2</td> <td>'00'-'FF'</td> </tr> <tr> <td>'000'</td> <td>3</td> <td>'00'-'FF'-'00'</td> </tr> <tr> <td>'030'</td> <td>6</td> <td>'00'-'FF'-'00'-'01'-'02'-'03'</td> </tr> <tr> <td>'FF1'</td> <td>1026</td> <td>'00'-'FF'-'00' through 'FF', '00' through FF, and so on.</td> </tr> <tr> <td>'001'</td> <td>1027</td> <td>'00'-'FF'-'00' through 'FF', '00' through 'FF', and so on.</td> </tr> <tr> <td>'052'</td> <td>2056</td> <td>'00'-'FF'-'00' through 'FF', '00' through 'FF', and so on.</td> </tr> </tbody> </table> <p>† multiplier times 1024</p> | Byte Count | Number of Characters Written | Data Written | 'FF0' | 2 | '00'-'FF' | '000' | 3 | '00'-'FF'-'00' | '030' | 6 | '00'-'FF'-'00'-'01'-'02'-'03' | 'FF1' | 1026 | '00'-'FF'-'00' through 'FF', '00' through FF, and so on. | '001' | 1027 | '00'-'FF'-'00' through 'FF', '00' through 'FF', and so on. | '052' | 2056 | '00'-'FF'-'00' through 'FF', '00' through 'FF', and so on. |
| Byte Count | Number of Characters Written | Data Written | | | | | | | | | | | | | | | | | | | | |
| 'FF0' | 2 | '00'-'FF' | | | | | | | | | | | | | | | | | | | | |
| '000' | 3 | '00'-'FF'-'00' | | | | | | | | | | | | | | | | | | | | |
| '030' | 6 | '00'-'FF'-'00'-'01'-'02'-'03' | | | | | | | | | | | | | | | | | | | | |
| 'FF1' | 1026 | '00'-'FF'-'00' through 'FF', '00' through FF, and so on. | | | | | | | | | | | | | | | | | | | | |
| '001' | 1027 | '00'-'FF'-'00' through 'FF', '00' through 'FF', and so on. | | | | | | | | | | | | | | | | | | | | |
| '052' | 2056 | '00'-'FF'-'00' through 'FF', '00' through 'FF', and so on. | | | | | | | | | | | | | | | | | | | | |

| Seq | Condition/Instruction |
|-----|--|
| 15 | <p>Obtain 24 Sense Bytes</p> <p>This function can only be performed offline, after an offline failure. Taking the tape control offline following an online failure causes a General Reset.</p> <ol style="list-style-type: none"> Disable the Channel Interface (Seq 5). Enable the CE Panel (Seq 2). Set the Display Select and Data Entry Select switches to Cmpr Reg. Set the Data Entry switches to '20A' and operate the Set CE/Cmpr switch. Set up the CE Panel to execute a command sequence (Seq. 13). Turn on both the Control Check and Data Flow Check Stop On switches. This will prevent the compare stop and allow a data flow error stop. Set the ROS Mode switch to Stop and operate the Set ROS Mode switch. Run the command chain until a Data Flow Check stops the tape control. ALU1 will be at '301' or '303'. <p>Without Resetting the Error:</p> <ol style="list-style-type: none"> Enter Sense commands '04X' (X = drive address) into command positions Cmnd 1 through Cmnd 4. B.Turn off both the Control Check and Data Flow Check Stop On switches. C.Set the Mple/Single switch to Single. After the last sense byte is read out, ALU1 will loop at '7FF' until the next sense command is executed. Set the Display Select switch to IC. Select ALU1. Operate the Command Controls Start switch. The sense command should begin execution, stopping ALU1 at address '20A'. G.Sense Byte 0 can now be displayed by selecting Bus In with the Display Select switch. H.After recording Byte 0, return the Display Select switch to the IC position. <p>The Compare Stop can only occur with the Display Select switch in the IC position.</p> <ol style="list-style-type: none"> Operate the Start or Step switch one time. Turn the Display Select switch to Bus In. One sense byte is now displayed. J.Return the Display Select switch to the IC position, Repeat steps I and J until all 24 sense bytes have been obtained. <p>Each time ALU1 runs to '20A', the next sequential byte is read out.</p> <ol style="list-style-type: none"> When the last byte has read out, ALU1 will again begin looping at '7FF'. L.If you wish to repeat the sense operation, operate the Command Controls Start switch to start the next sense command. <p>Only a few errors, such as ALU hardware error, are reset on a Sense command. Most sense can be extracted repeatedly.</p> |

| Seq | Condition/Instruction |
|-----|---|
| 16 | <p>Display Local Storage Register (LSR) Contents (See LSR contents chart on this page)</p> <p>A. Enable the CE Panel (Seq 2). B. Turn the Control Check Stop On switch off. C. Set Data Entry Select switch and Display Select switch to Cmpr Reg. D. Set '500' in Data Entry switches. E. Press the Set CE/Cmpr momentary switch down to enter address '500' into the compare register. The indicator lamps should now display '500'. F. Move the ALU1/ALU2 switch to the desired ALU. G. Set the Display Select switch to IC. H. Set the ROS Mode rotary switch to Set IC. I. Set the ROS Mode momentary switch to Set ROS Mode. (Address '500' is displayed in indicator lights.) J. Set the ROS Mode switch to Step. K. Operate the Set ROS Mode momentary switch. L. Operate the Start/Step switch. When address '502' is displayed, the functions of address '501' have been performed and LSR 0 can now be displayed. If the ALU1/ALU2 switch was at ALU1, move the Display Select switch to Bus In. If the ALU1/ALU2 switch was at ALU2, move the Display Select switch to Bus Out.</p> <p>Moving the Display Select switch back to IC allows the address positions to be monitored. To display any LSR, advance the address to the proper point and display the bus lines for that ALU.</p> <p>Note: The lower order LSRs (0-15) are displayed at addresses '502-511'. Two program steps are then taken to set the high order LSRs (16-31), and branch back to '502'. The routine then repeats with addresses '502-511'. When the routine is completed, operate the Start/Step switch repeatedly to advance the routine continuously through LSRs 16-31.</p> <p>M. To restart the operation with LSR 0, set IC to '500' again by: 1. Setting ROS Mode to Set IC. 2. Raising the Set ROS Mode momentary switch. 3. Performing steps J, K, and L again.</p> <p>Note: For any LSR not used, parity is not assured. To allow further displaying of LSRs with B-Bus parity errors, turn on the Control Check Stop switch.</p> <p>1. B-Bus parity errors can occur when displaying LSRs because LSRs are not initialized on power up. Always put Control Check Stop on. 2. Disregard the P-bit indicator when displaying LSR.</p> <p>On some error-stop conditions, it is impossible to alter the CE commands or the contents of the Compare Register. Display ALU1 LSR 1 for the current command. Display ALU1 LSR 3 for the current tape unit address.</p> |
| 17 | <p>Display ROS Bits (ALU Instructions)</p> <p>Normally this function will be performed in Step Mode, or while reading out a failing instruction. The ROS bits displayed in the indicators are the actual bits being read out of the MAL card for the displayed IC address. The IC display, ROS bit display, and the microlisting for the selected ALU (ALU1/ALU2 switch) should all agree.</p> <p>Be aware that the IC address and ROS bits being displayed are for the next instruction to be displayed. The contents of the ROS Register will still contain the previous instruction.</p> <p>A. Select the proper ALU with the ALU1/ALU2 switch. B. Turn the Display Select switch to IC to display the instruction address (IC). C. Turn the Display Select switch to Hi ROS. (Indicators 0-7 display the first byte, bits 0-7 of the microprogram instruction.) D. Turn the Display Select switch to Low ROS (indicators 0-7 display the second byte, bits 8-15 of the microprogram instruction.)</p> |

| Seq | Condition/Instruction |
|-----|--|
| 18 | <p>Display the Channel and Device Bus and Tags</p> <p>Display the Device Bus and Tags:</p> <p>A. Select ALU2 with the ALU1/ALU2 switch. B. Select either Bus In or Bus Out with the Display Select switch.</p> <p>Indicators 0 through 7 display the bus, and indicators 8 through 11 display the device address if Bus In is selected, or device tags if Bus Out is selected. The associated positions are labeled on the CE panel.</p> <p>Display the Channel Bus and Tags:</p> <p>A. Select ALU1 with the ALU1/ALU2 switch. B. Select either Bus In, Bus Out, or the Channel Request Tags (Hi ROS, Channel A; Low ROS, Channel B, with the Display Select switch.</p> <p>Indicators 0 through 7 display the bus, and indicators 8 through 11 display the tags. The associated positions are labeled on the CE panel.</p> |
| 19 | <p>Data Security Erase Procedure Offline</p> <p>Tape unit address 0 must be used for this procedure.</p> <p>To execute a DSE command from the CE panel:</p> <p>A. Set commands as follows: Cmnd 1 = 17 (Erase Gap) Cmnd 2 = 97 (DSE) Cmnd 3 = 04 (Sense) Cmnd 4 = 04 (Sense)</p> <p>B. Set Mple/Single switch to Mple. C. Set Cmpr Reg to '123'. 1. Set the Display Select and the Data Entry Select switches to Cmpr Reg. 2. Set the Data Entry switches to '123'. 3. Press the Set CE/Cmpr switch. D. Set the ALU1/ALU2 switch to ALU1. E. Set the ROS Mode switch to Stop. F. Set the Display Select switch to IC. G. Press the Command Control Start switch once. Note: If IC = '122', press Start or Step switch once. H. Set ROS Mode switch to Step. J. Press Start or Step switch once. IC should display '124'. K. Press Reset switch once. L. Set Cmpr Reg to '125'. 1. Set the Display Select and the Data Entry switches to Cmpr Reg. 2. Set the Data Entry switches to '125'. 3. Press the Set CE/Cmpr switch. M. Set Display Select switch to IC. N. Set ROS Mode switch to Set IC. IC should equal '125'. O. Set ROS Mode switch to Stop. Note: If normal DSE is desired, set ROS Mode switch to Norm and press Start or Step switch once. If statically analyzing Control Status Reject, proceed to next step. P. Set ALU1/ALU2 switch to ALU2. Q. Set Cmpr Reg to '168'. 1. Set the Display Select and the Data Entry switches to Cmpr Reg. 2. Set the Data Entry switches to '168'. 3. Press the CE/Cmpr switch. R. Set Display Select switch to IC. S. Press Start or Step switch once. T. Tape unit should start DSE. Reset the tape unit to statically analyze. U. Go to 16-210 for Control Status Reject analysis.</p> |

| Display Local Storage Register (LSR) Contents | | | |
|---|-------------------|-----|---------------------------|
| MP1 | Address Displayed | LSR | MP2 |
| Current Command | 502 | 0 | Work 1 |
| CTI Image | 503 | 1 | Work 2 |
| XOUTA | 504 | 2 | Work 3 |
| Current Address | 505 | 3 | Work 4 |
| Scratch Reg | 506 | 4 | Stat Image |
| Pending Status | 507 | 5 | Flags |
| Pending Address | 508 | 6 | Sense 1 |
| Sense Byte 0 | 509 | 7 | Sense 2 |
| Stat Reg Image | 50A | 8 | Tracer (Read or Write Op) |
| Flags | 50B | 9 | FRU Identifier |
| Flags 1 and REOTAGS | 50C | 10 | DTachk2 |
| Flags 2 | 50D | 11 | TU Address |
| Set DIAG 1 | 50E | 12 | DTachk1 |
| Set DIAG2 | 50F | 13 | XOUTA Image |
| Set CT1 DMR | 510 | 14 | LODEPA |
| Set CT2 DMR | 511 | 15 | LODEPB |
| | 512 | | Xfer-Set High LSRs |
| | 513 | | BU 502 (recycle) |
| Link 1 | 502 | 16 | Work 1 (high) |
| Link 2 | 503 | 17 | Work 2 (high) |
| Link 3 | 504 | 18 | Work 3 (high) |
| Link 4 | 505 | 19 | Work 4 (high) |
| XOUTB Image | 506 | 20 | Stat Image (high) |
| ALU1 Error | 507 | 21 | Work 5 |
| ALU2 Error | 508 | 22 | Sense 1 (high) |
| Work 2 | 509 | 23 | Sense 2 (high) |
| Link 5 | 50A | 24 | MPGMERR |
| Link 6 | 50B | 25 | Link 2 |
| 7-Trk Mode Reg A Intf | 50C | 26 | Link 3 |
| 7-Trk Mode Reg B Intf | 50D | 27 | TU Address |
| Work 4 (7-Trk) | 50E | 28 | Link 1 |
| FRU Reg | 50E | 29 | Equipment Check |
| FRUSAV | 510 | 30 | LODEPA (high) |
| Format | 511 | 31 | LODEPB (high) |

3803-2/3420

| | | | | | | | |
|----------------------|------------------------|-------------------|--------------------|--|--|--|--|
| XE0400 Seq 2 of 2 | 2735855 Part Number | See EC History | 845958 1 Sep 79 | | | | |
|----------------------|------------------------|-------------------|--------------------|--|--|--|--|

CE PANEL FAILURES

| SECOND LEVEL INDEX | |
|---|-------------------------|
| Title | Page |
| 1. Set and Display CE Registers A. Display Bits 0-11 B. 4 Bit Bus 0, 4 or 8 4 Bit Bus 1, 5 or 9 4 Bit Bus 2, 6 or 10 4 Bit Bus 3, 7, or 11 | 12-021 |
| 2. Set and Display Compare Register A. Display Bits 0-11 B. Compare Bits 0-11 | 12-022 |
| 3. Display Select Switch and Compare A. CE Select Reg Indicators 0-11 B. Bits 0-11 are Equal | 12-023 |
| 4. ROS Mode Switch and Gates A. CE Mode B. Panel Enable C. Set IC D. CE ROS Stop Mode E. Single Step or Start ALU F. ROS Step Mode G. ROS Cycle Mode H. Stop on Hdw Err (to ALU) J. Stop on Hdw Err K. Compare Stop or Step ALU1 L. Compare Stop or Step ALU2 M. CE Reset Switch N. Cmpr Equal Indicator | 12-024 and 12-025 |
| 5. Command Select Sequencer and Decoder A. Set Compare Register B. Address Cmnd 1 C. Address Cmnd 2 D. Address Cmnd 3 E. Address Cmnd 4 F. Address Byte Count G. Address WR Data or Go Down | 12-026 |
| 6. CE Entry A. CE Entry Bits 0-7 B. CE Entry Bit P | 12-027 |
| 7. Byte Count or Go Down A. Counter Compare Equal | 12-028 |

| Diagnosing CE Panel Failures | | |
|--|--|--|
| Use the best guess to determine the most logical FRUs, or use the index to locate the timing chart and second level diagram section applicable to the failing function. | | |
| Most Probable Cause: A. A1S2, A1T2 B. A1U2 C. B2G2, A2J2 D. -4 V (See decal on back of TCU) | | |
| Always start with Seq 1 and follow the procedure in sequence unless directed otherwise. Remember to END all problems or maintenance calls by going to MAP 00-030. | | |
| Seq | Condition/Instruction | Action |
| 1 | Is this a Data Entry Select switch problem? | Change: 1. A1S2 2. A1T2 3. A1U2 |
| 2 | Is this a Display Select switch problem? A. If CE Reg or Cmpr Reg fails: B. If Bus In or Bus Out or Hi ROS or Low ROS fails: | Change: 1. A1S2 2. A1T2 3. A1U2 Change: 1. A1T2 2. ALU1, B2G2 ALU2, A2J2 3. A1U2 |
| 3 | Is this a ROS Mode switch problem and Stop On Control Check or Stop On Data Flow Check problem? | Change: 1. A1T2 2. A1U2 |
| 4 | Is this a Command Execution problem? | Go to 13-050. |
| 5 | Is +CE Mode (A1T2B12) plus? | Go to Seq 7. |
| 6 | Go to ALD PK011 and resolve problem. | |
| 7 | Determine the section of the CE panel that is not working. Use the second level index on this page to locate the proper second level to isolate the problem. | |

Important: Verify that the TCU dc voltages are within tolerance. (See decal on back of TCU.)

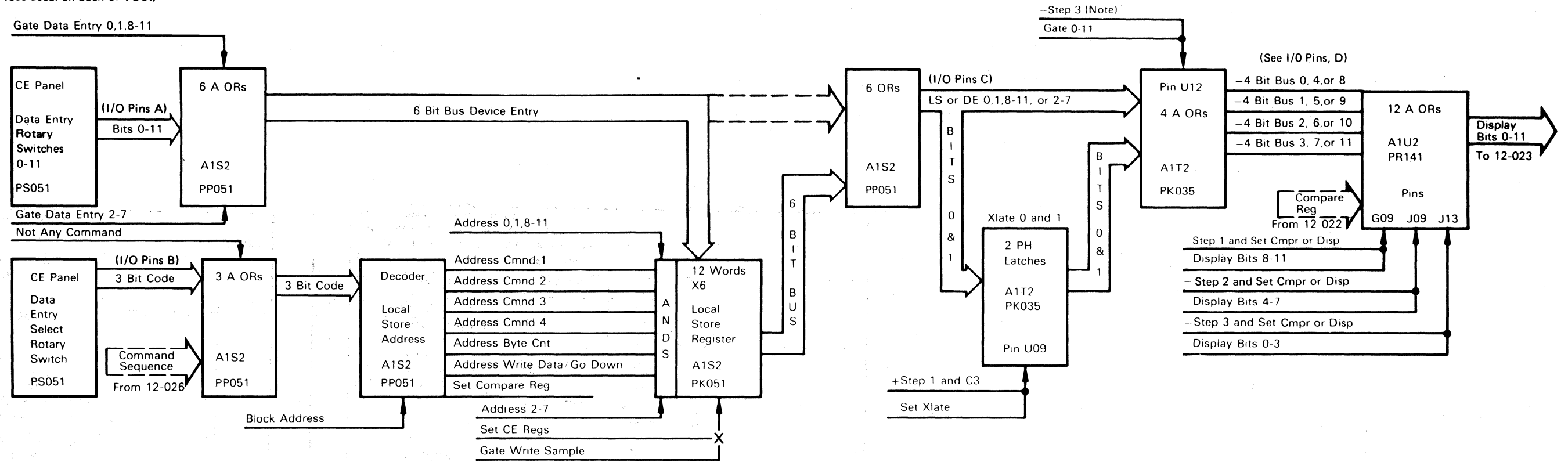

Note:
 During -Step 3, Bits 2,3 and Xlate Bits 0 and 1 are gated.
 During Not Step 3, Bits 4-7 are gated.

Timing Chart

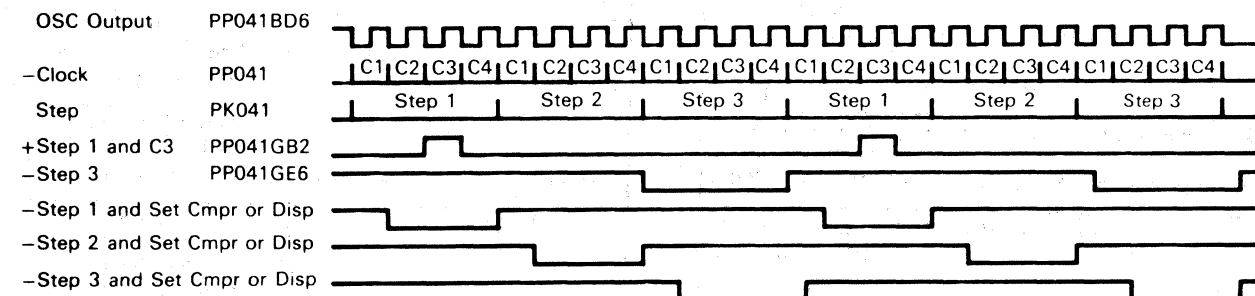

I/O Pins

A. Bits 0-11

| NAME | PIN |
|--------------------|---------|
| -Data Entry Bit 0 | A1S2B02 |
| -Data Entry Bit 1 | A1S2D02 |
| -Data Entry Bit 2 | A1S2B03 |
| -Data Entry Bit 3 | A1S2D03 |
| -Data Entry Bit 4 | A1S2B04 |
| -Data Entry Bit 5 | A1S2D04 |
| -Data Entry Bit 6 | A1S2B05 |
| -Data Entry Bit 7 | A1S2D05 |
| -Data Entry Bit 8 | A1S2D06 |
| -Data Entry Bit 9 | A1S2B07 |
| -Data Entry Bit 10 | A1S2D07 |
| -Data Entry Bit 11 | A1S2B09 |

B. 3 Bit Code

| NAME | PIN |
|--------------------------|---------|
| -Data Entry Select Bit 1 | A1S2D09 |
| -Data Entry Select Bit 2 | A1S2B10 |
| -Data Entry Select Bit 4 | A1S2D10 |

C. LS or DE 0,1,8-11 or 2-7

| NAME | PIN |
|-------------------|---------|
| -LS or DE 0 or 2 | A1T2M02 |
| -LS or DE 1 or 3 | A1T2P02 |
| -LS or DE 4 or 8 | A1T2M03 |
| -LS or DE 5 or 9 | A1T2P03 |
| -LS or DE 6 or 10 | A1T2M04 |
| -LS or DE 7 or 11 | A1T2P04 |

D. 4 Bit Bus

| NAME | PIN |
|-----------------------|---------|
| -4 Bit Bus 0,4, or 8 | A1U2P02 |
| -4 Bit Bus 1,5, or 9 | A1U2M02 |
| -4 Bit Bus 2,6, or 10 | A1U2P03 |
| -4 Bit Bus 3,7, or 11 | A1U2G13 |

3803-2/3420

| | | | | | | | | |
|-----------------------------|-------------------------------|-----------------------|---------------------------|--|--|--|--|--|
| XE0500 Seq 2 of 2 | 2735856 Part Number | See EC History | 845958 1 Sep 79 | | | | | |
|-----------------------------|-------------------------------|-----------------------|---------------------------|--|--|--|--|--|

© Copyright International Business Machines Corporation 1976, 1979

SET AND DISPLAY COMPARE REGISTER

Note: Verify that TCU dc voltages are within the tolerance. (See the decal on back of the TCU.)

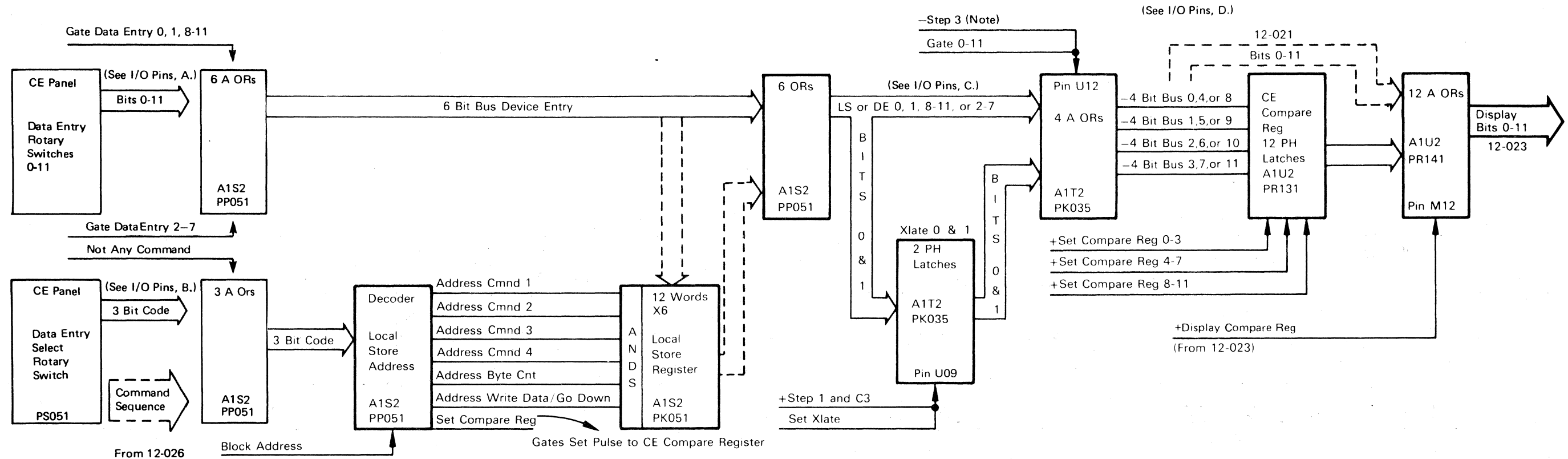

Note:
During -Step 3, Bits 2,3 and Xlate Bits 0 and 1 are gated.
During Not Step 3, Bits 4-7 are gated.

Timing Chart

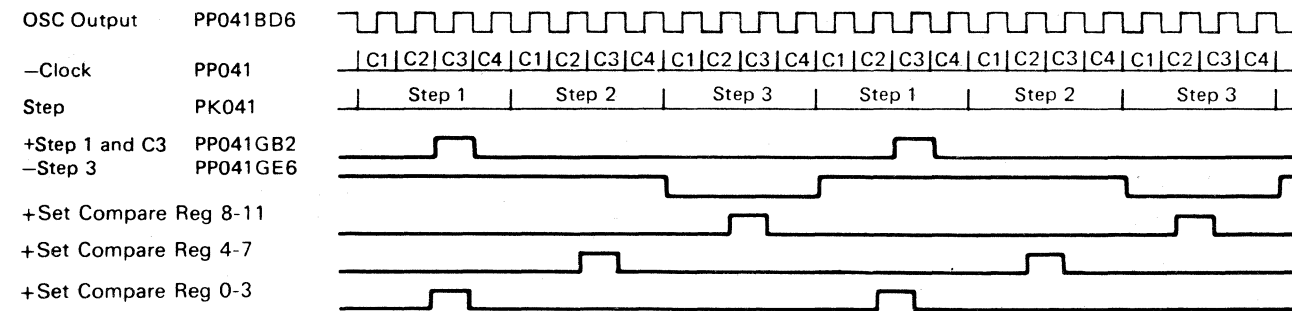

I/O PINS

A. Bits 0-11

| NAME | PIN |
|--------------------|---------|
| -Data Entry Bit 0 | A1S2B02 |
| -Data Entry Bit 1 | A1S2D02 |
| -Data Entry Bit 2 | A1S2B03 |
| -Data Entry Bit 3 | A1S2D03 |
| -Data Entry Bit 4 | A1S2B04 |
| -Data Entry Bit 5 | A1S2D04 |
| -Data Entry Bit 6 | A1S2B05 |
| -Data Entry Bit 7 | A1S2D05 |
| -Data Entry Bit 8 | A1S2D06 |
| -Data Entry Bit 9 | A1S2B07 |
| -Data Entry Bit 10 | A1S2D07 |
| -Data Entry Bit 11 | A1S2B09 |

B. 3 Bit Code

| NAME | PIN |
|--------------------------|---------|
| -Data Entry Select Bit 1 | A1S2D09 |
| -Data Entry Select Bit 2 | A1S2B10 |
| -Data Entry Select Bit 4 | A1S2D10 |

C. LS or DE 0,1,8-11 or 2-7

| NAME | PIN |
|-------------------|---------|
| -LS or DE 0 or 2 | A1T2M02 |
| -LS or DE 1 or 3 | A1T2P02 |
| -LS or DE 4 or 8 | A1T2M03 |
| -LS or DE 5 or 9 | A1T2P03 |
| -LS or DE 6 or 10 | A1T2M04 |
| -LS or DE 7 or 11 | A1T2P04 |

D. 4 Bit Bus

| NAME | PIN |
|----------------------|---------|
| -4 Bit Bus 0,4,or 8 | A1U2P02 |
| -4 Bit Bus 1,5,or 9 | A1U2M02 |
| -4 Bit Bus 2,6,or 10 | A1U2P03 |
| -4 Bit Bus 3,7,or 11 | A1U2G13 |

3803-2/3420

| | | | | | | | | |
|------------|-------------|----------------|----------|--|--|--|--|--|
| XE0600 | 2735857 | See EC History | 845958 | | | | | |
| Seq 1 of 2 | Part Number | | 1 Sep 79 | | | | | |

I/O Pins (3 Bit Code)

| NAME | PIN |
|-----------------------|---------|
| -Display Select Bit 1 | A1T2B02 |
| -Display Select Bit 2 | A1T2B03 |
| -Display Select Bit 3 | A1T2B04 |

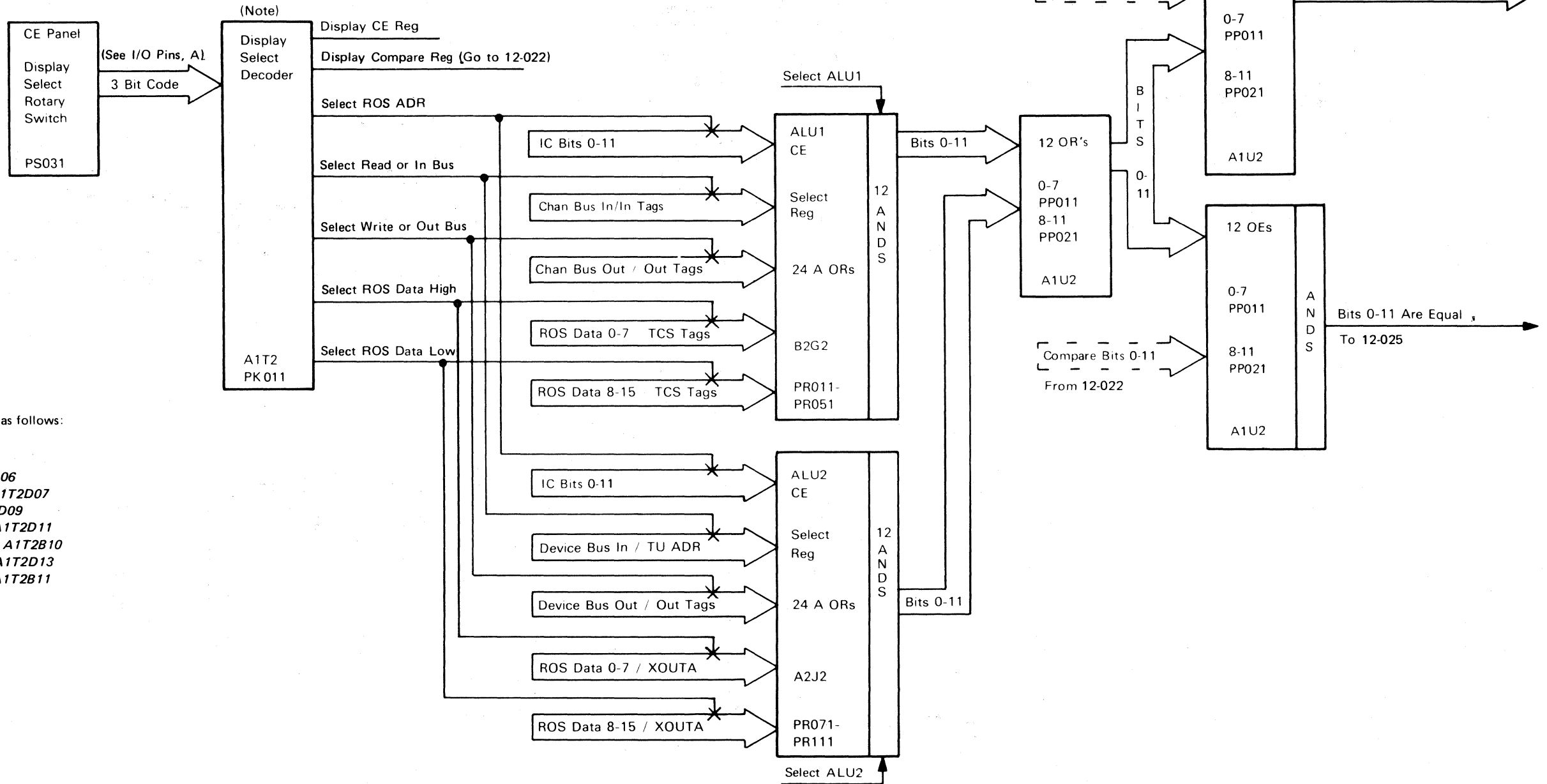

Note:
Line names that change from CE panel to logic are listed as follows:

| CE PANEL | LOGIC PK011 |
|-------------|----------------------------------|
| 1. CE Reg | -Display CE Reg A1T2D06 |
| 2. Cmpr Reg | +Display Compare Reg A1T2D07 |
| 3. IC | +Select ROS ADR A1T2D09 |
| 4. Bus In | +Select Read or In Bus A1T2D11 |
| 5. Bus Out | +Select Write or Out Bus A1T2B10 |
| 6. Hi ROS | +Select ROS Data High A1T2D13 |
| 7. Low ROS | +Select ROS Data Low A1T2B11 |

3803-2/3420

| | | | | | | | | | |
|------------|-------------|---------|----------|--|--|--|--|--|--|
| XE0600 | 2735857 | See EC | 845958 | | | | | | |
| Seq 2 of 2 | Part Number | History | 1 Sep 79 | | | | | | |

ROS MODE SWITCH AND GATES

12-024

Note: Verify that TCU dc voltages are within the tolerance (see the decal on back of TCU).

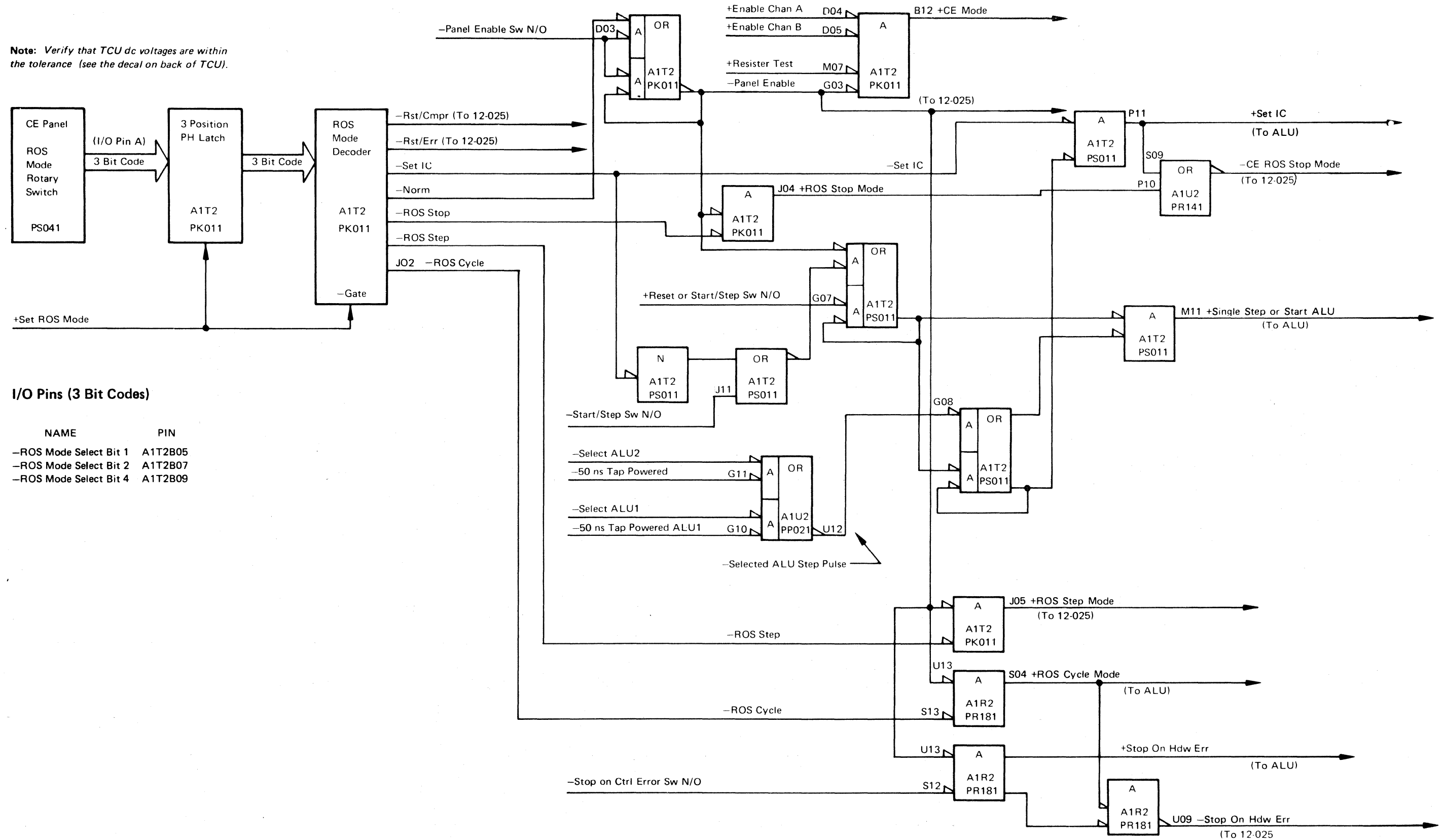

I/O Pins (3 Bit Codes)

| NAME | PIN |
|------------------------|---------|
| -ROS Mode Select Bit 1 | A1T2B05 |
| -ROS Mode Select Bit 2 | A1T2B07 |
| -ROS Mode Select Bit 4 | A1T2B09 |

3803-2/3420

| | | | | | | | |
|------------|-------------|----------------|----------|--|--|--|--|
| XE0700 | 2735858 | See EC History | 845958 | | | | |
| Seq 1 of 2 | Part Number | | 1 Sep 79 | | | | |

Copyright International Business Machines Corporation 1976, 1979

12-024

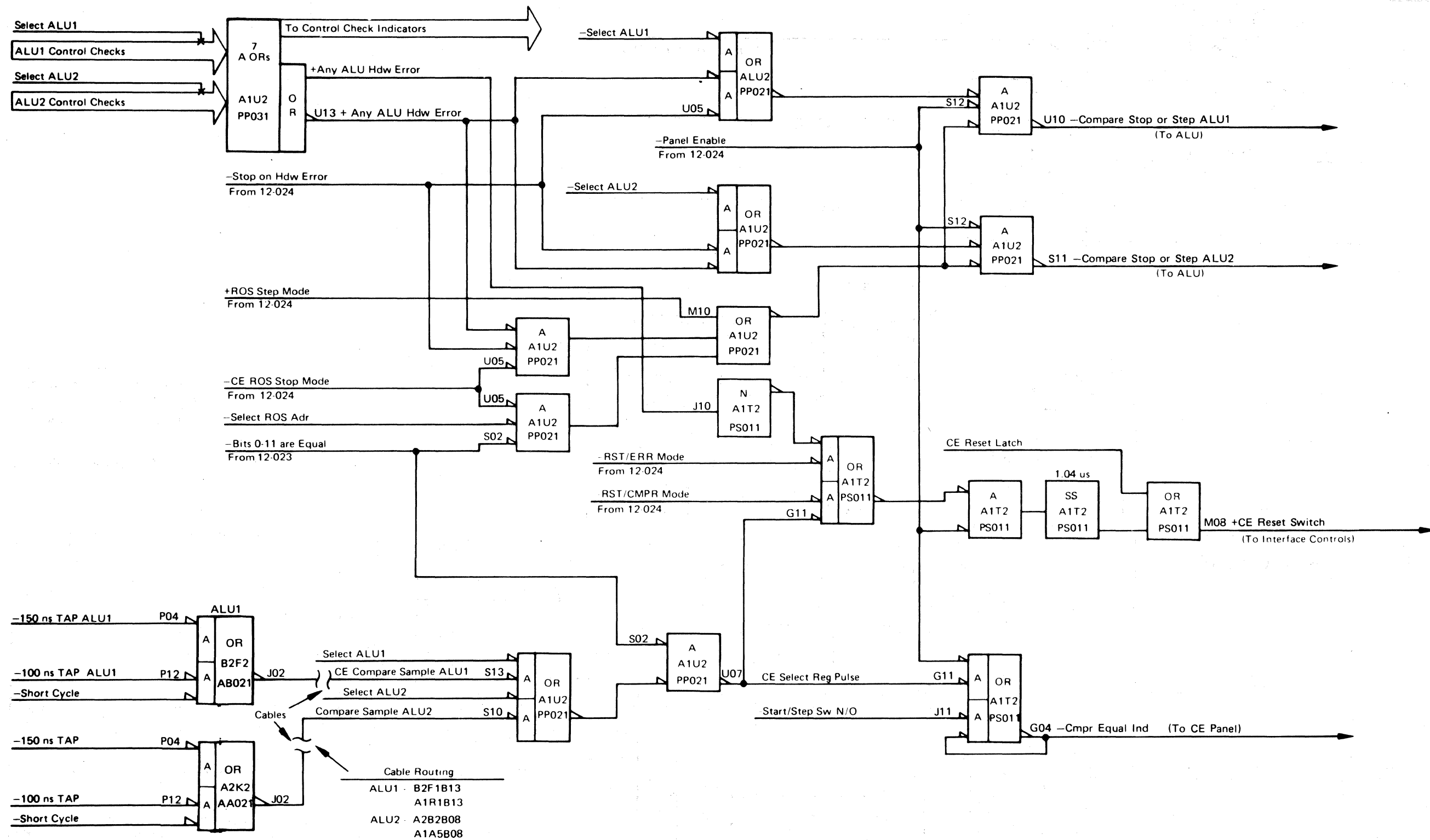

3803-2/3420

| | | | | | | | | |
|------------|-------------|----------------|----------|--|--|--|--|--|
| XE0700 | 2735858 | See EC History | 845958 | | | | | |
| Seq 2 of 2 | Part Number | | 1 Sep 79 | | | | | |

COMMAND SELECT SEQUENCER AND DECODER

12-026

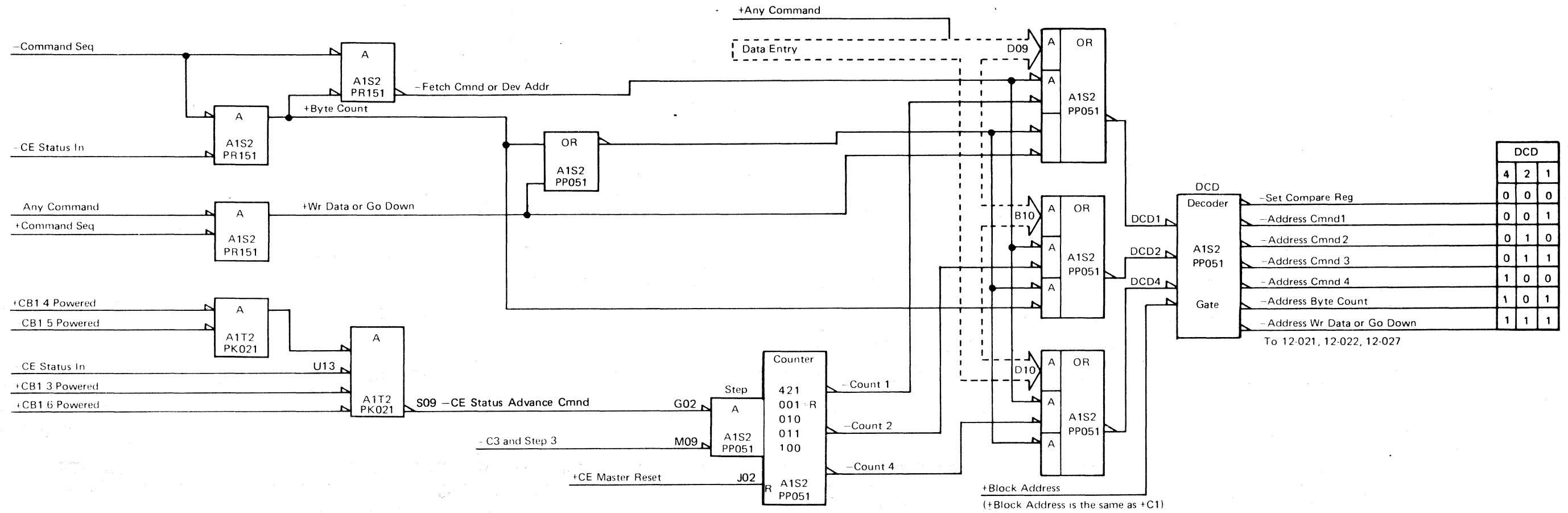

Timing Chart

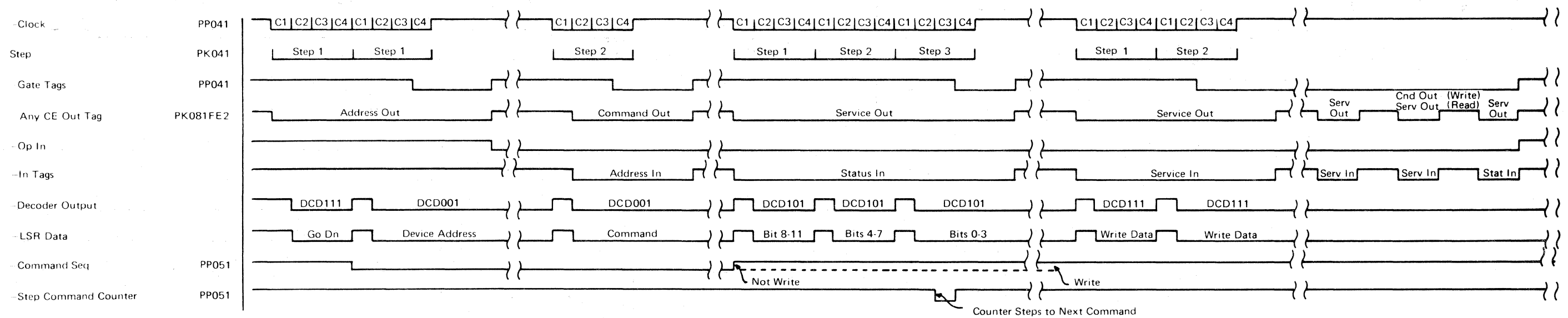

3803-2/3420

| | | | | | | | | |
|------------|-------------|----------------|----------|--|--|--|--|--|
| XE0800 | 2735859 | See EC History | 845958 | | | | | |
| Seq 1 of 2 | Part Number | | 1 Sep 79 | | | | | |

12-026

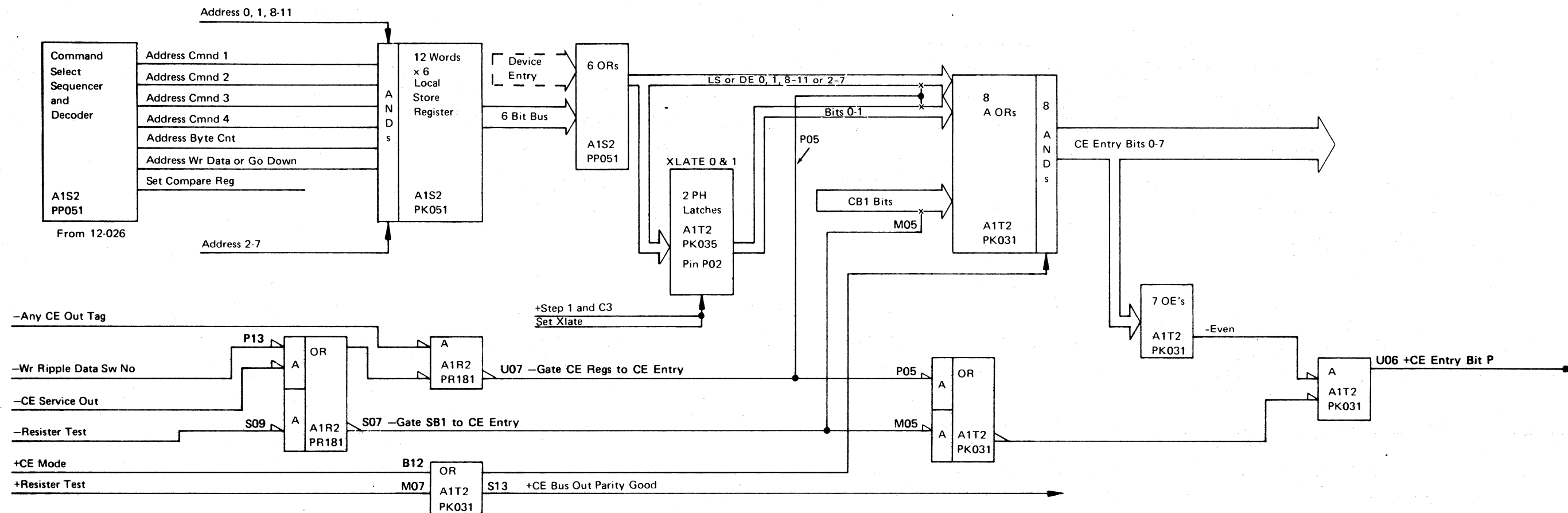

Timing Chart

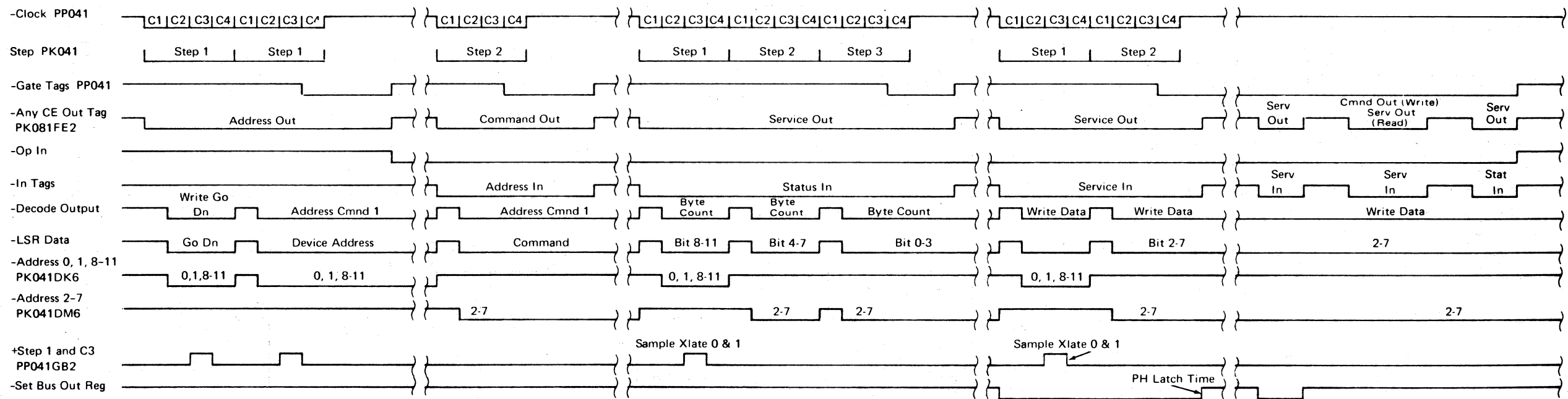

3803-2/3420

| | | | | | | | | |
|------------|-------------|----------------|----------|--|--|--|--|--|
| XE0800 | 2735859 | See EC History | 845958 | | | | | |
| Seq 2 of 2 | Part Number | | 1 Sep 79 | | | | | |

© Copyright International Business Machines Corporation 1976, 1979

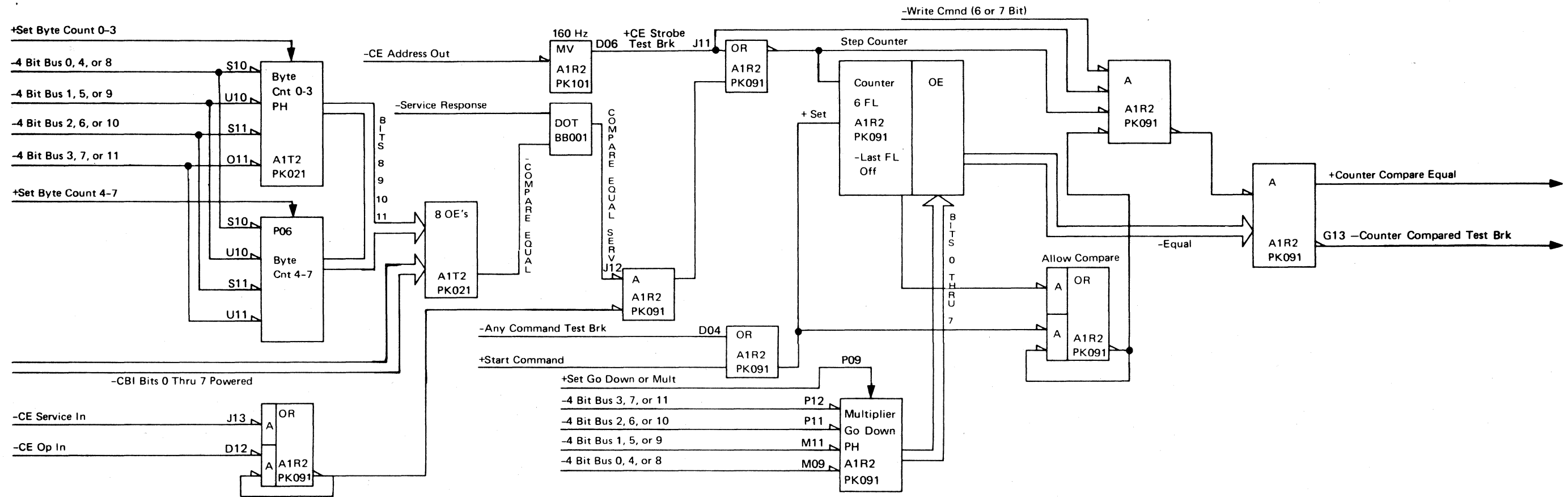

Timing Chart

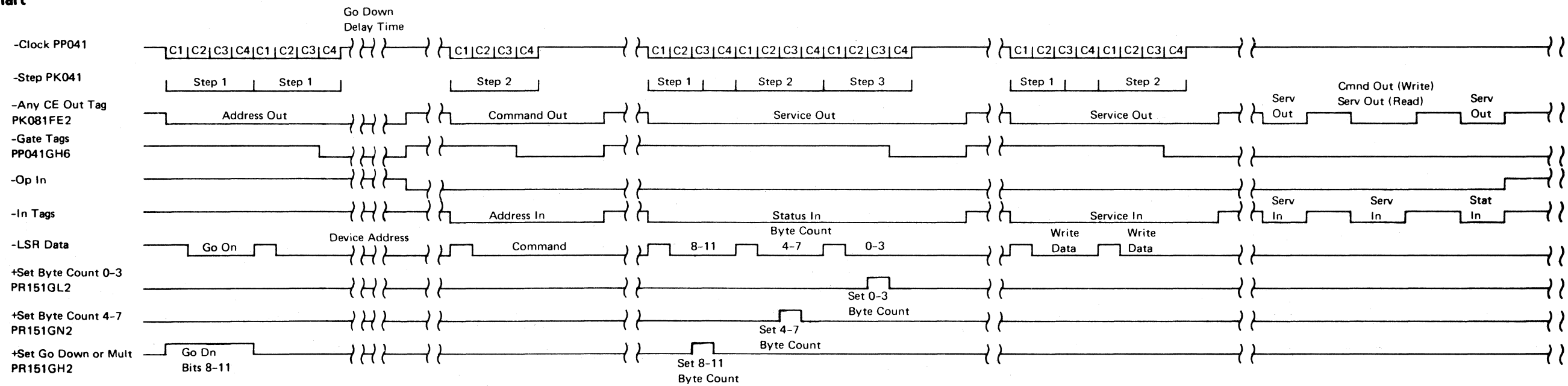

3803-2/3420

| | | | | | | | | |
|------------|-------------|----------------|----------|--|--|--|--|--|
| XE0900 | 2735860 | See EC History | 845958 | | | | | |
| Seq 1 of 2 | Part Number | | 1 Sep 79 | | | | | |

NOTES:

12-029

3803-2/3420

| | | | | | | | | | |
|-----------------------------|-------------------------------|---------------------------------|---------------------------|--|--|--|--|--|--|
| XE0900 Seq 2 of 2 | 2735860 Part Number | See EC History | 845958 1 Sep 79 | | | | | | |
|-----------------------------|-------------------------------|---------------------------------|---------------------------|--|--|--|--|--|--|

© Copyright International Business Machines Corporation 1976, 1979

12-029

ALU1 OR ALU2 HANGS

13-000

| From: Start 1, 00-010, 13-050, 13-070, 13-080 | | |
|--|---|--|
| Follow this procedure if the subsystem is having ALU hardware errors, tape "runaway", ALU "hangs" or "loops", channel busy, or "timeout" indications. | | |
| Notes: | | |
| <ol style="list-style-type: none"> For intermittent clock stopping, the basic cause is electrostatic discharge (ESD) problems. If clock stop problems persist, run an ESD test on the subsystem. If you have a recorded ALU "loop" or "hang" address from an online failure, retain this information for later use. Try using the offline procedure in this MAP first. (Return cards to original position.) One service technique is to interchange cards between ALU1 and ALU2 (see list on 16-001). If the symptoms change after an interchange, the failing FRU has been identified. An interchange of these cards should be tried before leaving this procedure. See 16-000 for additional information. | | |
| Always start with Seq 1 and follow the procedure in sequence unless directed otherwise. Remember to END all problems or maintenance calls by going to MAP 00-030. | | |
| Seq | Condition/Instruction | Action |
| 1 | The dc voltages are extremely critical — check/adjust the dc gate voltages to the tolerances specified on the decal. Do any voltages fail to meet specs? | Go to 11-000. |
| 2 | Enable the CE panel. Set Compare register to 'FFF'. A. Set the Display Select and Data Entry Select switches to Cmpr Reg. B. Set the Data Entry switches 'FFF'. C. Press the Set CE/Cmpr switch. Turn ROS Mode switch to Stop. Raise Set ROS Mode switch momentarily. Turn Control Check switch On. Do you have Control Check error lights from running in Stop Mode, or Sense Byte 4, bit 0 from LOGREC? | ALU hardware error See Note 3, go to Seq 31. |
| 3 | Is ALU1 hung at address '301'? Note: Address may appear as '303' due to IC lookahead. Go to Step mode and verify that IC is at '301'. | See Note 3, go to 13-240. |
| 4 | Is ALU1 hung at address '302'? | See Note 3, go to 13-220. |
| 5 | If ALU1 or ALU2 is hung at a single address: A. Turn the ROS Mode switch to Norm. B. Raise the Set ROS Mode switch. C. Operate Start or Step switch. Scope ALU2 -0 ns tap (A2K2G12) and ALU1 -0 ns tap (B2F2G12) to verify that the clocks are stopped (see Notes 1 and 3). | |

| Seq | Condition/Instruction | Action |
|-----|---|---------------------------|
| 6 | Prepare to duplicate the failure offline, using a 6250 bpi tape unit first, if possible. A. Enable the CE panel: Turn the Panel Enable switch On. Turn the ROS Mode switch to Norm. Raise the Set ROS Mode switch. B. Turn the Meter switch to Disabled, then wait for the Intf's Disabled lamp. C. Turn both the Control Check and Data Flow Check Stop On switches On. D. Set the Display Select switch to IC. E. Set the ALU1/ALU2 switch to ALU1. F. Turn the ROS Mode to Stop. G. Raise the Set ROS Mode switch. | |
| 7 | A. Select the ALU1 lamp display with the ALU1/ALU2 switch. B. Reset the tape control with the Reset/Start or Step switch. C. Alternately select the lamp display for ALU1, then ALU2 with the ALU1/ALU2 switch. Repeat these three steps several times, recording any error lights and IC addresses for both ALUs. | |
| 8 | A. Select the ALU2 lamp display before resetting the tape control. B. Reset the tape control and display ALU1 and ALU2 as before. Repeat this sequence several times, noting any change in the address. | |
| 9 | Were there any control check red lights? | See Note 3, go to Seq 31. |
| 10 | Did both ALU1 and ALU2 idle at '7FF' without error? | Go to Seq 17. |
| 11 | Note: If ALU1 and ALU2 do not equal '7FF', but all offline functions work normally, change A-B2G2. Were the indicated IC addresses the same each time sequence 7 failed? (If failures are intermittent, does each failure stop at the same address?) | See Note 3, go to Seq 13. |
| 12 | Were the indicated IC addresses different? | See Note 3, go to 13-090. |
| 13 | Did ALU1 IC address = '000'? | Go to 13-010. |
| 14 | To reach this Seq, you have an ALU loop or "hang". A. Turn the ROS Mode switch to Step and raise the Set ROS Mode switch. B. Display ALU1 IC address. C. Using ALU1 microprogram listing, look up the hex address under the column labeled "LOC". D. Under the "SOURCE STATEMENT" column, on the line immediately above the failing address, you should find a statement "*Go to MAP 13-xxx". 13-xxx is the number of the MAP addressing your particular loop. *Did you find a "Go to MAP 13-xxx" statement? | Go to the MAP specified. |

| Seq | Condition/Instruction | Action |
|-----|---|---------------------------|
| 15 | Press the Start or Step switch and check a few more addresses. Did you find a "Go to MAP 13-xxx" statement? | Go to the MAP specified. |
| 16 | There is a loop not identified in the MAPs. | Go to Seq 47. |
| 17 | Set up the CE panel: (See Section 12-000.) A. Load the CE Registers: Command 1 - '07x' Command 2 - '01x' Command 3 - '0Cx' Command 4 - '02x' Byte Count - 'FE0' Write Data /Go Down - 'FF0' (x = TU address) B. Set switches: ALU Select switch to ALU2 Mple/Single switch to Mple Display Select switch to IC Both Stop On switches up ROS Mode switch to Stop Operate Set ROS Mode switch Ripple/Wr Data switch to Wr Data C. Rewind tape to load point. | |
| 18 | Did the CE Registers fail to load? | See Note 3, go to 12-000. |
| 19 | With ALU2 selected: press the Command Start (Stop/Start) switch to start the command chain. Record any Control Check red lights. Select ALU1: Press Reset and then Command Start. Record any Control Check red lights and the IC address. | |
| 20 | Were any Control Check red lights On from Seq 19? | Go to Seq 34. |
| 21 | Did ALU1 stop at address '301'? Note: Address may appear as '303' due to IC lookahead. Go to Step mode and verify that IC is at '301'. | Go to Seq 25. |
| 22 | Are ALU1 and ALU2 idling at '7FF' without executing the command chain? | See Note 3, go to 13-050. |
| 23 | Is the tape control executing the command chain without error? | Go to Seq 27. |
| 24 | To reach this point, ALU1 should be looping. Is it looping? | Go to Seq 13. |

| | | | | | | | | |
|-------------|----------------------|------------------------|-------------------|--------------------|--|--|--|--|
| 3803-2/3420 | XE1000 Seq 1 of 2 | 2735861 Part Number | See EC History | 845958 1 Sep 79 | | | | |
|-------------|----------------------|------------------------|-------------------|--------------------|--|--|--|--|

13-000

| Seq | Condition/Instruction | Action |
|-----|---|-------------------------------------|
| 25 | <p>Address '301' indicates a Unit Check</p> <p>A. Set Mple/Single switch to Single; Reset; then press Start repetively until you determine the failing command.</p> <p>B. Using the procedure "Obtain Sense Data," set Compare register to 20A, turn Control Check Stop switch Off, and try to obtain offline sense information. Is offline sense information available?</p> <p>See Note 3, go to 14-000 and perform the manual sense analysis.</p> <p>Obtain Sense Data</p> <p>ALU1 should be stopped at address '301' with a Data Flow Check Indicator On; however, the '301' failure may not light an indicator.</p> <ol style="list-style-type: none"> Do not reset the tape control or the sense data will be lost. Set the Display Select switch to Cmpr REG and verify that the Compare Register is still set to '20A'. Enter a Sense command into all four Command Registers. Set the Data Entry rotary switches to '04X'. Set the Display Select switch to CE Reg. Set the Data Entry Select switch to Cmnd 1, Cmnd 2, Cmnd 3, Cmnd 4, and operate the SET CE/Cmpr switch for each position. 4. Set the CE Panel switches: ALU1/ALU2 switch to ALU1. Display Select switch to IC. Stop On Control Check switch Off. Stop On Data Flow Check switch Off. Mple/Single switch to Single. 5. Operate the Command Control Start switch. The indicators should be displaying an IC address of '20A'. Move the Display Select switch to Bus In. The indicators will now display Sense Byte 0. Move the Display Select switch back to IC and operate the Start or Step switch one time. Sense Byte 1 can now be displayed by setting the Display Select switch to Bus In. Obtain all 24 bytes of sense data by selecting IC, operating Start or Step once, then displaying Bus In. Do not operate Start or Step unless IC is selected. With the Mple/Single switch on Mple, ALU1 will go back to idlescans ('7FF') after the 24th sense byte is obtained. To repeat the sense routine, operate the Command Control Start switch again. Contact bounce in the Start or Step switch may cause this routine to skip over several sense bytes. If this occurs, complete the routine to obtain remaining sense bytes, then go back to Seq 5 to get the sense bytes skipped. | |
| 26 | Does ALU1 hang at IC '301' without executing Sense? | See Note 3 on 13-000; Go to 13-240. |
| 27 | <p>Initial setup did not fail. Try varying the command chain:</p> <p>Command 1 - '07x' Command 2 - 'C3x' Command 3 - '01x' Command 4 - '0Cx'</p> <p>Then try using a 'CB' Mode Set for Command 2, or use the failing command from original failure, if known. Does failure occur now?</p> | Go to Seq 18. |
| 28 | <p>Failure is either intermittent or cannot be duplicated offline. Is a set of loop addresses available from the original online failure, or can you recreate the loop or hangs with OLTs?</p> | Go to Seq 13. |

| Seq | Condition/Instruction | Action |
|-----|---|--|
| 29 | Is the failure from only one side of the two-channel switch in the channel interface, or a single-channel interface problem? | Channel failure. See Note 3 on 13-000. Go to 18-040. |
| 30 | Try running the failing job online with Stop On Control Check On and ROS Mode set to Stop. Try to get at least one failure with the ALU1/ALU2 switch in each position. If failure cannot be re-created, and you have insufficient information to proceed, go to 00-010, Seq 15. | |
| 31 | <p>ALU Hardware Error</p> <p>It is imperative to know the status of both ALU1 and ALU2 when the failure occurs. Is there any sense information?</p> <p>Note: If tape control power is turned on while the CE panel is enabled and Stop On Control Check is On, it is possible to get normal control check errors.</p> | Go to Seq 34. |
| 32 | Is there error information recorded for ALU1 and/or ALU2 while running in Check Stop mode? | Go to Seq 34. |
| 33 | If not: | Go to Seq 6. |
| 34 | Refer to ALU listing. Does the Error Stop occur at an invalid address? See Note 3, on 13-000. | Go to 13-090 if problem is in ALU1. Go to 13-191, Seq 59, if problem is in ALU2. |
| 35 | Is Sense Byte 11, Bit 2 on or is Lo IC/Lo ROS parity indicator on for ALU1 | See Note 3 on 13-000. Go to 16-010. |
| 36 | Is Sense Byte 11, Bit 3 on or is Hi IC/Hi ROS parity indicator on for ALU1 | See Note 3 on 13-000. Go to 16-020. |
| 37 | Is Sense Byte 12, Bit 2 on or is Lo IC/Lo ROS parity indicator on for ALU2 | See Note 3 on 13-000. Go to 16-080. |
| 38 | Is Sense Byte 12, Bit 3 on or is Hi IC/Hi ROS parity indicator on for ALU2 | See Note 3 on 13-000. Go to 16-090. |
| 39 | Is Sense Byte 11, Bit 0 on or is B-Bus parity indicator on for ALU1 | See Note 3 on 13-000. Go to 16-030. |
| 40 | Is Sense Byte 12, Bit 0 on or is B-Bus parity indicator on for ALU2 | See Note 3 on 13-000. Go to 16-100. |
| 41 | Is Sense Byte 11, Bit 5 on or is D-Bus parity indicator for ALU1 | See Note 3 on 13-000. Go to 16-040. |

| Seq | Condition/Instruction | Action |
|-----|--|---|
| 42 | Is Sense Byte 12, Bit 5 on or is D-Bus parity indicator on for ALU2 | See Note 3 on 13-000. Go to 16-110. |
| 43 | Is Sense Byte 11, Bit 7 on or is BOC parity indicator on for ALU1 | See Note 3 on 13-000. Go to 16-050. |
| 44 | Is Sense Byte 12, Bit 7 on or is BOC parity indicator on for ALU2 | See Note 3 on 13-000. Go to 16-120. |
| 45 | Is Sense Byte 12, Bit 4 on or is Microprogram Detected error indicator on for ALU2? | See Note 3 on 13-000. Go to 16-130. |
| 46 | Is Sense Byte 11, Bit 4 on or is Microprogram Detected error indicator on for ALU1? | See Note 3 on 13-000. Go to 16-060. |
| 47 | Consult the microcode listing and use the comments to identify the failure mode of the loop. See Chart 1 to find the MAP to fix the failure. Is a MAP available? | Go to MAP for the failure. (If the MAP does not fix the failure, return to Seq 48 on this MAP.) |
| 48 | Is this a channel interface problem? | Go to 18-040. |
| 49 | Is this a device interface problem? | Go to 18-000 without the device switch or to 18-010 with the device switch. |
| 50 | If not: | Go to 00-030. |

3803-2/3420

| | | | | | | | |
|----------------------|------------------------|-------------------|--------------------|--|--|--|--|
| XE1000 Seq 2 of 2 | 2735861 Part Number | See EC History | 845958 1 Sep 79 | | | | |
|----------------------|------------------------|-------------------|--------------------|--|--|--|--|

ALU1 OR ALU2 HANGS (Cont'd)

13-005

Chart 1

| Condition/Instruction | MAP Page |
|---|----------|
| ADDRESS OUT Inactive | 13-360 |
| ALU Hung in "ADD" Loop | 13-370 |
| ALU1 Cannot Reset CUE Latch on Interface A | 13-200 |
| ALU1 Cannot Reset CUE Latch on Interface B | 13-500 |
| ALU1 Cannot Xfr LINK1 to IC | 13-130 |
| ALU1 Found "Hot" COMMAND OUT During Power On Reset | 13-290 |
| ALU1 Found "Hot" SERVICE OUT During Power On Reset | 13-280 |
| ALU1 Hardware Error Trap Failure | 13-400 |
| ALU1 Hung During Channel Bus Check in Power On Reset | 13-380 |
| ALU1 or ALU2 Hangs | 13-000 |
| ALU1 steps improperly through Power On Reset | 13-090 |
| ALU2 steps improperly through Power On Reset | 13-190 |
| ALU1 Trapped at Address 000 | 13-010 |
| ALU1 Trapped at Address 301 | 13-240 |
| ALU1 Trapped at Address 302 | 13-220 |
| ALU1 Waiting for ADDRESS OUT to Fall | 13-300 |
| ALU1 Waiting for ALU2, Caused by Tach Failure | 13-510 |
| ALU1 Waiting for ALU2, Stat B to Fall | 13-460 |
| ALU1 Waiting for ALU2, Stat B to Fall After a Write | 13-470 |
| ALU1 Waiting for ALU2, Stat B to Rise | 13-450 |
| ALU1 Waiting for ALU2, Stat D | 13-440 |
| ALU1 Waiting for ALU2, to Complete a Read or Readback Check | 13-410 |
| ALU1 Waiting for ALU2, to Complete a Sequence | 13-420 |
| ALU1 Waiting for ALU2, to Complete a 6250 Write | 13-480 |
| ALU1 Waiting for COMMAND OUT | 13-140 |
| ALU1 Waiting for COMMAND OUT, SERVICE IN/OUT or DATA IN/OUT to Fall | 13-100 |
| ALU1 Waiting for EOD on 7- or 9-Track NRZI Write | 13-520 |
| ALU1 Waiting for OP IN to Fall | 13-250 |
| ALU1 Waiting for OP IN to Fall After CTI Reset | 13-210 |
| ALU1 Waiting for Response to STATUS IN | 13-110 |
| ALU1 Waiting for SERVICE OUT to Fall | 13-170 |
| ALU1 Waiting for SUPPRESS OUT to Fall | 13-310 |

| Condition/Instruction | MAP Page |
|--|----------|
| COMMAND OUT Inactive Reset or Power On Reset | 13-330 |
| SERVICE OUT Inactive During Reset or Power On Reset | 13-350 |
| SIO Trap Failure | 13-320 |
| SUPPRESS OUT Inactive During Reset or Power On Reset | 13-340 |
| Unable to Perform Commands from the CE Panel | 13-050 |
| Wrong Interface Responding | 13-080 |
| XOUTA Register Problems | 13-430 |

3803-2/3420

| | | | | | | | | |
|-----------------------------|-------------------------------|-----------------------|---------------------------|--|--|--|--|--|
| XE1050 Seq 1 of 2 | 8492591 Part Number | See EC History | 845958 1 Sep 79 | | | | | |
|-----------------------------|-------------------------------|-----------------------|---------------------------|--|--|--|--|--|

13-005

NOTES:

13-006

3803-2/3420

| | | | | | | | | | |
|-----------------------------|-------------------------------|---------------------------------|---------------------------|--|--|--|--|--|--|
| XE1050 Seq 2 of 2 | 8492591 Part Number | See EC History | 845958 1 Sep 79 | | | | | | |
|-----------------------------|-------------------------------|---------------------------------|---------------------------|--|--|--|--|--|--|

© Copyright International Business Machines Corporation 1976, 1979

13-006

ALU1 HANGS AT 000

13-010

| From:t 13-000 | | |
|--|--|--|
| ALU1 is either being held to address 000 with a solid reset, or after being trapped to 000, was not allowed to restart. | | |
| Most Probable Cause: | | |
| A. A1C2 | | |
| B. B2M2—without EC733814 B2L2—with EC733814 | | |
| C. A2P4 | | |
| D. A2P3 and A2D2 (both) | | |
| Additional cards referenced: | | |
| A. B2F2 | | |
| Always start with Seq 1 and follow the procedure in sequence unless directed otherwise. Remember to END all problems or maintenance calls by going to MAP 00-030. | | |
| Seq | Condition/Instruction | Action |
| 1 | Have cards been interchanged between ALU1 and ALU2 (see chart on 16-001)? | Go to Seq 3. |
| 2 | Interchange the cards between ALU1 and ALU2 (see chart on 16-001). If the symptoms change, the failing FRU has been identified. Did the symptoms change? | Change bad card and go to 00-030. |
| 3 | Is -System Reset (B2F2D10) minus? | Go to Seq 10. |
| 4 | Is -20.48 MHz OSC TP (A1C2U04) pulsing? | Go to Seq 6. |
| 5 | If not: | Change A1C2. |
| 6 | Is -20.48 MHz (A1C2J06) pulsing? | Go to Seq 8. |
| 7 | If not: | Change A1C2. |
| 8 | Is -20.48 MHz (B2F2B09) pulsing? | Recheck the symptoms. |
| 9 | Check for broken land in net BS011GL6. | |
| 10 | Is +Reset ALU1 IC plus? With EC733814—B2L2P12 Without EC733814—B2M2P12 | Go to Seq 18. |
| 11 | Is +Mach Reset plus? With EC733814—B2L2B07 Without EC733814—B2M2B07 | Go to Seq 13. |
| 12 | If not: | Change B2F2. |
| 13 | Is +CE Reset Switch (A1T2M08) plus? | This is the failing line. Go to ALD, PS011, and follow line back to the failing point. |
| 14 | Is +Power On Reset plus? With EC733814—B2L2G05 Without EC733814—B2M2G05 | Go to Seq 16. |
| 15 | If not: | With EC733814, change B2L2. Without EC733814, change B2M2. |
| 16 | Is -Power Reset minus? With EC733814—B2L2J03 Without EC733814—B2M2J03 | This is the failing line. Go to ALD, FC141, and follow line back to failing point. |

| Seq | Condition/Instruction | Action |
|-----|---|---|
| 17 | If not: | With EC733814, change B2L2. Without EC733814, change B2M2. |
| 18 | Is -Gate Trap Pulse pulsing? With EC733814—B2L2G11 Without EC733814—B2M2G11 | Go to Seq 20. |
| 19 | Is -Gate Trap Pulse (B2F2G07) pulsing? | Check this net for open lands. (ALD, AB031.) |
| 20 | Is +5.12 MHz (B2F2J10) pulsing? | Change B2F2. |
| 21 | Is +5.12 MHz (A1C2B03) pulsing? | Check this net for open lands. |
| 22 | If not: | Change A1C2. |
| 23 | Is -Hardware Error ALU1 minus? With EC733814—B2L2M08 Without EC733814—B2M2M08 | Go to Seq 25. |
| 24 | If not: | With EC733814, change B2L2. Without EC733814, change B2M2. |
| 25 | Is -Hardware Error ALU1 (A2P4J03) minus? | Go to Seq 27. |
| 26 | Check net AA451GA6 for open lands and cable. | |
| 27 | Is +System Reset (A2P4G02) plus? | Change A2P4. |
| 28 | Is +System Reset (B2F2D12) plus? | Check this net for open lands or cables. |
| 29 | If not: | Change B2F2. |

3803-2/3420

| | | | | | | | | |
|---------------|----------------|---------------|---------------|--|--|--|--|--|
| XE1100 | 2735862 | See EC | 845958 | | | | | |
| Seq 1 of 2 | Part Number | History | 1 Sep 79 | | | | | |

13-010

| From 13-000, 12-020 | | |
|--|--|---|
| This procedure is entered when the Power-On-Reset and ALU Checkout sequences operate normally, but the tape control does not begin a command sequence when the START switch is operated. | | |
| Most Probable Cause: A. With EC733814—B2L2 Without EC733814—B2M2. B. A2D2 C. A2E2 D. A2P4 E. A2R2 F. A1R2, A1R4 G. A1S2 H. A1T2 | | |
| Additional Cards Referenced: A. B2F2 | | |
| Always start with Seq 1 and follow the procedure in sequence unless directed otherwise. Remember to END all problems or maintenance calls by going to MAP 00-030. | | |
| Seq | Condition/Instruction | Action |
| 1 | Have the cards been interchanged between ALU1 and ALU2 (see chart on 16-001)? | Go to Seq 3. |
| 2 | Interchange the cards between ALU1 and ALU2 (see chart on 16-001). If the symptoms change, the failing FRU has been identified. Did the symptoms change? Return cards to their original positions. | Change defective card and go to 00-030. |
| 3 | Set up the CE panel: A. Set ROS Mode to Stop. B. Raise Set ROS Mode switch. C. Raise both Stop On switches On. D. Set the command sequence of: Command 1 — Write (01x) Command 2 — Write (01x) Command 3 — Write (01x) Command 4 — Write (01x) E. Byte Count = 'FD9' F. Write Data = 'FF0' G. Set Mple/Single switch to Mple. | |
| 4 | Did the CE register set? | Go to Seq 6. |
| 5 | If not: | Go to 12-000. |
| 6 | Raise Reset momentarily and then operate Start momentarily. | |
| 7 | Select ALU1 and then ALU2. Are there any red light errors? | Go to 13-000. |
| 8 | Does the tape unit execute only one command each time Start is operated momentarily. (Operate Start several times.) | Check Mple/Single switch output at A1V4B10, gnd = Single, - V = Mple. If ok, change A1R2. |

| Seq | Condition/Instruction | Action |
|-----|--|---|
| 9 | Set Display Select switch to IC. Select ALU1. Does ALU1 hang or loop at any address other than '7FF'? | Go to 13-000. |
| 10 | Change CE panel setup: A. Turn ROS MODE to Norm B. Raise Set ROS Mode switch C. Turn both Stop On switches Off D. Raise Reset momentarily. Operate Start momentarily to start the command sequence. | |
| 11 | Is +CE Command Out (A1R2G13) pulsing continuously (500 ns pulses)? | Go to Seq 49. |
| 12 | Raise Reset momentarily. Is +General Reset Chan A-B (B2Q2S10) plus? | Go to Seq 24. |
| 13 | Is -25 NS Tap ALU1 (B2F2S10) failing to pulse? | Change B2F2. |
| 14 | Is +Block ALU1 IC (A2P4G03) plus? | Change A2P4. |
| 15 | Is +CE Address Out (A1R2P02) a solid plus? | Go to Seq 22. |
| 16 | Operate Start momentarily. Does +CE Address Out (A1R2P02) pulse or go plus? | Go to Seq 32. |
| 17 | Does -Any Command Test Brk (A1R2D05) go minus when Start is operated momentarily? | Go to Seq 27. |
| 18 | Is -Not Run Clock (A1S2J13) always plus? | Go to Seq 56. |
| 19 | Does +Start NB Latch (A1T2G05) go plus when Start is operated momentarily? | Change A1R2. |
| 20 | Go to Action column. | Change A1T2 and go to Seq 21. |
| 21 | If problem is fixed, go to 00-030; otherwise, go to Action column. | Go to ALD PK035DN2 to resolve. |
| 22 | Raise and hold Reset. Is -Any Command Test Brk (A1R2D05) plus? | Change A1R2. |
| 23 | If not: | Change A1R2. |
| 24 | Is +General Reset Chan B (B2P2S10) plus? | With EC733814, change B2L2. Without EC733814, change B2M2. |
| 25 | Does +Reset CUE Chan A (B2E2G07) pulse (50 ns) when Reset is raised momentarily? | See Caution, then change B2Q2. |
| 26 | If not: | Change B2E2. |
| 27 | Is -CE Op In (A1R2D12) minus? | Go to Seq 30. |
| 28 | Is +CE Mode (A1R2M12) plus? | Change A1R2. |
| 29 | Go to Action column | Go to ALD PK011FH2 to resolve. |
| 30 | Is -Operational In (A1R2J03) minus? | Change B2L2. |
| 31 | If not: | Change A1R2. |

| Seq | Condition/Instruction | Action |
|-----|--|---------------|
| 32 | Set scope time base to 5 ms/cm. Does +CE Strobe Test Brk (A1R2D06) pulse? | Go to Seq 34. |
| 33 | If not: | Change A1R2. |
| 34 | Does -Counter Compare EQ Test Brk (A1R2G12) pulse minus? | Go to Seq 36. |
| 35 | If not: | Go to Seq 54. |
| 36 | Raise Reset momentarily. Operate Start momentarily. Does -Gate Tags (A1S2J06) pulse minus? | Go to Seq 40. |
| 37 | Raise Reset momentarily. Does +1.25 MHz (A1S2M07) pulse? | Change A1S2. |
| 38 | Is +Any CE Out Tag (A1R2M03) plus? | Change A1R2. |
| 39 | If not: | Change A1S2. |
| 40 | Does -Operational In (A1R2J03) go minus when Start is operated momentarily? | Go to Seq 42. |
| 41 | If not: | Change B2L2. |
| 42 | Raise Reset momentarily. Operate Start momentarily. Does +CTI Bit 6 To CE (A1R2M02) pulse plus? | Go to Seq 44. |
| 43 | If not: | Change A2R2. |
| 44 | Raise Reset momentarily. Operate Start momentarily. Does +CE Command Out (A1R2G13) pulse plus? | Go to Seq 46. |
| 45 | If not: | Change A1R2. |
| 46 | Raise Reset momentarily. Operate Start momentarily. Does -CE Status In (A1R2D13) pulse minus? | Go to Seq 49. |
| 47 | Raise Reset momentarily. Operate Start momentarily. Does +CTI Bit 5 To CE (A1R2M13) pulse plus? | Change A1R2. |
| 48 | If not: | Change A2R2. |
| 49 | Raise Reset momentarily. Operate Start momentarily. Does -CE Status Advance Cmnd (A1T2S09) pulse minus for 10-12 usec? | Change A1S2. |
| 50 | Raise Reset momentarily. Is -Interrupt (A2D2G12) minus? | Change A2D2. |
| 51 | Is -50 NS Tap Powered (B2F2B02) a solid level? | Change B2F2. |

3803-2/3420

| | | | | | | | |
|----------------------|------------------------|-------------------|--------------------|--|--|--|--|
| XE1100 Seq 2 of 2 | 2735862 Part Number | See EC History | 845958 1 Sep 79 | | | | |
|----------------------|------------------------|-------------------|--------------------|--|--|--|--|

COMMAND SEQUENCE (Cont'd)

| Seq | Condition/Instruction | Action |
|-----|---|--|
| 52 | Raise Reset momentarily. Operate Start momentarily several times. Does -TUTAG Bit 7 Move (A2R2D03) pulse minus? | Go to 18-010 and determine why MOVE tag is not reaching the tape unit. |
| 53 | If not: | Change in order: 1. A2R2 2. A2E2 |
| 54 | Raise Reset momentarily. Is +Write Cmnd (A1S2G08) plus? | Change A1R2. |
| 55 | If not | Change A1S2. |
| 56 | Raise Reset momentarily. Is +CE Master Reset (A1R2J04) plus? | Change A1R2. |
| 57 | Is -Panel Enable Sw (A1T2D03) plus? | Go to ALD PS041AA4 and resolve. |
| 58 | Is +CE Mode (A1R2M12) minus? | Change A1T2. |
| 59 | Raise Reset momentarily. Operate Start momentarily. Does +Start Or Status In (A1R2J06) pulse or go plus? | Change A1S2. |
| 60 | Raise Reset momentarily. Does +1.25 MHz (A1S2M07) pulse? | Change A1R2. |
| 61 | If not: | Change A1S2. |

CAUTION: Removing this card may cause channel errors even with power off. Put CPU in the Single Cycle mode before removing card.

3803-2/3420

| | | | | | | | | |
|------------|-------------|---------|----------|--|--|--|--|--|
| XE1150 | 2735741 | See EC | 845958 | | | | | |
| Seq 1 of 2 | Part Number | History | 1 Sep 79 | | | | | |

NOTES:

13-070

3803-2/3420

| | | | | | | | | |
|-----------------------------|-------------------------------|---------------------------------|---------------------------|--|--|--|--|--|
| XE1150 Seq 2 of 2 | 2735741 Part Number | See EC History | 845958 1 Sep 79 | | | | | |
|-----------------------------|-------------------------------|---------------------------------|---------------------------|--|--|--|--|--|

© Copyright International Business Machines Corporation 1976, 1979

13-070

TCS: ALU1 LOOP

13-080

| From: 13-000 | | |
|--|--|---|
| <p>This failure occurs only on two channel switch (TCS) machines as a result of the wrong interface responding on a polled interrupt or ALU1 branching incorrectly. It may also occur as a result of electrostatic discharge (ESD) problems.</p> | | |
| <p>Most Probable Cause:</p> <p>A. B2L2 with EC733814 B2M2 without EC733814</p> <p>B. B2N2</p> | | |
| <p>Additional Cards Referenced:</p> <p>A. B2P2</p> | | |
| <p>Always start with Seq 1 and follow the procedure in sequence unless directed otherwise. Remember to END all problems or maintenance calls by going to MAP 00-030.</p> | | |
| Seq | Condition/Instruction | Action |
| 1 | Does ALU1 loop at label WRONGCHN? (See ALU1 microcode cross-reference listing.) | Change in order: 1. B2L2 with EC733814 B2M2 without EC733814 2. B2N2 3. B2P2 Go to 00-030. |
| 2 | If not: | Go to 13-000. |

3803-2/3420

| | | | | | | | | |
|----------------------|------------------------|-------------------|--------------------|--|--|--|--|--|
| XE1200 Seq 1 of 2 | 2735863 Part Number | See EC History | 845958 1 Sep 79 | | | | | |
|----------------------|------------------------|-------------------|--------------------|--|--|--|--|--|

13-080

| From 13-000, 13-190, 13-400 | | |
|--|---|---|
| ERROR DESCRIPTION: You have reached this page because ALU1 is stepping improperly through the Power-on Reset routine, ALU is looping in a routine that is not defined by an EQUATE statement, or the hang address is not constant. | | |
| Most Probable Cause: A. B2H2 B. B2L2—with EC733814 B2M2—without EC733814 C. A2Q2 D. A1T2 E. A1R2 F. A1U2 G. SMS card, location J1 in 6 V power supply | | |
| Additional Cards Referenced: A. B2F2 B. B2E2 | | |
| Always start with Seq 1 and follow the procedure in sequence unless directed otherwise. Remember to END all problems or maintenance calls by going to MAP 00-030. | | |
| Seq | Condition/Instruction | Action |
| 1 | Have the cards been interchanged between ALU1 and ALU2 (see chart on 16-001)? | Go to Seq 3. |
| 2 | Interchange the cards between ALU1 and ALU2 (see chart on 16-001). If the symptoms change after an interchange, you have identified the bad FRU. Did the symptoms change? Return the cards to the original position. | Change defective card and go to 00-030. |
| 3 | Go to the microcode listing cross-reference section located behind the ALU1 and ALU2 sections. Look up "Step" under the "Symbol" column. STEP0001 through STEP00XX determine the proper path through the Power-On Reset routine. Single-step the machine and compare the hex addresses listed under the "Value" column against the IC address displayed on the CE panel. | |
| 4 | CE PANEL SETUP: A. Turn the ROS Mode switch to Step; raise Set ROS Mode. B. Set Compare Register to '000'. C. Turn the Stop On Control Check and Stop On Data Flow Check switches Off. D. Set the Display Select switch to IC. E. Select ALU1. F. Operate the Reset switch momentarily. G. Step through the ALU1 POR routine. | |
| 5 | Does ALU1 IC reset to '000', then step to STEP0002 when the Reset switch is released? See ALU1 microprogram cross-reference listing for the address of STEP0002. | Go to Seq 11. |

| Seq | Condition/Instruction | Action |
|-----|---|---|
| 6 | Turn ROS Mode switch to Norm. Raise Set ROS Mode switch. Operate Reset momentarily. Is +Clk1 L3 ALU1 (B2F2G05) at a solid level? | Change B2F2. |
| 7 | Does -BOC Oper ALU1 (B2D2M09) remain plus when the Reset switch is operated? | Change B2D2. If still failing, go to Seq 9. |
| 8 | Scope +BOC Met (B2L2M11) with EC733814. Scope +BOC Met (B2M2M11) without EC733814. Does line remain minus when the Reset switch is operated? | With EC733814, change B2L2. Without EC733814, change B2M2. Then change B2D2. If still failing, go to Seq 9. |
| 9 | While holding the Reset switch up, operate the Display Select switch to display Hi and Lo ROS. Does ROS instruction readout agree with the microcode listing for address '000'? Each half of the instruction is displayed in lights 0 to 7. | Change B2E2. |
| 10 | If not: | Change B2H2. |
| 11 | Turn the ROS Mode switch to Norm and operate the Set ROS Mode switch. Operate Start or Step. Is -Compare Stop Or Step ALU1 (A1U2U10) always minus? | Change in order: 1. A1U2 2. A1T2 |
| 12 | At this point, ALU1 should be capable of cycling. The following CE panel operation allows ALU1 to ripple addresses sequentially in Page 0, without executing commands. A. Turn the Stop On Control Check switch Off. B. Select ALU1. C. Operate the Reset switch. D. Turn the ROS Mode switch to Set IC. E. Operate the Set ROS Mode switch. F. Turn the Stop On Control Check switch On and operate Set ROS Mode again. G. Set the Display Select switch to IC. IC should display hex 'OFF' as the addresses are being cycled. Does the ALU fail to cycle? | Change in order: 1. B2F2 2. B2E2 |
| 13 | Scope the following points: B2F2G03 +Clk1 Not CE Cycle L2 ALU1 B2F2J05 +Clk1 Not CE Cycle L1 ALU1 B2F2M08 +Clk6 ALU1 B2F2M13 +Clk8 ALU1 B2F2S09 -Clk11 ALU1 B2F2P12 -100 ns Tap B2F2D05 +Reset Hi Order ROS Is any line failing to switch? | Change B2F2. If line still fails, go to ALD AB021 through AB041 and follow line back to failing point. |
| 14 | Scope the IC triggers, ROS Data Bits, and ROS Register Positions 8-15 (Charts 1, 2, and 4). Does any line fail to switch or have incorrect levels or bad rise or fall times? | Change the associated card. |
| 15 | Does ALU1 step properly to STEP0085 of the POR routine when in Step mode? See ALU1 microprogram cross-reference listing. Note: STEP0075 is bypassed in Step mode. | Problem may be slow bits from the MAL. Change B2H2. If still failing, go to Seq 17. |

| Seq | Condition/Instruction | Action |
|-----|--|---|
| 16 | Set the Compare Register to the address of the first bad branch in the Power-On Reset routine. Change the CE panel setup: A. Turn the Stop On Control Check switch Off. B. Select ALU1 and display IC. 3. Turn the ROS Mode switch to Rst/Cmpr. 4. Reset the tape control and let ALU1 cycle between address '000' and the "compare" address. The last instruction executed is probably causing the failure. Refer to the charts and compare the ROS Register, LSR Decode, Command, and Branch conditions with respect to the instruction listed in the microcode. Does any condition fail to match the instruction being performed? | Change the associated card. |
| 17 | If not, you must determine the reason for the bad branch, using the microcode listing. Display the failing sequence of instructions on the scope. The charts on 13-091 should provide most of the necessary test points. | Refer to the interchangeable card listing for ALU1 and ALU2 (see 16-001). |

3803-2/3420

| | | | | | | | | |
|----------------------|------------------------|-------------------|--------------------|--|--|--|--|--|
| XE1200 Seq 2 of 2 | 2735863 Part Number | See EC History | 845958 1 Sep 79 | | | | | |
|----------------------|------------------------|-------------------|--------------------|--|--|--|--|--|

ALU1 CHARTS 1 TO 7

Chart 1

| ALU1 | | |
|---------------------------|------------------|-------------------------|
| ROS ADDRESS LAMP POSITION | IC TRIG POSITION | Test Point B2E2 +Active |
| 4 | 8 | P11 |
| 5 | 9 | G13 |
| 6 | 10 | G12 |
| 7 | 11 | J13 |
| 8 | 12 | M02 |
| 9 | 13 | M03 |
| 10 | 14 | P03 |
| 11 | 15 | P02 |

Chart 2

| ALU1 | |
|--------------|-------------------------|
| ROS DATA BIT | Test Point B2H2 +Active |
| 0 | U13 |
| 1 | U12 |
| 2 | U11 |
| 3 | U10 |
| 4 | U05 |
| 5 | U04 |
| 6 | U03 |
| 7 | U02 |
| 8 | P11 |
| 9 | P10 |
| 10 | P09 |
| 11 | P07 |
| 12 | P06 |
| 13 | P05 |
| 14 | P04 |
| 15 | M03 |
| P1 | M02 |
| P2 | P02 |

Chart 3

| ALU1 | |
|-----------|---------------------|
| CLOCK | Test Point B2F2 PIN |
| 75 ns tap | U07 |
| CLK6 | M08 |
| CLK8 | M13 |
| CLK11 | S09 |
| CLK1 L1 | J05 |
| CLK2 L2 | G03 |

Chart 4

| ALU1 | |
|------------------|--------------------|
| ROS REG POSITION | PIN & ACTIVE LEVEL |
| 0 | B2D2B10(-) |
| 0 and 1 | B2D2P09 (-) |
| 0 and 2 | B2D2P12 (-) |
| 3 | B2D2D10 (-) |
| 4 | B2D2B13 (-) |
| 5 | B2D2D05 (-) |
| 6 | B2D2D09 (-) |
| 7 | B2D2D07 (-) |
| 8 | B2E2M05 (+) |
| 9 | B2E2G04 (+) |
| 10 | B2E2G03 (+) |
| 11 | B2E2J04 (+) |
| 12 | B2E2B07 (+) |
| 13 | B2E2B10 (+) |
| 14 | B2E2B02 (+) |
| 15 | B2E2B03 (+) |

Chart 5

| ALU1 | | | | |
|------------------|-------|-------|---------------|-----|
| B2D2 LSR DECODES | | | | |
| Without EC733838 | | | With EC733838 | |
| 0 | U02 | U07 | 8 | U02 |
| 1 | P13 | U05 | 4 | P13 |
| 2 | M13 | S05 | 2 | M13 |
| 3 | U03 | S07 | 1 | U03 |
| 4 | D13 | U12 | | |
| 5 | B11 | S09 | | |
| 6 | B12 | U10 | | |
| 7 | G02 | U06 | | |
| | AB071 | AB191 | | |

Chart 6

| ALU1 | | |
|---------------------------|----------|---------------------------|
| ROS ADDRESS LAMP POSITION | PAGE BIT | Test Point B2D2 (-Active) |
| 0 | 4 | B04 |
| 1 | 5 | B05 |
| 2 | 6 | B02 |
| 3 | 7 | P06 |

Chart 7

| ALU1 | |
|-------------|-------------------------|
| INSTRUCTION | Test Point B2D2 -Active |
| ADD | J12 |
| STORE | J13 |
| BOC | M09 |
| XFR | G12 |
| BU | G04 |
| BU or BOC | J04 |
| LOGIC OP | P02 |

3803-2/3420

| | | | | | | | |
|----------------------|------------------------|-------------------|--------------------|--|--|--|--|
| XE1300 Seq 1 of 2 | 2735864 Part Number | See EC History | 845958 1 Sep 79 | | | | |
|----------------------|------------------------|-------------------|--------------------|--|--|--|--|

| From: 13-000 | | |
|---|--|---|
| ALU1 is waiting for Command Out and/or Service Out (only on Write Ops), Service In or Service Out (on Read Ops) to fall. | | |
| Most Probable Cause: A. A1C2 B. A2R2 C. With EC733814—B2M2 (see 00-000) Without EC733814—B2L2 D. With EC733814—B2L2 Without EC733814—B2M2 E. A1R2, A2Q2 | | |
| Always start with Seq 1 and follow the procedure in sequence unless directed otherwise. Remember to END all problems or maintenance calls by going to MAP 00-030. | | |
| Seq | Condition/Instruction | Action |
| 1 | Turn ROS Mode switch to Norm. Operate Set ROS Mode switch momentarily. Operate Start or Step switch momentarily. | |
| 2 | Is +Service Out Chan A B CE a solid plus? With EC733814—B2L2G03 Without EC733814—B2M2G03 | Go to Seq 24. |
| 3 | Is +Data Service Active plus? With EC733814—B2L2D13 Without EC733814—B2M2D13 | Go to Seq 14. |
| 4 | Is -Command Out A B CE minus? With EC733814—B2L2U02. Without EC733814—B2M2U02. | Go to Seq 6. |
| 5 | If not: | With EC733814, change B2L2. Without EC733814, change B2M2. |
| 6 | Is +CE Command Out Tag plus? With EC733814—B2L2D10 Without EC733814—B2M2D10 | Go to Seq 10. |
| 7 | Is +Command Out Chan A Gated (B2Q2D12) plus? | See Caution, then change B2Q2. |
| 8 | Is +Command Out Chan B Gated (B2P2D12) plus? | See Caution, then change B2P2. |
| 9 | If not: | With EC733814, change B2L2. Without EC733814, change B2M2. |
| 10 | Is +CE Command Out Tag (A1R2S05) plus? | Go to ALD PK081FJ6 and resolve. |
| 11 | Is +Command Out Chan A Gated (B2Q2D12) plus? | See Caution, then change B2Q2. |
| 12 | Is +Command Out Chan B Gated (B2P2D12) plus? | See Caution, then change B2P2. |
| 13 | If not: | With EC733814, change B2L2. Without EC733814, change B2M2. |

| Seq | Condition/Instruction | Action |
|-----|--|---|
| 14 | Is -Stat Bit 0 Tape Op To ALU1 minus? With EC733814—B2M2S07 Without EC733814—B2L2S07 | Change A2Q2 and go to Seq 22. |
| 15 | Is +Service In For Data (A1C2P06) plus? | Change A1C2 and go to Seq 20. |
| 16 | Is +Data In (A1C2G13) plus? | Change A1C2 and go to Seq 18. |
| 17 | If not: | With EC733814, change B2M2. Without EC733814, change B2L2. |
| 18 | Is problem resolved? | Go to 00-030. |
| 19 | If not: | Go to ALD BS041GJ6 and resolve. |
| 20 | Is problem resolved? | Go to 00-030. |
| 21 | If not: | Go to ALD BS041GG4 and resolve. |
| 22 | Is problem resolved? | Go to 00-030. |
| 23 | If not: | Go to ALD AA141GD6 and resolve. |
| 24 | Is +CE Service Out Tag (A1R2S11) plus? | Change in order: 1. A1R2 2. A2R2 Go to Seq 28. |
| 25 | Is +Service Out Chan A Gated (B2Q2D11) plus? | See Caution. Change B2Q2, and go to Seq 30. |
| 26 | Is +Service Out Chan B Gated (B2P2D11) plus? | See Caution. Change B2P2 and go to Seq 32. |
| 27 | If not: | With EC733814, change B2L2. Without EC733814, change B2M2. |
| 28 | Is problem resolved? | Go to 00-030. |
| 29 | If not: | Go to ALD PK081FL6 and resolve. |
| 30 | Is problem resolved? | Go to 00-030. |
| 31 | If not: | Go to ALD FC021GF2 and resolve. |
| 32 | Is problem resolved? | Go to 00-030. |
| 33 | If not: | Go to ALD XM021GF2 and resolve. |

Caution: Removing this card may cause channel errors even with power off. Put CPU in the Single Cycle mode before removing card.

3803-2/3420

| | | | | | | | | |
|----------------------|------------------------|-------------------|--------------------|--|--|--|--|--|
| XE1300 Seq 2 of 2 | 2735864 Part Number | See EC History | 845958 1 Sep 79 | | | | | |
|----------------------|------------------------|-------------------|--------------------|--|--|--|--|--|

ALU1 WAITING

13-110

| From: 13-000 | | |
|--|--|---|
| ALU1 is waiting for Service Out or Command Out to become active in response to Status In. | | |
| Most Probable Cause: A. A2R2 B. A1R2 C. With EC733814—B2L2 Without EC733814—B2M2 | | |
| Additional Cards Referenced: A. B2Q2 | | |
| Always start with Seq 1 and follow the procedure in sequence unless directed otherwise. Remember to END all problems or maintenance calls by going to MAP 00-030. | | |
| Seq | Condition/Instruction | Action |
| 1 | Were you able to get a failure in 13-000? | Go to Seq 6. |
| 2 | Does machine have the two-channel switch (TCS) feature? | Go to Seq 4. |
| 3 | Go to Action column. | Change in order: 1. B2L2, with EC733814 B2M2, without EC733814 2. See Caution, then change B2Q2. |
| 4 | Interchange TCS ALU1 and ALU2 cards (see chart on 16-001) (4 cards). If symptoms change, the bad FRU has been identified. Did the symptoms change? | Change defective card and go to 00-030. |
| 5 | If not: | With EC733814, change B2L2. Without EC733814, change B2M2. Go to 00-030. |
| 6 | ALU1 should be looping at WATESUM. (See ALU1 microcode cross-reference listing for address.) | |
| 7 | Is +CE Service Out Tag plus? With EC733814—B2L2D09. Without EC733814—B2M2D09. | With EC733814, change B2L2. Without EC733814, change B2M2. |
| 8 | Is -CE Status In (A1R2D13) minus? | Change A1R2. |
| 9 | Is +CTI Bit 5 To CE (A1R2M13) plus? | Change A1R2. |
| 10 | If not: | Go to ALD FC161GJ2 and follow line to point of failure. |

Caution: Removing this card may cause channel errors even with power off. Put CPU in the Single Cycle mode before removing card.

3803-2/3420

| | | | | | | | |
|-----------------------------|-------------------------------|-----------------------|---------------------------|--|--|--|--|
| XE1400 Seq 1 of 2 | 2735865 Part Number | See EC History | 845958 1 Sep 79 | | | | |
|-----------------------------|-------------------------------|-----------------------|---------------------------|--|--|--|--|

13-110

| From: 13-000 | | |
|--|---|----------------------|
| ALU1 cannot transfer (XFR) LINK1 to IC | | |
| Most Probable Cause: B2E2 | | |
| Always start with Seq 1 and follow the procedure in sequence unless directed otherwise. Remember to END all problems or maintenance calls by going to MAP 00-030. | | |
| Seq | Condition/Instruction | Action |
| 1 | Turn ROS Mode switch to Norm. Operate Set ROS Mode switch. Operate Start OR Step switch. | |
| 2 | Set scope to 1 us/cm. Operate the Reset switch. Sync plus and display +Xfr B Bus To IC (B2E2J12). Does line ever go plus? | Recheck the symptom. |
| 3 | If not: | Change B2E2. |

3803-2/3420

| | | | | | | | | |
|----------------------|------------------------|-------------------|--------------------|--|--|--|--|--|
| XE1400 Seq 2 of 2 | 2735865 Part Number | See EC History | 845958 1 Sep 79 | | | | | |
|----------------------|------------------------|-------------------|--------------------|--|--|--|--|--|

ALU1 WAITING

| From: 13-000 | | |
|--|--|--|
| ALU1 is waiting for Command Out to become active. | | |
| Most Probable Cause: A. A2R2 B. A1R2 C. With EC733814—B2L2 Without EC733814—B2M2 | | |
| Additional Cards Referenced: A. B2Q2 B. B2P2 | | |
| Always start with Seq 1 and follow the procedure in sequence unless directed otherwise. Remember to END all problems or maintenance calls by going to MAP 00-030. | | |
| Seq | Condition/Instruction | Action |
| 1 | Does failure occur online only? | Go to Seq 14. |
| 2 | Turn ROS Mode switch to Norm. Operate Set ROS Mode switch momentarily. Operate Start or Step switch momentarily. | |
| 3 | Operate Reset switch momentarily. Does ALU1 IC indicate '7FF'? | Go to Seq 10. |
| 4 | Turn ROS Mode switch to Step. Operate Set ROS Mode switch momentarily. | |
| 5 | While holding Reset switch in operated position, do ALU1 IC indicators show '080'? | Go to Seq 8. |
| 6 | Is +Inst Count 10 ALU1 (B2E2G12) plus? ALD AB195-CH4 | Recheck symptoms. |
| 7 | If not: | Change B2E2. |
| 8 | Is +Inst Count 8 ALU1 (B2E2P11) plus when Reset switch is held in reset position? ALD AB195-CB4 | Change B2E2. |
| 9 | If not: | Recheck the symptoms. |
| 10 | Is +CTI Bit 6 To CE (A2R2D10) plus? | Go to Seq 12. |
| 11 | If not: | Change A2R2. |
| 12 | Is +CE Command Out (A1R2G13) plus? | With EC733814, change B2L2. Without EC733814, change B2M2. |
| 13 | If not: | Change A1R2. |
| 14 | Does the machine have two channel switch (TCS) feature installed? | Channel A, change B2Q2, A2R2 (see Caution). Channel B, change B2P2, A2R2 (see Caution). |
| 15 | If not: | Change B2Q2. (See Caution.) |

Caution: Removing this card may cause channel errors even with power off. Put CPU in the Single Cycle mode before removing card.

3803-2/3420

| | | | | | | | |
|----------------------|------------------------|-------------------|--------------------|--|--|--|--|
| XE1500 Seq 1 of 2 | 2735866 Part Number | See EC History | 845958 1 Sep 79 | | | | |
|----------------------|------------------------|-------------------|--------------------|--|--|--|--|

| From: 13-000 | | |
|--|--|---|
| ALU1 is waiting for SERVICE OUT to become inactive. | | |
| Most Probable Cause: A. A2R2 B. A1R2 C. With EC733814—B2M2 Without EC733814—B2L2 D. Channel A—B2Q2 (See CAUTION.) Channel B—B2P2 (See CAUTION.) E. With EC733814—B2L2 Without EC733814—B2M2 | | |
| Always start with Seq 1 and follow the procedure in sequence unless directed otherwise. Remember to END all problems or maintenance calls by going to MAP 00-030. | | |
| Seq | Condition/Instruction | Action |
| 1 | Does failure occur only online? | Go to Seq 10. |
| 2 | Turn ROS Mode switch to Norm. Operate Set ROS Mode switch momentarily. Operate Start or Step switch momentarily. | |
| 3 | +CTI Bit 4 Service In (A2R2B11) plus? | Go to Seq 5. |
| 4 | If not: | Change A2R2. |
| 5 | Is +Service In plus? With EC733814—B2M2U06 Without EC733814—B2L2U06 | Go to Seq 7. |
| 6 | If not: | With EC733814, change B2M2. Without EC733814, change B2L2. |
| 7 | Is -CE Op In (A1R2D12) minus? ALD PK081. | Go to Seq 9. |
| 8 | If not: | Change A1R2. |
| 9 | Is -CE Service In (A1R2J13) minus? ALD PK081. | Recheck the symptoms. Change A1R2. |
| 10 | Does machine have two channel switch (TCS) feature installed? | Go to Seq 12. |
| 11 | If not: | Change in order: 1. B2Q2 (See Caution.) 2. B2L2, with EC733814 B2M2, without EC733814. |
| 12 | Interchange the TCS card (see chart on 16-001). If symptoms change, the bad FRU has been found. Did symptoms change? | Change defective card and go to 00-030. |
| 13 | Go to Action column. | Change in order: 1. B2L2, with EC733814 B2M2, without EC733814 2. B2Q2, Channel A (see Caution) B2P2, Channel B (see Caution) 3. B2M2 Go to 00-030. |

Caution: Removing this card may cause channel errors even with power off. Put CPU in the Single Cycle mode before removing card.

3803-2/3420

| | | | | | | | | | |
|------------|-------------|---------|----------|--|--|--|--|--|--|
| XE1500 | 2735866 | See EC | 845958 | | | | | | |
| Seq 2 of 2 | Part Number | History | 1 Sep 79 | | | | | | |

| | | |
|--|--|---|
| From 13-000 | | |
| ERROR DESCRIPTION: Enter this MAP if ALU1 is looping in a power-on reset sequence, waiting for ALU2 to set STAT D after it completes one of 16 passes through the ALU2 POR routine. | | |
| Note: Go to STEP sequences in the cross-reference located behind the ALU microcode listing to determine the correct path through ALU checkout. | | |
| Most Probable Cause: | | |
| A. A2Q2 B. A2D2 C. A1C2 D. With EC733814—B2L2 Without EC733814—B2M2 E. A1U2 F. A1B2/S2 G. A1B2/K4 H. SMS card, location J1 in 6 V power supply | | |
| Additional Cards Referenced: | | |
| A. B2P2 B. A2K2 C. A2H2 D. A2P2 E. B2E2 F. A2K2 | | |
| Set up the CE Panel: | | |
| 1. Set the ROS Mode switch to Step, and press Set ROS Mode. 2. Set Compare Register to '000'. 3. Turn off Stop On Control Check and Stop On Data Flow Check. 4. Set Display Select switch to IC. 5. Select ALU1. 6. Operate Reset, then step thru ALU1 routine. | | |
| Compare the IC address displayed in the lights against the address cross-referenced in the listing. | | |
| Always start with Seq 1 and follow the procedure in sequence unless directed otherwise. Remember to END all problems or maintenance calls by going to MAP 00-030. | | |
| Seq | Condition/Instruction | Action |
| 1 | Interchange the cards between ALU1 and ALU2 (see list on 16-001). If symptoms change after an interchange, the failing FRU has been identified. Has the bad FRU been identified. Return cards to their original positions. | Change defective card and go to 00-030. |
| 2 | Go to the microcode listing cross-reference section located behind the ALU1 section. Look up the step under "Symbol" column. STEP0001 through STEP00xx determine the proper path through the ALU1 Power-on-Reset routine. Single-step your machine and compare the hex addresses listed under the "Value" column against the IC addresses displayed on the CE panel. | |
| 3 | Did ALU1 reach STEP0075 through the proper path? | Go to Seq 5. |

| Seq | Condition/Instruction | Action |
|-----|--|---|
| 4 | If not: | Go to 13-090. |
| 5 | Set ALU1/ALU2 switch to ALU2. | |
| 6 | Does ALU2 IC reset to '000' when the Reset switch is held up? | Go to Seq 13. |
| 7 | Is +Reset Or Trap ALU2 (A2K2D10) minus when the Reset switch is operated? | Change A2K2. |
| 8 | Does IC display 'hot' bits in positions 4 through 7 while the Reset switch is held in the operated position? | Change A2L2 and go to Seq 10. |
| 9 | Is +Clk 8 (A2K2M13) solid minus when the Reset switch is held in the Reset position? | Change A2K2 and go to Seq 10. |
| 10 | Does IC display 'hot' bits in positions 0 through 3 while the Reset switch is held in the reset position? | Change A2M2 and go to Seq 11. |
| 11 | Is the problem fixed? | Go to 00-030. |
| 12 | If not: | Go to 13-191, Charts 1 and 4 and follow failing line. |
| 13 | Does ALU2 IC remain locked at '000' when the Reset switch is released? | Go to Seq 20. |
| 14 | Go to the microcode listing cross-reference section located behind the ALU2 sections. Look up the step under the "Symbol" column. STEP0001 through STEP00xx determine the proper path through the ALU2 Power-on-Reset routine. Single-step your machine and compare the hex addresses listed under the "Value" column against the IC address displayed on the CE panel. Note: If Step Mode works properly, suspect MAL card at A2H2 of having slow bits. | |
| 15 | Does ALU2 step to STEP0063 in the proper sequence? Note: If a loop is encountered, refer to the ALU listing to ensure it an error condition. | Go to Seq 51. |
| 16 | Was an error loop encountered in ALU2 during the POR routine? | Go to Seq 18. |
| 17 | If not: | Change A2Q2 and go to Seq 35. |
| 18 | Is ALU2 looping at label HUP1? | Change A2Q2. |
| 19 | If not: | Go to Seq 23. |
| 20 | Turn ROS Mode switch to Norm and operate Set ROS Mode. Does -Trap ALU2 (A2P4J05) pulse once each time the Reset switch is operated? Note: Approximately 50 ns pulse. | Go to Seq 23. |

| Seq | Condition/Instruction | Action |
|-----|--|--|
| 21 | Does +Xfr XOUTB To Trap ALU2 (B2E2D11) pulse once each time the Reset switch is operated? | Change A2P4. |
| 22 | If not: | Change B2E2. |
| 23 | Is +Stat D ALU2 To ALU1 (A2Q2D02) always plus? | Change A2Q2. |
| 24 | Does +5.12 MHz (A1K2J10) or +20.48 MHz (A2K2B09) fail to pulse? | Change A1C2. |
| 25 | Does +Reset ALU2 IC (A2D2G04) remain minus when the Reset switch is operated and released? | Change A2P4. |
| 26 | Is -Gate Trap Pulse (A2D2D03) pulsing? | Go to Seq 28. |
| 27 | If not: | Change A2K2. |
| 28 | Does -25 NS TAP (A2D2D05) pulse each time the Reset switch is operated? | Go to Seq 30. |
| 29 | Does +Reset ALU2 IC (A2D2G04) remain plus when the Reset switch is operated and released? | Go to Seq 32. |
| 30 | Is +System Reset (A2K2D12) minus with Reset released? | Change A2K2. |
| 31 | Does +Trap ALU2 Latch2 (A2P4D06) remain minus when Reset is operated? | Change A2D2. |
| 32 | Is +Lock ALU2 IC (A2P4G09) a solid plus? | Change A2P4. |
| 33 | Is -ALU2 Lock Status (A2P4D13) a solid plus? | Change A2P4. |
| 34 | If not: | Change in order: 1. A2P2 2. A2D2 |
| 35 | If Seq 35 is reached, ALU2 should be free to run, although it may be branching incorrectly. The CE panel setup in Seq 36 should ripple through Page 0 of ALU2 reading out consecutive addresses and ROS bits without performing any commands. | |
| 36 | Set up the CE panel: A. Turn Stop On Control Check switch Off. B. Select ALU2. C. Operate Reset. D. Turn ROS Mode switch to Set IC, and operate Set ROS Mode. E. Turn the Stop On Control Check switch On and operate Set ROS Mode to set IC again. Lamps should display 'OFF' with the Display Select switch set to IC. | |

| | | | | | | | | |
|-----------------------------|-------------------------------|-----------------------|---------------------------|--|--|--|--|--|
| XE1600 Seq 1 of 2 | 2735867 Part Number | See EC History | 845958 1 Sep 79 | | | | | |
|-----------------------------|-------------------------------|-----------------------|---------------------------|--|--|--|--|--|

| Seq | Condition/Instruction Action | |
|-----|--|---|
| 37 | Using Charts 1, 2, 3, and 6 on 13-191, scope: A. ALU2 Clock controls. B. Instruction Counter positions 4 through 11 (8 through 15 in ALDs). C. ROS bits P1 through P15, and ROS Register 8 through 15. | |
| 38 | Ensure that all lines are switching and that the rise and fall times are within specifications. Are any lines bad? | Change the card shown in the chart. Go to Seq 42. |
| 39 | Change CE panel setup: 1. Turn the Stop On Control Check switch Off. 2. Set the ROS Mode switch to Rst/Cmpr. 3. Set Compare Register to the first incorrect address. (If '000', entire loop will be executed.) 4. Operate Set ROS Mode. 5. Operate Reset to allow ALU2 to cycle the POR routine between '000' and the Compare Register address. | |
| 40 | Scope the following points: A2K2P04 -150 ns A2K2P09 -Clk15 A2K2G12 -0 ns A2K2U11 +Rst Hi ROS L2 A2L2M04 +Xfr Opr B2D2U07 -LSR Decode 0B ALU1 Does any line fail to switch? | Change card associated with the failing line. |
| 41 | If not: | Change in order: 1. A2K2 2. A2H2 Go to Seq 42. |
| 42 | Is problem fixed? | Go to 00-030. |
| 43 | Does first bad step occur after STEP0062? | Go to Seq 48. |

| Seq | Condition/Instruction | Action |
|-----|--|--|
| 44 | ALU2 should be stepping properly past STEP0013. Is ALU2 stepping to the wrong page or staying in wrong page? | Change A2M2. See Chart 4. |
| 45 | ALU2 is probably failing to overflow out of an adder routine. Use the CE panel setup in Seq 39. Set Compare register to highest numerical address of loop. | |
| 46 | Go to Charts 3 through 7. Scope high order ROS registers, clocks, LSR, and command decodes, registers, and buses. | |
| 47 | Do any lines fail to switch? | Change card according to the chart. Go to Seq 51. |
| 48 | Set up the CE panel: A. Turn ROS Mode switch to Norm. B. Press Set ROS Mode. While operating the Reset switch, scope the following points: A2D2G04 +Reset ALU2 IC A2L2B13 +Xfr LSR2 To Stat A2Q2M09 -Stat D ALU2 To ALU1 A2P4D13 -ALU2 Locked Status Does any line fail to switch? | Change card associated with failing line. Go to Seq 57. |
| 50 | If not: | Go to Seq 62. |
| 51 | Does ALU2 complete the first pass of POR and then lock at '000'? | Go to Seq 53. |
| 52 | If not: | Change A2H2 and then go to Seq 32 if the problem is not fixed. |
| 53 | Set up the CE panel: A. Turn Stop On Control Check switch Off. B. Set contents of Compare register to the hex address of STEP0063. C. Turn the ROS Mode switch to Stop. D. Operate Set ROS Mode switch. E. Set Display switch to IC. F. Select ALU2. Operate the Reset switch and ensure that ALU2 stops at STEP0063. | |
| 54 | A. Turn ROS Mode switch to Step. B. Operate Set ROS Mode switch. C. Operate Start or Step switch one time. | |
| 55 | Is -Stat D ALU2 To ALU1 (A2Q2M09) minus? | Go to Seq 32. |
| 56 | If not: | Change A2Q2. |
| 57 | Did the new card correct the problem? | Go to 00-030. |
| 58 | If changing the card did not resolve the problem, return to the failing sequence which sent you here. Following the failing line to the source of the failure. | |

| Seq | Condition/Instruction | Action |
|-----|--|--|
| 59 | You have entered this page from 13-001 because ALU2 branches to an illegal address causing Hi and Lo ROS parity errors. Set up the CE panel: A. Turn the Stop On Control Check switch Off. B. Turn the ROS Mode switch to Rst/Err. C. Select ALU2. D. Operate Set ROS Mode, and then Reset. Does ALU2 begin looping? | Go to Seq 61. |
| 60 | If not: | Go to Seq 59 and repeat Steps A through D. |
| 61 | Scope the following points: B2D2B10 -ROS Reg 0, ALU1 B2D2D10 -ROS Reg 3, ALU1 A2M2D07 -ROS Reg 7, ALU2 See LSR -LSR Decode 4 Decodes -LSR Decode 1 Chart 7 -LSR Decode 58 for pin -LSR Decode 08 numbers. Is any line failing to switch? | Change card associated with failing line. |
| 62 | The MAPs cannot resolve the problem. Use the microcode listing and logics to resolve the problem. Refer to 16-000 for microprocessor troubleshooting information. | |

3803-2/3420

| | | | | | | | |
|----------------------|------------------------|-------------------|--------------------|--|--|--|--|
| XE1600 Seq 2 of 2 | 2735867 Part Number | See EC History | 845958 1 Sep 79 | | | | |
|----------------------|------------------------|-------------------|--------------------|--|--|--|--|

© Copyright International Business Machines Corporation 1976, 1979

ALU2 POWER-ON RESET (Cont.)

Chart 1

| ALU2 | | |
|---------------------------|---------------------|------------------------------|
| ROS Address Lamp Position | IC Trigger Position | Instruction Count Test Point |
| 4 | 8 | A2L2P11+ |
| 5 | 9 | A2L2G13+ |
| 6 | 10 | A2L2G12+ |
| 7 | 11 | A2L2J13+ |
| 8 | 12 | A2L2M02+ |
| 9 | 13 | A2L2M03+ |
| 10 | 14 | A2L2P03+ |
| 11 | 15 | A2L2P02+ |

Chart 2

| ALU2 | |
|--------------|--------------|
| ROS Data Bit | A2H2 +Active |
| 0 | U13 |
| 1 | U12 |
| 2 | U11 |
| 3 | U10 |
| 4 | U05 |
| 5 | U04 |
| 6 | U03 |
| 7 | U02 |
| 8 | P11 |
| 9 | P10 |
| 10 | P09 |
| 11 | P07 |
| 12 | P06 |
| 13 | P05 |
| 14 | P04 |
| 15 | M03 |
| P1 | M02 |
| P2 | P02 |

Chart 3

| ALU2 | |
|-----------|---------|
| Clock | Pin |
| 75 ns Tap | A2K2U07 |
| Clk 6 | M08 |
| Clk 8 | M13 |
| Clk 11 | S09 |
| Clk1 L2 | G03 |
| Clk1 L1 | J05 |

Chart 4

| ALU2 | |
|-------------|-----------------------|
| ROS Reg Bit | Page Bit A2M2 -Active |
| 0 | B04 |
| 1 | B05 |
| 2 | B02 |
| 3 | P06 |

Chart 5

| ALU2 | |
|-------------|--------------|
| Instruction | A2M2 -Active |
| ADD | J12 |
| STORE | J13 |
| BOC | M09 |
| XFR | G12 |
| BU | G04 |
| BU or BOC | J04 |
| LOGIC OP | P02 |

Chart 6

| ALU2 | |
|-------------------|----------------------|
| ROS REG. Bit Pos. | Pin and Active Level |
| 0 | A2M2B10 (-) |
| 0 & 1 | P09 (-) |
| 0 & 2 | P12 (-) |
| 3 | D10 (-) |
| 4 | B13 (-) |
| 5 | D05 (-) |
| 6 | D09 (-) |
| 7 | D07 (-) |
| 8 | A2L2M05 (+) |
| 9 | G04 (+) |
| 10 | G03 (+) |
| 11 | J04 (+) |
| 12 | B07 (+) |
| 13 | B10 (+) |
| 14 | B02 (+) |
| 15 | B03 (+) |

Chart 7

| ALU2 | | | |
|------------------|--------|---------------|--|
| A2M2 | | | |
| LSR Decodes | | | |
| U02 | U07 | | |
| P13 | U05 | U02 | |
| M13 | S05 | P13 | |
| U03 | S07 | M13 | |
| D13 | U12 | U03 | |
| B11 | S09 | | |
| B12 | U10 | | |
| G02 | U06 | | |
| Lo LSR | Hi LSR | | |
| without EC733838 | | with EC733838 | |

The following cards are interchangeable between the ALUs.

| B2 Panel | A2 Panel |
|----------|----------|
| F | K |
| D* | M* |
| E | L |
| C | N |

* contains feature jumpers

3803-2/3420

| | | | | | | | | |
|----------------------|------------------------|-------------------|--------------------|--|--|--|--|--|
| XE1650 Seq 1 of 2 | 2736035 Part Number | See EC History | 845958 1 Sep 79 | | | | | |
|----------------------|------------------------|-------------------|--------------------|--|--|--|--|--|

3803-2/3420

| | | | | | | | | | |
|-----------------------------|-------------------------------|---------------------------------|---------------------------|--|--|--|--|--|--|
| XE1650 Seq 2 of 2 | 2736035 Part Number | See EC History | 845958 1 Sep 79 | | | | | | |
|-----------------------------|-------------------------------|---------------------------------|---------------------------|--|--|--|--|--|--|

© Copyright International Business Machines Corporation 1976, 1979

ALU1 RESET FAILURE

| From: 13-000 | | |
|--|--|--------------------------------|
| ALU1 has attempted to reset the CUE latch for interface A. The reset was not effective and ALU1 keeps attempting the reset. | | |
| Most Probable Cause: A. B2Q2 (see Caution) B. B2E2 C. B2D2 | | |
| Always start with Seq 1 and follow the procedure in sequence unless directed otherwise. Remember to END all problems or maintenance calls by going to MAP 00-030. | | |
| Seq | Condition/Instruction | Action |
| 1 | Set ROS Mode switch to Norm. Operate Set ROS Mode switch. Operate Start or Step switch. | |
| 2 | Sync the scope plus on and display +Reset Cue Chan A (B2E2J11). A 50 ns pulse should appear at approximately 850 ns intervals. Is this line good? | Go to Seq 4. |
| 3 | If not: | Change B2E2. |
| 4 | Sync the scope as in Seq 1. Scope +Cue Pending Chan A (B2Q2U13). This line should go minus and stay there after the resets checked in Seq 2. Is this line good? | Change B2D2. |
| 4 | If not: | See Caution, then change B2Q2. |

Caution: Removing this card may cause channel errors even with power off. Put CPU in the Single Cycle mode before removing card.

3803-2/3420

| | | | | | | | | |
|------------|-------------|---------|----------|--|--|--|--|--|
| XE1700 | 2735868 | See EC | 845958 | | | | | |
| Seq 1 of 2 | Part Number | History | 1 Sep 79 | | | | | |

ALU1 FAILURE TO RESET CTI

| From: 13-000 | | |
|--|--|---|
| ALU1 attempted to reset all channel tag in (CTI) lines. A check is made to ensure that OP IN is inactive. ALU1 hangs at this address until OP IN is inactive. | | |
| Most Probable Cause: | | |
| A. B2Q2 Chan A (See Caution) | | |
| B. B2P2 Chan B (See Caution) | | |
| Additional Cards Referenced: | | |
| A. B2L2 | | |
| B. B2R2 | | |
| C. B2S2 | | |
| D. B2M2 | | |
| Always start with Seq 1 and follow the procedure in sequence unless directed otherwise. Remember to END all problems or maintenance calls by going to MAP 00-030. | | |
| Seq | Condition/Instruction | Action |
| 1 | Turn ROS Mode switch to Norm. Operate Set ROS Mode switch momentarily. Operate Start or Step switch momentarily. | |
| 2 | Is -Operation In minus? With EC733814—B2L2G04 Without EC733814—B2M2G04 | Go to Seq 4. |
| 3 | If not: | With EC733814, change B2L2. Without EC733814, change B2M2. |
| 4 | Is -Select Signal Chan A (B2Q2G03) minus? | Go to Seq 7. |
| 5 | Does the tape control have two channel switch (TCS) feature installed? | Go to Seq 11. |
| 6 | If not: | Go to Seq 17. |
| 7 | Is +Select Out To Line Receiver plus? With EC733814—B2S2S08 (Gnd to +4v) Without EC733814—B2R2S08 | Go to Seq 9. |
| 8 | If not: | See Caution, then change B2Q2. |
| 9 | Is +Select To Receivers Or Bypass plus? With EC733814—B2S2P09 (Gnd to +4v) Without EC733814—B2R2P09 | Go to ALD FC281EC4 and resolve. |
| 10 | If not: | With EC733814, change B2S2. Without EC733814, change B2R2. |
| 11 | Is -Select Signal Chan B (B2P2G03) minus? | Go to Seq 13. |
| 12 | If not: | Go to Seq 17. |
| 13 | Is +If Select Sig Chan B plus? With EC733814—B2R2S08 (Gnd to +4v) Without EC733814—B2S2S08 | Go to Seq 15. |
| 14 | If not: | See Caution, then change B2P2. |

| Seq | Condition/Instruction | Action |
|-----|---|---|
| 15 | Is +Select To Receivers Or Bypass plus? With EC733814—B2R2P09 (Gnd to +4v) Without EC733814—B2S2P09 | Go to ALD XM181EC4 and resolve. |
| 16 | If not: | With EC733814, change B2R2 (see Caution) Without EC733814, change B2S2 (see Caution) |
| 17 | Is -CTI Bit 7 Op In (A2R2B04) minus? | Change A2R2. |
| 18 | If not: | With EC733814, change B2L2. Without EC733814, change B2M2. |

Caution: Removing this card may cause channel errors even with power off. Put CPU in the Single Cycle mode before removing card.

3803-2/3420

| | | | | | | | |
|-----------------------------|-------------------------------|-----------------------|---------------------------|--|--|--|--|
| XE1700 Seq 2 of 2 | 2735868 Part Number | See EC History | 845958 1 Sep 79 | | | | |
|-----------------------------|-------------------------------|-----------------------|---------------------------|--|--|--|--|

3803 STATUS PENDING

13-220

| | | |
|---|---|---|
| From: 13-000 | | |
| ERROR DESCRIPTION: 302 is a trap address that indicates that Pending Status is held by the 3803. Request in A or B should be active at the CE panel if command chaining. If status is suppressible (Device End alone or previously stacked status), as indicated by SUP Req A or B indicators, the 3803 is under control of Suppress Out. | | |
| Most Probable Cause: | Additional Cards Referenced: | |
| A. A2R2 | A. B2E2 | |
| B. Chan A, B2Q2 (See Caution.) Chan B, B2P2 (See Caution.) | B. A2M2 | |
| C. Without EC733814, B2L2 Chan A, B2R2. (See Caution.) Chan B, B2S2. (See Caution.) | C. B2C2 | |
| D. With EC733814, B2M2 Chan A, B2S2. (See Caution.) Chan B, B2R2. (See Caution.) | D. B2D2 | |
| E. Chan B, B2N2 | E. B2B2 | |
| F. B2H2 | F. A2N2 | |
| G. A2H2 | G. B2F2 | |
| Always start with Seq 1 and follow the procedure in sequence unless directed otherwise. Remember to END all problems or maintenance calls by going to MAP 00-030. | | |
| Seq | Condition/Instruction | Action |
| 1 | Is Req In A or B indicator On at CE panel? | Go to Seq 5. |
| 2 | Are Sup O and Sup Req A or B indicator On at CE panel? | Go to Seq 14. |
| 3 | Is Sup Req A or B indicator On at CE panel? | Go to Seq 15. |
| 4 | If not: | Go to Seq 26. |
| 5 | Was Req In B indicator On at CE panel? | Go to Seq 10. |
| 6 | Is -Request In Chan A (B2Q2G02) minus? | Go to Seq 8. |
| 7 | If not: | See Caution, then change B2Q2. |
| 8 | Is +Intf Request In Chan plus? (This line is an interface level—ground to +4 V.) With EC733814—B2S2B03. Without EC733814—B2R2B03. | Check interface cable or suspect channel. |
| 9 | If not: | With EC733814, change B2S2 (see Caution). Without EC733814, change B2R2 (see Caution). |
| 10 | Is -Request In Chan B (B2P2G02) minus? | Go to Seq 12. |
| 11 | If not: | Change B2P2 (See Caution.) |
| 12 | Is +Intf Request In Chan plus? (This line is an interface level—ground to +4 V.) With EC733814—B2R2B03. Without EC733814—B2S2B03. | Check interface cable or suspect channel. |

| Seq | Condition/Instruction | Action |
|-----|--|--|
| 13 | If not: | With EC733814, change B2R2 (see Caution). Without EC733814, change B2S2 (see Caution). |
| 14 | 3803 must wait for SUPPRESS OUT from channel to drop. The 3803 is under control of SUPPRESS OUT at this point. | |
| 15 | Was Sup Req B indicator On at CE panel? | Go to Seq 20. |
| 16 | Is -Request In Chan A (B2Q2G02) minus? | Go to Seq 18. |
| 17 | Is +If Sup Out Chan A (B2Q2D04) plus? (This line is an interface level—ground to +4 V.) | Go to ALD FC011 GE2 and follow net to line driver to determine why the indicator isn't being turned on. Then go to Seq 14. |
| 18 | Is +Intf Request In Chan plus? (This line is an interface level—ground to +4 V.) With EC733814—B2S2B03. Without EC733814—B2R2B03. | Go to Seq 14. |
| 19 | If not: | With EC733814, change B2S2 (see Caution). Without EC733814, change B2R2 (see Caution). |
| 20 | Is -Request In Chan B (B2P2G02) minus? | Go to Seq 22. |
| 21 | Is +If Sup Out Chan B (B2P2D04) plus? (This line is an interface level—ground to +4 V.) | Go to ALD XM011 GE2 and follow net to line driver to find out why indicator isn't being turned on. Then go to Seq 14. |
| 22 | Is +Intf Request In Chan plus? This line is an interface level—ground to +4 V. With EC733814—B2R2B03. Without EC733814—B2S2B03. | Go to Seq 24. |
| 23 | If not: | With EC733814, change B2R2 (see Caution). Without EC733814, change B2S2 (see Caution). |
| 24 | Determine whether problem is in tape control or channel. A. Take tape control offline. See 12-010. B. Set ROS Mode switch to Norm and press Set ROS Mode. C. Turn Panel Enable switch ON. D. Operate Reset switch. E. Make sure both Panel Enabled and Intf's Disabled indicators are On. F. Operate Data Entry Select switch: 1. Cmnd 1 '07x' Rewind (operate Set CE/Cmpr) 2. Cmnd 2 '01x' Write (operate Set CE/Cmpr) 3. Cmnd 3 '0Cx' Read Bkwd (operate Set CE/Cmpr) 4. Cmnd 4 '02x' Read Fwd (operate Set CE/Cmpr) | |

| Seq | Condition/Instruction | Action |
|-----|---|---|
| 24 | (continued) G. Set ALU1/ALU2 switch to ALU1. H. Set Mple/Single switch to Mple. I. Operate Start. J. Does ALU1 IC indicate '302' or '303'? | Go to Seq 26. |
| 25 | Interrupt should have been honored by channel. | |
| 26 | 1. Set scope to 5 us/cm. 2. Set Compare Register to '302' (operate Set CE Cmpr), then set Display Select switch to IC. 3. Set ROS Mode switch to Step (operate Set ROS Mode). Make sure the Stop on Control Check and Stop on Data Flow Check switches are OFF. | |
| 27 | Set ALU1/ALU2 switch to ALU2. Set Display Select switch to IC and operate Reset. Does the IC stop at '001'? | Go to Seq 30. |
| 28 | Set the ALU1/ALU2 switch to ALU1. Set the ROS Mode switch to Rst/Cmpr, operate Set ROS Mode, then operate Reset. Is +Inst Count B ALU1 (B2E2M03) pulsing? | Recheck the symptoms. |
| 29 | If not: | Change B2E2. |
| 30 | Set the ALU1/ALU2 switch to ALU1. Set the ROS Mode switch to Rst/Cmpr, operate Set ROS Mode, then operate Reset. Does -LSR Decode 3 ALU2 (A2M2U03) pulse? | Go to Seq 32. |
| 31 | If not: | Change A2M2. |
| 32 | Does -ALU Output All Zero ALU1 (B2C2B09) pulse? | Go to Seq 34. |
| 33 | If not: | Change B2C2. |
| 34 | Does -ROS Reg 3 L3 ALU1 (B2D2D10) pulse? | Go to Seq 36. |
| 35 | If not: | Change B2D2. |
| 36 | Does +Cik4 ALU1 (B2F2B04) pulse? | Change in order: 1. A2R2 2. A2N2 3. B2E2 |
| 37 | If not: | Change B2F2. |

Caution: Removing this card may cause channel errors even with power off. Put CPU in the Single Cycle mode before removing card.

3803-2/3420

| | | | | | | | |
|------------|-------------|----------------|----------|--|--|--|--|
| XE1800 | 2735869 | See EC History | 845958 | | | | |
| Seq 1 of 2 | Part Number | | 1 Sep 79 | | | | |

13-220

| | | |
|--|--|-------------------|
| From: 13-000 | | |
| ERROR DESCRIPTION: | | |
| Two Channel Switch (TCS) | | |
| A '301' Trap Address indicates a unit-check condition has occurred and a contingent connection has been set. A contingent connection is necessary to prevent destruction of sense information from the other channel. To clear a contingent connection, another successful start input/output (SIO) (one that does not result in a unit check) must be issued to the same device from the channel that issued the failing SIO. If device switching is installed, the DEVICE COMMITTED latch remains On until a successful SIO has been completed. This ensures that the other tape control does not destroy sense data pertaining to that device. The Hold Interface indicator is On at the CE panel if the tape control has a two channel switch installed. | | |
| Device Switching Without Two Channel Switch: | | |
| A '301' Trap Address indicates the last attempted operation resulted in a unit check condition. After the DEVICE COMMITTED latch turns On, it is up to the channel to issue another successful SIO (one that does not result in a unit check) to the same tape unit and tape control to turn off the DEVICE COMMITTED latch. If the channel does not issue a successful SIO to the tape unit, the DEVICE COMMITTED latch stays On, and the tape unit becomes BUSY to the other tape control. | | |
| Most Probable Cause For 301 Hangs Offline: | | |
| A. With EC733814—B2M2 Without EC733814—B2L2 | | |
| B. B2N2 | | |
| C. Y1P2 | | |
| Additional Cards Referenced: | | |
| A. A2R2 | | |
| B. A2L2 | | |
| C. A1T2 | | |
| D. A1S2 | | |
| Always start with Seq 1 and follow the procedure in sequence unless directed otherwise. Remember to END all problems or maintenance calls by going to MAP 00-030. | | |
| Seq | Condition/Instruction | Action |
| 1 | Is the tape control offline? | Go to Seq 4. |
| 2 | When the local storage registers (LSRs) were read out in 00-010, did ALU1 LSRs 3 and 6 compare bit-for-bit? | Recheck symptoms. |
| 3 | There must be a channel problem because LSR 3 (which contains the address of the tape unit for which the last SIO was issued) and LSR 6 (which contains the address of the tape unit for which a Contingent Connection was made) do not compare. For further information, see Two Channel Switch in the heading of this MAP. | |
| 4 | Does the tape unit continue to move tape when ALU1 is at '301'? | Change A2R2. |
| 5 | Is +CE Stop Conditions (A1T2J06) plus? | Change A1T2. |
| 6 | Is -C3 And Step 3 (A1S2M09) a solid minus? | Change A1S2. |

| Seq | Condition/Instruction | Action |
|-----|---|---|
| 7 | Turn ROS Mode switch to Norm. Operate Set ROS Mode switch momentarily. Operate Reset momentarily. | |
| 8 | Set scope to 5 μ sec/cm. Is +Xfr LSR2 To TU Tags (A2L2G02) pulsing? | Go to Seq 10. |
| 9 | If not: | Change A2L2. |
| 10 | Is -LSR Decode 3 ALU1 (B2D2U03) pulsing? | Go to Seq 12. |
| 11 | If not: | Change B2D2. |
| 12 | Is -Service In always minus? With EC733814—B2M2S08 Without EC733814—B2L2S08 | With EC733814, change B2M2. Without EC733814, change B2L2. |
| 13 | If not: | Change Y1P2. Recheck the symptoms. |

3803-2/3420

| | | | | | | | | |
|-----------------------------|-------------------------------|-----------------------|---------------------------|--|--|--|--|--|
| XE1800 Seq 2 of 2 | 2735869 Part Number | See EC History | 845958 1 Sep 79 | | | | | |
|-----------------------------|-------------------------------|-----------------------|---------------------------|--|--|--|--|--|

ALU1 OP IN WAIT

| From: 13-000 | | |
|--|--|---|
| ALU1 is waiting for OP IN to become inactive. | | |
| Most Probable Cause | | |
| A. A2R2 B. With EC733814—B2L2 Without EC733814—B2M2 C. Chan A, B2Q2 (See Caution.) Chan B, B2P2 (See Caution.) D. With EC733814 Chan A, B2S2 (See Caution.) Chan B, B2R2 (See Caution.) Without EC733814 Chan A, B2R2 (See Caution.) Chan B, B2S2 (See Caution.) | | |
| Always start with Seq 1 and follow the procedure in sequence unless directed otherwise. Remember to END all problems or maintenance calls by going to MAP 00-030. | | |
| Seq | Condition/Instruction | Action |
| 1 | Have the cards been interchanged between ALU1 and ALU2 (see chart on 16-001)? | Go to Seq 3. |
| 2 | Interchange cards between ALU1 and ALU2 (see chart on 16-001). If the symptoms change, the failing FRU has been identified. Did the symptoms change? | Change defective card and go to 00-030. |
| 3 | Turn ROS Mode switch to Norm. Operate Set ROS Mode switch momentarily. Operate Start or Step switch momentarily. | |
| 4 | Is —Operational In minus? With EC733814—B2L2G04 Without EC733814—B2M2G04 | Go to Seq 6. |
| 5 | If not: | With EC733814, change B2L2. Without EC733814, change B2M2. |
| 6 | Is —Select Signal Chan A (B2Q2G03) minus? | Go to Seq 9. |
| 7 | Does the tape control have a TCS (two channel switch) feature installed? | Go to Seq 13. |
| 8 | If not: | Go to Seq 19. |
| 9 | Is +Select Out To Line Receivers plus? With EC733814—B2S2S08 Without EC733814—B2R2S08 | Go to Seq 11. |
| 10 | If not: | See Caution, then change B2Q2. |
| 11 | Is +Select To Receivers Or Bypass plus? With EC733814—B2S2P09 (Gnd to +4 V) Without EC733814—B2R2P09 | Go to ALD FC281EC4 and resolve. |

| Seq | Condition/Instruction | Action |
|-----|---|---|
| 12 | If not: | With EC733814, change B2S2 (see Caution). Without EC733814, change B2R2 (see Caution). |
| 13 | Is —Select Signal Chan B (B2P2G03) minus? | Go to Seq 15. |
| 14 | If not: | Go to Seq 19. |
| 15 | Is +If Select Sig Chan B plus? With EC733814—B2R2S08 (Gnd to +4 V) Without EC733814—B2S2S08 | Go to Seq 17. |
| 16 | If not: | See Caution, then change B2P2. |
| 17 | Is +Select To Receivers Or Bypass plus? With EC733814—B2R2P09 (Gnd to +4v) Without EC733814—B2S2P09 | Go to ALD XM181EC4 and resolve. |
| 18 | If not: | With EC733814, change B2R2 (see Caution). Without EC733814, change B2S2 (see Caution). |
| 19 | Is —CTI Bit 7 Op In (A2R2B04) minus? | Change A2R2. |
| 20 | If not: | With EC733814, change B2L2. Without EC733814, change B2M2. |

Caution: Removing this card may cause channel errors even with power off. Put CPU in the Single Cycle mode before removing card.

3803-2/3420

| | | | | | | | | |
|-----------------------------|-------------------------------|-----------------------|---------------------------|--|--|--|--|--|
| XE1900 Seq 1 of 2 | 2735870 Part Number | See EC History | 845958 1 Sep 79 | | | | | |
|-----------------------------|-------------------------------|-----------------------|---------------------------|--|--|--|--|--|

| From: 13-000 | | |
|---|---|--------------|
| This failure occurs because of a failure in the ALU2 trap circuitry. ALU2 traps on STAT 0 but will not trap back to zero on a TRANSFER XOUTB from ALU1. If at zero, a TRANSFER XOUTB from ALU1 starts ALU2 running. | | |
| Most Probable Cause: | | |
| A. A2D2 | | |
| B. A2K2 | | |
| Always start with Seq 1 and follow the procedure in sequence unless directed otherwise. Remember to END all problems or maintenance calls by going to MAP 00-030. | | |
| Seq | Condition/Instruction | Action |
| 1 | Turn ROS Mode switch to Norm. Operate Set ROS Mode switch. Operate Start or Step switch. | |
| 2 | Scope -25 NS TAP (A2D2D05). You should see a negative 50 ns pulse occurring every 150-200 ns. Is this line pulsing? | Change A2D2. |
| 3 | If not: | Change A2K2. |

3803-2/3420

| | | | | | | | | | |
|----------------------|------------------------|-------------------|--------------------|--|--|--|--|--|--|
| XE1900 Seq 2 of 2 | 2735870 Part Number | See EC History | 845958 1 Sep 79 | | | | | | |
|----------------------|------------------------|-------------------|--------------------|--|--|--|--|--|--|

Copyright International Business Machines Corporation 1976, 1979

SERVICE OUT TAG ACTIVE

| From: 13-000 | | |
|--|--|---|
| ALU1, while doing a Power-On Reset routine, found the Service Out tag is always active. | | |
| Most Probable Cause: | | |
| A. A2R2 B. B2M2 C. B2L2 D. A1R2 | | |
| Additional Cards Referenced: | | |
| A. B2D2 B. B2P2 C. B2Q2 | | |
| Always start with Seq 1 and follow the procedure in sequence unless directed otherwise. Remember to END all problems or maintenance calls by going to MAP 00-030. | | |
| Seq | Condition/Instruction | Action |
| 1 | Turn ROS Mode switch to Norm. Operate Set ROS Mode switch. Operate Start or Step switch. | |
| 2 | Is EC733814 installed? | Go to Seq 20. |
| 3 | Is +Service Out Chan A B CE (B2M2G03) plus? | Go to Seq 9. |
| 4 | Is +Data Service Active (B2L2S02) plus? | Change B2L2. |
| 5 | Is +Branch Cond Met ALU1 (B2M2M11) plus? | Go to Seq 7. |
| 6 | If not: | Change B2D2. |
| 7 | Is -ROS Reg 6 ALU1 (B2D2D09) minus? | Change B2D2. |
| 8 | If not: | Change B2M2. |
| 9 | Is +Service Out Chan A Gated (B2Q2D11) plus? | See Caution, then change B2Q2. |
| 10 | Is Two-Channel switch feature installed? | Go to Seq 18. |
| 11 | Is +CE Service Out Tag (A1R2S11) plus? | Go to Seq 13. |
| 12 | If not: | With EC733814, change B2L2. Without EC733814, change B2M2. |
| 13 | Is +Register Test (A1R2U11) plus? | Go to Seq 16. |
| 14 | Is +CTI Bit 5 To CE (A1R2J02) plus? | Change A2R2. |
| 15 | If not: | Change A1R2. |
| 16 | Is -Register Test (A2R2S09) minus? | Change A2R2. |
| 17 | If not: | Change A1R2. |
| 18 | Is +Service Out Chan B Gated (B2P2D11) plus? | See Caution, then change B2P2. |
| 19 | If not: | Go to Seq 11. |
| 20 | Is +Service Out Chan A B CE (B2L2G03) plus? | Go to Seq 9. |

| Seq | Condition/Instruction | Action |
|-----|--|---------------|
| 21 | Is +Data Service Active (B2M2S02) plus? | Change B2M2. |
| 22 | Is +Branch Cond Met ALU1 (B2L2M11) plus? | Go to Seq 24. |
| 23 | If not: | Change B2D2. |
| 24 | Is -ROS Reg 6 ALU1 (B2D2D09) minus? | Change B2D2. |
| 25 | If not: | Change B2L2. |

Caution: Removing this card may cause channel errors even with power off. Put CPU in the Single Cycle mode before removing card.

3803-2/3420

| | | | | | | | |
|----------------------|------------------------|-------------------|--------------------|--|--|--|--|
| XE2000 Seq 1 of 2 | 2735871 Part Number | See EC History | 845958 1 Sep 79 | | | | |
|----------------------|------------------------|-------------------|--------------------|--|--|--|--|

| From 13-000 | | |
|--|--|--------------------------------|
| ALU1, while doing the Power-On Reset routine, found the Command Out tag is always active. | | |
| Most Probable Cause: A. A2R2 B. With EC733814—B2L2 Without EC733814—B2M2 C. A1R2 | | |
| Always start with Seq 1 and follow the procedure in sequence unless directed otherwise. Remember to END all problems or maintenance calls by going to MAP 00-030. | | |
| Seq | Condition/Instruction | Action |
| 1 | Turn ROS Mode switch to Norm. Operate Set ROS Mode switch. Operate Start or Step switch. | |
| 2 | Is EC733814 installed? | Go to Seq 13. |
| 3 | Is -Command Out A B CE (B2M2U02) minus? | Go to Seq 5. |
| 4 | If not: | Change B2M2. |
| 5 | Is two channel switch feature installed? | Go to Seq 11. |
| 6 | Is +Command Out Chan A Gated (B2Q2D12) plus? | See Caution, then change B2Q2. |
| 7 | Is +CE Command Out Tag (A1R2S05) plus? | Go to Seq 9. |
| 8 | If not: | Change B2M2. |
| 9 | Is +CTI Bit 6 To CE (A2R2D10) plus? | Change A2R2. |
| 10 | If not: | Change A1R2. |
| 11 | Is +Command Out Chan B Gated (B2P2D12) plus? | See Caution, then change B2P2. |
| 12 | If not: | Go to Seq 6. |
| 13 | Is -Command Out A B CE (B2L2U02) minus? | Go to Seq 15. |
| 14 | If not: | Change B2L2. |
| 15 | Is two channel switch feature installed? | Go to Seq 19. |
| 16 | Is +Command Out Chan A Gated (B2Q2D12) plus? | See Caution, then change B2Q2. |
| 17 | Is +CE Command Out Tag (A1R2S05) plus? | Go to Seq 9. |
| 18 | If not: | Change B2L2. |
| 19 | Is +Command Out Chan B Gated (B2P2D12) plus? | See Caution, then change B2P2. |
| 20 | If not: | Go to Seq 16. |

Caution: Removing this card may cause channel errors even with power off.
Put CPU in the Single Cycle mode before removing card.

3803-2/3420

| | | | | | | | | |
|----------------------|------------------------|-------------------|--------------------|--|--|--|--|--|
| XE2000 Seq 2 of 2 | 2735871 Part Number | See EC History | 845958 1 Sep 79 | | | | | |
|----------------------|------------------------|-------------------|--------------------|--|--|--|--|--|

ADDRESS OUT ACTIVE

13-300

| From: 13-000 ALU1 is waiting for Address Out to become inactive. | | |
|--|--|---|
| Most Probable Cause: A. With EC733814—B2L2 Without EC733814—B2M2. B. Chan A, B2Q2 (See Caution). Chan B, B2P2 (See Caution). C. A1R2 | | |
| Always start with Seq 1 and follow the procedure in sequence unless directed otherwise. Remember to END all problems or maintenance calls by going to MAP 00-030. | | |
| Seq | Condition/Instruction | Action |
| 1 | Turn ROS Mode switch to Norm. Operate Set ROS Mode switch momentarily. Operate Start or Step switch momentarily. | |
| 2 | Is -Address Out A B CE minus? With EC733814—B2L2S05 Without EC733814—B2M2S05 | Go to Seq 4. |
| 3 | If not: | With EC733814, change B2L2. Without EC733814, change B2M2. |
| 4 | Is +Addr Out Chan A Gated (B2Q2D13) plus? | See Caution, then change B2Q2. |
| 5 | Is -Any Command Test Branch (A1R2D05) minus? | Change A1R2. |
| 6 | Is Two-Channel switch (TCS) feature installed? | Go to Seq 8. |
| 7 | If not: | With EC733814, change B2L2. Without EC733814, change B2M2. |
| 8 | Is +Addr Out Chan B Gated (B2P2D13) plus? | See Caution, then Change B2P2. |
| 9 | Is +CE Addr Out Tag (A1R2U05) plus? | Change A1R2. |
| 10 | If not: | With EC733814, change B2L2. Without EC733814, change B2M2. |

Caution: Removing this card may cause channel errors even with power off. Put CPU in the Single Cycle mode before removing card.

3803-2/3420

| | | | | | | | | |
|------------|-------------|----------------|----------|--|--|--|--|--|
| XE2100 | 2735872 | See EC History | 845958 | | | | | |
| Seq 1 of 2 | Part Number | | 1 Sep 79 | | | | | |

13-300

| From: 13-000 | | |
|--|--|---|
| ALU1 is waiting for Suppress Out to become inactive. | | |
| Most Probable Cause: | | |
| A. With EC733814—B2L2 Without EC733814—B2M2 | | |
| B. A1R2, A2R2 | | |
| C. A2P4 | | |
| Additional Cards Referenced: | | |
| A. B2P2 | | |
| Always start with Seq 1 and follow the procedure in sequence unless directed otherwise. Remember to END all problems or maintenance calls by going to MAP 00-030. | | |
| Seq | Condition/Instruction | Action |
| 1 | Turn ROS Mode switch to Norm. Operate Set ROS Mode switch momentarily. Operate Start or Step switch momentarily. | |
| 2 | Is -Suppress Out A B minus? With EC733814—B2L2S02 Without EC733814—B2M2S02 | Go to Seq 4. |
| 3 | If not: | With EC733814, change B2L2. Without EC733814, change B2M2. |
| 4 | Is +Suppress Out Chan A Gated (B2Q2D03) plus? | See Caution, then change B2Q2. |
| 5 | Is +Register Test (A1R2U11) plus? | Change in order: 1. A1R2 2. A2R2 |
| 6 | Is Two-Channel switch (TCS) feature installed? | Go to Seq 8. |
| 7 | If not: | With EC733814, change B2L2. Without EC733814, change B2M2. |
| 8 | Is +Suppress Out Chan B Gated (B2P2D03) plus? | See Caution, then change B2P2. |
| 9 | If not: | With EC733814, change B2L2. Without EC733814, change B2M2. |

Caution: Removing this card may cause channel errors even with power off. Put CPU in the Single Cycle mode before removing card.

3803-2/3420

| | | | | | | | | | |
|-----------------------------|-------------------------------|-----------------------|---------------------------|--|--|--|--|--|--|
| XE2100 Seq 2 of 2 | 2735872 Part Number | See EC History | 845958 1 Sep 79 | | | | | | |
|-----------------------------|-------------------------------|-----------------------|---------------------------|--|--|--|--|--|--|

SIO TRAP FAILURES

| From: 13-000 | | |
|--|--|---------------|
| Most Probable Cause | | |
| A. A2Q2 B. A2R2 C. A2J2 D. B2L2 with EC733814 B2M2 without EC733814 E. A1R2 F. A2P4 | | |
| Additional Cards Referenced: | | |
| A. B2F2 B. B2E2 C. B2D2 D. B2C2 E. A2T2 | | |
| Always start with Seq 1 and follow the procedure in sequence unless directed otherwise. Remember to END all problems or maintenance calls by going to MAP 00-030. | | |
| Seq | Condition/Instruction | Action |
| 1 | Turn ROS Mode switch to Norm. Operate Set ROS Mode switch. Operate Start or Step switch. | |
| 2 | Set scope to 1 us/cm. Is +125 ns Tap ALU1 (B2F2J12) a solid level? | Change B2F2. |
| 3 | Is -100 -175 ns (B2F2S04) a solid level? | Change B2F2. |
| 4 | Is -75 ns Tap ALU1 (B2F2U07) a solid level? | Change B2F2. |
| 5 | Is +Clk 4 ALU1 (B2F2B04) plus all the time? | Change B2F2. |
| 6 | While operating Reset switch, sync plus and display +Clk 22L1 ALU1 (B2F2D06). Is line pulsing? | Go to Seq 8. |
| 7 | If not: | Change B2F2. |
| 8 | Is +Clk 21 ALU1 (B2F2G02) plus all the time? | Change B2F2. |
| 9 | While operating Reset switch, sync plus and display +Clk 22 ALU1 (B2F2P02). Is line pulsing? | Go to Seq 11. |
| 10 | If not: | Change B2F2. |
| 11 | While operating Reset, sync minus and display -Clk 15 ALU1 (B2F2P09). Is line pulsing? | Go to Seq 13. |
| 12 | If not: | Change B2F2. |
| 13 | Is -Resistor Test (A2R2S11) minus? | Go to Seq 17. |
| 14 | While operating Reset switch, sync plus and display +Xfr LSR 1 To Channel Tags (B2E2D12). Is line pulsing? | Go to Seq 19. |
| 15 | While operating Reset switch, sync minus and display -Xfr Oper ALU1 (B2D2G12). Is line pulsing? | Change B2E2. |

| Seq | Condition/Instruction | Action |
|-----|--|---|
| 16 | If not: | Change B2D2. |
| 17 | Is +CE Initial Sel Tag (A1R2U04) plus? | Change B2D2. |
| 18 | If not: | Change A1R2. |
| 19 | Is +Mach Reset minus? With EC733814—B2L2B09. Without EC733814—B2M2B09. | Go to Seq 21. |
| 20 | If not: | With EC733814—change B2L2. Without EC733814—change B2M2. |
| 21 | While operating Reset switch, sync minus and display -LSR Decode 5 ALU1 (B2D2B11). Is line pulsing? | Go to Seq 23. |
| 22 | If not: | Change B2D2. |
| 23 | While operating Reset switch, sync minus and display -Sto Oper ALU1 (B2D2J13). Is line pulsing? | Go to Seq 25. |
| 24 | If not: | Change B2D2. |
| 25 | Is -ROS Reg 0 and 1 ALU1 (B2D2P09) minus? | Change B2D2. |
| 26 | While operating Reset switch, sync minus and display -LSR Decode 1 ALU 1 (B2D2P13). Is line pulsing? | Go to Seq 28. |
| 27 | If not: | Change B2D2. |
| 28 | Is -Xfr XINB To LSR1 (B2E2M10) minus? | Change B2E2. |
| 29 | Is -Xfr XINA To LSR1 (B2E2P12) minus? | Change B2E2. |
| 30 | Is +Bus Out Bit 7 to ALU1 plus? With EC733814—B2M2B13 Without EC733814—B2L2B13. | With EC733814—change B2M2. Without EC733814—change B2L2. |
| 31 | While operating Reset switch, sync minus and display -D Bus 1 ALU1 (B2C2U04). Is line pulsing? | Go to Seq 33. |
| 32 | If not: | Change B2C2. |
| 33 | Is -D Bus 2 ALU1 (B2C2P13) plus? | Change B2C2. |
| 34 | Is -D Bus 3 ALU1 (B2C2P12) plus? | Change B2C2. |
| 35 | While operating Reset switch, sync minus and display -D Bus 4 ALU1 (B Is line pulsing? | Go to Seq 37. |
| 36 | If not: | Change B2C2. |
| 37 | While operating Reset switch, sync minus and display -D Bus 5 ALU1 (B2C2M02). Is line pulsing? | Go to Seq 39. |

| Seq | Condition/Instruction | Action |
|-----|--|-----------------------|
| 38 | If not: | Change B2C2. |
| 39 | While operating Reset switch, sync minus and display -D Bus 6 ALU1 (B2C2G11). Is line pulsing? | Go to Seq 41. |
| 40 | If not: | Change B2C2. |
| 41 | While operating Reset switch, sync minus and display -D Bus 7 ALU1 (B2C2J09). Is line pulsing? | Go to Seq 43. |
| 42 | If not: | Change B2C2. |
| 43 | While operating Reset switch, sync minus and display -D Bus 0 ALU1 (B2C2G09). Is line pulsing? | Go to Seq 45. |
| 44 | If not: | Change B2C2. |
| 45 | Is -B Bus 7 ALU1 (B2C2G02) minus? | Change B2C2. |
| 46 | Is -B Bus 7 ALU1 (A2T2D11) plus? | Recheck the symptoms. |
| 47 | If not: | Change A2T2. |

3803-2/3420

| | | | | | | | |
|-----------------------------|-------------------------------|-----------------------|---------------------------|--|--|--|--|
| XE2200 Seq 1 of 2 | 2735873 Part Number | See EC History | 845958 1 Sep 79 | | | | |
|-----------------------------|-------------------------------|-----------------------|---------------------------|--|--|--|--|

| From: 13-000 | | |
|--|--|---|
| Most Probable Cause: A. With EC733814—B2L2 (see 00-000) Without EC733814—B2M2 B. A1R2, A2R2 Additional Cards Referenced: A. A1S2 | | |
| Always start with Seq 1 and follow the procedure in sequence unless directed otherwise. Remember to END all problems or maintenance calls by going to MAP 00-030. | | |
| Seq | Condition/Instruction | Action |
| 1 | Turn ROS Mode switch to Norm. Operate Set ROS Mode switch. Operate Start or Step switch. | |
| 2 | Is -Command Out A B CE plus? With EC733814—B2L2U02. Without EC733814—B2M2U02. | With EC733814, change B2L2. Without EC733814, change B2M2. |
| 3 | Is +CE Command Out TAG (A1R2S05) minus? | With EC733814, change B2L2. Without EC733814, change B2M2. |
| 4 | Is -Gate Tags (A1S2J06) minus? | Go to Seq 6. |
| 5 | If not: | Change A1S2. |
| 6 | Is +CE Command Out (A1R2G13) plus? | Change A1R2. |
| 7 | If not: | Change in order: 1. A2R2 2. A1R2 |

3803-2/3420

| | | | | | | | | |
|----------------------|------------------------|-------------------|--------------------|--|--|--|--|--|
| XE2200 Seq 2 of 2 | 2735873 Part Number | See EC History | 845958 1 Sep 79 | | | | | |
|----------------------|------------------------|-------------------|--------------------|--|--|--|--|--|

SUPPRESS OUT INACTIVE DURING RESET OR POWER-ON RESET

13-340

| From: 13-000 | | |
|--|--|---|
| Most Probable Cause: | | |
| A. With EC733814—B2L2 Without EC733814—B2M2 | | |
| B. A1R2, A2R2 | | |
| Always start with Seq 1 and follow the procedure in sequence unless directed o therwise. Remember to END all problem or maintenance calls by going to MAP 00-030. | | |
| Seq | Condition/Instruction | Action |
| 1 | Turn ROS Mode switch to Norm. Operate Set ROS Mode switch. Operate Start or Step switch. | |
| 2 | Is -Suppress Out A B minus? With EC733814—B2L2S02 Without EC733814—B2M2S02 | With EC733814, change B2L2. Without EC733814, change B2M2. |
| 3 | Is +Register Test (A1R2U11) plus? | With EC733814, change B2L2. Without EC733814, change B2M2. |
| 4 | Is -Register Test (A2R2S11) minus? | Change A1R2. |
| 5 | If not: | Change A2R2. |

3803-2/3420

| | | | | | | | | |
|-----------------------------|-------------------------------|---------------------------------|---------------------------|--|--|--|--|--|
| XE2300 Seq 1 of 2 | 2735874 Part Number | See EC History | 845958 1 Sep 79 | | | | | |
|-----------------------------|-------------------------------|---------------------------------|---------------------------|--|--|--|--|--|

13-340

| From: 13-000 | | |
|---|--|---|
| Most Probable Cause: A. With EC733814—B2L2 Without EC733814—B2M2 B. A1R2, A2R2 | | |
| Always start with Seq 1 and follow the procedure in sequence unless directed otherwise. Remember to END all problem or maintenance calls by going to MAP 00-030. | | |
| Seq | Condition/Instruction | Action |
| 1 | Turn ROS Mode switch to Norm. Operate Set ROS Mode switch momentarily. Operate Start or Step switch momentarily. | |
| 2 | Is +Service Out Chan A B CE plus? With EC733814—B2L2G03. Without EC733814—B2M2G03. | With EC733814, change B2L2. Without EC733814, change B2M2. |
| 3 | Is +Service Out TAG (A1R2S11) plus? | With EC733814, change B2L2. Without EC733814, change B2M2. |
| 4 | If not: | Change in order: 1. A1R2 2. A2R2 |

3803-2/3420

| | | | | | | | | | |
|------------|-------------|---------|----------|--|--|--|--|--|--|
| XE2300 | 2735874 | See EC | 845958 | | | | | | |
| Seq 2 of 2 | Part Number | History | 1 Sep 79 | | | | | | |

ADDRESS OUT INACTIVE

13-360

| From: 13-000 | | |
|--|--|---|
| Most Probable Cause: | | |
| A. Check interface cable connections for bent pins. | | |
| B. With EC733814—B2L2 Without EC733814—B2M2 | | |
| C. A1R2 | | |
| Always start with Seq 1 and follow the procedure in sequence unless directed otherwise. | | |
| Remember to END all problems or maintenance calls by going to MAP 00-030. | | |
| Seq | Condition/Instruction | Action |
| 1 | Turn ROS Mode switch to Norm. Operate Set ROS Mode switch. Operate Start or Step switch. | |
| 2 | Is +CE Addr Out Tag (A1R2U05) minus? | Change A1R2. |
| 3 | Is -Address Out A B CE plus? With EC733814—B2L2S05. Without EC733814—B2M2S05. | With EC733814—change B2L2. Without EC733814—change B2M2. |

3803-2/3420

| | | | | | | | | |
|-----------------------------|-------------------------------|-----------------------|---------------------------|--|--|--|--|--|
| XE2400 Seq 1 of 2 | 2735875 Part Number | See EC History | 845958 1 Sep 79 | | | | | |
|-----------------------------|-------------------------------|-----------------------|---------------------------|--|--|--|--|--|

13-360

| From: 13-000 | | |
|--|--|-----------------------|
| Most Probable Cause: A. B2D2. B. B2F2. | | |
| Always start with Seq 1 and follow the procedure in sequence unless directed otherwise. Remember to END all problems or maintenance calls by going to MAP 00-030. | | |
| Seq | Condition/Instruction | Action |
| 1 | Turn ROS Mode switch to Norm. Operate Set ROS Mode switch. Operate Start or Step switch. | |
| 2 | Operate Reset switch. Set scope to 5 us/cm. Is +ROS Reg 3 L3 ALU1 (B2D2B09) plus all the time? | Change B2D2. |
| 3 | Sync minus and display -Add Oper ALU1 (B2D2J12). Does line go minus? | Go to Seq 5. |
| 4 | If not: | Recheck the symptoms. |
| 5 | Sync plus and display +Clk 19 ALU1 (B2F2M03). Does line go plus? | Go to Seq 7. |
| 6 | If not: | Change B2F2. |
| 7 | Is -150 ns Tap ALU1 (B2F2P04) pulsing? | Recheck the symptoms. |
| 8 | If not: | Change B2F2. |

3803-2/3420

| | | | | | | | | | |
|-----------------------------|-------------------------------|-----------------------|---------------------------|--|--|--|--|--|--|
| XE2400 Seq 2 of 2 | 2735875 Part Number | See EC History | 845958 1 Sep 79 | | | | | | |
|-----------------------------|-------------------------------|-----------------------|---------------------------|--|--|--|--|--|--|

CHANNEL BUS IN/OUT CHECKING

| | | |
|--|---|---------------|
| From: 13-000 | | |
| ERROR DESCRIPTION: This error occurs during the channel Bus In/Bus Out check of the Power-On Reset routine. The Channel Bus Ins are wrapped around through the CE section to the Channel Bus Outs. A comparison is then made by exclusive ORing the Channel Bus Outs with what was expected on the Channel Bus Ins. If there is no Compare, ALU1 is trapped at the PICKDROP address. | | |
| Most Probable Cause: A. With EC733814—B2L2 (see Caution) Without EC733814—B2M2 B. A1K2 C. A2Q2 D. A2T2 E. B3Q2 F. A1R2 G. A1C2 H. B2H2 | Interchangeable cards between ALUs | |
| | A2 | B2 |
| | N | C |
| | M* | D* |
| | L | E |
| | K | F |
| | * Feature Jumpers | |
| | Caution: Removing this card may cause channel errors even with the power off. Put the CPU in Single Cycle mode before removing this card. | |
| Always start with Seq 1 and follow the procedure in sequence unless directed otherwise. Remember to END all problems or maintenance calls by going to MAP 00-030. | | |
| Seq | Condition/Instruction | Action |
| 1 | If this procedure is exhausted without fixing the problem, go to 13-381, which lists the lines that could be bad by sequence number. | |
| 2 | CE panel setup: A. Put STEP0029 address in the Cmpr Reg. See ALU1 microprogram cross-reference listing. B. Turn both Stop On switches Off. C. Set ROS Mode switch to Stop and operate Set ROS Mode switch. D. Set ALU1/ALU2 switch to ALU1. E. Turn Display Select switch to IC. F. Operate the Reset switch. | |
| 3 | Turn Display Select switch to Bus In. Are any indicators 0-7 On? | Go to Seq 19. |
| 4 | CE panel setup: A. Put the STEP0029 address in the Cmpr Reg. See ALU1 microprogram cross-reference listing. B. Operate Reset switch. | |
| 5 | Did ALU1 stop at the STEP0029? | Go to Seq 35. |
| 6 | CE panel setup: A. Put 500 Address in the Cmpr Reg. B. Turn Display Select switch to IC. C. Turn ROS Mode switch to Set IC and operate Set ROS Mode switch D. Turn ROS Mode switch to Step and operate Set ROS Mode switch. E. Keep operating Start or Step switch until IC indicators = '503'. Set Display Select switch to Bus In to read out LSR1. Record indicators 0-7. F. Turn Display Select switch to IC. Keep operating Start or Step switch until IC indicators = '506'. Turn Display Select switch to Bus In to read out LSR4. Do LSR1 and LSR4 compare bit-for-bit? | Go to Seq 13 |

| Seq | Condition/Instruction | Action |
|-----|---|---|
| 7 | Turn ROS Mode switch to Norm and operate Set ROS Mode switch. Interchange B2C2 and A2N2. Operate Reset switch. Does ALU1 stop at PICKDROP? | Go to Seq 9. |
| 8 | If not: | Return the cards to their original locations and change B2C2. |
| 9 | Interchange B2D2 and A2M2 and operate Reset switch. Does ALU1 stop at PICKDROP? | Return the cards to their original locations and go to Seq 11. |
| 10 | If not: | Return the cards to their original locations and change B2D2. |
| 11 | Interchange B2F2 and A2K2 and operate Reset switch. Does ALU1 stop at PICKDROP? | Change B2F2. |
| 12 | If not: | Return the cards to their original locations and change B2H2. |
| 13 | Set ROS Mode switch to Norm and operate Set ROS Mode switch. Interchange B2E2 and A2L2 and operate Reset switch. Does ALU1 stop at PICKDROP? | Go to Seq 15. |
| 14 | If not: | Return the cards to their original locations and change B2E2. |
| 15 | Interchange B2C2 and B2N2. Operate Reset switch. Does ALU1 stop at PICKDROP? | Go to Seq 17. |
| 16 | If not: | Return the cards to their original locations and change B2C2. |
| 17 | Interchange B2D2 and A2M2. Operate Reset switch. Does ALU1 stop at PICKDROP? | Return the cards to their original locations and change: With EC733814—B2L2 (see Caution) Without EC733814—B2M2 (see Caution) |
| 18 | If not: | Return the cards to their original locations and change B2D2. |
| 19 | Is -Stat Bit 0 Tape Op to DF (A2Q2J07) minus? | Change A2Q2 |
| 20 | Is -Stat Bit 0 Tape Op to DF (A2Q2D04) minus? | Change A2Q2 |
| 21 | Is +Stat Bit 1 Sense (A2T2D05) plus? | Change A2T2. |
| 22 | Is -Wrt and Tape Op Not Control (A1K2P09) minus? | Change A1K2 |
| 23 | Is -Tape Op A (A1K2B10) minus? | Change A1K2 |
| 24 | Turn ROS Mode switch to Norm and operate Set ROS Mode switch. Interchange B2D2 and A2M2 and operate Reset switch. Does ALU1 stop at PICKDROP? | Return the cards to their original locations and go to Seq 26. |
| 25 | If not: | Return the cards to their original locations and change B2D2. |
| 26 | Interchange B2E2 and A2L2 and operate Reset switch. Does ALU1 stop at PICKDROP? | Go to Seq 28 |

| Seq | Condition/Instruction | Action |
|-----|---|---|
| 27 | If not: | Return the cards to their original locations and change B2E2. |
| 28 | Interchange B2F2 and A2K2 and operate Reset switch. Does ALU1 stop at PICKDROP? | Go to Seq 30. |
| 29 | If not: | Return the cards to their original locations and change B2F2. |
| 30 | Interchange B2C2 and A2N2 and operate Reset switch. Does ALU1 stop at PICKDROP? | Go to Seq 45. |
| 31 | If not: | Return the cards to their original locations and change B2C2. |
| 32 | Is +Inhibit Ripple Bus Chan A (B2E2M13) plus? | Change B2Q2. See Caution. |
| 33 | Is +Inhibit Ripple Bus Chan B (B2E2P13) plus? | Change B2P2. See Caution. |
| 34 | If not: | Change in order: 1. A2R2 2. A1C2 |
| 35 | Is -Gate CBI to CE Entry (A1R2S07) minus? | Go to Seq 37. |
| 36 | If not: | Change A1R2. |
| 37 | Is +Inhibit Ripple Bus Chan A (B2E2M13) plus? | Change B2Q2. See Caution. |
| 38 | Is +Inhibit Ripple Bus Chan B (B2E2P13) plus? | Change B2P2. See Caution. |
| 39 | Turn ROS Mode switch to Norm and operate Set ROS Mode switch. Interchange B2E2 and A2L2 and operate Reset switch. Does ALU1 stop at PICKDROP? | Go to Seq 41. |
| 40 | If not: | Return the cards to their original positions and change B2E2. |
| 41 | Interchange B2C2 and A2N2 and operate Reset switch. Does ALU1 stop at PICKDROP? | Go to Seq 43. |
| 42 | If not: | Return the cards to their original locations and change B2C2. |
| 43 | Interchange B2D2 and A2M2 and operate Reset switch. Does ALU1 stop at PICKDROP? | Return the cards to their original locations and change: With EC733814—B2L2 (see Caution) Without EC733814—B2M2 (see Caution) |
| 44 | If not: | Return the cards to their original locations and change B2D2. |
| 45 | Remove A1C2. Set Display Select switch to Bus In. Are any of indicators 0-7 On? | Reinstall A1C2 and go to Seq 32. |
| 46 | If not: | Change A1C2. |

3803-2/3420

| | | | | | | | | | |
|----------------------|------------------------|-------------------|--------------------|--|--|--|--|--|--|
| XE2500 Seq 1 of 2 | 2735876 Part Number | See EC History | 845958 1 Sep 79 | | | | | | |
|----------------------|------------------------|-------------------|--------------------|--|--|--|--|--|--|

| From: 13-380, Seq 1 | | |
|---|-----------|-----------------------------------|
| Seq | Card | Checking |
| These are the items that are being checked. The procedure was broken out into four different trouble areas and so is the following: | | |
| LSR 1 AND 4 DO NOT COMPARE (FIRST TIME THROUGH LOOP) | | |
| 7 | B2C2 | LSRs |
| 9 | B2D2 | LSR DECODE BITS |
| 11 | B2F2G08 | +CLK 16 ALU1 |
| | B2F2G02 | +CLK 21 ALU1 |
| LSR 1 and 4 Do Compare (First Time Through Loop) | | |
| 13 | B2E2M07 | -XFR LSR to A Register |
| 15 | B2C2B09 | -ALU0 ALU1 |
| 17 | B2D2 | LSR Decode Bits |
| | See Note. | +Reset ALU1 IC and -Reset ALU1 IC |
| Hot Bus In Bits | | |
| 19 | A2Q2J07 | -Stat Bit 0 Tape Op to DF |
| 20 | A2Q2D04 | -Stat Bit 0 Tape Op to DF |
| 21 | A2T2D05 | +Stat Bit 1 Sense |
| 22 | A1K2P09 | -Wrt and Tape Op Not Control |
| 24 | B2D2P09 | -ROS Reg 0 and 1 ALU1 |
| | B2D2P12 | -ROS Reg 0 and 2 ALU1 |
| | B2D2 | LSR Decode Bits |
| 26 | B2E2B11 | +XFR LSR1 to Chan Bus In |
| | B2E2M07 | -XFR to A Register |
| 28 | B2F2P02 | +Clk 22 ALU1 |
| 30 | B2C2 | LSRs |
| 32 | A1C2 | Data Bus In (Bits 0-7) |
| 34 | B2E2M13 | +Inhibit Ripple Bus Chan A |
| 35 | B2E2P13 | +Inhibit Ripple Bus Chan B |
| 36 | A2R2 | CBI Bit (Bits 0-7) |
| First Time Through Loop OK, Second Time Through Loop Failed | | |
| 37 | A1R2S07 | -Gate CB1 to CE Entry |
| 39 | B2E2M13 | +Inhibit Ripple Bus Chan A |
| 40 | B2E2P13 | +Inhibit Ripple Bus Chan B |
| 41 | B2E2B11 | +XFR LSR1 to Chan Bus In |
| 43 | B2C2 | LSRs |
| 45 | B2D2 | LSR Decode Bits |

| Note: | WITH EC733814 | W/O EC733814 |
|----------------|---------------|--------------|
| +Reset ALU1 IC | B2L2P12 | B2M2P12 |
| -Reset ALU1 IC | B2L2P09 | B2M2P09 |

3803-2/3420

| | | | | | | | |
|-----------------------------|-------------------------------|-----------------------|---------------------------|--|--|--|--|
| XE2500 Seq 2 of 2 | 2735876 Part Number | See EC History | 845958 1 Sep 79 | | | | |
|-----------------------------|-------------------------------|-----------------------|---------------------------|--|--|--|--|

ALU1 FAILS TO TRAP TO 000

13-400

| From: 13-000 | | |
|--|--|---------------|
| This one-step loop is an unconditional branch to itself if ALU1 hardware error fails to trap ALU1 to 000. | | |
| Most Probable Cause: B2E2. | | |
| Always start with Seq 1 and follow the procedure in sequence unless directed otherwise. Remember to END all problems or maintenance calls by going to MAP 00-030. | | |
| Seq | Condition/Instruction | Action |
| 1 | Scope –Hardware Error ALU1 (A2P4J03), enable panel, disable interface, and operate the Reset switch several times. | |
| 2 | Did A2P4J03 go minus? | Go to 16-060. |
| 3 | Problem may be an incorrect branch into the loop. | Go to 13-090. |

3803-2/3420

| | | | | | | | |
|----------------------|------------------------|-------------------|--------------------|--|--|--|--|
| XE2600 Seq 1 of 2 | 2735877 Part Number | See EC History | 845958 1 Sep 79 | | | | |
|----------------------|------------------------|-------------------|--------------------|--|--|--|--|

13-400

ALU1 HANG ON ALU2 FAILURE

From: 13-000

ERROR DESCRIPTION:
 The ALU1 hang is caused by the failure of ALU2 to finish the readback after a write or a read. ALU2 is waiting for one of three conditions to occur; the fall of data ready (DATARDY), the end of data (ENDATA), or the fall of positioning (WAIT SOME), or the rise of IBG (WAITEND).

If ALU2 is at WRITING (refer to ALU2 microprogram listing for location), DATARDY is active and is not going inactive. If ALU2 is at WAIT SOME, positioning is active and not going inactive. If ALU2 is at WAITEND, IBG is inactive and not going active.

MOST PROBABLE CAUSE:

Tape Control (NRZI operation)
 A. Y1C2
 B. Y1D2

Tape Control (1600/6250 operation)
 A. Y1R2, Y1S2, Y1T2
 B. Y1P2, Y1Q2
 C. A2D2

Tape Unit
 Model 4, 6, 8 Model 3, 5, 7
 A. T-A1E2 A. T-A1E2
 B. T-A1H2 B. T-A1H2
 C. T-A1G6 C. T-A1E2
 D. T-A1L2 D. T-A1L2

Additional Cards Required:
 A. Y1H2

Always start with Seq 1 and follow the procedure in sequence unless directed otherwise.
Remember to END all problems or maintenance calls by going to MAP 00-030.

| Seq | Condition/Instruction | Action |
|-----|--|---|
| 1 | Is the failure in 1600 or 6250 bpi mode? | Go to Seq 8. |
| 2 | Turn ROS Mode switch to Norm. Operate Set ROS Mode switch. Operate Start or Step switch. | |
| 3 | Is ALU2 at WRITING? See ALU2 microprogram cross-reference listing. | Change Y1C2. This failure is caused by +NRZI CHAR GATE (Y1C2J12) becoming plus and then not being reset. If replacing this card does not correct the problem, check the above line and the two lines which follow to find the problem. +RESET FIRST BIT (Y1C2G13) and +BLOCK NRZI ONES (Y1C2U09). |
| 4 | Is +EOD NRZI (Y1C2P10) plus? | Change Y1H2. |
| 5 | Is -SET NRZI FIRST BIT (Y1D2P11) plus or pulsing? | Change Y1C2. |
| 6 | Is ALU2 at WAIT SOME? | Failure is caused by positioning bit active too long. For Models 4, 6, or 8 change T-A1E2 and T-A1H2. For Models 3, 5, or 7 change T-A1F2 and T-A1H2. |
| 7 | If not: | Change Y1D2. |

| Seq | Condition/Instruction | Action |
|-----|---|---|
| 8 | Is IBG (Y1P2M07) pulsing during runaway? | Change A2D2. |
| 9 | Is one of the TIME SENSE lines always active? (See Logic CC001) | Change: A. Y1R2, Y1S2, Y1T2 B. Y1P2, Y1Q2 |
| 10 | If not: | Change Y1P2. |

3803-2/3420

| | | | | | | | |
|-----------------------------|-------------------------------|-----------------------|---------------------------|--|--|--|--|
| XE2600 Seq 2 of 2 | 2735877 Part Number | See EC History | 845958 1 Sep 79 | | | | |
|-----------------------------|-------------------------------|-----------------------|---------------------------|--|--|--|--|

ALU1 WAITING FOR ALU2 TO COMPLETE A SEQUENCE

| From: 13-000 | | |
|--|---|---------------|
| Most Probable Cause: A. A2Q2 B. A2K2 C. A2D2 D. A2P4 Additional Cards Required: A. A2M2 B. A2L2 | | |
| Always start with Seq 1 and follow the procedure in sequence unless directed otherwise. Remember to END all problems or maintenance calls by going to MAP 00-030. | | |
| Seq | Condition/Instruction | Action |
| 1 | Turn ROS Mode switch to Norm. Operate Set ROS Mode switch. Operate Start or Step switch. | |
| 2 | Is ALU2 at address 000? | Go to Seq 9. |
| 3 | Set scope to 1 us/cm and scope +Clk4 ALU2 L1 (A2K2G09). While operating Reset, does line pulse? | Go to Seq 5. |
| 4 | If not: | Change A2K2. |
| 5 | Scope +RESET ALU2 IC (A2D2G04). While operating Reset switch, does line pulse? | Go to Seq 7. |
| 6 | If not: | Change A2D2. |
| 7 | Is +ROS REG 5 ALU2 (A2M2P04) plus? | Change A2M2. |
| 8 | Is -STAT B ALU2 to ALU1 (A2Q2M05) plus? | Change A2Q2. |
| 9 | Sync minus and display -TRAP ALU2 (A2P4J05). While operating the Reset switch, does line pulse? | Go to Seq 11. |
| 10 | If not: | Change A2P4. |
| 11 | Sync plus and display +TRAP ALU2 LATCH 2 COM SEL (A2D2B03). While operating Reset switch does line pulse plus? | Go to Seq 13. |
| 12 | If not: | Change A2D2. |
| 13 | Is +CLK 6 ALU2 (A2K2M08) plus? | Change A2K2. |
| 14 | Sync minus and display -B BUS 7 (A2N2G02). While operating the Reset switch, is the line always minus? | Change A2M2. |
| 15 | Sync minus and display -B BUS 7 ALU2 (A2Q2D11). While operating the Reset switch, is the line always minus? | Change A2Q2. |

| Seq | Condition/Instruction | Action |
|-----|--|-----------------------|
| 16 | Is +SET PAGE REG CLK (A2K2M13) plus? | Change A2K2. |
| 17 | Is +XFR LSR2 TO STAT (A2L2B13) plus? | Change A2L2. |
| 18 | Is -STAT D ALU2 TO ALU1 (A2Q2M09) minus? | Change A2Q2. |
| 19 | If not: | Recheck the symptoms. |

3803-2/3420

| | | | | | | | | |
|----------------------|------------------------|-------------------|--------------------|--|--|--|--|--|
| XE2700 Seq 1 of 2 | 2735878 Part Number | See EC History | 845958 1 Sep 79 | | | | | |
|----------------------|------------------------|-------------------|--------------------|--|--|--|--|--|

XOUTA REGISTER NOT FUNCTIONING

13-430

| From: 13-000 | | |
|--|---|-----------------------|
| Most Probable Cause: A2L2 | | |
| Always start with Seq 1 and follow the procedure in sequence unless directed otherwise. Remember to END all problems or maintenance calls by going to MAP 00-030. | | |
| Seq | Condition/Instruction | Action |
| 1 | Set ROS Mode switch to Norm. Operate Set ROS Mode switch. Operate Start Or Step switch. | |
| 2 | Is +XFR LSR2 TO XOUTA (A2L2B12) plus? | Change A2L2. |
| 3 | Is +XFR LSR2 TO XOUTB (A2L2D11) plus? | Change A2L2. |
| 4 | If not: | Recheck the symptoms. |

3803-2/3420

| | | | | | | | | | |
|----------------------|------------------------|-------------------|--------------------|--|--|--|--|--|--|
| XE2700 Seq 2 of 2 | 2735878 Part Number | See EC History | 845958 1 Sep /9 | | | | | | |
|----------------------|------------------------|-------------------|--------------------|--|--|--|--|--|--|

© Copyright International Business Machines Corporation 1976 1979

13-430

ALU1 IS WAITING FOR ALU2 STATD INDICATION

13-440

| From: 13-000 | | |
|--|--|-----------------------|
| Most Probable Cause: A2T2 | | |
| Always start with Seq 1 and follow the procedure in sequence unless directed otherwise. Remember to END all problems or maintenance calls by going to MAP 00-030. | | |
| Seq | Condition/Instruction | Action |
| 1 | Turn ROS Mode switch to Norm. Operate Set ROS Mode switch. Operate Start Or Step switch. | |
| 2 | Is +STAT BIT 0 ALU1 UNUSED (A2T2B04) minus? | Change A2T2. |
| 3 | Is -STAT BIT 0 ALU1 TO ALU2 (A2T2D04) plus? | Change A2T2. |
| 4 | If not: | Recheck the symptoms. |

3803-2/3420

| | | | | | | | | |
|-----------------------------|-------------------------------|-----------------------|---------------------------|--|--|--|--|--|
| XE2800 Seq 1 of 2 | 2735879 Part Number | See EC History | 845958 1 Sep 79 | | | | | |
|-----------------------------|-------------------------------|-----------------------|---------------------------|--|--|--|--|--|

* Copyright International Business Machines Corporation 1976, 1979

13-440

ALU1 IS WAITING FOR ALU2 STATB INDICATION

13-450

| From: 13-000, 13-530 | | |
|--|--|-----------------------|
| ERROR DESCRIPTION: This error occurs while ALU1 is waiting for ALU2 STATB indication. Waiting for tape motion to start when tape is at load point. | | |
| Most Probable Cause: A. A1K2 B. A1C2 | | |
| Always start with Seq 1 and follow the procedure in sequence unless directed otherwise. Remember to END all problems or maintenance calls by going to MAP 00-030. | | |
| Seq | Condition/Instruction | Action |
| 1 | Turn ROS Mode switch to Norm. Operate Set ROS Mode switch. Operate Start Or Step switch. | |
| 2 | Is -10.85 mHz (A1K2D04) at a solid level? | Change A1K2. |
| 3 | Is -6.78 mHz (A1K2J04) at a solid level? | Change A1K2. |
| 4 | Is -5.12 mHz (A1C2J03) at a solid level? | Change A1C2. |
| 5 | Is -3.2 mHz (A1K2U04) at a solid level? | Change A1K2. |
| 6 | Is 1.92 mHz (A1K2P12) at a solid level? | Change A1K2. |
| 7 | Is -READ TIME (A1K2M12) at a solid level? | Change A1K2. |
| 8 | If not: | Recheck the symptoms. |

3803-2/3420

| | | | | | | | | |
|------------|-------------|---------|----------|--|--|--|--|--|
| XE2800 | 2735879 | See EC | 845958 | | | | | |
| Seq 2 of 2 | Part Number | History | 1 Sep 79 | | | | | |

© Copyright International Business Machines Corporation 1976, 1979

13-450

ALU1 IS WAITING FOR ALU2 TO DROP STATB

13-460

| From 13-000 | | |
|--|--|-----------------------|
| ERROR DESCRIPTION: ALU1 is waiting for ALU2 to drop STATB after writing ID burst. | | |
| Most Probable Cause: A2D2 | | |
| Always start with Seq 1 and follow the procedure in sequence unless directed otherwise. Remember to END all problems or maintenance calls by going to MAP 00-030. | | |
| Seq | Condition/Instruction | Action |
| 1 | Turn ROS Mode switch to Norm. Operate Set ROS Mode switch. Operate Start Or Step switch. | |
| 2 | Set scope to 2 ms/cm and scope -TACH VELOCITY (A2D2B02). Does the line pulse? | Recheck the symptoms. |
| 3 | If not: | Change A2D2. |

3803-2/3420

| | | | | | | | | |
|----------------------|------------------------|-------------------|--------------------|--|--|--|--|--|
| XE2900 Seq 1 of 2 | 2735880 Part Number | See EC History | 845958 1 Sep 79 | | | | | |
|----------------------|------------------------|-------------------|--------------------|--|--|--|--|--|

13-460

ALU1 IS WAITING FOR ALU2 TO DROP STATB

13-470

| From: 13-000 | | |
|--|--|---|
| ERROR DESCRIPTION: ALU1 is waiting for ALU2 to drop STATB after completing a write operation. | | |
| Most Probable Cause: | | |
| A. Y1R2 | | |
| B. A1G2 | | |
| C. A1H2 | | |
| D. A2T2 | | |
| E. With EC733814—B2M2 (see Caution). Without EC733814—B2L2 (see Caution). | | |
| Caution: Removing this card may cause channel errors even with power off. Put CPU in single cycle mode before removing card. | | |
| Always start with Seq 1 and follow the procedure in sequence unless directed otherwise. Remember to END all problems or maintenance calls by going to MAP 00-030. | | |
| Seq | Condition/Instruction | Action |
| 1 | Turn ROS Mode switch to Norm. Operate Set ROS Mode switch. Operate Start Or Step switch. | |
| 2 | Is the U Pgm check lamp on? | Go to Seq 7. |
| 3 | Operate Reset switch. | |
| 4 | Is -TIME SENSE TK4 (Y1R2D10) minus? | Change Y1R2. |
| 5 | Is -TIME SENSE 1 (Y2R2M03) minus? | Change Y1R2. |
| 6 | Is -TIME SENSE 3 (Y1R2U05) minus? | Change Y1R2. |
| 7 | Is -WC11 (A2G2D09) pulsing? | Go to Seq 9. |
| 8 | If not: | Change A1G2. |
| 9 | Is -WRITE CNTR 4 (A1H2S07) pulsing? | Go to Seq 11. |
| 10 | If not: | Change A1H2. |
| 11 | Is +STAT BIT 0 ALU1 STOP SERV (A2T2G10) minus? | Change A2T2. |
| 12 | Is -STOP STAT TO DF minus? With EC733814—B2M2U09. Without EC733814—B2L2U09. | Recheck the symptoms. |
| 13 | If not: | With EC733814—change B2M2. See Caution. Without EC733814—change B2L2. See Caution. |

3803-2/3420

| | | | | | | | | |
|----------------------|------------------------|-------------------|--------------------|--|--|--|--|--|
| XE2900 Seq 2 of 2 | 2735880 Part Number | See EC History | 845958 1 Sep 79 | | | | | |
|----------------------|------------------------|-------------------|--------------------|--|--|--|--|--|

© Copyright International Business Machines Corporation 1976, 1979

13-470

6250 WRITE OPERATIONS

From: 13-000

ERROR DESCRIPTION:
This loop is used in 6250 bpi write operations to look for the ending ALL ONES character, which is the normal exit. It also monitors for HALT I/O and ALU2 error conditions. The loop is also used to write the Resync Bursts by monitoring CLOCK B to determine the number of groups written.

Most Probable Cause:

- A. A1C2
- B. A1F2
- C. A1G2
- D. A2T2
- E. A1E2
- F. A1H2
- G. A1K2
- H. A1L2
- I. A2Q2
- J. With EC733814—B2M2 (see Caution)
Without EC733814—B2L2 (see Caution)
- K. A1S2
- L. A1R2
- M. A1T2

Caution: Removing this card may cause channel errors even with power off. Put CPU in single cycle mode before removing card.

Be sure to remove the jumper before returning the subsystem to the customer.

Additional Cards Referenced:

- A. A2L2
- B. B2E2
- C. B2Q2
- D. B2P2
- E. Y1H2

The following procedure sometimes calls for the command sequence to be reset and restarted. To simplify these operations, follow these instructions:

- A. Set one of the addresses from ROS2 "hang" loop into the Compare Register.
- B. Install a jumper from +START NB LTH (A1T2G05) to +GENERAL RESET CHAN AB (B2L2U04) (B2M2U04 without EC733814). When entering data into the CE panel it may be necessary to remove the jumper.
- C. Turn the ROS Mode switch to Rst/Cmpr and raise the Set ROS Mode switch.
- D. Make sure that the Stop On Control Check switch is down.
- E. Operate Reset switch.

When the address loaded into the Compare Register is reached, the tape control is reset and the command sequence is started. To disable the reset and restart, turn the Stop On Control Check switch ON.

Always start with Seq 1 and follow the procedure in sequence unless directed otherwise. **Remember** to END all problems or maintenance calls by going to MAP 00-030.

| Seq | Condition/Instruction | Action |
|-----|--|--------|
| 1 | Turn the ROS Mode switch to Norm. Operate Set ROS Mode switch. Operate Start or Step switch. | |

| Seq | Condition/Instruction | Action |
|-----|---|---|
| 2 | Perform an offline Write operation from load point on a Model 4, 6, or 8 tape unit. This will set the tape unit to 6250 bpi mode. Load an LWR (8B) command into all 4 command registers. Use a byte count greater than 32 if it causes failures. Install a jumper from A1S2G08 to A1S2J08 to allow LWR operation with IBGs. Caution: If using the Reset and Restart jumper, verify that the ROS2 "hang" loop addresses have not changed from the online failure. | |
| 3 | Does the failure only occur offline? | Go to Seq 96. |
| 4 | Does the failure only occur online? | Go to Seq 106. |
| 5 | Operate the Stop/Start switch to start the command sequence. Is -GROUP OR DFLER BRANCH (B2D2P11) pulsing? | Go to Seq 23. |
| 6 | Is it always minus? | Go to Seq 8. |
| 7 | Is -STAT BIT 0 TAPE OP TO DF (A1K2U06) plus? | Change in order: 1. A2Q2 2. A2L2 |
| 8 | Is -TAPE OP A (A1G2D13) plus? | Change A1K2. |
| 9 | Is -WRITE CNTR 0 (A1G2G09) pulsing? | Change in order: 1. A1G2 2. A1K2 |
| 10 | Is -XOUTA BIT 4 ALU2 TO DF (A1H2S12) plus? (Ensure you are using a Model 4, 6, or 8 tape unit away from load point.) | Change A2Q2. |
| 11 | Are both -WC9 (A1H2U10) and -WC11 (A1H2U09) pulsing? | Change A1H2. |
| 12 | Is -WRITE CONDITION (A1G2G07) plus? | Go to Seq 16. |
| 13 | Is -6250 bpi MODE (A1G2M07) plus? | Change A1K2. |
| 14 | Is USECFREQ (A1G2M13) pulsing? | Change A1G2. |
| 15 | If not: | Change A1K2. |
| 16 | | |
| | Is -STAT BIT 1 START WR RD (A1G2G05) plus? | Change in order: 1. A2Q2 2. A2L2 |
| 17 | Is -WRITE AND TAPE OP (A1G2D03) plus? | Go to Seq 21. |
| 18 | Is -STOP STAT TO DF (A1G2G13) plus? | Change A1G2. |
| 19 | Is +STAT BIT 0 ALU 1 STOP SERV plus? With EC733814—B2M2M08. Without EC733814—B2L2M08. | With EC733814—change B2M2. See Caution. Without EC733814—change B2L2. See Caution. |

| Seq | Condition/Instruction | Action |
|-----|--|--|
| 20 | If not: | Change in order: 1. A2T2 2. B2E2 |
| 21 | Is -XOUTA BIT 5 ALU1 TO DF (A1K2U07) plus? | Change in order: 1. A2T2 2. B2E2 |
| 22 | If not: | Change A1K2. |
| 23 | Is -WRITE AND TAPE OP (A1H2D03) plus? | Go to Seq 21. |
| 24 | Does -XOUTA BIT 1 ALU1 TO DF (A1G2G10) stay plus? | Change in order: 1. A2T2 2. B2E2 |
| 25 | Reset and restart the command sequence. Does -READ CYCLE (A1F2B05) ever go minus? This pulse may be hard to see. | Go to Seq 82. |
| 26 | Is either the -0-50 CLOCK BUS A1 DELAYED (A1F2S04) or -25-75 CLOCK BUS A1 DELAYED (A1F2S03) at a solid level? | Change A1C2. |
| 27 | Reset and restart the command sequence. Does -WRT BUFFER EMPTY DOT (A1F2P09) ever go minus? | Go to Seq 44. |
| 28 | Reset and restart the command sequence. Does -WRITE GROUP BUFFER EMPTY (A1E2J07) ever go minus? | Go to Seq 37. |
| 29 | Is +SET 2ND BUFFER (A1G2G11) always plus? | Change A1G2. |
| 30 | Is -6250 bpi MODE (A1G2M07) plus? | Go to Seq 10. |
| 31 | Is +SET BYTE 4 (A1G2J11) plus? | Go to Seq 34. |
| 32 | Reset the command sequence. Is WRITE AND TAPE OP (A1G2D03) minus? | Go to Seq 42. |
| 33 | If not: | Change A1G2. |
| 34 | Is +SET WRITE DATA (A1F2P03) plus? | Change A1F2. |
| 35 | Is +SET WRITE DATA B (A1F2J02) plus? | Change A1E2. |
| 36 | If not: | Change A1F2. |
| 37 | Is -DATA CONVERTER ON (A1E2M12) plus? | Go to Seq 40. |
| 38 | Is -STAT BIT 3 7-TRACK (A1L2D12) minus? | Change in order: 1. A2Q2 2. A2L2 |
| 39 | If not: | Change A1L2. |
| 40 | Is -STAT BIT 3 7-TRACK (A1E2P09) minus? | Change in order: 1. A2Q2 2. A2L2 |
| 41 | If not: | Change A1E2. |

| Seq | Condition/Instruction | Action |
|-----|--|---|
| 42 | Reset the tape control. Is -STAT BIT 0 TAPE OP TO DF (A1K2U06) minus? | Change in order: 1. A2Q2 2. A2L2 |
| 43 | If not: | Change A1K2. |
| 44 | Reset and restart the command sequence. Is either -FULL FRAME (A1F2J10) or +STOP TO DATA FLOW (A1F2G11) active? | Go to Seq 57. |
| 45 | Is -TAPE OP A (A1F2S02) plus? | Go to Seq 7. |
| 46 | Is -ALLOW CRIC (A1F2B04) minus? | Go to Seq 51. |
| 47 | Is -XOUTA BIT 1 ALU2 TO DF (Y1H2M12) plus? | Change in order: 1. A2Q2 2. A2L2 |
| 48 | Is -PE MODE (Y1H2J05) plus? | Change Y1H2. |
| 49 | Is -XOUTA BIT 0 ALU2 TO DF (A1K2S13) minus? | Change in order: 1. A2Q2 2. A2L2 |
| 50 | If not: | Change A1K2. |
| 51 | Are you using a byte count greater than 6? | Go to Seq 58. |
| 52 | Is -STAT BIT 0 TAPE OP TO ALU1 plus? With EC733814—B2M2S07. Without EC733814—B2L2S07. | Change in order: 1. A2Q2 2. A2L2 |
| 53 | Does the tape control only fail offline? | Change in order: 1. A1R2 2. A1Y2 3. A1D2 |
| 54 | Does the tape control fail only on interface A? | Change B2Q2. See Caution. |
| 55 | Does the tape control fail only on interface B? | Change B2P2. See Caution. |
| 56 | Failure must be occurring both online and offline. | With EC733814—change B2L2. See Caution. Without EC733814—change B2M2. See Caution. |
| 57 | Is -ORC GATE (A1F2M05) minus? | Go to Seq 76. |
| 58 | Reset and restart the command sequence while scoping +BUFFER WRITE CYCLE OR REQ (A1F2G02). Does it pulse? | Change A1F2. If that does not fix the problem, go to Seq 63. |
| 59 | Reset and restart the command sequence while scoping +BUFFER WRITE CYCLE OR REQ (A1F2G02). Does it stay minus? | Go to Seq 61. |
| 60 | If not: | Change A1F2. |

Caution: Removing this card may cause channel errors even with power off. Put CPU in the single cycle mode before removing card.

| Seq | Condition/Instruction | Action |
|-----|--|---|
| 61 | Is -50-100 CLOCK BUS DEL (A1F2G04) pulsing? | Go to Seq 63. |
| 62 | If not: | Change A1C2. |
| 63 | Reset and restart the command sequence. Does -WRITE DATA READY (A1F2P10) ever go minus? | Change A1F2. |
| 64 | Is -WR AND TAPE OP NOT CTL (A1C2P12) plus? | Go to Seq 72. |
| 65 | Reset and restart the command sequence while looking at +RESET SENSE DATA (A1C2P05). Does it pulse? There will be only one 50 ns pulse. | Go to Seq 67. |
| 66 | If not: | Change B2E2. |
| 67 | Reset and restart the command sequence while scoping -SERVICE RESPONSE (A1C2M07). Does this line pulse once for each byte to be written? CE Panel Byte Count: 00—writes 3 bytes. 01-FE—writes 3 bytes more than hex value. | Go to Seq 70. |
| 68 | Reset and restart the command sequence. Does -SERVICE IN FOR DATA ever pulse? With EC733814—B2M2U12. Without EC733814—B2L2U12. | With EC733814—change B2M2. See Caution. Without EC733814—change B2L2. See Caution. |
| 69 | If not: | Change A1C2. |
| 70 | Reset and restart the command sequence while looking at -WRITE DATA READ (A1F2P10). Does this line pulse once for each byte to be written? CE Panel Byte Count: 00—writes 3 bytes 01-FE—writes 3 bytes more than hex value. | Change A1F2. |
| 71 | If not: | Change A1C2. |
| 72 | Is -STAT BIT 2 TO DF (A1K2U09) minus? | Change in order: 1. A2T2 2. B2E2 |
| 73 | If not: | Change A1K2. |
| 74 | Is -XOUTA BIT 0 ALU1 TO DF (A1G2S05) minus? | Change in order: 1. A2T2 2. B2E2 |
| 75 | If not: | Change A1G2. |
| 76 | Is -6250 bpi MODE (A1G2M07) plus? | Go to Seq 10. |

| Seq | Condition/Instruction | Action |
|-----|---|--|
| 77 | Is +SET BYTE 4 (A1G2J11) always plus? | Change A1F2. |
| 78 | Reset and restart the command sequence. Sync the scope plus on +SET WRITE DATA (A1F2P03) and compare it to SET WRITE DATA B (A1F2J02). Are they the same? | Go to Seq 80. |
| 79 | If not: | Change A1E2. |
| 80 | Reset and restart the command sequence. Sync the scope minus on -STEP BYTE COUNTER (A1F2B02). Does it pulse minus at least 4 times? | Go to Seq 74. |
| 81 | If not: | Change A1F2. |
| 82 | Reset and restart the command sequence. Sync the scope minus on -ORC GATE (A1F2M05). Does it ever go minus? | Go to Seq 84. |
| 83 | If not: | Go to Seq 76. |
| 84 | Scope -ORC GATE (A1F2M05) while in loop. Does it stay minus? | Go to Seq 76. |
| 85 | Is +STOP TO DATA FLOW (A1F2G11) minus? | Go to Seq 58. |
| 86 | Reset and restart the command sequence. Does -PARTIAL OR LAST FRAME (A1G2J10) ever go minus? | Go to Seq 92. |
| 87 | Reset and restart the command sequence. Does -PARTIAL OR LAST FRAME (A1E2J10) ever go minus? | Go to Seq 89. |
| 88 | If not: | Change A1F2. |
| 89 | Is -DATA CONVERTER ON (A1E2M12) plus? | Change A1E2. |
| 90 | Is -STAT BIT 3 7-TRACK (A1L2D12) minus? | Change in order: 1. A2Q2 2. A2L2 |
| 91 | If not: | Change A1L2. |
| 92 | Does -XOUTA BIT 1 ALU1 TO DF (A1G2G10) stay plus? | Change in order: 1. A2T2 2. B2E2 |
| 93 | Reset and restart the command sequence. Does -OVRUN OR ONES OR RD BFR BRCH ever go plus? With EC733814—B2L2U06. Without EC733814—B2M2U06. | With EC733814—change B2L2. See Caution. Without EC733814—change B2M2. See Caution. |
| 94 | Does -WCO (A1G2M05) pulse? | Change in order: 1. A1G2 2. A1F2 3. With EC733814, change B2L2. See Caution. Without EC733814, change B2M2. See Caution. |
| 95 | If not | Go to Seq 12. |

3803-2/3420

| | | | | | | | |
|----------------------|------------------------|-------------------|--------------------|--|--|--|--|
| XE3000 Seq 2 of 2 | 2735881 Part Number | See EC History | 845958 1 Sep 79 | | | | |
|----------------------|------------------------|-------------------|--------------------|--|--|--|--|

© Copyright International Business Machines Corporation 1976, 1979

6250 WRITE OPERATIONS (Cont'd)

| Seq | Condition/Instruction | Action |
|-----|--|---|
| 96 | Reset and restart the command sequence. Is -STAT BIT 1 SENSE (A1S2U09) ever minus? | Change in order: 1. A2T2 2. B2E2 |
| 97 | Is -GATE TIE (A1C2B12) minus? | Change A1S2. |
| 98 | Is +CE MODE (A1C2J09) minus? | Go to ALD PK011 FH2 and trace line back to failing point. |
| 99 | Is -WR AND TAPE OP NOT CTL (A1C2P12) plus? | Go to Seq 72. |
| 100 | Are any of the following lines plus? +6250 bpi 1 Or 2 TRK CORR (A1S2S02) +CRC A NOT EQUAL B (A1S2S03) +NEW CRC ERR (A1S2U03) | Change A1D2. |
| 101 | Reset and restart the command sequence. Does -COMPARE EQUAL SERV (A1R2J12) ever go minus? | Go to Seq 104. |
| 102 | Is -SERVICE RESPONSE (A1D2D10) ever minus? | Change in order: 1. A1C2 2. A1T2 3. A1S2 |
| 103 | If not: | Go to Seq 53. |
| 104 | Reset and restart the command sequence. Sync the scope minus on -CE STATUS IN (A1R2D13). Is +CBI BITS 3-6 ORED (A1R2B13) plus the second time the sync is minus? | Change A1R2. |
| 105 | If not: | Change in order: 1. A1T2 2. A2R2 3. B2E2 |
| 106 | Using ONLINE Friend program (OLT Section 0200), loop on the failure. See OLT User's Guide for instructions. | |
| 107 | Is +RESET SENSE DATA (A1C2P05) ever plus? | Go to Seq 109. |
| 108 | If not: | Change in order: 1. A2T2 2. B2E2 |
| 109 | Sync the scope plus on +CTI BIT 4 SERVICE IN. With EC733814—B2M2S09. Without EC733814—B2L2S09. Does -SERVICE RESPONSE (A1C2M07) become minus while the sync is plus? | Go to Seq 114. |
| 110 | Is +DATA IN plus while the sync is plus? With EC733814—B2M2U07. Without EC733814—B2L2U07. | Go to Seq 112. |
| 111 | If not: | With EC733814—change B2M2. See Caution. Without EC733814—change B2L2. See Caution. |

| Seq | Condition/Instruction | Action |
|-----|---|---|
| 112 | Is the failure occurring on Interface A? | Change B2Q2. See Caution. |
| 113 | If not: | Change B2P2. See Caution. |
| 114 | Are you operating on a System/370 channel or on a System/360 channel with DATA IN/DATA OUT feature? | Go to Seq 120. |
| 115 | Is +SERVICE IN FOR DATA (A1C2P06) always minus? | Go to Seq 117. |
| 116 | If not: | Change A1C2. |
| 117 | Is -SERVICE IN always minus? With EC733814—B2M2S08. Without EC733814—B2L2S08. | With EC733814—change B2M2. See Caution. Without EC733814—change B2L2. See Caution. |
| 118 | Are you operating on Interface A? | With EC733814—change B2S2. See Caution. Without EC733814—change B2R2. See Caution. |
| 119 | If not: | With EC733814—change B2R2. See Caution. Without EC733814—change B2S2. See Caution. |
| 120 | Does -DATA IN TO DRIVERS (A1C2J13) ever become minus? | Go to Seq 122. |
| 121 | If not: | Change A1C2. |
| 122 | Does +DATA OUT (A1C2U05) ever become plus? | With EC733814—change B2M2. See Caution. Without EC733814—change B2L2. See Caution. |
| 123 | If not: | Go to Seq 112. |

3803-2/3420

| | | | | | | | | |
|------------|-------------|---------|----------|--|--|--|--|--|
| XE3050 | 8492587 | See EC | 845958 | | | | | |
| Seq 1 of 2 | Part Number | History | 1 Sep 79 | | | | | |

NOTES:

13-483

3803-2/3420

| | | | | | | | | |
|----------------------|------------------------|-------------------|--------------------|--|--|--|--|--|
| XE3050 Seq 2 of 2 | 8492587 Part Number | See EC History | 845958 1 Sep 79 | | | | | |
|----------------------|------------------------|-------------------|--------------------|--|--|--|--|--|

© Copyright International Business Machines Corporation 1976, 1979

13-483

CUE RESET ON INTERFACE B

| From: 13-001 | | |
|---|---|---|
| ERROR DESCRIPTION: In this loop, ALU1 is attempting to reset a CUE on Interface B. If, after the RESET is issued, a CUE still exists, additional attempts are made until the CUE is reset. A loop occurs if the RESET is not effective. | | |
| Most Probable Cause: A. B2P2, see Caution. B. B2E2 C. With EC733814—B2L2. Without EC733814—B2M2. | | |
| Caution: Removing this card may cause channel errors even with power off. Put CPU in single cycle mode before removing card. | | |
| Always start with Seq 1 and follow the procedure in sequence unless directed otherwise. Remember to END all problems or maintenance calls by going to MAP 00-030. | | |
| Seq | Condition/Instruction | Action |
| 1 | Turn ROS Mode switch to Norm. Operate Set ROS Mode switch. Operate Start or Step switch. | |
| 2 | Sync the scope plus on +RESET CUE CHAN B (B2E2J11). A 50 ns pulse should appear at approximately 850 ns intervals. Is the line pulsing? | Go to Seq 4. |
| 3 | If not: | Change B2E2. |
| 4 | Scope +CUE PENDING CHAN B (B2P2U13). This line should go and stay minus after the resets in Seq 2. Is this line minus? | With EC733814—change B2L2. Without EC733814—change B2M2. |
| 5 | If not: | Change B2P2. See Caution. |

3803-2/3420

| | | | | | | | | |
|-----------------------------|-------------------------------|-----------------------|---------------------------|--|--|--|--|--|
| XE3100 Seq 1 of 2 | 2735882 Part Number | See EC History | 845958 1 Sep 79 | | | | | |
|-----------------------------|-------------------------------|-----------------------|---------------------------|--|--|--|--|--|

TACH VELOCITY ERROR

13-510

| From: 13-000 | | |
|---|--|--------------|
| ALU1 is waiting for ALU2 to complete a Write operation away from load point which it cannot complete because of a tach velocity failure. | | |
| FRU List: | | |
| 1. A2D2 | | |
| 2. A2M2 | | |
| Always start with Seq 1 and follow the procedure in sequence unless directed otherwise. Remember to END all problems or maintenance calls by going to MAP 00-030. | | |
| Seq | Condition/Instruction | Action |
| 1 | Perform multiple Write operations away from load point. Tape will probably run away. | |
| 2 | Does -TACH VELOCITY (A2D2B02) pulse? | Change A2M2. |
| 3 | If not: | Change A2D2. |

3803-2/3420

| | | | | | | | | |
|-----------------------------|-------------------------------|-----------------------|---------------------------|--|--|--|--|--|
| XE3100 Seq 2 of 2 | 2735882 Part Number | See EC History | 845958 1 Sep 79 | | | | | |
|-----------------------------|-------------------------------|-----------------------|---------------------------|--|--|--|--|--|

© Copyright International Business Machines Corporation 1976, 1979

13-510

ALU1 IS WAITING FOR END OF DATA (EOD) ON WRITE

13-520

| From: 13-000 | | |
|--|--|--|
| ALU1 is in a 7- or 9-track Write operation waiting for EOD to be written. | | |
| Most Probable Cause: Y1C2 | | |
| Always start with Seq 1 and follow the procedure in sequence unless directed otherwise. Remember to END all problems or maintenance calls by going to MAP 00-030. | | |
| Seq | Condition/Instruction | Action |
| 1 | Turn ROS Mode switch to Norm. Operate Set ROS Mode switch momentarily. Operate Start or Step switch momentarily. | |
| 2 | Is ALU1 at 000? | Recheck symptoms. Return to the MAP that initiated this entry. |
| 3 | If not: | Change Y1C2. |

3803-2/3420

| | | | | | | | | |
|------------|-------------|---------|----------|--|--|--|--|--|
| XE3150 | 2736044 | See EC | 845958 | | | | | |
| Seq 1 of 2 | Part Number | History | 1 Sep 79 | | | | | |

13-520

| |
|---|
| From ALU1 Listing |
| ERROR DESCRIPTION: Waiting for STATB to rise. Go to Map 13-450. |

3803-2/3420

| | | | | | | | | | |
|-----------------------------|-------------------------------|---------------------------------|---------------------------|--|--|--|--|--|--|
| XE3150 Seq 2 of 2 | 2736044 Part Number | See EC History | 845958 1 Sep 79 | | | | | | |
|-----------------------------|-------------------------------|---------------------------------|---------------------------|--|--|--|--|--|--|



ALU1 LOOP

13-540

| | |
|--|-----------------------|
| From ALU1 Listing | |
| ERROR DESCRIPTION: This loop is used in 1600 bpi write operations to look for ending ALL ONES character which is the normal exit. It also monitors for HALT I/O and ALU2 error conditions. | |
| Most Probable Cause: | |
| A. A1C2 | H. A1L2 |
| B. A1F2 | I. A2Q2 |
| C. A1G2 | J. B2M2—with EC733814 |
| D. A2T2 | B2L2—without EC733814 |
| E. A1E2 | K. A1S2 |
| F. A1H2 | L. A1R2 |
| G. A1K2 | M. A1T2 |

3803-2/3420

| | | | | | | | | | |
|------------|-------------|---------|----------|--|--|--|--|--|--|
| XE3160 | 4169696 | See EC | 845958 | | | | | | |
| Seq 1 of 2 | Part Number | History | 1 Sep 79 | | | | | | |

Copyright International Business Machines Corporation 1976, 1979

13-540

NOTES:

13-550

3803-2/3420

| | | | | | | | | |
|------------|-------------|---------|----------|--|--|--|--|--|
| XE3160 | 4169696 | See EC | 845958 | | | | | |
| Seq 2 of 2 | Part Number | History | 1 Sep 79 | | | | | |

© Copyright International Business Machines Corporation 1976, 1979

13-550

SENSE ANALYSIS

14-000

| From: 12-000, Customer Errors, Start 1, 00-010, 13-000 | | | |
|--|-------------------|-------------------------------|--|
| <p>Note: Refer to sense chart 00-005 and examine sense data to determine its validity. Look for bits that should always be on or off, such as EC number, and features. Next, look for bits that are not logical such as EOT and Load Point both on, and 7-track and dual density both on.</p> <p>If sense data is not valid, replace TU cards L2, K2, K6, and M2.</p> | | | |
| <p>Caution: Removing this card may cause channel errors even with power off. Put the CPU in Single Cycle mode before removing this card.</p> | | | |
| <p>Always start with Seq 1 and follow the procedure in sequence unless directed otherwise. Remember to END all problems or maintenance calls by going to MAP 00-030.</p> | | | |
| Seq | Sense Information | Error | Action |
| 1 | Byte 0 Bit 1 | Intervention Required | If Byte 1, Bit 1 (Tape Unit Ready) is on, go to 15-010, otherwise go to 14-010, Seq 47. |
| 2 | Byte 0 Bit 0 | Command Reject | Change: 1. B2L2 2. B2P2. See Caution. Go to 15-020. |
| 3 | Byte 0 Bit 3 | Equipment Check | Go to Seq 26. |
| 4 | Byte 0 Bit 2 | Bus Out Check | Change: 1. With EC733814, B2L2. See Caution. Without EC733814, B2M2. See Caution. 2. B2N2 If Byte 4, Bit 0 (ALU Check) is on, go to Seq 100, otherwise go to 15-030. |
| 5 | Byte 0 Bit 5 | Overrun | Go to 14-010, Seq 1. |
| 6 | Byte 0 Bit 6 | Word Count Zero | Change: 1. B2Q2. See Caution. 2. B2P2. See Caution. Go to 15-050. |
| 7 | Byte 0 Bit 7 | Data Convert Check | Change: 1. A1L2 2. Y1P2 Go to 15-070. |
| 8 | Byte 4 Bit 6 | TU Check | Go to 14-010, Seq 49. |
| 9 | Byte 0 Bit 4 | Data Check | Make sure the read/write head, tape path, and the capstan are clean. See 85-005 then retry. Proceed to Seq 11A. |
| 10 | | If not: | Go to Seq 17. |
| 11A | | Does the problem still exist? | Go to Seq 11C. |

| Seq | Sense Information | Error | Action |
|-----|-------------------|--|--|
| 11B | | If not: | Inform the customer of the importance of cleaning. Return the subsystem to the customer. |
| 11C | Byte 1 Bit 5 | Write Status | Go to Seq 14. |
| 12 | Byte 4 Bit 5 | LWR | Go to Seq 43. |
| 13 | | Read Data Check | Go to Seq 73. |
| 14 | | Write errors only at beginning of tape? | Strip some tape from the beginning of the reel or try another reel and proceed to Seq 15. |
| 15 | | Same error? | Go to Seq 43. |
| 16 | | If not: | Tape damage is likely. Try to find which tape unit caused the damage and check tracking and reel positioning on that unit. |
| 17 | | Sense printout missing or all zeros? | Change: 1. A1C2 2. Y1Q2 Go to 15-080. |
| 18 | Byte 7 Any bit | Sets TU Check | Change: 1. A1H2 2. A2R2 3. Y1Q2 Go to 15-090. |
| 19 | Byte 4 Bit 0 | ALU Hardware Error | Go to Seq 100. |
| 20 | Byte 1 Bit 7 | Not Capable | Go to 14-010, Seq 10. |
| 21 | Byte 8 Bit 4 | SAGC Check | Go to 14-010, Seq 13. |
| 22 | Byte 5 Bit 3 | ID Burst Check | Change: 1. A1K2 2. A2Q2 3. Y1Q2 Go to 17-050. |
| 23 | | Was the failing OP code a Rewind (07) command? | The expected sense data was not received after the completion of a Rewind command. Change: 1. A2D2 2. A2E2 Go to 15-140. |
| 24 | Byte 9 Bit 0 | 1 or 2 Trk 6250 correction. | Go to 14-010, Seq 79. |

| Seq | Sense Information | Error | Action |
|-----|-------------------|---------------------------------------|---|
| 25 | | If not: | There is a Unit Check without the supporting sense information. Go to 14-013, Seq 179. |
| 26 | Note | Sequences 27-42 are Equipment checks. | |
| 27 | Byte 4 Bit 0 | ALU Hardware Error | Go to Seq 100. |
| 28 | Byte 4 Bit 6 | TU Check | Go to 15-090. |
| 29 | Byte 4 Bit 1 | Reject TU | Go to Seq 34. |
| 30 | Byte 10 Any bit | | Go to Seq 36. |
| 31 | Byte 8 Bit 4 | SAGC Check | Go to 14-010, Seq 13. |
| 32 | Byte 8 Bit 3 | Early Begin Read Back Check. | Change: 1. Y1R2/S2/T2 2. Y1P2 Go to 17-100. |
| 33 | | If not: | There is an Equipment Check without the supporting sense information. Go to 14-013, Seq 179. |
| 34 | Byte 6 Bit 1 | Write Current Failure | Change: 1. A2R2 2. Y1Q2 Go to 15-090. |
| 35 | Byte 7 Any bit | Sets TU Check | Go to 14-011, Seq 56. |
| 36 | Byte 10 Bit 0 | Command Status Reject | Change: 1. A2Q2 2. A2R2 3. A2D2 Go to 16-160. |
| 37 | Byte 10 Bit 2 | Control Status Reject | Change: 1. A1H2 2. A2R2 Go to 16-210. |
| 38 | Byte 10 Bit 5 | Tach Start Failure | Go to 14-011, Seq 58. |
| 39 | Byte 10 Bit 7 | Velocity Check | Change: 1. A2D2 2. A2E2 Go to 16-180. |

3803-2/3420

| | | | | | | | |
|-----------------------------|-------------------------------|-----------------------|---------------------------|--|--|--|--|
| XE3200 Seq 1 of 2 | 2735883 Part Number | See EC History | 845958 1 Sep 79 | | | | |
|-----------------------------|-------------------------------|-----------------------|---------------------------|--|--|--|--|

14-000

| Seq | Sense Information | Error | Action |
|-----|---|---|--|
| 40 | Byte 10 Bit 3 | Write TU or Record Not Detected. Block Read Back Check. | Change: 1. Y1P2 2. A2T2 Go to 16-190. |
| 41 | Byte 10 Bit 4 | Dynamic Reversal/Load point time out. | Change: 1. A2D2 2. A2E2 Go to 16-200. |
| 42 | Byte 4, bit 1 or byte 21, bit 4 or byte 7, bit 4 without byte 4, bit 6. | Reject TU or REW or DSE without TU Check. | Go to 14-013, Seq 179. |
| 43 | | Is this entry because of a failure on Section A, Routine 01, Message 47 (AA0147)? | Go to Seq 46. |
| 44 | Note | Sequences 45-53 are Write Data Checks. | |
| 45 | Byte 3 Bit 7 | P Compare or C Compare | Go to 14-011, Seq 73. |
| 46 | Byte 4 Bit 3 | Write Trigger VRC | Go to 14-010, Seq 18. |
| 47 | Byte 9 Bit 1 | Velocity change during Write | Go to Seq 115. |
| 48 | Byte 5 Bit 2 | Write Tape Mark Check | Go to 14-010, Seq 38. |
| 49 | Byte 8 Bit 0 | IBG Detected While Writing | Change: 1. A1C2 2. A1K2 Go to 17-080. |
| 50 | Byte 8 Bit 3 | Early Begin Read Back Check | Change: 1. Y1R2/S2/T2 2. Y1P2 Go to 17-100. |
| 51 | Byte 6 Bit 0 | Seven-track tape unit | Go to Seq 65—NRZI Write Data Checks |
| 52 | Byte 6 Bit 4 | 6250 bpi tape unit | Go to Seq 54. |
| 53 | Byte 6 Bit 3 | 3420 not set to 1600 bpi. | Go to Seq 65—NRZI Write Data Checks |
| 54 | Note | Sequences 55-64 are 6250/PE Write Data Checks. | |
| 55 | Byte 3 Bit 2 | Skew Error | Go to 14-014, Seq 194. |

| Seq | Sense Information | Error | Action |
|-----|-------------------|--|--|
| 56 | Byte 5 Bit 4 | Start Read Check | Go to 14-012, Seq 102. |
| 57 | Byte 3 Bit 0 | Read/Write VRC | Change: 1. Y1N2 2. Y1S2 3. A1F2 Go to 17-170. |
| 58 | Byte 8 Bit 6 | Slow End Read Back Check | Go to 14-010, Seq 30. |
| 59 | Byte 3 Bit 4 | VRC Envelope Check | Go to 14-010, Seq 35. |
| 60 | Byte 3 Bit 1 | MTE/LRC | Go to 14-010, Seq 26. |
| 61 | Byte 5 Bit 6 | Postamble Error | Change: 1. Y1H2 2. A1D2 3. Y1Q2 Go to 17-190. |
| 62 | Byte 3 Bit 3 | End Data Check/CRC | Go to 14-011, Seq 87. |
| 63 | Byte 1 Bit 0 | Noise | Go to 14-010, Seq 28. |
| 64 | | If not: | To reach this point, there is a Data Check Error without a sense bit to support it. Go to 14-013, Seq 179. |
| 65 | Note | Sequences 66-72 are NRZI Write Data Checks. If the failure occurs on 9-track NRZI operation only, change: 1. Y1C2 2. Y1D2 If the failure occurs on 7-track NRZI operation only, change: 1. A1E2 2. A1L2 If the failure occurs on both 9-track and 7-track NRZI operations, change: 1. Y1C2 2. Y1D2 | |
| 66 | Byte 3 Bit 4 | NRZI Hi Clip VRC | See note in Seq 65 for changes. Go to 17-310. |
| 67 | Byte 3 Bit 2 | Skew Error | See note in Seq 65 for changes. Go to 17-160. |
| 68 | Byte 3 Bit 1 | LRC Error | See note in Seq 65 for changes. Go to 17-310. |

| Seq | Sense Information | Error | Action |
|-----|-------------------|---|---|
| 69 | Byte 3 Bit 3 | End Data Check (PE)/CRC | Change: 1. Y1C2 2. Y1D2 Go to 17-590. |
| 70 | Byte 1 Bit 0 | Noise | See note in Seq 65 for changes. Go to 17-370. |
| 71 | Byte 3 Bit 0 | R/W VRC | See note in Seq 65 for changes. Go to 17-170. |
| 72 | | If not: | To be here there is a NRZI Data Check without supporting sense information. Go to 14-013, Seq 179. |
| 73 | Note | Sequences 74-91 are 6250/PE Read Data Checks. | |
| 74 | | Does the tape unit read other tapes okay? | Check the OBR/SDR for the tape unit that wrote this tape. If the OBR/SDR doesn't show a higher number of errors than other tape units in the account, recheck symptoms. If it shows a higher number of errors than other tape units in the account, go to 00-011 and develop the tape to determine the cause of the errors. |
| 75 | Byte 6 Bit 0 | Seven-track tape unit | Go to Seq 92—NRZI Read Data Checks. |
| 76 | Byte 6 Bit 4 | 6250 bpi TU | Go to Seq 78. |
| 77 | Byte 6 Bit 3 | 3420 Not Set to 1600 bpi | Go to Seq 92—NRZI Read Data Checks. |
| 78 | Byte 8 Bit 4 | SAGC Check | Go to 14-010, Seq 13. |
| 79 | Byte 5 Bit 4 | Start Read Check | Go to 14-012, Seq 102. |
| 80 | Byte 5 Bit 5 | Partial Record | Go to 14-010, Seq 42. |

3803-2/3420

| | | | | | | | | |
|----------------------|------------------------|-------------------|--------------------|--|--|--|--|--|
| XE3200 Seq 2 of 2 | 2735883 Part Number | See EC History | 845958 1 Sep 79 | | | | | |
|----------------------|------------------------|-------------------|--------------------|--|--|--|--|--|

SENSE ANALYSIS (Cont'd)

| Seq | Sense Information | Error | Action |
|-----|-------------------|--|---|
| 81 | Byte 3 Bit 0 | Read/Write VRC. | Go to 14-012, Seq 143. |
| 82 | Byte 3 Bit 2 | Skew Error | Go to 14-012, Seq 124. |
| 83 | Byte 3 Bit 1 | MTE/LRC | Go to 14-010, Seq 26. |
| 84 | Byte 3 Bit 7 | P Compare or C Compare | Go to 14-011, Seq 61. |
| 85 | Byte 6 Bit 3 | 3420 Not Set To 1600 bpi | Go to Seq 87. |
| 86 | Byte 3 Bit 3 | End Data Check/CRC (PE) | Change: 1. A1D2 2. Y1H2 Go to 17-530. |
| 87 | Byte 3 Bit 3 | End Data Check/CRC (6250 bpi) | Go to 14-011, Seq 87. |
| 88 | Byte 5 Bit 6 | Postamble Error | Change: 1. Y1H2 2. A1D2 3. Y1Q2 Go to 17-190. |
| 89 | Byte 8 Bit 6 | Slow End | Go to 14-010, Seq 30. |
| 90 | Byte 1 Bit 0 | Noise | Change A1K2. Go to 17-370. |
| 91 | | If not: | To get to this point there is a Read Data Check without supporting sense information. Go to 14-013, Seq 179. |
| 92 | Note | Sequences 93-99 are NRZI Read Data Checks. | |
| 93 | | Read error in only one direction? | Check NRZI tracking and skew. See 08-000. |
| 94 | Byte 3 Bit 7 | P Compare or C Compare | Change: 1. A1E2 2. A1L2 Go to 17-010. |
| 95 | Byte 1 Bit 0 | Noise | See note in Seq 65 for changes. Go to 17-370. |
| 96 | Byte 3 Bit 0 | Read/Write VRC | See note in Seq 65 for changes. Go to 17-170. |

| Seq | Sense Information | Error | Action |
|-----|-------------------|--|---|
| 97 | Byte 3 Bit 3 | End Data Check/CRC Error | Change: 1. Y1C2 2. Y1D2 Go to 17-590. |
| 98 | Byte 3 Bit 1 | MTE/LRC Error | See note in Seq 65 for changes. Go to 17-310. |
| 99 | | If not: | There is a Data Check without supporting sense information. Go to 14-013, Seq 179. |
| 100 | | —ALU HARDWARE ERROR It is imperative that you know the status of both ALU1 and ALU2, when the failure occurs. If you do not have sense bytes 11 and 12, or have not had a failure in Check Stop mode with the ALU1/ALU2 switch in each position, try the offline procedure beginning at Sequence 3 of 13-000. | Go to Seq 101. |
| 101 | | Referring to ALU listing, do the lamps indicate an invalid address? | Change: 1. B2F2 2. B2E2 Go to 13-090. |
| 102 | Byte 11 Bit 2 | Lo IC/Lo ROS parity? (ALU1) | Change: 1. B2H2 2. B2E2 Go to 16-010. |
| 103 | Byte 11 Bit 3 | Hi IC/Hi ROS parity? (ALU1) | Change: 1. B2H2 2. B2D2 Go to 16-020. |
| 104 | Byte 12 Bit 2 | Lo IC/Lo ROS parity? (ALU2) | Change: 1. A2L2 2. A2H2 Go to 16-080. |
| 105 | Byte 12 Bit 3 | Hi IC/Hi ROS parity? (ALU2) | Change: 1. A2K2 2. A2D2 Go to 16-090. |
| 106 | Byte 11 Bit 0 | B-Bus parity? (ALU1) | Change: 1. B2C2 2. A2P4 Go to 16-030. |

| Seq | Sense Information | Error | Action |
|-----|-------------------|-------------------------------|---|
| 107 | Byte 12 Bit 0 | B-Bus parity? (ALU2) | Change: 1. A2M2 2. A2K2 Go to 16-100. |
| 108 | Byte 11 Bit 5 | D-Bus parity? (ALU1) | Change: 1. B2C2 2. A2Q2 Go to 16-040. |
| 109 | Byte 12 Bit 5 | D-Bus parity? (ALU2) | Change: 1. A2N2 2. A2T2 Go to 16-110. |
| 110 | Byte 11 Bit 7 | BOC parity? (ALU1) | Change: 1. With EC733814, B2L2. See Caution. Without EC733814, B2M2. See Caution. 2. A2P4 Go to 16-050. |
| 111 | Byte 12 Bit 7 | BOC parity? (ALU2) | Change: 1. A2D2 2. A2M2 Go to 16-120. |
| 112 | Byte 12 Bit 4 | Microprogram detected? (ALU2) | Change: 1. A2M2 2. A2N2 Go to 16-130. |
| 113 | Byte 11 Bit 4 | Microprogram detected? (ALU1) | Change: 1. B2D2 2. B2C2 Go to 16-060. |
| 114 | | If not: | There is an ALU error without supporting sense information. Go to 14-010, Seq 179. |
| 115 | | 6250 Operation? | Go to Seq 117. |
| 116 | | If not: | Change: 1. A2D2 2. A2E2 Go to 16-180. |
| 117 | Byte 3 Bit 1 | MTE? | Go to Seq 119. |
| 118 | | If not: | Change: 1. A2D2 2. A2E2 Go to 16-180. |
| 119 | Byte 3 Bit 4 | ENV CHK? | Go to 14-010, Seq 35. |
| 120 | | If not: | Go to 14-010, Seq 26. |

Caution: Removing this card may cause channel errors even with power off.
Put CPU in the Single Cycle mode before removing card.

3803-2/3420

| | | | | | | | |
|----------------------|------------------------|-------------------|--------------------|--|--|--|--|
| XE3300 Seq 1 of 2 | 2735884 Part Number | See EC History | 845958 1 Sep 79 | | | | |
|----------------------|------------------------|-------------------|--------------------|--|--|--|--|

Sense Byte to Bit Conversion

| ▽ | | | | hex 00 ▽ | | | | | |
|---------------------|------|---|---|----------|---------------------|------|---|---|---|
| 1st hex digit | Bits | | | | 2nd hex digit | Bits | | | |
| | 0 | 1 | 2 | 3 | | 4 | 5 | 6 | 7 |
| 0 | | | | | 0 | | | | |
| 1 | | | | X | 1 | | | | X |
| 2 | | | X | | 2 | | | X | |
| 3 | | | X | X | 3 | | | X | X |
| 4 | | X | | | 4 | | X | | |
| 5 | | X | | X | 5 | | X | | X |
| 6 | | X | X | | 6 | | X | X | |
| 7 | | X | X | X | 7 | | X | X | X |
| 8 | X | | | | 8 | X | | | |
| 9 | X | | | X | 9 | X | | | X |
| A | X | | X | | A | X | | X | |
| B | X | | X | X | B | X | | X | X |
| C | X | X | | | C | X | X | | |
| D | X | X | | X | D | X | X | | X |
| E | X | X | X | | E | X | X | X | |
| F | X | X | X | X | F | X | X | X | X |
| 1st hex digit | 0 | 1 | 2 | 3 | 2nd hex digit | 4 | 5 | 6 | 7 |
| | Bits | | | | | Bits | | | |

3803-2/3420

| | | | | | | | | |
|-----------------------------|-------------------------------|---------------------------|---------------------------|--|--|--|--|--|
| XE3300 Seq 2 of 2 | 2735884 Part Number | See EC History | 845958 1 Sep 79 | | | | | |
|-----------------------------|-------------------------------|---------------------------|---------------------------|--|--|--|--|--|

© Copyright International Business Machines Corporation 1976-1979

NOTES:

14-006

3803-2/3420

| | | | | | | | | |
|----------------------|------------------------|-------------------|--------------------|--|--|--|--|--|
| XE3350 Seq 1 of 2 | 8492589 Part Number | See EC History | 845958 1 Sep 79 | | | | | |
|----------------------|------------------------|-------------------|--------------------|--|--|--|--|--|

Copyright International Business Machines Corporation 1976-1979

14-006

| From: 14-000 | | | |
|---|-------------------|----------------------|---|
| Always start with Seq 1 and follow the procedure in sequence unless directed otherwise. Remember to END all problems or maintenance calls by going to MAP 00-030. | | | |
| Seq | Sense Information | Error | Action |
| 1 | Byte 1 Bit 5 | Write Status | Go to Seq 4. |
| 2 | Byte 0 Bit 4 | Data Check | Change: 1. A1C2 2. A1E2 Go to 15-040. |
| 3 | | If not: | Change: 1. A1F2 2. A1C2 Go to 15-040. |
| 4 | Byte 9 Bit 3 | CRC III | Go to Seq 7. |
| 5 | Byte 3 Bit 3 | End Data Check/CRC | Change: 1. A2T2 2. A1C2 Go to 15-040. |
| 6 | | If not: | Change: 1. A1C2 2. A1F2 Go to 15-040. |
| 7 | Byte 9 Bit 2 | Channel Buffer Check | Change: 1. A1C2 2. A1F2 Go to 15-040. |
| 8 | Byte 9 Bit 0 | 6250 Correction | Change: 1. A1F2 2. A1C2 Go to 15-040. |
| 9 | | If not: | Change: 1. A2Q2 2. B2L2 Go to 15-040. |
| 10 | Byte 8 Bit 4 | SAGC Check | Change: 1. A1K2 2. A1L2 Go to 15-060. |
| 11 | Byte 3 Bit 4 | VRC/ENV Check | Change Y1P2. Go to 15-060. |
| 12 | | If not: | Change: 1. A1K2 2. Y1Q2 3. A2Q2 Go to 15-060. |

| Seq | Sense Information | Error | Action |
|-----|-------------------|-----------------|--|
| 13 | Byte 1 Bit 5 | Write Status | Go to Seq 15. |
| 14 | | If not: | Change: 1. A2Q2 2. A1K2 Go to 16-220. |
| 15 | Byte 5 Bit 3 | ID Burst Check | Change: 1. A1H2 2. A1K2 Go to 16-220. |
| 16 | Byte 4 Bit 3 | Write TRG VRC | Change A1G2. Go to 16-220. |
| 17 | | If not: | Change: 1. A1K2 2. A2Q2 Go to 16-220. |
| 18 | Byte 9 Bit 0 | 6250 Correction | Change: 1. A1G2 2. A2T2 Go to 17-020. |
| 19 | Byte 9 Bit 3 | CRC III | Go to Seq 22. |
| 20 | Byte 3 Bit 4 | VRC/ENV Check | Change: 1. A1G2 2. A2T2 Go to 17-020. |
| 21 | | If not: | Change: 1. A1G2 2. A1H2 Go to 17-020. |
| 22 | Byte 3 Bit 4 | VRC/ENV Check | Go to Seq 24. |
| 23 | | If not: | Change: 1. A1G2 2. A2T2 Go to 17-020. |
| 24 | Byte 3 Bit 0 | R/W VRC | Change: 1. Y2K2/L2/M2 2. Y1J2 Go to 17-020. |
| 25 | | If not: | Change: 1. Y1H2 2. Y1J2 Go to 17-020. |

| Seq | Sense Information | Error | Action |
|-----|-------------------|--------------------------|--|
| 26 | Byte 1 Bit 5 | Write Status | Change: 1. Y1F2 2. Y1G2 3. Y1N2 Go to 17-110. |
| 27 | | If not: | Change: 1. A1K2 2. Y1D2 Go to 17-110. |
| 28 | Byte 3 Bit 4 | VRC/ENV Check | Change A1K2. Go to 17-370. |
| 29 | | If not: | Change: 1. A1D2 2. A2Q2 3. A2T2 Go to 17-370. |
| 30 | Byte 1 Bit 5 | Write Status | Go to Seq 32. |
| 31 | | If not: | Change Y1Q2. Go to 17-150. |
| 32 | Byte 3 Bit 1 | Multi-Trk Error | Change Y1Q2. Go to 17-150. |
| 33 | Byte 3 Bit 4 | VRC/ENV Check | Change: 1. Y1H2 2. Y1C2 3. Y1N2 Go to 17-150. |
| 34 | | If not: | Change A1H2. Go to 17-150. |
| 35 | Byte 2 No Bits | Track In Error | Change: 1. Y1R2/S2/T2 2. Y1K2/L2/M2 3. Y1G2 4. Y1N2 Go to 17-220. |
| 36 | Byte 9 Bit 0 | 6250 Correction | Change A1K2. Go to 17-220. |
| 37 | | If not: | Change Y1H2. Go to 17-220. |
| 38 | Byte 8 Bit 6 | Slow End Read Back Check | Go to Seq 40. |

3803-2/3420

| | | | | | | | |
|----------------------|------------------------|-------------------|--------------------|--|--|--|--|
| XE3350 Seq 2 of 2 | 8492589 Part Number | See EC History | 845958 1 Sep 79 | | | | |
|----------------------|------------------------|-------------------|--------------------|--|--|--|--|

SENSE ANALYSIS (Cont'd)

| Seq | Sense Information | Error | Action |
|-----|--------------------|--------------------|--|
| 39 | | If not: | Change: 1. Y1R2/S2/T2 2. A1G2 3. A1H2 Go to 17-180. |
| 40 | Byte 8 Bit 0 | IBG Detect | Change A1K2. Go to 17-180. |
| 41 | | If not: | Change A2Q2. Go to 17-180. |
| 42 | Byte 9 Bit 0 | 6250 Correction | Go to Seq 45. |
| 43 | Byte 3 Bit 2 | Skew | Change: 1. Y1D2 2. Y1Q2 Go to 17-410. |
| 44 | | If not: | Change Y1G2. Go to 17-410. |
| 45 | Byte 2 All Bits | Track In Error | Change A1G2. Go to 17-410. |
| 46 | | If not: | Change Y1N2. Go to 17-410. |
| 47 | Byte 0 Bit 3 | Equipment Check | Change: 1. A2Q2 2. A2R2 Go to 15-090. |
| 48 | | If not: | Change: 1. A2T2 2. A1K2 3. A2R2 4. A2D2 Go to 15-090. |
| 49 | Byte 1 Bit 5 | Write Status | Go to Seq 53. |
| 50 | Byte 3 Bit 3 | End Data Check/CRC | Change A2T2. Go to 15-090. |
| 51 | Byte 3 Bit 0 | R/W VRC | Change A2T2. Go to 15-090. |
| 52 | | If not: | Change: 1. A1H2 2. A2R2 3. Y1D2 4. Y1Q2 Go to 15-090. |
| 53 | Byte 0 Bit 4 | Data Check | Change A2T2. Go to 15-090. |

| Seq | Sense Information | Error | Action |
|-----|-------------------|----------------------|--|
| 54 | Byte 6 Bit 1 | Wrt Curr Fail | Change A1K2. Go to 15-090. |
| 55 | | If not: | Change: 1. A1H2 2. A2R2 3. Y1D2 4. Y1Q2 Go to 15-090. |
| 56 | Byte 1 Bit 5 | Write Status | Change: 1. A1H2 2. A2R2 3. Y1Q2 Go to 15-090. |
| 57 | | If not: | Change: 1. A1H2 2. A2R2 3. Y1D2 4. Y1Q2 Go to 15-090. |
| 58 | Byte 4 Bit 3 | Wrt TRG VRC | Change A1G2. Go to 16-170. |
| 59 | Byte 3 Bit 4 | VRC/ENV Check | Change A2Q2. Go to 16-170. |
| 60 | | If not: | Change: 1. A1K2 2. A1G2 3. A2Q2 4. A2T2 Go to 16-170. |
| 61 | Byte 9 Bit 0 | 6250 Correction | Go to Seq 66. |
| 62 | Byte 9 Bit 2 | Channel Buffer Check | Go to Seq 68. |
| 63 | Byte 9 Bit 3 | CRC III | Change: 1. A1E2 2. Y1K2/L2/M2 3. Y1G2 4. Y1D2 Go to 17-010. |
| 64 | Byte 1 Bit 0 | Noise | Change: 1. A1F2 2. A1D2 Go to 17-010. |

| Seq | Sense Information | Error | Action |
|-----|-------------------|----------------------|---|
| 65 | | If not: | Change: 1. A1C2 2. A1D2 3. A1F2 4. A1G2 5. A1L2 Go to 17-010. |
| 66 | Byte 9 Bit 2 | Channel Buffer Check | Change: 1. Y1F2 2. Y1R2/S2/T2 Go to 17-010. |
| 67 | | If not: | Change: 1. Y1F2 2. Y1J2 Go to 17-010. |
| 68 | Byte 9 Bit 3 | CRC III | Go to Seq 71. |
| 69 | Byte 3 Bit 3 | End Data Check/CRC | Change: 1. A1F2 2. A1K2 Go to 17-010. |
| 70 | | If not: | Change A1C2. Go to 17-010. |
| 71 | Byte 3 Bit 4 | VRC/ENV Check | Change Y1J2. Go to 17-010. |
| 72 | | If not: | Change: 1. A1F2 2. A1G2 Go to 17-010. |
| 73 | Byte 9 Bit 0 | 6250 Correction | Go to Seq 77. |
| 74 | Byte 9 Bit 2 | Channel Buffer Check | Change: 1. A1F2 2. A1C2 Go to 17-010. |
| 75 | Byte 9 Bit 3 | CRC III | Change: 1. A1E2 2. A1G2 3. A1F2 4. A1K2 Go to 17-010. |

3803-2/3420

| | | | | | | | | |
|------------|-------------|----------------|----------|--|--|--|--|--|
| XE3400 | 2735885 | See EC History | 845958 | | | | | |
| Seq 1 of 2 | Part Number | | 1 Sep 79 | | | | | |

| Seq | Sense Information | Error | Action |
|-----|-----------------------------|---------------------------------------|---|
| 76 | | If not: | Change: 1. A1F2 2. A1L2 3. A1G2 Go to 17-010. |
| 77 | Byte 9 Bit 3 | CRC III | Change A1F2. Go to 17-010. |
| 78 | | If not: | Change: 1. A1G2 2. A1F2 Go to 17-010. |
| 79 | Byte 1 Bit 5 | Write Status | Change: 1. Y1K2/L2/M2 2. Y1N2 Go to 17-600. |
| 80 | Byte 3 Bit 4 | VRC/ENV Check | Go to Seq 82. |
| 81 | | If not: | Change: 1. Y1R2/S2/T2 2. Y1F2 3. Y1K2/L2/M2 Go to 17-600. |
| 82 | | Is more than one bit on in Byte 2? | Go to Seq 86. |
| 83 | Byte 2 Bit 0 or 5 | Track In Error | Change: 1. Y1T2 2. Y1M2 3. Y1P2 Go to 17-600. |
| 84 | Byte 2 Bit 1, 3, or 4 | Track In Error | Change: 1. Y1R2 2. Y1K2 3. Y1P2 Go to 17-600. |
| 85 | Byte 2 Bit 2, 6, or 7 | Track In Error | Change: 1. Y1S2 2. Y1L2 3. Y1P2 Go to 17-600. |
| 86 | | If not: | Change: 1. Y1T2/S2/R2 2. Y1F2 3. Y1M2/L2/K2 Go to 17-600. |
| 87 | Byte 1 Bit 5 | Write Status | Go to Seq 91. |

| Seq | Sense Information | Error | Action |
|-----|-------------------|-----------------|--|
| 88 | Byte 9 Bit 0 | 6250 Correction | Change: 1. Y1J2 2. Y1N2 Go to 17-540. |
| 89 | Byte 2 No Bits | Track In Error | Change: 1. A1F2 2. Y1H2 3. Y1J2 4. A1C2 Go to 17-540. |
| 90 | | If not: | Change Y1J2. Go to 17-540. |
| 91 | Byte 9 Bit 0 | 6250 Correction | Go to Seq 95. |
| 92 | Byte 3 Bit 1 | Multi-Trk Error | Go to Seq 98. |
| 93 | Byte 9 Bit 3 | CRC III | Go to Seq 189. |
| 94 | | If not: | Change: 1. Y1H2 2. A1D2 3. Y1K2/L2/M2 4. Y1D2 Go to 17-540. |
| 95 | Byte 2 No Bits | Track In Error | Change A1G2. Go to 17-540. |
| 96 | Byte 9 Bit 3 | CRC III | Change: 1. A1G2 2. Y1J2 Go to 17-540. |
| 97 | | If not: | Change Y1F2. Go to 17-540. |
| 98 | Byte 2 No Bits | Track In Error | Change Y1F2. Go to 17-540. |
| 99 | | If not: | Change: 1. Y1N2 2. Y1J2 Go to 17-540. |
| 100 | Byte 2 No Bits | Track In Error | Change: 1. A1D2 2. A1E2 3. Y1G2 4. Y1K2/L2/M2 Go to 17-540. |

| Seq | Sense Information | Error | Action |
|-----|--------------------|-----------------|--|
| 101 | | If not: | Change Y1F2. Go to 17-540. |
| 102 | Byte 1 Bit 5 | Write Status | Go to Seq 108. |
| 103 | Byte 3 Bit 2 | Skew | Go to Seq 113. |
| 104 | Byte 9 Bit 0 | 6250 Correction | Change: 1. Y1N2 2. A2Q2 Go to 17-070. |
| 105 | Byte 2 No Bits | Track In Error | Change: 1. Y1N2 2. A1C2 3. A1K2 4. A2Q2 Go to 17-070. |
| 106 | Byte 2 All Bits | Track In Error | Change Y1Q2. Go to 17-070. |
| 107 | | If not: | Change Y1P2. Go to 17-070. |
| 108 | Byte 9 Bit 0 | 6250 Correction | Change Y1K2/L2/M2. Go to 17-070. |
| 109 | Byte 3 Bit 4 | VRC/ENV Check | Go to Seq 111. |
| 110 | | If not: | Change: 1. A1K2 2. A2L2 Go to 17-070. |
| 111 | Byte 8 Bit 4 | SAGC Check | Change: 1. A1C2 2. A1K2 3. A2Q2 4. Y1N2 Go to 17-070. |
| 112 | | If not: | Change: 1. Y1D2 2. Y1N2 Go to 17-070. |
| 113 | Byte 9 Bit 0 | 6250 Correction | Go to Seq 118. |
| 114 | Byte 3 Bit 4 | VRC/ENV Check | Go to Seq 121. |

3803-2/3420

| | | | | | | | | |
|------------|-------------|-------------------|----------|--|--|--|--|--|
| XE3400 | 2735885 | See EC History | 845958 | | | | | |
| Seq 2 of 2 | Part Number | | 1 Sep 79 | | | | | |

SENSE ANALYSIS (Cont'd)

14-013

| Seq | Sense Information | Error | Action |
|-----|--------------------|--------------------------|---|
| 115 | Byte 2 No Bits | Track In Error | Change: 1. Y1N2 2. A1C2 3. Y1D2 Go to 17-070. |
| 116 | Byte 2 All Bits | Track In Error | Change: 1. Y1K2/L2/M2 2. Y1Q2 Go to 17-070. |
| 117 | | If not: | Change: 1. Y1Q2 2. A1C2 Go to 17-070. |
| 118 | Byte 2 No Bits | Track In Error | Change Y1N2. Go to 17-070. |
| 119 | Byte 2 All Bits | Track In Error | Change Y1N2. Go to 17-070. |
| 120 | | If not: | Change Y1J2. Go to 17-070. |
| 121 | Byte 2 No Bits | Track In Error | Change: 1. Y1N2 2. Y1P2 Go to 17-070. |
| 122 | Byte 2 All Bits | Track In Error | Change Y1P2. Go to 17-070. |
| 123 | | If not: | Change: 1. Y1K2/L2/M2 2. Y1P2 Go to 17-070. |
| 124 | Byte 1 Bit 5 | Write Status | Go to Seq 127. |
| 125 | Byte 1 Bit 0 | Noise | Change: 1. Y1K2/L2/M2 2. Y1C2 Go to 17-160. |
| 126 | | If not: | Change: 1. A1K2 2. Y1P2 Go to 17-160. |
| 127 | Byte 8 Bit 6 | Slow End Read Back Check | Go to Seq 139. |
| 128 | Byte 9 Bit 0 | 6250 Correction | Go to Seq 132. |

| Seq | Sense Information | Error | Action |
|-----|--------------------------|------------------------------------|---|
| 129 | Byte 3 Bit 1 | Multi-Trk Error | Change: 1. Y1Q2 2. Y1N2 Go to 17-160. |
| 130 | Byte 9 Bit 3 | CRC III | Go to Seq 134. |
| 131 | | If not: | Change: 1. Y1Q2 2. Y1P2 Go to 17-160. |
| 132 | Byte 3 Bit 0 | R/W VRC | Change: 1. Y1N2 2. Y1S2 3. A1F2 Go to 17-170. |
| 133 | | If not: | Change: 1. Y1K2/L2/M2 2. Y1R2/S2/T2 Go to 17-160. |
| 134 | | Is more than one bit on in Byte 2? | Go to Seq 138. |
| 135 | Byte 2 Bit 0 or 5 | Track In Error | Change: 1. Y1T2 2. Y1M2 Go to 17-160. |
| 136 | Byte 2 Bit 1, 3, or 4 | Track In Error | Change: 1. Y1R2 2. Y1K2 Go to 17-160. |
| 137 | Byte 2 Bit 2, 6, or 7 | Track In Error | Change: 1. Y1S2 2. Y1M2 Go to 17-160. |
| 138 | | If not: | Change: 1. Y1T2/S2/R2 2. Y1M2/L2/K2 3. Y1Q2 Go to 17-160. |
| 139 | Byte 9 Bit 0 | 6250 Correction | Change: 1. Y1J2 2. Y1N2 Go to 17-160. |

| Seq | Sense Information | Error | Action |
|-----|-------------------|-----------------|---|
| 140 | Byte 3 Bit 1 | Multi-Trk Error | Change: 1. Y1Q2 2. Y1N2 3. Y1P2 Go to 17-160. |
| 141 | Byte 8 Bit 4 | SAGC Check | Change: 1. Y1Q2 2. A1C2 Go to 17-160. |
| 142 | | If not: | Change Y1J2. Go to 17-160. |
| 143 | Byte 1 Bit 5 | Write Status | Go to Seq 147. |
| 144 | Byte 9 Bit 0 | 6250 Correction | Go to Seq 156. |
| 145 | Byte 3 Bit 4 | VRC/ENV Check | Change: 1. Y1R2/S2/T2 2. Y1J2 Go to 17-170. |
| 146 | | If not: | Change: 1. Y1R2/S2/T2 2. Y1P2 Go to 17-170. |
| 147 | Byte 3 Bit 1 | Multi-Trk Error | Go to Seq 152. |
| 148 | Byte 9 Bit 0 | 6250 Correction | Go to Seq 150. |
| 149 | | If not: | Change Y1J2. Go to 17-170. |
| 150 | Byte 9 Bit 3 | CRC III | Change: 1. Y1K2/L2/M2 2. A1F2 3. Y1N2 Go to 17-170. |
| 151 | | If not: | Change: 1. Y1F2 2. A1F2 3. Y1K2/L2/M2 Go to 17-170. |
| 152 | Byte 9 Bit 0 | 6250 Correction | Go to Seq 154. |

3803-2/3420

| | | | | | | | |
|----------------------|------------------------|-------------------|--------------------|--|--|--|--|
| XE3500 Seq 1 of 2 | 2735886 Part Number | See EC History | 845958 1 Sep 79 | | | | |
|----------------------|------------------------|-------------------|--------------------|--|--|--|--|

14-013

| Seq | Sense Information | Error | Action |
|-----|-----------------------------|--------------------|--|
| 153 | | If not: | Change: 1. Y1K2/L2/M2 2. Y1H2 Go to 17-170. |
| 154 | Byte 9 Bit 3 | CRC III | Change Y1N2. Go to 17-170. |
| 155 | | If not: | Change: 1. Y1J2 2. Y1N2 Go to 17-170. |
| 156 | Byte 9 Bit 3 | CRC III | Go to Seq 159. |
| 157 | Byte 3 Bit 3 | End Data Check/CRC | Change Y1F2. Go to 17-170. |
| 158 | | If not: | Change: 1. Y1F2 2. Y1J2 Go to 17-170. |
| 159 | Byte 3 Bit 7 | C or P Compare | Change: 1. Y1F2 2. Y1G2 Go to 17-170. |
| 160 | Byte 2 Bits 3 & 7 | TIE | Change Y1F2. Go to 17-170. |
| 161 | Byte 2 Bits 3, 6, & 7 | TIE | Change: 1. Y1R2/S2/T2 2. Y1K2/L2/M2 Go to 17-170. |
| 162 | Byte 2 Bits 3, 5, & 7 | TIE | Change Y1L2. Go to 17-170. |
| 163 | Byte 2 Bits 3, 5, 6, & 7 | TIE | Change: 1. Y1L2 2. Y1M2 Go to 17-170. |
| 164 | Byte 2 Bits 3, 4, & 7 | TIE | Change: 1. Y1R2/S2/T2 2. Y1P2 Go to 17-170. |
| 165 | Byte 2 Bits 3, 4, & 6 | TIE | Change: 1. Y1T2 2. A1G2 Go to 17-170. |

| Seq | Sense Information | Error | Action |
|-----|--------------------------------|--------------|--|
| 166 | Byte 2 Bits 3, 4, 6, & 7 | TIE | Change: 1. A1K2 2. Y1K2 Go to 17-170. |
| 167 | Byte 2 Bits 3, 4, & 5 | TIE | Change Y1C2. Go to 17-170. |
| 168 | Byte 2 Bits 2, 3, & 7 | TIE | Change Y1R2/S2/T2. Go to 17-170. |
| 169 | Byte 2 Bits 2, 3, 6, & 7 | TIE | Change: 1. Y1L2 2. Y1M2 Go to 17-170. |
| 170 | Byte 2 Bits 2, 3, 5, 6, & 7 | TIE | Change Y1M2. Go to 17-170. |
| 171 | Byte 2 Bits 1 & 7 | TIE | Change Y1S2. Go to 17-170. |
| 172 | Byte 2 Bits 1, 3, 6, & 7 | TIE | Change Y1K2. Go to 17-170. |
| 173 | Byte 2 Bits 1, 3, & 4 | TIE | Change Y1R2/S2/T2. Go to 17-170. |
| 174 | Byte 2 Bits 1, 2, 3, & 7 | TIE | Change Y1S2. Go to 17-170. |
| 175 | Byte 2 Bits 0, 3, & 7 | TIE | Change Y1K2. Go to 17-170. |
| 176 | Byte 2 Bits 0, 3, 6, & 7 | TIE | Change: 1. Y1M2 2. Y1F2 Go to 17-170. |
| 177 | Byte 2 Bits 0, 3, & 4 | TIE | Change Y1J2. Go to 17-170. |
| 178 | | If not: | Change Y1K2/L2/M2. Go to 17-170. |
| 179 | Byte 1 Bit 5 | Write Status | Go to Seq 186. |
| 180 | Byte 0 Bit 4 | Data Check | Change: 1. A1K2 2. A1G2 Go to 15-100. |

| Seq | Sense Information | Error | Action |
|-----|--------------------------|--|--|
| 181 | Byte 2 No Bits | TIE | Change: 1. A1C2 2. A2R2 3. Y1P2 4. A2Q2 Go to 15-100. |
| 182 | Byte 2 Bit 0 or 5 | TIE | Change: 1. Y1J2 2. Y1P2 3. Y1G2 Go to 15-100. |
| 183 | Byte 2 Bit 1, 3, or 4 | TIE | Change Y1G2. Go to 15-100. |
| 184 | Byte 2 Bit 2, 6, or 7 | TIE | Change: 1. Y1P2 2. Y1D2 3. Y1G2 Go to 15-100. |
| 185 | | If not: | Change: 1. Y1N2 2. Y1P2 Go to 15-100. |
| 186 | Byte 0 Bit 4 | Data Check | Change: 1. Y1N2 2. A1C2 3. A2T2 4. A1K2 Go to 15-100. |
| 187 | Byte 2 No Bits | TIE | Change: 1. A1H2 2. A2R2 3. A1G2 Go to 15-100. |
| 188 | | If not: | Change Y1Q2. Go to 15-100. |
| 189 | | Is this entry because of a failure on Section A, Routine 1, Message 47 (AA0147)? | Go to Seq 191. |
| 190 | | If not: | Go to Seq 100. |
| 191 | | Are Bits 2 and 3 of Byte 9 both ON? | Change: 1. A1F2 2. A1C2 3. A1E2 4. Y1H2 Go to 17-010 |

3803-2/3420

| | | | | | | | |
|----------------------|------------------------|-------------------|--------------------|--|--|--|--|
| XE3500 Seq 2 of 2 | 2735886 Part Number | See EC History | 845958 1 Sep 79 | | | | |
|----------------------|------------------------|-------------------|--------------------|--|--|--|--|

SENSE ANALYSIS (Cont'd)

14-020

| Seq | Condition/Instruction | Action |
|-----|--|---|
| 192 | Are Bits 3 and 4 of Byte 9 both ON? | Change: 1. A1G2 2. A1E2 3. A1F2 |
| 193 | If not: | Change Y1R2/S2/T2. |
| 194 | Is this entry because of a failure on Section A, Routine 1, message 47 (AA0147)? | Go to Seq 196. |
| 195 | If not: | Go to Seq 124. |
| 196 | Are Bits 2 and 3 of Byte 3 both ON? | Go to Seq 199. |
| 197 | Are Bits 2 and 4 of Byte 3 both ON? | Go to Seq 203. |
| 198 | If not: | Change: 1. Y1J2 2. Y1Q2 3. Y1N2 4. Y1C2 |
| 199 | Are Bits 3 and 4 of Byte 9 both ON? | Go to Seq 201. |
| 200 | If not: | Change Y1R2/S2/T2. |
| 201 | Is Byte 3, Bit 1 ON? | Change Y1N2. |
| 202 | If not: | Change: 1. Y1Q2 2. Y1P2 3. Y1R2/S2/T2 |
| 203 | Are Bits 0 and 4 of Byte 9 both ON? | Change: 1. Y1J2 2. Y1N2 Go to 17-160. |
| 204 | If not: | Change: 1. A1C2 2. Y1R2/S2/T2 3. Y1Q2 |

3803-2/3420

| | | | | | | | | | |
|----------------------|------------------------|-------------------|--------------------|--|--|--|--|--|--|
| XE3550 Seq 1 of 2 | 8492590 Part Number | See EC History | 845958 1 Sep 79 | | | | | | |
|----------------------|------------------------|-------------------|--------------------|--|--|--|--|--|--|

14-020

NOTES:

14-021

3803-2/3420

| | | | | | | | | | |
|-----------------------------|-------------------------------|---------------------------------|---------------------------|--|--|--|--|--|--|
| XE3550 Seq 2 of 2 | 8492590 Part Number | See EC History | 845958 1 Sep 79 | | | | | | |
|-----------------------------|-------------------------------|---------------------------------|---------------------------|--|--|--|--|--|--|

Copyright International Business Machines Corporation 1976, 1979

14-021

INTERVENTION REQUIRED

| From: 14-000 | | |
|---|--|--|
| ERROR DESCRIPTION: Sense Byte 0, Bit 1 is set whenever TU status A is inactive (for example, the selected tape unit is not ready or nonexistent). See Sense Byte 1, Bit 1. In addition to Sense Byte 0, Bit 1, channel end, device end, and unit check are set in the unit status byte if TU status A becomes inactive because the tape unit drops Ready while performing a command. (Sets Unit Check). | | |
| Most Probable Causes: The cards are listed with the highest probability first. Lines with multiple cards have the same probability. | | |
| Tape Control A. A2Q2 B. A1K2, A2T2, A2R2 C. A2D2 | | |
| Tape Unit (Model 4, 6, or 8) T-A1K2, T-A1L2, T-A1M2, T-A1L6 T-A1C2, T-A1B2 (Model 3, 5, or 7) T-A1H2, T-A1L2, T-A1L6, T-A1C2, T-A1B2 | | |
| Additional Cards Referenced: A. T-S1K6 B. T-S1K4 | | |
| Notes: 1. Plus level = +6 Vdc, minus level +0 Vdc. 2. Plus level = 0 Vdc, minus level -4 Vdc. | | |
| Always start with Seq 1 and follow the procedure in sequence unless directed otherwise. Remember to END all problems or maintenance calls by going to MAP 00-030. | | |
| Seq | Condition/Instruction | Action |
| 1 | Does more than one tape unit fail? | Go to 18-000 if this is a 1x8 selection, otherwise go to 18-010. |
| 2 | Is the online/Offline switch (on the tape unit) in the Offline position? | Put the switch in the Online position, then go to 00-030. |
| 3 | Is the tape unit being addressed Ready? | Go to Seq 5. |
| 4 | If not: | If you cannot make it Ready, or if it drops Ready, go to 2A/2B-000. Otherwise, make it Ready and go to 00-030. |
| 5 | Is -Pick On Line Relay (T-A1L6B10) plus? (See Note 1.) | Go to ALD WB021ABH and follow the line to the failing point. |
| 6 | Is -Interface Disable (T-A1L6D04) minus? (See Note 1.) | Change T-A1L6, then go to 00-030. |
| 7 | Is +Int Dis Or Offline (T-A1L6B03) plus? (See Note 2.) | Change T-A1L6, then go to 00-030. |

| Seq | Condition/Instruction | Action |
|-----|---|--|
| 8 | With the tape unit Unloaded, install the field tester. Load tape and make Ready. Set up the field tester for Write, St/Stp. Sync the scope minus on + Sum of Tags (T-A1M2P07—Model 4, 6, or 8) (T-A1H2P07—Model 3, 5, or 7) Is -Gated Ready (T-A1M2M12)—Model 4, 6, or 8) (T-A1H2M12—Model 3, 5, or 7) plus? | Change T-A1C2. If further analysis is needed, go to ALD FT261CN6. Otherwise, go to 00-030. |
| 9 | With the same set-up as in Seq 8, is T-A1M2M13 (Model 4,6, or 8) or T-A1H2M13 (Model 3,5, or 7) plus? | Change T-A1M2 for Model 4, 6, or 8 or T-A1H2 for Model 3, 5, or 7. If further analysis is needed, go to ALD FT116. Otherwise, go to 00-030. |
| 10 | While running the field tester, is +Status Bus 5 (T-A1M2P06 — Model 4, 6, or 8) T-A1H2P06 — Model 3, 5, or 7) minus? | Change T-A1M2 for Model 4, 6, or 8, or T-A1H2 for Model 3, 5, or 7. If further analysis is needed, go to ALD FT115. Otherwise, go to 00-030. |
| 11 | While running the field tester, is +Status Bus 7A (T-A1K2G13 — Model 4, 6, or 8) minus? While running the field tester, is +Status Bus 7 (T-A1H2J02 — Model 3, 5, or 7) minus? | Change T-A1K2 for Model 4, 6, or 8. If further analysis is needed, go to ALD FT181. Change T-A1H2 for Model 3, 5, or 7. If further analysis is needed, go to ALD FT115. |
| 12 | While running the field tester, is -Bus In 5 (T-A1L2D09) pulsing? | Go to Seq 14. |
| 13 | If not: | Change T-A1L2. If further analysis is needed, go to ALD FT146. Otherwise, go to 00-030. |
| 14 | Is -Bus Out 7 (T-A1M2M02 — Model 4, 6, or 8) (T-A1H2M02 — Model 3, 5, or 7) plus? While running the field tester, sync minus on T-A1L2D09.) | Change T-A1K6 for Model 4, 6, or 8, or T-A1K4 for Model 3, 5, or 7. For further analysis, go to ALD FT112. Otherwise, go to 00-030. |
| 15 | Are any bits On in Byte 7? | Go to 15-090. |
| 16 | Does the TCU have a device switch feature? | Go to Seq 18. |
| 17 | If not: | Ensure the tape unit has the correct address. Check the cables. Go to 00-030. |
| 18 | Is the Enable/Disable switch on the TCU in the Enable position? | Go to 18-015. |
| 19 | If not: | Put the switch in the Enable position. Go to 00-030. |

3803-2/3420

| | | | | | | | |
|------------|-------------|---------|----------|--|--|--|--|
| XE3600 | 2735887 | See EC | 845958 | | | | |
| Seq 1 of 2 | Part Number | History | 1 Sep 79 | | | | |

| From: 14-000 | | |
|---|---|--|
| Command Reject Sense Byte 0, Bit 0 is set: | | |
| <ol style="list-style-type: none"> When a Write, Loop Write-to-Read (LWR), Write Tape Mark (WTM), or Erase Record Gap (ERG) command is issued to a file-protected tape unit. See Sense Byte 1, Bit 6. When a Sense Reserve command or a Sense Release command is issued to a tape control that does not have the two channel switch feature. When a Sense Reserve command or a Sense Release command issued to tape control that has the two channel switch feature is not the first command in a chain. When a Data Security Erase (DSE) command is not chained to a previous ERG command. When the command format of any Channel Command Word (CCW) is decoded as invalid by the tape control. | | |
| Most Probable Cause: | | |
| The following is a list of cards that can cause the problems covered in this procedure. The cards are listed with the highest probability first. Lines with multiple cards have the same probability. Cards separated by a slash are interchangeable. | | |
| <ol style="list-style-type: none"> B2L2/B2P2 (Failing command is a Reserve/Release). See Caution. A2T2/A2D2 (Failing command is a Write type) A1K2 | | |
| Additional Cards Referenced: | | |
| B2C2 | | |
| Caution: Removing this card may cause channel errors, even with power off. Put the CPU in Single Cycle mode before removing this card. | | |
| Look up ROS stop or compare value in microlist cross-reference for specified ALU. | | |
| Always start with Seq 1 and follow the procedure in sequence unless directed otherwise. Remember to END all problems or maintenance calls by going to MAP 00-030. | | |
| Seq | Condition/Instruction | Action |
| 1 | Determine failing CCW strings. | Run OLTs or try all commands offline. Go to Seq 2. |
| 2 | Is the failing CCW hex 'D4' or 'F4'? | Go to Seq 14. |
| 3 | Is the failing CCW hex '97'? | Go to Seq 17. |
| 4 | Do hex '01', '17', '1F', '8B' all fail? | Go to Seq 18. |
| 5 | Stop on error; then using procedures in Section 12, display ALU1 LSR 0 for current command stored. Note: In offline mode, command reject causes 301 "hang". Let TCU execute failing command and enter loop. Reset and display LSR. Reset does not affect LSR. | |
| 6 | Are bits 5, 6, and 7 all off? (XXXXX000) | Only hex '00' is valid (TIO). Go to Seq 23. |
| 7 | Is bit 7 off? (XXXXXXX0) | Only hex '00', '02', '04', '0C', 'D4', 'F4' are valid. Go to Seq 23. |
| 8 | Is bit 6 off? (XXXXXX01) | Only hex '01' is valid. Go to Seq 23. |
| 9 | Is bit 5 off? (XXXXX011) | Recheck data. Mode Set should set Not Capable, not Command Reject. |
| 10 | Is bit 0 off? (0XXXX111) | Go to Seq 14. |

| Seq | Condition/Instruction | Action |
|-----|--|--|
| 11 | Is bit 0 on? (1XXXX111) | Only hex '97' is valid. Go to Seq 23. |
| 12 | Is bit 1 off? (00XXX111) | All combinations are valid. Command Reject error is false. Change B2C2. |
| 13 | Is bit 1 on? (01XXX111) | This combination is invalid. Go to Seq 23. |
| 14 | Does this unit have a two channel switch feature? | Go to Seq 16. |
| 15 | If not: | Reserve/Release Commands are invalid to TCU without TCS. Verify tape control plugging and Sense Byte 17, Bit 0. |
| 16 | Recheck CCW string. Reserve/Release commands must be first in chain. | Change A-B2L2, B2P2. See Caution. |
| 17 | Ensure that DSE command is chained to a previous ERG. Chaining is not possible from CE panel. Set up failing ERG/DSE chain, check set of chain, and allow DSE flags at ALU1 routines located at SETCHAIN and ENABLDSE. | |
| 18 | Perform any command to TU, and address stop ALU2 after executing instruction at FCHSNS. (See MPL book for address.) Display Bus In, ALU2. | |
| 19 | Is Bus In Bit 1 on? (NFP bit) | Change A2T2 and verify that NFP Flag stores properly into LSR 4 when ALU1 instruction at GETSNS0 is executed. Display LSR 4, Bit 1. |
| 20 | Does this tape unit fail? | Go to Seq 26. |
| 21 | With TUBI selected, as in Seq 18, scope A2D2J02 (-Device Bus In To DF). Are either A2D2J09 or A2D2D10 at GND level when A1D2J02 is plus? | Change A2D2. |
| 22 | If not: | In offline mode, command reject causes 301 hang. Let TCU execute failing command and enter loop. Reset & display LSR. Reset will not affect LSR. Replace switch card in tape control for selected tape unit. See 18-010. |
| 23 | Is command being issued from channel invalid? | Review channel program to isolate program or channel failure. |
| 24 | Does command match byte stored in ALU1 LSR 0? | Address stop on addresses listed in table in MPL to determine microprogram branch failing. |

| Seq | Condition/Instruction | Action |
|-----|--|---|
| 25 | With ROS Mode switch on Normal, operate the ROS mode switch, sync on address compare value of CMSPAREX (ALU1). See MPL book for address. Scope logic from channel to input of LSR. | |
| 26 | Is the Write Enable ring on the tape reel? | Change T-A1Ms for Model 4, 6, or 8. Change T-A1H2 for Model 3, 5, or 7. If problem still exists, go to ALD FT111. |
| 27 | If not: | Install write enable ring, then go to 00-030. |

3803-2/3420

| | | | | | | | | | |
|------------|-------------|---------|----------|--|--|--|--|--|--|
| XE3600 | 2735887 | See EC | 845958 | | | | | | |
| Seq 2 of 2 | Part Number | History | 1 Sep 79 | | | | | | |

BUS OUT CHECKS

15-030

| From: 14-000 | | | | | | | | | | | | | | | | | | | | | | |
|---|---|---------------|-------|---------|---|---------|---|---------|---|---------|---|---------|---|---------|---|---------|---|---------|---|---------|---|--|
| Bus Out Check Sense Byte 0, Bit 2 is set: | | | | | | | | | | | | | | | | | | | | | | |
| <ol style="list-style-type: none"> Whenever Bus Out has incorrect (even) parity during command or data byte transfer When a ROS hardware error has occurred (any bit on in Sense Byte 11 or 12) and there are no other bits on in Sense Byte 0. | | | | | | | | | | | | | | | | | | | | | | |
| Most Probable Cause: | | | | | | | | | | | | | | | | | | | | | | |
| <p>A. With EC733814 — B2M2 Without EC733814 — B2L2</p> <p>B. B2N2</p> <p>C. B2D2</p> | | | | | | | | | | | | | | | | | | | | | | |
| <p>Always start with Seq 1 and follow the procedure in sequence unless directed otherwise. Remember to END all problems or maintenance calls by going to MAP 00-030.</p> | | | | | | | | | | | | | | | | | | | | | | |
| Seq | Condition/Instruction | Action | | | | | | | | | | | | | | | | | | | | |
| 1 | Run OLTs. Loop on error. Is TCU without EC733814? | Go to Seq 25. | | | | | | | | | | | | | | | | | | | | |
| 2 | Sync scope negative on -Command Out A B CE (B2L2U02). Is B2D2M02 minus at any time during sync? | Go to Seq 5. | | | | | | | | | | | | | | | | | | | | |
| 3 | Sync scope negative on -Service Response (B2M2U05). Does B2D2M02 go minus during sync pulses? | Go to Seq 16. | | | | | | | | | | | | | | | | | | | | |
| 4 | If not: | Change B2D2. | | | | | | | | | | | | | | | | | | | | |
| 5 | Does +Bus Out Parity Odd (B2M2M10) go minus during sync? | Go to Seq 7. | | | | | | | | | | | | | | | | | | | | |
| 6 | If not: | Change B2M2. | | | | | | | | | | | | | | | | | | | | |
| 7 | Is tape control operating on interface B? | Go to Seq 12. | | | | | | | | | | | | | | | | | | | | |
| 8 | Is +Bus Out Parity Odd Chan A (B2L2G12) minus during sync? | Go to Seq 10. | | | | | | | | | | | | | | | | | | | | |
| 9 | If not: | Change B2L2. | | | | | | | | | | | | | | | | | | | | |
| 10 | <p>Do the following pins have even parity during sync?</p> <p>+If Bus Out x Chan A</p> <table border="1"> <thead> <tr> <th>Pin</th> <th>Track</th> </tr> </thead> <tbody> <tr><td>B2M2S12</td><td>P</td></tr> <tr><td>B2M2M13</td><td>0</td></tr> <tr><td>B2M2M05</td><td>1</td></tr> <tr><td>B2M2S04</td><td>2</td></tr> <tr><td>B2M2M09</td><td>3</td></tr> <tr><td>B2M2D12</td><td>4</td></tr> <tr><td>B2M2U04</td><td>5</td></tr> <tr><td>B2M2G03</td><td>6</td></tr> <tr><td>B2M2S10</td><td>7</td></tr> </tbody> </table> | Pin | Track | B2M2S12 | P | B2M2M13 | 0 | B2M2M05 | 1 | B2M2S04 | 2 | B2M2M09 | 3 | B2M2D12 | 4 | B2M2U04 | 5 | B2M2G03 | 6 | B2M2S10 | 7 | Check interface cables, channel to tape control and I/O connector to B2 Board for proper seating. If this does not correct error, compare bits to command issued to locate failing bit or bits. These are plus active interface levels. Trace bits to tape control interface by using ALD FC061. |
| Pin | Track | | | | | | | | | | | | | | | | | | | | | |
| B2M2S12 | P | | | | | | | | | | | | | | | | | | | | | |
| B2M2M13 | 0 | | | | | | | | | | | | | | | | | | | | | |
| B2M2M05 | 1 | | | | | | | | | | | | | | | | | | | | | |
| B2M2S04 | 2 | | | | | | | | | | | | | | | | | | | | | |
| B2M2M09 | 3 | | | | | | | | | | | | | | | | | | | | | |
| B2M2D12 | 4 | | | | | | | | | | | | | | | | | | | | | |
| B2M2U04 | 5 | | | | | | | | | | | | | | | | | | | | | |
| B2M2G03 | 6 | | | | | | | | | | | | | | | | | | | | | |
| B2M2S10 | 7 | | | | | | | | | | | | | | | | | | | | | |
| 11 | If not: | Change B2M2. | | | | | | | | | | | | | | | | | | | | |
| 12 | Is +Bus Out Parity Odd Chan B (B2L2J12) minus during sync? | Go to Seq 14. | | | | | | | | | | | | | | | | | | | | |
| 13 | If not: | Change B2L2. | | | | | | | | | | | | | | | | | | | | |

| Seq | Condition/Instruction | Action | | | | | | | | | | | | | | | | | | | | |
|---------|---|--|-------|---------|---|---------|---|---------|---|---------|---|---------|---|---------|---|---------|---|---------|---|---------|---|--|
| 14 | <p>Do the following pins have even parity during sync?</p> <p>+If Bus Out x Chan B</p> <table border="1"> <thead> <tr> <th>Pin</th> <th>Track</th> </tr> </thead> <tbody> <tr><td>B2N2U06</td><td>P</td></tr> <tr><td>B2N2J09</td><td>0</td></tr> <tr><td>B2N2S07</td><td>1</td></tr> <tr><td>B2N2G12</td><td>2</td></tr> <tr><td>B2N2B13</td><td>3</td></tr> <tr><td>B2N2D04</td><td>4</td></tr> <tr><td>B2N2U07</td><td>5</td></tr> <tr><td>B2N2S08</td><td>6</td></tr> <tr><td>B2N2P11</td><td>7</td></tr> </tbody> </table> | Pin | Track | B2N2U06 | P | B2N2J09 | 0 | B2N2S07 | 1 | B2N2G12 | 2 | B2N2B13 | 3 | B2N2D04 | 4 | B2N2U07 | 5 | B2N2S08 | 6 | B2N2P11 | 7 | Check interface cables, channel to tape control and I/O connector to B2 Board for proper seating. If this does not correct error, compare bits to command issued to locate failing bit or bits. These are plus active interface levels. Trace bits to tape control interface by using ALD XM055. |
| Pin | Track | | | | | | | | | | | | | | | | | | | | | |
| B2N2U06 | P | | | | | | | | | | | | | | | | | | | | | |
| B2N2J09 | 0 | | | | | | | | | | | | | | | | | | | | | |
| B2N2S07 | 1 | | | | | | | | | | | | | | | | | | | | | |
| B2N2G12 | 2 | | | | | | | | | | | | | | | | | | | | | |
| B2N2B13 | 3 | | | | | | | | | | | | | | | | | | | | | |
| B2N2D04 | 4 | | | | | | | | | | | | | | | | | | | | | |
| B2N2U07 | 5 | | | | | | | | | | | | | | | | | | | | | |
| B2N2S08 | 6 | | | | | | | | | | | | | | | | | | | | | |
| B2N2P11 | 7 | | | | | | | | | | | | | | | | | | | | | |
| 15 | If not: | Change B2N2. | | | | | | | | | | | | | | | | | | | | |
| 16 | <p>Check the following two pairs of pins.</p> <p>B2M2U06 +Service In B2M2B12 +Service Out and B2M2U07 +Data In B2M2U13 -Data Out.</p> <p>Does the scope sync occur only during the time that both pins in either pair are active?</p> | Go to Seq 18. | | | | | | | | | | | | | | | | | | | | |
| 17 | If not: | Change B2M2. | | | | | | | | | | | | | | | | | | | | |
| 18 | Are -Stat Bit 0 Tape Op To ALU1 (B2M2S07) and -CTI Bit 7 Op In (B2M2U11) both minus during the entire time that +Bus Parity OK (B2M2M12) is minus? | Go to Seq 20. | | | | | | | | | | | | | | | | | | | | |
| 19 | If not: | Change B2M2. | | | | | | | | | | | | | | | | | | | | |
| 20 | Is tape control operating on channel B? | Go to Seq 23. | | | | | | | | | | | | | | | | | | | | |
| 21 | Do the pins listed in Seq 10 have even parity during sync? | Check interface cables, channel to tape control and I/O connector to B2 Board for proper seating. If this does not correct error, use ALD FC061 to trace bits to tape control interface. | | | | | | | | | | | | | | | | | | | | |
| 22 | If not: | Change B2M2. | | | | | | | | | | | | | | | | | | | | |
| 23 | Do the pins listed in Seq 14 have even parity during sync? | Check interface cables, channel to tape control and I/O connector to B2 Board for proper seating. If this does not correct error, use ALD XM055 to trace bits to tape control interface. | | | | | | | | | | | | | | | | | | | | |
| 24 | If not: | Change B2N2. | | | | | | | | | | | | | | | | | | | | |
| 25 | Sync scope negative on -Command Out A B CE (B2M2U02). Is B2D2M02 minus at anytime during sync? | Go to Seq 28. | | | | | | | | | | | | | | | | | | | | |
| 26 | Sync scope negative on -Service Response (B2L2U05). Does B2D2M02 go minus during sync pulses? | Go to Seq 37. | | | | | | | | | | | | | | | | | | | | |
| 27 | If not: | Change B2D2. | | | | | | | | | | | | | | | | | | | | |

| Seq | Condition/Instruction | Action | | | | | | | | | | | | | | | | | | | | |
|---------|---|--|-------|---------|---|---------|---|---------|---|---------|---|---------|---|---------|---|---------|---|---------|---|---------|---|--|
| 28 | Does +Bus Out Parity Odd (B2L2M10) go minus during sync? | Go to Seq 30. | | | | | | | | | | | | | | | | | | | | |
| 29 | If not: | Change B2L2. | | | | | | | | | | | | | | | | | | | | |
| 30 | Is tape control operating on interface B? | Go to Seq 35. | | | | | | | | | | | | | | | | | | | | |
| 31 | Is +Bus Out Parity Odd Chan A (B2M2G12) minus during sync? | Go to Seq 33. | | | | | | | | | | | | | | | | | | | | |
| 32 | If not: | Change B2M2. | | | | | | | | | | | | | | | | | | | | |
| 33 | <p>Do the following pins have even parity during sync?</p> <p>+If Bus Out x Chan A</p> <table border="1"> <thead> <tr> <th>Pin</th> <th>Track</th> </tr> </thead> <tbody> <tr><td>B2L2S12</td><td>P</td></tr> <tr><td>B2L2M13</td><td>0</td></tr> <tr><td>B2L2M05</td><td>1</td></tr> <tr><td>B2L2S04</td><td>2</td></tr> <tr><td>B2L2M09</td><td>3</td></tr> <tr><td>B2L2D12</td><td>4</td></tr> <tr><td>B2L2U04</td><td>5</td></tr> <tr><td>B2L2G03</td><td>6</td></tr> <tr><td>B2L2S10</td><td>7</td></tr> </tbody> </table> | Pin | Track | B2L2S12 | P | B2L2M13 | 0 | B2L2M05 | 1 | B2L2S04 | 2 | B2L2M09 | 3 | B2L2D12 | 4 | B2L2U04 | 5 | B2L2G03 | 6 | B2L2S10 | 7 | Check interface cables, channel to tape control and I/O connector to B2 Board for proper seating. If this does not correct error, compare bits to command issued to locate failing bit or bits. These are plus active interface levels. Trace bits to tape control interface by using ALD FC061. |
| Pin | Track | | | | | | | | | | | | | | | | | | | | | |
| B2L2S12 | P | | | | | | | | | | | | | | | | | | | | | |
| B2L2M13 | 0 | | | | | | | | | | | | | | | | | | | | | |
| B2L2M05 | 1 | | | | | | | | | | | | | | | | | | | | | |
| B2L2S04 | 2 | | | | | | | | | | | | | | | | | | | | | |
| B2L2M09 | 3 | | | | | | | | | | | | | | | | | | | | | |
| B2L2D12 | 4 | | | | | | | | | | | | | | | | | | | | | |
| B2L2U04 | 5 | | | | | | | | | | | | | | | | | | | | | |
| B2L2G03 | 6 | | | | | | | | | | | | | | | | | | | | | |
| B2L2S10 | 7 | | | | | | | | | | | | | | | | | | | | | |
| 34 | If not: | Change B2L2. | | | | | | | | | | | | | | | | | | | | |
| 35 | Is +Bus Out Parity Odd Chan B (B2M2J12) minus during sync? | Go to Seq 14. | | | | | | | | | | | | | | | | | | | | |
| 36 | If not: | Change B2M2. | | | | | | | | | | | | | | | | | | | | |
| 37 | <p>Check the following two pairs of pins.</p> <p>B2L2U06 +Service In B2L2B12 +Service Out and B2L2U07 +Data In B2L2U13 -Data Out.</p> <p>Does the scope sync occur only during the time that either pair of pins are active?</p> | Go to Seq 39. | | | | | | | | | | | | | | | | | | | | |
| 38 | If not: | Change B2L2. | | | | | | | | | | | | | | | | | | | | |
| 39 | Are -Stat Bit 0 Tape Op To ALU1 (B2L2S07) and -CTI Bit 7 Op In (B2L2U11) active the entire time that +Bus Parity OK (B2L2M12) is minus? | Go to Seq 41. | | | | | | | | | | | | | | | | | | | | |
| 40 | If not: | Change B2L2. | | | | | | | | | | | | | | | | | | | | |
| 41 | Is tape control operating on interface B? | Go to Seq 23. | | | | | | | | | | | | | | | | | | | | |
| 42 | Do the pins listed in Seq 33 have even parity during sync? | Check interface cables, channel to tape control and I/O connector to B2 Board for proper seating. If this does not correct error, use ALD FC061 to trace bits to tape control interface. | | | | | | | | | | | | | | | | | | | | |
| 43 | If not: | Change B2L2. | | | | | | | | | | | | | | | | | | | | |

3803-2/3420

| | | | | | | | | |
|--------|---------|----------------|--------|----------|--|--|--|--|
| XE3700 | 2735888 | See EC History | 845958 | 1 Sep 79 | | | | |
|--------|---------|----------------|--------|----------|--|--|--|--|

15-030

| | | |
|--|--|---------------|
| From: 14-000 | | |
| Overrun (Sense Byte 0, Bit 5) Overrun is set when the tape control requests Service and finds either Service In or Service Out line active. If data check is on, overrun is suppressed. Overrun is set during a: 1. Write operation if Stop has not occurred, and at a media group boundary sample there are insufficient bytes in the channel buffer to generate a GCR group. 2. Read operation if Stop has not occurred, and at the time the error-correcting circuits are ready to output a GCR group and there is not room in the channel buffer to accept it. Overrun can occur only during a read, read backward, or write operation. Setting the overrun indicator stops data transfer. | | |
| Most Probable Cause: The following is a list of cards that can cause the problems covered in this procedure. The cards are listed with the highest probability first. Lines with multiple cards have the same probability. A. A1C2 B. A1F2 C. A1E2, A1G2, A1K2, B2L2, (without EC733814) B2M2, (with EC733814) Y1C2 D. A2Q2, A2T2, Y1H2, Y1J2 Additional Card Referenced: Y1C2 | | |
| Always start with Seq 1 and follow the procedure in sequence unless directed otherwise. Remember to END all problems or maintenance calls by going to MAP 00-030. | | |
| Seq | Condition/Instruction | Action |
| 1 | Do an LWR or write operation in the failing density from the CE panel or channel Use a byte count greater than 64. Does it still fail only from the channel? | Go to 18 040. |
| 2 | Sync minus on -Stat Bit 0 Tape Op To DF (A1K2U06). If no failure occurs in the WRT OP, then write a tape of 64 bytes or more and read it back. | |
| 3 | Is -Overrun (A1K2P06) always plus? | Change A1K2. |
| 4 | Is the failure a read-only failure? | Go to Seq 41. |
| 5 | Does -Write Data Ready (A1C2S04) line have 32 pulses, then pause? (See timing chart on 15-041.) | Go to Seq 11. |
| 6 | Is -Write Data Ready (A1C2S04) always plus? | Go to Seq 17. |
| 7 | Does -Write Data Ready (A1C2S04) have more than 32 pulses? | Change A1F2. |
| 8 | Is -Write Data Ready (A1C2S04) minus at beginning of record and does it stay minus? | Go to Seq 26 |
| 9 | Is +Stop To Dataflow (A1F2G11) plus when -Write Data Ready (A1C2S04) stops pulsing? | Go to Seq 31. |
| 10 | If not | Go to Seq 35. |

| Seq | Condition/Instruction | Action |
|-----|---|--|
| 11 | Is +Stop To DF (A1F2G11) plus before the error is flagged Overrun (A1F2D04)? | Change A1F2. |
| 12 | Is +Command Out or HIO (refer to timing chart on 15-041 for test points) plus before -Overrun (A1F2D04) is flagged? | With EC733814, change B2M2. Without EC733814, change B2L2. |
| 13 | Is +CE Command Out Tag (see timing chart on 15-041 for test points) plus before -Overrun (A1F2D04) is flagged if running from CE panel? Or, is +Command Out Channel A Gated (see timing chart on 15-041 for test points) or +Command Out Channel B Gated (see timing chart on 15-041 for test point) plus before -Overrun if running from Channel A or B? | With EC733814, change B2L2. Without EC733814, change B2M2. |
| 14 | Write 31 bytes. | |
| 15 | Is +Stop To Dataflow (A1F2G11) plus when -Write Data Ready (A1C2S04) has 31 pulses? | Change A1F2. |
| 16 | If not: | Follow Command Out line back to failing point. For CE operation go to PK081FJ6. For Channel A operation, go to FC021FE2. For Channel B operation, go to XM071FE2. |
| 17 | Is -Wrt And Tape Op Not Ctl (A1C2P12) always plus? | Go to Seq 24. |
| 18 | Is -Read And Tape Op (A1C2J10) always minus? | Go to BW231 and follow back to failing point. |
| 19 | Is +Buffer Wrt Cycle (A1F2G02) always plus? | Change A1F2. |
| 20 | Is -Service Response (A1C2M07) always plus? | Go to Seq 22. |
| 21 | If not: | Change A1C2. |
| 22 | Are -Service In For Data (refer to timing chart on 15-041 for test points) and +Service Out and +Service Out Channel A, B, CE (refer to timing chart on 15-041 for test points) ever active at the same time? | With EC733814, change B2M2. Without EC733814, change B2L2. |
| 23 | If not: | Follow +Service Out Channel A, B, CE (FC151CF6) and +Service In For Data (BS041FF6) to determine which is bad. |
| 24 | Is -Stat Bit 2 To DF (A1K2U09) always plus? | Go to ALD AB141EF6 and follow back to failing point. |
| 25 | If not: | Change A1K2. |
| 26 | Does +Buffer Write Cycle Or Req (A1C2P07) ever become plus? | Change A1C2. |

| Seq | Condition/Instruction | Action |
|-----|---|---|
| 27 | Is -50-100 Clock (A1F2G04) at a solid level? | Change A1C2. |
| 28 | Is -25-75 Clock (A1F2S03) at a solid level? | Change A1C2. |
| 29 | Is -0-50 Clock (A1F4S04) at a solid level? | Change A1C2. |
| 30 | If not: | Change A1F2. |
| 31 | Is -Overrun (A1F2D04) minus before +Stop To Dataflow (A1C2B02) becomes plus? | Change A1F2. |
| 32 | Does +Command Out or HIO (see timing chart on 15-041 for test points) become plus when +Stop To Data Flow (A1C2B02) becomes plus? | Go to ALD FC151EN4 and follow back to failing point. |
| 33 | Does -CT1 Bit 7 Op In (see timing chart on 15-041 for test points) become minus when +Stop To Data Flow (A1C2B02) becomes plus? | Go to FC161GM6 and follow back to failing point. |
| 34 | If not: | With EC733814, change B2M2. Without EC733814, change B2L2. |
| 35 | Does -Write Data Ready (A1C2S04) have more than one pulse? | Go to Seq 39. |
| 36 | Does +Buffer Write Cycle Or Reg (A1C2P07) fail to pulse or have more than one pulse? | Change A1F2. |
| 37 | Does +Write Service In (A1C2P06) ever pulse? | Change A1F2. |
| 38 | If not: | Change A1G2. |
| 39 | Is -Write Group Buffer Empty (A1G2S10) minus? | Change A1F2. |
| 40 | If not: | Change A1G2. |
| 41 | Does -P or C Compare (A1K2B13) ever become minus? | Go to 17-010. |
| 42 | Is +Combined Resid 32 Cmpr (A1F2D02) minus? | Change in order: 1. Y1H2 2. Y1C2 |
| 43 | Is -Reg CB Write Cyc Dot (A1F2D03) plus? | Go to Seq 46. |
| 44 | Is +NRZI Wrt Reg (Y1J2S10) ever plus? | Change Y1C2. |
| 45 | If not: | Change in order: 1. Y1J2 2. A1E2 |
| 46 | Is the -Read Byte Buffer Empty (A1F2M10) minus? | Change A1F2. |
| 47 | If not: | Change A1C2. |

3803-2/3420

| | | | | | | | |
|-----------------------------|-------------------------------|-----------------------|---------------------------|--|--|--|--|
| XE3700 Seq 2 of 2 | 2735888 Part Number | See EC History | 845958 1 Sep 79 | | | | |
|-----------------------------|-------------------------------|-----------------------|---------------------------|--|--|--|--|

Copyright International Business Machines Corporation 1976-1979

TIMING CHART FOR OVERRUN

15-041

Overrun 6250 bpi

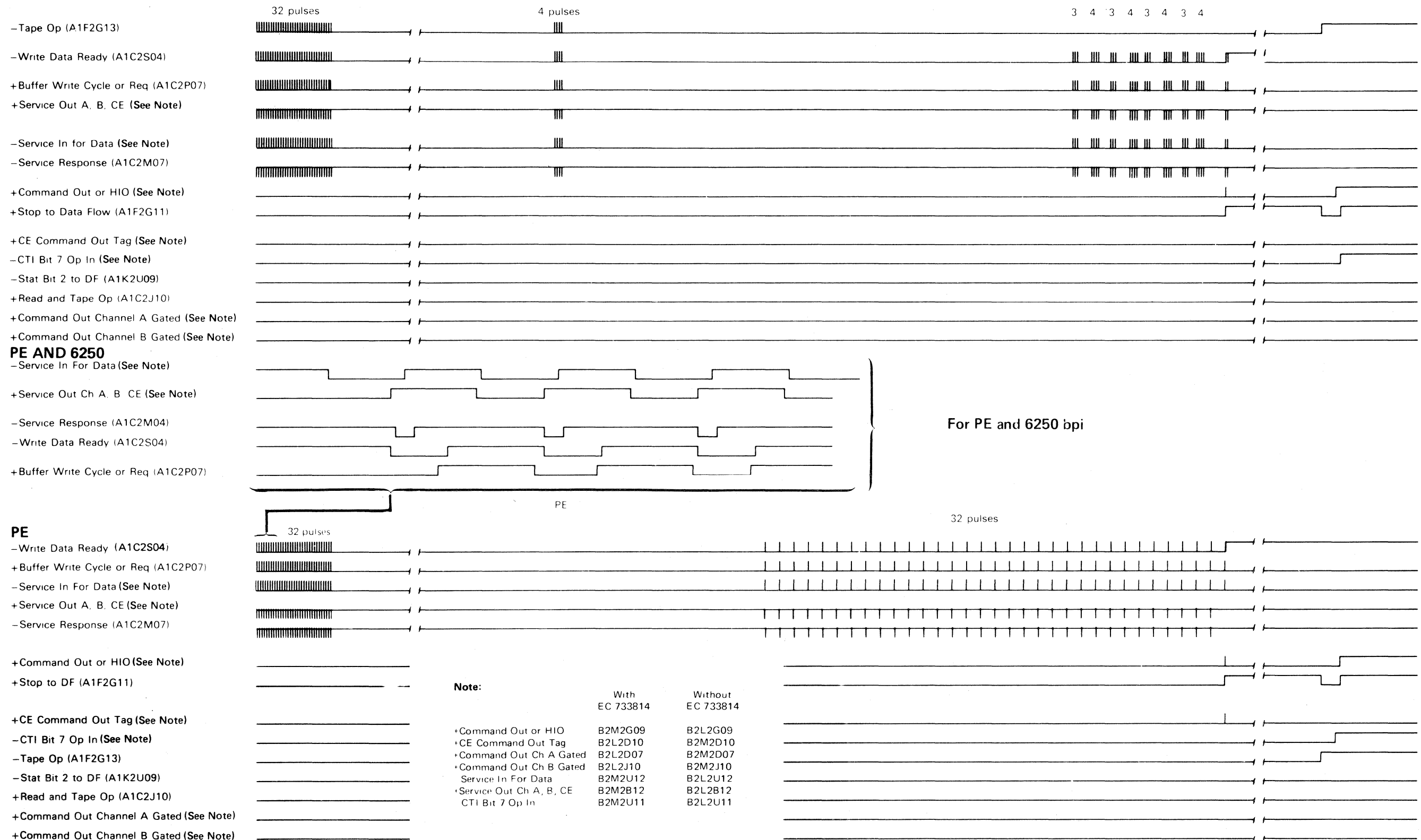

3803-2/3420

| | | | | | | | | | |
|-----------------------------|-------------------------------|-----------------------|---------------------------|--|--|--|--|--|--|
| XE3800 Seq 1 of 2 | 2735889 Part Number | See EC History | 845958 1 Sep 79 | | | | | | |
|-----------------------------|-------------------------------|-----------------------|---------------------------|--|--|--|--|--|--|

15-041

Overrun can occur with three possible conditions.

1. Channel buffer full on a Read operation. Data is not removed from the channel buffer fast enough.
2. Write buffer is empty. There are six or fewer bytes left in the channel buffer. Data is removed from the channel buffer too fast.
3. On a Read operation, if there is a P Compare or a CRC Error.

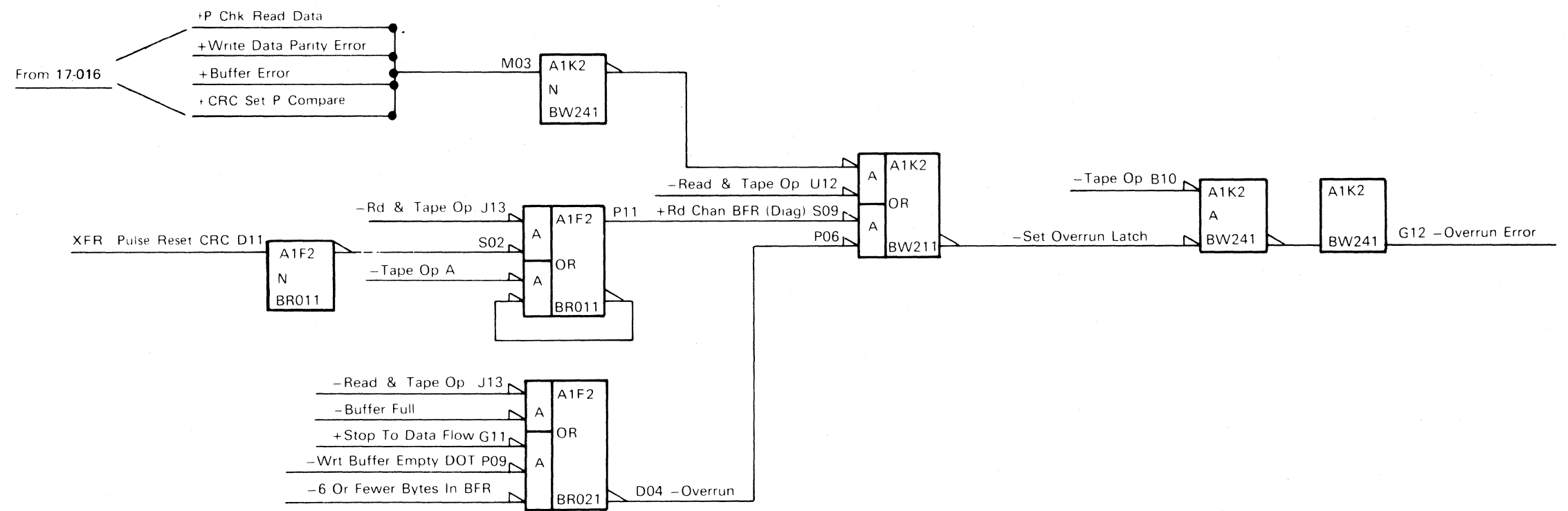

3803-2/3420

| | | | | | | | | |
|------------|-------------|---------|----------|--|--|--|--|--|
| XE3800 | 2735889 | See EC | 845958 | | | | | |
| Seq 2 of 2 | Part Number | History | 1 Sep 79 | | | | | |

Copyright International Business Machines Corporation 1976, 1979

WORD COUNT ZERO

15-050

| | | |
|---|---|---|
| From: 14-000 | | |
| ERROR DESCRIPTION: Sense Byte 0, Bit 6 is set when: The channel responds to first Service In with Command Out on a write operation. The channel issues a HIO (Address Out active with Select Out inactive) immediately following initial Status In on either a read or write operation. | | |
| Most Probable Cause: This is a channel-forced failure. A. B2Q2. See Caution. B. B2P2. See Caution. Caution: Removing this card may cause channel errors, even with power off. Put the CPU in Single Cycle mode before removing this card. | | |
| Always start with Seq 1 and follow the procedure in sequence unless directed otherwise. Remember to END all problems or maintenance calls by going to MAP 00-030. Look up ROS STOP or COMPARE VALUE in the MPL listing for the specified ALU. | | |
| Seq | Condition/Instruction | Action |
| 1 | Look up ROS STOP or COMPARE VALUE in the MPL listing for the specified ALU. Set the address value for HIOPERG in Compare register with CE panel enabled. Select ALU1, and set ROS Mode switch to Norm with the Interface switch enabled. See 12-010, Seq 4. | |
| 2 | Does Compare Equal indicator lamp come on when failing job is run? | Channel is issuing an HIO command-interrogate channel program. |
| 3 | Sync on first Service In (A2R2B11) and look for Command Out tag at time of sync. | |
| | Is Command Out active at Sync time? For channel A, scope B2Q2D09. | |
| | For channel B, scope B2P2J03. | The channel is doing a write operation with CCW word count = 0, or the channel is issuing a false Command Out. (Suspect the channel.) |
| 4 | Is Command Out Tag "hot" all the time? | Channel A, change B2Q2. See Caution. Channel B, change B2P2. See Caution. |
| 5 | If not: | Determine failing operation and go to CPU channel MAPs if available. |

3803-2/3420

| | | | | | | | |
|-----------------------------|-------------------------------|-----------------------|---------------------------|--|--|--|--|
| XE3900 Seq 1 of 2 | 2735890 Part Number | See EC History | 845958 1 Sep 79 | | | | |
|-----------------------------|-------------------------------|-----------------------|---------------------------|--|--|--|--|

15-050

| From: 14-000 and 00-040 | | |
|---|---|----------------|
| ERROR DESCRIPTION: Sense Byte 1, Bit 7 is set: 1. When a 3803/3420 subsystem without NRZI capability attempts to read a NRZI tape (one that was written without a PE or 6250 bpi identification burst at load point). 2. When an attempt is made to read or write on a 7-track tape unit, and the tape control does not have the 7-track NRZI feature. 3. When an attempt is made to read or write NRZI on a 9-track tape unit, and the tape control does not have the 9-track NRZI feature. 4. When an attempt is made to read or write PE on a tape unit that does not have the PE capability. 5. When an attempt is made to read or write 6250 bpi on a tape unit that does not have the 6250 bpi capability. | | |
| Most Probable Cause: The following is a list of cards that can cause the problems covered in this procedure. The cards are listed with the highest probability first. Cards on the same line have the same probability. A. Models 3, 5, and 7: Check high-speed rewind plunger for free movement. Models 4, 6, and 8: Check Autocleaner. See 08-380. B. A1K2 C. T-A1L2, A2Q2 D. Dirty or defective read/write head. | | |
| Additional Cards Referenced: A. A2T2 E. Y1R2 I. A2Y2 B. A2K2 F. Y1P2 J. Y1Q2 C. A2L2 G. A2D2 K. A1L2 D. Y1T2 H. A2M2 | | |
| Always start with Seq 1 and follow the procedure in sequence unless directed otherwise. Remember to END all problems or maintenance calls by going to MAP 00-030. | | |
| Seq | Condition/Instruction | Action |
| 1 | Make sure that the tape control, the tape unit, and the tape to be read are compatible (features and density). Also be sure that another path has not set the tape unit to a density which requires a tape control feature that is not present on the failing tape control. See chart on 15-063 for Not Capable Conditions. | |
| 2 | Make sure the tape control is offline before performing the steps in this procedure. (See 12-000 for instructions.) | |
| 3 | Does failure occur while attempting a read-type operation on a 6250 bpi tape? | Go to Seq 137 |
| 4 | Does failure occur while attempting a read-type operation on a 7- or 9-track NRZI tape? | Go to Seq 116. |
| 5 | Does failure occur while attempting a read-type operation on a 1600 bpi PE tape? | Go to Seq 89. |
| 6 | Does failure occur while attempting a 6250 bpi write-type operation? (No Mode Set is required to write 6250 bpi.) | Go to Seq 77. |

| Seq | Condition/Instruction | Action |
|-----|---|---|
| 7 | Does failure occur while attempting a write-type operation in 7- or 9-track NRZI mode? | Go to Seq 20. |
| 8 | Failure must occur while attempting a write-type operation in 1600 bpi (PE) mode. Make sure the failing tape unit is a Model 4, 6, or 8 with dual density feature or a 9-track Model 3, 5, or 7. | |
| 9 | 1. Enter the failing command sequence in the CE panel. 2. Look up the label "STEP0033" in the ROS2 cross-reference (in back of microprogram listing) and enter ROS address that appears under the VALUE heading in the Compare Register. 3. Set the Mple/Single switch to Single. 4. Reset the tape control, then operate the Stop/Start switch once for command preceding the failing write- or read-type operation. 5. Set ALU1/ALU2 switch to ALU2. 6. Set Display Select switch to IC. 7. Make sure Stop On Control Check switch is down (Off). 8. Set ROS Mode switch to Stop. 9. Operate the Set ROS Mode switch. 10. Operate the Start switch to start the write-type operation. 11. The tape control should stop at the ROS address that was in the Compare Register. If so, set the Display Select switch to Bus In. The bits displayed are Device Bus In positions 0-7. | |
| 10 | Is Device Bus In Indicator 3 On? | Go to Seq 12. |
| 11 | If not: | Change in order: 1. A2T2 2. A2K2 3. A2L2 Cards A2K2 and A2L2 are can be exchanged with cards B2F2 and B2E2 in ALU1. |
| 12 | Bit 3 On indicates the tape unit is set to a density other than 1600 bpi (PE). A check will be made to determine if the bit was generated in the device switch logic. | |

| Seq | Condition/Instruction | Action |
|-----|--|---|
| 13 | Is -Bus In 3 (T-A1L2D06) minus at this time in the tape unit? | At this time, the tape control is requesting TU Sense Byte 1. All tags (Move, Command, and Control) should be inactive and Bus Out 6 should be the only active Bus Out bit. Bus In 3 active tells the tape control the tape unit is not set to 1600 bpi. Go to ALD WK001 GK5 and follow line back to failing point. |
| 14 | Is the failing tape control a 1x8? | Change A2D2. |
| 15 | Is the tape unit you are using attached directly to the failing tape control? | Go to Seq 18. |
| 16 | Is -Device Bus In 3 Primary (A2D2G13) minus? (Voltage level is +4.5 V to ground.) | Go to 18-010. Device Bus In 3 Primary should not be minus. Go to 18-010. |
| 17 | If not: | Change A2D2. |
| 18 | Is -Device Bus In 3 Secondary (A2D2M12) minus? (Voltage level is +4.5V to ground.) | Device Bus In 3 Secondary should not be minus. Go to 18-010. |
| 19 | If not: | Change A2D2. |
| 20 | Does the failure occur while attempting a write-type operation in 7-track NRZI Mode? | Go to Seq 63. |
| 21 | Failure must occur while attempting a write-type operation in 9-track NRZI Mode. Make sure that the failing tape unit is a Model 3, 5, or 7 with dual density feature and the tape control has the 9-Track NRZI feature. | |
| 22 | Perform Seq 9, then return to Seq 23. | |
| 23 | Is Device Bus In Indicator Bit 0 On? | Go to Seq 53. |
| 24 | Is Device Bus In Indicator Bit 4 On? | Go to Seq 45. |
| 25 | Is Device Bus In Indicator Bit 2 On? | Go to Seq 35. |
| 26 | Bit 2 Off indicates the tape unit does not have NRZI feature. A check will be made to determine if the bit was lost in the device switch logic. | |
| 27 | Is -Bus In 2 (T-A1L2D05) minus in the tape unit? (Voltage level is +4.5 V to ground.) | Go to Seq 29. |
| 28 | If not: | At this time, the tape control is requesting TU Sense Byte 1. All tags (Move, Command, and Control) should be inactive and BUS OUT 6 should be the only active Bus Out bit. Bus In 2 tells the tape control the tape unit has the dual density feature. Go to ALD WK001 GK4 and follow line back to failing point. |
| 29 | Is the failing tape control a 1x8? | Change A2D2. |

3803-2/3420

| | | | | | | | | | |
|-----------------------------|-------------------------------|-----------------------|---------------------------|--|--|--|--|--|--|
| XE3900 Seq 2 of 2 | 2735890 Part Number | See EC History | 845958 1 Sep 79 | | | | | | |
|-----------------------------|-------------------------------|-----------------------|---------------------------|--|--|--|--|--|--|

| Seq | Condition/Instruction | Action |
|-----|--|---|
| 30 | Is the tape unit you are using attached directly to the failing tape control? | Go to Seq 33. |
| 31 | Is -Device Bus In 2 Primary (A2D2J06) minus? (Voltage level is +4.5 V to ground.) | Change A2D2. |
| 32 | If not: | Device Bus In 2 Primary should be minus. Go to 18-010. |
| 33 | Is -Device Bus In 2 Secondary (A2D2P10) minus? (Voltage level is +4.5 V to ground.) | Change A2D2. |
| 34 | If not: | Device Bus In 2 Secondary should be minus. Go to 18-010. |
| 35 | Does the failure (Not Capable) occur at load point? | Go to Seq 38. |
| 36 | Failure must be occurring only if tape unit is set to NRZI before command is started. Check feature jumper on tape control A2M2. See 90-120. Was jumper plugged correctly? | Change A2M2. |
| 37 | If not: | Correct jumper plugging. |
| 38 | Is -Bus In 3 (T-A1L2D06) minus in the tape unit? (Voltage level is +4.5 V to ground.) | At this time, the tape control is requesting TU Sense Byte 1. All tags (Move, Command, and Control) should be inactive and Bus Out 6 should be the only active Bus Out bit. Bus In 3 tells the tape control the tape unit is set to other than 1600 bpi. Go to ALD WK001 GK5 and follow line back to failing point. |
| 39 | Is the failing tape control a 1x8? | Change A2D2. |
| 40 | Is the tape unit you are using attached directly to the failing tape control? | Go to Seq 43. |
| 41 | Is -Device Bus In 3 Primary (A2D2G13) minus? (Voltage level is +4.5 V to ground.) | Bus In 3 Primary should not be active at load point. Go to 18-010. |
| 42 | If not: | Change A2D2. |
| 43 | Is -Device Bus In 3 Secondary (A2D2M12) minus? (Voltage level is +4.5 V to ground.) | Device Bus In 3 Secondary should not be active at load point. Go to 18-010. |
| 44 | If not: | Change A2D2. |
| 45 | Bit 4 On indicates the tape unit is a 6250 bpi unit. A check will be made to determine if the bit was generated in the device switch logic. | |

| Seq | Condition/Instruction | Action |
|-----|---|---|
| 46 | Is -Bus In 4 (T-A1L2D07) minus in the tape unit? (Voltage level is +4.5 V to ground.) | At this time, the tape control is requesting TU Sense Bit 1. All tags (Move, Command, and Control) should be inactive and Bus Out 6 should be the only active Bus Out bit. Bus In 4 tells the tape control the tape unit is a 6250 bpi unit, which cannot have a NRZI feature. Go to ALD WK001 GK6 and follow line back to failing point. |
| 47 | Is the failing tape control a 1x8? | Change A2D2. |
| 48 | Is the tape unit you are using attached directly to the failing tape control? | Go to Seq 51. |
| 49 | Is -Device Bus In 4 Primary (A2D2G08) minus? (Voltage level is +4.5 V to ground.) | Device Bus In 4 Primary should not be active. Go to 18-010. |
| 50 | If not: | Change A2D2. |
| 51 | Is -Device Bus In 4 Secondary (A2D2D04) minus? (Voltage level is +4.5 V to ground.) | Device Bus In 4 Secondary should not be active. Go to 18-010. |
| 52 | If not: | Change A2D2. |
| 53 | This condition sets Not Capable if the tape control does not have the 7-track feature. Bit 0 should not be On when operating a 9-track tape unit. | |
| 54 | Is A2M2P03 a minus level (-3.5 V to -4.0 V)? | If this tape control has the 7-track feature, check jumper list on ALD AA 131 for proper jumpering. Then go to Seq 56. |
| 55 | If not: | Change A2M2. |
| 56 | Is -Bus In 0 (T-A1L2D02) minus in the tape unit? (Voltage level is +4.5 V to ground.) | At this time the tape control is requesting TU Sense Byte 1. All tags (Move, Command, and Control) should be inactive and Bus Out 6 should be the only active Bus Out bit. Bus In 0 tells the tape control the tape unit is a 7-track model. Go to WK001 GK2 and follow line back to failing point. |
| 57 | Is the failing tape control a 1x8? | Change A2D2. |
| 58 | Is the tape unit you are using attached directly to the failing tape control? | Go to Seq 61. |
| 59 | Is -Device Bus In 0 Primary (A2D2M05) minus? (Voltage level is +4.5 V to ground.) | Device Bus In 0 Primary should not be active. Go to 18-010. |
| 60 | If not: | Change A2D2. |
| 61 | Is -Device Bus In 0 Secondary (A2D2P05) minus? (Voltage level is +4.5 V to ground.) | Device Bus In 0 Secondary should not be active. Go to 18-010. |

| Seq | Condition/Instruction | Action |
|-----|---|---|
| 62 | If not: | Change A2D2. |
| 63 | To perform a 7-track operation, you must be using a Model 3, 5, or 7, seven track tape unit and have both 9-track NRZI and 7-track NRZI features on the tape control. | |
| 64 | Perform Seq 9, then return to Seq 65. | |
| 65 | Is Device Bus In Indicator Bit 4 On? | Go to Seq 45. |
| 66 | Is Device Bus In Indicator Bit 0 Off? | Go to Seq 69. |
| 67 | Is A2M2P03 a plus level (ground)? | Change A2M2. |
| 68 | If not: | Check jumper list on ALD AA005 for proper jumpering. |
| 69 | Is -Bus In 0 (T-A1L2D02) minus in the tape unit? (Voltage level is +4.5 V to ground.) | Go to Seq 71. |
| 70 | If not: | At this time the tape control is requesting TU Sense Byte 1. All tags (Move, Command, and Control) should be inactive and Bus Out 6 should be the only active Bus Out Bit. Bus In 0 tells the tape control the tape unit is a 7-track model. Go to ALD WK001 GK2 and follow line back to failing point. |
| 71 | Is the failing tape control a 1x8? | Change A2D2. |
| 72 | Is the tape unit you are using attached directly to the failing tape control? | Go to Seq 75. |
| 73 | Is -Device Bus In 0 Primary (A2D2M05) minus? (Voltage level is +4.5 V to ground.) | Change A2D2. |
| 74 | If not: | Device Bus In 0 Primary should be active. Go to 18-010. |
| 75 | Is -Device Bus In 0 Secondary (A2D2P05) minus? (Voltage level is +4.5 V to ground.) | Change A2D2. |
| 76 | If not: | Device Bus In 0 Secondary should be minus. Go to 18-010. |
| 77 | 6250 bpi is the basic frequency for the 3803 Model 2 tape control. A Model 4, 6, or 8 tape unit is required. | |
| 78 | Perform Seq 9, then return to Seq 79. | |
| 79 | Is Device Bus In Indicator 4 On? | Change in order: 1. A2Y2 2. A2K2 3. A2L2 Cards A2K2 and A2L2 are interchangeable with cards B2F2 and B2E2 in ALU1. |

| Seq | Condition/Instruction | Action |
|-----|--|---|
| 80 | Bit 4 Off indicates tape unit is not a Model 4, 6 or 8. A check will be made to determine if the bit was lost in the device switch logic. | |
| 81 | Is -Bus In 4 (T-A1L2D07) minus in the tape unit? (Voltage level is +4.5 V to ground.) | Go to Seq 83. |
| 82 | If not: | At this time the tape control is requesting TU Sense Byte 1. All tags (Move, Command, and Control) should be inactive and Bus Out 6 should be the only active Bus Out bit. Bus In 4 tells the tape control the tape unit is a Model 4, 6 or 8. Go to ALD WK001 GK6 and follow line back to failing point. |
| 83 | Is the failing tape control a 1x8? | Change A2D2. |
| 84 | Is the tape unit you are using attached directly to the failing tape control? | Go to Seq 87. |
| 85 | Is -Device Bus In 4 Primary (A2D2G08) minus? (Voltage level is +4.5 V to ground.) | Change A2D2. |
| 86 | If not: | Device Bus In 4 Primary should be minus. Go to 18-010. |
| 87 | Is -Device Bus In 4 Secondary (A2D2D04) minus? (Voltage level is +4.5 V to ground.) | Change A2D2. |
| 88 | If not: | Device Bus In 4 Secondary should be active. Go to 18-010. |
| 89 | A PE (1600 bpi) tape can be read on a Model 4, 6 or 8 tape unit with the dual density feature and all Model 3, 5, and 7 tape units with 9-track read/write heads. | |
| 90 | 1. Check the alignment of the auto cleaner or the high-speed rewind plunger. 2. Check for contamination on the head and tape path. | |
| 91 | Perform Seq 9, then return to Seq 92. | |
| 92 | Is Device Bus In Indicator Bit 0 On? | Go to Seq 56. |
| 93 | Is Device Bus In Indicator Bit 4 On? | Go to Seq 109. |
| 94 | Set up the CE panel to perform the following command sequence: REWIND — 07 READ FORWARD — 02 REWIND — 07 READ FORWARD — 02 Start the command sequence and sync negative on -Stat Bit 0 Tape Op To DF (A1K2U06). | |

| Seq | Condition/Instruction | Action |
|-----|--|--|
| 95 | Is -XOUTA Bit 4 ALU2 To DF (A1K2D09) ever minus during the sync? | Go to Seq 112. |
| 96 | Does +P Track Env Branch (A1K2U02) become plus during the sync? | Change A2D2. |
| 97 | Does -Time Sense P (A1K2S11) become minus during the sync? | Go to Seq 107. |
| 98 | Does -Device Bus In P To DF (Y1T2S04) pulse while the sync is minus? | Change in order: 1. Y1T2 2. Y1Q2 |
| 99 | Does -Bus In P (T-A1L2D12) pulse at the tape unit while the sync is minus? If you cannot scope the tape unit while syncing at the tape control, sync on -Move Tag I/O (T-A1K6D13 for Model 4, 6, or 8 and T-A1K2D13 for Model 3, 5, or 7) at the tape unit. (Voltage levels are +4.5 V to ground.) | Go to Seq 101. |
| 100 | If not: | Tape unit should be reading P Burst on tape. Follow ALD WK001 GK1 back to failing point. |
| 101 | Is the failing tape control a 1x8? | Change A2D2. |
| 102 | Is the tape unit you are using attached directly to the failing tape control? | Go to Seq 105. |
| 103 | Does -Device Bus In P Primary (A2D2S07) pulse while the sync is minus? (Voltage level is +4.5 V to ground.) | Change A2D2. |
| 104 | If not: | Go to 18-010. |
| 105 | Does -Device Bus In P Secondary (A2D2M03) pulse while the sync is min (Voltage level is +4.5 V to ground.) | Change A2D2. |
| 106 | If not: | Go to 18-010. |
| 107 | Does +Block Or Env Loss Branch (A1K2U10) stay plus while the sync is minus? | Change Y1P2. |
| 108 | If not: | Change A1K2. |
| 109 | Is this a Model 3, 5, or 7 tape unit? | Go to Seq 45. |
| 110 | Is Device Bus In Indicator Bit 2 On? | Go to Seq 94. |
| 111 | If not: | Go to Seq 27. |
| 112 | Is +1 Track Env Branch (A2K2P13) plus before -XOUTA Bit 4 ALU2 To DF (A1K2D09) becomes minus during sync time? | Go to Seq 114. |

| Seq | Condition/Instruction | Action |
|-----|--|---|
| 113 | If not: | Change A2D2. |
| 114 | Is -Time Sense 1 (A1K2U13) minus before -XOUTA Bit 4 ALU2 To DF (A1K2D09) becomes minus during sync time? | Change Y1R2. |
| 115 | If not: | Change in order: 1. A1K2 2. A1L2 (tape units with 7-Track feature). |
| 116 | Does the failure occur while attempting a read-type operation on a 7-Track NRZI tape? | Go to Seq 131. |
| 117 | A 9-Track NRZI tape can only be read on a Model 3, 5, or 7 tape unit with the dual density feature. The tape control must have either the 9-Track NRZI feature or the 7- and 9-Track NRZI feature. | |
| 118 | Perform Seq 9, then return to Seq 119. | |
| 119 | Is Device Bus In Indicator Bit 0 On? | Go to Seq 56. |
| 120 | Is Device Bus In Indicator Bit 4 On? | Go to Seq 45. |
| 121 | Is Device Bus In Indicator Bit 2 On? | Go to Seq 123. |
| 122 | If not: | Go to Seq 26. |
| 123 | Set up the CE panel to perform the following command sequence: REWIND — 07 READ FORWARD — 02 REWIND — 07 READ FORWARD — 02 Start the command sequence and sync negative on -Stat Bit 0 Tape Op To DF (A2K2U06). | |
| 124 | Does + 7 Track Env Branch (A1K2P13) become plus during the sync? | Go to Seq 129. |
| 125 | Does +P Track Env Branch (A1K2U02) become plus during the sync? | Go to Seq 127. |
| 126 | If not: | Change in order: 1. A2D2 2. A2M2 |
| 127 | Does -Time Sense P (A1K2S11) become minus during the sync? | Change Y1T2. |
| 128 | If not: | Change A1K2. |
| 129 | Does -Time Sense 1 (A1K2U13) become minus during the sync? | Change Y1R2. |

3803-2/3420

| | | | | | | | |
|----------------------|------------------------|-------------------|--------------------|--|--|--|--|
| XE4000 Seq 2 of 2 | 2735891 Part Number | See EC History | 845958 1 Sep 79 | | | | |
|----------------------|------------------------|-------------------|--------------------|--|--|--|--|

| Seq | Condition/Instruction | Action |
|-----|--|--|
| 130 | If not: | Change A1K2. |
| 131 | A 7-Track NRZI tape can only be read on a 7-Track Model 3, 5, or 7 tape unit with the 7-Track feature. The tape control must have the 7- and 9-Track NRZI feature. | |
| 132 | Perform Seq 9, then return to Seq 133. | |
| 133 | Is Device Bus In Indicator Bit 0 On? | Go to Seq 135. |
| 134 | If not: | Go to Seq 69. |
| 135 | Is Device Bus In Indicator Bit 4 On? | Go to Seq 45. |
| 136 | If not: | Change A2M2. |
| 137 | A 6250 bpi tape can only be read on a Model 4, 6 or 8 tape unit. | |
| 138 | Is SAGC Check (Sense Byte 8, bit 4) On? | Go to 16-220. |
| 139 | 1. Check the alignment of the autocleaner. 2. Check for contamination on the read/write head and tape path. | |
| 140 | Perform Seq 9, then return to Seq 141. | |
| 141 | Is Device Bus In Indicator Bit 0 On? | Go to Seq 56. |
| 142 | Is Device Bus In Indicator Bit 4 On? | Go to Seq 144. |
| 143 | If not: | Go to Seq 80. |
| 144 | Set up the CE panel to perform the following command sequence: REWIND — 07 READ FORWARD — 02 REWIND — 07 READ FORWARD — 02 Start the command sequence and sync negative on —Stat Bit 0 Tape Op To DF (A1K2U06). | |
| 145 | Does +1 Track Env Branch (A1K2P13) become plus during the sync? | Go to Seq 156. |
| 146 | Does —Time Sense 1 (A1K2U13) become minus during the sync? | Go to Seq 107. |
| 147 | Does —Device Bus In 1 To DF (Y1R2M04) pulse while the sync is minus? | Change in order: 1. Y1R2 2. Y1Q2 |
| 148 | Does —Bus In 1 (T-A1L2D04) pulse while the sync is minus? If you cannot scope the tape unit while syncing at the tape control, sync on —Move Tag I/O (T-A1K6D13) in the tape unit. (Voltage levels are +4.5 V to ground.) | Go to Seq 150. |

| Seq | Condition/Instruction | Action |
|-----|--|--|
| 149 | If not: | A tape unit should be reading Track 1 burst on tape. Follow ALD WK001 GK3 back to failing point. |
| 150 | Is the failing tape control a 1x8? | Change A2D2. |
| 151 | Is the tape unit you are using attached directly to the failing tape control? | Go to Seq 154. |
| 152 | Does —Device Bus In 1 Primary (A2D2J09) pulse while the sync is minus? (Voltage level is +4.5 V to ground.) | Change A2D2. |
| 153 | If not: | Go to 18-010. |
| 154 | Does —Device Bus In 1 Secondary (A2D2D10) pulse while the sync is minus? (Voltage level is +4.5 V to ground.) | Change A2D2. |
| 155 | If not: | Go to 18-010. |
| 156 | Does +SAGC Burst ID (Y1P2S11) become plus during the sync? | Change A2D2. |
| 157 | Reference the time —BOR Or DT Branch Cond (Y1P2J13) falls during the sync on the scope. Are the following Time Sensors in Zones 2 and 3 minus and in Zone 1 plus? Allow 2 or 3 bit periods for Time Sensors to fall after fall of BOR Or DT Branch Cond. Zone 1 —Time Sense P Y1P2P03 —Time Sense 0 Y1P2P09 —Time Sense TK5 Y1P2D10 Zone 2 —Time Sense 2 Y1P2G13 —Time Sense 6 Y1P2M12 —Time Sense TK7 Y1P2G12 Zone 3 —Time Sense 1 Y1P2P02 —Time Sense 3 Y1P2P10 —Time Sense TK4 Y1P2S12 | Change Y1P2. |
| 158 | Are there any Time Sensors in Zone 1 minus? | Go to Seq 162. |
| 159 | Scope the following Device Bus In To DF lines using the same time reference as in Seq 157: —Device Bus In 1 To DF Y1R2S04 —Device Bus In 3 To DF Y1R2M04 —Device Bus In 4 To DF Y1R2D13 —Device Bus In 2 To DF Y1S2M04 —Device Bus In 6 To DF Y1S2S04 —Device Bus In 7 To DF Y1S2D13 Are they all pulsing? | Change Y1R2. |
| 160 | Is the problem a single tape unit problem? It may be necessary to exchange tape units to determine a single tape unit failure from a single path failure. | Go to 5A-000 for Model 3, 5, or 7. Go to 5B-000 for Model 4, 6, or 8. |

| Seq | Condition/Instruction | Action |
|-----|--|---|
| 161 | If not: | Go to 18-010. |
| 162 | Scope the following lines using the same time reference as in Seq 157: +0 Pct Ampl Ctrl Trk P Y1Q2P13 +0 Pct Ampl Ctrl Trk 0 Y1Q2P03 +0 Pct Ampl Ctrl Trk 5 Y1Q2G08 Are any plus? | Go to ALD CB131 and follow the active line back to its failing point. |
| 163 | Scope the following lines using the same time reference as in Seq 157: —Device Bus In P To DF Y1T2S04 —Device Bus In 0 To DF Y1T2M04 —Device Bus In 5 To DF Y1T2D13 Are any pulsing? | Go to Seq 160. |
| 164 | If not: | Go to 00-030. |

| | | | | | | | | |
|------------|-------------|---------|----------|--|--|--|--|--|
| XE4100 | 2735892 | See EC | 845958 | | | | | |
| Seq 1 of 2 | Part Number | History | 1 Sep 79 | | | | | |

Not Capable Conditions

X = Not Capable set on read from load point.
 * = Not Capable set if one of the following error conditions exist.
 1. SAGCID was not seen on read.
 2. No BOR with a TU Interrupt reading SAGC.
 Δ = Not Capable set if tape unit is this density (read or write)

| Tape Unit Model and Feature Attempting to Read or Write This Type of Tape | Models 4, 6, and 8 No Feature | | | | Models 4, 6, and 8 with Features | | | | X | | | |
|---|-------------------------------|-----------|------------------|------------|----------------------------------|-----------|------------------|------------|---------------------------------|-----------|------------------|------------|
| | 6250 | PE (1600) | 9-Trk NRZI (800) | 7-Trk NRZI | 6250 | PE (1600) | 9-Trk NRZI (800) | 7-Trk NRZI | | | | |
| 3803-2 (Basic) | * | X | X | X | * | | X | X | | | | |
| 3803-2 (9-Track NRZI) | * | X | X | X | * | | X | X | | | | |
| 3803-2 (7 and 9-Track NRZI) | * | X | X | X | * | | X | X | | | | |
| | Models 3, 5, and 7 No Feature | | | | Models 3, 5, and 7 with Features | | | | Models 3, 5, and 7 with 7-Track | | | |
| | 6250 | PE (1600) | 9-Trk NRZI (800) | 7-Trk NRZI | 6250 | PE (1600) | 9-Trk NRZI (800) | 7-Trk NRZI | 6250 | PE (1600) | 9-Trk NRZI (800) | 7-Trk NRZI |
| 3803-2 (Basic) | X | | X | X | X | | X Δ | X | X | X | X | X Δ |
| 3803-2 (9-Track NRZI) | X | | X | X | X | | | | | | | Δ |
| 3803-2 (7- and 9-track NRZI) | X | | X | X | X | | | | | | | |

3803-2/3420

| | | | | | | | | |
|----------------------|------------------------|-------------------|--------------------|--|--|--|--|--|
| XE4100 Seq 2 of 2 | 2735892 Part Number | See EC History | 845958 1 Sep 79 | | | | | |
|----------------------|------------------------|-------------------|--------------------|--|--|--|--|--|

DATA CONVERTER CHECK

15-070

From: 14-000

ERROR DESCRIPTION (Sense Byte 0, Bit 7):
 Data conversion is part of the 7-track NRZI feature and is used only during 7-track write and read-forward operations. The data converter is disabled during read-backward operations. A Read Backward command overrides (but does not reset) a previous Mode Set command which turned on the data converter.
 Writing a tape with data converter On causes four 6-bit tape characters to be written for every three 8-bit storage bytes. Reading such a tape reverses the process by converting four tape characters into three storage bytes. (Data conversion reduces the data transfer rate to 3/4 of the rate for 9-track NRZI operation.)
Write Operation: When data written from storage is not a multiple of three bytes, the last one or two bytes are written as follows:
 1. One 8-bit byte is converted to two 6-bit tape characters; bits 8, 4, 2, and 1 of the second character are written as zeros.
 2. Two 8-bit bytes are converted to three 6-bit tape characters; bits 2 and 1 of the third character are written as zeros.
 If the byte count is not a multiple of three, any remaining bits of the last 6-bit character are set to zero.
Read Operation: The first four 6-bit tape characters of the block are converted to 8-bit data bytes in storage. When reading tape written in the data conversion mode, the number of characters read back is the same as the number of characters written. Data Converter Check is not set.
 Data Converter Check and Unit Check are set only during a 7-track NRZI read operation.
 When the number of bytes on tape is not an even multiple of four bytes and:
 * The remainder is one byte
 * The remainder is two bytes, and bits 1, 2, 4, and 8 of the second byte are not zeros
 * The remainder is three bytes, and bits 1 and 2 are not zeros.

Most Probable Cause:
 The following is a list of cards that can cause the problems covered in this procedure. The cards are listed with the highest probability first. Lines with multiple cards have the same probability.
 A. A1L2
 B. Y1P2

Additional Cards Referenced:
 A. Y1C2
 B. A1E2

Always start with Seq 1 and follow the procedure in sequence unless directed otherwise.
Remember to END all problems or maintenance calls by going to MAP 00-030.

| Seq | Condition/Instruction | Action |
|-----|--|---|
| 1 | Run diagnostic OLT Section P. Does diagnostic fail? | Go to Seq 6. |
| 2 | Can the failing record be read using another tape control? | Go to Seq 6. |
| 3 | Was record written with data converter On? | Go to Seq 5. |
| 4 | If not: | This record should be read with data converter Off. |
| 5 | Tape damage is likely. If not, try to locate tape control and tape unit on which tape was generated and check for possible write problems. | |

| Seq | Condition/Instruction | Action |
|-----|---|--------------|
| 6 | Set up CE panel to cycle over a failing record. Use a command sequence of appropriate mode set, with data converter on 02, 0C, 04. Sync scope negative on Data Converter On (A1L2B13) and display full record. Does -EOD NRZI (A1E2J13) go negative 2-3 byte periods after last -First Bit Latch pulse? | Go to Seq 8. |
| 7 | If not: | Change Y1C2. |
| 8 | Scope -Wr Or Rd Forward (A1L2B12). Is sync negative only during the period that this line is negative? | Change A1E2. |
| 9 | If not: | Change A1L2. |

3803-2/3420

| | | | | | | | | |
|------------|-------------|----------------|----------|--|--|--|--|--|
| XE4150 | 8492596 | See EC History | 845958 | | | | | |
| Seq 1 of 2 | Part Number | | 1 Sep 79 | | | | | |

15-070

3803-2/3420

| | | | | | | | | | |
|-----------------------------|-------------------------------|---------------------------------|---------------------------|--|--|--|--|--|--|
| XE4150 Seq 2 of 2 | 8492596 Part Number | See EC History | 845958 1 Sep 79 | | | | | | |
|-----------------------------|-------------------------------|---------------------------------|---------------------------|--|--|--|--|--|--|

© Copyright International Business Machines Corporation 1976, 1979

SENSE ALL ZEROS

15-080

| From: 14-000 or OLT Section AA | | |
|--|--|---|
| The OLT diagnostics print sense data equal to all zeros for one of two reasons: | | |
| <ol style="list-style-type: none"> The Sense command was not issued before printing a standard error message format (broken chain). The sense command was not executed correctly. | | |
| All OLT routines use command chains which include a Sense command. If the command chain is broken before executing the Sense command, the operation is turned over to I/O supervisor. If unit check is on in the ending status, the I/O supervisor will issue a Sense command; otherwise, the error message will print with a blank sense field. | | |
| A few of the errors causing a blank sense field are: | | |
| <ol style="list-style-type: none"> Unit exception due to reading an unexpected tape mark Incorrect record length (byte count error). Channel check | | |
| Most Probable Cause: | | |
| The following is a list of cards that can cause the problems covered in this procedure. The cards are listed with highest probability first. Lines with multiple cards have the same probability. | | |
| <ol style="list-style-type: none"> A1C2 A2D2 A2R2 Y1P2, Y1C2 A2Q2 Y1S2 A1H2 | | |
| Note: The dc voltages are very critical. Ensure that the TCU voltages are within specifications. If the voltages will not adjust within specifications, go to 11-000. | | |
| Always start with Seq 1 and follow the procedure in sequence unless directed otherwise. | | |
| Remember to END all problems or maintenance calls by going to MAP 00-030. | | |
| Seq | Condition/Instruction | Action |
| 1 | Examine the channel status word (CSW) status bytes received by the OLT. CSW bits 32 through 39 are for device status. CSW bits 40 through 47 are for channel status. Are CSW bits 'RCVD' the same as CSW bits 'XPTD' in the error message? | Go to Seq 9. |
| 2 | Is bit 39 (unit exception) on in the CSW? | Go to Seq 12. |
| 3 | Are any bits on in CSW bit positions 40 through 47? | This is a channel error. Go to 18-020. |
| 4 | Probe +Bus In Bit 0 through 6. See Chart A on this page. Is the line for the CSW bit position a solid plus level with the tape control reset? | Change A1C2 and go to Seq 15. |
| 5 | Probe -CBI Bit 0 through 6. See Chart A on this page. Is the line for the failing CSW bit position minus? | Change A2R2 and go to Seq 15. |
| 6 | While looping the failing command, sync negative on -CTI Bit 5 Status In (A2R2U11), and probe -CBI Bits 0 through 7. See Chart A on this page. Do the CBI bits agree with the expected CSW bits at the time of the sync? | Change card shown in Chart B on this page. See Caution. |

| Seq | Condition/Instruction | Action |
|-----|--|---|
| 7 | Using the procedure in Seq 6, probe +Bus In Bits 0 through 7. Do these lines agree with the expected CSW bits at the time of the sync? | Change A2R2 and go to Seq 15. |
| 8 | If not: | Change A1C2 and go to Seq 15. |
| 9 | Probe +Bus In Bit for the CSW bit positions being received. See Chart A on this page. Are any lines a solid plus level? | Change A1C2 and go to Seq 15. |
| 10 | Probe -CBI Bits for the CSW bit positions being received. Are any lines a solid minus level? | Change A2R2 and go to Seq 15. |
| 11 | If not: | Change card shown in Chart B. |
| 12 | Probe +TM Configuration (Y1P2M02) while looping the failing command. Does this line go plus without reading a valid tape mark? | Change Y1P2, then Y1C2 and go to Seq 15. |
| 13 | Probe -CBI Bit 7 (A2R2J10) with the tape control reset. Is this line a solid plus level? | Change A2R2 and go to Seq 15. |
| 14 | If not: | Change A2D2. |
| 15 | Did changing the card correct the problem? | Return subsystem to customer. |
| 16 | If not: | Go to ALDs and follow back on the failing line. |

Chart A

| +Bus In Bits (A1C2) | | | -CBI Bits (A2R2) | | |
|---------------------|------------|--------------|------------------|------------|--------------|
| CSW Bit | Bus In Bit | Pin Location | CSW Bit | Bus In Bit | Pin Location |
| 32 | 0 | A1C2G09 | 32 | 0 | A2R2S09 |
| 33 | 1 | A1C2G12 | 33 | 1 | A2R2S07 |
| 34 | 2 | A1C2D04 | 34 | 2 | A2R2G09 |
| 35 | 3 | A1C2D06 | 35 | 3 | A2R2S05 |
| 36 | 4 | A1C2J04 | 36 | 4 | A2R2S04 |
| 37 | 5 | A1C2G07 | 37 | 5 | A2R2G11 |
| 38 | 6 | A1C2D13 | 38 | 6 | A2R2G10 |
| 39 | 7 | A1C2G02 | 39 | 7 | A2R2J10 |

Chart B

| | Channel A | Channel B | Without TCS |
|------------------|-----------|-----------|--------------------|
| With EC733814 | B2S2 | B2R2 | B2S2 (See Caution) |
| Without EC733814 | B2R2 | B2S2 | B2R2 (See Caution) |

Caution: Removing this card may cause channel errors even with power off. Put CPU in the Single Cycle mode before removing card.

3803-2/3420

| | | | | | | | | |
|---------------|----------------|-----------------------|---------------|--|--|--|--|--|
| XE4200 | 2735893 | See EC History | 845958 | | | | | |
| Seq 1 of 2 | Part Number | | 1 Sep 79 | | | | | |

15-080

| | | |
|---|---|---|
| From: 14-000, 17-410 | | |
| ERROR DESCRIPTION: Write Current Failure (Sense Byte 6, Bit 1) is set when one or more write drivers are turned on while the tape unit is in read status. Write Current Failure causes Ready to become inactive on Models 4, 6, and 8. A write head monitoring circuit checks the Write Current On line during a read operation when Go Internal is activated. If Write Current On is active, the Write Current unit check latch is turned on, and unit check is set. Sense Byte 7 bits 0, 1, 2, 5, and 6 are only valid if Sense Byte 4, bit 6 is on. Bit 0 On: The fiber optic lamp failed and Ready is inactive. Bit 1 On: Tape reached bottom in the left vacuum column and Ready is inactive. Bit 2 On: Tape reached bottom in the right vacuum column and Ready is inactive. Bit 3 On: The Reset switch or the Door Interlock switch deactivated Ready. Bit 4 On: A Data Security Erase command is in progress and Ready is active. When End of Tape (EOT) is reached, bit 4 is turned off. Bit 5 On: The erase head is open with the tape unit in write status, or current is flowing in the erase head with the tape unit in Read status. Ready is not active. Bit 6 On: Pressure at the air bearing and/or machine reel hub has dropped to a critical level. Ready is not active. Bit 7 On: The tape unit failed to load correctly. Ready is not active. | | |
| Most Probable Cause: The following is a list of cards that can cause the problems covered in this procedure. The cards are listed with the highest probability first. Lines with multiple cards have the same probability. A. A2R2, Y1Q2 B. A1H2 C. A2Q2, A2T2, Y1D2 D. A1K2, Y1M2, Y1P2 Single Tape Unit FRUs Models 3, 5, 7 T-A1E2, T-A1H2 T-A1C2, T-A1G2 Models 4, 6, 8 T-A1D4, T-A1M2 T-A1L2, T-A1J2 | | |
| Note: A reference with the format "Go to 5x-000" means go to 5A-000 for tape unit Models 3, 5, or 7 and go to 5B-000 for tape unit Models 4, 6, or 8. | | |
| Always start with Seq 1 and follow the procedure in sequence unless directed otherwise. Remember to END all problems or maintenance calls by going to MAP 00-030. | | |
| Seq | Condition/Instruction | Action |
| 1 | Does the failure occur on more than one tape unit? | If Byte 10, any bit is on, go to 14-000, Seq 36; otherwise, go to Seq 27. |
| 2 | Is the TU loading incorrectly? | Go to MAP 2x-000 (See Note). |
| 3 | Is Sense Byte 7, Bit 0 (Lamp Failure) On? | Go to Seq 11. |
| 4 | Is Sense Byte 7, Bit 1 on (Tape Bottomed in Left Column.) | Go to Seq 33. |
| 4A | Is Sense Byte 7, Bit 2 on? | Go to Seq 35. |

| Seq | Condition/Instruction | Action |
|-----|---|---|
| 5 | Is Sense Byte 7, bit 3 (Reset Key) On? | Go to the tape unit and: A. Check if door is open. B. Check Door Interlock switch. C. Try to find out if Reset switch was on while the TU was running. D. Go to Seq 25 if above checks were okay. |
| 6 | Is Sense Byte 7, bit 5 (Erase Head Failure) On? | Go to Seq 12A. |
| 7 | Is Sense Byte 7, bit 6 (air bearing or right reel hub pressure failure) on? | Possible causes: • Broken or loose belt. • Right reel hub is leaking. • Right reel hub switch. • Air bearing switch. • Air system leak. • Models 4, 6, 8 change: T-A1D4, T-A1M2 • Models 3, 5, 7 change: T-A1E2, T-A1H2 • If problem still exists, go to ALD FT |
| 8 | Is Sense Byte 7, bit 7 (Load Failure) On? | If the TU does not load correctly, go to 2x-000 (see Note). If the TU is loaded and ready, go to Seq 20. |
| 9 | Is Sense Byte 6, bit 1 (Write Current Failure) On? | Go to the TU and perform the following: A. Check output of the +6 volt supply (See 1x-000). See Note. B. Go to Seq 22. |
| 10 | If not: | Replace logic cards listed under Single Tape Unit FRUs. |
| 11 | Sync negative on -Bus Out 5 (T-A1M2P12 for Models 4, 6, and 8 and T-A1H2P12 for Models 3, 5, and 7). Execute a Sense command. Is +Lamp Off minus and +Status Bus 0 plus? -Bus Out 5: Models 4, 6, and 8: T-A1M2P12 Models 3, 5, and 7: T-A1H2P12 +Lamp Off: Models 4, 6, and 8: T-A1M2S07 Models 3, 5, and 7: T-A1H2S07 +Status Bus 0: Models 4, 6, and 8: T-A1M2B05 Models 3, 5, and 7: T-A1H2B05 | Change: T-A1H2 for Models 3, 5, 7. T-A1M2 for Models 4, 6, 8. |

| Seq | Condition/Instruction | Action |
|-----|---|--|
| 12 | If not: | Check for a defective or dirty fiber optics lamp. Go to 08-620 for cleaning instructions. Change T-A1D2. |
| 12A | Is Sense Byte 1, Bit 5 (Write Status) On? | Go to Seq 13. |
| 12B | Set up the CE panel to do a Read command offline using a tape previously written on a good TU. Sync negative on: T-A1K4B12 for Models 3, 5, or 7; T-A1K6B12 for Models 4, 6, or 8. Probe +Erase UK Latch T-A1H2S05 for Models 3, 5, or 7; T-A1M2S05 for Models 4, 6, or 8. Is +Erase UK plus? | Go to Seq 12D. |
| 12C | If not: | Change T-A1H2 and T-A1C2 (one at a time) on Model 3, 5, or 7. Change T-A1M2 and T-A1L2 (one at a time) on Model 4, 6, or 8. |
| 12D | For Models 3, 5, and 7, probe -Erase Head On (T-A1H2P13) For Models 4, 6, and 8, probe -Erase Current On (T-A1M2P13) Is the line minus? | Change the write head card on Model 3, 5, or 7. Change T-A1G2 on Model 4, 6, or 8. Then change the write head card. |
| 12E | If not: | Perform erase head checks as instructed on 08-320. |
| 13 | Set up the CE panel to do a Write command offline. Sync negative on -Move Tag. Models 4, 6, and 8: T-A1K6B12 Models 3, 5, and 7: T-A1K4B12 | |
| 14 | Is -Erase Head On minus? Models 4, 6, and 8: T-A1G2D11 Models 3, 5, and 7: T-A1H2P13 | For Models 4, 6, and 8, go to Seq 18. For Models 3, 5, and 7, change T-A1H2. |
| 15 | For Models 4, 6, and 8 only: Is +Erase Status (T-A1K2U04) plus? For Models 3, 5, and 7 only: Is -Write Status (T-A1H2M09) minus? | Interchange write card from the failing tape unit with a write card from a good tape unit. If the problem still exists, change the erase head. |
| 16 | For Models 4, 6, and 8 only: Is +Bkwd Status (T-A1K2P11) plus? For Models 3, 5, and 7 only: Is -Write Status (T-A1H2M09) plus? | For Models 4, 6, 8: Change T-A1J2. For Models 3, 5, 7: Go to 00-030. Write Status should be On at this time. Recheck symptoms. |
| 17 | If not: For Models 4, 6, and 8 only: | Change T-A1K2. |

3803-2/3420

| | | | | | | | | | |
|-----------------------------|-------------------------------|-----------------------|---------------------------|--|--|--|--|--|--|
| XE4200 Seq 2 of 2 | 2735893 Part Number | See EC History | 845958 1 Sep 79 | | | | | | |
|-----------------------------|-------------------------------|-----------------------|---------------------------|--|--|--|--|--|--|

WRITE CURRENT FAILURE AND TAPE UNIT CHECK (Cont'd)

| Seq | Condition/Instruction | Action |
|-----|--|--|
| 18 | For Models 4, 6, and 8 only: Is -Gated Erase Current (T-A1G2S04) minus? | Models 4, 6, 8: Change T-A1G2. |
| 19 | If not: For Models 4, 6, and 8 only: | Change T-A1F2. |
| 20 | Is +Load Check minus? +Load Check: For Models 4, 6, and 8: T-A1M2U06 For Models 3, 5, and 7: T-A1H2U06 | Models 4, 6, 8: Change T-A1M2. Models 3, 5, 7: Change T-A1H2. |
| 21 | If not: | For Models 4, 6, 8: Change T-A1D4. For Models 3, 5, 7: Change T-A1E2. |
| 22 | Write a portion of tape on a working drive and then do a read operation on the failing drive. Is -Write Current On minus during the read operation? -Write Current On: For Models 3, 5, and 7: T-A1H2G05 For Models 4, 6, and 8: T-A1M2G05 | Change the write head card. |
| 23 | Is +Write Current UK plus? For Models 4, 6, and 8: T-A1M2P10 For Models 3, 5, and 7: T-A1H2P10 | Models 4, 6, 8: Change T-A1M2. Models 3, 5, 7: Change T-A1H2. |
| 24 | If not: | Go to 5x-000 (See Note). |
| 25 | Is -Operator Intervention (T-A1C2M13) for all models minus? | Change T-A1C2. If problem still exists, go to ALD FT263. |
| 26 | If not: | For Models 4, 6, and 8: Change T-A1M2. For Models 3, 5, and 7: Change T-A1H2. |
| 27 | Do a rewind, write operation. Does the tape unit do a Rewind Unload, go backward from load point off the end of tape, or drop Ready? | Change in order: 1. A2Q2 2. Y1Q2 |

| Seq | Condition/Instruction | Action |
|-----|---|---|
| 28 | Using the failing command, sync minus on -TU Tag Bit 6 Command (A2R2J06). This line comes up twice per command; once for tape unit reset and once for the rest of the command. Check -Bus Out 6: 1. For TCU with switching: a. A2E2M09; -Bus Out 6 Primary b. A2E2M08; -Bus Out 6 Secondary 2. For TCU without switching: a. A2E2M08; -Bus Out 6. Are any of these points minus? (It may be necessary to operate the Start-Stop switch.) | Go to 16-160. |
| 29 | Is -Bus Out 3 minus? 1. For TCU with switching: a. -Bus Out 3 Primary A2E2B09. b. -Bus Out 3 Secondary A2E2B12. 2. For TCU without switching: a. -Bus Out 3 A2E2B12. | Go to 16-160. |
| 30 | Is -Bus Out 7 minus? 1. For TCU with switching: a. -Bus Out 7 Primary A2E2P02 b. -Bus Out 7 Secondary A2E2U11 2. For TCU without switching: a. -Bus Out 7 A2E2U11 | Go to 16-160. |
| 31 | Is -Bus Out 0 minus? 1. For TCU with switching: a. -Bus Out 0 Primary A2E2G09 b. -Bus Out 0 Secondary A2E2G08 2. For TCU without switching: a. -Bus Out 0 A2E2G08 Go to 16-160. | |
| 32 | Is -Bus Out 4 minus? 1. For TCU with switching: a. -Bus Out 4 Primary A2E2D09 b. -Bus Out 4 Secondary A2E2D13 2. For TCU without switching: a. -Bus Out 4 A2E2D13 | Go to 16-160. |
| 33 | Is Byte 18, bit 0 (OV/Uv) On? (This will cause reel board emergency power off (EPO) to drop, resulting in loss of motor control, causing the tape to reach bottom). | <ul style="list-style-type: none"> Check TU voltages. Check for dirty air flow filter. Check for defective cooling blower Check mercury switch located on the air vane below the capstan board. Go to 1A/1B-000. |

| Seq | Condition/Instruction | Action |
|-----|---|---|
| 34 | If not: Probable FRUs: | <ul style="list-style-type: none"> L4 Vacuum switch. Capstan tachometer is dirty, glazed, or need adjustment. (See 08-000.) For Models 4,6, and 8 change: T-A1M2, T-A1C2, T-A1D4. For Models 3,5, and 7 change: T-A1H2, T-A1C2. If the problem still exists, go to 3A/3B-110. |
| 35 | Is Byte 18, bit 0 (OV/UV) On? (This will cause the reel board EPO to drop, resulting in loss of motor control, causing tape to reach bottom). | <ul style="list-style-type: none"> Check TU voltages with Digitec* voltmeter. Check for dirty filter. Check for defective cooling blower. Check the mercury switch located on the air vane below the capstan board. |
| 36 | If not: | Possible FRUs: <ul style="list-style-type: none"> R4 Vacuum switch. Transfer valve is leaking. See 08-400. Capstan tachometer is dirty, glazed, or needs adjustment. See 08-000. For Models 4, 6, and 8 change: T-A1M2, T-A1C2, T-A1B2; For Models 3, 5, and 7 change: T-A1H2, T-A1C2, T-A1G2. If the problem still exists, go to 3A/3B-110. |

*Trademark of United Systems, Corp.

3803-2/3420

| | | | | | | | |
|------------|-------------|---------|----------|--|--|--|--|
| XE4300 | 2735894 | See EC | 845958 | | | | |
| Seq 1 of 2 | Part Number | History | 1 Sep 79 | | | | |

| | | |
|---|---|---------------|
| From: 14-000 | | |
| ERROR DESCRIPTION: | | |
| 1. | Unexpected sense: The sense data received from the tape unit did not match the expected sense byte mask. (For example: a hot track-in-error (TIE) byte.) | |
| 2. | Unit Check without supporting sense: A data check or equipment check has been set without any other indications; or a unit check has occurred without data check, equipment check, or ID burst check being set. | |
| 3. | Reject tape unit without supporting sense: This error is set if the microprogram reaches Endup on a DSE or Rewind command and busy drops without EOT or BOT coming on. | |
| 4. | Unexpected ending status: The ending status did not match the expected status mask. | |
| 5. | Unexpected Data: The data received did not match the data expected. | |
| Most Probable Cause: | | |
| The following is a list of cards that can cause the problems covered in this procedure. The cards are listed with the highest probability first. Lines with multiple cards have the same probability. | | |
| A. | Y1G2 | |
| B. | A1C2, Y1P2 | |
| C. | A2R2 | |
| D. | A1K2 | |
| D. | A2D2, Y1D2, Y1J2, Y1M2 | |
| F. | A1G2, A2Q2 | |
| G. | A1H2, Y1N2, Y1Q2 | |
| H. | A1D2, A1E2, Y1H2, Y1K2 | |
| Additional Cards Referenced: | | |
| A. | A2H2 | |
| B. | A1G2 | |
| C. | A2T2 | |
| Always start with Seq 1 and follow the procedure in sequence unless directed otherwise. Remember to END all problems or maintenance calls by going to MAP 00-030. | | |
| Seq | Condition/Instruction | Action |
| 1 | Was the failure in section F, G, or H of OLT? | Go to 21-000. |
| 2 | Did failure occur during a rewind sense operation? | Go to 15-140. |

| Seq | Condition/Instruction | Action |
|-----|--|--|
| 3 | <p>Set up the CE panel as follows: (If CE panel fails to load correctly, go to 12-000.)</p> <ol style="list-style-type: none"> 1. Raise the Panel Enable switch. Turn the ROS Mode switch to Norm and operate the Set ROS Mode switch. 2. Turn the meter switch to Disable, then wait for the Intf's Disabled light to come On. 3. Lower the Stop On Control Check and Stop On Data Flow Check switches to off position. 4. Use the Data Entry Select switch to enter the following commands (operate the CE/Cmpr switch to load each command): <p style="padding-left: 40px;">CMND1 = 8BX (LWR) CMND2 = 8BX (LWR) CMND3 = 8BX (LWR) CMND4 = 8BX (LWR) Byte Count = FE0 Write Data/Go Down = FF0 (=TU address)</p> <ol style="list-style-type: none"> 5. Add jumper between A1S2G08 to A1S2J08. 6. Set: <p style="padding-left: 40px;">ALU1/ALU2 switch to ALU2; Mple/Single switch to Mple; Display Select switch to IC.</p> <ol style="list-style-type: none"> 7. Rewind and ready the tape unit. 8. Operate the Start switch. | |
| 4 | Is the error equipment check or reject TU without Sense Byte 6, Bit 1, or Byte 7 or 10, any bit? | Go to Seq 12. |
| 5 | Does the error occur in LWR mode? | Go to Seq 22. |
| 6 | Was unexpected data received in a read forward operation? | Go to Seq 43. |
| 7 | Does the sense data indicate a Data Check without supporting sense data? | Go to Seq 59. |
| 8 | Is the error a backspace block that did not detect a tape mark? | Go to Seq 64. |
| 9 | Operate the Start switch. Does -End Data Check (A1K2M11) ever go minus? | Change A1K2. |
| 10 | Does -End Data Check (A1S2U07) ever go minus? | Go to ALD PR161 and follow line back to the failing point. |
| 11 | If not: | Recheck the symptoms. |

| Seq | Condition/Instruction | Action |
|-----|---|--|
| 12 | <p>Set up the CE panel as follows:</p> <ol style="list-style-type: none"> 1. Turn Display Select switch to Compare Reg. 2. Turn Data Entry Switches to the equivalent hex address of ALU2 statement HUP1 (2E8). 3. Operate Set CE/Cmpr switch. 4. Operate the Reset switch. 5. Set ALU1/ALU2 switch to ALU2. 6. Turn ROS Mode switch to Stop and operate the ROS Mode switch. 7. Turn Display Select switch to IC. 8. Operate the Start switch. | |
| 13 | Do IC indicators 0 through 11 display HUP1 (2E8)? | Go to Seq 15. |
| 14 | If not: | Go back to Seq 12 and recheck setup. |
| 15 | Turn Display Select switch to Bus In. Are indicators 0, 3, 5 and 7 on and Bit 6 off? (This is TU Sense Byte 0.) | Go to Seq 17. |
| 16 | If not: | Change A2D2. |
| 17 | <p>Set up CE Panel as follows:</p> <ol style="list-style-type: none"> 1. Operate the Reset switch. 2. Load Compare Register with SKIPMOD (16F). 3. Turn Display Select switch to IC. 4. Operate the Start switch. 5. IC should indicate SKIPMOD (16F). | |
| 18 | Turn Display Select switch to Bus In. Are only indicators 0 and 2 on in the command byte? (This is the command byte coming back from the TU.) | Go to Seq 20. |
| 19 | If not: | Change A2D2. |
| 20 | Interchange A2N2 and B2C2. | Change A2H2. |
| | <ol style="list-style-type: none"> 1. Turn ROS Mode switch to Norm. 2. Operate the Set ROS Mode switch. Does program fail in the same manner? | |
| 21 | If not: | Change cards back and replace A2N2. |
| 22 | Operate the Start switch. Is -ROC Cycled (Y1P2U04) pulsing? | Go to Seq 24. |
| 23 | If not: | Change Y1P2. |
| 24 | Does -2 Ptrs On Pwr (Y1J2G09) ever go minus? | Change Y1J2. |
| 25 | Does -2 Ptrs On Pwr, (Y1F2U07) ever go minus? | There is a broken line between Y1J2G09 and Y1F2U07. Go to ALD CH021 and follow line back to the failing point. |
| 26 | Is +Degate Serialize S1 (Y1J2S02) pulsing? | Go to Seq 28. |

3803-2/3420

| | | | | | | | |
|-----------------------------|-------------------------------|-----------------------|---------------------------|--|--|--|--|
| XE4300 Seq 2 of 2 | 2735894 Part Number | See EC History | 845958 1 Sep 79 | | | | |
|-----------------------------|-------------------------------|-----------------------|---------------------------|--|--|--|--|

**UNIT CHECK WITHOUT SUPPORTING SENSE OR UNEXPECTED SENSE
(Cont'd)**

| Seq | Condition/Instruction | Action |
|-----|--|--|
| 27 | If not: | Change Y1J2. |
| 28 | Is -Pointer Bus In 0 (Y1G2B12) pulsing? | Go to Seq 30. |
| 29 | If not: | Change Y1G2. |
| 30 | Is -Pointer Bus Bit 1 (Y1G2M02) pulsing? | Go to Seq 32. |
| 31 | If not: | Change Y1G2. |
| 32 | Is -Pointer Bus Bit 2 (Y1G2D13) pulsing? | Go to Seq 34. |
| 33 | If not: | Change Y1G2. |
| 34 | Is -Pointer Bus Bit 3 (Y1G2P02) pulsing? | Go to Seq 36. |
| 35 | If not: | Change Y1G2. |
| 36 | Is -Pointer Bus Bit 4 (Y1G2P05) pulsing? | Go to Seq 38. |
| 37 | If not: | Change Y1G2. |
| 38 | Is -Pointer Bus Bit 5 (Y1G2M08) pulsing? | Go to Seq 40. |
| 39 | If not: | Change Y1G2. |
| 40 | Is -Pointer Bus Bit 6 (Y1G2M05) pulsing? | Go to Seq 42. |
| 41 | If not: | Change Y1G2. |
| 42 | Is -Pointer Bus Bit 7 (Y1G2M07) pulsing? | Recheck the symptoms. |
| 43 | Operate the Start switch. Does +Bus In Bit 0 (A1C2G09) pulse? | Go to Seq 45. |
| 44 | If not: | Change in order: 1. A1C2 2. A1S2 |
| 45 | Does +Bus In Bit 1 (A1C2G12) pulse? | Go to Seq 47. |
| 46 | If not: | Change in order: 1. A1C2 2. A1S2 |
| 47 | Does +Bus In Bit 2 (A1C2D04) pulse? | Go to Seq 49. |
| 48 | If not: | Change in order: 1. A1C2 2. A1S2 |
| 49 | Does +Bus In Bit 3 (A1C2D06) pulse? | Go to Seq 51. |
| 50 | If not: | Change in order: 1. A1C2 2. A1S2 |
| 51 | Does +Bus In Bit 4 (A1C2S04) pulse? | Go to Seq 53. |

| Seq | Condition/Instruction | Action |
|-----|--|---|
| 52 | If not: | Change in order: 1. A1C2 2. A1S2 |
| 53 | Does +Bus In Bit 5 (A1C2G07) pulse? | Go to Seq 55. |
| 54 | If not: | Change in order: 1. A1C2 2. A1S2 |
| 55 | Does +Bus In Bit 6 (A1C2D13) pulse? | Go to Seq 57. |
| 56 | If not: | Change in order: 1. A1C2 2. A1S2 |
| 57 | Does +Bus In Bit 7 (A1C2G02) pulse? | Change A1C2. |
| 58 | If not: | Change in order: 1. A1C2 2. A1S2 |
| 59 | Operate the Start switch. Does +Tape Op Delayed (Y1N2M05) pulse? | Go to Seq 61. |
| 60 | If not: | Change Y1N2. |
| 61 | Set up the CE panel as follows: 1. Use the Data Entry Select switch to enter the following commands (operate Set CE/Cmpr switch to load each command): CMND1 = 04X (Sense) CMND2 = 04X (Sense) CMND3 = 04X (Sense) CMND4 = 04X (Sense) = TU ADDRESS 2. Remove jumper between A1S2G08 and A1S2J08. 3. Set ALU1/ALU2 switch to ALU1. 4. Operate the Start switch. | |
| 62 | Does -Stat Bit 1 Sense (A2T2B03) pulse? | Change A1K2. |
| 63 | If not: | Change A2T2. If problem is not resolved, suspect noise on the TU Interrupt Line. |

| Seq | Condition/Instruction | Action |
|-----|---|-------------------|
| 64 | Set up the CE panel as follows: 1. Use the Data Entry Select switch to enter the following commands (operate the Set CE/Cmpr switch to load each command): CMND1 = 1F (WTM) CMND2 = 1F (WTM) CMND3 = 1F (WTM) CMND4 = 1F (WTM) = TU ADDRESS 2. Remove LWR jumper between A1S2G08 and ground. 3. Operate the start switch. | |
| 65 | Does -BOT Or DT Branch Cond (Y1P2J13) ever go minus? | Change Y1P2. |
| 66 | If not: | Recheck symptoms. |

| From: 14-00, 15-1000 | | |
|--|--|--|
| Refer to Charts A, B, and C on this page for sense information and test points. | | |
| <p>Most Probable Cause: The cards are listed with the highest probability first. Lines with multiple cards have the same probability.</p> <p>A. A2D2, Y1P2 B. A2E2, A2R2 C. A1K2, B2E2, A2Q2 D. B2S2. See Caution. E. A2T2 F. B2R2. See Caution. G. A1S2 H. A1D2, A1C2 J. Y1N2, Y1J2</p> <p>Single Drive Model 3, 5, 7 T-A1E2 T-A1H2 Model 4, 6, 8 T-A1D4 T-A1M2</p> <p>Additional Cards Referenced: A. B2S2</p> <p>Caution: Removing this card may cause channel errors even with power off. Put CPU in the Single Cycle mode before removing card.</p> | | |
| <p>Always start with Seq 1 and follow the procedure in sequence unless directed otherwise. Remember to END all problems or maintenance calls by going to MAP 00 030.</p> | | |
| Seq | Condition/Instruction | Action |
| 1 | Take the tape control offline and reset it with the Stop On Control Check and Stor On Data Flow Check switches up. | |
| 2 | Do you get any errors? | Go to 14 000 and analyze the sense data. |
| 3 | Set up the CE Panel with the following command sequence: REW 07 WRT 01 WRT 01 WRT 01 Execute the sequence first with a byte count of FE0; then with a count of EF0. | |
| 4 | Does the tape run away? | Go to 13 000. |
| 5 | Are sense bytes 13 and 14 all zeros? | Check A2R2 for proper address jumpers. Correct, if necessary, and go to Seq 6. |
| 6 | Does the tape control have the two channel switch feature? | Go to Seq 29. |
| 7 | Do a write operation from the CE panel. | |
| 8 | Does the tape control stop on any errors? | Do an offline sense operation, then go to 14 100 and analyze the sense data. |

| Seq | Condition/Instruction | Action |
|-----|---|--|
| 9 | Do a rewind followed by a sense command from the CE panel and step to the failing sense byte. See Chart A for correct sense data. | |
| 10 | Does Sense Byte 2 equal something other than 00? | Change Y1P2. |
| 11 | Is an extra bit On in the failing sense byte? (See Chart A for correct sense data.) | Go to Seq 18. |
| 12 | Determine which bit is missing in the failing sense byte. | |
| 13 | Is that bit minus on - CBI Bit? (See Chart C.) | Change B2S2. See Caution. |
| 14 | Is the failure in bytes 13 and 14? | Go to Seq 16. |
| 15 | If not: | Change A2R2. |
| 16 | Is +Stat Bit 1 Sense (A2T2D05) plus? | Change A2R2. |
| 17 | If not: | Change A2T2. |
| 18 | Determine which bit is extra in failing sense byte. | |
| 19 | Is that bit inactive on - CBI Bit? | Change B2S2. See Caution. |
| 20 | Is that bit inactive on +Data Bus In? See Chart B. | Go to Seq 27. |
| 21 | Is -R/W VRC (A1S2U05) minus? | Change A1K2. |
| 22 | Is -MTE (A1S2U06) minus? | Change A1K2. |
| 23 | Is -End Data Check (A1S2U07) minus? | Change A1K2. |
| 24 | Is -Skew Error (A1S2S09) minus? | Change A1K2. |
| 25 | Is -P Or C Comp (A1S2M13) minus? | Change A1K2. |
| 26 | If not: | Go to Seq 32. |
| 27 | Are +Stat Bit 1 Sense (A2T2D05) and -Stat Bit 1 Sense (A2T2B03) at the same level? | Change A2T2. |
| 28 | If not: | Change A2R2. |
| 29 | Does tape control fail on both channels? | Go to Seq 8. |
| 30 | Does tape control fail on channel A? | Change B2S2. See Caution. |
| 31 | If not: | Change B2R2. See Caution. |
| 32 | Is +6250 1 Or 2 Trk Corr TP (A1S2S02) minus? | Change A1S2. |
| 33 | Is +1 Or 2 Trk Corr TP (A1D2P06) minus? | Change in order: 1. A1D2 2. A1C2 |
| 34 | Is -Set I Cnt Cmpr (Y1N2P09) plus? | Change Y1N2. |
| 35 | If not: | Change Y1J2. |

Chart A

| Sense Byte Mask For Sense Data After Rewind | | | | | | | | | |
|---|-----------|---|---|---|---|---|---|---|---|
| Sense Byte Number | Hex | Bit or Indicator Display | | | | | | | |
| | | 0 | 1 | 2 | 3 | 4 | 5 | 6 | 7 |
| Sense Byte 1 | 48 | | X | | | X | | | |
| Sense Byte 2 | 00 | | | | | | | | |
| Sense Byte 3 | 06 | | | | | | X | X | |
| Sense Byte 4 | 00 | | | | | | | | |
| Sense Byte 5 | 40 | | X | | | | | | |
| Sense Byte 6 | not=00 | The bits contained in this sense byte vary according to the tape unit model attached to the tape control. | | | | | | | |
| Sense Byte 7 | 00 | | | | | | | | |
| Sense Byte 8 | 00 | | | | | | | | |
| Sense Byte 9 | 08 | | | | | X | | | |
| Sense Byte 10 | 00 | | | | | | | | |
| Sense Byte 11 | 00 | | | | | | | | |
| Sense Byte 12 | 00 | | | | | | | | |
| Sense Bytes 13 and 14 | not=00 00 | The bits contained in these two bytes vary according to the features and serial number of the tape control. | | | | | | | |
| Sense Bytes 15 and 16 | not=00 00 | The bits contained in these two bytes vary according to the serial numbers of the attached tape units. | | | | | | | |
| Sense Byte 21 | 1A | | | | X | X | | X | |

X=bit or indicator on

Chart B

| + DATA BUS IN | |
|---------------|----------------------|
| X | Data Bus In Location |
| 0 | A2R2P07 |
| 1 | A2R2P03 |
| 2 | A2R2M04 |
| 3 | A2R2J12 |
| 4 | A2R2P06 |
| 5 | A2R2P02 |
| 6 | A2R2P04 |
| 7 | A2R2J11 |

Chart C

| -CBI X | |
|--------|--------------|
| X | CBI Location |
| 0 | A2R2S09 |
| 1 | A2R2S07 |
| 2 | A2R2G09 |
| 3 | A2R2S05 |
| 4 | A2R2S04 |
| 5 | A2R2G11 |
| 6 | A2R2G10 |
| 7 | A2R2J10 |

3803-2/3420

| | | | | | | | |
|-----------------------------|-------------------------------|-----------------------|---------------------------|--|--|--|--|
| XE4400 Seq 2 of 2 | 2735895 Part Number | See EC History | 845958 1 Sep 79 | | | | |
|-----------------------------|-------------------------------|-----------------------|---------------------------|--|--|--|--|

PICKING/DROPPING RECORDS

| From: 00-010 | | |
|--|--|---|
| ERROR DESCRIPTION: This failure is usually the result of a tape positioning problem caused by a tape crease encountered while executing an error recovery procedure. | | |
| Most Probable Cause: 1. T-A1H2, Models 4, 6, and 8 only. 2. 1600 and 6250 bpi—a crease longer than 0.15 inch (3.8 mm) can cause positioning problems if tape stops with the read/write head positioned within the crease. 3. NRZI—a crease that is longer than 0.025 inch (0.64 mm) can cause positioning problems if tape stops with the read/write head positioned within the crease. 4. On 3420 Models 4, 6, or 8, the only time the write head does not erase is after a read operation. In rewriting a bad record, tape is positioned with the erase head in the IBG area. This means the write head is situated over the previous record. If the write head is energized at the wrong time, it can erase part or all of the previous record. 5. 1600 bpi Only—an area at least 2.7 inches (68.6 mm) behind load point must be free of blocks. If the tape was written on a 2400 or 2415 tape unit, blocks within 2.7 inches (68.6 mm) of load point can cause this failure. | | |
| Notes: 1. Several ECs are available on an "as required" basis for Model 3, 5, and 7 tape units. a. EC734030 This EC prevents splashes on tape resulting from a write operation after a read operation. These splashes can be recognized on read operations and result in positioning problems. b. EC734391 This EC prevents electrostatic discharge (ESD) from inadvertently dropping the rewind plunger solenoid and possibly activating the rewind plunger. 2. EC 734866 is available on an "as required" basis for 3803-1. This eliminates dropping a record when a backward error recovery initiates a cleaner blade action over a crease or contamination that disappears during the cleaner action. a. EC 734866 This EC eliminates dropping a record when the backward error recovery initiates a cleaner blade action over a crease or contamination that disappears during the cleaner action. b. EC 443935 Install if problem is causing records to be dropped. | | |
| Always start with Seq 1 and follow the procedure in sequence unless directed otherwise. Remember to END all problems or maintenance calls by going to MAP 00-030. | | |
| Seq | Condition/Instruction | Action |
| 1 | Develop tape. (See 00-011) If problem is not corrected, return here. | |
| 2 | Is this a single tape unit failure? | See Note 1. Perform the Pneumatic Pressure/Vacuum Level Checks. See 08-400. Also check for drag. See 6A-010 or 6B-150. Go to Seq 3. |
| 3 | If not: | Read Note 2 and go to 00-030. |
| 4 | Is the problem resolved? | Go to 00-030. |
| 5 | If not: | Change T-A1H2 and go to Seq 6. |
| 6 | Is the problem resolved? | Go to 00-030. |
| 7 | If not: | Go to 00-040, Seq 14. |

3803-2/3420

| | | | | | | | | | |
|------------|-------------|---------|----------|--|--|--|--|--|--|
| XE4500 | 2735896 | See EC | 845958 | | | | | | |
| Seq 1 of 2 | Part Number | History | 1 Sep 79 | | | | | | |

NOTES:

15-201

3803-2/3420

| | | | | | | | | | |
|-----------------------------|-------------------------------|---------------------------------|---------------------------|--|--|--|--|--|--|
| XE4500 Seq 2 of 2 | 2735896 Part Number | See EC History | 845958 1 Sep 79 | | | | | | |
|-----------------------------|-------------------------------|---------------------------------|---------------------------|--|--|--|--|--|--|

Copyright International Business Machines Corporation 1976, 1979

15-201