

The IBM logo, consisting of the letters "IBM" in a bold, sans-serif font, is positioned inside a dark square.

Systems Reference Library

**IBM 7090-7040 Direct Couple Operating System
Operator's Guide**

This publication provides detailed information for the machine operator who runs jobs under the IBM 7090-7040 Direct Couple Operating System (DCOS), #7090-PR-161. Included are basic system concepts, control cards, operating procedures, and messages to the operator.

PREFACE

This publication is a guide for the machine operator who runs jobs under the IBM 7090-7040 Direct Couple Operating System (DCOS). It contains a functional description of DCOS and detailed information for operating the system.

DCOS is designed for five major machine configurations:

1. 7090-DC-7040
2. 7094-DC-7040
3. 7094-DC-7044
4. 7094 II-DC-7040
5. 7094 II-DC-7044

Throughout this publication, the term 7090 refers to the 7090, 7094, or 7094 II and the term 7040 refers to the 7040 or 7044.

The minimum machine configuration required by the distributed version of DCOS is given in Appendix A.

Further information on DCOS is provided in the publication IBM 7090-7040 Direct Couple Operating System: Programmer's Guide, Form C28-6382, which contains infor-

mation required by the applications programmer. A more detailed description of the system, intended for use by the systems programmer, is provided in the publication IBM 7090-7040 Direct Couple Operating System: Systems Programmer's Guide, Form C28-6383.

For further information on the IBJOB Processor, the major subsystem of DCOS, the reader is referred to the following IBM publications:

IBM 7090/7094 IBSYS Operating System: IBJOB Processor, Form C28-6389
IBM 7090/7094 Programming Systems: FORTRAN IV Language, Form C28-6390
IBM 7090/7094 Programming Systems: Macro Assembly Program (MAP) Language, Form C28-6392
IBM 7090/7094 Programming Systems: COBOL Language, Form C28-6391
IBM 7090/7094 IBSYS Operating System: IBJOB Processor Debugging Package, Form C28-6393

Major Revision (March 1965)

This edition, Form C28-6384-2, is a major revision of Form C28-6384-1. This publication amplifies material previously presented, and, in some cases, provides additional material. Major changes and additions are concerned with: the use of sense switch 1, the use of 7040 entry keys, system messages to the operator, utility routines, and load from disk and start procedures.

Additions or changes are indicated by a vertical line to the left of the text.

The following publications are made obsolete by this revision: C28-6384-1, C28-6384-0, and the Technical Newsletter N28-0143-0.

This publication was prepared for production using an IBM computer to update the text and to control the page and line format. Page impressions for photo-offset printing were obtained from an IBM 1403 Printer using a special print chain.

Copies of this and other IBM publications can be obtained through IBM Branch Offices.

A form for readers' comments appears at the back of this publication. It may be mailed directly to IBM. Address any additional comments concerning this publication to the IBM Corporation, Programming Systems Publications, Department D39, 1271 Avenue of the Americas, New York, N Y., 10020.

CONTENTS

INTRODUCTION	5	OPERATING THE SYSTEM	16
General DCOS Machine Configuration	5	Starting the System Initially	16
IBM 7090 Data Processing System	5	Initiating Job Processing	16
IBM 7040 Data Processing System	5	Load from Disk and Start Procedures	17
IBM 1402 Card Read Punch	5	Initiating Subsequent Job Processing	17
IBM 1403 Printer	5	Using Tape Input to DCOS	17
IBM 1014 Remote Inquiry Unit	6	Using 7040 Console Controls	18
IBM 729 Magnetic Tape Units	6	Using 7040 Sense Switches	18
IBM 1301 Disk Storage	6	Using 7040 Entry Keys	19
IBM 7320 Drum Storage	6	Using the 1014	21
DCOS Supervisory Programs	6	Job-Status Inquiry	21
DCOS Multiprocessor	6	System Response to Job-Status Inquiry	21
IBM 7090 Operating System with DC Capability	7	Change-of-Status Requests	22
Modes of Operation	7	Duplicating 7040 Entry-Key Functions on 1014	22
Direct Mode	7	Save-Restore Disk and Drum Routine	22
Compatibility Mode	8	Save Procedures	22
Standard DCOS Record Format	8	Restore Procedures	23
Input	8	Save-Restore Card	23
Output	8	Stopping the System Immediately	23
System Communication	9	7040 and DCOS Failures	24
Job Flow	9	Restarting the System	24
Input Stage	9	UTILITY ROUTINES	25
Setup Stage	10	DCOS-Controlled Utility Routines	25
Execution Stage	10	Utility Routines Specified on \$SETUP Card	25
Breakdown Stage	10	Utility Routines Specified on \$UTILITY Card	25
Punch Stage	10	7040/7044 Utility Routines	26
Print Stage	10	7040 DUMP Program	27
Utility Stage	11	MESSAGES	28
Purge Stage	11	APPENDIX A: MACHINE CONFIGURATION	34
Example of Typical Job Flow	11	INDEX	35
CONTROL CARDS	12		
General Control Card Format	12		
\$JOB Card	12		
\$EXECUTE Card	13		
\$EOF, %EOF, %, \$DATA Cards	13		
\$ID Card	13		
\$SETUP Card	13		
\$ATEND Card	14		
\$* Card	14		
\$PAUSE Card	14		
\$ENDREEL Card	15		
\$DATE Card	15		
Sample Job Deck	15		

INTRODUCTION

The IBM 7090-7040 Direct Couple Operating System (DCOS) is a set of supervisory routines that permit continuous job processing on systems with the Direct Couple feature. DCOS provides a framework within which other 7090 programming systems may function.

When this system is in control, operator intervention between the jobs is unnecessary and operator control over job scheduling and processing is minimized. The operator may rely on messages from the system to provide pertinent information for running jobs. Because printing and punching of job output is performed by the system, rather than off-line, the need for operator handling of tapes is reduced.

GENERAL DCOS MACHINE CONFIGURATION

The general DCOS machine configuration, shown in Figure 1, includes a 7090 and a 7040 (connected by a direct-couple channel), which, with their related units, form an integrated data processing system. The functions of each of these devices are described below.

IBM 7090 DATA PROCESSING SYSTEM

The major function of the IBM 7090 Data Processing System is to perform actual job processing, i.e., compilation, assembly, and execution. It has no input/output facilities other than the Direct-Couple feature. Instead, it requests input/output activity, which is performed by 7040 routines.

IBM 7040 DATA PROCESSING SYSTEM

The basic function of the IBM 7040 Data Processing System is to service the input/output requirements of the 7090. In addition, 7040 routines select jobs for 7090 processing and supplant the 7090 operator in controlling this processing.

The 7040 console provides the operator with his primary means of communicating with and controlling the system. The operator sets sense switches and makes entries

in the entry keys to exercise control options.

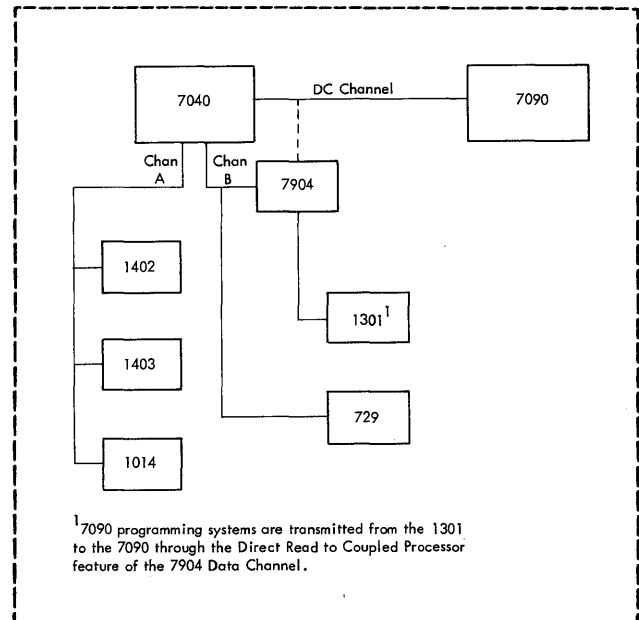

Figure 1. Direct Couple Operating System-- General Machine Configuration

Messages that (1) request operator action, (2) respond to operator inquiries, or (3) provide other information to the operator appear on the 7040 console typewriter.

IBM 1402 CARD READ PUNCH

The IBM 1402 Card Read Punch is used by the system for punched card input and output.

IBM 1403 PRINTER

The IBM 1403 Printer is used by the system for all printed output.

IBM 1014 REMOTE INQUIRY UNIT

The IBM 1014 Remote Inquiry Unit is a device used, in addition to the 7040 console, for communication between the system and the operator. Messages from the system, including requests to set 7090 sense switches, and messages typed on the 1014 by the operator may appear on the 1014 typewriter.

IBM 729 MAGNETIC TAPE UNITS

IBM 729 Magnetic Tape Units are used for jobs that require tape, rather than card, input/output. These units are also used during system initialization and during system maintenance and editing operations.

IBM 1301 DISK STORAGE

One module of IBM 1301 Disk Storage, attached as module 0 on channel B, is required. It is used for 7090 programming systems residence, for 7040 supervisor routine residence, and for intermediate storage of system input and output data. Any additional channel B modules are used for systems residence (systems are shared among all modules). All modules are used for intermediate storage of system input and output data.

IBM 7320 DRUM STORAGE

IBM 7320 Drum Storage may be substituted for any even numbered module except the one required module of disk (module 0 on channel B). Functions of additional modules of drum storage are identical to those of the additional disk storage modules that are allowed.

Throughout this publication, the term disk may refer either to IBM 1301 Disk Storage or to IBM 7320 Drum Storage.

DCOS SUPERVISORY PROGRAMS

A fundamental concept of DCOS is that many unrelated jobs may be processed concurrently. To facilitate control over these jobs, each job proceeds through three phases: preprocessing, processing, and postprocessing. This is illustrated in

Figure 2. Supervision of these phases and control over the entire system is performed by two programs: the IBM 7090/7094 IBSYS Operating System with Direct Couple Capability (DC-IBSYS) and the DCOS Multiprocessor (DCMUP). Additionally, certain utility functions not requiring 7090 processing are available with DCOS.

DC-IBSYS resides in the 7090 and exercises control over the processing phase. DCMUP resides in the 7040 and exercises control over both the preprocessing and postprocessing phases. DC-IBSYS and DCMUP perform their functions asynchronously. This overlapping of processing of one job with preprocessing and postprocessing of other jobs significantly reduces job turn-around time (the interval between the time the job is introduced into the system and the time job results are obtained). For example, while the operator is mounting tapes required for one job, 7090 execution of another job, punching of output for a third job, and printing of output for several additional jobs may be in progress.

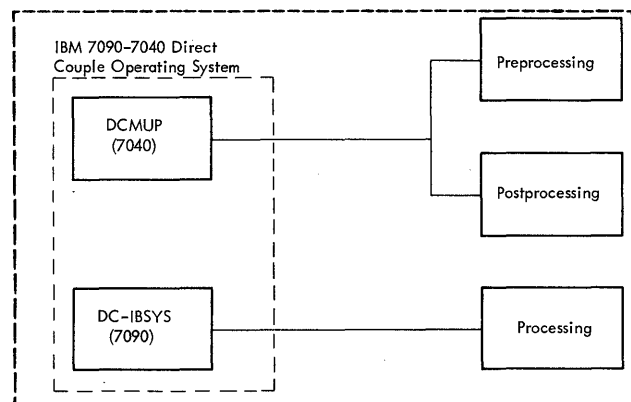

Figure 2. Phases of Processing

DCOS MULTIPROCESSOR

The DCOS Multiprocessor (DCMUP) contains routines that perform preprocessing and postprocessing functions and that service the input/output requirements of the 7090. These routines prepare input files for the 7090, direct the operator to mount tapes, interpret 7090 input/output requests and initiate the activity, perform all postexecution breakdown, and control printing and punching. DCMUP routines are entered from a master control program called the commutator. When a routine is entered, one unit of its work (e.g., printing one line) is performed, control is returned to the commutator, and another

routine is entered. Thus, preprocessing, postprocessing, and input/output servicing appear to occur simultaneously.

IBM 7090 OPERATING SYSTEM WITH DC CAPABILITY

The IBM 7090 Operating System with DC Capability (DC-IBSYS) supervises the processing of jobs. As shown in Figure 3, it consists of the DC-IBSYS Monitor and the IBJOB Processor.

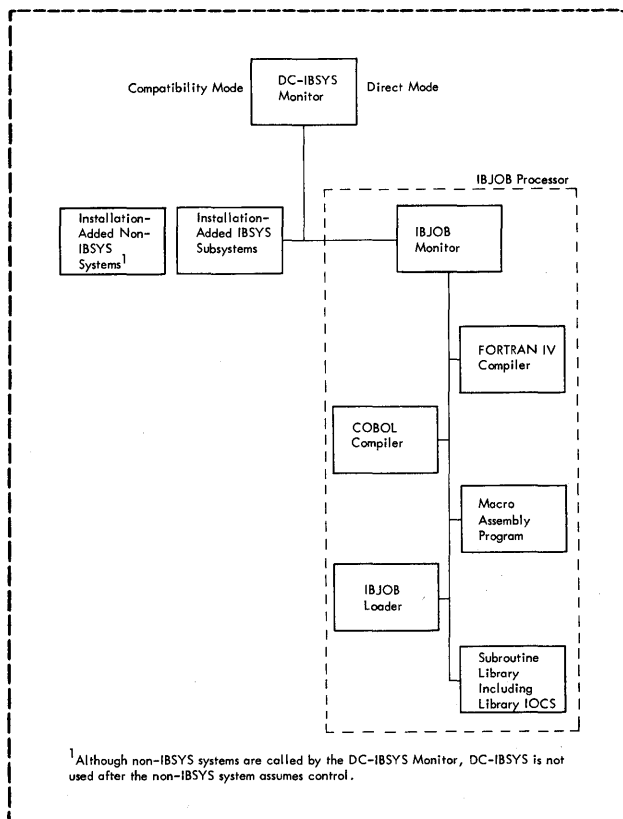

Figure 3. IBM 7090 Operating System with DC Capability (DC-IBSYS)

Included in the DC-IBSYS Monitor are:

1. Facilities for communication and control among subsystems and between the DC-IBSYS Monitor and the subsystems.
2. Facilities for coordinating job processing by passing control from one subsystem to another.
3. An Input/Output Executor to communicate with 7040 input/output routines and to coordinate and control input/output trapping.
4. A Core Storage Dump Program to facili-

tate testing and analysis of programs executed by the system.

5. A System Editor to be used by systems programmers to maintain and modify DCOS monitors and subsystems operating under them.

The DC-IBSYS Monitor may also contain an installation accounting routine tailored to the specific requirements of the installation.

The IBJOB Processor controls programs written in the FORTRAN IV, COBOL, and Macro Assembly Program (MAP) languages. This subsystem also contains a comprehensive library of relocatable subroutines, including a complete Input/Output Control System (Library IOCS). The IBJOB Processor is the only subsystem included in the distributed version of DCOS.

IBSYS subsystems other than the IBJOB Processor may be executed under control of the DC-IBSYS Monitor if they are edited into the system library. Non-IBSYS subsystems that are not executed under control of the DC-IBSYS Monitor may be read into the system on cards or tape, or may be edited into the system library. Procedures for editing the system library to include subsystems are described in the publication IBM 7090-7040 Direct Couple Operating System, Systems Programmer's Guide, Form C28-6383.

MODES OF OPERATION

In the DCOS machine configuration, the absence of data channels attached to the 7090 does not limit applications to those written especially for DCOS. Two modes of operation are provided in DCOS: the direct mode and the compatibility mode. Basically, the difference between the two modes is the manner in which input/output activity is handled. Input/output conventions for the direct mode are tailored especially for DCOS and the direct-couple channel, whereas, in the compatibility mode, input/output conventions are adapted to programs written for the standard 7090 Data Processing System (with data channels).

DIRECT MODE

When a request for input/output activity is encountered for a job being processed in the direct mode, a description of the desired input/output function is placed in locations 22₈ and 23₈ of 7090 core storage.

The 7090 traps the 7040 (7090 processing continues), and DCMUP interprets the function description and initiates the input/output activity through the direct-couple channel. Data transmission and 7090 execution occur simultaneously. When the activity is finished, DCMUP issues an instruction that traps the 7090 and indicates that transmission has been completed.

The IBM 7090/7094 IBJOB Processor has been modified to operate in the direct mode. Programs written in the FORTRAN IV, COBOL, or MAP (with Library IOCS) languages are automatically provided with input/output routines adapted to the direct-couple channel.

COMPATIBILITY MODE

The compatibility mode is provided for execution of programs or programming systems that do not employ direct-mode input/output conventions. In the compatibility mode, each 7090 input/output instruction and each instruction that tests input/output status causes the 7090 to stop and traps the 7040; DCMUP interprets each instruction, restarts the 7090, and initiates the specified input/output activity. As in the direct mode, data transmission and 7090 execution occur simultaneously. If trapping is enabled by the 7090 program, the 7040 traps the 7090 when transmission has been completed.

IBSYS subsystems, other than IBJOB, and all non-IBSYS systems are processed in the compatibility mode.

When the 7090 is processing a job in the compatibility mode, the PROGRAM STOP light on the 7090 console will be on whenever an input/output instruction or an instruction testing input/output status has caused a 7090 halt.

STANDARD DCOS RECORD FORMAT

All files to be processed by the 7090 operating under DCOS must be in the standard DCOS record format. This format consists of 460-word physical records, each record containing a two-word identifier and a maximum 458-word area into which the logical records are placed.

INPUT

Input to the system may be on punched cards or tape. It may consist of DCOS and subsystem control cards, symbolic source programs, binary object programs, and data cards. If on tape, the job input file must not be blocked, and must contain look-ahead bits.

If card input is used, separating job decks after they have been read into the system may be time consuming. To expedite this procedure, the operator may place a separator card, containing \$IBSYS in the first six columns, between jobs before stacking them into the hopper.

OUTPUT

System output may be in the form of a printed BCD listing, punched cards, or tape. If a file is on tape, it will be blocked in DCOS format unless breakdown deblocking is specified on the \$SETUP card.

During the punch stage, a card of the following form is punched by the system for each job:

<u>1</u>	<u>31-36</u>	<u>61-80</u>
contents of columns	date	9's
31-60 of \$JOB card		

If punched output is requested for the job, this card will precede the output.

Most jobs read into the system will also have some 1403 printed output, which may include a program listing, messages, output data, and a system core storage dump listing. (An asterisk (*) to the left of the printed line indicates a printer malfunction.) Following the output of each job are two identical pages which aid the operator in separating output from different jobs. Each page contains:

1. Four lines of x's.
2. The contents of columns 31 through 60 of the \$JOB card.
3. A listing of the total job processing time, the 7090 job execution time, the number of cards read, the number of cards punched, the number of lines

printed, and the tapes used for that job.⁴
4. Four lines of x's.

JOB FLOW

The three processing phases (preprocessing, processing, and postprocessing) are each subdivided into stages, as shown in Figure 5. The preprocessing phase includes the input and setup stages; the processing phase includes the execution stage; and the postprocessing phase includes the breakdown, punch, print, and purge stages.

SYSTEM COMMUNICATION

Close communication between the operator and DCOS is required to ensure efficient job processing. To communicate with the system, the operator uses the 7040 console sense switches and entry keys and the 1014 typewriter. The 7040 and 7090 transmit information to the operator by issuing messages printed on either the 7040 console typewriter or the 1014 typewriter. The device printing each message depends on system specifications.

A 10- or 12-character prefix is included in each message from the system. It identifies the originator of the message (4 = 7040, 9 = 7090), specifies with an asterisk (*) if the message is operator pertinent, and indicates the time that the message was typed (except for messages printed during system initialization).

Messages typed by the operator on the 1014 appear on the 1014 as typed, with no prefix.

A comprehensive listing of communication between the operator and the system, called the operator's log, is typed on the 7040 console typewriter and 1014. Numerous system messages requesting operator action, responding to operator inquiries, and providing job and system information appear on this log. In addition, all requests and inquiries entered by the operator through the 7040 entry keys are typed on the log. For example, when the code 37 is entered in the keys, the message

OCTAL KEYS 37 SET

will be typed. A sample operator's log is shown in Figure 4 (with 1014 discontinued).

All messages pertinent to the operator are included in the section "Messages."

⁴The number of cards read will be one greater than the actual number of cards read, unless a physical end of file in the card reader was reached at the end of the job. If punching was discontinued, the number of cards punched will not reflect the actual number.

```

USE DISK LOAD PROCEDURE TO INITIATE JOB PROCESSING
ENTER BCD TIME OF DAY IN KEYS, HHMMSS, TURN ON CLOCK, PUSH START.
4 000000 7090 IS IDLE
4 000000 OCTAL KEYS 26 SET
ALL 7090 JOBS AND 7040 SUPPORT FUNCTIONS ARE COMPLETE
4 000032 JOB 001 IN QUEUE. $JOB EDIT28 DELETE UNITS INSERT LAT
4 000050 JOB 001 READY DCSDT ON UNIT C1 (WITH NO RING)
4 000050 JOB 001 READY Y0014 ON UNIT C2
4 000050 7090 IS IDLE, SETUP PENDING

4 000114 JOB 001 ON 90
9 000129 0 LIBRARIAN DONE
4 000342 7090 IS IDLE
4 000345 JOB 001 ON PUNCH
4 000354 OCTAL KEYS 24 SET
4 000354 JOB 001 ON PUNCH DISCONTINUED
4 000355 JOB 001 IS PRINTING ON 1
4 000750 JOB 001 PURGED
ALL 7090 JOBS AND 7040 SUPPORT FUNCTIONS ARE COMPLETE
4 001012 JOB 002 IN QUEUE. $JOB EDIT 03A
4 001038 JOB 003 IN QUEUE. $JOB EDIT 03B
4 001040 JOB 002 READY 3LIST ON UNIT C1
4 001040 JOB 002 READY 3PNCH ON UNIT C2
4 001040 JOB 002 READY DCSDT ON UNIT C3 (WITH NO RING)
4 001040 JOB 002 READY Y0014 ON UNIT C4
4 001040 7090 IS IDLE, SETUP PENDING
4 001042 JOB 003 READY 3LIST ON UNIT C5
4 001341 JOB 002 ON 90
9 002040 0 ASSEMBLIES ARE DONE
9 002338 0 FIRST EDIT IS DONE
9 002387 0 POST EDIT IS DONE
9 002448 0 LAST EDIT IS DONE
4 004419 7090 IS IDLE
4 004421 JOB 002 TAPE C1 - 000 READ ERRS 009 WRITE ERRS
4 004421 JOB 002 TAPE C2 - 000 READ ERRS 002 WRITE ERRS
4 004422 JOB 002 ON PUNCH
4 004532 OCTAL KEYS 24 SET
4 004532 JOB 002 ON PUNCH DISCONTINUED
4 004533 JOB 002 IS PRINTING ON 1
4 004648 JOB 000 <NOISE RECORD - C5
4 005047 JOB 003 READY 3PNCH ON UNIT C1
4 005121 JOB 003 ON PUNCH
4 005416 JOB 002 PURGED
4 005928 JOB 003 IS PRINTING ON 1
4 006031 JOB 004 IN QUEUE. $JOB EDIT28 DELETE UNITS INSERT LAT
4 006049 JOB 004 READY DCSDT ON UNIT C1 (WITH NO RING)
4 006049 JOB 004 READY Y0014 ON UNIT C2
4 006049 7090 IS IDLE, SETUP PENDING
4 006156 JOB 004 ON 90
9 006330 0 LIBRARIAN DONE
9 00631 0 IBSYS SYSTEMS EDIT COMPLETED.
9 00633 0 $REWIND SYSLB2
9 00633 0 FIRST EDIT IS DONE
9 00633 0 $SWITCH SYSUT1,SYSCK1

9 006633 0 $EXECUTE I$JOB
9 006642 0 FILES READY FOR USE
9 006642 0 SYSUNI FILE NAME UNIT

9 006642 0 IN1 CCDS A2
9 006642 0 UT2 INTER B4
9 006642 0 UT2 INTERI B4
9 006642 0 CK1 INPUT B1
9 006642 0 CK2 OUTPT B5
9 006642 0 PPI PUNCH A4

9 006655 0 EXECUTION
9 006655 0 TRACK ALLOCATION - OCTAL - SIZE IN TRACKS
9 006655 0 NAME TYPE 1ST TRACK SIZE

9 00911 0 SRNT 1 00051 00026
9 00950 0 .IBSYS 1 00100 00116
9 00955 0 STPTP 2 00147 00001
9 00956 0 STPK 2 00150 00001
9 00957 0 BTPTP 2 00151 00001
9 00957 0 BDKTP 2 00152 00001
9 00958 0 B7DBLK 2 00153 00001
9 00958 0 00CDTP 2 00155 00001
9 00958 0 00TPPR 2 00156 00001
9 00958 0 00TPPU 2 00157 00001

```

Figure 4. Sample Operator's Log (with 1014 discontinued)

INPUT STAGE

A job first enters the input stage, during which the job is read into the system and assigned a job number by DCMUP. In addition, control cards are analyzed by DCMUP and the following actions are performed:

1. The input deck is blocked into the standard DCOS record format and written on the disk.
2. A job description is prepared and written on the disk. The job description contains the job number and the disk location assigned to the job.
3. A one-word job identifier is formed. The identifier contains the disk location assigned to the job description, the priority code of the job, and a stage number. The priority code is obtained from the \$JOB control card, described in the section "Control Cards." The stage number is maintained by DCMUP and always reflects either the current stage of processing or, if the previous stage has been completed, the next stage.
4. Job identifiers are placed into a table called a job queue table. DCMUP selects jobs from this table by first examining the priorities assigned to the jobs.

SETUP STAGE

If the job requires tape setup, DCMUP selects an available tape unit and types a message directing the operator to mount a specified tape on that unit. If control card specifications indicate that the tape is not in standard DCOS format, the records are read into the system, converted into the standard DCOS format, and stored on the disk (or, at the programmer's option, on another tape). Tapes in standard DCOS format are not read into the system during this stage.

EXECUTION STAGE

During the execution stage, DCMUP selects jobs from the job queue table, interprets the job description block, and determines whether or not to load DC-IBSYS into the 7090. (IBSYS will not be reloaded if the last cards processed by the previous job were \$IBSYS, \$STOP cards. In all other cases, IBSYS will be reloaded.) Con-

trol is then transferred to the programming system, which processes the job.

Program processing on the 7090 is essentially the same as it would be on a standard 7090 Data Processing System without the Direct Couple feature except that all input/output requests are handled by the 7040. Blocked records are read from the disk or from tape, deblocked, and transmitted to the 7090. Output from the 7090 is transmitted to the 7040, blocked, and written onto the disk (or tape). Punch and print files are written onto the disk to await postprocessing.

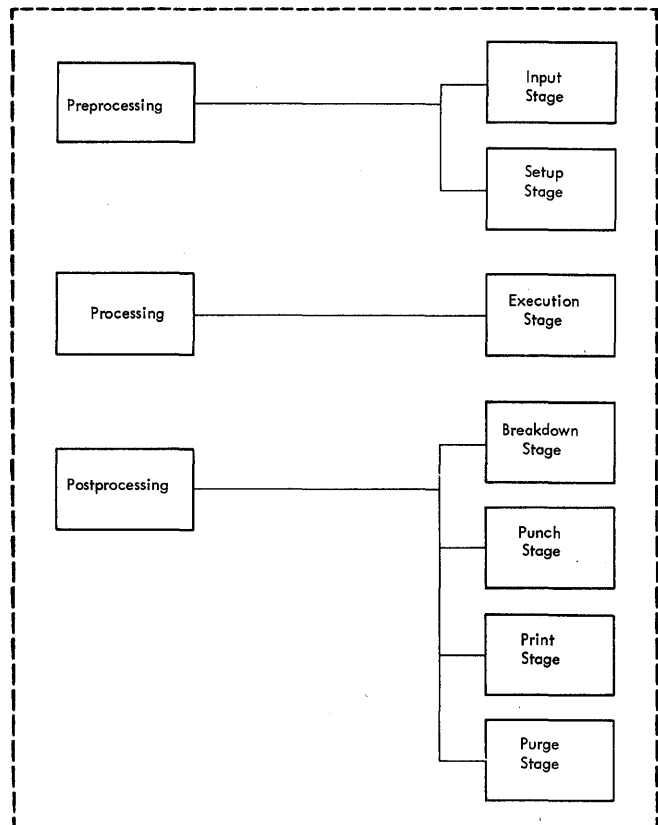

Figure 5. Stages of Processing for Non-utility Jobs

BREAKDOWN STAGE

During the breakdown stage, 7090 output may be deblocked and written on tape. Any intermediate tapes are rewound; other tapes used by the job are either rewound (if they are work tapes) or rewound and unloaded, and the respective 7040 tape units are returned to availability status.

PUNCH STAGE

During the punch stage, a card identifying the job is punched. If punched output has been requested, it is also punched at this time.

PRINT STAGE

During the print stage, all printed output for the job is printed on the 1403.

UTILITY STAGE

The utility stage is provided for jobs that do not require processing but only peripheral utility functions (see the section "Utility Routines Specified on \$UTILITY Card").

PURGE STAGE

When all other postprocessing of a job is completed, the job is scheduled for the purge stage. During this stage, the job description, the job identifier, and the data files pertaining to the job are deleted from the disk.

EXAMPLE OF TYPICAL JOB FLOW

As a general example of job flow, consider a FORTRAN IV compilation and execution. This job requires one input tape (F281) which is not blocked in standard DCOS record format. Punched and printed output is desired. The job deck, which includes a control card specifying the tape, is placed in the 1402 card reader. The 7040 reads in the deck, and DCMUP assigns a job number (003), blocks the input, prepares the job description and job identifier, and stores the records on the disk. The message

JOB 003 IN QUEUE

is written on the 7040 console typewriter to inform the operator that the job has entered the system.

When the job is selected for setup, DCMUP locates an available tape unit (C2) and prints the following message to instruct the operator to mount the tape:

JOB 003 READY F281 ON UNIT C2

After the tape has been mounted, DCMUP reads the input into core storage buffers,

converts the records to the standard DCOS record format, and stores the records on the disk.

When the job is selected for 7090 processing, the message

JOB 003 ON 90

is typed. The job description is read from the disk into 7040 core storage. DCMUP then loads IBSYS into the 7090, which in turn calls the IBJOB Processor. The job is processed in direct mode. DCMUP determines the input files and begins reading them from the disk into buffers in 7040 core storage. Thus, DCMUP can respond immediately when the 7090 issues a request for input from one of these files. When it does, DCMUP deblocks and transmits the desired number of words from a core storage buffer.

DCMUP also establishes buffers to receive all output data and messages, which are later printed on a 1403 as part of the output of the job. As the buffers become filled, the records are stored on the disk.

When DCMUP selects the job for punching, punch files are read from the disk into 7040 core storage buffers and punched on the 1402. When the job is selected for printing, the print files are read from the disk into 7040 buffers and printed on the 1403 printer. The operator is notified by the messages:

JOB 003 ON PUNCH
JOB 003 IS PRINTING ON 1

when punching and, later, printing are initiated.

When all job output has been delivered and the job is selected for purging, the job description, the job identifier, and all remaining data files pertaining to the job are deleted from the disk. Disk areas are returned to availability status. The operator is then notified by the message:

JOB 003 PURGED

that the job has been completed.

CONTROL CARDS

The control cards discussed in this section are supplied by the programmer and are presented here to facilitate the running of the program. Five control cards--\$JOB, \$EXECUTE, \$SETUP, \$ATEND, and \$EOF--will be used for most applications.

Pertinent utility control cards, other than the \$SETUP card, are described in the section "Utility Routines." Detailed descriptions of control cards used by the applications programmer are provided in the publication IBM 7090-7040 Direct Couple Operating System: Programmer's Guide, Form C28-6382. Input/output unit assignment control cards are not included in this publication because they are primarily intended for use by the systems programmer. They are described in the publication IBM 7090-7040 Direct Couple Operating System: Systems Programmer's Guide, Form C28-6383.

GENERAL CONTROL CARD FORMAT

The general format of the control cards discussed in this section is:

<u>1 2-8</u>	<u>16-72</u>	<u>73-80</u>
\$ Control card name, left-justified	Variable field information (parameter 1, parameter 2, ..., parameter n)	Ignored

All parameters must appear in the order shown and must be separated by commas. The omission of a parameter must be indicated by a comma (except where the parameter would have been the last on the card). Embedded blanks are not allowed within the variable field. A blank must separate the last parameter in the variable field from comments.

The following conventions are used for variable field information.

1. Lower-case letters indicate that a substitution must be made.
2. Upper-case letters must be punched exactly as shown.
3. Brackets [] contain a parameter that may be omitted or included at the user's choice.
4. Braces { } indicate that a choice of the contents is to be made.
5. A number over the first character of a parameter indicates the first card column of the field.

\$JOB CARD

The \$JOB control card is the first card in each job deck. It thus defines a job, which includes all cards beginning with a \$JOB card and ending with, but not including, the next \$JOB card. When the 7090 encounters a \$JOB card, control is transferred to the 7090 installation accounting routine, if such a routine exists.

The format of the \$JOB card is:

```
1 16  
$JOB [priority],[time estimate],  
  
31 60  
[line estimate] [job identification]
```

The parameters are:

priority

This is the priority assigned to the job. The digits 0 through 9 may be specified. A priority of 0 is the lowest that can be assigned. When this parameter is omitted, a priority of zero is assumed.

time estimate

This is the estimated total 7090 job-processing time in minutes. A maximum specification of 32767 is allowed.

line estimate

This is the estimated line count of the job output printed on the 1403 printer. A maximum specification of 262,143 lines is allowed.

If either the time estimate or the line-count estimate is exceeded, the job is automatically terminated unless otherwise specified at the installation. If either or both estimates are omitted, the maximum values are assigned by system assembly parameters.

job identification

Columns 31 through 60 are normally used to identify a job and may contain any combination of characters and blanks.

\$EXECUTE CARD

The \$EXECUTE control card defines the beginning of each job segment. At least one \$EXECUTE card is required for each job to be processed on the 7090.

The format of the \$EXECUTE card is:

```

1           16
$EXECUTE     { system name }
              { CARDS       }
              { TAPE       }
    
```

The parameters are:

system name

This is the name of the subsystem (six or fewer characters) that resides on the disk. In the distributed DCOS, IBJOB is the only subsystem that may be specified. Subsystems other than IBJOB and those edited onto the disk should be specified with the parameters CARDS or TAPE.

CARDS

CARDS should be specified when the subsystem to be executed is a self-loading card deck. A \$ROW control card must follow the \$EXECUTE card, and a \$ENDROW card must indicate the end of the row-binary deck. When a \$EXECUTE card with CARDS specified is recognized by the 7090, pressing of the 7090 LOAD CARD button is simulated. Therefore, no operator action is required when a subsystem is on cards.

TAPE

TAPE should be specified when a non-IBSYS subsystem that is to be executed resides on tape. The subsystem tape must be in standard DCOS format and must be specified on a \$SETUP control card. Before the job is loaded into the 7090, a message will instruct the operator to mount the tape on some 7040 tape unit. When a \$EXECUTE card with TAPE specified is recognized by the 7090, pressing of the 7090 LOAD TAPE button is simulated.

\$EOF, ⚡EOF, ⚡, \$DATA CARDS

The \$EOF, ⚡EOF, ⚡, and \$DATA control cards perform the same function and may be used interchangeably. Each, when included in a deck being read from the 1402 card reader, causes an end-of-file condition to be simulated in the input buffer. Some 7090 systems, including IBJOB, require that

one of these cards be included in each job deck, although DCOS does not require it. The formats of the \$EOF, ⚡EOF, ⚡, and \$DATA cards are:

```

1
$EOF
⚡EOF
⚡
$DATA
    
```

\$ID CARD

The \$ID control card is used for intrajob accounting purposes at installations that employ a 7090 installation accounting routine. This card causes a transfer of control to that routine. Columns 7 through 72 of the \$ID card may contain any combination of alphameric characters and blanks.

The \$ID card may appear after a \$EXECUTE card with IBJOB specified. However, it should appear before a \$EXECUTE card that refers to any other subsystem, because it may not be recognized by that subsystem.

The format of the \$ID card is:

```

1           7-72
$ID          any text
    
```

\$SETUP CARD

The \$SETUP control card is included in the job deck when the programmer wants to (1) use an input tape, or (2) obtain an output tape. One \$SETUP card is required for each reel of tape referred to by a 7090 program. This card provides information that results in a message instructing the operator to mount a desired tape reel at the appropriate time.

For example, should the system encounter a \$SETUP card for job 542 specifying reel DS23, the setup routine might determine that 7040 tape unit C5 is available and issue the message

```

4*hhmss JOB 542 READY DS23 ON UNIT
C5 (WITH NO RING)
    
```

Because the message specifies NO RING, the operator should remove the file-protect ring before mounting the reel.

The format of the \$SETUP card is:

1 8 16
\$SETUP unit option 1, [option 2],
 [LABITS] [REELS], [file count]
 [720]

Refer to the section "Utility Routines Specified on \$SETUP Cards" for a discussion of utility routines that may be specified on the \$SETUP card.

\$ATEND CARD

The \$ATEND control card allows the programmer to specify dump procedures to be taken when 7090 processing of a job is terminated, successfully or unsuccessfully. Limits of 7090 core storage to be dumped, the format of the dump, and other termination procedures, are specified on this card.

On all unsuccessful runs, the programmer is given a dump of the 7090 panel and the location at which execution was terminated, regardless of the options specified on the \$ATEND card. This data, together with a job termination message, is the only information provided if the \$ATEND card is not included in the job deck; no core storage dumps are taken.

Because all dumps are programmer controlled, the operator cannot effect a dump by placing a \$ATEND card in the 1402 card reader. He can only terminate 7090 job processing, after which a dump is automatically taken.

The format of the \$ATEND card is:

1 16
\$ATEND [limit 1], [limit 2],
 [format], [DUMP], [POST]

The parameters are:

limit 1, limit 2
These are the limits, in octal (0000-7777), of the area to be dumped. If limits are not specified, a dump is not taken.

format
This is the format of the dump. Valid entries are the digits 1 through 6 which provide dumps in various formats. If this parameter is omitted, the digit 3 is assumed. (For code definitions, refer to the publi-

IBM 7090-7040 Direct Couple Operating System: Programmer's Guide, Form C28-6382.

DUMP

When DUMP is specified, the desired dump is taken whether or not 7090 job processing was successfully completed.

POST

When POST is specified, the IJOB Debugging Postprocessor is called if 7090 processing is terminated prior to completion.

\$* CARD

The \$* control card is a comments card. Columns 7 through 72 may contain any combination of alphameric characters and blanks. These columns, frequently providing instructions to the operator, are typed on the 1014 or the 7040 typewriter and/or the system output unit. If a \$* card appears after a \$EXECUTE card, it is written only on the system output unit. If a \$* card appears before a \$EXECUTE card, it is written on the 1014 and the system output unit.

The format of the \$* card is:

1 7-72
\$* any text

\$PAUSE CARD

The \$PAUSE control card causes the 7090 to halt after the following messages are typed:

9*hhmmss contents of columns 7-72 of \$PAUSE card
9*hhmmss PAUSE

This card thus enables the programmer to temporarily interrupt 7090 processing so that the operator can perform a specific task or tasks, such as setting 7090 entry keys. Instructions to the operator may be provided in card columns 7 through 72, which may contain any combination of alphameric characters and blanks. After the operator has performed the specified task(s), he should restart the 7090 by entering the code 50 in the 7040 entry keys and setting 7040 sense switch 6 on.

If used, the \$PAUSE card may appear before or after the \$EXECUTE card for a

job. If the \$PAUSE card appears before the \$EXECUTE card, the contents of columns 7-72 are written on the 1014 and on the system output unit. If the \$PAUSE card appears after the \$EXECUTE card, it is written only on the system output unit.

The format of the \$PAUSE card is:

```

1      7-72
$PAUSE  any text

```

\$ENDREEL CARD

The \$ENDREEL control card is used when job input to DCOS is on tape rather than cards. This card indicates the end of the last job to be read from the job input tape. Therefore, it must be the last card image on the tape. When the \$ENDREEL card is encountered by the system, tape input is terminated. (Refer to the section "Using Tape Input to DCOS" for detailed information on tape input.)

The format of the \$ENDREEL card is:

```

1
$ENDREEL

```

\$DATE CARD

The \$DATE control card is normally used by the operator at the beginning of each day and whenever loading DCOS from the disk, so that the correct date appears on each page of printed output.

The format of the \$DATE card is:

```

1          16
$DATE      mmdyy

```

where: mm = month (01 through 12)
dd = day (01 through 31)
yy = year (00 through 99)

SAMPLE JOB DECK

An example of the use of control cards for a DCOS run is shown in Figure 6, which illustrates a MAP job deck. The job is given a priority of three. It is expected to run no more than six minutes and to produce no more than 1,700 lines of printing. The output will be deblocked and written onto a tape assigned the installation reel identification R365. If the job is terminated before 7090 job processing is completed, a dump will be taken of 7090 core storage from location 3000₈ through location 7777₈.

```

-----
1      78      16-72
-----
$JOB          3,6,1700
$ID  DEPT A40 0078213542
$SETUP A(1)  TAPE,R365
$ATEND       03000,77777
$EXECUTE     IBJOB
$IBJOB       MAP,GO
$IBMAR PROG2
.
.  MAP Source Program
.
$EOF
-----

```

Figure 6. Sample Job Deck

OPERATING THE SYSTEM

The following sections include procedures for initiating job processing, for exercising the variety of control options afforded the operator, and for performing other functions made available by DCOS.

STARTING THE SYSTEM INITIALLY

The complete Direct Couple Operating System is contained on the DCOS Distribution Tape. To prepare the system for use, the operator must:

1. Mount DCOS Distribution Tape on a tape unit set to proper density.
2. Set 7040 entry keys to select tape unit. For example, if the Distribution Tape is on unit C0, the entry key setting is +076200003232.
3. Press 7040 CLEAR button.
4. Press 7040 RESET button.
5. Set sense switches as follows:

- a. If the disk format tracks, or home and record addresses, have not been written, place the disk format control cards supplied by the installation in the 1402 and set sense switch 4 on.

Note: The 7040/7044 utility routines, which generate format tracks, home address identifiers, and record addresses, and the required disk format control cards are described in the sections "7040/7044 Format Track Generator Program" and "7040/7044 Home Address and Record Address Generator Program" of the publication IBM 7040/7044 Utility Programs, Form C28-6317.

- b. To load an operational DC system onto a disk with established format tracks, set sense switch 3 on.
- c. To punch the miscellaneous DCOS card decks contained on the DCOS Distribution Tape, set sense switch 2 on. (If this option is

chosen, card decks will be punched before the disk format tracks are written and before the system is loaded onto the disk.)

6. Press 7040 LOAD button.

If sense switches 2, 3, and 4 are all on, the disk format tracks can be written, the system tape loaded onto the disk, and the miscellaneous card decks punched during the same run.

The card decks punched when sense switch 2 is on include load-disk card, Save-Restore, Master Alter-edit, and tape blocking and deblocking routines. It is recommended that these decks be interpreted. Each deck is preceded by a card that acts as a separator only, and may be discarded. This card has an asterisk (*) in column 1, the deck name beginning in column 8, and the deck serialization in column 73. Columns 74 through 80 contain zeros. For further explanation of these DCOS card decks, refer to the publication IBM 7090-7040 Direct Couple Operating System: Systems Programmer's Guide, Form C28-6383.

After system initialization has been completed, the following message is typed:

```
USE DISK LOAD PROCEDURE TO INITIATE  
JOB PROCESSING
```

The operator should then follow the procedure outline in the section "Load from Disk and Start Procedures."

INITIATING JOB PROCESSING

There are several methods of initiating job processing after the system is on the disk. The set of procedures to be followed depends on the status of the system.

To run jobs under DCOS, the DCOS Multiprocessor must be in 7040 core storage. It is not in 7040 core storage after a system halt caused by (1) completion of a Save/Restore operation, (2) pressing the 7040 CLEAR button, or (3) a system or machine failure. To initiate job processing after such a system halt, the instructions contained in the section "Load from Disk and Start Procedures" should be followed. If DCMUP is in 7040 core storage, the operator should perform the procedures described in the section "Initiating Subsequent Job Processing."

The procedures above pertain to jobs that are to be read into the system from punched cards. To use tape as input, the instructions in the section "Using Tape Input to DCOS" should be followed in addition to the required procedures for initiating job processing.

Note: The END OF FILE button on the 1402 card reader should not be pressed until the last job deck is being read into the system.

Also note that since physical tape units are assigned by the setup routine in the 7040, operators are cautioned not to dial, ready, or take out of ready, any tape unit unless so requested by the system.

LOAD FROM DISK AND START PROCEDURES

To load DCMUP into 7040 core storage and to initiate job processing, the operator should:

1. Place load-disk card in 1402. Note that if Snap-Patch deck is being loaded, do not use load-disk card.
2. Place job decks in 1402, preceded by the optional \$DATE card, and ready the reader.
3. Place a read select (+076203001230) for the 1402 in entry keys.
4. Sense switch 3 on reinitializes the disk. For restoring the system, see the section "Sense Switch 3."
5. Press 7040 CLEAR button.
6. Press 7040 RESET button.
7. Press 7040 LOAD button.

After the procedures above have been performed, the 1402 card reader will begin reading cards. When the load-disk card or Snap-Patch deck has been read, the message

ENTER BCD TIME OF DAY IN KEYS,
HHMMSS, TURN ON CLOCK, PUSH START

will be typed. The operator should then:

8. Enter time of day, in BCD, in entry keys. The hour, minute, and second each require four keys. For example, if the time is 9:38:23, the operator should enter +001103100203 in the keys.
9. Turn on 7040 console storage clock.
10. Press 7040 START button.

INITIATING SUBSEQUENT JOB PROCESSING

This section includes descriptions of the operator action required to introduce jobs into the system through the 1402 card reader when (1) the system is idle and DCMUP is in 7040 core storage or (2) the system is processing other jobs.

System Is Idle

The system is idle when it has (1) completed all requested job processing or (2) completed load-from-disk-and-start procedures and there are no job decks in the 1402 card reader. In either case, the following message will be the last one appearing on the operator's log:

ALL 7090 JOBS AND 7040 SUPPORT FUNCTIONS ARE COMPLETE

To initiate processing when the system is idle and DCMUP is in 7040 core storage, the operator should proceed as follows:

1. Place job decks in 1402 and ready the reader.
2. Set sense switch 1 on. (See the section "Sense Switch 1.")
3. Press 7040 START button.

System Is in Operation

If the system is in operation and there are cards in the 1402 card reader hopper, the operator should place the additional job decks in the hopper. No other action is required.

To initiate processing of additional jobs when all previous card decks have been read into the system and are being processed, the operator should:

1. Place job decks in 1402 and ready the reader.
2. Set sense switch 1 on. (See the section "Sense Switch 1.")

Note: The 7040 START button should not be pressed.

USING TAPE INPUT TO DCOS

The procedures required to direct the system to read job input from tape are described below. When the system is proc-

essing jobs and tape input is desired, only these procedures are necessary. In all other cases, these procedures are performed in conjunction with action described in the section "Starting the System Initially" or in the section "Initiating Job Processing." They should be performed at the time the operator is directed to place job decks in the 1402 card reader. Card and tape input may occur simultaneously.

The job input tape must be prepared by a card-to-tape routine that inserts look-ahead bits in the last word of each physical record. The tape must be unblocked. A \$ENDREEL control card must be the last card image on the input tape. Job decks containing \$ROW and \$ENDROW control cards cannot be read from tape.

To direct the system to read input from tape, the operator should:

1. Mount input tape on tape unit C0, set density, and make unit ready.
2. Enter code 35 in 7040 console entry keys.
3. Set sense switch 6 on.
4. If the 1402 is not currently reading cards, set sense switch 1 on.

The system will read jobs from tape until one of the following conditions occurs:

1. The \$ENDREEL control card is recognized.
2. The operator discontinues tape input.

The \$ENDREEL card indicates the end of the last job to be read in from tape. When this card is encountered, tape input is terminated.

The operator may discontinue tape input by entering the code 25 in the entry keys and setting sense switch 6 on. This action will delete the job presently being read in from tape. Only those jobs completely read in before tape input is terminated will be processed.

Should a read error occur, the job being read in will automatically be deleted from the system.

USING 7040 CONSOLE CONTROLS

The operator's primary means of controlling the Direct Couple Operating System after it is in operation is by setting sense switches and entry keys on the 7040 console. Certain standard uses of the various controls are recognized by the system.

USING 7040 SENSE SWITCHES

The operator uses the 7040 console sense switches for communication with the system during normal system operation and for system initialization. The sense switches are used as follows:

Sense Switch 1

To initiate processing of jobs when DCMUP is in 7040 core storage and when all previous jobs have been read into the system, sense switch 1 must be on. (See the section "Initiating Subsequent Job Processing.") When sense switch 1 is on, input may be read from either the 1402 or tape unit C0.

Note: If sense switch 1 is on and all 7040 and 7090 processing is completed, the system will not print the terminal message, but will continually interrogate the card reader for additional input.

Sense Switch 2

Normal System Operation: During normal system operation, sense switch 2 affects 7090 intermediate halts and the unit on which certain 7090 messages are typed.

If this sense switch is off, all 7090 messages intended for printing on the 716 printer will be written off-line only. After valid 7090 intermediate stops, processing will resume automatically without operator action. However, the message

```
4*hhmmss JOB xxx 90 WAS STOPPED AT
xxxxx
```

will be typed to inform the operator of the halt. If two successive halts occur at the same 7090 location, the system terminates the job with normal termination procedures.

If sense switch 2 is on, all 7090 messages intended for printing on the 716 printer will be typed on both the 1014 and the system output unit. All valid 7090 intermediate or terminal stops will be indicated by the message

```
4*hhmmss JOB xxx 90 IS STOPPED AT
xxxxx
```

Intermediate stops require operator action to resume processing. (See the section "Using 7040 Entry Keys.") Terminal stops do not require operator action. Two succes-

sive 7090 halts at the same location do not cause a terminal condition.

System Initialization: During system initialization, sense switch 2 must be on in order to punch DCOS card decks contained on the DCOS Distribution Tape. (See the section "Starting the System Initially.")

Sense Switch 3

To place the DCOS Distribution Tape on a disk unit having an established track format during system initialization, sense switch 3 must be on. (See the section "Starting the System Initially.") To restart a system containing uncompleted jobs, sense switch 3 must be off. All preprocessing, processing, and postprocessing not completed at the time of the original stop will be restored. No jobs will be lost. This could be done if the contents of 7040 core storage have been destroyed or if the 7040 is needed for non-DCOS use.

Sense Switch 4

To write disk format tracks during system initialization, sense switch 4 must be on. (See the section "Starting the System Initially.") Note that sense switch 3 must also be on.

Sense Switch 5

Sense switch 5 is used when the contents of disk or drum are to be saved or restored.

If this switch is on, all current job tasks will be completed; no additional tasks will be started. The operator can then direct the system to write the contents of disk or drum onto tape.

When the contents of the tape are to be loaded onto the disk or drum, sense switch 5 must be off. (See the section "Save-Restore Disk and Drum Routine.")

Sense Switch 6

To enter the contents of the 7040 console entry keys, sense switch 6 must be on. (See the section "Using 7040 Entry Keys.")

USING 7040 ENTRY KEYS

The 7040 console entry keys offer the operator numerous system control options. He exercises control by entering a code in the two low-order positions of the entry keys (and sometimes by also entering a job number in the decrement portion of the keys) and then setting sense switch 6 on. The console service routine tests the status of this sense switch and responds once each time the switch is set on. Therefore, the operator must set the switch on each time he wishes to enter the contents of the keys.

Sometimes valid 7040 console key settings have no effect on 7090 operations. This is caused by the 7090 program placing such a load on the 7040 CPU that the keys are not tested. The recommended procedure is to put the 7090 in manual, and then back into automatic. This will halt input/output requests from the 7090, thereby allowing the 7040 to test the keys.

Control Codes

The rightmost character of the control codes determines the unit or function requested. Codes are assigned as follows:

UNIT: 7090

<u>Code</u>	<u>Request</u>
00	Terminate 7090 job; \$ATEND card options will be applied.
10	Terminate 7090 job because of probable 7090 loop; \$ATEND card options will be applied.
20	Reserved.
30	Restart 7090 job from first segment.
40	Reserved.
50	Resume 7090 job processing. Used when 7090 is at some valid intermediate stop. (See the section "Code 50.")

UNIT: 1403 PRINTER

The n in the codes below is the number assigned to an attached 1403 printer. It is normally 1, 2, or 3. For example, if n = 2, it refers to the 1403 printer attached as printer 2.

<u>Code</u>	<u>Request</u>
0n	Single-space printer n (affects current job only).
1n	Repeat output of job being printed on printer n. (Job output on printer n may be repeated only once.)
2n	Discontinue output of job being printed on printer n (does not affect punch).
3n	Restart printing of job output being printed on printer n.
4n	Backspace printer n. (See the section "Code 4n.")

UNIT: 1402 PUNCH

<u>Code</u>	<u>Request</u>
14	Repeat punch output for this job.
24	Discontinue punch output for this job (does not affect printer).
34	Restart job output on punch.

UNIT: TAPE INPUT UNIT

<u>Code</u>	<u>Request</u>
25	Discontinue use of tape as input.
35	Use tape as input. (See the section "Using Tape Input to DCOS.")

UNIT: TYPING DEVICES

(7040 console typewriter,
1014 Remote Inquiry Unit)

<u>Code</u>	<u>Request</u>
06	Discontinue 7040 console typewriter output. All on-line messages will appear on the 1014 typewriter.
16	Restart 7040 console typewriter.
26	Discontinue 1014 typewriter output. All on-line messages will appear on 7040 console typewriters.
36	Restart 1014 typewriter.

FUNCTION: INQUIRY/REQUEST

<u>Code</u>	<u>Request</u>
07	Locate job xxx (job number entered in decrement of entry keys).

17	Give highest priority to job xxx (job number entered in decrement of entry keys).
27	Delete job xxx (job number entered in decrement of entry keys).
37	Reserved.
47	Reserved. (See the section "Codes m7.")

Codes 00, 10, and 27: 7090 Job Termination Procedures: Normally jobs are processed by the 7090 without operator intervention. However, when program errors are encountered, the operator may terminate 7090 job processing by entering one of the following codes: 00, 10, 27.

Code 00 is the one generally used to terminate job processing. This code causes a transfer of control to the 7090 Core Storage Dump Program, which applies the specifications on the \$ATEND control card if that card is included in the job deck. (If a \$ATEND card is not part of the job deck, the status of the 7090 panel and the location at which execution was stopped is the only information provided for the programmer.)

The message

4 hhmss JOB xxx TERMINATED

will appear both on-line (typed on the 7040 console typewriter or on the 1014) and off-line (printed for programmer use as part of the job's output). After dump procedures have been performed, the job will enter the postprocessing phase.

Code 10 is used when the operator suspects that a program is in a loop. This code also causes a transfer of control to the Core Storage Dump Program, which applies the \$ATEND card specifications if that card is included in the job deck. In addition, the message

4 hhmss JOB xxx TERMINATED POSSIBLE LOOP

will appear on-line and off-line. The job will then enter the postprocessing phase.

Code 27 is used only if either code 00 or code 10 will not terminate the job. No \$ATEND card specifications are applied. The message

4 hhmss JOB xxx TERMINATED

will be printed on-line. The job will immediately enter the purge stage and there will be no output for the jobs. If code 27 is not effective, the operator should re-

start the system. (See the section "Restarting the System.")

Code 50: The code 50 is used when a valid intermediate 7090 stop has occurred. The message printed on the 7040 typewriter to indicate this stop may be any one of the following:

```
9*hhmmss PAUSE
9*hhmmss PAWS
4*hhmmss JOB xxx 90 IS STOPPED AT
          xxxxx
```

The first two messages will be preceded by instructions for operator action. To resume 7090 processing after performing any required action, the operator should enter the code 50 in the entry keys and set sense switch 6 on.

Codes 4n: These codes are used when a portion of a job's output currently being printed on printer n is to be reprinted. They effectively backspace the printer from 0 to 25 pages unless the file being printed is under single or double space control (rather than program control), in which case the number of pages backspaced is unpredictable.

Codes m7: These codes are used for job-status inquiries and change-of-status requests; these inquiries and requests are discussed in the section "Using the 1014." The job number must be entered in the decrement portion of the entry keys. Code 27 will delete a job in any stage of processing unless the job is being processed in the utility stage.

Restart and Repeat Requests: Distinguishing between a restart and a repeat of a job task is important. A restart is necessary when a mechanical difficulty occurs that requires interrupting the execution of the task. Under such circumstances, the operator should make a restart request. The specified device will discontinue its task, no matter how nearly completed, and begin the task again. For example, should cards become jammed in the 1402 punch, the operator should remove the jammed cards, enter the code 34 in the entry keys, and set sense switch 6 on. Punching will start again at the beginning of the job. The final output will consist of the entire desired punched output plus the portion of the job that was punched prior to the restart request. Care should therefore be taken in separating the output; partial jobs should, of course, be discarded.

If more than one complete set of printed or punched output is required for a job, a repeat of the job task is necessary. When the operator requests a repeat, the current task is not discontinued. Instead, it is

completed and the same task is again executed. Two or more identical sets of printed output may be processed concurrently if printers are available.

Note that restart and repeat requests must be made while the task is being performed, not before the job has entered or after it has passed the stage. Also, no record is kept by the system of any console requests except those affecting job status. Therefore, should a system reload be performed, all other requests will have to be repeated.

USING THE 1014

Communication between the operator and the system is also effected through the 1014 Remote Inquiry Unit. This device, with typewriter input and output, may be used by the operator to interrogate the system and to exercise control options. In addition, it is used by the system for messages. System assembly parameters determine which system messages appear on the 1014.

Messages that the operator may type include job-status inquiries, change-of-status requests, and 7040 entry-key duplication messages. These messages are used to determine or change the current activity of a job in the system and to simulate the functions of the 7040 entry keys on the 1014.

JOB-STATUS INQUIRY

To determine the status of a job, the operator should type the following message:

```
LOCATE JOB xxx
```

where xxx is the number assigned to the job by the system.

SYSTEM RESPONSE TO JOB-STATUS INQUIRY

The message that the 7040 issues in response to a job-status inquiry will be of the following type:

```

4 hhmss JOB xxx IN { INPUT
                     { SETUP
                     { EXECUTION } { QUEUE }
                     { BREAKDOWN } { PROCESS }
                     { PUNCH
                     { PRINT
                     { PURGE
                     { UTILITY

```

This message indicates the current stage of the job and whether the job is waiting to enter (QUEUE) or has entered (PROCESS) the specified stage.

An example of such a response is

```
4 080520 JOB 131 IN PRINT QUEUE
```

This message informs the operator that, at 8:05:20, job 131 was waiting to enter the print stage. If, at the time of the inquiry, a 1403 printer had already started printing the job, the response would have been

```
4 080520 JOB 131 IN PRINT PROCESS
```

CHANGE-OF-STATUS REQUESTS

The operator may request that the job be given highest priority by typing the message

```
DO JOB xxx
```

The job will retain highest priority for all succeeding stages.

To request that the job be deleted, the operator should type the message

```
DELETE JOB xxx
```

In this case, no \$ATEND card parameters will be applied. The job immediately enters the purge stage and there will be no output for the job.

DUPLICATING 7040 ENTRY-KEY FUNCTIONS ON 1014

To duplicate on the 1014 any of the functions initiated through the 7040 console entry keys (except for job-status inquiries and requests), the operator should type the message

```
KEY kk
```

where kk is the desired 7040 key entry in octal.

SAVE-RESTORE DISK AND DRUM ROUTINE

When DCOS processing must be interrupted to permit processing of non-DCOS jobs or to take periodic checkpoints of the system, the Save-Restore Disk and Drum Routine may be used. This routine enables the operator to save (dump) the contents of selected tracks and modules of disk and drum on tape. These contents can later be loaded into their original locations by the same routine.

The operator specifies the desired dumps on the Save-Restore control card, which is described in the section "Save-Restore Card."

SAVE PROCEDURES

To dump the contents of disk and/or drum onto tape, the operator should:

1. Set sense switch 5 on. (This switch should remain on throughout the procedure.)
All current 7040 and 7090 tasks will be completed; no additional tasks will be started.
2. Ready a work tape on tape unit C1. If more than one tape will be required, ready additional work tapes on subsequent tape units C2, C3, ..., etc.

When the message

```
ALL 7090 JOBS AND 7040 SUPPORT FUNCTIONS ARE COMPLETE
```

is typed on the 7040 typewriter, all current tasks have been completed. The operator should then:

3. Place a Save-Restore control card behind the Save-Restore Routine card deck, stack entire deck in 1402, and ready the reader.
4. Enter into the entry keys a read select (+076203001230) for the reader.
5. Press 7040 CLEAR button.
6. Press 7040 RESET button.
7. Press 7040 LOAD button.

The following message will be typed on the console typewriter after the disk and/or drum have been saved on tape:

```
4 hhmss THE DISK HAS BEEN DUMPED
```

The system will then halt.

RESTORE PROCEDURES

To restore the contents of the disk and/or drum, the operator should:

1. Mount and ready on tape unit C1 the tape containing the contents of the disk and/or drum. If additional tapes were used for save procedures, mount these tapes, in order, on subsequent tape units C2, C3, ..., etc.
2. Place a Save-Restore control card behind the Save-Restore Routine card deck, stack entire deck in 1402, and ready the reader.
3. Enter into the entry keys a read select (+076203001230) for the reader.
4. Set sense switch 5 off.
5. Press 7040 CLEAR button.
6. Press 7040 RESET button.
7. Press 7040 LOAD button.

After the contents of the disk and/or drum have been restored, the following message will be typed:

```
4 hhmss THE DISK HAS BEEN LOADED
```

To resume normal job processing, the operator should follow the procedures described in the section "Load from Disk and Start Procedures."

SAVE-RESTORE CARD

The Save-Restore control card is used in conjunction with the Save-Restore Disk and Drum Routine. (This routine enables the operator to take checkpoints and to run non-DCOS jobs without destroying the contents of disk and drum storage units.) Tracks and/or modules to be saved (dumped) on tape are specified on this card.

The parameters may be any of the following:

```
DISK
DRUM
track number (0-9999 for disk)
              (0-399 for drum)
```

The parameters DISK and DRUM are used when an entire module is to be saved. A track number is specified when a portion of a module is to be saved, in which case all tracks up to and including that number will be dumped.

One or more parameters may be specified on the card. Each parameter may be punched anywhere within a specific five-column field. This field depends on the channel and module concerned, as shown below.

Card Columns	Channel	Module
1-5	B	0
6-10	B	1
11-15	B	2
16-20	B	3
21-25	C	0
26-30	C	1
31-35	C	2
36-40	C	3
41-46	D	0
46-50	D	1
51-55	D	2
56-60	D	3
61-65	E	0
66-70	E	1
71-75	E	2
76-80	E	3

Example of Save-Restore Card

```

          1   1   2   2           8
1   6   1   6   1   6           0
bDISKbb25bDRUMbbbbbb520bbb.....b
```

This card specifies the following dumps:

1. Module 0 of disk attached through channel B.
2. Tracks 0 through 25 of module 1 of unit attached through channel B.
3. Module 2 of drum attached through channel B.
4. Tracks 0 through 520 of module 0 of unit attached through channel C.

STOPPING THE SYSTEM IMMEDIATELY

If the system must be stopped immediately, the operator should press the CLEAR button on the 7040 console. Note that only current task processing will be negated. The operator may restart the system, and thus start again all tasks that were being performed when the system was stopped, by following the procedures described in the section "Load from Disk and Start Procedures." He should also refer to the section "Restarting the System" for further information. All tracks ready for PURGE, but not yet purged, will be lost to the system.

7040 AND DCOS FAILURES

If a 7040 stop occurs and the message

ALL 7090 JOBS AND 7040 SUPPORT FUNCTIONS
ARE COMPLETE

does not appear as the last message on the operator's log, a 7040 machine failure or DCOS malfunction has occurred. In this event, a stop will occur at 7040 octal location 270 and a message will be typed on the console typewriter indicating the possible cause of the failure and appropriate operator action to be taken.

A card reader error (e.g., a reader check) encountered while reading patches to the system or snapshot debugging requests will cause a system stop, at 7040 core location 270.

To restart the system, the procedures in the section "Load from Disk and Start

Procedures" should be followed. The operator should also refer to the section "Restarting the System."

RESTARTING THE SYSTEM

To restart the system after a system failure or an immediate stop, the operator should follow the procedures described in the section "Load from Disk and Start Procedures." All tasks being performed when the halt occurred will be restarted. All partially processed jobs and unprocessed jobs that were completely read into the system will be preserved. If, at the time of the halt, a job deck on cards has not been completely read into the system, that entire deck must be restacked in the 1402 card reader before restart procedures are carried out.

UTILITY ROUTINES

Utility routines provide the means for transmitting, blocking, and deblocking records. They are of special importance when running jobs under DCOS control because all tape input, except jobs being introduced on tape, must be in the standard DCOS record format. In addition, tape output, unless otherwise specified, is in the same format. These routines are handled either by DCOS or by the IBM 7040/7044 Operating System (16/32K), depending on the utility function desired.

DCOS-CONTROLLED UTILITY ROUTINES

DCOS-controlled utility routines are requested on \$SETUP and \$UTILITY control cards.

UTILITY ROUTINES SPECIFIED ON \$SETUP CARD

Utility functions that may be specified on the \$SETUP card pertain to tapes containing records of 457 or fewer words per physical record. (Tapes containing records of more than 457 words must be handled by 7040/7044 IJOB Tape Blocking utility routines.) These DCOS 7040/44 utility routines and the job phase in which they are performed are:

Preprocessing Phase

1. Tape-to-Tape Blocking Routine: This routine blocks tape records of 3 to 457 words into standard DCOS format and writes these records on another tape.
2. Tape-to-Disk Blocking Routine: This routine blocks tape records of 3 to 457 words into standard DCOS format and loads these records onto the disk.

For jobs with both multiple reels and multiple files, tape-to-tape blocking by the 7040/7044 IJOB Tape Blocking Utility Routine, rather than by DCOS, is advised. Otherwise, job turnaround time may be significantly increased.

Postprocessing Phase

1. Tape-to-Tape Deblocking Routine: This routine converts records written on tape in standard DCOS format to the format (3 to 457 words) specified in the program and writes them on another tape.
2. Disk-to-Tape Deblocking Routine: This routine writes records, stored on the disk, onto tape in the format (3 to 457 words) specified by the programmer.

On-line messages will notify the operator to mount and ready the required tapes at the appropriate time.

UTILITY ROUTINES SPECIFIED ON \$UTILITY CARD

When a job involves only transmission of records to or from tape in standard DCOS format, the \$UTILITY control card is used. (No 7090 processing will be performed.) The desired utility routine, the format and spacing of printed output, the type of paper or cards to be used for the output, and the number of files to be processed, are specified on this card. It is placed after the \$JOB card and before any associated data cards.

The format of the \$UTILITY card is:

1 16
\$UTILITY utility name,tape ident,
 [option 1], [option 2], [option 3]

The parameters are:

utility name
The utility name parameter may be any one of the following:

<u>Parameter</u>	<u>Explanation</u>
TPPR	Requests the Tape-to-Printer Routine, which causes tape records in standard DCOS format to be printed on the 1403 printer.

TPPU Requests the Tape-to-Punch Routine, which causes tape records in standard DCOS format to be punched on cards.

CDTP Requests the Card-to-Tape Routine, which reads records from cards and writes them on tape in standard DCOS format.

The Card-to-Tape Routine, the Tape-to-Printer Routine, and the Tape-to-Punch Routine may be requested within the same job. However, care must be taken to place the \$UTILITY cards correctly in the job deck. The card specifying the Card-to-Tape Routine must immediately precede the data cards.

tape ident

The tape ident parameter is the installation reel identification; that is, the identification written on a label affixed to the tape reel. It may be a maximum of six alphanumeric characters.

option 1, option 2, option 3

As shown below, these options depend upon the utility specified.

Utility

<u>Name</u>	<u>option 1</u>	<u>option 2</u>	<u>option 3</u>
TPPR	form control	form ident	file count
TPPU	form ident	file count	
CDTP			

The form control parameter specifies the desired format and spacing of printed output. It may be any of the following:

{ PROGRAM }
 { SINGLE }
 { DOUBLE }
 { 720 }

If PROGRAM is specified, desired spacing must be provided in the program. 720 has no effect on the distributed system, and is recognized only for compatibility with previously existing jobs. If form control is not specified, PROGRAM will be assumed.

The form ident parameter defines the type of paper or cards to be used for output. Any available type, for example, 2PART or VELLUM, may be specified. A maximum of six characters is allowed. Any characters except blanks or commas may be used.

When DCMUP selects the job for processing, the \$UTILITY card is analyzed. If the form ident is not included, cards or paper

currently ready will be used. If the form ident has been specified, the following message will be typed:

4*hhmmss JOB xxx READY xxxxxx

FORM ON {PRINTER n}
 {PUNCH }

The operator should take the printer or punch out of ready status, provide the proper paper or cards, and then return the unit to ready status. When these procedures have been performed, processing of the job will resume. After using special card forms in the punch, accounting cards put out by the system will be punched on these special forms until a job with punched output is to be processed. The operator will then be requested, by the system, to revert to the previous forms.

The file count is the number of files to be processed. If this option is omitted, a file count of 1 is assumed.

7040/7044 UTILITY ROUTINES

The three 7040/7044 IBJOB tape blocking and deblocking routines included on the DCOS Distribution Tape are:

1. Tape Blocking Routine: This routine blocks tapes that are to be edited onto the disk into the standard DCOS record format. Records that are to be blocked may contain from 3 to 17,400 words per record.
2. System Tape Blocking Routine: When a non-IBSYS system tape is to be edited into the system library, it must contain a loading program and must be blocked into the standard DCOS format. The System Tape Blocking Routine performs these functions.
Note: Detailed information for using this routine is provided in the section "Incorporating Non-IBSYS Systems or Programs" in the publication IBM 7090-7040 Direct Couple Operating System: Systems Programmer's Guide, Form C28-6383.
3. Tape Deblocking Routine: This routine deblocks any tape records written in standard DCOS format into their original record format. Logical records that are to be deblocked may be from 3 to 17,400 words.

These utility routines are relocatable object programs written for the 7040/7044 Operating System (16/32K) which has been assembled for 32,768 words of core storage. No other routine or system, including DCOS, can operate while the 7040/7044 System is in control.

Each reel of tape to be blocked or deblocked requires one control card. This card should be placed after the appropriate utility program deck. The format of this card is:

<u>1-30</u>	<u>31-36</u>	<u>37-42</u>
job ident	output reel number (right justified)	number of files to be processed (right justified)

where:

job ident
The identification assigned by the user; it may be any combination of characters and blanks.

output reel number
The numeric identification assigned to the output reel by the user. (The control card for the system tape blocking routine should have the system name (left justified) in columns 31-36.)

number of files to be processed
Must be a decimal integer.

Multiple reels of tape may be blocked or deblocked during the same run, with each reel specified on a separate control card. Multiple input reels will yield an equal or greater number of output reels (a single input reel may yield more than one output reel).

Prior to actual job execution, the following tape-mounting message will be issued to the operator:

```
SET UP JOB job ident MOUNT INPUT ON  
xx AND SCRATCH TAPE CN yy
```

where xx and yy are 7040 tape units.

Should a read error occur during processing, a message identifying the record and file number of the record in error will be typed. The record will be assumed to be valid, and processing will continue.

If an end-of-tape mark is encountered on the output tape before processing has been completed, the system will take the following action:

1. A message noting the condition and identifying the record and its reel number will be typed.
2. System Tape Blocking Routine: When a non-IBSYS system tape is to be edited into the system library, it must contain a loading program and must be blocked into the standard DCOS format. The System Tape Blocking Routine performs these functions.
3. Processing will continue on an alternate unit with the reel number increased by one.

After the specified number of files have been blocked or deblocked, the following message will be typed:

```
JOB job ident IS COMPLETED, TAPE ON  
yy IS NOW TAPE NUMBER output reel  
number
```

where yy is a 7040 tape unit.

Procedures for operating the 7040/7044 IBSYS Operating System are described in the publication IBM 7040/7044 Operating System (16/32K): Operators Guide, Form C28-6338.

7040 DUMP PROGRAM

This absolute object program is used to dump 7040 core storage on line, using an intermediate work tape on tape unit C5. After reading in the card deck, the message

READY CARDS OR KEYS

will appear on the console typewriter. At this point the operator should

1. Set in the keys:
+10aaaaa0bbbb
where aaaaa,bbbb are the lower and upper limits, respectively, of the core storage area to be dumped.
2. Set sense switch 6 on, and
3. Press START.

The dump will appear on the printer connected with interface 3 of the 7040.

MESSAGES

This section contains, in alphabetical order, the DCOS messages that are typed on either the 7040 console typewriter or the 1014. An explanation of each message and any required operator action are also provided.

In addition to the messages in this section, any label handling or label error messages given by IOCS in the IJOB Processor will be typed on-line.

Most messages from the system are preceded by a 12-character prefix of the form

bo [*] hhhmssb [c] b

where:

- b signifies a blank.
- o identifies the originator of the message (4=7040, 9=7090).
- * indicates that the message is operator pertinent (may require operator action).
- hhhmss is the time (hour, minute, second) at which the message was typed.
- c is a 0 for message originated by the 7090.

All disk and tape error messages are indicated by the sign < preceding the body of the message.

ALL CARDS PUNCHED, PUT UP SW2, PUSH START

Explanation: The DCOS card decks contained on the DCOS Distribution Tape have been punched.

Action: Self-explanatory.

ALL 7090 JOBS AND 7040 SUPPORT FUNCTIONS ARE COMPLETE

Explanation: The system has halted after having completed all 7040 and 7090 tasks.

Action: No operator action is required.

CORE ERROR

Explanation: A 7040 core storage parity error was encountered while reading the system from tape.

Action: Restart the system initialization process.

CXSUM ERROR

Explanation: A redundancy was encountered while reading the system from tape.

Action: Restart the system initialization process.

DELETE JOB xxx

Explanation: The operator has requested that job xxx be deleted from the system.

Action: No operator action is required.

4 hhhmss <DISK ERROR CHANNEL x disk command

- INVALID SEQUENCE
- INVALID CODE
- FORMAT CHECK
- NO RECORD FOUND
- INVALID ADDRESS
- RESPONSE CHECK
- DATA COMPARE CHECK
- PARITY CHECK
- ACCESS INOPERATIVE
- ACCESS NOT READY
- 7631 CIRCUIT CHECK
- 7631 ADAPTER CHECK

Explanation: The specified disk error has occurred on channel x after the disk command was given. The error has been corrected, and processing will proceed normally.

The disk command is of the form

8x	0	x	xxxx
↑	↑	↑	↑
opera-	access	module	track
tion	arm		
code			

where the operation code is one of the following:

- 80 = seek
- 84 = write command
- 85 = read command

Action: No operator action is required. However, a customer engineer should be notified of the condition.

DO JOB xxx

Explanation: The operator has requested that job xxx be given highest priority.

Action: No operator action is required.

END OF TAPE ON UNIT xx. REMOVE, MOUNT BLANK REEL TO CONTINUE.

Explanation: An end-of-tape was reached before the end of the job.

Action: Self-explanatory

ENTER BCD TIME OF DAY IN KEYS, HHMMSS, TURN ON CLOCK, PUSH START

Explanation: The system has halted after DCMUP was loaded from the disk into 7040 core storage. This halt allows the operator to enter the time of day and turn on the clock.

Action: Place time of day, in BCD (hour, minute, second), in entry keys, turn on 7040 console storage clock, and press 7040 START button.

4*hhmmss FCB NOT FOUND FOR PRIMARY BUFFER.
DUMP, NOTIFY SE, AND USE DISK RESTART PROCEDURE.

or possibly

4*hhmmss FCB NOT FOUND FOR SECONDARY BUFFER.
DUMP, NOTIFY SE, AND USE DISK RESTART PROCEDURE.

Explanation: A stop at 7040 octal location 270 has occurred because a file control block has not been found that corresponds to a primary or secondary buffer.

Action: Self-explanatory

4*hhmmss JOB xxx<ALTERNATE INPUT TAPE CHECK

Explanation: A tape record error has been detected while job xxx was being read into the system. The job has been deleted.

Action: No operator action is required.

4 hhhmmss JOB xxx BEING DELETED FROM QUEUE

Explanation: Upon operator request, job xxx has been deleted from the system.

Action: No operator action is required.

4*hhmmss JOB xxx CARD READER CHECK

Explanation: An error has been detected while a card was being read into the system. Job xxx has been deleted. (This message can only occur in systems assembled with parameter RDRCK set to 0.)

Action: The operator may take one of the following two actions:

1. If card is correctly punched, restack job in 1402.
2. If card is mispunched or if it was jammed, repunch card, if possible, and restack job in 1402.

4*hhmmss JOB xxx CARD READER CHECK, RE-READ CARD.

Explanation: An error was detected while a card was being read into the system. Job xxx has not been deleted, and the card may be reread. (This message occurs only when assembly parameter RDRCK is set to 1.)

Action: Clear reader, insert unread cards, ready the card reader, reread card.

4 hhhmmss JOB xxx DISCONTINUE PRINTER x

Explanation: The system has responded to the operator's request to discontinue or restart printed output for job xxx on printer x.

Action: No operator action is required.

4 hhhmmss JOB xxx HAS BEEN GIVEN HIGHEST PRIORITY

Explanation: Upon operator request, job xxx has been given highest priority.

Action: No operator action is required.

4 hhhmmss JOB xxx HAS EXCEEDED ITS JOB DESCRIPTION BLOCK

Explanation: Too many task descriptions have been created for job xxx. The job has been terminated.

Action: No operator action is required.

4 hhhmmss JOB xxx IN

}	SETUP	}	{	
	EXECUTION			
	BREAKDOWN			QUEUE
	PRINT			PROCESS
	PUNCH			
	PURGE			
UTILITY				

Explanation: This message is a response to a job-status inquiry. It indicates the current stage of job xxx or speci-

DO JOB xxx

Explanation: The operator has requested that job xxx be given highest priority.

Action: No operator action is required.

ENTER BCD TIME OF DAY IN KEYS, HHMMSS, TURN ON CLOCK, PUSH START

Explanation: The system has halted after DCMUP was loaded from the disk into 7040 core storage. This halt allows the operator to enter the time of day and turn on the clock.

Action: Place time of day, in BCD (hour, minute, second), in entry keys, turn on 7040 console storage clock, and press 7040 START button.

4*hhmmss FCB NOT FOUND FOR PRIMARY BUFFER.
DUMP, NOTIFY SE, AND USE DISK RESTART PROCEDURE.

or possibly

4*hhmmss FCB NOT FOUND FOR SECONDARY BUFFER.
DUMP, NOTIFY SE, AND USE DISK RESTART PROCEDURE.

Explanation: A stop at 7040 octal location 270 has occurred because a file control block has not been found that corresponds to a primary or secondary buffer.

Action: Self-explanatory

4*hhmmss JOB xxx<ALTERNATE INPUT TAPE CHECK

Explanation: A tape record error has been detected while job xxx was being read into the system. The job has been deleted.

Action: No operator action is required.

4 hhhmmss JOB xxx BEING DELETED FROM QUEUE

Explanation: Upon operator request, job xxx has been deleted from the system.

Action: No operator action is required.

4*hhmmss JOB xxx CARD READER CHECK

Explanation: An error has been detected while a card was being read into the system. Job xxx has been deleted. (This message can only occur in systems assembled with parameter RDRCK set to 0.)

Action: The operator may take one of the following two actions:

1. If card is correctly punched, restack job in 1402.
2. If card is mispunched or if it was jammed, repunch card, if possible, and restack job in 1402.

4*hhmmss JOB xxx CARD READER CHECK, RE-READ CARD.

Explanation: An error was detected while a card was being read into the system. Job xxx has not been deleted, and the card may be reread. (This message occurs only when assembly parameter RDRCK is set to 1.)

Action: Clear reader, insert unread cards, ready the card reader, reread card.

4 hhhmmss JOB xxx DISCONTINUE PRINTER x

Explanation: The system has responded to the operator's request to discontinue or restart printed output for job xxx on printer x.

Action: No operator action is required.

4 hhhmmss JOB xxx HAS BEEN GIVEN HIGHEST PRIORITY

Explanation: Upon operator request, job xxx has been given highest priority.

Action: No operator action is required.

4 hhhmmss JOB xxx HAS EXCEEDED ITS JOB DESCRIPTION BLOCK

Explanation: Too many task descriptions have been created for job xxx. The job has been terminated.

Action: No operator action is required.

4 hhhmmss JOB xxx IN

{	SETUP	}	{	
	EXECUTION			
	BREAKDOWN			QUEUE
	PRINT			PROCESS
	PUNCH			
PURGE				
UTILITY				

Explanation: This message is a response to a job-status inquiry. It indicates the current stage of job xxx or specifies that the job requires record transmission only (UTILITY). It also indicates whether the job is waiting to enter (QUEUE) or has entered (PROCESS) the specified stage.

An inquiry about a job that is in the

fies that the job requires record transmission only (UTILITY). It also indicates whether the job is waiting to enter (QUEUE) or has entered (PROCESS) the specified stage.

An inquiry about a job that is in the

process of being purged will result in the message

4 hhmss JOB xxx NOT IN QUEUE

rather than the message

4 hhmss JOB xxx IN PURGE PROCESS

Action: No operator action is required.

4 hhmss JOB xxx IN QUEUE. \$JOB
(contents of columns 31-60
of \$JOB card)

Explanation: Job xxx is being read into the system.

Action: No operator action is required.

4 hhmss JOB xxx IS NOT IN THE QUEUE

Explanation: This message is a response to a job-status inquiry made by the operator. It indicates that job xxx is not in any stage of processing.

Action: No operator action is required.

4 hhmss JOB xxx IS PRINTING ON x

Explanation: Output for job xxx is being printed on printer x.

Action: No operator action is required.

4*hhmss JOB xxx 90 IS STOPPED
AT xxxxx

Explanation: A valid 7090 intermediate or terminal stop has occurred at location xxxxx. This message is typed only if sense switch 2 is on.

Action: To continue 7090 processing after an intermediate stop, enter code 50 in entry keys and set sense switch 6 on. Terminal stops do not require operator action.

4*hhmss JOB xxx 90 WAS STOPPED
AT xxxxx

Explanation: A valid 7090 intermediate stop occurred at location xxxxx. Processing of job xxx has been automatically resumed. This message is typed only if sense switch 2 is off.

Action: No operator action is required.

4 hhmss JOB xxx<NOISE RECORD ON xx

Explanation: A noise record has been detected while the tape mounted on 7040 tape unit xx was being read. The record has been ignored.

Action: No operator action is required.

4 hhmss JOB xxx ON 90

Explanation: Job xxx is being loaded into the 7090 for processing.

Action: No operator action is required.

4 hhmss JOB xxx ON PUNCH

{REPEAT
DISCONTINUED
RESTART}

Explanation: The system has responded to the operator's request for job xxx.

Action: No operator action is required.

4*hhmss JOB xxx PUNCH ERROR - CLEAR
PUNCH

Explanation: A punch error has occurred while output for job xxx was being punched.

Action: Clear punch, enter code 34 in entry keys, and set sense switch 6 on. If the START button on the punch is pressed after clearing the punch, when sense switch 6 is off, and when 34 is not entered in the entry keys, punching will continue, but duplicate cards might be punched.

4*hhmss JOB xxx PUNCH TRANSFER ERROR -
CARD DROPPED

Explanation: A card has dropped into the 1402 Punch error hopper.

Action: No operator action is required.

4 hhmss JOB xxx PURGED

Explanation: Job xxx has been purged from the system.

Action: No operator action is required.

4 hhmss JOB xxx<READ ERROR ON xx

Explanation: A permanent read error has occurred on 7040 tape unit xx. Job xxx has been terminated.

Action: No operator action is required.

4*hhmss JOB xxx READY xxxxxx FORM ON

Explanation: This message will also be printed if the file contains a BCD record greater than 14 words or a binary record greater than 28 words.

process of being purged will result in the message

4 hhmms JOB xxx NOT IN QUEUE

rather than the message

4 hhmms JOB xxx IN PURGE PROCESS

Action: No operator action is required.

4 hhmms JOB xxx IN QUEUE. \$JOB
(contents of columns 31-60
of \$JOB card)

Explanation: Job xxx is being read into the system.

Action: No operator action is required.

4 hhmms JOB xxx IS NOT IN THE QUEUE

Explanation: This message is a response to a job-status inquiry made by the operator. It indicates that job xxx is not in any stage of processing.

Action: No operator action is required.

4 hhmms JOB xxx IS PRINTING ON x

Explanation: Output for job xxx is being printed on printer x.

Action: No operator action is required.

4*hhmms JOB xxx 90 IS STOPPED
AT xxxxx

Explanation: A valid 7090 intermediate or terminal stop has occurred at location xxxxx. This message is typed only if sense switch 2 is on.

Action: To continue 7090 processing after an intermediate stop, enter code 50 in entry keys and set sense switch 6 on. Terminal stops do not require operator action.

4*hhmms JOB xxx 90 WAS STOPPED
AT xxxxx

Explanation: A valid 7090 intermediate stop occurred at location xxxxx. Processing of job xxx has been automatically resumed. This message is typed only if sense switch 2 is off.

Action: No operator action is required.

4 hhmms JOB xxx<NOISE RECORD ON xx

Explanation: A noise record has been detected while the tape mounted on 7040 tape unit xx was being read. The record has been ignored.

Action: No operator action is required.

4 hhmms JOB xxx ON 90

Explanation: Job xxx is being loaded into the 7090 for processing.

Action: No operator action is required.

4 hhmms JOB xxx ON PUNCH

{REPEAT }
{DISCONTINUED}¹
{RESTART }

Explanation: The system has responded to the operator's request for job xxx.

Action: No operator action is required.

4*hhmms JOB xxx PUNCH ERROR - CLEAR
PUNCH

Explanation: A punch error has occurred while output for job xxx was being punched.

Action: Clear punch, enter code 34 in entry keys, and set sense switch 6 on. If the START button on the punch is pressed after clearing the punch, when sense switch 6 is off, and when 34 is not entered in the entry keys, punching will continue, but duplicate cards might be punched.

4*hhmms JOB xxx PUNCH TRANSFER ERROR -
CARD DROPPED

Explanation: A card has dropped into the 1402 Punch error hopper.

Action: No operator action is required.

4 hhmms JOB xxx PURGED

Explanation: Job xxx has been purged from the system.

Action: No operator action is required.

4 hhmms JOB xxx<READ ERROR ON xx

Explanation: A permanent read error has occurred on 7040 tape unit xx. Job xxx has been terminated.

Action: No operator action is required.

4*hhmms JOB xxx READY xxxxxx FORM ON

¹This message will also be printed if the file contains a BCD record greater than 14 words or a binary record greater than 28 words.

{ PRINTER n }
{ PUNCH }

Explanation: The programmer has requested a particular type of paper or of cards to be used for output for a DCOS utility job.

Action: Take printer or punch out of ready status, provide specified form, and return printer or punch to ready status.

4*hhmmss JOB xxx READY {BLANK}
{ident}
ON UNIT xx [WITH NO RING]

Explanation: The operator is requested to mount and ready a tape on 7040 tape unit xx.

Action: Mount and ready tape according to specifications provided in the message.

4*hhmmss JOB xxx SYSTEM NOT ASSEMBLED
FOR COMPATIBILITY MODE

Explanation: The system has been requested to run in compatibility mode, but has not been assembled to do so. Job xxx is deleted. This message occurs only when DCMUP is assembled with CMPKG set to 0.

Action: No operator action is required.

4 hhhmss JOB xxx<TAPE xx - xxx READ ERRS
yyy WRITE ERRS

Explanation: After 7040 tape unit xx has been rewound and unloaded, a summary of permanent read errors (xxx) and write errors (yyy), if any occurred, is written out for use at the installation.

Action: No operator action is required.

4 hhhmss JOB xxx TERMINATED

Explanation: 7090 processing of job xxx has been terminated prior to successful completion, possibly upon operator request for termination or restart. (See section on "Entry Keys.")

Action: No operator action is required.

4 hhhmss JOB xxx TERMINATED POSSIBLE LOOP

Explanation: The operator has terminated 7090 processing of job xxx by entering code 10 in the entry keys. This message will also appear when list or time estimate has been exceeded.

Action: No operator action is required.

4 hhhmss JOB xxx <UNIT xx-25 ERASES ON
WRITE

Explanation: Twenty-five consecutive attempts to write on unit xx have failed due to write redundancy. The system will continue attempting to write successfully on this unit.

Action: No operation action is necessary. If the error persists, the job may be deleted.

KEY kk

Explanation: The operator has made a request on the 1014 by duplicating the 7040 entry-key setting kk.

Action: No operator action is required.

4*hhmmss KEYS OUT OF RANGE, TRY AGAIN

Explanation: An invalid entry-key setting has been encountered by the system.

Action: Place correct entry in keys and set sense switch 6 on.

LOCATE JOB xxx

Explanation: The operator has made this request to determine the status of job xxx. The system will type a response to this request.

Action: No operator action is required.

4 hhhmss MULTI-PROCESSOR SKIPPING FOR
\$JOB CARD

Explanation: A job that was being read into the system from cards or tape has been deleted. The system is ignoring all input for this job.

Action: No operator action is required.

4 hhhmss OCTAL KEYS xx SET

Explanation: Entry-key setting xx has been recognized by the 7040.

Action: No operator action is required.

9*hhmmss 0 contents of columns 7-72 of
\$PAUSE card

9*hhmmss 0 PAUSE

Explanation: The 7090 has read a \$PAUSE card included to allow time for some programmer-specified operator action(s). The contents of columns 7 through 72 of the \$PAUSE card may contain instructions to the operator.

Action: Perform task(s) specified in 7090 message(s) preceding the message

9*hhmmss 0 PAUSE

To resume 7090 processing, enter code 50 in the entry keys and set sense switch 6 on. The message

9*hhmmss 0 PROCEEDING

will then be typed.

9*hhmmss 0 PAUSE

Explanation: The 7090 .PAUSE routine has been called by the program to enable the operator to perform action specified in the 7090 message(s) preceding this one.

Action: Perform task(s) specified in preceding 7090 message(s). To resume 7090 processing, enter code 50 in entry keys and set sense switch 6 on. The message

9*hhmmss 0 PROCEEDING

will then be typed.

9*hhmmss 0 PAWS

Explanation: An object program has transferred control to the .PAWS routine which has printed the above message and caused the 7090 to halt. This stop allows time for the operator to perform action specified in the 7090 message(s) preceding this one.

Action: Perform task(s) specified in preceding message(s). To resume 7090 processing, enter code 50 in entry keys and set sense switch 6 on. The message

9*hhmmss 0 PROCEEDING

will then be typed.

4*hhmmss <PERMANENT DISK ERROR - disk command

Explanation: A permanent disk error has occurred after the specified disk command was given.

The disk command is of the form

8x	0	x	xxxx
↑	↑	↑	↑
opera-	access	module	track
tion	arm		
code			

where the operation code is one of the following:

80 = seek

84 = write command
85 = read command

Action: Contact a customer engineer.

4*hhmmss <PERMANENT DISK ERROR - READY FILE CONTROL

Explanation: The disk is inoperative either because one or more of the switches has been set incorrectly or because a disk malfunction has occurred.

Action: Correct switch setting(s) if in error. If disk remains inoperative, contact a customer engineer.

4*PERMANENT REDUNDANCY ON SYSTEM TAPE. PUSH START TO BEGIN AGAIN

Explanation: The system has halted because a permanent read error on the DCOS Distribution Tape occurred during system initialization.

Action: To restart system initialization, press 7040 START button. If error persists, use another DCOS Distribution Tape.

9*hhmmss 0 PROCEEDING

Explanation: 7090 processing has been resumed by the operator after a valid intermediate stop.

Action: No operator action is required.

PUNCH HOLE COUNT ERROR. RUN OUT BAD CARDS, PUSH START

Explanation: A hole count error has been detected while punching the DCOS card decks contained on the DCOS distribution tape.

Action: Self-explanatory.

PUNCH TRANSFER ERROR. BAD CARD DROPPED

Explanation: A punch error has occurred while punching the DCOS card decks contained on the DCOS distribution tape.

Action: No operator action is required.

4*hhmmss PUSH START TO BEGIN AGAIN SEQUENCE ERROR RECORD xxx

Explanation: This message appears during the loading of DCSYS if the record sequence is out of order.

Action: Push start and try again. If error persists, re-edit or use another system tape.

RDY CD

Explanation: Sense switch 4 is on for system initialization, but the disk format control cards have not been placed in the 1402.

Action: Place the disk format control cards in the 1402 and ready the card reader.

4*hhmmss <READY DRIVE xx

Explanation: 7040 tape unit xx has been made ready, but is no longer ready.

Action: Ready 7040 tape unit xx. Processing of the job will then be resumed.

4*hhmmss REPEAT LAST REQUEST

Explanation: The latest request cannot be serviced because the system has not responded to the previous request. A job in the utility stage will cause this message in response to keys 27.

Action: Re-enter the request.

4*hhmmss REPEAT REQUEST, INCLUDE VALID JOB NUMBER

Explanation: The operator has specified the number of a job not currently being processed by the system.

Action: Enter request with correct job number (in octal).

4*hhmmss REPEAT REQUEST, 1014 ERROR

Explanation: An error has occurred during transmission of an operator request from the 1014 to 7040 core storage.

Action: Repeat request. If message occurs several times, notify a customer engineer of condition.

4*hhmmss REPEAT REQUEST WITH VALID VERB

Explanation: The operator has entered on the 1014 a job-status inquiry or a change-of-status request containing a verb that the system cannot recognize. (The verbs LOCATE, DO, and DELETE are the only ones recognized.) The request is ignored.

Action: Enter valid request.

4*hhmmss STORAGE PARITY CHECK AT LOC xxxxxx, NOTIFY CE.

Explanation: A stop has occurred at 7040 octal location 270 because of a storage parity check indicating that stored data is unreliable. Notify a customer engineer at once.

Action: Self-explanatory.

4*hhmmss STR AT LOC xxxxxx
DUMP, NOTIFY SE, AND USE DISK
RESTART PROCEDURE

Explanation: A stop has occurred at 7040 octal location 270 because an STR (Store and Trap) instruction has been encountered during DCOS processing.

Action: Self-explanatory.

4*hhmmss SYSTEM OUT OF TRACKS, PROCEEDING WITH OUTPUT ONLY.

Message Written on: Both the console typewriter and 1014.

Explanation: All tracks on all modules of disk are currently in use by previous jobs. The job currently on the 7090 is terminated and returned to the execution queue.

Action: When the message

ALL 7090 JOBS AND 7040 SUPPORT
FUNCTIONS ARE COMPLETE

is typed, use the disk restart procedure with sense switch 3 out.

4 hhhmmss 7090 IS IDLE

Explanation: No job is currently being processed by the 7090.

Action: No operator action is required.

4*hhmmss 7090 IS IDLE, SETUP PENDING

Explanation: No job is currently being processed on the 7090. One or more jobs requiring the mounting of tapes is waiting in the SETUP queue.

Action: Mount and ready any tapes for which mounting has been requested but not yet performed.

TAPE ERROR

Explanation: A redundancy was encountered while reading data from the system tape. There is a halt at 121₈.

Action: Restart the system initialization process.

4 hhhmmss 1014 NO LONGER USED DUE TO PARITY ERRORS

Explanation: Because an excessive number of parity errors has occurred on the 1014, all messages will be typed on the 7040 typewriter and none will appear on the 1014.

Action: Contact a customer engineer.

4 hhmss THE DISK HAS BEEN DUMPED

Explanation: The specified contents of disk and/or drum have been saved on tape during a Save procedure.

Action: No operator action is required. (Non-DCOS jobs may be processed.)

4 hhmss THE DISK HAS BEEN LOADED

Explanation: The specified contents of disk and/or drum have been restored during a Restore procedure.

Action: No operator action is required. (DCOS job processing may be initiated by following procedures described in the section "Load from Disk and Start Procedures.")

4 hhmss TSL FROM LOC xxxxxx-PROBABLE

LOGIC OR MACHINE ERROR
DUMP, NOTIFY SE, AND USE DISK
RESTART PROCEDURE.

Explanation: A general trap stop has occurred at 7040 octal location 270.

Action: Self-explanatory.

9*hhmss 0 contents of columns 7-42 of \$* card.

Explanation: The contents of columns 7 through 72 of a \$* card are typed in this message. These columns frequently contain instructions to the operator that should be followed when the message

9*hhmss 0 PAUSE

is typed.

Action: Perform specified task during 7090 halt.

APPENDIX A: MACHINE CONFIGURATION

As distributed, DCOS requires at least the following equipment:

1. An IBM 7090, 7094, or 7094 II Data Processing System. (Data channels are neither required nor used.)
2. The Direct Couple Feature.
3. An IBM 7040 or 7044 Data Processing System with 32,768 words of core storage, the Extended Performance Instruction Set, the Storage Clock and Interval Timer, and the following input/output units:
 - a. An IBM 1014 Remote Inquiry Unit.
 - b. An IBM 1402-2 Card Read Punch, attached through an IBM 1414-4 Input/Output Synchronizer with the Read and Punch Column Binary Feature and the Read Card Image Feature.
 - c. An IBM 1403 Model 2 or 3 Printer.
 - d. An IBM 1301 Model 1 Disk Storage Unit and an IBM 7631 File Control with the Cylinder Mode feature, attached through an IBM 7904 Data Channel with the Direct Read to Coupled Processor feature.

- e. Five IBM 729 Model II, IV, V, or VI Magnetic Tape Units.¹

Additional input/output units may be attached to the 7040 or 7044 to achieve the following configuration:

1. Four IBM 7904 Data Channels.
2. Three IBM 1403 Model 2 or 3 Printers.
3. As many as ten modules of IBM 1301 Model 1 or 2 Disk Storage Units (a maximum of four modules on any one channel).
Note: Except for the one module of 1301 Disk Storage required, IBM 7320 Drum Storage Units may be substituted for any of the even numbered modules of disk storage. A maximum of five drum modules is allowed.
4. Forty IBM 729 II, IV, V, or VI Magnetic Tape Units.

¹Certain applications may be performed satisfactorily with two IBM 729 Magnetic Tape Units. The five required tape units ensure satisfactory performance for system operation.

INDEX

This is a master index for all three Direct Couple Operating System guides. References are keyed to the individual publications by the following codes:

- PG = Programmer's Guide, Form C28-6382
- SPG = Systems Programmer's Guide, Form C28-6383
- OG = Operator's Guide, Form C28-6384

Accounting routines			
for installations	61	SPG	
under DC-IBSYS	61	SPG	
Add Unit Designation to Message Routine			
calling sequence	36	PG	
Alphameric Punch Routine			
calling sequence	35	PG	
Alteration cards			
absolute column binary	50	SPG	
octal	52	SPG	
Backspace printer			
request to	20	OG	
Basic Supervisor			
\$EXECUTE	22	SPG	
\$ID	22	SPG	
Binary-to-BCD Conversion Routine			
MQ decrement	35	PG	
s,1-14 of MQ	35	PG	
Binary-to-Decimal Conversion Routine			
AC address	35	PG	
AC decrement	35	PG	
Bit maps			
master	83	SPG	
peripheral	82,83	SPG	
scratch	83	SPG	
Blocking records			
\$SETUP card	9,17,18	PG	
\$SETUP card	13,25	OG	
setup stage	10	OG	
stand-alone 7040/44 utility			
routines	26	OG	
utility routine	16	PG	
Breakdown stage			
description of	10	OG	
description of	13	PG	
Card input			
using	8,13	OG	
Card Read Punch			
function of	5	OG	
function of	8	PG	
Card-to-Tape Routine			
description and use of	26	OG	
Change-of-job-status request			
means of making	20,21,22	OG	
Channel			
activating a	34	SPG	
balancing at setup stage	12	PG	
indicators	10	SPG	
information block	10	SPG	
priority location	33	SPG	
registers	10	SPG	
trap	7	SPG	
unit priority on a	33	SPG	
Checkpoint of disk/drum			
control card for	23	OG	
procedures for taking	22,23	OG	
Codes			
system control	19	OG	
Comments card			
description of	14	OG	
function of \$* card	21	PG	
Communication region			
DC-IBSYS Nucleus	27,31,87	SPG	
SYSACC	61	SPG	
SYSCOR	62	SPG	
SYSCUR	63	SPG	
SYSGET	29	SPG	
SYSIDR	30,61	SPG	
SYSIOX	31	SPG	
SYSJOB	29,30	SPG	
SYSPID	62	SPG	
SYSRET	29	SPG	
SYSTRA	50,63	SPG	
symbolic and octal addresses	28	SPG	
Communication region table (DC-IOEX)			
description of	27	PG	
symbolic addresses of entries	27	PG	
Communication system			
THIS and THIS+1	8,37	SPG	
Commutator			
main DCOS commutator	10	SPG	
SETUP commutator gate	14	SPG	
Compatibility mode			
description of	14	PG	
description of	8	OG	
example of select plus entry	31	PG	
input/output activity	11,12	PG	
programming considerations	37-39	PG	
programs operating in	8	OG	
programs operating under	11	PG	
Console controls, 7040			
entry keys	19	OG	
sense switches	18	OG	
Control cards			
\$* card	21	PG	
\$* card	14	OG	
\$ASSIGN card	23	SPG	
\$ATEND card	20	PG	
\$ATEND card	14	OG	
\$CARDS card	24	SPG	
\$DATA card	13	OG	
\$DATA card	20	PG	
\$DATE card	15	OG	
\$DATE card	42	SPG	
\$ENDFILE card	24	SPG	
\$ENDREEL card	15	OG	

\$ENDROW card	13	OG	pool control word	13	SPG
\$ENDROW card	16	PG	Data processing system		
\$ENDROW card	25	SPG	7040, function of	5	OG
\$EOF card	13	OG	7090, function of	5	OG
\$EOF card	20	PG	DC Operating System		
\$EXECUTE card	13	OG	Core Storage Dump Program	21,27	SPG
\$EXECUTE card	15	PG	DC-IBSUP	7	SPG
\$EXECUTE card	7,8,22,30	SPG	DC-IBSYS	7	SPG
\$FILE card	33,75	SPG	DC-IBSYS Loader	27	SPG
\$IBEDT card	26,48	SPG	DC-IBSYS Monitor	21	SPG
\$IBSYS card	25,30	SPG	DC-IBSYS Nucleus	21,27,33,87	SPG
\$ID card	13	OG	DC-IBSYS Supervisor	22	SPG
\$ID card	20	PG	DC-IOEX	8,21,31-36	SPG
\$ID card	23,30	SPG	distribution tape	41	SPG
\$IOBASE card	17	PG	DC-IBSYS		
\$IOBASE card	13,14	SPG	components of	7	OG
\$JOB card	22	SPG	components of	10	PG
\$JOB card	12	OG	DC-IBSYS Monitor	10	PG
\$JOB card	15	PG	description of	7	OG
\$PAUSE card	21	PG	diagram of	7	OG
\$PAUSE card	14	OG	diagram of	11	PG
\$RELEASE card	24	SPG	execution stage	12	PG
\$REMOVE card	25	SPG	dump interpretation	40	PG
\$RESET card	24	SPG	execution stage	10	OG
\$RESTORE card	25	SPG	function of	10	PG
\$REWIND card	24	SPG	IBJOB processor	10	PG
\$ROW card	16	PG	phase controlled by	9	PG
\$ROW card	23,25	SPG	processing phase	9	PG
\$SETUP card	17	PG	subsystems operating under	7	OG
\$SETUP card	13,25	OG	DC-IBSYS Core Storage Dump Program		
\$SETUP card	13	SPG	(see also "dump")	10,24	PG
\$STOP card	25	SPG	DC-IBSYS Monitor		
\$SWITCH card	24	SPG	DC-IBSYS core storage dump		
\$TAPE card	24	SPG	program	10,24	PG
\$UNITS card	26	SPG	DC-IBSYS Nucleus	10	PG
\$UNLOAD card	25	SPG	DC-IBSYS patch routine	91	SPG
\$UTILITY card	25	OG	DC-IBSYS Supervisor	10	PG
\$UTILITY card	21	PG	DC-Input/Output Executor	10,27	PG
*AFTER card	53	SPG	diagram of	10	PG
*CHECK card	54	SPG	System Editor	10	PG
*DUP card	53	SPG	DC-IBSYS Nucleus		
*EDIT card	48	SPG	function of	10	PG
*INSERT card	52	SPG	DC-IBSYS Supervisor		
*MODIFY card	51	SPG	function of	10	PG
*PLACE card	48	SPG	DC-Input/Output Executor		
*REMARK card	54	SPG	(see also "DC-IOEX")		
*REMOVE card	53	SPG	description of	27	PG
*REPLACE card	51	SPG	function of	10	PG
*REWIND card	54	SPG	DC-IOEX		
checklist	61	PG	calling sequence for	30	PG
format index	58	PG	communication region table	28,29	PG
general format of	15	PG	functions of	27	PG
general format of	12	OG	location .COMM	32	PG
sample job deck	15	OG	location MODSW	31	PG
7/8EOF card	13	OG	maintenance of UCB fields	30	PG
7/8EOF card	20	PG	non-data selects	33	PG
Control words			redundancy message, suppression of	32	PG
buffer	13	SPG	select routine exits	31	PG
buffer pool	13	SPG	select routines	31	PG
logical record	13	SPG	sense indicators, contents of	32	PG
physical records	13	SPG	trap supervisor, description of ..	27	PG
Core storage, saving	92	SPG	trap supervisor, use of	27,30	PG
			unit control blocks	29	PG
			use of	27	PG
Data buffer			DC-IOEX utility routines		
control words	13	SPG	Alphameric Punch	35	PG
format	13	SPG			

Binary-to-BCD Octal Conversion ...	35	PG	input/output activity in	11	PG
Binary-to-Decimal Conversion	35	PG	program languages operating in ...	11	PG
Convert and Add Unit Designation to Message	36	PG	programming considerations	37-38	PG
Message Writer	34	PG	Discontinue		
Pause Routines	35	PG	job	19	OG
Post-Mortem Dump	35	PG	printed output	20	OG
Symbolic Unit Conversion	36	PG	punched output	20	OG
DCMUP			1014 typewriter	20	OG
description of	6	OG	7040 console typewriter	20	OG
function of	9	PG	7090 job processing	19	OG
patches to	91	SPG	Disk		
phases controlled by	9	PG	checkpoint of	23	OG
stages controlled by	12	PG	function of	8	PG
track allocation maps	82,83	SPG	function of	6	OG
utilities controlled by	9,10	PG	writing format tracks on	16	OG
DCOS concepts			Disk (drum)		
presentation of	8	PG	direct-read-to-processor bit	67	SPG
DCOS debugging aids program	90	SPG	existence and availability of modules	70	SPG
DCOS failures			format track generator	41	SPG
handling	24	OG	respecification of	67	SPG
DCOS Multiprocessor (see also "DCMUP")	9	PG	track allocation for utilities ...	67	SPG
DCOS Posteditor			track allocation/module definition	70	SPG
output	69,71	SPG	Disk-to-Tape Deblocking Routine		
phase I	67	SPG	description of	25	OG
phase II	67	SPG	Disk-to-Tape Deblocking Utility Routine		
restrictions and error messages	71.1	SPG	function of	10	PG
role of	67	SPG	Distribution		
DCOS PRESYS library			DCOS tape	41	SPG
arrangement of	43,50	SPG	DCSYS	41	SPG
location on tape	43	SPG	Drum		
preparation and maintenance	57-61,67	SPG	checkpoint of	23	OG
preparation of DCSYS from	68	SPG	function of	6	OG
preparing a backup	57	SPG	Dump		
DCOS record format			format of	24	PG
control words	91	SPG	\$ATEND card	20	PG
description of	9	PG	in DCOS	14,20	OG
description of	8	OG	instructions for	20	PG
DCOS-controlled utility routines			interpretation of	40	PG
use of	25	OG	limits of	25	PG
Deblocking records			machine status after	25	PG
breakdown stage	10	OG	panel dump	20,25	PG
\$SETUP card	13,25	OG	parameter control word	24	PG
\$SETUP card specifications	17-19	PG	post-mortem dump	24,35	PG
stand-alone 7040/44 utility routines	26	OG	snap dump	24	PG
utility routines	21	PG	specifications for	20,24	PG
Deck setups			System Core Storage Dump Program .	24	PG
examples of	22-23	PG	7040	27	OG
Deleting a job			7040 core storage snapshot	91	SPG
methods of	20	OG	Echo checking		
Direct Couple Input/Output Executor			routines relying on	38	PG
activating a channel	34	SPG	Editing		
assigning priority	34	SPG	examples	54,59-60	SPG
communication table	32	SPG	relocatable records	54	SPG
DC-IOEX	8,21,31-36	SPG	System Editor	20,24,43-56	SPG
non-data selects	35	SPG	termination of	54	SPG
organization	31	SPG	End-of-tape		
RDUN	35	SPG	condition	29,32,37	PG
structuring input/output requests	35	SPG	condition	19,19.1	SPG
unit control blocks	28,31,37,73	SPG	flag	29	PG
Direct mode			procedure	37	PG
description of	11	PG	Entry keys		
description of	7	OG	use of	19	OG
example of select plus entry	33	PG	Execution stage		

description of	10	OG	Input/output requests	
description of	12	PG	backspace file	39 SPG
Failures			backspace record	38 SPG
handling 7040	24	OG	channel indicator tests	40 SPG
File control block			compatibility mode	40 SPG
availability	16,74	SPG	data transmission	40 SPG
relationship to 7090 UCBS	73	SPG	direct mode	31,37,38 SPG
selection of	73	SPG	enable traps	40 SPG
7040	10,16,73	SPG	load and enter compatibility mode	39 SPG
7090	33	SPG	non-data selects	40 SPG
GETBUF			processing	7,37 SPG
as system macro or subroutine	92	SPG	read--compatibility mode	40 SPG
IBJOB Processor			read--direct mode	37 SPG
description of	7	OG	restore traps	40 SPG
description of	10	PG	rewind and unload	38 SPG
program languages operating under	10	PG	rewind input files	38 SPG
IBJOB unit assignment			rewind output files	38 SPG
considerations for using	46	PG	scatter-load DC-IBSYS	39 SPG
IBLDR unit assignment			sense instructions	40 SPG
considerations for using	46	PG	store channel	40 SPG
Immediate stop			time request	39 SPG
procedure for	24	OG	write--compatibility mode	40 SPG
Incorporating systems/programs under			write--direct mode	38 SPG
DCOS			write end of file	39 SPG
accounting routine into a			Input/output trapping	
subsystem	61	SPG	direct mode	11 PG
DCMUP utilities	63	SPG	Input/output units	
IBSYS systems in compatibility			compatibility mode	11 PG
mode	62	SPG	determining availability of	30 PG
IBSYS systems in direct mode	62	SPG	Installation accounting routine	
non-IBSYS systems	64	SPG	designing an	61 SPG
Initial start procedures			incorporating into a system	61 SPG
initiating job processing	16	OG	incorporating under DC-IBSYS	61 SPG
system initialization	16	OG	transfer to	23 SPG
Initiating job processing			Intermediate halts	
DCMUP in 7040	17	OG	restrictions for using	37,38,39 PG
DCMUP not in 7040	17	OG	Interpretation of dumps	
Input			communication region locations ...	42 PG
card	8,13	OG	DC-IBSYS 1obs	41 PG
data file requirements	8,25	OG	examining unit control blocks	44 PG
job file requirements	8,25	OG	key machine locations	40 PG
tape	8,18,25	OG	non-DC-IBSYS jobs	40 PG
Input stage			Interrupting 7090 processing	
description of	12	PG	by operator	20,22 OG
description of	9	OG	by programmer	15 OG
Input/output			Intersystem communication cells	
(see also "input" and "output") ...	8	OG	IBSNXT	29 SPG
compatibility mode	11	PG	IBSXEC	29 SPG
DC-IOEX, supervision of	27	PG	IBSYST	29 SPG
direct mode	11	PG	STOP	29 SPG
printing output file	19	PG	IOBASE tables	
punching output file	19	PG	description of	14 PG
servicing of	11	PG	Job	
tape	16,18	PG	breakdown	17 SPG
trapping	11	PG	definition of	12 OG
unit availability	30	PG	definition of	15 PG
utility routines	9,10	PG	description block	10,14,82 SPG
Input/output file control block base			number	13,16 SPG
DC-IBSYS (IOBASE 0)	13,78	SPG	number of	9 OG
IOBASE	12	SPG	priority of	12 OG
IOBASE table	12	SPG	queue table	7,8,10,11,14 SPG
IOBASE1	78	SPG	sample job deck	15 OG
number	12	SPG	separator card	16 SPG
			setup	14 SPG
			Job description	

preparation of	12	PG	messages	48	PG
use of	13	PG	DCOS	28	OG
Job execution			Message Writer Utility Routine ...	34	PG
execution stage	12	PG	prefix	9,28	OG
Job flow			tape mounting	13,18	PG
description of	10	OG	Modes of operation		
example of typical job flow	13	PG	compatibility	11	PG
description of stages	12	PG	compatibility mode	8	SPG
Job identifier			description of	7	OG
contents of	12	PG	difference between	11	PG
use of	12	PG	difference between	8	SPG
Job number			direct	11	PG
assignment of	9	OG	direct mode	8	SPG
Job processing			mode switch (MODSW)	35	SPG
description of	9	PG	MODSW		
description of	10	OG	use of	31	PG
example of	13	PG	Multiprocessor control program (DCMUP)		
initiating	16	OG	arrangement of	48	SPG
interrupting	15,20,22	OG	background utilities	16	SPG
restarting	21	OG	commutator	8	SPG
stages of	12,13	PG	control	21	SPG
stages of	9	OG	input service routine	14	SPG
supervision of	9	PG	introduction	7	SPG
terminating	20	OG	job breakdown	17	SPG
Job segment			job setup	14	SPG
definition of	13	OG	logic flow	8	SPG
occurrence within a job	15	PG	post-execution utilities	18	SPG
Job-status change			pre-execution utilities	17	SPG
means of making	22	OG	print routine	18	SPG
Job-status inquiry			punch routine	17	SPG
means of making	22	OG	Non-data selects		
Line estimate			calling sequence for	33	PG
description of	12	OG	NOPs		
Load from disk and start procedures			instructions treated as	38	PG
description of	17	OG	Operator's log		
Locating a job			description of	9	OG
via operator's log	9	OG	sample	9	OG
via 1014	22	OG	Output		
via 7040	19	OG	printed	8	OG
Machine configuration			punched	8	OG
description of	5	OG	tape	8,13,25	OG
function of each unit	8,9	PG	Panel dump		
minimum	66	PG	obtaining a	26-27	PG
Magnetic tape units			Pause Routines		
function of	8	PG	.PAUSE Routine	35	PG
Magnetic tapes			.PAWS Routine	36	PG
function of	6	OG	Phases of processing		
Maintenance control cards			description of	9	PG
*AFTER	53	SPG	description of	6,9	OG
*CHECK	54	SPG	diagram of	6	OG
*DUP	53	SPG	diagram of	9	PG
*INSERT	52	SPG	postprocessing	6,9	OG
*MODIFY	51	SPG	preprocessing	6,9	OG
*REMARK	54	SPG	processing	6,9	OG
*REMOVE	53	SPG	Posteditor (see DCOS Posteditor)		
*REPLACE	51	SPG	Post-Mortem dump		
*REWIND	54	SPG	DC-IOEX utility routine	34	PG
Message Writer Utility Routine			description of	24	PG
calling sequences for	34	PG	initiating	24	PG
classification of operator			specifications for	24	PG
messages	34	PG	Postprocessing phase		
message length	35	PG	breakdown stage	10	OG
Messages			breakdown stage	13	PG
classification of operator					

description of	6,9	OG	description of	8	OG
diagram of	12	PG	Punching output file		
print stage	10	OG	\$SETUP card specifications for 17-19	PG	
print stage	13	PG	Purge stage		
punch stage	10	OG	description of	11	OG
punch stage	13	PG	description of	13	PG
purge stage	11	OG	PUTBUF		
purge stage	13	PG	as system macro or subroutine	92	SPG
utilities	9	PG	Queue table		
utility stage	25	OG	contents of	13	PG
Preprocessing phase			Record format		
description of	6,9	OG	description of	8	OG
diagram of	12	PG	Record formats		
input stage	9	OG	data buffer	13	SPG
input stage	12	PG	library records	50,54	SPG
setup stage	10	OG	Records		
setup stage	12	PG	blocking	10,25	OG
utilities	9	PG	deblocking	10,25	OG
utility routines	25	OG	standard DCOS format	8	OG
PRESYS library (see DCOS PRESYS library)			transmission to and from tape	25	OG
Print			Redundancy indication		
IBM 720A simulation	19	SPG	meaning of	37	PG
routine	18	SPG	Remarks card		
Print stage			description of	14	OG
description of	10	OG	Remote inquiry unit		
description of	13	PG	discontinuing typewriter	20	OG
Printed output			function of	6	OG
description of	8	OG	function of	8	PG
Printer			restarting typewriter	20	OG
backspace	20	OG	use of	6,19,21	OG
discontinue job output on	20	OG	Repeat requests		
function of	5	OG	means of making	20	OG
function of	8	PG	Restart		
repeat job output on	20	OG	description of	21	OG
restart job output on	20	OG	printing of output	20	OG
simulation of 720A printer	13,25	OG	punching of output	20	OG
single space	20	OG	system	24	OG
Priority			1014 typewriter	20	OG
assignment of	10,12	OG	7040 console typewriter	20	OG
giving highest priority to job ...	20	OG	7090 job	19	OG
Priority code			Restore disk (drum) procedures		
in job identifier	13	PG	description of	23	OG
on job card	15	PG	Resume 7090 processing		
Processing phase			methods used to	21	OG
description of	12	PG	Save disk (drum) procedures		
description of	6,9	OG	description of	23	OG
diagram of	12	PG	Save-restore card		
execution stage	12	PG	description of	23	OG
Programming considerations			Save-Restore Disk/Drum Routine		
compatibility mode systems	38	PG	description of	23	OG
direct and compatibility mode			restore procedures	23	OG
systems	37	PG	save procedures	23	OG
direct mode systems	38	PG	save-restore card	23	OG
Punch			Select minus entry		
activity routine	18	SPG	relinquishing control of a unit ..	32	PG
discontinue job output on	20	OG	Select plus entry		
errors	18	SPG	compatibility mode	31	PG
function of	5	OG	direct mode example	31	PG
hole-count error	18	SPG	general entry	32	PG
repeat job output on	20	OG	Select routines		
restart job output on	20	OG	design of	31,32	PG
routine	17	SPG	distinguishing between	31	PG
Punch stage			error recovery procedures	33	PG
description of	10	OG			
description of	13	PG			
Punched output					

exits	31	PG	(see also "dump")	24	PG
general considerations	33	PG	System Editor		
redundancy checking	33	PG	function of	10	PG
select minus entry	32	PG	System initialization		
select plus entry	31	PG	procedure used for	16	OG
Sense indicators			System Output Unit		
contents of	32	PG	use of	37	PG
Sense switches			System Peripheral Punch (SYSPP)		
use of	18	OG	use of	37	PG
Set-density instructions			System units		
issued form 7090 program	37	PG	SYSCK1	23	SPG
Setup stage			SYSCK2	23	SPG
description of	10	OG	SYSCRD	24	SPG
description of	12	PG	SYSIN1	24,51,52	SPG
Simulation			SYSLB1	23,24,39	SPG
data channel trap	40	PG	SYSLB2	51,52,53	SPG
devices simulated	7,46	PG	SYSUT1	51,52,53	SPG
of 7090 units	73	SPG	SYSUT2	51,52	SPG
7090 LOAD CARD button	21	SPG	UNISYM table	16,75	SPG
7090 LOAD CARD button, pressing of,	16	PG	unit availability table	29	SPG
7090 LOAD TAPE button, pressing of,	16	PG	unit function table	28	SPG
7090 tape load routine	22	SPG			
720A printer	10	PG	Tables		
720A printer	25	OG	DC-IBSYS system name	48,51,53	SPG
Single-space printer			DC-IOEX communication	32	SPG
request to	20	OG	direct mode name	21	SPG
limits of	25	PG	IOBASE	12,14,16	SPG
machine status after	25	PG	system unit function (SYSUNI) .	27,28	SPG
parameter control word	24	PG	track allocation/module		
Snap dump			definition	67,70	SPG
formats of	24-25	PG	unit availability	27,29	SPG
Snapshot routine	91	SPG	unit control block	27,31	SPG
Stage number			unit symbol (UNISYM)	16,75	SPG
assignment of	10	OG	utility name	67,71	SPG
use of	12	PG	7040 system name	39,67,69	SPG
Stages of processing			Tape		
breakdown	10	OG	blocking	10,25-27	OG
description of	9	OG	deblocking	10,25-27	OG
diagram of	10	OG	discontinuing tape input	18,20	OG
execution	11	OG	initiating tape input	18,20	OG
execution	12	PG	input	18	OG
input	12	PG	output	8	OG
input	9	OG	preparation of	18,25-27	OG
print	10	OG	procedure for input to DCOS	18,25-27	OG
print	13	PG	specified on \$SETUP card	13,25	OG
punch	10	OG	subsystem on tape	13	OG
punch	13	PG	Tape Blocking Routine (7040/44)		
purge	11	OG	description and use of	25-27	OG
purge	13	PG	Tape Deblocking Routine (7040/44)		
setup	10	OG	description and use of	25-27	OG
setup	12	PG	Tape input/output		
Stand-alone 7040/44 utility routines			assigning units	19	PG
description of	26	OG	blocking	9,11,19	PG
Standard DCOS record format			deblocking	10,19	PG
description of	9	PG	mounting input files	18	PG
description of	8	OG	requesting output files	19	PG
Starting the system			specifying on \$SETUP card	18	PG
procedure for	16	OG	Tape manipulation control cards		
Stopping the system			\$ENDFILE	24	SPG
procedure for	24	OG	\$REMOVE	25	SPG
Storage units			\$REWIND	25	SPG
disk	6	OG	\$UNLOAD	25	SPG
drum	6	OG	Tape mounting messages		
Symbolic Unit Conversion Routine			appearance of	13	PG
instructions for using	36	PG	with \$SETUP card	19	PG
System Core Storage Dump Program			Tape-to-Disk Blocking Routine		

description and use of	25	OG	Unit control block		
Tape-to-Disk Blocking Utility Routine			(see also "UCB")	29	PG
description of	10	PG	table	27	SPG
Tape-to-Printer Routine			7040 tape units	10,16,74	SPG
description and use of	25	OG	7090 simulated units	38,74	SPG
Tape-to-Punch Routine			Utility		
description and use of	26	OG	arrangement of	63	SPG
Tape-to-Tape Blocking Routine			background utilities	16,19	SPG
description and use of	25	OG	breakdown utilities	19	SPG
Tape-to-Tape Blocking Utility Routine			communication region	64	SPG
description of	9	PG	design of	64	SPG
Tape-to-Tape Deblocking Routine			incorporating DCMUP utilities	63	SPG
description and use of	25	OG	monitored utilities	19	SPG
Tape-to-Tape Deblocking Utility Routine			name table	67,71	SPG
description of	10	PG	post-execution utilities	18	SPG
Termination			pre-execution utilities	17	SPG
job	20	OG	setup utilities	19	SPG
printed output	20	OG	tape blocking routine	65	SPG
punched output	20	OG	track allocation for	67	SPG
0004 typewriter	21	OG	720A printer utility	19	SPG
7040 console typewriter	20	OG	Utility routines		
7090 processing	19	OG	Add Unit Designation to Message ..	36	PG
Time estimate			Alphameric Punch	35	PG
description of	12	OG	Binary-to-BCD Octal Conversion ...	35	PG
Trap supervisor			Binary-to-Decimal Conversion	35	PG
description of	27	PG	blocking	9,11,19	PG
use of	30	PG	Card-to-Tape Routine	26	OG
UCB			DC-IOEX	10,27	PG
end-of-tape flag	29	PG	DCOS-controlled	25	OG
examining in dump	44	PG	deblocking	10,19	PG
file count	30,44	PG	Disk-to-Tape Deblocking	10	PG
format of	29-30	PG	Disk-to-Tape Deblocking Routine ..	25	OG
location of select routine	30,44	PG	Message Writer	34	PG
maintenance of fields	30	PG	Pause Routines	35	PG
record count	30,44	PG	Post-Mortem Dump	35	PG
reserve status flag	29	PG	print	9	PG
select type	30,44	PG	punch	9	PG
symbolic unit designation	30,44	PG	specified on \$SETUP card	25	OG
unit address	29,44	PG	specified on \$UTILITY card	25	OG
Unit assignment control cards			specified on \$UTILITY card	21	PG
\$ASSIGN	23	SPG	specifying on \$SETUP card	17	PG
\$CARDS	24	SPG	Symbolic Unit Conversion	36	PG
\$RELEASE	24	SPG	Tape Blocking Routine	26	OG
\$RESET	24	SPG	Tape Deblocking Routine	27	OG
\$SWITCH	24	SPG	Tape-to-Disk Blocking	10	PG
\$TAPE	24	SPG	Tape-to-Disk Blocking Routine	25	OG
Unit assignment under DCOS			Tape-to-Printer Routine	25	OG
basic precepts	73	SPG	Tape-to-Punch Routine	26	OG
control cards	22	SPG	Tape-to-Tape Blocking	9	PG
IBJOB	75	SPG	Tape-to-Tape Blocking Routine	25	OG
IBLDR	75	SPG	Tape-to-Tape Deblocking	10	PG
non-IBSYS systems	78	SPG	Tape-to-Tape Deblocking Routine ..	25	OG
operational inconsistencies	79	SPG	6040/44 Utility Routines	27	OG
other IBSYS subsystems	76	SPG	720A simulation	10	PG
special considerations	78	SPG	720A Simulation Routine	25	OG

File Number 7090-36

Re: Order No. GC28-6384-2

This Newsletter No. GN28-0159-0

Date June 11, 1965

Previous Newsletter Nos. None

IBM 7090-7040 Direct Couple Operating System:
Operator's Guide

This Technical Newsletter amends the publication IBM 7090-7040 Direct Couple Operating System: Operator's Guide, Form C28-6384-2. The pages attached to this newsletter document the use of the IJOB Processor and the System Editor of the Version 13 IBSYS Operating System under the Direct Couple system.

In the referenced publication, replace the pages listed below with the corresponding pages attached to this newsletter.

Pages 1 through 4
Pages 9 and 10
Pages 13 through 16
Pages 23 through 34

A vertical line to the left of the column shows where text has been changed.

File this Newsletter at the back of the manual. It will provide a reference to changes, a method of determining that all amendments have been received, and a check for determining if the manual contains the proper pages.

IBM**Technical Newsletter**

File Number 7090-36

Re: Order No. GC28-6384-2

This Newsletter No. GN28-0173-0

Date December 7, 1965

Previous Newsletter Nos. GN28-0159-0

IBM 7090-7040 Direct Couple Operating System: Operator's Guide

This technical newsletter amends the publication IBM 7090-7040 Direct Couple Operating System: Operator's Guide, Form C28-6384-2.

In the publication, replace the pages listed below with the corresponding pages attached to this newsletter.

Pages 29, 29.1 and 30

Pages 35 through 42

A vertical line to the left of a column shows where text has been changed.

File this newsletter at the back of the manual. It will provide a reference to changes, a method of determining that all amendments have been received, and a check for determining if the manual contains the proper pages.

COMMENT SHEET

IBM 7090-7040 DIRECT COUPLE OPERATING SYSTEM
OPERATOR'S GUIDE

GC28-6384-2

FROM

NAME _____

OFFICE NO. _____

FOLD

CHECK ONE OF THE COMMENTS AND EXPLAIN IN THE SPACE PROVIDED

FOLD

SUGGESTED ADDITION (PAGE)

SUGGESTED DELETION (PAGE)

ERROR (PAGE)

EXPLANATION

CUT ALONG LINE

FOLD

FOLD

NO POSTAGE NECESSARY IF MAILED IN U. S. A.
FOLD ON TWO LINES, STAPLE, AND MAIL

FOLD

FOLD

FIRST CLASS
PERMIT NO. 81
POUGHKEEPSIE, N. Y.

BUSINESS REPLY MAIL
NO POSTAGE STAMP NECESSARY IF MAILED IN U. S. A.

POSTAGE WILL BE PAID BY
IBM CORPORATION
P. O. BOX 390
POUGHKEEPSIE, N. Y.

ATTN: PROGRAMMING SYSTEMS PUBLICATIONS
DEPARTMENT D39

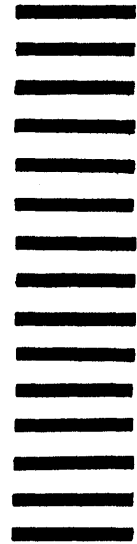

CUT ALONG LINE

FOLD

FOLD

