

IBM Customer Engineering Reference Manual

**IBM 7040-7044 Data Processing Systems
Channels B, C, D, and E**



**Customer Engineering Reference Manual
IBM 7040-7044 Data Processing Systems
Channels B, C, D, and E**

PREFACE

This manual contains logic diagrams for IBM 7904 tape operations only. A future edition will include simplex interface operations, direct data operations, and other reference material.

The order of the diagrams in this manual closely follows that of the text of the 7904 Data Channel manual, Form R23-2595; therefore, the diagrams can be used as instruction aids as well as for troubleshooting.

Your ideas and comments concerning Customer Engineering manuals are of great value to Product Publications. Please use the comments sheet at the back of this manual.

Figure	Title	Page
1	Tape Unit Selection	5
2	Channel and Interface Selection	6
3	WRS, Write Tape Operation	7
4	RCH, Write Tape Operation	8
5	B Cycle, Write Tape Operation	8
6	Character Writing, Write Tape Operation	9
7	End Operation and Disconnect, Write Tape Operation	10
8	Data Flow, Write Tape Operation	11
9	I-O Check and Redundancy Check, Write Tape Operation	12
10	Word Parity Error, Write Tape Operation	13
11	ETT, End-of-Tape Operation	14
12	Disconnect Trap, Write Tape Operation	15
13	Disconnect Trap Timing	15
14	RDS, Read Tape Operation	16
15	RCH, Read Tape Operation	16
16	Character Reading, Read Tape Operation	17
17	B Cycle, Read Tape Operation	18
18	End Operation and Disconnect, Read Tape Operation	19
19	Data Flow, Read Tape Operation	20
20	I-O Check and Redundancy Check, Read Tape Operation	21
21	Word Parity Error, Read Tape Operation	22
22	BSR, Backspace Operation	23
23	WEF, Write-End-of-File Operation	24
24	REW, Rewind Operation	25
25	RUN, Rewind Unload Operation	26
26	WBT, Write Blank Tape Operation	27
27	SEN, Tape Ready Test Operation	28
28	RCH, Tape Ready Test Operation	29
29	Asm Reg to CDR, B Cycle, and Disconnect, Tape Ready Test Operation	29

SAFETY

Accidents do not always happen to "the other fellow."
Be smart! When servicing any equipment, remove rings and watches, roll up your sleeves, and tuck in your tie. Put on your safety glasses! If power must be on when working on power supplies, probe with one hand only; keep the other hand off the frame. You know the safety rules--follow them!

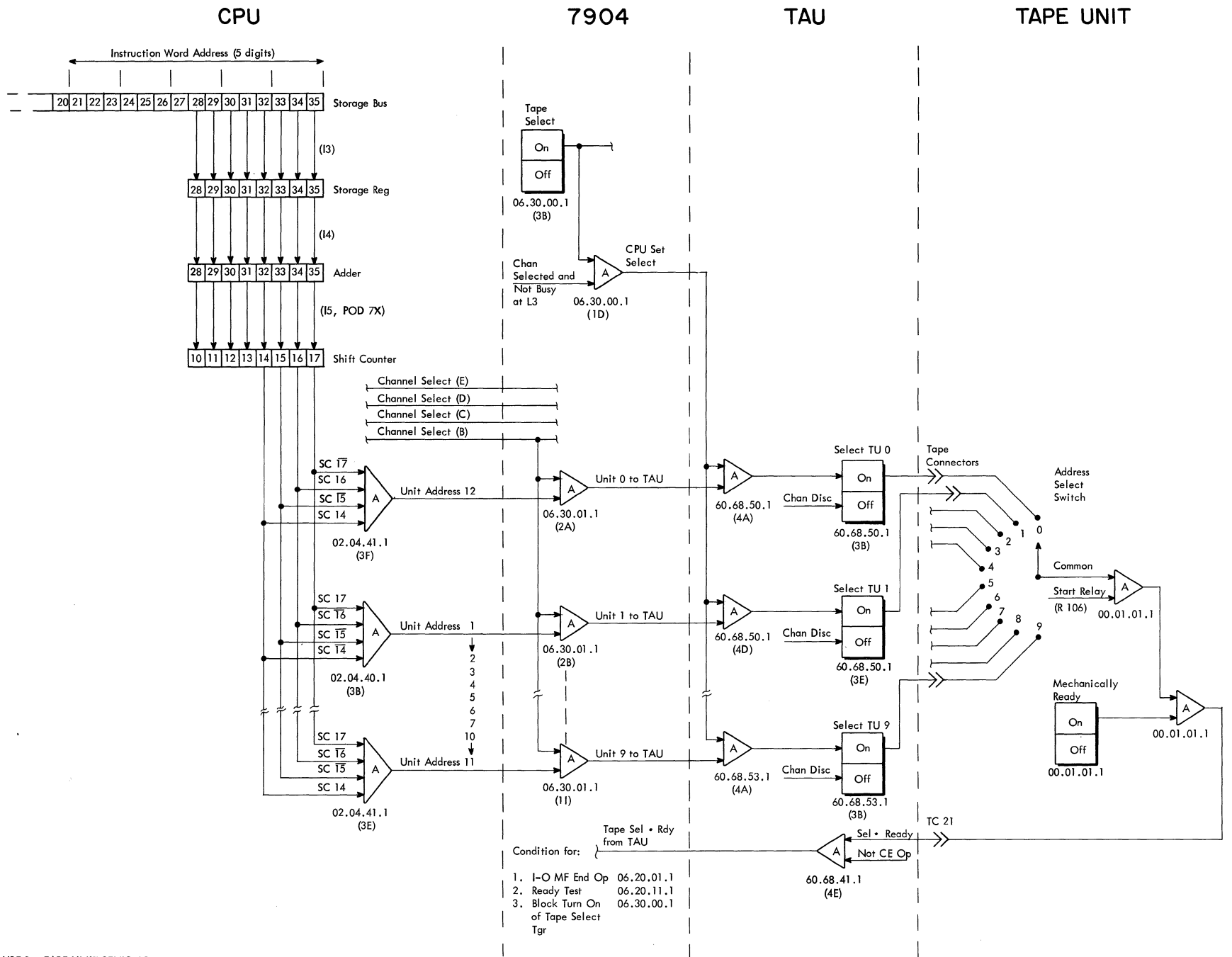

FIGURE 1. TAPE UNIT SELECTION

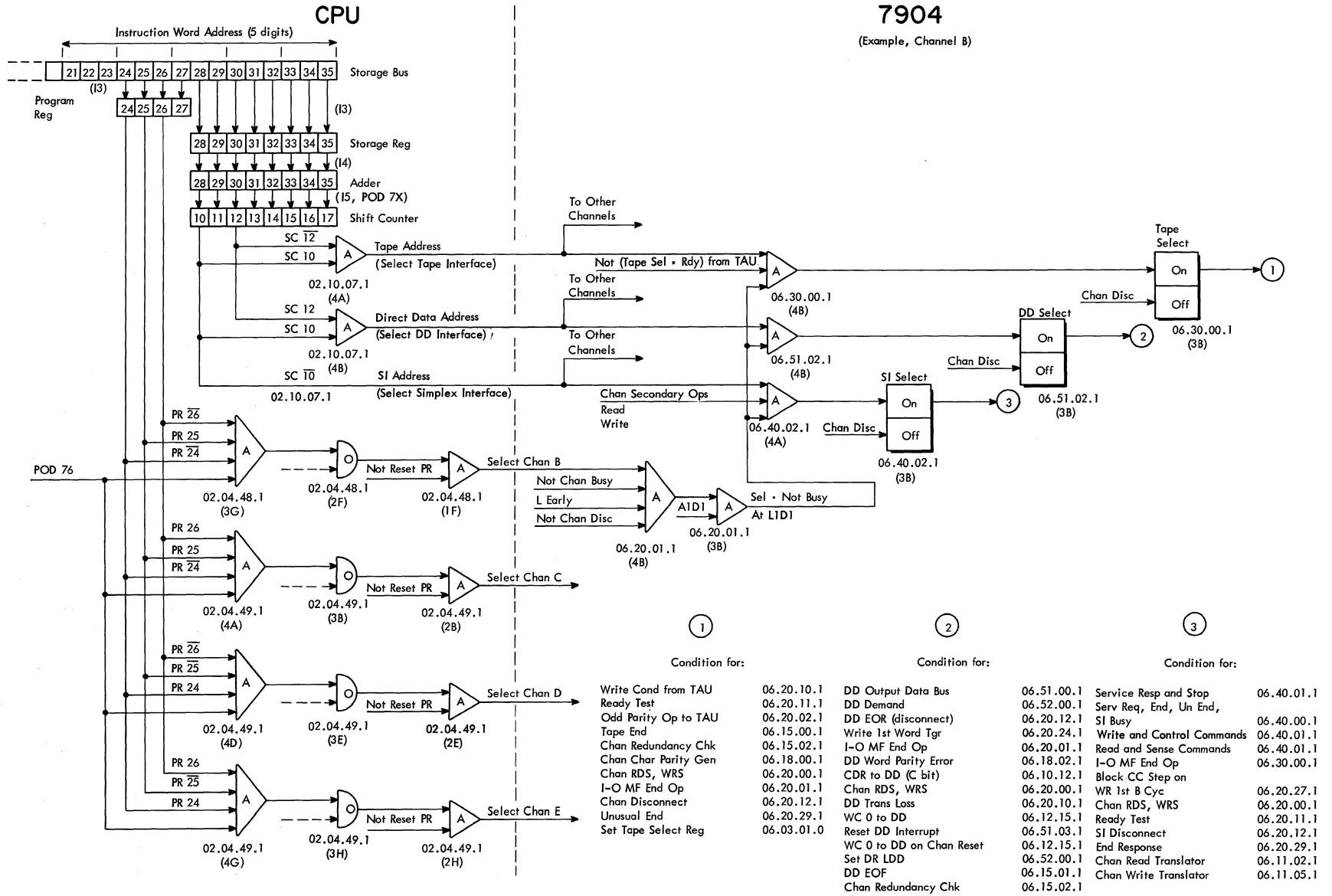

FIGURE 2. CHANNEL AND INTERFACE SELECTION

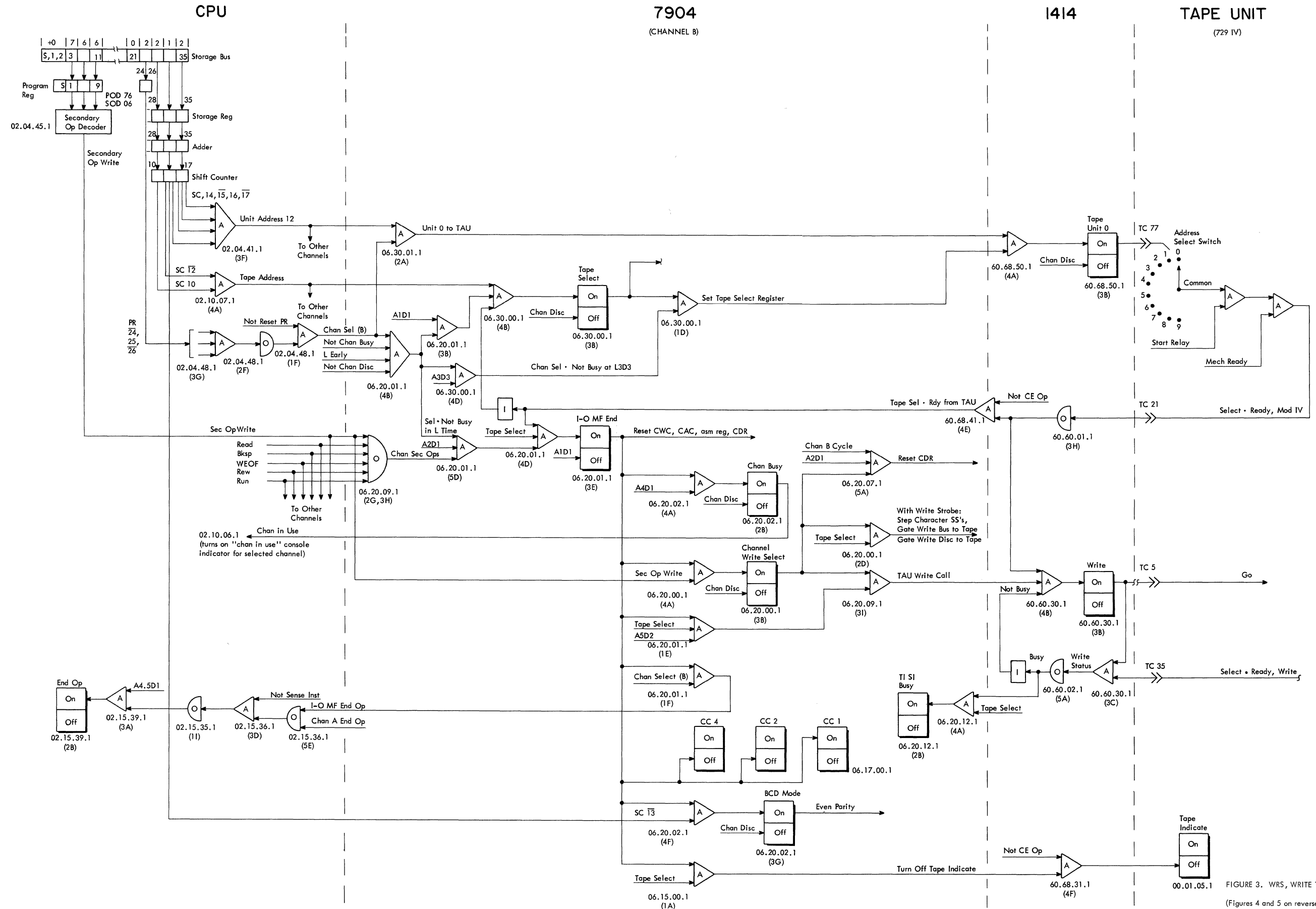

FIGURE 3. WRS, WRITE TAPE OPERATION
 (Figures 4 and 5 on reverse)
 7040-7044 Channels B-E CERM (8-63) 7

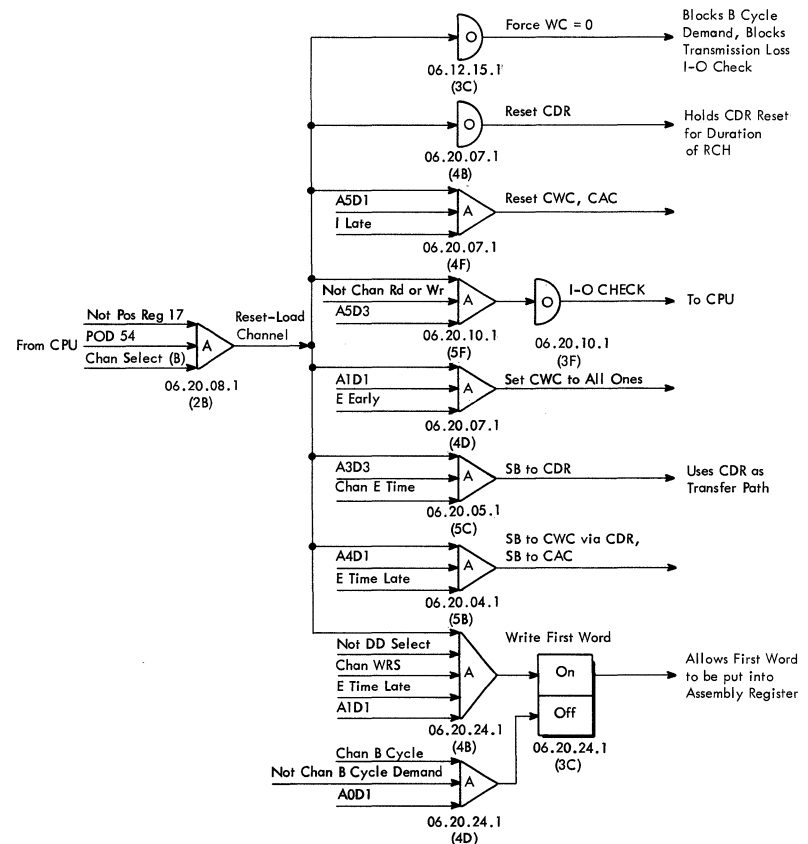
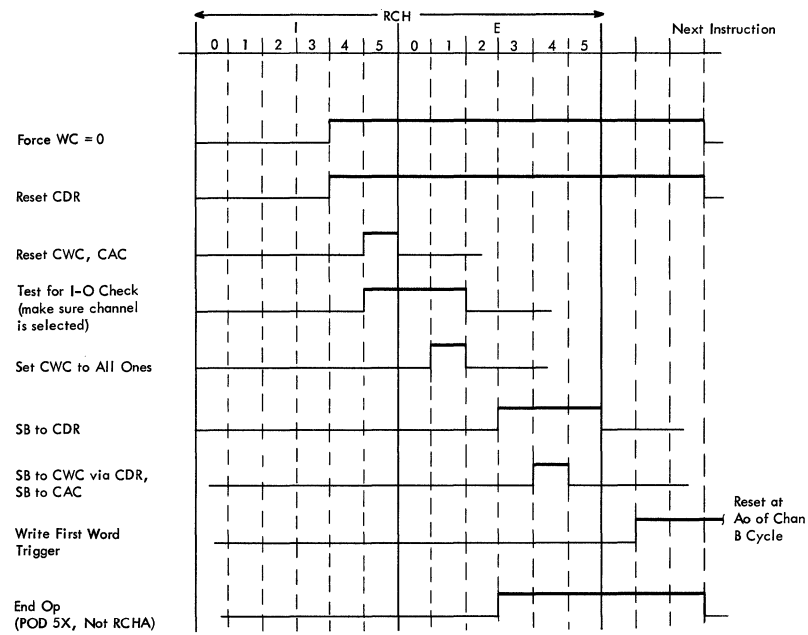

FIGURE 4. RCH, WRITE TAPE OPERATION

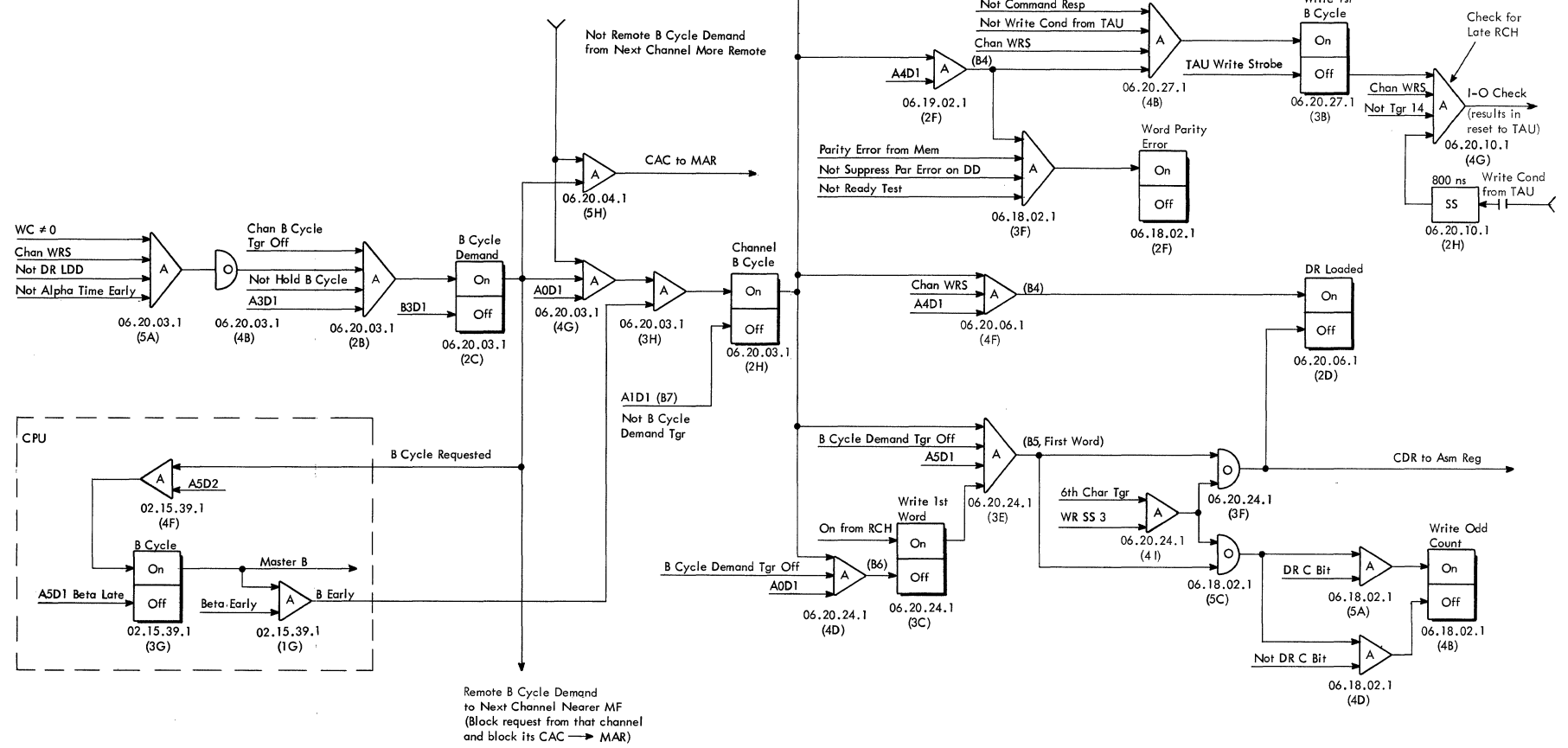
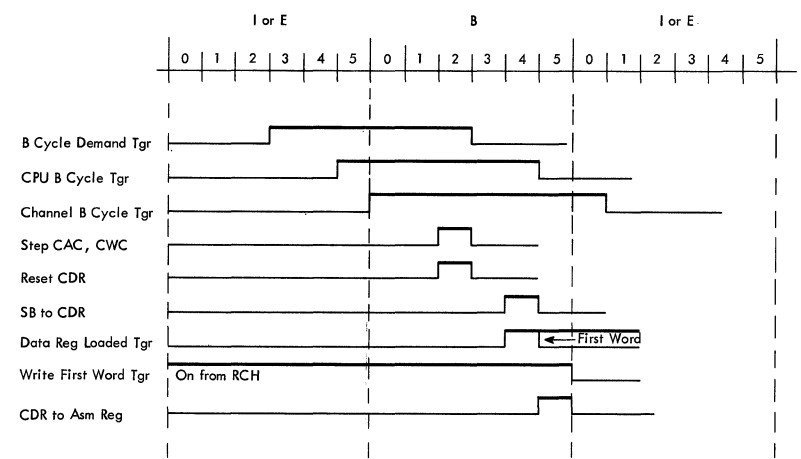

FIGURE 5. B CYCLE, WRITE TAPE OPERATION

FIGURE 4. RCH, WRITE TAPE OPERATION
FIGURE 5. B CYCLE, WRITE TAPE OPERATION

(Figure 3 on reverse)

Character counter set to 1 on WRS

1st B Cycle Load CDR with first word, turn on DR LDD tgr, CDR to Asm reg, turn off DR LDD tgr

2nd B Cycle Load CDR with second word, turn on DR LDD tgr

3rd B Cycle Load CDR with third word, turn on DR LDD tgr

First Word

CC 1 Tape unit writes first char from asm reg, TAU Write Strobe
 SS 1 SS 2 SS 3
 Reset 6th Char tgr, Step CC
 Complement odd count tgr if odd char

CC 2 Tape unit writes second char from asm reg, TAU write strobe
 SS 1 SS 2 SS 3
 Complement odd count tgr if odd char Step CC

CC 3 Tape unit writes third char from asm reg, TAU write strobe
 SS 1 SS 2 SS 3
 Complement odd count tgr if odd char Step CC

CC 4 Tape unit writes fourth char from asm reg, TAU write strobe
 SS 1 SS 2 SS 3
 Complement odd count tgr if odd char Step CC

CC 5 Tape unit writes fifth char from asm reg, TAU write strobe
 SS 1 SS 2 SS 3
 Complement odd count tgr if odd char Step CC

CC 6 Tape unit writes sixth char from asm reg, TAU write strobe
 SS 1 SS 2 SS 3
 Complement odd count tgr if odd char Reset CC to 1 CDR to asm reg (2nd word)
 Test for xmission loss Reset asm reg Turn on odd count tgr if data reg has C bit
 Turn on 6th char tgr Sample odd count tgr for word parity error Turn off DR LDD tgr

Second Word

CC 1 Tape unit writes first char from asm reg, TAU write strobe
 SS 1 SS 2 SS 3
 Reset 6th char tgr Step CC
 Complement odd count tgr if odd char

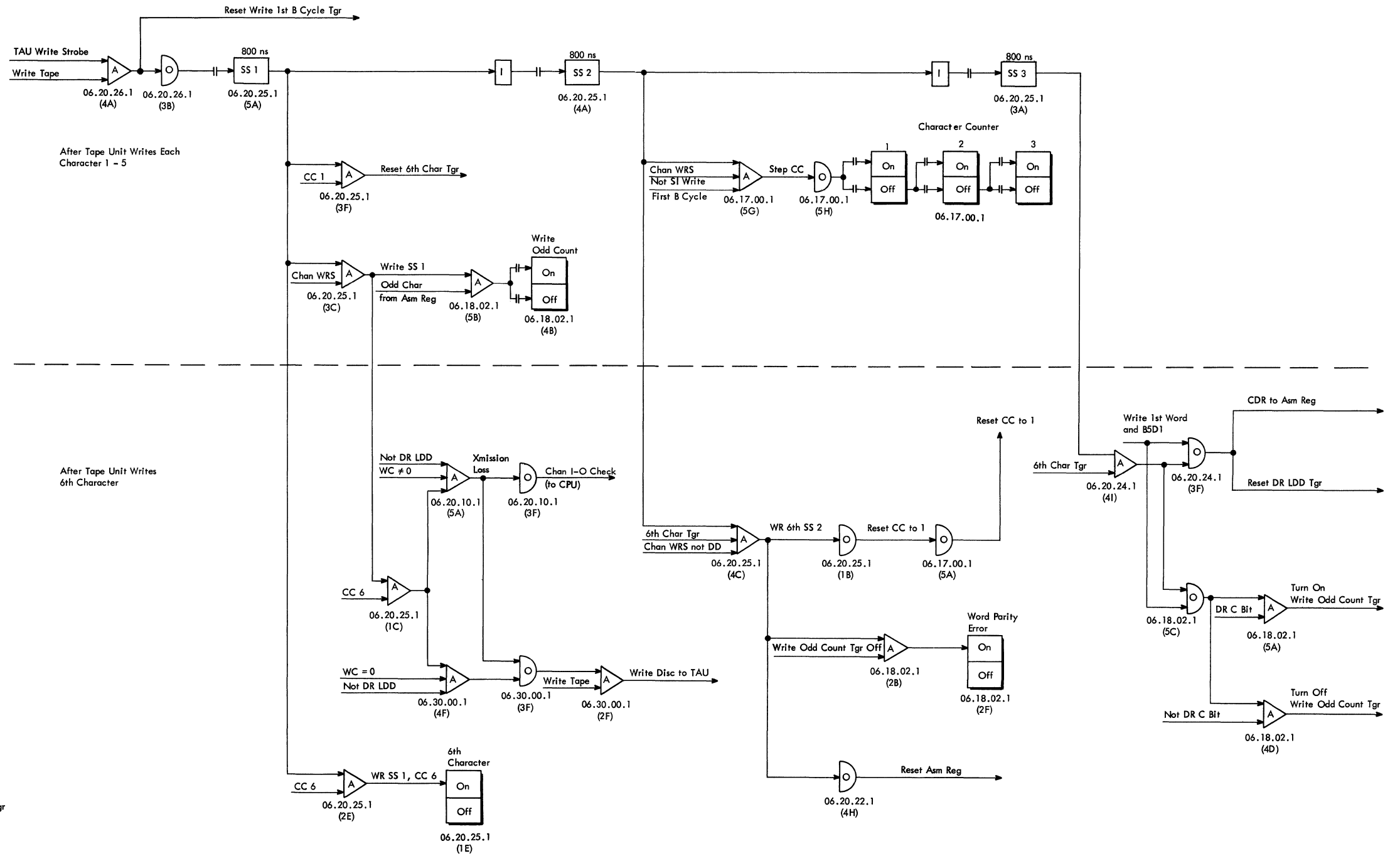

FIGURE 6. CHARACTER WRITING, WRITE TAPE OPERATION
 (Figure 7 on reverse)

7904

1414

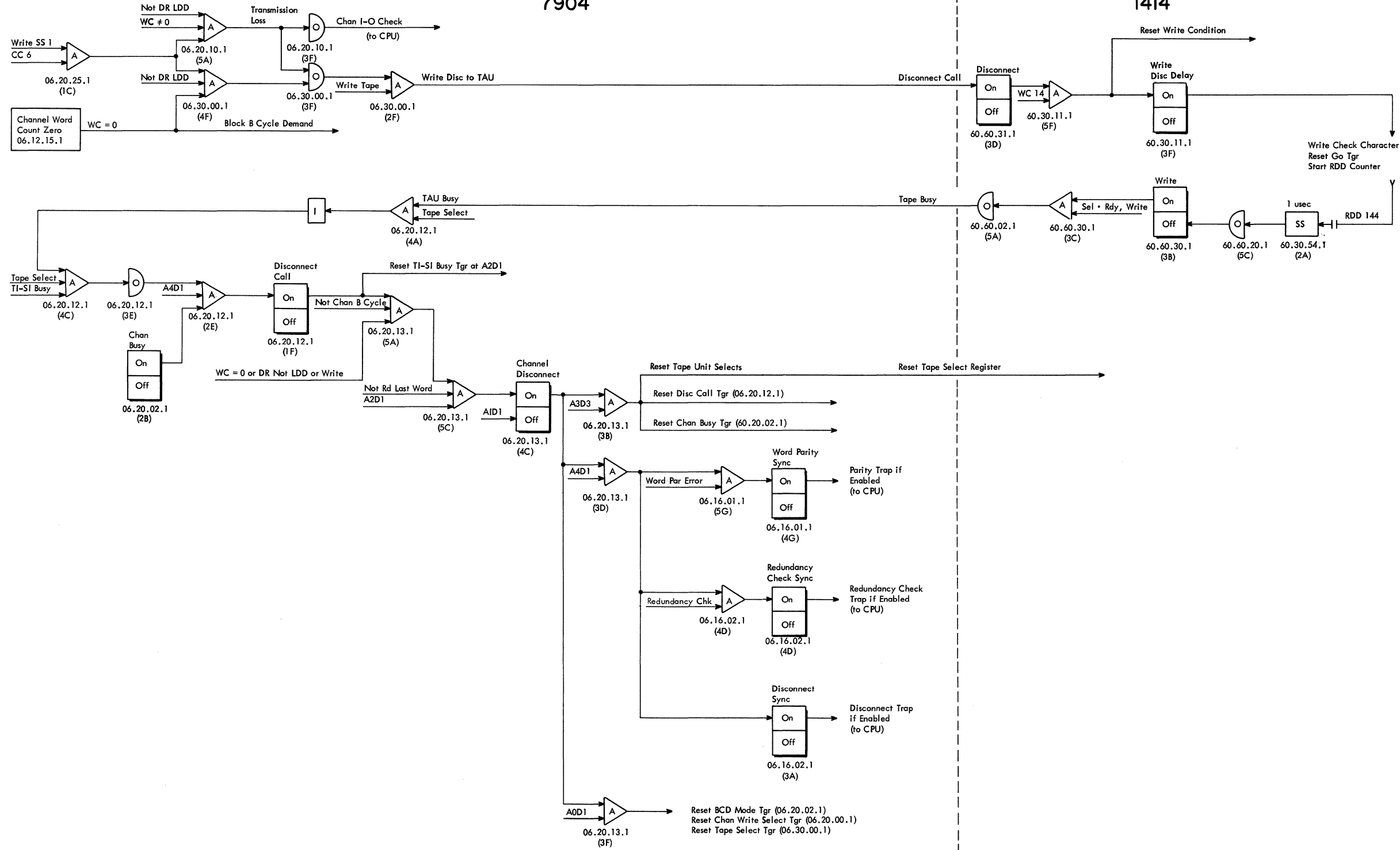

FIGURE 7. END OPERATION AND DISCONNECT, WRITE TAPE OPERATION

(Figure 6 on reverse)

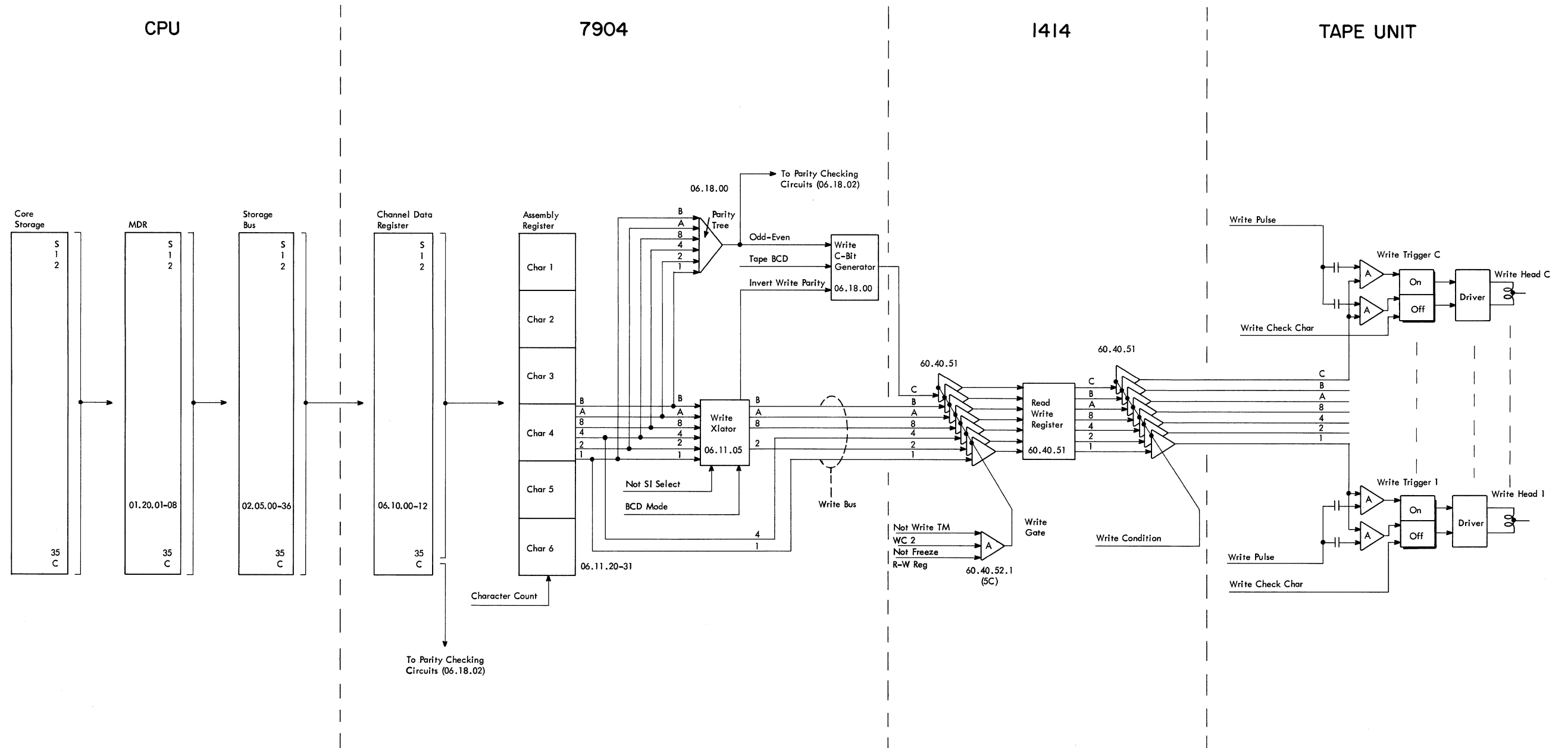

FIGURE 8. DATA FLOW, WRITE TAPE OPERATION

(Figure 9 on reverse)

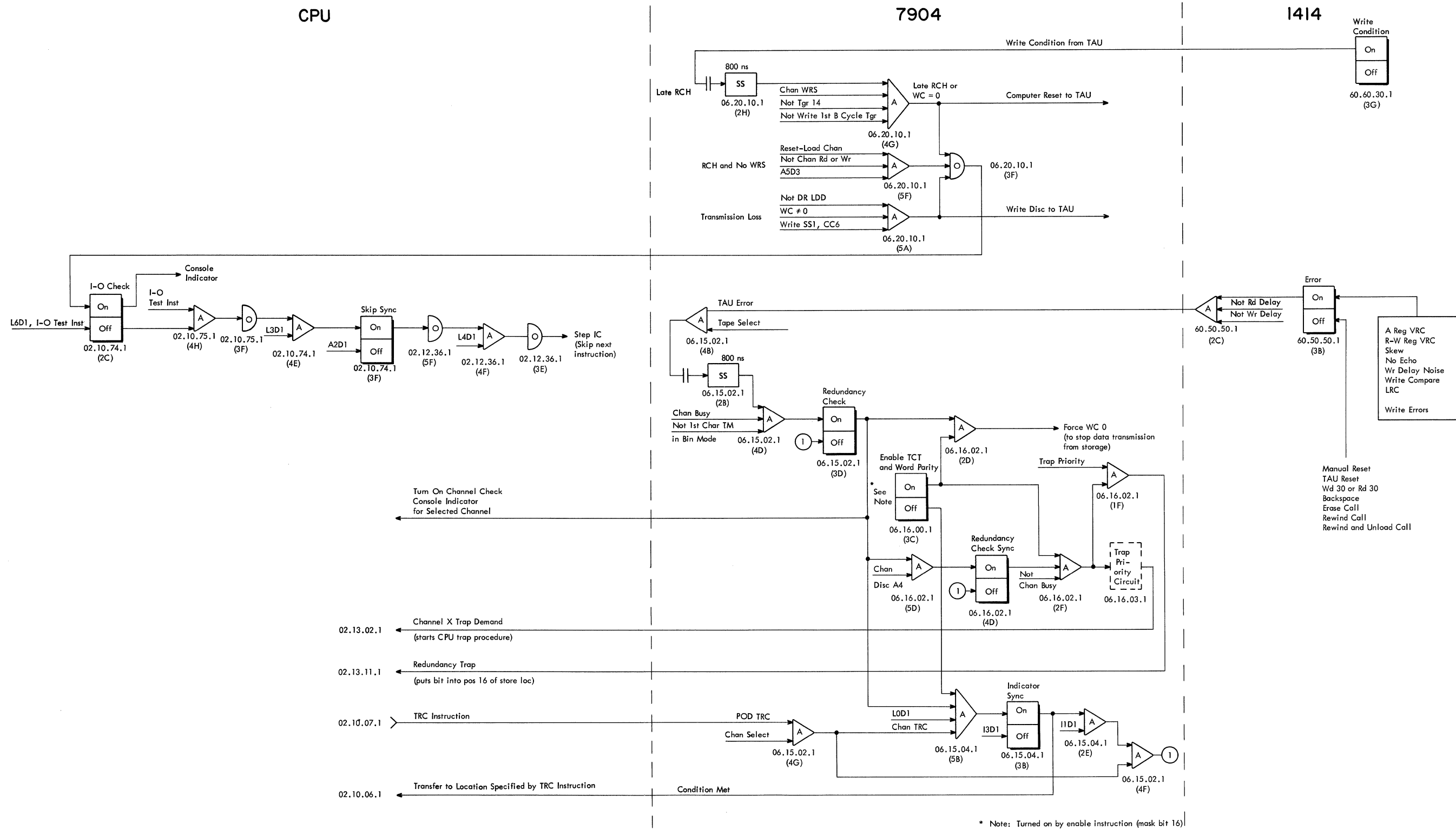

FIGURE 9. I-O CHECK AND REDUNDANCY CHECK, WRITE TAPE OPERATION
(Figure 8 on reverse)

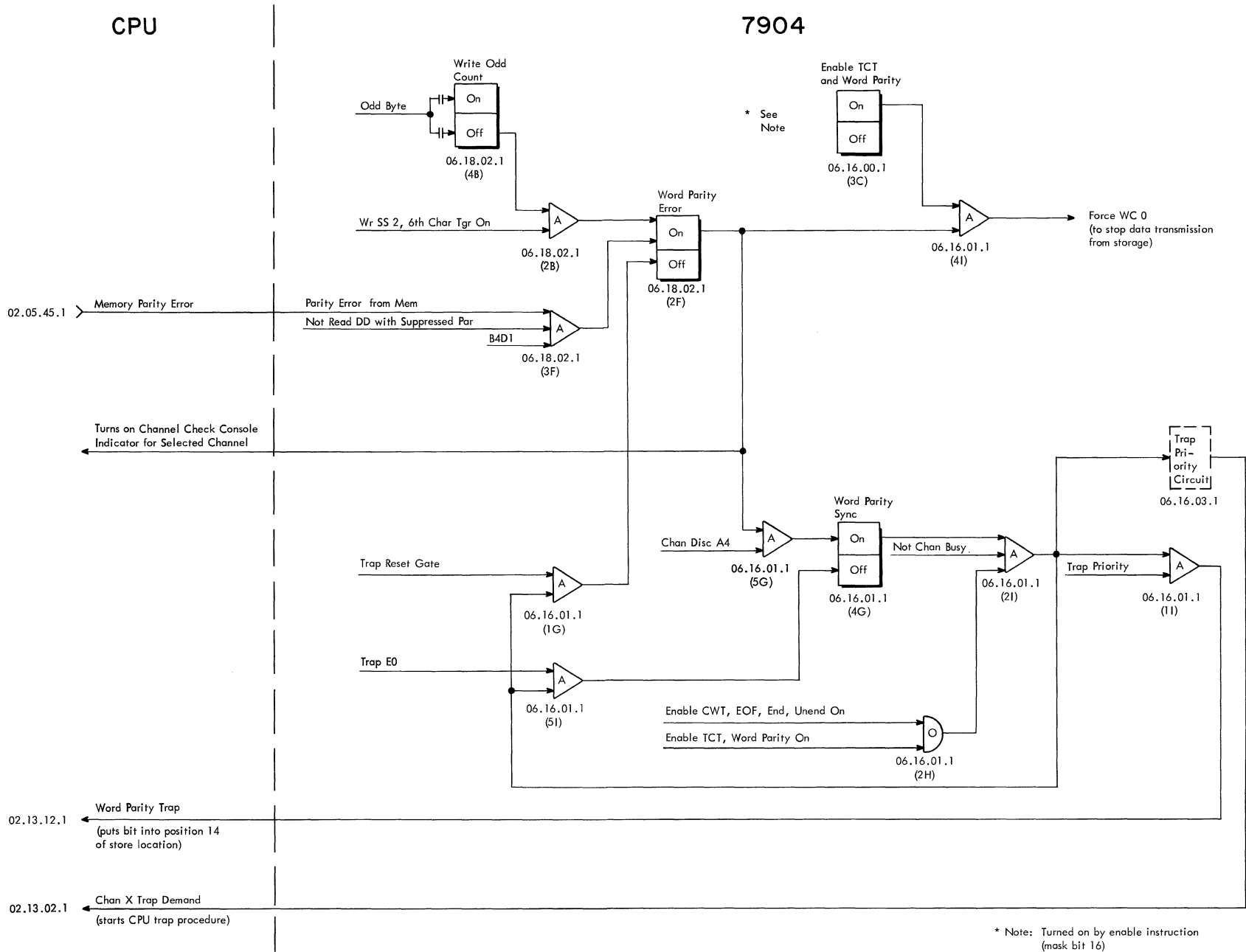

FIGURE 10. WORD PARITY ERROR, WRITE TAPE OPERATION

CPU

Note: If ETT instruction is executed with tape end trigger on, tape end trigger is turned off and program does not skip.

If ETT instruction is executed with tape end trigger off, program skips the next instruction.

7904
(CHANNEL B)

1414

TAPE UNIT
(729 IV)

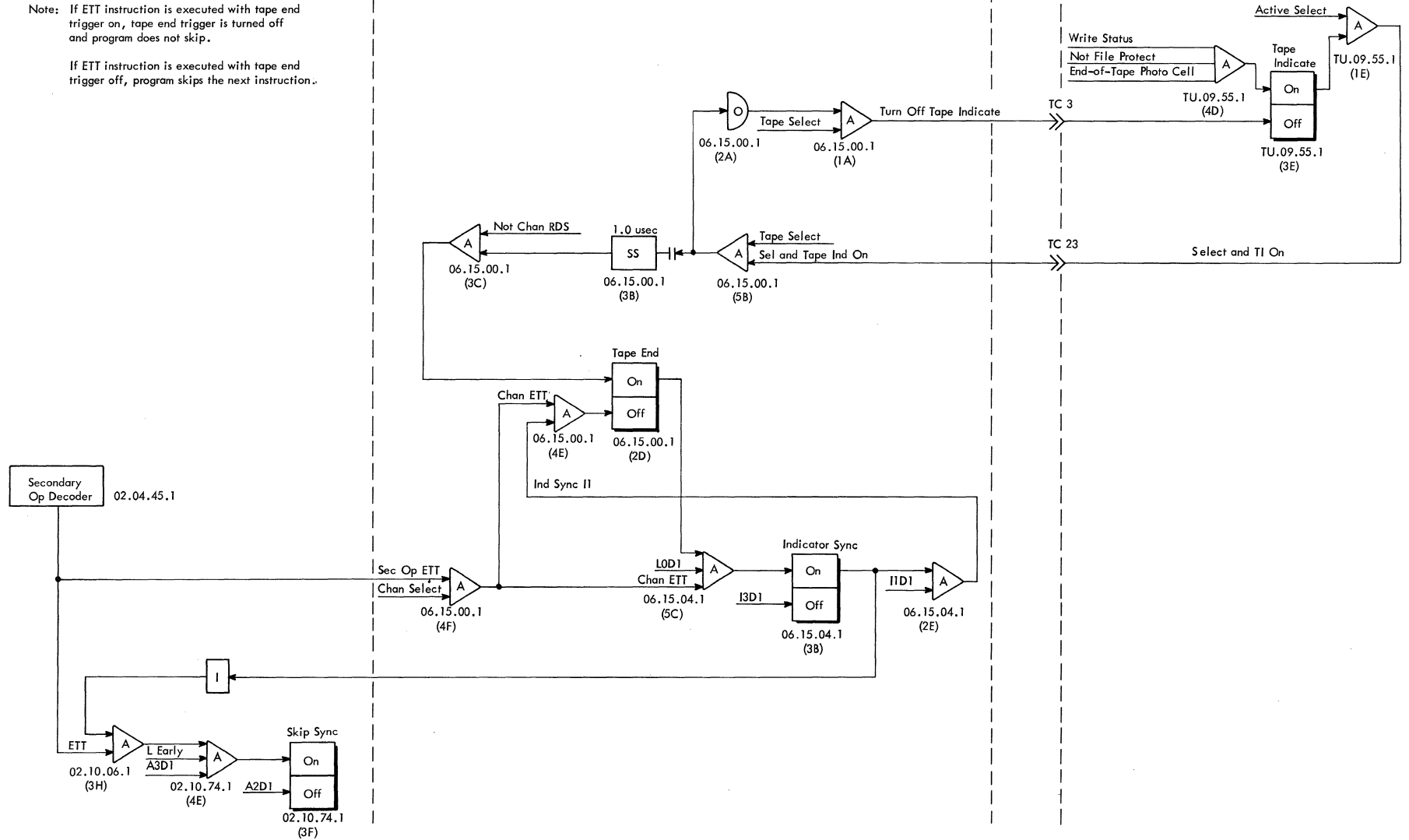

FIGURE 11. ETT, END-OF-TAPE OPERATION

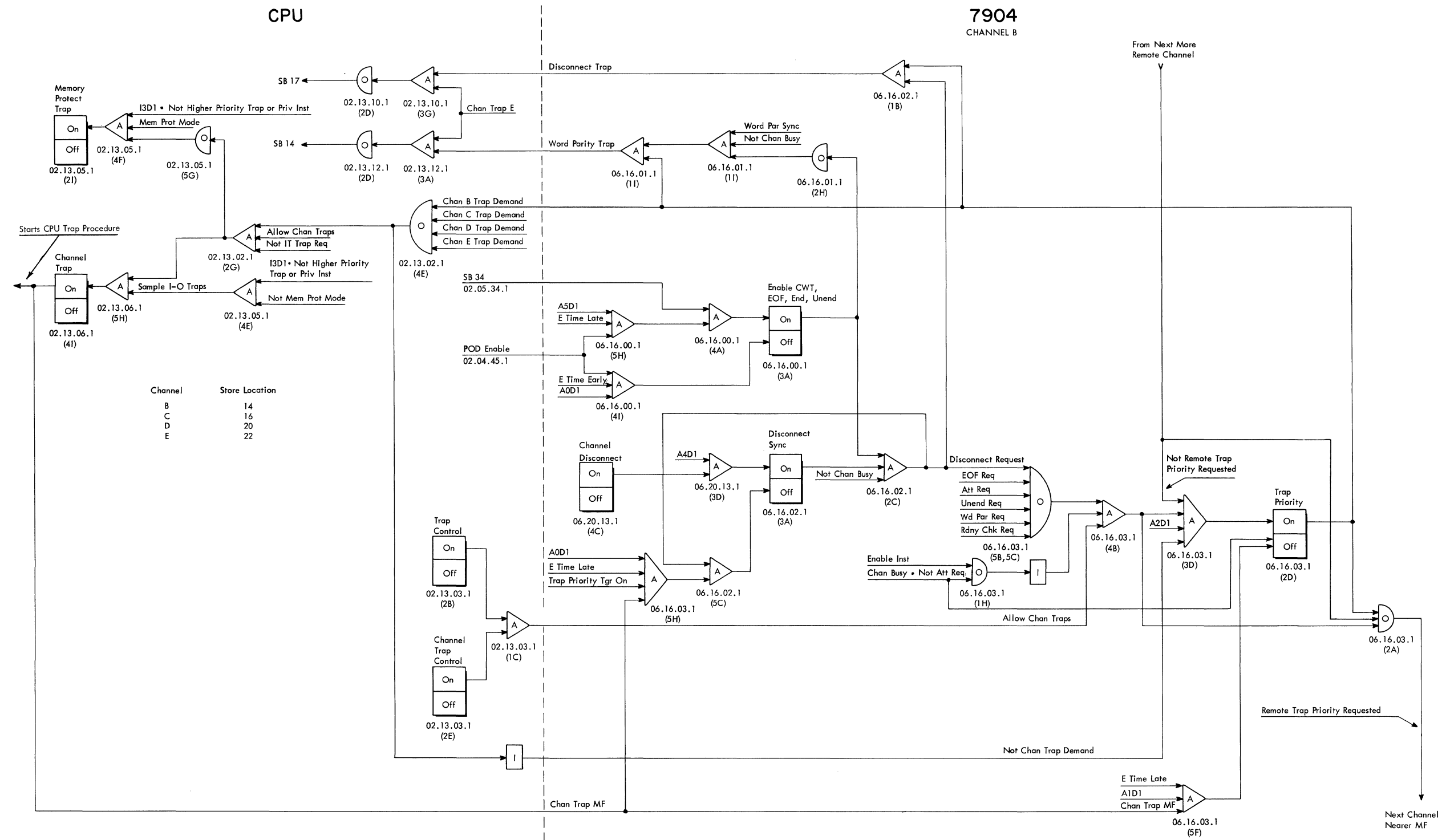

FIGURE 12. DISCONNECT TRAP, WRITE TAPE OPERATION

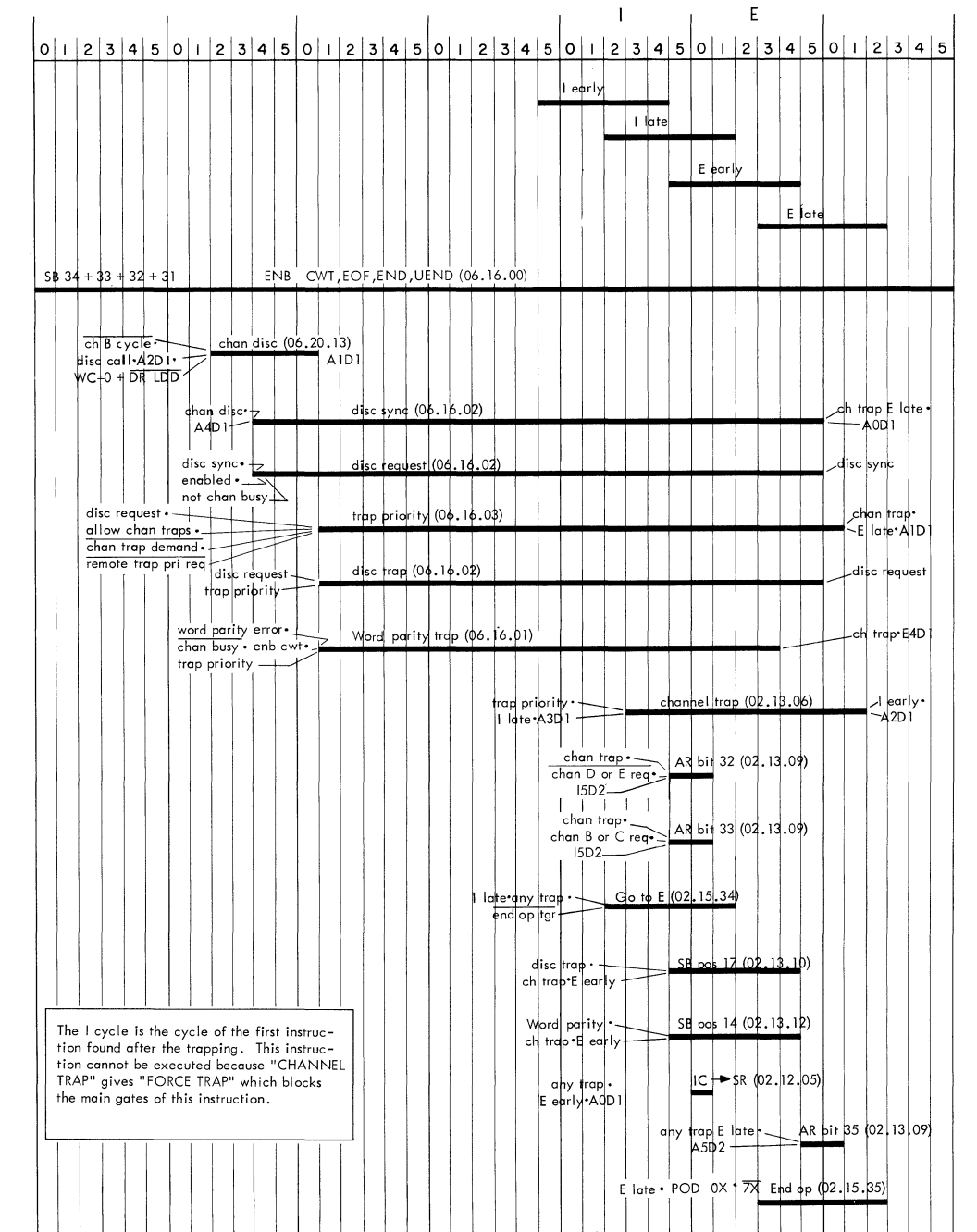

FIGURE 13. DISCONNECT TRAP TIMING

FIGURE 12. DISCONNECT TRAP, WRITE TAPE OPERATION
FIGURE 13. DISCONNECT TRAP TIMING

(Figures 14 and 15 on reverse)

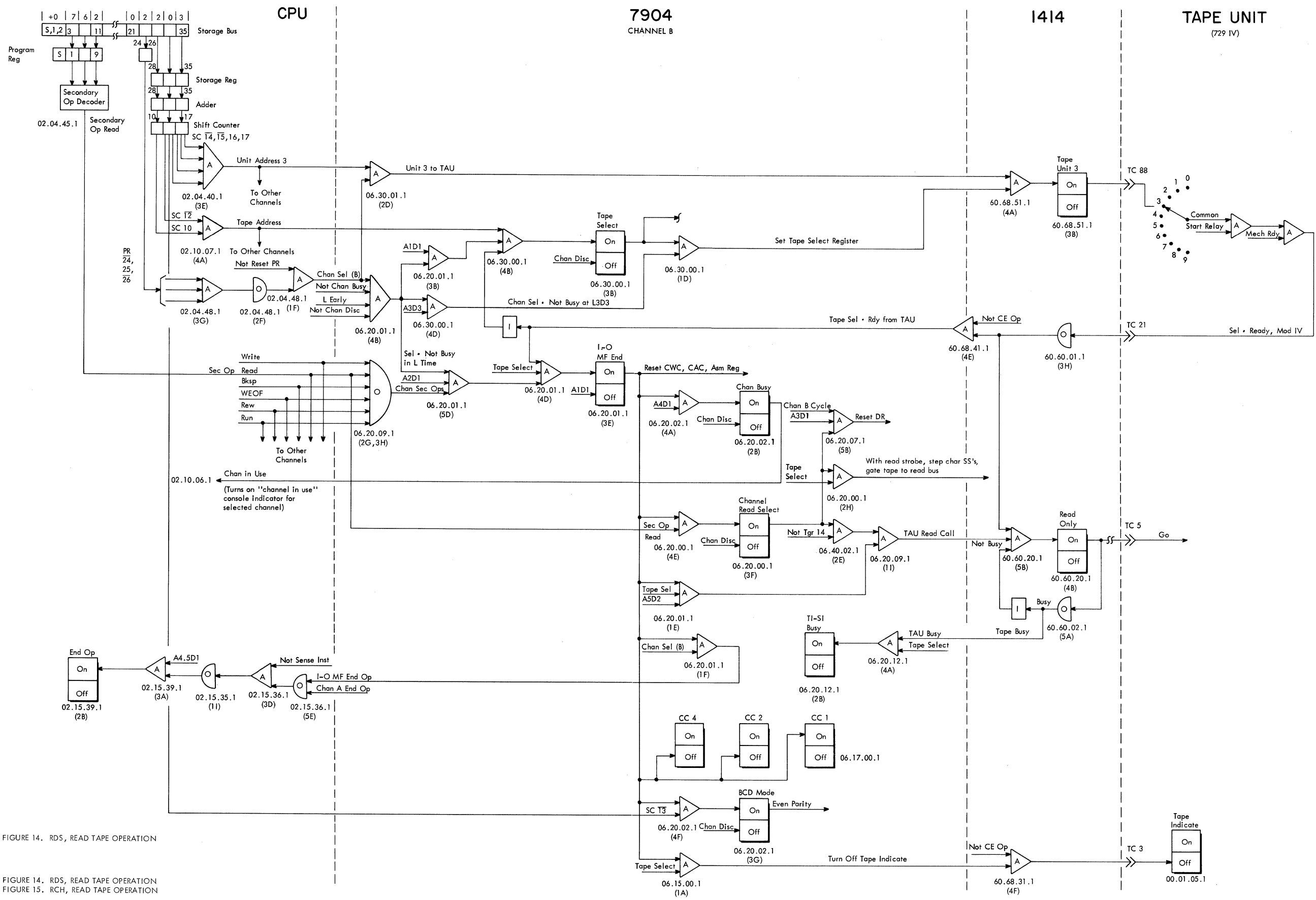

FIGURE 14. RDS, READ TAPE OPERATION

FIGURE 14. RDS, READ TAPE OPERATION
FIGURE 15. RCH, READ TAPE OPERATION

(Figures 12,13 on reverse)

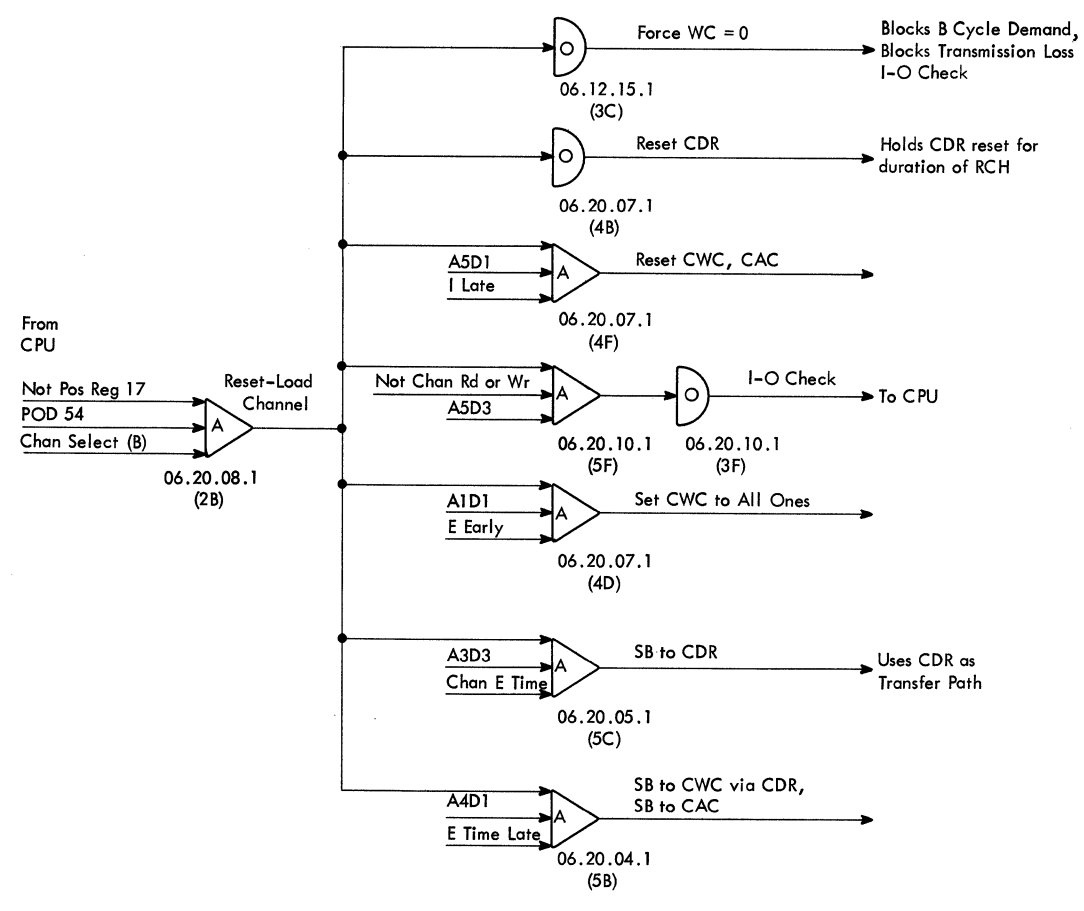
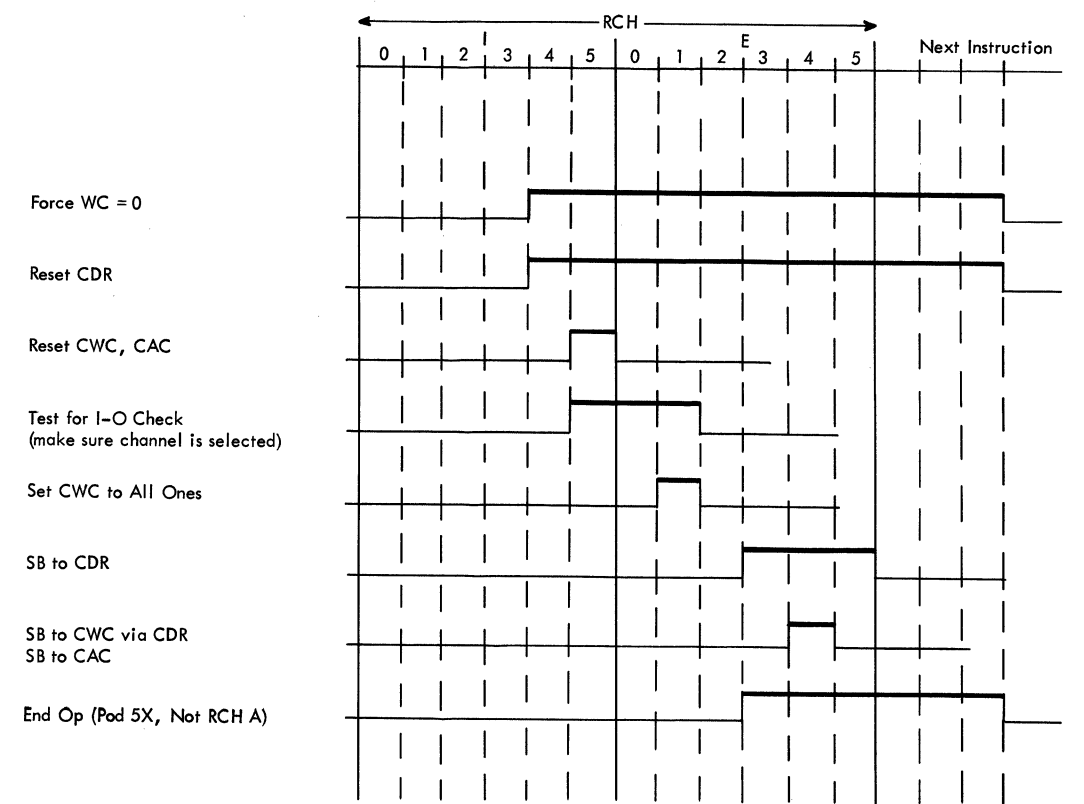

FIGURE 15. RCH, READ TAPE OPERATION

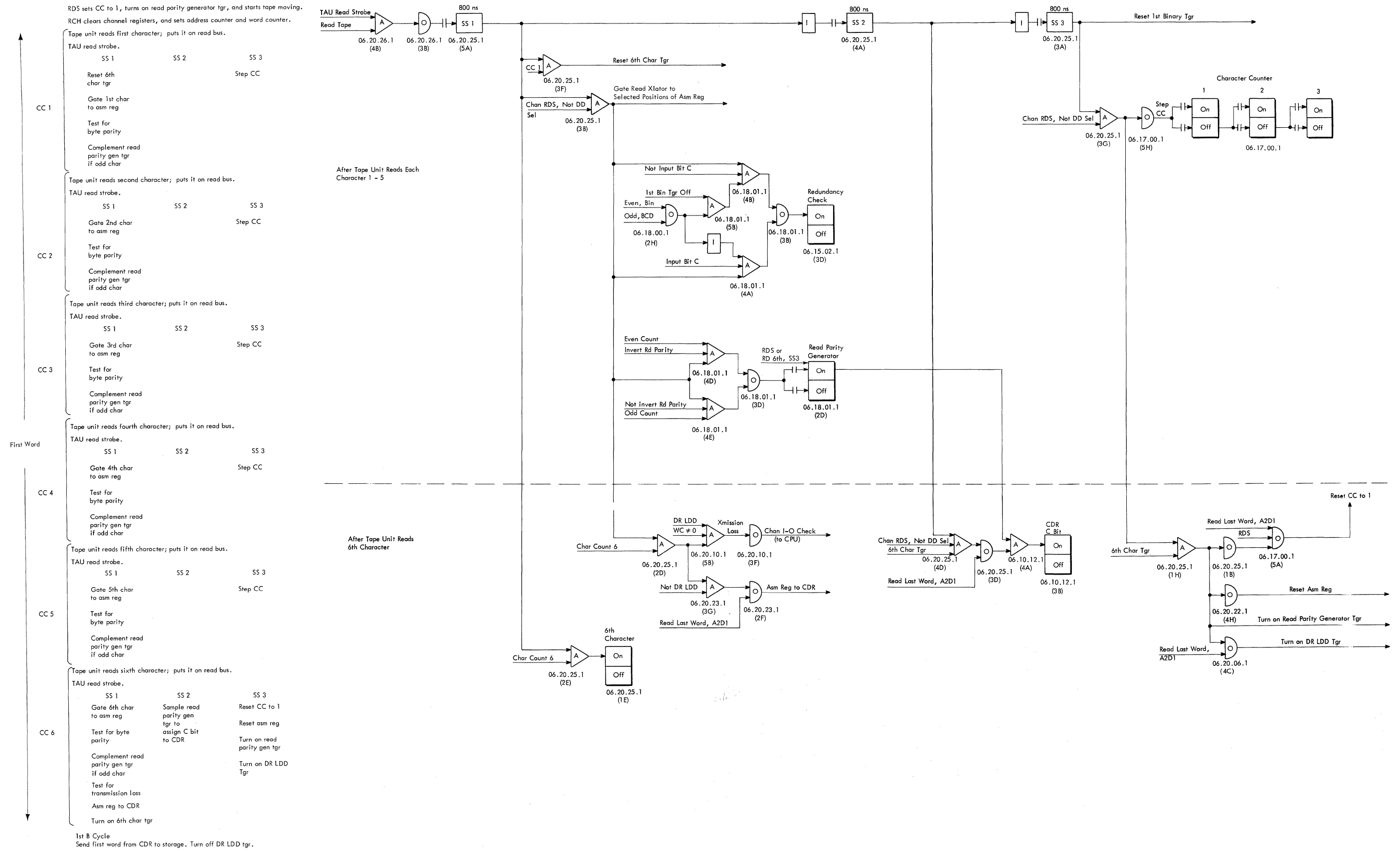

FIGURE 16. CHARACTER READING, READ TAPE OPERATION

(Figure 17 on reverse)

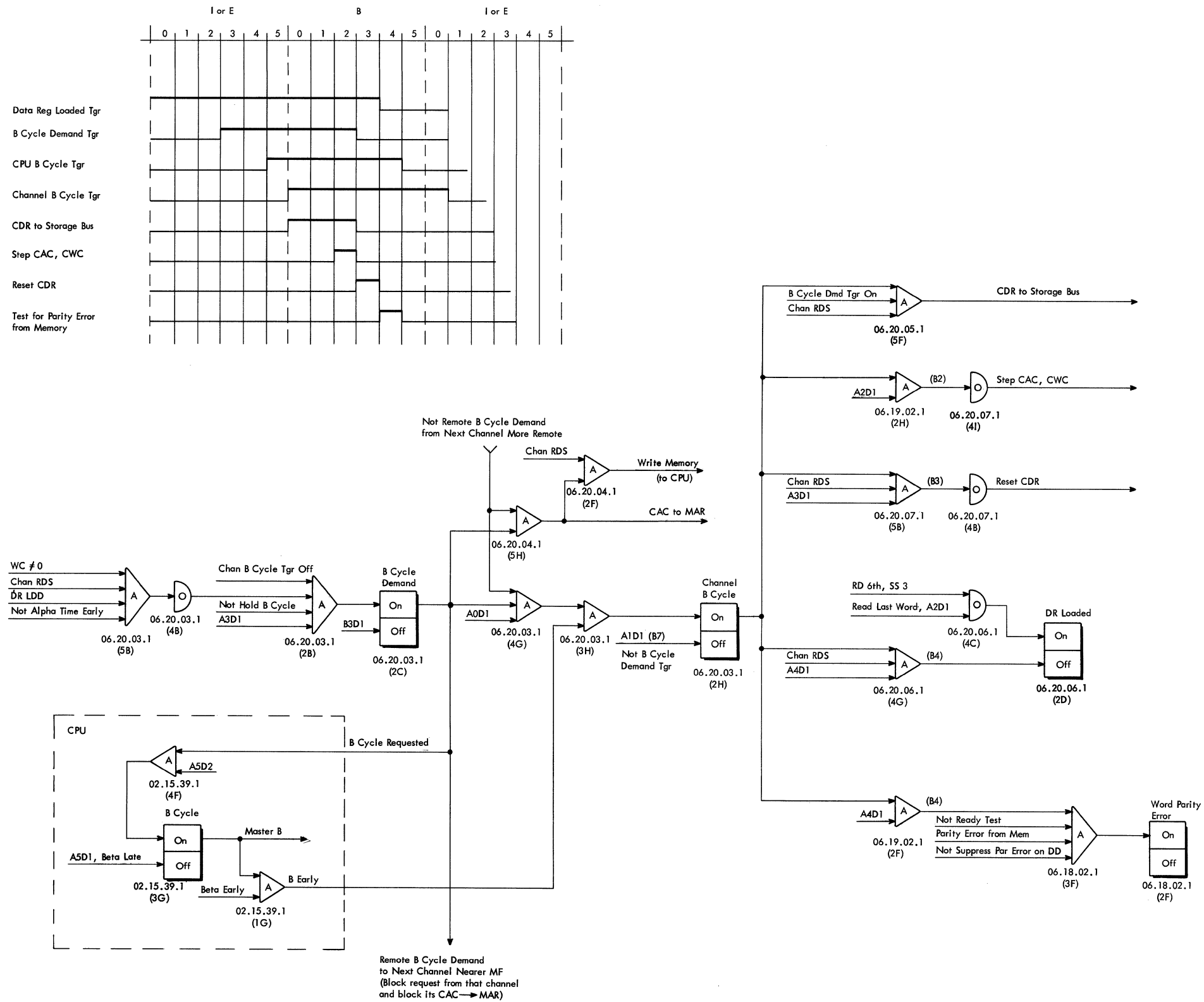

FIGURE 17. B CYCLE, READ TAPE OPERATION

(Figure 16 on reverse)

7904

1414

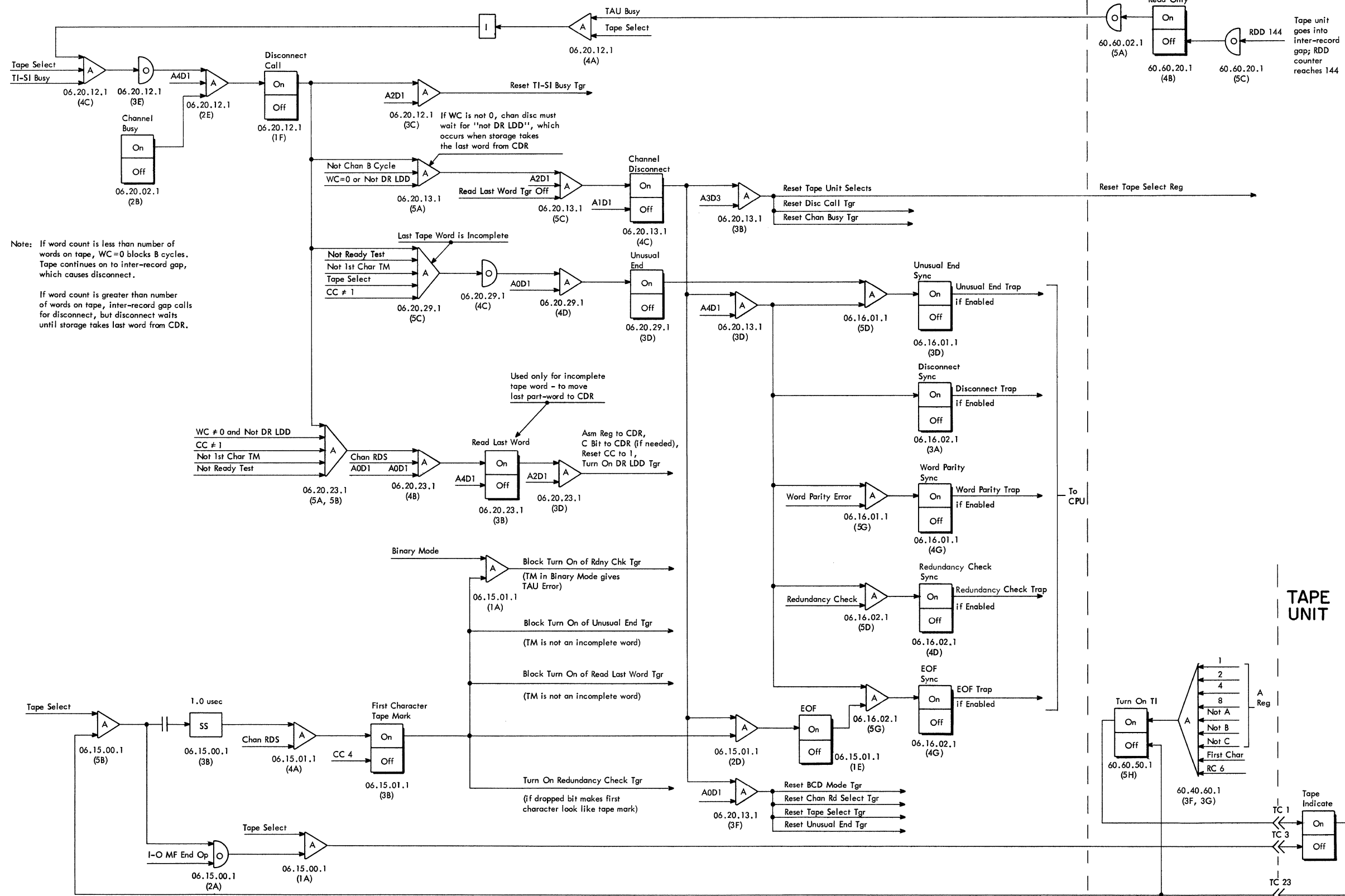

FIGURE 18. END OPERATION AND DISCONNECT, READ TAPE OPERATION (Figure 19 on reverse)

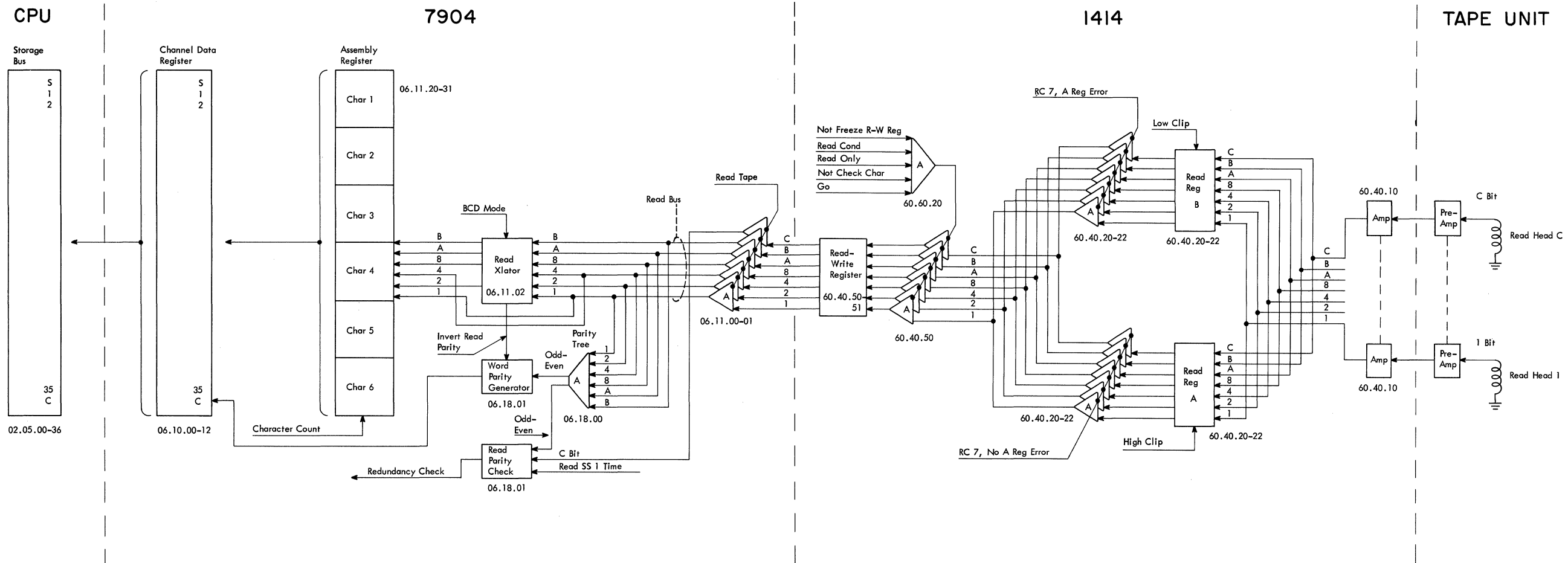
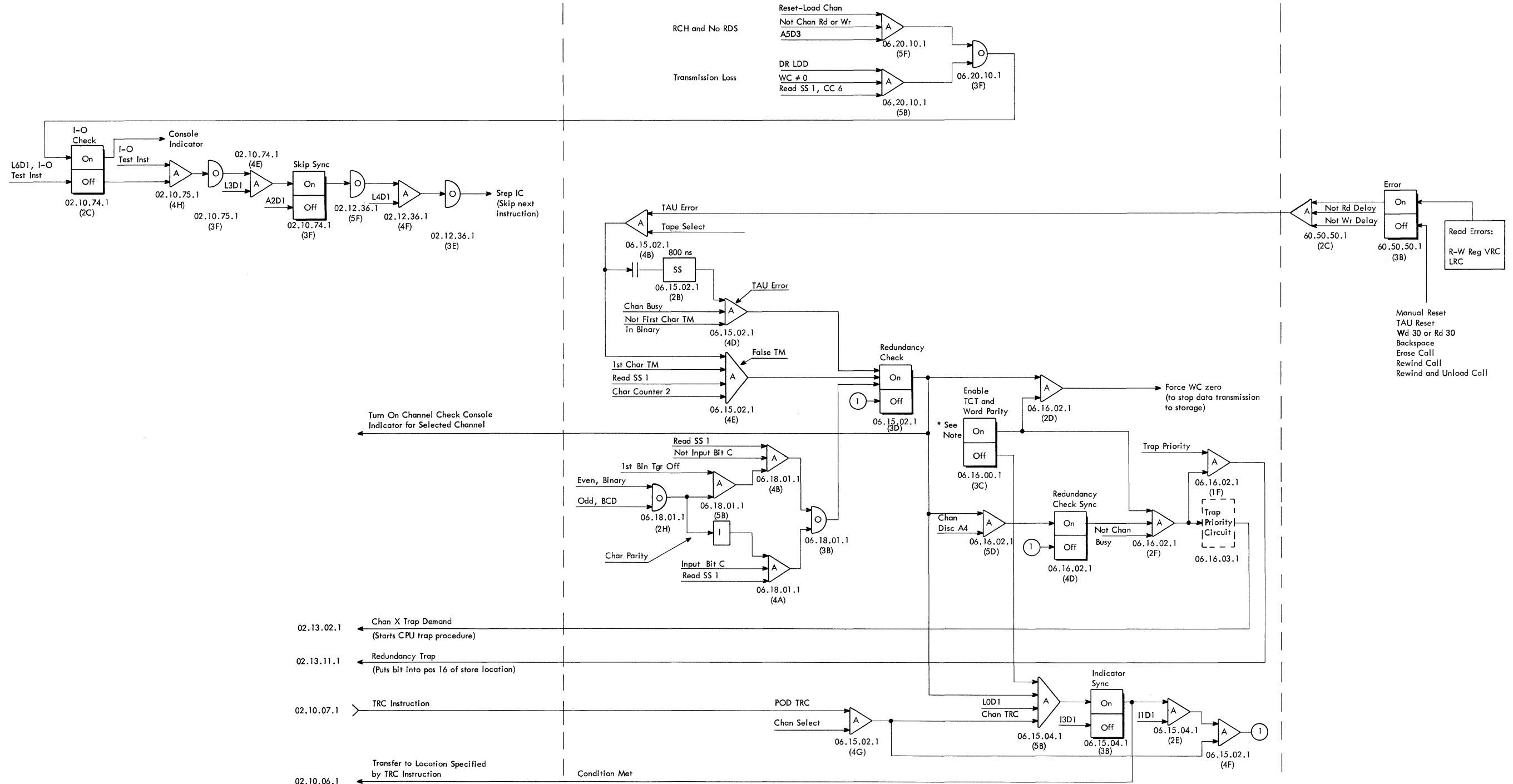

FIGURE 19. DATA FLOW, READ TAPE OPERATION

(Figure 18 on reverse)



* Note: Turned on by unable instruction (mask bit 16)

FIGURE 20. I-O CHECK AND REDUNDANCY CHECK, READ TAPE OPERATION

(Figure 21 on reverse)

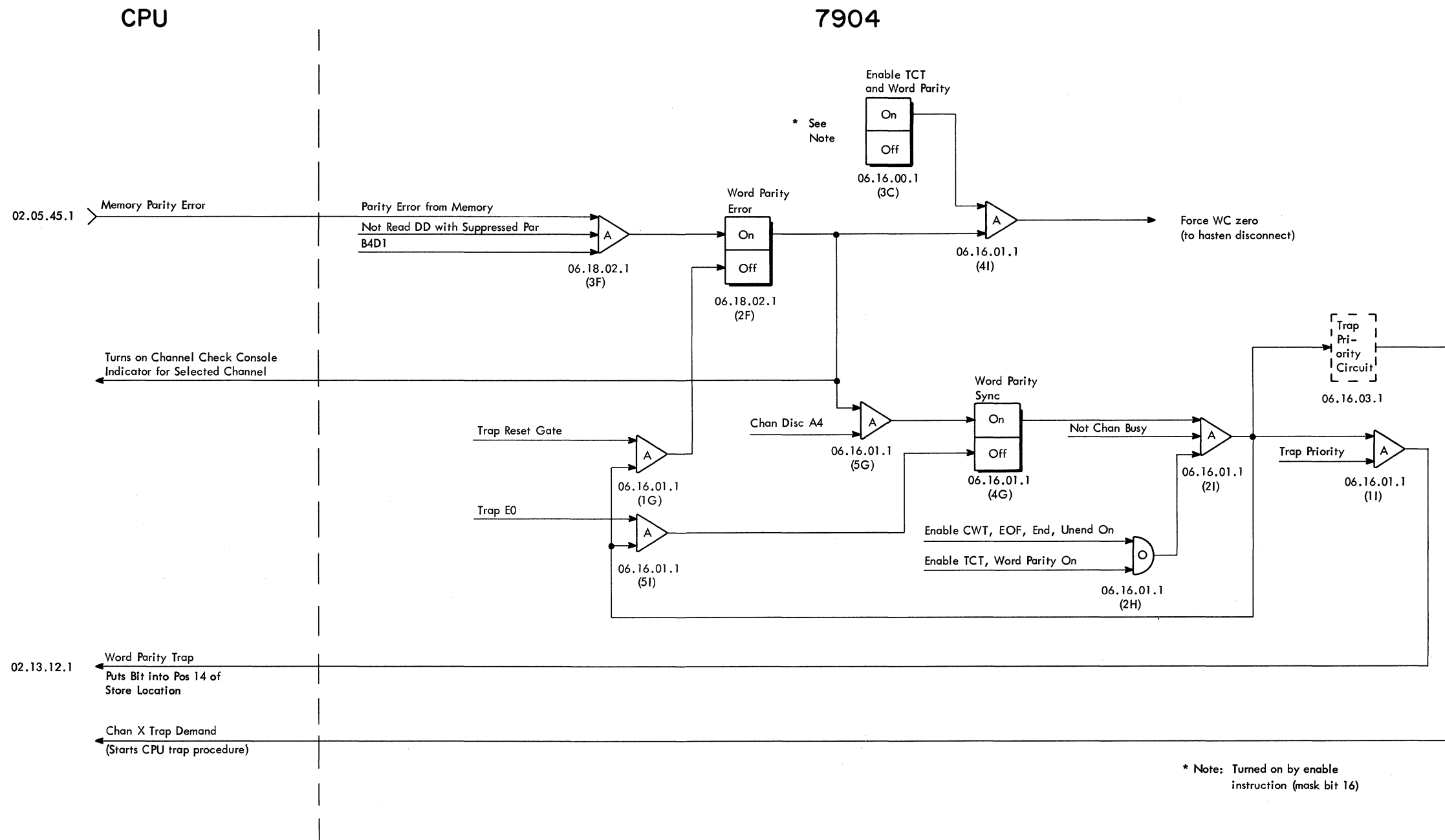
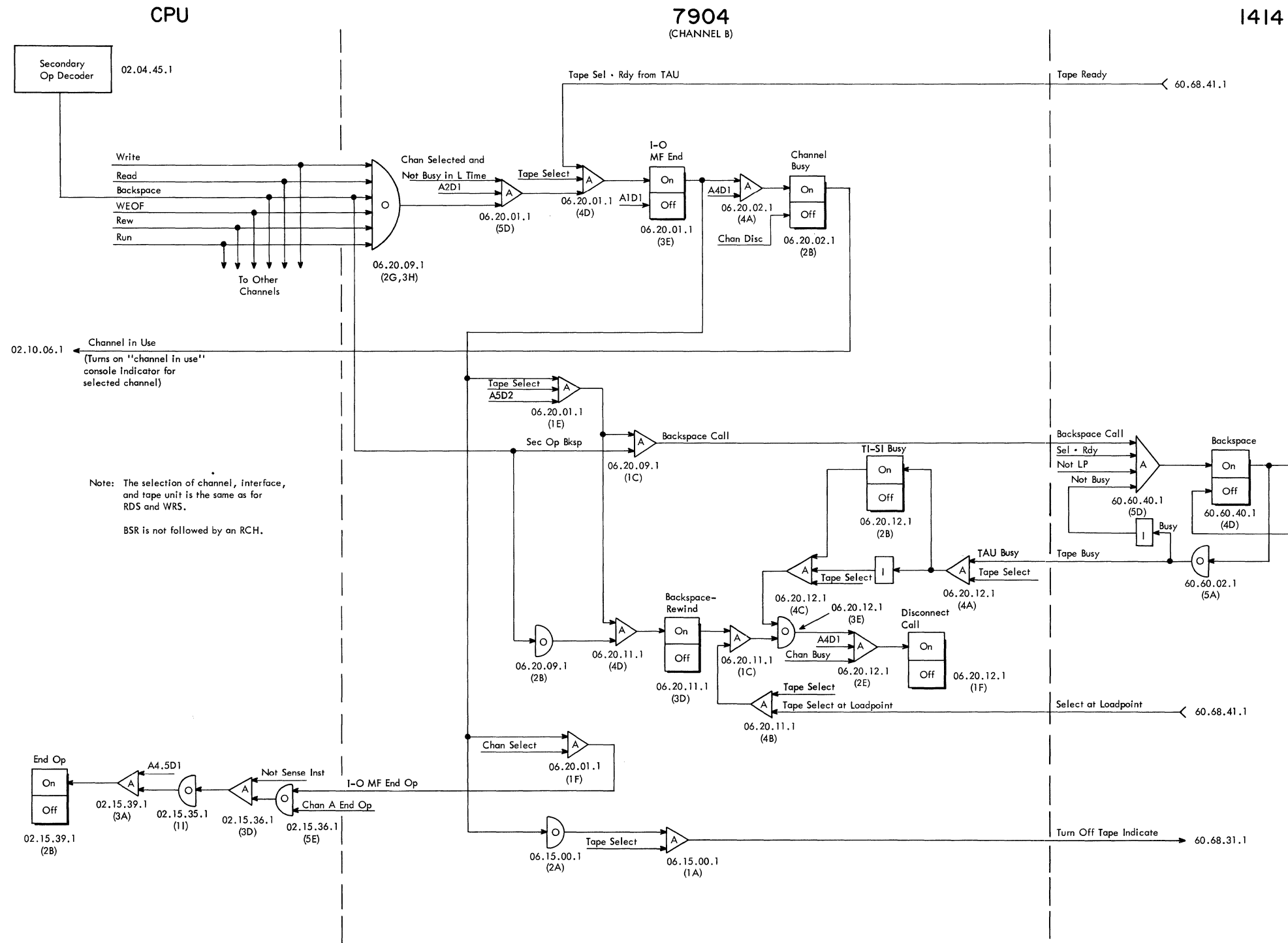

FIGURE 21. WORD PARITY ERROR, READ TAPE OPERATION

(Figure 20 on reverse)



1. Start delay counter (MS mode); set Go if in write status.
2. D50 - reset Go (coast to a stop)
3. D96 - set backward tgr (puts tape unit in read status).
4. D160 - set Go, gate on final amps.
5. D180 - set read condition (gates A and B regs).
6. Read first character encountered, set first bit tgr, and start the read clock (first character encountered is the check character).
7. RC7 - set RDD tgr and run RDD ctr.
8. Read next character, start read clock, and reset RDD at RC4.
9. RC7 - again set RDD tgr and run RDD ctr.
10. Keep looking for RDD ctr count of 16; if counter reaches 16, all characters have passed read head.
11. RDD16 - reset read condition.
12. RDD22 - reset Go.
13. RDD64 - reset backward tgr.
14. RDD 152 - bring up 144 reset, reset backspace tgr (drops busy).

FIGURE 22. BSR, BACKSPACE OPERATION
 (Figure 23 on reverse)
 7040-7044 Channels B-E CERM (8-63) 23

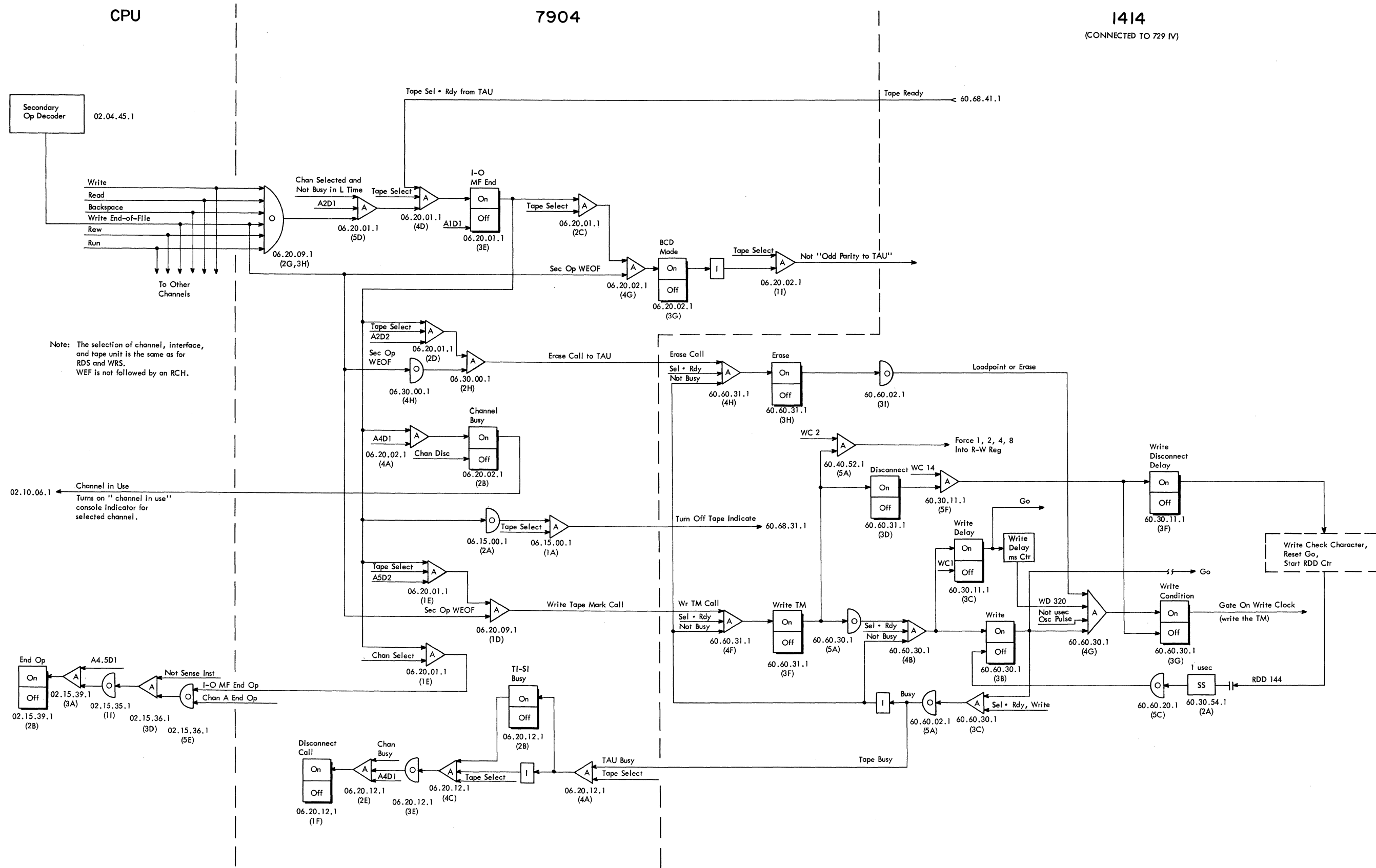

FIGURE 23. WEF, WRITE-END-OF-FILE OPERATION
 (Figure 22 on reverse)

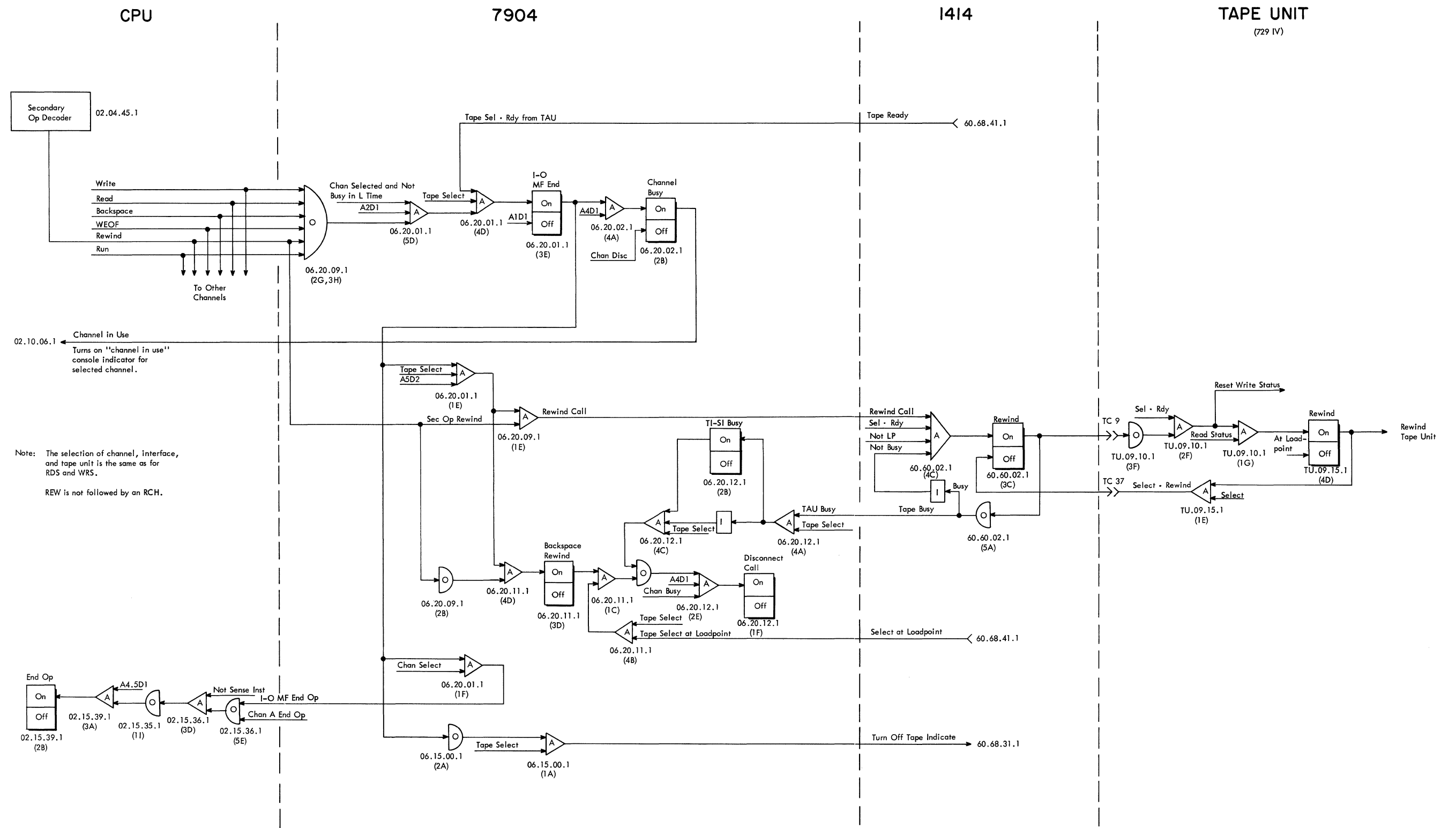
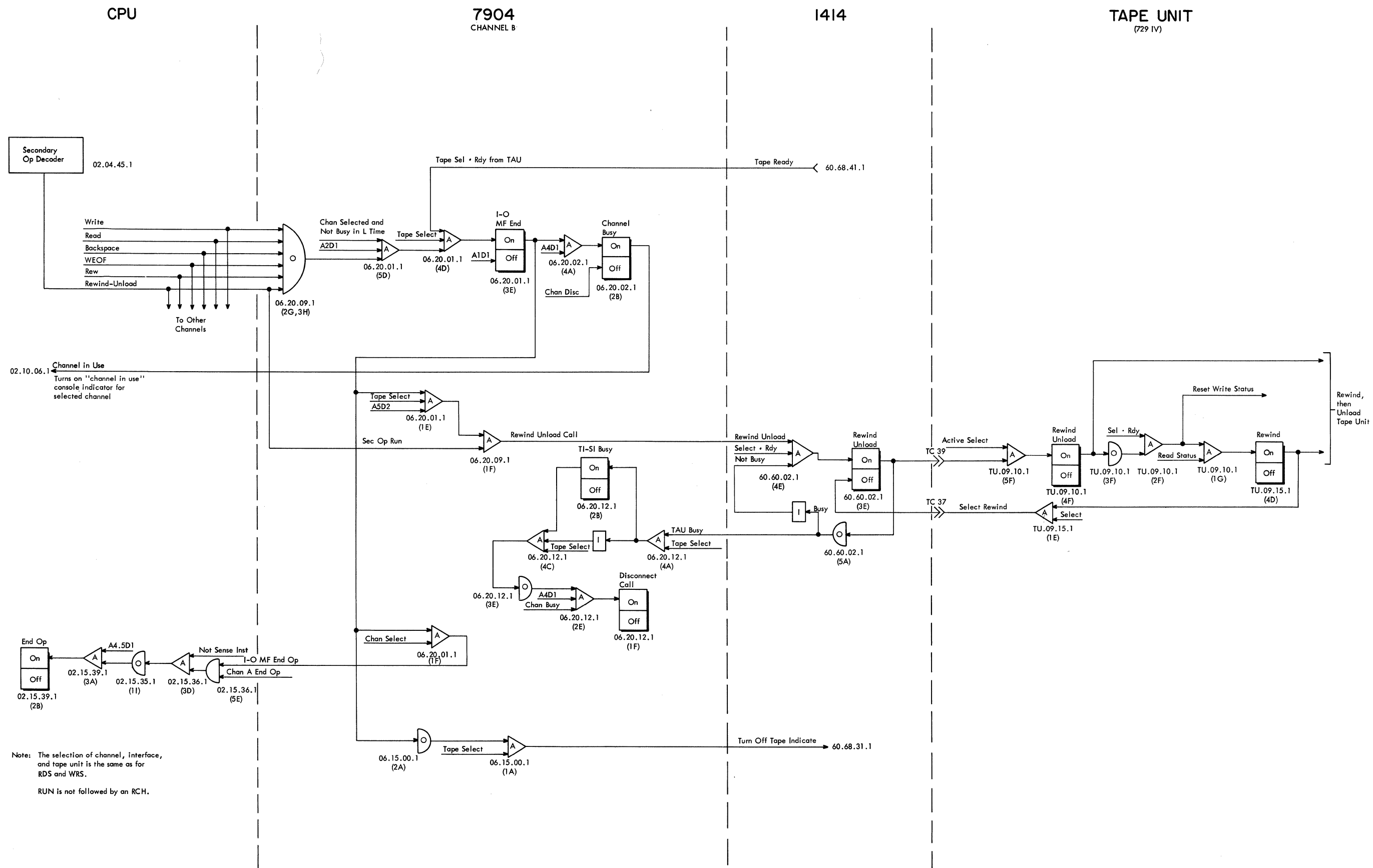

FIGURE 24. REW, REWIND OPERATION
(Figure 25 on reverse)
7040-7044 Channels B-E CERM (8-63) 25



Note: The selection of channel, interface, and tape unit is the same as for RDS and WRS.
 RUN is not followed by an RCH.

FIGURE 25. RUN, REWIND UNLOAD OPERATION
 (Figure 24 on reverse)

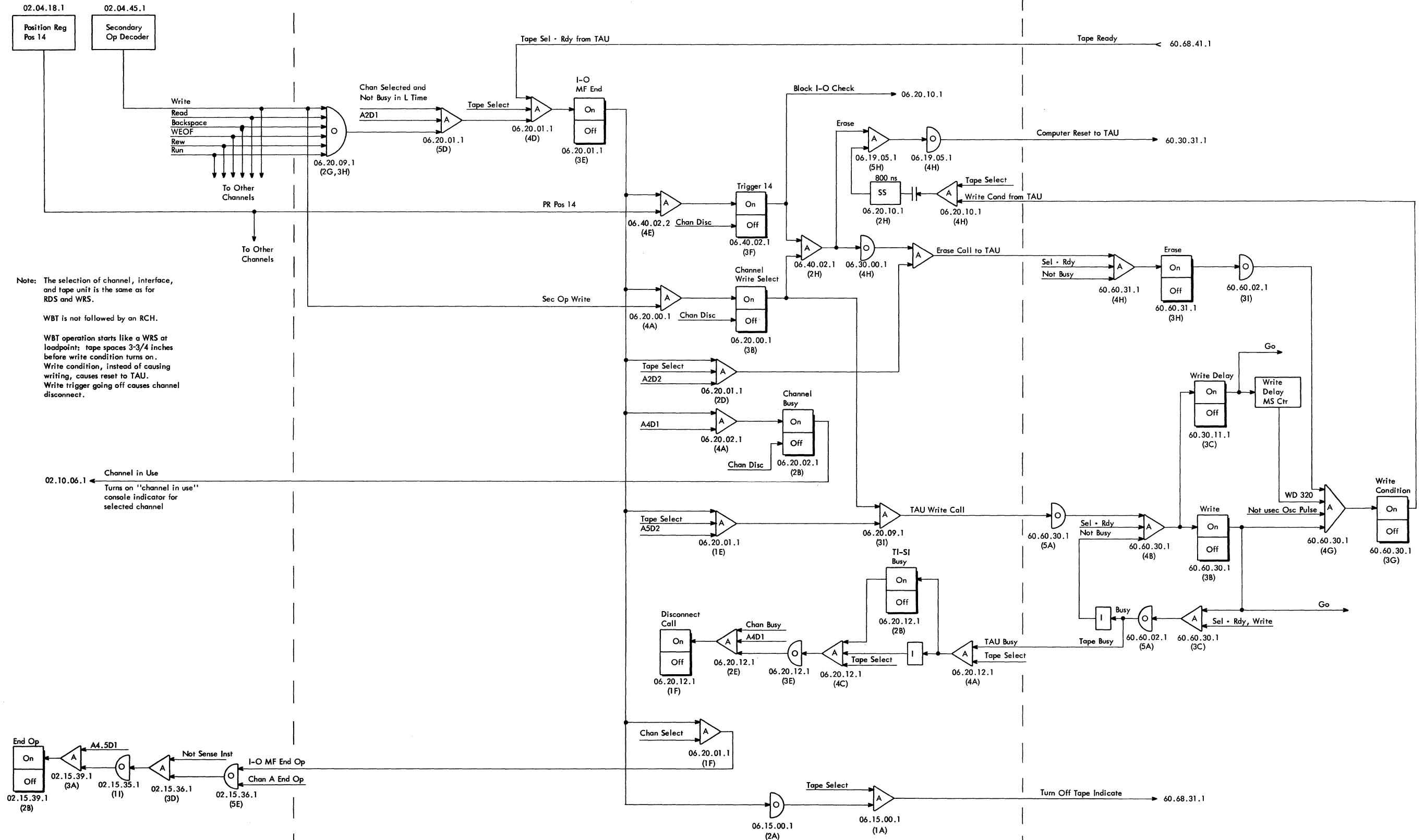

FIGURE 26. WBT, WRITE BLANK TAPE OPERATION

(Figure 27 on reverse)

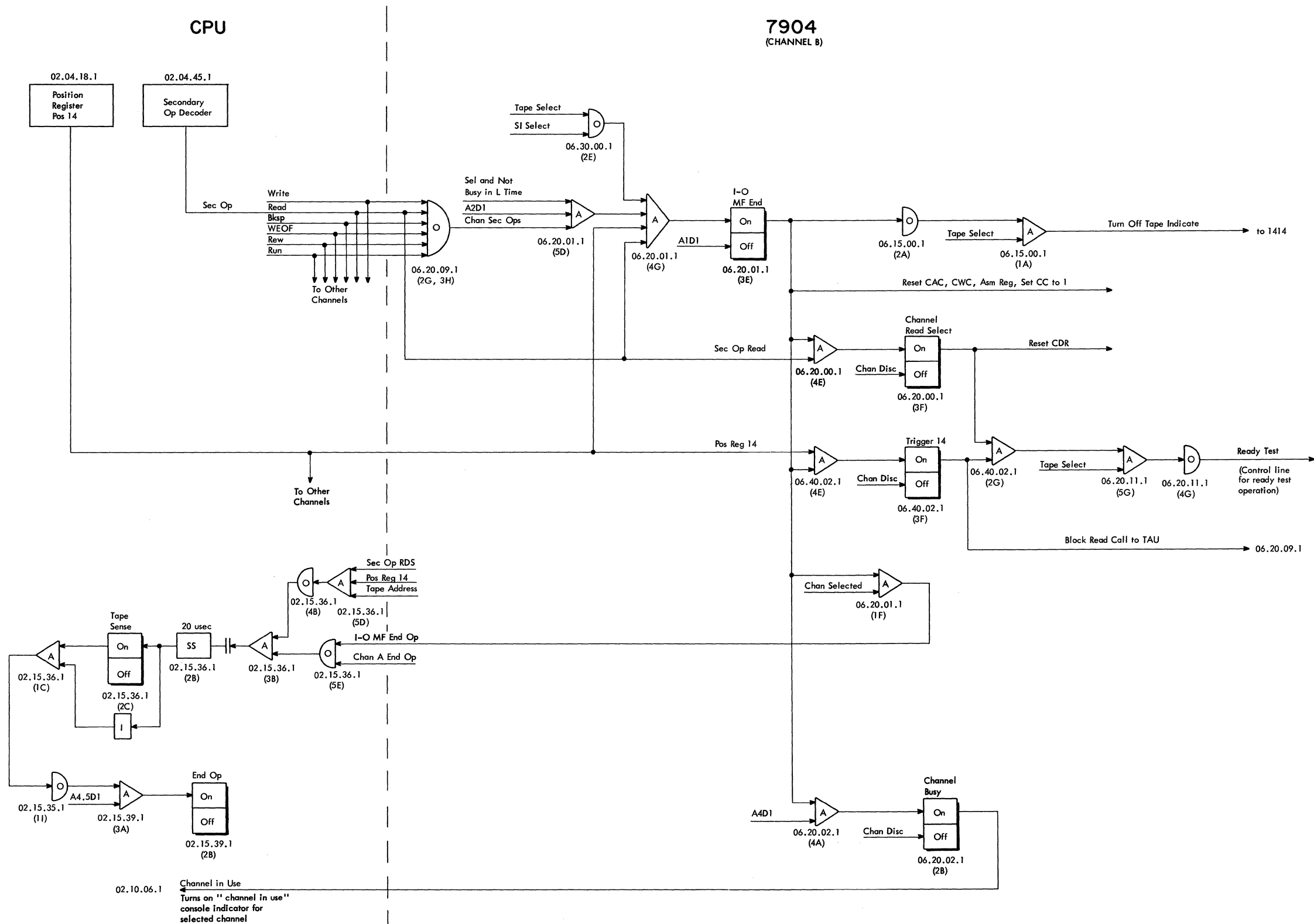

FIGURE 27. SEN, TAPE READY TEST OPERATION

(Figure 26 on reverse)

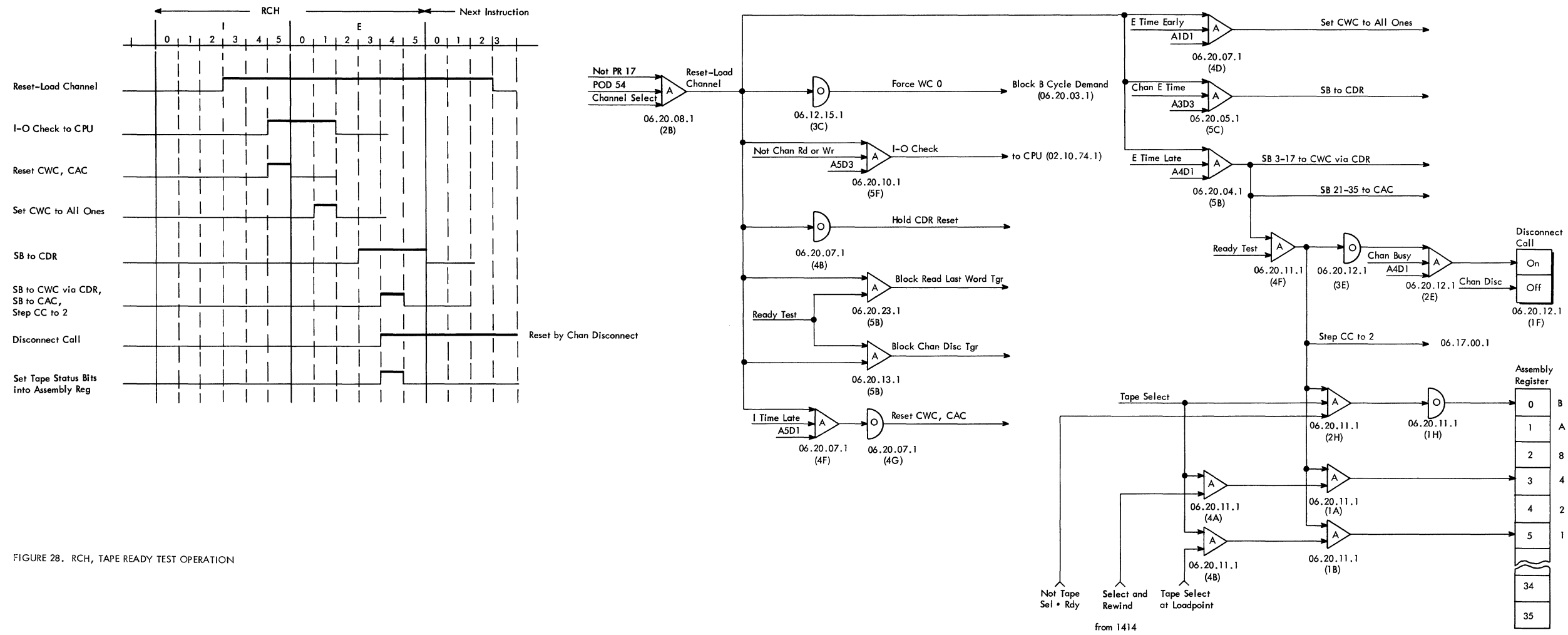

FIGURE 28. RCH, TAPE READY TEST OPERATION

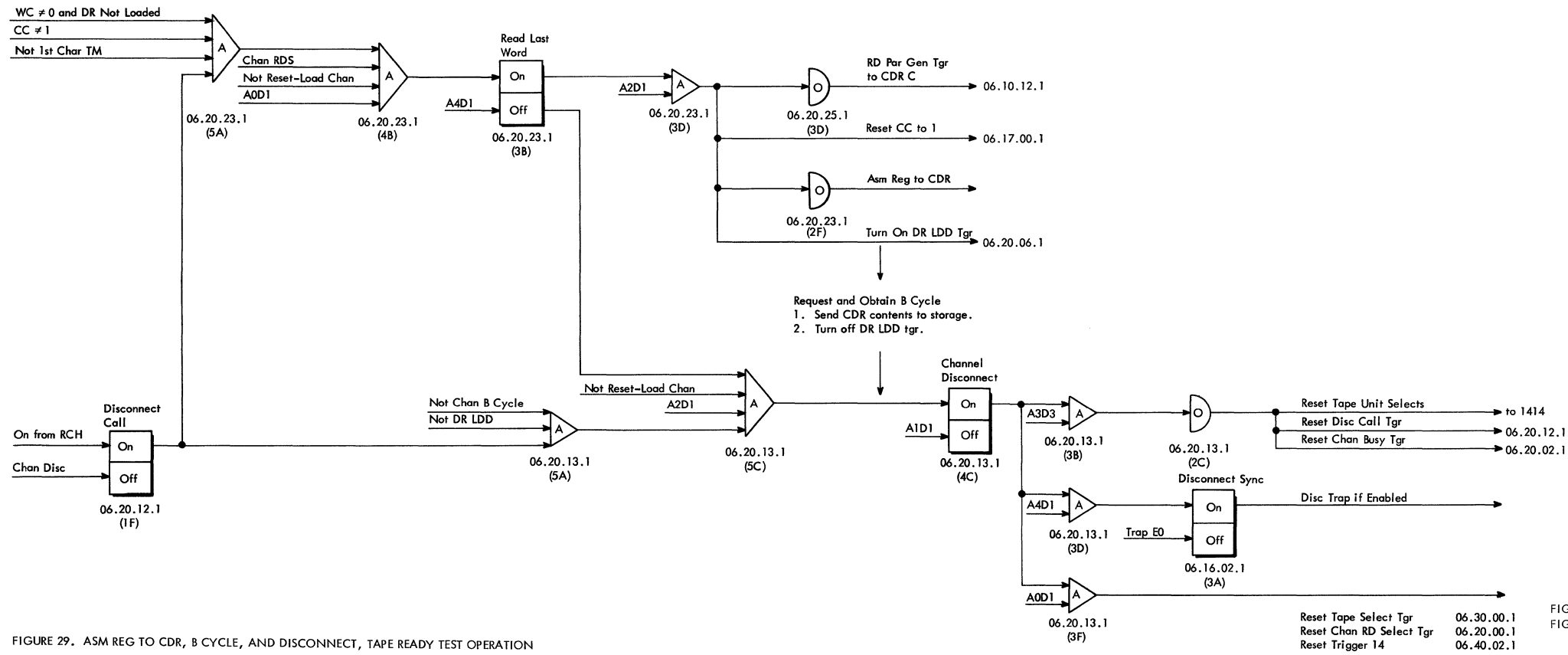

FIGURE 29. ASM REG TO CDR, B CYCLE, AND DISCONNECT, TAPE READY TEST OPERATION

FIGURE 28. RCH, TAPE READY TEST OPERATION
FIGURE 29. ASM REG TO CDR, B CYCLE, AND DISCONNECT, TAPE READY TEST OPERATION

COMMENT SHEET

IBM 7040-7044 DATA PROCESSING SYSTEMS, CHANNELS B, C, D, AND E

CUSTOMER ENGINEERING REFERENCE MANUAL, FORM 223-2712

FROM

NAME _____

OFFICE NO. _____

FOLD

Your comments regarding this manual will help Product Publications increase the value of future reference manuals. Please consider the following questions and mail this form.*

FOLD

1. If used in school, did the logic diagrams help you understand the relationship of the various machine units in the overlap channel-tape operations?
2. Have these diagrams helped you fix any overlap channel-tape troubles?
3. Has the scarcity of timing charts in this manual been a handicap in learning the tape operations? In fixing troubles?
4. General comments.

CUT ALONG LINE

FOLD

*Note: Suggestions giving specific solutions and intended for award considerations should be submitted through the IBM suggestion plan.

NO POSTAGE NECESSARY IF MAILED IN U. S. A.
FOLD ON TWO LINES, STAPLE, AND MAIL

STAPLE

STAPLE

FOLD

FOLD

BUSINESS REPLY MAIL
 NO POSTAGE STAMP NECESSARY IF MAILED IN U. S. A.

FIRST CLASS
PERMIT NO. 81
POUGHKEEPSIE, N. Y.

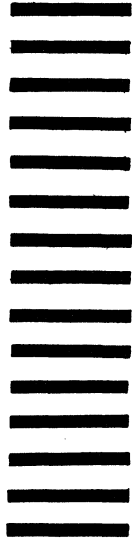

CUT ALONG LINE

POSTAGE WILL BE PAID BY
IBM CORPORATION
P. O. BOX 390
POUGHKEEPSIE, N. Y.

ATTN: CE MANUALS, DEPARTMENT B95

FOLD

FOLD

STAPLE

STAPLE



International Business Machines Corporation
Data Processing Division
112 East Post Road, White Plains, New York