

# **IBM** Field Engineering Installation Manual

This information is furnished in accordance with requirements of Contract FA64WA-5223 and is subject to clause 24 thereof entitled "Reproduction and Use of Technical Data" which provides for its use, reproduction or disclosure by the Government for Governmental purposes.

**9020** D System (FAA United Kingdom Simplex)

## PREFACE

This manual is a guide for installing the IBM 9020D (UK) Simplex System. It provides pre-system planning, external cabling, and system tests information.

The system installation manual together with the applicable unit manuals, provide a complete package of instructions for installing the system.

Keep these manuals with the system for possible use when reinstalling the equipment. New or revised installation manuals obtained at the time of re-installation may lack information pertinent to system or units.

Address comments concerning the contents of this publication to:  
IBM Corporation, Federal Systems Division, FAA Project Office,  
18100 Frederick Pike, Gaithersburg, Maryland 20760

## CONTENTS

|            |  |     |
|------------|--|-----|
| CHAPTER 1. | INTRODUCTION. . . . .  | 1-1 |
| 1.1        | System Configuration. . . . .  | 1-1 |
| 1.2        | 9020 Element and Unit Installation Reference. . . . .                    | 1-3 |
| 1.3        | Installation Planning . . . . .  | 1-3 |
| 1.3.1      | Records . . . . .  | 1-3 |
| 1.3.2      | Maintenance Room. . . . .  | 1-4 |
| 1.3.3      | Pre-Installation Checks . . . . .  | 1-4 |
| 1.4        | Unloading and Unpacking . . . . .  | 1-6 |
| 1.4.1      | Shipping Groups . . . . .  | 1-6 |
| CHAPTER 2. | EXTERNAL CABLES . . . . .  | 2-1 |
| 2.1        | Cable Shipment. . . . .  | 2-1 |
| 2.2        | Floor Preparation . . . . .  | 2-1 |
| 2.3        | Cable Identification. . . . .  | 2-1 |
| 2.4        | Cable Plugging. . . . .  | 2-2 |
| 2.4.1      | Computing Element (CE). . . . .  | 2-2 |
| 2.4.2      | Storage Element (SE). . . . .  | 2-2 |
| CHAPTER 3. | IBM 7231-02 IOCE SYSTEM TEST. . . . .                                    | 3-1 |
| 3.1        | MACH Storage Ripple Tests . . . . .                                      | 3-1 |
| 3.2        | Fault Locating Test (IOCE). . . . .                                      | 3-1 |
| 3.3        | Internal IPL (Diagnostic Mode). . . . .                                  | 3-1 |
| 3.3.1      | IPL Diagnostic Mode . . . . .  | 3-1 |
| 3.3.2      | IPL Troubleshooting . . . . .  | 3-2 |
| 3.4        | Bring-Up Programs . . . . .  | 3-2 |
| 3.4.1      | Go/No-Go Test . . . . .  | 3-2 |
| 3.4.2      | Basic Storage Test. . . . .  | 3-2 |
| 3.4.3      | Programs Run Under IDM. . . . .  | 3-2 |
| 3.4.4      | Programs Run Under SDM. . . . .  | 3-2 |
| 3.5        | Interface and Normal Mode Tests . . . . .                                | 3-3 |
| 3.5.1      | IOCE to CE Interface Check (Condition Code) . . . . .                    | 3-3 |
| 3.5.2      | Response. . . . .  | 3-3 |
| 3.5.3      | FLT Complete. . . . .  | 3-3 |
| 3.5.4      | Reset Time Out. . . . .  | 3-4 |
| 3.5.5      | PSBAR Lockout . . . . .  | 3-4 |
| 3.5.6      | Element Check . . . . .  | 3-4 |
| 3.5.7      | Subsystem Reset . . . . .  | 3-4 |
| 3.5.8      | System Reset. . . . .  | 3-4 |
| 3.5.9      | FLT Load (External) . . . . .  | 3-4 |
| 3.5.10     | IPL (External). . . . .  | 3-5 |
| 3.5.11     | CCR Checks. . . . .  | 3-5 |
| 3.6        | Disabling of Manual Controls. . . . .                                    | 3-5 |
| 3.6.1      | CLU Controls Operative in all States. . . . .                            | 3-6 |
| 3.6.2      | CLU Controls Operative in States 1 or 0 and<br>Diagnostic Mode . . . . . | 3-6 |
| 3.6.3      | CLU Control Operative in State 0 and<br>Diagnostic Mode . . . . .        | 3-7 |
| 3.6.4      | CLU Controls Operative in State 0 with<br>Test Switch On. . . . .        | 3-7 |
| 3.7        | Test State Latched. . . . .  | 3-7 |

|            |  |     |
|------------|--|-----|
| CHAPTER 4. | IBM 7201-02 CE SYSTEM TEST . . . . .                               | 4-1 |
| 4.1        | Bring-Up Aid (QY051) . . . . .                                     | 4-1 |
| 4.2        | Reset. . . . .   | 4-1 |
| 4.2.1      | Subsystem Reset. . . . .   | 4-1 |
| 4.2.2      | System Reset . . . . .   | 4-2 |
| 4.3        | Main Storage Ripple Tests. . . . .                                 | 4-2 |
| 4.3.1      | Write All Ones . . . . .   | 4-2 |
| 4.3.2      | Read All Ones. . . . .   | 4-3 |
| 4.3.3      | Write/Read All Zeros . . . . .                                     | 4-3 |
| 4.3.4      | Write/Read Alternate Patterns. . . . .                             | 4-3 |
| 4.4        | Read Only Storage (ROS) and Fault Locating<br>Tests (FLT). . . . . | 4-3 |
| 4.5        | IPL Subsystem Check. . . . .                                       | 4-3 |
| 4.6        | Load PSW and Address Compare . . . . .                             | 4-4 |
| 4.6.1      | Load PSW . . . . .   | 4-4 |
| 4.6.2      | Address Compare. . . . .   | 4-4 |
| 4.7        | Configuration Check, CE-TCU-IOCE-SE-PAM-DASF<br>Interface. . . . . | 4-5 |
| 4.8        | CE Bring-Up Programs . . . . .                                     | 4-5 |

LIST OF ILLUSTRATIONS

| <u>FIGURE</u> |   | <u>PAGE</u> |
|---------------|---|-------------|
| 1-1           | 9020D System (UK Simplex) Configuration . . . . . | 1-2         |
| 1-2           | Typical Maintenance Room. . . . .                 | 1-5         |
| 2-1           | External Cable Identification . . . . .           | 2-3         |
| 2-2           | CE Cabling. . . . .                               | 2-4         |
| 2-3           | SE1 Tailgate Plugging Locations . . . . .         | 2-5         |
| 2-4           | SE2 Tailgate Plugging Locations . . . . .         | 2-6         |
| 2-5           | SE3-SE8 Tailgate Plugging Locations . . . . .     | 2-7         |
| 2-6           | SE Cable Support Ladder . . . . .                 | 2-8         |

## SAFETY

In addition to the safety practices outlined in CE Safety Practices card, Form 229-1264, observe the following precautions:

Do not work alone on equipment that has power on.

Wear Safety glasses when performing maintenance and repair work. Be sure that fire extinguishers are readily available and of the right type (CO<sub>2</sub>).

When it is necessary to work near power connectors, convenience outlets, or power supplies, disconnect the power cables or turn off the main circuit breakers and remove the pull-type fuse holder from the battery box. Convenience outlets are live unless you pull the emergency power off switch or trip the main circuit breaker.

Discharge capacitors before working on dc power supplies.

Turn off power and use a fuse puller when replacing fuses. Replace any safety covers that have been removed.

Use only grounded tools and test equipment. Ungrounded equipment is dangerous and can cause serious SLT card damage. An example of such a hazard is ungrounded Wire-Wrap\* guns.

Learn location of emergency exits.

Train personnel in:

1. Procedures to shut off all power and air conditioning.
2. Handling fire extinguishers.
3. Evacuating records and personnel.
4. Calling the fire department.
5. Administration of first aid.

Power phasing of all units is critically important to your safety. Before turning power on, be sure to follow to the letter all instructions on power phasing.

Before working on the 9020 system battery package, become familiar with the following safety instructions.

### DANGER

The full dc potential of the batteries is present across the red and black binding posts on the power control box inside the battery cabinet when both battery switches are ON and 24 vdc is applied to the EPO contactor coil. This voltage ranges from

300 to 350 vdc and can cause dangerous electrical shock. Interrupting the 24 vdc to the contactor coil, turning off both battery switches or removal of the pull type fuse holder will remove the battery potential from the binding posts if the battery charger is not active. However, if J1 is connected and the charger is active, full charger potential (450 to 500 vdc) is present at the binding posts even when the battery switches and contactor are inactive and the pull type fuse holder is removed.

DANGER

Outriggers (safety legs) are used to move the CE, and SE power wall frames; the CE DAT and battery frames. Do not remove outriggers until frames are placed at designated floor locations.

\*Trademark of Gardner - Denver Company

This manual provides installation instructions for the IBM 9020D Simplex. The following information is included:

1. System Configuration
2. Element and unit installation reference
3. Pre-installation planning
4. Unloading and unpacking
5. External Cables
6. System testing

Separate element and unit installation manuals are available; they provide installation instructions for each system component and should be used in conjunction with this manual.

## 1.1 SYSTEM CONFIGURATION

The 9020D Simplex System configuration consists of:

One IBM 7201-02 Computing Element (CE).

One IBM 7231-02 Input/Output Control Element (IOCE).

Four IBM 7251-09 Storage Elements(SE). Expandable to eight SE's.

One IBM 7289-02 Peripheral Adapter Module.

One IBM 1052-07 Printer Keyboard.

One IBM 2314-A1 Storage Control Unit.

One IBM 2312-A1 Disk Storage Unit.

One IBM 2821-01 Control Unit.

One IBM 1403 Printer.

One IBM 2540 Card Read Punch.

Two IBM 2803A-01 Tape Control Units(TCU).

Eight IBM 2401 Magnetic Tape Units (expandable to 8 tape units per TCU).

The CE, and SE's are physically attached via a common power wall. The wall also contains a battery frame. See Figure 1-1 for locations and order of expansion for the SE's.



9020D SYSTEM (UK SIMPLEX)  
 NUMBERING AND ORDER OF EXPANSION

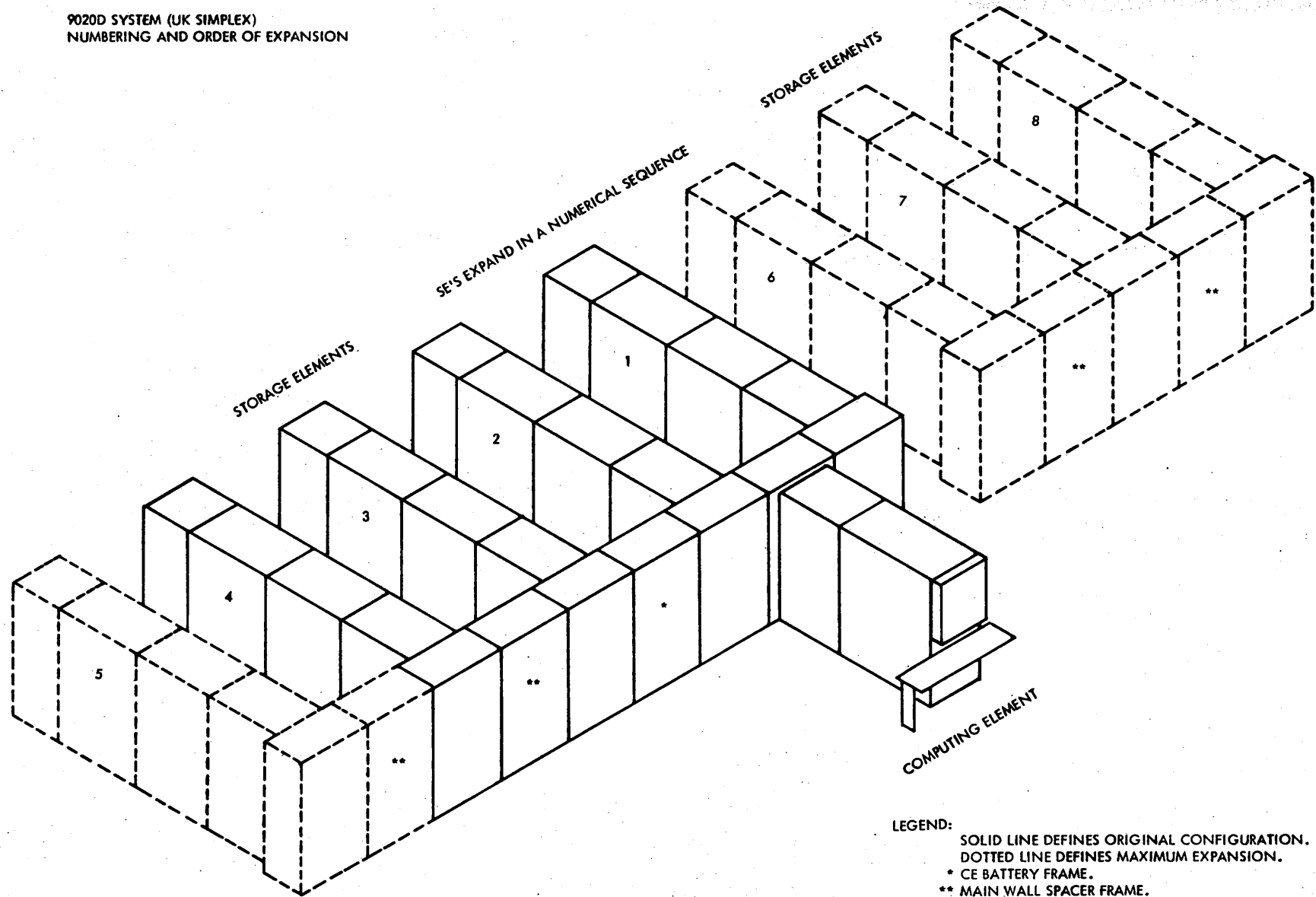

FIGURE 1-1. 9020D System (UK Simplex) Configuration

## 1.2 9020 ELEMENT AND UNIT INSTALLATION REFERENCES

Separate installation manuals are available for each system component. They facilitate assembly and test of individual units. Unit assembly, interframe cabling, and test procedure information is contained in the following manuals:

IBM 7201-02 Computing Element, Form SFN-0204

IBM 7231-02 I/O Control Element, Form 123, 9513

IBM 7251-09 Storage Element, Form SFN-0304

IBM 7289-02 Peripheral Adapter Module, Form 123-9515

IBM 2314-A1 Storage Control Unit, Form SY27-2309

IBM 9020 I/O Unit Installation Manual, Form 123-9516 includes:  
2803 Tape Control, 2401 Magnetic Tape Units  
2821 Control Unit, 1403 Printer, and 2540 Card Read Punch

IBM 2401/02/03/04, 2420, 2803/04 Magnetic Tape Units and Controls,  
Form SY22-9506

## 1.3 PRE-INSTALLATION PLANNING

Installation time for the 9020D Simplex System can be shortened if site preparations are completed before the system arrives. This section provides the customer engineer with a guide for these preparations.

Physical planning requirements for the installation of the IBM 9020D Simplex System are specified in the IBM 9020 System Physical Planning Manual, Form ZC22-6878.

The customer is responsible for proper preparation of the installation site. However, before the system is delivered, a check of the facility should be made by the customer engineer in charge and the physical planning coordinator.

### 1.3.1 Records

The account customer engineers must maintain the following records and files:

Spare parts tub file  
Engineering change history card for each machine  
Systems log  
Diagnostic test decks, tapes, and writeups  
(Duplicate diagnostic card decks and tapes should be maintained.)

### 1.3.2 Maintenance Room

Arrange the furniture to make best use of power outlets and provide space for units that will be serviced in the maintenance room. See Figure 1-2 for a suggested maintenance room layout. The room must have both 115 and 208 volt (60HZ) ac outlets adequate for any unit that will be serviced there. Equivalent outlets to service 50HZ machines are also located in the room. They should be identified to avoid misuse.

Dimensions of typical maintenance room furniture and fixtures follows:

|               | Length |     | Width  |    | Height |     |
|---------------|--------|-----|--------|----|--------|-----|
|               | in.    | cm  | in.    | cm | in.    | cm  |
| Desk          | 45     | 114 | 34     | 86 | 29     | 74  |
| Workbench     | 72     | 183 | 30     | 76 | 35     | 89  |
| Shelf Cabinet | 36     | 91  | 18     | 46 | 72     | 183 |
| Parts Cabinet | 42     | 107 | 24     | 61 | 87     | 221 |
| File Cabinet  | 18     | 46  | 28     | 71 | 60     | 152 |
| Bookcase      | 33-1/4 | 84  | 15-1/4 | 39 | 42     | 107 |
| Study Table   | 60     | 152 | 30     | 76 | 29     | 74  |
| Book Cart     | 40     | 102 | 13     | 33 | 31     | 79  |
| Card File     | 17     | 43  | 24     | 61 | 9      | 23  |

### 1.3.3 Pre-Installation Checks

#### 1.3.3.1 Air Conditioning

Before the system arrives, make sure the air conditioning system is adequate and is functioning properly. Optimum "power on" conditions are: temperature 75°F (24°C) and 50% relative humidity. The customer should balance the air conditioning as soon as possible after the installation.

#### 1.3.3.2 Power Requirements

Check power source for conformity to specifications and safety regulations. Display "Do not turn on Power" signs at the wall panels while the machines are being installed. Check the building supply for grounds, shorts, and correct phasing before turning power on.

Check power phasing of all underfloor receptacles per instructions contained in the Unit Checkout section of the Unit Installation Manuals.

#### 1.3.3.3 System Bond

Check the underfloor locations of the system bond plates furnished by the customer. Each plate must have a sufficient amount of 1/4 x 20 tapped holes to accommodate a bond cable from each element or unit located within a 30 foot radius.

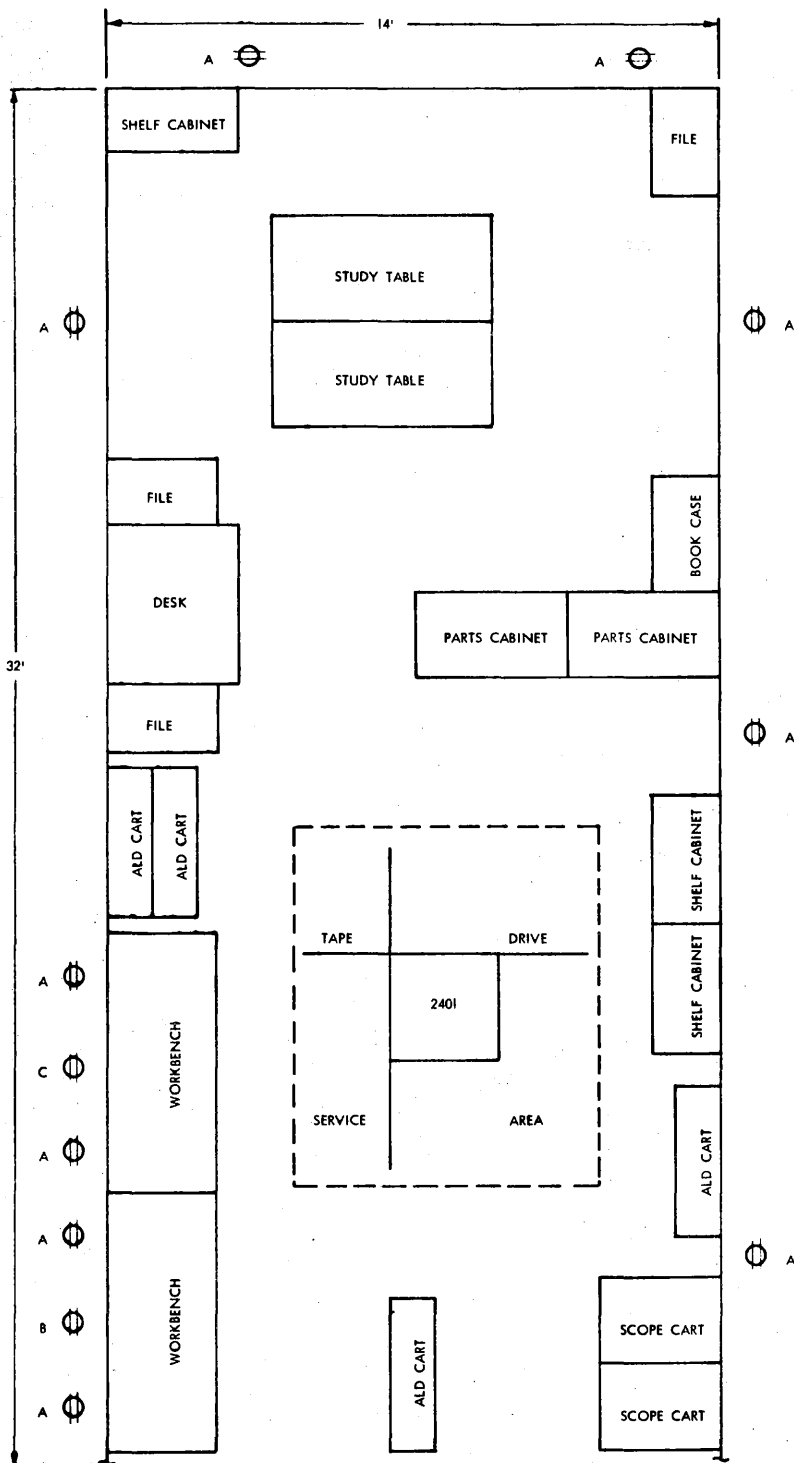

- A. 115VAC DUPLEX CONVENIENCE OUTLET
- B. 115VAC 1Ø OUTLET ( P&S 5661 OR EQUIVALENT )
- C. 208VAC 3Ø OUTLET ( P&S 7250 OR EQUIVALENT )

Figure 1-2. Typical Maintenance Room

#### 1.3.3.4 System Floor Preparation

Check that floor cable cut-outs match the floor plan. Check to see that each hole has protective trim around sharp edges and that extra pedestals are used for support where necessary. If area under raised floor is used as an air plenum, make sure it is clean. Clean under-floor area before the system arrives. Use masking tape to mark the unit name on the floor near its respective cable cut-out.

#### 1.3.3.5 Check List (Complete Prior To Receipt of System)

1. Prepare maintenance room.
2. Set up files
3. Set up logic carts and books
4. Inventory and store spare parts
5. Check cable hole cutouts, using floor plan
6. Mark machine designations on floor near respective cable hole
7. Mark frame outlines on floor using masking tape
8. Mark frame serial number within outline
9. Designate external cable storage drop-off areas
10. Inventory and place cables in drop-off areas
11. Label and remove necessary floor panels
12. Lay external cables
13. Lay system bond cables and terminate
14. Replace floor panels
15. Check power and air conditioning

#### 1.4 UNLOADING AND UNPACKING

To prevent damage to the frames during shipment, and to facilitate handling, most covers and exterior hardware have been removed and packed in separate crates. A storage area should be designated for these boxes and crates within the computer room. Covers and hardware should be inventoried and shortages reported immediately.

The customer engineer should assist in placing the elements and units. Individual frames should be placed in the same locations they occupied at the factory. Labels have been placed on the frames, prior to shipping, to identify these locations. Outriggers (safety legs) are required to move the CE, DE, and SE power wall frames; the CE DAT and battery frames. These frames should be positioned before the outriggers are removed.

Check units for damage (bent frame members, damaged cards or gates, broken wires, etc.). If damage is found, report it immediately.

##### 1.4.1 Shipping Groups

All parts removed from the units prior to shipment, additional parts

required at installation, maintenance documents, and reference drawings are all components of the shipping group. Each unit within the system has a shipping group. For packaging convenience, these groups are combined. These groups should be inventoried and shortages reported immediately. Cartons which contain documentation should be opened first.

## 2.1 CABLE SHIPMENT

External cables should arrive about two weeks before the system. Upon receipt, the cables should be inventoried and checked for damage. Any discrepancy or damage must be reported immediately and corrective action taken before arrival of the system.

All external cables must be installed before the system components are brought into the computer room.

## 2.2 FLOOR PREPARATION

Using the system floor plan and the Physical Planning Manual, Form ZC22-6878 as reference, check that all cable access holes are properly located and of correct dimensions. Indicate, on the floor near the respective cable access holes, the location of each system component; use masking tape and a marking pen. This will aid in cable installation and system component placement. The floor marking should indicate machine type as well as number designation, e.g., CE-1, SE-1, 2803#1, etc.

## 2.3 CABLE IDENTIFICATION

Cables connecting two machines constitute a cable group; more than one group may be used to connect these machines. Each external cable has a group number consisting of a prefix, key number, and a suffix letter. A "6F" prefix is used to identify 9020D/E groups.

Identifying labels are attached to both ends of each external cable. A red label is attached to the "From" end and a plain label to the "To" end. The label contains the following identifying information:

Part Numbers - Part number of the cable assembly, including connectors.

Key Number - Provides the correlation between the associated cable and the external cabling ID reference drawing, part number 5781406.

The ID cabling chart contains the number of the cable group to which the cable belongs, cable part number, the element or unit to which the cable connects, and the cable terminations within each element or unit.

In addition to the above, the label also contains the EC number and cable length information. To further identify cable groups that are configuration dependent and/or require special application, an

additional label is used on both ends of the cable assembly to identify the dependent unit by designation and/or describes the application. An example of cable labeling is shown in Figure 2-1.

## 2.4 CABLE PLUGGING

Do not plug in the external cables until all interframe cabling on the unit is completed. Do not plug in power cables until preliminary unit checks and tests are made in accordance with the test sections of the unit installation manuals.

### 2.4.1 Computing Element (CE)

Because of the limited tailgate access, special attention should be given to routing and plugging CE external cables. The following is a guide for plugging these cables.

1. Sort cables into four groups as depicted in Figure 2-2. Identify cables using CE tailgate layout, ALD, Volume 3, page A7021.
2. Route the cables contained in these groups to the areas defined within the cable entry hole.
3. Plug cables, starting with the bottom inside cable of Group One, working outward, across the row, continue plugging the above rows and groups in the same manner.

### 2.4.2 Storage Element (SE)

Inter-wall and external cables plug into the SE tailgate. The inter-wall cables are furnished with the SEs and the external cables with the system.

The Computing Element Installation Manual, Form SFN-0204 and IBM reference drawing Part No. 1838428 and 5781377 contain information related to inter-wall cabling.

External cable information can be found on IBM reference drawing Part No. 5781406.

#### 2.4.2.1 Storage Element Tailgates

Figure 2-3, 2-4 and 2-5 are tailgate layouts for SE-1, SE-2 and SE-3 through SE-8 respectively and can be used as a guide for plugging inter-wall (6F-XXX groups) and external (6F-XX groups) cables.

Terminator locations for the Computing Element and the I/O Control Element buses are given and can be used as a guide for terminating the buses, using Part No. 5807046.



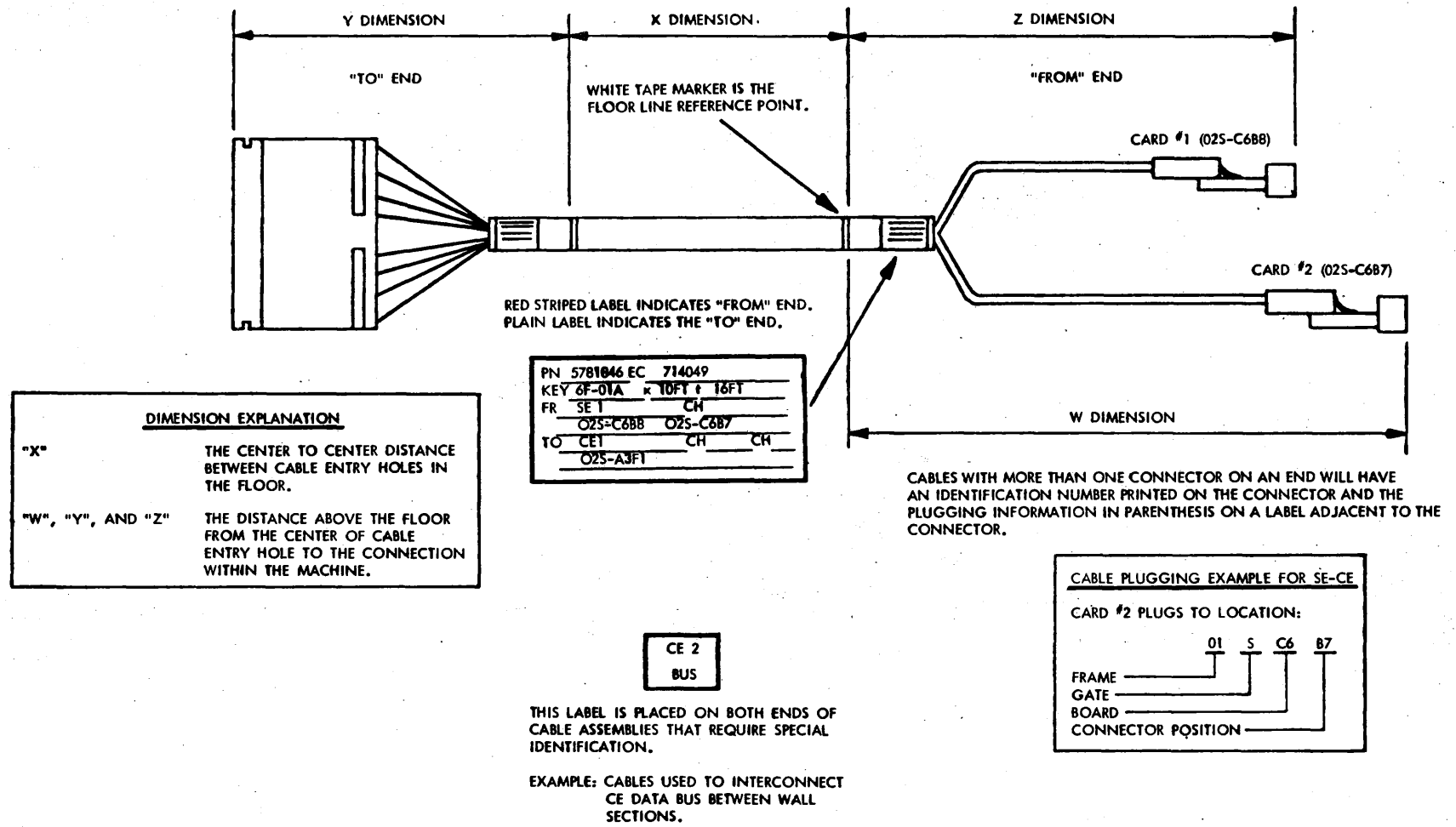

Figure 2-1. External Cable Identification

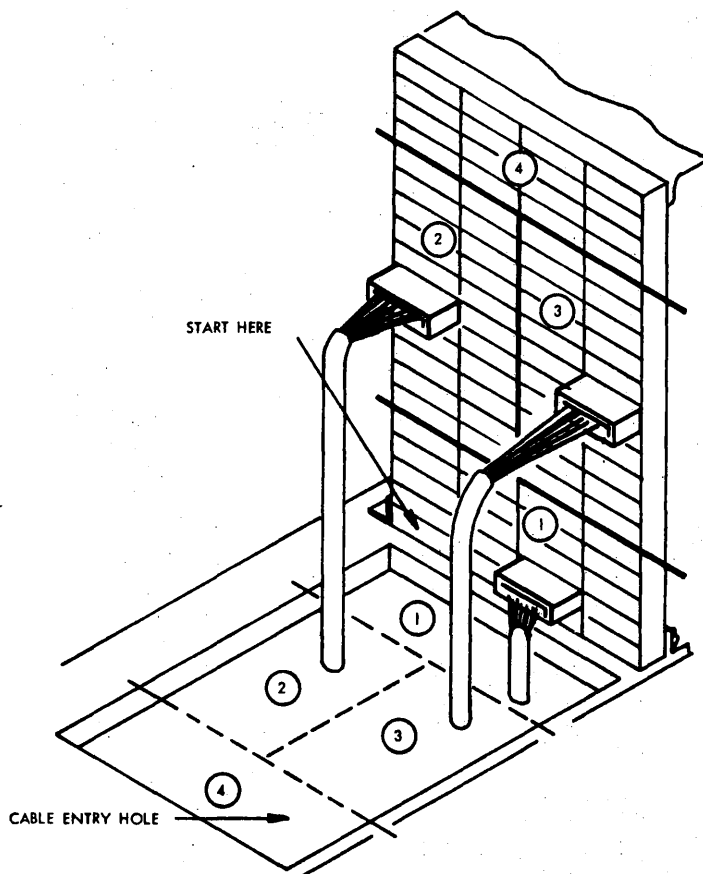
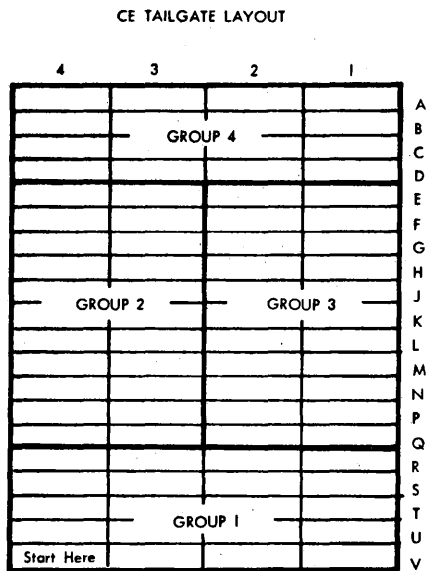

Figure 2-2. CE Cabling

#### 2.4.2.2 SE Cable Support

A cable support ladder is installed in SE-1 for supporting external cables.

Arrange cables in an orderly fashion and route up the ladder to plugging locations, clamping at each rung. Figure 2-6 is an example of how cables are routed and clamped.

#### 2.4.2.3 Tailgate Plugging Reference

Additional cable plugging information is contained in the following documentation:

- CE (7201-02) ALD Logic
- IOCE (7231-02) ALD Logic
- SE (7251-09) Maintenance Manual, Form SFN-0303
- PAM (7289-02) ALD Logic
- DASF (2314-A1) Installation Manual, Form SY27-2309

The 9020 I/O Unit Installation Manual, Form 123-9516, contains sufficient information for other I/O units.

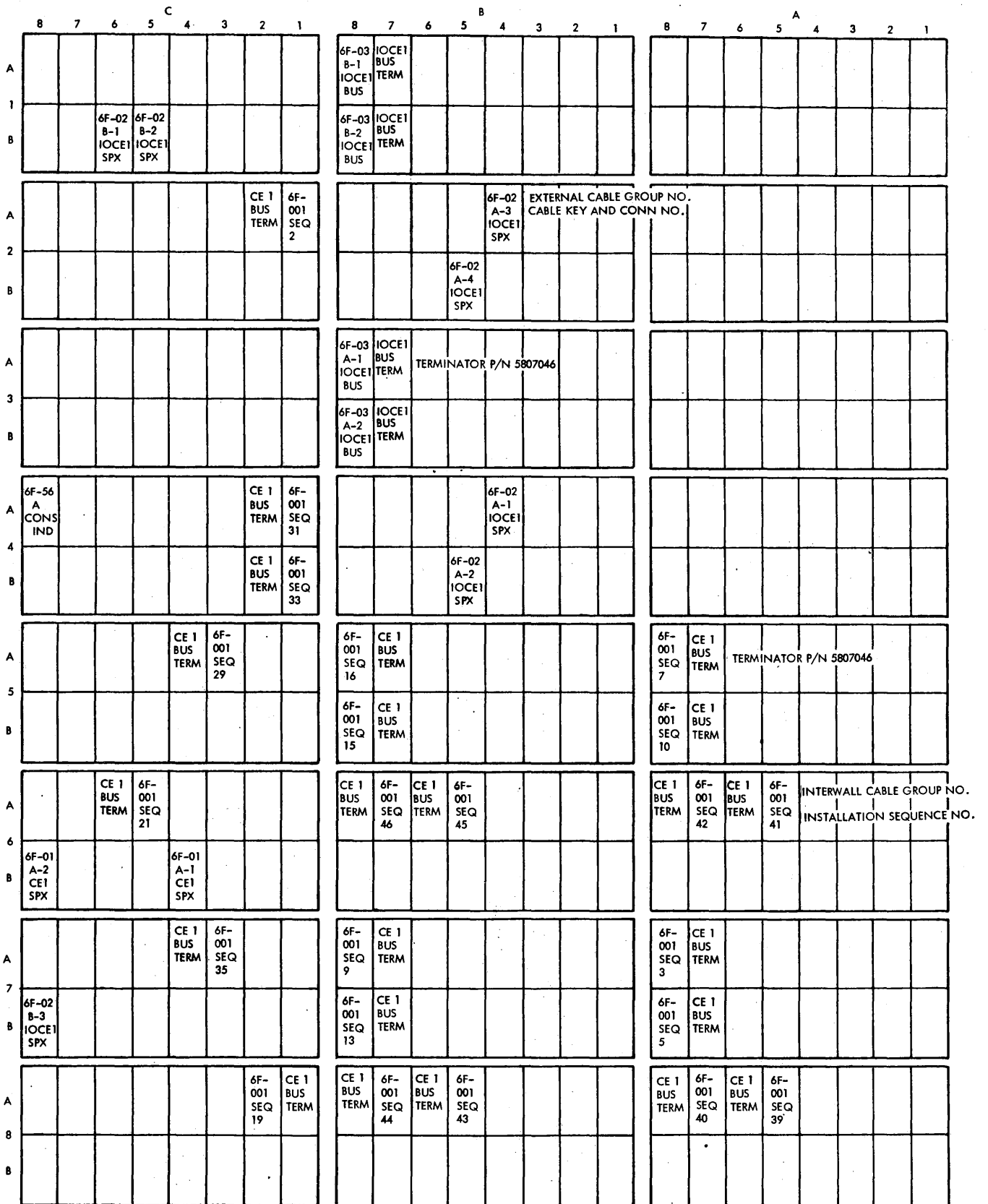

FIGURE 2-3. SEL TAILGATE PLUGGING LOCATIONS

|   |   | 8                            | 7 | 6                            | 5                            | 4                          | 3                   | 2 | 1                   |                              |                     | 8                   | 7                   | 6                            | 5                            | 4                        | 3 | 2 | 1 |                     |                     | 8                   | 7                   | 6  | 5 | 4 | 3 | 2 | 1 |
|---|---|------------------------------|---|------------------------------|------------------------------|----------------------------|---------------------|---|---------------------|------------------------------|---------------------|---------------------|---------------------|------------------------------|------------------------------|--------------------------|---|---|---|---------------------|---------------------|---------------------|---------------------|--|---|---|---|---|---|
| A | 1 |                              |   |                              |                              |                            |                     |   |                     | 6F-03<br>B-1<br>IOCE1<br>BUS | 6F-020<br>SEQ<br>1  |                     |                     |                              |                              |                          |   |   |   |                     |                     |                     |                     |  |   |   |   |   |   |
|   | B |                              |   | 6F-02<br>B-1<br>IOCE1<br>SPX | 6F-02<br>B-2<br>IOCE1<br>SPX |                            |                     |   |                     | 6F-03<br>B-2<br>IOCE1<br>BUS | 6F-020<br>SEQ<br>2  |                     |                     |                              |                              |                          |   |   |   |                     |                     |                     |                     |  |   |   |   |   |   |
| A | 2 |                              |   |                              |                              |                            |                     |   | 6F-004<br>SEQ<br>23 |                              |                     |                     |                     |                              | 6F-02<br>A-3<br>IOCE1<br>SPX | EXTERNAL CABLE GROUP NO. |   |   |   |                     |                     |                     |                     |  |   |   |   |   |   |
|   | B |                              |   |                              |                              |                            |                     |   |                     |                              |                     |                     |                     | 6F-02<br>A-4<br>IOCE1<br>SPX | CABLE KEY AND CONN NO.       |                          |   |   |   |                     |                     |                     |                     |  |   |   |   |   |   |
| A | 3 |                              |   |                              |                              |                            |                     |   |                     | 6F-03<br>A-1<br>IOCE1<br>BUS | 6F-020<br>SEQ<br>3  |                     |                     |                              |                              |                          |   |   |   |                     |                     |                     |                     |  |   |   |   |   |   |
|   | B |                              |   |                              |                              |                            |                     |   |                     | 6F-03<br>A-2<br>IOCE1<br>BUS | 6F-020<br>SEQ<br>4  |                     |                     |                              |                              |                          |   |   |   |                     |                     |                     |                     |  |   |   |   |   |   |
| A | 4 | 6F-56<br>A<br>CONS<br>IND    |   |                              |                              |                            |                     |   | 6F-004<br>SEQ<br>6  |                              |                     |                     |                     |                              | 6F-02<br>A-1<br>IOCE1<br>SPX |                          |   |   |   |                     |                     |                     |                     |  |   |   |   |   |   |
|   | B |                              |   |                              |                              |                            |                     |   | 6F-004<br>SEQ<br>22 |                              |                     |                     |                     |                              | 6F-02<br>A-2<br>IOCE1<br>SPX |                          |   |   |   |                     |                     |                     |                     |  |   |   |   |   |   |
| A | 5 |                              |   |                              |                              | 6F-004<br>SEQ<br>3         | 6F-002<br>SEQ<br>30 |   |                     | 6F-002<br>SEQ<br>17          | 6F-004<br>SEQ<br>2  |                     |                     |                              |                              |                          |   |   |   | 6F-002<br>SEQ<br>8  | 6F-004<br>SEQ<br>1  |                     |                     |  |   |   |   |   |   |
|   | B |                              |   |                              |                              |                            |                     |   |                     | 6F-002<br>SEQ<br>18          | 6F-004<br>SEQ<br>5  |                     |                     |                              |                              |                          |   |   |   | 6F-002<br>SEQ<br>11 | 6F-004<br>SEQ<br>4  |                     |                     |  |   |   |   |   |   |
| A | 6 |                              |   | 6F-004<br>SEQ<br>11          | 6F-002<br>SEQ<br>22          |                            |                     |   |                     | 6F-004<br>SEQ<br>10          | 6F-002<br>SEQ<br>27 | 6F-004<br>SEQ<br>9  | 6F-002<br>SEQ<br>28 |                              |                              |                          |   |   |   | 6F-004<br>SEQ<br>8  | 6F-002<br>SEQ<br>25 | 6F-004<br>SEQ<br>7  | 6F-002<br>SEQ<br>37 | INTERWALL CABLE GROUP NO.<br>INSTALLATION SEQUENCE NO. |   |   |   |   |   |
|   | B | 6F-01<br>A-2<br>CE1<br>SPX   |   |                              |                              | 6F-01<br>A-1<br>CE1<br>SPX |                     |   |                     |                              |                     |                     |                     |                              |                              |                          |   |   |   |                     |                     |                     |                     |  |   |   |   |   |   |
| A | 7 |                              |   |                              |                              | 6F-004<br>SEQ<br>14        | 6F-002<br>SEQ<br>36 |   |                     | 6F-002<br>SEQ<br>12          | 6F-004<br>SEQ<br>13 |                     |                     |                              |                              |                          |   |   |   | 6F-002<br>SEQ<br>4  | 6F-004<br>SEQ<br>12 |                     |                     |  |   |   |   |   |   |
|   | B | 6F-02<br>B-3<br>IOCE1<br>SPX |   |                              |                              |                            |                     |   |                     | 6F-002<br>SEQ<br>14          | 6F-004<br>SEQ<br>16 |                     |                     |                              |                              |                          |   |   |   | 6F-002<br>SEQ<br>6  | 6F-004<br>SEQ<br>15 |                     |                     |  |   |   |   |   |   |
| A | 8 |                              |   |                              |                              |                            |                     |   | 6F-002<br>SEQ<br>20 |                              |                     |                     |                     |                              |                              |                          |   |   |   | 6F-004<br>SEQ<br>18 | 6F-002<br>SEQ<br>24 | 6F-004<br>SEQ<br>17 | 6F-002<br>SEQ<br>38 |  |   |   |   |   |   |
|   | B |                              |   |                              |                              |                            |                     |   |                     | 6F-004<br>SEQ<br>20          | 6F-002<br>SEQ<br>23 | 6F-004<br>SEQ<br>19 | 6F-002<br>SEQ<br>26 |                              |                              |                          |   |   |   |                     |                     |                     |                     |  |   |   |   |   |   |

FIGURE 2-4. SE2 TAILGATE PLUGGING LOCATIONS

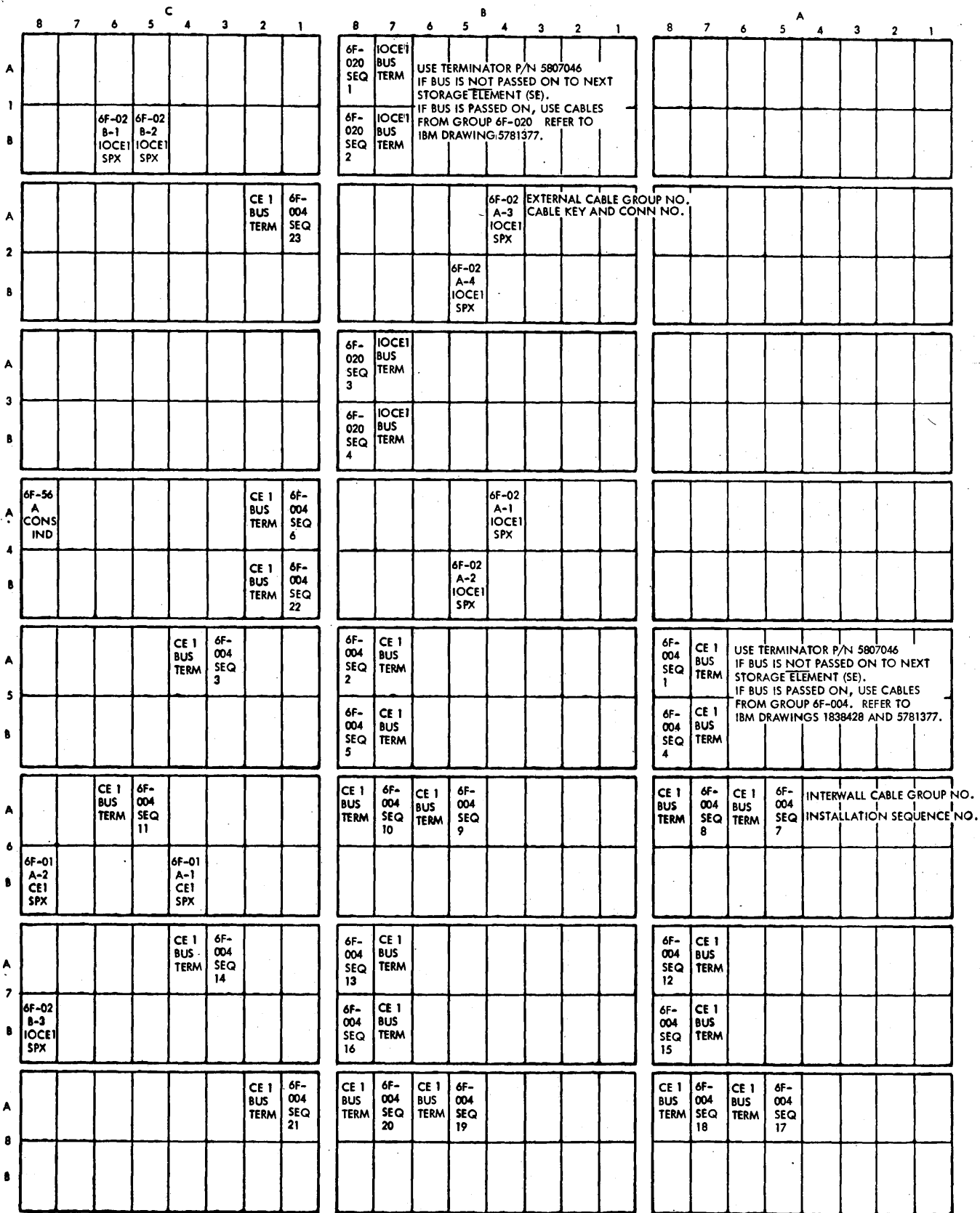

FIGURE 2-5. SE3 THROUGH SE8 TAILGATE PLUGGING LOCATIONS

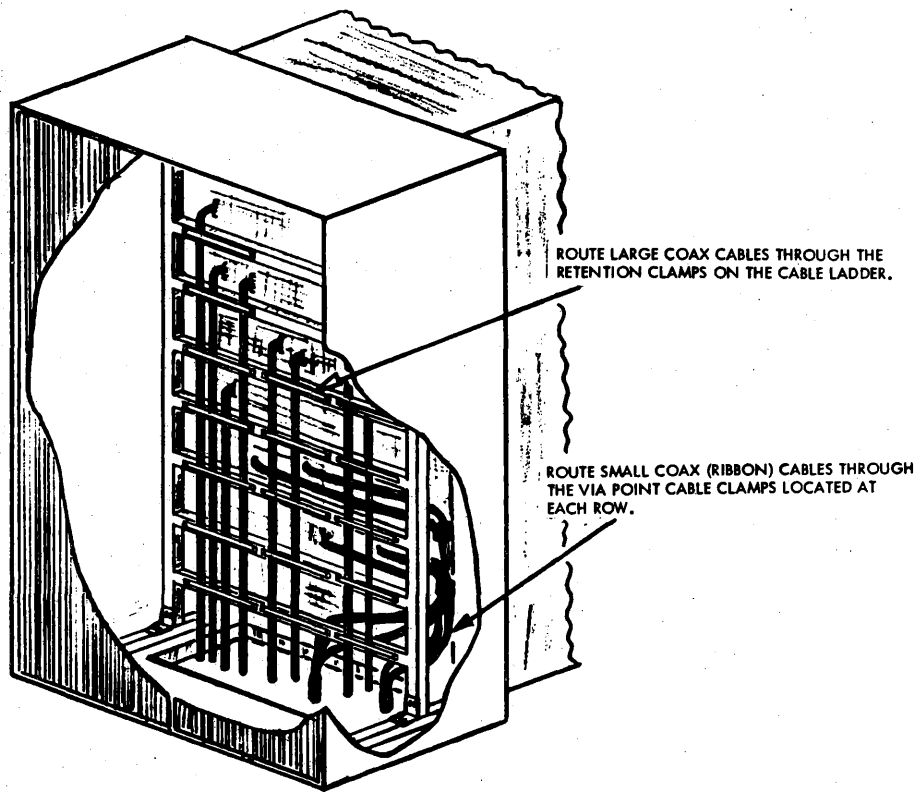

Figure 2-6. SE Cable Support Ladder

## CHAPTER 3. IBM 7231-02 IOCE SYSTEM TEST

The following tests will apply primarily to the 7231-02 IOCE. However, all diagnostic sections applicable to the devices and control units attached to the IOCE will be run. Therefore, the following units should be included in the configuration: CE, SE, PAM, SCU, TCU, Tape drives, 1052 printer, ICU, 1403 Printer, 2540 Reader/Punch.

### 3.1 MACH STORAGE RIPPLE TESTS

1. Set rotary switch to worst position; set Write toggle switch down to write worst case into MACH storage.
2. Set Write toggle switch to Read position; set Stop On Check toggle switch down. If no stop occurs, worst case is stored correctly.
3. Repeat steps 1 and 2, setting the rotary switch to zeros position.
4. Repeat steps 1 and 2, setting the rotary switch to ones position.

### 3.2 FAULT LOCATING TESTS (IOCE)

FLT tapes 1-3 contain the following IOCE tests:

| <u>FLT-1</u> | <u>FLT-2</u> | <u>FLT-3</u> |
|--------------|--------------|--------------|
| MSHC         | MSHC         | MSHC         |
| ROSBIT       | ROSHC        | ROSHC        |
| ROSHC        | LO           | LO           |
| 6XCROSRIPL   | SEG 1-7      | LSA/R        |
|              | ROSHC        | CH MON       |
|              | LSA/R/B      | MPX          |
|              | ROSHC        | SEL          |
|              | SXROSHC      | ROSHC        |
|              |              | SXROSHC      |

Run FLT tapes 1-3 after performing the MACH storage ripple tests. (See IBM Data Processing System Off-Line Maintenance Programs Manual - Fault Locating Tests Part 5400291, for detailed information on FLTs.)

### 3.3 INTERNAL IPL (DIAGNOSTIC MODE)

#### 3.3.1 IPL Diagnostic Mode

1. Enter device address into Load Unit rotary switches.

2. Enter an address stop in ROS address 4AB.
3. Depress Load switch; after stopping at address 4AB, see that the condition code is set to 11 and the Load indicator is off.

### 3.3.2 IPL Troubleshooting

The following CAS pages and comments may aid in IPL troubleshooting:

| <u>Page</u> | <u>Address</u> | <u>Comments</u>  |
|-------------|----------------|--|
| QU100       | 240            | First microprogram address.                              |
| QU100       | 6A9            | First address of UCW area reset loop.                    |
| QK800       | 119            | Start I/O to common channel.                             |
| QK801       | 180            | No hang-up due to channel and unit status analysis.      |
| QK801       | B8E            | Start of load PSW routine.                               |
| QJ200       | 4AA            | Load indicator off.                                      |
| AJ200       | 52B            | PSW restored to address 1 with condition code set to 11. |

## 3.4 BRING-UP PROGRAMS

### 3.4.1 Go/No-Go Test

This test checks the 14 basic instructions and the ability to form an effective address. A failure is indicated by a hung-up condition (IAR displays the failing area address). Register three contains the address of the initial instruction of each routine. This test also provides tracing ability if an error causes loss of control.

### 3.4.2 Basic Storage Test

This test is loaded with the go/no-go test and provides a worst pattern test for the MACH storage.

### 3.4.3 Programs Run Under IDM

Run these tests after the go/no-go and basic storage tests run error-free.

### 3.4.4 Programs Run Under SDM

Run these tests after the IDM programs have run error-free. Run all sections appropriate to the devices and control units attached to the IOCE.



NOTE: IOCE Processor test will be run during CE system test under MDM.

### 3.5 INTERFACE AND NORMAL MODE TESTS

Perform the tests under heading 3.5 only if CE-IOCE communications fail.

#### 3.5.1 IOCE to CE Interface Check (Condition Code)

1. Store the following data in the specified locations:

| <u>Data</u>                                     | <u>Location</u>    |
|---|--------------------|
| 00 00 00 01                                     | General register 1 |
| 00 00 00 00                                     | General register 2 |
| 00 00 01 00                                     | General register 3 |
| 19 11 07 F3 (compare<br>and branch instruction) | Location 100 (hex) |

2. Set IAR to 100 hex.
3. Depress Start switch; scope J-D1L6B02 (CC position 1) and J-D1L6D02 (CC position 0) for a minus level (no bits). Display the condition for verification.
4. Store 19 12 07 F3 in location 100.
5. Scope the test points specified in step 3 and verify a condition code of 10.
6. Store 19 21 07 F3 in location 100.
7. Scope the test points specified in step 3 and verify a condition of 01.

#### 3.5.2 Response

1. Set ROS address to OB8C (block C9 on QK801).
2. Set Repeat ROS Instruction switch to On position.
3. Scope J-D1L7B13 (BB047) for a plus level.

#### 3.5.3 FLT Complete

1. Repeat steps 1 and 2 of paragraph 3.5.2
2. Scope J-D1L7B02 (BB037, FLT complete) for a plus level.

#### 3.5.4 Reset Time Out

1. Ground J-E2C2D06.
2. Repeat ROS address F28 (QY310).
3. Observe a positive level at J-D1L7D13 (BB047).

#### 3.5.5 PSBAR Lockout

1. Load the CE-1 bit in the CCR and turn the Test switch Off.
2. Ground J-D1H6B10 (KA009) and J-E2H4B02 (KT007).
3. Repeat ROS address B2A (QK705).
4. Observe a positive level at J-D1L6B13.

#### 3.5.6 Element Check

1. Load the CE-1 bit in the CCR and turn the Test switch off.
2. Set the Rate rotary switch to Process position and press the Logout pushbutton.
3. Observe a minus element check at J-D1L7D02 (BB037) and a minus machine check interrupt request at J-E2J7B02 (BB057). Observe log status trigger B (CLU roller 2).

#### 3.5.7 Subsystem Reset

1. Set the IOCE for address stop on ROS address 6AB (QU100).
2. Momentarily ground J-D1H6B07 (KM097); the IOCE will start the reset sequence and stop at current ROS address 6AB.

#### 3.5.8 System Reset

1. Set the IOCE for address stop on ROS address 6AB (QU100).
2. Momentarily ground J-D1K5D10 (KM107); the IOCE will start the reset sequence and stop at current ROS address 6AB. Check that the SCON field of the CCR is set to ones.

#### 3.5.9 FLT Load (External)

1. Place IOCE in halt loop (QT200) by pressing the Reset switch.

2. Set Rate switch to single cycle position.
3. Jumper J-E2L5D11 (KM117) to ground. Single-cycle the IOCE out of the halt loop to the micro-programs as shown on QK807, QK907, and QK800. Initial sequence is 28F, B4C, BD5, etc. If not accepted by channel, test will end by looping on B50 (QK800).

#### 3.5.10 IPL (External)

1. Place IOCE in halt loop (QT200) by pressing the Reset switch.
2. Set Rate switch to Single Cycle position.
3. Jumper J-E2L5 D10 (KM117) to ground. See that the micro-program advances through the addresses shown on QK807 and QK800. Initial sequence is 28F, B4D, etc. If not accepted by channel, test will end by looping on B50 (QK800).

#### 3.5.11 CCR Checks

1. With the Test switch set to On position, enter E0 FC 00 (hex) into the Data keys.
2. Depress the Register Set switch and see that the CCR displays the data entered in step 1 with parity bits of: P1=0, P2=1, P3=1.
3. Set the Test switch to Off position and see that the state bits have been reset to zeros.
4. Jumper J-E2E3B08 (KM057) to ground and verify the following:
  - a. CCR contains all zeros when displayed.
  - b. CCR parity error is a minus level on J-E1E6D04 (RC138) and the CCR indicator in the error register at CLU2, roller position 8, is on.
  - c. ELC signal at J-D1L7D02 (BB037) is at a minus level.
  - d. Diagnostic mode signal at J-E2J5D09 (DA007) is at a plus level and the diagnostic mode indicator is on.

### 3.6 DISABLING OF MANUAL CONTROLS

This section contains lists of controls and the states in which they are operative. Correct operation of the controls may be checked either in an IOCE-CE subsystem with the proper state bits or by manually forcing the various states in the IOCE.

### 3.6.1 CLU Controls Operative in All States

1. Monitor Voltage Select rotary switch.
2. Marginal Voltage Select rotary switch.
3. Emergency Power Off (EPO) switch.
4. Roller switches 1, 2, 3, 4 (PL041, PL051).
5. Lamp Test toggle switch (PS121).
6. Selector Channel Display switch (PK081).
7. MC voltage adjust potentiometers.

### 3.6.2 CLU Controls Operative in State 1 or 0 and Diagnostic Mode

#### 3.6.2.1 Pushbuttons:

|             |                     |
|-------------|---------------------|
| Load        | PK001, PK021, PL031 |
| Interrupt   | PK001, PK031, PL031 |
| Display     | PK001, PK021        |
| Set IC      | PK001, PK021        |
| Store       | PK001, PK011        |
| PSW Restart | PK001, PK031        |
| Check Reset | PK001, PK021        |
| Start       | PK001, PK011        |

#### 3.6.2.2 Rotary Switches:

|                |              |
|----------------|--------------|
| Load Unit      | PL001        |
| Rate           | PK041, KS701 |
| Storage Select | PK041        |
| FLT Control    | PK041        |

#### 3.6.2.3 Lever Switches:

|                         |              |
|-------------------------|--------------|
| Address Keys            | PA111, PA131 |
| Data Keys               | PD001, PD031 |
| Reverse Data Parity     | PK041        |
| FLT force indicator     | PK041        |
| FLT Mode                | PK041        |
| Address Compare IAR     | PK041        |
| *Disable Interval Timer | PK041        |

\*With the disable interval timer off, the interval timer (address 50 hex in MACH storage) should update if the IOCE is in Processor Mode or Diagnostic state 1 or 0.

### 3.6.3 CLU Controls Operative in State 0 and Diagnostic Mode

#### 3.6.3.1 Pushbuttons:

|               |       |
|---------------|-------|
| Stop          | PK001 |
| Element Reset | PK001 |
| Logout        | PK001 |

#### 3.6.3.2 Rotary Switches:

|               |       |
|---------------|-------|
| Check Control | PK041 |
|---------------|-------|

#### 3.6.3.3 Lever Switches:

|                          |       |
|--------------------------|-------|
| Repeat Instruction       | PK041 |
| Address Compare (ROS)    | PK041 |
| Repeat Instruction (ROS) | PK041 |
| Test Switch              | PK041 |
| Invert SAR Bit 17        | PK071 |

### 3.6.4 CLU Controls Operative in State 0 with Test Switch On

#### 3.6.4.1 Lever Switches:

|                    |       |
|--------------------|-------|
| Register Set (CCR) | PK041 |
| Power On/Off       |       |

### 3.7 TEST STATE LATCHED

The CLU test level should remain up when in state 0 with Test switch On regardless of the value of the CCR state bits. Check as follows:

1. Place CLU in test state with Test switch on.
2. Set CCR state bits to 1,1 by using the Register Set switch and the Data keys.
3. Scope 01C-A4B5B02 for a plus level; manual control usage should not be affected.
4. Set CCR state bits to 1,0.
5. Repeat step 3.

## CHAPTER 4. IBM 7201-02 CE SYSTEM TEST

The following tests will apply primarily to the 7201-02 CE. However, all diagnostic sections applicable to the devices and control units attached to the CE will be run. Therefore, the following units should be included in the Configuration: IOCE, SE, PAM, SCU, Disk Storage Unit, TCU, Tape Drives, 1052 Printer, ICU, 1403 Printer, 2540 Reader/Punch.

### 4.1 BRING UP AID (QY051)

To Write any bit pattern, in all locations of an SE, as determined by the Data Keys, do the following:

1. Reset machine, then set ATR and CCR to SE in use; set PSBAR.
2. Place Storage Select switch in Main position.
3. Set  $80\ 00\ 06_{16}$  in Storage Address Keys.
4. Depress ROS Transfer pushbutton. Observe D Register Stepping (Roller One, Position Two). Allow to run approximately 10 sec.
5. Place Storage Select switch in Local position.
6. Depress System Reset pushbutton.
7. To check results, display any main storage location.

### 4.2 RESET

#### 4.2.1 Subsystem Reset

1. Manually configure all available elements to one controlling CE.
2. Verify Test switch OFF on all elements.
3. Activate OTC switch on all elements in subsystem.
4. Observe DAR on Roller five, Position six of CE. Bits corresponding to elements configured, plus "CE OWN OTC", should be ON.
5. Depress System Reset.
6. Observe DAR indicators off (P bits ON), and CE should be in Stop Loop.

#### 4.2.2 System Reset

1. In the CE jumper 01C-A3H5B10 to 01E- E1M4D09. (This will enable Stop on Ros Address Compare).
2. Set ROS Address Compare keys to 033E.
3. Set Main Storage Select and Load Unit Rotary switches to any valid setting.
4. Verify that all elements have Test switch OFF.
5. System Interlock key ON.
6. Depress Load pushbutton.
7. CE should stop at ROS Address 033E.
8. Check the CCR of all IOCE, CE, SE, PAM and SCU, TCU for zeros with only the four SCON bits on.
9. Depress System Reset on CE.
10. Remove jumper installed in Step 1.

#### 4.3 MAIN STORAGE RIPPLE TESTS

##### 4.3.1 Write All Ones

1. Set ATR and CCR for SE.
2. Depress Address keys 8, 29 and 30.
3. Set all Data switches to Ones.
4. Set Storage Select switch to Main.
5. Set Rate switch to Process.
6. Depress ROS Transfer pushbutton.
7. Run at nominal voltage for 1/2 minute.
8. To stop test, place Storage Select switch in Local and depress System Reset.

#### 4.3.2 Read All Ones

1. Set Address key 8 to One. Set all other Address keys to Zero.
2. Set CPU Check switch to Stop.
3. Depress ROS Transfer pushbutton.
4. Run at nominal voltage for 1/2 minute.
5. To stop test, place Storage Select switch in Local and depress System Reset.

#### 4.3.3 Write/Read All Zeros

Repeat procedures given in paragraphs 4.3.1 and 4.3.2, with Data switches set to Zero.

#### 4.3.4 Write/Read Alternate Patterns

1. Repeat procedures given in paragraphs 4.3.1 and 4.3.2 with Data switches set to AA<sub>16</sub> in bytes 0-7.
2. Repeat procedures given in paragraphs 4.3.1 and 4.3.2 with Data switches set to 55<sub>16</sub> in bytes 0-7.

#### 4.4 READ ONLY STORAGE (ROS) AND FAULT LOCATING TESTS (FLT'S)

ROS tests and FLTs are located on tapes 8 and 9 respectively.

Set up a simplex subsystem consisting of a CE, IOCE, SE, TCU and Tape Unit. Refer to CE LADS for ROS and FLT operating procedures.

#### 4.5 IPL SUBSYSTEM CHECK

1. Set the Main Storage Select switch to 10; set the Load Unit switches to 7FF. Load ATR slot 1 to A; remainder of ATR to 0s. System Interlock key off.
2. Press Load; check the External register for:  
0-7=FF, 8-15=14, 16-23=07, 24-31=00.
3. See that physical PSBAR contains (1010), logical PSBAR (0000), and ATR-1 position 1 (1010). The CCR should not change. ROS should be in a loop at Address 0B9A and the Load indicator On.



## 4.6 LOAD PSW AND ADDRESS COMPARE

### 4.6.1 Load PSW

1. Set ATR and CCR in CE and CCR in SE.
2. Store the following data at the specified Addresses:

| <u>DATA</u>             | <u>ADDRESSES</u> |
|-------------------------|------------------|
| 00 00 00 00 00 00 08 00 | 0000             |
| 82 00 00 00 00 00 00 00 | 0800             |

3. Set Main Storage Select switch to SE being used.
4. Depress PSW Restart switch; the Load PSW instruction should loop on itself.

### 4.6.2 Address Compare

1. Store the following program at the specified Addresses:

| <u>Description</u> | <u>Data</u>             | <u>Address</u> |
|--------------------|-------------------------|----------------|
| Initial PSW        | 00 00 00 00 00 00 01 00 | 0000           |
| LPSW (A)           | 82 00 04 00 00 00 00 00 | 0100           |
| LPSW (B)           | 82 00 05 00 00 00 00 00 | 0200           |
| LPSW (C)           | 82 00 06 00 00 00 00 00 | 0300           |
| (A)                | 00 00 00 00 00 00 02 00 | 0400           |
| (B)                | 00 00 00 00 00 00 03 00 | 0500           |
| (C)                | 00 00 00 00 00 00 03 00 | 0600           |

2. Set Rate switch to Process position; set Main Store select switch to SE being used.
3. Depress Reset, then PSW Restart switches; machine will loop on the LPSW instruction at Address 300.
4. Set Address switches to 0300; observe storage address sync pulses at jack directly behind Console Panel.
5. Set Storage Address Compare lever switch to Stop position; Machine should enter Stop loop with the IC at 0600 (next Instruction Address).
6. Set Data switches 40-63 to 00 02 00; Set Address switches to 0200.

7. Set the Storage Address Compare lever switch to Loop position.
8. Depress Stop, Reset, and PSW Restart switches in sequence; machine will continuously execute the LPSW instruction at Address 0200.
9. Set the Storage Address Compare lever switch to Process position.

#### 4.7 CONFIGURATION CHECK, CE-TCU-IOCE-SE-PAM-SCU INTERFACE

1. Set the CE Main Storage Select and Load Unit rotary switches to select a valid SE, IOCE and TCU.
2. Load an MDM tape on the selected tape drive.
3. Set CE Rate switch to Instruction Step position.
4. Turn System Interlock key on ON position and Press Load switch; system reset and load will occur.
5. Check TCU, IOCE, SE, PAM and SCU for CCR Equal to State Three, SCON Bit and communicate bits corresponding to CE and IOCE used for IPL.

#### 4.8 CE BRING-UP PROGRAMS

Using a simplex subsystem, perform an IPL from the CE to load and run all unit and system diagnostics under SDM and MDM. Refer to Diagnostic Program Manuals for operating instructions.

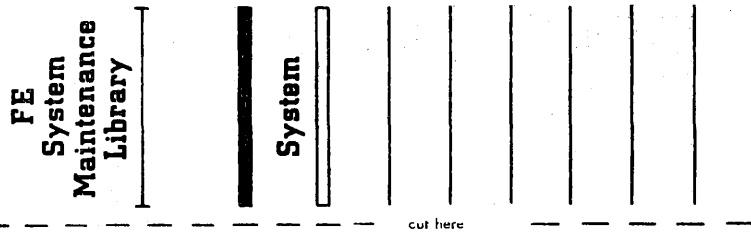

SFN-0108-0

Printed in U.S.A. SFN-0108-0

**IBM**

International Business Machines Corporation  
Federal Systems Division, FAA Project Office  
18100 Frederick Pike, Gaithersburg, Maryland 20760