

BOOK I  
PROCEEDINGS  
OF  
THE CARMEL CONFERENCE

THE FIRST ANNUAL SYMPOSIUM ON THE APPLICATION OF  
COMMUNICATIONS TECHNOLOGY TO HIGH DENSITY  
MAGNETIC RECORDING

JANUARY 13, 14, 15, 1981

SYMPOSIUM CHAIRMAN  
R. L. COMSTOCK  
SAN JOSE

PROGRAM CHAIRMAN  
R. C. SCHNEIDER  
TUCSON

IBM CONFIDENTIAL

TABLE OF CONTENTS

BOOK I

Partial Response Tutorial	R. C. Schneider	TUC	1
Zurich Activity	F. Dolivo	ZUR	35
Detection Alternatives	T. Howell	SJR	61
Timing Viterbi Decoder	H. Burkhardt	SJR	73
Partial Response for ( $d \neq 0$ ) Codes	R. C. Schneider	TUC	83
Partial Response and Run-Length Codes	J. Eggenberger	SJ	95
Zero-Filled Bipolar Codes	M. K. Haynes	TUC	117
Equalization/Integrated NRZI	E. Hopner	SJ	129
Objectives of Frontier	R. L. Comstock	SJ	147
Tucson Recording Technology	M. R. Cannon	TUC	153
Saguaro Recording Channel	J. A. McDowell	TUC	161
Precoding	N. R. Davie	ROCH	181
Post Compensation	E. Cunningham	ROCH	195

BOOK II

Pulse Slimming Equalization	L. Barbosa	SJR	227
Adaptive Equalization	G. H. Sonu	TUC	245
Equalization and SNR	D. P. Turner	SJ	261
Write Step Equalization	G. H. Sonu	TUC	291
Sliding Block Codes	M. Hassner	YKTN	309
ECC Tutorial	R. E. Blahut	OWGO	351
ECC for Tapes and Disks	R. E. Blahut	OWGO	383
Read Solomon Decoder Architecture	S. C. West	TUC	395
Rochester ECC Activity	W. Bliss	ROCH	417
Error Recovery Scheme for Future DASD	A. Patel	SJ	425

## CONFERENCE SUMMARY

The purpose of the conference was to explore the potential application of communication technology to the writing, reading and detection of high density magnetic recording signals. Seven domestic and three overseas locations were represented by the 38 attendees. Included were: Boulder, Tucson, Rochester and San Jose Product Development Laboratories; Owego, Electronic Systems Center; San Jose, Yorktown, and Zurich Research; as well as Hursley and La Grande. Twenty-three formal and two informal papers were presented during the two and a half day conference. The papers were divided into three broad areas: Partial Response Signaling, Equalization, and Error Correcting and Modulation Codes. A separate panel discussion was conducted on each of these areas after the presentation of papers in that field. All sessions were 100% attended indicating both the high level of attendee interest and the benefit of the offsite location. All seemed to concur that the conference was extremely enlightening and the topics very applicable and useful in their work.

The first day was devoted to Partial Response Signaling. Partial Response is a method of reducing the channel bandwidth requirements such that more data can be transmitted

in a given bandwidth. In magnetic recording this implies more bits per inch for a fixed set of device technologies (heads, media, etc.). Viterbi Decoding is a method of enhancing detection in partial response systems by decoding sequences of bits rather than one bit at a time. All agreed that the most likely choice for magnetic recording was either class IV or class I partial response. The majority favored class IV since it more closely matches the recording channel transfer function. Viterbi decoding in conjunction with partial response appears to be the most reliable detection approach. It remains to be shown whether Viterbi Decoders can be built fast enough for fixed disk needs or low cost enough for multi track tape requirements.

The second day concentrated on Equalization. The general consensus is the Equalization is the most likely communication technology to be used in most of IBM's recording devices. Extensive write and read equalization is already in use in Tucson products. Write precompensation has been used in San Jose and Rochester products in addition to shaping the amplitude response of low pass read filters. Much interest was generated in papers describing methods of equalizing on the write side. This avoids the potential problems of boosting high frequency noise - the most significant limitation of read equalization. As recording densities increase,

IBM CONFIDENTIAL

some form of adaptive equalization is likely to be required. There are strong indications that adaptive equalization may be required for products that follow the Saguaro half inch tape drive. Disks may require changing the equalizer response from outside to inside tracks. It was generally felt that partial response signaling would require more accurate equalization than in conventional recording systems. Equalization in magnetic recording is a discipline that is very well understood today compared to five or six years ago.

The latter part of the second day and the morning of the third day were devoted to modulation codes and error correcting codes. A paper was presented on sliding block modulation codes where a wide variety of run-length and spectral constraints can be realized. Much of the ECC discussion centered on a proposed universal Reed Solomon Decoder. All agreed such an effort should be pursued. However, local efforts directed toward specific products should also continue. Serious concern was expressed that IBM may lose the initiative to a competitor if we do not maintain a strong ECC effort on magnetic recording products.

The abstracts and foil copies that follow are meant to give the reader the main ideas of what each speaker presented. The informal nature of the presentations are reflected in

the variable quality seen in the foils. The intention was to communicate as many technical ideas as possible with a minimum of time required to prepare the talks. Additional technical details may be obtained by contacting the authors directly.

Richard C. Schneider

Technical Program Chairman

## PARTIAL RESPONSE TUTORIAL

By

R. C. Schneider, 68Y/060-1, Tucson

This talk gives a quick overview of partial response signaling as applied to a magnetic recording channel. An excellent formal paper is: "Partial Response Signaling" by P. Kabal and S. Pasupathy, IEEE Trans Comm, Vol. COM-23, No. 9, Sept. 1975. The talk begins with a review of basic definitions. This is followed with several examples of unequalized channel responses and equalizer requirements. There are many types of partial response systems as outlined in the above reference. It is shown that class IV partial response has several desirable properties: a null at dc, a null at  $1/2T$  (the "all ones" frequency), and three level detection. Class IV, therefore, appears most appropriate for magnetic recording systems. A possible alternative is Class I or duobinary. However, duobinary does not have a null at dc. Therefore, a dc balanced code and/or write waveform restoration may be required. Another alternative to reduce bandwidth is the use of  $(d,k)$  codes where  $(d \neq 0)$  such as the  $(2,7)$  or  $(1,k)$  codes. Other partial response systems require the detection of five or more levels. The Viterbi Algorithm may be used (as an effective way of improving detection reliability. It does this by

IBM CONFIDENTIAL

2

detecting sequences of bits rather than bit by bit. A brief explanation of each of the foil figures is given below.

Figure 1 is a block diagram description showing the un-equalized recording channel, the equalized recording channel, the equalizer and other major channel components. Figure 2 illustrates two methods of obtaining the channel transfer function. Figure 3 is a typical transfer function magnitude of an unequalized recording channel. Figure 4 shows one possible desired equalized read pulse. Figure 5 shows the transfer function magnitude for the read pulse of Figure 4. Figure 6 compares the desired transfer function with the un-equalized recording channel transfer function. Figure 7 shows the equalizer response required to convert the un-equalized response to the desired response. Figure 8 compares the unequalized channel response with the desired response for a "double density" system. In this case, significant high frequency boost is required in the equalizer. The equalizer response shown in Figure 9 has a maximum gain of 190. The desired response for a class IV partial response system for double density is shown in Figure 10. The required equalizer response is shown in Figure 11, a maximum gain of only 3.5 is needed. The general block diagram of an infinite bandwidth partial response system is given in

IBM CONFIDENTIAL



Figure 12. Figure 13 compares the ideal equalized read pulses for cosine squared and class IV partial response. Figure 14 shows the block diagram relationship between the recording channel and a partial response representation. Figure 15 shows the pulse response of the class IV partial response system. Figure 16 shows an ideal infinite bandwidth class IV partial response block diagram, transfer function and magnitude response. Figure 17 illustrates a finite bandwidth class IV partial response system. Figure 18 shows how a pulse input can be used as an input to the class IV system. Figure 19 shows a simplified block diagram and transfer function magnitude for the class IV system with pulse input. Figure 20 is a repeat of Figure 10. It compares the transfer function response derived in Figure 19 with the unequalized channel response. Figure 21 shows a block and timing diagram for a class IV system without a precoder. Figure 22 is the truth table for the digital read filter shown in Figure 21. Figure 23 outlines a class IV system using a precoder. Note that the number of bits between write current transitions is  $k+2$  if a precoder is used with a  $(0,k)$  code. Figure 24 is taken from the reference article and shows the transfer functions and impulse responses of various partial response systems. Figure 25 outlines a class I  $(1+D)$  duobinary partial response system including a  $1/1+D$  precoder. The precoder is shown to be an NRZ to NRZI

4

converter. Figure 26 shows a read signal that would be in error in a threshold decoder. A Viterbi decoder would be able to correctly decide that ideal sequence #3 was the correct sequence.

# PARTIAL RESPONSE TUTORIAL

## DEFINITIONS

- UNEQUALIZED RECORDING CHANNEL
- EQUALIZED RECORDING CHANNEL
- COSINE-SQUARED RESPONSE

## EXAMPLES

- TYPICAL UNEQUALIZED RECORDING CHANNEL
- COMPARISON WITH DESIRED
- NECESSARY EQUALIZATION
- DOUBLE DENSITY  $\Rightarrow$  ?? EQUALIZATION
- CLASS IV PARTIAL RESPONSE BENEFITS

## PARTIAL RESPONSE

GENERAL FORM

### CLASS IV

- STEP RESPONSE
- PULSE RESPONSE
- DELAY LINE FORM

GENERALIZED PARTIAL RESPONSE T. F.

## CONCLUSIONS

IBM - TS - 53

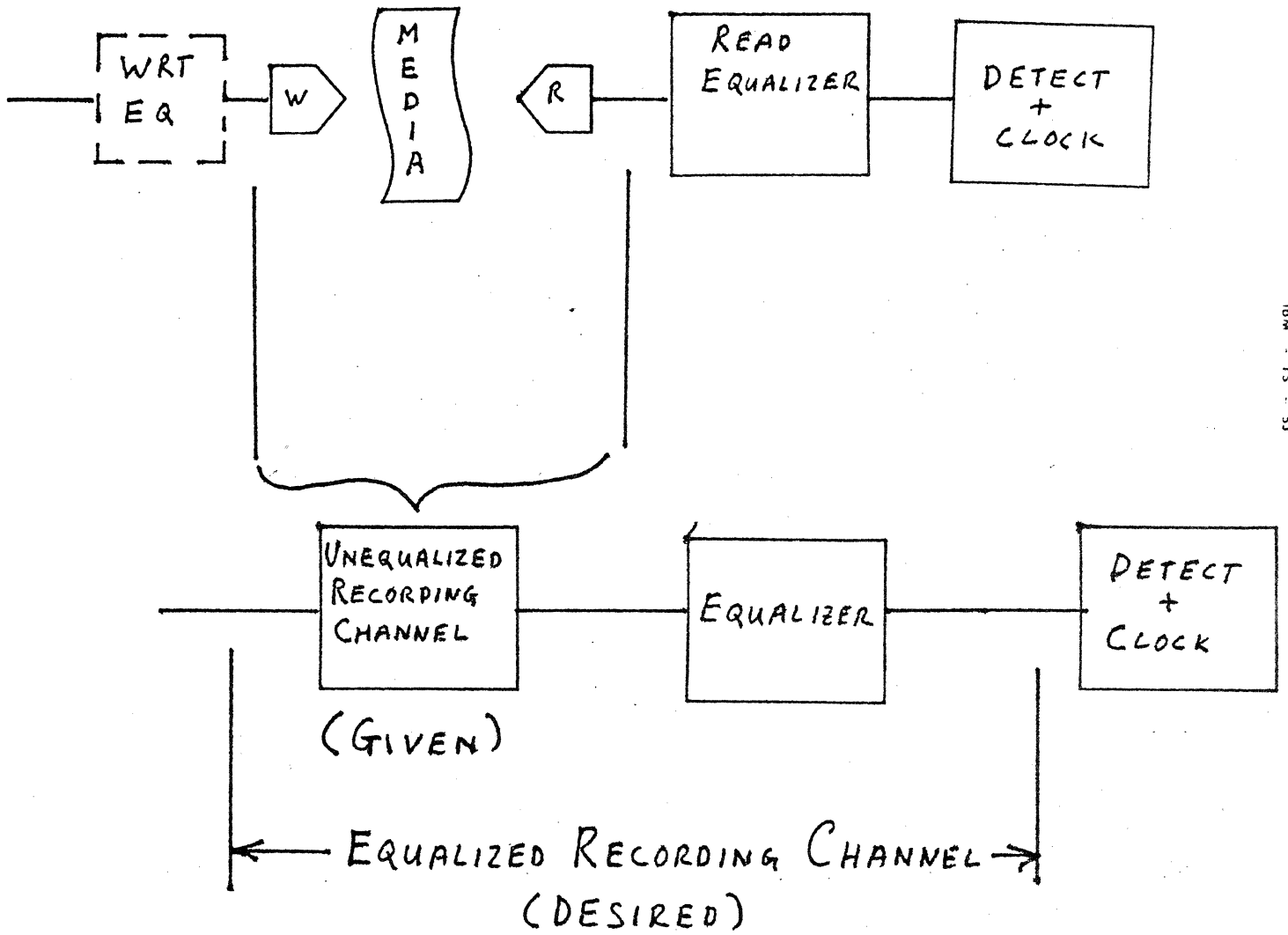

FIGURE 1

IBM

CONFIDENTIAL

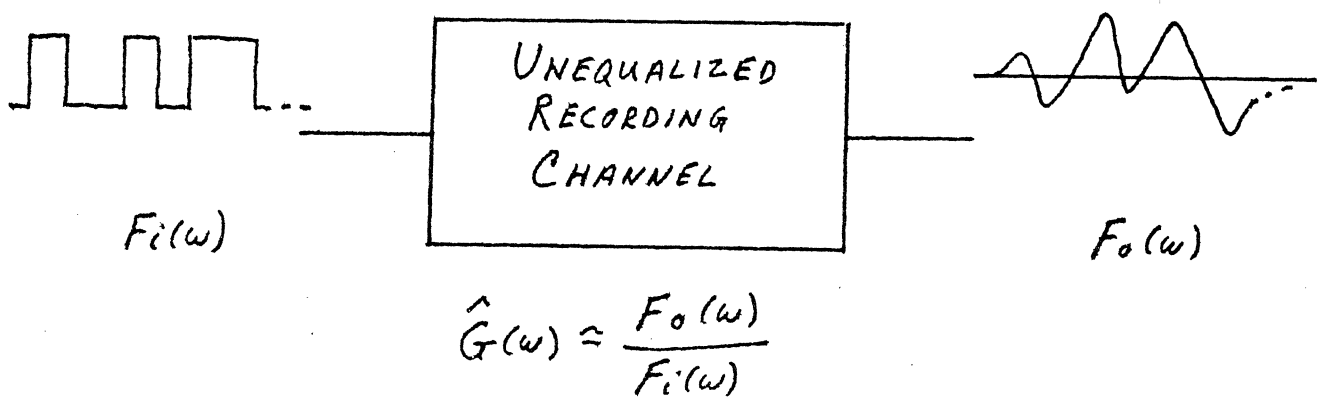
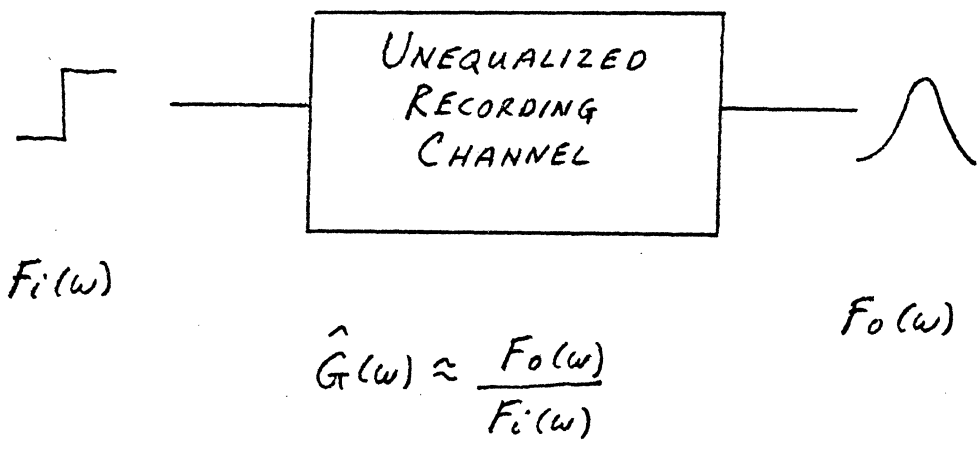

FIGURE 2

IBM  
CONFIDENTIAL

IBM  
TS  
53

RCS LPLT MAGE1 VS FR1

(TRANSFER FUNCTION)  
MAGNITUDE  
RESPONSE  
OF  
TYPICAL UNEQUALIZED  
RECORDING CHANNEL

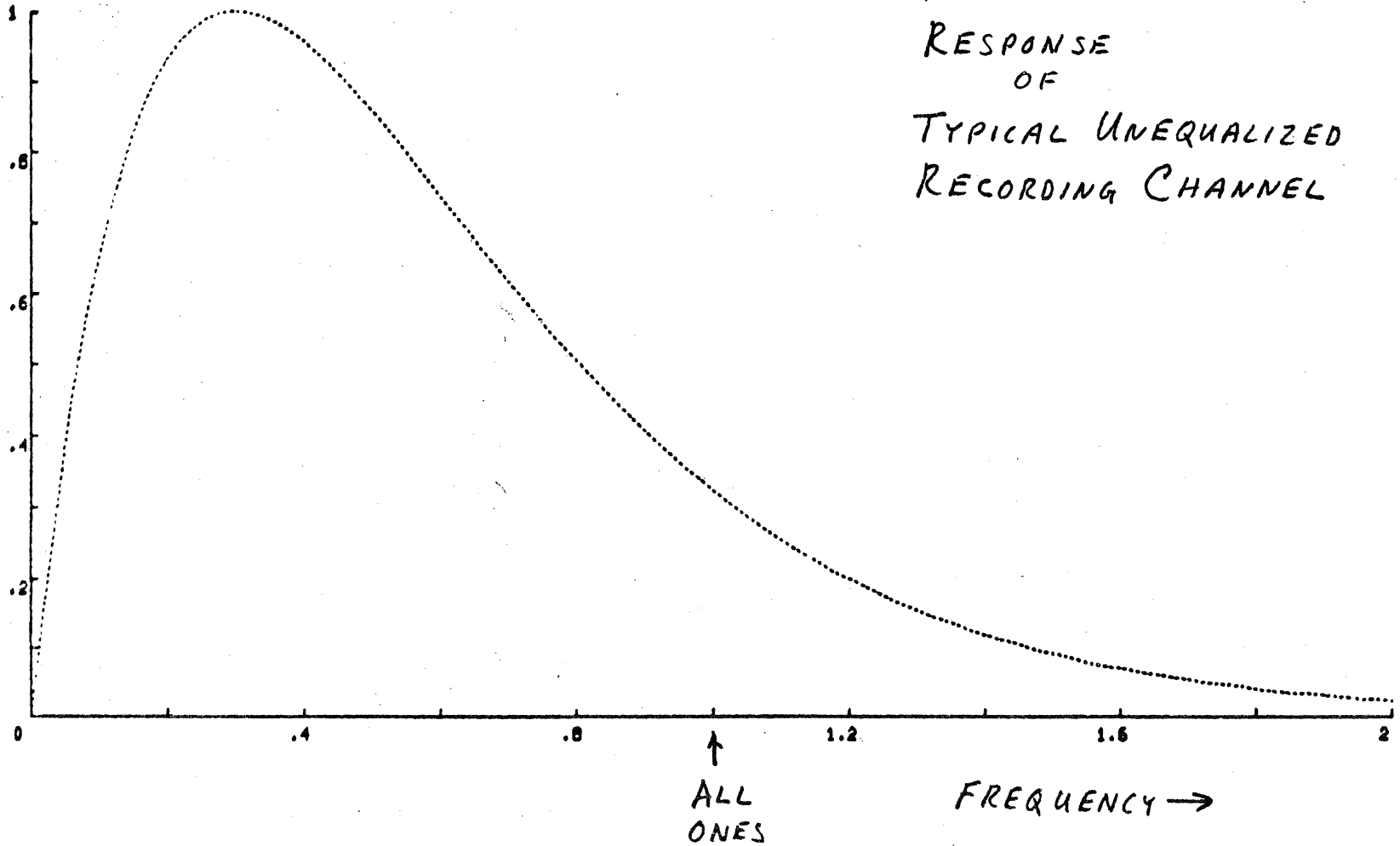

FIGURE 3

IBM CONFIDENTIAL

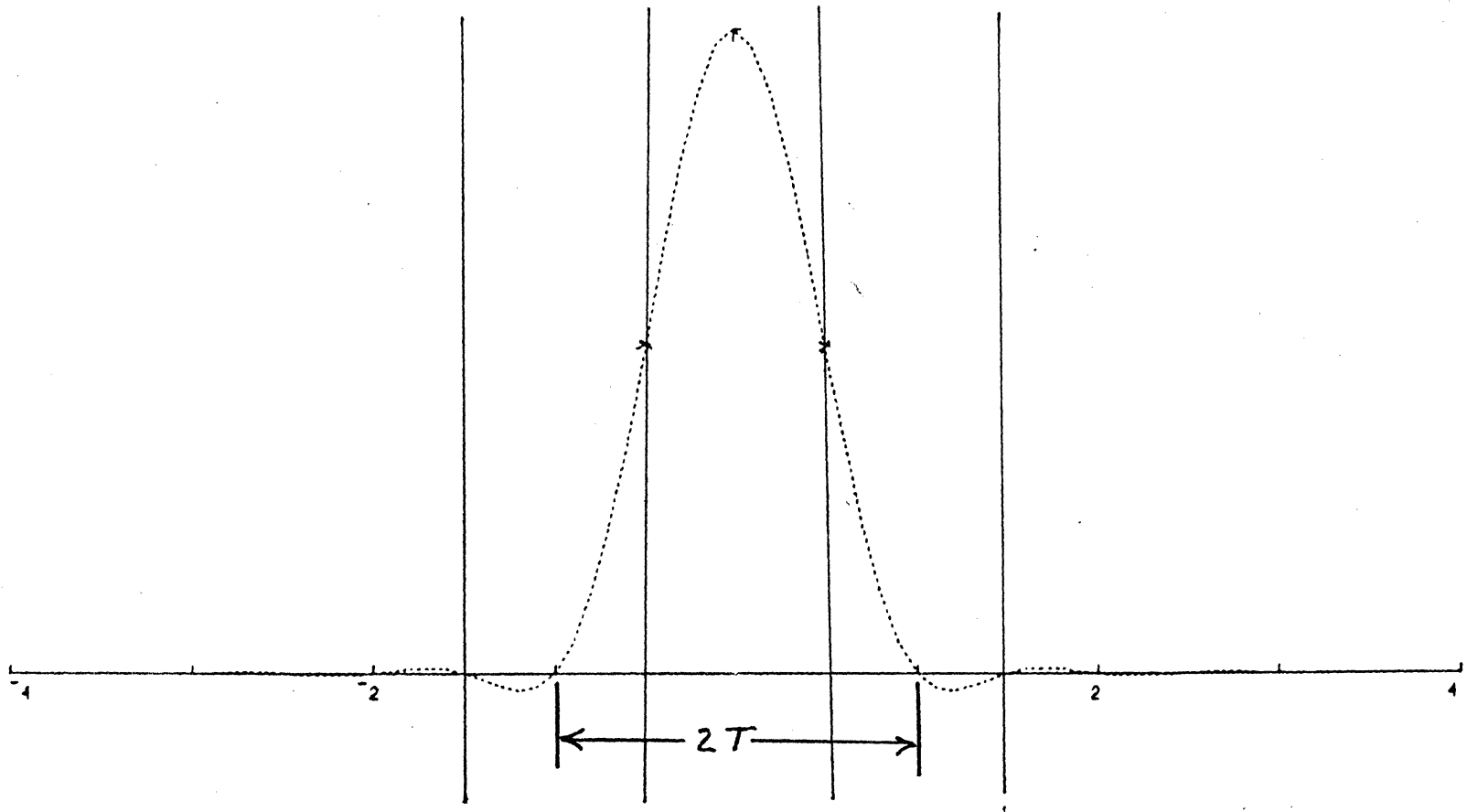

FIGURE 4 COSINE SQUARED CHANNEL READ SIGNAL PULSE

IBM CONFIDENTIAL

RCS LPLT MAG1 VS FR1

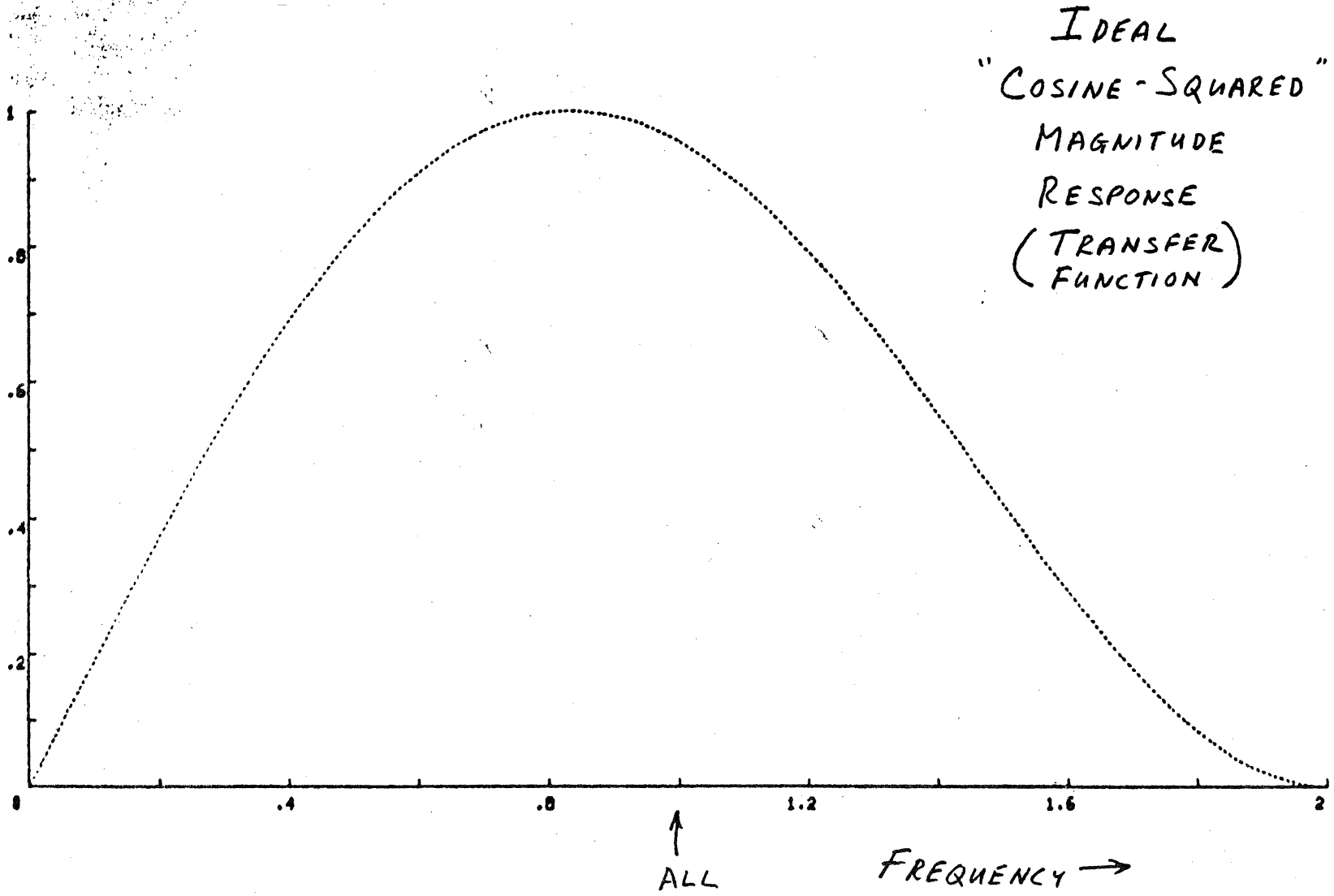

FIGURE 5

IBM CONFIDENTIAL



RCS LPLT (MAGE1 AND MAG1) VS FR1

COMPARISON OF  
UNEQUALIZED RESPONSE  
&  
"DESIRED"  
COSINE SQUARED RESPONSE

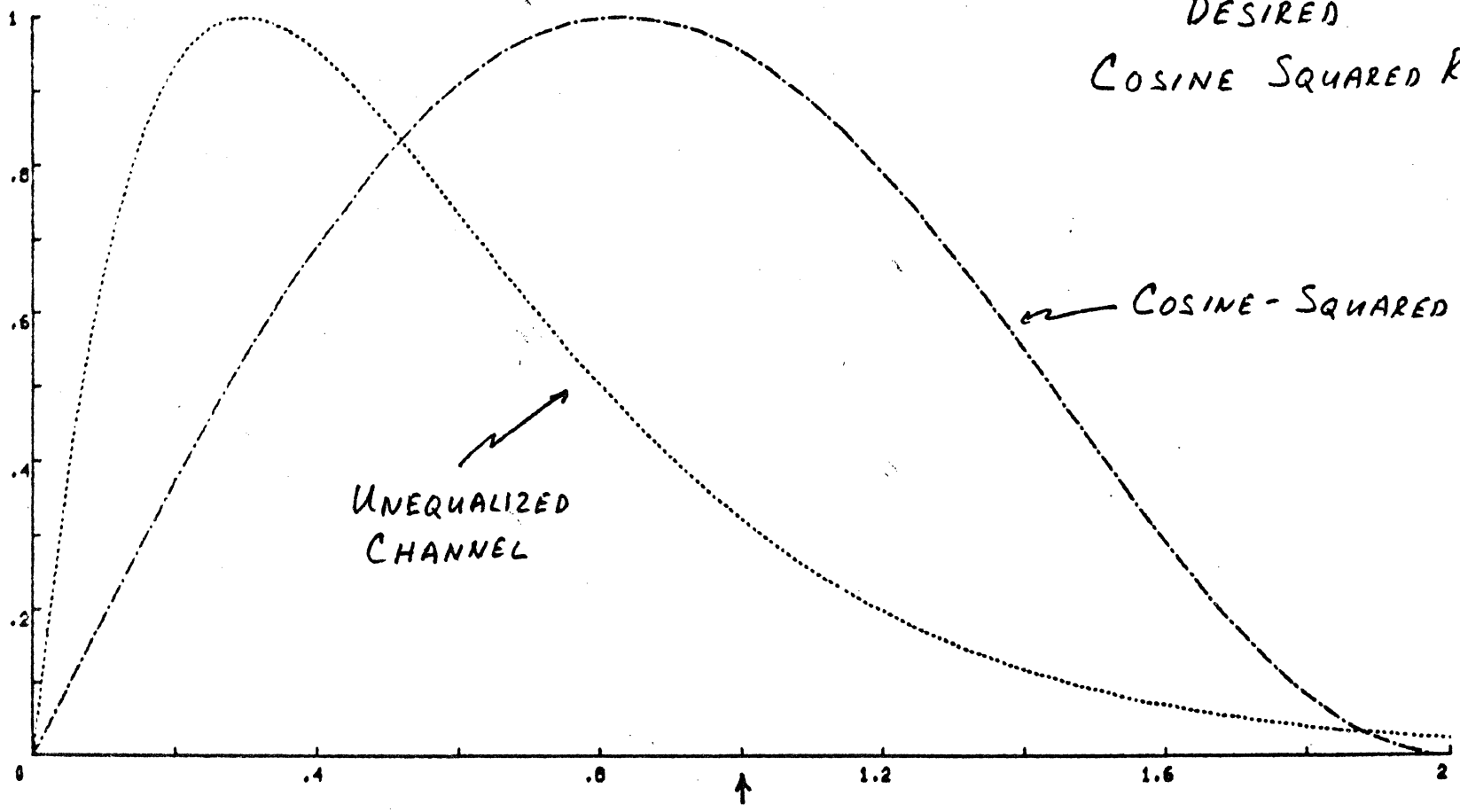

FIGURE 6

↑  
ALL  
ONES

FREQUENCY →

IBM CONFIDENTIAL

RCS LPLT EQ1 VS FR1

REQUIRED  
EQUALIZER  
RESPONSE

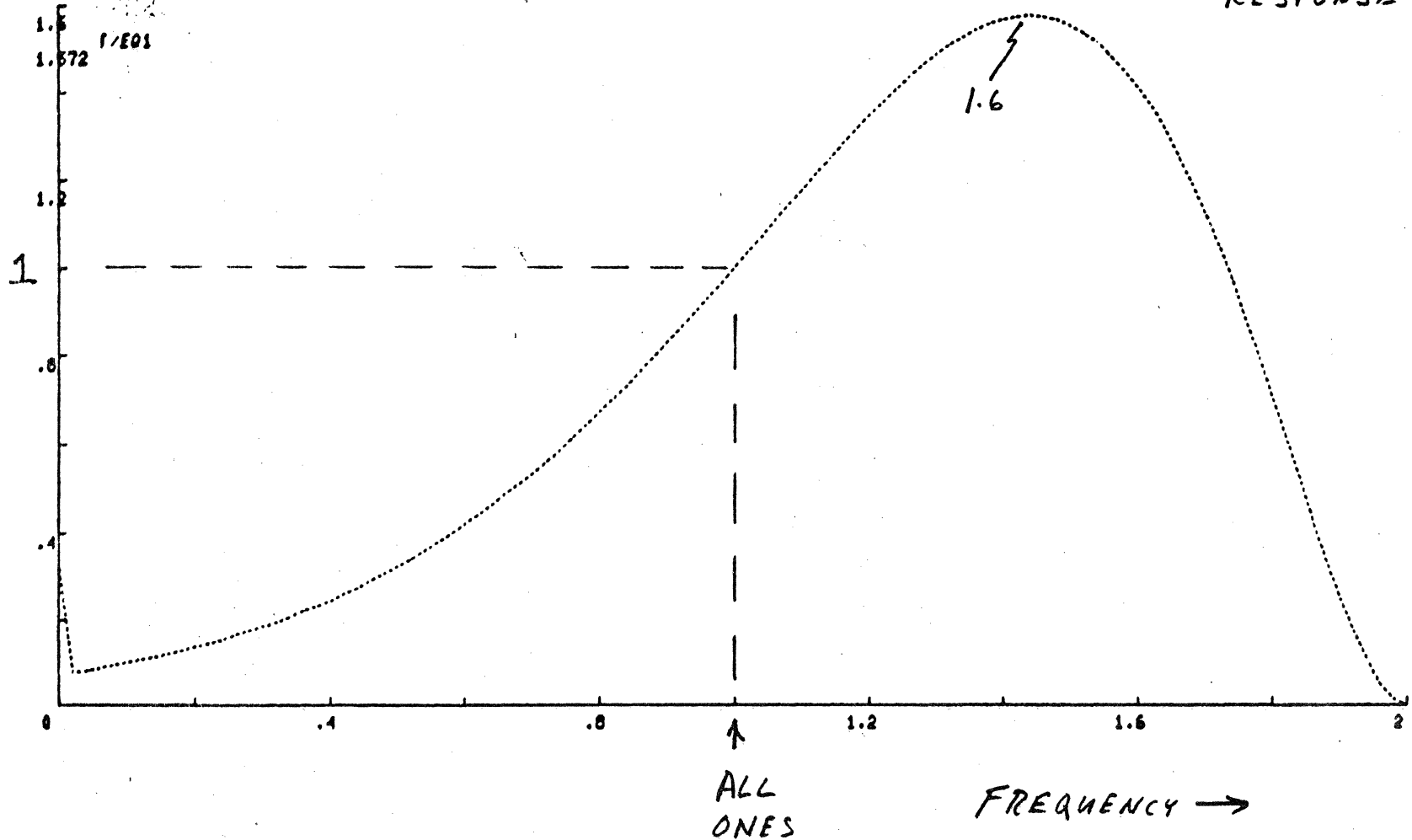
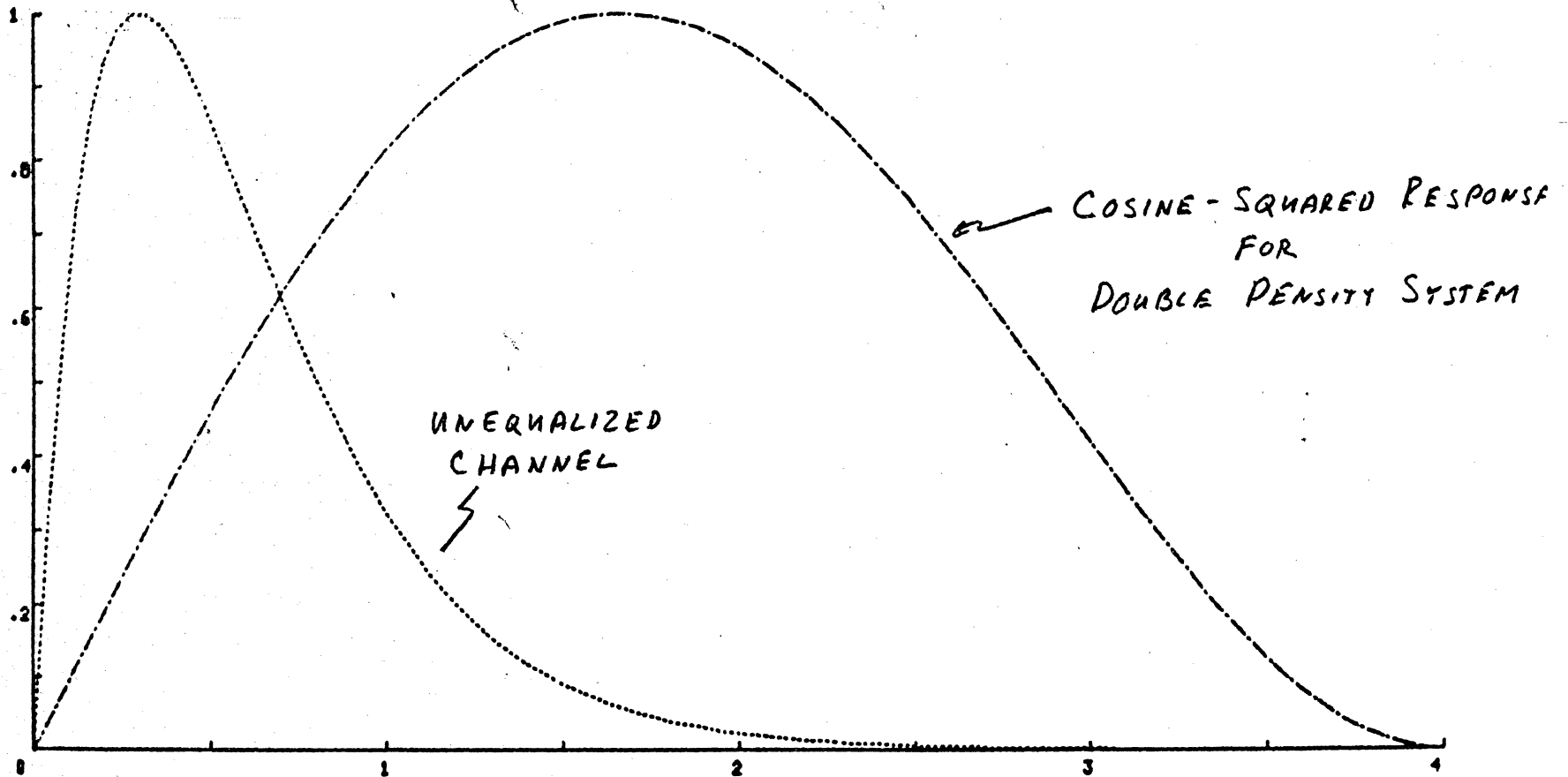

FIGURE 7

IBM CONFIDENTIAL

# RCS LPLT (MAGE2 AND MAG1) VS FR2



↑  
NEW  
ALL  
ONES

## FIGURE 8

# IBM CONFIDENTIAL

RCS LPLT EQ2 VS FR2

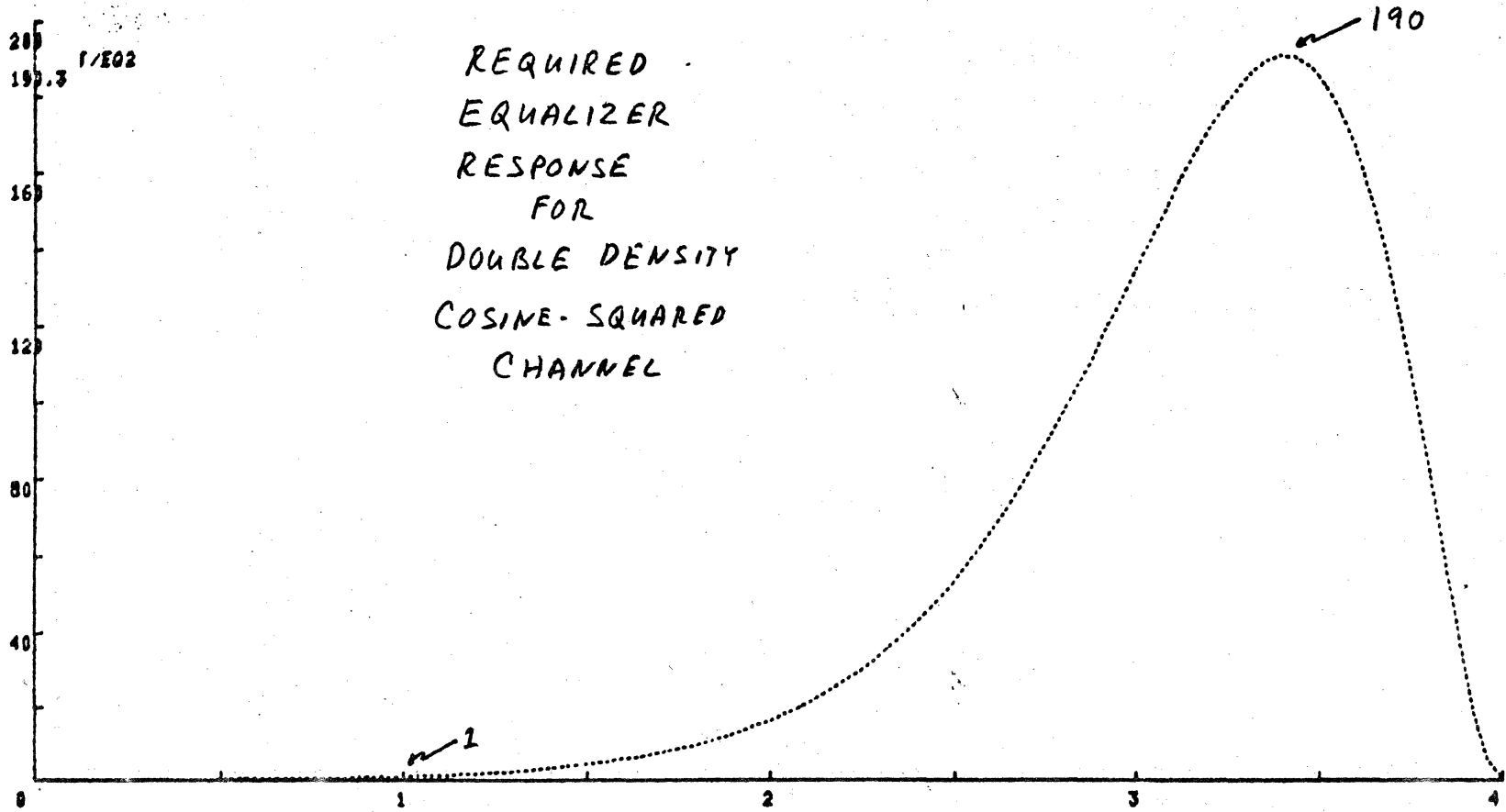

REQUIRED  
EQUALIZER  
RESPONSE  
FOR  
DOUBLE DENSITY  
COSINE-SQUARED  
CHANNEL

FREQUENCY →

IBM  
CONFIDENTIAL

↑  
NEW  
ALL  
ONES

FIGURE 9

RCS LPLT (MAG1, MAGX1, MAGX0 AND MAGZ) VS FR

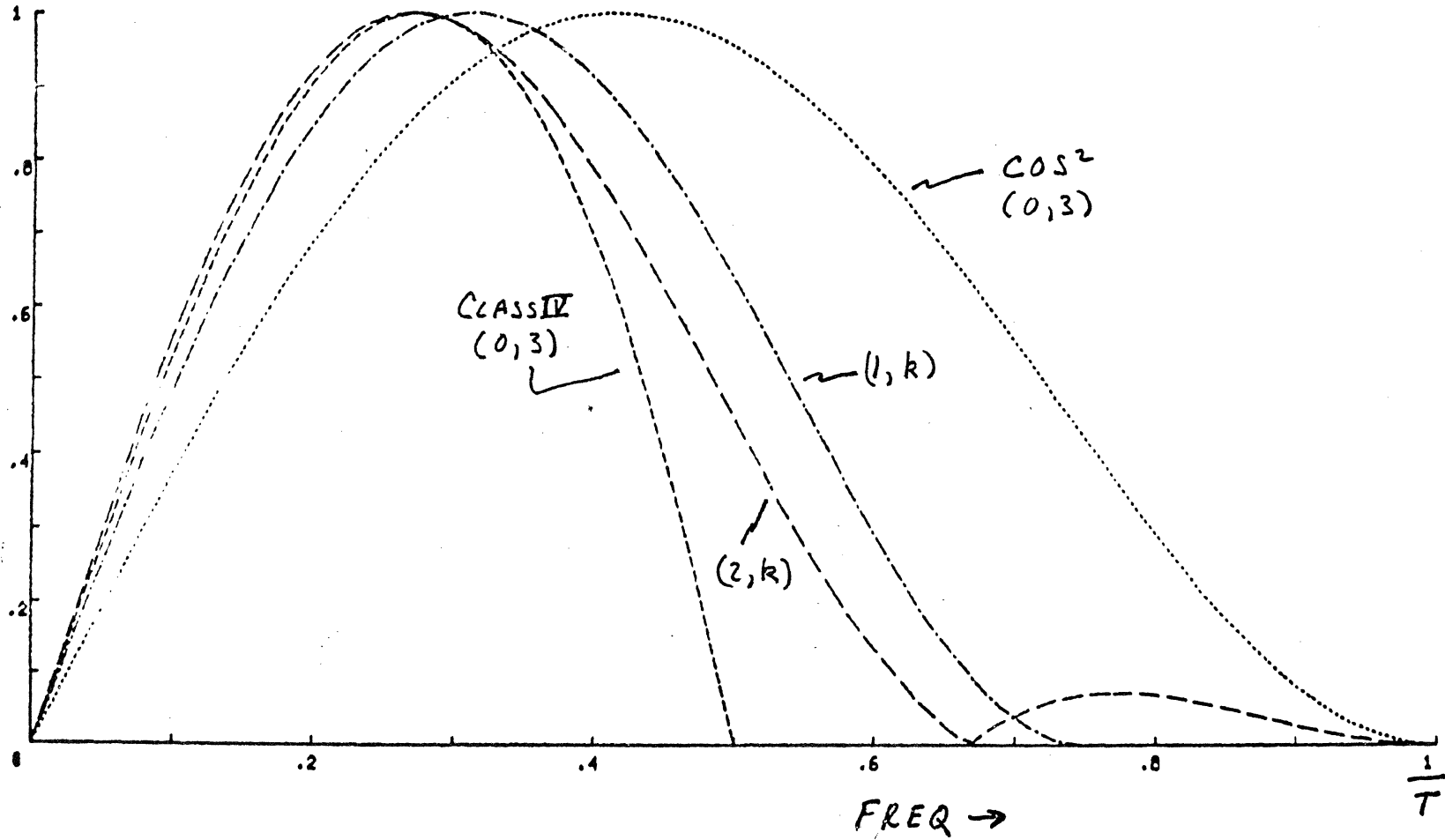

IBM  
CONFIDENTIAL

FIGURE 9

RCS LPLT (MAGE2 AND MAGX0) VS FR2

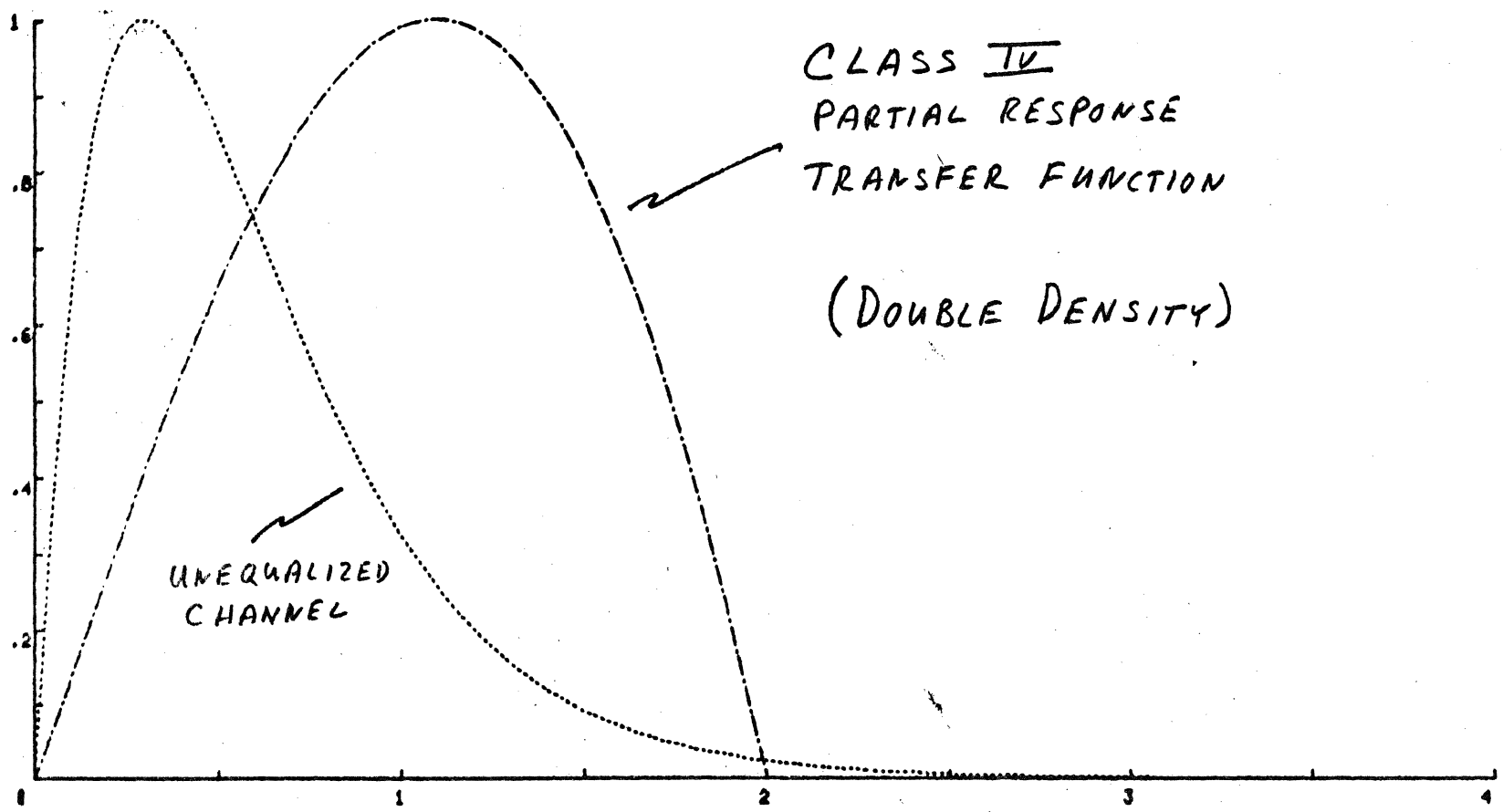

CLASS IV  
PARTIAL RESPONSE  
TRANSFER FUNCTION

(DOUBLE DENSITY)

UNEQUALIZED  
CHANNEL

FREQUENCY →

↑  
NEW  
ALL  
ONES

IBM  
CONFIDENTIAL

FIGURE 10

RCS LPLT EQ3 VS FR2

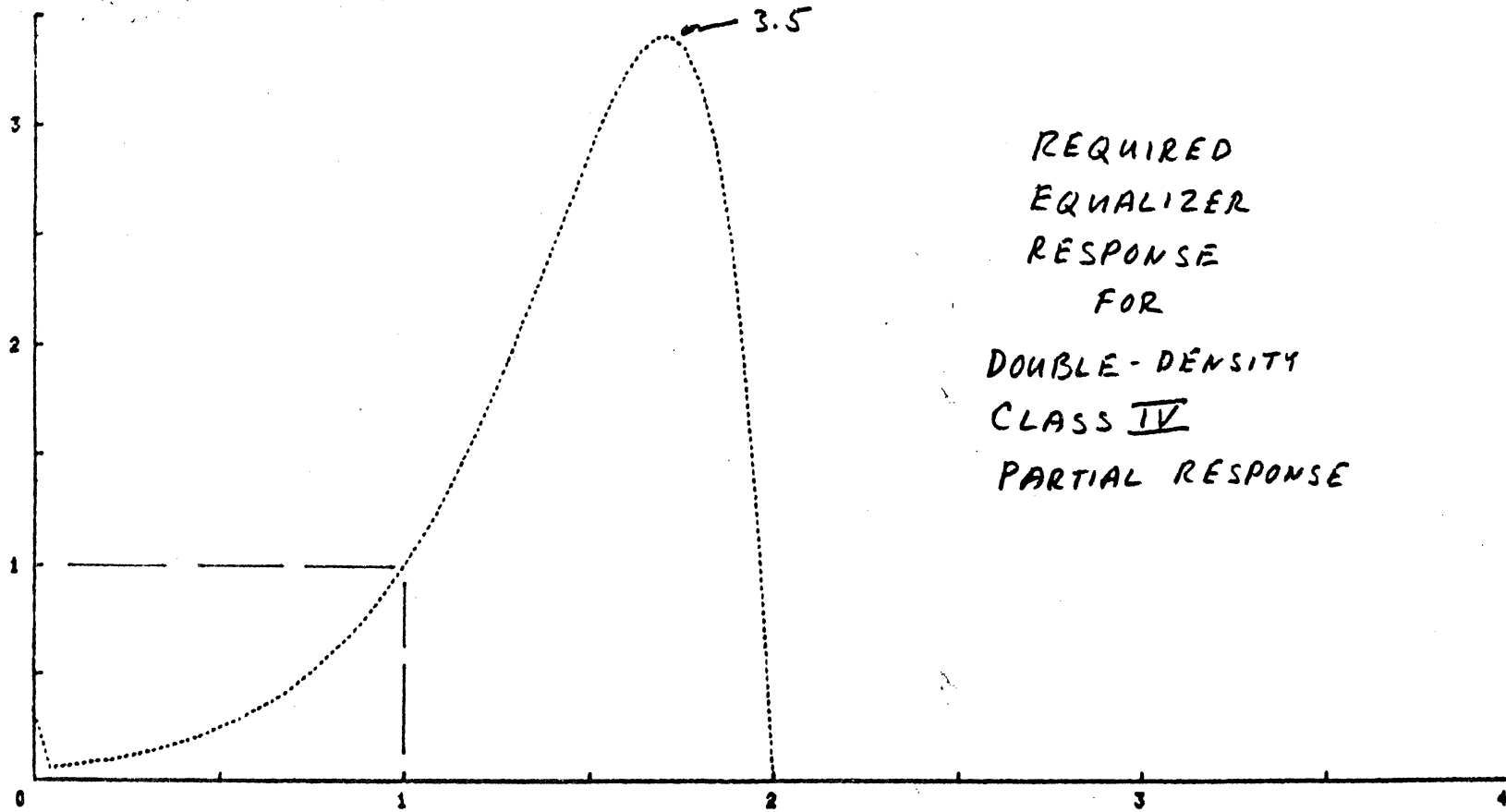

REQUIRED  
EQUALIZER  
RESPONSE  
FOR  
DOUBLE-DENSITY  
CLASS IV  
PARTIAL RESPONSE

IBM  
CONFIDENTIAL

↑  
NEW  
ALL ONES

FREQUENCY →

FIGURE 11

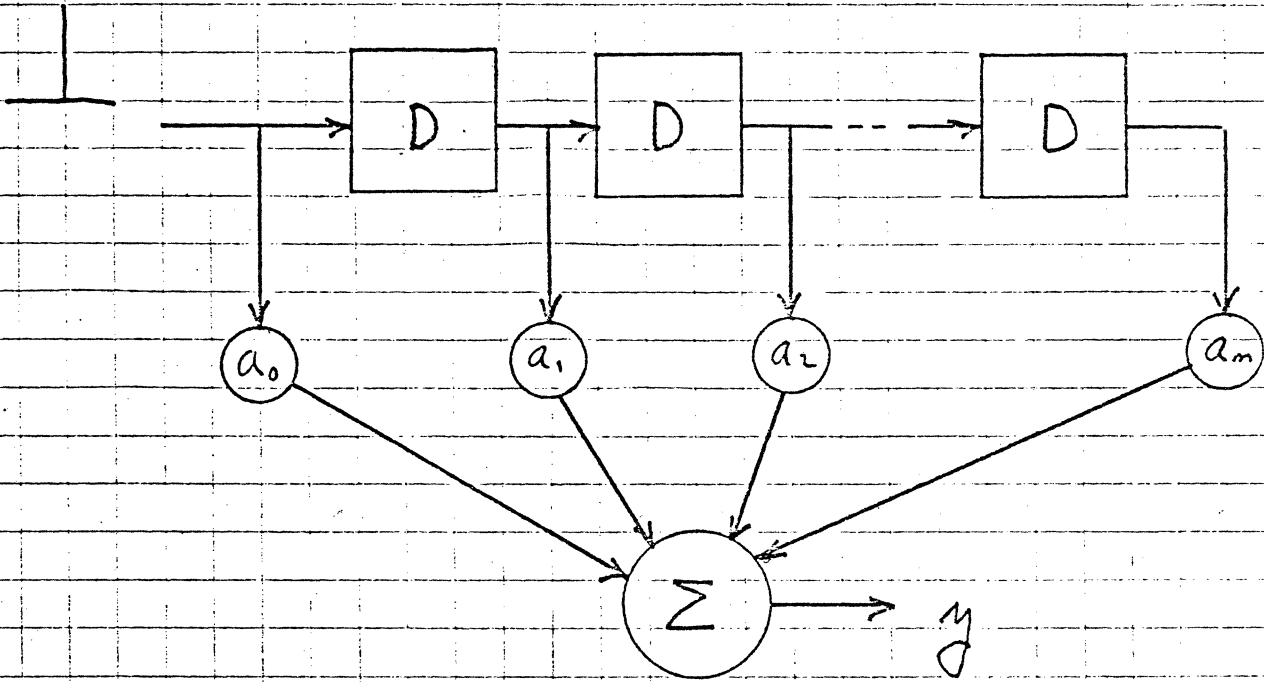

$$y_m = a_0 + a_1 D + a_2 D^2 + a_3 D^3 + \dots + a_m D^m$$

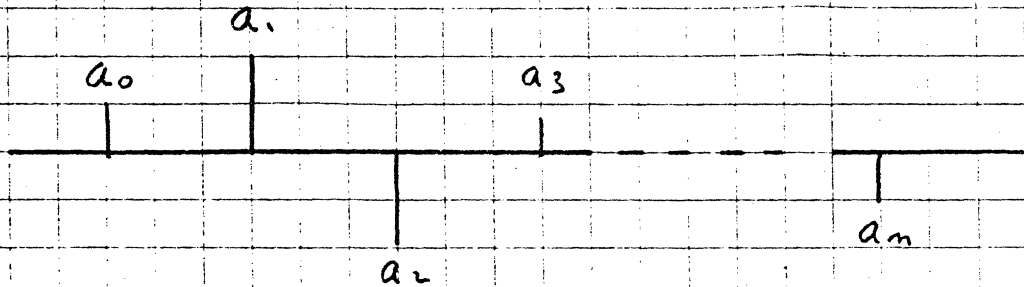

IBM

CONFIDENTIAL

FIGURE 12



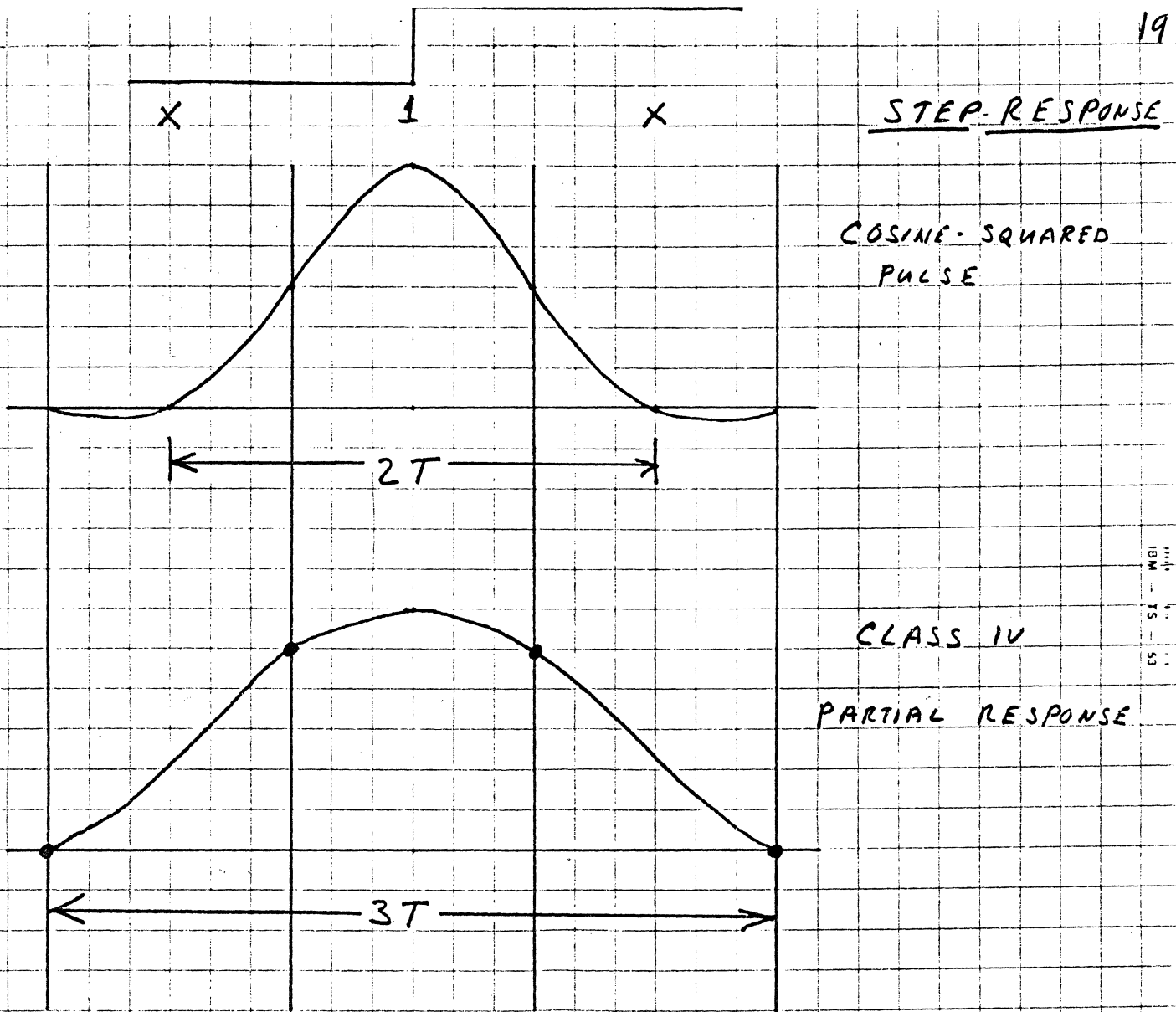

IBM

CONFIDENTIAL

FIGURE 13

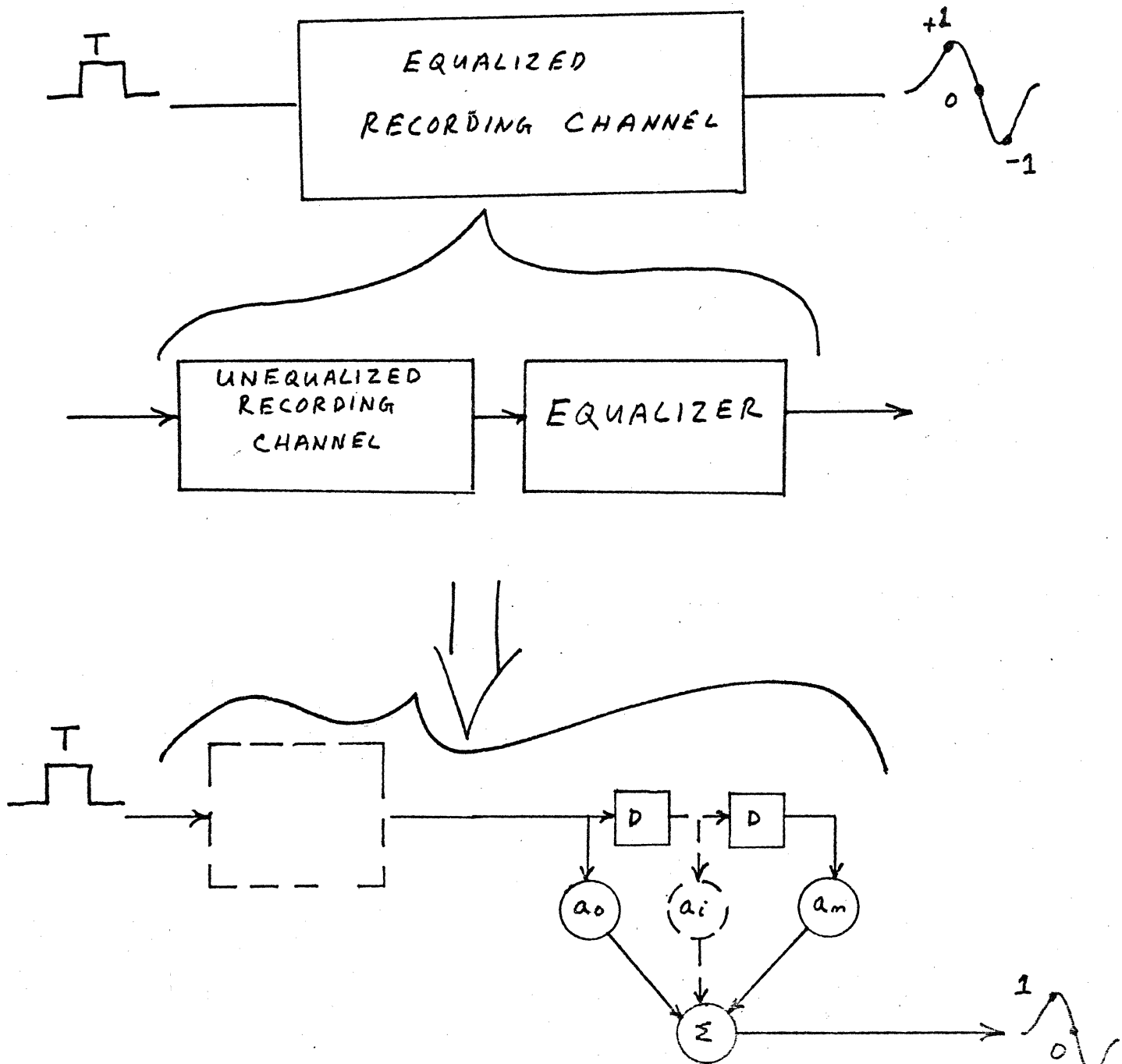

FIGURE 14

IBM  
CONFIDENTIAL

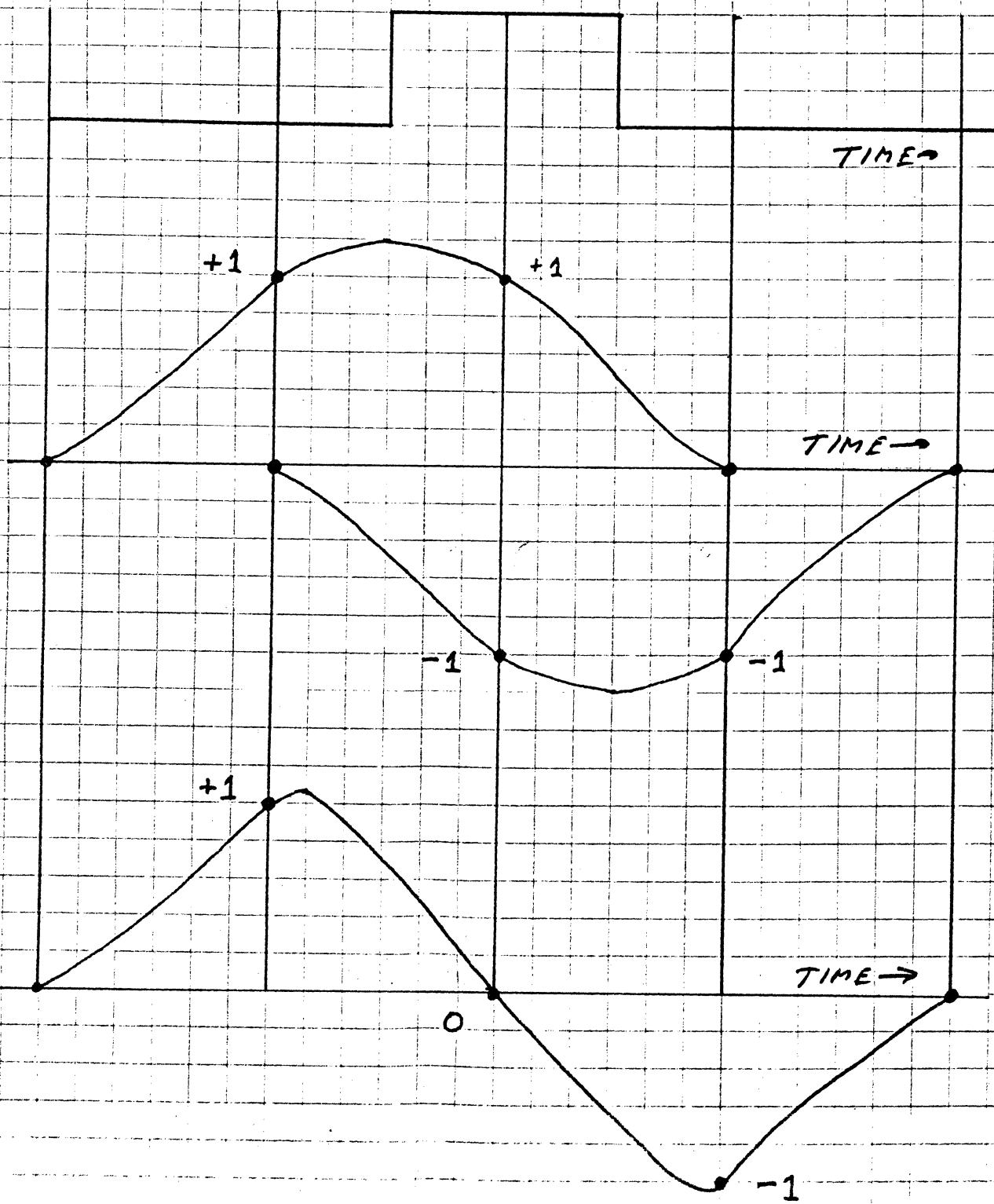
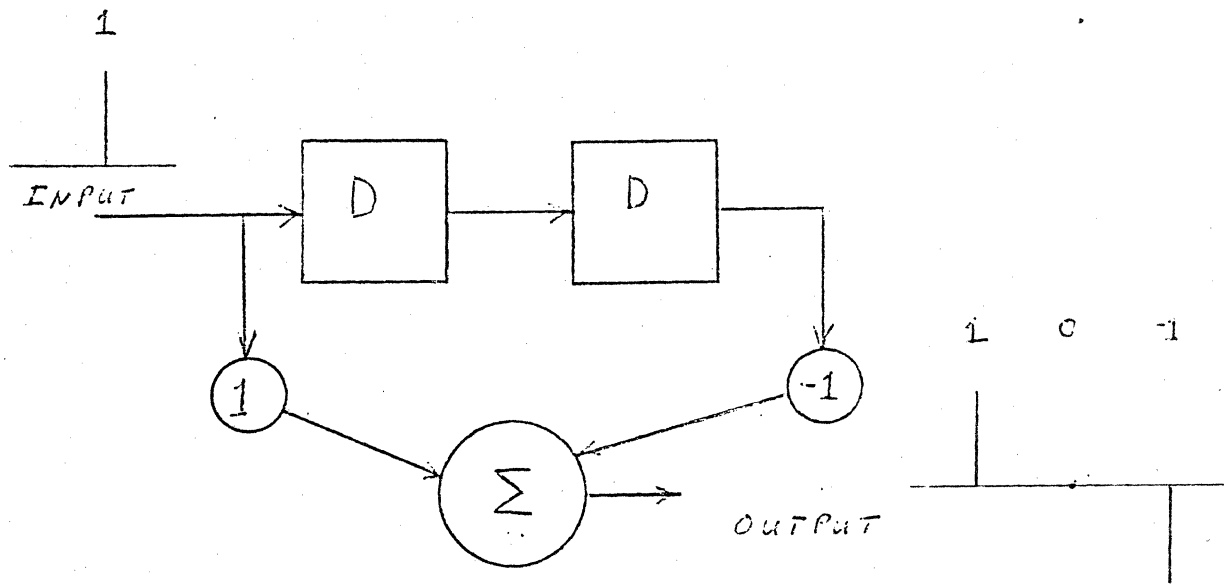

FIGURE 15

IBM  
CONFIDENTIAL

IBM  
ST  
CS



(a)

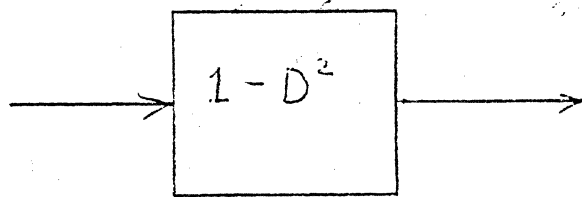

(b)

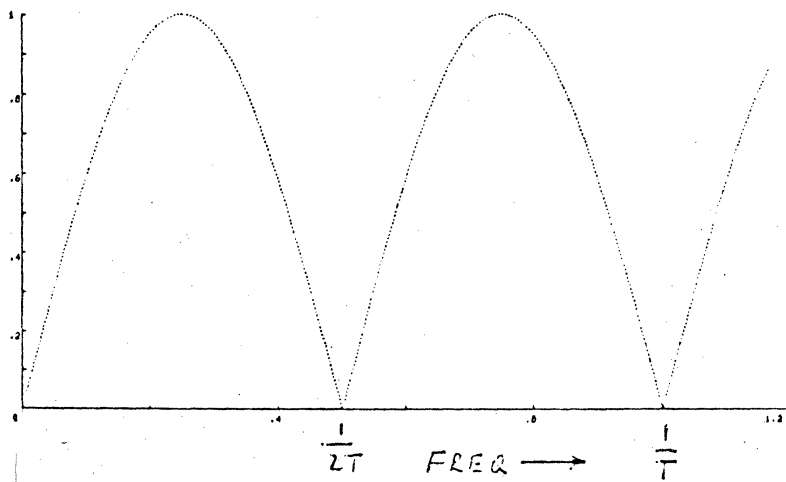

(c)

**FIGURE 16** (a) IDEAL CLASS IV PARTIAL RESPONSE SYSTEM  
 (b) TRANSFER FUNCTION  
 (c) MAGNITUDE RESPONSE

IBM CONFIDENTIAL

22  
 IBM TS  
 IBM TS  
 IBM TS

IBM TS 20

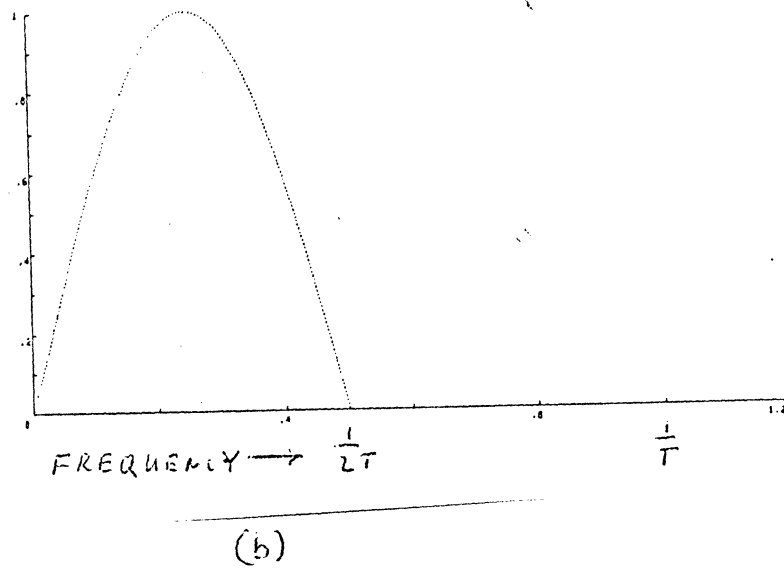
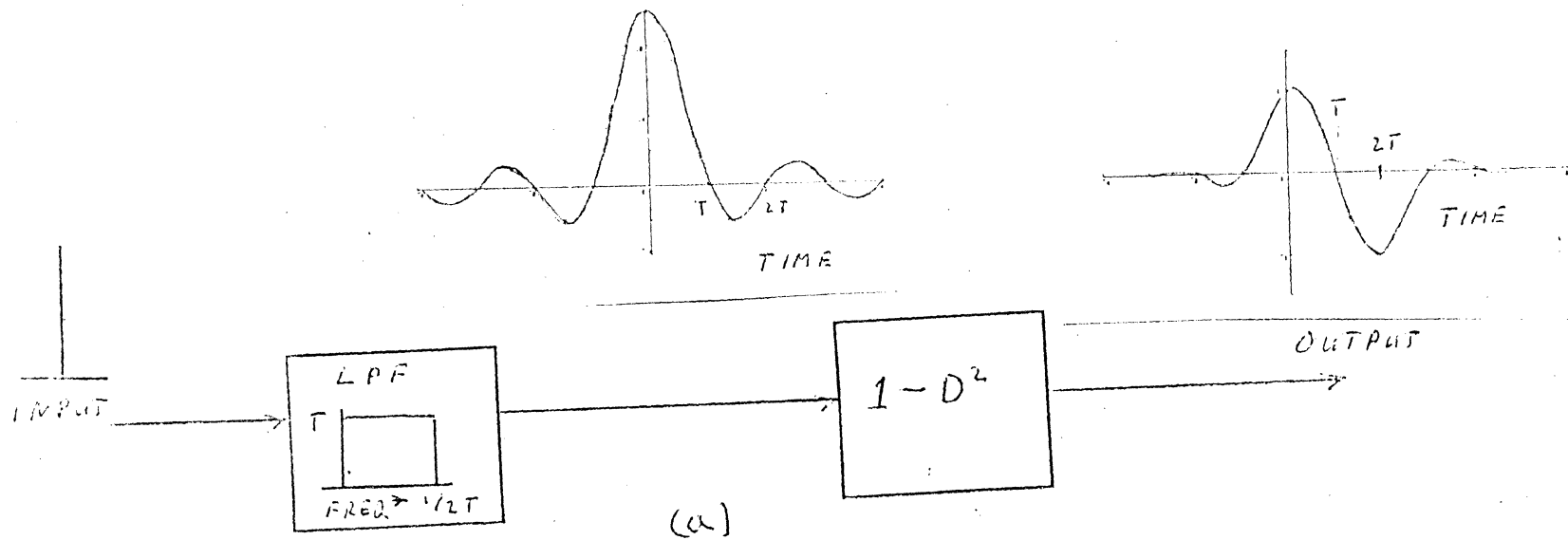
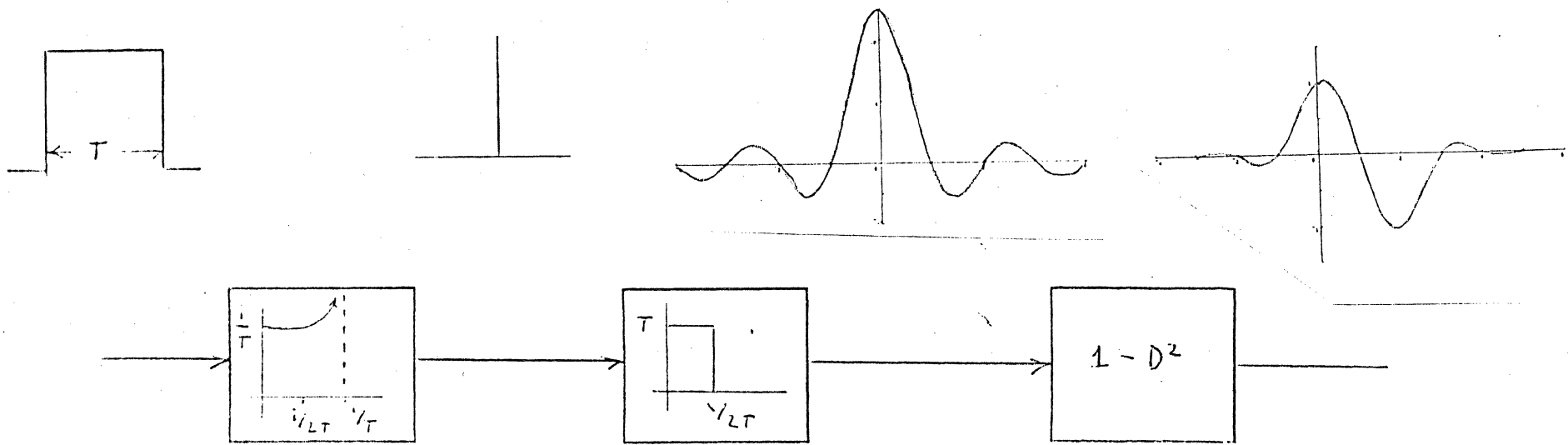

FIGURE 17

- (a) BANDLIMITED CLASS IV PARTIAL RESPONSE SYSTEM
- (b) MAGNITUDE RESPONSE

IBM  
CONFIDENTIAL



PULSE INPUT TO BANDLIMITED CLASS IV SYSTEM

FIGURE 18

IBM  
CONFIDENTIAL

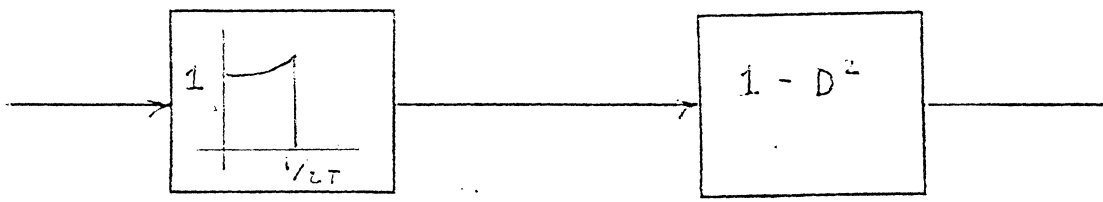
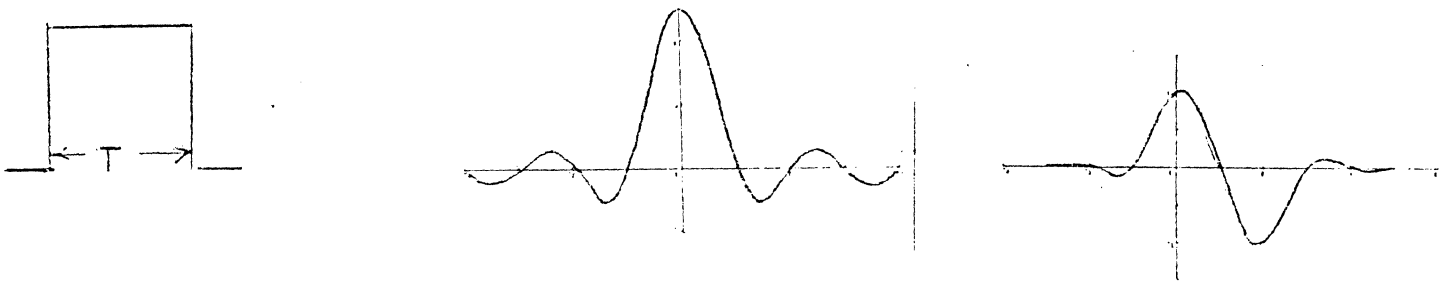

(a)

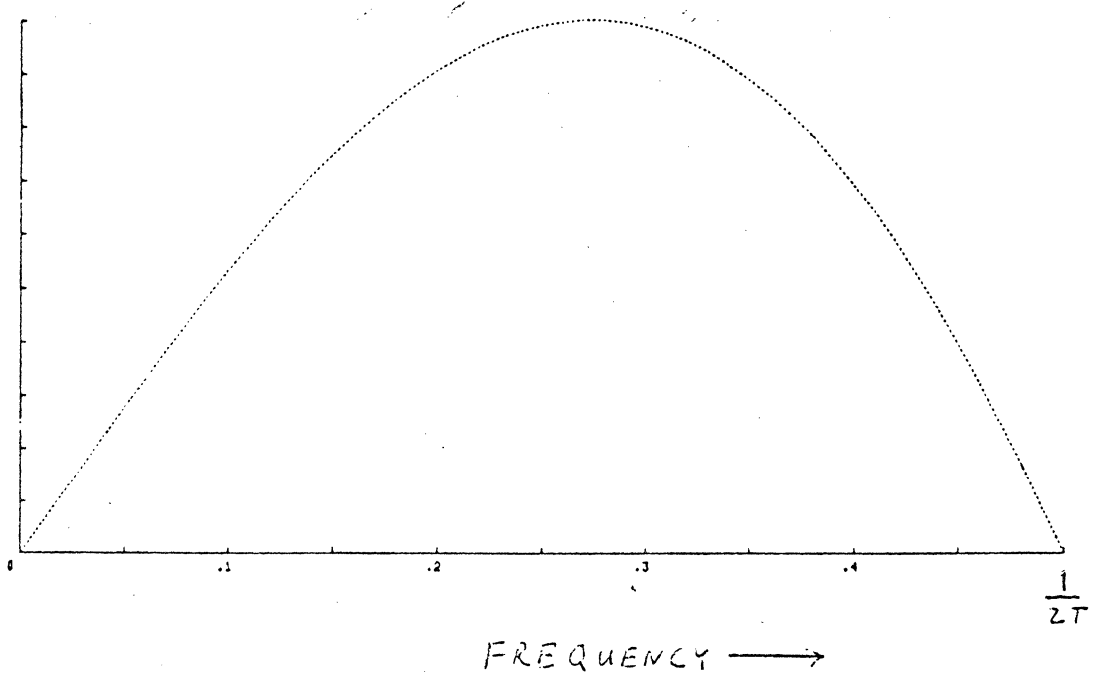

(b)

**FIGURE 19** (a) PULSE INPUT TO CLASS IV SYSTEM  
 (b) TOTAL TRANSFER FUNCTION MAGNITUDE

IBM  
 CONFIDENTIAL

RCS LPLT (MAGE2 AND MAGX0) VS FR2

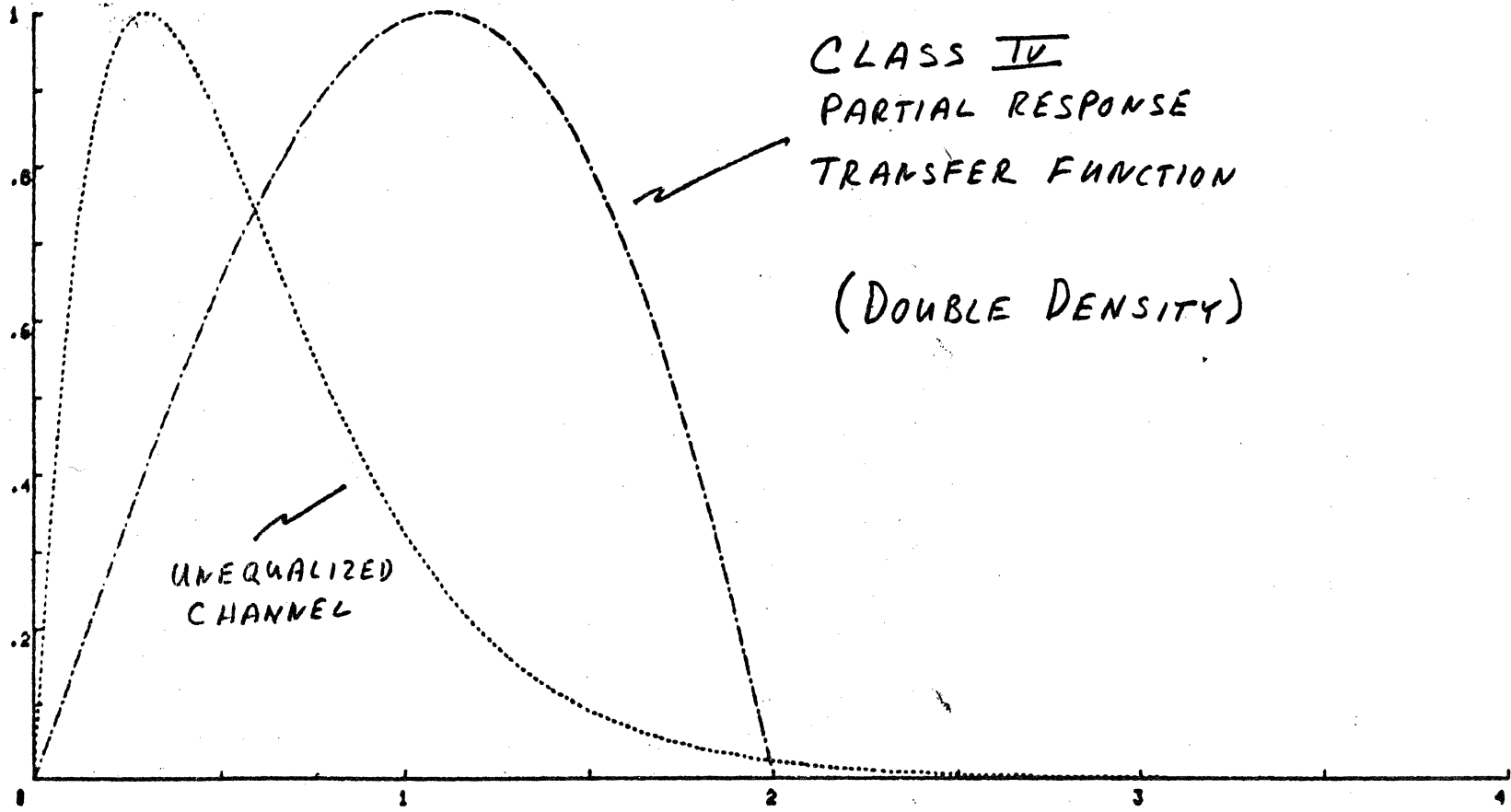

CLASS IV  
PARTIAL RESPONSE  
TRANSFER FUNCTION

(DOUBLE DENSITY)

UNEQUALIZED  
CHANNEL

FREQUENCY →

IBM  
CONFIDENTIAL

↑  
NEW  
ALL  
ONES

FIGURE 20



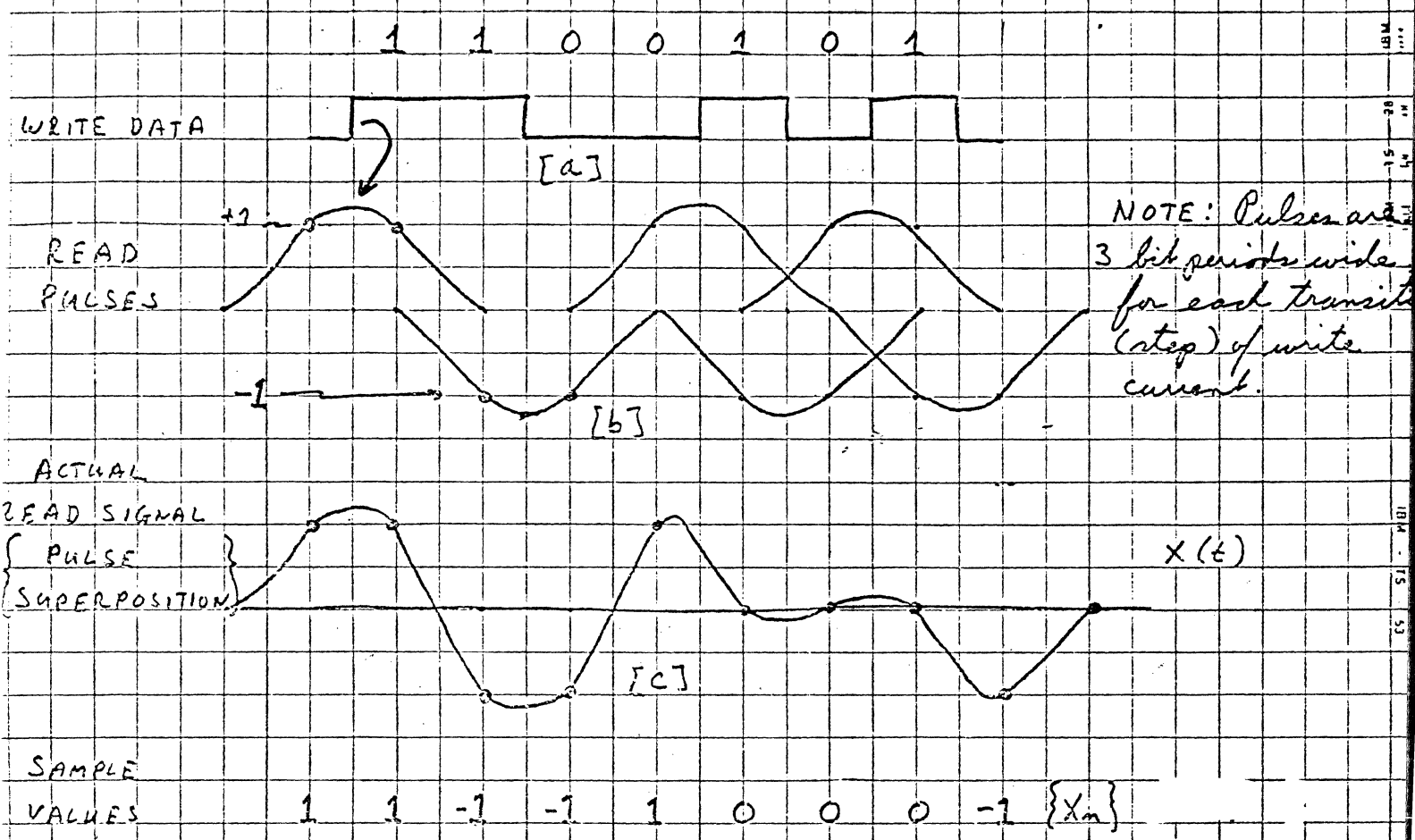

In order to convert the sample data values to the original data sequence, a  $1/1-D^2$  recursive filter can be used. Call the sample data sequence  $\{X_n\}$  and the estimated data sequence  $\{Y_n\}$ . Note, the absolute value of the  $\{X_n\}$  sequence is used.

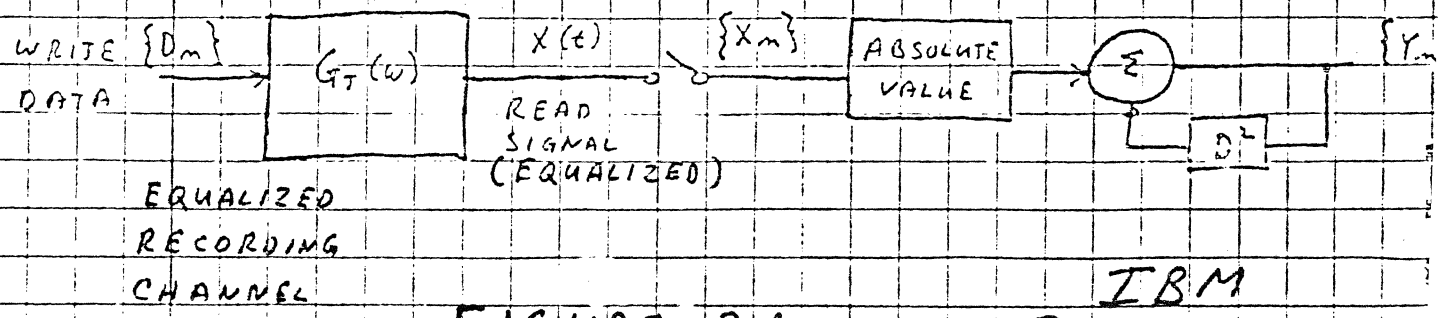

FIGURE 21

# IBM CONFIDENTIAL

$\{X_n\}$	$Y_{n-2}$	$Y_{n-1}$	$Y_n$		
1	0	0	1	}	
1	0	1	1		WRITE
1	1	1	0		DATA
1	1	0	0	}	
1	0	0	1		ESTIMATE
0	0	1	0		
0	1	0	1		
0	0	1	0		
1	1	0	0		
0	0	0	0		

## FIGURE 22

The problem with this technique is that a single error in the  $X_n$  sample data sequence can propagate indefinitely because of the recursive filter used to generate the  $Y_n$  sequence.

The solution is to put the recursive filter on the transmitter side of the channel. This corresponds to a precoder on the WRITE side of a magnetic recording channel. Note that the use of NRZI is really a precoder for a  $1-D$  type of partial response channel. An example of a

An example of a  $\frac{1}{1-D^2}$  precoder used with our

$1-D^2$  class IV partial response system is given on the following page.

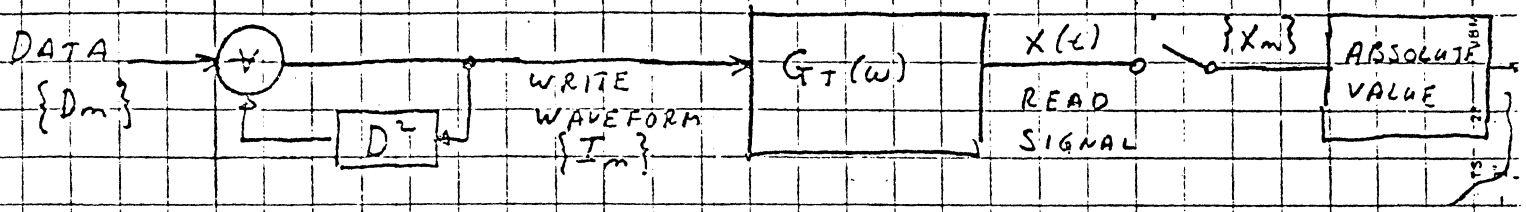

ESTIMATED DATA SEQUENCE

	$D_N$	$I_{N-2}$	$I_{N-1}$	$I_N$
DATA	1	0	0	1
	1	0	1	1
	0	1	1	1
	0	1	1	1
	1	1	1	0
	0	1	0	1
	1	0	1	1
	0	1	1	1

DATA 1 1 0 0 1 0 1

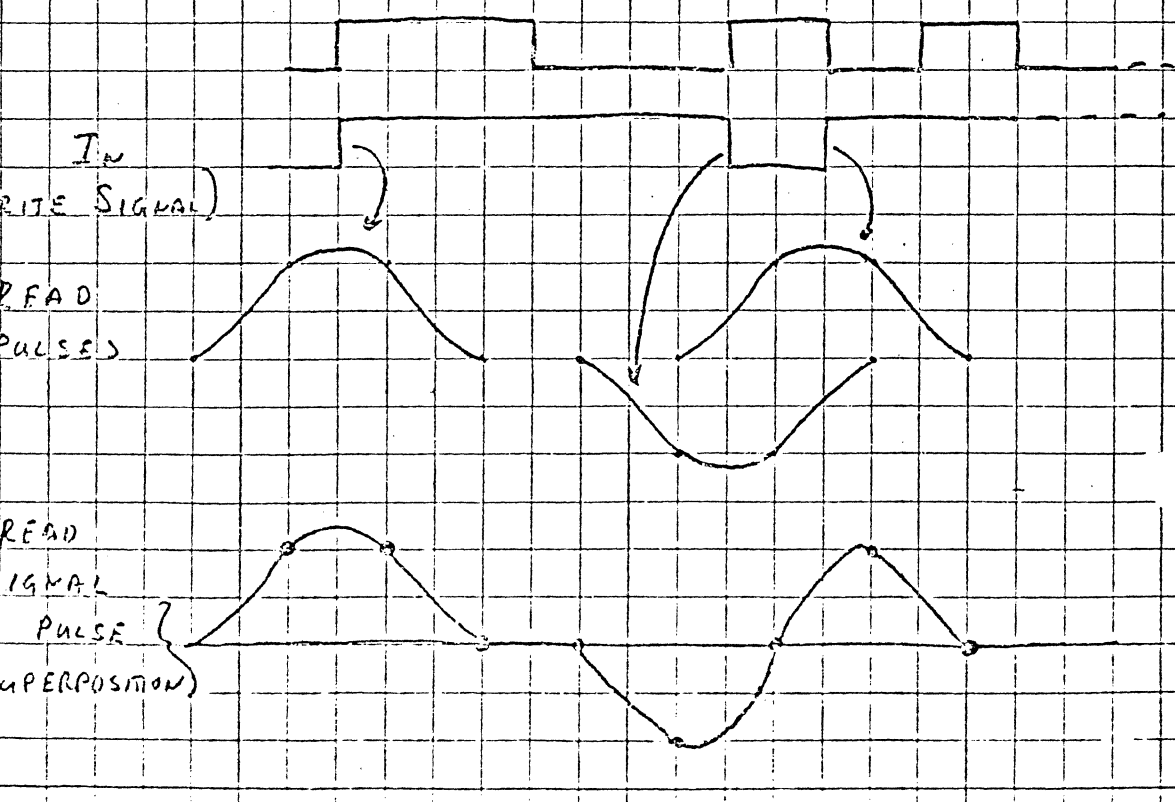

AMPLITUDE VALUES 0 1 1 0 0 -1 0 1 0

ABSOLUTE VALUE 0 1 1 0 0 1 0 1 0

FIGURE 23

CLASS 4  $\Rightarrow$   
 a) NO DC  
 b) NULL AT  $\frac{1}{2}T$   
 c) 3 LEVELS

$F(D)$	$ H(\omega) $	$h(t)$
$1+D$ (duobinary-class 1)		
$1-D$ (duobinary-class 2)		
$(1+D)(1-D)$ $= 1-D^2$ (modified duobinary-class 4)		
$(1+D)^2$ $= 1+2D+D^2$ (class 2)		
$(1+D)^2(1-D)$ $= 1+D-D^2-D^3$		
$(1+D)(1-D)^2$ $= 1-D-D^2+D^3$		
$(1+D)^2(1-D)^2$ $= 1-2D^2+D^4$ (class 5)		
$(1+D)(2-D)$ $= 2+D-D^2$ (class 3)		
$(1+D)(1-D)(2+D^2)$ $= 2-D^2-D^4$		

P. KABAL + S. PASUPATHY "PARTIAL RESPONSE SIGNALING"  
 IEEE TRANS COMM, VOL. COM-23, NO. 9, SEPT. 1975

FIGURE 24

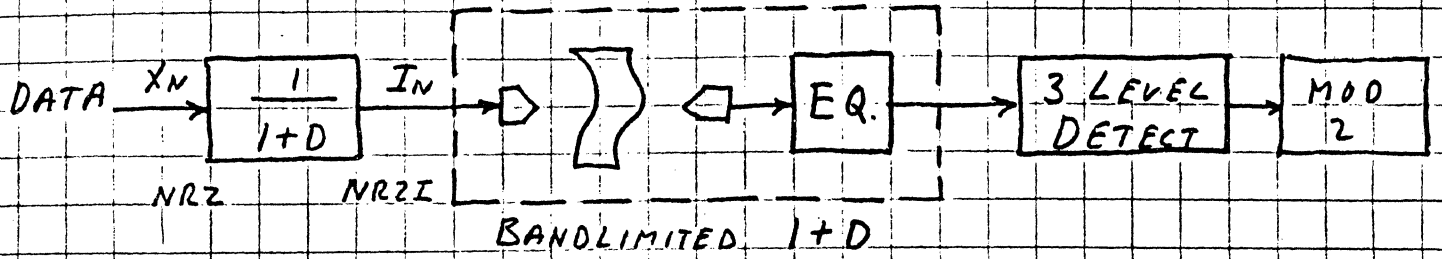

IBM - TS - 18  
(suppl. P. 18, 19)

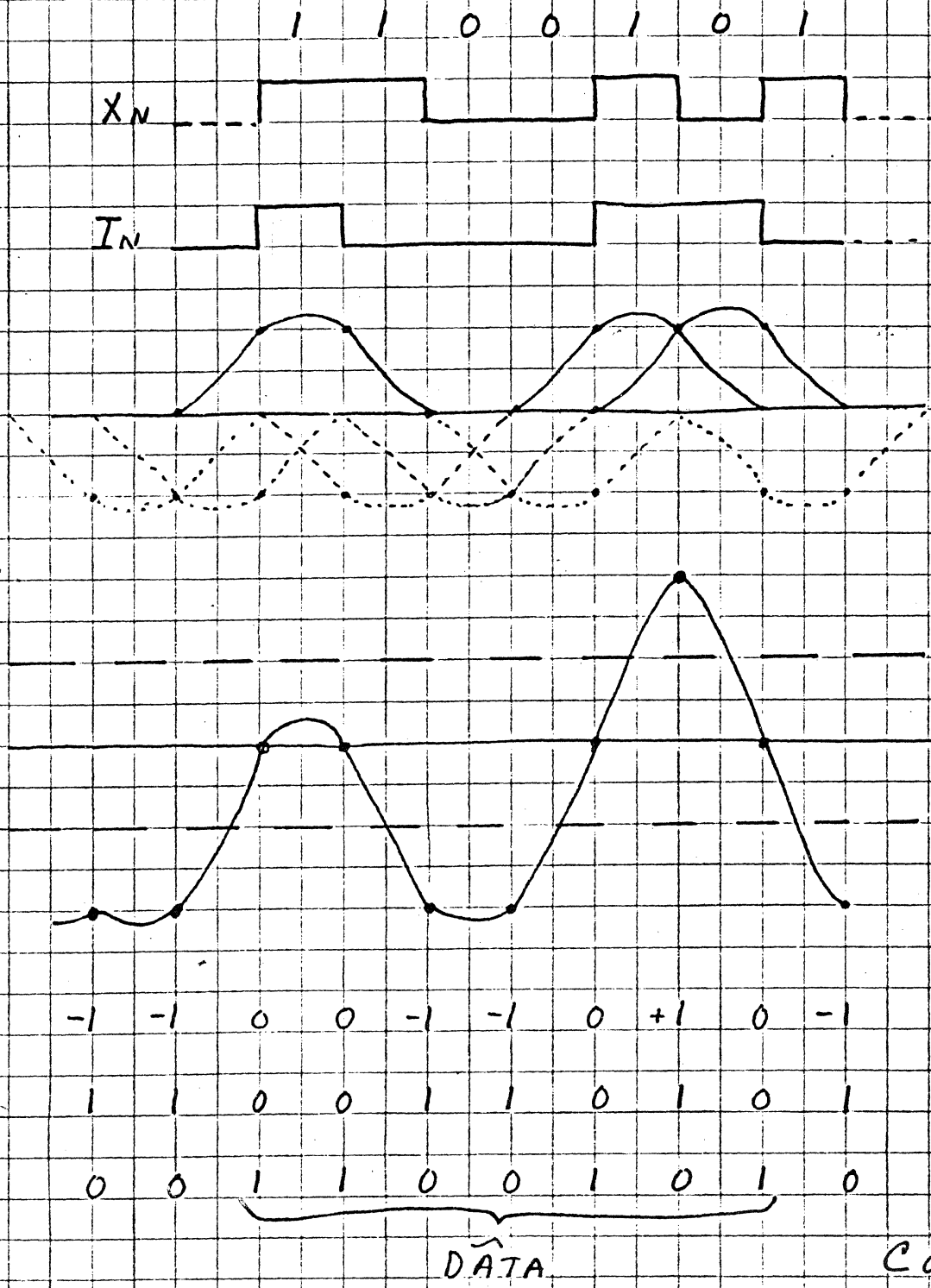

IBM  
CONFIDENTIAL

FIGURE 25

IBM - TS - 1  
IBM - TS - 18

1 1 0 0 1 0 1

READ SIGNAL

IDEAL SEQUENCE  
# 1

IDEAL SEQUENCE  
# 2

IDEAL SEQUENCE  
# 3

FIGURE 26

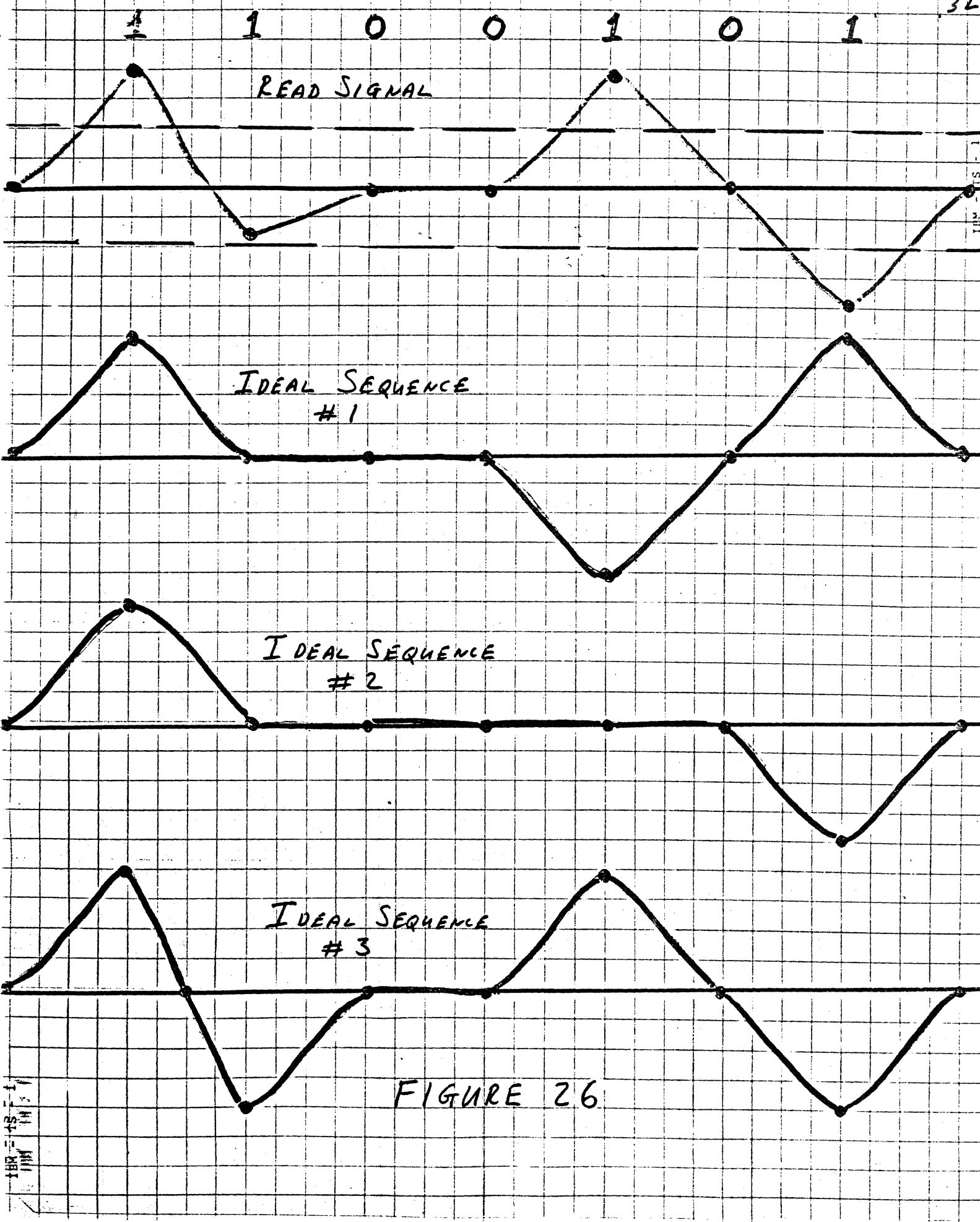

100-105-1  
100-105-1

## CONCLUSIONS

PARTIAL RESPONSE REDUCES CHANNEL B. W. NEED  
 " " HANDLES ISI

CLASS IV (a) NO DC  
 (b) 3 LEVELS  
 (c) NULL AT "ALL ONES"

CLASS I (a) DC  
 (b) 3 LEVELS  
 (c) NULL AT "ALL ONES"

OTHER PARTIAL RESPONSE  $\Rightarrow$  5+ LEVELS

ALTERNATIVES:  $(d, k)$  CODES;  $d \neq 0$   
 EG:  $(2, 7)$ ;  $(1, k)$

PARTIAL RESPONSE PROBLEMS

NARROW EYE

SNR

VITERBI ALGORITHM COST/PERF

IBM CONFIDENTIAL





## ZURICH ACTIVITY IN MAGNETIC RECORDING

F. Dolivo  
IBM Research Laboratory, Zurich, Switzerland  
January, 1981

ABSTRACT: We proposed earlier a magnetic recording system using partial-response class IV signaling in conjunction with soft Viterbi decoding. This system is presently in an advanced stage of implementation. In partial-response class IV signaling, no energy is transmitted at DC and at the Nyquist frequency. This scheme is thus well suited for the magnetic recording-channel. The Viterbi decoder working on the sampled outputs of a matched receiver filter is optimum, performing maximum likelihood sequence estimation.

After exposing the theory, the implementation of the Viterbi decoder for partial-response class IV signaling is discussed in detail, and shown to be very simple. Codes encoding  $K$  bits into  $K + 1$  ( $K = 8$  or  $9$ ) are then presented. These codes, developed by us, further concentrate the energy in the transmission band of the channel, insure transitions for timing recovery and allow the Viterbi decoder to achieve its theoretical performance with a memory length of 12 bits only.

The Viterbi decoder and the block encoder/decoder have been implemented in vendor low power Shottky technology, and work up to 10 Mbits/sec using 8 bits A/D (soft decoder) and 12 bits arithmetic. With Advanced Low power Shottky Technology (ALS), 5 bits A/D and 8 bits arithmetic the speed could be pushed up to 40 Mbits/sec and higher speeds can be achieved with an analog implementation.

An 8th order filter simulating precisely a recording channel (ACE, POLARIS XI) has been built. The sender and receiver filters for this channel are designed and presently in construction. The sender consists of a 2nd order low pass, and the receiver is a 4th order filter. All the filters are implemented with the IBM filter module 5119519.

Future work will be concerned with timing recovery and automatic gain control. In both cases data-directed schemes are envisaged.

# ZURICH ACTIVITY IN MAGNETIC RECORDING

F. DOLIVO

COMPLETE THE IMPLEMENTATION OF A RECORDING SYSTEM USING PARTIAL RESPONSE CLASS IV SIGNALING IN CONJUNCTION WITH SOFT VITERBI DECODING

## CONTENT

P. R. IV + VITERBI DECODER

- . THEORY
- . IMPLEMENTATION

STATUS OF HARDWARE

FILTER DESIGN

FUTURE WORK

- . TIMING RECOVERY
- . A.G.C

SUMMARY

# SIGNALING: PARTIAL RESPONSE CLASS IV

$$a_n = \pm 1$$

ONE SYMBOL IS SENT EVERY T

$$\text{BIT RATE} = 1/T$$

$\{a_n\}$

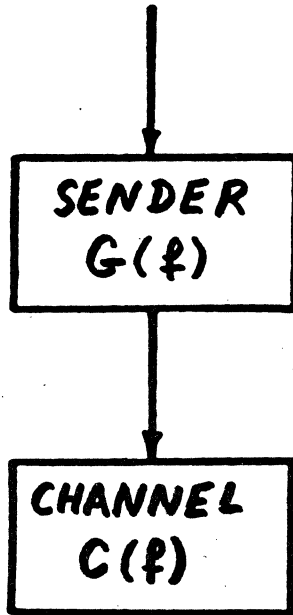

FOR P.R IV:

$$G(f)C(f) =$$

$$\begin{cases} j 2T \sin(2\pi fT) & f < 1/2T \\ 0 & \text{OTHERWISE} \end{cases}$$

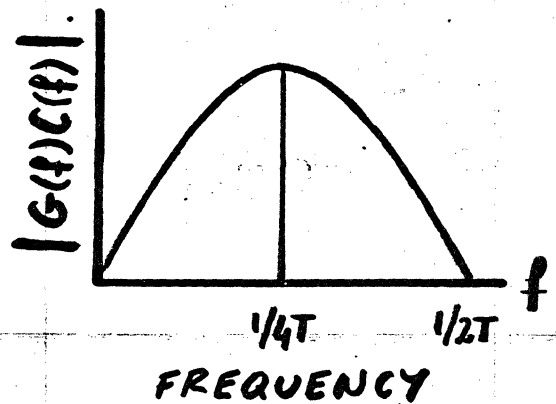
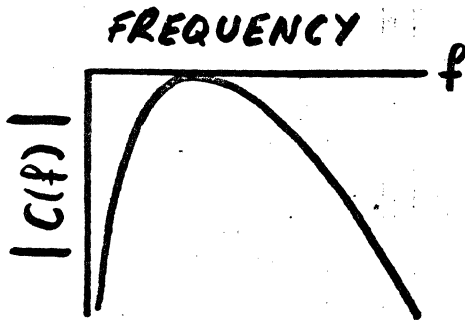

$$f(t) =$$

$$\sum_n a_n R(t - nT)$$

SIGNAL ELEMENT  $R(t)$

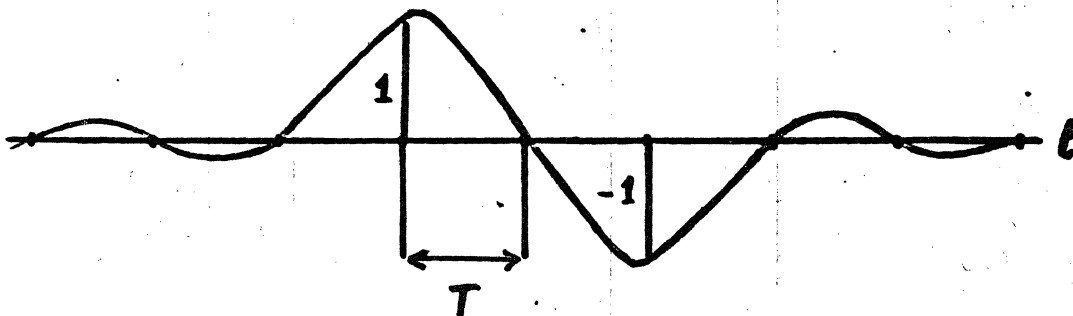

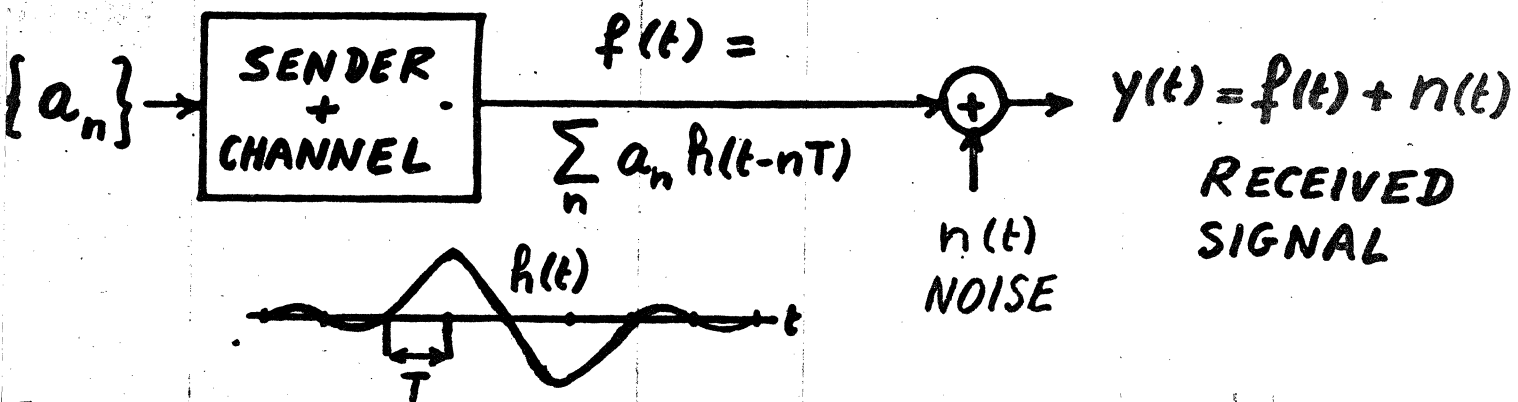

OPTIMUM STRATEGY : HAVING OBSERVED THE RECEIVED SIGNAL  $y(t)$  FOR AN INTERVAL OF TIME  $LT$ , THE BEST ESTIMATE OF THE TRANSMITTED SEQUENCE IS THE SEQUENCE  $\{\hat{a}_n\}$  WHICH SATISFIES

$$\hat{\epsilon} = \int_0^{LT} [y(t) - \sum_n \hat{a}_n h(t-nT)]^2 dt \leq \epsilon = \int_0^{LT} [y(t) - \sum_n a_n h(t-nT)]^2 dt$$

FOR ANY OF THE  $2^L$  POSSIBLE SEQUENCES  $\{a_n\}$ .

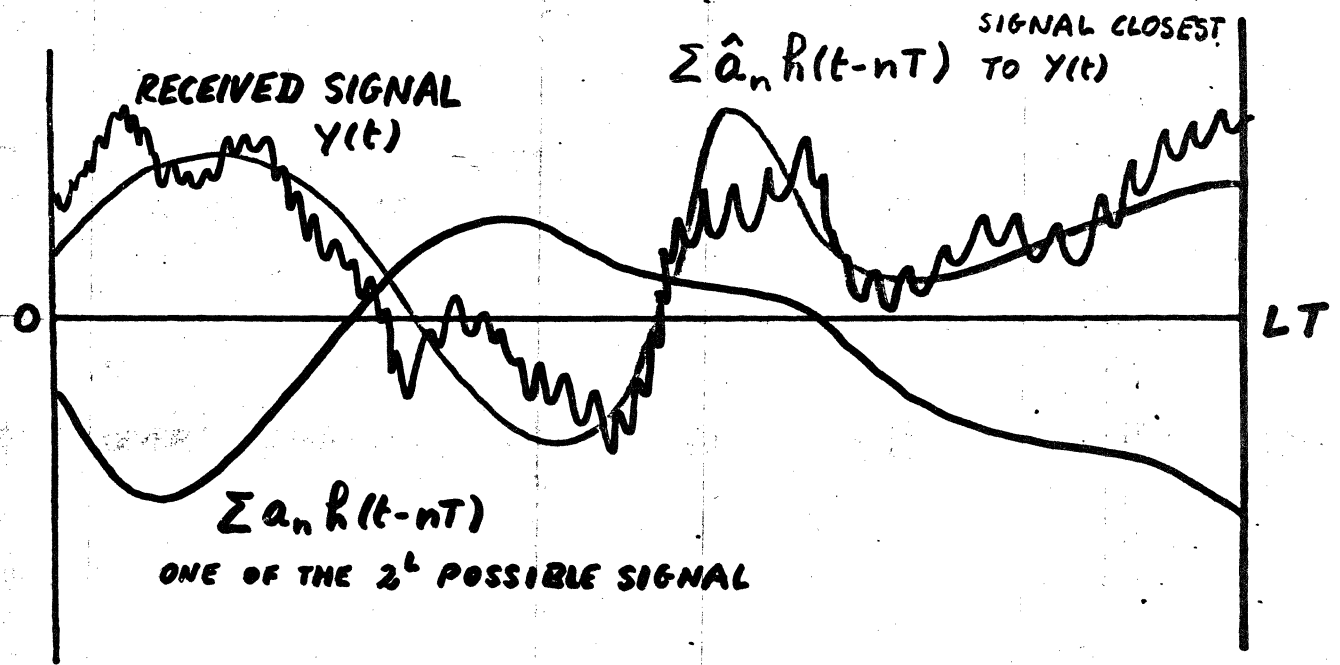

- NO ASSUMPTION ON NOISE : LMS ERROR CRITERION
- IF NOISE IS WHITE GAUSSIAN , THEN THIS SCHEME PERFORMS MAXIMUM LIKELIHOOD SEQUENCE ESTIMATION, i.e.

965-IBM-03

STRATEGY: FIND  $\{\hat{a}_n\}$  WHICH

MINIMIZES  $\int_0^{LT} [y(t) - \sum_n a_n h(t-nT)]^2 dt$

OR MAXIMIZES  $\int_0^{LT} \left\{ y(t) \sum_n a_n h(t-nT) - \frac{1}{2} \left[ \sum_n a_n h(t-nT) \right]^2 \right\} dt$

OR MAXIMIZES  $\sum_n a_n z_n - \frac{1}{2} \sum_i \sum_j a_i a_j s_{i-j}$

WHERE

$z_n = \int y(z) h(z-nT) dz$  : OUTPUT OF MATCHED FILTER

$s_{i-j} = s_{j-i} = \int h(z) h[z-(i-j)T] dz$  : SIGNAL ELEMENT AFTER MATCHED FILTER

THE MAXIMIZATION IS ACHIEVED BY DYNAMIC PROGRAMMING  
 $\Leftrightarrow$  VITERBI ALGORITHM

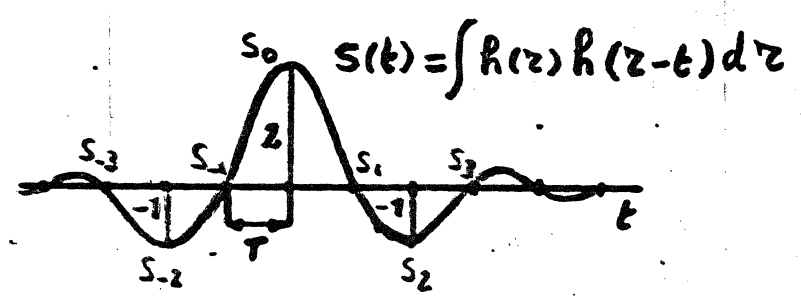
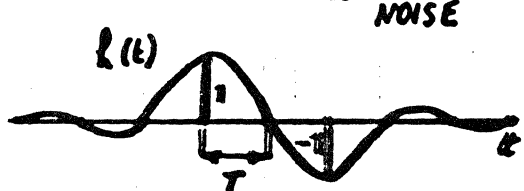
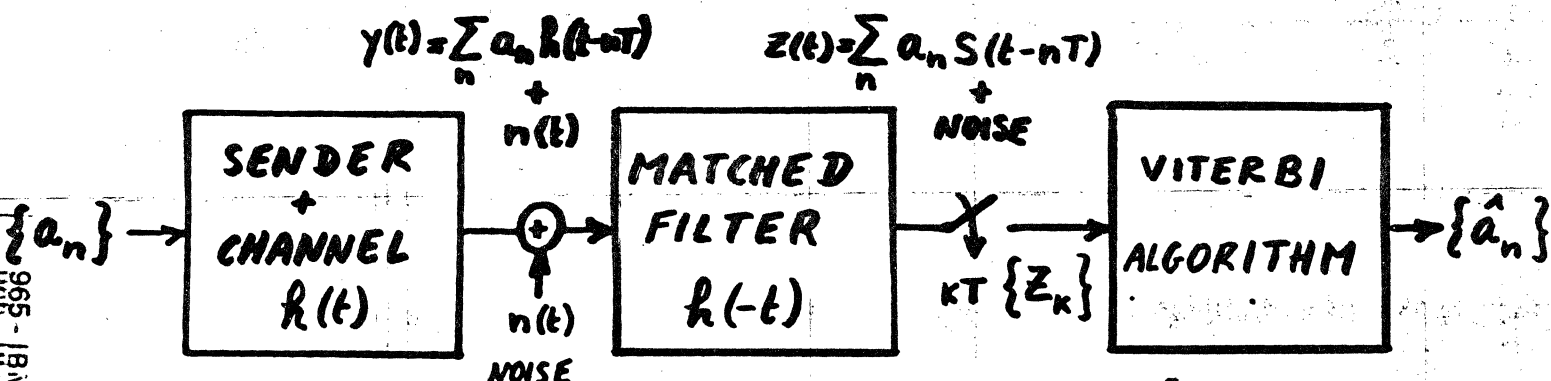

FIND  $\{\hat{a}_n\}$  WHICH MAXIMIZES  $J = \sum_n a_n (z_n + a_{n-2})$   
 WHERE  $z_n$  IS THE SAMPLED OUTPUT OF THE MATCHED FILTER

965 - BM - 03

FIND  $\{\hat{a}_n\}$  WHICH MAXIMIZES  $J = \sum_n a_n (z_n + a_{n-2})$   
 WHERE  $z_n$  IS THE RECEIVED SAMPLE

REWRITE  $J$  AS

$$J = \underbrace{\sum_k a_{2k} (z_{2k} + a_{2(k-1)})}_{J_E} + \underbrace{\sum_k a_{2k+1} (z_{2k+1} + a_{2k-1})}_{J_O}$$

$J_E$ : DEPENDS ONLY ON  
 SYMBOLS WITH  
 EVEN INDICES

$J_O$ : DEPENDS ONLY ON  
 SYMBOLS WITH  
 ODD INDICES

$J_E$  AND  $J_O$  CAN BE OPTIMIZED SEPARATELY

EVEN AND ODD SAMPLES ARE TREATED IN AN INTERLEAVED  
 FASHION, EACH INTERLEAVED STREAM CORRESPONDING TO  
 A PARTIAL-RESPONSE DICODE SCHEME

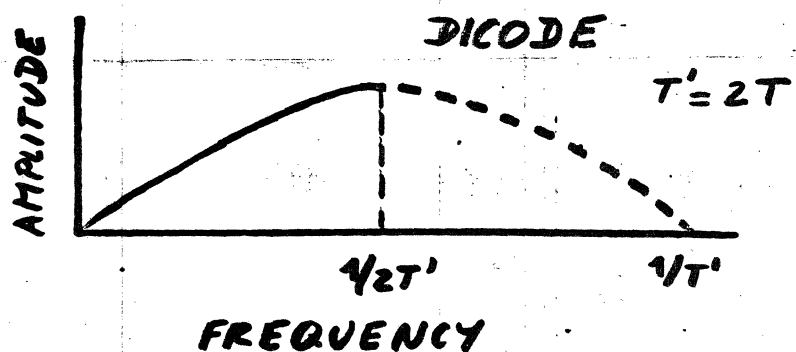
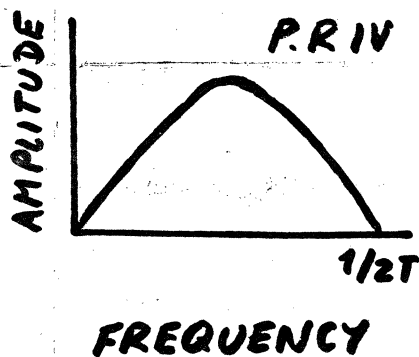

VITERBI ALGORITHM FOR P.R IV HAS THE COMPLEXITY  
 OF THE VITERBI ALGORITHM FOR A DICODE SCHEME  
 HARDWARE REDUCED ALMOST BY A FACTOR OF TWO

# VITERBI ALGORITHM

EXAMINE ONLY  $J_E$  (EVEN STREAM)

FIND  $\{\hat{a}_n\}$  WHICH MAXIMIZES  $J_E = \sum_{n \text{ EVEN}} a_n (z_n + a_{n-2})$

ALL SEQUENCES  $\{a_n\}$  CAN BE DESCRIBED BY A PATH IN THE FOLLOWING TRELLIS

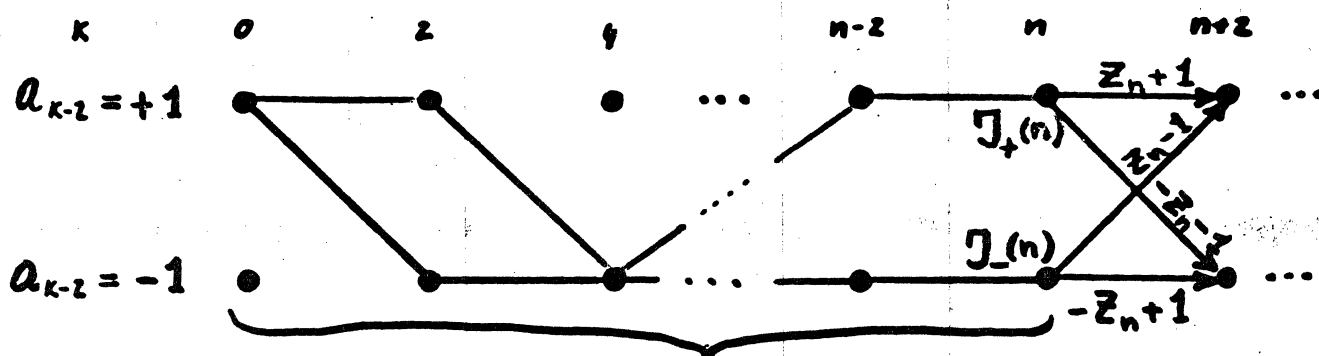

$$J = \sum_m a_m (z_m + a_{m-2}) + a_n (z_n + a_{n-2})$$

DENOTE BY  $J_+(n)$  BEST METRIC FROM ORIGIN TO  $a_{n-2} = +1$

$J_-(n)$  BEST METRIC FROM ORIGIN TO  $a_{n-2} = -1$

## VITERBI ALGORITHM

I: UPDATE METRICS

$$J_+(n+2) = \max \{ J_+(n) + z_{n+1}, J_-(n) + z_n - 1 \}$$

$$J_-(n+2) = \max \{ J_+(n) - z_n - 1, J_-(n) - z_{n+1} \}$$

II: EXTEND THE SURVIVOR SEQUENCES

III: AT THE END OF TRANSMISSION, CHOOSE SURVIVOR SEQUENCE WITH LARGEST METRIC

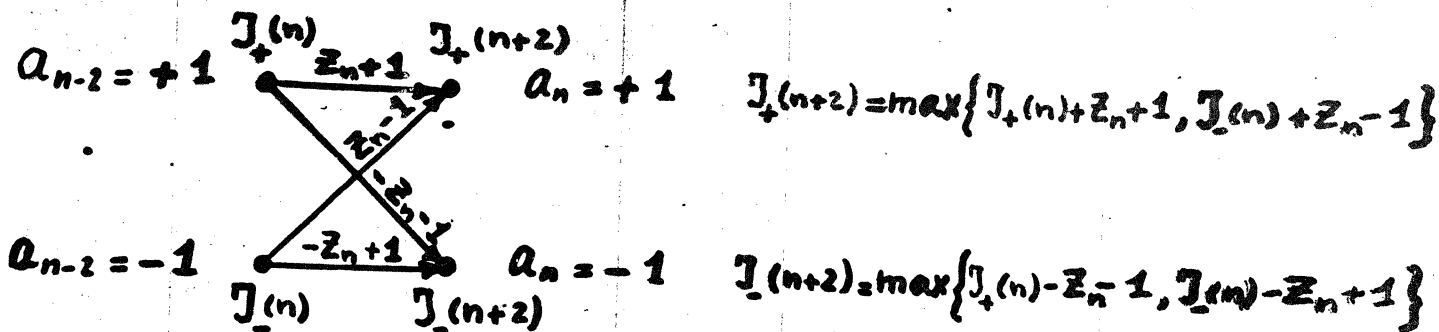

PRECOMPUTATION OF  $z_n \pm 1, -z_n \pm 1$

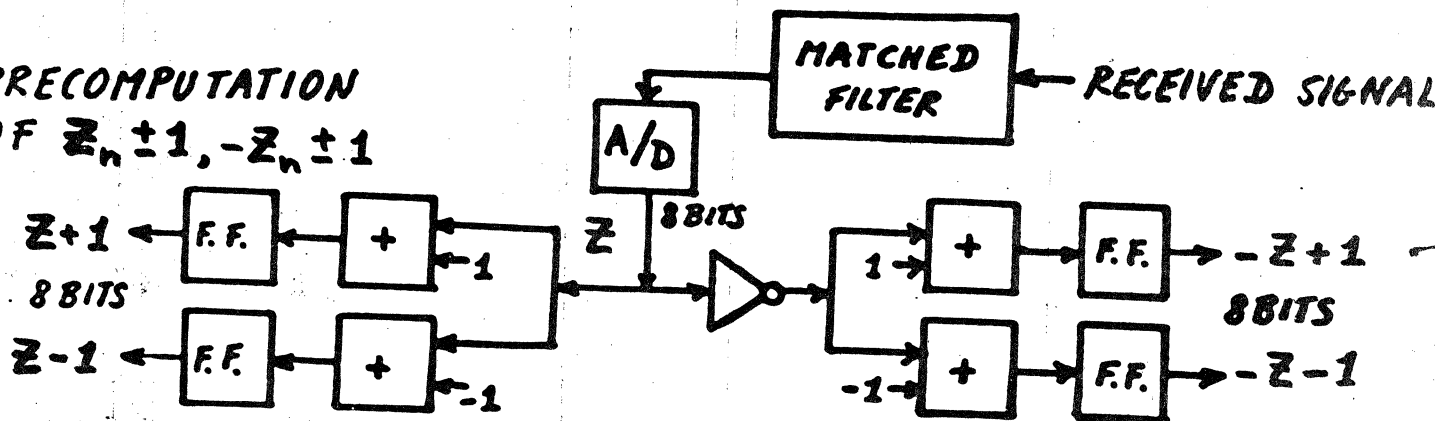

METRICS UPDATING

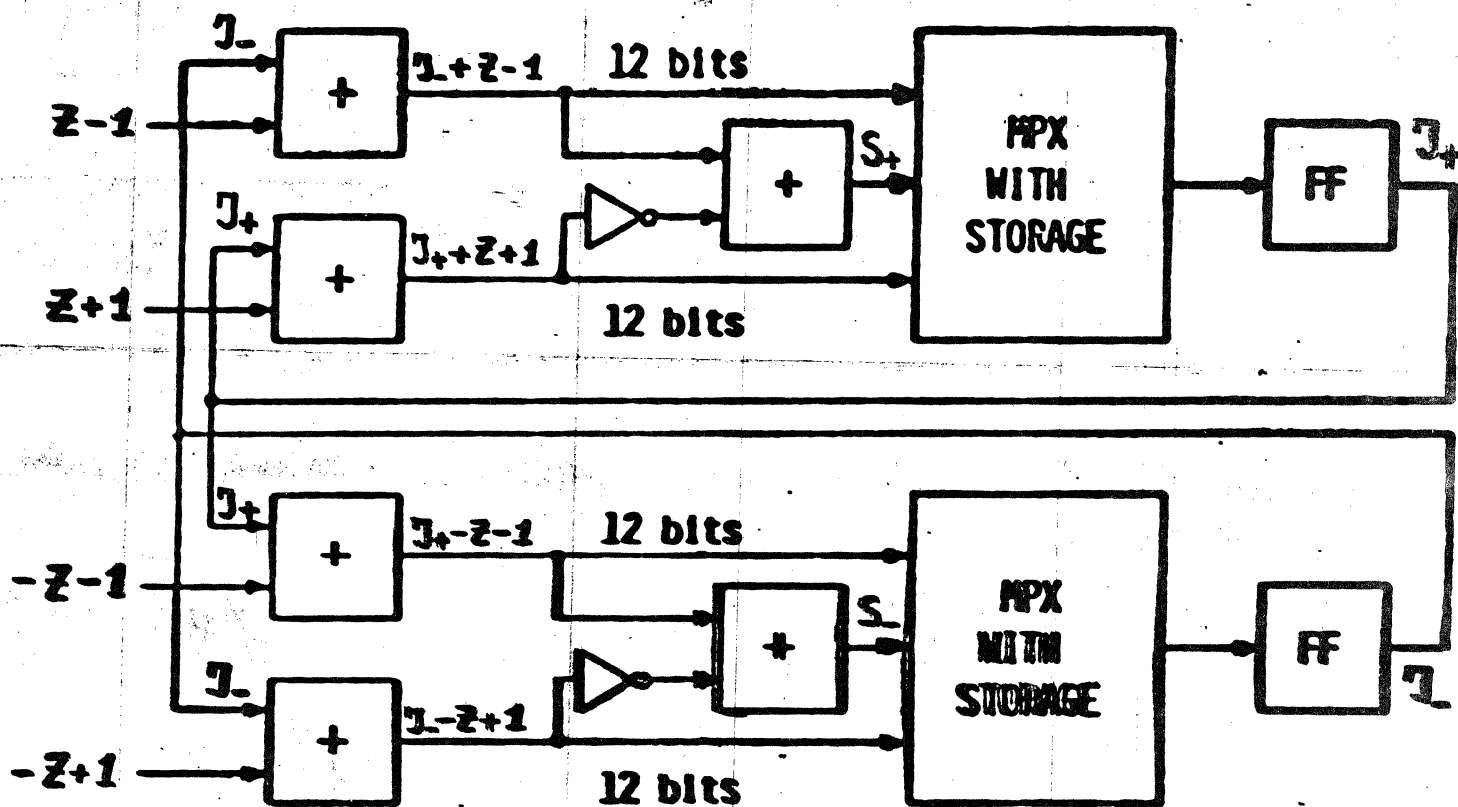

- MOVE F.F. IN FRONT OF MPX
- OPERATIONS DURING A CYCLE:



A/D

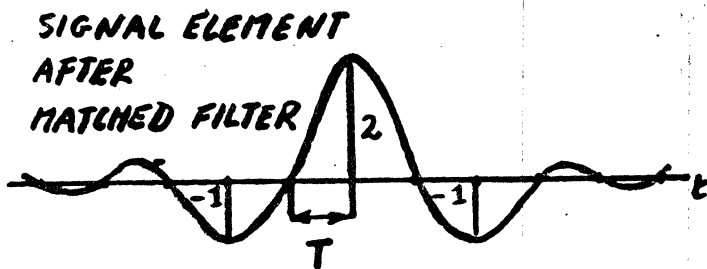

OUTPUT LEVELS:

$0, \pm 2, \pm 4$



QUANTIZATION WITH 5 bits A/D

## ARITHMETIC

- TWO'S COMPLEMENT REPRESENTATION
- LET ALL ADDERS WRAP AROUND  
NO OVERFLOW
- FOR A CORRECT COMPARISON BETWEEN METRICS, THE DIFFERENCE BETWEEN THE TWO METRICS SHOULD NEVER EXCEED HALF THE RANGE SPANNED BY THE NUMBER OF BITS USED FOR THE ARITHMETIC

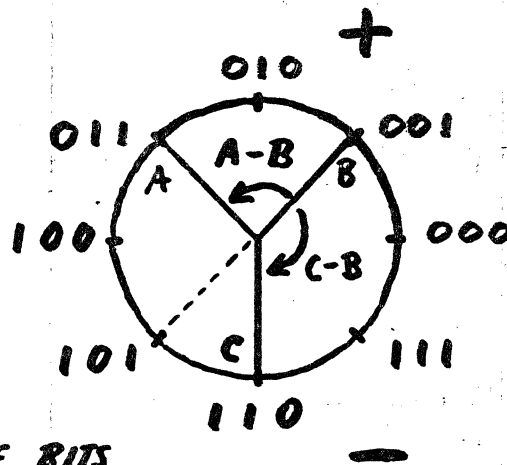

ONE CAN SHOW THAT

$$\left| \text{DIFFERENCE BETWEEN METRICS} \right| \leq 2(Z_n + 1) \leq 18$$

IF  $8 \leftrightarrow 5$  bits THEN  $2 \times 18 = 36 < 64 \leftrightarrow 8$  bits

IN GENERAL

# OF BITS FOR ARITHMETIC = # OF BITS FOR A/D + 3

- PRESENT IMPLEMENTATION: 8 BITS A/D  
12 BITS ARITHMETIC

TIME  $n$

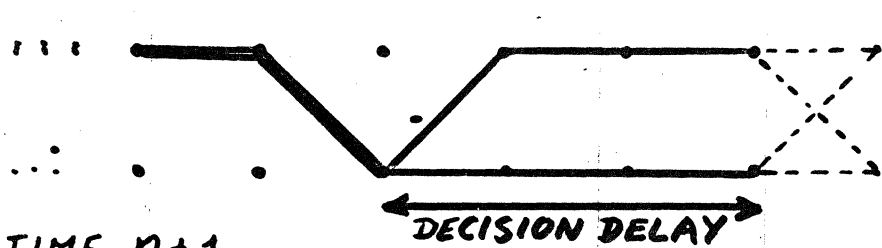

+ 1 "H"  
- 1 "L"

TIME  $n+1$

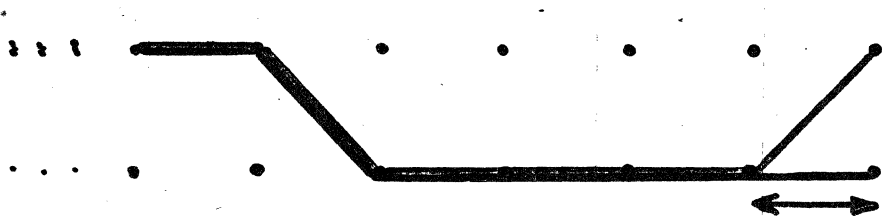

+ 1 "H"  
- 1 "L"

TIME  $n+2$

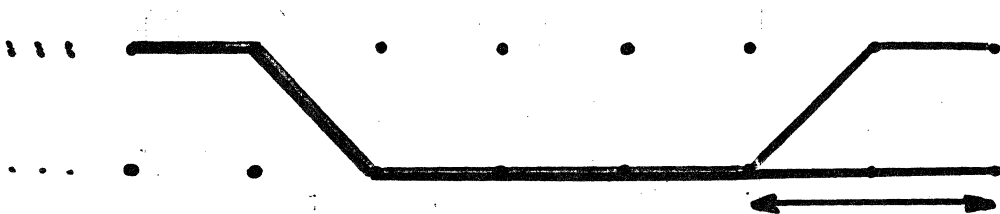

+ 1 "H"  
- 1 "L"

IMPLEMENTATION

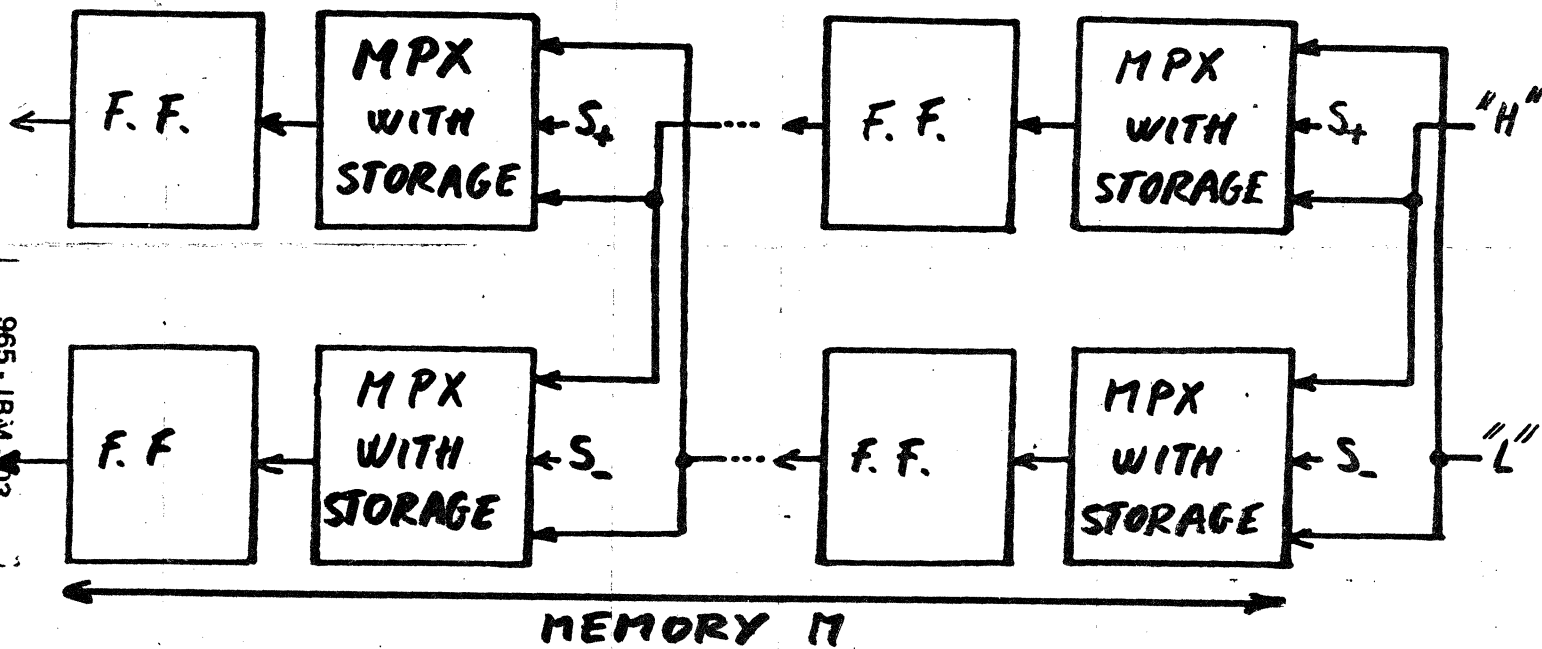

DECISION

LAST BIT OF ONE OF THE SURVIVOR SEQUENCES

965 - IBM 702

FOR UNCORRELATED INPUT DATA

### INFINITE MEMORY

$$P_E = P_{E\infty} = 4 Q(\sqrt{SNR})$$

$$SNR = 2 E(a^2) / \sigma^2,$$

$$Q(x) = 1/\sqrt{2\pi} \int_x^\infty e^{-y^2/2} dy$$

SNR : SIGNAL/NOISE RATIO AT CHANNEL OUTPUT

$\sigma$  : r.m.s VALUE OF NOISE

### FINITE MEMORY M

$$P_E \cong P_{E\infty} + P_{EM}$$

$$P_{E\infty} = P_E \text{ WITH INFINITE MEMORY}$$

$$P_{EM} = P_E \text{ DUE TO SURVIVOR SEQUENCES WHICH DO NOT MERGE WITHIN THE MEMORY LENGTH } M$$

$$P_{EM} = 2^{-(1+M/2)} \sum_{N=1}^{\infty} \frac{N}{N+M/2} 2^{-N}$$

EXAMPLE: FOR  $P_E \cong 10^{-6}$  THEN ONE SHOULD HAVE  $P_{EM} \cong 10^{-8}$

THIS WOULD REQUIRE A MEMORY LENGTH  $M = 44$

o **PROBLEM:** FOR UNCORRELATED INPUT DATA, THE MEMORY LENGTH IS TOO LARGE. FURTHERMORE, FOR ANY GIVEN MEMORY LENGTH, THERE WILL ALWAYS BE SOME SPECIFIC SEQUENCES WHICH CANNOT BE CORRECTLY RECEIVED

o **SOLUTION:**  $k/k+1$  BLOCK CODES ( $k=8$  OR  $9$ ) WHICH ELIMINATE UNDESIRABLE SEQUENCES AND ENFORCE MERGING OF THE SURVIVOR SEQUENCES WITHIN A MEMORY LENGTH  $M=12$

THESE CODES FURTHER CONCENTRATE THE ENERGY IN THE TRANSMISSION BAND AND INSURE TRANSITIONS FOR CLOCKING RECOVERY

IDEA: ELIMINATE SEQUENCES OF THE TYPE

...  $x_1 y x_2 y x_3 y x_4 y x_5 y$  ...

$x_i = 1 \text{ OR } 0$  ;  $y = 1 \text{ OR } 0$

TECHNIQUE:

1) ELIMINATE ALL CODE WORDS WITH  
IDENTICAL SYMBOLS IN THESE POSITIONS

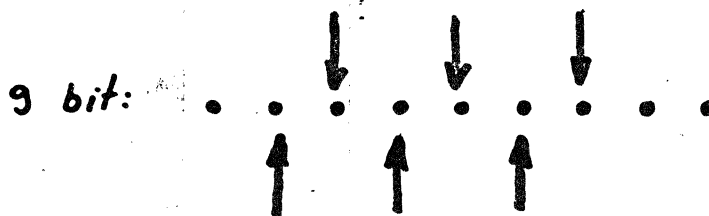

2) ELIMINATE ALL CODE WORDS WITH  
IDENTICAL SYMBOLS IN THESE POSITIONS

$$(2^3 - 2)(2^3 - 2)2^3 = 288 \text{ CODEWORDS REMAIN}$$

3) ELIMINATE

001100110	WHICH ARE
011001100	RESERVED
110011001	FOR PREAMBLE
100110011	

4) ELIMINATE 28 CODE WORDS AT WILL -  
COULD BE USED FOR SPECIAL PURPOSES

9/10 CODE CAN BE CONSTRUCTED IN THE SAME WAY SUCH THAT THE 8/9 CODE  
IS OBTAINED FROM THE 9/10 CODE BY DROPPING THE FIRST BIT

BOTH THESE CODES REQUIRE A MEMORY LENGTH OF  $M = 12$  ONLY

# BLOCK SYNCHRONIZATION

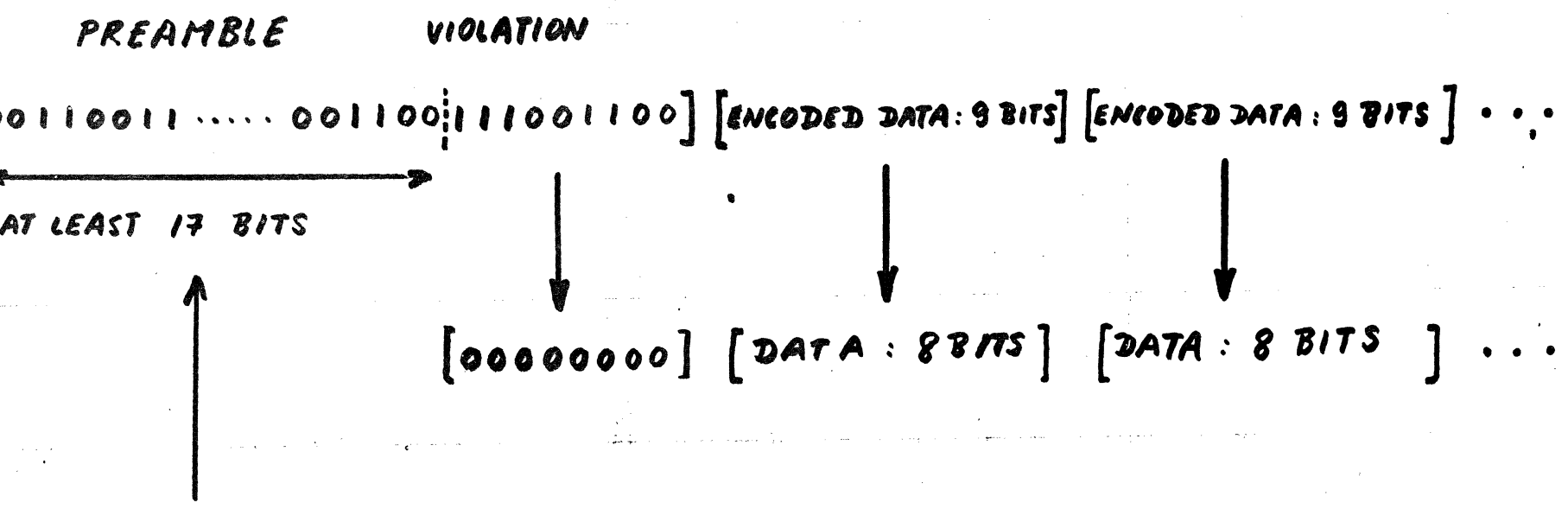

ALSO USED FOR INITIAL  
LOCKING ACQUISITION

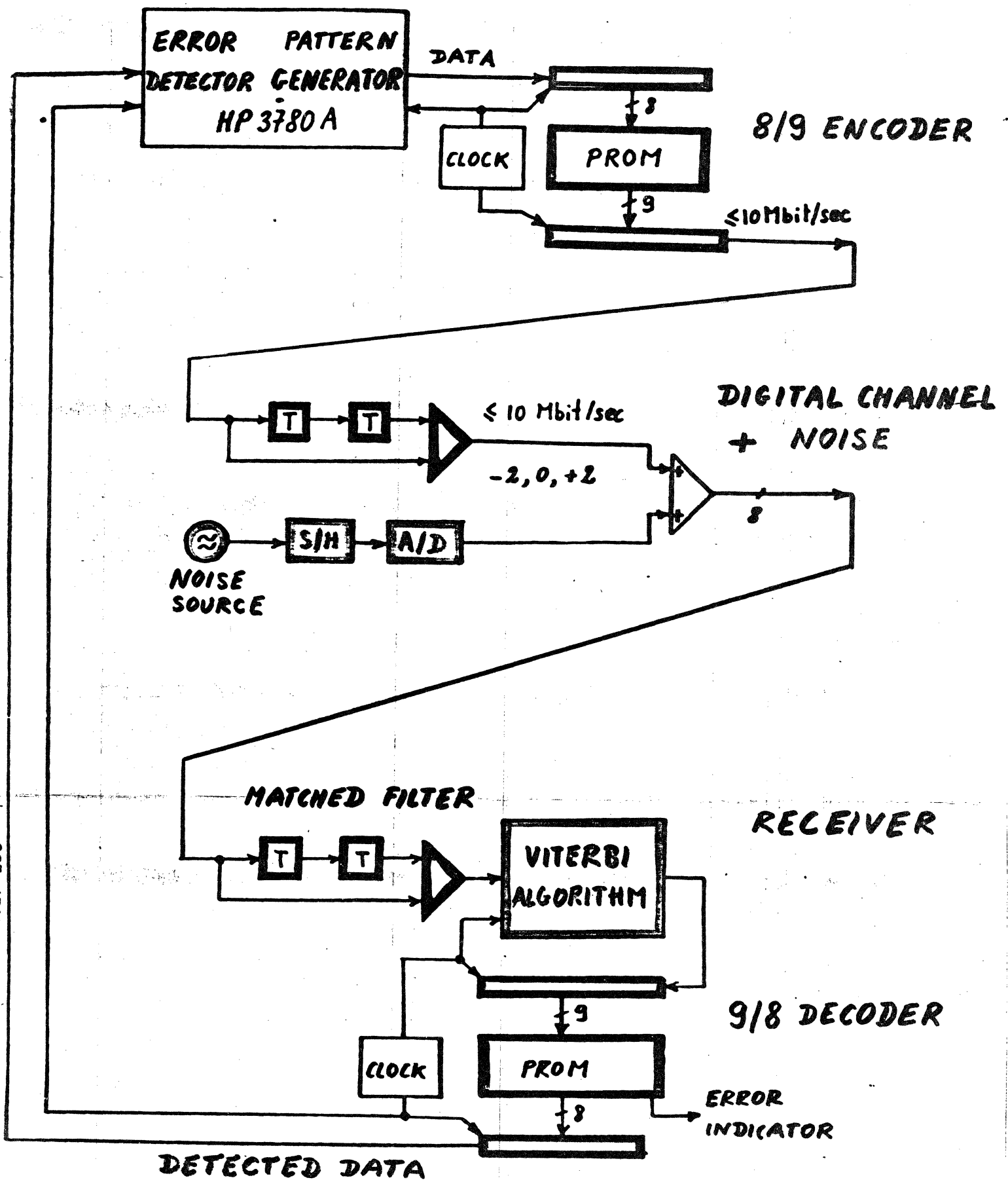

965 - IBM - 02

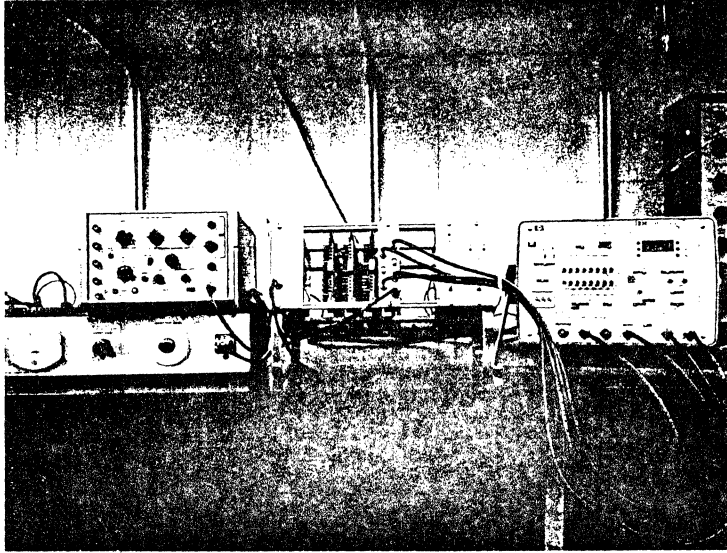

METRIC  
UPDATING

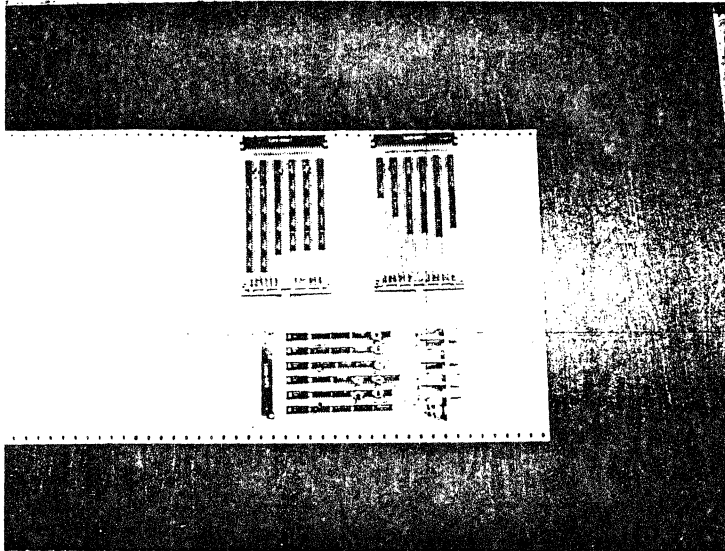

PRECOMPUTATION  
+  
SURVIVOR SEQUENCES  
UPDATING

819 ENCODER/DECODER

RESENT STEP:

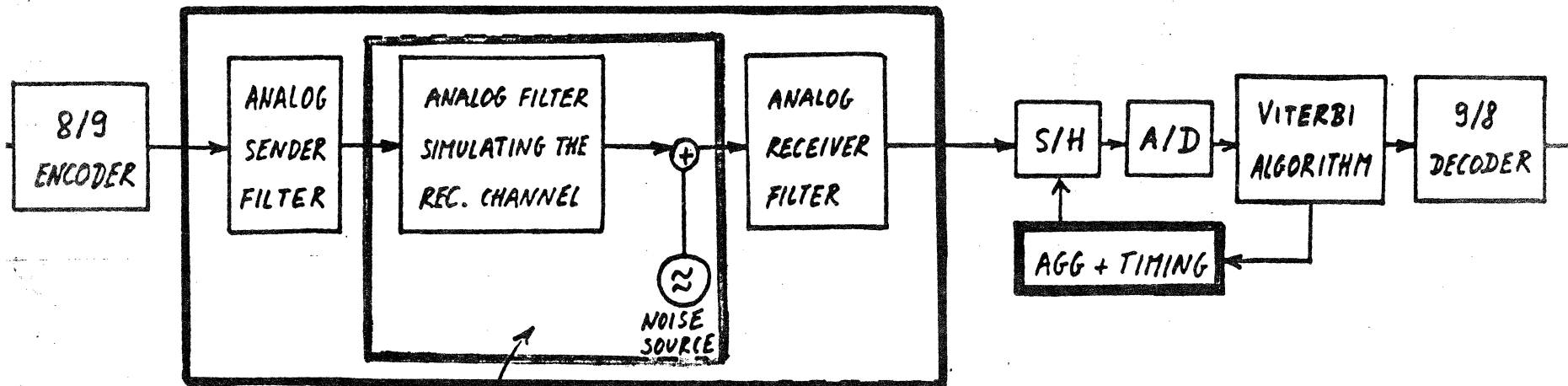
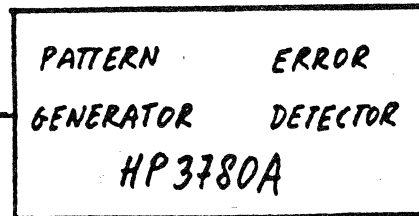

FINAL STEP: REPLACE THIS BOX BY AN ACTUAL RECORDING CHANNEL

ANALOG FILTER SIMULATING RECORDING CHANNEL: COMPLETED

SENDER AND RECEIVER FILTERS: DESIGNED - IN CONSTRUCTION



# FILTER DESIGN

## APPROXIMATION METHOD

REFERENCE:  $H_R(f)$

APPROXIMATION:  $H_A(f) = g \cdot \frac{\prod_{n=1}^{N_z} (j2\pi f - z_n)}{\prod_{n=1}^{N_p} (j2\pi f - p_n)}$

$z_n$ : ZERO  
 $g$ : GAIN  
 $p_n$ : POLE

THE FLETCHER/POWELL CONJUGATE GRADIENT METHOD IS USED TO FIND THE GAIN  $g$ , THE ZERO'S  $z_n$ , THE POLES  $p_n$  AND THE TIME DELAY  $t_0$  WHICH MINIMIZE THE COST FUNCTION

$$\sum_i \left\{ W(f_i) \left[ H_R(f_i) - H_A(f_i) e^{j2\pi f_i t_0} \right] \right\}^P$$

WHERE  $W(\cdot)$  IS A WEIGHTING FUNCTION

EXAMPLE: ACE CHANNEL (POLARIS XI)

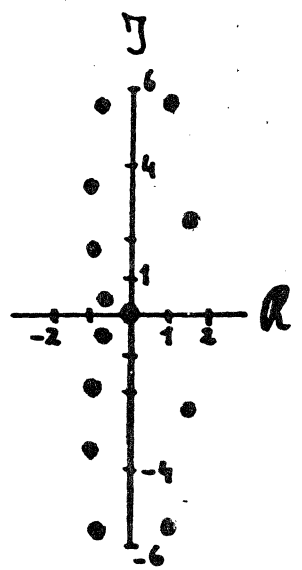

<u>ZERO'S</u>	<u>POLES</u>
0	$-0.7 \pm j 0.46$
$1.5 \pm j 2.54$	$-0.8 \pm j 5.6$
$1 \pm j 5.62$	$-1.1 \pm j 1.75$
	$-1.17 \pm j 3.51$

GAIN: 8.57

# CHANNEL FILTER: AMPLITUDE

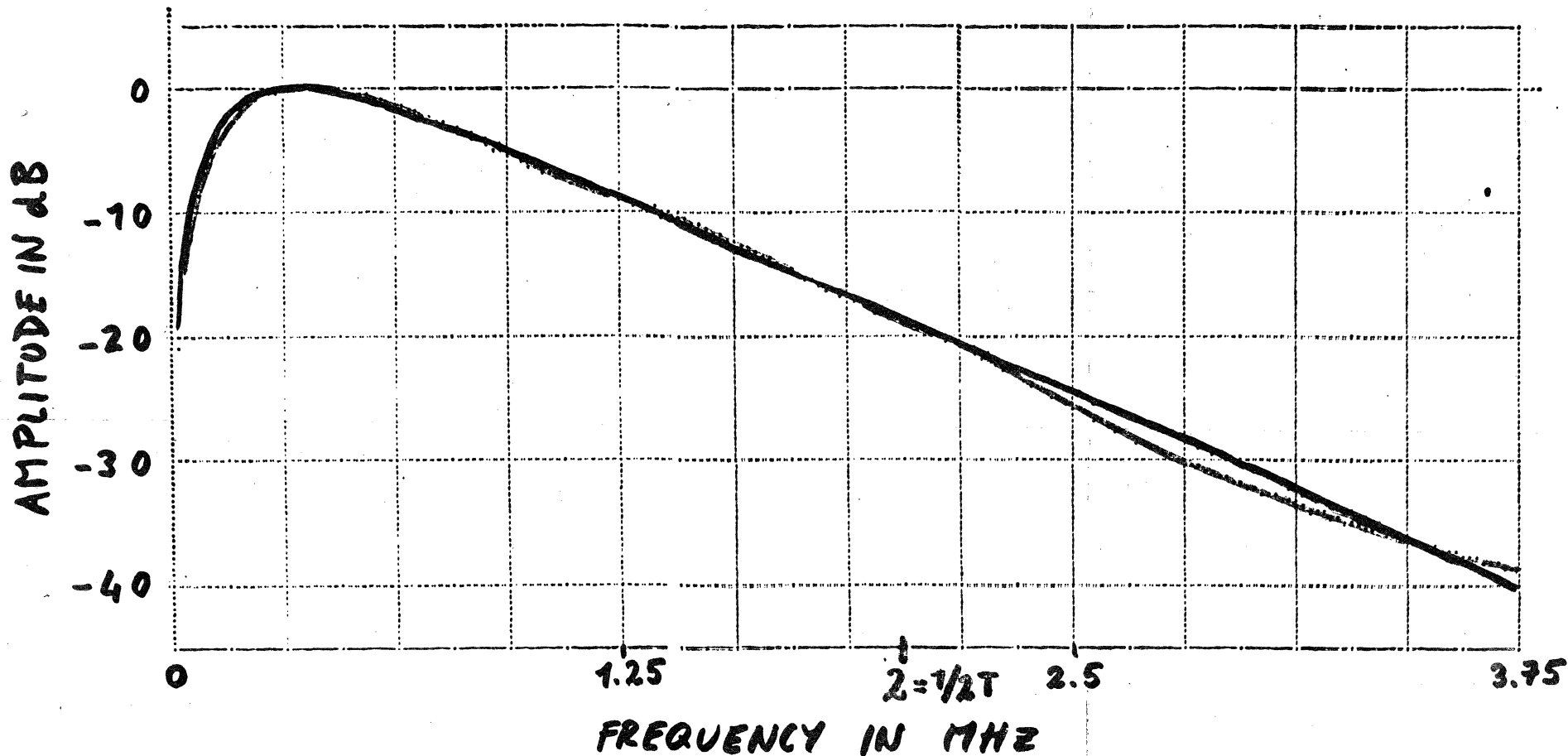

CHANNEL FILTER

— REFERENCE (ACE)

— 8TH-ORDER APPROXIMATION

# CHANNEL FILTER : PHASE

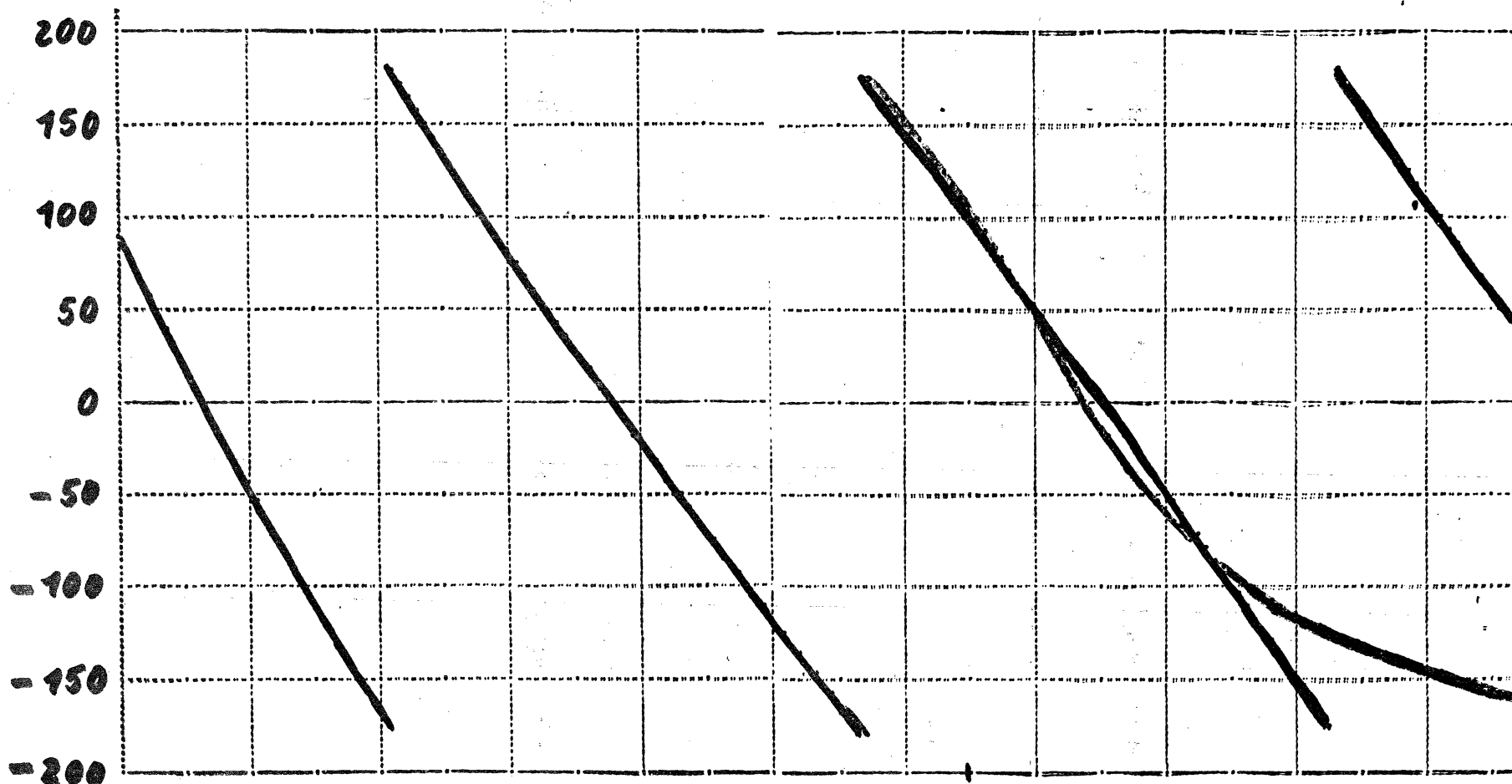

1.25      2 = 1/2T      2.5  
FREQUENCY IN MHZ

CHANNEL FILTER

— REFERENCE (ACE)

— 8<sup>TH</sup>-ORDER APPROXIMATION

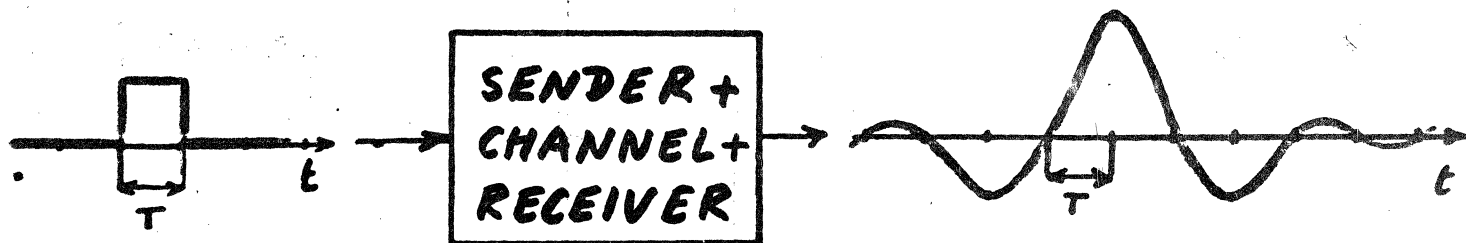

$$\text{SENDER} \times \text{RECEIVER} = \begin{cases} \frac{4\pi f T \sin^2(2\pi f T)}{\sin(\pi f T)} \times \frac{1}{\text{CHANNEL}} & f < 1/2T \\ 0 & \text{OTHERWISE} \end{cases}$$

CAN BE ACCURATELY APPROXIMATED BY 10<sup>TH</sup>-ORDER FILTER.

POLES/ZERO'S CONFIGURATION : 0 ZERO  
+ POLE

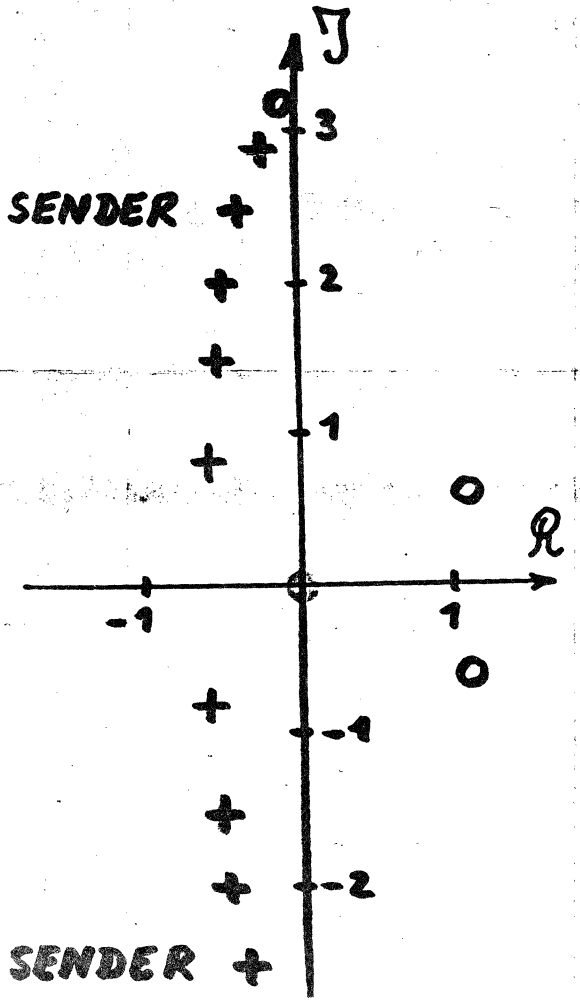

- o + : NOTCH
- + : LOW PASS
- o + : BANDPASS
- o + : ALL PASS

965-1244-02

SENDER: 2ND. ORDER LOW PASS

FD20

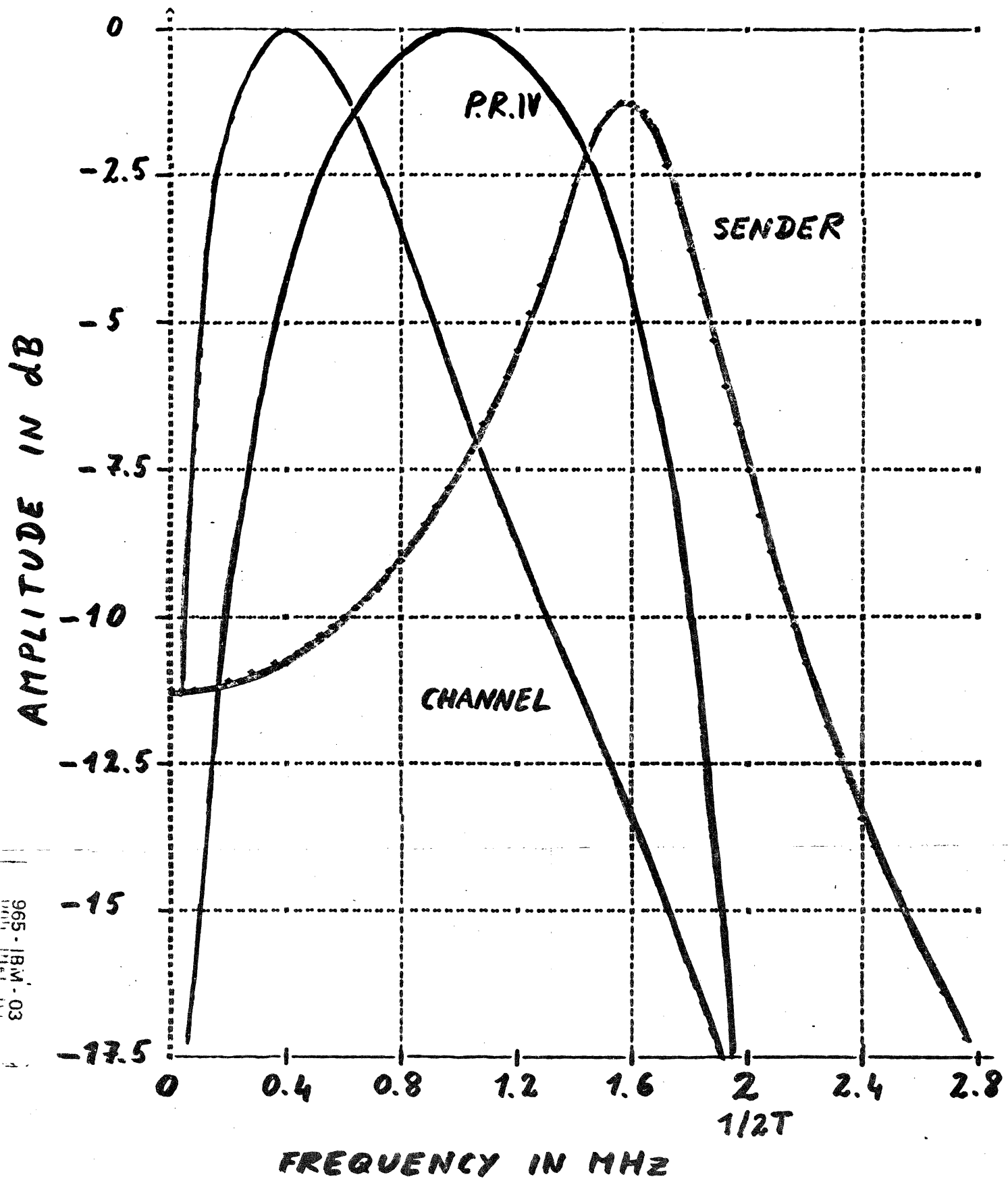

DATA RATE: 4 MBITS/S

965-18W-03

# RECEIVER: 8<sup>th</sup>-ORDER FILTER

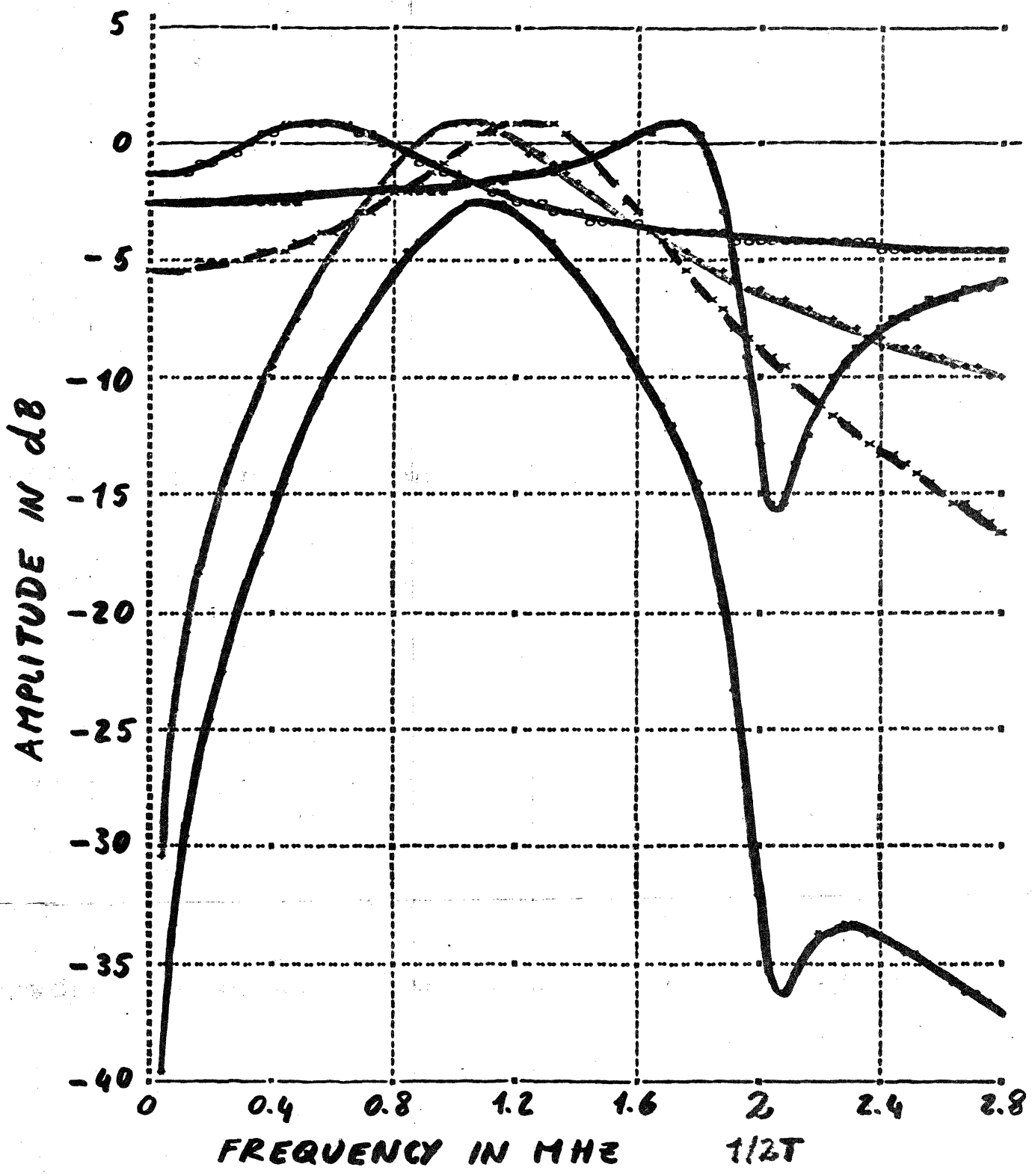

— RECEIVER: 4 x 2ND-ORDER SECTIONS  
 - - - BANDPASS      . . . LOW PASS

# RECEIVER : 8<sup>th</sup> - ORDER FILTER

FD22

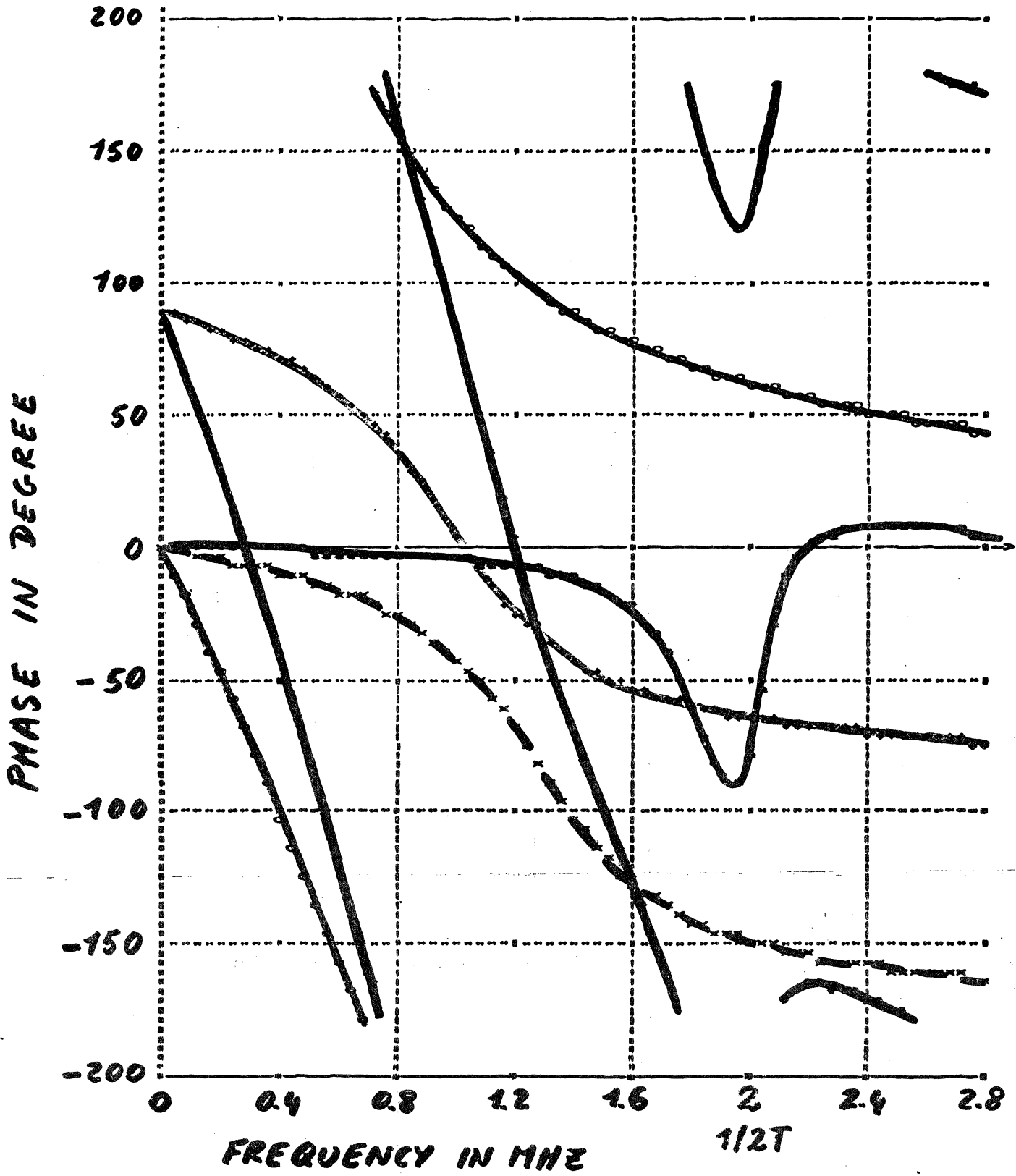

- RECEIVER = 4 x 2ND-ORDER SECTIONS
- BANDPASS
- ~ ALL PASS
- LOW PASS
- ~ NOTCH

965 - BM - 03

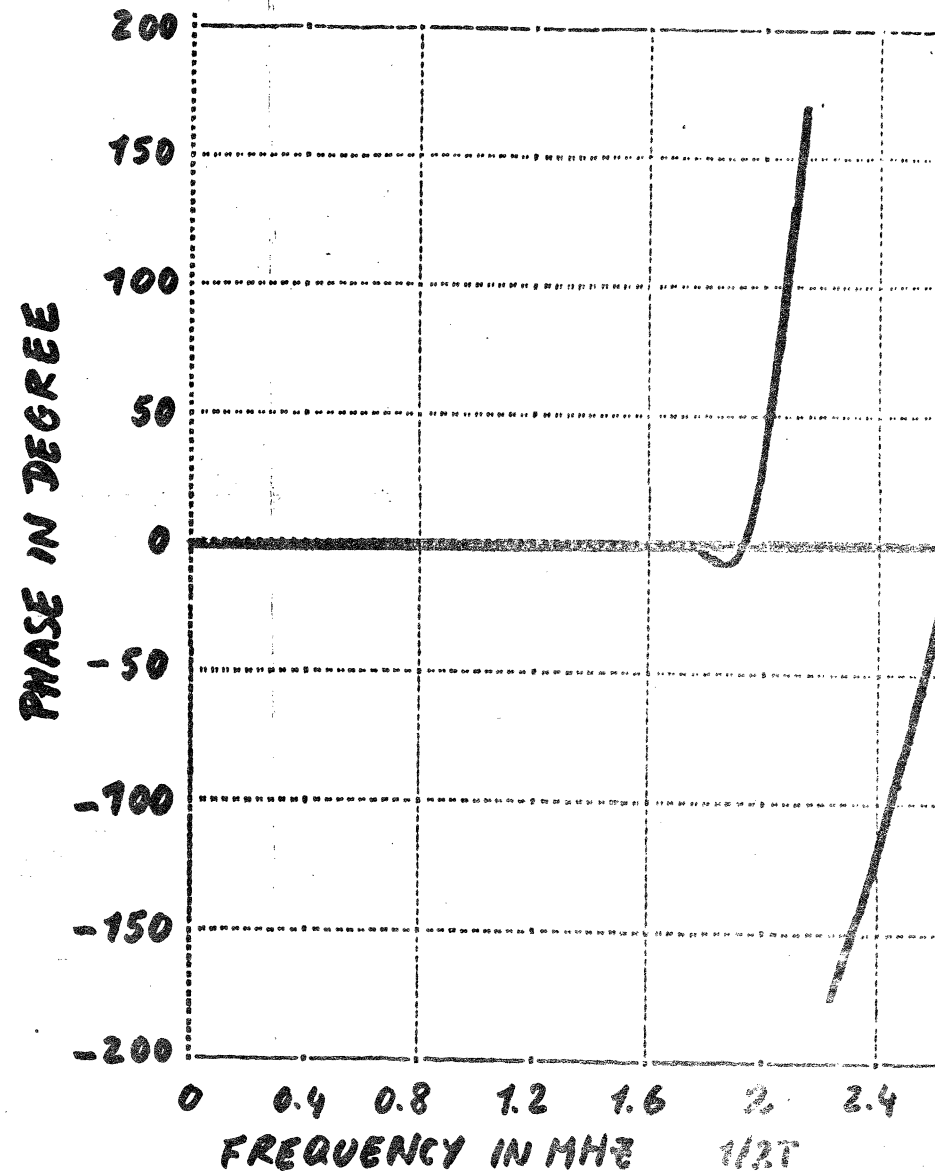
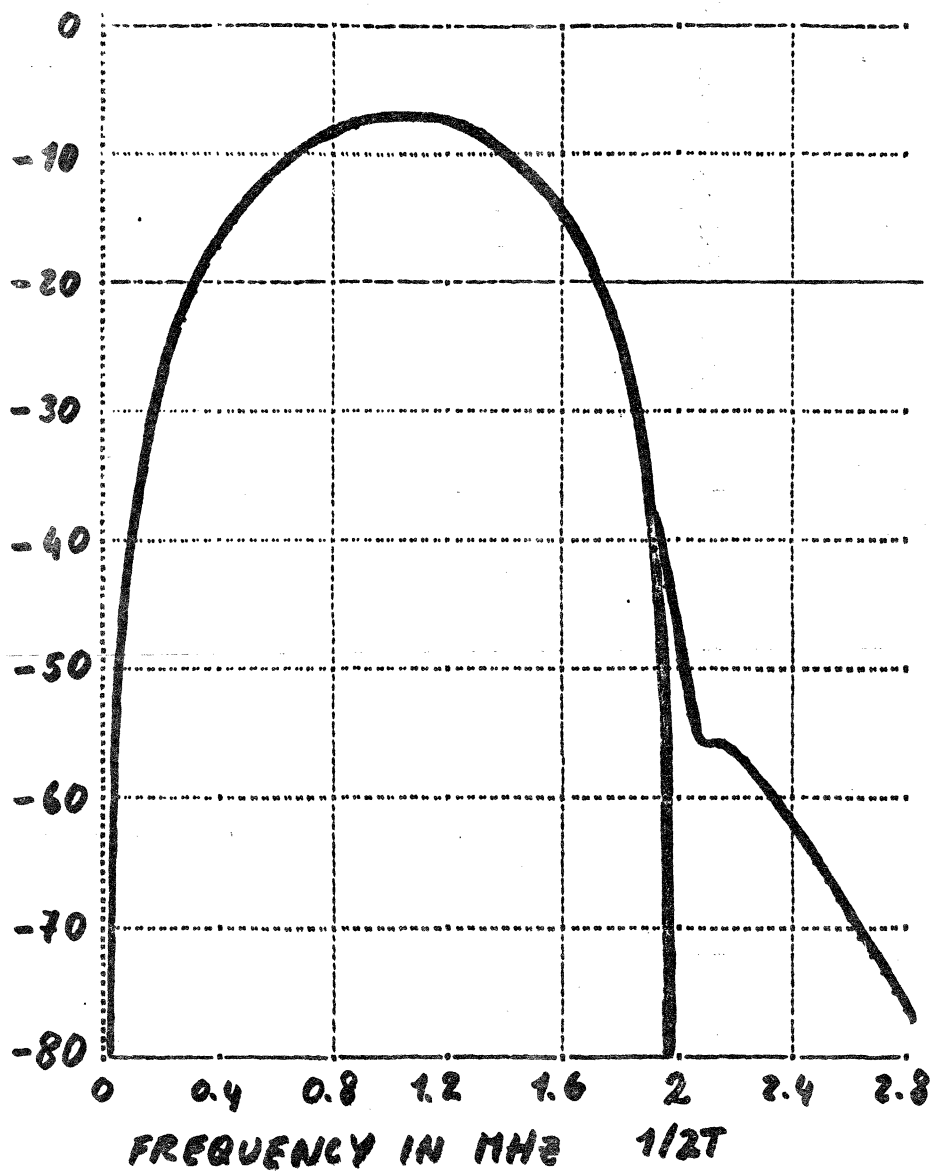

SENDER x CHANNEL x RECEIVER

— DESIRED RESPONSE

— 10TH-ORDER APPROXIMATION



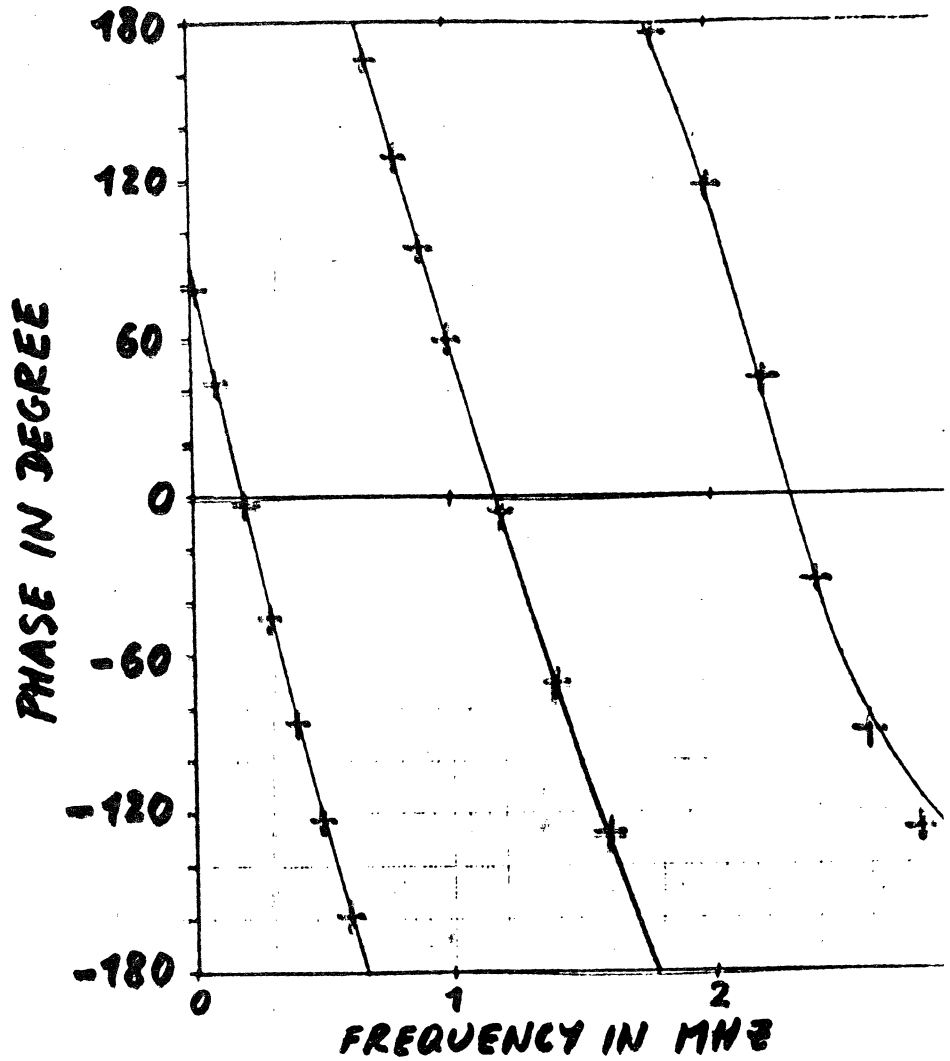
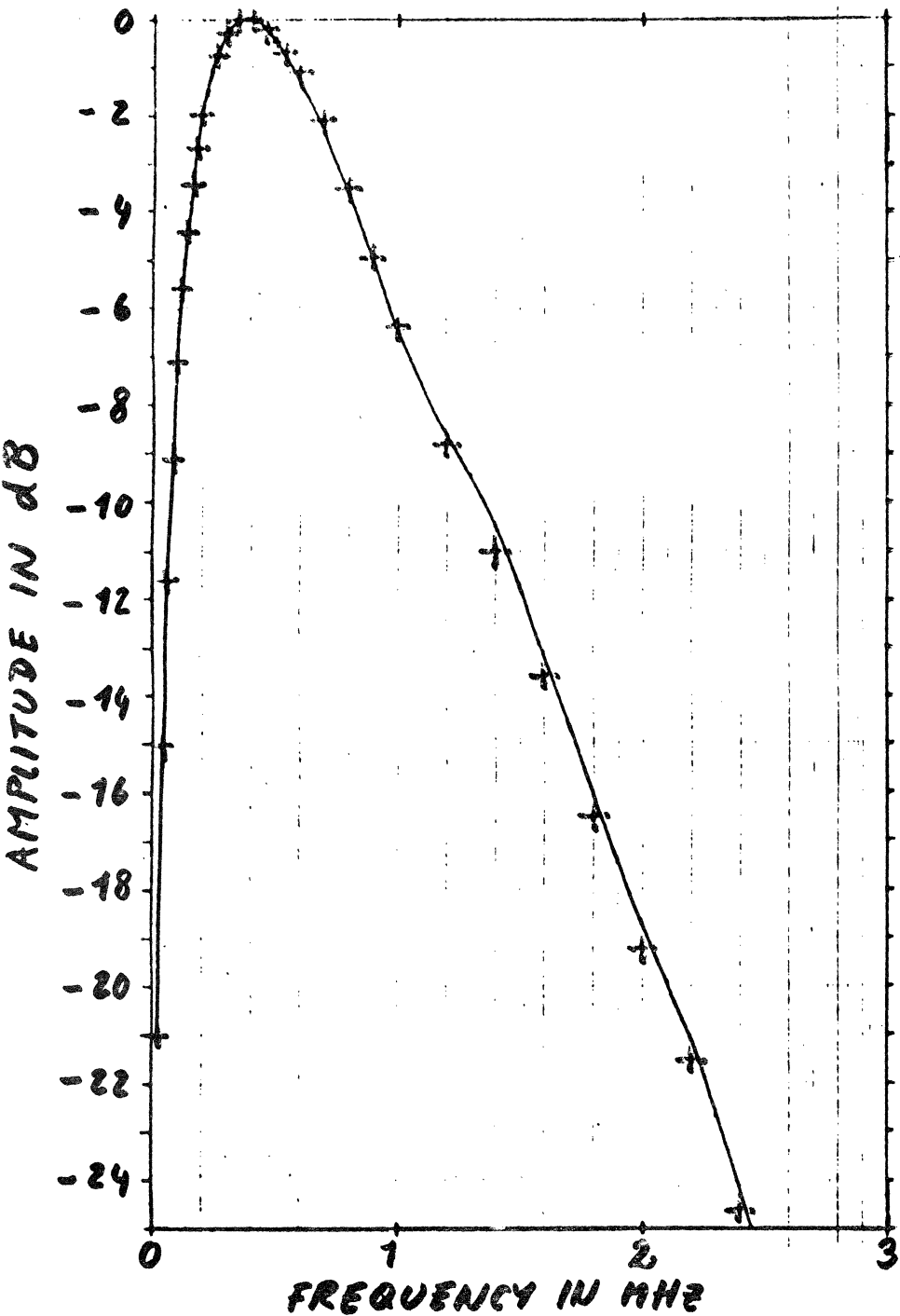

IMPLEMENTATION: CHANNEL FILTER  
 — 8<sup>TH</sup>-ORDER APPROXIMATION  
 + MEASUREMENT

# PARTIAL RESPONSE IV: SYNCHRONIZATION

• ACQUISITION BY CLOCKING SEQUENCE: | 1-1-1 | 1-1-1 | 1-1-1 | ...

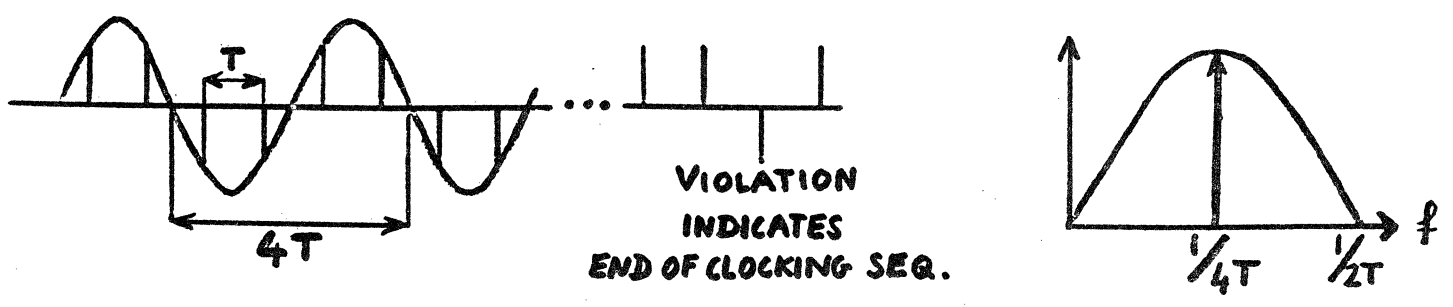

• DECISION-AIDED DURING DATA-TRANSMISSION

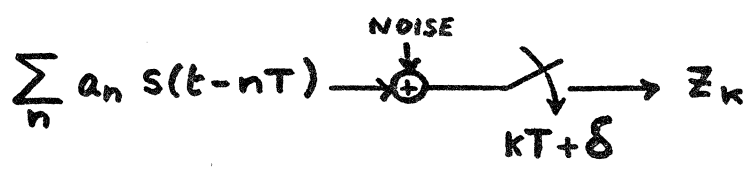

- GOAL: FIND  $\delta$  WHICH MINIMIZES THE MEAN-SQUARED ERROR  $E\{e_k^2\}$  WHERE  $e_k = z_k - \text{DESIRED RESPONSE}$

- GENERAL SCHEME:  $\delta_{k+1} = \delta_k - \gamma e_k \sum_n \{ a_{k-n} \frac{d}{dt} s(t) |_{t=nT} \}$

- PARTIAL RESPONSE IV:

$$\delta_{k+1} = \delta_k - \gamma e_k (a_{k+1} - a_{k-1})$$

$$e_k = z_k + a_{k+2} - 2a_k + a_{k-2}$$

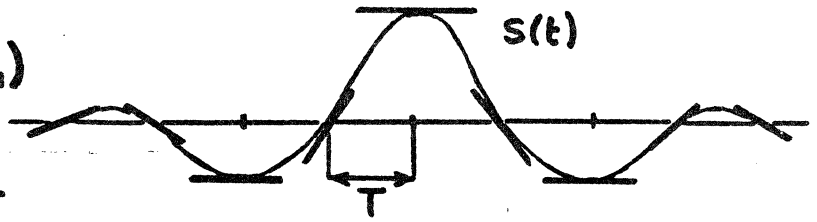

IMPLEMENTATION:

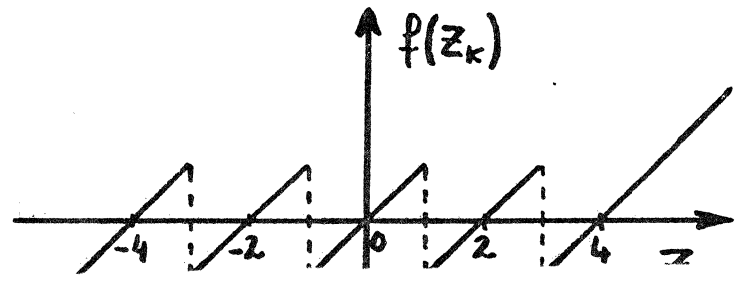
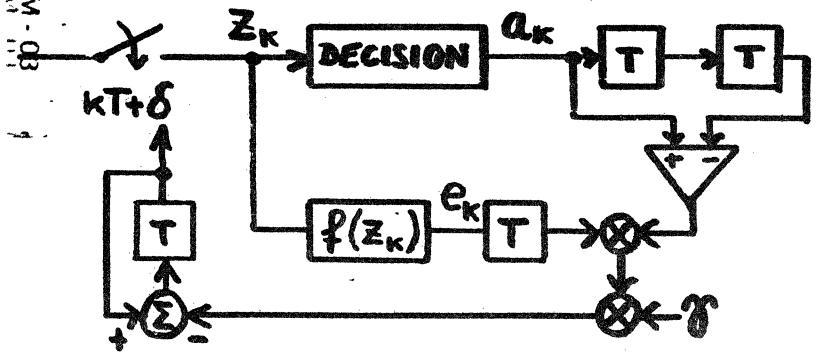

965-IBM-03

# COUNTERING

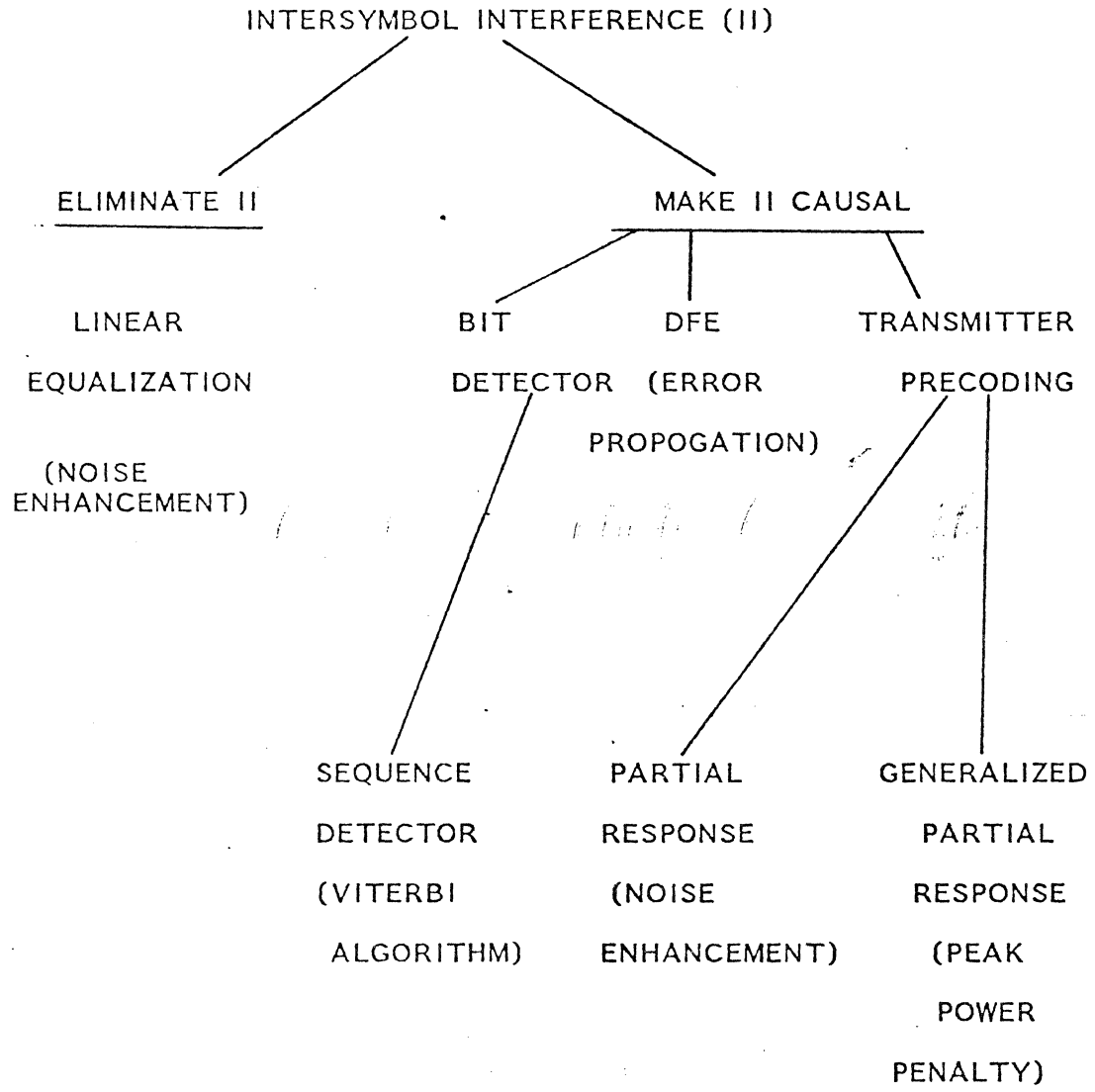

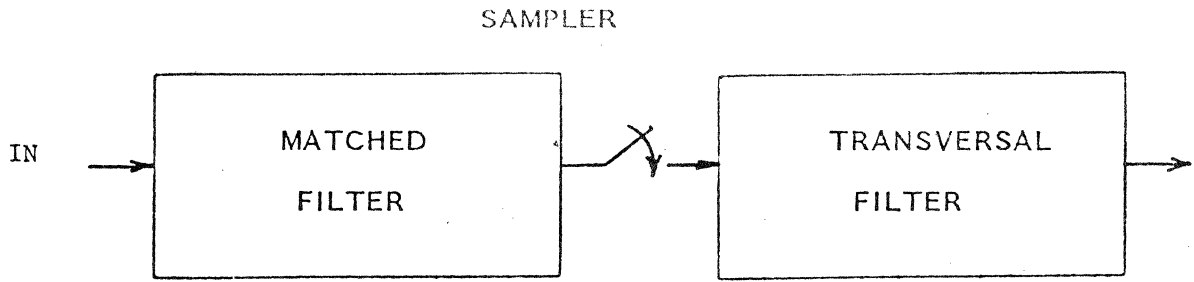

A) LINEAR EQUALIZER OR WHITENED MATCHED FILTER

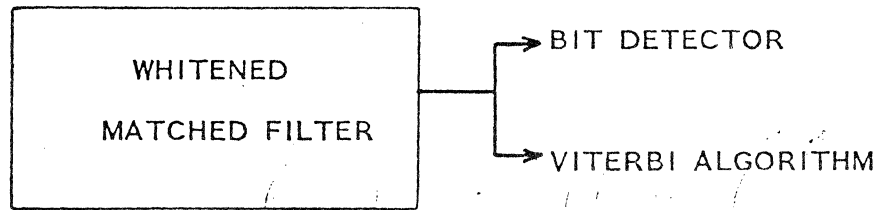

B) MINIMUM PROBABILITY OF ERROR METHODS

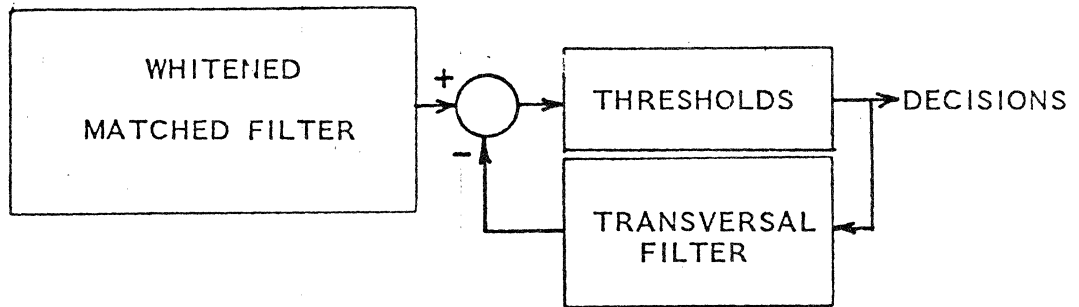

C) DECISION-FEEDBACK EQUALIZER

METHODS OF COUNTERING INTERSYMBOL INTERFERENCE

FIGURE 2.

10 5/8

# DECISION-FEEDBACK EQUALIZATION

RATHER THAN EQUALIZE TO:

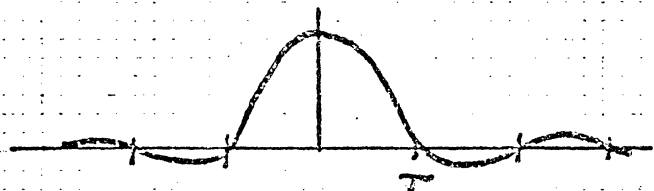

EQUALIZE INSTEAD TO:

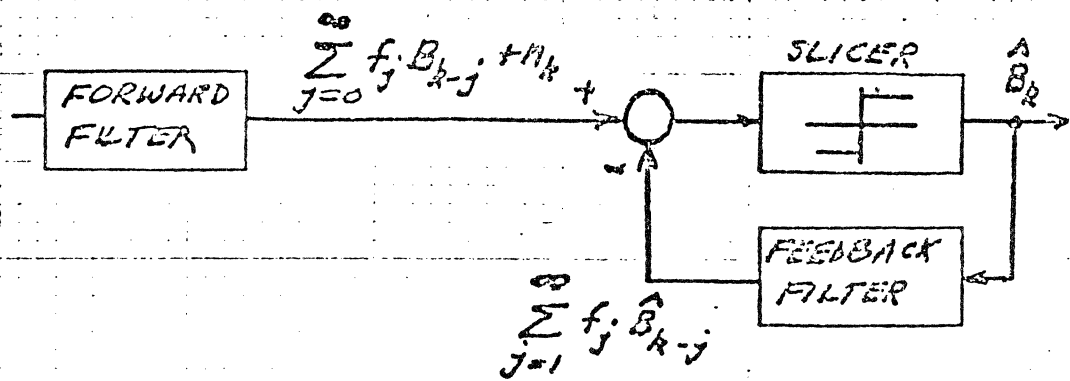
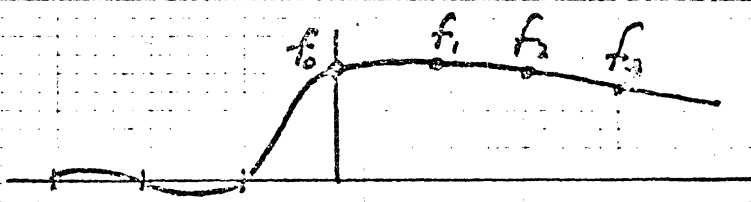

965-181M-06

ISSUE	ENGR	TITLE	BELL TELEPHONE LABORATORIES INCORPORATED	
	DRAWN		SHEET	
			NO. OF SHEETS PER SET	

64

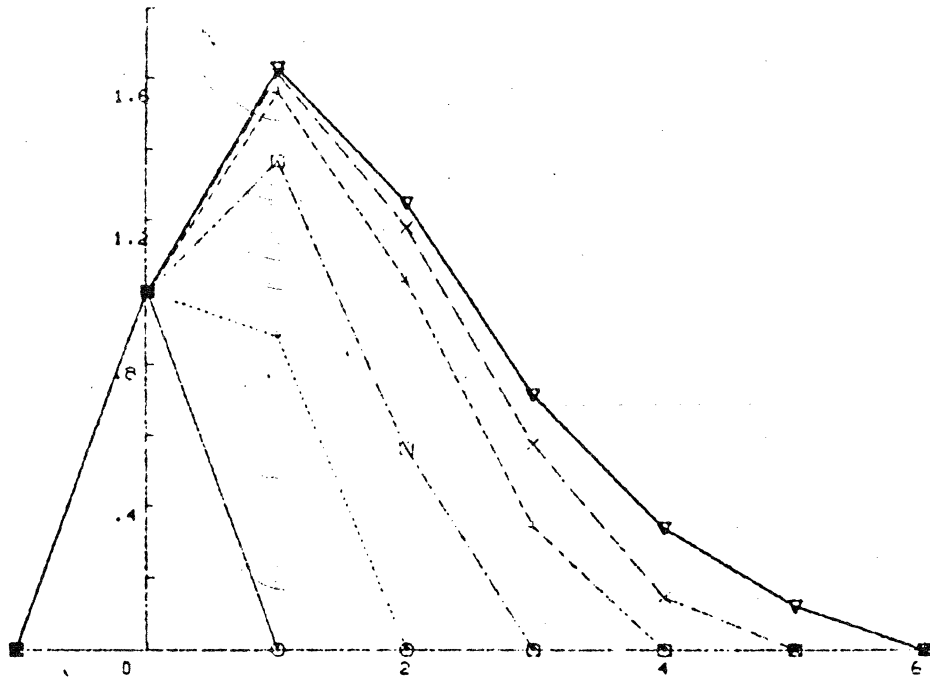

PULSE SHAPES FOR DECISION FEEDBACK

dB over  
matched filter

U

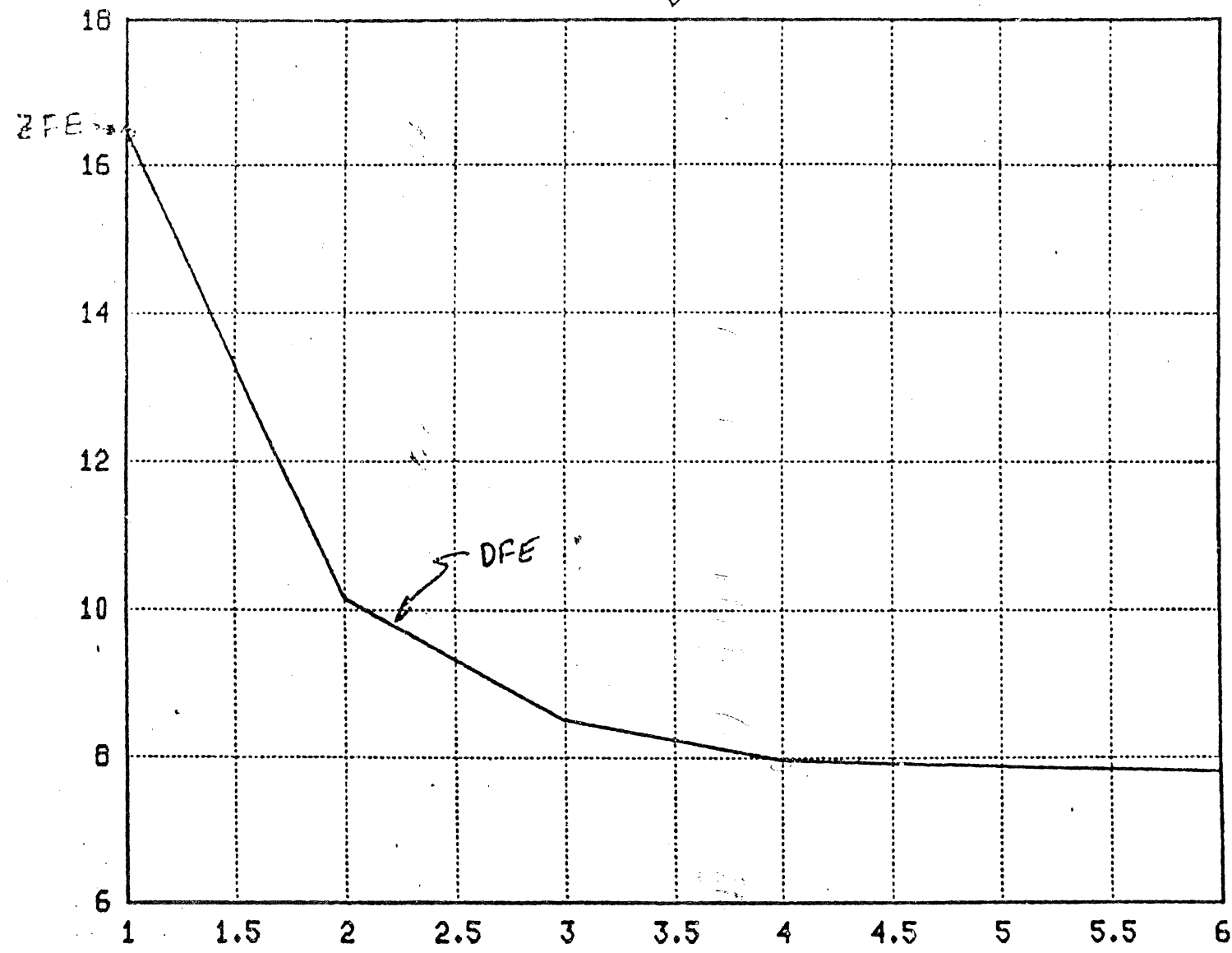

TUESDAY, JUNE 17, 1969 2:25 P.M.

MESAB1 37ns = T

65

# DIBIT PEAK SHIFT DISTRIBUTIONS

OBSERVED      - - - - -  
PREDICTED      \_\_\_\_\_

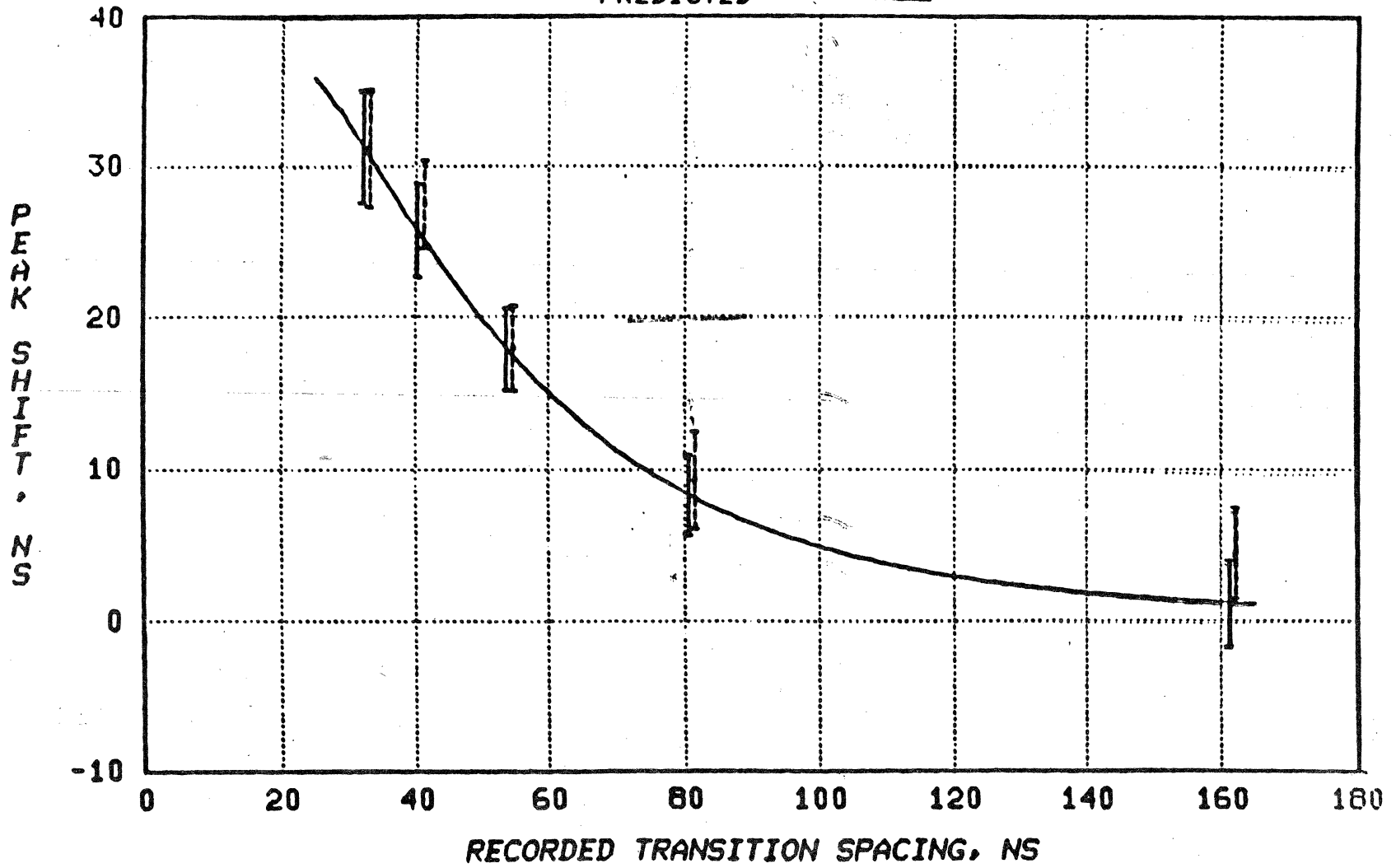



### DEALING WITH ISI

19 KBPI

<b>ISI STRATEGY</b>	<b>MARGIN</b> $\sigma$
<b>ELIMINATE</b>	3.9
<b><u>PARTIALLY ELIMINATE</u></b>	<u>6.2</u>
<b>DECISION FEEDBACK</b>	9.2
<b>SEQUENCE ESTIMATION</b>	13

965-IBM-06

Sampling Methods for Countering Intersymbol  
Interference in Magnetic Recording

One method of countering the effects of intersymbol interference in magnetic recording, which is a departure from past practice, is to use a sampling detector rather than peak-picking algorithms. In fact, the sampling detector has been used most frequently in telecommunications systems with intersymbol interference.

Figure 1 shows a summary of these sampling methods. The most common method is to eliminate the intersymbol interference entirely through use of a linear equalization filter. This filter simply amplifies high frequencies to precisely compensate for the high frequency attenuation of the channel. This is, of course, at the expense of amplification of noise (the so-called noise enhancement). The optimum (minimum noise enhancement) technique in the presence of additive Gaussian noise is to first apply a filter matched to the basic pulse shape, sample the output at the pulse rate, and use a transversal filter (tapped delay line) to remove the intersymbol interference, as shown in Figure 2a. The result is a pulse shape which does not interfere with its neighbors, and hence a simple threshold can be applied to the output to make the data decision.

The remaining techniques all fall into the class of algorithms in which a linear filter is used not to eliminate the intersymbol interference, but rather to make it causal.

By causal we mean that the pulse shape consists of a main lobe (on which the decision is made) followed by residual intersymbol interference, as shown by a typical pulse of this type on Figure 1. The optimum such filter consists again of a matched filter, sampler, and transversal filter, and is often called a "whitened matched filter". Figure 2a again represents this filter, the only difference with the optimum linear equalizer being in the choice of tap weights in the transversal filter. The causality of the resulting intersymbol interference makes the subsequent processing simpler. One way to look at the whitened matched filter is as a phase-only filtering (which is strictly speaking true only if aliasing effects are ignored) which does not enhance the noise. The subsequent processing is then nonlinear, resulting in less noise enhancement than with linear equalization. Hence, this class of techniques gives uniformly better performance (as measured by error rate in the presence of additive Gaussian noise) than the linear equalizer.

The two most sophisticated techniques in this class are the "bit detector", and the "sequence detector" or "Viterbi algorithm", shown in Figure 2b. The bit detector is the processing which minimizes the probability of a bit error. This processing is quite complicated, and is therefore not practical. The sequence detector gives comparable performance to the bit detector at high signal-to-noise ratios, and is the processing which minimizes the probability of one

70

or more errors occurring in a long sequence of bits (this criterion is actually more appropriate than probability of bit error in systems which use block error control techniques). The sequence detector can be mechanized with a dynamic programming algorithm called the Viterbi algorithm, and can be practically implemented (although it is still more complicated than the other techniques yet to be mentioned).

The remaining techniques on Figure 1 all trade a simpler implementation relative to the sequence detector for poorer error rate performance. They compensate for the causal intersymbol interference in either the transmitter ("transmitter precoding") or the receiver ("decision feedback equalization" or "DFE"). In the DFE, shown in Figure 2c, the decisions are made as in the linear equalizer by a threshold, and are fed back through a transversal filter which replicates the causal intersymbol interference to cancel the intersymbol interference in future decisions. If an incorrect decision does occur due to noise, this causes the incorrect value to be fed back, and results in lower margin against noise at future decisions (or in the case of severe intersymbol interference, future errors even in the absence of noise). This is called "error propagation", and is one price paid for the simplicity of the technique.

Transmitter precoding is similar to the DFE, except that the compensation for the causal intersymbol

interference is done in the transmitter rather than the receiver, thus eliminating the error propagation. In "partial response", the channel must be equalized to integer-valued samples, resulting to some noise enhancement relative to the optimal whitened matched filter which is used for the DFE. Except for this noise enhancement, the performance is identical to the DFE, but without error propagation. In "generalized partial response", the requirement for integer-valued samples is eliminated (and hence so is the noise enhancement penalty relative to the DFE), but there is a doubling in the peak transmitted voltage. This results in a 6 dB penalty in systems with limited peak transmitted power.

Of these techniques, the linear equalizer, DFE, and Viterbi algorithm are being investigated for the magnetic recording channel. In particular, the DFE and Viterbi algorithm have shown a substantial advantage over linear equalization on this channel. However, when off-track performance is considered, where there is crosstalk from other channels, the situation changes somewhat. The equalization to a broader on-track causal pulse shape causes a broadening of the crosstalk pulse shape also, and this cannot be compensated for by the DFE or Viterbi algorithm. Hence, the optimum DFE and Viterbi algorithm pulse shapes in the presence of synchronous crosstalk is currently under investigation.



AN EVENT-DRIVEN MAXIMUM-LIKELIHOOD PEAK POSITION DETECTOR  
FOR RUN-LENGTH-LIMITED CODES IN MAGNETIC RECORDING

H. Burkhardt

IBM Research Laboratory, San Jose, California 95193  
On leave from the Institut für Mess- und Regelungstechnik  
University of Karlsruhe, Germany

Introduction

Many of the current digital magnetic recording devices use a peak position data detector, making a local decision with respect to a given data-derived clock window. As a consequence of an increased linear density with large intersymbol interference (ISI) and peak shifts more sophisticated linear and nonlinear detection schemes will be necessary which take advantage of the correlation between the pulses. Besides equalization and decision feedback the maximum-likelihood sequence estimation applied to pulse amplitude detection (PAM) [1] seems to give superior performance. As an alternative this invention will describe a Viterbi detector [2] working on pulse position data (PPM). This detector could be added to current products without redesigning the whole magnetic readback channel. Due to the nonlinearity of the PPM-channel and the fact that the restrictions of run-length-limited (RLL) codes [3] will be imbedded, the design and analysis will differ from known results.

Theoretical Background

For the sake of clarity the following derivations will be made for a MFM-code but could easily be extended to other RLL-codes.

The ideal peak positions of written magnetic transitions in saturated recording  $\{t^n\}$  are distorted by ISI and become

$$t'^n = t^n + \tau^n \quad (1)$$

where the  $\{\tau^n\}$  are functions of the correlated environment. The distances between subsequent peak positions will be

$$\Delta t'^n = t'^{n+1} - t'^n = \Delta t^n + \Delta \tau^n \quad (2)$$

These peak positions or the corresponding differences may be modelled as nonlinear observations of a discrete Markov process, Fig.1. Using the distances between peaks  $\{\Delta t^n\}$  makes the scheme independent from phase offset or phase jitter of the timing recovery. For the MFM-code with run-length constraints ( $d=1, k=3$ ) we get the following possible distances

$$\Delta t^n \in \{ \Delta t_0 = 2, \Delta t_1 = 3, \Delta t_2 = 4 \} \quad (3)$$

This is a normalized notation in multiples of  $T_c$  which denotes the time interval between subsequent transitions of the clock. For the following example a ISI-range of  $\pm 4T_c$  is taken into consideration.

Defining the states of the discrete Markov model with a fixed number of events, namely the maximum number of  $\Delta t$ 's which fall into the ISI-range (in our case 4), we would get a Viterbi-trellis in analogy to a three-level ( $B=3$ ) PAM-scheme and  $3^4=81$  states. This scheme, however, would be highly redundant

because in most cases only two subsequent  $\Delta t_i$ 's are sufficient to define the corresponding peak shift.

To reduce that complexity the states of the discrete model are defined by all the combinations  $\{\Delta t_1, \Delta t_2, \dots\}$  which fall into the ISI-range. Consequently this gives in contrast to PAM a dynamic influence range. For the chosen example we get the decision trellis of Fig. 2 with 16 states

$$\{x_i\} = \{(4,4); (4,3); (4,2); (4,22); \dots; (22,22)\} \quad (4)$$

and 48 transitions

$$\{y^{r,r+1}\} = \{(4,4,4); (4,4,3); (4,4,2); (4,4,22); \dots; (22,22,22)\} \quad (5)$$

This trellis could also be viewed as a merge of the former mentioned full-size trellis with 81 states.

It is assumed here that the discrete observations  $z^r = \Delta t^r + n^r$  coming from an appropriately designed peak detector forms a sufficient statistics. The peak positions are assumed to be distorted by additive white Gaussian noise which is a reasonable approach for high signal to noise ratios (SNR). Consequently we get an Euclidean metric for the edge weights of the trellis

$$\lambda_{i,j}^r = (z^r - \Delta t'(x_i, x_j))^2 = (z^r - \Delta t'(y^{i,j}))^2, \quad (6)$$

using the notations of [2]. For the sake of simplicity equiprobable  $\{\Delta t_i\}$  were chosen, an assumption which, however, could easily be dropped. Therefore as shown in [2] we get an optimum structure for maximum likelihood estimation of the entire transmitted sequence. Taking into account the a priori probability of the  $\{\Delta t_i\}$  would result in a maximum a posteriori estimator.

### Implementation

The implementation of a detector may be derived from the decision trellis of Fig. 2. Because of the uniform interconnection scheme of subsequent layers it is possible to implement one layer and use it recursively by feeding back the data of each cycle. Fig.3 shows the implementation flow chart for such a recursive parallel processor. The detector is event-driven. The calculations within one layer are triggered by the detection of a new peak. The implementation has to be fast enough to work on the highest possible transition rate. Digital implementations with the current technology will hardly meet the speed requirements. Analog implementations of a Viterbi detector in satellite communication [4] claim a speed which would also meet the requirements of current magnetic recording channels.

### Example and Performance

In the following, simulated data with Lorentzian readback pulses  $p(t)$  are presented. It would be easy, however, to make the calculations for different channel characteristics. For ISI a 30% amplitude drop of an isolated pulse to the next possible transition was assumed (Fig.4).

$$T_d = 2 T_c = \frac{2}{3} \tau \quad (7)$$

or

$$p(T_d) = 0.7, \quad (8)$$



where  $\eta$  represents the inflection point and  $T_d$  is the distance between data bits which in the MFM-case corresponds to the highest transition density. Fig.5 shows the computed peak shifts where the influence from outside of  $\pm 4T_c$  was truncated. Because of the symmetry of  $p(t)$  we also get a symmetric peak shift distribution which, however, is not a necessary assumption.

The worst case peak shifts turned out to be  $\pm 0.6T_c$ . So with respect to a detection window of  $\pm 0.5T_c$  we already have a closed eye pattern by 20% and consequently making local decisions an error rate of almost 100% for critical data constellations, without taking into consideration additional phase jitters of the reference clock.

The performance of the Viterbi algorithm is dominated by the minimum distance  $\delta$  in the vector space of the channel output. In contrast to linear channels the  $\delta$ -calculations turn out to be more difficult. It can be shown, however, that these calculations can efficiently be done with dynamic programming using a slightly modified Viterbi trellis. The minimum distance turned out to be

$$\delta = 0.505 \quad (9)$$

So the closed eye could be opened to 50% of the value of isolated pulses with no ISI. The error probability of the worst case error event  $P_w(\epsilon)$  is dominated by  $\delta$  and therefore simply given by a two-hypothesis decision problem. The critical error event causing the minimum distance turned out to be a single  $\Delta t$ -error so that the symbol error corresponds to the event error. We get

$$P_w(\epsilon) \approx Q\left(\frac{\delta}{2\sigma_{\Delta t}}\right) \quad (10)$$

where  $Q$  represents the Gaussian error probability function  $|2|$ . Assuming a 20dB ratio of  $T_c/\sigma_{\Delta t}$ , which corresponds to the signal to noise ratio of isolated pulses, we get an error probability of

$$P_w(\epsilon) \approx 2.8 \cdot 10^{-7} \quad (11)$$

As a consequence of observing the  $\Delta t$  instead of the absolute values  $t$ , to be independent of phase errors with respect to the clock, we get, however, a 3dB loss in SNR

$$\sigma_{\Delta t} = \sqrt{2} \sigma_t \quad (12)$$

So the error probability of equ.(10) holds for a 23dB ratio of  $T_c/\sigma_t$ , or we get with a 20dB SNR an error rate of

$$P_w(\epsilon) \approx Q\left(\frac{\delta}{2\sqrt{2}\sigma_t}\right) \approx 2 \cdot 10^{-4} \quad (13)$$

Fig.6 shows the simulated results of a Viterbi detector. The columns represent the corresponding decisions in the different layers. White Gaussian noise was added with standard deviations of  $\sigma_{\Delta t} = 0.285$  and  $\sigma_{\Delta t'} = 0.570$ , still getting the right decisions. The different paths converged 4 layers back from the current observation. The trellis was started with a known sequence. The column far to the right contains the accumulated lengths along the different trellis paths.

Another advantage of a PPM versus a PAM detector would be the insensitivity against amplitude variations caused e.g. by flying height variations.

References:

- |1| F. Dolivo, D. Maiwald, G. Ungerboeck, "Partial-Response Class-IV Signaling with Viterbi Decoding versus Conventional Modified Frequency Modulation (MFM) in Magnetic Recording", Internal Report from IBM Zurich Research Laboratory, July 1979
- |2| G. Forney, "The Viterbi Algorithm", Proc. of the IEEE, vol. 61, no. 3, 1973, pp. 268-278
- |3| P.A. Franzaszek, "Sequence-State Methods for Run-Length-Limited Coding", IBM J. Res. Develop., vol. 14, no. 2, 1970, pp. 376-383
- |4| A.S. Acampora, R. Gilmore, "Analog Viterbi Decoding for High Speed Digital Satellite Channels", Proc. Nat. Telecomm. Conf., NTC-77, 1977, pp. 34:6.1-6.5

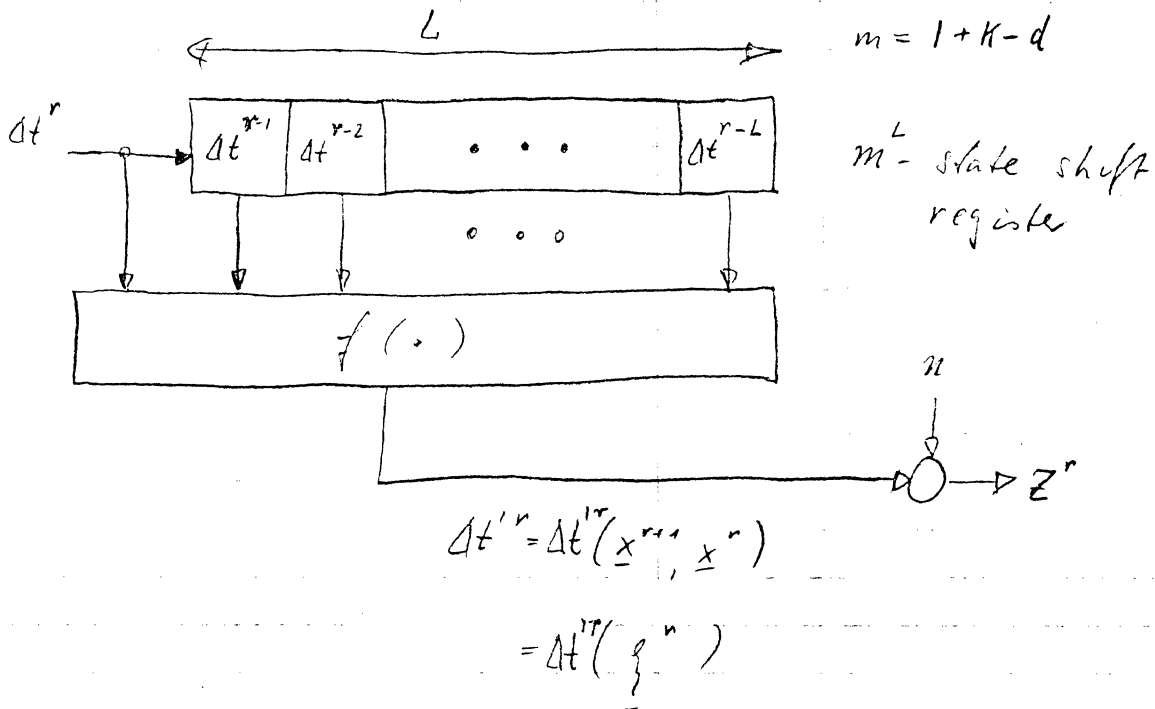

$$\underline{x}^r = (\Delta t^{r-1}, \Delta t^{r-2}, \dots, \Delta t^{r-L})$$

$$\underline{\xi}^r = (\Delta t^r, \Delta t^{r-1}, \dots, \Delta t^{r-L})$$

Fig. 1 Shift-Register Model of a PPM-Channel

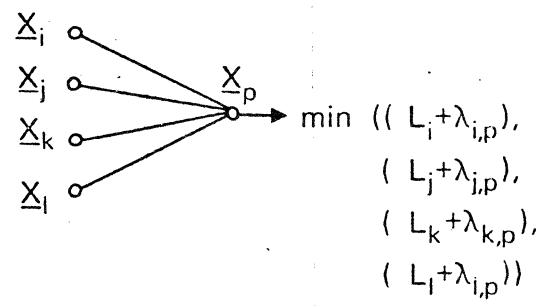
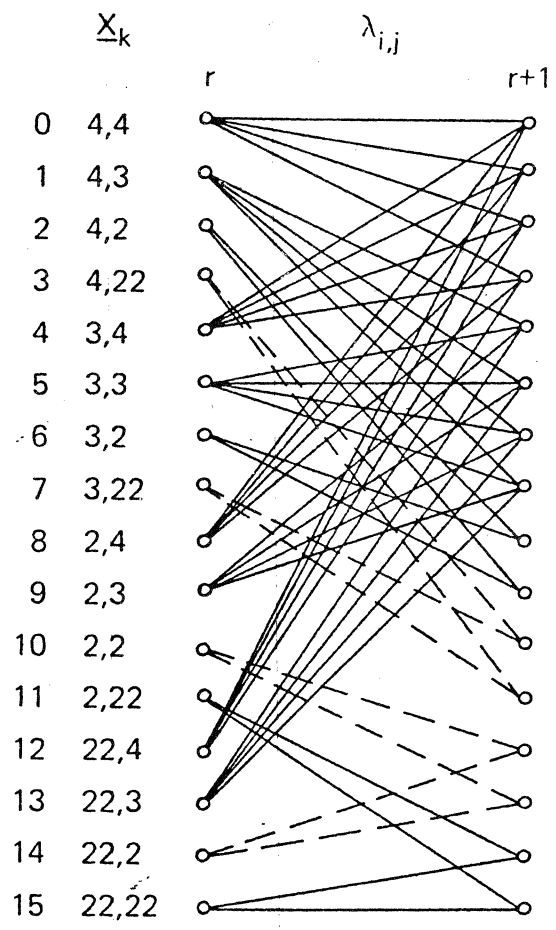
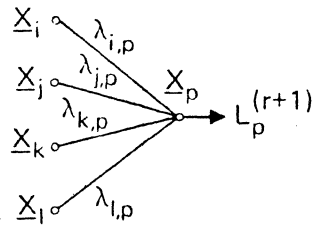
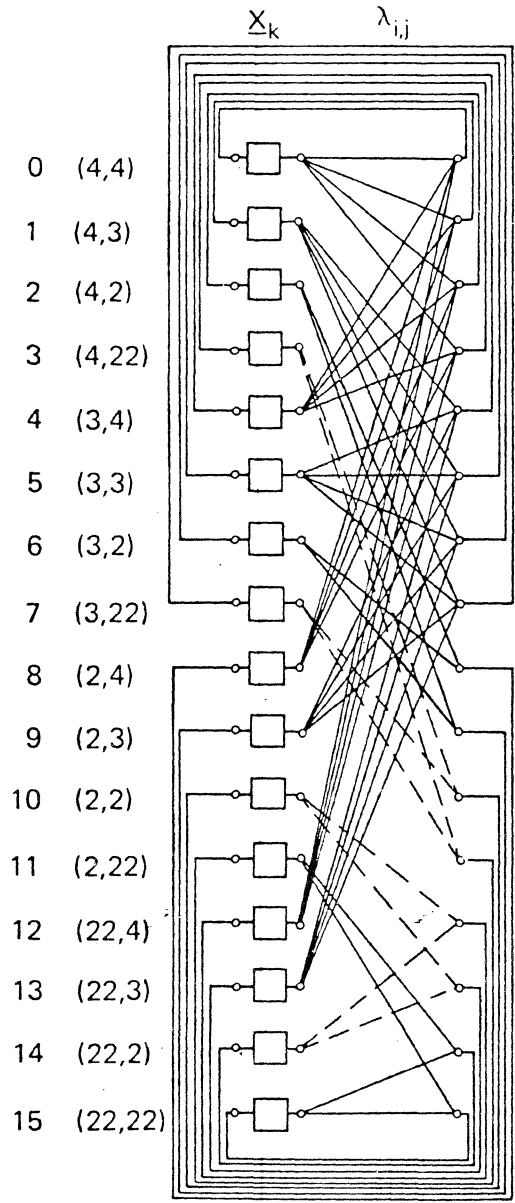

Fig. 2 Viterbi-Trellis for a PPM-detector of MFM-encoded data (ISI:  $\pm 4T_c$ )



$$L_p^{(r+1)} = \min ((L_i^r + \lambda_{i,p}), (L_j^r + \lambda_{j,p}), (L_k^r + \lambda_{k,p}), (L_l^r + \lambda_{l,p}))$$

Storage cell

Fig. 3 PPM-Viterbi detector for MFM-encoded data, implemented as recursive parallel processor (ISI:  $\pm T_c$ )

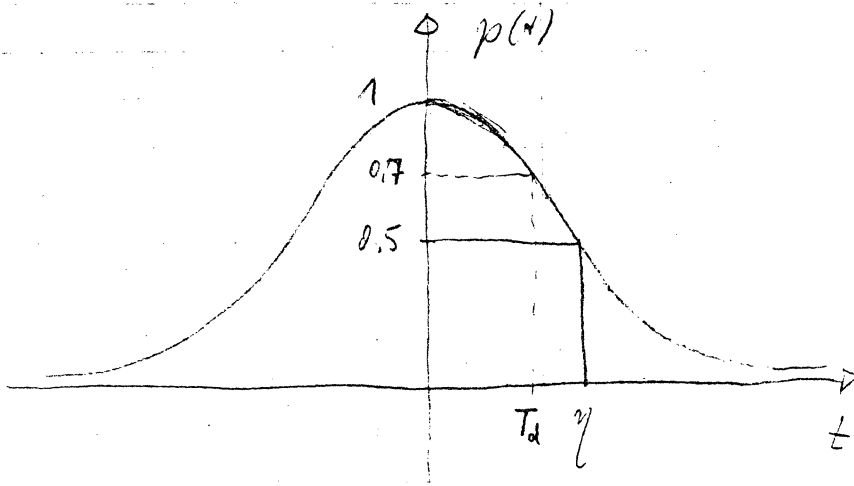

965 - IBM - 08

Fig. 4 Lorentzian readback pulse  
( $\eta$  - inflection point)

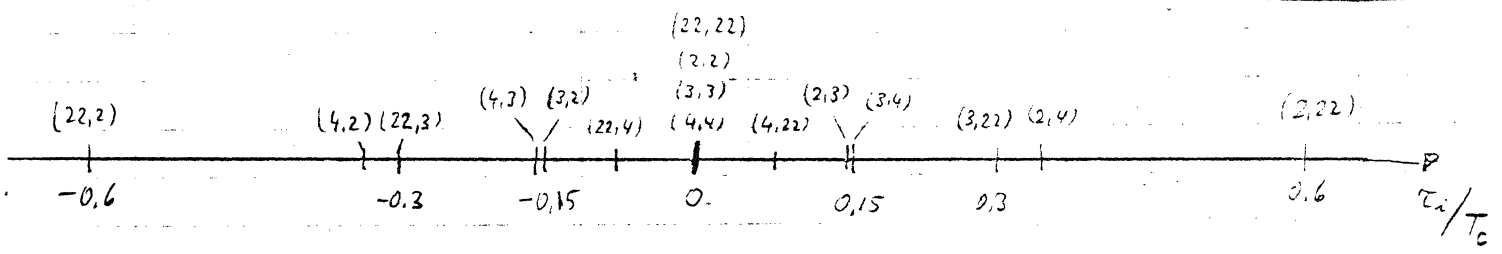

$x_i$	$x_0$	$x_1$	$x_2$	$x_3$	$x_4$	$x_5$	$x_6$	$x_7$
	(4,4)	(4,3)	(4,2)	(4,2,2)	(3,4)	(3,3)	(3,2)	(3,2,2)
$\tau_i(x_i)$	0	-0.16	-0.33	0.07	0.16	0	-0.15	0.29

$x_i$	$x_8$	$x_9$	$x_{10}$	$x_{11}$	$x_{12}$	$x_{13}$	$x_{14}$	$x_{15}$
	(2,4)	(2,3)	(2,2)	(2,2,2)	(2,2,4)	(2,2,3)	(2,2,2)	(2,2,2,2)
$\tau_i(x_i)$	0.33	0.15	0	0.6	-0.07	-0.29	-0.6	0

5. Peak shifts used in the example

$\{\Delta t^n\}$	4.00	4.00	4.00	2.00	3.00	4.00	2.00	2.00	2.00	3.00	4.00	4.00	4.00
$\{\Delta t'^n\}$	4.00	4.00	3.67	2.48	3.01	3.91	2.53	.80	2.31	3.45	3.84	4.00	4.00
$\{n^n\}$	-.26	-.11	.11	.02	-.03	.72	-.03	.15	-.34	-.07	-.20	.39	.22
$\{\Delta t'^n + n^n\}$	3.74	3.89	3.78	2.49	2.98	4.63	2.50	.95	1.97	3.38	3.64	4.39	4.22
$\{\Delta t'^n + 2 \cdot n^n\}$	3.48	3.78	3.90	2.51	2.95	5.36	2.47	1.10	1.63	3.31	3.44	4.78	4.44

965 - IBM - 08

$L_i$

- 4 4 4 4 2 3 4 2 2 2 3 4 4 4 4 2.937043165E-31
- 4 4 4 4 2 3 4 2 2 2 3 4 4 4 3 0.02543543829
- 4 4 4 4 2 3 4 2 2 2 3 4 4 4 2 0.1067239355
- 4 4 4 4 2 3 4 2 2 2 3 4 4 4 2 0.005132361184
- 4 4 4 4 2 3 4 2 2 2 3 4 4 3 4 0.4892378419
- 4 4 4 4 2 3 4 2 2 2 3 4 4 3 3 0.7319010455
- 4 4 4 4 2 3 4 2 2 2 3 4 4 3 2 1.009116171
- 4 4 4 4 2 3 4 2 2 2 3 4 4 3 2 0.3294320749
- 4 4 4 4 2 3 4 2 2 2 3 4 4 2 4 1.920130305
- 4 4 4 4 2 3 4 2 2 2 3 4 4 2 3 2.423274843
- 4 4 4 4 2 3 4 2 2 2 3 4 4 2 2 4.296826721
- 4 4 4 4 2 3 4 2 2 2 3 4 4 2 2 2.167833474
- 4 4 4 4 2 3 4 2 2 2 3 4 2 2 4 8.588520877
- 4 4 4 4 2 3 4 2 2 2 3 4 2 2 3 9.537062448
- 4 4 4 4 2 3 4 2 2 2 3 4 2 2 2 12.42093022
- 4 4 4 4 2 3 4 2 2 2 3 4 2 2 2 8.93318015

$$G_{\Delta t'} = 0$$

b)

L:

4 4 4 4 2 3 4 2 2 2 3 4 4 4 4 1  
 4 4 4 4 2 3 4 2 2 2 3 4 4 4 3 1.09629594  
 4 4 4 4 2 3 4 2 2 2 3 4 4 4 2 1.251873429  
 4 4 4 4 2 3 4 2 2 2 3 4 4 4 2 0.9733018791  
 4 4 4 4 2 3 4 2 2 2 3 4 4 3 4 1.9164026  
 4 4 4 4 2 3 4 2 2 2 3 4 4 3 3 2.229926203  
 4 4 4 4 2 3 4 2 2 2 3 4 4 3 2 2.574361523  
 4 4 4 4 2 3 4 2 2 2 3 4 4 3 2 1.698982686  
 4 4 4 4 2 3 4 2 2 2 3 4 4 2 4 3.7736303  
 4 4 4 4 2 3 4 2 2 2 3 4 4 2 3 4.35470397  
 4 4 4 4 2 3 4 2 2 2 3 4 4 2 2 6.16131421  
 4 4 4 4 2 3 4 2 2 2 3 4 4 2 2 3.765279121  
 4 4 4 4 2 3 4 2 2 2 3 4 2 2 4 12.1557492  
 4 4 4 4 2 3 4 2 2 2 3 4 2 2 3 13.20093483  
 4 4 4 4 2 3 4 2 2 2 3 4 2 2 2 16.02093102  
 4 4 4 4 2 3 4 2 2 2 3 4 2 2 2 12.26614368

$G_{dt} = 0.285$

c)

L:

4 4 4 4 2 3 4 2 2 2 3 4 4 4 4 4  
 4 4 4 4 2 3 4 2 2 2 3 4 4 4 3 4.167156442  
 4 4 4 4 2 3 4 2 2 2 3 4 4 4 2 4.397022923  
 4 4 4 4 2 3 4 2 2 2 3 4 4 4 2 3.941471397  
 4 4 4 4 2 3 4 2 2 2 3 4 4 3 4 5.343567359  
 4 4 4 4 2 3 4 2 2 2 3 4 4 3 3 5.727951361  
 4 4 4 4 2 3 4 2 2 2 3 4 4 3 2 6.139606875  
 4 4 4 4 2 3 4 2 2 2 3 4 4 3 2 5.068533297  
 4 4 4 4 2 3 4 2 2 2 3 4 4 2 4 7.627130295  
 4 4 4 4 2 3 4 2 2 2 3 4 4 2 3 8.286133098  
 4 4 4 4 2 3 4 2 2 2 3 4 4 2 2 10.0258017  
 4 4 4 4 2 3 4 2 2 2 3 4 4 2 2 7.362724767  
 4 4 4 4 2 3 4 2 2 2 3 4 2 2 4 17.72297752  
 4 4 4 4 2 3 4 2 2 2 3 4 2 2 3 18.86480721  
 4 4 4 4 2 3 4 2 2 2 3 4 2 2 2 21.62093181  
 4 4 4 4 2 3 4 2 2 2 3 4 2 2 2 17.5991072

$G_{dt} = 0.570$

d)

Fig 6 Simulation results of the detector

a) recorded data on write and read side

b) trellis history  $G_{dt} = 0$

c) " "  $G_{dt} = 0.285$

d) " "  $G_{dt} = 0.570$



PARTIAL RESPONSE FOR (d ≠ 0) CODES

By

R. C. Schneider, 68Y/060-1, Tucson

This talk demonstrates that partial response signaling techniques can be applied as an alternative detection method for (d ≠ 0) codes. As the value of d increases from 0 to 1 to 2, the number of detection levels increases from 3 to 5 to 9. Both partial response and (d ≠ 0) codes are methods of lowering channel bandwidth requirements. However, in general, the combination of these two techniques does not result in a compound bandwidth reduction effect. Figure 10 and 11 show a case where the major part of the bandwidth is reduced to below class IV partial response with (d=0), however, 13 levels are required.

Figure 1 is a general infinite bandwidth partial response channel. Figure 2 compares two equalized read pulses-- one for a (0, k) code and the second for a (1, k) code. Figure 3 shows how the pulse response for the (1, k) code channel can be expressed in partial response terms  $1+D-D^2-D^3$ .

Figure 5 shows a complete (1, k) partial response detection system including a precoder. Note that 5 levels must be

detected. Figure 6 shows the reduced bandwidth of a (1, k) system compared with a  $\text{COS}^2$  equalized (0, k) system. Figure 7 shows that the class IV partial response used with a (0, k) code still has the lowest bandwidth requirement. Figure 8 shows the equalized read pulse for a (2, k) code. Nine levels would be required for detection. The partial response polynomial would be  $1+2D+D^2-D^3-2D^4-D^5$ . Figure 9 compares the required (2, k) transfer function with  $\text{COS}^2$  (0, k), (1, k) and class IV (0, k). The class IV (0, k) has the lowest bandwidth requirement. Figure 10 shows an extra wide (2, k) pulse that might be used to further reduce bandwidth. Thirteen detection levels are needed. The required transfer function is shown in Figure 11. Although the main lobe is below  $0.4/T$ , the response is required to at least  $0.66/T$ .

The principle conclusion is that the marriage of partial response and ( $d \neq 0$ ) codes does not bring a significant bandwidth reduction or channel capacity increase. If partial response is used, the most likely case is with a (1, k) code with either  $1-D^2$  (class IV) three level detection or the  $1+D-D^2-D^3$  five level detection shown in Figure 5.

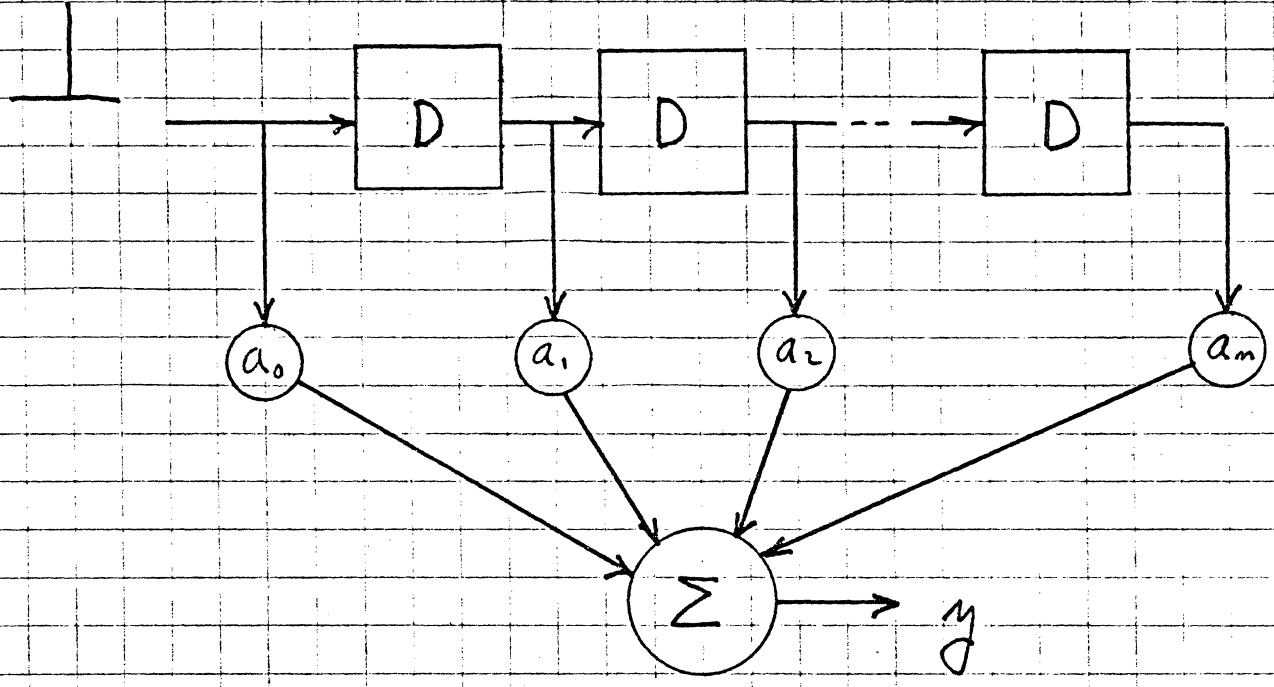

$$y_m = a_0 + a_1 D + a_2 D^2 + a_3 D^3 + \dots + a_m D^m$$

IBM

CONFIDENTIAL

FIGURE 1

IBM 11/15/51

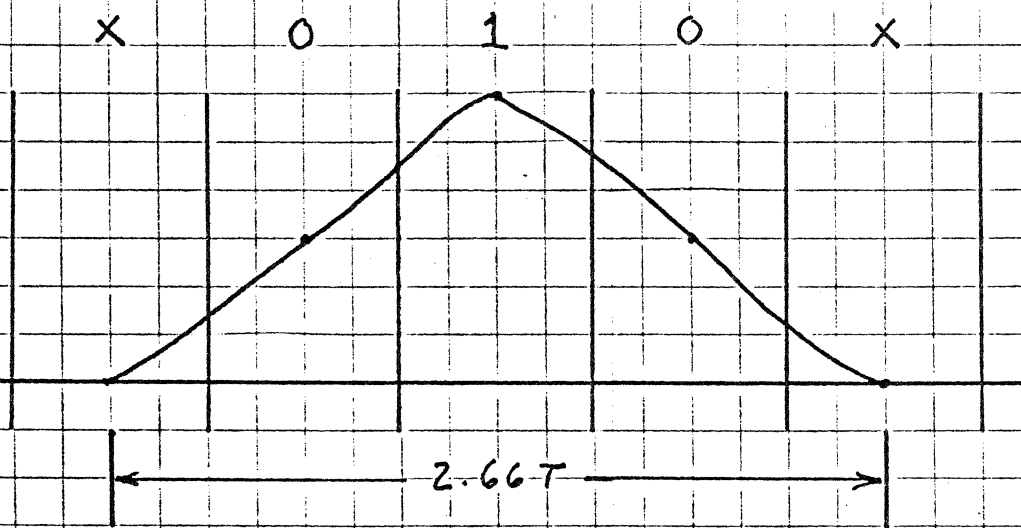
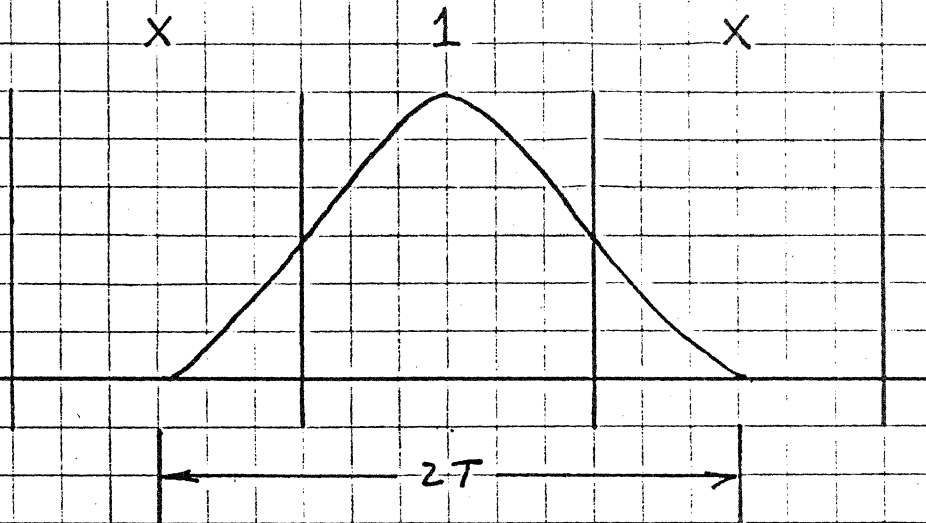

IBM

CONFIDENTIAL

FIGURE 2

INPUT PULSE

READ PULSE FOR EACH TRANSITION

RESULTANT DIPULSE

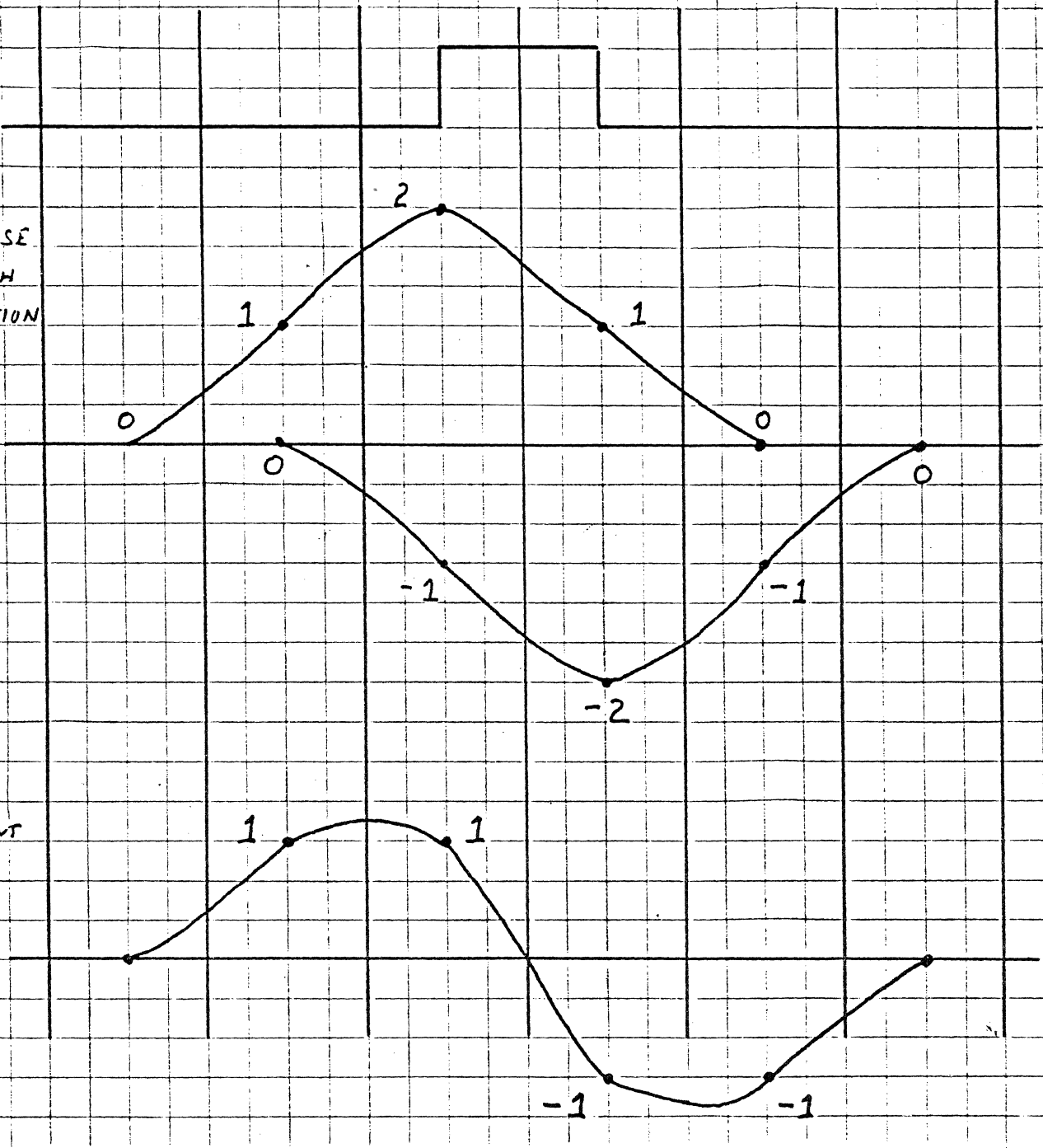

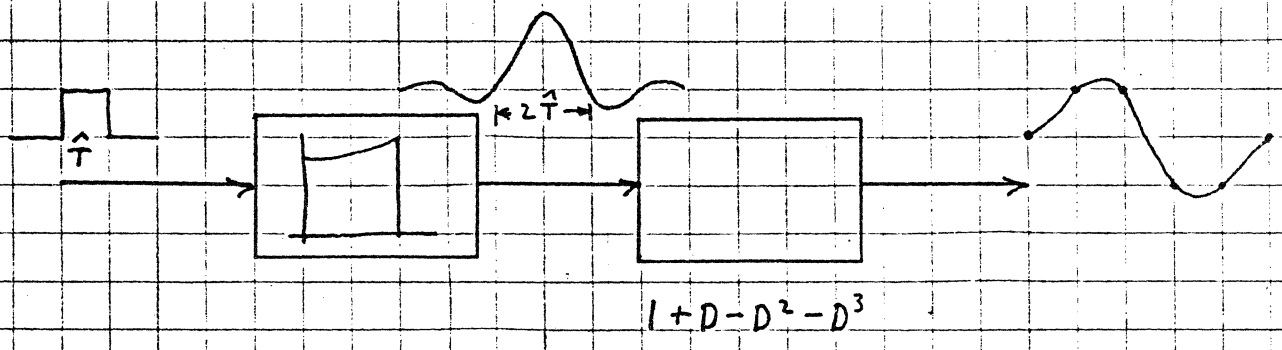
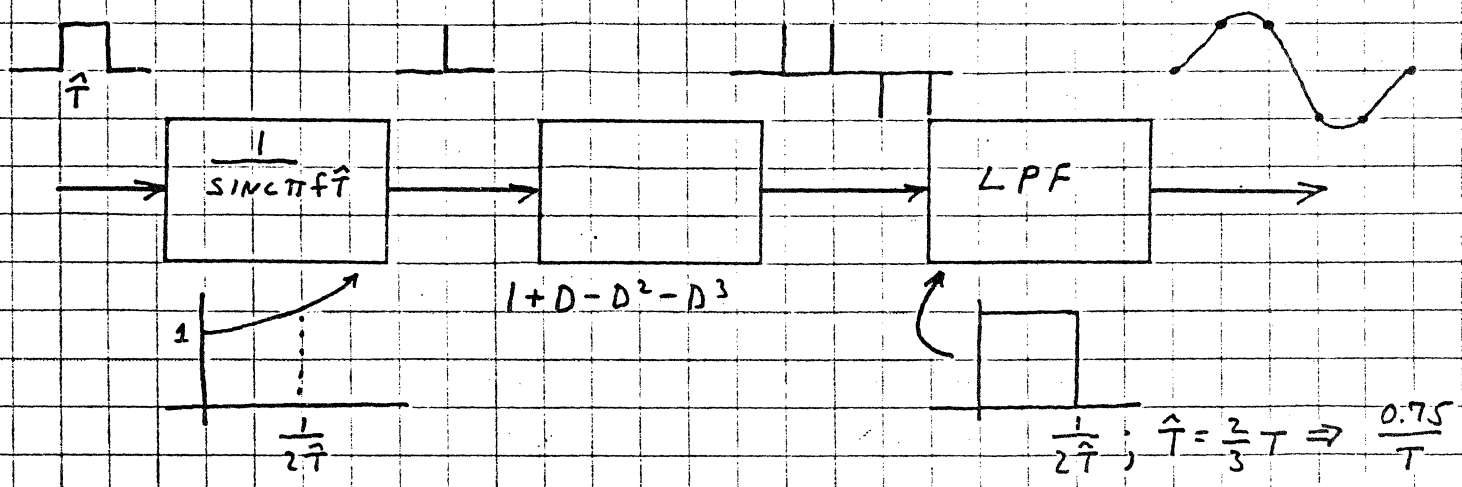
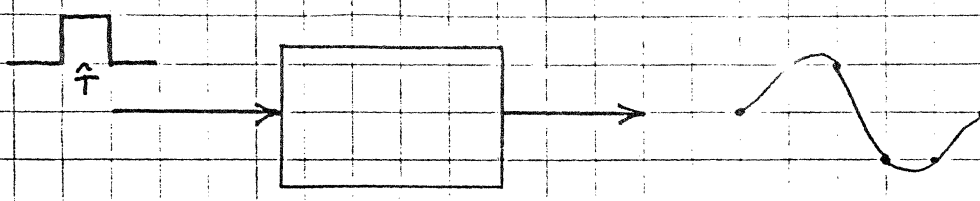

$$G(f) = 8j\pi \hat{T}^2 f \cos^2(\pi f \hat{T})$$

IBM

CONFIDENTIAL FIGURE 4

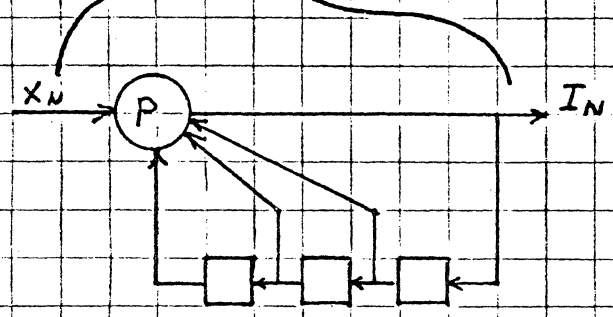
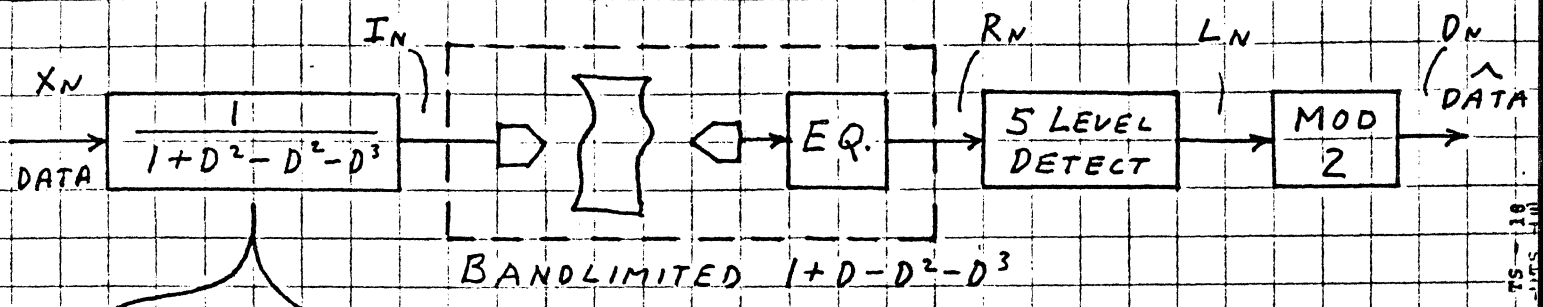

$X_N$	$I_{N-3}$	$I_{N-2}$	$I_{N-1}$	$I_N$
1	0	0	0	1
0	0	0	1	1
0	0	1	1	0
0	1	1	0	0
1	1	0	0	0
1	0	0	0	1
0	0	0	1	1
1	0	1	1	1

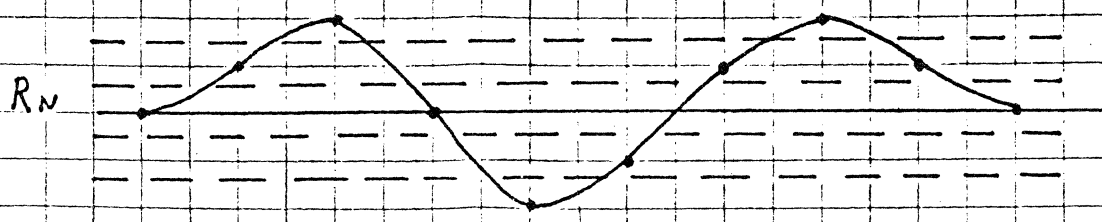
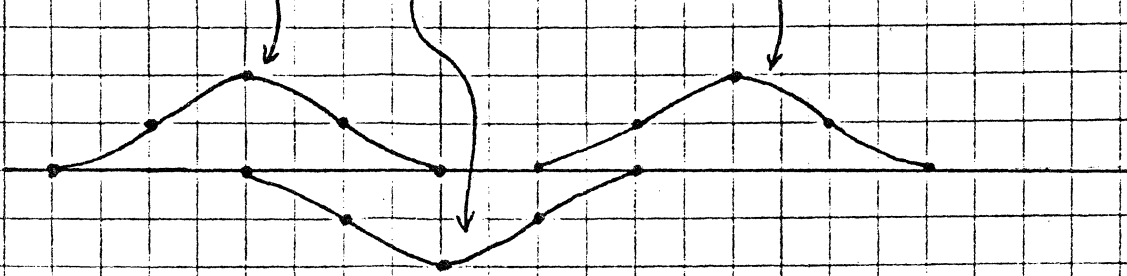
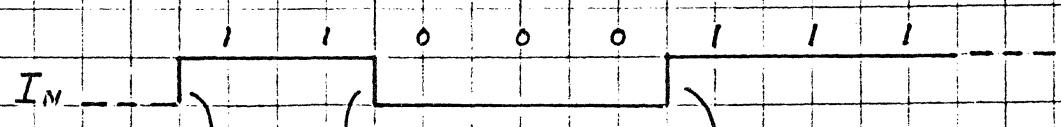
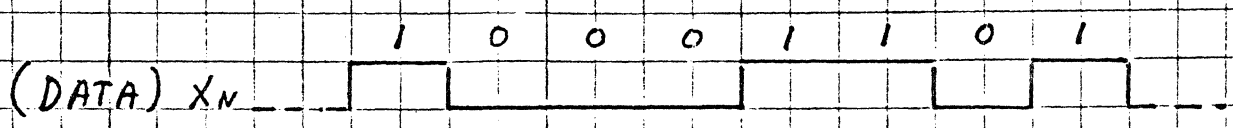

$L_N$	0	1	2	0	-2	-1	1	2	1	0
$D_N$	0	1	0	0	0	1	1	0	1	0

$\hat{DATA}$

IBM CONFIDENTIAL

FIGURE 5

### RCS LPLT (MAG1 AND MAGX1) VS FR

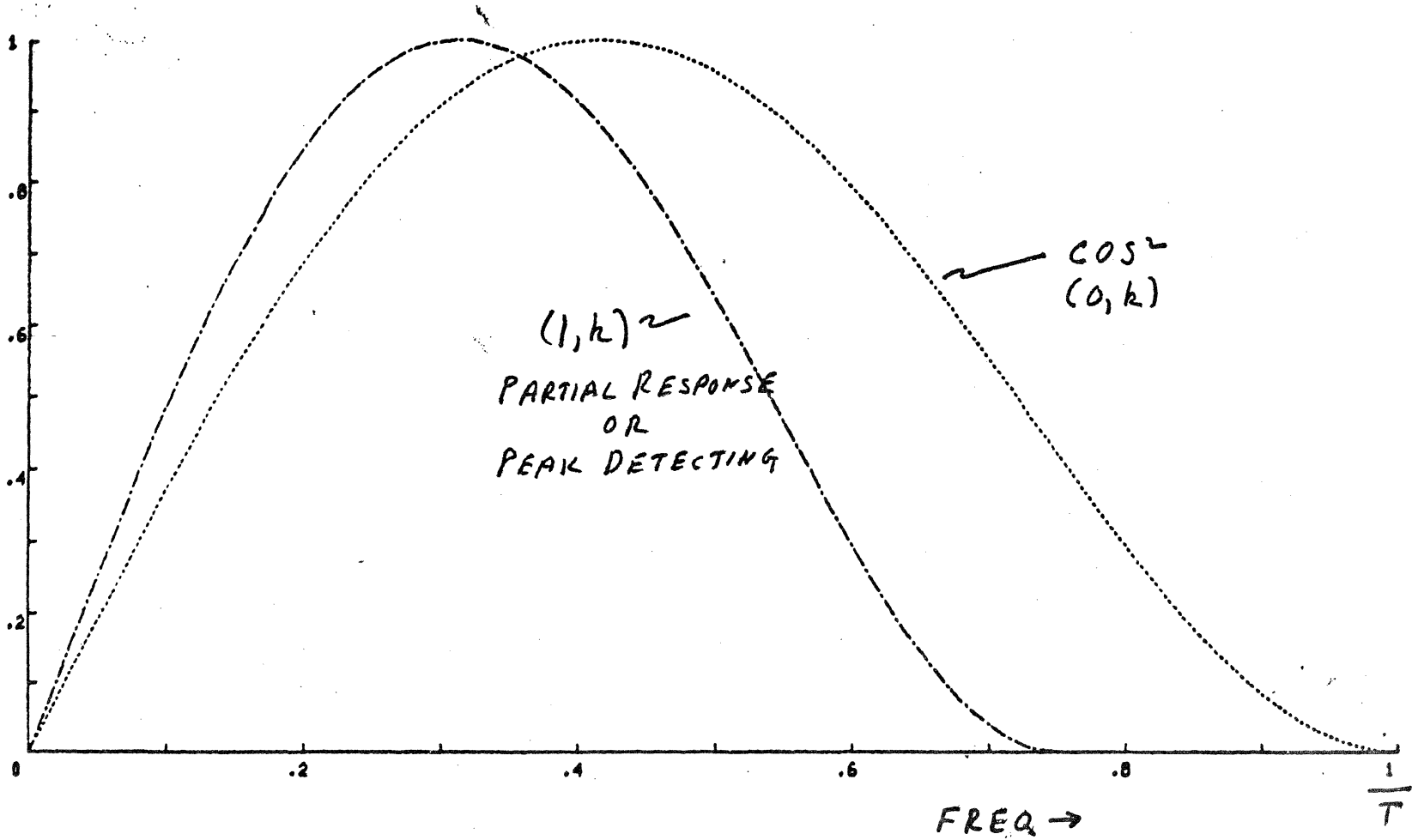

IBM  
CONFIDENTIAL

FIGURE 6



### RCS LPLT (MAG1, MAGX1 AND MAGX0) VS FR

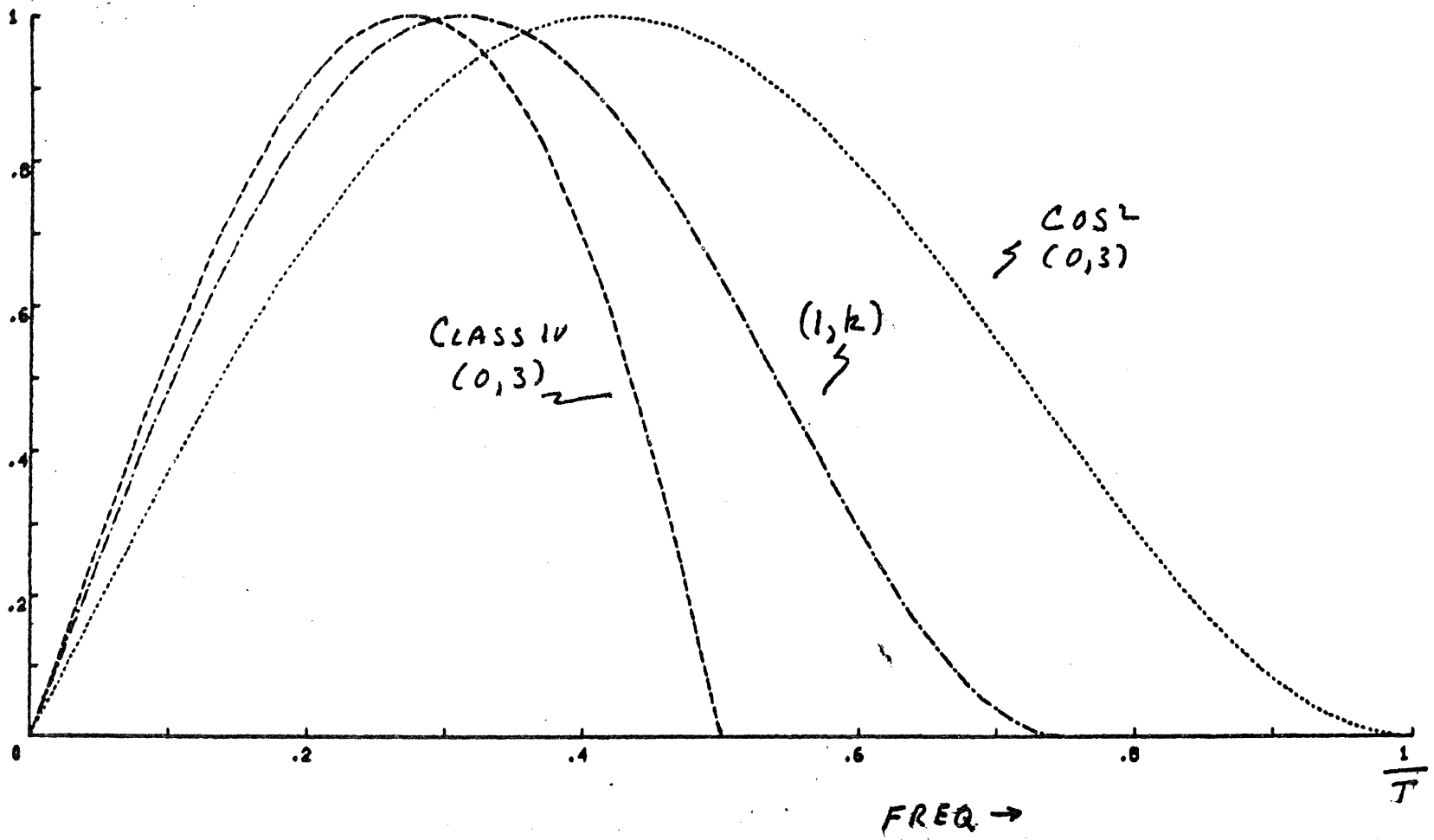

IBM  
CONFIDENTIAL

FIGURE 7

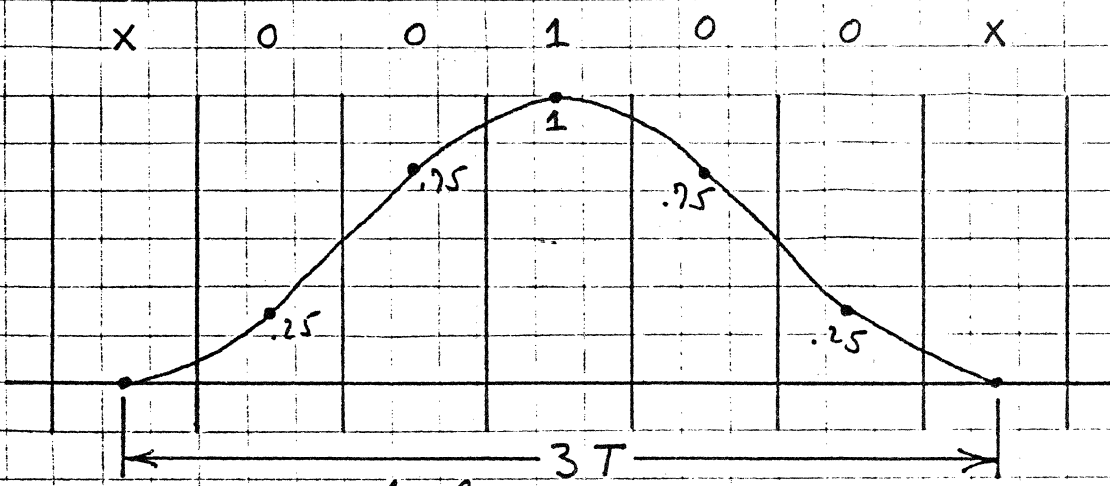

3 (+) levels  
 3 (-) levels  
 1 (0) level  
2 ± 0.5  
 9 LEVELS

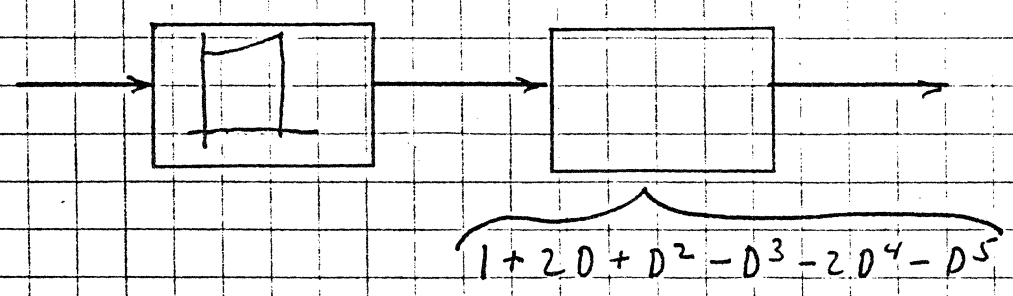
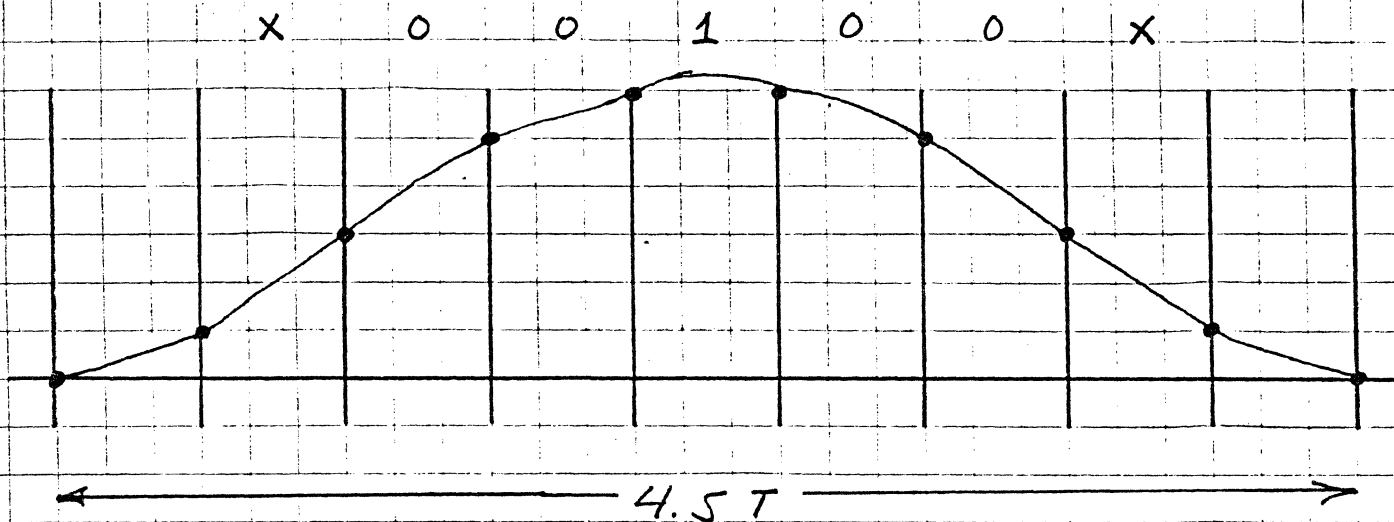

FIGURE 8

IBM

CONFIDENTIAL

IBM = TS = 1



4 (+) LEVELS

4 (-) LEVELS

1 (0) LEVEL

$4 \pm \frac{2}{16}, \pm \frac{4}{16}$

13 LEVELS

POLYNOMIAL  $\Rightarrow 1 + 3D + 5D^2 + 6D^3 + 6D^4 + 5D^5 + 3D^6 +$

FIGURE 10

IBM

CONFIDENTIAL

RCS LPLT MAG27M VS FR

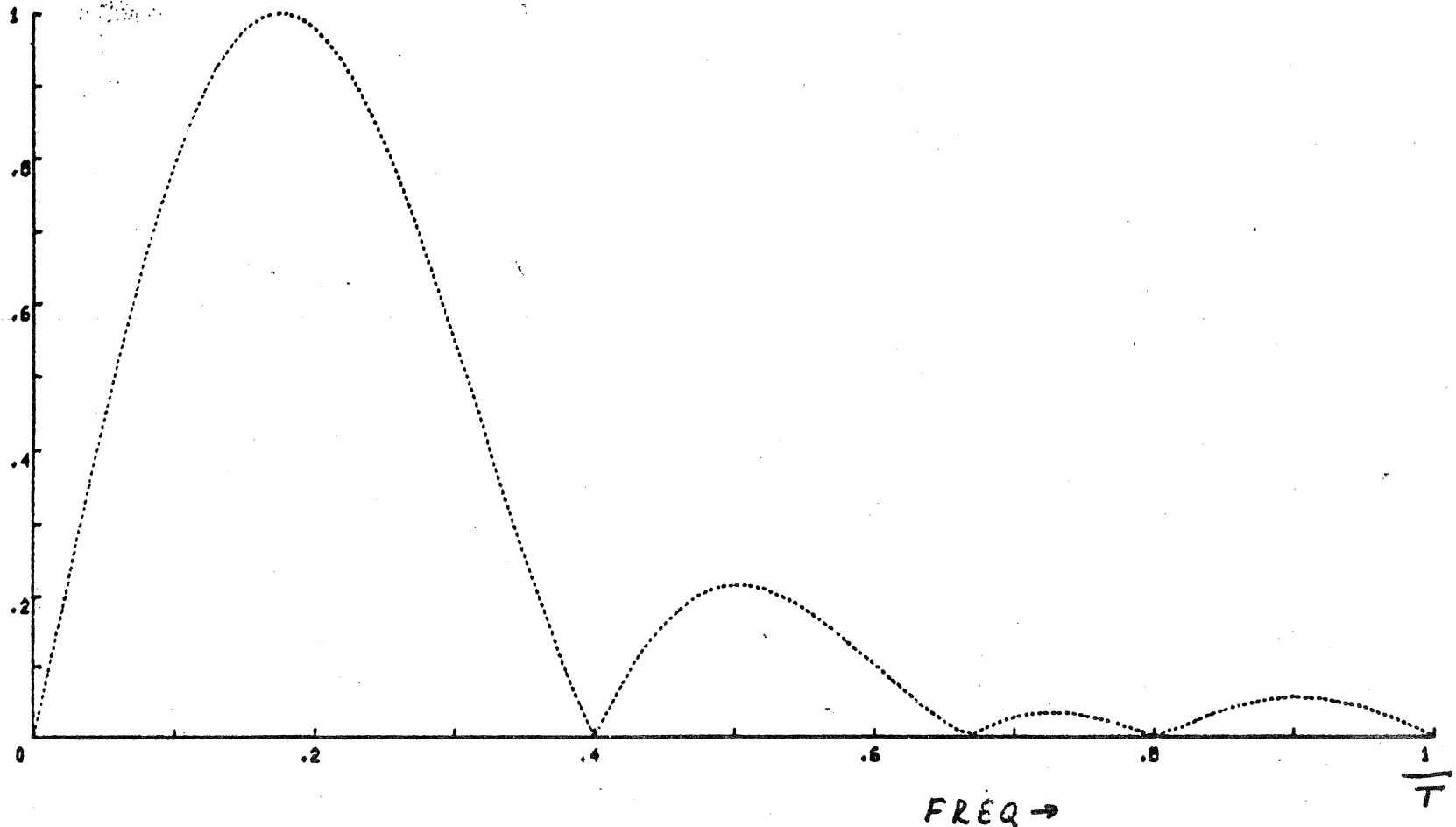

IBM  
CONFIDENTIAL

FREQ ->

FIGURE 11

## PARTIAL RESPONSE AND RUN-LENGTH LIMITED CODES

JOHN FEGENBERGER  
San Jose GPD, Dept. F80

Foil 2 presents the basic question addressed by the investigations reported, specifically, can a run-length limitation enhance the performance of a partial response channel? Foils 4 and 5 develop the standard mathematical description of a partial response channel from which we extract the point shown on Foil 6 which gives an over-simplified description of partial response in terms of what it can do potentially and what it cannot do. The basic point is that we rely on the channel impulse response being negligible at sampling times for  $t$  less than zero to avoid interference from future data.

Foil 7 shows equations in support of the statement that we can construct a band-width-limited impulse response which has periodic zeros for  $t$  less than zero and the period of these zeros is twice the cut-off frequency of the channel. Thus, we can signal at a symbol rate of the Nyquist rate (twice the cut-off frequency) with no unpredictable interference from future data. The final equation on Foil 7 indicates that a band-width-limited impulse response which is zero at all sampling times for  $t$  less than zero can be represented by a polynomial in  $D$ , where  $D$  is a delay of one-half the period corresponding to the cut-off frequency.

Foil 13 points out that an implication of the run-length constraint is that run-length-limited codes contain less than 1 bit of information per symbol and gives examples of the near-optimum codes used for examples. Foil 14 presents the consequence of this decreased information rate. The rationale is that both partial response and the  $d$  constraint are means of decreasing unpredictable intersymbol interference. For a data rate equal to or less than the Nyquist rate, we can eliminate this unpredictable interference without using a  $d$  constraint simply by using partial response, and the  $d$  constraint would gain us nothing. If the  $d$  constraint can aid a partial response channel, the aid must be in increasing the speed tolerance, that is, the extent to which the Nyquist rate can be exceeded while maintaining a detectable signal. Foil 15a shows a graphical aid to demonstrating this consequence.

In order to quantify the behavior sketched in Foil 15, calculations were made of the eye opening obtainable from various partial response systems at data rates higher than the Nyquist rate both with and without a  $d$  constraint. Foil 16 shows the basis of these calculations and foils 17 through 21 show the results. Similar calculations have been made without a formal band width limitation using Lorentzian, Gaussian and triangular impulse responses. The results are all similar and support the hypothesis presented on Foil 27. If we accept the hypothesis of Foil 27, there appears to be little potential in using the  $d$  constraint to enhance the performance of partial response channels. The only instances where the  $d$  constraint could increase the eye opening is when more than 40% of the maximum eye opening has already been lost to unpredictable interference from future data. Since there are many contributions to signal interference (off-track, random noise, etc.), it is not realistic to allot this large a portion to a single source.

Foil 28 demonstrates why the  $d$  constraint is ineffective. The  $d$  constraint decreases the interference between adjacent ONFs. However, in amplitude detection (sampled detection), there are two sources of interference, interference between ONFs and interference between a ONF and a ZFPO. The  $d$  constraint decreases the former interference while increasing the later. Foil 29 demonstrates the effectiveness of the  $d$  constraint in reducing interference when peak detection is used, both in improving peak positioning and increasing peak sharpness.

Foil 30 presents the conclusion of this investigation.

Partial Response  
and  
Run-Length-Limited  
Codes

John Eggenberger  
1-13-81

Partial Response and Run-Length-Limited Codes are both methods of increasing data rate and storage density.

The question is: Are these techniques complementary, that is, can they be used in conjunction to achieve more improvement than could be obtained with either alone?



# PARTIAL RESPONSE (a naive view)

WE CHARACTERIZE THE CHANNEL BY ITS IMPULSE RESPONSE;

$$f[t-\tau]$$

WHERE THE DELAY TERM,  $\tau$ , IS INCLUDED FOR GENERALITY.

INFORMATION SYMBOLS  $a_n$  ARE INPUT TO THE CHANNEL AS IMPULSES OF AMPLITUDE  $a_n$  AT TIME  $nT$ , WHERE  $T$  IS THE SYMBOL PERIOD.

THUS, THE CHANNEL INPUT,  $x(t)$ , IS:

$$x(t) = \sum_{n=-\infty}^{\infty} a_n \delta[t-nT]$$

AND THE CORRESPONDING OUTPUT,  $y(t)$ , IS:

$$y(t) = \sum_{n=-\infty}^{\infty} a_n f[t-\tau-nT]$$

SAMPLING WITH PERIOD  $T$ ,

$$y_k = y(kT) = \sum_{n=-\infty}^{\infty} a_n f[(k-n)T-\tau] = \sum_{n=-\infty}^{\infty} a_n f_{k-n}$$

$$y_k = \sum_{n=-\infty}^{\infty} a_n f_{k-n}$$

IF  $f_i = 0$  FOR ALL  $i \neq 0$

$$y_k = a_k f_0$$

IF  $f_i = 0$  FOR ALL  $i < 0$ .

$$y_k = \sum_{n=-\infty}^k a_n f_{k-n}$$

$$= a_k f_0 + \sum_{n=-\infty}^{k-1} a_n f_{k-n}$$

$$a_k = \frac{1}{f_0} \left[ y_k - \sum_{n=-\infty}^{k-1} a_n f_{k-n} \right]$$

Partial Response provides a method for compensating for interference from past data potentially perfectly, but relies on the channel impulse response to avoid interference from future data.

7  
102

# SAMPLING THEOREM (again, naive)

$$f(t) = \sum_{n=-\infty}^{\infty} f_n \frac{\sin(\omega_c t - n\pi)}{\omega_c t - n\pi}$$

$$f\left(\frac{n\pi}{\omega_c}\right) = f_n$$

$$f(t) \approx 0 \text{ for } t < 0 \Rightarrow f_n = 0 \text{ for } n < 0$$

$$P(D) = f_0 + f_1 D + f_2 D^2 + f_3 D^3 + \dots$$

# RUN-LENGTH-LIMITED CODES (in particular, $d$ constrained)

WE CAN ALLEVIATE PROBLEMS CAUSED BY THE CLOSE PROXIMITY OF TRANSITIONS (ONES) BY ENCODING THE INFORMATION IN SUCH A WAY THAT THERE ARE ALWAYS AT LEAST  $d$  "NO-TRANSITIONS" (ZEROS) BETWEEN TRANSITIONS. THE PENALTY IS THAT, DUE TO THIS CONSTRAINT, THE INFORMATION CONTENT OF THE CODE IS NO LONGER 1 BIT PER SYMBOL.

AS REPRESENTATIVE, WE USE:

$d$	BITS/SYMBOL	SYMBOL PERIOD FOR EQUAL DATA RATES
0	1	T
1	$2/3$	$2T/3$
2	$1/2$	$T/2$

In using RLL and PR,  
the symbol rate must  
be higher than the  
Nyquist rate.

Any decrease in net  
interference must be  
due to the decrease  
from the d constraint  
being greater than  
the increase due to  
the higher symbol rate.

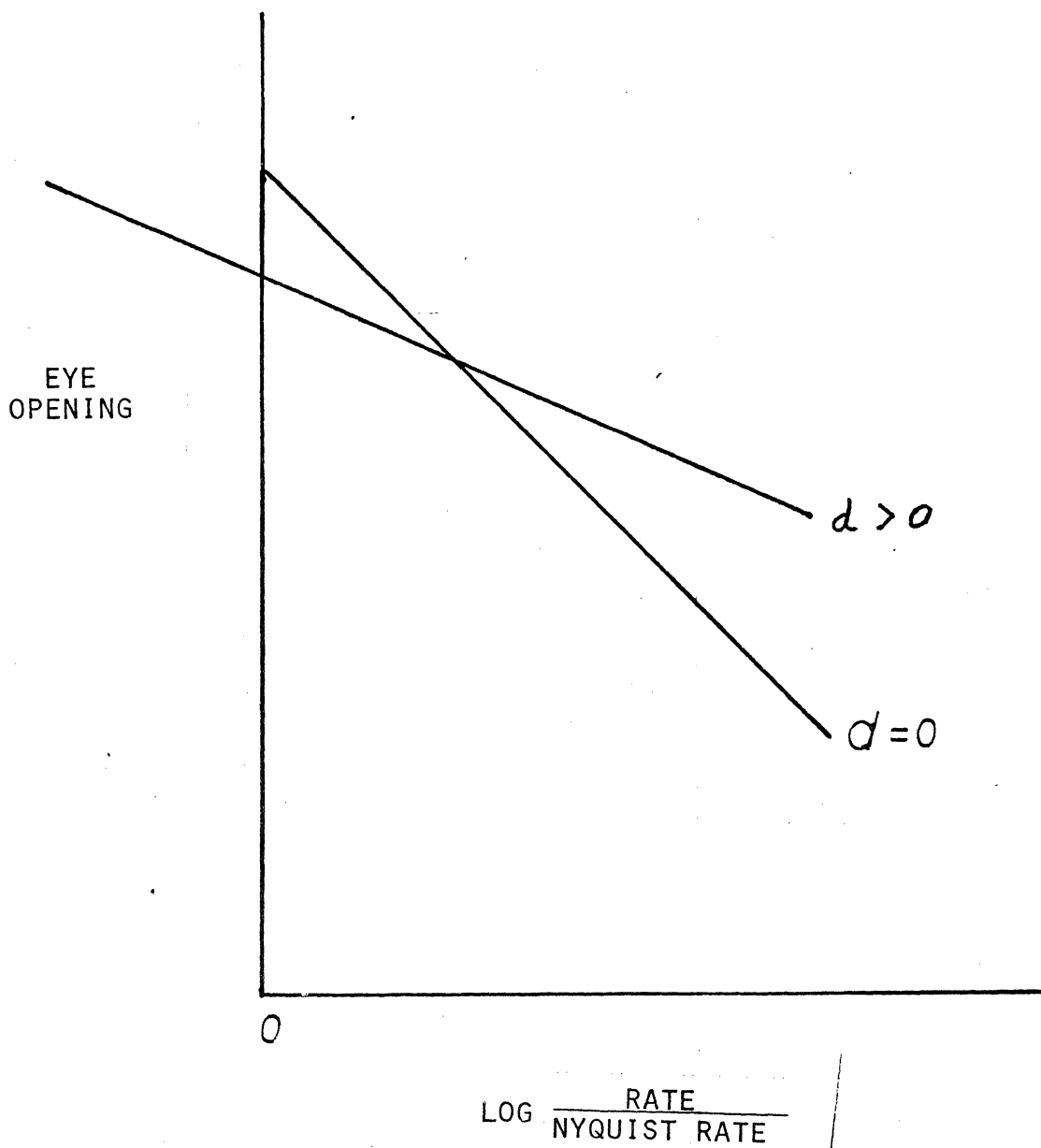

## CALCULATION GROUND RULES:

1. Impulse response given by system polynomial.
2. PR compensates perfectly for all interference from the past.
3. Rate is actual data rate, not symbol rate.
4. Eye opening is the minimum positive 'ONE' signal minus the maximum 'ZERO' signal.



17  
107

DUOBINARY (1 + D)

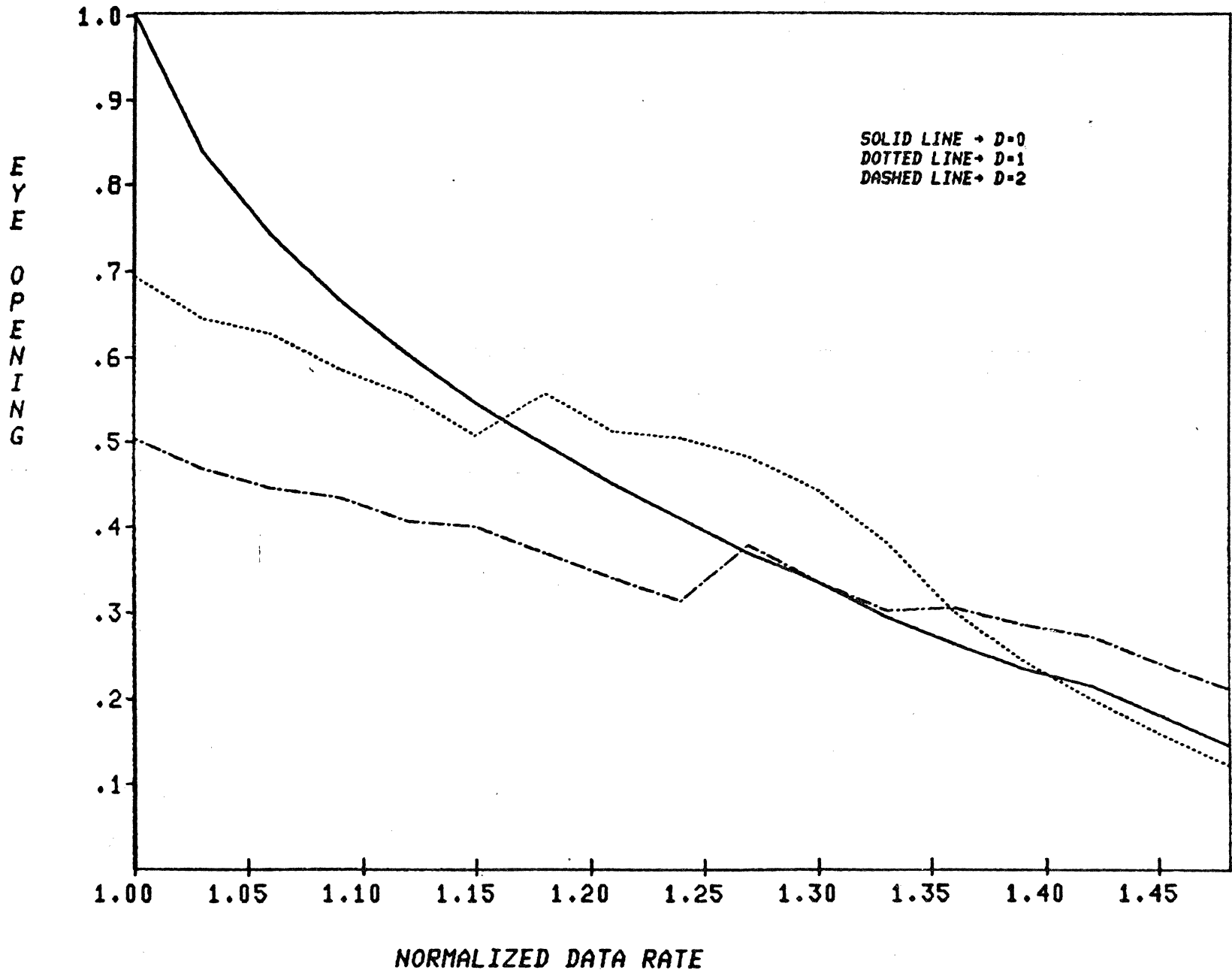

CLASS IV (1 - D\*2)

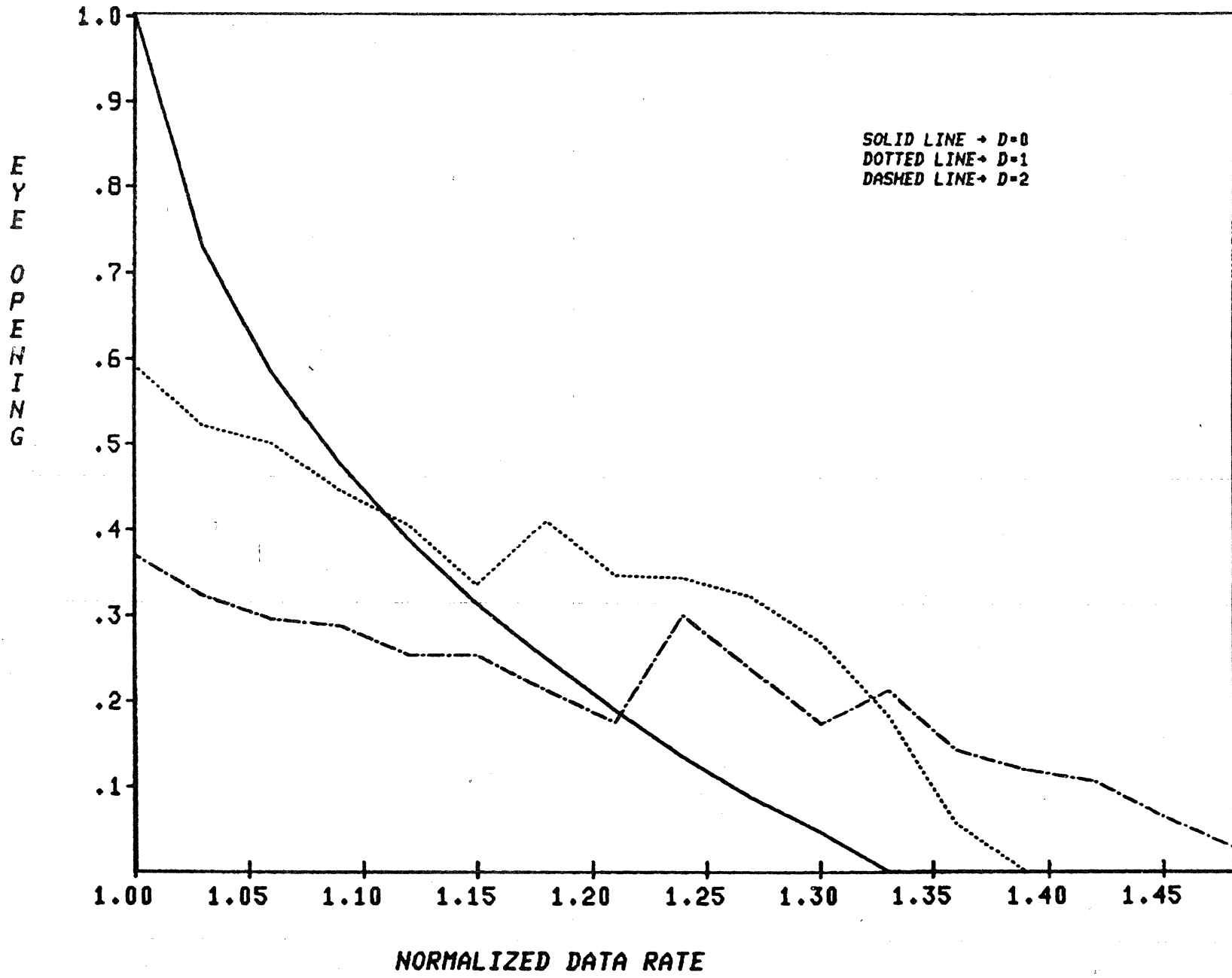

CLASS V (1 - 2D\*2 + D\*4)

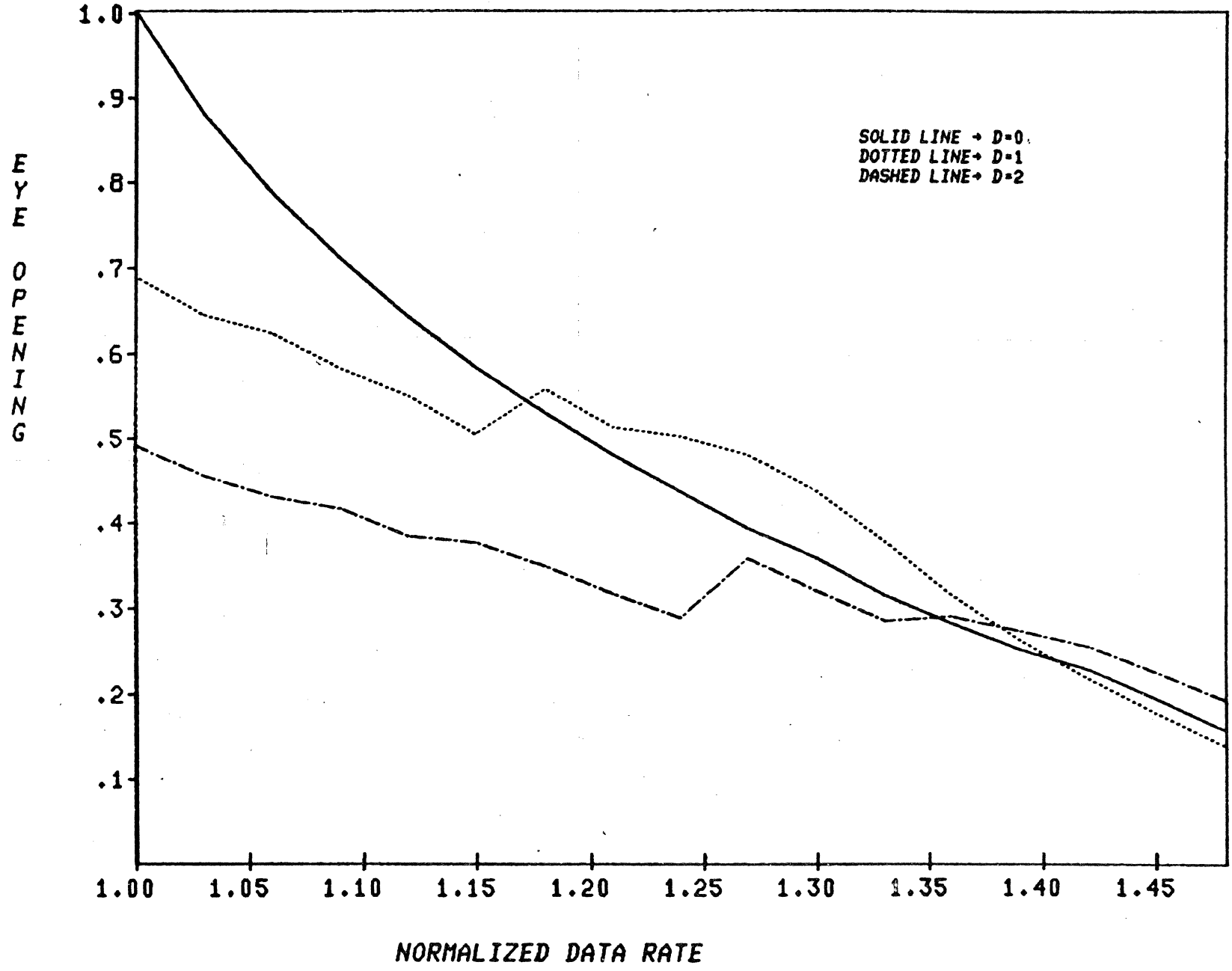

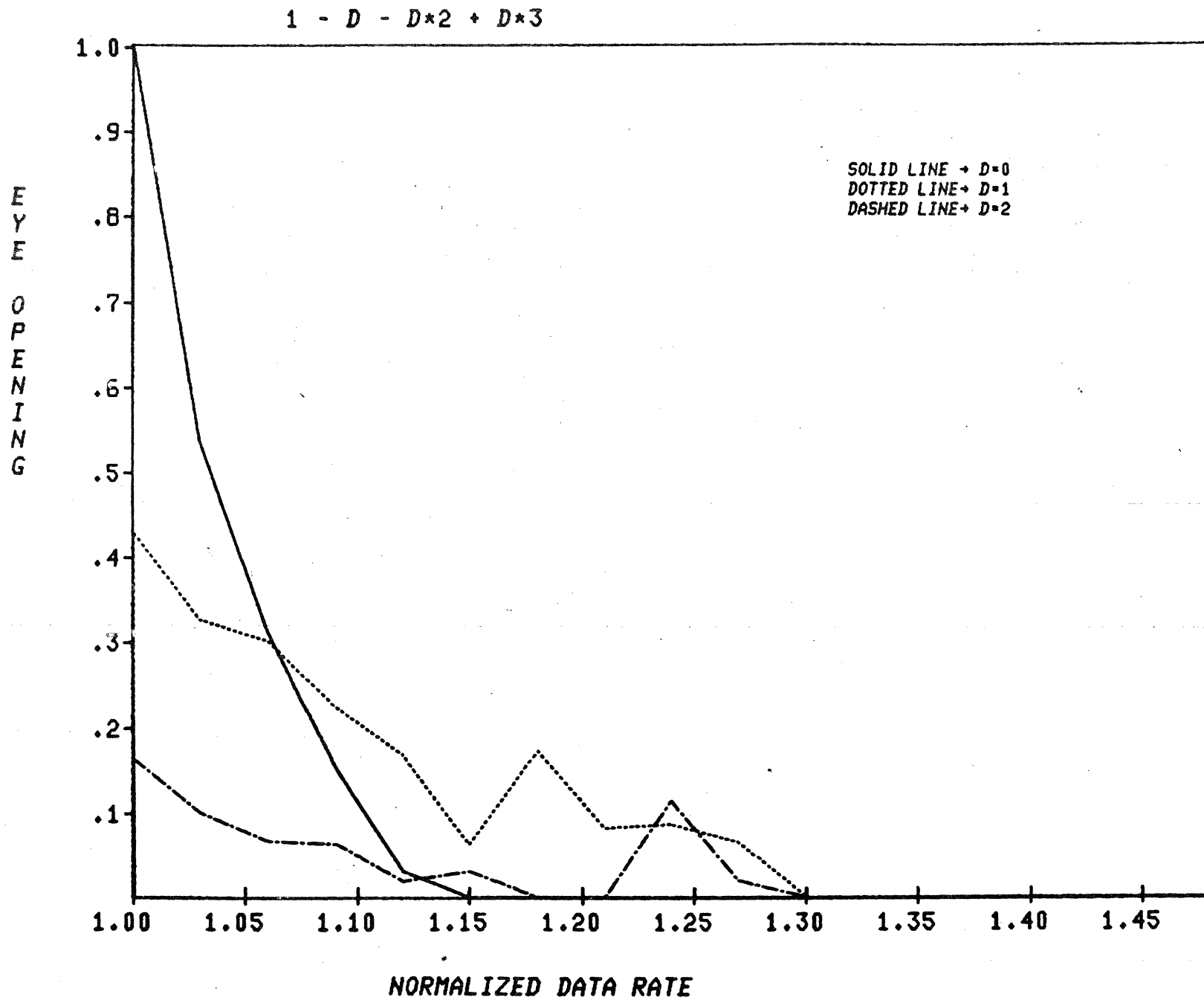

21  
111

CLASS II (1 + 2D + D\*2)

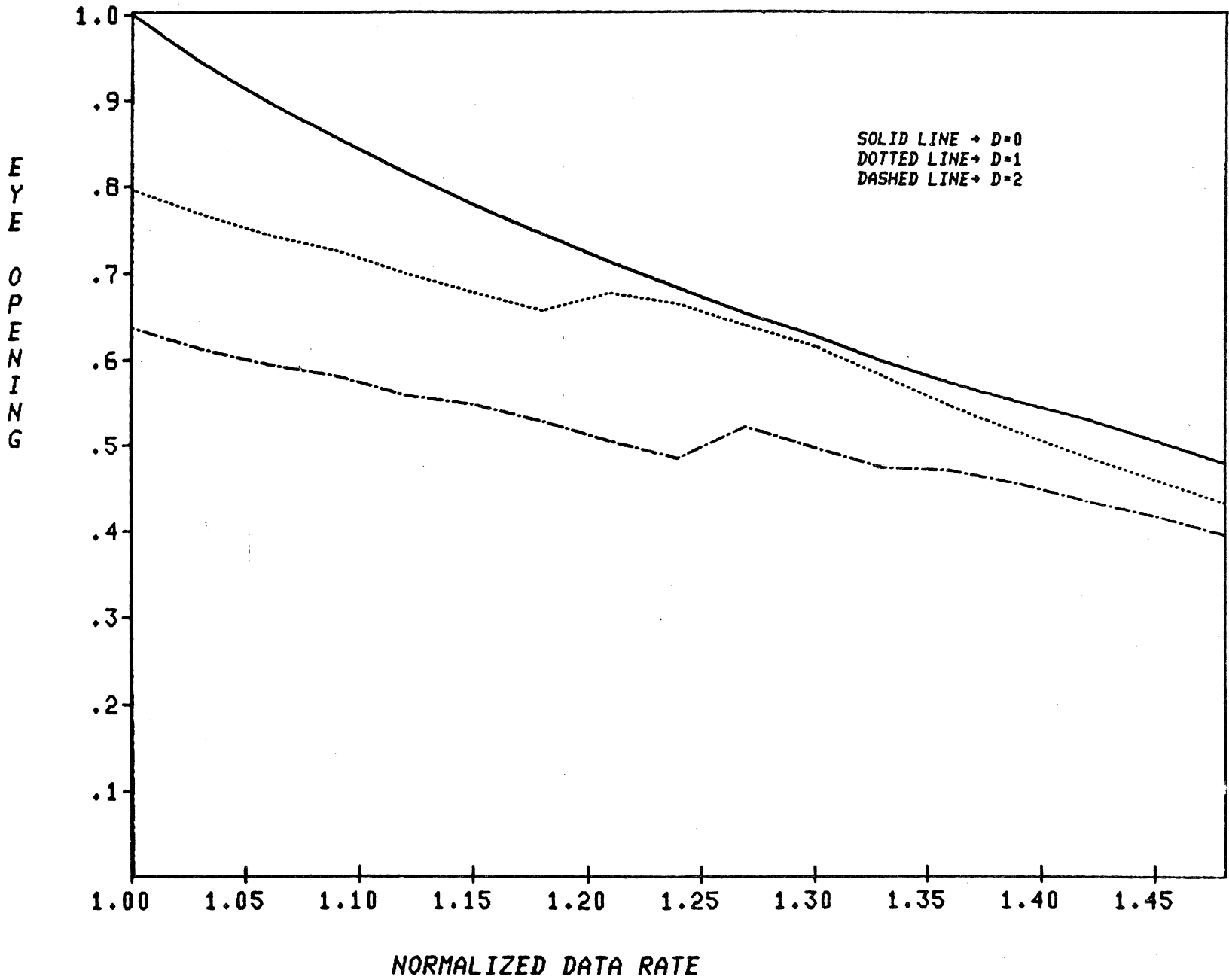

# HYPOTHESIS:

At a data rate where a  $d=0$  code with a rate of 1 has an eye opening from 60% to 100%, use of a  $d=1$ ,  $rate=2/3$  or a  $d=2$ ,  $rate=1/2$  code at the same data rate will decrease the eye opening.

# AMPLITUDE DETECTION

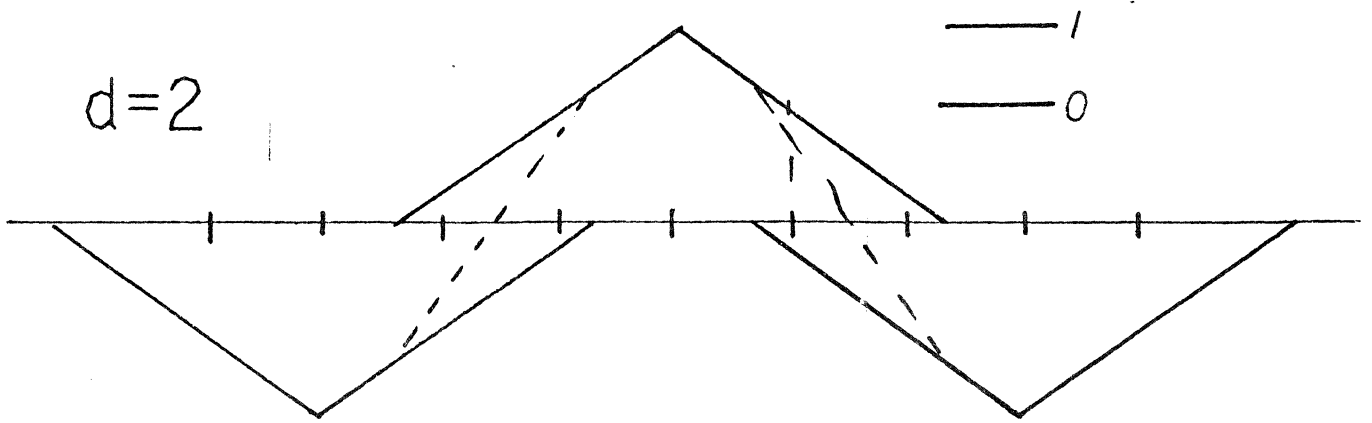
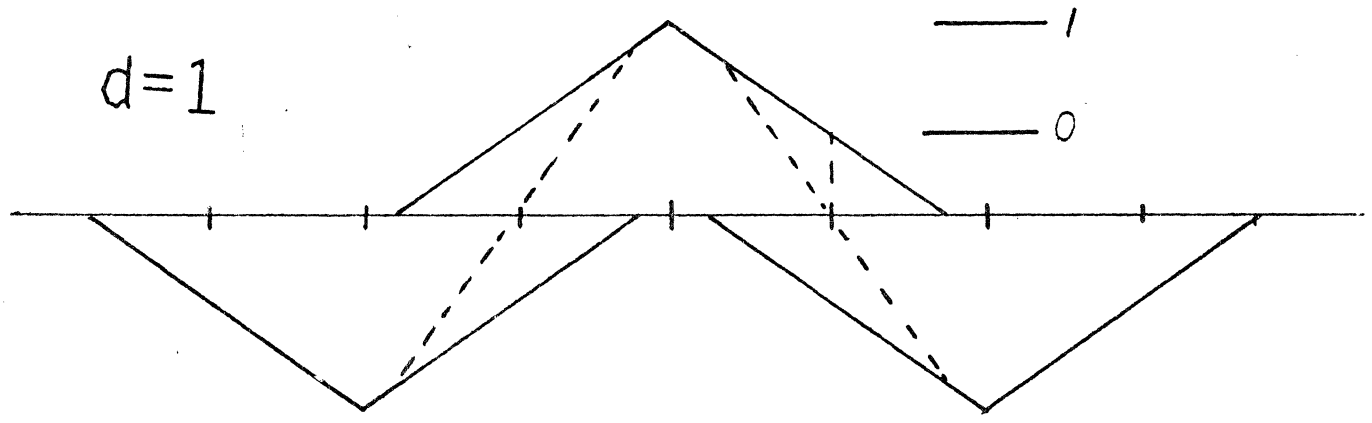
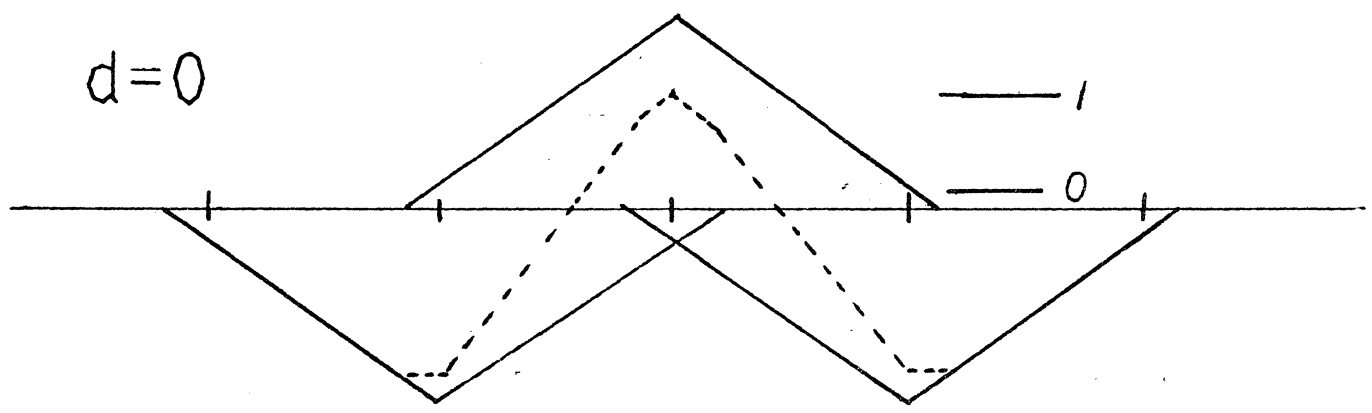

# PEAK DETECTION

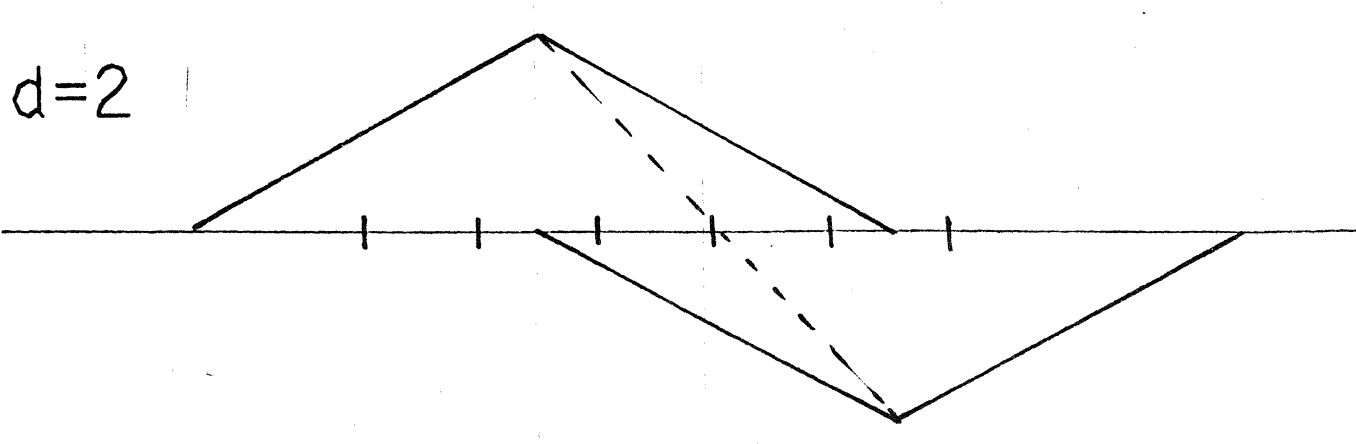
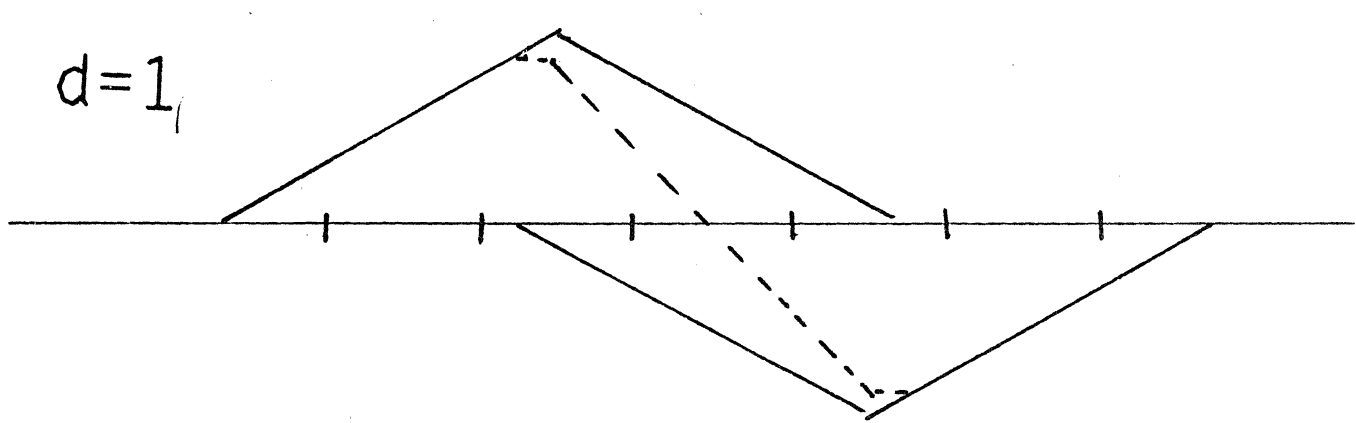
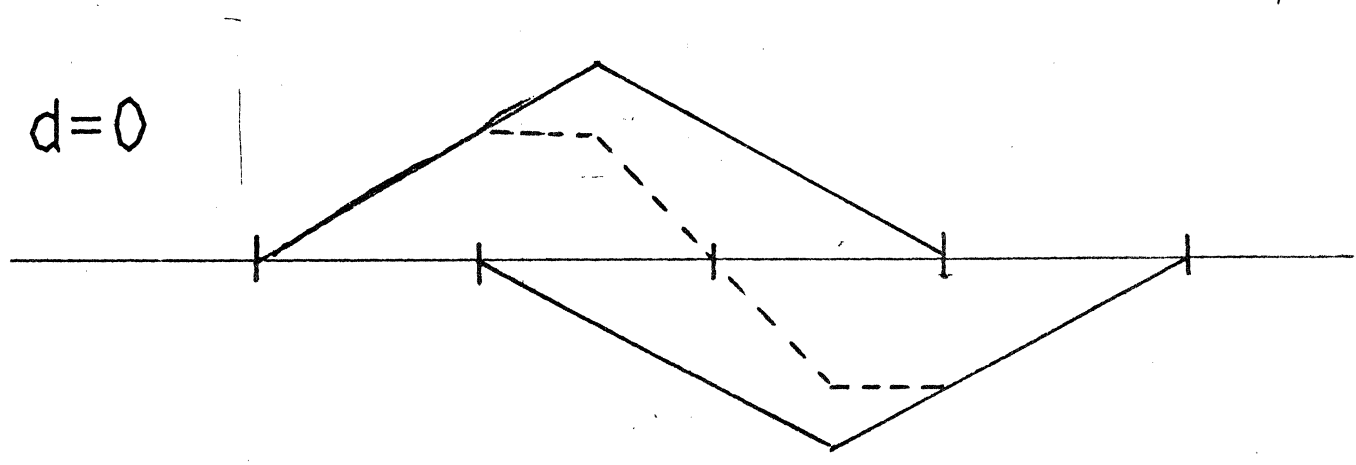



## CONCLUSION:

RLL is generally ineffective when used with partial response due to the fact that partial response, as presently considered, entails amplitude detection and RLL does not complement amplitude detection



ZERO-FILLED BIPOLAR CODES

A read clock must be recovered from the reproduce signal waveform even in the presence of long strings of zeros. Much effort has gone into finding codes that are self-clocking, and also those that have no dc component. The purpose of this talk is to describe advantageous methods that are in common use in the communications area, but that have not seen use in magnetic recording.

The basic principle<sup>1</sup> is to scan the input data stream for groups of  $n$  adjacent zeros. When found, they are replaced by a special fill sequence. After detection, the fill sequences are recognized by some special properties not possible in the original data, and are replaced by zeros.

Bipolar codes, which are used in PCM telephone transmission,<sup>2,3</sup> obey a polarity alternation rule: --successive input signals alternate in polarity. Fill sequences can then be constructed with violations of the polarity rule, and can be recognized by this property.

Class IV partial response is readily achievable (and was first proposed<sup>2</sup>) by interleaving bipolar signals, and thus can also be filled. The even and odd bits each obey the polarity alternation rule separately within the two subsequences. Fill sequences can again be recognized by the pattern and polarity of violations.

The scope pictures show examples of fill sequences as reproduced from an instrumentation recorder, filled bipolar at 33 KFCI, and filled interleaved bipolar at 40 KFCI, on standard coercivity  $\gamma$ -Fe<sub>2</sub>O<sub>3</sub> tape. While the equalization is not good, the fill sequences are quite clear. Spectra of filled and unfilled codes, taken at a higher data rate, show that zero-filling does not greatly change the energy distribution versus frequency.

Note that filling changes neither the signaling rate nor the clocking window.

<sup>1</sup>V. I. Johannes, A. G. Kaim, and T. Walzman, "Bipolar Pulse Transmission with Zero Extraction," IEEE Trans. Comm. Tech. COM-17, p. 303 (1969).

<sup>2</sup>M. R. Aaron, "PCM Transmission in the Exchange Plant," BSTJ, V41, p. 99 (1962).

<sup>3</sup>A. Croisier, "Introduction to Pseudoternary Transmission Codes," IBM J. Res. Devel., V14, p. 354 (1970).

ZERO-FILLED

BIPOLAR

CODES

M. K. Haynes  
IBM Tucson

## CLOCKING METHODS

Pilot Tone

Parallel Channels

Constrained Input Code

Self-Clocking Code

FM, PE

MFM, ZM, MMFM

RLC:- 0,3; 2,7

Zero Filling

# ZERO-FILLING

Replace Group of n Zero's  
with Fill Sequence

Recognize Unique Property  
of Fill Sequence, and  
Replace with Zero's

MFM -- a Filled Code

Bipolar Code  
Polarity Alternation  
Violation of Rule

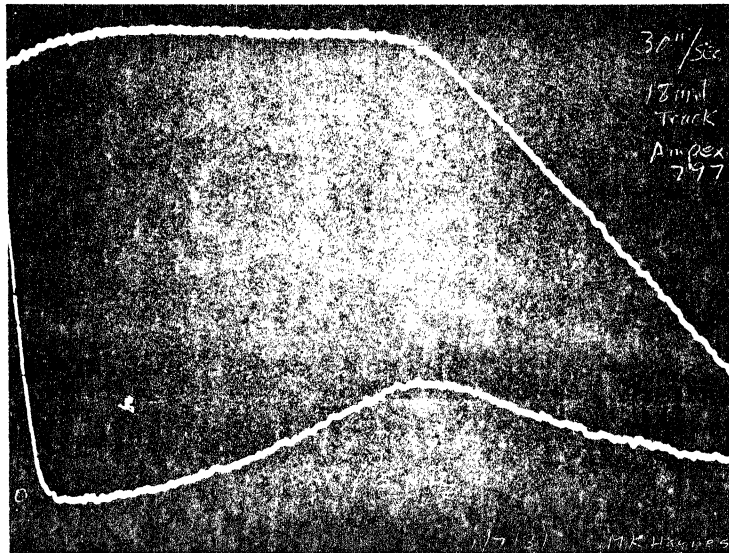

10 db/div.

0.1 MHz/div

IBM - FS - 22  
1000 - 15 - 1

### Transfer Function & Noise Floor - Equalized

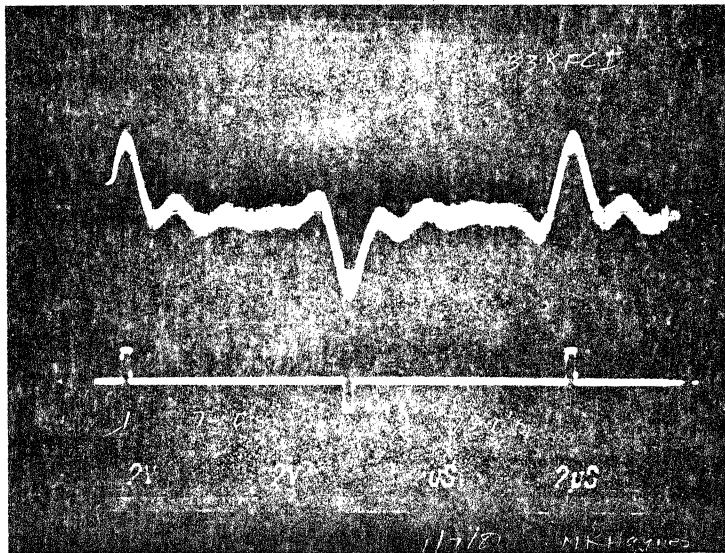

### Isolated Pulse Response

93 C Recorder :- 30"/sec , 18 mil Track  
 Ampex 797 Tape ( $\gamma$ -Fe<sub>2</sub>O<sub>3</sub>, H<sub>c</sub> 300. Oe)

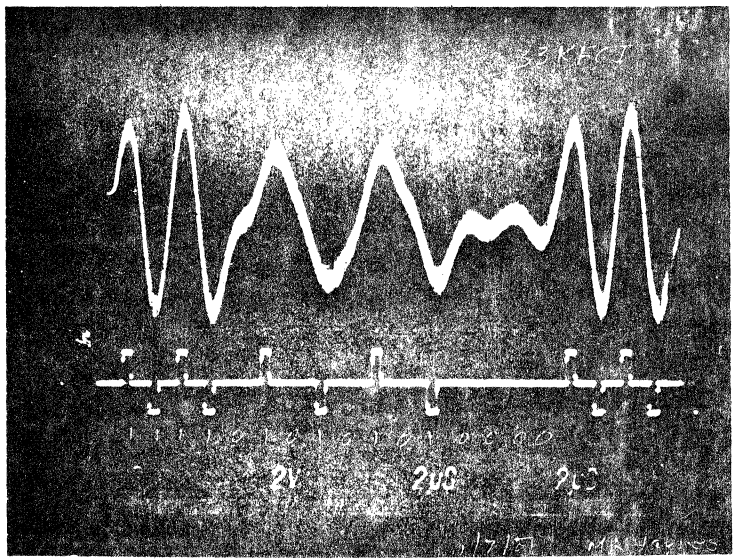

Bi Polar Code - 33KFCI

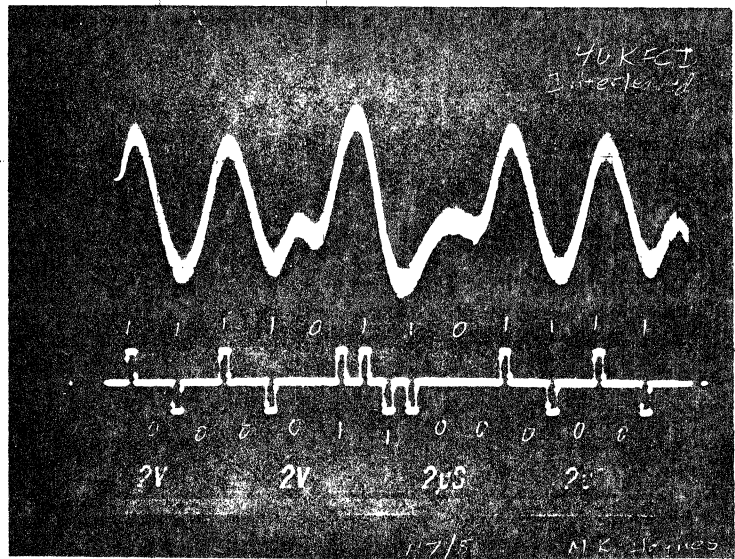

Interleaved Bi Polar - 40KFCI  
(Partial Response - Class IV)



## FILLED BIPOLAR CODE

Choose Fill Sequence:-

'XOVBOV'

Choose X to make 1st V +  
Second V is -

0,5 Code Results

DSV = 2

Single-Bit Errors

Always Detected

Cannot Propagate, or

Simulate Fill

Resync Sequence

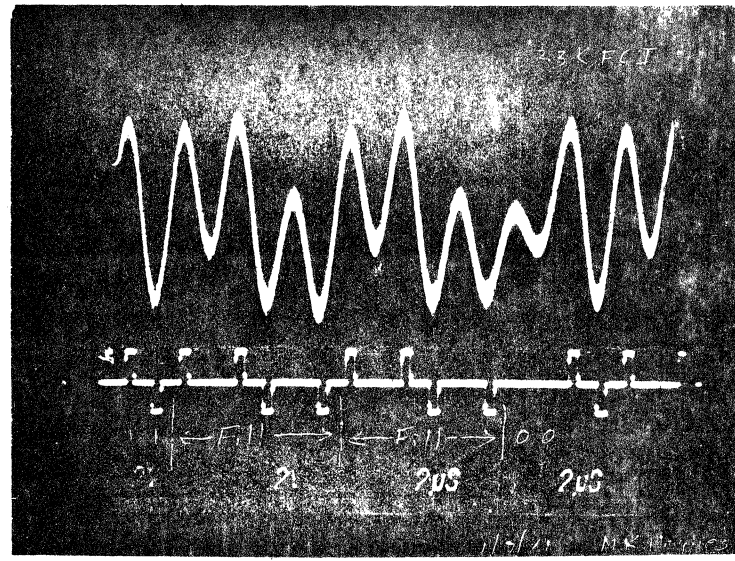

Filled BiPolar - 33KFCI

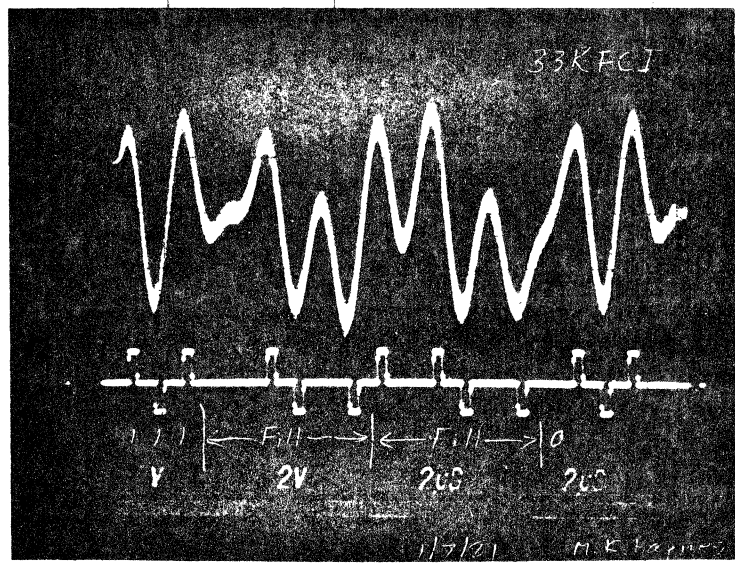

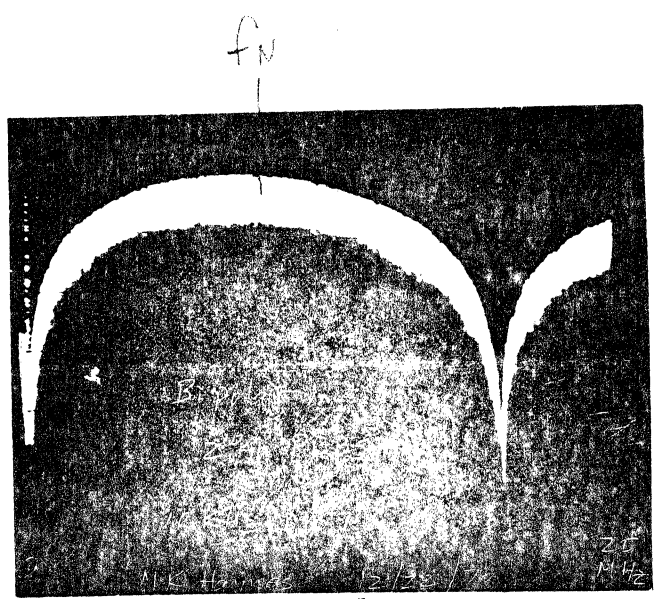

Bipolar Code Spectrum

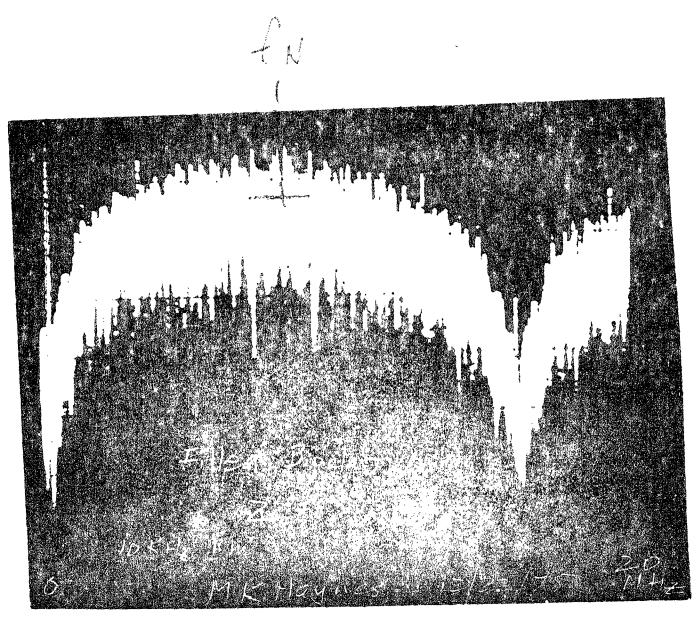

Filled Bipolar Spectrum

FILLED INTERLEAVED BIPOLAR

Class IV Partial Response

Polarity Alternation in  
each Subchannel

Choose Fill Sequence:-  
'XX00VV'

Choose X's for Odd Parity  
in each Subchannel

One V in each Subchannel  
Opposite Polarities  
Alternates from last

Other Features Similar

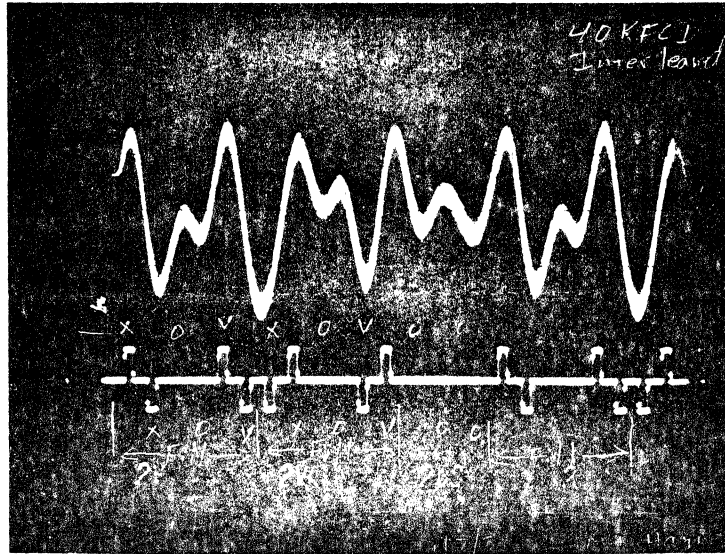

Filled Interleaved Bipolar - 40 KFCI

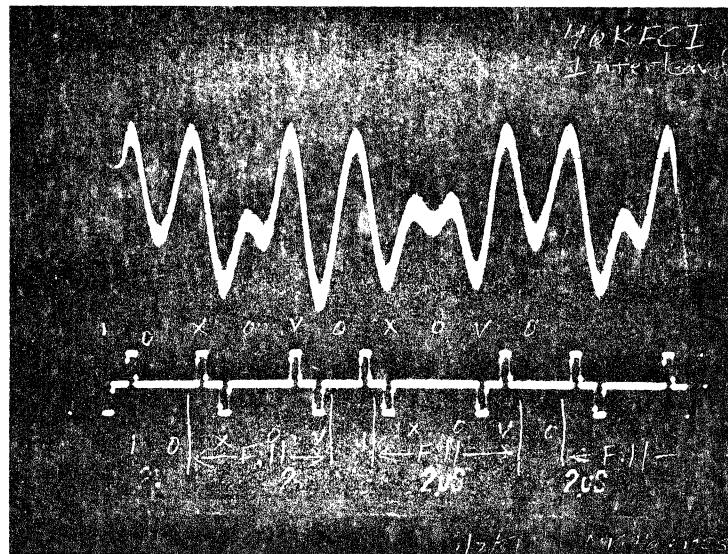

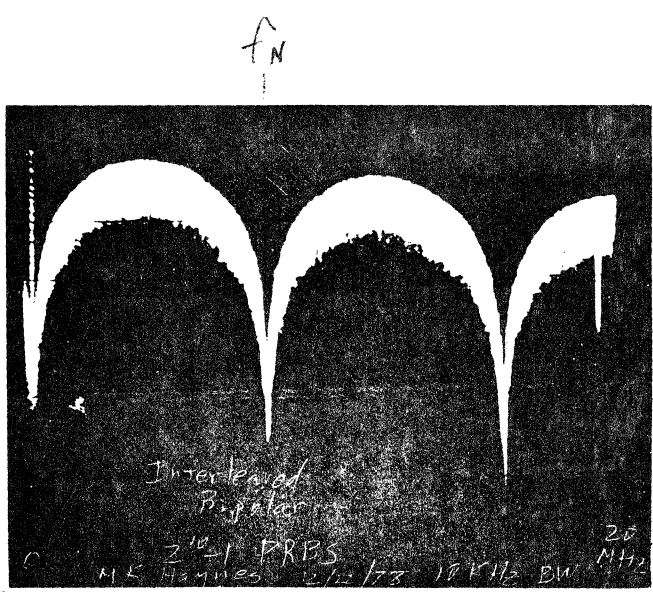

Interleaved Bipolar Spectrum

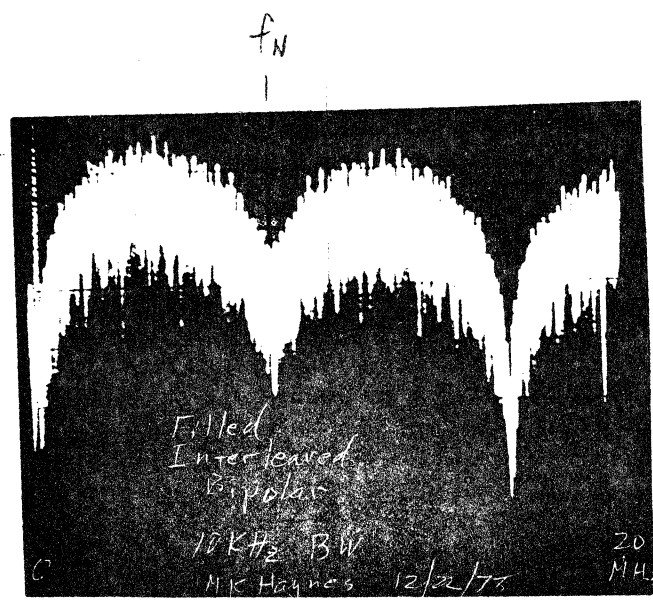

Filled Interleaved Spectrum

IBM CONFIDENTIAL

THE POWER OF EQUALIZATION  
AND INTEGRATED NRZ1 DETECTION

By

E. Hopner, Carmel, 1/13/81

I. PARTIAL DELAY LINE (Si-Kee Au)

A. Flexible Disk Implementation

Fig. 1A shows a delay line equalizer with total reflection and a delay of a fraction of the bit time. Fig. 1b indicates graphically the time domain equalization process.

Fig. 2 shows the measured transition frequency response of an implemented partial delay line equalizer. The net effect is doubling of the available band width.

Fig. 3 shows the drastic improvement of the pulse (slimming) and the detection capability of the equalized signal at twice the density of the original NRZ1 signal. The recorded density of a 1 mil Mylar chromium oxide disk was 40 Kbits/inch at 20 Mbits/sec.

B. Coronado Simulation

Way Mun Syn simulated a typical Coronado pulse using SDL, which is shown in Fig. 4. A composite Coronado output signal was simulated by linear superposition for a characteristic binary sequence 1 1 1 0 1 0 1 0 0 0. This sequence was chosen because it contains the highest frequency ( $f_{B/2}$ ) as well

B. Coronado Simulation (continued)

as the lowest (DC), together with  $f_b$  and is convenient for signal processing studies. The "eye" diagram of the Coronado signal (Fig. 6, sampled at the peaks of the undistorted  $f_b$  frequency) indicates considerable closing at Coronado rates (10 K transitions per inch or 16 Mbits/sec.)

Fig. 7 shows the simulated equalized signal using partial delay line principles as per Fig. 1B. As compared to the original Coronado pulse of Fig. 4, significant pulse slimming has been achieved.

Fig. 8 shows the composite equalized Coronado signal at 15 K transitions per inch, or a 15 M bits/sec. for the same binary sequence as shown in Fig. 5. Fig. 9 shows the corresponding "eye" diagram which shows little distortion (open) at 50% increase of density.

II. INTEGRATED NRZI

A. Experimental System (Si-Kee Au)

Fig. 10 explains the detection principles of INRZI.

Fig. 11 shows the measured transition frequency response of an experimental system.

Fig. 12 shows the performance of INRZI at the -28 dB point of Fig. 11, which is at 4 M bits/sec., or 2 MHz. This is a 4X increase in density as compared to the NRZI 3 dB working point (500 KHz or 1 M bits/sec.). Integration and DC restoration shows an open "eye" diagram at 4 M bits/sec.

B. Bell and Howell Implementation (Au)

Fig. 13 shows the INRZI results achieved on a Bell and Howell instrumentation recorder, designed to operate at 33 K bits/inch, with a nine-track head. 100 K bits per inch have been demonstrated at 6 M bit rate and at 60 IPS. Fig. 13 shows an open "eye" and a completely restored binary signal, using a clock derived from the INRZI signal.



C. Coronado Simulation

The partial delay line equalized signal shown in Fig. 7 was used as a basis for linear super-position simulations by Way Mun Syn.

Fig. 14 shows the composite Coronado signal at 15 K transitions/inch with partial delay line equalization only (broken line) and after straight integration (solid line).

Fig. 15 shows the Coronado signal before (broken line) and after straight integration (solid line) at 50% increased density (23 K transitions/inch). The "eye" opening is 20% reduced, or it is approximately 80% open for the test pattern shown (1 1 1 0 1 0 1 0 0 0).

PARTIAL DELAY LINE  
EQUALIZER

**IV Apply a Peak Amphasized Equalization Technique for Extension of Existing Channel Bandwidth (Cont'd.)**

**(a) Basic Circuit Configuration**

T = Bit Time

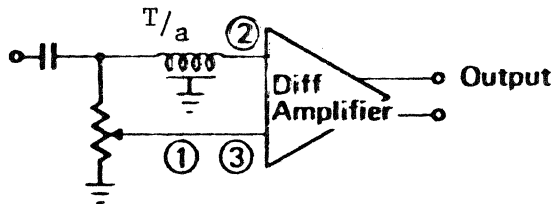

**(b) Basic Principle of the Equalization Process in Time Domain**

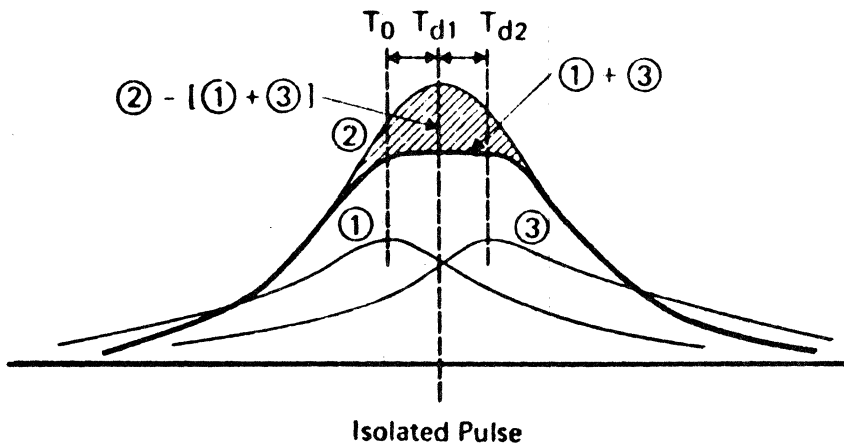
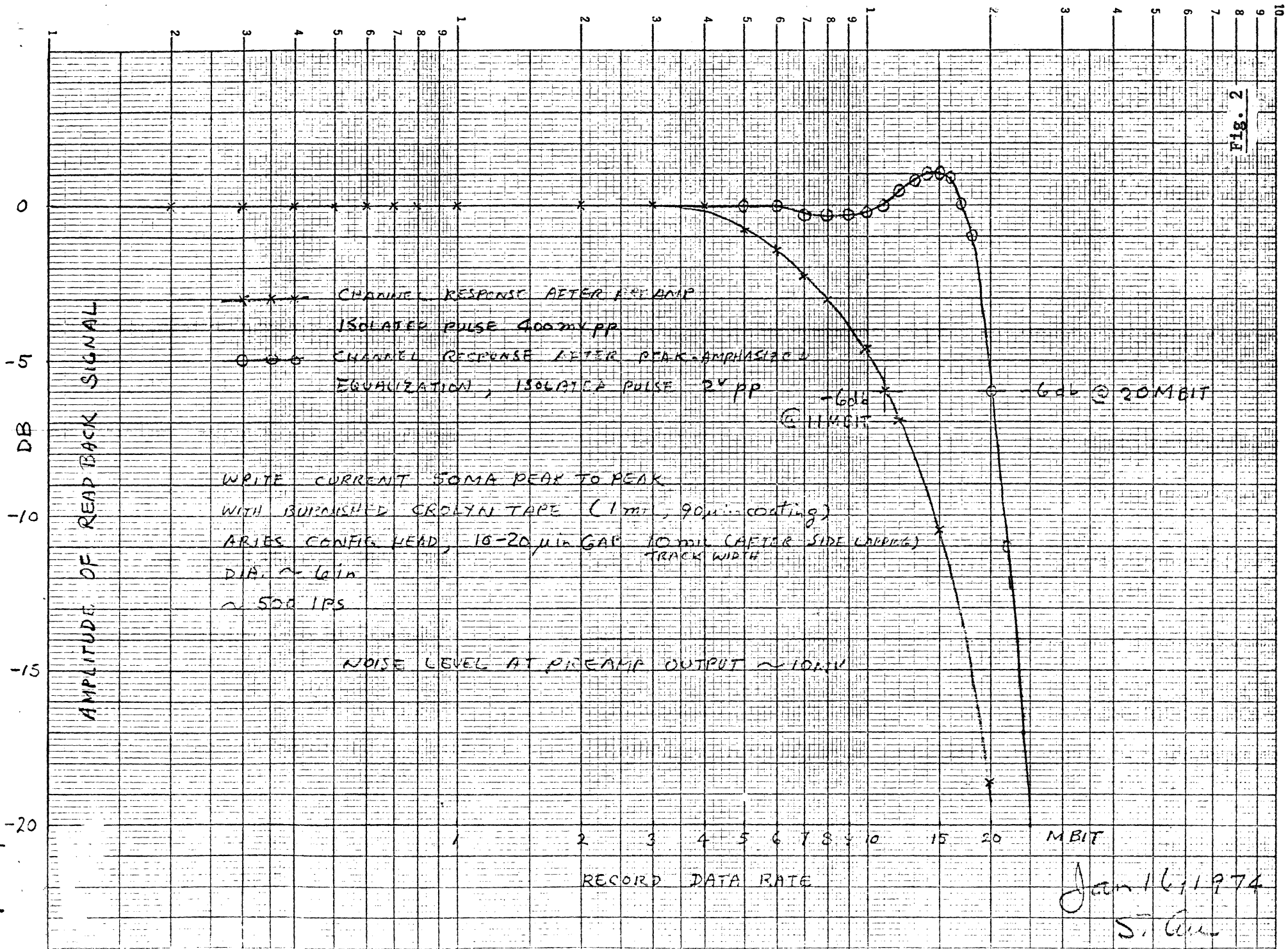

Fig. 1



Jan 16, 1974  
S. G. ...

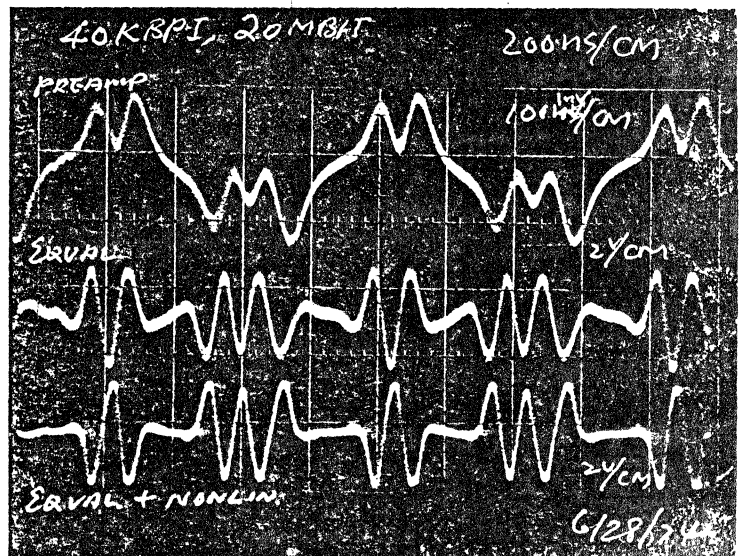
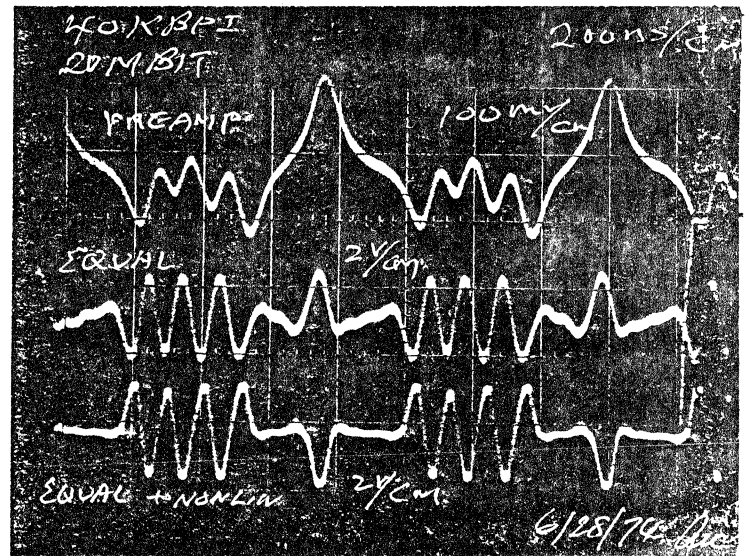
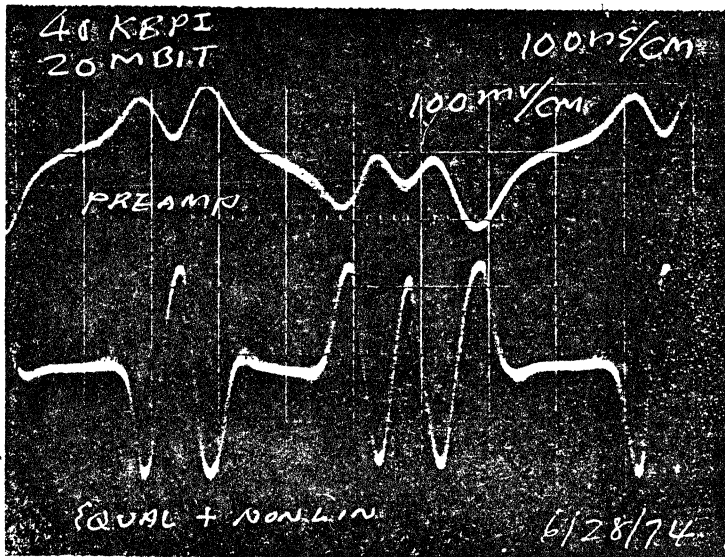
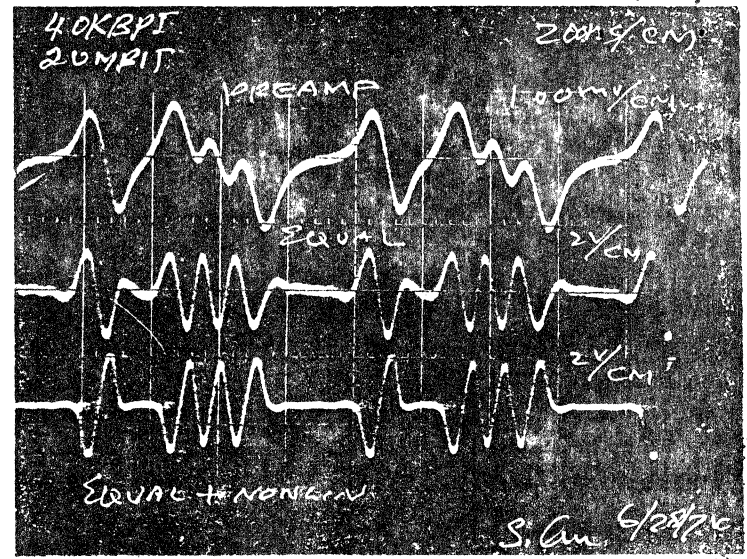
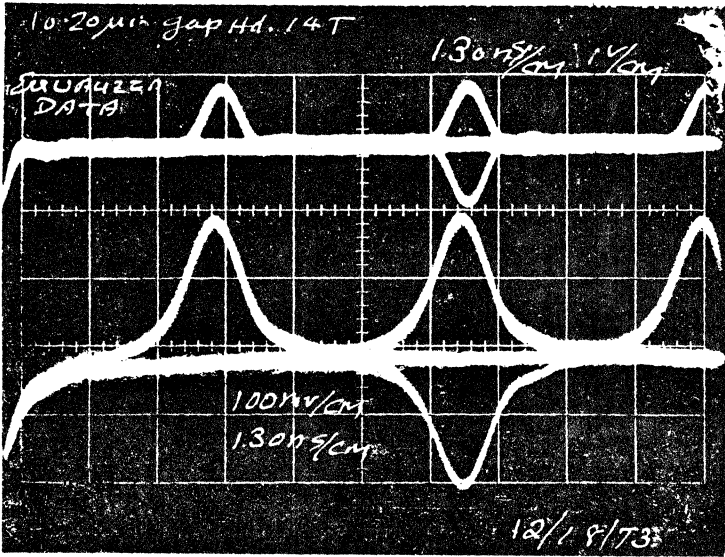
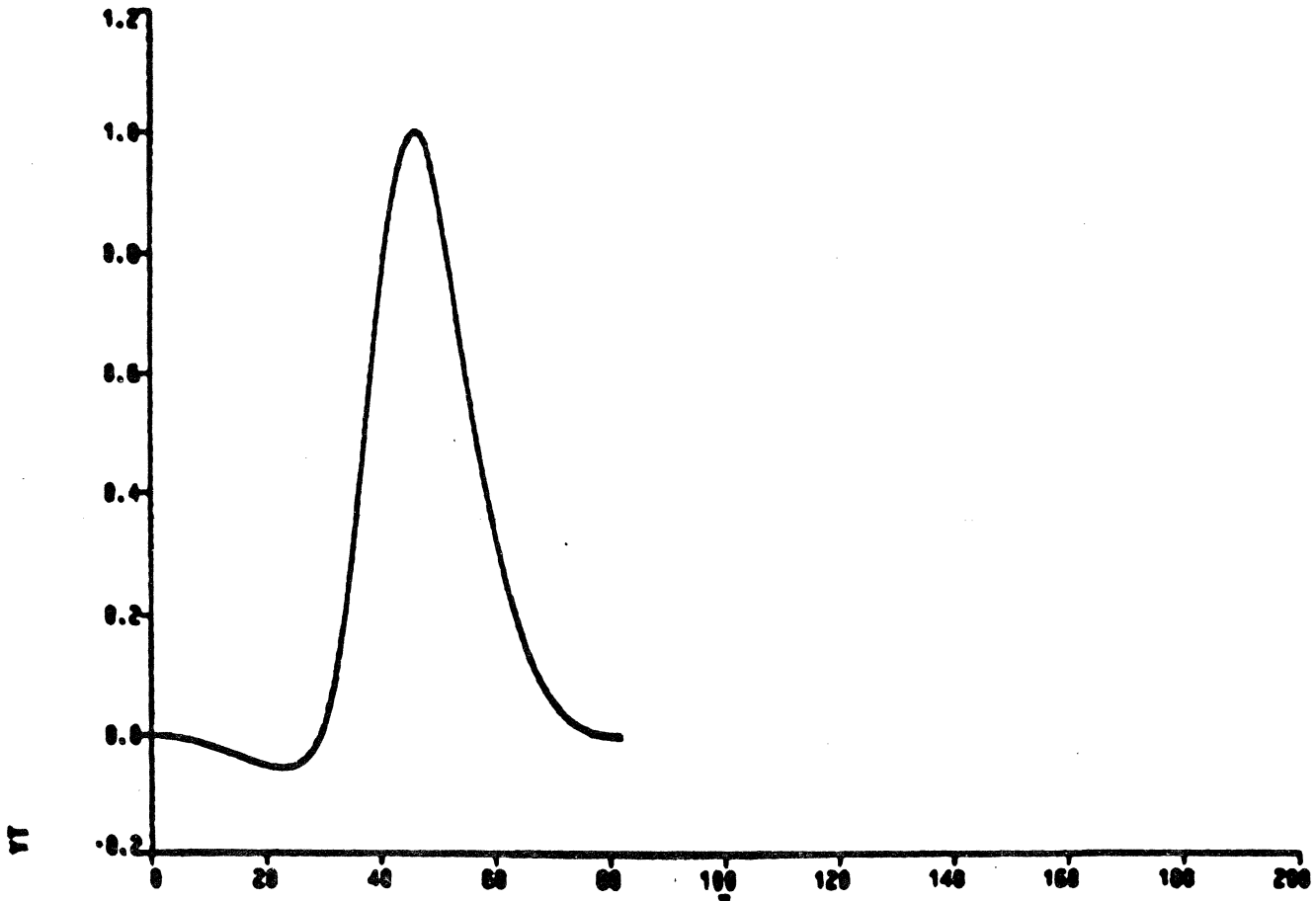

Fig. 3

05:02:00 00/00/01  
0000/ 19



• CHANNEL •

(IDLE10) ORIGINAL PULSE WITH SPLINE OVERLAY

Fig. 4

Fig. 5

G1 /BLANK  
11/11/80 14:02:28

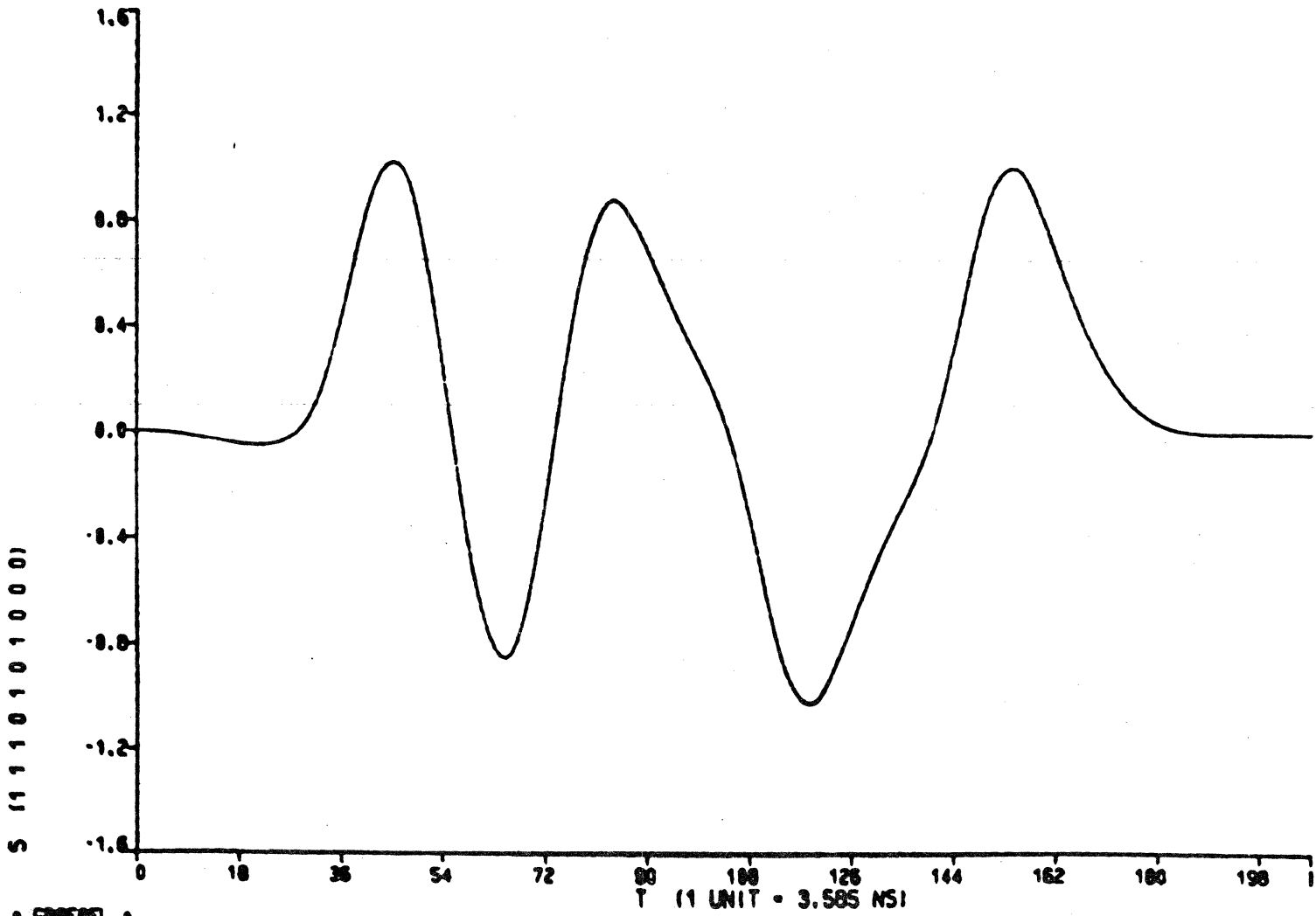

• GRAFREL •

• ORIGINAL CURVE, CBC = 64.53 NANoseconds

G2 /BLANK  
11/11/80 14:03:07

Fig. 6

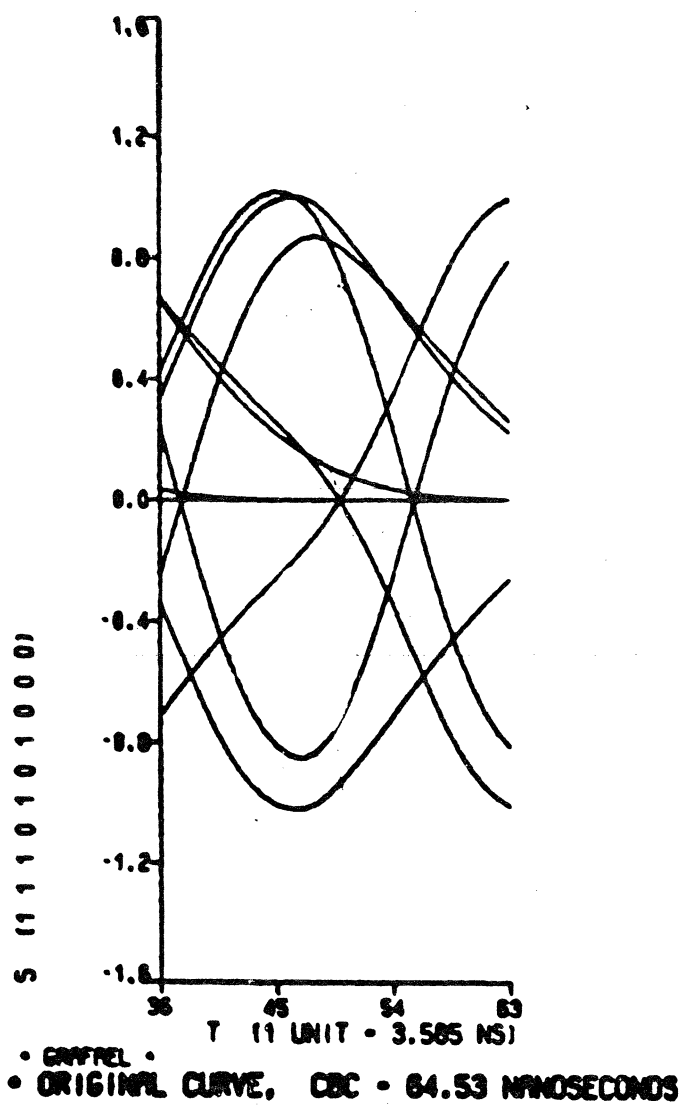

G3SR / ECU  
10/20/80 15:11:35

FIG. 7

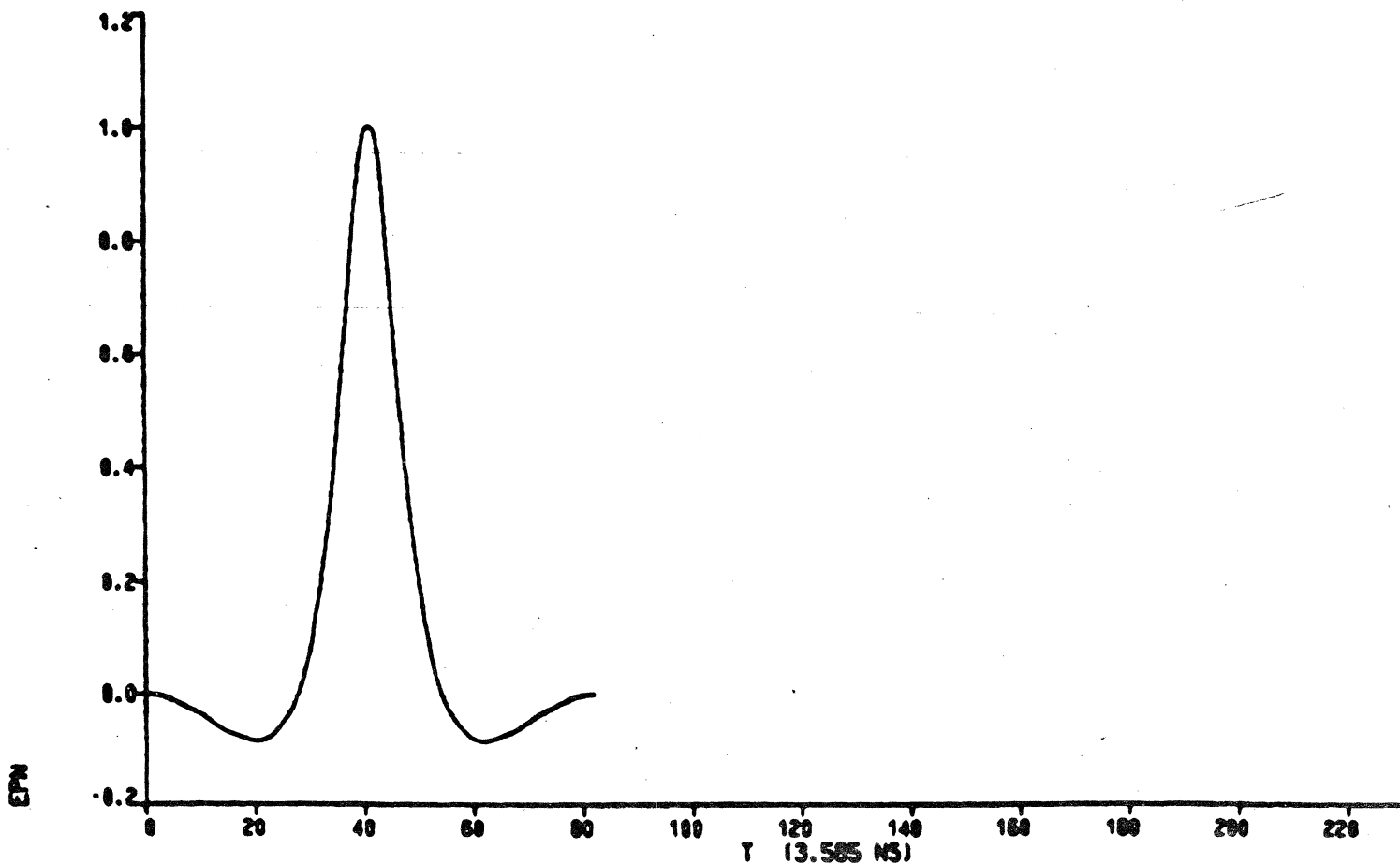

• GRVREL •

N.E.P: TO • 0,5,10; AM • .45,1,.45



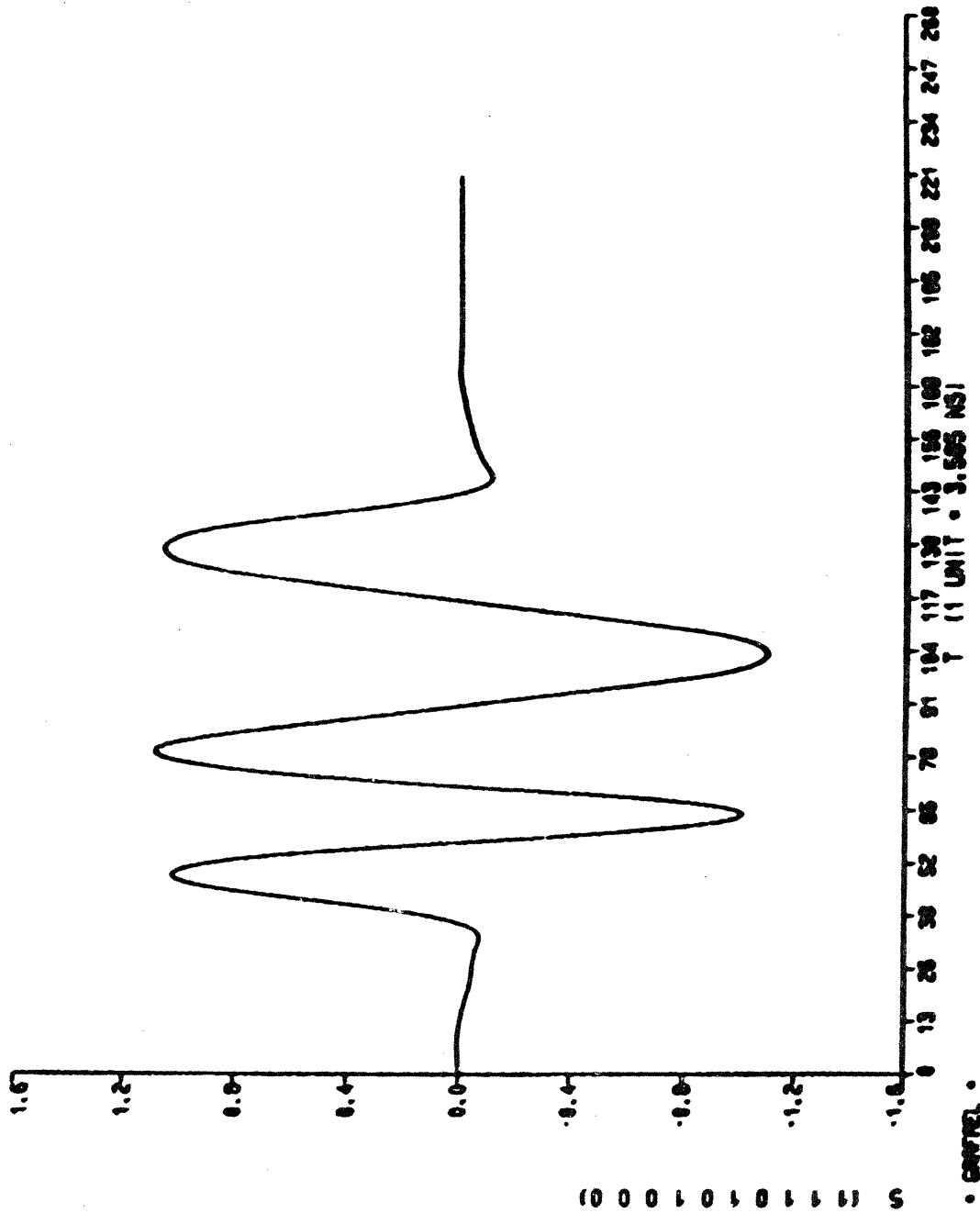

G1 /BLANK 11/12/80 16:16:55

Fig.

62 /BL/MSK  
11/12/80 16:17:19

FIG. 9

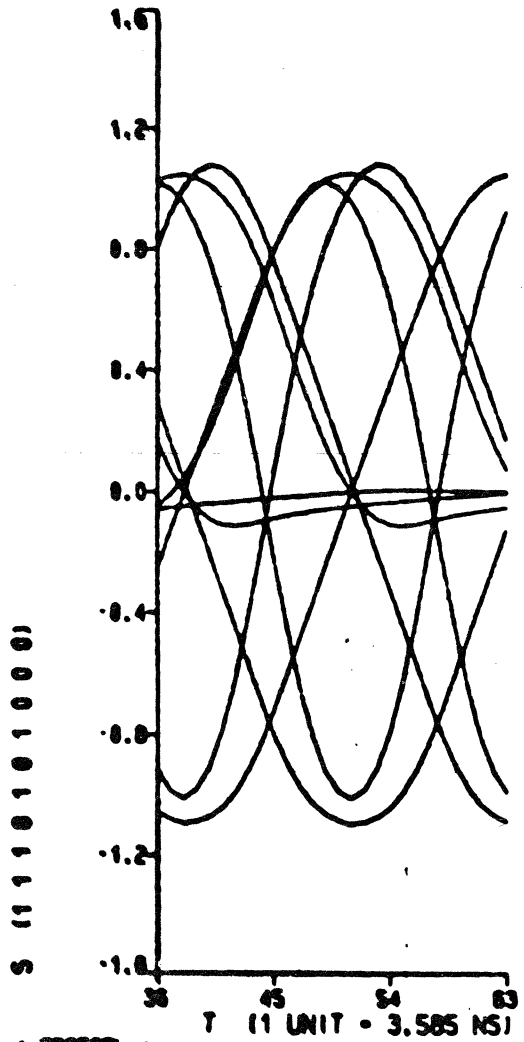

• GPPREL •  
• INPUT: LS(5,..29), CBC = 46.605 NANoseconds

# INTEGRATED NRZI

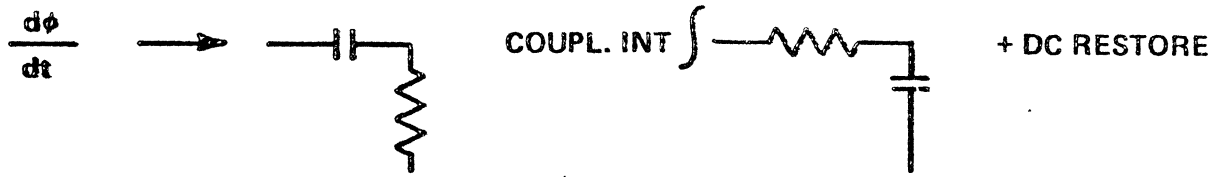

Figure 2. EQUIVALENT CIRCUITS

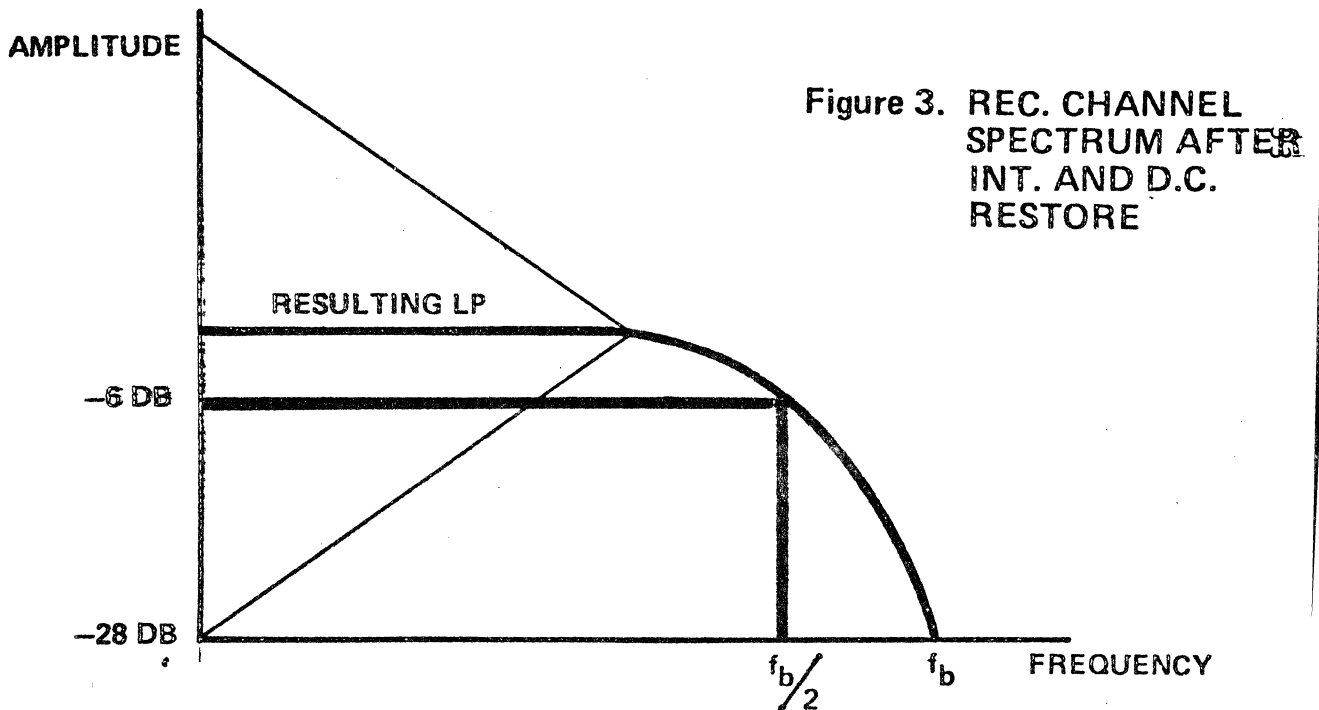
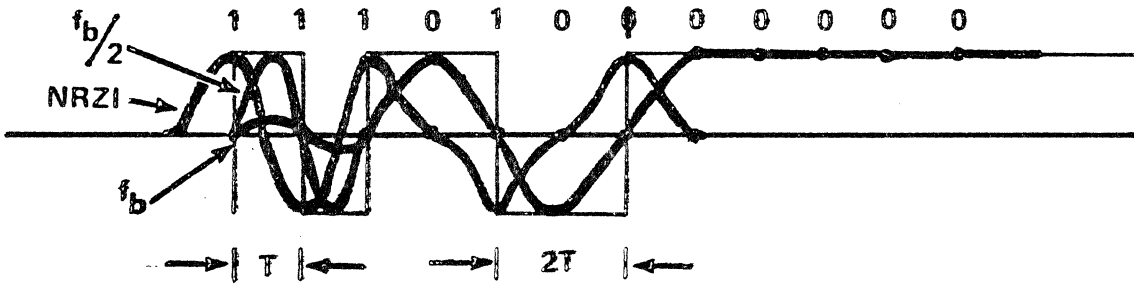

Figure 3. REC. CHANNEL SPECTRUM AFTER INT. AND D.C. RESTORE



<u>NRZI</u>	<u>INRZI</u>	<u>CODE</u>
Pulse	No Pulse	$\pm 1$
No Pulse	Pulse	0

Figure 4. WAVE FORMS AT  $f_{b/2}$  AND  $f_b$

SAMPLE TIME: - BIT TRANSITION TIME

5

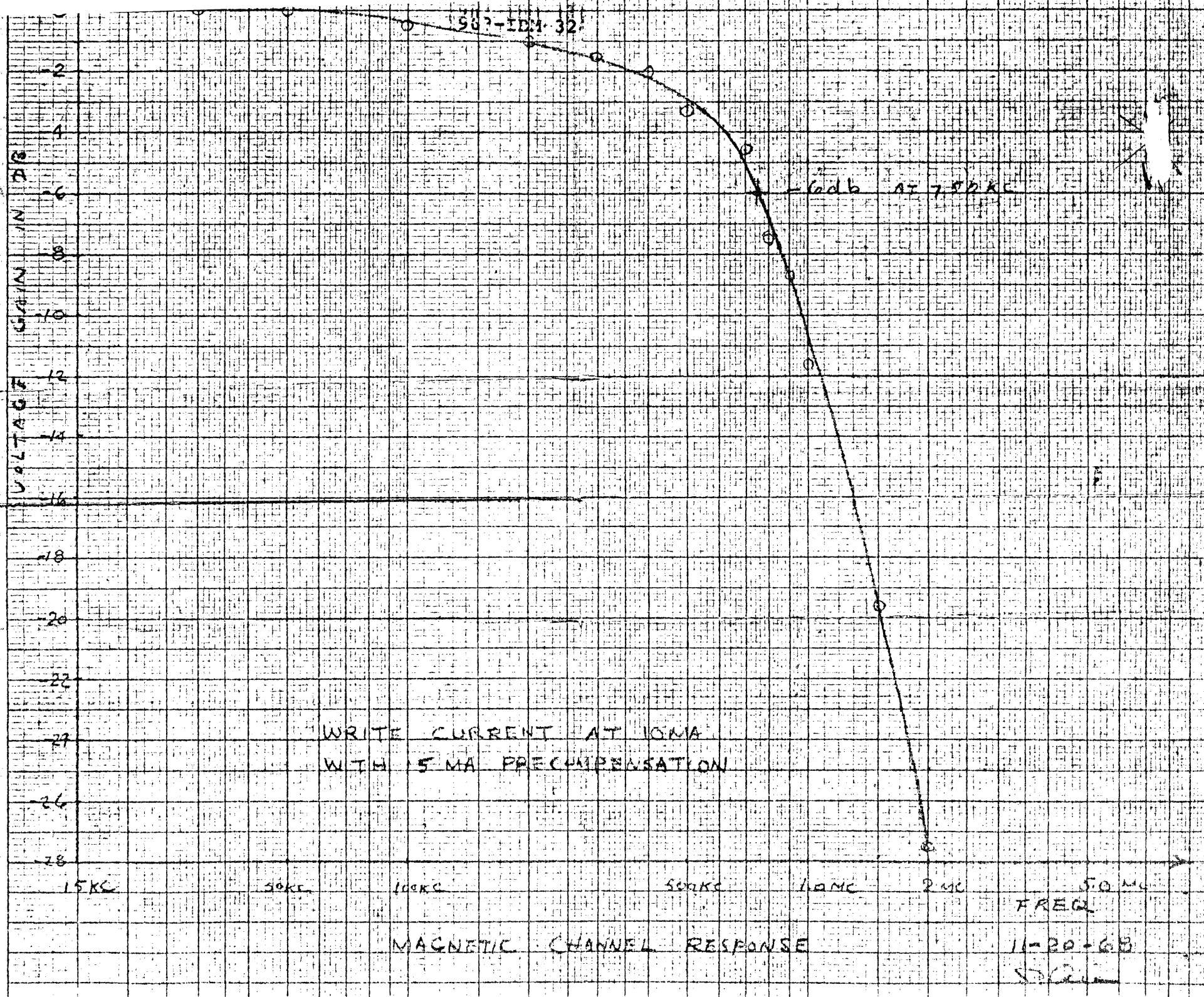

FIG. 11

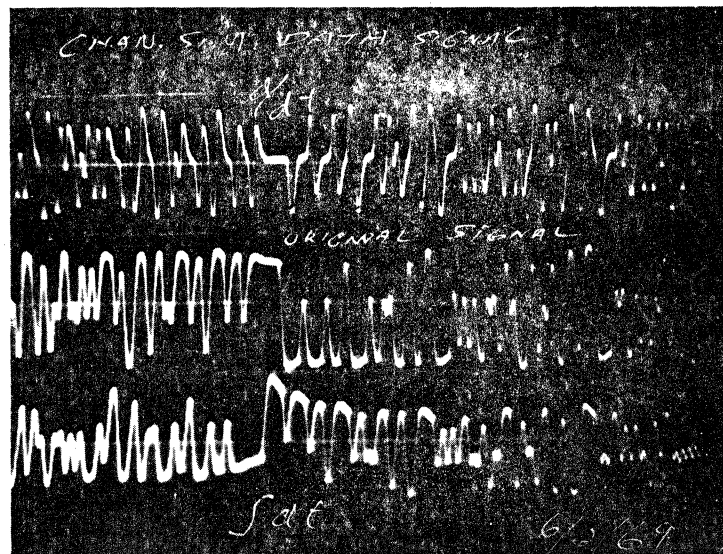
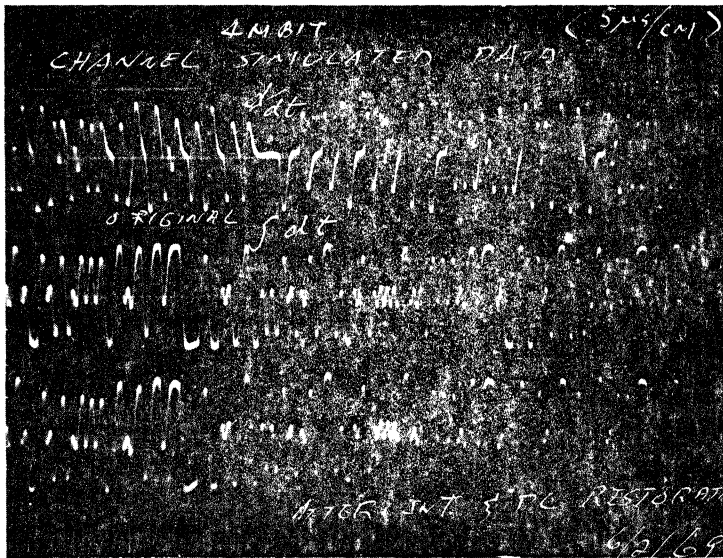
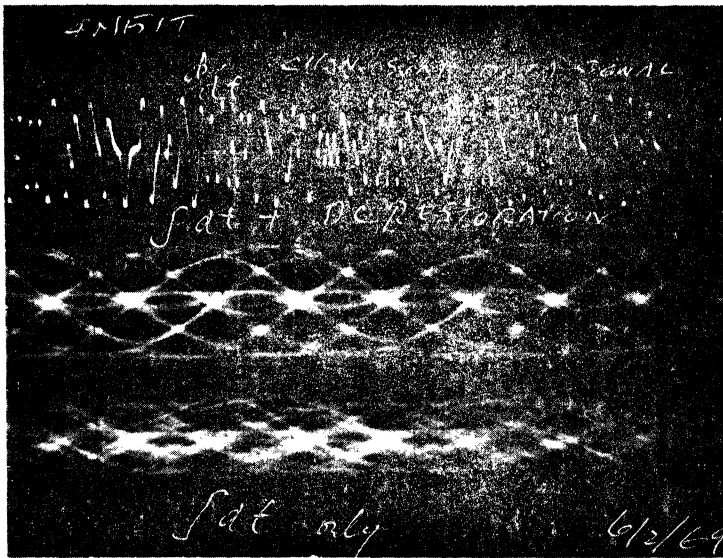

Fig. 12

144  
7

Actual results at 100 Kbits/inch are shown in Figure 2.

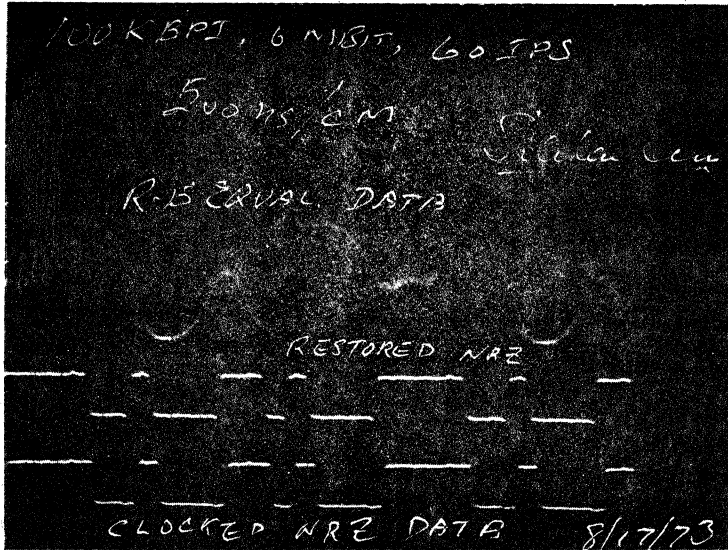

Figure 2a.

Recovered read-back signal, after signal processing and recovered NRZI data at 100K bpi.

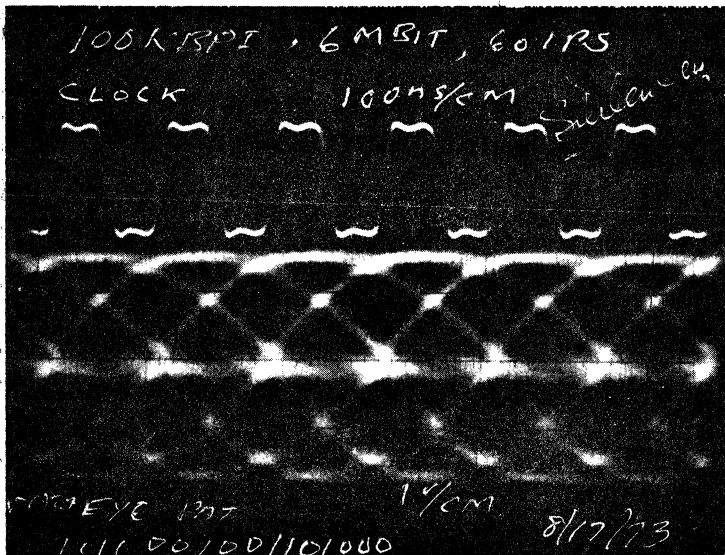

Figure 2b.

Superposition of recovered data signals indicating negligible interbit interference at sampling times. Clock signal was derived from the analog data signal.

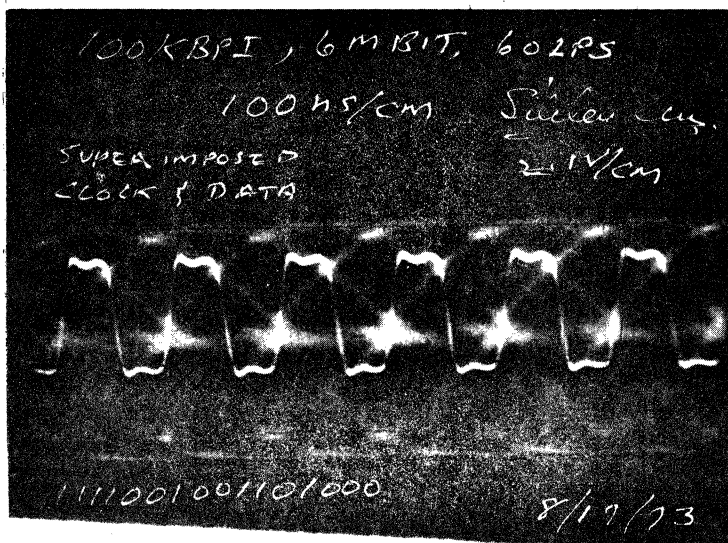
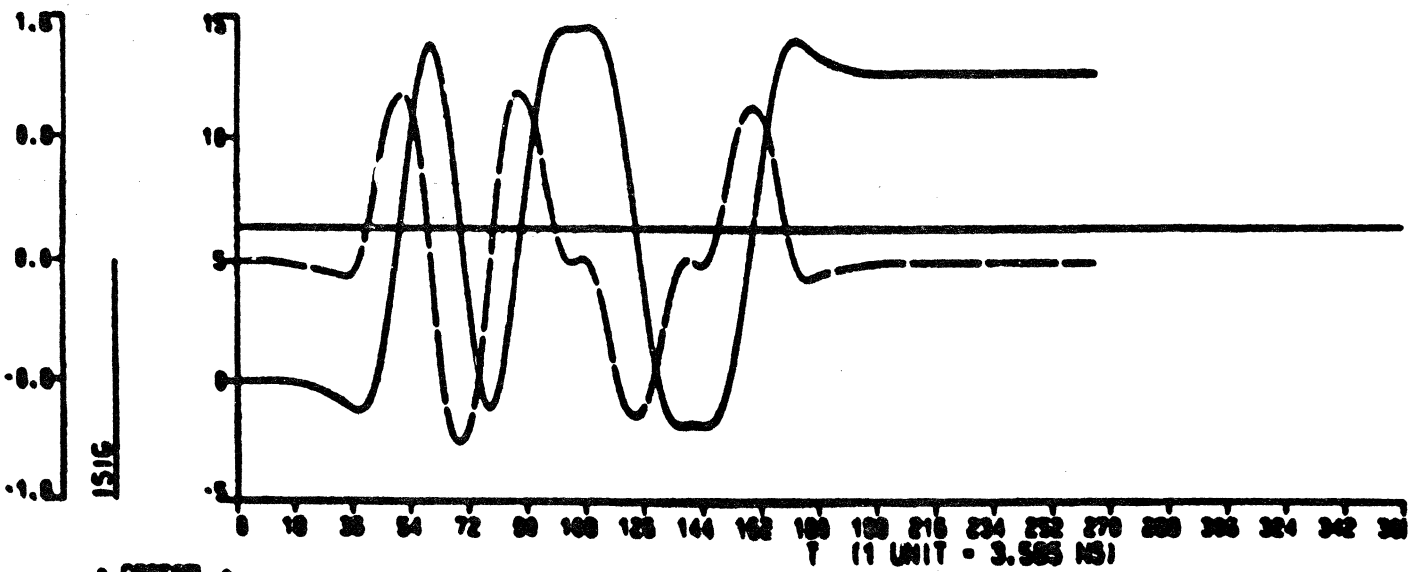

Figure 2c.

Superposition of processed signal with derived clock for the same data sequence. At sampling time (the positive going edge of the clock) the "1"-condition signal is near the 0-voltage (center) level, while the "0"-condition signals are at unambiguous positive or negative levels.

12/15/88 16:13:48

SIG (111101010000)



• 00000 •

LS(5..20), CBC = 84.59 NS. WITH INTEGRATION

Fig. 14

11:27:01 00/51/21  
12/15/80 16:21:11  
69

Fig. 15

10001010111111 515

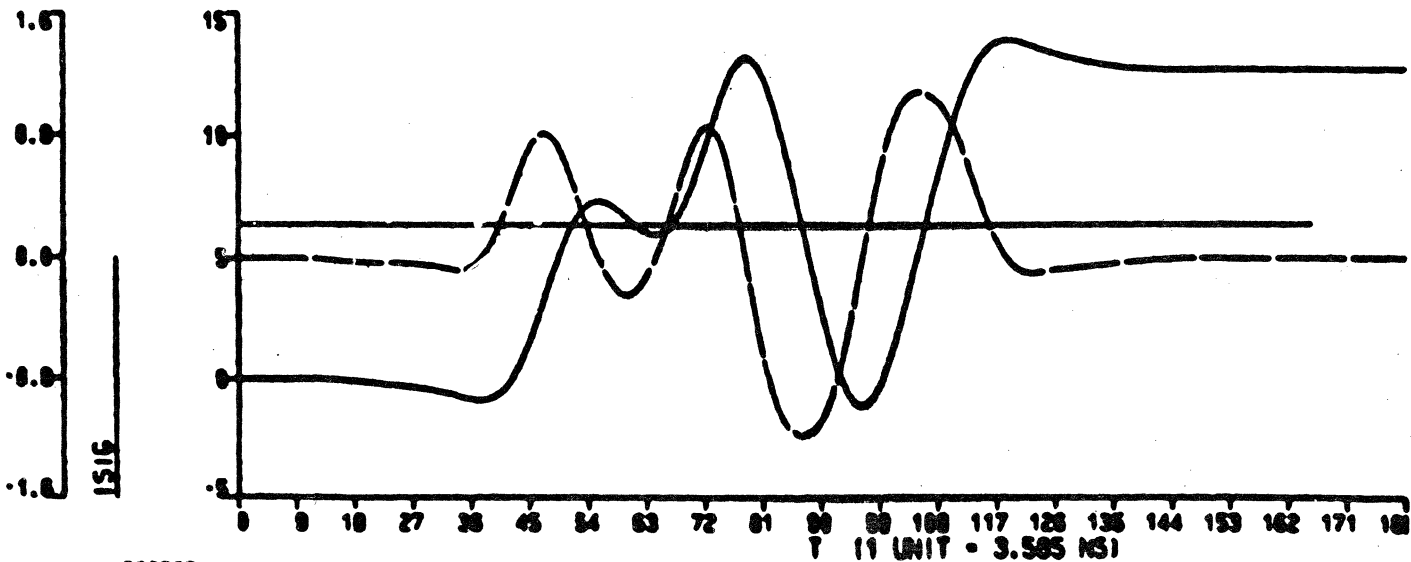

• 5151 •

LS(5..20), CBC = 32.265 NS. WITH INTEGRATION



IBM CONFIDENTIAL

FRONTIER TECHNOLOGY

GOALS

FRONTIER

CORONADO

30 Kb/in.  
 6 MB/sec.  
 1600 tracks/in.  
 12 Msec average access time  
 Head-arm assembly  
 independently controlled

15 Kb/in.  
 3 MB/sec.  
 800 tracks/in.  
 18 Msec average access time

158-1001-324

COLUMBIA FILES

C1	FCS	1Q86
C2	FCS	3Q86

RLComstock  
 1/12/81

FRONTIER

Objectives

Data Transfer Rate:  $6 \times 10^6$  Bytes/Sec  
 or  $48 \times 10^6$  Bits/Sec (8 Bit Byte)

Data Density {  $1600$  Tracks/in (63)  
 $30 \times 10^3$  Bits/in (1180)

2,7 Code Requirements

Coding Example:

Data	1	0	1	0	1	0	0	0	1	1	1	1	...	...												
Coded Data	0	1	0	0	0	1	0	0	0	1	0	0	0	0	0	1	0	0	0	1	0	0	0	...	...	
Clock	1	1	1	1	1	1	1	1	1	1	1	1	1	1	1	1	1	1	1	1	1	1	1	1	...	...

Clock Rate :  $96 \times 10^6$  Hz

Transition Density :  $15 \times 10^3$  Transitions/in (786)

		<u>Max</u>	<u>Min</u>
Transition Rate :	$32 \times 10^6$ Tr./sec		$12 \times 10^6$ Tr./sec

Readback Frequency :  $16 \times 10^6$  Hz  $6 \times 10^6$  Hz  
 (equiv. sinewave)

Media Velocity : 1600 In/sec ( $4.06 \times 10^4$ )

( )  $\Rightarrow$  mm

50-301-321

IBM CONFIDENTIAL

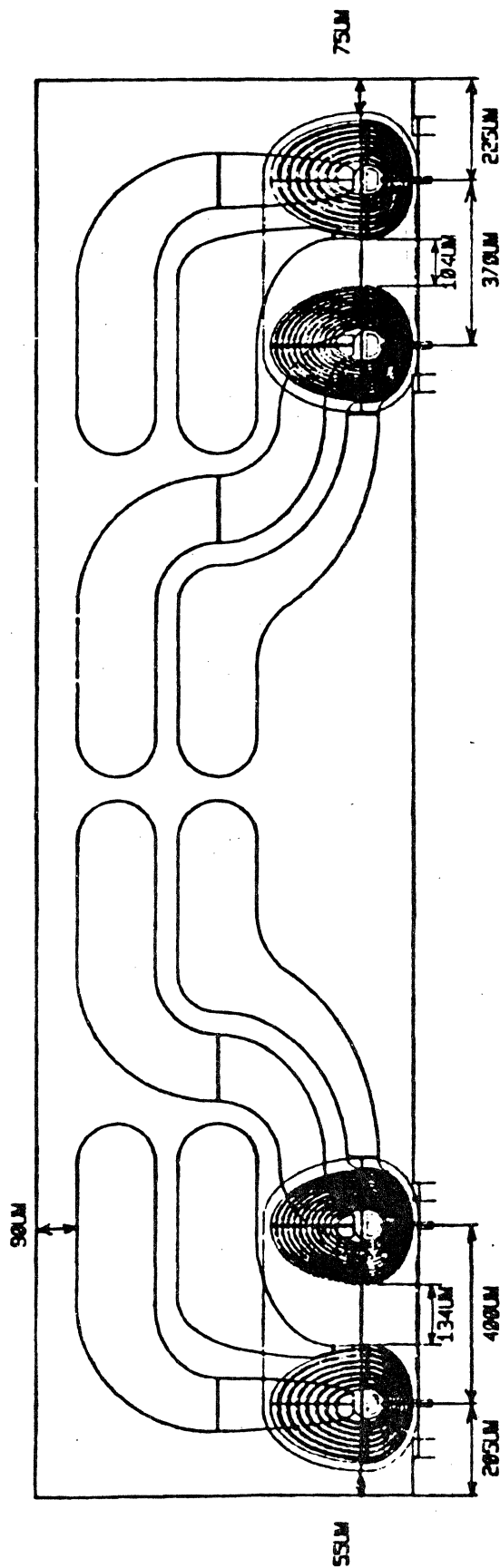

Track width

P1	29.5 µm
P2	26.5 µm

Track width

P1	18.5 µm
P2	12.5 µm

562-IBM-32

562-IBM-32

IBM CONFIDENTIAL

Possible Combinations of Head/Disk/System Choices

1) Embedded Servo:

- a) side-by-side dual element head
- b) ac-bias recording
- c) disks thick particulate  
or  
dual layer film

2) Sector Servo:

- a) single element R/W head  
or  
superimposed dual element R/W head
- b) saturation recording
- c) disks - thin particulate  
or  
single layer film

58-IBM-32

12/9/80

REDean

IBM CONFIDENTIAL

DATA BASE  
SINGLE ELEMENT  
THIN FILM HEADS

<u>DISK</u>	<u>HEAD</u>		
MAMMOTH B	3/1.18/3	2.2/1.1/1.6	1.7/0.9/1.6
H <sub>C</sub> = 320 OE			
S = 18 μ"			
PVC = 30%			
D <sub>3DB</sub> (KFC/IN)	8	11	10.8
AMPLITUDE (μVPP)	170	175	260
 MEP			
H <sub>C</sub> = 600 OE			
S = 23 μ"			
PVC = 20%			
D <sub>3DB</sub>	8.8	12.7	12.6
AMPLITUDE	140	77°	170
 AURORA			
H <sub>C</sub> = 750 OE			
D <sub>3DB</sub>	11.4	14.6	14.7
AMPLITUDE	75	58	110

• MARGINAL SATURATION

LMB1SP506

RLC--12/5/80



## TUCSON RECORDING TECHNOLOGY

## MISSION

LOW COST INFORMATION STORAGE ON MAGNETIC TAPE.

## ADVANTAGES OF MAGNETIC TAPE

LOW COST ( $< \$1/\text{FT}^2$ ,  $< 10¢/\text{MBYTE}$ )

HIGH VOLUMETRIC EFFICIENCY (MSS=7, SAGUARO=15 GB/FT<sup>3</sup>)

EASILY REMOVABLE FROM MACHINE

CONFIGURATION FLEXIBILITY

## DISADVANTAGES OF MAGNETIC TAPE

POOR SURFACE QUALITY

THICK COATINGS (SAGUARO THICKNESS = 4 BIT LENGTHS)

DROPOUTS ( $< 20\%$  SIGNAL FOR SEVERAL HUNDRED BIT LENGTHS)

## PROBLEMS WITH MAGNETIC TAPE

REMOVABILITY LEADS TO INTERCHANGEABILITY

DOWNWARD COMPATIBILITY IS REQUIRED

MRC/GH/111

1/09/81

IBM CONFIDENTIAL

SUBSTRATE SURFACE  
MYLAR PB  
360X

7/29/74

PB Mylar

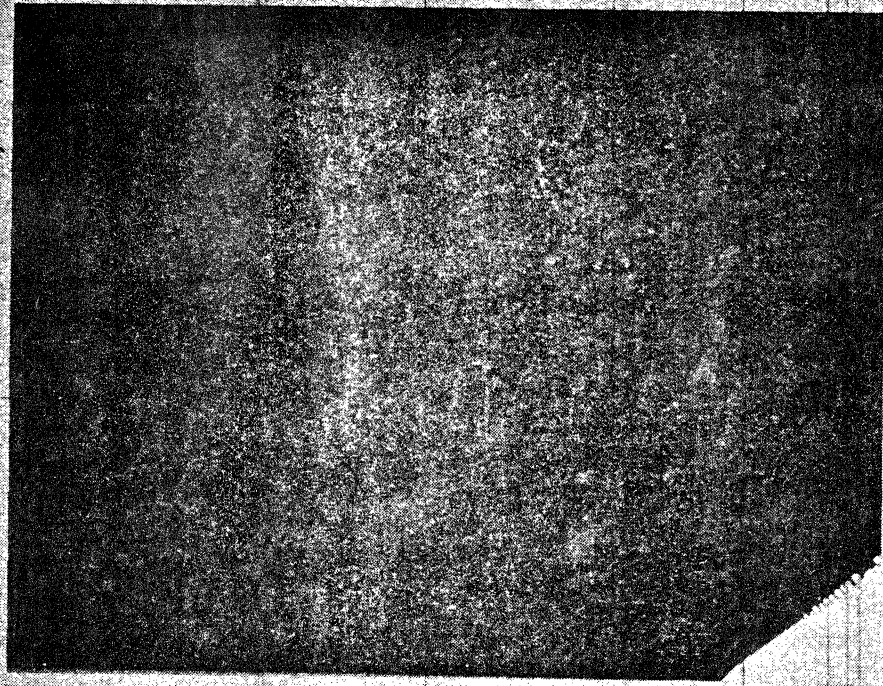

1.5 ml 360x

8740-3-0006

7/29/74

PB Mylar

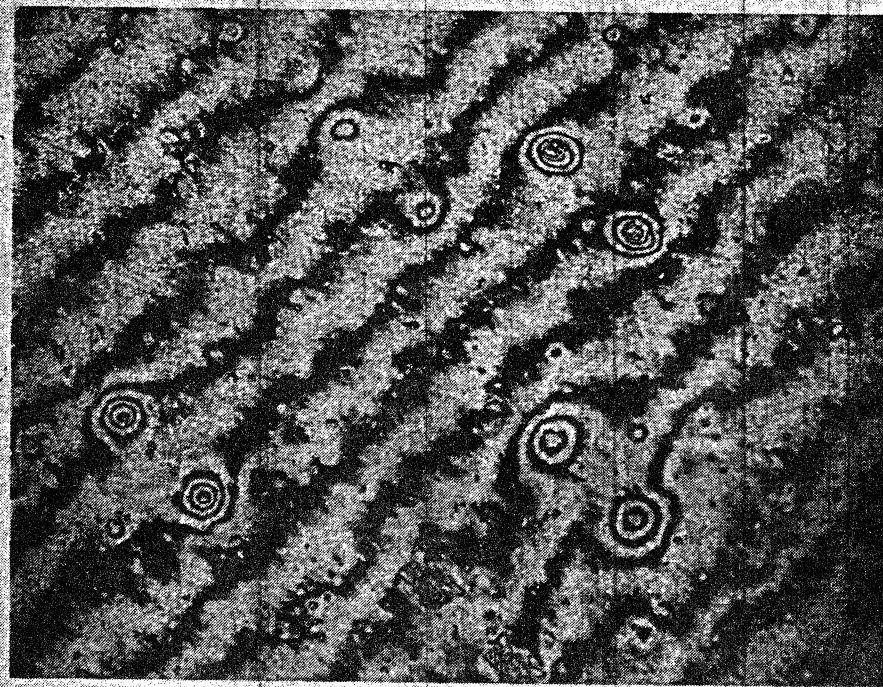

1.5 ml 360x



TYPICAL DROPOUTS - AC ERASE  
MASSIVE T<sub>A</sub> HARDWARE

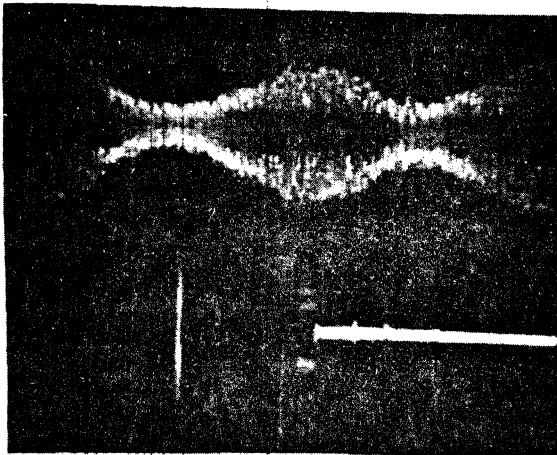

ERROR FREE

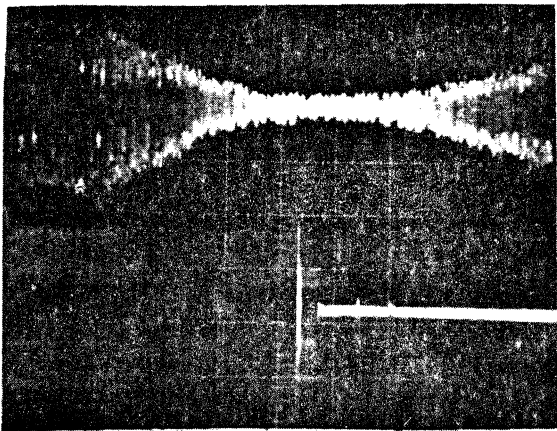

ERROR - NO  
SYNC LOSS

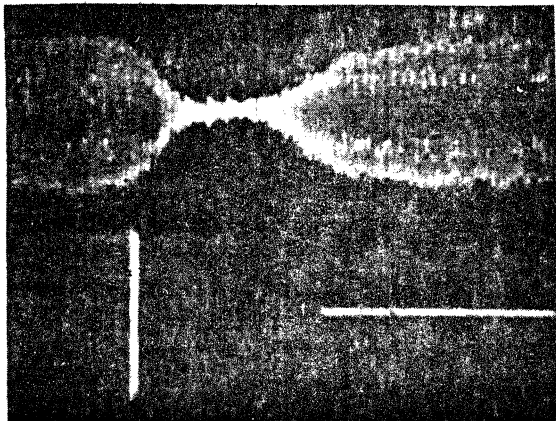

ERROR - SYNC  
LOSS

IBM - 1<sup>st</sup> - 41  
IBM - 75 - 41

IBM CONFIDENTIAL

IBM CONFIDENTIAL

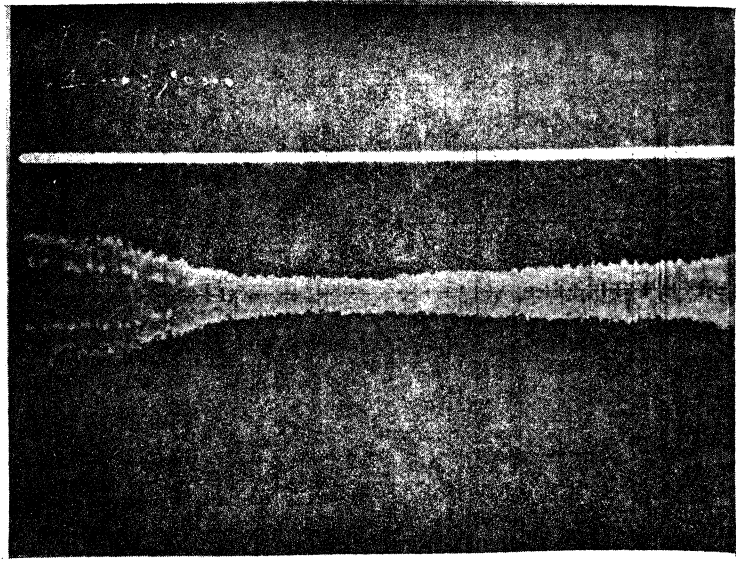

Error Line

Signal

125 bits/division

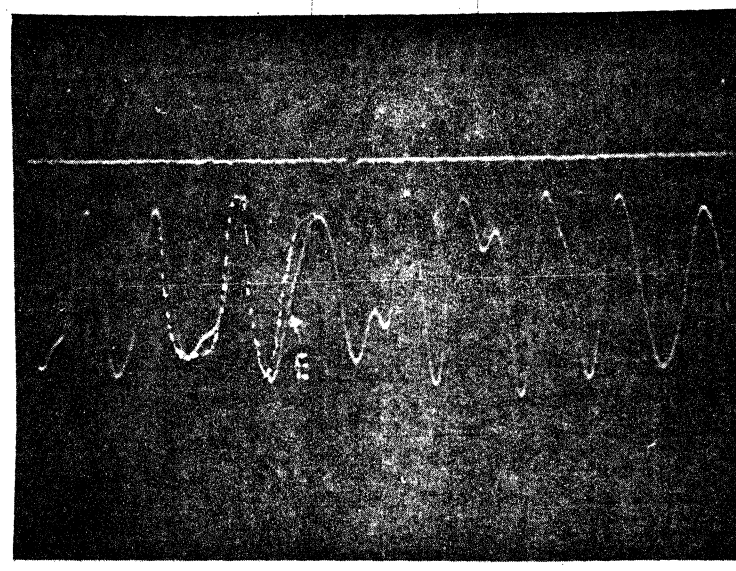

Error Line

Signal

2.5 bits/division

Fig. 3 - Typical Random Error -- Linear Density = 800 BPM,  
 Track Density = 5 TPM, Track Width = 178 Microns.  
 SNR is 26 dB average, 12 dB during dropout.

IBM CONFIDENTIAL

IBM - TS - 41

Pluto XVIII

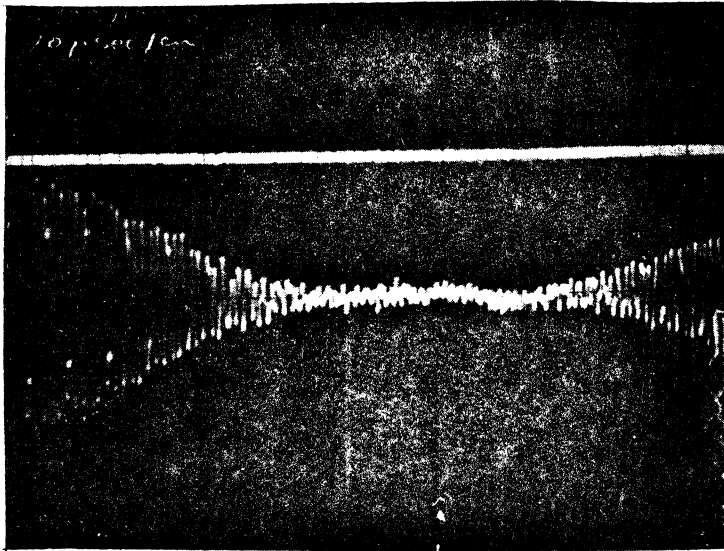

Error Line

Signal

25 bits/division

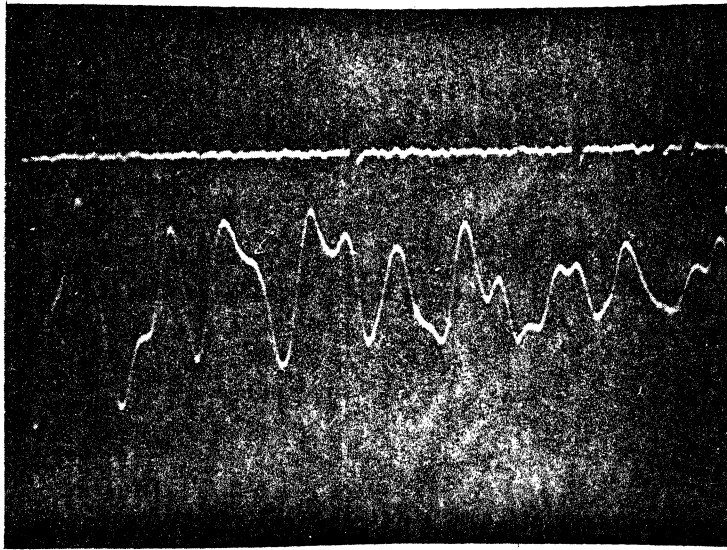

Error Line

Signal

2.5 bits/division

Fig. 4 - Typical Burst Error -- Linear Density = 800 BPM,  
 Track Density = 5 TFM, Track Width = 178 Microns  
 SNR is 26 dB average, 4 dB during dropout.

IBM - TS - 41

## DEL ORO TECHNOLOGY

PRODUCT NAME	SAGUARO	PALO VERDE	NONE
FCS	1982	1985	1989
DATA RATE (MB/SEC)	3	6	12
CAPACITY (GB)	1/6	1	2
NUMBER OF TRACKS	18	18	18
TAPE VELOCITY (MPS)	2	2	2
LINEAR DENSITY (K BYTES/INCH)	38.1	76.2	152.4
(K BYTES/M M)	1.5	3	6
DATA RELIABILITY (BYTES/ERROR)	$10^{12}$	$6 \times 10^{14}$	$10^{16}$
BIT LENGTH ( $\mu$ IN)	45	23	11
SEPARATION FOR 6 DB LOSS ( $\mu$ IN)	10	5	2.4
READ DOWNWARD	No	YES	YES
WRITE DOWNWARD	No	YES	YES
TAPE	PEGASUS	PEGASUS	NEW

How?

.....  
 IMPROVED SIGNAL PROCESSING

.....  
 IMPROVED ERROR CORRECTION

MRC/GH/112

1/8/81

IBM CONFIDENTIAL

11  
 10  
 9  
 8  
 7  
 6  
 5  
 4  
 3  
 2  
 1  
 IBM

## TECHNOLOGY PLANS

MORE EFFICIENT MODULATION CODES (REDUCE FCI/BPI)

IMPROVED EQUALIZATION (WRITE, ADAPTIVE)

BETTER SNR (ELECTRONICS ON HEAD)

MORE POWERFUL ECC (R-S DECODER, CONVOLUTIONAL CODES)

PARTIAL RESPONSE CHANNEL

VITERBI DECODING

HEAD/TAPE DEPENDENCIES

INCREASED LINEAR DENSITY

VERTICAL COMPONENT

SHORT GAP HEADS (10  $\mu$  IN)

ULTRA SMOOTH TAPE SURFACE

ELECTRONICS PACKAGED ON HEAD

MRC/GH/116

1/12/81

IBM CONFIDENTIAL

11

1

## Saguaro Recording Channel

### Introduction

Saguaro is the code name for a 1/2 inch eighteen track tape product now in development. The recording channel developed for this product has a number of unique characteristics. Many of the special characteristics are related to the use of a two-turn inductive write head and a Magneto-Resistive (MR) read head.

### Write System

The power dissipation in the 18 track two-turn write head required the use of a pulse write technique. Early testing showed that pulse writing even with large variations in pulse width made no discernible difference in read signal amplitude or shape. A pulse width of 1/6 the bit period was finally chosen for time multiplexing convenience.

An early problem with the MR-read head was a distortion problem with high amplitude long wave length signals. The MR head was designed to provide high sensitivity to the low amplitude short wavelength signals. High amplitude signals tended to flatten the peaks. The solution to this problem was to precode the write data so that all read signals were of the same amplitude. The precoder can be modeled as a digital filter. The filter response has zero gain at dc, unity gain at the all 1's and amplification for those

162

harmonics above the all 1's. This response has the advantage of increasing the signal-to-noise-ratio (SNR) for these higher harmonics. This improved high frequency SNR significantly reduces the ISI during media defects. The reduction in low frequency energy content in the write signal also decreases the write-over-modulation problem.

#### Read Equalization and Detection

The MR read signal using the write-precoder looks very much like the write wave form. The method of detection that had been implemented before the precoder introduction was based on a peak sampling detection scheme. The only change that was made to the read system (when the precoder was implemented) was to change the read filter (equalization) response. The principal parts of this filter system are a simple two pole band pass filter in the preamplifier, and a complex pole pair for a low pass filter on the Read-Detection card. The final filter sections are parallel simple pole sections for producing the 90 degree phase shifted derivative for clock extraction.

The detection system samples the equalized read signal once each read clock period. The sampled signal is compared to a threshold. If a positive peak is expected, a peak (one) will be called if the sampled data exceeds the threshold, if not then a zero is called. Once a positive peak is detected



the comparison is switched so that the next one is detected when the sampled signal falls below the negative threshold. The equalized signal is formed such that zero samples have values that are further from the threshold than the zero baseline. As a result the threshold is normally set at about 35% of the average peak amplitude.

The amplitude histogram indicates that the nominal SNR for this system is very high. The dominant failure mode is dropouts (fades). The log of the histogram shows that the low amplitude part of the data is not due to the tails of a normal distribution centered at nominal signal amplitude. This supports the conclusion from failure analysis that most error conditions are associated with some significant loss in nominal amplitude.

#### Reliability and ECC

The average raw reliability for interior tracks is well above the initial objective of  $1E7$ . However, the exterior tracks especially track 18 may be from a factor of two-to-ten lower than the interior tracks. A large variation in edge track performance has been a traditional problem. Continuing effort is being made to better understand and control this variation.

One of the major concerns about the present recording channel is its cliff-like sensitivity to many parameter variations. Additional testing is necessary to better understand this phenomenon.

The Error Correction Code (ECC) has the ability to correct up to four tracks in error at one time. The tracks in error must be divided so that not more than three tracks in either subgroup are in error. For some of the error conditions the error correction system needs the assistance of hardware pointer (eraser) information. The ECC system has the ability to take 4E6 raw error performance and map that into 1E12 mean bytes to failure. This 1E12 mean bytes to failure is the recording system's performance objective.

J. A. McDowell

## SAGUARO RECORDING CHANNEL

WHAT IS IT

WHY IS IT

INITIAL PULSE WRITE

MR HEAD - DISTORTION

WRITE PRECODER

METHOD OF DETECTION

NOISE AND FAILURES

HOW IS IT - RELIABILITY

RAW RELIABILITY

ECC

JAM/GH

IBM CONFIDENTIAL

1/9/81

## S A G U A R O

DENSITY 972FCMM (24.8KFCI)

MODULATION CODE 8/9 (0, 3)

ECC - AXP 14/18 TKS

HEAD - 2 TURN INDUCTIVE WRITE  
MR - DC BIASED READ

TRACK	PITCH	630UM (24.8 MILLS)
WRITE	WIDTH	540UM (21.3 MILLS)
READ	WIDTH	410UM (16.1 MILLS)

MEDIA - PEGASUS CRO2

MEDIA VELOCITY 2.0M/SEC (78.7 IPS)

READ CLOCKING RATE 1.944 MHZ

CUSTOMER DATA RATE 3.0 M BYTES/SEC.

JAM/GH/115  
1/9/81

IBM CONFIDENTIAL

## CHANNEL MODEL

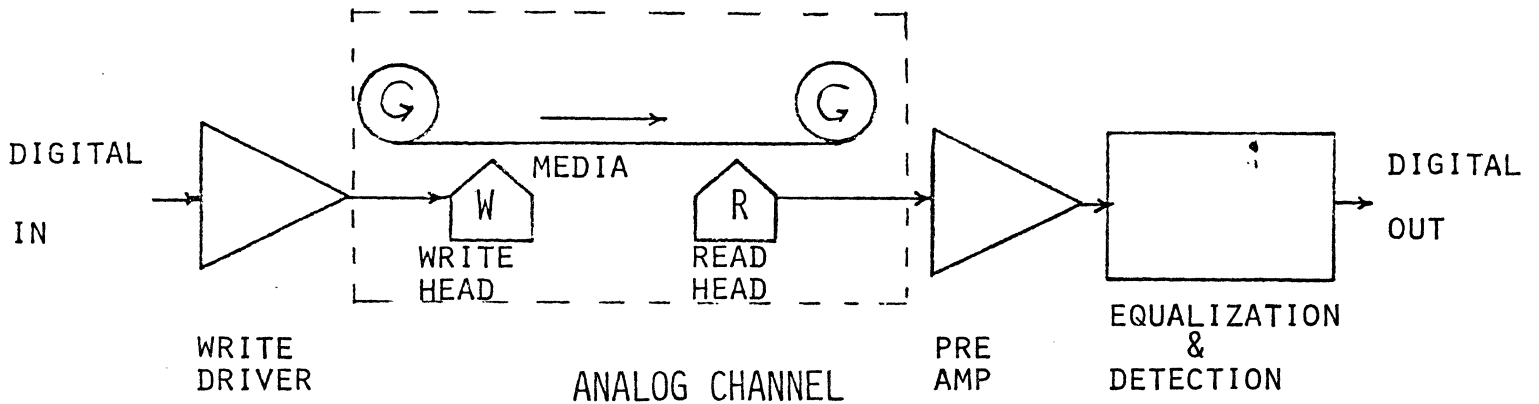

## CHARACTERIZED BY:

- INPUT - OUTPUT TRANSFER FUNCTION
- PEAK AMPLITUDE LIMITED
- NOMINAL SNR > 30 DB
- • DOMINANT DETECTION FAILURE DURING DROPOUT (MEDIA DEFECTS?)

PULSE WRITE

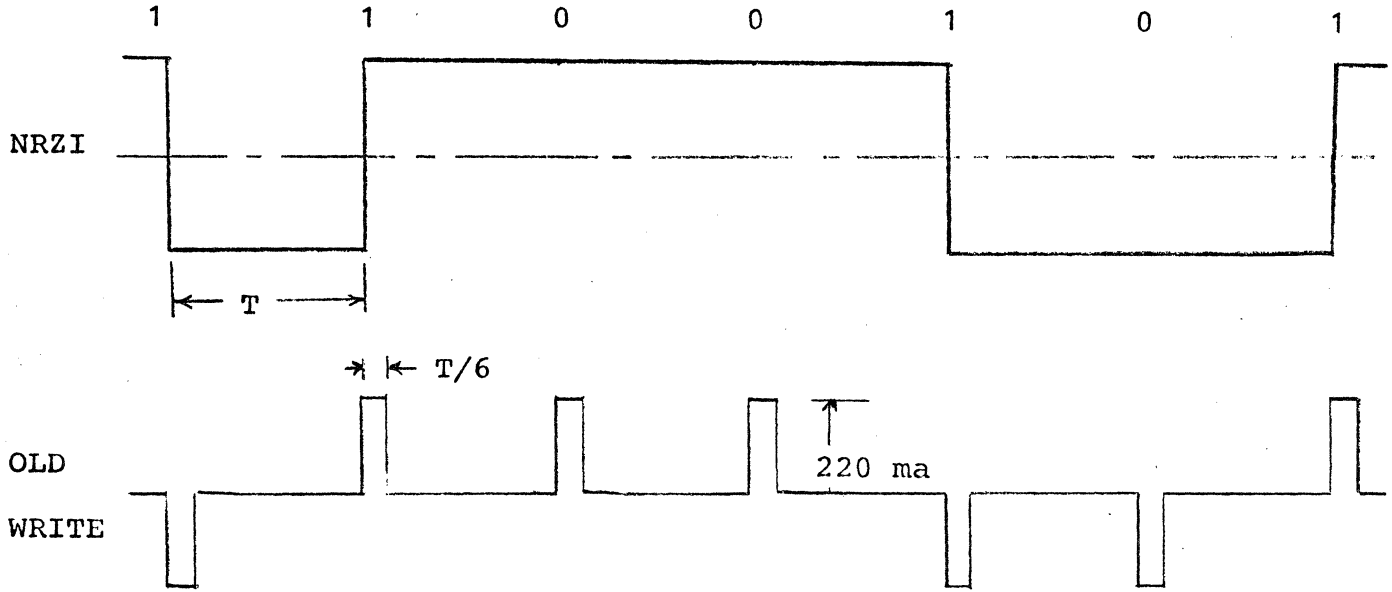

# MAGNETO-RESISTIVE HEAD

## MR HEAD

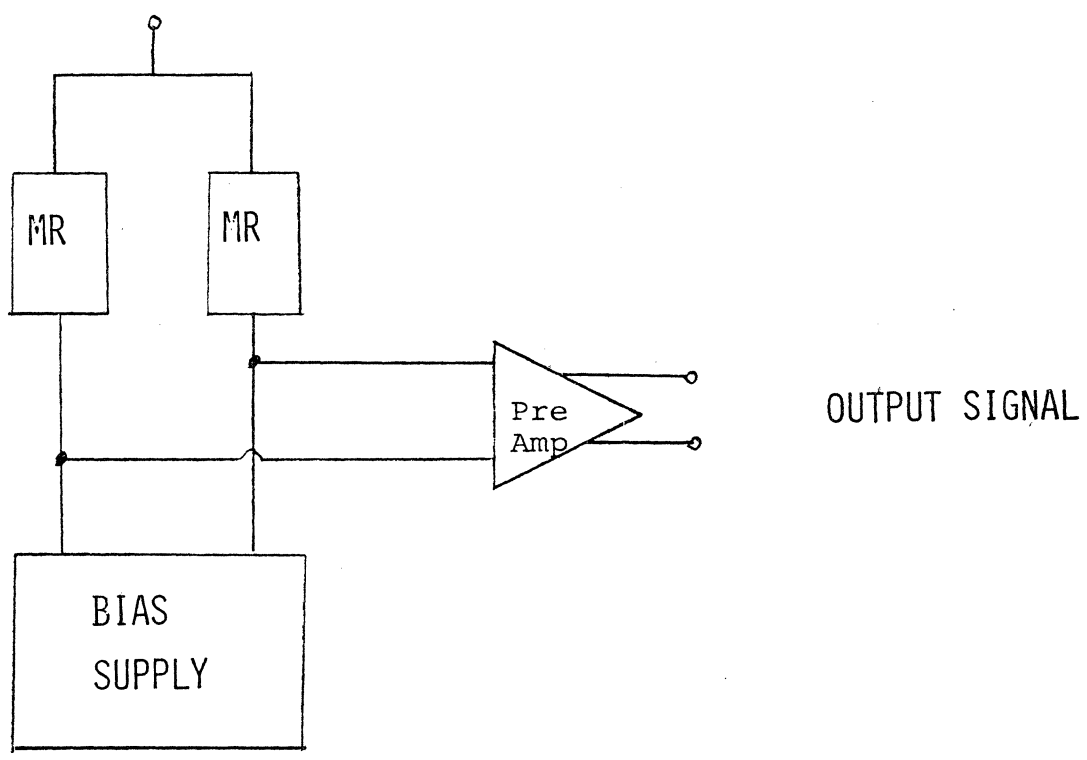
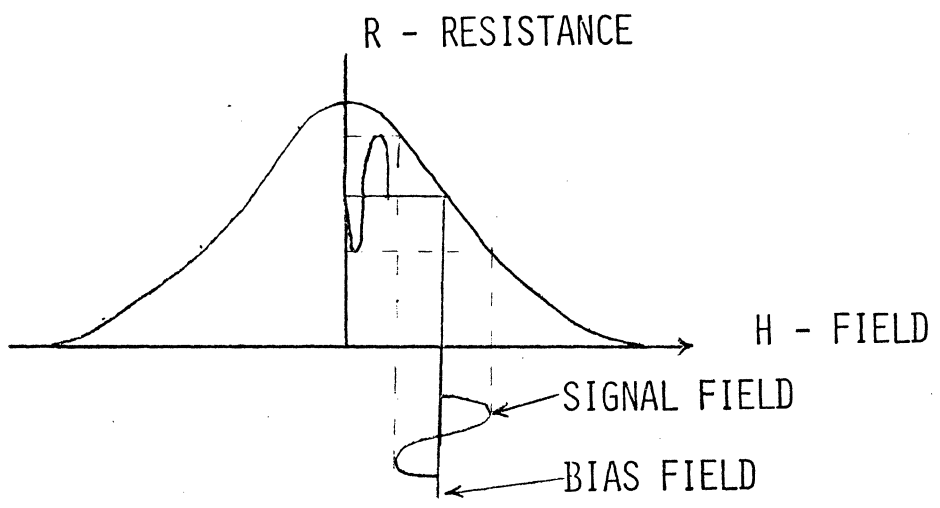

DEL ORO PRECODER

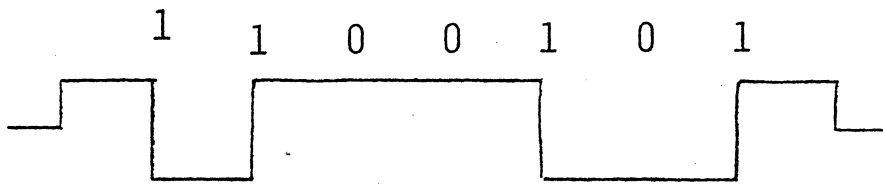

NRZI



PRECODED

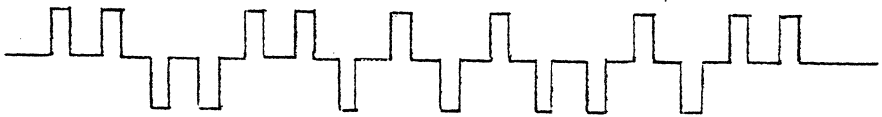

PULSE PRECODED

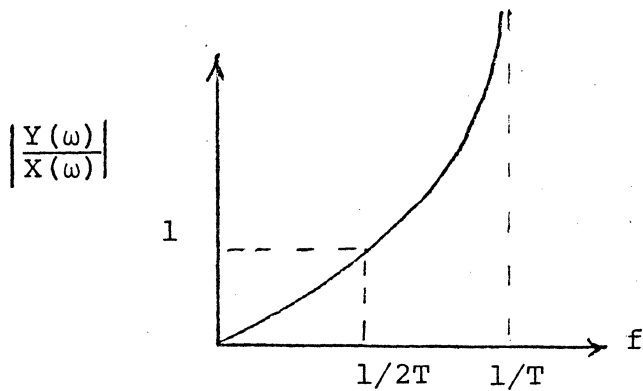
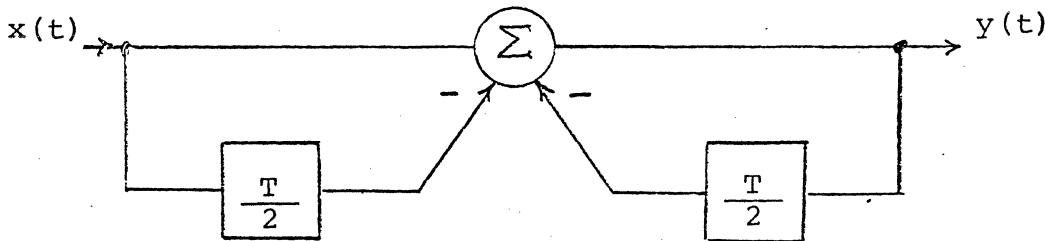

$$\frac{Y(\omega)}{X(\omega)} = j \frac{\sin \omega T/4}{\cos \omega T/4}$$



# PRECODER COMPARISON

## MAGNITUDE

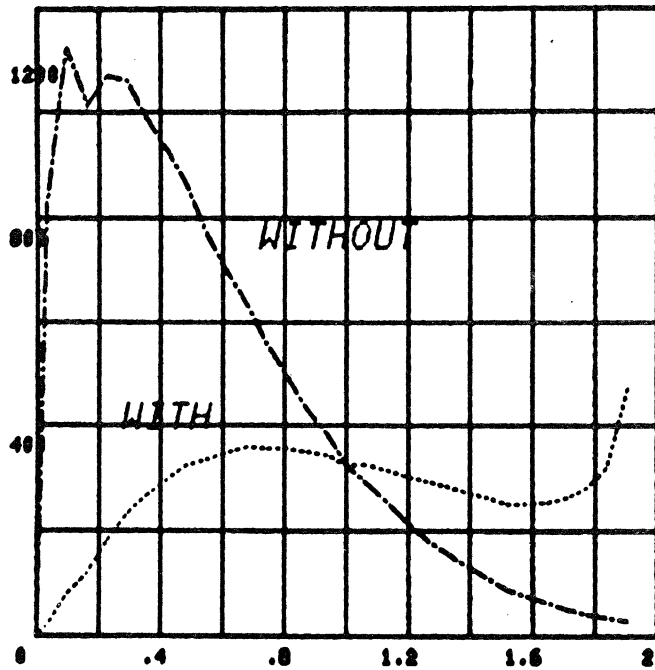

## PHASE (IN RADIANS)

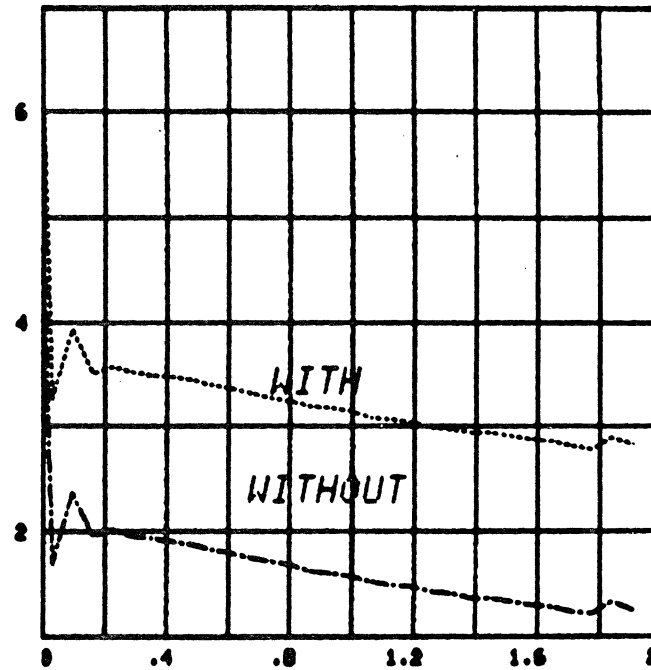

IBM CONFIDENTIAL

117

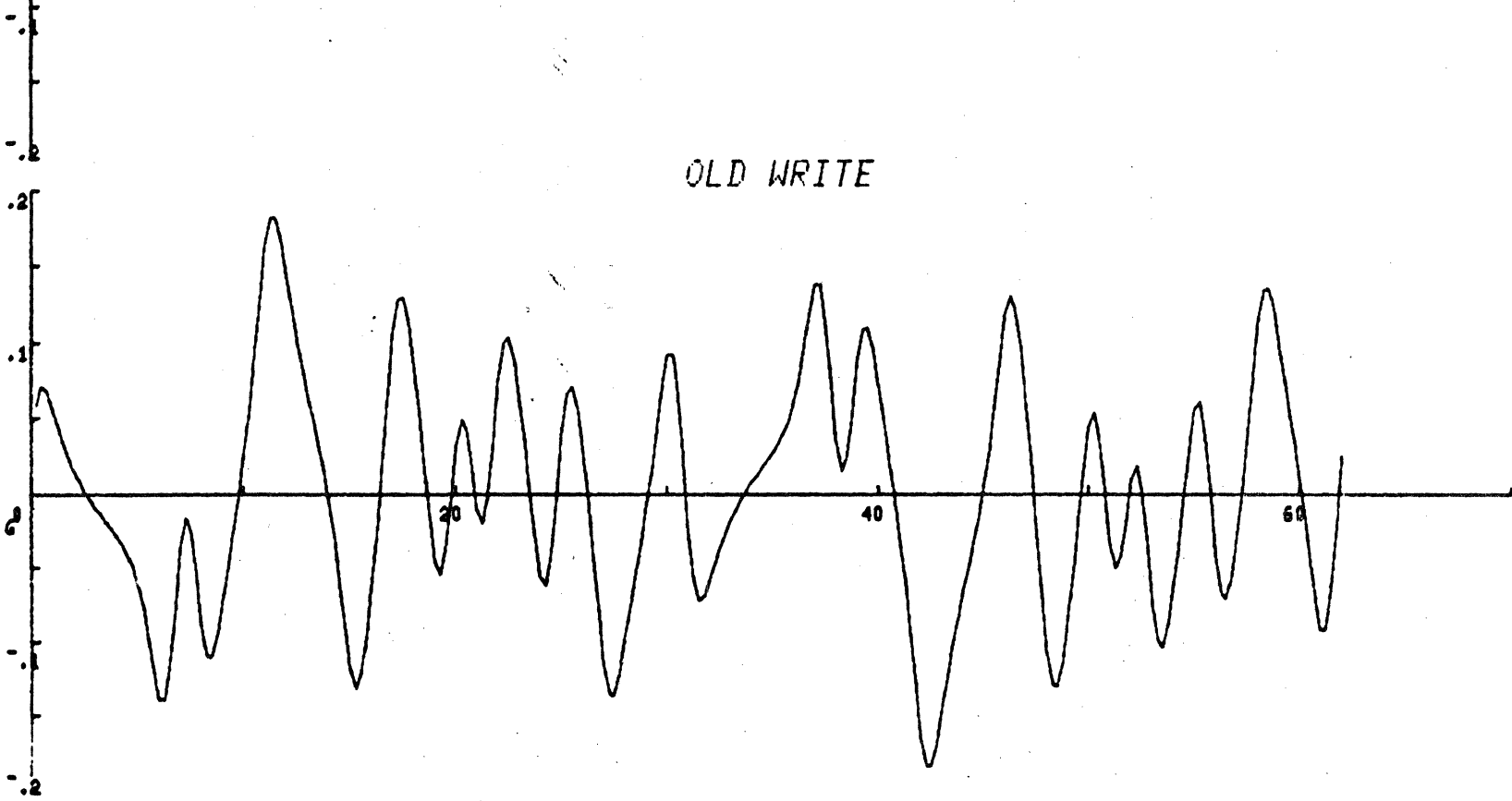
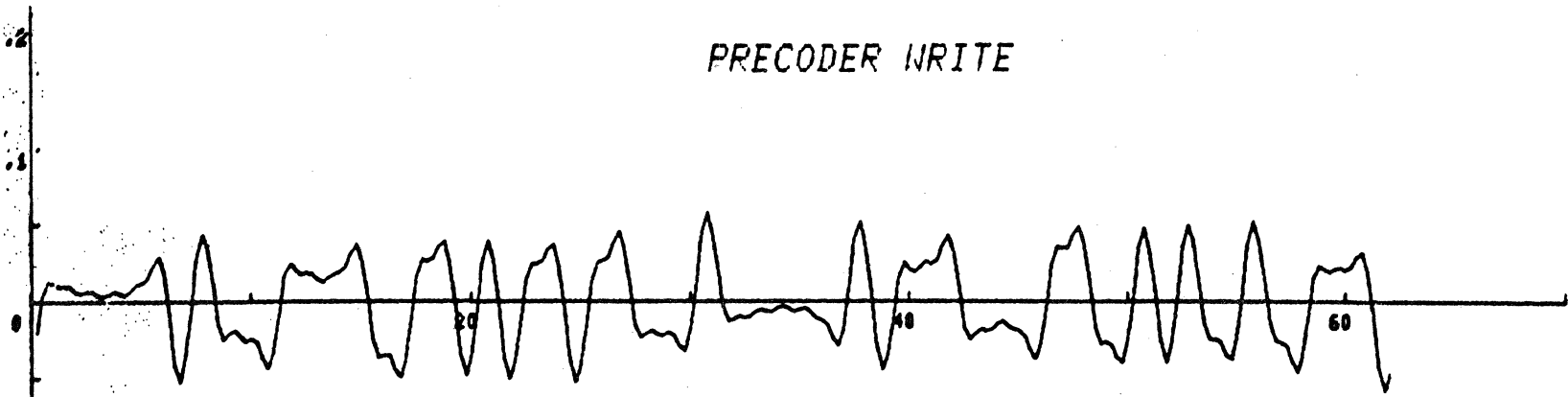

PRECODER WRITE

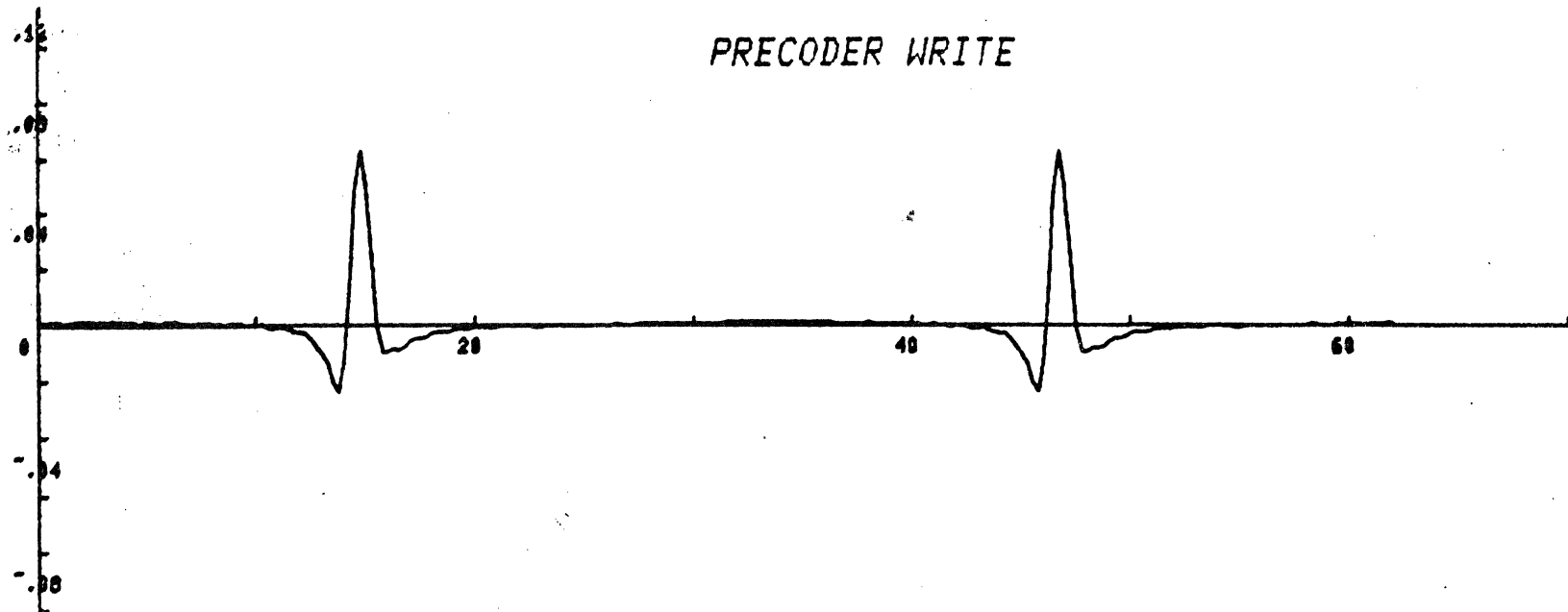

OLD WRITE

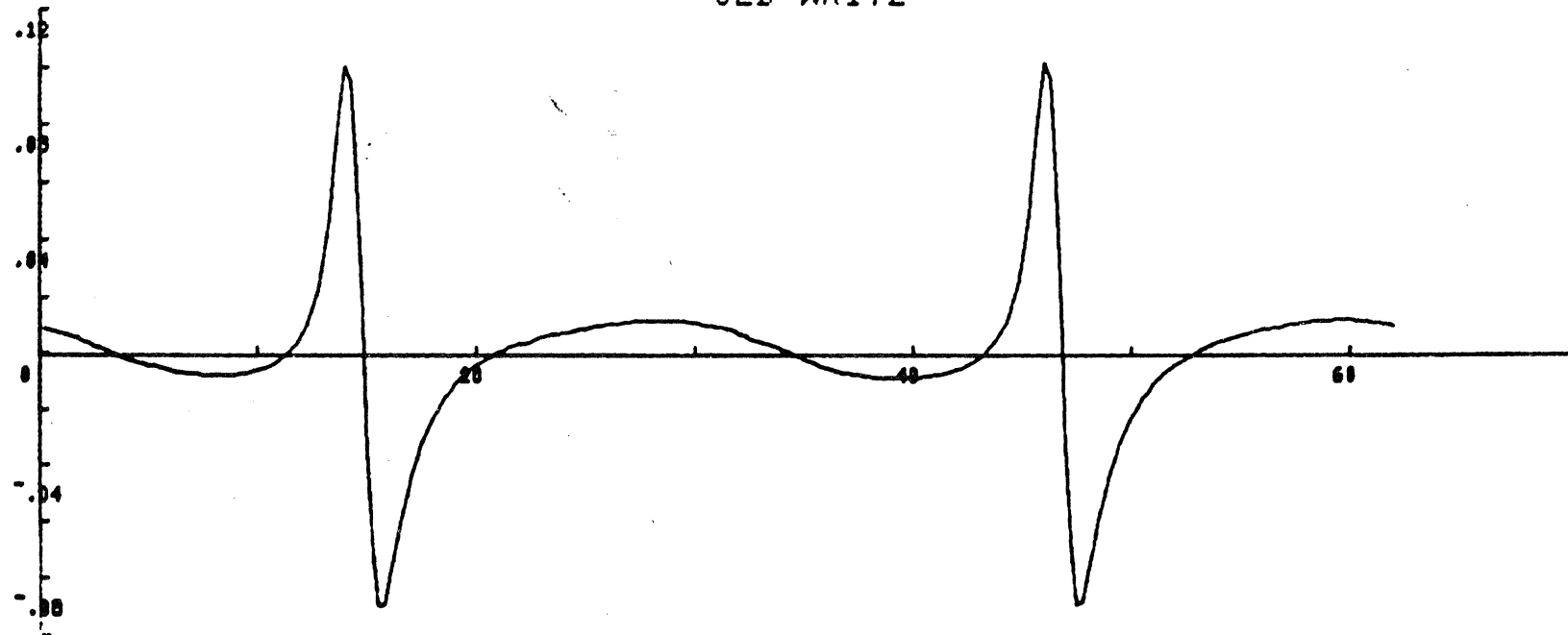

SAGUARO ANALOG EQUALIZATION

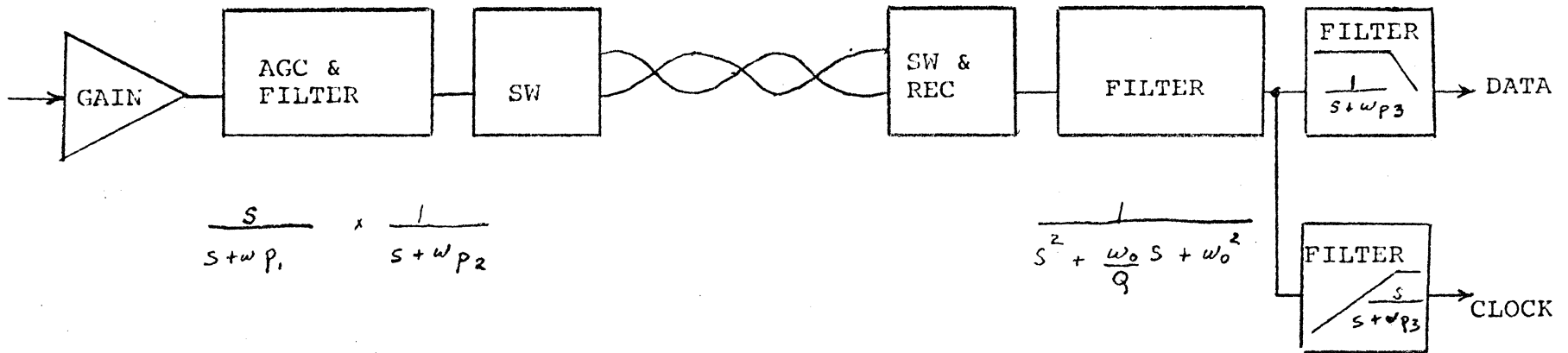

$$\frac{s}{s + \omega p_1} \times \frac{1}{s + \omega p_2}$$

$$\omega p_1 = .63 \times \omega_1$$

$$\omega p_2 = 1.3 \times \omega_1$$

$$\frac{1}{s^2 + \frac{\omega_0 s}{Q} + \omega_0^2}$$

$$\omega_0 = 1.46 \times \omega_1$$

$$Q = 2.25$$

$$\omega p_3 = 1.8 \times \omega_1$$

HEAD OUTPUT + FILTER INPUT

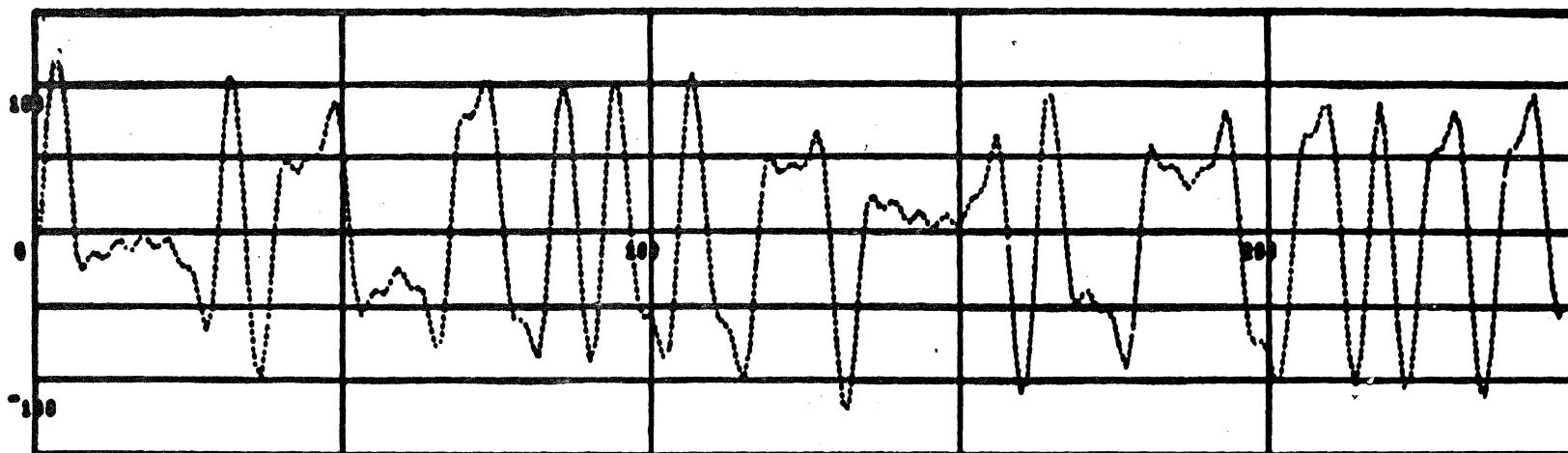

FILTER OUTPUT

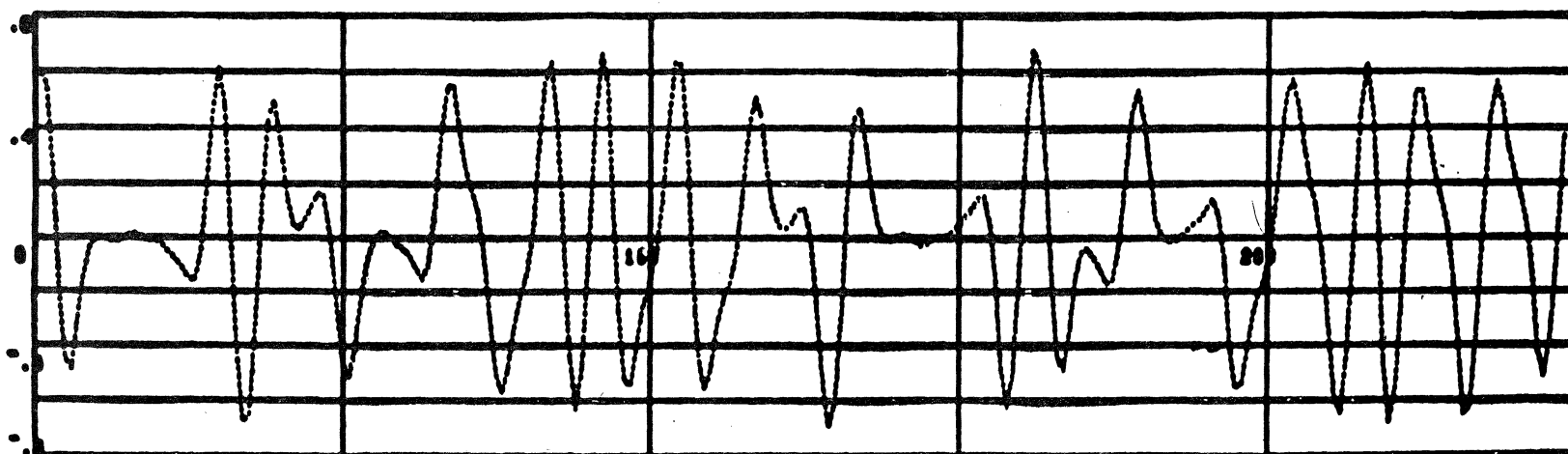

# PEAK DETECTION

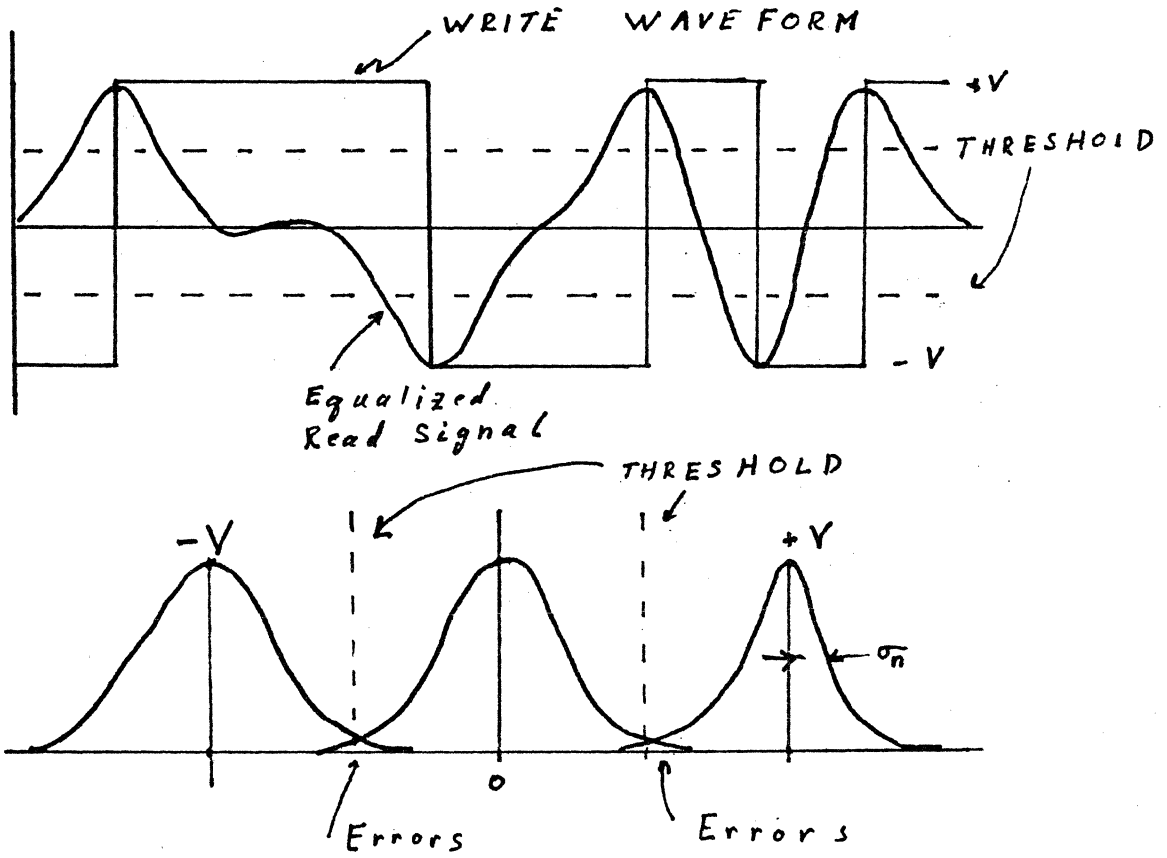

## CHANNEL FAILURE

## MODES

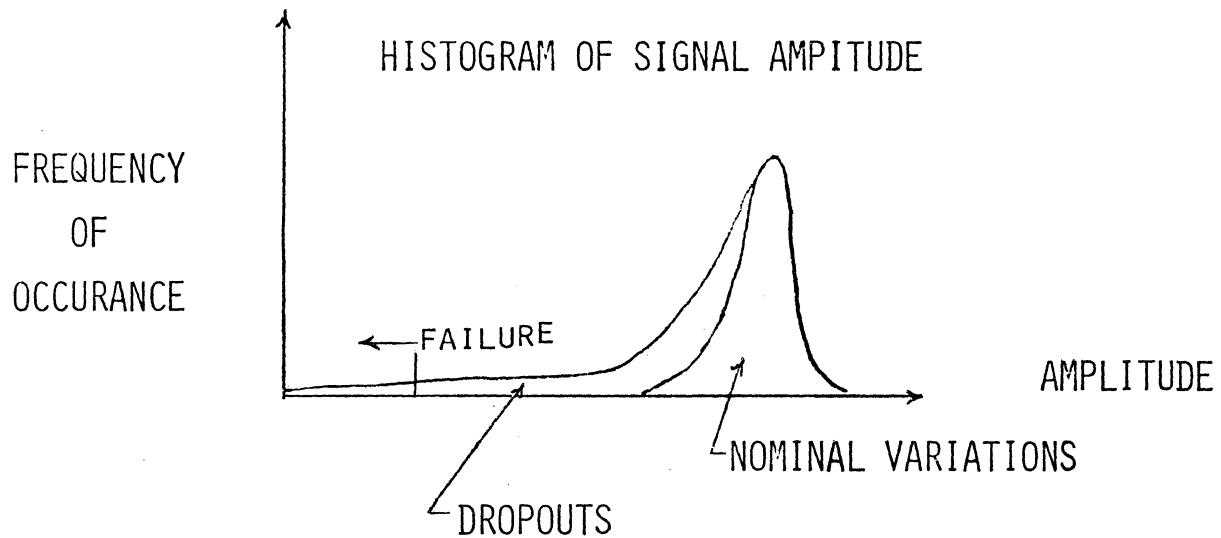

1. FAILURE USUALLY RELATED TO DROPOUT
2. LEVEL OF FAILURE DETERMINED ISI
3. ISI - CONTROLLED BY EQUALIZER - CHANNEL MATCH
4. ACCURACY OF MATCH - RELATED TO INITIAL TOLERANCE, INTERCHANGE, AND DEGRADATION WITH TIME.

SIGNAL AMPLITUDE HISTOGRAM

PEGASUS MEDIA

20 KFCI

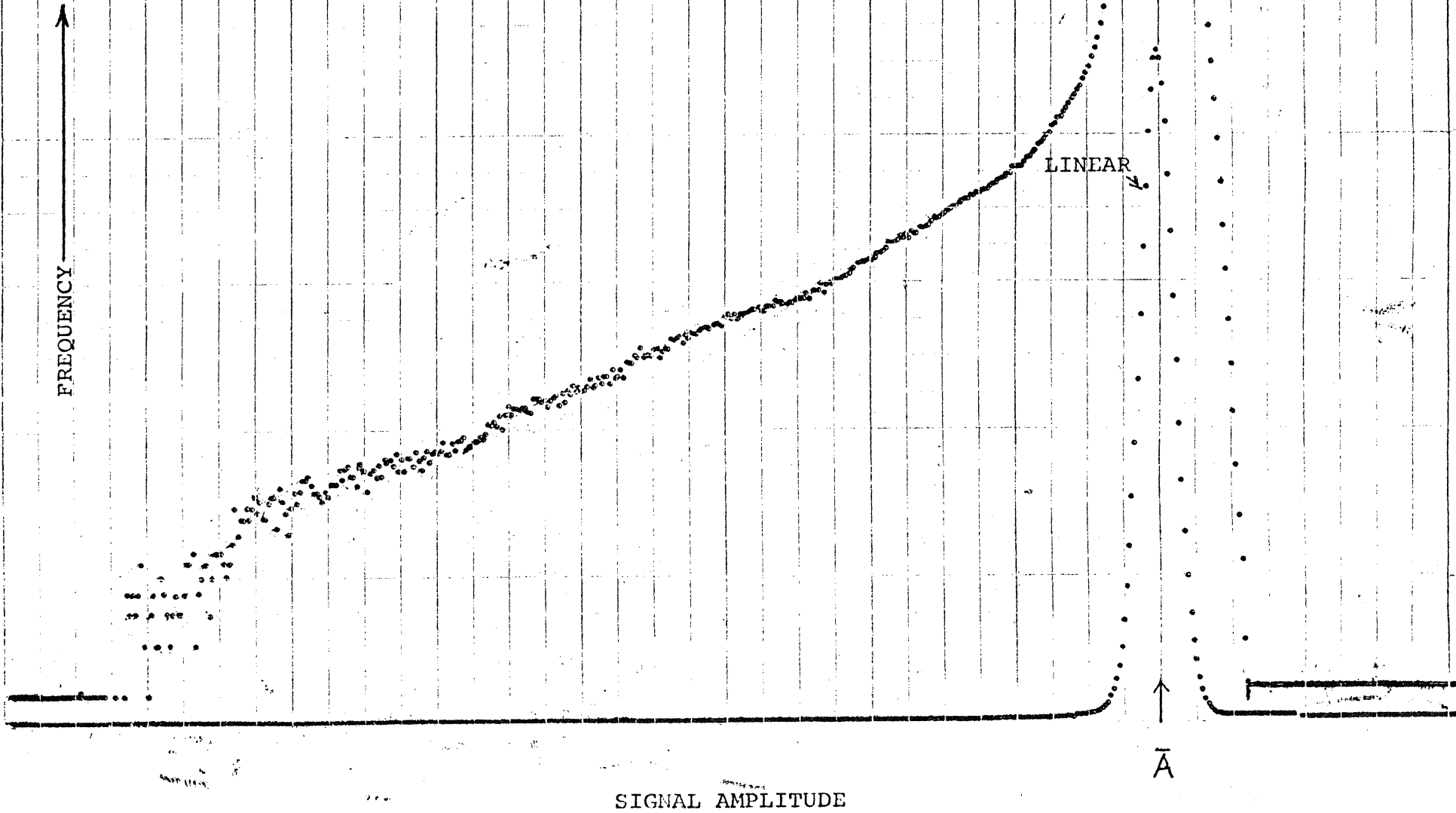



## HOW IS IT DOING

## RELIABILITY - 18 CARTRIDGES

	TK1	4	9	13	18	
MIN	.3	2.3	2.8	3.4	4.7	
MEAN	29.2	47.1	45.3	57.1	17.2	E6 MBF
MAX	82.9	79.7	82.7	83.0	81.2	

HARMONIC MEAN 42.65 E6 MBF

## PROBLEMS:

EDGE TRACKS LOWER ESPECIALLY 18

BACKWARD PERFORMANCE VARIABLE

CLIFF LIKE SENSITIVITY TO MANY PARAMETER VARIATIONS

JAM/GH  
1/9/81

IBM CONFIDENTIAL

SAGUARO ERROR CORRECTION  
ADAPTIVE CROSS PARITY (Ax:P)

A. PATEL

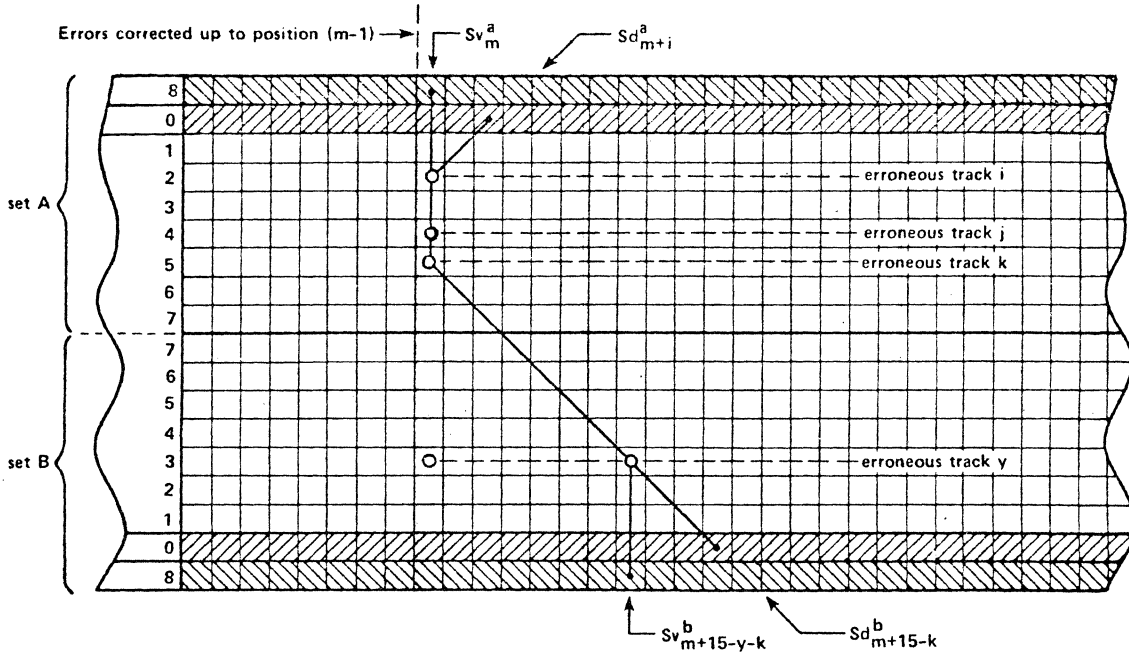

Will correct the following error combinations:

GROUP A	1	0	1	1	2	2	1	3	Tracks in error group A
GROUP B	0	1	1	2	1	2	3	1	Tracks in error group B

With pointers will map 4E6 MBF raw reliability into greater than 1E12 mean bytes to failure.

PRECODING

N. R. Davie

1/14/81

- ▶ Precoding is a recording channel technique allowing additional flexibility in maximizing S/N and minimizing ISI.
- ▶ Implementation consists of applying coding rules to the write data specifically designed to perform channel transfer function operations.
- ▶ S/N enhancement can occur due to performing the transfer function on the write, before noise sources.
- ▶ Low frequency spectral content of information written on media is decreased, improving write current operating point and overwrite modulation characteristics.

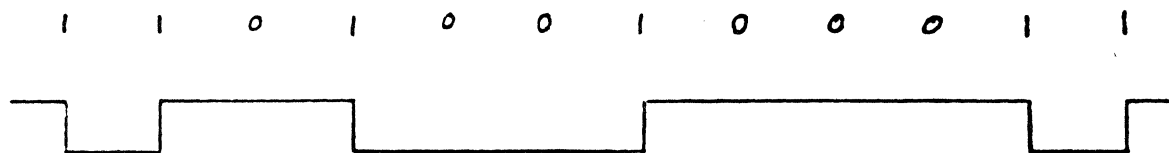
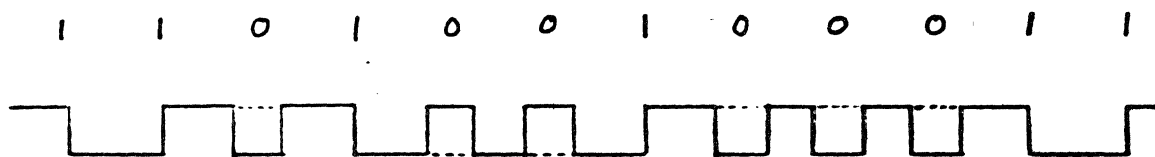
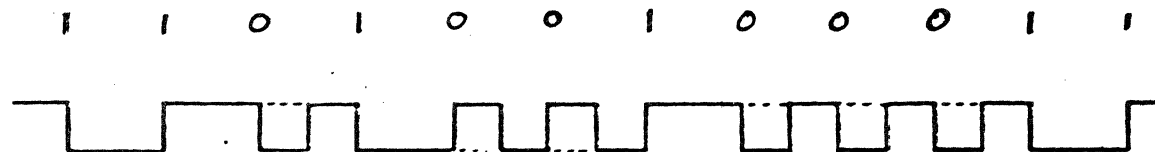
PRECODING - RULESA. NRZI with  $2/9(0,3)$  EncodingB. Type-1 PrecodingC. Type-2 Precoding

# PHOTO LOG

Proj. No.: PC

Date: 9-13-80

Page No.: \_\_\_\_\_

184  
IBM 47  
1981-11

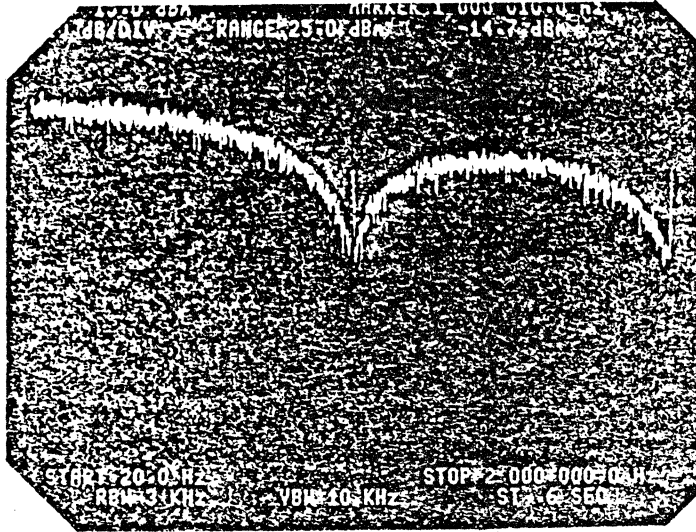

Title: Straight NRZI

Horz: Power Spectrum

Vert: \_\_\_\_\_

Comments: 4 MHz Data Rate  
Random Data

Title: \_\_\_\_\_  
Horz: Power Spectrum - Type I

Vert: \_\_\_\_\_

Comments: 4 MHz Data Rate  
Random Data

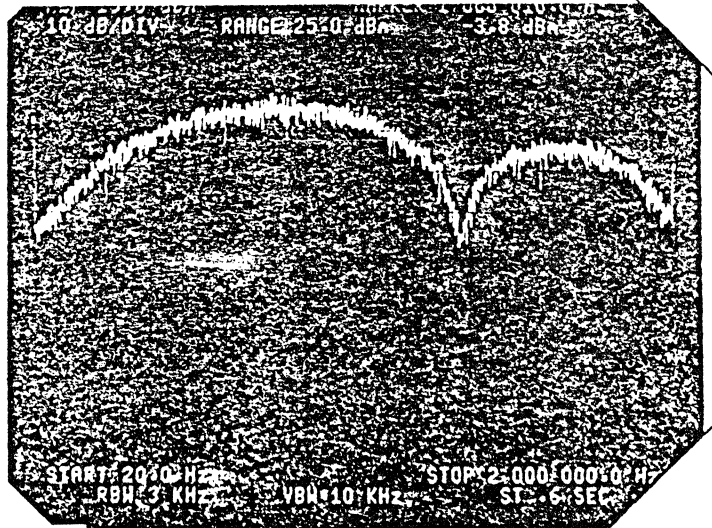

Title: Transfer Function - Type I

Horz: \_\_\_\_\_

Vert: \_\_\_\_\_

Comments: 4 MHz Data Rate  
Random Data

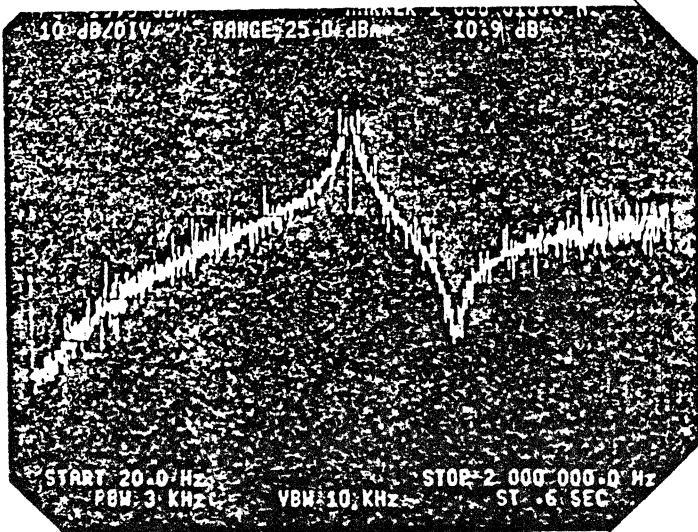

IBM 30

# PHOTO LOG

Proj. No.: PL  
 Date: 9-13-80  
 Page No.: \_\_\_\_\_

185-47

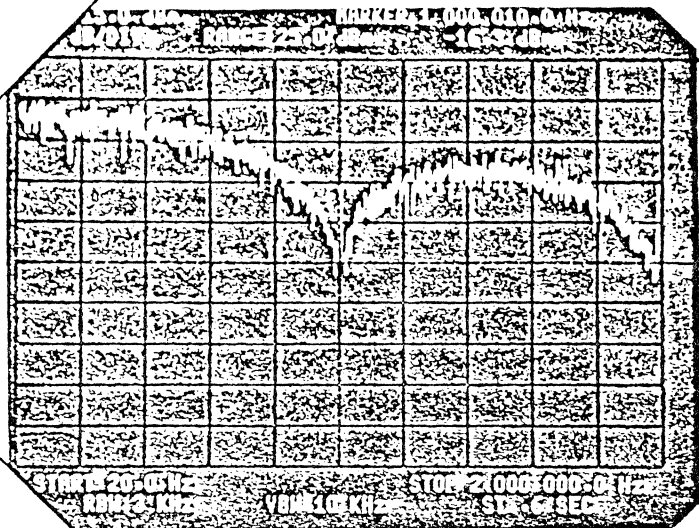

Title: Straight NRZI  
 Horz: Power Spectrum  
 Vert: 1 MHz  
 Comments: Data Rate  
Random Data

Title: \_\_\_\_\_  
 Horz: Power Spectrum  
 Vert: 1 MHz  
 Comments: Data Rate  
Random Data

TYPE II PRE-CODING

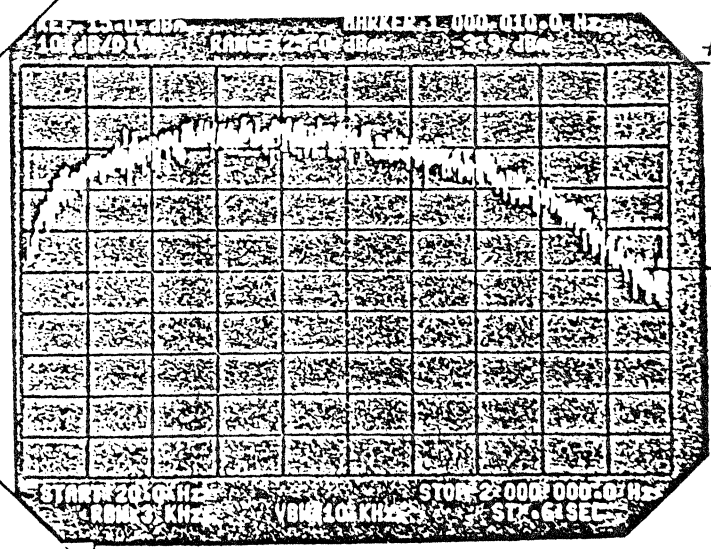

+15 dBu  
-35 dBu

Title: Transfer Function  
 Horz: \_\_\_\_\_  
 Vert: 1 MHz  
 Comment: Data Rate  
Random Data

TYPE II P.C.  
 T.F. = STRAIGHT NRZI

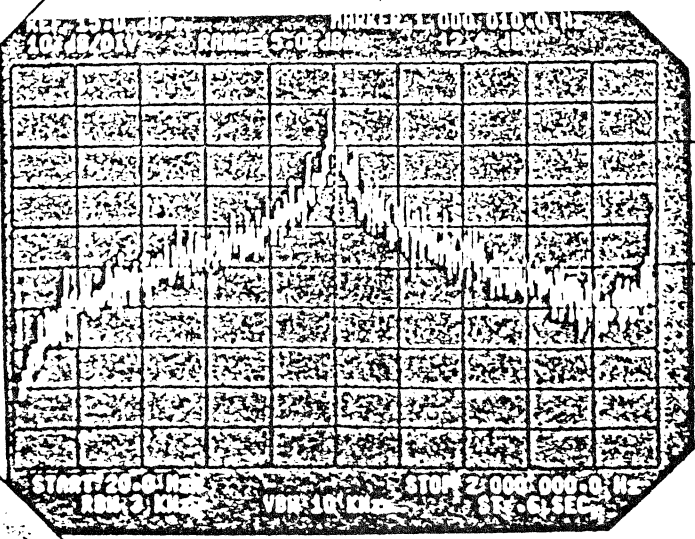

+30 dBu  
0 dBu  
-30 dBu

Reference: \_\_\_\_\_

# Precoding and Physical Significance

## A. NRZI

0 0 0 1 0 0 0

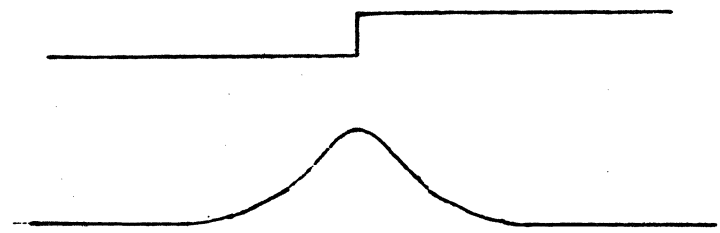

$\sim f(t)$

## B. Precoding type-2

0 0 0 1 0 0 0

The bit stream 0 0 0 1 0 0 0 is shown above a square wave. The square wave starts at a high level, drops to low for the first three bits (0s), and then drops to low for the fourth bit (1), remaining low for the remaining three bits (0s).



$\sim \frac{d}{dt} f(t)$

## C. Precoding type-1

0 0 0 1 0 0 0

The bit stream 0 0 0 1 0 0 0 is shown above a square wave. The square wave starts at a low level, drops to low for the first three bits (0s), and then drops to low for the fourth bit (1), remaining low for the remaining three bits (0s).



$\sim \frac{d^2}{dt^2} f(t)$



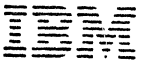

PHOTO

50 mV

500 ns

Proj. No.: \_\_\_\_\_

Date \_\_\_\_\_

Page No.: ISOLATED PULSES

Title: \_\_\_\_\_

Horz: STRAIGHT NRZI

Vert: CODING

Comments: \_\_\_\_\_

$f(t)$

$t_{50\%} = 1.25 \mu s$

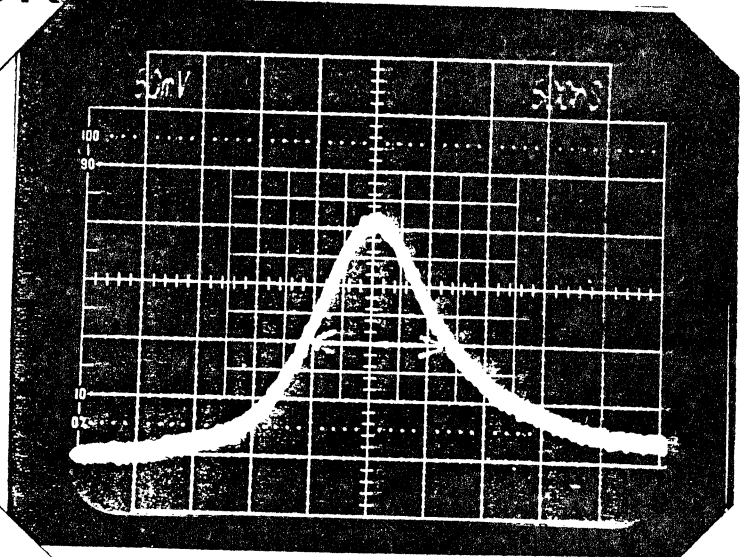

20 mV

500 ns

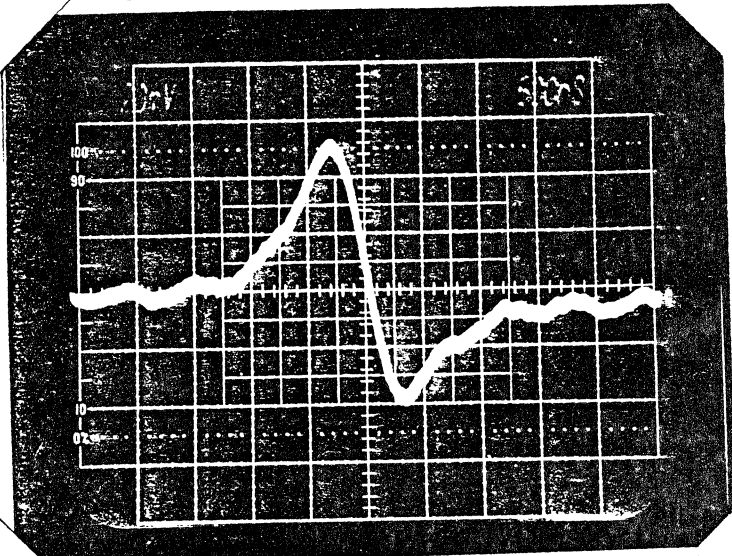

Title: \_\_\_\_\_

Horz: TYPE II PRECODING

Vert: \_\_\_\_\_

Comments: \_\_\_\_\_

$\frac{d^2}{dt^2} f(t)$

$t_{50\%} \text{ N/A}$

Title: \_\_\_\_\_

Horz: TYPE I PRECODING

Vert: \_\_\_\_\_

Comments: \_\_\_\_\_

$\frac{d^2}{dt^2} f(t)$

$t_{50\%} = 500 \text{ ns}$

10 mV

500 ns

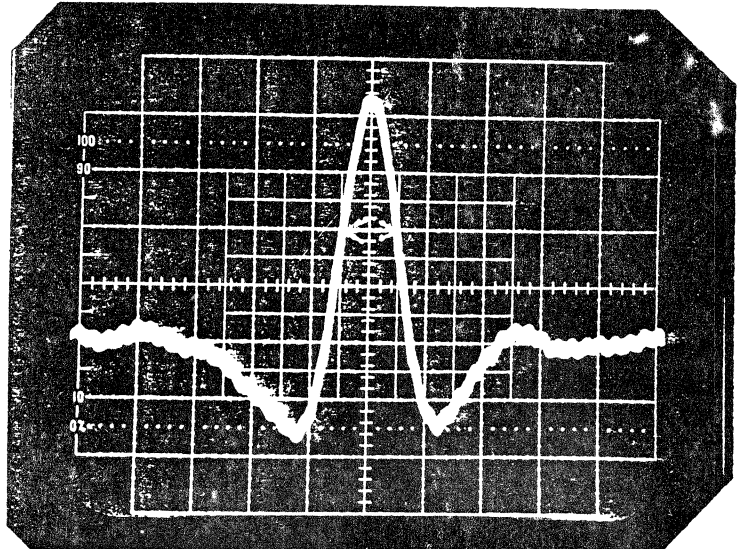

Reference: \_\_\_\_\_

# Channel Alternatives considered for Sovereign

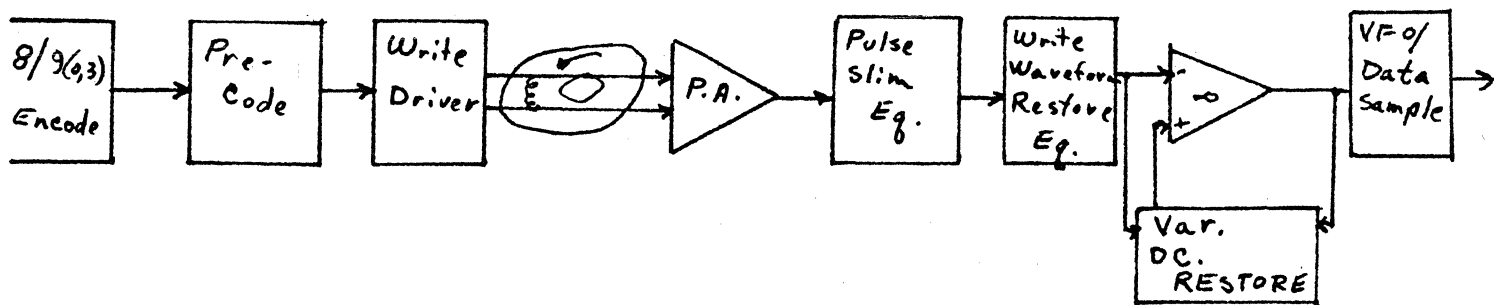
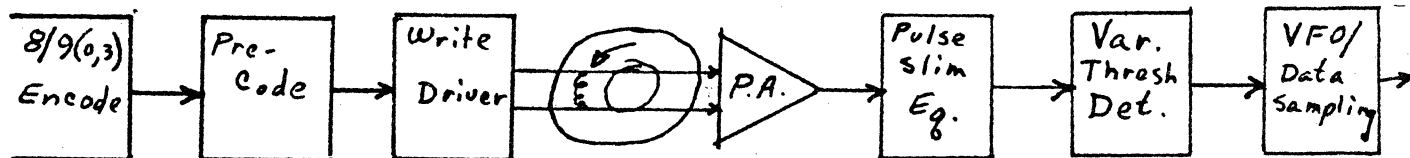

# PULSE SHAPING

## A. No Precoding

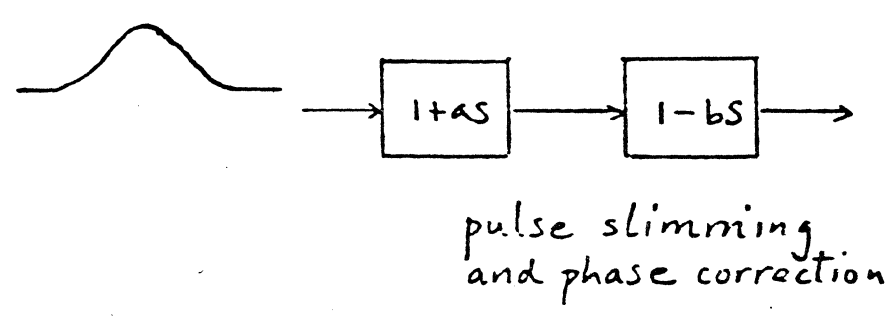

## B. Precoding Type-2

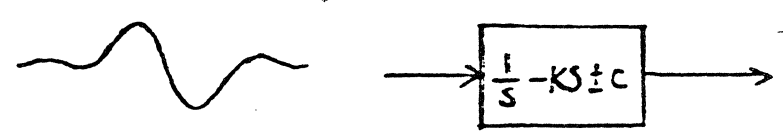

## C. Precoding Type-1

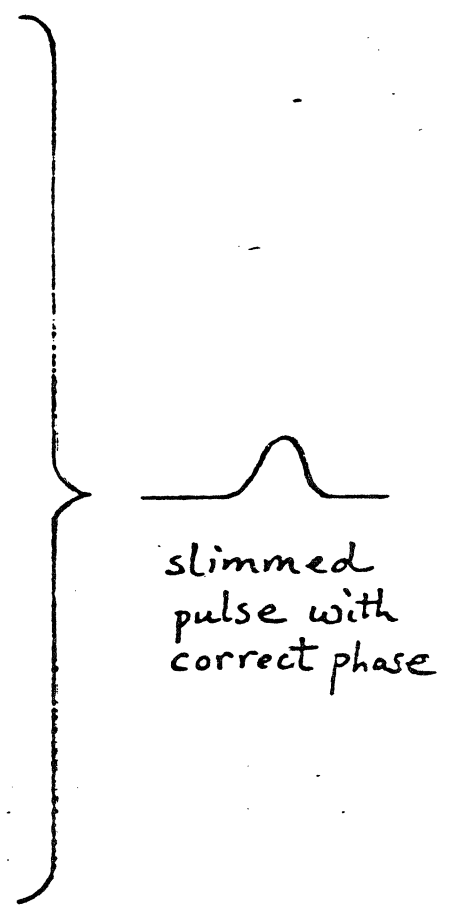
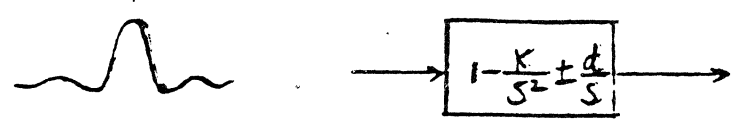

### ► Criteria for channel-method selection

- S/N - this includes all factors, including actual pre-amp, head, & channel  $t(s)$ . Results can be biased by low pass filter selection, ac coupling, etc, so care needed to optimize each case. Included in S/N effect is write current selection.

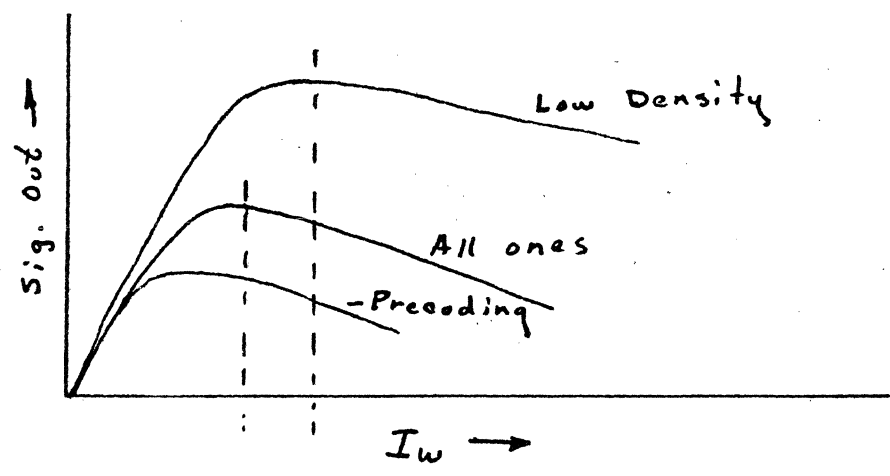

- Overwrite modulation, due to power spectral density change. On a higher tpi product, where reading off the side of the head becomes more significant, adjacent track interference becomes a criteria.

## Channel selection criteria

- Channel transient response.
  - Due to criteria selected, write current rise time was not a factor, but may be in some systems.
- ▶ Type 2 precoding, with write waveform restore equalization was selected for development level implementation. - because of low frequency noise and longer transient response with type 1, and high frequency noise with none. (and ovm, etc)

► Summation of waveform derivatives can be performed totally on the write data with precoding.

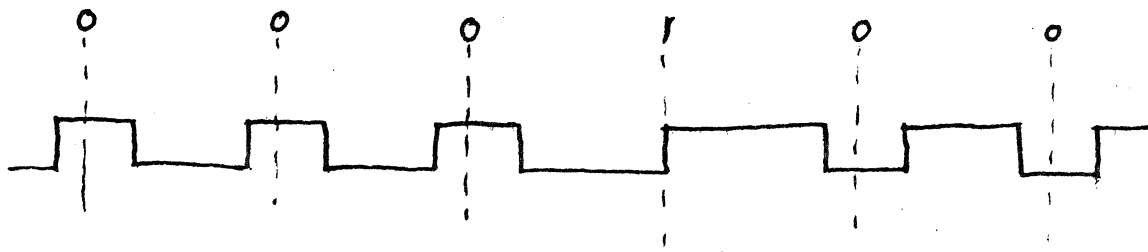

- Requires more complex write data timing.
- S/N effects not yet evaluated, but should be superior in most cases.
- Channel transient response should be improved.
- Eliminates some read circuitry.

- Precoding can be applied to codes with  $D \neq 0$ , for instance  $1/2(2,7)$  code.

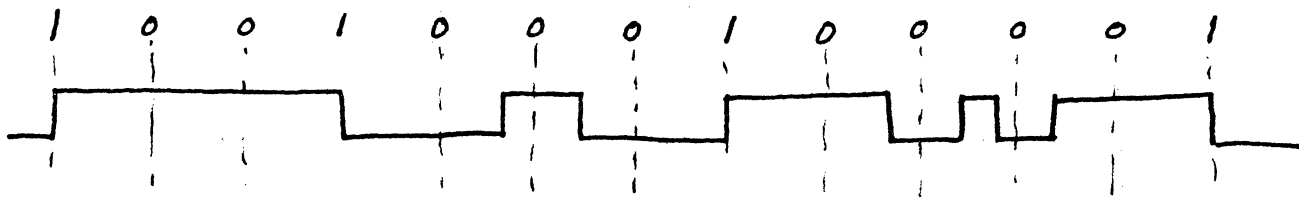

- Retains signal amplitude on highest data bit.
- Output can look identical, but with higher resolution.
- Benefits of OWM and adjacent track interference minimization maintained.
- Could operate with no change in detection method, for instance  $\Delta V - \Delta T$ .

# Utilization of Precoding to synchronize Data Clock.

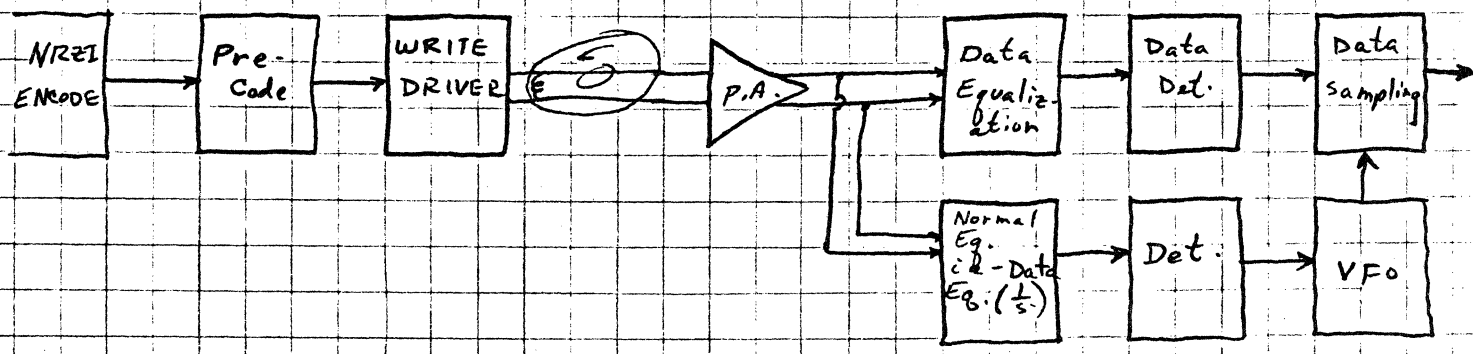

▶ Precoded information must have adequate amplitude out of read head - essentially valid if not operating near gap null.

▶ The two equalization paths differ by only the inverse of the precode transfer function,  $s, s^2$  etc.

▶ High read reliability not necessary for VFO sync -

▶ High sample rate achieved enhances VFO phase margin - ∴ Easier lock on.

▶ Higher efficiency NRZI than RLL w/o coding ckt. overhead.



IBM CONFIDENTIAL

IBM 43

POST COMP

Our concept is to provide an improvement in magnetic recording performance by skewing the normal detection windows for a peak detection system.

The skew is determined by logic applied to past detected bits, providing a form of Decision Feedback, or examining information past and future (via delay of signal) to provide more information on the proper skew of the window edges to minimize the effect of intersymbol interference. This provides some of the benefits that a verterbi system would give.

Post Comp is compared to other signal processing using an 8 out of 9 code specific example.

Pre Comp is very effective in reducing ISI for codes with low FCI/BPI such as RLL(2,7) by increasing the high frequency content into the recording. However a high rate code such as 8 out of 9 already provides very nearly maximum high frequency content into the recording and any pre comp will actually reduce the S/N. In this case post comp is superior as it increases the margin at the detector without increasing noise content.

Time shifting of windows has a very similar effect to shifting the amplitude threshold as in a DC and low frequency restoring system. The restoring system is shown to be beneficial in improving detector margin if only partial ISI reduction is used. Since there are some distinct differences in post comp and restore systems, one may be superior or easier to implement in a specific case.

It is also interesting to note that a sampling detector will fail on the same signal that a peak detector runs adequately and with post comp implemented, would run even better. This does not mean that a peak detector is necessarily superior to a sampling detector, but that for proper operation, both cannot operate from the same waveform. Actually the sampling detector must have a higher amount of equalization (high boost) to run properly. If one considers that a peak detector is really a differentiator followed by a zero crossing detector, it can be seen that the differentiator actually provides more high frequency boost so that the zero crossing detector will operate properly. Although phase differences exist, the magnitudes of optimally equalized waveforms (and also noise spectrums) for a zero crossing detector and a sampling detector are very similar. The performance of each system should then be very similar.

Post Comp applied to a peak detector may therefore function better than an optimized sampling detector. Post Comp should also be able to be implemented without much difficulty in a system using standard peak detection with delta V extra bit elimination.

EARL A CUNNINGHAM  
2G7 / 050-1  
ROCHESTER, MN  
TIE 456 - 4048

# POST COMP

WHAT IS IT?

HOW DOES IT RELATE TO:

NORMAL PEAK DETECTION ( $d/dt \rightarrow 0$ -xing);

PRECOMP WITH PEAK DETECTION;

HIGH FREQUENCY BOOST AND PEAK DETECTION;

LOW FREQUENCY BOOST (OR RESTORE) AND PEAK DETECTION?

SAMPLING DETECTION?

WHEN SHOULD POSTCOMP BE USED?

EXAMPLE OF ISI IN 8 OUT OF 9 CODE.

EXAMPLE OF POST COMP FOR 8 OUT OF 9 CODE.

## POST COMP.

A METHOD OF PARTIALLY COMPENSATING FOR INTERSYMBOL INTERFERENCE (I.S.I) AFTER READBACK BY SHIFTING THE NOMINAL WINDOW POSITIONS.

IT IS VERY SIMILAR TO M<sup>2</sup>FM DETECTION WHERE "CLOCK" WINDOWS ARE MADE SMALLER AND "DATA" WINDOWS ARE MADE LARGER, SINCE THE CODE HAS LESS I.S.I FOR "CLOCK" BITS THAN FOR DATA BITS.

POST COMP. USES THE READBACK PEAK POSITIONS TO PROVIDE INFORMATION ON I.S.I. AND LOGICALLY PROVIDES AN APPROPRIATE WINDOW TO DECIDE THE RECORDED DATA POSITION.

\* INTER SYMBOL INTERFERENCE IS ONE OF SEVERAL CONTRIBUTORS TO SHIFTED BIT ERRORS.

\* HOWEVER, REDUCING I.S.I, MAY NOT IMPROVE SYSTEM PERFORMANCE.

\* IT IS OF LITTLE IMPORTANCE WHERE A PEAK OCCURS, PROVIDED IT IS INSIDE THE PROPER WINDOW.

\* VOLTAGE MARGIN AT THE WINDOW EDGE (RELATIVE TO ELECTRONIC NOISE) IS IMPORTANT.

\* INTEGRAL SYSTEMS CAN REDUCE I.S.I, TO ZERO, BUT ACTUALLY REDUCE THE MARGIN. (INTEGRAL SYSTEMS CAN ALSO IMPROVE PERFORMANCE IF DONE RIGHT.)

\* HIGH FREQUENCY BOOST (PULSE SLIMMING) MAY REDUCE I.S.I, AND INCREASE MARGIN BUT ALSO INCREASE THE NOISE LEVEL SO THAT ERROR RATE MAY INCREASE.

\* PRE COMP (WHEN EFFECTIVE) IS SUPERIOR TO OTHER METHODS SINCE IT PROVIDES HIGH FREQUENCY BOOST INTO THE RECORDING — IMPROVES MARGIN — LOWERS ERROR RATE.

\* POST COMP IS SUPERIOR TO PULSE SLIMMING METHODS IN REDUCING THE AFFECT OF ISI, AND LOWERS ERROR RATE.

\* WHEN PRE COMP IS NOT EFFECTIVE, POST COMP IS MOST EFFECTIVE.

# APPROXIMATE DIPULSE PEAK SEPARATION AND AMPLITUDE

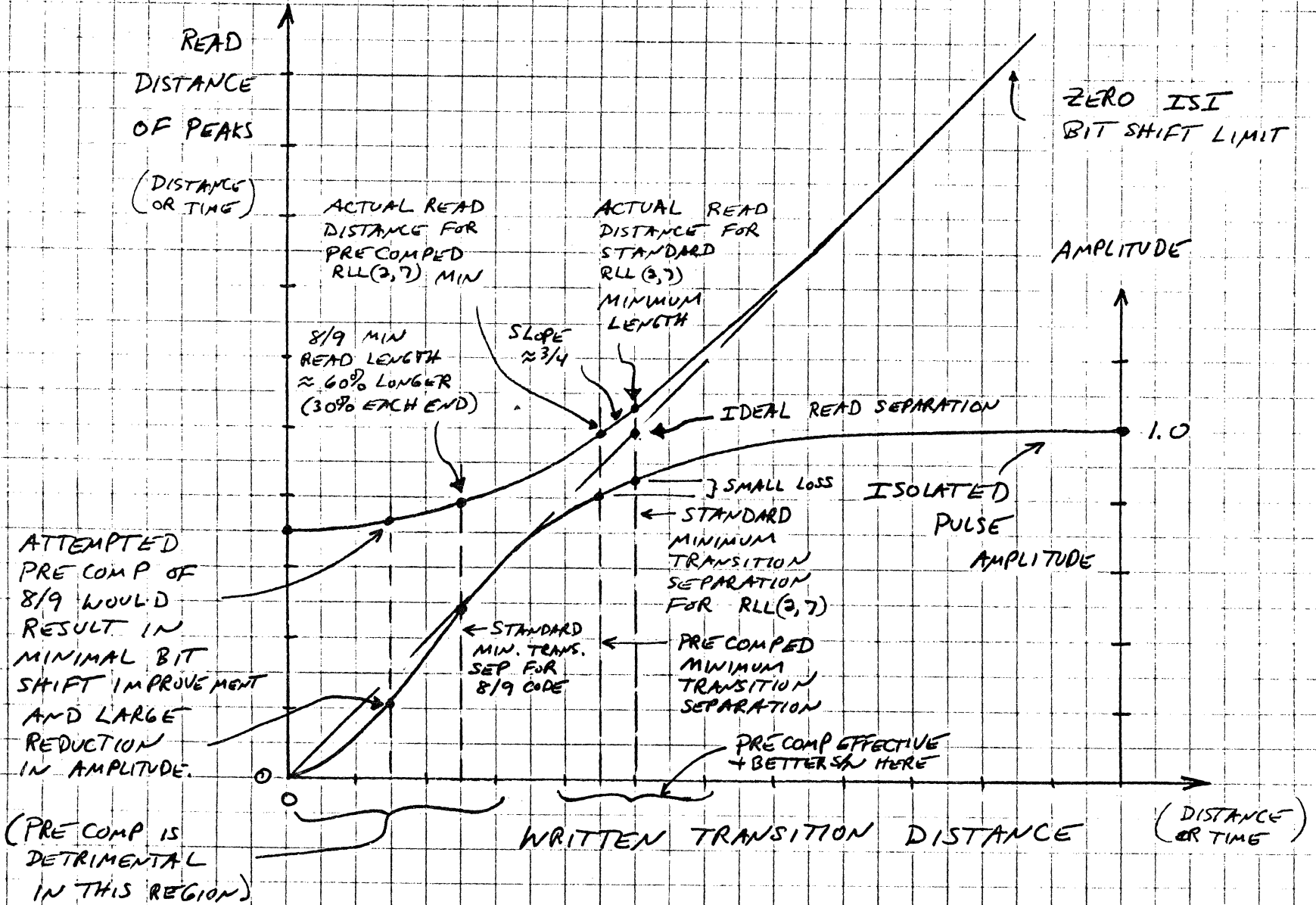

# EXAMPLE PULSE

(CLOSE TO EXPERIMENTAL PULSE TESTED)

RESOLUTION  
RELATIVE  
TO ISOLATED  
PULSE

$$1^{15} \text{ RES} = 1.000 - 2(.432) + 2(.084) - 2(.012) + 2(.001)$$

$$= \underline{0.282} \quad (8 \text{ MHz})$$

$$2^{15} \text{ RES} = 1.000 - 2(.084) + 2(.001)$$

$$= \underline{0.834} \quad (4 \text{ MHz})$$

$$3^{15} \text{ RES} = 1.000 - 2(.012)$$

$$= \underline{0.976} \quad (2^{2/3} \text{ MHz})$$

$$4^{15} \text{ RES} = 1.000 - 2(.001)$$

$$= \underline{0.998} \quad (2 \text{ MHz})$$

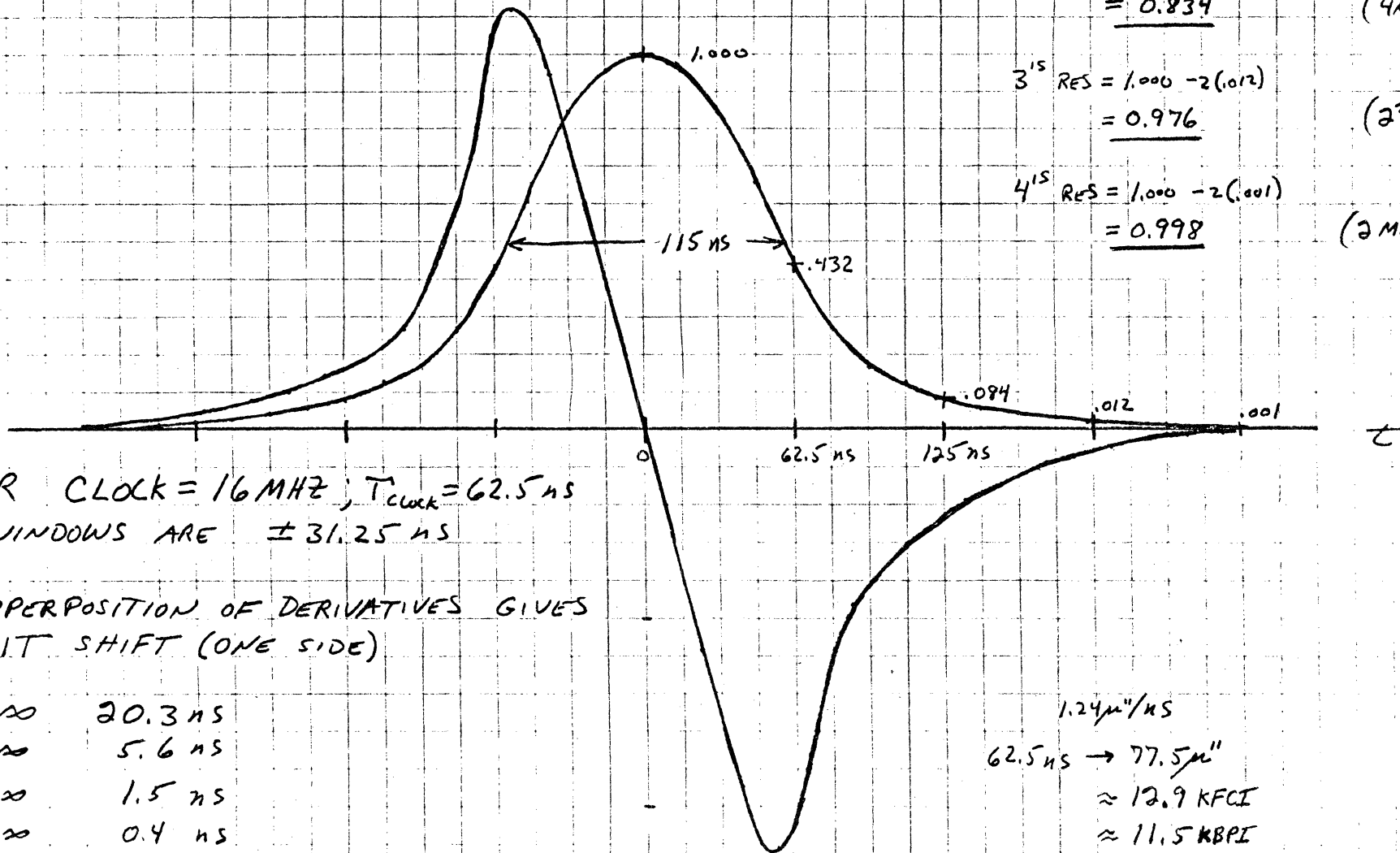

FOR CLOCK = 16 MHz,  $T_{\text{clock}} = 62.5 \text{ ns}$   
WINDOWS ARE  $\pm 31.25 \text{ ns}$

SUPERPOSITION OF DERIVATIVES GIVES  
BIT SHIFT (ONE SIDE)

1-∞	20.3 ns
2-∞	5.6 ns
3-∞	1.5 ns
4-∞	0.4 ns
5-∞	0.1 ns

$1.24 \mu\text{s}/\text{ns}$   
 $62.5 \text{ ns} \rightarrow 77.5 \mu\text{s}$   
 $\approx 12.9 \text{ KFCI}$   
 $\approx 11.5 \text{ KBPI}$

THE DERIVED ISI BIT SHIFTS  
ARE USED IN THE TIME DOMAIN  
EXAMPLE LATER ON.

THE RESOLUTIONS LISTED AND  
THE FUNDAMENTAL FOURIER COEFFICIENT  
AT LOWER FCI ARE USED TO  
CALCULATE POINTS ON THE  
FOLLOWING FREQUENCY RESPONSE  
GRAPH.

THE PULSE SHAPE AND RESOLUTIONS  
AND FREQUENCY RESPONSES ARE  
QUITE CLOSE TO AN EXPERIMENTALLY  
TESTED SYSTEM.

# FREQUENCY RESPONSE

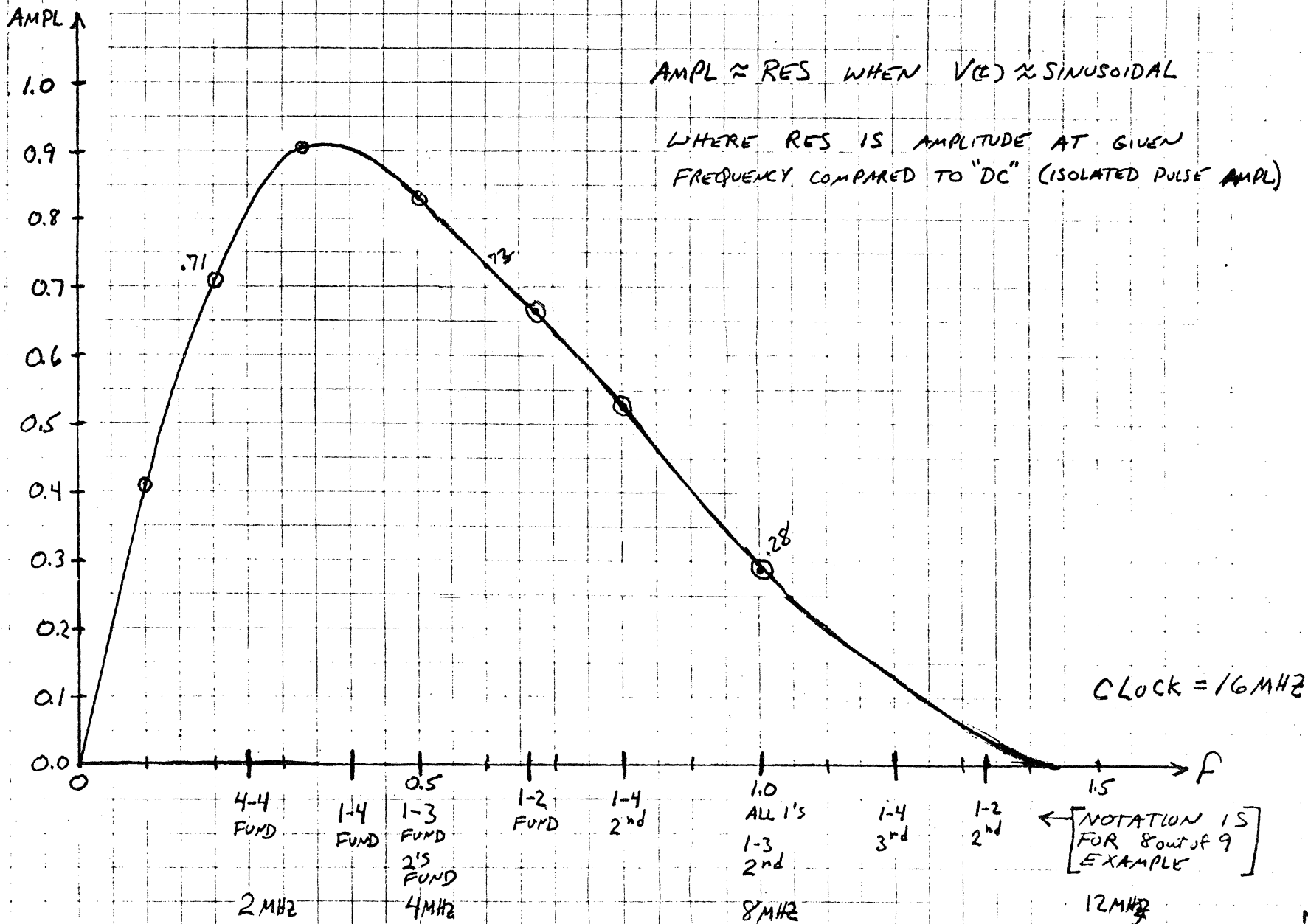



EXAMPLE OF FOURIER  
RECONSTRUCTION OF 1.6 MHz  
IS SIMILAR TO LOWEST RLL(3,7)  
RECORDED DENSITY OF EXISTING PROGRAMS.

IT IS TYPICAL THAT ONLY  
1<sup>ST</sup>, 3<sup>RD</sup> AND 5<sup>TH</sup> HARMONICS  
CAN EXIST. THE SYMMETRY OF  
THE PATTERN ELIMINATES EVEN  
HARMONICS.

HIGHER DENSITY PATTERNS FURTHER  
RESTRICT THE NUMBER OF HARMONICS.

SOME OF THE HIGH FREQUENCY PATTERNS  
WILL ONLY HAVE THE FUNDAMENTAL FREQUENCY  
AND SOME WILL HAVE A SMALL AMOUNT  
OF SECOND HARMONIC ONLY.

1.6 MHz  
 WAVE SHAPE  
 (FOURIER RECONSTRUCTION)

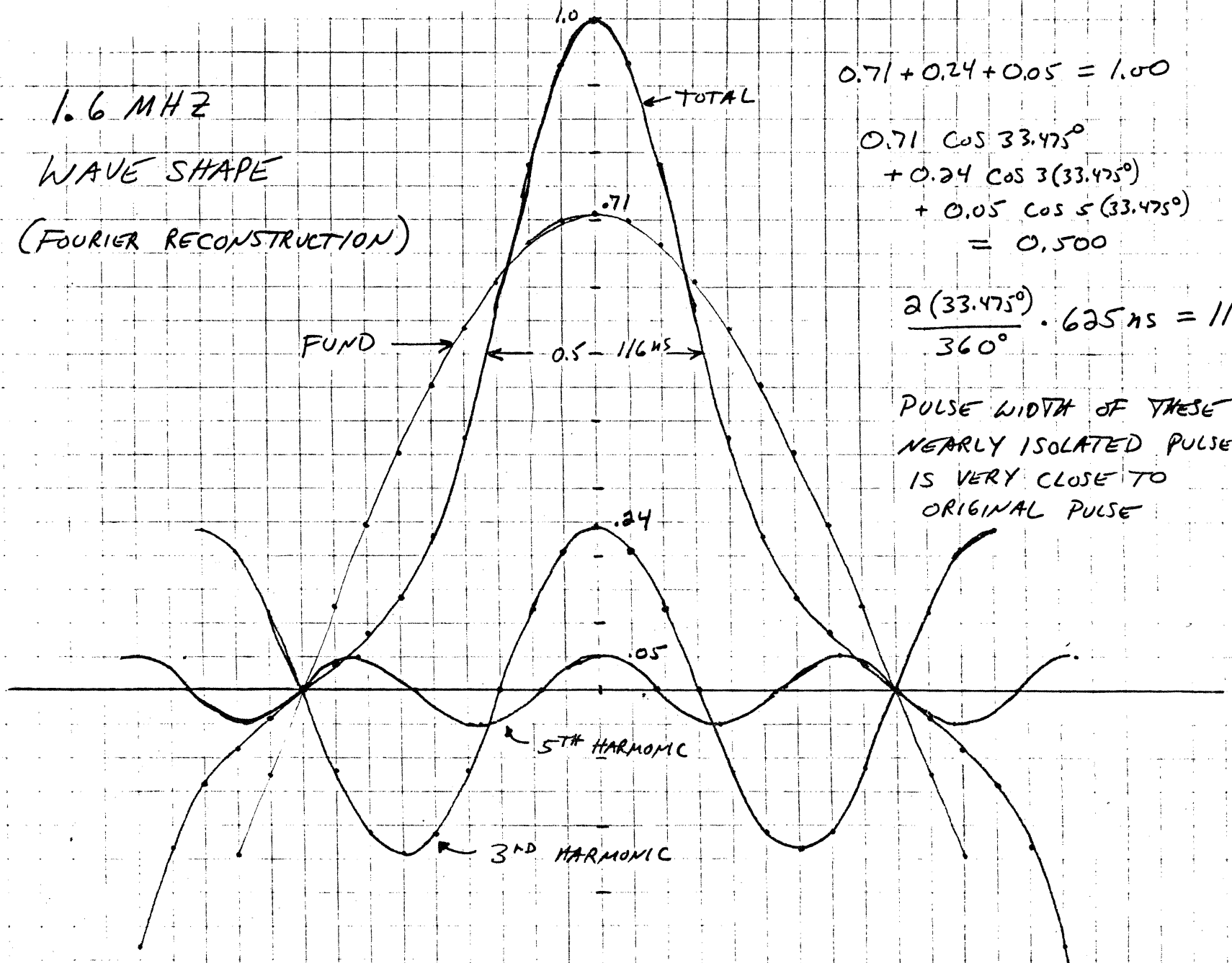

$$0.71 + 0.24 + 0.05 = 1.00$$

$$0.71 \cos 33.475^\circ + 0.24 \cos 3(33.475^\circ) + 0.05 \cos 5(33.475^\circ) = 0.500$$

$$\frac{2(33.475^\circ)}{360^\circ} \cdot 625 \text{ ns} = 116$$

PULSE WIDTH OF THESE NEARLY ISOLATED PULSES IS VERY CLOSE TO ORIGINAL PULSE

READ BACK SIGNAL  
FOR 4<sup>1</sup>'S PATTERN  
(DATA = 1000/000/000--)

	AMP	FOUR	1/n
FUND	= 0.81	x 1,000	x 1,000 = 0.810
3 <sup>rd</sup>	= 0.58	x 1,000	x 0.333 = 0.193
5 <sup>th</sup>	= 0.09	x 1,000	x 0.200 = 0.018

(LONGEST MAGNETS FOR NORMAL 8/9 CODE)

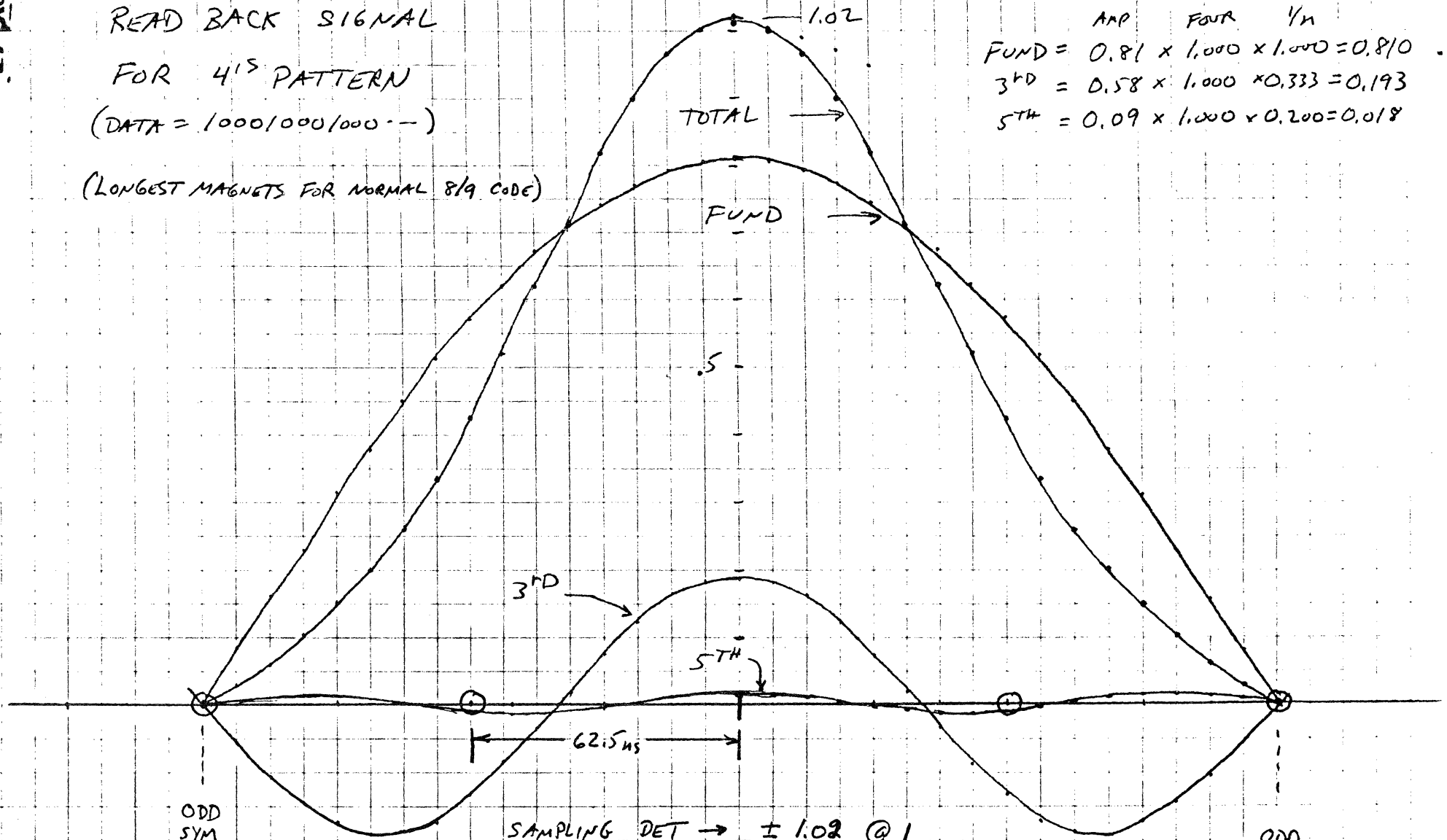

SAMPLING DET → ± 1.02 @ 1  
 ± 0.424 @ 0  
 0.000 @ 0

ODD SYM

# DERIVATIVE OF 4'S PATTERN

(DIFFERENTIATOR  
|GAIN| = 1.0 @ ALL 1'S FREQ)

FUND = .2025  
3RD = .1448  
5TH = .0225

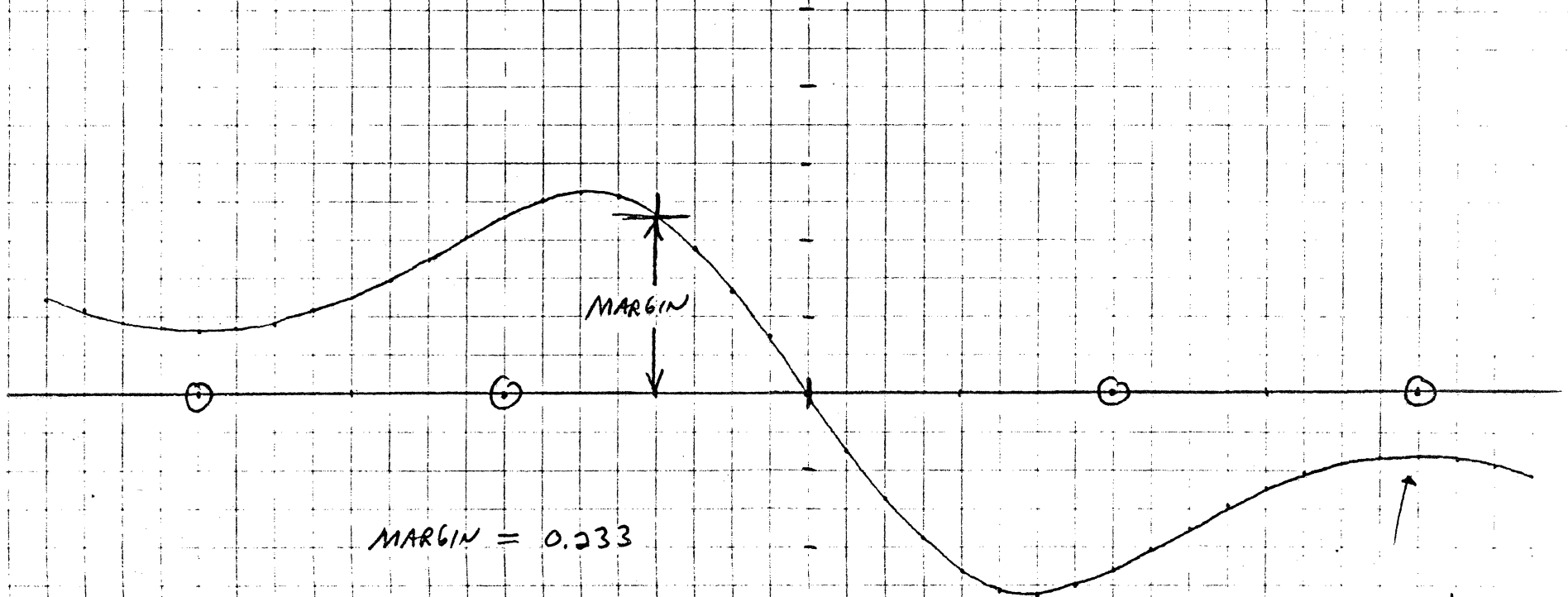

MARGIN = 0.233

LESS MARGIN HERE  
IS IMPROVED BY  
AN EXTRA BIT  
DETECTOR AND  
POLARITY TEST

READ BACK SIGNAL FOR 1-2 PATTERN (REPETATIVE) FOR 8 OUT OF 9 CODE  
 (DATA = 110110110 ---)

	AMPL.	FOUR.	1/n
FUND =	0.67	× 0.866	× 1.000 = 0.580
2 <sup>nd</sup> =	0.04	× 0.866	× 0.500 = 0.017

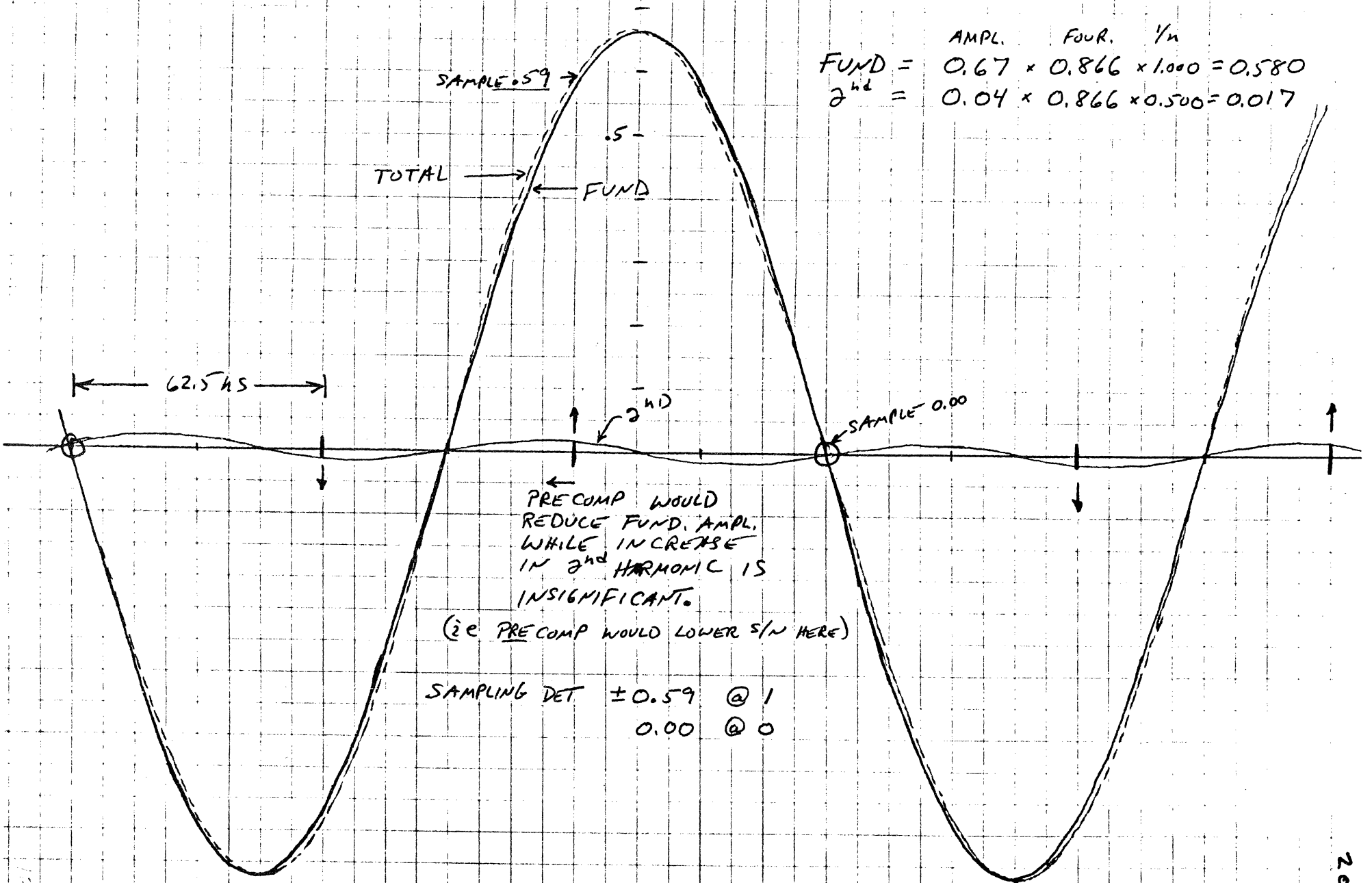

← PRECOMP WOULD  
 REDUCE FUND. AMPL.  
 WHILE INCREASE  
 IN 2<sup>nd</sup> HARMONIC IS  
 INSIGNIFICANT.

(i.e. PRECOMP WOULD LOWER S/N HERE)

SAMPLING DET ±0.59 @ 1  
 0.00 @ 0

# DERIVATIVE OF 1-2 SIGNAL

DIFFERENTIATOR  
 $|GAIN| = 1.0$  @ ALL 1<sup>st</sup> FREQ.

FUND = .387  
2<sup>nd</sup> = .073

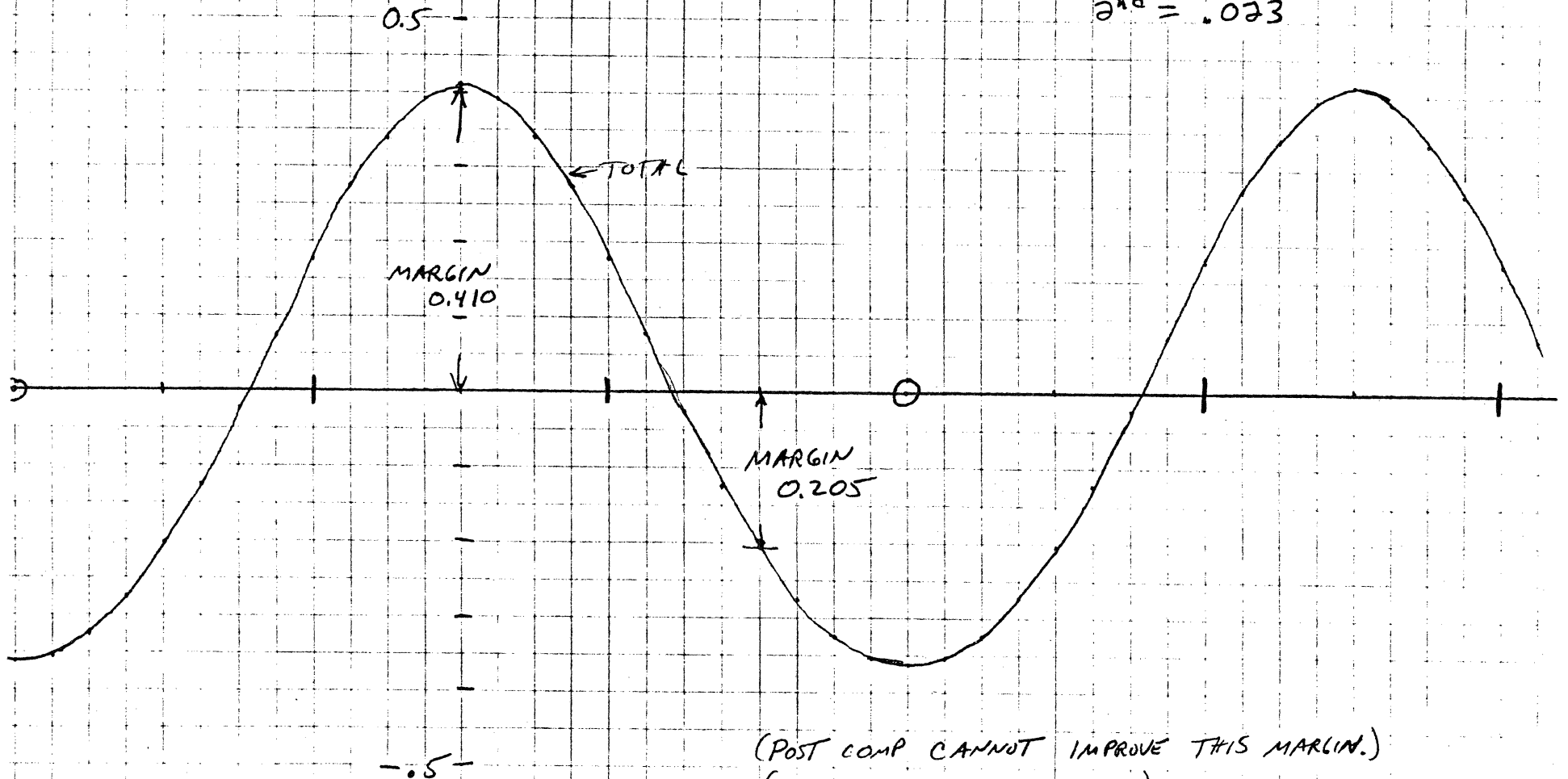

(POST COMP CANNOT IMPROVE THIS MARGIN.)  
(SEE TIME DOMAIN ARGUMENTS.)

DERIVATIVE + INTEGRAL (+DC RESTORE) FOR 1-2 PATTERN

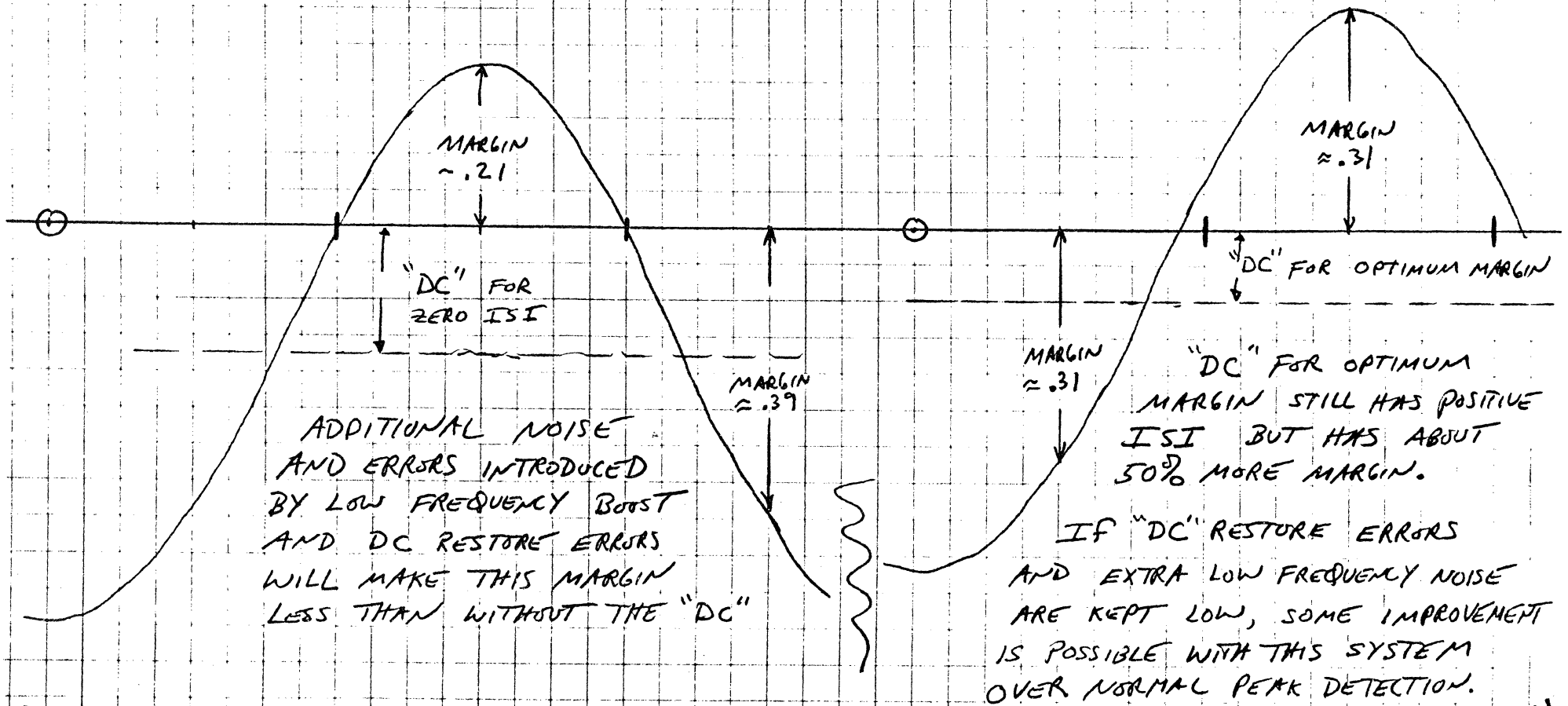

# READ-BACK SIGNAL FOR 1-3 PATTERN (REPEATING)

(DATA = 11001100---)

$$\text{FUND} = 0.830 \times 0.707 = .587$$

FOURIER

$$\text{2<sup>nd

FOURIER 1/2</sup>$$

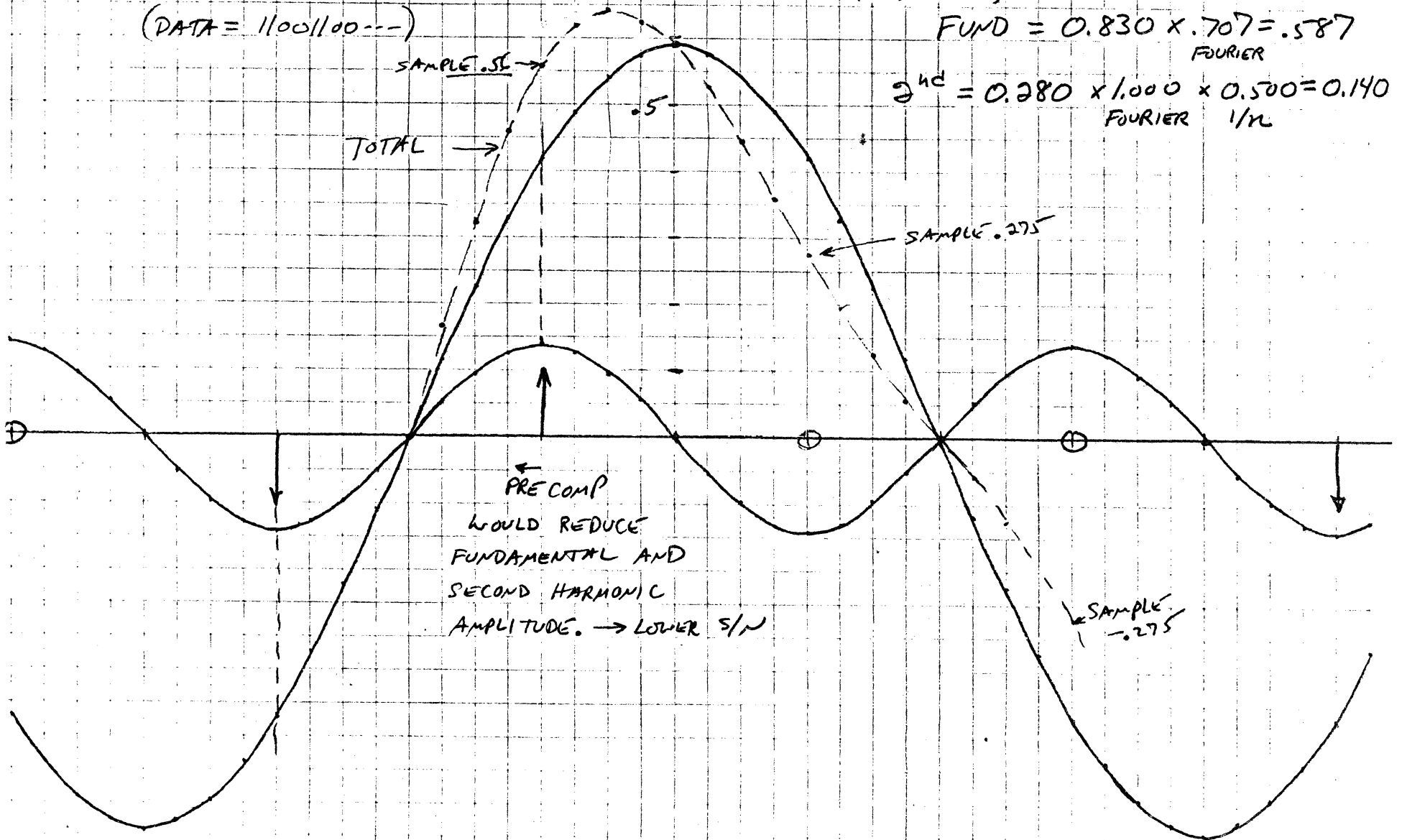



# DIFFERENTIATED 1-3 SIGNAL

(DIFFERENTIATOR  
 $|GAIN| = 1.0$  AT ALL 1'S FREQ)

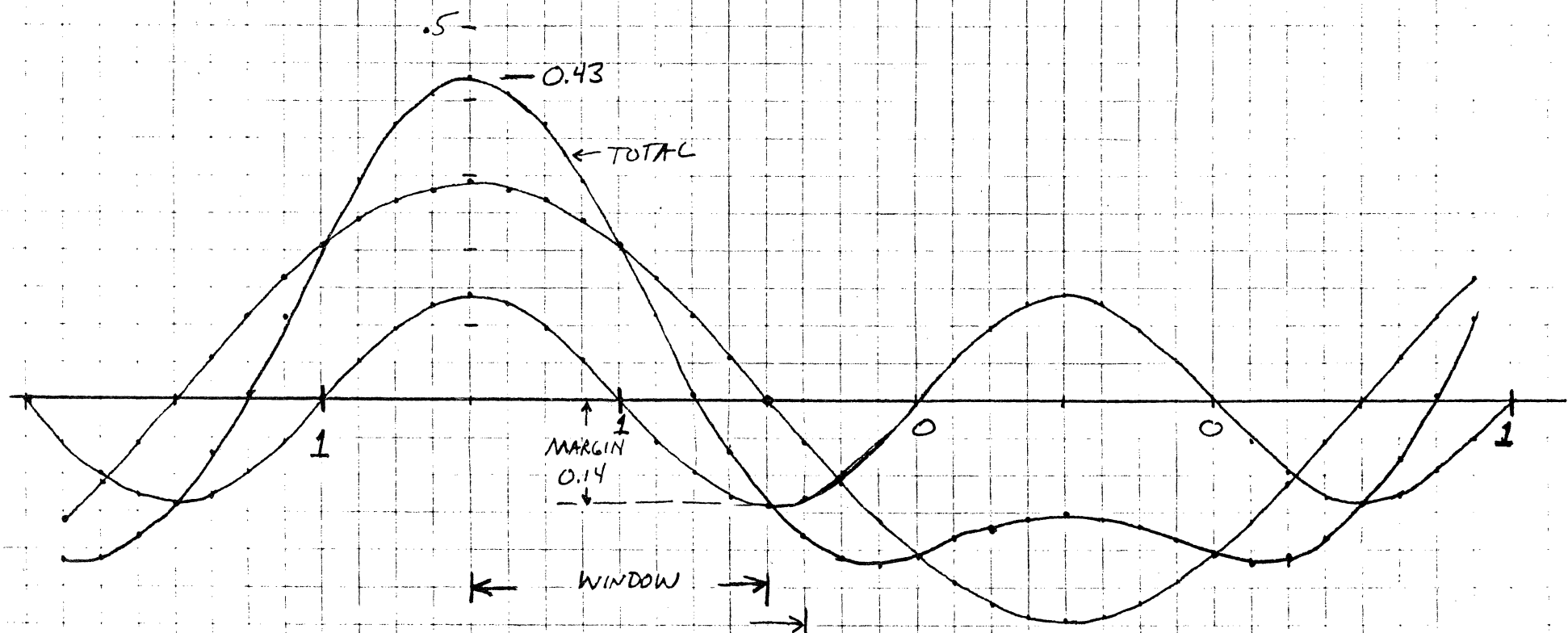

LEAST MARGIN = 0.140

POST COMP  
CAN IMPROVE MARGIN  
WITH NO NOISE INCREASE

# READ-BACK SIGNAL FOR 1-4 PATTERN (REPETITIVE)

(DATA = 110001100011000---)

FOUR  $\frac{1}{4}$

$$\begin{aligned} \text{Fund} &= 0.900 \times \sin 36^\circ \times 1.000 = .529 \\ 2^{\text{nd}} &= 0.530 \times \sin 72^\circ \times 0.500 = .252 \\ 3^{\text{rd}} &= 0.130 \times \sin 108^\circ \times 0.333 = .041 \end{aligned}$$

NOTE:  $\sin 72^\circ = \sin 108^\circ = .951$

PRECOMP WOULD BE DETRIMENTAL.  
 ONLY A VERY SLIGHT IMPROVEMENT  
 IN  $3\omega_0$  IS POSSIBLE, THE  $2\omega_0$  AMPLITUDE  
 WOULD BE SOMEWHAT REDUCED, &  
 $\omega_0$  SIGNAL WOULD BE SIGNIFICANTLY  
 REDUCED.

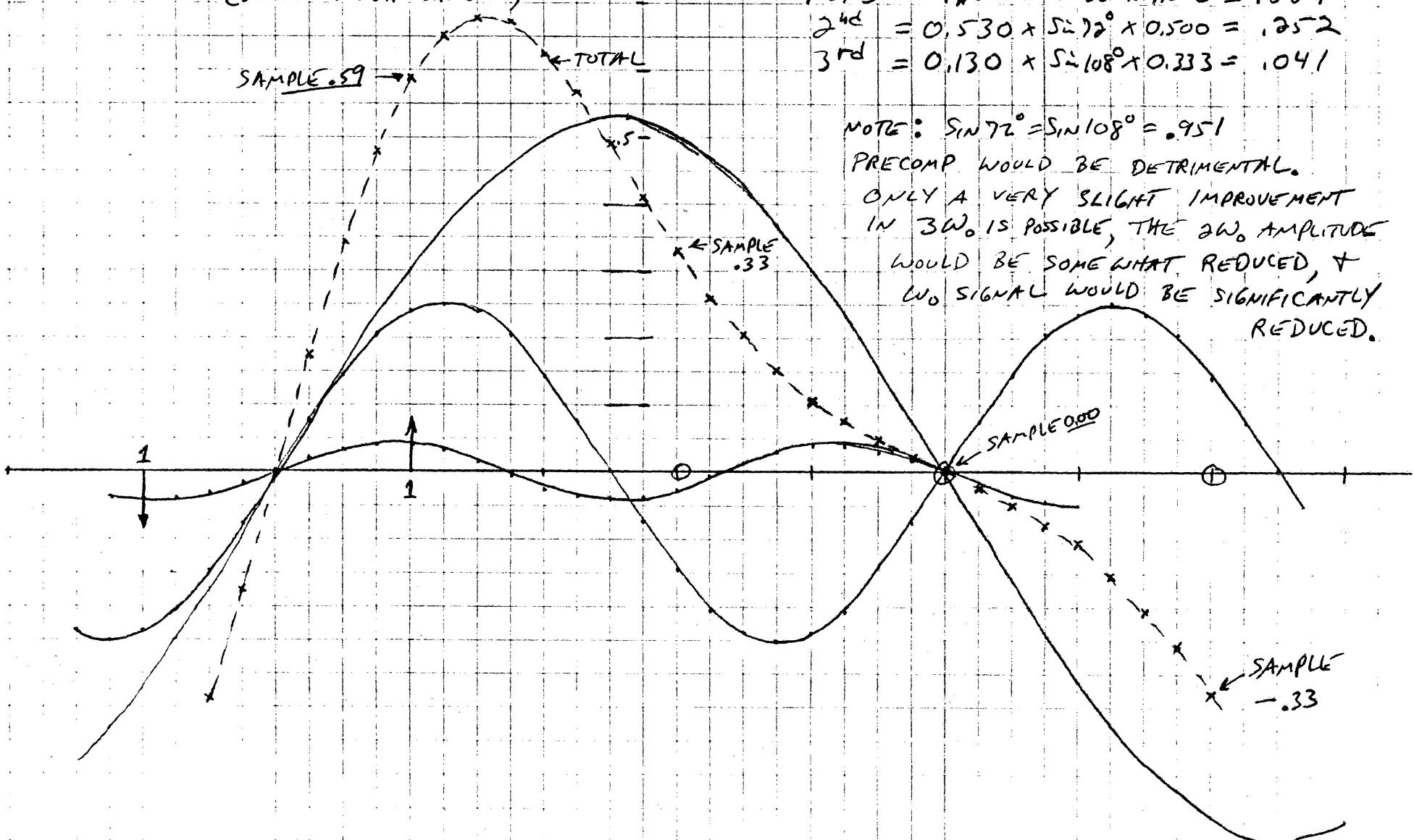

# DIFFERENTIATED 1-4 SIGNAL

(DIFFERENTIATOR  
|GAIN| = 1.0 AT ALL 1'S FREQ)

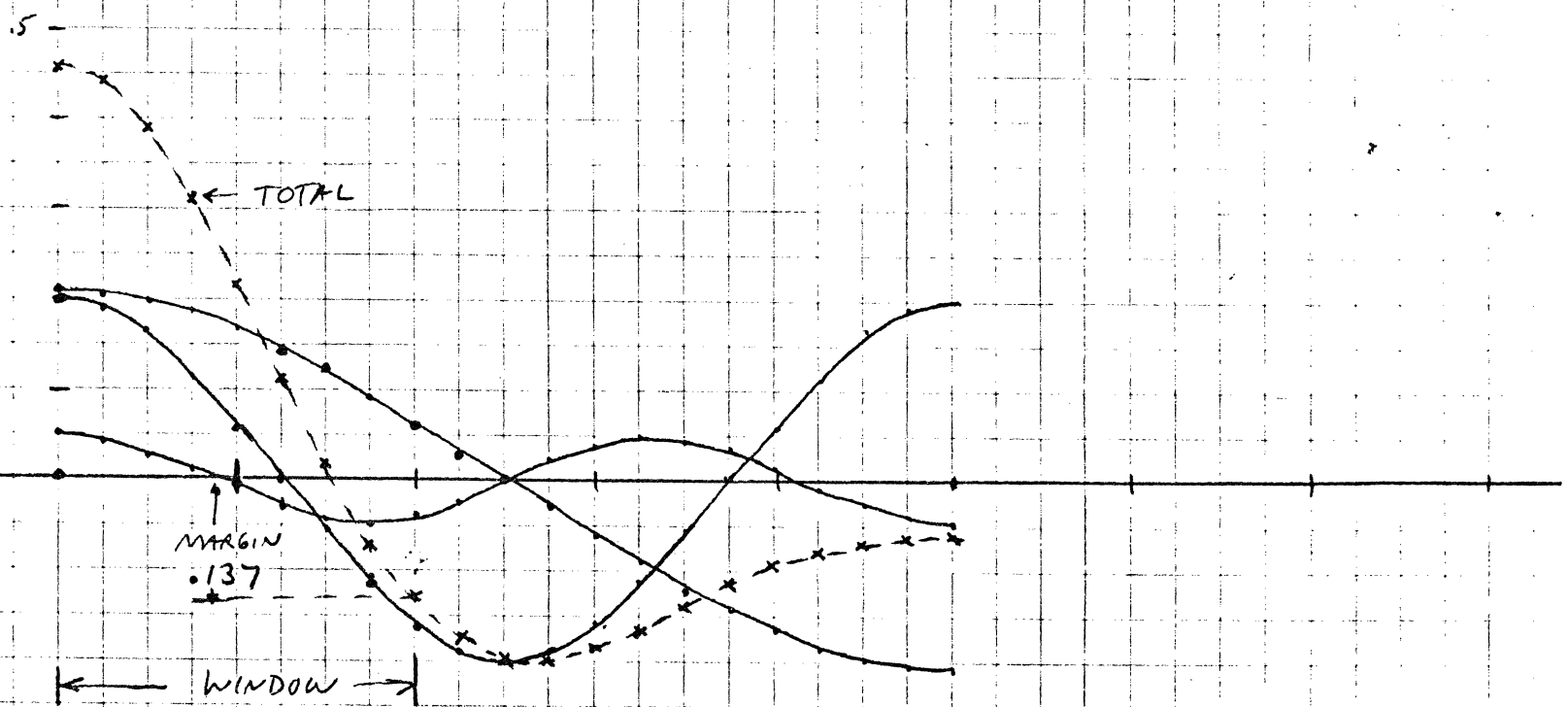

POST COMP OF WINDOW CAN INCREASE MARGIN SOMEWHAT WITHOUT ANY NOISE INCREASE.

# READ BACK SIGNAL

FOR 1-1-4 PATTERN

(MAGNET LENGTHS)  
REPETITIVE

(DATA = 111000111000...)

	Fund.	$1/n$	
FUND =	$.62 \times .732 \times 1,000$		$= +.454$ (133 MHz)
3 <sup>rd</sup>	$.83 \times 1,000 \times .333$		$= -.277$ (40 MHz)
5 <sup>th</sup>	$.49 \times 2,732 \times .200$		$= -.267$ (6.67 MHz)
7 <sup>th</sup>	$.15 \times 2,732 \times .143$		$= -.059$ (2.33 MHz)
9 <sup>th</sup>	$= 0$		(12.0 MHz)

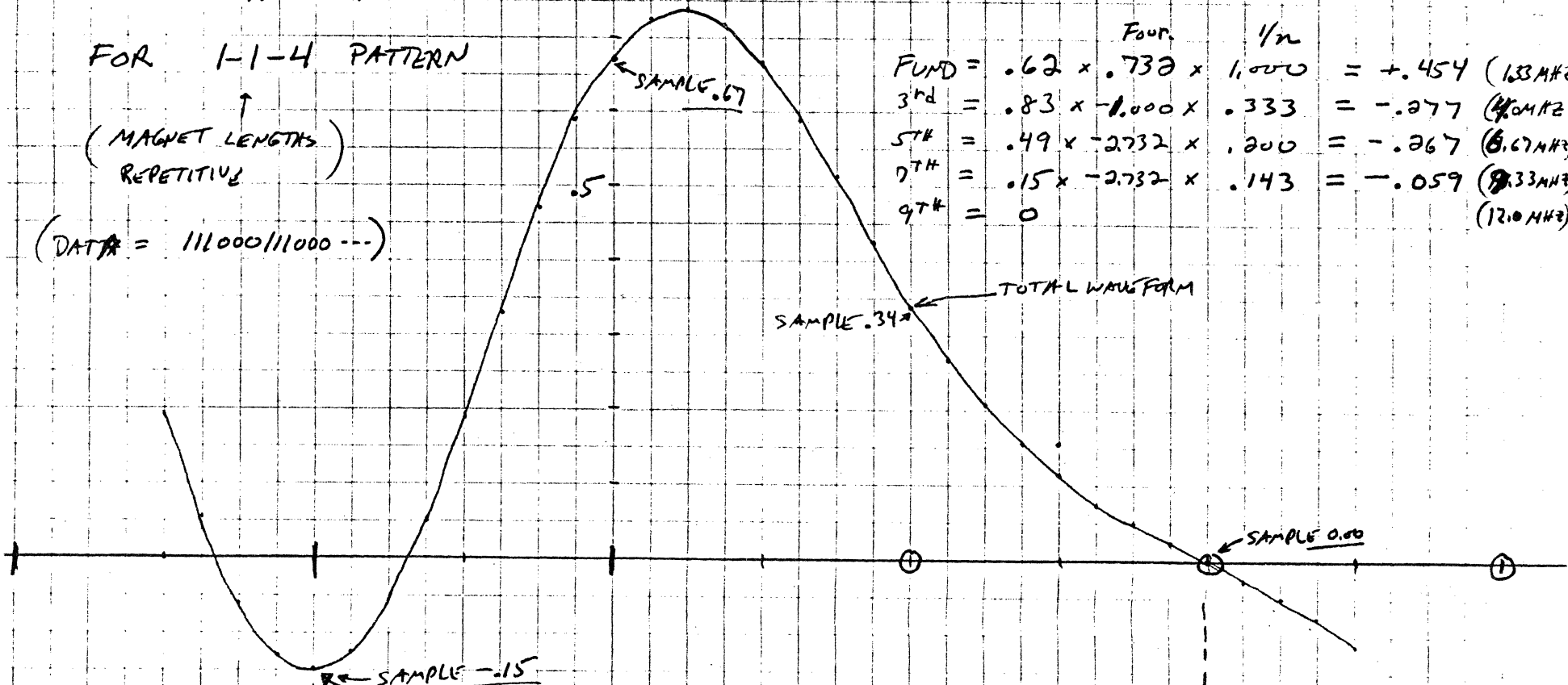

SAMPLING DETECTOR  
WILL FAIL FOR ANY  
REASONABLE THRESHOLD  
ON NEGATIVE PEAK  
OF TRIPULSE

EVEN SYMMETRY

ODD SYMMETRY

FOR SAMPLING DETECTOR, MORE EQUALIZATION  
(PULSE SLIMMING) IS REQUIRED. THE EFFECT ON SIGNAL AND  
NOISE AMPLITUDES IS COMPARABLE TO THE EFFECT OF  
THE DIFFERENTIATOR IN THE PEAK DETECTOR.



REARBACK SIGNAL FOR 1-1-4 PATTERN

EQUALIZED\* BY FACTOR OF GAIN & FREQ.

WITH |GAIN| = 1.0 @ all 1's FREQ  
(NO PHASE SHIFT FROM ORIGINAL)

$$\begin{aligned} \text{Fund} &= .076 = 1/6 (A_{f_0}) \\ 3^{\text{rd}} &= -.138 = 1/2 (A_{3f_0}) \\ 5^{\text{th}} &= -.223 = 5/6 (A_{5f_0}) \\ 7^{\text{th}} &= -.069 = 7/6 (A_{7f_0}) \end{aligned}$$

(SAME SPECTRAL DENSITY AS FOR DIFFERENTIATED SIGNAL)

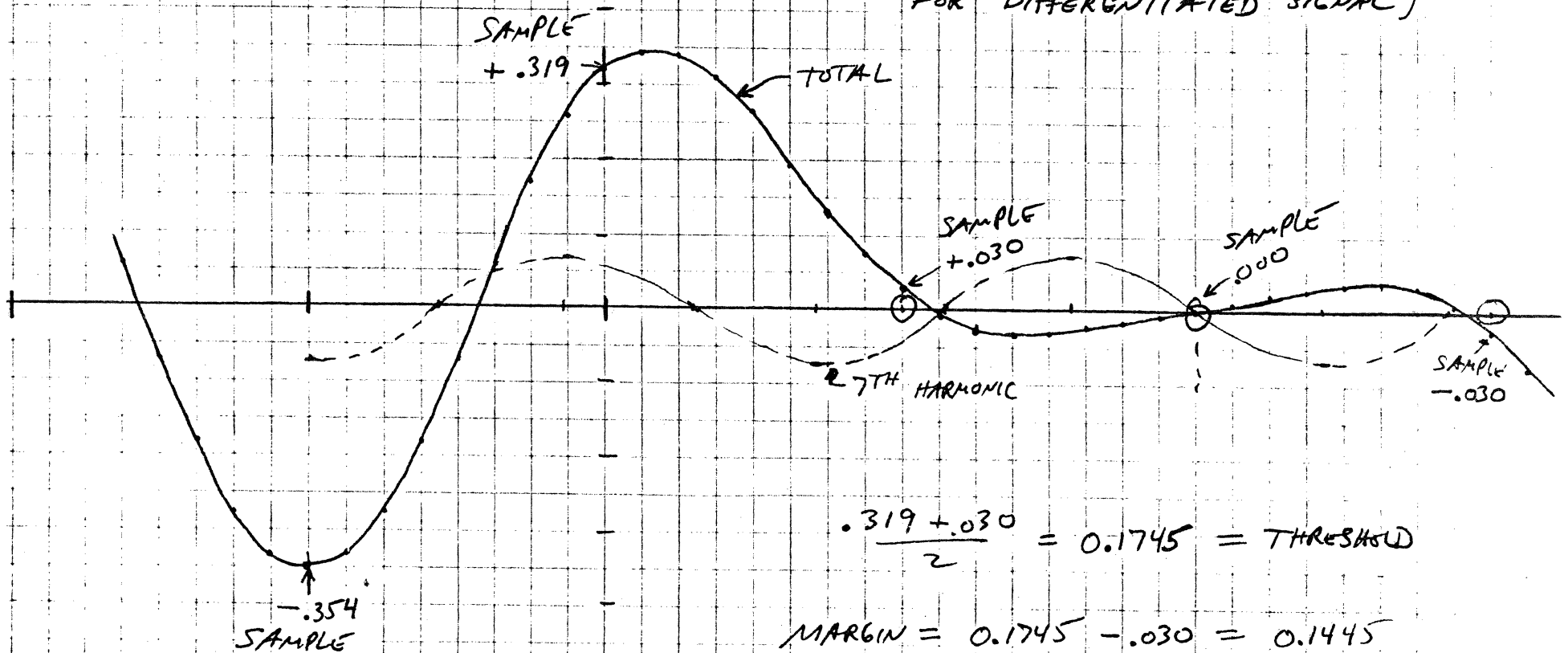

$$\frac{.319 + .030}{2} = 0.1745 = \text{THRESHOLD}$$

$$\begin{aligned} \text{MARGIN} &= 0.1745 - .030 = 0.1445 \\ &= .319 - .1745 = 0.1445 \end{aligned}$$

\* APPROXIMATELY OPTIMUM FOR SAMPLING DETECTOR.

SAMPLING

8/9 PATTERN	DERIVATIVE MARGIN	1'S AMP	0'S AMP
4'S	0.233	±1.02	±0.424 0.000
2'S	0.293	±0.83	0.000
1'S	0.280	±0.28	0.000
1-2	0.205	±0.59	0.000
1-3	0.140 (≈.18)*	±0.56	±0.275
1-4	0.137 (≈.18)*	±0.59	±0.330 0.000
1-1-4	0.176 (≈.21)* 0.375	±0.67 ±0.15	±0.340 0.000

SAMPLING OF WAVE FORM HAS GUARANTEED FAILURE.

PEAK DETECTION HAS EXCESS MARGIN FOR DEFECTS, OFFTRACK, NOISE ETC (AND HAS BEEN DEMONSTRATED FOR GIVEN PULSE SHAPE)

DIFFERENTIATION IN PEAK DETECTION IS ADDITIONAL HIGH FREQUENCY BOOST WHICH ALLOWS SYSTEM TO FUNCTION.

ADDITIONAL HIGH FREQUENCY BOOST WOULD ALLOW SAMPLING SYSTEM TO RUN.

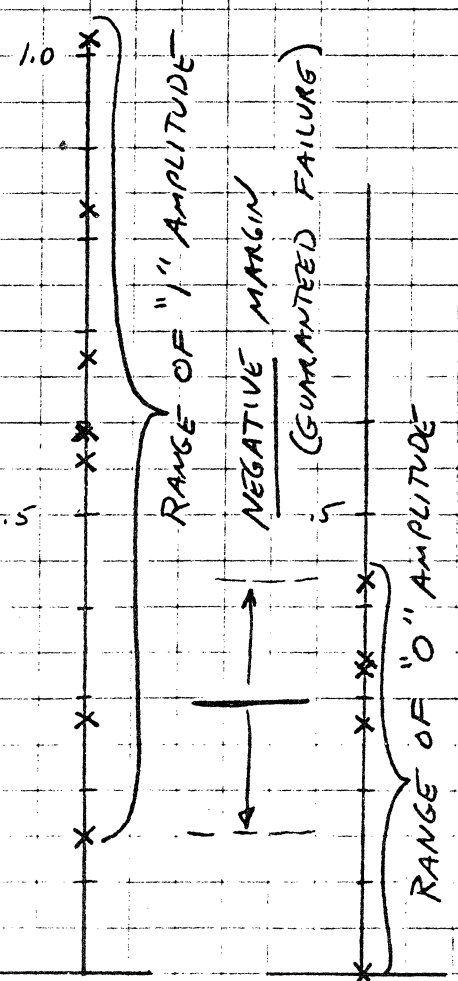
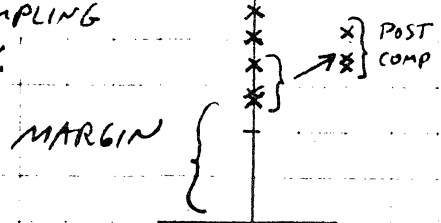

NOISE  
POWER  
DENSITY

# APPROXIMATE NOISE POWER DENSITY FOR INDICATED FREQUENCY RESPONSE.

(ASSUMES BANDPASS  $\approx 1.3 f_{1/2}$ )

- FOR SIGNAL
- - - FOR DERIVATIVE OF SIGNAL  
(DIFFERENTIATOR |GAIN|=1.0 AT ALL'S FREQ)

INCREASE OF HEAD IMPEDANCE WITH  
FREQUENCY AND HIGHER MEDIA NOISE  
GIVE INCREASED NOISE LEVEL WITH  
FREQUENCY UNTIL BANDPASS REDUCES  
NOISE LEVEL.

DERIVATIVE GIVES HIGHER  
NOISE LEVEL AT HIGH  
FREQUENCY AND LOWER  
NOISE LEVEL AT  
LOWER FREQUENCIES  
WHICH GIVES  
NEARLY EQUAL  
NOISE LEVEL  
FOR EITHER  
CASE. (SPEECH)

2.0

1.0

0

0.5

1.0

1.5

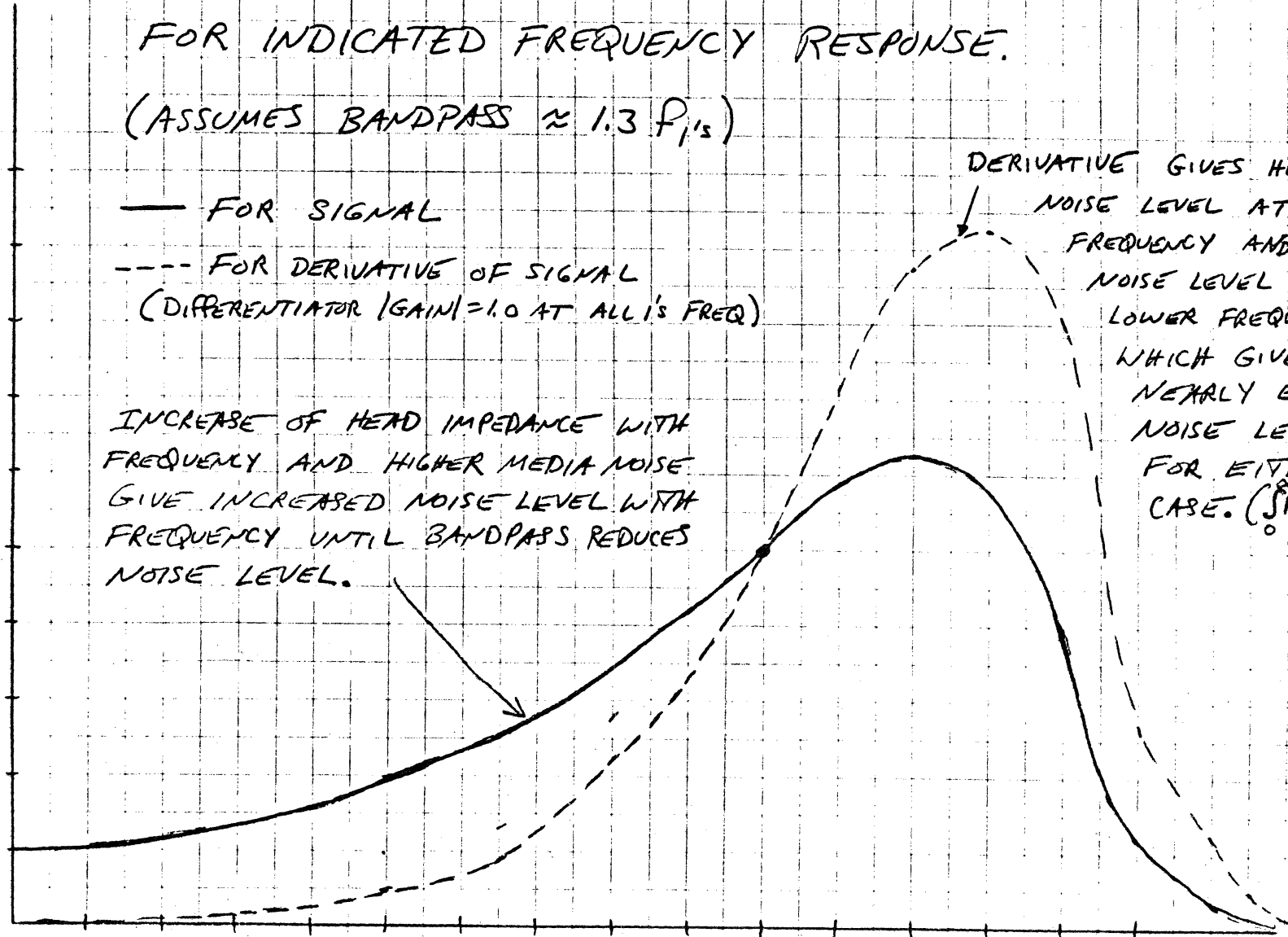



- \* THE PRECEDING HIGH DENSITY PATTERNS FROM A 8 out of 9 CODE EXAMPLE CAN BE SHOWN TO CONTAIN NEAR MAXIMUM FOURIER CONTENT OF THE HIGHER HARMONICS FOR THE GIVEN TRANSITION POSITIONS. ATTEMPTS TO PRE-COMP CAN BE SHOWN TO DEGRADE THE SIGNAL TO NOISE PERFORMANCE. FOR THIS EXAMPLE, THE SYSTEM IS SAID TO BE NOT PRECOMPABLE.
- \* HIGH FREQUENCY BOOST CAN LOWER THE ISI BUT INCREASES THE NOISE CONTENT.
- \* THE POST COMPING IS SHOWN TO IMPROVE MARGIN WITHOUT A NOISE INCREASE.
- \* INTEGRAL SYSTEM (WITH DC RESTORE) ARE SHOWN TO NOT IMPROVE MARGIN IN SOME CASES WHERE ISI IS REDUCED TO ZERO. PARTIAL ISI REDUCTION IS ACTUALLY SUPERIOR.

# TIME DOMAIN ANALYSIS

THE TWO TRANSITION ISI VALUES FOR INTEGER NUMBER OF CLOCK CELLS WERE INDICATED EARLIER. THESE WERE DERIVED BY THE SUPERPOSITION OF THE ISOLATED PULSE DERIVATIVES. (20.3 ns, 5.6 ns, 1.5 ns, 0.4 ns, 0.1 ns,  $\approx 0$ ).

IF FURTHER SIMPLIFYING ASSUMPTIONS ARE MADE, THEN THE TOTAL ISI FOR MULTIPLE TRANSITIONS IS THE SUM OF ALL THE ISI DUE TO EACH OF THE OTHER TRANSITIONS RELATIVE TO THE TRANSITION UNDER CONSIDERATION.

CONSIDERING RLL (0,3) GIVES LENGTHS FROM 1 TO 4.

THE MAXIMUM ISI PATTERN IS THEN GIVEN BY;

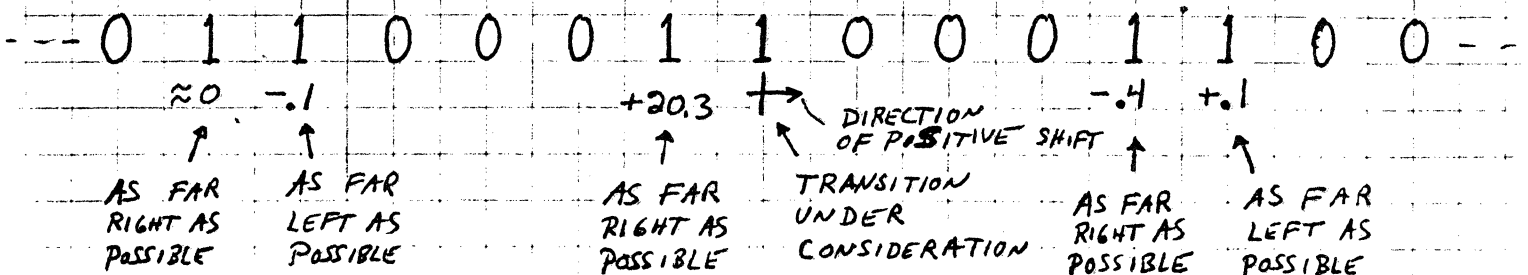

MAXIMUM ISI  $\approx +20.3 - 0.4 - 0.1 + 0.1 \dots = \underline{+19.9 \text{ ns}}$   
BIT SHIFT

ASSUMING PERFECT KNOWLEDGE OF ALL TRANSITIONS EXCEPT THE ONE UNDER CONSIDERATION, THE DECISION IS WHETHER THE BIT WAS AS INDICATED OR IF IT WAS ACTUALLY FROM THE NEXT POSITION TO THE RIGHT.

IF IT WAS IN THE SECOND POSITION, THE ISI BIT SHIFT FROM THAT POSITION SHOULD BE KNOWN.

$$\begin{array}{cccccccccccccccc} \dots & 0 & 1 & 1 & 0 & 0 & 0 & 1 & 0 & 1 & 0 & 0 & 1 & 1 & 0 & 0 \\ & \approx 0 & \approx 0 & & & & & +5.6 & & \rightarrow & & & -1.5 & +.4 & & \end{array}$$

BIT SHIFT  $\approx 5.6 - 1.5 + .4 = \underline{\underline{+4.5 \text{ ns}}}$

A FURTHER APPROXIMATION IS TO ASSUME THAT THE OPTIMUM WINDOW EDGE POSITION IS MIDWAY BETWEEN THE TWO NOMINAL BIT SHIFTED POSITIONS FOR THE TWO POSSIBLE WRITTEN POSITIONS OF THE TRANSITION.

THE SHIFT OF THE WINDOW EDGE FROM NOMINAL

IS THEN 
$$\Delta W \approx \frac{BS_1 + BS_2}{2} = \frac{+19.9 + 4.5}{2} = \underline{\underline{12.2 \text{ ns}}}$$

DUE TO THE BROAD PULSE, THE OPTIMUM SHIFT IN ANY CASE DEPENDS ON THE VALUES OF SEVERAL BITS ON EACH SIDE OF THE TRANSITION UNDER CONSIDERATION.

A SECOND CASE IS OF INTEREST, TO FIND THE MAXIMUM BIT SHIFT WHERE THE OPTIMUM WINDOW SHIFT IS ZERO. THIS OCCURS WHEN THE BIT SHIFT TO THE RIGHT FOR A TRANSITION IN THE LEFT POSITION EQUALS THE LEFT BIT SHIFT IF THE TRANSITION IS IN THE RIGHT POSITION. THIS IMPLIES A SYMMETRY ABOUT THE CENTER OF THE POSSIBLE POSITIONS. THE OTHER TRANSITIONS ARE PLACED FOR MAXIMUM SHIFT UNDER THE SYMMETRY CONSTRAINT.

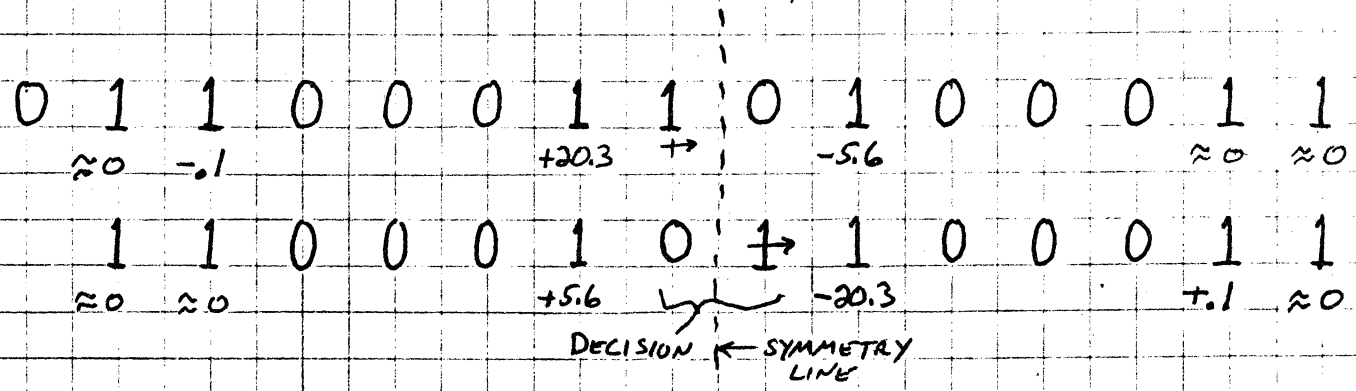

THE SHIFTS ARE ±14.6 ns.

THIS IS THE MAXIMUM SHIFT THAT WOULD HAVE TO BE TOLERATED COMPARED WITH 19.9 ns, IF ONLY ONE TRANSITION POSITION WERE IN QUESTION.

IN GENERAL, ALL TRANSITIONS ARE SUSPECT IN POSITION RATHER THAN ONLY THE ONE AT THE DECISION POINT.

THE QUALITY OF A DECISION WILL THEREFORE BE DEGRADED FROM THAT ASSUMING ABSOLUTE KNOWLEDGE.

IN THE SENSE OF DECISION FEEDBACK EQUALIZATION, THE PREVIOUS DECISIONS MAY BE CONSIDERED AS ABSOLUTELY CORRECT DATA.

(THIS IMPLIES THAT INCORRECT DATA MAY CAUSE ERROR PROPAGATION.) THE PAST DATA PROVIDES HALF THE INFORMATION ON THE ISI.

USING ONLY THE PAST DATA CAN PROVIDE AN IMPROVED PERFORMANCE BY SHIFTING THE WINDOW EDGE.

THE FOLLOWING DEMONSTRATES THE IMPROVEMENT POSSIBLE WHEN THE LAST TWO DATA BITS ARE USED FOR POST-COMP INFORMATION.

CONSIDER PREVIOUSLY DETERMINED DATA TO BE CORRECT + USE AS D.F.E. TO ADJUST WINDOW FOR NEXT BIT DECISION.

← ΔW

0 1 1 0 0 0 | 1 0 0 1 0 0

-1 +.4

→ -1.5

MIN = -1.2 ns

1 1 0 0 0 1 1 | 0 0 0 1 1 0

2.0 -1

+20.3 →

-1.4 +.1

MAX = 19.9 ns

OPTIMUM ΔW ≈ +9.35 ns  
(BASED ON LAST 2 BITS) → BS' ≈ 10.55 ns

VERY GOOD IMPROVEMENT

0 1 1 0 0 0 | 1 0 1 0 0 0 1

-1 +.4

→ -5.6

2.0

MIN = -5.3 ns

1 1 0 0 0 1 1 | 0 0 1 1 0 0

2.0 -1

+20.3 →

-1.5 +.4

MAX = 19.1

OPT. ΔW ≈ +6.9 ns → MAX BS' ≈ 13.2 ns

VERY GOOD IMPROVEMENT

$$\begin{array}{cccc|cccc}
 1 & 1 & 0 & 0 & 0 & 1 & \boxed{1} & 0 & 0 & 0 & 1 & 1 \\
 & & & & & & & & & & & \\
 & & & & & & & & & & & \\
 \end{array}$$

$\begin{matrix} -1 & +.4 \\ \rightarrow & \end{matrix}$ 
 $\begin{matrix} \rightarrow & -20.3 \\ & \end{matrix}$ 
 $\begin{matrix} +.1 & 20 \\ \rightarrow & \end{matrix}$

MIN = -19.9 ns

$$\begin{array}{cccc|cccc}
 1 & 1 & 0 & 0 & 0 & 1 & 1 & 0 & \boxed{1} & 0 & 1 & 0 & 0 & 0 \\
 & & & & & & & & & & & & & \\
 \end{array}$$

$\begin{matrix} 20 & -1 \\ \rightarrow & \end{matrix}$ 
 $\begin{matrix} +20.3 \\ \rightarrow & \end{matrix}$ 
 $\begin{matrix} \rightarrow & -5.6 \\ & \end{matrix}$ 
 $\begin{matrix} +.4 \\ \rightarrow & \end{matrix}$

MAX = 15.0 ns

OPT.  $\Delta W \approx -2.45 \mu s \rightarrow$  BS' = 17.45 ns

---

$$\begin{array}{cccc|cccc}
 0 & 1 & 1 & 0 & 0 & 0 & 1 & \boxed{1} & 1 & 1 & 0 & 0 & 0 \\
 & & & & & & & & & & & & \\
 \end{array}$$

$\begin{matrix} -1 & +.4 \\ \rightarrow & \end{matrix}$ 
 $\begin{matrix} \rightarrow & -20.3 & +5.6 & -45 \\ & & & \end{matrix}$

MIN = -15.9 ns

$$\begin{array}{cccc|cccc}
 1 & 1 & 0 & 0 & 0 & 1 & 1 & 0 & 1 & 1 & 0 & 0 & 0 & 1 \\
 & & & & & & & & & & & & & \\
 \end{array}$$

$\begin{matrix} 20 & -1 \\ \rightarrow & \end{matrix}$ 
 $\begin{matrix} +20.3 \\ \rightarrow & \end{matrix}$ 
 $\begin{matrix} \rightarrow & -5.6 & +1.5 \\ & & \end{matrix}$ 
 $\begin{matrix} 20 \\ \rightarrow & \end{matrix}$

MAX = 16.1

OPT  $\Delta W = -.1 \rightarrow$  BS' = 16.0 ns

---

ONLY SLIGHT IMPROVEMENT ON THESE.  
NEED DATA FROM LEFT SIDE.

(DATA NOT DECIDED YET)

ONLY NEED APPROXIMATE POSITION TO  
PROVIDE A GOOD IMPROVEMENT.

