

IBM System/36

**Preparing to Install Your Work
Stations – 5364**

Program Number 5727-SS6

File Number
S36-15

Order Number
SA21-9845-1

Second Edition (December 1986)

This major revision makes obsolete SA21-9845-0.

This edition applies to Release 5, Modification Level 0, of IBM System/36 System Support Program Products (Program 5727-SS6), and to all subsequent releases and modifications until otherwise indicated.

References in this publication to IBM products, programs, or services do not imply that IBM intends to make these available in all countries in which IBM operates. Any reference to an IBM licensed program in this publication is not intended to state or imply that only IBM's licensed program may be used. Any functionally equivalent program may be used instead.

The numbers at the bottom right of illustrations are publishing control numbers and are not part of the technical content of this manual.

Publications are not stocked at the address given below. Requests for IBM publications should be made to your IBM representative or to your IBM-approved remarketer.

This publication could contain technical inaccuracies or typographical errors. A form for readers' comments is provided at the back of this publication. If the form has been removed, comments may be addressed to IBM Corporation, Information Development, Department 245, Rochester, Minnesota, U.S.A. 55901. IBM may use or distribute whatever information you supply in any way it believes appropriate without incurring any obligation to you.

Contents

About This Manual	v
Who should use this manual . . .	v
How this manual is arranged . . .	v
What you should know . . .	vi
Preparing to Install the Work Stations	1
About Work Stations . . .	2
Making a Floor Plan	4
Assigning Work Station Addresses	6
Planning and Ordering Work Station Cables	13
Drawing the Cable Path	13
Determining the Cable Length	18
Ordering the Work Station Cables	21
Cable Installation Considerations	22
Signal Separation Guide for Work Station Cables	22
Preparing the Work Station Cables	24
Appendix A. Bulk Cable Information	30
Cable Specifications	31
Vinyl-Covered Twinaxial Cable	31
Teflon-Covered Twinaxial Cable	32
Ordering Information	33
Assembly Instructions	34
Cable-to-Cable Adapters	39
Line Continuity and Polarity Tests	40
Appendix B. Noise Considerations	42
Acoustic Environments	42
General Business Area	43
Quiet Office Area	43
Product Noise Emission Values	44
Appendix C. Forms	45

Glossary 61

About This Manual

Who should use this manual . . .

This manual should be used by the person responsible for installing the work stations on the System/36 PC.

The planning work done in this manual will be used later during setup and system configuration.

How this manual is arranged . . .

This manual contains information on the following:

- A brief description of work stations and how they connect to the System/36 PC
- Completing the *Work Station Diagram* forms in preparation for setup
- Planning, ordering, and preparing cables for work stations

It also includes copies of the forms you will need as you prepare to install your work stations.

Note: This manual may refer to products that are announced, but are not yet available. Such information is for planning purposes only and is subject to change before general availability.

What you should know . . .

You should be familiar with these publications for your personal computer:

- *IBM Personal Computer Guide to Operations*
- *IBM Personal Computer Disk Operating System*

The personal computer can be one of the following:

- IBM Personal Computer
- IBM Personal Computer XT
- IBM PERSONAL COMPUTER AT®

If you are installing *remote* work stations, you should have completed the applicable sections of the manual, *IBM 5250 Information Display System Planning and Site Preparation Guide*, GA21-9337.

Preparing to Install the Work Stations

If you are attaching printers or display stations other than the system console personal computer (PC) and its attached PC printer to your system, you must do some preparation.

- If you are not familiar with work stations and how they connect to the system, read the topic “About Work Stations . . .” in this manual for background information.

Even if you are familiar with work stations, at least review the topic for any information that is specifically applicable for this system.

- Make a floor plan of some kind to show where you want to place your work stations and the cable path between them and the computer. Some suggestions are given in this manual.
- Assign the addresses and device codes on the *Work Station Diagram* forms (Forms F, H, H1, and H2).
- Determine the cable lengths you need and order the cables.
- Prepare the cables for setup.

About Work Stations . . .

Work stations are display stations and printers that can be attached to a computer to send and/or receive information.

- *Local* work stations are located within approximately 1525 meters (5000 feet) of the system unit and are attached to the system *using twinaxial cable*.
- *Remote* work stations are attached to the computer through a remote controller device which in turn is connected to the system unit *using a communications line*.

Work station cables are attached to the system unit or to the remote controller through openings usually located in the back of the device. The openings are generally called:

- **Ports** in the system unit and the remote controllers
 - The 5364 System Unit has three ports, numbered 0, 1, and 2
 - The 5251-12 controller with
 - Single cluster feature (CF1) has four ports
 - Dual cluster feature (CF2) has eight ports
 - The 5294-1 controller has four ports
 - The 3274 Model C controller can have 8, 12, or 16 ports
- **Sockets** in the work stations
 - Most of the display stations and printers can have either one or two sockets, numbered 1 and 2; if they have two sockets, they have Cable Thru capability.
 - If a device has one *unnumbered* socket, it connects to other devices on the line with a D- or T-connector. If the device is not a 5251 Model 11, it can still be considered to have Cable Thru capability.
 - The personal computers do not have Cable Thru, but they can attach to other devices with an integrated attachment cable. They can also have a PC printer attached. The PC printers cannot have any additional devices attached to them.

Work stations can be attached *directly* to the system unit or the remote controller, or they can be attached *indirectly*, through another device that has Cable Thru. Work stations can be placed in any sequence on a line if they have Cable Thru; if they do not have Cable Thru, they must be either the only or the last device on the line.

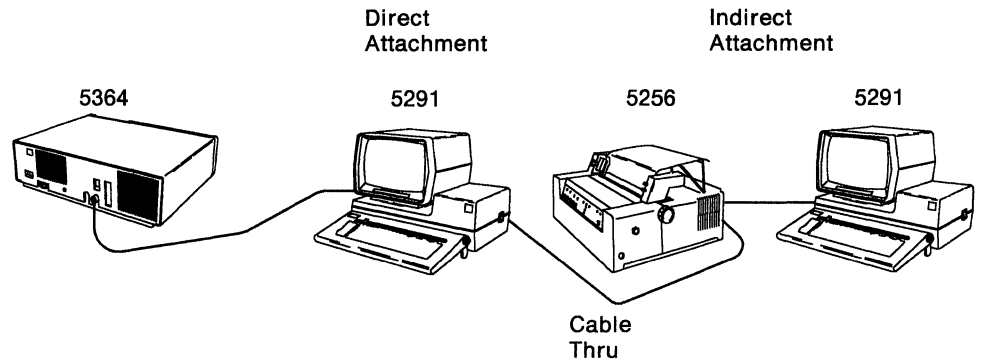

B9084016-1

Making a Floor Plan

Your layout of where in your offices the system devices are located can be very simple or quite elaborate:

- The *Work Station Diagram* (Form F for locals, Form H, H1, or H2 for remotes) that you complete in the task “Assigning Work Station Addresses” might work as a floor plan as well. On it, you can show:
 - The name, location, and telephone number of the person using each device
 - The order in which the devices are arranged on a line
 - The number of the cable connecting the devices

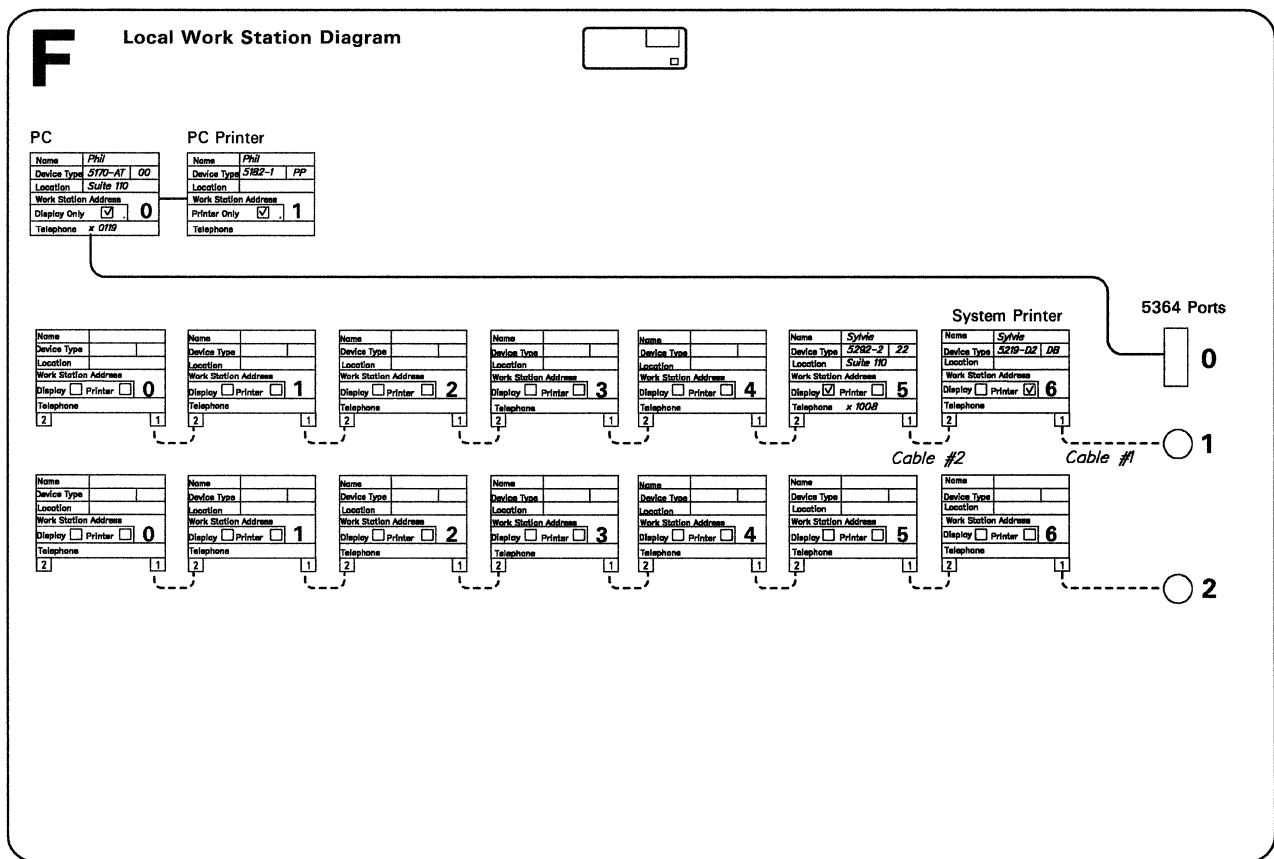

AAQ001-0

- If you have existing blueprints of your location, you could use these to draw in the device locations and cable paths.
- You could use grid paper to draw a layout of your office(s) and show where the devices and cables will be located in relation to your existing equipment and furniture.

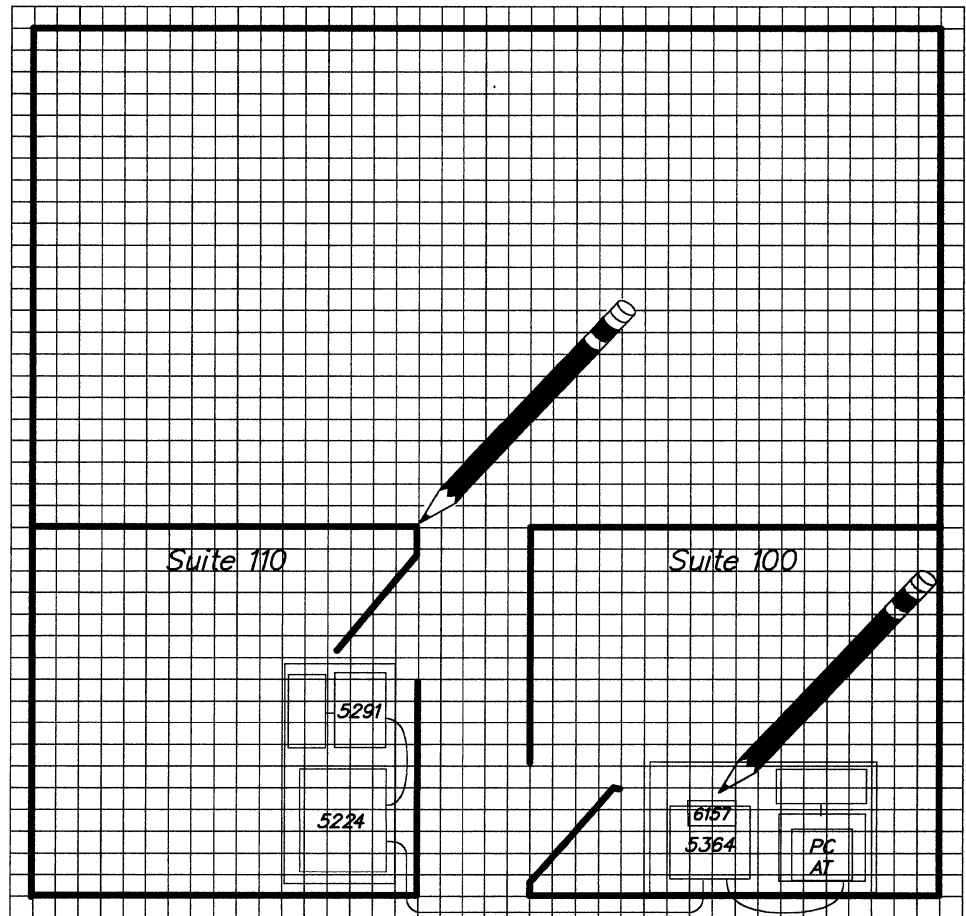

B9084130

Assigning Work Station Addresses

Besides the system console and its attached PC printer, your system can have additional local work stations, as well as remote work stations, which are attached through a remote controller.

You must identify each device to the system with a device code and a work station address, so the system knows what model the device is and where on the line the device is located.

- For **local work stations**, use Form F, *Local Work Station Diagram* to:
 - Assign the addresses
 - Record the device codes

Note: Device codes are used during system configuration to identify the particular model of the display stations and printers.

- For **remote work stations**, use Form H if you have a 5251-12 remote controller, Form H1 if you have a 5294-1 remote controller, or Form H2 if you have a 3274 remote controller.

You will also need a copy of the *Communications Network Setup Form* that was completed for the remote controller from the manual *5250 Installation and Site Preparation Guide*.

The F and H forms are in Appendix C.

You will use the addresses when you label the cables and also later, during setup, when you actually attach the work stations to the computer. You will use the device codes (listed later in this book) when you configure the system.

1. Complete Form F for *local* work stations.

a. Read the following considerations for local work stations before assigning the addresses:

- The system console personal computer is attached with an expansion cable to port 0 (the rectangular one) on the 5364. The console must have an address of 0 on port 0.
- If you attach a PC printer to the system console (a PC printer cannot attach directly to the 5364 unit), the printer must have an address of 1 on port 0.

If you do *not* attach a PC printer, address 1 on port 0 can also be assigned to the console; this gives you a second logical display station. No additional hardware or cabling is required.

Neither the PC printer nor the second display station is required.

- On port 1 and port 2, addresses from 0 to 6 are valid for work stations connected in a line using Cable Thru capability, but each work station on a line must have a different address.

If a device does not have Cable Thru capability, it must be either the only or the last device on the line. An address of 0 should be assigned to this device.

b. Complete the following information for each device you will be attaching:

- Who will operate the device
- The device type and model (if any)
- The device code (from the chart in step 1c)
- Where the device is located
- Whether the device is a display station or printer
- The telephone number nearest the device

The work station address is preprinted in each box.

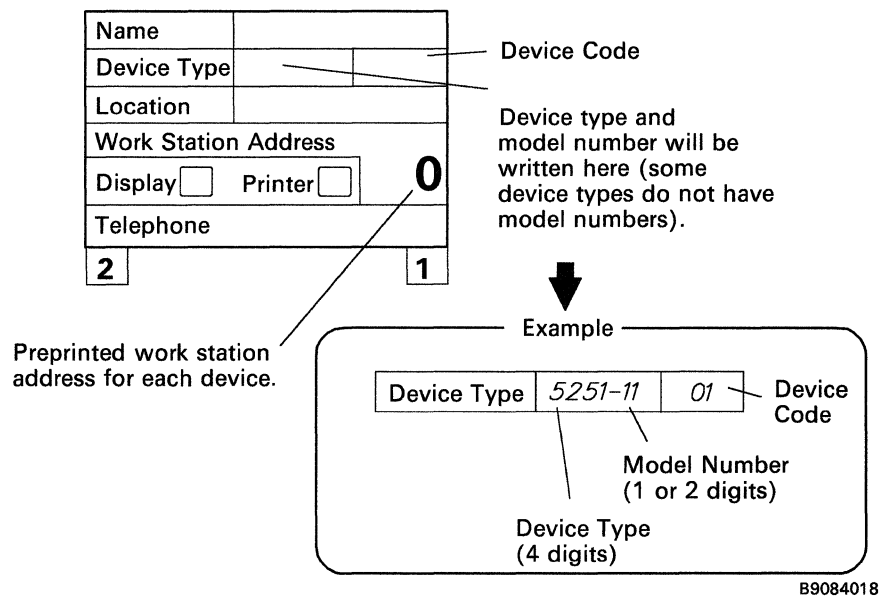

c. Copy the appropriate device codes from the chart onto the diagram:

Device Type (Machine Number and Model)	Device Codes	
	Specific ^a	Universal
Display stations: Single-color displays 3180-2 5251-11 5251-12 5291-1 5291-2 PC with 5151 Emulating a 5291 3196 Multiple-color displays: 3179-2 5292-1 5292-2 PC with 5153 Emulating a 5292-1 Emulating a 5292-2	11 01 02 10 10 00 10 15 25 21 22 00 21 22	00 20
Printers: 3812 4214-2 4224-1 4224-2 4234-2 4245-T12 4245-T20 5219-D01 5219-D02 5224-1 5224-2 5225-1 5225-2 5225-3 5225-4 5256-1 5256-2 5256-3 5262-1 PC printer as 5256 PC printer as 5219	DA EA HA HB KA MA MB DA DB BA BB CA CB CC CD AA AB AC AD -- --	PD PG PH PH PK PM PM PD PD PC PC PC PC PC PB PB PB PB PB PB PD
^a Use the specific code (rather than universal) to make use of the device's special characteristics.		

Name	Sylvie	
Device Type	5292-2	22
Location	Suite 110	
Work Station Address		
Display	<input checked="" type="checkbox"/>	Printer <input type="checkbox"/>
Telephone	x 1008	
2		1

B9084021-1

2. Complete Form H, H1, or H2 for *remote* work stations.

- a. Copy the information from the *Communications Network Setup Form* that was completed for the remote controller to the box in the upper right corner of Form H, H1, or H2.

The controller ID is created by System/36 during remote work station configuration. When you do your system configuration, copy the controller ID from configuration display 13 onto the appropriate H form.

5294 Information

Name Accounting Office
Location Headquarters
City, State New York, New York
Telephone 212-777-6742
System Line/Port Number 1
 Location Computer Center
 Telephone 212-338-5112
Communications Type EIA/CCITT
CE assistance required for communications
line connection? Yes No

5294 Information

Controller ID _____

Controller Description:

Name Accounting Office
Location Headquarters
City, State New York, New York
Telephone 212-777-6742
Controller Station Address _____
Communications Line Number 1
Alternative Lines _____
Communications Type EIA/CCITT

AAQ007-1

- b. For each work station attached to the remote controller, copy the information from the *Setup Form*.

Note: A boxed arrow pointing to the right indicates socket 2. A boxed arrow pointing to the left indicates socket 1.

Name	Glen	←
Device Type	5251-11	
Location	Accounting	
Work Station Address	0	
Unit Address	00	
Keyboard Code	00	
Telephone		→

Does not apply to System/36.

Form H1

Name	Glen	
Device Type	5251-11	
Location	Accounting	
Work Station Address		0
Display <input checked="" type="checkbox"/>	Printer <input type="checkbox"/>	
Telephone		
2		1

Look at the keyboard code box on the remote setup form. If you see a 2-digit code, check (✓) the display box. If the keyboard code box is blank, check (✓) the printer box.

AAQ004-1

- c. Copy the appropriate device codes (from the chart in step 1c for *local work stations*) onto the diagram.

d. Check the information you have transferred. The work station address and port numbers on the Communications Network Setup form must match those on the appropriate H form. For example:

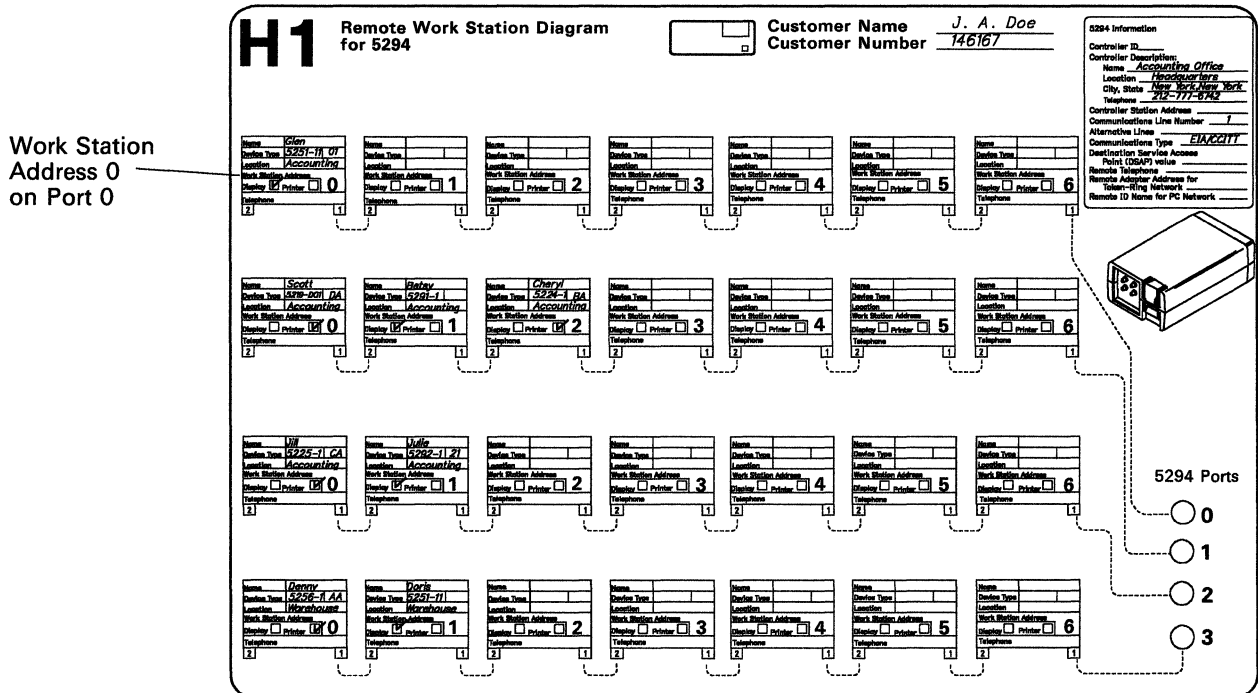
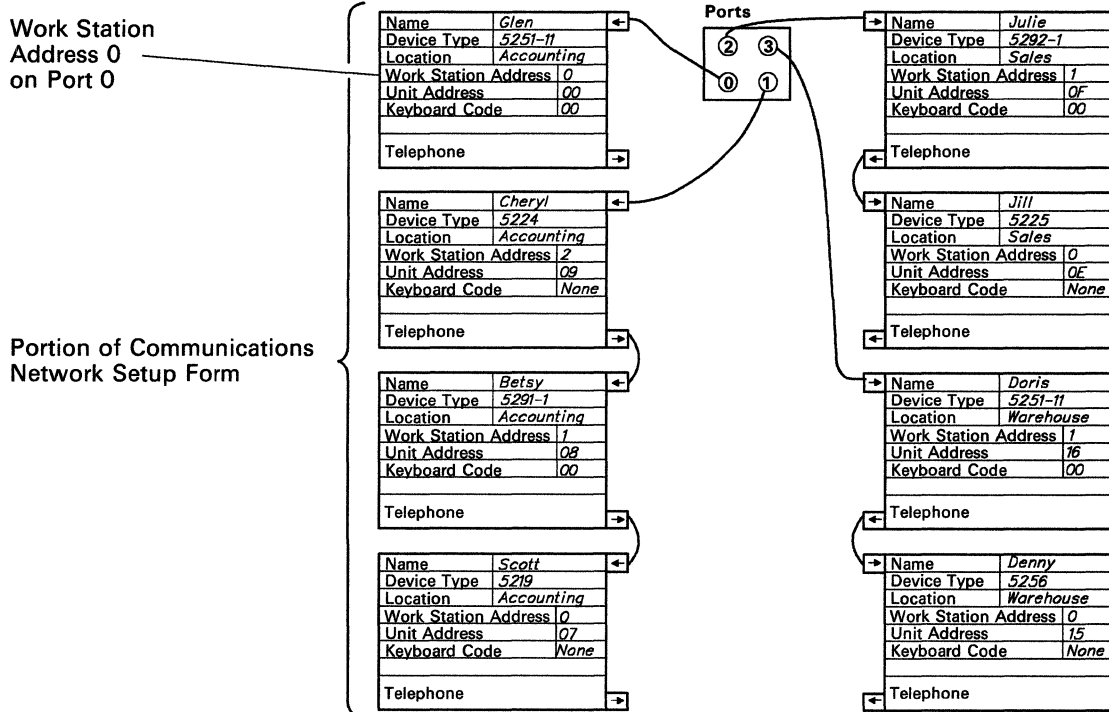

AAQ011-0

Planning and Ordering Work Station Cables

Planning the work station cable requirements for your computer is an important part of planning for setup. In this task you will:

- Draw the cable path(s) between the computer and work stations
- Determine the cable length
- Order the cables

Also included in this task are some cable installation considerations.

You will need to use the floor plan that you prepared earlier. If you have existing blueprints of your location, you can use them as a reference to draw your cable path. Keep in mind that the scale of the floor plans might be different.

Drawing the Cable Path

Planning your work station cable requirements begins by drawing cable paths on a floor plan indicating how each work station will be attached to the computer.

1. Before you begin drawing your cable paths, read the following considerations:
 - The system console personal computer is attached to port 0 on the 5364 System Unit with an expansion cable that is included with the unit.
 - The personal computer printer attaches directly to the personal computer with a printer cable.
 - Port 1 and port 2 are used to attach the rest of the local work stations.

- When drawing the cable paths, consider how the cables will be routed in the building. Cable paths should be planned to avoid:
 - Creating a safety hazard, such as running a cable in front of a door
 - Exposing the cable to possible damage
 - Routing the cable into a physical barrier, such as a block wall
- The last work station on a line cannot be more than 1525 meters (5000 feet) in cable distance from the computer.
- A work station has either one or two sockets for attaching cables.
 - A work station with two sockets has Cable Thru. The sockets may have numbers or arrows to indicate which is socket 1 and which is socket 2.

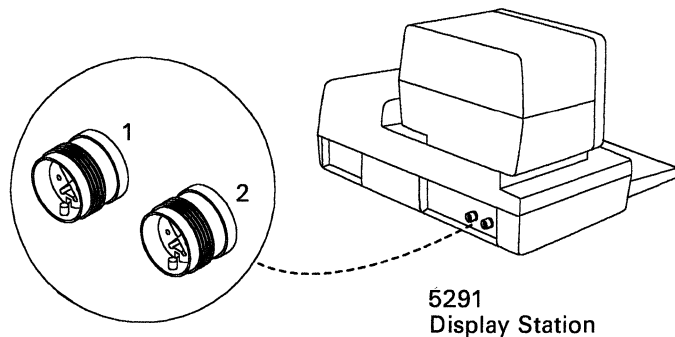

5291
Display Station

B9084024-1

Socket 1 is shown by an arrow pointing toward a socket.

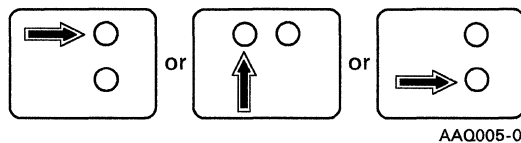

AAQ005-0

Socket 2 is shown by an arrow pointing away from a socket.

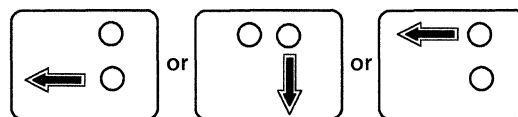

AAQ006-0

- Some work stations with only one unnumbered socket use a D- or a T-connector to attach to other devices on the line (so they can also be *cabled thru*).
- A work station with one socket may be connected to other devices on the line by using an Auto Termination Unit (IBM part 6457102). The socket ends of the Auto Termination Unit are not numbered; they are interchangeable.

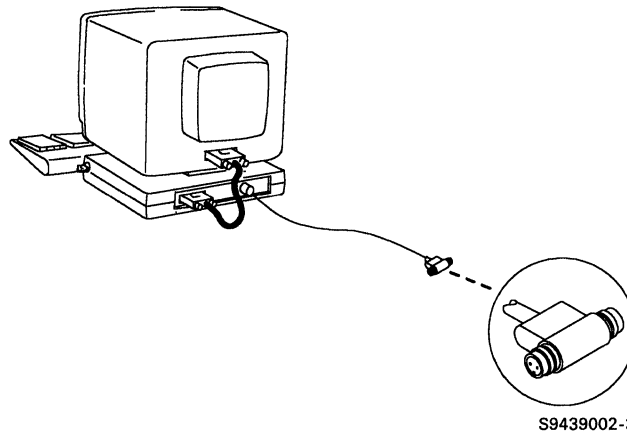

- A cable to be connected to the port on the system unit must always go to socket 1 on the work station.

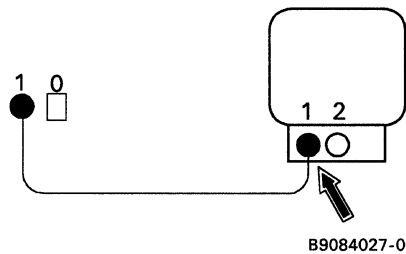

- A cable to be connected to socket 2 on a work station must always go to socket 1 on the next work station.

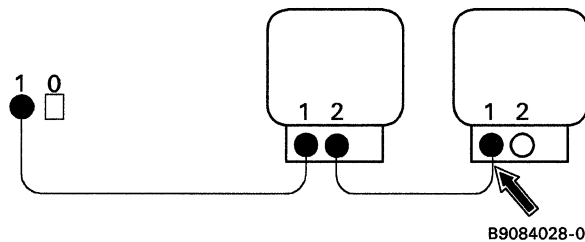

- Cables attach to the display stations and printers in back of the device except for the 5251 Model 11. For the 5251 Model 11, the cable passes from the back through a cable tunnel to the front.

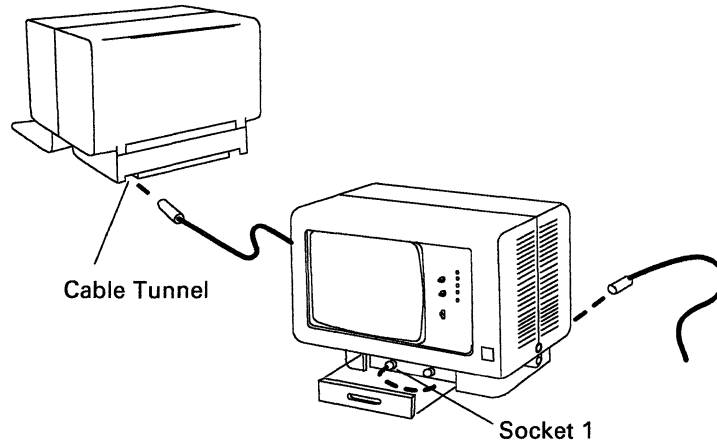

S9439060

- Cables lying on the floor should be placed around the edge of the room.
- Cables dangling from the ceiling in a work area should be dropped next to a wall.

2. Draw the cable path on your floor plan, showing how your work stations will be attached to the 5364 (and to the remote controllers, if any).

Notes:

- a. *Before drawing a path from one device to the next, make sure the device that the cable will come from has Cable Thru. (You should have ordered the Cable Thru feature for devices on which Cable Thru is not standard.)*
- b. *There is no decal for the 6157 Tape Drive. If your computer will have a 6157 attached to it, draw a small box on the computer decal and label it 6157.*

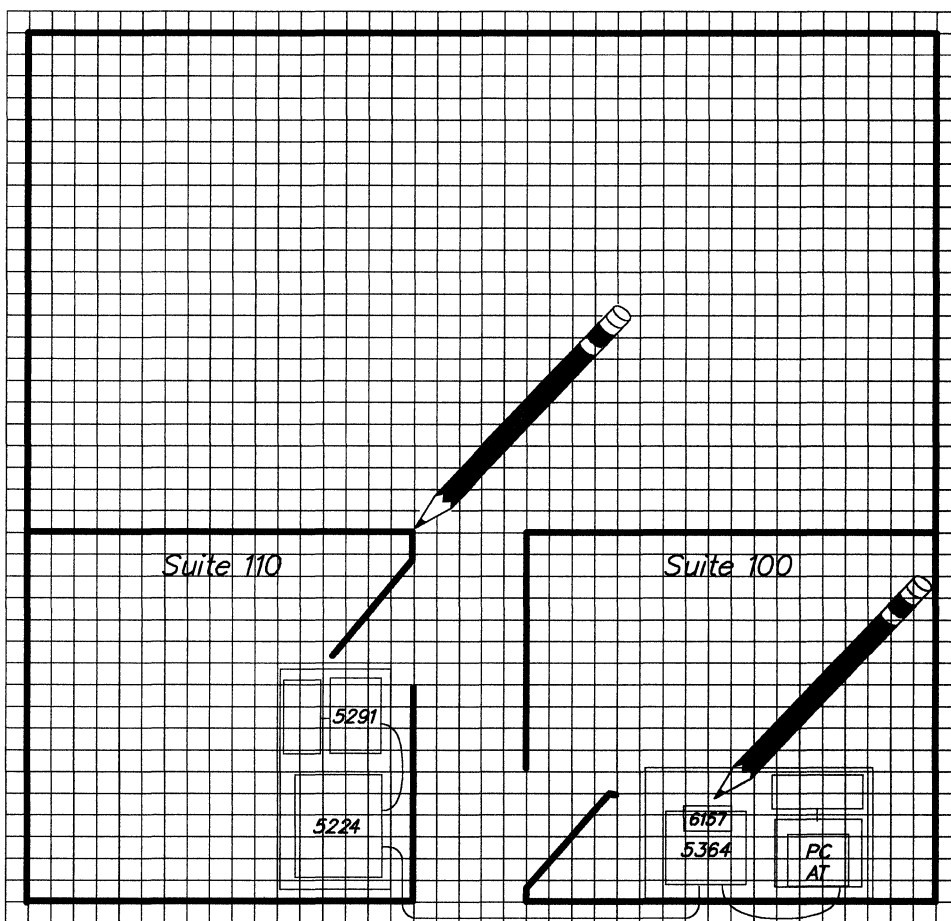

B9084130

Determining the Cable Length

Before you can order the work station cables, you must know the length of each cable.

Use your floor plan to help you determine cable lengths.

1. Read the following considerations:

- Allow enough cable to move the machines for servicing.

For cables lying on the floor, you can use the following guidelines to determine the length of each cable:

- Determine the cable path distance.
- Add a minimum of 0.6 meters (2 feet) at each end.
- Add 0.9 meters (3 feet) for the connection to a device resting on a table.

In the following illustration, the total length required is 9 meters (29.5 feet).

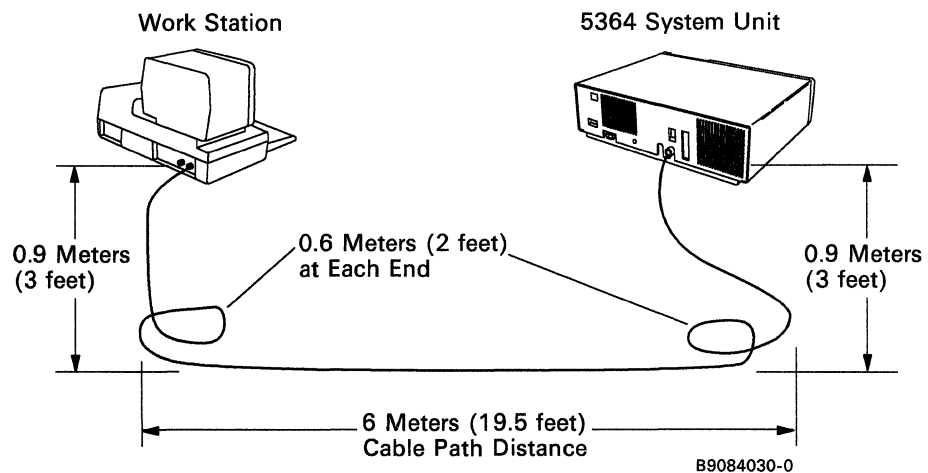

The cable you order to assemble yourself should be at least 2.1 meters (7 feet) longer, for a total length of 11.1 meters (36.5 feet) in this illustration.

- If the cable path is to be under false flooring, add the distance from the false floor to the real floor on each end of the cable.

- A 5251 Model 11 requires an additional 0.6 meters (2 feet) of cable because it passes through the rear of the display station and attaches to the front.

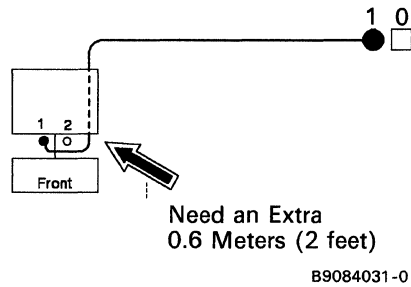

Ensure that the additional 0.6 meters (2 feet) is included in your cable length estimate.

- If cables will be installed in the ceiling, use the distance from the ceiling to each unit, instead of the floor to table top distance.
- The sockets on the stand-alone printers are at floor level. If the 5364 System Unit is to stand vertically in an enclosure, its ports will also be at or near floor level.
- Be sure to measure from room to room and from building to building, if required.

- After you determine the length of each cable, record the length of each cable on the floor plan.

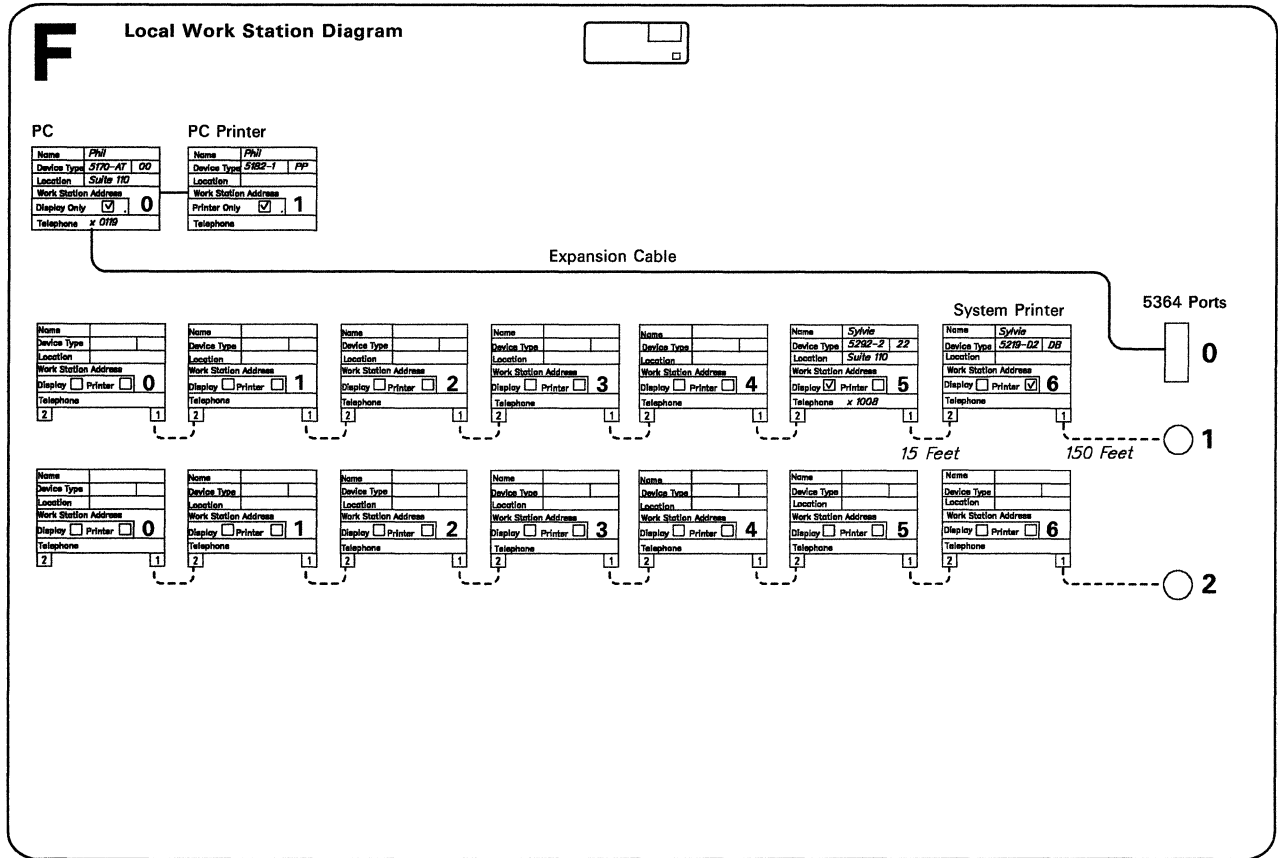

AAQ002-0

Ordering the Work Station Cables

If you are not familiar with cables and the local electrical codes, give the *ordering cables* task to someone, such as an electrician.

Make sure you have a copy of your floor plan.

1. To order *preassembled* cables:¹
 - a. Use part number 7362267 for each vinyl-covered cable or part number 7362062 for each Teflon²-covered cable you order.
 - b. Record the length of each cable in the following space:

Cable Number	Length	Cable Number	Length
_____	_____	_____	_____
_____	_____	_____	_____
_____	_____	_____	_____
_____	_____	_____	_____

2. When the order is complete, review it to be sure that the cable lengths match the floor plan.
3. Then, call your IBM marketing representative or your IBM-approved remarketer and place the order. Your order will take about 6 weeks.
4. If you want to order *bulk* cables (cables that you assemble yourself), see Appendix A.

¹ Each end of the cable will have a connector of the following dimensions:

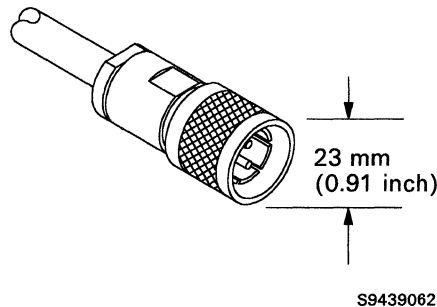

Do not remove any connectors. If the cable must pass through a wall, be sure that a large enough opening can be provided.

² Trademark of E. I. duPont de Nemours & Co., Inc.

Cable Installation Considerations

Following are some considerations for installing your cables:

- Cable paths, both horizontal and vertical, must be supported every 3 meters (10 feet).
- Cables can be run in the same conduit as telephone lines, if adequate openings are made for cable connectors.
- If you will have cables going outdoors between buildings, you should read the topic “Outdoor Cable Installation” in the manual *IBM 5250 Information Display System Planning and Site Preparation Guide*, GA21-9337.

Signal Separation Guide for Work Station Cables

Work station cables should not be installed near power lines that carry or electrical equipment that uses more than 440 volts. The following distances are a guide for voltages up to 440 volts:

- The minimum distance between a work station cable and fluorescent, neon, or incandescent lighting fixtures is 127 millimeters (5 inches).
- The minimum distance between a work station cable and unshielded power lines or electrical equipment depends upon the power consumption of the equipment:
 - 2 kVA or below: 127 millimeters (5 inches)
 - 2 through 5 kVA: 305 millimeters (12 inches)
 - Over 5 kVA: 610 millimeters (24 inches)
- The minimum distance between a work station cable and unshielded power lines or electrical equipment with the work station cable in a grounded metallic conduit is:
 - 2 kVA or below: 63.5 millimeters (2.5 inches)
 - 2 through 5 kVA: 152 millimeters (6 inches)
 - Over 5 kVA: 305 millimeters (12 inches)

- The minimum distance between a work station cable and power lines in a grounded metallic conduit is:
 - 2 kVA or below: 63.5 millimeters (2.5 inches)
 - 2 through 5 kVA: 152 millimeters (6 inches)
 - Over 5 kVA: 305 millimeters (12 inches)

- The minimum distance between a work station cable enclosed in a grounded metallic conduit and power lines in a grounded metallic conduit is:
 - 2 kVA or below: 30.5 millimeters (1.2 inches)
 - 2 through 5 kVA: 76 millimeters (3 inches)
 - Over 5 kVA: 152 millimeters (6 inches)

Preparing the Work Station Cables

Once your cables arrive, you should label them and place them near your system unit and other devices. You should finish this task before you set up your computer.

To label the work station (or *signal*) cables, you will need the following:

- *IBM Labels for Signal Cables*, which are in Appendix C.

Connect this end to:	Other end connects to:
Device type/name	Device type/name
Location	Location
Work station address	
Socket/port	Socket/port
	GX21-9345

B9084035-0

- Form Q, *IBM Number Labels for Signal Cables*, which is also in Appendix C.

Q										1	2	3	4	5	6	7	8	9	
0	1	2	3	4	5	6	7	8	9	10	11	12	13	14	15	16	17	18	19
20	21	22	23	24	25	26	27	28	29	30	31	32	33	34	35	36	37	38	39
40	41	42	43	44	45	46	47	48	49	50	51	52	53	54	55	56	57	58	59

B9084093-0

You will need four labels for each cable on your system, one of each type for each end.

When you have decided the physical arrangement of the devices on your system, use your plan (in whatever form it is) to identify what information to record on the labels.

You may also be able to use the plan to help you determine which cable goes between which devices, by measuring the cable length and comparing it to the length noted on the floor plan.

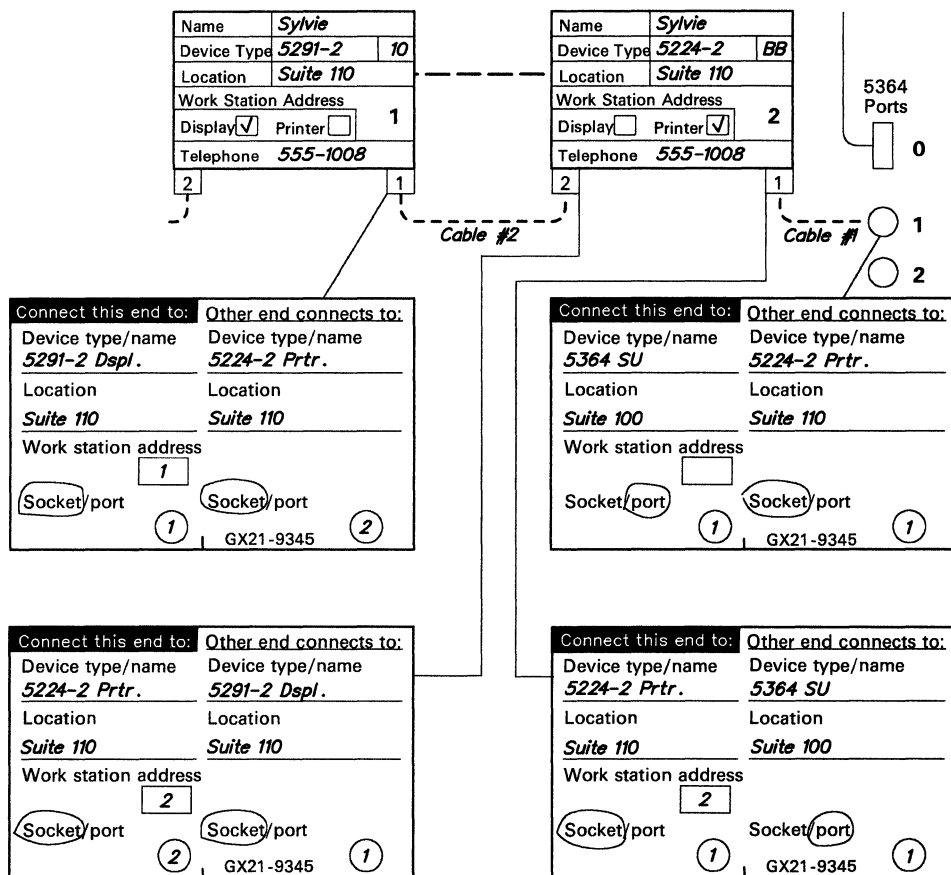

AAQ012-0

1. When each label has been completed and each cable identified, fasten the appropriate signal cable labels to each end of the cable:

a. Peel off the label.

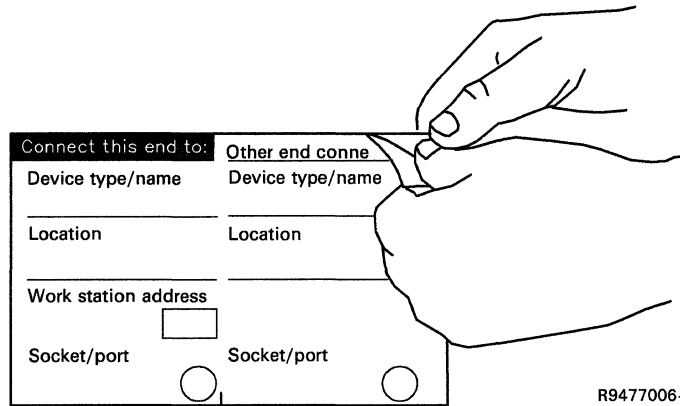

b. Make sure the black bar on the label is positioned near the connector end and properly aligned on the center of the cable.

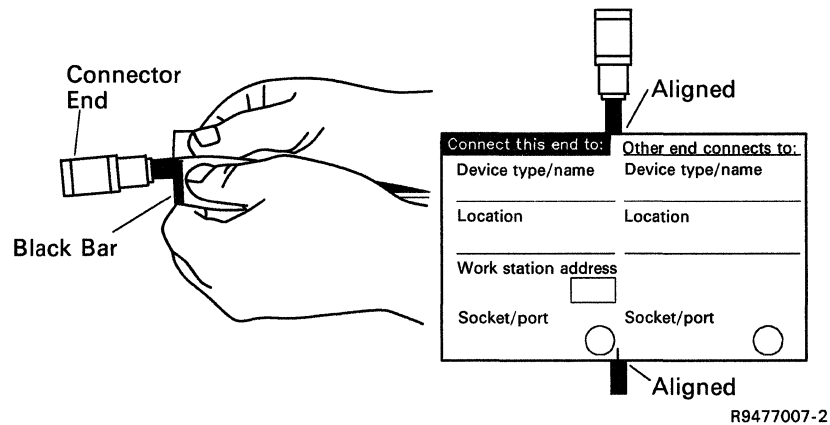

c. Fold the label over and press the ends together.

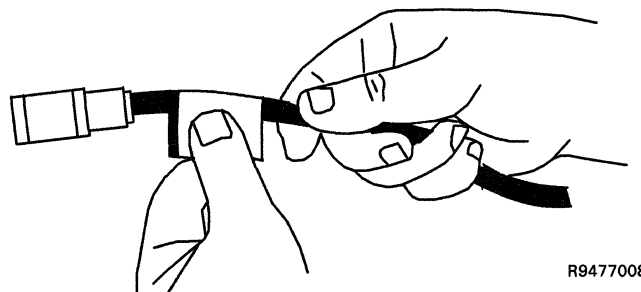

b. Wrap the label around the cable as shown:

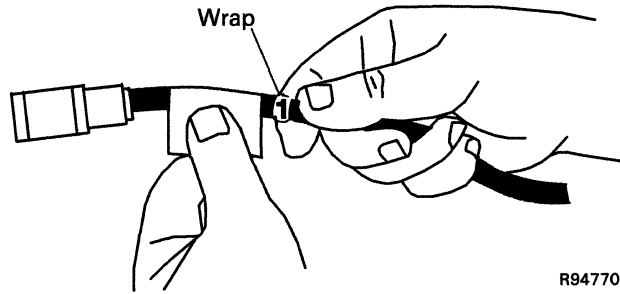

R9477012

This is an example of what your cable should look like:

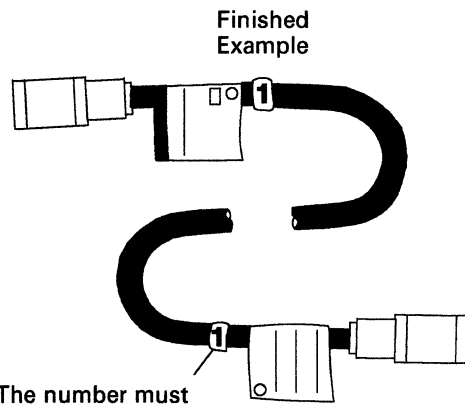

The number must be visible.

R9477013

Appendix A. Bulk Cable Information

This appendix contains the following information about twinaxial vinyl-covered and Teflon-covered bulk cable:

- Cable specifications
- Ordering information
- Assembly instructions

Both vinyl- and Teflon-covered cables can be used in the same configuration.

Cable Specifications

Vinyl-Covered Twinaxial Cable

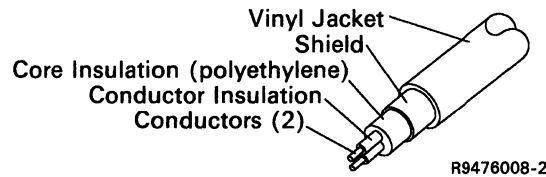

Conductor	AWG wire size	20
	Stranding	7 x 28
	Material	Copper
	Coating	Tin (1 conductor only)
	Resistance	11 ohms maximum per 305 meters (1000 feet)
Core insulation	Material	Polyethylene
	Outside diameter	6.1 millimeters (0.24 inch) nominal
Shield	Material	Tinned copper
	Type	Braid, 34 AWG, 7 ends/24 carriers, 9.7 ±10% picks/inch
	Coverage	95% minimum
	Resistance	3 ohms maximum per 305 meters (1000 feet)
Jacket	Material	Vinyl
	Color	Black
	Average single wall thickness	0.76 millimeter (0.029 inch)
	Outside diameter	8.25 millimeters (0.325 inch) nominal
Rating	Dielectric strength	4500 Vdc for 3 seconds at 28°C (82°F)
Capacitance		53.1 pF/meter (16.2 pF/foot) maximum
Impedance, characteristic		111 ±5% ohms at 0.5 MHz 107 ±5% ohms at 1 MHz 105 ±5% ohms at 1 MHz and above
Attenuation at 100 MHz		4.5 dB/30.5 meters (100 feet) maximum at 25°C (77°F) 4.7 dB/30.5 meters (100 feet) maximum at 80°C (176°F)
Velocity of propagation		66% ±5%
Operating environment		-40°C to 80°C (-40°F to 176°F) 10% to 90% relative humidity

Teflon-Covered Twinaxial Cable

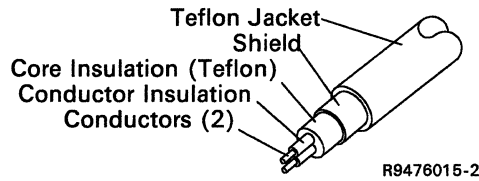





Conductor	AWG wire size	20
	Stranding	7 x 28
	Material	Copper
	Coating	Tin (1 conductor only)
	Resistance	11 ohms maximum per 305 meters (1000 feet)
Core insulation	Material	Teflon
	Outside diameter	6.1 millimeters (0.24 inch) nominal
Shield	Material	Tinned copper
	Type	Braid, 34 AWG, 8 ends/16 carriers, 10.1 ±10% picks/25.4 millimeters (inch)
	Coverage	95% minimum
	Resistance	3 ohms maximum per 305 meters (1000 feet)
Jacket	Material	Teflon
	Color	Translucent (white, natural, or light gray)
	Average single wall thickness	0.63 millimeter (0.025 inch)
	Outside diameter	7.00 millimeters (0.275 inch) nominal
Rating	Dielectric strength	4500 Vdc for 3 seconds at 28°C (82°F)
Capacitance		53.1 pF/meter (16.2 pF/foot) maximum
Impedance, characteristic		111 ±5% ohms at 0.5 MHz 107 ±5% ohms at 1 MHz 105 ±5% ohms at 1 MHz and above
Attenuation at 100 MHz		4.5 dB/30.5 meters (100 feet) maximum at 25°C (77°F) 4.7 dB/30.5 meters (100 feet) maximum at 80°C (176°F)
Velocity of propagation		65%-75%
Operating environment		-40°C to 105°C (-40°F to 221°F) 10% to 90% relative humidity

Notes:

1. *Teflon-covered cables comply with requirements of the National Electrical Code (NEC) for low smoke-producing, air plenum installed cables.*
2. *Teflon-covered cables do not have to run through a conduit.*

Ordering Information

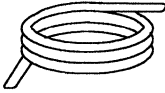
The following table provides cable information for twinaxial cable.

Part Name	Twinaxial Cable Indoor or Outdoor
Cable Assembly ^a (cable in specified length with connectors at both ends)	IBM part 7362267 (with vinyl covering) IBM part 7362062 (with Teflon covering) 
Adapter (cable-to-cable)	IBM part 7362230 Amphenol 82-5588 
Bulk Cable (cable in specified length, without connectors)	IBM part 7362211 (with vinyl covering) IBM part 7362061 (with Teflon covering) IBM part 483619 ^b (tubing used with teflon-covered cables) See this appendix for instructions on how to assemble cables. 
Connector (one connector)	IBM part 7362229 Amphenol 82-5589 AMP 22724-1
Connector Kit (two connectors)	IBM part 7362268 (for vinyl-covered cable) IBM part 7362063 (for Teflon-covered cable) 
<p>^a Specify the total length of each cable when ordering. (This includes the distance from the work station to what it is attached to (host system, remote work station controller, or another work station) plus a sufficient length of cable to reach the cable connection on the units on both ends of the cable, which is approximately 1.8 meters (6 feet).)</p> <p>^b Two pieces of this tubing are included with a connector kit for Teflon-covered cables (IBM part 7362063).</p>	

R9476016-4

Assembly Instructions

If you purchase bulk twinaxial cables, assemble them as follows. Refer to the illustrations following these instructions for dimensions and assistance in doing these procedures. If you use connectors provided by a company other than IBM, use the instructions provided by the manufacturer.

1. Be certain that the connector kit has all of the required parts. Check the cross-sectional diagram for location of the cable layers.

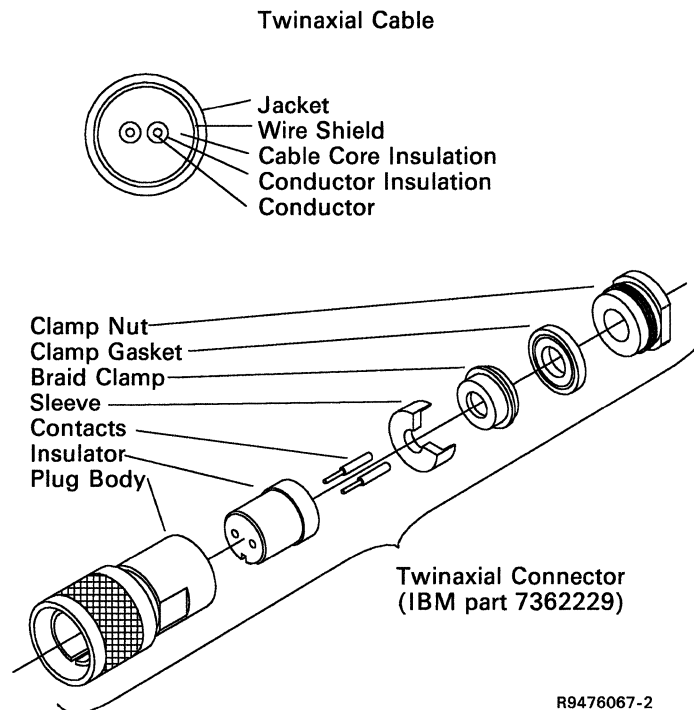

2. Cut the end of the cable sharp and square. Then slide a clamp nut and clamp gasket over the cable jacket and trim the jacket to the dimension given. Push the wire shield back to expose the inner insulation core, and cut the core and conductors to the dimension shown (16 millimeters [0.63 inch]). Slide the wire shield back over the core, and taper it to a point for ease of braid clamp assembly in step 3.

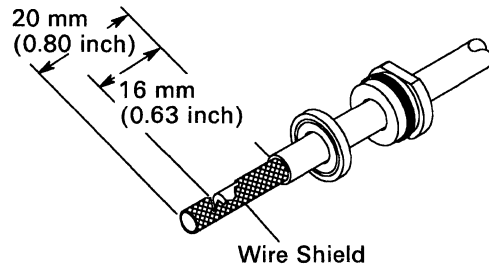

AAQ020-0

Note: If you are assembling a Teflon cable, install the heat shrink tubing before you continue with step 3.

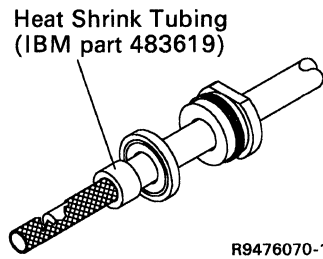

R9476070-1

3. Slide a braid clamp over the shield so that its inner shoulder butts against the cable jacket. Then, fold the shield back over the braid clamp and trim below the shoulder.

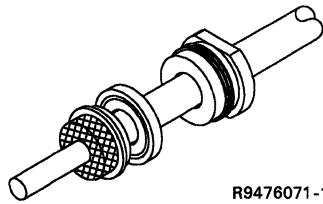

R9476071-1

Note: Placement of shield wires over the braid clamp must be uniform to provide good radio frequency connection of the shield, and to prevent breaking the shield strands.

4. Cut the cable core and the conductor insulation to the dimensions shown. *Do not nick the conductors or the insulation.* If the shield is frayed, trim the shield again as in step 2.

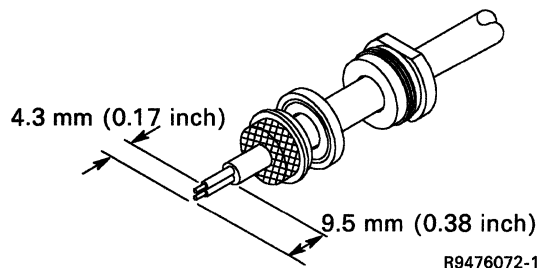

R9476072-1

5. Slide the sleeve over the cable core and press the sleeve against the braid wires.

Using minimum heat, solder the contacts to the conductors.
Clean off any excess solder.

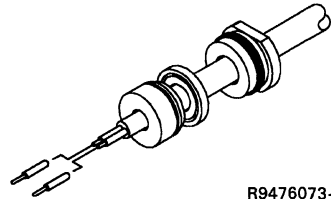

R9476073-1

6. Bend the conductors and the contacts out at right angles to the cable axis (approximately 6.4 millimeters [0.25 inch]). Then bend the conductors and contacts back parallel to each other.

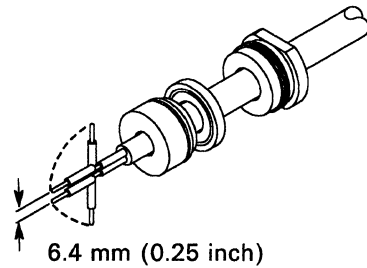

R9476074-1

7. Slide the insulator over the contacts and the cable so that the insulator butts against the sleeve. Press all parts together. The contact on the bare copper lead of the cable goes into the insulator hole that has a dot next to it.

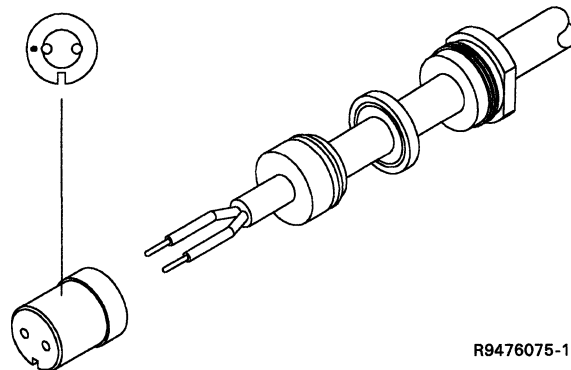

R9476075-1

8. Insert the assembly into the plug body, aligning the slot in the insulator with the pin inside the plug body. Tighten the clamp nut with 5.7 to 6.8 N·m (Newton meters) (50 to 60 inch lbs) torque. (The cable and plug body should not be allowed to twist as the clamp nut is tightened.)

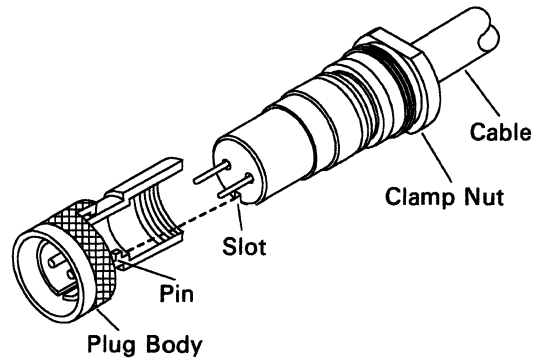

R9476076-0

9. Check for shorts between the conductors and between each conductor and plug body.

Cable-to-Cable Adapters

Do not splice cables; instead, use an adapter. You may use IBM part 7362230, Amphenol part 82-5588, or an equivalent for twinaxial cable.

This adapter and the attached cable connectors should be covered with shrink or insulated tubing to prevent accidental grounding of the connection.

The following illustrates the cable adapter for joining twinaxial cables.

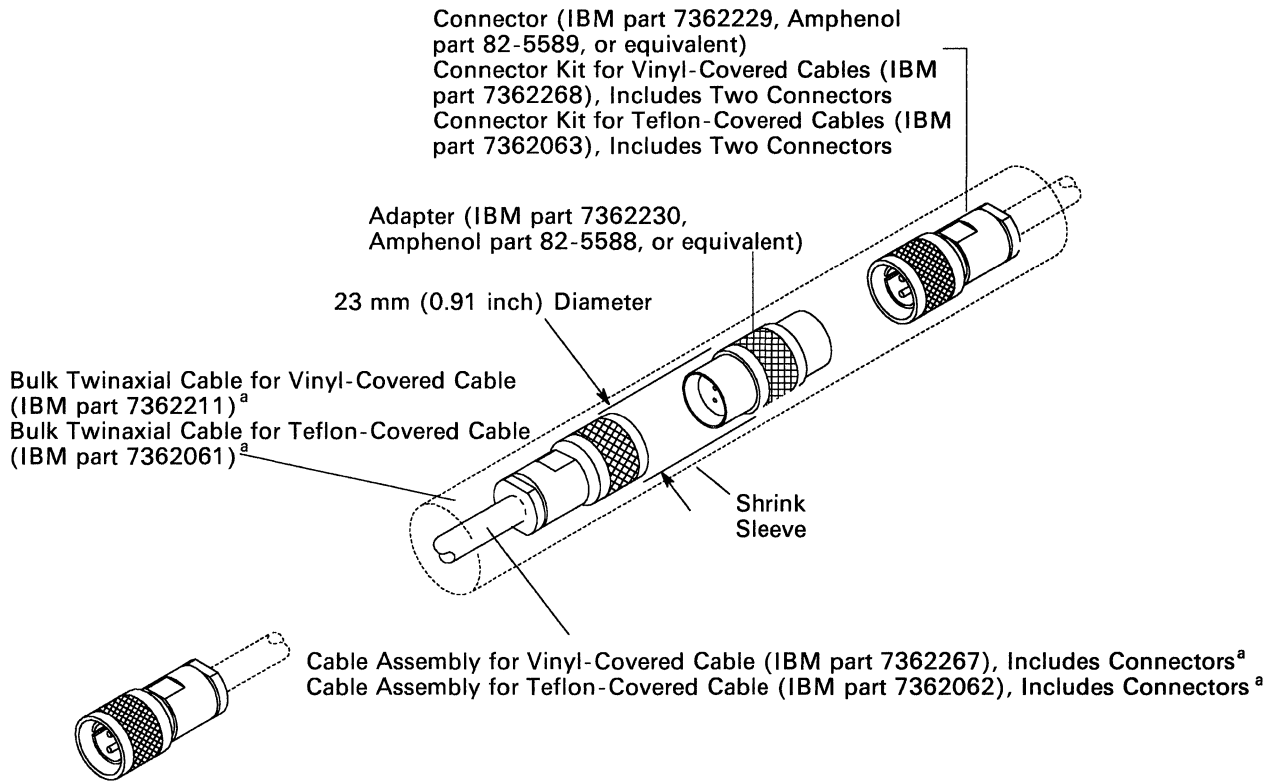

^a Specify the total length of each cable ordered.

Line Continuity and Polarity Tests

Installation of cabling should include completion tests to ensure that there are no faults, no high-resistance connections, and no circuit imbalances. The tests for faults should ensure there are no:

- Open circuits in individual conductors or shields
- Short circuits between conductors of the same pair
- Grounds on individual conductors, either between a conductor and a shield or between a conductor and a grounded object
- Reversed polarities

The following guidelines can be used for testing line continuity and polarity. The tests should be made for individual cable segments; however, they may be used for a complete cable if the station junctions are connected via an adapter or a work station having Cable Thru (if the power is off).³

Line Continuity

The only tools required for line continuity checks are an ohmmeter and jumpers to connect between the connector pins (signal lines) and the plug body (cable shield). When the following checks are made, the resistance values measured should fall within the indicated ranges for the maximum 1525 meters (5000 feet).

With both ends of the cable open and the cable not plugged into a machine, measure (at either end):

- Conductor-to-conductor: Greater than 1,000,000 ohms
- Each conductor to shield: Greater than 1,000,000 ohms

A reading less than 1,000,000 ohms means there is a short circuit.

³ Measurements are not valid with station protectors connected to the line.

With both lines tied to the shield at the far end, measure (at the nearest end):

- Conductor-to-conductor: Less than 110 ohms⁴
- Each conductor to shield: Less than 70 ohms⁴

A reading greater than 110 or 70 ohms, respectively, means there is an open circuit.

Line Polarity

After testing the line continuity and making any necessary corrections, check the polarity as follows.

With conductor A of the cable plug tied to the shield at the far end, measure (at the nearest end) from conductor A to the shield. This should be less than 70 ohms; if it is over 70 ohms, lines are crossed.

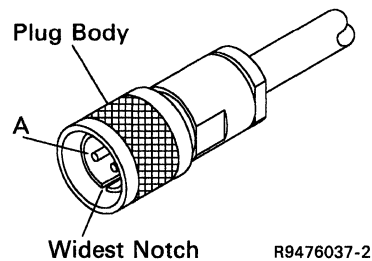

The polarity of the line must be maintained for each cable segment and for the entire cable run to ensure proper machine operation.

⁴ Values for shorter length are proportional because this is a linear function. For example, a cable with half the maximum length would have half the resistance.

Appendix B. Noise Considerations

You can reduce noise by modifying your ceiling. A dropped porous ceiling works best. If there are overhead ducts, prevent these ducts from transmitting sound from another area into your data processing area.

In large rooms, you can reduce noise by applying acoustical material to the floor. If carpeting is used as a floor covering in the data processing area, it should be an antistatic type or should be treated to prevent or minimize static buildup.

Acoustic Environments

The 5364 System Unit and the devices that attach to it described in this manual, were acoustically designed for the *general business area* and/or the *quiet office area*. For the best satisfaction with the noise level, devices acoustically designed only for the general business area should not be installed in a quiet office area. If the 5364 is installed in a quiet office area, devices attached to it intended for use in a general business area should be located in an area less sensitive to noise.

The following are intended for use in the general business area:

- 4214 Model 2 Printer
- 4224 Printer
- 4234 Model 2 Printer
- 4245 Models T12 and T20 Printers
- 5219 Printer
- 5224 Printer
- 5225 Printer
- 5256 Printer
- 5262 Model 1 Printer

General Business Area

A general business area is where the main activity is routine office work or similar activity that may depend upon the equipment installed in the area. People may work at a work station, and several work stations may be installed in the area. Medium-size data processing equipment may also be installed in the area, but not usually in the immediate vicinity of the work stations.

Examples of general business areas are open plan areas, administrative or bookkeeping offices, word processing and typing centers, display station or printer areas, laboratory rooms, and customer service work stations (bank teller stations, hotel or motel lobbies, retail point-of-sale stations, telephone operator rooms, and transportation display station areas).

Quiet Office Area

A quiet office area is where a high degree of mental concentration or creativity is required. Examples of quiet office areas are offices of business professionals, offices for scientific work, private offices, system and program development departments, libraries, classrooms, conference and meeting rooms, hospital operating rooms, medical treatment rooms, and private residences.

Product Noise Emission Values

The following chart shows the noise emission values for various IBM work stations.

Declaration of IBM Product Noise Emission Values									
Type	Description	L_{wAd}		L_{pAm}		$\langle L_{pA} \rangle_m$		I	T
		Operating (bels)	Idling (bels)	Operating (dB)	Idling (dB)	Operating (dB)	Idling (dB)		
3179-2	Color Display	Note	Note	Note	Note	Note	Note	No	No
3180-2	Display	Note	Note	Note	Note	Note	Note	No	No
3196	Display	Note	Note	Note	Note	Note	Note	No	No
3812	Pageprinter	6.4	5.0	N/A	N/A	52	39	No	No
4214-2	Printer	--	--	N/A	N/A	60	43	No	No
4224	Printer	7.3	5.4	N/A	N/A	57	40	No	No
4234-2	Printer	--	--	N/A	N/A	57	44	No	No
4245	Printer	--	--	N/A	N/A	64	54	No	No
5219	Printer	--	--	N/A	N/A	57	--	No	No
5224	Printer	--	--	N/A	N/A	61	44	No	No
5225	Printer	--	--	N/A	N/A	60	51	No	No
5251-11	Display	4.9	4.9	41	41	37	37	No	No
5251-12	Display	5.3	5.3	43	43	41	41	No	No
5256	Printer	7.2	--	N/A	N/A	59	46	No	No
5262-1	Printer	7.8	--	N/A	N/A	62	42	No	No
5291-1	Display	Note	Note	Note	Note	Note	Note	No	No
5291-2	Display	Note	Note	Note	Note	Note	Note	No	No
5292-1	Color Display	5.0	5.0	37	37	34	34	No	No
5292-2	Color Display	5.1	5.1	40	40	36	36	No	No
5294	Control Unit	5.4	5.4	N/A	N/A	39	39	No	No
PC	Display	Note	Note	Note	Note	Note	Note	No	No

Legend	
L_{wAd}	is the declared sound power emission level.
L_{pAm}	is the mean value of the sound pressure for emission levels at the operator position (if any).
$\langle L_{pA} \rangle_m$	is the mean value of the spaced-average sound pressure for emission levels at the one-meter positions.
I	Impulsive noise.
T	Prominent discrete tones.
N/A	Not applicable (no operator position).
Note	There is no audible noise emitted in the frequency range below 10,000 Hertz.
All measurements made in accordance with ISO DIS 7779, and reported in conformance with ISO DIS 7574/4. The L_{wAd} levels are based on a reference standard deviation of 2 dB.	

Appendix C. Forms

This appendix contains (in alphabetic order) the forms to be used while completing the preparation tasks. The forms can be removed and copied.

- Local Work Station Diagram (Form F)
- Remote Work Station Diagrams (Forms H, H1, and H2)
- IBM Labels for Signal Cables
- IBM Number Labels for Signal Cables (Form Q)

F

Local Work Station Diagram

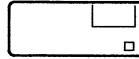

PC

PC Printer

Name	
Device Type	
Location	
Work Station Address	
Display Only <input type="checkbox"/>	0
Telephone	

Name	
Device Type	
Location	
Work Station Address	
Printer Only <input type="checkbox"/>	1
Telephone	

Name	
Device Type	
Location	
Work Station Address	
Display <input type="checkbox"/> Printer <input type="checkbox"/>	0
Telephone	
2	1

Name	
Device Type	
Location	
Work Station Address	
Display <input type="checkbox"/> Printer <input type="checkbox"/>	1
Telephone	
2	1

Name	
Device Type	
Location	
Work Station Address	
Display <input type="checkbox"/> Printer <input type="checkbox"/>	2
Telephone	
2	1

Name	
Device Type	
Location	
Work Station Address	
Display <input type="checkbox"/> Printer <input type="checkbox"/>	3
Telephone	
2	1

Name	
Device Type	
Location	
Work Station Address	
Display <input type="checkbox"/> Printer <input type="checkbox"/>	4
Telephone	
2	1

Name	
Device Type	
Location	
Work Station Address	
Display <input type="checkbox"/> Printer <input type="checkbox"/>	5
Telephone	
2	1

Name	
Device Type	
Location	
Work Station Address	
Display <input type="checkbox"/> Printer <input type="checkbox"/>	6
Telephone	
2	1

Name	
Device Type	
Location	
Work Station Address	
Display <input type="checkbox"/> Printer <input type="checkbox"/>	0
Telephone	
2	1

Name	
Device Type	
Location	
Work Station Address	
Display <input type="checkbox"/> Printer <input type="checkbox"/>	1
Telephone	
2	1

Name	
Device Type	
Location	
Work Station Address	
Display <input type="checkbox"/> Printer <input type="checkbox"/>	2
Telephone	
2	1

Name	
Device Type	
Location	
Work Station Address	
Display <input type="checkbox"/> Printer <input type="checkbox"/>	3
Telephone	
2	1

Name	
Device Type	
Location	
Work Station Address	
Display <input type="checkbox"/> Printer <input type="checkbox"/>	4
Telephone	
2	1

Name	
Device Type	
Location	
Work Station Address	
Display <input type="checkbox"/> Printer <input type="checkbox"/>	5
Telephone	
2	1

Name	
Device Type	
Location	
Work Station Address	
Display <input type="checkbox"/> Printer <input type="checkbox"/>	6
Telephone	
2	1

5364 Ports

0

1

2

(

(

,

H2

Remote Work Station Diagram for 3274

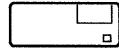

Customer Name _____
Customer Number _____

3274 Information

Controller ID _____
Controller Description:
Name _____
Location _____
City, State _____
Telephone _____
Controller Station Address _____
Communications Line Number _____
Alternative Lines _____
Communications Type _____
Destination Service Access
Point (DSAP) value _____
Remote Telephone _____
Remote Adapter Address for
Token-Ring Network _____

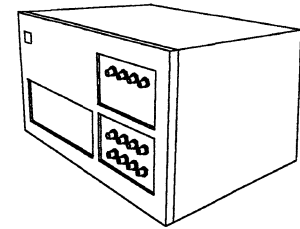
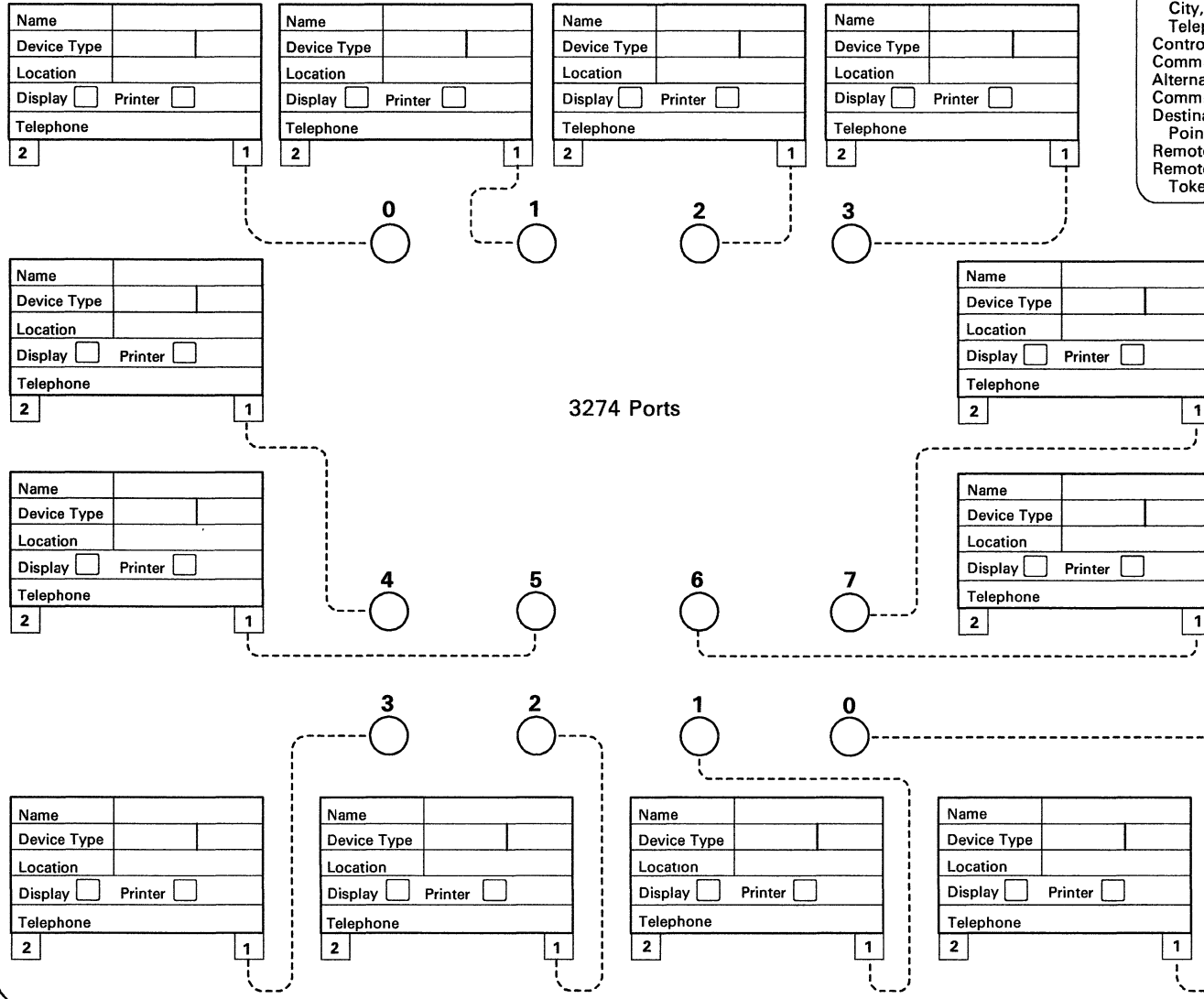

Glossary

address. A name, label, or number that identifies a location in storage, a device in a network, or any other data source.

address switches. Switches that you set to represent the address of a work station.

align. To bring into or be in line with another or with others. For example, to align numbers on the decimal point.

bulk. Not packaged in separate units.

cable thru. A standard function or special feature that allows multiple work stations to be attached to a particular line.

cluster feature. A feature that provides four cable connections and allows the attachment of up to four work stations to a 5251 Model 12 Display Station.

coaxial cable. A cable made of a conducting outer metal tube enclosing and insulated from a central conducting core.

communications. See *data communications*.

conduit. A pipe, tube, or tile for protecting electric wires or cables.

configuration. The group of machines, devices, and programs that make up a data processing system. See also *system configuration*.

controller. Circuitry or a device used to coordinate and control the operation of one or more devices.

data communications. The transmission of data between computers and/or remote devices (usually over a long distance).

device code. A two-character code used during system configuration to identify the models of display stations and printers.

display station. A device that includes a keyboard from which an operator can send information to the system and a display screen on which an operator can see the information sent to or the information received from the system.

emulation. Imitation; for example, the imitation of a computer or device.

Enhanced 5250 Emulation. A feature that allows an IBM personal computer and a printer to be attached to a System/36 and perform the functions of one or two 5250 work stations on one twinaxial cable. The work station(s) can be defined as one display, two displays, or one display and one printer.

feature. A programming or hardware option, usually available at an extra cost. For example, Communications is a feature of the System Support Program Product.

hardware. The equipment, as opposed to the programming, of a system.

local. Pertaining to a device, file, or system that is accessed directly from your system, without the use of a communications line. Contrast with *remote*.

port. A part of the system unit or remote controller to which cables for display stations and printers are attached.

power cord. A cord that plugs into a wall outlet supplying electrical power.

printer. A device that provides printed output.

remote. Pertaining to a device, file, or system that is accessed by your system through a communications line. Contrast with *local*.

remote attachment. Attachment of work stations to the host system through communications lines.

remote controller. A device, attached to a communications line, that controls the operation of one or more remote display stations and printers.

remote work station. A work station that is attached to the host system via communications lines.

route. To send by a selected or predefined course.

signal. A detectable physical quantity or impulse (as a voltage, current, or magnetic field strength) by which messages or information can be transmitted.

socket. Another name for a port on the system unit or remote controller.

station protector. A device used on the system cable to offer protection against lightning for work station attachments made in different buildings.

system. The computer and its associated devices and programs.

system configuration. A process that specifies the machines, devices, and programs that form a particular data processing system.

system console. A display station from which an operator can keep track of and control system operation.

system printer. The printer that is used for any printed output that is not specifically directed to another printer.

system unit. The part of the system that contains the processing unit, the control panel, the disk drive and the disk, and either a diskette drive or a diskette magazine drive.

twinaxial cable. A cable made of two twisted wires inside a shield.

work station. A device that lets people transmit information to or receive information from a computer; for example, a display station or printer.

work station address. (1) A number used in a configuration member to identify a work station attached to a port. (2) The address to which the switches on a work station are set, or the internal default address.

work station address switches. Two or three switches on the access panel of a work station that has a Cable Thru feature. The switches are set to the assigned work station address.

READER'S COMMENT FORM

Please use this form only to identify publication errors or to request changes in publications. Direct any requests for additional publications, technical questions about IBM systems, changes in IBM programming support, and so on, to your IBM representative or to your IBM-approved remarketer. You may use this form to communicate your comments about this publication, its organization, or subject matter, with the understanding that IBM may use or distribute whatever information you supply in any way it believes appropriate without incurring any obligation to you.

- If your comment does not need a reply (for example, pointing out a typing error), check this box and do not include your name and address below. If your comment is applicable, we will include it in the next revision of the manual.
- If you would like a reply, check this box. Be sure to print your name and address below.

Page number(s):

Comment(s):

Please contact your IBM representative or your IBM-approved remarketer to request additional publications.

Name

Company or
Organization

Address

City

State

Zip Code

Phone No.

Area Code

Fold and tape. **Please do not staple.**



NO POSTAGE
NECESSARY
IF MAILED IN THE
UNITED STATES

BUSINESS REPLY MAIL

FIRST CLASS / PERMIT NO. 40 / ARMONK, NEW YORK

POSTAGE WILL BE PAID BY ADDRESSEE

International Business Machines Corporation
Information Development
Department 245
Rochester, Minnesota, U.S.A. 55901



Fold and tape. **Please do not staple.**



READER'S COMMENT FORM

Please use this form only to identify publication errors or to request changes in publications. Direct any requests for additional publications, technical questions about IBM systems, changes in IBM programming support, and so on, to your IBM representative or to your IBM-approved remarketer. You may use this form to communicate your comments about this publication, its organization, or subject matter, with the understanding that IBM may use or distribute whatever information you supply in any way it believes appropriate without incurring any obligation to you.

- If your comment does not need a reply (for example, pointing out a typing error), check this box and do not include your name and address below. If your comment is applicable, we will include it in the next revision of the manual.
- If you would like a reply, check this box. Be sure to print your name and address below.

Page number(s):

Comment(s):

Please contact your IBM representative or your IBM-approved remarketer to request additional publications.

Name

Company or
Organization

Address

City

State

Zip Code

Phone No.

_____ Area Code

Fold and tape. **Please do not staple.**

Cut Along Line



NO POSTAGE
NECESSARY
IF MAILED IN THE
UNITED STATES

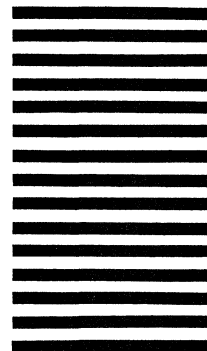

BUSINESS REPLY MAIL

FIRST CLASS / PERMIT NO. 40 / ARMONK, NEW YORK

POSTAGE WILL BE PAID BY ADDRESSEE

International Business Machines Corporation

Information Development
Department 245
Rochester, Minnesota, U.S.A. 55901

Fold and tape. **Please do not staple.**

Cut Along Line





Preparing to Install Your Work Stations - 5364

International Business Machines Corporation

File Number
S36-15

Order Number
SA21-9845-1

Printed in U.S.A.

SA21-9845-01

