

TECHNICAL INFORMATION EXCHANGE

IBM®

January 15, 1969

AN INTRODUCTION TO OS/360 MVT CONTROL
LOGIC AND DEBUGGING WITH MVT CORE
DUMPS

This paper presents, in a logical, step-by-step manner, an approach to debugging an OS/360 MVT program using a core dump. Techniques for both programming and data management errors are presented. A discussion of MVT control program logic and the use of control blocks is also included.

Mr. David G. Norris
IBM Corporation
1720 Zollinger Road
Columbus, Ohio 43221

For IBM Internal Use Only

CONTENTS

PREFACE 1

AN OUTLINE OF THE MVT SYSTEM. 2
 General 2
 The Physical MVT System 2
 The Logical MVT System. 5

MVT CONTROL LOGIC AND CONTROL BLOCKS. 11
 General 11
 Task Management and Control Blocks. 11
 Data Management and I/O Control Blocks. 16

JOB MANAGEMENT IN AN MVT SYSTEM 20
 General 20
 The READER/INTERPRETER. 20
 The INITIATOR 24
 Program Execution 25
 The TERMINATOR. 26
 The OUTPUT WRITER 27
 Comments. 28

CORE DUMPS IN MVT 29
 Introduction. 29
 The MVT Core Dump in General. 30
 An Approach to Debugging. 31
 The Newspaper Approach to Programming Errors. 31
 The Newspaper Approach to Data Management Errors. 46

APPENDIX A. 51
 Event Synchronization 51

PREFACE

OS/360 is an awesome creation. In the process of designing, generating and installing an MVT system, one vital area of the effort is often overlooked - in depth debugging by the application programmer. Then one day this programmer timidly enters the systems engineer's office carrying a card deck and a three inch listing of an ABEND dump. His eyes declare an obvious state of panic and desperation. "What is this? - What does it mean? - What do I do?" he implores.

Suddenly the realization sinks in that the poor devil has no idea what actually goes on in the guts of OS/360. He knows the "concepts" learned from OS/360 class, but is totally bewildered when faced with a dump and required to find the error.

The present literature is, in the author's opinion, inadequate - it merely lists the contents of a dump and deals superficially with its interpretation. This paper is an attempt to fill this (in the author's opinion) deficiency.

The author bases his paper upon three axioms:

- 1) A good applications programmer must have a good, if superficial, knowledge of the internal workings of OS/360;
- 2) An applications programmer feels extremely uneasy with an ABEND dump, and is interested in but a very few of the fields and control blocks displayed;
- 3) What is needed by applications programmers is not only an understanding of the contents of a dump, but far more importantly a method of attack, an approach, to debugging with a core dump.

This manual, then, is based upon these three axioms, and is divided into three general corresponding areas:

- 1) An overview of the physical and logical system;
- 2) System control and the use of control blocks;
- 3) Debugging with core dumps.

This paper arises from the author's experience and notes used in teaching a debugging class to applications programmers and consultants at the Ohio State University. Thanks is given to that legion of OSU students whose ABEND dumps became the object of this writer's efforts, and appear in some form in this paper. No attempt is made herein at exhaustiveness or rigor. The object is to get the programmer's feet on the ground. Skill comes only with necessity's practice.

AN OUTLINE OF THE MVT SYSTEM

GENERAL:

An outline of the Operating System falls easily into two major categories: The physical system, and the logical use of this system.

In the broadest sense, the physical Operating System consists of a number of system data sets and the devices upon which they reside. In main storage the system is physically divided into discrete regions of core which are used for various specific reasons. When we study the use of these regions and data sets, we are concerned with the logical system.

THE PHYSICAL MVT SYSTEM:

When considering the physical Operating System two areas should be discussed: First the system data sets and devices; Secondly core storage. We must note, however, that as in figure 1, communication exists between all these areas.

System Data Sets and Devices:

Generally we refer to the devices upon which the system data sets reside (i. e. direct access devices) as "SYSRES" or systems residence.

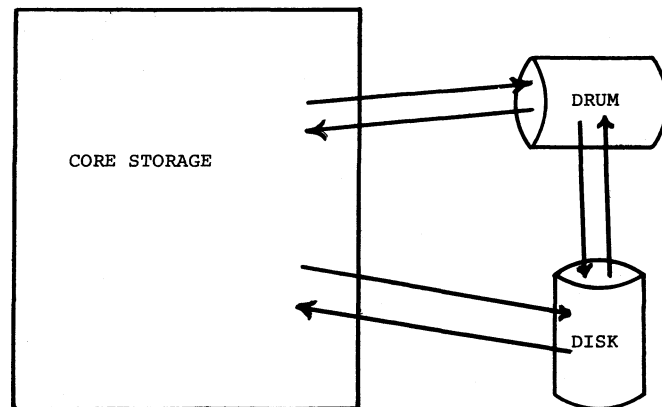

Figure 1: The overview of the logical OS/360.

Every MVT system consists of a number of required system data sets. The more important of these are discussed below.

SYS1.NUCLEUS: The NUCLEI of the system are kept in this library. This data set is referenced only at IPL (initial program load) time when the desired nucleus is loaded into core storage by NIP (NUCLEUS initialization program). The NUCLEUS is discussed in the next section.

SYSCATLG: Data set and index pointers are kept in the system catalogue, called SYSCATLG. Using the catalogue, references to existing data sets may be made by data set name alone. For a discussion of cataloguing, see OS/360 Concepts and Facilities, and OS/360 Supervisor and Data Management Services SRL's.

SYS1.LINKLIB: This is the main system program library; it contains the language processors, such as FORTRAN and the assembler, the job scheduling modules, task management routines and other system programs and utilities.

SYS1.SVCLIB: Transient supervisor call routines (SVC's) are kept in this library until they are called by the system, at which time they are loaded into core storage. Transient SVC's are discussed in the section describing the NUCLEUS. The I/O access routines and error recovery routines are also kept in this data set.

SYS1.PROCLIB: This is the system procedure library; it contains the catalogued procedures called by the 'PROC=' parameter on the EXEC job control statement. The reader, writer, initiator and remote job entry procedures are also kept in this data set.

SYS1.SYSJOBQE: The system input and output queues are kept in this data set. Here the system keeps track of which jobs are to be executed, and which jobs have yet to have their output processed. SYSJOBQE is discussed in the section describing job management.

SYS1.LOGREC: When a machine error is encountered, a record of the failure and the machine environment at the time of failure is made in this data set.

In addition to the required system data sets, a number of optional data sets may be included on SYSRES at the user's discretion. Some of these are discussed below.

- SYS1.MACLIB:** Assembler language macro definitions are kept in this library.
- SYS1.SORTLIB:** Many of the SORT/MERGE routines are kept in this library; they are loaded into core by the SORT/MERGE control routines which are kept in LINKLIB.
- SYS1.ALGLIB:** ALGOL subroutines are kept in this library.
- SYS1.FORTLIB:** In this library are kept FORTRAN subroutines.
- SYS1.COBLIB:** This data set contains the COBOL subroutines.
- SYS1.PL1LIB:** Subroutines required by PL/I are kept in this library.
- SYS1.TELCMLIB:** Modules which are used to handle telecommunication lines are stored in this data set.
- SYS1.SYSVLOGX and SYS1.SYSVLOGY:** When the write to log (WTL) macro is used, the message referenced is written into one of these data sets. The operator may display these messages upon the system console as it pleases him.
- SYS1.ROLLOUT:** This data set is used to roll out low priority jobs when a high priority job needs the storage occupied by the low priority job. When the storage required by the high priority job is no longer needed, the low priority job is rolled back into core from this data set.
- SYS1.ASRLIB:** When the asynchronous machine check handler is included in the system, this data set is used. For further discussion, see the OS/360 Concepts and Facilities SRL.

In MVT, two additional groups of data sets are used; these are generally called IEFDATA data sets. The MVT job scheduler SPOOL's input stream data (i. e. data following a DD * card) to these data sets; SYSOUT data is also placed in these data sets, to be SPOOL'ed at a later time to the SYSOUT device.

MVT in Core Storage:

Our second area of concern in understanding MVT is the physical layout of core storage. Four general areas comprise the MVT system in storage: The NUCLEUS; the SYSTEM QUEUE SPACE; the DYNAMIC AREA; and the LINK PACK AREA.

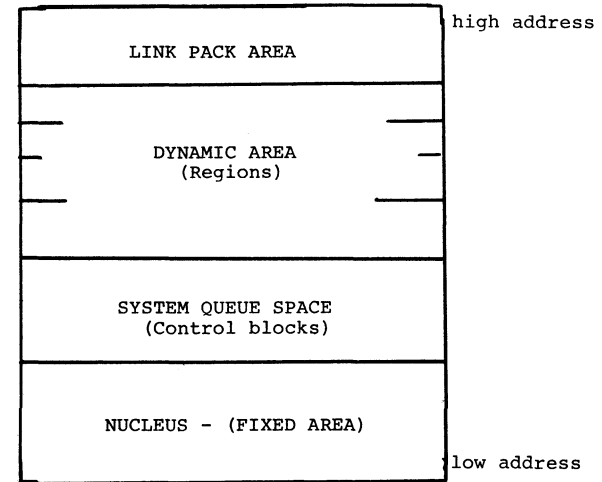

Figure 2:
Core storage layout of an MVT system.

THE LOGICAL MVT SYSTEM:

THE NUCLEUS

Part of MVT remains in storage at all times; that is, it is permanently resident. This is called the NUCLEUS, and is loaded by NIP at IPL from SYS1.NUCLEUS into the low address portion of storage. In this area reside the most frequently used MVT routines, such as interrupt handlers, the input/output supervisor, I/O channel scheduling routines, task schedulers, storage supervisors etc. The NUCLEUS has a storage protection key of zero, and its routines execute in the supervisor state.

I/O error analysis and recovery routines are brought into the I/O supervisor transient area in the NUCLEUS; these are brought in from SYS1.SVCLIB. This transient area is 1024 bytes long, and is used for all transient error recovery routines.

Other transient areas exist in the NUCLEUS; these consist of pairs of 1024 byte areas. A minimum of one pair exists; more pairs may be generated into the system at the user's option. These are called the supervisor call transient areas.

There are four types of SVC's in OS/360.

TYPE I SVC's are resident in the NUCLEUS and are executed with all interrupts masked off (i. e. disabled). The WAIT, EXCP, POST and GETMAIN SVC's are examples.

TYPE II SVC's are resident in the NUCLEUS and are executed in an enabled state (i. e. interrupts are allowed). The LINK, XCTL and LOAD SVC's are type II.

TYPE IIISVC's are transient, and consist of a single load into the transient area (i. e. they are less than or equal to 1024 bytes long). The WTO and WTL SVC's are type III.

TYPE IV SVC's are transient, and consist of multiple loads into the transient areas; each load LINKS to the following load. ABEND, OPEN and CLOSE are examples of type IV SVC's.

Hence the NUCLEUS consists of a fixed area of core, containing a fixed portion of MVT, with the exception of the I/O supervisor transient area and pairs of supervisor call transient areas which contain, of course, variable routines loaded dynamically.

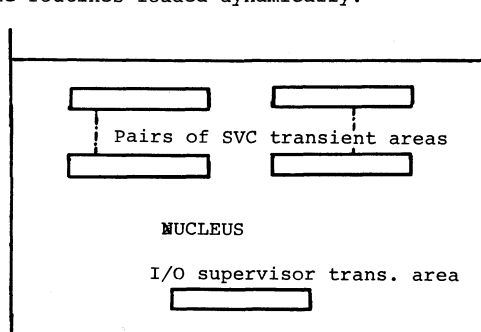

Figure 3 : The NUCLEUS.

THE SYSTEM QUEUE SPACE

Immediately above the NUCLEUS in core is the SYSTEM QUEUE SPACE; it is set up at IPL by NIP. This area is fixed in size (the size may be changed at IPL) and has protect key zero.

Here MVT creates and maintains control blocks in order to control multi-programming and supervise the system. The SYSTEM QUEUE SPACE may be likened to a work area for the MVT system in core; that is, SYS1.SYSJOBQE is the work area for controlling the jobs before and after execution and the SYSTEM QUEUE SPACE for maintaining the jobs once selected and brought into core for execution.

These control blocks are formed into queues which are maintained by MVT to manage storage, protect keys, to keep track of what programs are in storage, where they are, their status, protect keys, where free core exists and how much, what devices are allocated etc. When multi-programming, task switching and task control is maintained through these queues.

Each region in the DYNAMIC AREA has a queue of control blocks in the SYSTEM QUEUE SPACE; by using these queues the system manages each region and also multi-programs between regions. These queues and their uses are discussed in the section describing MVT control logic and control blocks.

THE LINK PACK AREA

Beginning at the top core address and extending downward is the LINK PACK AREA. This area is built at IPL by NIP; it is assigned a protect key of zero. The contents of the LINK PACK AREA may be altered at IPL; the contents remain fixed from one IPL to the next.

At the top of the LINK PACK AREA is the system BLDL list. This is a list of TTR's (relative track and record address) of commonly used routines in SYS1.LINKLIB and SYS1.SVCLIB. When these routines are needed, the system can directly access the module through the TTR; this eliminates the time consuming search through the VTOC for the data set, the search through the data set directory for the member, then the actual reading of the member. The BLDL area is built by NIP at IPL.

Directly below the BLDL list in core is an area in the LINK PACK AREA which contains re-entrant routines from SYS1.LINKLIB and SYS1.SVCLIB; these are not SVC routines. Usually these routines are common access routines, such as GET locate mode fixed, parts of the MVT initiator, step start and termination routines, parts of the READER/INTERPRETER and OUTPUT WRITERS. User written re-entrant routines may be included. All regions and the NUCLEUS will share these routines as they are re-entrant.

The reader should be familiar with the three kinds of code in OS; these are: Non-re-usable; serially re-usable; and re-entrant. Non-re-usable code is that which alters itself, in the form of switches, data etc., in such a way that for each execution of the module a fresh copy must be loaded; it is neither re-usable or may it be shared.

Serially re-usable code is that which is self initializing - i. e. which starts by resetting counters to zero, resetting switches and clearing data areas. This code may be re-used without loading a fresh copy, but only in a serial manner; that is, task 2 must wait for task 1 to complete its use of the code before it may use it. Tasks may not be restarted in the code other than at the beginning.

Re-entrant code is that which in no way alters itself. Any switches or data areas are kept external from the code by using GETMAIN's and registers to isolate any changes. A task using this code may, at any time, be interrupted by a higher priority task which uses this code. As the code is in no way altered, and the data is isolated and pointed at by a register, the higher priority task does not alter the code, as it obtains its own data area through a GETMAIN during execution. When it relinquishes the code, the registers of the lower priority task are restored, which point to the lower priority task's data area. In this way the lower priority task may resume execution at the point of interruption rather than at the beginning of the code. This code may be shared and re-used by tasks in a priority fashion, each interrupted task resuming execution at the point of interruption. It is this type code which is in the LINK PACK AREA.

The third and final section of the LINK PACK AREA, immediately under the second section, contains re-entrant modules of type III and type IV SVC's. Usually these will be the commonly issued SVC's such as OPEN, CLOSE etc. By residing 'permanently' in core much time is saved by eliminating searches through SYS1.SVCLIB for them. Not all type III or type IV SVC's are re-entrant; great care must be taken in selecting routines to reside here. This area, like the rest of the LINK PACK AREA, is set up and filled by NIP at IPL.

These three areas, then, considered together, make up the LINK PACK AREA.

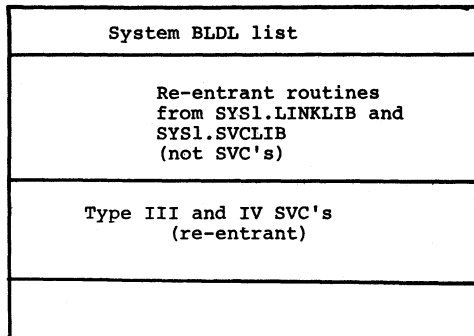

Figure 4 : The LINK PACK AREA.

THE DYNAMIC AREA

The remaining area of core, that which is between the SYSTEM QUEUE SPACE and the LINK PACK AREA, is called the DYNAMIC AREA. It is into this area that processing programs and data are loaded and executed. The DYNAMIC AREA is divided into dynamically assigned regions; roughly speaking there is one region per job in the system. These regions are allocated dynamically as needed, and will vary in size and location; there will be one region per initiator active in the system. Initiators are discussed in the section on job management in an MVT system.

Let us now examine the make up of an individual region. A region consists of three general areas: Subpool 251; subpool 252; and the data area. These areas are assigned dynamically within the region as the need arises.

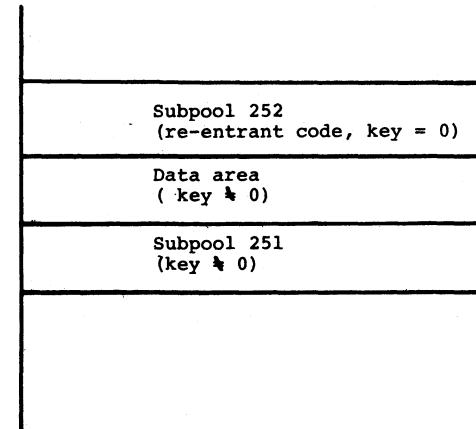

Figure 5 : One region in the DYNAMIC AREA.

Subpool 252 is assigned from the top end of the region. Here re-entrant code for the job will be loaded; subpool 252 is assigned a protection key of zero. This is analagous to the LINK PACK AREA; in fact, the LINK PACK AREA is actually the subpool 252 for the NUCLEUS.

MVT CONTROL LOGIC AND CONTROL BLOCKS

From the bottom of the region is assigned subpool 251; this will be assigned a non-zero protect key. Here will be placed non-re-usable and serially re-usable routines for the job. These two subpools, 251 and 252, are sometimes lumped together in the term JOB PACK AREA.

Between these two subpools is the data area. It is from this area that GETMAIN's will be satisfied. Usually I/O buffers will reside in this area. The same non-zero protect key assigned to subpool 251 will be used for the data area.

There is one region which is permanently assigned; that of the MASTER SCHEDULER. This is assigned and loaded by NIP at IPL; it is always immediately below the LINK PACK AREA. The reader will recall that the MASTER SCHEDULER is the communication link between OS/360 and the operator; it accepts and schedules commands, and displays the system status upon request.

GENERAL:

A job in an OS/360 system is controlled through queues of control blocks. In order to analyse or debug a job it is necessary to re-construct the flow of control and I/O; to do this one must have a basic understanding of the contents and usage of some of these control blocks. We will discuss these in two stages: Task control and I/O control.

TASK MANAGEMENT AND CONTROL BLOCKS:

The reader should be familiar with the concept of a task. A TASK is work to be done; a program is merely a series of steps to perform a function. There is not a one to one relationship of TASK's in the system and programs in the system. For example, consider the square root program, SQRT. The program SQRT is simply a series of machine instructions; the actual performance or taking of the square root is a TASK. Hence the difference: The taking of the square root is a TASK; the TASK uses the program SQRT. Now, if many jobs (TASKS) in the system require the taking of the square root, and SQRT is serially re-usable or re-entrant, is it necessary for each TASK to have its own copy of SQRT? Of course not; we will load one copy of SQRT into the LINK PACK AREA, and allow all TASK's to share this code; we will QUEUE TASK's on this code. This will be particularly true in the case of common I/O routines. Hence we will have many TASK's and one program. This QUEUING and sharing and controlling of TASK's and programs is what is meant by TASK CONTROL.

For each TASK in the system, a TCB (Task Control Block) is created. There is at least one TCB per region. The TCB is created by an ATTACH macro, and consists of roughly 190 bytes; it resides in the SYSTEM QUEUE SPACE. The TCB contains a multitude of flags indicating the status of the TASK, and pointers to every conceivable queue of related control blocks and tables; it is the communication and control center for the TASK. The contents of the TCB will be discussed in the section on core dumps in MVT; for more detail refer to the OS/360 System Control Blocks SRL.

For each PROGRAM required for the performance of the task, an RB (Request Block) is created in the SYSTEM QUEUE SPACE. These RB's contain program control information, PSW's, size etc. RB's are created by the LINK and XCTL macros. Four types of RB's are created: PRB's for programs; SVRB's for resident and non-resident SVC's; IRB's for system interrupt blocks (asynchronous requests such as STIMER); and SIRB's for asynchronous I/O error recovery routines. We will concern ourselves with PRB's and SVRB's.

These RB's are formed into the ACTIVE RB QUEUE for the task; the TCB points to the ACTIVE RB QUEUE. This queue represents programs which are active or have been active.

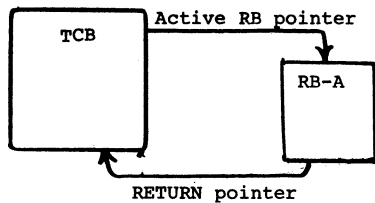

Figure 6:
Active RB queue with one active RB in the queue.

as the example in Figure 7.

The TCB always points to the RB which is ACTIVE (i. e. the RB for the program currently executing); in Figure 7 this is RB-B. This RB points back (via the RETURN pointer) to the next most recent RB (in this case RB-A).

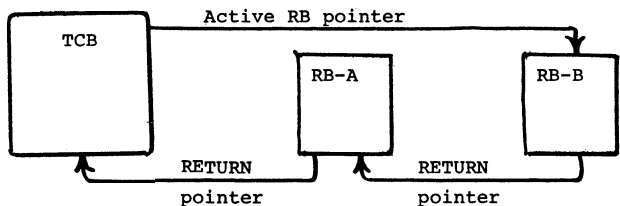

Figure 7:
Active RB queue with two RB's in the queue. RB-B is the active RB at this time; it was the object of a LINK macro in program A.

Upon completion of program B, the RETURN is made, via the RETURN pointer, to program A. After execution of this RETURN, the active RB queue would appear as in Figure 8.

For example, if program A is the only program needed by the task, the active RB queue would look like that in Figure 6.

Consider, however if program A contains a LINK to program B. At the conclusion of this "LINK B" macro execution, the active RB queue would look

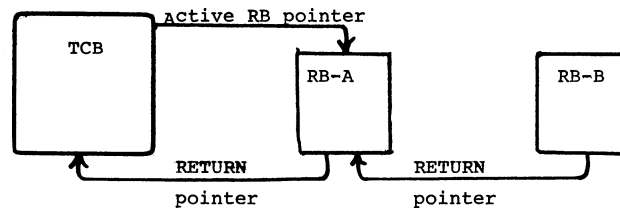

Figure 8:
Active RB queue after execution of the RETURN in program B via the RETURN pointer in RB-B. The active RB queue now has one RB in it.

In this manner, the system controls the flow of control of the task through the required programs; return of control will follow the RETURN pointers. Hence we can reconstruct the control flow through the programs necessary for the completion of the task.

One should be aware that an XCTL macro is handled differently. If in our example program B executed an XCTL to program C, the active RB queue would appear as in Figure 9.

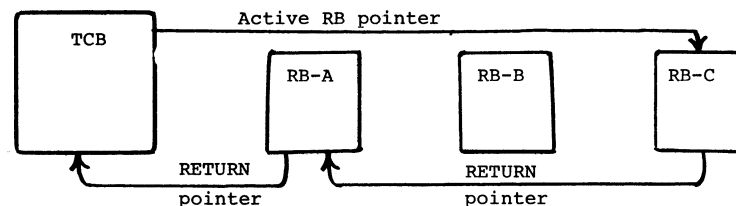

Figure 9:
Active RB queue after program A LINK'ed to program B which XCTL'ed to program C.

Note that in Figure 9 the RETURN pointer in RB-C indicates return to program A; this is consistent with the fact that RETURN is always made to the next higher level of control, and XCTL brings in a program at the SAME level of control. LINK, however, brings in the program at the next lower level of control. Note, however, that the system is now unaware of the existence of RB-B; there is no way of returning to it, as it has in effect disappeared.

For programs which are brought into core as the result of a LOAD macro, a control block similar to an RB is constructed, called an LLE (Load List Element). Since there is no such thing as an "active" LOAD'ed program, LLE's are simply chained together into an LLE queue. The TCB points to the LLE queue, which resides in the SYSTEM QUEUE SPACE.

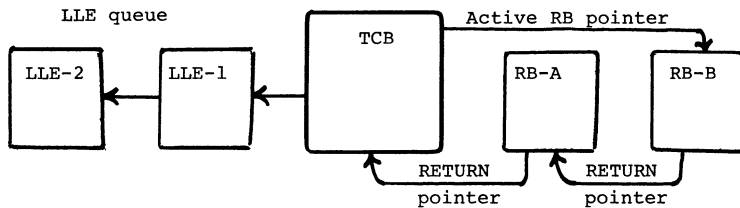

Figure 10:

Active RB queue and LLE queue, pointed at by the TCB.

One other important control block for task management should be discussed. The CDE (Contents Directory Entry) queue contains one CDE for every load module in the region, or being used by the region. There is one CDE queue for each region; this queue is used by MVT to manage the contents of storage. Three important pieces of information are kept in the CDE: 1) The pointer to the corresponding RB; 2) the entry point address of the related program; 3) the module name. Hence we can quickly "inventory" our region by scanning the CDE queue. This queue resides in the SYSTEM QUEUE SPACE.

In the section on core dumps in MVT we will use these control blocks to pinpoint the program in error.

Figure 11 illustrates the relationships of all the control blocks so far discussed.

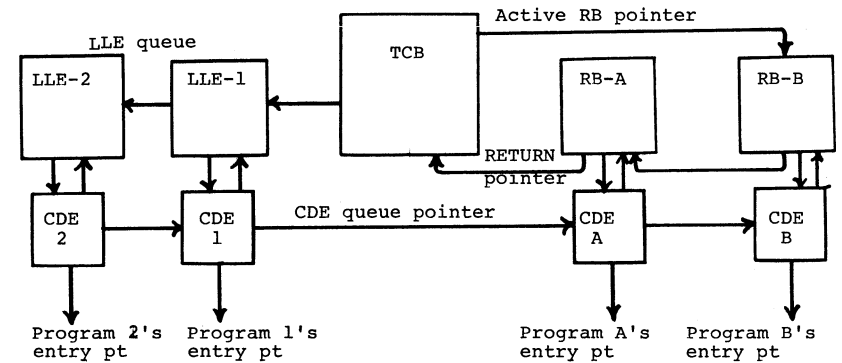

Figure 11:

MVT task control queues and control blocks for a region. All control blocks and queues shown reside in the SYSTEM QUEUE SPACE.

One additional, extremely important area must be discussed and understood to completely master program control - that of register SAVE areas. The reader should know the OS/360 register conventions:

- Register 0: Used for passing parameters;
- 1: Used for a pointer to parameter lists;
- 2-12: For general program use;
- 13: Points to the current SAVE area;
- 14: Used for the RETURN address;
- 15: For entry point address or return code.

Also he must know and follow the OS/360 conventions concerning forward and backward chaining of SAVE areas; only if he knows and follows these conventions will register contents be of any value to him in debugging. For a discussion of chaining conventions, see the OS/360 Supervisor and Data Management Services SRL.

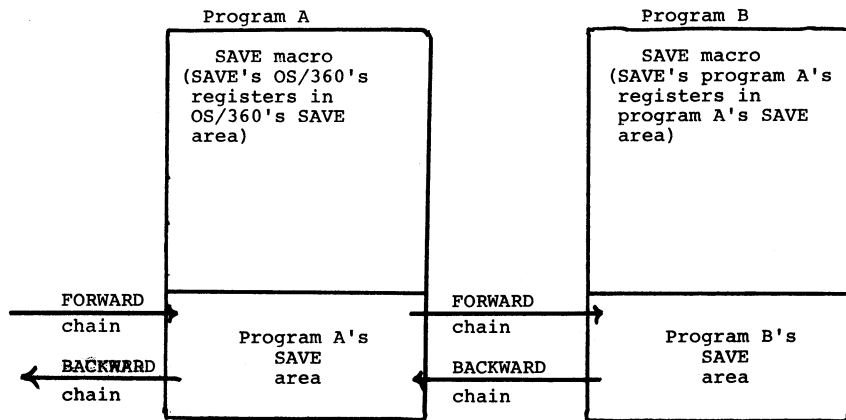

Figure 12:
SAVE area conventions, showing forward and backward chains; those to the left of program A point to and from OS/360's SAVE area.

DATA MANAGEMENT AND I/O CONTROL BLOCKS:

Many times the source of an error appearing in a program lies in the data or data management, such as improper data definition, illegal data or improper data manipulation. OS/360 performs data management in a manner similar to task management; that is, with a series of control blocks and queues.

Five major control blocks need be considered; these are located through the task's TCB.

The DCB (Data Control Block) is the final residing place of the control information for logical data manipulation. This control block is assembled into the program, and may be filled in and supplemented from the DD card and data set label at OPEN time. The reader should be familiar with the DCB. For further information see the OS/360 Concepts and Facilities manual.

While the DCB does contain most of the information concerning the data set, it does not contain device dependent information or the channel program necessary to actually perform the I/O operation. Other I/O blocks and I/O routines must be present; to co-ordinate and manage these, the OPEN routine constructs in the SYSTEM QUEUE SPACE a DEB (Data Extent Block) for each DCB. This control block is the "communications center" for IOS (Input Output Supervisor). It contains the addresses of the I/O modules such as Start I/O (SIO), end of extent and channel end. The DEB also contains pointers to the TCB, DCB, IRB and UCB (Unit Control Block) and the next DEB in the queue. The TCB points to the first DEB in the DEB queue. For direct access data sets, the extents (beginning and ending TTR's) are kept in the DEB, giving it its name. No I/O operations may take place outside this extent.

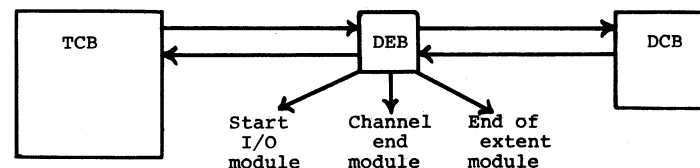

Figure 13: The DCB and DEB.

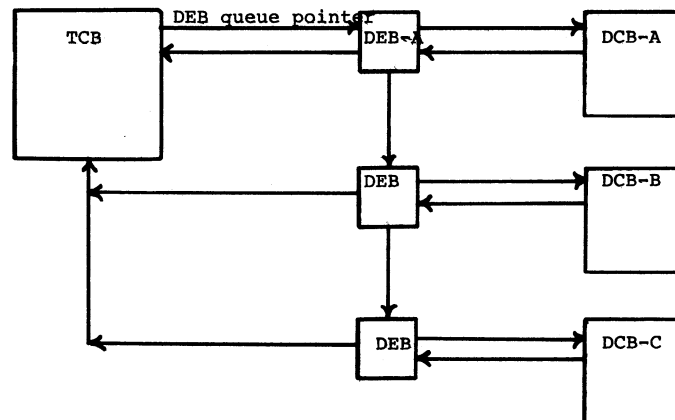

Figure 14: The DEB queue.

IOS uses the DEB to locate the proper start I/O module for the allocated device, and the proper channel end routine for interrupt handling and interpretation.

Communication between IOS and the problem program takes place through the IOB (Input Output Block); here the CCW list (the channel program) and the Completion code for an I/O request are placed for program inspection. Contents of the IOB include a pointer to the DCB, a pointer to the ECB (Event Control Block) and a pointer to the CCW list. Also such things as the block count, sense bytes, the last word of the CSW and error counts are kept in the IOB. In most cases the actual channel program is built in the IOB. For direct access devices, the initial seek TTR is kept here. There is one IOB for each I/O request; it is constructed in the user's region by the user himself. Normally the programmer will re-use the same IOB for all similar requests. The READ, WRITE, GET and PUT routines usually construct this IOB.

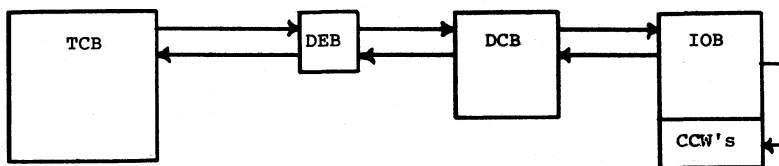

Figure 15: The DEB, DCB and IOB.

At this point the only thing missing is the link between these control blocks and the actual physical device. This is accomplished through the UCB (Unit Control Block). The UCB contains all information necessary pertaining to the device and its status, such as unit type, unit address, volume serial of the volume presently mounted, TTR of the VTOC for direct access devices and the sense bytes last read. Flags in the UCB are set and used by IOS to indicate whether the device is ready, on-line, busy, seeking or has encountered a permanent I/O error. Contained in the NUCLEUS, there is one UCB per device, which is placed there during system generation; the DEB contains a pointer to the allocated UCB for the DCB.

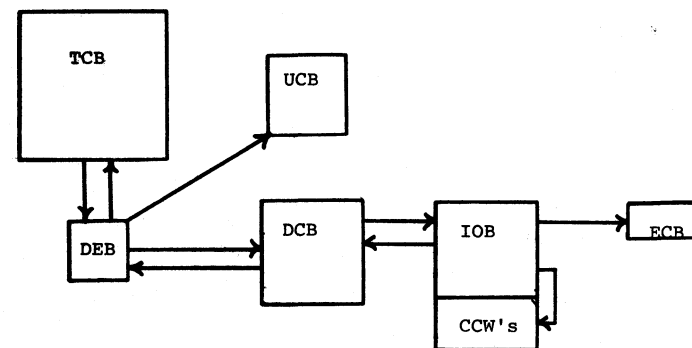

Figure 16: The DEB, DCB, IOB, ECB and UCB.

One additional table should be mentioned which is of minimal value for debugging but is of considerable importance in programming. This is the TIOT (Task Input Output Table), constructed by the INITIATOR in the SYSTEM QUEUE SPACE during I/O allocation. The TIOT contains the jobname, stepname, and one entry for each DD card containing the DD card name and the address of the allocated UCB for that DD card. The TCB points to the TIOT.

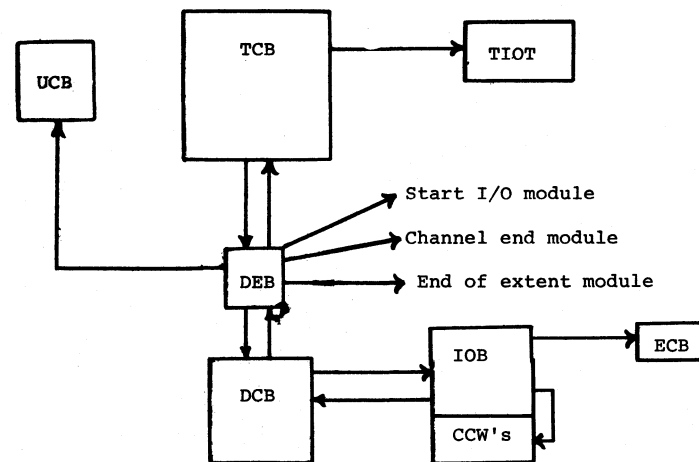

Figure 17: Complete I/O control blocks for one data set.

JOB MANAGEMENT IN AN MVT SYSTEM

GENERAL:

A JOB passing through an OS/360 MVT system encounters five distinct stages. These stages involve systems routines grouped under the function of JOB MANAGEMENT; to understand the system we should be familiar with JOB MANAGEMENT.

The five stages in which a JOB is involved are:

- * Entry into the MVT system;
- * Initiation of the JOB;
- * Execution of the JOB;
- * Termination;
- * The writing of standard output classes to punches, printers and tapes.

Handling these stages are the following routines:

- * A JOB is read into the system by a READER/INTERPRETER;
- * Selecting a JOB for execution and initiating it is an INITIATOR (sometimes called an INITIATOR/TERRMINATOR);
- * While executing, use is made by the program of supervisor services such as OPEN, CLOSE etc.;
- * The INITIATOR terminates the JOB by disposing of the data sets etc.;
- * Standard output is SPOOLED to the printers and punches by an OUTPUT WRITER or SYSOUT WRITER.

THE READER/INTERPRETER:

The main function of the READER/INTERPRETER is to read the JOB STREAM. The JOB STREAM consists of JCL (Job Control Language) statements and DD * data (that is, data following a //ddname DD * card and preceding a /* card), sometimes called SYSIN data. In other words, the READER/INTERPRETER reads the INPUT STREAM, which is usually cards or tape.

As the JCL statements are read, the READER/INTERPRETER converts them to internal table form and places these tables on SYS1.SYSJOBQE; these will form the input queue.

The JOB statement is converted to a JCT (Job Control Table), containing the information necessary to control the JOB. JOB name, priority, message class, region size, condition codes and a pointer to the accounting information are contained in the JCT.

As the EXEC card is encountered it is converted into an SCT (Step Control Table), containing the step name, PARM field values, program name, condition codes and region size. With the SCT we begin the real building of the input queue entry for this JOB; the JCT points to the first SCT, each SCT points to the next SCT. For the following discussion we will consider a three step JOB; our queue so far would appear as in figure 18.

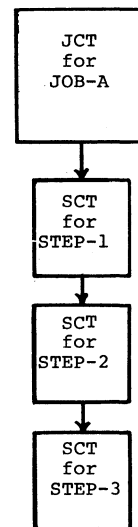

Figure 18:
Entries built in SYS1.SYSJOBQE from a JOB card and three EXEC cards by the READER/INTERPRETER.

Each DD card encountered by the READER/INTERPRETER is converted into a JFCB (Job File Control Block). The JFCB contains all information for allocating and disposing of the referenced data set during the job's execution. OPEN and CLOSE use the JFCB, which contains all the DCB information coded in the DCB parameter on the DD card, and the data set label to complete the DCB coded in the program. This is discussed in the section on the execution of the program. In the JFCB is stored the data set name (DSNAME), label type, sequence number, volume serial numbers, space allocation information (from the SPACE parameter), disposition and all the DCB information coded in the DD card. All JFCB's for a job step are chained together; the SCT points to the JFCB queue (through the step I/O table, which we shall not discuss). Hence the total entry in SYS1.SYSJOBQE created by the READER/INTERPRETER for our job would appear as in Figure 19.

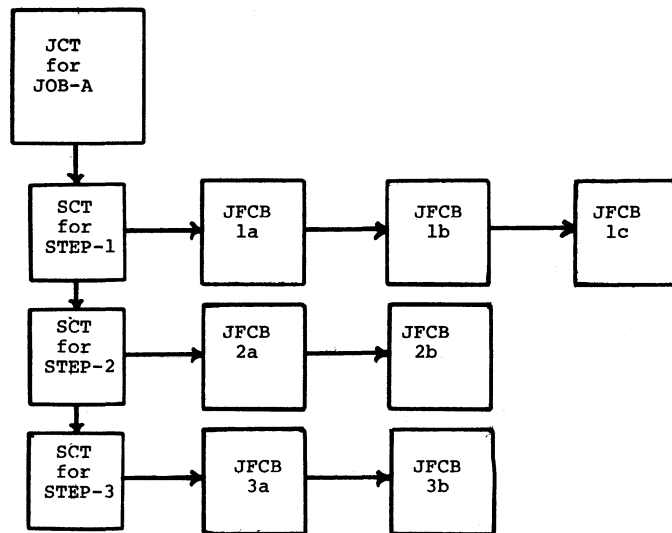

Figure 19:
Complete entry built by a READER/INTERPRETER in SYS1.SYSJOBQE for a job containing three steps (SCT's STEP-1, STEP-2, STEP-3). STEP-1 contains three DD cards (JFCB's 1a, 1b, 1c), STEP-2 contains two (JFCB's 2a and 2b) and STEP-3 contains two (JFCB's 3a and 3b)

When the READER/INTERPRETER encounters SYSIN data (that is, DD * data) it SPOOL's the data to an IEFDATA data set on a direct access device and builds the JFCB for the DD * card to point to the direct access data set.

When a DD card referencing SYSOUT data (i. e. a SYSOUT=x card) is encountered, the READER/INTERPRETER allocates space for it in the OUTPUT QUEUE; notice that SPACE is allocated, it is not ENQUEUED or placed in the OUTPUT QUEUE.

At this time the READER/INTERPRETER has completed building the queue entry for the job in SYS1.SYSJOBQE, and now the job is ENQUEUED into the INPUT QUEUE by the READER/INTERPRETER. The system is now, for the first time, aware of the job's presence in the system. The INPUT QUEUE is kept in priority sequence, and the job's queue entry consists of a pointer to its JCT. The INPUT QUEUE resides in SYS1.SYSJOBQE.

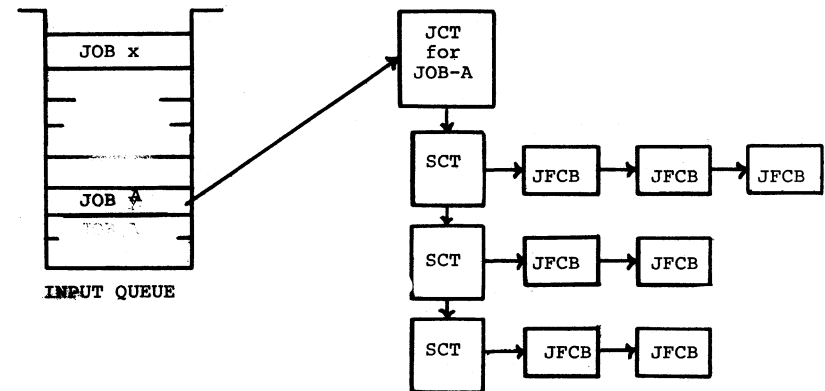

Figure 20: Complete INPUT QUEUE entry for JOB-A.

This sequence continues until either the READER/INTERPRETER is stopped or the input stream is exhausted. Many READER/INTERPRETER's may, and probably will be, be active at one time, each reading a separate job stream.

In summary, the READER/INTERPRETER:

- * Reads the JOB STREAM;
- * Builds control tables in SYS1.SYSJOBQE from JCL;
- * SPOOL's SYSIN data;
- * Reserves space for SYSOUT data;
- * ENQUEUES the job into the INPUT QUEUE.

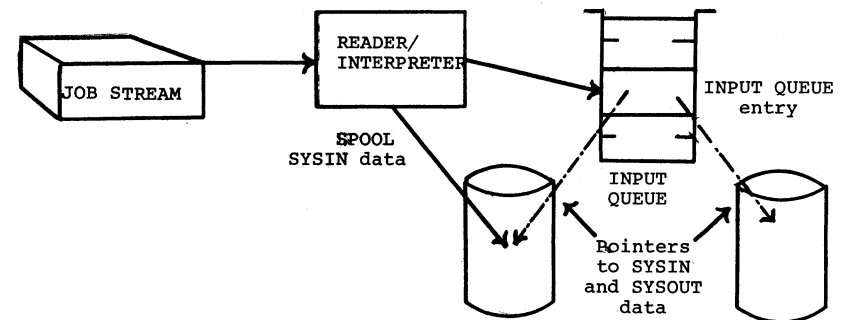

Figure 21: The READER/INTERPRETER

THE INITIATOR:

Once a job has been placed into the INPUT QUEUE, there it remains, until it becomes the next job for execution (i. e. all jobs of a higher priority have been started). The INITIATOR selects jobs from the INPUT QUEUE in priority sequence for initiation. The INITIATOR finds all information for selection and initiation by following the pointer in the job queue to the job's JCT, SCT's and JFCB's; these contain all information necessary to the INITIATOR.

From the JCT the INITIATOR determines the region requirements from the region field. The INITIATOR will request a region the size of which is determined by the larger of the region parameter in the JCT (filled in by the READER/INTERPRETER if not present in the JOB card) or the size of the main INITIATOR modules to be brought into the region. That is, a region will not be allocated smaller than the INITIATOR size. This also takes place for each step, the value being taken from the step's SCT. The INITIATOR then removes the job's entry from the INPUT QUEUE.

Into this just allocated region the resident portion of the INITIATOR fetches the non-resident INITIATOR modules and ATTACH'es to these modules. The INITIATOR queries any condition codes passed at termination by a previous job step against those in the JCT and next SCT for possible termination conditions. The INITIATOR (in the region) now examines the JFCB's for this step (through the JFCB chain found through this step's SCT) and allocates devices and DASD space. This allocation is done through the JFCB's and UCB's; the TIOT is built in the SYSTEM QUEUE SPACE at this time.

After I/O device and space allocation, the INITIATOR goes to the SCT to determine the program to be initiated. The INITIATOR then issues an XCTL to this program; this brings the program into the region on top of the INITIATOR, overlaying it, and places the program's RB as the only RB in the ACTIVE RB QUEUE. The INITIATOR has supplied a SAVE area in the region through a GETMAIN (protect key non-zero). A similar technique is used to relocate the PARM information from the SCT to the region.

One INITIATOR exists per region; it is created and dedicated to that region through the START INIT operator command.

In summary, the INITIATOR:

- * Selects jobs from the INPUT QUEUE for execution;
- * DEQUEUES the job from the INPUT QUEUE;
- * Allocates a region for the job;
- * Allocates I/O and DASD space - builds the TIOT;
- * XCTL's to the problem program.

PROGRAM EXECUTION:

Control of problem program execution is, of course, handled by the program itself. Occasionally, however, the program will issue SVC's to request supervisor assistance for particular functions, such as performing I/O, bringing other programs into the region etc. It is important to understand the general flow of control during these SVC's, and in some detail for two particular SVC's, OPEN and CLOSE.

When a program issues an SVC, the SVC interrupt handler receives control. This interrupt handler determines what is to be done, and routes control to the proper SVC routine. For a request for a type I SVC control is routed via a branch, and the routine is basically transparent to the user, as no interrupts are permitted during execution of a type I SVC. When a type II, III or IV SVC is issued, however, the interrupt handler builds an SVRB for the proper routine, and enqueues it as the active RB in the active RB queue. That is, the RB of the program which issued the SVC becomes the second most active RB, and is chained, via the RETURN pointer, to the newly created SVRB, which is now the active RB. If the SVC routine is resident, it will then be given control; if transient, it will be loaded (if not already present) into one of the SVC transient areas in the NUCLEUS and given control. Return will be made in the normal manner to the issuing RB's program via the RETURN pointer in the SVRB.

Two type IV SVC's are often enough the place of a programmer's Waterloo to warrant separate discussion; these are OPEN and CLOSE.

OPEN is an SVC designed to locate and attach a data set to the program, and make it ready and available for processing. CLOSE is the logical converse of OPEN; it detaches the data set from the program, and makes it no longer available for processing by that program.

OPEN performs a great deal of its processing in what is called the forward and backward merge of the DCB, JFCB and the data set label; here a great number of errors in data management coding will be discovered. As previously mentioned (in the section on control blocks), the DCB is the final repository of most of the logical characteristics of a data set. The forward and backward merges of OPEN fill in information in the DCB which was either unavailable or not included at assembly or compile time; this information is supplied from the DD card, via the JFCB, and the data set label, if present. The JFCB, recall, contains the DCB information which was coded on the DD card; it was placed in the JFCB by the READER/INTERPRETER.

The FORWARD MERGE consists of two steps:

- 1) The ZERO fields in the JFCB are filled in from the data set label if possible; note that only ZERO fields are merged. Data already present in the JFCB CANNOT be overridden;
- 2) The ZERO fields in the DCB are filled in from the JFCB; note that, as before, only the ZERO fields are merged. Data coded into the DCB CANNOT be overridden.

At this time the DCB is complete, and the two step BACKWARD MERGE begins, consisting of:

- 1) For INPUT data sets, the ZERO fields of the JFCB are filled in from the DCB; note that no fields are overridden.
For OUTPUT data sets, ALL JFCB fields except DSORG are OVERRIDDEN from the DCB;
- 2) For DASD OUTPUT data sets, all fields in the DSCB are overridden by the JFCB; for INPUT data sets, the labels are already existent, and remain inviolate.

After the merges, OPEN builds and fills in the DEB's for the data sets in the SYSTEM QUEUE SPACE.

CLOSE is the logical converse of OPEN. CLOSE creates any required trailer labels, and detaches the data set from the program by dequeuing the data set's DEB from the DEB queue.

THE TERMINATOR :

Execution of a job step terminates when the program controlled by the highest level RB in the active RB queue issues its RETURN. This returns control to the resident portion of the INITIATOR, which XCTL's to the transient portion of the INITIATOR, consisting of the TERMINATION routines, which overlays the program in the region.

This TERMINATOR performs any accounting functions and routines. It then examines the JFCB's for the step and disposes of the data sets (i. e. DELETE's, catalogues, PASS'es or KEEP's them). Any I/O devices no longer needed are de-allocated. If this was not the last SCT on the SCT queue for this job (i. e. it was not the last step), the TERMINATOR returns control to the resident portion of the INITIATOR which begins all over with the examination of the next SCT and continues as described in the section on the INITIATOR. If this just terminated step was the last step in the job (i. e. the last SCT), the TERMINATOR ENQUEUE's all SYSOUT data sets in the OUTPUT QUEUE in priority sequence. Note that all SYSOUT from the job is enqueued at one time, at job end; recall that the READER/INTERPRETER reserved space for this SYSOUT data, which was written by the problem program. Now, for the first time, the system is aware of this SYSOUT data.

After the termination of the last step of a job, the TERMINATOR returns to the resident portion of the INITIATOR, which selects the next job for initiation from the INPUT QUEUE, thus starting again the entire sequence described in the section discussing the INITIATOR. This sequence continues until either the INITIATOR is stopped, or the INPUT QUEUE is empty, at which time the INITIATOR waits for the next entry to be ENQUEUED, when the sequence begins again.

In summary, the TERMINATOR:

- * Performs the accounting function;
- * Handles data set disposition;
- * Frees I/O devices no longer needed;
- * If this was the last step in the job, ENQUEUE's, by priority, all SYSOUT data sets into the OUTPUT QUEUE, then returns to the INITIATOR;
- * If this was not the last step in the job, returns to the INITIATOR for initiation of the next step.

THE OUTPUT WRITER:

An OUTPUT WRITER is started for a SYSOUT class; this writer is then dedicated to that class' OUTPUT QUEUE. For instance, if an OUTPUT WRITER is started for output class A, it will be dedicated to the OUTPUT QUEUE containing the entries for SYSOUT=A data sets.

The SYSOUT WRITER selects the top entry in the OUTPUT QUEUE; these entries were enqueued, recall, by the TERMINATOR at job end. These are selected in priority sequence. Once selected, the OUTPUT WRITER then SPOOL's the data set to the specified device (usually a printer of punch). This data set can consist of SYSOUT= data and system messages (SMB's) such as allocation and disposition messages for data sets.

The OUTPUT WRITER then DEQUEUE's this data set's entry from the OUTPUT QUEUE; it then returns to the first function and selects the next entry in the OUTPUT QUEUE for output.

The OUTPUT WRITER continues this sequence until either stopped or there are no more entries in its OUTPUT QUEUE for SPOOL'ing, at which time it waits for the next entry to be ENQUEUE'd, when it begins the sequence again.

In summary, the SYSOUT WRITER:

- * Selects a completed data set for SPOOL'ing from the OUTPUT QUEUE;
- * Writes (or SPOOL's) the data set;
- * DEQUEUE's the entry from the OUTPUT QUEUE;
- * Returns to the first step.

COMMENTS:

It is perhaps important to remember that these three functions, the READER/INTERPRETER, INITIATOR/TERMINATOR and SYSOUT WRITER, are operating continuously, asynchronously and independently, which is part of the power of the MVT system. Their only real communication with one another is through the INPUT QUEUE and the OUTPUT QUEUE's.

CORE DUMPS IN MVT

INTRODUCTION:

There are generally five kinds of core dumps in an MVT system.

An INDICATIVE dump consists of a single printed line on the MSGCLASS data set, containing the system completion code. It is produced automatically, without control cards and marks the termination of the job. In many cases, such as step timing violation, this single line is adequate for determining the cause of abnormal termination.

A UDUMP or SYSUDUMP is a full core dump listing all control blocks for the user's region (i. e. TCB's, RB's, DEB's etc.), and the user's region itself. In addition, any routines being used in the LINK PACK AREA are dumped. A SYSUDUMP is given when a terminal error occurs and a //SYSUDUMP DD card has been included in the JCL for the current step. This is usually a large data set, so care should be exercised not to exceed space allocation in a SYSOUT data set. A SYSUDUMP marks the termination of the job. As this is the most common dump used in an MVT environment, it is this dump that the remainder of this paper discusses.

When a //SYSABEND DD card is used rather than a //SYSUDUMP DD card, a terminal error causes an ABEND dump. ABEND dumps are identical to UDUMPS except that the NUCLEUS and a TRACE TABLE are also included. As the NUCLEUS is likely to be very large, this is a very large data set and care should be taken not to overrun a SYSOUT data set. The NUCLEUS is usually of little help to the average programmer, and an ABEND dump should be taken only when a UDUMP is inadequate.

A SNAP dump may be produced by an assembler language programmer. A SNAP macro causes a dump to be taken which is similar to an ABEND dump; the job, however, then continues, rather than terminating. The SNAP macro also specifies which control blocks and areas of core are to be dumped. For further details, see the OS/360 Supervisor and Data Management Macro Instructions manual.

The fifth kind of dump is the stand-alone or unformatted dump. It is used when an error causes the operating system to become inoperable. Not an OS/360 program, it simply dumps all of core, with little or no formatting of control blocks.

What causes an ABEND error? ABEND is actually an SVC; in fact it is the "unlucky" SVC 13. An ABEND SVC is issued when either the processing program or the supervisor is unable to continue with the job. The reader should notice that we refer to ABEND and UDUMP dumps, which are caused by the ABEND SVC.

The ABEND is usually issued by the control program in response to some interrupt, such as a program interrupt, from which the job cannot recover. For example, if the program generates an address outside its region and tries to execute an MVC to this address, a program interrupt will occur with a protection violation interrupt code. This interrupt will be handled by the MVT program interrupt handler in the NUCLEUS. Upon determination of the cause of the interrupt (i. e. a protection violation), the interrupt handler then determines if the error is recoverable (it is not). Hence an ABEND is to be issued, so the interrupt handler next determines which task caused the error (i. e. which region). At this point the interrupt handler issues the ABEND for the program.

Two things should be noted from the preceding paragraph. First that the executing program in error did not issue the ABEND; it was issued by the MVT interrupt handler in the NUCLEUS. This is usually the case, and for this reason the PSW at entry to the ABEND processor will rarely contain the address of the actual error; it will contain the address of the MVT routine in the NUCLEUS which actually issued the SVC 13, the ABEND SVC. Secondly, a considerable amount of processing occurred in the interrupt handler before the ABEND was issued. That is, the actual ABEND was quite removed from the actual error.

The reader should be aware, however, that the problem program may issue its own ABEND, which make the PSW and general registers at entry to ABEND the program's own. Several language processors produce controlling routines which do this, such as IBCOM produced by FORTRAN. IBCOM, for instance, intercepts most interrupts, and occasionally issues its own ABEND.

THE MVT CORE DUMP IN GENERAL:

The MVT SYSUDUMP is divided into six general sections (see figures 22a, 22b, 22c, and 22d):

- 1) General status, indicative and TCB area, consisting of the top of the dump through the TCB section;
- 2) Region contents, showing ACTIVE RB QUEUE, LOAD LIST, CDE's (contents directory) and XL's (extents list);
- 3) The I/O section, consisting of the DEB QUEUE and TIOT;
- 4) Storage management and queue control blocks (the MSS, D-PQE, FBQE and QCB TRACE);
- 5) Register contents, consisting of the SAVE AREA TRACE and REGS AT ENTRY TO ABEND;
- 6) Load modules, consisting of the load modules being used by the task.

There are a few fields in the general and TCB area of which we should be aware before continuing. While many examples of dumps have been included, it is strongly urged that the reader have a dump readily at hand for his perusal.

Look at the TCB entry in Figure 23; this is followed by the address of the TCB - note this address, as we shall use it later. The following fields are of interest:

RBP is the pointer to the active RB; note this address matches that of the last SVRB in the ACTIVE RB QUEUE;

DEB points to the first DEB in the DEB queue;

TIO is the TIOT address;

CMP 80322000 contains the system completion codes; positions three through five contain the SYSTEM COMPLETION CODE (i. e. 322 which matches that printed at the top of the dump), and positions six through eight contain the user code, if any (none in this case);

PK-FLG contains in the first position the user protection key; in this example it is "E";

LLS points to the beginning of the LOAD LIST;

JLB contains the address of the JOBLIB DCB, if present.

AN APPROACH TO DEBUGGING:

When debugging a program using a dump, knowing the layout and contents of the dump is not always adequate; what is needed is a method of attack. The debugger is usually overwhelmed by the wealth of data displayed; he must have a plan for debugging to prevent his thrashing aimlessly through assorted control blocks. The author has evolved a plan for "normal" debugging which has proved generally useful; it usually brings one, in an orderly fashion, to a place where productive debugging can be accomplished. Most of the time the plan will determine the error itself.

Based on the old newspaper dictum of "Who, Where, Why, When and What," the author has developed his approach into two "The five W's approaches to debugging." Plan one, THE NEWSPAPER APPROACH TO PROGRAMMING ERRORS, is used for tracking down the general programming error, while plan two, THE NEWSPAPER APPROACH TO DATA MANAGEMENT ERRORS, is an alternate, aimed at tracking down I/O errors.

THE NEWSPAPER APPROACH TO PROGRAMMING ERRORS:

When approaching a core dump there are generally five things in which we are interested; these are the same five things a newspaper reporter wishes to know. They are:

- 1) WHY does OS/360 think we erred;
- 2) WHEN in our processing did we terminate;
- 3) WHO was executing - ourselves or OS;
- 4) WHERE in storage did we fail;
- 5) WHAT actually caused the error.

We shall begin interpreting our dump in the order listed.

Why:

The first thing we should examine is the reason OS/360 gives for producing the dump. OS tries to tell us why he thinks we erred; this is not always the actual reason for the ABEND.

At the top of the dump are displayed the job name, step name and a COMPLETION CODE, either SYSTEM or USER. A USER code is the code supplied by the programmer when he issues his own ABEND macro; the reason is in his own program. Normally a SYSTEM code will be listed; this indicates that OS/360 issued the ABEND. The meanings of these codes are listed in the Messages and Completion Codes manual.

Often this code itself is sufficient to determine the cause of the error. For example:

COMPLETION CODE 804 tells us that insufficient core was available for a GETMAIN macro. This usually indicates that the program to be loaded is too large; that is, the region allocated is too small;

COMPLETION CODE 001 informs us of an I/O error. In this case we might use the alternate approach to I/O errors discussed later;

COMPLETION CODE 806 indicates that a module was not found by the BLDL SVC. This usually occurs during the FETCH to a program. It indicates that either the incorrect program library was specified, or that we failed during a preceding link edit step. We may have merely mis-spelled the program name.

COMPLETION CODE 0Cx indicates a program check and will probably require further analysis.

If examination of the reason OS/360 gives for the dump is not adequate, we proceed to the next step. In our example, we ABEND'ed because we exceeded the time allowed for the job step.

When:

We should like to know WHEN in our processing we developed our error. This usually means in what module were we when something occurred which caused an ABEND to be issued. To determine this we need to know what modules were in core, and where they resided in our region.

We begin by examining the ACTIVE RB QUEUE (Figure 24a), which tells us which programs are in our region and being used. The ACTIVE RB QUEUE is listed with the oldest RB first, and the newest RB last. That is, the last RB to have control of the TCB is the RB on the bottom of the ACTIVE RB QUEUE. Notice that this is the RB whose address is contained in the RBP field of the TCB at the top of the dump.

Two kinds of RB's normally appear in the ACTIVE RB QUEUE: PRB's for programs and SVRB's for supervisor call routines. Let us examine the RB queue, starting with the most recent RB (i. e. the RB on the bottom of the queue).

The NEWEST RB is an SVRB controlling a module of ABDUMP (SVC 51). ABDUMP does the actual formatting and dumping of the control blocks for the region; this is of course the most recent RB, as it is printing the dump we are reading.

The next RB (second from bottom on the queue) is an SVRB controlling a module of ABEND (SVC 13). ABEND was called (by someone) by the issuing of an SVC 13. ABEND goes to the TIOT to check whether a SYSUDUMP or SYSABEND DD card was supplied by the user. If none was present, an INDICATIVE dump is produced and the job is terminated. If such a card is found (one obviously was, or we would not have a dump) then ABEND issues an SVC 51 to bring in ABDUMP which actually formats and prints the dump.

Hence, the RB which had control of the TCB at the time the ABEND was issued is the third most recent; that is, the third RB from the bottom of the ACTIVE RB QUEUE represents the program active at the time of the ABEND.

Now that we know which RB was in control of the TCB at the time of ABEND, let us map out the modules in our region to get an idea of the region's make up. Let us glance first at some of the fields in a PRB (see Figure 24a).

PRB 018C88 is the address of the PRB in the SYSTEM QUEUE SPACE;

APSW 400FF162 is the last half of the program's OLD PSW at the time of the last interrupt;

FI-CDE 00018DD8 contains, in the last six positions, the address of the corresponding CDE for this PRB. In our example this is 018DD8;

PSW FFE5000D 40003716 is the RESUME PSW.

Now, to map out the region, we go to the corresponding CDE's for the RB's (the address of each CDE is in the left hand column in the CDE section of the core dump). The CDE contains the following information (for our example, we are using the first CDE at location 018DD8):

018DD8 is the CDE address; note this is the CDE for our third most recent RB;

NCDE 000000 is the address of the Next Contents Directory Entry; note that, starting at the bottom of the CDE queue, each NCDE points to the next CDE up the queue. The last element on the queue has an NCDE field of zeroes, marking it as the last;

ROC-RB 00018C88 shows the address of the corresponding RB for this CDE in the last six digits. Note that this points back to our third most recent RB;

NM PDS tells us the load module name for this PRB - in this case PDS;

EPA 0B2C80 tells us the Entry Point Address of the module;

XL/MJ 018E18 gives us a pointer to the extent list (XL) element for this CDE (i. e. for this module). More on the extent list in a moment.

Hence, at this point we now know the names and entry point addresses for all the modules in our region and those we are using in the LINK PACK AREA.

We should like to know the EXTENTS of all these modules - i. e. their beginning and ending addresses. To find these for each module we find the corresponding extent list element for each CDE. Let us examine the XL entry for the module PDS (see Figure 24b).

018E18 in the left hand column is the address of this XL entry. Note that this is the address pointed to in the XL/MJ for the PDS CDE;

80003B80 in the fourth column contains the length, in bytes, of the module (the "8" in the first position signifies that this is the only entry for this module);

000B2C80 in the fifth column contains the starting address of this module (note: Not the entry point address).

Upon examination of the CDE list and the XL queue, we notice a great number of entries which have no corresponding RB. Note, for instance, that all CDE's except the one for module PDS have a ROC-RB pointer of zeroes; this implies that there is no RB for this CDE and XL pair. CDE's with zero RB pointers correspond to LOAD'ed modules;

that is, modules which were the object of a LOAD macro. Recall that for such a module, a LOAD'ed module, the LLE (Load List Element) is the equivalent of the RB. Let us examine the LOAD LIST (see Figure 26).

The list goes across the page rather than up and down. The first entry contains:

NE 00018258 points to the Next Element.

RSP-CDE 020180A8 points to the corresponding CDE in the last six positions; note that 0180A8 is the CDE for IGC0A05A.

The CDE for IGC0A05A points to the proper XL which gives us our starting address and length. We rarely use the LOAD LIST, as the CDE and XL contain most of the needed information.

We now can map out the core used by our job step; for illustrative purposes let us do it. We list the modules in ascending core addresses.

Module	Occupies
PDS	0B2C80 through 0B6700
IGC0A05A	0CD1E0 through 0CD7FC
IGG019AC	0D1918 through 0D1A00
IGG019BB	0FEB40 through 0FEB98
IGG019BA	0FEB98 through 0FED18
IGG019CI	0FED80 through 0FEDF8
IGG019CD	0FEDF8 through 0FF000
IGG019CC	0FF070 through 0FF0C8
IGG019AR	0FF0C8 through 0FF138
IGG019AQ	0FF138 through 0FF1B0
IGG019AK	0FF1B0 through 0FF288

Notice that some modules are contiguous in core. IGG019BB is contiguous with IGG019BA; IGG019CI with IGG019CD, while IGG019CC, IGG019AR, IGG019AQ and IGG019AK are all contiguous.

Upon examination of the list, it becomes clear that modules PDS, IGC0A05A and IGG019AC reside in our region, while the rest lie in the LINK PACK AREA at the extreme high end of core.

In summary, to discern WHEN in our processing we were ABEND'ed we:

- * Examine the third most recent RB in the ACTIVE RB QUEUE; this RB had control of the TCB at the time the task was ABEND'ed;
- * Map out the region, by examining the CDE queue and XL list for module names, entry points, starting addresses and module lengths.

Who:

Because we know that the third most active, or recent, RB is that which was in control of the TCB at the time of the error does not mean that the error occurred in the corresponding program code. Recall that transfer is made to a LOAD'ed routine via a branch instruction; that is, no supervisor action is involved as in a LINK, ATTACH or XCTL. For this reason, the supervisor is unaware of the transfer, and the RB queue will not reflect this branch. This is particularly true of the I/O access routines, all of which are LOAD'ed modules. In other words, in the case of the common READ or WRITE in a program, the program BRANCHES to the I/O routine, which is a LOAD'ed module. If an error occurs in such a LOAD'ed routine, the RB queue will not reflect that LLE, but the RB for the program which issued the BRANCH instruction.

To determine where the ABEND was issued, in your program or in a LOAD'ed routine (usually a system routine) check the RESUME PSW in your RB (i. e. the third most active RB). If the last six positions (in our case 003716) point to an address outside your program (they do), check the LOAD'ed programs to determine if it falls in one of them; if the address falls within one of these LOAD'ed modules, we may assume that the ABEND was issued in that routine. In our example, the address 003716 does not lie within any of our routines - it is clearly well within the NUCLEUS. The RESUME PSW is the address (plus four) of the ABEND instruction; that is, it gives us the address of the SVC 13. This address (003716) matches the PSW AT ENTRY TO ABEND address; this would follow, as the ABEND macro causes an SVC interrupt. A high proportion of the time the RESUME PSW will point to an address within the NUCLEUS; the ABEND was issued by an interrupt handler. For instance, the I/O interrupt handler or program check interrupt handler determined that the task cannot be continued and must be abnormally terminated. In our example, the time interval for the job step expired, and the timer routine issued the SVC 13 at address 003716.

The other PSW in a PRB is the APSW; this is the last half of the user's old PSW at the time of the last interrupt (the APSW field in an SVRB is discussed later). Since these two PSW's (the APSW and RESUME PSW) usually differ, let us discuss their contents in more detail.

The RESUME PSW is loaded with the user's OLD PSW at the time of the interrupt; that is, when an interrupt is taken, say an I/O interrupt, the I/O interrupt handler stores the program's OLD PSW in the RESUME PSW slot in the module's RB. This PSW will point to the instruction following the last instruction executed. The APSW field in the RB is not touched at this time. The same will be true of a program check interruption or SVC interrupt.

Now, if the interrupt handler decides it must ABEND the task, such as in the case of an uncorrectable I/O error, the interrupt handler branches to the NUCLEUS routine ABTERM which moves the last half of the RESUME PSW, which marks the last instruction executed under control of the RB, into the APSW field of the RB, and MOVES THE ADDRESS OF AN SVC 13 ABEND INSTRUCTION IN THE NUCLEUS INTO THE RESUME PSW ADDRESS FIELD. Then ABTERM returns control to the task. Control is returned, of course, by using the RESUME PSW, which now contains the address of an ABEND SVC 13 in the NUCLEUS. Hence an ABEND is issued; ABEND does not alter the RESUME PSW or APSW fields in the RB. The APSW field will contain, in this instance, the instruction address following the interrupted instruction, and the RESUME PSW field will contain the address of the SVC 13 in the NUCLEUS.

Now let us consider the case where we in our code issue an ABEND SVC 13. Like any interrupt handler, the SVC interrupt handler places the user's OLD PSW (containing, in this case, the address of our SVC 13) into the RESUME PSW slot in our RB. Since WE issued the ABEND, we did not branch to the ABTERM routine, as the interrupt handlers do, which stores the right half of the RESUME PSW into the APSW, this field (the APSW) remains unchanged, and its contents are unpredictable.

Let us list the sequence of events in this extremely important function.

- 1) An interrupt occurs (I/O, PROGRAM, EXTERNAL or SVC);
- 2) The appropriate interrupt handler stores the program's OLD PSW, marking the point of interruption, into the RESUME PSW slot in the program's RB;

Then performs one of the following:

- 3a) For a normal interrupt, with no errors detected, and which was NOT an SVC 13 interrupt, the interrupt handler returns to the program using the RESUME PSW; the APSW is untouched;

or

- 3b) If an error condition is discovered, the interrupt handler branches to ABTERM which moves the right half of the RESUME PSW to the APSW field, inserts the address of a NUCLEUS SVC 13 instruction into the RESUME PSW, then returns control to the program by restoring the RESUME PSW. This causes an SVC 13, thereby going to the explanation of step 3c below;

or

- 3c) For an SVC 13 interrupt, calls the ABEND routine. This routine does not touch the RESUME PSW or the APSW. The RESUME PSW remains as in 2 above, pointing to the SVC 13 instruction.

To further reinforce this concept, let us examine the contents of the APSW and RESUME PSW in some specific instances.

- * For a PROGRAM CHECK INTERRUPT:
 - ** APSW contains the address of the instruction following the error; that is, the user's PSW at the time of the program interrupt.
 - ** RESUME PSW contains the address of the SVC 13 in the NUCLEUS. The program check interrupt handler branched to ABTERM in the NUCLEUS which inserted this address in the RESUME PSW, then returned control to the user via this RESUME PSW.
- * For an I/O INTERRUPT:
 - ** APSW contains the address of the instruction following the last user instruction executed; that is, the instruction at the time of the I/O interrupt.
 - ** RESUME PSW contains the address of the SVC 13 in the NUCLEUS. The I/O interrupt handler branched to ABTERM in the NUCLEUS which inserted this address into the RESUME PSW, then returned control to the user via this RESUME PSW.
- * For an EXTERNAL INTERRUPT:
 - ** APSW contains the address of the instruction following the last instruction executed before the timer interrupt. This address should be within the user's or a LOAD'ed program.
 - ** RESUME PSW contains the address of the SVC 13 in the NUCLEUS. The external interrupt handler branched to ABTERM in the NUCLEUS which inserted this address into the RESUME PSW, then returned control to the user via this RESUME PSW.
- * For an ABEND issued by the user's code or in a LOAD'ed routine:
 - ** APSW - unpredictable, as ABTERM was not entered. ABTERM is the only routine which alters this field.
 - ** RESUME PSW contains the address of the instruction following the SVC 13, placed there by the SVC interrupt handler. This should be within your code or LOAD'ed code.

- * For an ABEND issued during and by a type II, III or IV supervisor call:
 - ** APSW is used for a different purpose in an SVRB. This use will be discussed shortly.
 - ** RESUME PSW indicates the address of the instruction following the SVC. This will be an address within the SVC routine; it will not lie in the user's code.

In our example, the APSW points to 0FF162, which is the address following a WAIT instruction (SVC 1), while the RESUME PSW points to the SVC 13 in the NUCLEUS. The module IGG019AQ issued the WAIT SVC; the SVC interrupt handler placed this address into the RESUME PSW. Hence when the event occurred, the program would RESUME at the address following the WAIT, as this is the address in the RESUME PSW. In this case, however, the event never occurred, and the job step timed out. This caused an external interrupt; the timer routine determined that the job was to be abnormally terminated, and branched to ABTERM in the NUCLEUS, which moved the last half of the RESUME PSW, which points to the WAIT, to the APSW, which we see now. It then placed the address of an SVC 13 in the NUCLEUS into the RESUME PSW. This is 003714. ABTERM then returned to the program PDS, via the RESUME PSW. This, of course, caused an SVC 13; the SVC interrupt handler placed PDS's OLD PSW into the RESUME PSW (the 003716 we now see) and we ABEND'ed.

We have, thus far, blithely assumed that our third most active RB was a PRB - indeed, this has been our example. Alas, this is not always true. Many times we call upon a system function, such as OPEN or CLOSE, which is a type II, III or IV SVC, and this routine discovers serious errors, and is unable to continue, necessitating its issuing an ABEND. As type II, III and IV SVC's enter SVRB's into the ACTIVE RB QUEUE, we now have the case of an SVRB as the third most active on the queue, and our PRB as the fourth, or even further removed.

There are two fundamental differences in our approach to an SVC, or SVRB. First, as SVC's are either resident in the NUCLEUS, or operate from the SVC transient areas in the NUCLEUS, we do not have these modules available in a UDUMP, as the NUCLEUS is not dumped. Secondly, the format of an SVRB is different from that of a PRB. This clearly necessitates a slightly different approach.

Let us first examine the fields of an SVRB. We quickly note the absence of an FL-CDE entry; this makes sense, as there are CDE's only for routines in our region or LOAD'ed routines in the LINK PACK AREA, and an SVC is neither. We note also that the other fields are present, such as the RB address, the RESUME PSW and the APSW; but that the APSW looks very odd. The APSW looks "odd" as it is used for a different purpose in an SVRB; it contains the SVC module name for type III and IV SVC's. The name is represented in the hexadecimal form of the zoned decimal name. Let us examine, for example, our two SVRB APSW fields.

The bottom SVRB we know represents ABDUMP. The last two zoned digits in the APSW contain the signed SVC number. ABDUMP is SVC 51; note that the last four hex digits in the APSW are F5C1 which are the characters +51, i. e. the SVC number. Note in the next to last SVRB, the last four hex digits in the APSW are F1C3, which are the signed characters +13, the SVC number of ABEND. The first character (two hex digits) is the sequential number of the load of the SVC, starting with zero (hex F0). Notice that the first character of the ABDUMP APSW is F1 which is the character 1, implying that this is the second load of ABDUMP. In the ABEND SVRB's APSW this is F2, the character 2, implying this is the third load of the ABEND SVC.

As the APSW field of an SVRB is used differently and indeed would be useless if used as in a PRB without the module dumped, we must approach the case of an SVRB as the third most active RB differently. This will be discussed in the section on What.

In summary, then, to answer our question WHO:

- * Check if the third most active RB is an SVRB; if so check the APSW, as above, to determine in which system routine we ABEND'ed;
- * If the third most active RB is a PRB, check the address portion of the RESUME PSW. If this points to an address higher than the entry point address corresponding to the PRB, check the CDE's and XL's for the region to determine in which module we executed the SVC 13 ABEND. In this case the RESUME PSW pinpoints the SVC 13 in the region's code;
- * If the RESUME PSW points to an address lower than our PRB's entry point address, we continue to the next step analysing WHERE we ABENDED.

Where:

When determining the actual instruction and location where the error occurred, we need consider two cases: When the third most recent RB on the active RB queue is a PRB; and the case when this is an SVRB.

We have already discussed in some detail the case of a PRB being the third most recent RB in the preceding section. We examine the RESUME PSW in the PRB; if it contains an address less than any in the region (reflected in the CDE's and XL's), we probably blew in a system routine which issued a branch to the ABTERM routine in the NUCLEUS. The address of the instruction following the last instruction executed should be in the APSW field of the PRB. This is actually

the last half of the user PSW at the time of interrupt, so the instruction length field will be in the first two bits. To find the last instruction, subtract the length of the next instruction from this APSW address value. In our example, the address portion of the APSW is 0FF162; the length is 4 which means a length of one half word (i. e. of bits 0 and 1 of the last half of the PSW, only bit 1 is on, signifying one half word length). Hence, 0FF162 less 2 points to 0FF160; in our case the 0A01 WAIT SVC.

If the RESUME PSW points to an address within our region, we locate the module, as discussed previously, through the CDE's and XL's for the region. This implies that the SVC 13 ABEND was given by code in our region or the LINK PACK AREA. The RESUME PSW should point to the byte following the 0A0D SVC 13 instruction; the APSW is probably meaningless.

The case of an SVRB being the active RB at the time of error requires a slightly different approach. These routines usually issue their own ABEND SVC 13; hence the RESUME PSW should point to the SVC location. Also we have seen that the APSW field of an SVRB has a different use; in type III and IV SVC's it contains the SVC name, as explained in the preceding section, or, if the SVC ABENDED, it contains the SVC's OLD PSW during execution of ABEND or ABTERM; it occasionally contains zeroes. For type II SVC's, the APSW will contain either the OLD PSW during execution of ABEND or ABTERM, or zeroes. Another basic difference to be faced is the fact that the code for the SVC does not appear in our dump; we cannot examine the module to locate the actual point of error. We must try to discern the error from the FUNCTION of the SVC; further techniques in SVC debugging are discussed in the section on data management debugging.

Note, though, that the RESUME PSW for the fourth most active RB should point just past the SVC which called this SVC routine, giving us the SVC number, from which we can determine the SVC's function. This also tells us where we were when we issued the SVC. These two facts are often enough to determine the cause of the error.

In summary, if the third most recent active RB is a PRB;

- * Examine the PRB's RESUME PSW address;
- * If the RESUME PSW points at an address outside our code, the APSW should point to the last executed instruction in our program;
- * If the RESUME PSW points to an address within our code, this should be the address of the ABEND SVC 13. The contents of the APSW are unpredictable.

In the case of the third most active RB being an SVRB:

- * The RESUME PSW should point to the SVC routine's ABEND instruction;
- * The APSW should contain the SVC routine's PSW during ABEND, or the SVC name;
- * The RESUME PSW of the preceding RB should point to the SVC instruction which called this routine;
- * Find the function of the SVC and try to surmise the error from this and the location of the SVC in the calling program.

What:

Much as the author would like to be able to espouse a "plan" to pinpoint the actual cause of the error, he of course cannot. What he will attempt to do is supply the programmer (and/or debugger) with some additional bits of information which he might need in order to continue.

Perhaps the most useful information which is desired are the contents of the registers at the time of the error. Let us therefore examine the register SAVE areas, and the SAVE AREA TRACE.

One of the first things incumbent upon a CALL'ed program is SAVE'ing the registers in the SAVE area provided for him by the CALL'ing program, and pointed at by register 13. The CALL'ed program is also responsible for constructing the FORWARD and BACKWARD CHAIN'S so as to chain all SAVE areas in the region together. One of the prime reasons for this chain's construction is that the ABDUMP routine will print out a SAVE AREA TRACE of all SAVE areas in the region, thus making it far easier to find the register contents upon entry to and exit from any routine used by the region. Let us look at the SAVE AREA TRACE (see Figures 24c and 24d).

The first line, PDS WAS ENTERED VIA LINK, is self explanatory; following this line is the SAVE AREA TRACE for our job step, reconstructed from the FORWARD and BACKWARD chains. Let us examine the first SAVE area.

SA 0D17B0 marks this as the SAVE area at location 0D17B0; notice that this lies outside any of our modules, but well within the region (reference the region map in the section on WHEN). This is the "highest level" SAVE area, it was set up with a GETMAIN by the INITIATOR. When the INITIATOR issued the XCTL to the program PDS, it had loaded register 13 with the address of this SAVE area. The first program initiated will use this SAVE area; in this case our program PDS. The SAVE that PDS executes will store the previous program's (in this case the INITIATOR'S) registers in this area; that is, this SAVE area contains the INITIATOR'S registers. This is an

important point: The SAVE area in a program will (if used) contain that program's registers. Some of the fields of interest in a SAVE area are discussed below.

WD1 00000000 are the contents of the first word of the SAVE area.

HSA 00000000 contains the address of the next higher, or previous, SAVE area. As the INITIATOR is the first program in the region, there is none higher, hence the address of zeroes. This is the BACKWARD CHAIN.

LSA 000B2CB0 points to the next lower SAVE area; in this case, the SAVE area within our program, PDS. Note that in our example the next SAVE area is indeed at 000B2CB0; this is the FORWARD CHAIN.

RET 000085DA displays the contents of the standard RETURN register, register 14. This is the address RETURN'ed to by a RETURN macro. The INITIATOR placed in register 14 the address of its resident portion in the NUCLEUS.

EPA 010B2C80 shows the contents of register 15, the ENTRY POINT REGISTER. Notice that 0B2C80 is the entry point of PDS (check the EPA field in the CDE for PDS).

R0 through R12 show registers 0 through 12; register 13's contents, the SAVE area address, is shown immediately following the SA field.

Examining the next SAVE area, SA 0B2CB0, we note that the HSA does indeed point to the next higher SAVE area, at 0D17B0; the LSA has indeterminate contents, as there is no lower SAVE area.

Examining the next SAVE area, SA 0B2CB0, we note that the HSA does indeed point to the next higher SAVE area, at 0D17B0; the LSA has indeterminate contents, as there is no lower SAVE area.

Continuing in our SAVE area trace, we find INTERRUPT AT 003716; this is the address portion of the RESUME PSW in the RB for PDS. PROCEEDING BACK VIA REG 13 indicates that the following SAVE areas are those starting from the lowest (the current value in register 13) to the highest following the BACKWARD CHAIN. In our case these match those in the FORWARD CHAIN; this is not necessarily true, for if the two chains do not correspond neither will the SAVE areas.

Now, the question is, what were my register contents at the time of the error? One is tempted to say, "They are displayed in the lowest SAVE area; that is, in our example, SA 0B2CB0." But this is not always true. Let us examine the usage of this lowest SAVE area.

Who uses this SAVE area? Well, if we use no systems routines, such as the LOAD'ed routines in our example, or if we have not yet progressed that far, the answer is, "No one." In this case, fields

R0 through R12 would contain no meaningful information. Well, what if we do use some of these routines? These routines are branched to, and they do save some registers, but they do not always save ALL the registers; often they save only those registers which they alter. The different routines may save different registers, so our SAVE area may well contain a composite of register contents, some from the time one routine was entered, some from the time another was entered. The point is that we cannot always rely on this SAVE area to contain our registers unless we know that the routine saved them all. And what of the registers the LOAD'ed routine was itself using? Where might they be? To answer these questions we need delve a little more deeply into the system's use of SAVE areas.

When an interrupt occurs, the interrupt handler stuffs the user's registers into a SAVE area in low core. All the interrupt handlers begin in a masked state, so there is no chance of these registers being overlaid. When the interrupt handlers decide what is to be done, they dispose of these registers. If control is to be returned to the user, they are simply restored, and the user continues as before; this is usually the case of an I/O interrupt. If the interrupt handlers find that a service needs to be performed, such as OPEN or CLOSE, or if they have determined that an ABEND need be issued, they first build an SVRB (recall, in our dump we have an SVRB for ABEND and one for ABDUMP). Into this SVRB the interrupt handlers stuff the user's registers they have so long held in lower core. These, then, are our registers; they will be contained in ABEND's SVRB. Let us therefore examine ABEND's SVRB.

Recall that the SVRB for ABEND is the one at 017CC0. Notice the third and fourth lines in this RB indicate RG 0-7 and RG 8-15; these are our registers. Let us note some interesting things about these registers in our example. First, register 13 contains 000B2CB0; this, notice, is the address of the SAVE area in PDS, which is correct, as register 13 is to point to the current SAVE area. Notice that registers 2, 12 and 13 contain addresses very close together and slightly above the entry point of PDS; these could well be base registers. Register 8 contains 000FF138, and the last instruction executed, recall, was just before 00FF162 (note the APSW in the RB for PDS). We determined, recall, that we were ABEND'ed while in routine IGG019AQ (notice that the entry point address in the CDE for IGG019AQ is 0FF138). This module must have a base register; it appears that it was using register 8 (IGG019AQ does indeed use register 8 as a base register).

Observe that at the bottom of the SAVE AREA TRACE is a SAVE area entitled REGS AT ENTRY TO ABEND, and that these match those in the SVRB for ABEND. These are indeed the same, as ABDUMP picks up these registers from this SVRB.

If we ABEND with an SVRB as the third most recent RB in the active RB queue, then the registers belonging to the program which issued the SVC will be in this third most recent RB, and the SVC's register contents will be in ABEND's SVRB. This becomes extremely important when we ABEND in a data management SVC such as OPEN or CLOSE, as will be explained in the next section.

Summary:

In summary, then, the NEWSPAPER APPROACH TO PROGRAMMING ERRORS consists of the following steps:

- * Check the completion code in the dump to determine why OS/360 thinks we erred;
- * Find which program was in control of the TCB at the time of the ABEND. This will be the third most active RB in the active RB queue;
- * Determine the location of the ABEND instruction which caused the dump. The RESUME PSW in the third most recent RB should point to this instruction; this address should match that in the PSW AT ENTRY TO ABEND. Check if this SVC was issued within the code of the region; this may require mapping the region from the CDE's and XL's. If this RESUME PSW points within the region's code, then check which module issued it, and discover from documentation why the routine issues such a code;
- * If the RESUME PSW in the third most recent RB in the active RB queue points to an address outside the region's code, it is probably in the NUCLEUS. If this is the case, then the APSW in this RB points to the last instruction executed in the region's code before the interrupt which caused the ABEND to be issued;
- * When the third most active RB is an SVRB, then the SVC number is contained in the APSW field of this RB. In this case, the RESUME PSW points to the last instruction executed before the ABEND SVC 13 (indeed this is the ABEND SVC 13);
- * The user's register contents at the time of the last interrupt will be displayed in the ABEND SVRB register save area if the third most active RB is a PRB. If the third most active RB is an SVRB, this SVC's register contents will be held in the ABEND SVRB's save area. The program's registers at the time of the SVC which called the type II, III or IV routine will be contained in this SVC's SVRB register save area;
- * If the indication is at this time that the error was an I/O error, or occurred in an I/O service, such as OPEN or CLOSE, continue on to the section on the NEWSPAPER APPROACH TO DATA MANAGEMENT ERRORS.

THE NEWSPAPER APPROACH TO DATA MANAGEMENT ERRORS:

Many times when debugging, we determine that the error occurred in, or was caused by, a data management routine. This might mean an improperly declared data set or data definition, bad data, or some logical misuse of data management. In addition to, or in place of, our questions concerning programming errors, we have five basic questions we ask concerning what are generally termed "I/O errors." They are:

- 1) WHY does OS/360 think we erred;
- 2) WHO caused the error - i. e. in which data set were we processing at the time of the error;
- 3) WHEN did the ABEND occur; that is, had we successfully OPEN'ed or CLOSE'd the data set;
- 4) WHERE were we in the data set; that is, at which record or block;
- 5) WHAT actually happened with respect to hardware and software indicators.

Let us begin interpreting our dump with respect to these questions.

Why:

As in the case of a programming error, OS will give us a completion code, this time indicating an I/O error. For examples, let us consider the following codes:

COMPLETION CODE 001 tells us that an I/O error occurred; further study will be necessary to determine the cause;

COMPLETION CODE 400 indicates that some or all of the I/O control blocks such as the IOB, DCB, DEB or ECB are incorrect; further study will be necessary to determine which and why;

COMPLETION CODE 213 usually informs us that a data set's DSCB could not be found.

Many times this code alone is enough to allow us to determine the cause of the error. Code 213 usually means that the DD card is in error, pointing to the incorrect DASD volume, or the DSNAME is incorrect. If this is not the case, we proceed to the next step.

Who:

We wish to determine WHO has the error; that is, which data set.

At this point we might wish to map out the I/O control blocks to gain a better idea of the available information.

Recall that the DEB is the communication center for a data set's control blocks; we logically should begin with the DEB queue. Each DEB is nicely displayed (see figure 25), with the storage addresses in the left hand column. To find the beginning of the DEB queue we examine the DEB field in the TCB; this points to the beginning of the first DEB in the DEB queue. Our example's TCB DEB pointer contains 00017064. Look at this location in our first DEB; notice that it contains 000169E8, which is the address of the TCB. A DEB always begins with a pointer back to the TCB; in this way we can verify that we have found the beginning of the DEB. The code in front of this pointer to the TCB is called the DEB prologue, and contains a work space for portions of IOS.

The word following the TCB pointer contains a pointer to the next DEB in the DEB queue; notice that our DEB pointers do point to the beginnings of the DEB's, each DEB beginning with a pointer to the TCB. The last DEB pointer contains a DEB pointer of zeroes to indicate that it is the last DEB on the queue. Five words past the DEB pointer, or six words past the TCB pointer, is the address of the related DCB; two words past the DCB pointer, or eight words past the TCB pointer, is a pointer to the allocated UCB for this DCB. At this point we have the addresses of the UCB's and DCB's of all OPEN'ed data sets (OPEN, recall, builds the DEB's).

Following the DEB queue in the dump is a display of the job step's TIOT. The third column lists the DD card ddnames for the step; this is followed by the TTR for the JFCB corresponding to that DD card. The last column contains the address of the allocated UCB for this DD card. Sometimes we can make the correspondence of DD card to DCB through the UCB pointers in the DEB and TIOT. This cannot always be done, as many data sets may be allocated on a single direct access device, giving many duplicate UCB pointers; in our example, however, all UCB's except the SYSUDUMP and SYNPRINT UCB's are unique, so the relationship may be attempted. We note, then, that the first DEB has a DCB at 0D1FA0 which corresponds to the UCB at 001444, the SYSUDUMP DD card (as the DCB lies outside our program, it is not the SYNPRINT DCB); the second DEB has a DCB at 0B51B0 corresponding to the UCB at 001830 and the WRTANS data set. The third DEB's DCB is at 0B512C with a UCB at 001800 for the READ002 data set, while the fourth DEB has its DCB at 0B5210 for the UCB at 001860 for the ANSFILE data set. The other data sets shown in the TIOT have not been OPEN'ed, as there are no DEB's for them.

DCB's which have not been OPEN'ed may be found by scanning the EBCDIC portion of the dump for the associated ddnames for the DCB, which are contained in bytes hex 28 through 30.

Now, in the DCB's we find another pointer of interest: That of the associated IOB. This pointer is contained at varying locations depending upon the logical organization of the DCB (hex 44 for BSAM, BPAM, QSAM and BDAM; hex 1C for QTAM, BTAM and GAM). Hence we can now find the IOB's for the OPEN'ed data sets.

Looking at the IOB's we find a pointer to the actual channel program to perform the I/O. This pointer is at hex 10 within the IOB.

At this point we have a fairly complete map of the control blocks for the OPEN'ed data sets. The ddnames, DEB's, UCB's, DCB's, IOB's and CCW lists have been located.

Now, what we are after is WHO caused the error; that is, which DCB or data set. There are a number of techniques to determine this. If the interrupt which caused the ABEND occurred during an I/O access routine, examine register 1 in the ABEND SVRB (i. e. the problem program's registers); it may still contain the address of the DCB being operated upon. Register 2 may point to the work area (if any) and 14 and 15 were probably stored in the problem program's SAVE area. Registers 14 and 15 are used as the return and entry registers for I/O routines. If register 1 does not point to a DCB then scan the DCB's for a possible error flag. Hex 31 in the DCB contains the error flags; if bit zero, or bits zero and one are on, then the data set represented by the DCB encountered an error. This scanning of DCB's is usually the technique used to detect an error DCB for an error discovered at I/O interrupt time, such as a data check etc.

If the third most recent RB in the active RB queue is an SVRB for OPEN (SVC 19), then to identify the data set which was being OPEN'ed at the time of the ABEND, we should know the register usage of OPEN; these registers will be contained in the register save area of the ABEND SVRB. OPEN uses register 2 to point to the DCB being OPEN'ed; register 3 is used as the base register, while 4 points to the OPEN work area. Register 5 is a pointer to the parameter list passed to OPEN, while 7 contains the address of the current entry in the parameter list. The address of the TIOT is contained in register 9, while the UCB and DEB addresses are contained in registers 10 and 11 respectively. From these register contents we are usually able to tell which DCB we were trying to OPEN.

In summary, to determine in which data set we encountered the error:

- * Map out the DCB's and IOB's from the DEB queue;
- * Check register 1 of the problem program at the time of ABEND - it may still point to the sought after DCB;
- * Check byte 31 in the DCB's for error flags;
- * If the error occurred during OPEN, register 2 of OPEN points to the DCB being OPEN'ed.

When:

When determining when a data management error occurred, we are trying to determine when with respect to OPEN, CLOSE, READ or WRITE. The actual data output, if any, will aid us in determining this. For more concrete indication, however, we examine the DCB. Hex 28 BEFORE OPEN is performed will contain the DD name; OPEN overlays this field with other information. If this field has been overlaid, check the byte at hex 30 in the DCB; bit 3 is set to one if an OPEN has been successfully performed. If OPEN was successful, we can examine this byte to determine if the last I/O performed was a READ or WRITE (bit zero) or a READ BACKWARD (bit one), or whether a tape mark has been sensed (bit five). Hex 31 in the DCB tells us of any error conditions. We also have a hint as to the status of the data set by the DEB; OPEN'ed data sets have a DEB, others have not.

Where:

When determining WHERE we blew in processing a data set, we wish to know which record we were processing at the time of the error. Hex 4C in the DCB points to the current or next logical record in the I/O buffer. Block count for tape processing is also contained in the DCB.

What:

WHAT caused the error depends upon a great many things; the author can only supply additional information to allow the debugger to determine the actual cause of the ABEND.

If the error was caused by a logical inconsistency in the data definition, recall that the DCB is the final repository of the logical data definition, containing such things as LRECL, DSORG, BLKSIZE, etc.

Perhaps as important is the pointer in the DCB to the IOB. The IOB contains a wealth of information as to the physical status of the data set. In the IOB are contained such things as the last sense bytes read. Recall that sense bytes are read from a control unit after the I/O supervisor determines that an I/O error has occurred. The CSW (Channel Status Word) is stored after each I/O interrupt; this tells whether the I/O was successful, and the reason for the interrupt (channel end, device end, unit check etc.). If the CSW indicates an error, IOS issues a sense command which is sent to the appropriate control unit. From two to six bytes of detailed information are read into storage, indicating the specific cause of the error (see the Programmer's Guide to Debugging SRL for a chart of sense byte meanings). The first two of these sense bytes are placed

into the IOB (all the sense bytes are placed into the appropriate UCB).

The second half of the CSW is also stored in the IOB; this tells the reason for the interrupt, as mentioned before. Perhaps as important is the residual byte count shown in the CSW byte field. This is the difference between the number of bytes which were to be manipulated according to the CCW, and the actual number of bytes acted upon. This is extremely useful in the case of a wrong length record error, or in determining the end of a variable length or undefined record.

Byte four in the IOB contains the completion code from the ECB indicating whether the I/O was successful; this is the only place which will indicate a DEB violation (the attempt at I/O outside the limits prescribed in the DEB).

Summary:

In summary, then, the NEWSPAPER APPROACH TO DATA MANAGEMENT ERRORS with a dump consists of the following steps:

- * Check the completion code in the dump to determine why OS/360 thinks we erred;
- * Find the DCB which identifies the data set in error, by the contents of register one, or scanning the DCB's for error flags;
- * If the error occurred during OPEN, check register two of OPEN for the DCB address;
- * Check the DCB for OPEN flags, READ/WRITE flags, tape mark etc.;
- * Look at the present or next data record for data errors;
- * From the DCB find the IOB for:
 - ** Completion code from the ECB;
 - ** Last half of the CSW;
 - ** Sense bytes;
 - ** Actual CCW's.

EVENT SYNCHRONIZATION:

When many events in a computer are taking place simultaneously (such as channel programs, etc.), some technique must be found to synchronize these events, or else utter chaos reigns. In MVT, in addition to many events occurring concurrently in the computer hardware, different programs and routines are also executing asynchronously in storage during multi-programming.

The reader will recall that the different events taking place concurrently in the S/360 hardware are synchronized through the interrupt mechanism. For example, when the CPU wishes an asynchronous, or concurrent, event to take place, such as I/O, it communicates this desire to the channel via a START I/O command. The channel immediately tells the CPU whether the command was accepted and started by supplying the CPU with a condition code in the current PSW. Assuming the command was started successfully, the CPU and channel continue with their different and divergent tasks, with no relationship to or knowledge of the other's progress. When the channel finishes its assigned task, it notifies the CPU of its completion by causing an I/O interrupt, and storing a channel status word (CSW) containing the reason for the interrupt. In this way the concurrent hardware functions have been synchronized.

In an OS/360 multi-programming environment we have, in addition to the hardware concurrency, programming concurrency. That is, we have different programs in different regions executing concurrently; between regions, however, there is little need for communication, as these are independent jobs. The user may, however, multi-task within his own region - this will demand synchronization of these concurrent tasks. The same is true of I/O buffering; IOS must have a way of communicating to the program that the channel has completed its task, and the outcome of this task. The communication technique for both of these needs is handled identically, through the ECB, and the WAIT and POST macros.

Event synchronization takes place through the medium of the ECB (Event Control Block). This is a full word, bit zero being the wait bit, bit one the post or completion bit, bits 2 through 31 containing the completion code or RB address.

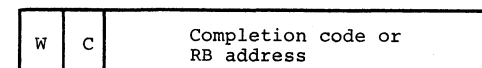

Figure 27: The Event Control Block.

When a program issues a request for a service that will require synchronization, such as a READ, it supplies the asynchronous routine with the address of one or more ECB's which have been set to zeroes. The ECB now becomes associated with this asynchronous event.

Now, when synchronization becomes necessary, a WAIT (SVC 1) macro is issued by the program; this macro points to the ECB's upon which to be waited. The WAIT routine then examines the ECB; if the completion flag is on, the event has occurred, and WAIT immediately returns control to the instruction following the WAIT macro in the program. If the completion flag is not on, the event has not occurred; the WAIT routine then turns the wait flag on, places the address of the WAIT'ing program's RB into the completion code field of the ECB, and places the program into the WAIT state. That is, a task switch is performed, the CPU being given to the next task which is ready to continue processing. The WAIT'ing program will remain in this state until the event occurs or the task is cancelled.

When the awaited event occurs, such as the completion of a physical I/O event, the WAIT'ing program must be notified. This will be done through the ECB. When the asynchronous routine, such as the I/O routine or ATTACH'ed task, determines that an event has occurred which requires synchronization, it issues a POST SVC for synchronization and notification of the WAIT'ing routine. The POST macro points to the ECB to be POST'ed.

POST examines the ECB; if the wait flag is off, which implies that the event has not had a WAIT issued for it, the complete bit is set on, the completion code is placed in the ECB, and control is returned to the next ready task. In this case the subsequent WAIT issued upon this event will be an effective NO-OP, as explained previously. If the wait flag in the ECB is on, implying that some program is WAIT'ing on this event, the completion code is placed in the ECB, and the task which was WAIT'ing is placed in the ready queue for dispatching. The program to be placed in the ready queue was found from the RB address which was placed in the ECB by the WAIT routine. When the task is dispatched, the RESUME PSW will be used; the SVC interrupt handler placed the OLD PSW in this slot at the time the WAIT SVC was issued. This will contain the address of the instruction following the WAIT SVC 1. Hence processing will continue at the address following the WAIT SVC.

PAGE 1

TIME 121442 DATE 3307

STEP EXECI

JOB / 71854

COMPLETION CODE SYSTEM = 322

PSW AT ENTRY TO ABEND FFE5000 4000716

TCR 0169E8 RBP 00017080 PIF 00000000 DEF 00016080 CMP 80322000 TRN 00000000
 MSS 020195A8 PK-FLG 0854409 FLG 000181B LLS 000180A0 JUB 00000000 JPQ 000180A8
 FSA 01001780 TCR 00017558 THE 00000000 JST 000169E8 NTC 00000000 DTC 00016380
 LTC 00000000 TOE 00000000 ECR 00018C00 STA 00000000 D-POE 0001A6C8 SQS 00016688

ACTIVE RRS

PRB 018C88 RESV 00000000 APSW 400FF162 WC-SZ-STAR 01040082 FL-CDE 000180D8 PSW FFE50000 40003716
 Q/TTR 00000000 WT-LNK 000169E8

SVRB 017C00 TAB-LN 000037AB APSW F2F0F1C3 WC-SZ-STAR 0012D002 TQN 00000000 PSW 00040033 50002C8A
 Q/TTR 00000013 WT-LNK FF018C88 000B512C 000014E8 000CEFFF 00000051 00000028
 RG 0-7 00000018 00000000 00000000 00000995 00008C86 00082C80 00001900 600049DA
 EXTSA 0000ZINE 00001FA0 20000000 00001D0F FF030000 00017D3C 00017D44 E2E8E2C9
 CSCIF0F1 C9C5C1E8 C1C2C5D5 C4403110

SVRB 017080 TAB-LN 001803A3 APSW F1F0F5C1 WC-SZ-STAR 0012D002 TQN 00000000 PSW FF040001 400FEB64
 Q/TTR 00000027 WT-LNK 00017C00 00003640 000169E8 00017C00 000180D8 00000000
 RG 0-7 00000000 00017020 800029CC 0001FA0 00016080 00017D44 40002C7A 00000000
 RG 8-15 000169E8 400029A2 000169E8 0001FA0 00016080 00017D44 F303C740 4780C1A6
 EXTSA 000E0C00 E306C340 00017124 700059F0 C44205EF E2E8E2C3

LOAD LIST

NE 00018258 RSP-CDE 020180A8
 NE 00018970 RSP-CDE 0101A270
 NE 000192E8 RSP-CDE 0301A360
 NE 00000000 RSP-CDE 0201A400
 NE 00018760 RSP-CDE 0101A3A0
 NE 00018E58 RSP-CDE 0101A430
 NE 00019410 RSP-CDE 0201A300
 NE 00018448 RSP-CDE 0101A2A0
 NF 00018E80 RSP-CDE 0101A3D0
 NF 00019470 RSP-CDE 02017770

CDE

0180D8 ATR1 08 NCDE 080000 ROC-RR 00018C88 NM PDS USE C1 EPA 082C80 ATR2 20 XL/MJ 0181E1
 0180A8 ATR1 30 NCDE 017270 ROC-RR 00000000 NM ICG0A05A USE 02 EPA 0C01E0 ATR2 20 XL/MJ 018248
 01A3A0 ATR1 88 NCDE 01A300 ROC-RR 00000000 NM ICG019C0 USE 03 EPA 0FEDF8 ATR2 20 XL/MJ 01A590
 01A2A0 ATR1 89 NCDE 01A200 ROC-RR 00000000 NM ICG0198A USE 03 EPA 0E820 ATR2 20 XL/MJ 01A260
 01A430 ATR1 80 NCDE 01A440 ROC-RR 00000000 NM ICG019A8 USE 03 EPA 0E1F80 ATR2 20 XL/MJ 01A320
 01A300 ATR1 80 NCDE 01A400 ROC-RR 00000000 NM ICG0194R USE 02 EPA 0EFC08 ATR2 20 XL/MJ 01A3C0
 01A360 ATR1 81 NCDE 01A3A0 ROC-RR 00000000 NM ICG019C0 USE 04 EPA 0FE070 ATR2 20 XL/MJ 01A350
 01A300 ATR1 80 NCDE 01A3A0 ROC-RR 00000000 NM ICG019C0 USE 03 EPA 0FE070 ATR2 20 XL/MJ 01A2E0
 017270 ATR1 30 NCDE 0180D8 ROC-RR 00000000 NM ICG019A0 USE 02 EPA 0D1918 ATR2 20 XL/MJ 017260
 01A400 ATR1 80 NCDE 01A430 ROC-RR 00000000 NM ICG019A0 USE 04 EPA 0FF138 ATR2 20 XL/MJ 01A3F0

XL

018E18	SZ	00000010	NO	00000001	80003880	000B2C80
018248	SZ	00000010	NO	00000001	8000061C	000CD1E0
01A390	SZ	00000010	NO	00000001	80000708	000FFDF8
01A290	SZ	00000010	NO	00000001	80000180	000FFB98
01A260	SZ	00000010	NO	00000001	80000058	000FFER40
01A420	SZ	00000010	NO	00000001	80000008	000FF1R0
01A3C0	SZ	00000010	NO	00000001	80000070	000FF0C8
01A350	SZ	00000010	NO	00000001	80000058	000FF070
01A2F0	SZ	00000010	NO	00000001	80000078	000FFD80
017260	SZ	00000010	NO	00000001	800000E8	000D1918
01A3F0	SZ	00000010	NO	00000001	80000078	000FF138

Figure 22b: MVT SYSUDUMP - Page 2 of 4

54

```

DEB
017040 00000C2F 00000C2E 00000C2E 00000C2E 00000C2E 00000000 3200000C 00002BEO *.....*
017060 0E000000 000169E8 04016E24 88000000 8F000000 01000000 18000000 EF001FA0 *.....Y.....*
017080 04017040 10001444 0000000C 00000000 00130028 0001F0F4 C2C2C2C1 C3C41800 *.....04BBBACD.*
0170A0 0A0218E7 07FE0000 0083D600 C612211F *.....X.....0.F.....205A.....*

```

```

DEB
016E00 00000C2E 00000C2E 00000C2E 00000C2E 00000C2E 00000000 00000000 000198F0 *.....*
016E20 00000000 030169E8 04016F94 C8000000 0F000000 01000000 18000000 FF0851B0 *.....Y.....H.....*
016E40 02016E00 33001830 00010000 C1D9C1D2 C3C3C002 00000000 FF040000 00005A34 *.....ARAKCC.....*
016E60 00000000 00016F68 *.....8.....*

```

```

DEB
016E60 00000C2F 00000C2E 00000C2E 000FED80 *.....8.....*
016E80 00000C2E 00000000 00000000 000098E0 00000000 040169E8 04017624 48000000 *.....Y.....*
016EA0 00000000 01000000 18000000 EF08512C 02016E70 33001800 00010000 C1D8C1C3 *.....AQAC*
016EC0 C3C9C3C3 00000000 00000000 00000000 000B1810 00000000 *CICC.....*

```

```

DEB
017600 00000C2E 00000C2E 00000C2E 000FED80 00000C2E 00000000 00000000 000098E0 *.....*
017620 00000000 040169E8 04000000 C8000000 00000000 01FFFFFF 18000000 EF085210 *.....Y.....H.....*
017640 02017600 33001860 00010000 C1D8C1C3 C3C9C3C3 00017978 00000000 04FF1294 *.....AQACCICC.....*
017660 0000F3D3 C7017970 *..TLG.....*

```

```

TIOT JOR A0001854 STEP EXEC1
DD 14040100 PGM=*.DD 001E0C00 80001204
DD 14040100 SYSUDUMP 000E3700 80001444
DD 14040100 SYNFILE 00123600 80001294
DD 14040100 SYNPRINT 000E3900 80001444
DD 14020100 READ002 00123C00 80001800
DD 14040100 WRITANS 001D2F00 80001830
DD 14050100 ANSFIL 001D3100 80001860
DD 14050100 WRIT001 001D3500 80001890

```

```

DD 14040100 WRITELN 00210600 80001444
DD 14040100 READCRD 001D3700 800014D4

```

```

MSS ***** SPOE ***** ***** DQE ***** *****
      *FLGS NSPQE SPID DOE      BLK FQE LN NDQE      NFQE FQE LN
0195A8 00 019680 251 018DC8 00082800 00082800 00004000 00000000 00000000 00000480
019680 80 01A6C8 000 017960 00000000 00000000 00001000 00017190 00000000 00000430
017960 60 000000 000 018DF0 00000000 00000000 00001000 00017F88 00000000 00000678
00000000 000CF000 00001000 00017F88 00000000 00000030
000CF000 000CE000 00001000 00017750 00000000 00000678
00000000 000CD800 00000800 00000000 0000000C 000000C8
01A6C8 40 000000 252 018FC8 000D1800 000D1A00 00000800 00017C80 000D1800 000005A0
00000000 00000000 00000000 00017968 00000000 00000118
00000000 00000000 00000000 00000000 00000000 000001E0
00000000 00000000 00000000 00000000 00000000 000001A0

```

```

D-PQE 0001A6C8 FIRST 00018E00 LAST 00018E88
PQF 018F88 FFR 00086800 LFR 00086800 NPQ 00000000 PPQ 00000000
      TCB 00016300 RSI 0001F800 RAD 00082800 FLG 00
FBQE 086800 NFB 00018E88 PFR 00018E88 SZ 00016000

```

QCB TRACE

```

MAJ 01A6F8 NMAJ 00018A00 PMAJ 0000A2C0 FMIN 00019480 NM SYSDSN
MIN 019480 FQEL 00019700 PMIN 0001A6F8 NMIN 00019070 NM FF CTSRCH
      NQFL 00000000 PQEL 00019480 TCB 00016300 SVRR 00016E20
MIN 019070 FQEL 00019440 PMIN 00019480 NMIN 00018FA8 NM FF SYS1.SORTLIB
      NQEL 00000000 PQEL 80019070 TCB 00016300 SVRB 00016E20
MIN 018F88 FQFL 00019200 PMIN 00019070 NMIN 00018FE8 NM FF SYS1.LINKLIB
      NQFL 00000000 PQEL 80018E88 TCB 00016300 SVRR 00016E20
MAJ 017978 NMAJ 00000000 PMAJ 00018A00 FMIN 00017758 NM SYSTEAO1
MIN 017758 FQEL 00017CA0 PMIN 00017978 NMIN 00000000 NM EO IEA
      NQEL 00000000 PQEL 00017758 TCB 000169E8 SVRB 00016F68

```

SAVE AREA TRACE

```

PDS WAS ENTERED VIA LINK
SA 0D1780 WD1 00000000 HSA 00000000 LSA 00082C80 RET 000085DA EPA 010B2C80 RO FD000006

```

Figure 22c: MVT SYSUDUMP - Page 3 of 4.

55

```

R1 00017F8 R2 0018C8B R3 50018CD R4 00015EC8 R5 00016300 R6 00016078
R7 00017008 R8 00018C0 R9 00009DD R10 00000114 R11 00015EC8 R12 600FF41A
SA 0B2C80 WD1 00070003 H5A 00001780 L5A 00080003 RET 4C002088 EPA 00090003 R0 50084F76
R1 120D1918 R2 000B2069 R3 0000005C R4 0008512C R5 00088944 R6 00083C86
R7 000B2FDB R8 0000005C R9 000830A0 R10 00082E98 R11 400D1900 R12 000FF138

```

INTERRUPT AT 003716

PROCEEDING BACK VIA REG 13

```

SA 0B2C80 WD1 00070003 H5A 00001780 L5A 00080003 RET 4C002088 EPA 00090003 R0 50084F76
R1 120D1918 R2 000B2069 R3 0000005C R4 0008512C R5 00088944 R6 00083C86
R7 000B2FDB R8 0000005C R9 000830A0 R10 00082E98 R11 400D1900 R12 000FF138

```

POS WAS ENTERED VIA LINK

```

SA 0D1780 WD1 00000000 H5A 00000000 L5A 00082C80 RET 00008EDA EPA 01082C80
R1 00017F8 R2 00018C8 R3 50018CD R4 00015EC8 EPA 001640 R0 00016078
R7 00017008 R8 00018C0 R9 00009DD R10 00000114 R11 00015EC8 R12 600FF41A

```

REGS AT ENTRY TO ABEND

```

FLTR 0--6 0000144+00018C4 0000000100018CEC 00016F8000000000 00090009D7C4E240
REGS 0-7 00000001 000014EC 0008512C 000814E8 000CEFFF 000CEFFF 00000051 00000028
REGS 8-15 000FF138 00000000 00000AEE 00000995 00084C86 00082C80 400D1900 600049DA

```

Figure 22d: MVT SYSUDUMP - Page 4 of 4.

JOB / 11854 STEP EXEC1 TIME 121442 DAT 1307

```

COMPLETION CODE SYSTEM = 322
PSW AT ENTRY TO ABEND FFE50000 40007176
TCR 0169E8 00000000 00000000 00000000 00000000 00000000 00000000 00000000
PSA 01001780 00001780 00001780 00001780 00001780 00001780 00001780 00001780
LTC 00000000 10E 00000000 10E 00000000 10E 00000000 10E 00000000
ACTIVE ABS
PRB 08C88 RESV 00000000 APSW 400FF162 WC-SZ-STAR 01040082 FL-CDE 00018DD8 PSW FFE50000 40003716
Q/TTR 00000000 WT-LNK 000169E8
SVRR 07CC0 TAB-LN 00003AB APSW F2F0F1C3 WC-SZ-STAR 0012D002 TQN 00000000 PSM 00040033 50002CRA
Q/TTR 00000D13 WT-LNK FFO18C88 0008512C 000014E8 00000000 00000000 00000000 00000000 00000000 00000000
RG 0-7 00000001 000014EC 00000000 00000000 00000000 00000000 00000000 00000000 00000000
RG 8-15 000FF138 0000218E 00001FA0 20000000 00001DFA FFO30000 00017D3C 00017044 00000000
EXTSA CSCIF0F1 C9C5C1E9 C1C2C5D5 C4403110
SVRR 01700 TAB-LN 001801A3 APSW F1F0F5C1 WC-SZ-STAR 0012D002 TQN 00000000 PSM FFO40001 400FE864
Q/TTR 00000000 WT-LNK 0017CC1 00003640 000169E8 000160R0 00017044 00000000
RG 0-7 00000000 00017D20 800029CC 00003640 000169E8 00017044 00000000
RG 8-15 000169E8 40002942 000169E8 00001FA0 00017044 00017044 00000000
EXTSA 000FF5F8 D2001000 700059F0 C44205E8
LOAD LIST
NE 00018258 RSP-CDE 020180A8 NE 00018760 RSP-CDE 0101A7A0 NE 00018448 RSP-CDE 0101A2A0
NE 00018970 RSP-CDE 0101A270 NE 00018E58 RSP-CDE 0101A430 NE 00018E80 RSP-CDE 0101A3D0
NE 000192E8 RSP-CDE 0301A360 NE 00019410 RSP-CDE 0201A300 NF 00019470 RSP-CDE 02017770
NE 00000000 RSP-CDE 0201A400
CODE
018008 ATR1 08 NCDE 000000 ROC-RR 00018E88 NM PDS USE 01 EPA 0B2C80 ATR2 70 XL/MJ 0181E8
0180A8 ATR1 36 NCDE 017270 ROC-RR 00000000 NM IGG0A05A USE 02 EPA 0C01E0 ATR2 20 XL/MJ 018268
0181A0 ATR1 88 NCDE 01A330 ROC-RR 00000000 NM IGG019C0 USE 03 EPA 0FDF8R ATR2 20 XL/MJ 01A390
018270 ATR1 89 NCDE 01A200 ROC-RR 00000000 NM IGG0198A USE 01 EPA 0FEB98 ATR2 20 XL/MJ 01A260
01A270 ATR1 88 NCDE 01A2A0 ROC-RR 00000000 NM IGG0198R USE 03 EPA 0FEB98 ATR2 20 XL/MJ 01A260
01A430 ATR1 80 NCDE 01A460 ROC-RR 00000000 NM IGG019AK USE 02 EPA 0FF0B0 ATR2 70 XL/MJ 01A420
01A300 ATR1 80 NCDE 01A400 ROC-RR 00000000 NM IGG019AK USE 06 EPA 0FF0C8 ATR2 70 XL/MJ 01A3C0
01A360 ATR1 80 NCDE 01A330 ROC-RR 00000000 NM IGG019CC USE 03 EPA 0FF070 ATR2 70 XL/MJ 01A350
01A300 ATR1 80 NCDE 01A330 ROC-RR 00000000 NM IGG019C1 USE 06 EPA 0FF080 ATR2 70 XL/MJ 01A2F0
017270 ATR1 70 NCDE 0180D8 ROC-RR 00000000 NM IGG019AC USE 03 EPA 0D1918 ATR2 70 XL/MJ 01A260
01A400 ATR1 80 NCDE 01A430 ROC-RR 00000000 NM IGG019A0 USE 04 EPA 0FF138 ATR2 20 XL/MJ 01A3F0

```

Figure 23: MVT SYSUDUMP - The TCB.

COMPLETION CODE SYSTEM = 322

PSW AT ENTRY TO ABEND PFE50000 40031716

TCR 0169EB RBP 00017080 PIF 00000000 DEF 00017044 TIO 00016080 CMP 80322000 TRN 00000000
 MSS 020195A8 PK-FLG 00854409 PK-FLG 00001818 LLS 00018040 JLB 00000000 JPO 000180A8
 FSA 01001780 TCB 00017558 TME 00000000 JST 000169E8 NTC 00000000 OTC 00016300
 LTC 00000000 TOE 00000000 ECR 00018C00 STA 00000000 D-PQE 0001A6C8 SOS 00016688

ACTIVE RBS

PRB 018C8B RESV 00000000 APSM 400FE162 WC-SZ-STAR 01040082 FL-CDE 00018DD3 PSM FFE50000 40003715
 Q/TTR 00000000 WT-LNK 000169E8

SVRB 017CC0 TAB-LN 000R03AB APSM F2F0F1C3 WC-SZ-STAR 0012D002 TQN 00000000 PSM 00040033 50002CBA
 Q/TTR 00000013 WT-LNK F018C8B 0008512C QMPTKER 000CEFFF 000CEFFF 00000051 00000028
 RG 0-7 00000001 000014EC 0000DAEE 00000995 00084C86 00017044 40002C7A 00000000
 RG 8-15 000FF138 00000000 00000000 00001DF8 00017D3C 00017D44 EZE8E2C9
 EXSTA 000021RE 000D1FA0 20000000 00000000 C4403110

SVRB 0170R0 TAB-LN 00180743 APSM F40F5FC1 WC-SZ-STAR 0012D002 TQN 00000000 PSM FF040001 400FEB64
 Q/TTR 00000020 WT-LNK 00017CC0 800029CC 00003640 000169E8 00017CC0 00018D08 00000000
 RG 0-7 00000000 00017070 40002942 000169E8 000D1FA0 00016080 40002C7A 00000000
 RG 8-15 000169E8 40002942 E3D8C340 00017124 EZE8E2C3 E3D3C740 F3D3C740 4780CL16
 EXSTA 00000000 D7001000 700059F0 C4A205EF

LOAD LIST

NE 00018260 RSP-CDE 020180A8 NE 00018260 RSP-CDE 0101A3A0 NE 00018448 RSP-CDE 0101A2A0
 NE 00018970 RSP-CDE 0101A270 NE 00018E58 RSP-CDE 0101A430 NE 00018E80 RSP-CDE 0101A300
 NE 000192E8 RSP-CDE 0301A360 NE 00019410 RSP-CDE 0201A300 NE 00019470 RSP-CDE 02017270
 NE 00000000 RSP-CDE 0201A400

CDE

01800B ATRI 08 NCDE 000000 R0C-RR 00018C8B NM PDS USE 01 EPA 082C80 ATR2 20 XL/HJ 018E1B
 0180A8 ATRI 30 NCDE 017270 R0C-RR 00000000 NM IGG0A05A USE 02 EPA 0C01E0 ATR2 20 XL/HJ 018748
 01A3A0 ATRI B8 NCDE 01A300 R0C-RR 00000000 NM IGG019CD USE 03 EPA 0FFDF8 ATR2 20 XL/HJ 01A390
 01A270 ATRI B9 NCDE 01A270 R0C-RR 00000000 NM IGG019A9 USE 01 EPA 0FFB98 ATR2 20 XL/HJ 01A290
 01A430 ATRI B8 NCDE 01A2A0 R0C-RR 00000000 NM IGG019AK USE 03 EPA 0FFB40 ATR2 20 XL/HJ 01A260
 01A430 ATRI B0 NCDE 01A460 R0C-RR 00000000 NM IGG019AK USE 02 EPA 0FF1B0 ATR2 20 XL/HJ 01A420
 01A300 ATRI B0 NCDE 01A400 R0C-RR 00000000 NM IGG019CC USE 06 EPA 0FF0C8 ATR2 20 XL/HJ 01A3C0
 01A360 ATRI B1 NCDE 01A340 R0C-RR 00000000 NM IGG019CC USE 06 EPA 0FF070 ATR2 20 XL/HJ 01A350
 01A300 ATRI B0 NCDE 01A330 R0C-RR 00000000 NM IGG019AC USE 03 EPA 0FFD80 ATR2 20 XL/HJ 01A2F0
 017270 ATRI 30 NCDE 01A330 R0C-RR 00000000 NM IGG019AC USE 03 EPA 0D1918 ATR2 20 XL/HJ 017260
 01A400 ATRI B0 NCDE 01A430 R0C-RR 00000000 NM IGG019AQ USE 04 EPA 0FF138 ATR2 20 XL/HJ 01A3F0

Figure 24a: MVT SYSUDUMP - The Active RB Queue and CDE List.

XL LN ADR LN ADR LN ADR LN ADR

018E18 SZ 00000010 NO 00000001 80003B80 00082C80 USE 01 EPA 082C80 ATR2 20 XL/HJ 018E1B
 018748 SZ 00000010 NO 00000001 8000061C 000C0D1E 000C0D1E 000C0D1E USE 02 EPA 0C01E0 ATR2 20 XL/HJ 018748
 01A390 SZ 00000010 NO 00000001 80000708 0000FFDF 80000708 0000FFDF USE 03 EPA 0FFDF8 ATR2 20 XL/HJ 01A390
 01A290 SZ 00000010 NO 00000001 80000180 0000FFB8 80000180 0000FFB8 USE 01 EPA 0FFB98 ATR2 20 XL/HJ 01A290
 01A260 SZ 00000010 NO 00000001 80000058 0000FER4 80000058 0000FER4 USE 03 EPA 0FFB40 ATR2 20 XL/HJ 01A260
 01A420 SZ 00000010 NO 00000001 80000098 0000FF1R 80000098 0000FF1R USE 02 EPA 0FF1B0 ATR2 20 XL/HJ 01A420
 01A3C0 SZ 00000010 NO 00000001 80000070 0000FF0C 80000070 0000FF0C USE 06 EPA 0FF0C8 ATR2 20 XL/HJ 01A3C0
 01A350 SZ 00000010 NO 00000001 80000058 0000FF07 80000058 0000FF07 USE 06 EPA 0FF070 ATR2 20 XL/HJ 01A350
 01A350 SZ 00000010 NO 00000001 80000058 0000FF07 80000058 0000FF07 USE 06 EPA 0FF070 ATR2 20 XL/HJ 01A350
 01A2F0 SZ 00000010 NO 00000001 80000078 0000FF08 80000078 0000FF08 USE 03 EPA 0FFD80 ATR2 20 XL/HJ 01A2F0
 017260 SZ 00000010 NO 00000001 800000E8 000D1918 800000E8 000D1918 USE 03 EPA 0D1918 ATR2 20 XL/HJ 017260
 01A3F0 SZ 00000010 NO 00000001 80000078 0000FF13 80000078 0000FF13 USE 04 EPA 0FF138 ATR2 20 XL/HJ 01A3F0

DEB

0170A0 00000C2E 00000C2E 00000C2E 00000C2E 3200000C 00002BEO *
 017040 0E000000 0001A9E8 04016E24 85000000 *
 017080 040170A0 0001444 0000000C 00000000 *
 0170A0 0A0218E7 07FF0000 00830A60 C612211F 00130028 0001F0F4 C2C2C2C1 C3C41800 *
Y.....H.....4488BACD.
X.....0.F.....205A.....

DEB

016E00 00000C2E 00000C2E 00000C2E 00000C2E 00000000 0000198FO *
 016E20 00000000 030169E8 04016F94 C8000000 *
 016E40 02016E00 33001830 00010000 C1D9C1D2 *
 016E60 00000000 00016F68 *
Y.....H.....ARAKCC.....
8.....

DEB

016E60 00000C2E 00000000 00000000 0000098E *
 016E80 00000000 01000000 18000000 EF08512C *
 016E00 C3C9C3C3 00000000 00000000 00000000 00001800 00010000 C1D8C1C3 *
 C1CC.....
8.....
Y.....H.....ADAG
Y.....H.....ADACC.....

DEB

017600 00000C2E 00000C2E 00000C2E 00000000 0000098E *
 017620 01000000 040169E8 04000000 C8000000 *
 017640 02017600 33001860 00010000 C1D8C1C3 *
 017660 0000F3D3 C7017970 *
Y.....H.....ADACC.....
TLG.....

TINT JOB A0001854 STEP EXEC1

DD 14040100 PGM=**DD 001E0C00 80001204
 DD 14040100 SYSUDUMP 000F1700 80001444
 DD 14040100 SYNFILE 00123600 80001294
 DD 14040100 SYNPRINT 000E3900 80001444
 DD 14040100 READ002 00123C00 80001800
 DD 14040100 WRITANS 001D2F00 80001A30
 DD 14050100 ANSFLE 001D3100 80001A60
 DD 14050100 WRIT001 001D3500 80001A90

Figure 24b: MVT SYSUDUMP - The XL List.

```

MSS ***** SPOE *****
FLOS NSPOE SPID DOE BLK FQE LN NODE
019548 00 019680 251 018058 000B2800 000B2800 00004000 00000000
019680 80 0196C8 000 017940 00001000 00001768 00000800 00018480
017960 60 000000 000 0180F0 00000000 00000000 00001000 00017190
00000000 00000000 00001000 00001000 00017190
000CF000 000CF000 00001000 00017F88
000CF000 000CF000 00001000 00017750
000CD800 000CD800 00000800 00000000
000D1800 000D1800 00000800 00017C80
000CD000 000CD000 00000800 00017968
000CC800 000CC800 00000800 00000000
D-PQE 0001A6CB FIRST 00018EB8 LAST 00018EB8
PQF 018FB8 PFB 00068800 LFR 00068800 NPQ 00000000 PPQ 00000000
TCB 00016300 RSI 0001F800 RAD 000R2800 FLG 00
FBQE 0B6800 NFB 00018EB8 PFB 00018EB8 SZ 00016000
QCR TRACE
MAJ 01A6FB NMAJ 00018A80 PMAJ 0000A2C0 FMIN 00019480 NM SVSDSN
MIN 019480 FQEL 00019700 PMIN 0001A6F8 NMIN 00019070 NM FF CTSKCH
NGLF 00000000 PQEL 00019480 TCR 00016300 SVRR 0001AE20
MIN 019070 FQEL 00019440 PHIN 00019480 NMIN 00018FA8 NM FF SYSI-SORTLIB
NGL 00000000 PQEL 80019070 TCB 00016300 SVRR 0001AE20
MIN 018FAB FQFL 00019200 PMIN 00019070 NMIN 00018FE8 NM FF SYSI-LINKLIB
NGL 00000000 PQEL 80018EAB TCB 00016300 SVRR 0001AE20
MAJ 017978 NMAJ 00000000 PMAJ 00018A00 FMIN 00017758 NM SYSTEA01
MIN 017758 FQEL 00017CA0 PMIN 00017978 NMIN 00000000 VM EO IEA
NGL 00000000 PQEL 00017758 TCB 000169E8 SVRR 00016F68

```

SAVE AREA TRACE

PDS WAS ENTERED VIA LINK

SA 0D17R0 W01 00000000 HSA 00000000 LSA 000R2C80 RET 0000R5DA EPA 010B2C80 RO FD000006

To next SAVE AREA

Figure 24c: MVT SYSUDUMP - The SAVE Area Trace.

```

R1 00017758 R2 00018C80 R3 50018C0C R4 00015E68 R5 00016300 R6 00016078
R7 00017008 R8 00018C80 R9 00008000 R10 00000114 R11 00015E68 R12 600FF41A
SA 0B2C80 W01 00070003 LSA 00000000 LSA 000D17B0 LSA 000R2C80 EPA 00090003 RO 500R4F76
R1 00019480 R2 000R2D69 R3 000R512C R4 000R8944 R5 400R2C86 R6 000R3C86
R7 000R2F69 R8 0000005C R9 000R30A0 R10 000R2E98 R11 400D19D0 R12 000FF138
PDS WAS ENTERED VIA LINK
SA 0D17R0 W01 00000000 HSA 00000000 LSA 000R2C80 LSA 000R2C80 EPA 010B2C80 RO FD000006
R1 00017758 R2 00018C80 R3 50018C0C R4 00015E68 R5 00016300 R6 00016078
R7 00017008 R8 00018C80 R9 00008000 R10 00000114 R11 00015E68 R12 600FF41A
REGS AT ENTRY TO AREND
FLTR 0-6 0000144400018CR4 0000000100018CEC 00016F800000000000 00090009D7C4E240
REGS 0-7 00000001 000014EC 000R512C 000D14E8 000CEFFF 000CEFFF 00000051 00000028
REGS 8-15 000FF138 00000000 000DDAAE 000D0995 000B4C86 000R2C80 400D19D0 600049DA
LOAD MODULE PDS
0B2C80 90ECD00C 05305000 302E18CD 41D0307A 50DC0008 07005840 301E58C0 302247F0
0B2CA0 44F20000 000R3C86 000R4C86 4C00205C 00070003 000D1780 00080003 4C0020A8
0R2CC0 00090003 500R4F76 12001918 000B2D69 000B5120 00089844 000B2C86 000B3C86
0R2CC0 000R2F69 0000005C 000R30A0 000B2F98 400D19D0 000FF138 0110003 5C0D2958
0B2D00 F0F8F140 40E9D602 C81FA660 F0F0F3F8 60FF18F8 F8A04040 40404040 40404040
0B2D00 40404040 40404040 40404040 40404040 40404040 40404040 40404040 40404040
0B2D00 40404040 40404040 40404040 40404040 40404040 40404040 40404040 40404040
0R2D60 0000229C F0F6F140 40E9C1D2 C81CF860 F0F0F2F3 60FF1E1F F440F2F1 40F2D6D3
0R2D80 E5C5D9E3 40C5E7E3 D9C1C3F3 C90E8340 D8C840C1 40C3C8C5 D1C1F5C5 40C3D664
0R2D80 D7D8E4D5 C44006C6 40C140F3 09C1C3C5 40404040 40404040 40404040 40404040
0R2D00 00150015 4000374C 088A5000 00000R8A 60R88874 088A600E 8AE80000 897C0889
0R2F00 088A4000 00000R8A 00000000 000R74C0 00000000 00000000 00000000 00000000
F0000000 00000000 00000000 00000000 00000000 00000000 00000000 00000000
0R2E00 00000011 A0000000 00007FFE E980020F 00000000 00000000 00000000 00000000
0B2E60 4000400C 00000008 00184040 40400000 CDF1C547 0207C602 000B8978 00010000
0R2EAD 4000400C 000B8880 000B8C8C 000B8D0E 00000000 00000000 00000000 00000000
0R2EAD F9F9E9F9 C8C5C1C4 C5D940C3 C1D9C448 F4C9D9F8 40D5D6A8 40404040 40C8C1F7
0R2EAD 4005D640 89C5F9E9 F9E9E9F9 00C9D5D8 C3F3E2D9 C3C4C1E3 C5E3C5D9 D4E24076
0R2FE0 0540E3C1 D7C5C510 47R0C3E0 5030C504 58R020C4 47F0C5B4 5830C4FC 00002000
0R2FE0 00004000 07000700 000B88A0 000R0D0R 000D1658 F0F8F1E0 F10F0008 58F0F030
0R2FE0 00000000 0057001F F0F8F140 40E9D7C3 C6C1F760 F0F0E5F9 A0F0F2F9 F9404040

```

Figure 24d: MVT SYSUDUMP - The SAVE Area Trace.

