



ELECTRIC TYPEWRITERS

CUSTOMER ENGINEERING REFERENCE MANUAL Preventive Maintenance and Adjustments

Issued To

Branch Office Chicago South

Department E. T. Customer Eng.

Address

Chicago 20, Illinois

If this Manual is lost or mislaid please return to above address

INTERNATIONAL BUSINESS MACHINES CORPORATION

NEW YORK 22, NEW YORK



ELECTRIC TYPEWRITERS MAINTENANCE GUIDE

CUSTOMER ENGINEERING REFERENCE MANUAL

CONTENTS

	<i>Page</i>
Impression and Type Alignment	1
Paper Feed	3
Carriage Return	3
Motor	5
Noise	5
Shift	6
Tabulation	7
Back Space	8
Space Bar	9

INTERNATIONAL BUSINESS MACHINES CORPORATION
NEW YORK 22, NEW YORK

Copyright, 1953, by
INTERNATIONAL BUSINESS MACHINES CORP.
590 Madison Avenue, New York 22, N. Y.

Printed in USA October, 1954

Form 25-6021-1

IBM ELECTRIC TYPEWRITERS

MAINTENANCE GUIDE

THE FOLLOWING Maintenance Guide has been compiled from the experience of Electric Typewriter Customer Engineers and is presented as an exchange of information. It is not intended to take the place of any material in the manuals or memorandums but, rather, to supplement that material.

IMPRESSION AND TYPE ALIGNMENT

VERY WEAK OR NO IMPRESSION

- Multiple copy lever in wrong position.
- Ribbon color control button in stencil position.
- Wrong platen for thickness of form.
- Platen too soft.
- Improper power roll speed.
- Bind in power roll and drive mechanism.
- Ribbon failing to feed properly.
- Darker ribbon may be needed.
- Oil on ribbon.
- Ring and cylinder out of adjustment.
- Dirty or glazed power roll. Power roll may need to be replaced.
- Cam serrations worn at the knockout position. Replace cam.
- Loose rubber on power roll.
- Improper cam clearance.
- Dirt in segment or on type bars in the slots.
- Impression indicator set too low.
- Universal bar or escapement choking off type bar action.
- Impression control screws set too light.
- Type impression may be set too light to avoid cutting the paper. Polish the type faces per Section 1, page 16.

INTERMITTENT LIGHT IMPRESSION

- Dirt in segment.
- Non-repeat lug should be removed from the ribbon cam.
- Finger prints or grease on paper, especially if the machine is equipped with carbon ribbon.
- Cam serrations worn at the knockout position. Replace cam.
- Bind in type bar linkage or type guide.
- Misadjustment of type bar.
- Worn type bar on universal bar.
- Loose platen guide reinforcing plates.
- Loose carriage.

Aluminum cam bearing support slots worn, indicated by trip lever springs worn off on side adjacent to next cam lever. Replace cam lever bearing support.

Eccentric power roll due to loose rubber.

Dirty or glazed power roll. Power roll may need to be replaced.

LIGHT OR DARK IN ONE CASE ONLY

Place shims under segment guide springs according to instruction in the manual.

DIFFERENT HEIGHT ON END TYPE BAR

Type bar guide may be leaning to right or left.

OVERPRINTING AND UNDERPRINTING

Check for light top or bottom.

Check motion.

Improper platen.

Cushion of paper too deep in the form.

Check card holder adjustment.

Check multiple copy lever.

Check ring and cylinder adjustment.

Form card holder or install offset card holder.

TYPE CUTTING

Check power roll speed.

Impression indicator set too high.

Platen too hard.

Check ring and cylinder adjustment.

Type may need polishing. Section 1, page 16.

Impression control screws may require adjustment.

Some papers are brittle and cut too easily. Such paper may be reinforced by using a sheet of tough tissue behind the original or by using a tough carbon paper.

PILING

Insufficient carriage tension.

Improper universal bar adjustment.

Dirt in segment.

Dirt on power roll.

Escapement tripping too late or too early.

Dirt in carriage ways and rails.

Worn type bar.

Broken or worn universal bar.

It is possible for an operator to pile the type by uneven rhythm or by striking two or more keys nearly simultaneously.

Strict adherence to adjustment procedures will minimize this occurrence.

PAPER FEED

CARBON MARKS

- Carbon paper too soft.
- Paper release lever snapped.
- Feed roll bind—too much pressure or lack of grease.
- Bent deflectors.
- Card holders too close to platen.
- Front paper scales bent.
- Hard feed rolls.
- Snapping the paper bail.
- Sand a crown on individual rear feed rolls.

PAPER SLIPPING

- Feed roll pressure weak.
- Weak actuating shaft.
- Weak actuating shaft spring.
- Actuating shaft bowed, adjust center support.
- Actuating shaft arm side play.
- Equalizing rod side play.
- Platen side play.
- Platen loose at platen yokes.
- Feed roll side play.
- Feed roll bind—lack of grease or bent deflectors.
- Hard feed rolls.
- Hard platen.
- Dirty feed rolls or platen.
- Bail springs.
- Plastic back carbon.

PAPER ROLLBACK SLIPPAGE

- Hitting rear feed rolls—form guide lip in deflector.
- Bail roll bind.
- Feed roll tension.
- Plastic back carbon.
- Check all feed roll slippage pointers.

PAPER AND STENCIL WRINKLING

- Slippery stencil backing sheet.
- Swollen platen and feed rolls.
- Uneven feed roll pressure.
- Cockle finish paper.
- Bent deflectors.
- Check all paper feed pointers.
- Sand a crown on individual rear feed rolls.
- Install paper ironing bail.
- Partial feed roll contact.

CARRIAGE RETURN

FAILS TO OPERATE

- Faulty cam link adjustment.
- Bind in cam.

Back space pawl may be binding the interlock which will cause carriage return failure.

INCOMPLETE RETURN (TOGGLE TYPE)

May not have toggle going over center because of improper adjustments.

Toggle stop out of adjustment.

Lack of lubrication.

INCOMPLETE RETURN (ALL MODELS)

Faulty cam adjustment.

Escapement pawls pulled too far out of the rack.

Tip of the clutch knockout lever or toggle knockout lever adjusted too high.

Clutch lever bracket adjusted too loosely.

Nut on compression spring under machine should be tightened.

INCOMPLETE RETURN (LATCH TYPE)

Lack of tension of the latch spring.

Improper cam link adjustment.

Improper latch adjustment.

CARRIAGE LOCKS (TOGGLE TYPE)

Clutch toggle stop allowing toggle to go too far over center.

Increase tension on hairpin spring on toggle knockout lever.

Toggle linkage adjustment allowing toggle to go too far over center.

CARRIAGE LOCKS (LATCH TYPE)

Latch link adjustment allows too deep a latch engagement.

Excessive latch spring tension.

CARRIAGE LOCKS (ALL MODELS)

Weak motor.

Bind in power roll and drive mechanism.

Belts slipping.

Tip of clutch knockout lever too low.

Clutch knockout lever link adjusted so knockout lever is too low.

Margin rack adjustment allows too much overbank.

Clutch lever bracket adjusted too tightly.

Adjusting nut on compression spring adjusted too tightly.

UNEVEN MARGIN

Margin rack out of adjustment.

Broken tab lever assembly or margin stop.

Escapement pawls sticking or binding.

Weak pawl spring.
Failure to group or latch properly in Executive Typewriters.
Air cylinder.

MOTOR

FAILS TO START OR RUN

Faulty condenser. Check by turning motor by hand.
Faulty motor.
Broken switch.
Switch link improperly adjusted.
Frozen bearing.
Belts too tight.
Excessive end play in armature (DC).

NOISE

TOP COVER VIBRATES

Open cover and spread sides slightly.

REAR COVER VIBRATES

Reposition rear cover.

CARRIAGE END COVERS VIBRATE

Reform spring clips.

PAPER TABLE VIBRATES

Reset positioning collars.

NOISY PAPER BAIL

Check for broken paper bail spring.
Reposition bail rolls on shaft.

NOISY DRIVE

Check motor and pulley lubrication.
Align pulleys.
Replace worn belts.
Adjust belts.
Left-hand fastening screw rubbing on belt.
Check power roll adjustment and lubrication.
Loose power roll torsion spring.

Model 1 below 34,750

Model 4 below 8,901

Desk or stand may be cause of trouble.
Check other location.

NOISY TYPING

Type bar hitting front scale.
Type bar hitting card holder.
Type rest pad worn.
Platen too hard.

NOISY SHIFT

Broken shift stop bracket.
Broken segment guide.
Cracked bumper on shift pusher.
Shift stop screw rubbing on bracket.

NOISY SPACE BAR

Improper stop bracket adjustment.
Space bar mechanism hitting case.

NOISY TAB

Friction governor link dragging on governor ratchet.
Improper pawl release lever adjustment allowing escapement pawls to drag.

NOISY CARRIAGE RETURN

Improper adjustment of the eccentric on the pawl release lever allowing the pawls to drag.
Clutch adjusted to return the carriage too hard.

SHIFT

INCOMPLETE SHIFT

Pusher too high or too low.
Binds in basket or shift mechanism.
Excessive or uneven pin clearance.
Broken hairpin spring.
Keybutton binding.

FAILS TO SHIFT

Check cam adjustment.
Improper pin clearance.
Pusher too high or too low.
Improper cam link adjustment.
Lack of lubrication.
Cam may be binding.
Shift equalizing rod out of place or warped.

MOTION FAULTY

Improper adjustment of adjusting nuts.
Adjusting lock nuts.
Left and right-hand shift motion adjustments not made equal. Test with strips of paper between the stop washers and the brackets in each position of the basket.
Lock nut on stop bracket adjusting screw loose.
Broken stop bracket (basket should rest evenly on both brackets to prevent breakage).
Broken segment guide.

LIGHT TOP OR BOTTOM

Adjust shift stop bracket screws.

- Wrong platen for thickness of form.
- Copy control lever set at improper position.
- Check platen guide yokes for loose platen.

UPPER AND LOWER CASE IMPRESSION UNEQUAL FROM SHIFTING OFF CYLINDER

- Install shims under the segment guides according to the instructions in the manual.

SLOW OR BOUNCING SHIFT

- Improper cam adjustment.
- Improper pin clearance.
- Improper pusher adjustment.
- Broken pusher buffer.
- See that operator is not "beating the shift."
- Power roll glazed.
- Cam bind.
- Worn cam.
- Loose V belts.

TABULATION

FAILS TO OPERATE OR TABULATES ONLY A FEW SPACES

- Improper cam adjustment.
- Fractured cam or link.
- Improper key lever link adjustment.
- Tab lever not being pulled far enough to latch.
- Linkage too long.
- Improper latch adjustment.
- Improper latch stop adjustment.
- Tab lever binding on margin rack.
- Bind in tab lever fulcrum.
- Improper tab rack adjustment which may cause tab lever to strike tab stop.
- Tab lever binding with tab rebound check lever either at the stud or at the tip of the tab lever.
- Tab lever stop on rear rail set too far forward.
- Friction governor adjustment may be faulty, causing a bind.
- Weak tab lever spring may prevent tab lever from restoring properly.
- Back space pawl may be binding the back space interlock which will cause tab failure.
- Lack of lubrication.

TABULATES SHORT

- Tab rebound check lever has excessive clearance with the tab stop.
- Worn tab stop.
- Tab lever moving too far into the tab rack.
- Tab lever binding on the margin rack.
- Bind in the tab lever.

Improper latch stop adjustment, allowing excessive clearance between tab lever and tab rack.

Friction governor too tight.

Insufficient carriage tension.

Tab stop not completely set.

See that the operator is not beating the tabular operation. This would appear as tabulating short by less than a full space.

Rebound check lever may be too low and passing under the tab stop or may have excessive clearance with the tab stop.

TABULATES EXTRA SPACES

Tab lever not getting sufficient bite on the tab stop.

Friction governor too loose.

Excessive carriage tension.

Tab stop improperly set.

CARRIAGE LOCKING

Tab rebound check lever holding tab stop too tightly. Improper latch adjustment not allowing tab lever to unlatch.

Friction governor too tight not allowing the tab lever to knock off.

Rebound check lever too high, catching and holding the tab lever out.

BACK SPACE

FAILS TO OPERATE

Bind in cam.

Improper cam adjustment.

Bind in linkage.

Broken, bent or improperly adjusted guide lug.

Fractured cam or links.

Broken escapement spring or corner bell crank spring.

Final stop adjusted too close.

Adjust height of back space pawl.

Interlock binding or interfering with back space pawl.

Binding keybutton.

Glazed power roll.

BACKS TWO SPACES

Cam repeats.

Excessive play in linkage.

Improper final stop adjustment.

Improper guide lug adjustment.

INTERMITTENT FAILURE

Lack of lubrication on back space pawl.

Improper cam adjustment.

Fractured cam.

Excessive play in linkage.
Improper final stop adjustment.
Improper guide lug adjustment.
Adjust height of back space pawl.

SPACE BAR

FAILS TO OPERATE

Check cam adjustment.
Bind in cam.
Space bar binding on cover.
Improper stop bracket adjustment.
Improper cam link adjustment.
Spring on escapement lever plate loose or stretched.
Improper escapement link adjustment.

REPEATING

Faulty cam (do not confuse with need for stop bracket or cam link adjustment.)
Stop bracket adjustment too low.
Improper cam link adjustment.
Operator may be operating the space bar twice.



ELECTRIC TYPEWRITERS

MODEL 01

Preventive Maintenance and Adjustments

CUSTOMER ENGINEERING REFERENCE MANUAL

Preventive Maintenance and Adjustments

CONTENTS

	<i>Page</i>
Motor and Electrical Parts	3
Power Frame Removal	4
Gear Drive and Power Roll	5
Key Levers	6
Cams	7
Type Bars	8
Bell Cranks	10
Escapement	11
Space Bar Mechanism	14
Carriage and Rails	15
Paper Feed	17
Shift Mechanism	18
Carriage Return and Line Space	22
Tabular Mechanism	30
Backspace Mechanism	37
Ribbon Feed Mechanism	42

INTERNATIONAL BUSINESS MACHINES CORP.

NEW YORK 22, NEW YORK

Form No. 25-6619-0 (This section only)

**Copyright 1955 by
International Business Machines Corp.
590 Madison Avenue, New York 22, New York
Printed in U.S.A. February, 1955
Form 25-6619-0**

IBM ELECTRIC STANDARD TYPEWRITER

Model 01

MOTOR AND ELECTRICAL PARTS

THE MOTOR used in the model 01 typewriter is rated at 1/60 HP and uses 65 watts of power. All motors whether AC or DC are series wound and governor controlled (Figure 1).

DC MOTORS are marked by a stripe of red paint. The name plate of an AC motor will always have the frequency rating marked.

Using an AC motor on DC current will cause the governor points to pit rapidly. If a DC motor is run on AC current it will overheat and lose power.

IBM MOTORS require a front mounting bracket. When replacing other types with an IBM motor it may be necessary to drill holes in the machine base to accommodate the mounting bracket screws. Use template 9522944 to locate these holes.

When selecting motors for replacement, regard should be given to voltage, and to frequency if AC. Consult the Parts Catalogue for specifications and the pocket parts price list for wiring diagrams.

THERMOGUARD PROTECTED MOTORS. The late model 01 motors of all types are equipped with a thermoguard designed to break the circuit when the motor becomes overheated. One minute allows the motor to cool sufficiently to again establish contact. A thermoguard is present in a motor if the patent plate is located on the motor instead of on the machine base.

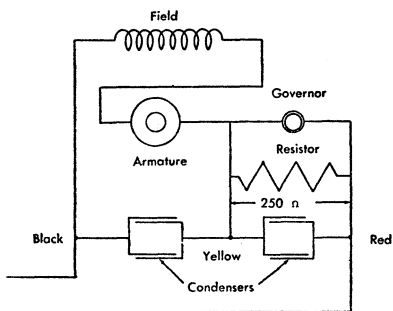

Figure 1. Wiring Diagram

CONDENSER AND RESISTOR ASSEMBLY. The resistor, together with the condenser, reduces arcing across the governor contact points. The condenser box contains two condensers. One acts with the resistor to protect the governor points. The other reduces arcing between the motor brushes and the commutator. Under DC operation, the latter condenser must be sacrificed to protect adjacent electrical instruments. Simply disconnect and tape the black condenser lead.

If the resistor fails, it will not warm when the motor is running. Failure of the condenser results in high arcing at the points, causing them to pit rapidly.

RADIO FILTER. The radio filter eliminates radio interference whenever the typewriter is installed near a radio receiver or a broadcasting station. The wiring diagram for this hook-up is shown in the pocket parts price list. Motors used with the radio filter have built-in choke coils and condenser and can be identified by the letter "F" stenciled on the motor housing.

THE SWITCH turns the power on or off and, through a locking bar, keeps the keys from being depressed when the switch is off. Poor electrical contact may often be traced to a weak or broken switch spring which can be replaced.

Maintenance

LUBRICATE THE MOTOR BEARINGS with six or eight drops of IBM ET oil at each inspection or every three months.

ARMATURE END PLAY must be kept to .005" by use of shim washers.

MOTOR BRUSHES must be installed in exactly the same manner in which they are removed. Mark them *left*, *right*, *top*, and *bottom* when removing. New motor brushes may be noisy until they wear in.

Mark on the motor or terminal block the date when motor brushes are replaced or checked. If replaced, the motor brushes need not be inspected for a year; but if only checked, they should be re-checked in six months. This procedure will save on inspection time and also insure that the brushes do not wear down to the springs.

Carbon dust must be cleaned from the brushes and brush holders because it may lower the resistance of the motor. Loss of power and overheating will result.

POWER FRAME REMOVAL

Power frame removal will be necessary to replace or repair the following:

- Ribbon lift bar
- Shift actuating levers assembly
- Shift T-lever head assembly

REMOVAL PROCEDURE:

1. Disconnect motor wiring at terminal block.
2. Remove switch.
3. Remove condenser and resistor.
4. Disconnect return and tension tapes.
5. Disassemble clutch and clutch pulley.
6. Remove operating arm and link to carriage return cam. (Note that link enters from rear.)
7. Remove motor and worm housing assemblies together.
8. Remove the governor link. (Note that link enters from left-hand side.)
9. Disconnect tab operating link.
10. Disconnect backspace operating link.
11. Remove escapement trip link and spring.
12. Remove tab set and clear links.
13. Remove ribbon reverse springs and ribbon.
14. Remove front and rear cover plates.
15. Remove three remaining power frame screws.
16. Swing power frame part way out of base. Avoid bending the pin on the left-hand end of the key lock bar and the side clutch knockout lever on the right.

GEAR DRIVE AND POWER ROLL**Gear Drive**

The worm drive and clutch assembly provide speed reduction between the motor and the power roll to return the carriage and index the platen. The standard gear reduction is 12 to 1.

ADJUSTMENT OF WORM END PLAY. Loosen the bottom set screw. With the motor running, turn the thrust adjusting screw until the motor is stalled and all end play is eliminated; then turn the screw back $\frac{1}{4}$ of a turn and retighten the set screw (Figure 2).

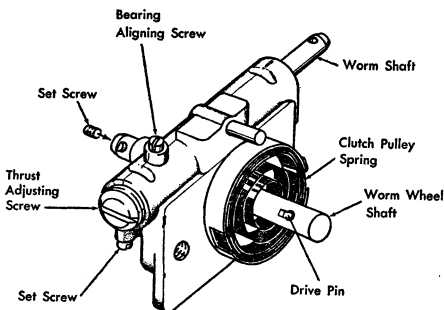

Figure 2. Worm Housing Assembly

LUBRICATE, using only IBM non-fluid oil in packing the housing. It should be necessary to repack the housing only when overhauling the machine. Make sure there is lubrication between the thrust screw and the end of the worm shaft to prevent a whistling squeak.

Power Roll

The power roll drives the cam units, turning continuously when the power is on. The serrated surfaces of the cams engage the power roll when they are tripped by the various key levers.

THE POWER ROLL SHAFT is held in place by two oilite bearings. It should be lubricated with non-fluid oil, lubricant 17 or IBM ET oil. If ET oil is used, do not over-oil or allow the oil to come in contact with the power roll rubber.

WHEN THE RUBBER SURFACE becomes worn, cam failure results. A glazed surface may cause the cams to fail, or bounce and repeat.

IF THE POWER ROLL develops a squeak or chatter, soak the fish paper shim washer in IBM ET oil. See that the shaft turns freely. When the roll is in place in the machine, adjust the power roll latch screw to take up all end play. Too tight a power roll adjustment will overload the motor. If the power roll "runs out" or "wobbles" after it has been replaced, turn it around $\frac{1}{2}$ revolution.

KEY LEVERS

Key levers control the different cam units which in turn operate the various functions of the machine. They are mounted on the bell crank bearing wire and are guided by the front guide comb. Key lever springs hold them against the top of the slot in the front guide comb. Their lower ends, which are forked, engage the release levers on the various cam units (Figure 3).

REMOVAL. Follow the procedure given for bell crank removal.

ADJUSTMENTS. A $2\frac{1}{2}$ oz. weight placed on any key button should just trip the cam. The tension may be adjusted by lifting the key lever spring with pointed pliers and turning the spring adjusting screw. The front guide comb is adjustable. It is correctly set if the key levers still have about $\frac{1}{64}$ inch to travel after they have released the cams (Figure 3).

If some particular cam does not release at the same point as the rest, that cam may be adjusted slightly by forming the pin on the cam release lever. Remove the cam from the machine for this adjustment. Forming the pin forward will cause the cam to trip earlier in the downward travel of the key levers.

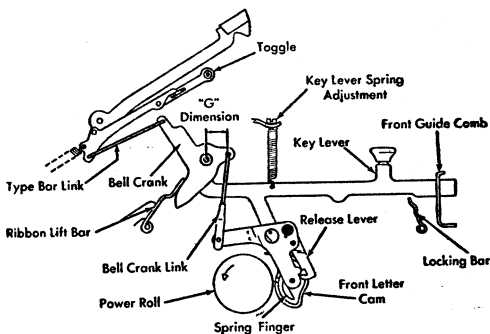

Figure 3. Cam and Type Bar Mechanism

LUBRICATION. Use IBM lubricant 17 on the forked ends of the key levers during machine overhauls and removal for servicing.

CAMS

Cam units are held out of engagement with the power roll by a stop lug on each cam release lever. When a key is depressed, the stop lug releases the cam lug, forcing the cam into the power roll by a spring finger. Rotation of the cam on the power roll causes the cam frame to energize a type bar, by pulling on a link to a bell crank and on another link to the type bar toggle lever. A non-repeat lug, adjacent to the stop lug on each cam release lever, keeps the cam from repeating when a key lever is held down.

Removal

Loosen the three screws which hold the cam bearing clamp plate in place. Using an auxiliary bearing wire, push the cam bearing wire in the machine until the joint between the two wires is opposite the cam unit to be removed. Pull the two wires a short distance apart. The cam unit will fall out and the adjusting link can be unhooked.

Adjustment

The letter cams are adjusted to the power roll by a link from each cam frame to a bell crank (Figure 3). Tripping the cams with the power off allows the cams to rotate and rest against the power roll. When properly adjusted, the release levers should come to rest on the back edge of the cam lugs, or just strike the back edge and slip off. Check both lobes of the letter cams. The release levers of the single

lobe operational cams should fall just behind the lugs of the cam.

Maintenance

CAM STICKING. If a cam sticks, check the release lever and the spring finger to see that they are not binding the cam. If the cam itself is sluggish, brush or blow out the dirt. Apply IBM ET oil very sparingly to the cam unit bearing points using a small drop on the end of a spring hook. A groove worn in the lug of the cam release lever also causes a cam to stick and requires replacement of the cam unit.

NOISY CAMS. A cam that makes a buzzing sound is rubbing the power roll when at rest. It can be readjusted for greater clearance. If the noise is still present under correct settings, speed up the action of the cam; or, as a final step, replace the cam unit. To speed up the action, remove the power roll and locate the end of the spring that provides tension on the spring finger. Grip the spring with the long-nose pliers and pull out about $\frac{1}{8}$ ". Reform the end of the spring so that it holds against the cam frame and clears the power roll.

TYPE BARS

The type face is curved to the same arc as that of the platen so that all parts of the type face will strike squarely. To insure a clean, even impression, the type bar is designed and adjusted to strike the anvil, or ring, just before the type face strikes the paper. The type bar can be operated only by a pull on the bell crank or a lift on the toggle of the type bar (because the toggle linkage locks the type bar down against the type rest). This permits faster operation by preventing rebound and collision of type bars.

Removal

1. Shift the segment support to the small letter position. Loosen the type bar fulcrum wire stop-screws and the toggle fulcrum wire clamp plate-screws (Figure 4).
2. Press the pointed end of an auxiliary type bar fulcrum wire against the one in the segment and move it until it contacts the type bar to be removed. Separate the two wires to drop that type bar and five adjacent bars toward the outside of the machine.
3. Using an extra toggle fulcrum wire, drop only the toggle lever of the bar to be taken out.
4. With a spring hook under the front end of the toggle lever, pull up until it is against the type bar which is held in the left hand, push down on the back end of the type bar, turn to the outside and pull forward on the type bar. This brings the type bar assembly, with link and spring still attached, to the front of the segment and up between the adjacent type bars. The

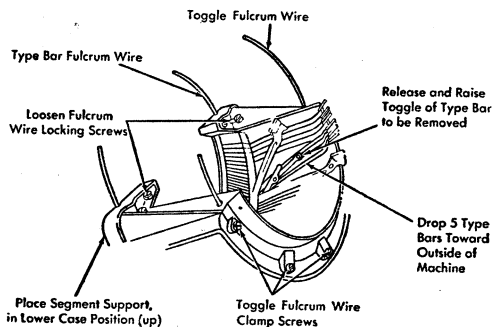

Figure 4. Type Bar Removal

type bar is then easily unhooked from the link. Also the spring can be detached and hooked on to the new type bar without unhooking it from the spring plate.

5. Oil the pivot points on the new type bar, hook on the link, drop the toggle link between the type bars and insert the new type bar in the reverse manner from which it was removed.
6. Push both fulcrum wires back into their original position and tighten the screws.

Adjustments

TYPE BAR ADJUSTMENT. Check the following items if the type bars do not lock down against the type rest:

1. The cam may be adjusted too close to the power roll.
2. There may be a bind in the toggle levers.
3. If the bars on one side of the segment are not locking, change the number of brass shims between the segment and the segment support. Usually, adding shims will improve the condition. Readjustment of ring and cylinder will be necessary.
4. If the bars in the center of the segment do not lock, spread apart the two prongs of the segment spacer link to allow them to lock. After the type bar toggles are locked, minimize the rebounding of the type bars by bringing the two prongs of the spacer link closer together. Proper adjustment will allow the type heads to be lifted about $\frac{1}{4}$ " from the type rest when tried by hand.
5. A type bar rest may be worn.

TYPE BAR ALIGNMENT. This procedure is given in the Model 1 Reference Manual.

TYPE CUTTING. If a type bar strikes too heavily, install a heavy type bar spring listed in the Parts List. Polish the

type face by wrapping abrasive paper, Behr-Manning Durite 600 A, around the platen. Hold the bare type face against the abrasive and polish lightly by moving the carriage and rotating the platen.

LIGHT IMPRESSION. Load the head of the type bar with solder along the top edge. Use flux to obtain a good bond. Be careful that heat does not loosen the type slug. The type head should not be so bulky that it binds against other type bars.

ALTERNATE LIGHT AND DARK IMPRESSION from one type bar. Determine which cam lobe is delivering the light blow and peen carefully (Figure 5).

BELL CRANKS

LETTER BELL CRANKS transfer motion from the cam units to the type bars and operate the ribbon lift and feed mechanisms. Bell cranks are numbered for position in the machine. If they are replaced, use a corresponding number.

OPERATIONAL BELL CRANKS transfer motion from the cam units to operating links which pull on their respective parts to give back space, tab, and space bar operation.

Removal

BELL CRANKS may be removed without removing the power frame as follows:

1. Drill a hole in each side of the machine base frame with drill 21 after using template 9004820 to locate the proper positions. Tap both holes with a 10-32 tap.
2. Remove the cam unit and the adjusting link clevis.
3. Remove the type bar and its connecting link.
4. Unhook the key lever tension spring and three additional springs on each side.
5. Push an extra bearing wire into one of the tapped holes. Move the bell crank bearing wire until the joint between the two wires is in the bell crank to be removed. Separate the wires. Drop only the bell crank and its key lever and work the bell crank to the front between the key levers. More clearance can be obtained to pass the bell crank if the key lever is removed and the key lever spring support is raised about $\frac{1}{8}$ " after loosening four corner screws.
6. Replace the parts and confine the bearing wire by turning two 10-32 screws in the tapped holes until they are $\frac{1}{16}$ " from the end of the bearing wire.

Maintenance

BELL CRANKS are case hardened and do not wear appreciably. Forming them is not recommended. They may break. Inspect the bell crank bearing wire for wear during over-



Figure 5. Peening a Cam Lobe

hauls. Replace if it is grooved or rusted. Lubricate the wire with IBM lubricant 17 or IBM ET oil whenever it is removed.

ESCAPEMENT

The universal bar transfers motion from the type bar to the escapement mechanism. It allows the carriage to move one space under main spring tension for each type bar stroke. The escapement mechanism uses two pawls operating in a rack having one tooth every two spaces. As a type bar is driven toward the platen, it pushes the universal bar, the trip link, and the bottom of the trip lever to the rear. This action rocks the trip lever. The pawl spacer (located between the pawls) is driven forward against the tail of the escapement pawl that is holding the escapement rack. The pawl is tripped out and is snapped about $\frac{3}{64}$ " along the rack to the next tooth. The other pawl holds the rack and carriage (Figure 6).

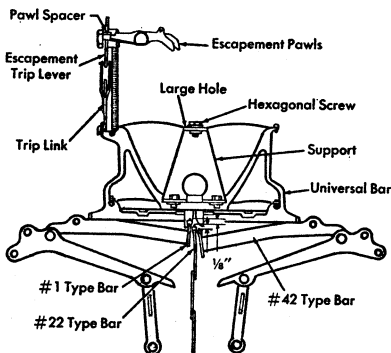

Figure 6. Adjusting the Universal Bar

A LONG-TOOTH ESCAPEMENT mechanism was used in 10 and 12 pitch machines below serial numbers 45900 and 49800. This mechanism included escapement pawls, rack and backspace pawls of a different design than that of the short tooth escapement.

THE SHORT-TOOTH ESCAPEMENT has an advantage of speed and ease of operation over the long-tooth escapement.

Removal

UNIVERSAL BAR REMOVAL. If the universal bar and type bar segments are removed together and then disassembled, the U-bar can be accurately centered in the slot of the segment before it is replaced in the machine.

1. Remove the ribbon lift guide.
2. Remove the right hand screw in the carriage final stop plate on the front rail.
3. Remove the front rail dust cover.
4. Unhook the escapement trip link and spring.
5. Remove the type bar fulcrum wire.
6. Remove the two screws that hold the segment to the segment support. Push the segment off its dowel pins. Put the segment support in the small letter position and move the carriage to the extreme left. Then move the segment down and to the left so that the assembly can be removed through the opening in the segment support. Push down on the left-hand type bars to give more clearance.
7. Unscrew the two hex-headed screws in the U-bar support. Remove the U-bar. Note the two spacer washers between the front spring and the segment.

The U-bar can be removed without the segment by following steps 1, 3 and 4 under removal procedure and taking off the carriage and rails together.

ESCAPEMENT PAWL ASSEMBLY REMOVAL. Unhook the toggle knockout link at the corner bell crank. Unhook the two springs from the escapement pawls and the trip link at the trip lever. Remove two shoulder screws in the toggle knockout lever. The pawl assembly will come off its dowel pins.

Adjustments

1. THE UNIVERSAL BAR should be adjusted so that all type bars will trip the escapement at about the same point (no more than $\frac{1}{8}$ " variation). The left side of the universal bar should rest a few thousandths farther away from the segment than does the right side. This position insures that the right side of the universal bar will be struck slightly earlier than the left, compensating for the yield inherent in the universal bar design.

Obtain this condition by placing three type bars up to the guide simultaneously, to bind each other in position with type bar 1 leading by $\frac{1}{8}$ ". Type bar 22 should rest beside type bar 1 and should be $\frac{1}{8}$ " farther from the platen than type bar 1.

Next, place type bar 42 beside type bar 22 but lagging away from the platen by $\frac{1}{8}$ " from type bar 22 (Figure 6). With the universal bar held in this position, loosen the hex-head stud that holds the rear flat spring to the bracket, to permit the universal bar to be held against the three type bars. Tighten the hex-head stud to retain the bar in this position. Test the tripping point with type bars 1, 22 and 42 to determine that they all trip the escapement at an equal distance from the platen (Figure 6).

2. THE TRIP LINK should disengage the escapement pawl from the rack when any type face is $\frac{3}{8}$ ", plus or minus $\frac{1}{16}$ ", from the platen for the short-tooth escapement. Adjust the trip link in long-tooth escapement machines to trip the pawl when any type face is just striking the ribbon. Check that the pawl spacer does not choke off against the escapement pawl bracket when a type bar is held against the platen (Figure 6).

3. THE TRIPPING POINTS in upper and lower case should be within $\frac{1}{8}$ " of each other when tested with the same type bar. If the upper case type trips earlier than the lower case, form the trip link lug of the universal bar downward.

4. MAIN SPRING TENSION is adjusted by rotating the main spring drum and attaching the pin of the tension tape in a key hole slot in the drum. Check the tension by holding the carriage so that the tab lever is even with the last tab stop. With this stop in the set position, latch the tab lever out and release the carriage. There should be just enough main spring tension to unlatch the tab lever without hesitation.

Maintenance

PITCH IDENTIFICATION. Pica assemblies such as back-space and escapement pawls have no marking. Elite assemblies are stamped with a "0". Other pitches are stamped with identification numbers.

TYPE PILING. Check for binds in the following:

1. Carriage
2. Main spring drum assembly
3. Escapement trip link
4. Universal bar rubbing the segment

The trip link spring, connecting the trip lever and the universal bar, helps to eliminate type piling by restoring the trip lever and pawl spacer faster.

SKIPPING SPACES. If an open space is encountered at the same position on each writing line, check the escapement

rack for a worn tooth. Shimming the rack so that the escapement pawls have a different contact area or replacement of the rack will be necessary.

LUBRICATE the universal bar with IBM lubricant 17 on its contact surface during installation or replacement. Apply IBM ET oil sparingly to the pivot points of the escapement pawls and trip lever whenever they appear dry.

SPACE BAR MECHANISM

The space bar mechanism operates the escapement without printing characters. The space bar key lever trips the cam which (by means of a short link, bell crank and an operating link) pulls on the escapement lever plate. This action causes the escapement lever to actuate the escapement pawl assembly and allows the carriage to move one space (Figure 7).

Adjustments

1. Check for binds in the space bar and key lever.
2. Adjust the cam unit the same as a letter cam.
3. Adjust the operating link so that, when turning the motor coupling by hand, the escapement pawls will be tripped just before the high point of the cam is reached. On the high point of the cam, check that the pawl spacer does not choke off.

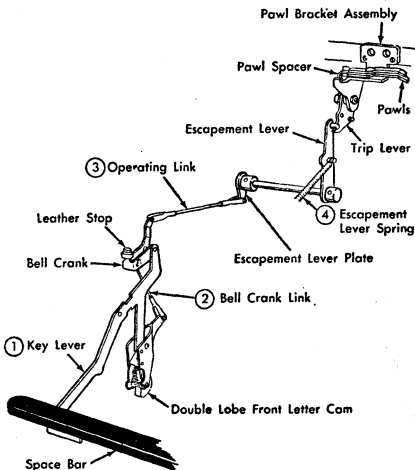

Figure 7. Space Bar Mechanism

4. Be certain that the escapement lever spring is providing enough tension to keep the space bar cam from slipping on the power roll.

Maintenance

Lubricate the pivot points of the space bar equalizing rod with IBM ET oil during inspections.

CARRIAGE AND RAILS

The carriage is mounted on ground carriage rails and travels on hollow steel rollers held in wire containers called trucks (Figure 8). The trucks are retained by star wheels which engage drilled holes in the carriage ways. When the end of carriage travel is reached past the margin stops, final stops on the carriage end plates strike the final stop plate on the bottom of the front rail.

Removal

Truck assemblies and carriage may be removed by the following procedure:

1. Loosen the locking nuts on the rear rail adjusting screws and back the screws out flush with the screw supports.
2. Remove the left-hand rear rail clamping screw and loosen the right-hand screw.
3. From the bottom of the machine, loosen two screws in the rail support eccentrics and turn the eccentrics so that the rails are forced apart as far as possible.
4. Move the carriage to the extreme left, push the rear rail back and use a spring hook to pull the rear truck assembly out to the left. Push the carriage to the rear and remove the front truck assembly.
5. Before lifting the carriage from the rails, remove the carriage return and tension tapes.

Adjustments

Replace carriage and truck assemblies as follows:

1. Place the carriage between the rails so that the carriage release bar is in front of the pawl release lever and the escapement pawls are clear of the rack. Move the carriage to the left against its final stop.
2. As shown in Figure 8, hold the points of the front truck assembly plates down and the star wheel to the left. Then push the assembly into place until it is flush with the end of the rail.
3. Insert the rear truck assembly in the same manner as the front until it is flush with the end of the rear rail.
4. Hold the rear rail forward and move the carriage to the extreme right. Check that both truck assemblies

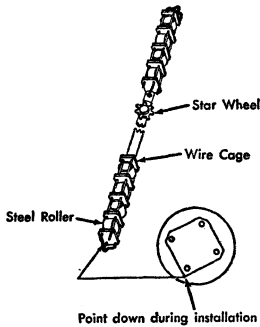

Figure 8. Carriage Truck Assembly

are flush with the ends of the rails, or repositioning of the assemblies will be necessary.

5. Replace and turn down the rear rail clamping screws to hold the rail loosely.
6. Center the carriage and adjust the rail brace eccentrics to remove all play from the carriage and yet permit perfect freedom of movement (Figure 9).
7. Move the carriage to the left and tighten the left side rear rail adjusting screw to just remove all play. Adjust the right side screw with the carriage to the right. Lock the locking nuts and tighten all rail screws. Carriage rails longer than 16" will have end brackets which must be adjusted in the same manner.
8. Fasten the carriage tension and return tapes. Be certain that they have proper tension as described under *Escapement and Carriage Return Mechanisms*.

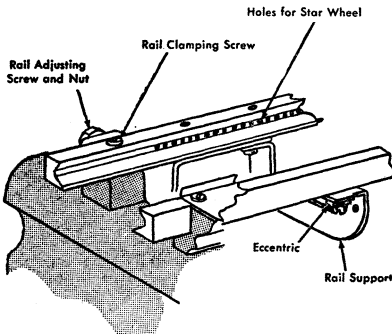

Figure 9. Rail Adjustments

Maintenance

FOR CARRIAGE BINDS, check the following:

1. Broken or cracked roller
2. Binds between the rails
3. Binds between the carriage ways and the plates of the truck assemblies
4. Worn star wheels
5. Worn star wheel holes in the rails
6. Wear in the rails and carriage ways

LUBRICATE the truck assemblies and rollers with IBM lubricant 17 during replacement to eliminate the possibility of carriage squeaking noises.

PAPER FEED

The paper is held against the platen by the pressure of the feed rolls exerted from the platen latch springs through the actuating shaft and the feed roll lift arm.

Adjustments

FEED ROLL PRESSURE can be adjusted by altering the tension of the platen latch springs. On carriages longer than 12", it may be necessary to form the feed roll lift arm on the feed roll actuating shaft to maintain equal pressure on all feed rolls. The lift arm should be formed at a point near the feed roll actuating shaft.

Measure feed roll pressure by rotating a one-inch-wide prepared paper test-strip between the outer feed rolls of each deflector and the platen. Rotate the platen a distance of two teeth for a coarse-tooth ratchet, or three teeth for a ratchet of 44 or more teeth. Hook a tension scale into the eye of the strip. Hold the platen stationary and pull the paper out. The pressure required to withdraw this strip should be two pounds, plus or minus $\frac{1}{4}$ pound.

Pulling down on a spring hook as shown in Figure 10 would decrease feed roll pressure. To increase the pressure,

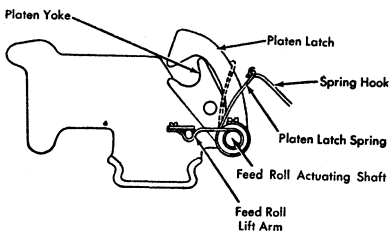

Figure 10. Feed Roll Pressure Adjustment

form the spring with pliers so that the end loop rests higher on the platen latch. Some causes of uneven feed roll pressure can be traced to a bowed feed roll actuating shaft, swollen feed rolls and platen, or warped deflectors.

Maintenance

HORIZONTAL PAPER SLIPPAGE may often be traced to side play of the feed roll actuating shaft. Check for this condition by gripping the actuating shaft with pliers and move right and left while holding the carriage stationary. To eliminate the play, loosen a set screw in the collar that holds the platen latch spring and hold the collar against the carriage end plate while pushing the shaft in the other direction. With the parts in this position, tighten the set screw in the collar (Figure 13).

WRINKLING of stencils and carbon copies can often be eliminated by replacing the black rear feed rolls with a new assembly having gray rollers and larger diameter shaft.

LUBRICATE the pointed screws in the feed rolls shafts with IBM lubricant 17 whenever they are noisy or do not rotate freely. Use IBM ET oil on the rivets in the feed roll release lever and on the pivot points of the feed roll actuating shaft when they appear dry.

SHIFT MECHANISM

The shift mechanism, on the left side of the machine, is operated by a cam and shift head assembly consisting of a T-shaped lever and a bell crank. The T-shaped lever carries an eccentric stud which slides in a slot in the rear of the left-hand key lever. Depressing the key lever raises the T-shaped lever behind the upper of two pins on a plate of the shift toggle levers assembly. When the key lever has traveled two-thirds downward, the cam is released, pulling the T-shaped lever and the upper pin forward. This action rotates the plate and moves the segment support down into the upper case position. Two hairpin springs complete and hold the motion of the segment support. Releasing the key permits the T-shaped lever to pull on the lower pin just as the second lobe of the cam is released.

This process rotates the plate of the shift toggle lever assembly in the opposite direction, to move the segment support back up into the lower case position. Again the same two hairpin springs complete and hold the motion of the segment support. The segment support is guided by four flat springs called segment guides. These guides permit free vertical motion and prevent horizontal motion. Shift stop brackets limit the motion of the segment support (Figure 11).

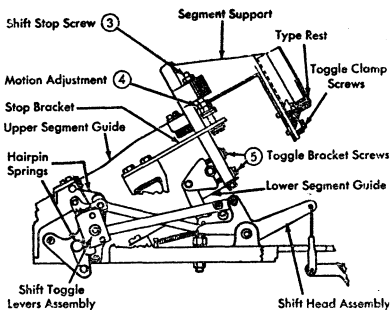

Figure 11. Shift Mechanism

Removal

SEGMENT GUIDE REMOVAL may be accomplished by first removing both mounting screws. Never remove more than one segment guide at a time. When the guides are replaced, they should be permitted to lie in position while the screws are tightened so that the normal position of the segment support will not be disturbed (Figure 11).

STOP BRACKET REMOVAL requires removing the front screws and the shift stop screw. The rear screws need only be loosened, since the rear ends of the stop brackets are open (Figure 11).

SHIFT TOGGLE LEVERS ASSEMBLY REMOVAL may be effected by first removing the power frame. Then remove the shift T-head assembly (Figure 11) and the shift toggle levers assembly.

Adjustments

1. T-LEVER ECCENTRIC. The eccentric on the T lever should be adjusted so that when the shift key lever is slowly depressed the T lever will safely engage the upper pin of the shift toggle levers assembly before the cam trips. When the key lever is slowly released, the T lever will safely engage the lower pin before the cam is again tripped. This adjustment should be checked with the power on.

To move the eccentric, insert a small screwdriver through a hole in the left side frame. Loosen the hex-lock nut with the 12-point box wrench and rotate the screw to the desired position, then re-tighten the hex-nut (Figure 12).

2. RING AND CYLINDER. Adjustment of the shift mechanism cannot be properly made without first setting ring and cylinder. To test for proper ring and cylinder, insert a sheet of bond paper in the typewriter. Raise a type bar toward

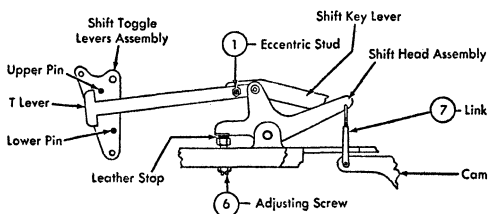

Figure 12. Shift Head Assembly

the platen. With the color control button in a ribbon lift position, insert a small test strip of paper between the ribbon and the platen. With the thumb applying pressure to the type bar directly opposite to the ring, pull the test strip of paper from between the platen and the ribbon. As the test strip is removed a slight drag should be felt. This procedure should be repeated with the test strip of paper between the type bar and the ring.

With the thumb in the same position again, apply the same pressure and remove the test strip of paper. At this time a heavy drag should be felt. Following this same procedure, check for the same drag on the majority of the type bars. If ring and cylinder do not satisfy these conditions, loosen the large hex-nuts that serve as a guide for the hand carriage release levers and, with a screwdriver, rotate the eccentric screw to obtain proper ring and cylinder adjustment (Figure 13).

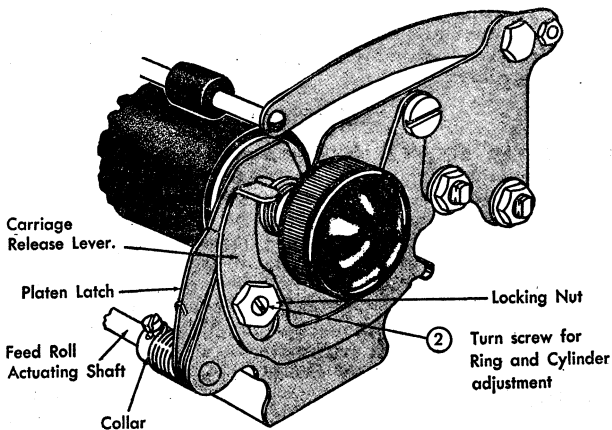

Figure 13. Ring and Cylinder Adjustment

To insure that the platen is parallel to the rails, place a center type bar against the platen. Again, with the thumb applying pressure to the type bar just opposite to the ring, the amount of drag on a test strip of paper should be checked first at the left margin and then at the right margin. The drag should be the same at both positions while using the same type bar. An unequal amount of drag indicates that one of the eccentric screws needs to be readjusted to maintain the platen in a parallel condition.

3. EVEN TOP AND BOTTOM. The shift stop screws should be adjusted so that, when a strike-up is made, the type impressions will appear even on the top and bottom for the majority of the characters (Figure 11). The shift stop screws should be resting evenly on both the left and right-hand stop brackets. This adjustment can be gaged by inserting a small piece of paper between the fibre washer and the stop bracket. When the test strip is removed a drag will be felt. This drag should be the same for both sides. When checking for even top and bottom, the lower case characters should be used for the aluminum segment support and the upper case characters for the steel segment support.

4. MOTION. Adjust the locking nuts on the shift stop screws of the aluminum segment support so that the upper case characters will print on the same line as the lower case (Figure 11). On the steel segment support, adjust the locking nuts on the shift stop screws so that the lower case characters will print on the same line as the upper case. Check the stop washers to be sure they rest evenly on both the right and left-hand stop brackets.

5. EQUAL PIN CLEARANCE. Adjust the toggle link brackets screws until the clearance between the shift T-head and either pin on the toggle lever assembly is equal, without regard for the actual amount of clearance. To check this clearance, remove the power roll and turn the switch on. Place the basket in the lower case position and depress the shift key. This action positions the shift T-head behind the upper pin. Move the shift cam by hand to see how much movement the cam has.

To check the lower pin clearance, move the basket to the upper case position, release the key lever and again see how much movement the cam has. Equal cam movement in both positions indicates equal pin clearance. If there is more upper pin clearance, loosen the two bottom shift toggle screws slightly and tighten the upper screws an equal amount (Figure 11).

6. PIN CLEARANCE $\frac{1}{16}$ ". The clearance between the T lever and the pins should be approximately $\frac{1}{16}$ ". With the basket in the upper case this clearance can be checked from the bottom of the machine. Regulate this clearance by turning the stop retaining screw. Turning this screw in will decrease the pin clearance (Figure 12).

7. **CAM.** Adjust the cam so that the release lever falls on the rear of the cam lug (Figure 12).

Maintenance

SEGMENT SUPPORT. If the segment support does not restore solidly to the lower case position, the segment guide may be weak. With the shift toggle hairpin springs removed, the segment support should float freely about $\frac{1}{16}$ " below a point halfway between the upper and lower shift stops. If the support is too low, remove one of the upper segment guides and reform it upward so that it supports the segment support higher. Duplicate the operation on the other upper segment guide until the proper position is reached. Remove only one segment guide at a time.

UPPER HAIRPIN SPRING. If the upper hairpin spring has been installed with the offset the wrong way it may cause the segment support to stop before it completes its full movement.

SHIFT TOGGLE LEVERS. A bind in this assembly may result if the shift toggle bracket screws are not properly balanced in adjustment. This can be corrected by first removing the hairpin springs and then loosening completely the two right-hand toggle bracket screws. This will allow any twist in the toggle shaft to straighten out. The segment support should then vibrate freely when struck. Turn the loosened toggle bracket screws slowly and when it is felt that the screws begin to tighten, work from one screw to the other and test the segment support for vibration at each step. In this manner the toggle bracket screws may be tightened, equal pin clearance may be maintained, and the segment support will shift with a quick, free movement.

SHIFTING OFF. Shim washers, .010" thick, may be placed under the front ends of the upper segment guides one at a time, to cause the upper case characters to shift off cylinder. This should give an equal density of blackness between upper and lower case. Ring and cylinder adjustment of the platen must be made after shimming the guides. This procedure will be most useful when applied to a machine with a carbon ribbon attachment.

LUBRICATE the pivot points of the shift toggle hairpin springs with IBM lubricant 17. IBM ET oil may be used to lubricate all pivot points of the shift toggle levers assembly and shift T-head assembly.

CARRIAGE RETURN AND LINE SPACE

When the carriage return key lever trips the single lobe cam, the motion of the cam pulls down the clutch operating lever assembly (Figure 14). This action does two things:

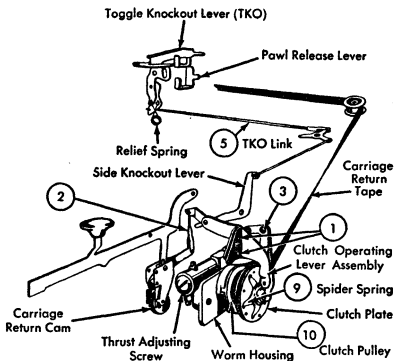

Figure 14. Carriage Return Mechanism

a. It pulls down on the side knockout lever which through linkage raises the toggle knockout lever (Figure 14). The TKO lever strikes an ear on the pawl release lever and rotates it in such a manner as to release the escapement pawl from the rack and actuate the backspace interlock.

b. It moves the toggle link past center which locks the clutch operating lever and causes pressure on the friction disc. This pressure makes the clutch pulley turn and winds up the carriage return tape. The first action of the carriage return tape is to pull down on the hook lever assembly. This action allows the index pawl to enter a platen ratchet tooth. The platen ratchet is then rotated until the index pawl reaches its lower stop (Figure 15). All line spacing motion is halted at this instant and the carriage starts to move to the right. This motion continues until the left-hand margin stop strikes the raised TKO lever. The TKO lever is

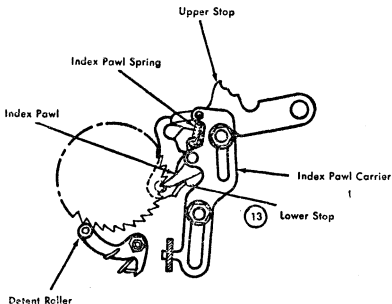

Figure 15. Index Pawl Stop Adjustment

then forced down and, through linkage and the side KO lever, it actuates the clutch operating lever assembly to unlock the clutch.

Removal

CAMS. Refer to the *Cams* section of this manual for removal procedure.

CLUTCH OPERATING LEVER ASSEMBLY. First disconnect the link that connects the carriage return cam to the clutch operating lever assembly. Remove the two screws that hold the clutch operating lever assembly to the side frame so that the complete assembly may be removed. During reassembly, make sure that the side KO lever is under the clutch operating lever before tightening the mounting screws for the clutch operating lever assembly (Figure 14).

CLUTCH FRICTION DISC. Back out the clutch operating lever assembly mounting screws almost completely. Remove the thrust bushing, end plate, and outer clutch plate. The clutch disc can then be removed.

THE CLUTCH PULLEY SPRING. Remove the clutch operating lever assembly mounting screws. Disconnect the carriage return tape from the clutch pulley and let the pulley slowly unwind. Remove the clutch pulley to obtain access to the clutch pulley spring. The removal of the spring will be made easier by using long-nose pliers. When replacing the clutch parts, make certain that the side KO lever is under the clutch operating lever before tightening mounting screws for the clutch operating lever assembly. If this precaution is not taken, the clutch will not unlock when the carriage reaches the left margin (Figure 14).

THE TKO LEVER. Disconnect the TKO link and remove the two screws which secure it to the rear rail.

INDEX PAWL CARRIER ASSEMBLY. Remove the two nuts and washers which retain the carrier on its mounting studs. In replacing the washers, the burr side, or sharp side, of the washers should be mounted away from the carrier to permit the carrier to travel freely without the possibility of binding on the washers (Figure 15).

DETENT ROLLER. Remove the lock nut, the eccentric nut, and the detent spring from their mounting stud (Figure 15).

HOOK LEVER ASSEMBLY. Detach the hook lever spring. This is easily accomplished by inserting the push end of the spring hook into the spring's end curl and pushing downward. Unhook the carriage return tape from the hook lever assembly and remove the two screws which secure the assembly to the carriage bed.

PLATEN RATCHET. First remove the platen variable button. To prevent damage to this button a platen variable button tool is provided. Back out the two set screws which

secure the platen knob to the clutch cover and sleeve assembly. Remove the platen bushing and the four screws from the clutch cover and sleeve assembly. Then remove the platen ratchet carefully, because the platen ratchet driver compression spring will probably force the driver and shaft assembly from the end of the platen.

Adjustments

1. **BRACKET.** Check the two screws which mount the clutch operating lever assembly to the side frame to insure that they are not loose or broken. Check to see that the pivot points of the toggle are free from binds (Figure 14).
2. **CAM.** Adjust the cam to the power roll, so that the lug on the cam release lever just drops behind the lug on the cam when the cam is tripped with the power off (Figure 14).
3. **CLUTCH CLEARANCE.** By loosening the screw in the elongated slot of the clutch operating lever assembly, position the clutch lever so that there is a clearance of .010" between the clutch disc and the clutch plate (Figure 14).
4. **SIDE KNOCKOUT LEVER.** Form the lower arm of the side knockout lever so that it rests within $\frac{1}{4}$ to $\frac{1}{8}$ " from the link to the carriage return cam (Figure 16).
5. **TKO LINK.** Before adjusting the TKO link, the height of the tab lever should be properly set to clear the margin rack by .010" to .015" as outlined in the *Tabular Mechanism* section, adjustment 2 (Figure 22). Adjust the TKO link so that, with the clutch locked, the left margin stop will con-

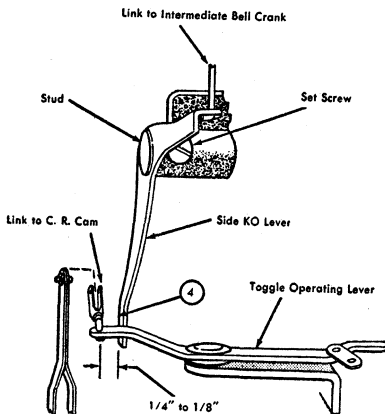

Figure 16. Side Knockout Lever Adjustment

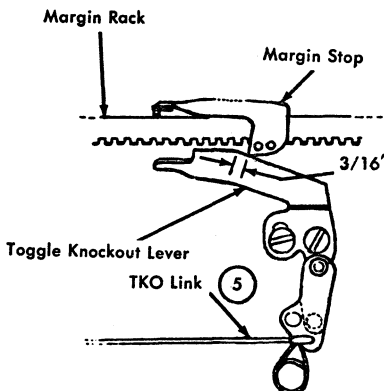

Figure 17. Toggle Knockout Link Adjustment

tact the TKO lever at a point on its inclined surface $\frac{3}{16}$ " down from the TKO's upper surface (Figures 14, 17). If the TKO lever cannot be raised high enough, it may be necessary to form the TKO tip down temporarily (Figures 14, 17).

6. TKO TIP. Form the tip so that, with the clutch locked, the tip will just touch the bottom of the angular plate of the tab lever when the tab lever is at rest (Figure 18). To test this adjustment, use a simultaneous operation of the carriage return and tab. The tab lever should safely unlatch the clutch and proceed to the next set tab stop.

7. PAWL CLEARANCE. Adjust pawl clearance by loosening the locking screw at the mounting point of the pawl release lever and rotating the eccentric nut to obtain a $\frac{1}{64}$ " clearance between the escapement pawls and the escapement rack when the clutch is latched. To obtain proper

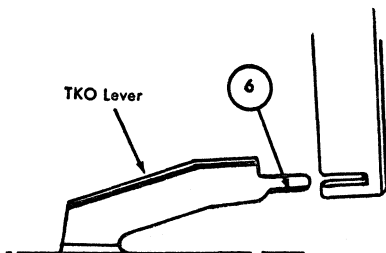

Figure 18. Forming the TKO Tip

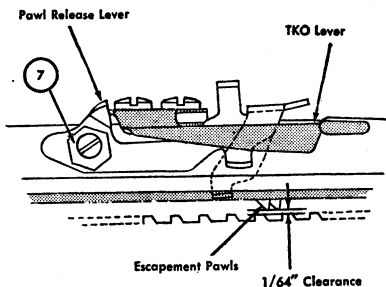

Figure 19. Pawl Release Lever Eccentric

leverage, keep the high point of the eccentric toward the front of the machine (Figure 19).

8. OVERBANK. This term is applied to the amount of play between the left-hand margin stop and the head of the tab lever when the carriage is resting at the left-hand margin. Overbank is adjusted by moving the margin rack to the left or right. Position the margin rack so that, at the instant the left-hand margin stop contacts the head of the tab lever, an escapement pawl will click into the tooth of the escapement rack. Observe this adjustment by slowly moving the carriage to the left-hand margin from a position of one or more spaces from the left margin (Figure 20).

9. SPIDER SPRING. By turning the retainer and spring assembly, adjust the spider spring tension for the proper carriage return action. With the line space mechanism in the triple line space position, the carriage should occasionally fail to return to the margin from a spot about one inch from the margin. It should never fail on double or single line space position from any distance (Figure 14).

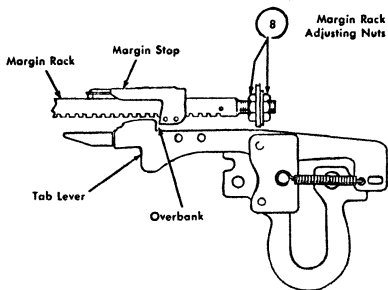

Figure 20. Overbank Adjustment

10. CLUTCH PULLEY SPRING. Completely wind this spring. Then back off two to four turns before the carriage return tape is attached to the clutch pulley (Figure 14).

11. HOOK LEVER SPRING. Form this spring so that it will positively restore the index pawl carrier to its upper stop. Make this observation with the carriage at the extreme right and with the line space lever to the rear. Too much tension on the spring can cause excessive whip of the carriage return tape, which tends to slow down the speed of repeat line spacing.

12. DETENT ECCENTRIC. Adjust the eccentric nut of the detent arm so that the index pawl will enter the ratchet one-third of the distance down on a tooth. The high point of the eccentric should be kept in the upper half of its circle (Figure 21).

13. LOWER INDEX PAWL STOP. Loosen its lock nut and move the stop so that it halts all downward movement of the line space mechanism when the detent roller is squarely positioned between two teeth. Check this by pulling on the carriage return tape until the index pawl strikes the lower stop. Then slowly relax the tension. There should be no further rotation of the platen, either forward or backward (Figure 15).

Maintenance

CAM STICKING. If the carriage return cam occasionally fails to restore after an operation, check the link from the cam to the clutch operating lever assembly. This link should be inserted in the hole of the clutch operating lever from the rear. Binds are sometimes caused if the link enters from the front. For further information, refer to the *Cams* section of this manual.

Three sizes of clutch pulleys are available. Consult the parts catalogue for the appropriate pulley to be used on the various carriage lengths.

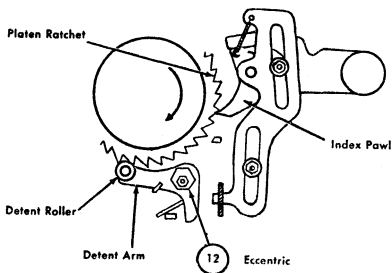

Figure 21. Detent Eccentric Adjustment

SLOW OR WEAK CARRIAGE RETURN. Causes are the following:

1. Oily clutch disk
2. Weak spider spring
3. Micro-switch not making contact
4. Excessive clutch plate clearance
5. Loose power frame screws
6. Loose clutch operating lever assembly mounting screws
7. Gummy grease in worm gear housing
8. Shiny clutch disk
9. Clutch pulley rubbing the black metal base
10. Weak motor
11. Wrong motor
12. Wrong governor

CLUTCH TOGGLE FAILING TO LOCK. Causes are the following:

1. Worn or binding toggle joints
2. Broken clutch operating lever assembly screws
3. Backspace interlock choking off on backspace pawl
4. Cam clearance excessive
5. TKO tip too high
6. TKO link too short
7. Loose margin rack
8. Excessive escapement pawl clearance
9. Excessive clutch plate clearance
10. Tab lever not in rest position

CARRIAGE RETURNING TOO HARD. Causes are the following:

1. Clutch plate clearance too close
2. Spider spring adjusted too tight
3. Dirty or gummy clutch disk

CLUTCH TOGGLE FAILING TO UNLOCK. Causes are the following:

1. TKO link too long
2. Hairpin spring on TKO lever too weak
3. Side knockout lever not under toggle operating lever
4. Binding toggle joints
5. Clutch plate clearance small and spider spring tight
6. Side KO lever too far from the link to carriage return cam
7. Weak motor or low line voltage
8. An open micro-switch
9. Gummy grease in worm gear housing
10. Loose stud in side KO lever
11. DC motor on AC

LINE SPACE FAILURE. Causes are the following:

1. Slow repeat line space action. (Wind up clutch pulley spring all the way and attach tape.)
2. Slippage between platen ratchet and platen ratchet driver
3. Lower index pawl stop improperly adjusted

4. Index pawl spring broken or loose
5. Detent roller arm out of adjustment
6. Broken or weak hook lever spring, causing failure to rotate the platen backwards
7. Worn detent roller
8. No lubrication on the hook lever spring

Maintenance

Lubricate all links, clevises, and pivot points with IBM ET oil. To prevent the clutch pulley spring from rusting lubricate it by running the spring through an oily cloth. Grease springs and bearing or sliding surfaces.

TABULAR MECHANISM

Depression of the tab key lever releases a single lobe cam. As the cam assembly moves it develops a pull on the tab bell crank. The tab operating link transfers the motion of the bell crank to the tab actuating lever. As the tab actuating lever moves toward the front of the machine, it contacts the tab lever and pivots it about its mounting point. This motion moves the right end of the tab lever toward the rear, striking the pawl release lever and removing the escapement pawls from the rack. The tab lever moves far enough to the rear to allow the tab latch to spring in front of it and hold the tab lever in the latched-out position. Tab lever extension parts contact an upright stud of the rebound check lever, moving the rebound check lever to the rear.

The carriage begins to move to the left under tension of the main spring until the tip of the tab lever strikes a set tab stop. This forces the tab lever over to the left and allows it to become disengaged from the tab latch. Now the tab lever begins to restore to its rest position, allowing the pawls to re-enter the escapement rack. The rebound check lever moves into place to the right of the set tab stop as the tab lever is forced to the left. It is now in a position to block any movement of the carriage toward the right as the carriage tends to rebound. When the tab lever restores to rest, it moves the rebound check lever to rest (Figure 22).

As the tab lever is latching out, it moves the tab governor pawl which engages the friction plate to regulate the speed at which the carriage moves.

Removal

KEY LEVER, BELL CRANK AND CAM. To remove these parts, follow the procedure outlined under the appropriate sections of this manual.

TAB LEVER ASSEMBLY. Unhook the tab lever spring and remove the two mounting screws which secure the tab lever assembly to the rear rail. Remove the margin rack, being

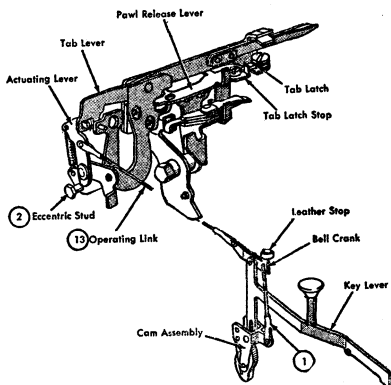

Figure 22. Tabular Mechanism

careful not to disturb the adjustment of the inside nut on the left end of the rack. In this manner the overbank adjustment should not change. Move the tab lever assembly to the rear far enough to clear the dowel pin and lift the assembly out through the top of the carriage.

TAB LATCH. To facilitate removal of the tab latch, it is advisable to back out the mounting screws that mount the TKO lever to the rear rail. Obtain further clearance by removing the margin rack.

Adjustments

1. CAM CLEARANCE. Adjust cam clearance to the power roll so that the cam release lever will drop behind the cam lug when tripped with the power off. Be sure the leather stop of the tab bell crank is touching the underneath side of the key lever spring support when this adjustment is observed (Figure 22).

2. TAB LEVER HEIGHT. Adjust height so that it will just clear the under side of the margin rack by .010" to .015". This adjustment is made by means of the eccentric stud on which the tab actuating lever rests (Figure 22).

3. TAB RACK (two ways.) Clearance between the left-hand faces of the tab stops and the engaging face of the tab lever is from .002" to .015", tested at both ends and the middle of the rack. Position the carriage so that a set tab stop is even with the tab lever. Slowly move the tab lever out toward the rear by hand and observe the amount of clearance between the parts indicated. The continued motion of the tab lever will remove the escapement pawl from the rack. The reading will have no value, unless the carriage

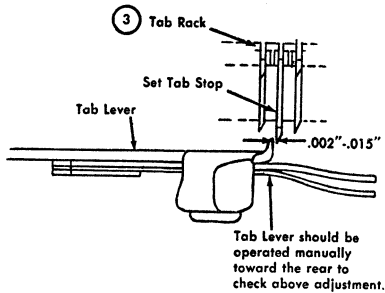

Figure 23. Tab Rack Lateral Adjustment

is held rigidly during the test. Adjust nuts on the ends of the tab rack. The tab rack must be squared so that the engaging tip of the tab lever is parallel to the set tab stops when sighted from the end of the carriage (Figure 23).

4. TAB LATCH. Adjust by first loosening the lock nut under the rear rail on the tab latch eccentric screw. Latch out the tab lever and rotate the eccentric screw until the engaging tip covers a set tab stop by $\frac{1}{2}$ to $\frac{2}{3}$ of the exposed surface of the stop. Tighten the lock nut (Figure 24).

5. TAB LATCH STOP. Position the tab latch stop so that, with the tab lever held toward the extreme left, there will be a clearance of .005" to .010" between the left-hand edge of the latch and right-hand edge of the tab lever where the tab lever, at rest, meets the latch (Figure 24).

6. REBOUND CHECK LEVER. Adjust this lever by rotating the eccentric nut at its mounting point so that, when the tab lever is held in the latched-out position and is forced to the left by a set tab stop, the rebound check lever will spring into place with a maximum clearance of .010". Keep the high point of the eccentric nut in the rear half of its circle (Figure 25).

7. REBOUND CHECK ECCENTRIC STUD. Located just behind the tab rebound check lever, the eccentric stud should

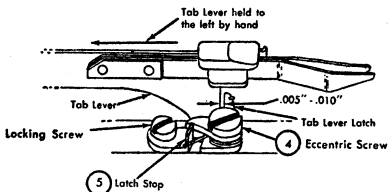

Figure 24. Tab Latch Stop Adjustment

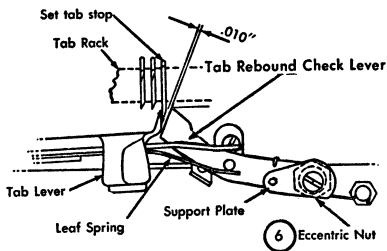

Figure 25. Rebound Check Lever Adjustment

be adjusted so that, when the tab lever is latched out, the check lever will have a minimum clearance of .010" between the tip of the check lever and the tab rack (Figure 26).

8. SUPPORT PLATE. The rebound check lever must not rub the bottom of the tab lever, but must be high enough to catch securely on the tab stops. It must be flush with the bottom of the tab stops or preferably .010" above the bottom. Height of the rebound check lever is adjusted by forming the support plate up or down (Figure 26).

9. TAB LEVER EXTENSION. Form this extension so that, at rest, the engaging tip of the tab lever and the rear corner of the rebound check lever are even when viewed from the top of the machine (Figure 27).

10. TAB LEVER LEAF SPRING. Form this spring to just touch the stud on the rebound check lever while in its rest position (Figure 27).

11. REBOUND CHECK BRACKET STOP. Form this stop to hold the rebound check in a position to cause the tab lever to lie parallel with the rear rail. Early model 01 machines may not have this bracket. It can be installed and

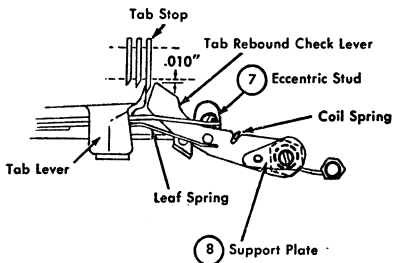

Figure 26. Rebound Check Eccentric Stud Adjustment

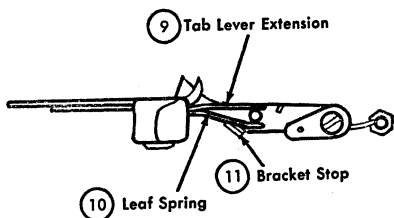

Figure 27. Tab Lever Extension and Leaf Spring

is often helpful in preventing the tab lever from binding in its bracket (Figure 27).

12. PAWL CLEARANCE. (a) The rear upright lug on the pawl release lever is formed to remove the escapement pawls $\frac{1}{64}$ " from the escapement rack during tabulation. (b) The two pawls are drawn from the rack an equal amount. Unevenness may be corrected by forming the lower lug on the pawl release lever that contacts the pawls (Figure 28).

13. TAB OPERATING LINK. Adjust so that when the cam is on its high point, the tab lever will over-throw the tab latch by .010" to .020" to insure that the latch will move into place (Figure 22).

14. TAB LEVER STOP. Adjust so that when the cam is on its high point there will be a clearance of from .000" to .005" between the stop and the tab lever (Figure 29).

15. TAB GOVERNOR PAWL LINK. Adjust so that, when the tab lever is latched out, the governor pawl will engage

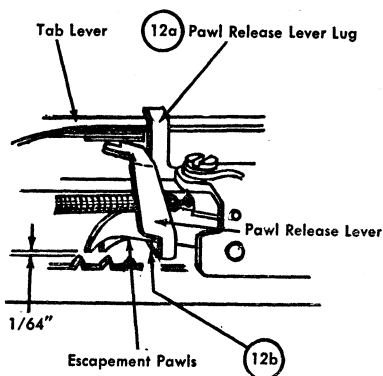

Figure 28. Pawl Clearance Adjustment

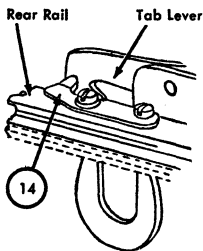

Figure 29. Tab Lever Stop

the friction governor plate by the thickness of the metal of the governor pawl (Figure 30).

16. THE TAB FRICTION GOVERNOR. Adjust by turning the double nuts and increasing or decreasing the pressure of the spider spring until the speed of tabulation approximates the speed of carriage return (Figure 30).

17. TAB SET. The holes in the rear cover plate are elongated for adjusting the set lever to strike squarely on the tab stops. Adjust the tab set link so that, when the tab set button is depressed, it will push the stop down fully in the set position. When in a rest position, the tab set lever should clear the unset tab stops by $\frac{1}{32}$ ".

18. TAB CLEAR. Loosen the clamping screw which secures the clear lever to its shaft and center the "V" of the clear lever with respect to the tab set lever. Adjust the tab clear lever link to fully clear a set tab stop when the tab

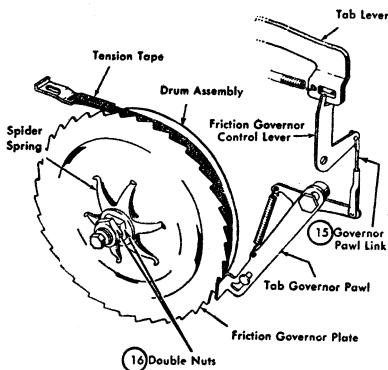

Figure 30. Tab Friction Governor

clear button is pushed down. When in a rest position, the tab clear lever should clear the set tab stops by $\frac{1}{32}$ ".

Maintenance

Improper forming of the tab lever extension could allow the rebound check to be slow in restoring as the tab lever comes to rest. This condition could cause a lock-up of the carriage during a simultaneous operation of carriage return and tab.

In some cases, the carriage release universal bar may rub the tab rebound check lever if the high point of the rebound check lever eccentric is not kept toward the rear.

At times the tab governor pawl may drag on the friction plate during carriage return or fail to release after the tab lever has unlatched. This may be caused by the following conditions: (1) The tab operating link is too short and holds the tab lever out of its true rest position. (2) There is too much play in the fork of the tab governor control lever. (3) The rebound check bracket stop is formed too far to the rear and holds the tab lever to the rear. (4) The governor pawl link is out of adjustment. (5) The tab latch is not adjusted far enough to the rear to give full motion of the tab lever.

TAB REBOUNDING. This condition occurs when the tab lever comes to rest less than two spaces past the set tab stop. The following factors may cause rebounding:

1. Too little clearance between the tab lever and the tab latch when the tab lever is pulled to the left
2. Excessive rebound check lever clearance
3. The support plate formed too low, causing the rebound check lever to operate below the set tab stop
4. Leaf spring broken or malformed
5. Tab governor pawl not holding in the friction governor plate
6. Insufficient friction governor pressure
7. Too little clearance between tab lever and a set tab stop
8. Tab stops not parallel to the tip of the tab lever

TAB SKIPPING. This is a condition in which the tab lever comes to rest more than two spaces past the set tab stop. The following factors may cause skipping:

1. Too little clearance between the tab lever and the tab latch when the tab lever is held to the left
2. Excessive pawl clearance
3. Tab governor pawl not holding in the friction governor plate
4. Too much clearance between the tip of the tab lever and a set tab stop
5. Insufficient bite of the tab lever on a set tab stop

CARRIAGE LOCK-UP. This condition may occur during a simultaneous operation of tab and carriage return. It may be caused by the TKO tip's being too low or the TKO link's being too long. In addition, the tab rebound check lever may be locked against a set tab stop. This lock occurs when the rebound check lever lags behind the tab lever while the parts are restoring. Form the tab lever extension to the front to correct this condition.

If the tab lever fails to latch out, check the following items:

1. Excessive cam clearance
2. Operating link too long
3. Binds in the tab lever
4. Tab lever stop too far to rear
5. Bind in tab latch
6. Broken or weak tab latch spring
7. Tab latch stop too far to rear
8. Loose tab latch eccentric screw

NOISY, SKIPPING CONDITION. This is caused by insufficient bite of the governor pawl into the friction plate. Lengthening the governor pawl link to overcome this condition sometimes causes the pawl to drag when the tab lever is at rest. Under these circumstances, check the following:

1. Worn teeth on the friction plate
2. Worn or rounded engaging surface of the governor pawl
3. Tab lever's failing to rest parallel to the rear rail, the result of a short adjustment of the tab operating link or of a maladjustment of the tab rebound check bracket stop
4. The governor control bracket which should be positioned as far to the left as possible
5. Play (which should be at a minimum) between the tab lever and the fork of the governor control lever
6. The tip of the tab lever which should engage at least $\frac{1}{2}$ the exposed surface of the set tab stop
7. Play in the linkage which may be removed by connecting a spring to the tab governor pawl assembly and the friction governor control lever

LUBRICATION. IBM ET oil may be used on the following points:

1. Tab lever pivot or mounting point
2. Tab latch
3. Rebound check lever pivot
4. Tab actuating lever and governor control lever pivots
5. The sliding points of the governor pawl

BACKSPACE MECHANISM

When the backspace key is depressed, it releases a single lobe cam. The cam pulls on the link to the backspace bell

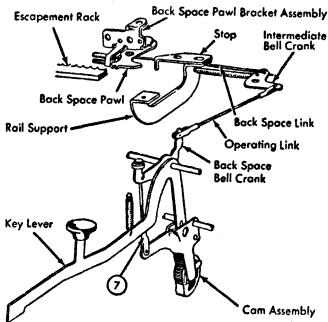

Figure 31. Backspace Mechanism

crank which moves the backspace operating link. This action rotates the intermediate bell crank, pulling on the backspace link to move the backspace pawl. When the pawl begins to move, it is cammed toward the escapement rack because of the angular slot of the pawl and the fact that the springs hold the pawl against the guide lug. When the pawl has moved as far as the slot will permit, it then is engaged with the teeth of the escapement rack. Further motion moves the pawl to the right which moves the carriage over one space. At this time the backspace pawl hits the backspace pawl stop and halts any more motion to the right (Figure 31).

The backspace interlock is actuated by the pawl release lever during carriage return, hand carriage release, and tabulation. If a backspace is attempted at the time one of these three operations is taking place, the backspace pawl will not enter the escapement rack. However, if the backspace is operating and hand carriage release, carriage return, or tabulation is attempted the interlock will be choked off on the backspace pawl, and these operations may fail.

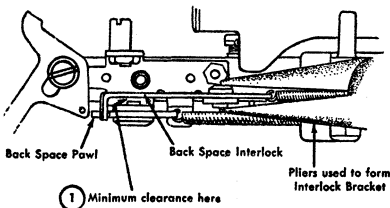

Figure 32. Adjusting Height of Interlock

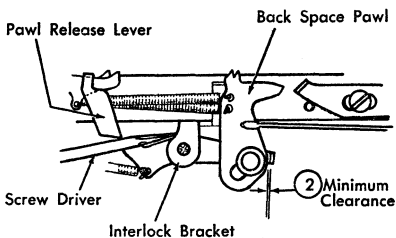

Figure 33. Increasing Interlock Clearance

Removal

Remove the backspace pawl bracket assembly by first detaching two springs (a spring to the interlock and a spring to the bell clapper) from the pawl. Remove the two studs that mount the bracket assembly to the rear rail. On the new style backspace pawl assembly, the spring that formerly ran from the interlock to the tab lever mounting stud is now connected to the interlock and the rear spring hole of the backspace pawl. This spring may remain attached during backspace pawl removal.

Adjustments

1. HEIGHT OF INTERLOCK. The interlock mounting bracket must be formed up or down to obtain a minimum amount of clearance between the interlock and the riveted stud that mounts the backspace pawl to its bracket (Figure 32).

2. INTERLOCK BRACKET POSITION. Form the interlock mounting bracket left or right to obtain a minimum clearance between the right angle lug of the interlock and the backspace pawl while the backspace pawl is in the rest position and the interlock is in its actuated position (Figures 33 and 34).

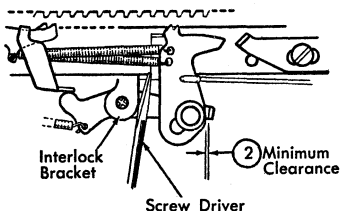

Figure 34. Decreasing Interlock Clearance

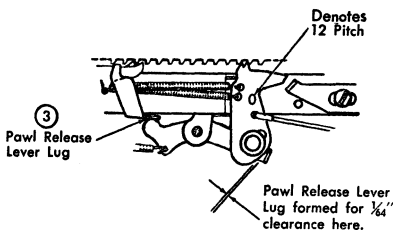

Figure 35. Pawl Release Lever Lug against Interlock

3. PAWL RELEASE LEVER LUG AGAINST INTERLOCK.

The final adjustment of the interlock requires the pawl release lever to lie flat against the rear rail. Maladjustment of the two upper lugs on the pawl release lever could prevent this. Then, with a T-bender, form the projecting lug on the rear of the pawl release lever so that, with the interlock at rest, the backspace pawl may be moved past it with $\frac{1}{64}$ " clearance (Figure 35).

4. BACKSPACE PAWL GUIDE LUG. Adjust the backspace guide lug by forming left or right so that the backspace pawl enters the escapement rack with approximately $\frac{1}{64}$ " clearance between the working surfaces of the pawl and the rack teeth. Figure 36 illustrates a method of forming the guide lug to the right. Figure 37 illustrates a method for forming it to the left.

5. BACKSPACE PAWL STOP (two ways). Loosen the two screws that secure the backspace pawl stop to the rear rail and move the stop to the extreme right. Trip the backspace cam with the power off and rotate the motor coupling by hand. At the instant the carriage has moved far enough for

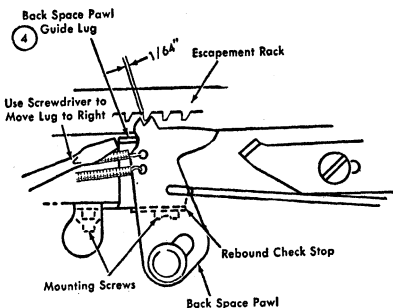

Figure 36. Guide Lug Adjustment

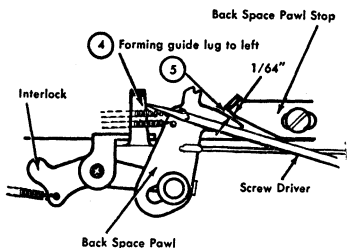

Figure 37. Space Stop Clearance

an escapement pawl to drop into the next rack tooth, stop turning the motor coupling. Move the backspace pawl stop so that it just touches the backspace pawl. Lock the screws (Figure 38). The stop should also be positioned front or rear so that, when the interlock is actuated and the backspace is operated, the backspace pawl will clear the stop by about $\frac{1}{64}$ " (Figure 37).

6. THE OPERATING LINK. Adjust so that the working side of the hole in the intermediate bell crank will have a clearance with the working side of the backspace link of $\frac{1}{64}$ " (Figure 39).

7. CAM CLEARANCE. Adjust cam clearance to the power roll so that the cam release lever will drop behind the cam lug when tripped with the power off. Be sure the leather stop of the backspace bell crank is touching the underneath side of the key lever spring support when this adjustment is observed (Figure 31).

Maintenance

CAM RUBS THE POWER ROLL. This can often be traced to a missing leather stop in the backspace bell crank. Coat the stop with glue and replace by using a pair of long-nose pliers.

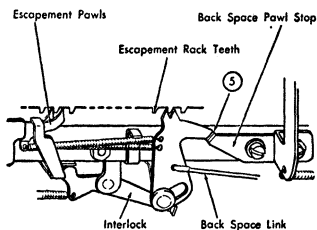

Figure 38. Backspace Pawl Stop Adjustment

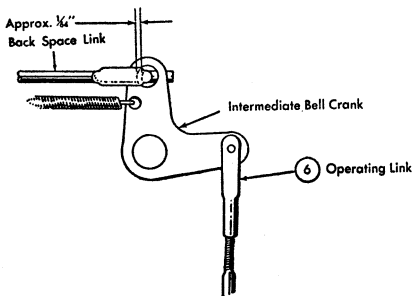

Figure 39. Operating Link Adjustment

NO BACKSPACE MOTION can often be traced to a broken cam, a broken backspace bell crank, a broken backspace link or operating link.

BACKSPACING TWO SPACES may be caused by too much motion between the hole in the backspace intermediate bell crank and the backspace link. The backspace stop could be loose, adjusted wrong, or broken. Also the guide lug may be malformed or broken.

LUBRICATE with IBM ET oil the backspace pawl, the interlock, and both bell cranks.

RIBBON FEED MECHANISM

When a type bar moves toward the platen its bell crank rotates the ribbon lift bar, transferring motion to the ribbon feed levers. The top portion of the feed lever moves toward the front of the machine and moves the ribbon feed pawl. Simultaneously, a ribbon check pawl keeps the ribbon spool from rotating. As the mechanism restores, the ribbon feed pawl restores toward the rear of the machine by the tension of the feed pawl spring and rotates the spool for one full tooth of ribbon feed. Approaching the end of the ribbon spool, the ribbon is drawn tight by feeding on the opposite spool. The tension pulls the ribbon reversing lever to the rear and moves the spring arm at the bottom of the reversing lever.

When the spring arm moves, it positions a lug on the front end of the ribbon reverse pawl in the path of the ribbon feed lever. As the ribbon feed lever again moves to the front, it will contact this lug and pull the reversing pawl forward. This action rotates the ribbon reverse bar and disengages the feed and check pawls from one spool, allowing the pawls on the other side to become engaged.

The hairpin spring on the ribbon reverse bar completes

the rotation and holds the reverse bar in position until another reversing action takes place (Figure 40).

The color control button positions a small roller attached to the ribbon guide link. When the button is pushed all the way in, the small roller is positioned closest to the pivot point of the ribbon lift control plate. This permits typing in the black ribbon position. When the button is pulled out one notch from the black position, the roller is over a slot in the ribbon lift control plate. This position prevents ribbon lift when the control plate is moved. It also determines the stencil position. Pulling the button out as far as its stop will permit brings the roller farthest away from the pivot point of the control plate. This position gives maximum ribbon lift and allows typing on the bottom portion of the ribbon (Figure 41).

Removal

RIBBON LIFT BAR AND CONTROL PLATE ASSEMBLY may be removed by first removing the power frame from the base.

RIBBON FEED LEVERS may be removed by following the procedure given for bell crank removal.

Adjustments

1. THE ENDS OF THE RIBBON LIFT BAR should be formed so that, with a type bar held against the platen, there

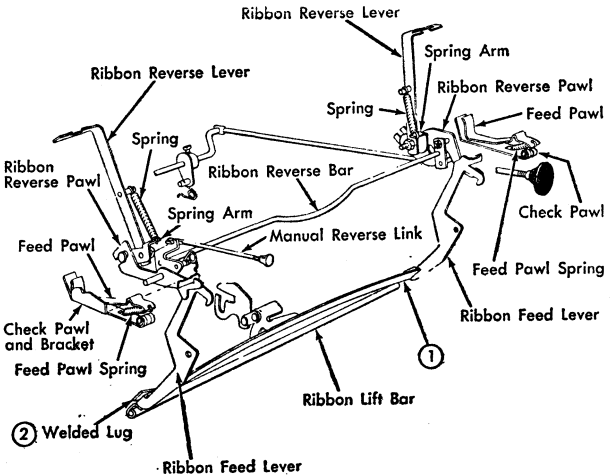

Figure 40. Ribbon Feed Mechanism

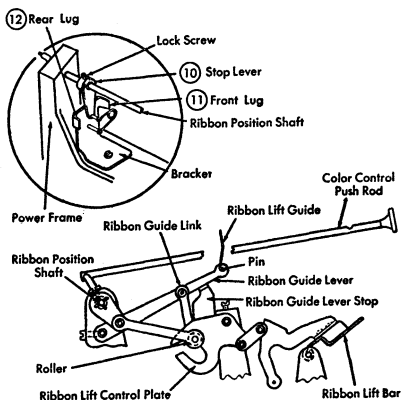

Figure 41. Ribbon Lift Control Mechanism

will be a minimum of clearance between the ribbon lift bar and the ribbon feed levers. To check this adjustment, hold a type bar against the platen and observe that the feed pawls can be moved slightly farther before they choke off. Check with type bars at both ends and at the center of the basket (Figure 40).

2. THE WELDED LUG on the ribbon lift bar should be formed so that it just touches the ribbon feed lever lug when the ribbon lift bar is in the rest position. Check the movement of feed pawls to ascertain this clearance (Figure 40).

3. THE RIBBON CHECK OR FEED PAWL should be formed so that they rest about $1\frac{1}{2}$ teeth apart when engaging the spool. When operating a type bar by hand, the feed pawl must stay bottomed in a tooth of the spool. It should have a minimum motion of $1\frac{1}{2}$ teeth to insure a positive one-tooth feed. Use a left-hand type bar to check the right-hand feed. Use a right-hand bar to check the left-hand feed. This method will provide a critical test for satisfactory ribbon feed (Figure 42).

4. REVERSE LEVER SPRINGS must be just strong enough to keep the reverse levers in their normal position, when the ribbon feed mechanism is operated (Figure 43).

5. RIBBON SPOOL TEETH should contact the middle of the feed and check pawls. Obtain this position by moving the spool retaining springs up and down, after first loosening their mounting screws. The retaining spring should also have sufficient pressure against the side of the spool to prevent the ribbon's becoming so loosely wound on the spools that the reverse operation is sluggish (Figure 43).

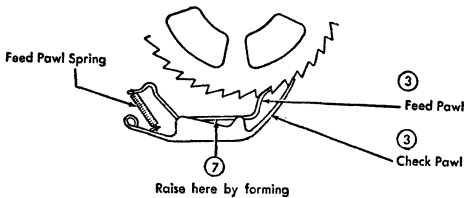

Figure 42. Ribbon Feed Pawl and Check Pawl Adjustment

6. RIBBON REVERSE LEVERS must clear the ribbon spool teeth by about $\frac{1}{16}$ ". Their position can be adjusted by forming the lug of the spring arm against which they rest (Figure 43).

7. THE RIBBON FEED PAWL on the supply side should not drag against the spool. Select the type bar closest to the supply side, hold it against the platen, and rotate the supply spool. If the feed pawl drags, remove it and form a raised curvature in the area that contacts the reversing bar (Figure 42). Recheck the ribbon feed.

8. THE RIBBON REVERSING MECHANISM requires checking for a positive reversing action when the left spool is feeding. Make this check by typing with type bar 1 and

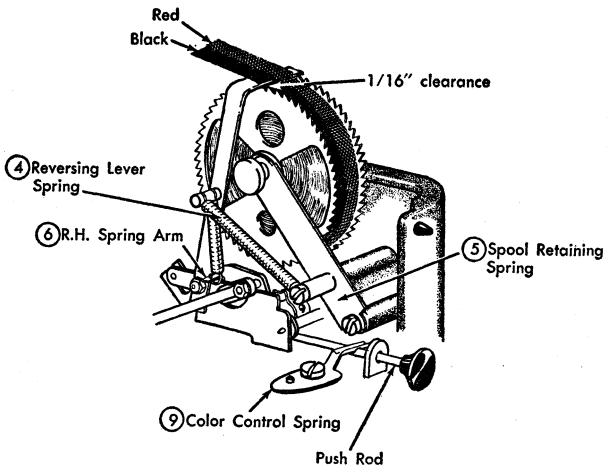

Figure 43. Ribbon Reverse Lever Adjustment

moving the right-hand reversing lever to the rear. When the right spool is feeding, type with type bar 42 and move the left-hand reversing lever to the rear. If the reversing operation is sluggish or faulty, refer to the maintenance guide at the end of this section.

9. THE COLOR CONTROL SPRING should be adjusted to obtain the stencil position. In machines above serial number 56770, engage the spring in the "V" groove of the push rod. Position the spring so that the ribbon will not lift during typing (Figure 43). This will place a roller directly over a vertical slot in the ribbon lift control plate. In machines below serial number 56770, repeat the above procedure with the color control spring engaging the center of three pointed projections on the push rod.

10. THE COLOR CONTROL STOP LEVER should be adjusted to a central position within the lugs of the color control stop bracket when the color control spring is in the "V" of the push rod (Figure 41).

11. THE FRONT LUG of the color control bracket should be formed so that, when the color control stop lever is against it, the tallest characters will strike the ribbon $\frac{1}{32}$ " down from the top edge (Figure 41). In machines below serial number 56770, this condition is obtained by moving the color control spring a small distance when it is engaging the front projection of the push rod. If the spring is moved, recheck and maintain the stencil position.

12. THE REAR LUG of the color control bracket should be formed so that, when the stop lever is against it, the underscore will print $\frac{1}{32}$ " above the bottom edge of the ribbon (Figure 41). In machines with serial numbers below 56770, achieve this adjustment by moving the color control spring when it engages the rear projection on the push rod. Any change in the position of the spring will change the tracking of the type on the upper half of the ribbon and could affect the stencil position. Balance these adjustments carefully.

13. RIBBON REVERSE FAILURE may often be traced to the following items:

1. A bind in the ribbon reverse bar
2. Too much or too little tension in the ribbon reverse bar hairpin spring
3. Ribbon wound too loosely on the spools
4. Failure of the ribbon to feed a full $1\frac{1}{2}$ teeth
5. Worn ribbon reverse pawl tip
6. Worn feed pawl or check pawl
7. Weak spring arm spring

14. RIBBON FEED FAILURE may often be traced to the following items:

1. Weak feed pawl springs
2. Worn feed pawl or check pawl

3. Defective teeth on a ribbon spool
4. Spool's being in backward
5. Bent sides of spool
6. Spool retaining-springs too strong
7. Too much lost motion between the feed lever and ribbon lift bar

15. THE RIBBON LIFT PIN may be replaced with a type bar rest rivet in case the pin should become lost.

Maintenance

Use IBM ET oil to lubricate the pivot points of the ribbon feed levers, the spring arm and reverse lever, ribbon reverse bar, the color control plate link and all other pivot points of the ribbon lift mechanism. Use IBM lubricant 17 on the points of contact between the ribbon feed levers and the ribbon lift bar, the pivot points of the reversing bar spring, the color control stop lever spring, and the points of contact of the roller and ribbon control plate.



**EXECUTIVE ELECTRIC TYPEWRITER
MODEL 04
CUSTOMER ENGINEERING REFERENCE MANUAL**

Preventive Maintenance and Adjustments

CONTENTS

	<i>Page</i>
Motors	3
Gear Drive and Power Roll	3
Key Levers, Cams, and Type Bars	3
Interlock Bar	4
Selection Mechanism	4
Escapement Mechanism	9
Carriage Release	13
Carriage Return	15
Tabulation	17
Detent-Pawl Assembly	19
Backspace	20
Space Bars	22
Ribbon Feed	22
Ribbon Lift	22
Margin Release	23
Card Holder	23
Platens	23
Carriage	23
Power Frame	24

INTERNATIONAL BUSINESS MACHINES CORP.

NEW YORK 22, NEW YORK

Form 25-6672-0 (This section only)

**Copyright 1955 by
International Business Machines Corporation
590 Madison Avenue, New York 22, N. Y.**

Printed in U.S.A.

Form 25-6672-0

IBM ELECTRIC EXECUTIVE TYPEWRITER

Model 04

ADJUSTMENT procedures for parts and assemblies on this machine which are the same as those for the Model 01 will not be covered in this section. Refer to the Model 01.

MOTORS

Old style Westinghouse motors with the Lee governor cannot be used because their extra length interferes with the selector mechanism. Short motor wire leads cannot be used because the terminal block is positioned farther to the rear of the typewriter.

Refer to the Model 01 reference sections for further motor information.

GEAR DRIVE AND POWER ROLL

Power Roll Removal

Twelve to fourteen long selector bars should be dropped before the power roll can be removed.

Refer to the Model 01 reference sections for further gear drive and power roll information.

KEY LEVERS, CAMS, AND TYPE BARS

TYPE BARS should be adjusted heavier on ring than on cylinder for the best results. Type bar slugs are soldered $\frac{1}{32}$ " higher on the type bars than they are on the standard E.T. This allows a greater type-bar spread in the basket, tending to prevent the type-bar slugs from catching on each other as they are actuated toward the platen. It may be necessary to grind off a portion of a type-bar slug to completely eliminate all interference. While grinding, be careful not to damage the type face.

Shims are located under the front and rear rails to compensate for the additional height of the type-bar slugs.

TYPE BAR RESTS should be replaced whenever they are worn.

Cam Removal

A SELECTOR BAR must be unhooked before any letter cam can be removed.

Refer to the Model 01 reference sections for further key-lever, cam and type bar information.

INTERLOCK BAR

The interlock bar, attached to the front guide comb assembly, contains one less interlock roller than there are letter key levers. The rollers are spaced so that only one key lever at a time may be depressed (Figure 1). This spacing eliminates type-bar collisions and helps to keep the type bars in alignment. The bottom edge of the key levers is rounded to prevent binding on the rollers as they are depressed.

Removal

Force a small screwdriver between the front guide-comb assembly and each section of the interlock bar. Form each section until it breaks off and the rollers fall out. As this is a permanent removal, it is necessary to have the customer's approval.

Adjustment

THE TWO INTERLOCK STOPS (Figure 1), located on each end of the interlock bar, are to be adjusted so that only one key lever at a time can be depressed easily.

Maintenance

FAILURE OF A KEY LEVER TO DEPRESS may be caused by:

1. Lack of proper lubrication on the interlock rollers.
2. Interlock stops out of adjustment.
3. Dirty interlock roller race.
4. Typist's using an irregular typing rhythm. It is necessary to allow a key lever to completely restore before another key lever can be actuated. For example, the word "and" may be typed "ad."

LUBRICATION. Use a small amount of powdered graphite on the interlock rollers.

SELECTION MECHANISM — SELECTOR BARS

When a cam is operated, its selector bar is raised to operate a bail or a combination of bails. The projections on a selector bar provide the spacing needed for each type face (Figure 2).

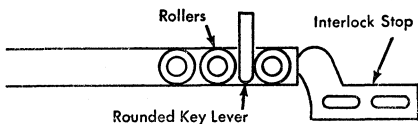

Figure 1. Keyboard Interlock

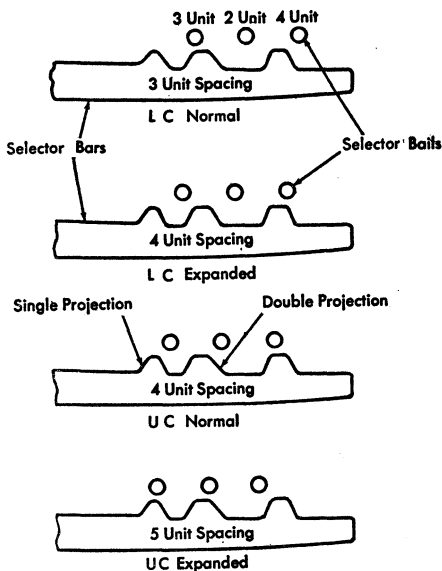

Figure 2. Upper Case and Lower Case Selector Bail Positions

Removal

Remove the two lock nuts from the right end of the selector-bar fulcrum shaft. Loosen the collars that position the rear selector-bar guide-comb assembly and the escapement operating levers. Then the selector-bar fulcrum shaft may be moved left or right (Figure 3). Use the six-inch screwdriver (medium size) or a similar tool as a follower to drop the desired selector bar.

Adjustment

SELECTOR-BAR FULCRUM-SHAFT BRACKETS (Figure 3). Move these brackets so that some of the pointed selector-bar projections are directly underneath the center of the bails (Figure 2). To be sure that the selector-bar fulcrum shaft is parallel, check this adjustment on both ends of the bails.

SELECTOR-BAR LINKS. With the bail assemblies resting on their stop brackets, adjust the selector-bar links so that there is $\frac{1}{64}$ " clearance between the selector bars and the bail assemblies (Figure 3).

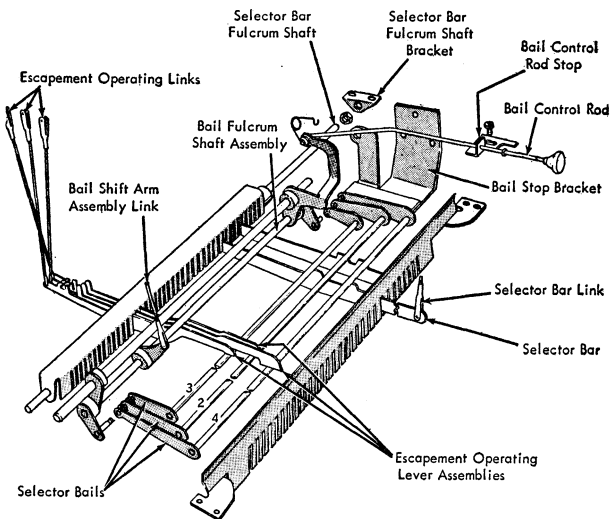

Figure 3. Selection Mechanism

Maintenance

IRREGULAR SELECTION may result from too great a clearance between the bars and the bail assemblies. Too little clearance may cause light impression.

LUBRICATION. Oil the pivot points of the selector bars and their links and clevises.

SELECTION — BAIL ASSEMBLIES

These assemblies transmit the motion from the selector bars to the escapement operating levers. From front to rear, the bails provide four, two and three units of escapement (Figure 3). As the bails are moved by the action of the shift mechanism or the bail control rod, different units of escapement may be obtained.

Removal

1. Unhook all the selector bars.
2. Take off the short selector-bar links. These links must go back to their original order to prevent re-adjustment of each link.
3. Unhook the bail-shift-arm-assembly link.

4. Unhook the bail control rod and its spring.
5. Take out the bail-stop-mounting screws.
6. Lift the bail assembly over the escapement operating levers.

Adjustments

Center bail assemblies, left and right, on the bail stop brackets. Do this by positioning the two collars on the left end of the bail-assembly shaft.

Adjust the bails, in relation to the selector bars, as follows:

1. Check shift motion for proper adjustment. Any change in shift motion adjustment produces a corresponding change in the position of the bails.
2. Shift the basket to the upper-case position and place the bail control rod in the expand position. Adjust the bail-shift-arm-assembly link (Figure 3) so that the three-unit bail is directly over the rear-most pointed projection on the selector bars.
3. Shift the basket to the lower-case position and push the bail control rod in the non-expand position. Adjust the bail control-rod stop (Figure 3), located on the key-lever spring-support plate, so that the four-unit bail is directly over the pointed projection on the front end of the selector bar for the letter "W."

Maintenance

IRREGULAR SELECTION may occur when:

1. A change in shift motion has been made, changing the relationship between the selector bars and bails.
2. There is a loose bail control-rod stop.
3. There is a bind between the bail assembly and a Westinghouse motor.

LUBRICATION. Oil all links, clevises and the pivot points of the bail assembly.

SELECTION — ESCAPEMENT OPERATING-LEVER ASSEMBLIES

These levers, through their links, transmit the motion from the bails to the latches on the escapement-pawl carriers.

Removal

Refer to the section entitled "Selection Mechanism—Selector Bars."

Adjustment

ESCAPEMENT OPERATING-LEVER COLLARS are located on both sides of the escapement operating levers and should be positioned so that there are no binds between the levers and the rear selector-bar guide comb.

Maintenance

IRREGULAR SELECTION may result from a bind on the rear selector-bar guide comb.

LUBRICATION. Oil the pivot points, links, and clevises. Grease the ends of the escapement operating-lever hair-pin springs.

SELECTION — LATCH ASSEMBLIES

These assemblies are mounted on the pawl carriers. The action of the escapement operating-lever links pulls them down in front of the eccentric studs on the trip lever and slide assembly (Figure 4).

Removal

Unhook the escapement pawl-carrier springs and the escapement operating-lever links. Back off the upper pawl-carrier pivot screw and remove the pawl-carrier assembly which includes the latch. When replacing the pawl carriers, do not over-tighten the pivot screws.

Adjustments

ESCAPEMENT OPERATING LINKS are to be adjusted so that the latches clear the top of the eccentric studs on the trip lever and slide assembly by $\frac{1}{32}$ " (Figure 5).

Maintenance

LUBRICATION. Oil the pivot points of the latches.

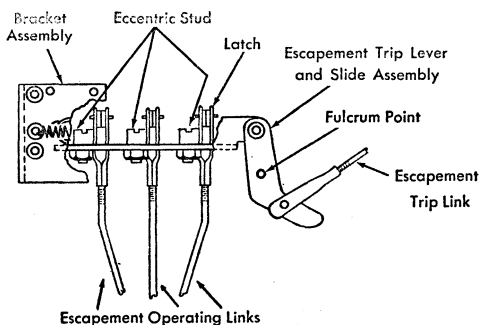

Figure 4. Escapement Trip Lever and Slide Assembly

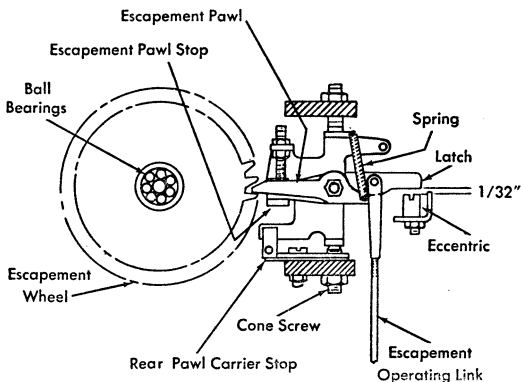

Figure 5. Escapement Wheel and Pawl Carrier Assembly

ESCAPEMENT MECHANISM — WHEELS

There are three escapement wheels. When each wheel turns one tooth, the carriage can travel a definite number of units. From front to rear, each wheel allows four, three, and two units of escapement, respectively. Because some characters require more than four units, it is necessary for two escapement wheels to turn at the same time.

Removal

Remove the cotter pin from the rear end of the escapement-wheel shaft. Remove the lock nuts that hold the escapement-wheel-shaft bushing in place and remove the bushing. Remove the rail screws from the right ends of both rails and loosen the left rail screws. This procedure allows the carriage and rails assembly to be lifted up so that the escapement-wheel shaft may be pushed forward without hitting the spring of the universal bar.

As the shaft moves forward, the two-unit escapement wheel drops off, followed by the three- and four-unit wheels. This action allows the ball bearings to drop out. When replacing the escapement wheels, position the machine upright on its front panel to help in the installation of the ball bearings.

Use a screwdriver to replace the escapement-wheel shaft. By prying downward and against the right-hand front rail support on the base frame, the shaft may be moved as far as the screwdriver will push it, or until the front end of the shaft disappears into the front bushing. In this position, the rear end of the shaft should project far enough through the

rear hole of the escapement frame to permit the insertion of a small pin punch in the cotter-pin hole of the shaft. The pin punch may then be used to pull the shaft far enough through the hole so that when the rear bushing is again installed, the shaft may be lined up with the cotter-pin hole in the end of the bushing.

Use extreme caution to prevent the escapement wheels from separating and releasing the ball bearings.

Adjustments

THE REAR BUSHING may be adjusted by its two lock nuts so that there is a minimum of end play in the center escapement wheel. This adjustment should insure free operation of all escapement wheels and should position the escapement-pinion ratchet wheel so that it does not bind against the rear rail.

Maintenance

LUBRICATION. Oil, sparingly, the gears located on the escapement wheels. *Do not* oil the teeth of the escapement wheels.

ESCAPEMENT — RACK

Removal

Remove the four escapement-rack screws and back off the adjustment screws until they are flush with the bottom of the carriage. Pry out the escapement-rack dowel from the left end of the carriage and remove the rack.

Adjustments

There should be .005" backlash between the escapement pinion ratchet wheel and escapement rack. Check this clearance by positioning each escapement-rack screw directly over the escapement-pinion ratchet wheel. Move the margin stop against the margin lever; depress a carriage-release lever and hold the carriage to the right. Test the backlash by wiggling the escapement-pinion ratchet wheel with a screwdriver or similar tool. By unhooking the paper-table springs and allowing the paper table to rotate farther to the rear, it is possible to reach the escapement-pinion ratchet wheel from the top of the machine.

Adjust the escapement rack by following this procedure (Figure 6):

1. Loosen the escapement-rack screws.
2. Loosen the adjusting screw lock nuts.
3. Lower the rack by lowering the adjusting screws and tightening the escapement rack screws.

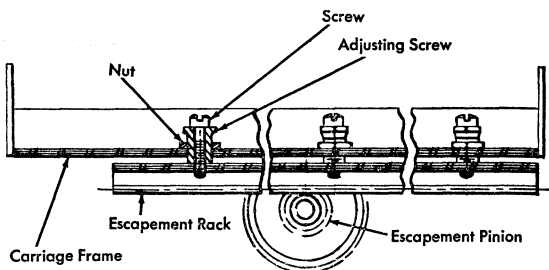

Figure 6. Carriage and Escapement Rack

4. Raise the rack by raising the adjusting screws and tightening the escapement rack screws.
5. Lock the adjusting screws in place by their lock nuts.

Maintenance

TYPE PILING may be the result of a bind between the escapement rack and the escapement-pinion ratchet-wheel assembly.

LUBRICATION. Oil, very sparingly, the gear that engages the escapement rack.

ESCAPEMENT — TRIP LINK, TRIP-LEVER AND SLIDE ASSEMBLY

THE ESCAPEMENT TRIP LINK transmits motion from the type-bar universal to the escapement trip lever and slide assembly (Figure 4).

THE ESCAPEMENT TRIP-LEVER and slide assembly transmits motion from the trip link to the latch assemblies on the pawl carriers (Figure 4).

Removal

To remove the escapement trip lever and slide, unhook the escapement trip slide spring and the escapement trip link. Remove the trip-lever-pivot screw and the toggle-knockout-lever screws.

Adjustments

1. **TYPE BAR UNIVERSAL** must be adjusted for an even type-bar tripping point.
2. **ECCENTRIC STUDS** on the escapement trip lever and slide should be positioned so that their high points are toward the escapement wheels (Figure 5).

3. **ESCAPEMENT TRIP LINK** is to be adjusted so that there is about $\frac{1}{16}$ " clearance between each latch and each eccentric stud (Figure 7).

4. **EACH ESCAPEMENT** trip-lever-slide eccentric stud should be adjusted so that the rear edge of the inclined plane on the pawl-carrier assembly is flush with the rear face of its escapement wheel when a corresponding type bar is held against the platen.

Maintenance

LUBRICATION. Oil links, clevises, and the pivot point of the trip lever and slide assembly.

ESCAPEMENT — PAWL-CARRIER ASSEMBLY

The action of the latch and the trip lever slide eccentric stud rotates the pawl-carrier assembly. When the pawl carrier rotates on its cone screws, its escapement pawl is removed from the escapement wheel (Figure 5). When a type bar is raised by hand, the edge of the inclined plane on the bottom of the pawl carrier engages the escapement wheel and holds this wheel until the escapement pawl is in position to hold on the next tooth. This is not the case when a type bar is operated under power. Because of the rapid rotation of the pawl carrier, the escapement pawl releases a tooth and is in position to hold on the next tooth without any assistance from the inclined plane. This plane is for the convenience of the aligner during alignment, because it prevents the carriage from skipping to the right margin when a type bar is raised to the platen.

Removal

Refer to the section entitled "Selection Mechanism — Latch Assemblies."

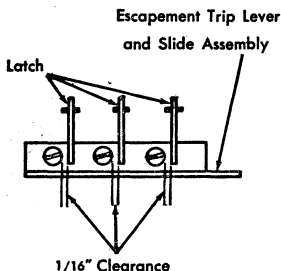

Figure 7. Latch and Escapement Trip Lever and Slide Assembly

Adjustments

1. **THE PAWL CARRIER FRONT STOP** is positioned so that, with the pawl carrier at rest, the forward face of the escapement pawl is flush with the forward face of its escapement wheel.
2. **THE PAWL CARRIER** overthrow stop is positioned so that the edge of the inclined plane protrudes past its escapement wheel $\frac{1}{16}$ ". As this is an overthrow position, it is necessary to rotate the pawl carrier by hand to observe this adjustment.
3. **THE PAWL CARRIER** should rotate freely on its cone screws with no end play or binds (Figure 5).
4. **THE ESCAPEMENT PAWL STOPS** should be adjusted so that, when the pawl carrier is forced against its overthrow stop and the inclined plane is holding on a tooth of the escapement wheel, the escapement pawl is held midway between two teeth.

Maintenance

IRREGULAR SPACING may be the result of:

1. Pawl-carrier cone screws too loose or too tight.
2. A worn escapement pawl.
3. Weak or missing springs on the pawl-carrier assemblies.

LUBRICATION. Oil, sparingly, the pivot points of the pawl-carrier assemblies and the escapement pawls.

CARRIAGE RELEASE

Any carriage-release operation, whether by carriage return, tabulation or manual carriage release, actuates the carriage-release-pawl lever (Figure 8). The carriage release-pawl-lever pushes against the intermediate release lever, actuating the carriage-release pawl.

A lug on the carriage-release pawl engages the release ratchet, rotating the release ratchet counterclockwise (as seen from the back of the machine). Located on the release ratchet is a stud that moves the release arm. A stud, on the release arm that goes through the carriage-return ratchet assembly, lifts the carriage-return pawl out of the escapement-pinion ratchet-wheel assembly.

Springs return the carriage-release pawl, the release ratchet, and the release arm to their rest positions after a carriage-release operation.

Removal

CARRIAGE-RELEASE-PAWL LEVER. Take out the pivot screw of this lever and unhook the carriage-return-pawl release link and the tabular-pawl release link (Figure 8).

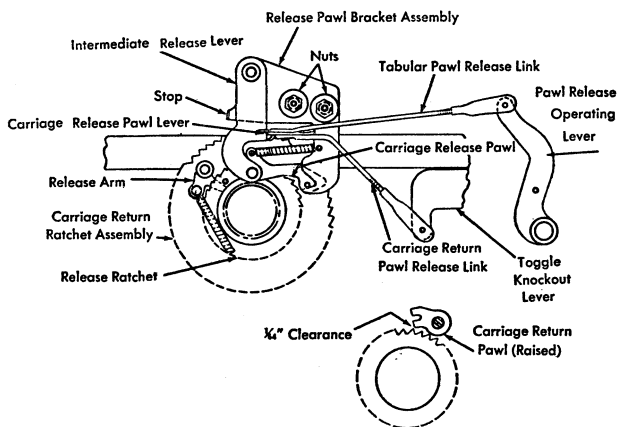

Figure 8. Carriage Release Mechanism

RELEASE-PAWL BRACKET ASSEMBLY. Disconnect the carriage-release-pawl spring. Take off the two nuts that mount the assembly (Figure 8).

CARRIAGE-RETURN AND RELEASE RATCHETS. Refer to the section entitled "Escapement Mechanism—Wheels."

Adjustments

1. **THE 2, 3, and 4 UNIT ESCAPEMENT WHEELS** are positioned by rotating the pawl carriers until the holes in the escapement wheels permit a clear view of the engagement of the carriage-release pawl into the release ratchet.
2. **THE RELEASE PAWL BRACKET NUTS** should be loosened just enough to tap the bracket into position (Figure 8).
3. **THE RELEASE PAWL BRACKET** is positioned in the following manner. When the lug of the carriage-release pawl enters the ratchet, its leading edge should contact the approximate center of the horizontal surface of the ratchet tooth. When at rest, the carriage-release pawl must clear the teeth of the release ratchet.
4. Tighten the release-pawl-bracket nuts.
5. **THE STOP** on the release-pawl bracket may interfere during a pawl-release operation. Should this occur, form the stop out of the way or remove it (Figure 8).

Maintenance

CARRIAGE RELEASE FAILURE may result from:

1. Inaccurate engagement of the carriage-release pawl in the release ratchet. Correct by adjusting the release-pawl bracket.
2. Weak or missing springs on the carriage-release or carriage-return pawl.
3. A bind between the release arm and the TKO link when the release arm is at its lowest point.
4. A bind between the release arm and the carriage-return ratchet.

LUBRICATION. Oil the pivot points of the following:

1. Intermediate release lever.
2. Carriage-release-pawl lever.
3. Carriage-release pawl.
4. Carriage-return pawl.

CARRIAGE RETURN

The operation of the carriage-return cam actuates the clutch mechanism in the same manner as in the Model 01.

The action of the side knockout lever and the carriage-return operating link pivots a bell crank. The motion is then transferred to a toggle knockout link, raising a toggle knockout lever. This lever moves the carriage-return-pawl release link which pushes the carriage-release-pawl lever (Figure 8). This condition causes carriage release, as described in "Carriage Release."

Speed of carriage return is reduced because of a smaller carriage-return pulley. The carriage-return tape is also different in that it is attached to the pulley with a screw. A tape can be made from a standard tape by cutting off the end, doubling it over, and making a hole for the screw.

The line-space mechanism is similar to that of the Model 01.

Removal

MARGIN RELEASE LEVER. Remove the following parts:

1. Tabular-pawl release link.
2. Margin-release and tab-lever-assembly locking nuts.
3. Tab-lever spacing link.
4. Tab-latch-lever assembly.
5. Tab lever.
6. Toggle-knockout-lever mounting screws.
7. Two screws that secure the margin-release lever and tab-lever assembly to the rear rail.

TKO LEVER. Remove the TKO-lever screws. By following the margin-release-lever removal procedure (outlined above), take off the tab lever. By pivoting the TKO lever, remove it along with the TKO link.

Adjustments

The carriage return adjustments up to and including the TKO lever are the same as those for the Model 01.

To decide whether carriage return difficulty is located in the clutch or in the carriage-release mechanism, disconnect the TKO link. If the clutch latches up under power, the difficulty may be in the carriage-release mechanism.

1. THE CARRIAGE-RETURN-PAWL RELEASE LINK is adjusted so that, with the clutch latched, the carriage-return pawl should clear the escapement-pinion ratchet wheel by $\frac{1}{64}$ " (Figure 8). To check this clearance, rotate the carriage-return ratchet, by using the space bars, until the carriage-return pawl can be observed.

2. THE RELEASE ARM must be free of binds. If a bind exists, place the small 3-inch screwdriver between the release arm and the carriage-return ratchet. Carefully form the release arm away from the carriage-return ratchet.

3. THE TKO LINK must not bind the release arm when it is at the bottom of its travel. If there is no clearance between the two when the release arm is in this position, form the TKO link.

4. THE MARGIN RACK must be adjusted after the tab rack is correctly located ("Tabulation Adjustments"). Tabulate to any stop and run the left-hand margin stop to the right as far as it can go. It is stopped by the margin-release lever. When the margin stop reaches the margin-release lever, it must seat itself in the margin rack and still be just touching or within one or two thousandths of an inch from the margin-release lever. If this does not occur, adjust the margin rack to the left or right until it does.

To insure an even left-hand margin, move the carriage by hand toward the left margin. Just as the left margin stop touches the margin-release lever, the carriage-return pawl should just fall into a tooth in the escapement-pinion ratchet wheel. If this does not happen, move the margin rack the needed distance to the left, only.

Maintenance

PARTIAL CARRIAGE RETURN may be caused by:

1. A short TKO link.
2. A long carriage-return pawl-release link.
3. A bind between the above link and the carriage release pawl lever.
4. Loose margin rack.
5. Refer to Model 01 reference section, "Carriage Return—Maintenance."
6. Refer to maintenance in the section entitled "Carriage Release."

LUBRICATION. Oil links, clevises, TKO lever, and the carriage-return pawl.

TABULATION

The tab mechanism includes two tab cams. One raises the tab lever and releases the carriage. The other unlatches the tab lever after tabulation is completed. The tab-lever cam is the same as a Model 01 tab cam. The tab-unlatching cam is a small single-lobe cam and its contour is such that about one-half revolution is necessary before any movement of the cam frame takes place. The purpose of this dwell is to allow the carriage to come to rest before the carriage-return pawl engages the escapement-pinion ratchet wheel.

When the tab cam is operated, its motion is transmitted by the tab operating link to a bell crank mounted on the escapement trip-bell-crank-and-bracket assembly. This bell crank actuates the tab-lever operating arm which, through two short springs mounted on the left end of the tab lever, raises the tab lever into the path of the tab stops (Figure 9). The tab-lever operating arm also actuates the pawl-release operating lever which, through the tabular pawl-release link, actuates the carriage-release-pawl lever. This action releases the carriage.

The tab lever is held in a raised position by a spring-loaded latch which slides over the lowered end of the tab-lever operating arm.

As the carriage moves and a tab stop comes to rest against the tab lever, this lever is forced to the left. This movement rotates the tab cam lever (Figure 9) which, through a shaft assembly, pushes the unlatching trip link. This link pivots the tab-unlatching trip lever and releases the tab-unlatching cam.

This cam actuates the tab-unlatching bell crank, and pulls on the unlatching link. This motion removes the tab-lever

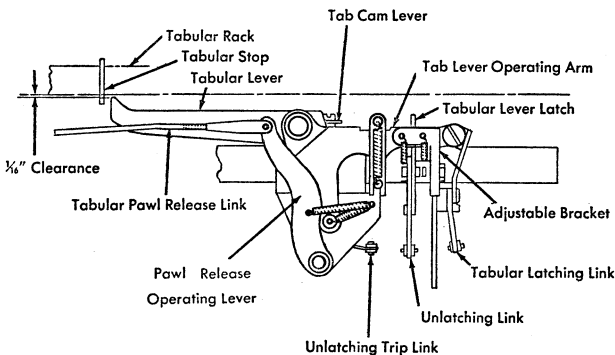

Figure 9. Tab Mechanism

latch from the top of the tab-lever operating arm and allows the tab lever to restore to its rest position. At the same time, the tabular pawl-release link allows the carriage-return pawl to enter the escapement pinion ratchet wheel.

THE TAB GOVERNOR is of the centrifugal type; the friction of the shoes increases as the speed of the carriage increases. It is driven by the escapement-pinion ratchet wheel assembly through an idler gear. When the carriage is moved to the right, as in carriage return, the governor rotation is reversed and does not set up enough friction to interfere.

THE MAIN-SPRING-DRUM CONTOUR is such that it keeps constant tension on the carriage during its full travel. The carriage-tension tape is held to the escapement rack with a screw.

Removal

TAB LEVER. Refer to margin-release lever removal in the section entitled "Carriage Return."

Adjustments

1. **CAM.** Same as the Model 01.
2. **UNLATCHING CAM** should be made a repeat cam. Adjust the cam so that the release lever falls on the center of the cam lug.
3. **TAB LEVER** height should be adjusted by moving the adjustable bracket up or down to obtain $\frac{1}{16}$ " clearance between the tip of the tab lever and the bottom of the tab rack with the tab lever in the latched position (Figure 9).
4. **LATCHING LINK** should be adjusted so that, just as the cam rolls over its high point, the tab-lever operating arm goes slightly below the tab latch and then restores against it.
5. **TABULAR PAWL-RELEASE LINK** should be adjusted so that the carriage-return pawl clears the escapement-pinion ratchet wheel by $\frac{1}{64}$ " when the tab lever is latched up (Figure 8).
6. **UNLATCHING TRIP LINK** should be adjusted so that the tab unlatching cam is released just as the tab lever reaches its full travel to the left (Figure 9).
7. **UNLATCHING LINK** should be adjusted so that with the tab unlatching cam on its high point, the tab-lever latch safely unlatches the tab-lever operating arm by .005"-.010".
8. **TAB CAM-LEVER-SHAFT SPRING**, located on the lower part of the tab-cam-lever shaft, is adjustable and should be set so that the tab cam lever returns freely to its normal position against the tab lever. Too much tension on this spring may delay unlatching.
9. **ADJUST** the tab rack as follows:
 - a. Space the carriage until the carriage-return pawl is in its upper position and visible.
 - b. Unhook the tabular pawl-release link (Figure 9).

- c. With the machine off, latch up the tab lever by hand.
 - d. Using the manual carriage-release levers, move the carriage until a set tab stop forces the tab lever to the left.
 - e. With the carriage resting against the tab lever, actuate the manual carriage-release levers and observe the entry of the carriage-return pawl into the escapement-pinion ratchet wheel. The carriage-return pawl should enter halfway between two teeth.
 - f. Perform the above step at the left end, center, and right end of the tab rack, and position the tab rack for the best average condition in all areas.
 - g. Replace the tabular pawl-release link.
 - h. Check tabulation by tabulating to a stop, backspacing three times and checking to see whether the tabular lever again engages the same tab stop.
- 10. GOVERNOR BRACKET** should be adjusted so that there is a .002" to .010" backlash between the idler gear and the driving gear on the escapement-pinion ratchet-wheel assembly. Use the hole in the rear frame, next to the motor, when adjusting or removing the governor bracket.

Maintenance

IRREGULAR TABULATION may be caused by the following:

1. An unlatching cam that does not repeat.
2. A single-lobe repeat-letter cam in place of a Model 04 special unlatching cam.
3. Too little tab-lever bite on a set tab stop.
4. Tab-lever spacing link on wrong.
5. Tight tab cam-lever-shaft spring.
6. Dirty or hard power roll.
7. Improper clearance between the power roll and the unlatching cam.
8. Inaccurate adjustment of the unlatching trip and the unlatching links.
9. Bind in tab governor.
10. Excessive speed caused by a worn governor.

DETENT-PAWL ASSEMBLY

This assembly is mounted on the rear rail and is used during carriage return and backspace. By constant engagement with the carriage-return ratchet wheel, the detent pawl prevents the backward rotation of this ratchet and the entire escapement mechanism (Figure 10).

Removal

This assembly is easily removed by removing both its mounting screws, one of which is the pivot point for the bell clapper.

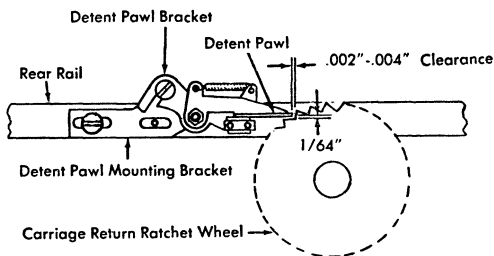

Figure 10. Detent Pawl Assembly

Adjustments

1. **DETENT-PAWL MOUNTING BRACKET** should be adjusted so that there is $.002''-.004''$ clearance between the end of the detent pawl and the vertical side of a tooth on the carriage-return ratchet. Because of an accumulation of tolerances, the clearance may vary. It is necessary to turn the ratchet and make the adjustment to that tooth which gives the least clearance (Figure 10).

2. **DETENT-PAWL STOP** should be adjusted for $\frac{1}{64}''$ clearance between the underside of the detent pawl and the horizontal side of a tooth on the carriage-return ratchet. Position the detent-pawl bracket to obtain this adjustment (Figure 10).

Maintenance

LUBRICATION. Oil the detent pawl.

BACKSPACE

The backspace assembly is attached to the escapement mechanism frame by two screws. It is operated by a cam, a backspace bell-crank assembly and side and rear operating links. The backspace pawl moves downward to engage the escapement-pinion ratchet wheel which it rotates until the carriage-return pawl engages an adjacent tooth. This rotation has moved the carriage one unit to the right. Because the original backspace-pawl bracket had a non-adjustable final pawl stop, it was possible to lock up the carriage on a simultaneous operation of backspace and carriage return. This final stop was not needed; hence it was discontinued in order to prevent this condition (Figure 11).

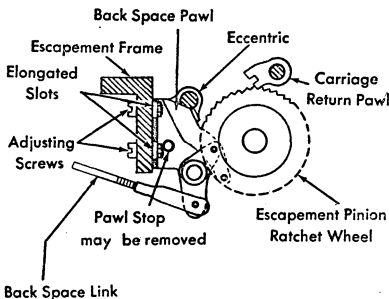

Figure 11. Backspace Mechanism

Removal

Remove the backspace-pawl link and the lower backspace-pawl bracket-mounting screw. Loosen the nut of the upper-bracket mounting screw and remove the assembly from the bottom of the machine (Figure 11).

Adjustments

1. **CAM** is the same as the Model 01.
2. **BACKSPACE-PAWL BRACKET** should be positioned on the escapement mechanism frame so that the pawl enters about in the center of the vertical side of a tooth on the escapement-pinion ratchet wheel. To see this condition, move the carriage to the extreme left and place a dental mirror between the rails and inside the right-hand rail support.
3. **BACKSPACE OPERATING LINK** is adjusted when the cam and backspace assembly are at rest. The right-hand arm (containing the pins for a clevis) should be parallel with the rear rail.
4. **BACKSPACE-PAWL LINK** (Figure 11) is adjusted for $\frac{1}{64}$ " clearance between this link and the working side of the round hole in the intermediate bell crank. Check this condition with all parts at rest. (Because it is easier to adjust the backspace operating link, any minor adjustments can be made with this link.)

Maintenance

THE CARRIAGE may lock when the carriage return and backspace are operated together. To clear this bind, turn the machine off and move the carriage to the left. A noisy backspace may be the result of an insufficient clearance of

the backspace-pawl link in the hole of the intermediate bell crank.

SPACE BARS

The machine is equipped with a two-unit and a three-unit space bar. Each space bar has its own cam, bell crank, operating link, space bar shaft and escapement trip lever. The escapement trip levers are positioned behind the two- and three-unit latch assemblies. These parts operate the escapement mechanism.

Adjustments

1. **CAMS** have the same adjustments as in the Model 01.
2. **SPACE-BAR OPERATING LINKS.** Adjust each link so that with a space-bar cam on its high point, the rear edge of the inclined plane on the pawl-carrier assembly protrudes through its escapement wheel by $\frac{1}{16}$ ". When the escapement operating levers are to the rear as far as they will go, any additional lengthening of their links causes excessive cam and power-roll clearance.

Maintenance

LUBRICATION. Oil links, space bar shafts and escapement trip levers.

RIBBON FEED

This mechanism is designed for the use of a carbon ribbon $\frac{3}{32}$ " wide. The ribbon feed mechanism operates when the escapement mechanism allows the carriage to move, thus giving proportional ribbon feed. Because of this feeding design, any binds in the ribbon feed cause faulty spacing of the carriage. The ribbon stripper, located adjacent to the ribbon-feed roller, must keep this roller free of the carbon ribbon.

As there is no ribbon-rewind wheel, the ribbon may have a tendency to pile up beside the machine. Occasionally, the carriage picks up some of this ribbon and pulls it into the escapement mechanism causing faulty carriage escapement.

RIBBON LIFT

This machine does not have a ribbon-lift control rod. The ribbon is used only once. For a stencil application, it is necessary to break the ribbon.

To change the amount of ribbon lift, it is necessary to reposition the ribbon-guide-lever assembly on the ribbon-positioning-lever shaft. Loosen the hex-headed screw in the ribbon-guide lever to make this adjustment. Move the screw down to decrease ribbon lift and up to increase it.

MARGIN RELEASE

With the margin release lever at rest, there should be .010" to .015" clearance between it and the margin rack. Adjust the hex-headed eccentric stud located on the escapement-trip bell-crank and bracket assembly to make this adjustment.

CARD HOLDER

Position the card holder as follows:

1. Type six capital H's.
2. Space the carriage twenty to thirty units and type six more capital H's.
3. Move the carriage so that the type-bar guide is about centered between these two groups; type two more H's.
4. Backspace the carriage sixteen units and adjust the card holder vertically to the writing line of the H's. Also position the right-hand card holder left or right so that its positioning edge is centered between the two "H's" in the middle group.

PLATENS

The platen usually used is a No. 8 with a 29-tooth ratchet. There are only four type styles, Modern, Secretarial, Documentary and Bold Face #1.

CARRIAGE

Removal

1. Disconnect the tension and return tapes.
2. Remove the two screws holding the escapement frame to the front rail.
3. Loosen the right-hand rear-rail screw. Remove the left-hand rear-rail screw.
4. Remove the carriage trucks.

Replacement

Always replace the trucks and rollers in the same position that they were in before removal. Because of a difference in the amount of wear on the various truck rollers, the carriage may ride in a lower plane if these rollers are replaced in the rails in a different position. This condition may cause a bind between the escapement rack and the escapement pinion and ratchet-wheel assembly, requiring an adjustment of the escapement rack.

POWER FRAME**Removal**

1. Remove the selector-bar fulcrum shaft and the selector bars.
2. Remove the selector-bar guide comb.
3. Remove the bail assembly and brackets.
4. Disconnect the motor wires at the terminal block.
5. Remove the switch.
6. Remove the condenser and resistor.
7. Disconnect the carriage-return tape.
8. Remove the clutch operating lever and its link.
9. Remove the motor and worm housing.
10. Disconnect the tab operating, unlatching trip, and unlatching links.
11. Disconnect the backspace operating link.
12. Remove the escapement trip link.
13. Remove the ribbon-feed shaft.
14. Remove the tab governor.
15. Disconnect the space-bar escapement trip-levers from their support.
16. Remove the front and rear cover plates.
17. Remove all the power-frame screws.
18. Swing the power frame part way out of the base. Avoid bending the extension on the left-hand end of the key-lever locking bar and the side-clutch knock-out lever.



ELECTRIC TYPEWRITERS

MODEL A1

Electric Standard Typewriter

CUSTOMER ENGINEERING REFERENCE MANUAL

Preventive Maintenance and Adjustments

CONTENTS:

This section includes material common to all current models as well as specific information for the Standard Models.

	Page
Inspection	1
Preventive Maintenance and the Operator	4
Mounting Machines	5
Motor and Belt Drive	6
Keyboard	8
Cam and Type Bar	10
Preparation for Alignment	11
Alignment	12
Impression	15
Escapement and Space Bar	17
Shift Mechanism	18
Carriage and Rails	20
Paper Feed	21
Clutch	28
Line Space	37
Back Space	39
Tabular Mechanism	43
Ribbon Feed	50

INTERNATIONAL BUSINESS MACHINES CORPORATION

NEW YORK 22, NEW YORK

Form 25-6015-1 (This section only, less binder)

Copyright 1952, by
INTERNATIONAL BUSINESS MACHINES CORPORATION
590 Madison Avenue, New York 22, N. Y.

Printed in U. S. A.

December, 1952

Form 25-6015-1

IBM ELECTRIC TYPEWRITERS

CUSTOMER ENGINEERING REFERENCE MANUAL Preventive Maintenance and Adjustments

This reference manual combines the accepted practices of preventive maintenance with a listing of the adjustments for the Electric Typewriter for the information and guidance of Customer Engineers. Information labeled ALL MODELS pertains to current models.

INSPECTION

An inspection is a scheduled preventive maintenance call which affords the Customer Engineer an opportunity to locate potential trouble and take the necessary corrective steps before the trouble becomes an emergency call.

DISCUSS THE PERFORMANCE OF THE MACHINE briefly with the operator to learn of any need for adjustment or replacement of worn parts. Check machine operations.

CLEAN THE TYPEWRITER. Remove the necessary covers, platen, and feed rolls. Special attention should be given to cleaning the carriage bed and the carriage rails. Remove all visible particles of dirt. Rubber parts should be cleaned during each inspection with cleaning fluid. The cams may be wiped with cleaning fluid provided care is used to avoid excess.

EXAMINE FUNCTIONS AND CORRECT ADJUSTMENTS. Be thorough, concentrate on prevention of future calls. Detect any excess wear or loose parts. Observe any signs of rust or binding.

SWITCH should function without hesitation and should hold its position securely either **ON** or **OFF**.

POWER ROLL AND DRIVE should be checked for power roll speed, cam clearance, releasing of functional cams, condition of power roll rubber and the condition and tension of the belt drive.

CARRIAGE RETURN should be positive on short returns with the line space lever set at 3. The Executive typewriter should hold the margin on repeated line spacing at single and double, but may just fail on triple. Carriage return must not slam or lock up during repeated line spacing with the line space lever set on single.

LINE SPACING should be positive and the index pawl should clear the ratchet at rest.

TAB SET AND CLEAR buttons should operate without undue strain and without bottoming.

TABULATION should be positive. Note the position of the tab stops set by the operator, then clear and set stops to tabulate the following pattern on a 12 inch machine.

10	20	70	85	100
x	x	x	x	x
x	x	x	x	x
xx	xx	xx	xx	xx
xxx	xxx	xxx	xxx	xxx
xxxx	xxxx	xxxx	xxxx	xxxx

Back space twice after tabulation, the first time across, and tabulate again from the same stop. On Executive models, check grouping and latching of pawls.

With all tab stops cleared and with the tab lever latched out, the carriage should be run back and forth several times by hand. This action serves to polish the friction governor plate and will insure smoother action. The carriage should tabulate at the same rate of speed as on carriage return. Reset the operator's tab stops and again check tabulation.

BACK SPACE operation should be tested on each end and in the middle section of carriage travel. Press down on the carriage release levers and repeat the test to insure that the back space interlock functions. The back space test on the Executive model should be made with a series of i's typed alternately with back space operations (iiiiiii) at the left, center and right of the carriage. On longer than 12-inch Executive carriages, a test should be made with the escapement pawls in the left-hand escapement rack section while the back space pawls work in the right-hand section of the rack.

SHIFT is to be tested for rapid, easy operation. The shift lock should hold through other operations and should easily unlock with either shift key.

SPACE BARS should permit rapid, easy operation and should not bounce and repeat when operated with a "flicking" motion.

MARGIN SET AND RELEASE must operate without undue strain or interference with other parts.

CARRIAGE RELEASE must operate so the carriage can be moved to either extreme with either release lever depressed.

RIBBON MECHANISM should feed two teeth on a cloth ribbon spool and should reverse on the first type bar stroke after the ribbon reverse lever is actuated. Carbon ribbon should feed and guide properly. Check the ribbon track (impressions of type on the ribbon) at various settings.

PAPER FEED must be checked for wrinkling or slippage of paper, or stencils if used. Check for roll-back of forms from any position, especially from two inches to two and

one-fourth inches from the bottom of the form. Paper release lever should free the paper so it can be easily removed or straightened.

TYPING. Check the operation of the keyboard by slowly testing each key twice at the lowest setting of the impression control lever and again twice at the highest setting. This will check the functioning of all key levers and cams. All type bars must operate freely in the segment and in the guide. Clean the segment slots and wipe off each type bar at the segment surface. Check for proper shift motion HhHhHhHhHh. Check for proper type alignment by preparing a complete strike-up of all type in combinations. Check for proper operation of the space bar — a b c d e f g h i j k l.

IMPRESSION. One original and two copies will show up the condition of the machine for impression adjustment. Polish any type faces that cut.

ESCAPEMENT should be checked the full length of the carriage to insure a fast, unhesitating action in any position of the carriage. The Executive machine should be checked to insure that the projecting lugs on the selector bars have an even meeting with the selector bails.

LINE LOCK should be tested for operation.

If the machine is equipped with any special features, such as a special-purpose platen, special type, repeating cams, etc., a check should be made of these features.

LUBRICATION. Lightly lubricate all moving parts including the bail springs on the carriage with IBM Lubricant 6. Place a small amount of Shell Alvania No. 1 in the bearings of the platen and the feed rolls and replace them in the carriage. Apply a few drops of oil to the carriage rails, move the carriage back and forth and wipe the rails clean.

Lubricate the moving parts of the rear rail with a small brush dipped in No. 6 oil.

Oil the motor by placing several drops of No. 6 oil in the oil wells.

Examine the machine for indications of wear or rust and apply oil or, if there is a chance that oil would get onto rubber parts or the clutch disc, use Shell Alvania No. 1.

IBM 6 can serve as a general purpose oil and Shell Alvania No. 1 can be used as a general purpose grease. It is advisable to use the recommended lubricants shown in the instructional manual whenever a machine has had all lubricants removed during a shop overhaul or cleaning process.

COVER SECTIONS should fit tightly to prevent noisy vibration.

ASK THE OPERATOR TO TRY THE MACHINE.

When an inspection has been completed, it should always be properly recorded together with a special note of any extraordinary action required or taken during the

inspection, such as replacing parts, special treatment of parts, etc. Average time for inspection and lubrication procedure is forty-five minutes.

PREVENTIVE MAINTENANCE AND THE OPERATOR

The typewriter operator has closer personal contact with the machine and employs more variable materials than does the operator of any other kind of office equipment. It quite naturally follows that the typewriter will reflect some of the operator's own personal traits and modes of operation, including minor and subconscious actions of which the operator is not always aware. To assist the operator in understanding her machine, the following listed points may prove helpful.

Instructing the operator on these points may prevent a service call.

REMOVAL OF THE PLATEN should be done so as to avoid damaging the index pawl spring. Platen and feed rolls should be cleaned frequently, especially on stencil applications. Place a sheet of paper around the platen overnight after using stencils.

REMOVAL OF THE DEFLECTOR requires care in replacement so it will be properly seated.

THE PAPER BAIL should be kept down to help prevent overprinting. Bail rolls should ride the margins and should be kept clean.

THE MULTIPLE COPY LEVER should be kept forward normally and moved back only when added copies result in smeared capital letters.

TABULATION. The operator should first clear all stops before making a new setting.

RIBBON INSTALLATION. The operator should always remove the left-hand spool for fabric ribbon changes.

IMPRESSION CONTROL. Type faces should be cleaned with a dry brush. Impression should be set heavy enough to insure positive type bar action. Operators should not type on a cold stencil. Oxidization can cause poor impression on plates. Finger prints can cause poor impression on any medium, particularly plates. Brittle paper is more susceptible to cutting and can be corrected by placing a sheet of tough tissue behind the original or a sheet of tough carbon paper can be used.

BEATING THE SHIFT can result if the operator depresses the shift key at the same time as a character key.

BEATING CARRIAGE RETURN can result in a margin that is irregular by less than a full space.

BEATING TABULATION can result in tabulated columns that are irregular by less than a full space, because the operator types within the rebound period of tabulation.

TRANSPOSITION OF CHARACTERS may result when the operator temporarily loses her timing in fingering the keyboard.

MOUNTING MACHINES

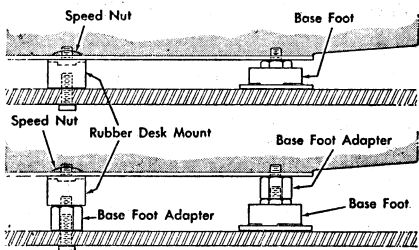

Figure 1. Mountings for Drop Well Desks

Figure 1 shows two methods of mounting machines in drop-well desks.

Location of mounting holes may be marked with a pointed cam bearing rod by raising the top cover and reaching down through the mounting holes in the side frames. Mounting bolts are $1/4''$ x 20 and may be purchased locally in any length.

POSITIONING PINS may require the use of a carriage roller as a spacer on the left-hand pin to prevent the pin from striking the belt.

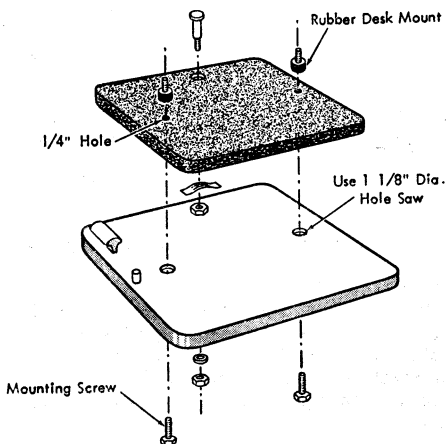

Figure 2. Swivel Platform Mountings

MOUNTINGS ON GENERAL FIREPROOFING desks with swivel platforms should be made as shown in Figure 2.

MOTOR AND BELT DRIVE

Preventive Maintenance, All Models

Motor — AC

ROTOR SHAFT may become gummed because of incompatibility of different oils. Flush bearings and re-lubricate with standard approved lubricant every three months if the shaft is not equipped with oil slinger washers, — every six months if oil slinger washers are present. Motors equipped with bakelite covers have oil slinger washers. Clean the rotor shaft with a solvent. Do not use an abrasive.

BEARINGS. After assembly, self-aligning bearings require a tap on the side of the motor to align them.

MOTOR WINDINGS are protected by a bakelite cover. This motor is called a permanent, split capacitor, induction motor. The bearings and shaft should be checked for a bind or faulty lubrication before condemning the windings.

CONDENSER. The condenser is placed in the circuit with the starting winding to create a leading current so a starting torque will be placed on the rotor shaft. If the condenser fails, or if a break develops anywhere in the starting winding circuit, the motor will run only if it is started by hand. Replace the condenser and repeat the test. Motor hum can be caused by a mismatch between the condenser and the motor windings. Replacement of the condenser may effect a cure for AC motor hum.

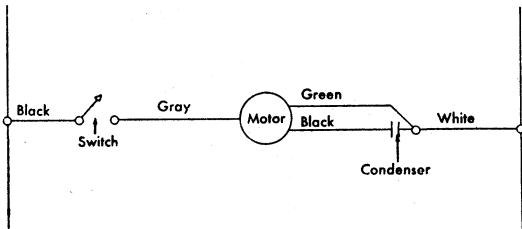

Figure 3. AC Motor Wiring Diagram

Motor — DC Shunt Wound

ARMATURE requires that the commutator be cleaned bright with crocus cloth to insure good contact. Every six months should be sufficient for a motor in continuous operation eight hours per working day.

BEARINGS should have the same care as those of the AC motor.

BRUSHES leave a carbon deposit in the vicinity of the brush holders which must be cleaned out every six months to prevent the motor weakening and running hot. Brushes must be re-assembled exactly as they were removed to prevent noise.

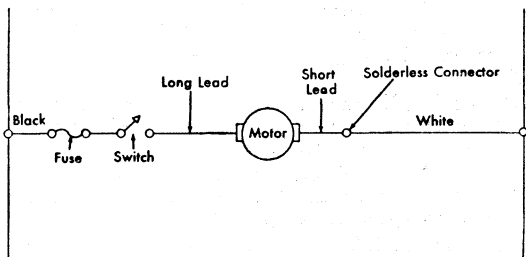

Figure 4. DC Shunt Wound Motor Wiring Diagram

Motor — DC IBM Governor Controlled

GOVERNOR contact points must be maintained flat and smooth. The governor adjusting ring must be maintained tight.

ARMATURE, BEARINGS AND BRUSHES require the same care as those of the other typewriter motors.

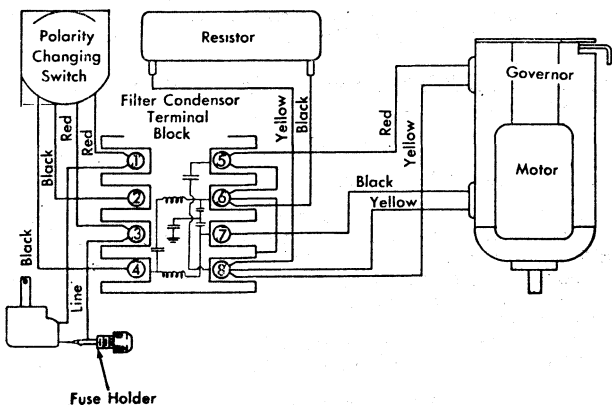

Figure 5. DC Governor Controlled Motor Installation

A POLARITY CHANGE SWITCH for DC governor controlled motors is installed as a measure of preventive maintenance to minimize pitting of contact points.

Belts

Oil must be prevented from contacting the belts.

Adjustments, All Models

Motor

END PLAY of the rotor shaft in the AC motor and the armature shaft in the shunt wound motor, should be adjusted, by using shim washers if necessary, to a maximum of 1/64".

END PLAY of the armature shaft in the DC governor controlled motor must be held to .004" to .007" to hold the operation of the governor stable.

Belt Drive

V-BELT TENSION should be adjusted by moving the motor back until there is 1/8" normal deflection in the lower span of the driven belt.

POSITIVE BELT DRIVE, with the toothed belts and pulleys, should be adjusted so the belts can be deflected 1/4" \pm 1/16" with an approximate pressure of 3/4 pounds.

POWER ROLL SPEED should be adjusted to 95 feet per minute (242 revolutions per minute) for all machines, including Executive models with any type, excluding Lift Platen machines, which should have a power roll speed of 103 feet per minute (263 revolutions per minute) to permit extra impression required for manifold forms. Plus or minus one foot per minute is tolerable.

SOLID SHAFT POWER ROLL end play should be adjusted to a minimum by locking the driven pulley in the proper position on the shaft. Steel washers, used to face the bronze bearings, should be assembled with the burr side away from the bearing. Test the power roll for freedom of operation.

POWER ROLL RUBBER must be tight to its core and not run eccentric.

KEYBOARD

Preventive Maintenance, All Models

KEY BUTTONS should be protected when covers are removed. A tab card inserted over the Decimal Tab keys will protect them from being scratched by the covers. Cleaning agents containing alcohol should not be used on key buttons or similar plastic parts.

KEY LEVERS must be maintained straight and should be so formed that no key buttons bind.

SPACE BARS must be prevented from rubbing on the case.

Adjustments, All Models

KEY LEVER BEARING SUPPORT should be adjusted up or down so that the key levers trip their respective cams when the key levers are 1/32" plus or minus 1/64" from the bottom of the key lever guide comb (Figure 6).

KEY PLATE should be adjusted so all key buttons will be perfectly free and so it will match the front case.

MARGIN RELEASE should be adjusted so the key lever link is as long as possible and still keeps the bell crank from rubbing on the power roll. The adjustable clevis on the push rod should be adjusted so the tab lever or margin lever will just clear under the margin stops when the key lever is depressed to the bottom of the guide comb.

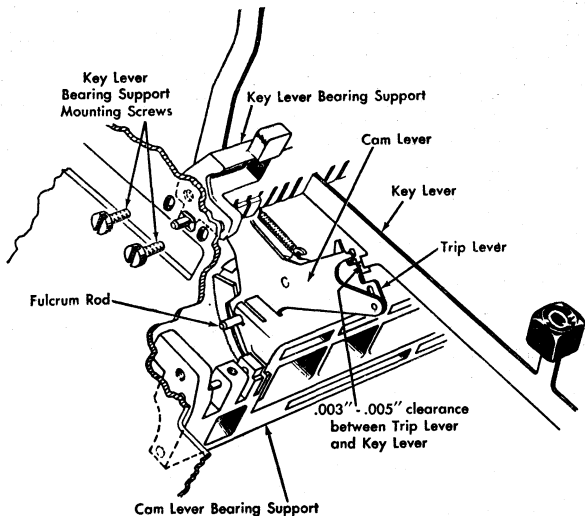

Figure 6. Key Lever Adjustment

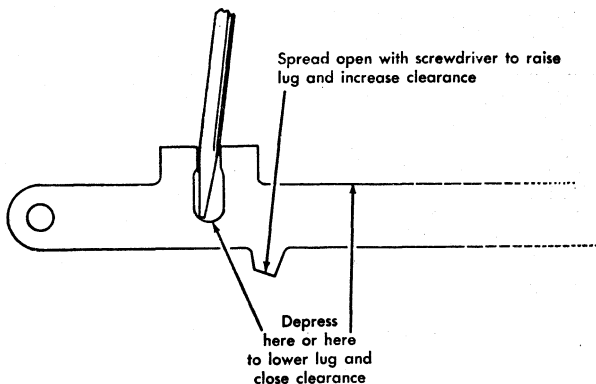

Figure 7. Adjustable Key Lever

Individual key levers which do not respond with the rest of the key levers must be formed or pene-
 up or down to secure this adjustment. The adjustable key lever
 may be treated as in Figure 7.

MARGIN SET lever should be adjusted to enter squarely into the notched top of the margin stop when the carriage is resting at the margin position. The link must be adjusted to such a length that when the key is fully depressed, the stop clears the teeth of the margin rack sufficiently to travel the full length of the carriage in either direction, or to the brace for the margin rack on long carriage machines.

LINE LOCK bracket should be adjusted so the margin stop lug will contact the drag link within one space of the end of carriage travel. The drag link should have a slight additional motion when the margin stop is against the tab lever.

KEY LEVER LOCKING BAR should be adjusted, by means of the push link, to lie $1/32''$ behind the key lever hooks with the switch on. With the switch off, the locking bar should lie under the key lever hooks and effectively block their downward travel, except for the shift keys.

CAM AND TYPE BAR

Preventive Maintenance, All Models

LETTER CAMS must not be oiled because oil could cause them to repeat. Serrations must be kept clean.

CAM LEVER BEARING SUPPORT should be replaced if cam trip lever springs show signs of rubbing on adjacent cam levers.

REPEATING LETTER CAMS that wear the power roll excessively can be treated by dressing down the serrations at the point where the nylon contacts the rubber during cam knockout. Repeating of regular letter cams can be eliminated by adjusting cam clearance for $.020''$ to $.025''$, or by installing new steel-bodied cams in positions 15 through 28. The cam trip levers, on automatic typewriter applications or on repeating cams, should be oiled regularly.

SEGMENT SLOTS must be kept clean. Erasures and dust must be removed with a segment cleaning tool. A light oiling of the type bars is helpful provided the application does not have an excess of erasure which might combine with the oil to produce a sludge.

TYPE BAR LINKS must be free from binds.

TYPE BARS must pass freely through the type guide.

Adjustments, All Models

CAM CLEARANCE should be adjusted to $.015''$ to $.020''$ for all letter cams. Individual cam clearance can be increased when necessary by inserting medium fine sand paper or emery cloth between the cam and the power roll with the rough surface against the nylon. The key should be held down firmly as the abrasive is withdrawn to dress the cam. The shift pusher link should be checked and if

necessary adjusted after any movement of the cam lever bearing support. Operational cams and trip links should be checked also.

REPEATING CAMS can be improvised by grinding off $1/16''$ from the front corner of the lug that contacts the cam trip lever. The trip lever spring can be shortened to about half its length. A special floating type rest is required for smooth impressions on Standard and Lift Platen typewriters below serial number 90,000 and Executive models below 22,300. From the keylever remove the hook that engages the line lock bar.

Preparation for Alignment

1. Check power roll speed for 95 ± 1 feet per minute for Standard and Executive models, 103 ± 1 feet per minute for Lift Platen models.
2. Set the impression indicator on 5 for a scale of 0 to 10, or on 3 for a scale of 0 to 6.
3. Set the multiple copy lever at 0 and adjust platen for ring and cylinder to satisfy the majority of the type bars.
4. Type a strike-up of all characters.
5. Check the shift for even top and bottom and for proper motion.
6. Check the escapement mechanism for freedom of operation.
7. Check the ribbon control mechanism for binds.
8. Check the type guide for centering.

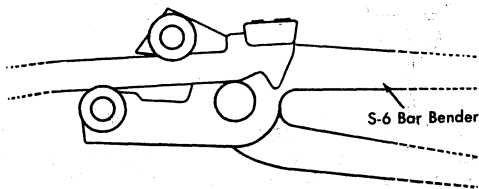

Figure 8. Bending Bar Toward Platen also Lowers Type Considerably

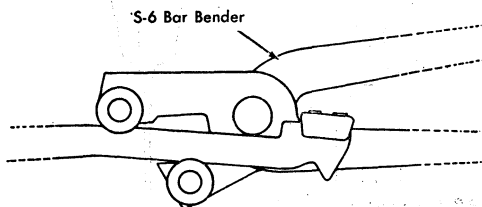

Figure 9. Bending Bar away from Platen also Raises Type Slightly

Alignment

1. Adjust the type bar for ring and cylinder with the bar benders set low on the bar if no raising or lowering is desired or as in Figures 8 and 9 if the elevation of the type face is to be changed.
2. Center the type bar in the guide with the 3-prong pliers (Figure 10).

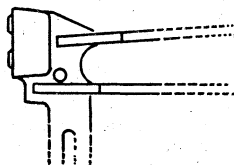
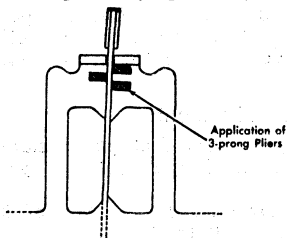

Figure 10. Type Bar Bent at the Throat **Figure 11. Application of Two Type Aligning Wrenches**

3. Twist the type bar with aligning wrenches so it strikes evenly on both sides (Figure 11).

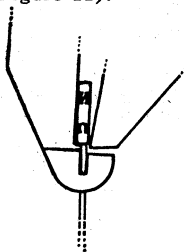
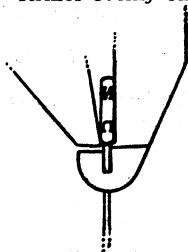

Figure 12. Moving Lower Case to Left or Right

4. Center the lower case letters between two lower case n's, using the knockover pliers (Figure 12).

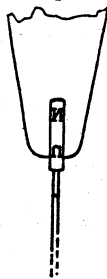
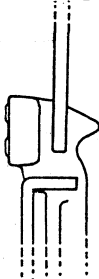

Figure 13. Moving Upper Case Type to Right or Left

5. Center the upper case letters between two upper case N's using a type aligning wrench (Figure 13).

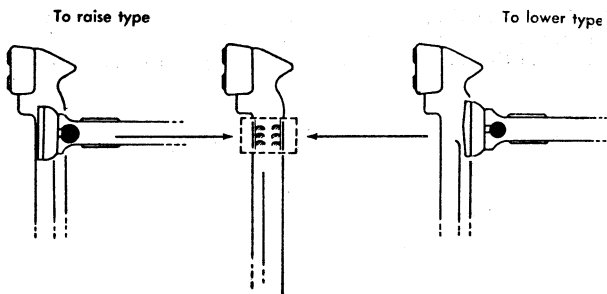

Figure 14. Peening Restricted to Area Indicated

6. When a type face needs to be raised a considerable amount, place the type maulers, or peening pliers, on the front edge of the bar and peen (Figure 14). To lower a type, slightly, peen on the back edge, away from the platen (Figure 14), although a type face may be lowered a greater amount by applying the S-6 bar benders as in Figure 8, remembering to keep the bar benders high on the type bar for the greatest lowering effect.
7. Cut type only when necessary. Use caution to avoid loosening the soldered type slug. Place cutter jaws on slug $1/32''$ behind the type face and cut. Cutters should have been adjusted to prevent their closing to less than $1/16''$.

END TYPE BAR ALIGNMENT. The end type bars may sometimes fail to respond to the same treatment for raising or lowering if the bar has become twisted. If the bar is twisted toward the platen, upper case will be heavy on cylinder and if the bar is twisted away from the platen, upper case will be light on cylinder. With the ribbon in stencil position, hold the type face up to the platen and determine if the upper case is heavy or light on cylinder. Twist the type bar until the proper ring and cylinder relationship exists between upper and lower case (Figure 15).

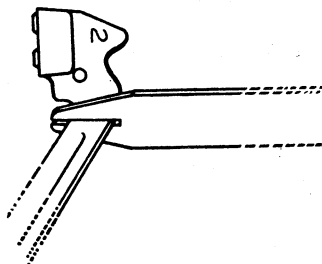

Figure 15. End Bar Alignment

After correcting ring and cylinder, the type face may be raised to the writing line by peening or lowered by using the S-6 bar bender high on the type bar (Figure 8).

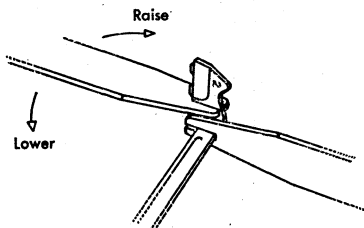

Figure 16. End Type Bar Adjustment

Another method of raising or lowering end type bar faces involves the use of two type aligning wrenches (Figure 16). A left-hand bar is illustrated but a right-hand bar will respond to the same treatment in reverse. This procedure requires forming the type bar just a little at a time and must be checked after each forming to insure that the type bar enters the guide properly.

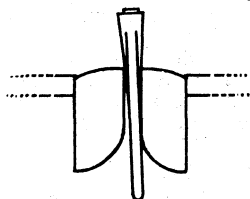

Figure 17. Type Bar Binding in Guide

If the type bar has a tendency to bind in the guide, (Figure 17), it indicates that the type bar has been formed too far. Some of such a bind may be relieved by a slight twist while observing the bar as in Figure 15.

TYPE SOLDERING FIXTURE may be attached to the type bar to facilitate resoldering a type slug which may be too far out of alignment for the aligning tools (Figure 18). When a type face requires raising or lowering by .025" or more it will generally prove profitable to use the fixture.

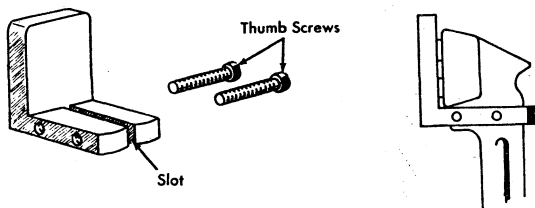

Figure 18. Type Soldering Fixture

IMPRESSION CONTROL ADJUSTMENT. Do not adjust the impression control screws until all of the following items are satisfactory.

The **IMPRESSION INDICATOR** should be properly set for the application.

The **MULTIPLE COPY LEVER** must also be properly set. The **CAM KNOCKOUT BAR LEVELING SCREW** should be set and locked so the knockout bar rests with equal pressure on both ends.

The **MOTOR** should be checked for speed, freedom from binds and lubrication.

The **POWER ROLL** should run true and concentric, the rubber must be tight to the core, bearings must be free and well lubricated and the power roll must be clean.

The **KNOCKOUT FINGERS** may be lubricated with a thin application of Shell Alvania No. 1.

CAM LEVERS must be perfectly free of binds.

The **CAM LEVER BEARING SUPPORT** must properly guide the cam levers and must not permit the trip lever springs to wear against adjacent cam levers.

CAM CLEARANCE must be .015" to .020".

The **CAM LEVER GUIDE COMB** must permit free travel of the cam levers. Apply a thin layer of Shell Alvania No. 1. The **TYPE BAR LINKS** must be free enough at rest to be moved from side to side in both upper and lower case.

The **TYPE BAR SEGMENT SLOTS** must be clean and free from burrs or dirt or binds.

The **TYPE GUIDE** must be open and clean.

UPPER AND LOWER CASE CHARACTERS must balance in density. Check shift adjustments for "shifting off".

The **ESCAPEMENT MECHANISM** must be checked for binds which could be reflected in impression.

The **RIBBON OPERATING BAIL** should be lubricated with Shell Alvania No. 1.

The **RIBBON LIFT MECHANISM** must not choke off the free motion of the cams.

The **PLATEN** must be as soft as possible for the application. It must be borne in mind that the typewriter may also be used for other applications. A more firm platen must be used when the customer requires greater sharpness of writing.

The **CARRIAGE** must be adjusted for no play but free travel. If the platen is permitted to rock forward, a high, heavy impression will result alternating intermittently with low, light impressions. All carriage adjustments must be set to prevent this.

The **RIBBON FEED CAM** should have the non-repeat lug removed from the cam release lever. Be sure the cam operates on every type stroke. Uneven ribbon feed can look like uneven impression.

FINGER PRINTS on any typing materials can contribute to spotty, uneven impression.

PAPER, RIBBONS AND CARBON PAPER should be examined with a view to improving impression. (Refer to Typing Materials section, IBM Electric Typewriters Manual of Instruction.)

TYPE FACES that cut the original, when certain brands of paper are used, will sometimes dictate a lower impression setting than is safe and this will result in uneven impression. If no relief can be secured through selection of material, platen, adjustments, etc., the particular type faces that cut must be polished to prevent their cutting.

POLISHING TYPE FACES can aid greatly in overcoming type cutting and will often produce a uniformity of impression not otherwise possible. Care must be exercised to avoid broadening the type face too much.

1. Be certain that all type alignment adjustments have been checked.
2. Place an original and two carbon copies in the typewriter.
3. Set the impression indicator so the lower case period and comma print satisfactorily.
4. Strike up a sample of the keyboard in numerical order starting with No. 1 position.
q a 2 z w s 3 x - - - etc.
Q A @ Z W S # X - - - etc.
5. Remove the paper, place the typewriter on its back and study the original sheet. Turn out any impression screws for light-striking type faces and turn in the screws for cutting or heavy impressions.
6. Re-strike the characters that have been altered and select any type that cannot be made strong enough to print a strong, firm impression without cutting the paper. *These type faces are recommended for polishing.*
7. Put the color control in stencil position and wrap a sheet of Behr-Manning Durite 600A abrasive paper around the platen. Hold the type bar firmly against the abrasive, applying pressure to the type bar where it contacts the ring and polish the type by moving the carriage to left and right once or twice and also by rotating the platen up and down once or twice. All movements of the carriage should be slow and even to produce best results. The part number for the abrasive is 460107. This paper is sometimes available at auto body paint shops.
8. Test the type face by making another strike-up of the type in question and repeat step No. 7 if required.
9. Check the impression on the customer's application.
10. Do not use an abrasive heavier than that recommended. A lighter abrasive works too slowly. Stoning would destroy the curvature of the type face.

ESCAPEMENT AND SPACE BAR

Preventive Maintenance, All Models

UNIVERSAL BAR should be lightly coated with grease on its contact surface during installation or replacement.

CARRIAGE ADJUSTMENTS must be made free enough to permit rapid escapement.

MAIN SPRING DRUM must be free of binds.

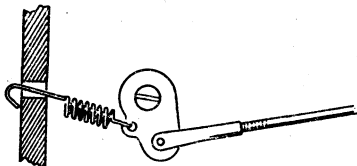

Figure 19. Escapement Lever Spring

ESCAPEMENT LEVER SPRING must provide sufficient tension to keep the space bar cam from slipping on the power roll. (Figure 19)

STANDARD ESCAPEMENT AND SPACE BAR Adjustments

UNIVERSAL BAR SPRING TENSION should be 1 to 1-1/4 pounds, measured by a spring scale attached, in turn, to each of the two rear extremities of the bar by means of a wire led in through the rear frame.

ESCAPEMENT TRIPPING POINT should be adjusted equally for the left, center and right-hand type bars (Figure 20). Place type bars in position as illustrated, loosen hexagonal screw and the universal bar will assume its proper tripping position. Tighten the screw and test for an equal tripping point.

TRIP LINK must be adjusted to trip the escapement pawl out of the rack when the type face of any bar is $3/8'' \pm 1/16''$ from the platen.

UPPER AND LOWER CASE TRIPPING POINTS must be equal. Form the trip link lug of the U-bar up or down if necessary. Use adjusting plate if installed.

SPACE BAR KEY LEVER LINK to the cam release lever should be adjusted to trip the cam when the key lever has traveled $2/3$ downward. If the operator tends to flick the space bar and the cam repeats, adjust for a later trip.

SPACE BAR CAM should clear the power roll sufficiently to permit the cam to trip, with the power off, so the stop lug of the release lever just clears the back of the cam lug, or rests on the rear half of the lug.

ESCAPEMENT OPERATING LINK should be adjusted so the escapement trips just before the cam reaches its highest point.

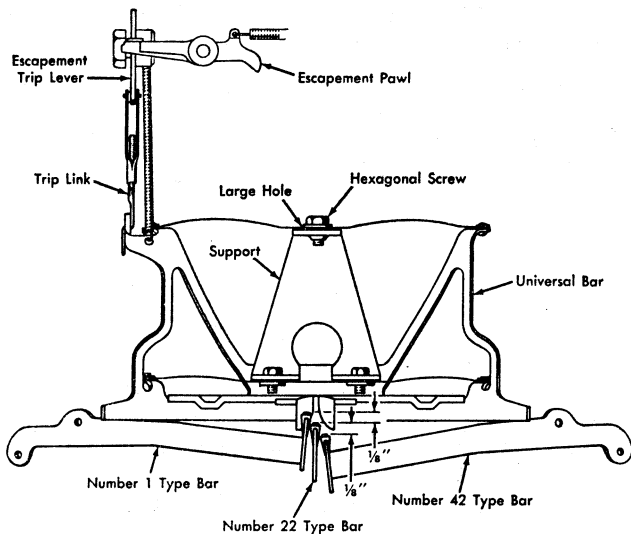

Figure 20. Adjusting the Universal Bar to Produce an Even Tripping Point.

SHIFT MECHANISM

Preventive Maintenance, All Models

HAIRPIN SPRINGS or torsion springs on the shift toggle levers assembly should be greased for free operation and the hooks of the springs must be so formed that they are in line and do not bind on their studs.

SPRING MOUNTED TYPE REST should be regarded when the operator cleans type. Rough, harsh treatment might possibly deform the curvature of the type rest and induce a change in cam clearance.

Adjustments, All Models

SHIM WASHERS, .010" thick, may be placed under the front ends of the upper segment guides, one at a time, to cause the upper case characters to shift off cylinder to obtain equal density of blackness between upper and lower case. Ring and cylinder adjustment of the platen must be made after shimming the guides. The application of this treatment would be required if upper case characters appeared too dark.

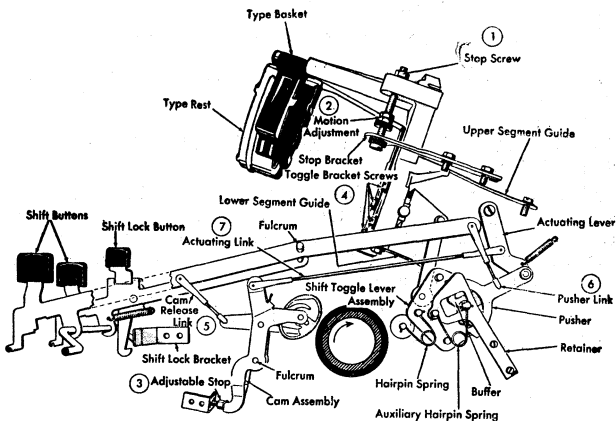

Figure 21. Shift Mechanism.

RING AND CYLINDER adjustment of the platen must be properly set before attempting to adjust the shift mechanism.

1. **SHIFT STOP SCREWS** should be adjusted so the lower case characters appear even on top and bottom (Figure 21).
2. **MOTION ADJUSTMENT** consists of setting the pair of locking nuts on each stop screw so the upper characters print on the same line as the lower case.
3. **CAM CLEARANCE** should be adjusted by means of the adjustable stop so the cam release lever lug will drop behind and clear the cam lug by the amount of the release lever lug width when tripped with the power off.
4. **LINK BRACKETS** should be adjusted by means of the toggle bracket screws until the clearance between the pusher and either pin on the toggle lever assembly is equal without regard for the actual amount of the clearance. Recheck motion after any adjustment of these brackets.
5. **CAM RELEASE LINK** should be adjusted so the cam will be released when the key is depressed $1/2$ to $3/4$ of its travel.
6. **PUSHER LINK** should be adjusted so that when the key lever is fully depressed, the upper pusher arm can contact the upper pin at a point $3/32$ " above the lower edge of the upper pusher arm. The upper arm should not override the upper pin.
7. **ACTUATING LINK** is to be adjusted so the pusher clears the pin by $1/32$ " to $1/16$ ".

CARRIAGE AND RAILS

Preventive Maintenance, All Models

CARRIAGE TRUCKS should be assembled in the rails so they are flush with the carriage at either end of carriage travel, plus or minus two teeth.

RAILS must be kept clean and lubricated with the specified lubricant.

TRUCKS are equipped with star wheels carrying ten teeth which engage the milled teeth in the racks to keep the trucks from running out either end of the rails. If the racks are not recessed (Figure 22), then the nine-toothed star wheel should be used.

Adjustments, All Models

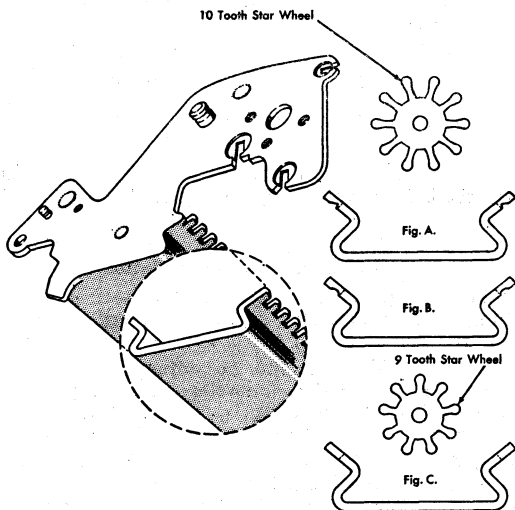

Figure 22. Carriage Truck Star Wheels

RAILS are to be adjusted by positioning the front rail tightly against the power frame and tightening the front rail screws. The carriage should then be centered and the eccentrics taken up just enough to eliminate side play. Move the carriage to the left, press the rear rail forward tightly by hand and drive the rear rail screw down tight. Repeat this operation on the right-hand side and test the carriage fit for free travel without side play. Secure the adjusting screws against the rail so that the carriage will be free to travel, without side play, from one extreme to the other. Carriage rails longer than 16" will have end brackets which must be adjusted in the same manner.

The Executive carriage is mounted on 1/32" shims to raise the writing line of the platen up to the writing line of the type faces. Executive type slugs are soldered 1/32" higher on the type bars to permit them to fan out better and eliminate interference.

MAIN SPRING TENSION should be adjusted by placing the loop of the tension tape on the proper lug of the main spring drum, until the tension of the carriage is just sufficient to trip the tabular mechanism with the last tab stop. The carriage should be positioned at the last tab stop before latching the tab lever to avoid the braking influence of the tab governor. If the tab lever should be latched out while the carriage is further back and the carriage travelled up to the last stop, the effect of the tab governor would be felt, and an erroneous reading would result, causing the adjuster to set the main spring too tight. Carriage tension may be measured, by pulling the carriage with a spring scale at a slow and steady rate from extreme left to extreme right. The tension should read as follows:

12" carriage 2 lbs. at start, 2-1/2 lbs. maximum

16" carriage 2 lbs. at start, 2-3/4 lbs. maximum

20" carriage 2 lbs. at start, 3 lbs. maximum

24" carriage 2 lbs. at start, 3-1/4 lbs. maximum

30" carriage 2 lbs. at start, 3-1/4 lbs. maximum

PAPER FEED

Adjustments, All Models

FEED ROLLS must have all end play removed by the adjusting screws, except as noted under **PAPER SLIPPAGE**. However, the feed rolls must be free to spin. Grease should be used as a lubricant, because oil would travel and destroy the rubber.

PAPER SLIPPAGE can usually be controlled by holding all side play of paper feed parts to a minimum, however, on some applications it may help to adjust for .010" end play of the feed rolls. Beveled grooves in the center and in one end of the equalizing shaft serve this purpose. A feed roll lift arm with maximum contact on the actuating shaft and made for a snug fit on the shaft will also minimize side play of feed rolls. Installation of a helper spring, inside the standard feed roll pressure spring, will increase pressure and assist in overcoming paper slippage. The helper spring is wound in the opposite spiral to the standard pressure spring so that the two springs will not become intertwined. When the helper spring is installed, paper release will be difficult unless a support is installed beside each lift arm to brace the actuating shaft and prevent it from bowing.

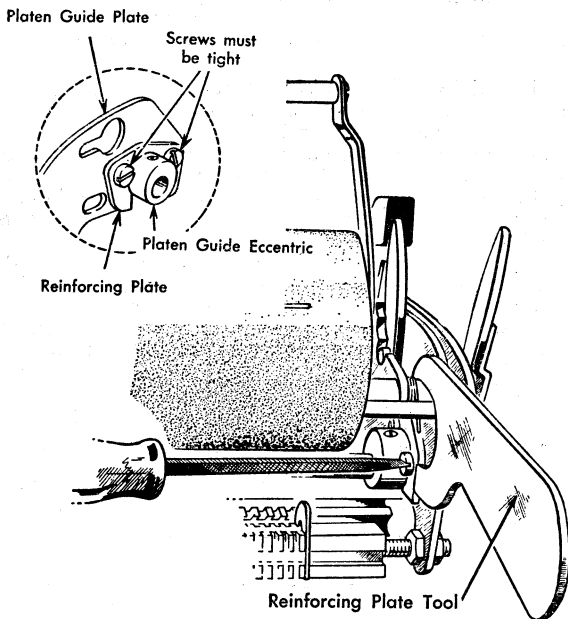

Figure 23. Reinforcing Plate Tool

REINFORCING PLATES, attached to the platen guide plates, serve to hold the platen guide eccentric bushings more stable. Adjustment of these small plates should not be necessary unless their mounting screws become loose (Figure 23). Loose screws will usually be evidenced by type impressions appearing high and heavy, alternating irregularly with an appearance of the same type being low and light due to the platen shifting back and forth from front to rear. If the screws are found to be loose, or if there is play between the reinforcing plate and its eccentric, then, while the plate is held tightly by means of the carriage reinforcing plate tool (Figure 23), the screws should be well tightened. The tool should be hooked on to the paper bail spacers and pressure applied downward. This will draw the platen guide plate back while pushing forward on the reinforcing plate so as to remove play between the platen guide plate and the eccentrics.

FEED ROLL PRESSURE is adjusted by means of pressure springs and adjusting screws located in the bottom of the carriage under the feed roll lift arms. Feed roll pressure is measured by inserting a one-inch wide paper strip between a rear feed roll and the platen to a distance of two-tooth feed for a standard or coarse tooth ratchet, or three-tooth feed for a fine tooth ratchet with 44 teeth or more. At the factory a tension scale is attached through an eyelet in the outer end of the test paper strip to measure the tension required to withdraw the strip, holding the platen so it will not rotate. Test the outer rear rolls of each deflector. Two pounds, plus or minus 1/4, should be required to withdraw the paper strip. Pressure must be equal on all deflectors of 16" or longer carriage.

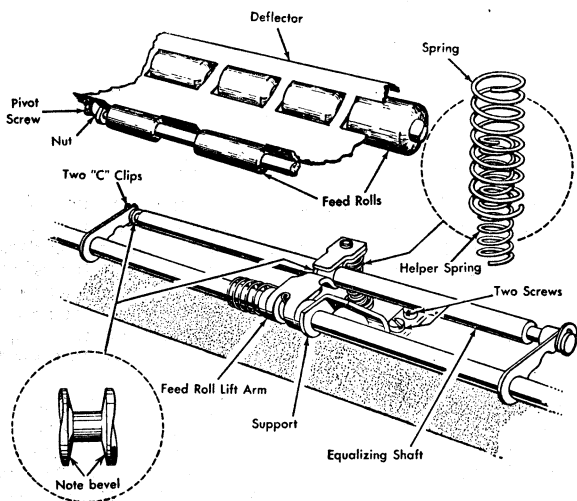

Figure 24. Feed Roll Support Assembly

FEED ROLL RELEASE MECHANISM should permit the easy straightening of a pack of paper equivalent to an original and ten carbon copies, with the feed roll release lever and the multiple copy control lever in their forward position. If difficulty is experienced in trying to shift paper with the release lever forward, examine the feed rolls and determine whether the front feed rolls interfere on the paper while the rear feed rolls clear properly. This would indicate that the backward tilt of the deflector should be corrected.

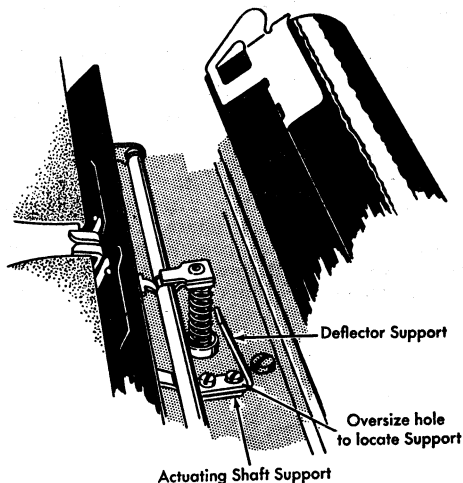

Figure 25. Deflector Support

DEFLECTOR SUPPORT consisting of a small angular plate with two holes may be attached on top of the actuating shaft support in such a manner that the upright section of the plate will catch and support the deflector when the paper release lever is operated. The plate will support the rear feed rolls and will thus move the front feed rolls away from the platen. It may be necessary on some applications to undercut the front feed roll if it interferes with the front scale collar.

RING AND CYLINDER should be adjusted by placing the multiple copy lever or platen guide arm (Figure 26) toward the front of the machine and, with a sheet of paper in place, adjust the eccentric nuts on the rear corners of the carriage until the platen has equal and correct ring and cylinder adjustment on both ends of carriage travel. To test for ring and cylinder, place a piece of bond paper, about 1/2" wide and 4" long, between the type bar and the ring. The paper should be gripped tightly when a type bar is held up to the platen with the thumb against the type bar at the ring. Place the paper between the ribbon and the paper on the platen, and, holding the type bar as before, a noticeable drag should be felt as the test paper is withdrawn. Repeat this test at both ends of the platen, using the same type bar each time. An even finer check for ring and cylinder may be made by repeated typing of periods at each end of the platen with the impression set light. The amount of embossing on the back of the paper will indicate any differences.

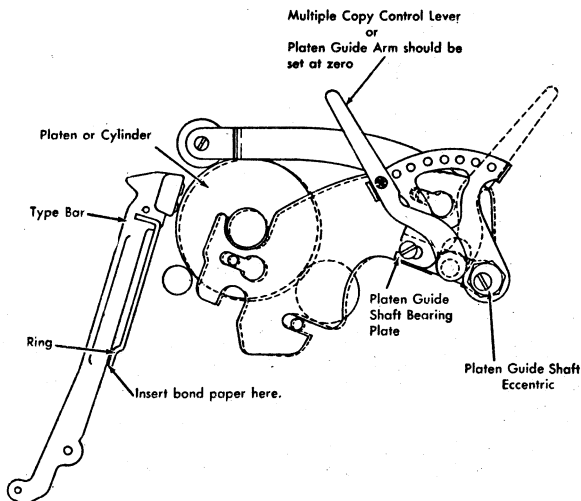

Figure 26. Ring and Cylinder.

PAPER AND STENCIL WRINKLING can be traced to unequal feed roll pressure, too heavy feed roll pressure, misalignment of feed rolls and platen or the limp qualities of some papers or stencils. The following procedure will help overcome such difficulties:

Remove the platen and feed rolls. Remove the springs under the actuating arms. Check the actuating shaft to be sure that it is not bowed. If a bow is observed in the shaft, loosen the center support screws and allow the actuating shaft to be restored to its normal straight position, and tighten the center support screws. Replace the springs beneath the actuating arms, replace the deflectors and platen, and check the paper clearance. Straightening the actuating shaft allows the feed rolls to assume a parallel position with the platen.

Form the rolled edge on the deflectors as illustrated in Figure 27. The normal clearance between the platen and the curled lip on the deflector is approximately .100". This clearance should be reduced to about .040" by forming, which will tend to iron out the wrinkles before the paper enters the feed rolls. The forming operation may be more easily accomplished if a fulcrum rod is temporarily inserted in the formed lip along the back of the deflector. This will provide a means of gripping the roll-

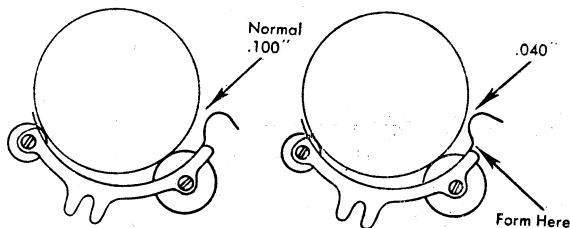

Figure 27. Forming Feed Roll Deflectors

edge with a pair of pliers to push it forward. After the deflectors are formed (Figure 27), the paper table should be raised sufficiently to conform, approximately $3/16''$ to $1/4''$. The last two steps will remove air from between the sheets as the copy is fed into the machine.

If the foregoing steps do not correct the wrinkling and slippage, the following procedure should be used:

Check the feed roll pressure and reduce it as low as possible.

Hold down the feed roll lift arms and see if they can be moved to the right or left. This side play can cause wrinkling as well as paper slippage.

In the case of a long carriage machine, disconnect the equalizing arms from the equalizing shafts and replace the deflectors and platen. Rotate the platen forward and backward and watch the deflectors carefully while so doing to see if they move to the right or left. As an aid to seeing this movement, hold the front scale down. If only one deflector has side movement, or if both deflectors move toward the center, interchange deflectors. The best condition prevails when both deflectors tend to move outward when the platen is rotated in a normal feeding direction.

To insure straight paper feeding, the deflector must be straight. Test by holding the deflector level in one hand, rest the platen in the deflector and spin it. If the platen tends to run out one end of the deflector, reform the deflector by twisting gently until the platen runs true.

Sanding a bevel on the corners of the feed rolls with trimate paper will also help.

ROLL BACK OF FORMS becomes a problem if certain papers or forms do not lend themselves to rolling back the platen after having made an erasure. The operator may complain of paper slippage and show an indication of vertical slippage or displacement of the paper where the correction is typed in lower than the writing line. Examination may reveal that the paper has formed a bulge during typing and as a result of the operator having raised the bail to erase, the bulge is gone when the cor-

rection is typed, leaving the corrected typing below the proper writing line. Instruct the operator to roll back well below the writing line and line space back up to the line.

Another kind of **ROLL BACK** trouble may appear approximately 2-1/4" from the bottom of the page, just after the paper has left the rear feed rolls. Rolling the platen back to recover the writing line can result in the form being disturbed when the bottom edge of the first sheet contacts the rear feed rolls and becomes slightly displaced upward. The next typing done will fall slightly below the writing line. This condition may be rectified in either of two ways. With a screw driver inserted down between the rear feed roll and the deflector, pry upward to form the deflector into a slight ramp which can guide the paper up on to the rear feed rolls during roll back. Make the same form at each rear feed roll but keep the formation low enough to prevent carbon marking.

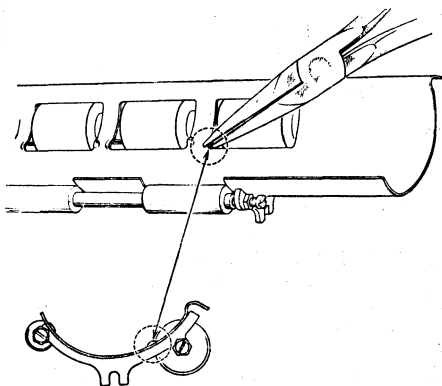

Figure 28. Forming Paper Deflector

Correction may also be made by forming two raised lips at each section of the deflector between the rear feed rolls (Figure 28). Forming should be done a little at a time with long nosed pliers to avoid raising the lips too high and causing carbon marking.

CLUTCH

Preventive Maintenance, All Models

PREVENTIVE MAINTENANCE in all clutches consists of maintaining clutching parts free from grease, oil, and dirt. All adjustments should first be made so the clutch can readily unlock, then adjust to have the clutch lock easily.

Lubrication plays an important part in the operation of the clutch, both in locking and unlocking.

Adjustments, Toggle Type Clutch, Standard Models

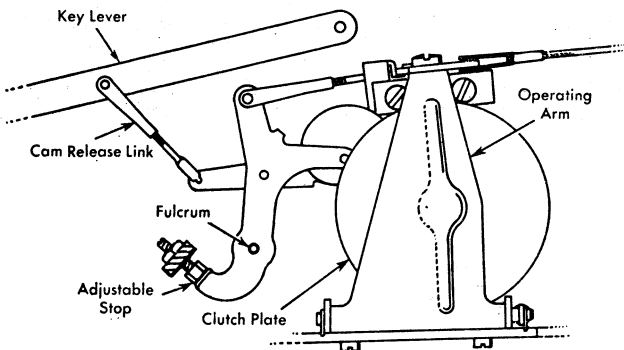

Figure 29. Carriage Return Clutch

CARRIAGE RETURN CAM should be adjusted, by means of its stop (Figure 29), so the cam lug will fall just behind the cam release lever when the cam is tripped with the power off. The cam release lever lug may rest on the rear half of the cam lug.

CAM RELEASE LINK should be adjusted so that the cam will be released when the key has completed two-thirds of its downward travel.

TOGGLE OPERATING LINK from the cam to the toggle (Figure 30), should be adjusted so when the cam is positioned with its high point resting on the power roll, the toggle will be brought just to rest against its stop. Adjust the clutch toggle lever and link assembly initially so the link swings $1/32''$ past its fixed center when the clutch mechanism is engaged. Elongated holes in the toggle bracket provide this adjustment.

SIDE LINK has an adjustable end on the rear which may be so adjusted that the elongated hole in the bell crank will lie parallel to the rear rail, with the cam at rest (Figure 31).

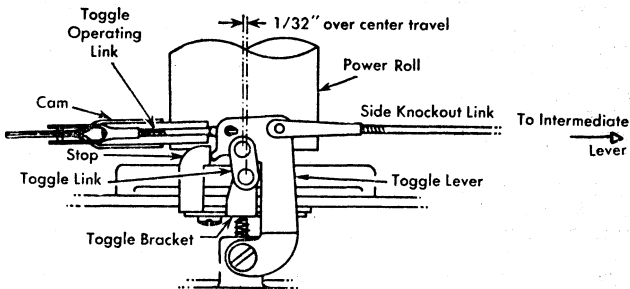

Figure 30. Clutch Toggle

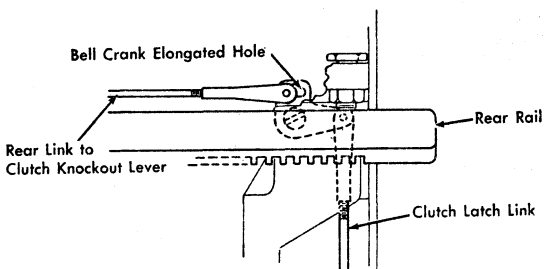

Figure 31. Side Knockout Link Adjustment

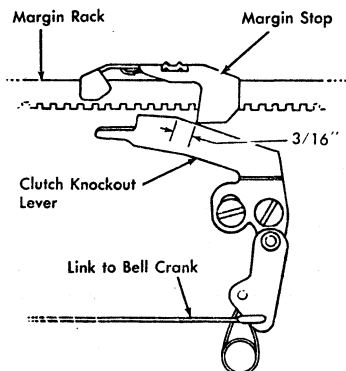

Figure 32. Clutch Knockout Link Adjustment

REAR LINK may be adjusted to lift the clutch knockout lever, so that with the clutch locked, the left margin stop will contact the upper surface of the clutch knockout lever $3/16''$ down from the top of the incline and will glide approximately $1/16''$ at which point the clutch will be knocked out or released (Figure 32). Check the switch insulator to see that it does not interfere with the clevis of the rear link and cause failure of carriage return.

IF THE CLUTCH FAILS TO UNLOCK EASILY, review the adjustments of the clutch toggle lever and reduce the amount of over-center travel from $1/32''$ to $1/64''$. Failure after this adjustment may be traced to a bind in the riveted mechanism, or to a weak hairpin spring on the bottom of the knockout lever. The intermediate lever or bell crank, where the side link and the rear link join, should be examined also, since the link clevis may join the lever at an angle sufficient to cause a bind.

TIP OF THE CLUTCH KNOCKOUT LEVER is designed to prevent locking of the carriage during simultaneous operation of the carriage return and tabular mechanism. The tip of the knockout lever will bear against the lower part of the angular plate under the flat top of the tab lever and will prevent the clutch from locking, or if locked, will unlock it. This tip is adjusted by forming with a bending tool (Figure 33) until, with the clutch locked,

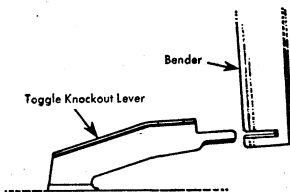

Figure 33. Forming the Tip of the Knockout Lever

the tip will just touch the bottom of the angular plate of the tab lever at rest, and the knockout lever should be allowed to rise to its proper height as in Figure 32. To test for proper operation, lock the clutch and slowly swing the tab lever out by hand. The clutch should unlock before the tab lever reaches its latching position.

THE ESCAPEMENT PAWL RELEASE LEVER is provided with a tip which bears against the shoulder of the toggle knockout lever. Movement of the knockout lever, as it rises, will move the pawl release lever so as to pull the pawl out of the rack. The amount of clearance may be observed by

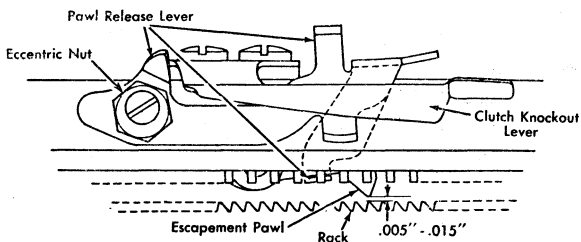

Figure 34. Pawl Release Lever Eccentric

sighting along the rear of the rack from either end of the carriage. Adjust the clearance by means of the eccentric nut on which the pawl release lever is mounted, until the pawl clears the rack by $1/64$ ". This adjustment is made with the clutch unlocked and is read with the clutch locked (Figure 34). The high point of the eccentric nut must be kept in the front half of its orbit.

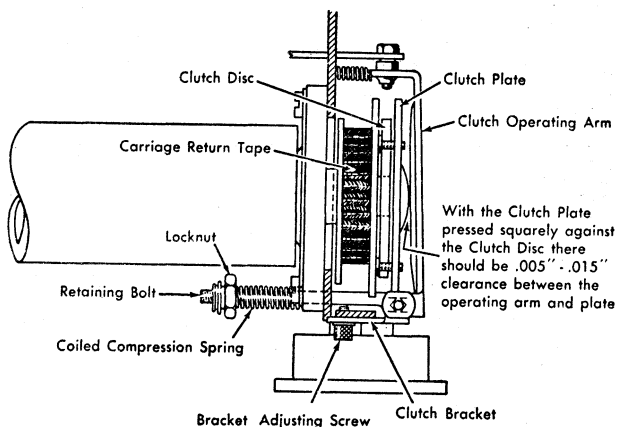

Figure 35. Clutch Parts

CLEARANCE BETWEEN THE CLUTCH PLATE AND THE CLUTCH DISC should be adjusted to $.005$ " to $.015$ " by positioning the bracket on the bottom of the frame, using the elongated holes at the bottom of the clutch plate bracket for this purpose (Figure 35).

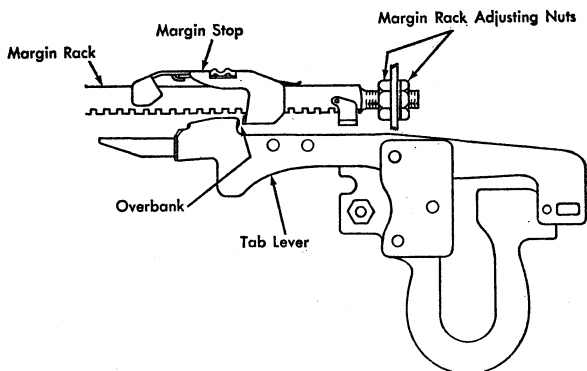

Figure 36. Overbank Adjustment

OVERBANK is adjustable by moving the margin rack to the left or right after having loosened the rack nuts at the ends of the carriage. The rack should be positioned so that when the carriage is moved slowly to a position of contact between the left margin stop and the flat top of the tab lever, the escapement pawl will click into the escapement rack under the carriage at the instant of contact. No pressure should be exerted to force the tab lever during this test (Figure 36).

ADJUST THE SELF-LOCKING NUT AGAINST THE COILED COMPRESSION SPRING under the clutch until the carriage will just make a 1-1/2" return with the line space lever to the rear. (Figure 35).

Adjustments, Latch Type Clutch, Standard Models

THE LATCH SPRING is required to actuate the latch and, through the two long links and the bell crank under the rear rail, it is also required to lift the clutch knockout lever, operate the pawl release lever so as to pull the escapement pawl out of the rack and finally, to actuate the back space interlock. All of these associated parts must be free from binds. The latch spring is not adjustable.

1. **THE ADJUSTABLE CAM STOP** should be adjusted so the cam lug will fall just behind the cam release lever lug when the cam is tripped with the power off.
2. **THE CAM RELEASE LINK** should be adjusted so the cam will be released when the key has completed two-thirds of its downward travel.

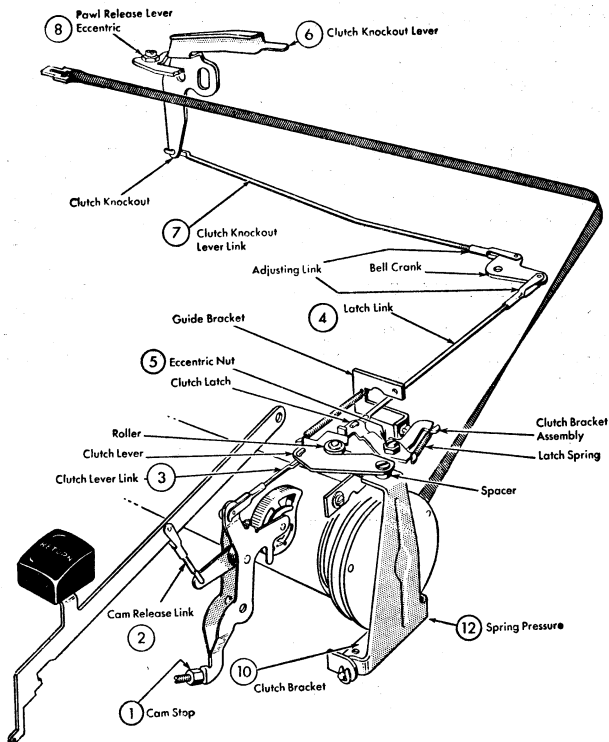

Figure 37. Standard Latch Clutch

3. **ADJUST THE CLUTCH LEVER LINK** so when the clutch is open as far as the roller will permit, the cam will be just touching its stop.

4. **ADJUST THE LATCH LINK** so when the clutch is unlatched, the slot in the clutch bell crank will be parallel with the rear rail.

5. **ADJUST THE LATCH ECCENTRIC NUT** for a clearance of .005" to .015" between the latch and the clutch lever when the cam is on its high point. The high point of the eccentric must be kept in the outer half of its orbit. If the minimum clearance cannot be obtained by adjusting the eccentric, the cam link may be set one or two turns tighter but this should be avoided if possible because it would prevent the cam lever from resting on the roller.

6. **ADJUST THE TIP OF THE CLUTCH KNOCKOUT LEVER** by forming the tip so it touches the underside of the tab lever angle plate and permits a clearance of .010" to .015" between the margin rack and the knockout surface of the clutch knockout lever. This should be checked with the tab lever in rest position and with the clutch latched.

7. **ADJUST THE CLUTCH KNOCKOUT LEVER LINK** so when the cam is on its high point, the latch will engage the clutch lever by $3/64$ ", the thickness of the latch. Check the switch insulator to see that it does not interfere with the adjustable clevis on the clutch knockout lever link.

8. **ADJUST THE PAWL RELEASE LEVER ECCENTRIC** so when the clutch is latched, the escapement pawl will clear the rack by $1/64$ ". The high point of the eccentric should be kept toward the front of the machine to provide the best leverage for its operation.

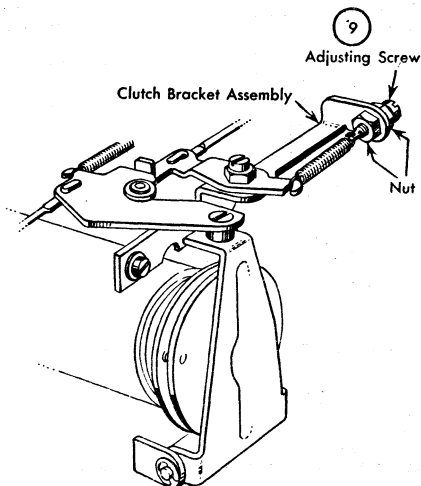

Figure 38. Adjustable Tension Latch Spring

9. A variation of the roller latch type of clutch incorporates an **ADJUSTABLE TENSION LATCH SPRING** (Figure 38). Insufficient tension in the latch spring can cause a partial carriage return. After clutch and carriage return adjustments have been properly made, spring tension should be adjusted to insure proper return by adjusting locking nuts on the latch spring bracket. Excessive tension on the latch spring can cause the carriage to

lock if carriage return and tabular are operated simultaneously. The clutch bracket assembly is interchangeable with similar parts on other machines.

10. **ADJUST THE CLUTCH BRACKET** on the bottom frame so that, when the clutch plate is held against the disc by hand, the bronze insert of the plate clears the clutch operating arm by .005" to .015". When the clutch is unlatched, the clutch pulley should be free to rotate, and there should be no drag on the carriage return tape. When the clutch is latched, the lower, rear corner of the clutch operating arm should be free to move at least 1/32" in the spring control slot of the bracket.

11. **ADJUST THE MARGIN RACK FOR OVERBANK** to the right or left so that when the carriage is moved slowly to a position of contact between the margin stop and the flat top of the tab lever, the escapement pawl will click into the escapement rack at the instant of contact (Figure 36).

12. **ADJUST THE SELF-LOCKING NUT** against the coiled compression spring under the clutch so the carriage will just return to the margin when operated on a 1-1/2" return with the line space lever to the rear.

Adjustments, Single Link Clutch, Standard Models

The single link, roller latch clutch (Figure 39) is a modification of the standard latch type clutch, which simplifies adjustment. This type of clutch can be used as a replacement on any application, except the Executive machine.

The single-link clutch employs a single link, running from the carriage return cam, passing through the latch and on to the bell crank under the rear rail. The link makes it possible to use the power of the cam to raise the knockout lever, pull the pawl out of the rack, actuate the back space interlock lever and latch the clutch.

1. **THE CAM STOP** should be adjusted so the cam release lever lug will fall just behind, or on the rear half of the cam lug.

2. **THE CAM RELEASE LINK** should be adjusted so the cam will be released when the key has completed two-thirds of its downward travel.

3. **THE LATCH LINK**, at the cam end, should be adjusted so that, with the cam at rest, the clutch unlatched and the latch held against the lever, the holes in the clevis will match the pins on the cam.

4. **THE TIP OF THE CLUTCH KNOCKOUT LEVER** should be formed so the upper surface of the knockout lever will be .005" to .015" below the margin rack when the tip of the knockout lever is touching the angular plate of the tab lever.

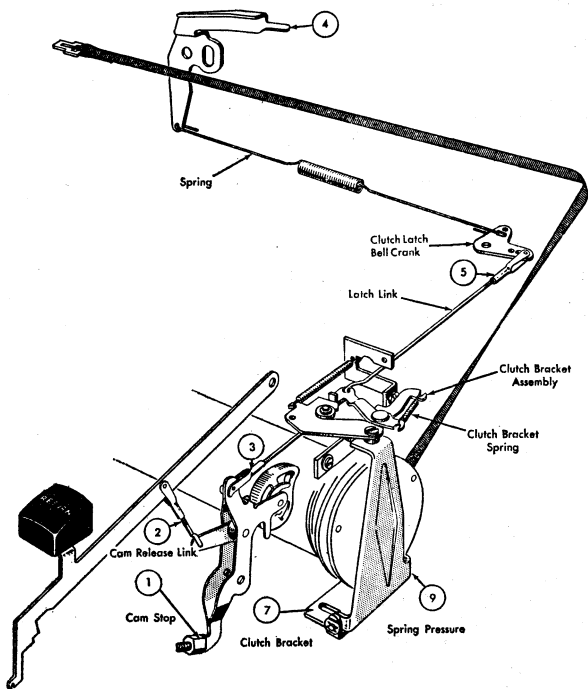

Figure 39. Single Link Latch Clutch

5. **THE REAR CLEVIS OF THE LATCH LINK** should be set, with the cam on its high point, to just match the outside hole of the clutch bell crank when the clutch knockout lever is raised to its full limit and is touching the under side of the tab lever.

These adjustments should permit the latch to hold the clutch lever by approximately $1/16''$ when the clutch is latched. If the engagement is too deep to permit positive unlatching action, shorten the latch link slightly at the rear clevis. If, on the other hand, the engagement of the latch is too shallow to hold for a positive and complete carriage return operation, then adjust the cam slightly closer to the power roll and again match the front end of the latch link with the pins in the cam. It may also be necessary to attach the rear clevis of the latch link to the second hole of the clutch bell crank in order to obtain a good unlatching action.

During the latching operation it will be noted that the

latch goes forward and then drops back to its normal latched position. This overthrow is normal to insure safe latching.

5a. If a "horseshoe type" clutch knockout lever link is installed, the rear clevis of the latch link should be adjusted so that the slot in the clutch latch bell crank lies parallel to the rear rail with the parts at rest.

5b. The clutch knockout lever link should be adjusted so that the clutch latch engages the clutch lever by .050" to .060", approximately the thickness of the latch.

6. **ESCAPEMENT PAWL CLEARANCE** should be adjusted by means of the eccentric on the pawl release lever to obtain 1/64" clearance with the escapement rack with the clutch latched (Figure 34).

7. **CLUTCH PLATE CLEARANCE** should be set for .005" to .015" between the clutch plate and the disc.

8. **ADJUST THE MARGIN RACK FOR OVERBANK** to the right or left so that when the carriage is moved slowly to a position of contact between the margin stop and the flat top of the tab lever, the escapement pawl will click into the escapement rack at the instant of contact (Figure 36).

9. **SPRING PRESSURE** should be adjusted just sufficiently to insure a 1-1/2" return with the line space lever set to the rear.

Clutch Adjustments, All Models

THE CLUTCH PULLEY SPRING should be wound completely and backed off two turns before attaching the carriage return tape. If the pulley is wound too loosely, the carriage may tend to creep away from the margin on repeated line spacing because of excessive whip in the tape.

LINE SPACE

Preventive Maintenance, All Models

THE DETENT ROLLER should be properly oiled and should be examined on inspections for nicks in its surface which indicate need for replacement.

THE HOOK LEVER SPRING should be properly greased and should be so formed that it will just restore the index pawl carrier to its upper position in triple space position and will hold the pawl out of engagement with the ratchet. More tension than this can contribute to whipping of the carriage return tape and may cause an uneven margin on repeated line spacing.

WASHERS which retain the index pawl carrier should be assembled so they "dish" away from the carrier to avoid binding.

Adjustments, All Models

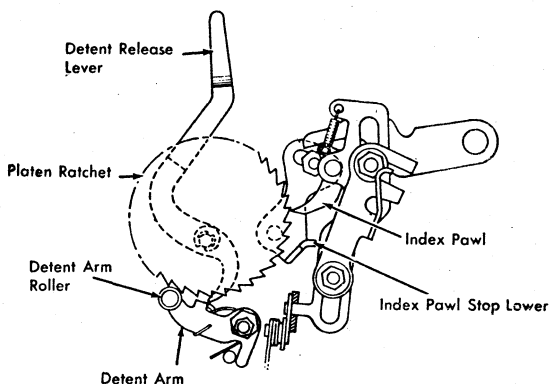

Figure 40. Line Space Mechanism

THE PLATEN DETENT ARM (Figure 40) should be adjusted, by means of the eccentric nut on which it is mounted, so that the index pawl may enter the ratchet one-third of the distance down on a tooth. The platen must be removed to make the adjustment. The high point of the eccentric nut should be kept in the upper half of its circle.

THE LOWER INDEX PAWL STOP must be adjusted, after any change in the detent adjustment, so that it stops the travel of the index pawl carrier at the instant when the ratchet has positioned itself securely on the detent roller with no play forward or backward.

Proper line spacing depends very largely on proper paper feed. After having checked the adjustments outlined here, the adjustments listed under the heading Paper Feed should be reviewed.

Special attention should be given to the detent arm pressure spring. If the spring is not sufficiently strong to hold the ratchet securely, heavy paper forms or cards may advance an extra part of a line space just as the bottom edge drops off the rear feed rolls. A complete line may be written with the paper in this position. When the paper is advanced to the next line, the space will then appear too small. Such a fault will appear only at a distance of approximately 2-1/4" from the bottom edge of the paper. The detent arm spring may be removed and formed stronger.

PLATEN INDEXING

Platen Ratchet Part No.	No. of Teeth	Number of Spaces in 10" of Form					Parts for Standard Executive & Pin Feed Models.		Parts for Lift Platen Model	
		Count the number of spaces in 10" of form, and find nearest number in chart					Upper Index Pawl Stop	Detent Arm Assembly	Upper Index Pawl Stop	Detent Arm Assembly
		1	2	3	4	5				
1002224	24	43.7	21.8	14.5			1076865	1072875		
	25	45.5	22.7	15.2						
	26	47.3	23.7	15.8						
1002227	27	49.1	24.6	16.4			1076865	1072875		
	28	50.9	25.5	17.0						
1002229	29	52.5	26.4	17.6			1000325	1076864	1012729	1002281
1002230	30	54.6	27.3	18.2			1076865	1076880		
1002231	31	56.4	28.2	18.8			1000325	1076880		
1002232	32	58.2	29.1	19.4			1000325	1072875		
1002233	33	60.0	30.0	20.0			1000325	1076864	1012729	1000305
1002234	34	61.8	30.9	20.6			1000325	1076882		
1002235	35	63.7	31.8	21.2			1000325	1072875		
1002236	36	65.5	32.7	21.8			1000325	1076880		
	37	67.3	33.7	22.4						
1002238	38	69.1	34.6	23.0			1000325	1076864	1012729	1000305
1002239	39	70.9	35.5	23.7			1000325	1076880		
1002240	40	72.8	36.4	24.3			1000325	1076880		
1002241	41		37.3	24.9	18.6		1000325	1076882		
	42		38.2	25.5	19.1					
1002243	43		39.1	26.1	19.5		1000325	1072875		
1002244	44		40.0	26.6	20.0		1000325	1076864	1012729	1002281
1002244	44	80.0	40.0	26.6			1002273	1076864		
1002245	45	81.8	40.9		20.5		1076866	1076880		
1002246	46	83.7	41.8		20.9		1076866	1072880		
	47	85.5	42.8		21.4					
1002248	48		43.7	29.1		17.5	1076865	1072875		
1002249	49		44.6	29.7		17.8	1000325	1076864		
1002250	50		45.5	30.3	22.7		1002272	1076884		
1002251	51		46.4	30.9	23.2		1002272	1076884		
1002252	52		47.3	31.5	23.7		1002272	1076884		
1002253	53		48.2	32.1	24.1		1002272	1076884		
	54		49.1	32.7	24.6					
1002255	55		50.0	33.3	25.0		1002272	1076886	1012729	1002285
1002256	56		50.9	34.0	25.5		1002272	1076884		
1002257	57		51.8	34.6	25.9		1002272	1076884		
1002258	58		52.8	35.2	26.4		1002272	1076886		
1002259	59		53.7	35.8	26.8		1002273	1076886		
1002260	60		54.6	36.4	27.3		1002273	1076886		
1002261	61		55.5	37.0	27.7		1002273	1076884		
1002262	62		56.4	37.6	28.2		1002273	1076884	1013596	1002285
	63		57.3	38.2	28.7					
	64		58.2	38.8	29.1					
	65		59.1	39.4	29.6					
1002266	66		60.0	40.0	30.0		1002273	1076884	1013596	1002285

Standard Index Pawl Carrier Assembly, 1073401, unstamped, serves for Ratchets 24T through 49T.
 Special Index Pawl Carrier Assembly, 1076862, stamped 62, serves for Ratchets 50T through 66T.
 Lift Platen Index Pawl Carrier Assembly, 1012723, unstamped, serves for Ratchets 29T through 41T.
 Lift Platen Index Pawl Carrier Assembly, 1002286, unstamped, serves for Ratchets 42T through 62T.

Pawl Stop	Identification	Detent Arm	Identification
1076865	29	1076864	29
1000325	Unstamped	1076880	31
1076866	45	1072875	Unstamped
1002272	55	1076882	45
1002273	62	1076886	55
		1076884	62

Allowance for the thickness of the form should be made when selecting the Ratchet. Each additional .030" of form thickness requires additional teeth in the Ratchet according to the following table:

- 24T to 34T - 1 additional tooth
- 35T to 57T - 2 additional teeth
- 58T to 66T - 3 additional teeth

This allowance will reduce to a minimum the need for using the Platen Variable Button.

BACK SPACE

Preventive Maintenance, Standard Models Except Decimal Tabulation

BACK SPACE PAWL must be lubricated and kept clean. **ESCAPEMENT PAWLS** must operate freely and without binds to insure good back space operation.

Adjustments

Standard Models Except Decimal Tabulation

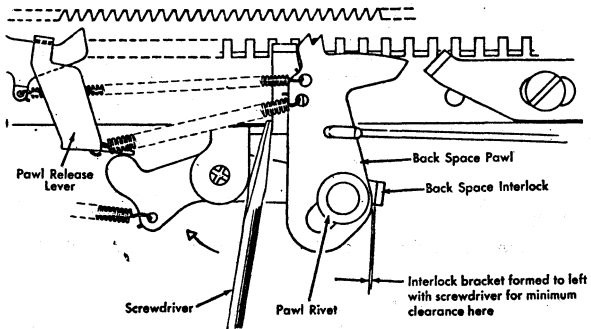

Figure 41. Back Space Interlock

ADJUST THE INTERLOCK by forming the bracket which supports the interlock lever, in such a manner that all clearances are very close. Figure 41 shows how the bracket may be pried in one direction with a screwdriver to close the clearance between the lug on the end of the interlock lever and the edge of the back space pawl. Figure 42 illustrates a method of increasing the clearance between the lug on the end of the interlock lever and the back space pawl. The clearance must be held to an absolute minimum to block any motion of the back space pawl while the interlock is in the operating position. Test by holding down a carriage release button and moving the back space pawl by hand.

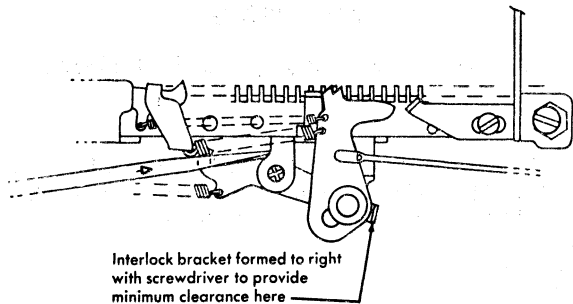

Figure 42. Increasing Interlock Clearance

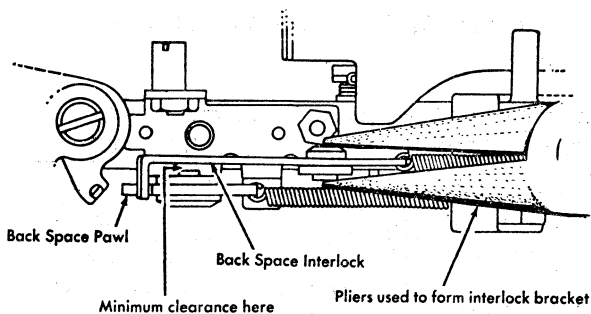

Figure 43. Adjusting the Height of the Interlock

THE HEIGHT OF THE INTERLOCK LEVER may be adjusted (Figure 43) to keep the interlock as low as possible and not actually touch on the back space pawl. The back space pawl will slip under the interlock if it is formed too high.

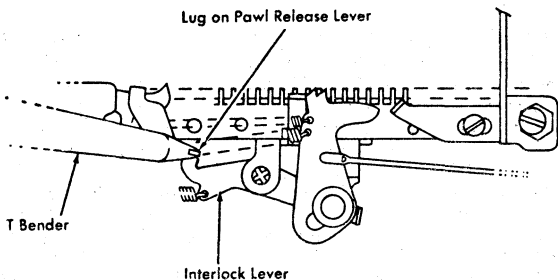

Figure 44. Adjusting the Back Space Interlock Motion

THE FINAL ADJUSTMENT OF THE INTERLOCK (Figure 44) requires the pawl release lever to lie flat against the rear rail. Maladjustment of the two upper lugs of the pawl release lever could prevent this. Then, with a T bender, form the projecting lug on the rear of the pawl release lever so that, with the interlock at rest, the back space pawl may be moved past it with a minimum of clearance.

CAM STOP should be adjusted so the cam will clear the power roll sufficiently that, when tripped with power off, the cam lug will fall just behind the cam release lever lug or on the rear half of the lug.

ADJUST THE CAM RELEASE LINK so that the cam will be released when the key has completed two thirds of its downward travel.

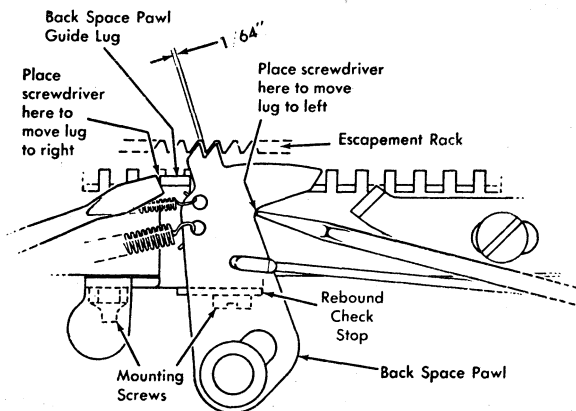

Figure 45. Back Space Pawl Guide Lug

ADJUST THE BACK SPACE PAWL GUIDE LUG (Figure 45) so the pawl will enter the escapement rack with approximately $1/64$ " clearance between the faces of the pawl teeth and the rack teeth. The lug must be formed either to the right or to the left until this condition is achieved.

THE BACK SPACE STOP must be adjusted by loosening its holding screws just enough to permit the stop to be tapped into position. The stop should halt the travel of the carriage by stopping the back space pawl as soon as the escapement pawl drops into the next tooth of the escapement rack (Figure 46). The adjustment of the guide lug and back space pawl stop must be set very close for heavier carriage machines such as formswriters and long carriage machines.

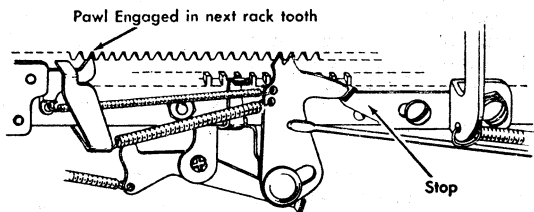

Figure 46. Back Space Stop Adjustment

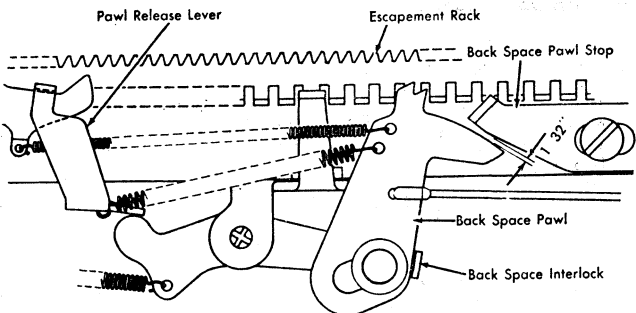

Figure 47. Back Space Stop Clearance

THE SIDE OPERATING LINK should be adjusted so that with the parts at rest there will be $1/64''$ play between the back space link and the hole in the bell crank on the rear rail.

THE BACK SPACE STOP must also be set so that with the interlock lever actuated, the back space pawl will clear the stop by $1/32''$ when the pawl is operated (Figure 47). This adjustment, as well as the other back space adjustments, may be checked visually with the aid of a mirror while operating the power roll by hand. With the parts at rest, there should be approximately $1/64''$ of play between the back space link and the hole in the bell crank on the rear rail.

TABULAR MECHANISM

Preventive Maintenance, All Models

THE TAB GOVERNOR can pick up moisture when unused for long periods and can contribute to sluggish tabulation. Clear all stops, latch the tab lever out and run the carriage back and forth several times to polish the friction surface.

THE TAB LATCH, as well as all moving parts of the tab mechanism, must be properly and regularly lubricated to avoid corrosion and wear.

Adjustments

Standard Models Except Decimal Tabulation

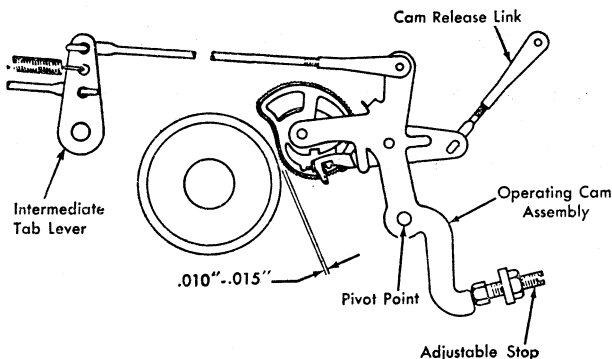

Figure 48. Double Link Tabular Mechanism

TO ADJUST THE CAM, first adjust the cam stop so that when the cam is released, with the power off, the cam lug will just drop behind the rear lug of the release lever. With the single link tabular mechanism, which has a single link from the cam to the tab lever, the cam may be set a trifle closer so the cam release lever will rest on the rear half of the cam lug.

ADJUST THE CAM RELEASE LINK so that the cam is released when the key lever has traveled two-thirds of its downward stroke.

THE LINK BETWEEN THE CAM AND THE INTERMEDIATE TAB LEVER should be adjusted so that the forward edge of the intermediate lever will be vertical with respect to the frame. This adjustment applies only to machines with the double links (Figure 48).

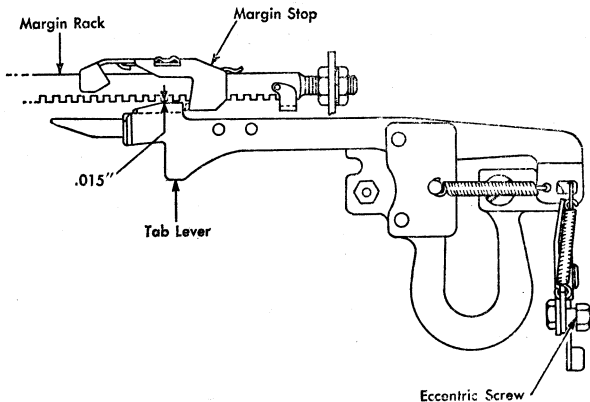

Figure 49. Adjusting Tab Lever Height

THE HEIGHT OF THE TAB LEVER should be adjusted so that it will just clear the under side of the margin rack by .015". This adjustment is made by means of an eccentric stud on which the tab actuating lever rests.

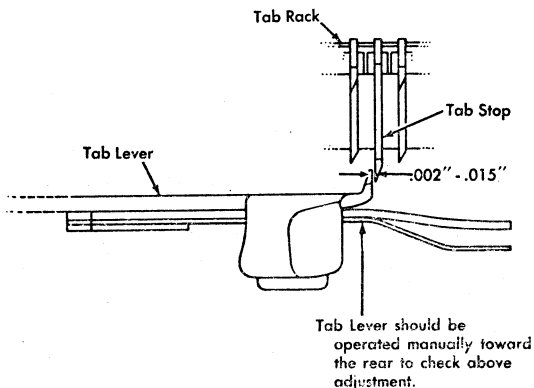

Figure 50. Tab Rack Lateral Adjustment

CLEARANCE BETWEEN THE LEFT-HAND FACES OF THE TAB STOPS AND THE ENGAGING FACE OF THE TAB LEVER should be from .002" to .015", tested at about 10 or 15 different places along the rack, depending on its length (Figure 50). Hold the carriage so a set tab stop

is even with the tab lever. Slowly move the tab lever out toward the rear by hand and observe the amount of clearance between the parts indicated. Adjustment may be made by means of the mounting nuts on the ends of the tab rack. The tab rack must be squared up so that the engaging tip of the tab lever is parallel with the set tab stops when sighted from the end of the carriage.

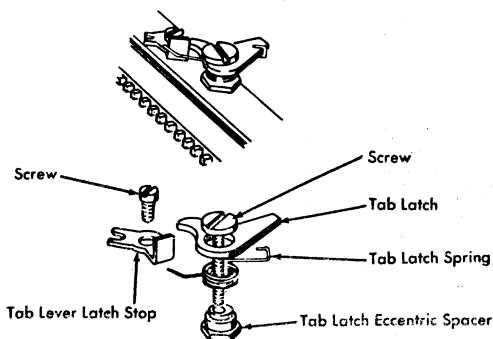

Figure 51. Tab Latch Eccentric

THE TAB LATCH should be adjusted (Figure 51) so that the engaging end of the tab lever will overlap the tab stop when set, by $1/2$ to $2/3$ of the distance between the forward edge of the tab stop and the front face of the tab rack when the tab lever is latched out.

At one time, the tab latch was mounted on an eccentric shoulder of the tab latch stud which was tightened in place by a nut on the bottom of the rear rail (Figure 52). In either case the high side of the eccentric should be kept toward the left, while the eccentric is turned to bring the latch forward or back to its proper location.

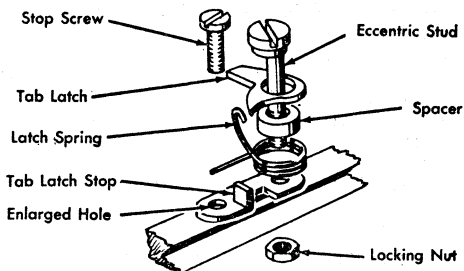

Figure 52. Tab Latch Eccentric Stud

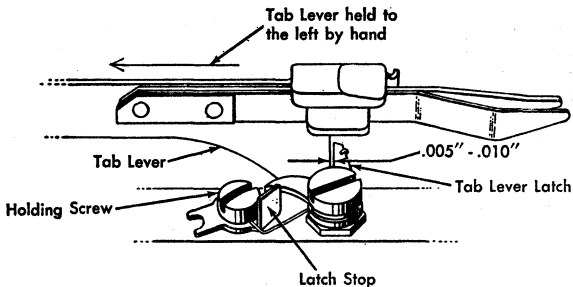

Figure 53. Tab Latch Stop

THE TAB LATCH STOP should be positioned under its holding screw so that, with the tab lever held toward the extreme left, there will be a clearance of .005" to .010" between the left-hand edge of the latch and the right-hand edge of the tab lever at the point where the tab lever meets the latch during rest (Figure 53).

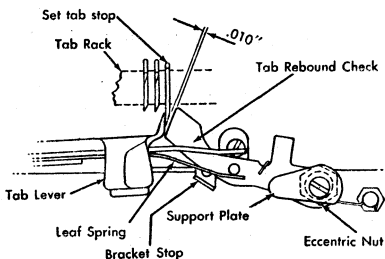

Figure 54. Tab Rebound Check

THE TAB REBOUND CHECK is to be set, by means of the eccentric nut on which it is mounted so that, with the high side of the eccentric toward the rear of the machine, the left end of the rebound check lever will spring into the checking position with a maximum of .010" clearance between the rebound check and the right-hand face of the tab stop (Figure 54). Excessive clearance at this point will result in rebound trouble during tabulation. Rebound trouble always appears as short tabulation, as if the carriage had actually stopped short of the required position. Actually the carriage reaches the proper position but bounces backward to the right if the rebound check does not operate correctly.

THE TAB LEVER LEAF SPRING should be so formed that it just touches the stud, or the right-hand of two studs, on the rebound check at rest.

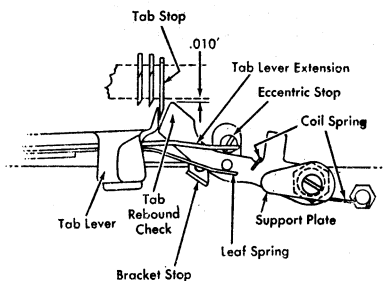

Figure 55. Rebound Eccentric Stop

THE TAB REBOUND ECCENTRIC STOP, located just in rear of the rebound check lever (Figure 55), must be set to allow .010" clearance between the corner of the rebound check and the front face of the rack.

HEIGHT OF THE REBOUND CHECK must be adjusted, by forming the support plate (Figure 55) up or down, so the rebound check is high enough to catch securely on the tab stops but not high enough to interfere with the tab lever.

THE TAB LEVER EXTENSION should also touch the stud of the rebound check and should be so formed as to permit the engaging tip of the tab lever and the tip of the rebound check to lie in the same plane at rest. Maintain the leaf spring adjustment as the tab lever extension is being formed.

THE BRACKET STOP FOR THE REBOUND CHECK LEVER should be so formed as to eliminate any binding of the tab lever on the sides of its mounting bracket and still maintain the tab lever approximately parallel to the rear rail. (Figure 55).

THE REBOUND CHECK SPRING, coiled around the rebound check support, should be so formed that if the coiled spring is unhooked from the stud the beginning of its hook will lie just over the front edge of the rear rail.

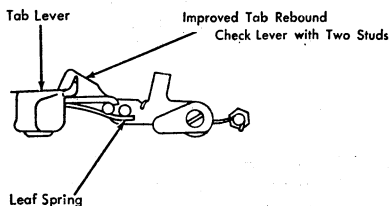

Figure 56. Tab Lever Tip and Leaf Spring

A **SECOND STUD** has been installed on the rebound check lever to aid it to restore to rest position more readily after tabulation (Figure 56).

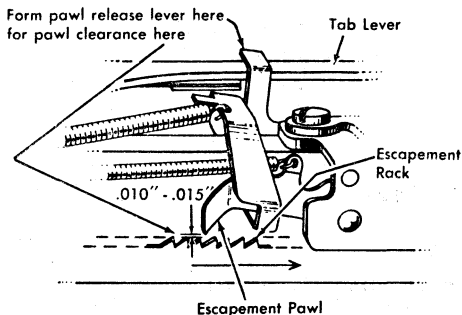

Figure 57. Tabular Pawl Release Adjustment

THE REAR, UPRIGHT LUG ON THE PAWL RELEASE LEVER should be so formed as to remove the escapement pawl .010" to .015" from the escapement rack during tabulation (Figure 57).

THE LINK ON THE LEFT-HAND END OF THE TAB LEVER should be adjusted so that when the cam is on its high point, the tab lever will just clear the front face of the tab rack. This adjustment should be made in the same manner whether the tab lever is connected by one or two links to the cam.

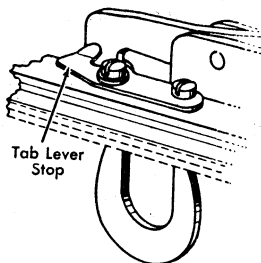

Figure 58. Tab Lever Stop

THE TAB LEVER STOP on the top of the rear rail may be adjusted in position to prevent overthrow of the tab lever (Figure 58). Adjustment should be made while the tabular cam is on its high point.

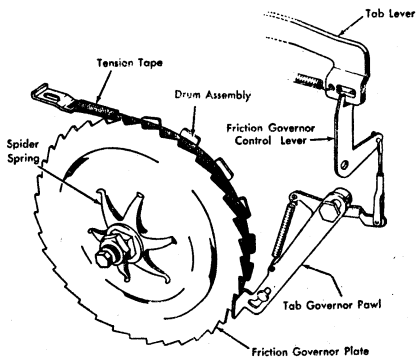

Figure 59. Tab Friction Governor

CARRIAGE TENSION should be checked by holding the carriage so that the tab lever is even with the last tab stop. Latch the tab lever out and let go of the carriage. There should be just enough main spring tension to unlatch the tab lever without hesitation. Tension may be adjusted by placing the loop in the carriage tension tape on different prongs of the main spring drum.

THE TAB GOVERNOR PAWL LINK should be so adjusted that when the tab lever is latched out in the operating position, the end of the pawl will engage the teeth of the ratchet by the thickness of its own metal (Figure 59).

THE PRESSURE OF THE FRICTION GOVERNOR PLATE is to be adjusted, by means of the two locking nuts on the hub of the main spring drum, until excessive shock has been eliminated. The tab lever should dependably unlatch when tabulating from a point ten spaces to the left of the last tab stop.

THE TAB SET BRACKET should be formed so that when the tab stops are in the non-operating position, there will be a clearance of approximately $1/32''$ between the tab stops and the tab set lever.

THE TAB CLEAR BRACKET should be so formed that when the tab stops are in the operating position, there will be a clearance of approximately $1/32''$ between the tab stops and the tab clear lever.

THE TAB SET AND CLEAR LINKS should be adjusted to such a length that when the buttons are at rest, the slope of their upper surfaces will point in a line parallel to the plane of the keyboard.

The carriage may be made to tabulate to any space on machines of 6-2/5, 8, 9, 10, and 12 pitch; every other space on 14 and 16 pitch machines. Repeat tabulation may be made to every stop on 6-2/5 pitch machines; every other stop on others.

RIBBON FEED

Preventive Maintenance, All Models

THE CAM RELEASE LEVER was originally designed with two lugs, the lower one of which would arrest the rotation of the cam after one-half revolution. The lower lug should be broken off because it can strike on one of the cam lugs if the cam happens to be in just the right position when the next key is released. If the cam lug interfered with the release lever travel in this manner, a light impression or typing failure would result, because the release lever for the ribbon feed cam is actuated by the cam lever, through the ribbon lift bail.

THE CAM SPRING must be maintained tight in a vertical position to insure good engagement between the cam serrations and the power roll.

ALL MOVING PARTS of the ribbon feed and reverse mechanism should be given a light lubrication with the approved oil during inspections.

THE RIBBON FEED CAM is required to perform more operations than any other cam in the machine and should have proportionately more attention for preventive maintenance.

RIBBON GUIDES must be smooth and properly aligned to permit free movement of the ribbon.

Adjustments, All Models

1. **THE RIBBON FEED CAM** should be set to clear the power roll just enough to permit its release lever lug to drop behind the cam lug upon release of the cam. This adjustment is made by means of an eccentric stud upon which the cam rests.

2. **THE CAM RELEASE LEVER LINK** (Figure 60) should be adjusted so that the cam will be released when the type face is approximately $3/4$ " from the platen.

3. **THE LINK FROM THE CAM TO THE END PLATE** on the ribbon operating bail is to be adjusted until the formed lug which passes through the side frame rests $1/16$ " above the bottom of the arc shaped slot in the side frame. This adjustment may be made by disconnecting the cam link and, by reaching down with a spring hook from the position of the left-hand ribbon spool, the link may be turned.

4. **THE RIBBON FEED CONNECTING LINKS** should be adjusted so that when the ribbon feed cam is on the high point, the reversing latches can just clear the lugs on the ribbon feed bell cranks. Observe the adjustments with the feed pawls engaged in first one spool and then the other, with the ribbon reverse lever held toward the rear.

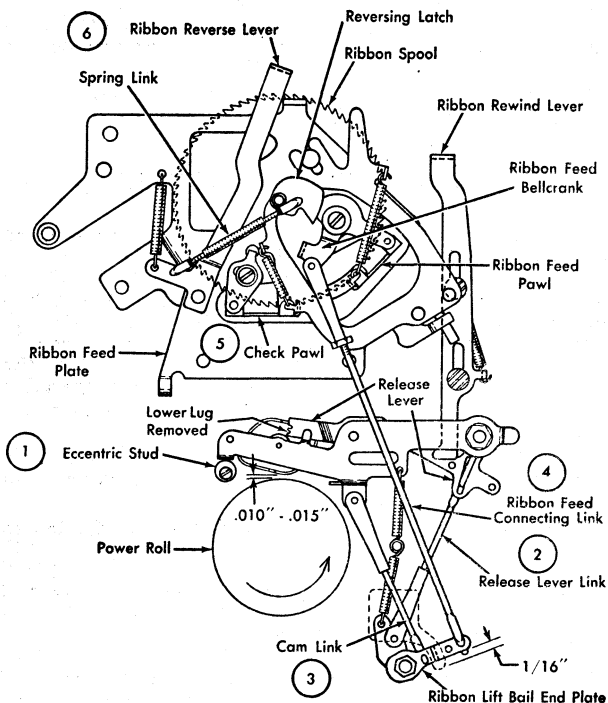

Figure 60. Ribbon Feed Mechanism

5. THE CHECK PAWL is to be adjusted by means of its mounting screw. Loosen the screw and move the pawl backward or forward until, with a spool tooth resting against the check pawl, the feed pawl will rest half way between two teeth. With the cam rotated to its high point, the feed pawl should feed two teeth plus enough to engage the check pawl safely.

6. THE REVERSING LATCH SPRING LINKS should be so adjusted that, with the reversing levers at rest in their forward position, the reversing latches will clear the paths of the ribbon feed bell cranks by $\frac{5}{32}$ " and the latches will engage the bell cranks when the reversing levers have moved $\frac{1}{2}$ " from their rest stops.

THE RIBBON SPOOL RETAINING SPRINGS should be so formed that the ribbon spools are held straight and do not bind or reel out too freely.

THE TORSION SPRING ON THE RIBBON REVERSING ROD should be so formed as to have just enough tension to complete the reversing action when the reversing rod has rotated through $2/3$ of its prescribed travel.

AUTOMATIC UNLATCHING RIBBON REWIND adjustments are made in a similar manner.

Adjustments, Ribbon Lift, All Models

THE RIBBON LIFT CONNECTING LINK should be adjusted to take up all the play in the linkage when the cam levers and lift bail are at rest, but not push the ribbon lift lever up off its stop. Check by holding the ribbon lift lever against its stop and, with the ribbon lift bail against the cams, see that the link just meets the hole in the bottom end of the actuating lever. Observe that the toggle comes nearly into a straight line upon operation of a type bar by hand. In stencil position the toggle will pass its center slightly.

THE VINYLITE STOP should be shimmed so as to hold the lift lever high enough to prevent any movement of the center guide during shifting.

THE RIBBON LIFT GUIDE CLEVIS should be adjusted so that when the ribbon lift is at its lowest, or **BLACK**, setting, the tops of the tallest characters strike $1/32''$ below the upper edge of the ribbon. The color control button should then be moved to its highest, or **RED**, position and the rear lug on the positioning plate should be formed so the underscore will strike the ribbon $1/32''$ above the lower edge of the ribbon. In the attainment of this setting, if it appears that the underscore throws the ribbon too high, the underscore cam lever hook may be peened as indicated in Figure 61. This would be evident if other characters appeared to track too high on the ribbon after setting the upper rear lug. Readjust the ribbon lift guide clevis and the upper, rear lug after peening the cam lever hook. Peening the hook on the opposite edge would give the opposite effect.

LIGHT IMPRESSION, which may be noticeable only in the **RED** or high lift position, may be corrected by shimming or forming the vinylite stop bracket upward slightly to raise the lift lever and tend to straighten the toggle to a point where cramping will be relieved.

Observe that, as the operating link moves toward the rear, the actuating lever rotates counter clockwise (Figure 61). If the vinylite stop is quite low, the link from the top of the actuating lever to the center of the toggle will be too near to parallel with the lower link of the toggle. This will cause a cramping condition as the actuating lever starts its movement. After movement is under way this cramping condition will not be present, and the actu-

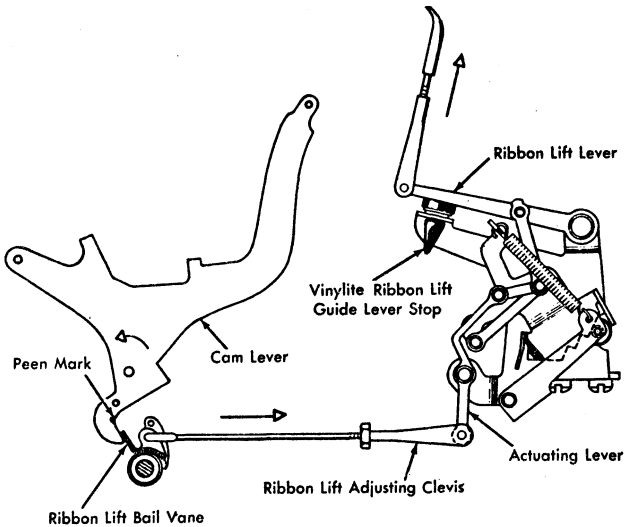

Figure 61. Peening Cam Lever to Prevent Ribbon Lifting Too High.

ating lever will have a straighter, easier pull. However, the type bar impression for this stroke will be lighter because the cramp in the ribbon lift will have reduced the velocity of the cam travel.

If it is necessary to raise the vinylite stop by an appreciable amount to correct light impression in the upper position of the ribbon, type impression on stencil position may become light. This is due to the toggle linkage being held too tightly or too straight by the high position of the stop, which will tend to bind the mechanism. This condition may be relieved by forming the front lug on the positioning plate toward the rear of the machine to allow the toggle a small amount of free motion in stencil position.

With other ribbon adjustments properly made, the ribbon should track properly in the black position. If the tracking in high lift or **RED** position does not coincide, then the rear lug on the positioning plate may have to be formed downward to prevent the ribbon from rising too high in **RED** position.

THE COLOR CONTROL BUTTON LINKAGE should be adjusted so that when the ribbon lift control button is in the so-called black ribbon position, the slope of the button will be parallel to the slope of the keyboard.

IBM[®]

ELECTRIC TYPEWRITER MODEL B 1

STANDARD (Serial 300,000 and above)

CUSTOMER ENGINEERING REFERENCE MANUAL

Preventive Maintenance and Adjustments

CONTENTS

	<i>Page</i>
Motor Drive	3
Key Levers, Letter Cams, Type Bars	5
Escapement	10
Margin Set	13
Margin Release	14
Line Lock	16
Carriage and Rails	17
Paper Feed	23
Space Bar	29
Shift	32
Tabulation	34
Carriage Return and Line Space	43
Backspace	54
Ribbon	57
Type Impression	62
Type Alignment	63
IBM Standard Type Styles	71

INTERNATIONAL BUSINESS MACHINES CORP.

NEW YORK 22, NEW YORK

Form 25-6170-2 (this section only)

COPYRIGHT 1957
INTERNATIONAL BUSINESS MACHINES CORP.
590 Madison Avenue, New York 22, New York
Printed in U. S. A. April 1957
Form 25-6170-2

IBM ELECTRIC STANDARD TYPEWRITER MODEL B1

MOTOR AND DRIVE Removal

MOTOR. Remove the following:

1. Rear case of the typewriter.
2. Adjusting screw that positions the motor to the left side frame (Figure 1).
3. Drive belt from the motor pulley.
4. Inside C-clip which retains the motor shaft. Slide the shaft out of the side frame.
5. Remove the rear bottom plate and the motor may be maneuvered through the bottom of the machine and disassembled without opening its connections.

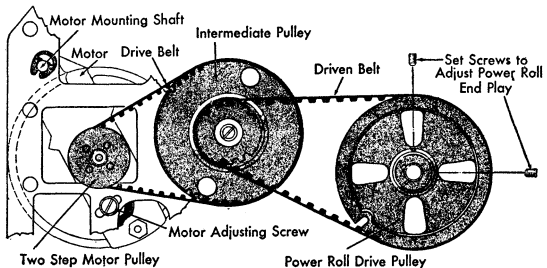

Figure 1. Motor and Drive

RING-MOUNTED MOTOR. This change occurred on machines above serial number 391,522 for Standard Models and 127,935 for Executive Models. To remove this motor the removal procedure for the previous type of motor may be used except for steps 2 and 4. On the ring-mounted motor it is necessary to remove the screw which holds the right ring mounting bracket to the motor bracket. Remove the left ring clamp, and the motor may then be removed. On machines above serial number 399,945 for standard and 130,005 for executive the adjustable brace must be disengaged by removing the two screws from the rear frame (Figure 2).

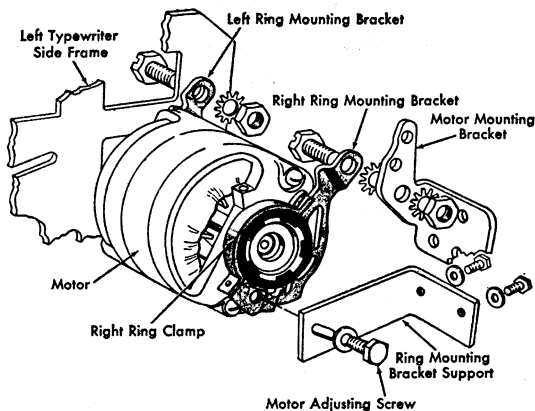

Figure 2. Ring-Mounted Motor

POWER ROLL.

1. Remove the front case.
2. The clutch should be latched before removing the power roll. This precaution will serve to hold the clutch parts in place when the shaft is removed, thereby facilitating reassembly. It will be noted that the right end of the power roll shaft is chamfered for easy insertion into the clutch disc slot.
3. Remove the driven belt from the power roll drive pulley.
4. Loosen the two setscrews in the power roll drive pulley and remove the pulley (Figure 3).
5. Remove the three screws holding the bearing retainer to the left side frame.
6. Remove the power roll assembly through the hole in the left side frame.

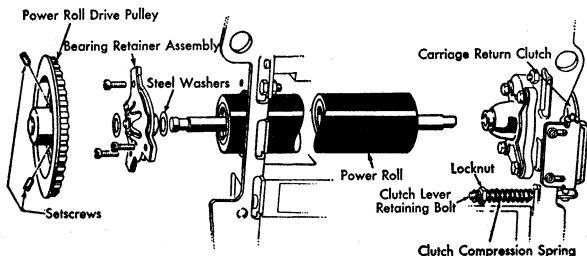

Figure 3. Power Roll Removal

Adjustments

1. THE TYPEWRITER SWITCH should function without hesitation and have even positive overthrow in both positions.

2. THE SELF-ALIGNING OILITE BEARINGS of the motor and power roll should be aligned to their shafts to eliminate binds. If a bind should occur, a slight tapping action on the pulleys with the handle of a screwdriver should produce satisfactory results.

3. POWER ROLL END PLAY should be .002" to .010". Make the adjustment by positioning the power roll drive pulley on the shaft while tightening the set screws (Figure 3).

4. DRIVEN BELT. Adjust by positioning the intermediate pulley shaft. The shaft incorporates a *left-hand thread* so that the pulley rotation tends to tighten the shaft. The deflection of the belt should be approximately 3/8" (Figure 1).

5. POWER ROLL SPEED is obtained by a two-step motor pulley. The 14-tooth step provides 95 feet per minute and the 15-tooth step provides 103 feet per minute. The motor pulley should be positioned on the motor shaft to align the belts and the pulleys (Figure 1).

6. DRIVE BELT. Place this on the 15-tooth pulley on machines of 6-2/5, 8, 9, and 10-pitch escapement. On machines having a 12 or 14-pitch escapement, place the drive belt on the 14-tooth pulley. Adjust the play of this belt for approximately 3/16" deflection by positioning the motor adjusting screw forward or backward in its elongated mounting hole (Figure 1).

To adjust the drive belt tension on the ring-mounted motor, loosen the motor adjusting screw and the ring-mount bracket screw. The motor may then be moved to the front or rear for proper belt tension. After tightening these screws, check the motor housing to be sure that it is parallel to the rear frame and that the ring-mount screws are tight (Figure 2).

KEY LEVERS, LETTER CAMS AND TYPE BARS

Removal

KEY LEVERS

1. Remove the front case.
2. Remove the key plate and the key lever stabilizer.
3. Remove the speed clip on either end of the key lever fulcrum wire (Figure 4).

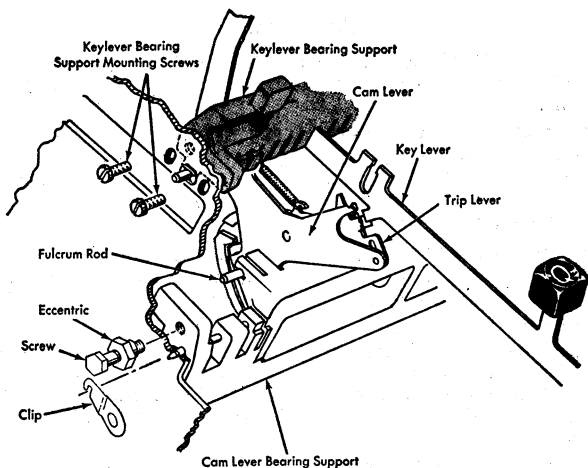

Figure 4. Key Lever Bearing Support

4. Force the fulcrum wire to the desired key lever by using a follow-up fulcrum wire.
5. Remove the spring from the front end of the key lever.
6. Remove the key lever by pushing it toward the rear of the machine until the front end clears the front guide comb.
7. Key buttons may be removed from the key levers without removing the key plate, by exerting a force from the bottom of the machine against the bottom of the button. Be careful to avoid damaging the key plate or the button.
8. The rubber may be removed from the front guide comb and a repeat plunger and spring may be installed to obtain a repeat/non-repeat key lever. The guide comb is designed for this in five letter positions and two operational positions.

TYPE BARS

1. Loosen the two type bar fulcrum wire retaining screws (Figure 5).
2. Push the wire out with a follow-up wire until the desired type bar is reached.
3. Pull the type bar toward the front of the machine until it will pass in front of the type segment. Disconnect the type bar from the link.

CHANGEABLE TYPE BARS may be removed by raising the type bar to the type guide. With the basket in lower case, place the thumb low on the type bar and push the type bar toward the rear of the machine. With a downward circular motion the type bar may be disengaged from the fulcrum wire. Unhook the special type bar link and the type bar may be removed from the machine.

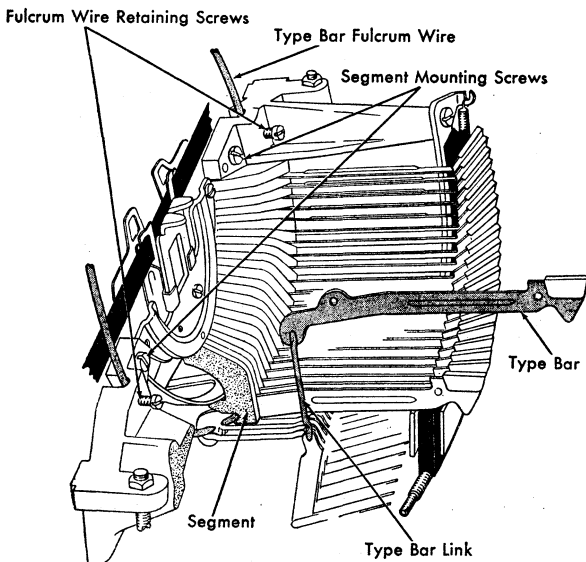

Figure 5. Type Bar Removal

LETTER CAMS

1. Remove the front case.
2. Remove the power roll.
3. Remove the type bar of the cam lever to be removed.
4. Loosen the screw that holds the fulcrum wire clip in place and disengage the clip from the fulcrum wire.
5. Insert a follow-up cam bearing fulcrum wire through the side frame until the cam to be removed is reached. Then separate the two fulcrum wires just enough to drop the desired cam assembly (Figure 4).
6. Disconnect the cam lever spring and remove the assembly from the bottom of the machine (Figure 4).

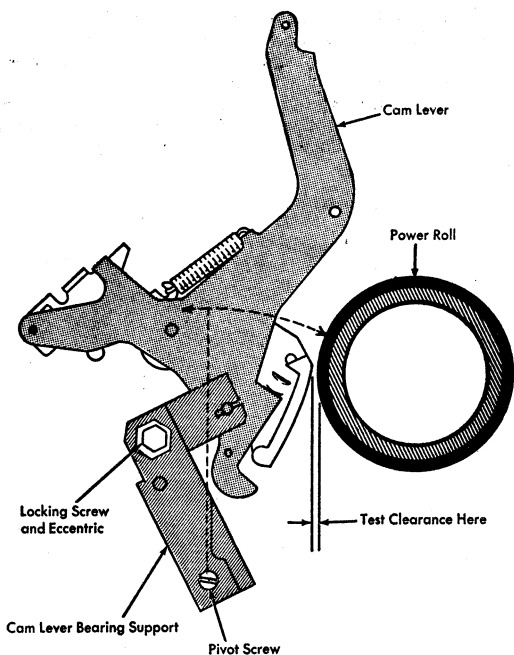

Figure 6. Letter Cam Clearance Adjustments

Adjustments

CAM CLEARANCE. Adjust cams so that there is a clearance of .015" to .020" between all the letter cams and the power roll (Figure 6). This clearance may be obtained by inserting three IBM cards between the letter cams and the power roll. Move the cam lever bearing support to allow the letter cams to just rest on the three cards. Tighten the screws in the cam bearing support. Withdraw the three cards and check the clearance by reinserting two cards. The two cards should pass between the cams and the power roll with a slight drag. When three cards are reinserted, they should meet with considerable drag. It may be necessary to readjust functional cam clearance since changing letter cam clearance also changes functional cam clearance.

Key Lever Adjustments

1. KEY LEVER BEARING SUPPORT. Adjust this up or down so that the key levers trip their respective cams when the key levers are $1/32''$ plus or minus $1/64''$ from the bottom of the key lever guide comb (Figure 4). The individual keys should be checked to be certain that each cam trip lever can reset beneath the lug on the key lever when the key lever restores to its full upward position.

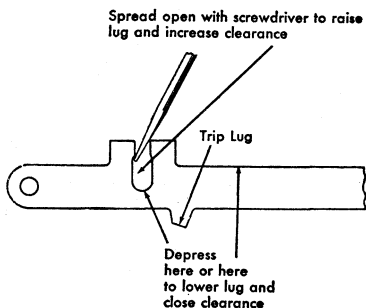

Figure 7. Individual Key Lever Adjustment

2. INDIVIDUAL KEY LEVERS which do not respond with the majority of the key levers may be treated as illustrated in Figure 7.

3. REPEAT/NON-REPEAT OPERATION. It is recommended that for field installation, a two-piece key lever be used for any letter key position. Installing a one-piece key lever in the field requires too much time, this should be done only at the factory.

The repeat/non-repeat operation may be rendered inoperative by installing a plunger bushing in place of the plunger spring in the front guide comb. When making this change it is necessary to use the repeat plunger used on the space bar key lever.

Crippling the repeat/non-repeat feature in ET's equipped with the two-piece key levers will require installing a standard key lever.

For ease of adjustment and positive non-repeat operation, crippling of the operational keys should include replacement of cam assemblies with the non-repeat style cams.

4. THE FRONT GUIDE COMB on machines with approximate serial number 309,194 to 357,196 for standards and serial number 102,192 to 116,831 for executives has an adjustable stop in the front guide comb for repeat/non-

repeat key levers. This reduces the range of repeat operation, thereby minimizing variation in impression. This adjustment may be made by inserting a screwdriver in the slot of the guide comb (Figure 8), and twisting to raise the spring mounting.

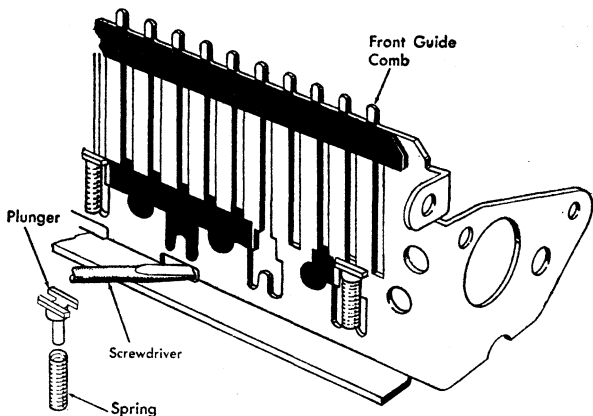

Figure 8. Key Lever Guide Comb

On machines above approximate serial number 357,196 for the standard and 116,831 for executives, the step in the key lever lug was increased to allow the cam to repeat as the key lever bottomed in the guide comb, thereby eliminating the necessity for adjustment of the stop in the front guide comb.

5. KEY PLATE. Adjust to match the front case and so that all key buttons will be free of binds.

TYPE BAR ADJUSTMENTS

Refer to "Type alignment" section for adjustments of Type Bars.

ESCAPEMENT

Removal

UNIVERSAL BAR

1. Remove the platen and paper deflector.
2. Remove the front rail dust cover.
3. Disconnect the ribbon lift guide clevis and remove the guide from the top.

4. Remove the type bar fulcrum wire to permit the type bars to drop out of their slots and rest below the segment.
5. Disconnect the clevis of the escapement trip link, also the trip lever spring if present.
6. Remove the two segment screws so that the type segment and universal bar may be removed through the front of the segment support.
7. Remove the two hexagonal screws holding the universal bar to the rear of the segment.

Replacement is accomplished by reversing the above procedure. The universal bar should be installed to rest as high as possible without binding against the segment. Coat the contact surface of a replacement universal bar with IBM #17 grease when installed.

Removal may be accomplished by two other methods. (1) Remove the ribbon lift mechanism and take the universal bar out through the bottom of the machine. (2) Move the carriage to the left slightly beyond the final stop, disconnect the universal bar from the segment and remove it up through the rails.

ESCAPEMENT PAWL ASSEMBLY

1. Remove the rear cover and paper table.
2. Remove the spring connecting the intermediate pawl release lever to the hex-head spring stud.
3. Remove the two springs attached to the pivot stud of the margin control bellcrank.
4. Remove the margin control bellcrank by removing the nuts from its pivot stud.
5. Block the carriage so that the main spring cannot pull the carriage to the left when the escapement pawl is released.
6. Remove the two shoulder screws that mount the intermediate pawl release lever and pawl release bellcrank.
7. Disconnect the clevis of the escapement trip link and the spring connected to the universal bar if present.
8. As the escapement pawl bracket assembly is moved away from its locating pins, the escapement pawl spring can be disconnected. The pawl bracket assembly may then be removed by bringing the assembly up between the two rails.

Adjustments

1. THE MAIN SPRING tension is adjusted by placing the loop of the carriage tension tape on various lugs of the main spring drum. This adjustment may be checked through the following steps:

- a. Position the carriage so that the tip of the tab check lever is directly opposite the last tab stop on the right end of the rack.
- b. Set the last tab stop.
- c. Hold the carriage to prevent any movement and latch the tab lever out.
- d. Gently position the set tab stop against the tab check lever and release the carriage.
- e. The main spring should have sufficient tension to safely unlatch the tab.

A push pull scale may be used to measure carriage tension in the following manner. Pull the carriage at a slow and steady rate from the extreme left position to the extreme right position (excluding air cylinder range). Tension shall be as follows:

12" Carriage—2-1/2 pounds plus 1/4 minus 0 pounds at start to 3-3/8 pounds maximum.

16" Carriage—2-1/2 pounds plus 1/4 minus 0 pounds at start to 3-1/2 pounds maximum.

20" Carriage—2-3/4 pounds plus 1/4 minus 0 pounds at start to 3-5/8 pounds maximum.

24" Carriage—2-3/4 pounds plus 1/4 minus 0 pounds at start to 3-7/8 pounds maximum.

30" Carriage—3 pounds plus 1/4 minus 0 pounds at start to 4-1/8 pounds maximum.

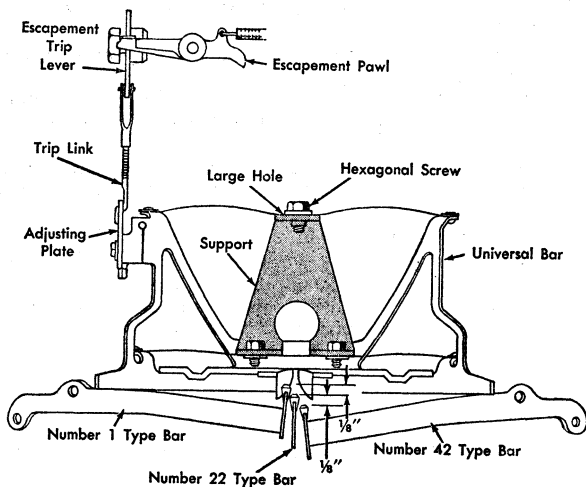

Figure 9. Universal Bar Adjustment

2. UNIVERSAL BAR. Adjust so that all type bars trip the escapement pawl at the same distance from the platen. The rear spring of the universal bar is mounted to the support by a hexagonal screw which passes through an enlarged hole in the spring. To position the universal bar for an equal tripping point, loosen the screw to free the spring from the support (Figure 9). Then position the three type bars close to the type guide as shown in Figure 9, so that they hold each other in position. Tighten the screw to lock the universal bar in position and test the adjustment by operating the type bars by hand to observe that the tripping point is equal.

If the center type bars trip too late or early in relation to the end type bars, the support of the universal bar may be formed slightly up or down to correct this condition.

3. ADJUSTING PLATE ON UNIVERSAL BAR. Position this so that the escapement pawl will be tripped at the same point for both upper and lower case (Figure 9).

4. TRIP LINK. Adjust the link (Figure 9) to trip the escapement pawl when any type face is $3/8'' \pm 1/8''$ from the platen or within areas designated in Figure 10.

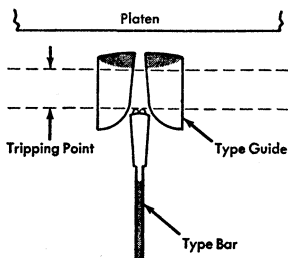

Figure 10. Escapement Tripping Point

MARGIN SET

Removal

The margin set lever may be removed by removing the mounting shaft or screw which holds it to the margin set bracket (Figure 11).

Adjustments

1. MARGIN SET BRACKET. Adjust by positioning the bracket on the rear frame so that the set lever enters squarely into the notch on top of the stop when the carriage is resting at the margin.

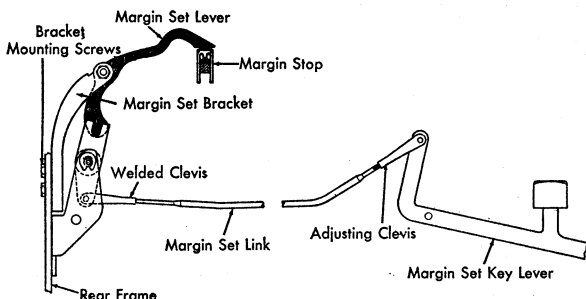

Figure 11. Margin Set Adjustment

2. **THE SCREW AND LOCK NUT** that mount the set lever to the bracket are adjusted to eliminate all side play in the set lever without binding the set lever. The spring tension on the margin control lever may cause the left-hand margin stop to jump to the left and result in improper setting. In case the margin stop attempts to set one space too far to the left, the margin set lever should be adjusted to enter slightly off center toward the right.

3. **MARGIN SET LINK.** Adjust this at the front so that the margin set lever will just clear the top of either margin stop when all parts are at rest (Figure 11).

4. **MARGIN SET KEY LEVER INTERLOCK** shall operate the key lever locking bar so as to prevent operation of carriage return when the margin set key is fully depressed.

MARGIN RELEASE

Removal (New Style)

1. Remove the front and rear cases.
2. Remove the key plate and the margin release key button.
3. Unhook the tab operating link at the cam end.
4. Move the key lever fulcrum wire to the right enough to drop the margin release key lever.
5. Remove the belts and the intermediate pulley.
6. Remove the margin release lever pivot screw and remove the key lever through the front of the machine (Figure 12).

Adjustments

1. **ECCENTRIC STUD.** Adjust this stud under the tab actuating lever, so that the margin control lever clears the

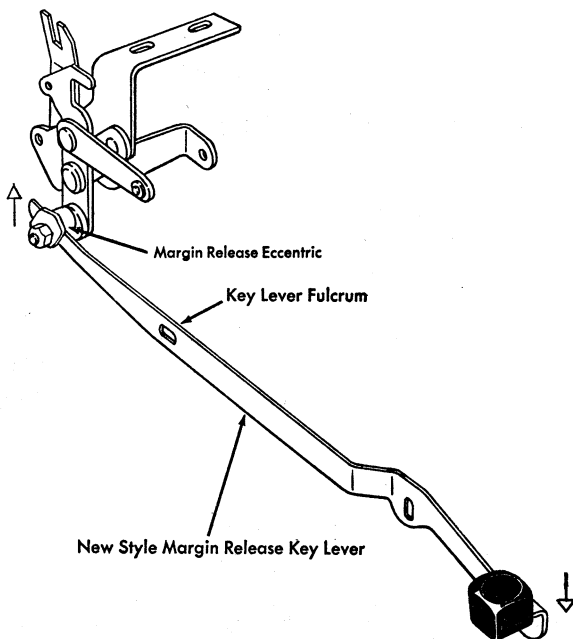

Figure 12. Margin Release

bottom of the margin rack by .010" to .015" (Figure 12 or 13).

2. MARGIN RELEASE KEY LEVER LINK. Adjust as long as possible and still prevent the bellcrank from rubbing on the power roll (Figure 13). NOTE: Be sure machine is turned off during this adjustment.

3. PUSH ROD. Adjust so that when the margin release key lever is fully depressed, the margin control lever will safely clear the bottom of the margin stop (Figure 13). The push rod clevis may be spot-welded to the push rod. In this case, enough motion for margin release must be obtained from adjustment of the margin release key lever link.

4. THE IMPROVED MARGIN RELEASE mechanism, above serial 401,569 on Standard Models and 130,300 on Executive Models, (Figure 12) requires an adjustment only at the eccentric on the tab actuating lever, to obtain .010" to .015" clearance between the margin control lever and the margin rack.

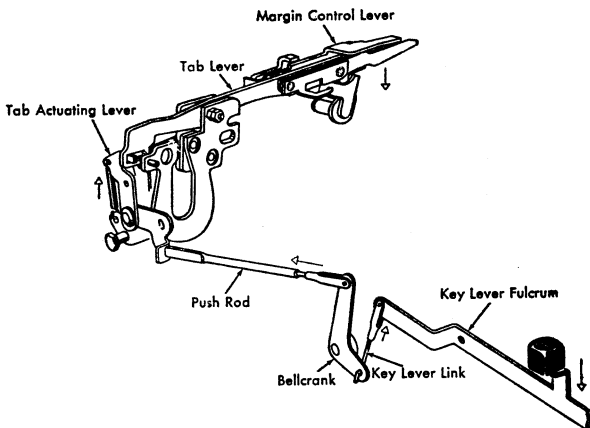

Figure 13. Margin Release

LINE LOCK Adjustments

1. **THE VERTICAL LINK** from the upper line lock bellcrank is adjusted so that the angle between the link and the arm of the lower bellcrank is approximately 90° (Figure 14).
2. **LINE LOCK PUSH ROD.** Adjust in the following manner (Figure 14).
 - a. Unhook the push rod.
 - b. Position the carriage at the right margin.
 - c. Push the switch lever far enough to the rear to allow the line lock bracket to unlock the key levers.
 - d. Push down and hold a letter key lever.
 - e. Push forward on the push rod until it stops.
 - f. Match the pin in the push rod clevis with the hole in the lower line lock bellcrank.

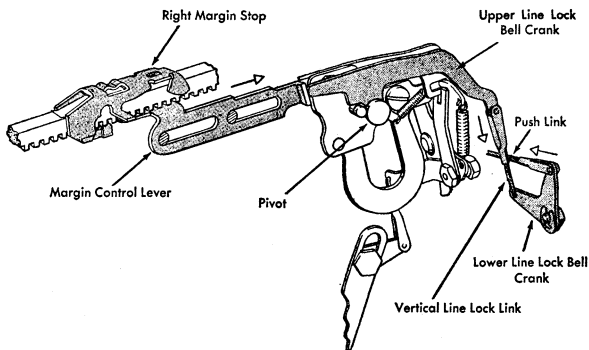

Figure 14. Line Lock Adjustment

CARRIAGE AND RAILS

Removal

CARRIAGE

1. Remove the rear case.
2. Remove the right-hand carriage end cover.
3. Disconnect the carriage tension and carriage return tapes from the carriage.
4. Remove the margin set lever.
5. Move the carriage to the extreme left and lower the spring-loaded carriage final stop until the carriage end plate passes over it. Depress the margin control lever and release the escapement pawl from the escapement rack to move the carriage off the rails toward the left. The carriage and rails have teeth throughout their entire length, permitting over-travel of the star wheels. Because of an interference between the tab lever assembly and the left-hand carriage end plate, the carriage cannot be removed from the right side of the typewriter.

THE STEEL ROLLERS may be pressed out of the trucks after the trucks are removed from the rails.

CARRIAGE TRUCKS must be installed in the rails so that the flat portion of the indicator lug on the end of the truck faces down (Figure 15). This eliminates the possibility that the star wheel will ride under the teeth of the carriage top plate and bind the carriage movement.

The diagram (Figure 15) shows how to start the trucks to obtain the correct position in relation to the carriage length. After the trucks are completely installed, the car-

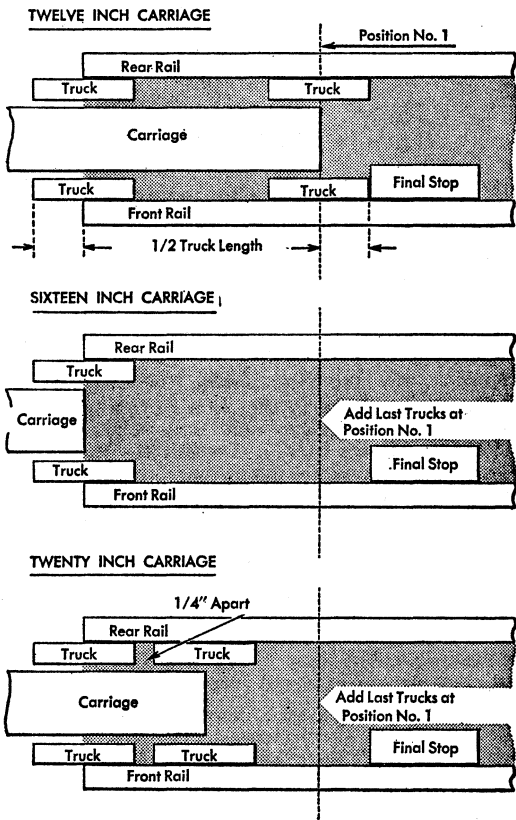
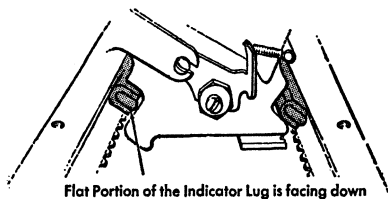

Figure 15. Insertion of Carriage Trucks

riage should be moved to its extreme limits of travel to see that the trucks are flush plus 0 minus two teeth with the ends of the carriage.

THE 12-INCH CARRIAGE shows all four trucks being inserted at once. The right-hand trucks are even with the carriage final stop and the carriage is placed even with the star wheel pins of these trucks. Insert the left-hand trucks until their star wheel pins are even with the left end of the rails. Then move the carriage to the right while lowering the carriage final stop until it is in its normal operating position.

THE 16-INCH CARRIAGE shows the starting point to insert the three sets of trucks. Place the first set as shown so that the star wheels are even with the left end of the rails. Place the carriage so that the right-hand carriage end plate is even with the star wheel pins. Move the carriage to the right until it is in position 1, and proceed as for the 12-inch carriage to insert the remaining two sets of trucks (Figure 15).

THE 20-INCH CARRIAGE shows the starting position for the insertion of four sets of trucks. Start with the left-hand set of trucks. Insert these trucks until the star wheel pins are even with the left end of the rails. Place the right-hand set of trucks so that there is a clearance of two teeth between them and the left-hand set of trucks. Place the right end of the carriage even with the star wheel pins in the right-hand set of trucks. Move the carriage to the right until it is in position 1, and proceed as for the 12-inch carriage to insert the remaining two sets of trucks (Figure 15).

THE 24-INCH CARRIAGE has five sets of trucks. Start exactly as for the 16-inch carriage. Then move the carriage until a set of trucks may be inserted from the left and a set from the right. Butt these three sets together and move the carriage on to the right until two more sets of trucks can be inserted, and butt together with the previous sets (Figure 15).

THE 30-INCH CARRIAGE has six sets of trucks. Start the same as for the 20-inch carriage. Then move the carriage to the right until a set of trucks can be inserted from each end of the carriage. Butt these two sets of trucks with the first two sets of trucks. Again move the carriage and in the same manner insert the last two sets of trucks (Figure 15).

INNER CARRIAGE

1. Remove the platen and both platen retaining plates (Figure 16).
2. Remove the front rail dust cover and eccentric collar from the left end of the platen guide shaft (Figure 16).

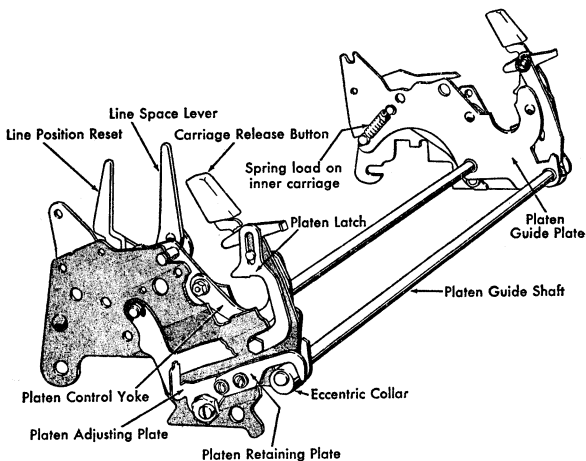

Figure 16. Carriage Adjustments

3. Unhook the copy control lever link by removing the horseshoe clip at the platen guide shaft (Figure 17).
4. Release the detent roller spring and unhook the carriage return tape from the indexing assembly.
5. On machines which have no carriage side-frame eccentric nuts, a spring connects the inner carriage to a stud on the outer carriage at each end. This must be unhooked (Figure 16).

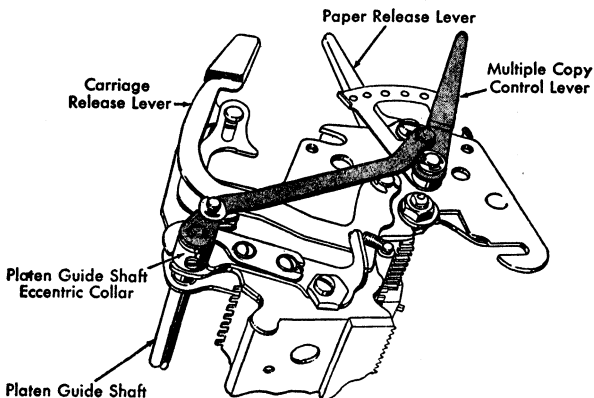

Figure 17. Copy Control Lever

6. Remove the top screw of the right fabric ribbon corner guide and loosen the bottom screw. This will allow the corner guide to tilt forward. Remove the right carbon ribbon corner guide if present.
7. Move the carriage to the extreme right and pull forward on the inner carriage to remove it from the outer carriage.

PAPER RELEASE AND LINE POSITION RESET LEVERS.

To remove the paper release lever and line position reset lever, it is necessary to first remove the inner carriage.

Rail Adjustments

1. **FRONT RAIL.** Pull the rail forward and lock it in place against the power frame.
2. **RAIL SUPPORT ECCENTRICS.** Adjust when the carriage is centered on the rails to just eliminate front to rear motion of the carriage (Figure 18).
3. **REAR RAIL ADJUSTING SCREWS.** Adjust these when the carriage is at each extreme margin to just eliminate any front-to-rear motion of the carriage. Then tighten the rear rail clamping screws (Figure 18).

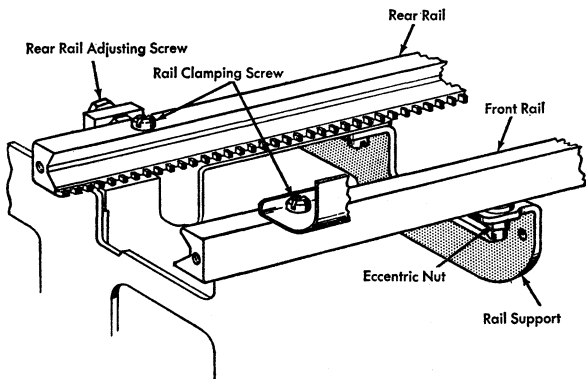

Figure 18. Rail Adjustments

Carriage Adjustments

1. **PLATEN LATCH ECCENTRICS.** Adjust eccentrics to just (Figure 16) eliminate the up or down movement of the platen bushings. They must not be adjusted too tight or the platen will be difficult to latch or unlatch.
2. **PLATEN CONTROL YOKES.** Adjust the yokes (Figure 16) by loosening the front and rear screws and turning the

eccentric nuts to just eliminate all front or rear motion of the platen bushing. On machines which contain no eccentrics, loosening the screws allows the platen control yokes to be pushed to the rear and locked in place to eliminate this motion. Be sure that the platen may be easily removed or reinserted after this adjustment.

3. PLATEN RETAINING PLATES. Position the plates to hold the eccentric collars on the ends of the platen guide shaft tightly against the platen adjusting plates (Figure 16). When making this adjustment the multiple copy control lever must be forward.

4. RING AND CYLINDER. Adjust by first loosening the feed roll center support screw through a hole in the bottom of the carriage bed (Figure 19). Loosen the rear screw in each platen retaining plate (Figure 20). Rotate the eccentric nuts in the platen adjusting plates.

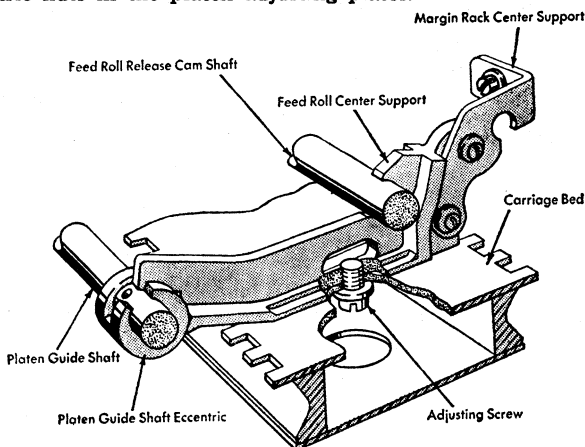

Figure 19. Feed Roll Center Support Adjustment

To test for ring and cylinder, insert a sheet of bond paper into the typewriter and move the multiple copy control lever to A. Place a piece of bond paper, about one-half inch wide and four inches long, between the type bar and ring (Figure 20). The paper should be gripped tightly between the type bar and the ring when a type bar is held up to the platen with the thumb against the type bar at the ring. Place the paper between the ribbon and the paper on the platen, and by holding the type bar as before, check that there is a slight drag as the test paper is withdrawn. Repeat this test at both ends of the platen, using the same type bar each time. To be sure the platen

is adjusted the same on each end, or is parallel to the rails, the same drag should be felt. On long carriages, if the platen is to be moved it is necessary to loosen the margin rack center supports.

5. FEED ROLL CENTER SUPPORT. Reposition this to touch the eccentric collar on the platen guide shaft after any change in ring and cylinder adjustment. On carriages longer than 12 inches, loosen the margin rack center supports to reposition the feed roll center supports (Figure 19).

6. CARRIAGE SIDE FRAME ECCENTRICS. Rotate these until their high points are at the top. These eccentrics occur on the early Model B's only.

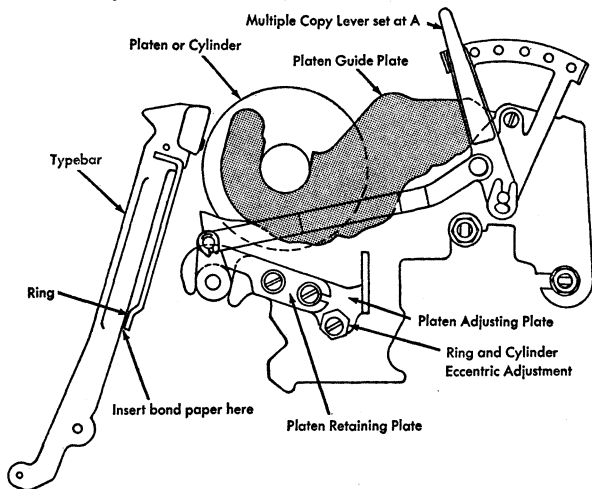

Figure 20. Ring and Cylinder Adjustment

PAPER FEED

Removal

THE FEED ROLLS may be removed by depressing the spring-loaded plunger in the end of the feed roll shaft until it drops free of the pressure lever (Figure 21). The rear shaft is solid on machines above serial number 519,557 on Standard Models and 152,720 on Executive Models. The feed rolls are held in place by two clips. By removing one clip the rear shaft can be taken out.

FRONT AND REAR PRESSURE LEVERS may be removed in the following manner:

1. Remove the feed rolls of the pressure lever to be removed.

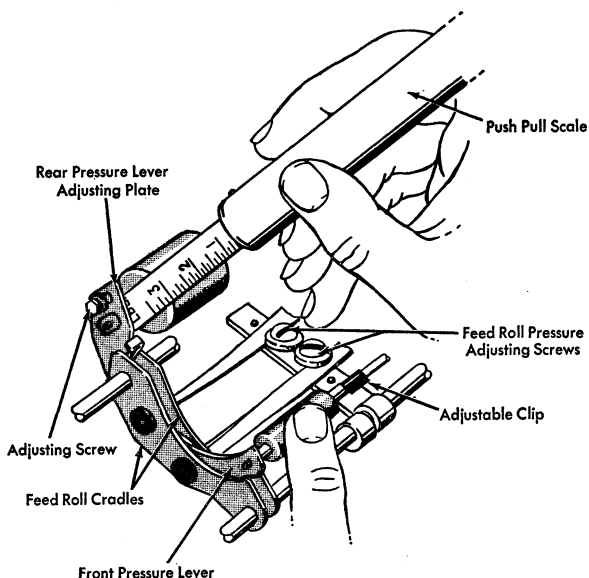

Figure 21. Feed Roll Pressure Adjustments

2. Loosen the feed roll tension adjusting screws and remove the tension springs (Figure 21).
3. Remove the four spring clips which prevent side motion of the feed roll cradles (Figure 21).
4. Move the cradles aside to allow clearance for removal of the pressure levers.

Adjustments

1. THE LINE GAGE CARD HOLDERS should be adjusted two ways:

- a. Up or down so when viewed from the operator's position, a thin line of white shall be visible between the feet of the characters and the reference edge of the card holder (Figure 22).
- b. Left or right by loosening the screws in the front rail dust cover and positioning the dust cover to align the marks on the card holder with the bottom of the V's typed on the paper (Figure 22).

2. INDICATOR POINTER. Center the pointer with respect to the type bar guide throat. Do this by loosening the line

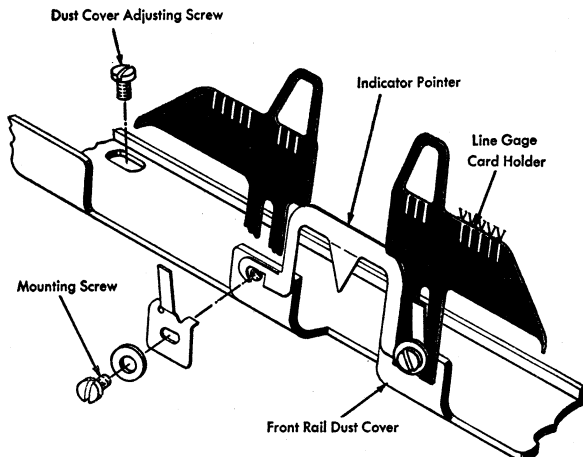

Figure 22. Line Gage Card Holder Adjustment

gage card holder screws which secure the indicator pointer to the front rail dust cover (Figure 22).

3. **FRONT PAPER SCALE.** Adjust in the following manner:
 - a. Loosen the collar on the platen guide shaft which positions the front paper scale.
 - b. Position the left margin stop to its extreme left position.
 - c. Move the carriage to the left margin.
 - d. Position the front paper scale to align the zero with the indicator pointer and tighten the collar screw.

On machines with a carriage length of more than 12 inches, the eccentric collar that positions the front paper scale can interfere with the front feed rolls during feed roll release. To prevent this, keep the setscrew in the eccentric collar in line with the setscrews in the platen guide shaft eccentric collars.

4. **FRONT PAPER TABLE.** Adjust this so that the graduations on the front paper table are in line with those on the front paper scale. Do this by loosening the positioning collars on the carriage tie rod and moving the rear paper table.

5. **REAR PAPER TABLE.** Adjust this so that the relationship between the deflector and the paper table will allow the paper to pass freely in either direction without catching. This is adjusted by the locking screws that clamp the

adjusting plates to the paper table bracket (Figure 23). Check to be sure that the rear paper table is not touching the deflector.

6. FRONT PAPER TABLE. Adjust this to rest evenly on the platen throughout its entire length. This is accomplished by forming the stop lugs which contact the carriage tie rod (Figure 23).

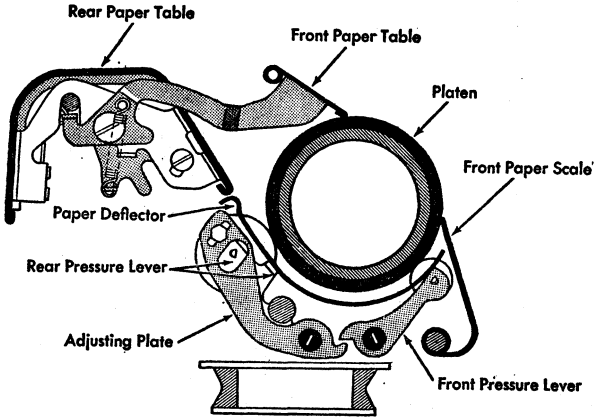

Figure 23. Paper Table and Deflector Adjustments

7. ADJUSTING PLATES. Position these on the rear pressure levers by means of their adjusting screws so that the plates will cause the front pressure levers to be deflected an equal amount during paper release (Figure 21). When two IBM cards are inserted between the rear feed rolls and the platen, the front feed rolls should have a slight amount of drag. If five IBM cards are inserted, the front feed rolls should be free to turn. Too much clearance at the front feed rolls will decrease their tension and add greater tension to the rear feed rolls.

8. SUPPORT LUGS. Form the lugs on the rear pressure levers so that there is a clearance of .007" to .030" (one to four IBM cards) between the paper deflector and the platen. Card strips can be inserted at the ends of the deflector and between feed rolls to accurately check the clearance between the paper deflector and platen (Figure 23).

9. FEED ROLL PRESSURE. Adjust by turning the feed roll pressure adjusting screws until a pressure of 12 to 16 ounces is necessary to deflect each feed roll pressure lever (Figure 21). A push pull scale may be applied at the ends

of each feed roll shaft to make a reading of this adjustment. NOTE: Depress the front feed roll pressure levers when checking the pressure of the rear feed roll pressure levers.

Pressure between two feed rolls on the same shaft, either front or rear, may be equalized by forming the feed roll tension spring. The screw plate should be centered before making this adjustment. To decrease the tension, grasp the spring with long-nose pliers approximately 1/8" from the tension screw and form toward the feed roll.

10. ROLL-BACK. The following adjustment procedure may be used as an aid in eliminating roll-back difficulties where standard adjustments fail to do so.

- a. Increase the front feed roll pressure to 22-24 ounces. This pressure should be equal from feed roll to feed roll.
- b. Equalize rear feed roll pressure at 14-16 ounces. (In some cases reversing the feed roll tension as given in adjustment a and b has been helpful.)
- c. Adjust the feed roll center support casting forward so that it just rests against the platen guide shaft. This adjustment should be made with the platen in the typewriter and the deflectors removed.
- d. Adjust the adjusting plates as set forth in this section.
- e. Check front feed roll pressure to insure that the 22-24 ounces specified has been maintained after making the adjustment in step d.
- f. Form the deflector to conform to the curvature of the platen. The deflector guide lugs should permit free movement of the deflector in all directions with the paper in any position in the feed mechanism. It may be necessary to file the sides of the guide lugs slightly to accomplish this.
- g. Reposition the paper table to conform to the contour of the deflector.
- h. Position the line gage card holder for proper clearance.
- i. Where necessary, polish the rear of the front paper scale with Behr Manning Durite No. 600A abrasive paper, or equivalent, to effect a smooth surface.
- j. Repeated tab and carriage return are excellent operations to determine the results of the preceding adjustments. Set the tab stops and type several columns of the numeral 1. Roll back from all positions, including beyond the rear feed rolls, striking over the typed figures. If slippage still occurs, increase the front feed roll pressure. In the event of carbon marking, rear feed roll pressure may be decreased.

- k. Form guide lips in the deflector just below the rear feed rolls to cam the paper over the rear feed rolls.
- l. Check the bail rolls for binds.

11. PAPER AND STENCIL WRINKLING.

- a. Form the rear portion of the deflectors closer to the platen to provide for an "ironing" action of the paper. Adjust the front of the paper table upward to compensate for changes made to the deflectors.
- b. Feed roll tension should be equal between each pair of feed rolls throughout the entire carriage length. Use the push pull scale to check tension and, if necessary, move the feed roll tension screw plate to the right or left to equalize tension between each pair of feed rolls.
- c. Increase front feed roll tension and decrease rear feed roll tension, being certain that feed roll tension between each pair of feed rolls is equal.
- d. Crown-grind the rear feed rolls by removing rubber from both ends of the feed rolls, leaving an unground portion in the center approximately 1/8" to 1/4" in width.
- e. Raise the deflectors to force them closer to the platen, using electrical tape on the underside of the deflector in the area that rests on the adjusting plates.
- f. In cases of stencil wrinkling, insert an IBM backing sheet between the stencil and the stencil backing sheet in place of the cushion sheet.
- g. Reposition the paper guide to insure full feed roll contact.
- h. Folding of the paper may occur as it strikes the front paper scale. This can be corrected in the following manner:

Form the front tips of the deflector toward the platen. Polish the rear of the front paper scale with crocus cloth.

Inspect the front paper scale for proper form and, if necessary, reform the mounting clamps so that the bottom of the scale is closer to the platen.

The scale must clear the front feed rolls and the front rail dust cover.

SPACE BAR

Removal

THE SPACE BAR may be removed by first removing the space bar equalizing rod and by removing the screws from the space bar.

SPACE BAR KEY LEVER. The space bar key lever may be removed by first removing the front frame which is held by two hexagonal-head screws on each side of the machine. Pushing the key lever fulcrum wire with another fulcrum wire will release the key lever which may then be pulled out through the key lever guide comb.

SPACE BAR CAM.

1. Remove the front case and the impression indicator.
2. Loosen the cam knockout bar by removing the fulcrum wires held by setscrews. Disconnect the knockout bar springs from the typewriter side frames and remove the knockout bar from the bottom of the machine.
3. Remove the impression control shaft by removing the two screws which hold the bearing to the left side frame.
4. Disconnect the space bar operating link and the cam release link.
5. Move the operational cam fulcrum wire enough to remove the cam. The fulcrum wires are held in place by a setscrew on top of the cam bearing support or a clip on the side frame.

ESCAPEMENT LEVER ASSEMBLY.

1. Remove the intermediate pulley.
2. Disconnect the space bar operating link at the rear end.
3. Unhook the escapement lever plate spring.
4. Remove the screw that holds the escapement lever plate to the shaft.
5. Remove the escapement lever shaft toward the center of the machine. The ribbon lift mechanism may be loosened to permit easier passage of the shaft.

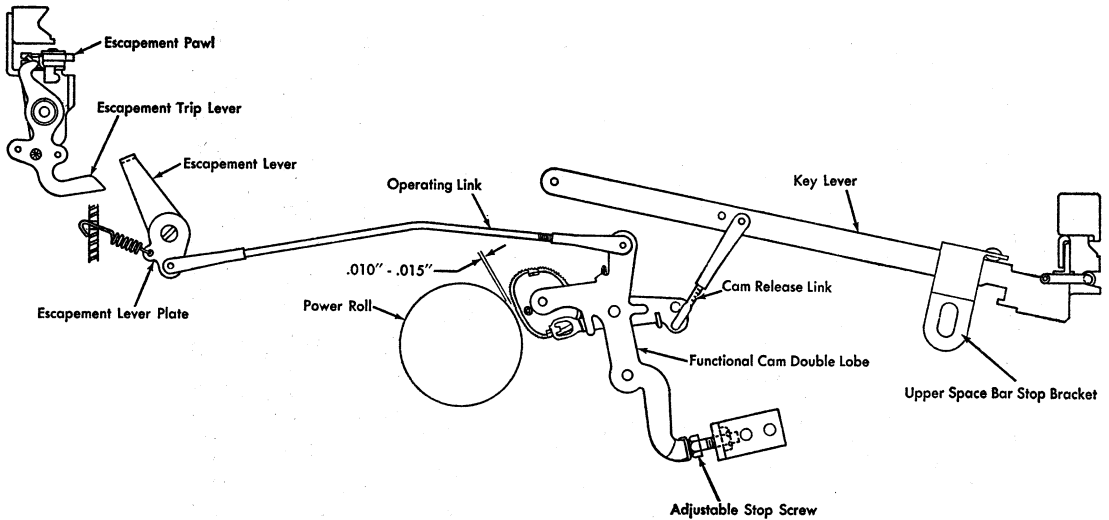

Figure 24. Space Bar Mechanism

Adjustments

1. CAM CLEARANCE. Use the adjustable stop screw to make the cam clear the power roll by .010" to .015" (Figure 24). This adjustment can be observed by releasing the cam with the power off, and noting the position of the cam release lever with respect to the cam lug. The adjustment is correct when the cam release lever rests on the rear half of the cam lug as shown in Figure 25. Check the adjustment on both cam lugs.

2. CAM RELEASE LINK. Adjust this so that the cam will repeat when the spring-loaded plunger in the front guide comb is depressed approximately 1/16".

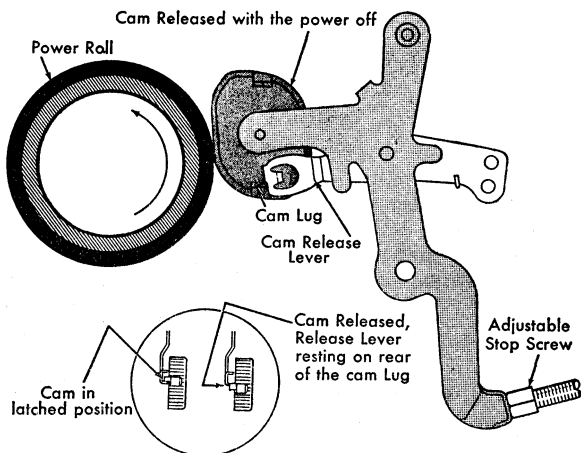

Figure 25. Space Bar Cam Adjustment

3. UPPER SPACE BAR STOP BRACKET. Adjust this up or down to allow the cam to reset just before the key lever strikes the stop bracket (Figure 24).

4. OPERATING LINK. Adjust so that the escapement pawl will be tripped out of the escapement rack just as the cam reaches its high point. With the power turned off, trip the space bar cam. Rotate the power roll by hand to be sure that the escapement pawl is tripped when the cam reaches each high point.

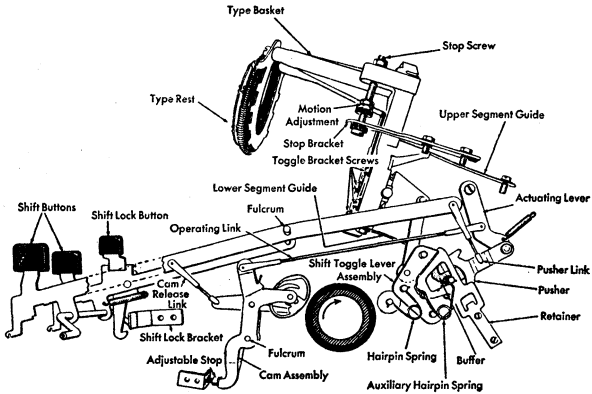

Figure 26. Shift Mechanism

SHIFT Adjustments

The ring and cylinder must be properly adjusted before attempting to adjust the shift mechanism. Refer to "carriage, adjustment 4," this section.

1. EVEN TOP AND BOTTOM. Turn the shift stop screws until even printing on the top and bottom for the majority of the lower case characters is obtained. The heads of these screws should rest with equal pressure on the left and right stop washer (Figure 26).

2. MOTION is adjusted by moving the lock nuts on each stop screw so that the upper case characters print on the same line as the lower case. The lock nuts should rest on the upper stop washers with equal pressure (Figure 26).

3. CAM CLEARANCE is observed by tripping the cam with the power off and noting that the cam release lever lug comes to rest behind the cam lug with a clearance equal to the thickness of the cam lug. To obtain this clearance adjust the cam stop screw (Figure 27).

4. CAM RELEASE LINK. Adjust this so that the cam will be released when the key lever is depressed $1/2$ to $3/4$ of its total travel (Figure 26).

5. EQUAL PIN CLEARANCE is obtained by turning the toggle bracket screws (Figure 26). Loosening the two upper screws and tightening the two lower screws will increase the clearance between the upper pin and the pusher, and vice versa. Be sure to make the same adjustments on each set of toggle bracket screws, to prevent any binding of the

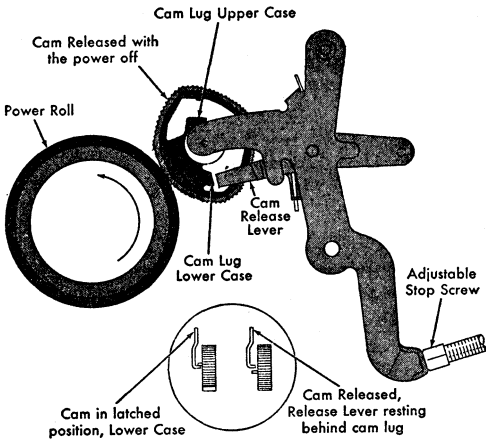

Figure 27. Shift Cam

shift toggle shaft. Recheck motion after any adjustment of these brackets.

6. PUSHER LINK. Adjust this so that the top edge of the upper arm of the pusher strikes slightly above the upper pin when the cam is released. Turn the power on and slowly depress the key lever to observe this adjustment. Let the key lever slowly restore to its rest position to check for similar engagement of the lower pin (Figure 28).

7. OPERATING LINK. Adjust so that the pusher clears the pin by $1/32''$ to $1/16''$ (Figure 28).

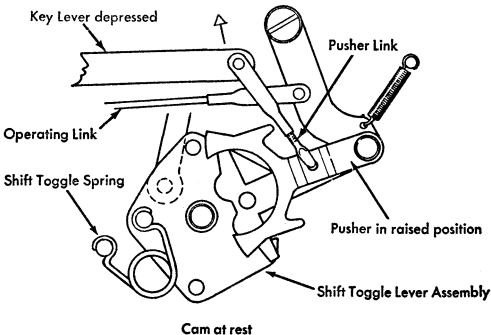

Figure 28. Pin Clearance Adjustment.

8. SHIFT LOCK BRACKET. Adjust so that the basket will shift as or just before the shift lock engages. The shift lock shall dependably hold the shift key lever in the depressed position, shall lock freely and unlock easily using either shift button.

TABULATION

Removal

TAB LEVER

1. Remove the paper table and the carriage end covers. It is not necessary to remove the rear typewriter case but it may aid the removal and reassembly of parts.
2. Remove the margin rack.
3. Disconnect the tab operating link and the vertical line lock bellcrank link.

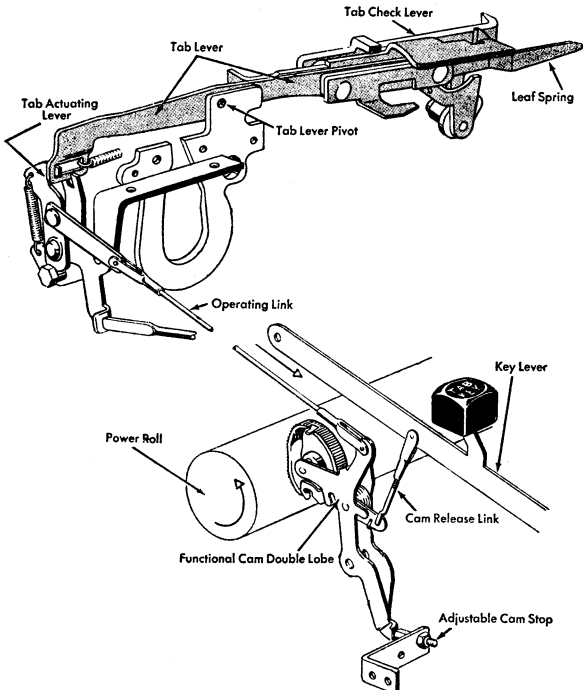

Figure 29. Tab Adjustment

4. Remove the tab lever pivot stud and two lock nuts. Clearance may be obtained by pivoting the upper line lock bellcrank out of the way.
5. Disconnect the three springs from the tab lever, and lift the tab lever from the top of the machine.

During reassembly of the tab lever to the horseshoe bracket, allow a slight end play of the pivot stud when tightening the lock nuts. Over-tightening the nuts on the pivot stud can cause the tab lever to move away from a true rest position.

TAB LEVER MOUNTING BRACKET

1. Remove the rear cover and paper table.
2. Disconnect the tab operating link and the vertical line lock bellcrank link.
3. By rotating the upper line lock bellcrank to get clearance, remove the tab lever pivot stud.
4. Remove the two screws from the horseshoe bracket so that the bracket may be maneuvered under the left end of the carriage and out of the machine.

Adjustments

1. **CAM CLEARANCE:** Refer to "Space bar adjustment 1," this section.
2. **CAM RELEASE LINK.** Adjust so that the cam is released when the key lever is depressed $\frac{2}{3}$ of its downward travel (Figure 29).
3. **TAB LEVER HEIGHT.** Refer to "Margin Release adjustment 1," this section.

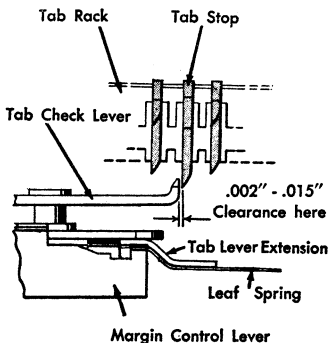

Figure 30. Tab Rack Lateral Adjustment

4. THE TAB RACK must be adjusted two ways:

- a. Position the rack left or right so that there is a clearance between the left-hand face of any set tab stop and the engaging face of the tab check lever of .002" to .015" (Figure 30). Slowly move the tab lever to the rear by hand and observe the amount of clearance between the parts indicated. The continued motion of the tab lever removes the escapement pawl from the rack. The reading has no value unless the carriage is held rigidly during the test.
- b. Position the right end of the tab rack front or rear in its elongated mounting slot so that the tab check lever takes an equal bite on tab stops at both ends of the tab rack. When tightening the adjusting nuts, maintain the front face of any set tab stop parallel to the tip of the tab check lever (Figure 31), and at the same time be sure that the carriage end plates are not sprung.

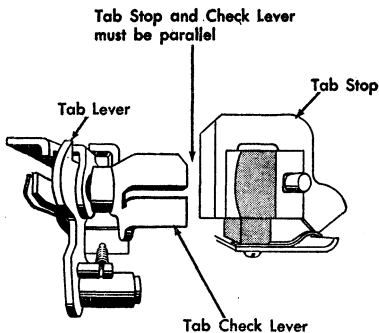

Figure 31. Tab Rack Parallel with Tab Check Lever

5. TAB LATCH KEEPER. Adjust in the following manner:

- a. Set a tab stop just to the right of the engaging tip of the tab check lever.
- b. Latch out the tab lever by hand and prevent the carriage from moving.
- c. Position the carriage so that the set tab stop just touches the tip of the tab check lever and observe that there is $1/2$ to $2/3$ overlap of the tab check lever on the tab stop (Figure 32).
- d. Move the keeper left or right to obtain .030" to .050" overlap of the tab latch on the keeper (Figure 32).

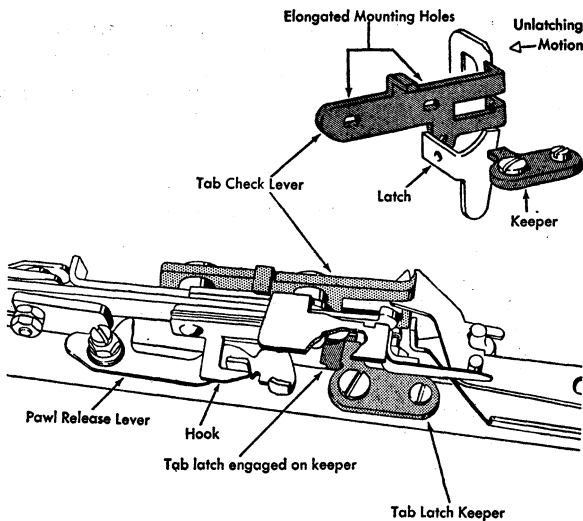

Figure 32. Tab Latch Keeper Adjustments

6. TAB OPERATING LINK. Adjust this so that, with the cam on its high point, there is .010" to .015" clearance between the tab latch and the tab latch keeper (Figure 33).

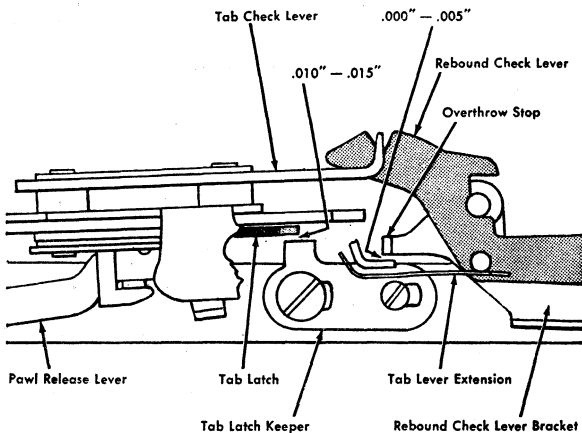

Figure 33. Tab Operating Link Adjustment

Observe this adjustment by releasing the tab cam and turning the power roll by hand. Make sure that the tab lever overthrow stop does not limit the travel of the tab lever before the tab cam is rotated to the high point. The operating link is not to be so short as to hold the tab lever out of its rest position.

7. PAWL CLEARANCE is obtained by forming the rear upright lug of the pawl release lever until the escapement pawl clears the escapement rack by $1/64$ " during tabulation (Figure 32). Observe this by latching the tab and preventing any carriage movement while sighting along the escapement rack.

8. REBOUND CHECK LEVERS. There are two different types of rebound check levers on the standard machine. Because of differences in adjustments, the V-slot type will be covered first, followed by the former style.

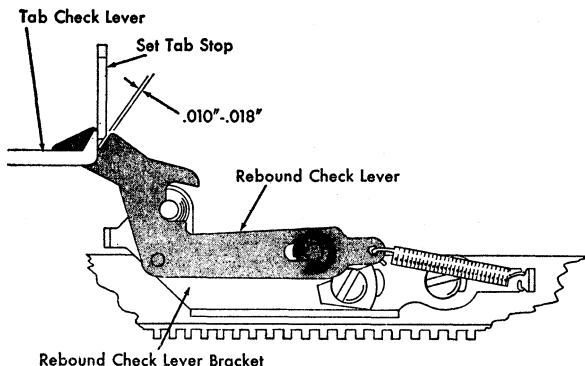

Figure 34. Tab Rebound Check Lever Adjustment

8a. V-SLOT REBOUND CHECK LEVER

- a. The rebound check bracket is adjusted two ways: Position the bracket left or right so that the right edge of the V-slot of the rebound check lever clears the right-hand face of any set tab stop by $.010$ " to $.018$ " when the left-hand face of the stop has pushed the tab check lever to the extreme left (Figure 34). At the same time the bracket should be positioned front or rear so that, when the rebound check lever is in its operated position and against the pin in its bracket, the leading edge of the rebound check lever is even with the tip of the tab check lever or is $.005$ " farther to the rear. The bracket can be conveniently adjusted for both conditions simultaneously. Set a tab

stop, release the tab cam, and rotate the power roll by hand until the tab lever latches. If the rotation of the power roll is stopped at this point, the cam and linkage holds the tab lever to the rear even though the tab check lever and latch are pushed to the left or unlatched position. The bracket can be loosened and adjusted while the tab lever is held in this position.

- b. The tab lever extension is formed so that, with the tab cam at its high point, the extension has $.000''$ to $.005''$ (paper clearance) with the upright stop on the rebound check lever bracket (Figure 33).
- c. The tab lever leaf spring is formed to just contact the upright stud of the rebound check lever when the rebound check lever is at rest against the pin in its bracket.

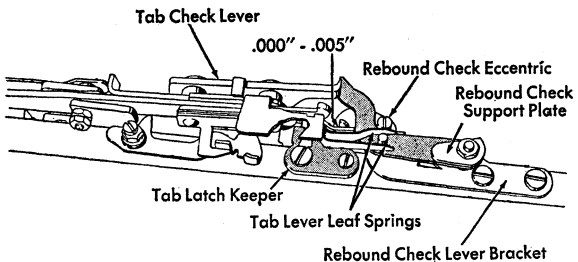

Figure 35. Rebound Check Adjustment (Former Style)

8b FORMER STYLE REBOUND CHECK LEVER

- a. The rebound check bracket is adjusted two ways: Position the bracket left or right so that the rebound check lever will clear the right face of any set tab stop by a maximum of $.010''$ when the left face of the stop is pressed firmly against the tab check lever (Figure 35). At the same time position the bracket front or rear so that, with the tab cam on its high point, there will be $.000''$ to $.005''$ between the over-throw stop on the rebound check bracket and the tab lever extension (Figure 35).
- b. Adjust the rebound check eccentric stop so that, when the tab lever is latched out, the tip of the rebound check lever will be even with the tip of the tab check lever or have a maximum lead of $.005''$. The high point of the eccentric must be kept toward the left (Figure 35).
- c. Form the rebound check support plate high enough so that the rebound check lever will safely engage the

bottom of a set tab stop but not high enough to interfere with the tab check lever (Figure 35).

- d. Form the tab lever leaf springs in the following manner. With the tab lever at rest, form the rear spring so that it just touches the upright stud of the rebound check lever, and form the front spring so that it has approximately 1/16" clearance with the upright stud of the rebound check lever (Figure 35).

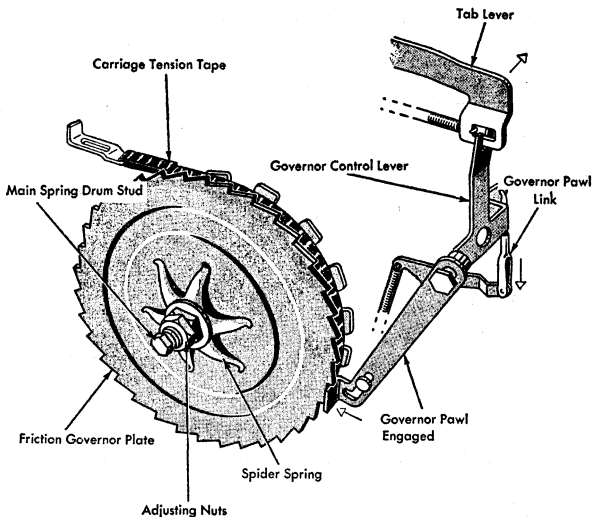

Figure 36. Tab Governor Adjustment

9. TAB GOVERNOR PAWL LINK. Adjust this so that, when the tab lever is latched, the governor pawl will engage the friction plate by the thickness of its own metal (Figure 36).

10. FRICTION GOVERNOR PRESSURE. Adjust this by means of the two lock nuts on the hub of the main spring drum until the speed of tabulation approximates the speed of carriage return (Figure 36). Check the speed by clearing all tab stops except the last one on the right. Operate the carriage return and tab several times to determine this speed. To check for accurate tabulation, latch out the tab lever under power and tabulate to several tab stops. Tabulation will be operating correctly if the tip of the tab check lever comes to rest two spaces past the tab stop which was just struck by the check lever. This test should be tried on long, short, and medium length tabulations.

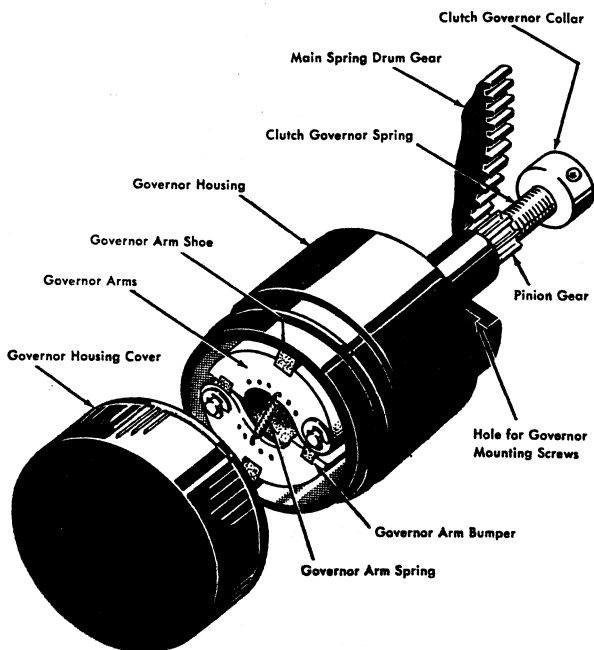

Figure 37. Centrifugal Tab Governor

10a. CENTRIFUGAL TAB GOVERNOR

- a. Position the governor by means of its mounting screws for a maximum of .005" backlash between the pinion gear and the main spring drum gear. Check full length of the carriage (Figure 37).
- b. Adjust the collar on the governor shaft for .003" to .005" end play in the shaft.
- c. Speed of the carriage on tabulation is adjusted by moving the governor arm spring. Move the spring closer to the governor arm pivots for more governor action, move the spring away from the pivots for less governor action (Figure 37). (This spring must be in a corresponding hole in each governor arm.)
- d. Additional main spring tension may be obtained by removing the tension tape and turning the drum gear in a counter clockwise direction looking from the front of the machine. Reconnect the tension tape.

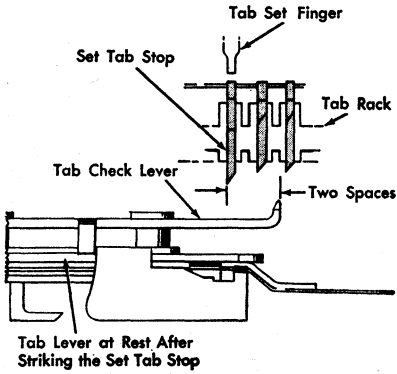

Figure 38. Tab Set and Clear Bracket Adjustment

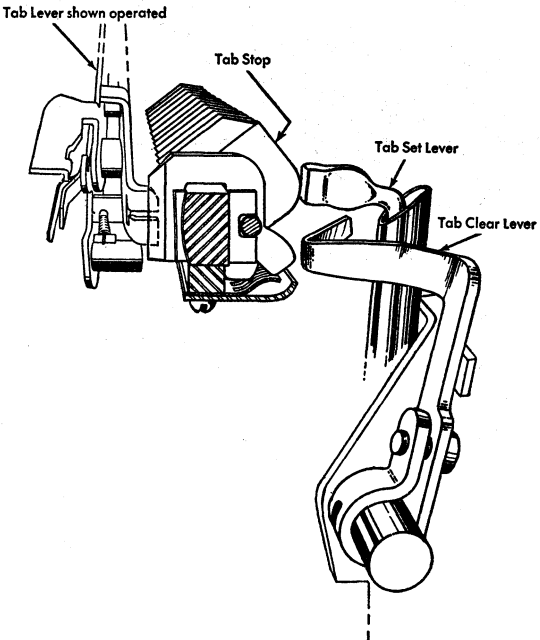

Figure 39. Tab Set and Clear Stops

11. TAB SET AND CLEAR BRACKET. Position this by loosening the three screws which hold it to the rear frame. Move the bracket right or left until the tab set lever strikes the center of the back of the tab stop which is second to the left of the tip of the tab check lever (Figure 38).

12. TAB SET LEVER STOP. Form this so that when the tab stops are in the cleared position and the set lever at rest, it will clear the stops by approximately $1/32''$ (Figure 39).

13. TAB CLEAR LEVER STOP. Form this so that when the tab stops are in the set position there will be a clearance of approximately $1/32''$ between the rear projection of the set tab stops and the tab clear lever (Figure 39).

14. TAB SET AND CLEAR LINKS. Adjust these so that when the set and clear buttons are at rest, the slope of their upper surfaces will be parallel to the slope of the keyboard (Figure 40).

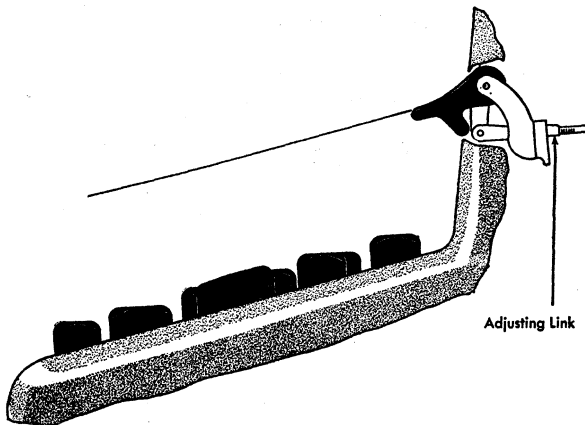

Figure 40. Tab Set and Clear Link Adjustment

CARRIAGE RETURN AND LINE SPACE

Removal

CLUTCH FRICTION DISC AND CLUTCH PLATE

1. Remove the screw which passes through U-shaped end of the clutch lever and screws into the operating arm.

2. The clutch operating arm will move far enough toward the outside of the machine to allow the clutch plate to clear its locating pins.
3. The friction disc may then be slipped off the end of the power roll shaft and removed from the machine.

CLUTCH PULLEY AND SPRING

1. Remove the screw at the top of the operating arm and remove the friction disc and plate.
2. Detach the clip from the pivot shaft on the bottom of the operating arm.
3. Move the pivot shaft to the rear and release the operating arm.
4. Disconnect the carriage return tape from the pulley and allow the spring to unwind slowly.
5. The clutch pulley may then be removed from the power roll shaft.
6. The clutch pulley spring may then be removed from its housing. Note that the outer loop of the spring passes outside of the lug provided in the housing.

PLATEN RATCHET (Figure 41).

1. Unscrew the platen variable button from the left-hand platen knob, using a platen variable button tool.
2. Remove the platen knob by loosening the setscrews securing it to the shaft.
3. Remove the four screws that hold the platen clutch cover and sleeve assembly to the platen end plug. The ratchet may then be removed.

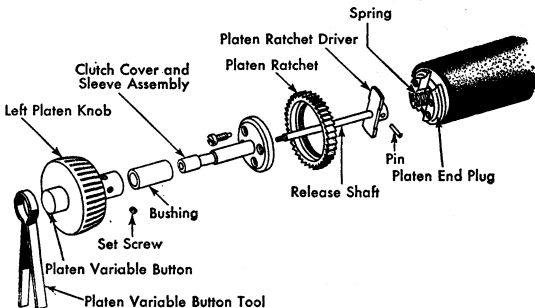

Figure 41. Platen Ratchet Removal

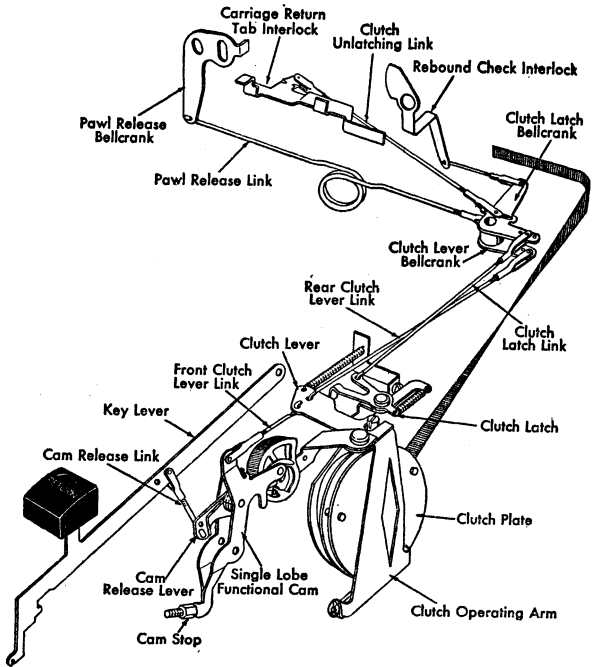

Figure 42. Carriage Return Mechanism

Adjustments

1. **CAM CLEARANCE:** Refer to "Space Bar adjustment 1," this section.
2. **CAM RELEASE LINK.** Place this first in the bottom hole of the cam release lever and in the rear hole of the key lever. Adjust it so that the cam will trip when the key lever is depressed from three-fourths up to and including its full normal travel (Figure 42). When properly adjusted, it will allow the cam to repeat when the key lever has depressed the spring loaded plunger $1/16''$.
3. **FRONT CLUTCH LEVER LINK.** Adjust so that, with the cam on its high point, the clutch lever will clear the clutch latch by $.020''$ to $.025''$ (Figure 43).
4. **THE REAR CLUTCH LEVER LINK** is to be placed in the outer hole of the clutch lever bellcrank. With the clutch in its rest position, adjust the link so that the slot in the

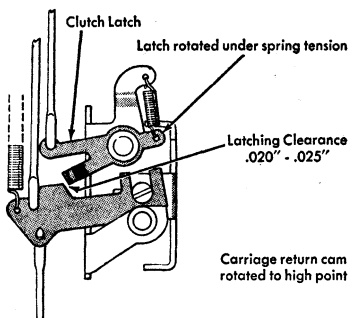

Figure 43. Clutch Latching Clearance

clutch lever bellcrank is parallel to the rear rail (Figure 42).

5. THE CLUTCH LATCH LINK is placed in the center hole of the clutch latch bellcrank. With the clutch at rest

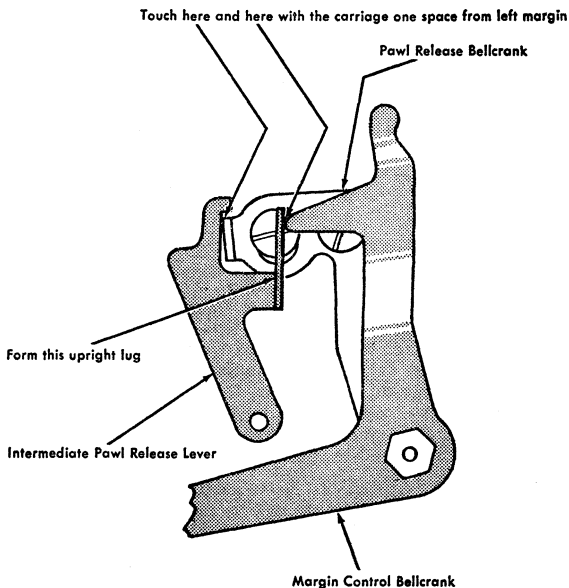

Figure 44. Intermediate Pawl Release Lever Adjustment

and the clutch latch resting against the clutch lever, adjust the link so that the slot in its bellcrank is parallel to the rear rail (Figure 42).

6. OVERBANK is the term applied to the amount of play between the margin control lever and its final stop when the carriage is resting at the left margin. Place the carriage one space to the left of the left margin. Slowly move the carriage to the right and observe that the escapement pawl drops into an escapement rack tooth just as the margin control lever strikes its final stop. Move the margin rack to the left or right to obtain this condition.

7. INTERMEDIATE PAWL RELEASE LEVER. There are two types. One has an eccentric nut which acts as a pivot point and the other is riveted. Turn the eccentric so that its high point is down.

8. INTERMEDIATE PAWL RELEASE LEVER UPRIGHT LUG. Form this to allow the intermediate pawl release lever to touch the margin control bellcrank and pawl release bellcrank when the carriage is one space from the left margin (Figure 44).

9. PAWL RELEASE LEVER ECCENTRIC. Adjust this so that the right side of the ear on the pawl release lever just clears the intermediate pawl release lever when all the parts are at rest (Figure 45). Keep the high point of the eccentric toward the front of the machine.

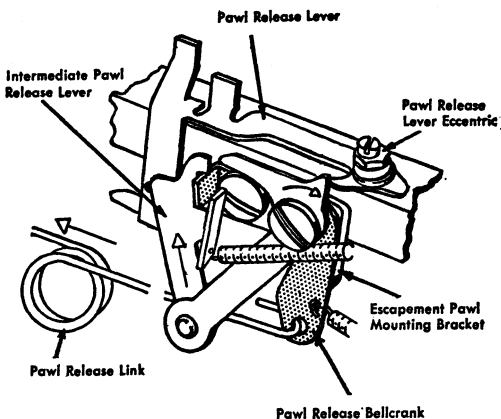

Figure 45. Pawl Release Lever Eccentric

10. THE MARGIN RACK WASHERS on the outside of the carriage end plates serve as adjustable overthrow stops for the carriage release levers. Position the washers front or

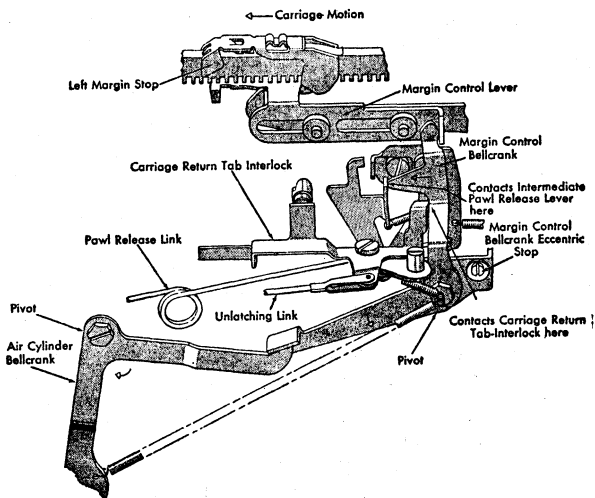

Figure 46. Margin Control Bellcrank Eccentric Stop

rear so that when either carriage release lever is fully depressed there will be a clearance of about .010" between the carriage universal bar and the pawl release lever eccentric.

11. PAWL RELEASE LEVER FRONT LUG. Form this to have a clearance of about .005" with the carriage universal bar when at rest and give pawl release when either carriage release lever is fully depressed.

12. THE MARGIN CONTROL BELLCRANK ECCENTRIC STOP is an eccentric stud or washer. In either case it is positioned so that the margin control lever has maximum motion left to right without restricting the movement of the tab check lever when the margin control bellcrank is against this stop (Figure 46).

13. CARRIAGE RETURN TAB INTERLOCK. Adjust this as follows:

- a. Unhook the clutch unlatching link.
- b. Turn the high point of the interlock eccentric stop to the rear of the machine as a preliminary adjustment.
- c. With the carriage at the left margin, form the interlock so that it clears the tab latch stud by about 1/16" when the left-hand lug on the interlock is in contact with the margin control bellcrank (Figure 47).

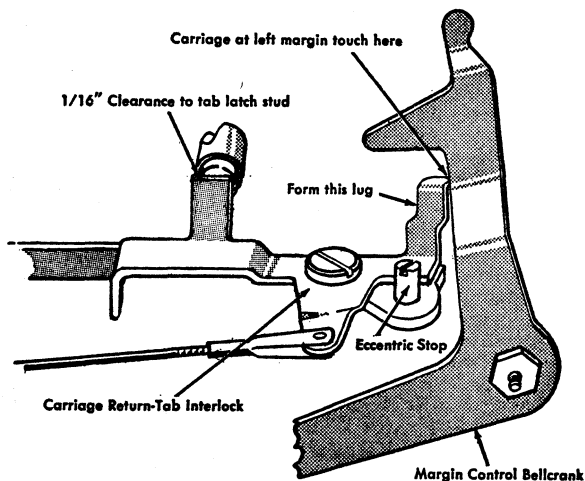

Figure 47. Carriage Return Tab Interlock Adjustment

14. CLUTCH UNLATCHING LINK. Adjust this link in the following manner: (Figure 46).

- Turn the switch on and hold the carriage to prevent any movement.
- Depress the carriage return button and slowly let the carriage approach the left margin.
- The unlatching link should provide sufficient pull to unlatch the clutch when the margin control lever is $1/64''$ to $1/32''$ from its final stop.

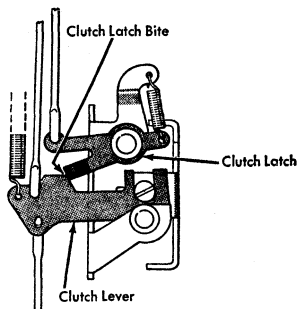

Figure 48. Clutch Latch Bite

15. THE ECCENTRIC STOP for the carriage return tab interlock (Figure 47) is adjusted to permit the clutch latch to engage the clutch lever by $1/3$ to $1/2$ of the clutch latch surface when the clutch is fully latched (Figure 48).

To observe this adjustment, remove the right-hand ribbon spool and latch the clutch.

16. THE PAWL RELEASE LINK should be adjusted so that, with the clutch latched, the escapement pawl will clear the escapement rack by $1/64$ " (Figure 42).

17. THE REBOUND CHECK INTERLOCK LINK is adjusted so that the interlock lever clears the tab rebound check lever by about $.010$ " when the rebound check lever is in its operated position. With the clutch unlatched, operate the tab lever by hand to observe this adjustment (Figure 49). Operate the carriage return cam by hand and observe that the rebound check interlock does not strike the rebound check lever at rest. Form the top of the interlock lever front to rear to provide a clearance of about $.010$ " (Figure 49).

18. CLUTCH PLATE CLEARANCE. Adjust this by positioning the bracket on the bottom of the right side frame. Obtain a clearance of $.005$ " to $.015$ " between the clutch operating arm and the clutch plate when the clutch plate is held firmly against the friction disc (Figure 50).

19. AIR CYLINDER. Position this front or rear on the side frame, to permit the plunger to move freely in the cylinder without binding (Figure 51).

20. AIR CYLINDER PORTS AND CLUTCH COMPRESSION SPRING ADJUSTMENTS should be considered together. The air cylinder must reduce the impact of the carriage return as much as necessary without noticeably reducing speed. The intake port, on the air cylinder shell, should be adjusted approximately half-way open (Figure 51).

Open the exhaust port on the air cylinder cover. With the line space lever set for triple spacing and the left margin stop moved to the extreme left, adjust the clutch compression spring to insure a positive return on short returns of one to two inches as well as on medium and long returns. Lack of sufficient tension can contribute to a slow carriage return (Figure 50).

Adjust the exhaust port so that the shock of carriage return is reduced, without noticeably slowing the carriage during the last half-inch of travel (Figure 51). Test this action on short, medium and full-length returns for positive, quiet operation. If an operator finds excessive resistance in pushing the carriage back to the margin, recheck the air cylinder ports. It may be advantageous to open the exhaust port slightly.

21. THE CLUTCH PULLEY SPRING should be wound up completely. Back off the pulley two turns before attaching

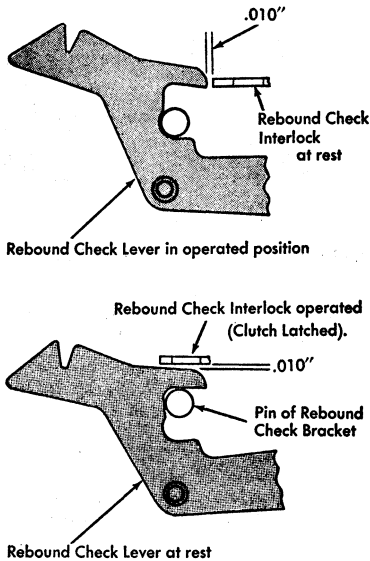

Figure 49. Rebound Check Interlock Lever

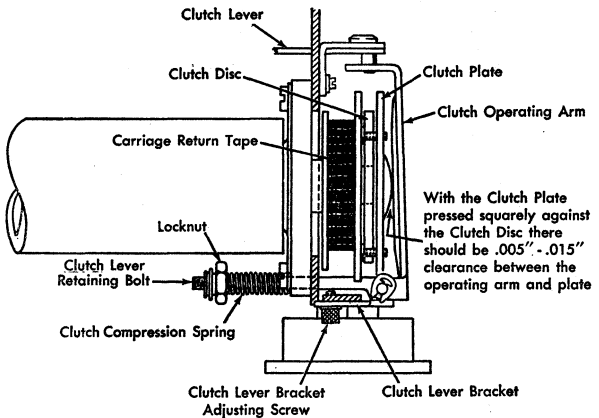

Figure 50. Clutch Plate Clearance Adjustment

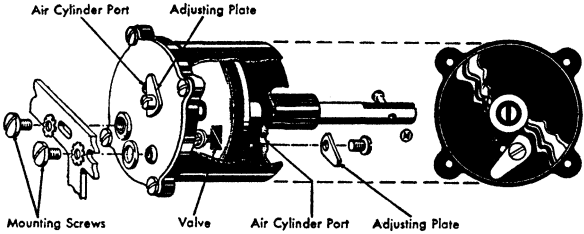

Figure 51. Air Cylinder Adjustments

the tape to the pulley. A spring which is not wound tight enough will increase the whip in the tape and slow down the action of repeat line space.

22. THE LOWER INDEX PAWL STOP is adjusted to stop the downward movement of the line space mechanism when the detent roller is positioned between two teeth on the platen ratchet. Check this by pulling on the carriage return tape until the index pawl strikes the lower stop. Then slowly relax the tension. There should be no further rotation of the platen, either forward or backward (Figure 52).

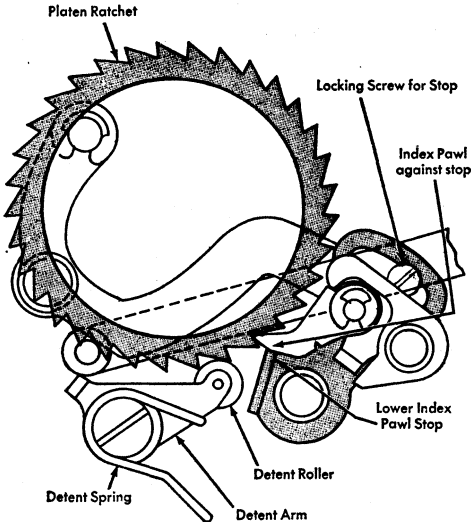

Figure 52. Lower Index Pawl Stop Adjustment

PLATEN INDEXING - STANDARD, EXECUTIVE & PIN FEED MACHINES

Platen Ratchet Part No.	No. of Teeth	Count the Number of Spaces in 10 Inches of Form and find the Nearest Number in the Chart.						Upper Index Pawl Stop
		1 Tooth	2 Teeth	3 Teeth	4 Teeth	5 Teeth	6 Teeth	
1107229	29	52.5	26.4	17.6				1103613
1107233	33	60.0	30.0	20.0				1103614
	34	61.8	30.9	20.6				1103614
	35	63.7	31.8	21.2				1103614
	36	65.5	32.7	21.8				1103615
	37	67.3	33.7	22.4				1103615
1104038	38	69.1	34.6	23.0				1103615
1104039	39	70.9	35.5	23.7				1103615
	40	72.8	36.4	24.3				1103615
1104041	41		37.3	24.9	18.6			1103603
	42		38.2	25.5	19.1			1103603
	43		39.1	26.1	19.5			1103603
1104044	44		40.0	26.6	20.0			1103604
1104044	44	80.0	40.0	26.6				1103603
	45	81.8	40.9		20.5			1103601
	46	83.7	41.8		20.9			1103601
	47	85.5	42.8		21.4			1103601
	48		43.7	29.1		17.5		1103602
	48		43.7		21.8		14.6	1103610
1104049	49		44.6	29.7		17.8		1103602
1104050	50		45.5	30.3	22.7			1103605
1104050	50		45.5		22.7		15.2	1103610
1104051	51		46.4	30.9	23.2			1103605
	52		47.3	31.5	23.7			1103606
	52		47.3		23.7		15.8	1103611
	53		48.2	32.1	24.1			1103606
	54		49.1		24.6		16.4	1103611
1104055	55		50.0	33.3	25.0			1103606
	56		50.9	34.0	25.5			1103607
	56		50.9		25.5		17.0	1103612
	57		51.8	34.6	25.9			1103607
1104058	58		52.8	35.2	26.4			1103607
1104058	58		52.8		26.4		17.6	1103612
	59		53.7	35.8	26.8			1103607
	60		54.6	36.4	27.3			1103608
	60		54.6		27.3		18.2	1103613
	61		55.5	37.0	27.7			1103608
1104062	62		56.4	37.6	28.2			1103608
1104062	62		56.4		28.2		18.8	1103613
	63		57.3	38.2	28.7			1103608
	64		58.2	38.8	29.1			1103609
	64		58.2		29.1		19.4	1103614
	65		59.1	39.4	29.6			1103609
1104066	66		60.0	40.0	30.0			1103609
1104066	66		60.0		30.0		20.0	1103614

Platen Ratchets,

Platen Ratchets

29 to 49

50 to 66

Index Pawl 1103599 1107452

Detent Arm Assembly 1103670 1103634

Detent Arm Spring 1108928 1103637

Index Pawl Carrier 1103592 is common to all machines.

Allowance for the thickness of the forms should be made when selecting the ratchet. Each additional .030" of form thickness requires additional teeth in the ratchet according to the following table:

29T to 34T - 1 additional tooth

35T to 57T - 2 additional teeth

58T to 66T - 3 additional teeth

This will reduce to a minimum the need for using the Platen Variable Button.

BACKSPACE

Removal

BACKSPACE PAWL BRACKET

1. Remove the rear case and paper table.
2. Remove the two screws which hold the backspace pawl bracket to the rear rail.
3. Disconnect the escapement pawl spring and the backspace link.
4. Remove the pawl bracket assembly.

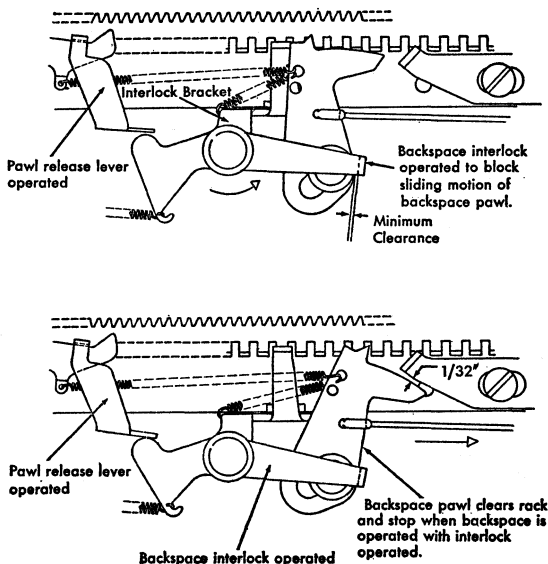

Figure 53. Backspace Interlock Bracket Adjustment

Adjustments

1. BACKSPACE INTERLOCK. Adjust by forming the bracket which supports the interlock lever, in such a manner that all clearances are very close, (Figure 53). The clearance must be held to an absolute minimum to block any motion of the backspace pawl while the interlock is in the operating position. Test by holding down a carriage release button and moving the backspace pawl by hand.

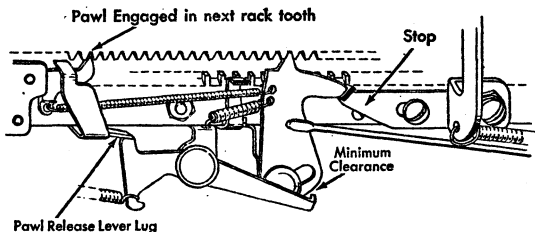

Figure 54. Backspace Interlock Adjustment

2. THE PAWL RELEASE LEVER LUG which contacts the backspace interlock is formed so that with the interlock at rest, the backspace pawl may be moved past it with a minimum of clearance (Figure 54).

3. BACKSPACE PAWL GUIDE LUG. Form this to the left or right so as to guide the pawl into the escapement rack with about $1/64''$ clearance between the working side of a tooth on the pawl and the escapement rack tooth (Figure 55).

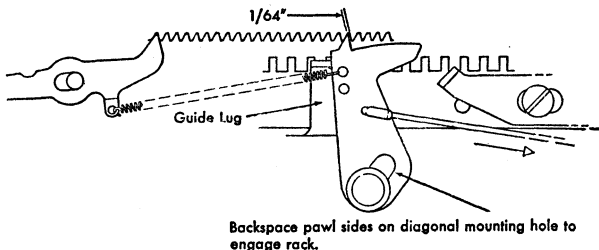

Figure 55. Backspace Guide Lug Adjustment

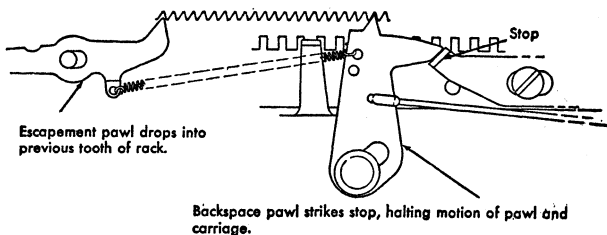

Figure 56. Backspace Stop Adjustment

4. THE BACKSPACE PAWL STOP is positioned so that it stops the backspace pawl as soon as the escapement pawl drops into the next tooth of the escapement rack. Observe this adjustment through the bottom of the typewriter after tripping the backspace cam and rotating the power roll by hand (Figure 56). The stop is also positioned far enough to the front of the machine so that the backspace pawl clears the stop by $1/32$ " when the interlock is operated and a backspace operation is attempted (Figure 53). Hold the carriage release levers depressed and operate the backspace by hand to observe this clearance.

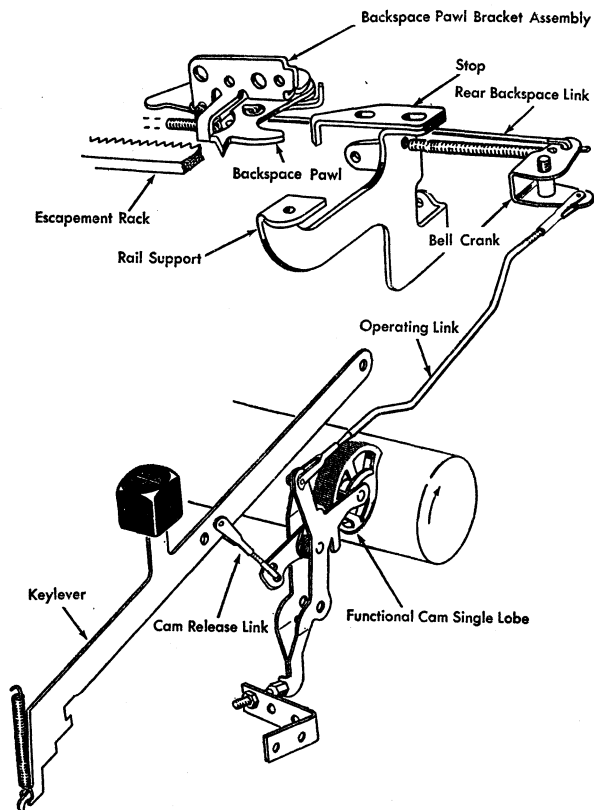

Figure 57. Backspace Mechanism

5. **CAM CLEARANCE.** Refer to "Space bar adjustment 1", this section.
6. **CAM RELEASE LINK.** Refer to "Tabulation adjustment 2", this section. Refer to "Carriage return adjustment 2", this section for repeat operation.
7. **BACKSPACE OPERATING LINK.** Adjust this so that the backspace pawl contacts its stop when there is approximately 1/4" travel left on the circumference of the cam (Figure 57).
8. **CARRIAGE RETURN TAB INTERLOCK BACKSPACE EXTENSION.** Form this toward the front of the machine just far enough to prevent lock up of the carriage during simultaneous operation of backspace and carriage return.

RIBBON

Removal

RIBBON FEED PLATE

1. Remove the front case.
2. Disconnect the ribbon feed link.
3. Remove the three mounting screws. Then the ribbon feed plate can be removed.

RIBBON FEED CAM

1. Remove the left-hand ribbon feed plate.
2. From the bottom of the typewriter, disconnect the cam release link.
3. Disconnect the link from the cam to the bail end plate.
4. Disconnect the spring from the cam frame to the stud on the side frame.
5. Remove the screw holding the cam pivot to the side frame. The cam may then be lifted out through the space normally occupied by the left ribbon spool.

RIBBON LIFT BAIL ASSEMBLY

1. Remove the front case.
2. Disconnect the ribbon feed links and remove them from the bail end plates.
3. Disconnect the ribbon cam release link and the spring attached to the lug on the tube.
4. Disconnect the link from the cam frame to the bail end plate.
5. Disconnect the ribbon lift link.
6. Loosen the lock nuts and back off the pivot screws to allow the bail assembly to drop free.

RIBBON LIFT MECHANISM

1. Remove the ribbon lift link.
2. Disconnect the ribbon lift guide clevis.
3. Disconnect the color control link where it is attached to the lever on the color control shaft.
4. Remove the two screws mounting the mechanism to the power frame. The mechanism may then be slipped to the right and out of the machine.

RIBBON LIFT GUIDE. Remove the ribbon lift guide by disconnecting its clevis from the lift lever. The lift guide may then be removed from the top of the typewriter.

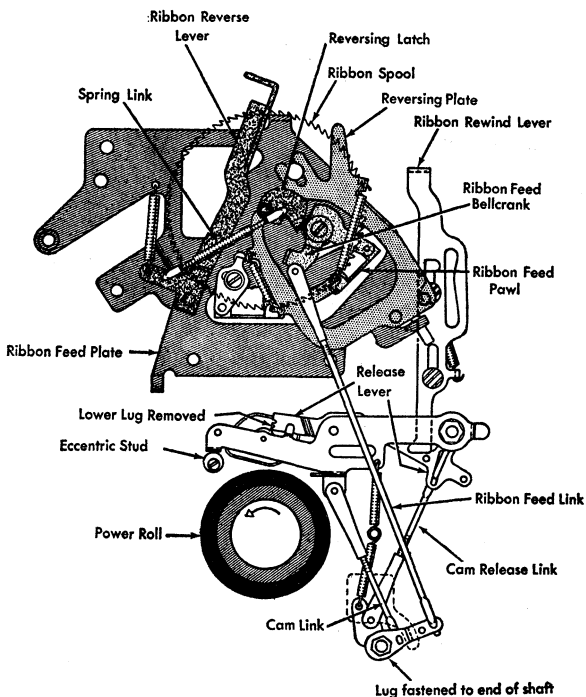

Figure 58. Ribbon Feed Mechanism

Ribbon Adjustments

The ribbon feed mechanism shall, when properly adjusted, provide a two-tooth feed at each stroke. The mechanism shall reverse dependably at either end of the ribbon.

1. CAM CLEARANCE. Adjust this by rotating its eccentric stop so that with the cam released and the power off, the release lever will rest on the rear half of the cam lug. The eccentric and lock nut are on the left side frame and may be reached through an opening of the power roll pulley (Figure 58).

2. CAM RELEASE LINK. Adjust this so that the ribbon cam is released when any type face is $3/4" \pm 1/8"$ from the platen (Figure 58). A variation in the tripping point between different type bars may be an indication that the vane on the ribbon lift bail is curved.

3. THE CAM LINK from the cam to the ribbon lift bail end plate is adjusted so that the bail end plate is $1/16"$ above the bottom of the slot in the side frame (Figure 58).

4. RIBBON FEED LINKS. Adjust these in the following manner:

- a. With the power off, trip the cam and rotate it to its high point.

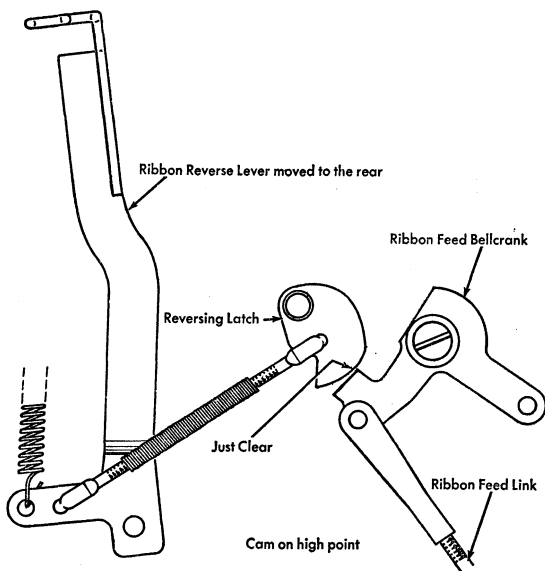

Figure 59. Ribbon Feed Link Adjustment

- b. Adjust the feed link on the feeding side so that the reversing latch will just clear the ribbon feed bell-crank as the latch is moved to the rear (Figure 59).
5. **SPRING LINKS.** Adjust these so that, with the power on and the ribbon feeding, the ribbon will reverse when the reversing lever is moved $3/8''$ to $1/2''$ toward the rear (Figure 59).
6. **CHECK PAWL.** Loosen its mounting screw (Figure 60) and move the check pawl front or rear until the pawl rotates the spool enough to allow the ribbon feed pawl to rest half-way between two teeth.

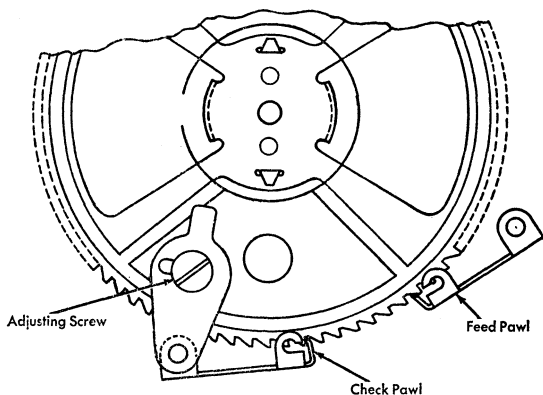

Figure 60. Ribbon Check Pawl Adjustment

7. **RIBBON SPOOL RETAINING SPRINGS.** Remove the ribbon feed plate. Loosen the two screws which hold the springs to the ribbon feed plates and move the springs up or down to center the teeth of the ribbon spools on the feed pawls.

Ribbon Lift Adjustments

1. **THE RIBBON LIFT BAIL ASSEMBLY** shall be centered between the side frames and shall pivot freely without binding. It shall have $.005''$ to $.015''$ end play on its bearings.
2. **THE RIBBON LIFT OPERATING LINK** (Figure 61) should be adjusted as follows:
- Unhook the link and push it toward the front of the machine.

- b. Push the actuating lever to the front and match the pin of the operating link clevis to the hole in the actuating lever.

3. RIBBON LIFT GUIDE CLEVIS. Adjust this so that the tops of the tallest characters strike $1/32''$ below the upper edge of the ribbon when the ribbon is at its lowest, or black, setting (Figure 61).

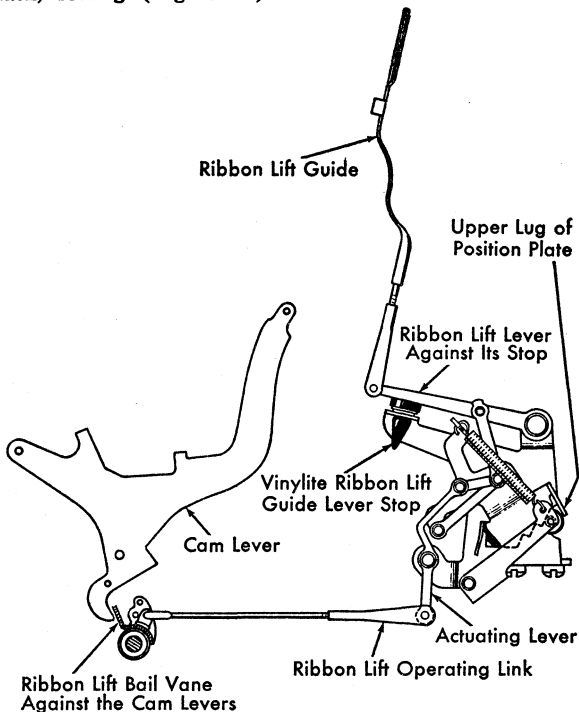

Figure 61. Ribbon Lift Mechanism

4. THE UPPER LUG on the positioning plate is formed so that the underscore prints $1/32''$ above the bottom edge of the ribbon when the ribbon lift is at its highest, or red setting (Figure 61). Check this at impression 0 and 10.

5. COLOR CONTROL LINK. Adjust this to make the slope of the color control button parallel to the slope of the keyboard when the color control button is in the black ribbon position.

TYPE IMPRESSION

Impression is affected by many items. Turn the impression control screws as a last resort.

Adjustments

Where the impression control screws of the entire keyboard require adjustment, the following procedure is suggested:

1. Place an original and two carbon copies in the typewriter.
2. Set the impression control lever at 5 and the multiple copy control lever at A.
3. Strike up a sample of the keyboard in numerical order starting with position 1:
q a 2 z w s 3 x . . . and so on.
4. Remove the paper, place the typewriter on its back, and study the original sheet. Turn out any impression screws for light-striking type faces and turn in the screws for cutting or heavy impression.
5. Restrike the characters that have been altered and select any type that cannot be made strong enough to print a strong, firm impression without cutting the paper. These type faces should be polished.
6. Put the color control in stencil position and wrap a sheet of Behr Manning Durite 600A abrasive paper (Part Number 9460107) around the platen. Hold the type bar firmly against the abrasive, applying pressure to the type bar. Polish the type by moving the carriage to the left and right once or twice and also by rotating the platen up and down once or twice. All movements of the carriage should be slow and even to produce best results.
7. Test the type face by making another strike-up of the type in question and repeat step 6 if required. Do not use an abrasive heavier than that recommended.

TYPE ALIGNMENT

Adjustments

- 1. RING AND CYLINDER:** Refer to "Carriage Adjustment 4", this section.
- 2. EVEN TOP AND BOTTOM.** Refer to "Shift adjustment 1," this section.
- 3. MOTION.** Refer to "Shift adjustment 2," this section.
- 4. THE TYPE GUIDE.** Check this to see that it is properly centered. Strike the keyboard with reference to the N to test the location of the guide. Start with the No. 1 Key (Q), No. 2 Key (A), etc., on through the complete keyboard, using the N between each one. The following test result indicates a type guide that is too far to the right.

nqnanznwnsnxnendncnrfnfvntngnbnynhnunjnmninknonlnpn

This pattern shows that all of the left-hand bars are being pulled downward by the guide, while the right-hand bars are being raised by it.

If the type guide is too far to the left, the pattern appears as follows:

nqnanznwnsnxnendncnrfnfvntngnbnynhnunjnmninknonlnpn

With the guide centered accurately, the type will appear on an even line from left to right (Figure 62).

The type bars are aligned in relation to each other by using one or more guide letters. The letter N is generally selected although other letters such as the H may be em-

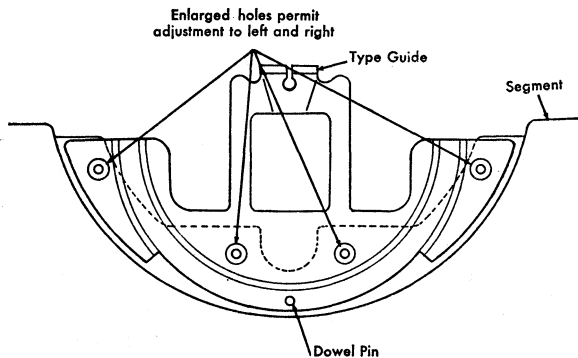

Figure 62. Type Guide Adjustment

ployed. Before using the letter N as a guide to align a complete set of type, it must be carefully checked to insure its accuracy as a guide letter. By using the platen variable button, it is possible to type several capital N's under each other so that they overlap. If the sides of the letters align themselves, the N will usually make a suitable guide (Figure 63).



Figure 63. Checking the N

The height of the N should compare favorably with the average height of the other type bars. A study of the strike-up will reveal whether the N is printing evenly on both sides and is centered between the other type bars generally (Figure 64).

NANBNCNDNEFNNGNHNIJNKNLNMNONPNQNRNSNTNUUNVWNXNYNZN
nanbncndnenfngnhninjknknlmnmnonpnqnrnsntnuunvwnxnyzn

N@N#N\$N%N&N*N(N)N_N½N'N:N?N.N,N
n2n3n4n5n6n7n8n9n0n-n½n'n;n/n.n,n

AMARANTH SECEDES SASESUSOS URUGUAY ORONOCO INITIAL PHILADELPHIA
amaranth secedes sasesusos uruguay oronoco initial philadelphia

.....----- 234567890

Figure 64. Strike-Up

ALIGNMENT. There is no set procedure which must be followed in aligning type because each type bar may need a slightly different adjustment. Until experience has been acquired, follow the procedure outlined here for the alignment of a single type bar.

1. After a new typebar is installed, first check it to see that it enters the type guide without striking either side. A piece of paper placed behind the type guide, but in front of the ribbon, helps in observing that there is a slight clearance between the type bar and the sides of the guide when the type bar is moved slowly into the guide by hand (Figure 65). The type bar may be formed to the

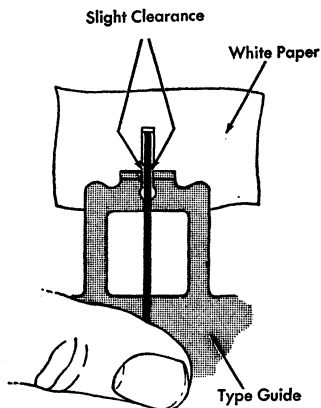

Figure 65. Type Bar Centered in Type Guide

right or to the left until it enters the center of the guide. To do this forming, the three-prong pliers should be used as illustrated in Figure 66. Centering of the type bar should be rechecked after every alignment operation.

2. After the type bar is centered in the guide, check the

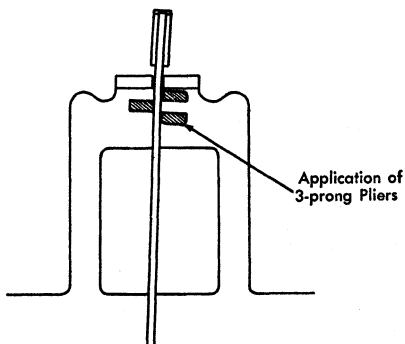

Figure 66. Three-Prong Pliers on Type Bar

ring and cylinder adjustment. Insert a sheet of bond paper in the typewriter and place a test strip of paper, about 1/2" wide and 4" long, between the type bar and ring. The paper should be gripped tightly between the type bar

and ring when the type bar is held up to the platen with the thumb against the type bar at the ring. Place the paper between the ribbon and the paper on the platen, and, holding the type bar as before, test for a slight drag as the strip of paper is withdrawn. If the ring and cylinder is out of adjustment, correction may be obtained by using the S-6 bar bender as shown in Figures 67 and 68. If no change in the elevation of the type face is desired, place the S-6 bar benders low on the type bar. Be careful not to burr the portion of the type bar which moves in the segment slot.

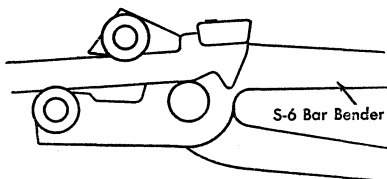

Figure 67. Moving Type Bar Off Ring

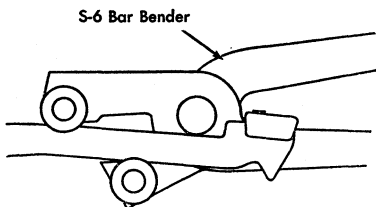

Figure 68. Moving Type Bar On Ring

3. If a type bar does not print evenly on both the right and left sides, it will be necessary to twist the head of the bar with one type wrench while holding the throat of the bar with another (Figure 69). This procedure may move the typed character slightly to the right or left. After each adjustment of a type bar, test the ring and cylinder and check the type bar to see that it enters the guide without binding.

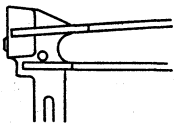
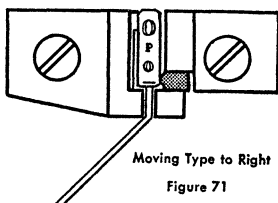
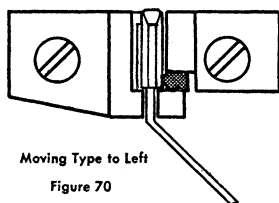

Figure 69. Twisting the Typehead

4. The lower case letters should center between two lower case n's. If a type bar fails to center equally between two lower case n's, it may be necessary to use the knock-over pliers and move the type either to the left or right (Figures 70 and 71).



5. The upper case characters should be centered between two upper case N's. This is accomplished by using one aligning wrench and the type bar in the guide as illustrated in Figure 72.

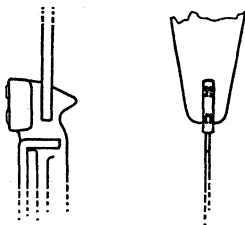

Figure 72. Moving Upper Case Type to Right or Left

6. The type face can be raised or lowered to the writing line by using the S-6 bar benders. By placing a bend toward the platen, near the top of the bar, the type may be lowered (Figure 67).

A bend away from the platen, near the top of the bar, raises the type slightly (Figure 68). Keep in mind that a second bend may be necessary with the benders placed low on the type bar to regain the proper ring and cylinder adjustment. A type face may be lowered considerably, by forming the type bar twice with the S-6 bar bender. The first forming should be high and toward the platen (Figure 67), and the second should be low and away from the platen to regain proper ring and cylinder.

The reverse order may be used to raise a type face. Another method for raising or lowering a type face is the use

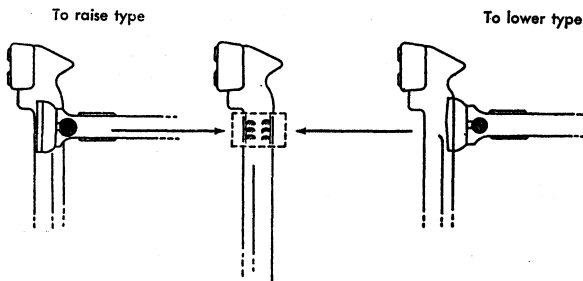

Figure 73. Peening Pliers Adjustment

of the type maulers, or peening pliers. This is accomplished as illustrated in Figure 73 and should be used only in the area indicated.

7. End type bars are more difficult to align and sometimes fail to respond to the same treatment as those located nearer the center of the segment. When twisting the type bar it is possible to have the lower case on the writing line and the upper case be too high.

A method of raising or lowering an end type bar is illustrated in Figures 74 and 75. Both steps are usually required and may be accomplished in the following manner: Apply the two type aligning wrenches as illustrated in Figure 74 to raise or lower a left-hand type bar. This will probably cause the type bar to bind in the guide. To correct this condition use the aligning wrenches as illustrated in Figure 75. This should correct the bind and result in the desired amount of raising or lowering of the type face. This method will also apply to right-hand type bars by applying the aligning wrenches in the same manner and reversing the motion to raise or lower a type bar.

SOLDERING TYPE SLUGS. When a type slug becomes loose on a type bar, it is advisable to replace the complete type bar. It is not always possible to do this, however. Consequently, it is necessary at times to resolder the type slug to the type bar. A satisfactory soldering job requires careful cleaning of the surfaces of the type bar and the type slug to be soldered. Apply the heat to the type slug until the solder runs down into the contact surfaces. Solder applied only around the edges of the slug will not retain the slug on the bar.

A type soldering fixture (Figure 76) may be used to hold a type slug in place, or to guide it into proper position during resoldering. It is not necessary to remove the type

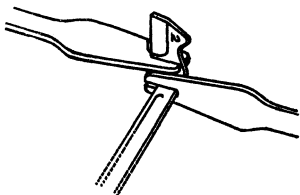

Figure 74. Raise or Lower End Type Bar

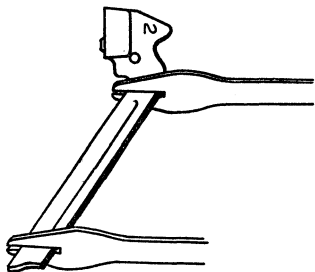

Figure 75. End Bar Alignment

bar from the machine. To solder a slug on a new type bar, the following procedure is recommended:

- a. Place the soldering fixture on the type bar as shown in Figure 76, and tighten the thumb screws securely.
- b. Heat the slug and remove it from the type bar.
- c. Clean the slug and the type bar thoroughly.
- d. Place the slug on the bar, being sure that the type face is flush against the fixture and is lowered until the slug rests on the fixture.
- e. Heat and re-solder. This should locate the slug with approximately the same ring and cylinder and even top and bottom adjustment.

RELOCATING TYPE SLUG. When a new type bar is installed and it is too high or too low to adjust by normal alignment procedures, it is necessary to relocate the type slug. This may be accomplished in the following manner: To raise the slug, place the fixture in the type bar with

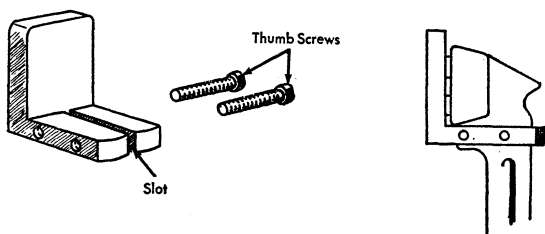

Figure 76. Type Soldering Fixture

its flat surface squarely against the face of type and lock the screws tightly. Heat the slug and carefully pry the slug upward the required amount with a screwdriver. To lower a slug, use the same procedure but lock the fixture in place far enough below the slug to permit the slug to be pressed down the required amount. Tilt the slug toward or away from the platen by first setting the fixture to the desired position and moving the slug to the fixture.

IBM STANDARD TYPE STYLES

TYPE CODES	TYPE NAMES	PITCH	TYPE MARK
10	*Bulletin	6 2/5	BU
14	Facsimile Gothic	6 2/5	O
27	*Gothic Bulletin	6 2/5	GB
29	Federal Slant	6 2/5	FS
35	Elite Wedding Gothic	6 2/5	EW
44	Facsimile Gothic Inverted	6 2/5	OI
58	Facsimile Gothic #2	6 2/5	OT
28	Large Roman Gothic	8	T
75	Manifold #8	8	H5
07	Modern Gothic	9	L
08	Medium Roman Gothic	9	XG
11	Pica Book	9	A
13	*Large Pica Book	9	LP
25	Great Primer	9	BP
43	Large Bookface	9	LB
74	Manifold #9	9	H4
01	Pica	10	P
03	Pica Gothic SC	10	G
04	Pica Gothic DC	10	H
09	Pin Point Gothic	10	GP
12	*Roman Book	10	D
15	Large Pica	10	B
20	Special Gothic	10	DC
21	Bookface Academic	10	BA
22	*Cloister Pica	10	BC
30	Pica Inverted	10	PI
37	Regent Gothic	10	RG
38	Pica Gothic Inverted	10	HI
48	Accounting Gothic	10	M
73	Manifold #10	10	H3
77	Prestige Pica	10	SP
80	Corinthian Script	10	FE
86	Artisan No 10	10	G3
87	Courier	10	SM
02	Elite	12	E
05	Elite Gothic DC	12	F
06	Elite Gothic SC	12	GE
17	Multigraph Elite	12	ME

IBM STANDARD TYPE STYLES

TYPE CODES	TYPE NAMES	PITCH	TYPE MARK
18	Elite Back Slant	12	EB
19	Elite Gothic Inverted	12	FI
23	Cloister Elite	12	BE
31	Large Elite	12	LE
33	*Miniature Gothic	12	MG
36	Dual Basic Gothic	12	DB
45	Elite Gothic Bold	12	FB
52	*Alternate Gothic	12	AG
67	Diplomat	12	B2
72	Manifold #12	12	H2
76	Prestige Elite	12	SE
85	Artison No 12	12	G2
24	Micro Elite	14	BM
41	Micro Gothic SC	14	FD
42	Micro Gothic DC	14	FF
54	Micro Gothic Condensed	16	FC

* These Type Styles have been discontinued.

IBM

ELECTRIC TYPEWRITER MODEL C-1

CUSTOMER ENGINEERING REFERENCE MANUAL Mechanical Principles and Adjustments

CONTENTS

	<i>Page</i>
New Features -----	3
Case and Covers -----	3
Motor and Drive -----	6
Keylevers, Letter Cams, Type Bars -----	7
Resilient Keyboard Control -----	10
Escapement -----	11
Space Bar -----	13
Margin Reset -----	15
Margin Release -----	16
Line Lock -----	17
Carriage and Rails -----	18
Paper Feed -----	21
Decelerator -----	22
Tabulation -----	25
Backspace -----	30
Carriage Return and Line Space -----	31
Shift -----	34
Ribbon, Carbon -----	36
Ribbon, Fabric -----	39

INTERNATIONAL BUSINESS MACHINES CORP.

New York 22, New York

Form 241-5002-0 (this section only)

© 1958

INTERNATIONAL BUSINESS MACHINES CORP.

590 MADISON AVENUE, NEW YORK 22, NEW YORK

Printed in U. S. A. 1958

Form 241-5002-0

IBM ELECTRIC STANDARD TYPEWRITER

MODEL C-1

This section describes the new features of the Model C1 typewriter, serial numbers 1,100,000 and above.

APPEARANCE. The case and cover sections have been completely redesigned to include many functional and aesthetic improvements.

DECELERATOR. The decelerator improves and quiets the carriage action during tabulation and carriage return by enabling the centrifugal governor to operate during either operation.

RESILIENT KEYBOARD CONTROL. This control positions spring fingers under the keylevers and permits the operator to set the touch to suit his or her individual requirements.

SHIFT. The shift mechanism has been improved in operation and the adjustments simplified.

MARGIN RESET. The margin reset mechanism has been made easier to operate and the possibility of malfunction eliminated.

PLATEN RATCHET. The platen ratchet has been enclosed within the left-hand carriage-end cover.

RIBBON MECHANISM—FABRIC. The fabric ribbon feed mechanism has been completely redesigned to provide cleaner, faster ribbon changing, and positive feeding.

RIBBON MECHANISM—CARBON. The carbon ribbon mechanism is completely contained within the typewriter case and has been improved to provide easier threading and more accurate feeding.

CARRIAGE. The Model C typewriter is available in 13, 17, 20, 24 and 30 inch carriage lengths.

CASE AND COVER SECTIONS

The typewriter is contained in a bottom case-section or shell. A rear cover-section mounts to the bottom case with two long screws. The front cover-section is hinged to the bottom case-section and latched down over the keyplate by a latch at each front corner of the bottom case-section (Figure 1). Lugs in the bottom case-section anchor the keyplate. Carriage-end covers contain the carriage-release buttons and are secured over each end of the carriage by Bristo screws inside of the end covers.

Four rubber mounts, screwed to the typewriter

side frames set into the bottom case. Base feet pass through the bottom case and screw into the rubber mounts. This gives the typewriter a resilient mounting when in its case and provides protection to the desk and typewriter when it is removed for servicing.

A locking bar inside the bottom case-section anchors the typewriter to two desk mounts, secured to the desk. By sliding the locking bar laterally the machine may be quickly and easily attached to or removed from the desk.

A removable bottom panel slides into the bottom-case section and serves to protect the typewriter. This panel can be easily removed to make adjustments and may also be used to protect the desk when working on the machine.

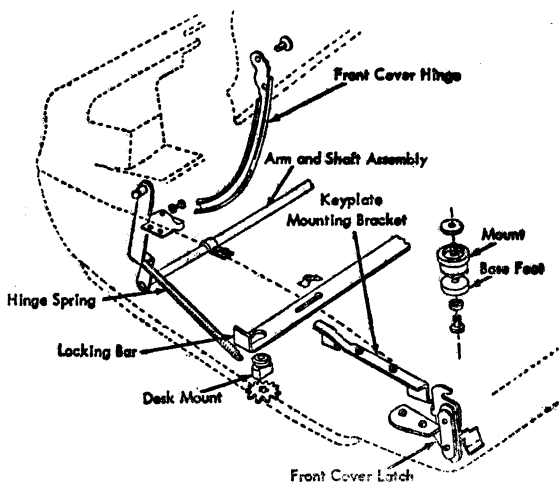

Figure 1. Case and Cover Mechanism

Removal

CASE and COVERS

1. Release the front cover-latches.
2. Remove the rear cover by removing its two mounting screws.
3. Disconnect the hinges from the arm and shaft assembly, on each side of the machine, by removing the C clips and pushing in on the arms, and remove the front cover.

4. Remove the keyplate by removing the keyplate mounting-brackets and raising the front edge of the keyplate.

5. Disconnect the line cord at the typewriter by separating the male and female plug.

6. Turn the machine up on its back, unscrew the four base feet, and allow the power frame to tip back free of the base section.

CARRIAGE END COVERS. Remove the platen, feed-roll-release, or detent-release lever and loosen the two end-cover mounting-screws.

TOP PAPER TABLE. Pull the rear edge up and forward.

Adjustments

CASE and COVERS

1. **KEYPLATE.** Adjust by forming the keyplate mounting-brackets so that the keyplate joins the front case-section smoothly. The keybuttons shall operate freely without binding.

2. **HINGES.** Adjust so there is sufficient vertical motion when the latches are released for the front case-section to clear the bottom case at the front edge. The front case shall not contact the bail roll in full raised position.

3. **LATCHES.** Adjust by positioning the latch

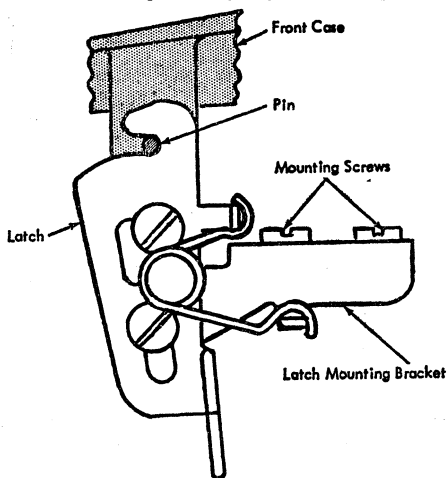

Figure 2. Front Cover Latch

mounting bracket so that the latches bottom against the front-case-section pin by stock thickness plus $\frac{1}{32}$ "-0. There shall be a maximum of $\frac{1}{64}$ " between the front and bottom case-sections when latched (Figure 2).

4. PLATEN KNOBS. Adjust to have equal clearance between the left and right carriage-end covers of $\frac{1}{32}$ " to $\frac{3}{64}$ ".

MOTOR AND DRIVE

The motor, drive, and electrical mechanisms remain essentially the same in operation as the Model B machine. Changes have been made in design to simplify removal and adjustment procedures, and to conform to the new case design.

The motor is a new 3" design used to allow more space for rear-rail mechanisms and to save weight. The ring mount is the same as the Model B; however, the left mounting has been placed on the rear frame to simplify motor removal procedures (Figure 3).

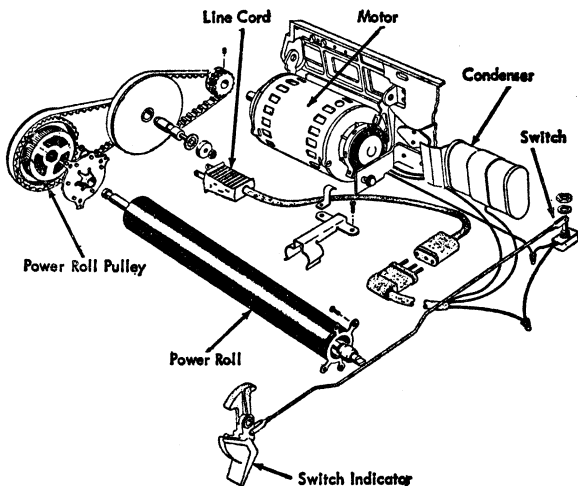

Figure 3. Motor and Drive

Removal

CAUTION: Unplug machine when servicing the motor, drive, and electrical components.

LINE CORD

The line cord is removable by means of a pluggable

unit attached to the rear frame. Access is through a slot low in the rear portion of the bottom case.

CAUTION: Plug must be properly seated, when re-installing, to prevent possible shock hazard.

MOTOR

1. Remove complete case and cover sections.
2. Remove the belts and the belt tension adjusting-screw from the left side-frame.
3. Disconnect the tab-lever spring, tab-actuating-lever spring, and the tab-set and tab-clear links.
4. Remove the six mounting studs that hold the rear frame to the side frames, and remove the motor and rear frame.

SWITCH

The switch may be removed from the right side-frame by removing the rear cover, the switch nut, and disconnecting the switch wiring.

POWER ROLL

1. Remove complete case and cover sections.
 2. Refer to Model B1, Power Roll Removal.
- Note: The lower power-roll-bearing-retainer screw is longer and serves also as a spring anchor for the ribbon mechanism.

Adjustments

1. **SWITCH.** Refer to Model B1, Motor and Drive, Adjustment 1.
2. **BEARINGS.** Refer to Model B1, Motor and Drive, Adjustment 2.
3. **POWER ROLL END PLAY.** Refer to Model B1, Motor and Drive, Adjustment 3.
4. **DRIVEN BELT.** Refer to Model B1, Motor and Drive, Adjustment 4.
5. **POWER ROLL SPEED.** Refer to Model B1, Motor and Drive, Adjustment 5.
6. **DRIVE BELT.** Refer to Model B1, Motor and Drive, Adjustment 6.
7. **MOTOR MOUNTINGS.** Belt tension may be adjusted without removing the typewriter from the bottom case-section by loosening the mounting screws and repositioning the motor.

KEYLEVERS, CAMS, TYPEBARS

The keylever, cam, and typebar operation of the Model C is theoretically the same as on the Model B. However, the keylevers, cams, and trip levers have

been slightly redesigned in order to improve their operation. These parts are not interchangeable with previous model typewriters.

An 86 or 88 character keyboard is available. The underscore is the only repeat/non-repeat letter key provided as standard equipment and is available in either position 39 or 41.

The keylevers are mounted in a redesigned keylever-bearing support and fulcrum on a heavier fulcrum rod held by formed lugs in the keylever-bearing support. The assembly is mounted to the side frames and is adjustable in order to obtain proper keylever to trip lever clearance (Figure 4).

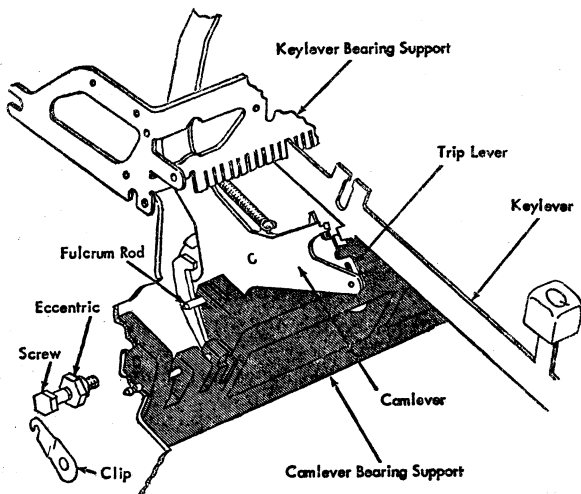

Figure 4. Keylever Bearing Support

Each row of keylevers has a different restoring spring, color coded for easy identification, to provide uniform touch. The keylever locking bar is designed so that all functional and letter keylevers except the shift are locked when the switch is in the OFF position.

Redesign of the repeat letter keylever to eliminate the spring-loaded plunger has caused the keylever guide-comb to be redesigned. Plunger positions are available for carriage return, tab, and backspace only. Repeat/non-repeat letter key operation has been altered by replacing the spring-loaded plunger with a single piece keylever containing an elongated

fulcrum-rod hole. A spring is connected between the keylever and a spring bracket above the keylever (Figure 5). As the keylever is depressed a single operation takes place. As more pressure is applied the resistance of the upper spring is overcome and the fulcrum point of the keylever lowered. This places the repeat step of the trip-lever lug in the operating position.

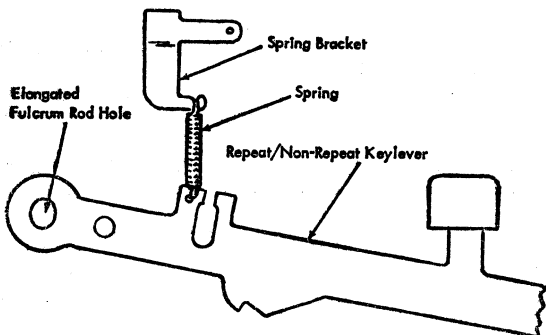

Figure 5. Repeat/Non-Repeat Keylever

If additional repeat/non-repeat letter cams are desired a two-piece keylever may be installed in any keylever position.

The letter cam has been reshaped for smoother operation and is not interchangeable with previous models.

Removal

KEYLEVERS

1. Remove the typewriter from the base section.
2. Remove the resilient-keyboard-control indicator.
3. Disconnect the spacebar-switch-lock shaft.
4. Remove the front frame by removing the four mounting studs.
5. Disconnect the keylever spring.
6. Insert a follow-up fulcrum rod to the depth of the desired keylever.
7. Remove the two mounting studs from the keylever guide-comb and pivot the guide-comb forward.
8. Lower the rear of the keylever between the cams and push it toward the rear of the machine until the keylever clears the guide-comb.
9. Remove the keylever by pulling forward.

LETTER CAMS

Refer to Model B1, Cam Removal Procedure.

Adjustments

1. CAM CLEARANCE. .015" to .020". Refer to Model B1 section.

2. KEYLEVER BEARING SUPPORT. Adjust by positioning the keylever-bearing support so that the keylevers trip the cams when the keylever is $\frac{1}{32}$ " plus or minus $\frac{1}{64}$ " from the bottom of the keylever guide-comb (Figure 4).

3. INDIVIDUAL KEYLEVERS. Raise or lower to conform to adjustment 2. Spread keylever lugs with screwdriver or compress lugs with pliers.

NOTE: Do not form keylevers with "T" bender or hammer as damage to the keylever-bearing support will result.

RESILIENT KEYBOARD CONTROL

The resilient-keyboard control, located to the left of the impression control indicator, provides the operator with a means of varying the resistance of the keylevers to suit her touch (Figure 6). This added resistance is supplied by flat springs, mounted in the path of travel of the keylevers, and is determined by varying the position of the flat springs. Three major settings are available to the operator:

1. L — No flat spring contact.
2. M — Some flat spring contact.
3. H — Maximum flat spring contact.

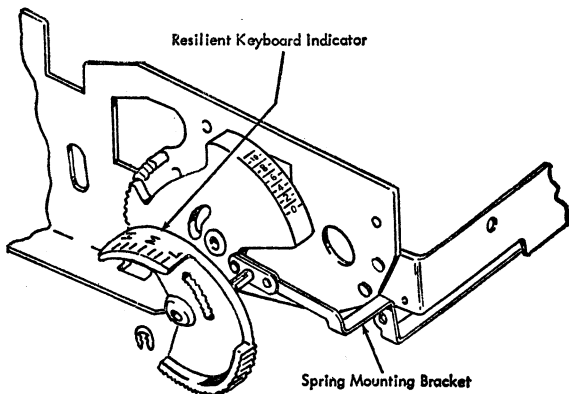

Figure 6. Resilient Keyboard Control

Removal

1. Remove the resilient keyboard indicator.
2. Remove the left-hand mounting stud.

Adjustment

SPRING FINGERS. Adjust by forming the spring-mounting bracket so that with the indicator at L and the keylevers depressed there is .001" to .010" between the spring fingers and the keylevers (Figure 7).

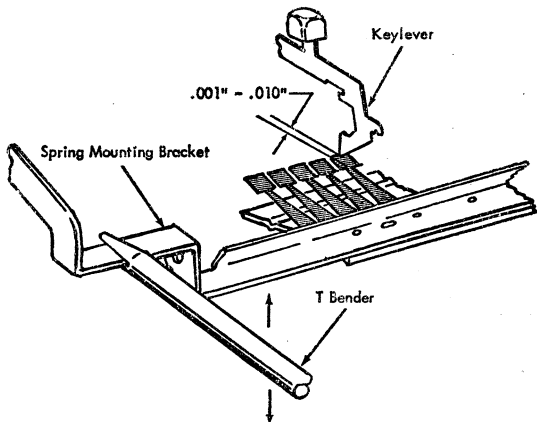

Figure 7. Resilient Keyboard Adjustment

ESCAPEMENT

Escapement remains essentially the same on the Model C machines as on the Model B. The pawl is the .058" motion pawl for 8, 9, 10, and 12 pitch machines and the .038" motion pawl for the 6½ and 14 pitch, decimal tab, and lift platen typewriters. The pawl and trip lever are no longer mounted on the same bracket. The trip lever is now a part of the left-hand rail-brace, and the escapement pawl and spacer are part of the tab-lever-mounting bracket (Figure 8). The horseshoe shaped tab-lever-mounting-bracket has been eliminated and the bracket anchored firmly to the rear rail.

Removal

UNIVERSAL BAR. Refer to Model B1, Escapement, Removal Procedure.

ESCAPEMENT PAWL ASSEMBLY. Refer to Model C1, Tabulation, Tab-Lever-Mounting Bracket Removal.

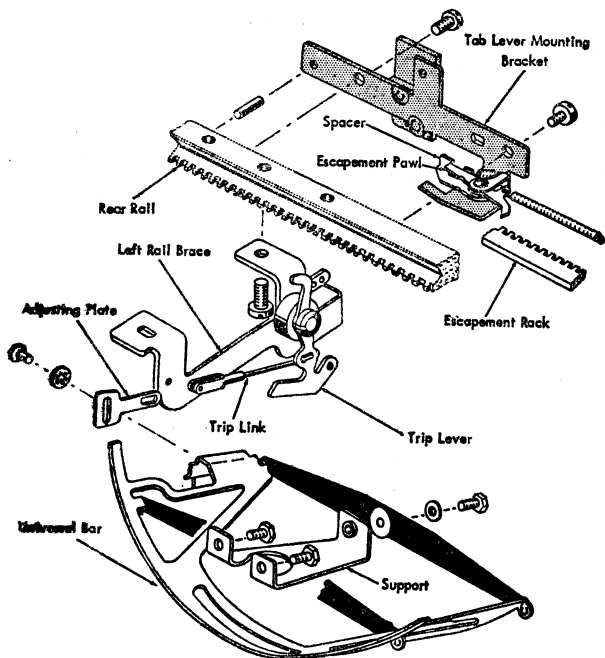

Figure 8. Escapement Mechanism

Adjustments

1. MAINSPRING. CAUTION: Extreme care must be exercised when servicing this assembly to avoid injury resulting from a disengaged mainspring.

Tension is adjusted by placing the loop of the carriage tension-tape on various lugs of the mainspring drum. This adjustment may be checked through the following steps:

- A. Position the carriage so that the tip of the tab check-lever is directly opposite the last tab-stop on the right end of the rack.
- B. Set the last tab-stop.
- C. Hold the carriage to prevent any movement and latch the tab lever out.
- D. Gently position the set tab-stop against the tab-check lever and release the carriage.

E. The main spring should have sufficient tension to unlatch the tab.

A push-pull scale may be used to measure carriage tension in the following manner. Pull the carriage at a slow and steady rate from the extreme left position to the extreme right position, (excluding decelerator range). Tension shall be as follows:

13" Carriage -- $2\frac{1}{2}$ lbs. + $\frac{1}{4}$ — 0 lbs. at start to $3\frac{3}{8}$ lbs. maximum.

17" Carriage -- $2\frac{1}{2}$ lbs. + $\frac{1}{4}$ — 0 lbs. at start to $3\frac{1}{2}$ lbs. maximum.

20" Carriage -- $2\frac{3}{4}$ lbs. + $\frac{1}{4}$ — 0 lbs. at start to $3\frac{5}{8}$ lbs. maximum.

24" Carriage -- $2\frac{3}{4}$ lbs. + $\frac{1}{4}$ — 0 lbs. at start to $3\frac{7}{8}$ lbs. maximum.

30" Carriage -- 3 lbs. + $\frac{1}{4}$ — 0 lbs. at start to $4\frac{1}{8}$ lbs. maximum.

2. UNIVERSAL BAR. Refer to Model B1, Escapement, Adjustment 2.

3. ADJUSTING PLATE ON UNIVERSAL BAR. Refer to Model B1, Escapement, Adjustment 3.

4. TRIP LINK. Refer to Model B1, Escapement, Adjustment 4.

SPACEBAR

The spacebar features a controlled repeat/non-repeat action. The spacebar cam release-lever rotation has been reversed to permit the use of a longer release link connected directly to the spacebar shaft. Depression of the spacebar through its normal travel

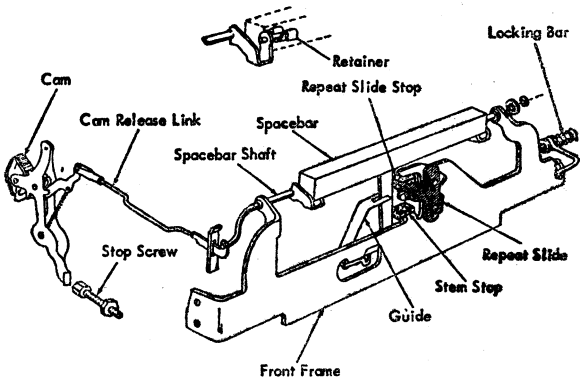

Figure 9. Spacebar Mechanism

trips the cam which in turn activates the escapement as in previous machines. The spacebar is restored to its rest position by a flat spring, mounted to the front frame by an adjustable support, which bears up against the spacebar stem (Figure 9).

Spacebar travel is limited by two rubber stops. The spacebar-stem stop is fixed to the front frame and determines the upper, or rest position, of the spacebar. The second stop is mounted to the repeat slide.

The repeat slide controls the downward travel of the spacebar during single or repeat actions. Two adjustable-shouldered-mounting screws pass through elongated holes in the repeat slide and front frame, and screw into the repeat stop (Figure 10). The repeat slide is spring loaded against the upper arm of the repeat stop. During repeat operation the spacebar stem moves the repeat slide down against this spring tension until the repeat slide contacts the lower arm of the repeat stop.

A locking bar is moved horizontally to a position below the spacebar stem, by an inclined surface on the switch lever, locking the spacebar when the switch is in the OFF position.

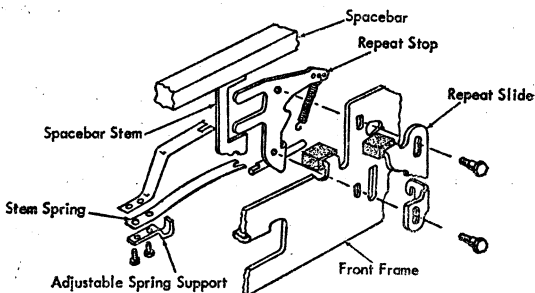

Figure 10. Repeat Slide Assembly
Removal

SPACEBAR. Remove the spring retainers inside the plastic spacebar.

CAM.

1. Remove the base cover-section.
2. Loosen the cam-knockout bar by removing the fulcrum pins and springs. The knockout bar may now be moved upward out of the way, or removed from the typewriter.
3. Remove the resilient keyboard and impression indicators.

4. Remove the impression-control shaft by lifting it up out of its fulcrum slots.
5. Disconnect the operating link and the cam release link.
6. Move the operational cam fulcrum rod enough to free the cam. The left fulcrum rod is held in place by a C clip between the cam bearing support and the left side frame.

Adjustments

1. **CAM CLEARANCE.** Adjust cam to power roll clearance at .010" to .015" using the adjustable-stop screw (Figure 9). Check by releasing the cam with the power OFF. The release-lever lug should rest on the rear half of the cam lug.
2. **CAM-RELEASE LINK.** Adjust so the cam trips when the keylever has been depressed $\frac{1}{8}$ " from its rest position.
3. **SPRING-RETURN SUPPORT.** Adjust by forming, so the spring will just restore the spacebar to its rest position.
4. **REPEAT STOP.** Adjust by vertically positioning the mounting screws, so the travel of the spacebar between the non-repeat tripping point and the contact of the repeat slide is .015" to .025" (Figure 10).
5. **OPERATING LINK.** Adjust to trip the escapement pawl just before the high point of the cam is reached. With the cam on its high point there should be no choking off.

MARGIN RESET

The margin-reset keylever is mounted to the right side-frame and fulcrums on a mounting stud (Figure 11). A keylever spring between the keylever and the side frame holds the keylever in its rest position. Depressing the key-button raises the push rod and causes the margin-reset lever to rotate about its mounting in the margin-reset bracket. The margin-reset lever passes in front of the margin rack and contains a pin that rides above the rack. In the operated position the margin-reset-lever pin engages the "V" shaped notch in the margin stop and depresses the spring-loaded slider. The pin on the slider disengages from the margin-rack teeth and allows repositioning of the stop. The carriage may be moved when the keylever is depressed without part damage.

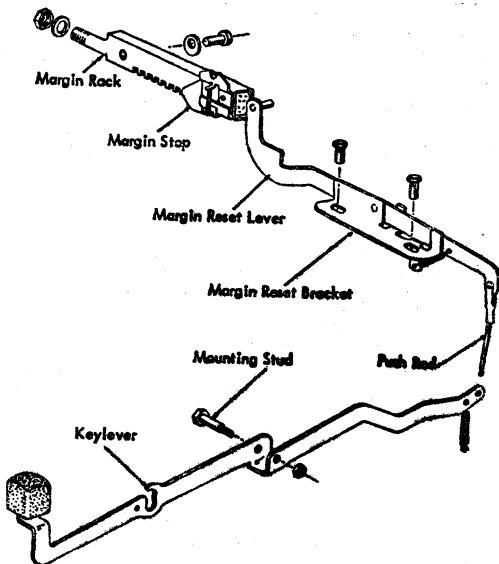

Figure 11. Margin Reset

Adjustments

1. **MARGIN-RESET LEVER.** Adjust the push-rod clevis so that with the parts at rest there is a clearance of .005" to .015" between the bottom surface of the reset-lever pin and the top surface of either margin stop.
2. **MARGIN-RESET BRACKET-ASSEMBLY.** Position left or right on the rear rail so that the margin-reset-lever pin will center in the "V" groove of the margin stop.
3. **MARGIN STOPS.** The margin stops shall operate freely without excessive play and without binding.

MARGIN RELEASE

The margin-release mechanism remains the same except for the redesigned actuating lever between the keylever and the tab-lever to conform with the new tab mechanism (Figure 12). The tab-lever spring provides positive contact between the tab-lever-actuating lever and margin-release lever.

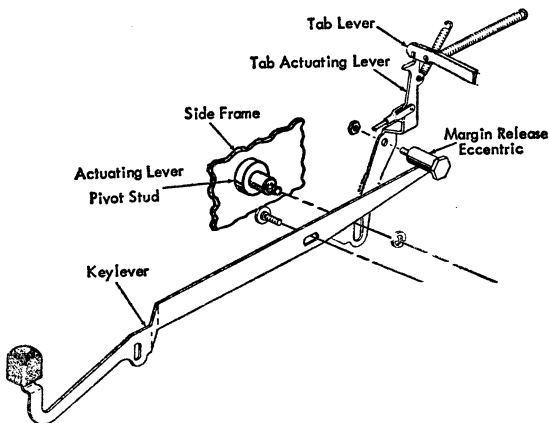

Figure 12. Margin Release

Removal

Refer to Model B1, Margin Release. It is not necessary to remove the typewriter from the base section.

Adjustment

MARGIN RELEASE ECCENTRIC. Adjust so that the margin control lever clears the underside of the margin rack by .010" to .015" (Figure 12).

LINE LOCK

The line lock is essentially the same as on the previous model (Figure 13). It has been altered to conform to the new rear rail parts and to lock all letter keylevers when at the right margin. All functional and letter keylevers except the shift are locked when the switch is in the OFF position.

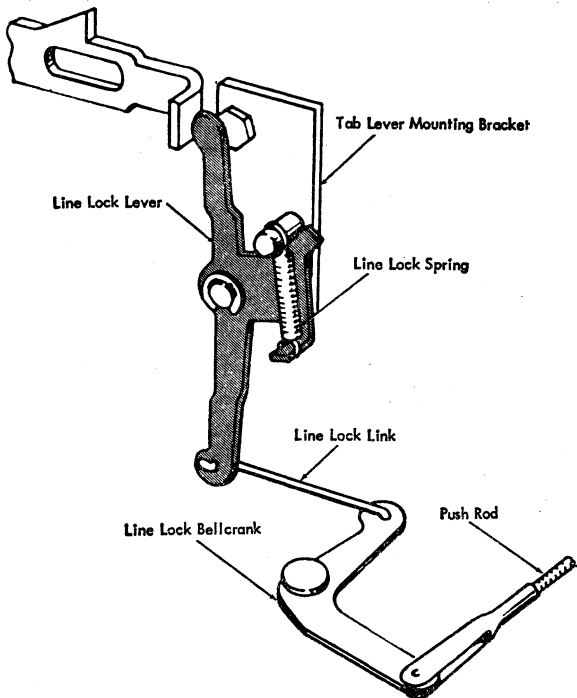

Figure 13. Line Lock

Adjustment

PUSH ROD. Refer to Model B1, Line Lock, Adjustment 2.

CARRIAGE AND RAILS

The carriage has retained its box-frame construction and operational characteristics. The following changes have been made to conform to the new case and cover section design and to increase machine flexibility.

Model C carriages are available in the following lengths: 13", 17", 20", 24" and 30". The margin and tab-rack center-support, on carriages 17" and longer, anchors to the carriage and bridges up and over the margin rack where it is attached at the rear (Figure 14). It mounts into the tab rack as before. This allows the operator to position either margin stop at any desired location on any length carriage.

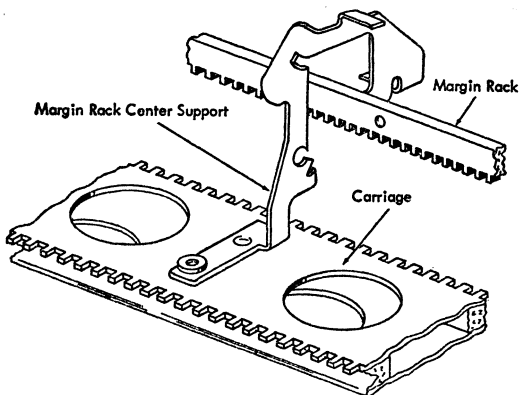

Figure 14. Margin Rack Center Support

Platen latches have been altered to make them self-locking. The new latch consists of two levers, pivoting on eccentrics, connected by a flat platen-latch link. Pulling the latch toward the front pivots the latch lever over the platen shaft. The latch engages a notch in the latch lever, locking the two together (Figure 15).

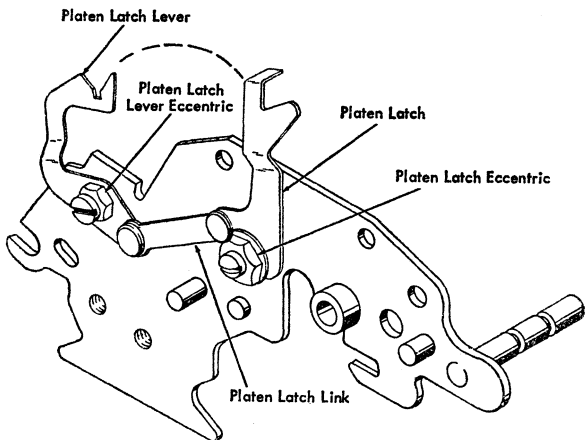

Figure 15. Platen Latches

The multi-copy lever, feed-roll-release lever, variable-line-space lever, and the detent-release lever

operate as before. They have been altered to conform to the new cover design.

The carriage-release levers are operated through buttons contained in the carriage-end covers.

RAILS

Rails, trucks, starwheels, and rollers remain the same as on the Model B. The carriage final-stop has been eliminated. Due to the new carriage lengths a new truck insertion method is used (Figure 16).

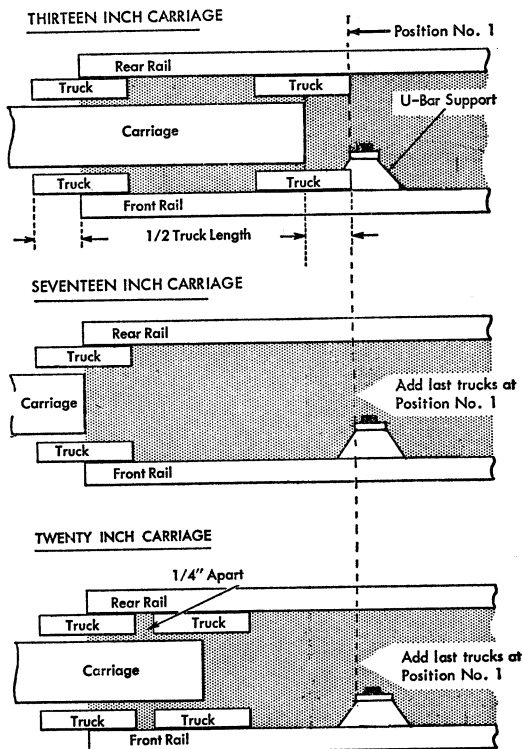

Figure 16. Carriage Truck Insertion

Removal

CARRIAGE AND RAILS. The carriage and rails may be removed together as an assembly as follows:

1. Disconnect the left-hand tab-lever spring and the two decelerator-arm springs.

2. Unhook the backspace operating-link and the margin-reset link.
3. Unhook the pawl-release and clutch-unlatching links.
4. Unhook the line lock push-rod and the escapement-trip link.
5. Remove the ribbon from the corner ribbon guides.
6. Disconnect the carriage-return and carriage-tension tapes.
7. Remove the four rail-mounting screws and lift off the carriage and rails assembly.

CARRIAGE. The carriage may be removed from between the rails as follows:

1. Remove the rear cover.
2. Remove the right-hand carriage end-cover.
3. Disconnect the carriage-return and carriage tension tapes at the carriage.
4. Remove the margin-reset-lever assembly.
5. Move the carriage to the extreme left and depress the margin-control lever allowing the carriage end-plate to pass over it.
6. Remove the carriage by moving it to the left.

INNER CARRIAGE. The inner carriage may be removed without disturbing the rails or carriage adjustments by following the procedure outlined in the Model B1 section of the Reference Manual.

Adjustments

1. **RAILS.** Refer to Model B1, Rail Adjustments, Adjustments 1, 2, and 3.
2. **PLATEN LATCH LEVER ECCENTRIC.** Adjust so that the platen is held firm with the high point of the eccentric in the forward half of its orbit. (Figure 15).
3. **PLATEN LATCH ECCENTRIC.** Adjust so that the latch firmly engages the platen latch lever.
4. **PLATEN CONTROL-YOKES.** Refer to Model B1, Carriage, Adjustment 2.
5. **PLATEN RETAINING-PLATES.** Refer to Model B1, Carriage, Adjustment 3.
6. **RING AND CYLINDER.** Refer to Model B1, Carriage, Adjustment 4.
7. **FEED-ROLL CENTER-SUPPORT.** Refer to Model B1, Carriage, Adjustment 5.

PAPER FEED

The paper-feed mechanism is the same in principle as on the Model B. An additional set of feed rolls have been added to the 13" and 17" carriages to prevent paper slippage on these new carriage lengths.

Removal

FEED ROLLS. Refer to Model B1 section.

FRONT AND REAR PRESSURE-LEVERS. Refer to Model B1 section.

Adjustment

Refer to Model B1 section.

DECELERATOR

The decelerator is a control mechanism for the centrifugal-governor. It consists of a series of spring clutches and cam arms that control the action of the centrifugal-governor (Figure 17). The decelerator-governor action absorbs carriage shock and controls the speed of the moving carriage. It eliminates the tab rebound check-lever, the air cylinder and the horseshoe shaped tab-lever mounting-bracket.

The centrifugal-governor operates as the carriage moves to the left during tabulation. As the main-spring and drum unwind they rotate the hub and gear assembly, which drives the pinion gear on the governor shaft. During left to right motion of the carriage, a spring clutch allows the mainspring and drum to rewind without rotating the hub and gear assembly and/or operating the governor.

A spring clutch is a ratchet like mechanism which utilizes a coiled spring fitted closely about a shaft. When turned in one direction the spring tightens

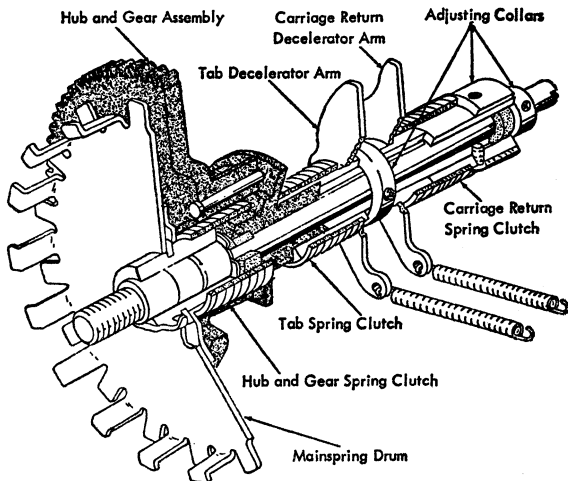

Figure 17. Decelerator

about the shaft and causes the shaft to rotate. When turned in the opposite direction the spring relaxes and slips about the shaft.

CARRIAGE RETURN DECELERATION

During carriage return the left-margin-stop picks up the margin-control lever and moves it to the right, causing the margin-control bellcrank to operate and rotate the carriage-return-decelerator bellcrank (Figure 18). The carriage-return-decelerator-bellcrank forces the carriage-return-decelerator arm to rotate, tightening its spring clutch, and rotating the gear and hub assembly. The gear and hub assembly drives the pinion gear of the centrifugal-governor which decreases carriage speed during the last portion of the carriage return operation.

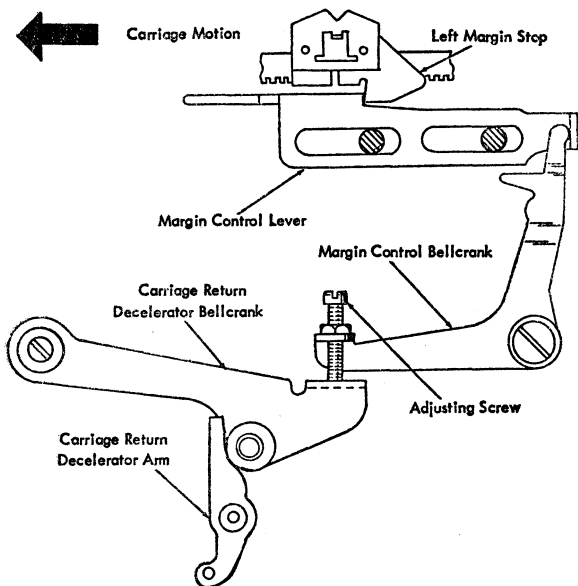

Figure 18. Carriage Return Deceleration

TABULATION DECELERATION

As the tab lever latches the tab check-lever moves to the right, as far as its elongated mounting-slots will permit, under tension of the tab-decelerator-arm spring. As a set tab-stop contacts the tab check-lever and moves it to the left, the tab decelerator-link causes the tab decelerator-bellcrank to rotate

and operate the tab decelerator-arm (Figure 19). This action tightens the tab spring-clutch and gives an increased rotation to the already operating centrifugal-governor. This increased rotation slows the carriage during the last portion of a tabulation and absorbs the shock.

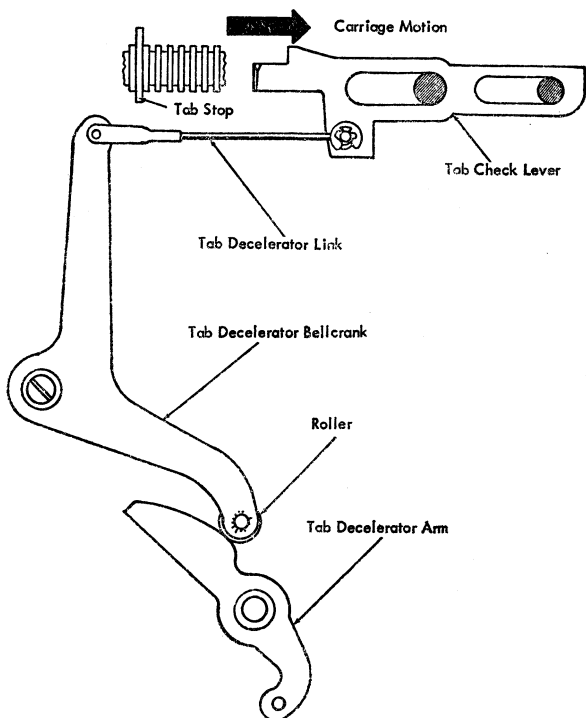

Figure 19. Tabulation Deceleration

Removal

The decelerator, gear and hub assembly, and main-spring drum may be removed as a complete unit by following these steps:

1. Remove typewriter from the base section.
2. Disconnect the carriage-tension tape at the main-spring drum. **CAUTION:** Allow mainspring to unwind slowly.

3. Loosen the centrifugal-governor mounting-screws sufficiently to prevent stripping gear teeth.
4. Unhook the springs to the carriage-return and tab decelerator-arms.
5. Remove the rear frame.
6. Unscrew the spring-clutch decelerator-mounting shaft.

Adjustments

1. SPRING - CLUTCH COLLARS. The tabulation and carriage-return spring-clutch collars should be positioned on the shaft so as to allow their decelerator arms to rotate freely without exceeding .003" end play of the arms on the shaft (Figure 17).

2. SPRING-CLUTCH SHAFT. Adjust by positioning the end collar so that the hub and gear assembly rotates freely with end play not to exceed .003".

TABULATION

Tabulation on the Model C has been redesigned to incorporate the advantages of the decelerator

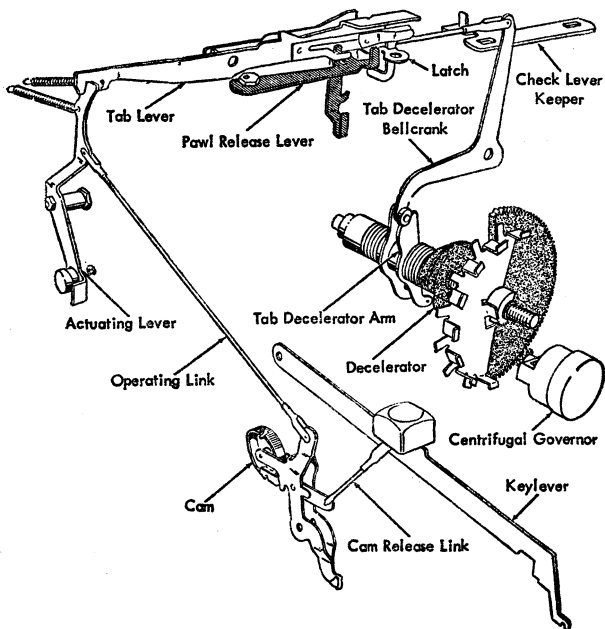

Figure 20. Tabulation

(Figure 20). One tab lever assembly serves all pitch Model C Typewriters. Tab stops may be set at every space on standard pitch machines without interfering with the operation. Tabulation is possible to each set tab stop on the 6 $\frac{1}{2}$ pitch machine and to every second tab stop, when consecutive stops are set, on all other standard pitches.

The tab latch is mounted atop the rear rail with an adjustable eccentric and works against a lower extension of the tab lever (Figure 27). The tab-check lever works against a lug on the tab latch to effect tab lever unlatching.

Removal

TAB LEVER

1. Remove the paper table and carriage end-covers. It is not necessary to remove the rear cover; however, it may aid the removal and reassembly procedure to do so.
2. Remove the margin rack.
3. Remove the line-lock operating-lever.
4. Disconnect the tab-lever spring, tab-latch spring, and the decelerator-bellcrank link.
5. Remove the tab-lever-pivot stud.
6. Remove the tab lever by lifting it up and toward the rear.

Reassembly may be accomplished by reversing the above procedure. Avoid over-tightening the self-locking nut on the tab-lever-pivot stud as this may cause binding of the tab lever.

TAB LEVER MOUNTING BRACKET

1. Remove the rear cover.
2. Remove the carriage from between the rails.
3. Disconnect the tab operating link.
4. Disconnect the tab-lever spring and escapement pawl spring.
5. Remove the margin-control bellcrank.
6. Remove the line-lock operating-lever.
7. Block the carriage to prevent movement when the tab-lever mounting-bracket is removed.
8. Remove three screws that secure the tab-lever mounting-bracket to the rear rail and remove the bracket.

Replacement may be accomplished by reversing the above procedure. The escapement pawl and pawl spacer must be in front of the escapement trip-lever. Care must also be exercised in replacing the mounting screws as their shoulder depths vary. Improper reassembly may result in binds in the pawl-release bellcrank and intermediate-pawl-release lever.

CAM

Refer to Spacebar cam removal, in this section of the manual.

Adjustments

1. **CAM CLEARANCE.** Refer to Model C1, Spacebar, Adjustment 1.

2. **CAM RELEASE LINK.** Adjust so that the cam is tripped when the keylever is depressed from $\frac{1}{2}$ to $\frac{3}{4}$ of its downward travel.

3. **MARGIN CONTROL LEVER ECCENTRIC.** Refer to Model C1, Margin Release, Adjustment 1.

4. **TAB RACK.** The tab rack must be carefully adjusted to satisfy three conditions.

A. LEFT TO RIGHT. The tab rack should be adjusted left or right so that there is a clearance of $.015'' \pm .002''$ between the working surfaces of the escapement pawl and an escapement rack tooth when the tab-check lever is in its extreme left position (Figure 21).

(1) Depress the tab cam with the power OFF and rotate the power roll by hand until the tab cam is near its high point.

(2) Allow the carriage to move to the left so that a set tab stop positions the tab-check lever to its extreme left position.

(3) Observe the clearance between the working surfaces of the escapement pawl and the escapement-rack tooth.

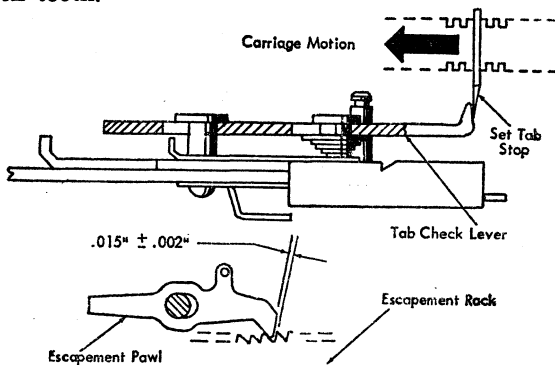

Figure 21. Tab Rack Adjustment, 4A

B. PARALLEL TO RAILS. Position the right end of the tab rack in its elongated mounting slot so that the rack is parallel to the carriage rails. This may be

checked by observing that the tab-check lever takes an equal bite on all set tab stops.

C. PARALLEL TO TAB CHECK LEVER. Position the tab rack about its axis so that the front face of a set tab stop is parallel to the tip of the tab-check lever (Figure 22).

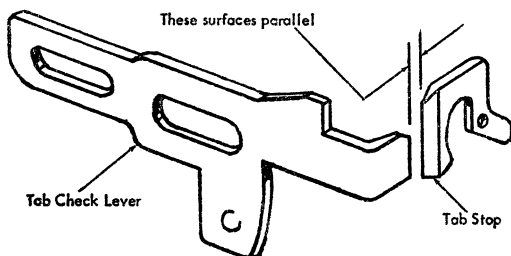

Figure 22. Tab Rack Adjustment, 4C

NOTE: Caution must be used in tightening the tab-rack mounting-nuts so as not to spring the carriage end-plates.

5. TAB LATCH. Adjust by positioning the eccentric mounting-stud so that the tab-check lever engages $\frac{1}{2}$ to $\frac{2}{3}$ of the exposed surface of a set tab stop when the tab lever is latched. The high side of the eccentric must be kept in the left half of its orbit (Figure 23).

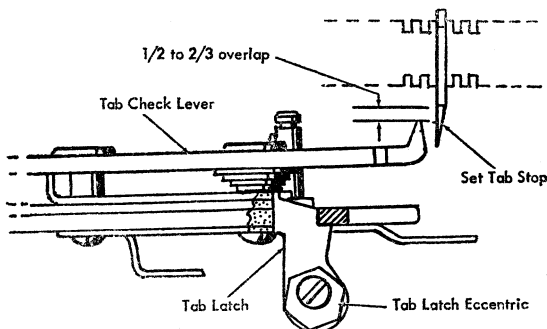

Figure 23. Tab Latch Adjustment

6. TAB-LATCH. Form the tab-latch, at the point of contact with the tab check-lever, so the tab unlatches when the tab check-lever is .040" to .045" from its full left-hand position (Figure 24.)

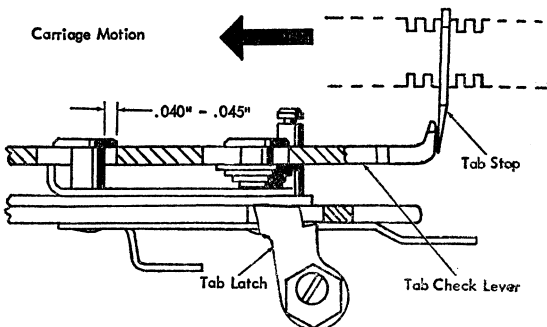

Figure 24. Tab Latch Adjustment

7. TAB CHECK-LEVER KEEPER. Position the tab check-lever keeper on the rear rail, left to right, so there is a clearance of .010" to .025" between the working surfaces of the tab check-lever and a tab stop when the parts are at rest (Figure 25). Position the keeper, front to rear, so that there is a clearance of .003" to .010" between the tab check-lever and the keeper with the tab lever latched to the rear (Figure 26.)

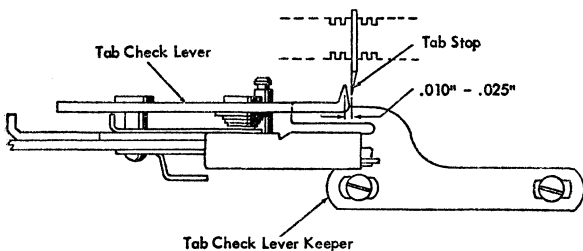

Figure 25. Tab Check Lever Adjustment

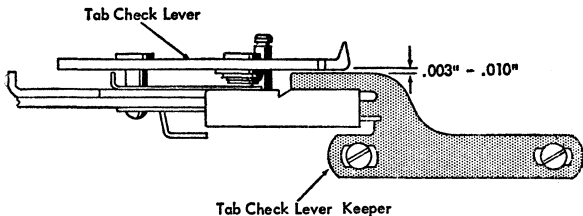

Figure 26. Tab Check Lever Adjustment

8. OPERATING LINK. Adjust the length of the link so there is a clearance of .015" to .020", between the contact surfaces of the tab latch and the tab lever, when the cam is on its high point (Figure 27).

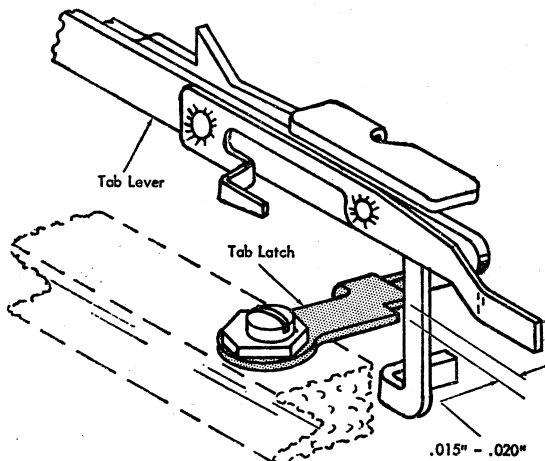

Figure 27. Operating Link Adjustment

9. TAB-LEVER EXTENSION. With the cam on its high point there should be a clearance of .001" to .005" between the overthrow stop on the tab check-lever keeper and the tab-lever extension. Obtain this clearance by forming the tab-lever extension.

10. PAWL RELEASE LEVER. Form the rear upright-lug so the escapement pawl clears the escapement rack by .010" to .020".

11. DECELERATOR LINK. Adjust the length of this link to obtain the maximum cushioning of the carriage without interfering with tabulation (Figure 19).

12. CENTRIFUGAL GOVERNOR. Refer to Model B1, Tabulation, Adjustment 10a.

13. TAB SET AND TAB CLEAR. Refer to Model B1, Tabulation, Adjustments 11, 12, 13, and 14.

BACKSPACE

The backspace mechanism is the same as on the Model B1. Refer to that section of this manual for Removal and Adjustment procedures.

CARRIAGE RETURN

The carriage return mechanism has been modified to permit the decelerator to replace the air cylinder. The clutch latch has been modified to provide a more positive latching and unlatching action (Figure 28).

Release of the carriage-return cam pulls the clutch lever forward causing the clutch to engage and develop a pull on the carriage-return tape. The line-space and pawl release operations remain the same as on the Model B1.

As the carriage approaches the left margin the margin stop picks up the margin-control lever. This

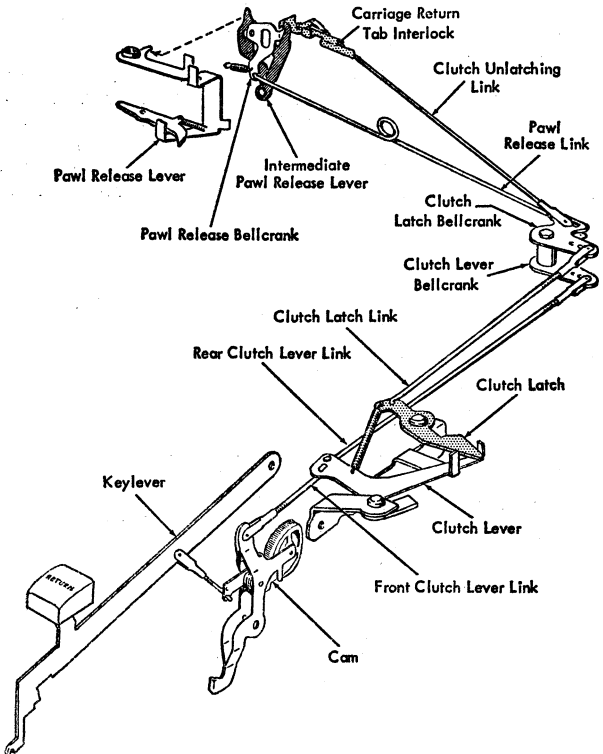

Figure 28. Carriage Return

pivots the margin-control bellcrank which performs three actions:

1. Allows the escapement pawl to restore by unlatching the intermediate-pawl-release lever from the pawl-release bellcrank.
2. Unlatches the clutch by rotating the carriage-return-tab interlock.
3. Cushions the shock of carriage return by operating the centrifugal-governor through the carriage-return-decelerator bellcrank. (Refer to Decelerator section of this manual).

Removal

Refer to Model B1 section.

Adjustments

1. **CAM CLEARANCE.** Refer to Model C1, Spacer-bar, Adjustment 1.
2. **CAM-RELEASE LINK.** Adjust so that the cam is released when the keylever is depressed from $\frac{3}{4}$ to full normal travel. This will allow the cam to repeat when the plunger has been depressed $\frac{1}{8}$ ".
3. **FRONT CLUTCH-LEVER LINK.** Adjust so that there is a clearance of .010" to .030" between the con-

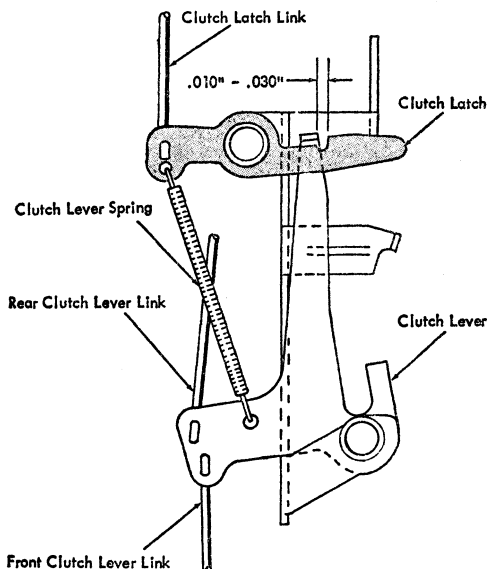

Figure 29. Front Clutch Lever Link Adjustment

tact surfaces of the clutch lever and the clutch latch when the cam is on its high point (Figure 29).

4. REAR CLUTCH-LEVER LINK. Position the clevis in the center hole of the bell-crank and adjust so with the clutch unlatched the elongated hole in the bellcrank is parallel to the rear rail.

5. CLUTCH LATCH LINK. Place in the center hole of the bellcrank and adjust so the slot in the clutch-latch bellcrank is in line with the hole in the carriage-return-tab interlock when the clutch is latched.

6. CLUTCH UNLATCHING LINK. Adjust the link so the clutch unlatches during the last .100" to .050" of the carriage travel. Latch the clutch and return the carriage by hand to observe this condition.

7. PAWL RELEASE LINK. Refer to Model B1, Carriage Return, Adjustment 16.

8. MARGIN-CONTROL-BELLCRANK STOP. Position the eccentric stop to permit maximum move-

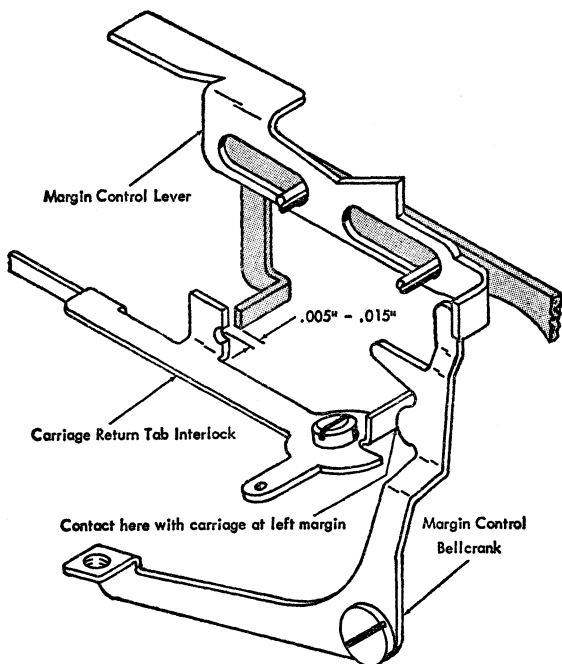

Figure 30. Carriage Return Tab Interlock Adjustment

ment of the margin-control lever without interfering with the linelock operating-lever.

9. INTERMEDIATE PAWL-RELEASE LEVER. Form the upright lug so the intermediate pawl-release lever touches the margin-control bellcrank and the pawl-release bellcrank when the carriage is 1 to 2 spaces from the left-hand margin.

10. CARRIAGE-RETURN-TAB INTERLOCK. Adjust the interlock as follows:

A. Disconnect the clutch unlatching link.

B. With the carriage at the left margin form the interlock so it clears the tab-lever lug by $.005''$ to $.015''$ when the left-hand lug of the interlock contacts the margin-control bellcrank (Figure 30).

11. CLUTCH PLATE CLEARANCE. Refer to Model B1, Carriage Return, Adjustment 18.

12. COMPRESSION SPRING. Adjust so the carriage will return to the left margin, from any position along the writing line, with the variable linespace lever to the rear.

13. MARGIN-CONTROL-LEVER DECELERATOR-SCREW. Adjust the screw so the carriage comes to rest with a minimum of shock. Lower the screw to increase the decelerator action (Figure 18).

14. OVERBANK. Move the carriage from left to right and observe that the escapement pawl drops over an escapement-rack tooth when the margin-control lever is from $.010''$ to $.015''$ from its full right position (Figure 31).

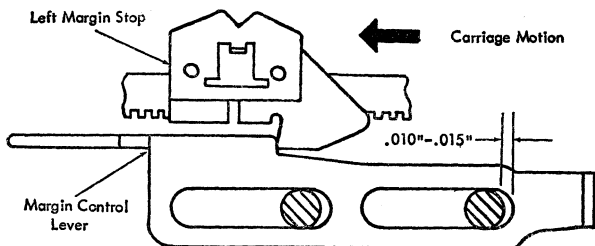

Figure 31. Overbank Adjustment

SHIFT

The shift mechanism has been improved operationally and to simplify adjustment. The equal pin-clearance adjustment has been relocated on the shift toggle assembly to simplify adjustment and minimize binding of the shaft assembly. Eccentric studs mount

the segment to the type basket and aid in establishing "even top and bottom" during manufacture without upsetting the pin clearance (Figure 32).

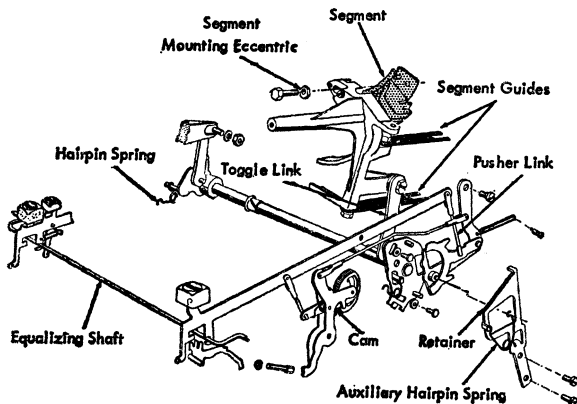

Figure 32. Shift Mechanism

Removal

PUSHER AND LEVERS ASSEMBLY

1. Remove the auxiliary hairpin-spring.
2. Remove the retainer mounting-screws and the retainer.
3. Disconnect the operating link at the rear.
4. Unhook the shift-pusher link at the keylever.
5. Disconnect the shift-pusher-lever spring.
6. Remove the shoulder screw and the pusher-and-levers assembly through the right side-frame.

Adjustments

Ring and cylinder must be properly adjusted before making any adjustments to the shift mechanism.

1. **CAM CLEARANCE.** Refer to Model B1, Shift Mechanism, Adjustment 3.
2. **CAM RELEASE LINK.** Refer to Model B1, Shift Mechanism, Adjustment 4.
3. **EVEN TOP-AND-BOTTOM.** Refer to Model B1, Shift Mechanism Adjustment 1.

NOTE: The eccentric segment-mountings may be used to adjust for even top and bottom. Care must be used to insure that the segment is not tilted.

4. **MOTION.** Refer to Model B1, Shift Mechanism, Adjustment 2.

5. EQUAL PIN-CLEARANCE. Loosen the adjusting screws and position the shift-pin toggle-plate so that the clearance between the upper and lower pins and their respective pusher arms are equal (Figure 33).

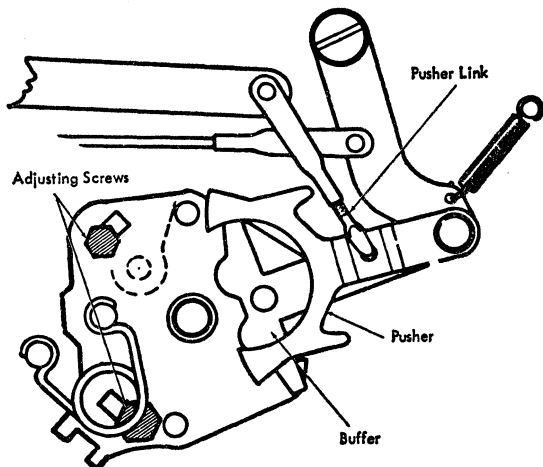

Figure 33. Pin Clearance Adjustments

6. PUSHER LINK. Refer to Model B1, Shift Mechanism, Adjustment 6.

7. OPERATING LINK. Refer to Model B1, Shift Mechanism, Adjustment 7.

8. SHIFT-LOCK BRACKET. Refer to Model B1, Shift Mechanism, Adjustment 8.

RIBBON MECHANISM - CARBON RIBBON

The Model C carbon ribbon mechanism is completely contained within the case of the typewriter and has been redesigned to provide easier threading and more accurate feeding.

It is not possible to accommodate both the fabric ribbon and carbon-paper ribbon mechanisms on the same machine simultaneously. If a change of ribbon type is desired the original mechanism must be removed and the alternate device installed.

The letter cams operate the ribbon-lift bail which accomplishes ribbon lift and trips the ribbon cam. The cam activates the ribbon-feed link and drives the pressure rollers as on the Model B.

The supply spool is held on an inclined plate mounted to the right side-frame (Figure 34). Ribbon

quantity is indicated by a lever mounted on the switch-lever stud and visible through the switch-indicator window. The indicator is controlled by a follower that contacts the ribbon spool.

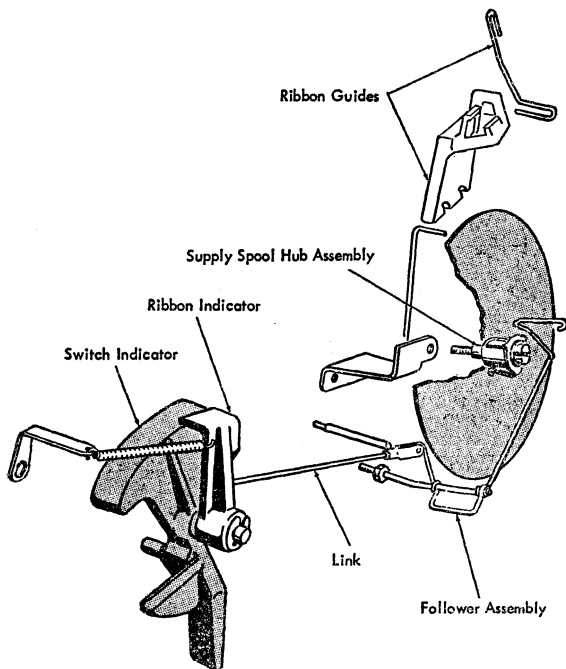

Figure 34. Carbon Ribbon Supply

Mounted to a bracket on the left-side-frame are the take-up spool assembly and the feed mechanism (Figure 35). The bracket is inclined for easier removal of the used ribbon. Take-up action is accomplished through a friction drive-gear attached to the power-roll pulley and engaging gear teeth on the inside flange of the take-up spool.

The take-up spool fits into a slot in the feed bracket so hinged that the gears may be disengaged and the spool removed. The two halves of the spool pull apart for removal of the used ribbon. A spring latch locks the bracket in the closed position and releases it whenever the release lever is operated to disengage the pressure rollers.

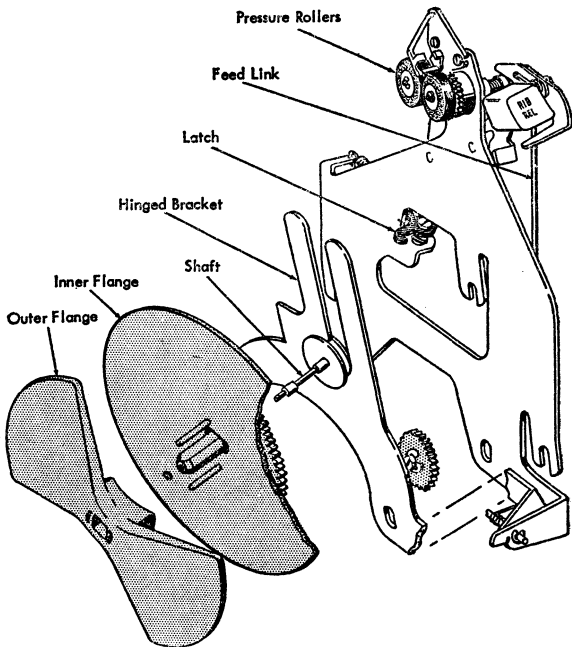

Figure 35. Carbon Ribbon Take Up
Installing the Ribbon

To install a ribbon on the new carbon-ribbon mechanism:

1. Push the ribbon-release button to the rear, opening the pressure rollers and unlatching the take-up spool.
2. Slide the take-up spool up and out of its mounting bracket.
3. Separate the two halves of the ribbon spool and discard the used ribbon.
4. Replace the re-assembled ribbon take-up spool and latch the mounting bracket.
5. Place a full spool of ribbon on the right mounting plate with the inked side of the ribbon toward you as it comes off of the spool.
6. Thread the ribbon through the right corner-guide, center lift-guide, left corner-guide, pressure guide and onto the take-up spool.
7. Push the ribbon-release button up, re-engaging the pressure rollers.

Adjustments

1. **CAM CLEARANCE.** Refer to Model B1, Ribbon, Adjustment 1.
2. **CAM RELEASE LINK.** Refer to Model B1, Ribbon, Adjustment 2.
3. **OPERATING LINK.** Refer to Model B1, Ribbon, Adjustment 3.
4. **FEED LINK.** Adjust the feed link to feed sufficient ribbon to accommodate the largest character without overlap.
5. **INDICATOR LINK.** Adjust the link so the ribbon indicator is fully visible when the ribbon spool is empty.
6. **REWIND MOUNTING PLATE.** Position the plate to insure positive engagement of the take-up spool gear teeth with the friction drive-gear on the power-roll pulley.

RIBBON MECHANISM - FABRIC

The fabric ribbon mechanism provides cleaner and faster ribbon changing, and positive ribbon feed. A rapid rewind feature enables the operator to wind the used ribbon onto the left spool, ready for changing, by depressing a key-button to the left of the ribbon-control button. An interlock system automatically reverses the direction of feed onto the left

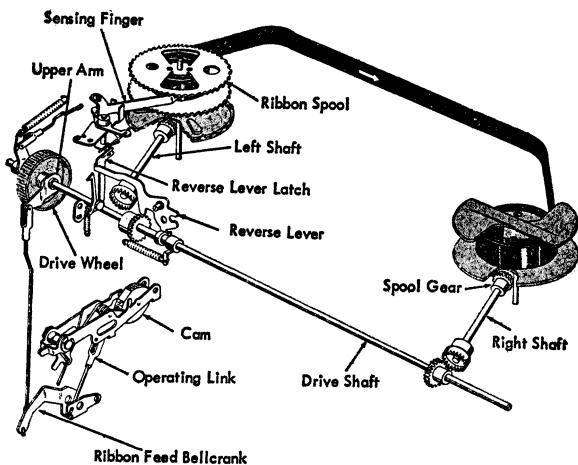

Figure 36. Ribbon Feed, Right Spool Driving

spool, if necessary, and stops the mechanism when the ribbon is rewound.

Operation

The ribbon-lift mechanism and the method of tripping the ribbon cam through the action of the ribbon-lift vane remain the same as on the Model B1.

An operating link from the ribbon cam connects to a bellcrank which in turn operates the ribbon feed-link and upper-arm assembly (Figure 36). Rotation of the upper arm causes the inside spring-clutch to tighten about a hub on the plastic drive-wheel, rotating the wheel and the drive shaft to which it is connected. Gears connected to the drive shaft transfer this rotation to the ribbon spools. The lateral position of the shaft controls which gears will be engaged and which ribbon spool will feed.

Ribbon reverse takes place as follows: As the left ribbon spool empties the sensing finger engages a notch in the spool, rotating the sensing finger cam (Figure 37). This forces the unlatching lever to the rear and develops a pull on the wire link connected to the reverse-lever latch, unlatching the reverse lever. Unlatching the reverse lever allows it to rotate clockwise about its mounting and position the

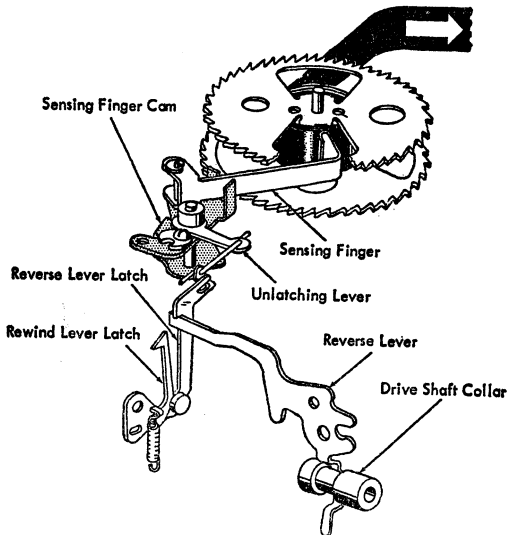

Figure 37. Ribbon Reverse, Left Spool Empty

drive shaft so the left spool is in the feeding position and the right spool is free to rotate.

To insure positive operation with various ribbon spools the sensing finger may also be forced to the left by the rotation of the empty ribbon spool. The resulting counterclockwise rotation of the sensing finger cam insures that the wire link will unlatch the reverse lever.

As the right spool empties, its sensing finger engages a notch in the right-hand ribbon spool allowing the sensing-finger shaft to rotate and position a pawl between teeth of the drive-shaft primary-cam (Figure 38). As the drive shaft rotates the secondary cam, pinned to the drive shaft, climbs the high points of the now stationary primary cam. This pulls the drive shaft to the right and engages the right gears in feeding position. This movement of the shaft is also transferred to the reverse-lever, latching it under the reverse-lever latch, so as to maintain this condition.

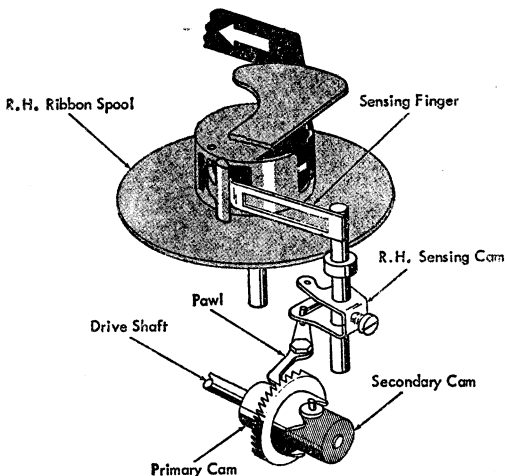

Figure 38. Ribbon Reverse, Right Spool Empty

Rapid rewind of the ribbon takes place as follows: Depressing the ribbon rewind keybutton raises the button link (Figure 39). A formed lug on the rear of the button link raises the button latch and causes the rewind lever, part of the same assembly, to pivot clockwise about its mounting. As the left end of the

rewind lever assembly raises, it carries the rewind-lever latch upward. This results in pivoting the reverse-lever latch to its unlatched position and allows the reverse lever to pivot clockwise about its mounting. This action moves the drive shaft to the left and insures that the left-hand spool will be feeding.

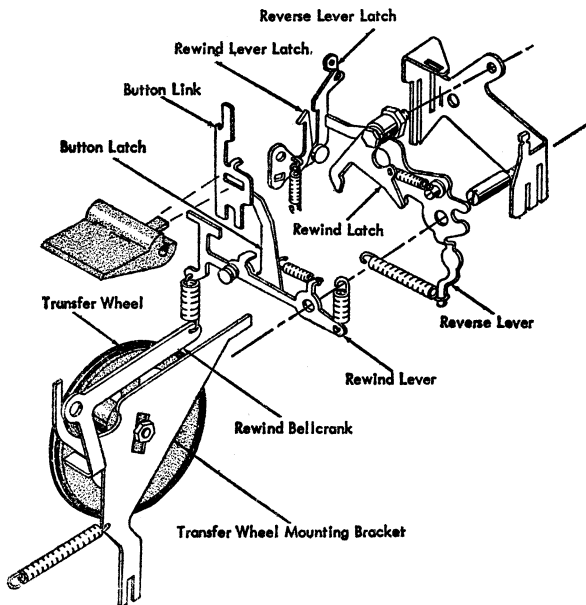

Figure 39. Rapid Ribbon Rewind

Adjustments

The ribbon mechanism will, when properly adjusted, provide positive ribbon feed in either direction and reverse dependably at either end.

1. LEFT - HAND AND RIGHT - HAND DRIVE SHAFT MOUNTING BRACKETS. Position the brackets on the keylever-bearing support so there is .002" to .005" play between the ribbon spools and their drive gears.

2. SPOOL GEARS. Position the spool gears on the left-hand and right-hand drive shafts for minimum backlash without binding (Figure 36).

3. LEFT-HAND SENSING CAM. Position the left-hand sensing cam vertically on its shaft so the sensing

finger is centered between the ribbon-spool flanges (Figure 37).

4. RIBBON CORNER GUIDES. Adjust so the ribbon feeds off each ribbon spool without touching either ribbon spool flange.

5. COVER INTERLOCK LINK. A cover interlock, linked to the left-hand sensing cam, permits the sensing finger to clear the left-hand ribbon spool when the front cover is open. Adjust the link to permit the sensing finger to clear the spool with the front cover open. The link must not prevent the sensing finger from bottoming in the slot in the empty ribbon spool.

6. CAM CLEARANCE. Refer to Model B1, Ribbon, Adjustment 1.

7. CAM RELEASE LINK. Refer to Model B1, Ribbon, Adjustment 2.

8. CAM LINK. Refer to Model B1, Ribbon, Adjustment 3.

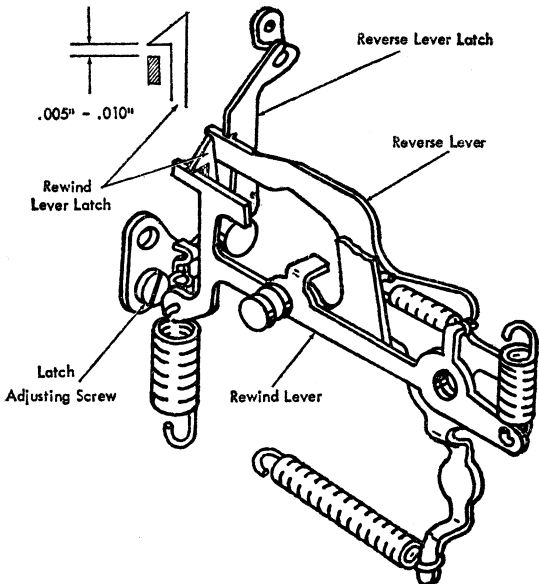

Figure 40. Rewind Lever Latch

9. RIBBON FEED LINK. Adjust the link to provide one revolution of the ribbon spool for 32 ± 4 cam operations.

10. REWIND LEVER LATCH. With the reverse lever latched down, position the rewind latch vertically by moving its mounting plate. There should be a clearance of .005" to .010" between the rewind lever and the rewind-lever latch (Figure 40).

11. DRIVE SHAFT. With the reverse lever unlatched, position the drive shaft to the left so there is a clearance of $\frac{3}{16}$ " between the C clip on the shaft and the left-hand bushing in the keylever bearing-support (Figure 41). Set the nylon primary cam against the keylever bearing-support and tighten the set screw in the secondary cam.

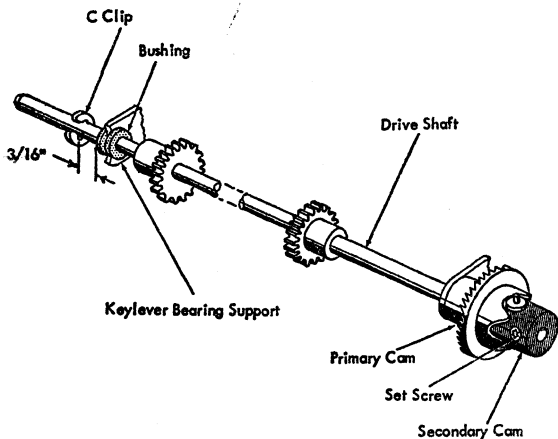

Figure 41. Drive Shaft Adjustment

12. DRIVE SHAFT COLLAR. With the reverse-lever latched move the drive shaft to the right until there is a clearance of $\frac{1}{8}'' + \frac{1}{64}'' - 0$ between the key-lever bearing support and the primary cam (Figure 42). Move the drive-shaft collar to the right until the left flange of the collar contacts the reverse lever.

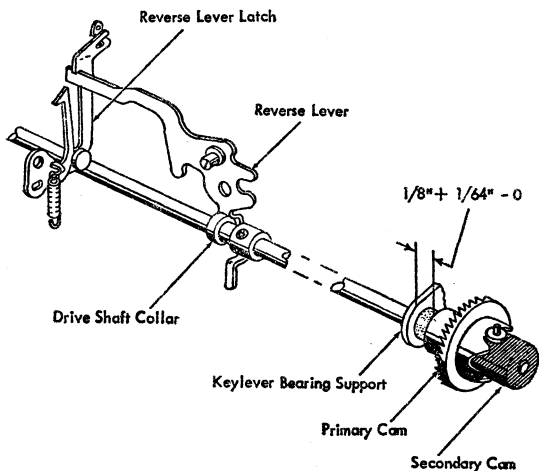

Figure 42. Drive Shaft Collar Adjustment

13. REVERSE - LEVER ECCENTRIC - STOP. With the reverse lever unlatched adjust the eccentric stop until the primary cam clears the keylever bearing-support by $.006'' \pm .002''$ (Figure 43).

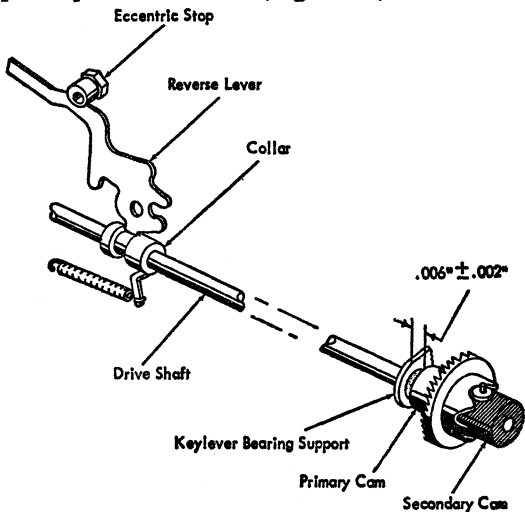

Figure 43. Reverse Lever Eccentric Stop

14. REVERSE LEVER STUD. To insure winding the ribbon fully onto the left ribbon spool during rapid rewind, the rewind lever must not be released from its raised position before the reverse lever is latched (Figure 44). Position the stud on the reverse lever to release the rewind latch from the rewind lever, when the reverse lever has moved counter clockwise past its latch .005" to .008".

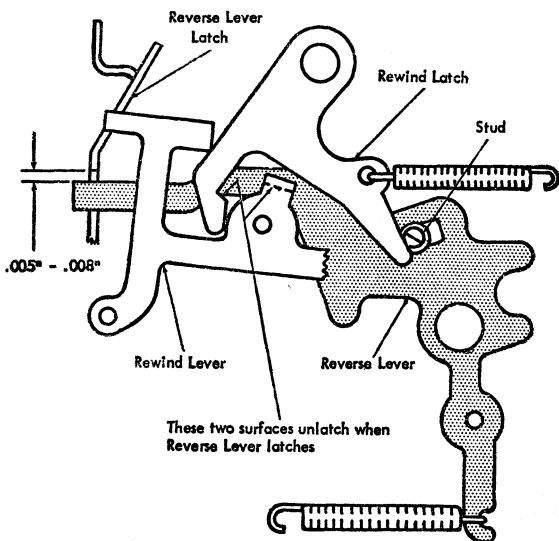

Figure 44. Reverse Lever Stud

15. BUTTON-LATCH LUG. Latch the reverse lever and hold the drive shaft to prevent movement. Form the button-latch lug so the button latch cams off of the button link when the button link is raised to a point $\frac{1}{16}$ " from its upper limit of travel (Figure 45).

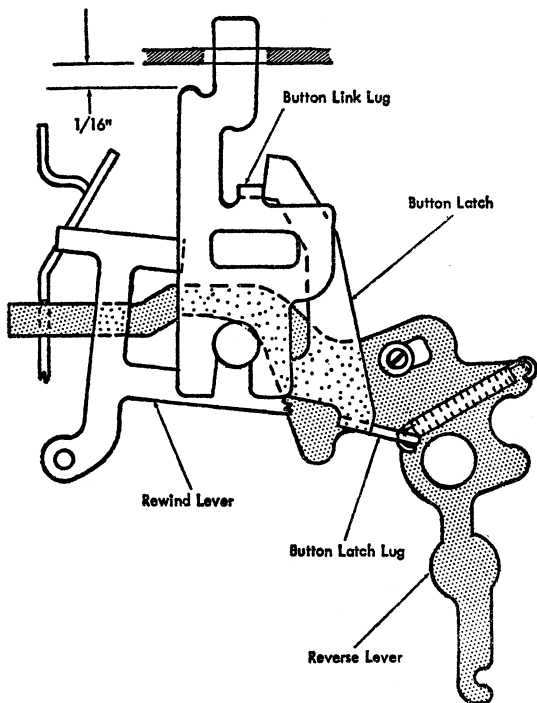

Figure 45. Button Latch Lug Adjustment

16. RIGHT REVERSING CAM. With the reverse lever unlatched and the right sensing finger bottomed in the right ribbon-spool notch, position the right-hand cam on the sensing finger shaft so the reversing pawl bottoms between the teeth on the primary cam (Figure 38). The sensing finger should be located vertically to center between the ribbon spool flanges.

17. LEFT REVERSING ECCENTRIC. With the reverse lever latched and the left sensing finger resting against the ribbon spool hub, position the eccentric washer to just contact the unlatching lever (Figure 37).

18. DRIVE SHAFT GEARS. With the reverse lever latched adjust the right gear for maximum engagement without binding. Unlatch the reverse lever and

adjust the left gear for maximum engagement without binding. Care must be taken to insure that only one of set gears is engaged at a given time.

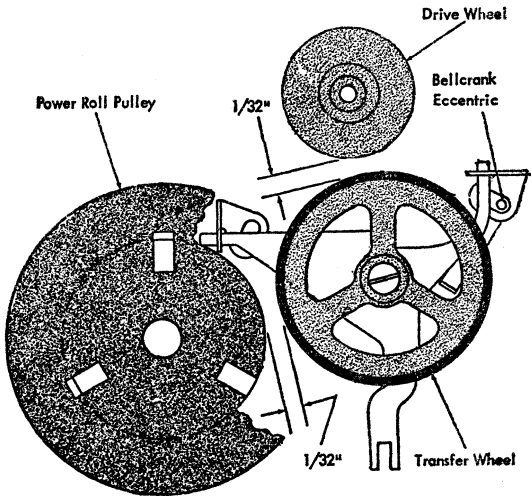

Figure 46. Transfer Wheel Adjustment

19. TRANSFER WHEEL. With the rewind lever latched down adjust the transfer wheel, by positioning its mounting, so it clears the drive wheel by $\frac{1}{32}$ " (Figure 46).

20. TRANSFER WHEEL BELLCRANK. With the rewind lever latched position the bellcrank-eccentric mounting-stud so that the transfer wheel clears the flange on the power roll pulley by $\frac{1}{32}$ " (Figure 46).
NOTE: Adjustments 19 and 20 should be considered together to insure that the transfer wheel contacts the drive-shaft wheel and the flange on the power-roll pulley when the rewind lever is $\frac{1}{16}$ " from its latched position.

Ribbon Lift Adjustments

Refer to Model B1, Ribbon Lift, Adjustments 1 through 5.

SHIFTING OFF CYLINDER IN UPPER CASE

For more even color and impression between upper and lower case characters, the amount of "shifting off cylinder" in upper case may require adjustment. Some type styles require a different amount of shifting off from other type styles. These exceptions are listed in the following chart.

The amount of shifting off may be increased by adding shims under the front or by removing shims from under the rear of the upper segment guide springs.

Shifting off may be checked by testing the difference in ring and cylinder between upper and lower case characters by using a strip of .003" paper as a feeler gauge between the platen and typebar when checking the lower case and additional strips when checking the upper case.

SHIFT OFF SPECIFICATIONS

Type Style	Type Mark	Shift Off Inches	
		Fabric Ribbon	Carbon Ribbon
Standard Styles	-	.001-.006	.004-.007
Executive Styles	-	.005-.008	.006-.010
Bookface Academic	BA	.004-.007	.006-.010
Pica Inverted	PI	.004-.007	.006-.010
Pica Gothic Inverted	HI	.004-.007	.006-.010
Diplomat	B2	.004-.007	.006-.010
Elite Gothic DC	F	.001-.006	.006-.010
Regent Gothic	RG	.001-.006	.006-.010
Large Bookface	LB	.001-.006	.006-.010
Prestige Elite	SE	.001-.006	.006-.010
Prestige Pica	SP	.001-.006	.006-.010
Boldface #1	PO	.005-.008	.007-.012



E.T. Manual

November 9, 1960

SUBJECT: Modified Fabric Ribbon Mechanism

PURPOSE: To announce a new Fabric Ribbon Mechanism.

INFORMATION: Current production Standard Model C ET's with fabric ribbon are equipped with a modified ribbon mechanism. It features simplified adjustments, more positive operation, and fewer parts. It also permits the operator to stop rewind by lifting the rewind button. The former style bearing support and ribbon feed assembly (P/N 1118354) will no longer be available. Individual parts for former style ribbon feed assembly will be available for replacement purposes. If the former style assembly must be replaced, it will be necessary to order B/M 1271389 (Modified Ribbon Feed).

Listed below are the adjustments for the modified ribbon mechanism:

Cam Clearance. Adjust so the release lever falls on the rear half of the cam lug when the cam is tripped with the power off.

Release Link. Adjust to trip the cam when any typebar is $3/4'' \pm 1/8''$ from the platen.

Operating Link. Adjust so the feed bellcrank arm rests $5/16'' \pm 1/32''$ from the frame (Figure 9).

Left and Right Drive Plates. Adjust the grip clip so there is $.002''$ to $.005''$ vertical end play (Figure 1).

CENTERED BETWEEN
SPOOL FLANGES

MINIMUM GEAR LASH,
BUT FREE AND SMOOTH
OPERATION FOR 360
DEGREE ROTATION

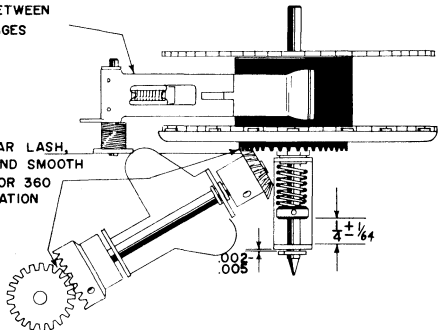

Figure 1

Left and Right Tension Springs. Adjust the retaining collars so they are approximately 1/4" from the mounting bracket. Be sure there is equal tension on both sides (Figure 1).

Spool Gears. Adjust the mounting brackets for minimum backlash but smooth operation for 360° (Figure 1).

Left Sensing Finger. There are two adjustments for the sensing finger. 1. Form the sensing finger so it centers between the spool flanges. 2. The sensing finger extension should be formed so that it unlatches the reverse lever when the tip of the sensing finger is 1/8" ± 1/16" from the spool shaft (Fig 1 & 2).

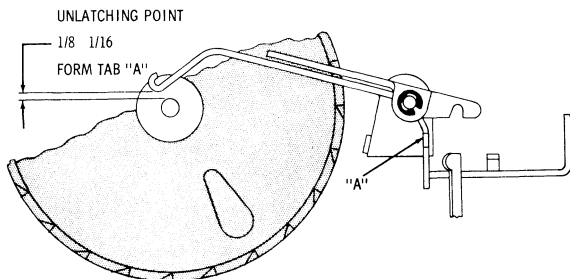

Figure 2

Drive and Check Clutches. Adjust for minimum lost motion without binds.

Primary Secondary Cam Assembly. Position on its shaft so when the secondary cam is on its high point there is no remaining "left-to-right" motion of the drive shaft. Do not spring the bearing support (Figure 3).

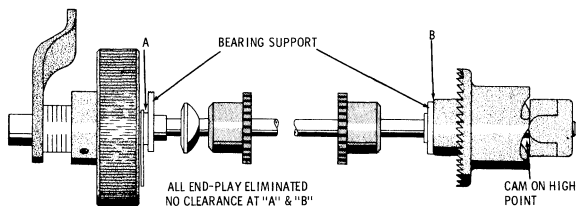

Figure 3

Drive Shaft Collar. With the reverse lever unlatched, adjust the collar so there is .002" to .005" clearance between the primary cam and keylever bearing support. Check both lobes (Fig 4).

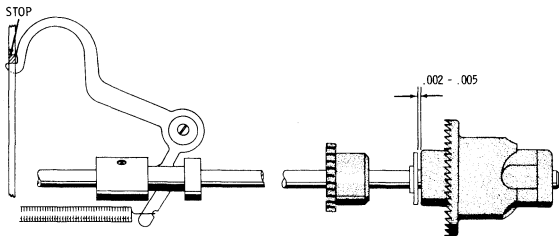

Figure 4

Drive Gears. Adjust the drive gears so when in a meshed position (Figure 5) the inside edge of the drive gear extends $.030''$ to $.040''$ away from the driven gear.

Driven Gears. Adjust the driven gears for minimum backlash but smooth operation for 360° .

Button Latch. Adjust left or right so the button unlatches when the left drive gear is $.005''$ to $.015''$ to the right of the driven gear (Figure 6).

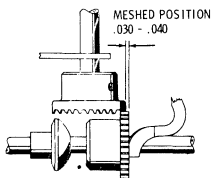

Figure 5

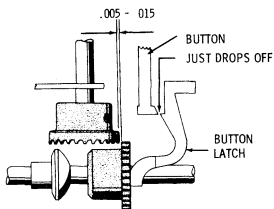

Figure 6

Right Sensing Cam. Adjust so when the sensing finger is bottomed in the spool notch the reversing pawl is bottomed in the teeth of the primary cam. Also center the sensing finger between the spool flanges.

Cone Follower. With the reverse lever unlatched and the side play in the cone follower held to the right, the follower should clear the right edge of the cone collar by $.010''$ to $.015''$ (Figure 7).

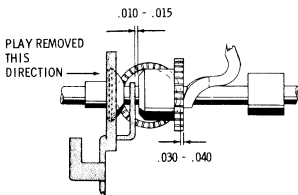

Figure 7

Upper Extension of Cone Follower. With the rewind button latched and the cone follower held in contact with the smallest diameter of the cone, form the upper extension so there is .001" to .005" clearance between the button extension and cone follower extension (Figure 8).

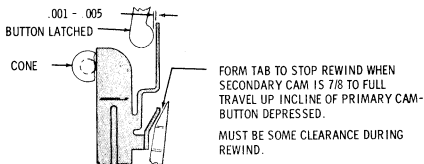

Figure 8

Side Extension of Cone Follower. Form the side extension of the cone follower so when the rewind button is held depressed at the end of a rewind cycle, the secondary cam will travel 7/8 to full travel up the incline of the primary cam. During rewind there should be clearance between the side extension and tip of the transfer wheel bracket (Figure 8). Note: Flicking the rewind button may cause the RH secondary cam to over-ride the primary cam occasionally.

Transfer Wheel Mounting Bracket. Form the lower stop so the transfer wheel clears the power roll pulley flange by .005" to .015" when at rest (Figure 9). There must be a clearance between the transfer wheel and the drive wheel.

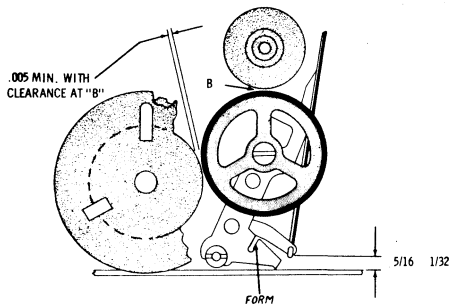

Figure 9

Cover Interlock Link. Form so the interlock lever clears the sensing finger extension when the cover is closed and the sensing finger tip is resting against the spool shaft.

Color Control Button. Adjust to be in line with the rewind button when in the center lift position.

NOTE: In order to rewind the ribbon to the right the following steps should be followed:

With the machine on and the left drive gear engaging the left driven gear, move the drive shaft to the right by pushing on the left end of the shaft until the right drive gear just contacts the right driven gear. While holding the shaft in this position, depress the rewind button. This will give you the desired rapid rewind to the right.

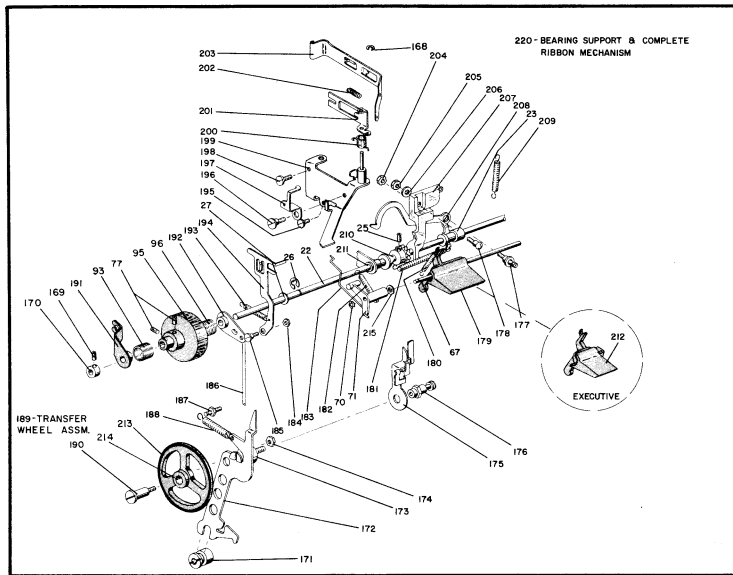

Ref	Part No.	Price	Description	Ref	Part No.	Price	Description	Ref	Part No.	Price	Description
22	1118270	.90	Shaft	183	1116195	.75	Link	210	1116106	.95	Hub & gear assm
23	1118292	.35	Collar	184	1090268	.05	Nut	211	1118253	.05	Bushing
25	1077919	.15	Screw, bristo	185	1110241	.10	Screw	212			Button, tan exec
26	264641	.05	C clip	186	1116135	.25	Link				Button, blue exec
27	1090394	.05	Washer	187	1117426	.05	Stud	213	1116164	.30	Tire
67	1118332	.50	Shaft	188	43373	.15	Spring	214	1116112	.60	Wheel, rapid rewind
70	219633	.01	Clip	189	1116148	.90	Wheel assembly	215	1090657	.05	Washer
71	1118331	.20	Lever, interlock	190	1116191	.75	Stud	220	1116379	30.00	Bearing support and complete ribbon mechanism
77	1077919	.15	Screw	191	1118353	.85	Arm				F.I. B/M modified fabric ribbon feed
93	1118296	.60	Clutch spring	192	1118274	.80	Lever				
96	1118295	.25	Clutch spring	193	1071687	.15	Spring	1271389	35.00		
168	219633	.01	Clip	194	1116341	1.00	Latch				
169	1078469	.15	Screw	195	196298	.01	Screw				
170	1063797	.35	Collar	196	1116391	.10	Screw				
171	1116189	.35	Nut	197	1116197	.55	Lever				
172	1116190	1.50	Bracket	198	196298	.01	Screw				
173	1116188	.40	Screw	199	1116124	1.00	Bracket				
174	38051	.04	Nut	200	1116146	.25	Spring				
175	1116111	.55	Lever	201	1116161	.65	Sensing finger				
176	1116125	1.05	Stud	202	1116102	.15	Spring				
177	1116340	.15	Screw	203	1116116	.50	Sensing finger				
178	1116375	.05	Screw	204	1090268	.05	Nut				
179	1116099	.55	Button, tan std	205	7341	.01	Nut				
	1116100	.55	Button, blue std	206	1090394	.05	Washer				
180	1090794	.15	Spring	207	1116163	.75	Lever				
181	1116343	.25	Spring	208			Lever				
182	1090435	.15	Spring	209	1091073	.15	Spring				

Parts not shown are listed under Model C Standard Fabric Ribbon Mechanism in the 1960 Parts Manual

NOTE: Part Numbers for Reference Numbers 208 and 212 will be provided when available.

CEM 550, page 8

ORDER:

All component parts of B/M 1271389 are available in EPC's.

B/M 1271389 is not available in EPC's. Order B/M 1271389 and P/N 1116379 on P & S Requisition from Lexington Plant.

RECORDS:

Substitution Data:

1118354 (Bearing support and ribbon feed assembly) is now obsolete. For replacement purposes order 1271389 (F.I. B/M - Modified Fabric Ribbon Feed).

B/M 1271009 is no longer available. Use present stock until depleted.

Parts Manual Changes:

Delete 1118354 (page 17) and 1271009 (page 18), Model C Section, 1960 Parts Manual.

Add 1116127 (Bearing support keylever - modified ribbon) to page 25, Model C Section, 1960 Parts Manual.

File: Under "Ribbon" index tab after CEM 549.

NOTE: Each Customer Engineer should receive two copies of this memo. One is for the CEM book and one to be kept in the Service Case.



ELECTRIC TYPEWRITERS MODELS 4 AND 5

Executive

CUSTOMER ENGINEERING REFERENCE MANUAL

CONTENTS

	<i>Page</i>
Principles Common to Standard Model	3
Selector Mechanism Adjustments	3
Expander	6
Space Bars	9
Back Space	10
Rotary Back Space	12
Grouping Adjustments	14
Tabulation	17
Carriage Return	19
Repeat Line Spacing	21
Carbon Ribbon Feed	21
Proportional Carbon Ribbon Feed	23
Line Gage Card Holder	24
IBM Type Styles	25
Unit Width Chart	26

INTERNATIONAL BUSINESS MACHINES CORP.

NEW YORK 22, NEW YORK

Form 25-6016-0 (this section only)



Copyright 1953 by
International Business Machines Corporation
590 Madison Avenue, New York 22, N. Y.
Printed in U. S. A. ,September, 1953
Form 25-6016-0

Faint text at the bottom of the page, possibly a footer or additional copyright information.

IBM ELECTRIC EXECUTIVE TYPEWRITER

Models 4 and 5

PRINCIPLES COMMON TO STANDARD MODEL

Several features of the Electric Executive Typewriter are common to the Standard model and will not be repeated in this section. These features include:

Motor	Margin Set
Belt Drive	Repeating Cams
Power Roll	Type Guide
Key Levers	Shift Mechanism
Key Buttons	Paper Feed
Margin Release	Clutch Pulley Spring
Cloth Ribbon Feed	

SELECTOR MECHANISM ADJUSTMENTS

SHIFT MOTION. Check for proper adjustment. Any change in shift motion adjustment produces a corresponding change in the bail shaft link adjustment.

THE BAIL SHAFT LINK should be adjusted so that the bail mounting plates will move to their upper extreme (upper case) and not bind off on the bail control shaft (Figure 1). When the mounting plates are in the lower extreme (lower case) they should not bind off on the bail mounting plate guide pins.

THE SUPPORT MOUNTING PLATES should be adjusted up or down so that the selector bars just clear the bails in the lower case.

THE SELECTOR BAR GUIDE COMB should be adjusted at its mounting screws, to allow free travel of the selector bars.

THE INTERPOSER BELL CRANK GUIDE BRACKET should be adjusted so that the three selective interposers rest .025" to .030" below the path of the tripping blade on the top of the trip lever. Check the adjustment by holding a 2-unit type bar against the platen and noting approximately .050" forward and backward movement on the bottom end of each interposer bell crank (Figure 1).

INTERPOSER BELL CRANK LINKS should be adjusted in the following manner: Type the "i" key repeatedly and move a 3-unit type bar slowly toward the platen. The spacing should increase from 2 to 3 units when the 3-unit type bar is 1/2 to 2/3 of the distance to the platen. This procedure should be used to check the 4-unit and 5-unit interposer bell crank connecting links by using a 4-unit and 5-unit type bar, respectively.

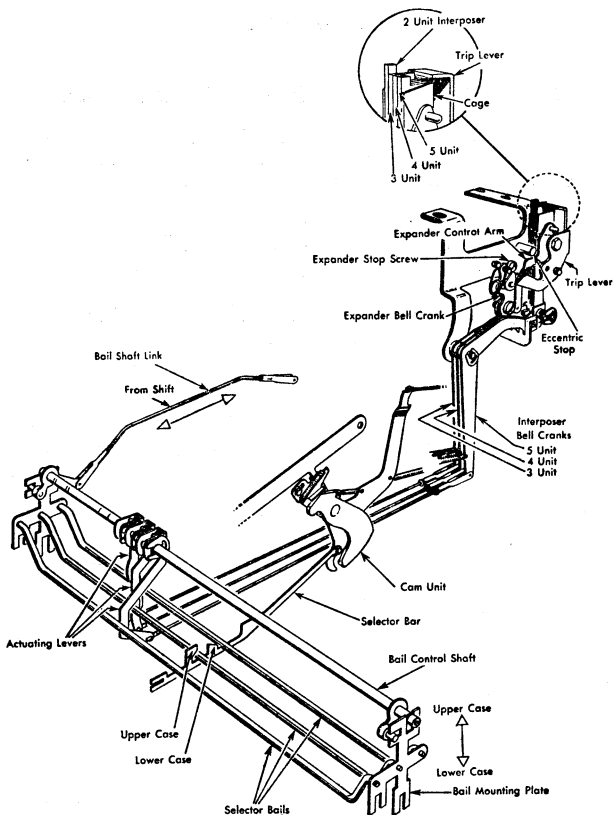

Figure 1. Escapement Selector Mechanism

SELECTOR BARS AND BAIL CONTACT. Where differences exist between the points of contact of bars and bails, bars should be formed (up to open, and down to close the clearance).

PAWL ENDS AND INTERPOSER CLEARANCE should be adjusted by moving the trip lever stud backward or forward until .010" to .020" clearance is obtained between the rear edge of the 8 pawl and the operating edges of the interposers (Figure 2). Move the left hand rail support to the rear if necessary.

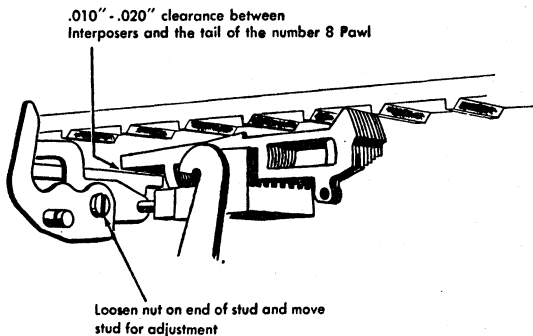

Figure 2. Pawl and Interposer Clearance

THE TRIP LINK should be adjusted so that the escape-ment trips when the type face is $1/4''$ to $3/8''$ from the platen. If the tripping point is not even across the basket, check the universal bar. Observe that the interposer selected rises in front of the trip lever blade, (inset, Figure 1).

THE TRIPPING POINT in both upper and lower case should be checked. The lug on the universal bar can be formed up or down to equalize the tripping point.

THE INTERPOSER OVERTHROW STOP should be adjusted so that by holding a type bar against the platen, a clearance the thickness of bond paper should be visible between the interposer and the eccentric stud which serves as the interposer overthrow stop (Figure 3). Test several type bars for this condition.

SELECTOR BAR REMOVAL AND REPLACEMENT. Selector bars used on machines equipped with cast iron cam lever bearing support can be removed by raising the affected

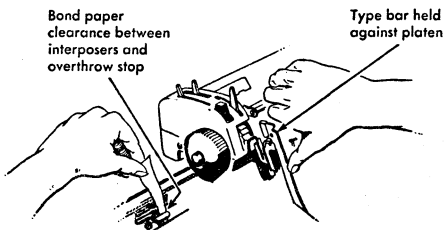

Figure 3. Testing Interposer Clearance

type bar to the platen and holding it there. Free the selector bar from the front support and gently twist the selector bar to the right or left until it is free. To install, the edges above the hook should be rounded slightly (.005" to .020").

On typewriters equipped with the aluminum cam lever bearing support, selector bars cannot be removed in this manner. Since the majority of selector bars are removed for the purpose of installing a new selector bar, the selector bar in the machine can be broken and removed to expedite service. Installation can be duplicated as mentioned above except that a greater amount of metal should be ground off the selector bar before installing it (Figure 4).

EXPANDER

EXPANDER. The expander cam for the 1/32" and the 1/36" pitch will have no marking, while the expander cam for the 1/45" pitch will carry a square. The expander adjustment can be best observed by the position of the 1 and 8 pawls, looking above and down, just in front of the rear rail with the carriage at the extreme right.

EXPANDER ADJUSTMENT. Move the carriage to the right, and check the expander in both the expanded and normal position. In both cases the pawl should project over the faces of the interposers by slightly less than one-half the width of the respective interposer faces. Check for this condition in the normal position by resting the carriage on the 1 pawl and observing the overlap of the 3 pawl on the three unit interposer (Figure 5). The 3 pawl should project over the face of the interposer by slightly less than one-half the width of the interposer face. Then move the expander button up and check to see that the interposers moved over one unit to the right by checking the overlap of the 4 pawl on the 3-unit interposer. Repeat this procedure with the carriage resting on the 5 pawl and observe the 8 pawl for overlap, still with the expander button up. If the above results are not apparent, proceed as follows:

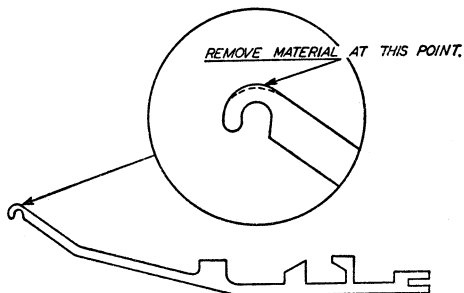

Figure 4. Selector Bar Removal

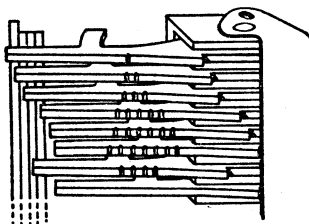

Figure 5. Interposer Overlap, Normal Setting

VERTICAL ALIGNMENT OF INTERPOSERS is adjusted by moving the rail support to the right or left as required.

INTERPOSER OVERLAP is adjusted by loosening the locking screw in the slot of the control arm bell crank and shifting the bell crank forward or backward until the correct amount of overlap is obtained (Figure 5).

THE EXPANDER BELL CRANK STOP SCREW is normally set in the center and should permit the formed offset on the bottom of the expander bell crank to cam the small bushing on the lower mounting interposer stud a full unit to the right (Figure 6). The expander bell crank stop screw differs with each different escapement.

ESCAPEMENT

1/32

1/36

1/45

APPROXIMATE DIAMETER

11/64"

7/32"

17/64"

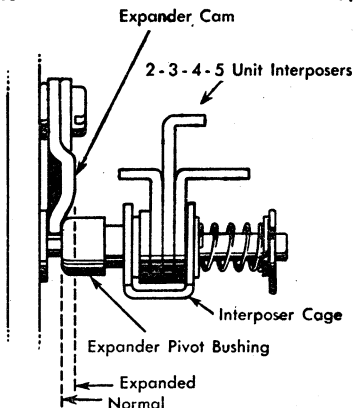

Figure 6. Interposers, Bottom View

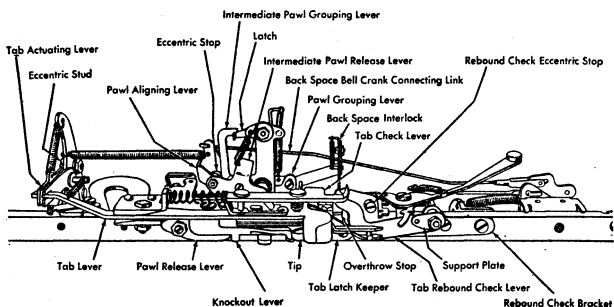

Figure 7. Rail Assembly, Top View

ESCAPEMENT PAWL REMOVAL. Remove the tab rack, tab lever bracket screw, clutch knockout lever screws and connecting links (Figure 7). Brace the carriage so that it will not move when the escapement pawls are removed from the rack. After the pawl block assembly is removed the individual pawls may be removed by removing the horseshoe clip that retains the escapement pawl pin which is located just below the 8 pawl. The steel band that serves as a stop for the notch on the front edge of the pawls may be removed by springing the top off from the small stud that retains it. The pin may then be removed through the top of the block. This will clear the pawls so that they may be removed. The pawl springs must be disconnected from the spring bracket, and the pawls must be turned so that they can be lifted upward off the pawl grouping lever.

Replacement should be accomplished in reverse order. Hold the escapement pawls out of the rack while setting the pawl bracket in place.

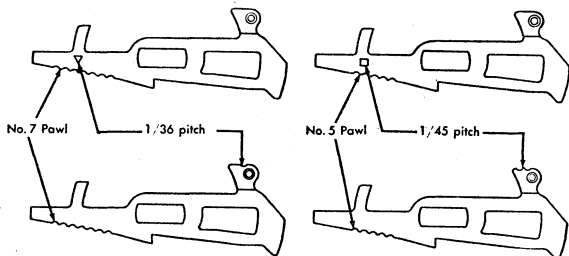

Figure 8. Number and Pitch Identification of Pawls

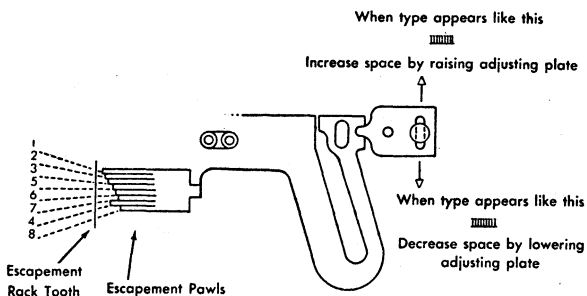

Figure 9. Adjustable Pawl Block Assembly

IDENTIFICATION OF ESCAPEMENT PAWLS. The notches cut along the front edge of all but the 8 pawl will show their numerical position. The escapement is identified either by notches cut in the spring lug of the pawl or a triangle or a square (Figure 8).

ESCAPEMENT PAWL TIPS. Squareness with the rack teeth can be tested by typing a series of lower case letter l's, backspacing after each l. Where a difference appears between the 8 pawl and the 1 pawl, an adjustment in the elevation of the escapement pawl block assembly can be made (Figure 9).

SPACE BARS

THE SPACE BAR CAM should be adjusted so that the release lever lug will just drop behind the cam lug when the key is tripped.

THE CAM TRIP LINK should be adjusted so that the cam will trip when the key lever has completed 1/2 to 3/4 of its downward stroke (Figure 10).

THE THREE-UNIT SPACE BAR INTERPOSER LINK from the key lever is to be adjusted to allow the interposer to clear the top of the formed lug on the 3-unit space bar actuating lever by 1/32" (Figure 10).

THE LINK FROM THE ACTUATING LEVER to the cam is adjusted so that the back of the lug on the actuating lever just clears the space bar interposer by 1/64" (Figure 10).

THE CONNECTING LINK from the space bar cam to the escapement lever should be adjusted so that, with the

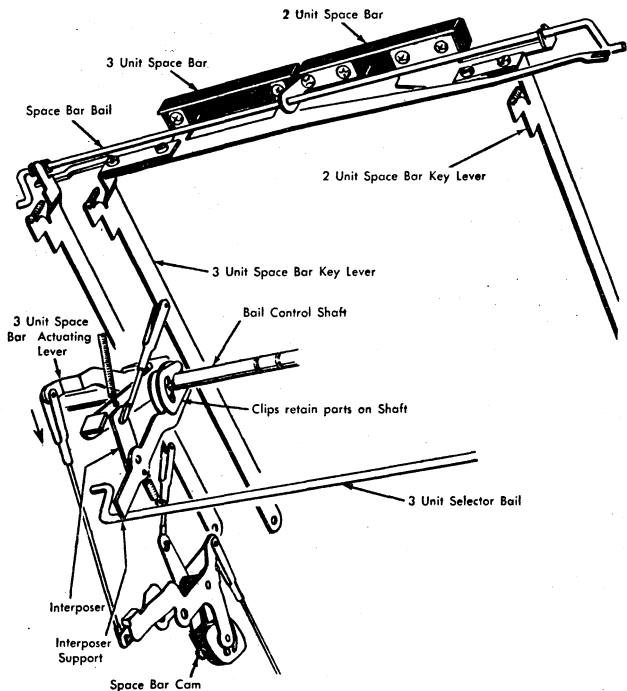

Figure 10. Space Bars

space bar cam rotated by hand, the lever will trip the escapement pawls when the cam has reached its high point.

A spring connects the 3-unit actuating lever to the selector bar support to give improved operation by eliminating the lost motion in the 3-unit actuating lever and linkage.

BACK SPACE

THE BACK SPACE GUIDE PIN BRACKET must be positioned by its mounting screws to meet two conditions (Figure 11):

1. The tails of the back space pawls must be held in a line perpendicular to the rail.
2. With the carriage resting on the 5 or 6 escapement pawl for the 1/32" escapement, or on the 7 or 8 escapement pawl for the 1/36" escapement, the back space guide pin should guide the back space pawls into the rack

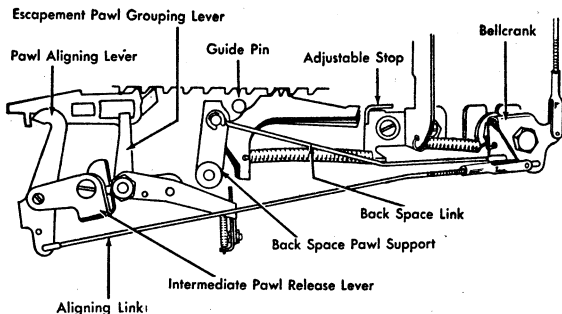

Figure 11. Back Space Mechanism

so that the number 4 back space pawl will bottom evenly between two teeth in the escapement rack. The number 4 back space pawl is the bottom pawl. The back space pawls should not lose contact with the pin during this adjustment (Figure 11).

THE BACK SPACE CAM ADJUSTABLE STOP should be set so that the release lever lug will just drop behind the cam lug when the key is tripped.

THE CAM RELEASE LINK should be adjusted to trip the cam when the key lever is 1/2 to 3/4 depressed.

THE BACK SPACE CONNECTING LINK should be adjusted with the cam at rest, so that the rear lugs of the back space pawls clear the riveted stud in the back space pawl support by 1/32" (Figure 12). If the cam fails to move the carriage far enough to back space properly, this clearance may be increased.

THE PAWL ALIGNING LINK. Place the back space cam on its high point. Fully align the escapement pawls by

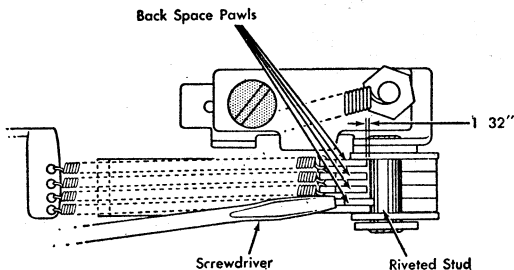

Figure 12. Back Space Link Adjustment

pulling on the aligning link. Match the clevis pin of the aligning link with the hole in the back space bell crank. If this link is too long, the back space may fail because the escapement pawls are not fully aligned. If this link is too short, it may hold the escapement pawls so tightly that some of them may be prevented from bottoming in the escapement rack after a back space attempt.

THE BACK SPACE PAWL STOP. Position the carriage to rest on the 1 escapement pawl. Operate the back space cam by hand and, when the rack has traveled approximately 1-1/2 units to the right, the stop should be locked in place against the back space pawl ends (Figure 11). The 1-1/2 units of travel will be indicated when the 8 pawl drops into the rack with 1/2 unit overtravel. Check the escapement pawl block assembly to insure that the pawls are square with the escapement rack (Figure 9). Check also to see that the aligning lever bail is straight and that the guide pin is not bent or loose.

ROTARY BACK SPACE

Adjustment of the rotary back space mechanism should be carefully checked according to the following procedure. No bending or forming adjustments are required or advised.

THE BACK SPACE PINION GEAR must mesh properly with the rack teeth (Figure 13). Adjustments may be made by removing the ratchet wheel and loosening the screw which holds the main bracket to the rear rail just over

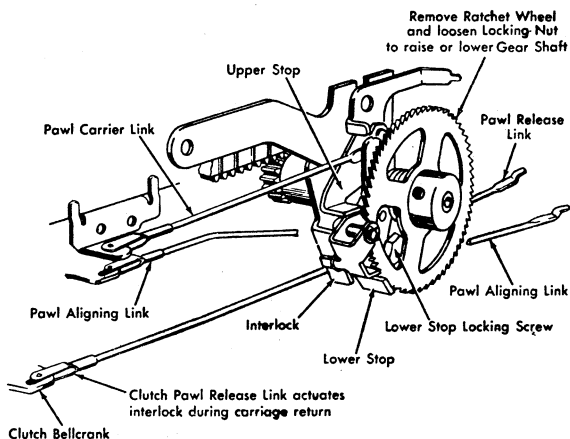

Figure 13. Rotary Back Space Mechanism

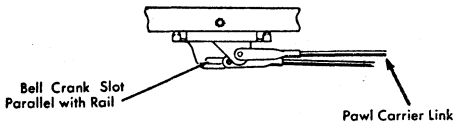

Figure 14. Pawl Carrier Link Adjustment

the ratchet wheel. Also loosen the hex nut, just below this screw, which locks the upper pawl stop. By loosening these two screws only slightly, the bracket may be tapped up or down until the pinion gear has a maximum of .005" back lash and will permit free movement of the carriage, without binding, for the full length of carriage travel. Replace the ratchet wheel.

THE BACK SPACE CAM STOP should be adjusted so that when the cam is released the release lever will just drop behind the cam lug.

THE BACK SPACE PAWL CARRIER LINK (Figure 14) should be adjusted so that the slot in the bell crank on the rear rail will lie parallel to the rear rail when the back space is at rest.

THE BACK SPACE LINK from the cam to the bell crank must be checked to insure that it just bridges the gap between the bell crank and the cam itself, with the cam resting against its stop.

THE BACK SPACE RATCHET must be adjusted and locked on its shaft by its setscrew. When the ratchet is properly positioned on the shaft, the pawl will enter about one-third to one-half down on a ratchet tooth (Figure 15).

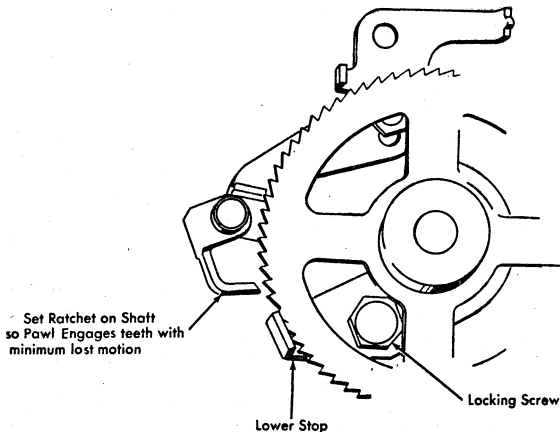

Figure 15. Stop and Ratchet Adjustment

THE LOWER PAWL STOP should be set by partially loosening the hex head locking screw just under the ratchet wheel and tapping the stop up or down (Figure 15). Select a position for the stop where it will limit the motion of the pawl just before the cam reaches its high point and lock the screw in place. The cam should then have about 1/4" of travel before passing its high point.

THE PAWL ALIGNING LINK. Place the back space cam on its high point. Fully align the escapement pawls by pulling on the aligning link. Match the clevis pin of the aligning link with the hole in the back space bell crank. If this link is too long, the back space may fail because the pawls are not fully aligned. If this link is too short, it may prevent the escapement pawls from bottoming in the rack after a back space attempt.

THE BACK SPACE INTERLOCK should be adjusted so that there is proper clearance between the interlock and the back space pawl (Figure 13). To adjust for this clearance first adjust the link from the intermediate pawl release lever to the interlock to permit .005" to .010" clearance between the back space pawl and the interlock lug with the back space cam on its high point.

With the back space cam at rest adjust the link from the interlock to the clutch bell crank so that the escapement pawls clear the rack by .010" to .015" during carriage return.

GROUPING ADJUSTMENTS

THE HEIGHT OF THE TAB LEVER should be checked to see that it clears the margin rack by .010" to .015".

THE TAB LATCH KEEPER adjustment should be checked for 1/2 to 2/3 bite on a set tab stop and for .030" to .040" overlap of the tab latch on the keeper.

THE ANGULAR TIP of the intermediate pawl release lever should be formed to allow the pawl aligning bail to lie against the pawl block. The angular tip of the intermediate pawl release lever should just or almost touch the pawl release lever, at the same time keeping in mind that the bail of the pawl aligning lever should be able to touch the pawl block.

THE PAWL RELEASE LEVER should be adjusted by forming the rear upright lug so that the pawls clear the rack by 1/64" when the tab lever is latched out. Check the rest position of the pawl release lever to see that it lies flat against the rear rail.

GROUPING LATCH ADJUSTMENT, SOLID TYPE LATCH. Operate the escapement until the carriage is held by the 1 or 5 pawl. Position the latch stud to the rear of its

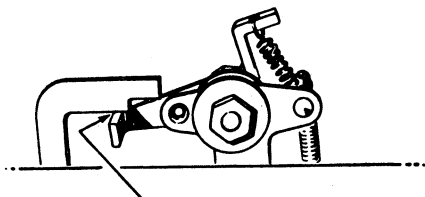

1 Unit or less Clearance

Figure 16. Unlatched Intermediate Grouping Lever

enlarged hole and move it to the right or left to obtain one unit, or slightly less, clearance between the latch and the intermediate pawl grouping lever (Figure 16). Note that the movement of the latch in the direction of the intermediate pawl grouping lever will increase the clearance.

GROUPING LATCH ADJUSTMENT, TWO-PIECE LATCH.

Position the latch stud to the rear of its enlarged hole. With the carriage resting on the 1 or 5 pawl, loosen the screw in the adjustable grouping latch (Figure 17). Position the latch for one unit or less clearance (Figure 16) between the intermediate pawl grouping lever and the latch.

THE INTERMEDIATE PAWL GROUPING LEVER is positioned by rotating the stud, which carries an eccentric collar located in the pawl aligning lever (Figure 17). Latch out the tabular lever. Turn this stud to obtain .001" to .004" clearance between the grouping latch and the short

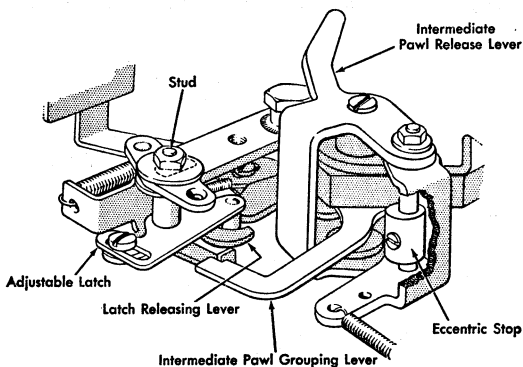

Figure 17. Adjustable Grouping Latch

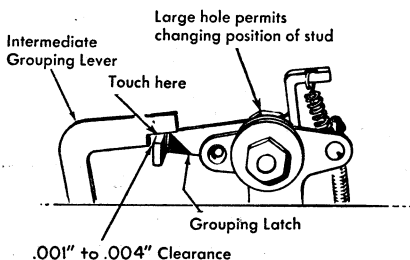

Figure 18. Latching of the Intermediate Grouping Lever

side of the notch in the intermediate pawl grouping lever (Figure 18).

The setscrew in the eccentric collar of the pawl aligning lever stud must always be tight. If the grouping latch does not bottom in the notch of the intermediate grouping lever, the grouping lever may be positioned too far toward the tails of the escapement pawls. This would cause the spring lugs of the 4 and 8 pawls to restrict the full travel of the latch.

THE PAWL GROUPING LEVER should be adjusted to just group the escapement pawls when the tab lever is in its latched position (Figure 20).

To move the grouping lever it is necessary to unlock it from the back space interlock lever in two places, the adjustment locking screw and the locking nut on the pivot stud (Figure 19). Tighten the two points securely when the grouping lever is positioned correctly. Note that the

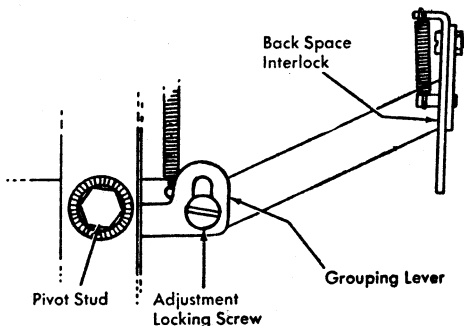

Figure 19. Pawl Grouping Lever

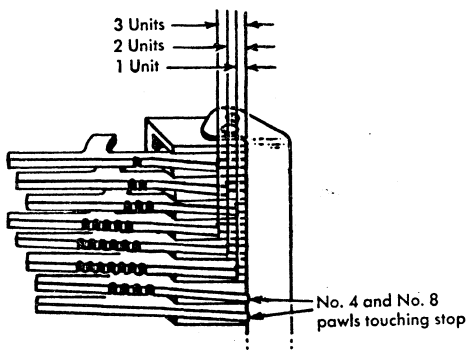

Figure 20. Pawls Grouped

escapement pawls are properly grouped when the 4 and 8 pawls touch the pawl stop strap while the 3 and 7 pawls lack one unit of touching the stop strap (Figure 20). If the 4 and 8 pawls are away from the strap, the pawls are overgrouped. If the 3 and 7 pawl are less than one unit from the strap, they are undergrouped.

In order to check proper grouping, hold the carriage to the extreme right and latch out the tab lever. Observe that the 4 and 8 pawls are touching the pawl stop strap. Move the back space interlock slightly in the direction of the back space pawls. This motion should immediately move the 4 and 8 pawls away from the pawl stop strap and upon release of the interlock, the pawls should again touch the stop.

TABULATION

THE TAB CAM should be adjusted by means of its stop so that the cam release lever will just drop behind the cam lug when the cam is released.

THE CAM RELEASE LINK should be adjusted so the cam will be tripped when the key lever has reached $1/2$ to $3/4$ of its total travel.

THE TAB LEVER HEIGHT should be adjusted by the eccentric stud under the tab actuating lever until the tab lever clears the bottom of the margin rack by $.010''$ to $.015''$ (Figure 21).

THE TAB LEVER BRACKET MOUNTING SCREW has been equipped with a locking plate and a hex head screw to maintain the bracket tight. A loose mounting screw can affect escapement, tabulation, back space and margin.

THE REBOUND CHECK LEVER is to be adjusted by forming the rebound check support plate up or down to per-

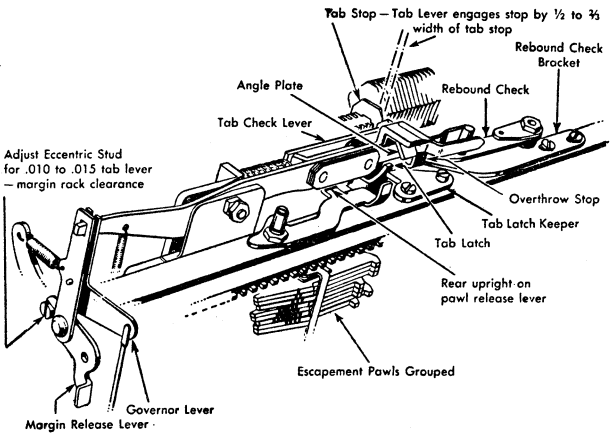

Figure 21. Tabular Mechanism

mit the rebound check to reach about .010" above the bottom edge of the tab stop. Care must be taken to prevent the rebound check from rubbing against the bottom of the tab lever.

THE TAB CHECK LEVER should be adjusted, by means of the latch keeper, to cover 1/2 to 2/3 of the tab stop in the latched position (Figure 21).

THE TAB LATCH KEEPER at the same time should be adjusted so that the tab latch is securely latched on the keeper by .030" to .040". The overthrow stop should be left loose for this adjustment.

THE REBOUND CHECK should be adjusted on its elongated holes until it clears the right-hand face of the tab stop by .010" with the tab lever latched.

THE OVERTHROW STOP is an upright lug on the tab rebound check bracket. It should be positioned to prevent the rear edge of the tab check lever from touching the front face of the tab rack. This adjustment should be made at the same time as the adjustment of the rebound check to avoid forming. If the tab lever motion is halted too early the tab lever may fail to latch.

THE REAR UPRIGHT LUG on the pawl release lever (Figure 21) should be formed so that the escapement pawls will clear the escapement rack by 1/64" when the tab lever is latched out.

THE CAM AND INTERMEDIATE LEVER CONNECTING LINKS must be balanced to deliver the proper motion to the tab lever on former models with two links from the

cam to the tab actuating lever. Adjust the front link so that the forward edge of the intermediate lever is perpendicular to the front link. Then set the rear link so that the tab latch just clears the keeper with the cam on its high point. On models with a single link, adjust the same as for the rear link. To check, rotate the cam to its high point; the tab check lever should just clear the front of the tab rack. In the rest position for all models, there should be a small amount of clearance, both front and back, between the tab actuating lever and the tab lever.

THE TAB RACK should be adjusted so that, with the carriage resting on the 2 or 6 pawl, the tip of the tab check lever will be in line with the nearest tab stop.

CARRIAGE TENSION should be checked by holding the carriage with the tab check lever positioned at the last stop. Latch the tab and release the carriage. There should be just enough main spring tension to unlatch the tab.

THE FRICTION GOVERNOR PAWL LINK should be adjusted to engage the pawl in the friction ratchet teeth by the thickness of its own metal. It should safely clear the ratchet with the tab at rest.

FRICTION GOVERNOR PRESSURE should be adjusted by means of the two locking nuts on the hub of the main spring drum until the tab speed is approximately the same speed as the carriage return and a solid positive action results.

THE TAB SET LEVER BRACKET should be adjusted to the right or left until the set lever can strike the nearest stop squarely in the center with the carriage resting on the 1 or 5 pawl.

CARRIAGE RETURN

Figure 22 shows the sequence of adjustments for the carriage return.

- 1. THE CARRIAGE RETURN CAM STOP** should be adjusted so that when the cam is released the release lever will just fall behind the cam lug.
- 2. THE CAM ELEASE LINK** should be adjusted so the key lever will trip the cam when the key has been depressed $1/2$ to $3/4$ of its total travel.
- 3. THE FRONT CLUTCH LEVER LINK** should be adjusted so that, when the clutch operating arm is as far out as the clutch lever and roller will permit, the cam will be just touching the cam stop with the clutch unlatched.
- 4. THE LATCH LINK** should be adjusted so that the right-hand arm of the lower bell crank lies parallel to the rear rail.

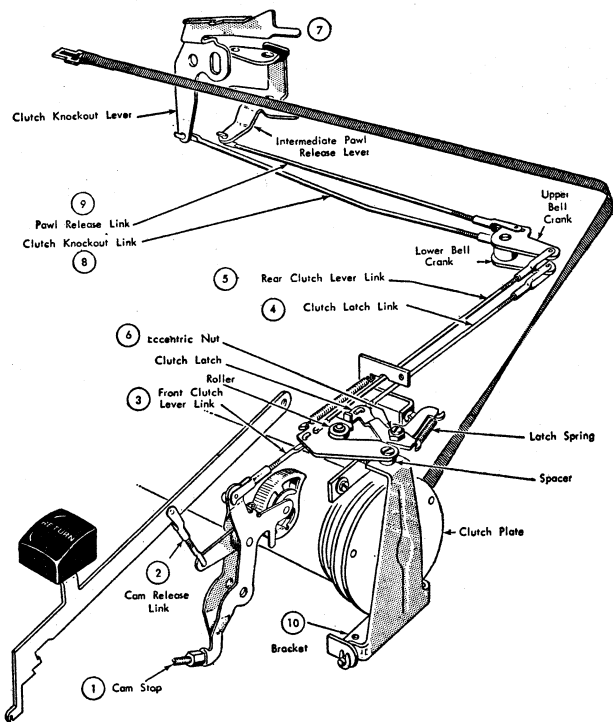

Figure 22. Carriage Return—Executive

5. THE REAR CLUTCH LEVER LINK should be adjusted, with the clutch unlatched, so that the slot in the upper bell crank will lie parallel to the rear rail.

6. THE LATCH ECCENTRIC is to be adjusted so that there is .005" to .015" clearance between the latch and the clutch lever with the cam on its high point. The lower reading is preferable.

7. THE CLUTCH KNOCKOUT LEVER TIP is adjusted so that when the C. K. O. tip touches the angular surface of the tab lever, with the tab lever in the rest position, the highest point of the C. K. O. lever will be .005" to .015" below the under surface of the margin rack.

8. THE CLUTCH KNOCKOUT LINK should be adjusted so that the latch will engage the clutch lever by $\frac{3}{64}$ ", or the thickness of the latch, with the clutch latched.

9. THE PAWL RELEASE LINK should be adjusted so that the tips of the escapement pawls clear the rack by .010" to .015" with the clutch latched.

10. THE CLUTCH BRACKET should be adjusted so that the bronze insert in the clutch plate clears the operating arm by .005" to .015" with the clutch unlatched and with the clutch plate held against the disc by hand.

11. THE CLUTCH PRESSURE is adjusted by means of the lock nut and compression spring under the clutch so that the carriage will just return to the left margin on triple line spacing.

Repeat Line Spacing

If the carriage tends to creep away from the margin during repeat line spacing, especially on double or triple line spacing, a number of extra adjusting steps may be taken to clear the difficulty. All of these adjustments are aimed at reducing the effects of whip in the carriage return tape.

5 REDUCE THE STRENGTH OF THE HOOK LEVER SPRING as much as possible without causing the index pawl to interfere while turning the platen backward. Frequently this adjustment alone will be sufficient.

1 REDUCE ESCAPEMENT PAWL CLEARANCE as low as possible and still not permit the pawls to drag.

7 ADJUST THE CLUTCH PULLEY SPRING by winding it up all the way and attaching the tape without backing off.

6 RE-FORM THE CLUTCH PULLEY SPRING by drawing the spring between the fingers, held in a cloth, in such a manner as to reverse partially the main part of its curve.

3 REDUCE THE CLUTCH PLATE CLEARANCE until only sufficient clearance exists to permit the tape to be free with power off.

8 READJUST THE LATCH ECCENTRIC for minimum latch clearance and readjust the pawl release link to again provide 1/64" clearance between the escapement pawls and the rack with the clutch latched.

4 ADJUST THE OVERBANK TO 5 UNITS to permit the pawls just a little more time to restore to the escapement rack.

CARBON RIBBON FEED

THE CARBON RIBBON PRESSURE ROLLER ARM has been equipped with a small guide loop to prevent the ribbon from feeding off into the gear teeth.

THE RIBBON CENTER GUIDE should be formed toward the platen as closely as possible. Care should be used to

avoid the possibility of a bind against the line gage card holder.

THE RIBBON LIFT GUIDE CLEVIS should be adjusted so that the diagonal will strike in the middle of the ribbon. If one character lifts the ribbon too high, or not high enough, the hook of the cam lever may be peened to compensate.

THE CORNER GUIDES should be adjusted high enough to relieve strain in the center guide in order to discourage breakage at that point. The ribbon corner guides have been redesigned with open ribs to create less drag and reduce ribbon breakage.

THE DRIVE SPRING BELT should be just tight enough to take up the slack ribbon as it is fed through the feed rollers. Tension should be checked when the rewind spool is nearly filled because greater tension is required as the spool fills up.

THE REWIND SPOOL has been equipped with a retaining spring that clips behind the flange of the spool and shaft assembly.

THE RIBBON FEED ACTUATING LINK should be adjusted so that the feed pawl arm rests $1/8''$ above the pin in the left-hand magazine plate.

THE RIGHT-HAND TAKE-UP SPRING is mounted on the right magazine plate to insure constant ribbon tension and uniform feeding (Figure 23).

THE CARBON RIBBON INDICATOR is designed as a one-piece lever. On former models this was an assembly.

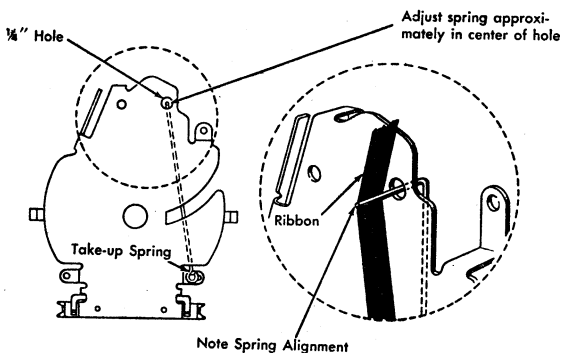

Figure 23. Take-Up Spring

PROPORTIONAL CARBON RIBBON FEED

THE PROPORTIONAL RIBBON FEED should be checked by typing twenty 3-unit or 5-unit escapements. The ribbon should feed an equivalent of 23 + 2 — 0 of these same characters.

THE SELECTOR BAR LINK should be adjusted so that the lower arm will drop off the selector lever when the type bar has completed 1/3 to 1/2 of its travel toward the platen (Figure 24).

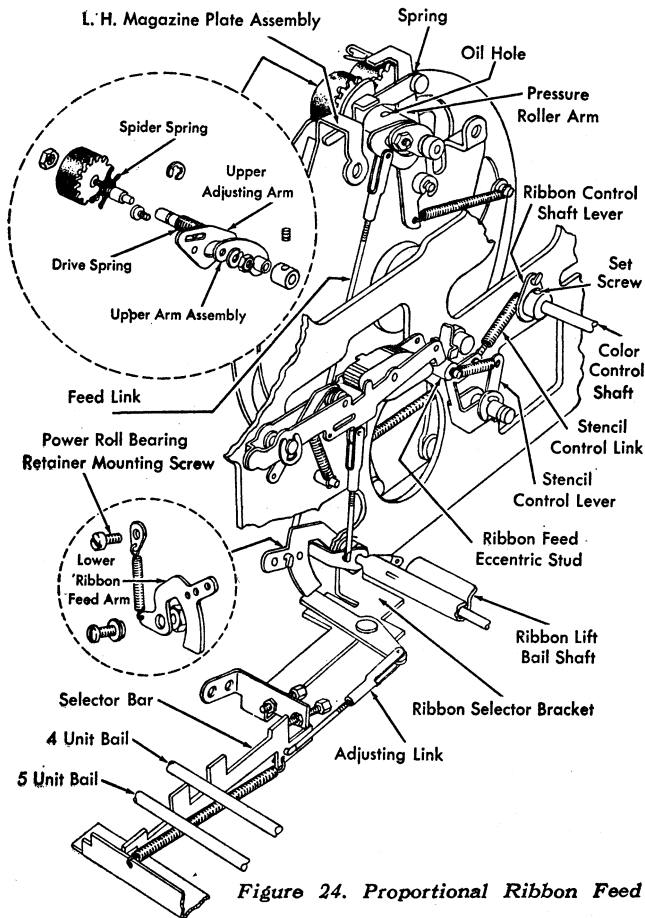

Figure 24. Proportional Ribbon Feed

THE FIVE-UNIT FEED should be adjusted by means of the upper adjusting arm. Moving the arm toward the shaft will increase the amount of feed, and away from the shaft will decrease the amount of feed.

THE THREE-UNIT FEED should be adjusted by varying the position of the ribbon selector bracket up or down. Lowering the bracket will increase the amount of feed, and raising it will decrease the feed. Re-check the five-unit adjustment, and change if necessary.

THE RIBBON FEED ECCENTRIC STUD should be adjusted so that the high point of the eccentric is down and toward the front of the machine and so that the cam release lever lug will drop just behind the cam lug when the cam is tripped with the power off.

THE RIBBON FEED MECHANISM has a lockout lever that disengages the ribbon feed pawl for the stencil position. This lever appears on machines with serial numbers between approximately 1500 to approximately 31,500. The ribbon feed on later machines has an automatic device to hold the ribbon feed cam away from the power roll whenever the color control is moved to the stencil position.

Because some type faces cut the ribbon and contribute to breakage, the following characters have been redesigned to reduce this condition:

/ over the 3, (over the 9,) over the 0,
 ? over the /, — over the -

LUBRICATION: ALL PURPOSE GREASE should be applied to the ribbon operating bail, ribbon feed spider spring, the coil drive spring, the bail tips, fulcrum and feed link holes, and to the pressure roller shaft.

IBM 6 oil should be used on the upper arm shaft.

LINE GAGE CARD HOLDER

The line gage card holder should be adjusted, up or down, until its upper edge is level with the bottom of the line of type and shows a thin line of white between the typing line and the gage. Move the front-rail dust cover to the right or left on its elongated mounting holes to position the right-hand gage for use as a position finder. Test for position by placing the right side of any typed character against the vertical edge of the scale, space according to the following table and type the next succeeding character.

ESCAPEMENT	UNITS
1/32" normal	12
1/32" expanded	13
1/36" normal	14
1/36" expanded	15
1/45" normal	16
1/45" expanded	17

IBM TYPE STYLES

IDENT. MARK	TYPE CODE	TYPE STYLE	ESCAPE- MENT	APPROX. POINT SIZE	RATCHET TEETH	PLATEN	
						CLOTH RIBBON	CARBON RIBBON
PO	16	Bold Face No. 1	1/32"	12	29	8	8
PS	26	Secretarial	1/32"	12	29	2	1
PM	32	Modern	1/32"	10	29	8	2
PE	40	Documentary	1/32"	11	29	8	2
PG	46	Copperplate Gothic	1/36"	12 & 6	29	8	2
PH	47	Text	1/45"	9	33	2	1 or 2
PF	50	Mid-Century	1/36"	12	29	8	2 or 8
PR	51	Charter	1/45"	8	33	2	1 or 2
PB	57	Bold Face No. 2	1/36"	10	29	8	2
PT	59	Bold Face Italic	1/32"	12	29	8	2 or 8
PJ	61	Heritage	1/36"	10	29	8	2
PV	71	Testimonial	1/32"	12	29	8	8

UNIT WIDTH CHART

The characters @ and %, formerly five units wide, have been reduced to four units.

BOLD FACE NO. 1, DOCUMENTARY, MODERN, SECRETARIAL, BOLD FACE ITALIC (1/32" unit types) or BOLD FACE NO. 2 (1/36" unit type)

All lower case alphabetical characters, and numbers, period and comma, are 3 units except:

flitj—2 units; w—4 units; m—5 units

All upper case alphabetical characters are 4 units except:

I—2 units; SJ—3 units; WM—5 units

CHARTER (1/45" unit type)

All lower case alphabetical characters, and numbers, period and comma, are 3 units except:

flitsjrz—2 units; w—4 units; m—5 units

All upper case alphabetical characters are 4 units except:

IJ—2 units; BEFLPSZ—3 units; MW—5 units

TEXT (1/45" unit type)

All lower case alphabetical characters, and numbers, period and comma, are 3 units except:

flitsjr—2 units; w—4 units; m—5 units

All upper case alphabetical characters are 4 units except:

IJ—2 units; BEFLPRS—3 units; MW—5 units

MID-CENTURY (1/36" unit type)

All lower case alphabetical characters, and numbers, period and comma, are 3 units except:

flitsjr—2 units; wm—4 units

Upper case alphabetical characters are mainly 3 and 4 units, as shown below:

I—2 units; BESTFJLPR—3 units;

HAYCUDKVXZ—4 units; NOWGMQ—5 units

COPPERPLATE GOTHIC (1/36" unit type)

All lower case alphabetical characters are 3 units except:

ij—2 units mw—4 units

All upper case alphabetical characters are 1 unit larger than lower case, except for "I" which is 2 units in both cases.

Numbers, period and comma are 2 units in the lower case, 3 units in the upper case.

HERITAGE (1/36" unit) or TESTIMONIAL (1/32" unit type)

All lower case alphabetical characters, and numbers, period and comma, are 3 units except:

flitjr—2 units; w—4 units; m—5 units

All upper case alphabetical characters are 4 units except:

IJ—2 units; SBP—3 units; WM—5 units

IBM

EXECUTIVE

ELECTRIC TYPEWRITER

MODEL B4

CUSTOMER ENGINEERING REFERENCE MANUAL

CONTENTS

	<i>Page</i>
Features Common to Model B1	3
Carriage and Rails	4
Floating Interposers Selection	5
Non-Floating Interposers	9
Escapement	12
Grouping	13
Tabulation	18
Carriage Return	22
Spacebars	26
Backspace	28
Rotary Backspace	32
Ribbon	35
Card Holders	38
Front Paper Scale	39
IBM Executive Type Styles	40
Unit Width Chart	40

INTERNATIONAL BUSINESS MACHINES CORP.

NEW YORK 22, NEW YORK

Form 25-6171-3 (This section only)

© 1957 by
INTERNATIONAL BUSINESS MACHINES CORP.
590 Madison Avenue, New York 22, New York
Printed in U. S. A. April, 1959
Form 25-6171-3

ELECTRIC TYPEWRITER**MODEL B4 (Serial 100,000 and above)****FEATURES COMMON TO MODEL B1**

Several features of the **Executive Electric Typewriter** are common to the standard model and will not be repeated in this section. These features include.

Motor and Drive	Repositioning Cams
Key Levers, Letter Cams,	Shift
Typebars	Carriage
Margin Set	Paper Feed
Margin Release	Cloth Ribbon Feed
Alignment	

CARRIAGE AND RAILS

Removal

1. Remove the three interposer bellcrank links and their springs.
2. Remove the lower interposer bellcrank guide comb.
3. Disconnect the tab governor pawl link if present.
4. Remove the rear case.
5. Disconnect the tab operating link.
6. Disconnect the expander link at the rear.
7. Unhook the escapement trip link.
8. Disconnect the rebound check interlock lever link if present.
9. Disconnect the backspace operating link at the bellcrank.
10. Disconnect the clutch unlatching link.
11. Remove the C clip from the carriage return pawl release lever.
12. Remove the margin set lever.
13. Disconnect the carriage tension tape and slowly let the main spring take it up until the end clip of the tape is caught by the small idler pulley where it will be held.
14. Disconnect the carriage return tape from the indexing mechanism and allow it to be drawn back as far as its idler pulley.
15. Remove the four rail screws and run the carriage all the way to the right side of the machine so that the interposer bellcranks will be visible from the top. Lift the carriage off, being careful of the tab operating link and the connection on the universal bar which normally holds the trip link. By twisting the carriage and the rails around slightly to the right, they will lift off.

Rail Adjustments

Refer to "Rail Adjustments, Model B1".

FLOATING INTERPOSERS SELECTION

Interposer Removal

INTERPOSERS may be easily removed after the carriage and rails are removed.

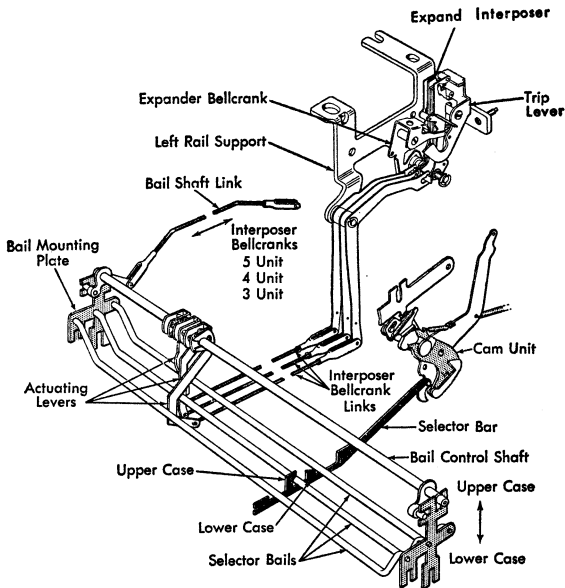

Figure 1. Escapement Selector Mechanism

Adjustments

1. SHIFT MOTION. Check for proper adjustment. Any change in shift motion necessitates a change in the bail shaft link adjustment.

2. BAIL SHAFT LINK. Adjust so that the bail mounting plates will move to their upper extreme (upper case) and not bind off on the bail control shaft (Figure 1). When the mounting plates are in the lower extreme (lower case) they should not bind off on the bail mounting plate guide pins.

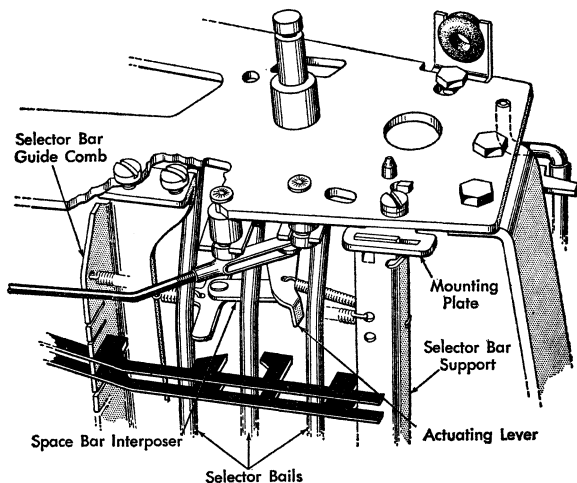

Figure 2. Selector Bar Adjustments

3. SELECTOR BAR SUPPORT MOUNTING PLATES Adjust up or down so that the selector bars just clear the bails in the lower case position (Figure 2).

4. SELECTOR BAR GUIDE COMB. Raise this as high as possible and lock it in place (Figure 2). This should allow free travel of the selector bars.

! Unit Interposer

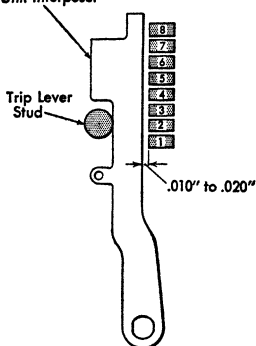

Figure 3. Pawl Tail to Interposer Clearance

5. PAWL TAIL TO INTERPOSER CLEARANCE. (Figure 3). Adjust the trip lever mounting stud for

a .010" to .020" clearance between the 2-unit interposer and the tails of the escapements pawls. Check by moving the trip lever while watching the movement of the 2-unit interposer. This should be checked while the carriage is being held by the 1 escapement pawl and also while the 8 pawl is holding the carriage. Adjustment should be made in relation to the closest pawl tail. Be sure a clearance is maintained between the right side of the interposer cage and the pawl tails. Check by pulling the cage to the left at the top and releasing it slowly, while exerting a pressure toward the front. It should not hang up on any pawl tails.

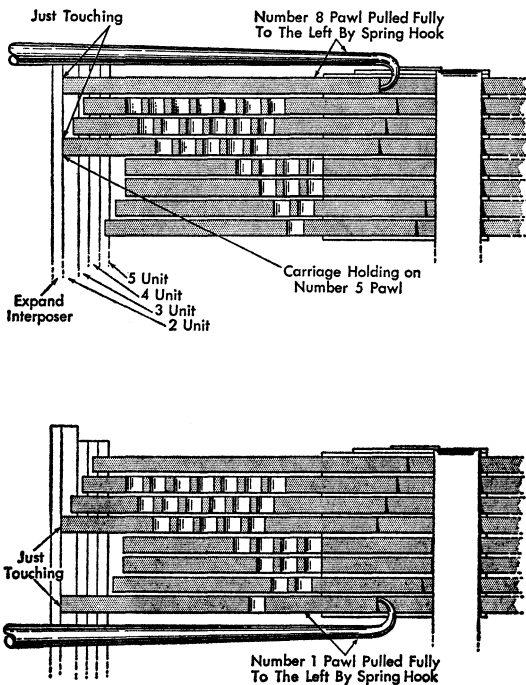

Figure 4. Interposer Verticalness

6. INTERPOSER VERTICALNESS. Adjust in the following manner:

- a. Position the carriage to the right so the pawl

tails are visible and the carriage is holding on the 5 escapement pawl (Figure 4).

b. Move the 1 and the 8 escapement pawls fully to the left. Each escapement pawl tail should just touch the expand interposer or move it an equal amount to the left (Figure 4). Unequal movement indicates need for shifting the rear of the rail support to the right or left.

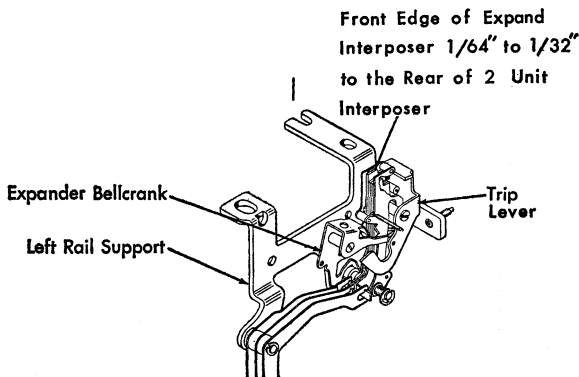

Figure 5. Expander Bellcrank Adjustment

7. EXPANDER BELLCRANK. Adjust this by moving its pivot stud front or rear. Position this stud so that the front edge of the expand interposer, when in the expand position, is $\frac{1}{64}$ " to $\frac{1}{32}$ " to the rear of the front edge of the 2-unit interposer (Figure 5).

8. EXPANDER BELLCRANK ARM. Form the expander bellcrank arm so that it will just clear the right side of the interposer cage when the interposer cage is in the expanded position.

9. TRIP LINK. Adjust so that the holding escapement pawl is tipped when the type face is $\frac{3}{8}$ " \pm $\frac{1}{8}$ " from the platen.

10. INTERPOSER BELLCRANK LINKS. (Figure 1). Adjust as follows: Type the "i" key repeatedly and move a 3-unit typebar slowly toward the platen. The spacing should increase from 2 to 3 units when the 3-unit typebar is one-half to two-thirds of the distance to the platen. This procedure should also be used to check the 4-unit and 5-unit interposer bellcrank links,

however, use a 4-unit and 5-unit typebar, respectively.

NON-FLOATING INTERPOSERS SELECTION

INTERPOSER REMOVAL is the same as for the floating interposers.

Adjustments

1-5. Refer to "Floating Interposers Selection, adjustments 1 through 5," this section.

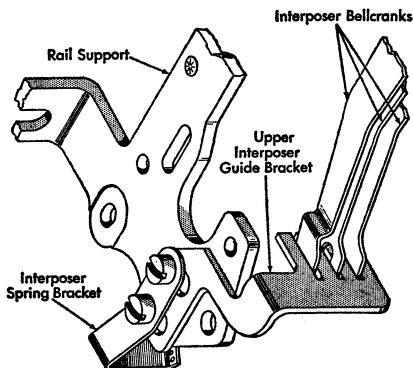

Figure 6. Upper Guide Bracket Adjustment

6. UPPER INTERPOSER BELLCRANK GUIDE BRACKET. Position this to its lower limit and lock it in place (Figure 6).

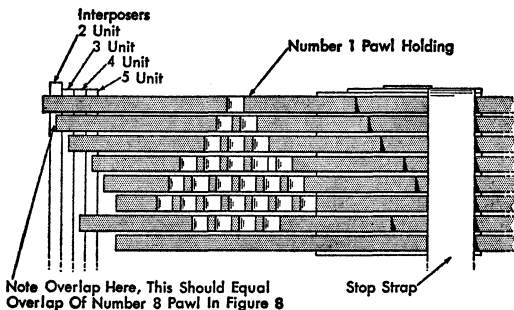

Figure 7. Overlap of Number 2 Pawl

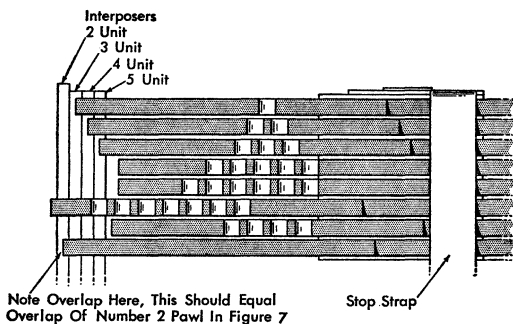

Figure 8. Overlap of Number 8 Pawl

7. INTERPOSER VERTICALNESS is obtained by moving the left rail support to the left or right. Position the carriage to hold on the 1 escapement pawl. Check the overlap of the 2 pawl tail on the 2-unit interposer (Figure 7). Position the carriage to hold on the 7 pawl and check the overlap of the 8 pawl on the 2-unit interposer (Figure 8). The overlap should be equal in both cases without regard for the actual amount of overlap. This will prove the interposers to be vertical with respect to the pawl tails.

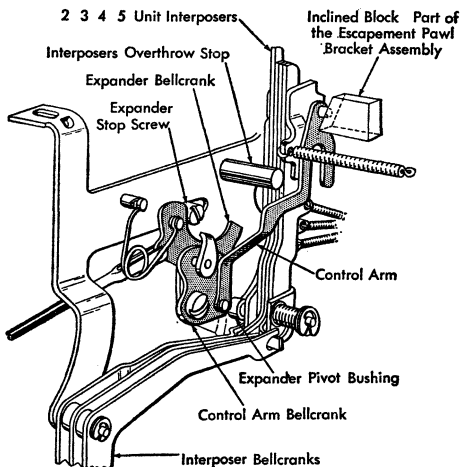

Figure 9. Expander Mechanism

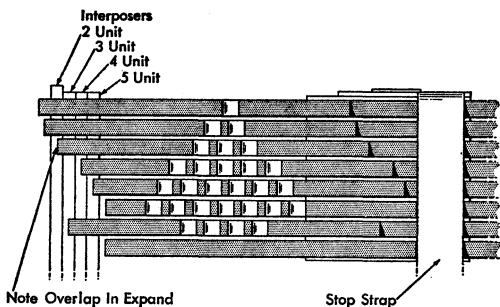

Figure 10. Interposers in Expand Position

8. EXPANDER STOP SCREW. Position this in its elongated hole (Figure 9) to allow for one full unit of expansion when the expand button is pushed up. To check this, have the carriage hold on the 1 escapement pawl (Figure 7) and observe the overlap of the 2 escapement pawl tail on the 2-unit interposer. Move the expand button to the expand position. Observe that the 3 escapement pawl tail now has the same overlap on the 2-unit interposer (Figure 10) as the 2 escapement pawl tail had in the non-expand position.

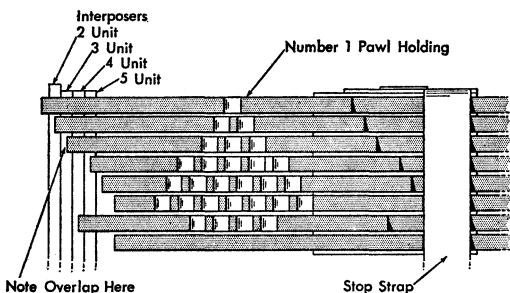

Figure 11. Interposer Overlap, Normal

9. OVERLAP. Adjust by moving the control arm bellcrank to the front or rear (Figure 9). Position the bellcrank so that when the carriage is held by the 1 escapement pawl the 3 escapement pawl tail will overlap the 3-unit interposer by one-half the thick-

ness of the interposer (Figure 11). The overlap should be observed by the 3 escapement pawl tail overlapping the 3-unit interposer, because the 2-unit interposer is the same thickness on all pitches.

10. PAWL TAIL TO INTERPOSER CLEARANCE. Refer to "Floating Interposers Selection, adjustment 5," this section.

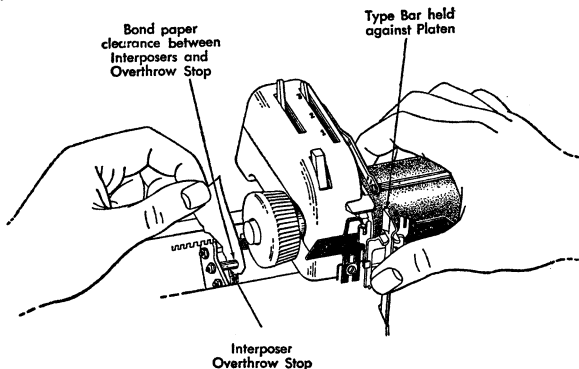

Figure 12. Interposer Overthrow Clearance

11. TRIP LINK. Refer to "Floating Interposers Selection, adjustment 9," this section

12. INTERPOSER OVERTHROW STOP. Adjust so that by holding a typebar against the platen, a clearance the thickness of bond paper will be visible between the interposer and the overthrow stop (Figure 12). Test several typebars for this condition.

13. INTERPOSER BELLCRANK LINKS. Refer to "Floating Interposers Selection, adjustment 10," this section.

14. INTERPOSER SPRING BRACKET. Form this slightly to the rear for more tension on the interposer springs if the interposers restore sluggishly (Figure 6).

ESCAPMENT Removal

PAWL BLOCK ASSEMBLY

1. Remove the rear case and both carriage end covers.

2. Remove the tab rack and margin rack.
3. Disconnect the pawl aligning link, pawl release link, and the clutch unlatching link.
4. Disconnect the air cylinder bellcrank spring at the pivot point for the margin control bellcrank.
5. Disconnect the pawl aligning lever spring.
6. Disconnect the spring from the left end of the tab lever.
7. Disconnect the tab latch spring.
8. Remove the spring from the escapement pawl stop strap which connects to the interposer cage.
9. Remove the margin control bellcrank.
10. Block the carriage to prevent movement and remove the two screws which secure the pawl block to the rear rail. The assembly may then be removed from the rear rail. The assembly may then be removed from the rear of the machine.

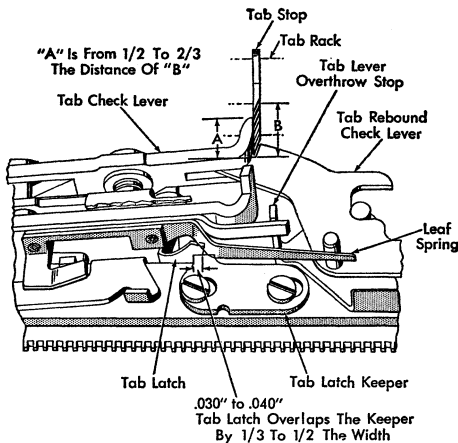

Figure 13. Latch Keeper Adjustment

GROUPING

Adjustments

Remove the carriage - return - tab interlock, and disconnect the pawl release link. These parts should not be replaced until grouping adjustments are completed.

1. **TAB LATCH KEEPER.** Position this so that the tab check lever covers one-half to two-thirds of the exposed surface of a set tab stop when the tab lever is held out by the keeper (Figure 13). At the same time the keeper should be moved left or right for .030" to .040" (.040" to .050" with floating selection) engagement of the latch on the keeper.

2. **THE ANGULAR TIP** of the intermediate pawl release lever is adjusted by forming so as to allow $\frac{1}{32}$ " to $\frac{1}{16}$ " clearance between the upright bail of the pawl aligning lever and the pawl tails when all parts are at rest (Figure 14). Before forming the tip, be sure it is resting against the pawl release lever and that the apron of the pawl release lever is flat against the rear rail.

3. **PAWL CLEARANCE** is obtained by forming the rear upright lug of the pawl release lever so that the escapement pawls clear the rack by $\frac{1}{64}$ " when the tab lever is latched out (Figure 14).

4. **THE GROUPING CONE** is adjusted up or down so that it is approximately $\frac{1}{16}$ " from its extreme down position. This is a preliminary adjustment which may be changed slightly, after adjusting the grouping lever, in order to facilitate obtaining accurate grouping.

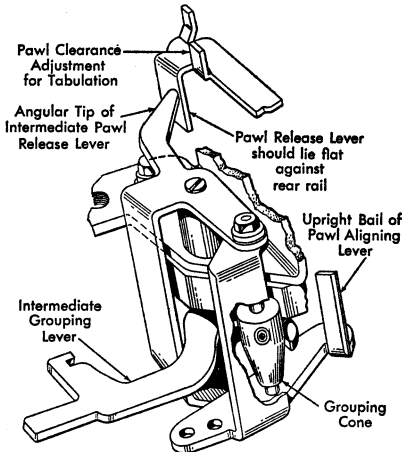

Figure 14. Pawl Release Mechanism

5. THE GROUPING LEVER. Adjust by repositioning this on the grouping lever adjusting arm (Figure 15) so that the escapement pawls are accurately grouped. Accurate grouping is observed by following these steps:

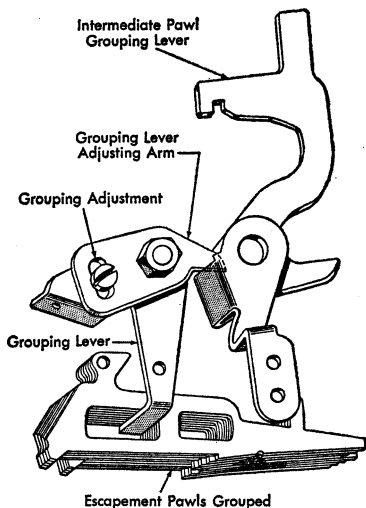

Figure 15. Grouping Adjustment

a. The left margin stop should be moved at least an inch to the right of its extreme left position so that the margin control lever can be positioned between this stop and the left carriage end plate. In this manner, the carriage may be held in an almost full right position so that the escapement pawls may be viewed without interference.

b. Position the carriage as described in "a" above and hold it to prevent movement.

c. Latch out the tab lever.

d. Check to see that the stop notches of the 4 and 8 escapement pawls are touching the pawl stop strap and that the stop notches of the 3 and 7 pawls are one unit away from the stop strap. The 2 and 6 pawls will be two units away from the stop strap and the 1 and 5 pawls will be three units from the stop strap (Figure 16). When looking down between the rails to check grouping, be sure that grouping is

maintained by the tab lever and not because the margin control plate has moved the automatic grouping lever. Because the numerical sequence of the

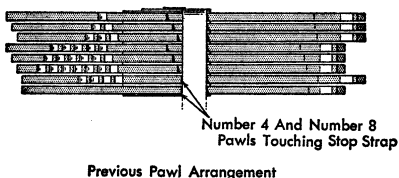
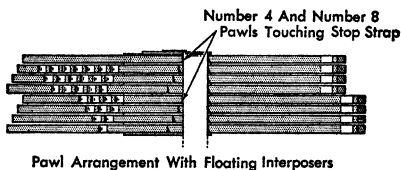

Figure 16. Escapement Pawls Grouped

escapement pawls may vary, note the number of the escapement pawl before checking its notch with relationship to the stop strap when in the grouped position (Figure 16).

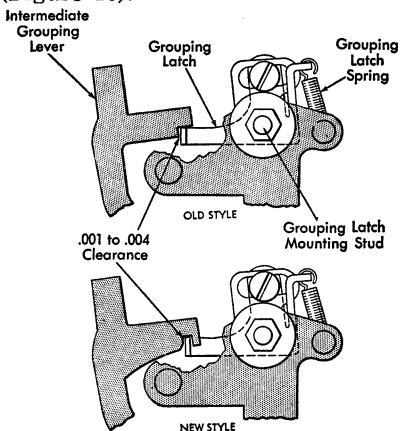

Figure 17. Grouping Latch Mounting Stud Adjustment

It may be necessary to readjust the pawl grouping cone if the grouping lever cannot be positioned far enough to obtain proper grouping.

6. GROUPING LATCH MOUNTING STUD. Adjust to the left or right so that with the tab lever latched and held by the keeper, the grouping latch will bottom in the notch of the intermediate grouping lever and clear the left side of this notch by .001" to .004" (Figure 17).

7. GROUPING LATCH ADJUSTING PLATE (Old Style). With the carriage resting on the 1 or 5 escapement pawl, move the grouping latch in relation

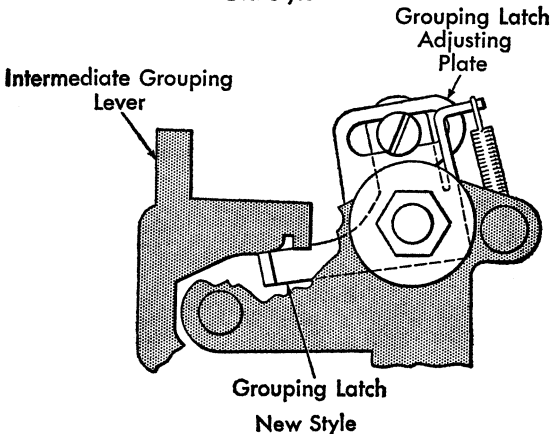
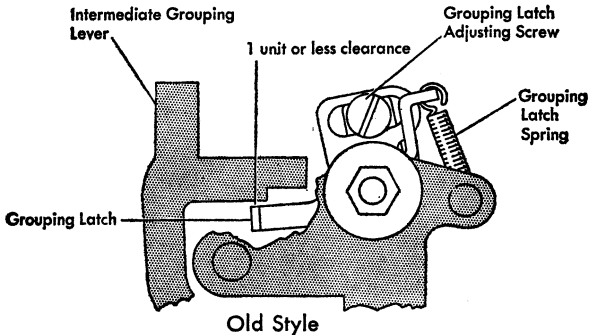

Figure 18. Grouping Latch Adjusting Plate

to the latch plate until the latch clears the intermediate grouping lever by one, or slightly less than one unit (Figure 18).

7a. GROUPING LATCH ADJUSTING PLATE (Floating Selection) (Figure 18). Adjust by centering the grouping latch adjusting screw in the slot of the grouping latch adjusting plate. To check this adjustment:

1. Hold the carriage so that the pawls will remain free of pressure by the rack teeth.

2. Latch up grouping by moving the automatic grouping lever by hand until the latch will drop into the notch of the intermediate grouping lever. This will allow the pawls to remain in the rack while grouped.

3. Hold the grouping latch in the notch of the intermediate grouping lever.

4. With a spring hook pull the 1 or 5 escapement pawl to the left until the spring lug is felt to strike the bail of the latch releasing lever. The distance the pawl moves should be one unit or slightly less and can be gaged by the movement of the escapement pawl tail across an interposer. It may be necessary to slightly readjust the grouping latch adjusting screw to satisfy this condition.

TABULATION

Adjustments

1. TAB LEVER PIVOT STUD. Adjust for a slight amount of end play to prevent binding of the tab lever (Figure 19).

2. CAM CLEARANCE. Refer to "Spacebar, adjustment 1, Model B1".

3. THE CAM RELEASE LINK should be placed in the front hole of the keylever. Adjust the link to trip the cam when the keylever has completed two-thirds to three-fourths of its downward travel (Figure 20).

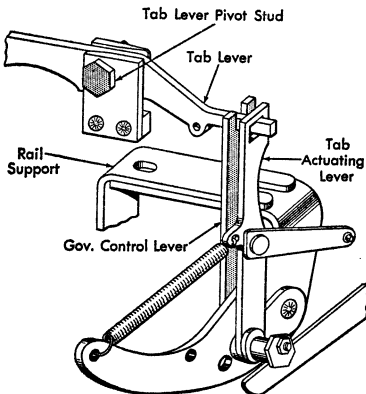

Figure 19. Tab Lever Pivot

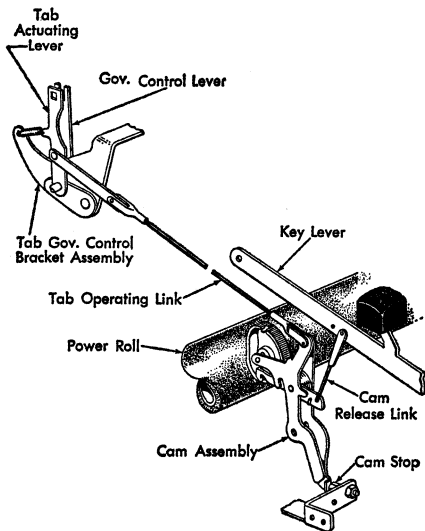

Figure 20. Tab Actuating Mechanism

4. **TAB LATCH KEEPER.** Refer to "Grouping, adjustment 1", this section.

5. **TAB OPERATING LINK.** Refer to "Tabulation, adjustment 6, Model B1".

6. **HEIGHT OF MARGIN CONTROL LEVER.** Refer to "Margin Release, adjustment 1, Model B1".

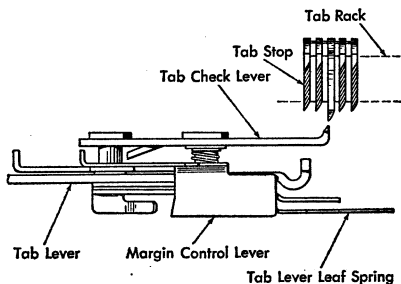

Figure 21. Tab Rack Adjustment

7. **THE TAB RACK** must be adjusted two ways:

a. With the carriage resting on the 2 or 6 escapement pawl, the tab rack should be adjusted left or right until the tip of the tab check lever will be in line with the nearest set tab stop (Figure 21). This adjustment will determine the correct re-entering position of the escapement pawls in relation to the escapement rack teeth upon completion of a tab operation.

b. Position the right end of the rack front or rear by means of its elongated mounting hole so that the tab check lever will take an equal bite on all set tab stops. When tightening the adjusting nuts, maintain the front face of any set tab stop parallel to the tip of the tab check lever and at the same time make sure that the carriage end plates are not sprung.

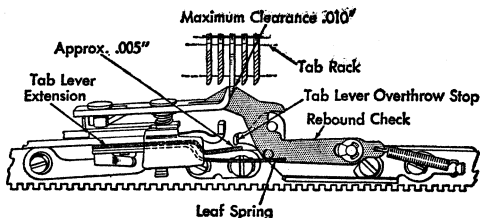

Figure 22. Rebound Check Bracket Adjustment

8. THE REBOUND CHECK BRACKET should be adjusted two ways:

a. Position the bracket left or right so that the rebound check lever will clear the right-hand face of any set tab stop by a maximum of $.010''$ when the left-hand face of the stop is pressed firmly against the tab check lever (Figure 22).

b. Position the bracket front or rear so that when the rebound check is in its operating position and against the pin in its bracket, the leading edge of the rebound check lever will clear the tab rack by $.010''$ to $.015''$ (Figure 22).

9. TAB LEVER EXTENSION. Form this so that, with the tab cam on its high point the extension will clear the tab lever overthrow stop by $.005''$ (Figure 22). Check both cam lobes and adjust to the one which gives maximum throw.

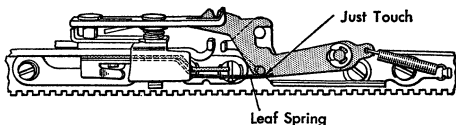

Figure 23. Leaf Spring Adjustment

10. LEAF SPRING. Form to just contact the upright stud of the rebound check lever when the check lever is at rest (Figure 23).

11. PAWL CLEARANCE. Refer to "Grouping, adjustment 3", this section.

12. TAB GOVERNOR PAWL LINK. Refer to "Tabulation, adjustment 9, Model B1".

13. FRICTION GOVERNOR PRESSURE. Refer to "Tabulation, adjustment 10, Model B1". Correct tabulation should not be checked by backspacing. It is suggested that a piece of paper be inserted and long and short tabs be checked by typing the lower case l to be sure a straight column is formed.

14. TAB SET AND CLEAR BRACKET. Adjust by tabulating to a set tab stop and then moving the tab set and clear bracket so that the tab set lever is directly behind that tab stop. Care should be taken not to adjust the bracket too low, because in that position the tab clear lever could damage the tab stop springs.

15. TAB SET LEVER STOP. Refer to "Tabulation, adjustment 12, Model B1".

16. TAB CLEAR LEVER STOP. Refer to "Tabulation, adjustment 13, Model B1".

17. TAB SET AND CLEAR LINKS. Refer to "Tabulation, adjustment 14, Model B1".

CARRIAGE RETURN

Adjustments

1. CAM CLEARANCE. Refer to "Spacebar, adjustment 1, Model B1".

2. THE CAM RELEASE LINK. Refer to "Carriage Return, adjustment 2, Model B1".

3. FRONT CLUTCH LEVER LINK. Adjust so that, with the cam on its high point, the clutch lever will clear the clutch latch by .020" to .025" (Figure 24).

4. REAR CLUTCH LEVER LINK. Adjust with the cam and the carriage return pawl release lever in their rest positions. The link should just span the distance between the clutch lever and the elongated hole of the clutch lever bellcrank (Figure 24).

5. CLUTCH LATCH LINK. Adjust with the cam at rest so that the elongated hole in the clutch latch bellcrank is parallel to the rear rail (Figure 24).

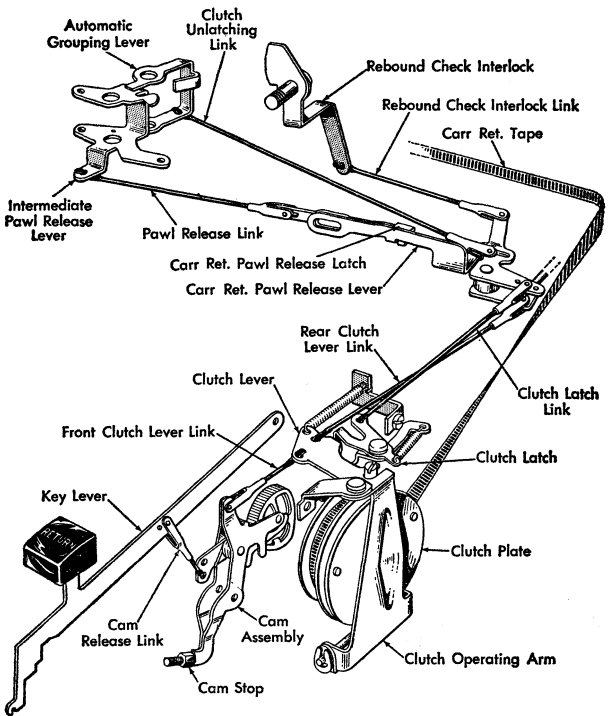

Figure 24. Carriage Return Mechanism

6. REBOUND CHECK INTERLOCK LINK. Refer to "Carriage Return, adjustment 17, Model B1".

7. THE CARRIAGE-RETURN-TAB INTERLOCK should reliably unlatch the clutch whenever the tab lever is moved to its latched position. With the tab lever latched, form the lug on the automatic grouping lever so that it clears the carriage-return-tab interlock by .010" to .015" (Figure 25).

8. MARGIN CONTROL PLATE. Adjust to allow .001" to .004" clearance between the grouping latch and the left side of the notch in the intermediate grouping lever. This clearance is observed when the carriage is held to the extreme right so that the margin control lever is against its final stop (Figure 26).

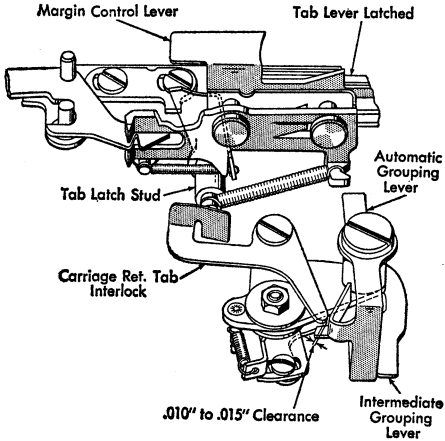

Figure 25. Carriage-Return-Tab Interlock Adjustment

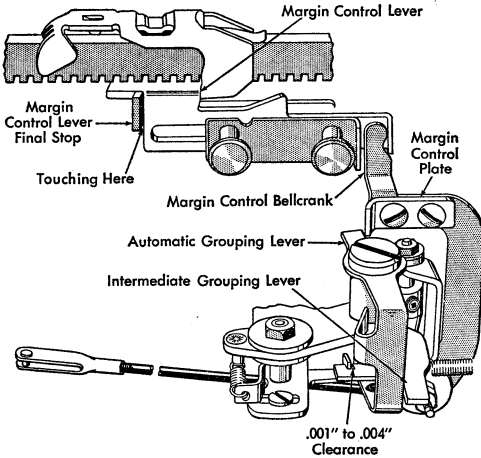

Figure 26. Margin Control Plate Adjustment

9. CLUTCH UNLATCHING LINK. Adjust so that the clutch will unlatch when the margin control lever is $\frac{1}{64}$ " from its final stop (Figure 27).

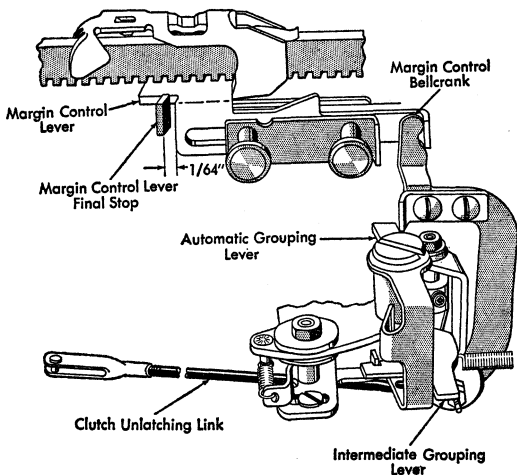

Figure 27. Unlatching Link Adjustment

10. PAWL RELEASE LINK. Adjust so that the escapement pawls clear the escapement rack by $\frac{1}{64}$ " when the clutch is latched (Figure 28).

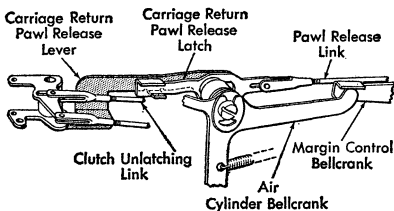

Figure 28. Pawl Release Adjustment

11. MARGIN RACK. Adjust to the left or right so that when the carriage is returned to the left margin there will be $4\frac{1}{2}$ units of overbank between the margin control lever and its final stop (Figure 29). Correct overbank can be observed by counting the number of backspaces in this area. When observing this adjustment, hold the backspace interlock to the rear away from the backspace pawls. Otherwise, the interlock may keep the backspace pawls from operating.

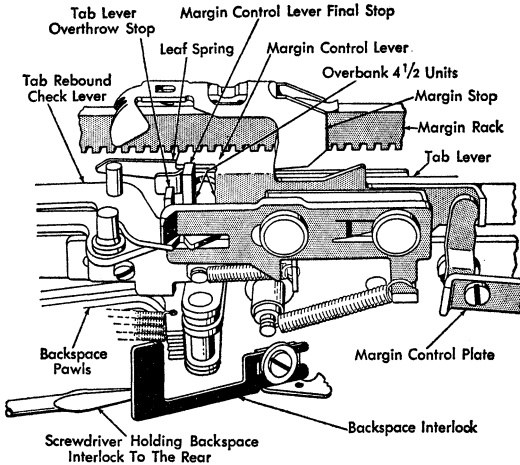

Figure 29. Overbank Adjustment

12. CLUTCH PLATE CLEARANCE. Refer to "Carriage Return, adjustment 18, Model B1".

13. AIR CYLINDER. Refer to "Carriage Return, adjustment 19, Model B1".

14. AIR CYLINDER PORTS AND CLUTCH COMPRESSION SPRING. Refer to "Carriage Return, adjustment 20, Model B1".

15. CLUTCH PULLEY SPRING. Refer to "Carriage Return, adjustment 21, Model B1".

SPACEBARS

Adjustments

1. CAM CLEARANCE. Refer to "Spacebar, adjustment 1, Model B1".

2. CAM RELEASE LINK. Adjust so that the cam will be released when the keylever has completed two-thirds to three-fourths of its downward travel (Figure 30).

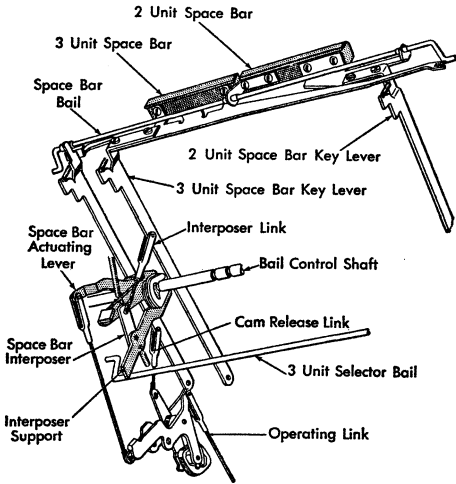

Figure 30. Spacebars

3. THREE-UNIT SPACEBAR INTERPOSER LINK from the keylever is to be adjusted to allow the interposer to clear the top of the formed lug on the spacebar actuating lever by $\frac{1}{32}$ " as the lug passes under the front of the interposer during 2-unit spacebar operation (Figure 31).

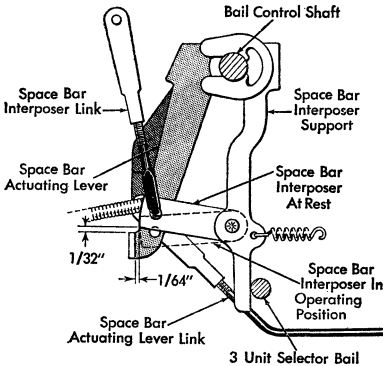

Figure 31. Spacebar Interposer Adjustments

4. **THE LINK FROM THE ACTUATING LEVER** to the cam is to be adjusted so that the back of the lug on the actuating lever clears the spacebar interposer by $\frac{1}{64}$ " as the 3-unit spacebar is depressed (Figure 31).

5. **OPERATING LINK.** Adjust so that just before the spacebar cam reaches its high point, when rotated by hand, it will trip the escapement pawls out of the escapement rack (Figure 30). This adjustment should be checked while holding the 3-unit spacebar depressed. When the operating link is properly adjusted the interposers will move about $\frac{1}{64}$ " farther forward after the last escapement pawl has been tripped.

BACKSPACE Adjustments

1. **PAWL BLOCK ADJUSTING PLATE.** Adjust up

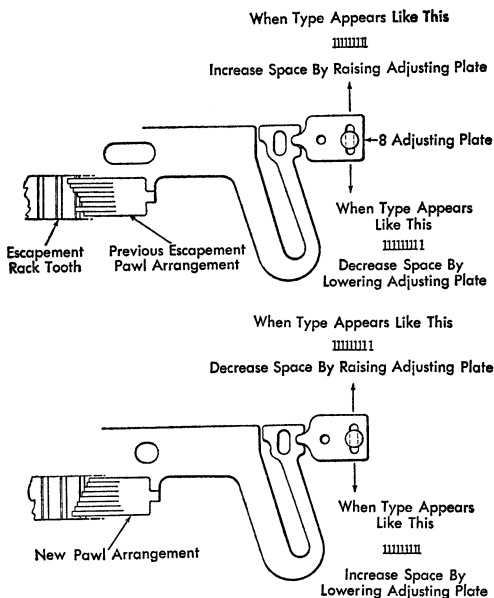

Figure 32. Pawl Block Adjustment

or down to position the escapement pawls perpendicular to a rack tooth. To check for this condition,

type a series of lower case i's, backspacing after each i. Where a difference in spacing between every eighth i exists, the adjusting plate may be moved up or down to correct this condition (Figure 32).

2. BACKSPACE GUIDE-PIN BRACKET. Position this on the rear rail to satisfy two conditions:

a. With the carriage resting on the 5 or 6 escapement pawl for the $\frac{1}{32}$ " escapement, or on the 7 or 8 escapement pawl for the $\frac{1}{36}$ " escapement, the backspace guide pin should guide the backspace pawls into the rack so that the points of the number 4 backspace pawl will bottom evenly between two teeth in the escapement rack (Figure 33).

b. The guide pin must guide the remaining backspace pawls into the escapement rack in the same manner as the 4 backspace pawl. To observe this, place the carriage on an escapement pawl so that when the backspace is operated the 1 backspace pawl will bottom in the rack between teeth. Raise the tails of the 4, 3, 2 backspace pawls to observe an equal clearance as the 1 backspace pawl bottoms in the rack (Figure 34).

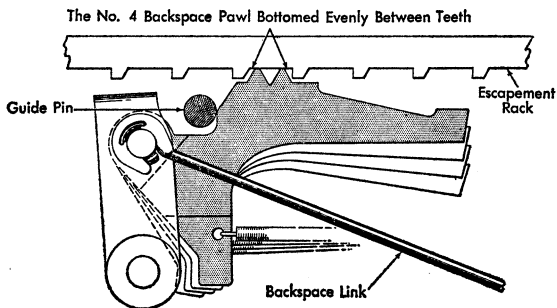

Figure 33. Guide Pin Adjustment

3. CAM CLEARANCE. Refer to "Spacebar, adjustment 1, Model B1".

4. CAM RELEASE LINK. Refer to "Tabulation, adjustment 3," this section.

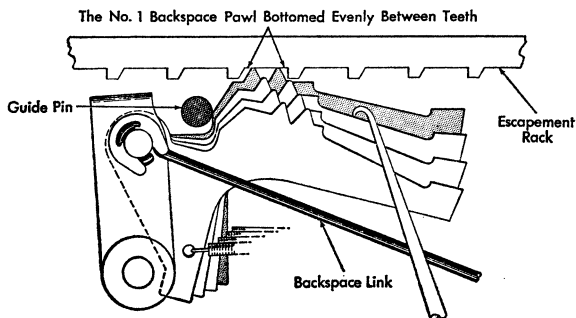

Figure 34. Checking Guide Pin Verticalness

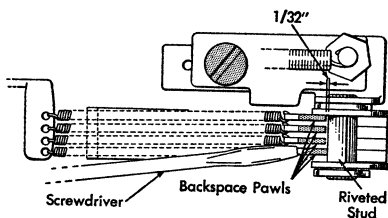

Figure 35. Operating Link Adjustment

5. BACKSPACE OPERATING LINK. Adjust so that when the cam is at rest, the backspace pawl spring lugs will clear the riveted stud in the backspace pawl support by $\frac{1}{32}$ " (Figure 35). If the cam fails to move the carriage far enough to backspace properly, this clearance may be increased slightly.

6. THE PAWL ALIGNING LINK is adjusted to fully align the pawls when the backspace cam is on its high point (Figure 36). Unhook the aligning link and place the backspace cam on its high point. Pull the aligning link to fully align the escapement pawls and match the pin in the clevis to the working side of the elongated hole in the backspace bellcrank. Check for full alignment at the high point of the backspace cam by checking for movement to the left by the escapement pawls when pulled or pushed with a spring hook. There should be no movement, but this may indicate over-alignment. In this case back off one-half turn on the aligning link and check the movement of the escapement pawls again to eliminate any choke-off.

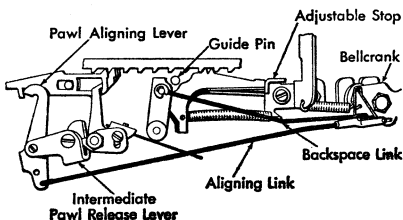

Figure 36. Aligning Link Adjustment

7. BACKSPACE PAWL STOP. Adjust as follows:
 a. Position the carriage to hold on the 1 escapement pawl.

b. Trip the backspace cam with the power off and rotate the power roll by hand while observing the 8 escapement pawl movement. When the 8 escapement pawl drops into the next rack tooth, the backspace pawl stop should be positioned to prevent any further movement of the backspace pawls (Figure 36).

On machines where the escapement pawls are arranged so that the 8 is on top and the 1 on the bottom, the carriage should be held by the 2 escapement pawl while the 1 escapement pawl is observed dropping into the next escapement rack tooth.

If backspace fails after completing the previous adjustments the backspace operating link may be shortened slightly. However, with the cam at rest the backspace pawls should be no less than $\frac{1}{64}$ " from the escapement rack. Any change in the operating link adjustment will necessitate a readjustment of the pawl aligning link and backspace pawl stop to satisfy the conditions previously described for those adjustments. If all adjustments are properly made, $\frac{1}{4}$ " travel should remain on the surface of the cam when the backspace pawls contact their stop.

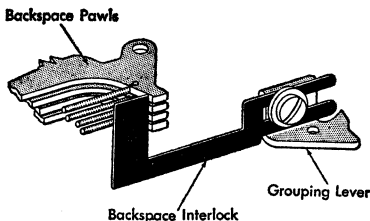

Figure 37. Backspace Interlock Adjustment

8. BACKSPACE INTERLOCK. Adjust so that when actuated, it will safely clear the right side of the backspace pawl spring lugs and keep the backspace pawls out of the escapement rack during any carriage release operation (Figure 37).

ROTARY BACKSPACE

Adjustments

1. CAM CLEARANCE. Adjust the cam stop screw for .010" to .015" clearance between the cam and the power roll. The pawl-carrier link must be disconnected when this adjustment is made.

2. CAM RELEASE. Adjust the cam release link so the the cam will be released after the backspace keylever has been depressed $\frac{2}{3}$ to $\frac{3}{4}$ of its full travel.

3. PAWL BLOCK ADJUSTING PLATE. Refer to "Backspace, adjustment 1," this section.

4. BACKSPACE RACK. Adjust this up or down to obtain equal mesh between the backspace rack and pinion gear (Figure 38). This mesh should be checked at several places along the length of the backspace rack.

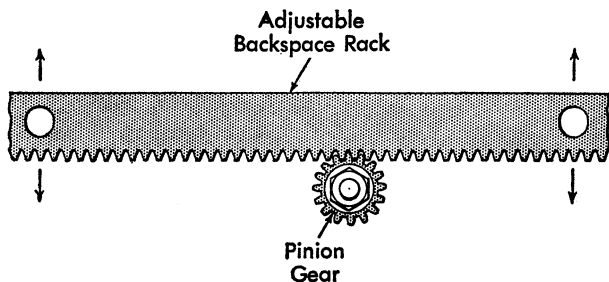

Figure 38. Backspace Rack Adjustment

5. UPPER PAWL STOP. Adjust so that when the backspace pawl is at rest it will clear the ratchet teeth by $\frac{1}{64}$ " to $\frac{1}{32}$ " (Figure 39).

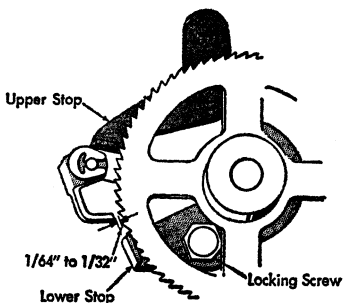

Figure 39. Upper Pawl Stop Adjustment

6. THE BACKSPACE PINION GEAR must mesh properly with the rack teeth (Figure 40). Adjustments may be made by loosening the screw which holds the main bracket to the rear rail just over the ratchet wheel. By loosening this screw slightly, the bracket may be tapped up or down until the pinion gear has a minimum of backlash and will still permit free movement of the carriage, without binding, for the full length of carriage travel. This is a very important adjustment which must be set carefully and critically. The screw must be tightened securely to prevent the adjustment from slipping during operation.

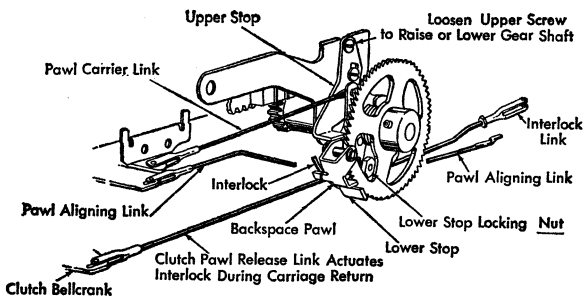

Figure 40. Rotary Backspace Mechanism

7. BACKSPACE PAWL CARRIER LINK. Adjust so that the slot in the bellcrank on the rear rail will lie at a 10 to 20 degree angle with the rear rail when the cam is at rest (Figure 41). **CAUTION.** If the angle is too great the backspace pawl may not be disengaged from the ratchet when the mechanism is at rest.

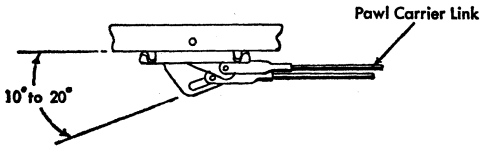

Figure 41. Pawl Carrier Link Adjustment

8. BACKSPACE OPERATING LINK. Adjust to just bridge the gap between the hole in the bellcrank and the backspace cam when the cam is at rest.

9. BACKSPACE RATCHET. Position this on its shaft so that the top surface of the backspace pawl will be even with the point of the ratchet tooth as the pawl enters the ratchet (Figure 42).

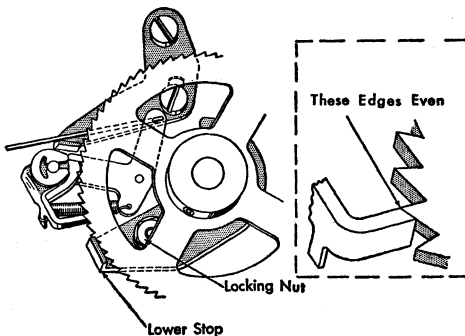

Figure 42. Backspace Ratchet Adjustment

10. ALIGNING LINK. Adjust the aligning link so that the escapement pawls will be fully aligned when $\frac{1}{4}$ " travel remains on the surface of the cam.

11. LOWER PAWL STOP. Set this by partially loosening the hex head locking nut just under the ratchet wheel and tapping the stop up or down (Figure 42). Select a position for the stop where it will limit the motion of the pawl just after the desired escapement pawl drops into the rack tooth and lock the stop in place. The cam should then have about $\frac{1}{4}$ " of travel before passing its high point. If less than $\frac{1}{4}$ " travel remains on the surface of the cam, the pawl

carrier link or operating link may be shortened slightly. After changing this adjustment, be sure there is still $\frac{1}{64}$ " to $\frac{1}{32}$ " clearance between the backspace pawl and the backspace ratchet with all parts at rest.

12. BACKSPACE INTERLOCK LINK. Adjust so that when the backspace cam is on its high point there will be approximately .007" clearance between the backspace interlock and the backspace pawl spring lug (Figure 40).

RIBBON

Adjustments

1. RIBBON CENTER GUIDE. Form this toward the platen as closely as possible. Be careful to avoid the possibility of a bind against the line gage card holder.

2. RIBBON LIFT GUIDE CLEVIS. Adjust so that the diagonal will strike in the middle of the ribbon.

3. CORNER GUIDES. Adjust high enough to relieve strain in the center guide in order to discourage breakage at that point.

4. RIBBON TAKE-UP, Tension of the spring-belt driven take-up mechanism should be sufficient to take up the slack ribbon as it is fed through the feed rollers. If there is insufficient take-up drive, the spring belt should be replaced with a new one.

4a. RIBBON TAKE-UP, Direct Drive. An improved, direct drive take-up mechanism is installed on later model B's. The take-up spool is mounted in such a way as to permit vertical motion. A large disc-shaped pulley, attached to the take-up spool and shaft assembly, runs directly on a rubber-tired pulley which is attached to the power roll pulley. This rotates the take-up spool in a direction opposite to that of previous take-up spools. Variable tension may be obtained by adjusting the hex-headed screw in the power roll pulley against a spring washer. A locking plate on the stud and next to the power roll pulley must be loosened before the screw can be adjusted.

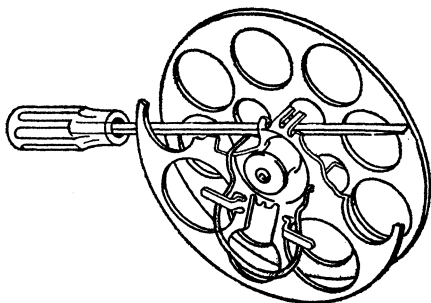

Figure 43. Take-up Tension Adjustments

To measure the tension of the direct drive take-up mechanism, insert the 5" square shank screwdriver in the empty take-up spool as shown (Figure 43). The end of the blade should be flush with the edge of the spool. With the machine turned on, the handle of the screwdriver will remain horizontal if the tension is correct. Check to be certain that the take-up spool is free to move vertically. Too much looseness in the retaining lugs may result in noise. This can be overcome by forming the lugs inward toward the magazine plate.

5. CAM CLEARANCE. Refer to "Ribbon, adjustment 1, Model B1".

6. CAM RELEASE LINK. Refer to "Ribbon, adjustment 2, Model B1".

7. CAM LINK. Refer to "Ribbon, adjustment 3, Model B1".

8. PROPORTIONAL RIBBON FEED. Check this by typing twenty 3-unit or 5-unit characters. The ribbon should feed an equivalent of 23 plus 2 minus 0 of these same characters.

9. SELECTOR BAR LINK. Adjust so that the lower ribbon feed arm will drop off the selector lever when a 4 or 5-unit typebar has completed one-third to one-half of its travel toward the platen (Figure 44).

10. FIVE-UNIT FEED. Adjust by means of the upper adjusting arm. Moving the arm toward the shaft will increase the amount of feed, and away from the shaft will decrease the amount of feed (Figure 44).

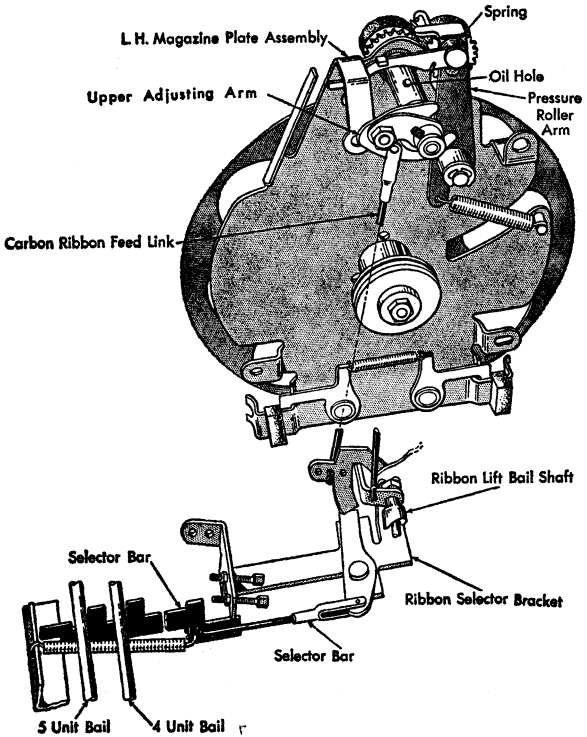

Figure 44. Carbon Ribbon Mechanism

11 THREE-UNIT FEED. Adjust by varying the position of the ribbon selector bracket up or down. Lowering the bracket will increase the amount of feed, while raising it will decrease the feed. Recheck the five-unit adjustment and selector bar link adjustment, and change if necessary (Figure 44).

12. STENCIL CONTROL LINK. Adjust so that with the color control button in the stencil position the ribbon feed cam will not rotate.

CARD HOLDERS

Adjustments

1. LINE GAGE CARD HOLDER. Adjust so that the horizontal edge is parallel with the feet of the type characters. When viewed from the operators position, a thin line of white should be visible between the feet of the characters and the reference edge of the card holder.

2. FRONT RAIL DUST COVER. For machines without a Repositioning Indicator move the front rail dust cover left or right until the card holders serve as a position finder. Test for proper position by placing the right side of any typed character even with the vertical edge of the right card holder. Space according to the following table and type the next succeeding character (Figure 45).

Pitch	Units
$\frac{1}{32}$ normal	12
$\frac{1}{32}$ expanded	13
$\frac{1}{36}$ normal	14
$\frac{1}{36}$ expanded	15
$\frac{1}{45}$ normal	16
$\frac{1}{45}$ expanded	17

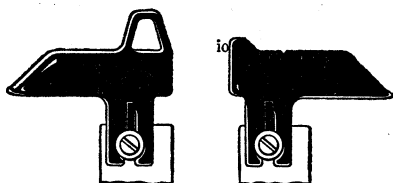

Position the "o" as shown above

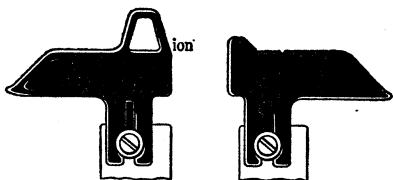

Space the Carriage 12 units and type the "n"

Figure 45. Card Holder Position

2a. FRONT RAIL DUST COVER, REPOSITIONING INDICATOR. For machines with a Repositioning Indicator adjust the front rail dust cover left or right until the raised indicator just clears the right edge of the last typed character (Figure 46). Cut the wire to a length so that the top of the wire in the raised position is even with the top of an upper case character such as the capital N.

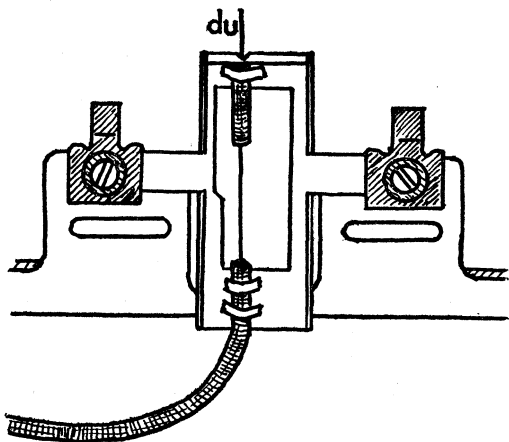

Figure 46. Repositioning Indicator

FRONT PAPER SCALE

Adjustments

- 1. FRONT PAPER SCALE.** With the left margin stop at its extreme left position and with the carriage resting at the margin, adjust so that the zero position on the scale will be aligned with the indicating pointer (cable pointer for machines with a Repositioning Indicator) on the dust cover.
- 2. FRONT PAPER TABLE.** Refer to "Paper Feed, adjustment 4, Model B1".

IBM EXECUTIVE TYPE STYLES

IDENT. MARK	TYPE CODE	TYPE STYLE	ESCAPE-MENT	APPROX. POINT SIZE	RATCHET TEETH	PLATEN	
						CLOTH RIBBON	CARBON RIBBON
PO	16	Bold Face No. 1	1/32"	12	29	8	8
PS	26	Secretarial	1/32"	12	29	2	1
PM	32	Modern	1/32"	10	29	8	2
PE	40	Documentary	1/32"	11	29	8	2
PG	46	Copperplate Gothic	1/36"	12 & 6	29	8	2
PH	47	Text	1/45"	9	33	2	1 or 2
PF	50	Mid-Century	1/36"	12	29	8	2 or 8
PR	51	Charter	1/45"	8	33	2	1 or 2
PB	57	Bold Face No. 2	1/36"	10	29	8	2
PT	59	Bold Face Italic	1/32"	12	29	8	2 or 8
PJ	61	Heritage	1/36"	10	29	8	2
PN	65	Registry	1/36"	12	29	2	2
PK	66	Directory	1/32"	14	44	8	8
PV	71	Testimonial	1/32"	12	29	8	8
JM	79	Arcadia	1/32"	10	29	2	2

MODEL B4

CUSTOMER ENGINEERING

40

UNIT WIDTH CHART

BOLD FACE #1, BOLD FACE ITALIC, DOCUMENTARY, MODERN, SECRETARIAL ($\frac{1}{32}$ " unit types) or **BOLD FACE #2** ($\frac{1}{36}$ " unit type)

All lower case alphabetical characters, and numbers, period and comma, are 3 units except:

flitj—2 units w—4 units m—5 units

All upper case alphabetical characters are 4 units except:

I—2 units SJ—3 units WM—5 units

ARCADIA ($\frac{1}{32}$ " unit type)

All lower case alphabetical characters, and numbers, period and comma, are 3 units except:

flitjr—2 units mw—4 units

All upper case alphabetical characters are 3 units except:

IJ—2 units CDGHNOQU—4 units MW—5 units

DIRECTORY ($\frac{1}{32}$ " unit type)

All lower case alphabetical characters, and numbers, period and comma, are 3 units except:

flitj—2 units hnuw—4 units m—5 units

All upper case alphabetical characters are 4 units except:

FLITJE—3 units MW—5 units

HERITAGE ($\frac{1}{36}$ " unit type) or **TESTIMONIAL** ($\frac{1}{32}$ " unit type)

All lower case alphabetical characters, and numbers, period and comma, are 3 units except:

flitj—2 units w—4 units m—5 units

All upper case alphabetical characters, are 4 units except:

IJ—2 units SBP—3 units WM—5 units

MID-CENTURY ($\frac{1}{36}$ " unit type)

All lower case alphabetical characters, and numbers, period and comma, are 3 units except:

flitsjr—2 units wm—4 units

Upper case alphabetical characters are mainly 3 and 4 units, as shown below:

I—2 units HAYCUDKVXZ—4 units

BESTFJLPR—3 units NOWGMQ—5 units

COPPERPLATE GOTHIC ($\frac{1}{36}$ " unit type)

All lower case alphabetical characters are 3 units except:

ij—2 units mw—4 units

All upper case alphabetical characters are 1 unit larger than lower case, except for "I" which is 2 units in both cases.

Numbers, period and comma are 2 units in the lower case, 3 units in the upper case.

REGISTRY ($\frac{1}{36}$ " unit type)

All lower case alphabetical characters, period and comma, are 3 units except:

flitjr—2 units mw and all numbers—4 units

All upper case alphabetical characters are 4 units except:

I—2 units J—3 units MW—5 units

CHARTER ($\frac{1}{45}$ " unit type)

All lower case alphabetical characters, and numbers, period and comma, are 3 units except:

flitsjr—2 units w—4 units m—5 units

All upper case alphabetical characters are 4 units except:

IJ—2 units BEFLPSZ—3 units MW—5 units

TEXT ($\frac{1}{45}$ " unit type)

All lower case alphabetical characters, and numbers, period and comma, are 3 units except:

flitsjr—2 units w—4 units m—5 units

All upper case alphabetical characters are 4 units except:

IJ—2 units BEFLPRS—3 units MW—5 units

IBM

ELECTRIC TYPEWRITERS

MODELS C4 and C5

Executive

CUSTOMER ENGINEERING

REFERENCE MANUAL

Mechanical Principles and Adjustments

CONTENTS

	<i>Page</i>
Features Common to Model C1	3
Carriage and Rails	3
Selection and Escapement	4
Grouping	5
Tabulation	5
Carriage Return	7
Space Bars	10
Proportional Carbon Ribbon Feed	10

INTERNATIONAL BUSINESS MACHINES CORP.

NEW YORK 22, NEW YORK

Form 241-5003-0 (this section only)

© 1958 by
INTERNATIONAL BUSINESS MACHINES CORP.
590 Madison Avenue, New York 22, New York
Printed in U. S. A. 1958
Form 241-5003-0

ELECTRIC TYPEWRITERS

MODELS C4 and C5

(Serial 2,001,000 and above)

FEATURES COMMON TO MODELS C1 and B4

Several mechanisms of the Executive Typewriter Model C4 are common to either the Standard Model C1 and/or the Executive Model B4 with floating interposers. These mechanisms are listed below and will not be repeated in this section.

Case and Cover Sections
Keylevers, Letter Cams, Typebars
Resilient-Keyboard Control
Margin Reset
Margin Release
Paper Feed
Decelerator
Backspace
Ribbon, Fabric
Shift

CARRIAGE and RAILS

The Model C4 typewriter uses the Model C1 carriage. The rails are similar to the Model B4 but have been redesigned to incorporate the decelerator and other Model C1 improvements.

Removal

1. Remove the rear cover.
2. Remove the three interposer-bellcrank links and their springs.
3. Remove the interposer-bellcrank guide-comb.
4. Disconnect the tab operating link.
5. Disconnect the expander link, at the rear.
6. Unhook the escapement trip link.
7. Disconnect the backspace operating link at the bellcrank.
8. Disconnect the clutch unlatching link.
9. Remove the margin-reset lever assembly.
10. Disconnect the carriage tension-tape at the carriage.
11. Disconnect the carriage-return tape at the carriage.
12. Remove the four rail mounting screws and position the carriage at the extreme right.
13. Lift the carriage straight up while rotating it slightly to the right. Watch the interposer bellcranks carefully so as to avoid interference with other parts.

Adjustments

Refer to Model B1, Rail Adjustments.

SELECTION and ESCAPEMENT

The Model C4 selection and escapement mechanisms are the "Floating" interposer style with the escapement pawls arranged in numerical order. These mechanisms are functionally unchanged from the Model B4; however, the removal procedure and adjustment sequence have been altered because of the redesigned rear rail.

Removal

INTERPOSERS

The interposer cage assembly may be removed from the left rail-brace after first removing the carriage and rails as an assembly.

PAWL BLOCK ASSEMBLY

1. Remove the rear case and both carriage end-covers.
2. Remove the tab rack and margin rack.
3. Disconnect the pawl-aligning link, pawl-release link, and clutch-unlatching link.
4. Disconnect the pawl-aligning-lever spring.
5. Disconnect the tab check-lever spring.
6. Disconnect the tab latch spring.
7. Remove the spring from the escapement-pawl stop-strap to the interposer cage.
8. Remove the margin-control bellcrank.
9. Block the carriage to prevent movement and remove the two pawl-block mounting screws. The assembly may then be removed from the rear of the machine.

Adjustments

1. **BAIL SHAFT LINK.** Refer to Model B4, Selection Adjustment 2.
2. **SELECTOR - BAR - SUPPORT MOUNTING-PLATES.** Refer to Model B4, Selection, Adjustment 3.
3. **SELECTOR-BAR GUIDE-COMB.** Refer to Model B4, Selection, Adjustment 4.
4. **LOWER INTERPOSER - BELLCRANK GUIDE-BRACKET.** Refer to Model B4, Selection, Adjustment 5.
5. **INTERPOSER TO PAWL CLEARANCE.** Refer to Model B4, Floating Interposers, Adjustment 1.
6. **INTERPOSER VERTICALNESS.** Refer to Model B4, Floating Interposers, Adjustment 2.

7. **EXPANDER BELLCRANK.** Refer to Model B4, Floating Interposers, Adjustment 3.
8. **EXPANDER BELLCRANK ARM.** Refer to Model B4, Floating Interposers, Adjustment 4.
9. **TRIP LINK.** Refer to Model B4, Floating Interposers, Adjustment 5.

GROUPING

The grouping mechanism is identical with the late Model B4 machines. The adjustment procedure is altered due to the new tab mechanism.

Adjustments

1. **TAB LATCH ECCENTRIC.** Refer to Model C1, Tabulation, Adjustment 5.
2. **INTERMEDIATE PAWL-RELEASE LEVER.** Refer to Model B4, Grouping, Adjustment 2.
3. **PAWL CLEARANCE.** Refer to Model B4, Grouping, Adjustment 3.
4. **PAWL-RELEASE LEVER.** Form the angular tip at the left end of the pawl-release lever so that there is a clearance of .001" to .005" between the angular tip and the tab lever with the parts in their rest positions (Figure 1).

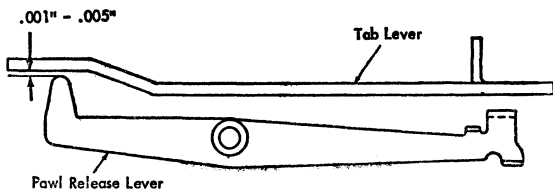

Figure 1. Pawl Release Lever

5. **GROUPING CONE.** Refer to Model B4, Grouping, Adjustment 4.
6. **GROUPING LEVER.** Refer to Model B4, Grouping, Adjustment 5.
7. **GROUPING LATCH MOUNTING STUD.** Refer to Model B4, Grouping, Adjustment 6.
8. **GROUPING LATCH ADJUSTING PLATE.** Refer to Model B4, Grouping, Adjustment 7a.

TABULATION

Model C4 executive tabulation varies from the Model C1 standard only in the area of the pawl-release-lever. This lever extends beyond its fulcrum point to the end of the tab-lever providing a smoother pawl release operation (Figure 2).

The same tab-lever is used on all pitch machines.

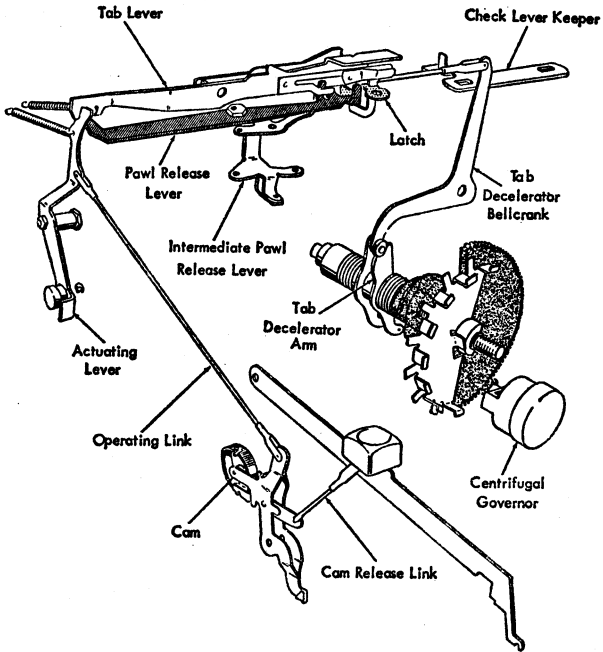

Figure 2. Tabulation

Adjustment

1. TAB-LEVER PIVOT-STUD. Refer to Model B4, Tabulation, Adjustment 1.

2. CAM CLEARANCE. Refer to Model C1, Space Bar, Adjustment 1.

3. CAM RELEASE LINK. Place the link in the lower hole of the release lever and the rear keylever-hole. Adjust the clevis to trip the cam when the keylever is depressed $\frac{1}{2}$ to $\frac{3}{4}$ of its downward travel.

4. TAB RACK. The tab rack must be carefully adjusted to satisfy three conditions:

A. LEFT TO RIGHT. With the carriage resting on the 1 or 5 escapement pawl, adjust the tab rack left or right until the tip of the tab check-lever is in line with the working surface of a set tab stop. The tab

check-lever must be held in its extreme left position when observing this adjustment (Figure 3).

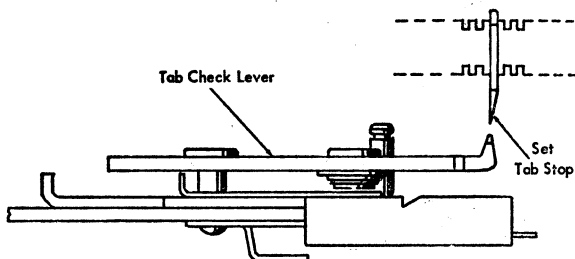

Figure 3. Tab Adjustment 4A

- B. PARALLEL TO RAILS.** Refer to Model C1, Tabulation, Adjustment 4B.
- C. PARALLEL TO CHECK LEVER.** Refer to Model C1, Tabulation, Adjustment 4C.
- 5. TAB LATCH ECCENTRIC.** Refer to Model C1, Tabulation, Adjustment 5.
- 6. TAB LATCH EXTENSION.** Refer to Model C1, Tabulation, Adjustment 6.
- 7. TAB CHECK-LEVER KEEPER.** Refer to Model C1, Tabulation, Adjustment 7.
- 8. OPERATING LINK.** Refer to Model C1, Tabulation, Adjustment 8.
- 9. TAB LEVER EXTENSION.** Refer to Model C1, Tabulation, Adjustment 9.
- 10. PAWL RELEASE LEVER.** Refer to Model B4, Grouping, Adjustment 3, and Model C4, Grouping, Adjustment 4.
- 11. DECELERATOR LINK.** Refer to Model C1, Tabulation, Adjustment 11.
- 12. CENTRIFUGAL GOVERNOR.** Refer to Model B1, Tabulation, Adjustment 10a.
- 13. TAB SET and TAB CLEAR.** Refer to Model B1, Tabulation, Adjustment 11, 12, 13, and 14.

CARRIAGE RETURN

The Model C4 carriage return employs the decelerator and improved clutch latch used on the Model C1 (Figure 4).

A simplified linkage permits the escapement pawls to remain in the escapement rack during repeat line spacing at the left margin. The pawl-release link ex-

tends from the clutch-latch bellcrank to the intermediate pawl-release bellcrank, that is riveted to the intermediate-pawl-release lever. This bellcrank extends toward the rear and engages a lug on the margin-control bellcrank. With the margin-control bellcrank in its rest position a pull on the pawl-release link rotates the intermediate-pawl-release lever assembly causing pawl release.

When the carriage is at the left margin the margin-control bellcrank is in its operated position. A pull on the pawl-release link at this time will rotate the intermediate-pawl-release bellcrank about its mounting rivet without operating the intermediate-pawl-release lever or causing pawl release.

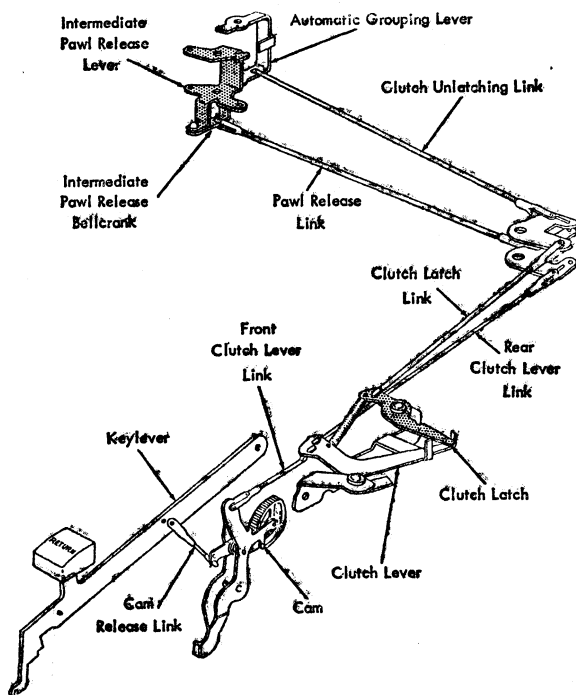

Figure 4. Carriage Return Mechanism
Adjustments

1. CAM CLEARANCE. Refer to Model C1, Space Bar, Adjustment 1.

2. **CAM RELEASE LINK.** Refer to Model C1, Carriage Return, Adjustment 2.
3. **FRONT CLUTCH LEVER LINK.** Refer to Model C1, Carriage Return, Adjustment 3.
4. **REAR CLUTCH LEVER LINK.** Refer to Model C1, Carriage Return, Adjustment 4.
5. **CLUTCH LATCH LINK.** Adjust the link so that with the clutch unlatched the slot in the bellcrank is parallel to the rear rail.
6. **MARGIN CONTROL PLATE.** Refer to Model B4, Carriage Return, Adjustment 7.
7. **CLUTCH UNLATCHING LINK.** Refer to Model C1, Carriage Return, Adjustment 6.
8. **MARGIN CONTROL BELLCRANK STOP.** Position the eccentric washer so that the intermediate-pawl-release bellcrank engages the ear on the margin control bellcrank by the thickness of its own metal. The carriage should be away from the left margin when checking this adjustment (Figure 5).

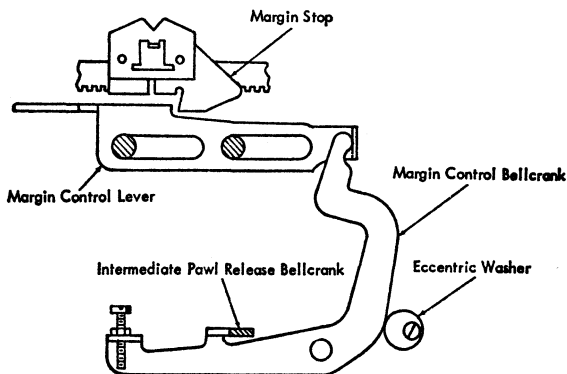

Figure 5. Margin Control Bellcrank Stop

9. **PAWL RELEASE LINK.** Refer to Model B4, Carriage Return, Adjustment 9.
10. **MARGIN RACK.** Refer to Model B4, Carriage Return, Adjustment 10.
11. **CLUTCH PLATE CLEARANCE.** Refer to Model B1, Carriage Return, Adjustment 18.
12. **COMPRESSION SPRING.** Refer to Model C1, Carriage Return, Adjustment 12.
13. **MARGIN CONTROL DECELERATOR SCREW.** Refer to Model C1, Carriage Return, Adjustment 13.

14. CARRIAGE RETURN TAB INTERLOCK. Refer to Model B4, Carriage Return, Adjustment 6.

SPACEBAR

The Model C4 spacebar mechanism is the same as that used on the Model B4. The three unit spacebar incorporates the repeat/non-repeat mechanism.

Adjustments

- 1. CAM CLEARANCE.** Refer to Model C1, Spacebar, Adjustment 1.
- 2. CAM RELEASE LINK.** Adjust the cam-release link so that the cam will repeat when the spring loaded plunger is depressed $\frac{1}{16}$ ".
- 3. STOP BRACKET.** Adjust the three-unit spacebar stop bracket to allow the cam to reset just before the keylever contacts the stop bracket.
- 4. THREE-UNIT SPACEBAR INTERPOSER LINK.** Refer to Model B4, Spacebar, Adjustment 3.
- 5. ACTUATING LEVER LINK.** Refer to Model B4, Spacebar, Adjustment 4.
- 6. OPERATING LINK.** Refer to Model B4, Spacebar, Adjustment 5.

PROPORTIONAL CARBON RIBBON FEED

The proportional carbon-ribbon feed employed on the Model C4 typewriter is a combination of the Model C1 carbon-ribbon mechanism and the proportional carbon-ribbon feed selector-mechanism used on the Model B4 machines.

Adjustments

- Refer to Model C1, Carbon Ribbon mechanism for the supply and take-up spool adjustments.
- Refer to Model B4, Proportional Carbon Ribbon, Adjustments 8 through 12 for the selector mechanism.



**ELECTRIC TYPEWRITERS
MODEL 6**

Electric Formswriter

CUSTOMER ENGINEERING REFERENCE MANUAL

CONTENTS

MACHINE FEATURES

	<i>Page</i>
Formscarrier Attachment	3
Carbon Blades	5
Ordering Blades	7
Lift Platen	7
Threading Forms	7
Removal and Adjustment Procedure	8
Formscarrier Attachment	8
Lift Platen Carriage	10
Backspace	12

**INTERNATIONAL BUSINESS MACHINES CORP.
NEW YORK 22, NEW YORK**

Form 25-6017-1 (This section only)

**Copyright 1957 by
International Business Machines Corporation
590 Madison Avenue, New York 22, N. Y.
Printed in U.S.A. June 1957
Form 25-6017-1**

IBM Electric Formswriter

Model 6

MACHINE FEATURES

All of the features of the standard electric typewriter are incorporated in the Electric Formswriter except the multiple copy control. Additional features include a lifting platen, forms carrier attachment and a tear-off knife. A leading edge gage or a register pin assembly is optional. Continuous forms of either the fanfold or open web design may be used. The Formswriter handles sheet carbon up to 28 inches in length, or carbon packs, and provides for slitting fanfold forms as desired.

The Formscarrier

The front of the formscarrier is attached to nylon bushings on the carriage tie rod by means of 2 latches. A wheel truck, with 2 nylon wheels, is located under the middle of the formscarrier and rides on a rail on the formscarrier support (Figure 1).

The formscarrier support is mounted to the typewriter by engaging two adjustable brackets mounted on the left and right side frames.

A truck, equipped with 10 nylon rollers mounted in pairs, rides on 3 rails that are a part of the body of the formscarrier. The truck is operated by a telescopic, adjustable handle. The telescoping handle is held in position by a pin seated in any one of a series of holes in the bottom of the larger handle section. The pin is released by a wire trigger on the back of the knob. This trigger extends through to the rear end of the inner section and is so formed that it disengages the pin from the holes by a lift camming action.

A carbon shift stop, similar to a margin stop, is located on a toothed rack on the top of the formscarrier. The stop serves to limit the movement of the truck to the rear. By moving the truck to the rear, against the carbon shift stop, a clockwise twist of the knob disengages the stop and permits it to be moved front or rear with the truck, to a new location. The telescopic arm should be shortened and the carbon shift stop reset, each time the operator tears off a portion of used carbon paper.

Two form guides, on the rear form guide assembly, position the form on the carrier. The form guides have small wrench like handles which allow the guides to be manually adjusted from right to left.

Blades for supporting the carbon sheets or packs are carried on slotted posts attached to a blade support. The

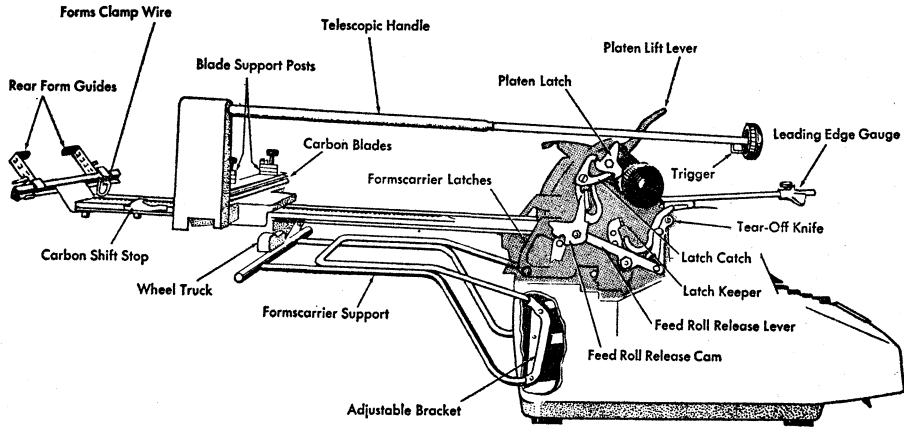

Figure 1. Electric Formwriter

blade support is attached to the truck by two positioning pins. The positioning pins, located under the blade support, are of different sizes. This assures the proper positioning of the blade support on the truck. The dimensions and spacing of the pins are the same as those used on former model formwriters.

Blade support assemblies are available in two styles; the 8-blade support assembly, accommodating up to a 9-part form, and the 16-blade support assembly which can support up to a 17-part form. Either style is available in 12" or 16" width.

The 12" size is for forms ranging up to 9-1/4" in width with slitters, or up to 9-5/8" without slitters. The 16" size is for forms ranging up to 13-1/4" in width with slitters, or up to 13-5/8" without slitters. Fanfold or open web forms may be used, each of which requires a different style of blade.

Carbon Blades

FANFOLD BLADES are used to hold carbon paper within the folds of a fanfold form. The alternate folding back and forth of the fanfold form paper resembles a fan in its design. The purpose of the folds is to keep the parts of the form in proper register. Fanfold blades are supported on one end, by one blade support. The free end of the fanfold blade must clear the inside folded edge of the form by 1/4" to 5/16" (Figure 2). The form guides must be positioned correctly so this clearance can exist. The clearance is necessary to permit free carbon shifting within the form.

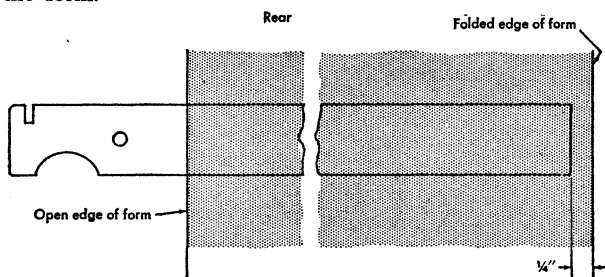

Figure 2. Fanfold Blade

SLITTER BLADES are used when it is necessary to separate the parts of a fan fold form. This is accomplished by the slitter blades during the carbon shifting operation. Slitter blades are supported on both ends by both blade

supports. The form guides should be adjusted so the edge of the form will bisect the edge of the slit (Figure 3).

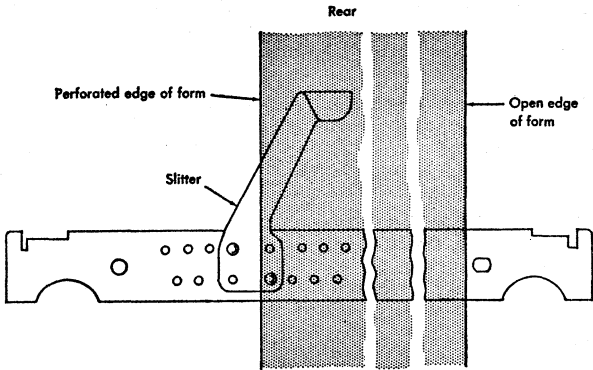

Figure 3. Slitter Blade

OPEN WEB BLADES are supported at both ends in the same manner as slitter blades for fanfold forms. Open web forms are so called because the web of forms and carbon paper is open at the edges, and registration is accomplished either by means of a register pin or visually by the operator. Open web forms may also be registered by using a pin feed platen if the forms have perforations along the sides.

A rivet in one of the holes in the open web blade serves as a marking for the edge of the carbon paper and the form (Figure 4). The edge of the carbon paper should

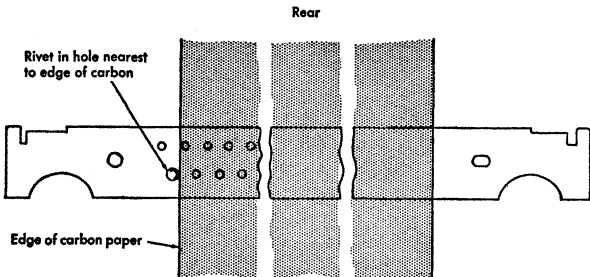
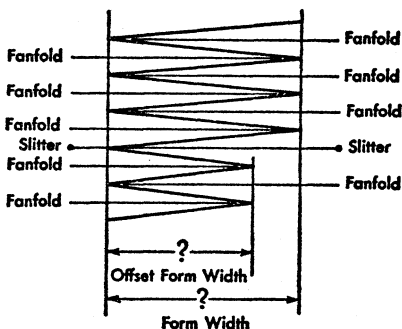

Figure 4. Open Web Blade

be aligned to the rivet in the blade when the carbon paper is attached to the blade. The form guides should align the form with the rivet marker so the form corresponds with the carbon paper.

Ordering Blades

It is necessary to provide accurate and complete information when ordering blades because of the many form designs. A sample of the form should be submitted with an order for blades. If a sample cannot be secured, an accurate sketch should accompany the order, indicating clearly the dimensions of each part of the form (Figure 5).



Form Face Down, Front View of Leading Edge

Figure 5. Sketch to Accompany Order for Blades

The sketch should also include the direction from which the sketch is shown (i.e., as the forms lie on the carrier, face down, the front view of their proper arrangement should be shown).

Lift Platen

THE PLATEN MAY BE RAISED by means of the lift lever, to allow the carbon to be pushed back to the next form. Because of this feature, thin hooked-wire springs are used to fasten the deflectors to the equalizing shaft. The platen is then lowered into position where it is securely latched and locks the tear-off knife in place. The tear-off knife is 15/16" above the writing line.

As the platen is being latched, the feed roll and deflector assembly is held down and away from the platen. As soon as the latches are in place, the feed roll and deflector assembly restores to its working position against the platen.

Threading Forms

Place the truck at the extreme rear, with the blade support in place, and the carbon blades assembled to it. The forms should be threaded forward between the rear form guides far enough to reach the top cover of the typewriter. Hold the forms in place by catching the right-

hand edge of the forms under the form clamp wire which slides out of the rear form guide. Position the form guides on the rear form guide assembly so the form parts feed properly into the carbon blades. Move the truck to the front of the carrier. Again position the form properly to the carbon blades and align the front form guides, located on the tear-off knife, to the edges of the form. Front and rear form guides should be set to the width of the form, allowing a clearance of about $1/32$ " at the edges.

The carbon blades should be loaded with carbon, either in sheets or in packs, by placing the fold over the blade and attaching a clip. The carbon side should face up and the carbon sheets should be clipped on the blades squarely. If there is a tendency for the carbon to run out of either side of the form, the carbon should be shifted on the blade slightly off from square. Set the carbon shift stop to allow the carbon to be shifted to a point approximately $5/8$ " below the next form.

Most applications require a heavier carbon sheet or a blank sheet behind the original form, to prevent the type from embossing the form. The supply of forms should always be located as high as possible under the rear form guide to facilitate paper feed and to insure faultless line spacing.

REMOVAL AND ADJUSTMENT PROCEDURE

Formscarrier Removal

THE FORMSCARRIER may be removed from the Formswriter by pressing inward and raising the small latches on the front formscarrier bracket, where it rests on the carriage tie rod bushings.

The formscarrier support may be removed by springing the frame of the support outward far enough to disengage the support from the mounting brackets.

Formscarrier Adjustments

1. THE FORMSCARRIER SUPPORT is adjusted by shifting its brackets on the elongated holes, where they attach to the side frames, until the bottom bracket holes have been moved to the rear. This adjustment will raise the rear of the formscarrier, aiding paper feed, since the carbon truck will run easily downward toward the front of the machine. Removal of the rear cover will be necessary for this adjustment.

2. THE TWO-WHEELED TRUCK attached to the bottom of the carrier by means of screws in elongated holes, should be adjusted forward or backward until its nylon rollers rest centrally on the rail of the formscarrier support. This adjustment is observed with the formscarrier latched to the formswriter.

3. THE FORMSCARRIER LATCHES are latched to nylon bushings on the carriage tie rod. The left-hand bushing has an elongated hole which permits the carriage to escape independently of the formcarrier to avoid piling. The right-hand bushing has a round hole and is mounted between two collars. One of the collars is positioned on the tie rod so the forms will be properly centered on the platen when the loaded truck is at the front of the carrier. The second of the collars should be set to permit the nylon bushing to have $3/32$ " side play. This adjustment of the collars is the most favorable for a free escapement of the carriage. If carriage rebounding trouble occurs during tabulation, the $3/32$ " side play may be reduced, gradually, until rebounding is eliminated. Other tabulation adjustments should be checked before reducing this clearance. At least $.005$ " side play should exist under any circumstances. It is possible to set the collars to suit the application, depending on whether escapement or tabulation is the prime factor.

4. THE NYLON TRUCK ROLLERS are adjusted to allow the truck to ride freely, with a minimum of side play on the carrier track. The rollers are adjusted by means of an eccentric mounting screw for each pair of rollers.

5. THE POSITIONING STRAPS on the blade support posts should be adjusted to remove excess motion of the carbon blades in the support posts.

6. THE BLADE SUPPORT POSTS should be positioned so the carbon blades are held parallel to the blade support. This adjustment can be made by loosening the blade support post mounting screws and turning the post. Fanfold forms require the blades be positioned so the carbons are directed slightly toward the inside fold.

7. THE LEADING EDGE GAGE (Figure 1) should be adjusted so that by holding the forms tight to the knurled plate when closing the platen, the tear-off line will fall directly along the tear-off knife. This should place the first writing line of the machine $15/16$ " from the top edge of the form provided the forms have been made to this standard. This is a fixed dimension and cannot be altered by adjustment. Positioning of the form on the leading edge gage is accomplished with the carriage at the margin so the center of the form is in line with the gage. The leading edge gage and register pin assembly attachments require a top cover drilled and fitted with a latch on the right hand corner.

8. THE REGISTER PIN ASSEMBLY (Figure 6) may be attached to the top cover for use with perforated, open web forms when the leading edge gage is not desired. By placing the perforations of the next successive form over the pins before closing the platen, the form parts are

brought into register. Springs on the pins permit them to be folded down when not in use.

The pins are set to accommodate forms with perforations measuring 2-3/4" between centers and are available in pin sizes of 7/32", 9/32" and 11/32" to fit holes of 1/4", 5/16" and 3/8" respectively.

An adapter bracket for the register pin assembly permits use of the same top cover as that for the leading edge gage.

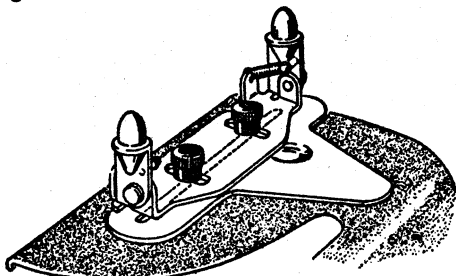

Figure 6. Register Pin Assembly

Lift Platen Removal

The lift platen may be removed from the platen lift arms by loosening the screws that hold the retaining clips on the platen bushings. Removal of the platen is recommended when making adjustments on the rear rail.

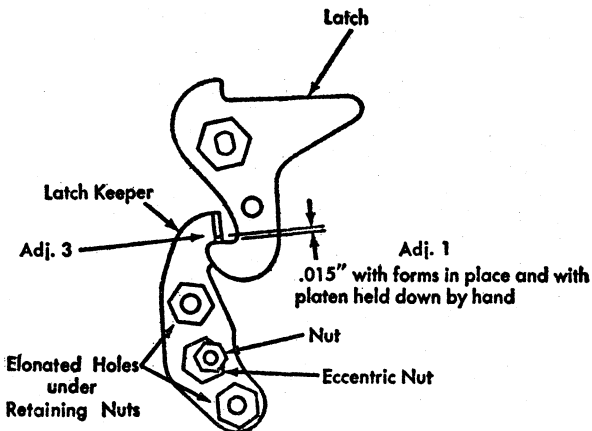

Figure 7. Latch Keepers Adjustment

Lift Platen Adjustments

1. **THE LATCH KEEPERS** should be adjusted to the thickness of the forms being used. With the forms in the machine, the platen should latch with .015" clearance between the latches and the lower edges of the latch keepers. This clearance is observed with the platen pressed down by hand on first one side and then the other (Figure 7). The keepers are adjusted by loosening the two locking nuts and the locking nut on the stud that holds the eccentric nut. Turn the eccentric nut until the keeper is positioned correctly.

2. **THE RING AND CYLINDER** adjustment is made by setting the double screws, located on the inside of the platen lift arms (Figure 8). When making this adjustment the form should be in the typewriter and the retaining nuts loosened.

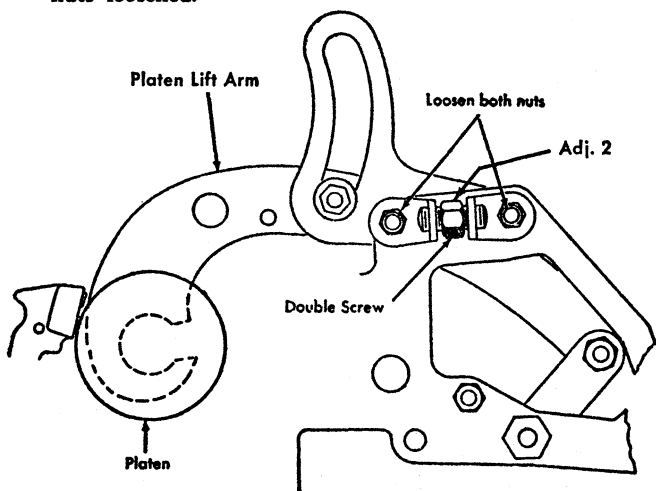

Figure 8. Lift Platen Ring and Cylinder Adjustment

3. **THE ECCENTRIC STUD** on the platen lift lever should be adjusted with the platen latched down, so the latches will rest half-way under the keepers (Figure 7).

4. **THE LATCH CATCH** works in conjunction with the latch and the trigger to time their operation. The latch catch is attached to the left hand platen lift lever (Figure 9).

a. The eccentric stud which supports the latch catch is adjusted by loosening the nut on the inside of the stud

and rotating the stud until the latches just clear the front surface of the keepers as the platen is lowered (Figure 9).

b. If one latch clears its keeper by more than the other, the keeper may be shifted forward or back on its mounting screws.

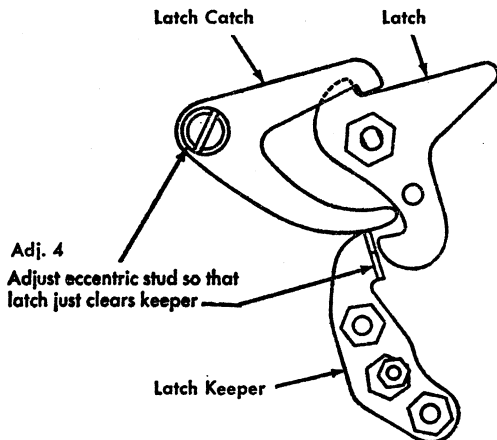

Figure 9. Latch Catch Adjustment

5. THE DETENT ROLLER ARM eccentric is adjusted so, on single line spacing, the index pawl enters a ratchet tooth one-third down on the tooth.

6. THE LOWER INDEX PAWL STOP is adjusted for a full one-tooth travel and a positive positioning of the platen. To observe these adjustments the platen should be lowered and latched in position.

7. PAPER CLEARANCE is adjusted by loosening the screw which holds the feed roll release lever to the lever and bushing assembly on the feed roll actuating shaft (Figure 10). Move the arm up or down to a position where forms may be shifted in the carriage when the paper release lever is moved to its rear position.

BACK SPACE

Because of the added weight of the carriage on forms-writers, the backspace cam will dig deeper into the power roll than on standard models. If the backspace pawl stop is too far to the right, the backspace pawl will not meet

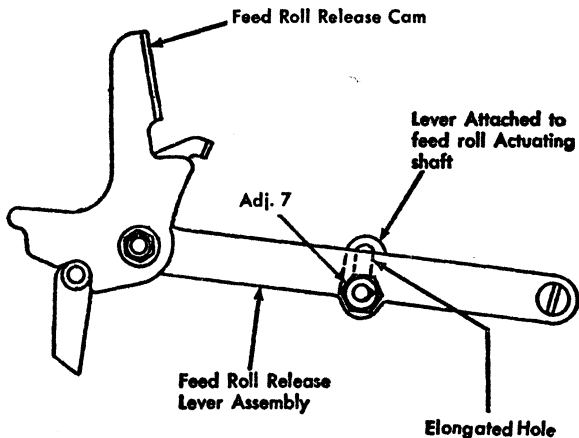

Figure 10. Paper Release Adjustment

the stop properly. The momentum of the heavier carriage will carry the carriage too far and result in extra backspaces. Adjust the backspace pawl stop as far to the left as possible and still have the escapement pawl just click into the rack on hand operation of the backspace.



ELECTRIC TYPEWRITERS

MODELS A15 AND A16

Decimal Tabulation

CUSTOMER ENGINEERING REFERENCE MANUAL

CONTENTS

	<i>Page</i>
Lubrication	4
Decimal Tabulation Adjustments	4
Carriage Return	9
Back Space	10
Removal of Interposers	11
Decimal Tabulation Margin Lever	14

INTERNATIONAL BUSINESS MACHINES CORP.

NEW YORK 22, NEW YORK

Form 25-6018-1 (this section only)

Copyright 1953 by
International Business Machines Corporation
590 Madison Avenue, New York 22, N. Y.
Printed in U. S. A. May, 1955
Form 25-6018-1

IBM DECIMAL TABULATION

Models A15 and A16

GENERAL INFORMATION

THE ELECTRIC DECIMAL TABULAR FEATURE provides a means of tabulating accurately to any desired figure position, electrically, by a single touch of any key in the decimal row. Setting tab stops will require some care and thought on decimal tabulation. For example, if it is desired that columns of 100,000,000.00 be listed as close together as possible, it will be necessary to set every 16th tabular stop, counting 15 spaces between the stops. Although the keyboard carries decimal tab keys numbered through 100,000,000, it may be required to write beyond that limit. By setting the tab stop at an earlier position, the carriage may be stopped earlier and larger numbers may be written, still using the decimal tabular mechanism. For example, if the tab stop is moved four spaces to the left, so as to accommodate an additional group, the operator may tabulate to any point from 100,000,000,000 to the comma before the hundreds position. If the tab stop is moved eight spaces to the left, the operator may tabulate to any point from 100,000,000,000,000 to the comma before the hundred thousands position. Since it is unlikely that very narrow columns would be combined with very wide columns, this method provides a practicable means of dealing with numbers of unlimited size. The use of the tabular key when using this expanded system, would not place the carriage at the decimal point, but if it was required for some purpose, another tab stop could be set to control it.

When instructing typists it should be made clear that a decimal tabular key must be fully depressed. Faulty strokes of the decimal tab keys should be avoided, because improper operation may also result in a lack of selection.

It is possible to get a similar response if the operator repeatedly strikes a decimal tab key out of time with the cam operation so that the latch on the front bell crank is not permitted to restore to its position. If it occurs, it will be necessary to request that the operator adjust the timing of her key stroke operations, not because the key is operated too fast, but because repeated operation of any key must be synchronized with the cam operation cycle.

The key lever locking bar has no effect on the decimal tab keys, and it is possible to depress one or more of the decimal tab keys when the switch is turned off.

Lubrication

A FINE GRADE OF POWDERED GRAPHITE may be used to lubricate the interposers. Oil causes the interposers to adhere to one another, and this results in more than one being raised, or in failure of a raised interposer to restore to rest.

Decimal Tabulation Adjustments

- 1. THE LUG IN THE CENTER OF THE DECIMAL TAB KEY GUIDE** should be formed so that the majority of the lugs on the bail rest $1/16''$ below the top of the notches cut in the back edges of the decimal tab key levers (Figure 1).
- 2. THE CAM RELEASE LINK** should be adjusted so that the cam will be released as late as possible but with positive action.
- 3. THE TABULAR KEY LEVER LUG** should be formed so that it just touches the left hand end of the decimal key lever bail.
- 4. THE KEY LEVER BAIL LUGS** should be checked to see that they clear the tops of the notches cut in the key levers by $1/16''$ clearance.
- 5. THE CAM STOP** should be adjusted so that the release lever lug will just drop behind the cam lug when the cam is released with the power off.
- 6. THE INTERPOSER ACTUATING LINKS** should be adjusted so that when the decimal tab keys are depressed

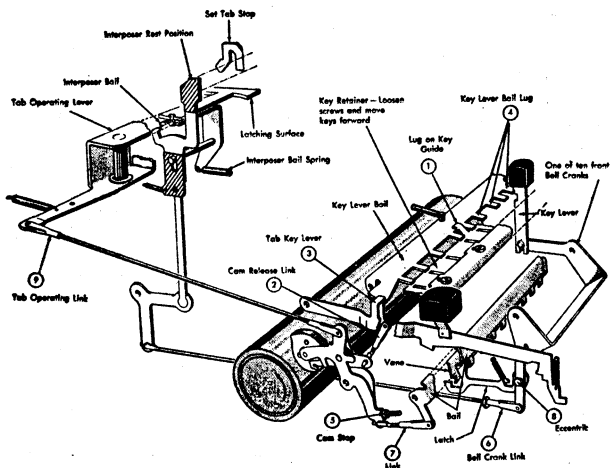

Figure 1. Decimal Tabular Mechanism

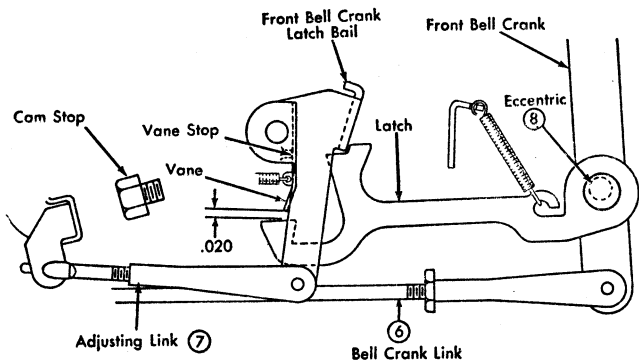

Figure 2. Cam on High Point

as low as possible the interposers will be raised as high as possible.

7. **THE ADJUSTING LINK ON THE BOTTOM OF THE TAB CAM** (Figure 1), should be adjusted so that with the key lever depressed and with the cam on its high point, the latch vane will clear the latches by .020" (Figure 2). With the key lever still depressed allow the tab lever to unlatch. The vane should then rest on the latch by approximately .020" (Figure 3). If this overlap is not evident, form the right extension of the vane to provide this condition.

If the adjusting link is too short, the latch may pass under the vane upon operation. Check to see that the vane safely engages the latch with the cam at rest and with a key depressed (Figure 4).

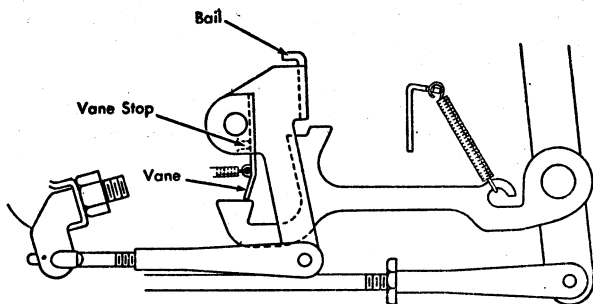

Figure 3. Cam Restored, Key Held Depressed.

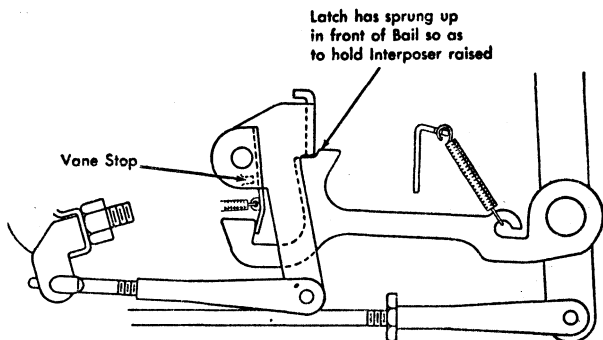

Figure 4. Cam at Rest, Key Depressed

8. **THE ECCENTRICS ON THE FRONT BELL CRANKS** (Figure 2) should be adjusted so that the front bell cranks will safely latch before the tab cam is released. With the front bell crank latched, its interposer should be high enough to allow the interposer bail on the rear rail to engage it properly.

9. **THE TAB OPERATING LINK** should be adjusted so that with the cam on its high point the tab operating lever will move far enough to latch safely (Figure 1). The tab operating lever should not restrict the interposers at rest.

10. **THE TAB RACK** should be adjusted to the left or right so that the escapement pawl will enter the rack as shown in Figure 5 after striking a tabular stop. This can be checked by raising an interposer and turning the power roll by hand until the tabular cam is on its high point. This will cause the carriage to move until the interposer meets and rests against a stop. At this point, slowly turn the power roll backward and observe the pawl entering the rack. The standard machine test of tabulating, back spacing twice and tabulating again to the same stop is not effective on Decimal Tabulation.

11. **THE TAB RACK** should be adjusted forward or back until a latched-out interposer covers $1/3$ to $1/2$ of a set tab stop. The tab rack center support should also be ad-

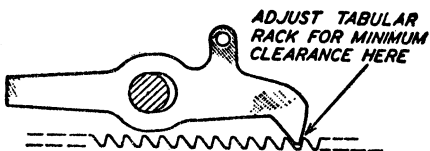

Figure 5. Tab Rack Adjustment

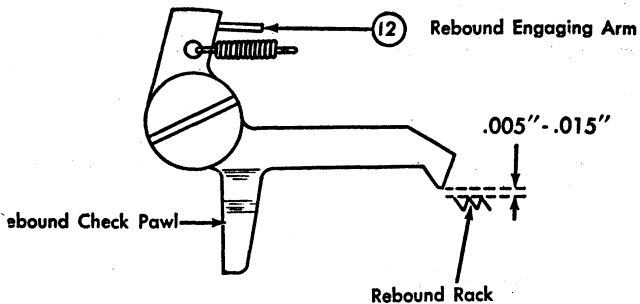

Figure 6. Rebound Adjustment

justed at this time. The tab rack should be tilted back to match the angle of the interposers when latched out.

12. **THE REBOUND ENGAGING ARM** on the right end of the interposer guide assembly is to be adjusted by means of its elongated holes so that, with the margin lever held to the extreme left, the rebound check pawl will clear the rack by $.005''$ to $.015''$ (Figure 6).

13. **THE TAB REBOUND CHECK PAWL ECCENTRIC STUD** should be adjusted so that when a set tab stop is pressed against a latched out interposer, moving the interposer guide assembly to the left, there will be $.005''$ clearance between the face of the check pawl and the face of the rebound rack tooth. The high point of the eccentric must be kept in the rear half of its orbit (Figure 7).

14. **THE FORWARD EXTENSION OF THE REBOUND CHECK PAWL** should clear the rebound engaging arm by

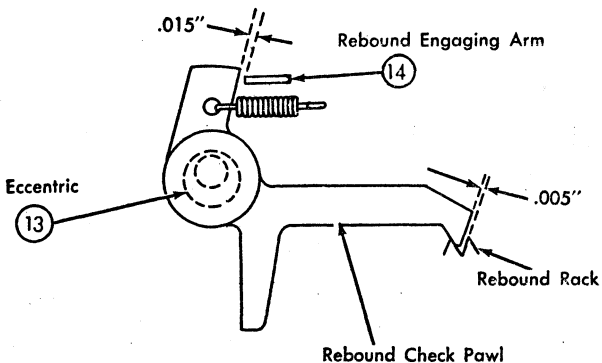

Figure 7. Rebound Clearance

.015" when the rebound check pawl has bottomed in its rack. Make this check with the interposer guide assembly pushed to the extreme left by means of a set tab stop (Figure 7).

15. **THE REBOUND CHECK PAWL** should not strike on the interposer guide assembly (Figure 8). With the interposer guide pushed to the extreme right and the tab operating lever actuated, no interference will result if the high point of the eccentric is kept to the rear.

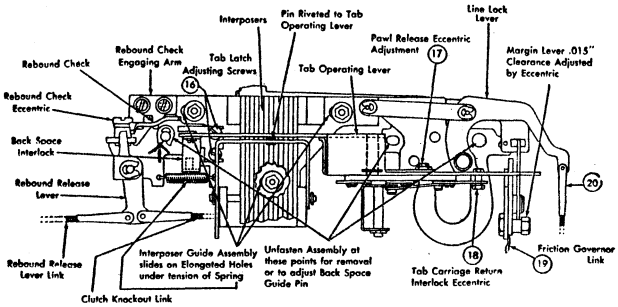

Figure 8. Rear Rail, Rear View

16. **THE TABULAR LATCH** should be adjusted to the right or left so that, with the interposer guide assembly held to the left, the latch will clear the operating lever by .036". A No. 1 gem paper clip can serve as a gage (Figure 9).

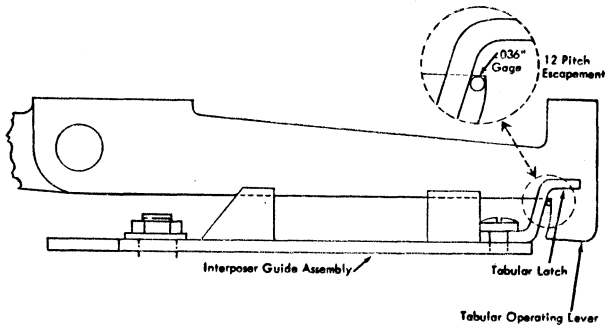

Figure 9. Tab Latch Adjustment

17. **THE PAWL RELEASE LEVER** must be adjusted by means of the eccentric nut on the tab operating lever (Figure 8) so that the escapement pawl clears the rack by .005" to .015" when the tab operating lever is latched out.

18. **THE TABULAR-CARRIAGE RETURN INTERLOCK** should be adjusted, by means of its eccentric attached to the underside of the tab operating lever, so that with the tab cam on its high point, the clutch knockout lever will be prevented from rising (Figure 8).

19. **THE FRICTION GOVERNOR PAWL LINK** should be adjusted so that the friction governor pawl engages the teeth of the friction governor plate by the thickness of its own metal (Figure 8).

20. **THE VERTICAL LINK FROM THE LINE LOCK LEVER** should be adjusted so that it pushes the bell crank at right angles to its lever arm when the margin stop is fully engaged with the margin lever (Figure 8).

21. **THE FRICTION GOVERNOR PRESSURE** should be adjusted so that the speed of tabulation equals approximately the speed of carriage return, but without excessive shock to the carriage.

22. **THE LINE LOCK PUSH ROD** is adjusted so that with the right hand margin stop resting against the margin lever and with a letter key lever locked down by the line lock, the clevis pin should just match its hole in the line lock bellcrank.

THE FLAT LINK connecting the line lock lever to the interposer guide assembly should be shortened by forming an offset if the right-hand margin stop fails to unlatch the tab operating lever.

Carriage Return

1. **THE CAM STOP** should be adjusted so that the cam release lever lug falls just behind the cam lug.

2. **THE CAM RELEASE LINK** should be adjusted so that the cam will trip when the key lever has completed 1/2 to 3/4 of its travel.

3. **THE MARGIN LEVER** should be adjusted to clear the under surface of the margin rack by .015".

4. **UNHOOK THE REAR CLEVIS** of the latch link.

5. **THE TIP OF THE CLUTCH KNOCKOUT LEVER** should be formed, so that with the clutch knockout lever held raised against the margin lever, the left hand margin stop will contact the clutch knockout lever 3/16" from the top of the incline. On current model machines, a dimple represents the point of contact.

6. **THE LATCH LINK AT THE CAM END** should be adjusted so that, with the cam at rest, the clutch unlatched, and the latch held against the lever, the holes in the clevis will match the pins on the cam.
7. **THE REBOUND RELEASE LEVER LINK** should be adjusted as short as its threads will permit.
8. **UNHOOK THE CLEVIS** of the CKO link.
9. **LATCH THE CLUTCH** and position the latch link so that the latch engages the clutch lever by the thickness of the latch lug. Rotate the intermediate bell crank until the rebound release lever holds the rebound check pawl .010" from the rebound rack. Then match the pin of the latch link clevis to the outer hole in the intermediate bell crank.
10. **CKO LINK.** With the clutch properly latched (as in adjustment 7), pull the CKO link toward the rebound release lever until the CKO lever is fully raised. Then match the pin in the CKO clevis to the hole in the rebound release lever.
11. **THE PAWL RELEASE LEVER ECCENTRIC** should be adjusted so that the escapement pawl will clear the rack by $1/64$ " when the clutch is latched.

Back Space

THE BACK SPACE MECHANISM is to be adjusted in the same manner as the standard back space mechanism.

1. **THE BACK SPACE PAWL BRACKET** should be adjusted on its elongated mounting holes so that the back space pawl can enter the escapement rack with $1/64$ " clearance (Figure 10). In order to gain access to the back space pawl bracket mounting screws, the tab lever operating bracket assembly may be backed away from the rail by removing the three screws on which the assembly is mounted (Figure 8).
2. **THE BACK SPACE PAWL STOP** must be adjusted on its elongated holes so that when the back space pawl touches the stop, the escapement pawl will just click into the next tooth of the rack (Figure 10).
3. **THE BACK SPACE CAM** is to be adjusted so that the release lever lug will drop just behind the cam lug.
4. **THE LINK FROM THE CAM TO THE BELL CRANK** under the rear rail should be adjusted so that the rear back space pawl link lies in place with $1/64$ " clearance between the link and the operating edge of the hole in the bell crank (Figure 10).

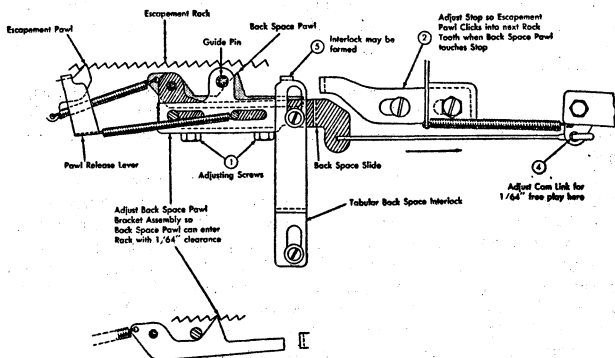

Figure 10. Back Space Mechanism

5. THE TAB-BACK SPACE INTERLOCK should require no adjustment unless it becomes damaged. The lug on the interlock is formed so that with the tab operating lever latched out, the back space pawl cannot touch the rack when the back space is operated (Figure 10).

The back space parts are designed so that the adjustments should hold indefinitely. In case of a malfunction of the back space mechanism, it is suggested that the parts be well lubricated and checked before the adjustments are changed. If a machine with decimal tabulation and a heavy carriage should occasionally back space more than one space at a time, it may be necessary to increase carriage tension about one-half pound and set the link a half turn longer.

Removal of Interposers

A procedure has been developed to aid in the alteration of the Decimal Tabular Typewriter to permit writing numbers without commas between the figure groups. Two interposer links, part numbers 1095276 and 1095278, are required for the change. This procedure may be used in any case requiring removal of the interposers.

Remove the rear case section.

Unhook the tab set and clear links.

Remove the horseshoe clip from the margin set shaft.

Unhook the margin set link.

Unhook the tab operating lever spring.

Remove the belt from the motor pulley.

Remove the motor adjusting screw.

Remove the horseshoe clip from the motor mounting shaft.

Remove the long interposer bell crank links from the bottom of the typewriter and keep them in their proper arrangement for reassembly.

Remove the rear bellcranks.

Remove the six frame screws to release the rear frame.

Remove the rear frame assembly, complete with the motor, using caution to avoid bending the flat interposer links.

Remove the tab-carriage return interlock operating bell-crank assembly from the tab lever bracket by removing the "C" clip from the lower end of its mounting stud, and removing the screw and bushing which support it.

Unhook all interposer springs from the spring bracket except the four on the right facing the rear of the machine. It will be necessary to place a tool to hold the carriage and keep it from running toward tabulation. The tab operating lever should be latched out.

Remove the horseshoe clip from the left end of the interposer fulcrum.

Remove the 100M interposer from its position while holding the other interposers together with a spring hook.

Use the 100M interposer as a spacer to hold the tops of the interposers together by inverting and placing this interposer in the opening in the interposer assembly. This will permit the interposer links to be removed except for the four on the right side, the 100, 10, 1 and decimal interposers. These should remain in the typewriter.

The six interposer links removed should be laid out in the following manner:

100M	10M	1M	100T	10T	1T	100	10	1	.
1095304	1095279	1095278	1095278	1095277	1095276	1095276	1095275	1095274	1095273

Arrangement of Interposer Links for Full Number Operation with Commas.

If the interposer links should become mixed, they may be identified by the amount of offset in their form as shown in Figure 11.

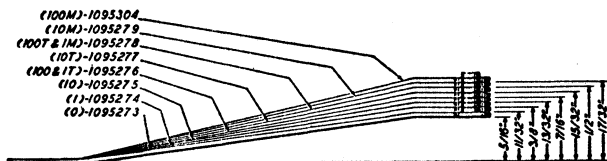

Figure 11. Identification of Interposer Links

Discard the links for the 100M and 10M positions and place one of the replacement links, 1095278, in the 100M position. Move the links for the 1M, 100T, and 10T positions each one space to the left and place the link, 1095276, in the 10T position so that the links will be arranged as shown here:

100M	10M	1M	100T	10T	1T	100	10	1	.
1095278	1095278	1095278	1095277	1095276	1095276	1095276	1095275	1095274	1095273

Arrangement of Interposer Links for Closed Number Operation without Commas.

Hold the 100, 10, 1 and decimal interposers together with a spring hook. Remove the other interposers and rearrange them so that the two inoperative interposers, those with the round fulcrum holes instead of elongated holes, are on the left end in the previous 100M and 10M positions as shown in Figure 12.

The left hand inoperative interposer should be temporarily inverted and placed in the 100M position to hold

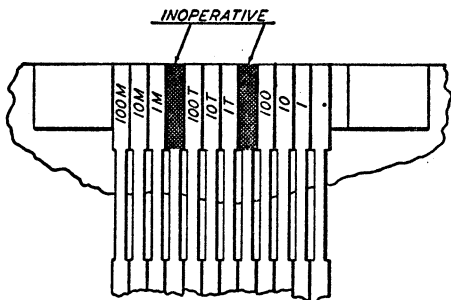

A. INTERPOSERS ARRANGED TO WRITE OPEN FIGURES WITH COMMAS

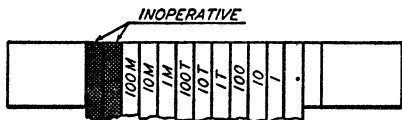

B. INTERPOSERS ARRANGED TO WRITE CLOSED FIGURES WITHOUT COMMAS

Figure 12. Rear View of Interposers

the tops of the interposers together and permit the bottoms to be spread to allow assembly of the interposer links. Assemble the inoperative interposer properly in the 100M position and replace the fulcrum rod and horseshoe clip.

Re-assemble the parts in the reverse order of that described, and check for binds.

Decimal Tabulation Margin Lever

A margin lever has been adopted which eliminates changing the entire margin lever bracket assembly if the margin lever is broken. It is similar to that used on the Model 4 in that it is mounted by a stud and two locking nuts. To remove a broken margin lever which is riveted to the tabular bracket it will be necessary to grind the head of the rivet before it can be driven out of the assembly.



ELECTRIC TYPEWRITERS
MODELS B15 and B16
Decimal Tabulation

CUSTOMER ENGINEERING REFERENCE MANUAL

CONTENTS

	<i>Page</i>
Operation	3
Carriage Return Adjustments	6
Other Adjustments	7

INTERNATIONAL BUSINESS MACHINES CORP.
NEW YORK 22, NEW YORK
Form 25-6620-0 (this section only)

Copyright 1954 by
International Business Machines Corporation
590 Madison Avenue, New York 22, N. Y.
Printed in U.S.A. August, 1954
Form 25-6620-0.

IBM DECIMAL TABULATION

Models B15 and B16

OPERATION

THE TABULAR operating mechanism of the Model B Decimal Tabulation is the same as that of the Model A Decimal Tabulation. The carriage return mechanism is altered considerably. The clutch latching is controlled by the air cylinder latch mounted on the rear rail and the air cylinder operating lever.

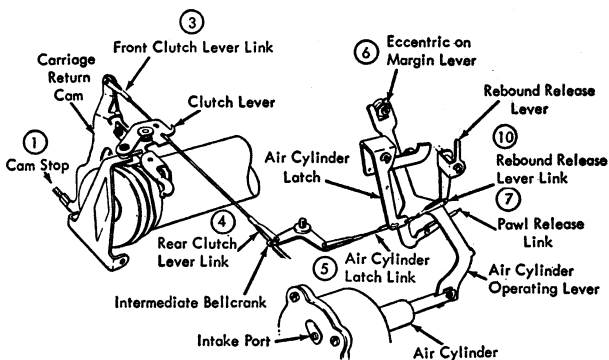

Figure 1. Clutch Latching Mechanism

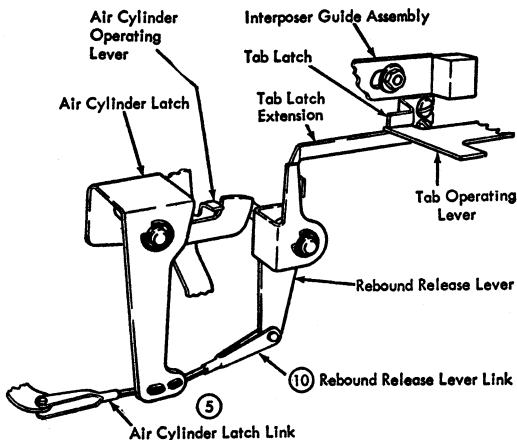

Figure 2. Tab Rebound Release

When the carriage return cam is tripped, it moves the clutch lever against its roller, bringing the clutch surfaces together. A link from the clutch lever to the intermediate bellcrank and another link from the bellcrank to the air cylinder latch serve to release the air cylinder operating lever (Figure 1).

A short link from the air cylinder latch operates the rebound release lever which serves two functions:

1. The rebound release lever strikes the rebound check pawl and prevents it from engaging the rebound rack when the clutch is engaged (Figure 3).
2. The rebound release lever strikes an extension on the tabular latch, moving the interposer guide assembly to the left. This action unlatches the tab operating lever (Figure 2).

When the air cylinder operating lever is released, a large spring pulls it to the left. A link to the pawl release bellcrank allows the escapement pawl to be removed from the escapement rack. At the same time the margin lever is moved to the left so that it will be in a position to unlatch the clutch when the carriage has returned to the left margin.

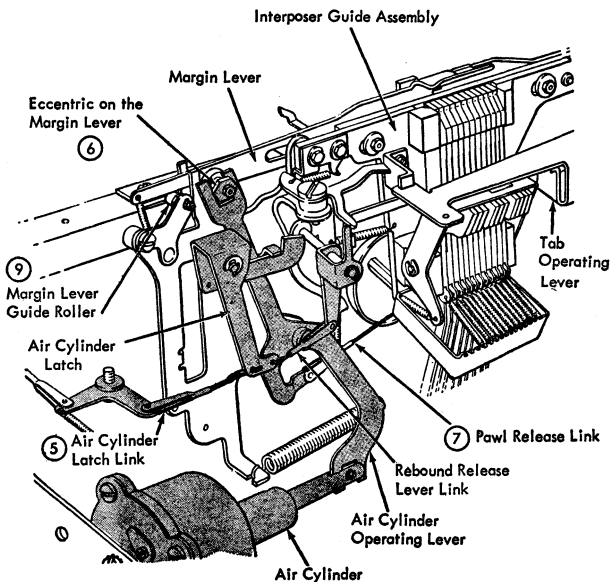

Figure 3. Release and Interlock Mechanism

As a result of this design, the following may be noted:

1. The partial carriage return action formerly obtained through simultaneous operation of the tab and carriage return is not a feature of the Model B Decimal Tabulation machine.
2. The escapement pawl will drag in the escapement rack for the first one to two inches of travel when the carriage return is operated.
3. The air cylinder is not actuated when the carriage is returned by hand to the left margin.
4. The intake and exhaust ports on Model B decimal tab air cylinder are the reverse of the intake and exhaust ports on the Model B1 and B4 air cylinders.
5. The backspace side operating link used on Model B decimal tabulation is the same as used on Model A partial carriage return.

The Model B decimal tab is equipped with typamatic operation of the space bar, carriage return, and underscore. However, field installation of the two-piece repeat/non-repeat key lever is limited to the third and fourth key lever row or position 41 in the second row because of the decimal tab key guide plate.

A backspace interlock arm attached to the pawl release lever prevents the backspace pawl from entering the escapement rack during tabular or carriage return operation (Figure 4).

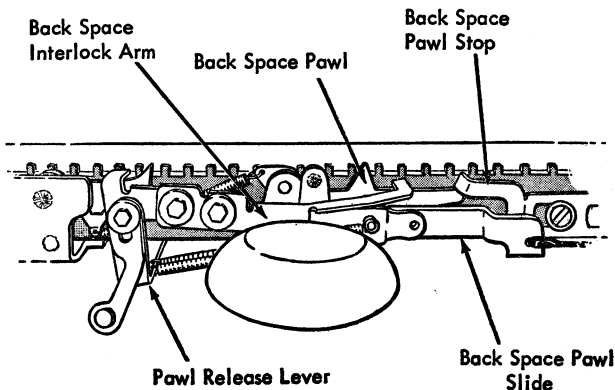

Figure 4. Backspace Interlock

CARRIAGE RETURN ADJUSTMENTS

1. **THE CAM STOP** is adjusted so that tripping the cam with the power off will allow the release lever lug to just drop behind the cam lug.
2. **THE CAM RELEASE LINK** is adjusted to trip the cam when the key lever is depressed from $\frac{3}{4}$, up to and including its full normal travel. The cam should repeat when the key lever is in its over-travel position and has depressed the spring-loaded plunger $\frac{1}{16}$ ".
3. **THE FRONT CLUTCH LEVER LINK** is adjusted to just span the distance between the cam at rest against its stop and the clutch lever at rest against the roller.
4. **THE REAR CLUTCH LEVER LINK** is adjusted so that the motion of the intermediate bellcrank will be evenly divided in front and back of its center position.

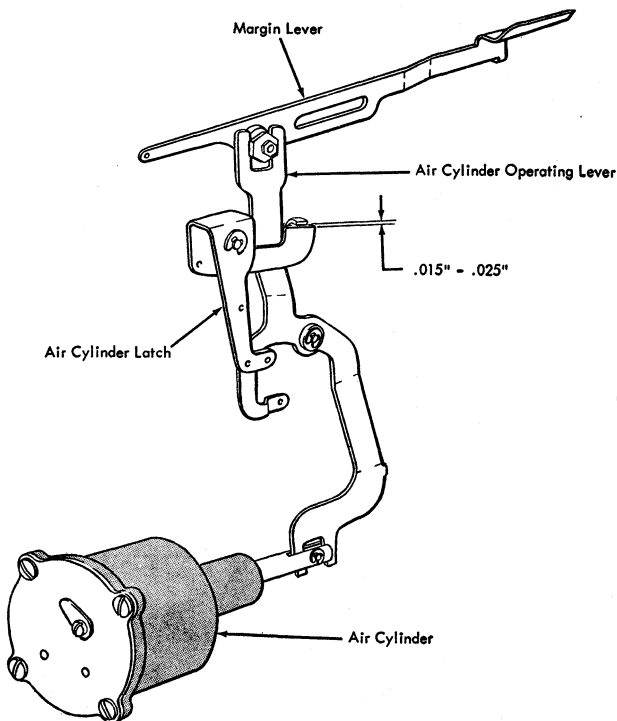

Figure 5. Air Cylinder Operating Lever Released (Cam on High Point)

5. THE AIR CYLINDER LATCH LINK from the intermediate bellcrank to the air cylinder latch is adjusted so that, when the carriage return cam is on its high point, the formed lug on the air cylinder lever will clear the latch by .015"-.025" (Figure 5).

6. THE ECCENTRIC ON THE MARGIN LEVER is adjusted for .010"-.015" clearance between the air cylinder lever and the air cylinder latch when the margin lever is held to the extreme right. The high point of the eccentric should be kept toward the top of the machine (Figure 5).

7. THE PAWL RELEASE LINK is adjusted so that the motion of the pawl release bellcrank is divided evenly right and left of its vertical position.

8. THE PAWL RELEASE ECCENTRIC is adjusted so that the escapement pawl clears the escapement rack by .030"-.040" when the air cylinder lever is released (clutch latched). If this adjustment cannot be obtained, it may be necessary to modify the pawl release link, adjustment 7.

9. THE MARGIN LEVER GUIDE ROLLER is positioned so that the upper surface of the margin lever clears the underside of the margin rack by .010"-.015" (Figure 3).

10. THE REBOUND RELEASE LEVER LINK is adjusted so that the rebound check pawl clears the rebound rack by approximately 1/16" when the air cylinder is released (clutch latched). This adjustment should also permit the rebound release lever to push the interposer guide assembly far enough to the left to unlatch the tab operating lever. It is possible to form the extension of the tab latch if necessary to guarantee safe unlatching of the tab mechanism.

OTHER ADJUSTMENTS

Other clutch adjustments, overbank, clutch plate clearance, clutch compression spring, and the air cylinder ports are adjusted in the conventional manner described in the model B1 section of this manual. The intake and exhaust ports of the decimal tab air cylinder are the reverse of those on the Model B1 air cylinder.

IBM

**ELECTRIC TYPEWRITERS
MODELS C15 AND C16**

**CUSTOMER ENGINEERING
REFERENCE MANUAL**

DECIMAL TABULATOR

INTERNATIONAL BUSINESS MACHINES CORP.

New York 22, New York

Form 241-5036-0 (this section only)

© 1959

INTERNATIONAL BUSINESS MACHINES CORP.

590 Madison Avenue, New York 22, New York--

Printed in U. S. A. May 1959

Form 241-5036-0

IBM
ELECTRIC TYPEWRITER
WITH
DECIMAL TABULATION
MODELS C15 and C16

The Model C Decimal Tabulator machine is almost identical to the Model C Standard Typewriter with the exception of the tabulator mechanism. Other related mechanisms have been modified slightly so as to function properly with the decimal tabulator. Only those mechanisms which are different from the standard model will be discussed in this section.

The Model C decimal tab mechanism has been completely redesigned from previous models and bears little resemblance to them. The tab stops are designed so that, when they are in the set position, the exposed surface of the tab stop is directly beneath the tab rack. The selective interposers are raised by springs which are attached to the interposer links (Figure 5). The operator need only release the interposer links from under their keeper in order for the interposers to be raised. The interposers are restored by the action of a restoring bail which is powered by a heavy spring. The restoring bail and spring are "cocked" by the action of the tab cam through the transfer lever and link, and are released by the movement of the interposer cage to the left during the tab unlatching action.

It is not necessary to latch the interposers in the raised position, since they are held up by their individual springs. Because of this feature, the interposer links, crossed-over front bellcranks, and intricate bellcrank latches of former models have been replaced by very simple bellcranks and interposer cables.

Adjustments

1. INTERPOSER LINK KEEPER. Adjust the keeper up or down in its elongated mounting holes so that, with the interposer links latched down and the cage at rest, the links will be $\frac{1}{32}$ " to $\frac{1}{16}$ " above their extreme down position. Check this by pulling down on the interposer links with a springhook. They should move $\frac{1}{32}$ " to $\frac{1}{16}$ " before bottoming (Figure 1). Adjusting the interposer link keeper too high may allow the interposers to drag on the bottom of the tab rack. Adjusting it too low may prevent the interposer links from latching down as they are restored. When making this adjustment, keep the front surface of the keeper about 10° off vertical (Figure 1) to insure proper latching and unlatching of the interposer links.

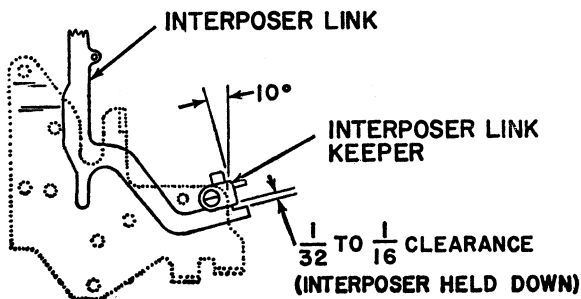

Figure 1. Interposer Link Keeper Adjustment

2. BAIL ASSEMBLY ECCENTRIC STOP. With all parts at rest, the restoring bail should overlap the restoring lugs of the interposer links by .015" to .025". Adjust the eccentric stop for this condition (Figure 2). The bail operating link must be disconnected when making this adjustment. Insufficient overlap could prevent the bail from restoring the interposers far enough for them to latch down.

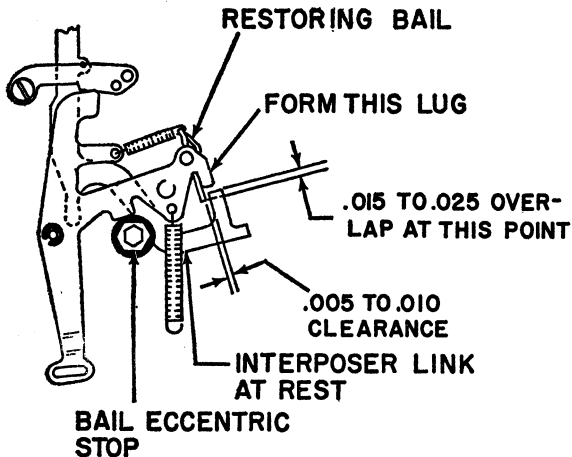

Figure 2. Restoring Bail Adjustments

3. RESTORING BAIL LUG. Form the lug on the left bail arm to obtain a clearance of .005" to .010" be-

tween the bail and the lugs of the interposer links when the interposers are latched down and the bail is at rest (Figure 2).

4. BAIL LATCH. Form the ear on the left bail arm forward or back to obtain $\frac{1}{32}$ " to $\frac{1}{16}$ " clearance between the bail and an interposer link when the link is raised and the bail is latched up (Figure 3).

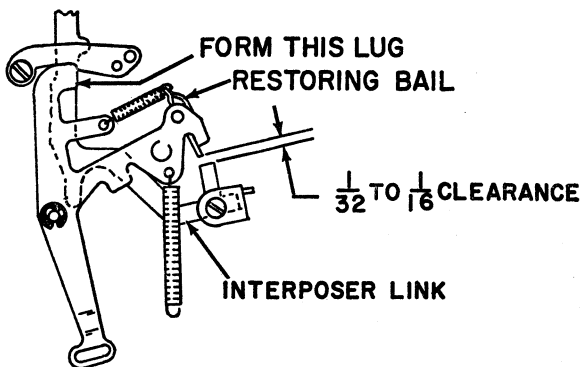

Figure 3. Bail Latch Adjustment

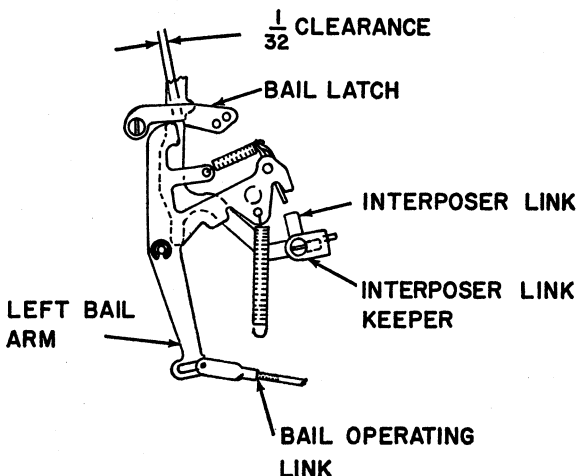

Figure 4. Bail Operating Link Adjustment

This can be formed with the small T-bender by inserting it from the top between the right motor mounting ring and the bail latch. Hold the latch up out of the way while making this adjustment.

5. BAIL OPERATING LINK. Adjust the bail operating link so that, when the cam reaches its high point, the restoring bail will have been pulled $\frac{1}{32}$ " past its latching point (Figure 4).

If the link is too short it will cause the right bail arm to choke off on the interposer control bracket as the cam reaches its high point.

If sufficient adjustment cannot be obtained with the bail operating link, the transfer lever mounting bracket may be moved slightly to provide more adjustment.

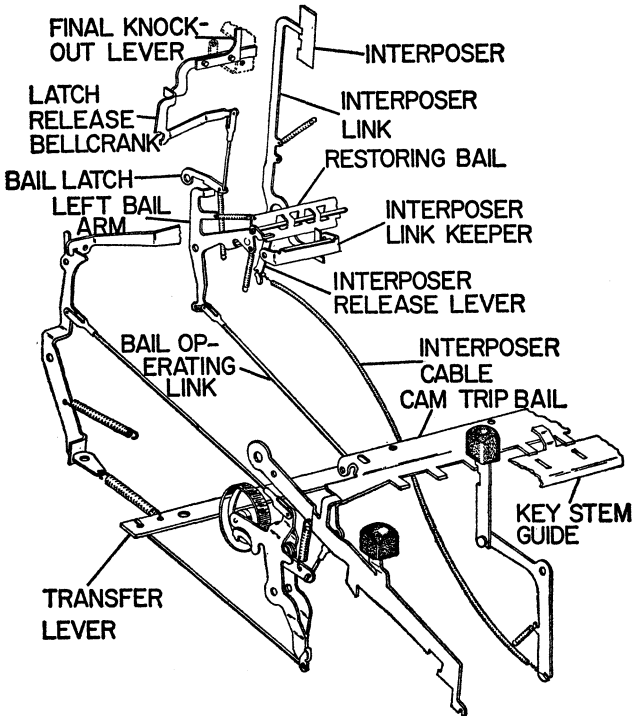

Figure 5. Decimal Tab Mechanism

6. INTERPOSER CONTROL BRACKET. This bracket is attached to the bottom of the rear frame by 2 screws through elongated holes and must be adjusted to satisfy 2 conditions.

a. The screws should be in the left side of the mounting holes for 12 and 14 pitch machines and in the right side for 10 pitch machines. This insures that the interposer links will be vertical when the interposer cage is at rest. The links must be vertical in order to move up and down freely. **CAUTION.** Be sure all links move up and down freely after any adjustment of the interposer control bracket.

b. Position either or both interposer control bracket mounting screws up or down slightly until the top of the interposer cage is parallel with the tab rack.

7. CAM CLEARANCE. Adjust the cam stop screw to obtain .010" to .015" clearance between the cam and the power roll when the cam is at rest against its stop.

8. HEIGHT OF CAM TRIP BAIL. Form the lug in the middle of the decimal tab key stem guide (Figure 5) to obtain a clearance of $\frac{1}{16}$ " between the fingers of the cam trip bail and the tops of the notches in the key stems. Insufficient clearance at this point may allow the cam to repeat.

9. CAM RELEASE LINK. Adjust the cam release link to allow the cam to be released as late as possible in the travel of the keybuttons but before the key stems bottom on the guide.

10. INDIVIDUAL CAM RELEASE. Form the fingers of the cam trip bail and the lug of the tab keylever so that all key stems and the tab keylever will cause the cam to be released just before they reach their full downward travel. Be sure that no key stem bottoms before the cam is released. This adjustment must be set carefully to insure tabulator selection.

11. INTERPOSER CABLE ASSEMBLIES. Loosen the front cable clamps and adjust the ends of the cables forward or back so that the interposer links are released when the key stems have been depressed $\frac{3}{4}$ of their downward travel. This should be about $\frac{1}{64}$ " to $\frac{1}{32}$ " before the cam is released.

If an interposer link is not being released soon enough, a flicking action or light tap on the keybuttons will cause the cam to be released without releasing an interposer link. This will result in no selection. If the interposer links are being released too soon they may not safely latch as they are restored.

12. MARGIN RELEASE ECCENTRIC. Adjust the eccentric so that the bottom of the margin control lever is even with the bottom of the left margin stop (Figure 6). Be sure that the right margin stop positively engages the margin control lever after making this adjustment.

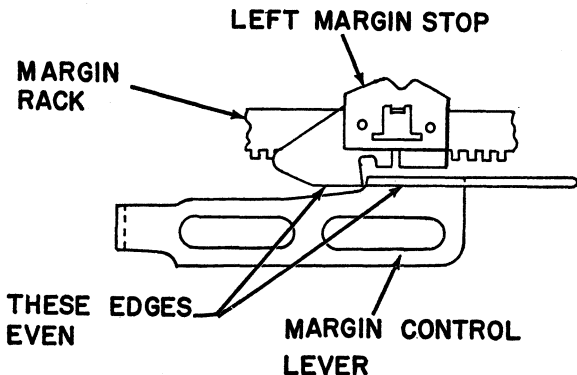

Figure 6. Margin Release Eccentric Adjustment

13. TAB RACK. The tab rack must be adjusted to satisfy 4 conditions.

a. Adjust the tab rack left or right so as to establish the correct re-entering position of the escapement pawl in relation to the escapement rack teeth. Check the adjustment in the following manner:

1. Set a tab stop.
2. Release the cam and an interposer link with the power off.
3. While holding the carriage, turn the power roll by hand until the cam has reached its high point.
4. Allow the carriage to move to the left until it comes to rest against the raised interposer.
5. Slowly turn the power roll backward while observing the escapement pawl from the bottom. The pawl should enter the rack with a clearance of .015" (Figure 7).

b. Rotate the tab rack about its axis so that the lower edge of a set tab stop is parallel with the top of the interposers.

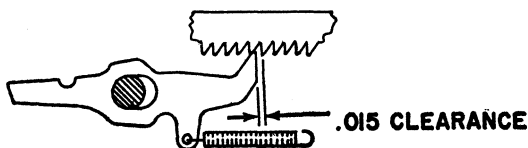

Figure 7. Horizontal Tab Rack Adjustment

c. Adjust the tab rack up or down at each end so that a raised interposer will overlap a set tab stop by .045" to .060". Adjustment can be observed by moving the carriage to the right by hand until the beveled side of a set tab stop contacts a raised interposer. The point of contact should be just below where the bevel begins (Figure 8). Adjust both ends of the rack the same. The tab rack center support must be adjusted up or down so that contact at the center is the same as at the ends. The contact point **MUST** be below where the bevel starts to insure that the carriage will not lock up during carriage return if an interposer fails to restore.

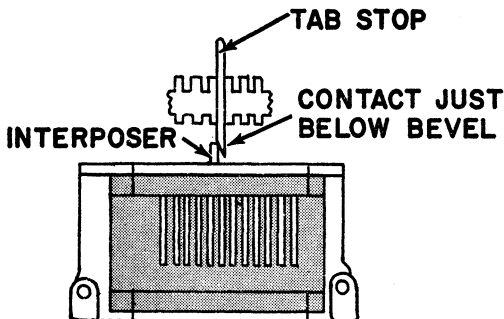

Figure 8. Tab Rack Height Adjustment

d. Adjust the right end of the tab rack forward or back so that it is parallel with the rear rail. Check by observing that the clearance between the unset tab stops and the tab set lever remains the same as the carriage is moved left-to-right.

14. TAB LATCH ECCENTRIC. Adjust the tab latch eccentric high point all the way to the rear.

15. TAB LATCH EXTENSION. The forming adjustment of the tab latch extension is directly related to the left-to-right adjustment of the tab rack. Both ad-

justments determine the re-entering position of the escapement pawl in relation to the escapement rack teeth as the tab lever is unlatched.

The interposers are not restored until after the tab lever unlatches. A raised interposer must be restored before the tab lever reaches its full left travel in order to prevent the carriage from coming to rest against the interposer.

The delay in restoring the interposers creates the need for additional travel in the tab check lever after unlatching to insure that the interposers are safely restored before the tab check lever reaches its limit. To obtain this extra margin of safety the tab lever is unlatched one full space sooner than it is on the Model C1. Unlatching the tab lever one space early allows the escapement pawl to restore to the rack one tooth early each time. The escapement pawl will then stop the movement of the carriage preventing the tab check lever from ever being pushed to its extreme left position. Since the length of one space is different for each pitch machine, the unlatching point varies with the pitch of the machine. Figure 9 illustrates the position of the tab check lever in relation to the head of its left mounting stud, at the time of unlatching. The tab latch extension should be formed left or right to obtain the correct unlatching point. The clearances shown in Figure 9 refer to the amount of elongated hole still visible at the time of unlatching. This is merely a convenient reference point at which to observe the unlatching.

A thorough operational check should be given the mechanism using each tab key for both long and short tabulations.

If the carriage stops one space past the correct point

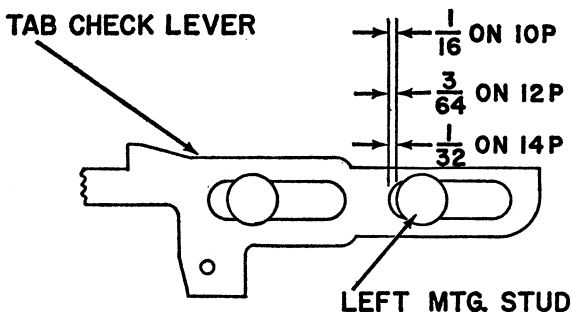

Figure 9. Tab Latch Extension Adjustment

on long tabulations, the tab lever is being unlatched too late. On short tabulations, tabulate to a stop, backspace twice, and tabulate again. If the carriage stops one space short of the correct point, the tab lever is being unlatched too soon.

The tab set and clear bracket must be adjusted to correspond to the carriage position when the decimal interposer is used.

16. TAB CHECK LEVER KEEPER. Adjust the tab check lever keeper to satisfy 2 conditions.

a. Tabulate to a tab stop and backspace twice. Depress the same key with the machine turned off. The raised interposer should clear the side of the tab stop by $.010''$ to $.025''$. Adjust the tab check lever keeper left or right to obtain this condition (Figure 10).

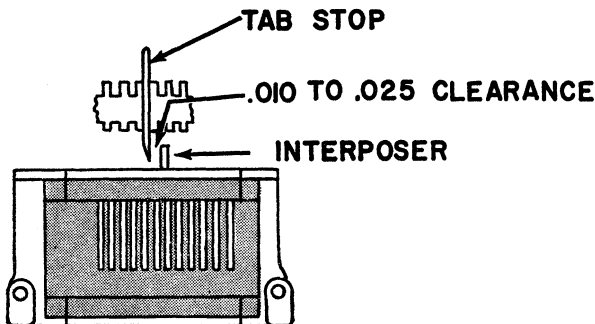

Figure 10. Tab Check Lever Keeper Adjustment

b. Adjust the left end of the tab check lever keeper forward or back to obtain $.003''$ to $.010''$ clearance between the check lever and the keeper when the tab lever is held to the rear by the tab latch (Figure 11).

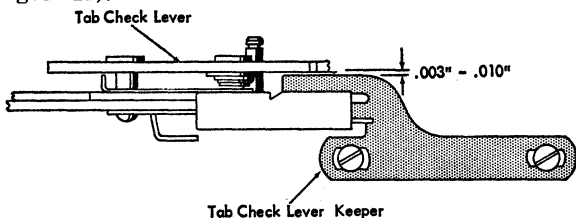

Figure 11. Tab Check Lever Keeper Adjustment

17. TAB OPERATING LINK. Adjust the tab operating link so that, with the cam on its high point, there is a clearance of .010" to .015" between the tab lever and the latching surface of the tab latch.

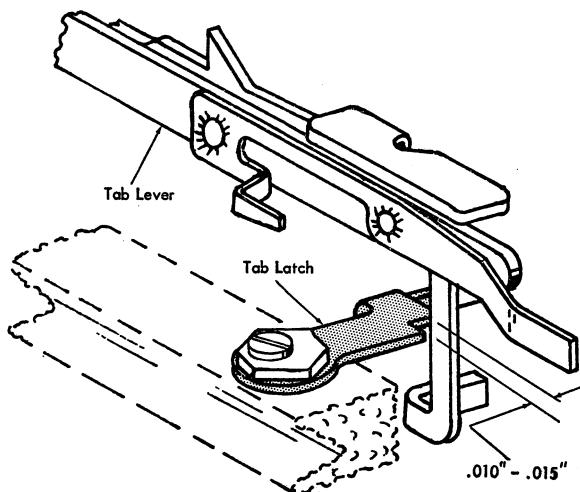

Figure 12. Operating Link Adjustment

18. TAB LEVER EXTENSION. Form the tab lever extension so that, with the cam on its high point, there is a clearance of .001" to .005" between the tab lever extension and the overthrow stop on the tab check lever keeper.

19. LATCH RELEASE LINK. Adjust the latch release link (Figure 5) so that the interposer restoring bail is released at the same time the tab lever is unlatched or just afterward. Both parts should be unlatched as near the same point as possible; however the restoring bail must never be released before the tab lever is unlatched.

20. PAWL CLEARANCE. Form the rear upright lug of the pawl release lever for $\frac{1}{64}$ " clearance between the escapement pawl tip and the escapement rack, when the tab lever is latched out.

21. FINAL KNOCKOUT LEVER. Adjust the final knockout lever (Figure 5) so that the interposer restoring bail will not latch up if the tab is operated

when the carriage is in its extreme left position past the right margin stop. With the carriage in this position, the tab check lever should not have been pushed fully to the left.

22. CENTRIFUGAL TAB GOVERNOR.

a. Position the governor housing left or right for a maximum of .005" backlash between the pinion gear and the decelerator hub gear. There must be no binds between the 2 gears throughout the full rotation of the decelerator hub gear.

b. Position the spring between the 2 centrifugal governor arms so that the speed of the carriage during tabulation is approximately the same as during carriage return.

23. TAB DECELERATOR LINK. The decelerator should permit the carriage to come to rest with a minimum of shock and without hesitation. Position the stud of the tab decelerator bellcrank in the hole of

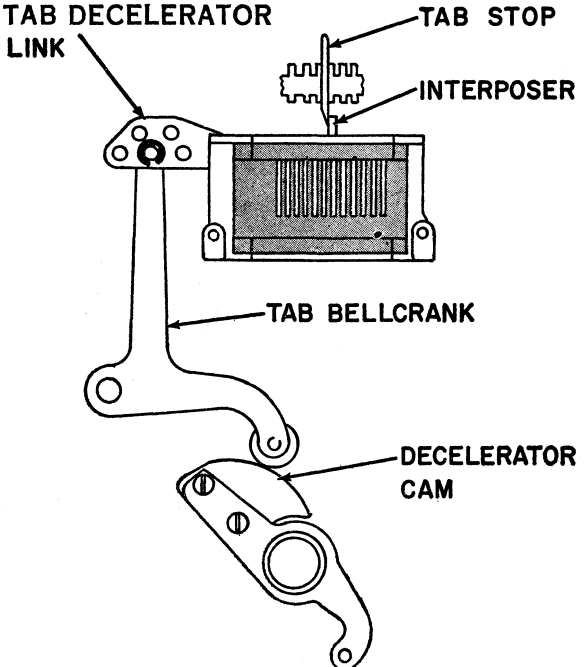

Figure 13. Decelerator Link Adjustment

the tab decelerator link which will give the desired deceleration (Figure 13).

Carriage Return

The carriage return mechanism has been modified to be compatible with the decimal tab mechanism (Figure 14). Instead of the decelerator and centrifugal governor, an air cylinder is used to cushion the shock of the carriage return. Clutch unlatching motion is transferred from the margin control bellcrank to the air cylinder bellcrank to which the clutch unlatching link is attached. A carriage return tab interlock has been designed which is operated by the left end of the tab lever to unlatch the clutch. A carriage return-backspace interlock is incorporated with the backspace bellcrank. This extension of the backspace bellcrank operates the clutch latch bellcrank to unlatch the clutch during backspace.

Adjustments

Only those adjustments which are different from the Model C1 will be discussed here. Refer to the carriage return section of the Model C1 reference manual for all other carriage return adjustments.

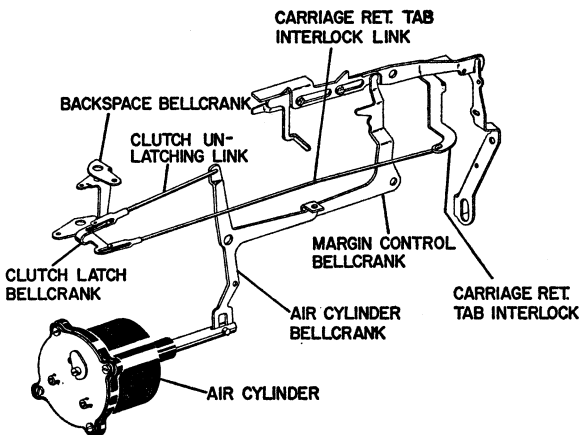

Figure 14. Clutch Unlatching

1. **CLUTCH UNLATCHING LINK (Figure 14).** Adjust the clutch unlatching link so that the clutch will be unlatched when the margin control lever is $\frac{1}{64}$ " from its extreme right position.

2. **CARRIAGE RETURN-TAB INTERLOCK LINK (Figure 14).** Adjust the link so that, with the tab lever latched out, there will be .005" to .010" clearance between the clutch latch and the lug on the clutch lever. Check by pushing the clutch lever toward the latching position (Figure 15). Be sure the clutch latch is not restricted when the tab lever is at rest.

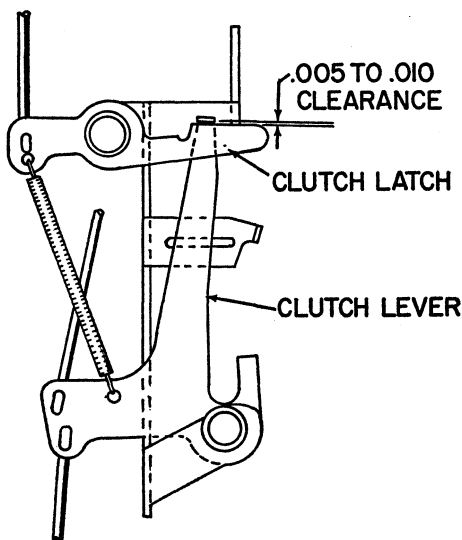

Figure 15. Carriage Return-Tab Interlock Adjustment

3. **CARRIAGE RETURN - BACKSPACE INTER-LOCK.** Form the extension of the backspace bellcrank so that it clears the clutch latch bellcrank by $\frac{1}{16}$ " when both parts are at rest. Check by depressing the backspace and carriage return keylevers together. Depress the backspace keylever slightly before the carriage return keylever. In doing this you allow the backspace bellcrank to be going in the restoring direction as the carriage return operates. The two mechanisms are most likely to lock with this type of operation. If the clearance is excessive, the mechanisms will lock. If

the clearance is insufficient, the clutch latch will be moved so far during a backspace operation that it will strike the side frame. Any change in the backspace operating link adjustment will have a direct affect on the adjustment of the backspace bellcrank extension.

4. AIR CYLINDER.

a. Adjust the air cylinder forward or back in its elongated mounting holes so that the air cylinder bellcrank will not bind against the air cylinder plunger.

b. Adjust the air cylinder ports so that the carriage will strike the left margin with minimum shock yet without hesitation.

Removal

Interposer Cage Assembly

1. Remove the machine from the case.
 2. Loosen the interposer cable clamps. Disconnect the cables from the front bellcranks and slide the cables from under the clamps.
 3. Remove the drive belts and motor adjusting screw.
 4. Disconnect the tab lever spring from the rear frame.
 5. Disconnect the tab set and clear links at the rear.
 6. Remove the 2 interposer control bracket mounting screws at the bottom of the rear frame.
 7. Remove the 6 rear frame mounting screws and remove the rear frame.
 8. Disconnect the bail operating link.
 9. Disconnect the bail latch release link.
 10. Remove the C-clip which holds the tab check lever link and the tab decelerator link to the interposer cage. The interposer cage assembly may then be removed from the machine.
- The interposer cage assembly may then be removed by reversing the above procedure. All adjustments which were disconnected or moved should be checked after installation.



**ELECTRIC TYPEWRITERS
CUSTOMER ENGINEERING REFERENCE MANUAL**

ELECTRONIC MAINTENANCE GUIDE

CONTENTS

	<i>Page</i>
Meters	3
Tubes	3
Diodes	3
Resistors	4
Capacitors	5
General Hints	6

INTERNATIONAL BUSINESS MACHINES CORP.
NEW YORK 22, NEW YORK
Form 25-5013-0 (This section only)

Copyright 1957
International Business Machines Corp.
590 Madison Avenue, New York 22, N. Y.
Printed in U.S.A. September 1957
Form 25-5013-0

IBM

ELECTRONIC MAINTENANCE GUIDE

In order to aid those Customer Engineers who may have occasion to service the electronic portion of ET equipment, the following information is presented:

WARNING: Observe all safety precautions pertaining to work on electrical equipment while power is on.

METERS

Check meter ranges and settings before using. Be sure the selector knob is set for volts when measuring volts as the meter will be damaged if it is set for ohms. **Never** attempt to measure ohms with the power on. Always start voltage measurements with meter set on the highest range, and observe proper polarity when measuring DC voltages to prevent meter damage.

TUBES

The method of counting or numbering pins on tubes and tube sockets is to start at the gap between pins and count around in a clockwise direction, starting with number one (Figure 1).

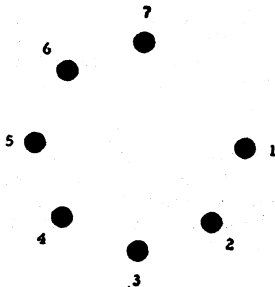

Figure 1. Bottom View of Tube or Tube Socket

DIODES

One method of determining whether a germanium or selenium diode is weak or bad is to measure its forward and back resistance. In order to do this, the anode and cathode leads must be determined. The symbol for the

diode is printed on the side of most diodes to identify the cathode (Figure 2). This is done for checking purposes and also so that proper polarity may be observed when they are placed into a circuit. This identification applies to most metal case diodes and some glass envelope diodes. Some metal case diodes are marked with a red dot on the cathode end and some glass and plastic envelope diodes have a white band on the cathode end. In all cases, the cathode is identified. On present production machines, the IN-111 diode has the cathode end identified by a band painted around the body of the diode.

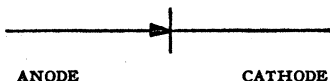

Figure 2. Cathode and Anode Identification

To measure the forward resistance of the diode, place the positive lead (plus or red jack) of the ohmmeter on the anode and the negative (minus, common, or black jack) lead on the cathode. If the positive or negative lead of the ohmmeter cannot be determined, take a reading with the leads one way, then reverse the leads and take another reading. The lowest reading is the forward resistance, and the highest reading is the back resistance. If both readings are high (40,000 ohms to 50,000 ohms or above) the diode should be replaced. If the diode is good, the forward resistance will be between approximately 5 ohms and 85 ohms.

WARNING: Excessive heat will destroy a germanium or selenium diode. A "heat sink" must be used to absorb excess heat when soldering or unsoldering diodes. A pair of long nose pliers gripping the wire lead between the solder joint and the diode will serve as an efficient method of absorbing excess heat.

RESISTORS

Axial lead resistors have three or more bands of color around the body of the resistor. Band "A", as shown in Figure 3 indicates the first significant figure of the resistance. Band "B", indicates the second significant figure and band "C", the decimal multiplier or number of zeros. Band "D", if any, indicates the tolerance limits of the resistor. For instance, if a resistor has a red band "A"

(Figure 4), red band "B", orange band "C", and "D" is silver, from the chart (Figure 5) it is found that red is 2, orange is 3, and silver is 10%. Therefore, the value of the resistor is 22,000 ohms with 10% tolerance. This may be written 22K where "K" means times 1,000.

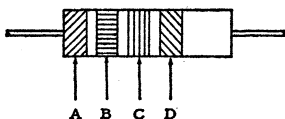

Figure 3. Resistor Bands

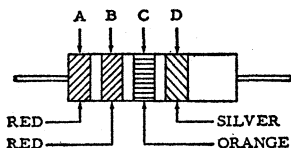

Figure 4. Resistor Color Code Identification

In case band "C" is black, it means that there is no zero or significant digit, i.e., if the "A" band is brown, "B" is black, and "C" black, the value of the resistor is 10 ohms.

CAPACITORS

The larger capacitors have their value and voltage rating printed on the outside cover. The symbol "uf" or "mf" means micro farad (one millionth) and "uuf" or "mmf" means micro-micro farad (one millionth of one millionth). The farad is the unit of capacitance.

RETMA STANDARD COLOR CODE					
Black	0	Yellow	4	Gray	8
Brown	1	Green	5	White	9
Red	2	Blue	6	Gold	5%
Orange	3	Violet	7	Silver	10%
				No Color	20%

Figure 5. Resistor Color Code Chart

GENERAL HINTS

1. Use only rosin or plastic core solder on electrical or electronic equipment. Acid core solder will corrode and cause a joint to have poor electrical contact.
2. Be sure that all solder joints are well heated and not "cold soldered". A cold soldered joint presents a very high resistance to the flow of electricity.
3. Hold all "stick joints" (unwrapped joints) steady until solder has hardened to prevent a fractured solder joint.
4. Use a burnishing tool, not flexstone, to clean contact points (such as the tab lever contact on the Electronic Tab Typewriter). Do not file or sandpaper them as rough surfaces will increase arcing and prevent good contact.
5. Have all contacts adjusted to make (close) with plenty of rise so that there is a wiping action to the contact surfaces. This means that after the contacts are closed initially, there should be an additional amount of travel on the moving or operating strap. The stationary or normally open side of the contact is then moved (raised) causing a wiping action on the contact surfaces which helps keep the surfaces clean.
6. When replacing capacitors, check to see if the leads or ends are marked plus or minus. If so, be sure to replace them with the proper polarity observed. The capacitors that have polarity markings are "electrolytic capacitors." They are filled with fluid or paste, and when voltage is applied in a reverse direction to the markings, they heat up and explode, spraying the electrolyte out with considerable force.



**ELECTRIC TYPEWRITERS
ATTACHMENTS**

CUSTOMER ENGINEERING REFERENCE MANUAL

**ELECTRONIC
TABULATION**

INTERNATIONAL BUSINESS MACHINES CORP.

NEW YORK 22, N. Y.

Form 25-6718-0 (Electronic Tabulation Section only)

Copyright 1956 by
International Business Machines Corporation
590 Madison Avenue, New York 22, N. Y.

Printed in U.S.A.

Form 25-6718-0

ELECTRONIC TABULATION

The electronic tabulation attachment is a programmed device for forms typing. The "program" is printed on the form with an ink which contains silver particles and is thereby electrically conductive. These lines are 1/32 inch wide and run vertically on the form. Lines are printed at the beginning of each area where a tab stop would normally be required.

Standard tabulation may be performed on a machine equipped with this electronic attachment. The electronic tabulation is in operation only when the tronic-tab button is depressed into its "down" position. This tronic-tab button is located beside the color-control button on the front case. When the tronic-tab button is depressed, a switch actuating lever is rotated which turns on a switch (Figure 6). This switch completes an electronic circuit and prepares it to supply power to a magnet assembly which will control the movement of the tab check lever (Figures 10 and 11).

To operate the electronic tab device, a complete bank of tab stops must be pre-set and remain set while the device is in use. This pre-setting consists of setting every third stop across the entire rack (Figure 8). This is accomplished by first clearing all set stops and moving the carriage to the right hand margin. The tronic-tab button is then depressed completely and held down while the carriage is returned to the left hand margin by depressing the carriage return button. A special tab set device called the auto tab set cam is used, in conjunction with special tab stops, in order to pre-set every third stop. The auto tab set cam is part of the auto tab operating shaft which is rotated when the tronic-tab button is depressed. The cam sets every third stop while it moves through a slot in all other stops (Figure 7).

As the auto tab operating shaft rotates, it moves the armature interlock actuating lever which is fastened to the right end of the shaft. The rear arm of this lever is raised, allowing the armature interlock lever to pivot toward the front of the machine under spring tension of the magnet armature. The magnet armature is then in its forward position, away from the magnet, and in the normal operating path of the latch lever (Figures 1 and 9). This mechanism works in the opposite direction when the tronic-tab button is raised. It then acts as an interlock to hold the magnet armature against the magnet and out of the path of the latch lever in order to permit standard tabulation (Figure 5).

When the tronic-tab button is in the down position and the tab cam is tripped, the tab lever becomes latched out. However, the tab check and rebound check levers are restricted from moving into the path of a set tab stop. The tab check lever extension pushes the latch plate and rotates the latch shaft in a clockwise direction. The latch lever is rotated with the shaft until it is restricted by the magnet armature, thereby preventing the tip of the tab check lever from moving into the path of a set tab stop. This "choke off" of the check lever is made possible by the compression spring on the right hand bushing of the check lever (Figure 3).

When the operating lever is rotated by the left side of the tab lever, it pulls down on the operating lever link. This permits the sensing finger bell crank to rotate under spring tension. When this bellcrank rotates, it pushes the sensing finger link to the right, which rotates the sensing finger into the vertical or operating position (Figure 1).

When the sensing finger is in this raised position, the two small contact studs meet the contact springs of the contact plate assembly which is solidly mounted to the front rail dust cover (Figure 1). When the sensing finger is in the vertical position, the four sensing wires contact the surface of the paper. As the moving carriage brings a conductive line in contact with the sensing wires, the electronic circuit is completed, allowing current to pass through the magnet and pull the armature to the rear.

After the armature is pulled to the rear and out of the path of the latch lever, it permits the latch lever to continue its rotation to the right under spring tension from the check lever compression spring. This permits the check lever to move into its complete latched out position, and into the path of a set tab stop. Tabulation is now completed in the normal manner (Figure 4).

Special left and right hand final stops are used with this attachment. The right hand final stop is fastened by the inside nut on the right end of the tab rack (Figure 8). The left hand final stop is spot-welded to the rear surface of the margin rack. These final stops prevent the carriage from being moved into a position where the sensing wires could catch on either end of the platen.

Forms

The forms to be used in electronic tabulation must be designed to fit into the pre-set stop sequence. This means that the space between the conductive lines must be in direct proportion to the space between the active tab stops. The width of this space would be three times the

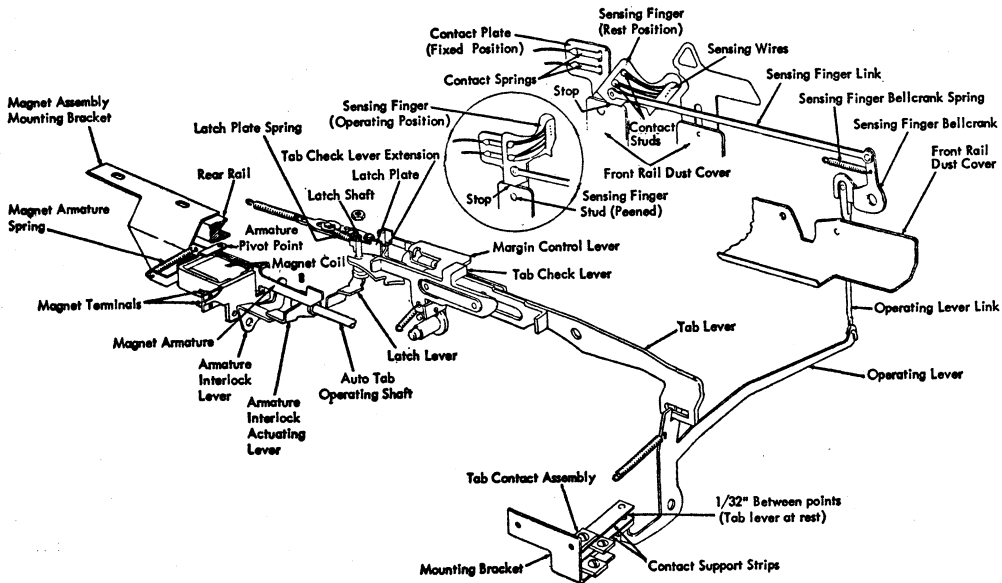

Fig. 1. Electronic Tab Sensing and Latching Mechanism

pitch of the machine, or any multiple of this figure. When inserting and adjusting forms in the machine, the conductive lines must be in proper horizontal registration with the set stops. Lines on the paper table indicate the proper points at which to set the paper table gage in order to insert the forms correctly. The left hand vertical edge of the gage serves as a pointer to be used in positioning it.

To determine the correct position of the paper table, the following procedure should be used.

1. Insert the conductive form into the machine with the left edge in the area of the lines on the paper table.

2. Hold the carriage and depress the tab key while in electronic tab.

3. Release the carriage slowly until a line is sensed, the tab lever unlatches, and the escapement pawl returns to the rack.

4. Backspace once, and the conductive line should be in the exact center of the type guide.

5. The left edge of the form should be in line with any one of the lines on the paper table.

6. If the above conditions do not exist, the form should be moved into the correct position and the paper table moved to the left or right accordingly.

The left margin stop must be set to allow a minimum of .6" and the right margin stop set to allow a minimum margin of .5". This is to insure that the sensing wires do not slip over either edge of the form at any time. If the form has holes punched on either side, the margin must be .6" or .5" from the inside edge of the holes. These precautions are necessary to prevent tearing the forms or bending the sensing wires.

Adjustments

1. TABULATION

All tab adjustments should be made and checked exactly as they would be on a standard typewriter. These adjustments should be checked to be correct before any adjustments are made on the electronic tab mechanism. The rebound check stop should be loosened before the tab adjustments are checked. This stop can remain loose for the present as it will be adjusted later.

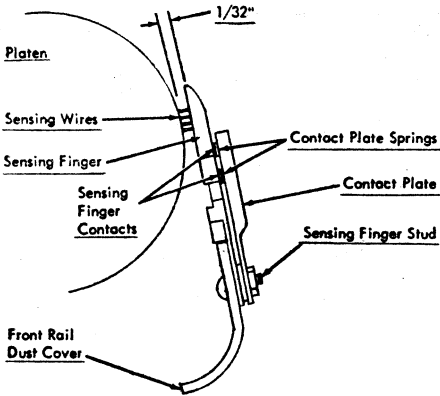

Fig. 2. Electronic Tab Sensing Mechanism

2. SENSING FINGERS

The sensing fingers and contact plate are mounted on the front rail dust cover in the area formerly occupied by the right hand line gage card holder. The contact plate is held in a fixed position, while the sensing finger is free to rotate. The left hand line gage card holder has been relieved to permit the sensing finger to be pivoted down and away from the paper when in its rest position (Figure 1). The sensing finger should be adjusted so that when it is in the upright or operating position, the sensing wires will rest lightly against the platen. At the same time the body of the sensing finger should be approximately

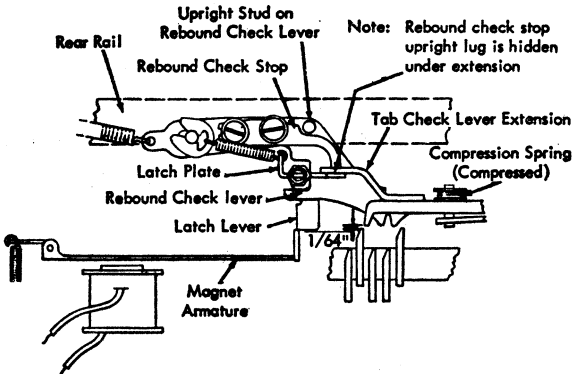

Fig. 3. Electronic Tab Latching Mechanism

1/32 away from the platen (Figure 2). These clearances can be obtained by moving the dust cover forward or back. The dust cover should be adjusted to the left or right the same as on a standard typewriter.

3. CONTACT PLATE

The contact plate should be adjusted to a vertical position (left to right) in relation to the machine. This can be accomplished by loosening the nut on the sensing finger stud and rotating the plate to the desired position. When the contact buttons of the sensing finger contact the springs of the plate, they should "spring" them slightly without forcing the plate itself. The plate can be moved forward by adding shims (.005 to .010") between the plate and the shoulder of the sensing finger stud. If contact is too loose, slightly bow the springs away from the plate (Figure 2).

4. BELLCRANK AND LINK ASSEMBLY

The sensing finger has a fixed stop in both directions of travel and should be adjusted to rest against these stops in either position. This adjustment is made by controlling the length of the operating lever link. This link should be adjusted so the sensing finger stop is resting against the dust cover when the tronic-tab button is down and the tab lever is latched out. When the tab lever is unlatched and restored to its rest position, the sensing finger bellcrank will be rotated, pulling the sensing finger link to the left and restoring the sensing finger to rest (Figure 1).

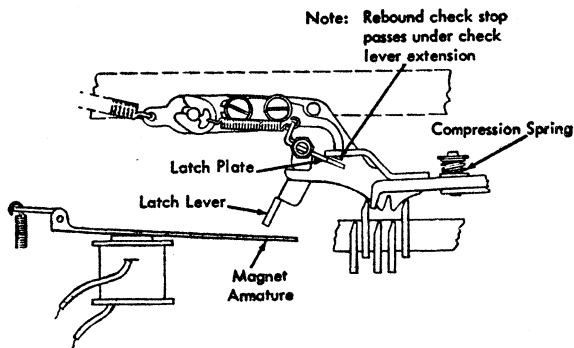
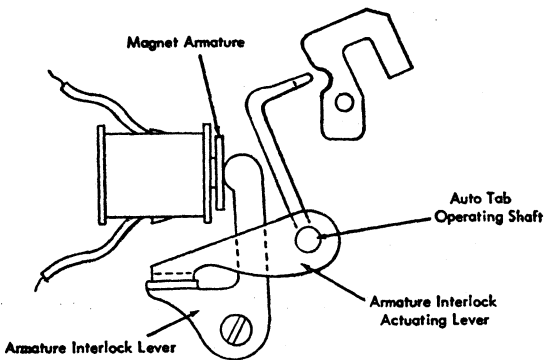

Fig. 4. Electronic Tab Latching Mechanism

5. TAB CONTACT

The contact assembly should be adjusted so there is $1/32$ inch clearance between points when the tab lever is in its rest position. Adjustment is made by reforming either the contact support strips or the mounting bracket (Figure 1). After adjustment is made, the points should close evenly as the tab lever becomes actuated, and should not reopen until the tab operation is completed and the tab lever is returning to the rest position.



Standard Tab Position

Fig. 5. Armature Interlock Mechanism

6. LATCH LEVER AND MAGNET ASSEMBLY

The magnet assembly must be positioned so that when the armature is in the forward position it will keep the latch lever from rotating past it. When the tab lever is latched out, the rear edge of the latch lever should overlap the end of the magnet armature by the metal thickness of the armature (Figure 3). To obtain this condition the magnet bracket can be moved slightly forward or back through the mounting holes by which it is fastened on the rear rail (Figure 1). At this time the latch plate should lie parallel to the rear rail (Figure 3).

7. TAB CHECK LEVER

When the tab lever is latched out and the latch lever is resting against the magnet armature, the tip of the check lever should have $1/64$ inch clearance with the

front edges of the set tab stops. To obtain this clearance the tab check lever extension may be reformed slightly and the magnet bracket moved to the left or right through its elongated mounting holes. For optimum condition the check lever extension should lie flush against the latch plate when in this position (Figure 3).

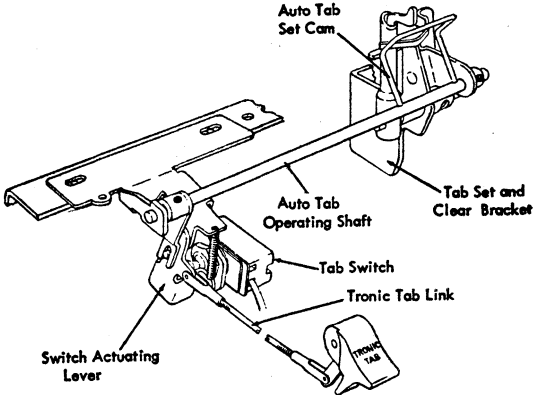

Fig. 6. Electronic Tab Switch and Set Mechanism

8. TAB REBOUND CHECK LEVER

When the machine is in electronic tab and the tab lever is latched out, the leading edge of the rebound check lever should just clear the set tab stops. This adjustment is made by positioning the rebound check lever stop through the enlarged hole and slot by which it is fastened to the rebound check lever. At this point the upright lug on this stop should engage the latch plate and prevent the rebound check lever from engaging a set

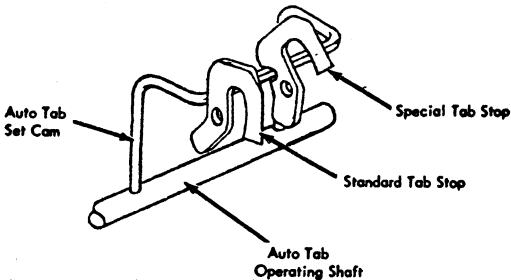

Fig. 7. Auto Tab Set Mechanism

tab stop until the electronic circuit is completed and tabulation is to take place (Figure 3).

9. MAGNET ARMATURE INTERLOCK

This mechanism is to be adjusted so it effectively disables the magnet armature when standard tabulation is desired. The armature interlock actuating lever is adjusted by means of the collar and set screw on the right end of the auto tab operating shaft (Figure 1). This lever should be positioned so it will rotate the armature interlock lever far enough to hold the armature in its closed position when the tronic-tab button is in "standard" tabulation (Figure 5).

10. TRONIC-TAB LINK

This link should be adjusted so the tronic-tab button is in line with the color control button when in its standard tab position. It should also toggle the tab switch when the button is depressed into the electronic tab position (Figure 6).

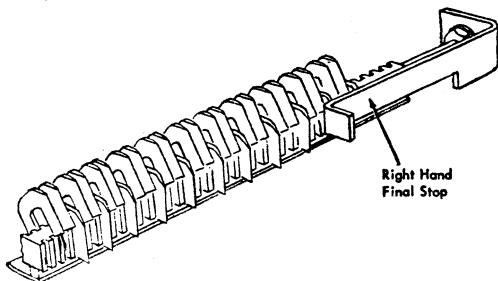
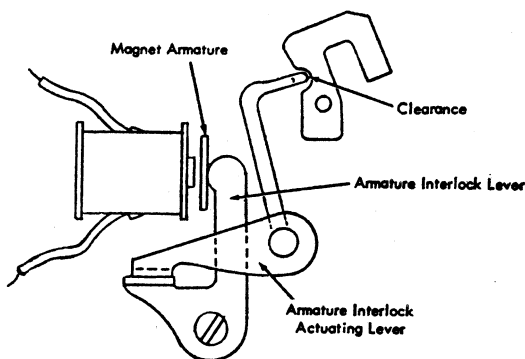

Fig. 8. Tab Stops Pre-Set for Electronic Tab

11. AUTO TAB SET

The auto tab set is in a fixed position in relation to the standard tab set and clear levers. In order to make an adjustment, the entire bracket which is fastened to the rear frame must be repositioned (Figure 6). When the tronic-tab button is depressed and held in its extreme downward position, the auto tab set cam should enter the slots of the tab stops without interference (Figure 7). At the same time it should fully set every third stop as the carriage is moved from side to side (Figure 8). When the button is released, the slight overtravel in the mechanism should permit the auto tab set cam to move away from the tab stops enough to prevent dragging during carriage movement (Figure 9).



Electronic Tab Position

Fig. 9. Armature Interlock Mechanism

12. RIGHT HAND FINAL STOP

The right hand final stop can be adjusted up or down through the elongated mounting hole. The inside nut on the right end of the tab rack holds the stop in place (Figure 8). The upright portion of the tab check lever should strike the left end of the stop whenever the carriage is moved to the extreme left. The stop should not interfere with other carriage or rear rail parts.

Electronic Tab Circuit

The electronic tabulation circuit consists of an on/off switch, a transformer, a Type 2D21 thyatron, a sensing finger and contact plate, a magnet and a contact which operates in conjunction with the tab lever.

When the tab key is depressed the tab lever contact is closed as the tab lever is latched out. This completes the anode circuit of the thyatron amplifier. The thyatron is prevented from conducting at this time, however, because the No. 1 grid is at minus potential with respect to the cathode.

At the same time that the tab lever contact is being closed, the sensing finger is raised into the upper position closing the sensing finger contacts. As a conductive line passes under the sensing wires it completes the circuit and changes the potential on the No. 1 grid to plus with respect to the cathode. As the No. 2 grid is at cathode potential at all times the thyatron now conducts and picks the magnet, releasing the tab check and rebound

check levers to the fully latched out position. The restoring of the tab lever opens the tab contact and restores the circuit to normal.

Maintenance

FAILURE TO STOP AT A CONDUCTIVE LINE during electronic tabulation may be caused by the failure of an electrical component part (Figure 10). These components should be checked by the following procedure:

1. The tube should be checked visually to be sure that the filament is lit.

Causes of failure:

blown fuse

open filament

failure of electronic tab on/off switch

2. Remove the platen and with the machine on and the tronic tab button down, block the carriage and depress the tab key. With the flat of a screwdriver, short the sensing wires. If the magnet is energized and the tab check lever is allowed to latch out fully, the cause of failure is between the sensing wires and the conductive line.

3. If the magnet is not energized in step 2, repeat the procedure but now short out the two contact plate springs. If the magnet is energized, the trouble is between the sensing finger contacts and the contact plate springs.

4. If the magnet is not energized in step 3, repeat the operation, this time shorting the two side frame terminals. Energizing of the magnet at this point would indicate an open lead between the side frame terminals and the contact plate springs.

5. If the magnet is not energized in step 4, the tab lever contact should be checked. Repeating the operation as in step 2, short the contact with a screwdriver across the springs. If the magnet picks up at this point it would indicate dirty or maladjusted contact points.

6. If in step 5, the magnet is not energized, the failure should be in the tube or electronic unit. If replacement of these parts does not correct the failure, the magnet coil may be open.

A TAB LEVER CONTACT that fails to open will result in the magnet remaining energized after the first electronic tab operation. This will cause the carriage to stop at every set stop as it would during normal tabulation.

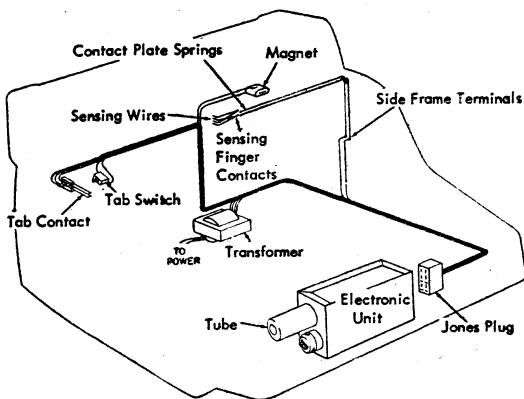

Fig. 10. Electrical Components

THE RIGHT HAND FINAL STOP must be removed before the carriage can be taken off the rails. Tab rack adjustments will have to be checked when the stop is replaced.

LATCHING MECHANISM adjustments should be checked after any movement of the rear rail.

SENSING MECHANISM adjustments should be checked after any movement of the front rail dust cover.

REGISTRATION OF FORMS should be checked after any readjustment of the front rail dust cover, sensing mechanism, paper table, or tab rack.

Machine Limitations

When instructing the user, sales personnel should cover the following limitations of the electronic tab machine:

1. Stencils, offset plates, or forms which have creases, perforations, holes or staples within the margins, should never be used if tabulation, either standard or electronic, is to be operated.
2. Continuous forms that are not used with a pin feed platen are not recommended for electronic tab use since perfect registration of the conductive lines is of such vital importance.
3. The ribbon lift mechanism cannot be used in the high lift position.

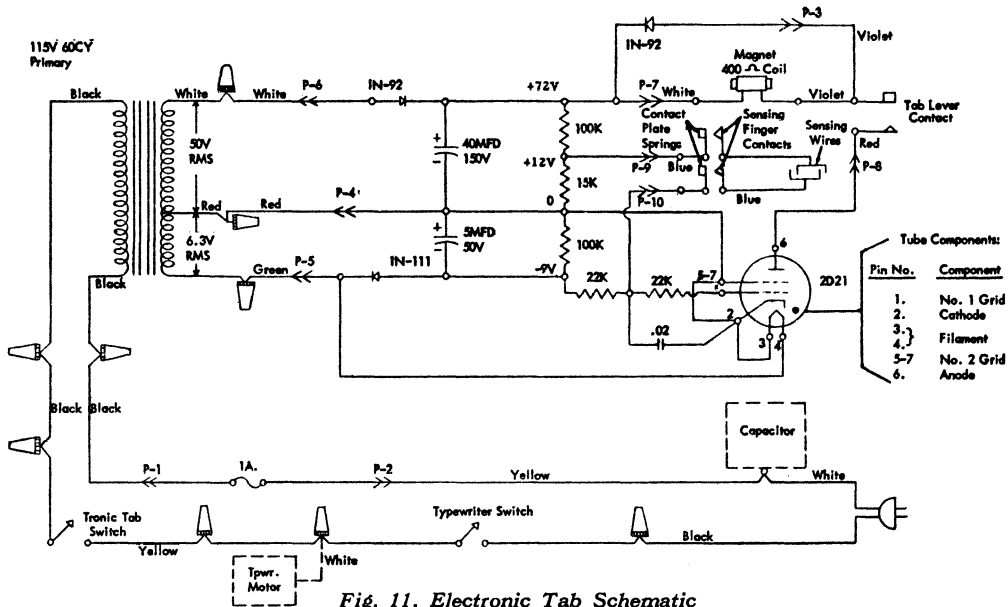

Fig. 11. Electronic Tab Schematic

The following information is presented as a guide to the Customer Engineer who is qualified to service the electronic components of the Electronic Tabulation Typewriter.

MACHINE TROUBLE	POSSIBLE CAUSE	DIAGNOSTIC TECHNIQUE
Magnet picks as soon as Tab lever contact closes	.02 capacitor shorted	Unsolder one end of capacitor from terminal ring, check for short (with ohmmeter) across capacitor.
	Grids of tube shorted together	Check for shorts between grid connections on plug-able unit, if no shorts appear, replace tube.
	22K ohm resistor in-9V line open (grid floats)	Unsolder one end of resistor from terminal, check for open circuit or proper resistance with ohmmeter.
	22K ohm resistor to tube pin #1 open	Unsolder one end of resistor from terminal, check for open circuit or proper resistance with ohmmeter.
	Bad IN-111 diode	Check forward and back resistance of diode according to instructions, or, if diode is good, the voltage measurement across the diode should read 9.4V D.C. when the tube is conducting, and 9.6V D.C. when not conducting. When diode is bad the voltages will measure in the vicinity of 3.2V D.C. nonconducting and 2.9V D.C. conducting.

MACHINE TROUBLE	POSSIBLE CAUSE	DIAGNOSTIC TECHNIQUE
Tube filament does not light	Fuse blown	Check fuse visually or measure across fuse with voltmeter. If 115V A.C. is indicated, the fuse is blown, if good, zero volts will be indicated. If a neon tester is used, a glow will occur on a blown fuse but will not glow on a good fuse.
	Open filament of 2D21 tube	Check across pins 3 and 4 of tube with ohmmeter for open filament. If open, replace tube. Correct resistance is one to two ohms.
No conduction at any time	100K ohm (brown, black, yellow) resistor to 72 volt line open	NOTE: (A faint violet glow will be visible in the tube when it is conducting. Check for glow by shorting contacts on contact plate together and closing tab contact.) Unsolder one end of resistor, check with ohmmeter for open or proper resistance.
Excessive arcing at Tab lever contact, points burned	IN-92 diode across magnet coil open, or high forward resistance	Unsolder one end of diode, check for open and/or proper forward resistance.



**ELECTRIC TYPEWRITERS
ATTACHMENTS**

CUSTOMER ENGINEERING REFERENCE MANUAL

VISIBLE INDEX-CARD HOLDER

INTERNATIONAL BUSINESS MACHINES CORP.

NEW YORK 22, N. Y.

Form 25-6703-0 (V.I.C. section only)

Copyright 1956 by
International Business Machines Corporation
590 Madison Avenue, New York 22, N. Y.

Printed in U.S.A.—August 1956

Form 25-6703-0

VISIBLE INDEX-CARD HOLDER

THE VISIBLE INDEX-CARD HOLDER is a card carrier which travels vertically in the area normally occupied by the front paper guide. Two elongated slots in the card carrier guide its vertical motion. The card carrier has a spring blade running the length of the platen which holds the card in the typing position. Two sector gears mounted on each end of the platen provide vertical motion for the carrier.

A PLATEN LATCH PAWL operates in the ratchet to hold the platen during line spacing of cards. The usual detent roller is used during line spacing of correspondence. Selection of the platen latch pawl, the detent, or release of both is made by a three-position detent release lever.

AN ADJUSTABLE FIRST LINE WRITING STOP and an adjustable horizontal card stop allow accurate positioning of the card.

CARDS of varying lengths can be used, depending upon the length of the carriage. From one to three writing lines can be typed on each card.

FLAT FEEDING of the cards past the writing line eliminates curvature of the card.

THE TYPEWRITER can be easily converted from card typing to correspondence use.

Operating Procedures

NORMAL CORRESPONDENCE. To prepare the machine for normal correspondence, use the following procedure:

1. Loosen the black plastic knob which locks the platen stop lever on the right end of the carriage. Raise the rear end of the platen stop lever so that the front end will allow the platen to rotate.
2. Place the detent release lever in the forward position.
3. Loosen the smaller knob on the right end of the platen and the hand-set screw on the left end of the platen. To loosen the smaller knob on the right end of the platen, rotate the knob clockwise as viewed from the right side of the typewriter.
4. Replace the line gage card holders.

VISIBLE INDEX CARD TYPING. To prepare for visible index card typing, use the following procedure:

1. Lift the line gage card holders out of the typewriter.

2. Hold the card carrier down and rotate the right-hand sector upward until the tops of its teeth just touch the tops of the square holes in the card carrier. Hold in this position while tightening the smaller knob on the right end of the platen. To tighten this knob, rotate it counterclockwise as viewed from the right side of the typewriter.
3. Hold the card carrier down and rotate the left-hand sector upward until the tops of its teeth just touch the tops of the square holes in the card carrier. Center the teeth of the sector (left-to-right) in the square holes of the card carrier and tighten the hand-set screw.
4. Push the detent release lever all the way to the rear.
5. Rotate the platen to bring the card carrier all the way up.
6. Loosen the plastic knob on the right end of the carriage. Push down on the rear of the platen stop lever and tighten the plastic knob.
7. Pull the paper release lever forward. (Installation of the paper release lever spring 1109870 will assist in keeping the paper release lever forward.)
8. Hold the platen variable button in and rotate the platen back until it stops.

NOTE: To maintain proper registration, do not use the platen variable button while the machine is set for card typing.

Platen Removal

1. Loosen the black plastic knob on the right end of the carriage, and position the rear of the platen stop lever upward. Then tighten the black plastic knob.
2. Loosen the smaller knob on the right end of the platen to disengage the right sector gear. To loosen this knob, turn clockwise as viewed from the right side of the typewriter.
3. Loosen the hand-set screw that mounts the left sector gear on the left end of the platen.
4. The platen may then be removed by rotating the platen latches and lifting the platen up.

NOTE: When reinstalling the platen, be sure that the top tooth of each sector is in the top holes of the card carrier.

Adjustments

1. THE PLATEN LATCH PAWL should be adjusted two ways:

- a. With both sectors loosened, position the detent release lever in the center position. Form the front end of the platen latch pawl for minimum clearance between the rear of the pawl and the teeth of the platen ratchet (Figure 1).

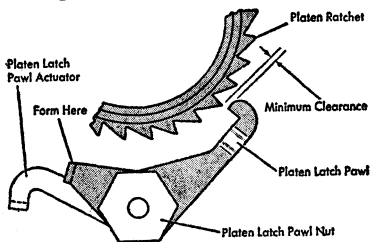

Figure 1. Platen Latch Pawl Adjustment

- b. Place the detent release lever in its forward position to obtain the proper position of the platen by means of the detent roller. Move the detent release lever to its rear position and check for a minimum clearance between the engaging surface of the platen latch pawl and a platen ratchet tooth. Minimum clearance may be obtained by rotating the platen latch pawl eccentric (Figure 2).

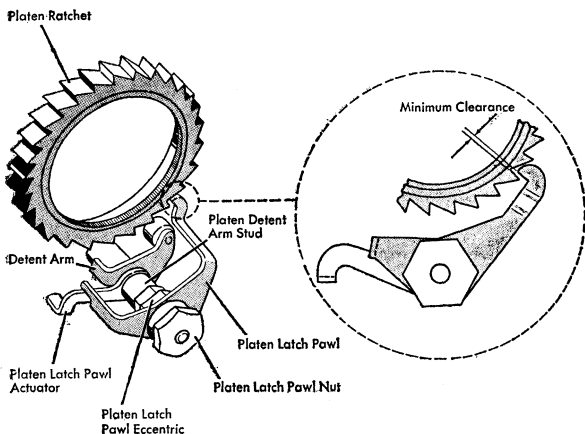

Figure 2. Platen Latch Pawl Eccentric Adjustment

2. THE CARD CARRIER BRACKET ASSEMBLIES may be positioned up or down to obtain a parallel condition of the card carrier (Figure 3). This may be checked by typing first

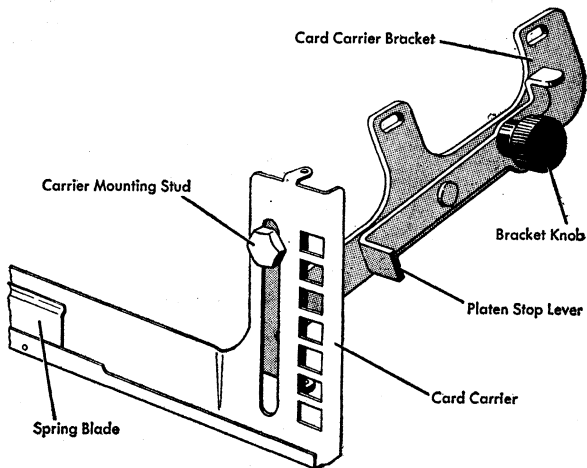

Figure 3. Card Carrier Bracket Adjustment

on the left side and then on the right side of the platen. Check for an equal writing height on each end.

NOTE: After any adjustment of either card carrier bracket, it is necessary to perform steps 2 through 8 of the preparation for visible index card typing before checking the parallel condition of the card carrier. This is necessary because the position of both sectors will be affected by any change in the height of the card carrier, and the height of the card carrier is controlled by the card carrier brackets.

3. POSITION THE FIRST WRITING LINE STOP on the collar of the right sector to establish the desired first writing line (Figure 4).

4. ADJUST THE CARD STOP (left-to-right) to determine the desired left margin on the card for a particular left margin stop setting (Figure 5).

Figure 4. First Writing Line Stop Adjustment

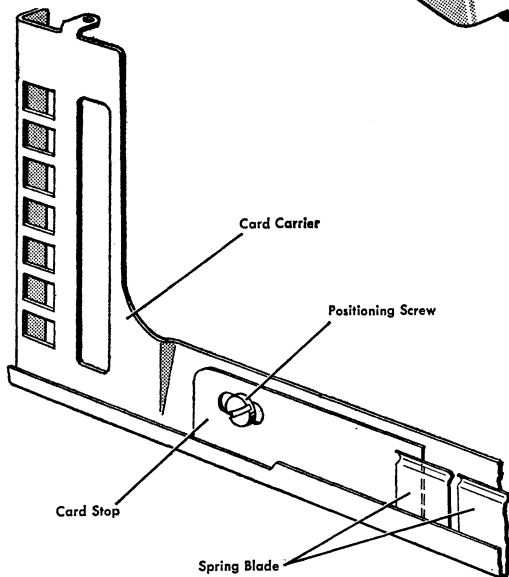
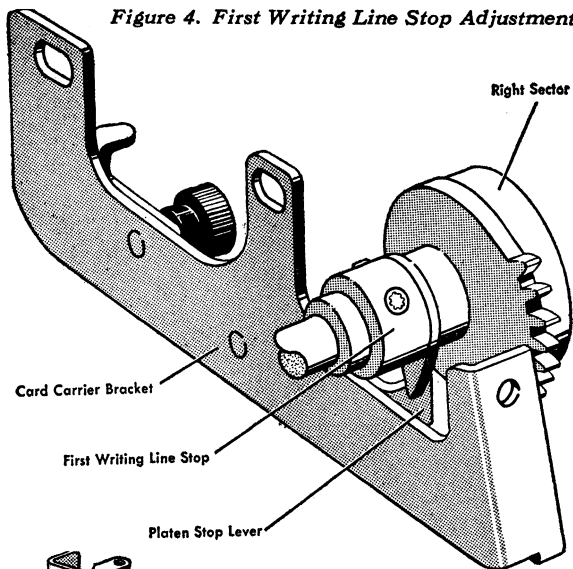

Figure 5. Card Stop Adjustment

IBM
®

**ELECTRIC TYPEWRITER
ATTACHMENTS**

MODELS A 6 AND B 6

CUSTOMER ENGINEERING REFERENCE MANUAL

PIN FEED LIFT PLATEN

**INTERNATIONAL BUSINESS MACHINES CORP.
NEW YORK 22, N. Y.**

Form 25-5000-0 (Pin Feed Lift Platen section only)

Copyright 1957

**International Business Machines Corporation
590 Madison Avenue, New York 22, New York**

Printed in U. S. A. March 1957

Form 25-5000-0

PIN FEED LIFT PLATEN

MODELS A6 and B6

THE PIN FEED LIFT PLATEN ASSEMBLY is attached to a standard lift platen carriage. It has all the advantages of the lift platen plus the advantage of positive form registration.

THE PLATEN DETENT is located on the lifter arm assembly shaft directly over the platen ratchet. This allows the platen to remain detented while the platen is in its raised position. The knife and holder assembly replaces the tear-off blade used on the standard lift platen machine.

THE KNIFE HOLDER ASSEMBLY serves two purposes:

1. To furnish an edge on which to tear off the completed form.
2. To hold the paper securely on the platen pins whether the platen is in the raised or lowered position. This is accomplished by having the knife and holder assembly connected to the platen shaft by the right and left upper arm and latch assemblies, and to the actuating shaft by the right and left lower arm assemblies in such a manner as to rotate it about the platen in a fixed arc when the platen is being raised (Figure 1).

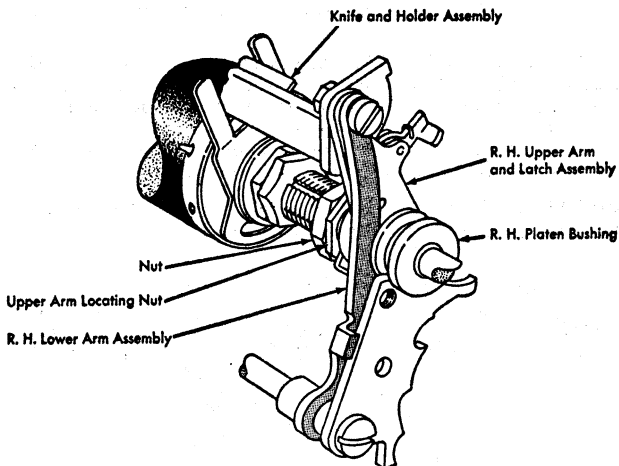

Figure 1. R. H. Platen Bushing and Lower Arm Assembly (Latched Down Position)

THE YOKES of the right and left pin wheel assembly straddle the knife and holder assembly thereby assuring that a protruding pin will always be adjacent to the knife and holder assembly in its rotation about the platen, and at the same time keep the form in its original registration.

THE LIFTER STOP STUD is located just below and to the rear of the tab rack on the carriage side frame. Its function is to limit the upward travel of the platen so that the upper arm will not travel past its toggle point (Figure 2).

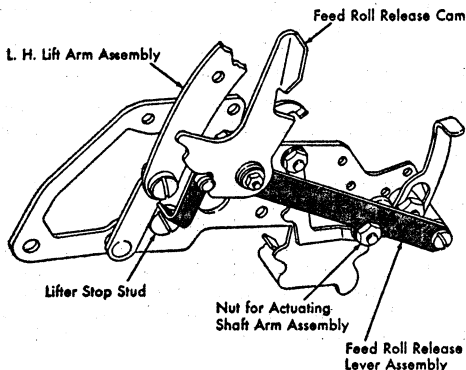

Figure 2. Paper Release Adjustment

THE RIGHT AND LEFT SPRING ARM AND LATCH ASSEMBLIES latch the knife and holder assembly in its normal position. When the platen is raised and the spring latch arms are released, the knife and holder assembly will drop away from the platen, allowing the form to be inserted easily from the rear of the machine.

THE LINE GAGE HOLDERS have been relieved to prevent the pins from striking them. (Figure 3).

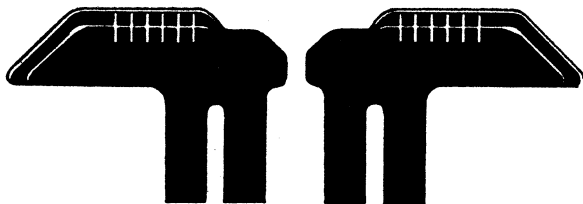

Figure 3. New Style Line Gage Card Holders

OPERATING PROCEDURES

THE CARBON SHEETS are fastened on the blades in the same manner as on the standard forms carrier. However, it is important that the blades are parallel with the platen when slight pressure is exerted on the rear of the blades and that the carbon is placed on the blades so that it will be perpendicular to the platen. This will keep the carbon away from the pins. When it becomes necessary to tear off the carbon paper you must reset the carbon shift stop by moving it forward one form length plus approximately one inch as a safety factor before typing a form. Type a complete form, then raise the platen and push the carbon back until contact is made with the shift stop. The stop is again picked up and moved back until the desired amount of carbon to be destroyed is left in the form just completed. The platen is then latched in its down position and the form and the used carbon are torn off together. The unused carbon paper is now even with the top edge of the forms. If the first writing line is considerably below the top of the form raise the platen and move the carbon shift stop to the rear until the top of the carbon paper is just above this line. This will eliminate excessive carbon paper waste.

ADJUSTMENTS

1. THE UPPER RIGHT ARM AND LATCH ASSEMBLY is attached to the upper arm locating nut. This nut is

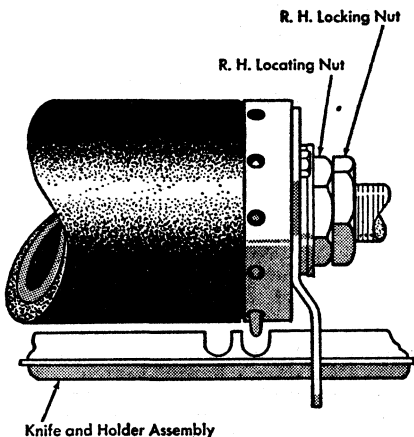

Figure 4. R. H. Pin Wheel Assembly

adjusted horizontally along the platen shaft to obtain a minimum clearance between the right platen bushing and the lower arm assembly so that the lower arm will not bind on the left edge of the right platen bushing, when the platen is in its latched down position (Figure 1).

2. POSITION THE PIN WHEELS and platen assembly right or left by loosening the platen locking nuts so that the pins will be aligned in the center of their respective slots in the knife and holder assembly. It is extremely important that the pins be centered (Figure 4).

3. THE DETENT ROLLER is adjust two ways:

- a. Rotate the detent clamp on its shaft and lock it in place to maintain sufficient pressure to hold the platen in position (Figure 5).
- b. Front or rear so that the index pawl enters the ratchet one-third down on a tooth.

THE LOWER STOP may be adjusted as outlined in the Forms writer section of the reference manual.

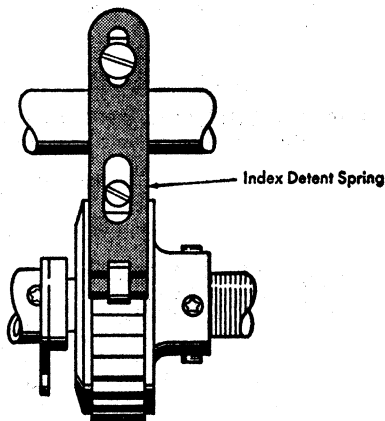

Figure 5. Detent Assembly

4. THE PINS are adjusted in a radial position by loosening the hex headed screws in the slotted opening of the locating plates and rotating the plate until the pins reach their maximum extension at the lower edge of the knife and holder assembly when the platen is in its latched down position (Figure 6).

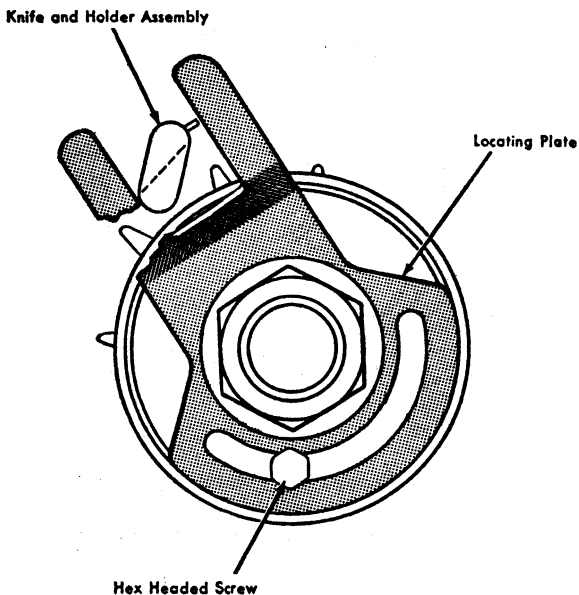

Figure 6. R. H. End View of Pin Adjustment

5. Adjust the front paper guide spacers so that the front paper scale just clears the platen in the latched down position. This is done so that the pins will not interfere with the scale when the platen is lowered (Figure 7). If the pins still contact the paper scale carefully file a slot in the scale at their point of contact.

6. The line gage card holder should be formed to permit the pins of the platen to clear the card holder with a minimum clearance. The remaining adjustments of the card holder are the same as those of the standard machine covered in the Reference Manual.

7. PAPER FEED CLEARANCE IS ADJUSTED by inserting the form to be typed, then loosen the locking nut of the screw which holds the arm assembly of the actuating shaft to the feed roll release lever assembly (Figure 2). Move the arm assembly up or down to just permit the rear edge of the deflectors to drop away from the form when the release lever has reached its maximum released position. This adjustment allows the feed rolls to guide the forms

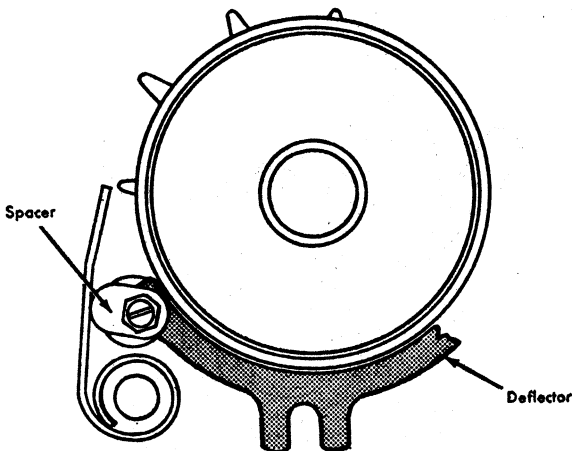

Figure 7. Front Paper Scale Adjustment

without exerting pressure on them. Difficulty may arise in rolling back if there is pressure from the feed rolls on the form. The release lever should always be in the released position for the normal operation of the pin feed mechanism. The spring under the actuating shaft arm and rear feed rolls may be removed if the feed roll release lever will not remain in a released position.

THE FORMS CARRIER SUPPORT should be adjusted by shifting its side frame brackets on the elongated holes so that the carrier support will be absolutely level.

ALL OTHER ADJUSTMENTS are the same as for the standard lift platen, which is covered in the Forms carrier section of the Reference Manual.



**ELECTRIC TYPEWRITER
ATTACHMENTS**

CUSTOMER ENGINEERING REFERENCE MANUAL

FORMS LINE SELECTOR

**INTERNATIONAL BUSINESS MACHINES CORP.
NEW YORK 22, N. Y.**

Form 25-5006-0 (Forms Line Selector section only)

**Copyright 1957 by
International Business Machines Corporation
590 Madison Avenue, New York 22, N. Y.**

Printed in U.S.A.

Form 25-5006-0

FORM LINE SELECTOR

With the exception of the Toll Biller, the IBM Form Line Selector is available for all 12-inch and 16-inch Model B Electric Typewriters. For its installation, all typewriters must be equipped with an IBM pin feed platen.

OPERATING PROCEDURES

THE IBM FORM LINE SELECTOR mechanism is located on the right end of the carriage. It is operated by a crank which is geared to the platen by three gears called the crank gear, intermediate gear and platen shaft gear, respectively. As the crank is turned in a clockwise direction (viewed from the right side of the machine) the platen is rotated the required amount to properly position a continuous form at its predetermined first writing line.

THE ACTIVATOR LOCATED ON THE CRANK, which, when turned by hand, is cammed into an activator stop. This action stops any further hand rotation of the crank and the platen. When the crank is released and a line space is made, the crank activator bypasses the activator stop and the crank is ready for re use whenever necessary.

THE ACTIVATOR STOP or stops are screwed into any of the 18 positions located on a ring on the outside of the frame cover assembly. A stop, called a first activator stop, contains a rounded tip called a pointer. This stop limits the motion of the crank at the predetermined first writing line. If there are to be other activator stops, they are without pointers and are generally used to skip from one predetermined writing line (not the first writing line) to another within the limits of a form. The exception to this would be on narrow, continuous forms, such as checks. Without intermediate activator stops, two or more of these forms might feed through as the crank was turned to a first activator stop.

THE CRANK GEAR, located inside the frame assembly, is available in seven sizes, each size containing a different number of teeth. The number of teeth is stamped on each crank gear. A "rule of thumb" in making a proper selection of this gear is to multiply the length of the customers form in inches by the number six and the resulting figure is the correct crank gear size. Forms smaller in length than six inches will necessitate the use of intermediate activator stops in order to arrive at the first writing line on each form.

INSTALLATION AND ADJUSTMENTS

1. Remove the right hand platen knob. Do not remove any of the spacers between this knob and the platen core (Figure 1).
2. Remove the right hand carriage end cover.
3. Remove the screw which retains the eccentric nut used for positioning the right hand platen adjusting plate. Replace this screw with the hex headed spacer (Figure 1).
4. Remove the cover assembly from the main frame assembly (Figure 2).
5. Mount the modified right hand carriage end cover and the guide upright. Using the two long screws, their collars and the short screw, mount the frame assembly on the right hand carriage end plate. The short screw fits into the hex-headed spacer (Figures 1 and 2).

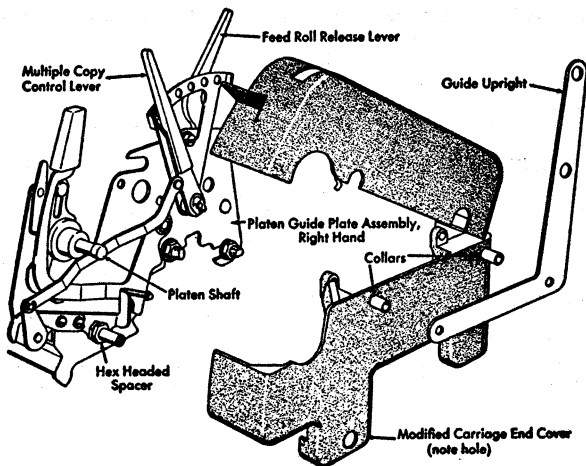

Figure 1. Standard Carriage, End View

6. Install the platen.
7. Fasten the platen shaft gear on the platen shaft and align it with the intermediate gear. A bristo setscrew driver has been furnished for this adjustment (Figure 2).
8. Install the crank gear on its bearing.

9. Adjust the intermediate gear (front to rear) so that there is a backlash of .002" to .012" between it and the crank gear (Figure 2).

NOTE: Possibly backlash to platen gear also.

10. Install the frame assembly on the main frame assembly and tighten the two screws.

11. Install the crank on the crank gear and tighten the bristo set screws (Figure 2).

12. Release the feed rolls. They must remain in the released position. Spring Part No. 1109870 must be installed to insure feed roll release.

13. Install the feed fingers on the front paper guide.

14. Locate the correct setting of the copy control lever. The platen variable button and the platen guide lever should not be used after the form line selector is properly set. If they are used, the activator stops may require new settings. Explain this to the operator. Then remove the platen variable button and insert a carriage truck roller before re installing the platen variable button to render it in operative.

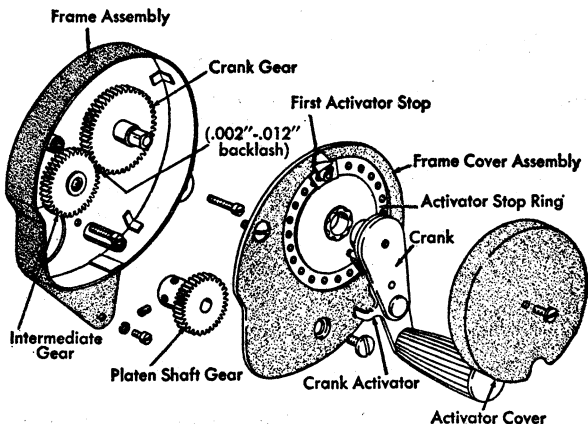

Figure 2. Form Line Selector

15. Place the form to the desired first writing line position. **IMPORTANT**—The center of the top pin feed holes must be $1/4$ " from the top edge of the form to obtain an accurate first writing line. If the form length is not evenly divisible

by 2, only every second or third form in the pack will have the required $1/4$ " between the top of the form and the center of the first holes. Therefore, with these forms, the form that is to be used as a guide for obtaining a first writing position will not always be the first one in the pack.

16. With the form at the desired first writing line, position the first activator stop (with pointer) so that it will have $1/64$ " clearance with the activator in the depressed position (Figure 2).

17. Add additional stops as needed to position the platen on other desired writing lines. Consult the chart for proper crank gear size and number of stops required for various form lengths.

18. Completed view of form line selector (Figure 3).

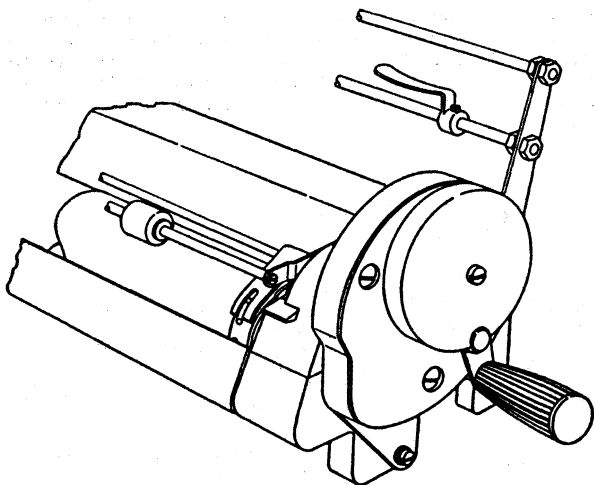

Figure 3. Form Line Selector Mounted

The following chart is a guide in choosing the correct crank gear and the correct number of activator stops that are needed for first writing line positions or forms of various sizes.

CRANK GEAR AND ACTIVATOR STOP CHART

<i>Form Lengths</i>	<i>Crank Gear Size</i>	<i>Required Stops for First Writing Line</i>
1 3/4"	42	4
1 5/6"	44	4
2"	48	4
2"	36	3
2 1/2"	60	4
2 3/4"	66	4
2 5/6"	51	3
3"	36	2
3 1/3"	60	3
3 1/2"	42	2
3 2/3"	44	2
4"	48	2
4 1/4"	51	2
5"	60	2
5 1/2"	66	2
6"	36	1
7"	42	1
7 1/3"	44	1
8"	48	1
8 1/2"	51	1
10"	60	1
11"	66	1
12"	72	1

LUBRICATION

Oil with ET oil No. 6 the following places:

Crank handle rivet

Platen Bearings

Grease with IBM Lubricant No. 17 the following places:

Crank gear bearing take off crank gear

Intermediate gear bearing .. take off intermediate gear

Teeth of all gears very lightly

Crank handle assembly bearing .. take off crank handle

Crank handle spring on the ends

INSTALLATION AND ADJUSTMENTS FOR LIFT PLATEN

1. Remove the lift arm assembly and install the modified lift arm assembly used to house the IBM Form Line Selector (Figure 4).
2. Replace all the parts and make necessary adjustments on the new lift arm assembly.
3. Remove the frame cover assembly from the frame assembly (Figure 4).
4. Install the frame assembly on the studs of the right hand lift arm assembly (Figure 4).
5. Remove the right hand platen knob and adapter.
6. Install the platen (Figure 4).
7. The balance of these adjustments are contained in the "Installation and Adjustment Procedures for the Standard Typewriter," beginning with step 7. Lubrication is also covered under the standard typewriter.

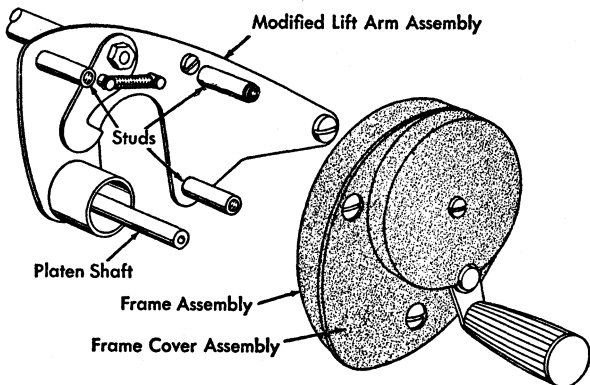

*Figure 4. Modified Lift Arm Assembly With
Form Line Selector*

IBM

ELECTRIC TYPEWRITER ATTACHMENTS

CUSTOMER ENGINEERING REFERENCE MANUAL HEKTOWRITER

**INTERNATIONAL BUSINESS MACHINES CORP.
NEW YORK 22, N. Y.**

Form 25-5009-1 (Hektowriter section only)

Copyright 1957 by
INTERNATIONAL BUSINESS MACHINES CORP.

590 Madison Avenue, New York 22, N. Y.

Printed in U.S.A.—August 1959

Form 25-5009-1

IBM HEKTOWRITER

The IBM Hektowriter has been developed to permit the production of a hectograph master simultaneously with normal typing. This is accomplished by means of a special second ribbon (spirit carbon coated) positioned between the platen and the paper. This ribbon feeds after each type stroke, but not during space bar operation, tabulation, carriage return, backspace, or hand carriage release. This device is designed to be field installed on Model B Standard ET's with 16" carriages.

INSTALLATION

1. Install the longer carriage final stop on the bottom of the front rail. This will reduce the maximum carriage travel to eliminate auxiliary carriage interferences.
2. Because of the longer carriage final stop, it is necessary to install a horseshoe type clamp on the right end of the margin rack to prevent the margin stop from being moved beyond the range of the margin set finger.
3. Relocate the right tab rack fulcrum wire stop to the left of its present position so that, with the carriage to the left, against the final stop, the tip of the tab check lever will contact the approximate middle of the stop. It will probably be necessary to clip the fulcrum wire and to remove one or more tab stops on the right end so as to maintain at least one blank space between the last tab stop and the fulcrum wire stop.
4. Mount the impulse emitter to the power frame in position to be operated by the ribbon lift link on each typebar stroke. Connect one lead at the solderless connector which joins the motor switch lead and the white lead from the motor. Connect the other emitter lead to the capacitor terminal to which are connected the green lead from the motor and one side of the line cord (Figure 1).

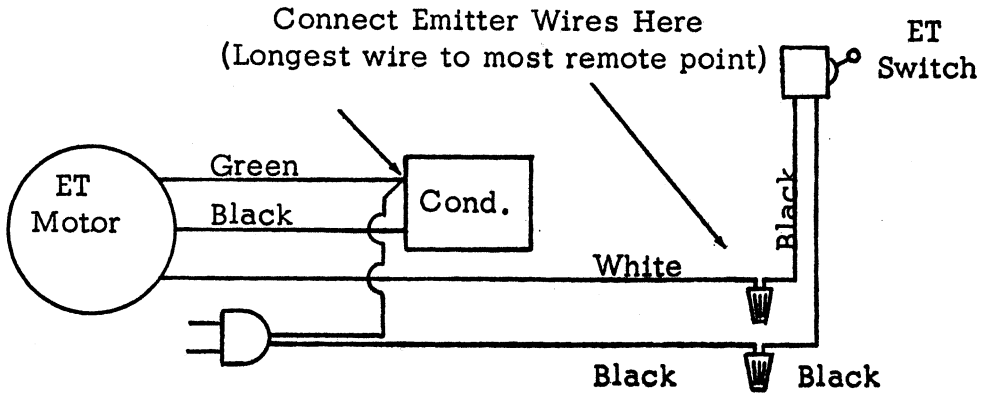

Figure 1. AC Installation Wiring Diagram

5. The forward protruding ears of the carriage end covers should be filed or ground off to prevent interference with the auxiliary carriage.

6. Install the wire stops under the front nuts that hold the platen control yokes to the platen guide plates. These stops should be adjusted to hold the front paper scale away from the platen slightly.

7. Install card holders without "ears".

8. Install the plastic ribbon guide between the lateral wings of the auxiliary carriage with the rounded edge toward the front.

a. Remove the 3 front screws at each end of the auxiliary carriage to allow slight inward deflection of the plates. This will allow easier insertion of the plastic ribbon guide behind the rectangular blocks.

b. Install the plastic ribbon guide behind the rectangular blocks and stretch tightly.

c. Replace the screws removed in step "a" above. This will stretch the ribbon guide even more.

9. Mount the knurled bearing screws loosely into the ends of the front rail leaving about $\frac{1}{8}$ " clearance between the screws' bearing surfaces and the ends of the rail.

10. Mount the eccentric knurled knobs loosely on the ends of the rear rail.

11. Attach and tighten the "Hektowriter" in place on the typewriter. Connect the attachment to the emitter.

12. Locate the left platen knob by installing washers as required between the knob and the left platen bushing.

13. If the platen variable lever contacts the variable button when the lever is in its rest position, remove material from the variable button by filing to eliminate this contact.

Round the button to facilitate latching the auxiliary carriage into place.

For hectowriting, feed a master sheet into the carriage as usual. A thin backing sheet can be used to protect the platen from deposits of hectograph ink. Lower the auxiliary carriage so that the ribbon and

ribbon guide are between the platen and the master, or if a backing sheet is used, in front of the platen and between the master sheet and backing sheet. Latch the auxiliary carriage to the platen shaft. Then lower the paper bail into typing position.

For proof reading purposes the front of the master sheet is imprinted with the regular ribbon. The "Hekto" is in reverse on the back of the master sheet. The backing sheet receives no carbon deposit.

Adjust the impression to obtain sharpness in the deposit of hectograph ink. The multiple copy control lever may be moved to compensate for the extra thickness of the Hektowriter ribbon and its guide. For best results a typewriter ribbon of thin silk or nylon should be used. Thick cotton ribbons will result in poor carbon deposit.

By turning off the Hektowriter switch located on the right side frame and tilting the attachment to the rear, the machine can be used for normal typing.

ADJUSTMENTS

1. AUXILIARY CARRIAGE ALIGNMENT. The upper frame of the auxiliary carriage is aligned by means of the adjusting levers on both mounting brackets. Adjust so the auxiliary carriage is not jammed in its guides on its travel from extreme right to extreme left position (Figure 2).

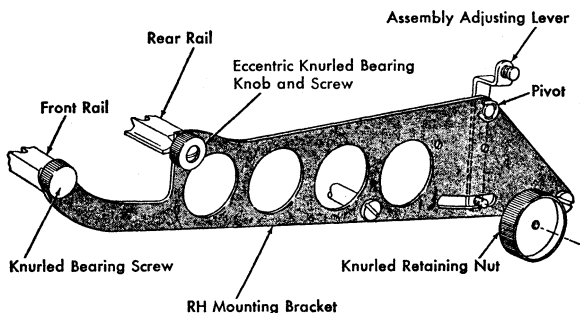

Figure 2. Mounting Bracket Adjustments

2. ECCENTRIC KNURLED BEARING KNOB AND SCREW. Adjust to raise or lower the Hektowriter attachment so that the typed characters are centered on the ribbon at both ends of the carriage (Figure 2). Characters must have correct "even top and bottom" after making this adjustment.

3. RIBBON FRICTION CLUTCH (Figure 3). Adjust by positioning the 3 adjusting screws in their slots so that a pull of $4\frac{1}{2}$ to $5\frac{1}{2}$ ounces is required to turn the take-up spool while the supply spool is held fast. Check by wrapping a string around the take-up spool and pulling it with the spring scale.

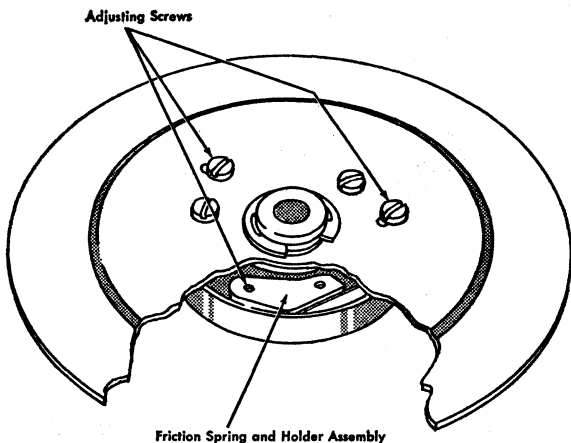

Figure 3. Intermediate Ribbon Spool Flange

4. MAINSPRING. Adjust the mainspring for $3\frac{1}{2}$ pounds tension. The additional amount is required to overcome the drag of feeding the ribbon.

5. IMPULSE EMITTER. The air gap between open emitter contact points should be $.016''$ to $.020''$. Adjust by forming the contact support. The contacts must close when a type face is $2\frac{3}{8}''$ to $2\frac{5}{8}''$ from the platen. Move the impulse emitter front to rear on its mounting screws to obtain this condition.

6. STATIONARY MAGNET UNIT ASSEMBLY. Adjust the magnet unit left or right by means of the magnet unit adjusting screws so that with the armature held manually against the magnet unit rubber stop, there is a clearance of .012" to .015" between the magnet core and the armature. With the armature attracted to the magnet, the brake shoe should clear the brake pad by .010" to .012". Adjust by means of the brake shoe adjusting screws. The ribbon must be held fast by the stationary brake with the armature dropped (Figure 4).

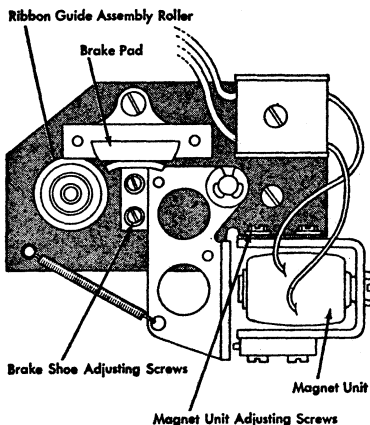

Figure 4. Stationary Magnet Unit Assembly

7. AUXILIARY CARRIAGE MAGNET UNIT ASSEMBLY. (Figure 5).

a. Center the brake shoe adjusting screws in the slots of the brake shoe as a preliminary adjustment.

b. The brake shoe must contact the rubber brake squarely. The shoe can be formed slightly to obtain this condition.

c. Adjust the magnet unit forward or back by means of its adjusting screws to obtain a clearance of .012" to .015" between the armature and the magnet core, when the brake shoe is manually pressed against the rubber brake. The magnet unit should not

be cocked in relation to the armature.

d. Position the adjusting screw so that, when the magnet is not attracting the armature, there will be a clearance of .010" to .012" between the brake shoe and the rubber brake.

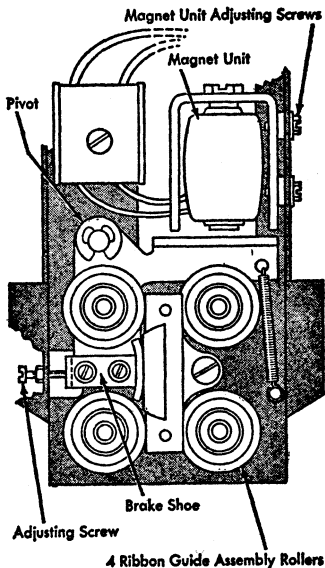

Figure 5. Auxiliary Carriage Magnet Unit Assembly

8. PLASTIC RIBBON GUIDE. This guide is mounted between the lateral wings of the auxiliary carriage. It must have enough tension so that it does not move up or down when the platen is turned in either direction. The guide may be stretched as indicated in the installation instructions.

If over or underprinting occurs due to the ridges at the top and bottom of the plastic guide, the offending ridge or ridges must be filed or stoned off.

9. AUXILIARY CARRIAGE END PLAY. To prevent partial overlapping of the first character typed after carriage return, the auxiliary carriage should have no end play where it attaches to the platen. End play

may be removed by slightly forming the yokes of the auxiliary carriage which fit over the shoulders of the platen knobs. Avoid making sharp forms which may damage the platen knobs.

After carefully making all adjustments, if ribbon feed is still not satisfactory, check the entire mechanism for binds. The ribbon must track correctly in the guide rollers. If the rollers are not perfectly vertical, the ribbon will ride up on the flanges of the rollers creating excessive drag and a tendency for the ribbon to break. If all other efforts fail, ribbon feed may be improved by slightly increasing the tension of the ribbon friction clutch above the limits outlined in adjustment number 3. Excessive tension will slow down the carriage speed during typing.

THREADING OF THE HEKTOWRITER RIBBON

1. Raise the upper frame cover, unscrew the knurled spool retaining nut, and take off the upper and intermediate spool flanges.
2. Set the ribbon and core assembly on the lower spool flange. The ribbon is held by a pin which extends up through one of the holes in the core. The ribbon will unwind counter-clockwise as indicated by the arrow on top of the core. The ribbon spool must be smaller in diameter than the rewind reel on the upper spool flange, (4 $\frac{5}{8}$ " maximum) otherwise the ribbon will slacken during feed action.
3. Reinstall the intermediate spool flange and the upper spool flange. The pin of the lower flange extends into one of the three holes in the friction drum of the intermediate flange, and the pin of the fixed knob in the upper flange reaches into one of the matching holes of the intermediate spool flange. Replace and tighten the spool retaining nut.
4. Unwind sufficient ribbon from the spool and thread it toward the right through the deflector rolls, ribbon guides and brakes on the auxiliary carriage, but by-pass the stationary brake (Figure 6).

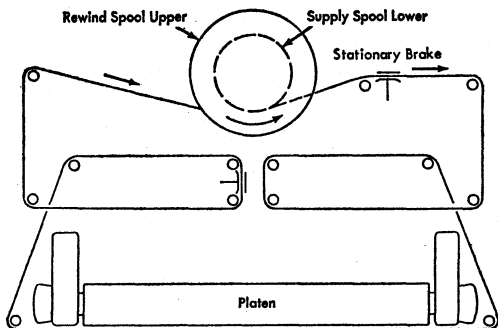

Figure 6. Ribbon Threading Diagram

5. Attach the ribbon to the rewind reel on the upper spool flange by pressing together the two knobs until the normally overlapping ears of the reel sections form slots. Thread the free ribbon end into one of these and release the knobs. Pressing the knobs together reduces the reel diameter and makes possible easy removal of used ribbon.

6. Make certain that the ribbon is centered in the deflector roll grooves. Tighten by manually revolving the upper spool flange counter-clockwise, while braking the lower spool flange with the brake lever (projecting from below). Shortly before the ribbon is taut, lift it between the bypassed brake shoe and the opposite rubber pad. Hold the magnet brake open and continue revolving the upper spool flange but cease braking the lower one, until the hectograph ink coat appears under the type bar guide. The ribbon thus acquires the tautness determined by the friction drum on the intermediate spool flange (see adjustments). Finally, shut the top cover.

7. A new ribbon may be installed by gluing it to the end of the old ribbon and threading it by revolving the upper spool flange.

LUBRICATION AND MAINTENANCE

The ribbon deflector rolls, the brake shoes and blocks of the magnet brakes, and the front ribbon guide

should be cleaned each inspection. Cases and covers may be cleaned by rubbing lightly with a soft rag. This can be done frequently by the operator.

The movable parts such as magnet armatures, deflector rolls (but not nylon rolls), spool mechanism, rewind-reel sectors on the upper flange, detent pawls and adjustment levers should be lightly lubricated on their bearings, pivot points, and friction faces with IBM No. 6. Avoid excess oil and keep lubricants off rubber parts and clutch surfaces.

Each inspection check and adjust the clearances of the impulse emitter contacts, magnet armatures, and brake shoes. Clean contacts with burnishing tool if they are dirty or use a flex stone if they are pitted. Tighten all screws. Check the front ribbon guide for secure fastenings and perfect alignment in relation to the deflector rolls.

The ribbon mechanism of the Hektewriter attachment may need service on occasions. The trouble can be analyzed as electrical or mechanical and may show up as either a complete failure to space, or as a partial spacing or crowding of characters on the ribbon.

MECHANICAL FAILURE

Raise a typebar manually to the platen to actuate the impulse emitter and operate the armatures of the magnet units. If the armatures operate properly the trouble is probably in the ribbon mechanism take-up device. Check the mechanism for proper ribbon tension, binds, and proper assembly and adjustment.

ELECTRICAL CIRCUIT DIAGNOSIS

If magnets fail to operate when a typebar is raised to the platen, the following "terminal-block checkout" procedure may be used to diagnose the problem after first visually checking the emitter for correct contact adjustment and cleanliness. (See adjustment 5). NOTE: Use the schematic in Figure 7 as a guide in making these checks.

1. With the emitter contacts closed, check for voltage across points D and E. There should be approximately 120 volts AC. If you read no voltage at this point and the typewriter motor is operative, the circuit is in-

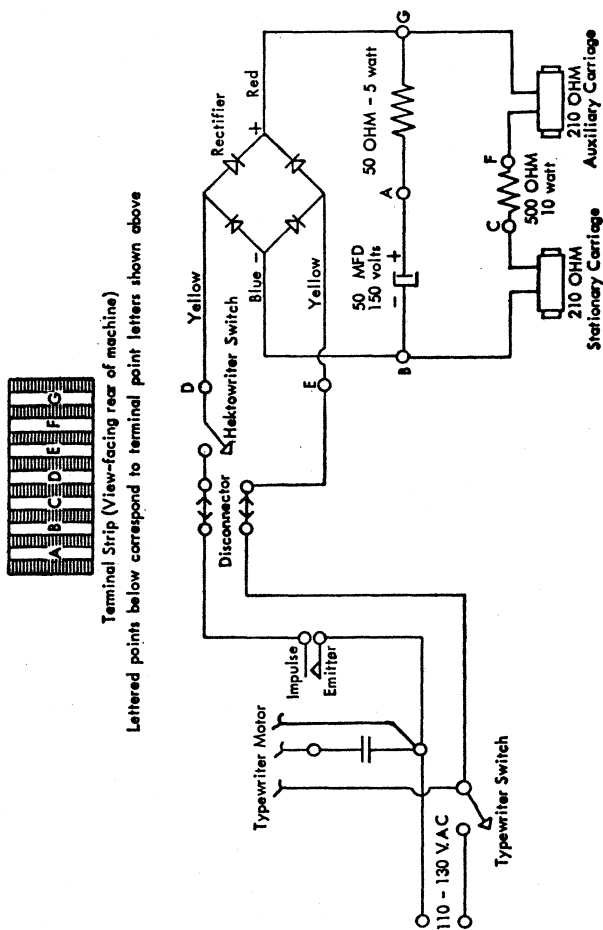

Terminal Strip (View-facing rear of machine)
 Lettered points below correspond to terminal point letters shown above

Figure 7. AC Wiring Diagram

- errupted somewhere between the connecting point of the Hektowriter cable and points D and E.
2. If the correct voltage is present at points D and E,

check for approximately 120 volts DC across points B and G. Failure to read a voltage here would indicate that the rectifier is defective. Normally a defective selenium rectifier gives off toxic fumes with and offensive odor.

3. If the correct DC voltage is read at points B and G, failure of the magnets to operate indicates that one of the magnet coils is open, that the 500 ohm resistor is defective, or that one or more of the connecting leads for these components is broken. These can be checked for continuity with an ohmmeter.

NOTE: When making this continuity check, it will be necessary to disconnect one of the wires at points B or G which go to the coils.

CAUTION: When making a continuity check, make sure that the typewriter is unplugged.

If the magnets operate when a typebar is raised to the platen, but ribbon feed is not satisfactory, the trouble may be in the capacitor circuit. This circuit may be checked as follows:

1. Disconnect the 50 ohm resistor at point G and measure its resistance value with an ohmmeter.

NOTE: Do not merely make a continuity check of this resistor since a shorted resistor would check out satisfactorily in this test but would seriously affect the discharge time of the capacitor.

2. With the resistor still disconnected and the power OFF, check the capacitor with an ohmmeter as follows:

a. Set the ohmmeter at $R \times 1,000$ scale and zero the meter.

b. Connect the positive lead of the ohmmeter to the positive lead of the capacitor and the negative lead of the meter to the negative capacitor lead. At the moment this connection is made, the meter needle should deflect sharply to the right and then proceed to the left toward infinite resistance. This should be done in a matter of a few seconds. If the needle fails to settle near the infinite resistance graduation, the capacitor "leaks" and is therefore defective.

NOTE: The capacitor must be discharged between checks. This can be done by "shorting" across the capacitor terminals with a screwdriver.

IBM[®]

ELECTRIC TYPEWRITER ATTACHMENTS

CUSTOMER ENGINEERING REFERENCE MANUAL

HEKTOWRITER

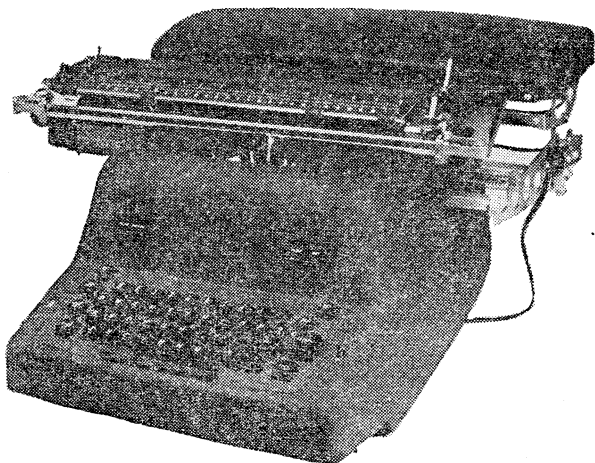

INTERNATIONAL BUSINESS MACHINES CORP.
NEW YORK 22, N. Y.

Form 25-5009-0 (Hektewriter section only)

Copyright 1957 by
INTERNATIONAL BUSINESS MACHINES CORP.
590 Madison Avenue, New York 22, New York
Printed in U.S.A. June 1957
Form 25-5009-0

IBM HEKTOWRITER

The IBM Hektowriter has been developed to permit the production of a hectograph master simultaneously with normal typing. This is accomplished by means of a special second ribbon (spirit carbon coated) positioned between the platen and the paper. This ribbon feeds after each type stroke, but not during space bar operation, tabulation, carriage return, backspace, or hand carriage release. The device is designed to be field installed on Model B Standard and Executive ET's with 16" carriages (Figure 2).

INSTALLATION

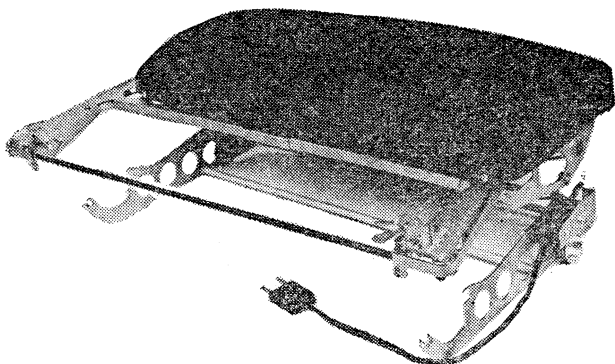

Figure 2. IBM Hektowriter Attachment

The Hektowriter attachment may be field installed in 0.8 of an hour. Steps in the installation procedure are outlined below:

1. Replace the carriage end covers. The protruding ears of the production covers interfere with the auxiliary carriage.
2. Install stops to prevent the front paper scale from contacting the paper.
3. Install card holders without ears.
4. Install the longer carriage final stop. The proper stop will reduce the maximum carriage travel to eliminate auxiliary carriage interferences.
5. The knurled bearing screws should be loosely turned into the front rail end faces. Leave approximately .080" clearance between screw head and rail (Figure 5).

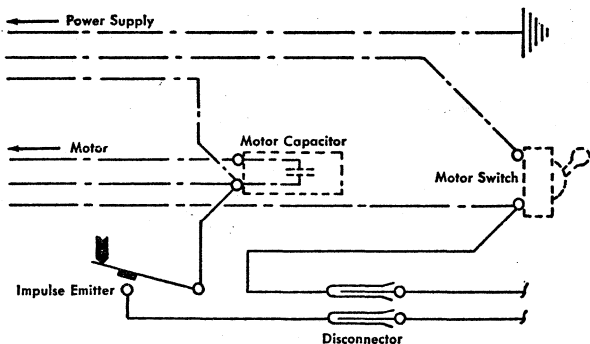

Figure 3. AC Installation Wiring Diagram

6. Mount the eccentric knurled bearing knobs on the rear rail end faces by means of their screws (Figure 5).

7. Mount the impulse emitter to the power frame so it can be actuated by the ribbon lift actuating link on each type stroke. Connect it to the motor switch, and the capacitor (Figure 3).

8. Mount the Hektowriter to the typewriter (Figure 4). Tighten the mounting screws and couple the connecting plug to that of the impulse emitter.

9. Latch the auxiliary carriage in operating position on the platen shaft. The latches are operated by pressing and releasing the two pairs of detent levers projecting at the front of the auxiliary carriage (Figure 2).

For hectowriting, feed a master sheet into the carriage as usual. A thin backing sheet can be used to protect the platen from deposits of Hectograph ink. Lower the auxiliary carriage so that the ribbon and ribbon guide are between the platen and the master, or if a backing sheet is used, in front of the platen and between the master sheet and backing sheet. Latch the auxiliary carriage to the platen shaft. Then lower the paper bail into typing position.

For proof reading purposes the front of the master sheet is imprinted with the regular ribbon. The "Hekto" is in reverse on the back of the master sheet. The backing sheet receives no carbon deposit.

Adjust the impression to obtain sharpness in the deposit of Hektograph ink. The multiple copy control lever may

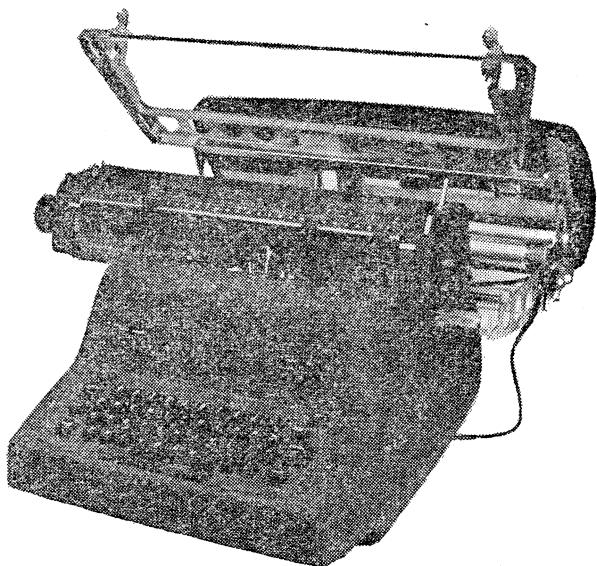

Figure 4. Hektewriter Attachment Raised

be moved to compensate for the extra thickness of the Hektograph ribbon and its guide. For best results a typewriter ribbon of thin silk or nylon should be used. Thick cotton ribbons will result in poor carbon deposit.

With the auxiliary carriage lowered in operating position, the motor switch connects both the typewriter and Hektewriter to the power supply. When the auxiliary carriage is tilted up by releasing its latches it automatically raises the paper bail and opens a microswitch, cutting off the power connection. With the auxiliary carriage in this raised position the typewriter can be used for normal typing (Figure 4).

ADJUSTMENTS

1. AUXILIARY CARRIAGE ALIGNMENT. The upper frame of the auxiliary carriage is aligned by means of the adjusting levers on both mounting brackets. Adjust so the auxiliary carriage is not jammed in its guides on its

travel from extreme right to extreme left position (Figure 5).

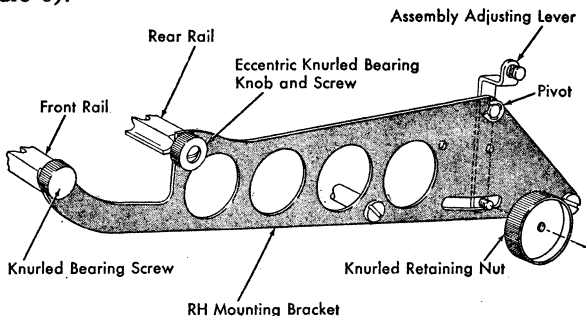

Figure 5. Mounting Bracket Adjustments

2. ECCENTRIC KNURLED BEARING KNOB AND SCREW.

Adjust to raise or lower the Hektowriter attachment so that the typed characters are centered on the ribbon at both ends of the carriage (Figure 5).

3. RIBBON FRICTION DRUM. The friction drum on the intermediate spool flange of the ribbon mechanism should be adjusted by shifting the three adjusting screws in their slots, so that unwinding of the ribbon supply spool requires 7 to 10.5 ounces pull (Figure 6).

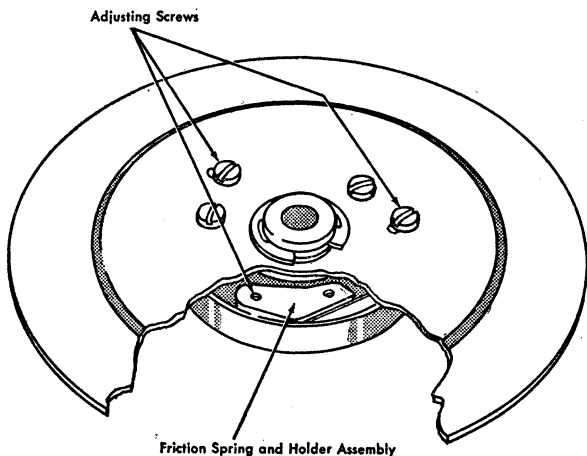

Figure 6. Intermediate Ribbon Spool Flange

4. IMPULSE EMITTER. The air gap between open impulse emitter contact points should be .016" to .020". Adjust by forming the contact support. The contacts must close when a type face is 1 3/4" to 2" from the platen. Move the impulse emitter front to rear on its mounting screws to obtain this condition.

5. STATIONARY MAGNET UNIT ASSEMBLY. Adjust the magnet unit left or right by means of the magnet unit adjusting screws so that with the armature held manually against the magnet unit rubber stop, there is a clearance of .016" to .020" between the magnet core and the armature. With the armature attracted to the magnet the brake shoe should clear the brake pad by a maximum of .016". Adjust by means of the brake shoe adjusting screws. The ribbon must be held fast by the stationary brake with the armature dropped (Figure 7).

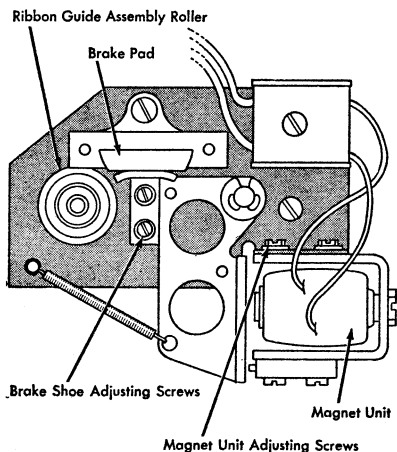

Figure 7. Stationary Magnet Unit Assembly

6. AUXILIARY CARRIAGE MAGNET UNIT ASSEMBLY. Adjust by first centering the brake shoe adjusting screws in the slots of the brake shoe. Tighten the screws to lock the brake shoe on the armature bracket. Adjust the magnet unit front or rear by means of the magnet unit adjusting screws, so that with the armature held manually toward the magnet core the brake shoe will contact the brake pad and there will be .016" to .020" between the armature and the magnet core. Position the adjusting screw so that when the magnet is not attracting the armature, the arma-

ture bracket will be spring loaded against the adjusting screw with a maximum of .016" between the brake shoe and the brake pad. The ribbon must be held fast by the brake on the auxiliary carriage with the armature attracted to the magnet (Figure 8).

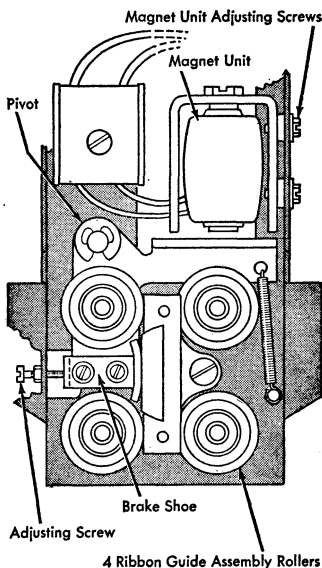

Figure 8. Auxiliary Carriage Magnet Unit Assembly

7. PLASTIC RIBBON GUIDE. This guide is mounted between the lateral wings of the auxiliary carriage. It must have enough tension so that it does not move up or down when the platen is turned in either direction. Adjustment is made by repositioning the guide under the clamping screws at each end.

THREADING OF THE HEKTOWRITER RIBBON

1. Raise the upper frame cover, unscrew the knurled spool retaining nut, and take off the upper and intermediate spool flanges.
2. Set the ribbon and core assembly on the lower spool flange. The ribbon is held by a pin which extends up

through one of the holes in the core. The ribbon will unwind counter clockwise as indicated by the arrow on top of the core. The ribbon spool must be smaller in diameter than the rewind reel on the upper spool flange, (4 5/8" maximum) otherwise the ribbon will slacken during feed action.

3. Re-install the intermediate spool flange and the upper spool flange. The pin of the lower flange extends into one of the three holes in the friction drum of the intermediate flange, and the pin of the fixed knob in the upper flange reaches into one of the matching holes of the intermediate spool flange. Replace and tighten the spool retaining nut.

4. Unwind sufficient ribbon from the spool and thread it toward the right through the deflector rolls, ribbon guides and brakes on the auxiliary carriage, but by-pass the stationary brake (Figure 9).

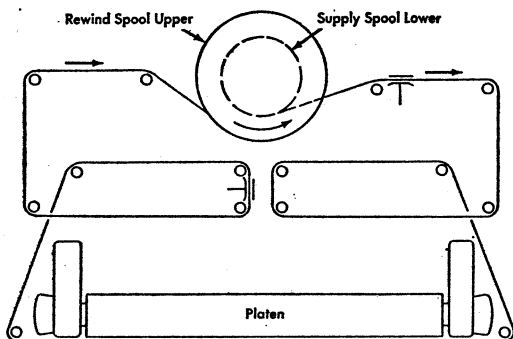

Figure 9. Ribbon Threading Diagram

5. Attach the ribbon to the rewind reel on the upper spool flange by pressing together the two knobs until the normally overlapping ears of the reel sectors form slots. Thread the free ribbon end into one of these and release the knobs. Pressing the knobs together reduces the reel diameter and makes possible easy removal of used ribbon.

6. Make certain that the ribbon is centered in the deflector roll grooves. Tighten by manually revolving the upper spool flange counter-clockwise, while braking the lower spool flange with the brake lever (projecting from below). Shortly before the ribbon is taut, lift it between the by-passed brake shoe and the opposite rubber pad. Hold the magnet brake open and continue revolving the upper

spool flange, but cease braking the lower one, until the Hektograph ink coat appears under the type bar guide. The ribbon thus acquires the tautness determined by the friction drum on the intermediate spool flange (see adjustments). Finally, shut the top cover.

7. A new ribbon may be installed by gluing it to the end of the old ribbon and threading it by revolving the upper spool flange.

LUBRICATION AND MAINTENANCE

The ribbon deflector rolls, the brake shoes and blocks of the magnet brakes, and the front ribbon guide should be cleaned each inspection. Cases and covers may be cleaned by rubbing lightly with a soft rag. This can be done frequently by the operator.

The movable parts such as magnet armatures, deflector rolls (but not nylon rolls), spool mechanism, rewind-reel sectors on the upper flange, detent pawls and adjustment levers should be lightly lubricated on their bearings, pivot points, and friction faces with IBM oil No. 6. Avoid excess oil and keep lubricants off rubber parts and clutch surfaces.

Each inspection check and adjust the clearances of the impulse emitter contacts, magnet armatures, and brake shoes. Clean contacts with a burnishing tool if they are dirty or use a flex stone if they are pitted. Tighten all screws. Check the front ribbon guide for secure fastenings and perfect alignment in relation to the deflector rolls.

The ribbon mechanism of the Hektewriter attachment may need service on occasions. The trouble can be analyzed as electrical or mechanical and may show up as either a complete failure to space, or as a partial spacing or crowding of characters on the ribbon.

Mechanical Failure

Raise a type bar manually to the platen to actuate the impulse emitter and operate the armatures of the magnet units. If the armatures operate properly the trouble is probably in the ribbon mechanism take-up device. Check the mechanism for proper ribbon tension, binds, and proper assembly and adjustment.

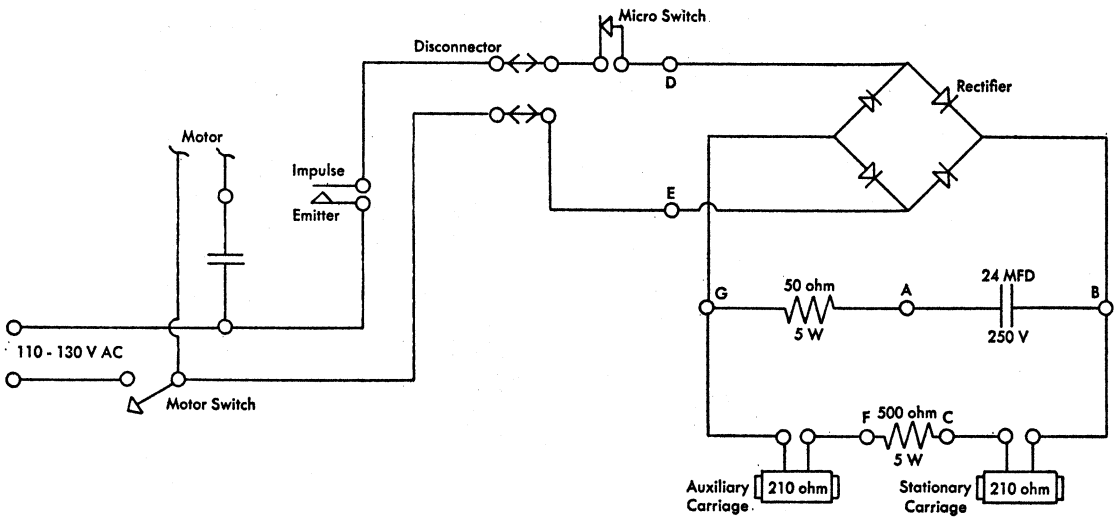

Figure 10. AC Wiring Diagram

Electrical Failures

Raise a type bar manually to the platen to actuate the impulse emitter and operate the armatures of the magnet units. If the armatures do not operate properly and no ribbon spacing occurs, proceed in the following manner. Use the wiring diagram in Figure 10 as a guide. NOTE: The terminal block on the back of the attachment has no letter designation as does the wiring diagram. However, "A" on the diagram will be the first terminal on the left looking from the rear of the machine.

1. Actuate the impulse emitter and check for voltage between points B and G with the test light (120V).
 - a. If there is voltage at these points, one of the magnet unit coils or the 500 ohm resistor must be open. To determine which component is defective, it will be necessary to use an ohm meter.
 - b. If there is no voltage between points B and G, but there is voltage between point D and E, the rectifier is probably burned out. A burned or burning selenium rectifier gives off toxic fumes with a repulsive odor, and can be detected in this way.
2. If there is no voltage between points D and E, (can also be checked with a test light), check to see if the microswitch is made. If it is made, unplug the Hektowriter attachment at the disconnecter and insert the test light into the female end. The light should light each time a type bar is moved to the platen and go out as the type bar is returned to rest. If the light does not light, clean and adjust the impulse emitter contacts.
3. Crowding of characters on the Hektowriter ribbon indicates that the 50 ohm resistor or the 24 mfd condenser is probably bad. This should be checked with an ohm meter.

Voltages may be checked with a voltmeter as follows: On 110 volt machines there should be approximately 120 volts DC between points B and G. There should be approximately 30 volts DC drop across each magnet unit coil, (between points F and G and points B and C), and 60 volts DC drop across the 500 ohm resistor, (between points C and F).



**ELECTRIC TYPEWRITERS
MODELS A2 AND B2**

CUSTOMER ENGINEERING REFERENCE MANUAL

**PARTIAL CARRIAGE
RETURN**

**INTERNATIONAL BUSINESS MACHINES CORP.
NEW YORK 22, N. Y.**

Form 25-5001-0 (Partial Carriage Return section only)

**Copyright 1957 by
International Business Machines Corporation
590 Madison Avenue, New York 22, N. Y.**

Printed in U. S. A.

Form 25-5001-0

PARTIAL CARRIAGE RETURN

Models A2 and B2

MACHINE FEATURES

Partial carriage return is accomplished by means of three selecting key buttons which will provide three lengths of carriage return. This is done by raising a margin lever to different heights and engaging margin stops of different depths.

Repeating cams may be used as usual on any function.

Margins may be set, using the margin set key, as close together as 8 pica spaces or 9 elite spaces. In setting margin stops observe that the stops seat themselves readily in the notches of the margin rack to insure correct carriage return.

The key for carriage return No. 1 is lower than that for carriage return No. 2 to prevent the operator from striking the wrong key.

After a return to the No. 1 or No. 2 position, the margin lever will remain raised until the selector latch is released through an action resulting from the first typebar stroke or space bar action after the partial return. This unlatching is effected by taking motion from the ribbon feed mechanism through a link under the right-hand side of the machine to an unlatching bell crank on the rear frame section.

As the No. 1 carriage return key lever is being depressed to release the cam, a link on the rear end of the key lever moves a transfer lever against a selector lever which is under the right end of the rear rail. The selector lever is moved down to its lowest position and is held there by a selector latch. This action of the selector lever allows the end of the margin lever that contacts the margin stop to rise to its highest position.

When the carriage return cam is released it moves the clutch lever against its roller, bringing the clutch surfaces together. A link from the clutch lever to the intermediate bell crank and another link from the bell crank to the air cylinder latch serve to unlatch the air cylinder operating lever. The air cylinder operating lever is pulled into its operating position by a large spring which releases the escapement pawl and moves the margin lever toward the center of the machine in the path of the No. 1 margin stop.

As the No. 1 margin stop strikes the margin lever, it moves the air cylinder operating lever into a position to be engaged and held by the air cylinder latch. This action restores the escapement pawl into the escapement rack and the clutch lever back to its rest position. Although the car-

riage return is complete to the proper margin, the selector latch is still maintaining No. 1 selection and an escapement operation must occur to restore the selector mechanism.

When the No. 2 key lever is depressed the action of all the parts is a duplication of the No. 1 carriage return except for the selector mechanism. The No. 2 key lever releases the same carriage return cam after the No. 2 transfer lever has moved the selector lever down to a position to be held by the upper notch in the selector latch. The downward travel of the selector lever is checked by an overthrow stop which is operated by the No. 2 transfer lever. With the selector lever in this position, the margin lever will move just high enough to be in the path of the No. 2 margin stop when the air cylinder is unlatched. After the carriage return is completed the No. 2 selection will be maintained until released by an escapement operation.

The full carriage return does not utilize any operation of the selector mechanism. The key lever releases the same carriage return cam which unlatches the air cylinder operating lever. The action of the air cylinder operating lever moves the margin lever only high enough to be in the path of the full carriage return margin stop.

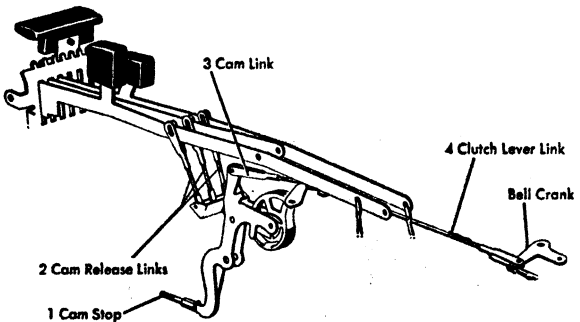
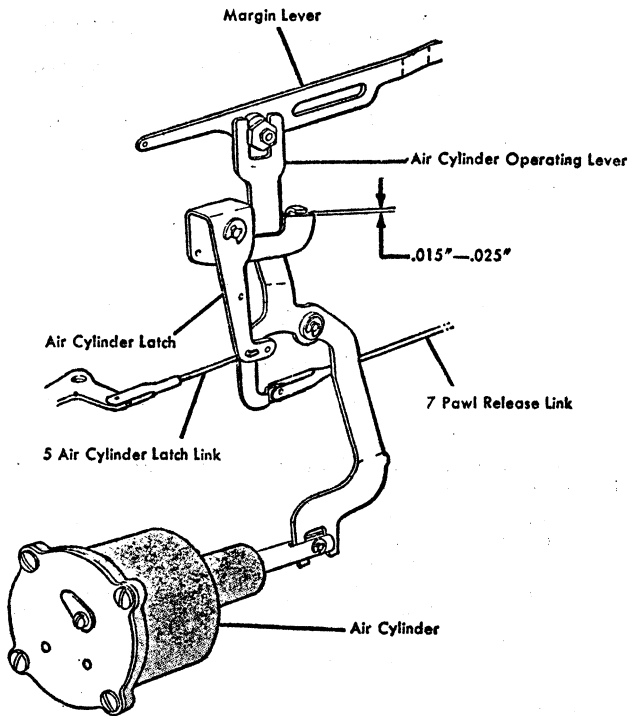

Figure 1. Cam Release Link Adjustments

SELECTION

Adjustments

1. **CAM CLEARANCE** (Carriage Return Cam): REFER to adjustment 1, Model A1.
2. **THE CAM RELEASE LINKS** should be adjusted in the following manner (Figure 1).
 - a. The link from the full carriage return key lever should release the cam when the key has completed two-thirds of its downward travel.
 - b. The links from the No. 1 and No. 2 key lever should trip the carriage return cam as late as possible. This will allow the selector latch to become engaged before the cam is released and guarantee proper carriage return.
3. **THE CAM LINK** to the clutch lever should be adjusted to just span the distance between the cam at rest against its stop and the clutch lever at rest against the roller (Figure 1).
4. **ADJUST THE CLUTCH LEVER LINK** so that the rear edge of the right arm on the bell crank will be parallel to the rear rail (Figure 1).
5. **THE AIR CYLINDER LATCH LINK** from the intermediate bell crank to the air cylinder latch is adjusted so that, when the carriage return cam is on its high point, the formed lug on the air cylinder lever will clear the latch by .015"-.025" (Figure 2).



*Figure 2. Air Cylinder Operating Lever Released
(Cam on High Point)*

6. THE ECCENTRIC ON THE MARGIN LEVER is adjusted for .010"-.015" clearance between the air cylinder lever and the air cylinder latch when the margin lever is held to the extreme right. The high point of the eccentric should be kept toward the top of the machine (Figure 3).

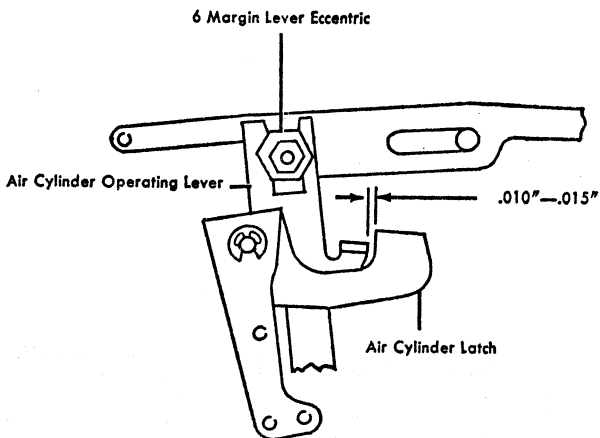

Figure 3. Margin Lever Eccentric Adjustment

7. THE PAWL RELEASE LINK should be adjusted to hold the escapement pawl .030" to .040" out of the escapement rack with the air cylinder lever in the unlatched position and with the margin lever away from a margin stop (Figure 2).

8. ADJUST THE SELECTOR LATCH by moving its fulcrum stud up or down in an elongated hole. With the overthrow stop actuated and the selector lever pressed down against it, adjust the latch until there is a .010" to .015" clearance between the selector lever and the upper notch in the selector latch (Figure 4).

9. OVERBANK: REFER to adjustment 6, Carriage Return, Model B1.

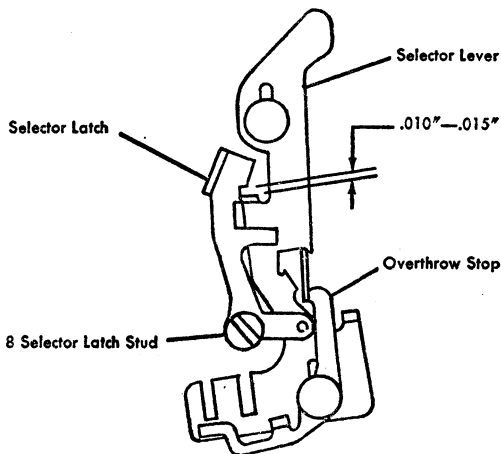

Figure 4. Selector Latch Adjustment

10. THE ECCENTRIC ON THE GOVERNOR CONTROL BRACKET ASSEMBLY must be adjusted in two steps so that the margin release lever will not block the upper position of the margin lever when it is latched in the No. 1 partial return position. Move the high point of the eccentric to its lowest position and tighten the locking nut. Also unhook the short link between the margin release key lever and the margin release bell crank. The final adjustment of the margin release cannot be made at this time.

11. THE SELECTOR LEVER ROLLER may be moved up or down in an elongated slot after loosening its locking nut. Adjust the roller to give approximately $3/32$ " bite on the full return margin stop. The clearance under the No. 2 margin stop should be approximately $1/64$ " (Figure 5).

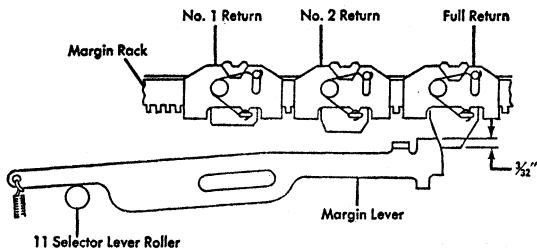

Figure 5. Selector Lever Roller Adjustment

As a further check, latch the selector lever in the No. 2 position (upper notch) which should provide an engagement of approximately $1/16''$ with the No. 2 margin stop and a clearance of approximately $1/64''$ with the No. 1 margin stop. Also latch the selector lever in the No. 1 position (lower notch) and see that the engagement of the margin lever with the No. 1 margin stop is approximately $1/16''$.

12. THE LINK IN THE NO. 2 TRANSFER LEVER is placed in the second hole from the front end and extends upward to the second hole from the end of the No. 2 key lever. Adjust the link so that the clearance between the selector lever and the upper notch in the selector latch is $.010''$ to $.015''$ when the No. 2 key lever is fully depressed. Check that the overthrow stop does not choke off the No. 2 key lever through the selector lever; form the stop if necessary. Be sure that the overthrow engages the selector lever without interference while the No. 2 selection is being made and is held in position by the selector lever after the latch engages (Figure 6). The stop must not interfere with the selector lever when the No. 1 selection is taking place.

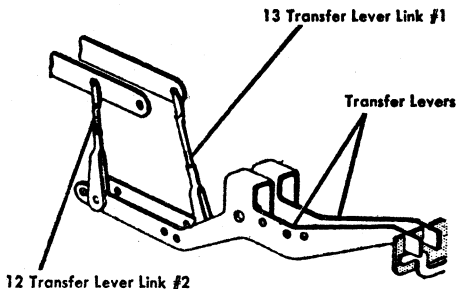

Figure 6. Transfer Link Adjustment

13. THE LINK IN THE NO. 1 TRANSFER LEVER is placed in the fourth hole from the end and connected to the back end of the No. 1 key lever (Figure 6). Adjust the link so that the clearance between the selector lever and the lower notch in the selector latch is $.010''$ to $.015''$ when the No. 1 key lever is fully depressed (Figure 7). After the above two adjustments have been made the cam release links should be rechecked.

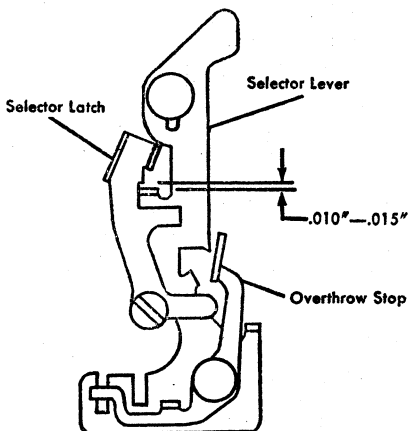

Figure 7. No. 1 Transfer Link Adjustment

14. ADJUST THE ECCENTRIC ON THE GOVERNOR CONTROL BRACKET ASSEMBLY to allow .005" to .010" clearance between the margin release lever and the margin lever in the No. 1 partial position with the air cylinder lever unlatched. Adjust the link between the margin release key lever and the margin release bell crank so that the above tolerance is not reduced and margin release past the extreme left-hand margin stop may be obtained (Figure 8).

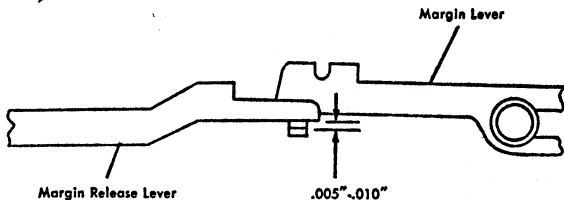

Figure 8. Margin Release Adjustment

15. ADJUST THE RIBBON CAM RELEASE LINK from the space bar key lever so that the ribbon cam will be tripped just before the space bar cam when the key lever is slowly depressed. In some cases it may be necessary to adjust the travel of the space bar but be certain that the ribbon cam operation does not actuate the space bar. Watch the travel of the slotted adjusting clevis from the space bar to the ribbon cam release lever when the ribbon cam is operated turning the power roll by hand.

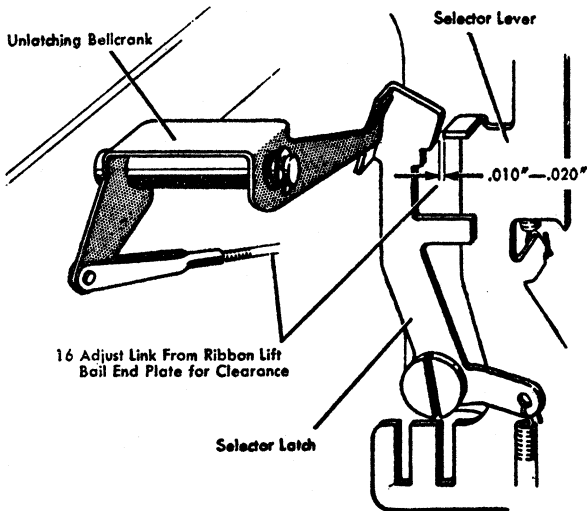

Figure 9. Unlatching Adjustment

16. ADJUST THE LINK FROM THE RIBBON LEFT BAIL END PLATE to the unlatching bell crank so that on the high point of the ribbon cam the selector lever in its highest position clears the selector latch by $.010''$ to $.020''$ (Figure 9).

CARRIAGE RETURN

Adjustments

1. **CLUTCH PLATE CLEARANCE:** REFER to adjustment 18, Carriage Return, Model B1.
2. **THE AIR CYLINDER AND CLUTCH COMPRESSION SPRING:** REFER to adjustment 20, Carriage Return, Model B1.

TABULATION

1. **CAM CLEARANCE:** REFER to adjustment 1, Tabulation, Model B1.
2. **CAM RELEASE LINK:** REFER to adjustment 2, Tabulation, Model B1.
3. **THE TAB LATCH ADJUSTING SCREW** is adjusted so that with the tab lever latched the tip of the tab lever will cover $1/2$ to $2/3$ of the exposed surface of a set tab stop (Figure 10).

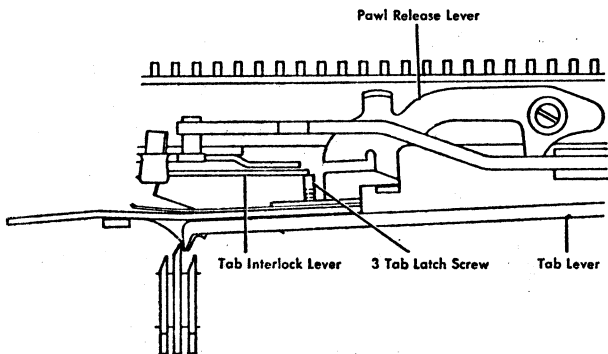

Figure 10. Tab Latch Screw Adjustment

4. **THE TAB OPERATING LINK** is adjusted so that when the cam is on the high point the tab latch screw will overthrow the tab interlock lever by approximately .010" (Figure 11).

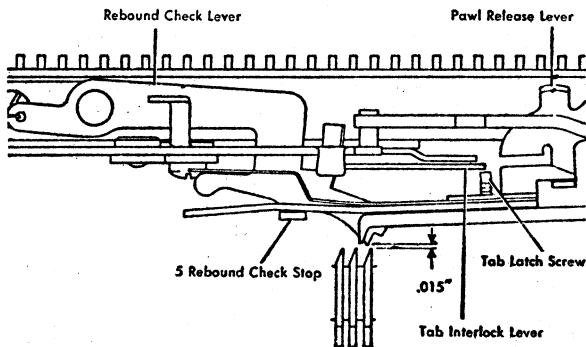

Figure 11. Tab Latching Adjustment

5. **THE REBOUND CHECK STOP** should be formed so that when the tab lever is latched the tip of the rebound check lever clears the tab rack by .015" with all tab stops cleared (Figure 11).

6. **THE TAB LEVER EXTENSION** serves two functions—it acts as an overthrow stop for the tab lever and controls the rest position of the rebound check lever. Push the link end of the tab operating lever toward the front of the ma-

chine and move the tab lever out past its latched position. Form the extension at a point close to the tab lever so that the extension strikes the rebound check stop and halts the tab lever when the tip is .015" from the tab rack (Figure 11).

Check that the tip of the tab lever and the tip of the rebound check lever are in the same place front to back when the tab lever is in a rest position, approximately parallel to the rear rail. To obtain this condition, the extension may be formed on the extreme end being careful not to change the extension close to the tab lever.

7. THE TAB INTERLOCK LINK must pull the interlock lever far enough to cam the rebound check lever down below the level of any set tab stop when the carriage return is operating. Unlatch the air cylinder operating lever and adjust the interlock link so that the rebound check passes just below the tab stops (Figure 12).

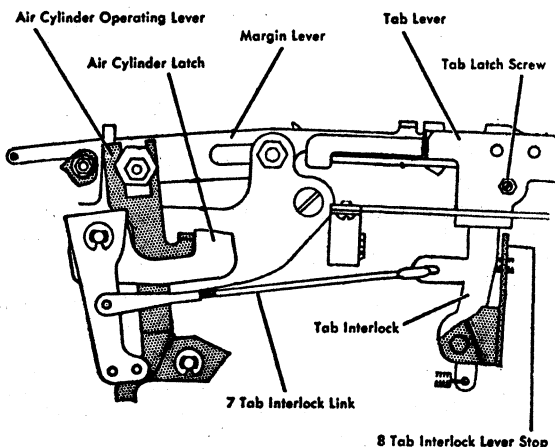

Figure 12. Tab Interlock Adjustment

8. FORM THE TAB INTERLOCK LEVER STOP to allow .005" to .010" between the interlock lever and the tab latch adjusting screw when the tab lever is at its extreme left position (Figure 12).

9. ADJUST THE PAWL RELEASE LUG so that there is a clearance of approximately .015" between the tip of the escapement pawl and the escapement rack teeth when the tab lever is latched.

10. THE REBOUND CHECK LEVER BRACKET is held to the top of the rear rail by two screws in elongated mounting holes. With the tab lever held in its latched position by hand and a tab stop firmly against the tab lever, move the bracket until the engaging tip of the rebound check lever clears the tab stop by $.005''$ to $.015''$. Generally, this clearance must be maintained at the lower tolerance when adjusting the longer carriage machines. Note that the lug on the rebound check bracket serves as a guide for the margin lever. Lock the bracket in such a manner that this lug does not bind or interfere with the freedom of the margin lever (Figure 13).

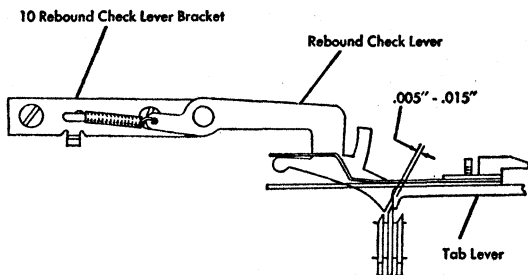

Figure 13. Rebound Check Adjustment

11. THE TAB RACK should be so positioned that the front face of a set tab stop is parallel to the tip of the tab lever and so that the carriage end plates are not sprung. It should be adjusted left or right with the escapement pawl engaged and the tab lever partly out so that there is a clearance between the striking face of the tab lever and any tab stop as follows: 14, 12 and 10 pitch, $.002''$ to $.010''$; 9 pitch, $.010''$ to $.020''$; 8 pitch, $.025''$ to $.035''$. It should be noted that as the pitch of the machine becomes larger the tolerance becomes greater. Position the right end of the tab rack front to rear by means of its elongated mounting hole so that the tab lever will take an equal bite on all set tab stops.

12. TAB GOVERNOR PAWL LINK: REFER to adjustment 9, Tabulation, Model B1.

13. CARRIAGE TENSION: REFER to Model A1 page 21.

14. FRICTION GOVERNOR: REFER to Adjustment 10, Tabulation, Model B1.



ELECTRIC TYPEWRITERS MODEL 3

Toll Biller

CUSTOMER ENGINEERING REFERENCE MANUAL

CONTENTS

MACHINE FEATURES

	<i>Page</i>
Adjustable Paper Chute	3
Self-Aligning Feed Rolls	3
Number 1 Platen	3
Gang Stop Tabular Rack	3
Government Billing Tabular Rack	3
Escapement	3
Automatic Carriage Return	3
First Writing Line Form Positioner	3
Margin Stops	3
Type Segment Support	3
Amount Keys	3
Block Numerals	4
Ditto Key	4
Keyboard	4
Carriage Return Key Button	4
Selective Tabulation	4
Page-End Keyboard Lock	4
Line Counter	4

ADJUSTMENT

Amount Keys	4
Carriage Return	5
Tabulation	5
Ditto Tabulation	7
First Writing Line Positioner	7
Page-End Keyboard Lock	8

INTERNATIONAL BUSINESS MACHINES CORP.

NEW YORK 22, NEW YORK

Form 25-6008-1 (this section only)

Copyright 1953 by
International Business Machines Corporation
590 Madison Avenue, New York 22, N. Y.
Printed in U. S. A. May, 1955
Form 25-6008-1

IBM ELECTRIC TOLL BILLER

Model 3

This section contains information pertinent only to the special features of the Toll Biller.

MACHINE FEATURES

The Model 3 Toll Biller is made in 12" carriage lengths only. The carriage has the following features:

ADJUSTABLE PAPER CHUTE.

SELF-ALIGNING FEED ROLLS.

NUMBER 1 PLATEN equipped with 38-tooth platen ratchet for 7 lines per inch spacing only. The line space lever is locked in single-spacing position.

GANG STOP TABULAR RACK to be supplied in accordance with entries on Toll Statement which must be attached to order.

FOR GOVERNMENT BILLING, a special tabular rack with hand-set tab stops is available for field installation.

THE ESCAPEMENT available is 10-pitch or 12-pitch.

AUTOMATIC CARRIAGE RETURN from the right margin.

FIRST WRITING LINE FORM POSITIONER. This device provides an automatic latching mechanism for the platen which permits the typist to remove the completed form by pulling it upward until the platen latches. The platen rotation will be automatically stopped and the completed form will be torn off. At this position the next form to be typed will be at the first writing line. This device also permits ejection of the form and positive location of the first writing line by manually rotating the platen knob for those instances where the forms are not to be disconnected. This device is effective only for forms 5 1/2" in length. Correction for variances due to form slippage is made through the use of the platen variable.

MARGIN STOPS must be set by hand because the space formerly provided for the margin set mechanism is now used for the page-end keyboard lock. A lift platen style of margin rack is used which permits a writing line of 9-11/32".

THE PAPER BAIL AND BAIL SPRINGS have been eliminated on this machine.

THE TYPE SEGMENT SUPPORT is locked and carries single-case type.

AMOUNT KEYS operate two block numeral characters on one type slug. The first digit is offset to print one-half escapement space to the left, and the second digit one-half escapement space to the right. The operation of any

amount key automatically causes the carriage to return to the left margin. Amount characters now available are: 05, 10, 15, 20, 25, 30, 35, 45 and 65. Others will be provided at the published charge for type matrices. An italic "Tgm" (1086117) and "Col" (1102639) are available for installation in positions 0, 36, 38, 40, 41, 42 or 43 and are centered on the type bar.

BLOCK NUMERALS 1 through 0 and the hyphen are offset one-half escapement space to the left so that they will align columnarly with the amount characters. Therefore, if one of these or an amount character is required directly after an alphabetic character, it will be necessary to activate the space bar between the two.

THE TYPING OF THE DITTO KEY, available in position 32 only, automatically causes the carriage to tabulate to the next column. This operation will be supplied as standard, unless specified to the contrary.

THE KEYBOARD has 43 standard keys, with 44 maximum.

THE CARRIAGE RETURN KEY BUTTON is for left-hand operation only, and is located in the approximate area normally occupied by the shift lock key button.

SELECTIVE TABULATION. A tabular key button located on the right side of the keyboard, in the normal carriage return position and of the same size and shape, permits one tabulation per key stroke, enabling the typist to tabulate from "Date Called" to "Place Called" and then to the first amount column. A palm skip-tab key located in the lower right corner of the keyboard provides two tabulations for each depression, enabling the typist to tabulate directly from the "Place Called" column to the second amount column.

PAGE-END KEYBOARD LOCK. This device provides a means for automatically locking the keyboard at a predetermined page-end position on the form and is adjustable to meet varying demands within a form length of 5-1/2". It prevents any typing over the printed matter at the bottom of the form.

THE STENCIL RIBBON POSITION has been eliminated on this machine.

A LINE COUNTER is an optional feature.

ADJUSTMENT

AMOUNT KEYS consist of two numerals on one type slug. Each machine usually is equipped with five amount keys. Each amount key lever is fitted with identical actuator levers which transfer its downward motion to a carriage return bail (Figure 1). The bail then releases the carriage return cam by actuating the right-hand carriage return key lever.

Because two operations occur on one amount-key lever stroke—the amount type bar striking the platen and the carriage return following—it is necessary to adjust the key lever so that it will trip the amount cam first and the carriage return cam second. The carriage return cam should trip before the key lever bottoms in the front guide comb so that excessive pressure need not be applied to the amount key button. Should the amount key lever bottom in the guide comb with no action on the carriage return cam, the cam release link located on the right-hand carriage return key lever should be adjusted.

CARRIAGE RETURN. When the carriage return button is depressed, the carriage return bail is pushed down by means of an actuator lever. This motion is transferred to the right side of the machine by the carriage return bail which pulls down on the right-hand carriage return key lever by means of an actuator hook. This trips the cam release lever through an adjustable link and in turn operates the carriage return mechanism.

The adjustable link from the right-hand carriage return key lever should not require readjustment as it is adjusted to the correct position when the amount keys are working properly.

The amount keys actuate the carriage return bail by means of the actuator levers and cause a normal carriage return after each amount key is depressed.

The automatic carriage return from the end of the line uses the standard line lock bracket. The drag link on the rear rail is actuated by the right-hand margin stop which transfers the motion to the push link by means of bell cranks. The push link is moved forward and the collar on the link strikes the carriage return bail plate (Figure 1), causing it to pull down on the carriage return bail and trip the carriage return cam.

Position the carriage at the last typing position in the second amount column. Move the right-hand margin stop as close as possible to the hook of the drag link without striking it. Adjust the line lock bracket so that the drag link contacts the margin stop extension not more than $1/32$ " before the right-hand margin meets the tab lever.

With the carriage at the last typing position on the form, as described in the preceding adjustment for the drag link bracket, trip the escapement one space. This action should actuate the drag link and move the push link forward to release the carriage return cam.

If the carriage return cam is not released, reposition the collar on the forward end of the push link. The push link should be screwed into the clevis only far enough to hold securely. If it is screwed too far into the clevis, the front end of the link might drop out.

TABULATION. The tab mechanism uses two executive-type double-lobe cams, one of which is modified. One cam

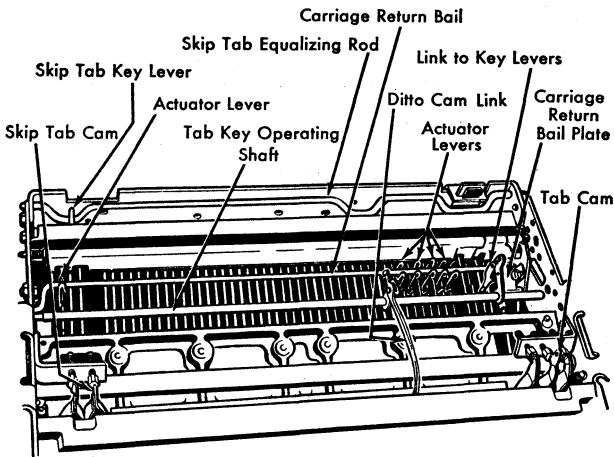

Figure 1. Keyboard Mechanism

replaces the shift cam and is single-acting. The other cam is in the normal position, has one cam lug broken off, and is double-acting (Figure 1). Both cams are interconnected because both operating links connect to a skip tab shaft and lever assembly that replaces the shift toggle shaft. A modified design of the tab actuating lever on the governor control bracket assembly will hold the tab cams away from the power roll during tabulation and make possible a skip tab operation to the second amount column.

The tab mechanism operated by the standard tab key button should be adjusted first. Disconnect the link from the top of the skip tab cam on the left side of the machine. Adjust the cam stop for the right-hand tab cam to obtain a conventional cam adjustment as described in the gray manual. Adjust the operating link on the top of the right-hand cam so that the tab lever latches reliably.

Adjust the left-hand tab cam stop for a conventional adjustment with the operating link unhooked and the cam held against its stop by hand. With the tab lever at rest and the left-hand cam against its stop, match the clevis to the cam without pulling or pushing the operating link. Recheck the cam clearance by tripping both cams with the power off. If the operating link to the left-hand cam is too long, the left-hand cam will move away from the power roll. If the link is too short the right-hand cam will be away from the power roll.

Other tab adjustments not included here are conventional adjustments which are covered in the gray manual.

DITTO TABULATION is a feature that permits the carriage to tab automatically to the next column whenever the ditto key is used. The ditto cam assembly, position 32, has a rivet that pulls a ditto cam link toward the rear, imparting motion to a tab key operating shaft. A link on the right side of the tab key operating shaft pulls the tab key lever down and releases the right-hand tab cam.

Adjust the ditto key lever so that in its downward travel it will release the cam early but will also allow the cam to reset dependably when the key lever is released. Adjust the link from the tab key operating shaft to the tab key lever so that the tab cam is released just as the ditto cam has reached the limit of its travel. Check by holding the ditto type bar up to the platen.

THE FIRST WRITING LINE POSITIONER assembly is mounted on a stud on the left-hand carriage inner end plate (Figure 2). An eccentric nut at the pivot point of the line-finder stop-pawl provides an adjustment of the stop pawl with the slot in the platen. Rotate the platen until the stop pawl drops into the platen slot. Disengage the stop pawl by hand and check that the detent roller is squarely in the "V" of a platen ratchet tooth. Release the stop pawl and it should drop freely into the platen slot. Maintain the high point of the eccentric nut downward during this adjustment.

A stop pawl actuating link is located in an elongated hole in the stop pawl and connects to the hook lever assembly. Upon carriage return operation, the stop pawl will be lifted out of the platen slot and the platen will be rotated to the next writing line. Should adjustment of the stop pawl link be necessary, hold the stop pawl bottomed in the platen slot and note that the pin clevis has .005"

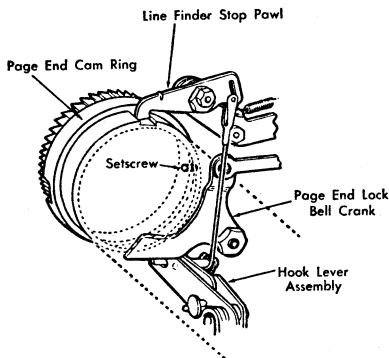

Figure 2. Page-End Lock and First Writing Line Positioner

to .015" motion at the bottom of the elongated slot.

When using forms other than 5-1/2" in length, this device is to be rendered inoperative by shortening the link so that the pawl is held out of the platen slot.

THE PAGE-END KEYBOARD LOCK is designed to lock the keyboard near the end of each form to prevent typing below the last writing line (Figure 2). A page-end lock bell crank assembly is mounted on the lower stud for the index pawl carrier assembly. The front end of the bell crank rides against an adjustable page-end cam ring, located next to the platen ratchet. On one writing line of the platen's rotation a spring pulls the bell crank into the slot in the page-end cam ring. The bell crank motion moves a bail on the rear of the carriage. When the bail moves to the rear it imparts motion to a lever and shaft assembly that moves an adjustable keyboard locking push link forward to actuate the line locking bar.

The platen should be turned to one line space past the last typing line allowed on the form. At this position loosen the setscrew in the page-end cam ring and turn the ring until the page-end lock bell crank moves squarely into the slot of the ring. Tighten the setscrew when the adjustment is completed. The clevis of the page-end locking link is attached to a lever arm just above the switch. With the page-end lock bell crank in the slot of the page-end cam ring, adjust the clevis to lock the keyboard.

When any amount key lever is depressed, the carriage return key lever is also depressed by means of the actuator levers and the carriage return bail. The first movement in the carriage return mechanism is the indexing of the platen which, through linkage, locks the keyboard of the machine. If, by this time, the amount key lever has not returned to its rest position, the locking of the keyboard will lock the amount key lever in its lower position. Since all amount key levers actuate the carriage return key lever, the carriage return key lever is also held down by the keyboard lock and the carriage return cam will not reset. It is necessary to release the keyboard lock by hand rotation of the platen, a normal action in the use of the first writing line positioner. This condition will eliminate any tendency to space from one form to the next by cam action. When the form is torn off, the platen will rotate to a point where it will be stopped by the action of the first writing line positioner. At this point the keyboard will be released and normal operation may be resumed.

When forms other than 5-1/2" in length are used, this device is to be rendered inoperative by loosening the setscrew in the cam ring and moving it to the right against the platen rubber. The lever which operates the push rod to the keyboard locking bar should be repositioned so that the push rod will not actuate the locking bar.