



CUSTOMER ENGINEERING
REFERENCE MANUAL

PREVENTIVE
MAINTENANCE
& ADJUSTMENTS

MODEL B1

ELECTRIC TYPEWRITER

As Modified for EAM Equipment

MACHINE NUMBER

Copyright 1955 by
INTERNATIONAL BUSINESS MACHINES CORPORATION
590 Madison Avenue, New York 22, N. Y.

Printed in U. S. A.

Form 22-6652-0

CONTENTS

	<i>Page</i>		<i>Page</i>		<i>Page</i>
PREVENTIVE MAINTENANCE		ADJUSTMENTS		Spacebar Escapement Lever	25
PREVENTIVE MAINTENANCE AND THE OPERATOR	4	MOTOR AND DRIVE	7	PAPER FEED	25
Margin Setting	4	LETTER CAM UNITS AND KEYLEVERS	7	Platen	25
Tab Stop Set and Clear	4	TYPE ALIGNMENT	8	Feed Roll	25
Multiple Copy Lever	4	SOLDERING TYPE SLUGS	9	Paper Table	25
Impression Control	4	CARRIAGE RAILS	10	Inner Carriage (Platen Guide Plates and Paper Feed Mechanism)	25
Ribbon Control	4	MAIN SPRING	10	Feed Roll Release Lever	25
Miscellaneous	4	ESCAPEMENT	10	CARRIAGE RETURN	25
INSPECTION PROCEDURE	4	SPACEBAR	11	Carriage Return Cam	25
Safety	4	CARRIAGE	11	Clutch Friction Disc and Clutch Plate	25
Cleaning	4	PAPER FEED	12	Clutch Pulley and Clutch Pulley Spring	25
Lubrication	4	CARRIAGE RETURN	13	Carriage Return Tape	26
Machine Operational Check	5	LINE SPACE	16	Line Space	26
PREVENTIVE MAINTENANCE FOR TYPEWRITER MECHANISMS	5	BACKSPACE	16	Platen Ratchet	26
Motor and Drive	5	MARGIN RELEASE	17	BACKSPACE PAWL BRACKET	26
Letter Cam Units and Keylevers	5	MARGIN SET	17	TAB MECHANISM	26
Typebars	5	LINE LOCK	17	Tab Cam	26
Carriage and Rails	5	TAB	17	Tab Lever	26
Escapement	5	TAB SET AND CLEAR	19	Tab Lever Mounting Bracket	26
Spacebar	6	RIBBON FEED AND REVERSE	19	RIBBON	26
Paper Feed	6	RIBBON LIFT	20	Ribbon Feed Plate	26
Carriage Return	6	SHIFT	21	Ribbon Feed Cam	26
Line Space	6			Ribbon Lift Bail Assembly	26
Backspace	6	REMOVAL PROCEDURES		Ribbon Lift Mechanism	26
Margin Release, Margin Set, and Line Lock Mechanism	6	COVERS	22	Ribbon Lift Guide	27
Tab	6	MOTOR AND DRIVE	22	SHIFT MECHANISM	27
Ribbon Mechanism	6	Motor	22	Shift Cam	27
Shift	6	Power Roll	22	Shift Pusher and Lever Assembly	27
LUBRICATION PROCEDURE		LETTER CAM UNIT AND KEYLEVER	23	MODIFICATIONS AND ATTACHMENTS	
CARRIAGE	6	Typebar	23	KEYLEVER INTERLOCKS	27
REAR RAIL MECHANISM	6	Keylever	23	SELECTOR UNIT (BAIL TYPE)	28
RIGHT SIDE OF MACHINE	7	Cam Lever	23	SELECTOR UNIT (CONTACT TYPE)	29
FRONT OF MACHINE	7	CARRIAGE	24	SELECTOR COMMON CONTACT	30
LEFT SIDE OF MACHINE	7	Carriage and Rails	24	FUNCTIONAL CAM CONTACTS	30
BOTTOM OF MACHINE	7	MAIN SPRING	24	SHIFT CONTACT	30
		ESCAPEMENT	24	TAB CONTACT	30
		Escapement Pawl Assembly	24		
		Pawl Release Lever	25		
		Escapement Universal Bar	25		
		SPACEBAR	25		
		Spacebar Keylever	25		
		Functional Cam (Spacebar, Tab, Backspace, Shift, Carriage Return)	25		

MODEL B1 ELECTRIC TYPEWRITER

AS MODIFIED FOR EAM EQUIPMENT

THE IBM Electric Typewriter, Model B1, is being used in various applications in the EAM Division. The following machine types incorporate a modified Model B1 Electric Typewriter:

- Type 824 Typewriter Card Punch
- Type 826 Typewriter Printing Card Punch
- Type 866 Cardatype Typewriter
- Type 868 Cardatype Transmitting Typewriter
- Type 884 Typewriter Tape Punch

This reference manual includes the adjustments and preventive maintenance procedures for all EAM adaptations of the Model B1 Electric Typewriter. The first portion of the manual is devoted to the basic typewriter which is common to all machine types. The rest of the manual is devoted to various attachments which are used on one or more of the machine types. Included in this section are the following modifications:

- Keylever interlocks
- Selector units
- Selector common contact
- Functional cam contacts
- Shift contact
- Tab contact

The information contained here is the latest available at the time the manual is published. Amendments to this material will be made available to customer engineers in the field through CEM's and EAM field letters. Space is provided at the end of the manual for listing CEM's, because they represent an important part of the reference material. At a later date, the manual will be revised to include any engineering changes or changes in maintenance procedure released after the date of original publication.

PREVENTIVE MAINTENANCE

EXPERIENCE has shown the value of a sound preventive maintenance program on any IBM machine. The IBM typewriter is no exception. Many years of typewriter experience bear out the fact that time spent in effective preventive maintenance measures is well spent. Besides reducing service calls and peak load break-downs, the life of the typewriter can be materially extended.

Inspection techniques, service hints, and testing methods are included for all units of the typewriter. Preventive maintenance time should be efficiently applied. Too much time spent in preventive effort is as undesirable as too little. The preventive maintenance section of the reference manual serves as a guide to enable you to concentrate on those units and parts of the ma-

chine that are most deserving of your time. In using this guide you should consider the use of the machine and the conditions in the customer's office.

Perform regularly scheduled inspections thoroughly, correcting not only the items in need of immediate attention but also those which may give trouble in the near future. Test machine completely before turning it over to the customer. Record the inspection.

Preventive Maintenance and the Operator

Preventive maintenance begins with the operator. Every inspection should include a discussion of machine performance with the operator. Correcting the small complaints increases customer satisfaction and often prevents future service calls. An informed operator does not cause unnecessary service calls. Instructing an operator, particularly a new one, on the following points is important preventive maintenance.

MARGIN SETTING

Stress the following one-two-three sequence in setting margins:

1. Move the carriage to the margin to be changed.
2. Depress the margin set key and hold it down.
3. Reposition the carriage to the desired point and release the margin set key.

TAB STOP SET AND CLEAR

First, clear all stops before making a new setting. A tab stop that is only partially set causes inaccurate tabulation.

MULTIPLE COPY LEVER

Keep this lever forward normally. Move it back only when added carbon copies cause smeared capital letters on the original or first sheet of paper.

IMPRESSION CONTROL

Set the impression indicator as low as possible and still maintain positive action on all typebars. The type faces should be cleaned with a dry brush. Liquid type cleaners can be harmful if the typebar segment, cams, or power roll are saturated.

RIBBON CONTROL

Greater ribbon life results if the position of the color control button is varied frequently. Avoid using a ribbon which has become frayed or shredded as the fibers will bind the typebars in the segment or bind up the ribbon feed cam. In changing a ribbon, have the operator install the new spool in such a way that the same

spool is not left on the machine every time the ribbon is changed. The following sequence is recommended:

1. Operate the automatic rewind lever to wind all ribbon onto the left-hand spool.
2. Remove and discard the left-hand spool.
3. Move the empty, right-hand spool to the left-hand side, first observing that the left-hand feed pawls are pushed down. The ribbon feed pawls may be moved down by the small lever projecting up on either side just outside of the spools. Pushing down on the lever on the side where the pawls are engaged moves the pawls down, out of engagement with the spool. It is then much easier to install the ribbon spool.
4. Install the new ribbon spool on the right-hand side, this time making sure that the right-hand feed pawls are pushed down.

NOTE: The spools are always installed so that the teeth of the spool point to the rear of the machine.

MISCELLANEOUS

Other difficulties are experienced infrequently by operators in the manual operation of the keyboard. "Beating the shift" can result if the operator depresses the shift key at the same time as a character key. "Beating carriage return" can result in a margin that is irregular by less than a full space. "Beating tabulation" can result in tabulated columns that are irregular by less than a full space, because the operator types before the carriage comes to rest. Transposition of characters may result when the operator temporarily loses her timing in fingering the keyboard.

Inspection Procedure

SAFETY

When the covers are removed and the power is on, make sure that the fingers are kept clear of the positive drive belts and pulleys.

CLEANING

It is essential that each typewriter inspection include some time spent in cleaning. Outside cleanliness improves the appearance of your installation; cleanliness inside is required if the machine is to perform its best. Remove the front and rear covers, platen and paper deflector. Brush dust and eraser particles from the carriage bed and especially from the carriage rails. Clean rubber parts with IBM cleaning fluid.

LUBRICATION

IBM 6 and IBM 17 are the general purpose lubricants used on IBM type-

writers. Refer to the lubrication section of this manual for the specific application and frequency of these lubricants.

MACHINE OPERATIONAL CHECK

There are many ways to proceed when checking a typewriter. In order to do a thorough job as quickly and efficiently as possible, establish a pattern. This pattern should permit the orderly checking of all units so that nothing is overlooked. The following pattern or sequence is suggested.

1. Start with the typewriter carriage. Check for freedom of travel without excessive play or binds. Check the platen to see that it is held rigidly, yet is free to rotate when the detent is released. Check for loose parts on the carriage, particularly the margin rack and tab rack. Note the condition of the carriage tension and return tapes.
2. Keyboard Check. Operate all keys at least twice to test all functions. Insert paper to check impression and alignment. Refer to the following section for checking procedures and service hints for all units of the typewriter.
3. Turn typewriter up on its back. Check the drive mechanism and power roll, and visually examine cam clearance.

This type of sequence can be developed so that the operation of the machine can be checked accurately without spending excessive time.

Preventive Maintenance for Typewriter Mechanisms

MOTOR AND DRIVE

The typewriter switch should function without hesitation and have even positive overthrow in both positions.

The motor and complete positive drive mechanism should coast freely when the power is turned off. Binds in the drive mechanism cause the motor to overheat. The rotor of the motor should spin freely in the oilite bearings. Tapping the end bell castings helps jar the bearings into line. The wrong lubricant used in the oilite bearings may form a gummy substance on the shaft and seal the pores of the bearings. If a motor fails to start but runs if started by hand, there is a good possibility that the condenser circuit is not complete or that the starting windings of the motor are open.

The motor pulley is installed on the rotor shaft with the flange to the outside and is positioned to align the belts and pulleys. A clicking sound may result if the intermediate pulley travels laterally on the shaft. Nylon washers and a C-clip are available to limit this motion if necessary. Excessive belt tension causes the drive to be noisy. Belts that are adjusted too loose can cause a light impression or complete printing failure of a character following a shift operation.

If the hole in the clutch friction disc is oversized, a clicking sound may result which appears to be in the drive

mechanism. A piece of tape installed through the hole usually eliminates this noise.

The power roll should turn freely in its oilite bearings without excess end play. A power roll which does not turn true would cause light and dark printing. This eccentric condition results if the power roll rubber is loose on the core. The composition of the rubber is identified by a code letter on the unused surface of the rubber between the backspace cam and the extreme right letter cam.

The present N power roll is the result of considerable research to produce a rubber best suited to work with the nylon cams with respect to wear, eccentricity and performance. The waxy substance impregnated in this power roll is necessary to guarantee smooth operation of the letter cams. Where unexplained loss of impression occurs, it may be necessary to band the power roll to clean its surface.

LETTER CAM UNITS AND KEYLEVERS

Cam clearance is one of the most critical adjustments in the machine because of its great effect on uniformity of impression and keyboard function. If cam clearance is set too close, uneven impression results. Also cams "tie up" on the power roll, fail to knock out, and repeat because they lie so close as to be jarred against the power roll by their own rebound. On the other hand, if the cams are too far from the power roll, the keylevers may bottom in the front guide comb before the cams are moved far enough to contact the power roll. Typewriters equipped with magnet units for automatic operation require a closer cam clearance than other typewriters. The armature push rods must have enough travel to engage the cams to the power roll.

Cams which "repeat" or deliver more than one operation for only one depression of the key usually occur in center positions. There is a greater tendency for repeats when the basket is in the upper case position. Close cam clearance or weak spring tension on the nylon cam causes this problem. Check to determine whether the cam rivet is too loose or too tight, as either condition could contribute to cause a repeating cam.

Key buttons are made of substance which may be affected by alcohol. Therefore, do not use a cleaning solution containing alcohol on the key buttons or other plastic parts. After replacing the front cover, make sure that none of the key buttons are binding in the guide plate.

Type impression is affected by many items. Before adjusting the impression control screws, the machine should be checked for:

1. Proper setting of the impression control lever and the multiple copy lever, normally 5 and A, respectively.
2. Correct speed of the drive mechanism with freedom from binds.
3. Correct letter cam clearance of .015"-.020".
4. Eccentricity or loose rubber on the power roll.
5. Burrs, dirt, or binds in the type bar segment slots.
6. Binds in the cam levers.
7. Binds in the escapement or ribbon mechanism.
8. Freedom of the typebar links at rest so that they may be moved from side to side in both upper and lower case.
9. Loose carriage adjustment.
10. Correct ring and cylinder adjustment.

It is possible to turn out an impression control screw so far that the nylon cam may fail to knock off at high impression settings. The cam may ride over the power roll and become damaged or it may stall or cut a groove in the power roll.

TYPEBARS

Type alignment can best be examined by typing the alignment sample (Figure 1) on a single sheet of bond paper. The letter N is used as a guide letter for comparative purposes. This sample usually shows typebars requiring adjustment. Check typebars appearing to be considerably off the writing line for loose type slugs. It is advisable to replace the typebar, where possible, instead of resoldering the type slug.

CARRIAGE AND RAILS

Excessive play between the carriage and rails causes type impressions to vary (sometimes low and heavy on top, sometimes high and heavy on bottom). Adjusting the rails too tightly causes the carriage to bind. Broken, cracked, or out-of-round rollers may cause the carriage to bind. An accumulation of dirt and oil on the rails may impede the free travel of the carriage.

ESCAPEMENT

Escapement should be checked the full length of the carriage to insure a fast, unhesitating action in any position of the carriage. Any binds in the carriage cause type piling or crowding of characters. The escapement mechanism must be free from binds. A

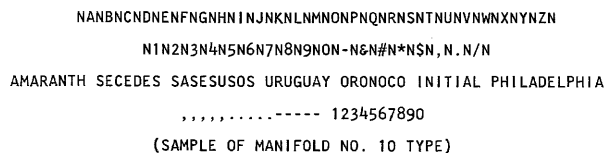

Figure 1. Type Alignment Sample

broken universal bar, a bouncing spacebar, or a binding backspace pawl can also cause type piling.

SPACEBAR

Depression of the spacebar keylever should permit easy, rapid operation of the spacebar mechanism. The cam should not repeat when the key lever is bounced or "flicked." When operated by turning the power roll by hand, the mechanism should not be choked off by the overthrow stop. The spacebar should not bind on the front cover.

PAPER FEED

Check the paper feed mechanism for straight feeding without horizontal slippage. There should be no vertical slippage when the paper is rolled back for corrections. The operation of the paper release lever should permit easy removal or straightening of thick forms. The platen and feed rolls should be free from binds.

CARRIAGE RETURN

The carriage return operation should be checked for a positive return from any position of the carriage. At the same time the air cylinder must reduce the impact of the carriage return as much as possible without noticeably slowing the carriage the last half-inch of carriage travel.

LINE SPACE

Faulty line spacing may result from paper feed troubles, binds in the platen bearings or feed rolls.

Excessive line space or overthrow can result from slippage between the platen ratchet driver and the platen ratchet. Whip in the carriage return tape, if excessive, can contribute to faulty line space, especially where rapid, repeated operation is required. Decrease clutch clearance to overcome this problem.

BACKSPACE

Test the backspace mechanism for positive, rapid action at each end and the middle of carriage travel. The action of the backspace interlock should be checked by operating the backspace with the carriage release levers depressed. Simultaneous operation of the carriage return and backspace should be tested to insure against jamming or locking of the carriage.

MARGIN RELEASE, MARGIN SET, AND LINE LOCK MECHANISM

The margin release and margin set keylevers should operate without undue pressure. All three mechanisms must be free from binds.

TAB

Tabulation can best be checked for accuracy by removing the paper table and noting the position of the tab check lever and the set tab stop after a tab operation is complete. The tip of the tab check lever should always be two spaces to the right of the set

tab stop after tabbing to that stop (Figure 2). Two backspace operations are required before the tab check lever will again strike the same set tab stop.

If the carriage comes to rest so that the tab check lever is only one space to the right of the tab stop, there is a possibility that the carriage is bouncing.

The accuracy should be checked on short, rapid tabs and on long tabs where the carriage has sufficient travel to build up momentum. Excessive carriage speed will make the tabular adjustment more critical and increase part breakage.

RIBBON MECHANISM

The ribbon feed cam and its associated mechanism operate more often than any other unit of the machine. The cam must be free from dirt and binds and have sufficient spring tension opposing its motion to insure positive engagement between the cam serrations and the power roll.

The non-repeat lug of the cam release lever should be removed to prevent interference and resulting light impression or typing failure. Check for repeat operation by holding a typebar up to the type guide.

Ribbon guides must be smooth and properly aligned to permit free movement of the ribbon.

SHIFT

Check the shift mechanism visually for basket motion and even impression on top and bottom of characters by examining results on a typed sample. Check the operation by slow, deliberate depression and also by rapid, repeated depression of the keylever. The shift lock should hold securely when operated and should easily unlock when either shift key is depressed. Excessive noise may result from faulty operation of buffer, broken segment guides, or shift stop brackets.

LUBRICATION PROCEDURE

EFFECTIVE lubrication is an essential part of typewriter preventive main-

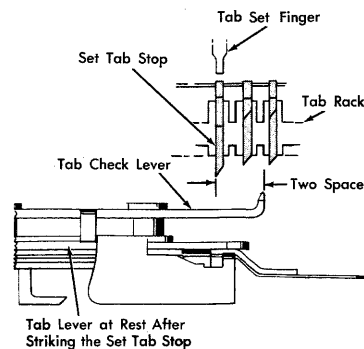

Figure 2. Checking the Accuracy of Tabulation

tenance. The following outline is intended to serve as a guide in lubrication of EAM typewriters. Because this manual is devoted to typewriters with different applications and varying amounts of usage, you will have to judge the requirements of each particular installation. Typewriters operated automatically by a magnet unit require more frequent lubrication than keyboard-operated typewriters. A typewriter operated on a 16- or 24-hour basis or under abnormal conditions requires more attention than others.

Because oil and grease are harmful to rubber and to frictional surfaces, special care should be taken to keep lubricants away from the platen, power roll, feed rolls, paper bail rolls, rubber mountings, belts, cams, and the clutch friction disc. Also avoid excess lubrication which might soil the paper or typewriter ribbon and cause dust accumulation.

Before any item is lubricated, it should be clean. After lubrication, excess oil or grease should be wiped off.

Inspect new machines for proper lubrication at the time of installation or within one week thereafter. Proper lubrication when the typewriter is new saves service time caused by wear.

To reduce time and yet lubricate thoroughly, establish a pattern. Circle the typewriter once, using a brush to apply IBM 6 to all bearing and pivot points, including links and clevises. Circle the typewriter again to apply IBM 17 to camming surfaces, hairpin springs, and so on. A three-month period lubrication list follows.

Carriage

Use IBM 6 on the following points:

1. Platen bearings.
2. Detent arm and roller.
3. Multiple copy control.
4. Paper release mechanism.
5. Feed roll pivots and pressure levers.
6. Paper bail pivot.

Use IBM 17 on the index lever spring and the detent spring and cam surface.

Rear Rail Mechanism

Use IBM 6 on these points:

1. Carriage rails (left side). Wipe rails clean.
2. Tab lever linkage.
3. Escapement pawl, trip lever, and linkage.
4. Tab governor pawl and linkage.
5. Pawl release lever pivot.
6. Pawl release bellcrank and intermediate pawl release lever.
7. Margin control bellcrank pivot.
8. Carriage return tab interlock pivot.
9. Tab check lever and margin control lever.
10. Tab latch, backspace pawl and interlock.
11. Air cylinder bellcrank, air cylinder.
12. Intermediate bellcranks and linkage.

13. Carriage rails (right side), carriage return pulley.

Right Side of Machine

Lubricate the following points with IBM 6:

1. Shift pusher and lever assembly, linkage.
2. Right-hand ribbon feed mechanism and linkage, including link holes in bail end plate.
3. Clutch lever and latch pivot (avoid excess here).

Use IBM 17 on the following points:

1. Latching surface of clutch lever.
2. Pivot screw at top of clutch operating arm.
3. Shift hairpin springs.

Front of Machine

Use IBM 6 on these points:

1. Link holes in typebars and cam levers.
2. Pivots of typebars, cam levers, and keylevers; wipe their fulcrum wires with a cloth moistened with IBM 6.
3. Spacebar and shift equalizing rod pivots.
4. Functional cam release levers and linkage.

Left Side of Machine

Use IBM 6 on these points:

1. Left-hand ribbon feed mechanism and linkages, including link holes in bail end plate.
2. Power roll drive pulley.
3. Motor oil wells.
4. Line lock linkage.

Lubricate the intermediate pulley shaft with IBM 17.

Bottom of Machine

Use IBM 6 to lubricate the ribbon lift mechanism and linkage and the ribbon lift tube bearings. IBM 17 is used for the ribbon lift bail pivot screws and the ribbon lift bail vane.

ADJUSTMENTS

ADJUSTMENTS are based on current engineering specifications for the typewriter. While the adjustments should be kept close to the specifications, the methods preferred in making the adjustments may vary among experienced customer engineers.

The adjustments are numbered in sequence for each unit of the typewriter. Where possible, the sequence numbers are shown on the figure of that unit to show exactly what part is to be adjusted.

Motor and Drive

1. The end play of the power roll should be .002" to .010". Make adjustment when locking the power roll drive pulley to the power roll shaft by its set screws (Figure 3).

2. Adjust the play in the driven belt by positioning the intermediate pulley shaft. The shaft incorporates a *left-hand thread* so that the pulley rotation tends to tighten the shaft. The

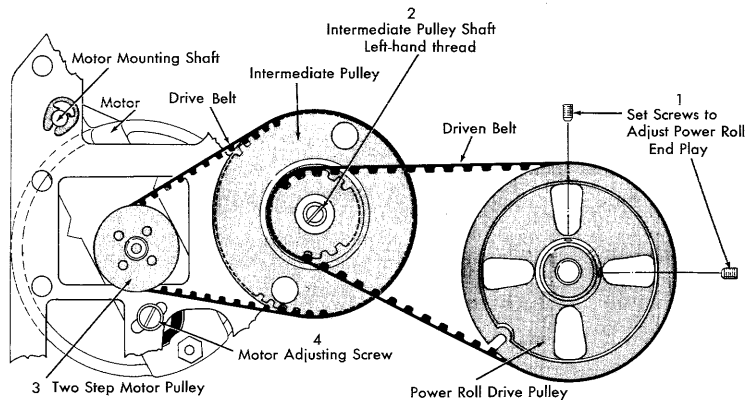

Figure 3. Motor and Drive Adjustment

deflection of the belt should be about 1/4" (Figure 3).

3. Power roll speed is obtained by a two-step motor pulley. The 14-tooth step provides 95 feet per minute and the 15-tooth step provides 103 feet per minute. The type faces using the higher speed are listed below:

- 03 Pica Gothic Single Case (Type Mark G)
- 04 Pica Gothic Double Case (Type Mark H)
- 05 Elite Gothic Double Case (Type Mark F)
- 06 Elite Gothic Single Case (Type Mark GE)
- 72 Manifold #12 (Type Mark H2)
- 73 Manifold #10 (Type Mark H3)

The motor pulley is positioned on the motor shaft to align the belts and pulleys.

4. Adjust play in the drive belt by positioning the motor backward or forward on its elongated mounting hole. The deflection of the belt should be about 1/4" (Figure 3).

Letter Cam Units and Keylevers

1. Adjust clearance between the cams and the power roll for all letter cams simultaneously by loosening the locking screws in the side frames and moving the cam lever bearing support on its pivot studs until the cams clear the power roll by .015"-.020". Observe that the clearance is within these limits for all cams (Figure 4). NOTE: The letter cam clearance on EAM typewriters equipped with magnet units (Type 866-868) is held within .012"-.018".

Check cam clearance for the functional cams whenever the letter cam clearance is changed because the functional cams are also mounted on the cam lever bearing support.

2. Adjust the keylever bearing support so that the keylevers trip their respective cams when the keylevers are 1/32" plus or minus 1/64" from the bottom of the keylever guide comb. The keylever bearing support can be positioned after loosening the two locking screws on each side frame

(Figure 5). The individual keys should be checked to be certain that each cam trip lever can reset beneath the lug on the keylever when the keylever restores to the top of the guide comb.

3. Form individual keylevers which are not within the specifications of the previous adjustment. The keylevers are designed to respond to the forming operation (Figure 6).

4. Where the impression control screws of the entire keyboard require adjustment, the following procedure is suggested:

a. Place an original and two carbon copies in the typewriter.

b. Set the impression control lever at 5 and the multiple copy lever at A.

c. Strike up a sample of the keyboard in numerical order starting with position 1:

1 q a 3 z w s 3 x . . . and so on.

d. Remove the paper, place the typewriter on its back, and study the original sheet. Turn out any impression screws for light-striking type faces and turn in the screws for cutting or heavy impression.

e. Restrike the characters that have been altered and select any type that cannot be made strong enough to print a strong, firm impression without cutting the paper. These type faces should be polished.

f. Put the color control in stencil position and wrap a sheet of Behr-Manning Durite 600A abrasive paper (part number 460107) around the platen. Hold the typebar firmly against the abrasive, applying pressure to the typebar where it contacts the ring. Polish the type by moving the carriage to the left and right once or twice and also by rotating the platen up and down once or twice. All movements of the carriage should be slow and even to produce best results.

Test the type face by making another strike-up of the type in question and repeat step 6 if required. Do not use an abrasive heavier than that recommended.

IBM Manifold type styles which are generally standard on EAM typewrit-

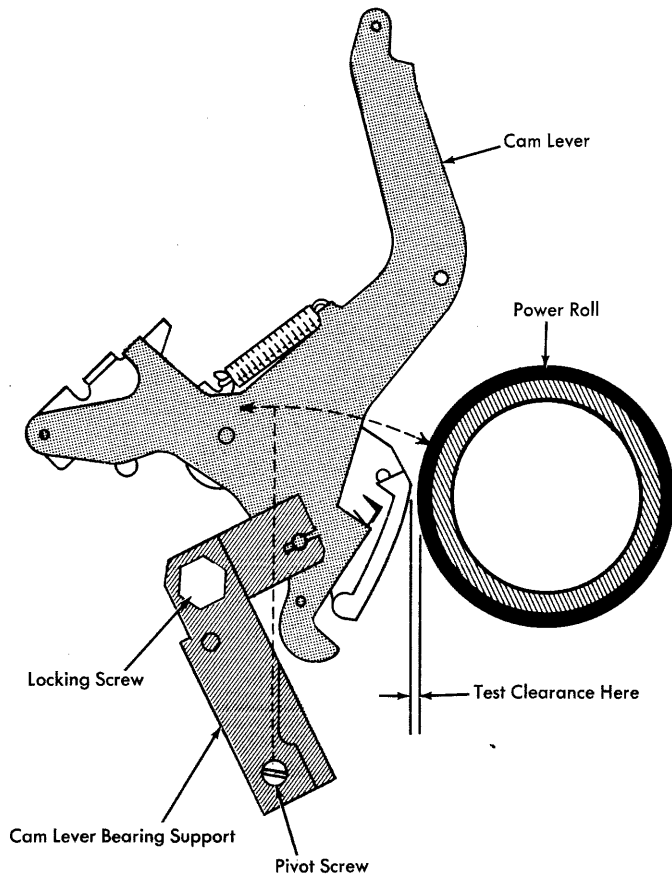

Figure 4. Letter Cam Clearance Adjustment

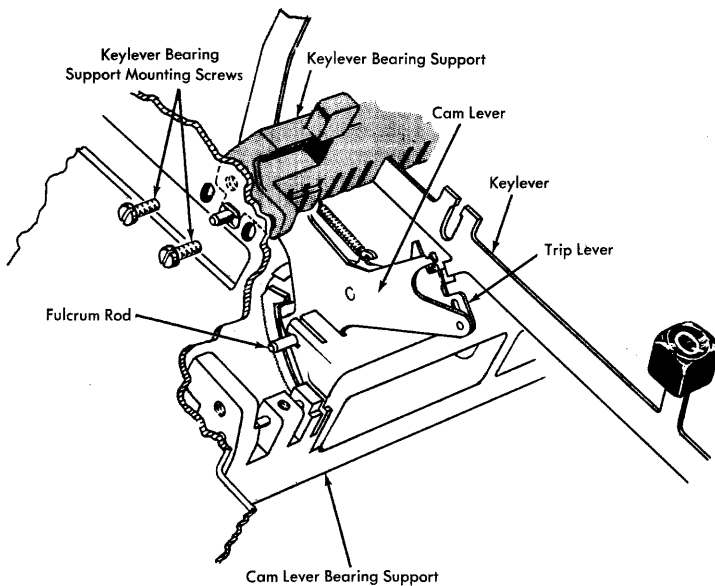

Figure 5. Keylever Bearing Support Adjustment

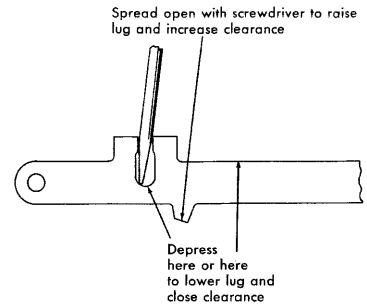

Figure 6. Individual Keylever Adjustment

ers are designed to prevent cutting the paper and should not require polishing.

Type Alignment

There is no set procedure which must be followed in aligning type, because each typebar may need a slightly different adjustment. Until experience has been acquired, follow the procedure outlined here for the alignment of a single bar after installation.

1. After a new typebar is installed, first check it to see that it enters the type guide without striking either side of the guide. A piece of white paper placed behind the type guide, but in front of the ribbon, helps in observing that there is a slight clearance between the typebar and the sides of the guide when the typebar is moved slowly into the guide by hand (Figure 7). The typebar may be formed to the right or to the left until it enters the guide centered. To do this forming, hold the typebar near the bottom with a pair of pliers and, with a type aligning wrench, adjust the upper part of the typebar enough to align it with the guide.

2. After the typebar is centered in the guide, check the ring and cylinder adjustment. Insert a sheet of bond paper in the typewriter and place a test strip of paper, about 1/2" wide and 4" long, between the typebar and ring.

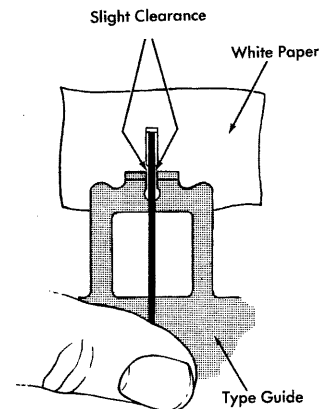

Figure 7. Typebar Centered in the Type Guide

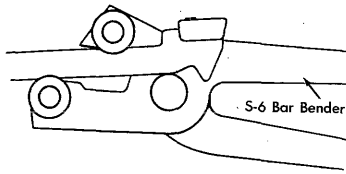

Figure 8. Bending Typebar on Cylinder

The paper should be gripped tightly when the typebar is held up to the platen with the thumb against the typebar at the ring. Place the paper between the ribbon and the paper on the platen, and, holding the typebar as before, test for a slight drag as the strip of paper is withdrawn. If the ring and cylinder is out of adjustment, correction may be obtained by using the S-6 bar bender as shown in Figures 8 and 9. If no change in the elevation of the type face is desired, place the S-6 bar benders low on the typebar. Be careful not to burr the portion of the typebar which moves in the segment slot.

3. If a typebar does not print evenly on both the right and left sides, it will be necessary to twist the head of the bar with one type wrench while holding the throat of the bar with another tool (Figure 10). The procedure will also move the type impression to the right or left.

After each adjustment of a typebar, test the ring and cylinder and check the typebar to see that it enters the guide without binding.

4. The type face can be raised or lowered to the writing line by using the S-6 benders. By placing a forward bend toward the platen, near the top of the bar, the type may be lowered. A backward bend away from the platen, near the top of the bar, raises the type slightly. Keep in mind that a second bend may be necessary with the benders placed low on the typebar to regain the proper ring and cylinder adjustment.

A type face may be lowered considerably, by forming the typebar twice with the S-6 bender. The first forming should be low and backward, away from the platen, with the second forming high and forward, toward the platen, to regain the ring and cylinder adjustment.

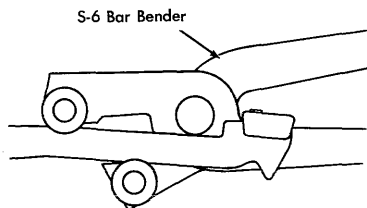

Figure 9. Bending Typebar off Cylinder

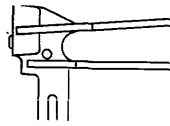

Figure 10. Twisting the Typehead

End typebars are the most difficult to align and sometimes fail to respond to the same treatment for raising or lowering if the bar has become twisted. If the bar is twisted toward the platen, upper case will be heavy on the cylinder and if the bar is twisted away from the platen, upper case will be light on the cylinder. With the ribbon in stencil position, hold the type face up to the platen to determine if the upper case is heavy or light on cylinder. Twist the typebar until the proper ring and cylinder relationship exists between upper and lower case (Figure 11). This twist also tends to raise or lower the type face.

5. An aligning wrench is used to center or straighten a type face between two N's. Place the typebar in the guide and pull the typebar slightly to either side with an aligning wrench (Figure 12). This procedure has greater effect on an upper case character of double case type than on the lower case. It can be used particularly well with the single case type styles used on EAM typewriters.

If a number of the typebars require alignment, the following procedure is suggested:

1. Check and set the ring and cylinder adjustment for the majority of typebars as described under carriage adjustments.

2. Select a typebar to serve as a guide in aligning the typebars in relation to each other. The letter N is generally chosen, although other letters such as the H may be used.

Before using the letter N as a guide to align a complete set of type, the N must be carefully checked to insure its accuracy as a guide letter. By using the platen variable button, it is possible to type several capital N's under each other so that they overlap. If the sides of the letters align themselves, then the N will usually make a suitable guide. The height of the N should compare favorably with the average height of the other typebars. A study of the strike-up reveals whether the N is printing evenly on both sides and is

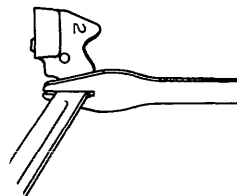

Figure 11. End Typebar Alignment

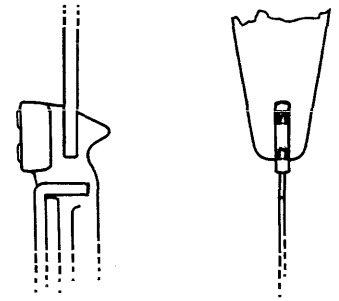

Figure 12. Moving Type to Right or Left

centered between the other typebars (Figure 1).

3. Determine from the type alignment strike-up the typebars which require adjustment and proceed as outlined previously for the alignment of a single bar after installation.

Soldering Type Slugs

When a type slug becomes loose on a typebar, it is advisable to replace the complete typebar. It is not always possible to do this immediately. Consequently, it is necessary at times to resolder the type slug to the typebar. A satisfactory soldering job requires careful cleaning of the surfaces of the typebar and the type slug to be soldered together. Apply the heat to the type slug until the solder runs down into the contact surfaces. Solder applied only around the edges of the slug will not retain the slug on the bar.

A type soldering fixture (Figure 13) may be used to hold a type slug in place, or to guide it into proper position during resoldering. It is not necessary to remove the typebar from the machine. To solder a slug on a new bar, install the bar and solder the slug in a trial position. Adjust the slug up or down by first adjusting the fixture. To raise the slug, place the fixture on the typebar with its flat surface squarely against the face of the type and lock the screws tightly. Heat the slug and carefully pry the slug upward the required amount with a screwdriver. To lower a slug, use the same procedure but lock the fixture in place far enough below the slug to permit the slug to be pressed down the required amount. Tilt the slug toward or away from the platen by first setting the fixture to the desired position and moving the slug to the fixture.

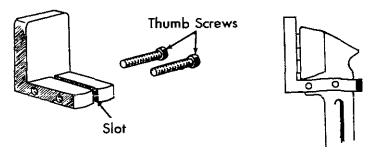

Figure 13. Type Soldering Fixture

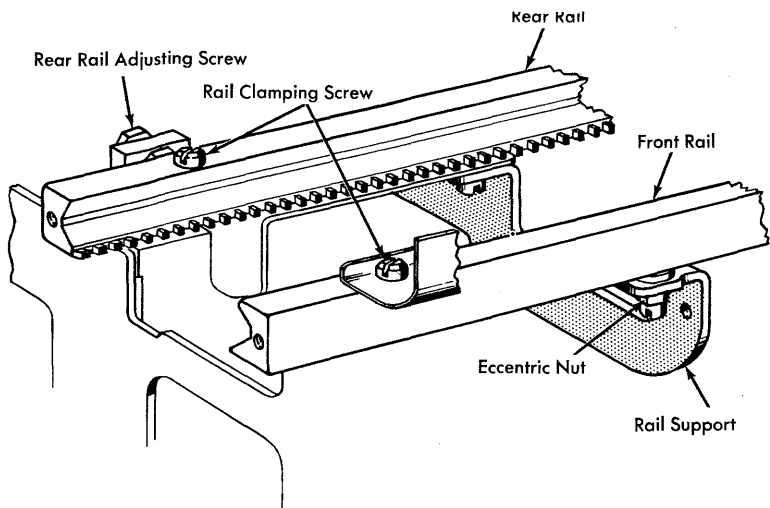

Figure 14. Rail Adjustment

Carriage Rails

Adjust the rails by eccentrics on the rail supports and by adjusting screws on the ends of the rear rail (Figure 14). The front rail should be locked in place against the power frame and the carriage centered over the rails. Adjust the rail support eccentrics to remove all play between the carriage and rails without binding the carriage. The rear rail clamping screws and adjusting screws should be loose when the eccentrics are rotated. Move the carriage to the extreme limits of travel and position the rear rail adjusting screws to eliminate play. Lock the adjusting screws with their lock nuts and tighten the rail clamping screws. Carriage rails, 20" in length, have additional end brackets to be adjusted in the same manner.

Main Spring

Main spring tension is adjusted by placing the loop of the carriage tension tape on the proper lug of the main spring drum. Measure carriage tension by pulling the carriage with a spring scale at a slow and steady rate from extreme left to extreme right (excluding the air cylinder range).

A redesigned main spring is now being incorporated into 16" and 20" EAM typewriters and will be incorporated into 12" typewriters at a later date. This spring provides for more constant carriage tension throughout the total length of carriage travel. The new main spring holder is secured to the power frame by the main spring drum stud instead of the two mounting screws. An ear on the holder contacts the edge of the power frame, preventing any movement of the holder. This ear, which can be seen at the bottom of the machine, identifies the improved spring. Typewriters equipped with the improved spring should have the carriage tension set as follows:

12" carriage,	2½ lbs. at start
16" carriage,	2½ lbs. at start
20" carriage,	2¾ lbs. at start

Typewriters equipped with the previous type spring should have the main spring tension set as follows:

12" carriage,	2¼ ± ¼ lbs. at start,	¾ lbs. maximum
16" carriage,	2¼ ± ¼ lbs. at start,	¾ lbs. maximum
20" carriage,	2¼ ± ¼ lbs. at start,	¾ lbs. maximum

NOTE: EAM typewriters equipped with program tape units (Types 884 and 868) should have the main spring tension set ¼ lb. heavier than the amount indicated in the above tables.

The tension can be approximated closely without a scale by setting the tension on the carriage properly to

trip the tabular mechanism with the last tab stop. Position the carriage at the last tab stop before latching the tab lever to avoid the braking influence of the tab governor. If the tab lever latches out while the carriage is farther back and the carriage travels up to the last stop, the effect of the friction governor will be felt. An erroneous reading will result, causing the main spring to be set too tightly.

Escapement

1. The universal bar is adjusted so that all typebars trip the escapement pawl at the same distance from the platen. The rear spring of the universal bar is mounted on an enlarged hole and is locked to the support by a hexagonal screw (Figure 15). The screw is located under the carriage final stop on the front rail and may be reached from the bottom of the machine. To position the universal bar, loosen the screw and make sure the spring is free from the support. Then position the three typebars close to the type guide as shown in Figure 15 so that they bind each other in position. Tighten the screw to lock the universal bar in position and test the adjustment by operating the typebars by hand to observe that the tripping point is equal.

If the center typebars trip too late or early in relation to the end typebars, the support of the universal bar may be formed slightly up or down to correct this condition.

2. The adjusting plate on the universal bar is positioned so that the tripping of the escapement pawl will be even in both upper and lower case (Figure 15).

3. The spring clevis of the trip link is adjusted to trip the escapement pawl out of the rack when the type face of any bar is ⅜" ± ⅛" from the platen (Figure 15).

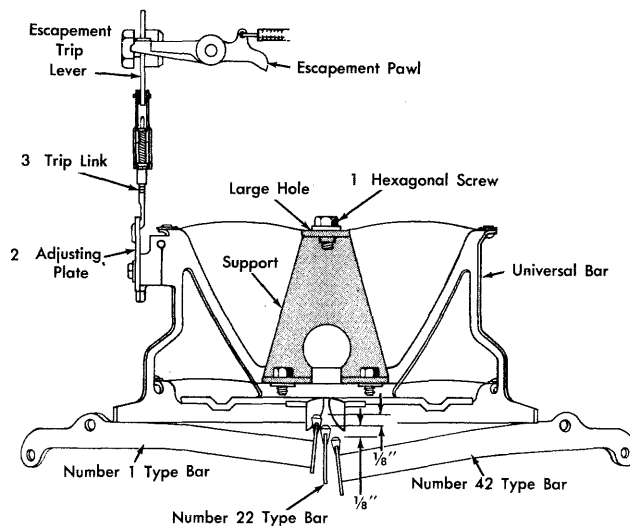

Figure 15. Escapement Adjustment

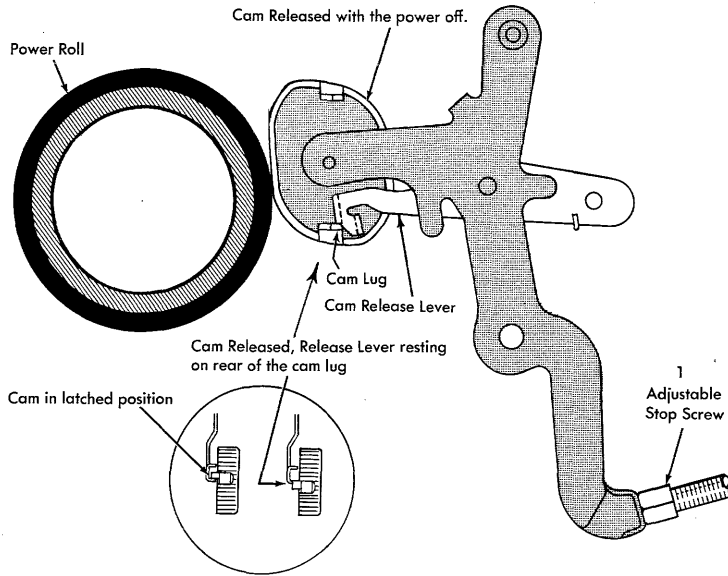

Figure 16. Spacebar Cam Adjustment

Spacebar

1. Cam clearance is adjusted by the stop screw so that the cam clears the power roll by .010"-.015" (Figure 16). This adjustment can be observed by releasing the cam with the power off, and noting the position of the cam release lever with respect to the cam lug. The adjustment is correct when the cam release lever rests on the rear half of the cam lug as shown in Figure 16. Check the adjustment on both cam lugs.

2. Adjust the cam release link to

trip the cam when the keylever is depressed $\frac{1}{2}$ to $\frac{3}{4}$ of its total travel (Figure 17).

3. Adjust the spacebar stop bracket (Figure 17) so that the cam lug safely resets from the non-repeat lug of the cam release lever with a minimum of over-travel of the keylever.

4. Adjust the spacebar operating link by the clevis on the front, or cam, end so that, when operated by hand, the escapement trips just before the cam reaches its highest point (Figure 17). Test to see that the mechanism does not choke off by noting that the

cam may still be moved a small distance away from the power roll after the cam has reached its highest point.

Carriage

1. Adjust the platen latches by their eccentric screws so that the platen is held firmly in position. Keep the high point of the eccentrics toward the front of the machine (Figure 18).

2. The platen control yokes are mounted on the outside of both platen guide plates (Figure 18). Loosen both the front and rear locking nuts and position the yokes to eliminate any motion between the platen bushings and the platen guide plates. Do not adjust so tightly as to bind the platen, thereby hindering its insertion and removal.

3. Adjust the platen retaining plates to hold the eccentric collars located on the ends of the platen guide shaft tightly against the platen adjusting plates (Figure 18).

4. Make the ring and cylinder adjustment by first loosening the feed roll center support screw through a hole in the bottom of the carriage bed (Figure 19). Loosen the rear screw in each platen retaining plate (Figure 20). Rotate the eccentric nuts in the platen adjusting plates.

To test for ring and cylinder, insert a sheet of bond paper into the typewriter and move the multiple copy lever to A. Place a piece of bond paper about one-half inch wide and four inches long, between the typebar and ring (Figure 20). The paper should be gripped tightly when a typebar is held up to the platen with the thumb against the typebar at the ring. Place the paper between the ribbon and the paper on the platen, and, by holding the typebar as before, check that there is a slight drag as the test paper is withdrawn. Repeat this test at both

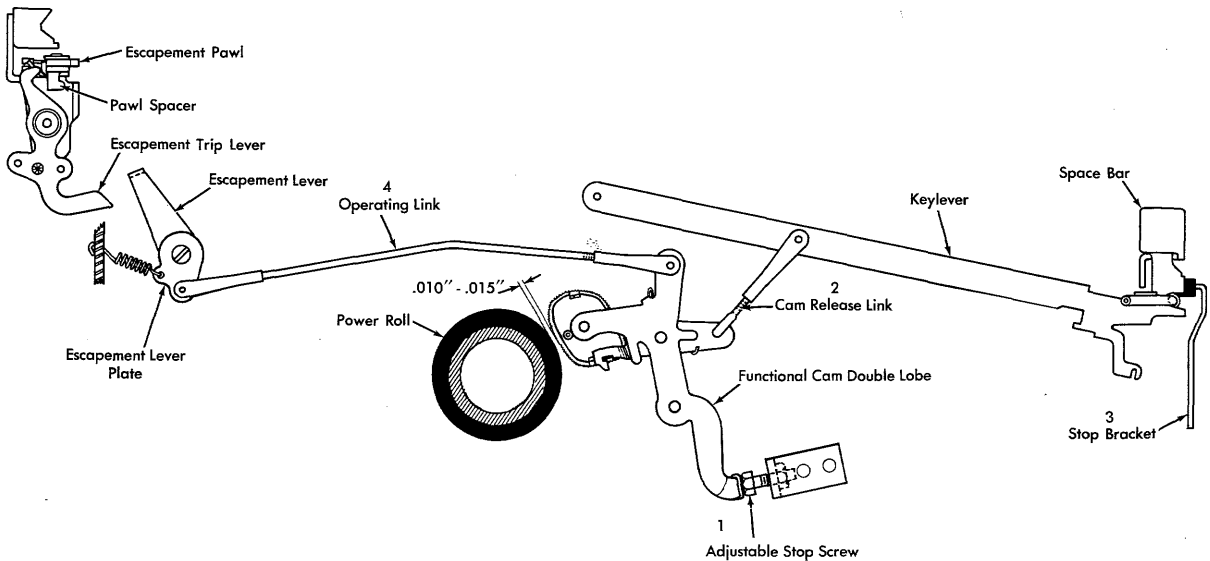

Figure 17. Spacebar Adjustment

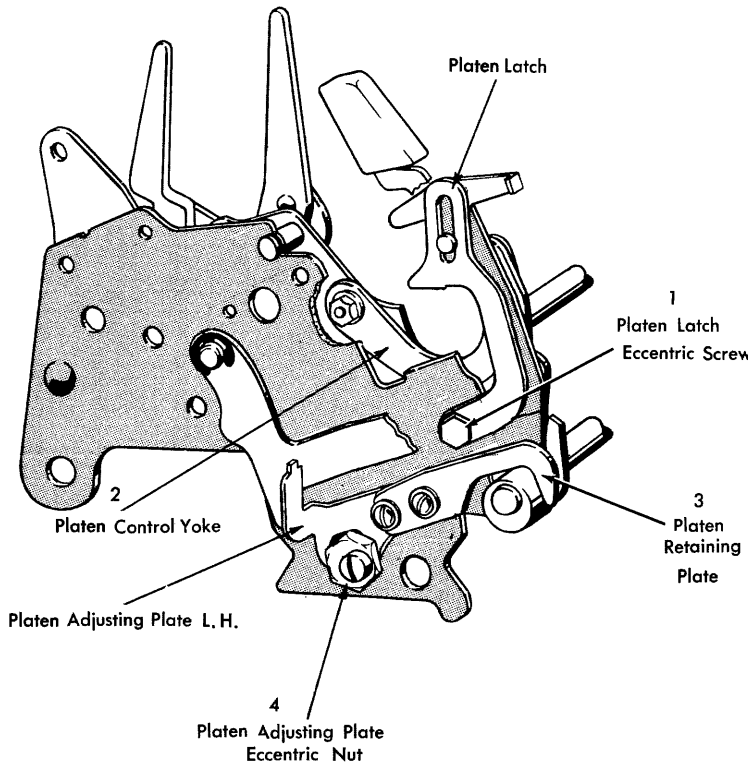

Figure 18. Carriage Adjustments

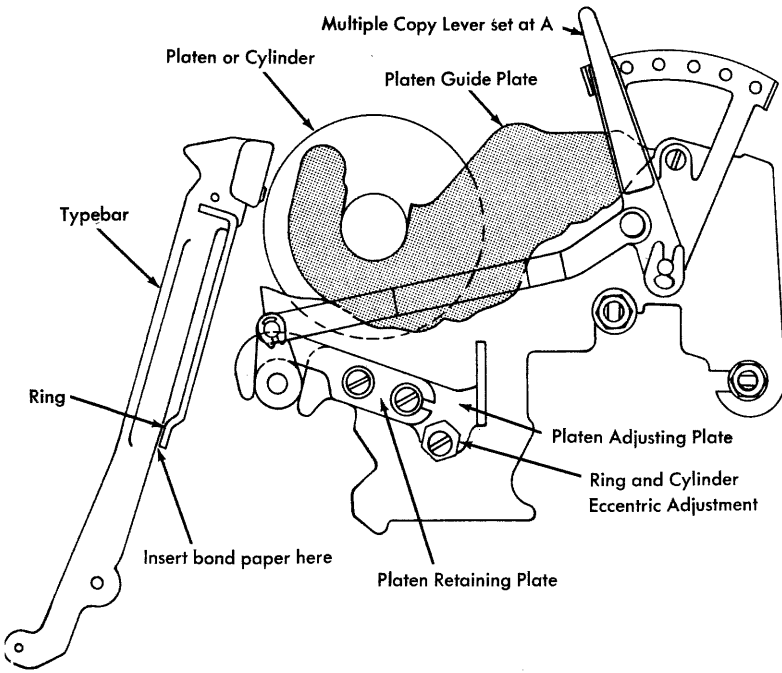

Figure 20. Platen Ring and Cylinder Adjustment

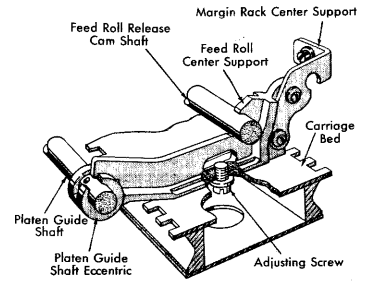

Figure 19. Feed Roll Center Support Adjustment

ends of the platen, using the same typebar each time.

5. The feed roll center support must be repositioned to touch the eccentric collar on the platen guide shaft after any change in ring and cylinder adjustment. On carriages longer than 12 inches, loosen the margin rack center support(s) to reposition the feed roll center support(s) (Figure 19).

Paper Feed

1. Position the line gage card holder laterally by shifting the entire front rail dust cover on its elongated mounting holes. Align the graduations with the typed V's (Figure 21).

2. Adjust the vertical position of the line gage card holder and the position of the indicator pointer by their mounting screws (Figure 21). Position each side of the line gage card holder up or down until the top edge of the gage is level with the bottom of the line of type. Position the indicator pointer laterally so that it is centered with respect to the typebar guide throat.

3. Adjust the front paper scale laterally so that when the left-hand margin stop is at the extreme left position and the carriage is moved to the margin stop, the zero position on the scale is aligned with the indicating pointer. On machines with a carriage length of more than 12 inches, the eccentric collar that positions the front paper scale can interfere with the front feed rolls during feed roll release. To prevent this, keep the setscrew in the eccentric collar in line with the setscrews in the platen guide shaft eccentric collars.

4. Adjust the paper table laterally so that the graduations on the front paper table are in line with those of the front paper scale. Adjust the position of the paper table by the pair of locating collars that are setscrewed to the carriage tie rod.

5. Regulate the tension between the platen and each pair of front or rear feed rolls by the adjusting screws which

determine the torque of the twisted flat springs. The screws are positioned so that a pressure of 12 to 16 ounces is necessary to deflect each feed roll pressure lever. A push-pull scale may be applied at the ends of each feed roll shaft to make a reading of this adjustment (Figure 22). **NOTE:** Depress the front feed roll pressure levers when checking the pressure of the rear feed roll pressure levers.

6. Position the rear-feed-roll pressure-lever adjusting plates by their adjusting screws so that the levers cause the front pressure levers to be deflected an equal amount during paper release (Figure 22). When two IBM cards are inserted between the rear feed rolls and the platen, the front feed rolls should have a slight amount of drag. If five IBM cards are inserted, the front feed rolls should be free to turn. Too much clearance of the front feed rolls decreases their tension and adds greater tension to the rear feed rolls.

7. Form the support lugs on the rear pressure levers so there is a clearance of .007"-.030" (one to four IBM cards) between the paper deflector and the platen. Card strips can be inserted at the ends of the deflector and between feed rolls to accurately check the clearance between the paper deflector and platen (Figure 23).

8. Adjust the rear paper table so that the relationship between the deflector and the paper table allows the paper to pass freely in either direction without catching. Adjust this relationship by the locking screws that clamp the adjusting plates to the paper table bracket (Figure 23).

Carriage Return

1. Adjust the cam stop until the cam clears the power roll enough so that, when tripped with the power off, the cam release lever will fall on the rear half of the cam lug (Figure 24).

2. Adjust the cam release link so that the cam is released when the key-lever is depressed approximately two-thirds of its downward travel (Figure 24).

NOTE: On EAM typewriters equipped with repeat/non-repeat carriage return operation (Type 824-826) adjust the cam release link so that the cam will trip when the keylever is depressed from 3/4 up to and including its full normal travel. When properly adjusted, it will allow the cam to repeat when the keylever has traveled far enough to depress the spring-loaded plunger 1/16" in the front guide comb.

3. Adjust the front clutch lever link so that, with the cam on its high point, the clutch lever will clear the clutch latch by .010" to .030" (Figure 24).

4. The rear clutch lever link engages the lower clutch lever bellcrank.

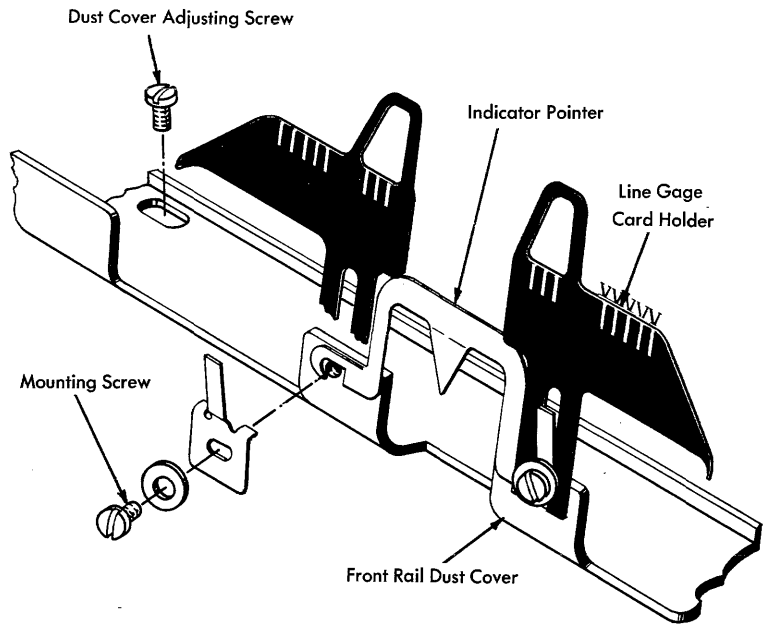

Figure 21. Line Gage Card Holder Adjustment

With the clutch at rest, adjust the link so that the slot in the clutch lever bellcrank is parallel to the rear rail (Figure 24).

lever, adjust the link so that the slot in its bellcrank is parallel to the rear rail (Figure 24).

5. The clutch latch link is placed in the center hole of the clutch latch bellcrank. With the clutch at rest and the clutch latch resting against the clutch

6. "Overbank" is the term applied to the amount of play between the margin control lever and its final stop when the carriage is resting at the left margin. Adjust overbank by moving

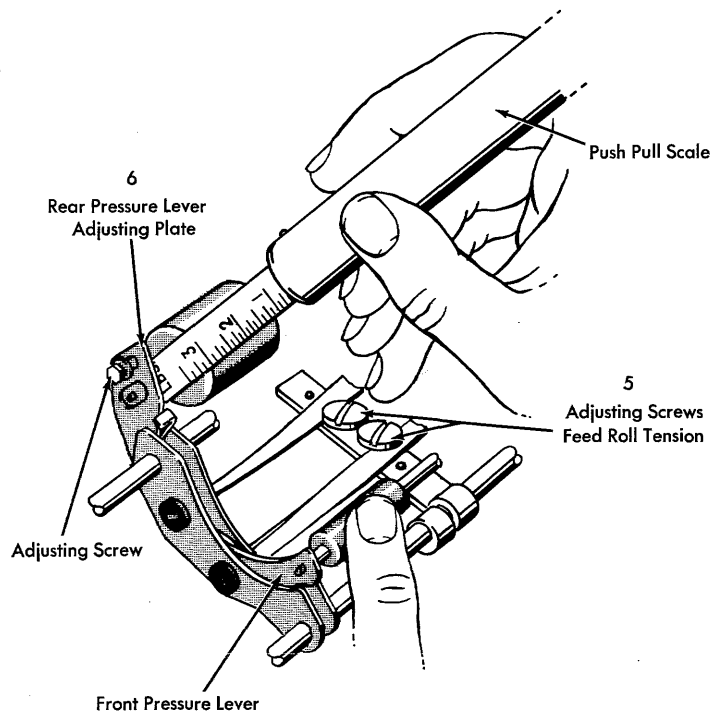

Figure 22. Feed Roll Pressure Adjustment

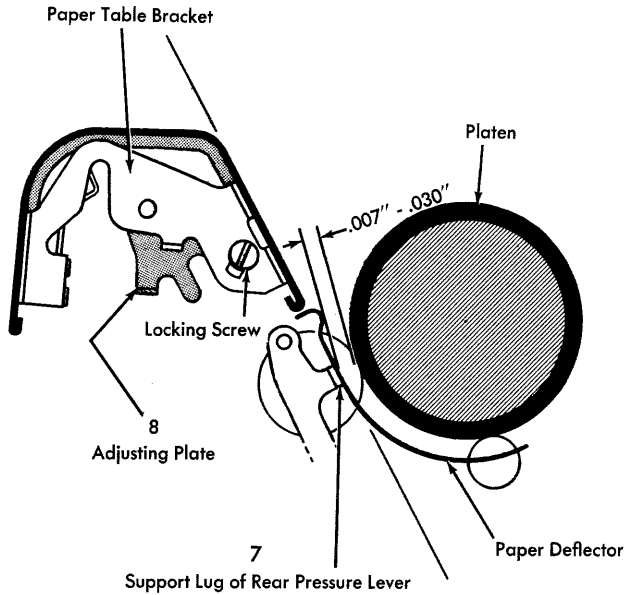

Figure 23. Paper Table and Paper Deflector Adjustment

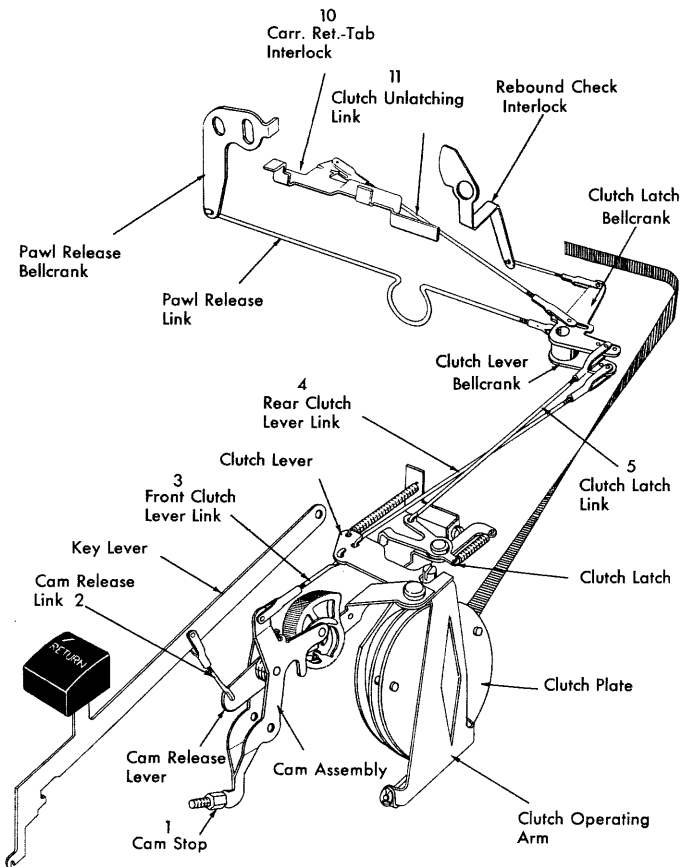

Figure 24. Carriage Return Adjustments

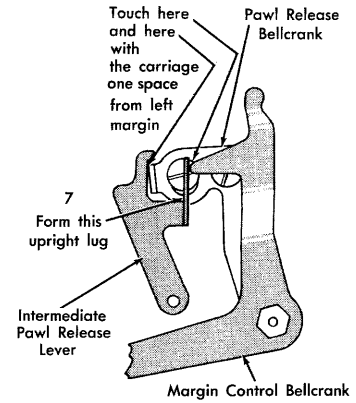

Figure 25. Intermediate Pawl Release Lever Adjustment

the margin rack to the left or right so that the escapement pawl just clicks into the escapement rack tooth as the margin control lever strikes its final stop. Position the carriage one space from the margin and observe the adjustment by slowly moving the carriage to the left margin.

The oversize washers under the margin rack nuts limit the travel of the carriage release levers. When tightening the nuts, make sure that these washers do not stop the carriage release levers too soon. The escapement pawl should be easily released by either lever when the carriage rests in either extreme position.

7. Form the upright lug of the intermediate pawl release lever so that the lug touches the margin control bellcrank and the pawl release bellcrank when the carriage is one space from the left margin (Figure 25).

8. Adjust the pawl release lever eccentric so that the ear of the pawl release lever just clears the intermediate pawl release lever when the parts are at rest (Figure 26). Keep the high point of the eccentric toward the front of the machine.

9. The eccentric washer serves as a rest position stop for the margin control bellcrank. It is positioned so that the margin control lever has about .005" motion left to right without any

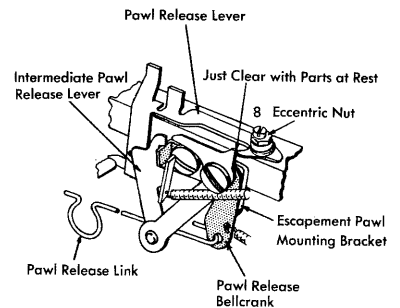

Figure 26. Pawl Release Adjustment

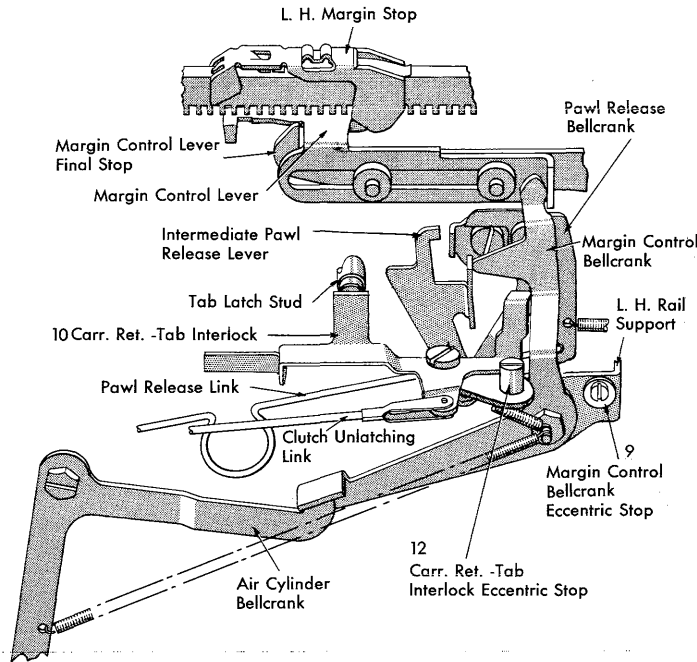

Figure 27. Margin Control Bellcrank Eccentric Stop

movement of the margin control bellcrank or tab check lever when the margin control bellcrank is against the eccentric washer (Figure 27).

10. Adjust the carriage return-tab interlock as follows:

- a. Unhook the clutch unlatching link.
- b. Turn the high point of the interlock eccentric stop to the rear of the machine.

c. With the carriage at the left margin, form the interlock so that it clears the tab latch stud by about $\frac{1}{16}$ " when the left-hand lug on the interlock is in contact with the margin control bellcrank (Figure 28).

11. Adjust the clutch unlatching link to unlatch the clutch within the last .050" travel of the margin control lever. Latch the clutch fully and return the carriage slowly by hand to

the left margin to observe the point at which the clutch unlatches.

12. Adjust the carriage return-tab interlock eccentric stop to permit the clutch latch to engage the clutch lever by $\frac{1}{3}$ to $\frac{1}{2}$ of the clutch latch surface when the clutch is fully latched (Figure 29). To observe this adjustment, remove the right-hand ribbon spool and latch the clutch.

13. Adjust the link to the rebound check interlock so that the interlock lever clears the tab rebound check lever by about .010" when the rebound check lever is in its operated position. With the clutch unlatched, operate the tab lever by hand to observe this adjustment (Figure 30). Operate the carriage return cam by hand and observe that the rebound check interlock does not strike the rebound check lever at rest. Form the

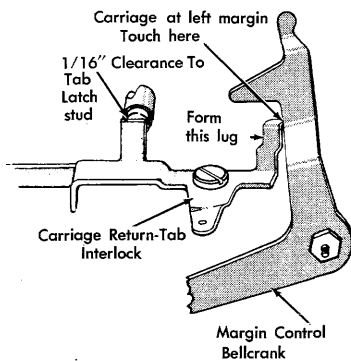

Figure 28. Carriage Return-Tab Interlock Adjustment

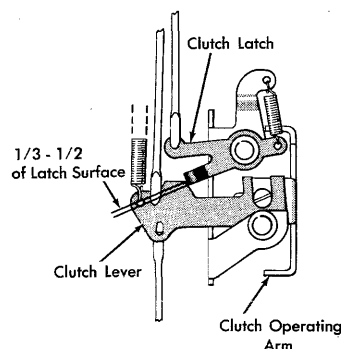

Figure 29. Clutch Latch Bite

top of the interlock lever to provide a clearance of about .010" (Figure 30).

14. Adjust the pawl release link so that the escapement pawl clears the escapement rack by about $\frac{1}{4}$ " during a carriage return operation. Latch the clutch and sight along the escapement rack to observe the amount of clearance.

15. Adjust the clearance between the clutch plate and the clutch disc to .010" \pm .005" by positioning the bracket on the bottom of the side frame (Figure 31).

16. Position the air cylinder front or rear on the side frame, by using the elongated mounting holes, to permit the plunger to move freely in the cylinder without binding (Figure 32).

17. Air cylinder ports and clutch compression spring adjustments should be considered together. The air cylinder must reduce the impact of the carriage return as much as possible without noticeably reducing speed.

The intake port, on the air cylinder shell, should be adjusted about half-way open. Use caution to avoid stripping threads.

Open the exhaust port on the air cylinder cover. With the line space lever set for triple spacing and the margin stop moved to the extreme left, adjust the clutch compression spring to insure a positive return on short returns of one to two inches as well as on medium and long returns. Lack of sufficient tension can contribute to a slow or weak carriage return.

Adjust the exhaust port so that the shock of carriage return is reduced, without abruptly slowing the carriage during the last half-inch of travel. Test this action on short, medium and full-length returns for positive, quiet operation.

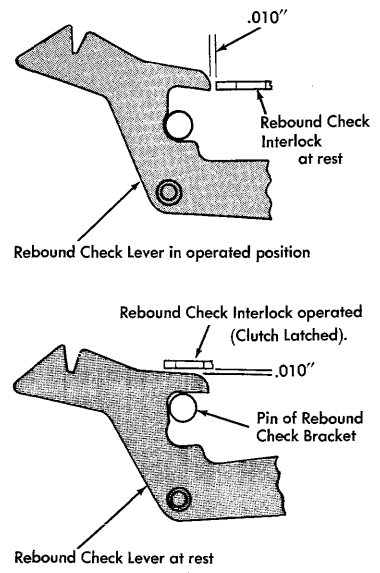

Figure 30. Rebound Check Interlock Lever

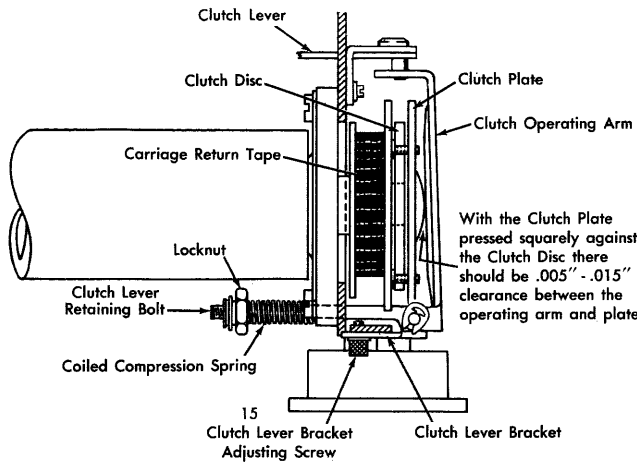

Figure 31. Clutch Clearance Adjustment

Line Space

1. Wind the clutch pulley spring completely. Back off the pulley two turns before attaching the carriage return tape to the pulley. The carriage should be at the extreme left when the tape is attached to the clutch pulley. A loose adjustment increases the whip of the tape and slows the line space operation.

2. Adjust the lower index pawl stop to stop the travel of the index pawl at a point where the detent roller is fully seated between two ratchet teeth, so that the platen will not move after completion of the stroke (Figure 33).

Backspace

1. Form the lug of the pawl release lever which contacts the backspace interlock so that, with the interlock at rest, the backspace pawl may be moved past it with a minimum of clearance (Figure 34).

2. Form the extension of the carriage return-tab interlock which contacts the backspace interlock, so that when the carriage return clutch is latched, the backspace interlock is moved just far enough around the

backspace pawl to block the sliding motion of the pawl. The backspace pawl should not be able to enter the escapement rack while the carriage is returning.

3. Adjust the lug, or backspace pawl guide by forming so that the pawl enters the escapement rack with about $\frac{1}{64}$ " clearance between the face of the pawl teeth and the face of the rack teeth (Figure 35).

4. Position the backspace pawl stop by its holding screws so that it stops the backspace pawl as soon as the escapement pawl drops into the next tooth of the escapement rack. This adjustment is observed through the bottom of the typewriter after tripping the backspace cam and rotating the power roll by hand.

The stop is also positioned far enough to the front of the machine so that the backspace pawl clears the stop by .010"-.020" when the interlock is operated (Figure 36). Hold the carriage release levers depressed and operate the backspace by hand to observe this clearance.

5. Adjust the cam stop until the cam clears the power roll enough so that, when tripped with the power off, the cam release lever falls on the rear

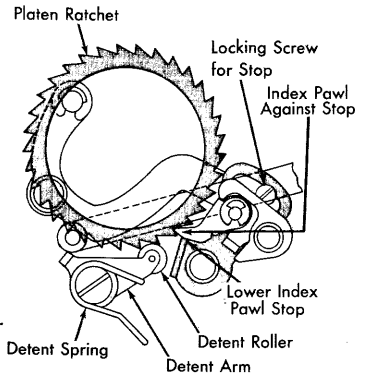

Figure 33. Lower Index Pawl Stop Adjustment

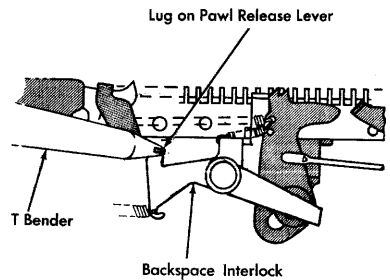

Figure 34. Backspace Interlock Motion Adjustment

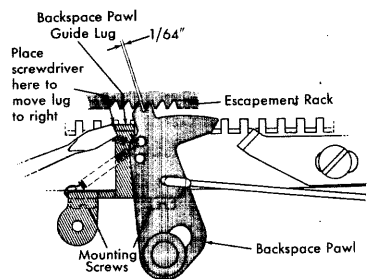

Figure 35. Backspace Guide Lug Adjustment

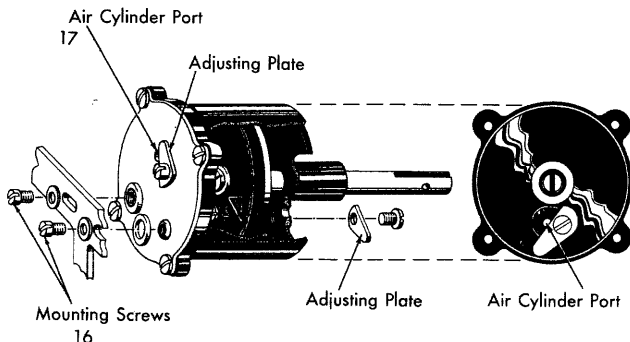

Figure 32. Air Cylinder Adjustment

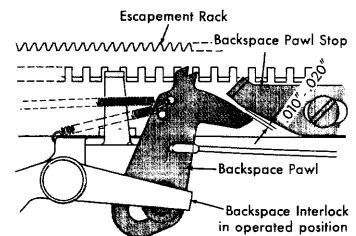

Figure 36. Backspace Pawl Stop Adjustment

half of the cam lug (Figure 37).

6. Adjust the cam release link so that the cam is released when the key-lever has been depressed about $\frac{2}{3}$ of its downward travel (Figure 37).

7. Adjust the side operating link so that, when the backspace pawl contacts its stop, there is no more than $\frac{1}{4}$ " travel left on the circumference of the cam. Check the adjustment at several carriage positions by tripping the cam, rotating the power roll by hand, and observing the amount of choking off (Figure 37).

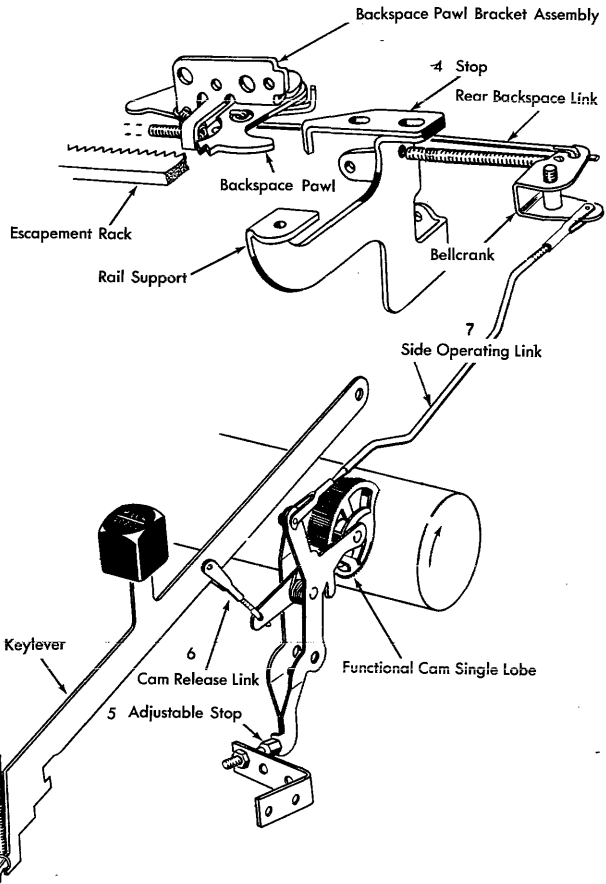

Figure 37. Backspace Adjustment

Margin Release

1. Adjust the eccentric stud under the tab actuating lever so that the margin control lever clears the bottom of the margin rack by .010"-.015" (Figure 38).

2. Adjust the margin release key-lever link as long as possible, still keeping the bellcrank from rubbing on the power roll (Figure 38).

Margin Set

1. Adjust the margin set bracket by positioning it on the rear frame so that the set lever enters squarely into the notched top of the stop when the carriage is resting at the margin (Figure 39). Adjust the screw and elastic stop nut that mount the set lever to the bracket to eliminate all side play in the set lever without binding the set lever.

2. Adjust the margin set link by the clevis at its front end so that the margin set lever will just clear the top of either margin stop when all parts are at rest (Figure 39).

Line Lock

1. Adjust the vertical link from the line lock lever so that the bellcrank is at a right angle to the link when fully actuated (Figure 40).

2. Adjust the push link clevis to just match the hole in the bellcrank when the bellcrank is fully actuated and the push link is held forward so that the keylock bar locks a depressed letter keylever down.

Tab

1. The cam stop adjustment must permit the cam to clear the power roll enough so that, when the cam is tripped with the power off, the cam release lever falls on the rear half of the cam lug (Figure 41).

2. Adjust the cam release link so that the cam is released when the key-lever is depressed $\frac{2}{3}$ of its downward travel (Figure 41).

3. Adjust the tab lever height by using the eccentric stud under the tab actuating lever so that the margin control lever clears the bottom of the margin rack by .010" to .015" (Figure 41). This adjustment is also listed under "Margin Release."

4. The tab rack is adjusted two ways:

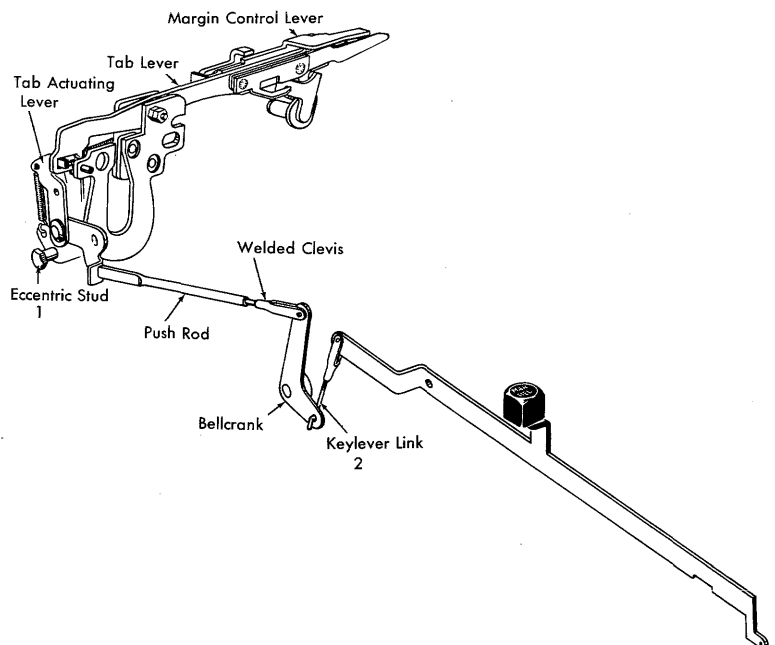

Figure 38. Margin Release Adjustment

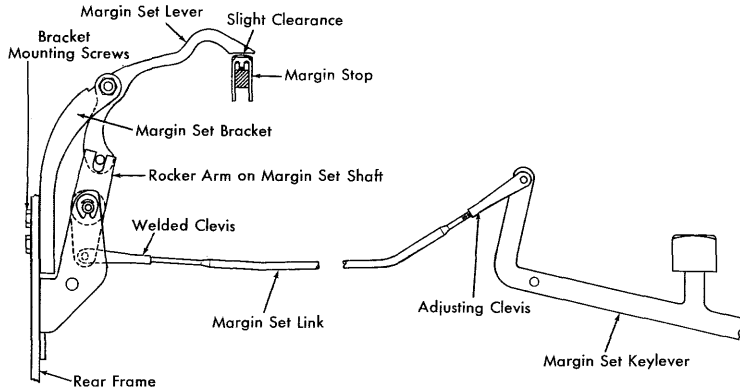

Figure 39. Margin Set Adjustment

Position the rack left or right so that there is a clearance between the left-hand face of any set tab stop and the engaging face of the tab check lever of .002"-.015" (Figure 42). Slowly move the tab lever to the rear by hand and observe the amount of clearance between the parts indicated. The continued motion of the tab lever removes the escapement pawl from the rack, and the reading has no value, unless the carriage is held rigidly during the test.

Position the right end of the tab rack front or rear by using its elongated mounting hole so that the tab check lever takes an equal bite on all set tab stops. When tightening the adjustment nuts, maintain the front face of any set tab stop parallel to the tip of the tab check lever (Figure 43), and at the same time make sure that the carriage end plates are not sprung.

5. Position the tab latch keeper so that the tab check lever covers $\frac{1}{2}$ to $\frac{2}{3}$ of the exposed surface of a set tab stop. At the same time, move the keeper left or right for .040"-.060" engagement of the latch with the keeper

when the tab lever is held out by the keeper (Figure 44).

6. Adjust the tab operating link so that, with the tab cam on its high point, there is .010" to .015" clearance between the tab latch and the tab latch keeper. Observe this adjustment by releasing the tab cam and turning the power roll by hand. Make sure that the tab lever overthrow stop does not limit the travel of the tab lever before the tab cam is rotated to its high point.

7. Form the rear, upright lug on

the pawl release lever for $\frac{1}{4}$ " escapement pawl clearance during tabulation (Figure 44). Observe this clearance by latching the tab lever by hand, preventing carriage movement, and sighting along the escapement rack.

8. The rebound check bracket is adjusted two ways:

Position the bracket left or right so that the right edge of the V-slot of the rebound check lever clears the right-hand face of any set tab stop by a maximum of .010" when the left-hand face of the stop has pushed the tab check lever to the extreme left (Figure 45).

At the same time the bracket should be positioned front or rear so that, when the rebound check lever is in its operating position and against the pin in its bracket, the leading edge of the rebound check lever is even with the tip of the tab check lever or leads it by .005". The bracket can be conveniently adjusted for both conditions simultaneously. Release the tab cam and rotate the power roll by hand until the tab lever latches. If the rotation of the power roll is stopped at this point, the cam and linkage holds the tab lever to the rear even though the tab check lever and latch are pushed to the left or unlatched position. The bracket can be loosened and adjusted while the tab lever is held in this position.

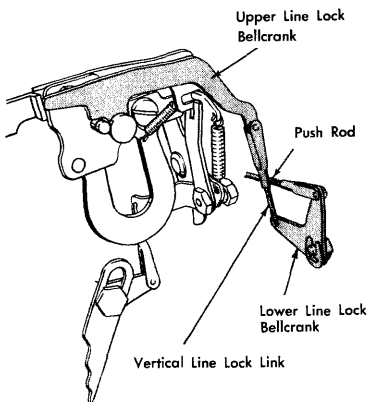

Figure 40. Line Lock Adjustment

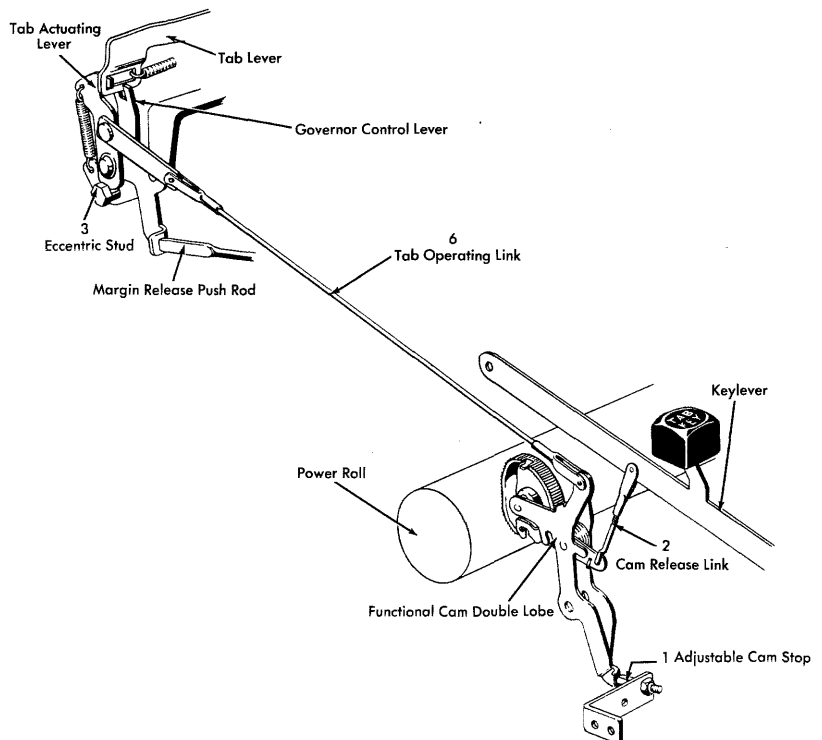

Figure 41. Tab Adjustments

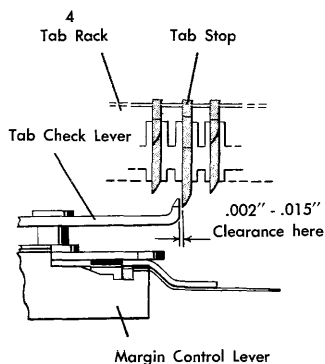

Figure 42. Tab Rack Lateral Adjustment

9. Form the tab lever extension so that, with the tab cam at its high point, the extension finger has .000"-.005" (paper clearance) with the upright stop on the rebound check lever bracket (Figure 44).

10. Form the tab lever leaf spring to just contact the upright stud of the rebound check lever when the rebound check lever is at rest against the pin in its bracket.

11. Adjust the tab governor pawl link so that the governor pawl engages the friction ratchet by the thickness of its own metal with the tab lever latched (Figure 46). Allow the carriage to move a short distance to fully extend the pawl before observing the engagement.

12. Adjust the friction governor pressure by the two locking nuts on the hub of the main spring drum until the speed of tabulation approximates the speed of carriage return (Figure 46). Observe this adjustment by clearing all tab stops except the last one on the right end of the rack and tabulating the complete carriage length.

Tab Set and Clear

1. Position the tab set and clear bracket on the rear frame of the typewriter by the three hex-head mounting screws so that the set finger engages the correct stop. The correct stop is the one that is two spaces to the left of the tab check lever at rest.

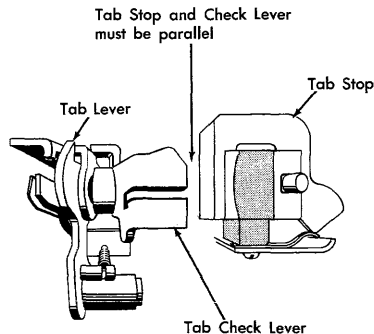

Figure 43. Tab Rack Parallel with Tab Check Lever

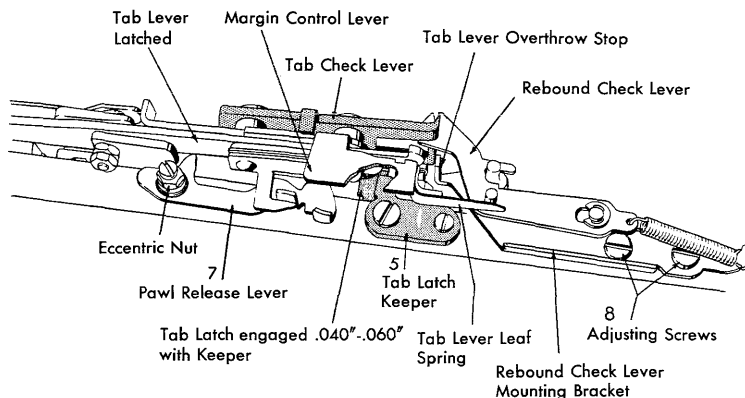

Figure 44. Tab Latch Keeper Adjustment

2. Form the tab set bracket (Figure 47) so that when the tab stops are in the non-operating position, there is a clearance of about 1/32" between the tab stops and the tab set lever.

3. Form the tab clear bracket so that, when the tab stops are in the operating position, there is a clearance of about 1/32" between the tab stops and the tab clear lever (Figure 47).

4. Adjust the tab set and clear links to such a length that, when the buttons are at rest, the slope of their upper surface points in a line parallel to the plane of the keyboard.

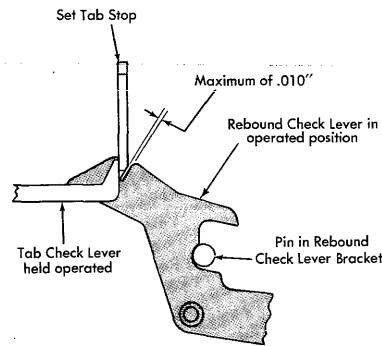

Figure 45. Tab Rebound Check Lever Adjustment

Ribbon Feed and Reverse

1. Set the ribbon feed cam, by its eccentric stud, to clear the power roll by .010"-.015". When the cam is released with the power off, the release lever should rest on the rear half of the cam lug. The eccentric stud and locking nut are located on the left side

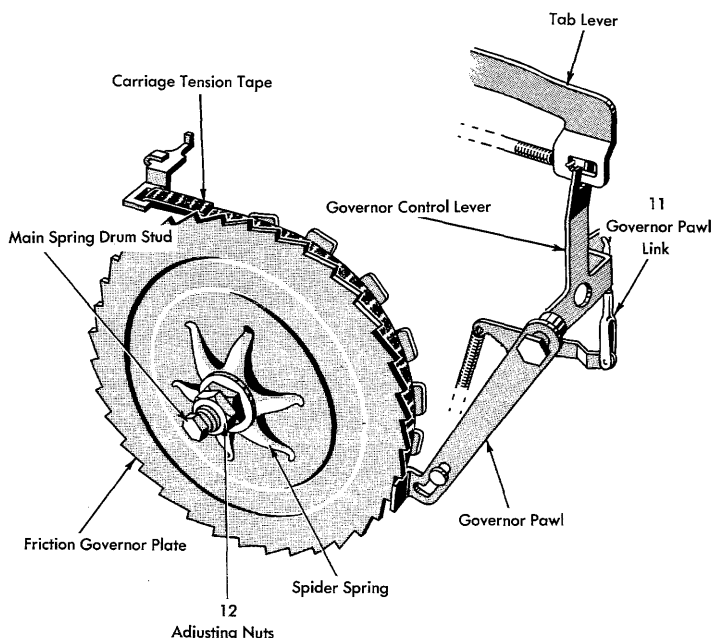

Figure 46. Tab Governor Adjustment

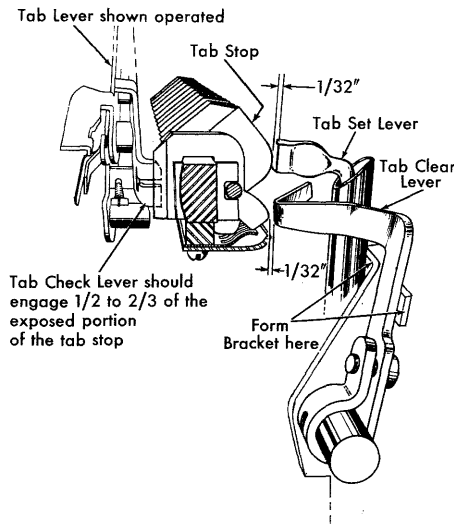

Figure 47. Tab Set and Clear Adjustment

frame and may be reached through an opening in the power roll drive pulley (Figure 48).

2. Adjust the cam release link so that the ribbon cam is released when any type face is $\frac{3}{4} \pm \frac{1}{8}$ from the platen (Figure 48). A variation in the tripping point between different type bars may be an indication that the vane on top of the ribbon lift bail is curved.

3. Adjust the link from the cam to the ribbon lift bail end plate so that the bail end plate is $\frac{1}{16}$ above the bottom of the slot in the side frame (Figure 48). Make this adjustment by disconnecting the link and turning the clevis with a spring hook, reaching down through the side frame of the machine.

4. Adjust the ribbon feed links so that, when the cam is on its high point, the reversing lug of the ribbon feed bellcrank can just contact the reversing latch when the latch is engaged and in its extreme high position (Figure 49). Observe the adjustments by moving the ribbon reverse levers to the rear when the pawls are engaged in first one spool and then the other. The lug should not choke off against the reversing latch.

5. Adjust the spring links so that, in the supply position with the pawls disengaged, the reversing latches clear the path of the ribbon feed bellcranks by about $\frac{5}{32}$ (Figure 50).

6. Adjust the check pawl by its mounting screw. Loosen the screw and move the pawl back or forward until

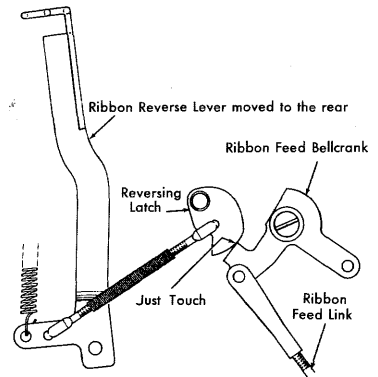

Figure 49. Ribbon Feed Link Adjustment

the pawl positions the ribbon spool, at which time the feed pawl should rest half-way between the two teeth (Figure 51). With the cam rotated to the highest point, the feed pawl should feed two full teeth, of the ribbon spool past the check pawl.

7. Adjust the ribbon spool retaining springs so that the tip of the retaining spring is about $\frac{1}{16}$ from the inner surface of the ribbon feed plate. Position them by loosening their mounting screws to hold the spools parallel to the side frames. Too little pressure against the spools allows the ribbon to reel out too freely, causing slow or complete failure of ribbon reverse.

8. Adjust the ribbon corner guides so that the ribbon feeds off each ribbon spool without touching either side of the ribbon spool.

Ribbon Lift

1. The ribbon lift operating link is adjusted to take up all the play in the linkage when the cam levers and lift bail are at rest, but not to push the ribbon lift lever up off its stop. Check by holding the ribbon lift lever against

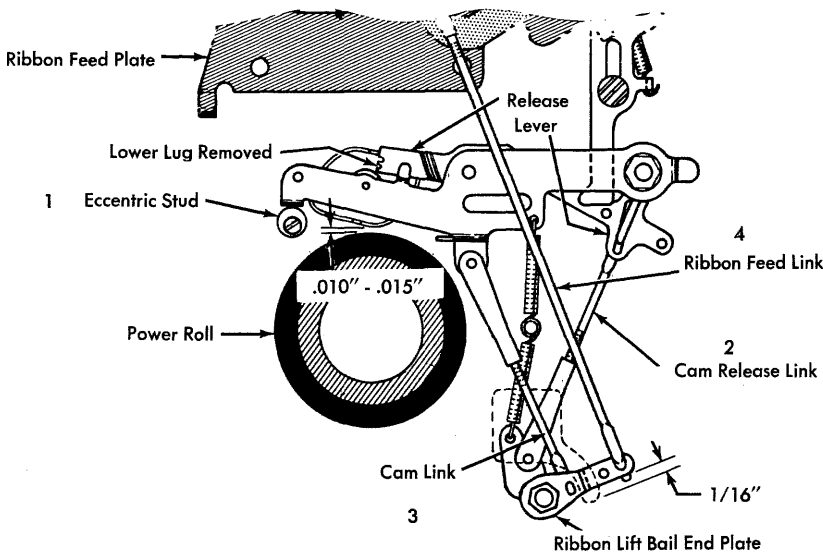

Figure 48. Ribbon Feed Adjustments

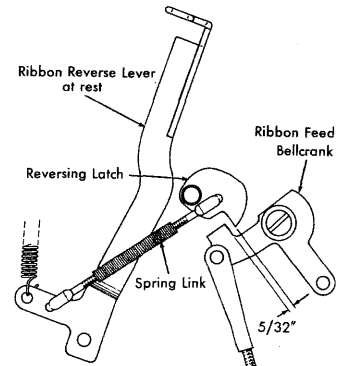

Figure 50. Ribbon Spring Link Adjustment

its stop and, with the ribbon lift bail against the cam levers, see that the link just matches the hole in the bottom end of the actuating lever (Figure 52).

2. Adjust the ribbon lift guide clevis so that the tops of the tallest characters strike $\frac{1}{32}$ " below the upper edge of the ribbon when the ribbon lift is at its lowest, or black, setting (Figure 53).

3. Form the upper lug of the positioning plate so that the diagonal strikes about $\frac{1}{32}$ " from the bottom edge of the ribbon when the ribbon lift is at its highest, or red, setting (Figure 53).

4. Adjust the color control button so that, when the ribbon lift control button is in the black ribbon position, the slope of the button is parallel to the slope of the keyboard.

Shift

Set ring and cylinder adjustment of the platen as explained under "Carriage Adjustments" before attempting the basket adjustments.

1. Adjust the shift stop screws so that the type impressions of the lower case characters appear even on the top and bottom. The screws should be set so that the basket rests evenly on both the right and left stop washers (Figure 54).

2. Adjust the motion by the pair of locking nuts on each stop screw so that the upper case characters print on the same line as the lower case. Again the basket should rest evenly on both the right and left stop washers (Figure 54).

3. Adjust the cam stop until the cam clears the power roll enough so that, when tripped with the power off, the cam release lever falls behind the cam lug by an amount equal to the thickness of the cam lug (Figure 54).

4. Adjust the link brackets on each side of the basket so that the clearance between the pusher and either pin on the actuating plate is the same. For example, loosening the top screws and tightening the bottom screws on each

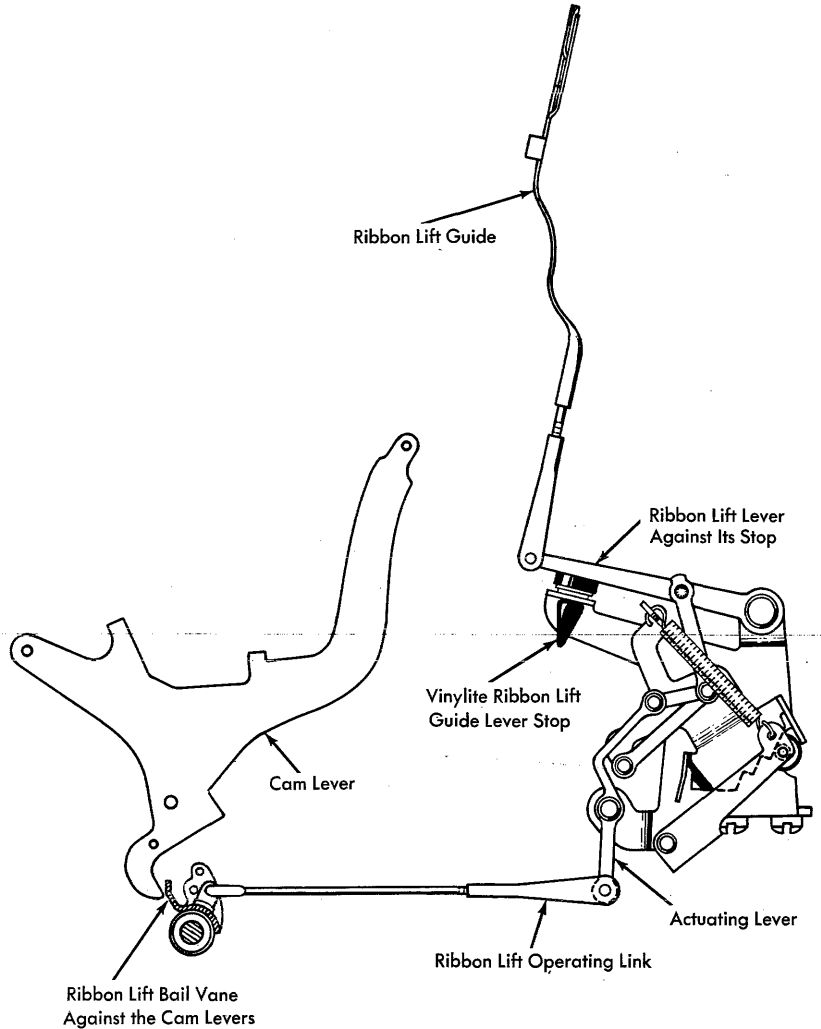

Figure 52. Ribbon Lift Operating Link

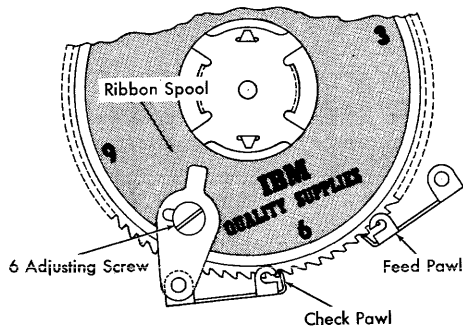

Figure 51. Ribbon Check Pawl Adjustment

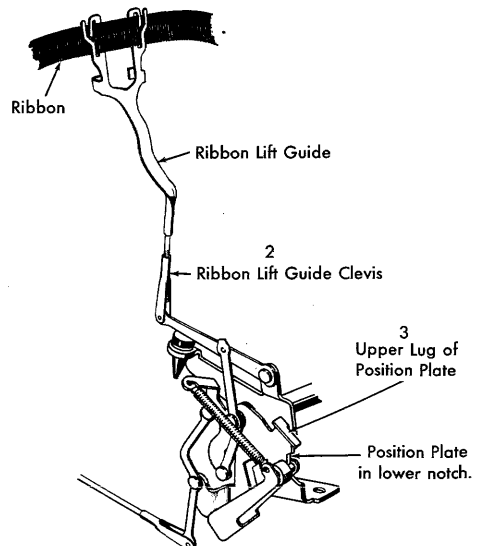

Figure 53. Ribbon Tracking Adjustments

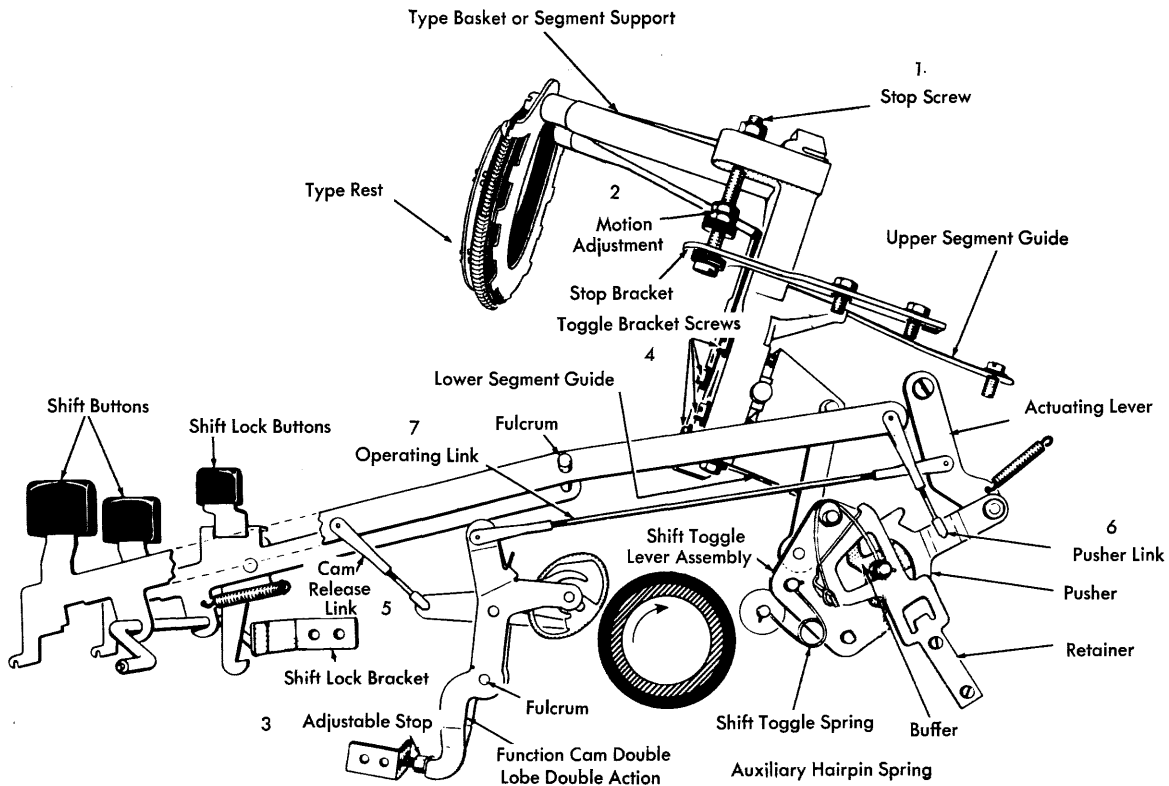

Figure 54. Shift Adjustment

side increases the clearance on the top pin and closes the clearance on the bottom pin. A bind may result if both brackets are not adjusted evenly (Figure 54).

5. Adjust the cam release link so that the cam is released when the key-lever is depressed $\frac{2}{3}$ of its downward travel (Figure 54).

6. Adjust the pusher link to such a length that the upper edge of the upper pusher arm is about in line with the top of the upper pin of the actuating plate at the instant the cam is released (Figure 54). This adjustment should allow the lower arm to safely engage the lower pin when the key-lever restores to its upper position.

7. Adjust the operating link so that the pusher clears the pins by $\frac{1}{32}$ " to $\frac{1}{16}$ " (Figure 54). The amount of pin clearance and the power roll speed directly affect the action of the buffer. The higher tolerance usually provides a smoother, quieter shift action.

8. The shim washers, .010" thick, may be placed under the front ends of the upper segment guides, one at a time, to cause the upper case characters to shift off cylinder to obtain equal density of blackness between upper and lower case. Ring and cylinder adjustment of the platen must be made after shimming of the guides. Use this treatment if upper case characters appear too dark.

REMOVAL PROCEDURES

THE FOLLOWING procedures have been established for the basic Model B1 Electric Typewriter. Other steps may have to be added on EAM typewriters when various contacts, magnet or selector units are added to the typewriter. The general procedure, however, should remain the same.

Covers

The front typewriter cover is mounted from the top by two long screws threading down into the adapter ring of the machine. These screws are exposed by lifting the top cover. The rear typewriter cover is fastened from the bottom by three screws that thread up into the covers through the adapter ring.

Both front and rear covers are mounted from the top on the earliest EAM typewriters. Two screws threading into speed nuts on the typewriter side frames lock the covers in place.

Motor and Drive

MOTOR

1. Remove the rear cover of the typewriter.
2. Remove the adjusting screw that

positions the motor on the left side frame.

3. Slip the drive belt from the motor pulley.

4. Remove the inside C-clip that retains the motor mounting shaft. Slide the shaft out of the side frame.

5. Remove the rear bottom plate so that the motor may be maneuvered through the bottom of the machine and disassembled without opening its connections.

POWER ROLL (Figure 55)

1. Place the clutch in a latched position before removing the power roll. This precaution serves to hold the clutch parts in place when the shaft is removed, thereby aiding in reassembly. Note that the right end of the power roll shaft is chamfered for easy insertion into the clutch disc slot.

2. Remove the front cover.

3. Remove the driven belt from the power roll drive pulley.

4. Loosen the two setscrews in the power roll drive pulley and remove the pulley.

5. Remove the three screws holding the bearing retainer to the left side frame.

6. Remove the power roll assembly through the hole in the left side frame.

NOTE: In replacing the power roll, check to see that power roll end play does not exceed .010".

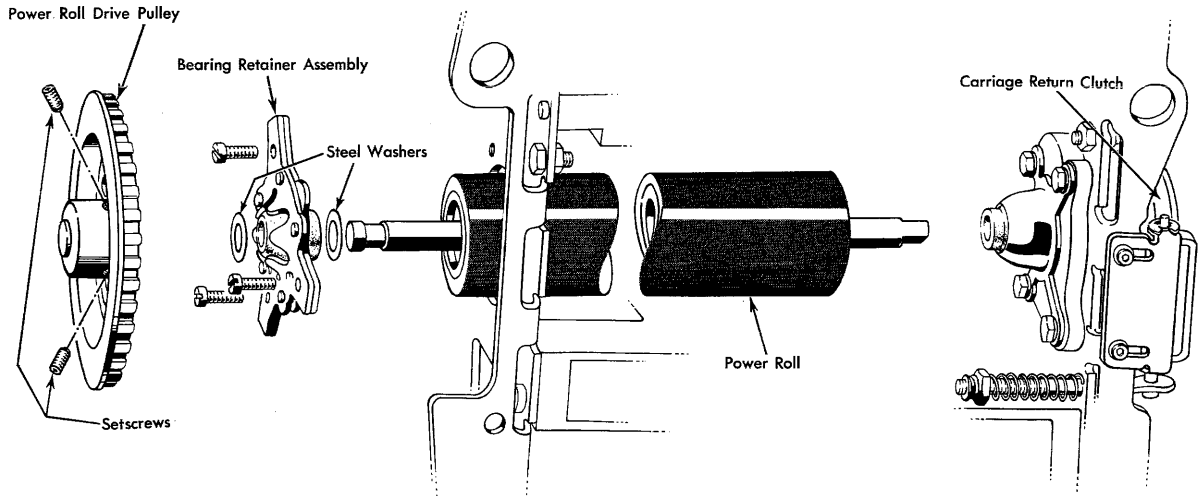

Figure 55. Power Roll Removal

Letter Cam Unit and Keylever

TYPEBAR (Figure 56)

1. Loosen the two retaining screws holding the typebar fulcrum wire in place.
2. Push the wire out with a follow-up until the desired typebar is reached.
3. Pull the typebar toward the front of the machine so that it passes over

the front edge of the type segment. Disconnect the typebar link.

The typebar may be replaced by reversing the procedure described above. Some difficulty may be experienced in lining up the typebar fulcrum wire hole with the wire. A small mark has been made on the upper edge of the typebar, about $\frac{5}{8}$ " from the segment. By aligning these marks and by holding the typebar level with the other bars, the holes should be aligned.

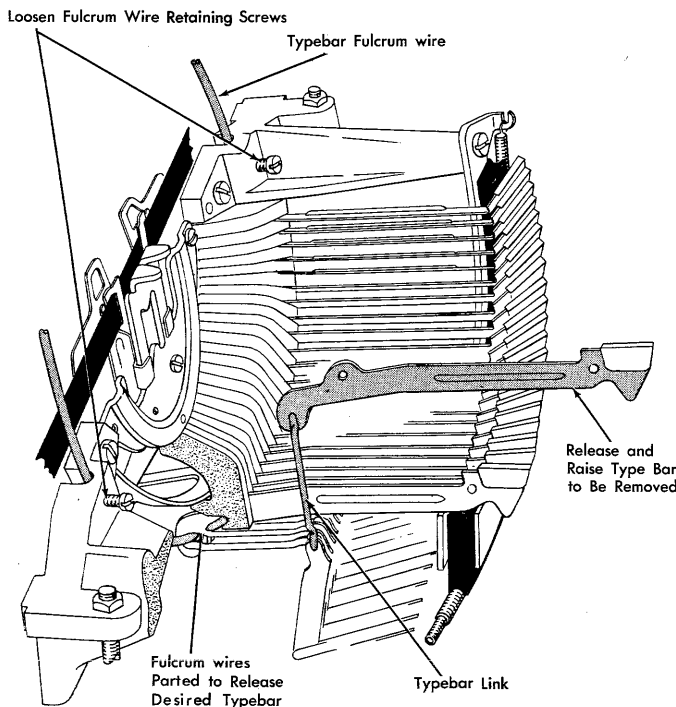

Figure 56. Typebar Removal

KEYLEVER

1. Remove the front cover.
2. Remove the key plate and the keyboard stabilizer.
3. The keylever fulcrum wire is held in the machine by a clip on either end. Remove one of the clips so that the fulcrum wire may be moved into the machine to drop the desired keylever.
4. Force the fulcrum wire to the desired keylever by using a follow-up fulcrum wire.
5. Remove the spring from the front end of the keylever.
6. Remove the keylever by pushing it toward the rear of the machine until the front end clears the front guide comb.

Key buttons may be removed from the keylevers without removing the key plate by exerting a force against the bottom of the button. Carefully avoid damaging the key plate.

CAM LEVER

1. Remove the power roll.
2. Remove the typebar of the cam lever to be removed.
3. Loosen the screw holding the right-hand fulcrum wire retaining clip, and pivot the clip out of the way.
4. Insert a follow-up cam bearing fulcrum rod through either side frame as far as is necessary to release the desired cam lever assembly.
5. Disconnect the letter cam lever spring. When the cam lever assembly is released, it may be removed by moving it toward the back of the machine and dropping it down as soon as the cam unit clears the cam lever bearing support.

The cam may be removed from the cam lever assembly by removing the rivet. Place the cam over a hole that passes the head of the rivet and drive the rivet out with a punch. When riv-

eting a new cam to the cam lever assembly, take care to avoid spreading the body of the rivet so that the cam is too tight. To avoid this, keep the rivet as level as possible with respect to the cam lever during the riveting operation. Test for binds by observing that the cam swings freely on the rivet. If the rivet is too loose, the cam may by-pass the cam lever and bind.

Carriage

1. Remove the rear cover.
2. Remove the right-hand carriage end cover.
3. Disconnect the carriage tension and carriage return tapes from the carriage.
4. Remove the margin set lever.
5. Move the carriage to the extreme left, lower the spring-loaded carriage stop until the right-hand carriage end plate by-passes it and continues out to the left. The carriage and rails have teeth throughout their entire length, permitting over-travel of the star wheels. Because of an interference between the tab lever assembly and the left-hand carriage end plate, the carriage cannot be removed from the right side of the typewriter.

As the carriage is removed, note the position of the carriage trucks and place a mark on the carriage bed as the star wheel leaves the rail. Repeat this for each set of trucks as it leaves the rail so that a reference point may be obtained for installing the trucks when the carriage is replaced.

The steel roller may be pressed out of the truck after the truck is released from the rails.

All carriage trucks must be installed in the rails so that the flat portion of the indicator lug on the end of the truck faces down (Figure 57). This eliminates the possibility of the star wheel's riding under the teeth of the carriage top plate and binding the carriage movement.

If a reference mark is not used to re-install the trucks, the diagram of Figure 57 shows how to start the trucks to obtain the correct position in relation to the carriage length. After the trucks are completely installed, the carriage should be moved to its extreme limits of travel to see that the trucks do not protrude.

The 12-inch carriage shows all four trucks being inserted at once. The right-hand trucks are even with the carriage final stop and the carriage is placed even with the star wheel pins of these trucks. Insert the left-hand trucks until their star wheel pins are even with the left end of the rails. Then move the carriage to the right while lowering the carriage final stop until it is in its normal operating position.

The 16-inch carriage shows the starting point to insert the three sets of trucks. Place the first set as shown so that the star wheels are even with the left end of the rails. Place the carriage so that the right-hand carriage

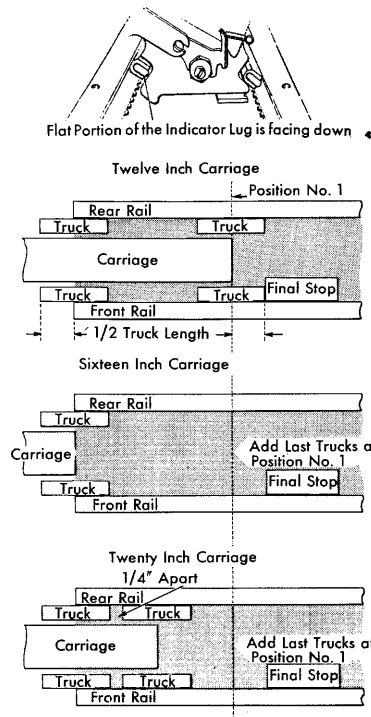

Figure 57. Insertion of Carriage Trucks

end plate is even with the star wheel pins. Move the carriage to the right until it is in position 1, and proceed as for the 12-inch carriage to insert the remaining two sets of trucks.

The 20-inch carriage shows the starting position for the insertion of four sets of trucks. Start with the left-hand set of trucks. Insert these trucks until the star wheel pins are even with the left end of the rails. Place the right hand set of trucks so that there is a clearance of two teeth between them and the left hand set of trucks. Place the right end of the carriage even with the star wheel pins in the right-hand set of trucks. Move the carriage to the right until it is in position 1, and proceed as for the 12-inch carriage to insert the remaining two sets of trucks.

CARRIAGE AND RAILS

1. Remove the rear cover.
2. Disconnect the tab governor link.
3. Disconnect the tab operating link.
4. Disconnect the spring clevis of the escapement trip link.
5. Disconnect the backspace operating link.
6. Remove the carriage return and tension tapes from the carriage.
7. Disconnect the margin set linkage at the rear so that the set finger is raised.
8. Remove the four rail screws and lift the carriage and rail assembly from the machine.

By securing a one-inch length of scotch tape to the link clevis where it attaches to the link, the adjustment of any link may be maintained during disassembly. Reassembly by reversing the above procedure.

Main Spring

1. Remove the carriage tension tape and allow the spring to uncoil. A safe method is to attach a 30-inch tension tape to the next drum lug before removing the typewriter tension tape. In this manner, it is possible to control the unwinding of the main spring without danger of the drum's slipping from your grasp. When the main spring is to be wound again, it is a simple process to do so by pulling on the extra tension tape. This method assures the same carriage tension as existed before the main spring was unwound.

2. Remove the main spring drum stud.

3. Remove the main spring drum with friction plate, spider spring, and felt ring assembled.

4. Remove the two screws which mount the main spring holder to the power frame if the main spring is not the improved type.

In reversing the above procedure to replace the main spring, be sure the washer is installed between the main spring drum stud and the power frame on the previous type spring. The washer is installed between the main spring drum and the holder on the improved type main spring.

Escapement

ESCAPEMENT PAWL ASSEMBLY

1. Remove the rear cover and lift off the paper table.

2. Remove the spring connecting the intermediate pawl release lever to the hex-head spring stud.

3. Remove the two springs attached to the pivot stud of the margin control bellcrank.

4. Remove the margin control bellcrank by removing its pivot stud.

5. Remove the shoulder screw that mounts the intermediate pawl release lever and remove the lever.

6. Block the carriage so that the main spring cannot pull the carriage to the left when the escapement pawl is released.

7. Disconnect the spring clevis of the escapement trip link.

8. Remove the remaining shoulder screw allowing the pawl release bellcrank to be moved out of the way.

9. As the escapement pawl assembly is moved away from the locating pins on the rear rail, the escapement pawl spring can be disconnected.

Replacement can be made by reversing the above procedure. Connect the escapement pawl spring before locking the assembly to the rear rail.

PAWL RELEASE LEVER

1. Remove the paper table and the carriage end covers. It is not necessary to remove the rear typewriter cover, but it may help in the removal and reassembly of parts.

2. Remove the margin rack. Retain the left inside nut in its adjusted position.

3. Disconnect the tab operating link and remove the pivot stud from the tab lever.

4. Raise the tab lever as high as possible without disconnecting the springs attached to it.

5. Remove the locking screw and eccentric from the pivot of the pawl release lever.

6. Slide the pawl release lever to the right to disengage its lower lug from the escapement pawl. By holding the backspace interlock in its operated position, the pawl release lever may be maneuvered out of the machine.

When reinstalling the pawl release lever, make sure that the lower lug is properly positioned with respect to the escapement pawl. The position may be observed from the bottom of the typewriter after the bottom pan has been removed.

ESCAPEMENT UNIVERSAL BAR

1. Remove the platen and paper deflector.

2. Remove the front rail dust cover.

3. Disconnect the ribbon lift guide clevis from the bottom of the typewriter and remove the guide from the top.

4. Remove the typebar fulcrum wire to permit the typebars to drop out of their slots and rest below the segment.

5. Disconnect the spring clevis of the escapement trip link.

6. Remove the two segment screws so that the type segment and universal bar may be removed through the front of the segment support.

7. Remove the two hexagonal screws holding the universal bar to the rear of the segment.

Replacement is accomplished by reversing the above procedure. The universal bar should be installed to rest as high as possible without binding against the segment. Coat the contact surface of a replacement universal bar with IBM 17 when installed.

Spacebar

The spacebar may be removed by first removing the spacebar bail and unscrewing the bar from its support.

SPACEBAR KEYLEVER

The spacebar keylever may be removed by first removing the front section of the frame which is held by two hexagonal-head screws on each side of the machine. Pushing the keylever fulcrum wire out with another fulcrum wire will release the keylever which may then be pulled through the keylever guide comb.

FUNCTIONAL CAM (SPACEBAR, TAB, BACKSPACE, SHIFT, CARRIAGE RETURN)**TYPEWRITERS WITH MAGNET UNITS (TYPE 866, 868)**

1. Remove the front cover, key plate, and magnet unit cover.

2. Remove the power roll.

3. Loosen the cam knockout bar by removing the pivot studs held by setscrews. Disconnect the knockout bar springs from the typewriter side frames.

4. Loosen the screw holding the fulcrum wire retaining clip and pivot the clip from the rod on the side corresponding to the cam to be removed.

5. Push the fulcrum wire out until the cam is released.

6. Disconnect the two links attached to the functional cam and remove the cam through the space occupied by the power roll.

TYPEWRITERS WITHOUT MAGNET UNITS (TYPE 824-826, 884)

1. Remove the front cover and the impression indicator.

2. Loosen the cam knockout bar by removing the pivot studs held by setscrews. Disconnect the knockout bar springs from the typewriter side frames.

3. Remove the eccentric shaft which positions the knockout bar by removing the two screws that mount its bearing to the left side frame.

4. Remove the bottom cover and remove the knockout bar from the machine.

5. If a right side cam is to be removed, loosen the screw that holds the right fulcrum wire retaining clip. Push the fulcrum wire out until the cam is released.

6. Disconnect the two links from the functional cam and remove the cam through the space occupied by the knockout bar and the eccentric shaft.

SPACEBAR ESCAPEMENT LEVER

1. Remove front and rear covers.

2. Remove the intermediate pulley of the drive mechanism.

3. Disconnect the rear clevis of the spacebar operating link at the escapement lever plate.

4. Unhook spring and remove screw holding the escapement lever plate on the left end of the escapement lever.

5. Remove the escapement lever from its bearings toward the center of the machine.

6. Loosen ribbon lift mechanism to permit passage of the escapement lever.

Paper Feed**PLATEN**

1. Raise the top of the carriage end covers.

2. Release the platen latches and lift the platen out of the carriage.

3. The paper deflector may be lifted out after the platen is removed.

FEED ROLL

1. Remove the platen.

2. Remove the paper deflector.

3. Remove the feed roll by depressing the spring loaded pin at the pressure lever until the feed roll shaft is released.

PAPER TABLE

First, raise the front paper table to its limit. Release the paper table by pulling it up from the carriage tie rod.

INNER CARRIAGE (PLATEN GUIDE PLATES AND PAPER FEED MECHANISM)

1. Remove platen, paper table, and paper deflector.

2. Remove both platen retaining plates.

3. Remove the front rail dust cover.

4. Remove the eccentric collar from the left end of the platen guide shaft.

5. Disconnect the copy control lever link from the platen guide shaft by removing the horseshoe clip.

6. Release the detent roller spring and unhook the carriage return tape from the indexing assembly.

7. Disconnect the springs that pull the platen guide plates to the rear.

8. Remove the top screw in the right-hand ribbon corner guide and pivot the guide down.

9. Position the carriage to the extreme right and pull the inner carriage forward to disengage it from the carriage plates. An IBM card may be placed between the ribbon lift guide and the front paper scale to prevent marring the scale.

Exercise caution during reassembly to prevent damage to the detent roller arm.

FEED ROLL RELEASE LEVER

1. Remove the inner carriage.

2. Detach the horseshoe clips at the pivot point of the lever and at the lower end of the link. Remove the lever.

Carriage Return**CARRIAGE RETURN CAM**

To remove the carriage return cam, use the same procedure outlined for a functional cam listed under "Spacebar."

CLUTCH FRICTION DISC AND CLUTCH PLATE

To remove the clutch friction disc, remove the screw at the top of the clutch operating arm. The clutch plate may also be removed.

CLUTCH PULLEY AND CLUTCH PULLEY SPRING

1. Remove the screw at the top of the clutch operating arm and remove the friction disc and plate.

2. Detach the front clip and remove the pin to the rear from the bottom of the operating arm.

3. Disconnect the carriage return tape from the pulley and allow the spring to unwind slowly.

4. The clutch pulley may then be removed from the power roll shaft.

5. The clutch pulley spring may then be removed from its housing. Note that the outer loop of the spring passes outside of the lug provided in the housing.

CARRIAGE RETURN TAPE

1. Disconnect the tape from the index pawl carrier by detaching the clip which retains it.

2. The tape can be disconnected from the clutch pulley by slipping the button on the tape out of the elongated hole in the pulley.

LINE SPACE

To remove the index pawl carrier, disconnect the carriage return tape and remove the clip at its pivot (Figure 58). Remove the index pawl by detaching a horseshoe clip at its mounting stud. The upper index pawl stop may be removed by detaching a "C" clip at its mounting point.

PLATEN RATCHET (Figure 59)

1. Unscrew the platen variable button from the left-hand platen knob, using a platen variable button tool.

2. Remove the platen knob by loosening the setscrews securing it to the shaft.

3. Remove the four screws that hold the platen clutch cover and sleeve assembly to the platen end plug. Then the ratchet can be removed.

Backspace Pawl Bracket

1. Remove the rear cover and paper table.

2. Remove the two screws holding the backspace pawl bracket.

3. Disconnect the escapement pawl spring and the rear backspace link attached to the pawl.

4. Remove the pawl bracket assembly.

Remove the tab rack to help the

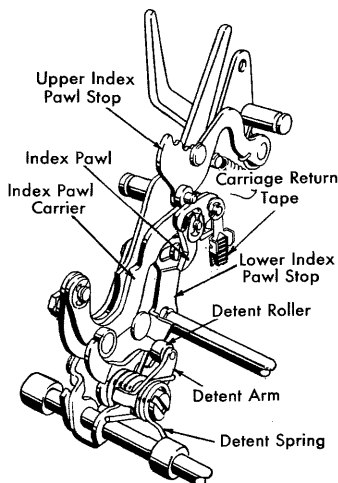

Figure 58. Line Space Mechanism

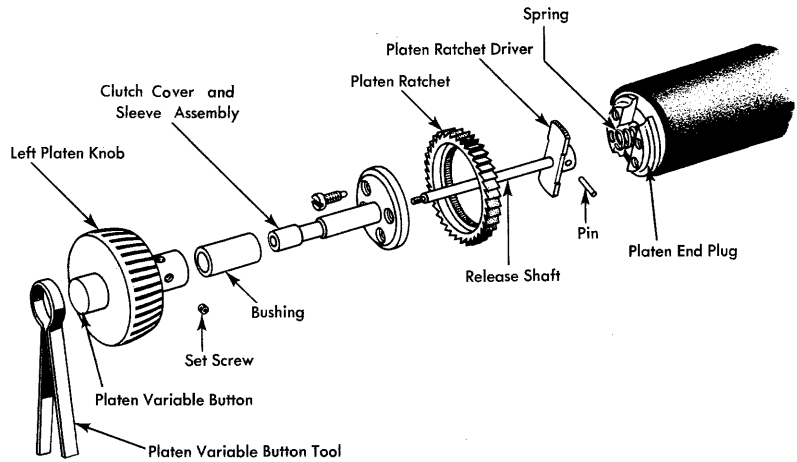

Figure 59. Platen Ratchet Removal

removal and replacement of the pawl bracket. Preserve the adjustment of the tab rack by keeping the left inside-nut in its adjusted position.

Tab Mechanism

TAB CAM

The tab cam may be removed by using the procedure outlined for the removal of a functional cam.

TAB LEVER

1. Remove the paper table and the carriage end covers. It is not necessary to remove the rear typewriter cover but it may aid the removal and reassembly of parts.

2. Remove the margin rack.

3. Disconnect the tab operating link and the vertical line lock bellcrank link.

4. Remove the tab lever pivot stud and two locking nuts. Clearance may be obtained by pivoting the upper line lock bellcrank out of the way.

5. Disconnect the three springs from the tab lever, and lift the tab lever from the top of the machine.

During reassembly of the tab lever to the horseshoe bracket, allow a slight end play of the pivot stud when tightening the locking nuts. Over-tightening the nuts on the pivot stud can cause the tab lever to move away from a true rest position.

TAB LEVER MOUNTING BRACKET

1. Remove the rear cover and paper table.

2. Disconnect the tab operating link and the vertical line lock bellcrank link.

3. By rotating the upper line lock bellcrank to get clearance, remove the tab lever pivot stud.

4. Remove the two screws from the horseshoe bracket so that the bracket may be maneuvered under the left end of the carriage and out of the machine.

Ribbon

RIBBON FEED PLATE

1. Remove the front cover.
2. Disconnect the ribbon feed link.
3. Remove the three mounting screws. Then the ribbon feed plate can be removed.

RIBBON FEED CAM

1. Remove the left-hand ribbon feed plate.

2. From the bottom of the typewriter, disconnect the cam release link and the spring from the lug on ribbon lift bail tube.

3. Disconnect the link from the cam to the bail end plate.

4. Disconnect the spring from the cam frame to the stud on the side frame.

5. Remove the screw holding the cam pivot to the side frame. The cam may then be lifted out through the space normally occupied by the left ribbon spool. The screw also mounts the front guide bracket for the line lock push rod.

RIBBON LIFT BAIL ASSEMBLY

1. Remove the front cover.

2. Disconnect the ribbon feed links and remove them from the bail end plates.

3. Disconnect the ribbon cam release link and the spring attached to the lug on the tube.

4. Disconnect the link from the cam frame to the bail end plate.

5. Disconnect the ribbon lift link.

6. Loosen the locking nuts and back off the pivot screws to allow the bail assembly to drop free.

RIBBON LIFT MECHANISM

1. Remove the ribbon lift link.

2. Disconnect the ribbon lift guide clevis.

3. Disconnect the color control link

where it is attached to the lever on the color control shaft.

4. Remove the two screws mounting the mechanism to the power frame. The mechanism may then be slipped to the right and out of the machine.

RIBBON LIFT GUIDE

Remove the ribbon lift guide by disconnecting its clevis from the lift lever. The lift guide may then be removed from the top of the typewriter.

Shift Mechanism

SHIFT CAM

Remove the shift cam by the same procedure outlined for the spacebar cam.

SHIFT PUSHER AND LEVER ASSEMBLY

1. Remove the rear cover.
2. Remove the auxiliary hairpin spring.
3. Remove the retainer by removing the two screws that mount it to the power frame.
4. Disconnect the pusher link.
5. Disconnect the operating link from the actuating lever.
6. Disconnect the spring on the actuating lever.
7. Remove the pusher and lever assembly by removing its pivot screw. A hole in the side frame provides access to this screw.

MODIFICATIONS AND ATTACHMENTS

THE FOLLOWING units and contacts are used on one or more of the EAM adaptations of the IBM Model B1 Electric Typewriter. The machine type or types using these modifications are indicated in parentheses. If the modification is an optional feature on a particular machine type, the abbreviation, opt., will follow the machine number.

Keylever Interlocks (Type 824-826, 868, 884)

It is not necessary to lubricate the interlock rollers periodically. How-

ever, if the rollers do not move freely and cause a tightness in the keyboard, apply IBM 6 sparingly.

For adjustments (Figure 60), use the following procedure:

1. Loosen the adjustable stops at each end of the front guide comb. Position both stops so that a keylever in the middle of the guide comb is centered in the guide comb slot.
2. Maintain adjustment number 1 and move the adjustable stops to allow the thickest keylever to pass between the rollers without binding. Lock the screws in the adjustable stops.
3. The interlocks must prevent the depression of two keylevers at the same time. Test by holding a key button down all the way and striking other key buttons including the space-

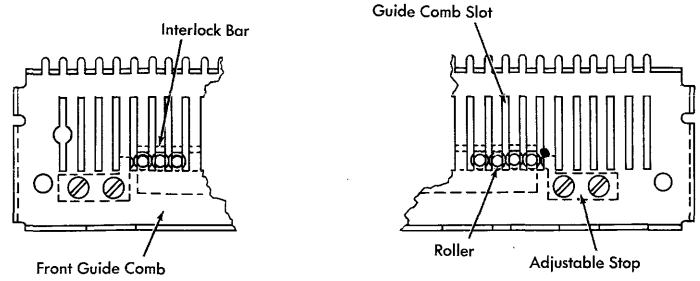

Figure 60. Keylever Interlocks Adjustment

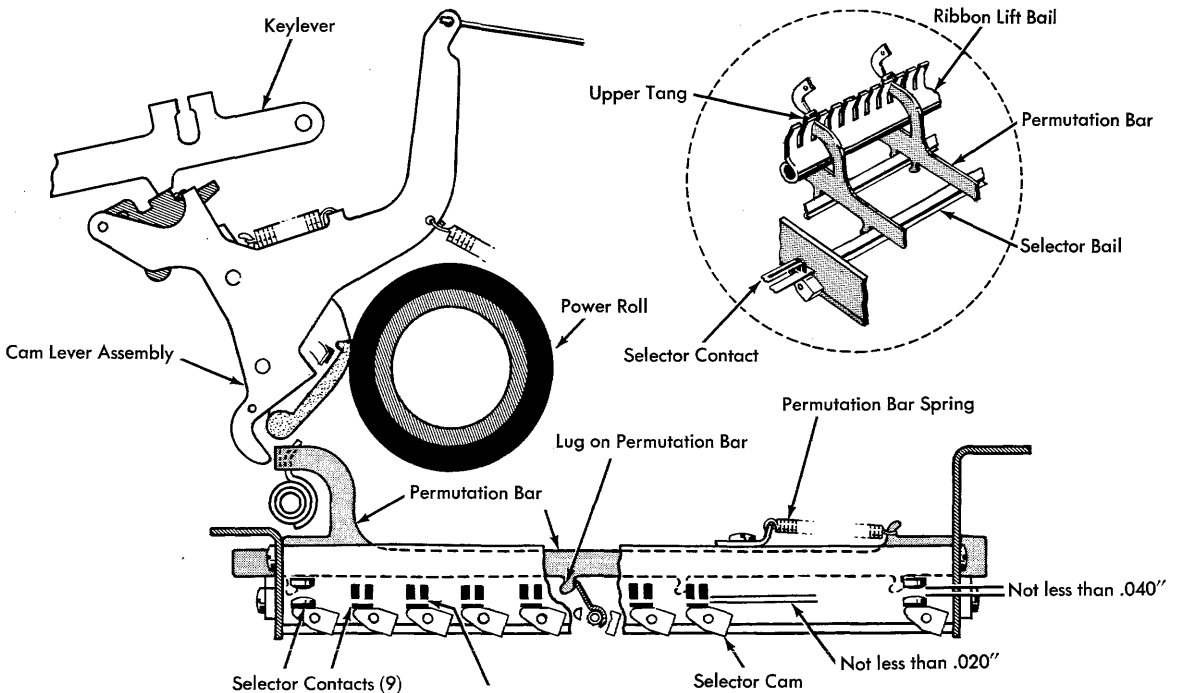

Figure 61. Selector Unit—Bail Type

bar. None of the cams should trip after the one released by the depressed keylever.

4. If two key buttons can be depressed together, the adjustable stops must be positioned closer together.

Selector Unit (Bail Type, Type 884)

Use IBM 6 for the 3-month lubrication of the permutation bars at front and rear guide combs, and selector bail pivot points.

For adjustments (Figure 61), proceed as follows:

1. The selector unit is positioned for about $\frac{1}{32}$ " clearance between the upper tangs of the permutation bars and the letter cam assemblies during factory assembly. It is then dowelled in place.

2. Check all permutation bars and selector bails for freedom of operation. Make sure all permutation bars will readily restore to their maximum forward limit of travel (in rest position). Make sure all selector bails will follow

the permutation bars during restoration. The selector bails should have some end play at their pivot points. Proper duration of the selector bail contacts is important. It is especially important in the case of contacts 1 and 12 since these two contacts actually time the impulses to the punch circuits. Binds in the selector unit mechanism or in the typing mechanism can cause improper duration of the selector bail contacts, even though the contacts themselves are adjusted properly. Changing the impression setting can affect the duration of these contacts.

3. The tips of all cam levers should line up centrally with the upper tang of each permutation bar. Form the cam levers if necessary.

4. Form the stationary straps of the beryllium copper contacts so that the contacts (2, 3, 4, 5, 6, 7, 8) make when a typebar has traveled $\frac{1}{2}$ of the distance to the platen. Check with a meter and do not reduce the air gap to less than .020".

5. Form the stationary straps of the bail contacts 1 and 12 (tungsten contacts) so that they make when the typebar is $\frac{2}{3}$ of the distance to the platen. Use a meter and do not reduce the air gap to less than .040".

If the contact support bracket is removed from the right side of the selector unit, the bracket should be repositioned to cause the contacts to make relative to typebar travel as described in the two previous adjustments. The four mounting screws should be locked in place after the support bracket and contacts are properly positioned.

For removal (Figure 62), use the following procedure:

1. Remove the two dowel pins in the selector unit.

2. Remove the two rear holding screws in the selector unit.

3. Unhook the release lever link from the left-hand end of the ribbon lift bail.

4. Loosen the two front mounting

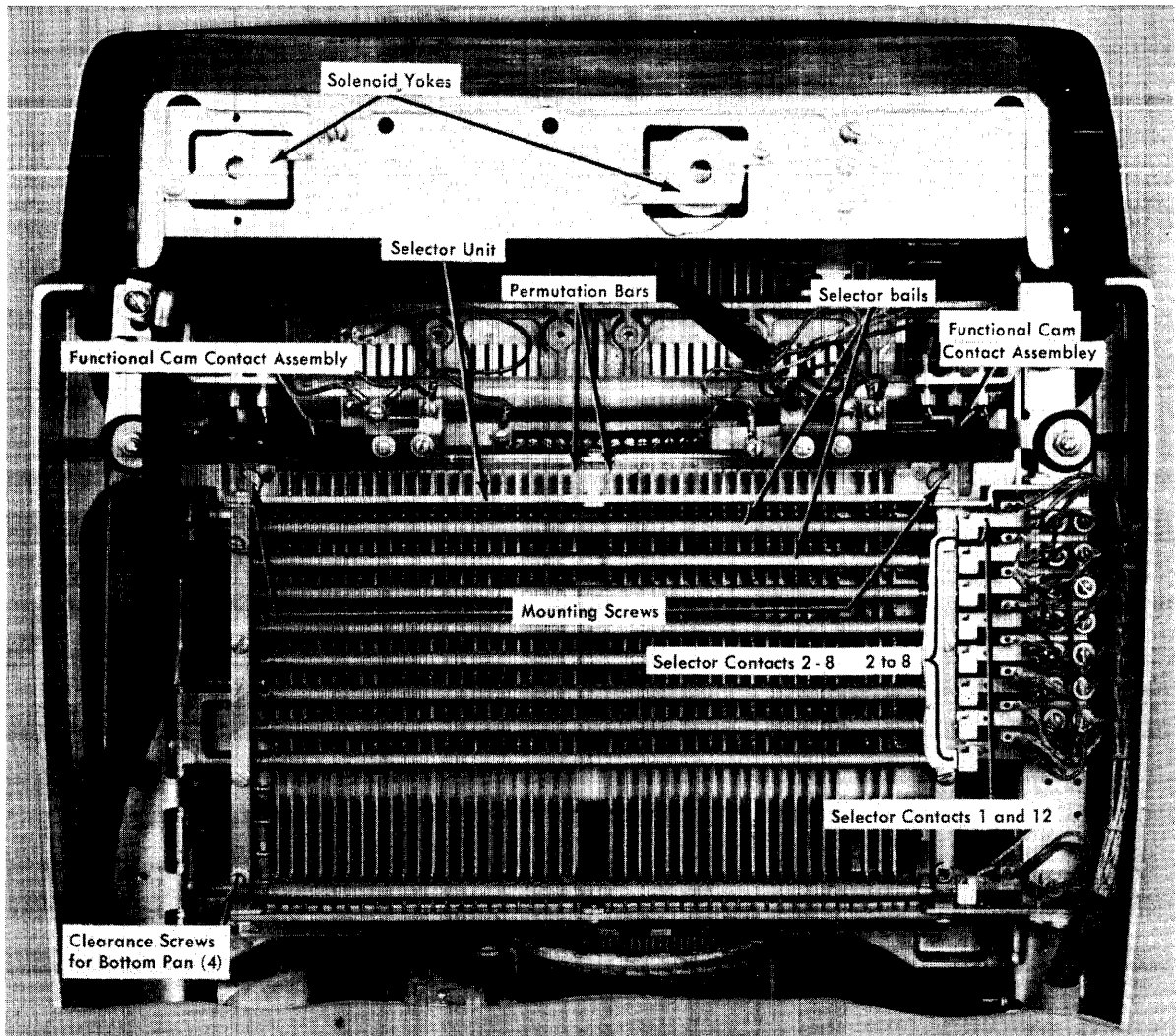

Figure 62. Bottom View of Selector Unit—Bail Type

screws in the selector unit, holding the unit as you do so.

5. Pivot the ribbon lift bail out far enough to allow the upper tangs of the permutation bars to pass down behind the bail. Be careful not to lose or break the ribbon lift bail spring on the left end of the bail.

6. Lower the selector unit down and out.

Selector Unit (Contact Type, Type 824-826, 868)

Use IBM 17 for the 6-month lubrication of the contact surface of cam levers and contact actuating levers.

The procedure for adjustments (Figure 63) is as follows:

1. The selector unit is adjusted by its two mounting screws to provide a clearance of .001" to .005" between the tips of the cam levers and the contact actuating levers.

2. Form the operating straps for a slight pressure on the actuating levers.

3. Form the N/O strap for .030" air gap.

4. The letter cam contacts should make when the typebar is 1/2 of the way to the platen as a result of steps 2 and 3.

The removal procedure is as follows (Figure 64):

1. Loosen the three mounting screws and move the unit to the rear of the machine.

2. Pull the ribbon lift link to the rear of the machine to rotate the ribbon vane and allow the cam contact actuating levers to clear the vane. It

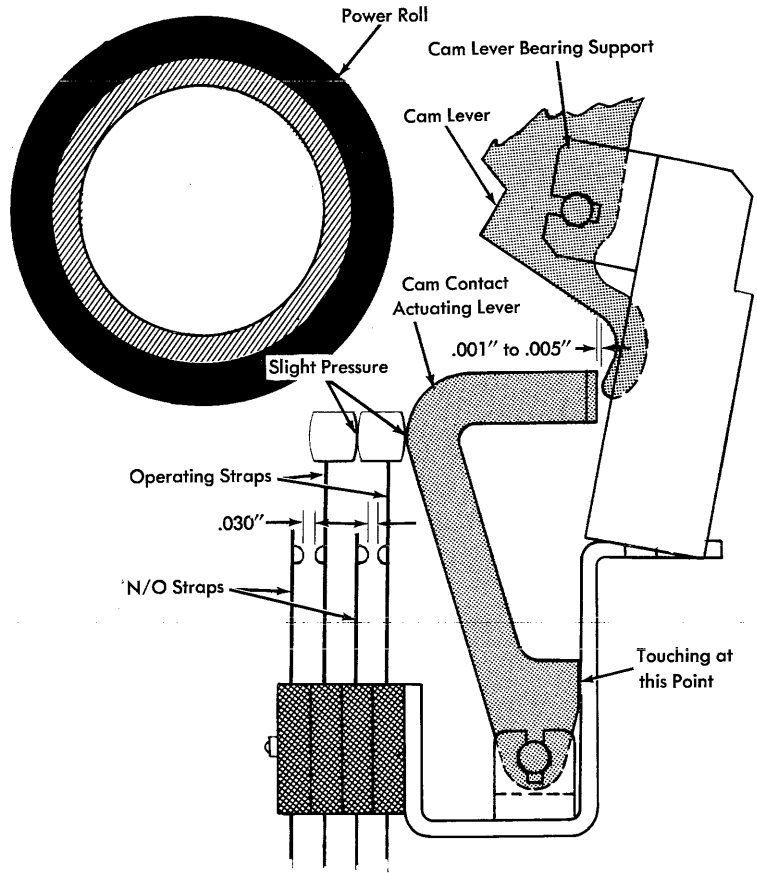

Figure 63. Selector Unit—Contact Type

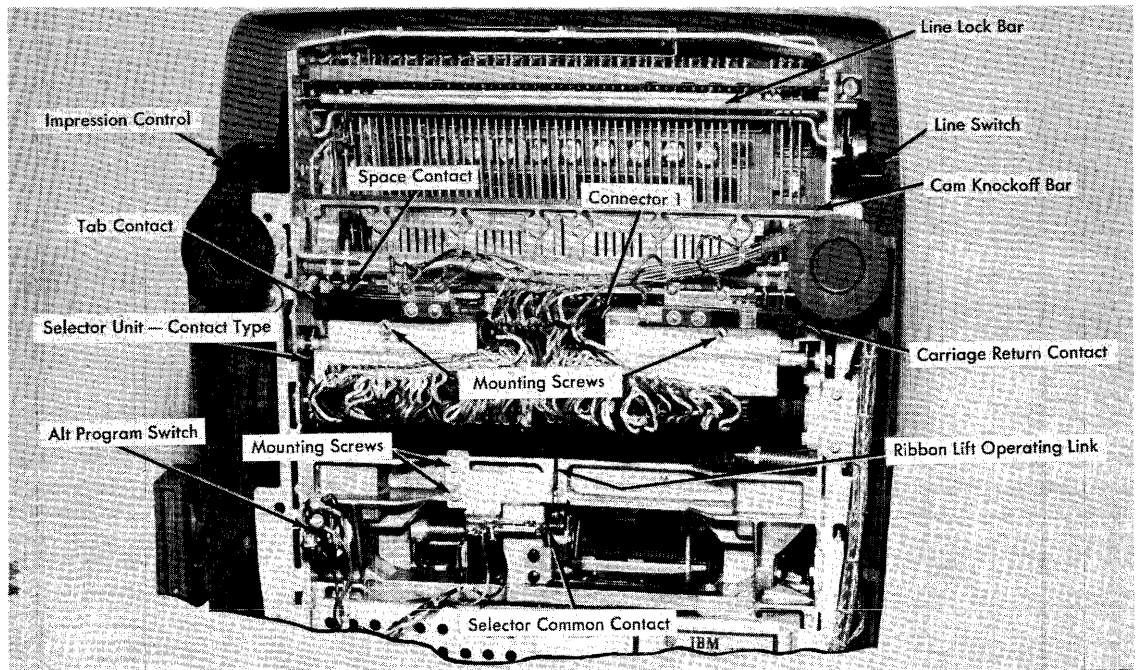

Figure 64. Bottom View of Selector Unit—Contact Type

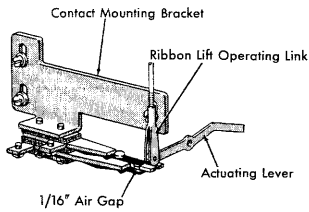

Figure 65. Selector Common Contact

may be necessary to unfasten the clevis from the release lever of the ribbon feed cam.

Selector Common Contact (Type 824-826, 868)

Make the following adjustments (Figure 65):

1. Position the contact mounting bracket to give a rise of $\frac{1}{32}$ " when a typebar contacts the platen.

2. Form the operating strap support to give an air gap of $\frac{1}{32}$ " when the contact is normal.

Check to see that the common contact makes when a typebar is about $\frac{3}{4}$ of the distance from the type rest to the platen as a result of these adjustments.

Functional Cam Contacts (Type 824-826, 868, 884)

Before adjusting the cam contacts (Figure 66), be sure that the functional cams are adjusted for proper clearance with the power roll.

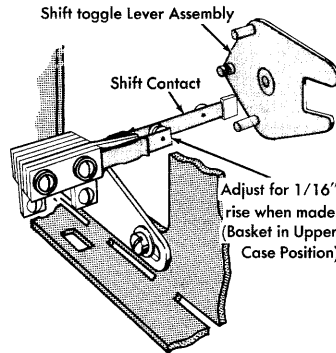

Figure 67. Shift Contact

1. Align all the contacts.
2. Loosen the three screws in the contact support and position it so that the operating straps of the N/O backspace and spacebar contacts just touch the nylon actuators. Lock the three screws. If necessary, the operating strap supports may be formed to obtain this adjustment.
3. Form the N/O strap supports to give an air gap of $\frac{1}{16}$ " on all contacts except carriage return. The air gap of the carriage return contact should be held to $\frac{1}{32}$ ". When the preceding adjustments are correctly made, all contacts should have a noticeable rise when the functional cam is rotated to its high point.

The functional cam contact bar is removed by removing its three mounting screws. Replace the bar so that all the operating straps just contact their nylon actuators.

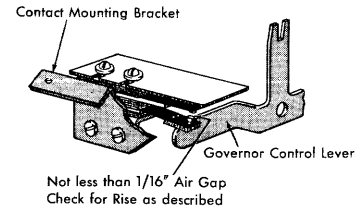

Figure 68. Tab Contact

Shift Contact (Type 824-826)

Use the following procedure for making adjustments (Figure 67).

1. Position the contact support bracket to provide $\frac{1}{16}$ " rise when the type basket is shifted to the upper case.

2. Form the operating strap to provide a $\frac{1}{16}$ " air gap when the basket is shifted to the lower case.

Tab Contact (Type 866, 868, 884, 824-826 opt.) See Figure 68.

Check the rise of the tab contact in the following manner:

1. Latch the tab lever by hand.
2. Allow the carriage to move about two inches to fully extend the tab governor pawl and hold the carriage at that position.
3. With the tab lever still latched, force the left end of the tab lever to the rear a small distance. The N/O strap should follow the operating strap $\frac{1}{4}$ " before the contacts open.

Form the contact straps to obtain this condition and allow $\frac{1}{16}$ " air gap.

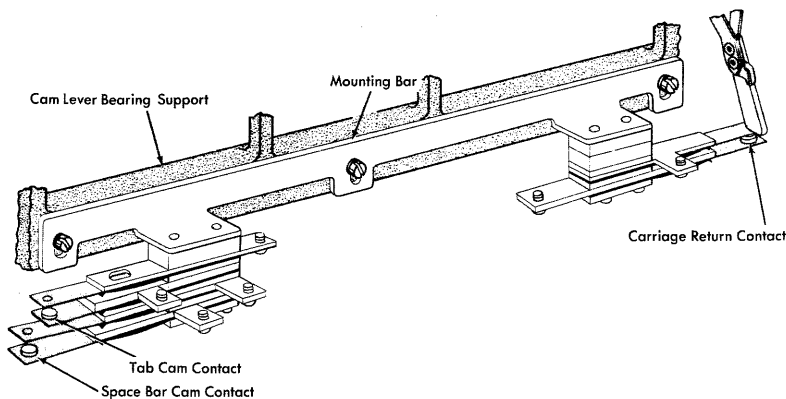

Figure 66. Functional Cam Contact

