



Personal Wheelwriter®
Typewriter 6781
Operator's Guide

First Edition (March 1988)

The following paragraph does not apply to the United Kingdom or any country where such provisions are inconsistent with local law:

INTERNATIONAL BUSINESS MACHINES CORPORATION PROVIDES THIS PUBLICATION "AS IS" WITHOUT WARRANTY OF ANY KIND, EITHER EXPRESS OR IMPLIED, INCLUDING, BUT NOT LIMITED TO, THE IMPLIED WARRANTIES OF MERCHANTABILITY OR FITNESS FOR A PARTICULAR PURPOSE. Some states do not allow disclaimer of express or implied warranties in certain transactions, therefore, this statement may not apply to you.

This publication could include technical inaccuracies or typographical errors. Changes are periodically made to the information herein; these changes will be incorporated in later editions of the publication. IBM may make improvements and/or changes in the product(s) and/or the program(s) described in this publication at any time.

Publications are not stocked at the address below. For copies, contact your IBM Authorized Dealer.

You can send comments or suggestions using the form in the back of this book. If the form has been removed, simply address your comments to the IBM Corporation, Dept. F98/962-3, 740 New Circle Road N.W., Lexington, KY 40511, USA. Information you supply may be used by IBM without obligation. You may, of course, use it yourself. Necessary changes will be made in later editions of the manual.

References to IBM products, programs, or services do not imply that IBM intends to make them available outside the United States.

© Copyright International Business Machines Corporation 1988. All Rights Reserved.

FCC Notice

The IBM Personal Wheelwriter® Typewriter 6781 generates and uses radio frequency energy. If the typewriter is not installed and used in accordance with the installation instructions, operating instructions, and service manual, it may interfere with radio or television reception. This typewriter has been tested and found to comply with the limits for a Class B computing device pursuant to Subpart J of Part 15 of FCC rules, which are designed to provide reasonable protection against such interference when operated in a residential area.

If this typewriter interferes with radio or television reception, which can be determined by switching the typewriter off and on, the user is encouraged to try one or more of the following:

- Move the receiving antenna on the radio or television.
- Relocate the typewriter in relation to the radio or television.
- Plug the typewriter into a different electrical outlet from the radio or television.

If necessary, consult your IBM Authorized Dealer. If anyone other than an IBM Authorized Dealer modifies the typewriter and it causes interference, the user is responsible for correcting the interference.

Safety Information

This machine has additional insulation which provides extra protection against the risk of electric shock and does not rely on grounding. This machine has a nongrounding-type (2-wire) power cord because grounding is not necessary.

For continued protection against the risk of electric shock and personal injury:

- Connect the machine only to an outlet of the correct voltage. The voltage your machine will accept is indicated on the machine.
- Make sure the machine is turned off before you connect or disconnect the power cord or interconnecting cables.
- Do not use the machine in an area where it can become wet.
- Keep hair and personal articles away from moving parts in the machine to avoid the possibility of getting them caught.
- Refer service or repair to qualified service personnel.
- There may be some increased risks of electric shock and personal injury during disassembly and servicing of this machine. Professional service personnel should understand this and take necessary precautions.
- The safety features of some parts may not always be obvious. Therefore, replacement parts must have the identical or equivalent characteristics as the original parts.
- The maintenance information for this machine has been written for the professional service person and is not intended to be used by others.

About Your Typewriter

This typewriter was designed to provide you with excellent typing quality and make the tasks you have to perform more enjoyable.

Special functions such as Correction, Automatic Centering, Continuous Underlining, Right Flush, and Bold Print are all designed to make your typing jobs easier, faster, and more productive.

The special set of keys located to the right of your keyboard allows you to move quickly and easily along the paper to any location—up, down, left, or right.

This typewriter is like having several typewriters in one. You can type in either pica, elite, or micro elite. Also, you have a choice of single, one-and-one-half, double, or triple spacing.

You can enhance the use of your IBM Personal Wheelwriter® by adding the following available options:

- Printer Option
- Soundhood
- Spell Check

A carrying case and a dust cover are also available from your IBM Authorized Dealer.

Contents

Operating the Typewriter	1-1
Parts of the Typewriter	1-1
On/Off Switch	1-2
Code Key	1-3
Line Space Key	1-3
Page End Indicator	1-4
Inserting Paper	1-5
Paper and Carrier Movement Keys	1-6
Removing Paper	1-6
Printwheels	1-7
Margin/Pitch Scale	1-8
Impression Control	1-9
Typematic (Repeat) Keys	1-9
Cardholder	1-10
Margins	1-11
Tabs	1-12
Shift and Lock Keys	1-13
Caps Key	1-13
Correction Memory	1-14
Erasing Manually	1-15
Automatic Carrier Return	1-16
Required Spaces	1-17
One-Half Backspace	1-17
Centering	1-18
Underlining	1-19
Indenting	1-20
Right Flush	1-21
Subscripts and Superscripts	1-22
Special Characters	1-23
Bold Print	1-23
Decimal Tabulation	1-24
Summary of Code Key Functions	1-25
Alternate Keyboards	2-1
Using Alternate Keyboards	2-2
Keyboard Alphabetic Cross-Reference	2-3
Keyboard Charts	2-5
Problem Determination	3-1

Problem Determination Index	3-2
Beeper and Light Signals	3-3
Erasing Problems	3-5
Print Quality Problems	3-6
Typing Problems	3-7
Spell Check Problems	3-8
Reference	4-1
Ordering Procedures for IBM Supplies	4-1
Typestyle Samples	4-1
Printwheel Application Recommendations	4-4
Removing the Printwheel	4-6
Installing the Printwheel	4-7
Ribbon Cassette System	4-8
Removing the Cassettes	4-8
Installing the Cassettes	4-9
Ribbon Application Recommendations	4-10
Batteries	4-12
Care and Maintenance	4-15
Serial Number	4-15
Appendix. Spell Check Option	A-1
Introduction	A-1
Using the Spell Check Option	A-3
Supplemental Dictionary	A-4
Changing the Sound of the Spelling Beeper	A-5
Index	X-1

Operating the Typewriter

Parts of the Typewriter

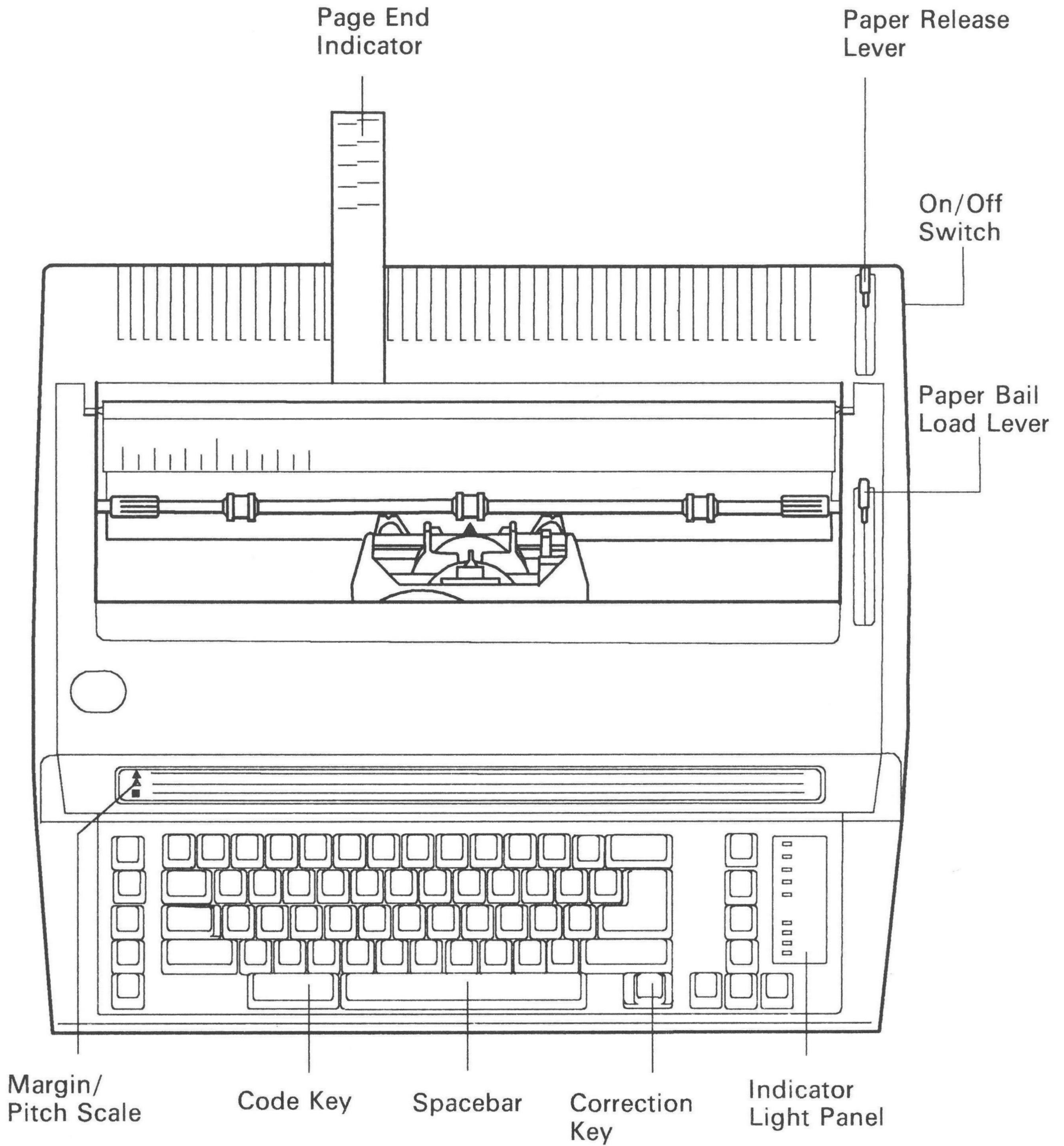

On/Off Switch

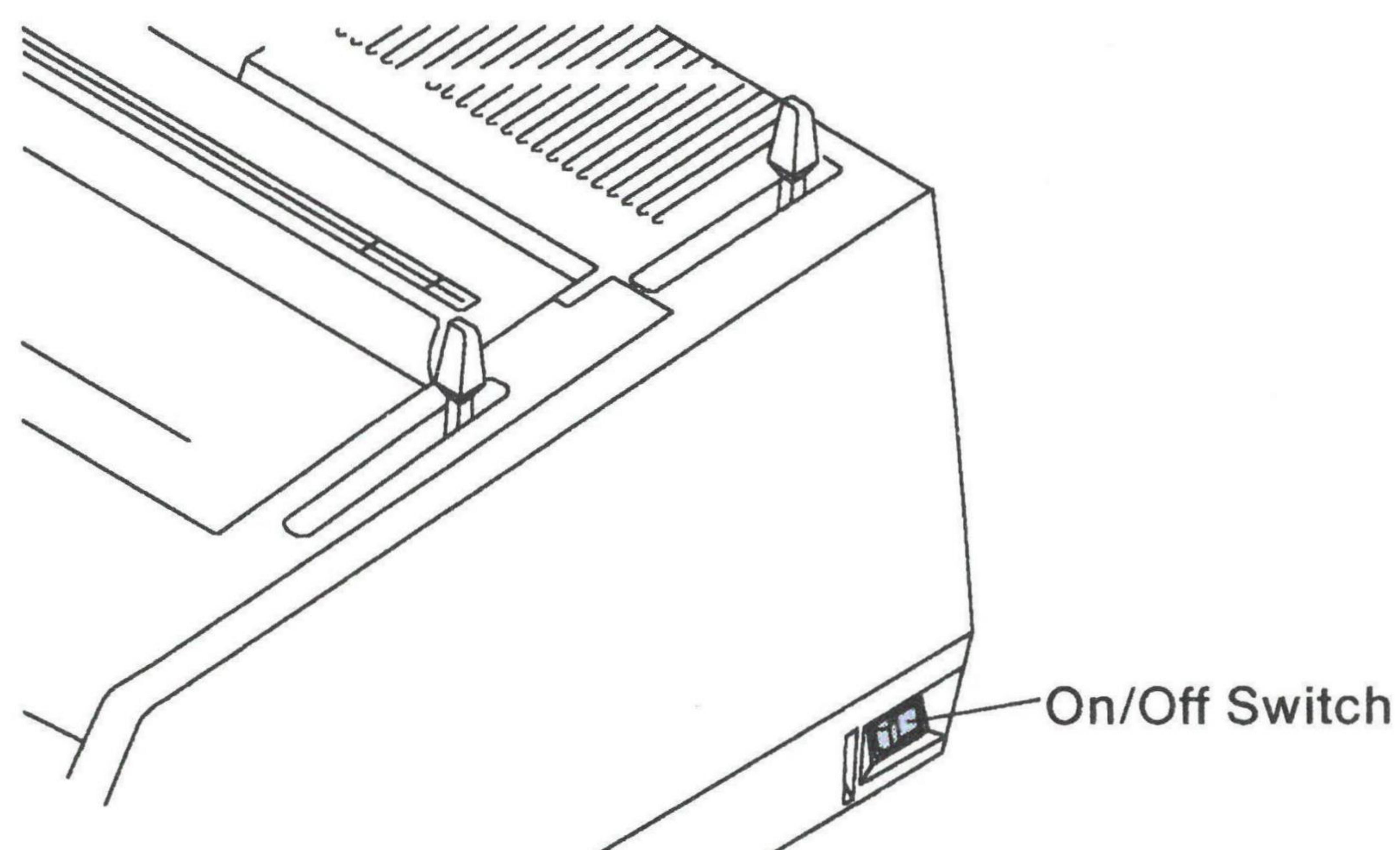

To turn the typewriter on and off, press the switch located on the right side of the typewriter.

If the **Line Space** lights flash when the typewriter is turned on, the batteries are low. See “Batteries” on page 4-12 for information.

Code Key

The **Code** key is used with other function keys. The **Code** key and the keys with green lettering can be used to print special characters and turn functions on and off.

When you use two keys at a time, hold down **Code** while you press the function key or special character key. For example, to turn on Bold Print, hold down **Code** while you press **B (Bold)**.

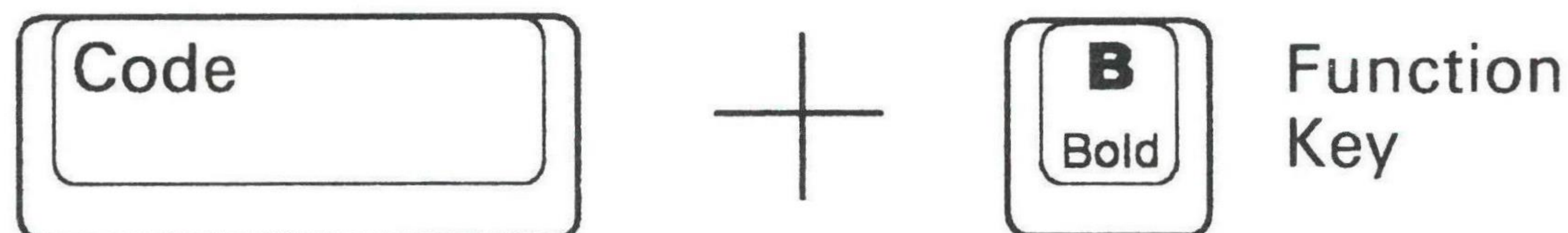

See "Summary of Code Key Functions" on page 1-25 for a listing of the keys that are used with the **Code** key.

Line Space Key

To set line spacing, hold down **Code** while you press **Reloc (Line Space)** until the desired **Line Space** light is on. You can choose from four line space settings: 1, 1½, 2, or 3.

- Always set the line spacing to the desired setting before you begin to type.
- The line space setting returns to 1 when the typewriter is turned off.

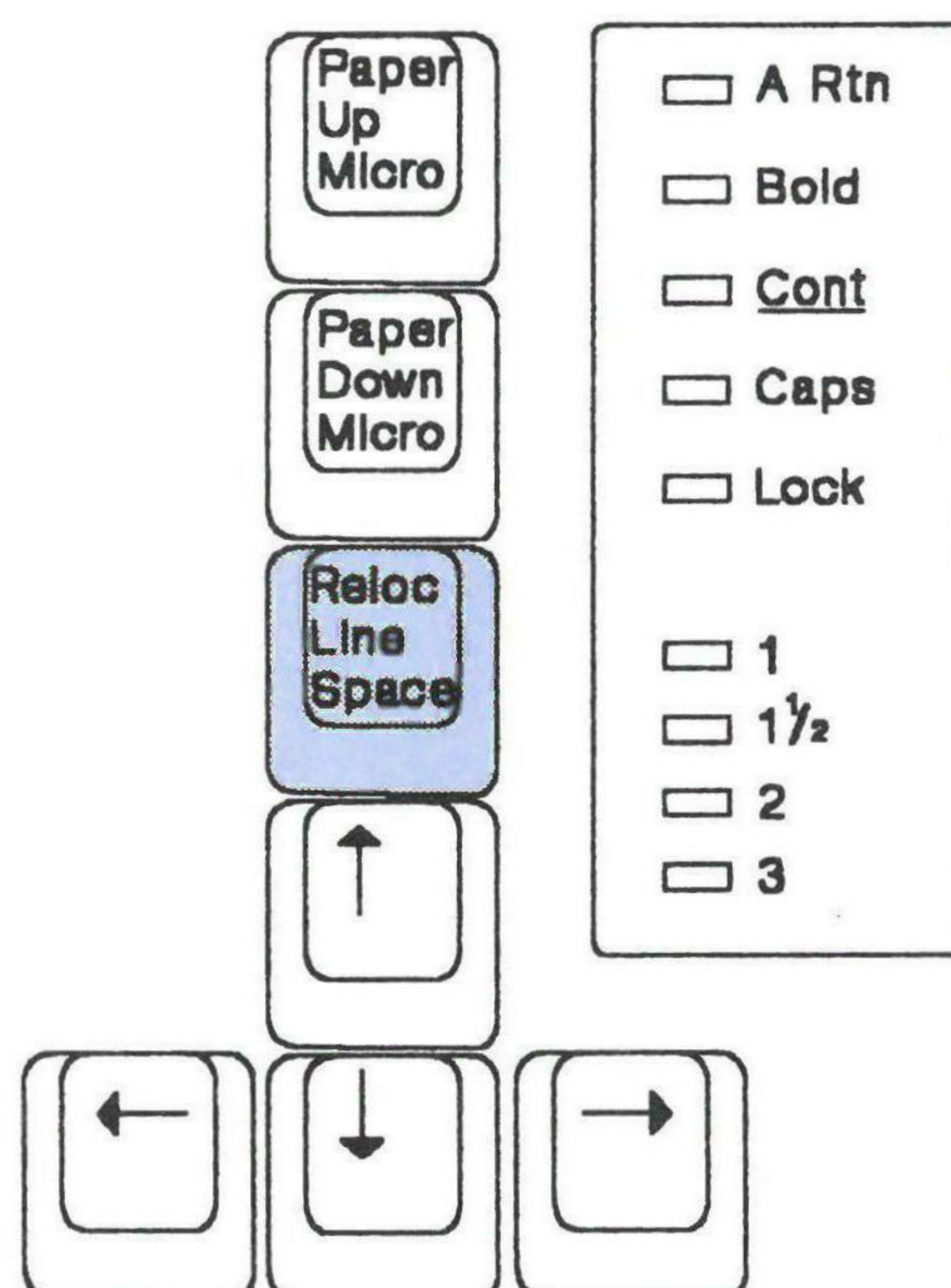

Page End Indicator

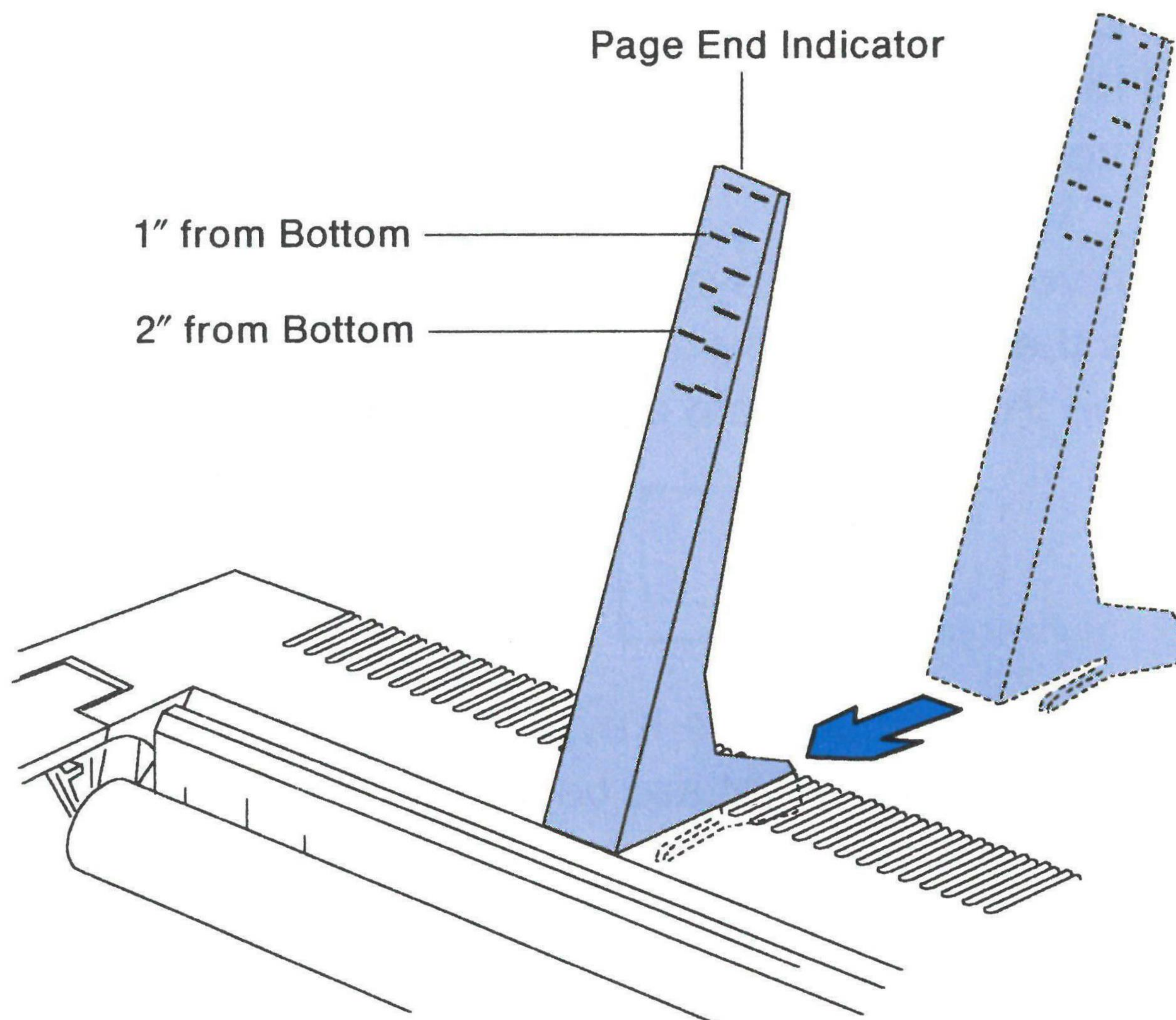

Insert the page end indicator by sliding the indicator into the air vents on top of the typewriter. Make sure you slide the indicator all the way forward.

- As you type, the top of the paper comes out of the typewriter and moves up to the lines on the indicator.
- The lines on the indicator tell you approximately how much space remains to the bottom of 27.9 cm (11 in) paper.
- The left side of the indicator is marked in inches. The right side is marked in centimeters.

Inserting Paper

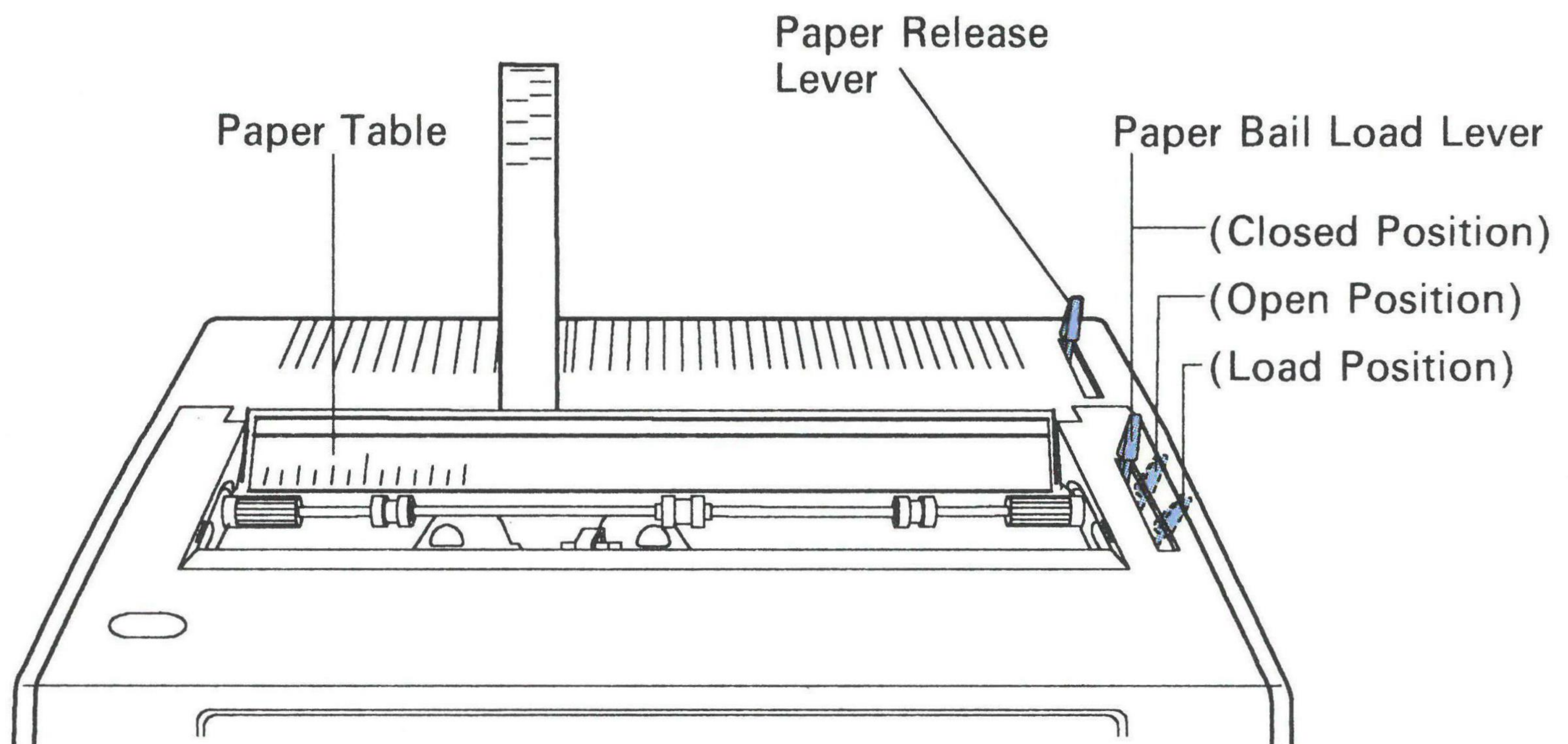

The typewriter has a **Paper Bail Load Lever** to assist you in loading the paper semiautomatically. The lever has three positions: closed, open, and load.

1. Make sure the typewriter is turned on and the *Paper Release Lever* is all the way to the back of the typewriter.
2. Align the paper in the typewriter using the indicator marks on the paper table.
3. Pull the **Paper Bail Load Lever** all the way forward to the load position. When the paper begins to feed, let go of the **Paper Bail Load Lever**.
 - The paper feeds to the top margin position.
4. Push the **Paper Bail Load Lever** all the way back until the paper bail holds the paper against the platen.

Note: When inserting loose carbon copies (five maximum), pull the *Paper Release Lever* forward and pull the **Paper Bail Load Lever** to the open position. Insert the copies, then push both levers all the way back.

Paper and Carrier Movement Keys

The paper and carrier movement keys allow you to move rapidly across the paper. You now have the advantage of express movement both right and left as well as top to bottom on a page of text.

Moving the Paper

- Press **Paper Up** or **Paper Down** once to move the paper up or down one-half line.
- Hold down **Code** while you press **Paper Up (Micro)** or **Paper Down (Micro)** to move the paper up or down one micro-index (1/48") for precise alignment.
- Press ↑ or ↓ to move the paper down or up as determined by the line space setting.

Moving the Carrier

- Press and hold ← to move backward quickly on the same typing line. When this key is held down, the carrier moves backward until it reaches the left margin.
- Press and hold → to move forward quickly on the same typing line.

Using Relocate

- Press **Reloc** to move the carrier to the end of the writing line after making corrections on the current line. After you move to another line and type a character, Relocate only causes the printwheel to spin. The correction memory is cleared.

Removing Paper

1. Pull the **Paper Bail Load Lever** toward you to the open position. (See the illustration on page 1-5.)
2. Pull the *Paper Release Lever* toward you, then lift the paper out of the typewriter.
3. Push the *Paper Release Lever* and the **Paper Bail Load Lever** all the way back to the closed position.

Printwheels

Your typewriter uses an IBM Cartridge Printwheel II. Printwheels are available in many different typestyles and pitches. See “Typestyle Samples and Pitches” on page 4-2 for a list of typestyles. To order supplies, see “Ordering Procedures for IBM Supplies” on page 4-1.

Automatic Pitch Selection

You can choose from three different pitches as shown in the chart below.

The correct pitch is automatically selected by the typewriter when you install a printwheel. The pitch determines the number of characters typed per horizontal inch.

The following table summarizes printwheel pitches with print examples of each pitch.

Pitch (Type Size)	Characters Per Inch	Pitch Symbol	Print Example
10P (Pica)	10	▲	This is a sample.
12P (Elite)	12	△	This is a sample.
15P (Micro Elite)	15	■	This is a sample.

Lines Per Vertical Inch

A printwheel for 10 or 12 pitch prints six lines per vertical inch. A printwheel for 15 pitch prints eight lines per vertical inch.

Margin/Pitch Scale

The typewriter has three margin scales: 10▲, 12△, and 15■. When typing, use the scale line that matches the pitch symbol on your printwheel.

- For 10▲ pitch (pica) type, use the upper scale.
- For 12△ pitch (elite) type, use the middle scale.
- For 15■ pitch (micro elite) type, use the lower scale.

An orange pointer moves along the scale on your typewriter to show the position of the next character to print.

The margin/pitch scale also contains centering marks. When the left edge of the paper lines up with zero on the margin/pitch scale:

- marks the approximate center of paper 215.90 mm (8.50 in) wide.
- marks the approximate center of paper 210 mm (8.27 in) wide.

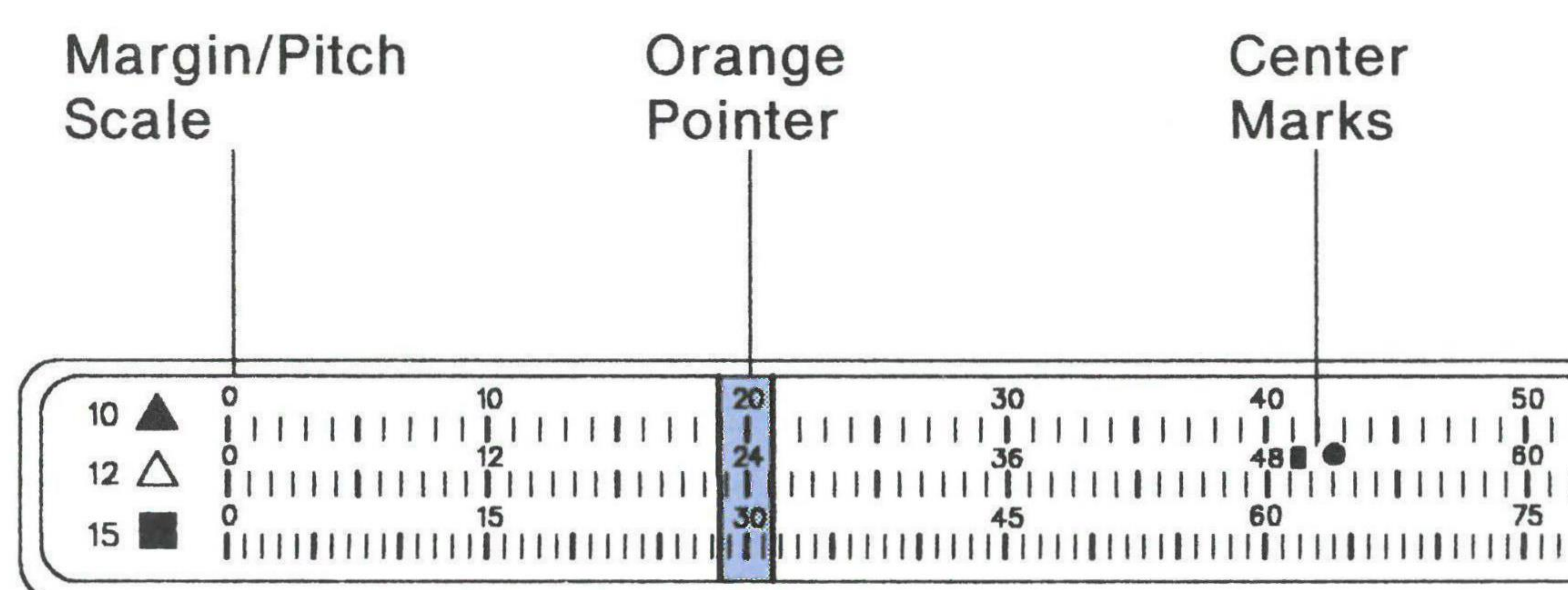

Impression Control

There are two impression settings: normal and high impression. To select high impression, hold down **Code** while you press **Q (Impr)**.

If you repeat this operation, the impression is set back to normal.

The impression setting returns to normal when you turn the machine off and back on. The difference between normal impression and high impression is most apparent when using several carbons.

Typematic (Repeat) Keys

Typematic keys have both single and repeat action. Press the desired typematic key lightly for a single action or hold down for more than one-half second for repeat action.

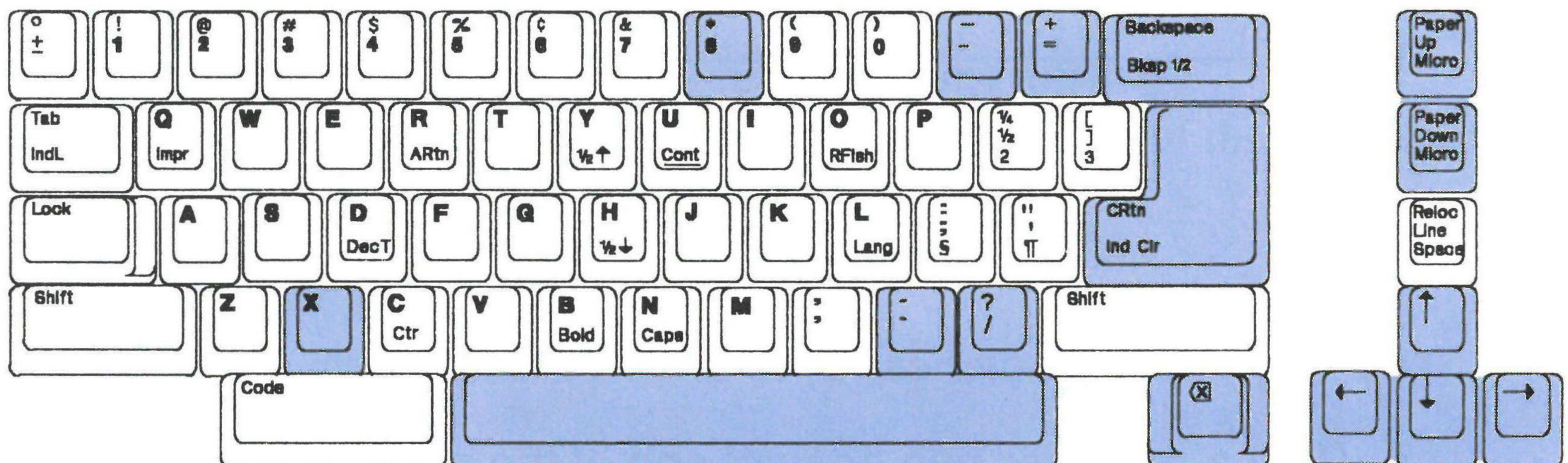

Cardholder

The cardholder holds paper, cards, and envelopes against the platen.

The printwheel pointer shows the position where the next character will print.

The top red portion (A) of the cardholder indicates the base of the printing line. As the typewriter prints, the bottom of each character rests just above the line, as shown below.

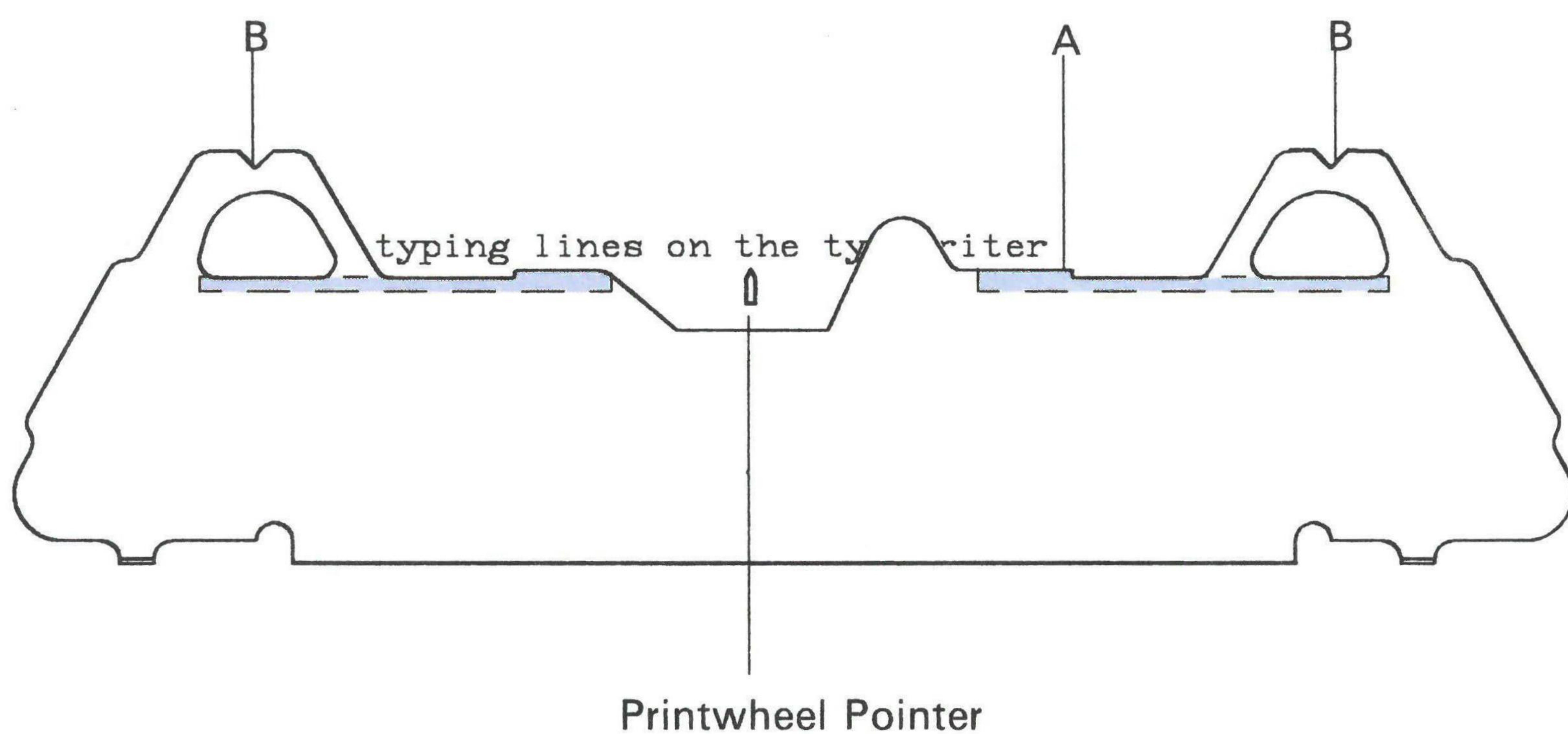

You may use the notches (B) to draw vertical lines.

- Hold a pencil or pen against one of the notches while pressing **Paper Up**, **Paper Down**, ↓, or ↑ to move the paper.

Margins

Setting Margins

1. Press **Spacebar**, **Backspace**, ←, or → to move the carrier to the desired position, then press **LMar** to set the left margin.
 - The old margin is automatically eliminated when a new margin is set.
2. Move the carrier to the desired position, then press **RMar** to set the right margin.
 - The old margin is automatically eliminated when a new margin is set.
 - The carrier does not lock at the right margin. This allows you to type or space through the right margin. The typewriter will beep five spaces before you reach the right margin.

Note: Margins are saved when your typewriter is turned off.

Margin Release Key

1. Press **MarRel** to release the left margin.
2. Press **Backspace** or ← to move to the left of the margin.

Tabs

Setting a Tab

1. Press **Spacebar**, **Backspace**, ←, or → to move the carrier to the desired tab position.
2. Press **TSet** to set a tab.

Clearing a Tab

1. Press **Tab** to move to the tab stop you want to clear.
2. Press **TClr** to clear the tab.

Clearing All Tabs

1. Hold down **TClr** while you press **CRtn**.
2. Release the keys.
 - The carrier moves to the left margin and all tabs are cleared.
 - The carrier can be at any position when you clear all tabs.

Helpful Hints

- Permanent tabs exist at the left and right margins and at the right limit. These tabs cannot be cleared.
- You can set up to 28 tabs on your typewriter.
- Tabs are saved when your typewriter is turned off.

Shift and Lock Keys

Use the **Shift** and **Lock** keys to type uppercase characters. The **Lock** key allows you to type continuously in uppercase (all capitals) without pressing the **Shift** key for each capital letter.

1. Press the **Lock** key to type in uppercase.
 - The **Lock** light comes on.
2. Press either the left or right **Shift** key to return to normal typing.
 - The **Lock** light goes off.

Note: The Caps function cancels the Lock function when you turn Caps on.

Caps Key

If you need to type numbers and capital letters together, use the **Caps** key.

Caps is similar to Lock. When the Caps function is on, *only* the alphabetic letters (a through z) are capitalized. The Caps function eliminates the shifting back and forth between uppercase and lowercase. All letters print in uppercase, and all numbers and punctuation marks print in lowercase.

Hold down **Code** while you press **N (Caps)** to turn Caps on or off.

- Caps is on when the **Caps** light is on.

Note: The Lock function cancels Caps when you turn Lock on.

Correction Memory

Your machine has a correction memory that allows you to erase and correct automatically on the line you are typing. You can also correct manually on previous lines you have typed.

Clearing Correction Memory

The correction memory is cleared if you:

- Turn your typewriter off
- Type any character or tab on another line
- Change the printwheel
- Type any character after **Bksp**^{1/2} on the line you are typing.

Erasing on the Line You Are Typing

To erase the character you have just typed, press the **Correction** key one time, and the character is automatically erased.

Press and hold down the **Correction** key to erase characters repeatedly.

Erasing Farther Back on the Same Line

1. Position the carrier over the incorrect character.
2. Press the **Correction** key to erase the incorrect character.
3. Type the correct character.
4. Press **Reloc** to return the carrier to the original typing position.

Erasing Manually

You may want to erase characters that are not on the current writing line. To do this, you must use manual erase.

1. Move the carrier to the incorrect word. Use the Micro paper movement keys for precise alignment, if necessary.
 - *If* the characters were typed in bold print, turn on Bold Print before erasing.
 - *If* the characters were underlined, turn on Underline before erasing.
2. Press the **Correction** key.
 - The printwheel spins, but the character is *not* erased.
3. Type the character to be erased.
 - The character is erased.
4. Type the correct character.

After you make manual corrections and type any character on another line, Relocate only causes the printwheel to spin. The correction buffer has been cleared.

Automatic Carrier Return

With Automatic Carrier Return on, you do not have to press **CRtn** when you reach the right margin. When the beep sounds as the carrier moves toward the right margin, continue typing. The carrier returns to the next line automatically when you end a word by typing a space near the right margin. By using Automatic Carrier Return, you can type faster because you do not have to think about line endings.

For some typing jobs, you will want to turn Automatic Carrier Return off. For example, do not use Automatic Carrier Return when typing tables, columns of numbers, or forms.

Turning Automatic Carrier Return On and Off

1. Hold down **Code** while you press **R** (**ARtn**) to turn Automatic Carrier Return on.
 - The **ARtn** light comes on.
2. Hold down **Code** while you press **R** to turn Automatic Carrier Return off.
 - The **ARtn** light goes off.

Note: Automatic Carrier Return is turned off when your typewriter is turned off.

Helpful Hints

- You can continue to type while the carrier returns to the left margin. You can type as many as 32 characters during carrier return.
- If you need to end a line before the right margin, press **CRtn**. Some examples of short lines are: date, inside address, salutation, short last line in a paragraph, closing, and short headings.
- The carrier will not return automatically if you space across the line with the **Spacebar** or type characters without spacing.

Required Spaces

Typing required spaces between words keeps them together if Automatic Carrier Return is on. When you type a required space, the carrier does not automatically return. Look at the examples below for typing words with required spaces.

Examples

Words typed *with* required spaces:

Lorraine's birthday is January 22, 1987.

Code + Spacebar | Code + Spacebar

Words typed *without* required spaces:

Lorraine's birthday is January
22, 1987.

Typing a Required Space

1. When the beep sounds as you reach the right margin, finish the word you are typing.
2. Hold down **Code** while you press **Spacebar**.
3. Type the next word.
4. Continue typing required spaces between words that must be kept together.
5. After you type the last word on the line, press **Spacebar** to return the carrier.

One-Half Backspace

Using **Bksp** $\frac{1}{2}$ moves the carrier one-half space backward.

If you leave a character out of a word, you can:

1. Move the carrier to the last letter in the incorrect word.
2. Press the **Correction** key repeatedly to erase the incorrect word.
3. Hold down **Code** while you press **Backspace** (**Bksp** $\frac{1}{2}$) to move the carrier back one-half space.
4. Type the correct characters. Correction memory is cleared.

Centering

Words can be centered automatically between the left and right margins or at any point on a line.

Centering between Margins

1. Make sure you have the left and right margins set.
2. Press **CRtn** to move the carrier to the left margin.
3. Hold down **Code** while you press **C (Ctr)**.
 - The carrier moves to the center point between the margins.
4. Type the words you want to center.
 - As you type, the carrier backs up without printing.
 - If you make an error, press the **Correction** key and type the correct character.
5. Hold down **Code** while you press **C**.
 - The words automatically center as they print.

Centering at Any Point on a Line

1. Move the carrier to the desired center point.
2. Hold down **Code** while you press **C**.
3. Type the words you want to center.
4. Hold down **Code** while you press **C**.
 - The words print.

Helpful Hints

- Pressing **CRtn**, **Tab**, or **DecT** also causes the words to print.

Underlining

You can underline words and spaces as you type using Continuous Underline.

Continuous Underline

1. Hold down **Code** while you press **U** (**Cont**) to begin underlining.
 - The **Cont** light comes on.
2. Type the words to be underlined.
 - The words and spaces are underlined automatically as you type.
3. Hold down **Code** while you press **U** to end underlining.
 - The **Cont** light goes off.

Indenting

The Indenting function allows you to set a temporary left margin anywhere. The carrier returns to the temporary left margin until you clear the indent margin. Indenting is helpful for typing blocked indented text or outlines because it saves you the time of tabbing on every line.

Example

Your new typewriter is designed to make typing easier and more enjoyable.

Temporary Left Margin

| For example, centering, underlining,
and indenting are done automatically
on this new typewriter.

|
Code + CRtn

Try using these new functions to help
you with your work!

|
CRtn

1. Type until you reach the *first* line where you want to indent.
2. Press **Spacebar**, **Tab**, ←, or → to move the carrier to the desired temporary left margin position.
3. Hold down **Code** while you press **Tab (IndL)** to set a temporary left margin.
4. Type the indented lines.
 - The carrier returns to the temporary left margin.
5. When you finish typing the indented lines, hold down **Code** while you press **CRtn (Ind Clr)** to clear the temporary left margin.
 - The carrier returns to the original left margin.
 - The temporary left margin is cleared.

Note: The Indenting function can also be used to set a temporary left margin *to the left* of the left margin setting.

Right Flush

The Right Flush function allows you to type text with an even (flush) right margin. Lines can also be typed right flush with any point on the typing line, such as a tab stop.

Typing Right Flush with the Right Margin

1. Make sure you have a right margin set and that the carrier is at the left margin.
2. Hold down **Code** while you press **O (RFlsh)**.
 - The carrier moves to the right margin.
3. Type the characters to be aligned.
 - As you type, the carrier backs up without printing.
 - If you make an error, press the **Correction** key and type the correct character.
4. Hold down **Code** while you press **O**.
 - The characters print flush with the right margin.
 - The Right Flush function is turned off when the words print.

Typing Right Flush with Any Point on a Line

1. Move the carrier point where you want the text to be right aligned.
2. Hold down **Code** while you press **O (RFlsh)**.
3. Type the words you want to be right flush at that point.
4. Hold down **Code** while you press **O**.
 - The characters print flush with the point you chose.
 - The Right Flush function is turned off when the words print.

Helpful Hints

- Pressing **CRtn**, **Tab**, or **DecT** also causes the characters to print.
- The last character printed will be one space to the left of the right margin or the point you chose.

Subscripts and Superscripts

Subscripts are characters typed *below* the writing line (for example, CuSO_4). Superscripts are characters typed *above* the writing line (for example, *Happy Living*⁵).

Typing Subscripts

1. Hold down **Code** while you press **H** ($\frac{1}{2}$ ↓).
 - The paper moves one-half line below the typing line.
2. Type the subscript.
 - The paper moves back to the typing line.

Typing Superscripts

1. Hold down **Code** while you press **Y** ($\frac{1}{2}$ ↑).
 - The paper moves one-half line above the typing line.
2. Type the superscript.
 - The paper moves back to the typing line.

Notes:

1. If you do not want your subscript or superscript underlined, make sure Continuous Underline is off before you type the subscript or superscript.
2. If you need to type several characters as a subscript or superscript, use **Paper Up** or **Paper Down** to position the typing line. Type the characters, then return to the normal typing line. **Paper Up** and **Paper Down** cannot be used to type subscripts or superscripts in a function where words are not printed as you type, such as centering, decimal tab, and typing right flush text.

Special Characters

Your typewriter has four special characters that you can print by using the **Code** key: §, ¶, ², and ³. You can print these characters without changing the printwheel.

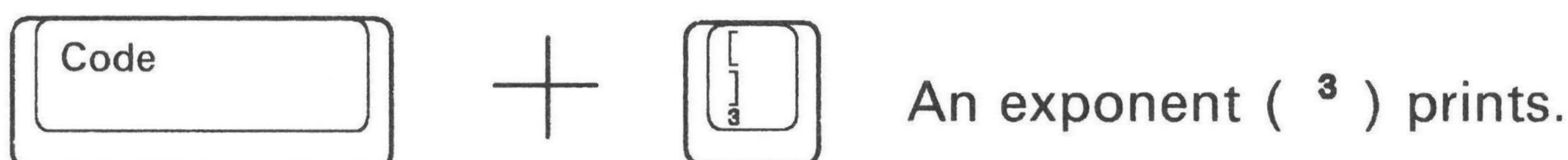
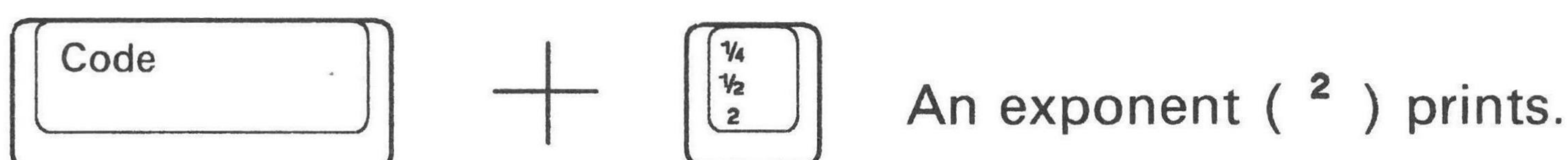

Bold Print

Hold down **Code** while you press **B (Bold)** to turn Bold Print on or off.

- The **Bold** light comes on to indicate that Bold Print is on.
- The characters print in bold as you type.

Note: Bold Print may be used in centering, decimal tab, and right flush text. Bold Print is turned off when you turn the typewriter off. For recommended readability in Bold Print, see "Printwheel Application Recommendations" on page 4-4.

Decimal Tabulation

Use the Decimal Tab function to type numbers in vertical columns. You can align numbers on decimal points or the column's right edge.

Typing Numbers with Decimals

Set Tab Here	Set Tab Here	Set Tab Here	Set Tab Here
234.56	456.79	1.32	1.50
2.87	20.13	.5	45.67

1. Turn Automatic Carrier Return off if it is on.
2. Set a tab for each column.
3. Move the carrier to the left margin.
4. Hold down **Code** while you press **D (DecT)** to move the carrier to the first tab stop.
5. Type the numbers *up to* the decimal point.
 - The carrier moves backward but does not print.
6. Type the decimal point.
 - The number and the decimal point print.
7. Type any characters or numerals after the decimal point.
8. Hold down **Code** while you press **D** to move to the next column.
 - Press **CRtn** after the last column at the end of each line.

Typing Numbers without Decimals



Set Tab Here	Set Tab Here	Set Tab Here	Set Tab Here
26,745	87,453	873	5%
387	3,498	34	234-

1. Repeat steps 1 through 4 above.
2. Type the number and any characters which follow it.
 - The carrier moves backward but does not print.
3. Hold down **Code** while you press **D (DecT)**.
 - The number prints.
 - The carrier moves to the next decimal tab position.
 - Press **CRtn** after the last column at the end of each line.

Summary of Code Key Functions

While holding down the **Code** key, press the key for the special character or function in column 1. Refer to the page listed for more information.

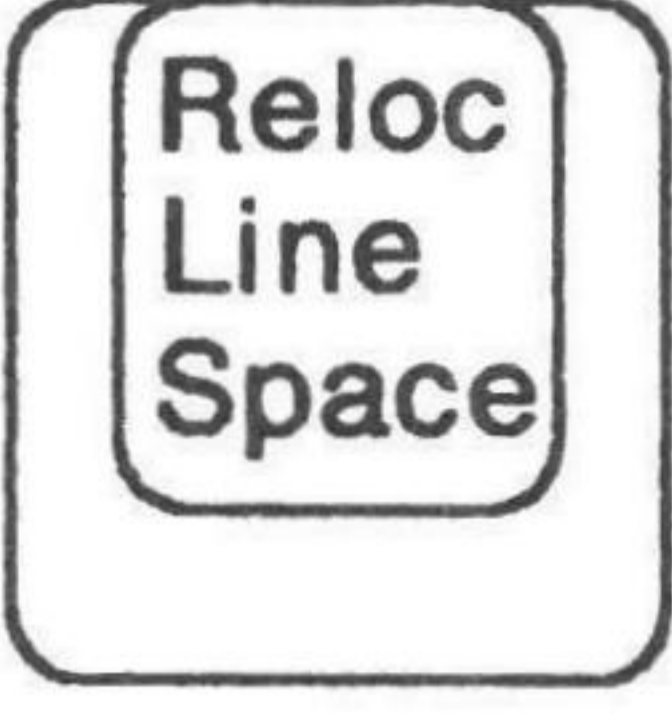
	<p>Automatic Carrier Return Turns Automatic Carrier Return on or off. If Automatic Carrier Return is on, the carrier automatically returns at the right margin. Page 1-16.</p>
	<p>Backspace One-Half Moves the carrier back one-half space so an extra character can be inserted. Page 1-17.</p>
	<p>Bold Prints characters in bold type. Page 1-23.</p>
	<p>Caps Turns Caps on or off. When Caps is on, capital letters, numbers, and punctuation can be typed without shifting. Page 1-13.</p>
	<p>Center Turns Centering on or off. Text can be centered between the margins or at a point on the typing line. Page 1-18.</p>
	<p>Decimal Tab Moves carrier to a decimal tab position. Page 1-24.</p>
	<p>Impression Sets Impression to normal or heavy. Page 1-9.</p>
	<p>Indent (Temporary Left Margin) Indents each line until Indenting is canceled. Page 1-20.</p>
	<p>Indent Clear Cancels Indent and performs a carrier return. Page 1-20.</p>

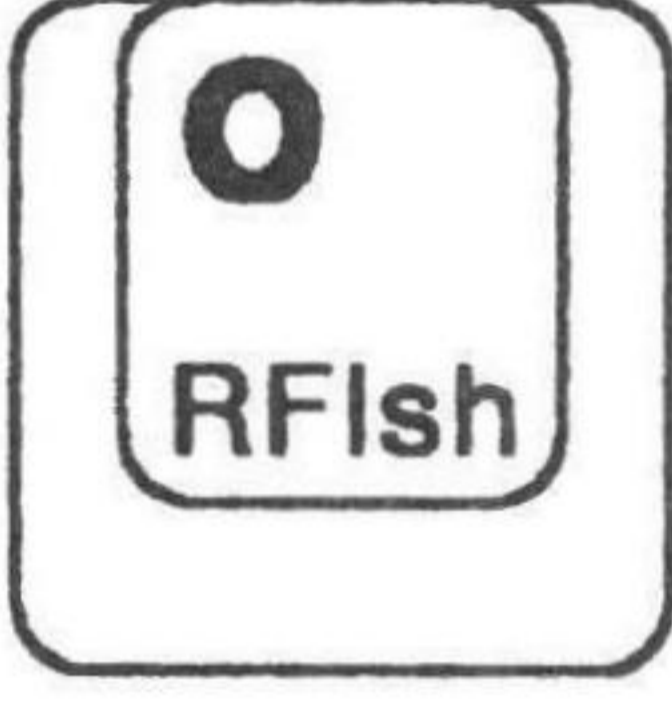
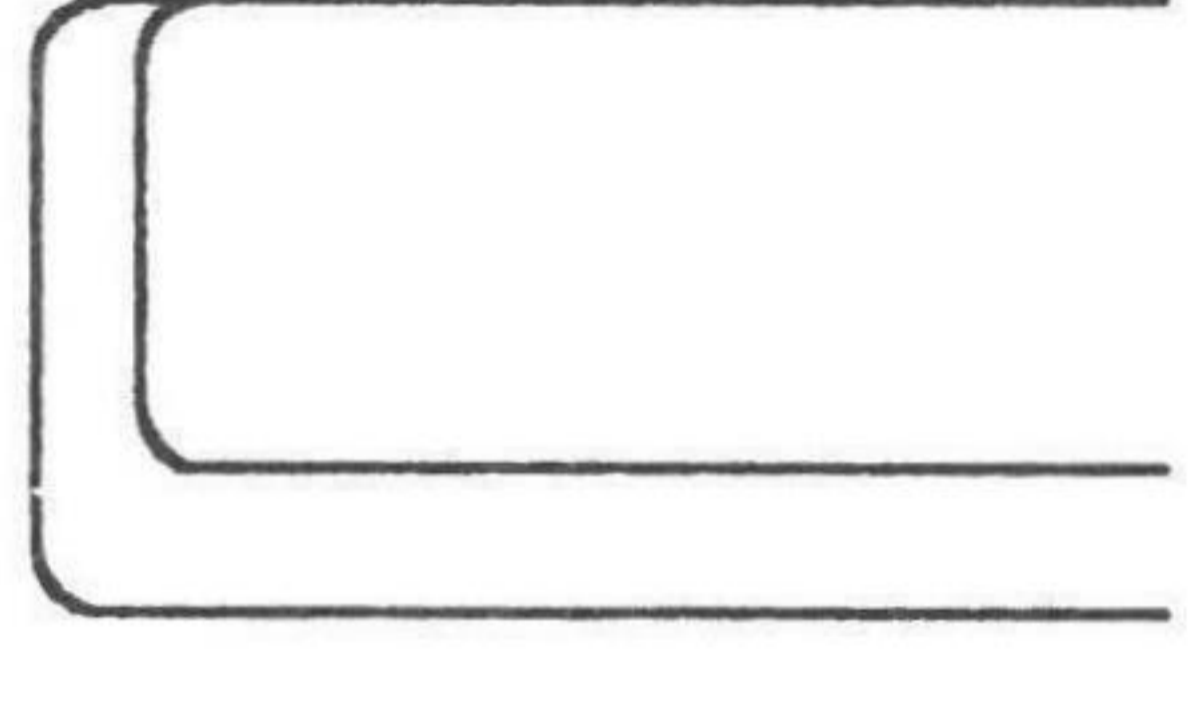
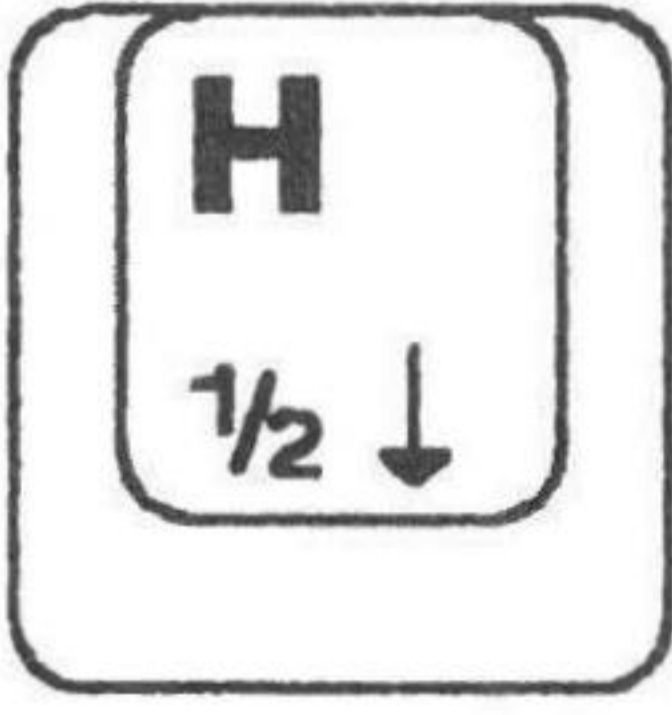
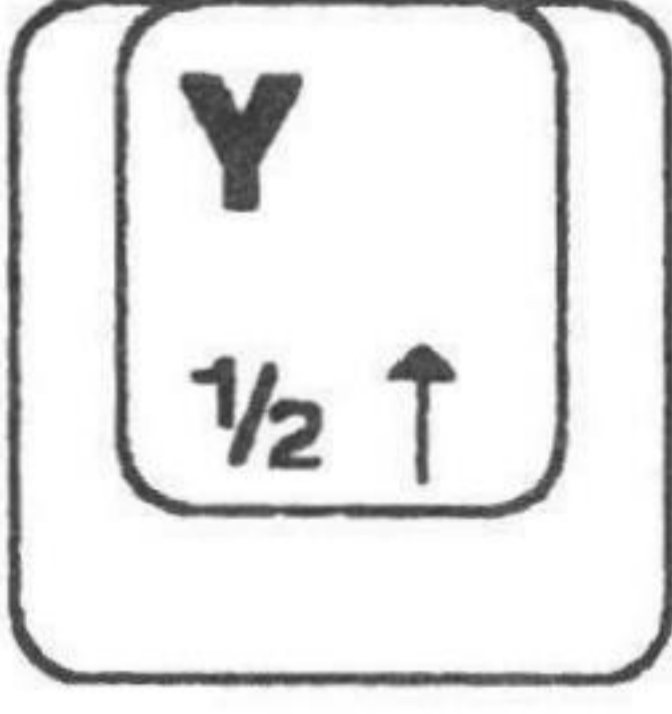
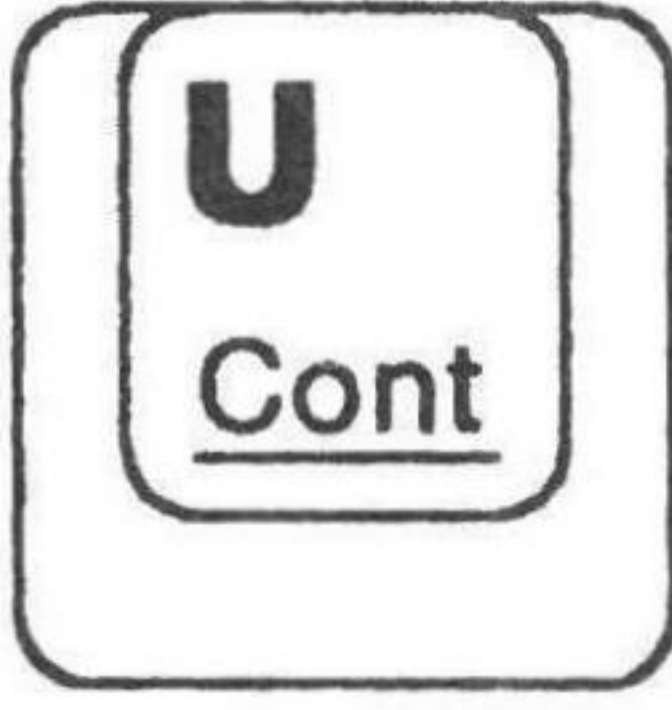
	<p>Language (Alternate Keyboard) Selects alternate keyboard or primary keyboard. The correct printwheel must be installed. Page 2-1.</p>
	<p>Line Space Selects line space settings: 1, 1½, 2, or 3. Page 1-3.</p>
	<p>Paper Down (Micro) Moves paper down one micro-index for precise alignment. Page 1-6.</p>
	<p>Paper Up (Micro) Moves paper up one micro-index for precise alignment. Page 1-6.</p>
	<p>Right Flush Turns Right Flush on or off. Text can be typed flush with the right margin or at any point on the typing line. Page 1-21.</p>
	<p>Space (Required) Keeps words together on the same line when Automatic Carrier Return is on. Page 1-17.</p>
<p>¶, §, ², and ³.</p>	<p>Paragraph Symbol, Section Symbol, and Special Characters (Exponents) Prints these special symbols and characters as shown on the keybuttons. Page 1-23.</p>
	<p>Subscript Prints the next number or character below the typing line. Page 1-22.</p>
	<p>Superscript Prints the next number or character above the typing line. Page 1-22.</p>
	<p>Underlining (Continuous) Turns Continuous Underline on or off. All text and spaces will be underlined automatically. Page 1-19.</p>

Alternate Keyboards

Complete this chapter *only* if you have a printwheel for other languages, ASCII (PC) or Latin Supplemental ISO.

Your typewriter has primary and alternate keyboards. You have already been using your primary keyboard.

- The primary keyboard allows you to type in your own language. Your typewriter automatically sets your primary keyboard to match the keybuttons on your typewriter.
- Alternate keyboards, when used with the appropriate printwheels, allow you to type in other languages such as French and Spanish, or ASCII (PC) and Latin Supplemental ISO.

Matching Printwheels and Keyboards

Each printwheel for alternate keyboards contains characters other than those printed on your typewriter keybuttons. You can access characters of an alternate keyboard by typing a keyboard change called a keyboard identification (ID) number.

The keyboard ID is printed on all printwheels. When more than one set of numbers is shown, the first number is the keyboard ID; for example: 001-008. The keyboard ID for the United States is 001 or 1. Look at the example below.

See the list on page 2-3 for alternate keyboard ID numbers.

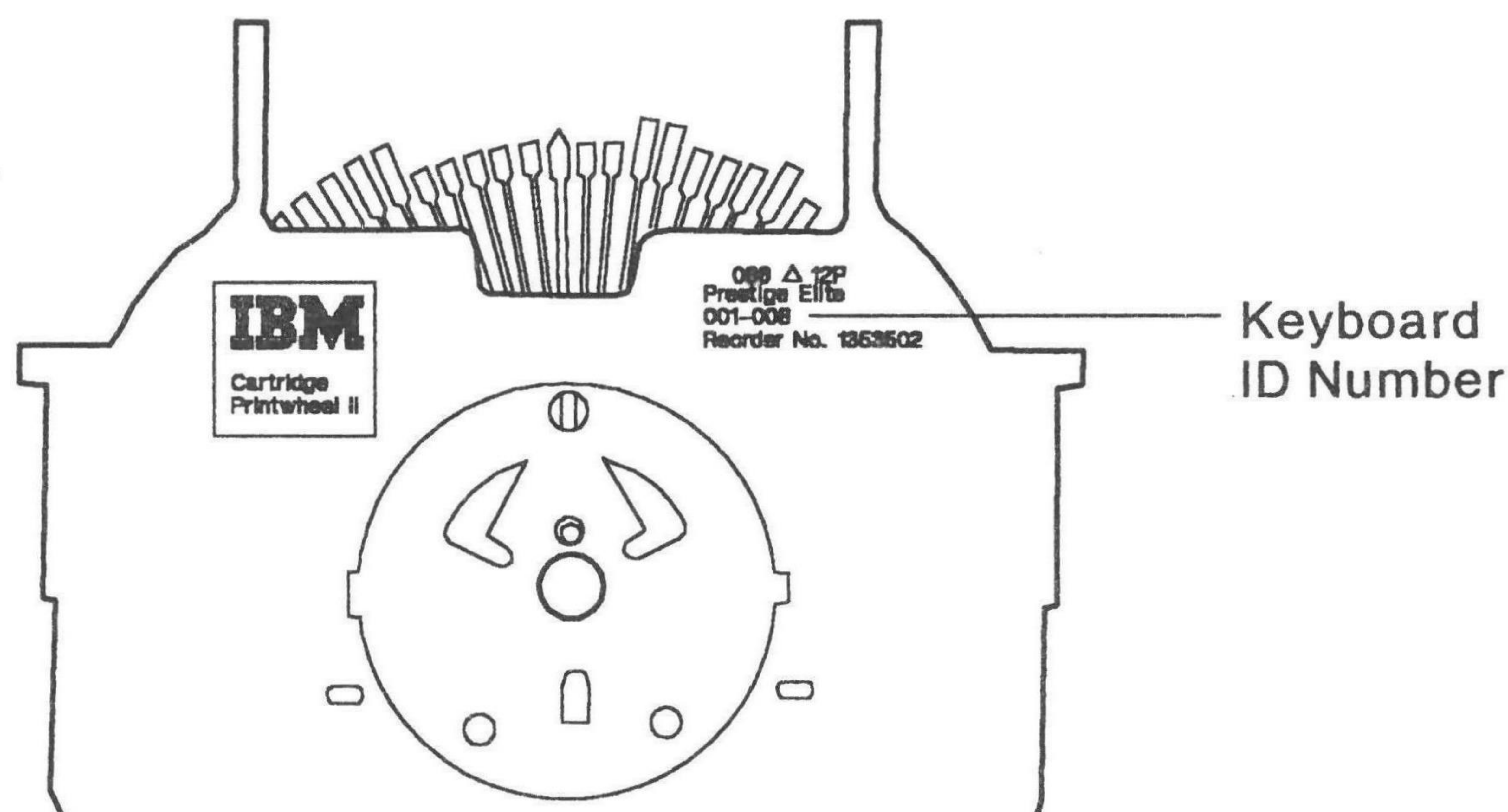

Using Alternate Keyboards

1. Select a keyboard and keyboard ID number for a country or special application from the charts on pages 2-5 through 2-10.
2. Insert the country or special application printwheel.
 - The ID number on the keyboard list should match the number on your printwheel.
3. Hold down **Code** while you press **L (Lang)** and type the keyboard ID; for example: **Code + L + 251**.
 - The keyboard is changed to the alternate keyboard.
4. Find the keyboard chart that matches your keyboard ID and use it to locate the character you want to type.
5. When you finish typing in the alternate keyboard, hold down **Code** while you press **L**.
 - The keyboard returns to the primary keyboard.
6. Remove the country or special application printwheel and install the 001 primary printwheel.

Helpful Hints

- Many alternate keyboards contain accent marks which are dead keys that print without advancing the carrier to the next space. To type accent marks over alphabetic characters:
 1. Type the accent mark first.
 - The carrier will not advance to the next space if the accent mark is a dead key.
 2. Type the alphabetic character.
- The alternate keyboard is not saved when you turn the typewriter off.

Keyboard Alphabetic Cross-Reference

Keyboard Name	ID Number	Page
ASCII (PC) ¹	103	2-10
Australia	1	2-5
Austria	29	2-5
Belgium	251	2-10
Brazil	61	2-8
Canada (Bilingual)	39	2-6
Canada (English)	1	2-5
Denmark	59	2-7
Finland	53	2-7
France	251	2-10
Germany (West)	29	2-5
Greece (Greek)	219	2-10
Greece (Latin)	207	2-10
Italy	41	2-6
Japan (English)	69	2-8
Latin America	25	2-5
Latin Supplemental ISO ²	99	2-8
Netherlands	43	2-6
New Zealand	1	2-5

¹ Personal computer keyboard chart.

² Special application keyboard chart.

Keyboard Alphabetic Cross-Reference (continued)

Keyboard Name	ID Number	Page
Norway	55	2-7
Portugal	63	2-8
South Africa	81	2-9
Spain	70	2-9
Sweden	53	2-7
Switzerland (French)	49	2-6
Switzerland (German)	51	2-7
Turkey	79	2-9
United Kingdom	67	2-8
United States	1	2-5

Keyboard Charts

The following keyboard charts show the keyboard ID numbers and the character locations. The charts are arranged numerically by Keyboard ID numbers.

Keyboard ID 1 — Australia, Canada (English), New Zealand, United States

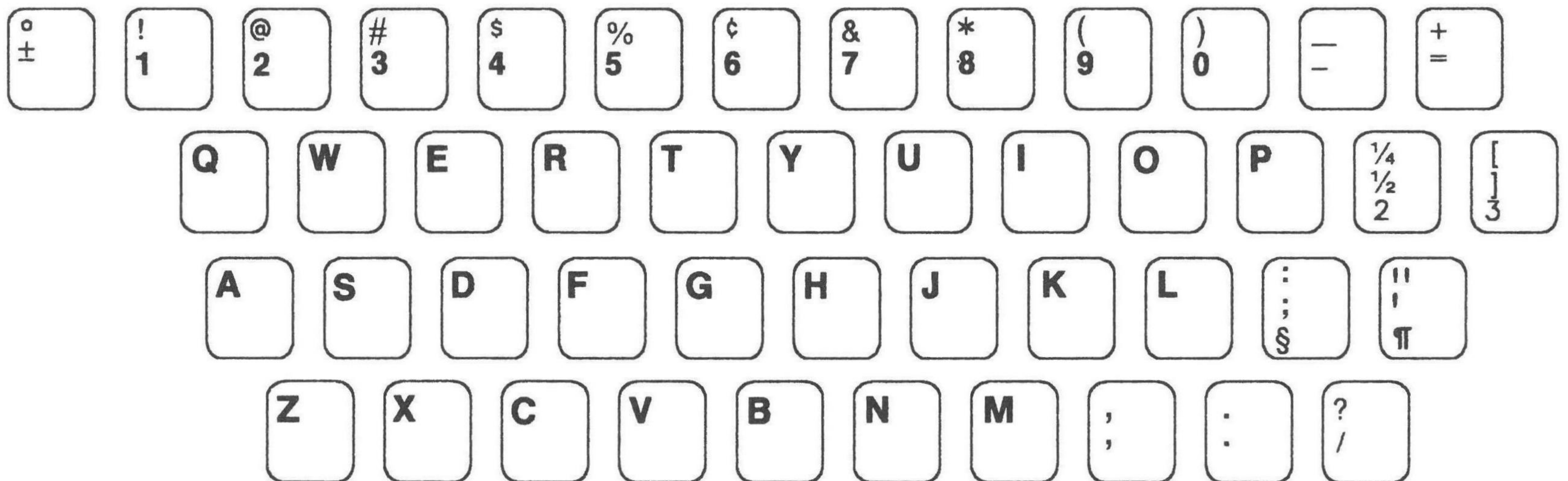

Keyboard ID 25 — Latin America

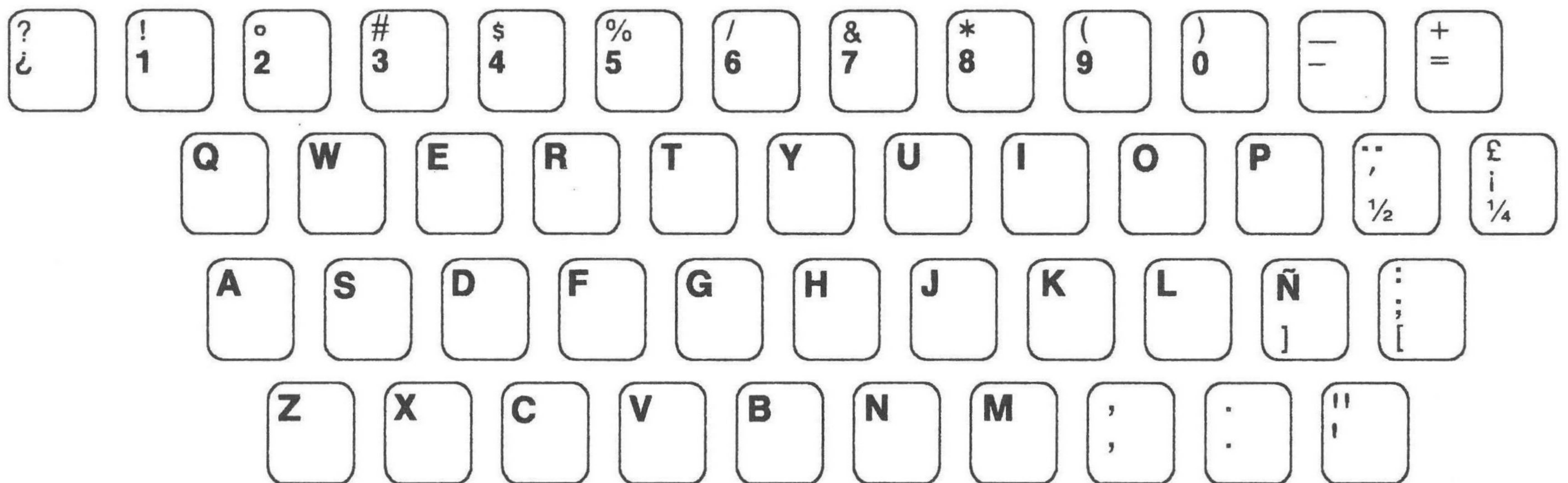

Keyboard ID 29 — Austria, Germany (West)

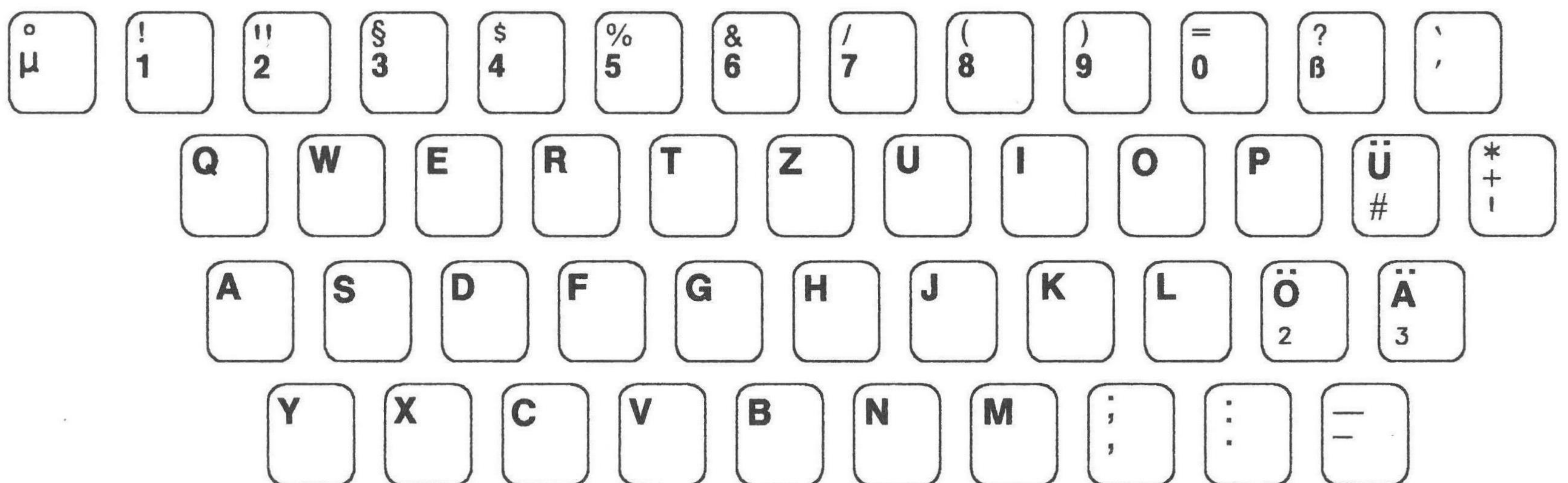

Keyboard ID 39 — Canada (Bilingual)

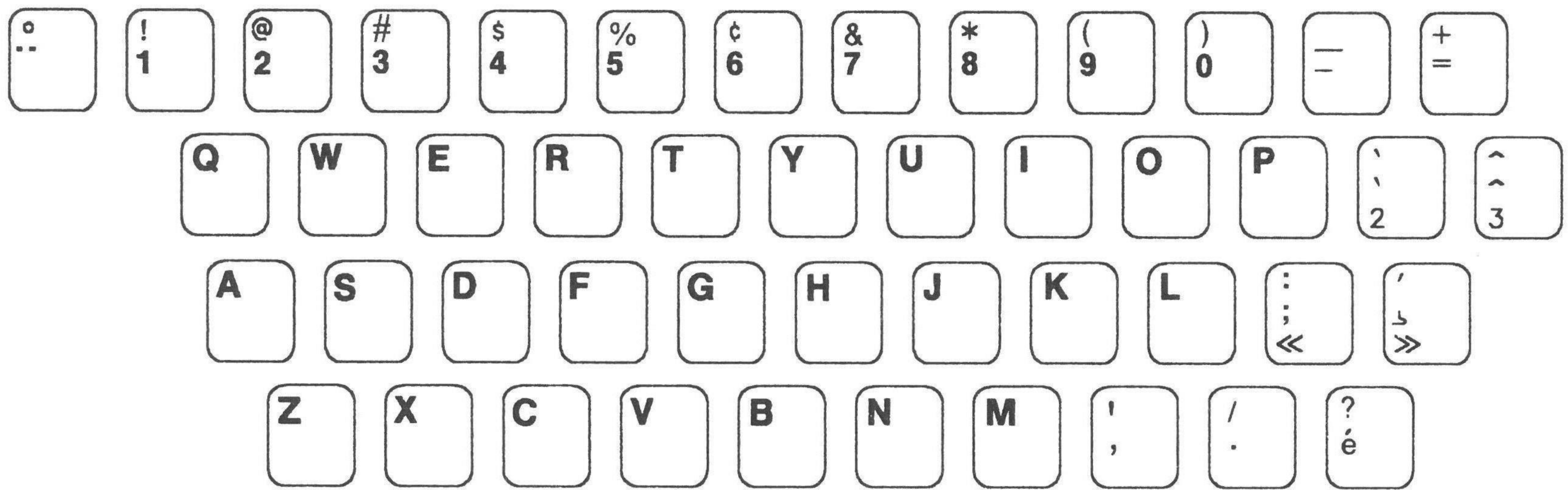

Keyboard ID 41 — Italy

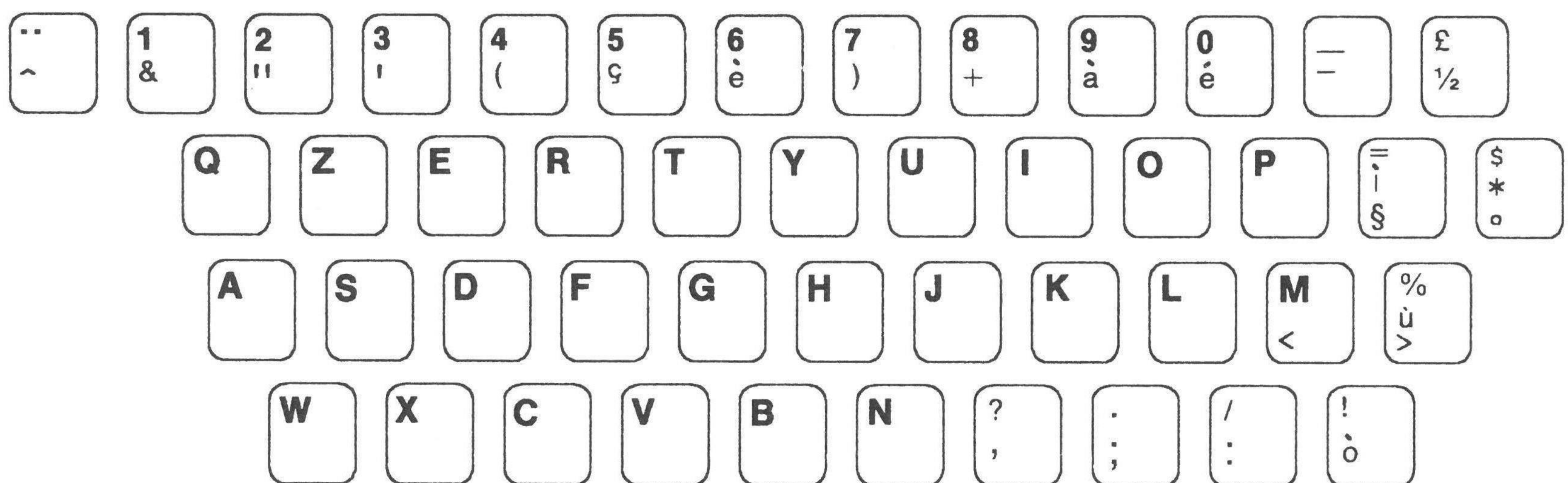

Keyboard ID 43 — Netherlands

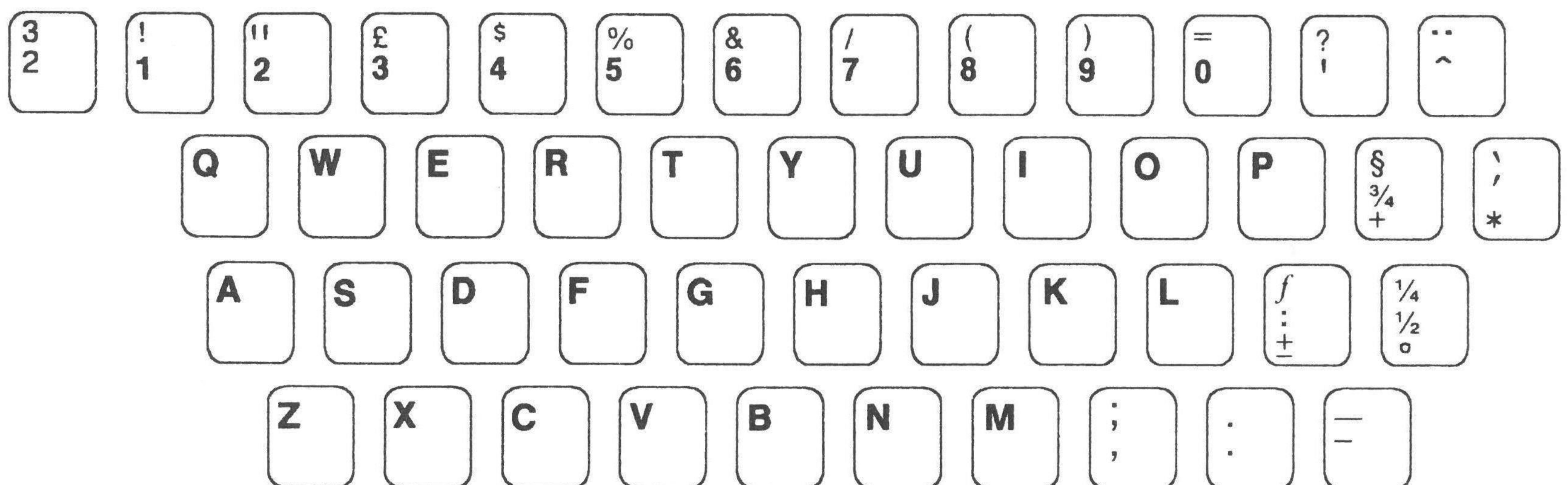

Keyboard ID 49 — Switzerland (French)

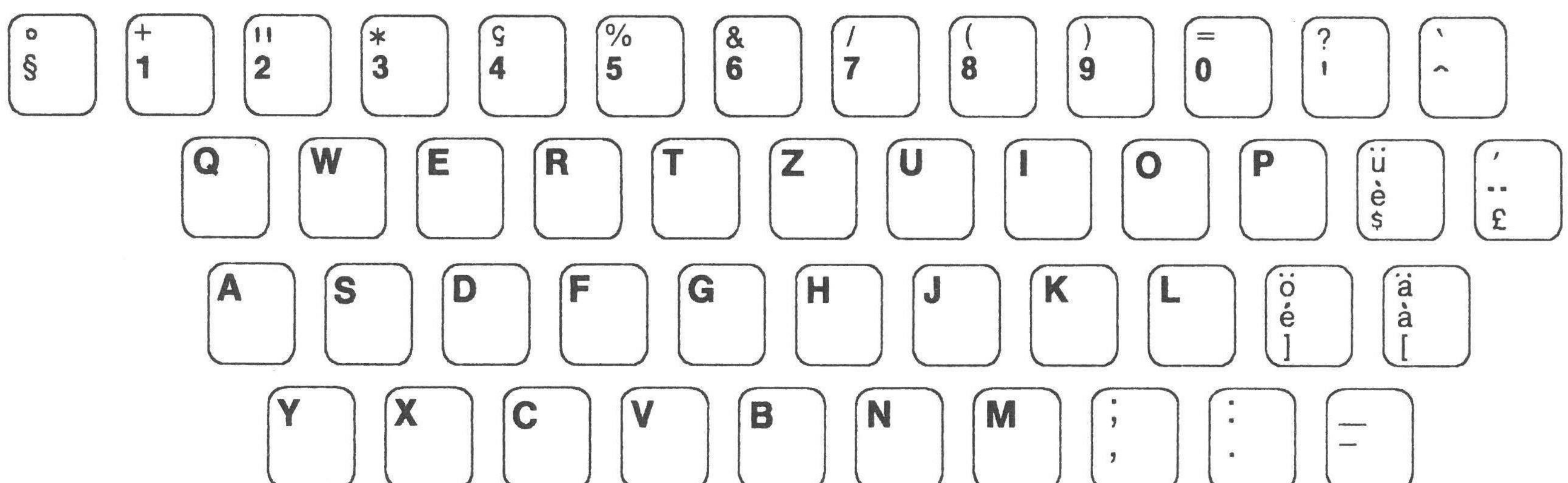

Keyboard ID 51 — Switzerland (German)

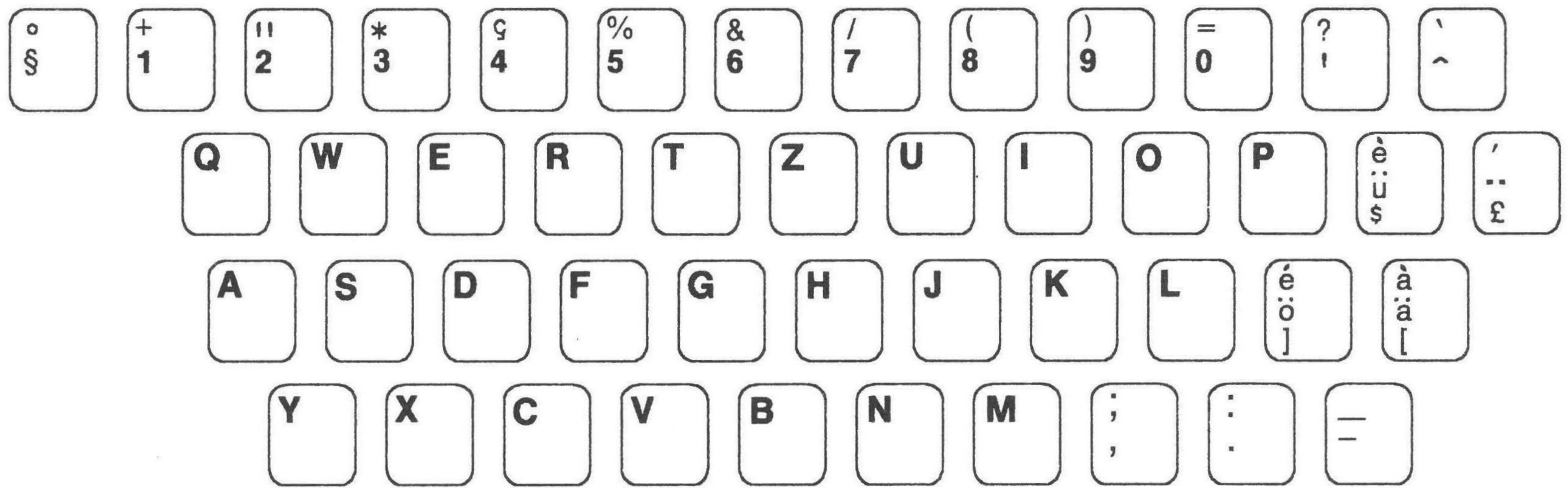

Keyboard ID 53 — Finland, Sweden

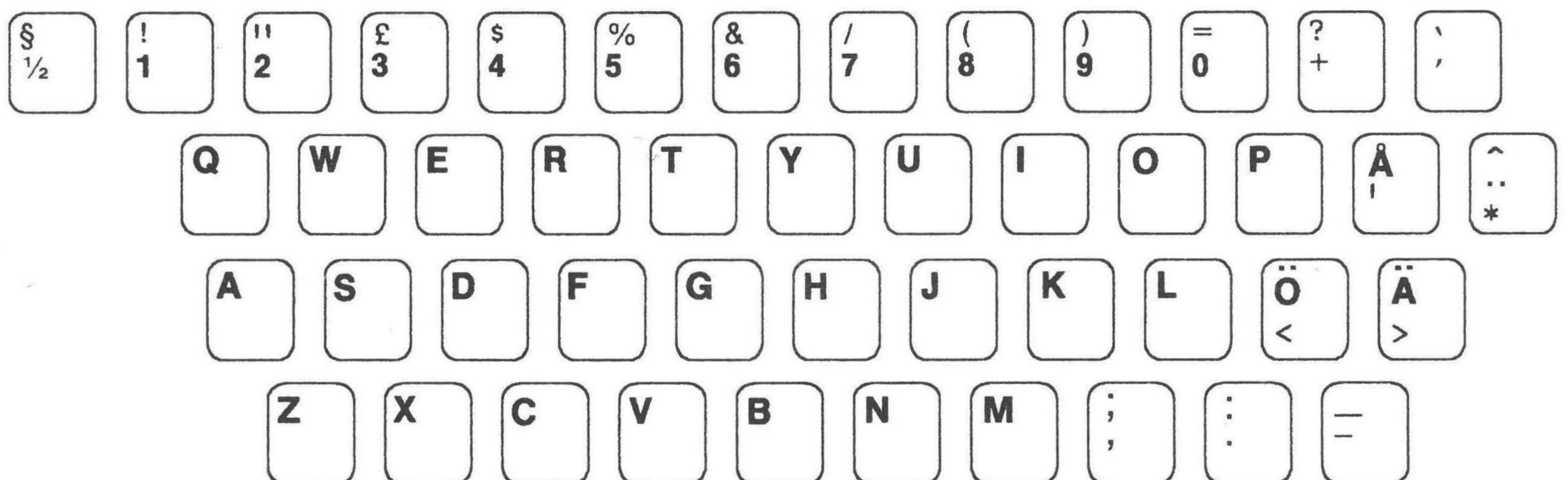

Keyboard ID 55 — Norway

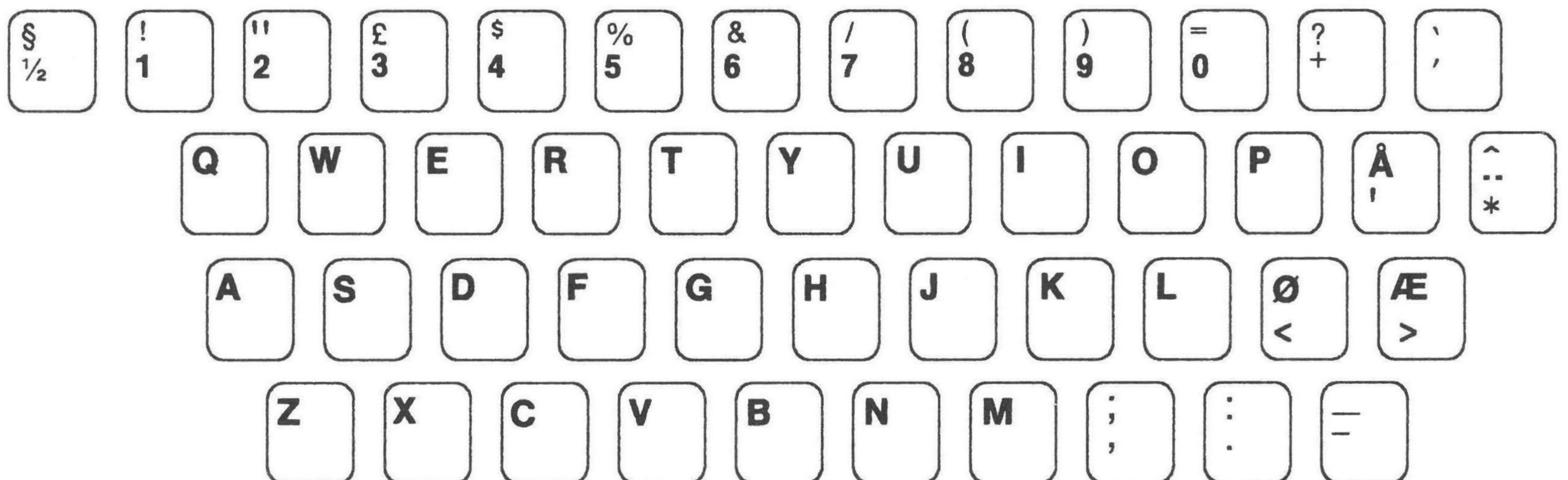

Keyboard ID 59 — Denmark

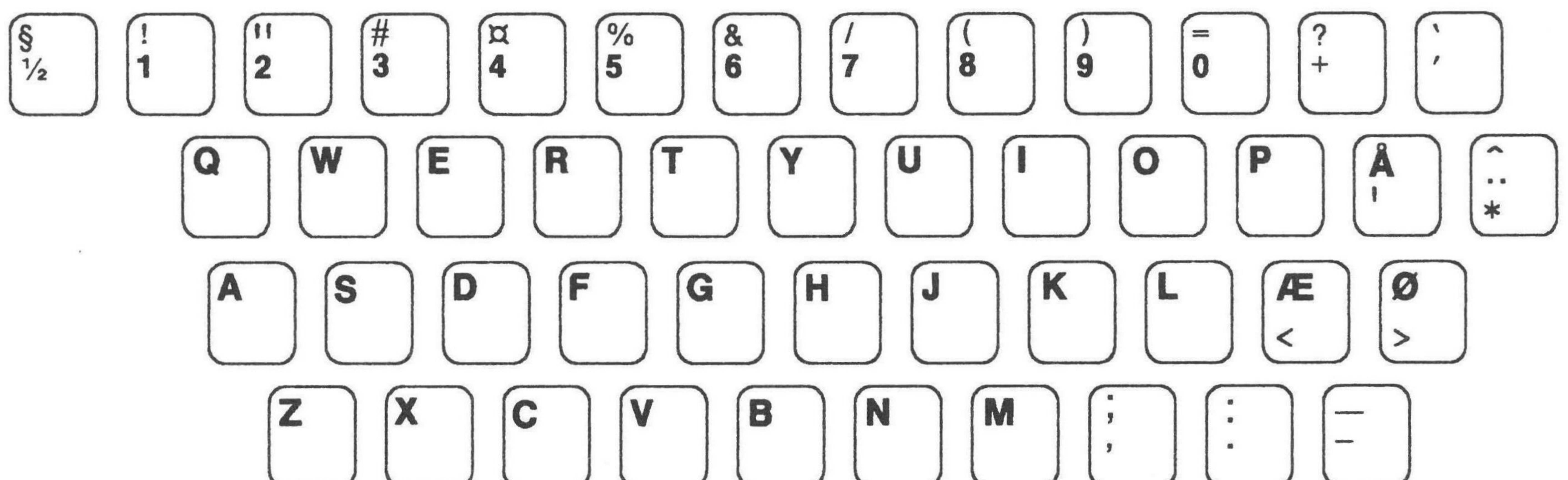

Keyboard ID 61 — Brazil

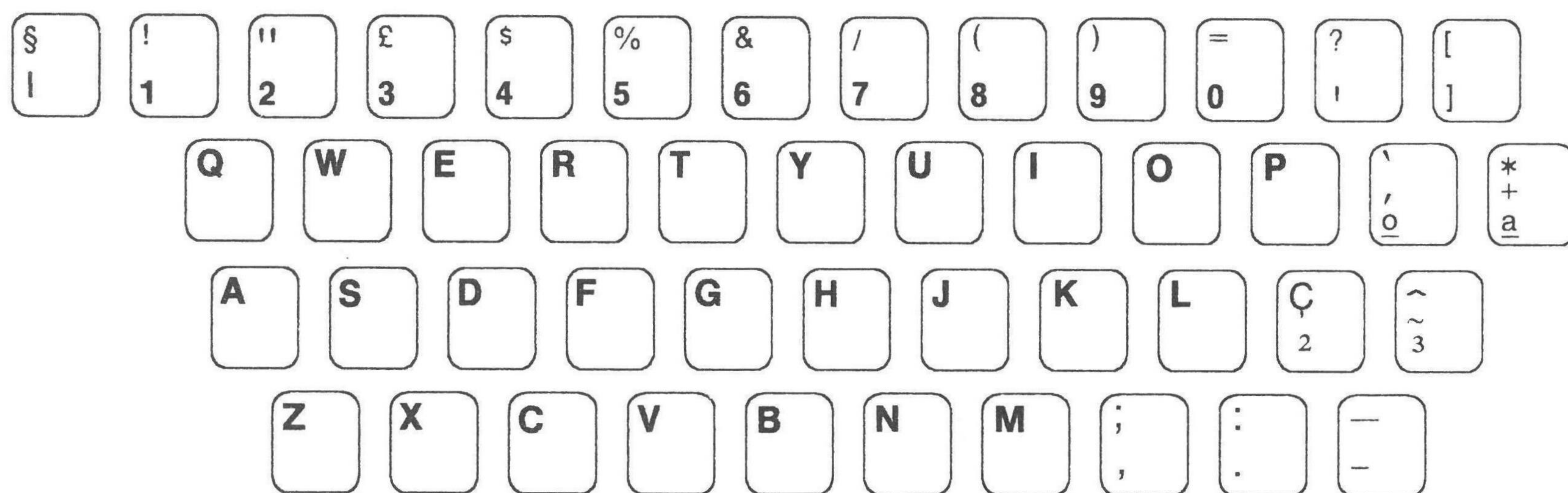

Keyboard ID 63 — Portugal

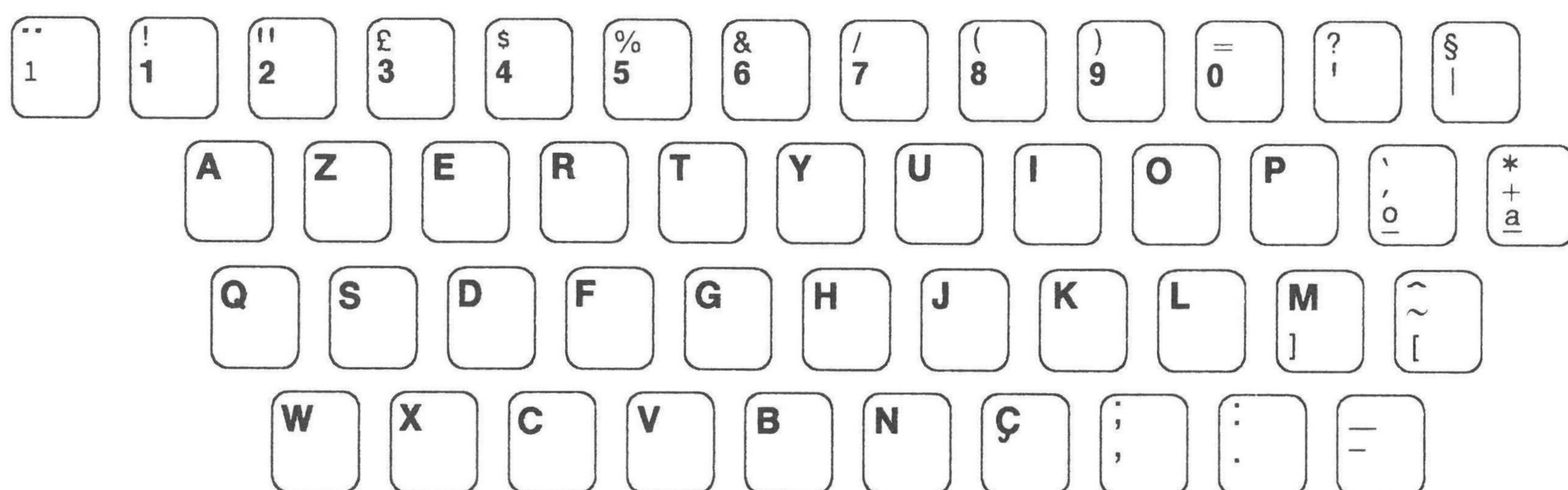

Keyboard ID 67 — United Kingdom

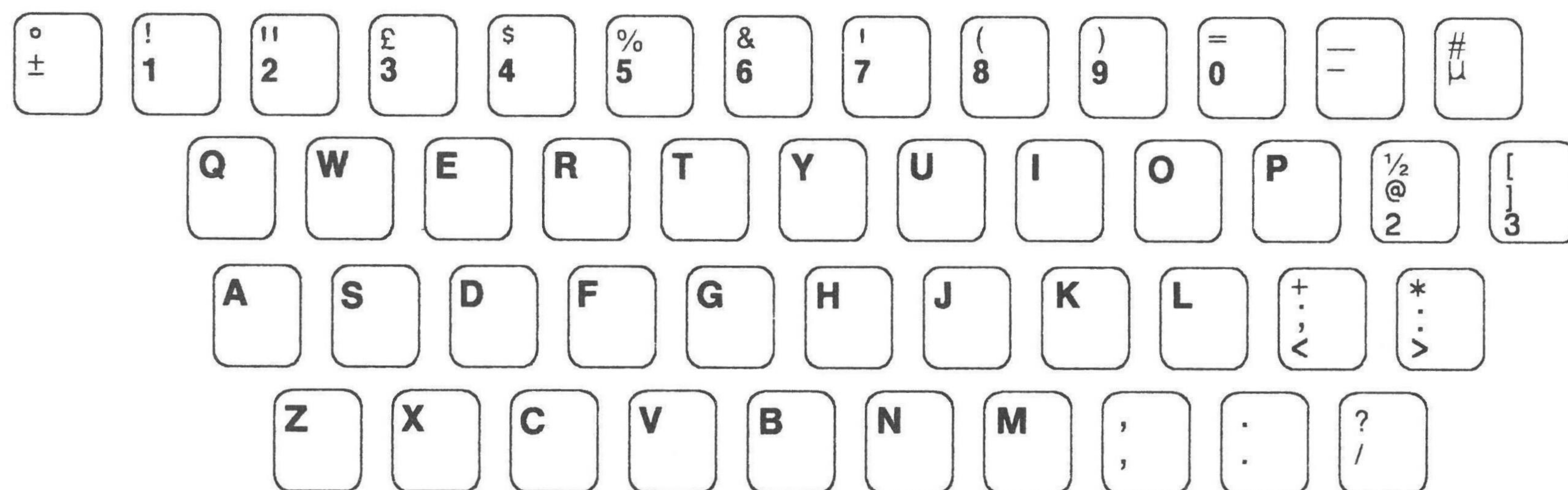

Keyboard ID 69 — Japan (English)

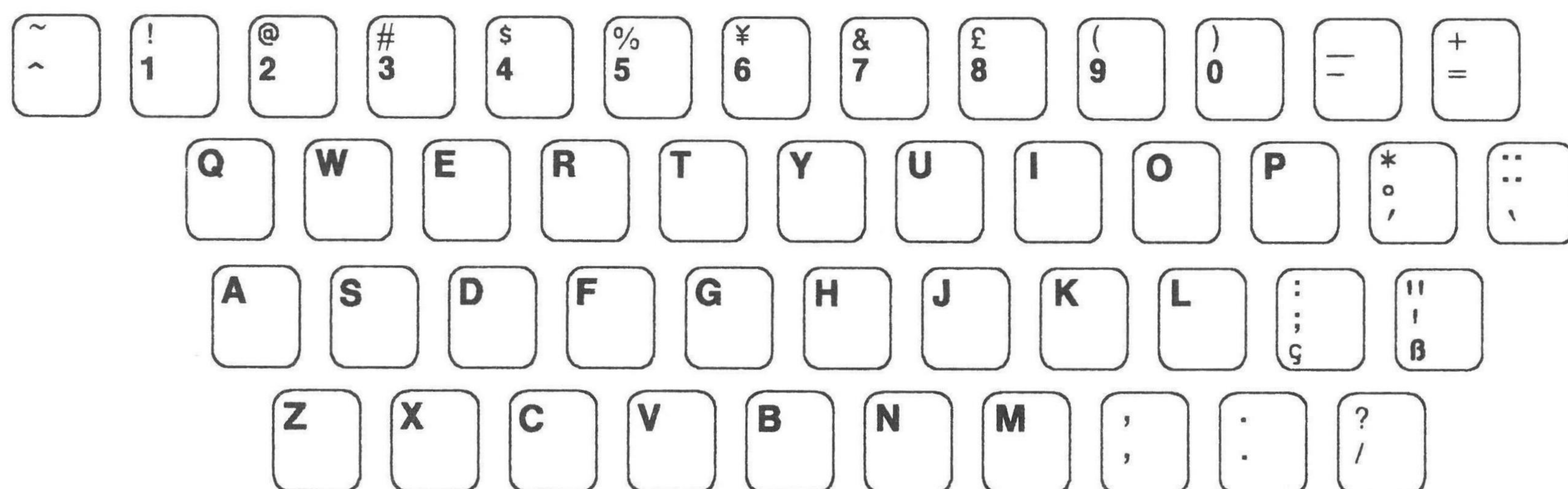

Keyboard ID 70 — Spain

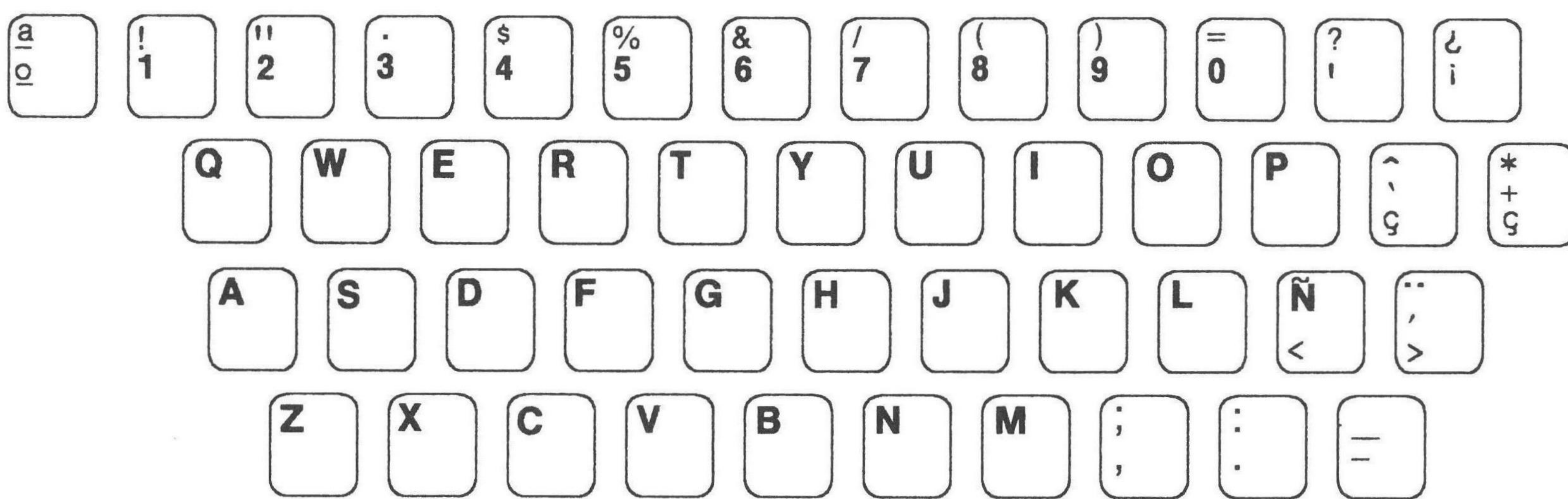

Keyboard ID 79 — Turkey

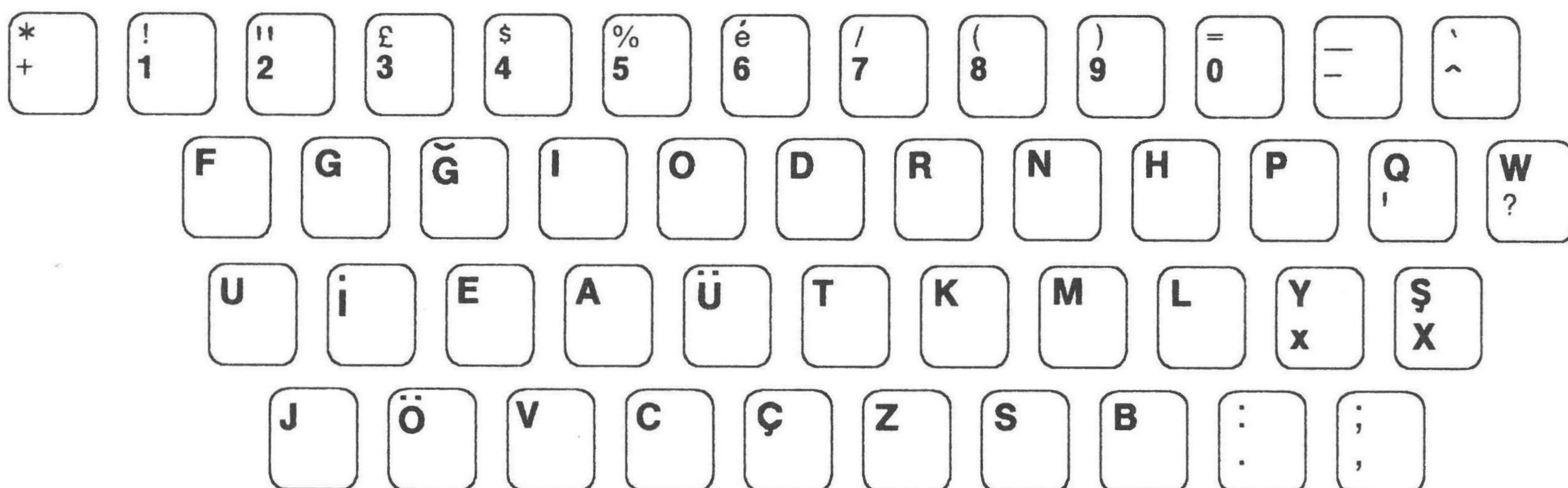

Keyboard ID 81 — South Africa

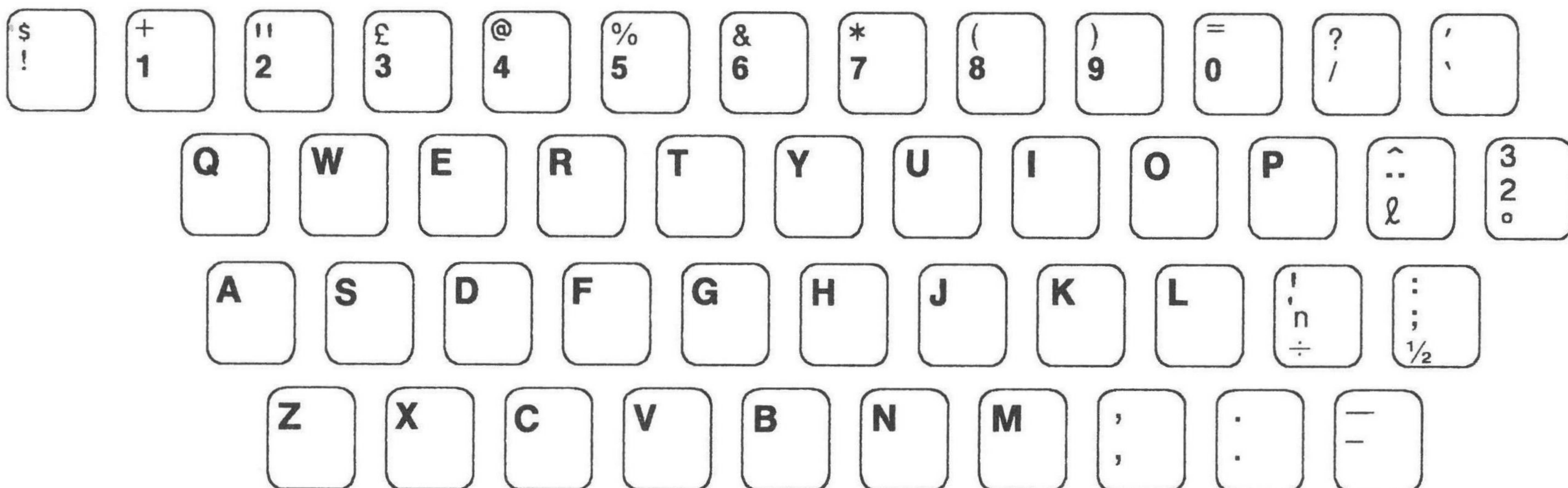

Keyboard ID 99 — Latin Supplemental ISO

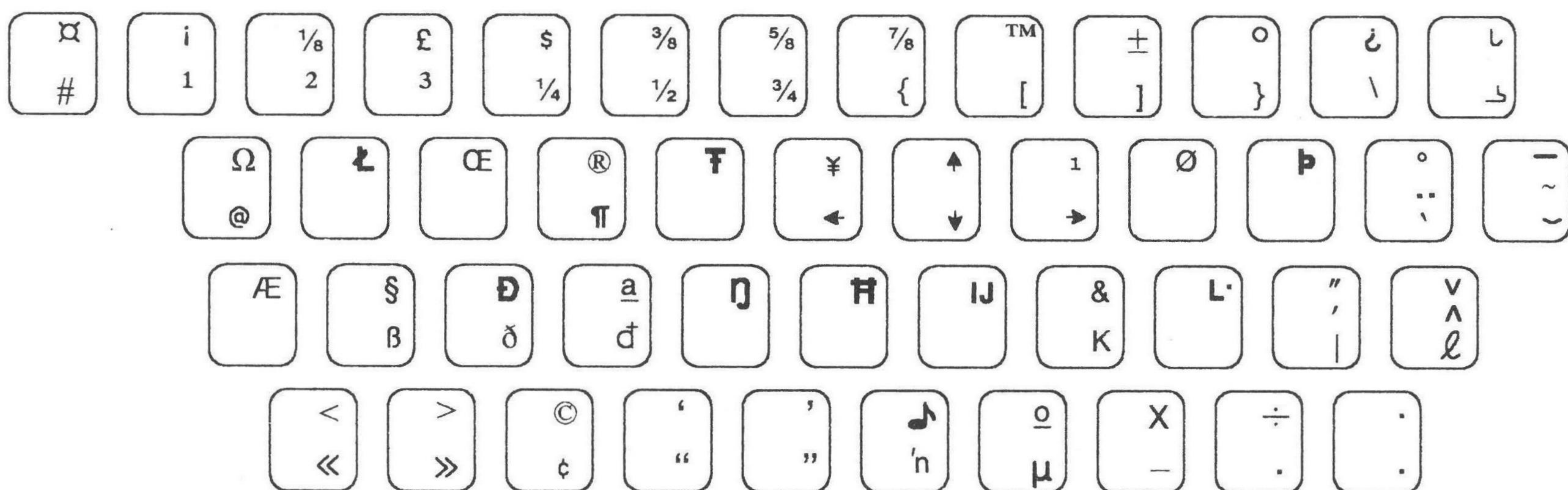

Keyboard ID 103 — ASCII (PC)

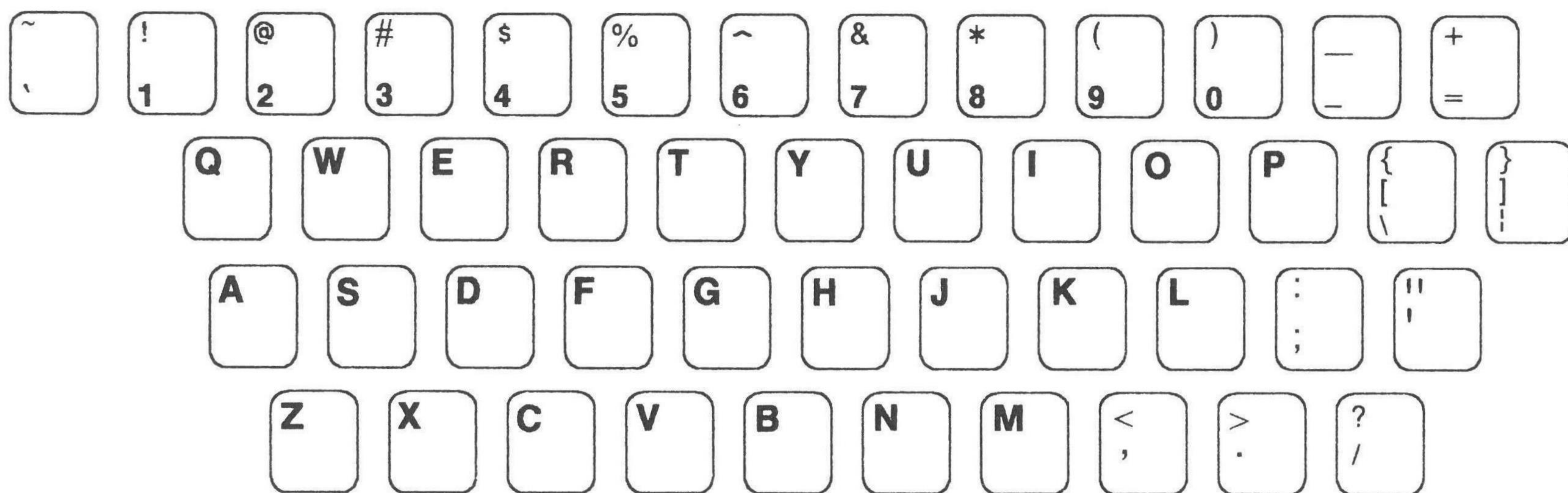

Keyboard ID 207 — Greece (Latin)

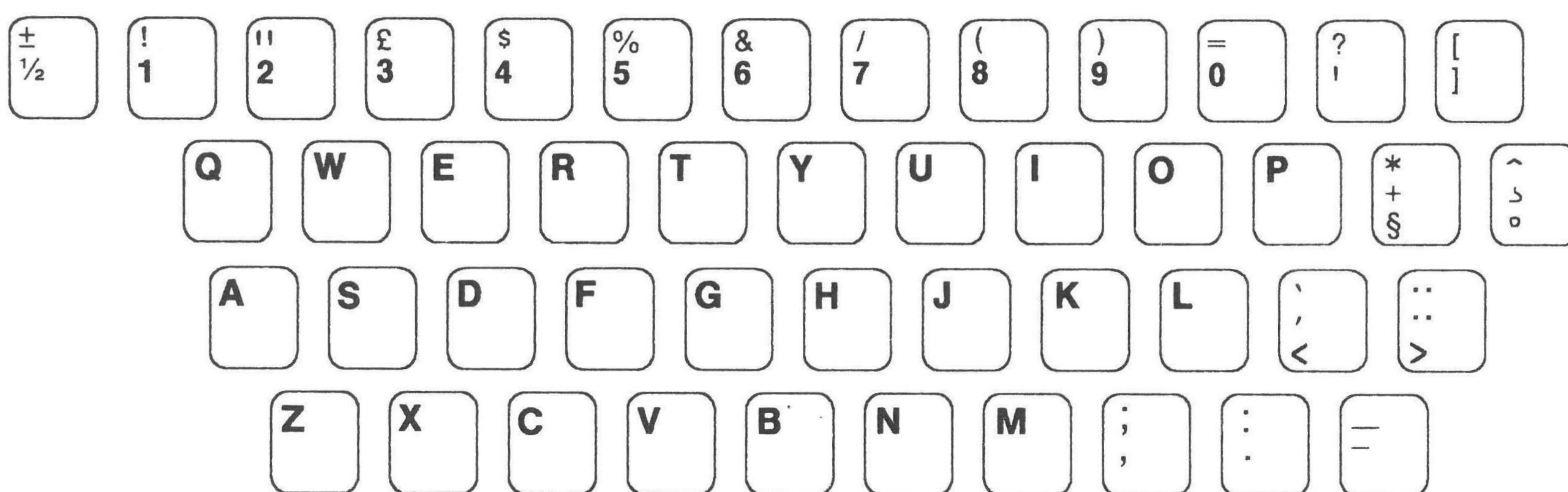

Keyboard ID 219 — Greece (Greek)

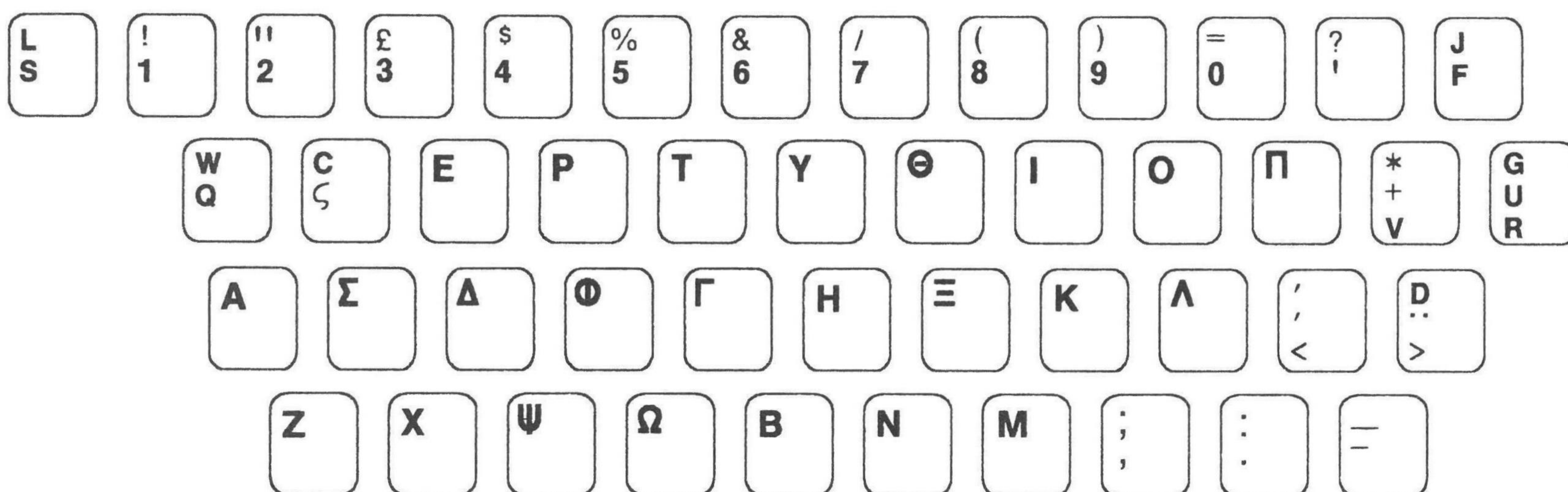

Keyboard ID 251 — Belgium, France

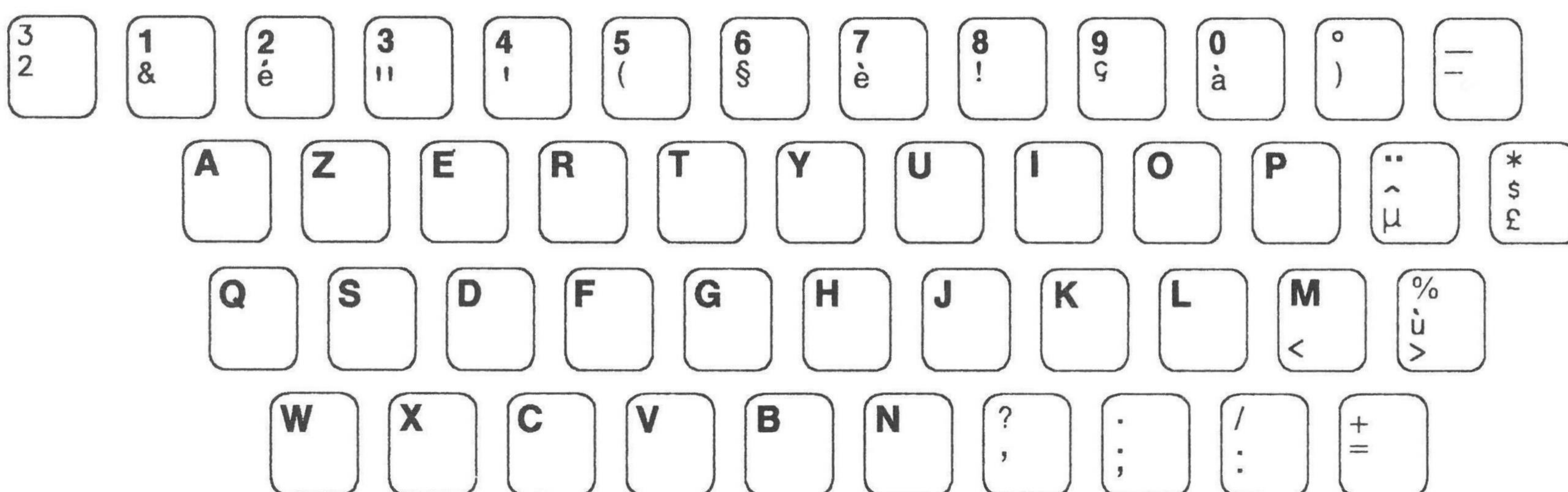

Problem Determination

How to Use This Section

If you have a problem while using your typewriter, use this information to help you solve the problem.

You may be able to correct the problem without help from a service representative and avoid unnecessary downtime and service costs.

Before you call for service:

1. Find your problem in the index on the next page.
2. Turn to the page referenced.
3. Complete as many steps as needed to correct the problem.
 - Try using the typewriter after completing each step.
4. If you cannot correct the problem or need help completing the steps, call your IBM Authorized Dealer.

Problem Determination Index

Beeper and Light Signals	3-3
Beeper Signals Three Times While You Are Typing	3-3
Beeper Signals Three Times and Line Space Lights Blink	3-3
Beeper Signals Six Times and One or More Lights Blink	3-4
All Lights Stay On	3-4
No Lights Come On	3-4
Erasing Problems	3-5
Correction Does Not Erase All of the Character or Correction Leaves Shadows	3-5
Typewriter Does Not Erase	3-5
Print Quality Problems	3-6
Characters Do Not Print	3-6
Characters Print Too Lightly	3-6
Characters Unclear	3-6
Typing Problems	3-7
Line Spacing Aligns Incorrectly	3-7
Paper Feeds Incorrectly	3-7
Wrong Characters Print or Characters Space Incorrectly.	3-7
Spell Check Problems	3-8
Spelling Beeper Beeped Three Times When You Turned the Typewriter On	3-8
Typewriter Beeped Five Times and Line Space Lights Are Blinking	3-8
Spell Check Functions Do Not Work	3-8

Beeper and Light Signals

Beeper Signals Three Times While You Are Typing

- Wait until the typewriter stops printing, then continue typing. You were typing faster than the typewriter could accept your typing.

Beeper Signals Three Times and Line Space Lights Blink

If the beeper signals three times and the **Line Space** lights blink alternately when you turn the typewriter on, check the following while the *typewriter is on*:

1. Look at the batteries for correct installation.
2. If the batteries are installed correctly, the batteries may be weak or dead.
3. Replace all three weak or dead batteries.
4. Do not turn the typewriter off while replacing the old batteries. If you turn the typewriter off without batteries installed, margins and other settings will be lost. (See page 4-14 for correct installation.)

Notes:

1. The **Line Space** lights blink *alternately* indicating the battery is low but you have not lost your settings.
2. The **Line Space** lights blink *continuously* indicating you have lost your settings.

Beeper Signals Six Times and One or More Lights Blink

1. Make sure the printwheel is installed correctly.
2. Make sure the ribbon and correction tape cassettes are installed correctly.
3. Turn the typewriter off, wait 10 seconds, then turn the typewriter on again. If the same thing happens, install another printwheel.
4. Turn the typewriter off, wait 10 seconds, then turn the typewriter on again. If the same thing happens, call for service.
 - Tell your service person which lights are blinking when you place the call.

All Lights Stay On

Turn the typewriter off, wait 10 seconds, then turn the typewriter on again. If all the lights still stay on, call for service.

No Lights Come On

1. Make sure the typewriter cord is plugged into the back of the typewriter.
2. Turn the typewriter off, wait 10 seconds, then turn the typewriter on again.
3. Make sure the typewriter is plugged into a wall outlet.
4. Look to see if any other equipment plugged into the same wall outlet operates.
5. Make sure the wall outlet does not turn off with the room lights.

Erasing Problems

Correction Does Not Erase All of the Character or Correction Leaves Shadows

1. Make sure the ribbon and correction tape cassettes are fastened together correctly.
 - Make sure the center latch is latched securely. (See page 4-9 in the Reference chapter.)
 - Make sure the gray tabs are pressed in.
2. Make sure the ribbon and correction tape cassettes are installed in the typewriter correctly. Make sure the correction tape matches the ribbon. (See page 4-11 and page 4-9 in the Reference chapter.)
3. Try a new correction tape.
4. Try plain bond paper.
5. Look for folds in the paper.
6. Make sure the typewriter is on a level surface.
7. Make sure you are using the same printwheel for both typing and erasing.
8. Make sure Bold Print is on if you are erasing bold characters.

Typewriter Does Not Erase

1. Make sure the correct printwheel is installed. You may be trying to erase with the wrong pitch printwheel.
2. Erase manually if the character is not on the current line. See “Erasing Manually” on page 1-15.

Print Quality Problems

Characters Do Not Print

1. Make sure the ribbon is installed correctly.
2. Make sure the printwheel is installed correctly.
3. Try a new ribbon.
4. Make sure the platen is latched down at both ends.
 - Pull the paper release lever all the way toward you.
 - Push down firmly on each end of the platen. Then push the paper release lever all the way back.
5. Make sure you are using the same pitch or language.
6. Try a new printwheel.

Characters Print Too Lightly

1. Make sure the ribbon is installed correctly.
2. Look for folds in the ribbon.
3. Change the impression control. See “Impression Control” on page 1-9 for more information.
4. Look for folds in the paper.
5. Try a new ribbon.
6. Try plain bond paper.
7. Try a new printwheel.

Characters Unclear

1. If excess ink particles from the ribbon appear on the paper, try a lower impression control setting.
2. Try a new printwheel.
3. Try a new ribbon.

Typing Problems

Line Spacing Aligns Incorrectly

1. Look for objects inside the typewriter.
2. Look at the number of carbon copies being used (five maximum).
3. Make sure the paper release lever is pushed all the way back.

Paper Feeds Incorrectly

1. Check the number of carbon copies being used (five maximum).
2. When inserting loose carbon copies, pull the paper release lever forward. Insert the copies, then push the lever all the way back.
3. Look for labels or paper caught under the platen.
4. Make sure the paper release lever is pushed all the way back.
5. Make sure the platen is latched down at both ends.
 - Pull the paper release lever all the way toward you.
 - Push down firmly on each end of the platen. Then push the paper release lever all the way back.

Wrong Characters Print or Characters Space Incorrectly

1. Turn the typewriter off, wait 10 seconds, then turn the typewriter on again.
2. Try typing again.
3. Try a new printwheel.
4. Look for objects in the path of the carrier.
5. Make sure the printwheel matches the keyboard selected if there is a language change. See "Matching Printwheels and Keyboards" on page 2-1.

Spell Check Problems

The following instructions apply only if you have the Spell Check option installed.

Spelling Beeper Beeped Three Times When You Turned the Typewriter On

There was an error in the supplemental dictionary, and the dictionary has been erased from memory. If you had selected a spelling beeper tone, it is erased from memory and will have to be selected again.

Typewriter Beeped Five Times and Line Space Lights Are Blinking

There is a problem with the spell check option. Turn the spell check option off and contact your authorized service representative.

Spell Check Functions Do Not Work

If a function of the option does not work, it might be caused by one of the following:

- The option is turned off.
- Another function is active on the typewriter which prevents the spell check option from being used (for example, printer option).
- You did not end the word with a word ending (space, punctuation, and so on).
- You are trying to add a word that is already in one of the dictionaries.
- You are trying to delete a word from the *main* dictionary.

Reference

Use this chapter to learn how to:

- Order IBM supplies for the typewriter.
- Remove and install the ribbon and printwheel in the typewriter.
- Change batteries.
- Take care of your typewriter.

This chapter also contains recommendations for ribbons and printwheels for various applications.

Ordering Procedures for IBM Supplies

To order IBM supplies, contact an IBM Authorized Dealer or call IBM Direct at 1-800-IBM-2468. In Canada, call IBM Direct at 1-800-465-1234.

Typestyle Samples

The IBM Cartridge Printwheel II is designed for use with IBM Wheelwriter® Typewriters and IBM Wheelprinters. The protective cartridge makes installation easy and protects the printwheel from damage. The wide variety of typestyles and sizes allows you to select one for readability, emphasis, or space requirements to make your work look the way you want.

The order number listed is for the American Standard Character Set. Personal computer, foreign language, and symbol character sets are also available.

▲ = 10 pitch

△ = 12 pitch

■ = 15 pitch

Note: Because of the differences between printed and typewritten impressions, the typestyle samples on the following pages should be used only as a guide.

Typestyle Samples and Pitches

10 Pitch

▲ Advocate 1353845	IBM's variety of attractive type
▲ Artisan 10 1353520	IBM's variety of attractive type
▲ Bookface Academic 1353844	IBM's variety of attractive type
▲ Courier 10 1353511	IBM's variety of attractive type
▲ Delegate 1353843	IBM's variety of attractive type
▲ Manifold 1353846	IBM'S VARIETY OF ATTRACTIVE TYPE
▲ OCR-A 1353246	IBM's variety of attractive type
▲ OCR-B 1353247	IBM's variety of attractive type
▲ Pica 1353829	IBM's variety of attractive type
▲ Presentor 1353015	IBM's variety of attractive type
▲ Prestige Pica 1353503	IBM's variety of attractive type
▲ P&P #3 OCR 1353054	IBM's variety of attractive type
▲ Rhetoric 1353736	IBM'S VARIETY OF ATTRACTIVE TYPE
▲ 1403 OCR 1353075	IBM'S VARIETY OF ATTRACTIVE TYPE

12 Pitch

△ Adjutant 1353047	IBM's variety of attractive typestyles suit
△ Artisan 12 1353050	IBM's variety of attractive typestyles suit
△ Auto Elite 1353080	IBM's variety of attractive typestyles suit
△ Courier 12 1353523	IBM's variety of attractive typestyles suit
△ Courier 12 Italic 1353890	<i>IBM's variety of attractive typestyles suit</i>
△ Dual Gothic 1353055	IBM's variety of attractive typestyles suit

12 Pitch (continued)

△ Elite 1353861	IBM's variety of attractive typestyles suit
△ Large Elite 1353017	IBM's variety of attractive typestyles suit
△ Letter Gothic 1353514	IBM's variety of attractive typestyles suit
△ Light Italic 1353764	<i>IBM's variety of attractive typestyles suit</i>
△ Olde World 1353875	IBM's variety of attractive typestyles suit
△ Prestige Elite 1353502	IBM's variety of attractive typestyles suit
△ Scribe 1353982	IBM's variety of attractive typestyles suit
△ Script 1353778	<i>IBM's variety of attractive typestyles suit</i>

15 Pitch

■ Courier 15 1353796	IBM's variety of attractive typestyles suit many
■ Gothic 15 1353719	IBM's variety of attractive typestyles suit many
■ Prestige 15 1353655	IBM's variety of attractive typestyles suit many

Printwheel Application Recommendations

Typestyle	1 – 3 Carbon Copies	3 – 5 Carbon Copies	Stencils	Bold Print
10 Pitch:				
Advocate	A	A	A	C
Artisan 10	A	A	A	A
Bookface Academic	B	C	B	A
Courier 10	A	A	B	A
Delegate	A	A	B	B
Manifold	A	A	B	A
Pica	A	A	A	C
Prestige Pica	A	B	B	A
Rhetoric	B	C	B	A
Rhetoric Presentor	B	C	B	A
Symbol 10	B	C	C	B
12 Pitch:				
Adjutant	A	A	B	B
Artisan 12	A	A	B	A
Auto Elite	A	A	A	A
Courier 12	A	A	B	A
Courier 12 Italic	A	A	B	A
Dual Gothic	A	B	B	C
Elite	A	A	A	C
Large Elite	A	A	A	C
Letter Gothic	A	A	A	A
Light Italic	A	A	A	B
Olde World	A	C	NR	A
Prestige Elite	A	B	A	A
Scribe	A	A	A	B
Script	B	C	C	A
Symbol 12	C	C	C	B

Ratings:

A – Good; B – Fair; C – Marginal; NR – Not Recommended
(Based on proper selection of ribbon, carbon paper, and stencils)

Printwheel Application Recommendations (continued)

Typestyle	1 – 3 Carbon Copies	3 – 5 Carbon Copies	Stencils	Bold Print
15 Pitch:				
Courier 15	A	B	B	A
Gothic 15	B	C	B	A
Prestige 15	A	B	A	C
Symbol 15	C	C	C	B

Ratings:

A – Good; B – Fair; C – Marginal

(Based on proper selection of ribbon, carbon paper, and stencils)

Note: There are three symbol printwheels: Symbol 10, Symbol 12, and Symbol 15. For best results, use a symbol printwheel that matches the pitch of your regular printwheel. For example, use Symbol 15 with 15-pitch typestyles.

Removing the Printwheel

CAUTION:

To prevent unwanted carrier motion, make sure the paper bail is against the platen.

1. Pull the print hammer all the way toward you and hold it.
2. While you are holding the print hammer, grasp the printwheel tab.
3. Lift the printwheel straight up and out of the slot. Be careful not to scratch the ribbon.
4. Release the print hammer.

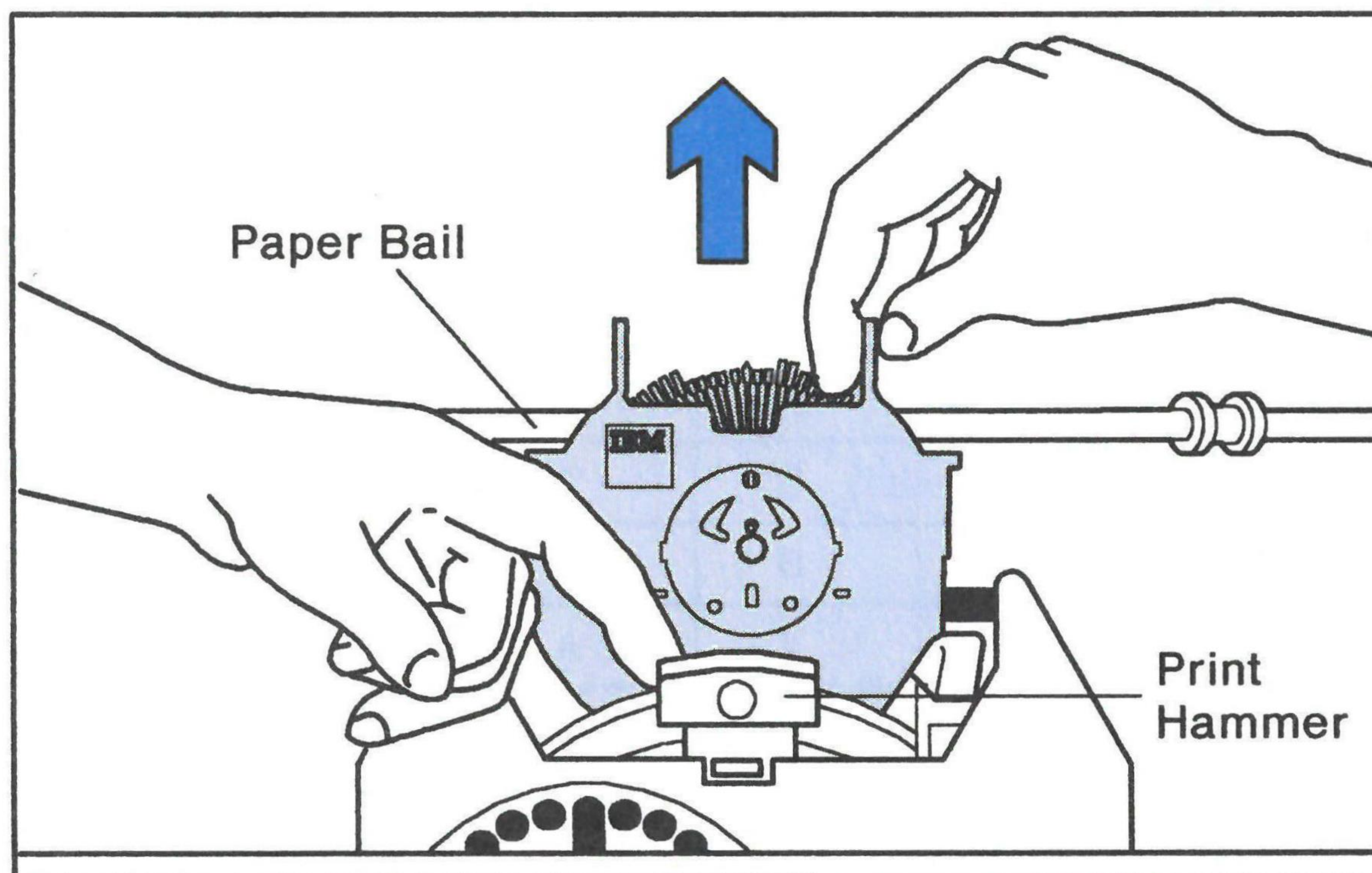
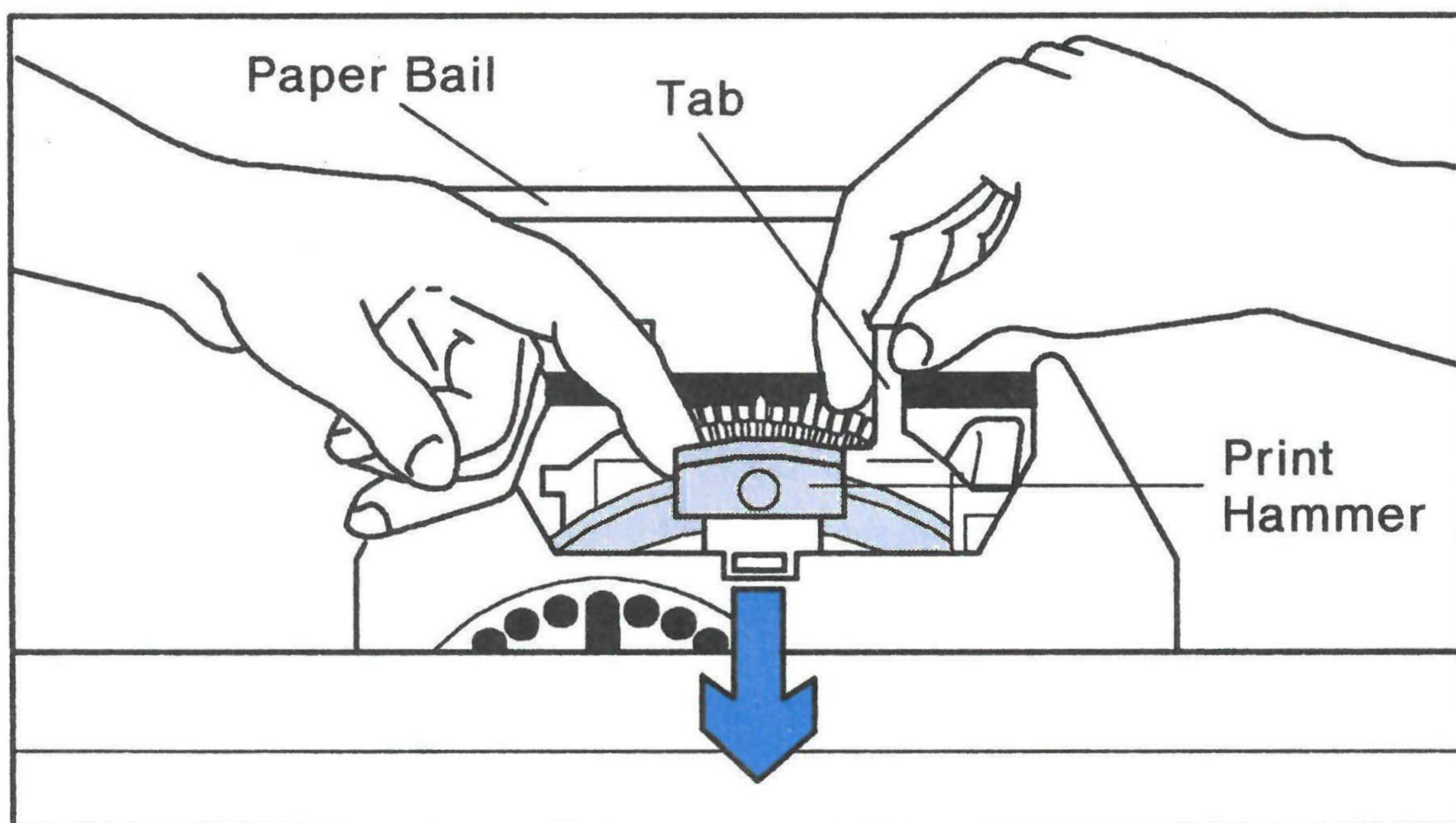

Installing the Printwheel

Important: Remove the yellow shipping seal from the center of a new printwheel before you install it.

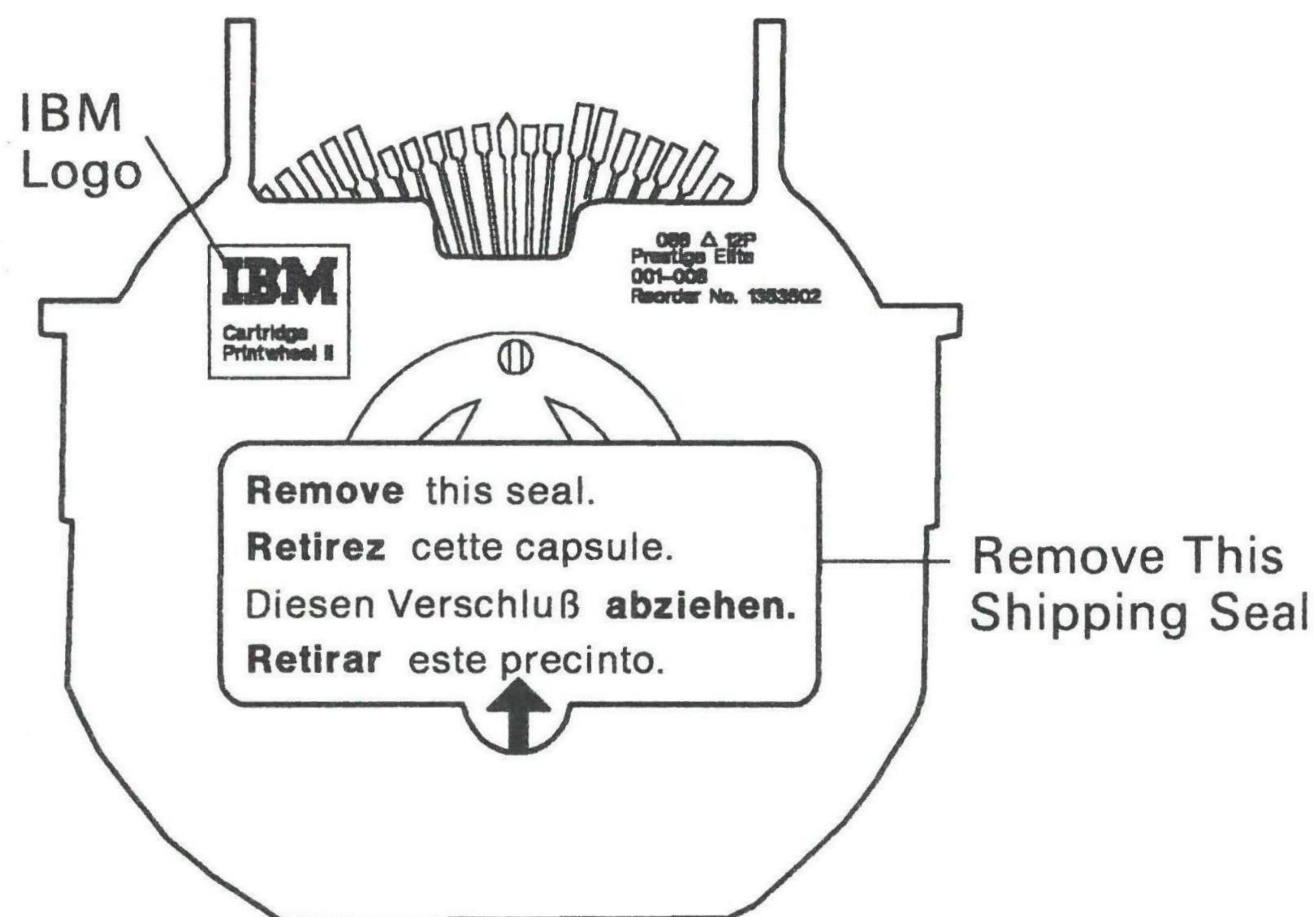

CAUTION:

To prevent unwanted carrier motion, make sure the paper bail is against the platen.

1. Hold the printwheel so the letters IBM are in the upper left corner.
2. Pull the print hammer all the way toward you and hold it.
3. While you are holding the print hammer, lower the printwheel into the slot. Be careful not to scratch the ribbon.
4. After the printwheel touches the bottom of the slot, release the print hammer.
5. Press the **Code** key:
 - The printwheel spins.

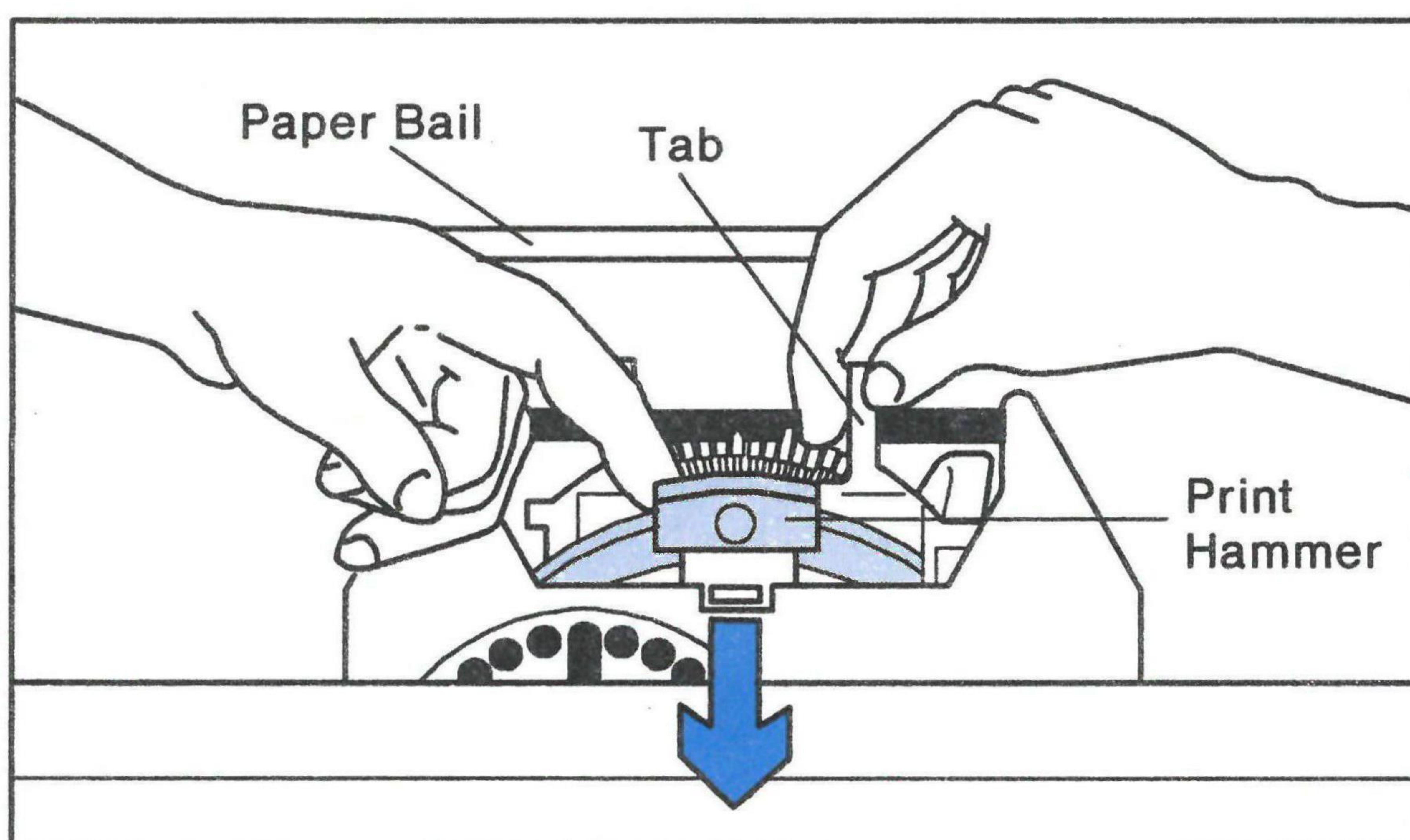

Ribbon Cassette System

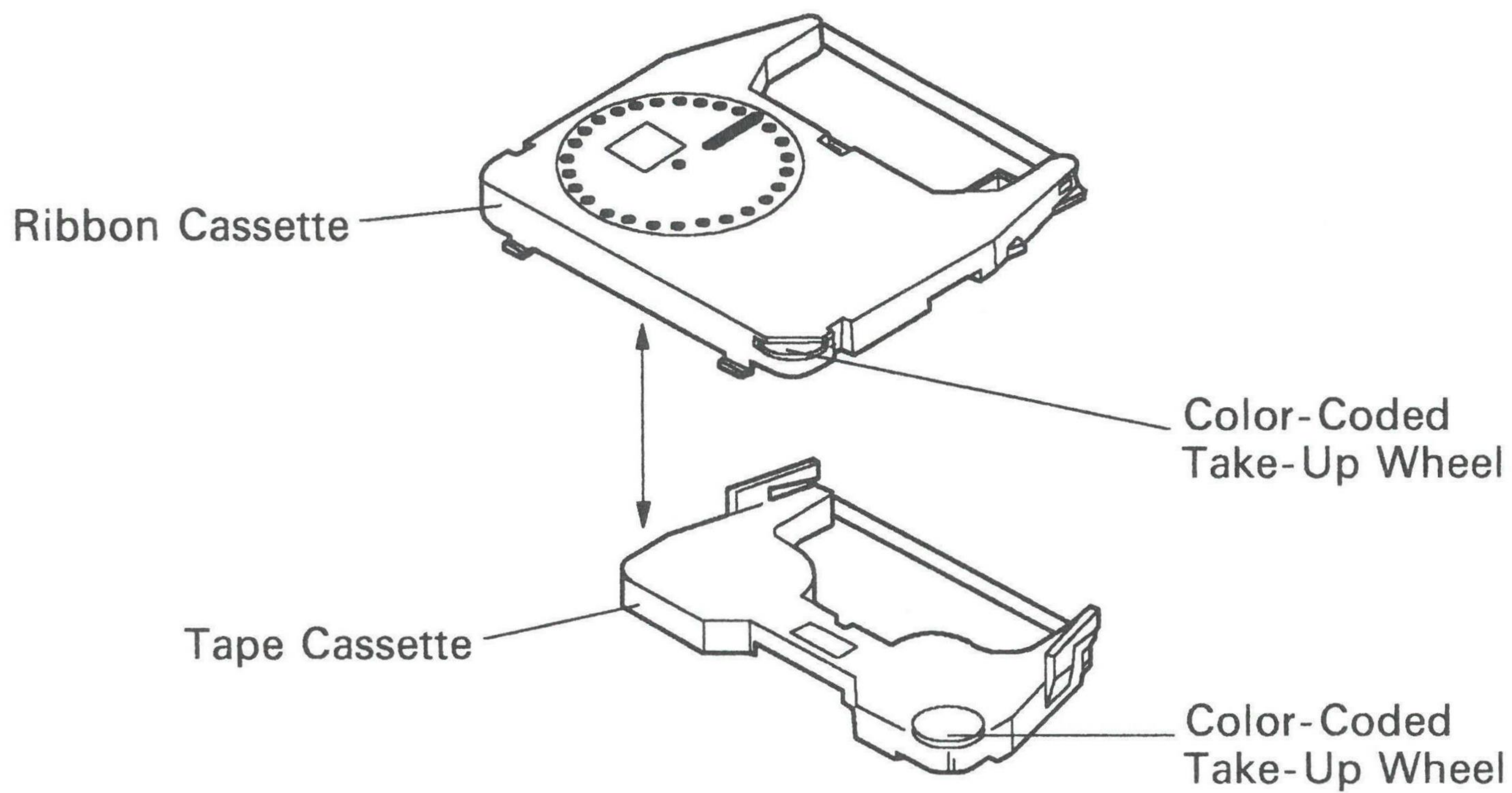

The ribbon and tape cassettes fasten together. Each type of ribbon and tape cassette has a color-coded take-up wheel. In most cases the wheel color helps you match the ribbon to the correction tape. (See "Ribbon Cassette Reorder Numbers" on page 4-11.) The color also tells you which type of ribbon you are using.

Removing the Cassettes

1. Space or tab to the center of your typewriter.
2. Raise the typewriter cover.
3. Make sure the paper bail is against the platen.
4. Push the release lever until the cassettes release.
5. Lift the cassettes up and out of the typewriter.

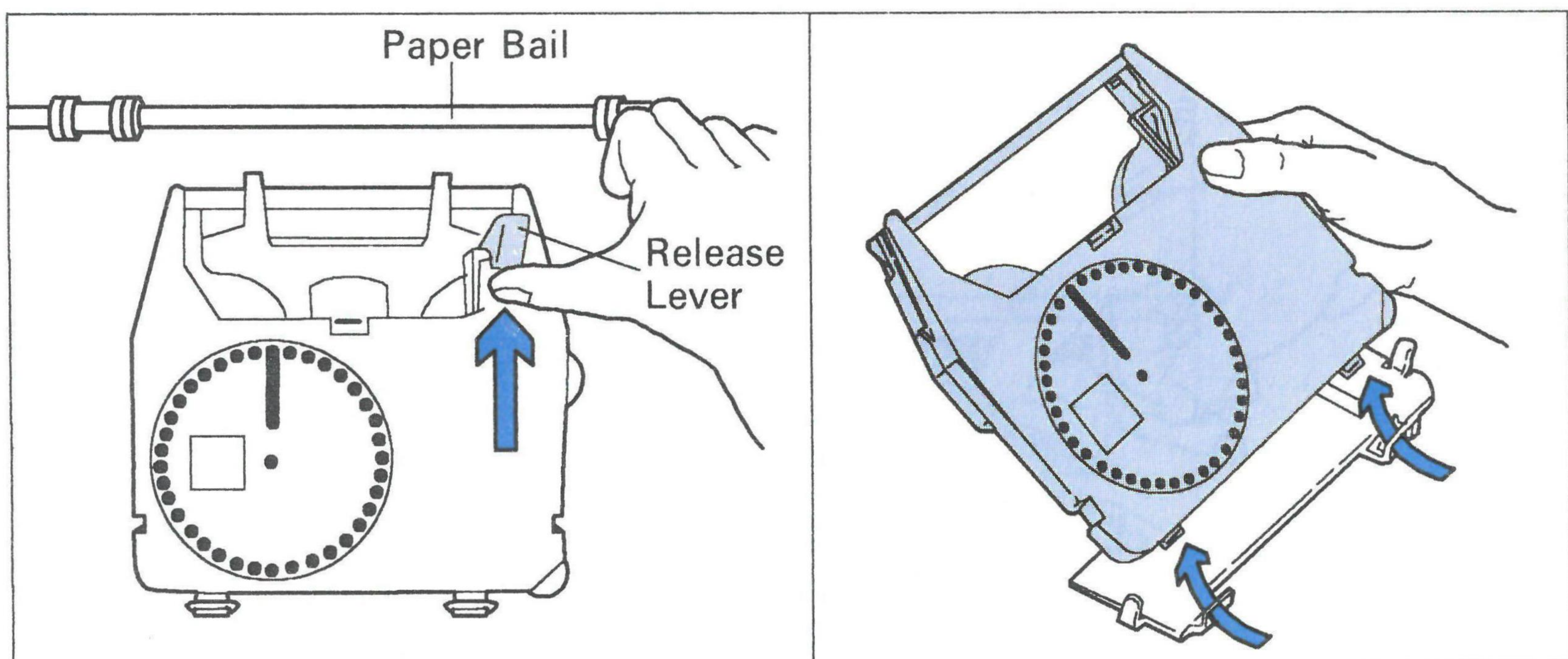

Installing the Cassettes

1. After you remove the cassettes from your typewriter, press on the top of the center latch, slide the cassettes apart, and throw away the used cassette.
2. Slide the ribbon cassette onto the tape cassette.
 - Be sure the center latch latches onto the correction tape.
3. Press the gray tabs (on both ends of the correction tape) to be sure the tape and ribbon cassettes are latched together.
4. *Before* installing the ribbon in the typewriter, tighten any slack in the ribbon by turning the take-up wheels to move the color-coded leaders past the center.
5. Install the cassettes in your typewriter.
6. Push down on the upper right corner of the ribbon cassette to snap it into place.

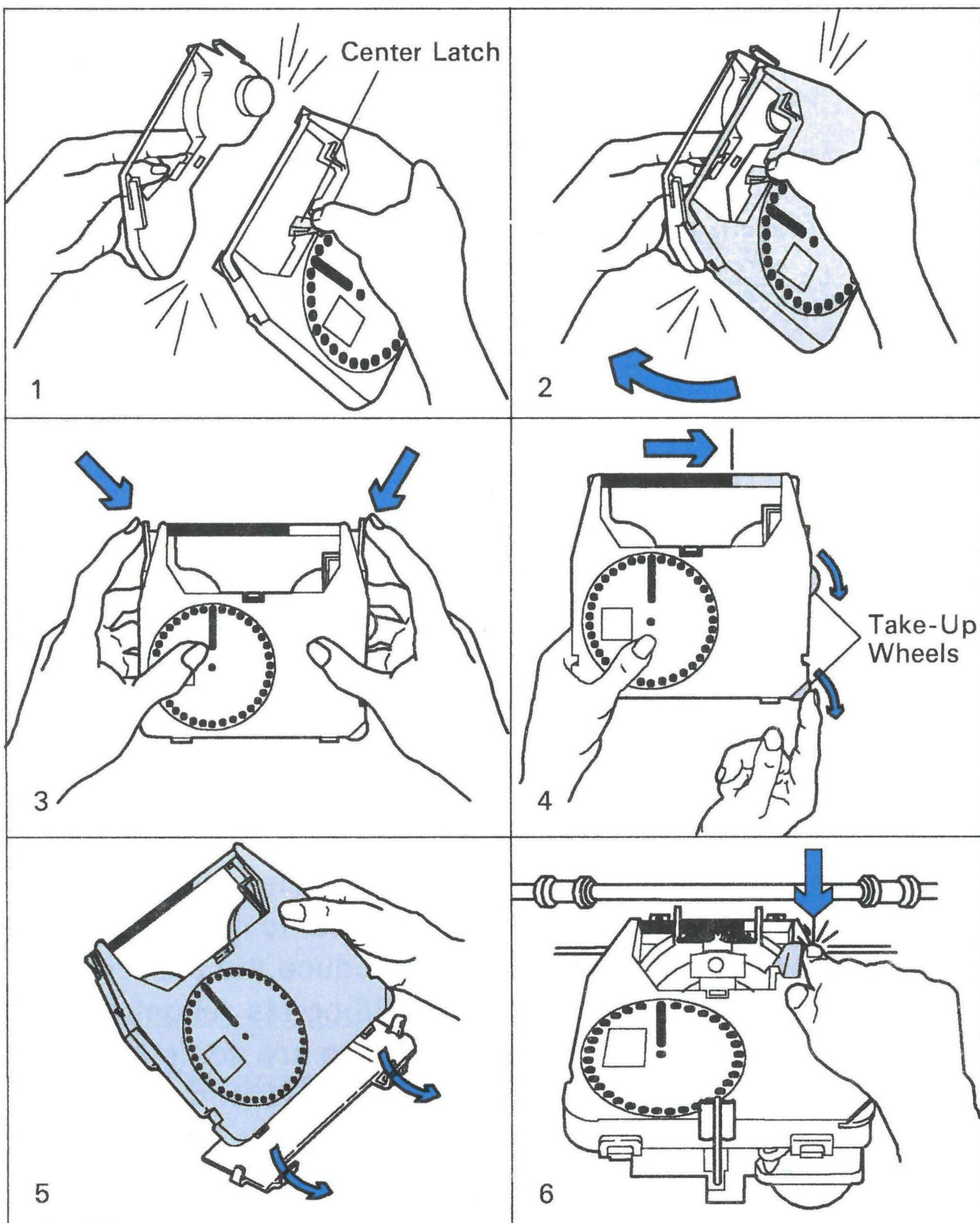

Ribbon Application Recommendations

Typing Applications	Multi-purpose Ribbon Cassette	High Yield Correctable Ribbon Cassette	Fabric Ribbon Cassette	Superior Write Correctable Ribbon Cassette
Legal Correspondence	•	•	NR	•
Executive Correspondence	•	•	NR	•
General Correspondence	•	•	•	•
Hard-to-Image Originals ¹	•	NR	•	•
OCR	•	NR	NR	NR
Speech Writing ²	•	NR	•	•
Negotiable Instruments – (checks, stocks, and so on)	•	NR	•	NR
Erasable Bond ¹	•	NR	NR	•
Quality of Original				
1 - 3 Carbons	Good	Good	Good	Good
3 - 5 Carbons	Fair	Marginal	Fair	Fair

¹ The receptivity of the surface of these materials varies widely; and care must be used in the selection of a specific material to be typed on, typestyle, impression control, and ribbon to produce the best result. The IBM EasyStrike® Superior Write Correctable Ribbon is recommended for most hard-to-image applications. However, there are some special coated or treated surfaces where the multipurpose ribbon must be used. When in doubt, prepare samples first.

² Best results with Rhetoric and other large typestyle printwheels are obtained by using the IBM EasyStrike® Multipurpose Ribbon.

Ribbon Cassette Reorder Numbers

Use the table below to find the reorder number for the matching cassettes you need.

Ribbon	Wheel Color	Correction Tape	Wheel Color
IBM Easystrike® High Yield Correctable Ribbon Cassette ³ <i>Reorder Number:</i> 1299845 (black only)	Orange	IBM Easystrike® Lift-Off Tape Cassette <i>Reorder Number:</i> 1337765	Orange
IBM Easystrike® Correctable Ribbon Cassette <i>Reorder Numbers:</i> 1337761 (black) 1337762 (brown) 1337763 (blue)	Orange	IBM Easystrike® Lift-Off Tape Cassette <i>Reorder Number:</i> 1337765	Orange
IBM Easystrike® Superior Write Correctable Ribbon Cassette ⁴ <i>Reorder Number:</i> 1380999 (black only)	Purple	IBM Easystrike® Lift-Off Tape Cassette <i>Reorder Number:</i> 1337765	Orange
IBM Easystrike® Multi-purpose Ribbon Cassette <i>Reorder Number:</i> 1337764 (black only)	Blue	IBM Easystrike® Cover-Up Tape Cassette <i>Reorder Number:</i> 1337766	Blue
IBM Easystrike® Fabric Ribbon Cassette <i>Reorder Number:</i> 1356000 (black only)	Red	None	None

³ Long-life correctable film ribbon; recommended for general correspondence.

⁴ Recommended for bold and dark print, especially on difficult-to-image papers.

Batteries

Your typewriter uses three size AA alkaline batteries. These batteries are used to save margins, tabs and other settings when the typewriter is turned off. They must be installed correctly and changed at least once every year (before they run down).

When changing the batteries, use only size AA alkaline batteries (for example, Duracell⁵ type MN 1500, Eveready⁶ type E91, Ray-O-Vac⁷ type 815, or equivalent). *Do not use rechargeable batteries.*

Checking the Batteries

If the beeper signals three times and the **Line Space** lights blink alternately when you turn the typewriter on, check the following while the *typewriter is on*:

1. Look at the batteries for correct installation.
2. If the batteries are installed correctly, the batteries may be weak or dead.
3. Replace all three weak or dead batteries.
4. Do not turn the typewriter off while replacing the old batteries. If you turn the typewriter off without batteries installed, margins and other settings will be lost. (See page 4-14 for correct installation.)

Notes:

1. The **Line Space** lights blink *alternately* indicating the battery is low, but you have not lost your settings.
2. The **Line Space** lights blink *continuously* indicating you have lost your settings.

⁵ Trademark of Duracell, Inc.

⁶ Trademark of the Union Carbide Corp.

⁷ Trademark of the Ray-O-Vac Corp.

Removing Old Batteries

Warning: Do not turn the typewriter off while replacing the old batteries. If you turn the typewriter off without batteries installed, margins and other settings will be lost.

1. Make sure the typewriter is turned on.
2. Raise the typewriter cover.
3. Locate the black plastic battery holder on the right front side of the typewriter.
4. Remove the holder by putting your finger under it and pushing up. Then carefully pull the holder out as far as it can go.
5. Push the batteries against the spring ends of the holder and pop them out.

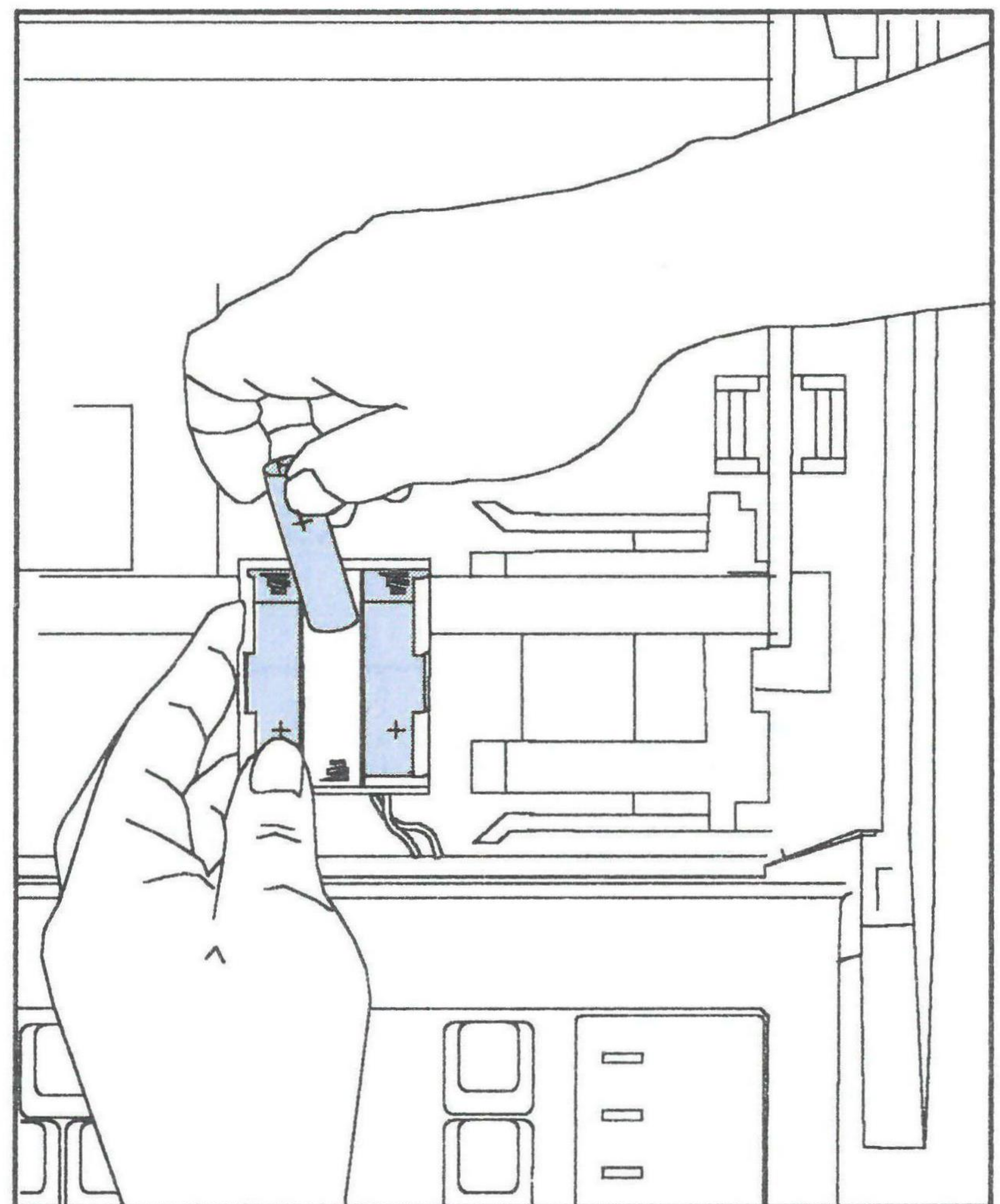
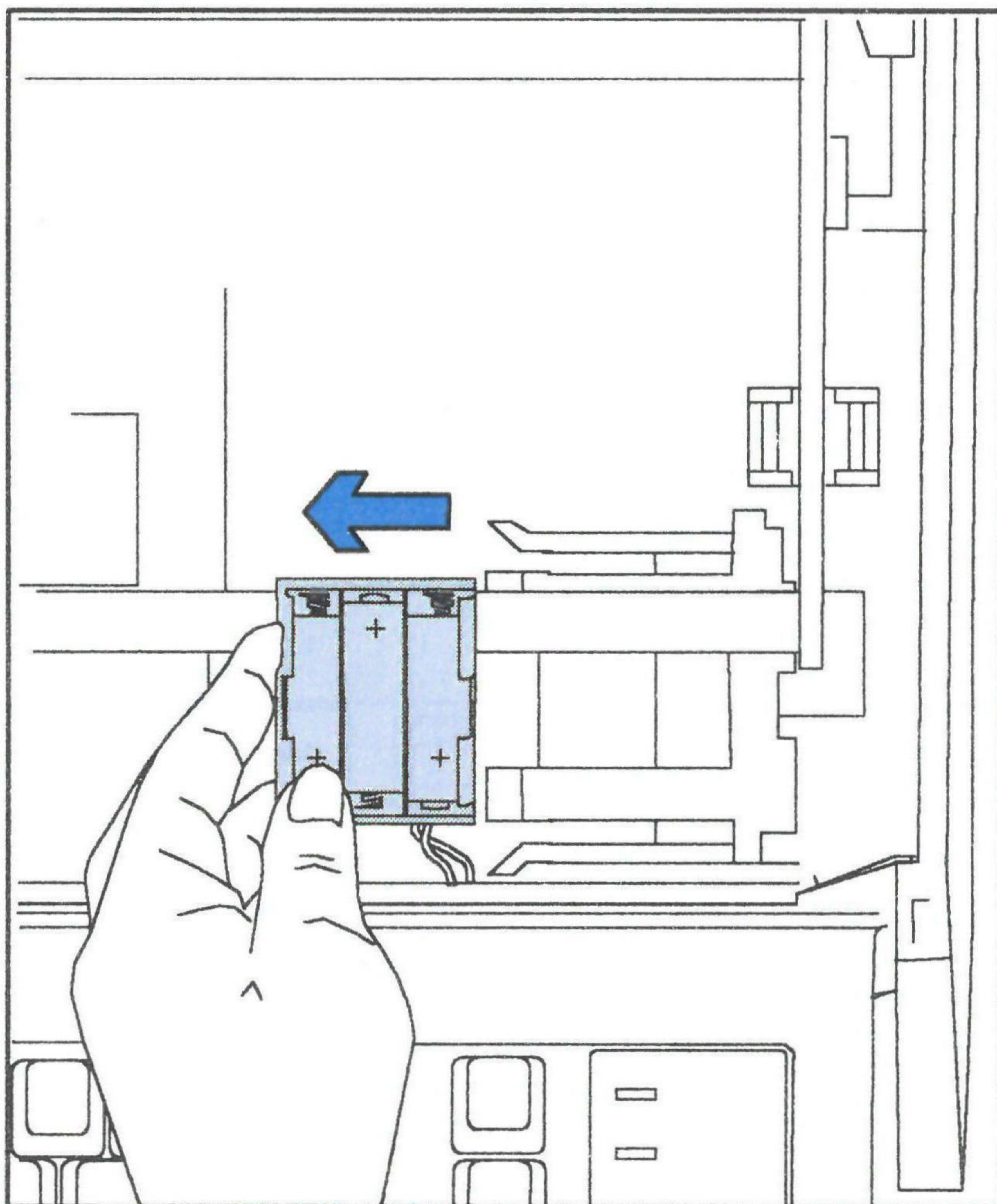

Installing New Batteries

1. Install three (3) new batteries in the holder by placing the flat end of the batteries against the springs.
 - Make sure the plus (+) signs on the batteries match the plus signs inside the holder.
2. Place the battery holder back into the typewriter.

Note: The batteries will *not* save margins and other settings in the correction memory unless the plus sign on each battery matches the plus sign inside the holder.

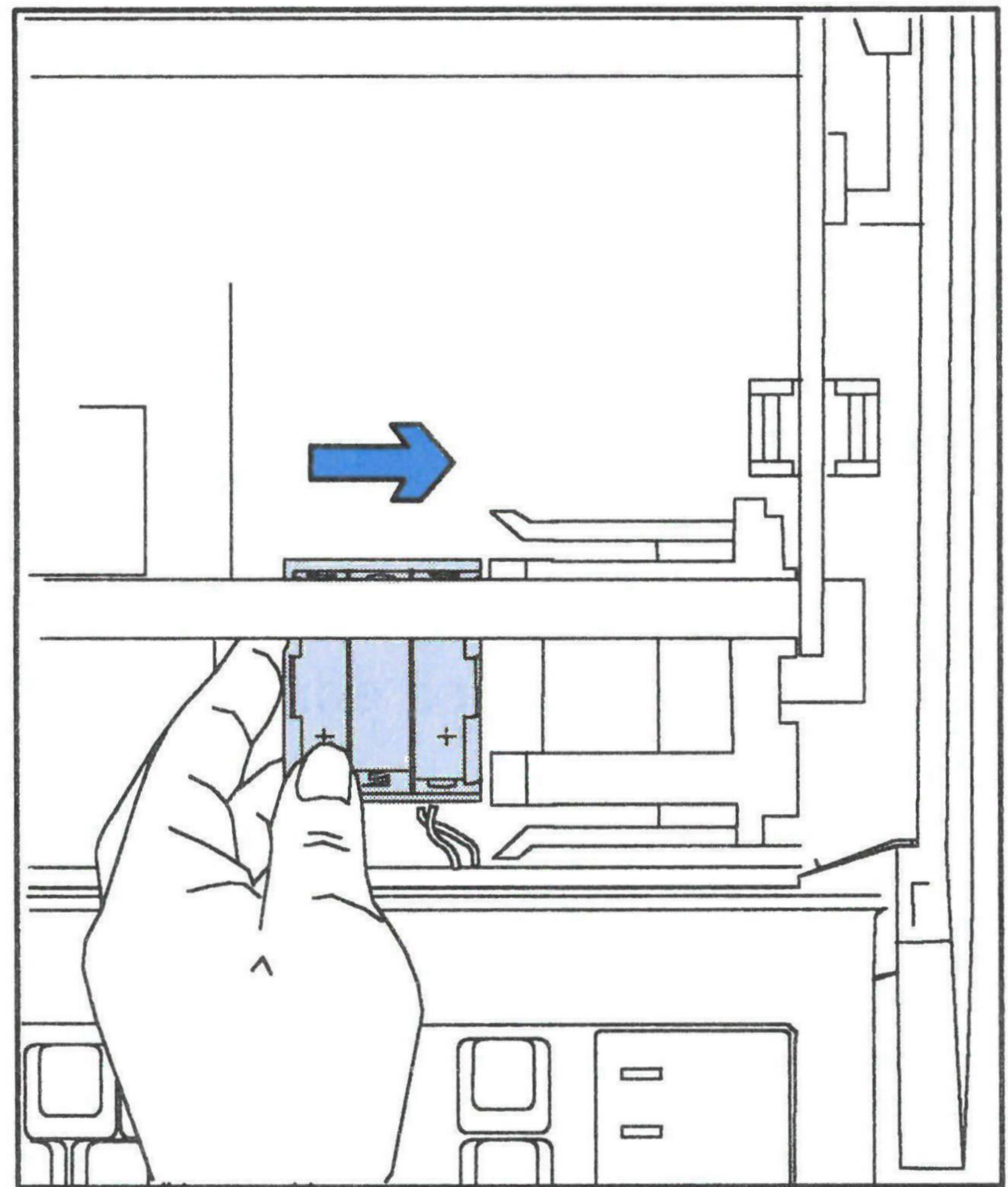
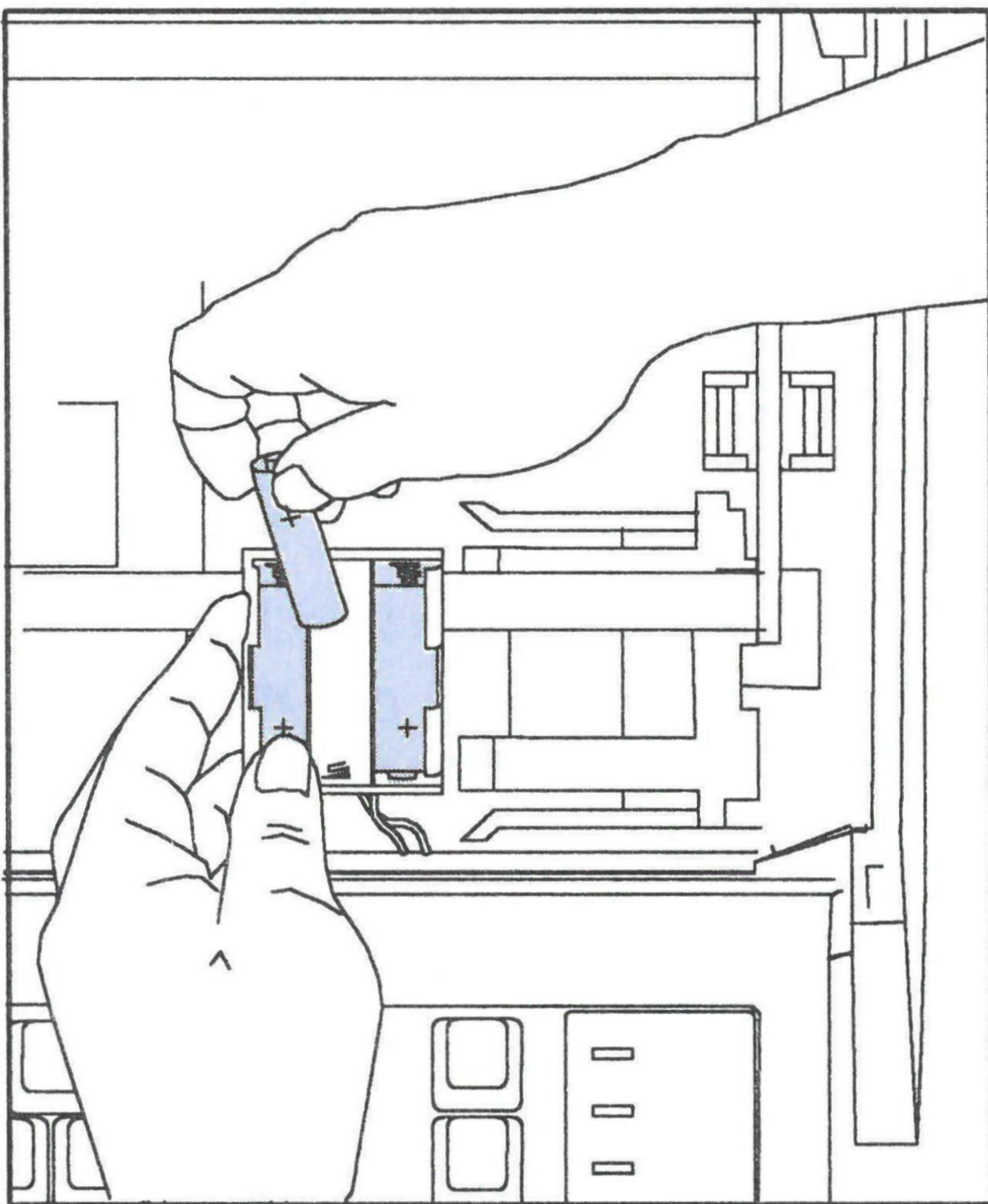

Care and Maintenance

Cleaning the Typewriter Cover

Important: Use only a damp cloth and mild detergent to clean the typewriter cover and keybuttons. Certain cleaning fluids may be harmful. *Do not use IBM cleaning fluid.*

Serial Number

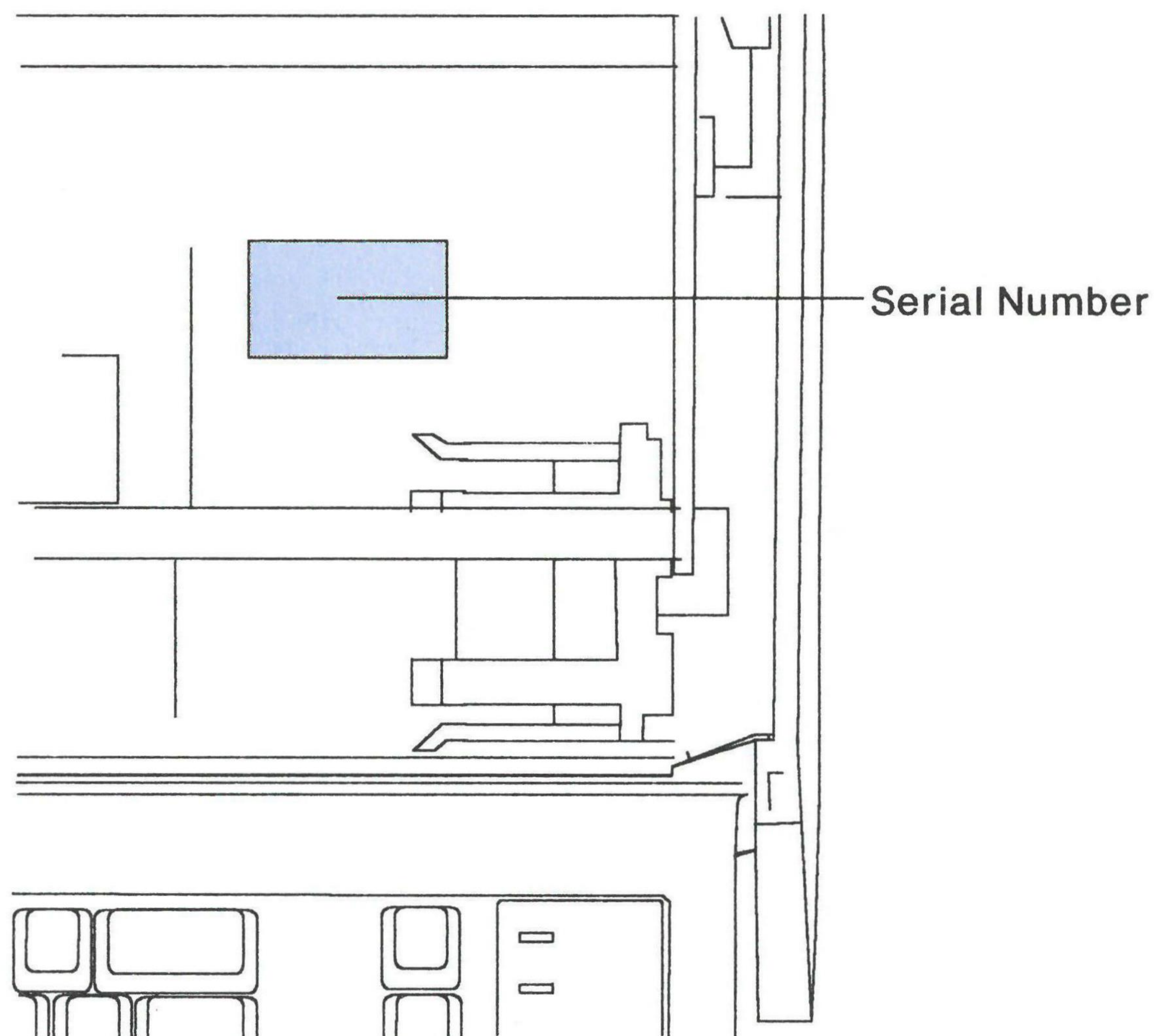

To locate the serial number on your typewriter, raise the typewriter cover and look on the right of the inside bottom cover. The serial number (S/N) is shown on the voltage label behind the batteries.

Appendix. Spell Check Option

Introduction

The Spell Check Option allows you to check the spelling of words as you type. After you type a word, the spelling is checked against a main dictionary and a supplemental dictionary. The main dictionary in both the U.S. and U.K. Spell Check contains approximately 50,000 words. The French and Spanish Spell Check dictionaries contain approximately 150,000 words. The supplemental dictionary can contain up to 300 words.



In the English Spell Check Option (U.S. and U.K.), only words containing 30 characters or fewer are checked. Spell Check will beep to indicate an error when a word with more than 30 characters is typed. In the French and Spanish Spell Check Options, only words containing 64 characters or fewer are checked.

You must *end the word* before it can be checked. The end of a word is recognized and the word is checked when you type a space after the word. The end of a word is also recognized after a tab, carrier return, number, or other operations such as decimal tab.

When you type a word that does not match a word in either dictionary, you will hear a beep. This beep has a different tone from the normal typewriter beep and is called the spelling beep. Some correctly spelled words may cause a spelling beep because they are not in either dictionary; for example, proper names, abbreviations, and technical terms. You will learn how to create a supplemental dictionary so that these words will not be treated as spelling errors.

In the main dictionary, valid prefixes and suffixes are ignored when checking the root word. Therefore, both *mother* and *motherly* are acceptable. Occasionally, this allows an invalid word to pass because of an incorrectly added prefix or suffix; for example, *laborly* or *prelabor*. However, words in the *supplemental* dictionary must be matched *exactly*.

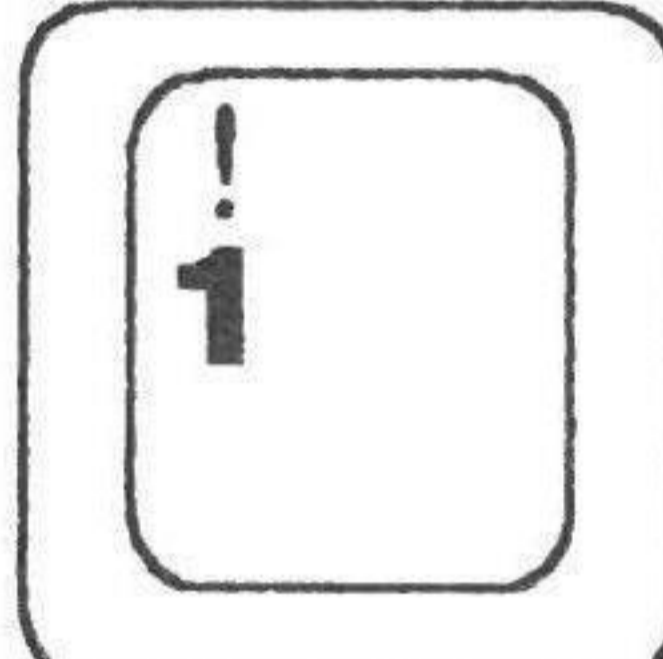
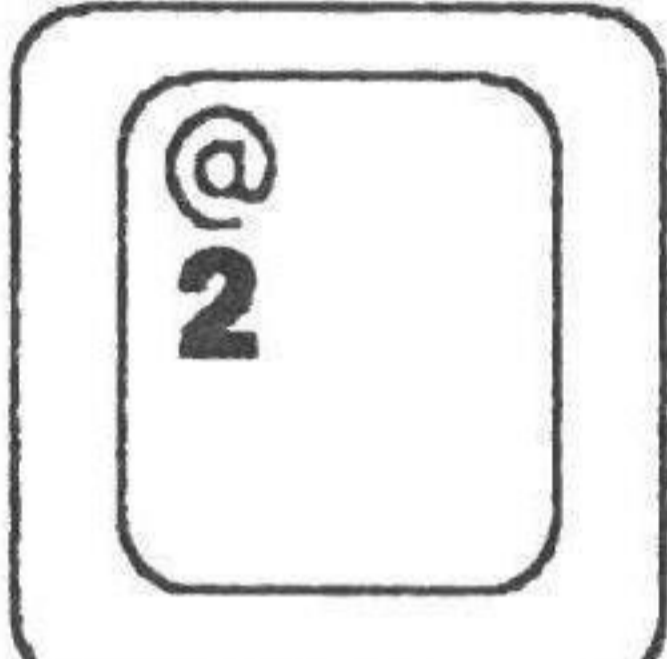
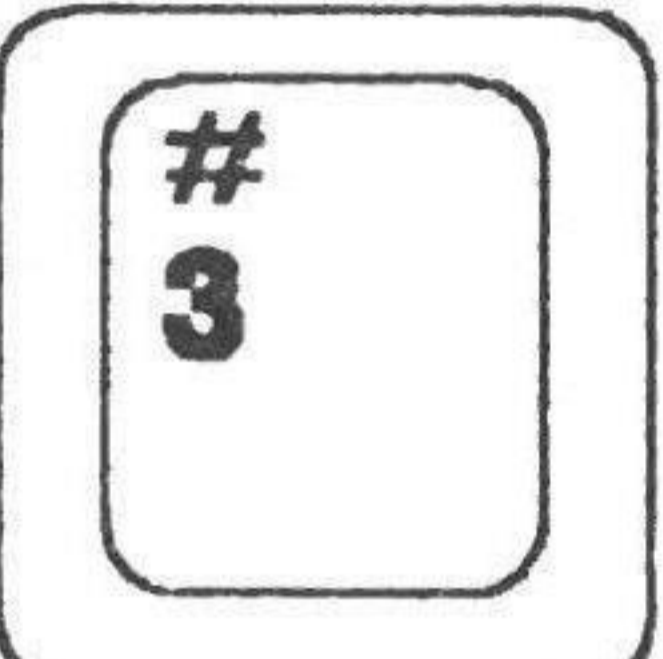
You use the **1**, **2**, **3**, and **4** keys with the **Code** key to activate the various functions of the Spell Check Option. The words labeled above the keys are printed in green to show that these keys are used with the **Code** key.

Spell On/Off	Add	Delete	Volume
			

Notes:

- The Spell Check Option is available for the following languages: U.S. English, U.K. English, French, and Spanish.
- Contact your IBM Authorized Dealer for ordering and installation information.

Using the Spell Check Option

You can use your typewriter with the Spell Check Option on or off. The Spell Check setting is retained when you turn the typewriter off as long as the typewriter batteries are good. In other words, if Spell Check is off when you turn the typewriter off, it will be off when you turn the typewriter back on.

To turn Spell Check on, hold down **Code** while you press **1**. The spelling beeper beeps to indicate that Spell Check is on.

To turn Spell Check off, hold down **Code** while you press **1**.

If you type a word not found in either the main or supplemental dictionary, the spelling beeper beeps. You can:

- Ignore the beep and continue typing.
- Correct the misspelled word.
- Decide that the word is not misspelled and should be added to the supplemental dictionary. (You will learn about this choice later in “Adding a Word to the Supplemental Dictionary” on page A-4.)

Supplemental Dictionary

The supplemental dictionary is a dictionary you create for your own needs. It contains special words that you use often which are not found in the main dictionary; for example, proper names or technical terms. The contents of the supplemental dictionary are retained when the typewriter is turned off as long as you have good batteries installed in the typewriter.

Unlike the main dictionary, the supplemental dictionary can only check a word *exactly* as you entered it. The word is not checked for plurals, prefixes, or suffixes. For example, if you enter the word *frog* into the supplemental dictionary, *frogs* will still cause the spelling beeper to beep as if it were a misspelled word.

Each time you add a word to the supplemental dictionary or type a word already in the supplemental dictionary, that word becomes the first word in the dictionary. All other words move back one place. The supplemental dictionary can hold up to 300 words. When you add the 301st word, that word becomes the first word in the dictionary and the last word in the dictionary is deleted.

Adding a Word to the Supplemental Dictionary

If the last word you typed caused the spelling beeper to beep, and it is 30 characters or less (64 for French and Spanish), you can add it to your supplemental dictionary. Remember, you must follow the word with a space or other word ending before adding it to the supplemental dictionary.

Hold down **Code** while you press **2** to add the last word you typed to the supplemental dictionary.

Deleting a Word from the Supplemental Dictionary

If you accidentally add a misspelled word to the supplemental dictionary, you can delete it. You cannot delete a word from the main dictionary. You must end the word with a space, punctuation, or other word ending before you can delete it.

Hold down **Code** while you press **3** to delete the last word you typed from the supplemental dictionary.

Changing the Sound of the Spelling Beeper

You may want to change the sound of the spelling beeper to a tone that is different from the typewriter next to you, or to a volume that is more suitable to the level of noise in your work area.

Hold down **Code** while you press **4** until the spelling beeper has the sound you desire. There are twelve choices. The beeper tone you selected is saved when you turn the typewriter off as long as the typewriter batteries are good.

Index

A

accent marks 2-2
alphabetic keyboard cross-
reference 2-3
alternate keyboards 2-1
ARtn key 1-16
ARtn light 1-16
automatic carrier return 1-16
automatic erase 1-14

B

B (Bold) key 1-23
Backspace (Bksp $\frac{1}{2}$) key 1-17
batteries
 checking 4-12
 installing 4-14
 removing 4-13
beeper signals 3-3
blinking light signals 3-3
Bold light 1-23
bold print 1-23

C

C (Ctr) key 1-18
Caps key 1-13
Caps light 1-13
cardholder 1-10
care and maintenance 4-15
carrier movement keys 1-6
 Reloc 1-6
 → 1-6
 ← 1-6
carrier return, automatic 1-16
centering 1-18
centering marks defined 1-8
characters per inch 1-7

checking the batteries 4-12
cleaning the typewriter cover 4-15

Code key 1-3

B (Bold) 1-23

C (Ctr) 1-18

D (DecT) 1-24

H ($\frac{1}{2}$ ↓) 1-22

L (Lang) 2-1

micro paper movement 1-6

O (RFlsh) 1-21

Q (Impr) 1-9

setting line spacing 1-3

summary of coded
functions 1-25

Tab (IndL) 1-20

U (Cont) 1-19

Y ($\frac{1}{2}$ ↑) 1-22

column, typing numbers in 1-24

Cont light 1-19

continuous underline 1-19

correction memory 1-14

cross-reference, keyboard alpha-
betic 2-3

CRtn key 1-12

D

D (DecT) key 1-24

dead keys 2-2

decimal tabs

 typing numbers in a
 column 1-24

drawing vertical lines 1-10

E

erase problems 3-5
erasing 1-14
 automatic 1-14
 manual 1-15

F

flush right text 1-21

H

H (½ ↓) key 1-22

I

ID number, keyboard 2-1
impression control 1-9
Ind Clr key 1-20
indenting 1-20
IndL key 1-20
inserting extra character 1-17
installing new batteries 4-14
installing printwheels 4-7
installing ribbon cassettes 4-9

K

keyboard
 alphabetic cross-reference 2-3
 alternate 2-1
 charts 2-5
 identification numbers 2-5
 primary 2-1
keyboard alphabetic cross-
reference 2-3
keys
 Code 1-3
 Code key summary 1-25
 Line Space 1-3
 Lock and **Caps** 1-13
margin 1-11
paper and carrier
movement 1-6

keys (*continued*)

Reloc 1-6
Tab 1-12
typematic (repeat) 1-9

L

latching the ribbon cassettes
together 4-9
left margin 1-11
left margin, temporary 1-20
levers
 paper bail load 1-5
 paper release 1-5
lights, indicator
 ARtn 1-16
 Bold 1-23
 Caps 1-13
 Cont 1-19
 Line Space 1-3
 Lock 1-13
Line Space key 1-3
LMar key 1-11
Lock key 1-13
Lock light 1-13
L(Lang) key 2-2

M

maintenance and care 4-15
manual erase 1-15
margins
 centering between 1-18
 indent, temporary 1-20
 left 1-11
 right 1-11
 scale 1-8
margin/pitch scale 1-8
MarRel key 1-11
matching printwheels and key-
boards 2-1
memory, correction 1-14

N

N (Caps) key 1-13
numbers, typing in columns 1-24

O

O (RFlsh) key 1-21
on/off switch 1-2
operating the typewriter 1-1
ordering supplies 4-1

P

page end indicator 1-4
paper
 inserting 1-5
 movement 1-6
 release lever 1-5
 removing 1-6
paper and carrier movement
 keys 1-6
paper bail load lever 1-5
Paper Down (Micro) key 1-6
paper movement keys
 Paper Down (Micro) 1-6
 Paper Up (Micro) 1-6
 ↑ 1-6
 ↓ 1-6
Paper Release Lever 1-5
paper table 1-5
Paper Up (Micro) key 1-6
parts of the typewriter 1-1
permanent tabs 1-12
pitch
 scale 1-8
 selection, automatic 1-7
pitch defined 1-7
pointer 1-8
primary keyboard 2-1
print hammer 4-6
print quality problems 3-6
printwheel
 applications 4-4

printwheel (*continued*)
 identification 1-7
 identification numbers 2-1
 installing 4-7
 pitch table 1-7
 pointer 1-7, 1-10
 removing 4-6
problem determination 3-1
 assistance 3-1
 how to use 3-1

Q

Q (Impr) key 1-9

R

reference 4-1
releasing left margin 1-11
Reloc key 1-6, 1-15
removing paper 1-6
removing ribbon cassettes 4-8
removing the batteries 4-13
removing the printwheel 4-6
repeat keys 1-9
required space 1-17
ribbon
 applications 4-10
 cassette system 4-8
 installing 4-9
 latching cassettes together 4-9
 removing 4-8
 reorder numbers 4-11
 take-up wheel color code 4-11
ribbon release lever 4-8
RMar key 1-11

S

safety information iv
samples, timesteps 4-1
scale, margin/pitch 1-8
serial number 4-15
Spacebar 1-17
space, required 1-17
special characters 1-23
Spell Check
 spelling beeper A-5
 supplemental dictionary, adding
 and deleting words A-4, A-5
 using A-3
Spell Check Option A-1
spell check problems 3-8
subscripts 1-22
superscripts 1-22
supplies, ordering procedures 4-1
switch, on/off 1-2

T

Tab key 1-12
tabs
 clearing 1-12
 permanent 1-12
 setting 1-12
TClr key 1-12
temporary left margin 1-20
TSet key 1-12
typematic keys 1-9
timestep samples 4-1
typing numbers in columns 1-24
typing problems 3-7

U

U (Cont) key 1-19
underlining
 automatic 1-19
 continuous 1-19

V

vertical lines, drawing 1-10

Y

Y (½ ↑) key 1-22

Reader's Comment Form

You may use this form to communicate your comments about this publication, with the understanding that IBM may use or distribute whatever information you supply in any way it believes appropriate without incurring any obligation to you.

1. Did you find the book well organized?

Yes No

2. Was the content of the book accurate and complete?

Yes No

3. Was the book easy to use?

Yes No

4. What can we do to improve the book?

5. What is your job title?

Questions or comments about supplies, service, applications, and so on will slow response time considerably. Please refer those questions or comments to your IBM Authorized Dealer or IBM Direct.

Note: Please direct all requests for copies of IBM publications to your IBM Authorized Dealer. Publications are not stocked at the location to which this form is addressed.



NO POSTAGE
NECESSARY
IF MAILED
IN THE
UNITED STATES

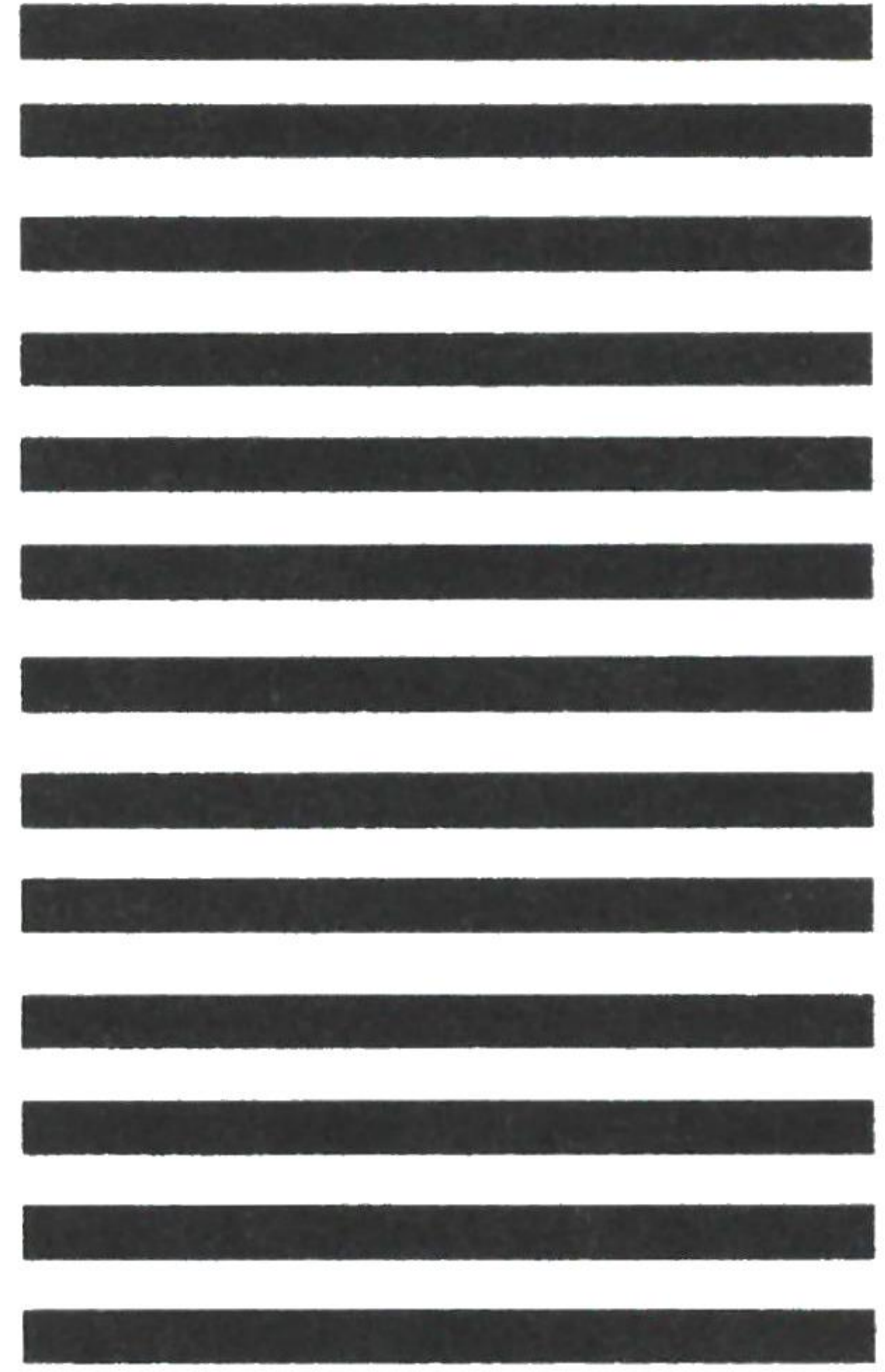

BUSINESS REPLY MAIL
FIRST CLASS PERMIT NO. 123 LEXINGTON, KY 40511

POSTAGE WILL BE PAID BY ADDRESSEE

International Business Machines Corporation
Department F98, Building 962-3
740 New Circle Road, N.W.
Lexington, Kentucky 40511



Fold Here

Cut Along Line

Tape

Please Do Not Staple

Tape

Reader's Comment Form

You may use this form to communicate your comments about this publication, with the understanding that IBM may use or distribute whatever information you supply in any way it believes appropriate without incurring any obligation to you.

1. Did you find the book well organized?

Yes No

2. Was the content of the book accurate and complete?

Yes No

3. Was the book easy to use?

Yes No

4. What can we do to improve the book?

5. What is your job title?

Questions or comments about supplies, service, applications, and so on will slow response time considerably. Please refer those questions or comments to your IBM Authorized Dealer or IBM Direct.

Note: Please direct all requests for copies of IBM publications to your IBM Authorized Dealer. Publications are not stocked at the location to which this form is addressed.



NO POSTAGE
NECESSARY
IF MAILED
IN THE
UNITED STATES

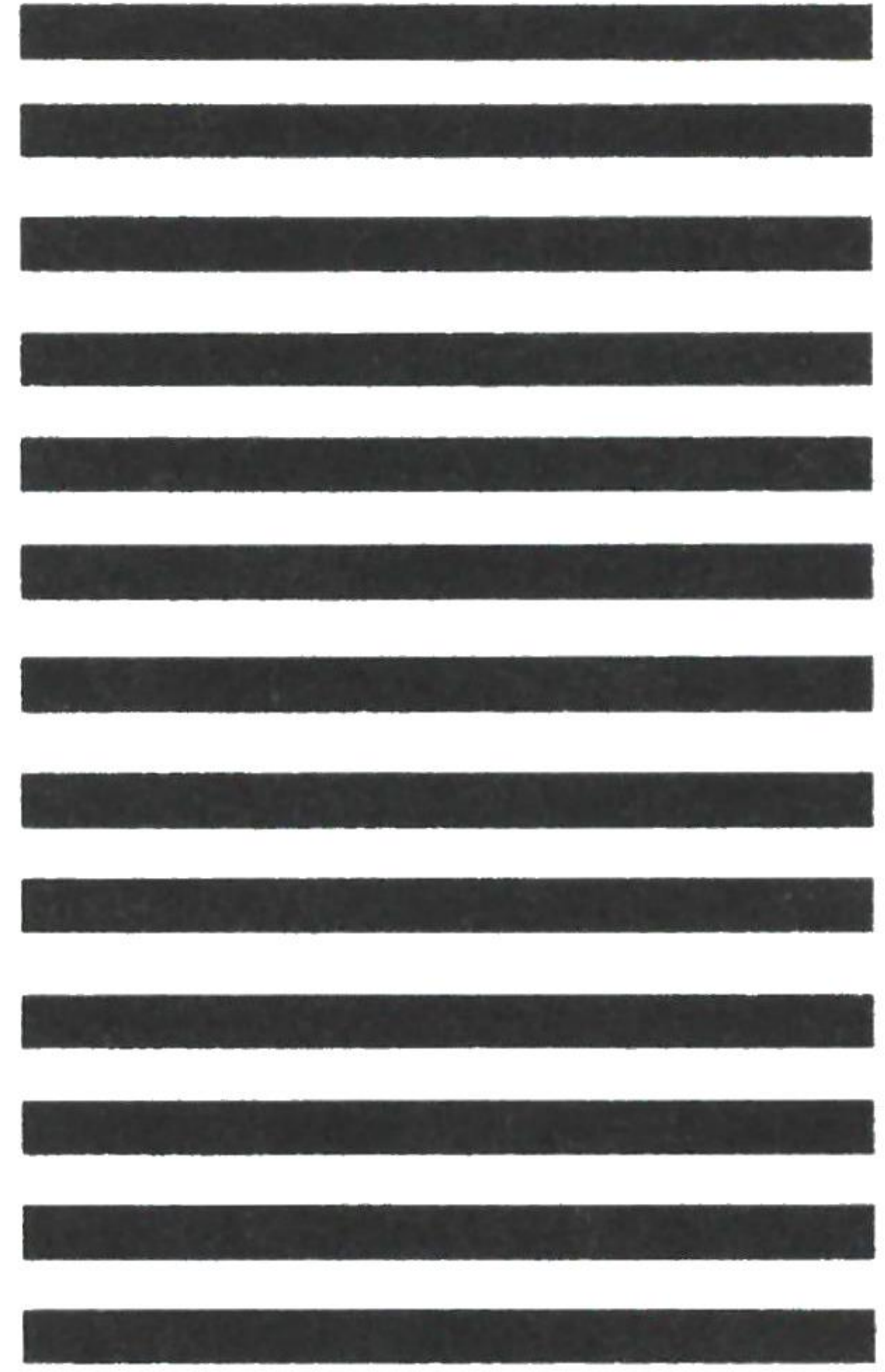

BUSINESS REPLY MAIL
FIRST CLASS PERMIT NO. 123 LEXINGTON, KY 40511

POSTAGE WILL BE PAID BY ADDRESSEE

International Business Machines Corporation
Department F98, Building 962-3
740 New Circle Road, N.W.
Lexington, Kentucky 40511



Fold Here

Cut Along Line

Tape

Please Do Not Staple

Tape

Do not expose to temperatures above 140° F, such as in a closed vehicle.



International Business Machines Corporation

Information Products Division

Form No. S544-4210-0

Printed in USA

P/N 1181112

3/88

S544-4210-00

