

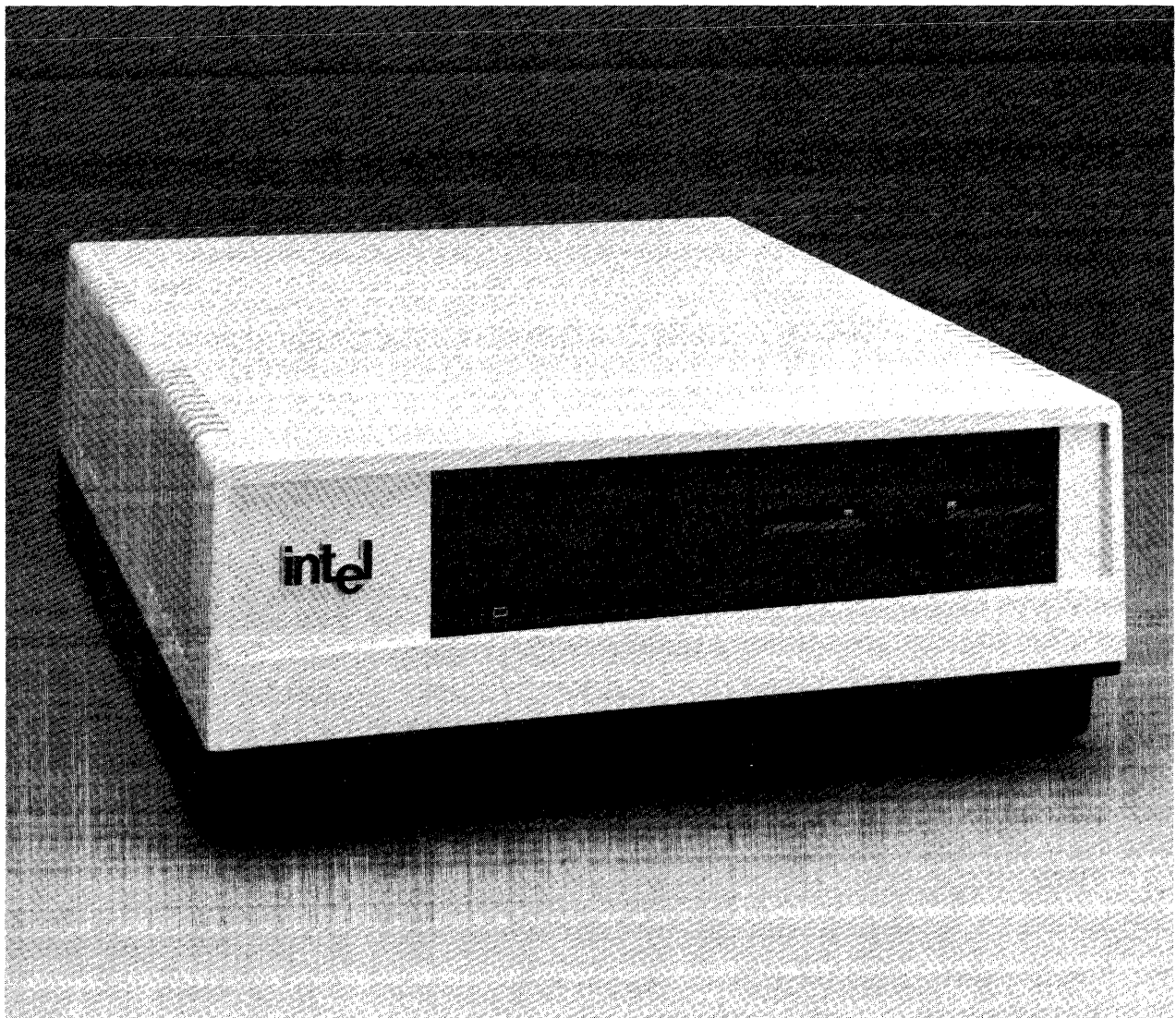

SYSTEM 310 INSTALLATION AND OPERATION GUIDE



SYSTEM 310 INSTALLATION AND OPERATION GUIDE

Order Number: 173211-002

CAUTION

This equipment generates, uses, and can radiate radio frequency energy and, if not installed and used in accordance with the instruction manual, may cause interference to radio communications. It has been tested and found to comply with the limits for Class A Computing Device pursuant to Subpart J of Part 15 of FCC rules, which are designed to provide reasonable protection against such interference when operated in a commercial environment. Operation of this equipment in a residential area is likely to cause interference, in which case the user, at his own expense, will be required to take whatever measures may be required to correct the interference.

WARNING

Risk of electric shock may be present on exposed metal parts unless this product is adequately grounded in accordance with the following guidelines.

- A) An insulated grounding conductor, at least as suitable in size, insulation material, and thickness as the building AC line circuit conductors, must be installed as part of the building wiring.
- B) The grounding conductor mentioned in item A is to be grounded to the earth at suitable building earth ground such as the steel frame or water pipe of a building if it is suitably earth grounded.
- C) The wall outlets in the vicinity of this product must be of the grounding type and must be constructed and connected as described in items A and B.

The information in this document is subject to change without notice.

Intel Corporation makes no warranty of any kind with regard to this material, including, but not limited to, the implied warranties of merchantability and fitness for a particular purpose. Intel Corporation assumes no responsibility for any errors that may appear in this document. Intel Corporation makes no commitment to update or to keep current the information contained in this document.

Intel Corporation assumes no responsibility for the use of any circuitry other than circuitry embodied in an Intel product. No other circuit patent licenses are implied.

Intel software products are copyrighted by and shall remain the property of Intel Corporation. Use, duplication or disclosure is subject to restrictions stated in Intel's software license, or as defined in ASPR 7-104.9 (a) (9).

No part of this document may be copied or reproduced in any form or by any means without prior written consent of Intel Corporation.

The following are trademarks of Intel Corporation and its affiliates and may be used only to identify Intel products:

BITBUS COMMputer CREDIT Data Pipeline Genius Δ I i I ² ICE ICE	iCS iDBP iDIS iLBX im iMMX Insite intel intelBOS Intelelevision	intelligent Identifier intelligent Programming Intellec Intellink iOSP iPDS iRMX iSBC iSBX iSDM	iSXM Library Manager Megachassis MICROMAINFRAME MULTIBUS MULTICHANNEL MULTIMODULE Plug-A-Bubble PROMPT Promware	QUEX QUEST Ripplemode RMX/80 RUPI Seamless SOLO SYSTEM 2000 UPI
--	--	--	--	---

XENIX is a trademark of Microsoft Corporation. Centronics is a trademark of Centronics Data Computer Corporation. Chassis Trak is a trademark of General Devices Company, Inc.

REV.	REVISION HISTORY	DATE
-001	Original issue	10/83
-002	Includes installation instructions for the floorstand model	06/84

CONTENTS

	PAGE
CHAPTER 1	
INTRODUCTION AND UNPACKING INSTRUCTIONS	
Audience	1-1
Manual Organization	1-2
Unpacking Instructions	1-2
CHAPTER 2	
SYSTEM DESCRIPTION	
The Front Panel	2-2
The 5¼-Inch Flexible Diskette Drive	2-2
The Winchester Disk Drive	2-2
The System Power and Run Indicators	2-2
The System RESET Button	2-2
The System INTERRUPT Button	2-2
The Back Panel	2-3
The ON/OFF Switch	2-4
The AC Power Plug	2-4
The Line Voltage Selector	2-4
The Fuse	2-4
The Fuse Cover and the Fuse-Pull Lever	2-5
The Terminal Connectors	2-5
The Printer Connector	2-5
CHAPTER 3	
PREPARATION FOR USE	
Attaching the Rubber Feet	3-1
Changing the Fuse	3-2
Changing the Line Voltage Selection	3-2
Changing the Power Cord Plug	3-4
Attaching a Terminal	3-6
Attaching a Printer	3-7
CHAPTER 4	
STARTUP AND VERIFICATION	
Powering Up the System	4-1
Running the System Confidence Test (SCT)	4-3
Installing the Operating System	4-4
Troubleshooting the System	4-4
Failure to Power Up	4-4
Failure to Start the SCT	4-4
Failure to Pass the SCT	4-4
Reseating the Circuit Boards	4-5
Modifying the System	4-7

	PAGE
CHAPTER 5	
MOUNTING INSTRUCTIONS	
Mounting the System in a Floorstand	5-2
Mounting the System in a Standard 19-Inch Rack	5-4
Removing the Top Cover	5-4
Removing the Mounting Bars from the Chassis Trak Slides	5-5
Attaching the Mounting Bars to the System	5-6
Mounting the System in the 19-Inch Rack	5-6
Mounting the System on a Desk	5-8
 CHAPTER 6	
FLEXIBLE DISKETTE DRIVE OPERATION	
Inserting a Diskette	6-1
Removing a Diskette	6-2
Write-Protecting a 5¼-Inch Diskette	6-2
Cleaning the Flexible Diskette Drive	6-2
 APPENDIX A	
INTERFACE REQUIREMENTS	
Terminal Interface Requirements	A-1
Printer Interface Requirements	A-2
 APPENDIX B	
SPECIFICATIONS	
 APPENDIX C	
SERVICE INFORMATION	
 APPENDIX D	
RELATED PUBLICATIONS	
 INDEX	

TABLES

TABLE	TITLE	PAGE
A-1	Pinouts for the Terminal Connector	A-1
A-2	Pinouts for the Printer Connector	A-2

FIGURES

FIGURE	TITLE	PAGE
1-1	How the System 310 Is Packaged	1-3
2-1	The System 310	2-1
2-2	The Back Panel	2-3
3-1	Attaching the Rubber Feet	3-1
3-2	Line Voltage Selector Board Orientations	3-3
3-3	Power Cord Plugs	3-5
3-4	Typical Terminal Connection	3-6
3-5	Typical Printer Connection	3-7
4-1	System Verification Chart	4-2
4-2	A Sample Screen After Failure to Load the Operating System	4-3
4-3	Removing the Back Panel	4-6
4-4	Removing the Board Retainers	4-6
4-5	Reseating the Circuit Boards	4-7
5-1	System 310 Operating Positions	5-1
5-2	The Floorstand Mounting Procedure	5-2
5-3	Removing the Top Cover	5-5
5-4	Rack-Mounting the System	5-7
5-5	Desk-Mounting the System	5-8
6-1	Proper Way to Insert a Diskette	6-1
B-1	System 310 Dimensions	B-2

The System 310 is a flexible microcomputer system that offers you a choice of processors, operating systems, and Winchester disk drives. You choose either:

- An 8086 or 80286 microprocessor
- An iRMX™ or XENIX operating system
- A 12-megabyte or 19-megabyte 5¼-inch Winchester disk drive

Each System 310 also contains a 5¼-inch double-sided, double-density flexible diskette drive. By offering these choices, Intel lets you customize the System 310 to meet the unique needs of your application.

When your system arrives, the processor and memory devices are already installed and ready to use. The operating system arrives separately. Intel also supplies a set of diagnostic diskettes and a diagnostic user's manual with every system. These are also shipped separately. The diagnostic diskettes contain tests to verify your system is working properly. (See Chapter 4 for information on installing the operating system and running the system diagnostic tests.)

This manual describes an 80286-based system having one 5¼-inch flexible diskette drive and one 5¼-inch Winchester hard disk drive. This is a typical system and is shown on the cover of this manual. The information contained in this manual, however, applies to all other System 310 configurations unless otherwise noted.

Audience

This manual will help you unpack, test, install, and operate your System 310 Microcomputer. It will also refer to other Intel publications for instructions on how to install the operating system, run detailed diagnostic tests, and clean the flexible diskette drives.

No special technical knowledge or previous computer experience is necessary to use this manual, except in two cases. The first is in Chapter 3 where users outside the United States are advised that they may have to change plugs on the system's power cord: this should only be done by technically qualified people having a knowledge of local electrical standards. The other exception is in Chapter 5 and only applies to users who wish to mount the System 310 in a standard 19-inch EIA equipment rack. Mounting the system in a rack involves removing the system's top cover. This allows direct access to the system's AC lines. Since accidentally touching the AC lines could result in severe electrical shock, only technically qualified people should attempt to rack-mount the System 310.

Manual Organization

This manual contains six chapters and four appendixes.

- | | |
|------------|--|
| Chapter 1 | discusses the organization of the manual, introduces the System 310 Microcomputer, and advises you to check the shipping carton for damage. |
| Chapter 2 | identifies the various switches, lights, indicators, and components on the System 310 chassis. |
| Chapter 3 | describes how to prepare your system for operation (e.g., how to select the appropriate line voltage setting). |
| Chapter 4 | shows you how to start your system and verify that it is working properly. It also tells you what to do -- prior to calling for service -- if your system is not working properly. |
| Chapter 5 | gives instructions for mounting the system in a standard 19-inch rack, the Intel floorstand, or a desk-like workstation. |
| Chapter 6 | discusses how to load and write-protect the flexible diskettes and tells you how often to clean the diskette drives. |
| Appendix A | describes the interface requirements for attaching an RS-232C ASCII terminal or a Centronics-compatible printer to the System 310. |
| Appendix B | lists system environmental, electrical, vibrational, and physical specifications. |
| Appendix C | provides information on how to obtain service for your system. |
| Appendix D | gives a list of related publications. |

Unpacking Instructions

Figure 1-1 shows how the System 310 Microcomputer is packaged in the shipping carton. The carton contains:

- The System 310 Microcomputer
- This manual and a customer letter
- A power cord
- A 3A NORM-BLO fuse (for use in 220-240 VAC European systems)
- Four self-adhesive rubber feet

Before continuing to unpack the system, inspect the shipping carton (inside and out) for damage or waterstains. If the carton is severely damaged or waterstained, keep it (or photograph it) to show to the shipping agent. If the system is damaged, contact the Intel Customer Support Center (see Appendix C).

After inspecting the carton, prepare a flat work area and remove the System 310 as follows:

1. Hold the sides of the system and lift it straight up until it clears the shipping carton. The system weighs about 40 pounds so be sure to use proper lifting techniques, or get help to lift it from the carton. Dropping the system can severely damage the disk drives.
2. Place the system on the flat work area and remove the front and rear foam packing material.
3. Remove the cardboard insert from the flexible diskette drive.
4. Open the plastic bag packaged with this manual and check to see if it contains the power cord, fuse, and four rubber feet. If any part is missing, contact your local Intel Sales Representative.

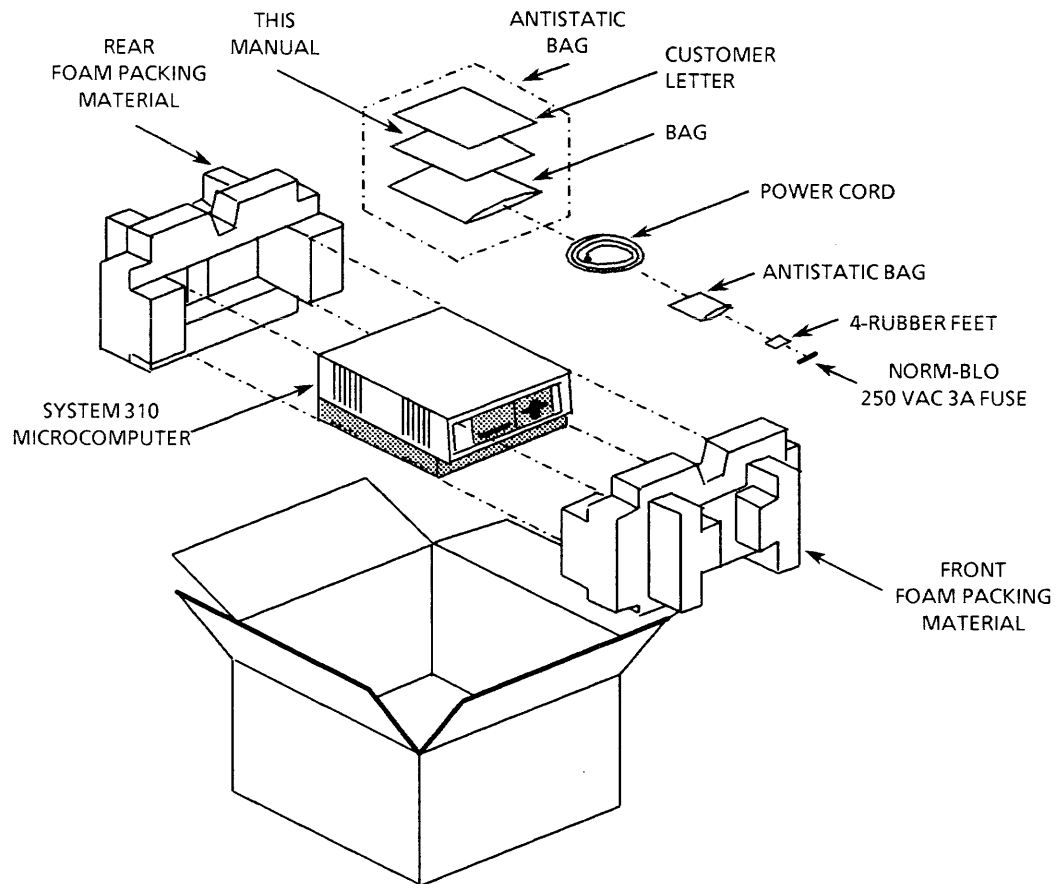

Figure 1-1. How the System 310 Is Packaged

F-0070

This chapter identifies the various components, switches, and indicators on the System 310 Microcomputer. Figure 2-1 shows the front and side of the system and the location of the following:

- 5¼-inch flexible diskette drive
- 5¼-inch Winchester disk drive
- Flexible diskette drive select light
- Winchester drive select light
- System INTERRUPT button
- System RESET button
- Red POWER ON indicator light
- Green RUN indicator light

The figure also shows the location of the holes used to mount the System 310 in a standard 19-inch rack (see Chapter 5).

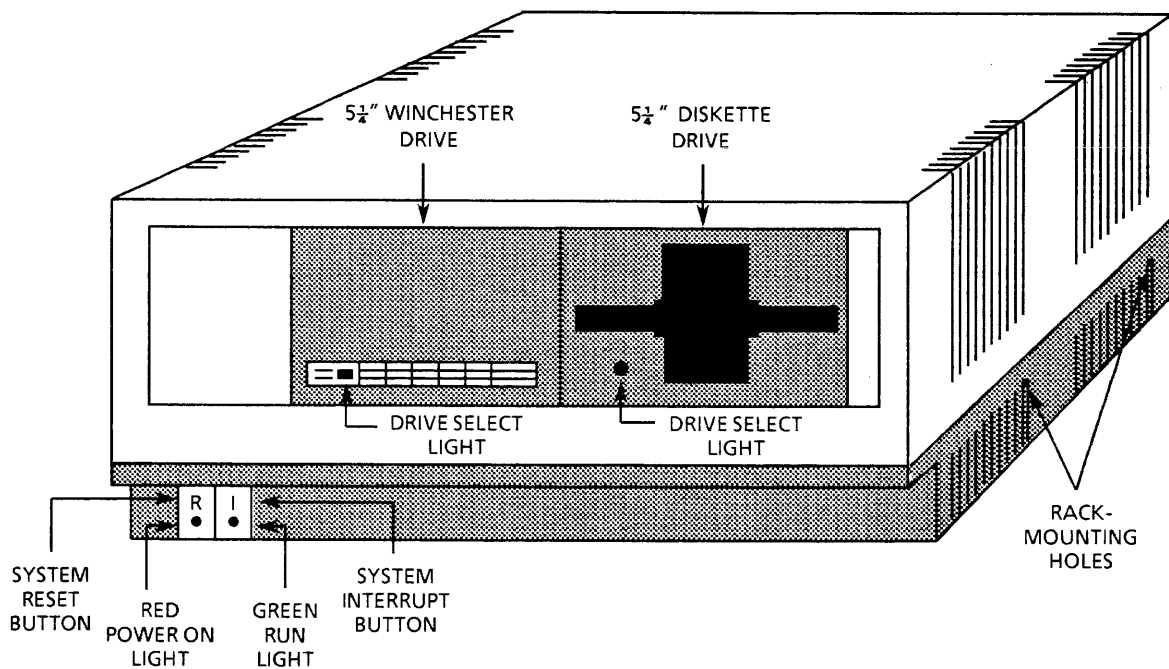

Figure 2-1. The System 310

F-0005-1

The Front Panel

This section describes the items on the front panel of the system.

The 5¼-inch Flexible Diskette Drive

The System 310 houses one 5¼-inch double-sided, double-density flexible diskette drive. This drive uses diskettes having a track density of 48 tracks per inch.

The Winchester Disk Drive

The System 310 accommodates one 5¼-inch Winchester hard disk drive. This drive is available in two memory sizes, 12 megabytes and 19 megabytes. The drive is sensitive to jarring and vibration. You should therefore avoid jarring or vibrating the system while it is operating.

CAUTION

To protect the drive's READ/WRITE heads, run "SDTWIN TEST 1A, UNLOCK HEADS FOR SHUTDOWN" to park the heads before transporting the system. This test is described in the diagnostic manual packaged with your diagnostic diskettes.

The System Power and Run Indicators

The red system POWER ON light, when lit, indicates the presence of +5 VDC power in the system. If the system loses power or is turned off, the red POWER ON light goes out.

The green system RUN light indicates the System 310 is running. If the system is halted for any reason, the green light goes out.

The System RESET Button

The system RESET button clears memory and restarts the system: all data not stored on disk is lost. Pressing RESET is equivalent to turning the system off and then turning it back on.

The System INTERRUPT Button

The system INTERRUPT button halts execution of the currently running task and passes control to the system monitor. The monitor is a built-in program that allows you to perform certain diagnostic and control functions without having the operating system installed. For more information about the system monitor, refer to the diagnostic manual packaged with your diagnostic diskettes.

The Back Panel

Figure 2-2 shows the System 310 back panel, which contains the following:

- ON/OFF power switch
- AC power plug
- 6A NORM-BLO fuse
- Line voltage selector board
- Fuse-pull lever
- Clear plastic fuse cover
- Terminal connectors (RS-232C ports J20 and J21)
- Printer connector (Centronics-compatible port J24)

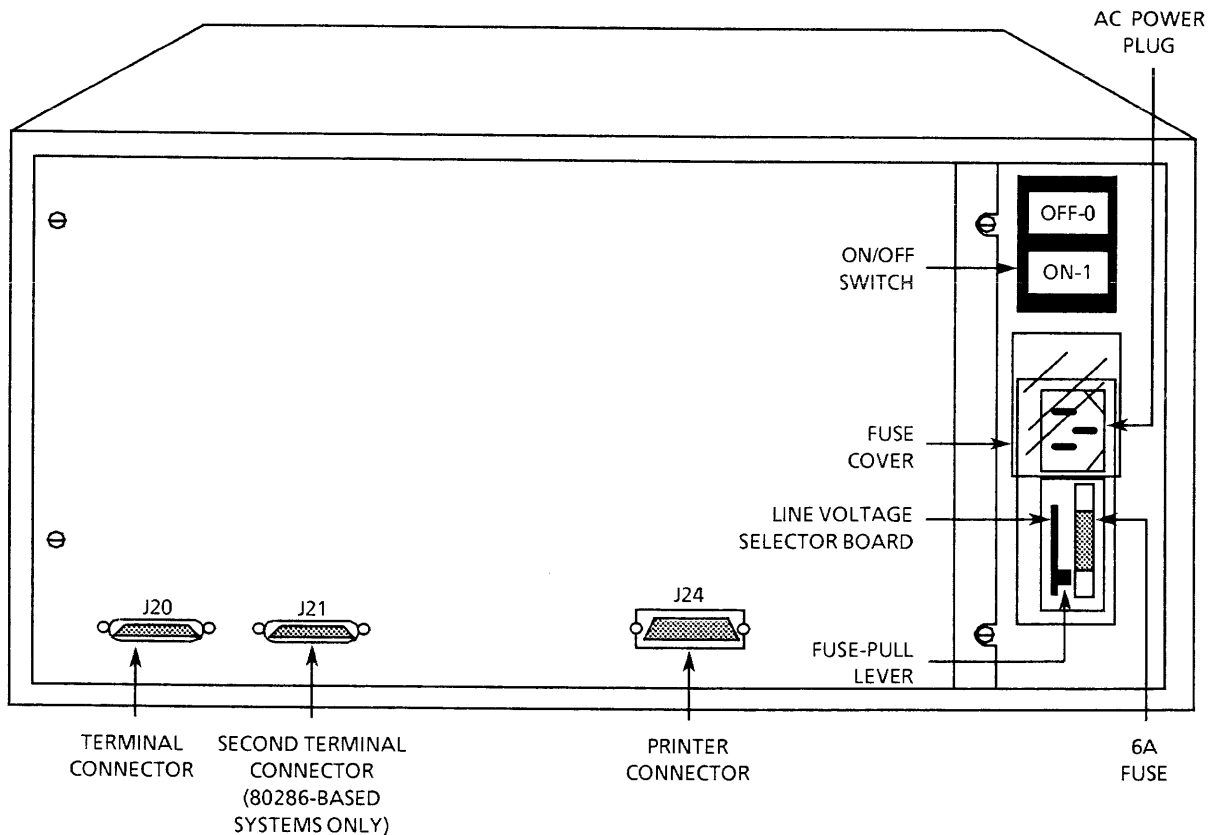

Figure 2-2. The Back Panel

F-0074-1

The ON/OFF Switch

The ON/OFF switch turns the System 310 on or off depending on which side of the toggle switch you press. When you turn the system on, the red POWER ON light on the front panel comes on, the Winchester disk drive select light comes on, and the System Confidence Test (described in Chapter 4) begins.

The AC Power Plug

The AC power plug accommodates the cord shipped with the System 310. This cord links the System 310 to the AC power source -- wall outlet or UPS (uninterruptable power source).

To use the system outside the United States, you may have to change the power plug to meet local electrical standards (see Chapter 3).

The Line Voltage Selector

The line voltage selector is a small board that inserts into the back of the System 310 next to the fuse. The board has four numbers written on it -- 100, 120, 220, and 240. These represent various AC line voltages. Typically, the 240 VAC setting is used in Europe, the 120 VAC setting is used in the United States, and the 100 VAC setting is used in Japan.

CAUTION

The board is factory-installed to accommodate 120 VAC and must be reset for use in 220 VAC or 240 VAC applications. Failure to change the line voltage selector (and the fuse) before using the system in a 220 VAC or 240 VAC application will destroy the system's power supply. Therefore, make sure you change the line voltage selector board (and fuse) before using it with line voltage sources greater than 120 VAC.

See Chapter 3 for instructions on how to change the line voltage selection (and fuse) to accommodate other AC source voltages, and to see how the line voltage board should be inserted in the system (see Figure 3-2).

The Fuse

The factory-installed fuse is a 250 VAC 6A NORM-BLO fuse and is appropriate for use in 100-120 VAC applications. For 220-240 VAC operation you must replace the factory-installed fuse with the 3A fuse packaged with the system. See Chapter 3 for instructions on how to change the fuse.

NOTE

Fuse ratings for various AC line source voltages are printed on the back panel next to the fuse cover.

The Fuse Cover and the Fuse-Pull Lever

The clear plastic fuse cover prevents changing the fuse or line voltage setting while power is applied to the system: to raise the cover, you must disconnect the power cord from the back of the system. This design protects the system from inappropriate voltages and protects you from accidental shocks.

The fuse-pull lever, when pulled, ejects the base of the fuse from the fuse holder. When the fuse is removed, the lever can be raised all the way up to prevent the plastic fuse cover from sliding down.

The Terminal Connectors

The 80286-based systems have two identically configured terminal connectors -- J20 and J21. The 8086-based systems have only one terminal connector, J20. Each terminal connector is a 25-pin RS-232C female connector. The connector allows you to attach a standard RS-232C ASCII terminal to the system. Appendix A gives terminal specifications and pinout definitions. Chapter 4 gives communication parameters for the terminal. The cable connecting the terminal to the system should be shielded, and the shielding should be grounded to maintain RFI integrity.

The Printer Connector

The printer connector located at J24 is a Centronics-compatible female connector. It allows you to attach a Centronics-compatible printer to the system. Appendix A gives pinout definitions for this connector. The cable connecting the printer to the system should be shielded, and the shielding should be grounded to maintain RFI integrity.

Before using the System 310 for the first time, you should install the four rubber feet and connect your terminal to the system. Depending on your application, you may also have to:

- Change the line voltage setting and fuse
- Change the power cord connector
- Mount the system in a floorstand, rack, or workstation (see Chapter 5)
- Connect a printer

Attaching the Rubber Feet

The four one-inch square self-adhesive rubber feet shipped with the system are designed to protect work surfaces, prevent the system from sliding, and reduce vibration.

To install the four rubber feet:

1. Tilt the system on its side as shown in Figure 3-1.
2. Peel the adhesive backing off each rubber pad.
3. Press each pad firmly into the square indentations on the bottom of the system.

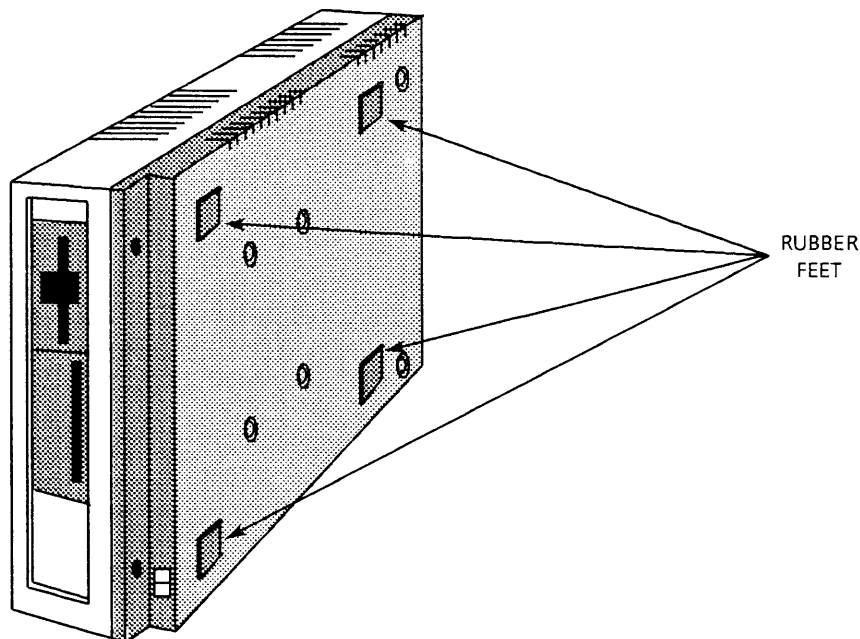

Figure 3-1. Attaching the Rubber Feet

F-0120-3

Changing the Fuse

The system is shipped with a 6A fuse already installed. This is adequate for line voltages up to 120 VAC. For higher voltages (220-240 VAC), you must replace the factory-installed fuse with the alternate 3A fuse packaged with the system. Otherwise the system power supply may be damaged. Fuse ratings are inscribed on the metal part of the fuse.

CAUTION

You must change the fuse before operating the System 310 in applications having line voltages higher than 120 VAC. Otherwise, the system power supply may be destroyed.

To change the fuse:

1. Turn the system off and unplug the AC power cord from the back of the system.
2. Slide the clear plastic fuse cover up so you can access the fuse.
3. Pull the fuse-pull lever toward you to eject the bottom of the fuse and pull the fuse loose from the fuse holder.
4. Snap either end of the fuse into the top of the fuse holder and then snap the other end into the bottom of the fuse holder. When you press the bottom of the fuse into the fuse holder, the fuse-pull lever will return to its original position.
5. Lower the plastic cover and plug the AC power cord into the system.

The fuse ratings for various line voltages are listed on the back of the system next to the fuse.

Changing the Line Voltage Selection

CAUTION

All systems shipped from Intel are set for 120 VAC for use in the United States. For use with higher line source voltages, you must change the line voltage selector board and fuse. Failure to change the line voltage selector board and fuse, and powering up the system while plugged into a 220 VAC or 240 VAC source, will destroy the system power supply. Therefore, make sure you change the line voltage selector board and fuse before operating the system with higher line voltages.

To change the line voltage setting, you must remove the line voltage selector board, rotate it so that the desired voltage can be read when reinserted, and then reinsert the board. Figure 3-2 shows proper orientations of the line voltage selector board.

To change the line voltage setting, do the following:

1. Turn the system off and unplug the AC power cord from the back panel.
2. Slide the fuse cover up and pull the fuse-pull lever toward you to eject the bottom of the fuse from the fuse holder. Then, remove the fuse.
3. Use needle-nose pliers to carefully grip the middle of the line voltage selector board (over the hole) and gently wiggle it up and down while pulling it loose from the system. Pull the board straight out until it clears the system.
4. The board has four numbers printed on it: 120 and 240 on one side, and 100 and 220 on the other side. Rotate the board so the desired voltage number is on the side of the board facing the fuse (see Figure 3-2).
5. Use the pliers again to reinsert the board, pressing it firmly back into place.
6. Install the new fuse as described in the previous section. Otherwise, press the fuse back into the fuse holder and let the plastic cover fall.
7. Plug the AC power cord back into the system.

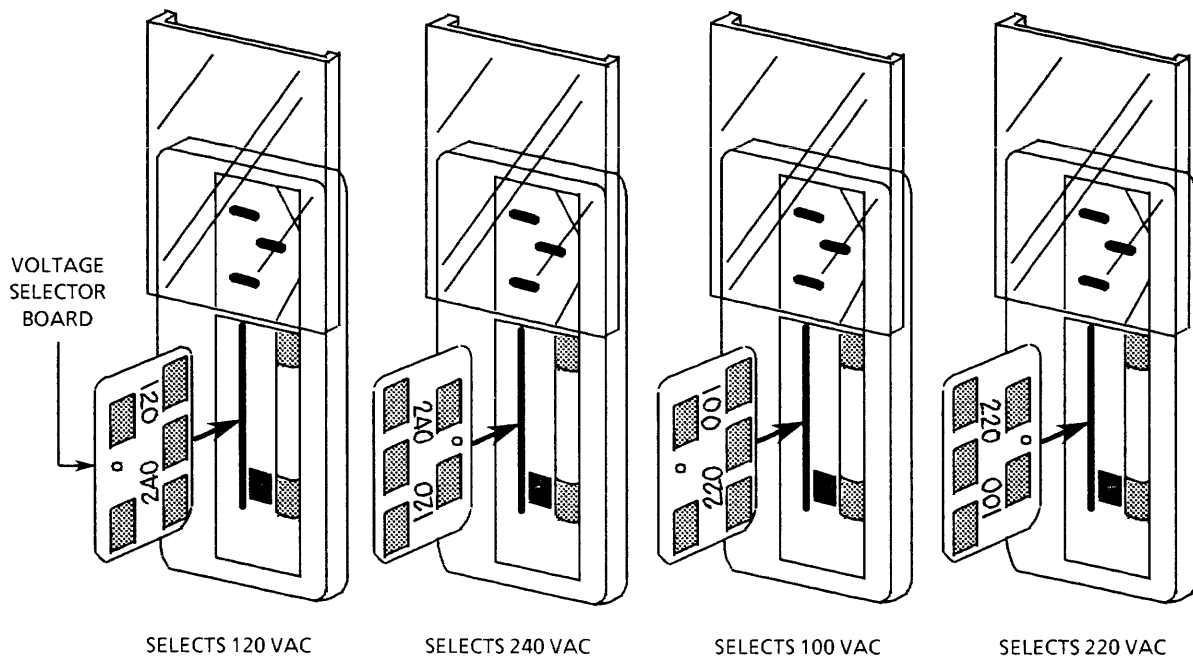

Figure 3-2. Line Voltage Selector Board Orientations

F-0086

Changing the Power Cord Plug

To use the system outside the United States, you may have to replace the power cord plug to conform to local electrical standards. Figure 3-3 shows typical connectors used in various parts of the world.

WARNING

To prevent possible electrical shock or damage to the system, only qualified technical personnel should change the power cord plug. Also, check local electrical standards before selecting a power cord plug. The information presented here does not cover all possibilities for all locations within the referenced areas.

When changing power cord plugs, make sure you connect all the wires properly:

- The green (or green and yellow striped) wire connects to earth ground.
- The white (or light blue) wire connects to the neutral side of the power line.
- The black (or brown) wire connects to the high (hot) side of the power line.

NOTE

The color of the earth, neutral, and high (hot) wires varies in different countries.

<p>N WHITE E GREEN/YELLOW L BLACK</p> <p>L BLACK E GREEN/YELLOW N WHITE</p>	<p>FURNISHED WITH THE SYSTEM</p>
<p>N LIGHT BLUE E GREEN/YELLOW L BROWN</p> <p>N LIGHT BLUE E GREEN/YELLOW L BROWN</p>	<p>6A EAST/WEST EUROPE, IRAN, ETC.</p>
<p>L BROWN N LIGHT BLUE E GREEN/YELLOW</p> <p>L BROWN E GREEN/YELLOW N LIGHT BLUE</p>	<p>5A GREAT BRITAIN, SOUTH AFRICA, INDIA, RHODESIA, SINGAPORE, ETC.</p>
<p>E GREEN N BLACK L RED</p> <p>L RED E GREEN N BLACK</p>	<p>6A NEW ZEALAND, AUSTRALIA, ETC.</p>
<p>LEGEND E: EARTH OR SAFETY GROUND L: LINE OF ACTIVE CONDUCTOR N: NEUTRAL OR IDENTIFIED CONDUCTOR</p>	

Figure 3-3. Power Cord Plugs

F-0241

Attaching a Terminal

NOTE

Appendix A gives requirements for attaching a terminal to the system. Make sure your terminal meets these requirements before attaching it.

To attach a terminal to your system, connect a shielded RS-232C cable between connector J20 on the back of the system and the RS-232C port on the back of your terminal. On 80286-based systems, connector J21 is available for a second terminal. Both ports are configured in DCE mode. Be sure to set the communication parameters of your terminal as follows:

- Baud rate = 9600 baud
- Parity = none (off)
- Number of stop bits = 1
- Duplex = full
- Number of data bits = 7
- Characters per line = 80
- XON/XOFF set active

Figure 3-4 shows a typical terminal connection.

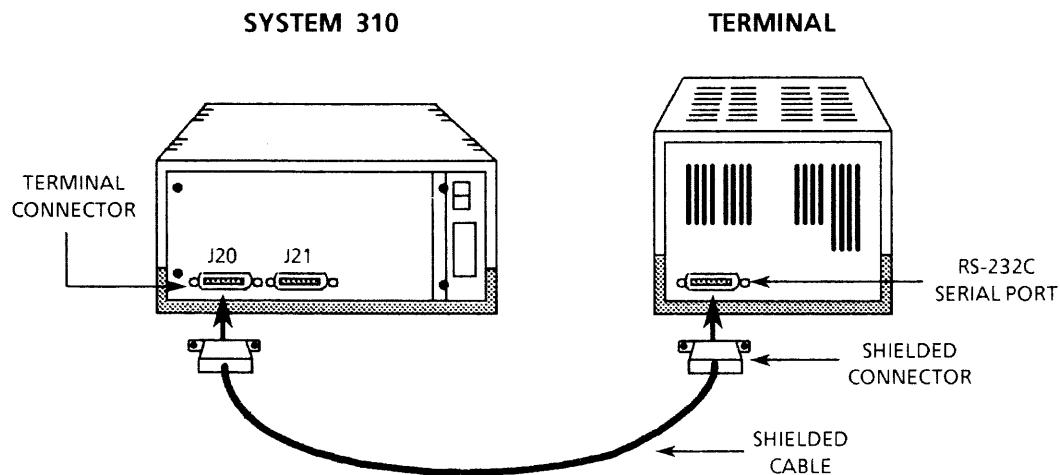

F-0063

Figure 3-4. Typical Terminal Connection

Attaching a Printer

NOTE

Appendix A gives requirements for attaching a printer to the system. Make sure your printer meets these requirements before attaching it.

To attach a printer to your system, connect a shielded Centronics-compatible cable between connector J24 on the back panel and the port on the back of your printer.

Figure 3-5 shows a typical printer connection.

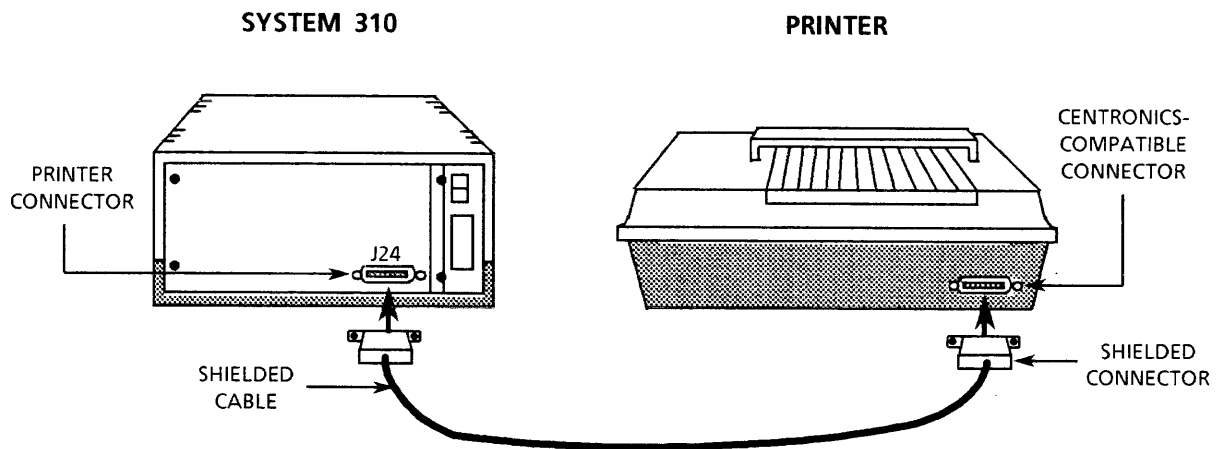

Figure 3-5. Typical Printer Connection

F-0063-1

The System 310 contains a self-diagnostic test, a bootstrap loader, and a monitor program. When you first turn the system on, the monitor program initiates the self-diagnostic System Confidence Test (SCT) and, upon successful completion of the test, attempts to load the operating system from disk. Since the system is shipped without an installed operating system, this attempt will fail. This is normal.

This chapter shows you how to start your system, view the SCT, and verify the system is working properly as received. It does not show you how to load the operating system or run the System Diagnostic Tests. Instead, this chapter refers you to the documentation shipped with the operating system and the diagnostic diskettes.

Intel strongly recommends that you verify your system by following the steps shown in the chart in Figure 4-1. This chart allows you to test the system to the confidence level you require. When the SCT completes successfully, you can be 80% confident that your system is working properly. To jump to a 99% confidence level, you must run the SDT described in the diagnostics manual.

If you intend to modify your system (e.g., by adding circuit boards), make sure you first verify your system is working properly. This will help isolate any difficulties that may arise after modifying your system.

Powering Up the System

To power up the System 310, do the following:

1. Make sure the proper fuse and power cord connector are installed, and make sure the line voltage selector board is set for the proper line voltage. Also make sure the system is plugged in.
2. Open the flexible diskette drive door and remove the protective cardboard insert.
3. Make sure the terminal is properly attached to connector J20 on the system's back panel. Also make sure the terminal's communication parameters are set as described in Chapter 3.
4. Make sure the terminal is plugged in.
5. Turn the terminal ON.
6. Turn the System 310 ON.
7. Press the RESET button.

The system responds by lighting the red POWER ON light on the front panel and by lighting the Winchester drive select light. The system then starts the SCT.

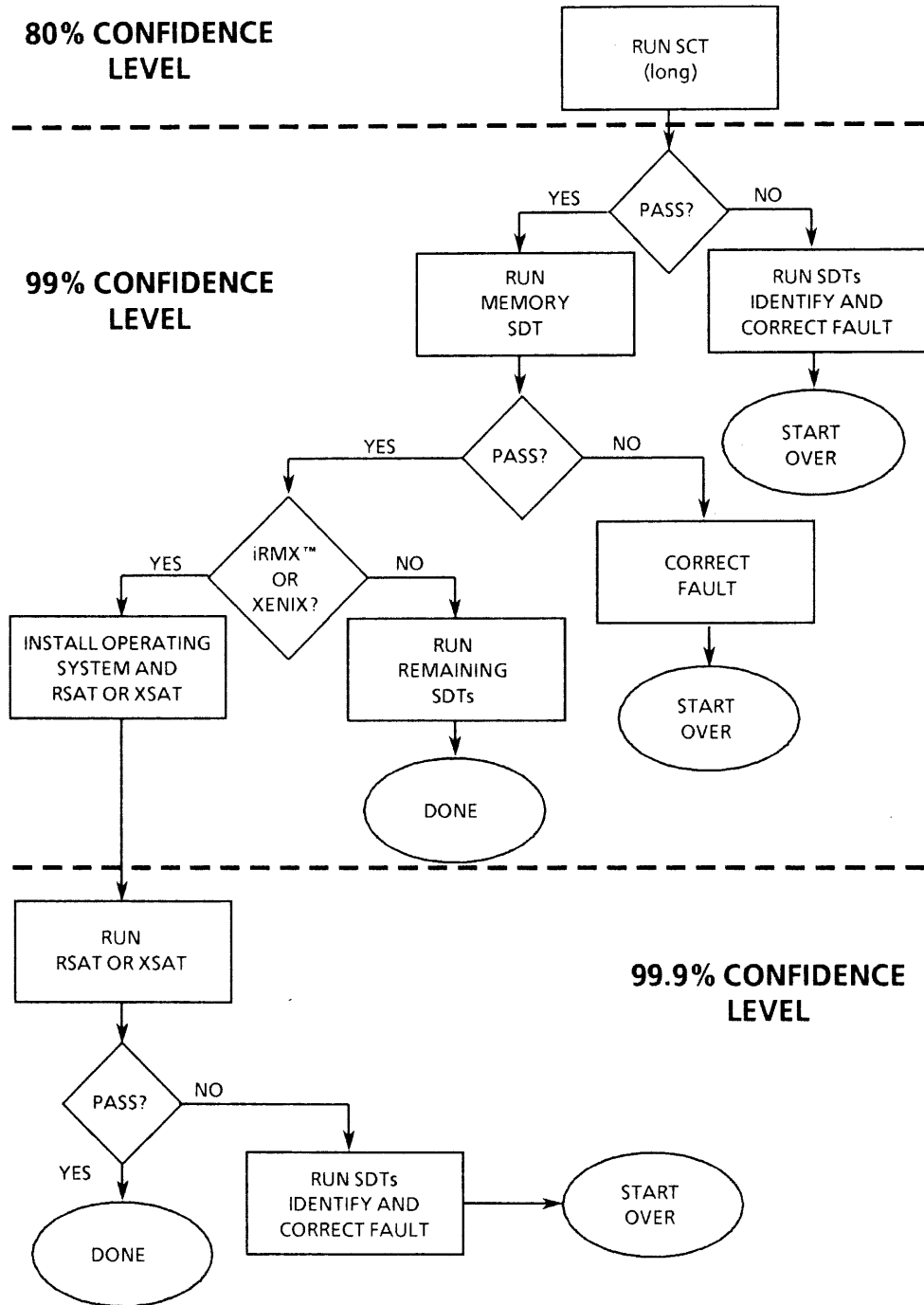

Figure 4-1. System Verification Chart

F-0253

Running the System Confidence Test (SCT)

The System Confidence Test checks critical components of the system's processor, memory, and boot subsystems to make sure they are working properly. The results of each test are displayed on the terminal. In 80286-based systems, if all components of the subsystem being tested are operating properly, the word **PASS** appears at the end of the subsystem test. Otherwise, the word **FAIL** appears and control returns to the monitor. In 8086-based systems, the results of the subsystem tests are displayed as **GO** or **NO GO** (unless you type on the keyboard while the test is running). See the diagnostic manual packaged with your diagnostic diskettes for a complete description of the SCT.

When the system successfully completes the SCT, it attempts to load the operating system. Since the operating system is not yet installed, this attempt will fail. In 80286-based systems, an interrupt message appears as shown in Figure 4-2. In 8086-based systems, no message is given. Refer to your operating system installation manual for instructions on how to load the operating system.

```
*  
SYSTEM CONFIDENCE TEST 286/300 -w- Version 1.2  
Copyright 1984, Intel Corporation  
Processor Subsystem..... PASS  
Memory Subsystem...512.K Tested..... PASS  
Boot Subsystem..... PASS
```

```
SCT SUCCESSFUL... Now Booting System
```

```
Loading :w0:  
Interrupt 6 at 7A37:5C90 Undefined Operation  
.
```

Figure 4-2. A Sample Screen After Failure to Load the Operating System

Installing the Operating System

To install the operating system, refer to the installation guide packaged with the operating system. If you do not wish to install the operating system at this time and you have verified your system is working properly, skip to the section on modifying your system (at the end of this chapter). The following sections deal with troubleshooting the system.

Troubleshooting the System

If your system does not power up properly, or if it fails any portion of the SCT, you may be able to isolate the problem by following the troubleshooting procedures listed in the diagnostic manual packaged with your diskettes. If your system fails the SCT, you can try the following remedies before calling for service (see Appendix C).

Failure to Power Up

If the red POWER ON light does not light when you turn the system on, either of the following can be wrong:

- The POWER ON light is burned out.
- The system is not receiving power.

If the POWER ON light is burned out, the Winchester drive select light will still come on and you will hear movement inside the drive.

If the system is not receiving power, check the following:

- The AC source -- make sure power is present.
- The power cord -- make sure it is plugged in at both ends (the AC source and the back panel).
- The fuse -- make sure it is intact and is installed properly.
- The line voltage selector -- make sure it is set to the proper AC line voltage.

Failure to Start the SCT

If the SCT does not start when you turn the system on or press the RESET button, check your terminal to make sure the RS-232C cable is properly connected to the system. Also, make sure the terminal is set to 9600 baud. If it is and the test still does not start, try reseating the circuit boards (see "Reseating the Circuit Boards" later in this chapter) prior to calling for service.

Failure to Pass the SCT

If the SCT starts and then fails, try reseating the circuit boards as described in the following section.

Reseating the Circuit Boards

Excessive vibration during transportation from Intel to your location can cause the circuit boards to loosen from their cardcage.

To reseat the boards do the following:

1. Turn the system OFF and disconnect the power cord.
2. Turn the system so its back panel is facing you and remove the four Phillips screws -- two sheet metal screws on the left and two machine screws on the right -- as shown in Figure 4-3.
3. Tilt the top of the back panel toward you and lift it out of the track in the bottom of the chassis and set it aside.
4. Loosen the four Phillips screws that hold the board retainers to the cardcage as shown in Figure 4-4. Then lift the retainers up and out, and set them aside. (Note that the bottom ends of the retainers are pointed.)
5. For each board in the cardcage, use the white ejector levers (shown in Figure 4-5) to pop the board loose. (You may have to disconnect cables from some boards.)
6. Reseat any MULTIMODULE™ boards located on the board.
7. Push the board back into the cardcage until you hear it lock into place. Tug on the board to make sure it is firmly seated. If the board feels loose, repeat this step.

NOTE

Although you may intend to install additional circuit boards in your system, Intel Corporation recommends that you first run the SCT and SDT to make sure the base system is working properly.

8. Connect any cables that you previously disconnected and check all connections to make sure none have come loose.
9. Replace the board retainers (pointed end down) and tighten the retaining screws.
10. Insert the back panel into the track at the bottom of the chassis and carefully fit any excess cable into the space between the cardcage and the back panel.
11. Reinsert and tighten the four screws that secure the back panel to the chassis.

If the system still fails to power up properly or complete the SCT successfully, call for service (see Appendix C).

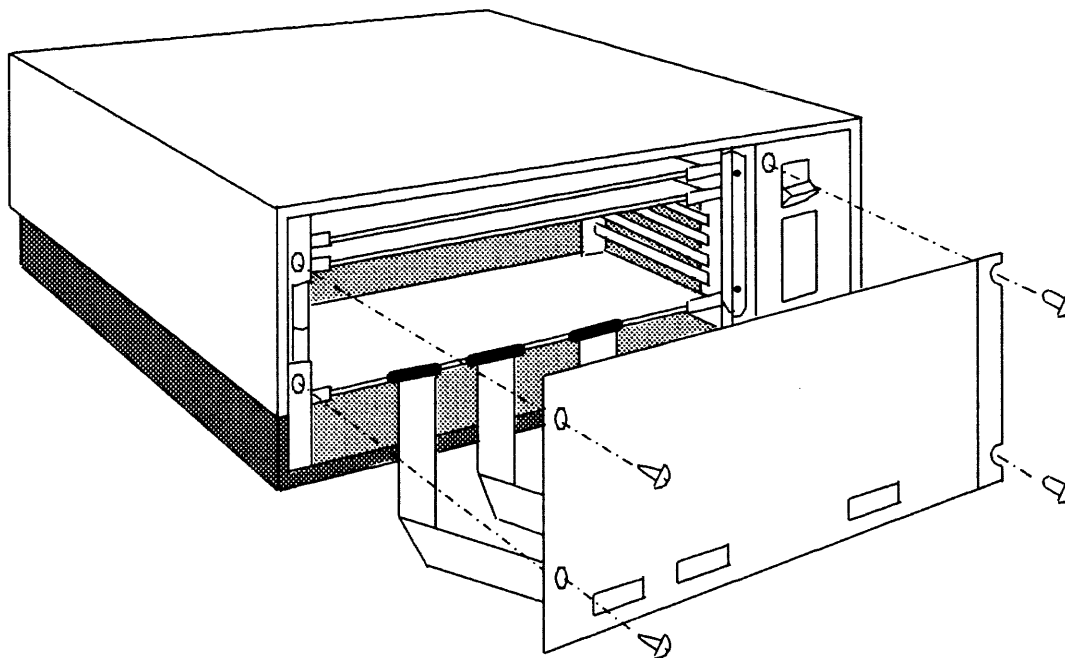

Figure 4-3. Removing the Back Panel

F-0240

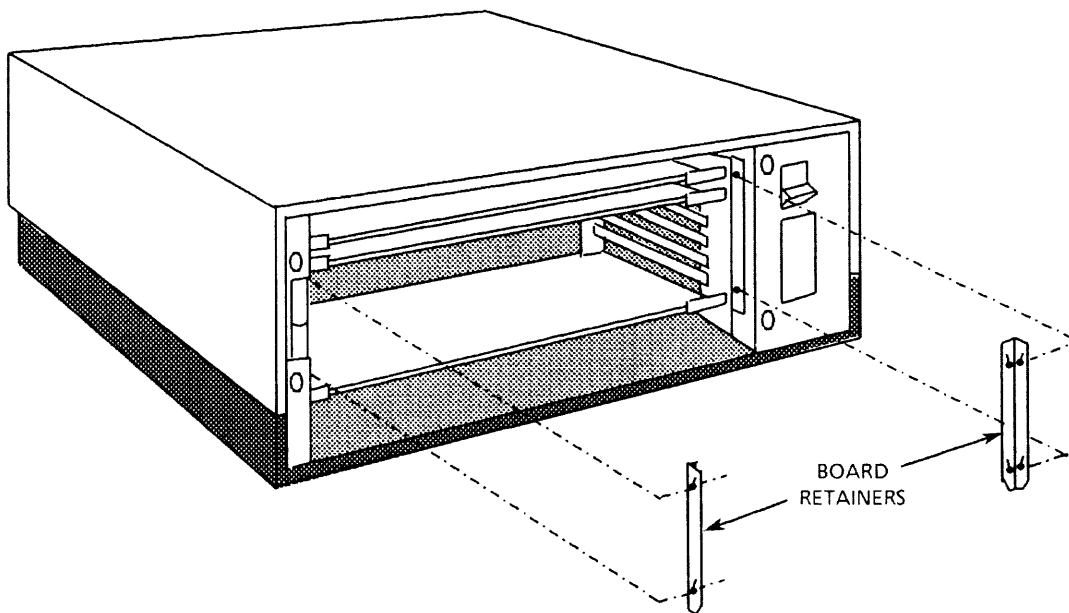

Figure 4-4. Removing the Board Retainers

F-0188

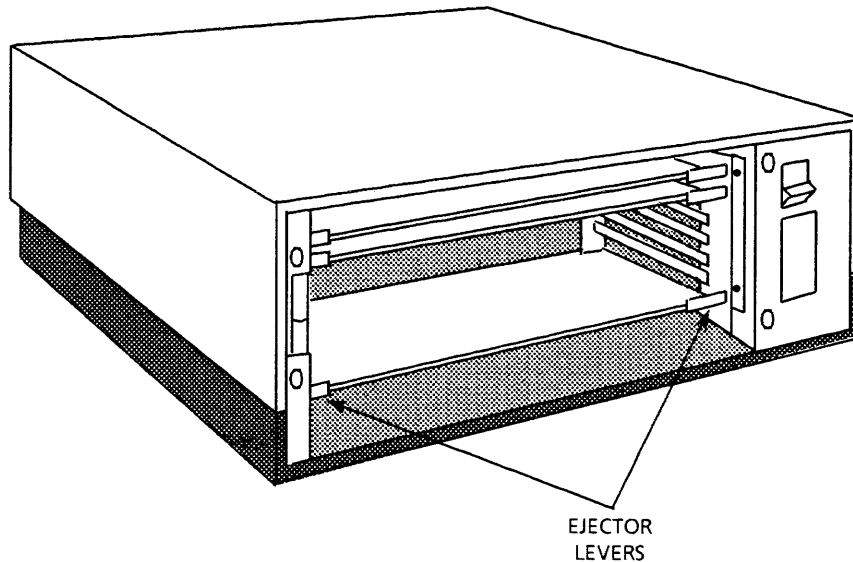

Figure 4-5. Reseating the Circuit Boards

F-0190

Modifying the System

After verifying that the system is functioning properly, you may make any modifications necessary for your application. The majority of these modifications will involve adding or removing MULTIBUS® boards or MULTIMODULE boards. In some cases you may want to disable the RESET and INTERRUPT buttons to prevent personnel from restarting or interrupting the system. These are system design tasks and should only be done by qualified personnel.

To add boards to your system, you need to remove the system's back panel, add the circuit boards, and replace the back panel. Instructions for adding a board are given in the *System 310 Chassis Hardware Reference Manual*.

CAUTION

Not all MULTIBUS-compatible boards can be added to the System 310. Adding the wrong type of board could severely damage your system. Therefore, add only boards that have been approved by your Intel representative.

To disable the RESET or INTERRUPT buttons, see the *System 310 Chassis Hardware Reference Manual*: this procedure should only be performed by a qualified service technician.

You can mount the System 310 in a variety of operating positions. The three most common are shown in Figure 5-1. Before mounting the system, check the specifications listed in Appendix B to ensure the system is being installed in a suitable environment. For example, the System 310 is not intended to be used in mobile or high-vibration environments.

MOUNTED IN A
FLOORSTANDMOUNTED
IN A RACKMOUNTED
ON A DESK

Figure 5-1. System 310 Operating Positions

F-0042-2

Mounting the System in a Floorstand

Intel provides an optional floorstand for vertically mounting the system. The floorstand is designed to fit next to a desk or under a table. This provides a convenient, space-saving way to mount the system.

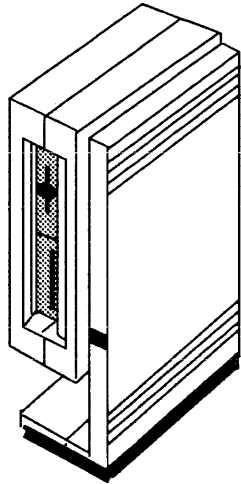
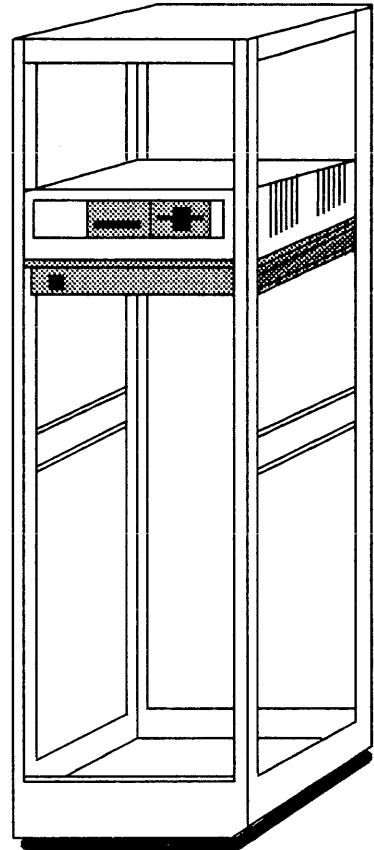
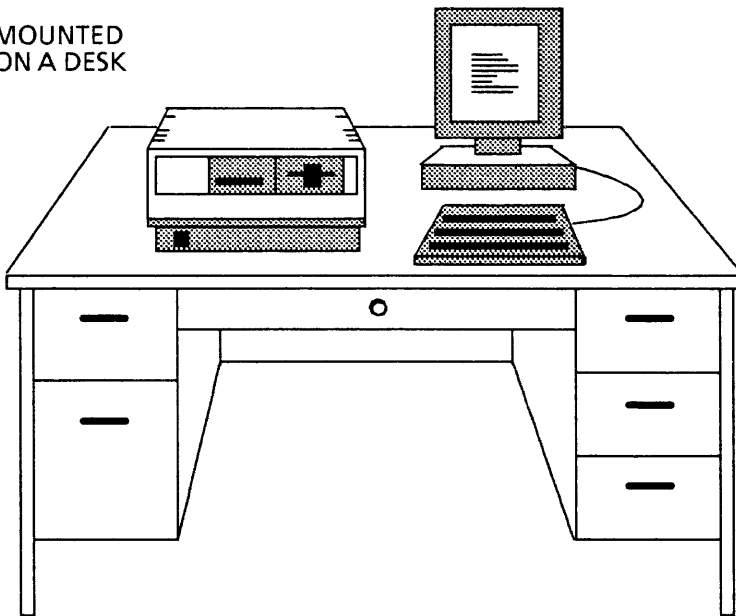
To install the system in the floorstand, do the following:

1. Lay the floorstand and the system on the floor next to each other as shown in Step A of Figure 5-2. Make sure the power cord and all cables are disconnected and the system is turned off.
2. Loosen the five Phillips screws also shown in Step A. The screws are captive screws and do not need to be removed, just loosened.
3. Grip the floorstand cover at each end and lift it straight up as shown in Step B; then, set it aside.
4. Grip the System 310 at each end (front top and back top), lift it, and lower it into the floorstand as shown in Step C. Slide the system forward until it is flush with the front of the stand.
5. Replace the floorstand cover and tighten the five Phillips screws.
6. Stand the floorstand upright, reattach the power cord and all cables, and insert the rear cable cover (packaged with the floorstand). See Step D.

Position the floorstand as desired.

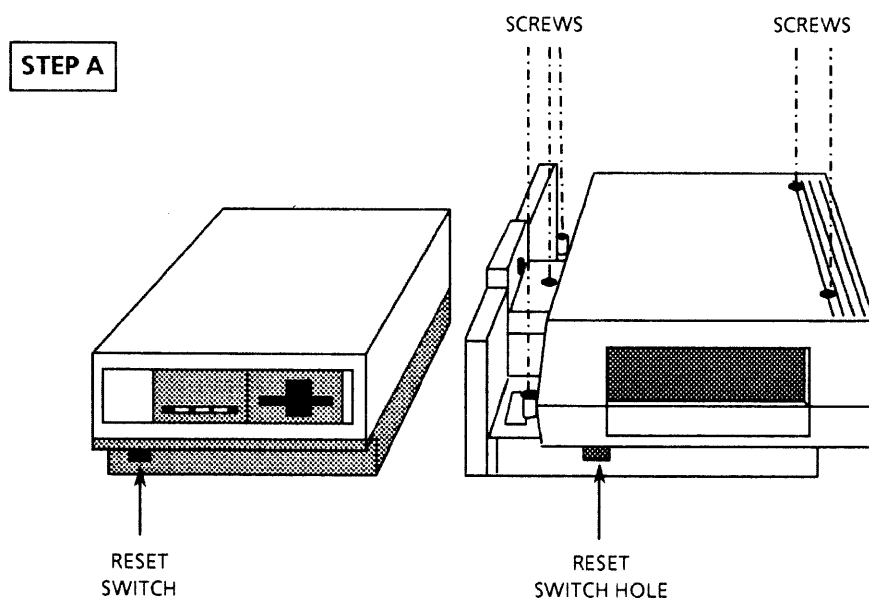

Figure 5-2. The Floorstand Mounting Procedure

F-0238

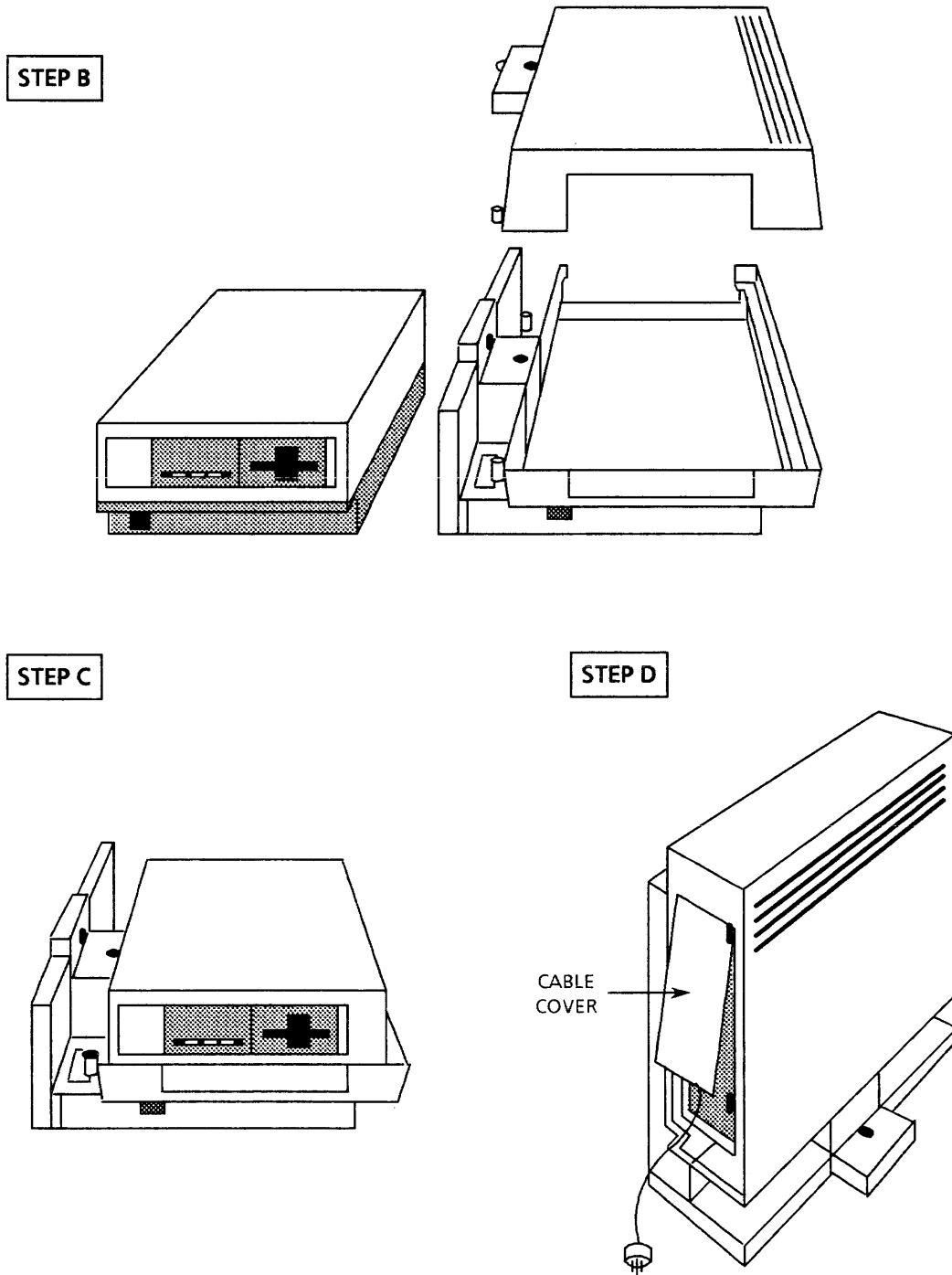

Figure 5-2. The Floorstand Mounting Procedure (Continued)

F-0239

Mounting the System in a Standard 19-Inch Rack

The system can be mounted in a standard 19-inch EIA equipment rack having Chassis Trak 300S nonpivoting rack slides (or equivalent).

To rack-mount the system, you must remove the system's top cover, remove the slide bars from the Chassis Trak slides, mount the slide bars onto the sides of the system, replace the system's top cover, and then lift the system and slide it into the Chassis Trak slides. The procedures for doing each of these steps are given below.

WARNING

Rack-mounting the system requires removing the system's top cover. This permits direct access to hazardous voltages. Accidental contact with these voltages may result in severe electrical shock or death. This procedure should only be performed by qualified technical personnel.

Removing the Top Cover

To remove the top cover, do the following:

1. Turn the power switch OFF and disconnect the power cord from the rear of the system and from the AC source.
2. Tilt the system on its side, as shown in Figure 5-3, to access the top cover retaining screws located in the bottom of the chassis.

CAUTION

Do not drop the system. Severely jarring the system may damage the Winchester drive or flexible diskette drive.

3. Remove the four retaining screws from the bottom of the chassis. Then, gently lower the system back onto the table.
4. Remove the two screws (upper left and upper right corners of the back panel) holding the top cover to the back panel.
5. Lift the top cover while moving it slightly forward to clear the disk drives, then set it aside.

NOTE

To replace the top cover, perform the above steps in reverse order.

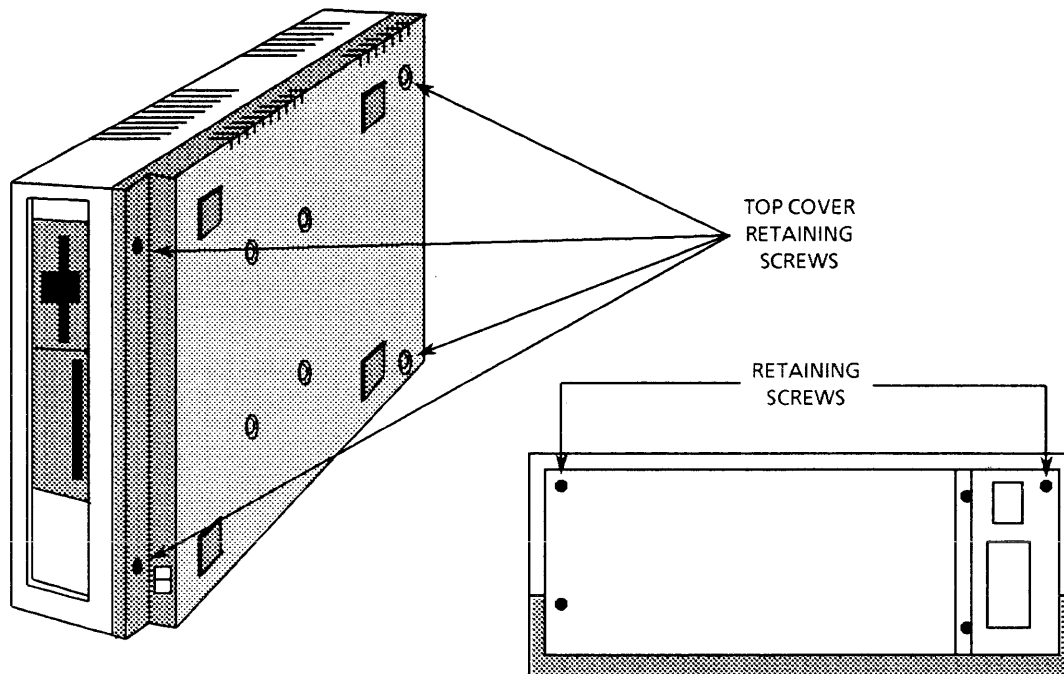

Figure 5-3. Removing the Top Cover

F-0120-2

Removing the Mounting Bars from the Chassis Trak Slides

The Chassis Trak slide consists of two parallel tracks, each having two telescoping bars. These bars extend to provide easy access to the system after it is mounted. The innermost of the two telescoping bars is called the mounting bar.

To rack-mount the system, you must first remove the mounting bars from the Chassis Trak slide. Each bar is held in place, when fully extended, by a spring lock.

To remove the bar, do the following:

1. Pull the mounting bar out of the track until it locks into place.
2. Press the spring-lock (where it comes through the slide) and pull the bar straight out from the slide.
3. Set the bar aside and repeat this procedure to remove the other mounting bar.

Attaching the Mounting Bars to the System

The mounting bar is 16½ inches long and 1½ inches high. It has five holes, two of which line up with the mounting holes in the side of the chassis. To mount the bars on the system, you need the following:

- 4 #10-32 slotted pan head screws -- maximum length 9/16 inch
- 4 #10 ASA machine screw nuts
- 1 screwdriver

To attach the mounting bars to the sides of the system, do the following:

1. Place the #10 ASA machine screw nuts in the nut holders located inside the system chassis. Figure 5-4, Step A, indicates the location of the nut holders.
2. Position one of the bars against the side of the system and pass the screws through the bar as shown in Figure 5-4, Step A.
3. Tighten the screws until the bar is secure, as shown in Figure 5-4, Step B.

CAUTION

Do not use screws longer than 9/16 inch. Longer screws can damage the system chassis.

4. Repeat the above steps to mount the other bar on the opposite side of the system.
5. Replace the top cover on the system (see "Removing the Top Cover" earlier in this chapter).

Mounting the System in the 19-Inch Rack

To mount the system in the 19-inch rack, do the following:

1. After securing both mounting bars to the system and replacing the top cover, extend the telescoping bars from the Chassis Trak slides and make sure they lock into place.
2. Lift the system and slide it into the extended bars of the Chassis Trak slides, as shown in Figure 5-4, Step C.
3. Slide the system into the track until it locks into place. Then push it in as far as it will go.

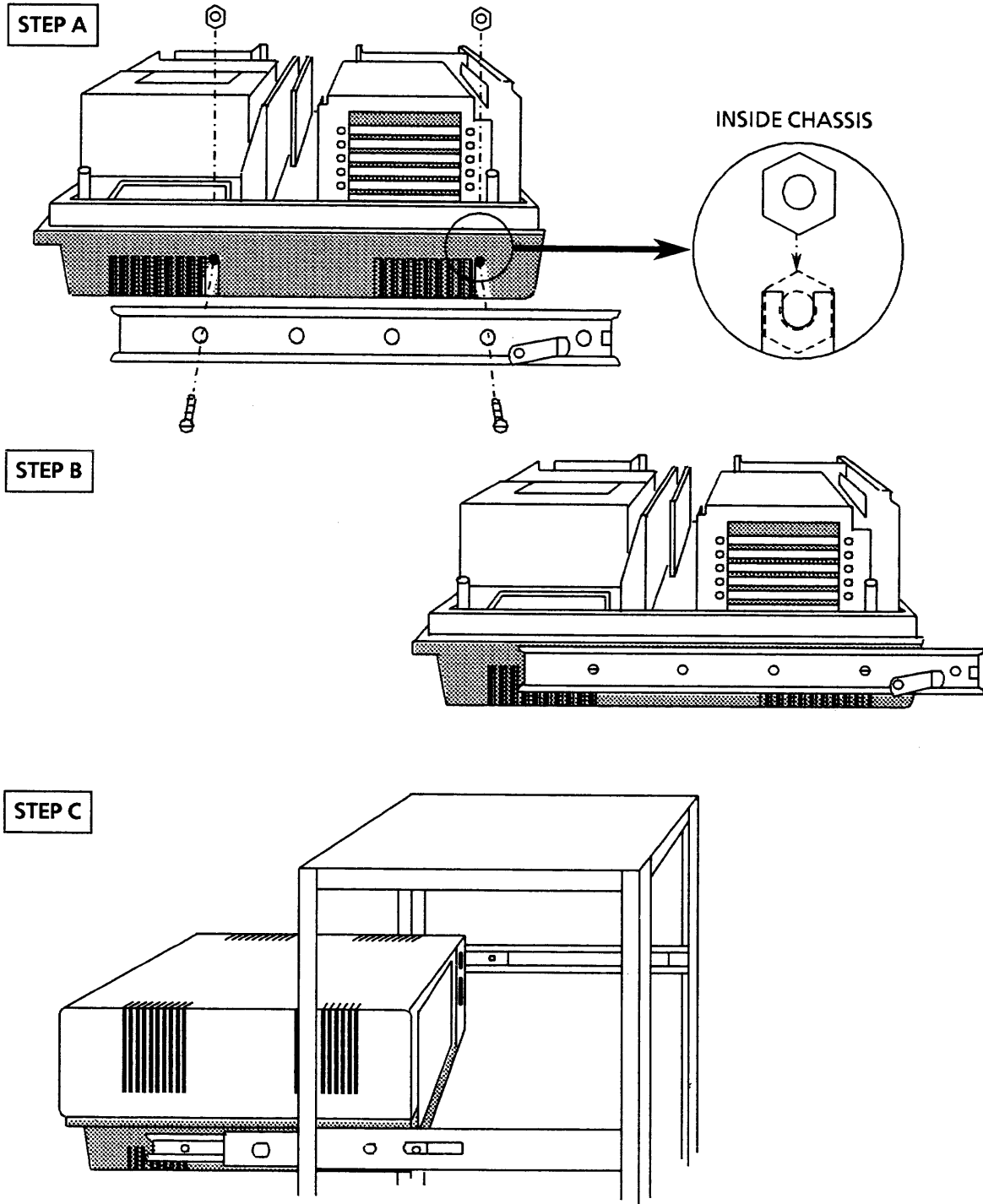

Figure 5-4. Rack-Mounting the System

F-0242

Mounting the System on a Desk

The system can be mounted on a desk, workstation, or any other flat surface with sufficient space to allow three to five inches on each side for air flow.

The terminal and the system should be mounted close to each other, as shown in Figure 5-5, to permit easy access to the system's disk drives.

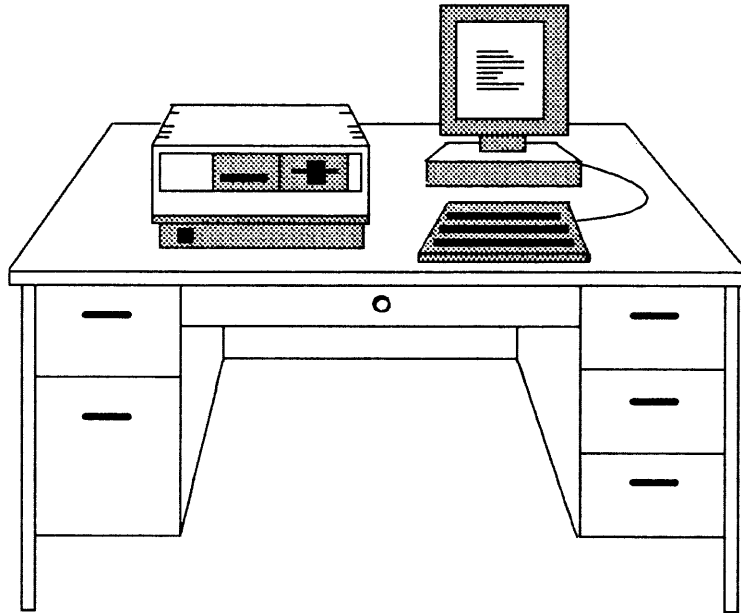

Figure 5-5. Desk-Mounting the System

F-0153-1

This chapter describes the use of the 5¼-inch flexible diskette drive. It shows you how to:

- Properly insert a diskette
- Remove a diskette
- Write-protect a diskette
- Determine how often to clean the diskette drive

Inserting a Diskette

Most commercially available diskettes have arrows showing you the proper way to insert the diskette into the drive. If your diskettes are not labeled, see Figure 6-1, which illustrates the proper orientation for inserting a diskette.

Make sure the diskette label is facing away from the drive select light and toward the open drive door.

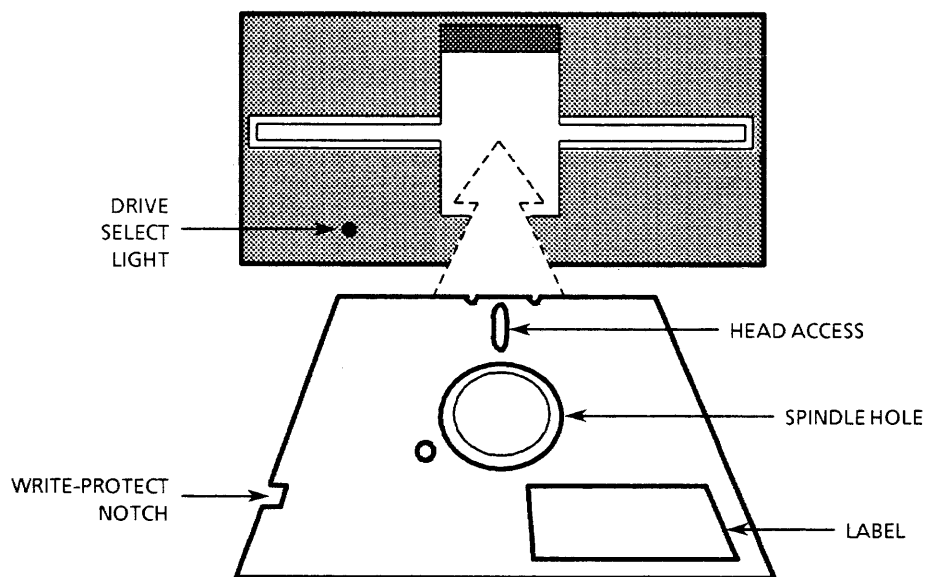

Figure 6-1. Proper Way to Insert a Diskette

F-0244

After inserting the diskette, you must logically mount it. Instructions and commands for logically mounting a diskette are described in the manual shipped with your operating system.

Removing a Diskette

When removing a diskette, you must logically dismount it before physically removing it from the system. The commands for logically dismounting the diskette are described in the manual shipped with your operating system.

CAUTION

If you fail to logically dismount a diskette before removing it from the system, the diskette may be damaged and the data destroyed.

Write-Protecting a 5¼-Inch Diskette

You can write-protect your diskettes by placing a small adhesive tab over the diskette's write-protect notch (shown in Figure 6-1). This protects information on the diskette from being accidentally overwritten.

As long as the write-protect notch is covered, data can be read from, but not written to, the diskette. Any attempt to write to the diskette results in an error message being displayed on the terminal's screen.

The write-protect function is most frequently used to protect diskettes containing application programs and operating systems.

To write information to the diskette, simply remove the write-protect tab.

Cleaning the Flexible Diskette Drive

The flexible diskette drive contains READ/WRITE heads that transfer data between the diskette and the System 310. During the data transfer (i.e., the READ and WRITE operations), the heads make contact with the diskettes. Over a period of time (typically 50 to 100 hours of accumulated drive run time), dust from the diskettes builds up on the heads. This buildup can interfere with the accurate transfer of information between the diskette and the system.

To prevent this buildup, Intel suggests that you periodically clean the drive's READ/WRITE heads using any commercially available 5¼-inch cleaning diskette and cleaning solution.

How often you clean the heads depends on how often you use the system and the type of programs the system executes. The more frequently you use the flexible diskette drive, the more often you should clean the heads. Also, if your program frequently accesses the diskette, you should clean the heads more frequently than if your program seldom accesses the diskette.

For instructions on cleaning the flexible diskette drive, refer to the diagnostic manual packaged with your diagnostic diskettes.

Terminal Interface Requirements

For most applications, any standard RS-232C ASCII terminal can be used. Some software, however, requires terminals having special capabilities. Refer to the manual accompanying your software to determine if a special terminal is required.

Always use a shielded cable having shielded connectors to attach the terminal to the System 310. Also, make sure the connector shield makes contact with the cable shield and with the system's back panel. This contact is necessary to comply with RFI ratings.

The terminal attaches to connector J20 on the 8086-based systems, and either connector J20 or J21 on the 80286-based systems. Each terminal connector is a female connector; its pin-out definitions are given in Table A-1.

Table A-1. Pinouts for the Terminal Connector (J20 and J21)

J20/J21 Pin Number	Signal Name	Signal Function
1	---	---
2	TxD	Transmit Data
3	RxD	Receive Data
4	RTS	Request To Send
5	CTS	Clear To Send
6	DSR	Data Set Ready
7	GND	Signal Ground
8	---	---
9	---	---
10	---	---
11	---	---
12	---	---
13	---	---
14	---	---
15	---	---
16	---	---
17	RxC	Receive Clock
18	---	---
19	---	---
20	DTR	Data Terminal Ready
21	---	---
22	---	---
23	---	---
24	DTE TxC	Transmit Clock
25	---	---

Printer Interface Requirements

Use a shielded cable having shielded connectors to attach the printer to the System 310. When attaching the printer to the system, make sure the connector shield makes contact with the cable shield and with the system's back panel. Contact is necessary to comply with RFI ratings.

The Centronics-compatible printer attaches to connector J24 on the System 310's back panel. This connector is a female connector, configured to provide a standard Centronics-compatible interface. Table A-2 lists the pinout definitions for this connector.

Table A-2. Pinouts for the Printer Connector

J24 Pin Number	Signal Function
1	Data Strobe
2	Data Bit 0
3	Data Bit 1
4	Data Bit 2
5	Data Bit 3
6	Data Bit 4
7	Data Bit 5
8	Data Bit 6
9	Data Bit 7
10	Acknowledge
11	Busy
12	Error
13	Not connected
14	Not defined
15	Not defined
16	Not defined
17	Not defined
18	Not defined
19	Ground
20	Ground
21	Ground
22	Ground
23	Ground
24	Ground
25	Ground
26	Ground
27	Ground
28	Ground
29	Ground
30	Not connected
31	Not connected

Characteristic	Limits
Temperature	
System operating	50 to 95°F (10 to 35°C)
System not operating	-29 to 140°F (-34 to 60°C)
Humidity	
System operating	
Relative humidity	20% to 80% noncondensing
Maximum wet bulb	78.8°F (26°C)
System not operating	
Relative humidity	5% to 95% noncondensing
Maximum wet bulb	78.8°F (26°C)
Altitude	
System operating	0 to 8,000 ft. (2,436 m)
System not operating	0 to 40,000 ft. (12,180 m)
Shock	
System operating	1.0 g, 10 to 20 ms
System not operating	15.0 g, 10 to 20 ms
Vibration	
System operating	
5 to 25 Hz	0.0014 in. (peak to peak)
25 to 55 Hz	0.0007 in. (peak to peak)
55 to 300 Hz	0.36 g
System not operating	
5 to 25 Hz	0.008 in. (peak to peak)
25 to 55 Hz	0.004 in. (peak to peak)
55 to 300 Hz	2.0 g
NOTE	
The System 310 is not intended for use in mobile or high-vibration environments.	

Characteristic	Limits
Electrical (AC)	
Voltage and maximum current AC	88 to 132 VAC, 4.6A 198 to 264 VAC, 2.3A
Frequency	47 to 63 Hz
Maximum power consumption	523W AC power
Fuses	6A NORM-BLO (100-120 VAC) 3A NORM-BLO (220-240 VAC)
Electrical (DC)	
Maximum total power output	220W DC power
Voltage and maximum current DC	4.75 to 5.25 VDC, 30A 11.4 to 12.6 VDC, 4.7A -11.4 to -12.6 VDC, 4.7A
Physical Dimensions	
Width	17 in. (43.18 cm)
Height	6.5 in. (16.51 cm)
Depth	20 in. (51.80 cm)
Weight	40 lbs. (18.16 kg)

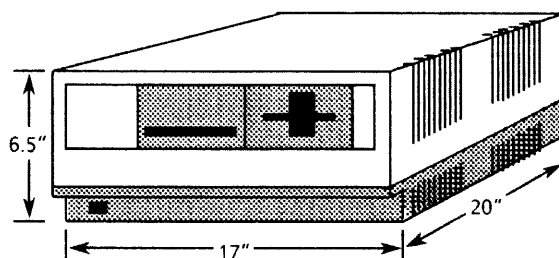

Figure B-1. System 310 Dimensions

F-0243



APPENDIX C SERVICE INFORMATION

United States customers may obtain service and repair assistance by contacting the Intel Customer Support Center in Phoenix, Arizona (phone numbers listed below). Customers outside the United States should contact their sales source (Intel Sales Office or Authorized Distributor) for service information.

Before calling Customer Support, you should have the following information:

- The date you received the product.
- The complete part number (including the dash number) of the product. This number is usually silk-screened onto printed circuit boards and printed on the label of other products.
- The serial number of the product. This is usually silk-screened onto printed circuit boards and printed on the label of other products.
- Your shipping and billing addresses.
- A purchase order number for billing purposes if your Intel product warranty has expired.
- Extended warranty agreement information, if applicable.

Service and Repair Assistance

Use the following telephone numbers to contact Customer Support:

Regional Telephone Numbers		TWX Numbers
Western Region	(602) 869-4951	910-951-1330
Midwestern Region	(602) 869-4392	910-951-0687
Eastern Region	(602) 869-4045	
International	(602) 869-4391	

Always contact Customer Support before returning a product to Intel for repair. When you make the request, you will be given an authorization number, shipping instructions, and other information that will help Intel provide you with fast, efficient service.

If you are returning a product because of damage sustained during shipment or if the product is out of warranty, a purchase order is required before Intel can initiate repair.

Use the original factory packaging material in preparing a product for shipment to the repair center. If that material is not available, ensure the product is adequately protected by wrapping it in cushioning material before enclosing it in a heavy-duty corrugated shipping carton. All cartons should be labeled "FRAGILE" to ensure careful handling. If a printed circuit board is being returned, a material such as Air Cap TH-240, manufactured by the Sealed Air Corporation of Hawthorne, New Jersey, should be used to give adequate cushioning. Address and ship only to the address specified by Customer Support.

The following documents contain additional information about the System 310:

System 310 Publications Guide, Order Number 173441

Introduction to the System 310 Microcomputer, Order Number 173202

System 310 Chassis Hardware Reference Manual, Order Number 174369

System 310 Memory Configuration Guide: 86-Based Systems, Order Number 173206

System 310 Memory Configuration Guide: 286-Based Systems, Order Number 173443

System 310 Processor Configuration Guide: iSBC® 86/30 Single Board Computer, Order Number 173205

System 310 Processor Configuration Guide: iSBC 286/10 Single Board Computer, Order Number 173442

System 310 Disk Configuration Guide, Order Number 173201

The following manuals contain detailed information on certain components of the System 310:

iSBC 86/14 and iSBC 86/30 Single Board Computer Hardware Reference Manual, Order Number 144044

Guide to Using the iSBC 286/10 Single Board Computer, Order Number 146271

iSBC 012B Memory Board Hardware Reference Manual, Order Number 112748

iSBC 028CX/056CX/012CX/010CX/020CX (CX-Series) RAM Boards Hardware Reference Manual, Order Number 145183

iSBX™ 218A Flexible Disk Controller Hardware Reference Manual, Order Number 121583

iSBC 215 Generic Winchester Controller Hardware Reference Manual, Order Number 144780

i213A 5¼" Winchester Disk Data Separator Hardware Reference Manual, Order Number 133144

The following documents contain information on diagnostic software for the System 310:

System 286/300 Series Diagnostic Software User's Guide, Order Number 173767

System 86/300 Series Diagnostic Maintenance Manual, Order Number 144813

The following documents contain information on general subjects related to the System 310:

OEM Systems Handbook, Order Number 210941

Intel MULTIBUS Specification, Order Number 980683

Intel iLBX™ Specification, Order Number 145695

- AC power cord, 1-2, 1-3, 4-4
- AC power plugs, 2-3, 2-4, 3-4, 3-5, 4-4
- Baud rate, 3-6, 4-4
- Buttons,
 - INTERRUPT, 2-1
 - ON/OFF, 2-1
 - RESET, 2-1
- Chassis Trak, 5-4 thru 5-8
- Cleaning the drive heads, 6-3
- Communication parameters, 3-6
- Connector,
 - printer (J24), 2-3, 2-5, 3-7, A-2
 - terminal (J20 or J21), 2-3, 2-5, 3-6, A-1
- Desk-mounting, 5-1, 5-8
- Diagnostic tests, 1-1, 4-1, 4-2
- Disk drives,
 - flexible, 1-1, 2-1, 2-2
 - Winchester, 1-1, 2-1, 2-2
- Diskettes,
 - cleaning, 6-3
 - inserting, 6-2
 - removing, 6-2
 - write-protecting, 6-2
- Floorstand,
 - mounting, 5-1, 5-2
- Fuse, 1-2, 1-3, 2-4, 5-2, 5-3
 - changing, 3-2
 - ratings, 3-2
- Fuse-pull lever, 2-5
- Indicator lights,
 - POWER ON, 2-1, 2-2
 - RUN, 2-1, 2-2
- INTERRUPT button, 2-1
- Line voltage selector, 2-4, 3-2
- Modifying the system, 4-7
- Monitor, 4-1, 4-3
- Operating systems, 1-1
- Parity, 3-6
- Rack-mounting the system, 5-4 thru 5-7
- Reseating circuit boards, 4-5
- RESET button, 2-1, 2-2, 4-1
- RUN indicator, 2-1
- SCT, 4-1, 4-4
- SDT, 4-1
- Troubleshooting, 4-4
- Verifying the system, 4-1, 4-2

REQUEST FOR READER'S COMMENTS

Intel's Technical Publications Departments attempt to provide publications that meet the needs of all Intel product users. This form lets you participate directly in the publication process. Your comments will help us correct and improve our publications. Please take a few minutes to respond.

Please restrict your comments to the usability, accuracy, organization, and completeness of this publication. If you have any comments on the product that this publication describes, please contact your Intel representative. If you wish to order publications, contact the Literature Department (see page ii of this manual).

1. Please describe any errors you found in this publication (include page number).

2. Does this publication cover the information you expected or required? Please make suggestions for improvement.

3. Is this the right type of publication for your needs? Is it at the right level? What other types of publications are needed?

4. Did you have any difficulty understanding descriptions or wording? Where?

5. Please rate this publication on a scale of 1 to 5 (5 being the best rating). _____

NAME _____ DATE _____

TITLE _____

COMPANY NAME/DEPARTMENT _____

ADDRESS _____

CITY _____ STATE _____ ZIP CODE _____

(COUNTRY)

Please check here if you require a written reply.

WE'D LIKE YOUR COMMENTS . . .

This document is one of a series describing Intel products. Your comments on the back of this form will help us produce better manuals. Each reply will be carefully reviewed by the responsible person. All comments and suggestions become the property of Intel Corporation.



**NO POSTAGE
NECESSARY
IF MAILED
IN THE
UNITED STATES**

BUSINESS REPLY MAIL
FIRST CLASS PERMIT NO. 79 BEAVERTON, OR

POSTAGE WILL BE PAID BY ADDRESSEE

**Intel Corporation
5200 N.E. Elam Young Parkway
Hillsboro, Oregon 97123**

ISO-N TECHNICAL PUBLICATIONS HF2-1-830





INTEL CORPORATION, 3065 Bowers Avenue, Santa Clara, California 95051 (408) 987-8080

Printed in U.S.A.

OEM SYSTEMS