

# Operator's Manual: IRIS 3024 Color Ink Jet Printer

Document Revision 3.1 — July 1, 1989

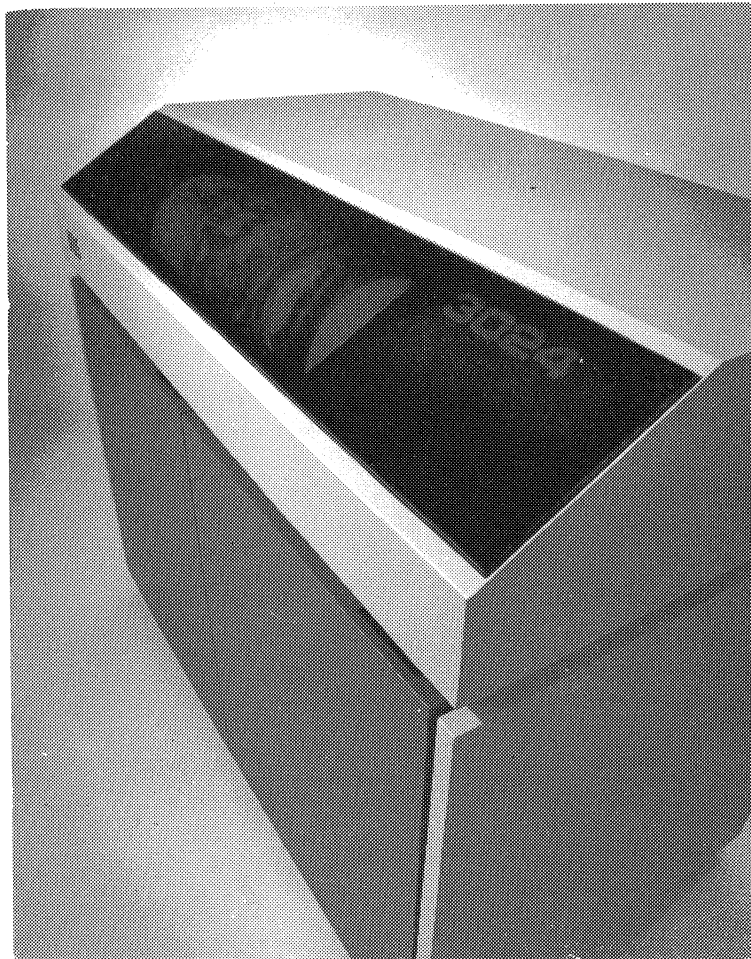

**IRIS**

IRIS Graphics, Inc.  
Six Crosby Drive  
Bedford, Massachusetts 01730

617-275-8777 (Luis)  
754-2884 (Kenny)

# Operator's Manual:

## IRIS 3024 Color Ink Jet Printer

IRIS Graphics Part Number 01250-301

*Reproduction of this document in any form without express written permission of IRIS Graphics, Inc., is prohibited.*

*This document contains confidential information and must not be circulated to third parties without written permission of IRIS Graphics, Inc.*

*Patents are pending for the technology described in this document.*

**IRIS**, IRIS Series 3000, and IRIS 3024 are trademarks of IRIS Graphics, Inc.  
IBM PC is a trademark of IBM Corporation.  
Other products are trademarked by their respective companies.

IRIS Graphics, Inc.  
Six Crosby Drive  
Bedford, Massachusetts 01730

(617) 275-8777  
Telex (510) 601-6598  
FAX (617) 275-8590

© 1989 IRIS Graphics, Inc.



## **FREQUENCY INTERFERENCE STATEMENT**

---

---

**WARNING:** This equipment generates, uses, and can radiate radio frequency energy and if not installed and used in accordance with the instruction manual, may cause interference to radio communications. It has been tested and found to comply with the limits for a Class A computing device pursuant to Subpart J of Part 15 of FCC Rules, which are designed to provide reasonable protection against such interference when operated in a commercial environment. Operation of this equipment in a residential area is likely to cause interference in which case the user at his own expense will be required to take whatever measures may be required to correct the interference.

---

---

# TABLE OF CONTENTS

<b>Section 1</b>	<b>Introduction</b> . . . . .	<b>1</b>
	Documentation and Applicable Software Revisions . . . . .	2
	How Host Systems Affect Printer Operation and Functionality . . . . .	4
	Printing Values Transmitted by Host System . . . . .	4
	The IRIS FEP (Front-End Processor) . . . . .	5
	Support Policies and Additional Information . . . . .	5
<b>Section 2</b>	<b>Preparation For Printing</b> . . . . .	<b>6</b>
	Printer Circuit Breaker . . . . .	6
	Printer Controls . . . . .	6
	Power and Print Switches . . . . .	6
	Starting, Pausing, and Aborting Print Runs . . . . .	7
	Mode Switch and Safety Switch . . . . .	8
	The System Controller and On/Off Switch . . . . .	8
	The Reset Button . . . . .	8
	Operator's Control Panel . . . . .	9
	Error Messages . . . . .	9
	Setting Printing Parameters . . . . .	10
	Using the Control Panel To Select Menus and Options . . . . .	10
	"Paper," Ink, and Operating Conditions . . . . .	12
	Paper Storage and Inks . . . . .	12
	Operating Conditions . . . . .	12
<b>Section 3</b>	<b>Basic Printing Procedures</b> . . . . .	<b>13</b>
	Routine Printing Procedures . . . . .	13
	Twelve "NEVERS" . . . . .	14
	Power-Up Procedures . . . . .	15
	Error Messages . . . . .	15
	Error Messages at Power-Up . . . . .	16
	Removing and Emptying the Waste Ink Bottle . . . . .	17
	Checking the Ink Level . . . . .	17
	Mounting Paper on the Drum . . . . .	19
	Recommended Paper Mounting Procedure . . . . .	19
	Setting Printing Parameters . . . . .	20
	Starting a Print Run — On-Line System . . . . .	20
	Starting a Print Run — Magnetic Tape Interface . . . . .	21
	Common Printing Error Conditions . . . . .	21
	Fatal Error Messages During Printing . . . . .	21
	What Happens During a Printing Cycle . . . . .	22
	Common Non-fatal Error Conditions . . . . .	23





	Pausing During a Print Run . . . . .	.24
	Routine Automatic Procedures of Idle Printer . . . . .	.25
	Shutting Down the Printer . . . . .	.25
<b>Section 4</b>	<b>Adjustment and Maintenance . . . . .</b>	<b>.26</b>
	Knife-Edge Alignment . . . . .	.26
	Conditions that Require Knife Edge Adjustment . . . . .	.27
	Computer-Assisted Knife Edge Adjustment . . . . .	.29
	Adjusting Color Registration . . . . .	.29
	“Horizontal” and “Vertical” . . . . .	.29
	Conditions that Require Adjustment of Convergence . . . . .	.29
	Adjusting Convergence . . . . .	.30
	Pausing During Test Pattern Run . . . . .	.32
	Selecting Crystal Frequency . . . . .	.32
	Selecting and Setting Crystal Frequency . . . . .	.33
	Examining the Frequency Color Run . . . . .	.34
	Setting the Crystal Frequency Value . . . . .	.34
	Cleaning the Deflection Assembly . . . . .	.35
	Removing the Deflection Assembly . . . . .	.35
	Cleaning the Deflection Assembly . . . . .	.36
	Cleaning the Bib . . . . .	.36
	Servicing Nozzle Assemblies . . . . .	.37
	Ink Pump Error Messages . . . . .	.39
	Calibrating the Ink Pumps . . . . .	.39
	User Diagnostics Tests . . . . .	.41
	Jet Offset RAM Test . . . . .	.41
	Test Autophase . . . . .	.42
	Vacuum Diagnostics for Service Personnel . . . . .	.42
	MCP and Other Diagnostic Tests . . . . .	.42
	Cleaning Printer Surfaces . . . . .	.42
<b>Section 5</b>	<b>Controlling Printing Parameters . . . . .</b>	<b>.43</b>
	Preparing To Change Parameters at the Control Panel . . . . .	.43
	How Panel Settings Affect Default Printer Settings . . . . .	.44
	Color Balance: Density and Contrast . . . . .	.44
	Color Look-Up Tables . . . . .	.45
	Setting Density from the Control Panel . . . . .	.45
	Setting Contrast . . . . .	.45
	Organization of Color Data . . . . .	.45
	Selecting the Number and Order of Colors . . . . .	.46
	Complement Colors . . . . .	.47
	Creating Color Separations . . . . .	.47
	Controlling Image Placement . . . . .	.48
	Selecting a Starting Position . . . . .	.48
	Creating Multiple Images from One Master . . . . .	.48
	Mirror Image Printing . . . . .	.49

	Resolution and Related Printing Values . . . . .	.49
	Horizontal and Vertical Resolution . . . . .	.49
	Doubling Image Density with Multistrike Features . . . . .	.50
	Creating Oversized Images with Pixel Replication . . . . .	.51
	Other Printer Parameter Settings . . . . .	.51
	Setting Drum Speed . . . . .	.51
	Autophase Displayed . . . . .	.52
	Setting the Printer Clock . . . . .	.52
	For More Detailed Information . . . . .	.53
<b>Section 6</b>	<b>Troubleshooting Guide . . . . .</b>	<b>.54</b>
<b>Appendix A</b>	<b>Menu Maps . . . . .</b>	<b>.58</b>
<b>Appendix B</b>	<b>Routine and Periodic Maintenance Procedures . . . . .</b>	<b>.61</b>
	Daily Maintenance . . . . .	.61
	As-Needed Maintenance . . . . .	.61
	Weekly Maintenance . . . . .	.62
<b>Appendix C</b>	<b>Operating Guidelines . . . . .</b>	<b>.63</b>
	Electrical Power Requirements . . . . .	.63
	Temperature . . . . .	.63
	Humidity . . . . .	.63
	Static Electricity . . . . .	.63
	Operating Conditions for Optional Equipment . . . . .	.63
	<b>Glossary . . . . .</b>	<b>.64</b>
	<b>Index . . . . .</b>	<b>.68</b>



# PROCEDURES AND ILLUSTRATIONS

---

## PROCEDURES

Procedure 4-1: Knife-Edge Adjustment . . . . .	28
Procedure 4-2: Adjusting Convergence and Running the Test Pattern . . . . .	31
Procedure 4-3: Removing and Reinstalling Nozzle Assemblies . .	38
Procedure 4-4: Pressurizing an Ink Pump . . . . .	40
Procedure 5-1: Selecting Color Density from the Control Panel . . . . .	46

---

## ILLUSTRATIONS

Figure 1-1: Host/Printer Configurations . . . . .	2
Figure 1-2: Deflection of Charged Droplets . . . . .	3
Figure 1-3: Halftone Image Production . . . . .	4
Figure 2-1: Location of Printer Controls and Major System Components . . . . .	7
Figure 2-2: System Controller and On/Off Switch . . . . .	9
Figure 2-3: The IRIS 3024 Printer Control Panel . . . . .	10
Figure 2-4: Printer Operating Modes . . . . .	11
Figure 3-1: Inserting the Dust Cover ("Hat") . . . . .	14
Figure 3-2: Waste Ink Disposal System . . . . .	17
Figure 3-3: Ink Bottles, Ink Status Indicator Lights, and Push Switches . . . . .	18
Figure 3-4: Location of Reference Marks on Drum and Proper Placement of Double-Sided Tape . . . . .	19
Figure 4-1: Knife-Edge Adjustment and Convergence Control Knobs . . . . .	27
Figure 4-2: Vertical and Horizontal Convergence . . . . .	30
Figure 4-3: Illustrations of "Bad" and "Good" Crystal Frequencies . . . . .	33
Figure 4-4: Removing the Deflection Assembly . . . . .	35
Figure 4-5: Removing an Ink Nozzle Assembly . . . . .	37

# Using the 3024 Operator's Manual

This manual describes the routine operation of the IRIS 3024 Color Ink Jet Printer. The descriptions and procedures in this document should enable you to print images, perform routine alignment procedures, and execute routine maintenance, including removal and cleaning of the components of the ink delivery system.

This manual does **not** provide information about installation, interfacing to external devices, and non-routine servicing.

---

## Conventions Used in this Manual

---

In the production of this manual we have used the following conventions of style:

- Phrases that are underscored are defined in the Glossary.
- Emphasis is indicated by **bold type**, not by italicization.
- In the text, messages displayed on the control panel are presented in SMALL CAPITALS.
- In detailed discussions of messages on the control panel, the control panel display is printed in the following style:

FIRST LINE OF DISPLAY  
SECOND LINE OF DISPLAY

Where the following text—the explanation of the message—is set in smaller type like this.

---

## Corrections and Comments

---

Although we have made every effort to make this Operator's Manual as accurate and complete as possible, there will inevitably be some errors and omissions. When you find such problems, please bring them to our attention so that we may correct them. In addition, we welcome suggestions for improving the information presented in this manual.

Please send your corrections and comments to:

Documentation Manager  
IRIS Graphics, Inc.  
Six Crosby Drive  
Bedford, Massachusetts 01730



## Document Error Report/Change Recommendation

Copy this form, fill out the document information, describe the errors/changes, and send this form to:

Documentation Manager  
IRIS Graphics  
6 Crosby Drive  
Bedford, Mass. 01887

### Document Information

Document Title:  
Document Revision No.:  
Applicable Software Rev. No:

Page \_\_\_\_\_ Paragraph \_\_\_\_\_ Line \_\_\_\_\_

**Describe Error or Change Recommended:**

Page \_\_\_\_\_ Paragraph \_\_\_\_\_ Line \_\_\_\_\_

**Describe Error or Change Recommended:**

Page \_\_\_\_\_ Paragraph \_\_\_\_\_ Line \_\_\_\_\_

**Describe Error or Change Recommended:**

Page \_\_\_\_\_ Paragraph \_\_\_\_\_ Line \_\_\_\_\_

**Describe Error or Change Recommended:**

Submitted by \_\_\_\_\_

Date \_\_\_\_\_

Title

Company Name



# 1

## Introduction

The IRIS Model 3024 Color Ink Jet Printer produces high-resolution output on plain paper from raster image data created on electronic pre-press systems and other computer systems.

- **Image Data Sources.** Your IRIS 3024 printer may be configured to accept data from tapes on a magnetic tape drive or via an on-line interface to a host system, including the IRIS Front End Processor (FEP). Printing procedures will differ to some extent depending on the interface configuration. (See Sections 2 and 3.)
- **Image Data Types Supported.** The IRIS 3024 can accept data stored in raster (bit-mapped) CMYK (Cyan, Magenta, Yellow, Black), CMY, or RGB (Red, Blue, Green) format. Color data must be pixel-interleaved, but colors may be in any order. (See Section 5.)
- **Imaging Technology.** To produce images, the printer forces water-soluble inks through four nozzles — one for each of the four primary printing colors — forming approximately 1,000,000 droplets per second. Each droplet is charged or uncharged under computer control by an electrode at the nozzle tip. Charged droplets are deflected into a waste chamber. Only the uncharged droplets reach the printing surface.
- **Printing Media.** The printing medium — mounted on a drum rotating at a continuous speed — can be of nearly any material whose surface can absorb IRIS water-based inks, including coated or uncoated stock, matte papers, and some clear acetates. The printer will accommodate any size media up to 24½ × 24½ inches. (See Sections 2 and 3.)
- **Printing Parameter Controls.** The IRIS 3024 printer allows the operator to control a variety of printing parameters at the printer control panel, including density and contrast of individual colors, printing color separations, placement and duplication of images, selection of resolution, and creation of oversize images by pixel replication. Additional printing features are provided through the optional FEP. When a host system is used, the host can download

printing parameters prior to sending image data. (See below and Section 5.)

- **Maintenance and Adjustment.** The operator uses the control panel to perform simple computer-assisted procedures, including adjusting the registration of the four ink jet streams and adjusting the path of travel of the ink jet streams in relation to the knife-edge that collects non-printing droplets. Normal daily maintenance procedures are included in this manual. (See section 4 and Appendix B.)

## Documentation and Applicable Software Revisions

This *Operator's Manual*, document revision 3.1, describes the operation and functionality of IRIS 3024 Color Ink Jet Printers equipped with Code Prom 01732-100, Display Prom 01733-100, and Safety Switch 00117-001, including printers shipped after June, 1989.

The *Operator's Manual* describes day-to-day use and maintenance of the printer for the printer operator. Other documentation available for the user of the IRIS 3024 Color Ink Jet Printer includes:

- *Installation Guide: IRIS 3024 Color Ink Jet Printer* (IRIS part number 01307-001). How to prepare the printer environment,

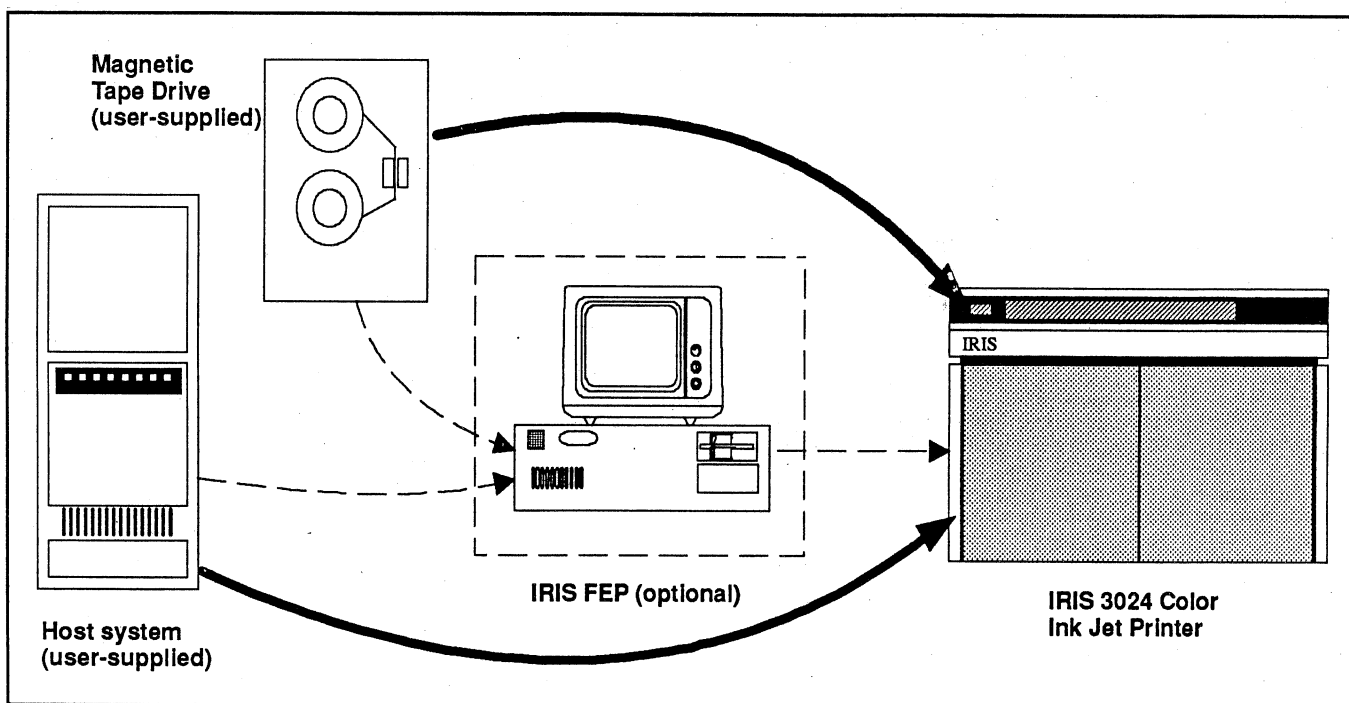

**Figure 1-1: Host/Printer Configurations.** Your IRIS 3024 Color Ink Jet Printer may be configured to receive data directly from a magnetic tape drive or from a host system. If your configuration includes the optional IRIS Front-End Processor (FEP), the FEP controls printing activities and can store image files for processing and retransmission.

unpack the printer, set up the printer for use, and re-crate the printer for shipment. This document accompanies the printer.

- *Nozzle Service Kit* (IRIS part number 01328-001). Accompanies the optional Nozzle Service Kit used for cleaning nozzle assemblies.
- *Reference Manual: IRIS 3024 Front End Processor (FEP)* (IRIS part number 01703-200). Operator reference manual for the optional IRIS FEP.
- *UPDATE NOTICE: IRIS 3024 Color Ink Jet Printer* (IRIS part number 01725-002). Describes the operator-visible differences between printers equipped with firmware changes of June, 1989, and those with previous versions of firmware.
- *Service Manual: IRIS 3024 Color Ink Jet Printer* (IRIS part number 01367-100). Optional manual for IRIS and end-user personnel trained by IRIS Graphics in service procedures for the IRIS 3024.

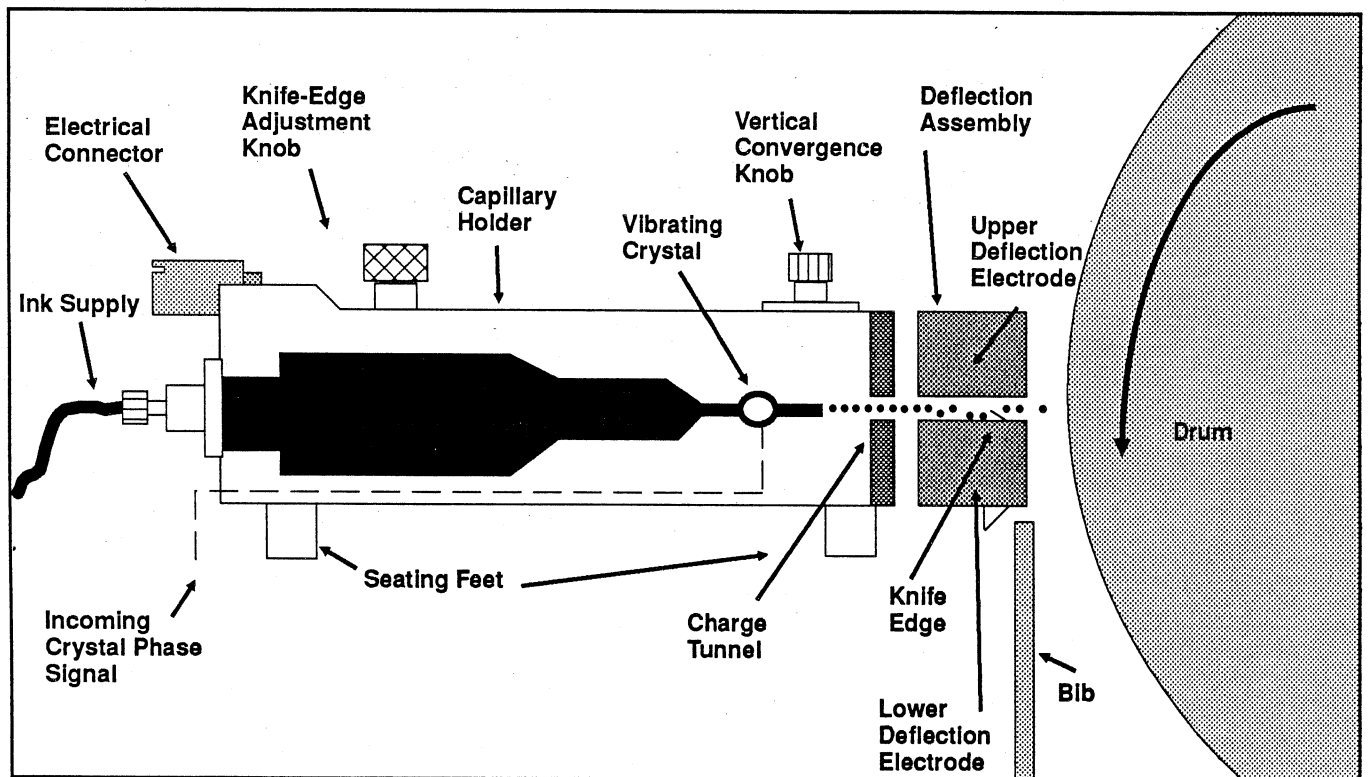

**Figure 1-2: Deflection of Charged Droplets.** Droplets charged individually in the "charge tunnel" are deflected downward in the deflection assembly and strike a "knife edge." Only uncharged droplets reach the printing surface. (Not drawn to scale.)



## How Host Systems Affect Printer Operation and Functionality

In its simplest configuration, the IRIS 3024 accepts image data from a nine-track magnetic tape drive. The printer operator sets all printing parameters at the printer control panel. The operator selects files by number from the magnetic tape and starts printing by pressing the Print switch.

In other configurations, the printer will accept data from an on-line host system, including electronic color pre-press systems, other computer systems that can generate color raster image data, or the IRIS 3024 Front-End Processor (described below).

In host configurations, operators may perform printing functions at the host instead of at the printer control panel, including selecting files to print and setting printing parameters. The operator makes the printer ready for printing and sets it to on-line status at the printer control panel. Printing begins after the host system starts sending image data to the printer. (Pausing a print run, however, must be performed at the printer).

### Printing Values Transmitted by Host System

The use of a host system with the 3024 printer offers another advantage over magnetic tape interfaces: host systems can send printing parame-

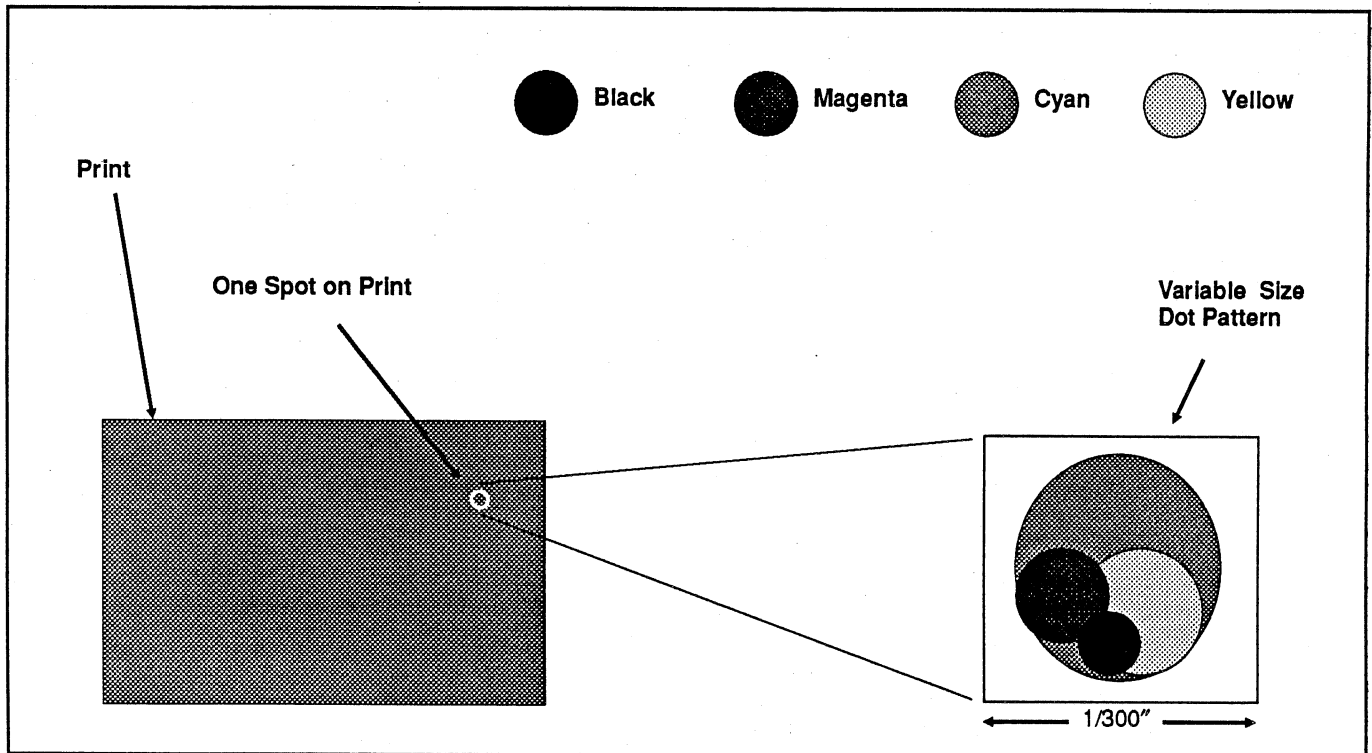

**Figure 1-3: Halftone Image Production.** Halftone image produced by varying the size of the spots (pixels) produces an image that is substantially superior to that produced by traditional techniques.

ters to the printer prior to sending the image data itself. These parameters will override the parameters selected at the printer control panel until new parameters are entered or until the printer is shut off and turned on again.

In addition, the user with a host system can create and modify "color lookup tables" at the host and download them to the printer. Color lookup tables allow the user to specify non-linear contrast characteristics, providing a very high level of programmability of image color values and helping users produce very close matches to images printed with other devices.

### **The IRIS FEP (Front-End Processor)**

The IRIS 3024 FEP is an optional method of input and printing control for the IRIS 3024 Color Ink Jet Printer. The FEP consists of

- an IBM-PC/AT™-compatible personal computer;
- an interface to the IRIS 3024 printer;
- optional interfaces that accept image data from external systems; and
- software developed by IRIS Graphics that uses these components to read and store image data from external sources and control all printing functions for the IRIS 3024 printer.

The FEP can store image data from several sources on its own disk for later transmission to the printer or control piping of data from other sources to the printer. If you have purchased an IRIS FEP, see its accompanying documentation, *Reference Manual: IRIS 3024 Front End Processor (FEP)*, for a complete description of how to use the FEP and how it adds to the functions available through the 3024 printer.

---

## **Support Policies and Additional Information**

---

Telephone and on-site support for your printer are available according to the terms of your sales and service contracts. Extended service contracts and spare parts kits are available. Telephone support is available during normal U.S. Eastern Time Zone business hours (8:00 A.M. to 6:00 P.M.) at

Customer Support Department  
IRIS Graphics, Inc.  
(617) 275-8777

Telex (510) 601-6598

FAX Number (617) 275-8590



# 2

## Preparation For Printing

Before you begin a print run, be certain that you are properly prepared. Familiarize yourself with the location of all printer controls. Figure 2-1 on the following page identifies the printer controls mentioned in this section. Make sure that you are using only IRIS-approved materials and that the operating environment is within the temperature and humidity limits recommended by IRIS Graphics.

---

### Printer Circuit Breaker

---

The circuit breaker for the printer is located in the center of the back of the printer — next to the power cord. Under most circumstances, the circuit breaker will be left in the ON position.

---

**IMPORTANT WARNING.** Before installing or performing any service or maintenance on IRIS 3024 printers, turn the circuit breaker to the "OFF" position. (The side of the switch bearing the symbol "o" must be depressed.) Turning the power switch on the front of the machine to the OFF position will **not** stop the flow of current to the printer.

---

---

### Printer Controls

---

You will control the printing activities of the IRIS 3024 Color Ink Jet Printer with two switches located on the front of the printer, with the two buttons on the operator control panel, and with the mode switch. The location of the mode switch is shown in Figure 2-1. See Figure 2-3 for an explanation of how switches, control panel buttons, and the position of the cover affect selection of printer activities.

### Power and Print Switches

The power switch is on the right, above the panel that covers the waste ink disposal system. Power should remain on at all times. If the unit is to be taken out of service for an extended period, contact IRIS Graphics Customer Support for instructions.

**NOTE:** Keep the cover closed and power on during all idle periods so that printer purge cycle runs. The purge cycle moistens the ink jets and prevents clogging.

### Starting, Pausing, and Aborting Print Runs

The print switch is located above the left swing-out panel. Press this switch when you are ready to begin a print run. You can **print only with the cover closed**. Raising the cover during a print run or diagnos-

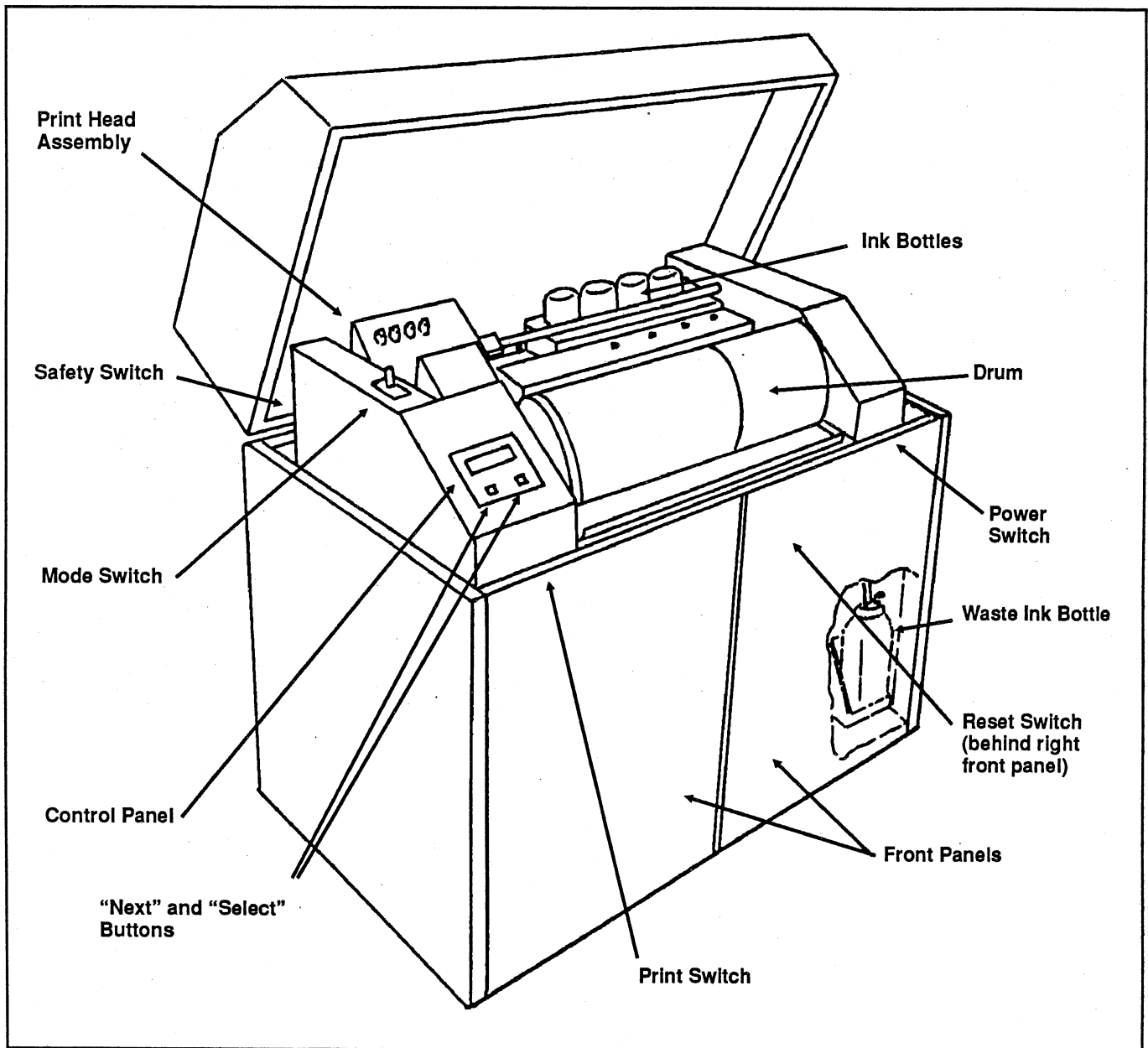

Figure 2-1: Location of Printer Controls and Major System Components.

tic test pattern will suspend printing for up to two minutes, allowing you to examine the print, resecure the paper, or examine other printer components. To restart printing, just close the cover.

If you do not close the cover within two minutes, the print run will be aborted automatically. When the hood is open and printing is paused, you can also abort the print run explicitly by pressing either button on the control panel.

---

---

**WARNING: DO NOT** touch the print head assembly while a print run is suspended. High voltage is present on the deflection assembly during all print cycles — including creation of test patterns. Perform all maintenance functions on the print head assembly in Service Mode only.

---

---

### Mode Switch and Safety Switch

When you raise the cover, you will be able to see the mode switch, located above the control panel on the left side of the printer. The mode switch has two positions.

- **Operator Mode position (switch half-way up)**, used to run test patterns, to check and adjust alignment of ink jets, and to perform other adjustment procedures. Whenever you open the hood, the mode switch will be in this position.
- **System Set-Up Mode position (switch pulled all the way up)**, used to set printing parameters at the control panel.

The mode switch is depressed completely when the cover is closed.

The safety switch is located at the rear of the left bulkhead. The safety switch has two positions: (1) depressed by the cover (enables printing) or (2) out (cover open). Whenever the cover is open, the safety switch is out and printing is disabled.

### The System Controller and On/Off Switch

Behind the left front panel you will find the system controller, a minicomputer chassis that houses the 3024 Machine Control Processor (MCP) and your printer's interface boards. The unit is mounted on a swing-out hinge. If you swing the system controller outward, you will be able to see an on/off switch on the top of the chassis (see Figure 2-2). The on/off switch should **not** be used during normal operations. It remains in the "on" position even when you shut the printer off with the power switch. The interface cable to your host system or magnetic tape unit is connected to the system controller.

### The Reset Button

The reset button located on the front panel of the MCP can be used to "clear" the printer interface to the host system or magnetic tape unit, but it is not used during normal printer operation. See the Troubleshooting Guide for conditions that indicate using the reset button.

## Operator's Control Panel

The IRIS 3024 Color Ink Jet Printer's control panel is a two-line, 40-character vacuum fluorescent display. It lets the 3024 printer communicate information about printing status, diagnostics, and alignment. When the printer is in its ready state, the control panel displays the following:

IRIS GRAPHICS INC.  
MODEL 3024 00:00:00

Where 00:00:00 represents the current time of day (24-hour clock).

## Error Messages

The printer displays error messages on the second line of the control panel display. In this manual, the explanations of these error messages — and the meanings of menu selections — will be presented in the following format:

### WASTE BOTTLE IS FULL

Check the Waste Ink Disposal Bottle. If it is full, empty the bottle according to disposal instructions in Section 4. If it is not full, make sure that it is seated correctly and that the waste tube assembly is inside the bottle.

Explanations of error messages that appear on the control panel during a normal print run are provided in Section 3.

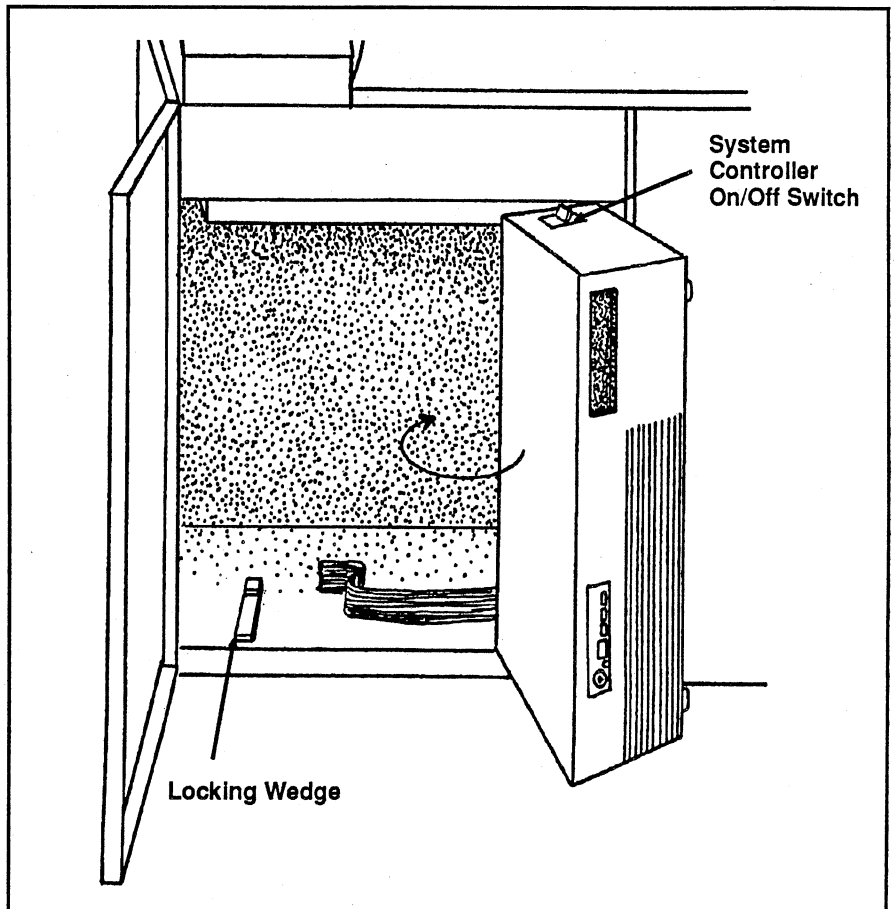

Figure 2-2: System Controller and On/Off Switch.

## Setting Printing Parameters

In System Set-Up Mode (cover open, Mode Switch in highest position), the control panel and its menus are used to step through selection of printing parameters, including drum speed, resolution, and color balance. In some cases, these printing parameters will be contained in the data received from the host computer. If the printer accepts data from magnetic tape, printing parameters must be selected at the control panel.

Printing parameters you can change at the control panel include resolution, drum speed, multiple imaging, color sequence, mirror imaging, density, and contrast. A full description of how to use the control panel to select printing parameters is found in Section 5. Use of the control panel during alignment and maintenance operations is described in Section 4. Appendix A contains menu maps that describe the organization of menus accessible through the control panel.

If your configuration includes an IRIS Front End Processor, you will specify all printing parameters at the FEP instead of at the control panel. The FEP also provides additional functionality, including the ability to store images for retransmission, editing of lists of images and Color Lookup Tables, optional image scaling, and controlled compensation for contrast characteristics of RGB image data.

## Using the Control Panel To Select Menus and Options

The two buttons on the control panel allow you to step through the menus and select values or options from those menus. The control panel displays two lines of information, each up to 20 characters long.

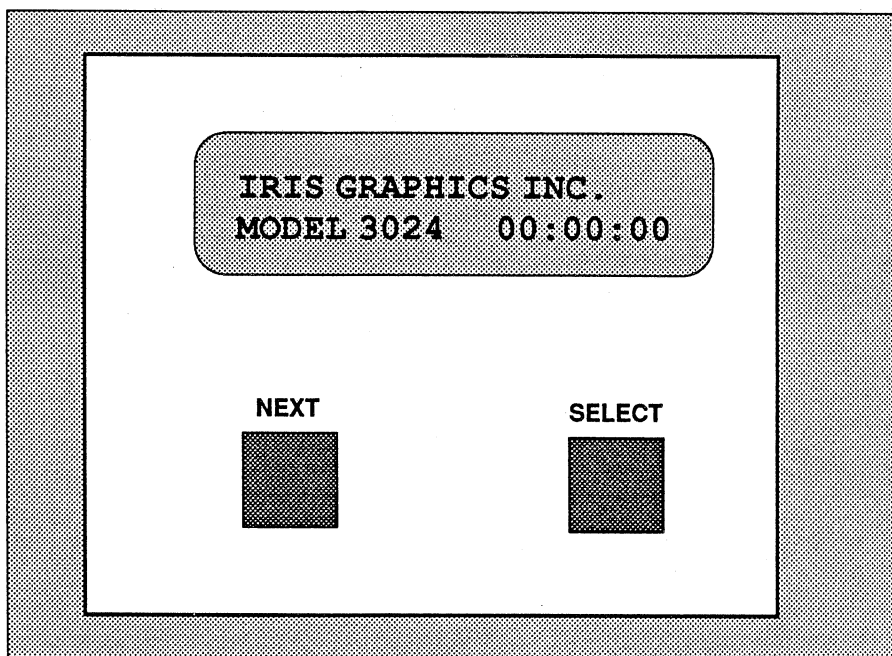

**Figure 2-3: The IRIS 3024 Printer Control Panel.** The left ("Next") button cycles through the choices on the second line. The right ("Select") button accepts the selection currently displayed on the second line.

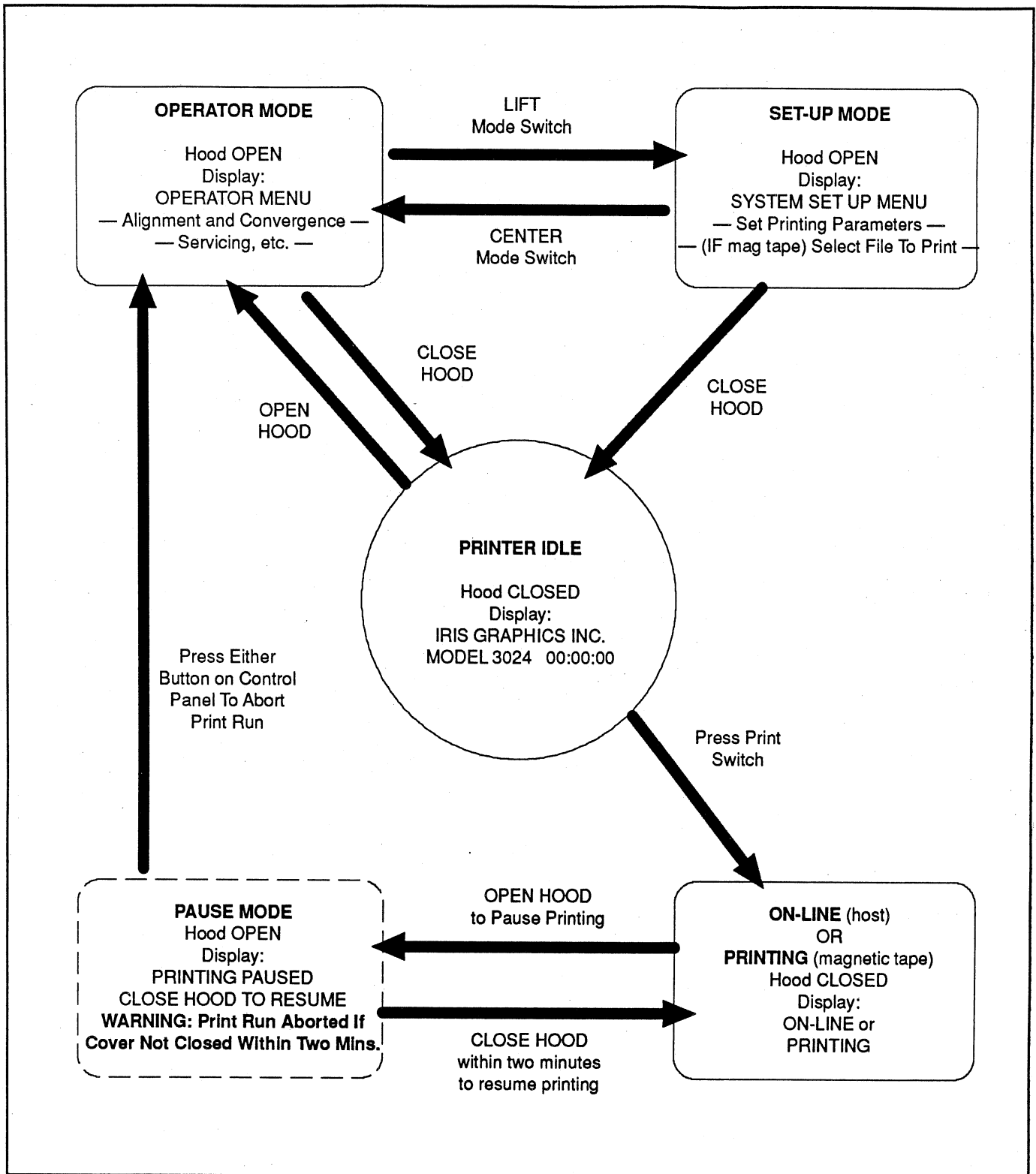

Figure 2-4: Printer Operating Modes





The first line describes the current category of operations (tasks). The second line lists the choices available within the category — either another level of menu selections or values for a particular parameter.

The buttons are used in much the same way that we use the buttons on a digital watch to change mode of operation and set the time or date. Use the button on the left (labelled “Next”) to cycle through the choices available in the menu. This will change the second line of the display. If multiple choices are available, pressing the left button repeatedly will eventually return the second line of the display to the first choice presented. Use the right button (labelled “Select”) to select the category presented on the second line or to accept the value displayed.

---

## “Paper,” Ink, and Operating Conditions

---

The IRIS 3024 printer accepts flexible hydrophilic printing media — that is, thin sheets of material that can absorb IRIS water-based inks, including plain and coated paper, coated clear acetates, and newsprint.

Use media up to 24½ by 24½ inches (622 mm. by 622 mm.). **Do not** use any printing material that is likely to tear or to detach easily from the drum. Loose or torn materials mounted on the drum can damage printer components. Media must not be thicker than 10 mils (.25 mm.). Throughout this manual, we will use the term “paper” (or “sheet”) to refer to the printing medium, whether it be paper, acetate, or some other material.

### Paper Storage and Inks

Paper may be stored in a compartment just below the drum. Do not overfill the compartment. If the paper you are using has a “right” and “wrong” side — that is, if only one side should be used for printing — place the paper in the compartment “right” (printing) side down. You will then be able to lift up the top sheet to mount it on the drum.

You must use IRIS-approved, water soluble, non-toxic inks in four colors. No other inks may be used. These inks are formulated especially for the 3024 printer. You may order paper and inks from the Order Administration Department of IRIS Graphics.

---

**WARNING:** Use only IRIS-approved inks for the 3024 printer. Other inks may destroy the deflection assembly and permanently clog the nozzles. **Using other inks will void your warranty or service contract.**

---

### Operating Conditions

Your IRIS 3024 printer must operate within a temperature range of 60°F (15°C) to 80°F (27°C) and a humidity range of 40% to 80% RH (relative humidity). Power requirements are 115/220 V 50/60 Hz, 500 W. Condensation at any humidity level must be prevented.



# 3

## Basic Printing Procedures

This section describes the “typical” procedures for printing images on the IRIS 3024 Color Ink Jet Printer — from power-up to shut-down. Included are detailed procedures for inserting paper, replacing inks, and responding to problems and error conditions during a print run.

---

### Routine Printing Procedures

---

During a typical print run, you will generally take the following steps:

1. Check the control panel for error conditions (for example, “INK PUMP ERROR”). Also check the ink level visually. Replace ink bottles as needed.
2. Mount paper on the drum, securing it with double-sided tape.
3. Enter any printing parameters required if they are not included in the incoming image data.
4. [*Magnetic tape interface only*] Select the number of the file on tape to print.
5. Close the printer cover.
6. Press the print switch to go “on-line” to the host system. The print cycle will start when the printer recognizes a “start print” command from the host system. (If the image data will be received from magnetic tape, press the print switch to start the print run.) The drum comes up to speed, the ink pumps come up to operating pressure, and the printer accepts data from the host system or tape drive.
7. To Pause the print run temporarily, raise the cover. Leaving the cover open longer than two minutes aborts the print run.
8. When the print run is complete, raise the cover. Check the control panel for error messages. The drum stops rotating and the carriage returns to its “home” position.
9. Remove the print.
10. To print the same image again, repeat the procedure.

---

## Twelve "NEVERs"

---

Before you begin using the IRIS 3024 printer, read and remember the following twelve important "nevers." Observing these rules will help insure your safety and the consistent performance of your printer.

- **Never** wear a tie or jewelry that might get caught in the rotating drum while you are operating the printer. Jewelry may also damage the surface of the printing medium.
- **Never** attempt to service the printer with the circuit breaker on the rear of the printer in the ON position.
- **Never** use media larger than 24½ by 24½ inches.
- **Never** use inks other than those approved by IRIS Graphics for the 3024 printer.
- **Never** mix ink supplies. Always use magenta ink in the magenta ink jet, black in the black ink jet, etc.
- **Never** break an ink bottle's seal unless the bottle will be used immediately. Changes in atmospheric pressure will cause an unused open ink bottle to leak ink even in an upright position.
- **Never** forget to replace the dust cover after you service nozzle assemblies.
- **Never** leave the printer cover open during idle periods. The purge cycle operates only when the printer cover is closed.

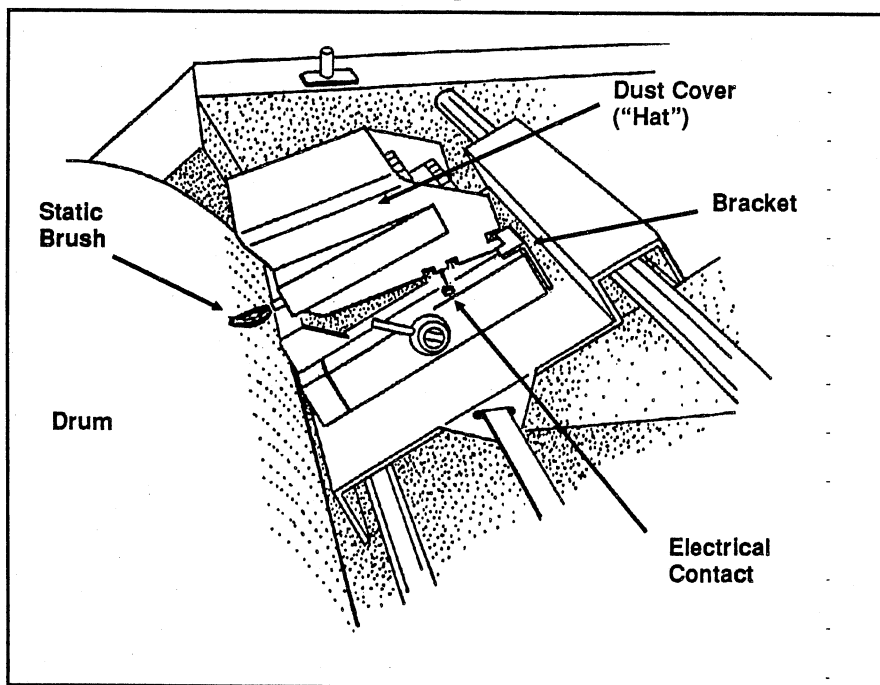

**Figure 3-1: Inserting the Dust Cover ("Hat").** Slide the rear of the dust cover under the bracket, then push the front of the cover down into place.

- **Never** install nozzle assemblies in a different color position after servicing.
- **Never** start to print if there are bubbles or wrinkles in your paper.
- **Never** use paper or other media thicker than 10 mils.
- **Never** touch the deflection assembly while the printer is printing or paused. High voltage is present on the deflection assembly during printing.

---

## Power-Up Procedures

---

Turn power to the printer on by putting the circuit breaker on the back of the printer in the ON ("I") position. Then press the power switch above the right front panel to activate the printer's computer system. The printer takes a few seconds to run initial power-up diagnostics and starts the program that will process image data. The print head assembly will move to the home position (to the left and behind the control panel) if it is not already in that position. When power-up is complete, the control panel will display the following information:

IRIS GRAPHICS INC.  
MODEL 3024            00:00:00

Where 00:00:00 represents the current time of day (24-hour clock).

There is no internal battery for the printer clock. If you want to reset the clock, you can use the procedure described in Section 5.

---

**IMPORTANT:** Under most conditions, you should leave the printer on and keep the cover closed. You should **not** shut the printer off at the end of each day.

---

---

## Error Messages

---

There are two kinds of error messages: non-fatal error messages and fatal error messages. **Non-fatal error conditions** occur during printing and will generate messages on the second line of the control panel display **at the end of a print run**, alternating with what the second line normally displays. Occasionally, several non-fatal error messages may be displayed in this way. The non-fatal error messages include, (1) CALIB. INK PUMP, (2) HIGH PRES. JET, (3) LOW PRES. JET, (4) HV SPIKE, (5) KNIFE EDGE, (6) STEPPER TIME OUT, and (7) JET PHASE ERROR.

The first five messages are associated with printing. In most cases they indicate conditions that might result in very minor imperfections

in the print. Examine the print closely. See below, "Common Printing Error Conditions." Section 6 for an explanation of all error messages and how to resolve the problems they indicate.

A **fatal error message** (for example, VOLTAGE OVERLOAD or INPUT ADDRESS ERROR) will abort the print run. The top line of the display will change to PRINT DONE and the fatal error message will alternate with the message that normally appears on the second line. This alternating message pattern may include non-fatal errors encountered before the fatal error condition.

Whenever error messages occur and the printer is waiting for the operator to acknowledge that errors have occurred, the control panel will display ACKNOWLEDGE MESSAGES on the second line of the display. Before the printer can be started again, the operator must clear the error displays by pressing the Select button on the control panel. Some specific error messages are explained in the following paragraphs. A list of all error messages and their meanings can be found in Part 6, the Troubleshooting Guide.

### Error Messages at Power-Up

Several error conditions are possible when you power up the system. The messages and what you should do in response to these messages are described below.

**IRIS GRAPHICS INC.  
WASTE BOTTLE MISSING**

**Explanation:** The waste ink bottle is missing or not seated properly.

**Remedy:** Open the right front panel and replace or reseat the waste ink bottle.

**IRIS GRAPHICS INC.  
WASTE BOTTLE FULL**

**Explanation:** The waste ink bottle is full.

**Remedy:** If the bottle is full, empty it according to disposal instructions in the following paragraphs. If the bottle is not full, make sure that it is seated correctly and that the waste tube extends into the bottle.

**INPUT BOARD ID ERROR**

**Explanation:** Problem with input board.

**Remedy:** Replace missing board or call IRIS Graphics Customer Support.

**PRINT DONE  
INK PUMP NOT HOME      1234**

**Explanation:** Where "1234" represents the numbers of the ink pumps whose pistons have not returned to home position. Ink pump "1" is the pump farthest to the right. Ink pump "4" is the pump farthest to the left.

**Remedy:** Wait until the pistons return to home position before trying to print again. If the error remains on the display for more than two minutes, an ink pump may have malfunctioned. This error will continue to be displayed until the ink pump returns home. It can be bypassed by the operator by pressing one of the control panel buttons. (NOTE: This message will occur during the pump calibration procedure. It does not indicate an error condition during that procedure.)



### Removing and Emptying the Waste Ink Bottle

The waste ink bottle is located inside the lower right front of the printer. To remove a full waste ink bottle from the printer:

1. Lift the bottle straight up.
2. Tilt the bottle to the right and pull out.
3. Dispose of the waste ink. (The inks are non-toxic.)
4. Replace with new waste bottle or wash and replace old bottle.

### Checking the Ink Level

The machine control microprocessor (MCP) that controls printer activities checks the ink supply for each pump at the start of every print cycle. If the control panel does not display an error message (for example, the INK PUMP ERROR message), the printer will be able to complete the print cycle without running out of ink, unless the print run exceeds 36 minutes. (While the printer is running, the jets are spitting ink continuously, even while the printer is waiting for data from the host system. The printer can run out of ink if the host system sends data too slowly.)

However, it is advisable not to let the ink bottles run completely dry. If the neck of an ink bottle is not full, replace it, using the following procedure:

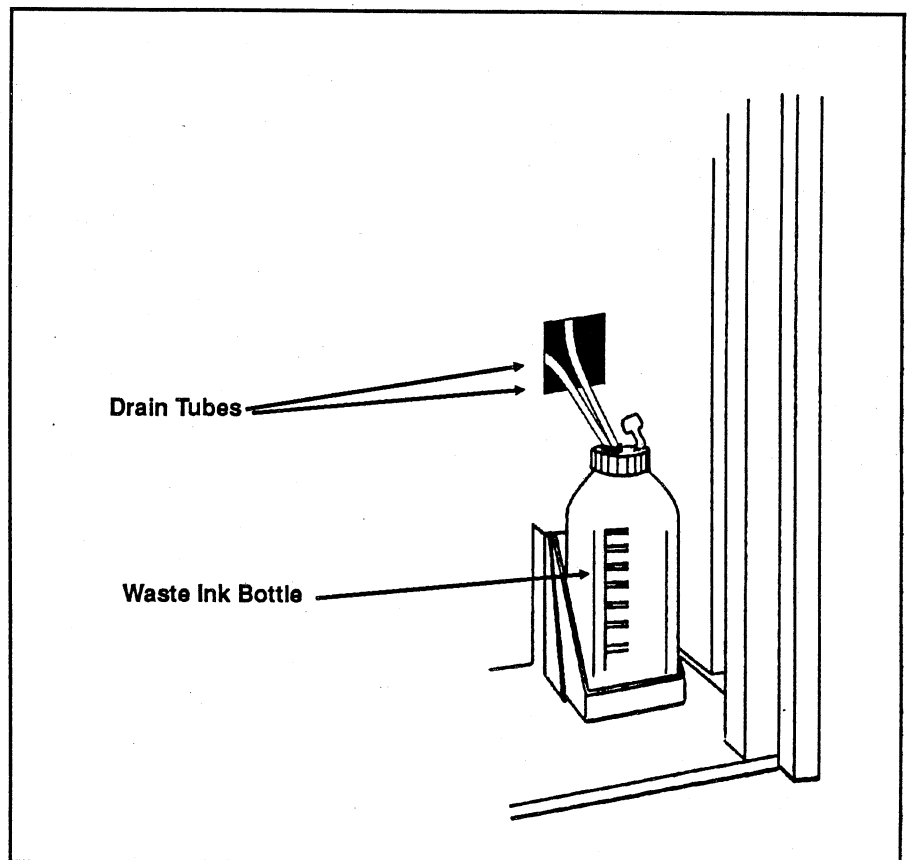

Figure 3-2: Waste Ink Disposal System (behind right front panel)

1. Pull the empty bottle straight up with a slight twisting motion. Discard the empty bottle.
2. Remove and discard the plastic wrapper from the new ink bottle. The bottle is ready for use.
3. Invert the ink bottle and press it over the ink intake cone with a slight twist. The septum (rubber diaphragm) is pierced and ink flows into the well.

Ink bottles can be removed without spilling ink. The septum closes when the bottle is lifted off the cone, forming a seal. If you need to keep partially full bottles out of the machine for more than a few minutes, insert a clean hollow coffee stirrer or similar device through the septum until the bottle is placed back in the machine. Be sure the stirrer does not reach **into** the ink. This stopgap measure will prevent changes in air pressure from forcing ink out the vent (pressure equalization) hole.

---

**IMPORTANT:** IRIS strongly recommends that you:

- **Never** use any inks other than those approved or supplied by IRIS Graphics.
  - **Always** replenish the ink supply color for color. Placing a different color ink in an ink jet system will result in clogged nozzles and color shifts.
  - **Do not** intermix the nozzle assemblies after servicing.
  - **Never** break an ink bottle's seal unless you plan to use the ink immediately. Atmospheric pressure changes cause open ink bottles to leak — even partially full bottles standing upright.
- 

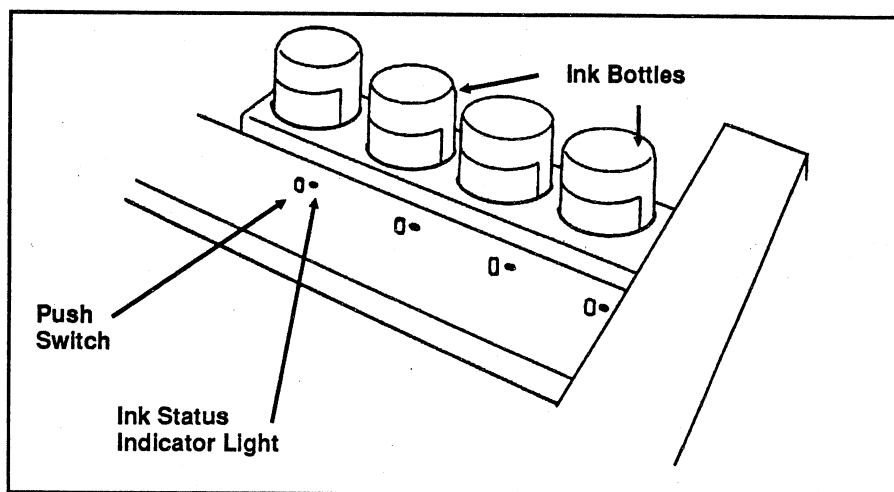

Figure 3-3: Ink Bottles, Ink Status Indicator Lights, and Push Switches.

## Mounting Paper on the Drum

You may store paper, or other printing media, in a compartment just beneath the drum. Store the paper with the surface to be printed face down. Double-sided tape applied to the drum holds the paper in place during printing. Use the reference marks (lines) on the drum as a placement guide.

### Recommended Paper Mounting Procedure

Apply two strips of double-sided tape to the drum. Use the vertical and horizontal reference marks as a guide to positioning the paper. (See illustration.) Partially withdraw the top sheet of paper from the holder. Rotate the drum to expose the reference marks. Align the top edge of the paper with the **lower** horizontal reference line. The top left corner of the paper must be placed at the intersection of the vertical reference line and the lower horizontal line. The paper must be placed in this position — regardless of the size of the paper — **unless** printing parameters specify a different vertical or horizontal position. (See Section 5.)

Working from the center of the sheet, affix the paper to the double-sided tape and smooth out any bubbles or wrinkles. Rotate the drum away from you, guiding the paper onto the drum surface. When you reach the end of the paper, tug gently to eliminate any possible bubbles or wrinkles. Secure this edge on the other strip of double-sided tape.

**WARNING:** Before printing, check the paper for bubbles. If you need to make adjustments, carefully lift the paper from the double-sided tape near the bubble, smooth it out, and resecure the paper.

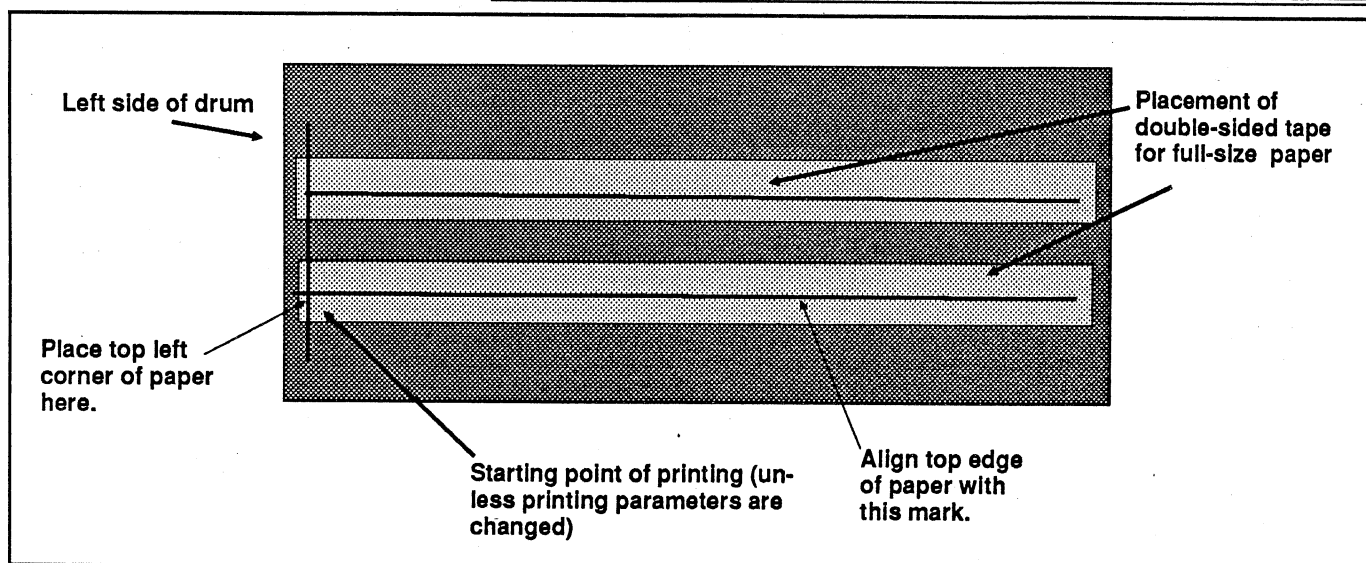

Figure 3-4: Location of Reference Marks on Drum and Proper Placement of Double-Sided Tape.



---

## Setting Printing Parameters

---

You can access nearly all printing functions through the control panel. Printing parameters transmitted by a host system will **temporarily** override the parameters accessed and saved through the control panel. Parameter commands transmitted by the host system or the operator may perform the following functions:

1. Define the horizontal and vertical resolutions.
2. Select the drum speed.
3. Define the type of image data (CMY, CMYK, etc.)
4. Set pixel replication factors.
5. Define color balance or download color lookup tables. (Color lookup tables from host only.)
6. Set multiple imaging with margins.
7. Set mirror imaging.
8. Select color separations.

If the incoming data does not contain a new set of parameter values, the printer will use default values or the values entered by the operator immediately before printing is started. See Section 5 for detailed information on setting printing parameters. If you are transmitting printing parameters as well as image data from an FEP or another host system, additional printing and color control functions may be available to you.

---

## Starting a Print Run — On-Line System

---

The following procedures apply if you are transmitting data to the 3024 printer from an FEP or another on-line host system. Procedures for starting a print run with a magnetic tape interface are described separately, below.

After you have mounted paper on the drum, checked the ink, and set your optional parameters, you are ready to begin a print run. The control panel will display:

**OPERATOR MENU**

Close the cover and place the printer on line by pressing the print switch. Printing will be controlled by the host system. Before the host system starts the print run, the control panel will display:

**PRINTER ON LINE**

00:00:00

Where "00:00:00" is the time of day.

After the host system starts the print run, the control panel will display:

```
PRINTING          0000
                   00:00:00
```

Where "0000" is the current raster (vertical line around the drum) being printed and "00:00:00" is the elapsed time since the beginning of the print run.

During a print run, the printer may encounter non-fatal error conditions. The non-fatal error messages are displayed on the control panel at the end of the print run. These conditions and their remedies are described below in the section "Common Printing Error Conditions."

---

## Starting a Print Run — Magnetic Tape Interface

---

If your printer receives its data from magnetic tape, the following information will be displayed on the control panel after you raise the cover and lift the mode switch to its highest position:

```
SYSTEM SETUP MENU
FILE TO PRINT
```

To select the FILE TO PRINT function, press the Select (right-hand) button on the control panel. The display will change to:

```
FILE TO PRINT
01
```

Where "01" represents a file number to print. The choices are 01 through 39 (files 1 through 39). You may select only one file.

The FILE TO PRINT menu selection allows you to select a file by number from the tape currently mounted on the magnetic tape drive. Use the Next and Select buttons to choose the file number. If the data will be transmitted from a host computer system instead of from magnetic tape, this message will not appear.

Close the cover. When you are receiving data from a magnetic tape drive, you will **start printing** by pressing the print switch.

---

## Common Printing Error Conditions

---

Several error conditions may occur during printing. Among the most common are the fatal and non-fatal conditions described in the following paragraphs. Fatal error conditions will abort the print run. When the printer encounters non-fatal error conditions, the corresponding error message will be displayed on the control panel at the end of the print run. (A more comprehensive list of troubleshooting tips and remedies can be found in Section 6, "Troubleshooting Guide.")

### Fatal Error Messages During Printing

At any point during printing, the control panel may display the following fatal error messages. The print run will be aborted when these error conditions occur.

**PRINT DONE** 00:00:00

**INK PUMP ERROR**

**Explanation:** The pressure in one of the ink jet systems is incorrect. If this error is displayed, one or more of the ink pump lights will be on, indicating a problem in that (or those) ink delivery system(s). This message usually indicates an empty ink bottle, but it may also occur if there are leaks in the ink delivery system or a pump failure.

**Remedy:** Check the ink level. If the bottle is empty, remove it and insert a new bottle according to the steps listed earlier in this Section ("Checking the Ink Level"). If the bottle is at least partially full, make sure the bottle is seated properly, then try to pressurize the ink system for that color by following Procedure 4-4, "Pressurizing an Ink Pump." It is advisable not to let the bottles run dry. As long as the neck of an ink bottle is full, the bottle can be used.

**PUMP TIMEOUT** 1234

**Explanation:** An ink pump failed to reach operating pressure within the specified time period (internal setting). The message will indicate a timeout for one to four colors (ink delivery systems).

**Remedy:** Call IRIS Graphics Customer Support.

**LOW PRESS JET** 1234

**Explanation:** Leak in ink delivery system or pump needs calibration. The message will indicate one, two, three, or four colors (ink delivery systems).

**Remedy:** Check the ink delivery system(s) for leaks and tighten or repair as needed. Then run the flow calibration routine (Section 4).

**HIGH PRESS JET** 1234

**Explanation:** Ink jet clogged or pump needs calibration. The message will indicate one, two, three, or four ink jets.

**Remedy:** Clean or replace the ink jet(s). Then run the pump calibration routine (Section 4).

A fatal condition related to voltage irregularities often indicates that foreign matter is shorting out the deflection assembly:

**PRINT DONE** 00:00:00

**VOLTAGE OVERLOAD**

**Explanation:** Indicates continuing voltage overload. When this error condition occurs, the printer often prints a solid bar of one or more colors. The print run is automatically aborted and the print head assembly returns to the home position.

**Remedy:** This condition can usually be remedied by removing and washing the deflection assembly. If the condition persists, the high-voltage power supply may have failed.

Error conditions that occur during printing of images can also occur during printing of test patterns.

### What Happens During a Printing Cycle

During a printing cycle, the printer will perform the following sequence of processes:

1. If the data from the host system contains printing parameters, those values are loaded into the printer's memory.



2. The ink pumps come up to pressure and the vacuum system cleans the ink jet tips. If there is no ink pressure, the print run will be aborted.
3. The printer performs an automatic knife-edge adjustment test and vacuums the target block.
4. The print drum starts spinning.
5. The print head assembly moves out to its standard starting position ("raster '0'"). If an additional horizontal offset has been specified, the print head assembly moves out to that point.
6. Printing begins (ink is deposited on the paper).
7. When the printer stops printing, the drum stops rotating, the print head assembly returns toward its home position, and the printer checks the flow rate of the nozzles. As the head returns home, error messages (if any) are displayed on the control panel. Error messages will continue to be displayed until they are acknowledged by the operator by pressing the Select button.
8. After the print head has reached vacuum position, the the ink pumps are replenished, and the printer vacuums all assemblies. Then the vacuum pump turns off and the head moves out to the home position.
9. After the vacuuming is complete, the waste ink is released to the waste ink bottle.

During the several phases of vacuuming, you will hear a number of "clicks," and the pitch and volume of the sounds of suction will change.

### Common Non-fatal Error Conditions

Several non-fatal error conditions may occur during printing. Printing will continue, and the corresponding error messages will be displayed at the end of the print run.

Among the most frequent error conditions is misalignment of the ink jet stream relative to the knife edge that collects the non-printing droplets. If all ink droplets fall below the knife edge, that color will not print. If the stream trajectory is too far above the knife edge, all the droplets reach the paper, forming a solid area of that color. These extreme conditions may occur after removing and replacing nozzle assemblies or the deflection assembly.

Less extreme misalignment of the stream may occur during normal printer use, often without a discernible effect on the print. The alignment should be adjusted during normal operation when you see the following message on the control panel:

```
PRINT DONE          00:00:00
KNIFE EDGE 1234
```

Where "1234" represents the numbers of the ink jets that should be checked for proper alignment. Ink jet "1" is the jet farthest to the right. Ink jet "4" is the jet farthest to the left.

This message can appear under several printing conditions — during a print run or while generating test patterns. Step-by-step procedures for knife-edge adjustment are described in Section 4, "Adjustment and Maintenance."

This is a non-fatal error message. The printer will not stop a print run when it senses this condition. In many cases, the print quality will be perfectly acceptable if the adjustment required for optimum alignment is only minor. Inspect the print carefully for defects after the print run is complete.

At the end of the print run, the control panel may also display the following error messages:

```
PRINT DONE
CALIB. INK PUMPS      1234
```

**Explanation:** Ink pump needs calibration. The message will identify by number the ink pump(s) that need calibration.

**Remedy:** Run the pump calibration routine (Section 4).

Intermittent changes or "spikes" in deflection voltage can cause error messages to appear on the control panel at the end of a print run. When this occurs, the following message will appear on the control panel:

```
PRINT DONE          00:00:00
HV SPIKE
```

**Explanation:** Often indicates that transient changes in voltage have produced small, sometimes indiscernible flaws in the print. You should inspect the print for defects.

**Remedy:** Check the deflection assembly for the presence of lint. Clean the assembly to avoid damage to knife edges and more serious defects in prints. (See Section 4.) When this message occurs, refer to the Troubleshooting Guide.

---

## Pausing During a Print Run

---

Printing cannot begin or resume unless the cover (hood) is closed. If you lift the printer cover during a print run, the run will be suspended temporarily. The control panel will display the following:

```
PRINTING PAUSED      2:00
CLOSE HOOD TO RESUME
```

The display counts down from two minutes. Closing the hood within two minutes restarts the suspended print run. When the print run is paused, you can check the print or examine the drum and other components.

---

---

**WARNING: DO NOT** touch the print head assembly while a print run is suspended. The assembly carries high-voltage current during all print cycles — including creation of test patterns. Always perform maintenance functions on the print head assembly with the head in service position.

---

---

If the hood remains open for longer than two minutes, the print run will be aborted and the following message will be displayed:

```
PRINT DONE           0:00
HOOD NOT CLOSED
```

The printer will reset. The print head moves back to the home position.

To **explicitly abort a print run**, raise the cover and press either button on the control panel. (If the print run has not yet begun, press **both** buttons at the same time to abort the run.) The control panel will display:

```
PAUSE MODE CANCELLED
```

---

## Routine Automatic Procedures of Idle Printer

---

The purge cycle automatically powers up the entire system, forces ink through all nozzles, and discards waste ink. This self-cleaning cycle keeps ink nozzles moist to eliminate clogging. The print head assembly remains in the “home” position and the system vacuums out the ink collected in the waste chamber of the deflection assembly. During this purge cycle, you cannot start a print run or start alignment procedures.

If the printer is idle and the cover is closed, the purge cycle runs automatically every two hours. The purge cycle operates only when the printer cover is closed. Leaving the cover down also keeps out dust and foreign matter that can harm the printing system. The purge cycle also automatically runs pump calibration and resets and verifies pump pressures.

### Shutting Down the Printer

We recommend that you leave the printer ON with the cover down so that the purge cycle automatically services the nozzle assemblies. Shut the printer down completely only for service calls and **extended** idle periods. Call IRIS Graphics Customer Support for additional guidelines and instructions.

# 4

## Adjustment and Maintenance

Although the IRIS 3024 Color Ink Jet Printer does not require extensive daily maintenance and adjustment, during normal operation you will need to perform several maintenance and adjustment routines from time to time. These tasks include:

1. Adjusting the “knife edge” — if prompted by the control panel — to ensure optimum print quality.
2. Running test patterns in order to adjust the registration (horizontal and vertical convergence) of the four ink jets, check the performance of ink jets, and observe the printing quality of colors separately and in combination.
3. Selecting an optimum frequency for the crystals that control the formation of the ink droplets.
4. Removing and cleaning the deflection assembly that catches waste ink.
5. Removing and cleaning the bib.
6. Removing and reinstalling the ink jet nozzles.
7. Resetting the ink pumps if the ink supply in one or more of the pumps has run dry and air has entered the pump chamber.
8. Calibrating the ink pumps.
9. Cleaning the drum and painted surfaces.

For a listing of **recommended** maintenance intervals, see Appendix B, “Routine and Periodic Maintenance Procedures.”

---

### Knife-Edge Alignment

---

Each ink jet delivers a continuous stream of droplets aimed at the paper. Uncharged droplets strike the surface to form the dots that make up the print. Charged droplets are deflected downward in the deflection assembly toward a “knife edge.”

The printer checks knife-edge alignment and will make minor adjustments electronically at the start of each print cycle. When the

printer detects knife-edge misalignment, the following message appears on the control panel after the run is finished:

```
PRINT DONE      00:00:00
KNIFE EDGE 1234
```

Where "1234" indicates the color channel(s) that require(s) knife-edge adjustment.

The KNIFE EDGE error condition can occur during other printing functions as well, including during generation of test patterns. The message does not always indicate a defective print. In many cases, the quality of the print is adequate because of the corrective adjustments made automatically by the printer.

### Conditions that Require Knife Edge Adjustment

Adjustment of knife-edge alignment may be required under several circumstances:

1. Servicing the nozzle assemblies will often cause misalignment. After servicing nozzles, always check knife-edge alignment and registration before printing.
2. Replacing the nozzles with new nozzles will usually involve adjusting the knife edge.
3. Cleaning and replacing the deflection assembly will usually require adjustment of knife edges.
4. Printing of solid lines (all droplets striking the paper) of one color is usually a clear indication of the need for knife-edge alignment.

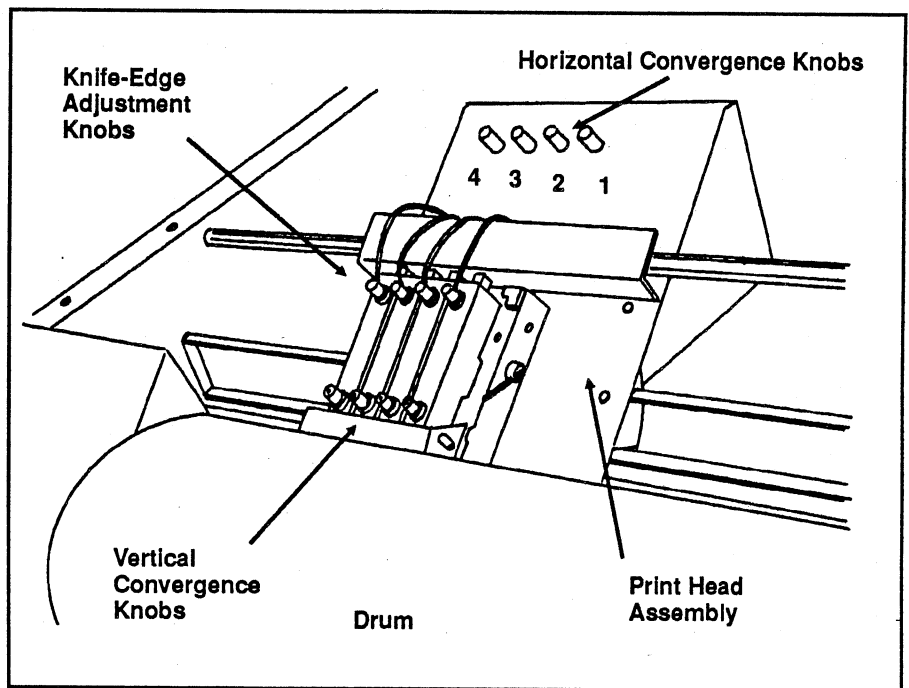

Figure 4-1: Knife-Edge Adjustment and Convergence Control Knobs.



### PROCEDURE 4-1: Knife-Edge Adjustment

Step	Action	System Response
1	Turn the printer on and raise the cover.	The control panel displays: OPERATOR MENU ALIGNMENT MENU
2	Press Select ("Yes").	The control panel displays: ALIGNMENT MENU PREVIOUS MENU
3	Press the Next (left) button on the control panel until the second line displays the ADJUST KNIFE EDGE message; then press Select.	The control panel displays: ADJUST KNIFE EDGE PREVIOUS MENU
4	Press the Next (left) button on the control panel until the second line displays the ink jet that you want to adjust.	If you have pressed the Next button until you selected color 3, the Control Panel displays: ADJUST KNIFE EDGE NEXT# . . 3
5	Press the Select button to start. Turn the knife-edge adjustment knob slightly left or right and observe the changes on the control panel display. <b>Your goal is to center the vertical bar between the left and right arrows.</b> If the vertical bar is not displayed, turn the knob in the direction indicated by the arrows until the bar appears. Then use smaller movements left or right until you have centered the bar. (NOTE: If gross movements of the knob do not produce any change on the display, the ink pump may have timed out or may be out of ink.)	The ink delivery system comes up to pressure and the control panel displays (for color 3): ADJUST KNIFE EDGE                    3 NEXT# . . 4    << >>>>>> The graphic display on the second line may be different and may fluctuate slightly even before you begin adjusting the knife edge. As you turn the knob, the vertical bar will shift left or right. When the knife edge adjustment is correct, the graphic indicator on the second line of the display will look like the following: <<<< >>>>
6	When the vertical bar is centered, select the next color by pressing the Next button and then the Select button. Repeat steps 4 through 6 as needed for the other jets.	The control panel displays: ADJUST KNIFE EDGE                    4 EXIT                                    << >>>>>> Where EXIT indicates that you can exit from the routine at this point. You may also choose the number of another ink jet.
7	To complete the procedure, press Next until EXIT appears on the bottom line of the display, then press Select. You can exit from the procedure at any time. Be sure to reinstall the dust cover before printing.	The control panel displays: ALIGNMENT MENU ADJUST KNIFE EDGE

5. Failure to print a color may indicate a need for knife-edge alignment. Check the ink bottle and ink delivery system first.
6. Poor print quality may be caused by improper knife-edge alignment. Run the knife-edge alignment and registration procedures. Check the quality of the incoming data as well.

### Computer-Assisted Knife Edge Adjustment

The “knife edge adjustment” is actually an adjustment of the direction of the ink jet stream relative to the knife edge — not a change in the position of the knife edge itself. The adjustments are made by moving the knife-edge adjustment knobs and watching the effects of those changes on a simple graphic displayed on the control panel. See Procedure 4-1, “Knife-Edge Adjustment.”

---

## Adjusting Color Registration

---

Printing registration is correct when the four separate color images that constitute a full-color print are superimposed precisely on each other. This process is also called convergence, because it refers to the effects of all four ink streams converging on the same spots.

You adjust both horizontal and vertical registration of the 3024 printer by running a test pattern, observing the degree of overlap of the lines in the pattern, and adjusting the overlap with the horizontal and vertical convergence knobs.

As you observe the test pattern, remember that each color is, in effect, a separate pass, printed with a delay to accommodate the 3/4-inch (19 mm.) offset of the ink jets. The second color does not begin overprinting until the first ink jet has traveled 3/4 inch. This delay applies to printing images as well as printing test patterns.

### “Horizontal” and “Vertical”

The IRIS 3024 always prints images from left to right on the paper mounted on the drum. But the printed images themselves may be oriented in any of four directions: upright, upside down, or rotated 90° to the left or to the right. Throughout this manual, “vertical” will refer to the up-and-down direction of the paper — your perspective of the sheet mounted on the drum as you stand in front of the printer. “Horizontal” will always mean the left-to-right direction of the paper — the direction of print head travel.

### Conditions that Require Adjustment of Convergence

Several conditions may require you to adjust registration of colors. Be sure that the knife edge is properly adjusted **before** performing adjustments on convergence.

1. Servicing the nozzle assemblies will often alter convergence.

2. Replacing the nozzles will alter convergence. Check knife edge alignment and adjust convergence before printing whenever the nozzles are replaced.
3. Poor print quality may be caused by improper convergence. Run the alignment and registration procedures. Check the quality of the incoming data as well.

### Adjusting Convergence

You will adjust both horizontal and vertical movement of the ink jet streams to create a pattern in which all four colors are precisely superimposed by running the grid pattern and pausing from time to time to examine the pattern under a glass.

The **vertical** convergence knobs are located at the front (drum end) of the nozzle assembly. Rotating the vertical convergence knob for a color changes the left-to-right position of that ink jet stream — that is, the convergence of vertical lines (for example, the vertical lines of the pattern). If the dot on the knob is in the 9:00–12:00–3:00 o'clock range, turning the vertical convergence knob clockwise moves the vertical lines in that color to the right. (See Figure 4-2.)

---

**NOTE:** The dot on the vertical convergence knobs should initially be pointed toward the rear of the printer. When replacing the cleaned nozzle assembly, it is advisable not to change the adjustment knobs. This will make it easier to make knife edge and convergence adjustments when you reinstall a nozzle.

---

The **horizontal** convergence knobs are located on the carriage electronics chassis to the rear of the knife edge adjustment knobs.

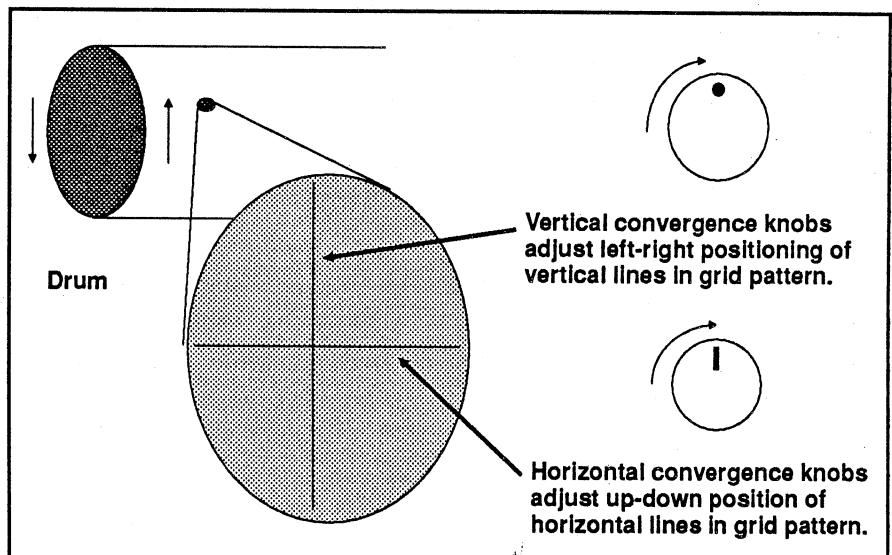

**Figure 4-2. Vertical and Horizontal Convergence.** You will use the convergence knobs on the print head assembly to adjust registration of colors (convergence of the three or four ink jet streams) as you run a test pattern.

## PROCEDURE 4-2: Adjusting Convergence and Running the Test Pattern

Step	Action	System Response
1	After adjusting knife-edge alignment (see Procedure 4-1), raise the cover and mount a sheet of paper.	The control panel displays: OPERATOR MENU ALIGNMENT MENU
2	Remove the dust cover ("hat") that protects the ink nozzle assemblies.	Ink nozzle assemblies are exposed and vertical convergence knobs (knobs closest to the drum) are accessible.
3	Press the Next (left) button on the control panel until the second line displays the TEST PATTERN message, then press Select.	The control panel displays: TEST PATTERN PREVIOUS MENU
4	[OPTIONAL] If you want to move the print head to a position other than the normal starting point for printing, use the Next button to select MOVE RIGHT, then press Select. (If you move the head too far to the right, use the Next button to select MOVE LEFT.)	The control panel displays: MOVE RIGHT MOVE RIGHT
5	To start printing the test pattern, press the Next (left) button on the control panel until the second line displays the choice you want — for example, ALL COLOR TEST — then press the Select (Yes) button. <b>Close the hood.</b>	The ink delivery system pressurizes, and the printer starts to generate a rectangular grid pattern and color pattern. The control panel displays: ALL COLOR TEST      0000 00:00:00 where 00:00:00 represents the elapsed time from the start of the print run.
6	To Pause the printer and inspect the developing pattern on the paper, lift the printer cover. Examine the horizontal and vertical lines, and, using the first color pattern as a master, adjust the placement of the other colors by turning the horizontal and vertical convergence knobs. <b>Important:</b> The printer will abort the Test Pattern run if you do not close the cover within two minutes of opening it. Turning the horizontal convergence knob clockwise moves the horizontal bars of that color down. If the mark on the vertical convergence knob is facing to the rear of the printer, turning the knob clockwise moves the vertical lines of that color to the right.	The control panel displays: PRINTING PAUSED      2:00 CLOSE HOOD TO RESUME While the printer is paused, you can use the MOVE RIGHT and MOVE LEFT to move the print head to a different position. ( <b>DO NOT</b> attempt to move the print head by hand; high-voltage current is present.) And you can also change your selection of colors to print.

(Continued on next page)

**PROCEDURE 4-2 (cont.): Adjusting Convergence and Running the Test Pattern**

Step	Action	System Response
7	After you have completed the convergence adjustments, press the Next button until EXIT is displayed on the control panel, then press the Select button.	The carriage returns to the home position, and the control panel displays: OPERATOR MENU TEST PATTERN
8	Return to the knife-edge adjustment procedure (Procedure 4-1) and double check adjustment of all knife edges.	—

Turning the horizontal convergence knob clockwise moves the horizontal lines in that color down — for example, the horizontal lines in grid patterns.

**Pausing During Test Pattern Run**

The test pattern, like printing images, must be run with the cover closed. To examine the convergence of the vertical and horizontal lines in the test pattern, lift the cover to suspend printing. The drum will stop spinning, and you can examine the pattern under a magnifying glass. Closing the cover will resume printing of the grid pattern. Be sure to close the cover within two minutes. When you leave the cover open longer than two minutes, printing of the test pattern is aborted.

Use the first color (the rightmost jet) as the “master” line. If the other lines print above the first color line, turn the horizontal convergence knobs clockwise to move the horizontal bars of those colors down. Turn the vertical convergence knobs clockwise to move the vertical lines in those colors to the right.

**Selecting Crystal Frequency**

A crystal attached to each of the four ink nozzles vibrates at a computer-controlled rate. The vibration helps form droplets at a very consistent rate and creates droplets of very uniform size. Slight differences in the physical properties of the crystals and nozzles result in variations in performance over a range of frequencies.

The printer provides tools that allow you to select a frequency that provides the best overall performance for all four ink jets. The operator prints a pattern of colors (“crystal frequency color bars”), examines the quality of printing at each of 16 frequencies, and then selects the frequency that produces the best results for all four colors.

This adjustment procedure is normally required only when replacing an ink nozzle assembly or when obvious print defects such as “graininess” start showing up in one or more colors.

[For procedures described in the text of this section, we will use the following notation to indicate the sequence of selection of menus: MENU ⇒ MENU ⇒ MENU ⇒ SELECTION.]

### Selecting and Setting Crystal Frequency

Before you run frequency color bars, set the crystal frequency to a value of 8 — the middle of the range of the sixteen possible values. To enter the crystal frequency value, open the cover and select ALIGNMENT MENU⇒FREQUENCY CALIBRATE⇒CRYSTAL FREQUENCY. The control panel will display:

```
CRYSTAL FREQUENCY
01
```

Enter the value 08 by pressing the Next button until “08” appears and press Select. Then adjust the knife edges for all colors (Procedure 4-1). To run frequency color bar patterns, lift the mode switch to the top position, and select ALIGNMENT MENU ⇒ FREQUENCY CALIBRATE ⇒ FREQ. COLOR RUN. The control panel will display:

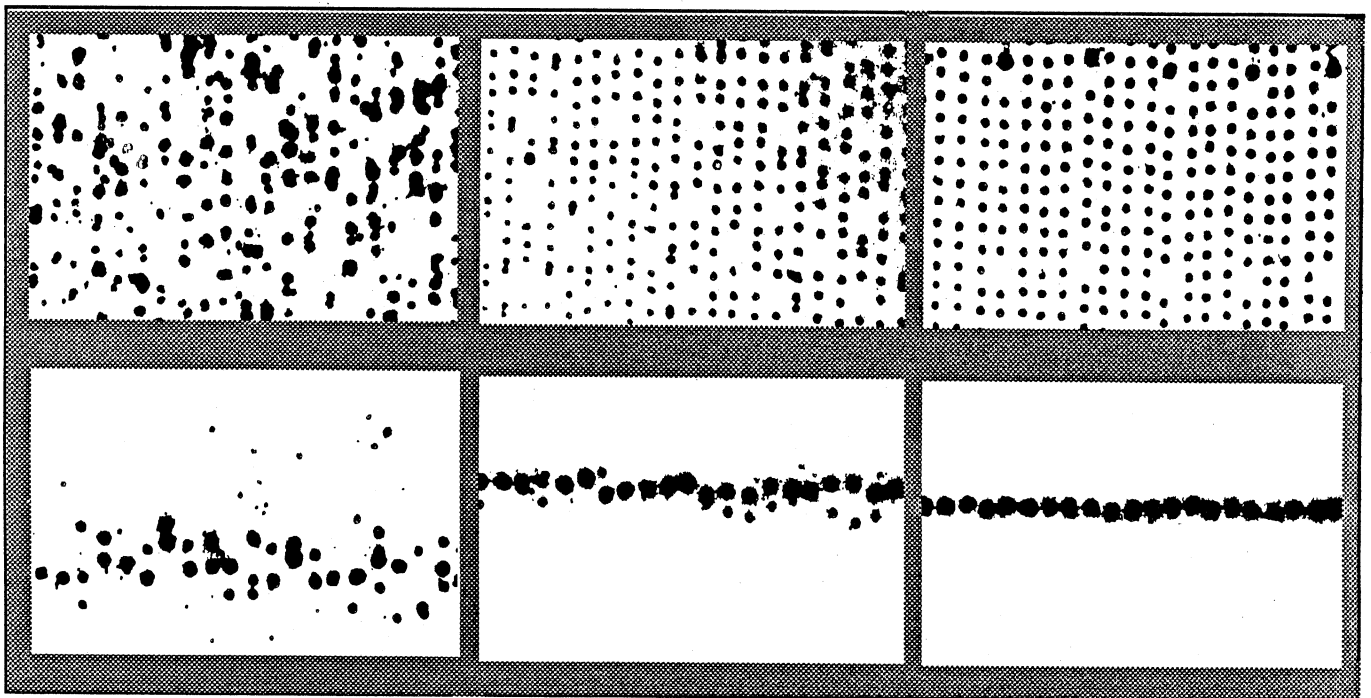

**Figure 4-3: Illustrations of “Bad” and “Good” Crystal Frequencies.** The photomicrograph samples on the left were taken from a frequency pattern that was clearly “bad” to the unaided eye. The samples in the middle looked “good” to the naked eye, but under magnification the bar (top) shows uneven alignment of rows and columns, and the horizontal lines (bottom) are split. The samples on the right are typical of patterns produced by good crystal frequencies.

```
FREQ. COLOR RUN
PREVIOUS MENU
```

Press the Next button once. COLOR: ALL appears on the second line. Press the Select button. The control panel then displays:

```
POSITION OF RUN?
LEFT                RIGHT
```

Use the Next or Select button to choose the position of the pattern on the paper — on the left-hand or right-hand side of a 24½ by 24½ inch sheet. The printer will print a pattern of 16 bars in each color — one bar in each of 16 different crystal frequencies. Each bar covers the full range of possible densities. Below each bar will be six parallel lines printed in six different densities. Remove the print and number the bars for each color 1 to 16. (Note: If the density for a color has been set to 0 [zero], the ink pump for that color will not be turned on.)

### Examining the Frequency Color Run

Examine the bars with the unaided eye for defective printing. Bars that have gross striations or some other easily visible pattern (including “waves” or graininess) indicate crystal frequencies that should not be used. If any bar is obviously darker or lighter than its neighbors, that frequency should not be used.

Then inspect the acceptable bars under magnification. (Magnifications of 7 to 25 are good choices.) In particular, carefully examine (1) the darkest part of each bar and (2) a section with a readily distinguishable pattern of separate dots about three quarters of the length of the bar from the darkest end. Look for evenness and regularity in the pattern of dots. Ideally, rows and columns of dots should line up. Eliminate any bars that have a noticeably wavy or uneven pattern. (See Figure 4-3.)

Then carefully examine the six horizontal lines below each bar under magnification. Lines that are wavy or split into discrete individual droplets vertically (sometimes forming two discrete horizontal lines) indicate crystal frequencies that should be avoided. Good frequencies form straight, clean lines. (See Figure 4-3.)

You will probably have several choices of frequencies that are “good” in all four colors. If so, choose a frequency in the middle of the range (6 to 10) rather than one at the extremes of the range. Please note that the frequency run is not affected by such changes in parameters as resolution, color density, and contrast. These parameters are automatically set to factory values during the color frequency run.

### Setting the Crystal Frequency Value

To enter the crystal frequency value, select ALIGNMENT MENU ⇒ FREQUENCY CALIBRATE ⇒ CRYSTAL FREQUENCY. The control panel will display:

```
CRYSTAL FREQUENCY
01
```

Enter the value (01–16) that is the best for all colors by pressing the Next button until the value is displayed. Then press Select. (All nozzles use the same frequency of vibration.) If you have to make an extreme compromise because there is no common frequency that produces good results in all colors, replace one of the nozzles and re-run the crystal frequency procedure.

## Cleaning the Deflection Assembly

The deflection assembly in the IRIS 3024 printer traps and collects waste ink during printing. Although the assembly is vacuumed out at the end of each print run — and periodically during automatic purge cycles — it is subject to build-up of ink residue. The deflection assembly also traps dust and paper fibers. Excessive residue may cause flooding and high voltage arcs.

Clean the assembly regularly — at least twice per week during periods of heavy use. You may find that you need to clean the assembly more frequently or less frequently, depending on the printing environment and on how often you use the printer.

### Removing the Deflection Assembly

The deflection assembly is located in front of the nozzles. To remove the assembly for cleaning:

1. Lift the cover and use the control panel to select SERVICE POSITION. Press the Select button. The carriage will move to the right for easy access.
2. Remove the dust cover (“hat”) by lifting the end facing the drum

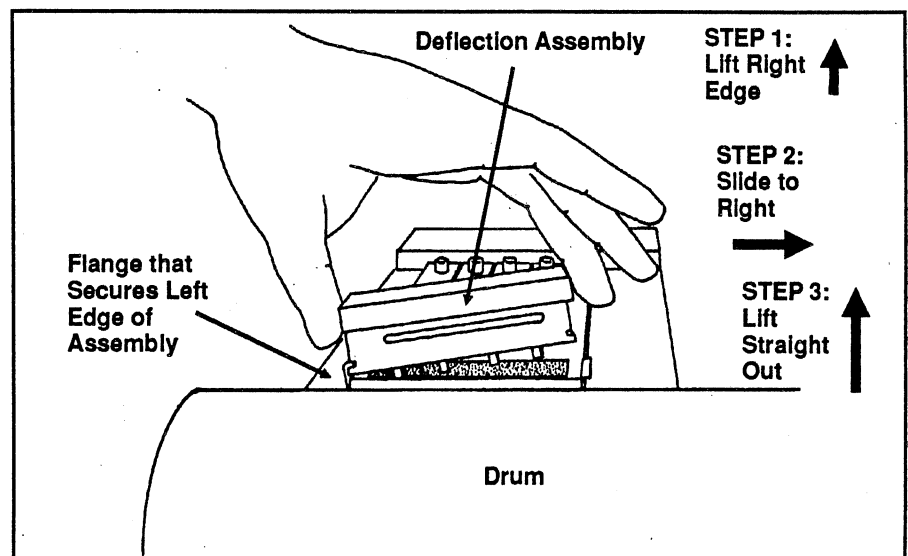

**Figure 4-4: Removing the Deflection Assembly.** The print head assembly must be in service position.



and sliding it toward you.

3. Grasp the deflection assembly with thumb and forefinger and lift the right edge. Slide the assembly slightly to the right, then lift it out. (See Figure 4-4.)

---

---

**IMPORTANT:** Handle the deflection assembly with extreme care. It contains fragile ceramic and can pick up lint that will cause arcing.

---

---

### Cleaning the Deflection Assembly

To clean the deflection assembly after you have removed it, follow these procedures:

1. Rinse the assembly in distilled water. (The inks are non-toxic.)  
**Do not re-use the waste water.**
2. Shake off excess water.
3. If you have an IRIS Nozzle Service Module (IRIS part number 01292-001), use the vacuum line to remove moisture from the deflection assembly. Otherwise, blot off excess water on plastic (black) parts with a lint-free cloth or paper towel. Avoid touching the ceramic (dark gray) parts with paper towels; paper fibers can impede operation.
4. Always remove the bib before you reinstall the deflection assembly. If you reinstall the same deflection assembly immediately, run a forced purge cycle in order to vacuum excess water from the ceramic electrodes.
5. **Never** use brushes or any sharp instrument to clean this unit.
6. **Never** use a detergent to clean this unit.

---

### Cleaning the Bib

---

The bib is a white filter that attaches to the front of the print head assembly below the deflection assembly. The bib should be washed in warm water approximately every 40 hours of printer use, or whenever you see blobs of ink or other unexplained ink deposits on prints. If the filter material becomes clogged with ink residue, it should be discarded and replaced with a new one.

To remove the bib, first lift the cover and use the control panel to select SERVICE POSITION. Press the Select button. The carriage will move to the right for easy access.

Reach for the lower edge of the bib from behind and push it up. The bib is held in place on the carriage front surface by a metal bar that fits into the "pocket" on the back of the bib. To avoid damage to the bib, be sure the deflection assembly is in place **before** reinstalling the bib. To reinstall, simply slide the bib down the front of the carriage so

that the metal bar slides securely into the pocket. Check to be sure the top of the bib is evenly lined up with the top surface of the carriage.

The printer must not be operated without a bib in place.

---

## Servicing Nozzle Assemblies

---

Conditions that warrant removing the nozzle assemblies include:

1. Clogged nozzle.
2. Inconsistent nozzle performance in spite of repeated cleaning.
3. Erratic performance, such as frequent "knife needed" messages.
4. Periodic cleaning of all nozzles. (Contact IRIS Graphics Customer Support for cleaning procedures.)

If a color does not print, check the ink delivery system and the knife-edge adjustment. Also check color density. (If density is set to 0, no ink of that color will be printed.) If the knife-edge adjustment and density are satisfactory, remove and clean the nozzle. Installing a new or cleaned ink jet will usually change the alignment of the jets. Follow Procedure 4-3 to remove and replace nozzles.

**For instructions for cleaning the nozzles, call IRIS Graphics Customer Support.** We recommend that you use the optional IRIS

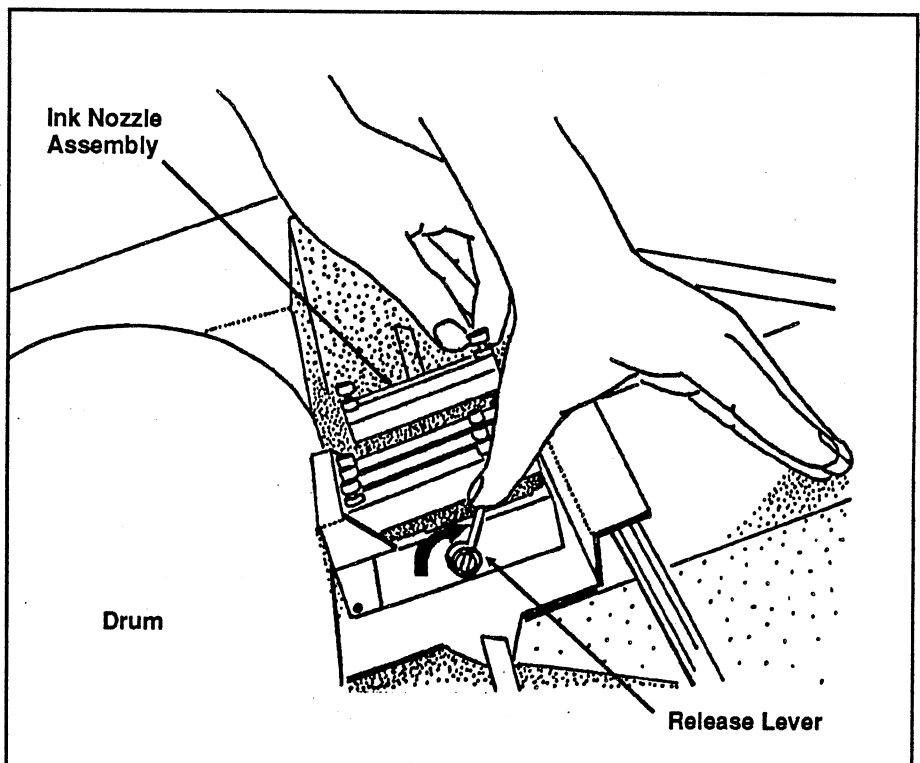

Figure 4-5: Removing an Ink Nozzle Assembly.

Nozzle Service Module (IRIS part number 01292-001) for cleaning nozzle assemblies.

When replacing the cleaned nozzle assembly, try to avoid changing the adjustment knobs. This will help make alignment easier after you reinstall the nozzle.

After you replace a nozzle, adjust knife-edge alignment and run the test pattern to check convergence, using the procedures described earlier in this section.

### PROCEDURE 4-3: Removing and Reinstalling Nozzle Assemblies

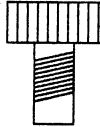
Step	Action	System Response
1	With the printer on, raise the cover and press the Next (left) button on the control panel.	The control panel displays: OPERATOR MODE ALIGNMENT MENU
2	Press the Next button on the control panel until the second line displays the SERVICE POSITION selection, then press Select.	The control panel displays: SERVICE POSITION NO YES
3	Press Select.	The carriage moves out to the service position, making the nozzles more accessible.
4	Remove the "hat" (dust cover).	The nozzle assemblies are exposed.
5	Remove the ink supply line by unscrewing the black knob connecting the ink line to the assembly. Disconnect the electrical connection. Hold both connectors as you remove each wire. Do not place any strain on the the wires.	—
6	Locate the release lever on the right side of the carriage and push the lever back. While holding the lever all the way back, lift out the nozzle assembly that needs replacement or cleaning. Release the lever gently. (See Figure 4-5.)	--
7	Cap the nozzle assembly with the M6 threaded plug (a grey plastic screw—shown, right), part no. 00385-001, to prevent loss of the O-ring and clogging of the jet.	— 
8	Reinstall the nozzle assembly by reversing steps 4 through 7. Do not overtighten the ink line connections to the jet. Finger-tight is sufficient.	—

---

---

**IMPORTANT:** Never interchange the nozzle assemblies. Always use the colors in the same channels. Mixing the inks can cause undesirable effects on color and may in some cases result in clogging of the ink nozzles and other parts of the ink delivery system.

---

---

---

## Ink Pump Error Messages

---

If the MCP senses an “out of ink” condition for one or more pumps, the corresponding ink status indicator lights will turn on, the print run will be aborted, and the control panel will display:

**PRINT DONE**

**INK PUMP ERROR**

**Explanation:** There is insufficient pressure in one or more of the ink delivery systems — usually an indication that there is not enough ink in a pump to complete a print run.

**Remedy:** Check the ink status indicator lights, located directly to the front of each ink bottle. The ink status indicator light turns on to indicate loss of pressure in that ink delivery system. Replace empty ink bottles by following the routine in Section 3. If the printer displays an ink pump error message, pressurize the pump according to Procedure 4-4.

The ink bottles can be replaced individually. You do **not** need to replace all four bottles when one is low or empty.

## Calibrating the Ink Pumps

The printer periodically makes automatic adjustments to the ink flow in the jets in order to insure that a consistent amount of ink is delivered by each nozzle to the printing surface. However, under the following conditions you should run the printer’s flow calibration routine:

1. After changing an ink jet.
2. Whenever the printer has been shut down for more than 12 hours in a row — or whenever the printer has been on but not running (printing or periodic automatic purge cycles) for 12 hours or more.
3. Printer displays any of the following error messages: LOW PRESS JET, HIGH PRESS JET, or CALIB. INK PUMPS.

If you encounter the low pressure warning, first check the ink lines. This message often indicates ink leaks. The high pressure warning often indicates that an ink jet has become clogged. If you encounter the high pressure warning, replace the ink jet with a jet previously used only with that color a new (neutral) jet from the factory.

If the control panel continues to display these messages, run the **flow calibration routine**. Open the cover, lift the mode switch to the

### PROCEDURE 4-4: Pressurizing an Ink Pump

Step	Action	System Response
1	Check the ink supply remaining in the bottle. If it is empty, replace the ink bottle. (See procedures in Section 3.) Start the knife-edge adjustment routine (Procedure 4-1) for the color associated with the pump whose ink status indicator light is on. Then press the push switch in front of that light.	<p>The pump piston moves back to its "home" position. The indicator light will go out when "home" is reached, and then the piston will reverse and try to pressurize.</p> <p><b>If the pump reaches operating pressure</b> within the time allowed and starts running normally, <b>go to Step 2.</b></p> <p><b>If the pump does not reach pressure</b> in time — indicating air is trapped in the piston chamber, <b>go to Step 3.</b></p>
2	With the pump running normally, press the push switch again.	<p>Same as Step 1.</p> <p>If the pump again reaches pressure before the indicator light comes on, the pump is ready for printing. Exit the knife-edge adjustment routine.</p>
3	To purge air from the chamber, press the push switch twice.	<p>At the first button press, the piston will start returning "home." At the second, the piston will reverse and the light will blink as the air is purged from the chamber.</p> <p><b>If the air is purged successfully</b>, the indicator light will go out and the pump will start running normally. <b>Go to Step 2.</b></p> <p><b>If the piston reaches the end of its travel without sensing pressure</b>, the pump motor will stop and the indicator light will continue to blink. This may indicate a loose ink line connection or a leak in the ink delivery system (pump, ink lines, nozzle, etc.). Check for leaks or for an empty bottle, then <b>go to Step 4.</b></p>
4	Reaching the limit of piston travel may also indicate that the valve between the ink bottle and the piston chamber is not seated properly. Press the push switch and wait until the piston returns home and reverses.	<p><b>If the pump begins functioning normally</b>, <b>go to Step 2.</b></p> <p><b>If the pump again stops with the Indicator light on</b>, <b>repeat Step 3.</b> In this case, however, tap lightly on the ink bottle while the pump is purging with the indicator light blinking.</p>
5	If the pump fails to sense pressure in Step 4, exit the knife-edge adjustment routine, press the push switch to return the piston to the "home" position, and call IRIS Customer Support.	

top position, and select ALIGNMENT MENU⇒CALIBRATE INK PUMPS. The control panel will display:

```
CALIBRATE INK PUMPS
NO                               YES
```

Press the Select button. The printer will run the flow calibration routine automatically. The routine typically takes between three and five and one-half minutes. The INK PUMP NOT HOME message that appears during calibration is normal. (The MCP is ready for the second phase of calibration before the pump pistons have returned to their home positions.) If the panel displays the CALIB. INK PUMP error message a second time, call IRIS Graphics Customer Support for recommendations.

---

## User Diagnostics Tests

---

A set of user diagnostics tests is available from the control panel under the USER DIAGNOSTICS menu. The user diagnostic tests described in this section are not needed under normal operating circumstances. They are not part of routine maintenance. Conditions that warrant user diagnostic testing include the presence of repeating patterns in prints and unexplained printing failures — especially sudden failures.

At times you may be asked by IRIS Customer Support personnel to run one or more of these tests if they determine that your printing problems are caused by the printer's computer hardware.

### Jet Offset RAM Test

You can run the Jet Offset RAM Test by opening the printer cover, selecting USER DIAGNOSTICS, and then selecting JET RAM TEST. When you select YES, the top line of the control panel displays PIGGYBACK RAM OPTION Do not select YES unless your printer is equipped with the Piggyback RAM option. If you select NO, the test will last approximately six minutes. If your printer is equipped with the Piggyback RAM option and you select YES, the test will last approximately 12 minutes. In both cases, the control panel will display the PRINTING PAUSED until you close the printer cover.

During the test, the drum will spin at 250"/sec. and the time of day will appear on the control panel. Because of this high speed of revolution, we recommend that you **not have paper mounted on the drum**. To abort the test, raise the cover and press either button on the control panel.

If you allow the test to run to completion, the second line of the control panel will display TEST PASSED or TEST FAILED. You must acknowledge the message by pressing the "Select" button before you proceed to additional operations.

### Test Autophase

The TEST AUTOPHASE function is a diagnostic tool intended for use by qualified service personnel to help isolate problems with nozzle assemblies and their related electronics. If you call IRIS Customer Support for assistance, as indicated in the Troubleshooting Guide, you may be asked to run the TEST AUTOPHASE routine, which is very similar to the procedure for knife-edge adjustment. (See the Menu Maps and Procedure 4-1.) In the case of TEST AUTOPHASE, four numbers in the 00-99 range will be displayed. IRIS Customer Support personnel will help you interpret the results.

### Vacuum Diagnostics for Service Personnel

The VACUUM SYSTEM TEST entry in the USER DIAGNOSTICS menu allows operators to exercise the various vacuum ports in the printer when vacuum leaks are suspected. The procedure applies vacuum to each port. Five choices are supplied: HIGH VOLTAGE PORT, WASTE INK SUMP, CONTROL ELECTRODE, NOZZLE PORT, and TARGET BLOCK. These options are designed primarily for use by service personnel.

### MCP and Other Diagnostic Tests

The Machine Control Processor (MCP) communications test verifies that the MCP can communicate with all of its peripherals, including interface PC boards, upper control PC board, and others. The MCP Memory Test checks main MCP memory. The Input Memory Test checks memory that buffers incoming data.

All of these tests are available from the USER DIAGNOSTICS menu. Each will produce a TEST PASSED or TEST FAILED message on the control panel. You must acknowledge the message by pressing the "Select" button before you proceed to additional operations.

---

## Cleaning Printer Surfaces

---

The only maintenance required on the drum is keeping it clean. The drum is made of fiberglass and has a polyurethane coating. **Avoid** any solvents that interact with fiberglass or the polyurethane coating (for example, paint remover).

**Always turn the printer off (power down) before cleaning the drum.** Use a damp cloth to clean the drum surface. If the double-sided tape used to secure paper leaves a sticky residue, you may use denatured alcohol to clean the surface. Use soap or detergents on the drum only in extreme cases. And be sure not to drip liquids into the printer's electronics.

You may use any appropriate commercial cleaner to clean the printer's painted surfaces. If ink spills on machine parts, clean it up completely before it dries.

# 5

## Controlling Printing Parameters

The IRIS 3024 Color Ink Jet Printer allows the operator to control a variety of printing parameters at the control panel, including:

- Density of individual colors.
- Contrast of individual colors.
- Order of incoming color data.
- Printing color separations.
- Placement and duplication of images.
- Resolution.
- Creation of over-size images by replication of data.
- . . . and other parameters.

The operator is **not required to set these parameters in most cases**. The data from the host system will often set all the parameters needed. If the printer is interfaced directly to a magnetic tape drive, the control panel provides the only method of changing printing parameters.

---

---

**IMPORTANT:** Printing parameters in data received from a host system will override settings made at the control panel. If the incoming data does not contain a new set of parameter values, the printer will use the last values entered by the operator before printing is started.

---

---

---

### Preparing To Change Parameters at the Control Panel

---

When the printer is in its ready state (cover closed), the control panel displays the following:

```
IRIS GRAPHICS INC.  
MODEL 3024      00:00:00
```

Where 00:00:00 represents the current time of day (24-hour clock).

In order to change printing parameters, the printer must be in System Set-Up Mode. When you lift the cover, the control panels displays the



Operator Menu. Pull the mode switch up to access the Set-Up Menu. The control panel displays:

SYSTEM SET UP MENU  
CHANGE PARAMETERS

If your printer is equipped to accept data on tape via an on-line magnetic tape interface, the system will instead display the following:

SYSTEM SET UP MENU  
FILE TO PRINT

The FILE TO PRINT menu selection allows the operator to select a file by number from the tape currently mounted on the magnetic tape drive. Use the Next button to cycle through the menu selections until CHANGE PARAMETERS appears on the second line of the display.

If you **don't** need to change any printing parameters, you can close the cover and start printing by pressing the print switch. (See Section 3 for routine printing procedures.)

### How Panel Settings Affect Default Printer Settings

In addition to SET SYSTEM CLOCK and — if your printer accepts files from magnetic tape — FILE TO PRINT, the System Set-Up Menu offers four choices for changing, saving, and restoring printing parameters:

#### CHANGE PARAMETERS

Allows you to change the value of parameters. This menu branches down several levels to menus that permit you to change resolution and color balance, specify printing of multiple images from the same master, and many other printing parameters.

#### SAVE PARAMETERS

Saves the new parameters you have selected and uses them as its **permanent** printing values — the values that will be used every time the system is powered up. These are your user defaults.

**Do not** use the SAVE PARAMETERS option to “save” values that you want to be in effect for the current print run only. You do **not** need to “save” the values you have set with the menu choices under CHANGE PARAMETERS unless you want them to be permanent.

#### RESTORE PARAMETERS

Restores your most recently “saved” set of printing parameters, overriding any more recent unsaved values.

#### FACTORY DEFAULT PARMS

Restores the parameters set and stored permanently on the printer by IRIS Graphics.

---

### Color Balance: Density and Contrast

---

Two factors control the color values of an IRIS 3024 color print: (1) density (darkness of color, the amount of ink placed in each printing spot); and (2) contrast, the degree of difference between the lightest

and darkest values in the color. These values are fully programmable on the IRIS 3024 Color Ink Jet Printer for all four printing colors individually. By setting these values, you can exercise a high degree of control over color values. You can also use these controls to compensate for the characteristics of different kinds of image data and variations in the absorption and reflectivity of printing papers and other printing media.

### Color Look-Up Tables

The host system can select these color balance factors by transmitting a color lookup table before it sends the print data itself. This table will convert all specific color values in the incoming image data into a pattern of spots arranged within a  $4 \times 4$  macro-pixel.

If the host system does not transmit a color look-up table or density and contrast values, the printer will use its default values. When you change the color contrast and density settings from the control panel, the printer computer constructs a new color look-up table by extrapolating values from those settings.

### Setting Density from the Control Panel

Procedure 5-1 contains a detailed, step-by-step explanation of how to select density values from the control panel. For all other Set-Up Mode Procedures in this Section, we will simply list the order of menus, explain the values and available choices, and describe any behavior that differs from this Procedure. For the remaining print parameter procedures in this section, we will use the following style to indicate the sequence of selection of menus: MENU  $\Rightarrow$  MENU  $\Rightarrow$  MENU  $\Rightarrow$  SELECTION.

### Setting Contrast

By selecting different contrast values, you change the degree of difference between darker and lighter values for each ink. To change the contrast of one color (color "2" in this example), select the following sequence of menus: CHANGE PARAMETERS  $\Rightarrow$  SET COLOR BALANCE  $\Rightarrow$  SET COLOR CONTRAST  $\Rightarrow$  COLOR 2 CONTRAST. The control panel will display the following:

```
COLOR 2 CONTRAST
1.00
```

You may select a value between 1.00 (lowest contrast) and 2.50 (highest) in increments of .01.

---

## Organization of Color Data

---

Image data transmitted from a host system or magnetic tape can be organized in many ways. The PRINTER CONTROL menus allow you to match the organization of the incoming data to the printer's characteristics or change the selection or order of data for special purposes.

### Selecting the Number and Order of Colors

The IRIS 3024 printer can print from 1 to 4 colors in any order. The data for a particular color can be directed to any jet. If you select the following sequence of menus — CHANGE PARAMETERS ⇒ PRINTER SET UP ⇒ SELECT DATA TYPE — you will have the following menu options:

**NUMBER OF COLORS**

**4**

You can select a value from 1 to 4.

**FIRST COLOR**

**1**

You can select a value from 1 to 4. If you select "1", the first byte of image data will be directed to ink jet "1" — the right-most ink jet.

#### PROCEDURE 5-1: Selecting Color Density from the Control Panel

Step	Action	System Response
1	Open the cover and lift the Mode Switch to its highest position.	Control Panel displays: SYSTEM SETUP MENU CHANGE PARAMETERS
2	Press the Select (right) button.	Control Panel displays: SET COLOR BALANCE PREVIOUS MENU
3	Press the Next button until the second line changes to SET COLOR DENSITY, then press the Select button.	Control Panel displays: SET COLOR DENSITY PREVIOUS MENU
4	Press the Next button until the second line changes to COLOR 1 DENSITY, then press the Select button.	Control Panel displays: COLOR 1 DENSITY 000 The "0" on the left will be flashing.
5	Enter a value between 000 and 100 by pressing the Next button until the desired digit appears in each position and then the Select button to accept the value. (Note that the printer prevents you from entering a value greater than 100.)	After the units entry (last digit) is selected, the Control Panel displays: SET COLOR DENSITY COLOR 1 DENSITY
6	Repeat Steps 4 and 5 for colors 2, 3, and 4 as needed.	After the units entry (last digit) is selected, the Control Panel displays: SET COLOR DENSITY PREVIOUS MENU
7	Select PREVIOUS MENU to return to the SET COLOR BALANCE menu.	The Control Panel displays: SET COLOR BALANCE PREVIOUS MENU

**COLOR SEQUENCE**

4-3-2-1

You can select order of printing (selection of ink jet to print this color) by cycling through the available combinations with the Next button. If you selected "4" in the FIRST COLOR option, "4" will always appear in the first position. Only the order of the remaining three colors will change. If you selected "3" in the NUMBER OF COLORS option, the choices will be displayed as "3-2-1," "3-1-2," "3-1-4," etc.

**Complement Colors**

The COMPLEMENT COLORS function allows you to change the interpretation of incoming color values. If you select the following sequence of menus — CHANGE PARAMETERS ⇒ PRINTER SET UP ⇒ SELECT DATA TYPE ⇒ COMPLEMENT COLORS — the control panel will present the following display:

**COMPLEMENT COLORS**

NO

Press the Next button to display YES on the second line. Pressing the Select button will then cause the printer to interpret high incoming data values as meaning a light shade and low values as a dark shade of color. Selecting NO will cause the printer to interpret low data values as a light shade and high values as a dark shade.

One of the uses of the COMPLEMENT COLORS function — in combination with COLOR SEQUENCE — is to convert RGB (Red, Yellow, Green) data into CMY values. The data values for Red can be converted into inverse values for Cyan; for Green, Magenta; and for Blue, Yellow.

**Creating Color Separations**

The IRIS 3024 Color Ink Jet Printer allows you to print each color in the incoming data individually on any designated jet — for example, print the four different colors in black ink in separate runs.

If you select the following sequence of menus — CHANGE PARAMETERS ⇒ PRINT TYPE ⇒ COLOR SEPARATION ⇒ COLOR SEP. ENABLE — the control panel will present the following display:

**COLOR SEP. ENABLE**

NO

Press the Next button to display YES on the second line. Pressing the Select button then enables printing from one color only.

If you respond Yes to COLOR SEP. ENABLE, the control panel will enable the following two menu choices:

**COLOR SEP. TO PRINT**

1

Where "1" represents a color in the incoming data.

**COLOR TO PRINT WITH**

1

Choose a value from "1" (right-most jet) to "4".

If you selected No in response to COLOR SEP. ENABLE, the COLOR SEP. TO PRINT and COLOR TO PRINT WITH menus will not appear.

---

## Controlling Image Placement

---

Several print features are available for controlling the placement, duplication, and orientation of images. A reminder: in the following paragraphs, "horizontal" always refers to the direction of the axis of the drum — left to right as you face the printer. "Vertical" always refers to the direction in which the drum is spinning. Don't confuse these directions with the orientation of the image itself.

### Selecting a Starting Position

The printer always places the first dot in the upper left corner of the paper as it is mounted on the drum. (See Figure 3-4.) The ink jet assembly travels from left to right (horizontally) during printing, laying down one raster or line at a time around the drum (in the vertical dimension).

By using the IMAGE PLACEMENT features of the printer, you can place the image anywhere on the sheet.

---

**IMPORTANT:** If you are placing more than one image on a sheet and you want them to be in exact placement relative to each other, **do not remove the sheet between the printing runs.** There is no method of providing precise "pin registration" for images. Placement of paper on the drum is unlikely to be in exactly the same place twice.

---

In order to change the **vertical** position of the image on the sheet of paper, select the following sequence of menus — CHANGE PARAMETERS ⇒ IMAGE PLACEMENT ⇒ VERTICAL OFFSET. The control panel will display:

**VERTICAL OFFSET**  
0000 PIXELS

You can enter a value from 0000 to 7999 — the number of dots of vertical offset (movement of image downward) from the "0" position **at the current resolution.** At the "standard" resolution of 240 dpi (dots per inch), a value of 240 will move the image down on the sheet one inch. (See "Resolution and Related Values," below.)

The HORIZONTAL OFFSET behaves in the same manner, moving the image to the right by the specified number of dots at the current horizontal resolution — actually a number of raster lines.

### Creating Multiple Images from One Master

The same master image data can be used to create duplicate images as many times as they will fit around the drum. The REPEAT IMAGE MARGIN option allows you to specify the amount of space between the duplicate images. If you select the following sequence of menus —

CHANGE PARAMETERS ⇒ PRINT TYPE ⇒ SET REPEAT IMAGE — the control panel will present the following display:

```
SET REPEAT IMAGE
NO
```

Press the Next button to change the second line of the display to YES. Pressing Select when YES is displayed repeats the image as many times as it will fit around the drum.

To set the amount of white space between repeated images, select the following sequence of menus — CHANGE PARAMETERS ⇒ PRINT TYPE ⇒ REPEAT IMAGE MARGIN. The panel will then display the following menu:

```
REPEAT IMAGE MARGIN
0000 PIXELS
```

Select a value in dots per inch between 0000 and 6999. For example, at a vertical resolution of 240 dpi, the value 480 will put two inches of white space between the repeated images.

## Mirror Image Printing

An image may be “flopped” to create a mirror image of the original. In this process, each raster is printed in reverse. The image on the printer drum will appear flopped from top to bottom. The mirror image printing feature is designed to accommodate systems that generate raster data in reverse order but may also be useful for creating special effects.

To activate mirror-image printing, select the following sequence of menus — CHANGE PARAMETERS ⇒ PRINTER SET UP ⇒ SET MIRROR IMAGE. The control panel will display:

```
SET MIRROR IMAGE
NO
```

Press the Next button to change the second line of the display to YES. Pressing Select when YES is displayed prints the image mirrored.

---

## Resolution and Related Printing Values

---

Operators can use the control panel to set several printing parameters that govern the placement and duplication of dots within an image.

### Horizontal and Vertical Resolution

Resolution refers to the closeness of all dots to each other. Changes in resolution do not affect the color density of the image, because the printer will compensate for closer dots at higher resolution by decreasing the number of droplets per dot in order to keep the “ink-per-unit-area” constant. But the overall size of the image will change.

Horizontal resolution (the left-to-right dimension as you face the printer) corresponds to the closeness of printer rasters to each other. Vertical resolution corresponds to the closeness of the dots within those rasters. Vertical and horizontal resolution can be changed independently.

If you select the following sequence of menus — CHANGE PARAMETERS ⇒ PRINTER SET UP ⇒ SELECT RESOLUTION ⇒ VERTICAL RESOLUTION — the control panel will display:

**VERTICAL RESOLUTION**  
**200 PIXELS PER INCH**

Six values are available: 8, 10, or 12 pixels per millimeter and 200, 240, or 300 pixels per inch. The 240 value is “standard.” You can cycle through the choices by pressing the Next button repeatedly.

To set **horizontal** resolution, select CHANGE PARAMETERS ⇒ PRINTER SET UP ⇒ SELECT RESOLUTION ⇒ HORIZ. RESOLUTION. Note that the choices for horizontal resolution are expressed in pixels per inch (200, 240, and 300 ppi) and pixels per millimeter (8, 10, and 12 ppm). However, only pixels per inch or pixels per millimeter are available, depending on the factory settings for your printer.

---

**NOTE:** Changing resolution will affect the absolute (but not relative) placement specified by SET REPEAT IMAGE features. (See above, “Controlling Image Placement.”)

---

### Doubling Image Density with Multistrike Features

Some media — including clear acetates — may require substantially more ink per dot than paper images. The IRIS 3024 Color Printer can meet this requirement by “striking” the same dots more than once — that is, by printing the same raster in the same place more than once.

If you select the following sequence of menus — CHANGE PARAMETERS ⇒ PRINT TYPE ⇒ RASTER MULTI-STRIKE — the control panel will display:

**RASTER MULTI-STRIKE**  
**1**

Only four values are available: “1” (do not multistrike), “2” (print all rasters twice in the same place), “3,” and “4.” You can cycle through the choices by pressing the Next button repeatedly. Selecting a value other than “1” will increase the time required to print by a factor of 2, 3, or 4.

Maximum Raster Length for Multistrike Mode				
Resolution	Multistrike Factor			
	1x	2x	3x	4x
200 dpi*	24"	24"	23.3"	17.4"
240	24"	24"	16.1"	12.1"
300	24"	15.5"	10.3"	7.7"
8.0 dpmm**	610 mm	610 mm	574 mm	431 mm
10.0	610 mm	551 mm	267 mm	275 mm
12.0	610 mm	383 mm	255 mm	191 mm

\* Dots per inch.

\*\* Dots per millimeter.

The multistrike features use jet RAM capacity and limit the raster length the printer can handle before RAM capacity is exhausted. The accompanying table illustrates the maximum raster length available.

### Creating Oversized Images with Pixel Replication

The IRIS 3024 allows you to create oversized images — prints that are 2 to 8 times as large as the images at their original resolution — from the same data as the original. The printer accomplishes this by shifting and repeating the raster lines (to expand the horizontal dimension) up to 8 times and replicating pixels in the vertical dimension up to 8 times. The horizontal and vertical replication are set independently.

As you increase replication factors, the printed images will appear coarser than the image printed at its original size. The “resolution” of the image has not increased. The original data is simply spread thinner across the page, and the “pixels” themselves start to become visible because of the magnifying effect of raster and pixel replication. (You can use this effect to your advantage at times. For example, you can print a greatly magnified image to examine what is happening at individual pixels.)

If you select the following sequence of menus — CHANGE PARAMETERS ⇒ PRINT TYPE ⇒ SELECT REPLICATION ⇒ HORIZ. REPLICATION — the control panel will display:

**HORIZ. REPLICATION**

1

Eight values are available: “1” through “8.” You can cycle through the choices by pressing the Next button repeatedly. Selecting a value other than “1” will increase the time required to print by a factor of 2 through 8 (horizontal replication only).

To set vertical replication, select CHANGE PARAMETERS ⇒ PRINT TYPE ⇒ SELECT REPLICATION ⇒ VERTICAL REPLICATION. The choices of replication factors and the behavior of the messages are the same as for setting horizontal values.

---

## Other Printer Parameter Settings

---

Additional printer settings not described in the previous categories include setting the drum speed, suppressing or displaying the printing of autophase color bands, and setting the printer clock.

### Setting Drum Speed

By changing the drum speed, you can increase or decrease the time to print. Printing time can be reduced in most, but not all, cases by increasing the drum speed. On the other hand, disadvantages of increasing the drum speed include:



- High drum speed reduces drop placement accuracy. The results of increased speed may be perceptible in precision, high-quality applications.
- High drum speed requires high host interface throughput rates (300 Kbytes/sec. for full 24" rasters at 300 pixels per inch and 250 inches per second drum speed). This may have negative effects on other host computer functions. If the host interface cannot sustain the throughput rate required at high drum speed, the print head assembly will intermittently start and stop to accommodate the incoming data rate. In such cases, the print time may actually be reduced by **decreasing** drum speed to eliminate the start/stop activity.
- High drum speed limits color saturation in maximum density areas, depending on print media, resolution, specified color density, etc.

When you select the following sequence of menus — CHANGE PARAMETERS ⇒ PRINTER SET UP ⇒ SELECT DRUM SPEED — the control panel will display:

```
SELECT DRUM SPEED
150 INCHES/SEC
```

Drum speed is expressed in linear inches per second (ips) of surface speed of the drum. The standard value is 150 ips. The possible range of values is 100–250 ips, in increments of 10 ips. The control panel will not allow you to modify the units (right-most) digit.

### Autophase Displayed

In order to evaluate the accuracy of ink jet phase adjustment during printing, the operator has the option to print or suppress a series of color bands on the sheet. By analyzing the density of these bands, an experienced operator can identify the misadjustment of individual printer ink jets. When you select the following sequence of menus — CHANGE PARAMETERS ⇒ PRINTER SET UP ⇒ PRINT AUTOPHASE — the control panel will display:

```
PRINT AUTOPHASE
NO
```

A "No" response means print the image(s) only. Press the Next button to change the second line of the display to YES. Selecting YES means "print the image(s) and the autophase color bands."

Note that printing the Autophase test pattern reduces the maximum raster length (vertical image size) to 22".

### Setting the Printer Clock

When the printer is in its idle or ready state, the control panel displays:

```
IRIS GRAPHICS INC.
MODEL 3024          00:00:00
```

Where 00:00:00 represents the current time of day (24 hour clock — hours, minutes, and seconds).



You can change the clock setting by selecting SET SYSTEM CLOCK from the top level SYSTEM SET UP MENU. The control panel will display:

SET SYSTEM CLOCK

00:00:00

Use the Next and Select buttons to enter a new time in 24-hour clock values. The clock will not be reset until you Select the units value of the seconds entry — the right-most digit.

---

### For More Detailed Information

---

For more specific information about setting parameters for your system configuration, refer to the Interface Specification for your system or consult your system manager.

# 6

## Troubleshooting Guide

This section of the manual includes the following troubleshooting aids:

1. A list of **diagnostic error messages** that are displayed on the second line of the control panel, including an explanation of causes and suggested remedies.
2. A list of **printing problems** that have no associated diagnostic error messages. Most of these problems concern print quality. The most likely remedy for each problem is listed first.

Note that the operator must acknowledge error messages that appear on the control panel at the end of a print cycle by pressing the Select button on the control panel. The printer will not begin another print run until error messages have been acknowledged.

If you encounter problems, try the remedies described in this section before you call IRIS Graphics Customer Support.

## Diagnostic Error Messages

In the following list, messages marked with an asterisk (\*) are "non-fatal" — that is, they do not cause print runs to abort.

Error Message	Probable Cause	Suggested Remedy
ACKNOWLEDGE MESSAGES*	Errors have been reported during printing.	Acknowledge report by pressing Select button on control panel.
ADC READ ERROR	Defective MCP	Call IRIS Graphics Customer Support.
BAD COMMAND COUNT	Host system has sent a command with an incorrect count value.	Check incoming printing data.
BAD HOST COMMAND	Host system has sent a non-existing command.	Check incoming printing data.
BAD RASTER LENGTH	Image data raster is not correct length—number of bytes received is not divisible by number of colors in data type OR number of bytes received changes during print cycle.	Check Data Type values in menus. Check incoming data.
CALIB. INK PUMP*	Ink pumps specified require re-calibration.	Run pump calibration routine (see Section 4).
CPU COMMUNIC. ERROR	Bad cable to Upper Control Board (UCB); no voltage to UCB; defective UCB.	Call IRIS Graphics Customer Support.
DRUM SPEED ERROR	Drum could not reach preset speed within time limit.	Call IRIS Graphics Customer Support.
HIGH PRES. JET*	Ink jet or filter clogged; pump needs calibration; ink line clogged. The message will indicate one, two, three, or four ink jets.	Clean or replace the ink jet[s]; replace filter in ink line; check ink lines. If these changes do not eliminate the message, run the pump calibration routine (Section 4).
HOOD NOT CLOSED	Hood was not closed within two minutes of opening cover to suspend the print run. The print run is aborted.	Restart print run.
HOST SHUT DOWN	Parallel version; abort command.	None — host aborted with command.
HOST STATE ERROR	Host system sent a command that violated system state rules. (See parallel interface spec.)	Check incoming data.
HV SPIKE*	Deflection voltage failed during printing of a raster but did not remain in that state.	Check for foreign matter causing arcs across upper/lower electrode gap in deflection assembly. If this message occurs, wash the deflection assembly. (See Section 4, "Cleaning the Deflection Assembly.")
ILLEGAL HOST VALUE	Host system has sent a command that contained an illegal parameter value.	Check incoming printing data.
INK PUMP ERROR	Ink pump is in error state during a print cycle.	Check for glowing ink status light. Use Procedure 4-4 to purge the pump and return it to operating pressure.
INK PUMP NOT HOME*	Pistons of one or more ink pumps have not returned to home position. (This message always occurs during pump calibration and does not indicate a problem.)	Wait until piston returns and retry printing.
INPUT ADDRESS ERROR	Defective interface board	Call IRIS Graphics Customer Support.



## Diagnostic Error Messages (continued)

Error Message	Probable Cause	Suggested Remedy
INPUT BOARD ID ERROR	Data input board identity is not known by MCP.	Call IRIS Graphics Customer Support.
INPUT DATA ERROR	Defective interface RAM	Call IRIS Graphics Customer Support.
INPUT MAPPING ERROR	CPU cannot read correct memory bank in interface board.	Call IRIS Graphics Customer Support.
INPUT TIME OUT	Data input was not received within time limit from host system.	Check data rate or tape drive.
JET PHASE ERROR 1234*	Phase circuitry encountered non-legal phase value for an ink jet. If the message persists, call IRIS Customer Support.	Clean deflection assembly and jet nozzles.
JET RAM ERROR	Error encountered during Jet RAM Test.	Reseat Jet RAM board and retest.
KNIFE EDGE 1234*	Knife-edge adjustment is recommended for the jet numbers listed.	Follow Procedure 4-1 for knife-edge adjustment of suspect jets.
LOW PRESS JET	Leak in ink delivery system or pump needs calibration. The message will indicate one, two, three, or four colors (ink delivery systems).	Check the ink delivery system[s] for leaks and tighten or repair as needed. If these changes do not eliminate the message, run the pump calibration routine (Section 4). If the message persists, call IRIS Customer Support.
MARGIN SWITCH	Right margin encountered during print run, causing abort. (Attempted to print data beyond right edge of drum.)	Check horizontal offset, size of image.
MCP ADDRESS ERROR	Defective MCP address lines.	Call IRIS Graphics Customer Support.
MCP DATA ERROR	Defective MCP chip.	Call IRIS Graphics Customer Support.
PAUSE MODE CANCELLED	Operator pushed "Next" or "Select" button during Pause Mode.	Avoid pushing Control Panel buttons during Pause unless you are trying to abort a print run.
PUMP TIMEOUT 1234	Pump failed to reach pressure within specified time period.	Follow Procedure 4-4 to attempt to pressurize the pump. If this fails, call IRIS Graphics Customer Support.
STEPPER TIME OUT*	Stepper did not complete stepping programmed number of steps within time limit.	Call IRIS Graphics Customer Support.
TAPE NOT ONLINE	(Tape version only.) Magnetic tape drive is not set to on-line status.	Put tape drive on-line and retry.
VACUUM ERROR	Vacuum level is not correct.	Check the fuse on the vacuum pump the waste filter. Call IRIS Graphics Customer Support.
VOLTAGE OVERLOAD	Deflection voltage has failed because of electrical short or malfunction in deflection assembly or electronics.	Wash deflection assembly or look for foreign matter across upper/lower electrode gap. Dry thoroughly and install. If the message persists, call IRIS Customer Support.
WASTE BOTTLE IS FULL	Waste ink bottle is detected as full.	Empty waste ink bottle and replace in printer.
WASTE BOTTLE MISSING	Waste ink bottle is not detected in holder.	Replace waste ink bottle in printer.



## Printing Problems

Problem	Suggested Remedy
Mottled appearance in solid color areas (especially in areas of 50% density).	<ul style="list-style-type: none"> <li>• Perform crystal frequency color run and select new crystal frequency.</li> </ul>
Striations in solid color areas.	<ul style="list-style-type: none"> <li>• Perform crystal frequency color run and select new crystal frequency.</li> </ul>
"Smearing" of edges—single color OR smearing within of single color within image.	<ul style="list-style-type: none"> <li>• Adjust knife edge.</li> <li>• Perform crystal frequency color run and select new crystal frequency.</li> <li>• Clean deflection assembly.</li> </ul>
Undesirable overall "background color" on print.	<ul style="list-style-type: none"> <li>• Adjust knife edge.</li> <li>• Run crystal frequency color bars and select new crystal frequency.</li> </ul>
Round blobs of ink on print.	<ul style="list-style-type: none"> <li>• Clean bib and remove foreign matter.</li> <li>• Clean deflection assembly.</li> <li>• Replace deflection assembly.</li> <li>• Replace bib.</li> </ul>
"Comets" of ink. (May not show long "tail.")	<ul style="list-style-type: none"> <li>• Check front (drum end) of deflection assembly for lint or other foreign matter; clean.</li> <li>• Check front of bib for lint; clean.</li> </ul>
Poor color registration.	<ul style="list-style-type: none"> <li>• Run grid patterns and adjust convergence.</li> </ul>
Surfaces inside machine begin to collect ink mist.	<ul style="list-style-type: none"> <li>• Run with dust cover ("hat") in place for mist control.</li> <li>• Check static brush and replace if necessary.</li> <li>• Clean all surfaces.</li> </ul>
No ink in one color.	<ul style="list-style-type: none"> <li>• Check knife-edge adjustment.</li> <li>• Run color bars and grid pattern to verify proper operation in Operator Mode.</li> <li>• Replace clogged nozzle.</li> <li>• Run crystal frequency color bars and select new crystal frequency.</li> </ul>
Spots or discolored areas. May indicate paper coating defect or foreign substance deposited on paper.	<ul style="list-style-type: none"> <li>• Run large area of solid colors — Cyan, Magenta, Yellow, or some combination of the three — to confirm that defect is in paper.</li> <li>• Replace paper. (Use IRIS-approved papers for best results.)</li> </ul>

## **APPENDIX A — Menu Maps**

The following two pages consist of “menu maps” that show all available menu choices and describe the paths you will take to reach the menus. Detailed procedures for using the control panel to select menu choices are contained in the text of this manual.

SYSTEM SETUP MENU ACCESSIBLE  
WHEN THE PRINTER COVER IS OPEN  
AND OPERATOR SWITCH IS UP

(TAPE SYSTEM ONLY)

SYSTEM SETUP MODE  
FILE TO PRINT  
01-89  
CHANGE PARAMETERS  
SAVE PARAMETERS  
RESTORE PARAMETERS  
FACTORY DEFAULT PARAM  
SET SYSTEM CLOCK  
90:00:00

CHANGE PARAMETERS  
PREVIOUS MENU  
SET COLOR BALANCE  
IMAGE PLACEMENT  
PRINT TYPE  
PRINTER SET UP  
PREVIOUS MENU  
SELECT DRUM SPEED  
100-250 INCHES/SEC

IMAGE PLACEMENT  
PREVIOUS MENU  
VERTICAL OFFSET  
HORIZONTAL OFFSET

PRINT TYPE  
PREVIOUS MENU  
SET REPEAT IMAGE  
REPEAT IMAGE MARGIN  
COLOR SEPARATION  
SELECT REPLICATION  
RASTER MULTI-STRIKE

VERTICAL OFFSET  
0000-7999 PIXELS  
HORIZONTAL OFFSET  
0000-7999 PIXELS

SET REPEAT IMAGE  
YES/NO

REPEAT IMAGE MARGIN  
0000-6999 PIXELS

COLOR SEP. ENABLE  
YES/NO

COLOR SEP. TO PRINT  
1-4

COLOR TO PRINT WITH  
1-4

VERTICAL REPLICATION  
1-8 TIME(S)

HORIZ. REPLICATION  
1-8 TIME(S)

NUMBER OF COLORS  
1-4

FIRST COLOR  
1-4

COLOR SEQUENCE  
4-3-2-1  
4-1-2-3  
4-2-3-1  
4-1-3-2  
4-2-1-3  
4-3-1-2

COMPLEMENT COLORS  
YES/NO

NOTE-  
Six possible color  
sequences illustrated  
for case of number of  
colors = 4, and first  
color = 4.

SET COLOR DENSITY  
PREVIOUS MENU  
COLOR 1 DENSITY  
0-100  
COLOR 2 DENSITY  
0-100  
COLOR 3 DENSITY  
0-100  
COLOR 4 DENSITY  
0-100

SELECT RESOLUTION  
PREVIOUS MENU  
VERTICAL RESOLUTION  
HORIZ. RESOLUTION  
200 PIXELS PER INCH  
240 PIXELS PER INCH  
300 PIXELS PER INCH  
360 PIXELS PER INCH

SET MIRROR IMAGE  
YES/NO

VERTICAL RESOLUTION  
200 PIXELS PER INCH  
240 PIXELS PER INCH  
300 PIXELS PER INCH  
360 PIXELS PER INCH  
HORIZ. RESOLUTION  
12 PIXELS PER MM  
18 PIXELS PER MM  
24 PIXELS PER MM

(MENU DISPLAYED FOR HORIZ  
RESOLUTION WILL DEPEND ON  
SETTING OF CONFIGURATION  
SWITCH ON UPPER CONTROL  
MODULE.)

SET COLOR DENSITY  
PREVIOUS MENU  
COLOR 1 CONTRAST  
1.00-2.50  
COLOR 2 CONTRAST  
1.00-2.50  
COLOR 3 CONTRAST  
1.00-2.50  
COLOR 4 CONTRAST  
1.00-2.50

SET COLOR DENSITY  
PREVIOUS MENU  
COLOR 1 DENSITY  
0-100  
COLOR 2 DENSITY  
0-100  
COLOR 3 DENSITY  
0-100  
COLOR 4 DENSITY  
0-100

SET COLOR CONTRAST  
PREVIOUS MENU  
COLOR 1 CONTRAST  
1.00-2.50  
COLOR 2 CONTRAST  
1.00-2.50  
COLOR 3 CONTRAST  
1.00-2.50  
COLOR 4 CONTRAST  
1.00-2.50

IRIS GRAPHICS, INCORPORATED  
6 CROSBY DRIVE, BEDFORD, MA. 01730

TITLE FLOW CHART  
3024 MENU INTERFACE

SIZE	CODE	NUMBER	REV
B	R	01489-001	B

DATE 6/9/89 SHEET 1 OF 2

FILE: \ROBBIE\RELEASED\MENUS\3024.MEN1

Operator switch is white knob on left side of printer -  
accessible when cover (hood) is up - to activate these  
commands pull knob up.



D

```

ADJUST KNIFE EDGE X
NEXT # 2 XX XX XX
NEXT # 3 XX XX XX
NEXT # 4 XX XX XX
NEXT # 1 XX XX XX
EXIT
    
```

```

ADJUST KNIFE EDGE
PREVIOUS MENU
NEXT # 1
NEXT # 2
NEXT # 3
NEXT # 4
    
```

```

TEST AUTOPIHASE X
COLOR 1 XX XX XX XX
COLOR 2 XX XX XX XX
COLOR 3 XX XX XX XX
COLOR 4 XX XX XX XX
EXIT
    
```

```

AUTOPIHASE TEST
PREVIOUS MENU
COLOR 1
COLOR 2
COLOR 3
COLOR 4
    
```

C

```

OPERATOR MENU
ALIGNMENT MENU
TEST PATTERNS
DIAGNOSTIC MENU
SERVICE POSITION
FORCED PURGE CYCLE
FIRMWARE VERSION
XXXXXXXXXX
FORCED PURGE CYCLE
NO YES
SERVICE POSITION
NO YES
TEST PATTERNS
PREVIOUS MENU/EXIT
ALL COLOR TEST
COLOR 4 TEST
COLOR 3 TEST
COLOR 2 TEST
COLOR 1 TEST
MOVE RIGHT
MOVE LEFT
    
```

```

*1
PREVIOUS MENU/EXIT
*2
ALL COLOR TEST
COLOR 4 TEST
COLOR 3 TEST
COLOR 2 TEST
COLOR 1 TEST
MOVE RIGHT
MOVE LEFT
    
```

```

DIAGNOSTIC MENU
PREVIOUS MENU
KNIFE EDGE TEST
TEST AUTOPIHASE
VACUUM SYSTEM TEST
JET RAM TEST
COMMUNICATION TEST
MCP MEMORY TEST
INPUT MEMORY TEST
INPUT MEMORY TEST
NO YES
MCP MEMORY TEST
NO YES
MCP COMM TEST
NO YES
JET RAM TEST
NO YES
PIGGYBACK RAM
NO YES
    
```

```

ALIGNMENT MODE
PREVIOUS MENU
ADJUST KNIFE EDGE
FREQUENCY CALIBRATE
CALIBRATE INK PUMPS
CALIBRATE INK PUMPS
NO YES
    
```

```

VACUUM SYSTEM TEST
PREVIOUS MENU
HIGH VOLTAGE PORT
WASTE INK SUMP
CONTROL ELECTRODE
NOZZLE PORT
TARGET BLOCK
    
```

```

HIGH VOLTAGE PORT
NO YES
WASTE INK SUMP
NO YES
    
```

```

CONTROL ELECTRODE
NO YES
NOZZLE PORT
NO YES
TARGET BLOCK
NO YES
    
```

B

```

ADJUST KNIFE EDGE
PREVIOUS MENU
COLOR 1
COLOR 2
COLOR 3
COLOR 4
NEXT # 1
NEXT # 2
NEXT # 3
NEXT # 4
EXIT
    
```

```

FREQUENCY CALIBRATE
PREVIOUS MENU
FREQ. COLOR RUN
CRYSTAL FREQUENCY
CRYSTAL FREQUENCY
01-16
    
```

```

FREQ. COLOR RUN
PREVIOUS MENU
COLOR 1
COLOR 2
COLOR 3
COLOR 4
    
```

A

IRIS GRAPHICS, INCORPORATED  
6 CROSSBY DRIVE, BEDFORD, MA. 01730

TITLE FLOW CHART  
3024 MENU INTERFACE

SIZE	CODE	NUMBER	REV
B	R	01489-001	B

DATE 6/9/89 SHEET 2 OF 2

## APPENDIX B — Routine and Periodic Maintenance Procedures

This appendix contains normal maintenance procedures that can be performed by printer operators without the assistance of IRIS service personnel. These are recommendations for “normal” use only. Maintenance requirements for printers will vary depending on usage and applications.

---

### Daily Maintenance

---

The following should be checked every day:

- Check knife-edge adjustment and adjust if necessary.
- Inspect bib for discoloration or ink saturation. Wash and reinstall or replace if necessary.
- Inspect surface beneath and behind drum for ink spillage. Clean up all ink and check for source of spilled ink.

---

### As-Needed Maintenance

---

If you encounter print-quality problems, check the following and perform the required maintenance:

- Perform knife-edge adjustment. (Always check knife-edge adjustment first when you encounter print-quality problems.)
- Run test patterns.
- Perform frequency color run.
- Check convergence.
- Clean the deflection assembly.
- Wash the ink jet nozzles.

See also Section 6 for a more detailed description of print-quality problems and their solutions.

---

## Weekly Maintenance

---

Weekly printer maintenance should include the following procedures:

- Clean the deflection assembly. (Clean at least twice per week during periods of heavy use. If you observe VOLTAGE OVERLOAD error messages on the control panel, clean the deflection assembly more frequently.)
- Check convergence and adjust if necessary.
- Check disposable waste ink filter. Replace if filter shows blotches of ink.
- Clean the bib at least once per week.

## APPENDIX C — Operating Guidelines

The IRIS 3024 Color Ink Jet Printer does not require a computer-room environment or a raised floor. However, it must be kept in an area that meets the environment and tolerance conditions described in the following guidelines:

### Electrical Power Requirements

Your printer will be configured at the factory for electrical service of (1) 115 volts A.C. at 60 Hertz or (2) 220 volts A.C. at 50 Hertz. IRIS recommends a dedicated, isolated circuit of at least 10 amps. This will help prevent power interruptions and/or surges. Voltage must remain within 10% of nominal value. As with any other computer equipment, if your electrical power exhibits rapid fluctuations or spikes, you may have to install power-conditioning equipment.

### Temperature

You must maintain the ambient temperature at the installation site between 60° F (16° C) and 80° F (26° C). Under normal conditions, the printer generates approximately 2,000 BTU/hour.

### Humidity

You must maintain the relative humidity at the installation site between 40% and 80%. Condensation at any humidity level must be prevented.

### Static Electricity

The area around the equipment must be free from conditions that result in build-up of electrostatic charges.

### Operating Conditions for Optional Equipment

Operating conditions for optional equipment may differ from the conditions required by the printer itself. These requirements are subject to change without notice. Contact IRIS Technical Service if you have any questions about the operating conditions required by such optional equipment.

---

---

**IMPORTANT WARNING.** Before installing or performing any service or maintenance on IRIS 3024 printers, turn the circuit breaker **on the back of the printer** to the "OFF" position. (The side of the switch bearing the symbol "o" must be depressed.) Turning the power switch on the front of the machine to the OFF position will not stop the flow of current to the printer.

---

---

## GLOSSARY

The following glossary entries define words and phrases that are underscored in the text of the manual.

**autophase** — Optional color bands printed at the edge of an image that allow the operator to evaluate accuracy of ink jet phase adjustment.

**bib** — Porous plate mounted below the deflection assembly that collects mist ink.

**charge tunnel** — An electrode placed at the point of droplet formation that creates a positive charge on all non-printing ink droplets.

**color lookup table** — An optional table of values transmitted by the host system to the printer that controls the interpretation of the color data transmitted by the host system. Color look-up tables allow the user to tailor image data to specific requirements and tastes.

**contrast** — The degree of difference in density between the lightest values in a color and the darkest values in that color.

**control panel** — The 40-character fluorescent display and two control buttons located on the left front of the printer. Used to display error and diagnostic messages, change printing parameters, and execute service and adjustment functions.

**convergence** — See *registration*.

**cyan** — Bluish primary subtractive printing color.

**CMYK** — Notation for the following selection and order of primary subtractive printing colors: Cyan, Magenta, Yellow, and Black (K).

**deflection assembly** — Portion of the print head assembly containing deflection electrode and knife edges for all jets. Deflects non-printing droplets into a waste-ink chamber. Removable for cleaning.

**density** — The degree of color saturation (“darkness”).

**dust cover** — Removable cover (“hat”) over the nozzles and deflection assembly; includes the mist suppression brush. The dust cover should always be in place during a print run.

**fatal error message** — Diagnostic error message appearing on the control panel indicating a condition that aborts a print run.

**flopped [image]** — Vertical mirror image of original.

**home position** — The position of the print head assembly when the printer is idle — to the left and behind the control panel.

- horizontal convergence knobs** — The black-and-silver knobs located on the uppermost part of the print head assembly above the knife-edge adjustment knobs. Used to adjust registration of horizontal lines.
- hydrophilic** — Capable of absorbing water. IRIS printers can only use print media that have a hydrophilic printing surface that can hold IRIS water-based inks.
- image data** — Digitized data from a host system or a file on magnetic tape that describes an image electronically — as opposed to printing parameters and instructions about how to process the image data.
- ink status indicator light** — Small light located to the front of ink bottles that is used to indicate loss of pressure (when light is on) or attempt to pressurize (flashing).
- knife edge** — Small plastic inserts in the deflection assembly that deflect non-printing droplets and allow them to flow into a waste ink chamber (sump).
- knife-edge adjustment knobs** — The knobs located on the rear of the nozzle assembly under the dust cover. Used to adjust the flight path of the ink jet streams relative to the knife edges.
- machine control microprocessor (MCP)** — Microprocessor of IRIS design and manufacture that controls the operation of printer components. (Part of the system controller.)
- macro-pixel** — Arrangement of pixels in a  $4 \times 4$  pattern to allow representation of up to 512 different shades in each color (matrix averaging).
- magenta** — Reddish-purple primary subtractive printing color.
- matrix averaging** — See macro-pixel.
- menu maps** — The diagrams of the relationships of the control panel menus and menu selections found in Appendix A of this manual.
- mode switch** — The two-position switch located under the cover and behind the control panel. When the printer cover is opened, the switch is in its middle position. Printing stops and the printer is in Operator Mode and the control panel displays menus for servicing, adjustment, and alignment. When the Mode switch is pulled up to its highest position, menus for System Set-Up Mode (setting printing parameters) are presented at the control panel.
- “Next” button** — The button on the left side of the control panel that allows you to cycle through entries or values shown on the second line of the control panel display.
- non-fatal error message** — Diagnostic error message appearing on the control panel that does not interrupt printing.
- nozzle** — A glass capillary located in the nozzle assembly through which ink is forced. The ink breaks up into droplets as it emerges from the capillary.

- nozzle assemblies** — The parts of the print head assembly that contain the ink jet nozzles, the vertical convergence knobs, and the knife-edge adjustment knobs.
- Operator Mode** — Printer operating mode in which you can generate test patterns, execute forced purges, move the print head assembly to service position, and execute alignment functions. Accessed by opening the cover (Mode switch in middle position).
- pixel** — One spot or dot of the many that form electronically-generated images on paper or on VDT screens. Short for “picture element.”
- pixel replication** — Duplication of incoming pixel data in horizontal and/or vertical dimensions to create an image larger than the original. This does not increase effective resolution. It simply makes “bigger pixels.”
- power switch** — Switch located on the right front of the printer that turns the printer on or off.
- power up** — Turning the printer on with the power switch.
- primary subtractive colors** — The three colors — cyan, magenta, and yellow — that are used in “process” color printing to form color images. A fourth subtractive “color” — black — is also used in most process printing.
- print head assembly** — The printing system — including nozzle assemblies, the deflection assembly, and supporting electronics — that prints the image as it travels parallel to the drum.
- printing medium** — Any sheet of material, usually paper, used to receive print images.
- print switch** — The switch on the left front of the printer that puts the printer on-line to a host system or triggers transmission of a file from a magnetic tape drive to the printer.
- purge cycle** — A cleaning cycle executed automatically by the printer every 30 minutes when the printer is idle (cover closed) to prevent build up of ink residue in the ink delivery systems. The operator can execute a forced purge cycle when the printer is in Operator Mode.
- raster** — One line of pixels (picture elements) in an electronically-generated image. In the case of a television, the raster lines go across the screen. The IRIS 3024 printer draws rasters around the drum.
- ready state** — Condition of printer with cover closed and control panel showing “IRIS GRAPHICS INC.” on the first line of the display.
- reference marks** — Marks on the drum that guide placement of the print media.
- registration** — Superimposition of printing colors to form a four-color (or three-color) image. Precise registration is accomplished by adjusting the vertical and horizontal convergence of the ink jet stream so that the three or four pixels (one for each primary color) in the incoming image data are placed exactly over each other.

- reset button** — The button inside the front right panel of the printer that resets the system controller. The reset button is sometimes used to “clear” the printer interface to the host system or magnetic tape unit.
- resolution** — The number of pixels per millimeter or inch used to form an image. A high-resolution monitor typically offers a resolution of 100 pixels per inch. High-resolution printers like the IRIS 3024 have resolutions of 240 pixels per inch or more.
- safety switch** — The switch under the cover in the left rear of the printer that is depressed by closing the cover. Opening the cover during a print run releases the safety switch and pauses the print run for up to two minutes. If the operator does not close the cover within two minutes, the print run is aborted.
- “Select” button** — The button on the right side of the control panel that allows you to select the entry or value shown on the second line of the control panel display.
- sump** — Waste ink chamber below deflection assembly.
- system controller** — The computer processing unit, located inside the left front panel of the printer, that controls all printer activities.
- System Set-Up Mode** — Printer operating mode in which operator can change printing parameters from the control panel. System Set-Up Mode menus for setting printing parameters are accessed by opening the cover and lifting the Mode switch to its highest position.
- target block** — Porous ink collector used during automatic knife-edge testing at the start of a print cycle.
- user defaults** — Default printing parameters that will be used by the printer when it is powered-up.
- vertical convergence knobs** — The black knobs located on the front (drum end) of the nozzle assemblies; used to adjust registration of vertical lines.
- waste ink bottle** — The bottle located behind the right front panel of the printer that collects non-printing ink.
- waste ink collector** — The chamber between the waste ink delivery system and the waste ink bottle that collects ink from the suction system, separates air and liquid, and deposits the separated ink into the waste ink bottle. Accessed through the rear of the machine.



# INDEX

## !

“nevers”, 14

## A

aborting a print run, 8  
acknowledging error messages  
    *See* error messages  
adjustment  
    conditions requiring, 26  
autophase  
    effects of printing on maximum image size, 52  
    explanation of, 52  
    printing autophase test pattern, 52

## B

bib  
    cleaning of, 36  
    conditions indicating cleaning required, 36  
    explanation of, 36  
    procedure for removal, 36  
bib discoloration, 61

## C

circuit breaker, 6, 14  
clearing error messages  
    *See* error messages  
color balance, 45  
color look-up tables, 45  
color lookup tables, 5  
color separations  
    selecting data and jet to print with, 47  
    specifying from control panel, 47  
color values, 45  
colors  
    selecting number of from control panel, 46  
    selecting order of from control panel, 46  
computer, 17  
contrast  
    explanation of, 44

    setting from control panel, 45  
    specification of non-linear values, 5  
control panel  
    functions of, 10  
    ready-state display, 9, 43  
    use of buttons, 10  
convergence  
    adjustment procedures, 30  
    conditions requiring adjustment of, 29  
    detailed procedures for adjustment, 31–32  
cover, 7  
crystal frequency  
    conditions requiring change, 33  
    explanation of, 32  
    procedure for selecting, 33  
crystal frequency color bars, 32

## D

data types supported, 1  
deflection assembly  
    affect of unapproved inks on, 12  
    cleaning of, 35–36  
    conditions requiring cleaning of, 35  
    frequency of cleaning, 35  
    procedure for removing, 35  
    purpose of, 35  
density  
    detailed procedures for changing, 46  
    explanation of, 44  
    increasing with multistrike features, 50  
    setting values from control panel, 45  
diagnostic tests, 41  
documentation, other, for IRIS 3024, 2  
drum  
    cleaning of, 42  
    paper placement reference marks, 19  
drum speed  
    effects of changing, 51  
    procedures for changing, 52  
dust cover, 14  
    procedure for removing, 35



**E**

- electrical hazards, 8, 25
- error conditions
  - common non-fatal, 23
- error messages, 15
  - acknowledging error messages, 16
  - at power up, 16
  - comprehensive list, 55
  - displayed on control panel, 9
  - fatal, 15
  - non-fatal, 15
  - See also* specific error conditions

**F**

- fatal error messages
  - See* error messages
- flopped images, 49
  - See also* mirror image printing
- flow calibration routine, 39
- Front-End Processor (FEP)
  - description of, 1, 5
  - printing functions of, 4

**H**

- hat
  - See* dust cover
- HIGH PRESS JET error message, 22
- horizontal
  - use of term in this manual, 29
- horizontal convergence knobs, 30
- horizontal offset of images, 23, 48
- horizontal replication
  - See* pixel replication
- horizontal resolution
  - See* resolution
- host systems, effect of on printer operation, 4
- HV SPIKE error message, 24

**I**

- image data sources for the IRIS 3024, 1
- image placement, 48
  - See* horizontal and vertical offset
- horizontal offset, 48
- ink bottles
  - opening of, 18
  - replacement of, 39
  - treatment of open bottles, 14, 18
- ink jet nozzles, 1

- INK PUMP ERROR error message, 22
- INK PUMP NOT HOME error message, 16, 41
- ink pumps
  - detailed procedure for pressurizing, 40
  - error messages, 39
- inks
  - avoid mixing of, 14
  - requirements, 12
- INPUT BOARD ID ERROR error message, 16
- interfaces to external systems, 1

**J**

- Jet Offset RAM Test, 41

**K**

- knife-edge adjustment
  - automatic check of, 23
  - computer-assisted procedure, 29
  - conditions requiring, 23, 27
  - detailed procedure, 28
  - error messages, 27
  - error messages indicating, 23
  - explanation of, 23
- knife-edge adjustment knob, 29
- knife-edge alignment
  - See* knife-edge adjustment

**L**

- LOW PRESS JET error message, 22

**M**

- Machine Control Processor (MCP), 8, 17
- macro-pixel, 45
- magnetic tape system
  - selecting a file to print from, 21, 44
- magnifying images
  - See* pixel replication
- maintenance, 26
  - as-needed, 61
  - daily, 61
  - weekly, 62
- MCP
  - See* Machine Control Processor
- mirror image printing
  - explanation of, 49
  - procedures, 49
- mode switch, 6, 8

modes of operation, 8  
multiple images, 48  
    creating from one master, 48  
    procedures for specifying, 49  
    specifying white space between, 49  
multistrike, 50  
    applications for, 50

## N

Next button, 12  
non-fatal error messages  
    *See* error messages  
nozzle assemblies  
    adjustments required after replacement, 30, 38  
    avoiding interchange of, 39  
    cleaning of, 38  
    conditions requiring servicing, 37  
    detailed procedures for removal, 38  
    effects of servicing, 27

## O

operating conditions, 12  
Operator Mode, 8

## P

painted surfaces, cleaning of, 42  
paper, 15  
    effects of autophase on image size, 52  
    mounting procedures, 19  
    placement of, 48  
    *See also* printing media  
    storage compartment, 12, 19  
pausing during printing  
    *See* suspending a print run  
Piggyback RAM option, 41  
pixel replication  
    applications of, 51  
    explanation of, 51  
    replication factors, 51  
poor print quality, causes of, 29  
power switch, 6  
power-up procedures, 15  
preparation for printing, 6  
print head assembly  
    electrical hazard, 25  
    in service position, 25  
    home position, 15  
print run, maximum duration of, 17  
print switch

    location of, 7  
    used to start printing from magnetic tape, 21  
print-quality problems, 61  
printer clock, 52  
printer controls, 6  
printing  
    aborting a print run, 8  
    appearance of control panel during, 20  
    basic printing procedures, 13  
    from host system, 20  
    from magnetic tape, 21  
    placing printer on-line, 20  
    preparation for, 6  
    starting a print run, 20  
    suspending a print run, 8  
printing cycle  
    printer operations during, 22  
printing media  
    size of, 1, 12  
    types of, 12  
printing parameters  
    autophase, 52  
    controlling, 1, 43–53  
    default printer settings, 44  
    drum speed, 51  
    effects of values transmitted by host, 43  
    factory defaults, 44  
    horizontal offset, 48  
    mirror image printing, 49  
    multiple images, 48  
    multistrike features, 50  
    overridden by host, 5  
    pixel replication, 51  
    repeat image margins, 49  
    resolution, 49  
    restoring, 44  
    saving, 44  
    setting from control panel, 10, 20, 43–44  
    *See also* specific printing values and parameters  
    specifying starting position, 48  
    transmitted by a host system, 4  
    user defaults, 44  
    vertical offset, 48  
printing procedures, typical, 13  
program revisions applicable for this manual, 2  
PUMP TIMEOUT error message, 22  
purge cycle, 7, 14, 25

## R

raster, 23, 48, 50  
registration of colors  
    *See also* convergence

explanation of, 29  
precision of, 48  
repeat image margins, 49  
reset button, 8  
resolution  
    effects on image offset, 48  
    explanation of, 49

## S

safety switch, 8  
scope of this manual, 2  
Select button, 12  
    used to clear error messages, 16  
Service Mode, 8  
service position, 25  
shutting down the printer, 25  
software revisions applicable for this manual, 2  
starting position of printing, 48  
suction  
    *See* vacuuming  
support policies, 5  
suspending a print run, 8, 24, 32  
switches, 6  
system controller, 8  
System Set-Up Mode, 8  
    top-level display for mag tape systems, 44

## T

telephone support number, 5  
test pattern, 29  
    running, 31–32

## U

user defaults, 44  
user diagnostic tests, 41

## V

vertical  
    use of term in this manual, 29  
vertical convergence knobs, 30  
vertical offset of images, 48  
vertical replication  
    *See* pixel replication  
vertical resolution  
    *See* resolution  
voltage irregularities  
    conditions indicating, 24  
    overload, 22  
VOLTAGE OVERLOAD error message, 22

## W

WASTE BOTTLE FULL error message, 16  
WASTE BOTTLE MISSING error message, 16  
waste ink bottle, 23  
    location of, 17  
    procedure for emptying, 17  
white space  
    *See* multiple images, white space between