

**Installation and Operation
Manual**

KENNEDY

A Division of Shugart Corporation

**Auto-Load Digital
Tape Drive**

Model 9610/9660

FCC CERTIFIED COMPUTER EQUIPMENT

This equipment, freestanding with shielded Data and Control Cables, complies with Part 15, Subpart J of FCC Rules Governing Class A Computing Devices Operated In A Commercial Environment. However, the equipment generates radio frequency energy and, when operated in a residential area, the user must take adequate precautions against interference to radio communications.

Copyright 1990 by Kennedy Company

All rights reserved. No part of this work covered by the copyright hereon may be reproduced or copied in any form or by any means - graphic, electronic, or mechanical, including photocopying, taping, or information storage and retrieval systems - without written permission of Kennedy Company.

TABLE OF CONTENTS

SECTION I	GENERAL DESCRIPTION AND APPLICATION DATA	Section	Page
		1.4.3.5	Write Edit1-16
1.1	General Description.....	1.4.3.6	Write File Mark1-16
1.1.1	Host Interfaces.....	1.4.3.7	Fixed Length Erase1-16
1.1.2	Microcomputer Based Design.....	1.4.3.8	Data Security Erase1-16
1.1.3	Diagnostics And Fault Isolation.....	1.4.3.9	Space Forward and Space Reverse1-16
1.2	Specifications.....	1.4.3.10	File Mark Search Fwd/Rev.....1-17
1.2.1	Operational Specifications.....	1.4.3.11	Erase Variable.....1-17
1.2.2	Physical/Environmental Specs.....	1.4.3.12	Density Select.....1-17
1.3	Interface Specifications.....	1.5	Host Interface Timing.....1-17
1.3.1	General.....	SECTION II INSTALLATION AND OPERATION	
1.3.2	Interface Connectors.....	2.0	Introduction 2-1
1.3.3	Interface Signal Characteristics.....	2.1	Unpacking 2-1
1.3.4	Interface Cables.....	2.2	Inspection 2-1
1.3.5	Receiver/Driver Configuration.....	2.3	Cabling and Daily Chaining Requirements..... 2-1
1.3.6	Daisy Chaining.....	2.4	Installation..... 2-5
1.4	Interface Input and Output Signals.....	2.4.1	Table-Top Installation..... 2-5
1.4.1	Interface Input Signals.....	2.4.2	Rack-Mount Installation..... 2-5
1.4.1.1	Transport Addr, Formatter Addr.....	2.4.2.1	Rail Assy Component Checkout.. 2-5
1.4.1.2	Initiate Command - GO.....	2.4.2.2	Mounting Procedure 2-5
1.4.1.3	Reverse.....	2.5	Power Up and Initial Checkout..... 2-9
1.4.1.4	Write.....	2.5.1	AC Line Voltage..... 2-9
1.4.1.5	Write File Mark.....	2.5.2	Power Up2-10
1.4.1.6	Edit.....	2.5.3	Checkout2-10
1.4.1.7	Erase.....	2.5.3.1	Loading Tape2-10
1.4.1.8	High Speed.....	2.5.3.2	Load Details2-10
1.4.1.9	Long Gap.....	2.5.3.3	Checkout Continued.....2-11
1.4.1.10	Rewind.....	2.5.3.4	Motion Test Summary.....2-12
1.4.1.11	Off-Line/Unload.....	2.5.4	Unit Selection2-12
1.4.1.12	Last Word.....	2.5.5	Data Density - Introduction.....2-14
1.4.1.13	Formatter Enable.....	2.6	Operating Instructions.....2-16
1.4.1.14	Write Data Lines.....	2.6.1	Operating Procedure2-16
1.4.1.15	Load On Line.....	2.6.2	Operation Notes2-16
1.4.2	Interface Outputs.....	SECTION III FUNCTIONAL DESCRIPTION	
1.4.2.1	Formatter Busy.....	3.0	General..... 3-1
1.4.2.2	Data Busy.....	3.1	System Description..... 3-1
1.4.2.3	Hard Error.....	3.1.1	Overview 3-1
1.4.2.4	Corrected Error PE, DDPE).....	3.1.2	Formatter Board..... 3-1
1.4.2.5	Corrected Error (GCR).....	3.1.3	Read Preamp Board 3-3
1.4.2.6	Check Char Gate (NRZI only)..	3.1.4	Read Analog Board 3-3
1.4.2.7	Ident Burst (PE, DDPE, GCR)..	3.1.5	Read/Write Digital Board..... 3-3
1.4.2.8	File Mark.....	3.1.6	Drive Electronics Board 3-5
1.4.2.9	Write Strobe.....	3.1.7	Servo Power Amplifier..... 3-5
1.4.2.10	Read Strobe.....	3.1.8	Operator Control Panel..... 3-5
1.4.2.11	Read Data Lines.....	3.1.9	Interconnect Board 3-5
1.4.2.12	Ready.....	3.1.10	Position Sensors Board..... 3-5
1.4.2.13	On Line.....	3.1.11	Power Supplies..... 3-5
1.4.2.14	Rewinding.....		
1.4.2.15	File Protect.....		
1.4.2.16	Load Point.....		
1.4.2.17	End of Tape.....		
1.4.2.18	Density.....		
1.4.2.19	Speed.....		
1.4.3	Command Execution.....		
1.4.3.1	Read Forward.....		
1.4.3.2	Read Reverse.....		
1.4.3.3	Write.....		
1.4.3.4	Read Reverse Edit.....		

missing page 2 of
Table of Contents

SECTION I
GENERAL DESCRIPTION AND APPLICATION DATA

1.1 GENERAL DESCRIPTION

The Kennedy Model 9610/9660 Tape Drive (Figure 1-1) is rack mountable (9610) and desk-top (9660) automatic load, tape drive that includes an embedded Formatter capable of communicating between an industry standard interface bus and ANSI-compatible PE 1600 and 3200 CPI, NRZI 800 CPI and GCR 8250 CPI tapes. The drive can operate in Streaming Mode at 100 ips or Start/Stop Mode at 50 ips, and can read in either forward or reverse direction in all densities.

1.1.1 HOST INTERFACE

The 9610/9660 Drive has Industry Standard Interface for Formatted 1/2-inch Tape Drives.

1.1.2 MICROCOMPUTER BASED DESIGN

The 9610/9660 uses two microprocessors; one in the Formatter, and one in the Drive Control Electronics.

1.1.3 DIAGNOSTICS AND FAULT ISOLATION

The 9610/9660 includes built-in diagnostics with front-panel eight-character LED readout.

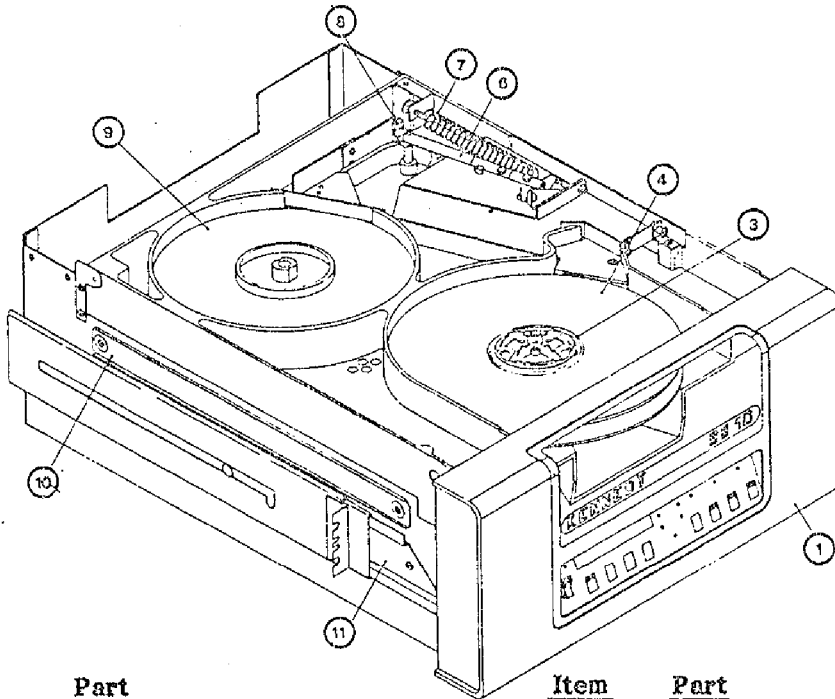

<u>Item</u>	<u>Part</u>	<u>Item</u>	<u>Part</u>
1	Panel Assembly	7	Spring, Extension
2	Supply Arm Assy (bottom, hidden)	8	Take-up Arm Limit Sensor PCBA
3	Supply Hub Assembly	9	Vacuum Hub Assembly
4	Supply Reel Tape	10	Support Bar
5	Magnetic Head Assembly (hidden)	11	Slide Set
6	Take-up Arm Assembly (top)		

Figure 1-1. Model 9610/9660 Auto-load Tape Drive

Table 1-1. Operational Specifications (Continued)

Reinstruct Time Limits for Auto Speed Transition to 100 IPS:			
<u>Operation</u>	<u>Density</u>	<u>Time</u>	
Read	800/1600/3200	2.8 ms	
	6250	1.5 ms	
Write	800/1600/3200	2.4 ms	
	6250	1.0 ms	
Reposition Time, Streaming Mode:			
<u>Operation</u>	<u>Density</u>	<u>Time</u>	
Read	800/1600/3200 6250	<u>50 IPS</u>	<u>100 IPS</u>
			42.5 ms 43.5 ms
Write	800/1600/3200 6250		42.5 ms 41.5 ms
		35	
Data Transfer Rate:			
<u>Speed</u>	<u>Density (CPI)</u>	<u>Rate (KB/SEC)</u>	
50 ips	NRZI 800	Normal	Maximum
	PE 1600	40	48
	DDPE 3200	80	96
	GCR 6250	160	192
100 ips	NRZI 800	312.5	375
	PE 1600	80	96
	DDPE 3200	160	192
	GCR 6250	320	384
		625	760
POWER REQUIREMENTS			
Input Voltage	100, 120, 220, 240 VAC +15% -10% 50 or 60 Hz +/-2 Hz		
Input current.	<u>120 VAC</u>	<u>220 VAC</u>	
	3.0 amps	1.5 amps	
Power:			
Nominal	300 watts	300 watts	
Peak	400 watts	400 watts	
Fuse (SLO-BLO)	6 amp at 110/120	3 amp at 220/240 VAC	
Heat Dissipation	1025 BTU/hr		

Table 1-2. Tape Reel Capacities

Reel Size (inches)	Tape Thickness				1.3 mil	Blocks (Bytes)
	6	7	1.9 mil 8.5	10.5		
NRZI (MBytes)	1	3	6	10	15	512
	1.5	5	9	17	25	2K
	1.8	5.5	11	21	32	8K
	2	6	12	23	34	64K
PE (MBytes)	1.3	4	8	15	22	512
	2.5	8	15	30	45	2K
	3.5	11	21	41	62	8K
	4	12	23	45	68	64K
DDPE (MBytes)	2.5	8	15	30	44	512
	5	15	30	60	90	2K
	7	21	41	82	120	8K
	8	23	45	90	134	64K
GCR (MBytes)	3.2	10	19	37	56	512
	8	23	46	91	136	2K
	12	37	73	145	218	8K
	15	44	88	175	262	64K

1.2.2 PHYSICAL/ENVIRONMENTAL SPECIFICATIONS (Table 1-3)

Table 1-3. Physical/Environmental Specifications

PHYSICAL SPECIFICATIONS		
Dimensions:		
Height	8.75 inches (22.23 cm)	
Width	17.00 inches (43.18 cm)	
Depth: From Mounting Surface	2.00 inches (5.38 cm)	
Depth: Overall	24.50 inches (62.23 cm)	
Mounting	Slide Mount in standard 19-inch RETMA Rack	
Weight:	9610 (with Slides)	9660
No Packing Material	110 lbs (49.5 Kgm)	122 lbs (54.9 Kgm)
With Packing Material	135 lbs (60.75 Kgm)	152 lbs (68.4 Kgm)
ENVIRONMENTAL SPECIFICATIONS		
Temperature operating	60° to 90° F (15.6° to 32.2° C)	
Temperature, non-operating	-40° to +122° F (-40° to +50° C)	
Humidity, (with wet bulb)	Operating (+78° max) Storage (+83° max)	
	20 to 80% 5 to 90%	
Altitude, operating	-1300 to 10,000 ft. (-400 to 3000 meters)	
Altitude, shipping	-1300 to 50,000 ft. (-400 to 15000 meters)	

1.3 INTERFACE SPECIFICATIONS

1.3.1 GENERAL

This section describes the signal requirements and characteristics of the interface between the tape drive and the controller. The connectors and cable requirements are described, as well as the actual lines and the commands derived from the lines. The interface lines are summarized in Tables 1-4A and 1-4B while the command structure is summarized in Table 1-5.

1.3.2 INTERFACE CONNECTORS

The interface connectors on the Model 9610/9660 are designed for standard fifty line, shielded cables. For each active connector pin there is an associated ground pin. The mating interface connectors are two 50-pin card edge connectors.

1.3.3 INTERFACE SIGNAL CHARACTERISTICS

Signals from the controller to the Model 9610/9660 must conform to the following specifications:

Levels:	1 = Low = True = 0V (+0.7 Vdc)	NOTE:
	0 = High = False = +3V (+/-0.5 Vdc)	Total edge transmission
Pulses:	1 = Low = True = 0V (+0.7 Vdc)	Delay =<200 nanosec over
	0 = High = False = +3V (+/-0.5 Vdc)	a 20 ft cable (6 meters).

All output signals from the Model 9610/9660 are driven by open collector type line drivers capable of sinking up to 36 mA (25 standard unit loads) in the low true state. Open lines will result in false signal levels.

1.3.4 INTERFACE CABLES

Per FCC and ESD specs, interface cables should be braided and shielded with maximum allowable length of 20 feet.

1.3.5 RECEIVER/DRIVER CONFIGURATION AND TERMINATION

The input lines to the transport are terminated with a 220 ohm resistor to plus five volts, and a 330 ohm resistor to ground (Figure 1-2). All input circuits have low level input voltage of 0.7 V maximum and a high level input voltage of 2.0 V minimum. The input receivers are all 74LS type circuits.

All output lines must be terminated at the far end of the daisy chained cable with a 220 ohm resistor to plus five volts and a 330 ohm resistor to ground. Output circuits are 7438 open collector drivers as shown in Figure 1-2.

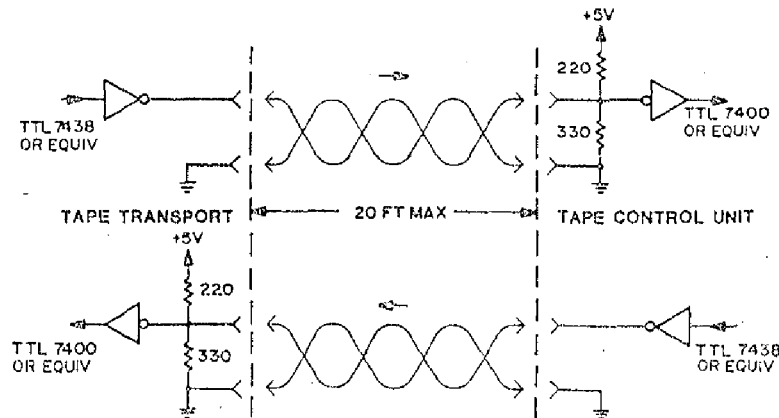

Figure 1-2. Receiver/Driver Interface Configuration

1.3.6 DAISY CHAINING

The 9610/9660 transport may be configured to allow operation of up to eight transports with a single controller as shown in Figure 1-3.

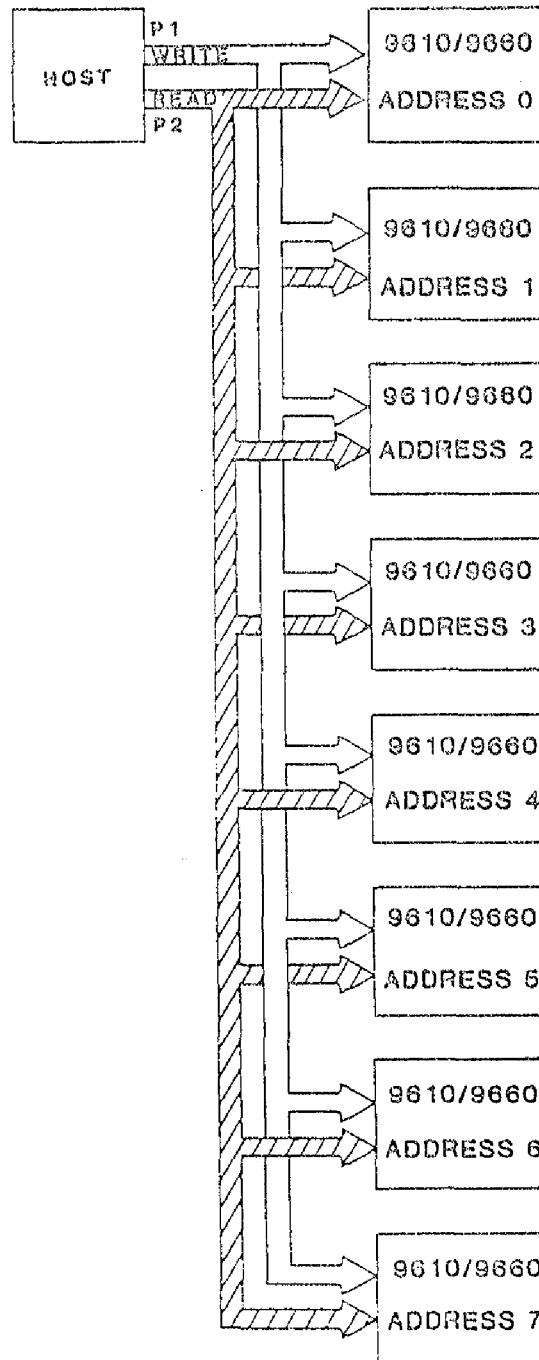

Figure 1-3. Daisy Chaining

1.4 INTERFACE INPUT AND OUTPUT SIGNALS

The following sections tabulate and describe Host/Drive interface signals. Input Signals (IN) are Signals from the Host; Output Signals (OUT) are Signals to the Host. Tables 1-4A and 1-4B list Host-to-Drive I/O Signals. Connector Signal/Fin assignments include Signal and Ground Pins and related Signal Mnemonic.

Table 1-4A. Drive Interface Summary, Connector P-2

Pin	Sig/Grd	Mnemonic	Signal Name	In/Out
P2-1/5		RP	Read Data P	Out
P2-2/5		R0	Read Data 0	Out
P2-3/5		R1	Read Data 1	Out
P2-4/5		LDP	Load Point	Out
P2-6/5		R4	Read Data 4	Out
P2-8/7		R7	Read Data 7	Out
P2-10/9		R6	Read Data 6	Out
P2-12/11		HER	Hard Error	Out
P2-14/13		FMK	File Mark	Out
P2-16/15		ID/CCG	ID Burst/Check Char Gate	Out
P2-18/17		FEN	Formatter Enable	In
P2-20/19		R5	Read Data 5	Out
P2-22/21		EOT	End of Tape	Out
P2-24/23		OFL	Off Line	In
P2-26/25		DEN1	Density 1	Out
P2-28/27		RDY	Ready	Out
P2-30/29		RWG	Rewinding	Out
P2-32/31		FPT	File Protect	Out
P2-34/33		RSTR	Read Strobe	Out
P2-36/35		WSTR	Write Strobe	Out
P2-38/37		DBY	Data Busy	Out
P2-40/39		SPD	Speed	Out
P2-42/41		CER	Corrected Error	Out
P2-44/43		ONL	On Line	Out
P2-46/45		TAD1	Transport Address 1	In
P2-48/47		FAD	Formatter Address	In
P2-50/49		HSP	High Speed	In

1.4.1.2 INITIATE COMMAND - GO

GO	Pulse	P1-3
----	-------	------

A pulse which initiates any command specified by the command lines described in the following paragraphs. Information on the command lines is copied into the unit on the trailing edge of the GO pulse. At the end of the reinstruct window in streaming write commands only, it is possible for the Host to extend the reinstruct window by asserting and holding the GO pulse in a true state. The unit will continue to stream for up to one inch waiting for the trailing edge of the GO pulse as the Host returns GO to the false state. If one inch is exceeded and the GO pulse has yet to be denied, the unit shall enter a reposition cycle. This feature in effect creates extended gaps.

1.4.1.3 REVERSE

REV	Level	P1-18
-----	-------	-------

Command line refer to Table 1-5.

1.4.1.4 WRITE

WRT	Level	P1-34
-----	-------	-------

Command line refer to Table 1-5.

1.4.1.5 WRITE FILE MARK

WFM	Level	P1-42
-----	-------	-------

Command line refer to Table 1-5.

1.4.1.6 EDTF

EDT	Level	P1-38
-----	-------	-------

Command line refer to Table 1-5.

1.4.1.7 ERASE

ERS	Level	P1-40
-----	-------	-------

Command line refer to Table 1-5.

1.4.1.8 HIGH SPEED

HSP	Level	P2-50
-----	-------	-------

When true, this signal causes the selected on-line unit to operate in the high speed mode (100 ips).

1.4.1.9 LONG GAP

LGP Level P1-36

When true during a Write Mode, this level causes the generation of a longer Interrecord Gap (erased area on tape) (selected in the Set Up Options - Section IV) to allow ample reconstruct periods as required for Host system latencies. Long Gap Time is limited by its setting in Set Up Options, but terminates automatically if a Write Command is received before the selected limit.

1.4.1.10 REWIND

REW Pulse P1-20

A pulse which causes the selected transport to rewind to load point. This pulse does not cause the formatter to go busy. The Ready status will remain false during rewind. In daisy chained systems, the rewind pulse can be issued to one or more of the units in the chain while allowing data transfer operations to occur on any other unit in the chain.

1.4.1.11 OFF LINE/UNLOAD

OFL Pulse P2-24

This pulse causes the transport to go off line immediately, then rewind to load point and unload the tape.

1.4.1.12 LAST WORD

LWD Level P1-4

When this level is true during a write or variable erase command, it indicates that the next character to be strobed into the formatter is the last character of the record. LWD should go true when the last data character is placed on the interface lines.

1.4.1.13 FORMATTER ENABLE

FEN Level P2-18

When false this level causes all units in a daisy chain configuration to revert to the quiescent state. This line may be used to disable the units if controller power is lost or to clear unit logic when illegal commands or unusual conditions occur. When denied during command execution, the unit will abort the command in an orderly fashion and stop motion. The unit Set Up Options (Section 7) allows the polarity of this level to be selected.

1.4.1.14 WRITE DATA LINES

WP, W0-W7 Level

These 9 lines transmit write data from the controller to the formatter. The 8 data bits appearing on W0-W7 are written onto the corresponding channels on tape; W7 corresponds to the least significant bit of the character. Line WP is optional and is utilized only if it is required to check the parity bit generated by the customer. The formatter generates odd parity internally on the basis of data contained on W0-W7.

NOTE: The HER may be reported as a real time pulse for each error condition as it occurs; or the occurrence of at least one HER or CER within the block can be captured by the Host before the falling edge of DBY at the end of the data block.

- a. Longitudinal parity error.
- b. Improper record format.
- c. CRCC parity error.
- d. Vertical parity error on a data character.
- e. Host write parity error (optional).
- f. No file mark detected in Read After Write mode when executing a Write File Mark command.
- g. If a gap of 25 feet is detected while executing a Read Block, Space Block or Search File Mark command (optional).
- h. Read after Write compare error.
- i. Excessive skew.
- j. Postamble error.
- k. Multiple channel error.
- l. CRC error.
- m. ACRC error.
- n. Simultaneous dropouts in two or more tracks during a write operation.
- o. Simultaneous dropouts in three or more tracks during a read operation.

1.4.2.4 CORRECTED ERROR (PE, DDPE MODE)

CER	Pulse	P2-42
-----	-------	-------

This pulse indicates that a single track dropout has been detected during read or write and the unit will perform a vertical parity correction.

1.4.2.5 CORRECTED ERROR (GCR)

CER	Pulse	P2-42
-----	-------	-------

This pulse indicates the following:

- a) A single or dual track dropout has been detected and the drive performs an error correction in a Read operation.
- b) A single track dropout has been detected and the drive performs an error correction in a Read after Write operation.

Note: Corrected error reporting can be disabled in GCR mode as one of the Set Up Options (Section IV).

1.4.2.6 CHECK CHARACTER GATE (NRZI MODE ONLY)

ID/CCG	Level	P2-16
--------	-------	-------

This level is set true by the unit when the read information being transmitted to the controller is the cyclic redundancy check character (CRCC) or the longitudinal redundancy check character (LRCC) of the data block. When data characters are transmitted, CCG goes false. Data and Check information can be distinguished by gating Read Strobe with CCG or its inverse. After leaving load point this line should only be used during NRZI mode.

NOTE: CCG and the Read Strobes (RSTR) for the check characters can be disabled as one of the Set Up Options (Section IV).

1.4.2.13 ON LINE

ONL Level P2-44

When ONL is true (low), the transport is under host or remote control. ONL false (high) indicates the transport is under local control.

1.4.2.14 REWINDING

RWG Level P2-30

RWG is true (low) when the transport is engaged in a rewind operation or returning to the load point at the end of the rewind operation.

1.4.2.15 FILE PROTECT

FPT Level P2-32

FPT is true (low) when a reel of tape without a write-enable ring is mounted on the transport supply hub.

1.4.2.16 LOAD POINT

LDP Level P2-4

LDP is true (low) when the load point marker is under the BOT sensor and the transport is not rewinding. After receipt of a motion command the signal will remain true until the load point marker leaves the BOT sensor area.

1.4.2.17 END OF TAPE

EOT Level P2-22

EOT is true (low) when the EOT marker is detected in the forward direction. EOT goes false (high) when the EOT marker is detected in reverse (REWIND).

1.4.2.18 DENSITY

DEN0, DEN1 Level P1-14, P2-26

Binary-coded signals that indicate the current density of the Drive. Two coding schemes are available. These schemes are:

<u>DENSITY</u>	<u>DENS OUT NRZ ONLY</u>		<u>DENS OUT CODED</u>	
	<u>DEN 1</u>	<u>DEN 0</u>	<u>DEN 1</u>	<u>DEN 0</u>
800	1	0	1	1
1600	0	0	0	1
3200	0	0	1	0
6250	0	0	0	0

The coding scheme used can be selected as one of the Set Up Options (Section IV).

1.4.2.19 SPEED

SPD

Level

P2-40

SPD true (low) indicates the selected transport is in the high speed (100 ips) streaming mode. A false level indicates low speed (50 ips).

1.4.3 COMMAND EXECUTION

The following section describes the appropriate combinations of signal lines required to achieve Command Execution followed by a description of the responses of the Model 9610/9660. Command configuration for the Model 9610/9660 is shown in Table 1-5. Write and read interface timing diagrams for each density at the two tape speeds are shown in Figures 1-4 through 1-19.

Table 1-5. Command Configuration

COMMAND	REV	WRT	WFM	EDT	ERS
READ FORWARD	0	0	0	0	0
READ REVERSE	1	0	0	0	0
READ REVERSE EDIT	1	0	0	1	0
WRITE	0	1	0	0	0
WRITE EDIT	0	1	0	1	0
WRITE FILE MARK	0	1	1	0	0
ERASE VARIABLE LENGTH	0	1	0	0	1
ERASE FIXED LENGTH	0	1	1	0	1
DATA SECURITY ERASE	0	1	1	1	1
SPACE FORWARD	0	0	0	0	1
SPACE REVERSE	1	0	0	0	1
FILE SEARCH FORWARD	0	0	1	0	0
FILE SEARCH REVERSE	1	0	1	0	0
FILE SEARCH FORWARD (IGNORE DATA)	0	0	1	0	1
FILE SEARCH REVERSE (IGNORE DATA)	1	0	1	0	1
SELECT 800 CPI	0	1	1	1	0
SELECT 1600 CPI	0	0	1	1	1
SELECT 3200 CPI	1	0	1	1	1
SELECT 6250 CPI	1	1	0	0	0

1.4.3.1 READ FORWARD

On receipt of the Read Forward command loaded into the unit with the GO pulse, the FBY signal goes true and the unit begins to accelerate the tape up to nominal velocity. When the tape is up to speed and the data block to be read is detected, DBY shall go true. Read Strokes (RSTR) accompany the decoded data. DBY will go false after the complete block has been read indicating readiness of the unit to accept a new command. If no command is received, the unit will either stop in the gap in 50 ips operation or enter a reposition operation in 100 ips operation and FBY will go false.

1.4.3.2 READ REVERSE

This command is similar to a read forward command except that the tape motion is in the reverse direction.

1.4.3.3 WRITE

On receipt of the Write command loaded into the unit with the GO pulse, the FBV signal goes true and the unit begins to accelerate the tape up to nominal velocity. When the tape is up to speed and the data block is ready to be written, DBY shall go true. Write Strokes (WSTR) are transmitted to the Host by the unit and the Host presents each data byte to be written. When LWD is received by the unit from the Host, the unit will finish reading the block, error status shall be made available to the Host and then the unit shall force DBY false indicating the end of the block just written. FBV will remain true if a new command in the same direction is received within the command restruct period. If no command is received, the unit will either stop in the gap in 50 ips operation or enter a reposition operation in all 100 ips or 50 ips GCR write operation and FBV will go false.

1.4.3.4 READ REVERSE EDIT

The Read Reverse Edit command besides providing data establishes the correct position of the tape relative to the magnetic head prior to the Host executing a Write Edit command.

1.4.3.5 WRITE EDIT

The Write Edit command must be preceded by a Read Reverse Edit command. The Write Edit command allows a block of the same length to be written over an already existing data block on the tape.

1.4.3.6 WRITE FILE MARK

This command invokes the writing of a file mark in the density selected.

1.4.3.7 FIXED LENGTH ERASE

This command invokes a 3.5 inch length of tape to be erased. This command is always executed in the forward direction of tape motion.

1.4.3.8 DATA SECURITY ERASE

This command invokes tape to be erased from the present tape position to a point 3 feet past End of Tape.

1.4.3.9 SPACE FORWARD AND SPACE REVERSE

These commands are similar to a Read Forward or Read Reverse command, except that no read strobes are returned to the Host and no error checking is performed. However, the unit will check and report if the record is a file mark.

1.4.3.10 FILE MARK SEARCH FORWARD/REVERSE

A file mark search forward command causes the unit to execute a series of read forward commands, and the reverse command, a series of read reverse commands searching for a file mark. Forward or reverse search is terminated by the presence of a file mark, 25 feet of blank tape, or BOT in reverse search. In the EOT region a gap of 5 feet results in a search termination. If the first block encountered is not a file mark and the command was issued at 50 ips, the unit will jump to 100 ips if autospeed is a selected option.

1.4.3.11 ERASE VARIABLE

This command causes the unit to execute a dummy write, erasing tape until Last Word (LWD) is issued by the Host. WSTR's are transmitted to the Host during the execution of this command.

1.4.3.12 DENSITY SELECT

The Density Select Command forces the unit to write tapes in the density specified. This Command is effective only when the unit is on line, selected, the tape is at BOT, and the unit has been placed in a remote density mode (the remote density LED is ON). However, if the unit performs a read from BOT of the tape, the unit will automatically read tape at the density of the tape.

1.5 HOST INTERFACE TIMING

The following Figures 1-4 thru 1-19 illustrate Host Interface Timing.

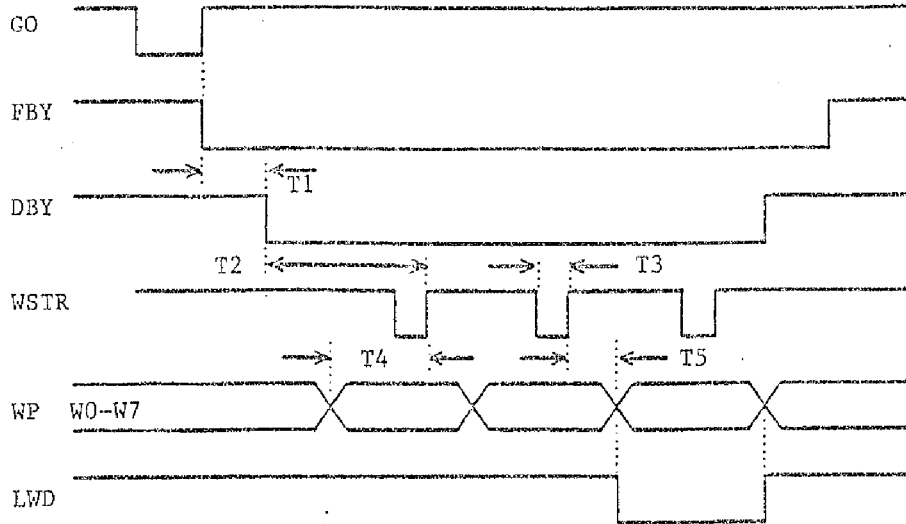

<u>Time</u>	<u>100ips Start/Stop</u>	<u>100ips On the Fly</u>	<u>50ips Start/Stop</u>	<u>50ips On the Fly</u>
T1	<18.0 mS	<4.0 mS	<8.0 mS	<5.0 mS
T2	>240 uS	>240 uS	>500 uS	>500 uS
T3	1.0 uS	1.0 uS	1.0 uS	1.0 uS
T4	>500 nS	>500 nS	>500 nS	>500 nS
T5	>250 nS	>250 nS	>250 nS	>250 nS

Figure 1-4. NRZI Write Data

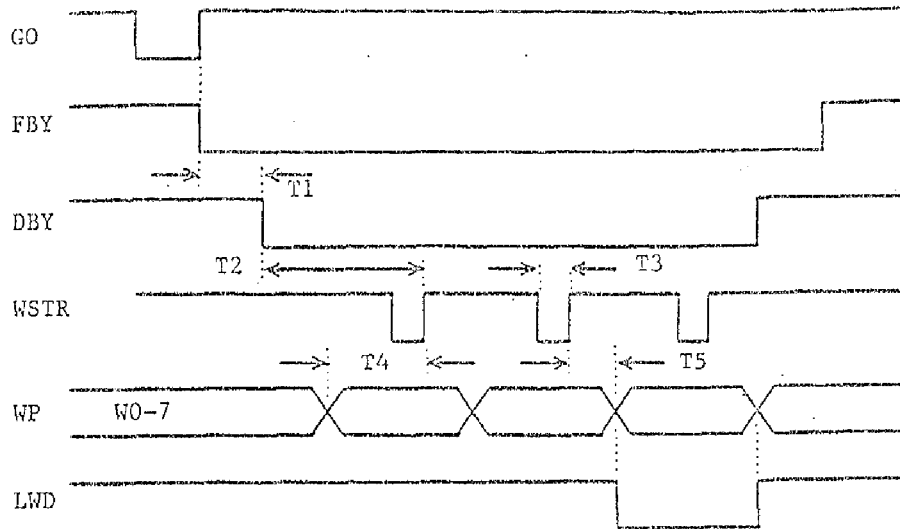

<u>Time</u>	<u>100ips Start/Stop</u>	<u>100ips On the Fly</u>	<u>50ips Start/Stop</u>	<u>50ips On the Fly</u>
T1	<18.0 mS	<4.0 mS	<8.0 mS	<5.0 mS
T2	>350 uS	>350 uS	>750 uS	>750 uS
T3	1.0 uS	1.0 uS	1.0 uS	1.0 uS
T4	>500 nS	>500 nS	>500 nS	>500 nS
T5	>250 nS	>250 nS	>250 nS	>250 nS

Figure 1-5. PE Write Data

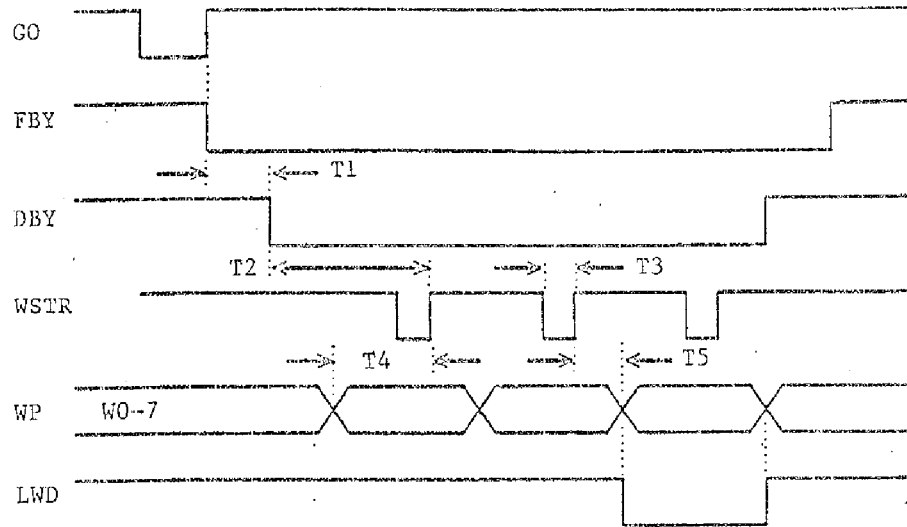

<u>Time</u>	<u>100ips Start/Stop</u>	<u>100ips On the Fly</u>	<u>50ips Start/Stop</u>	<u>50ips On the Fly</u>
T1	<18.0 mS	<4.0 mS	<8.0 mS	<5.0 mS
T2	>300 uS	>300 uS	>600 uS	>600 uS
T3	1.0 uS	1.0 uS	1.0 uS	1.0 uS
T4	>500 nS	>500 nS	>500 nS	>500 nS
T5	>250 nS	>250 nS	>250 nS	>250 nS

Figure 1-6. DDPE Write Data

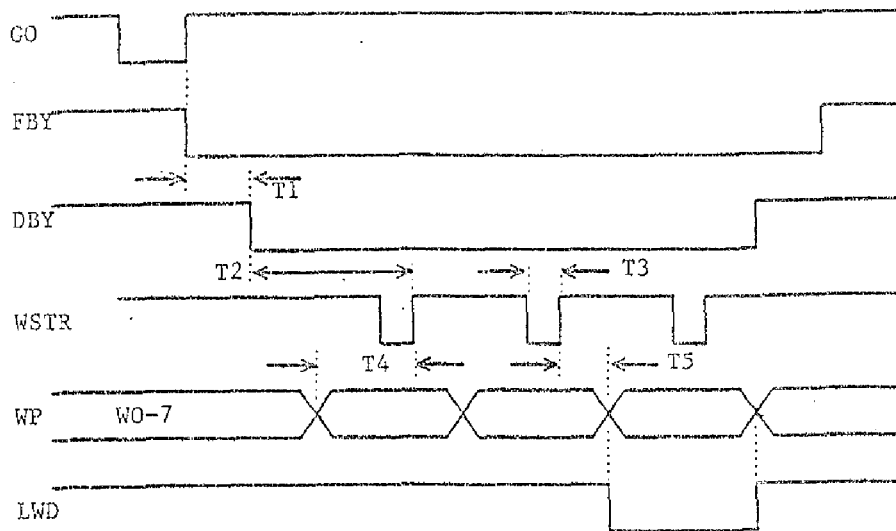

<u>Time</u>	<u>100ips Start/Stop</u>	<u>100ips On the Fly</u>	<u>50ips Start/Stop</u>	<u>50ips On the Fly</u>
T1	<18.0 mS	<2.0 mS	<18.0 mS	<3.0 mS
T2	>100 uS	>100 uS	>150 uS	>150 uS
T3	530 nS	530 nS	1.0 uS	1.0 uS
T4	>500 nS	>500 nS	>500 nS	>500 nS
T5	>250 nS	>250 nS	>250 nS	>250 nS

Figure 1-7. GCR Write Data

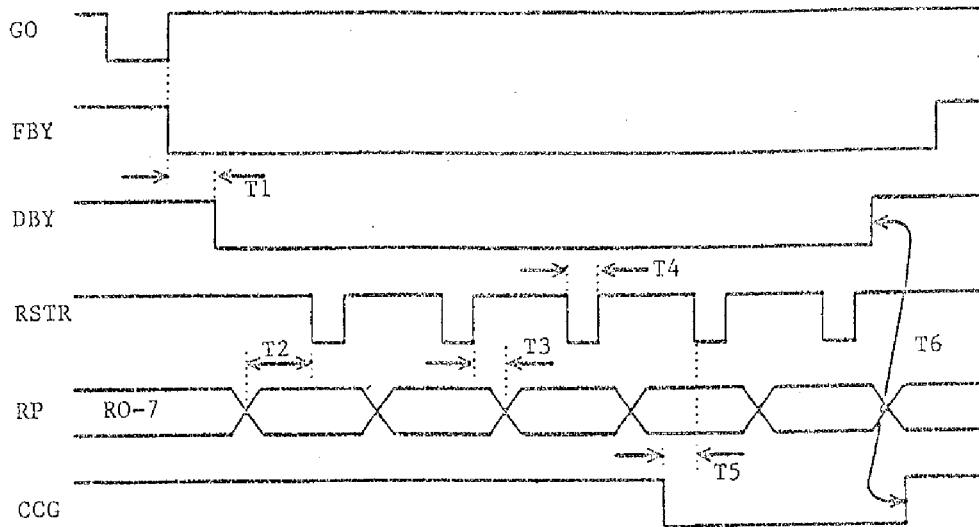

<u>Time</u>	<u>100ips Start/Stop</u>	<u>100ips On the Fly</u>	<u>50ips Start/Stop</u>	<u>50ips On the Fly</u>
T1	<18.0 mS	<4.0 mS	<8.0 mS	<5.0 mS
T2	>2.5 uS	>2.5 uS	>2.5 uS	>2.5 uS
T3	>250 nS	>250 nS	>250 nS	>250 nS
T4	2.36 uS	2.36 uS	2.36 uS	2.36 uS
T5	>2.5 uS	>2.5 uS	>2.5 uS	>2.5 uS
T6	* 70.5 uS	70.5 uS	67.3 uS	67.3 uS

* Nominal values

Figure 1-3. NRZI Read Forward

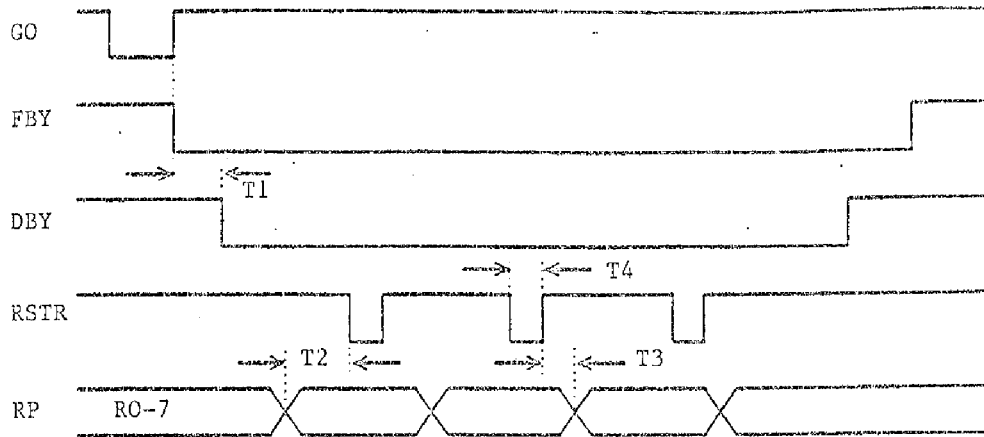

<u>Time</u>	<u>100ips Start/Stop</u>	<u>100ips On the Fly</u>	<u>50ips Start/Stop</u>	<u>50ips On the Fly</u>
T1	<18.0 mS	<4.0 mS	<8.0 mS	<5.0 mS
T2	>1.0 uS	>1.0 uS	>1.0 uS	>1.0 uS
T3	>250 nS	>250 nS	>250 nS	>250 nS
T4	670 nS	670 nS	670 nS	670 nS

Figure 1-9. PE Read Forward

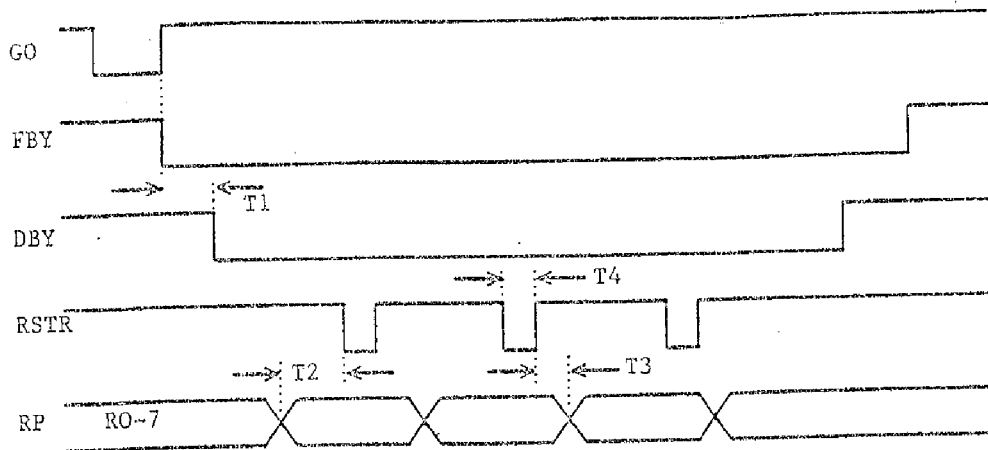

<u>Timer</u>	<u>100ips Start/Stop</u>	<u>100ips On the Fly</u>	<u>50ips Start/Stop</u>	<u>50ips On the Fly</u>
T1	<18.0 mS	<4.0 mS	<8.0 mS	<5.0 mS
T2	>1.7 uS	>1.7 uS	>1.0 uS	>1.0 uS
T3	>250 nS	>250 nS	>250 nS	>250 nS
T4	670 nS	670 nS	670 nS	670 nS

Figure 1-10. DDPE Read Forward

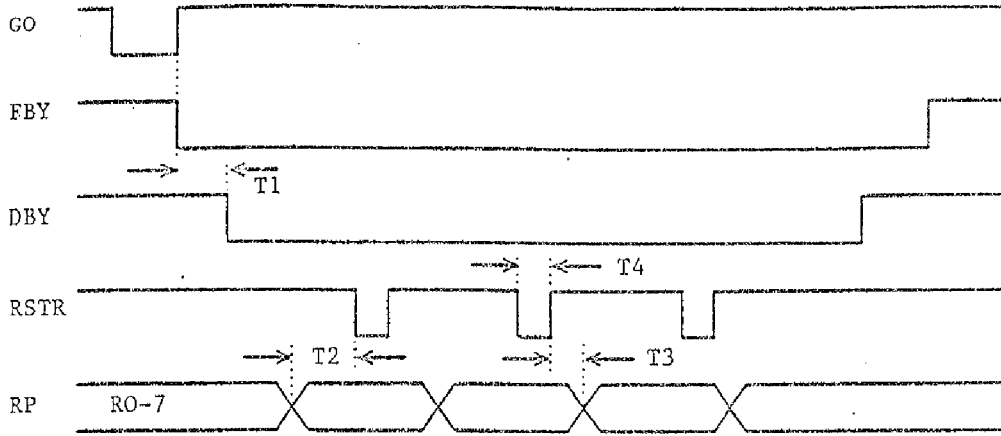

<u>Time</u>	<u>100ips start/Stop</u>	<u>100ips On the Fly</u>	<u>50ips Start/Stop</u>	<u>50ips On the Fly</u>
T1	<18.0 mS	<2.0 mS	<16.0 mS	<3.0 mS
T2	>500 nS	>500 nS	>1.0 uS	>1.0 uS
T3	>250 nS	>250 nS	>250 nS	>250 nS
T4	340 nS	340 nS	730 nS	730 nS

Figure 1-11. GCR Read Forward

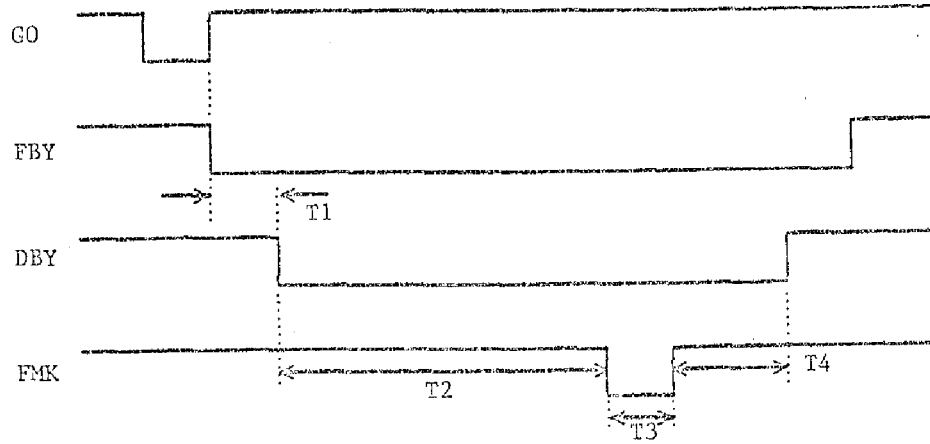

<u>Time</u>		<u>100ips Start/Stop</u>	<u>100ips On the Fly</u>	<u>50ips Start/Stop</u>	<u>50ips On the Fly</u>
T1		<54.0 mS	<40.0 mS	<80.0 mS	<80.0 mS
T2	*	1.8 mS	1.8 mS	3.6 mS	3.6 mS
T3		4.15 uS	4.15 uS	4.15 uS	4.15 uS
T4	*	53.0 uS	53.0 uS	53.0 uS	53.0 uS

* Nominal Values

Figure 1-12. NRZI Write File Mark

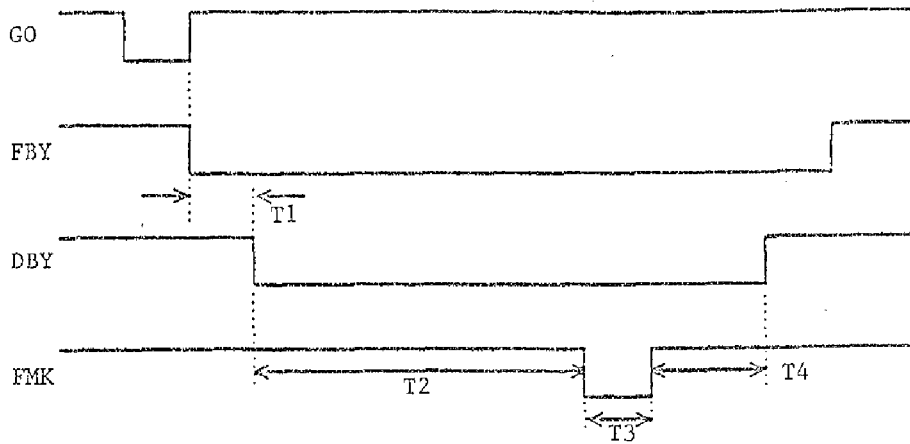

<u>Time</u>		<u>100ips Start/Stop</u>	<u>100ips On the Fly</u>	<u>50ips Start/Stop</u>	<u>50ips On the Fly</u>
T1		<54.0 mS	<40.0 mS	<80.0 mS	<80.0 mS
T2	*	1.8 mS	1.8 mS	3.6 mS	73.6 mS
T3		3.2 uS	3.2 uS	6.3 uS	6.3 uS
T4	*	220 uS	220 uS	220 uS	220 uS

* Nominal Values

Figure 1-13. PE Write File Mark

SECTION II
INSTALLATION/ADJUSTMENTS

INSTALLATION/ADJUSTMENTS

SECTION II - INSTALLATION AND OPERATION

2.0 INTRODUCTION

Section II describes unpacking, inspecting, installing, cabling, adjusting, and operating the Model 9610/9660 Tape Drive.

2.1 UNPACKING

WARNING

The Model 9610 Tape Drive weighs 110 pounds. Use safe lifting practices to remove the drive from the container.

The Model 9610 and 9660 Tape Drives are shipped cushioned by polyethylene foam supports in a heavy-weight cardboard container. Place the shipping container on a flat, horizontal, dry, non-slip surface. Carefully cut the binding straps, and remove the top lid. Remove the cardboard sides of the shipping container. The Drive can now be conveniently lifted from the shipping container. Set the Drive on a flat, horizontal surface. Save the following items: Slide Rails, AC Power Cord, 220/240-volt Fuse Kit, Hardware (two Shipping Retainer Brackets, Rack-Latch Angle Bracket, screws, etc.) and 9610/9660 Manual. Retain the shipping container, polyethylene wrap, and foam supports for possible future shipment.

Tape Drives shipped in racks may be held in place by the two Shipping Retainer Brackets mentioned above (Figure 2-1). These Brackets should be removed after the Rack is put in its final location at the installation site, and the Rack-Latch Angle Bracket (also mentioned above) must be installed in place of the left Retainer Bracket. This Bracket comprises the Catch (Figure 2-1) for the Retainer Latch located just inside the Front Panel.

2.2 INSPECTION

Inspect the drive for shipping damage such as scratches, dents, or cracks in the frame. On the Dust Cover (top of Drive), turn the two holding screws 1/4th turn counterclockwise and open the dust cover. With the Cover Support Bar (Figure 2-2), latch the Dust Cover in Maintenance Position. Check for loose or missing parts, and foreign material. Open the Tape Path Cover and verify that all parts/areas of the tape path are clean. Remove the PCBA Cover and verify that all PC Boards (Figure 2-4) are seated properly. Reinstall PCBA Cover.

2.3 CABLING AND DAISY CHAINING REQUIREMENTS

The user must provide Host-to-Drive interconnect cables. Up to eight Drives can be daisy chained, but combined cable length must not exceed 20 feet. Terminators U3, U4, and U11 must be removed from all Drive Formatter Boards except from the last Formatter Board on the daisy chain. To remove the Terminators:

1. Remove Top Cover at rear top of the Drive.
2. As applicable, disconnect two cables from the Formatter Board (Figure 2-4).
3. Grasp the PCB Ejectors firmly, and pull Ejectors toward the side of the unit. Board should pop partially out of the slot.
4. Locate Terminators U3, U4, and U11 (Figure 2-4), and remove them.
5. Replace the Formatter Board and Top Cover.

Recommended connectors and cables are as follows: - Daisy chains may optionally require a Cable Connector Adapter (See Figures 2-3 and 2-5).

<u>Item</u>	<u>Vendor</u>	<u>Part Number</u>	<u>Specifications</u>
Connectors:			50-pin, card edge
Adapter:	Kennedy	90-08018-001	50-pin, 3-port
Cables:			50-wire, 28-AWG, shielded/ flat/stranded/jacketed

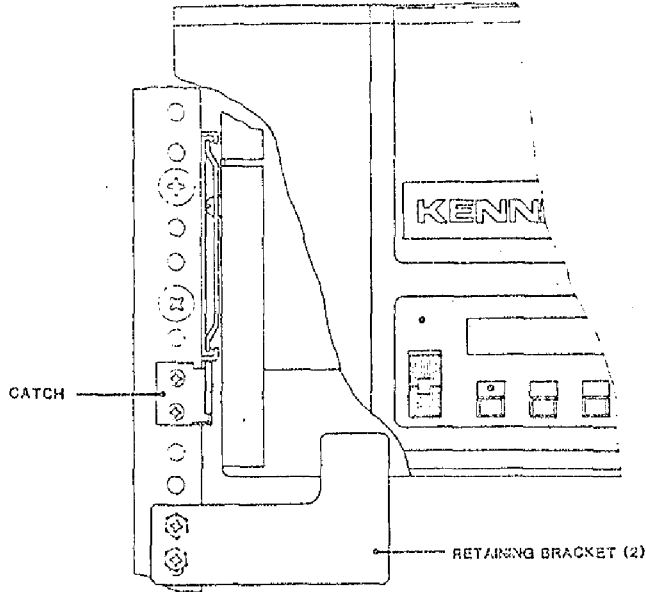

Figure 2-1. Shipping Retainer Bracket and Catch

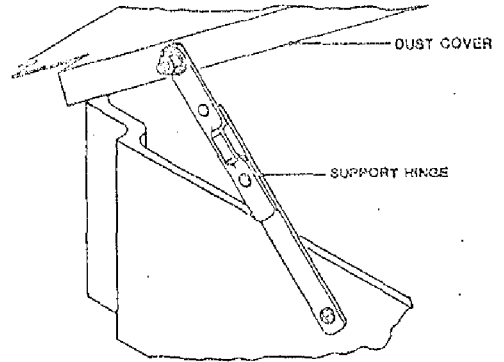

Figure 2-2. Dust Cover Support Bar

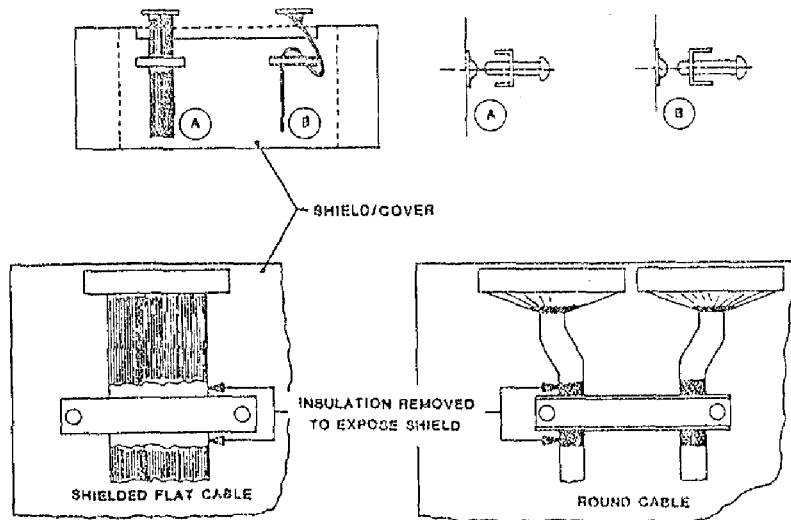

Figure 2-3. Grounding Cable Clamp Details

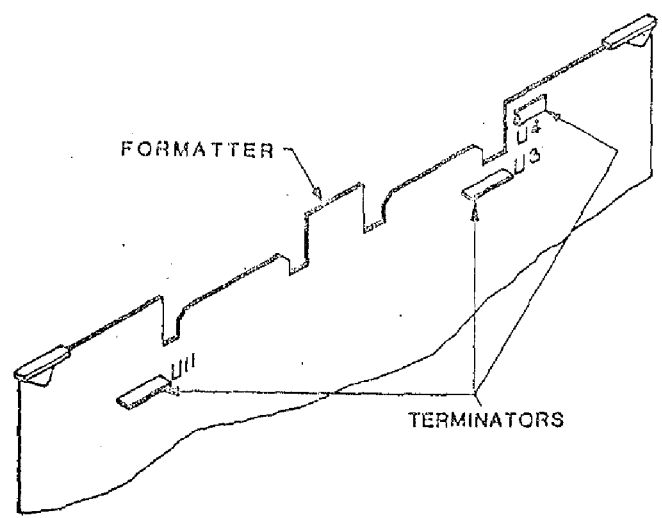
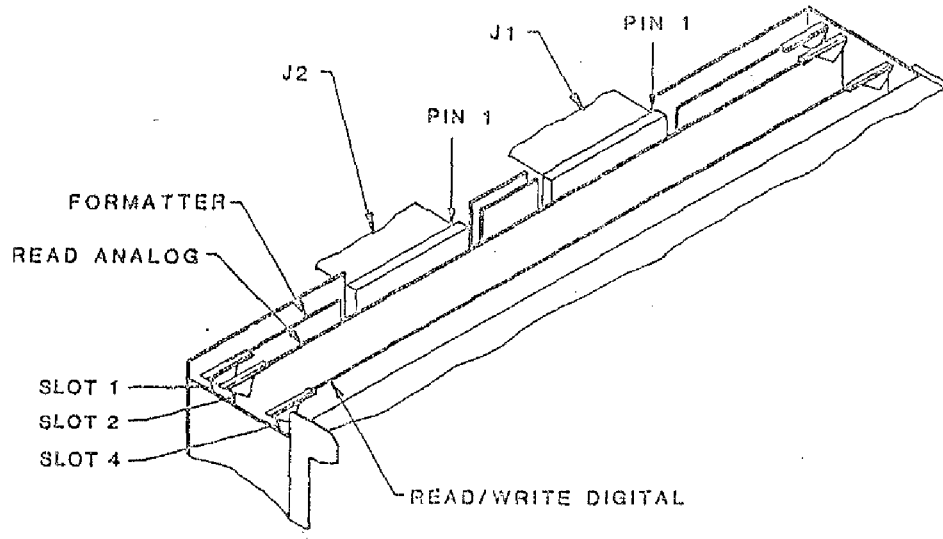
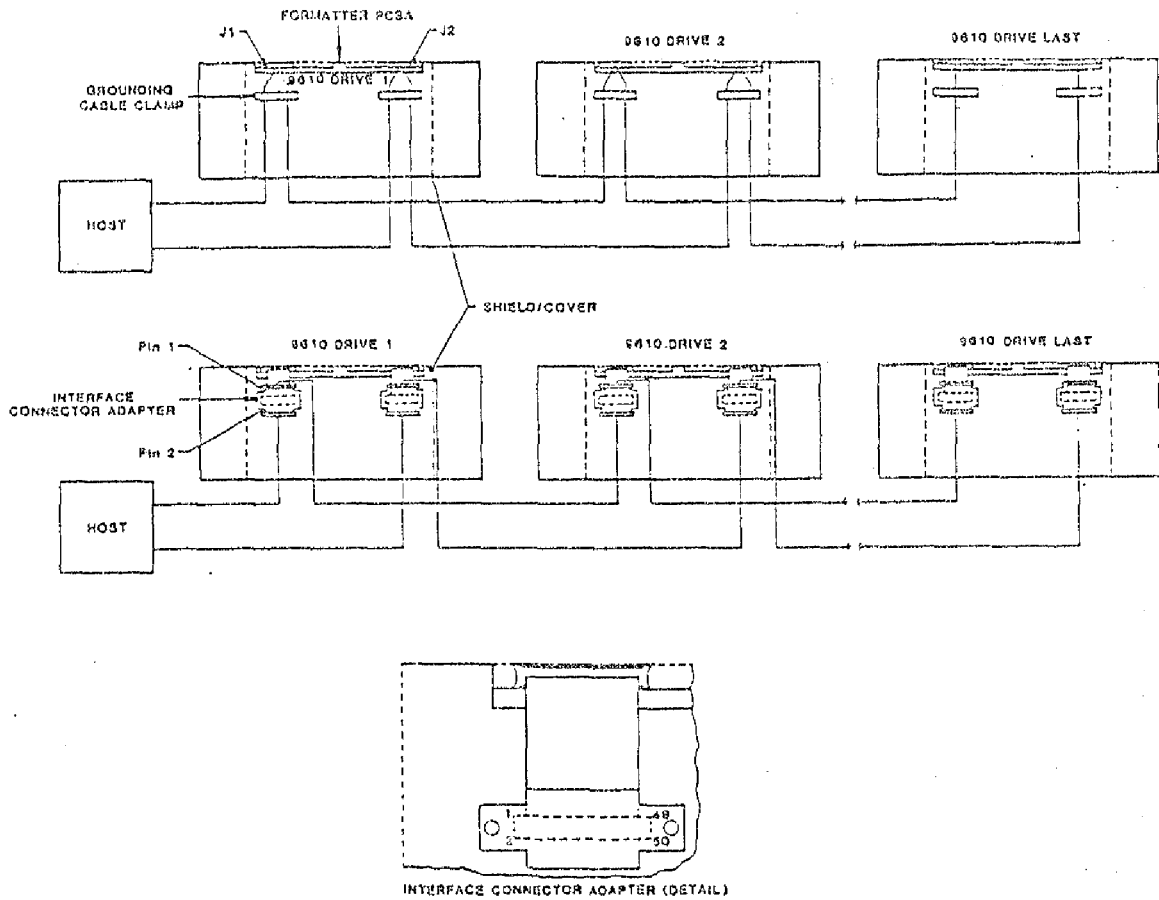

Figure 2-4. Card Cage, Cables, And Terminators



NOTE:

1. Terminators removed from all but last Drive.
2. Shielded Cables are required to meet FCC Regulations. Ground the shields as illustrated. For Interface Connector Adapter, remove some insulation from the cable and connect cable shield under an Adapter Mounting Screw.

Figure 2-5. Daisy Chaining

2.4 INSTALLATION

2.4.1 TABLE-TOP INSTALLATION

Place the Drive on a flat table top with dimensions to accommodate the Drive (Figure 2-6), of sufficient strength to support the weight of the Drive, and allow sufficient clearance for maintenance access. Do Steps E and F in paragraph 2.4.2.2.

2.4.2 RACK-MOUNT INSTALLATION

Mount the Tape Drive (Figure 2-7) in a standard EIA/RETMA 19-inch Rack allowing at least 8-3/4 inches vertical space. Install The Rack-Mount Rail Assembly supplied with the Drive as described in the following subparagraph 2.4.2.1.

2.4.2.1 RAIL ASSEMBLY COMPONENT CHECKOUT

The Rack-Mount Rail Assembly consists of two left/right interchangeable Track Subassemblies. Each consists of the following items:

ITEM	Outer/Center Track Assembly	ITEM	Outer/Center Track Assembly
1	Center Track	5	One Adjustable Mounting Bracket
2	Outer Track	6	Three Nut Plates
3	Fixed Mounting Bracket	7	Six 10-32 by 1/2-inch Panhead Screws
4	One Chassis Rail	8	Retention Latch Bracket

Note: The standard Rack-Mount Rail Assembly has rails that fit cabinets up to 24 inches deep. For deeper cabinets, use Slide Extender P/N 28-00352-101.

Order from Kennedy Co. Spare Parts Order Department, 9292 Jeronimo Rd., Irvine, CA 92718. Tel: (714) 770-1100.

2.4.2.2 MOUNTING PROCEDURE

- A. Install one of the Track Assemblies (Figure 2-8) on either side of the 19-inch Rack as follows:
 1. Using the 10-32 Slotted Screws (7) and Nut Plates (6)* provided, loosely assemble an Adjustable Mounting Bracket (5) to the rear of the Right Track Assembly.

*Nut Plates not required for Racks with threaded mounting holes.
 2. Measure upward 2 inches from the bottom of the Rack opening allotted for the Drive, and mark the Rack at that point.
 3. Aligning the bottom of the Fixed Mounting Bracket (3) at the 2-inch mark on the front of the 19-inch Rack, and using the 10-32 Screws (7) provided, mount the Fixed Mounting Bracket (3) to the front of the 19-inch Rack, and mount the Adjustable Mounting Bracket (5) (loosely attached to the rear of the Center Track) to corresponding holes in the the rear of the 19-inch Rack. Level the Track and tighten all Screws.
 4. Repeat Steps 1 through 3 for mounting the other Track Assembly.
- B. Inspect all work and check that all screws are tight.
- C. Remove power cable from the Drive Chassis.
- D. With a minimum of two persons, one on each side of the Drive, lift and guide the Chassis Rails onto the Left and Right Center Tracks. Verifying that the rails are correctly aligned, push the Drive into the Rack.

2.5 POWER UP AND INITIAL CHECKOUT

2.5.1 AC LINE VOLTAGE (100-, 120-, 220-, or 240-Volt Operation)

The Drive is normally factory-set for 120-volt operation. Other voltage choices can be 100, 220, or 240. Locate the Power-In Assembly (Figure 2-9) at the rear of the unit (Figure 2-6). The Voltage Selector Card behind the plastic slide cover is installed with "120" legible. This indicates that the Drive is set for 120-volt operation. The following subparagraph describes changing this setting as necessary.

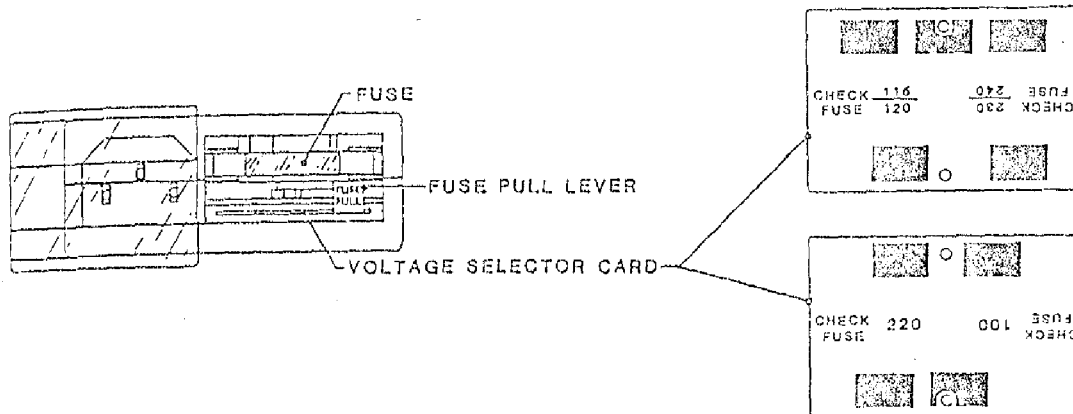

Figure 2-9. Power-In Assembly

Changing Operating Voltage:

Assuming that the Voltage Selector Card setting is other than the site voltage, proceed as follows:

- A. Remove the AC power cord (if installed) from the Power-In Assembly (Figure 2-9).
- B. Slide the plastic Fuse Cover to the left.
- C. Rotate the "FUSE PULL" lever to the left, and remove the fuse (if fuse is incorrect size).
- D. Using long nose pliers, remove the Voltage Selector Card.
- E. Position the Voltage Selector Card at the entrance to the card slot so that the correct voltage (100, 120, 220, or 240) is legible (facing upward), and install the Voltage Selector Card into the Power-In Assembly.
- F. Install the proper-size fuse (supplied: 3-amp slo-blo for 220/240-Volt; 6-amp slo-blo for 100/120-Volt).
- G. Slide the plastic Fuse Cover to the right.
- H. Install (as applicable) an appropriate power plug on the source end of the power cord.
- I. Reconnect the power cord to the Power-In Assembly and plug the other end of the power cord into an appropriate AC outlet.

2.5.3.3 CHECKOUT CONTINUED

Having loaded tape per 2.5.3.1 above:

- A. Depress ON-LINE. ON-LINE LED lights; the Readout continues to display "UNIT X". When the Drive is selected, the SELECT LED lights.
- B. Depress ON-LINE. ON-LINE LED goes out.
- F. Depress DIAG. DIAG LED lights and the Readout displays "DIAG".
- C. Depress ENTER. Readout displays "SELFTTEST".
- D. Repeatedly press SCAN and verify that the Readout displays, in turn, the following: "SELFTTEST, MOTION, DRV ADJ, SET UP, CAL, DATADIAG, SELFTTEST, MOTION."
- E. With "MOTION" displayed, press ENTER. Readout displays "50 FWD" (50 ips Forward).
- F. Repeatedly press SCAN and verify that each time SCAN is pressed the Readout displays as indicated in Table 2-1 beginning with Step 2, then to Step 1 and repeating the sequence.
- G. Repeatedly press SCAN until Readout displays "100 FWD".
- H. Press ENTER. Tape moves forward at 100 ips, the LOAD PT LED goes out, and the DIAG LED blinks. Let Drive run to the End of Tape (EOT). Readout displays "EOT".

Table 2-1. Motion Control Sequence

STEP	DISPLAY			MOTION
	NORMAL *	AT EOT	AT BOT	
1	50 FWD	EOT		50 ips Forward
2	50 REV		BOT	50 ips Reverse
3	50 FSS	EOT		50 ips Forward Start/Stop
4	50 RSS		BOT	50 ips Reverse Start/Stop
5	50 FRF	EOT	BOT	50 ips Forward/Reverse/Forward
6	100 FWD	EOT		100 ips Forward
7	100 REV		BOT	100 ips Reverse
8	100 FSS	EOT		100 ips Forward/Start/Stop
9	100 RSS		BOT	100 ips Reverse/Start/Stop
10	100 FRF	EOT	BOT	100 ips Forward/Reverse/Forward
11	50/100 F	EOT		50 ips / 100 ips Forward
12	50/100 R		BOT	50 ips / 100 ips Reverse
13	BURN IN			50 ips / 100 ips /50 ips (Forward)/ Auto Rewind/...(Repeat) etc.

*NOTE: Normal display is defined as any display when the tape is neither at BOT or EOT

- I. Scan through the entire menu. In the step for any Forward Motion Command, such as Step 1 (50 FWD), Step 3 (50 FSS), Step 5 (50 FRF), etc., the Display reads "EOT".
- J. Depress SCAN. Readout displays "100 REV".
- K. Depress ENTER. Tape runs at 100 ips in reverse. Let Drive run to the Beginning of Tape (BOT). Readout displays "BOT".
- L. Scan through the entire menu. In the step for any Reverse Motion Command, such as Step 2 (50 REV), Step 4 (50 RSS), etc., the Display reads "BOT" and the Command cannot be entered.
- M. Repeatedly depress DIAG until DIAG LED goes out and Readout displays "UNIT X".
- N. Depress RWND/UNL. Tape rewinds to the supply reel, and Readout displays "UNLDNG" until tape is unloaded (stops motion), then the readout displays "UNIT X".
- O. Open the Tape Access Door, remove the tape, and turn off power.
- P. Run DATATEST in Checkout procedure to verify Write/Read performance.

2.5.3.4 MOTION TEST SUMMARY

All Motion Tests, with the exception of Burn In, automatically stop at either BOT (Reverse Tests) or EOT (Forward Tests). Burn In consists of a 100/50/100 ips forward sequence until EOT is reached. At EOT, the Drive automatically rewinds tape to BOT at 200 ips. At BOT, the Drive repeats the 100/50/100 ips sequence and continues to repeat until the operator intervenes. All Motion Tests, including Burn In, may be stopped by depressing START/STOP, except when rewinding.

2.5.4 UNIT SELECTION

The Drive is factory-set for Unit Address 0. In daisy-chained systems, set the Unit Address for each Drive (other than Drive 0) as follows:

- A. Turn AC power ON.
- . In turn, depress DIAG, ENTER, SCAN, SCAN, SCAN. Readout displays in sequence: "DIAG", "SELFTEST", "MOTION", "DRV ADJ", SET UP".
- C. Depress ENTER. Drive enters SET UP Mode; Readout displays "UNIT NUM"
- D. Depress ENTER. Readout displays "UNIT X".
- E. Repeatedly depress SCAN until the Readout displays the desired Unit Number.
- F. Depress ENTER. Readout displays "LOAD?".
- G. Depress LOAD to save new Unit Number. Drive displays "DENS SEL" (the next parameter).
- H. The Drive will now respond to the new Unit Number (address) sent from the Host.
- I. Depress DIAG twice to return the Drive to Off Line status. The Readout displays the new Unit Number.

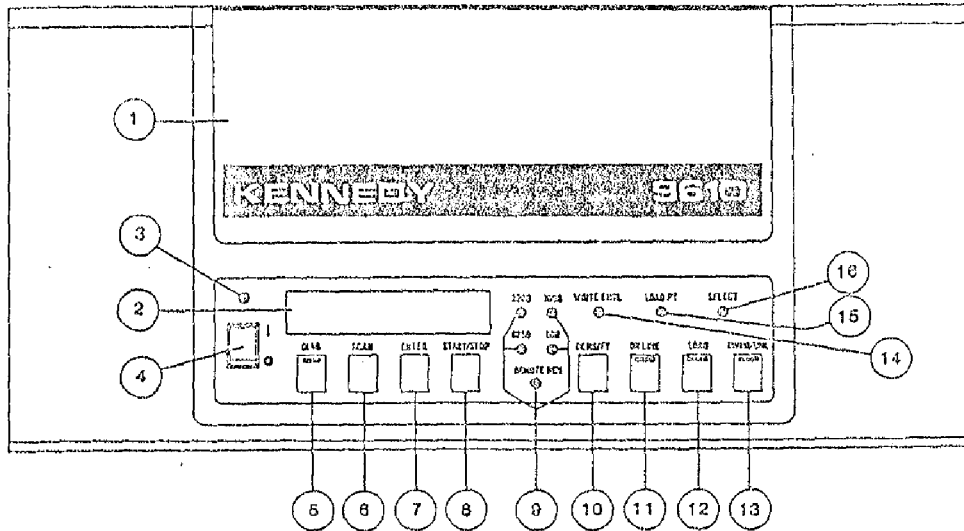

- (1) **Tape Access Door** - Supply Hub Access (Ref).
- (2) **Character Display Readout** - Displays operating mode, status, parameters, and diagnostic messages.
- (3) **Unmarked LED** - Lights when AC power is applied to Drive.
- (4) **ON/OFF Switch** - Controls AC power to Drive.
- (5) **DIAG Pushbutton** - Turns diagnostics ON and OFF when Drive is off-line. Internal LED lights when in the diagnostics mode.
- (6) **SCAN Pushbutton** - Scans diagnostics and calibrate menus.
- (7) **ENTER Pushbutton** - Enters selected commands when in diagnostics or calibrate mode.
- (8) **START/STOP Pushbutton** - Starts or stops selected commands in the diagnostics or calibrate mode.
- (9) **REMOTE DEN LED** - Lights when density is selectable by Host.
800/1600/3200/6250 LEDs - Indicates selected density.
- (10) **DENSITY Pushbutton** - Selects data density (800, 1600, 3200, or 6250) and REMOTE.
- (11) **ON-LINE Pushbutton** - Puts unit online or take unit offline. Lights when Drive is On-line.
- (12) **LOAD Pushbutton** - Initiates Load sequence. Lights when drive is loaded.
- (13) **RWND/UNL Pushbutton** - Initiates Rewind or Unload when Drive is Off-line.
- (14) **WRITE ENBL LED** - Lights when supply reel is not write protected.
- (15) **LOAD PT LED** - Lights when tape is at Load Point.
- (16) **SELECT LED** - Lights when Drive is selected by the Host.

Figure 2-10. Panel Controls and Indicators

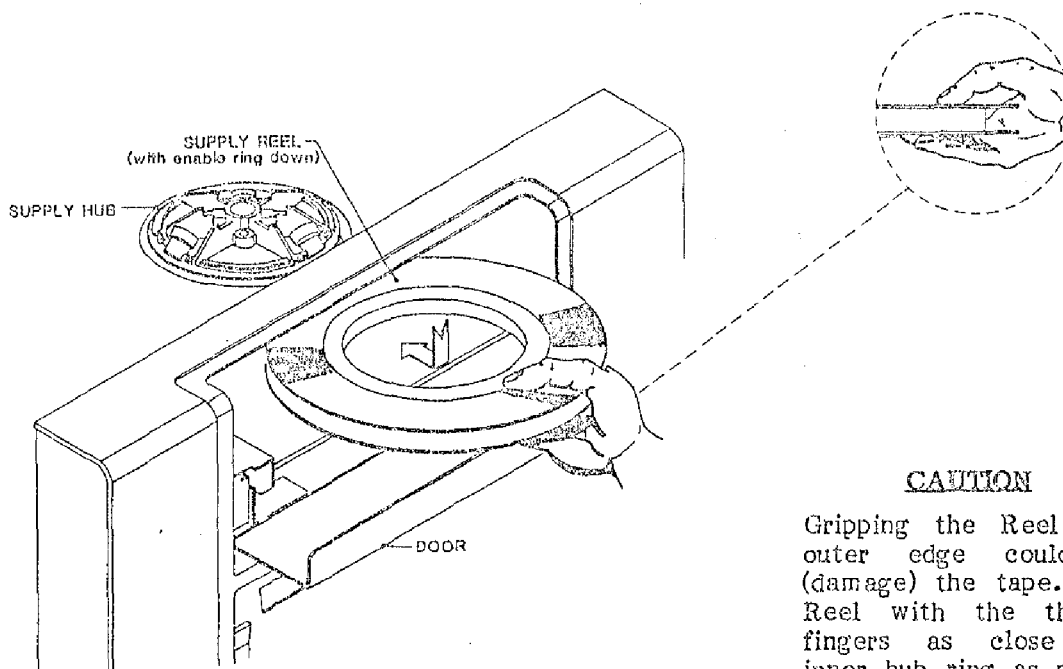
**CAUTION**

Gripping the Reel near its outer edge could distort (damage) the tape. Grip the Reel with the thumb and fingers as close to the inner hub ring as possible.

Figure 2-11. Installing Supply Reel

2.5.5 DATA DENSITY - INTRODUCTION

The Model 9610/9660 can operate at 800 CPI density in Nonreturn-to-Zero (NRZI) format, at 1600 CPI density in Phase-Encoded (PE) format, at 3200 CPI Density in Double Density PE (DDPE) format, and at 6250 CPI in Group Coded Recording (GCR) format. When powered up, the Drive automatically defaults* to 6250 REMOTE, in which the Host controls density selection for Write Operations.** The operator can override the defaulted operating density by operating the Front Panel DENSITY Switch as described under A below:

* Default Density is factory-set, but can be changed as described below under C. Changing Default Density.

**In Remote Density Mode, the Host controls Density by Command issued at BOT only; but when reading tape, the Drive automatically selects the density of the tape currently loaded.

A. Changing Operating Density:

1. If tape is loaded, rewind tape to BOT and set the Drive to off-line. The Readout displays UNIT X and the current operating density and mode on the density LEDs and the Remote Led. The Drive is in Remote PE Mode.

2. Repeatedly, as necessary, press DENSITY. The Indicators will light in the following sequence, putting the Drive in the corresponding Density Mode. Leave the Drive in the desired Mode.

Mode	LEDs Lit		Mode	LEDs Lit	
	Dens	Control		Dens	Control
a. Local NRZI	800		e. Local DDPE	3200	
b. Remote NRZI	800	REMOTE DEN	f. Remote DDPE	3200	REMOTE DEN
c. Local PE	1600		g. Local GCR	6250	
d. Remote PE	1600	REMOTE DEN	h. Remote GCR	6250	REMOTE DEN

NOTE: If the drive is configured to operate in REMOTE density only the local selections will be skipped.

B. Operation:

1. In Read operations, if the Drive is in Remote Mode, the Drive reads automatically in the density in which the tape was written.
2. In Write operations, the Drive writes in the density indicated by the Density LEDs.

C. Changing Default Density:

1. Enter diagnostics mode by pressing the DIAG button. The readout will display DIAG and the LED in the DIAG button will illuminate. Press the ENTER key to enter diagnostics mode.
2. Press the SCAN button 3 times. The readout will display, in sequence: "SELFTEST, MOTION, DRV ADJ, SET UP".
3. Press the ENTER button to enter set-up mode. The readout will display "UNIT NUM".
4. Press the SCAN key once. The readout will display "DENS SEL".
5. Press the ENTER button. The readout will display "NORMAL" indicating the drive will allow execution local density mode. If operation in remote mode only is desired, press the SCAN button and the readout will show "REM ONLY". When the desired option is shown, press the ENTER button to select it.
6. The readout will display "LOAD?". Press the LOAD button to save the selected option.
7. The readout will then display "DFLT DEN". Press the ENTER button to select the default density. The readout will display "6250 REM" (the factory set default density).
8. Repeatedly press SCAN until the desired default density is displayed. The sequence of displays is:

a. 800	c. 1600	e. 3200	g. 6250
b. 800 REM	d. 1600 REM	f. 3200 REM	h. 6250 REM
9. When the desired default density is selected press ENTER. The readout will display "LOAD?". Press the LOAD button to save the selection.
10. Press the DIAG button repeatedly until the LED in the DIAG button turns off to exit diagnostics mode.

2.6 OPERATING INSTRUCTIONS

2.6.1 OPERATING PROCEDURE

- A. Turn Power On. Readout displays "TESTING" and if the Drive passes all tests, the Readout displays "UNIT X". Fault Conditions that could occur during Power Up, and possible related failures, are listed and described in Section III.
- B. Place Tape Reel on Reel Hub with Write Enable Ring facing downward.
- C. Depress LOAD*. The Readout displays "LOADING" and the Drive automatically loads tape. When loading is successful, the Readout displays "UNIT X" and the WRITE ENBL, LOAD POINT, and LOAD LEDs light. If loading is unsuccessful, the Readout displays a diagnostic message such as: CHK HUB, ABORTED, REV REEL, etc, or a Failure Code, and the RWND/UNL LED flashes.

*Or Host can send a Load On-Line Command (LOL) to start Load.

If loading is unsuccessful, correct the condition indicated by the Failure Code Readout per Section IV, and depress LOAD to reattempt the load operation.

- D. Depress ON-LINE. ON-LINE LED lights and the Readout continues to display the Unit Number.
- E. The Tape Drive is now ready to accept commands from the Host. The Drive can be taken Off-line manually by the operator pressing ON-LINE or by the Host issuing an Off-Line Command.

2.6.2 OPERATION NOTES

A. On-line Operations:

When the Drive is on line, the Readout displays the Unit Number whether or not the Drive is selected.

B. Load Operations:

1. If the Drive is unable to Load, the Readout will display a diagnostic message such as: "CHK HUB", "ABORTED", "REV REEL" etc., and the RWND/UNL LED will flash.
 - a. Pressing LOAD will start another Load attempt.
 - b. Pressing RWND/UNL will clear flashing LED and Error Message.
 - c. If nothing is done, after one minute, the Drive displays "UNIT X".
 - d. See NOTE under paragraph 2.5.3.1, Step C.
2. Pressing RWND/UNL while the Drive is Loading, aborts the Load Sequence.

C. Rewind Operations:

1. If the Drive is off line, pressing RWND/UNLD once causes the Drive to rewind tape to BOT.
2. If the Drive is off line, pressing RWND/UNL while the Drive is rewinding, or while positioned at BOT, will initiate an Unload Operation after the Drive has completed Rewind.

D. Recovering From Tape Running Off Reel:

The Drive has a built-in feature to prevent tape runaway: If a block of data is not encountered within 25 feet of tape motion before EOT, or 5 feet of tape motion after EOT, the Drive will normally stop tape motion. However, the 25-foot/5-foot limit feature can be defeated in the Setup Mode, or by continued Read Commands being received from the Host after EOT has been passed. Either of these conditions could result in tape being run completely off the Supply Reel. The following procedure is recommended to recover from this predicament.

1. The display will read **TAPE END** and the **RWND/UNL** LED will be flashing. Press the **RWND/UNL** switch and wait for the arms to retract.
2. Manually thread tape backwards through the tape path from the Take-up Reel to the Supply Reel. Refer to Figure 2-12.
2. Wrap tape around the Supply Reel in a counterclockwise direction.
3. Manually rotate the Supply Reel counterclockwise until the EOT Tab is on the Supply Reel.
4. Press **LOAD**. Tension Arms will tension tape and tape will rewind back to Load Point.

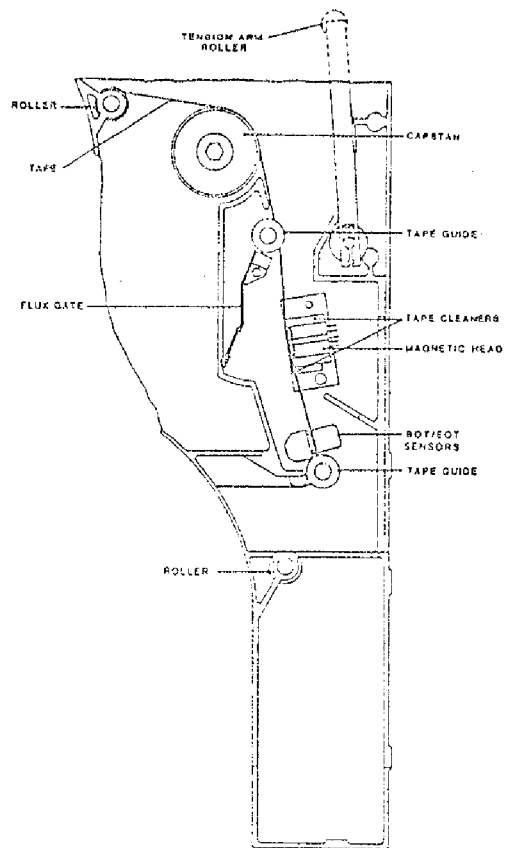

Figure 2-12. Tape Threading

E. Manually Locking/Unlocking Supply Reel on Supply Reel Hub:

The Supply Reel Hub normally automatically locks the Supply Reel in place during the loading sequence. However, the Supply Reel can be manually locked in place using the Manual Reel Locking Lever located just inside the Tape Access Door (illustrated in Section VI, Figure 6-1).

To manually install (lock) a Supply Reel onto the Hub:

1. Open the Tape Access Door and the Top Cover of the Drive.
2. Place a Supply Reel onto the Supply Reel Hub.
3. Press the Manual Reel Locking Lever inward (toward the rear of the Drive) while slowly turning the Supply Reel and Hub clockwise until the Reel Locking Fingers of the Hub extend outward and lock the Reel in place.

To manually release the Supply Reel from the Hub:

1. Press the Manual Reel Locking Lever inward while slowly turning the Supply Reel and Hub counterclockwise until the Reel Locking Fingers of the Hub retract and release the Supply Reel.

SECTION III
FUNCTIONAL DESCRIPTION

FUNCTIONAL DESCRIPTION

SECTION III

FUNCTIONAL DESCRIPTION

3.0 GENERAL

This section describes general operation of the major components of the 9610/9660 Drive.

3.1 SYSTEM DESCRIPTION

3.1.1 OVERVIEW

The 9610/9660 Drive is organized around a Motherboard mounted flat in the bottom of the chassis at the rear of the unit. The Motherboard interconnects the four major circuit cards: The Formatter Board, Read Analog Board, and Read/Write Digital Board, which slide into a card cage accessible at the rear of the unit, and the Drive Electronics Board, which mounts flat in the chassis underneath the deck plate.

The Servo Amplifier Assembly is located on the chassis under the deck plate, adjacent to the Power Supply Assembly and the Drive Electronics Board. The Position Sensors Board and the Interconnect Board mount directly to the Deck Plate, and the Read Preamp Board is connected directly to the Read Head on the Deck Plate. The Operator Control Panel is located on the front of the Drive.

3.1.2 FORMATTER BOARD

Along the top edge of the Formatter Board, there are two 50-pin card edge connectors. Cables which attach to these connectors convey Commands, Data, and Status Information between the Drive and the Host. Connector signals and pin assignments are defined by Industry Interface Standard.

The Host Interface includes buffers and line receivers to interface with the host, decoders to accomplish unit selection, and a latch to hold command bytes.

Read/Write Compare Buffer: The Read/Write Compare Buffer is a 1k byte RAM memory with address counters to configure it as a circular data file. This Buffer accomplishes a byte-by-byte data comparison of Write and Read Data during Read-After-Write Operations.

The Read/Write Compare Buffer momentarily stores Host Write Data that is currently being written to tape. The Drive, performing a Read After Write Operation, immediately reads the written data and sends it back to the Compare Buffer where it is compared with the stored Write Data. A favorable comparison allows the Drive to continue writing Data to tape. A comparison error is reported to the Host on the HER Status Lines along with Read data on the Read Data Lines.

The Buffer also serves during Data Diagnostics Operations as a data source for the Write Process, and evaluates the success of the Read Process.

Formatter Control Processor: The Formatter Control Processor is a micro-computer and its associated support devices. This device receives Commands from the Host Interface and schedules them for execution, sending them to the other functional units of the Drive via the Bus Interface and Formatter Control Bus.

The Formatter Control Processor tracks tape position by monitoring Counters in the Tachometer Interface that increment or decrement with the arrival of Tachometer Pulses from the Capstan Tachometer.

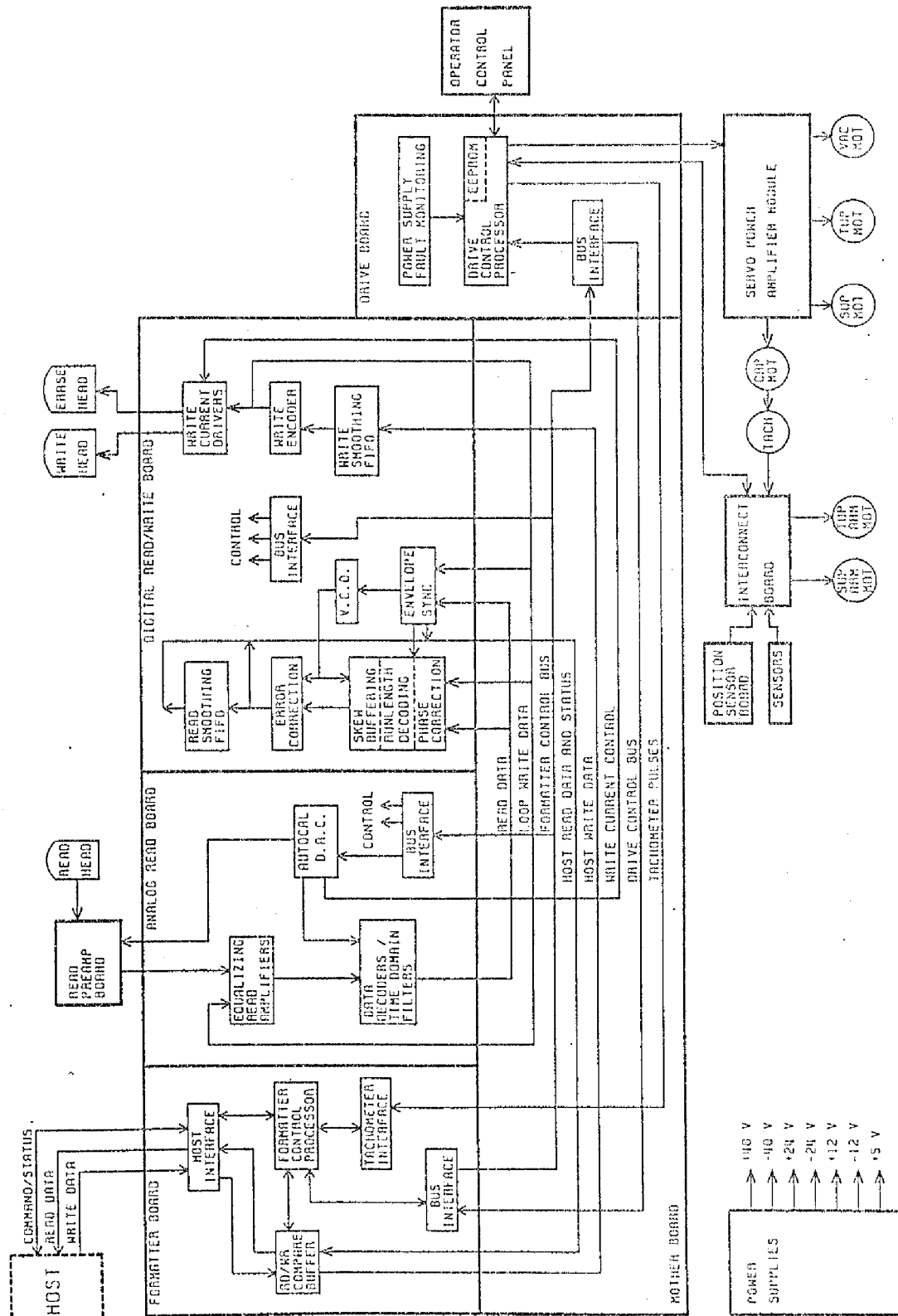

Figure 3-1. Model 9610/9660 Tape Drive General Block Diagram

Formatter Control Bus: The Formatter Control Bus consists of the 8-line Formatter Data Bus (FDB), the 7-line Formatter Select Bus (FSEL), and 5 handshaking lines. The Formatter Control Bus conveys Commands and Status to all major components of the Drive. The status of the Select lines determine distribution of Control and Status signals. The destination module signals acceptance or rejection of Control Signals by issuing an Acknowledge or Busy Signal.

The Formatter Control Bus also conveys all commands initiated by the Drive or Operator Control Panel to the Formatter to completely control the Read and Write Sections of the Drive. Note that the Formatter communicates with the Operator Control Panel via the Drive Electronics Board.

3.1.3 READ PREAMP BOARD

The Read Preamp Board contains a high-gain, low-noise preamplifier with electronic gain control, for each of the nine channels. For excellent noise performance, it is located very close to the magnetic Read Head. The Preamp connects to the Read Analog Board through a ribbon cable that passes under the deck plate.

3.1.4 READ ANALOG BOARD

Signals from the Read Preamp are processed by the Equalizing Read Amplifiers, which include CMOS switches that select the optimum equalization network for each speed and density.

Data Decoders: After equalization, the Read Signal is processed in the Data Decoders that include a time domain filter, which rejects any transitions which are too close together in time. This improves noise margins. The Data Decoders also verify threshold, squelching the Read Data if its amplitude falls below the threshold for several cell periods.

Digital-to-Analog Converter (DAC): The DAC is a multiplexed 8-bit digital-to-analog convertor with a small RAM used to hold digital calibration values. The DAC generates Gain control signals for the Read Preamp, and threshold values for the data detectors. Settings for the DAC come from the Control Processor in the Formatter Board via the Formatter Data Bus. These settings are written to the Read Analog Board at Power Up or can be entered manually from the Front Panel.

The DAC also generates values that control Write Current generated by Write Current Drivers in the Read/Write Digital Board)

3.1.5 READ/WRITE DIGITAL BOARD

The Read/Write Digital Board Decodes Read Data, encodes Write Data, and performs Error Correction as required.

Envelope Synchronization: Read Data from the Data Decoders in the Read Analog Board are applied to the envelope/synchronization circuit where file marks and other special blocks are recognized, and envelopes (signal-presence) are provided for the Processor in the Formatter Board to use during Calibration.

Voltage Controlled Oscillator (VCO): At the beginning of each data block, the Envelope Synchronization provides a series of sync signals which control the Voltage Controlled Oscillator (VCO) in a Phase-Lock-Loop (PLL) Synchronization Acquisition Process. Based on available envelope information, the Envelope Synchronization selects one data track to use for synchronizing the Phase Lock Loop.

The PLL is a feedback system which maintains the Voltage-Controlled Oscillator as an internal clock in synchronization with the arriving data stream. If the data stream speeds up or slows down because of variations in tape speed, the VCO also change its frequency to maintain synchronization with the data. During the Interblock Gap, the PLL is synchronized to a crystal controlled clock known as the Gapclock.

Phase Correction: One VCO controls the decoding process for all 9 tracks. However, individual tracks may vary slightly in phase due to a phenomenon known as "dynamic skew." To correct for this problem, each track is provided with a phase-corrector circuit, which is a first-order digital phase-lock loop of very low bandwidth, synchronized with the VCO. The phase correctors also provide additional rejection for low-rate changes in tape speed.

Runlength Decoding: For the GCR code, five bits of Read Data must be decoded to every four bits of Write data; for the PE codes, the data transitions must be separated from the phase transitions. Also, the special control characters marking the beginning and end of each block must be recognized. These requirements are accomplished by the Runlength Decoding Circuitry.

Skew Buffering: Data from the various tracks may arrive from the Read Head at different times. The resulting skew may be as much as several character times. To bring the data from the nine tracks into correct time phase, each track is provided with a First-In, First-Out (FIFO) buffer. Track Data flows into the FIFO Buffers asynchronously, and flows out from the FIFOs synchronously and in parallel.

Error Correction: Using GCR format (and, to a limited extent, the PE format), data lost to tape defects may be restored during the decoding process. Error Correction, using redundant data bytes which were placed on the tape during the record process, reconstructs missing or corrupted data. The GCR format includes two redundant bytes for every seven bytes, making it possible to recover up to two tracks with dropout-caused errors. The Drive can recover one bad track of PE formatted data. The GCR and NRZI formats also include redundant checksum bytes, which may be used to verify that the data has been received correctly.

Read Smoothing FIFO: From Error Correction, Read Data flows through a small transfer rate matching FIFO, from where it is multiplexed with Status and Envelope information and sent through the Motherboard, to the Formatter Board.

Write Processing: The Read/Write Digital Board includes the Write Data Processing System. Write Data from the Read/Write Compare Buffer in the Formatter Board is applied to the Write Smoothing FIFO, from where it is applied to the Write Encoder. The Write Encoder prepares the Write Data for application to the Write Current Drivers, and generates the File Mark and special blocks, for all densities. The encoded Write Data may also be passed to the Phase Correction and Envelope Synchronization Circuitry, or directly to the Equalizing Read Amplifiers in the Read Analog Board, for diagnostic purposes. The Write Current Drivers consist of discrete transistor current sources, which apply Write Data or Erase Power to Write Head or Erase Head.

3.1.6 DRIVE ELECTRONICS BOARD

The Drive Electronics Board controls all electro-mechanical tape handling devices in the unit, including the Capstan, Supply and Take-up Reel Motors, the Servo Systems, the Take-up and Supply Buffer Arms, and the Autoload Mechanisms, including the Vacuum Blower, Supply Reel Hub Locking Mechanism, and various monitoring sensors. The Drive Electronics Board also interfaces between the Operator Control Panel and the Motherboard.

Drive Control Processor: To control the above-mentioned devices, the Drive Electronics Board includes the Drive Control Processor, which is a microcomputer with its support circuits, and an EEPROM for non-volatile data storage.

The Drive Control Processor receives commands from the Formatter via the Formatter Control Bus, and sends commands and data to the Formatter via the Drive Control Bus. The Drive Control Bus is a unidirectional bus consisting of 8 data lines, one strobe line, and two select lines.

The Drive Electronics Board includes circuitry to monitor the Tachometer and establish the correct tape speed, and the Power Supply Fault Monitor to gracefully shut down the Tape Transport if a fault occurs.

3.1.7 SERVO POWER AMPLIFIER

The Servo Power Amplifier consists of three sets of Power Drivers that drive the Supply Reel Motor, Take-up Reel Motor and Capstan Motor. A balancing circuit interacts between the positive and negative power sources, restoring any imbalances that occur by the operation of the three Power Drivers. When enabled by the Drive Control Processor, the feedback loops in the Reel Motor Servo cause the tape reels to move so as to maintain the Tape Buffer Arms in their linear operating region, regardless of tape motion caused by the Capstan. Meanwhile, the Capstan Motor Servo maintains tape speed at any value requested by the Drive Control Processor.

3.1.3 OPERATOR CONTROL PANEL

The Operator Control Panel includes an alphanumeric display that conveys status messages, control and diagnostics options to the operator. The Control Panel also includes an array of switches and LED indicators to operate the unit.

3.1.9 INTERCONNECT BOARD

The interconnect board consolidates wiring that connects the Drive Electronics Board to the various sensors, motors and solenoids mounted on the Deck Plate.

3.1.10 POSITION SENSORS BOARD

The Position Sensors Board monitors capacitive sensors mounted on the shafts of the Supply and Take-up Arms. These sensors are automatically calibrated each time power is turned on.

3.1.11 POWER SUPPLIES

The Power Supplies are mounted on the chassis under the Deckplate. Unregulated +/-40 Volt and +/-24 Volt Supplies apply power to the servos, and a switching 5-Volt Regulator supplies logic power for the Drive. Power supply fault monitoring is provided on the Drive Electronics Board.

**SECTION IV
DIAGNOSTICS**

SECTION IV DIAGNOSTICS

4.0 GENERAL

The Model 9610/9660 Tape Drive incorporates extensive built-in Self-Test and Front-Panel Diagnostics providing tests for maintenance and troubleshooting aids. Self-Test Diagnostics occur automatically during Power Up, displaying appropriate failure codes if failure occurs. Front Panel Diagnostics are manually-controlled operations that exercise the Tape Drive, displaying appropriate readouts to indicate Drive condition.

4.1 CONTROLS AND INDICATORS

Controls and Indicators used in Diagnostics and Calibration Modes are listed and described in Section II, Figure 2-10.

4.2 TROUBLESHOOTING

Troubleshooting the Tape Drive consists of using diagnostics, and self-tests to diagnose mechanical, electromechanical, and electronic malfunctions.

Diagnostics include firmware-controlled tests and exercises that can be initiated by the Operator from the Drive Front Panel. The Digital Display on the Front Panel provides diagnostic readouts.

Self-Tests occur with each Power Up, or can be manually initiated using the Diagnostics Menu. Self-Tests include failure codes and diagnostic readouts on the Front Panel Digital Display.

4.2.1 ACCESSING THE DRIVE FOR TROUBLESHOOTING

CAUTION: A solidly grounded ESD Wrist Strap should be worn whenever touching or handling any Circuit Board or other electronic assembly in the Drive.

WARNING: Dangerous AC voltage exist in and about the Voltage Selector, the EMI Filter, the Power Transformer, Fan, and the Power Switch on the Front Panel. ALWAYS UNPLUG THE AC LINE CORD BEFORE WORKING IN THESE AREAS. (See Schematic Diagram 7109 (sheet 2) for illustration of AC voltage distribution.

The Drive includes personnel safety interlocks that operate when the Tape Access Door or Top Dust Cover is opened. To operate the Drive for troubleshooting, the technician must defeat the Interlocks as follows:

- A. With AC power ON, unload tape (as applicable).
- B. Raise the Deck assembly to Maintenance Position per 5.2.2.
- C. On the Drive Electronics Board, move the Diagnostics Jumper (ST4 - Ref Figure 5-31) from its present position as follows:
 1. If original position is EN: press and hold ENTER, and move from EN to DIS.
If original position is DIS: press and hold ENTER, and move from DIS to EN to DIS.
 2. If you intend to test, calibrate, or operate the Drive via Diagnostics Pushbuttons, move the Jumper from DIS to EN (Do not press ENTER).
 3. From Step 1 you have one minute to lower the Deck Assembly and load tape. If tape has not been loaded within one minute, repeat Step C.
- D. Display flashes "NO INTLK". Press DIAG to start Diagnostics.
- E. To reactivate the Interlock, unload tape.

4.3 POWER UP

Upon Power Up, and without a reel of tape inserted, the Readout normally displays: TESTING, for approximately 7 seconds. If TESTING continues to be displayed, this indicates that communication between Formatter and Drive is disrupted and no further testing can be accomplished. There is a problem in the Formatter or the interface between Formatter and Drive. Assuming that communication between Formatter and Drive is obtained, the Drive performs the Self-Tests described below. In addition to the Failure Codes, The Drive can display Failures in the form of words or abbreviations. Tables 4-1 and 4-2 list and describe the Failures represented by this type of display, and also indicate the possible causes of failure. If a failure should occur during Power Up, press REWIND/UNLOAD. This clears the error and permits the operator to load tape and perform diagnostics.

Each Power Up Self-Test exercises the following areas of the Drive:

- A. Drive Electronics:
 1. Power Supply
 2. Drive Electronics PCBA
 3. Front Panel
 4. Servo System including Reel and Capstan Motors.
- B. Formatter and Read/Write Electronics:
 1. Formatter Board
 2. Write/Read Board
 3. Read Analog Board

4.3.1 DRIVE ELECTRONICS FAILURE DISPLAYS

Table 4-1 lists failure displays

Table 4-1. Drive Electronics Failure Displays

DISPLAY	FAULT CONDITION/POSSIBLE FAILURE
TESTING	Formatter not communicating with the Drive: Diagnostics hangup: Formatter Board 8951, Drive Electronics Board 8952.
FMT ERR? and flash REW	Formatter Error (Formatter Timeout): Formatter Section has failed to interrogate Drive Electronics; or the Formatter has failed to send its Identification (ID) after request from the Drive Electronics. Check Formatter Board 8951.
TAK ARM?	Take-up Arm fails to calibrate.
SUP ARM?	Supply Arm fails to calibrate.
CAPSTAN?	No Tachometer Voltage. Check Capstan Motor, Capstan Power Amplifier, and Tachometer.
T MOTOR?	Take-up Reel Motor not running: Servo Preamplifier 7147, Servo Amplifier 7111, Drive Electronics Board 8952, Take-up Reel Motor.

Table 4-1. Drive Electronics Failure Displays (Continued)

DISPLAY	FAULT CONDITION/POSSIBLE FAILURE
S MOTOR?	Supply Reel Motor not running: Servo Preamplifier 7147, Servo Amplifier 7111, Drive Electronics Board 8952, Supply Reel Motor.
ROM ?	Drive Electronics Program PROM Checksum Error: Non-zero checksum detected.
EEPROM ? and Flash REW	Checksum Error: Non-zero checksum detected. Press RWND/UNL. The Drive will compute a new checksum and attempt to write it into the EEPROM. Check Drive Electronics Board 8952
+12V ?	Voltage below +10V
+40V ?	Voltage below +30V
-12V ?	Voltage above -7V
-40V ?	Voltage above -29V
FAIL XXX	(XXX refers to Failure Code - See Table 4-2)

4.3.2 FORMATTER FAILURE CODES

Table 4-2 lists the Failure Codes that could display during Power Up, indicating probable causes of failure. Note that Failure Codes 150 thru 159 include the option of obtaining a second Failure Code which indicates specific problems. If a Failure Code between 150 and 159 occurs, to obtain the second Failure Code, press DENSITY. NOTE: the Failure Code is preceded by the word: FAIL.

Table 4-2. Power Up Failure Codes

CODE	DESCRIPTION	PROBABLE FAILURE
128	External RAM Data Error	-Compare RAM Formatter 8951
129	External RAM Addressing Error	
131	No RBSY for Read Amp Gain Values	Read Analog Board 9017
132	Wrong Formatter Bd for 9610/9660	Formatter Board 8951
133	Wrong Analog Board for 9610/9660	-Read Analog Board 9017
134	Wrong Digital Board for 9610/9660	-Read Digital Board 9060
140	Auto Adjust Ranging Error	-Read Analog Board 9017
141	Dead Track found in Auto Adjust	
142	Over Range Signal in Auto Adjust	
150	No RBSY in Loop RAW Test	Press DENSITY Pushbutton for Second Code listed below:
151	No WBSY in Loop RAW Test	
152	Time-out on WBSY in Loop RAW Test	
153	Time-out on RBSY in Loop RAW Test	
154	WBSY ended too soon in Loop RAW Test	
155	Hard Error in Loop RAW Test	
156	Corrected Error in Loop RAW Test	
157	Compare Error in Loop RAW Test	
158	File mark during Loop RAW Test	
159	Block Size Error in Loop RAW Test	

4.4 LOADING FAILURE CODES :

The 9610/9660 also includes automatic diagnostics that can detect loading failures, giving appropriate displays to indicate failures and their possible causes. Table 4-3 lists and describes the displays and related Fault Condition, and Possible Failures that could occur during Loading. After successfully completing Power Up, load a reel of tape into the Drive. If there is a loading failure, one of the displays listed in Table 4-3 will appear.

Table 4-3. Loading Failures

DISPLAY	FAULT CONDITION/POSSIBLE FAILURE
1. CLOSE/DOOR COVER?	Door Interlock Circuit: (Drive cannot load) Tape Access Door open, Door Switch, Drive Electronics Board 8952, Interconnect Board 7228.
2. NO BOT?	No BOT Marker detected: Tape Marker missing from tape, Tape Leader too short, Faulty BOT Sensor, Drive Electronics Board 8952, Interconnect Board 7228.
3. ABORTED	Automatic Load aborted: No vacuum, Air leak in tape path, Drive Electronics Board 8952, Servo Boards 7111, 7147, Position Sensors, tape sticking (ref 2.5.3, Step C).
4. REV REEL	Reverse Reel - Reel upside down.
5. PLC REEL	Place Reel. Tape Reel not installed.
6. CHK SLND	Check Solenoid - Hub Lock Solenoid not locking: Hub Lock Solenoid defective or needs adjustment, Drive Electronics Board 8952, Interconnect Board 7228.
7. CHK HUB	Check Hub - Supply Reel not detected: Reel-In-Place Tab Adjustment, Reel-In-Place Sensor, Drive Electronics Board 8952, Interconnect Board 7228.
8. BKN TAPE	Broken Tape - Tape not detected: Broken Tape, No EOT Marker, EOT Sensor, Interconnect Board 7228, Drive Electronics Board 8952.
9. TAK ARM?	Take-up Arm not operating correctly: Take-up Arm Position Sensors (Check with Arm relaxed), Drive Electronics Board 7710, Interconnect Board 7228.
10. SUP ARM?	Supply Arm not operating correctly: Supply Arm Position Sensors (Check with Arm relaxed), Drive Electronics Board 7710, Interconnect Board 7228.

4.5 FRONT PANEL DIAGNOSTICS

NOTE: To perform Diagnostics, Diagnostics Jumper ST4 (on Drive Electronics Board 8952) must be in ENABLE Position per Figure 5-31.

Diagnostics are divided into six major sections represented by Displays as indicated below:

<u>Chart</u>	<u>Section</u>	<u>Display</u>	<u>Chart</u>	<u>Section</u>	<u>Display</u>
A	Self-Test	SELFTEST	D	Set Up	SET UP
B	Motion	MOTION	E	Calibration	CAL
C	Drive Adjustment	DRV ADJ	F	Data diagnostics	DATADIAG

Each section, when accessed, displays its own Menu which further divides into submenus. Figure 4-1 illustrates, and the following subparagraphs describe accessing the major diagnostic sections, their Menus and Submenus.

Note that although Set Up and Calibration are contained in the Diagnostics Menu, they are not Diagnostic Functions. They are for setting up the Drive for operation and for calibrating as required.

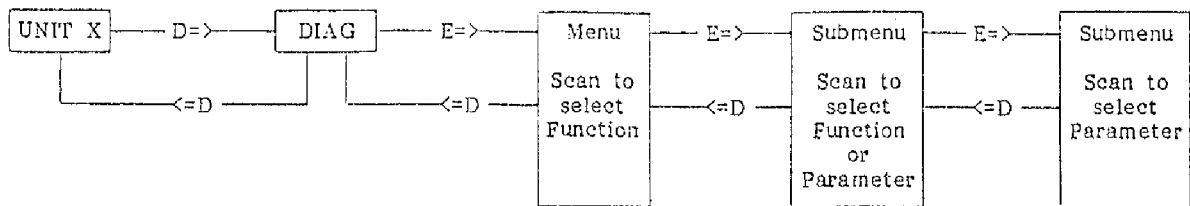

NOTE: D=> indicates press DIAG and proceed to the right.
 <=D indicates press DIAG and proceed to the left.
 E=> indicates press ENTER and proceed to the right.

Figure 4-1. Diagnostics Menu Dynamics (Simplified)

4.5.1 DIAGNOSTICS MENU

Table 4-4 illustrates the overall Diagnostics Menu structure. Each indent represents a Submenu accessible from the Main Menu, usually by pressing ENTER. Pressing SCAN accesses the next lower item in any Menu or Submenu.

4.5.2 OPERATING PROCEDURE

Running the diagnostics consists essentially of pressing specified pushbuttons on the front panel and following the direction provided by messages on the front panel display.

After a successful Power Up Self-Test, begin diagnostics by pressing the DIAG pushbutton. The Readout displays DIAG, and the Drive is ready to enter the Diagnostic Mode of operation. Subsequently, pressing the ENTER pushbutton accesses the Main Menu.

Generally, as illustrated in Figure 4-1, (proceeding from left to right) the Operator accesses a particular Menu or Submenu by pressing the ENTER pushbutton. He returns to a previous Menu or Submenu by pressing the DIAG pushbutton. Repeatedly pressing DIAG exits from the Diagnostics Mode.

In any Menu, repeatedly pressing the SCAN pushbutton scrolls through functions or parameters in that Menu. Generally, pressing ENTER activates that function or parameter. In certain Submenus, activating the parameter is done by pressing START/STOP, LOAD or ONLINE - these variations are described as applicable in the following subparagraphs. Note that pressing ONLINE in Diagnostics Mode does not place the Drive on line with the Host.

4.5.2.1 ENTERING THE DIAGNOSTICS MODE

In Diagnostic Mode, repeatedly pressing SCAN displays the Diagnostic Functions. Pressing ENTER enables the function displayed. This sequence is illustrated by the following chart:

NOTE: Be sure Diagnostics Jumper is in ENABLE Position. Ref Figure 5-31.

General Chart: Entering the Diagnostics Mode

Step	ACTION (Press:)	DISPLAY	ACTION (Press:)	DISPLAY	ACTION
0		UNIT X			
1	DIAG	DIAG			Press ENTER to activate selected operation.
2			ENTER	SELFTEST	
4			SCAN	MOTION	
5			SCAN	DRV ADJ	
6			SCAN	SET UP	
7			SCAN	CAL	Press DIAG to exit from Menu.
8			SCAN	DATADIAG	

Having selected a diagnostic function by pressing ENTER, repeatedly pressing SCAN scrolls through the selected Functions Menus illustrated by the following charts.

4.5.2.2 SELF-TEST

The front-panel-controlled Self-Test enables the Operator to rerun the Power Up Self-Tests (par. 4.3) without turning off power, and also to run a Data Write/Read Test. Chart A illustrates accessing the two Self-Tests. The following subparagraphs describe the Tests.

Chart A. Doing The Self-Test

Step	ACTION (Press:)	DISPLAY	ACTION (Press:)	DISPLAY	ACTION
0	DIAG	SELFTEST			Press ONLINE to run Test.
1	ENTER	PWUPTTEST	ENTER	CONFIRM?	Press DIAG to abort Test
2	SCAN	DATATEST	ENTER	CONFIRM?	and exit from Diagnostics.

NOTE: 1. Do not install tape when running PWUPTTEST. If tape is loaded when ONLINE is pressed, the Readout displays LOADED, and the test is not run.

2. When PWUPTTEST is done, if Drive passes Test, Drive exits from the Diagnostics Mode and displays UNIT X. When DATATEST is done, if Drive passes Test, Display indicates PASSED. If Drive fails either Test, Display indicates a Fail Code (Tables 4-2 and 4-3).

4.5.2.2.1 POWER UP SELF-TEST

The Power Up Self-Test consists of tests described in paragraph 4.3.3. To run this Test, unload tape (as applicable). Then with the Readout displaying UNIT X, press DIAG, then ENTER. Press ONLINE to run test, DIAG to abort and exit from Diagnostics.

4.5.2.2.2 DATA TEST

For Data Test, if tape is not at BOT, Drive rewinds tape to BOT, then selects NRZI Density and proceeds with the Data Test. Note that the Data Test includes the Loop Write to Read Test to confirm operation of the Digital and Analog Modules. This Test is also run in the Power Up Self-Test. Data Test consists of the following subtests in the order listed. The Subtest Event Number displays as TEST XX, where XX represents 01 thru 27. If a failure occurs, the Drive displays a Code per Table 4-5. Pressing DENSITY displays the Subtest Event Number.

The Drive Selects NRZI Density and after each complete series of Tests, selects a new Density in the following sequence: NRZI, PE, DDPE, GCR.

Subtest Event

- A. Write with Retries 2 Blocks at 50 ips in Streaming Mode.
 - 1. Set Mode to Streaming.
 - 2. Write with Retry one block.
 - 3. Write with Retry one block.
- B. Write with Retries 2 Blocks at 50 ips in Start/Stop Mode.
 - 4. Set Mode to Start/Stop.
 - 5. Write with Retry one block.
 - 6. Write with Retry one block.
- C. Write with Retries 2 Blocks at 100 ips in Start/Stop Mode.
 - 7. Write with Retry one block.
 - 8. Write with Retry one block.
- D. Write with Retries 2 Blocks at 100 ips in Streaming Mode.
 - 9. Set Mode to Streaming.
 - 10. Write with Retry one block.
 - 11. Write with Retry one block.
- E. Write 1 File mark at 50 ips.
 - 12. Write with Retry one File menus, activating the parameter mark.

- F. Read Reverse 1 Block at 100 ips. Check for File mark Status.
 - 13. Read Reverse on block.
 - 14. Check Status. Should be File mark and not BOT.

- G. Read Reverse 8 Blocks at 100 ips, Streaming Mode. Confirm that Drive does not reach BOT.
 - 15. Read Reverse one block.
 - 16. Read Reverse one block.
 - 17. Read Reverse one block.
 - 18. Read Reverse one block.
 - 19. Read Reverse one block.
 - 20. Read Reverse one block.
 - 21. Read Reverse one block.
 - 22. Read Reverse one block.

- H. Rewind
 - 23. Rewind.

- I. Read Forward 1 Block at 100 ips. Check proper ID Burst Detection.
 - 24. Set Mode to Start/Stop.
 - 25. Read Forward one Block.

- J. Read Forward 1 Block at 100 ips.
 - 26. Read Forward 1 Block.

- K. Read Forward 2 Block at 100 ips in Streaming Mode.
 - 27. Set Mode to Streaming.
 - 28. Read Forward one block.
 - 29. Read Forward one block.

- L. Read Forward 2 Block at 50 ips in Streaming Mode.
 - 30. Read Forward one Block.
 - 31. Read Forward one Block.

- M. Read Forward 2 Block at 50 ips in Start/Stop Mode.
 - 32. Set Mode to Start/stop.
 - 33. Read Forward one Block.
 - 34. Read Forward one Block.

- N. Read Forward 1 Block at 50 ips. Check for File mark Status.
 - 35. Read Forward one Block.
 - 36. Check Status. Should be File mark.

- O. Rewind.
 - 37. Rewind.

- P. Select next Density and go to Subtest A. If Density is GCR, abort Test and display PASSED.

- NOTE:**
- 1. Possible Messages that could occur during or after the Data Test are:
 - DATATEST - Data Test is being performed.
 - CAN'T WR - Tape not loaded or Write Protected.
 - PASSED - Drive has passed all Tests.
 - 2. Data Block = 2048 Bytes, Random Data

4.5.2.3 CONNECTOR OR CABLE FAILURES

Power Up, Loading, and Data tests can also indicate PCBA interconnection faults related to cables and PCBA connectors. These Tests and Failure Messages with associated possible Cable or Connector Failures are listed in Tables 4-6 and 4-7.

Table 4-6. Cable or Connector Faults

TEST	FAILURE MESSAGE	FAULTY CABLE OR CONNECTOR *
(Switch On)	CAPSTAN (immediate)	Connector J2 on 7147
Power Up	CAPSTAN	P1 on 7228 Bd P6 on 7228 Bd P1 on 7111 Bd
Power Up	TESTING	P2 on 7228 Bd P14 on 7228 Bd P17 on 7228 Bd
Loading	CAPSTAN	P3 on 7228 Bd
Loading	CLSE DOOR	P7 on 7228 Bd
Loading	CHK SLND	P8 on 7228 Bd
Loading	CHK ARMS	P4 on 7228 Bd
Loading	BOT ?	P9 on 7228 Bd
Loading	ABORTED	P10 on 7228 Bd P11 on 7228 Bd (P10 and P11 on 7228 reversed)
Loading	CHK HUB	P13 on 7228 Bd
Datatest	202, Subtest 25	P1 on 9060 Bd
Datatest	205, Subtest 2	P1 on 9060 Bd P1 on 9017 Bd P15 on 7228 Bd P16 on 7228 Bd
Datatest	CANT WR	P12 on 7228 Bd
<p>NOTE: For further information concerning a malfunction, access Data Diagnostics (par. 5.4.2.7) and scan through the Errors Menu.</p>		

NOTE:

* Connector not properly seated or cabled open circuited.

Table 4-7. Printed Circuit Board Assemblies in Card Cage

TEST	FAILURE CODE	PCBA NOT PROPERLY SEATED
Power Up	133	9017
	134	9060
	FMTR ERR	8951
Datatest	131 + RWND/UNL LED flashes	9017
	150 + Subtest Item 1	9060
	FMTR ERR	8951

4.5.2.4 MOTION DIAGNOSTIC TESTS

In Motion Mode, the operator can check and adjust the tape path, and Check Motors and Servos. Perform Motion Diagnostics Tests as follows:

After autoloading a tape, press the DIAG pushbutton. The Readout will display DIAG. Pressing the ENTER pushbutton will cause the Readout to display SELFTEST. Press SCAN and the Readout displays MOTION. Again pressing ENTER accesses the Motion Parameters Submenu. This sequence of events is illustrated in Chart B. Table 4-8 defines abbreviations displayed in the Motion Tests.

Chart B. Selection of Motion Parameters

Step	ACTION (Press:)	DISPLAY	ACTION (Press:)	DISPLAY	ACTION
0		MOTION			
1	ENTER			50 FWD	
2			SCAN	50 REV	
3			SCAN	50 FSS	Press START/STOP
4			SCAN	50 RSS	to select and initiate
5			SCAN	50 FRF	the displayed Test.
6			SCAN	100 FWD	
7			SCAN	100 REV	Press START/STOP
8			SCAN	100 FSS	again to stop motion
9			SCAN	100 RSS	
10			SCAN	100 FRF	Press DIAG to exit
11			SCAN	50/100 F	from Menu.
12			SCAN	50/100 R	
13			SCAN	BURN IN	

Table 4-8. Motion Test Definitions

DISPLAY	DEFINITION	DISPLAY	DEFINITION
50 FWD	50 ips Forward	100 FSS	100 ips Forward Start/Stop
50 REV	50 ips Reverse	100 RSS	100 ips Reverse Start/stop
50 FSS	50 ips Start/Stop	100 FRF	100 ips Fwd/Rev/Fwd
50 RSS	50 ips Reverse Start/Stop	50/100 F	50/100 ips Alternate Forward
50 FRF	50 ips Fwd/Rev/Fwd	50/100 R	50/100 ips Alternate Reverse
100 FWD	100 ips Forward	BURN IN	Continuous testing in Forward direction with Rewind at EOT.
100 REV	100 ips Reverse		

4.5.2.5 DRIVE ADJUSTMENT TESTS

Enter the Drive Adjustment Diagnostic Mode by repeatedly, as necessary, pressing DIAG until the Readout displays DIAG. Then press ENTER and SCAN until the Readout displays DRV ADJ. Chart C illustrates accessing the Submenus of the Drive Adjustment Mode.

Buffer Arm Test. Use the Buffer Arm Tests to verify if the calibration positions of each Buffer Arm are adjusted correctly per adjustment procedure, Section V.

Hub Sensor Test. The Hub Sensor Tests enable testing the operation of the Reel-In-Place Sensor and the File Protect Sensor. The digital display indicates the status of the tape reel (NOT IN = Not inserted; IN PLACE = Tape inserted). The WRITE ENBL light indicates the status of the Write Protect Sensor.

RL Servo (Reel Servo) — This test exercises the servo system. The RL Servo Test requires that a tape reel be inserted (not loaded) before beginning the test. The test executes a diagnostic load but does not perform a BOT search. If a reel of tape is not inserted at the start of this test, the readout displays **LOADING**, then, **ABORTED**. In the event that the reel had been loaded before the start of the test, the readout displays **G = 1.XX**. In either case, the test is not performed.

CAUTION

The RL Servo Test is also used in a critical adjustment procedure required if any component of the Reel Servo System is replaced. This procedure includes setting up parameters that govern operation of the Executive Program in the Calibration EEPROM. **To prevent corrupting the Executive Program, make sure that the Calibration Jumper (ST3) on the Drive Electronics Board is in NON-ENABLE Position (Ref Figure 5-31).**

Chart C. Drive Adjustment Tests

Step	DISPLAY	ACTION (Press:)	DISPLAY	ACTION (Press:)	DISPLAY	NOTE
0	DRV ADJ					*
1		ENTER	BUF ARMS	ENTER	RELAXING TAKE X.X SUPP X.X	**
				SCAN		
2		SCAN	HUB SENS	ENTER	NOT IN IN PLACE	^
3		SCAN	RL SERVO	ENTER	LOADING	^ #

NOTE:

- * Press DIAG to exit from any Menu or Submenu.
- ** RELAXING displays as the Arm relaxes, then TAKE X displays. Pressing DIAG causes display to indicate: RETRACT, and the Arm retracts.
- ^ This display varies according to Loading status.
- # The final display indicates as follows:

G = 1.XX displays if test is satisfactory. XX represents Reel Servo Gain.
An Error Messages per Table 4-3 displays if test fails.

4.5.2.6 SET UP

In the Set Up Mode, the operator sets the basic operating parameters of the Drive. Except for UNIT NUM, DENS SEL, and DEFL DENS, the Calibration Jumper* (ST3) must be placed in ENABLE Position (EN) for the Set Up Procedures. Set Up can be done with or without tape loaded. The basic parameters displayed and set up in this Mode are:

- * In most procedures of Set Up Mode, and all of Calibration Mode, the Calibration Jumper must be installed in the ENABLE Position to store the selected parameters. If the jumper is not installed, and a store (LOAD) operation is attempted, the Readout displays, "JUMPER?" and the RWND/UNL LED flashes. Pressing RWND/UNL aborts the Set Up or Calibration attempt. (See Section V - Calibration and Set Up, Electronic - for Calibration Jumper installation.)

When Set Up or Calibration is complete, replace the Calibration Jumper to its original position. **CAUTION: DO NOT TURN POWER OFF UNTIL CALIBRATION JUMPER IS RETURNED TO ITS ORIGINAL POSITION.** To do so could destroy vital data in the Calibration EEPROM.

- a. **UNIT NUM:** Unit Number. The Drive Unit Number (Address). This can be set to any logical number from 0 thru 7. (Cal Jumper can be in either position.)
- b. **DENS SEL:** Density selection. When set to normal the drive will operate in local or remote density modes, depending on the REMOTE light on the front panel. When in REM ONLY, the drive will only allow selection of REMOTE mode.
- c. **DEFL DEN:** Default Density. The Density to which the Drive will default to on Power Up. Default Density can be set to 800 epi, 1600 epi, 3200 epi, and 6250 epi, and can be set for Local or Remote (Host) Control. (Cal Jumper can be in either position.)
- d. **SPEED:** The Speed to which the Drive will default to on Power Up. Speed can be set to 50 or 100 ips, Host Select; or Automatic Select wherein the Drive automatically selects the speed for optimum performance, based on the Host Re-Instruct Time. In Host Select, if the Host does not designate, the speed is 50 ips.
- e. **TIMEOUT:** 25-foot Timeout. The 25-foot Timeout Parameter, when set to ON, causes the Drive to stop tape motion and report a Hard Error if no data is detected within 25 feet of tape. This feature prevents tape from running off the reel at the end of tape.
- f. **SECURITY:** Security Erase. Security Erase, when enabled, allows the Drive to accept a Security Erase Command from the Host which will cause the Drive to erase tape from its present position to 3 feet past EOT.
- g. **PARITY:** For Hosts that provide Parity, the Drive can be set either to check or ignore parity of Write Data from the Host.
- h. **LONG GAP:** Interrecord Gap. To accommodate certain Host requirements, the Interrecord Gap that results from the Host generated LONG GAP Command can be set to any one of the values: 0.45, 0.6, 1.2, or 2.5 inches. Regardless of its setting, however, Gap Length terminates if a Write Command is received before its set time.
- i. **ARA CAL:** Automatic Read Amplifier Calibration. With this feature enabled, the Drive automatically sets the gain of the Read Amplifiers when reading or writing the ARA Burst in GCR. With this feature disabled, the stored gain values are used.
- j. **GCR CERR:** GCR Corrected Error. When enabled, this feature causes the Drive to report errors corrected by the internal "on the fly" circuitry in GCR.
- k. **NRZI CCG:** NRZI Check Character Gate. When enabled, this option causes the Drive to send the CRC and LRC Characters to the Host following each data block.
- l. **CLR FBSY:** Clear Formatter Busy. Enabling this option, allows the Data Busy Signal (DBY) to clear the Formatter Busy Signal (FBSY). For Hosts that reinstruct after each FBSY, set this option to "WITH DBY" to facilitate streaming. To clear FBSY after repositioning, following a 100 ips Command, set to "POSTREPO" .
- m. **IFEN:** Interface Enable Polarity. Setting this option to INVERT, inverts the FEN Signal from the Host. Setting this option to NORMAL, leaves the Signal uninverted. For Hosts that use FEN as a pulse to enable the Formatter, set IFEN to INVERT. For Hosts that support FEN, set IFEN to NORMAL.
- n. **DENS OUT:** Density coding method used on the Host interface. Choose either coded for reporting of all 4 densities of NRZ ONLY or only report NRZI.

SECTION V
MAINTENANCE INSTRUCTIONS

SECTION V MAINTENANCE

5.0 GENERAL

Procedures described herein are limited to Preventive and Corrective Maintenance that can be accomplished in the field, and includes adjustment and replacement of PCBAs and other major components of the Drive. PCBAs are not considered field repairable and, if found defective, should be returned to the manufacturer for repair.

5.1 PREVENTIVE MAINTENANCE

To ensure continued trouble-free operation, complete the following preventive maintenance tasks regularly as recommended.

5.1.1 DAILY INSPECTION

All components in the tape path must be kept scrupulously clean. Daily, or after four hours of tape motion, inspect Deck Assembly, Read/Write/Erase Head, Rollers, and Sensors, for cleanliness. Look for dirt and oxide accumulation. Clean as required.

5.1.2 CLEANING

CAUTION

Using ~~non-recommended~~ cleaning fluids can damage components of the Tape Drive. Using excessive amounts of the recommended cleaning fluid can damage the Tape Drive by penetrating roller bearings, idler rollers, tape guides, capstan, or drive motor, and destroying lubrication.

5.1.2.1 TAPE REELS

Before installing any tape reel onto the Supply Hub, it is recommended that the inner surface of the Tape Reel Hub be cleaned with a lint free cloth dampened with clean water to remove any dirt, grease or other contamination.

5.1.2.2 ERASE/WRITE/READ HEAD CLEANING

Remove accumulation of oxide and/or dirt from the Erase/Write/Read Head surface (Fig. 5-1) using a clean lint-free cloth or cotton swab dampened with 1.1.1 trichloroethane or isopropyl alcohol (See CAUTION above). Wipe the Head with firm but gentle vertical strokes.

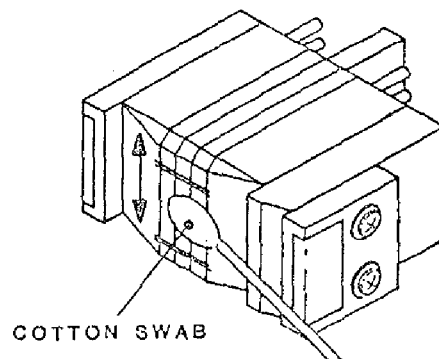

Figure 5-1. Erase/Write/Read Head Cleaning

5.1.2.3 TAPE PATH CLEANING

Miscellany (Figure 5-2)

Clean tape guides, rollers (except Capstan Roller), and the sapphire tape cleaners with a cotton swab dampened with isopropyl alcohol or 1.1.1 trichloroethane. Clean the Capstan rubber Roller with a cotton swab dampened with water or, if excessively dirty, dampened with mild soapy water. Dry thoroughly with a clean lint-free cloth.

Reel Locking Fingers (Figure 5-19)

With no tape reel on the Supply Hub, press the Manual Reel Locking Lever (See Section VI, Figure 6-1) while manually turning the Reel Hub clockwise until the Reel Locking Fingers extend fully outward. Then clean the Rubber Pads on the Fingers with a clean cotton swab or cloth dampened with water or if excessively dirty, with mild soapy water.

After cleaning the Rubber Pads, again press the Manual Reel Locking Lever and manually turn the Reel Hub counterclockwise until the Fingers retract to original position.

5.1.3 ROUTINE ADJUSTMENTS

There are no routine adjustments necessary to the Tape Drive. DO NOT make any adjustments except for corrective maintenance.

5.1.4 LUBRICATION

The Tape Drive uses only sealed, life-time lubricated bearings. No lubrication is required. **CAUTION:** Do not lubricate.

5.1.5 HEAD WEAR

The Kennedy Co. ceramic-coated Head normally lasts the lifetime of the Drive. However, the Head should be replaced after 5000 hours of tape motion.

5.2 CORRECTIVE MAINTENANCE

Corrective Maintenance consists of tests and diagnostics for isolating malfunctions to a field-replaceable component. Field replaceable components are itemized in the Recommended Spare Parts List (Section VI, Table 6-1).

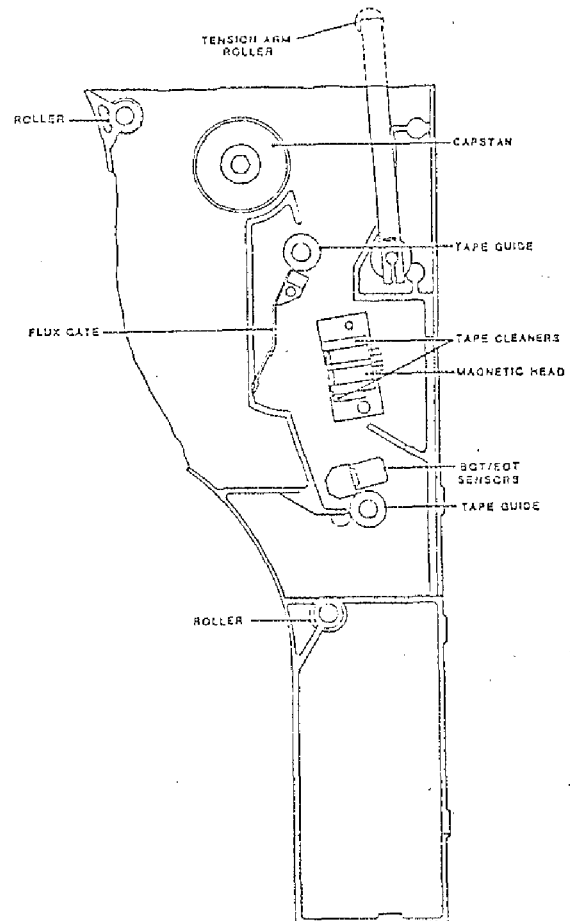

Figure 5-2. Tape Path Cleaning

5.2.3.1 ACCESSING THE DRIVE FOR TROUBLESHOOTING

CAUTION: A solidly grounded ESD Wrist Strap should be worn whenever touching or handling any Circuit Board or other electronic assembly in the Drive.

WARNING: Dangerous AC voltage exist in and about the Voltage Selector, the EMI Filter, the Power Transformer, Fan, and the Power Switch on the Front Panel. ALWAYS UNPLUG THE AC LINE CORD BEFORE WORKING IN THESE AREAS. (See Schematic Diagram 7109 (sheet 2) for illustration of ac voltage distribution.

5.2.3.2 SAFETY INTERLOCKS

The Drive includes personnel safety interlocks that operate when the Tape Access Door or Top Dust Cover is opened. To operate the Drive for troubleshooting, the technician must defeat the Interlocks as follows:

- A. With ac power ON, unload tape (as applicable).
- B. Raise the Deck assembly to Maintenance Position per 5.2.2.
- C. On the Drive Electronics Board, move the Diagnostics Jumper (ST4 - Ref Figure 5-31) from its present position as follows:
 1. If original position is EN: press and hold ENTER, and move from EN to DIS. If original position is DIS: press and hold ENTER, and move from DIS to EN to DIS.
 2. If you intend to test, calibrate, or operate the Drive via Diagnostics Pushbuttons, move the Jumper from DIS to EN (Do not press ENTER).
 3. From Step 1 you have one minute to lower the Deck Assembly and load tape. If tape has not been loaded within one minute, repeat Step C.
- D. Display flashes "NO INTLK". Press DIAG to start Diagnostics.
- E. To reactivate the Interlock, unload tape.

5.3 PARTS REPLACEMENT

Components and Major Assemblies of the Drive are not considered to be field repairable. If found defective, replace the Component or Assembly with an appropriate spare part. The following subparagraphs describe replacement procedures for these Components and Assemblies. For these procedures, unless otherwise directed, place the Drive on a table top right side up, and raise the Deck to Maintenance Position per par. 5.2.2.

Torque Requirements: Torque screws to the following standards (inch pounds): #4-40: 4 to 6; #6-32: 7 to 9; #8-32: 8 to 10; #10-32: 18 to 20.

5.3.1 PRINTED CIRCUIT BOARDS IN CARD CAGE (Fig. 5-3)

- A. Loosen two Cover Screws near ends of the Card Cage Cover, and remove Cover.
- B. As applicable, disconnect cables from PCB to be removed.
- C. Grasp PCB Ejectors firmly, and pull ejectors towards the side of the unit. Board should pop partly out of the slot.
- D. Grasp the PCB Ejectors and slide the Board out of the slot.

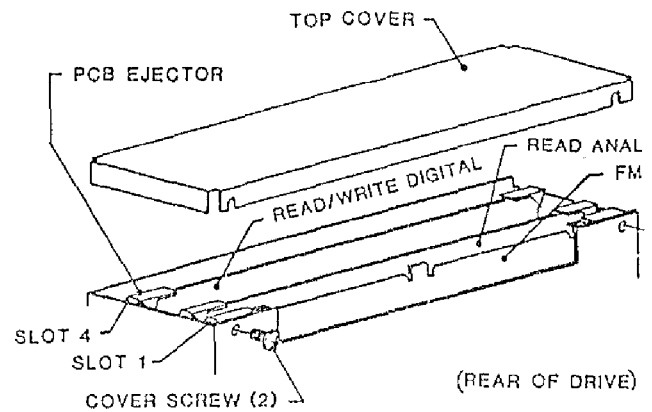

Figure 5-3.
Card Cage

To replace: Insert PCB in Card Cage and press firmly downward until PCB is fully seated in Mother Board.

Replace Card Cage Cover.

5.3.2 DRIVE ELECTRONICS BOARD

Refer to Section VI, Figure 6-4 for illustration of the Drive Electronics Board.

- A. Remove four nuts that hold the Power Supply Bracket to the Chassis, and slide the Power Supply with Bracket to the left.
- B. Disconnect cables from the Drive Electronics Board.
- C. Remove six Mounting Screws that hold the Drive Electronics Board to the Chassis.
- D. Unplug the Drive Electronics Board from the Mother Board, and lift it from Drive.

To replace: Reverse removal procedure*.

***Note:** Following Drive Electronics Board replacement, all electronic Set Ups and Calibration must be performed. See Sections 5.4.2.9 and 5.5.3.

5.3.3 INTERCONNECT PCBA

Refer to Section 6, Figure 6-3 for illustration of the Interconnect Board.

- A. Noting the location of each connector, disconnect all connectors from Interconnect Board, tagging each connector for identification and location.
- B. Remove four Board Mounting Screws.
- C. Lift the Interconnect Board out of the Drive.

To replace: Reverse removal procedure.

5.3.4 HUB LOCK SOLENOID (Fig. 5-4)

- A. Disconnect two wires from the Solenoid.
- B. Remove 2 screws holding Solenoid Mounting Bracket to Deck.
- C. Lift Bracket/Solenoid Assembly and detach it from Lock Actuator.
- D. Remove the Solenoid (2 screws) from the Bracket.

To replace: Reverse removal procedure. Adjust per paragraph 5.4.2.8. Torque screws to 13 +/- 1 inch-pounds.

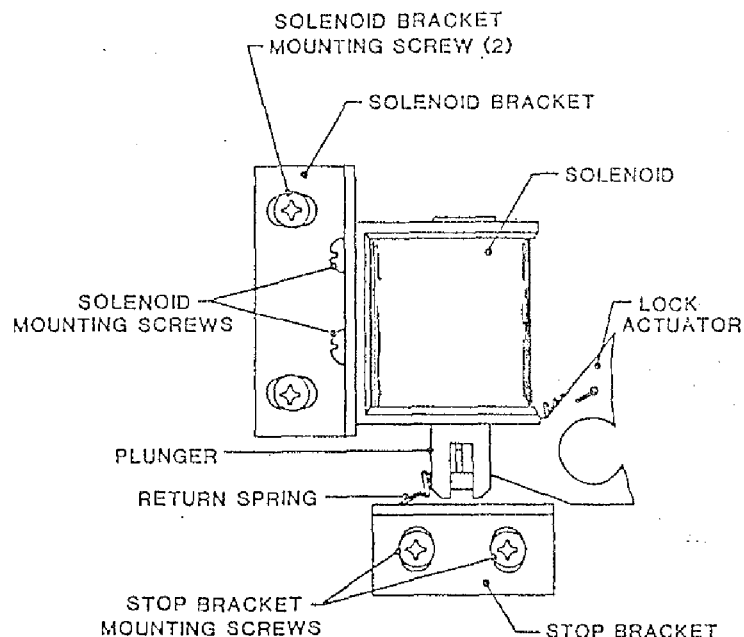

Figure 5-4.
Hub Lock Solenoid

5.3.5 READ PREAMPLIFIER

Refer to Figure 5-27, and Section VI, Figure 6-3 for illustration of the Read Preamp Board.

- A. Remove Clamp Plate (below Deck) that clamps cables and the Read Preamp Board.
- B. Unplug the Read Preamp Board from the Magnetic Head (top of Deck).
- C. Cut tie wraps that secure Read Preamp Cable, and unplug Cable Connector from Read Analog Board 9017.
- D. Remove the Read Preamplifier Board from the Drive.

5.3.6 FAN (Fig. 5-5)

- A. Remove all PCBs from Card Cage (paragraph 5.3.1).
- B. Unplug connector at Fan Body.
- C. Using stubby Phillips screwdriver, remove 4 screws holding Fan to sheetmetal support.
- D. Remove Finger Guard from Fan, and install it on new Fan, using original hardware.

To replace: Reverse removal procedure. Note direction of air flow.

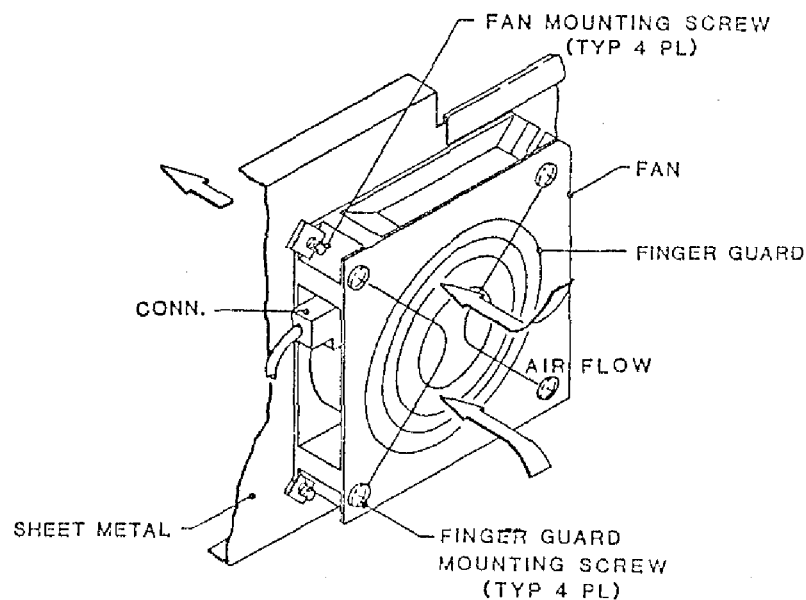

Figure 5-5. Fan

5.3.7 TAKE-UP REEL ASSEMBLY (Fig. 5-6)

Tools Required: 9/64th-inch Hex Wrench

- A. Lift open Top Cover of the Drive per 5.2.2.
 - B. Remove three Socket-Head Cap Screws from Top Flange, and remove Top Flange.
 - C. Remove two Socket-Head Cap Screws from the Vacuum Hub.
 - D. Grasp the Vacuum Hub firmly with both hands and remove by pulling upwards.
- To replace: Reverse removal procedure.

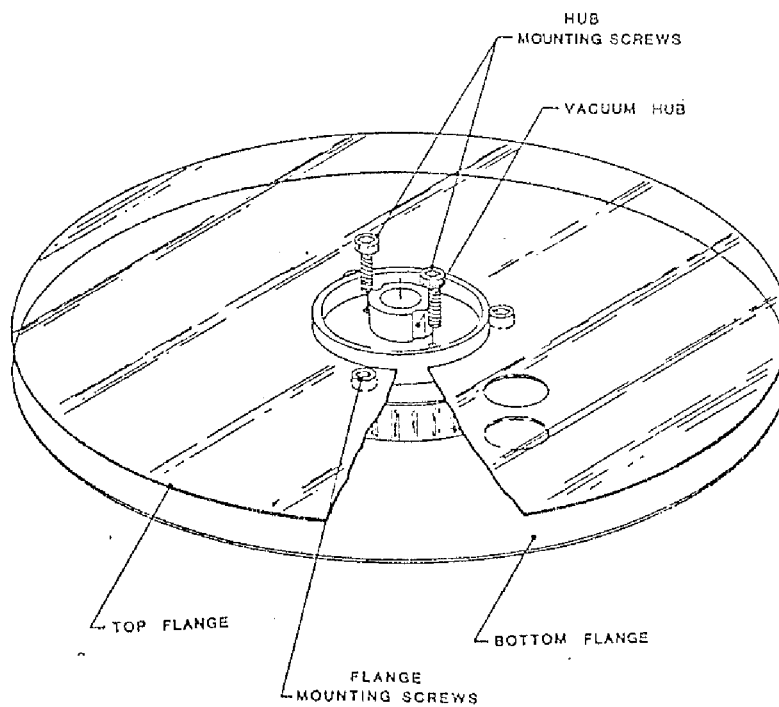

Figure 5-6. Take-up Reel Assembly

5.3.8 TAKE-UP ARM ASSEMBLY (Fig. 5-7)

- A. To ensure that the new Arm will be installed in approximately the same angular position on the Shaft as the original Arm, and the zero point will not be altered, mark the orientation of the original Arm on the Shaft. A small dot on the shaft in line with the Arm (as illustrated) will suffice.
- B. Remove the Take-up Arm Retraction Spring as follows:
 1. Turn AC power on.
 2. Move the Diagnostics Enable Jumper on the Drive Electronics Board to ENABLE Position (See Figure 5-31).
 3. Press DIAG, then ENTER, and scan to DRV ADJ. Mode.
 4. Again press ENTER. The Readout should display BUFF ARMS.
 5. Press ENTER again. The Readout should display RELAXING, and the Take-up Arm should unlock from its original position and move to the "relaxed" position.
 6. Remove the Retraction Spring from the Swivel with a Spring Hook or similar tool.
- C. Using a 1/4-inch box wrench, loosen the Clamp Bolt that secures the Arm to the Shaft, and lift the Arm Assembly off the Shaft being careful not to remove shims from under the Arm.

To replace: Reverse removal procedure:

- a. Snug the Clamp Bolt to prevent the Arm from turning on the Shaft.
- b. Check and as necessary adjust Buffer Arm Roller Height per paragraph 5.4.2.1.
- c. Check and as necessary adjust Spring Tension per paragraph 5.4.2.4.
- d. Torque Clamp Bolt to 20 inch-pounds.
- e. Replace Diagnostics Jumper to the Non-Enable Position (Power can now be turned off).

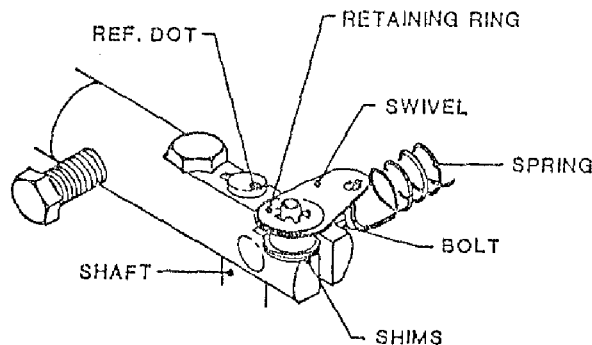

Figure 5-7. Take-up Arm and Supply Arm Assemblies

5.3.9 SUPPLY ARM ASSEMBLY (Fig. 5-7)

- A. Remove three Phillips screws and remove Supply Arm Cover Plate from the top of the Deck.
- B. Do procedure in paragraph 5.3.8.

5.3.10 RETRACT AND PIVOT SENSOR ASSEMBLIES, TAKE-UP ARM AND SUPPLY ARM (Fig. 5-8)

From above Deck:

- A. Remove the Supply-Arm or Take-up Arm Assembly per paragraph 5.3.8 or 5.3.9.
- B. Remove Hinge Bracket that holds the Tape Path Cover and remove the Tape Path Cover.
- C. For Take-up Arm only, remove screws that hold the Take-up Arm Stop and the Fixed Cover Plate and remove the Take-up Arm Stop and Fixed Cover Plate.
- D. For Supply Arm only, remove Supply Arm Cover Plate, and then with a Phillips Screwdriver, remove the Supply Arm Stop.

From below Deck:

- E. On Take-up Arm Assembly only, loosen the Lock Screw that attaches the Linkage to the Post, and remove the Linkage. Retain Linkage for later reinstallation.
- F. Cut tie-wraps and unplug connector P4 (for Take-up Assy) or P3 (for Supply Assy) from Interconnect Board 7228.
- G. Unplug P1 from Position Sensor PCBA 9069.
- H. Remove Phillips Screw and Cable Clamp from bottom corner of Motor. Disconnect the wires from the Microswitch, and unsolder the two Motor Wires. Note that on the Take-up Motor, the Red Wire connects to the side of the Motor toward the Cam, but on the Supply Motor, the Red Wire connects to the side of the Motor away from the Cam.

From above Deck:

I. (In this step, support and lower the Retract and Pivot Sensor Assy as the last Mounting Screw is unscrewed.) Using a Hex Wrench, completely unscrew, but do not remove, two Socket-Head Mounting Screws that attach the Retract and Pivot Sensor Assembly to the Deck.

To replace:

Reverse removal procedure. Check and adjust Buffer Arm per par. 5.4.2.1.

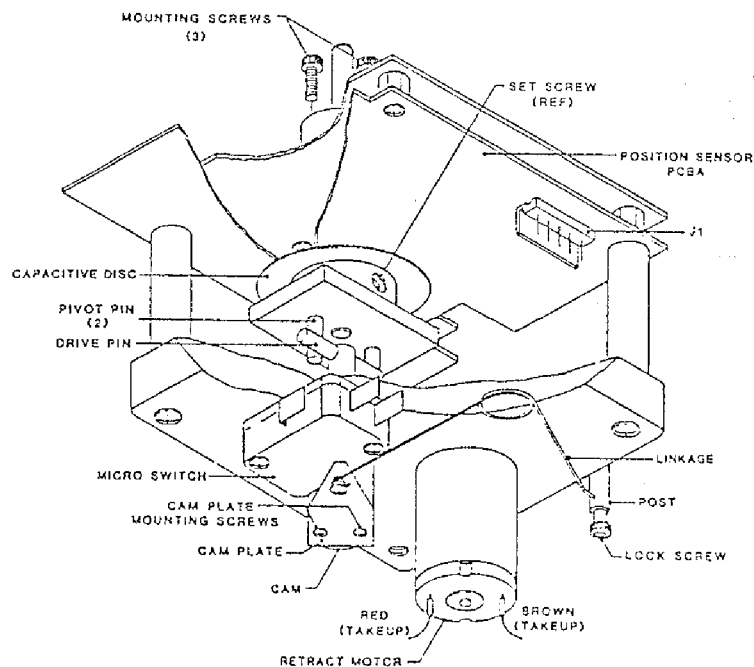

Figure 5-8. Take-up Arm Retract and Pivot Sensor Assembly

5.3.11 MOTHER BOARD PCBA (Fig. 5-9)

- A. Remove Card Cage Cover (paragraph 5.3.1).
- B. Remove all PCBAs from Card Cage.
- C. Unplug power connector J13 from Mother Board.
- D. Using Stubby or Offset Phillips Screwdriver, Remove six Mounting Screws and move Center Bulkhead out of way.
- E. Remove seven Phillips Head Screws that secure the Mother Board to the Chassis.
- F. Unplug Mother Board from Drive Electronics Board and ,being careful not to damage the Connectors on the Mother Board, slide the Mother Board back and rotate it upward and out.

To replace: Reverse removal procedure.

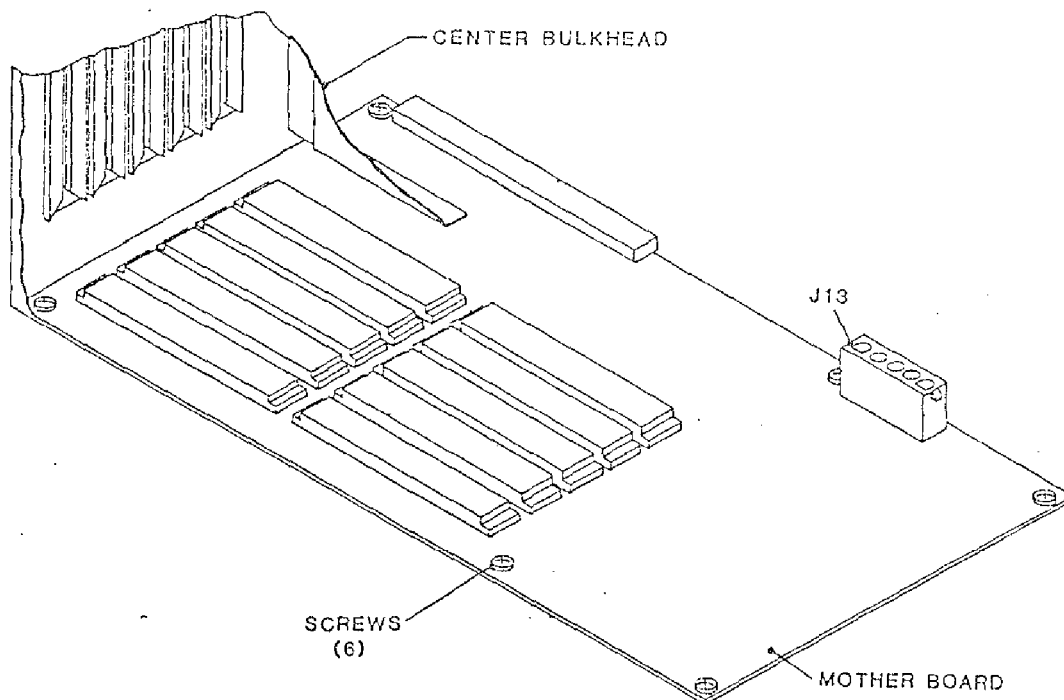

Figure 5-9. Mother Board

5.3.12 OPERATOR CONTROL PANEL PCBA (Fig. 5-10)

- A. Remove Panel Assembly from Deck per paragraph 5.3.22.
- B. Cut the Tie Wraps that attach the Switch and Solenoid Cable to the PCBA.
- B. Using A Nutdriver, remove six Mounting Nuts, and remove the Operator Control Panel PCBA.

To replace: Reverse removal procedure. Align the PCBA so that switch actuators can be moved freely in the openings in the Front Panel.

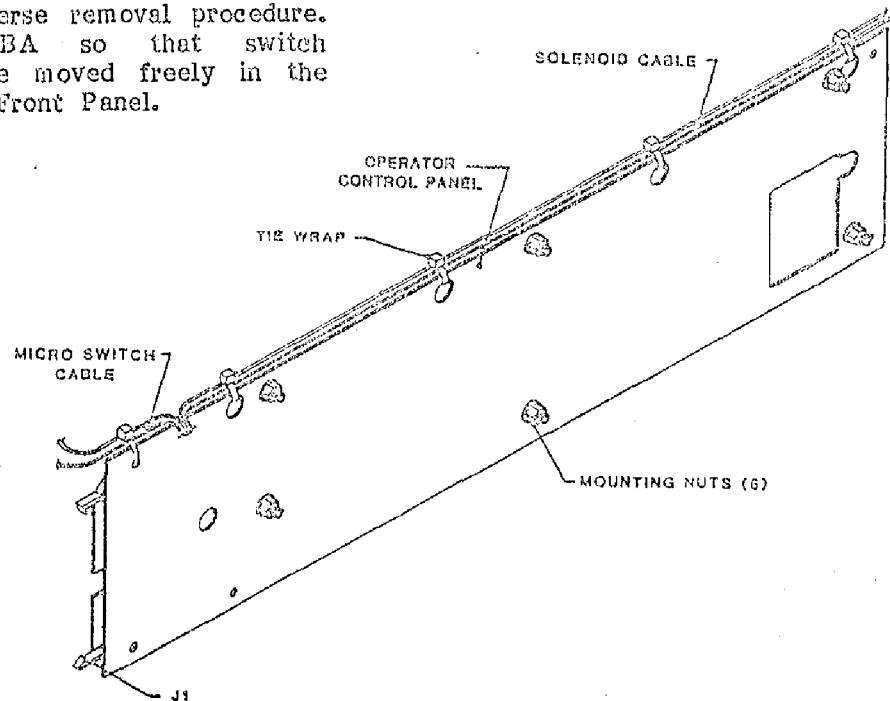

Figure 5-10. Operator Control Panel PCBA

5.3.13 EMI FILTER

Refer to Section VI, Figure 6-4 for illustration of EMI Filter.

- A. Turn off AC power and disconnect Line Cord from the AC power source.
- B. Lift Deck Assembly into Maintenance Position per 5.2.2.
- C. Disconnect input and output wires from EMI Filter.
- D. Remove two screws and remove EMI Filter.

To replace: Reverse removal procedure.

5.3.14 REEL-IN-PLACE SENSOR ASSEMBLY (Fig. 5-11)

Refer to Figure 6-2 for top view location of Sensor Assemblies.

- A. Remove two Phillips screws and two Spacers.
- B. Cut away Tie Wraps, and unplug the Cable from J13 on the interconnect PCBA.
- C. Remove the Reel-In-Place Sensor Assembly.

To replace: Reverse removal procedure. Align the Reel In Place Sensor Assembly centered within the chassis flanges and parallel with the Flange Surfaces, and with the specified space between the Sensor Assembly and the Sensor Tab. Torque Mounting Screws to 7 +/-1 inch-pounds.

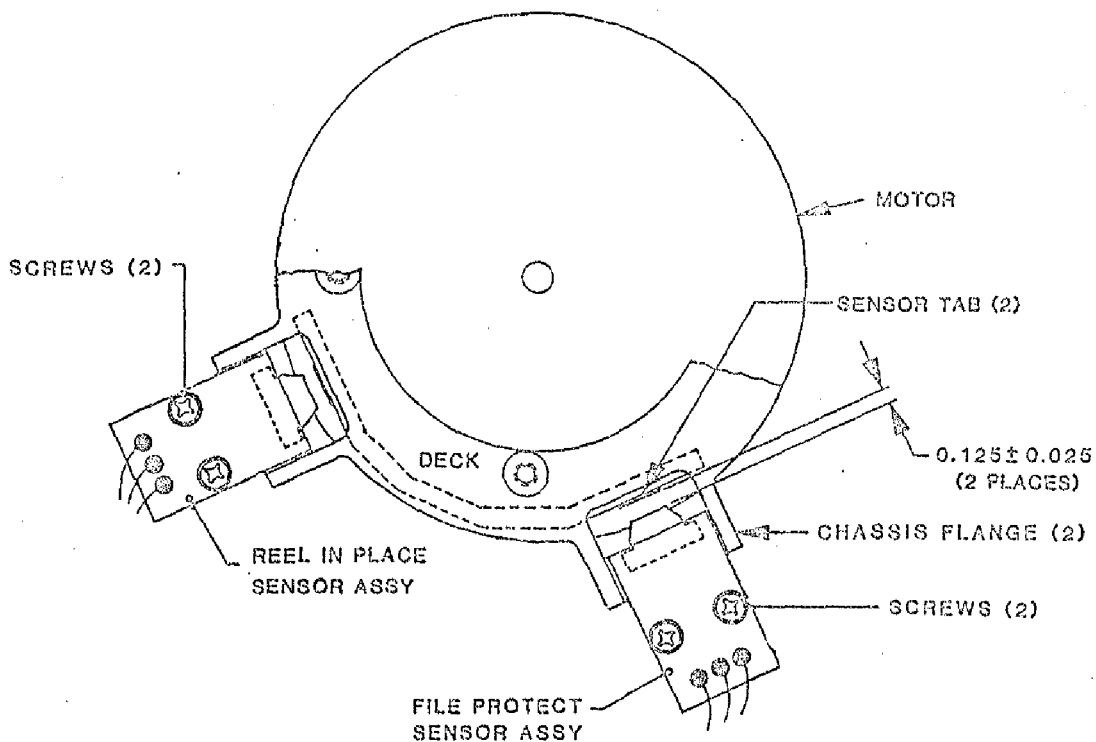

Figure 5-11. File-Protect and Reel-In-Place Sensor Assemblies (Bottom View)

5.3.15 FILE-PROTECT SENSOR ASSEMBLY (Fig. 5-11)

Refer to Figure 6-2 for top view location of Sensor Assemblies.

- A. Remove two Phillips screws and two Spacers.
- B. Cut away Tie Wraps, and unplug the Cable from J12 on the interconnect PCBA.
- C. Remove the File Protect Sensor Assembly.

To replace: Reverse removal procedure. Align the Reel In Place Sensor Assembly centered within the chassis flanges and parallel with the Flange Surfaces, and with the specified space between the Sensor Assembly and the Sensor Tab. Torque Mounting Screws to 7 +/-1 inch-pounds.

5.3.16 SUPPLY ARM LIMIT SENSOR (Figure 5-12)

- A. Open Top Cover of the Drive per 5.2.2.
Remove 3 phillips screws, and lift off the plate that covers the Supply Arm (Ref Figure 6-2).
 - C. Remove 2 Phillips screws that hold the Limit Sensor to its Mounting Plate.
 - D. Raise the Deck to Maintenance Position per 5.2.2.
 - E. Unplug Connector P16 from the Interconnect PCBA.
 - F. Remove two Cable Clamps from edge of Interconnect Board.
 - G. Remove three Screws and move the Interconnect Board and its Mounting Plate out of the way.
 - H. Remove tie wraps as necessary, and remove the Sensor.
- To replace: Reverse removal procedure.
No adjustment required.

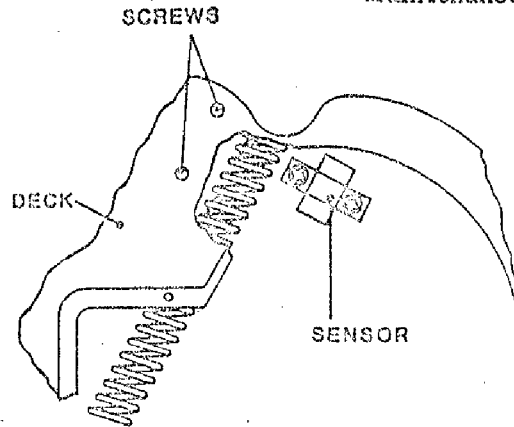

Figure 5-12. Supply Arm Limit Sensor

5.3.17 TAKE-UP ARM LIMIT SENSOR (Figure 5-13)

- A. Open Top Cover of Drive and raise Deck to Maintenance Position per 5.2.2.
 - B. Remove 2 Phillips screws that hold the Limit Sensor to the Mounting Bracket.
 - C. Unplug Connector P15 from the Interconnect Board and remove tie wraps.
 - D. Remove pins from connector housing, and pull the cable through the grommet in the Deck.
 - E. Remove two bolts and remove the Sensor from Sensor Bracket
- To replace: Reverse removal procedure.
Adjust per specifications illustrated. If it is necessary to adjust the Sensor Bracket, to access the Screws that hold the Bracket to the Deck, remove the Lower Screw from the Deck Cover Hinge, and open the Deck Cover as far as it will go.

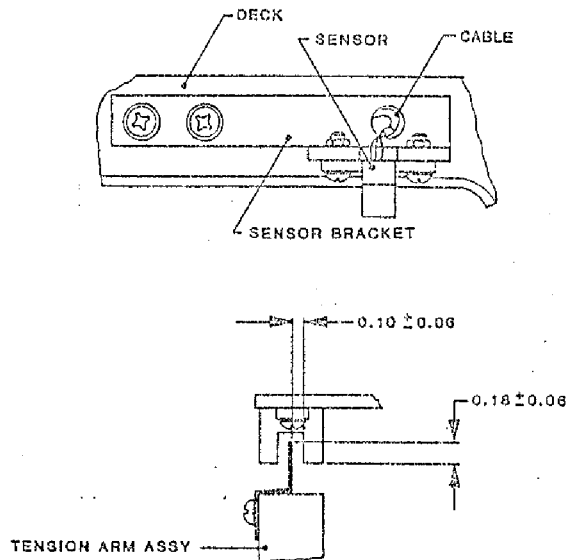

Figure 5-13. Take-up Arm Limit Sensor

5.3.13 12-VDC REGULATOR ASSEMBLY (Fig. 5-14)

- A. Remove 2 Phillips screws that hold the Heat Sink to the Deck.
- B. Unplug connector J1, and remove the Assembly and the Spacer under the Assembly.

To replace: Reverse removal procedure.

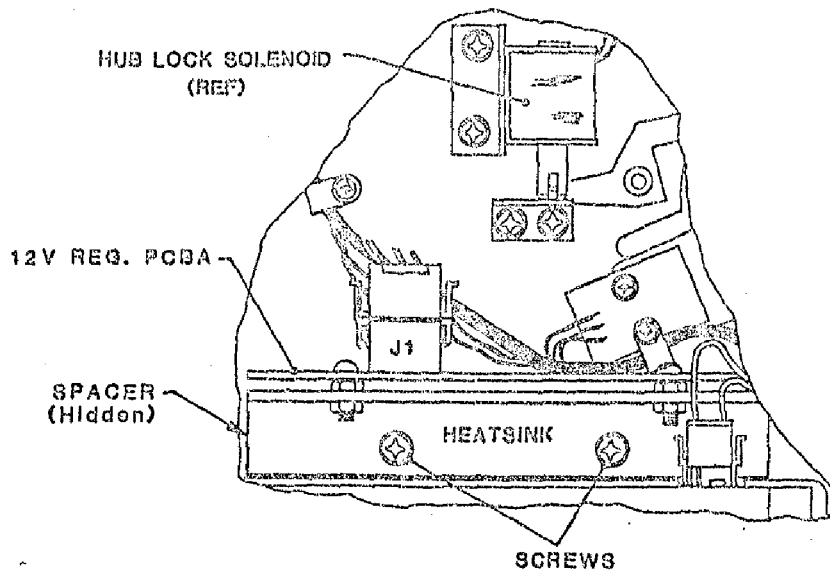

Figure 5-14. 12-VDC Regulator Power Supply

5.3.19 5-VDC REGULATOR POWER SUPPLY (Fig. 5-15)

- A. Lift the Deck and secure it in Maintenance Position per 5.2.2.
- B. Unplug the five connectors indicated in Figure 5-15 from the Power Supply.
- C. Remove four kepsnuts that hold the Power Supply Bracket to the Chassis, and remove Power Supply.

To replace: Reverse removal procedure. Connectors Cables route as follows:

- | | |
|-----------------------------|-------------------------------|
| J1 to Power Transformer | J5 to Drive Electronics Board |
| J3 to 12VDC Regulator | J6 to Mother Board |
| J4 to Servo Power Amplifier | |

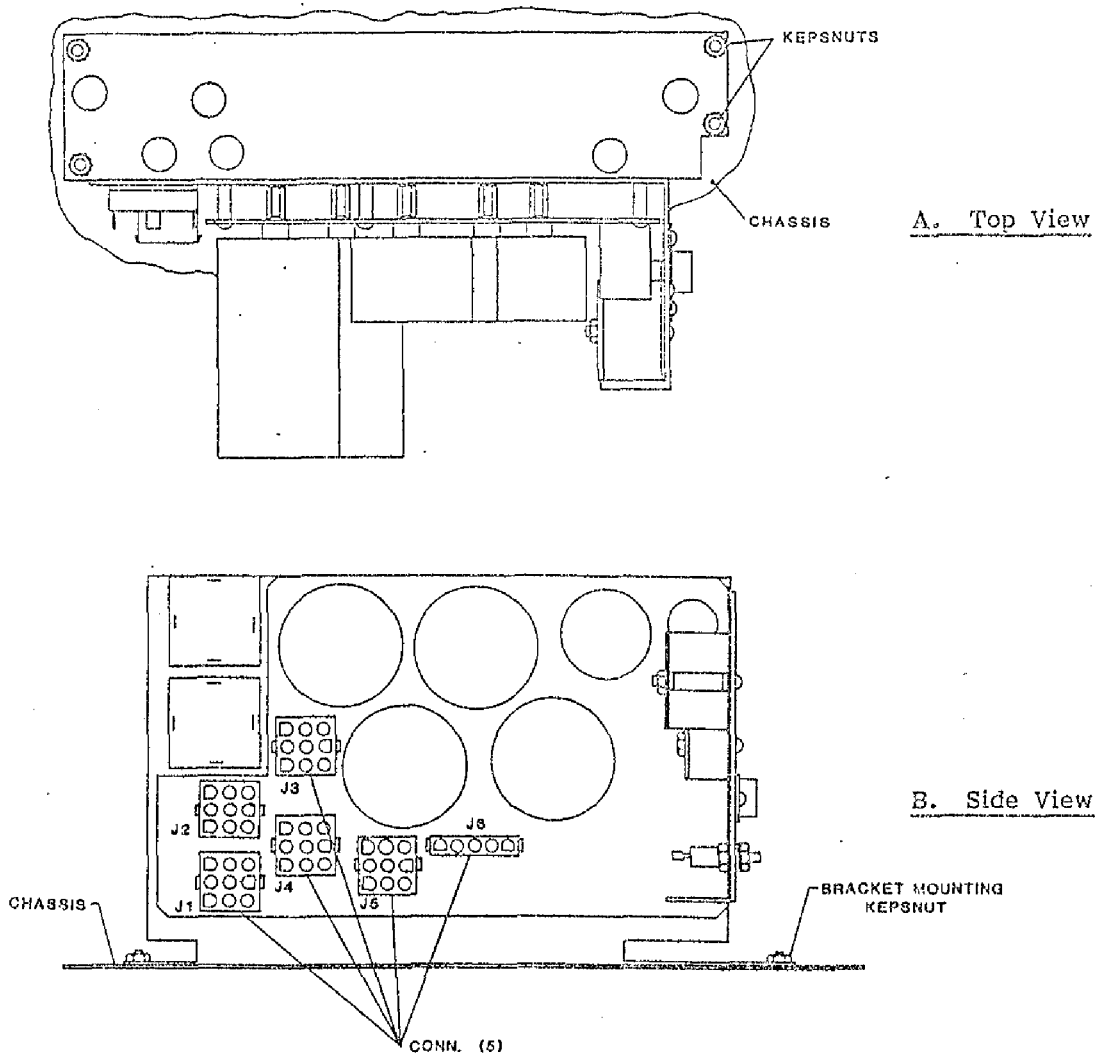

Figure 5-15. 5-VDC Regulator Power Supply

5.3.20 SERVO AMPLIFIER ASSEMBLY

The Servo Amplifier Assembly Figure 5-16) consists of Servo Power Amplifier PCBA P/N 90-07111-XXX mounted on a Heatsink, and Servo Preamplifier PCBA P/N 90-07147-XXX. The Servo Amplifier Assembly is mounted on the inside surface of the Chassis as illustrated in Figure 6-4. Remove the Servo Amplifier Assembly as follows:

- A. Raise the Deck Assembly to Maintenance Position per 5.2.2.
- B. Remove top left transformer lamination securing bolt from Power Transformer.
- C. Unplug Power (J1) , Control (J1) , and Motor Drive (J2) Connectors.
- D. Remove two Phillips Head Screw that hold the Servo Power Amplifier to the side of the Chassis.
- E. Remove two Nuts that hold the Heatsink to the floor of the Chassis.
- F. Lift the Servo Amplifier Assembly up and off the Spacer and Mounting Studs.

To replace: Reverse removal procedure. Adjust RL SERVO per paragraph 5.3.3.

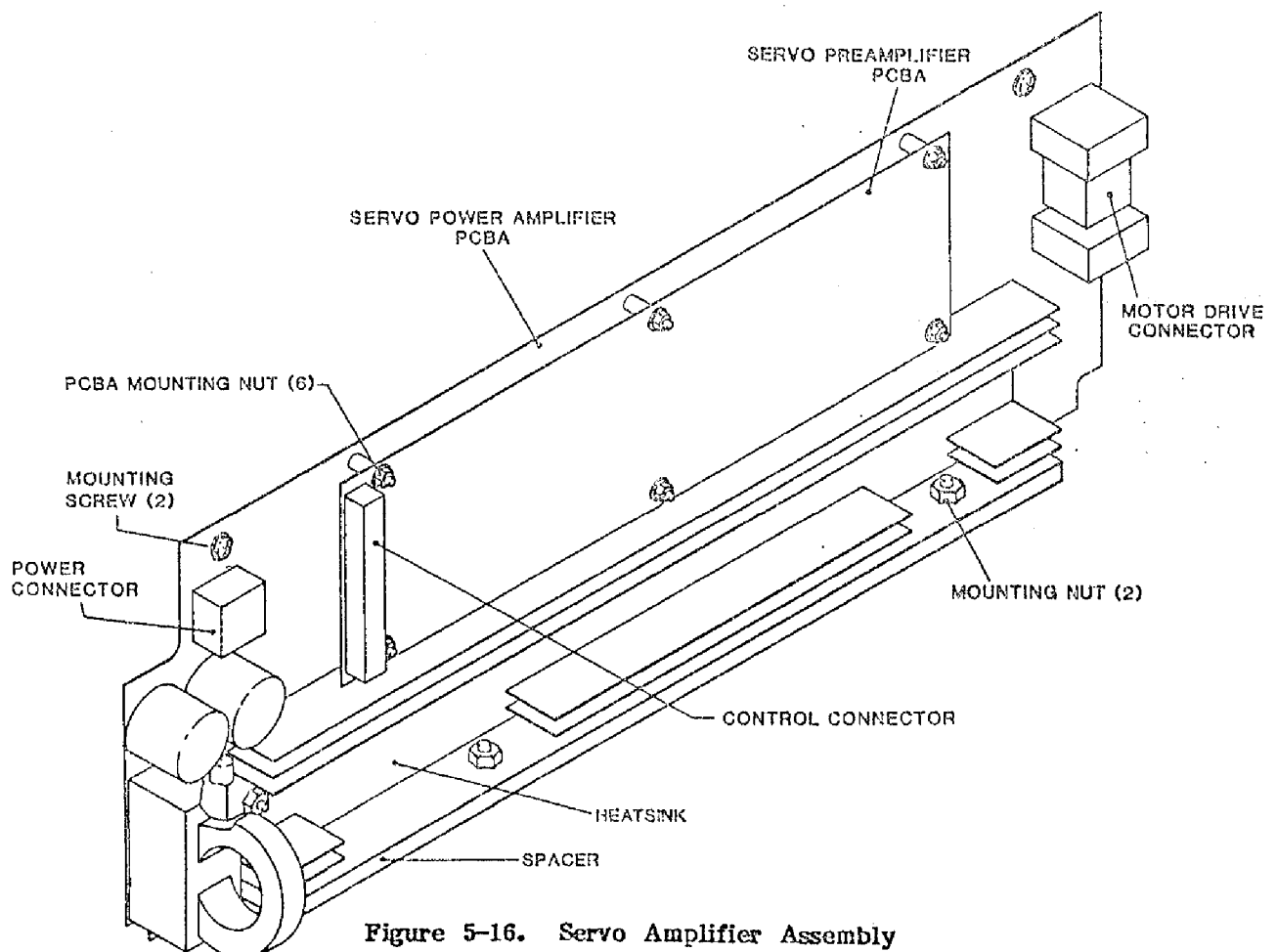

Figure 5-16. Servo Amplifier Assembly

5.3.21 BLOWER ASSEMBLY (Fig. 5-17)

- A. Remove eight Phillips Screws that secure the Blower Assembly Cover to the Blower Assembly, and remove the Cover.
- B. Remove the Take-up Reel Assembly per paragraph 5.3.7 (to access Blower Assembly Mounting Screws).
- C. Unplug the two Reel Motor Connectors.
- D. Unplug the Control Cable Connector from the Power Amplifier.
- E. Remove twelve Phillips Screws that attach the Blower Assembly to the Deck (these screws are accessible from the top of the Deck).
- F. Remove the Blower Assembly.

To replace: Reverse removal procedure.

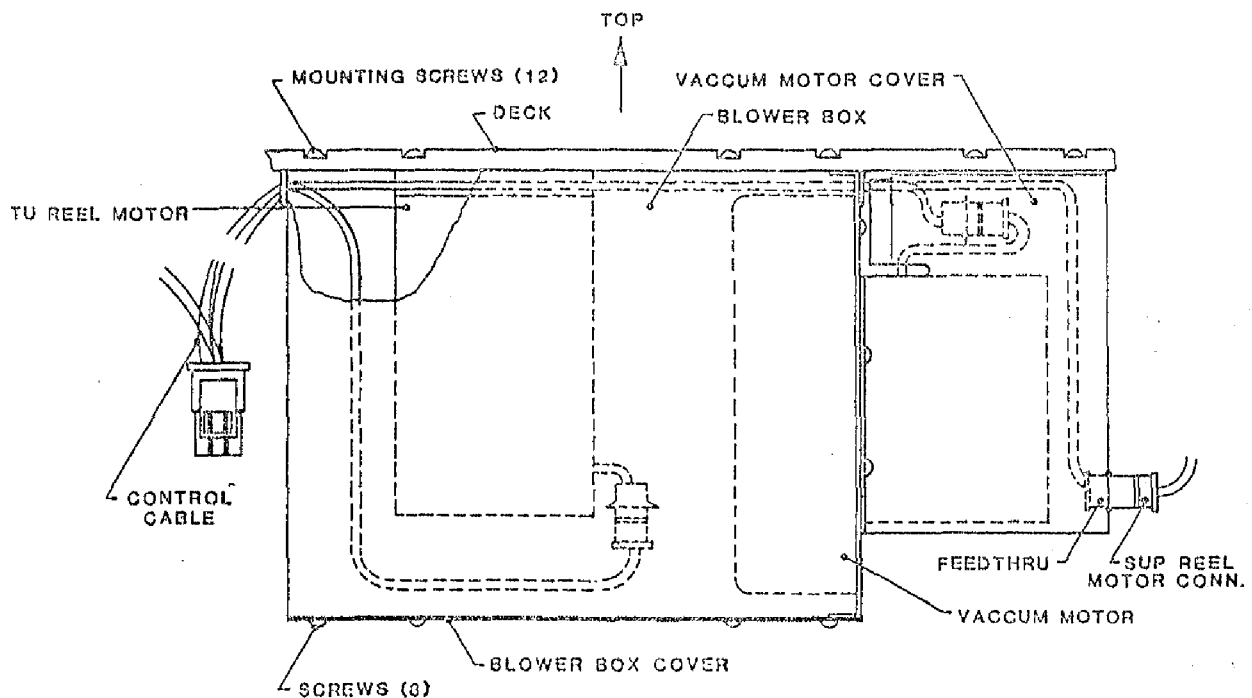

Figure 5-17. Blower Assembly

5.3.22 PANEL ASSY, DOOR MICROSWITCH, AND DOOR LOCK SOLENOID (Fig 5-18)

A. Remove four Phillips screws (two at each side) that attach the Panel Mount Angle Brackets to the Deck.

B. Slide the Panel forward, and disconnect wires from AC Power Switch.

C. Remove Connector P1 from the Operator Control Panel. When the Panel is clear, slide the Panel back away from the Deck.

D. Using a Phillips Screwdriver, as desired, remove the Door Microswitch or the Door Lock Solenoid:

1. For Microswitch, lower the Access Door and remove two Mounting Screw (Go to 3).

2. For Solenoid, remove two Bracket Mounting Screws that attach the Solenoid to the Panel Assembly (Go to 3).

3. Pull Item away from Panel Assembly and disconnect wires. For Solenoid, remove Solenoid from Mounting Bracket.

To replace: Reverse removal procedure. However, when removing the Solenoid, it was necessary to disturb the Hinge that connects the Door to the Panel Assembly. When replacing the Solenoid, before tightening the Mounting Bracket Screws, adjust the Door so that it fits correctly when closed.

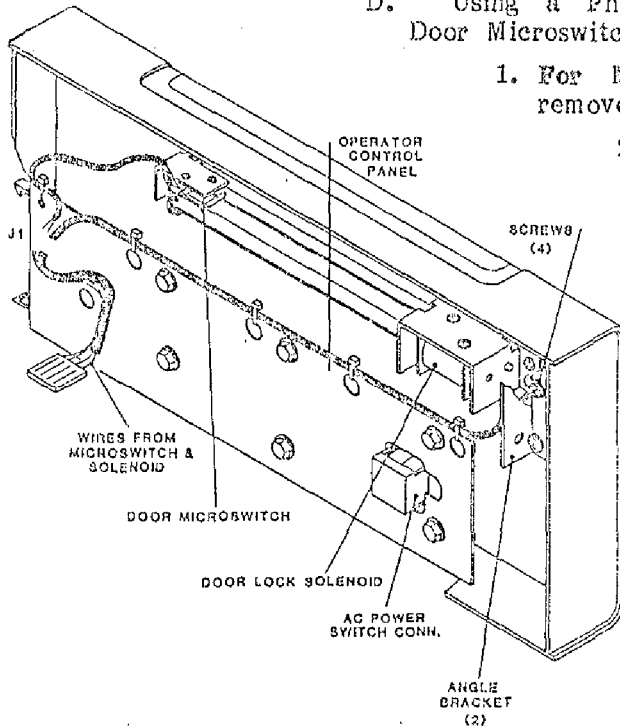

Figure 5-18. Panel Assembly

5.3.23 SUPPLY HUB ASSEMBLY (Figure 5-19)

A. Open Top Cover per 5.2.2.

B. Remove two Screws and remove Hub Cap.

C. Remove two Hub Mounting Screws.

D. Grasp the edges of the Hub firmly and pull upwards.

To replace: Reverse removal procedure.

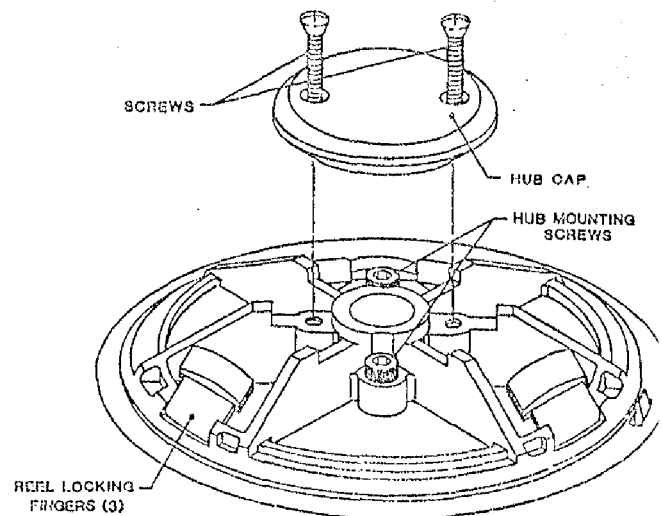

Figure 5-19. Supply Hub Assembly

5.3.24 FLUX GATE (Figure 5-20)

CAUTION: Do not disturb the two Nuts that hold the Flux Gate to the Mounting Block. To do so could throw the Flux Gate out of adjustment.

- A. Set the Drive so that the Buffer Arms are positioned all the way to the Limit Sensors (Buffer Arms fully retracted). This can be done by turning the Drive ON with no tape installed.
 - B. Turn the Drive OFF.
 - C. Tape a piece of plastic foam over the sensing surface of the Magnetic Head.
 - D. Raise the Deck to Maintenance Position per 5.2.2.
 - E. Loosen the Set Screw that holds the Spring at the base of the Flux Gate Shaft, and remove the Spring from the hole in the Shaft.
 - F. Using Snap Ring Pliers, remove Retainer Ring.
 - G. Slide the Flux Gate Shaft out of the Mounting Plate.
- To Replace: Reverse removal procedure.

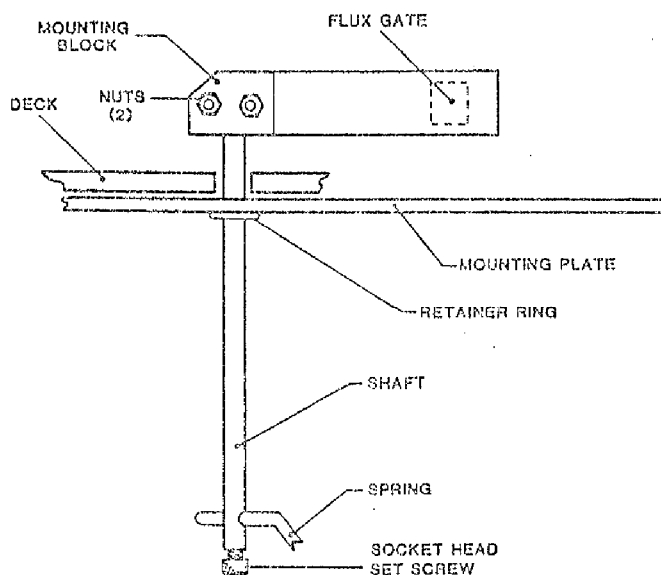

Figure 5-20.
Flux Gate Removal

5.3.25 CAPSTAN (Figure 5-21)

- A. Remove Hex-Head Screw and Washer from the center of the Capstan Wheel.
- B. Slide the Capstan Puller P/N 54-00100-001 over the Hub Flange. Tighten Thumb Screw to loosen the Capstan, and remove Capstan.

To replace: Reverse removal procedure.

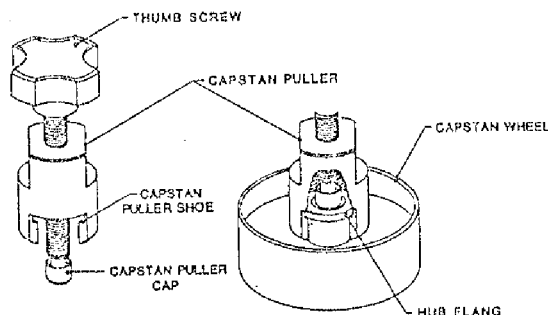

Figure 5-21.
Capstan Removal

CAUTION: Removing Capstan without a Capstan Puller could damage the Capstan. If Capstan is removed without a Puller, it is advisable to replace the Capstan.

5.3.26 CAPSTAN MOTOR

If the Capstan Motor is defective, and the Capstan Motor Mounting Plate is in good condition, replace the Capstan Motor as follows (DO NOT DISTURB THE MOUNTING OR ADJUSTMENT SCREWS FOR THE MOUNTING PLATE): (If the Mounting Plate is damaged, see paragraph 5.3.27.)

- A. Unplug two wires from the Capstan Motor, and unplug the Tachometer Cable from J6 on the Interconnect Board (remove tie wraps as required).
- B. Remove Capstan per 5.3.25.
- C. While supporting the Capstan Motor from below Deck, remove four Mounting Screws that hold the Capstan Motor to the Capstan Motor Mounting Plate.
- D. Lower and remove the Capstan Motor from the Deck.
- E. Calibrate the Capstan Servo per Section 5.5.3.

To replace: Remove Capstan and Capstan Motor Mounting Plate from Spare Capstan Motor Assembly. Reverse removal procedure. If the Capstan Motor Mounting Plate (still mounted on Deck) has not been damaged or disturbed, no adjustment is necessary.

5.3.27. CAPSTAN MOTOR ASSEMBLY (Figure 5-22)

Replace Capstan Motor Assembly ONLY IF CAPSTAN MOTOR MOUNTING PLATE IS DAMAGED OR DISTURBED:

- A. Unplug two wires from the Capstan Motor, and unplug the Tachometer Cable from J6 on the Interconnect Board (remove tie wraps as required).
- B. Remove three Phillips screws that hold the Capstan Assembly to the Deck (Access from the top).
- C. Remove the Capstan Motor Assembly by lowering it through the Deck. Retain the Spacer Washer that was between the Deck and the triangular Capstan Motor Mounting Plate. Note its position.

To replace: Reverse removal procedure. Adjust Capstan as follows:

Capstan Adjustment

The Capstan Motor is suspended on a triangular Mounting Plate, one corner of which is held firmly in place by a Mounting Screw, while the other two corners are held in place by the clamping action of two other Mounting Screws and the Lock Screws (See Detail A-A). Adjustment of the Capstan consists of adjusting the gap between the two adjustable corners of the Mounting Plate and the Deck Plate. Proceed as follows:

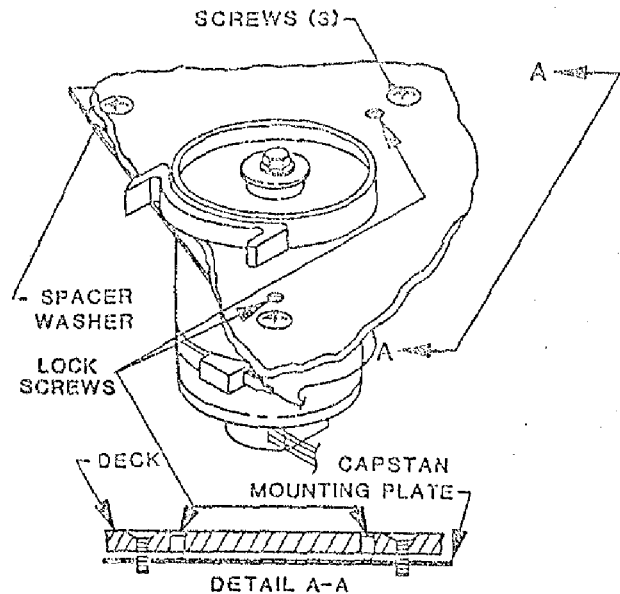
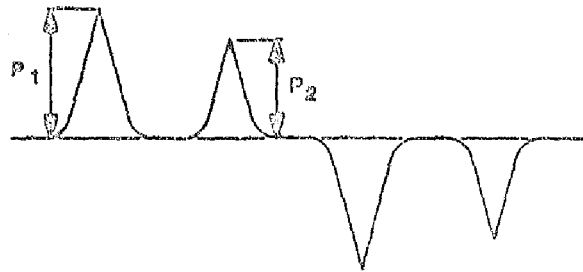

Figure 5-22. Capstan Motor Assembly

- A. Tighten the Mounting Screw located at the center point of the Buffer Arm path to 8 +/-1 inch-pounds.
- B. Tighten the remaining two Mounting Screws until the Capstan Motor Mounting Plate rests lightly against the two Lock Screws.
- C. From this point, adjust the Capstan per the following Procedure 1 or Procedure 2:

Procedure 1. (The more accurate procedure)

- a. Install and load a write-protected Pericomp Tracking Tape (Pericomp P/N TRK06884).
- b. Using Data Diagnostics in the Diagnostics Menu, select MODE, SPEED, 50 IPS; then, COMMAND, READ. With Front Panel DENSITY Switch, set Density to 800 CPI.
- c. Connect the vertical input of an Oscilloscope to TP 501 on Read Analog Board 9017. Set Oscilloscope controls to: Vert 0.2v/div, Horiz 0.1uSec/div.
- d. Press START/STOP to start the Read Operation selected. The display on the Oscilloscope should be as illustrated:



Capstan Tracking Waveform

- e. Adjust the Scope Vertical Gain to obtain a waveform amplitude of the higher peak (P1) of 5 cm. The amplitude of the lower waveform (P2) should be ~80% of the higher waveform.
- f. If waveform fails to meet the specification per Step e, **loosen** one of the **Lock Screws** slightly, and **tighten** the associated **Mounting Screw**, noting the effect on the waveform. If adverse, return Adjustment Screw and Mounting Screw to their original positions and repeat this step with the other Mounting Screw and Adjustment Screw. **NOTE:** During this adjustment, if necessary, readjust Scope Vertical Gain to keep higher peak at 5 cm.
- g. If in Step f the Capstan cannot be adjusted per specification, **Loosen** one of the **Mounting Screws** and **tighten** the associated **Lock Screw**. Then repeat as necessary with the other Mounting Screw and Lock Screw. **NOTE:** During this adjustment, if necessary, readjust Scope Vertical Gain to keep higher peak at 5 cm.
- h. Repeat Steps f and g until correct waveform relationship is obtained.

Procedure 2: (Do this Procedure only if Tracking Tape is not available)

- a. Install and load a reel of tape.
- b. Using the Diagnostic Menu and, while observing the tape as it runs over the Capstan, run tape in Forward/Reverse/Forward Mode at 50 ips.
Tape should run smoothly over the Capstan less than +/-0.01 inch sideward movement. If sideward movement is within tolerance, do all three of the following Substeps. If sideward movement is excessive, start with Substep 3.
 1. Evenly tighten the two Lock Screws.
 2. Recheck sideward movement. If satisfactory, adjustment is complete, omit the remaining steps in this procedure. If sideward movement is excessive, proceed with the following steps.
 3. With tape moving in Fwd/Rev/Fwd Mode, loosen one of the Lock Screws slightly, and tighten the associated Mounting Screw, noting its effect on lateral tape movement. If adverse, return Adjustment Screw and Mounting Screw to original positions and repeat this step with the other Mounting Screw and Adjustment Screw.
 4. Repeat Substeps 1 to 3 until adjustment is satisfactory or, if in Substep 3, proper adjustment cannot be obtained, loosen one of the Mounting Screws and tighten the associated Lock Screw. Then repeat as necessary with the other Mounting and Lock Screws.
 5. Calibrate the Capstan Servo per Section 5.5.3.

5.3.28 BOT/EOT SENSOR ASSEMBLY (Fig. 5-23)

- A. Raise the Deck Assembly to Maintenance Position per paragraph 5.2.2.
- B. Noting orientation of Connector in Receptacle, unplug the Connector from J9 on the Interconnect Board (Remove Tie Wraps as required).
- C. Noting wire color orientation, using a small common screwdriver, remove the pins from the cable connector.
- D. Remove three Phillips Screws from Plate on which the Interconnect Board is mounted, and move the Plate and Interconnect Board out of the way.
- E. Remove two Phillips Screws that hold the Sensor in place.
- F. Remove the Sensor and pull wires through the hole in the Deck.

To replace: Reverse removal procedure: Reconnect pins with wire color oriented as illustrated, and as noted in Step C. Plug Connector into Receptacle properly oriented as noted in Step B.

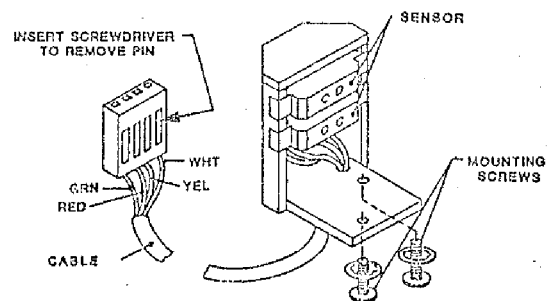

**Figure 5-23. EOT/BOT
Sensor Assembly**

5.3.29 TAPE-IN-CHANNEL EMITTER AND TAPE-IN-CHANNEL SENSOR ASSEMBLIES (Fig. 5-24)

- A. Lift the Deck Assembly and latch it in Maintenance Position.
- B. To remove Tape-In-Channel Emitter Assembly only:
1. Unplug Connector J10 from the Interconnect Board.
 2. Using a small common screwdriver, remove the two Pins from the Connector Housing. Note their positions.
 3. Remove two Cable Clamps from edge of Interconnect Board.
 4. Remove the three screws securing the Interconnect Board Mounting Plate to the Deck. Pull the Interconnect Board and its Mounting Plate away from the Deck.
 5. Cut the Tie Wraps that hold the two wires in the Harness Assembly.
 6. Remove the Emitter Assembly Mounting Screw through the opening provided by removal of the Interconnect Board.
 7. Remove the Emitter Assembly through the top of the Deck, bringing the two wires up with the Assembly: Push each Connector Pin through the hole in the Deck one at a time.
- C. To remove Tape-In-Channel Sensor Assembly only:
1. Unplug J11 from the Interconnect Board.
 2. Do Steps B.2 thru B.5 above.
 3. Remove the Sensor Assembly Mounting Screw through the opening provided by removal of the Interconnect Board.
 5. Cut the Tie Wraps that hold the two wires in the Harness Assembly.
 6. Pull the Sensor Assembly through the top of the Deck, pushing the wires through the opening one at a time.

To replace: Reverse removal procedure. Insert a 2-inch straight piece of wire into the holes provided in the Sensor and Emitter Assemblies, and align the Emitter with Sensor Assemblies by pointing the two wires directly at one another. Then, tighten the Assembly Mounting Screw to 3.5 +/-0.5 inch-pounds.

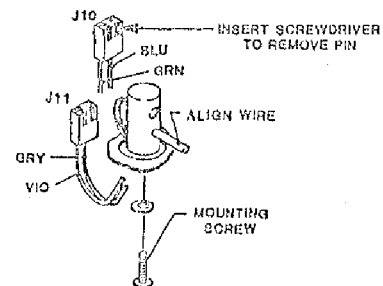

Figure 5-24.
Tape-In-Channel
Emitter Assembly
and Sensor Assembly

5.3.30 VACUUM MOTOR ASSEMBLY (Figure 5-25)

- Remove the Blower Assembly per paragraph 5.3.21.
- Remove four Phillips screws that hold the Vacuum Motor Cover to the Blower Box.
- Lift the Vacuum Motor Cover from the Blower Box, disconnect the Feedthru Connector from the Vacuum Motor Cover, and remove the Vacuum Motor Cover.
- Unplug the Vacuum Motor Connector.
- Remove four Phillips Screws that hold the Vacuum Motor to the Blower Box
- Cut Tie Wraps and remove Vacuum Motor Assembly from the Blower Box.

To replace: Reverse removal procedure.

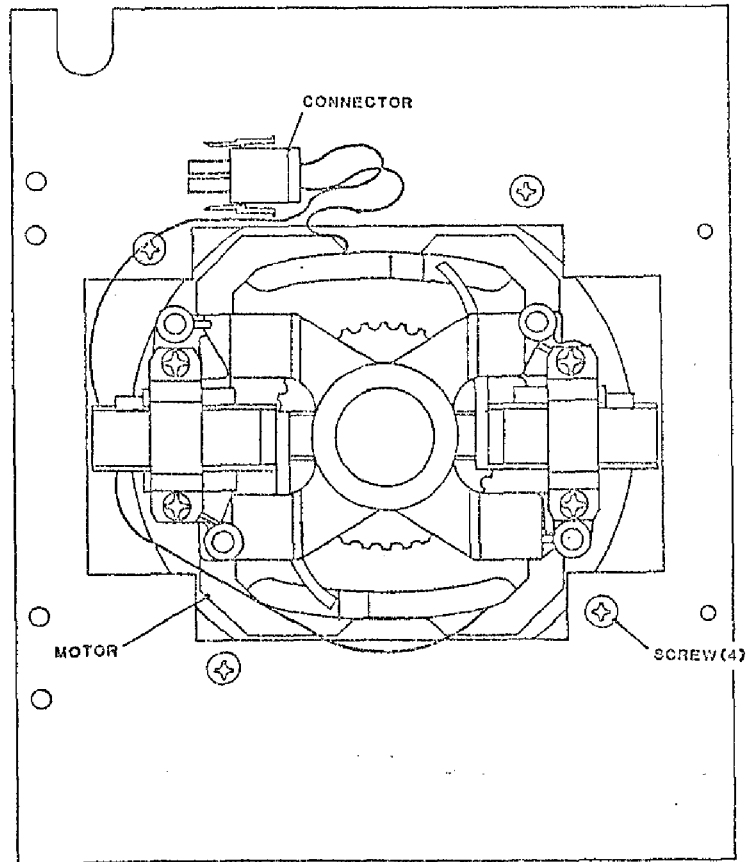

Figure 5-25. Vacuum Motor Assembly, Shaft End View (Cover Removed)

5.3.31 SUPPLY REEL MOTOR ASSEMBLY (Figure 5-26)

- A. Remove Supply Hub Assembly per paragraph 5.3.23.
- B. Remove four Phillips screws that attach The Reel Motor to the Deck.
- C. Unplug the Reel Motor Connector and remove the Reel Motor Assembly.
- D. Remove Collet from Reel Motor Assembly and transfer to new Reel Motor Assembly.

To replace: Reverse removal procedure. Adjust Collet with Collet Height Adjustment Tool P/N 54-00106-001:

- a. Mount the Tool on the Collet. Tighten the Tool Mounting Screws.
- b. Slide the Collet and Tool onto the Motor Shaft. Let the Spacer Pins rest on the surface of the Motor.
- c. Tighten the Collet Set Screw, and remove the Tool.
- d. Adjust RL SERVO per paragraph 5.5.3.

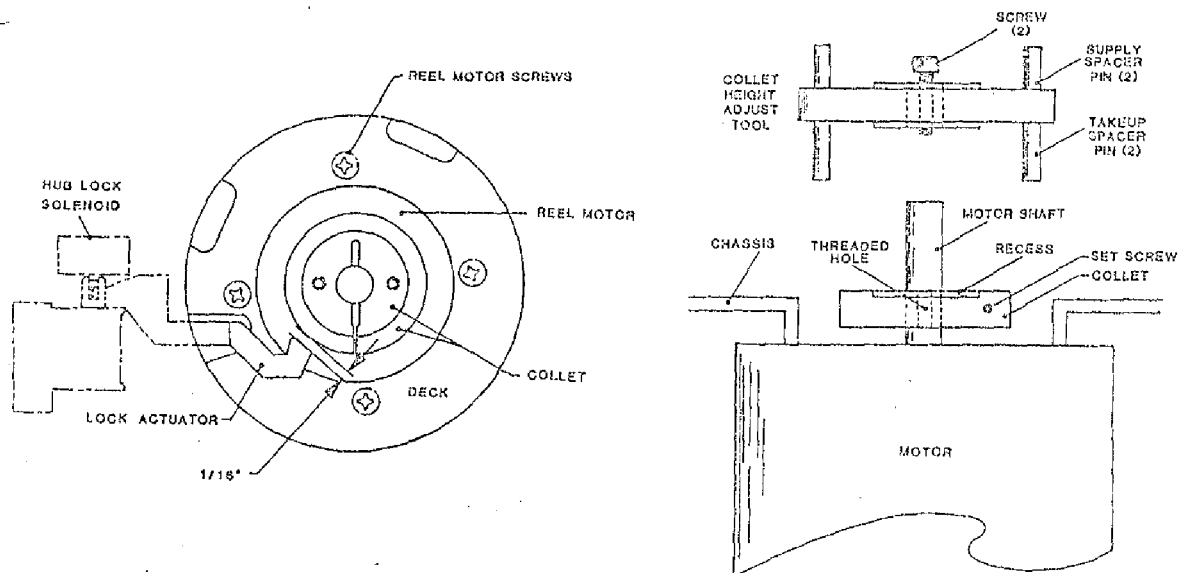

Figure 5-26. Supply Reel Motor Assembly

5.3.32 TAKE-UP REEL MOTOR ASSEMBLY

- A. Remove Take-up Reel Assembly per paragraph 5.3.7.
- B. Lift Deck Assembly and latch it in Maintenance Position.
- C. Remove eight Phillips Screws and remove Cover from Blower Box.
- D. Remove four Phillips Motor Mounting Screws (same as in Fig 5-26) and lower the Reel Motor enough to access the Motor Connector inside the Blower Box.
- E. Disconnect Motor Connector, and remove the Reel Motor.

To replace: Reverse removal procedure. Adjust Collet per 5.3.31. Adjust RL SERVO per paragraph 5.3.3.

5.3.33 MAGNETIC HEAD ASSEMBLY (Figure 5-27)

- A. Remove two Phillips head screws and remove Card Cage Cover.
- B. Unplug Erase Cable from the Read/Write Digital Board (9060)(Ref Fig. 6-5).
- C. Lift Deck Assembly to Maintenance Position per 5.2.2.
- D. Cut the tie wraps that secure the Erase Cable.
- E. Remove the Read Preamp-
lifier per paragraph 5.3.5.
- F. Unlatch and lower the Deck Assembly.
- G. Open the Top Cover per 5.2.2 and brace it open.
- H. Open the Tape Path Cover and pull the Erase Cable through the Deck.
- I. Disconnect the Write Cable from the Magnetic Head
- J. With a $7/64$ -inch Hex Wrench, remove the screw that holds the Magnetic Head; and remove the Magnetic Head.

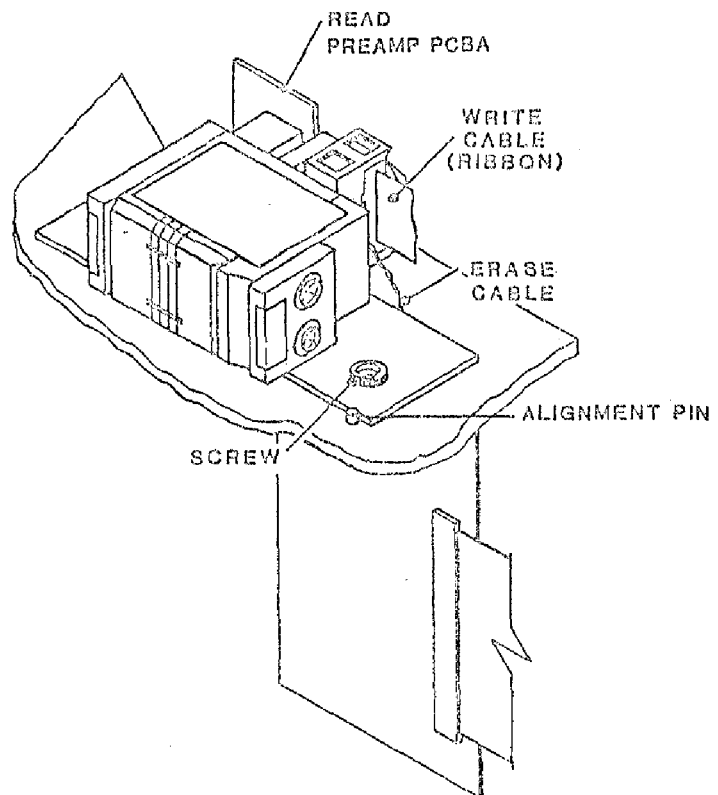

Figure 5-27.
Magnetic Head Assembly and Read Preamp PCBA

To replace: Reverse removal procedure. Be sure that the Magnetic Head is pushed tightly against the Alignment Pin before tightening the Hex Screw that holds the Head Plate. Adjust Read Skew per paragraph 5.4.2.9.2, Step D.

5.3.34 TAPE GUIDE REPLACEMENT (Figure 5-28)

Special Tool Required: Alignment Tool P/N 54-00103-001.

- A. Using a Hex Wrench, remove Mounting Screw and the applicable Tape Guide.
- B. Install new Tape Guide; but leave Mounting Screw loose.
- C. Align the Tape Guide by inserting the pins on the Alignment Tool into the holes in the top of both Tape Guides as illustrated. The Alignment Pins should insert all the way into the holes in the Tape Guides, and the Access Holes in the Tool should align with the Tape Guide Mounting Screws.
- D. Tighten the Mounting Screw by inserting the Hex Wrench through the Access Hole in the Alignment Tool.

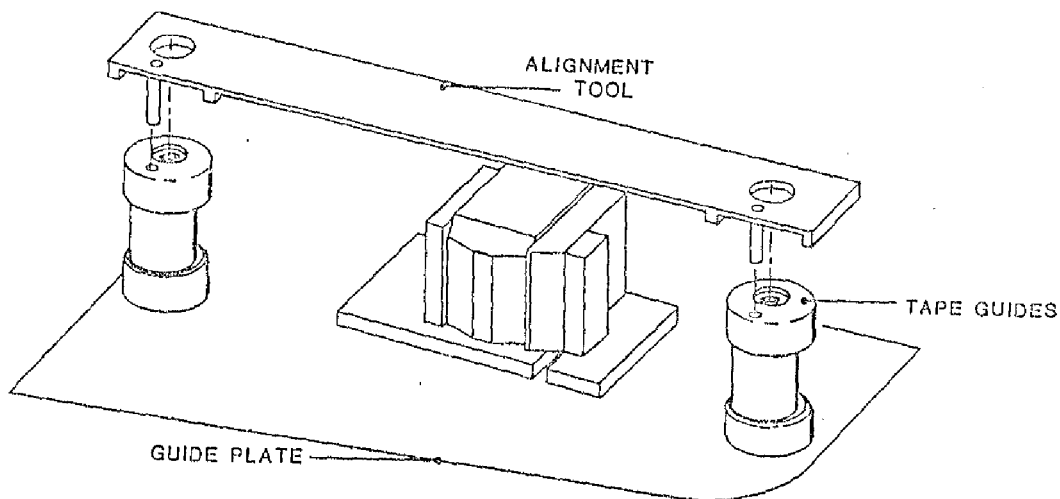

Figure 5-28. Tape Guide Alignment

5.4 ADJUSTMENTS

5.4.1 PRELIMINARY CHECKOUT

Power Supply Check: Verify Power Supply operation as follows:

- A. Raise the Deck Assembly to Maintenance Position per 5.2.2.
- B. Disconnect Power Connectors P4 from the Drive-Electronics PCBA and P1 from the Servo Power Amplifier PCBA.
- C. Connect the -AC Power Connector to the Drive and an AC outlet, and turn on AC power.
- D. Using a digital voltmeter, verify voltages at Power Connectors as follows:

<u>Conn</u>	<u>Pin</u>	<u>Voltage</u>	<u>Tolerance</u>	<u>Conn</u>	<u>Pin</u>	<u>Voltage</u>	<u>Tolerance</u>
P4	1	+5	+0.25/-0.05	P4	7	-50	+/-7.5V
P4	2	+12	+/-0.5	P4	8	+50	+/-7.5V
P4	3	-12	+/-0.5	P4	9	+24	+/-4.0V
				P3	1	-24	+/-4.0V

- E. Turn AC power off and Wait about 10 seconds; then reconnect Power Connectors P4 and P1 to Drive Electronics and Servo Power Amplifier PCBAs.

5.4.2 BUFFER ARMS ADJUSTMENT

5.4.2.1 BUFFER ARM ROLLERS & FIXED ROLLERS HEIGHT ADJUSTMENT (Fig 5-29)

- A. **General:** Height adjustment of the Fixed Rollers and Buffer Arm Rollers require the use of special Height Adjustment Gauge P/N 54-00104-001. Whenever one of these components is replaced, or its height disturbed, it must be checked for proper height and adjusted as necessary.

The Height Adjustment Gauge (Gauge) is a type of template that bolts onto the Deck Assembly at three points, and spans over the two Fixed Rollers and the two Buffer Arm Rollers at a specified height. These Rollers must be adjusted vertically so that they just touch the underside surface of the Gauge.

- B. **Adjusting Buffer Arm Tape Roller Height:** Adjust the applicable Buffer Arm Tape Roller as follows:

Special Items Required: Set of Shims P/N 28-0066-001/-002/-003/-004/-005. These correspond to dimensions: .032/.062/.003/.005/.010 inch respectively.

1. Remove The Supply Hub per paragraph 5.3.23.
2. Remove the Reel Motor Mounting Screw nearest to the Hub Lock Solenoid (Figure 5-26).
3. Remove the Tape Guide Mounting Screw from each Tape Guide (Fig. 5-28).
4. Remove the Cap (Fig. 5-28) from each Tape Guide. Leave the rest of the Guide in place.
5. Turn AC power on.

CAUTION: LEAVE AC POWER ON UNTIL ALL ADJUSTMENTS ARE COMPLETE.

6. Place the Drive in Drive Adjust (DRV ADJ) Mode. The display should indicate: RELAXING, and the Buffer Arms should relax.

CAUTION: DO NOT TOUCH FRONT PANEL CONTROLS AFTER THIS POINT UNTIL INSTRUCTED TO DO SO.

7. Place the Gauge onto the Deck so that the three threaded Pins fit into the center holes in the two Tape Guides and the vacated Motor Mount Hole.
8. Screw the three Threaded Pins into the holes vacated (per Steps 2 and 3), move the two Feeler Arms so as to clear the two Fixed Tape Rollers, and tighten the Threaded Pins to secure the Gauge to the Deck.
9. Construct a 3-inch circumference loop of tap.
10. Place the Tape Loop around the Tape Roller on the Buffer Arm, and move the Buffer Arm until the Tape Loop is near the Retaining Pin on the Gauge. Then, lift the Retaining Pin and drop it into the Tape Loop so that the Buffer Arm is held in position by the Tape Loop and Retaining Pin. The upper surface of the Tape Roller should just contact the lower surface of the Gauge.
11. Rotate the Tape Roller. The Tape Roller should be barely touching the Gauge, and should rotate easily with no friction against the Gauge. Distance between the Gauge and the Roller should be less than 0.001-inch feeler. Check this with a common Feeler Gauge.
12. If the height per step 11 is incorrect, release the Buffer Arm from the Tape Loop and remove the Buffer Arm per 5.3.8, Steps B.5 and C, and add or remove a shim as necessary to adjust the height of the Tape Roller. Then replace the Arm and Retention Spring, and tighten the Clamp Bolt.
13. Repeat Steps 11 and 12 as necessary until height is satisfactory.

C. Adjusting the Fixed Tape Rollers: With the Height Gauge still mounted as described above (Step B. 1 thru 8), check, and as necessary adjust either Fixed Tape Roller as follows:

Special Items Required: Set of Shims P/N 28-0176-015/-017/-019/-020/-021, which correspond to Shim Thicknesses 0.001/0.003/0.005/0.010/0.020 inch respectively.

1. Rotate the Feeler Arm of the Gauge until it is positioned over the top surface of the Roller. If this cannot be done because the Roller is too high, remove the Roller and remove shim from beneath it. Then, replace the Roller.
2. Rotate the Roller under the Feeler Arm. The Roller should just contact the Feeler Arm and rotate with a no friction. Distance between Feeler Arm and the Roller should be less than 0.001 inch. Check this with a common Feeler Gauge.
3. If height per step 2 is incorrect, remove or add a shim as required, and repeat Step 2 and 3 until satisfied.

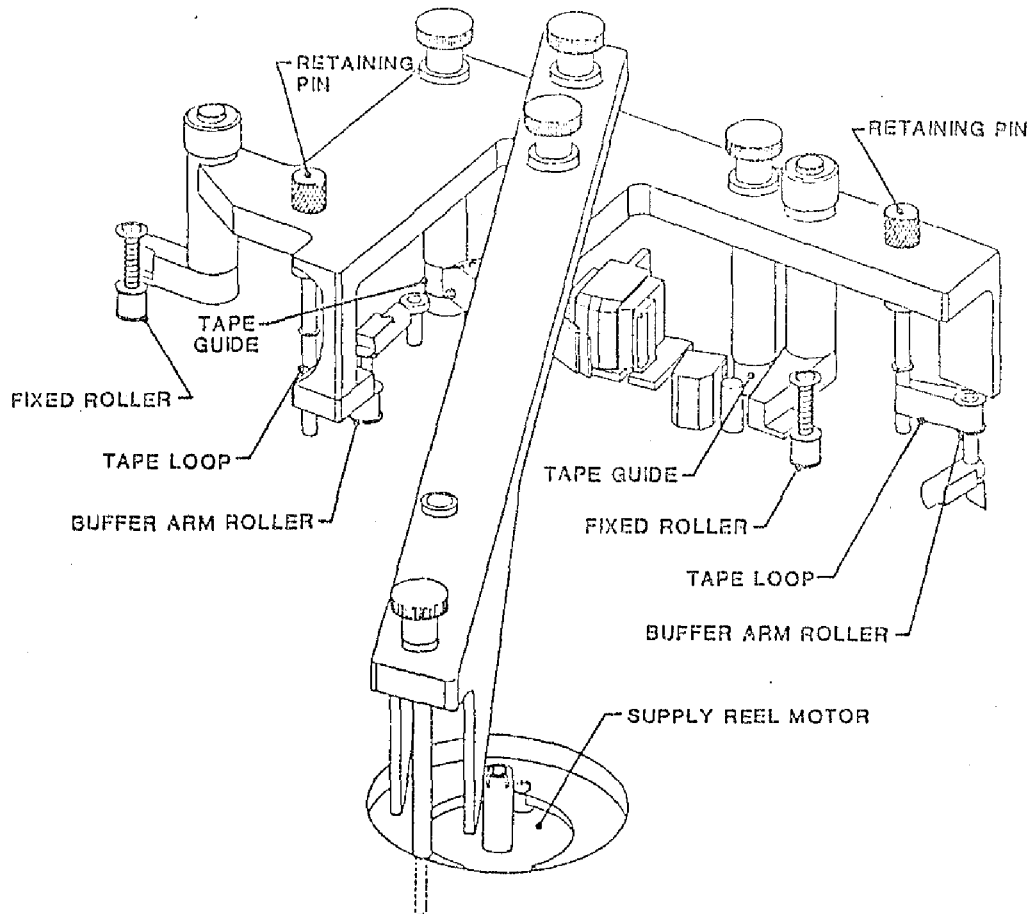

Figure 5-29. Tape Rollers Height Adjustment

SECTION VI
PARTS IDENTIFICATION

PARTS IDENTIFICATION

SECTION VI PARTS IDENTIFICATION

6.0 INTRODUCTION

This Section contains parts ordering information and lists replacement and recommended spare parts. Figures 6-1 thru 6-5 include parts lists that identify each part illustrated. Parts Tables 6-1 and 6-2 list parts recommended as spares. Table 6-3 lists recommended Maintenance Tools.

Field-Repair and -Change Kits consist of parts assembled and adjusted at the factory. Repair Kits are for repair of Kennedy products. Change Kits are for adding standard or special options not originally included in the equipment. Kits include installation instructions.

6.1 PARTS WARRANTY

Parts are warranted to be free from defects in materials and workmanship for 90 days from the date shipped from Kennedy. This warranty does not apply to Kennedy parts that have been neglected, misused, improperly installed, poorly maintained, or damaged by accident. Liability under this Warranty is limited to replacement or repair of defective parts. The equipment user must obtain Return Authorization (RA) from Kennedy Company before shipping the defective parts. The customer must send the package postage paid.

6.2 OUT OF WARRANTY EMERGENCY PARTS

Kennedy Company expedites shipment of emergency orders for out-of-warranty parts. The price of expedited orders includes the standard price for the part plus a \$75.00 Expediting Fee. Kennedy ships emergency orders within one week of receipt of the order.

6.3 PARTS ORDERING INFORMATION

Include the following information in all orders:

- a. Serial Number and Part Number of the equipment (printed on the Serial Number Tag located on the rear panel of the unit).
- b. Company Name, shipping and billing address.
- c. Purchase Order Number.
- d. Authorized person's name and phone number.
- e. Preferred method of shipment (FOB Monrovia, California).
- f. Name, Part Number, and quantity (Ref par. 6.3.3.d) of parts being ordered.
- g. Return Authorization Number.
- h. For items returned for repair or replacement, include description of malfunction.

6.3.1 MINIMUM PARTS ORDERS

The minimum domestic order value is \$50.00. Minimum international order value is \$100.00. Refer to Parts Price List Manual for parts prices. For Emergency Orders, order value does not include the \$75.00 Expedite Fee (Ref par. 6.2).

6.3.2 RETURNING PARTS TO KENNEDY

If a part must be returned for repair or replacement, the customer must first notify the nearest Customer Service Office listed in Paragraph 6.3.4 to obtain a Return Authorization Number (RA Number). If the part is available at that Office, the Kennedy Agent will issue the RA Number and give further instruction for returning the part. If the part is not available at that local office, the customer must notify the Kennedy Main Office at Monrovia, California to obtain the RA Number. The part must be returned to the Office that issued the RA Number. Orders will be accepted via Telephone or Telex, but will not be shipped until a confirming Purchase Order is received from the customer.

NOTE 1: Parts sent to Kennedy Company that do not include a Return Authorization Number will be returned to the sender COD unopened. The RA Number must be written on the outside of the package in a conspicuous place.

NOTE 2: Send only the item(s) needing repair or replacement. Use standard good packaging procedures. Kennedy Company will not be responsible for any accessories to the repair item. **DO NOT SEND ACCESSORIES.**

6.3.3 PARTS ORDER LEADTIME

- a. Delivery of spare parts: 60-90 days After Receiving Order (ARO).
- b. Delivery of tools and special parts: 90 days ARO
- c. Delivery of parts for obsolete equipment: 120 days ARO
- d. For quantities of six or more of one item or for items not covered by these guidelines, consult your nearest Kennedy Company Customer Service Department (Ref par. 6.3.4).

6.3.4 KENNEDY COMPANY CUSTOMER SERVICE ADDRESSES

For service and general information, contact the nearest Kennedy Company Customer Service Office listed below:

United States:

Kennedy Company
Main Office
1600 Shamrock Ave.
Monrovia, CA 91016
Tel: (818) 357-8831
Fax: (818) 303-8230

Kennedy Company
Eastern District
400 West Cummings Pk.
Suite 3650
Woburn, MA 01801
Tel: (617) 935-9787
Fax: (617) 932-3351

Kennedy Company
Eastern District
4364 L.B. McLeod
Orlando, FL 32811
Tel: (305) 843-9335

United Kingdom
Kennedy International Inc.
Ashville Way
Wokingham, Berkshire
RG11 2PL England,
Tel: 44/734 77.60.33
Fax: 44/734 77.60.23
Telex: 847871 KENUKS G

Central Europe
Kennedy Holdings Inc.
Koningin Elisabethplein 8
B-2700 Sint-Niklaas
Belgium
Tel: 32/3 777.19.62
Fax: 32/3 778.09.63
Telex: 71870 KEN CO

Shugart GmbH
Drygalski - Allee 33
D-8000 Muenchen 71
West Germany
Tel: 49/89 780 080
Fax: 49/89 780 0828
Telex: 524752

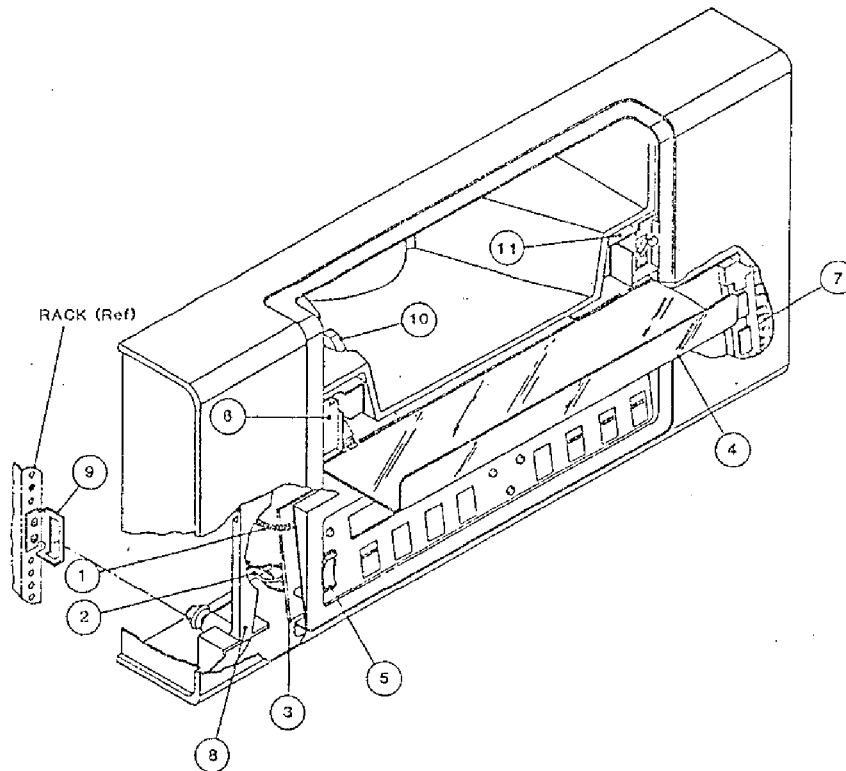

Parts List: Front Panel Assembly P/N 90-09191-XXX

Item	Part Number	Description
1	90-07587-003	Wire Assembly
2	90-09159-002	Power Switch Cable Assembly
3	90-07947-312	Operator Control Panel PCBA
4	91-09051-001	Tape Access Door
5	51-00099-001	Switch, Power
6	22-00008-002	Door Lock Solenoid, 24 VDC
7	90-07587-001	Front Panel Shielded Cable Assembly
8	91-08082-001	Latch
9	91-08084-001	Bracket Catch
10	(Reference)	Manual Reel Locking Lever
11	51-00196-001	Microswitch

Figure 6-1. Front Panel Assembly

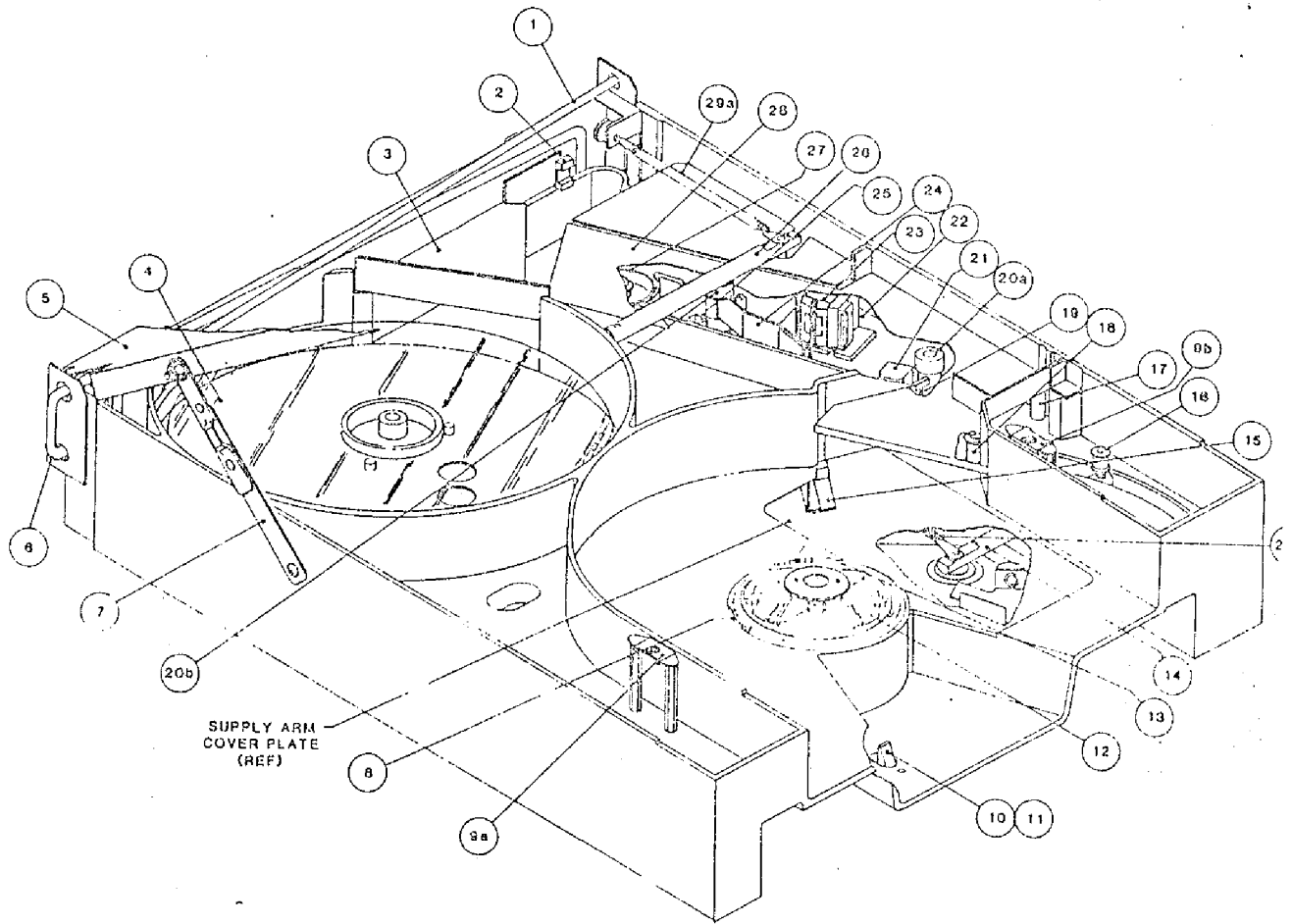
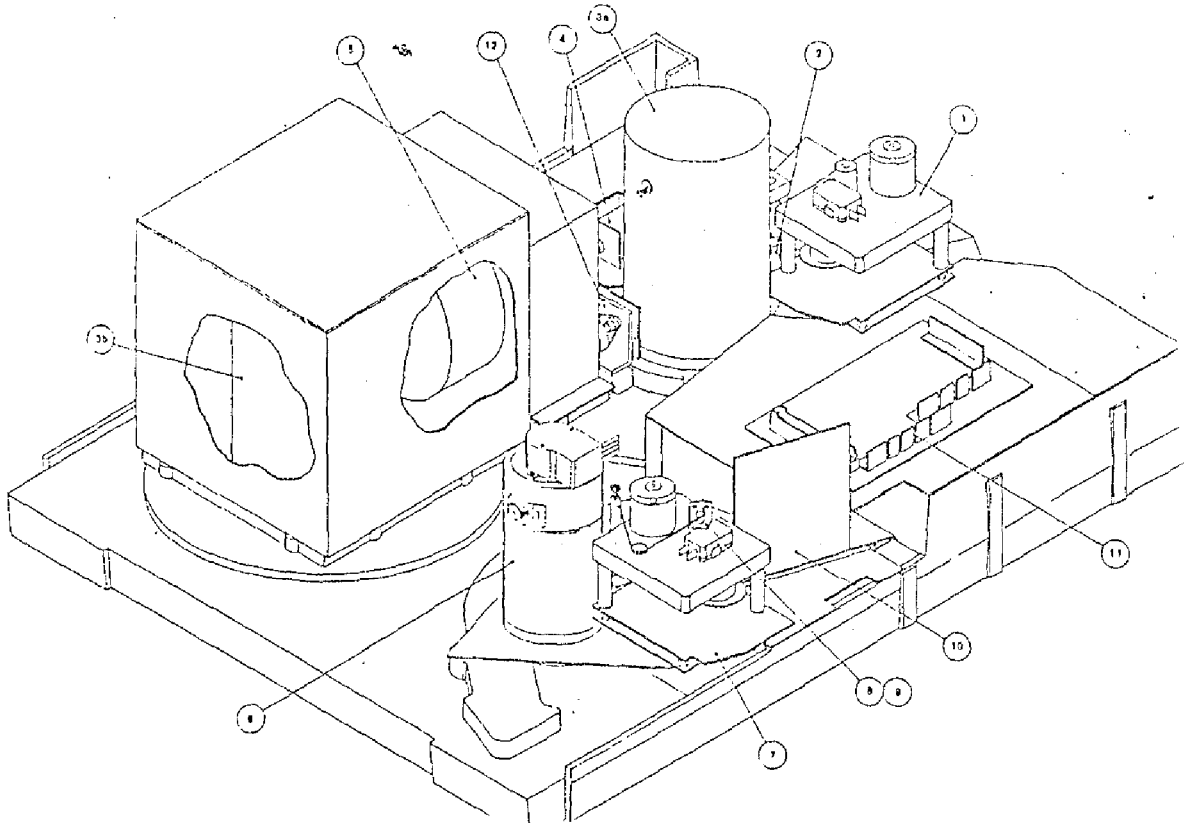

Figure 6-2. Deck Assembly, Top View (Sheet 1 of 2)

Parts List: Desk Assembly

Item	Part Number	Description
1	91-07731-201	Torsion Bar, Right
2	37-00053-101	Take-up Arm Limit Sensor
3	90-07454-003	Chute Plate Assembly
4	90-09014-003	Take-up Hub Assembly
5	91-07233-001	Cover, Deck
6	91-07731-101	Torsion Bar, Left
7	90-08028-001	Brace Assembly
8	90-07119-102	Reel-In-Place Sensor Assembly (hidden)
9(a,b)	28-00259-001	Fastener, 1/4-Turn, Rec., Clip-On
10	91-09037-001	Knob
11	91-09036-001	Release Lever
12	90-09021-004	Supply Hub Assembly
13	90-07144-001	File Protect Sensor Assembly (hidden)
14	90-09042-106	Supply Arm Assembly (Bottom)
15	37-00053-001	Supply Arm Limit Sensor
16	91-09041-002	Tension (Buffer) Arm Roller
17	90-07334-001	Tape-In-Channel Sensor Assembly
18	91-07211-002	Fixed Roller
19	90-07334-002	Tape-In-Channel Emitter Assy
20(a,b)	90-09154-001	Split Tape Guide
21	90-05906-103	Bot/Eot Sensor Assembly
22	90-09002-001	Head/Guide-Plate Assembly
23	90-07524-004	Magnetic Head Assembly
24	90-09171-001	Shield Assembly
25	91-09167-001	Post
26	90-09042-206	Take-up Arm Assembly (Top)
27	91-09087-001	Capstan
28	90-09169-001	Tape Path Cover Assembly
29(a,b)	25-00045-019	Spring, Extension

Figure 6-2. Desk Assembly, Top View (Sheet 2 of 2)



Parts List: Deck Assembly

Item	Part Number	Description
1	90-09048-002	Retract & Pivot Sensor Assy (same as Item 7)
2	90-09031-001	Actuator Arm Assembly
3(a,b)	90-09020-001	Reel Motor Assembly
4	22-00095-002	Hub Lock Solenoid
5	90-07483-001	Vacuum Motor Assembly
6	90-07333-101	Capstan Motor Assembly
7	90-09048-002	Retract & Pivot Sensor Assy (same as Item 1)
8	91-08180-001	Retract Cam Plate
9	91-08179-001	Linkage, Shield
10	90-06923-001	Read Preamplifier PCBA
11	90-07228-301	Interconnect PCBA
12	90-07295-002	+/-12 VDC Regulator Assembly

Figure 6-3. Deck Assembly, Bottom View

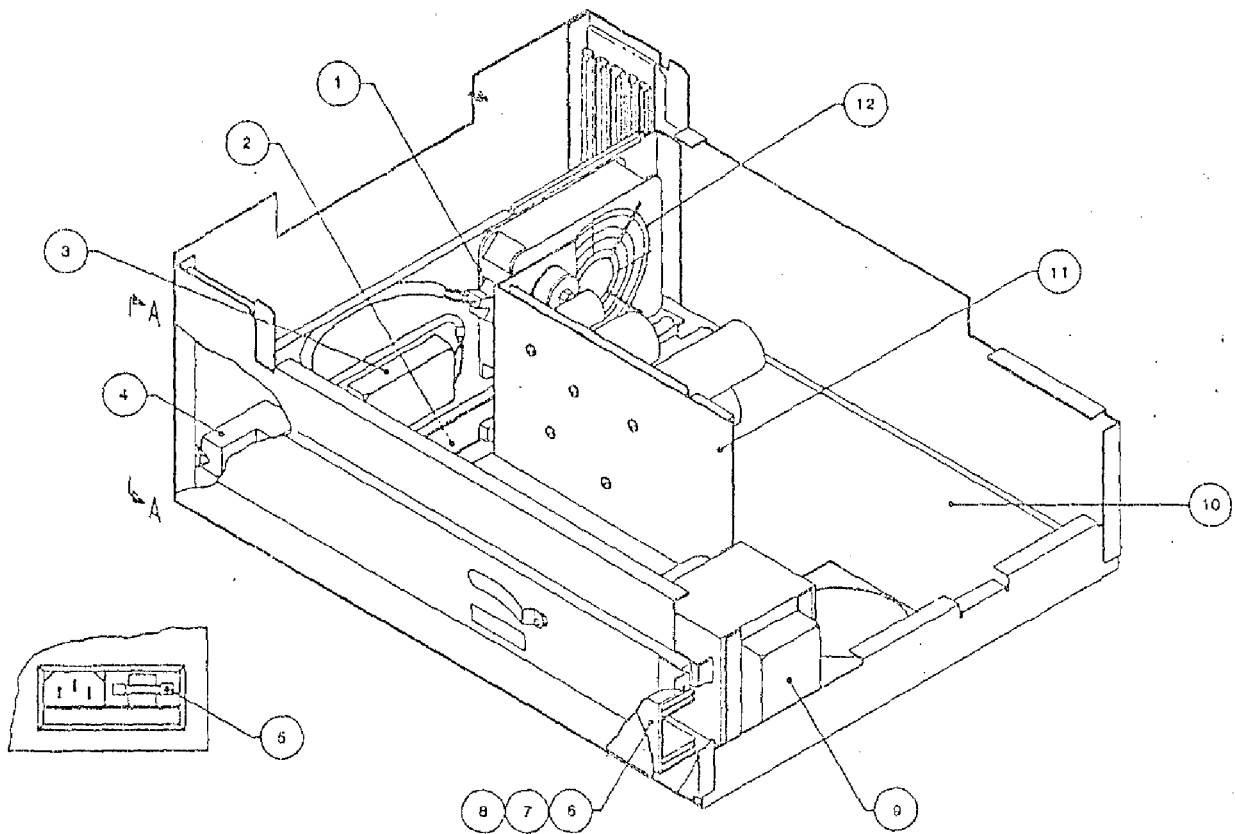

Parts List: Chassis Assembly

Item	Part Number	Description
1	26-00027-003	Fan, 115 VAC
2	90-07108-002	Mother Board PCBA
3	27-00012-001	Filter, EMI
4	90-09155-001	Power-In Assembly
5	51-00132-005	Fuse, 3A (for 220V Operation)
	51-00133-060	Fuse, 6A (for 115V Operation)
6	90-07516-005	Servo Amplifier Assy
7	90-07111-014	Servo Power Amplifier PCBA (P/O Item 6)
8	90-07147-004	Servo Preamplifier PCBA (P/O Item 6)
9	90-07318-003	Transformer Assembly
10	90-08952-001	Drive Electronics PCBA
11	90-07296-302	Power Supply Assembly
12	26-00027-501	Finger Guard

Figure 6-4. Chassis Assembly

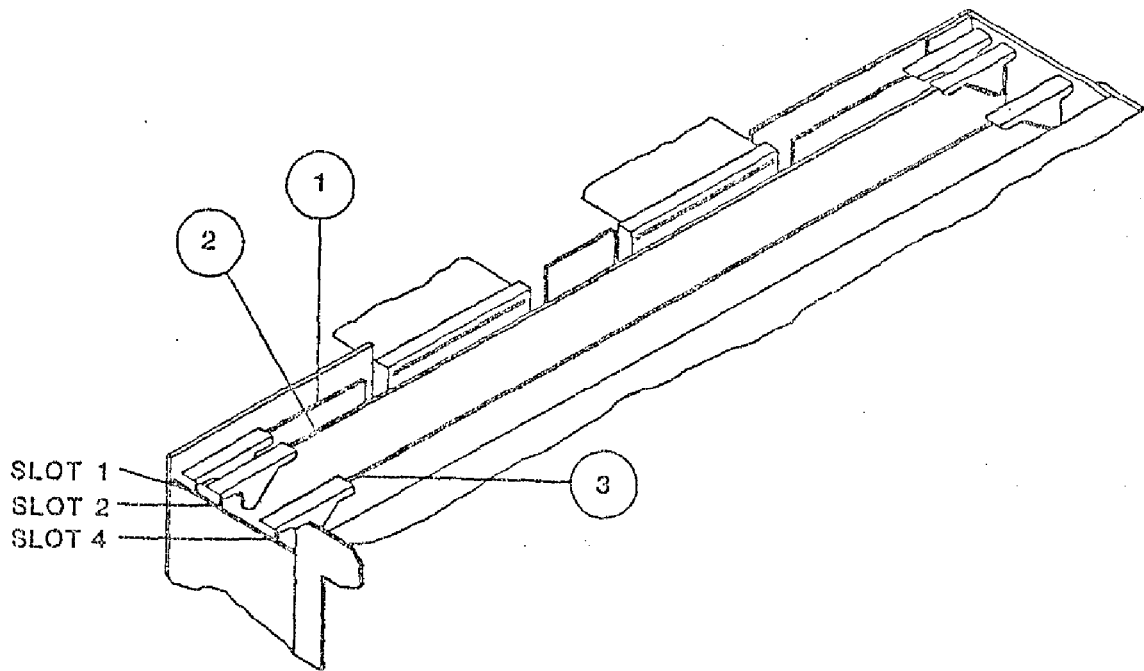

Parts List: Card Cage PCBAs

Item	Part Number	Description
1	90-08951-008	Formatter PCBA
2	90-09017-004	Read Analog PCBA
3	90-09060-008	Read/Write Digital PCBA

Figure 6-5. Card Cage Printed Circuit Boards

TABLE 6-1. RECOMMENDED SPARE PARTS
(Field Support)

Fig	Item	Part Number	Description	Recommended Quantity*
2	21	90-05906-103	EOT/BOT Sensor Assembly	
3	12	90-07295-002	+/-12 VDC Regulator Assembly	
4	5	51-00132-050	Fuse, Norm Blo, 3A 250V, Cer	
4	5	51-00132-060	Fuse, Norm Blo, 6A 250V, AGC3	
4	7	90-07111-014	Servo Power Amplifier PCBA	
4	8	90-07147-004	Servo Preamp PCBA	
4	10	90-08952-001	Drive Electronics PCBA	
4	11	90-07296-302	+5 VDC Regulated Power Supply	
4	13	90-08175-002	AC Inrush Limit PCBA	
5	1	90-08951-008	Formatter PCBA	
5	2	90-09017-004	Read Analog PCBA	
5	3	90-09060-008	Read/Write Digital PCBA	

NOTE: * Unless otherwise specified, Recommended Quantity is 1.

TABLE 6-2. RECOMMENDED SPARE PARTS
(Depot Support)

Fig	Item	Part Number	Description	Recommended Quantity*
All Items listed in Table 6-1.				
1	3	90-07947-312	Operator Control Panel PCBA	
1	6	22-00095-002	Door Lock Solenoid, 24VDC	
2	2	37-00053-101	Take-up Arm Limit Sensor	
2	8	90-07119-102	Reel-in-Place Sensor Assembly	
2	12	90-09021-004	Supply Hub Assembly	
		90-09091-001	Tab Assembly (Reel in Place, and File Protect) (P/O Item 2-12)	2
2	13	90-07144-001	File Protect Sensor Assembly	
2	14	90-09042-106	Supply-Arm Assembly	
2	15	37-00053-001	Supply Arm Limit Sensor	
2	17	90-07334-002	Tape-in-Channel Emitter Assembly	
2	18	91-07211-002	Fixed Roller	
2	19	90-07334-001	Tape-in-Channel Sensor Assembly	
2	20	90-09154-001	Split Tape Guide	2
2	21	90-05906-103	EOT/BOT Sensor Assembly	
2	23	90-07524-005	Magnetic Head Assy	
2	26	90-09042-206	Take-up Arm Assembly (Top)	
2	27	91-09087-001	Capstan	
2	29	25-00045-019	Spring, Extension	2
3	1,7	90-09048-002	Retract & Pivot Sensor Assembly	2

NOTE: * Unless otherwise specified, Recommended Quantity is 1.

Rev 1

Rev D

TABLE 6-2. RECOMMENDED SPARE PARTS (CONTINUED)
(Depot Support)

Fig	Item	Part Number	Description	Recommended Quantity*
3	3	90-09020-001	Reel Motor Assembly	2
3	4	22-00095-001	Hub Lock Solenoid	
3	5	90-07483-001	Vacuum Motor Assembly	
3	6	90-07333-101	Capstan Motor Assembly	
3	10	90-06923-001	Read Preamplifier Assembly	
3	11	90-07228-301	Interconnect PCBA	
4	1	26-00027-003	Fan, 115 VAC	
4	2	90-07108-002	Mother Board PCBA	
4	3	27-00012-001	Filter, EMI, 5A	

NOTE: * Unless otherwise specified, Recommended Quantity is 1.

TABLE 6-3. RECOMMENDED MAINTENANCE TOOLS

PART NUMBER	DESCRIPTION
54-00036-001	Skewmaster Tape
54-00103-001	Alignment Tool, Tape Guides
54-00104-101	Buffer Arms Height Adjustment Tool
54-00100-001	Capstan Puller
90-02324-001	Maintenance Kit
	Head Cleaner
	Hex Socket Keys - 6/16, 5/32, 1/8, 3/32
	Reflective Marker Strips
	Magnesium Visualizing Solution
	Lint-Free Swabs
	Loctite, Grade H
90-07117-001	Card Extender
(Common)	Set of Nut Drivers or Open-End Wrenches
(Common)	Phillips and Standard Screwdrivers