

Bulletin No. 161
Issue 1
March, 1940

TELETYPE

PRINTING TELEGRAPH SYSTEMS

DESCRIPTION
TYPE BAR PAGE PRINTER
(MODEL 20)



CORPORATION

SUBSIDIARY OF

Western Electric Company

CHICAGO, U. S. A.

TELETYPE

PRINTING TELEGRAPH SYSTEMS

DESCRIPTION
TYPE BAR PAGE PRINTER
(MODEL 20)



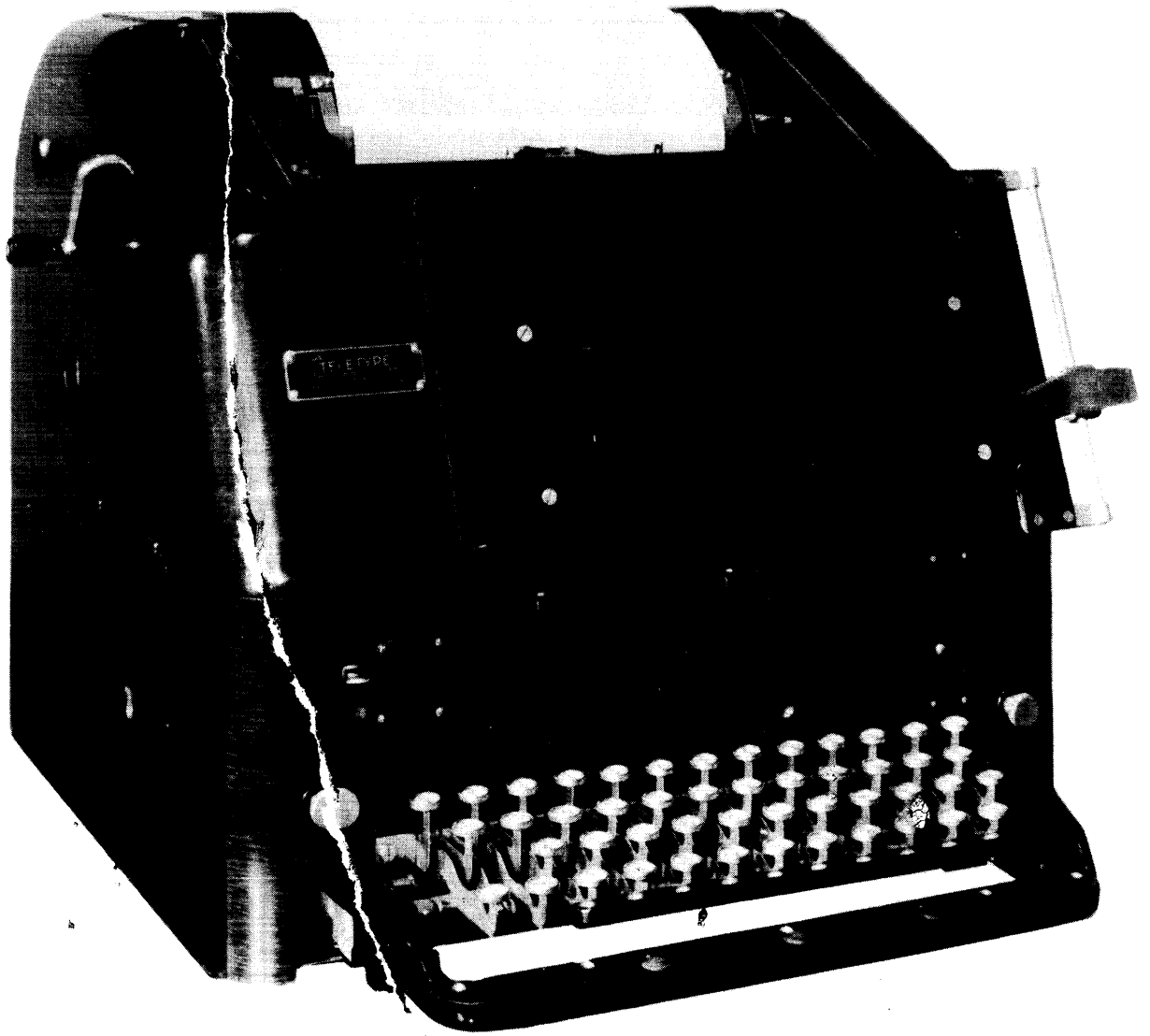

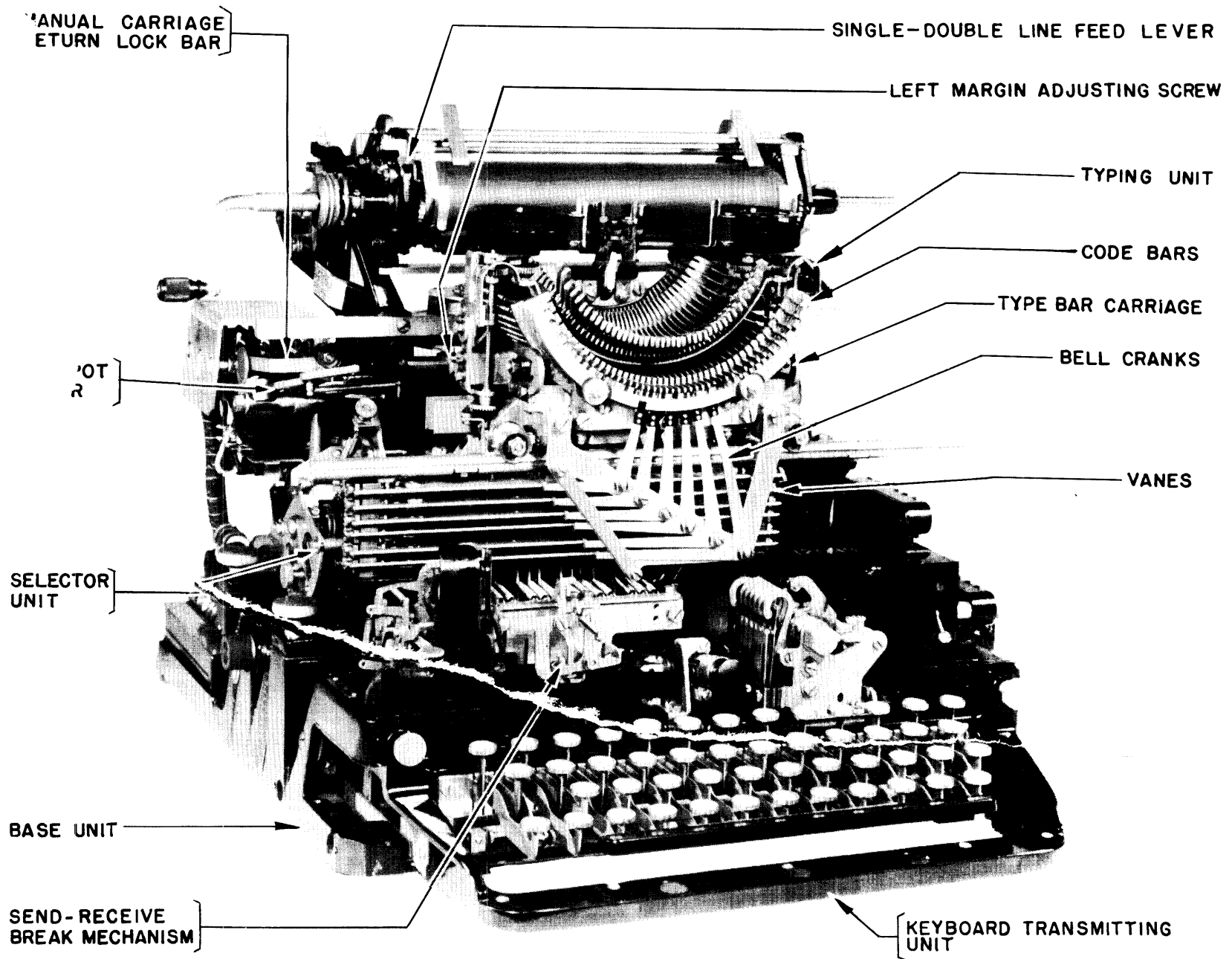

ILLUSTRATION I.

CONTENTS

DESCRIPTION OF THE MODEL 20 TYPE BAR PAGE PRINTER

	<u>Page</u>
GENERAL - - - - -	1
Signaling Code - - - - -	1
KEYBOARD TRANSMITTING UNIT - - - - -	1
TYPING UNIT - - - - -	3
Main Shaft Assembly - - - - -	4
Selector Unit - - - - -	4
Locking Cam - - - - -	7
Locking Function Lever - - - - -	8
Main Shaft Clutch Throwout Lever - - - - -	8
Printing - - - - -	8
Spacing - - - - -	9
Margin Bell - - - - -	14
Ribbon Feeding - - - - -	14
Ribbon Reverse - - - - -	14
Ribbon Oscillation - - - - -	15
Ribbon Lockout - - - - -	17
FUNCTIONS - - - - -	17
Carriage Return Function - - - - -	17
Shift and Unshift Functions - - - - -	20
Spacing Function - - - - -	20
Signal Bell Function - - - - -	20
Line Feed Function - - - - -	21
KEYBOARD LOCKING MECHANISM - - - - -	22
MOTOR SPEED CONTROL - - - - -	23
BASE UNIT - - - - -	24
SYNCHRONISM - - - - -	24
ORIENTATION - - - - -	26
LINE TEST KEY - - - - -	26
LINE RELAY - - - - -	26
WIRING DIAGRAM - - - - -	26

CHARACTER SENT

LINE SIGNAL

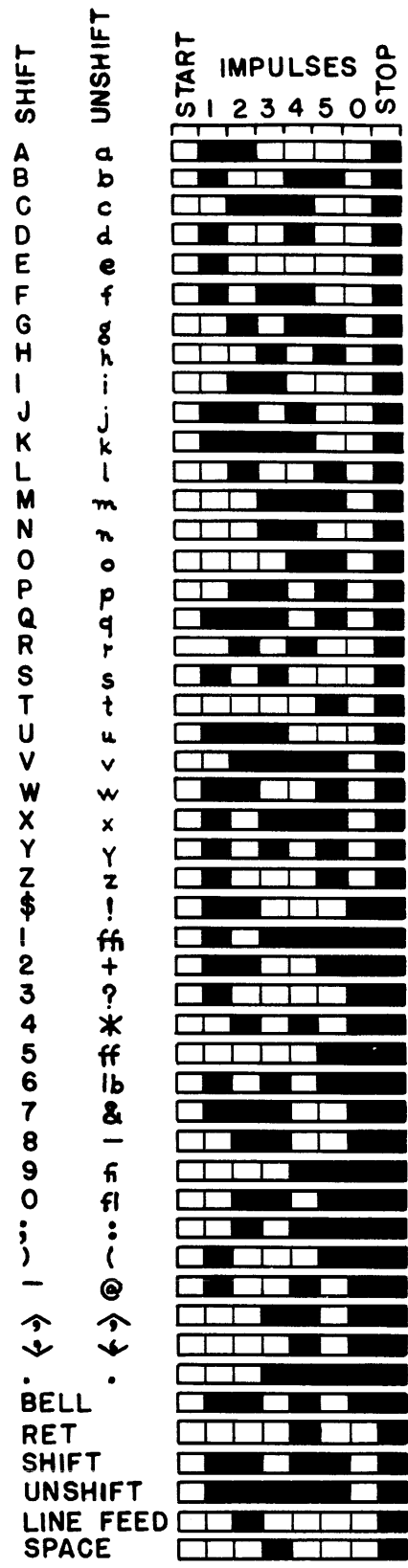

□ - SPACING IMPULSES
 ■ - MARKING IMPULSES

FIGURE 1.

DESCRIPTION OF THE MODEL 20 TYPE BAR PAGE PRINTER

GENERAL

The Model 20 Teletype Type Bar Page Printer is a machine designed for interchanging messages between two or more points. A sending-receiving station consists of a keyboard transmitting unit and a typing unit mounted on a base unit (Illustration 1).

The keyboard transmitting unit is used to send electrical impulses of the six unit code to the receiving mechanism of the typing unit at any station. These received signals will cause the typing unit to print a copy of the message sent by the keyboard operator.

Note: In all the figures in this bulletin, fixed pivot points are designated by solid black circles.

Signaling Code

The signaling code used to transmit characters is the start-stop, six unit code which consists of six selecting impulses used in various combinations of current and no-current intervals. Each group of six selecting impulses is preceded by a start impulse and followed by a stop impulse used to maintain synchronism between all stations on the circuit. Impulses which energize the selector magnets are known as marking and those which do not are known as spacing. Figure 1 shows graphically the code used.

KEYBOARD TRANSMITTING UNIT

The keyboard transmitting unit consists essentially of a set of key levers, selector bars, "Y" levers, "Y" lever connecting links and locking levers used in selecting the code combination to be transmitted; (Figures 2 and 3) a transmitting cam sleeve assembly, contact levers and contact springs for transmitting the selected code; a universal bar, trip-off pawl, intermediate pawl, clutch throwout lever, and a clutch used in starting and stopping transmission.

The transmitting cam sleeve assembly, its controlling clutch and the transmitting shaft gear are mounted on the transmitting shaft. The transmitting shaft gear derives its motive force from a gear on the main shaft of the typing unit (Illustrations 2 and 3). The transmitting cam sleeve assembly is normally held stationary due to the disengagement of the clutch teeth by the clutch throwout lever.

Beneath the key levers are six pairs of parallel motion selector bars and a universal bar, extending across the width of the keyboard (Figure 3).

The selector bars are guided at both ends so that they may be moved upward or downward. (Figures 2 and 3). They are provided with rectangular notches on their upper edges according to the requirements of the code. The notches in the front and rear selector bars, of each pair, are staggered so that there will always be a high portion on either one, of the pair, in the path of any key lever. The ends of each pair of selector bars rest on the arms of "Y" levers; the front selector bar, of each pair, resting on the left arms of the "Y" levers; and the rear selector bar, of each pair, resting on the right arms.

When a key lever is depressed, those selector bars having their high portions in line with that key lever are moved downward, causing the "Y" levers to move the other selector bar of each pair upward. Should the rear selector bar of any pair be moved downward, the lower extensions of the corresponding "Y" levers will be moved to the left; similarly, they will be moved to the right when the corresponding front selector bars are moved downward.

Attached to the lower extensions of the "Y" levers are connecting links which move to the left when the rear selector bars are moved downward, and to the right when the front selector bars are moved downward. Each of the first six "Y" lever connecting links engage a locking lever and positions it to correspond with the signal impulse to be transmitted. Each locking lever controls the motion of a contact lever by either allowing the contact lever to rotate on its pivot, due to the pressure exerted by the contact spring upon the contact lever, thereby permitting the contacts to close, or by engaging the contact lever and preventing closure of the contacts. When the upper end of a locking lever is positioned to

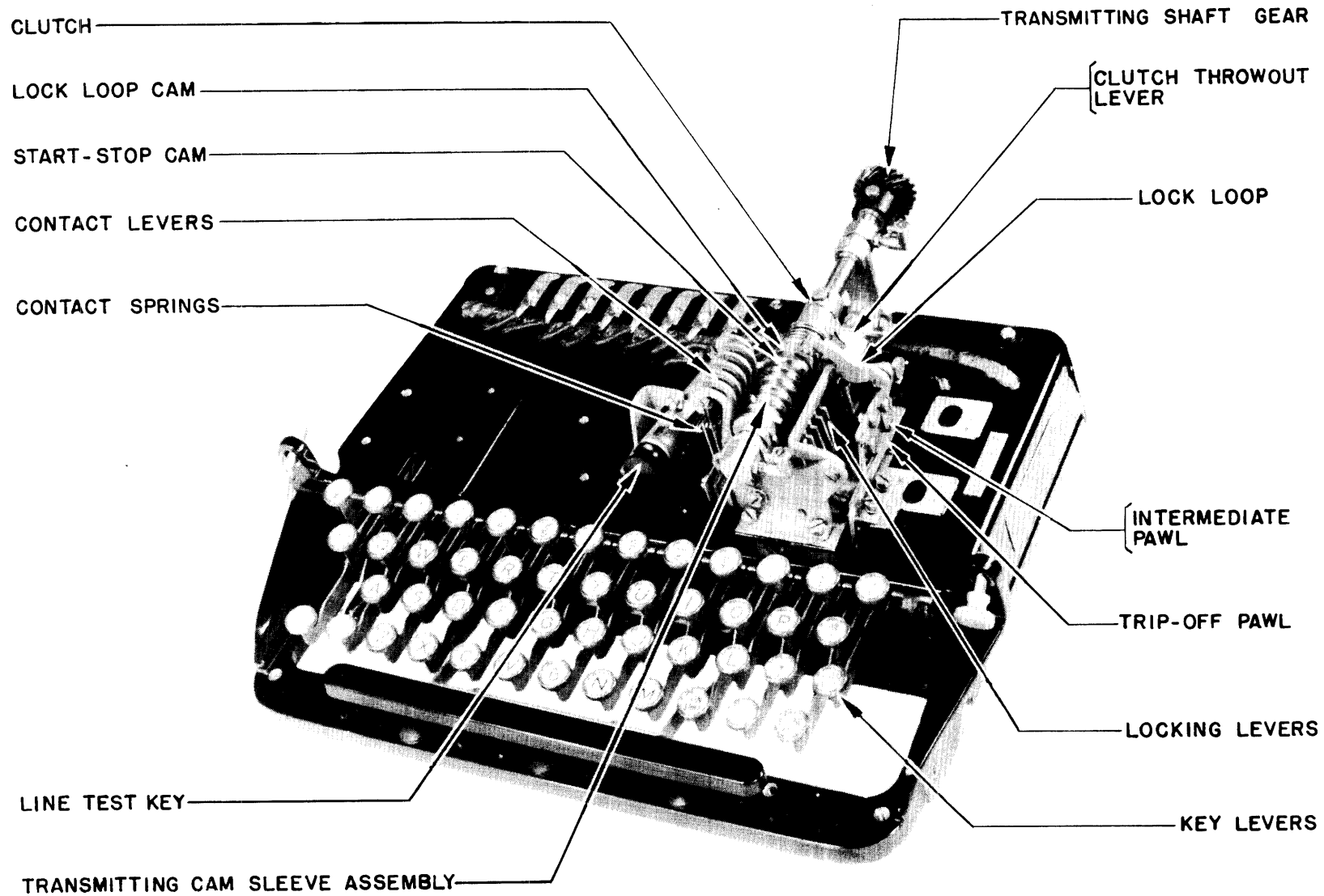

KEYBOARD
ILLUSTRATION 2.

the left, corresponding to a spacing impulse, it will engage and prevent its respective contact lever from rising into the indent of its cam as the cam sleeve rotates, thus holding the circuit open for that interval. When the upper end of a locking lever is positioned to the right, corresponding to a marking impulse, it will not interfere with the movement of its respective contact lever. Then, as the transmitting cam sleeve assembly rotates, the contact lever riding on its cam surface will rise into the indent of its cam, permitting its contacts to close and to send out a marking impulse.

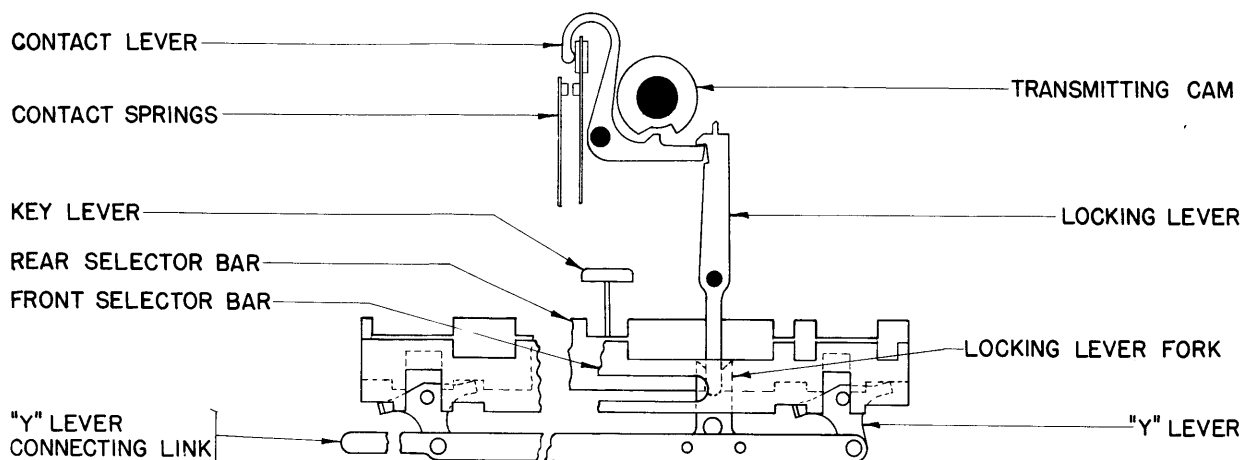

FIGURE 2.

The universal bar (Figure 3), which is connected to the trip-off pawl, controls the starting of the transmitting cam sleeve assembly. The universal bar is pivoted at both ends in such a manner that it will be rotated downward by the depression of any key lever and the trip-off pawl will move forward. This action releases the clutch throwout lever from the driven clutch member by means of the intermediate pawl, permitting the transmitting cam sleeve assembly to start rotating. As the transmitting cams rotate, the impulses, either marking or spacing, are transmitted in succession.

The start-stop cam (Figure 3) controls an additional contact lever which, in turn, actuates the start-stop contacts. These contacts are opened at the beginning of each revolution of the transmitting cam sleeve assembly to transmit the start impulse (spacing or no-current impulse), and remain open during the transmission of the six selected impulses. After the last selected impulse has been transmitted, the start-stop contacts will again close, sending the stop impulse (marking or current impulse) to the line. At the end of the revolution of the transmitting cam sleeve assembly, the driven clutch member is cammed out of mesh with the driving clutch member by the clutch throwout lever, which prevents the transmitting cam sleeve assembly from rotating further until the next key lever is depressed.

TYPING UNIT

The type bar carriage of the Model 20 typing unit consists of type bars similar to those of a typewriter together with other associated parts. The type bars are mechanically thrown against a platen causing letters to be printed. The type bar to be selected is determined by the setting of six code bars which are actuated by line signals through the medium of the selector mechanism. The code bars are so arranged that the notches on their upper sides will be lined up permitting a selected pull bar to move down into the path of the pull bar bail (Figure 9). This bail moves the pull bar forward causing the type bar to which it is connected to strike the platen. Illustration 1 shows the typing unit mounted on the base with a keyboard.

The various functions; line feed, space, carriage return, shift, unshift, etc. are also accomplished mechanically. A motor drives the main shaft assembly of the typing unit which supplies power to all mechanically operated parts.

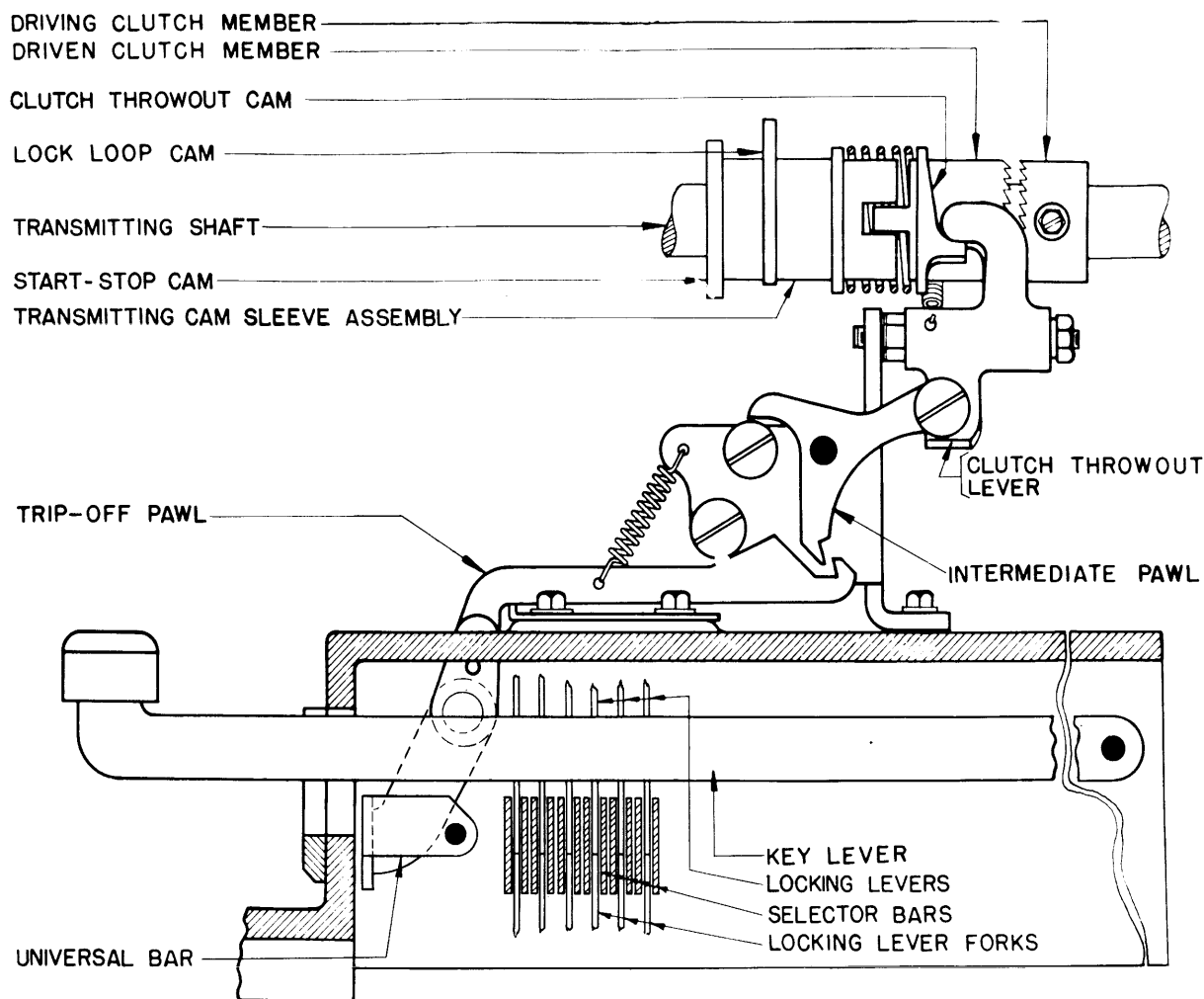

FIGURE 3.

Main Shaft Assembly (Illustration 3)

The main shaft rotates continuously while the motor is running and the printer is in operation. The main shaft gear, located near the right end of the main shaft, meshes with the motor pinion. The keyboard transmitting shaft driving gear, also located near the right end of the main shaft, meshes with the keyboard transmitting shaft gear.

The main shaft spacing gear meshes with the spacing shaft gear to provide the spacing action at the required time (Illustration 3 and Figure 9). The spacing escapement ratchet, sleeve and friction discs are associated with the spacing mechanism and are described under "Spacing". The function bail cam and the printing bail cam operate their respective bails. The main shaft clutch is used in conjunction with the selector to provide power to operate the printing and function bails immediately after the selection has been completed. The selector cam sleeve is fitted over the left end of the main shaft and is driven through the medium of a friction clutch.

Selector Unit

The purpose of the selector unit is to receive signals from the transmitting station, distributing them mechanically, thereby setting up various combinations on the vanes. These combinations will determine the character to be printed or the function to be operated. The selector mechanism is controlled by a magnet which

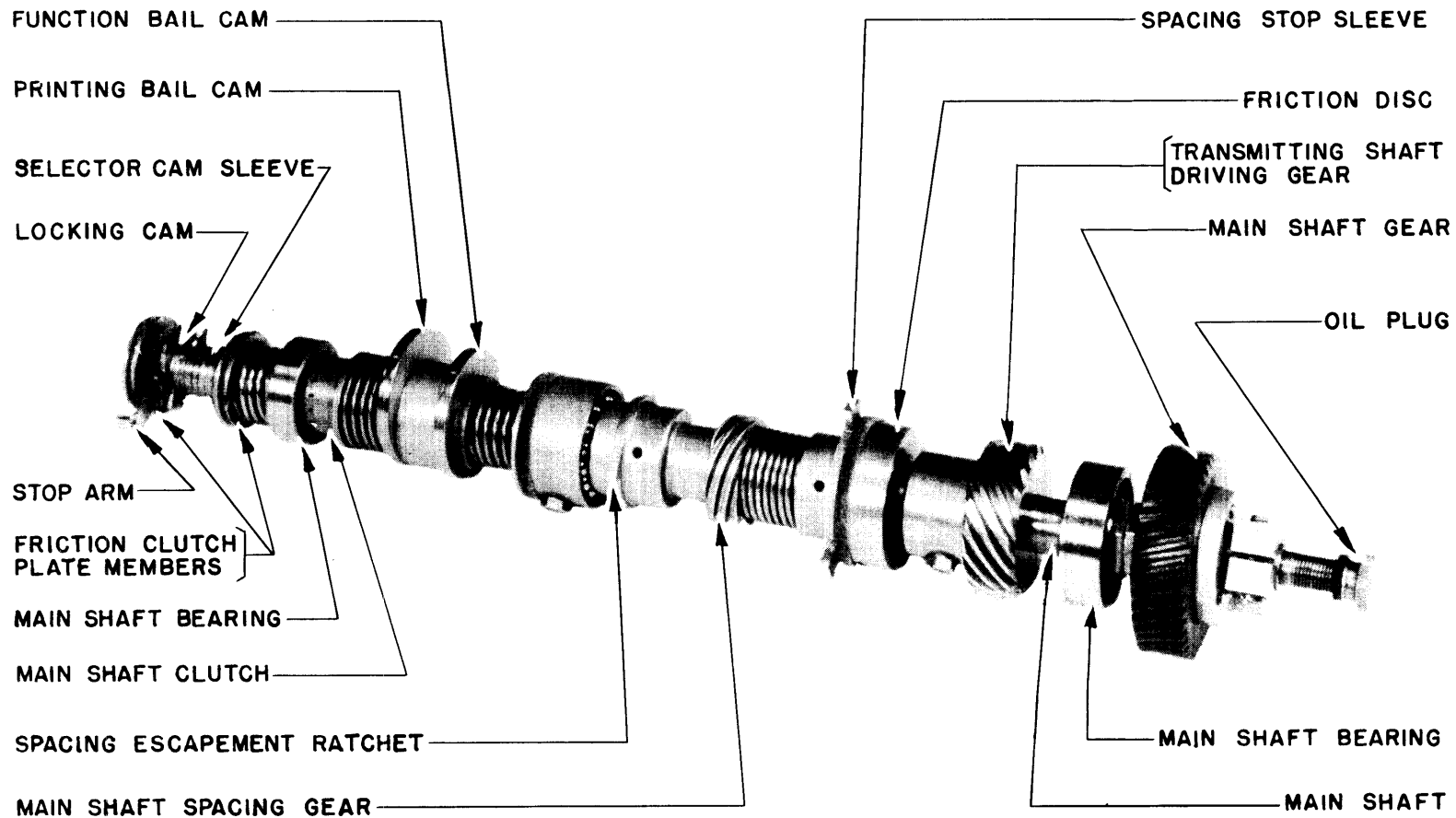

MAIN SHAFT ASSEMBLY
ILLUSTRATION 3.

receives the code impulses from the line. Normally the armature of this magnet is pulled up and the stop arm is against the stop lever which in turn is held by the trip latch. The selector cam sleeve is prevented from rotating (Figure 4), because the stop arm, which is a part of the selector cam sleeve, is engaged with the stop lever.

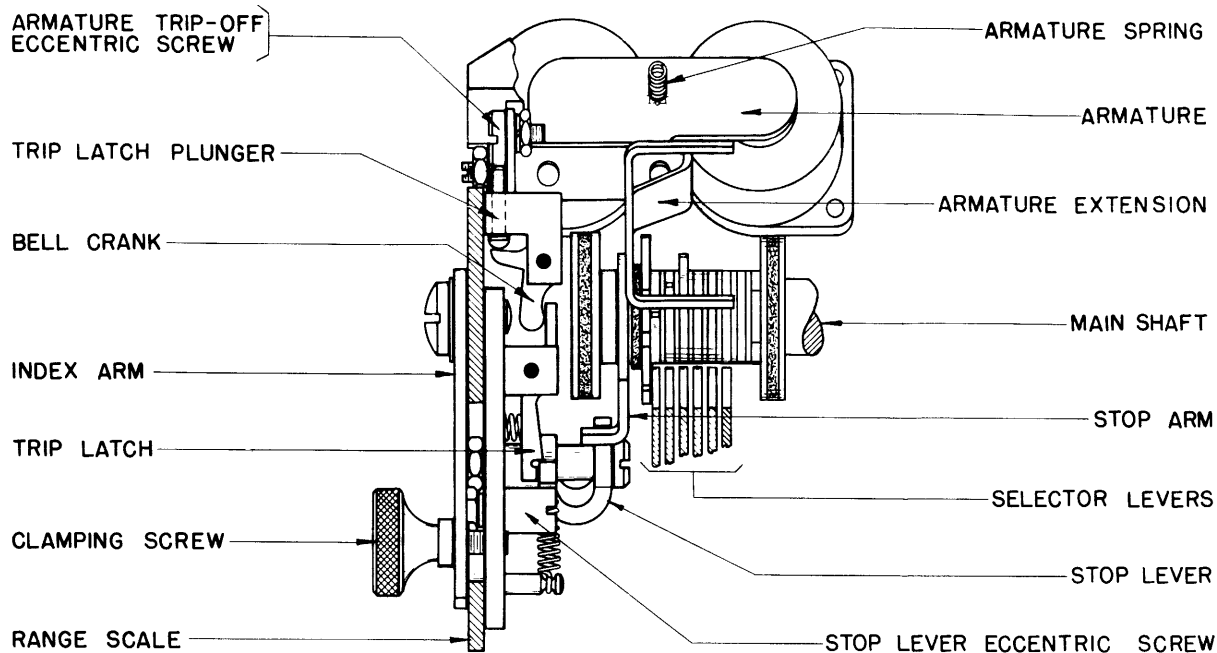

FIGURE 4.

When the start impulse, which is spacing (no current), is received, the armature is released and pulled away from the magnet pole pieces by the armature spring. The trip latch is then moved out of engagement with the stop lever, releasing the stop arm, allowing the selector cam sleeve to revolve with the main shaft.

Each vane is operated by a selector cam through the medium of a selector lever, a sword, and a "T" lever (Figure 5). For instance, suppose that the code for the letter "E" is received. Upon the reception of the start impulse (a no current impulse), the armature moves away from the magnet, imparting motion first to the trip latch plunger (Figure 4), which in turn causes the bell crank to move the trip latch out of engagement with the stop lever, releasing the stop arm as explained previously. The selector cams start to revolve (Figure 5) and the number 1 selector cam engages the number 1 selector lever when the first impulse of the letter "E" (marking or current impulse) has been received by the magnets from the line. The magnet armature is therefore pulled up, bringing the upper end of the armature extension up into the path of the upper sword arm. When the number 1 cam passes the number 1 selector lever, this lever is rotated counterclockwise, carrying with it the number 1 sword, which strikes the upper end of the armature extension and is in turn rotated clockwise about its pivot, point A. This positions the number 1 sword so that when the number 1 cam clears the number 1 selector lever, the selector lever spring moves the number 1 sword against the number 1 "T" lever and brings the front edge of the number 1 vane down. As no current is received while the 2, 3, 4, 5, and 0 selector cams are passing their selector levers, the magnet armature is released and the armature extension moves down so that the lower end of the armature extension is in the path of the lower sword arms (Figure 5). As the 2, 3, 4, 5, and 0 selector cams pass the 2, 3, 4, 5, and 0 selector levers, the 2, 3, 4, 5, and 0 vanes are moved so that their front edges are up. When the front edges of the vanes are moved to the upper position, the corresponding code bars are moved to the right, or unoperated position, through the medium of the bell cranks (Illustration 1). When the front edges of the vanes are moved to the lower position the corresponding code bars are moved to the left or operated position. When the number 1 code bar is moved to the

left and the 2, 3, 4, 5, and 0 code bars to the right, a notch in each code bar will be opposite the "E" pull bar.

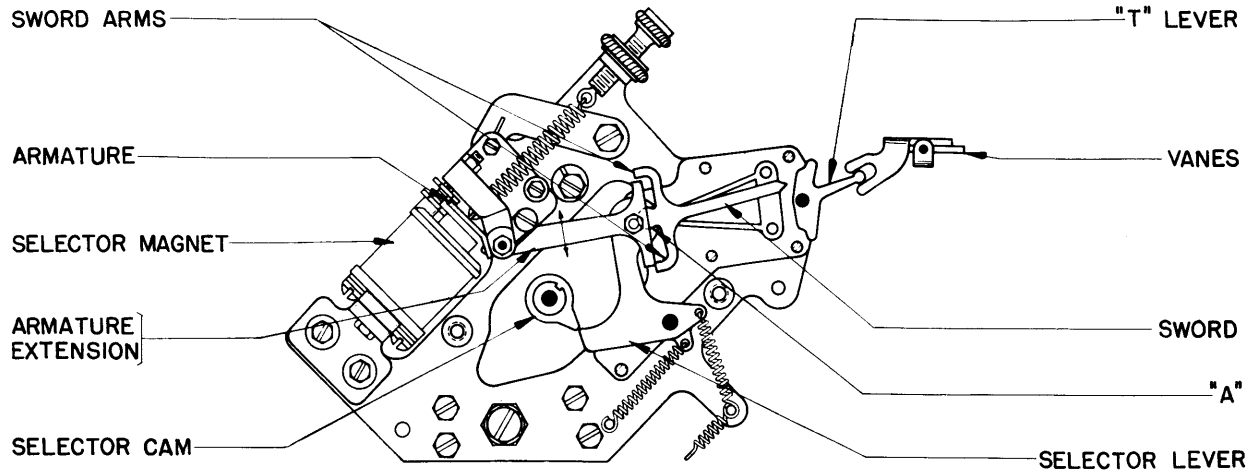

FIGURE 5.

The sixth cam releases the main shaft clutch through the medium of the cam arm, the clutch throwout lever and the clutch stop arm, allowing the printing and function bail cams to make one complete revolution (Figure 8). The printing bail cam will permit the printing bail to be pulled forward by its spring. The "E" pull bar will be pulled down by its spring into the path set up by the code bars, and the pull bar bail, actuated by the printing bail, will carry the pull bar forward causing the type bar to strike the platen, printing the letter "E" (Figure 9).

Locking Cam

The locking cam has six low and six high portions on its periphery against which the locking lever is held by its spring (Figure 6). During that part of each impulse when the swords are set by striking against the armature extension, (at the time the peak of any selector cam is operating the corresponding selector lever) a low portion of the locking cam is opposite the locking lever. The armature will now be held firmly in position by the "U" shaped extension of the locking lever engaging the locking wedge on the armature extension. When the locking lever is riding on a high portion of the locking cam the locking lever extension will be held away from the locking wedge and the armature will be free to move in response to the next impulse.

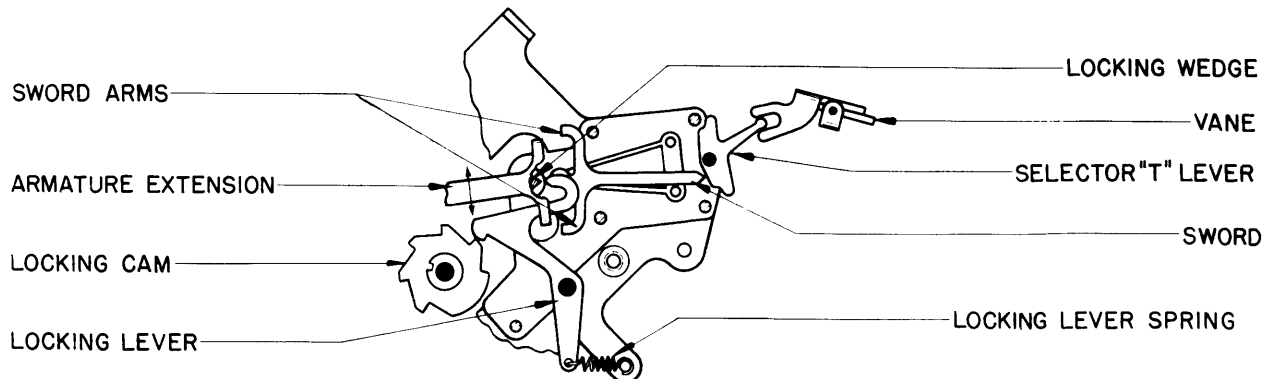

FIGURE 6.

Locking Function Lever

The vanes are held in their selected positions until the printing of the character has taken place. This is accomplished by means of the locking function lever. The locking function lever is the first on the right of the function levers, which are located immediately behind the vanes (Figure 7).

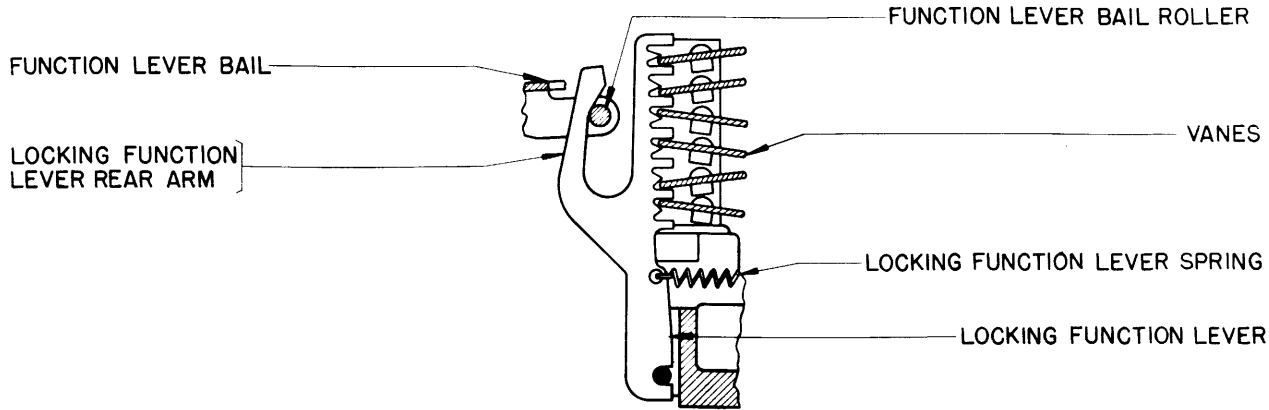

FIGURE 7.

When the printing bail is in its rear position, the function lever bail, mounted on the printing bail casting, is holding the locking function lever away from the vanes. When the printing bail is permitted to move forward, the function lever bail roller moves down, allowing the function lever spring to pull the locking function lever against the rear edges of the vanes. The locking function lever will engage each vane, whether its rear edge be raised by a marking impulse or brought down by a spacing impulse, locking the vanes in their selected positions.

The operation of the remaining function levers is described under "Functions".

Main Shaft Clutch Throwout Lever

As previously described, the sixth cam on the selector cam sleeve releases the main shaft clutch allowing the printing and function bail cams to make one complete revolution (Figure 8). At the end of each revolution of the printing and function bail cams the clutch stop arm engages with the projection on the driven clutch member and cams the driven clutch member out of mesh with the driving clutch member. Immediately after the zero impulse has been received, the peak of the sixth cam strikes the clutch throwout lever cam arm, moving the clutch throwout lever stop arm out of engagement with the projection on the driven clutch member. This will permit the spring to move the driven clutch member into mesh with the driving clutch member. Thus it may be seen that immediately after the completion of a selection for a character or function the printing and function bail cams will be permitted to revolve one revolution which will effect the printing of that character or the operation of that function. Any character or function may be selected while the printing or operation of the previous selection is taking place.

Printing

Mounted on the bail mounting shaft are the printing bail, the printing bail operating arm, the function bail and the spacing escapement pawls (Illustration 6). The printing bail spring, attached to the right end of the printing bail casting, holds the printing bail against the upper end of the bail operating arm and the operating arm roller against the printing bail cam on the main shaft. The printing bail cam controls the position of the printing bail at all times (Figure 9).

The pull bar bail, which is attached to the pull bar bail plunger, is controlled by the printing bail, and directly causes the actual printing of any character (Illustration 4). The pull bar bail plunger roller is attached to the lower surface of the pull bar bail plunger. This roller (when the type bar carriage is

in place) is located between the printing bail blades (Figure 9 and Illustration 6). This arrangement permits the type bar carriage to move from left to right and also allows the pull bar bail to be moved backward and forward by the printing bail regardless of the position of the type bar carriage.

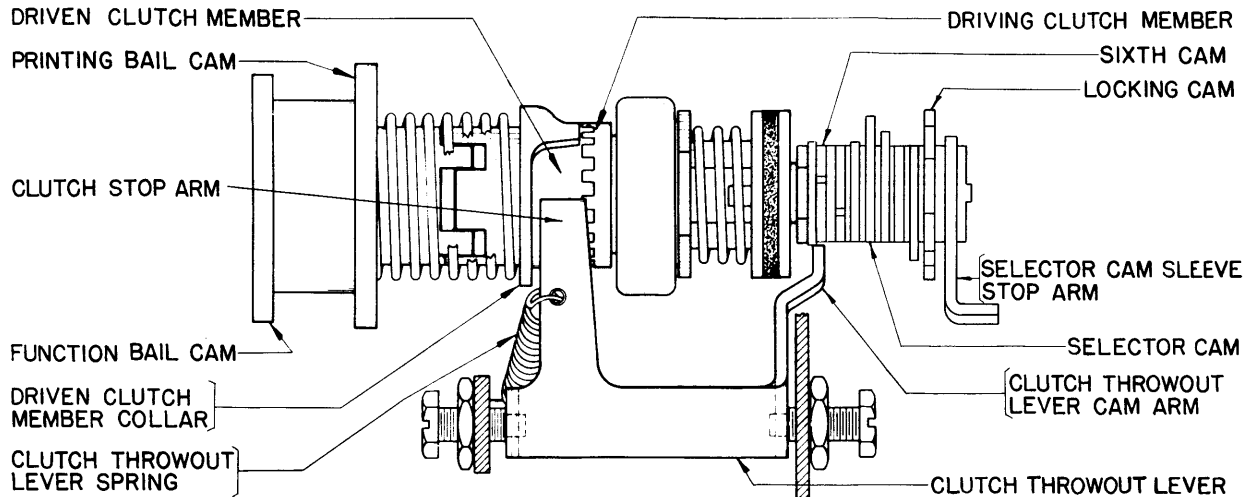

FIGURE 8.

At the end of each revolution of the printing bail cam, the printing bail operating arm roller will be on the high portion of its cam, (Figure 9), and the printing bail will be in its rearmost position, carried there against the tension of its spring.

As the printing bail cam revolves, the roller on the printing bail operating arm will move against the low portion of the cam. The printing bail will follow the upper end of the operating arm, being pulled forward by its spring, and will move the pull bar bail forward. The forward motion of the pull bar bail will first allow all of the pull bars to be pulled down against the code bars by their respective springs, the selected pull bar being pulled down farther than the rest, into the path set up for it in the code bars. As the pull bar bail continues on its forward stroke, it will engage the notch in the selected pull bar only, (the remaining ones being too high for their notches to engage), and carry the pull bar forward, throwing the type bar which is geared to it against the platen, printing the character.

The operating arm roller will again ride up onto the high portion of the printing bail cam as it completes its revolution. Thus the operating arm brings the printing and pull bar bails back to their rearmost positions. When the pull bar bail is in its rear position all of the pull bars are moved by it sufficiently high to clear the code bars so that they are free to move in either direction. The combination for the succeeding character then takes its place in the code bars and the printing operation is repeated as described in the foregoing.

Spacing

Spacing, on the Model 20 Printer, is accomplished by moving the type bar carriage. The type bar carriage is supported on two tracks. The upper track is a rectangular rod and is located to the rear. The front carriage track is a round rod and is located above the vanes (Figure 9 and Illustration 6). The type bar carriage is moved by the spacing gear which is meshed with the spacing rack and is facilitated by three carriage support rollers, two of which operate on the front track and one on the rear track. The front track is slotted throughout its length so that the heads of two carriage guide screws, located at either side of the carriage casting, will be guided therein.

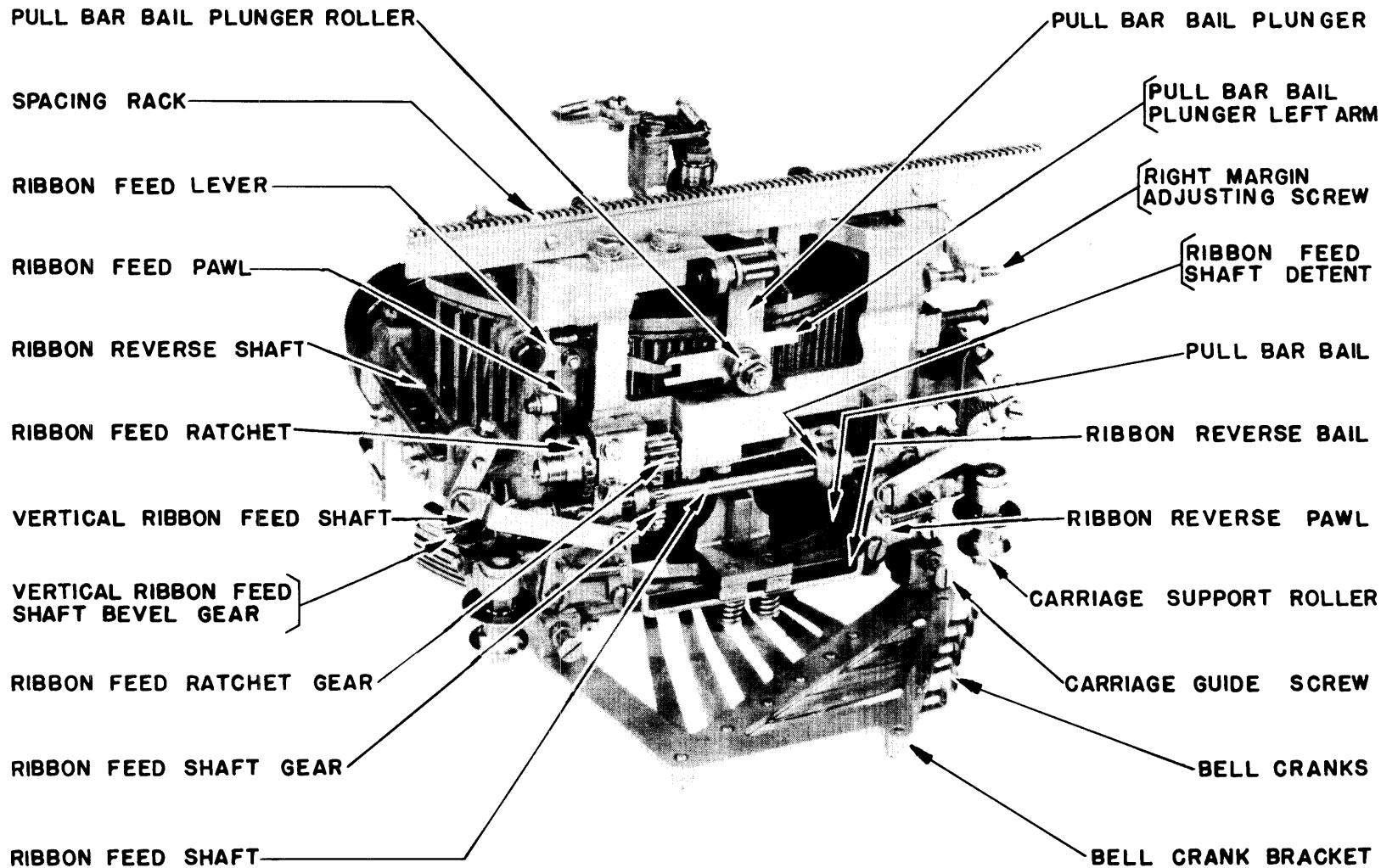

**TYPE BAR CARRIAGE — BOTTOM VIEW
ILLUSTRATION 4.**

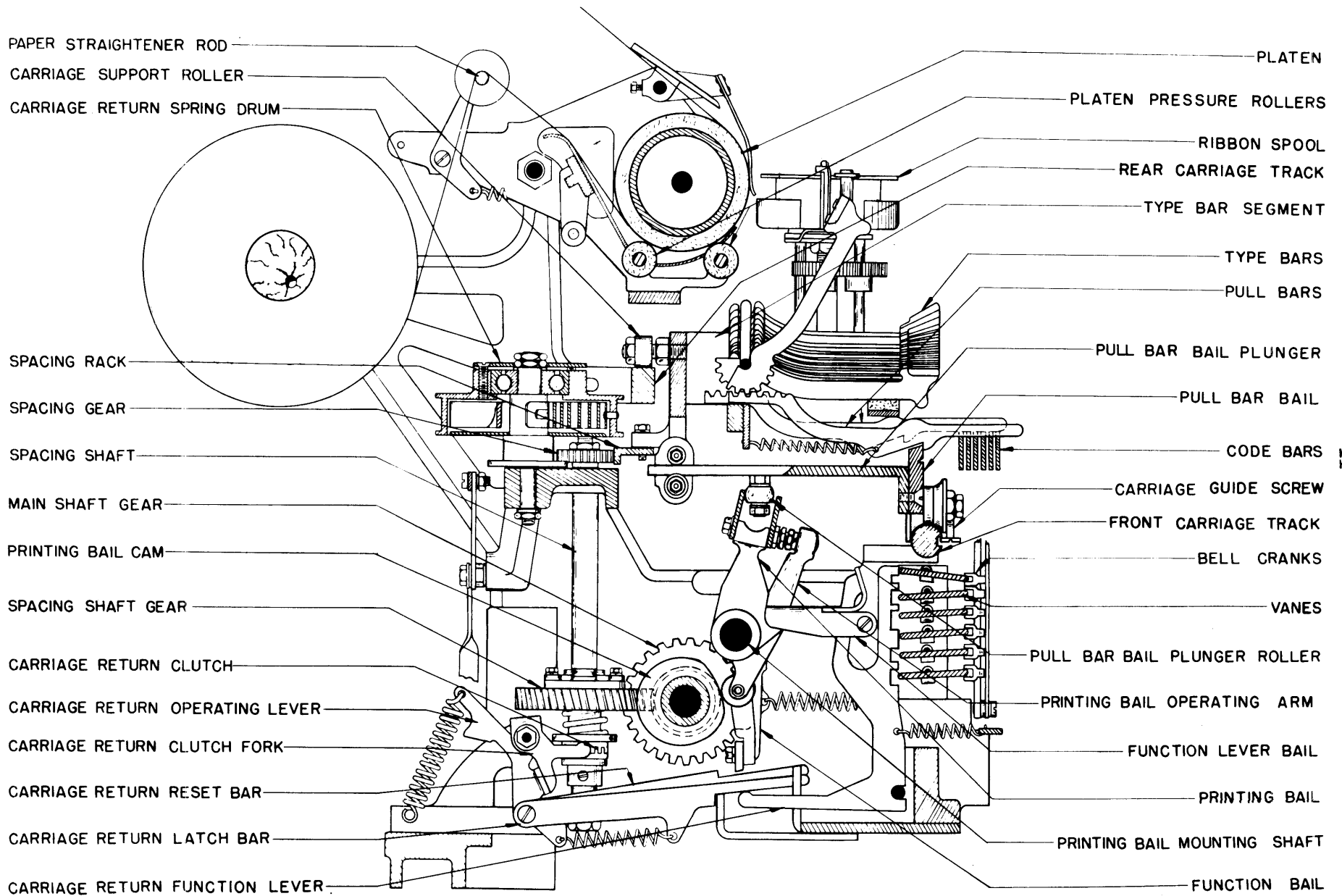
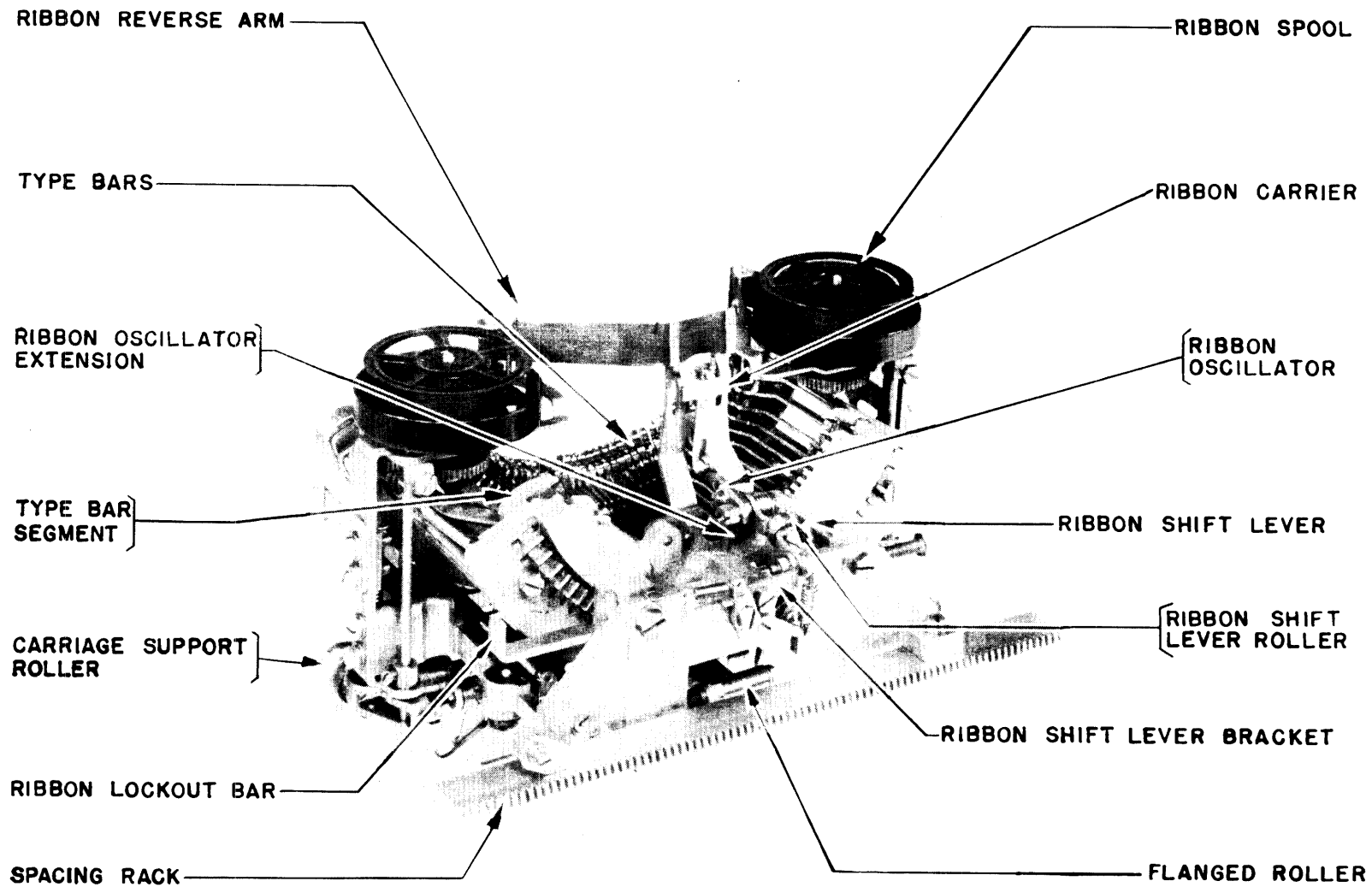

FIGURE 9.



TYPE BAR CARRIAGE— REAR VIEW
ILLUSTRATION 5.

The spacing rack is mounted on the rear of the type bar carriage casting and meshes with the spacing gear which is fastened to the upper end of the spacing shaft (Figure 9 and Illustration 7). The spacing shaft gear is located at the lower end of the spacing shaft and meshes with the main shaft spacing gear. The lower half of the carriage return clutch is fastened to the spacing shaft. The upper half of the clutch forms a sleeve on the spacing shaft to which the spacing shaft gear is attached. The carriage return clutch members are in engagement at all times except when the carriage is returning. The operation of this clutch is described under "Carriage Return".

The spacing friction clutch assembly consists of the main shaft spacing gear and sleeve, a ball bearing screwed to the shaft, a spacing escapement ratchet, a friction disc and felt washer, a spacing stop sleeve and a clutch spring (Illustration 3). The main shaft spacing gear will revolve with the main shaft unless stopped by holding either the spacing stop sleeve or the spacing escapement ratchet.

When the type bar carriage reaches the end of its travel, at the right end of the printer, the right margin adjusting screw (Figure 10-A) moves the spacing stop lever into the path of a projection on the spacing stop sleeve. This prevents spacing at the end of the carriage travel.

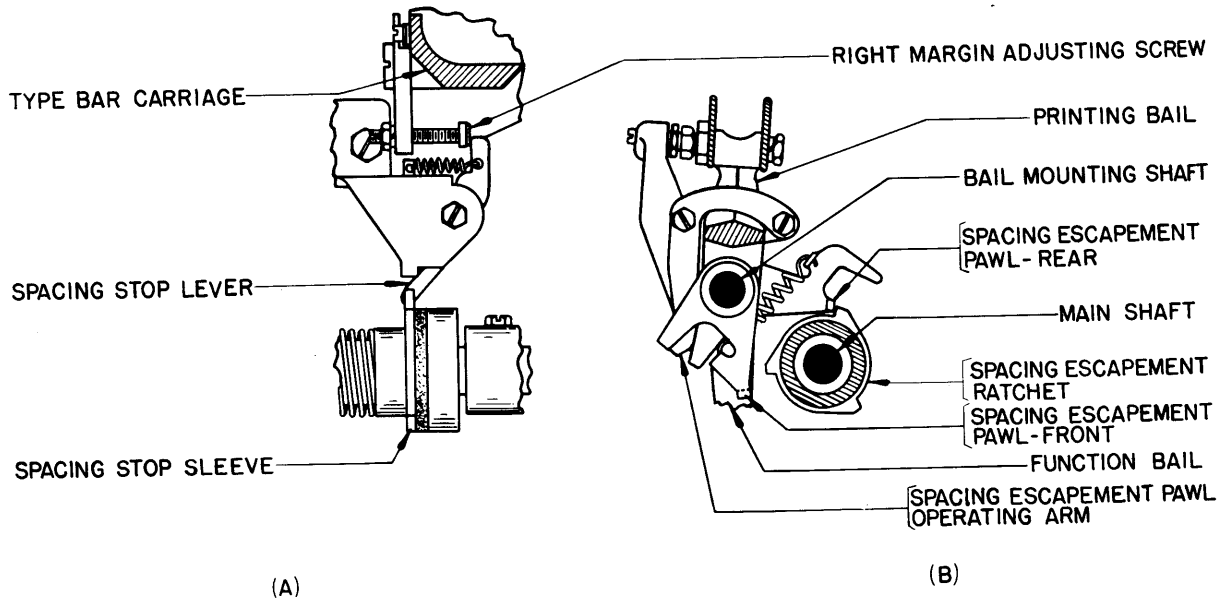

FIGURE 10.

The spacing escapement ratchet is regulated by the front and rear escapement pawls which are mounted on the bail mounting shaft. With the printing bail in its rear position, the rear escapement pawl is engaged in one of the teeth on the spacing escapement ratchet, holding the spacing gear sleeve (Figure 10-B). As the printing bail starts to move forward the operating arm strikes the lower end of the rear escapement pawl, moving it out of engagement with the tooth on the escapement ratchet. At the same time the front escapement pawl moves down against the escapement ratchet into the path of another tooth which it will engage after having traveled one-sixth of a space. The printing operation then takes place. Near the end of the return stroke of the printing bail, the escapement pawl operating arm lifts the front escapement pawl out of engagement with the escapement ratchet, and at the same time the rear escapement pawl moves against the escapement ratchet. This will allow the spacing gear to revolve far enough to complete the remaining portion of the space at the end of which time the rear escapement pawl will engage a tooth on the escapement ratchet.

Margin Bell

Before the type bar carriage reaches the end of its travel, it operates the margin bell as a warning to the operator that the end of the line is near (Figure 11 and Illustration 7). The margin bell pawl on the type bar carriage will depress the margin bell cam, tipping it, moving the bell hammer away from the bell against the tension of its spring. When the type bar carriage margin bell pawl has been spaced beyond the cam, the bell hammer will be released and its spring will pull the hammer against the bell.

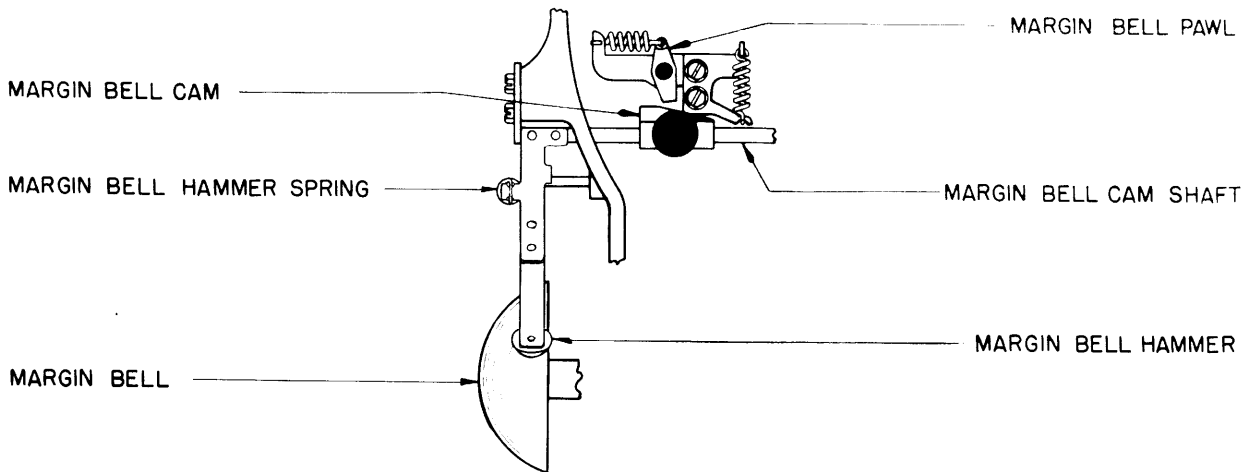

FIGURE 11.

Ribbon Feeding

The end of the ribbon feed lever engages with the notched extension on the pull bar bail plunger (Illustration 4 and Figure 12). The ribbon feed pawl, which actuates the feed ratchet, is attached to the ribbon feed lever. With each operation of the pull bar bail plunger, the ribbon feed ratchet and the ribbon feed ratchet gear, which are attached to a common shaft, are advanced one tooth. This motion is carried through a train of gears and shafts, causing one of the ribbon spools to be revolved.

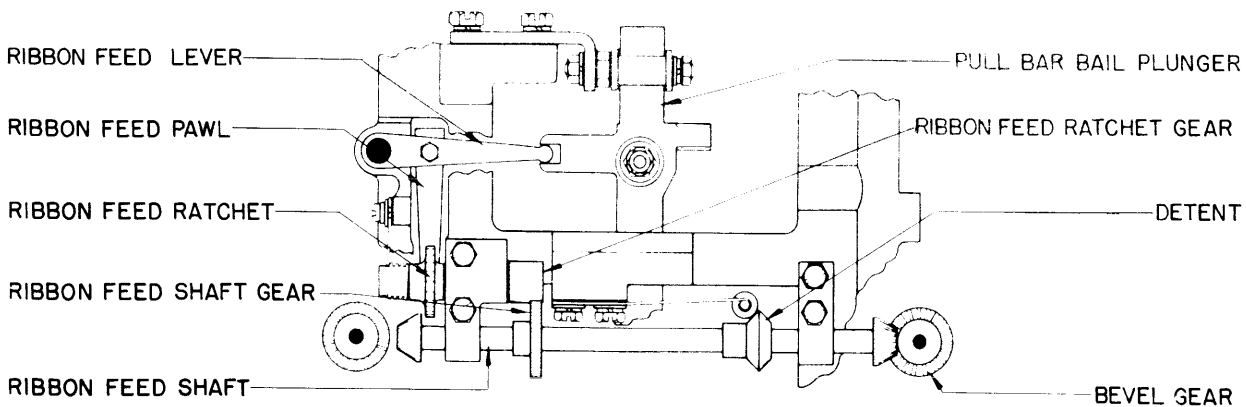
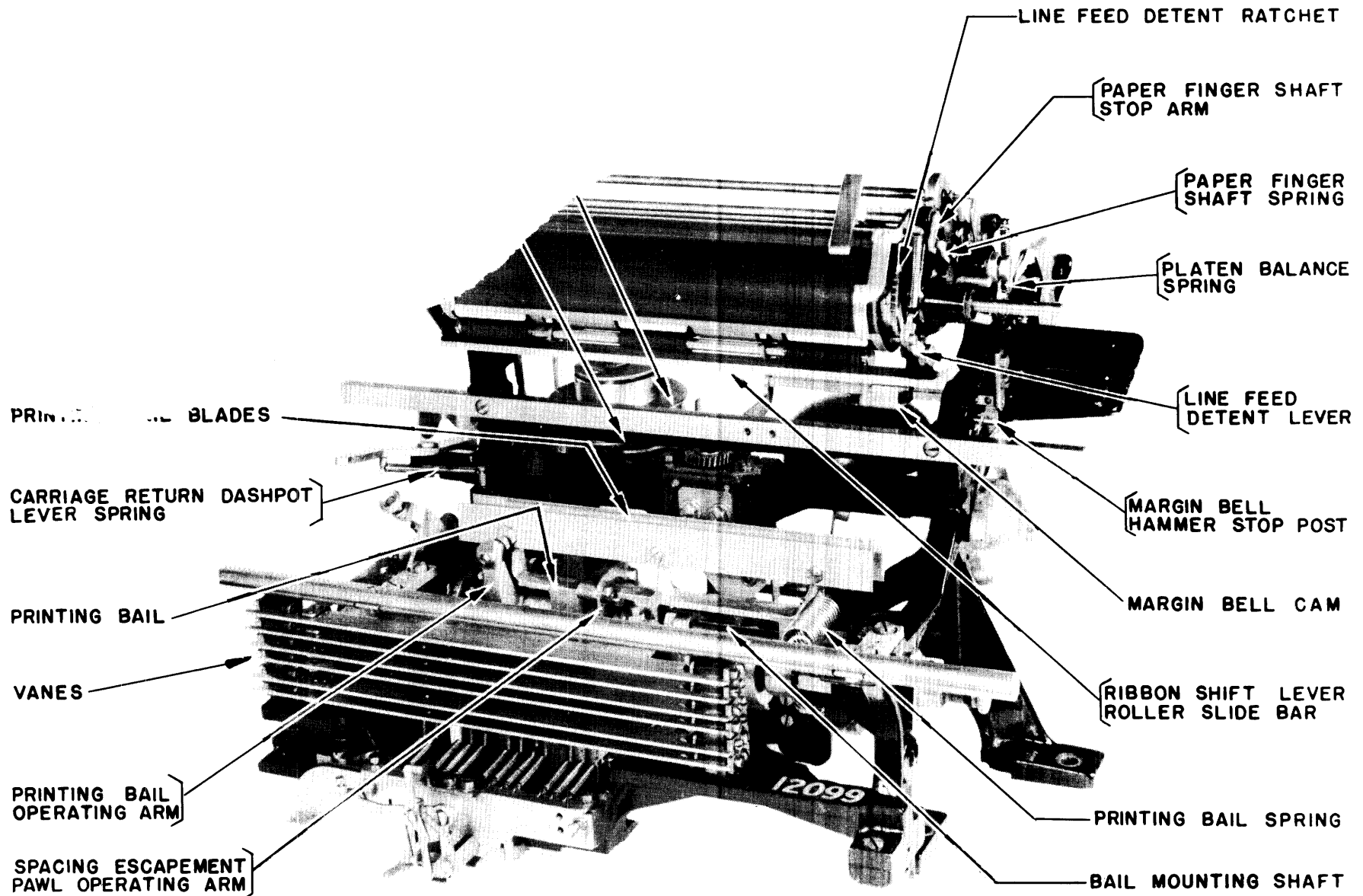

FIGURE 12.

Ribbon Reverse

is being wound on the right spool and is almost unwound
velet which is fastened to the ribbon will engage and move



TYPING UNIT—FRONT VIEW
ILLUSTRATION 6.

Ribbon Lockout

The ribbon lockout bar is provided for the purpose of locking the ribbon below the printing line when stencils are being made (Illustration 5). When the ribbon lockout bar is moved inward manually, it engages the oscillator extension, holding the oscillator assembly in the lower position, with the ribbon below the printing line.

FUNCTIONS

The function operations are accomplished through the medium of function levers. When the printing bail is in its rear or normal position, the function lever bail, which is attached to the printing bail, holds the function levers away from the vanes (Figure 15). As the printing bail moves forward, the function lever bail roller will move down off the high portions of the function lever rear arms, permitting the function lever springs to pull their respective levers against the vanes. The forward arms of the function levers are notched so that when a function combination is set up on the vanes the selected function lever will move forward farther than the other function levers.

When in the selected position, the carriage return, line feed, shift, unshift and bell function levers will be in the path of one of the blocking extensions on the function lever bail. This will prevent the printing bail from moving forward far enough to allow the type bar carriage to space. However, when the locking, universal or space function lever is selected, the function lever bail will not be blocked inasmuch as their operation depends upon a complete movement of the printing bail.

The function bail, mounted on the bail mounting shaft, is used to operate some of the functions and is actuated by the function bail cam. The function bail spring holds the function bail cam roller against the cam at all times. After the printing bail and the function lever bail move forward far enough to release the function levers, the function bail roller starts to ride up the high part of its cam. This moves the function bail blade toward the rear, engaging and operating any function push bar that may have been moved in its path by a selected function lever. The function bail roller will then ride down to the low portion of the function bail cam, the bail blade returning to its forward position in readiness for the next function.

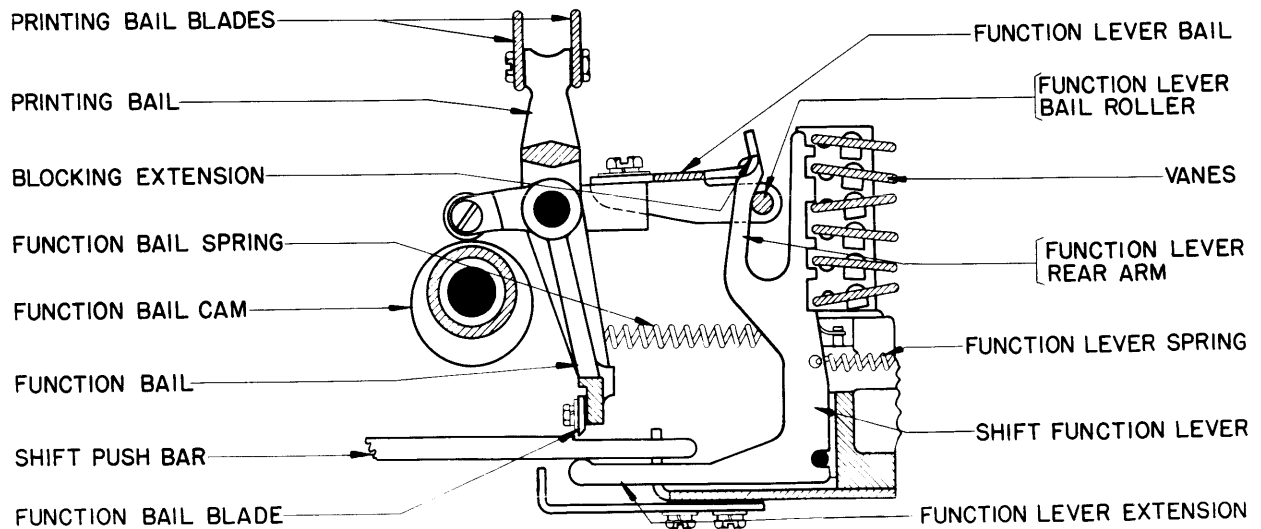

FIGURE 15.

Carriage Return Function

When the carriage return function lever (second from the right) moves into engagement with the vanes the function lever extension moves the carriage return latch bar upward out of engagement with its latch. This releases the carriage

return operating lever, which actuated by its spring, moves the carriage return clutch fork upward, disengaging the upper carriage return clutch member from the lower clutch member. The spacing shaft is then free to turn in its sleeve so that the type bar carriage may be pulled back to its extreme left position by the carriage return spring (within the carriage return spring drum) through the medium of the draw strap (Illustration 6). The notch on the carriage return reset bar will then be engaged by the function bail and moved to the rear. As the carriage return reset bar and the carriage return latch bar are both pivoted on the same screw, the carriage return latch bar will be reset into engagement with its latch (Figure 16). In the meantime the function lever bail will have been returned to its upper position and the carriage return function lever extension will have been moved down below the carriage return latch bar.

During the time that the carriage return operating lever is being operated by its spring, the lock bar is moved through a series of levers until its notch engages with the lock bar latch (Figure 16). This holds the carriage return clutch members disengaged so as to insure a complete return of the carriage.

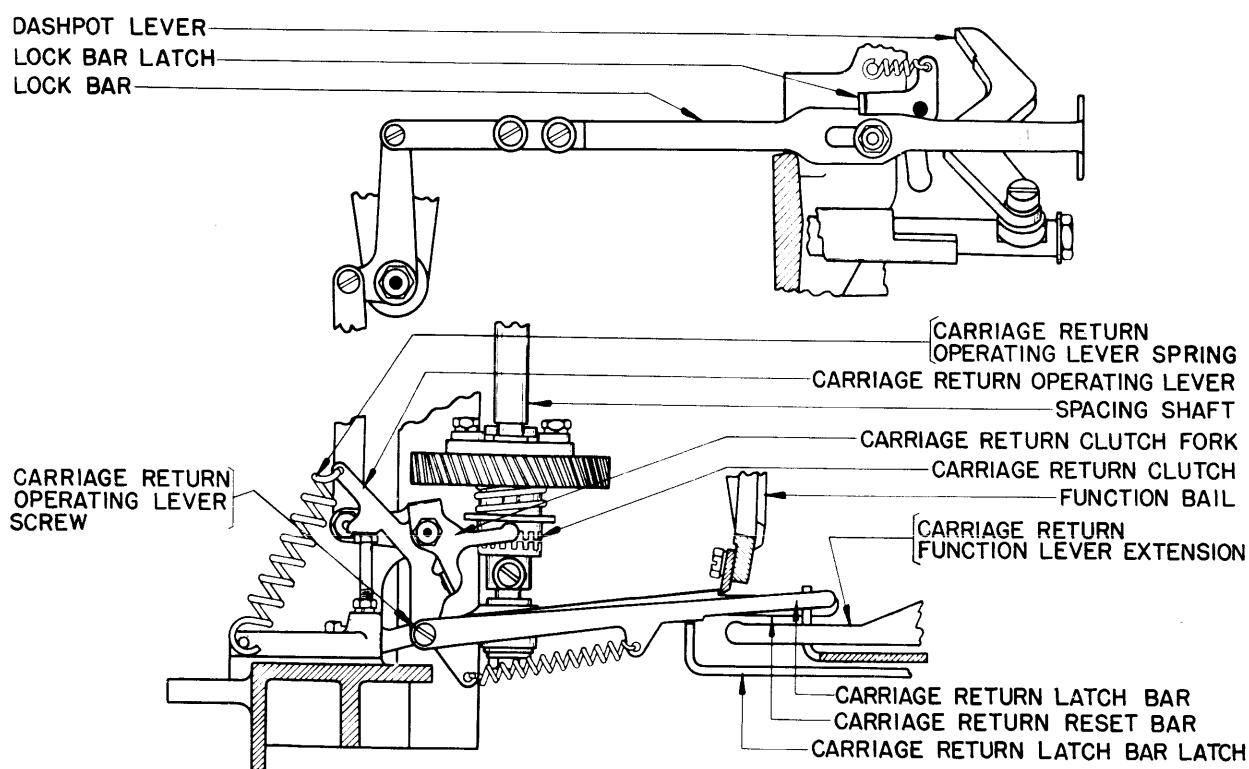
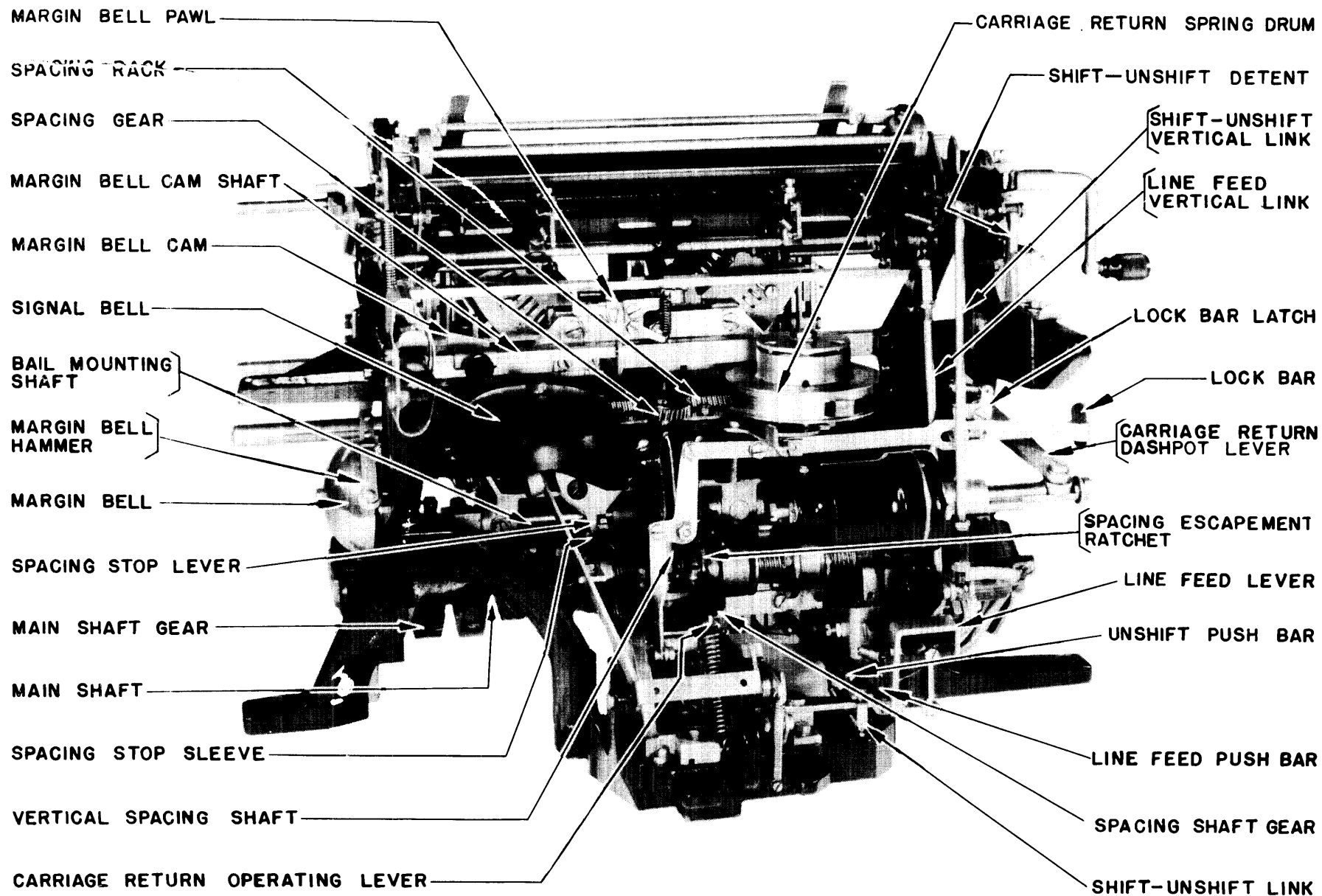

FIGURE 16.

One end of the dashpot lever is attached to the dashpot plunger and the other end projects into the path of the type bar carriage. Just before the type bar carriage has returned to the beginning of the line, the left margin adjusting screw (attached to the carriage) strikes the end of the dashpot lever driving the plunger into the dashpot air chamber absorbing the shock (Illustration 7).

When the type bar carriage returns to the beginning of the line, the dashpot lever strikes against the lower end of the lock bar latch, releasing the lock bar and carriage return clutch fork which in turn permits the carriage return clutches to engage.

The carriage return lock bar extends beyond its latch so that it may be operated manually.



TYPING UNIT—REAR VIEW
ILLUSTRATION 7.

Shift and Unshift Functions

The shift function lever, third from the right, when selected will move the shift push bar up to bring its notch into the path of the function bail (Figure 15). This push bar when moved by the function bail will turn the right end of the shift-unshift link, to which it is connected, toward the rear of the printer and the left end of the link toward the front of the printer (Figure 17 and Illustration 7). The shift-unshift lever which is engaged in the left end of the link is thus moved so as to pull the rear end of the platen assembly downward through the medium of the shift-unshift vertical link. The platen roll will be brought to its upper or shifted position.

The unshift push bar is connected to the left side of the shift-unshift link. When the unshift push bar is operated by the function bail, the action on the platen assembly will be reversed, bringing the platen down to the unshift position.

The shift-unshift detent is provided to hold the platen assembly firmly in either the shift or unshift position.

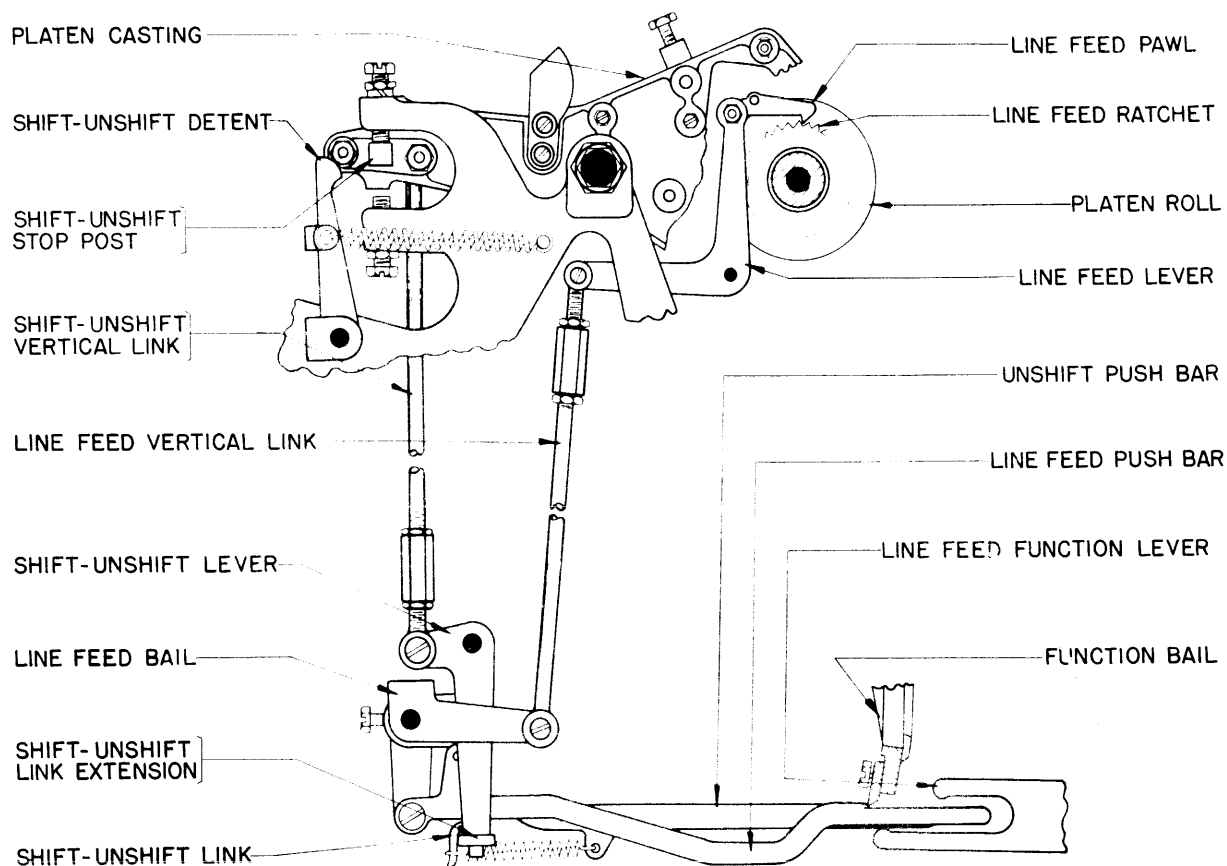

FIGURE 17.

Spacing Function

Spacing other than that accompanied by printing (such as spacing between words, etc.) is accomplished in the same manner as that described under "Spacing" except that there is no pull bar to be selected.

Signal Bell Function

When the bell combination is received, the signal bell function lever, fourth from the right, will be selected. The extension on the signal bell function lever will raise the bell latch bar out of engagement with the bell latch bar latch. This

releases the bell operating lever so that its spring may in turn rotate it, permitting the lever to strike the bell hammer arm extension throwing the bell hammer against the signal bell (Figure 18). The notch of the bell reset bar being in the path of the function bail blade will reset the bell latch bar when the function bail moves to the rear. The bell reset bar and the bell latch bar move together, because they are both pivoted on the bell operating lever screw.

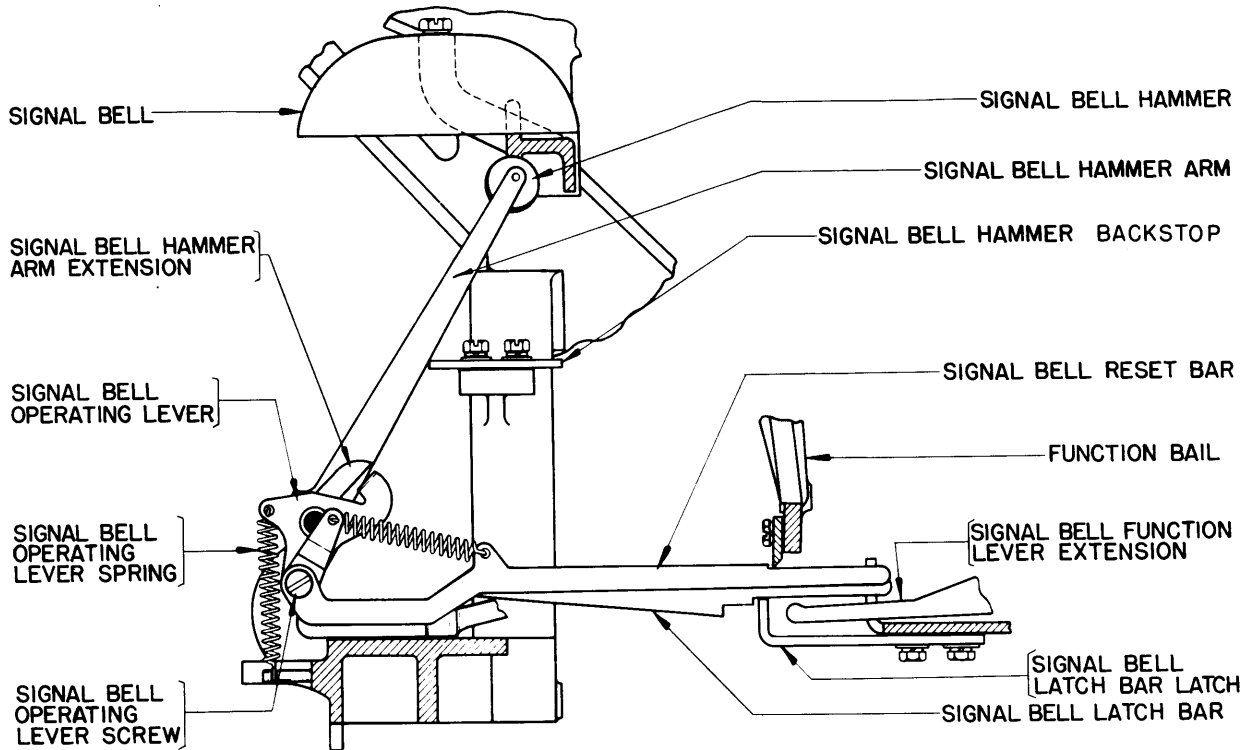

FIGURE 18.

Line Feed Function

When the line feed function lever, ninth from the right, is selected its lower extension raises the line feed push bar into the path of the function bail blade (Figure 17). When the bail moves toward the rear of the printer the line feed push bar rotates the line feed bail, pulling the line feed vertical link downward. This will operate the line feed lever, which in turn will move the line feed pawl into engagement with the line feed ratchet and rotate the platen one line space. When the line feed function lever is returned to its normal position by the function lever bail, the upper function lever extension moves the line feed push bar down below the path of the function bail and holds it there until a line feed combination is again selected.

After each line feed operation, the detent roller locates itself between two teeth on the line feed detent ratchet, thus holding the platen firmly in position during each line of printing (Illustration 6). The line feed detent ratchet is attached to the right end of the platen.

The single-double line feed lever in its lower position will allow the line feed pawl to engage two teeth, thereby causing the platen to rotate a double line space (Illustration 1). When the single-double line feed lever is in its upper position, the line feed pawl will be permitted to engage and operate only one tooth on the line feed ratchet, which will cause the platen to rotate a single line space.

In order to facilitate paper feeding, the paper straightener rod and a series of platen pressure rollers are provided (Figure 9). The paper straightener rod is used to guide the paper as it is unwound from the roll. It is also used as a slack rod to prevent the paper from tearing. The pressure rollers hold the paper firmly against the platen to prevent slippage while line feeding.

KEYBOARD LOCKING MECHANISM

The following description does not pertain to printers arranged to operate the bell on blank signal combinations. However on printers of this type the keyboard locking mechanism may be operated manually.

When the blank key lever of a keyboard is depressed twice, or the line is opened for a time interval equivalent to at least two revolutions of the keyboard transmitting shaft, the keyboard control contacts will be caused to close, short-circuiting the keyboard transmission (Figure 19). When the keyboard control contacts are closed, the send-receive handle will move to its lower position. All keyboards on the circuit will now be locked out until the send-receive handle is manually restored to its upper position.

The universal function lever (fifth from the right) moves with each operation of the printer and its extension is positioned above the right arm of the send-receive "T" lever (Figure 19). With each movement of the universal function lever the right arm of the send-receive "T" lever will be pushed downward and the top of the send-receive "T" lever and the pivot of the intermediate lever will be moved to the right. This will keep the lower end of the intermediate lever out of the path of the blank function lever extension.

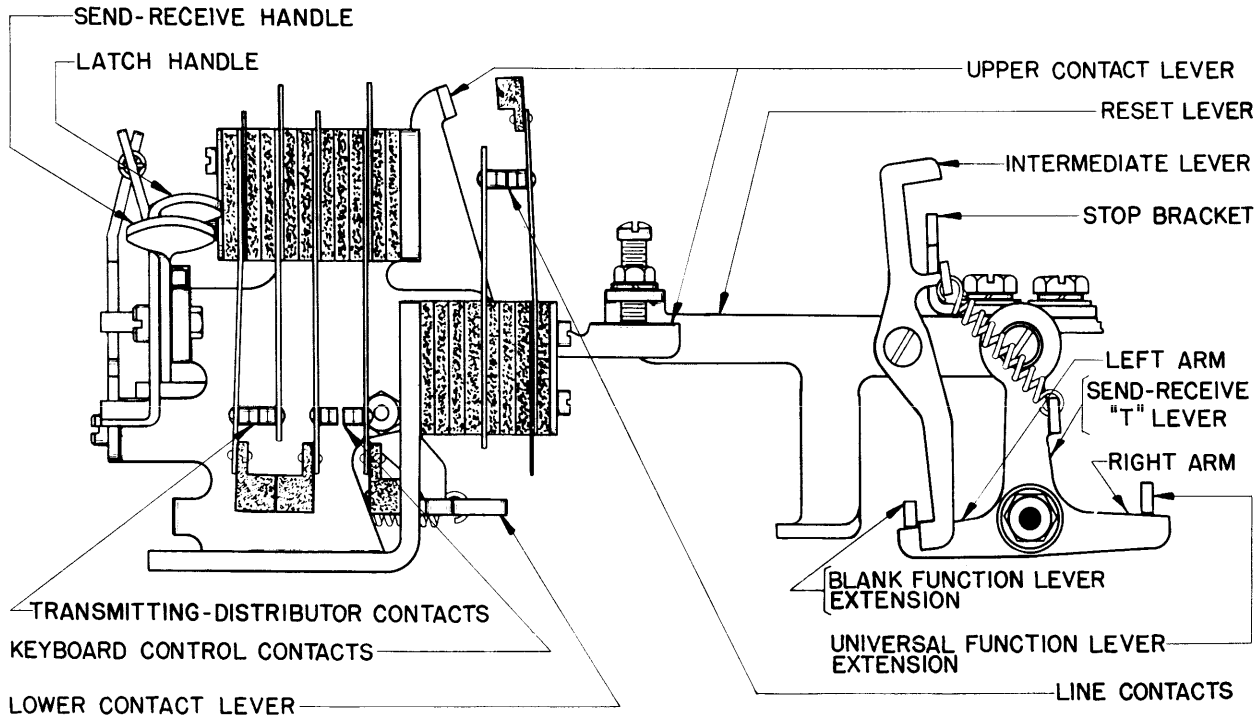

FIGURE 19.

When the blank function lever (sixth from the right) is selected its extension moves downward at about the same time as the universal function lever and because the spring on the blank function lever is considerably stronger than the spring on the universal function lever the left end of the send-receive "T" lever will be moved downward. The upper part of the send-receive "T" lever and the pivot of the intermediate lever will, therefore, be moved to the left, allowing the lower end of the intermediate lever to move against the side of the blank lever extension when the blank lever is in its lower position. When the blank lever extension moves upward at the end of the operating cycle it will permit the lower end of the intermediate lever to swing beneath the blank function lever (Figure 20). If another blank selection is now made the intermediate lever will be pulled downward moving the reset lever against the upper contact lever which will release the lower contact lever. The spring on the lower contact lever will move its extension against the contact springs which will close the keyboard control contacts and move the send-receive handle to the lower position.

If only one blank signal is received followed by a space or character the keyboard will not be locked out because the intermediate lever will be moved out of the path of the blank function lever extension by the universal lever extension. Thus it can be seen that two consecutive blank combinations will have to be received before the keyboard will be locked out. When it is desired to have the keyboard locking mechanism operate on a single blank signal, the universal function lever is omitted and the upper part of the send-receive "T" lever is securely locked to the left so that the lower end of the intermediate lever is always in the path of the blank function lever. Therefore, on the first selection of a blank signal, the blank function lever will operate the keyboard locking mechanism.

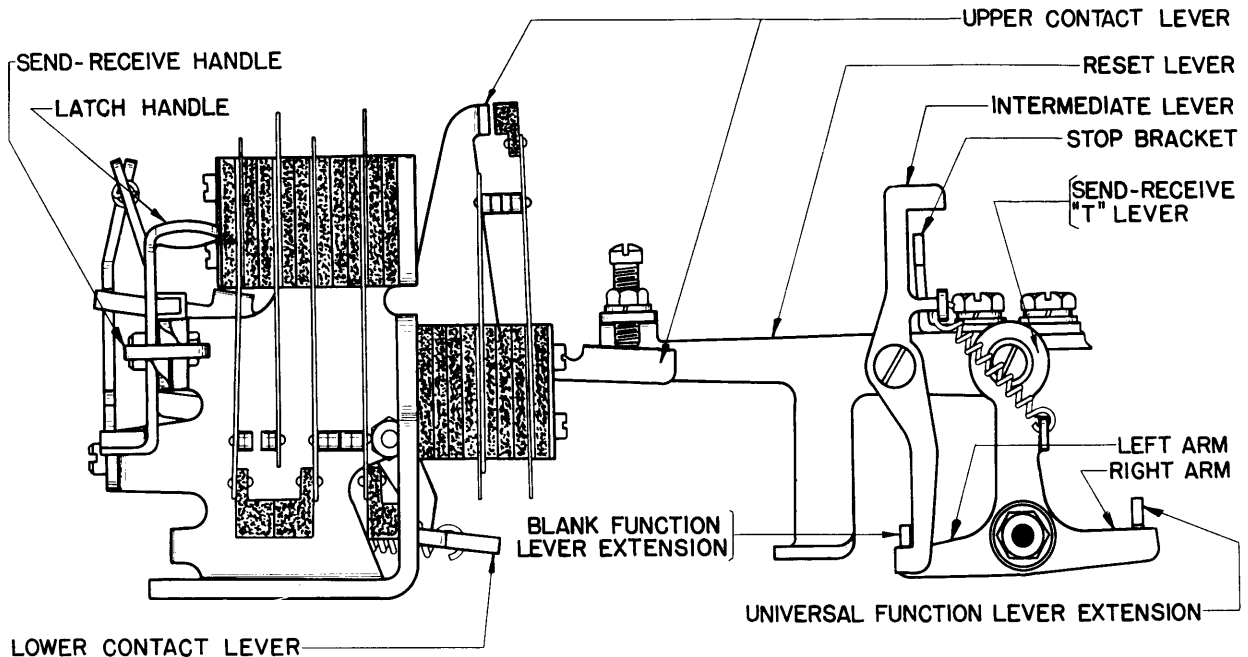

FIGURE 20.

At the same time the lower contact lever closes the keyboard control contacts, it is also opening a second pair of contacts. These contacts are used when it is desired to control a tape transmitting distributor.

MOTOR SPEED CONTROL

In order to maintain the transmitting and receiving stations at the proper speed, each motor (excepting synchronous motors) is equipped with a governor attached to one end of the motor shaft (Figure 21).

The governor contact arm consists of a bent strip of metal with a contact mounted on one end and fastened by a flat spring at the other end. The contact arm spring holds this contact against a companion contact until the centrifugal force of the contact arm overcomes the tension of the spring. When the contacts open, a resistance is connected into the motor circuit which tends to reduce the speed of the motor. The closing and opening of the contacts holds the motor speed constant to the value of the tension at which the spring is set. The spring tension (which determines the motor speed) is adjusted by turning the speed adjusting wheel which projects through the cover of the governor.

The governor is equipped with a speed target consisting of alternate black and white spots. A tuning fork with shutters attached to the ends of the tines is used to visually check the motor speed. With a properly adjusted spring tension, the spots on the target appear to be stationary when observed through the shutters of the vibrating tuning fork.

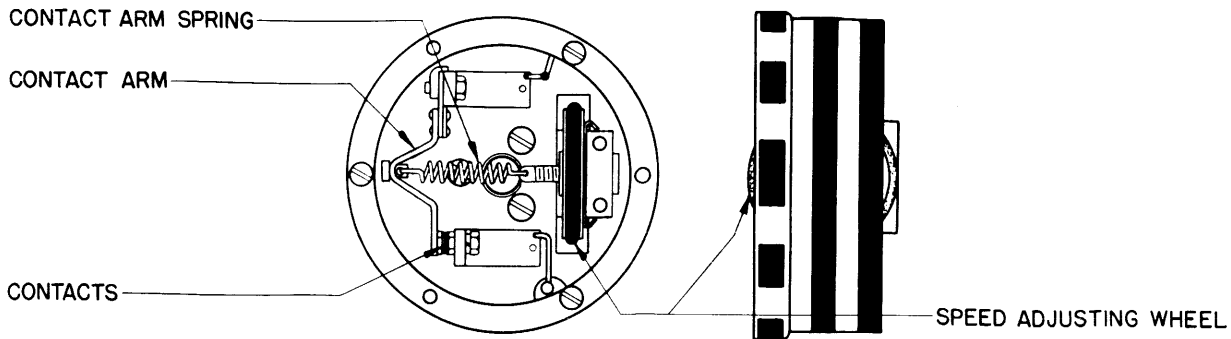

FIGURE 21.

Mounted on a bracket is a lamp with a switch, which provides illumination for the speed target when a governor equipped motor is used.

Printers equipped with synchronous motors (which are constant speed motors) require no speed setting.

BASE UNIT

The base unit provides facilities for mounting the typing, keyboard and motor units together with the necessary accessories such as mounting blocks, condensers, slip connections, terminals, etc. (Illustration 8).

SYNCHRONISM

In order that the signals sent out by the transmitter may be interpreted correctly by the receiving units, it is necessary to keep the receiving units in synchronism with the transmitted signals.

This is accomplished by having the selector cam sleeve rotate faster than the transmitting cam sleeve and using the start and stop impulses to maintain synchronism in the following manner:

As previously described, the reception of the start impulse starts the selector cam sleeve on the receiving unit revolving. At that moment, the selector cam sleeve is in unison with the transmitting cam sleeve. The selector cam sleeve revolves one-sixth faster than the transmitting cam sleeve, but the selector cam sleeve is so constructed that the distance traveled from the position where the cam sleeve starts to move a selector lever to the position where it starts to move the next selector lever is one-sixth greater than the distance traveled by the transmitter cam sleeve from where it can control the transmission of one impulse to where it can control the next. In other words, for a certain travel of the transmitting cam sleeve, the corresponding travel for the selector cam sleeve is one-sixth greater, but as the selector cam sleeve travels one-sixth faster, it will reach its second position at the same time the transmitting cam sleeve reaches its second position.

The selector cam sleeve completes its revolution before the transmitting cam sleeve but the transmitting cam sleeve sends out the stop impulse which stops the selector cam sleeve until the transmitting cam sleeve again sends out the start impulse. Normally, when the selector cam sleeve is one-sixth faster than the transmitting cam sleeve, the selector cam sleeve is at rest one-sixth of the transmission time. If the speed of the selector cam sleeve is faster or slower than the proper speed, the cam remains at rest more, or less, respectively. Of course, there will be a slight error in the relative position of the selector cam sleeve in the various positions, but the mechanism is so constructed to provide for this and, due to the fact that the selector cam sleeve starts each revolution in unison with the transmitting cam sleeve, this error does not become accumulative.

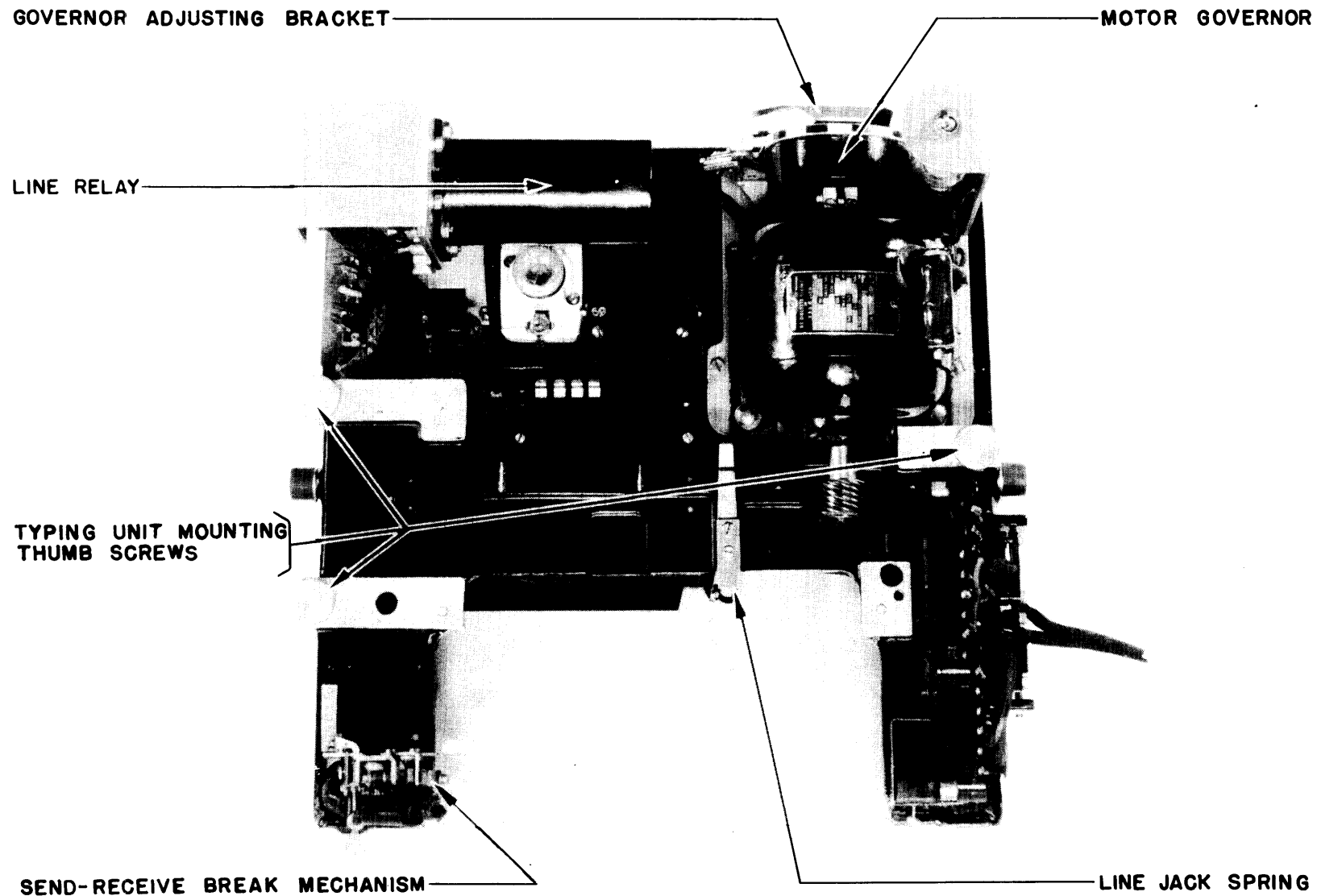

BASE - WITH MOTOR UNIT - TOP VIEW
ILLUSTRATION 8.

ORIENTATION

In order to properly operate the selector mechanism, it is necessary to place the starting point of the selector cam sleeve in the most favorable position. This is accomplished by means of the range finding mechanism, which is used to orient or take a range.

Mounted on the stop lever plate (which is a part of the range finding mechanism) are the stop lever and the trip latch which may be rotated, thereby varying the relation between the start of the selector cam sleeve and the time the selector cams operate the selector levers (Figure 4). A graduated scale indicates the setting of the stop mechanism, and a clamping screw holds it in place after having been set.

The range is determined while receiving "4Y" on the printer, by first moving the range finder index arm in one direction until errors appear and then back slowly until the errors disappear and noting the position on the scale. In a similar manner the other limit of the range is located by moving the index arm toward the opposite end of the scale. The proper setting is the midpoint of these two limits.

LINE-TEST KEY

Mounted on the keyboard (to the left of the transmitting contact assembly) is the line-test key (Illustration 2). It is provided for the purpose of testing the machine without interrupting the line circuit.

When the knob of the line-test key is pulled out, the selector magnets and keyboard contacts are disconnected from the line and a local circuit is established.

LINE RELAY

A line relay base is provided (mounted on a bracket located on the rear of the base unit) so that a line relay may be used (Illustration 8).

The wiring is arranged so that either the line relay or the selector magnets may be connected in the line circuit. In the former case, the contacts of the line relay repeat the signals to the selector magnets whereas in the latter the selector magnets are connected directly in the line.

WIRING DIAGRAM

Figure 22 shows the theoretical wiring of a typical Model 20 printer. The motor circuit shown is for use with 110 volt direct current motors. Refer to actual wiring diagram for circuits used with other types of motors.

When mechanical motor control is used, (see motor and motor control circuits, Figure 22) loops A'B' and G'H' are open and A' is connected to A, B' to B, G' to G and H' to H. When control relay is used, loops A'' B'', C' D' and E' F' are open and A'' is connected to A, B'' to B, C' to C, D' to D, E' to E and F' to F.

The bottom figure on the wiring diagram shows the line and line relay circuits.

When neither mechanical motor control nor control relay is used, loop A' B' is open and A' is connected to A and B' to B.

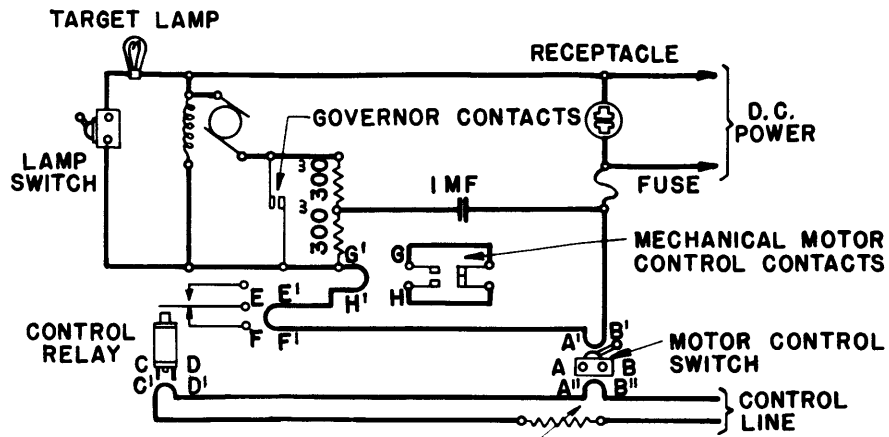

MOTOR AND MOTOR CONTROL CIRCUITS.

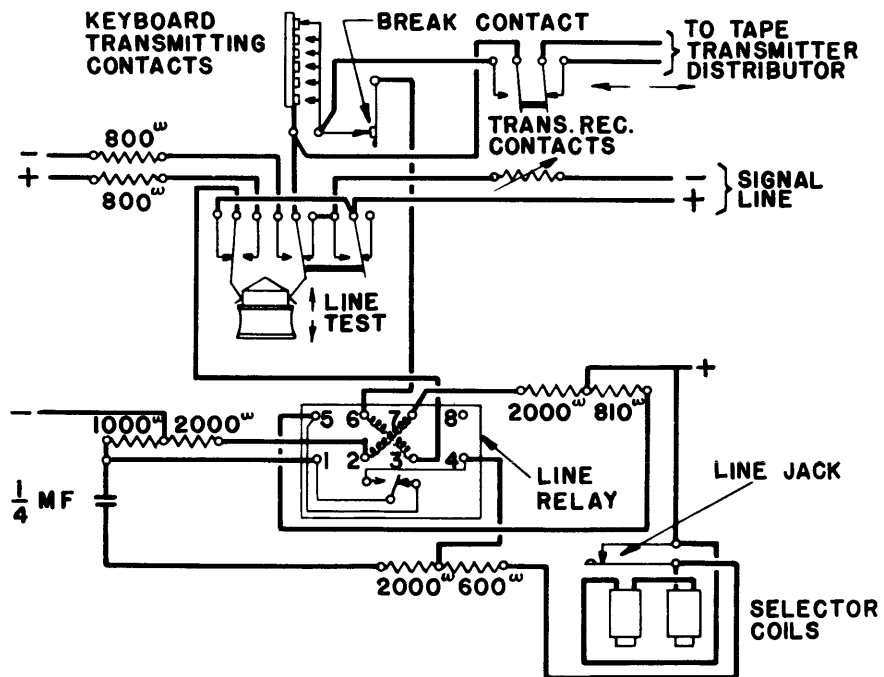

LINE AND RELAY CIRCUITS.

FIGURE 22.