

ULT

Operations and Maintenance

Honeywell-Based Systems

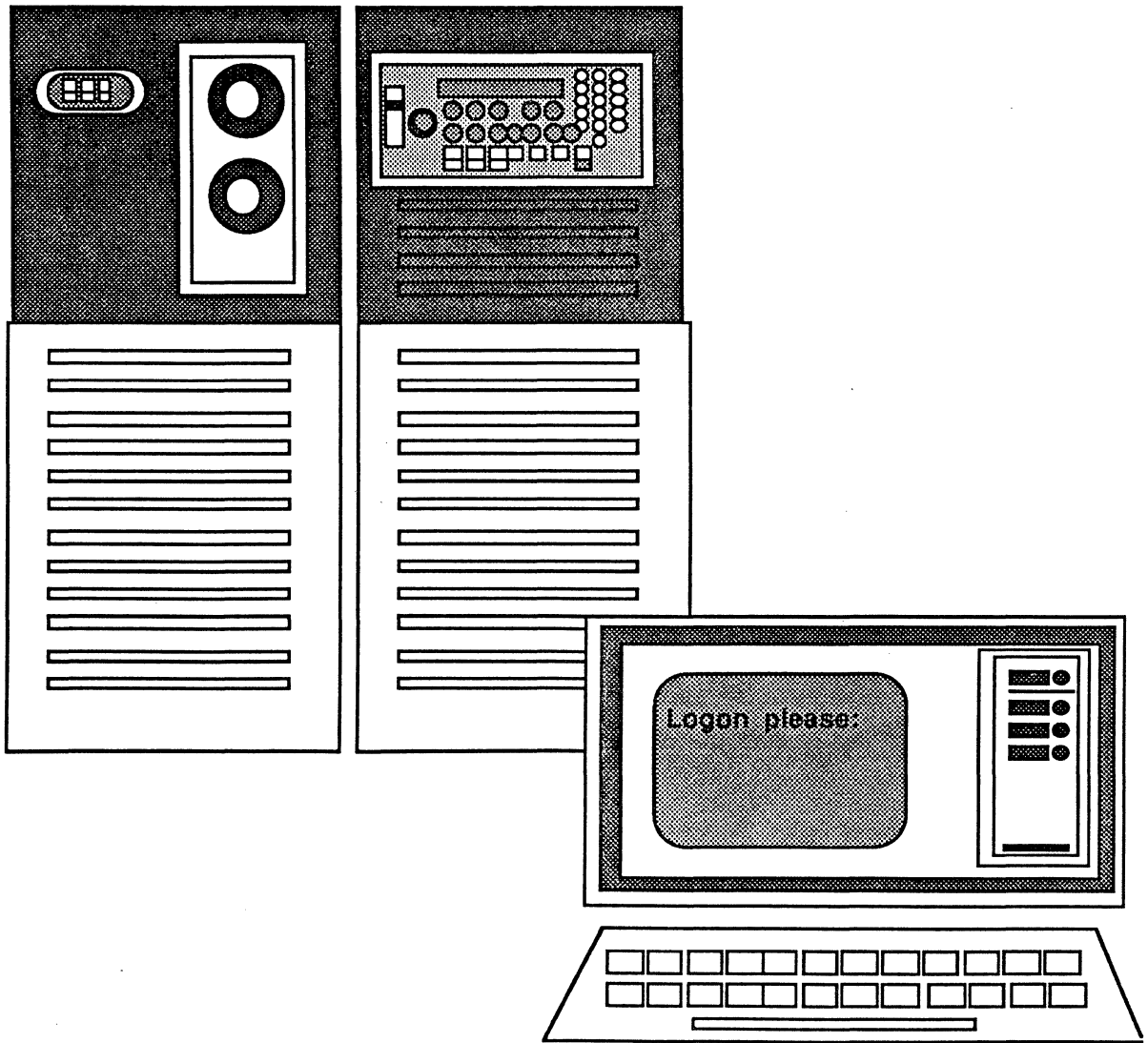

THE ULTIMATE CORP.



Honeywell Operations and Maintenance

PROPRIETARY INFORMATION

Copyright (c) 1987, The Ultimate Corp. All Rights Reserved. This work is the property of and embodies trade secrets and confidential information proprietary to Ultimate, and may not be reproduced, copied, used, disclosed, transferred, adopted, or modified without the express written approval of Ultimate.

This document applies to the Honeywell-based models of the 1400, 6000, and 7000 series.

Copyright July 1987, THE ULTIMATE CORP.
Document No. HOM-02.2

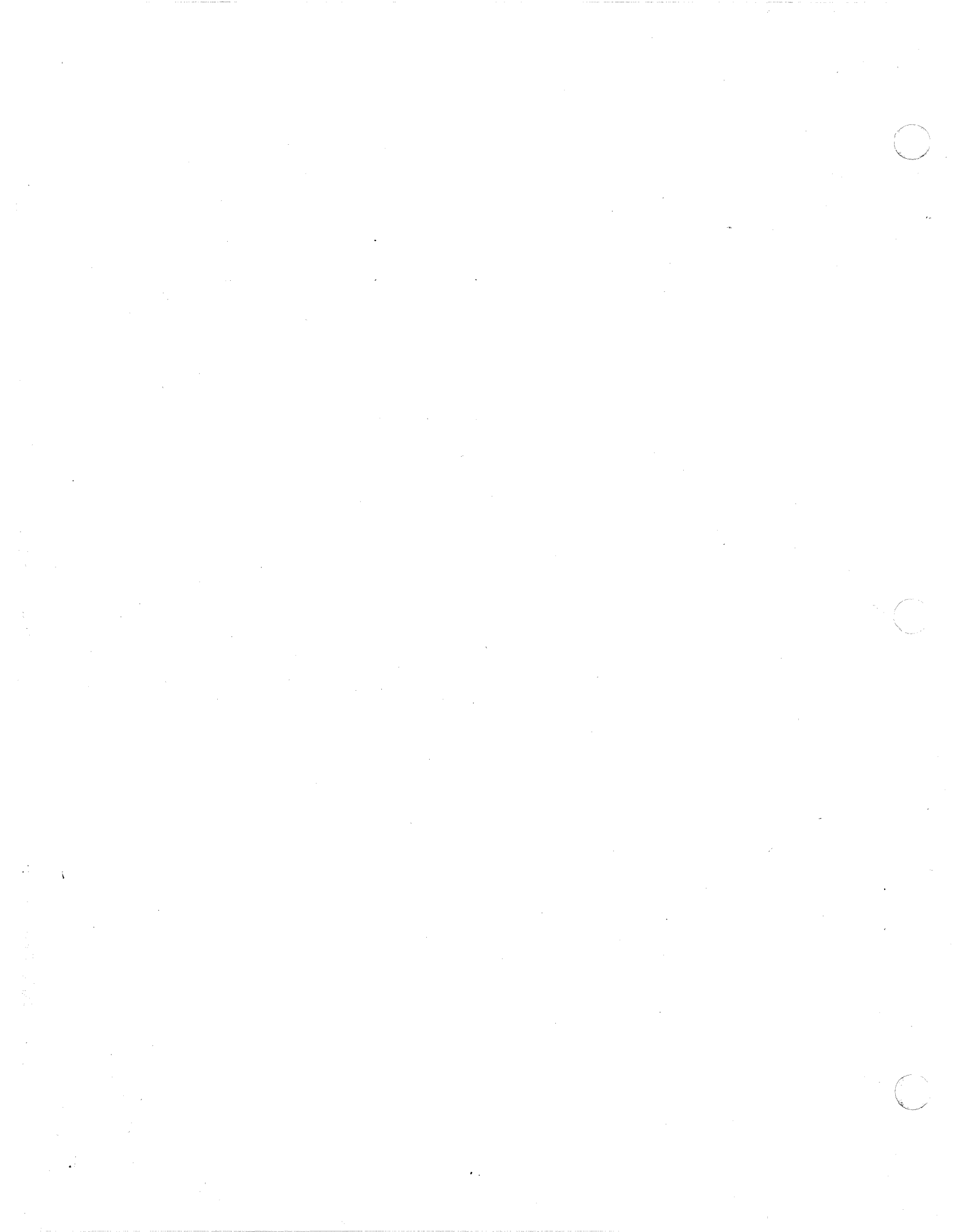

FCC WARNING

This equipment generates, uses, and can radiate radio frequency energy and, if not installed and used in accordance with the instruction manuals, may cause interference to radio communications. It has been tested and found to comply with the limits for a Class A computing device pursuant to Subpart J of Part 15 of FCC Rules, which are designed to provide reasonable protection against such interference when operated in a commercial environment. Operation of this equipment in a residential area is likely to cause interference, in which case the user, at his or her own expense, will be required to take whatever measures necessary to correct the interference.

ACKNOWLEDGEMENT

The illustrations in Section 4, and Figure 7 in Appendix B, are courtesy of Cipher Data Products, Inc.

Table of Contents

TABLE OF CONTENTS

FCC Warning.....	P-1
Table of Contents.....	P-2
How To Use This Manual.....	P-5
1. Getting Started.....	1-1
1.1 Power On.....	1-1
1.2 Boot the System.....	1-1
1.3 Format Disk(s).....	1-1
1.4 Check Equipment.....	1-1
1.4.1 Terminals.....	1-1
1.4.2 Printers.....	1-2
1.5 Check ACC and DICT ACC Files.....	1-3
1.6 Load UltiWord.....	1-4
1.7 Getting Started Checklist.....	1-12
2. Powering On.....	2-1
2.1 Powering On 6000 and 7000 Series Systems.....	2-1
2.2 Powering On 1400 Series Systems.....	2-3
3. Powering Off.....	3-1
3.1 Powering Off 6000 and 7000 Series Systems.....	3-1
3.2 Powering Off 1400 Series Systems.....	3-3
4. Disk and Tape Drive Procedures.....	4-1
4.1 Disk Drive Procedures for 6000 and 7000 Series Systems.....	4-1
4.1.1 EMD Drive.....	4-1
4.1.2 FSD Drive.....	4-1
4.1.3 SMD Drive.....	4-2
4.1.4 CMD Drive.....	4-3
4.2 Tape Drive Procedures for 6000 and 7000 Series Systems.....	4-5
4.3 Tape Drive Procedures for 1400 Series Systems...4-7	
4.3.1 One Quarter Inch (1/4") Cartridge Tapes...4-7	
4.3.2 One Half Inch (1/2") Reel Tapes.....4-7	
5. Booting the System.....	5-1
5.1 Full Control Panel.....	5-1
5.2 Basic Control Panel.....	5-3
5.3 System Control Facility (SCF).....	5-5
5.4 1400 Series Systems.....	5-8
6. System Startup Options.....	6-1
6.1 Boot.....	6-3
6.2 Coldstart.....	6-3
6.3 Diagnostics Monitor for 6000 and 7000 Series Systems.....	6-9
6.3.1 Formatting a Disk (For Systems with Tape Drive).....	6-9

Table of Contents

6.3.2 Formatting a Disk (For Disk-Only Systems).....	6-18
6.4 Diagnostics Monitor for 1400 Series Systems....	6-30
6.5 File-Restore.....	6-34
6.6 Offline Monitor.....	6-34
6.7 Utilities Monitor.....	6-35
6.8 Warmstart.....	6-35
6.8.1 From Menu.....	6-35
6.8.2 From TCL.....	6-36
7. Backing Up the System.....	7-1
7.1 Organizing Backup Tapes.....	7-1
7.1.1 Labeling.....	7-1
7.1.2 Rotating.....	7-2
7.2 File-Save.....	7-3
7.3 Account-Save.....	7-7
7.4 Binary-Save.....	7-10
7.5 Disk-to-Disk Copy.....	7-14
7.6 T-DUMP.....	7-20
7.7 Update-Saves and Transaction Logger.....	7-22
7.7.1 ALL-UPDATE-SAVE.....	7-22
7.7.2 PART-UPDATE-SAVE.....	7-25
7.7.3 Transaction Logger.....	7-28
7.7.4 Using Update-Saves and Transaction Logger Together.....	7-33
8. Restoring Data.....	8-1
8.1 File-Restore.....	8-1
8.2 Account-Restore.....	8-10
8.2.1 From File-Save or Account-Save Tape.....	8-10
8.2.2 From Update-Save Tape.....	8-12
8.3 Binary-Restore.....	8-18
8.4 T-LOAD.....	8-23
8.5 Selective-Restore.....	8-25
8.6 Restore From Update-Saves and Transaction Logger.....	8-28
9. Maintenance.....	9-1
9.1 Daily.....	9-1
9.1.1 Back Up Your Data.....	9-1
9.1.2 Check File Statistics Report.....	9-1
9.1.3 Verify-System.....	9-2
9.1.4 List-System-Errors.....	9-3
9.1.5 Check Print Overflow Table.....	9-4
9.1.6 Clean GCR Tape Drive.....	9-5
9.2 Weekly.....	9-7
9.2.1 File-Save.....	9-7
9.2.2 Clean Tape Heads.....	9-7
9.3 Monthly.....	9-8
9.3.1 File-Restore.....	9-8
9.3.2 Clear ACC File.....	9-8
9.4 Semi-Monthly.....	9-9
9.4.1 Format Disk Drives.....	9-9

Table of Contents

10. Adding Equipment.....	10-1
10.1 Adding Ports.....	10-1
10.2 Adding Disk Drives.....	10-1
10.3 Adding Tape Drives and Parallel Printers.....	10.1
10.4 Adding Communications Boards.....	10.1
11. Troubleshooting.....	11-1
11.1 General Procedures.....	11-1
11.2 Calling the Ultimate Support Group.....	11-3
11.3 Group Format Errors (GFES).....	11-4
11.4 Aborts.....	11-6
11.5 System Hangs.....	11-8
11.5.1 System.....	11-8
11.5.2 Terminals.....	11-8
11.5.3 Hangs During a File-Save.....	11-8
11.5.3.1 Disk Errors.....	11-9
11.5.3.2 Tape Errors.....	11-10
11.5.3.3 Checking for Parity Errors.....	11-10
11.5.3.4 Lock Errors.....	11-11
11.6 Printer Problems.....	11-12
11.7 System Errors.....	11-13
11.8 Mismatches.....	11-14
11.9 Traps.....	11-16
11.10 Debugger for the 1400 Series Systems.....	11-17
11.11 HPP Errors.....	11-18
11.12 Power Failures.....	11-19
11.12.1 Power Failure Recoveries.....	11-19
11.13 Creating a Memory Dump.....	11-21
11.13.1 System With Full Control Panel.....	11-21
11.13.2 6400 System With SCF and Reel Drive.....	11-22
11.13.3 1400 Series Systems.....	11-23
11.14 Troubleshooting Log Sheet.....	11-25
Appendix A: Glossary.....	A-1
Appendix B: Figures 1 - 8, Panel Layouts.....	B-1
Figure 1 - Full Control Panel.....	B-2
Figure 2 - Basic Control Panel.....	B-3
Figure 3 - EMD Drive.....	B-4
Figure 4 - FSD Drive.....	B-5
Figure 4A - FSD Drive Control Panel.....	B-6
Figure 5 - SMD Drive.....	B-7
Figure 6 - CMD Drive.....	B-8
Figure 7 - Tape Drive.....	B-9
Figure 8 - GCR Tape Drive.....	B-10
Figure 9 - 1400 Series System.....	B-11
Figure 10 - 1400 Series System Panel.....	B-12
Figure 11 - GCR Tape Drive Panel.....	B-13

Table of Contents

Appendix C: CRT Configurations.....C-1
 ADDS 2020 Terminal.....C-1
 Viewpoint/60 Terminal.....C-3
 Viewpoint/60+ Terminal.....C-6
 Viewpoint Plus Terminal.....C-9
 Viewpoint 1010 Terminal.....C-10
 Wyse WY-50 Terminal.....C-11
 Wyse 60 Terminal.....C-16
 Wyse-85 Terminal.....C-19

Appendix D: Printer Configurations.....D-1
 Data Comm Board.....D-1
 DEC Letterprinter 210.....D-4
 IGP-10.....D-6
 NEC 3500 Letter Quality Printer.....D-9
 NEC 5500 SpinWriter.....D-11
 Printronix A and B Logic Boards.....D-13
 Printronix MVP.....D-15
 Printronix Compress Print Mode.....D-17

Index.....I-1

How To Use This Manual

HOW TO USE THIS MANUAL

The Operations and Maintenance Guide for Honeywell-Based Systems is designed to guide you through normal operating procedures and scheduled maintenance of your Ultimate computer system.

You should have read and followed the instructions in the Site Preparation Guide before attempting any steps in this manual.

You should read and become familiar with all of the steps in this manual, and refer to specific sections as they are required.

Section 1 defines the steps necessary in GETTING STARTED with your Ultimate system. This section explains what you'll need to do before you can use your system, and it provides a checklist so you may check your progress and ensure you've completed all the steps necessary in getting started.

Section 2 explains the procedures for POWERING ON your Ultimate system.

Section 3 explains the procedures for POWERING OFF your Ultimate system. Normally, your Ultimate system can be left on, so you won't need to power off very often.

Section 4 explains DISK AND TAPE DRIVE PROCEDURES, such as loading and unloading disk packs and tapes, and cycling up disk drives. Although these procedures are included in the instructions on powering on and off, they are separated in this section in case they need to be performed separately.

Section 5 explains BOOTING THE SYSTEM, according to various hardware configurations.

Section 6 explains the SYSTEM STARTUP OPTIONS available for your system. These options are displayed when you boot your system, as explained in Section 5. Section 6 explains when and why each option should be used.

Section 7 explains various procedures for BACKING UP THE SYSTEM. These instructions are vital in preventing data losses.

Section 8 explains RESTORING DATA. If your data is lost or corrupted, it can be recovered if you've used one of the backup methods explained in Section 7.

How To Use This Manual

- Section 9 explains **MAINTENANCE**. Ultimate recommends that you periodically perform certain maintenance functions to keep your system running smoothly. Procedures are given for daily, weekly, monthly, and semi-monthly maintenance.
- Section 10 explains the steps necessary for **ADDING EQUIPMENT**. Whenever you add a piece of equipment, you need to make sure that your system recognizes it.
- Section 11 explains **TROUBLESHOOTING** procedures. If you experience a problem with your system, follow the steps in this section to try to determine the problem. Of course, whenever you need help with your system, you may contact the Ultimate Support Group.
- Appendix A is a **GLOSSARY** of terms used throughout the manual.
- Appendix B illustrates **PANEL LAYOUTS**, which may be helpful in locating components of your control panel and disk and tape drives. These layouts are labeled Figures 1 through 11, and are referenced throughout this guide.
- Appendix C provides **CRT CONFIGURATIONS**, to aid you in setting up your CRTs.
- Appendix D provides **PRINTER CONFIGURATIONS**, to aid you in setting up your printers.

Getting Started

1 GETTING STARTED

Now that your Ultimate system has been installed, you'll need to follow a few steps before you can begin working.

1.1 Power On

The first thing you'll need to do is power on your system. If you haven't already done this, do it now. Power-on instructions are explained in Section 2 of this manual.

1.2 Boot the System

Once your system has been powered on, it must be initialized, or booted. Boot methods differ, according to your hardware configuration. Refer to Section 5 for instructions on booting your equipment. You'll need to know whether you have a full control panel or a basic control panel. See Appendix B, Figures 1 and 2, for illustrations of both control panels.

1.3 Format Disk(s)

Once you have booted the system, you'll see a screen of boot options. Choose option D. You'll use this option to format your disk(s). Refer to Section 6.3 for instructions on formatting your disk(s).

1.4 Check Equipment

Follow the instructions in this section to locate your terminals (CRTs) and printers. You'll need to know what numbers are assigned to each terminal and printer, and where each terminal and printer is physically located. You'll also need to know at what baud rate your terminals and printers are running.

To start, you'll need a description or list of the physical layout of your system. You should have obtained this list when your system was installed.

1.4.1 Terminals

All CRT terminals attach to the system via asynchronous RS-232 ports. The base system contains 8 ports, of which 7 are available for CRTs (the 8th port is used for a serial printer.) Up to a maximum of 250 ports may be configured for your system (or if you have a 7000 system, you may have up to 400 ports). These are available in 4-port, 8-port, or 16-port increments. The baud rate for each port may be set independently, from 110 baud to 9600 baud. Note that port zero (the console) must be set at 9600 at all times.

NOTE: If your terminals have not yet been installed, refer

Getting Started

to Appendix C for options and switch settings for each terminal supported by Ultimate.

Location

Each terminal (or CRT) is identified by a line number. To list the line number of a particular terminal, at the TCL prompt type:

WHO and press RETURN.

The line number and the account that's logged on will be displayed. To list all line numbers and the accounts logged onto those lines, type:

WHO * and press RETURN.

(For more information on the WHO verb, refer to your System Commands Guide.)

Baud Rate

In addition to the line numbers, you should know the baud rates of each of your CRTs. To check the baud rate of a particular port, type:

LOGTO SYSPROG and press RETURN.

Then press RETURN to go to TCL. At the TCL prompt (>), type:

SET-BAUD and press RETURN.

The port (line number) and line speed (baud rate) will be displayed, along with other information about the port. (For more information about the SET-BAUD verb, refer to your System Commands Guide.)

1.4.2 Printers

Printers may be attached to your system via the standard asynchronous ports for serial printers, or via a parallel printer adapter for parallel printers. All printers are required to have the XON/XOFF protocol for proper operation.

NOTE: If your printers have not been installed, refer to Appendix D for options and switch settings of printers supported by Ultimate.

Location

Each printer is identified by a line number, logical printer number, and a job queue number. To list the line, logical, and job queue numbers of each printer, at TCL, type:

Getting Started

SP-LISTLPTR and press RETURN.

Information about each of your printers will be displayed. A sample screen is shown below.

```
>SP-LISTLPTR
```

```
Printer assignments                               time
Printer      Output queues  Page   Dev or  Status
Type         Number        skip   line #
Parallel     0           3      0      0   Active
Serial       1           0    15    0    31  Inactive
Serial       2           16     0    29  Inactive
Serial       3           60     0    60  Inactive
Serial       4           56     1    56  Inactive
```

In this example, the parallel printer has a logical number of 0, and a job queue number of 3. (Note that serial printer #1 has two job queue numbers: 0 and 15).

NOTE: If your printer numbers have not yet been assigned, refer to the System Commands Guide for instructions on assigning them (use the SP-STARTLPTR verb).

Baud Rate

To check the baud rate of all ports on your system, type:

LOGTO SYSPROG and press RETURN.

Then press RETURN to go to TCL. At the TCL prompt (>), type:

SET-BAUD Z and press RETURN.

The ports (line numbers) and line speeds (baud rates) will be displayed, along with other information about each port. (For more information about the SET-BAUD verb, refer to your System Commands Guide.)

1.5 Check ACC and DICT ACC Files

Your Ultimate system should already contain an Accounting History (ACC) File. This file contains information on your

Getting Started

system usage, and on each user. Information includes the dates and times that your users log on and off, and the amount of time spent on the computer (called "connect time"). This file also keeps track of "charge-units," which are numbers representing the computer usage, and "line-printer pages," which is the amount of pages printed during each logon session.

This file will only be updated if the Accounting option is in effect (refer to the System Management and Support Guide for details). Entries may be created in the dictionary portion of the ACC file to set baud rates and term types automatically when several devices are logged on.

1.6 Load UltiWord

If UltiWord (the word processing account, also referred to as WP) has not already been installed on your system, you may install it now, or you may refer to these instructions whenever you are ready to begin using UltiWord.

NOTE: Follow this procedure only if UltiWord has never been installed on your system. If UltiWord has already been installed and you want to load a new version of the WP account, then refer to your Upgrade Procedures document.

1. Make sure your system has been powered on and initialized. Mount the SYS-GEN tape and bring it to load point (see Section 4 for instructions).

2. At TCL, type:

LOGTO SYSPROG and press RETURN.

The following screen will be displayed.

Getting Started

SYSPROG MAIN MENU (Honeywell-Based Systems)

1. File-Save with automatic GFE fixer
- 1A. File-Save without automatic GFE fixer
2. ALL-UPDATE-SAVE
3. PART-UPDATE-SAVE
4. Documentation Menu
5. Spooler Menu
6. Automatic Async setup
7. Automatic File Reallocation Menu
8. Load WP account from SYS-GEN tape
9. Create Boot tape
10. Load UTILINK account from SYS-GEN tape
11. Load ATP account from SYS-GEN tape
12. Load ULTIMATION account from SYS-GEN tape

88. Logoff
99. Go to TCL

ENTER SELECTION _

Your menu may be different, according to your system configuration.

Enter 8 and press RETURN.

This will select "Load WP account from SYS-GEN tape."
The system will search for and load the WP account.

3. When the WP account has been loaded, remove the SYS-GEN tape.
4. Set up the accounts in which you want to enable UltiWord.
At the TCL prompt (>), type:

LOGTO WP and press RETURN.

You are now in the WP account. The WP main Menu, shown following, should be displayed.

Getting Started

```
***** The Ultimate Corp. *****
***** WORD PROCESSING *****
***** Document Manager *****
          Main Menu
```

```
YOUR USER NAME:
DOCUMENT NAME:
```

```
(C)opy documents
(D)elete user
(E)dit/Enter
(L)ist
(N)ew
(P)rint
(S)et up user account
(U)tility
(V)iew
e(X)it
```

Enter option wanted:

Enter S

This selects the program to set up user accounts. The following screen is displayed.

```
***** The Ultimate Corp. *****
***** WORD PROCESSING *****
***** Document Manager *****
          Main Menu
```

```
YOUR USER NAME:
DOCUMENT NAME:
```

Enter name of account to set up or <EDIT>

Enter the name of an account you want to set up for UltiWord, and press RETURN.

The following screen is displayed.

Getting Started

```
***** The Ultimate Corp. *****
***** WORD PROCESSING *****
***** Document Manager *****
          Main Menu
```

YOUR USER NAME:
DOCUMENT NAME:

Enter name of account to set up or <EDIT>
The master dictionary of XXXX contains the following

These will be overwritten if Y is answered. (Y)es or
<EDIT>

Enter Y

You will now be able to use WP from this account.
Repeat this step for all accounts for which you want
to enable WP.

5. Enter user names for each account in which you'll use WP.
One or more user names may be established within the same
user account.

If you set up an account for WP, logto that account. Then
type WP and press RETURN. The WP Main Menu will be dis-
played, as shown following.

Getting Started

```
***** The Ultimate Corp. *****
***** WORD PROCESSING *****
***** Document Manager *****
          Main Menu
```

```
YOUR USER NAME:
DOCUMENT NAME:
```

```
(C)opy documents
(D)elete user
(E)dit/Enter
(L)ist
(N)ew
(P)rint
(S)et up user account
(U)tility
(V)iew
e(X)it
```

```
Enter option wanted:
```

Enter N

The following screen is displayed.

Getting Started

```
***** The Ultimate Corp. *****
***** WORD PROCESSING *****
***** Document Manager *****
          Main Menu
```

```
YOUR USER NAME: _      <CR> for current User Name or
DOCUMENT NAME:   _      <EDIT> to exit
```

```
(C)opy documents
(D)elete user
(E)dit/Enter
(L)ist
(N)ew
(P)rint
(S)et up user account
(U)tility
(V)iew
e(X)it
```

```
Enter option wanted: N
```

Enter a User Name that you will use with WP. The name may consist of from one to 20 characters.

The following screen is displayed.

Getting Started

```
***** The Ultimate Corp. *****
***** WORD PROCESSING *****
***** Document Manager *****
      Main Menu
```

```
YOUR USER NAME: _      USER NAME NOT ON FILE! ADD IT (Y/CR)?
DOCUMENT NAME:
```

```
(C)opy documents
(D)elete user
(E)dit/Enter
(L)ist
(N)ew
(P)rint
(S)et up user account
(U)tility
(V)iew
e(X)it
```

```
Enter option wanted: N
```

Enter Y

to create this user name. The following screen is displayed.

Getting Started

```
***** The Ultimate Corp. *****
***** WORD PROCESSING *****
***** Document Manager *****
      Main Menu
```

```
YOUR USER NAME: _
DOCUMENT NAME: _
```

```
(C)opy documents The USER file will be created as follows
(D)elete user
(E)dit/Enter CREATE-FILE DATA WP-DOCUMENTS,USER 41,1
(L)ist
(N)ew Enter <CR>, New Modulo or <EDIT> to exit
(P)rint
(S)et up user account
(U)tility
(V)iew
e(X)it
```

```
Enter option wanted: N
```

Press RETURN to create the user name.

The cursor will then prompt you to enter a DOCUMENT NAME. If you are ready to begin creating documents, enter a name for your first document. This document will be stored in the user name and user account you specified.

6. Refer to the UltiWord Training and Reference Manuals for instructions on using UltiWord.

Getting Started

1.7 Getting Started Checklist

Make sure you have completed each item on the checklist below before you begin creating and using files on your Ultimate system.

- 1. The system has been powered up successfully.
- 2. You have booted the system, following the instructions for your hardware configuration.
- 3. You have formatted your disk(s).
- 4. You have checked the location and baud rate of each terminal on your system.
- 5. You have checked the location and baud rate of each printer on your system.
- 6. You have checked the ACC and DICT ACC files.
- 7. If you will be using UltiWord, you have loaded the WP account and set up user accounts and user names.

Congratulations on getting your system ready to work for you! Refer to the instructions in the remainder of this manual as they are required.

Getting Started

NOTES

C

C

C

Powering On

2 POWERING ON

2.1 Powering On 6000 and 7000 Series Systems

1. Place the main POWER switch in the ON position. (See Appendix B, Figures 1 and 2, for the location of this switch.)
2. Cycle up your disk drive. Depending on your disk drive, follow the instructions under one of the following headings: FSD Drive, EMD Drive, SMD Drive, and CMD Drive. For more information on FSD, EMD, SMD, and CMD drives, see Section 4 and Figures 3 through 6 in Appendix B.

FSD Drive

- a. Open the door on the front of the unit and make sure the MAIN AC circuit breaker is in the ON position.
- b. Press the START button. The READY indicator will flash. When the light stops flashing and remains lit, the drive is powered up.
- c. Make sure the FAULT indicator is not lit, and that the WRITE PROTECT is not set.

EMD Drive

- a. Open the door on the front of the unit, and make sure the red POWER switch is in the ON position.

SMD Drive

- a. Verify that the SYS-GEN disk pack has been installed and that the pack access door is closed. If not, follow steps 1 through 3.
 1. Release the latch on the pack access door and lift it up. Then remove the bottom cover from the disk pack, and place the disk pack in the drive.
 2. With the pack seated in the spindle, rotate the handle clockwise until it is snug.
 3. Pull the cover straight up and out of the drive. Be careful not to hit any of the other disk platters. Then close the top cover.
- b. Press the START/STOP switch on the disk drive control panel. The START light will come on.
- c. When the START and READY lights are both lit, the drive is cycled up.



Powering On

CMD Drive

- a. Verify that the SYS-GEN disk pack has been installed and that the cartridge door is closed. If not, follow steps 1 through 3.
 1. Unlatch the cartridge door by pulling it out and down.
 2. Remove the disk pack's protective cover. Store the cover upside down, in a safe place.
 3. Slide the pack along the guides and into the disk drive. Push the pack back as far as it will go, then close the cartridge door.
- b. Press the START/STOP switch on the disk drive control panel. The START light will begin flashing.
- c. When the START and READY lights are both lit (no longer flashing), the drive is cycled up.
3. If your system includes a tape drive, load the SYS-GEN tape in the tape drive. See Figures 7 and 8 in Appendix B.
 - a. Turn the power switch to ON position.
 - b. Release the hub latch.
 - c. Place the tape on the top tape hub. Make sure the tape is flush, and doesn't wobble. Follow the diagram on the front of the tape drive to thread the tape. Then close the hub latch.
 - d. Wrap the tape around the bottom reel 3 or 4 times, until moving the bottom reel causes the upper reel to move. This will secure the tape in place.
 - e. Press the LOAD switch on the tape drive control panel.
 - f. The tape drive will automatically go on-line when the tape has been loaded.
4. Boot the system. Refer to Section 4 for booting instructions according to your hardware configuration.

Powering On

2.2 Powering On 1400 Series Systems

1. Locate the main POWER switch on the back and turn to the ON position. If you have a dual-cabinet system, be sure to turn on both POWER switches.
2. Make sure AC PRESENT light is lit.
3. If your system includes a 1/2" reel tape drive, turn the POWER switch on. See the diagram in Appendix B.
4. Boot the system. Refer to Section 5 for booting instructions.

Powering Off

3 POWERING OFF

Generally, your Ultimate system may be left powered on. You may want to power off, however, during a long weekend or vacation, or if you are having power problems.

3.1 Powering Off 6000 and 7000 Series Systems

1. Make sure all users are logged off the system. To do so, go to the TCL prompt, and type:

LISTUSERS and press RETURN.

The console (line 0) should be the only terminal logged on. If other users are logged on, make sure they log off before you continue.

2. After all users have logged off, go to port 0 (the console terminal). Type:

LOGTO SYSPROG and press RETURN.

Then press RETURN again to go to TCL. Type:

:WARMSTOP and press RETURN.

A message similar to the following will be displayed.

```
-----  
Memory Flushed!  
Remote Panel  
B @ 00B64 TSA @ 00820  
A =  
-----
```

This message means that the system has halted all processing, flushed memory, and has entered the "Remote Panel" state.

3. After the WARMSTOP is complete, cycle down the disk drive. Refer to Figures 4 through 6 in Appendix B.

FSD Drive

- a. Press the START button. The READY indicator will flash. When the READY indicator goes off, the drive is powered down.
- b. Normally, you should leave the main circuit breaker ON.

Powering Off

EMD Drive

- a. Open the door on the front of the unit. Switch the red POWER switch to the OFF position.

SMD Drive

- a. Press the START/STOP switch on the disk drive control panel. The START and READY lights should go out. If you want to remove the disk pack, continue with steps b through d.
- b. Once the disk stops spinning, release the latch on the pack access door and lift it up.
- c. Place the disk pack cover on the disk pack. Rotate the handle counter-clockwise until it clicks.
- d. Lift the pack up and out of the drive. Place the bottom protective cover on the disk pack.

CMD Drive

- a. Press the START/STOP switch on the disk drive control panel. The READY light will go off, and the START/STOP light will flash.
 - b. The disk drive will be cycled down when the START/STOP light stops flashing. If you want to remove the disk pack, continue with steps c and d.
 - c. Unlatch the cartridge door. Pull it out and down.
 - d. Remove the disk pack by sliding it towards you. Place the pack in its protective cover, then close the cartridge door.
3. If your system is equipped with a tape drive, unload the tape. Refer to Figures 7 and 8 in Appendix B.
 - a. Press the ON-LINE switch on the tape drive control panel. The ON-LINE light will go out.
 - b. Press the REWIND button. The tape will unload.
 - c. When the tape stops moving, release the top tape hub's latch, and remove the tape reel.
 - d. Store the tape in a safe place.
 4. Place the main POWER switch in the OFF position.

Powering Off

3.2 Powering Off 1400 Series Systems

1. Make sure all users are logged off the system. To do so, go to the TCL prompt, and type:

LISTUSERS and press RETURN.

The console (line 0) should be the only terminal logged on. If other users are logged on, make sure they log off before you continue.

2. After all users have logged off, go to port 0 (the console terminal). Type:

LOGTO SYSPROG and press RETURN.

Then press RETURN again to go to TCL. Type:

:WARMSTOP and press RETURN.

A message similar to the following will be displayed.

|
| Memory Flushed!
|
|
|-----

This message means that the system has halted all processing and flushed memory.

3. After the WARMSTOP is complete, locate the POWER switch on the back and turn to the OFF position. See the diagram in Figure 9 of Appendix B.



Disk and Tape Drive Procedures

4 DISK AND TAPE DRIVE PROCEDURES

4.1 Disk Drive Procedures for 6000 and 7000 Series Systems

NOTE: (If you have a 1400 Series system, please see Section 4.3.)

Your system may be equipped with four types of disk drives: a removable Storage Module Disk (SMD), a removable Cartridge Module Disk (CMD), a fixed Eight-Inch Module Drive (EMD), and a Fixed Storage Device (FSD).

The SMD drive is the larger of the two removable drives. It is a standalone, 288 megabyte drive, with a 10 platter removable disk pack. The CMD drive is the smaller of the removable drives. It holds 67 megabytes of data. A 13 megabyte removable disc cartridge must be in the drive to be able to use the 67 mb fixed disc. The CMD disk is not used by the operating system, but it is used as a back-up drive. The FSD drive is a fixed-disk unit that is available in either 132 megabytes, or 413 megabytes. The EMD is also a fixed-disk unit that is available in either 295 megabytes, or with an add-on unit of another 295 megabytes.

1.1.1 EMD Drive

WARNING: Damage to the disk drives may result if the EMD cabinet is moved while the drives are installed. If you must move the cabinet, the drives must be removed from the cabinet and transported in their shipping container.

Refer to Figure 3 in Appendix B for an illustration of the EMD Operation Control Panel.

Powering On

1. Open the door on the front of the unit, and make sure the red POWER switch is in the ON position.

Powering Off

1. Open the door on the front of the unit, and switch the red POWER switch to the OFF position.

1.1.2 FSD Drive

WARNING: Damage to the disk drives may result if the FSD cabinet is moved while the drives are installed. If you must move the cabinet, the drives must be removed from the cabinet and transported in their shipping container.



Disk and Tape Drive Procedures

Refer to Figure 4 in Appendix B for an illustration of the FSD Operation Control Panel.

Powering On

1. Open the door on the front of the unit and make sure the MAIN AC circuit breaker is in the ON position.
2. Press the START button. The READY indicator will flash. When the light stops flashing and remains lit, the drive is powered on.
3. Make sure the FAULT indicator is not lit, and that the WRITE PROTECT is not set.

Powering Off

1. Press the START button. The READY indicator will flash. When the READY indicator goes off, the drive is powered off.
2. Normally, you should leave the main circuit breaker ON.

4.1.3 SMD Drive

Refer to Figure 5 in Appendix B for an illustration of the SMD drive.

Cycling Up

1. Verify that the SYSGEN disk pack has been installed and that the pack access door is closed. If not, follow steps a through c.
 - a. Release the latch on the pack access door and lift it up. Then remove the bottom cover from the disk pack, and place the disk pack in the drive.
 - b. With the pack seated in the spindle, rotate the handle clockwise until it is snug.
 - c. Pull the cover straight up and out of the drive. Be careful not to hit any of the other disk platters. Then close the top cover.
2. Press the START/STOP switch on the disk drive control panel. The START light will come on.
3. When the START and READY lights are both lit, the drive is cycled up.

Disk and Tape Drive Procedures

Cycling Down

1. Make sure all users are logged off the system. To do so, go to the TCL prompt, and type:

LISTUSERS and press RETURN.

The console (line 0) should be the only terminal logged on. If other users are logged on, make sure they log off before you continue.

2. Press the START/STOP switch on the disk drive control panel. The START and READY lights should go out. If you want to remove the disk pack, see "Removing Disc Pack."

Installing Disc Pack

1. Release the latch on the pack access door and lift it up. Then remove the bottom cover from the disk pack, and place the disk pack in the drive.
2. With the pack seated in the spindle, rotate the handle clockwise until it is snug.
3. Pull the cover straight up and out of the drive. Be careful not to hit any of the other disk platters. Then close the top cover.
4. If you want to cycle up the disc drive, see the section labeled "Cycling Up."

Removing Disc Pack

1. Follow the instructions in the section labeled "Cycling Down" to cycle down the disk drive.
2. Once the disk stops spinning, release the latch on the pack access door and lift it up.
3. Place the disk pack cover on the disk pack. Rotate the handle counter-clockwise until it clicks.
4. Lift the pack up and out of the drive. Place the bottom protective cover on the disk pack.

1.1.1 CMD Drive

Refer to Figure 6 in Appendix B for an illustration of the CMD drive.

Cycling Up

1. Verify that the SYSGEN disk pack has been installed and

Disk and Tape Drive Procedures

that the cartridge door is closed. If not, follow steps a through c.

- a. Unlatch the cartridge door by pulling it out and down.
 - b. Remove the disk pack's protective cover. Store the cover upside down, in a safe place.
 - c. Slide the pack along the guides and into the disk drive. Push the pack back as far as it will go, then close the cartridge door.
2. Press the START/STOP switch on the disk drive control panel. The START light will begin flashing.
 3. When the START and READY lights are both lit (no longer flashing), the drive is cycled up.

Cycling Down

1. Press the START/STOP switch on the disk drive control panel. The READY light will go off, and the START/STOP light will flash.
2. The disk drive will be cycled down when the START/STOP light stops flashing. If you want to remove the disk pack, see the section labeled "Removing the Disc Pack."

Installing the Disc Pack

1. Unlatch the cartridge door by pulling it out and down.
2. Remove the disk pack's protective cover. Store the cover upside down, in a safe place.
3. Slide the pack along the guides and into the disk drive. Push the pack back as far as it will go, then close the cartridge door.
4. If you want to cycle up the drive, see the section labeled "Cycling Up."

Removing the Disc Pack

1. Follow the instructions in the section labeled "Cycling Down" to cycle down the disk drive.
2. Unlatch the cartridge door. Pull it out and down.
3. Remove the disk pack by sliding it towards you. Place the pack in its protective cover, then close the cartridge door.

Disk and Tape Drive Procedures

4.2 Tape Drive Procedures for 6000 and 7000 Series Systems.

Refer to Figures 7 and 8 in Appendix B for illustrations of the Tape Drive Panels.

Loading

1. Turn the power switch to ON position.
2. Release the hub latch.
3. Place the tape on the top tape hub. Make sure the tape is flush, and doesn't wobble. Follow the diagram on the front of the tape drive to thread the tape. Then close the hub latch.
4. Wrap the tape around the bottom reel 3 or 4 times, until moving the bottom reel causes the upper reel to move. This will secure the tape in place.
5. Press the LOAD switch on the tape drive control panel.
6. The tape drive will automatically go on-line when the tape has been loaded.

Unloading

1. Press the ON-LINE switch on the tape drive control panel. The ON-LINE light will go out.
2. Press the REWIND button. The tape will unload.
3. When the tape stops moving, release the top tape hub's latch, and remove the tape reel.
4. Store the tape in a safe place.

Tape Handling Procedures

1. Always inspect the tape leader to make sure it's not damaged. If the tape leader is wrinkled, the unit may not load properly. If this happens, either try another tape reel, or squarely cut the damaged portion of the tape leader.
2. Handle the tape reel by the hub hole.
3. Never touch the portion of the tape between BOT (beginning of tape) and EOT (end of tape).
4. Do not use contaminated or dirty reels.
5. Store the tape inside its container.

Disk and Tape Drive Procedures

6. Do not smoke near the tape drive or tape storage area.
7. Clean the tape path frequently.

Cleaning the Tape Drive

1. Make sure you have a tape cleaning kit.
2. Unload the tape:
 - a. Press the ON-LINE switch on the tape drive control panel. The ON-LINE light will go out.
 - b. Press the REWIND button. The tape will unload.
 - c. When the tape stops moving, release the top tape hub's latch, and remove the tape reel.
 - d. Store the tape in a safe place.
3. Turn off the tape drive POWER switch.
4. Pull the tape head covers straight out from the tape drive, and remove them.
5. Dampen a cotton swab with transport cleaner. Swing the head shields to the right, and clean the erase and read/write heads with the cotton swab.
6. Pull the vacuum chamber door outward, and gently wipe the inside of the chamber.
7. Close the vacuum chamber door, and put both head covers back on the tape drive.
8. Turn the POWER switch on.

Disk and Tape Drive Procedures

4.3 Tape Drive Procedures for 1400 Series Systems

Refer to Appendix B for illustration.

4.3.1 One Quarter Inch (1/4") Cartridge Tapes

Loading

1. Lower the tape lever to the horizontal position.
2. Slide the tape tray toward you.
3. Insert the cartridge tape with the plastic side up and the tape opening to the right.
4. Slide the tape tray back into the tape drive.
5. Lock the tape in drive by raising the tape lever to the vertical position.

Unloading

1. Lower the tape lever to the horizontal position.
2. Slide the tape tray toward you.
3. Remove the cartridge from the tape drive.

Tape Handling Procedures

1. Never touch the tape.
2. Do not use contaminated or dirty cartridges.
3. Store the tape inside its container.
4. Do not smoke near the tape drive or tape storage area.

Cleaning the Tape Drive

Follow the instructions enclosed in a 1/4" cartridge tape cleaning kit. The kits are available from Ultimate's computer supplies catalog.

4.3.2 One Half Inch (1/2") Reel Tapes

Loading

1. Turn the power switch on, and make sure the UNLOAD indicator is lit.

Disk and Tape Drive Procedures

2. Make sure the tape is wound completely onto the reel.
3. Open the tape access door. Insert the tape, with the write-enable ring side down. Then close the tape access door.
4. Press the LOAD switch. The access door is now locked. The LOAD indicator will pulse.
5. When the LOAD indicator is on, the load sequence is complete. Press the ON-LINE switch to put the drive on-line. The ON-LINE LED will go on.

Unloading

1. Press the ON-LINE switch to take the tape drive off-line. The ON-LINE LED will go out.
2. Press the UNLOAD switch. The UNLOAD indicator will pulse.
3. When the unload sequence is complete, the UNLOAD indicator will remain on and the access door will unlock.
4. Open the access door and remove the tape.

Tape Handling Procedures

1. Always inspect the tape leader to make sure it's not damaged. If the tape leader is wrinkled, the unit may not load properly. If this happens, either try another tape reel, or squarely cut the damaged portion of the tape leader.
2. Handle the tape reel by the hub hole.
3. Never touch the portion of the tape between BOT (beginning of tape) and EOT (end of tape).
4. Do not use contaminated or dirty reels.
5. Store the tape inside its container.
6. Do not smoke near the tape drive or tape storage area.
7. Clean the tape path frequently.

Cleaning the Tape Drive

1. Make sure you have a tape cleaning kit that consists of:
 - a. cotton swabs
 - b. tape drive cleaner (Freon TF--Trichlorotrifluoroethane)
 - c. felt pads

Disk and Tape Drive Procedures

NOTE: Rough or abrasive materials can scratch sensitive surfaces of the tape head, resulting in permanent damage. Alcohol-based cleaners may cause read/write errors or load failures. Be sure to use only FREON TF to clean the tape head.

2. Unload the tape. See instructions in Section 4.3.
3. Turn off the tape drive POWER switch.
4. If you have a GCR tape drive, release the rack latch just inside the lower left side at the front panel (see illustration).

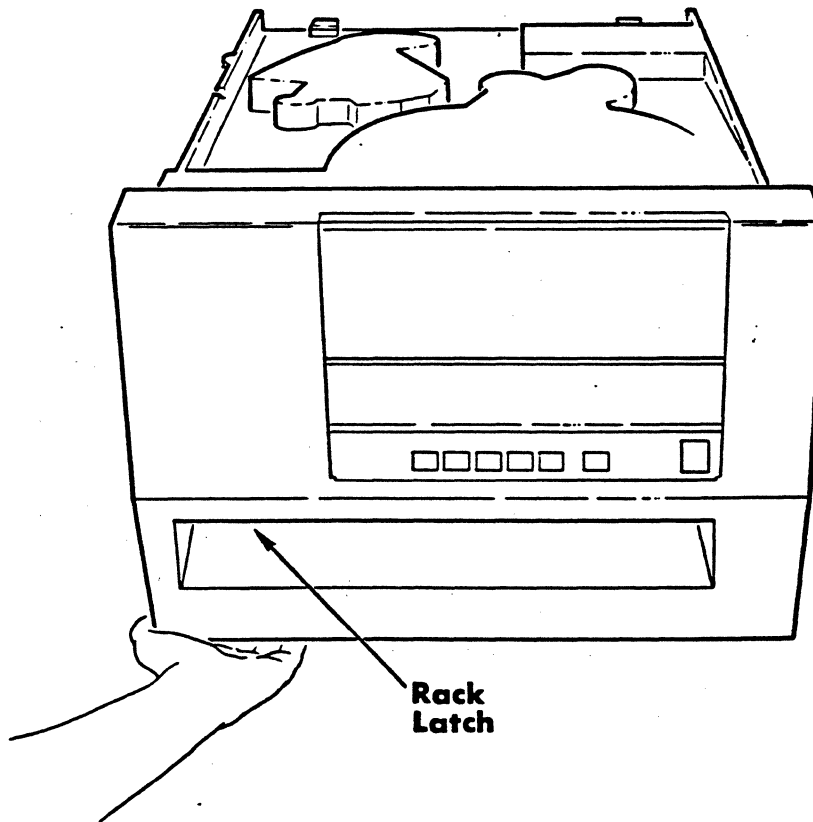

5. Pull from behind the lower left side of the front panel, and slide the unit out of the rack. Slide the unit forward until it is fully extended from the rack.

Disk and Tape Drive Procedures

6. Grasp the lower edges of the top cover and lift. While holding the top cover in the raised position, place the retainer bar in its slot (see illustration).

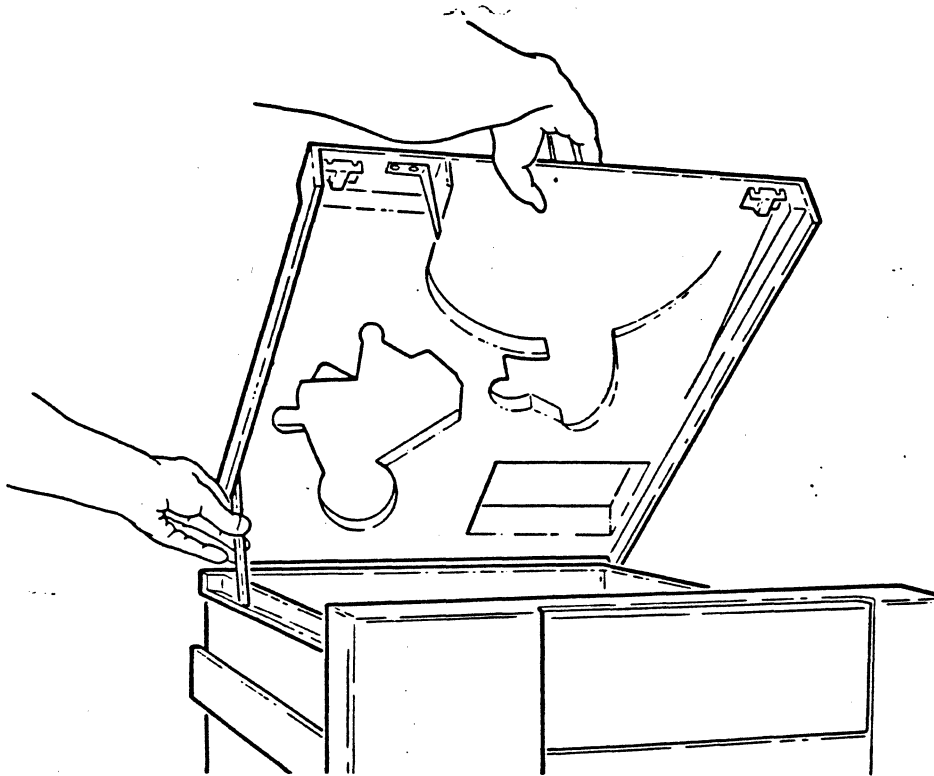

Disk and Tape Drive Procedures

7. Moisten a cotton swab with tape drive cleaner. Carefully swab the surface of the read/write head (see illustration).

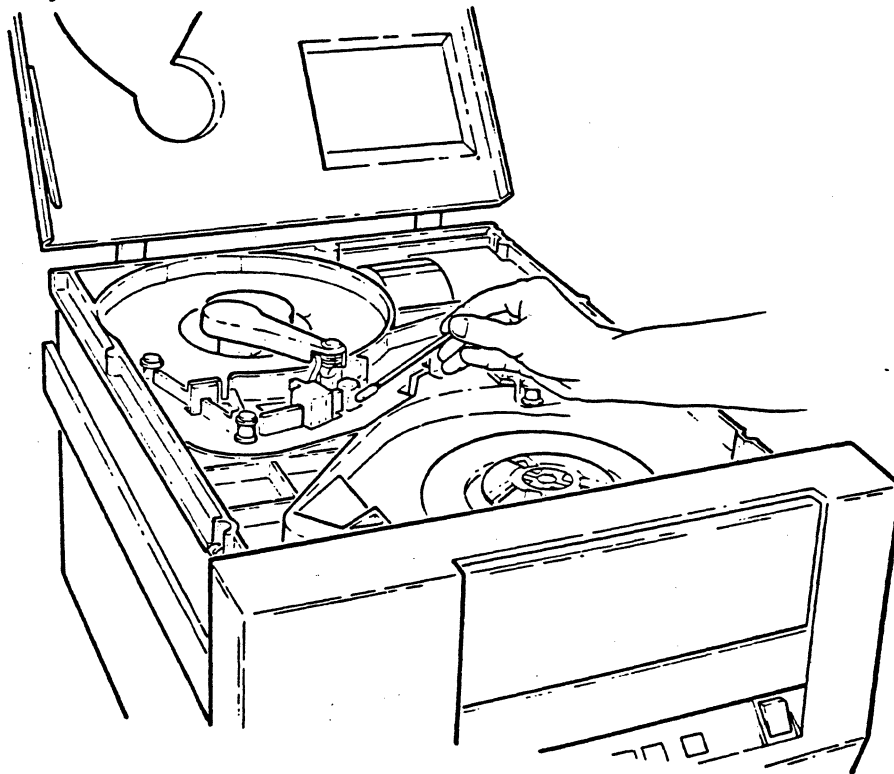

Disk and Tape Drive Procedures

8. Moisten a cotton swab with tape drive cleaner and clean the tachometer roller (see illustration).

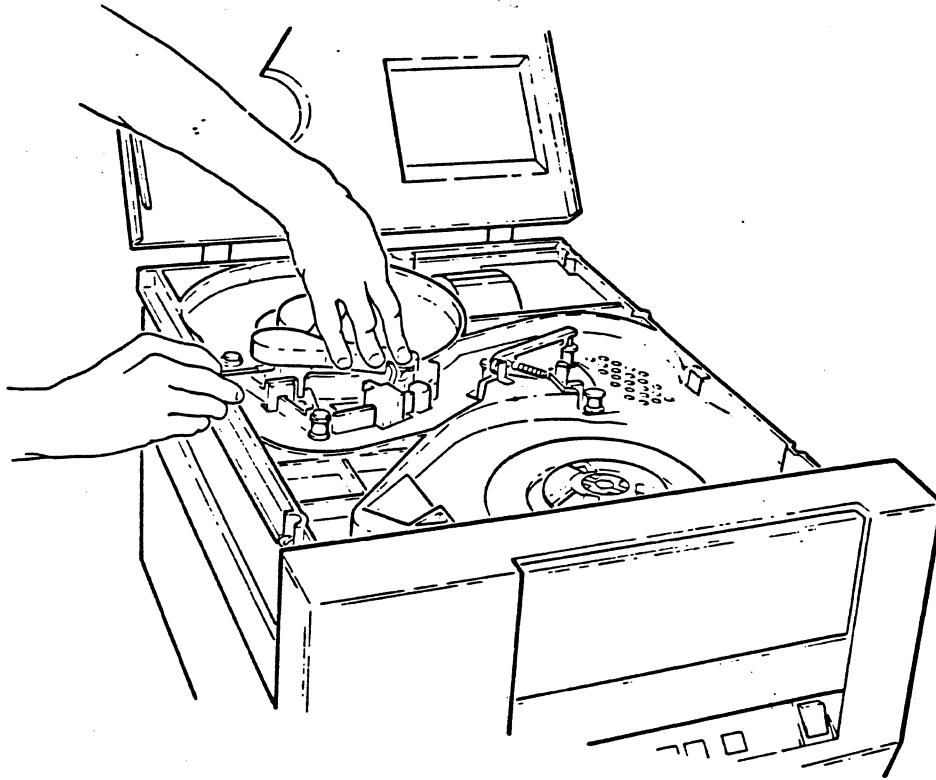

CAUTION: If the tape drive cleaner seeps into the tachometer housing, it could damage the tachometer. Do not release the tachometer while holding it away from the take-up hub. It will become damaged if it strikes sharply against the hub.

Disk and Tape Drive Procedures

9. Use the felt pads to clean the hub pads, take-up hub, and roller guides.

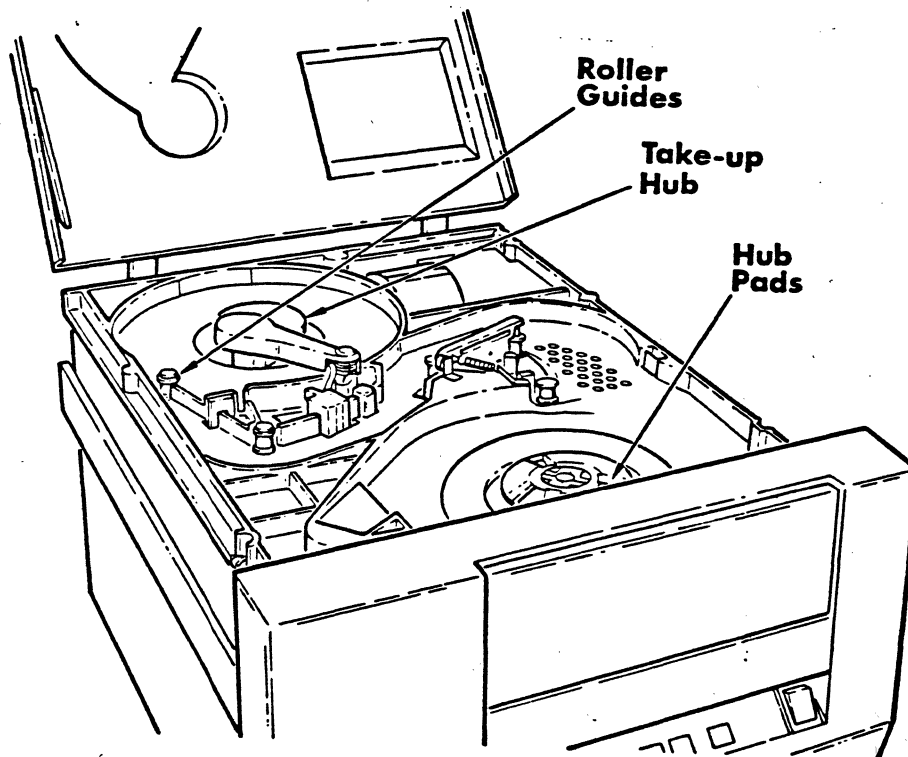

10. Lift the top cover until the retainer bar is clear of its slot. Push the retainer bar back and up so that it lies flat against the underside of the top cover. Then close the top cover.

Booting the System

5 BOOTING THE SYSTEM

Follow the instructions in this section to boot or initialize your 6000 and 7000 Series systems. Refer to Section 5.4 to boot 1400 Series systems.

The booting procedure varies from system to system, depending on the control panel. There is a procedure for systems with a full control panel, another procedure for systems with a basic control panel, and one for systems with System Control Facility (SCF). There is also a procedure for 1400 Series systems.

To identify which method to use for your system, refer to the illustrations of control panels in Appendix B, Figures 1, 2, and 9.

1.1 Full Control Panel

Refer to Figure 1 in Appendix B for an illustration of the Full Control Panel.

Before attempting to boot the system, you should have followed all steps in Section 2, Powering On. If you are rebooting a system that is up and running, you must first do a :WARMSTOP from the SYSPROG account.

1. Once the system has been powered on, turn the panel security key clockwise to enable (unlock) the control panel.
2. On the control panel, press the following buttons:

STEP CLEAR LOAD READY EXECUTE

The TRAFFIC and CHECK lights will come on, and then will go out after a few minutes.

3. Press the EXECUTE button again. The system will read the SYS-GEN tape on the tape drive. The following screen will be displayed.

Booting the System

This is the Ultimate Operating System

System Startup Options:

- (B)oot
- (C)oldstart
- (D)iagnostics Monitor
- (F)ile Restore
- (O)ffline Monitor
- (U)tilities Monitor
- (W)armstart

Enter Option(s) or ? for help:

4. Refer to Section 6 for information on each of the System Startup (Boot) Options.

NOTE: If the system was :WARMSTOPPED prior to being powered off, refer to Section 6.7 to WARMSTART the system. If the system was not :WARMSTOPPED prior to being powered off, then refer to Section 6.2 to COLDSTART the system.

CAUTION: If your system is equipped with a Battery Backup Unit (BBU), you must turn the panel security key counterclockwise to lock the control panel after your system is booted. The BBU cannot be enabled unless the key is in the LOCK position (counterclockwise).

Booting the System

5.2 Basic Control Panel

Refer to Figure 2 in Appendix B for an illustration of the Basic Control Panel.

Before attempting to boot the system, you should have followed all steps in Section 2, Powering On. If you are rebooting a system that is up and running, you must first do a :WARMSTOP from the SYSPROG account.

1. Once the system has been powered on, turn the panel security key clockwise to enable (unlock) the control panel.
2. On the control panel, press the INITIALIZE button. The TRAFFIC and CHECK lights will come on, and then will go out after a few minutes. Then the system will read the SYS-GEN tape on the tape drive. The following screen will be displayed.

This is the Ultimate Operating System

System Startup Options:

(B)oot
(C)oldstart
(D)iagnostics Monitor
(F)ile Restore
(O)ffline Monitor
(U)tilities Monitor
(W)armstart

Enter Option(s) or ? for help:

3. Refer to Section 6 for information on each of the System Startup (Boot) Options.

NOTE: If the system was :WARMSTOPPED prior to being powered off, refer to Section 6.7 to WARMSTART the system. If the system was not :WARMSTOPPED prior to being powered off, then refer to Section 6.2 to COLDSTART the system.

Booting the System

CAUTION:

If your system is equipped with a Battery Backup Unit (BBU), you must turn the panel security key counterclockwise to lock the control panel after your system is booted. The BBU cannot be enabled unless the key is in the LOCK position (counterclockwise).

Booting the System

5.3 System Control Facility (SCF)

1. Before you can boot the system, you must unlock the panel security key on the front of the CPU. On Honeywell 6000 systems, insert the key into the lock and turn the key counterclockwise, to the UNLOCK position. To unlock systems other than the 6000, insert the key into the lock and turn the key clockwise, to the UNLOCK position.
2. From the system console, press the ESC key twice, and press the # key three times.
3. From the system console, press RETURN.
4. From the system console, type:
H^LGX and press RETURN.

Within 30 seconds, the word "TRAFFIC" should disappear from the screen. Then, a list of system resources by channel address will be displayed on the system console.

5. Follow this step if booting from tape. (If booting from disk, go to Step 6.)
 - a. Make sure the SYS-GEN tape is at load point and on-line.
 - b. If you are booting a system other than a 6000, when the listing completes, type:
GX and press RETURN.
Then press the ESC key twice, press the # key once, and press RETURN.
 - c. If you are booting a 6000 system, when the listing completes, type:
HSD1M0500GX and press RETURN.
Then press the ESC twice, press the # key once, and press RETURN.
 - d. The operating system will now be loaded into memory. The following screen will be displayed (allow up to one minute for the screen to be displayed).

Booting the System

```
-----  
This is the Ultimate Operating System  
System Startup Options:  
  (B)oot  
  (C)oldstart  
  (D)iagnostics Monitor  
  (F)ile Restore  
  (O)ffline Monitor  
  (U)tilities Monitor  
  (W)armstart  
  
Enter Option(s) or ? for help:  
-----
```

6. Follow this step if booting from disk.
 - a. If you are booting a system other than a 6000, when the listing completes, type:

HSD1M9000GX and press RETURN.

Then press the ESC key twice, press the # key once, and press RETURN.
 - c. If you are booting a 6000 system, when the listing completes, type:

GX and press RETURN.

Then press the ESC twice, press the # key once, and press RETURN.
 - d. The operating system will now be loaded into memory. The following screen will be displayed (allow up to one minute for the screen to be displayed).

Booting the System

This is the Ultimate Operating System

System Startup Options:

- (B)oot
- (C)oldstart
- (D)iagnostics Monitor
- (F)ile Restore
- (O)ffline Monitor
- (U)tilities Monitor
- (W)armstart

Enter Option(s) or ? for help:

7. Refer to Section 6 for information on each of the System Startup (Boot) Options.

NOTE: If the system was :WARMSTOPPED prior to being powered off, refer to Section 6.7 to WARMSTART the system. If the system was not :WARMSTOPPED prior to being powered off, then refer to Section 6.2 to COLDSTART the system.

Booting the System

5.4 1400 Series Systems

Refer to Figure 9 in Appendix B for an illustration of the 1400 system.

Before attempting to boot the system, you should have followed all steps in Section 2, Powering On. If you are re-booting a system that is up and running, you must first do a :WARMSTOP from the SYSPROG account.

1. Make sure the AC PRESENT light is ON. (Refer to the POWERING ON instructions in Section 2.)
2. Load the Ultimate SYS-GEN tape. (Refer to the tape loading instructions in Section 4.)
3. If both the AC PRESENT and DC ON lights are on, press the RESET button. If only the AC PRESENT light is on, press the POWER ON button. The following screen will be displayed.

This is the Ultimate Operating System

System Startup Options:

(C)oldstart
(D)iagnostic Monitor
(F)ile Restore
(W)armstart

Enter Option:

4. Refer to Section 6 for information on each of the System Startup Options.

NOTE: If the system was :WARMSTOPPED prior to being powered off, refer to Section 6.7 to WARMSTART the system. If the system was not :WARMSTOPPED prior to being powered off, then refer to Section 6.2 to COLDSTART the system.

System Startup (Boot) Options

6 SYSTEM STARTUP (BOOT) OPTIONS

Whenever you boot or initialize your system, you are presented with a menu of System Startup Options, shown below. Remember that some of the options are not available with the 1400 Series.

This is the Ultimate Operating System

System Startup Options:

- (B)oot
- (C)oldstart
- (D)iagnostics Monitor
- (F)ile Restore
- (O)ffline Monitor
- (U)tilities Monitor
- (W)armstart

Enter Option(s) or ? for help:

A brief explanation of the purpose of each option is explained below. Refer to Sections 6.1 through 6.7 for instructions on performing each of these options.

Boot

The Boot procedure is used to boot the system from a user-specified disc channel address. It allows you to boot the system from a channel address different from the default boot address X'0400'. This option is especially useful if the system has only a basic control panel. It is not available for the 1400 Series.

Coldstart

The Coldstart procedure is used to load the MONITOR code into memory, and all virtual system software from the SYS-GEN tape onto your system. The procedure ensures that all system software has been properly loaded. This procedure will not load your files.

System Startup (Boot) Options

A Coldstart is normally required if your system fails.

Diagnostics Monitor

The Diagnostics Monitor is primarily used to format disks. It may also be used to check your system configuration, boot other channels, and perform other diagnostic utilities. Normally, you should not try to perform diagnostics unless instructed by the Ultimate Support Group.

The Diagnostics Monitor is run off-line. This means that you are not able to run your system in the normal mode. The Diagnostics Monitor will be activated on line zero (the console) only.

File-Restore

The File-Restore procedure is used to load the MONITOR, the program frames (Abs), and all the files, both dictionary and data, from tape. Unlike the Coldstart procedure, this option is used to restore your entire system from your File-Save tapes. The File-Restore will overwrite data previously written on your system.

Offline Monitor

The Offline Monitor is used for special system functions such as disk-to-disk copies, which apply only to systems with SMD disk drives. This option is not available for the 1400 Series.

Utilities Monitor

The Utilities Monitor is used for special system utilities such as disk-to-tape copies, Binary-Saves and Binary-Restores. This option is not available for the 1400 Series.

Warmstart

The Warmstart procedure is used to reload the MONITOR after a system failure. This procedure allows you to recover from a :WARMSTOP and then resume working where you left off, without losing your data. This option should only be attempted if your system was brought down with a :WARMSTOP.

NOTE: If you Warmstart a system that was not :WARMSTOPPED, you will cause Group Format Errors (GFES).

System Startup (Boot) Options

6.1 Boot

This option is used to boot from any channel address of a disk or tape. This option is not normally used, and is not discussed in detail in this manual.

6.2 Coldstart

The Coldstart procedure is used to load the MONITOR code into memory, and all virtual system software from the SYS-GEN tape onto your system. The procedure ensures that all system software has been properly loaded. This procedure will not load your files.

A Coldstart is normally required if your system fails.

1. Make sure you've followed the power-on instructions in Section 2. Also make sure your Ultimate SYS-GEN tape is mounted.
2. At the System Startup Options menu, enter C. Information about your disc configuration will be displayed. A sample screen is shown below. The memory size and number of communications lines are not displayed on the 1400 Series.

```
-----  
Disc Configuration  
  
chan   set name      # of  
0400   123 TEST      1 1  
L 2000# time date   ABS ULT REL XX  
  
Memory = 512KB  
00016 Comm. Lines  
Tape 0 attached Block size: 4000  
-----
```

In the next screen, you will be asked for your system serial number.

System Startup (Boot) Options

```
Memory = 512KB  
00016 Comm. Lines  
Tape 0 attached Block size: 4000
```

System serial # is presently

Enter system serial # or <CR> to accept

Enter your System Serial Number

(i.e., the "TN," "NE," or "NB" number of the system).
For example, enter TN1234. If the correct serial
number is shown, press RETURN to accept it.

The following screen is displayed.

```
Memory = 512KB  
00016 Comm. Lines  
Tape 0 attached Block size: 4000
```

System serial # is presently

Enter system serial # or <CR> to accept

Press RETURN if the number is correct.

You may re-enter the correct number if you made a
mistake. Press RETURN after you enter the correct
number.

The following screen is displayed.

System Startup (Boot) Options

```
Memory = 512KB
00016 Comm. Lines
Tape 0 attached Block size: 4000
```

System serial # is presently

Enter system serial # or <CR> to accept

Mount ABS tape and enter number of files to skip, if any

Press RETURN.

(Your SYS-GEN tape should already be mounted.) The following screen is displayed.

```
Mount ABS tape and enter number of files to skip,
if any:
```

```
XX-XXX
XXXX-XXX
XXXX-XXX
XXXX-XXX
XXXX-XXXX
```

```
Spooler started
Linking workspace for line 0
```

```
date      time      Logon Please:
```

```
<<< Welcome to the Ultimate Computer System >>>
<<< Copyright      date      The Ultimate Corp. >>>
<<<   time      Release XX Rev XXX      date      >>>
```

```
This is the Cold-Start Procedure
Enter <CR> to continue
```

System Startup (Boot) Options

Press RETURN.

The following screen is displayed.

```
-----  
      date      time  Logon Please:  
  
<<< Welcome to the Ultimate Computer System >>>  
<<< Copyright   date    The Ultimate Corp. >>>  
<<<   time   Release XX Rev XXX   date   >>>  
  
This is the Cold-Start Procedure  
Enter <CR> to continue  
  
Linking secondary TCL workspaces  
  
X additional task workspaces initialized  
  
      time      date  
  
Time =
```

Enter the time in military format (HH:MM:SS).

For example, enter 5PM as 17:00:00. The following screen is displayed.

System Startup (Boot) Options

```
This is the Cold-Start Procedure
Enter <CR> to continue

Linking secondary TCL workspaces

X additional task workspaces initialized

time      date

Time = 17:00:00
17:00:00  date
Date =
```

Enter the date in the following format: MM/DD/YY.

For example, enter February 3, 1986 as 02/03/86. The following screen is displayed.

```
This is the Cold-Start Procedure
Enter <CR> to continue

Linking secondary TCL workspaces

X additional task workspaces initialized

time      date

Time = 17:00:00
17:00:00  date
Date = 02/03/86
17:00:00  03 FEB 1986
```

NOTE: If you included other commands in the COLDSTART proc in SYSPROG's Master Dictionary (MD), those commands will be executed at this point.

The system will display several messages. If there

System Startup (Boot) Options

are any error messages (i.e.: System does not verify), call the Ultimate System Support Group immediately.

The following screen will be displayed.

```
-----  
date      time      Logon please:  
-----
```

3. You may now log on.

SUMMARY OF COLDSTART PROCEDURE

1. Power up system, and load the SYS-GEN tape.
2. Enter C at System Startup Options menu.
3. Enter system serial number.
4. Verify that SYS-GEN is loaded, and press RETURN.
5. Press RETURN at "This is the Cold-Start Procedure."
6. Enter the time and date in military format.
7. Check for error messages.

System Startup (Boot) Options

6.3 Diagnostics Monitor for 6000 and 7000 Series Systems

(If you have a 1400 Series system, refer to Section 6.4 for instructions on using the Diagnostics Monitor.)

The Diagnostics Monitor is used to perform many functions. The most-commonly used function, formatting disks, is described here. For more information on the Diagnostics Monitor, refer to the System Management and Support Guide.

The Diagnostics Monitor is run off-line. This means that you are not able to run your system in the normal mode. Only line zero (the console) is activated.

NOTE: If you format a disk, you will destroy all data on that disk. If you wish to save the data, perform a File-Save first (see Section 7.2).

6.3.1 Formatting a Disk (For Systems with Tape Drive)

1. Make sure you've followed the powering-up instructions in Section 2. Your Ultimate SYS-GEN tape should be mounted, and the disk to be formatted should be installed.

2. At the System Startup Options menu, enter D.

This will load the Diagnostics Monitor.

3. If you are not sure of the device addresses of your disk drives, type CONFIG and press RETURN. The channel addresses and descriptions of each device will be displayed.

4. At the TCL prompt (>) on the console, type:

FORMAT nnn and press RETURN.

The number nnn is the channel or device address of your disk drive. For example, you may enter FORMAT 600. If your system has multiple disk drives, you can format all packs at once by specifying all disk drive device addresses together. For example, you could enter

FORMAT 600 680 700

The following screen is displayed.

System Startup (Boot) Options

(F)ixed or (R)emoveable:

Enter F or R

This question is not asked when formatting multiple packs or free-standing disk drives.

If you're not sure whether to format the fixed or removable drive, call the Ultimate Support Group.

The following screen is displayed.

(F)ixed or (R)emoveable:

Will pack be used for (G)cos, (T)&V's or
(U)ltimate?

Enter U

This question is not asked when formatting multiple packs.

The following screen is displayed.

System Startup (Boot) Options

(F)ixed or (R)emoveable:

Will pack be used for (G)cos, (T)&V's or
(U)ltimate? U

Save Old Alternate Tracks? (Y/N)

Enter:

Y to make sure previous bad tracks are marked defective, or enter

N if you don't want to save previously marked bad tracks

CAUTION: If you are formatting a new FSD or EMD drive, you must enter N at this prompt. Then, at any time in the future, when formatting the drive, you may enter Y. If you enter Y when formatting an FSD or EMD drive for the first time, you will get disk errors.

The following screen is displayed.

Will pack be used for (G)cos, (T)&V's or
(U)ltimate? U

Save Old Alternate Tracks? (Y/N)

Do you wish to enter Defective Tracks? (Y/N)

Enter:

System Startup (Boot) Options

Y if you want to manually flag a track as defective
N if you don't want to flag a defective track

If you are formatting a new pack or drive, enter N.

If you entered Y, the following screen is displayed.

Will pack be used for (G)cos, (T)&V's or
(U)ltimate? U

Save Old Alternate Tracks? (Y/N)

Do you wish to enter Defective Tracks? (Y/N) Y

Enter Cylinder #

Enter the 3-digit cylinder number of the defective track.

The following screen is displayed.

System Startup (Boot) Options

(F)ixed or (R)emoveable:

Will pack be used for (G)cos, (T)&V's or
(U)ltimate? U

Save Old Alternate Tracks? (Y/N)

Do you wish to enter Defective Tracks? (Y/N) Y

Enter Cylinder #

Enter Track #

Enter the 2-digit track number.

The following screen is displayed.

System Startup (Boot) Options

(F)ixed or (R)emoveable:

Will pack be used for (G)cos, (T)&V's or
(U)ltimate? U

Save Old Alternate Tracks? (Y/N)

Do you wish to enter Defective Tracks? (Y/N) Y

Enter Cylinder #

Enter Track #

Enter Sector #

Enter the sector number.

This question is asked only if you have an FSD drive.
The following screen is displayed.

System Startup (Boot) Options

(F)ixed or (R)emoveable:

Will pack be used for (G)cos, (T)&V's or
(U)ltimate? U

Save Old Alternate Tracks? (Y/N)

Do you wish to enter Defective Tracks? (Y/N) Y

Enter Cylinder #

Enter Track #

Enter Sector #

Do you want to enter more? (Y/N)

Enter:

Y to continue entering tracks as defective.
N to go on to the next screen.

This question is not asked when formatting multiple
disk packs.

The following screen is displayed.

System Startup (Boot) Options

```
Save Old Alternate Tracks? (Y/N)
Do you wish to enter Defective Tracks? (Y/N)
Enter Cylinder #
Enter Track #
Enter Sector #
Do you want to enter more? (Y/N)
Enter Set Name (= < 12 char):
```

Enter a set name for the disk pack.

This can be any name you choose. On a multiple disk drive system, this name is used by the system to validate that only packs of the same set are loaded. For simplicity, Ultimate recommends that you use colors for pack names.

NOTE: Make sure that all packs in a sequence have the same set name. For example, if you have three disk packs in a set, make sure all three disk packs have the same set name.

The following screen is displayed.

System Startup (Boot) Options

```
-----  
Save Old Alternate Tracks? (Y/N)  
  
Do you want to enter more? (Y/N)  
  
Enter Set Name (= < 12 char):  
  
Enter # of Drives in Set:  
-----
```

Enter the number of drives on your system.

This is asked if you are formatting a fixed disk only. The following screen is displayed.

```
-----  
Enter Set Name (= < 12 char):  
  
Enter # of Drives in Set:  
  
Enter Sequence #:  
-----
```

Enter the sequence number of the disk pack.

For example, if this is the first pack, enter 1. This question is only asked when there are multiple drives on the system. Once you enter the sequence number, the system will automatically increment the disk (counter) number for remaining disks in the set.

5. The format process will begin. The following messages will be displayed.

System Startup (Boot) Options

```
Now Formatting (Pack #1 on Channel XXXX)
```

```
Start Phase 1
```

```
Start Phase 2
```

```
Start Phase 3
```

```
Start Phase 4
```

```
Format Complete
```

A string of asterisks (*) is displayed for each phase. Any bad tracks will be flagged. If the number of bad tracks exceeds the maximum number of allowable bad tracks, or if a bad track is found in a critical area of the disk pack, a message will be displayed, indicating that the disk pack cannot be used.

6. When you have finished formatting your disk(s), follow the instructions in Section 5 to boot your system.

6.3.2 Formatting a Disk (For Disk-Only Systems)

1. Make sure you've followed the power-on instructions in Section 2.

2. At the System Startup Options menu, enter D.

This will load the Diagnostics Monitor.

3. Remove the SYS-GEN disk. See instructions in Section 4.

4. Insert the disk to be formatted. See instructions in Section 4.

5. If you are not sure of the device addresses of your disks, type **CONFIG** and press RETURN. The channel addresses and descriptions of each device will be displayed.

6. At TCL on the console, type:

```
FORMAT nnn and press RETURN.
```

The number nnn is the channel or device address of your disk drive. For example, you may enter **FORMAT 400**. If your system has multiple disk drives, you can format all packs at once by specifying all disk

System Startup (Boot) Options

drive device addresses together. For example, you could enter

FORMAT 400 480 500

The following screen is displayed.

```
(F)ixed or (R)emoveable:
```

Enter F or R

This question is not asked when formatting multiple packs or free-standing disk drives.

If you're not sure whether to format the fixed or removable drive, call the Ultimate Support Group.

The following screen is displayed.

```
(F)ixed or (R)emoveable:
```

```
Will pack be used for (G)cos, (T)&V's or  
(U)ltimate?
```

Enter U

This question is not asked when formatting multiple packs.

The following screen is displayed.

System Startup (Boot) Options

(F)ixed or (R)emoveable:

Will pack be used for (G)cos, (T)&V's or
(U)ltimate? U

Save Old Alternate Tracks? (Y/N)

Enter:

Y to make sure previous bad tracks are marked
defective, or enter

N if you don't want to save previously marked bad
tracks

CAUTION: If you are formatting a new FSD or EMD drive, you must enter N at this prompt. Then, at any time in the future, when formatting the drive, you may enter Y. If you enter Y when formatting an FSD or EMD drive for the first time, you will get disk errors.

The following screen is displayed.

Will pack be used for (G)cos, (T)&V's or
(U)ltimate? U

Save Old Alternate Tracks? (Y/N)

Do you wish to enter Defective Tracks? (Y/N)

Enter:

System Startup (Boot) Options

Y if you want to manually flag a track as defective
N if you don't want to flag a defective track

If you are formatting a new disk, enter N.

If you entered Y, the following screen is displayed.

Will pack be used for (G)cos, (T)&V's or
(U)ltimate? U

Save Old Alternate Tracks? (Y/N)

Do you wish to enter Defective Tracks? (Y/N) Y

Enter Cylinder #

Enter the 3-digit cylinder number of the defective track.

The following screen is displayed.

System Startup (Boot) Options

(F)ixed or (R)emoveable:

Will pack be used for (G)cos, (T)&V's or
(U)ltimate? U

Save Old Alternate Tracks? (Y/N)

Do you wish to enter Defective Tracks? (Y/N) Y

Enter Cylinder #

Enter Track #

Enter the 2-digit track number.

The following screen is displayed.

System Startup (Boot) Options

(F)ixed or (R)emoveable:

Will pack be used for (G)cos, (T)&V's or
(U)ltimate? U

Save Old Alternate Tracks? (Y/N)

Do you wish to enter Defective Tracks? (Y/N) Y

Enter Cylinder #

Enter Track #

Enter Sector #

Enter the sector number.

This question is asked only if you have an FSD drive.
The following screen is displayed.

System Startup (Boot) Options

(F)ixed or (R)emoveable:

Will pack be used for (G)cos, (T)&V's or
(U)ltimate? U

Save Old Alternate Tracks? (Y/N)

Do you wish to enter Defective Tracks? (Y/N) Y

Enter Cylinder #

Enter Track #

Enter Sector #

Do you want to enter more? (Y/N)

Enter:

Y to continue entering tracks as defective.
N to go on to the next screen.

This question is not asked when formatting multiple
disk packs.

The following screen is displayed.

System Startup (Boot) Options

```
Save Old Alternate Tracks? (Y/N)
Do you wish to enter Defective Tracks? (Y/N)
Enter Cylinder #
Enter Track #
Enter Sector #
Do you want to enter more? (Y/N)
Enter Set Name (= < 12 char):
```

Enter a set name for the disk pack.

This can be any name you choose. On a multiple disk drive system, this name is used by the system to validate that only packs of the same set are loaded. For simplicity, Ultimate recommends that you use colors for pack names.

NOTE: Make sure that all packs in a sequence have the same set name. For example, if you have three disk packs in a set, make sure all three disk packs have the same set name.

The following screen is displayed.

System Startup (Boot) Options

Save Old Alternate Tracks? (Y/N)

Do you want to enter more? (Y/N)

Enter Set Name (= < 12 char):

Enter # of Drives in Set:

Enter the number of drives on your system.

This is asked if you are formatting a fixed drive only. The following screen is displayed.

Enter Set Name (= < 12 char):

Enter # of Drives in Set:

Enter Sequence #:

Enter the sequence number of the disk pack.

For example, if this is the first pack, enter 1. This question is only asked when there are multiple drives on the system. Once you enter the sequence number, the system will automatically increment the disk (counter) number for remaining disks in the set.

7. The format process will begin. The following messages will be displayed.

System Startup (Boot) Options

```
Now Formatting (Pack #1 on Channel XXXX)
```

```
Start Phase 1
```

```
Start Phase 2
```

```
Start Phase 3
```

```
Start Phase 4
```

```
Format Complete
```

A string of asterisks (*) is displayed for each phase. Any bad tracks will be flagged. If the number of bad tracks exceeds the maximum number of allowable bad tracks, or if a bad track is found in a critical area of the disk pack, a message will be displayed, indicating that the disk pack cannot be used.

8. When you have finished formatting your disk(s), follow the instructions in Section 5 to boot your system.

System Startup (Boot) Options

SUMMARY--FORMATTING DISKS FOR SYSTEMS WITH TAPE DRIVES

1. Power on the system. Make sure the SYS-GEN tape is mounted, and the disk to be formatted is installed.
2. Enter D at the System Startup Options menu.
3. Type CONFIG and press RETURN to determine the device addresses of your disks.
4. Enter FORMAT nnn at TCL on the console device.
5. Enter F or R to indicate fixed or removable drive.
6. Enter U to indicate that pack will be used for Ultimate.
7. Enter Y or N at "Save Old Alternate Tracks?"
8. Enter Y or N at "Do you wish to enter Defective Tracks?" If you enter Y, then enter the cylinder, track, and sector numbers of the defective track.
9. Enter Y or N at "Do you want to enter more?" If you enter Y, continue entering cylinder, track, and sector numbers.
10. Enter the set name of the disk.
11. If formatting a fixed disk, enter the number of drives.
12. If multiple drives, enter the sequence number of the drive to be formatted.
13. The format process will begin. When completed, check the console for error messages.
14. Boot your system.

System Startup (Boot) Options

SUMMARY--FORMATTING DISKS FOR DISK-ONLY SYSTEMS

1. Power on the system.
2. Enter D at the System Startup Options menu.
3. Remove the SYS-GEN disk.
4. Insert the disk to be formatted.
5. Type CONFIG and press RETURN to determine the device addresses of your disks.
6. Enter FORMAT nnn at TCL on the console device.
7. Enter F or R to indicate fixed or removable drive.
8. Enter U to indicate that pack will be used for Ultimate.
9. Enter Y or N at "Save Old Alternate Tracks?"
10. Enter Y or N at "Do you wish to enter Defective Tracks?" If you enter Y, then enter the cylinder, track, and sector numbers of the defective track.
11. Enter Y or N at "Do you want to enter more?" If you enter Y, continue entering cylinder, track, and sector numbers.
12. Enter the set name of the disk.
13. If formatting a fixed disk, enter the number of drives.
14. If multiple drives, enter the sequence number of the drive to be formatted.
15. The format process will begin. When completed, check the console for error messages.
16. Boot your system.

System Startup (Boot) Options

6.4 Diagnostics Monitor for the 1400 Series Systems

The Diagnostics Monitor is used to perform many functions. The most-commonly used function, formatting disks, is described here.

The Diagnostics Monitor is run off-line. This means that you are not able to run your system in the normal mode. Only line zero (the console) is activated.

NOTE: If you format a disk, you will destroy all data on that disk. If you wish to save the data, perform a File-Save first (see Section 7.2).

Formatting a Disk

1. Make sure you've followed the Booting instructions in Section 5.
2. At the System Startup Options menu, enter D.

This will load the Diagnostics Monitor. The following screen will be displayed.

```
-----  
ST506 disc sub-system  
Format and disc diagnostic utility  
  
(F)ormat a drive  
(B)ad sector map read  
(R)ead disc parameters (vtoc)  
(W)rite disc parameters (vtoc)  
(D)rive diagnostics menu  
(S)ystem debugger module  
(E)xit to options menu  
  
Select option:
```

Enter F

The following screen is displayed.

System Startup (Boot) Options

```
ST506 disc sub-system
Format and disc diagnostic utility
```

- (F)ormat a drive
- (B)ad sector map read
- (R)ead disc parameters (vtoc)
- (W)rite disc parameters (vtoc)
- (D)rive diagnostics menu
- (S)ystem debugger module
- (E)xit to options menu

Select option: F

Enter drive number (0-2)

Enter the number of the drive (0,1, or 2) that you want to format.

The following screen is displayed.

```
ST506 disc sub-system
Format and disc diagnostic utility
```

- (F)ormat a drive
- (B)ad sector map read
- (R)ead disc parameters (vtoc)
- (W)rite disc parameters (vtoc)
- (D)rive diagnostics menu
- (S)ystem debugger module
- (E)xit to options menu

Select option: F

Enter drive number (0-2).. 0

Enter (Y)es to continue

Type Y to continue the formatting process. This will destroy all previous data on the disc.

The following screen is displayed.

Operations and Maintenance Rev 2.2

Page 6 - 31

System Startup (Boot) Options

```
ST506 disc sub-system
Format and disc diagnostic utility
```

```
(F)ormat a drive
(B)ad sector map read
(R)ead disc parameters (vtoc)
(W)rite disc parameters (vtoc)
(D)rive diagnostics menu
(S)ystem debugger module
(E)xit to options menu
```

```
Select option: F
```

```
Enter drive number (0-2).. 0
Enter (Y)es to continue... Y
Use bad sector map (Y/N)
```

Enter:

```
Y to make sure previous bad tracks are marked defective
N if you don't want to save previously marked bad tracks
```

CAUTION: If you are formatting a new drive, you must enter N at this prompt. Then, at any time in the future when formatting the drive, you may enter Y.

The following screen is displayed.

System Startup (Boot) Options

ST506 disc sub-system
Format and disc diagnostic utility

- (F)ormat a drive
- (B)ad sector map read
- (R)ead disc parameters (vtoc)
- (W)rite disc parameters (vtoc)
- (D)rive diagnostics menu
- (S)ystem debugger module
- (E)xit to options menu

Select option: F

Enter drive number (0-2).. 0
Enter (Y)es to continue... Y
Use bad sector map (Y/N).. N

Verifying
cyl:xxxx trk:xx
Writing map
Writing VTOC

Once these messages have been displayed, then the formatting process is complete.

System Startup (Boot) Options

SUMMARY--FORMATTING DISKS FOR 1400 SERIES SYSTEMS

1. Power on the system. Make sure SYSGEN tape is mounted.
2. Boot the system.
3. Enter D at the System Startup Options menu.
4. Enter F to format the drive.
5. Enter 0, 1 or 2 to select the drive.
6. Enter Y to continue.
7. Enter Y or N at "Use Bad Sector Map."
8. The formatting process will begin. When completed, check the console for error messages.
9. Boot your system.

6.5 File-Restore

Use this procedure whenever you need to restore your entire system from your File-Save tape(s). This procedure should also be performed approximately once a month, to improve system performance. The File-Restore will reorganize your files into contiguous frames.

A File-Restore should also be done whenever you add communications boards to your system. The system will not recognize the boards until the File-Restore is performed.

NOTE: A File-Restore will overwrite your existing data, so you should do a File-Save first, then use that File-Save to do the File-Restore. File-Restores may only be done with File-Save tapes or disks.

Refer to Section 8.1 for instructions on performing a File-Restore.

6.6 Offline Monitor

The Offline Monitor is used to make a disk-to-disk copy of your data. This is an alternate back-up method, but one that is not recommended on a regular basis. It is not available for 1400 Series systems.

System Startup (Boot) Options

See Section 7.5 for instructions on making a disk-to-disk copy.

6.7 Utilities Monitor

The Utilities Monitor is used for special system utilities, such as Binary-Saves and Binary-Restores. A Binary-Save is an alternate backup method, but one that is not recommended on a regular basis. This method allows you to save your entire system as is, without checking for errors. The Binary-Save procedure is described in Section 7.4. The Utilities Monitor is not available for 1400 Series systems.

6.8 Warmstart

The Warmstart procedure reloads the monitor/firmware and all controller software. It then resumes execution of the process that was running previously. The Warmstart procedure is normally executed after a :WARMSTOP.

NOTE: Do not attempt a Warmstart unless your system was :WARMSTOPPED.

6.8.1 Warmstart From Options Menu

1. Make sure all users are logged off the system. To do so, go to the TCL prompt, and type:

LISTUSERS and press RETURN.

The console should be the only terminal logged on. If other users are logged on, make sure they log off before you continue.

2. If the system has not already been booted, do so now (see instructions in Section 4).
3. At the System Startup Options menu, enter W.

The following screen will be displayed.

```
-----  
THE DATE AND TIME MUST BE RE-SET!!!  
-----
```

4. To reset the date, type:

SET-DATE DD/MM/YY and press RETURN.

DD is the day, MM is the month, and YY is the year.

System Startup (Boot) Options

5. To reset the time, type:

`SET-TIME HH:MM:SS` and press RETURN.

HH is the hour, MM is the minutes, and SS is the seconds, in military format.

6. You may now log on to the system.

6.8.2 Warmstart from TCL

1. Make sure all users are logged off the system. To do so, go to the TCL prompt, and type:

`LISTUSERS` and press RETURN.

The console should be the only terminal logged on. If other users are logged on, make sure they log off before you continue.

2. After all users have logged off, go to port 0 (the console terminal). Type:

`LOGTO SYSPROG` and press RETURN.

Then press RETURN again to go to TCL. Type:

`:WARMSTART` and press RETURN.

This verb first flushes memory and then enters an automatic Warmstart.

The following screen will be displayed.

THE DATE AND TIME MUST BE RE-SET!!!

3. To reset the date, type:

`SET-DATE DD/MM/YY` and press RETURN.

DD is the day, MM is the month, and YY is the year.

4. To reset the time, type:

`SET-TIME HH:MM:SS` and press RETURN.

System Startup (Boot) Options

HH is the hour, MM is the minutes, and SS is the seconds, in military format.

5. You may now log on to the system.

SUMMARY OF WARMSTART FROM THE OPTIONS MENU

1. Make sure all users have logged off.
2. If the system has not been booted, do that now.
3. Enter W at the System Startup Options menu.
4. If necessary, reset the date and time.
5. You may now log on.

SUMMARY OF WARMSTART FROM TCL

1. Make sure all users have logged off the system.
2. Logto SYSPROG, then go to TCL.
3. Type :WARMSTART and press RETURN.
4. If necessary, reset the date and time.
5. You may now log on.



Backing Up the System

7 BACKING UP THE SYSTEM

Ultimate strongly recommends that you back up your system files at least once a day to ensure that you always have a method of recovery, in the event of data loss.

There are various backup procedures you may use to make an off-line copy of your data base files. If ever you need to recover your files, you can use the off-line copy to restore them.

Once you have made backup copies of your files, you must organize and store them so that they may be easily located and identified. Section 7.1 explains how to organize your backups. Various backup methods are explained in Sections 7.2 through 7.6.

7.1 Organizing Backup Tapes

Making backup tapes is very important in ensuring that you are able to restore your system in the event of data loss. It is equally important that you store your backups in an orderly manner, so that they may be quickly and easily identified when they are needed. When you need to restore from a backup tape, it's important that you use the most recent backup available. Otherwise, you may have to spend time recreating some of your data.

Ultimate recommends that you have separate daily backup tapes for one week's time, and a monthly backup for each month in the previous year. Some situations may also require a weekly backup cycle for the past month. That is, use a separate tape set for each day of the week, one for each week of the month, and one for each month of the year. The longer cycle tape sets should be stored off premises to provide protection in the event of physical damage, such as a fire or flood.

There are two steps in organizing your backup tapes: labeling and rotating.

7.1.1 Labeling

Be sure to label every one of your backup tapes (or disks) so that you may easily locate and identify them when they are needed. Make sure you label the tape reel itself, as well as the casing or cover, so that tapes separated from their covers won't be confused. The label should include:

1. The type of backup (FILE-SAVE, ACCOUNT-SAVE, BINARY-SAVE, DISK-TO-DISK, T-DUMP, ALL-UPDATE-SAVE, PART-UPDATE-SAVE, or TRANSACTION LOG). This is very important, as this will dictate the type of restore method that may be used. For example, Binary-Saves may only be restored via Binary-



Backing Up the System

Restores, and T-DUMPS may only be restored via T-LOADS.

2. The sequence number of the tape or disk (Tape 1 of 2, Tape 2 of 2, Disk 2 of 3, etc.). If your backup includes more than one tape or disk, you must preserve the sequence. When you restore from a multi-reel or multi-pack save, the tapes or disks must be restored in the exact order in which they were saved. Otherwise, you won't be able to fully restore your data.
3. The date the backup was made. It is very important to date every backup tape so that you'll be able to identify the most recent backups when they are needed. The date should be in the format DD/MM/YY, where DD is the day, MM is the month, and YY is the year.

7.1.2 Rotating

It is important to rotate the sets of tapes you use for backups, so that you don't always use the same set, and so that you don't take the chance of losing your most recent backup while you are creating another.

For example, if you use the same daily backup tape every day, it is possible that something could happen to that tape while you are creating a new File-Save with it. In this case, you may have lost your most recent daily backup.

Ultimate recommends that you keep a tape set for each day of the work week--one for Monday, one for Tuesday, etc. This set should only be used for daily backups, and only on the day of the week specified. (Monday's tape should only be used for each Monday's daily backup).

If you choose to maintain a weekly backup cycle in addition to the daily and monthly cycles, then you should maintain at least two sets of tapes for this cycle. Set 1 may be used for the first week's backup, and Set 2 may be used for the second week's backup. On the third week, you may use Set 1, and on the fourth week, use Set 2. This way, you'll always have a current weekly backup tape.

Your monthly backup tapes should include one tape for each month of the year. You should never reuse a monthly tape until a full year has passed. This way, you'll be able to recreate your data from the previous year, if necessary.

Backing Up the System

7.2 File-Save

The File-Save method is the most common backup method. This method allows you to easily backup your entire system files in one operation. Ultimate recommends you perform a File-Save at the end of each work day. You must also perform a File-Save immediately prior to performing a full File-Restore (see Section 8.1).

1. Select the tape or disk you want to use for the File-Save. If using a tape, mount a write-ring on the tape. Make sure the tape or disk doesn't contain data that you need to save, because the File-Save process will overwrite any data that already exists on the tape or disk.
2. Load the tape or disk. See instructions in Section 4.
3. Make sure all users are logged off the system. To do so, go to the TCL prompt, and type:

`LISTUSERS` and press RETURN.

The console should be the only terminal logged on. If other users are logged on, make sure they log off before you continue.

If users remain logged on during the File-Save, the process will take longer to complete, and any work updated while the File-Save is in process will not be backed up.

4. After all users have logged off, go to port 0 (the console terminal). Type:

`LOGTO SYSPROG` and press RETURN.

The following screen is displayed.

Backing Up the System

SYSPROG MAIN MENU
(Honeywell-Based Systems)

1. File-Save with automatic GFE fixer
- 1A. File-Save without automatic GFE fixer
2. ALL-UPDATE-SAVE
3. PART-UPDATE-SAVE
4. Documentation Menu
5. Spooler Menu
6. Automatic Async setup
7. Automatic File Reallocation Menu
8. Load WP account from SYS-GEN tape
9. Create Boot tape
10. Load UTILINK account from SYS-GEN tape
11. Load ATP account from SYS-GEN tape
12. Load ULTIMATION account from SYS-GEN tape

88. Logoff
99. Go to TCL

ENTER SELECTION _

(Your menu may be different, according to your system configuration.)

Enter 1 and press RETURN

to select File-Save with automatic GFE fixer, or

Enter 1A and press RETURN

to select File-Save without automatic GFE fixer.

The automatic GFE fixer will automatically truncate data that contains Group Format Errors (GFES). For more information on GFES, see Section 11.3.

The following questions will appear on your screen, and they will be automatically answered by the File-Save proc, as shown below.

NOTE: If you want to change the answers to any of the questions below, do not select File-Save from the SYSPROG menu. Instead, go to TCL and type:

FILE-SAVE and press RETURN.

You will be asked each question below indivi-

Backing Up the System

dually, and you may enter your own answers.

```
-----  
Now beginning File-Save Write/Read Test  
File-Save now beginning at XXXX  
Do you want the Console Listing to go to the Printer?(Y/N) N  
Enter tape block size (500 - 8192) 8000  
Do you want to generate File Statistics? (Y/N) Y  
Do you want to fix GFES? (Y/N)  
Enter Tape label: FILE-SAVE  
-----
```

The File-Save will begin. At "Do you want to fix GFES?", the answer will automatically be Y if you entered menu selection 1, and N if you entered menu selection 1A.

CAUTION: Do not open the door of the tape drive while the File-Save is in process!

The following information will appear on your terminal when the File-Save is complete.

NOTE: If your File-Save requires more than one tape, you will be prompted to mount the next reel.

Backing Up the System

```
# RECORDS WRITTEN  
END OF FILE-SAVE - (date)  
DUMPING STAT FILE  
# ITEMS DUMPED  
PREPARING FILE STATISTICS REPORT  
FILE SAVE COMPLETED
```

The File Statistics report should now be printing.

5. Unload the File-Save tape or disk. See instructions in Section 4.
6. Store the File-Save tape(s) or disk(s) in a safe place, along with the file statistics report. For more information on storing and organizing File-Saves, see Section 7.1.

SUMMARY OF FILE-SAVE PROCEDURE

1. Select the tape or disk to be used.
2. Load the tape or disk.
3. Make sure all users have logged off.
4. Log to SYSPROG from the console, and select 1 or 1A from the menu.
5. When the File-Save is complete, unload the tape or disk.
6. Store the File-Save tape or disk in a safe place, along with the corresponding file-stats report.

Backing Up the System

7.3 Account-Save

The Account-Save method allows you to backup all files for a particular account. (By contrast, the File-Save allows you to backup all accounts on your system.) You may want to perform an Account-Save if only one account has been updated since the last backup procedure.

1. Select the tape or disk you want to use for the Account-Save. If using a tape, mount a write-ring on the tape. Make sure the tape or disk doesn't contain data that you need to save, because the Account-Save process will overwrite any data that already exists on the tape or disk.
2. Load the tape or disk. See instructions in Section 4.
3. It is not necessary for all users to log off the system during the Account-Save, however, no work should be performed on the account that's being saved.
4. Go to port 0 (the console terminal). Type:

LOGTO SYSPROG and press RETURN.

Then press RETURN again to go to TCL. Type:

ACCOUNT-SAVE and press RETURN.

The following screen is displayed.

NOTE: If you want to generate a File-Statistics report for the account at the end of the Account-Save, do not type ACCOUNT-SAVE. Instead, type:

SAVE (D,F,I,T,S) and press RETURN.

```
-----  
>ACCOUNT-SAVE
```

```
Tape Label if desired  
-----
```

Enter a tape label and press RETURN.

For easy reference, Ultimate suggests you label your tapes in the following format: ACCOUNT-SAVE (MM-DD-YY). MM is the month, DD is the day, and YY is the year in which the Account-Save was performed.

Backing Up the System

The following screen is displayed.

```
>ACCOUNT-SAVE  
Tape Label if desired  
Account name?
```

Enter the account name you wish to save, and press RETURN.

The account name must be of a valid account in the system dictionary. The Account-Save will begin. **CAUTION:** Do not open the door of the tape drive while the Account-Save is in process!

The following information will appear on your terminal when the Account-Save is complete.

NOTE: If your Account-Save requires more than one tape, you will be prompted to mount the next reel.

```
ACCOUNT SAVE COMPLETED
```

5. If you entered the SAVE verb with the (D,F,I,T,S) options to generate File-Statistics, you may now print those statistics. To do so, at TCL type:

LIST-FILE-STATS and press RETURN.

The File Statistics report will be printed.

6. Unload the Account-Save tape or disk. See instructions in Section 4.
7. Store the Account-Save tape(s) or disk(s) in a safe place, along with the file statistics report. For more information on storing and organizing backup tapes, see Section 7.1.

Backing Up the System

SUMMARY OF ACCOUNT-SAVE PROCEDURE

1. Select the tape or disk to be used.
2. Load the tape or disk.
3. Make sure no work is being done on the account to be saved.
4. Log to SYSPROG from the console, and type ACCOUNT-SAVE and press RETURN, or type SAVE (D,F,I,T,S) and press RETURN.
5. Enter the tape or disk label.
6. Enter the account name to be saved.
7. If you entered SAVE (D,F,I,T,S), then type LIST-FILE-STATS and press RETURN to print the File Statistics report.
8. Unload the tape or disk.
9. Store the File-Save tape or disk in a safe place.

Backing Up the System

7.4 Binary-Save

NOTE: This is not available on 1400 Series systems.

Another backup method is the Binary-Save. This is an alternate method that may be used under certain circumstances. However, this method should not be used as the primary backup method.

The Binary-Save method allows you to save your entire system as is, starting from frame 1 to the last contiguous block of overflow. All frames in between, whether data frames or overflow frames, are stored. Therefore, the actual number of frames stored is normally greater than the number of frames stored by the File-Save method.

The Binary-Save runs at the maximum speed of the tape drive, and is usually faster than the File-Save. However, the actual speed depends on the speed and density of the tape drive and the number of frames to be saved.

The Binary-Save method does not check for GFES and is not recommended on a regular basis.

1. Make sure all users are logged off the system. To do so, go to the TCL prompt, and type:

`LISTUSERS` and press RETURN.

The console should be the only terminal logged on. If other users are logged on, make sure they log off before you continue.

2. After all users have logged off, go to port 0 (the console terminal). Type:

`LOGTO SYSPROG` and press RETURN.

Then press RETURN again to go to TCL. Type:

`VERIFY-SYSTEM` and press RETURN.

If there are any mismatches, make a note of this. You will need to know if there were any mismatches later.

3. Type:

`:WARMSTOP` and press RETURN.

A message similar to the following will be displayed.

Backing Up the System

```
Memory Flushed!  
Remote Panel  
B @ 00B64 TSA @ 00820  
A =
```

This message means that the system has halted all processing, flushed memory, and has entered the "Remote Panel" state.

4. Mount a SYS-GEN tape and boot your system (see instructions for booting your system in Section 5).

The System Startup Options menu will be displayed, as shown below.

```
This is the Ultimate Operating System
```

```
System Startup Options:
```

```
(B)oot  
(C)oldstart  
(D)iagnostics Monitor  
(F)ile Restore  
(U)tilities Monitor  
(W)armstart
```

```
Enter Option(s) or ? for help:
```

5. Enter U

The following screen is displayed.

Backing Up the System

(W)armstart Util from disc or (C)oldstart from tape:

If there were no mismatches from step 2 above, enter W. The system will load Util from disk. If there were mismatches from step 2 above, enter C. The system will load a good ABS from SYS-GEN.

Once the Util is loaded, the following screen will be displayed.

THIS IS THE ULTIMATE UTILITY SYSTEM YYYY/MM/DD

YYYY\MM\DD is the revision date of Util. Note: When Util is running, line 0 (the console) will be the only active terminal line.

6. Remove the SYS-GEN tape, and load a good tape for the Binary-Save. See instructions in Section 4.2.

7. At TCL, type:

SAVE A and press RETURN.

The A option indicates a save of all data to MAXFID. The Binary-Save will now begin. Unlike the File-Save procedure, the names of the files being saved are not output in the Binary-Save procedure.

If your Binary-Save requires more than one tape, you will be prompted to mount the second tape reel.

8. When the Binary-Save is completed, the TCL prompt will appear on your screen. Type:

T-UNLOAD and press RETURN

to rewind and unload the tape. When the tape stops moving, release the top tape hub's latch, and remove the tape reel. Store the tape in a safe place. (For more information on storing backup tapes, see Section

Backing Up the System

7.1.)

9. You should be at the TCL prompt. Type:

`BOOT` and press RETURN.

The system will initialize, and the System Startup Options menu will appear.

10. Enter W

to select Warmstart. The system will warmstart and then resume normal operation. Everyone may now log on.

SUMMARY OF BINARY-SAVE PROCEDURE

1. Make sure all users have logged off.
2. Log to SYSPROG and type `VERIFY-SYSTEM` and press RETURN. Note if there are any mismatches.
3. Type `:WARMSTOP` and press RETURN.
4. Mount the SYS-GEN tape and boot your system.
5. Enter U at the System Startup Options Menu. At "(W)armstart Util from disc or (C)oldstart from tape," enter W if there were no mismatches, or enter C if there were mismatches.
6. Remove the SYS-GEN tape, and load a tape for the Binary Save.
7. At TCL, type `SAVE A` and press RETURN.
8. When the save is completed, type `T-UNLOAD`. Then remove the tape.
9. At TCL, type `BOOT` and press RETURN.
10. At the System Startup Options menu, enter W for Warmstart. All users may now log on.

Backing Up the System

7.5 Disk-To-Disk Copy

NOTE: This is not available on 1400 Series systems.

Disk-to-disk copy is a utility that allows the rapid back-up of a multi-disk system by copying the "on-line" disk set to a back-up set of disks.

To use this utility, you must have two or more disk drives (5 or 10 platter removable), and at least one set of back-up disks. Note that only drives 0 and 1 can be used for a disk-to-disk copy. Note that the set name of the back-up disk set must be different from the on-line disk set. Throughout this procedure, the on-line disk set from which you are copying is called the master set, and the back-up disk set to which you are copying is called the copy set.

The disk-to-disk copy routine will copy one complete 75MB disk pack in approximately three minutes and 50 seconds. A 288MB pack is estimated to take approximately 15 minutes.

The disk-to-disk copy has a feature that allows it to copy only the data portion of the disk, and not the empty overflow area. This feature can reduce the copy time considerably. If, however, you wish to copy the entire disk pack, you may do so via the L option (explained below).

The disk-to-disk copy routine can handle existing bad tracks on both read and write (master and copy) packs.

It can also handle disk read and write errors. If the copy routine encounters a read or write error, 12 retries will be attempted, after which a message will be displayed. (It should be noted that each program retry equals 27 retry attempts by the monitor). If the operation has been unsuccessful after 12 retry attempts, you will be given the option to "retry," "accept," or "quit."

1. Make sure all users are logged off the system. To do so, go to the TCL prompt (>), and type:

`LISTUSERS` and press RETURN.

The console should be the only terminal logged on. If other users are logged on, make sure they log off before you continue.

2. After all users have logged off, go to port 0 (the console terminal). Type:

`LOGTO SYSPROG` and press RETURN.

Then press RETURN again to go to TCL. Type:

Backing Up the System

:WARMSTOP and press RETURN.

A message similar to the following will be displayed.

```
-----  
Memory Flushed!  
Remote Panel  
B @ 00B64 TSA @ 00820  
A =  
-----
```

This message means that the system has halted all processing, flushed memory, and has entered the "Remote Panel" state.

3. Determine the device address or channel number of your disk. To do this, follow the instructions in Section 5 to boot your system. At the System Startup Options menu, enter D to select Diagnostics Monitor. At TCL, type:

CONFIG and press RETURN.

The device address of your disk should be displayed.

4. Determine the sequence number of each master pack you will be copying by using the D-RDLBL verb on the Diagnostics Monitor. If you aren't in the Diagnostics Monitor, follow the instructions in Section 5 to boot your system. At the System Startup Options menu, enter D to select Diagnostics Monitor. At TCL, type:

D-RDLBL nnn and press RETURN.

The number nnn is the device address of your disk. The sequence number of your disk should be displayed.

5. Label each pack on the pack cover. Do not put a label on the disk pack itself because, if it comes off, it can cause a head crash. If you wish to label the pack itself, use a marker to write on the pack hub.

For added protection of your master disk, you may press the PROTECT button on the master drive. Make sure you don't press the PROTECT button on the copy disk.

Backing Up the System

6. Boot your system again (see instructions in Section 5). At the System Startup Options menu, enter 0 to select Offline Monitor. The system will display the 0, followed by a comma (,). Now type W. You have just executed an off-line warmstart.

7. From port zero, at the logon message type:

`SYSPROG` and press RETURN.

Then press RETURN again to go to TCL. Type:

`DISK.COPY` and press RETURN.

If you wish to copy the entire pack instead of data only, use the L option. Type:

`DISK.COPY (L` and press RETURN.

From this point, you are effectively running a memory-only system. Only those frames absolutely necessary for the disk-to-disk copy have been core-locked into memory. No further virtual communication with the disk set is possible.

NOTE: Although you may BREAK into debugger, you cannot END from the disk-to-disk copy.

The following screen is displayed.

Enter the sequence # to copy or 0 for a complete backup

Enter 0 to do a complete backup of all disks, or enter a sequence number to copy a single disk. (You should have determined sequence numbers in Step 1.

The following screen is displayed.

Backing Up the System

Enter the sequence # to copy or 0 for a complete backup

Enter name of copy set:

Enter the set name of the back-up packs to which you will be copying.

The on-line set will now be verified. All drives must be ready. The following screen is displayed.

Enter the sequence # to copy or 0 for a complete backup

Enter name of copy set:

Mount seq # 1 master and copy packs

Master pack 1 should already be mounted. Mount pack 1 of the copy set (see Section 4 for instructions). Then press RETURN.

If one of the drives is not ready, or if the correct packs cannot be found, the message "Missing master/copy packs x of n" will be displayed.

If the "copy" drive is write-protected, a message will be displayed.

The message "Copy in Progress" will appear, and below it an asterisk (*) will be printed for each 16 cylinders that are copied. This will give you an indication that the copy is proceeding.

8. After each copy is complete, you will be prompted to mount the next set of packs (master and copy). You may place the master and copy packs in any drive. The labels of all

Backing Up the System

packs mounted in "ready" drives will be read to locate and set up the proper master and copy packs for the next copy sequence.

After the last pack has been copied, the following screen will be displayed.

Enter the sequence # to copy or 0 for a complete backup

If you want to continue copying, enter 0 for a complete backup, or enter a sequence number to copy a single disk.

If you are finished copying, place either the master or copy set back in your disk drives. Then boot your system (see Section 5), and Warmstart (see Section 6.7).

Backing Up the System

SUMMARY OF DISK-TO-DISK COPY PROCEDURE

1. Make sure all users have logged off.
2. At port 0, type LOGTO SYSPROG and press RETURN. Press RETURN to go to TCL. Then type :WARMSTOP and press RETURN.
3. Determine the device address of the master pack you will be copying. Use the CONFIG verb on the Diagnostics Monitor.
4. Determine the sequence number of each master pack you will be copying. Use the D-RDLBL verb from the Diagnostics Monitor.
5. Label each pack on the pack cover.
6. Boot your system, and enter 0 to select Offline Monitor. After an 0 and comma are displayed, enter W.
7. From port 0 at the "Logon please" prompt, type SYSPROG and press RETURN. Press RETURN to go to TCL. Then type DISK.COPY and press RETURN.
8. Enter 0 (zero) to do a complete backup of all disks, or enter a sequence number to copy a single disk.
9. Enter the set name of the back-up packs to which you will be copying.
10. Make sure the master and copy packs are mounted, and press RETURN.
11. When prompted, mount the next set of packs.
12. To continue copying, start again at Step 8. When you are finished copying, place the master or copy set in your disk drives. Then boot and Warmstart your system.

7.6 T-DUMP

The T-DUMP verb allows you to copy a single file or individual items from disk to tape.

1. Load the tape to which you want to dump your file(s). See instructions in Section 4.2.
2. Use the T-DUMP verb to dump your file(s): T-DUMP is a RECALL verb, and its general form is as follows:

```
T-DUMP {DICT} filename {item-list} {selection-criteria}
      {HEADER "name"} {(options)}
```

The filename may be preceded by the DICT modifier to dump dictionary data. File definition items (such as D/CODE=D) will not be dumped.

The filename is the name of the source file to be dumped, or copied, onto the tape.

As explained in the Recall manual, the item-list and selection criteria select a sub-set of the items in the specified file which are to be written to tape. If the item-list and selection-criteria are omitted, then all items in the file will be written to tape.

The HEADER allows a "name" to be included in the tape label at the start of the file.

Options:

- (I) Inhibits listing to the terminal of items dumped.
- (O) Enables overwrite of items in the file with item-ids corresponding to the item-ids of items in the tape file.

An EOF mark is written to the tape at the completion of the T-DUMP. As in other Recall statements, each item-id must be enclosed in double quotes ("").

3. Unload the tape and store it in a safe place. See instructions in Section 4.2.

Backing Up the System

SUMMARY OF T-DUMP PROCEDURE

1. Load the tape to which you will dump your files.
2. Type T-DUMP {DICT} filename {item-list} {selection-criteria} {HEADER "name"} {(options)}
3. Unload the tape and store it in a safe place.

Backing Up the System

7.7 Update-Saves and Transaction Logger

NOTE: You must be on Rev 121A or later to use the Update-Save method.

The Update-Save, also called Incremental File-Save, allows you to save only those file groups that have been changed since the last File-Save. Associated with each group of each disk file is a flag indicating whether any item in the group has been updated. To allow you to do Update-Saves, two procs have been set up in your SYSPROG account. They are ALL-UPDATE-SAVE and PART-UPDATE-SAVE.

WARNING: Following a full File-Restore, you must do a full File-Save before you can use the Update-Save methods. It is by this full File-Save that the Update-Saves are referenced.

7.7.1 ALL-UPDATE-SAVE

The ALL-UPDATE-SAVE allows you to do an Update-Save, but it does not reset the "group-updated" flags. Therefore, each Update-Save tape will contain all the changes since the last full File-Save. To restore the system from this backup method, only the most recent full File-Save tape and the most recent ALL-UPDATE-SAVE tape are required.

If using this method, Ultimate recommends that you do an ALL-UPDATE-SAVE every day, and a full File-Save once a week.

1. Select the tape you want to use for the ALL-UPDATE-SAVE. Mount a write-ring on the tape. Make sure the tape doesn't contain data that you need to save, because the ALL-UPDATE-SAVE process will overwrite any data that already exists on the tape.
2. Load the tape. See instructions in Section 4.
3. Make sure all users are logged off the system. To do so, go to the TCL prompt, and type:

LISTUSERS and press RETURN.

The console should be the only terminal logged on. If other users are logged on, make sure they log off before you continue.

If users remain logged on during the ALL-UPDATE-SAVE, the process will take longer to complete, and any work updated while the ALL-UPDATE-SAVE is in process will not be backed up.

4. After all users have logged off, go to port 0 (the console

Backing Up the System

terminal). Type:

LOGTO SYSPROG and press RETURN.

The following screen is displayed.

```
-----  
SYSPROG MAIN MENU  
(Honeywell-Based Systems)  
  
1. File-Save with automatic GFE fixer  
1A. File-Save without automatic GFE fixer  
2. ALL-UPDATE-SAVE  
3. PART-UPDATE-SAVE  
4. Documentation Menu  
5. Spooler Menu  
6. Automatic Async setup  
7. Automatic File Reallocation Menu  
8. Load WP account from SYSGEN tape  
9. Create Boot tape  
10. Load UTILINK account from SYS-GEN tape  
11. Load ATP account from SYS-GEN tape  
12. Load ULTIMATION account from SYS-GEN tape  
  
88. Logoff  
99. Go to TCL  
  
ENTER SELECTION _
```

(Your menu may be different, according to system configuration.)

Enter 2 and press RETURN

to select ALL-UPDATE-SAVE. The ALL-UPDATE-SAVE will begin. **CAUTION:** Do not open the door of the tape drive while the ALL-UPDATE-SAVE is in process!

NOTE: If your ALL-UPDATE-SAVE requires more than one tape, you will be prompted to mount the next reel.

5. Unload the ALL-UPDATE-SAVE tape. See instructions in Section 4.
6. Store the tape(s) in a safe place. For more information on storing and organizing backup tapes, see Section 7.1.

Backing Up the System

SUMMARY OF ALL-UPDATE-SAVE PROCEDURE

1. Select the tape to be used.
2. Load the tape.
3. Make sure all users have logged off.
4. Log to SYSPROG from the console, and select 2, ALL-UPDATE-SAVE, from the menu.
5. When the ALL-UPDATE-SAVE is complete, unload the tape.
6. Store the tape in a safe place.

NOTE: For more information on the ALL-UPDATE-SAVE method, refer to the System Management and Support Guide.

Backing Up the System

7.7.2 PART-UPDATE-SAVE

The PART-UPDATE-SAVE allows you to do an Incremental File-Save, and it resets the "group-updated" flags. Therefore, each Update-Save tape will contain only those changes since the last Update-Save or File-Save. To restore the system from this backup method, the most recent full File-Save tape and every subsequent PART-UPDATE-SAVE tape are required.

If using this method, Ultimate recommends that you do a PART-UPDATE-SAVE every day, and a full File-Save once a week.

NOTE: If, for any reason, a PART-UPDATE-SAVE is aborted, the next save you attempt will automatically be a full File-Save.

1. Select the tape you want to use for the PART-UPDATE-SAVE. Mount a write-ring on the tape. Make sure the tape doesn't contain data that you need to save, because the PART-UPDATE-SAVE process will overwrite any data that already exists on the tape.
2. Load the tape. See instructions in Section 4.
3. Make sure all users are logged off the system. To do so, go to the TCL prompt, and type:

LISTUSERS and press RETURN.

The console should be the only terminal logged on. If other users are logged on, make sure they log off before you continue.

If users remain logged on during the PART-UPDATE-SAVE, the process will take longer to complete, and any work updated while the PART-UPDATE-SAVE is in process will not be backed up.

4. After all users have logged off, go to port 0 (the console terminal). Type:

LOGTO SYSPROG and press RETURN.

The following screen is displayed.

Backing Up the System

SYSPROG MAIN MENU (Honeywell-Based Systems)

1. File-Save with automatic GFE fixer
- 1A. File-Save without automatic GFE fixer
2. ALL-UPDATE-SAVE
3. PART-UPDATE-SAVE
4. Documentation Menu
5. Spooler Menu
6. Automatic Async setup
7. Automatic File Reallocation Menu
8. Load WP account from SYSGEN tape
9. Create Boot tape
10. Load UTILINK account from SYS-GEN tape
11. Load ATP account from SYS-GEN tape
12. Load ULTIMATION account from SYS-GEN tape

88. Logoff
99. Go to TCL

ENTER SELECTION _

(Your menu may be different, according to system configuration.)

Enter 3 and press RETURN

to select PART-UPDATE-SAVE. The PART-UPDATE-SAVE will begin. **CAUTION:** Do not open the door of the tape drive while the PART-UPDATE-SAVE is in process!

NOTE: If your PART-UPDATE-SAVE requires more than one tape, you will be prompted to mount the next reel.

5. Unload the PART-UPDATE-SAVE tape. See instructions in Section 4.
6. Store the tape(s) in a safe place. For more information on storing and organizing backup tapes, see Section 7.1.

Backing Up the System

SUMMARY OF PART-UPDATE-SAVE PROCEDURE

1. Select the tape to be used.
2. Load the tape.
3. Make sure all users have logged off.
4. Log to SYSPROG from the console, and select 3, PART-UPDATE-SAVE, from the menu.
5. When the PART-UPDATE-SAVE is complete, unload the tape.
6. Store the tape in a safe place.

NOTE: For more information on the PART-UPDATE-SAVE method, refer to the System Management and Support Guide.

Backing Up the System

7.7.3 Transaction Logger

NOTE: Before using the Transaction Logger, you should refer to the System Management and Support Guide.

The Transaction Logger records disk file updates on magnetic tape as the updates are made. In the event of a system failure, the tape can be used in conjunction with a File-Save tape to restore all files to their state at the time of the failure.

A transaction is considered any one of the following: item update, item deletion, file creation, file deletion, and file clearing for any disk file on the system. The Transaction Logger records all transactions on tape. It runs as an independent, transparent process.

Note that writing the same copy of an item back to the file is considered an "item update." For example, filing an item by the FI command of the Editor is considered an item update, even if no change was made to the item.

NOTE: Do not update items in DX files or a DX pointer while the transaction logger is activated. If you do, you will experience problems when you attempt to restore the data.

A transaction logging session starts when the logger is activated or restarted, and ends when the logger is deactivated or the tape operation is suspended.

During a transaction logging session, more than one reel of tape may be needed to log all transactions. The system will display the message "MOUNT REEL #" to prompt you to mount a new reel of tape. All reels of tape made in the same session are collectively called a transaction session tape set.

A new reel of tape should be mounted before each new transaction logging session. The tape should be at the BOT (beginning of tape) mark. When you deactivate the logger or suspend the tape operation, the logger writes an EOF (end of file) mark to the tape to signify the end of the transaction logging session.

1. Select the tape you want to use for the Transaction Logger. Mount a write-ring on the tape. Make sure the tape doesn't contain data that you need to save, because the Transaction Logger will overwrite any data that already exists on the tape.
2. Load the tape. See instructions in Section 4.
3. If you are using a tape, type:

Backing Up the System

T-ATT 0 and press RETURN.

If you are using a removable disk cartridge, type:

T-ATT C and press RETURN.

4. Select the terminal that will be dedicated to transaction logging. This should be any terminal other than port zero. At the selected terminal, type:

LOGTO SYSPROG and press RETURN.

The following screen is displayed.

```
-----  
SYSPROG MAIN MENU  
(Honeywell-Based Systems)  
  
1. File-Save with automatic GFE fixer  
1A. File-Save without automatic GFE fixer  
2. ALL-UPDATE-SAVE  
3. PART-UPDATE-SAVE  
4. Documentation Menu  
5. Spooler Menu  
6. Automatic Async setup  
7. Automatic File Reallocation Menu  
8. Load WP account from SYSGEN tape  
9. Create Boot tape  
10. Load UTILINK account from SYS-GEN tape  
11. Load ATP account from SYS-GEN tape  
12. Load ULTIMATION account from SYS-GEN tape  
  
88. Logoff  
99. Go to TCL  
  
ENTER SELECTION _
```

(Your menu may be different, according to system configuration.)

Press RETURN

to go to TCL. Then type:

LOG and press RETURN.

The following screen is displayed.

Backing Up the System

Logger status: Inactive

Transaction logger options:

1. Activate logger; start tape
2. Deactivate logger; exit menu
3. Suspend tape
4. Restart tape
5. Change tape attachment parameters

Enter option or <cr> to display status:

The logger status may be INACTIVE, ACTIVE AND STARTED, or ACTIVE AND SUSPENDED. INACTIVE indicates that the logger is invoked on a terminal but is not recording updates. ACTIVE AND STARTED means that updates are being recorded onto tape. ACTIVE AND SUSPENDED means that the logger is recording updates but that the tape operation is suspended. You may suspend a tape operation to use the tape drive temporarily for other purposes by another port (for example, a File-Save or T-DUMP). During suspension, transactions are recorded on disk. When tape operation is restarted for the transaction logger, these transactions are recorded onto tape.

Activate Logger

At the Transaction Logger menu, enter 1 and press RETURN to select Activate logger; start tape. A transaction tape must already be mounted on the tape drive and loaded at the BOT (beginning of tape) mark. All transactions will be recorded onto tape, until you deactivate the logger or suspend the tape.

NOTE: While the logger is active, be sure to check the tape drive frequently and mount a new tape reel as needed.

Deactivate Logger

At the Transaction Logger menu, enter 2 and press RETURN to select Deactivate logger; exit menu. If any transactions were queued to disk (if the tape was suspended), those transactions will be flushed to tape, and then an EOF mark is written to tape to signify the end of the transaction logging session. You will be returned to TCL.

Suspend Tape

Backing Up the System

At the Transaction Logger menu, enter 3 and press RETURN to select Suspend Tape. This option puts the transaction logger into the Active and Suspended state and ends the current transaction logging session. Transactions queued to disk are flushed to tape, and an EOF mark is written to tape. The tape drive is detached from the transaction logger. Remove the tape from the tape drive. The drive may now be used for other purposes (for example, a File-Save, T-DUMP, or T-LOAD). During the time the tape is suspended, transactions are queued to disk.

When the tape drive is ready to resume transaction logging, mount a new reel (see Section 4), and then select option 4 (Restart tape) from the Transaction Logger menu.

Restart Tape

Mount a new reel of tape before selecting this option. Then, at the Transaction Logger menu, enter 4 and press RETURN to select Restart tape. This option starts a new transaction logging session. All transactions queued to disk will be flushed to tape.

Change Tape Attachment Parameters

Use this option to change the block size and tape drive number. At the Transaction Logger menu, enter 5 and press RETURN to select Change tape attachment parameters. (You may only select this option if the logger is in the INACTIVE or ACTIVE AND SUSPENDED state.) You will be prompted for the new block size and tape drive numbers. Enter the new numbers, or press RETURN to keep the default values. The defaults are block size 4000 and tape drive 0.

Backing Up the System

SUMMARY OF TRANSACTION LOGGER PROCEDURES

1. Select the tape you'll use to record the transactions.
2. Load the tape.
3. Type T-ATT 0 and press RETURN if you are using a tape, or T-ATT C and press RETURN if you are using a removable disk cartridge.
4. Select the terminal (any one other than port zero) that will be dedicated to transaction logging.
5. Log to SYSPROG, and press RETURN to go to TCL. Type LOG and press RETURN.
6. At the Transaction Logger menu, enter 1 and press RETURN to activate the logger.

NOTE: For more information on the Transaction Logger, refer to the System Management and Support Guide.

Backing Up the System

7.7.4 Using Update-Saves and Transaction Logger Together

You may use Update-Saves along with the Transaction Logger. By using the transaction logger, system updates can be kept up-to-the-minute, and, by using Update-Saves regularly, fewer tapes are needed for transaction logging and less time is required for a full File-Restore.

1. Activate the transaction logger immediately after a full File-Save (see Section 7.8 for instructions).
2. Do an ALL-UPDATE-SAVE or PART-UPDATE-SAVE every day (see Section 7.7 for instructions).
3. Do a full File-Save regularly, at least once a week (see Section 7.2 for instructions).
4. Make sure each transaction tape is associated with the latest "save" tape (either Update-Save or File-Save). For example, if the latest "save" is a full File-Save, then the transaction tapes made after the save are associated with this File-Save tape. But if an Update-Save (ALL-UPDATE-SAVE or PART-UPDATE-SAVE) was done, then the transaction tapes made after the Update-Save are associated with the Update-Save tape.

Restoring Data

8 RESTORING DATA

There are basically three reasons to restore your files: a) to recover lost data, b) to improve system performance when disk space becomes fragmented, and c) to allow the system to recognize the addition of communications boards to your system.

Just as there are various methods to save your files, there are various methods to recover them. Each is discussed below.

8.1 File-Restore

The File-Restore is the most common recovery method. This method allows you to recover lost data, improve system performance, and to recognize added communications boards.

Ultimate recommends you do a full File-Restore every 4 to 6 weeks to improve system performance, which is affected when disk space becomes fragmented. By fully restoring your files, you decrease the amount of fragmented disk space.

NOTE: A File-Restore will overwrite your existing data, so you should do a File-Save first, then use that File-Save to do the File-Restore. File-Restores may only be done with File-Save tapes or disks.

1. Make sure all users are logged off the system. To do so, go to the TCL prompt, and type:

`LISTUSERS` and press RETURN.

The console (line 0) should be the only terminal logged on. If other users are logged on, make sure they log off before you continue.

2. After all users have logged off, go to port 0 (the console terminal). Type:

`LOGTO SYSPROG` and press RETURN.

Then press RETURN again to go to TCL. Type:

`:WARMSTOP` and press RETURN.

A message similar to the following will be displayed. Remote Panel information is not shown on the 1400 Series systems.

Restoring Data

```
Memory Flushed!  
Remote Panel  
B @ 00B64 TSA @ 00820  
A =
```

This message means that the system has halted all processing, flushed memory, and has entered the "Remote Panel" state.

3. Use the instructions in Section 5 to boot your system. Be sure your SYS-GEN tape is mounted.
4. Locate the File-Save tape (or disks) with which you will be restoring the system.
5. At the System Startup Options menu, enter F.

This initiates a complete File-Restore.

Information about your disc configuration will be displayed. A sample screen is shown below. The memory and communications lines are not displayed on the 1400 Series systems.

Disc Configuration

chan	set name	#	of	
0400	123 TEST	1	1	
L 2000#	time	date	ABS	ULT REL XX

```
Memory = 512KB  
00016 Comm. Lines  
Tape 0 attached Block size: 4000
```

In the next screen, you will be asked for your system serial number.

Restoring Data

```
Memory = 512KB
00016 Comm. Lines
Tape 0 attached Block size: 4000
```

```
System serial # is presently
Enter system serial # or <CR> to accept
```

Enter your System Serial Number

(i.e., the "TN," "NE," or "NB" number of the system). For example, enter TN1234. If the present serial number is shown, and is correct, press RETURN to accept it.

The following screen is displayed.

```
Memory = 512KB
00016 Comm. Lines
Tape 0 attached Block size: 4000

System serial # is presently TN1234
Enter system serial # or <CR> to accept
```

Press RETURN if the number is correct.

You may re-enter the correct number if you made a mistake. Press RETURN after you enter the correct number.

The following screen is displayed.

Restoring Data

```
Memory = 512KB  
00016 Comm. Lines  
Tape 0 attached Block size: 4000
```

System serial # is presently

Enter system serial # or <CR> to accept

Mount ABS tape and enter number of files to skip, if any

Press RETURN.

(Your SYS-GEN tape should already be mounted.) The following screen is displayed.

```
System serial # is presently
```

```
Enter system serial # or <CR> to accept
```

```
Mount ABS tape and enter number of files to skip, if any
```

```
XX-XXX
```

```
XXXX-XXX
```

```
XXXX-XXX
```

```
XXXX-XXX
```

```
XXXX-XXXX
```

```
Spooler started
```

```
Mount DATA tape and press RETURN
```

6. Unload the SYS-GEN tape (or disk pack). See instructions in Section 4.

Restoring Data

7. Mount the first reel (or pack) of the File-Save tape (or disk) and bring it to load point. See instructions in Section 4.

NOTE: If you specified new reallocation modulo and separation values via the UPDATE-ACCOUNT or UPDATE-FILE commands, those values will take affect when the File-Restore is complete. If you want to ignore the new reallocation modulo and separation for this File-Restore, type I and press RETURN after the File-Save tape or disk is on-line. If you want any new reallocation values to take affect, then just press RETURN when the File-Save tape or disk is on-line.

Press RETURN

once the File-Save tape or disk is on-line.

The following screen is displayed.

```
-----  
Mount ABS tape and enter number of files to  
skip, if any
```

```
XX-XXX  
XXXX-XXX  
XXXX-XXX  
XXXX-XXX  
XXXX-XXXX
```

```
Spooler started
```

```
Mount DATA tape and press RETURN  
L 2000# time date DATA SYS-GEN  
Seq# of this data tape: 0 0 0 0  
Is this the right tape (Y/N)?
```

Check the tape (or disk) label displayed to verify that this is your most recent File-Save tape (or disk).

NOTE: If you are not sure how to check the tape label, refer to the topic System Sequencing Information

Restoring Data

under the heading "Update Save Procedures" in the System Management and Support Guide.

Enter **Y** and press RETURN.

The File-Restore will begin. Each filename on the tape will be listed on your screen. If this is a multiple reel File-Save, you will be prompted to mount the next reel. After you mount the tape, enter **C** to Continue at the "(C)ontinue/(Q)uit?" prompt. When all the files on all the reels have been restored, the following screen is displayed.

```
-----  
Update/transaction tapes (Y/N)?
```

Enter **N** and press RETURN.

The following screen is displayed.

```
-----  
Update/transaction tapes (Y/N)? N  
Saving Monitor  
Linking workspace for line 0  
  
date time Logon Please:  
  
<<< Welcome to the Ultimate Computer System >>>  
<<< Copyright date The Ultimate Corp. >>>  
<<< time Release XX Rev XX date >>>  
  
This is the Cold-Start Procedure  
Enter <CR> to continue
```

Press RETURN.

The following screen is displayed.

Restoring Data

date time Logon Please:

```
<<< Welcome to the Ultimate Computer System >>>
<<< Copyright date The Ultimate Corp. >>>
<<< time Release XX Rev XX date >>>
```

This is the Cold-Start Procedure
Enter <CR> to continue

Linking secondary TCL workspaces

X additional task workspaces initialized

time date

Time =

Enter the time in military format (HH:MM:SS).

For example, enter 5PM as 17:00:00. The following screen is displayed.

This is the Cold-Start Procedure
Enter <CR> to continue

Linking secondary TCL workspaces

X additional task workspaces initialized

time date

Time = 17:00:00
17:00:00 date
Date =

Restoring Data

Enter the date in the following format: MM/DD/YY.

For example, enter February 3, 1986 as 02/03/86. The following screen is displayed.

```
-----  
This is the Cold-Start Procedure  
Enter <CR> to continue  
  
Linking secondary TCL workspaces  
  
X additional task workspaces initialized  
  
time          date  
  
Time = 17:00:00  
17:00:00      date  
Date = 02/03/86  
17:00:00      03 FEB 1986  
-----
```

The system will display several messages. If there are any error messages (i.e. "Ultimate system software does not verify"), call the Ultimate Support Group immediately.

The following screen will be displayed.

```
-----  
date          time          Logon please:  
-----
```

8. You may now log on.

Restoring Data

SUMMARY OF THE FILE-RESTORE PROCEDURE

1. :WARMSTOP the system.
2. Make sure the system has been booted, and that the SYS-GEN tape (or disk) is mounted.
3. Locate your File-Save tape (or disk).
4. Enter F at the System Startup Options menu.
5. Enter your system serial number.
6. Press RETURN at "Mount ABS tape."
7. At "Mount data tape," unload the SYS-GEN tape (or disk).
8. Mount the first reel (or disk) of the File-Save, and bring it to load point.
9. Press RETURN (or type I and press RETURN to ignore reallocation values).
10. Verify the tape (or disk) label, and enter Y and press RETURN. If you are using a multi-reel File-Save, mount the tapes as prompted, and then enter C at the "(C)ontinue/(Q)uit?" prompt.
11. Enter N and press RETURN at "Update/transaction tapes?"
12. Press RETURN at "This is the Cold-Start Procedure."
13. Enter the time and date in military format.
14. Check error messages.
15. Log onto the system.

Restoring Data

8.2 Account-Restore

An Account-Restore may be done to restore files from a single account, rather than restoring the entire system. An Account-Restore may be done from a File-Save tape, an Update-Save tape, or an Account-Save tape.

You cannot restore an account if it already exists on the system. If the account does exist, you may either delete it before performing the restore, or you may restore it under a different account name.

If restoring the account from a File-Save or Account-Save tape, an Account-Restore may be started from any multiple tape or disk on which the account resides. If restoring from an Update-Save tape, you must begin from File-Save reel #1. Then you may skip to the reel containing the account you want to restore. If you don't know which reel or disk the account is on, refer to the File Statistics report. Locate the account name on the report, and then look in the column labeled R# (reel number) to determine the reel on which the account is located.

8.2.1 Account-Restore From File-Save or Account-Save Tape

To begin the restore, mount the reel containing the account, or mount the first reel of the Account-Save. (The system will prompt you for successive reels until the desired account is found.)

1. Log on to the SYSPROG account, and go to TCL.
2. Load the save tape. See instructions in Section 4.
3. Type:

ACCOUNT-RESTORE accountname and press RETURN.

Enter the account name you wish to restore. If you wish, you can change the name of the account to a different account name. For more information, see your System Commands Guide.

The following screen will be displayed.

Restoring Data

```
>ACCOUNT-RESTORE accountname
```

```
Account name on tape:
```

Enter the name of the account from which you are restoring, and press RETURN.

NOTE: You must enter the exact name under which the account was originally saved.

The following screen will be displayed.

```
>ACCOUNT-RESTORE accountname
```

```
Account name on tape:
```

```
Password(s) (Y/N)?
```

If you want to assign one or more passwords to the account when it is restored, type Y and press RETURN. If you don't want to use passwords, enter N and press RETURN.

If you entered Y, you will be prompted:

```
Password(s) or <CR> (use password(s) from tape)
```

Either type the new password and press RETURN, or just press RETURN to use the password(s) that were stored on the tape along with the account. If you type a new password, it will not be displayed on the screen. You will be prompted to enter the password again:

Re-enter password(s) to confirm:

Type the password again. Multiple passwords must be separated with spaces.

4. The system will begin looking for the specified account, and it will list on the screen each account it finds. When the account you specified is found, the restore will begin, one file at a time. The filenames will appear on the screen as they are loaded. Once the account has been restored, the TCL prompt (>) will be displayed.

5. Unload the save tape and store it in a safe place. See

Restoring Data

instructions in Section 4.

8.2.2 Account-Restore From Update-Save Tape

To restore an account from an Update-Save, you must first restore the account from the latest File-Save. Then you will be prompted to mount the Update-Save.

NOTE: An account cannot be restored from a transaction logger tape.

If you have a multiple reel File-Save, you must start the restore with reel #1. If your account is located on another reel, then once reel #1 has been loaded, you may break into the restore, remove reel #1, and load the reel containing your account. For example, if your File-Save consists of three reels and the account you want to restore is on reel #3, you must start with reel #1. Then, as instructed in Step 5, you may break, remove reel #1, and load reel #3. You may then resume the account restore with reel #3.

WARNING: If, at any point in the Account-Restore from Update-Save procedure, the Update-Save tape label cannot be read, unload the tape and do not try to continue. Otherwise, your account may be deleted!

1. To begin the restore, mount Reel #1 of the File-Save tape that accompanies the Update-Save (each Update-Save must be accompanied by the latest full File-Save).
2. Log on to the SYSPROG account, and go to TCL.
3. Type:

ACCOUNT-RESTORE accountname (U and press RETURN.

Enter the account name you wish to restore. (Do not enter an account name that already exists on the system.) The (U option indicates that you are restoring from an Update-Save. The following screen will be displayed.

```
>ACCOUNT-RESTORE accountname (U
```

```
Account name on tape:
```

Enter the name of the account from which you are restoring,

Restoring Data

and press RETURN.

The following screen will be displayed.

```
-----  
>ACCOUNT-RESTORE accountname (U
```

```
Account name on tape:
```

```
Password(s) (Y/N)?
```

If you want to assign one or more passwords to the account when it is restored, type Y and press RETURN. If you don't want to use passwords, enter N and press RETURN.

If you entered Y, you will be prompted:

```
Password(s) or <CR> (use password(s) from tape)
```

Either type the new password and press RETURN, or just press RETURN to use the password(s) that were stored on the tape along with the account. If you type a new password, it will not be displayed on the screen. You will be prompted to enter the password again:

```
Re-enter password(s) to confirm:
```

Type the password again. Multiple passwords must be separated with spaces.

4. The system will display the sequence number on the File-Save tape, as displayed in the following screen.

```
-----  
L 2000#   time       date       DATA FILE-SAVE  
Seq# of this data tape:  0   0   0   0  
Is this the right tape (Y/N)?
```

Check the tape label displayed to verify that this is your most recent File-Save tape. Then enter Y and press RETURN.

WARNING: If the sequence number of the tape is not displayed, you will be prompted to Continue or Quit. Do not continue! If you continue, your account will be deleted.

Restoring Data

NOTE: If you are not sure how to check the tape label, refer to the topic System Sequencing Information under the heading "Update Save Procedures" in the System Management and Support Guide.

5. The system will begin looking for the specified account, and it will list on the screen each account it finds.

NOTE: At this point, if you have a multiple-reel File-Save and the account is on another reel, you may interrupt the restore to load the reel that contains the account. To do so, press the BREAK key (do not type END). You should see the debugger prompt: an exclamation point (!). Unload reel #1, and load the reel that contains the account. When the reel is on-line and at load point, type G and press RETURN to continue the restore.

When the account you specified is found, the account will be restored from the File-Save tape. Then you will be prompted to load the Update-Save tape. The following screen will be displayed.

Update/transaction tapes (Y/N)?

Remove the File-Save tape. If you are restoring from an ALL-UPDATE-SAVE, mount the latest Update-Save tape. If you are restoring from a PART-UPDATE-SAVE, you will have to load every Update-Save tape since the last full File-Save, in the same sequence in which the tapes were made. Mount the Update-Save tape. Then enter Y and press RETURN. The following screen will be displayed.

Restoring Data

Update/transaction tapes (Y/N)? Y

Account name on tape:

Enter the account name from which you are restoring, and press RETURN.

WARNING: Be sure to type the account name correctly. If you enter the wrong account name, the account will be deleted!

Once you have entered the account name, the following screen will be displayed.

Mount DATA tape and press RETURN

Make sure the update-save tape is on-line and at load point. Then press RETURN. The following screen will be displayed.

Mount DATA tape and press RETURN
L 2000# time date DATA ALL-UPDATE-SAVE
Seq# of this data tape:
Seq# of last data tape:
Is this the right tape (Y/N)?

Check the label displayed to verify that this is the correct Update-Save tape. Then enter Y and press RETURN.

WARNING: If an incorrect sequence number of the tape is displayed, enter Q to Quit at the "Continue/(Q)uit?" prompt. If you continue, your account will be deleted.

Restoring Data

NOTE: If you are not sure how to check the tape label, refer to the topic System Sequencing Information under the heading "Update Save Procedures" in the System Management and Support Guide.

Once the tape has been loaded, you will again be prompted to mount the next reel. When ready, enter C at the "(C)ontinue/(Q)uit?" prompt. Repeat this step until all of the Update-Save tapes have been loaded. When all Update-Save tapes have been loaded, enter N and press RETURN at the "Update/transaction tapes (Y/N)?" prompt.

6. The TCL prompt will be displayed. Unload the update-save tape and store it in a safe place. See the instructions in Section 4.

SUMMARY OF ACCOUNT-RESTORE FROM FILE-SAVE OR ACCOUNT-SAVE

1. Log to SYSPROG, and go to TCL.
2. Load the save tape.
3. Type ACCOUNT-RESTORE accountname and press RETURN.
4. Enter the account name from which you are restoring.
5. At "Passwords?", enter Y to restore the account with a password, or enter N for no password.
6. When the restore is complete, unload the tape, and store it in a safe place.

Restoring Data

SUMMARY OF ACCOUNT-RESTORE FROM UPDATE-SAVE

1. Log to SYSPROG, and go to TCL.
2. Load reel #1 of the File-Save tape.
3. Type ACCOUNT-RESTORE accountname (U and press RETURN.
4. Enter the account name from which you are restoring.
5. At "Passwords?", enter Y to restore the account with a password, or enter N for no password.
6. At "Is this the right tape?" verify the tape label and enter Y.
7. If restoring from a multi-reel File-Save and the account is on another reel, press the BREAK key after the list of account names begins. Remove reel #1, and load the reel that contains the account. Then enter G and press RETURN to resume.
8. When the account has been restored from the File-Save, mount the Update-Save, and enter Y at "Update/transaction tapes?"
9. Enter the account name from which you are restoring, and press RETURN.
10. At "Mount DATA tape," make sure the update-save tape is on-line and press RETURN.
11. At "Is this the right tape?" verify the tape label and enter Y.
12. If you have a multi-reel Update-Save, you will be prompted to mount the next reel. Then enter C at the "(C)ontinue/(Q)uit?" prompt. When there are no more reels, enter N and press RETURN at the "Update/transaction tapes (Y/N)?" prompt.
13. When the restore is complete and the TCL prompt is displayed, unload the tape, and store it in a safe place.

Restoring Data

8.3 Binary-Restore

NOTE: This is not available on the 1400 Series systems.

A Binary-Restore may only be done from a Binary-Save tape or disk. A Binary-Restore will restore all data "as is" onto your disk. All frames, whether data frames or overflow frames, are restored.

CAUTION: A Binary-Restore may only be attempted on a system with the same hardware configuration (same number of ports, and the same type and size of disk) as the system on which the Binary-Save was done.

1. Make sure all users are logged off the system. To do so, go to the TCL prompt, and type:

`LISTUSERS` and press RETURN.

The console should be the only terminal logged on. If other users are logged on, make sure they log off before you continue.

2. After all users have logged off, go to port 0 (the console terminal). Type:

`LOGTO SYSPROG` and press RETURN.

Then press RETURN again to go to TCL. Type:

`VERIFY-SYSTEM` and press RETURN.

If there are any mismatches, make a note of this. You will need to know if there were any mismatches later.

3. Type:

`:WARMSTOP` and press RETURN.

A message similar to the following will be displayed.

Restoring Data

```
Memory Flushed!  
Remote Panel  
B @ 00B64 TSA @ 00820  
A =
```

This message means that the system has halted all processing, flushed memory, and has entered the "Remote Panel" state.

4. Mount a SYS-GEN tape or disk and boot your system. See instructions for mounting the tape or disk in Section 4, and see instructions for booting your system in Section 5).

The system startup options menu will be displayed, as shown below.

```
This is the Ultimate Operating System
```

```
System Startup Options:
```

```
(B)oot  
(C)oldstart  
(D)iagnostics Monitor  
(F)ile Restore  
(U)tilities Monitor  
(W)armstart
```

```
Enter Option(s) or ? for help:
```

Enter U

The following screen is displayed.

Restoring Data

(W)armstart Util from disc or (C)oldstart from tape:

Enter C

The system will load a good ABS from SYSGEN before the restore begins. Once the Util is loaded, the following screen will be displayed.

THIS IS THE ULTIMATE UTILITY SYSTEM YYYY/MM/DD

YYYY\MM\DD is the revision date of Util. Note: When Util is running, line 0 (the console) will be the only active terminal line.

5. Remove the SYSGEN tape or disk, and load the Binary-Save tape or disk from which you wish to restore. See instructions in Section 4.
6. At TCL, type:

RESTORE and press RETURN.

The Binary-Restore will now begin. Unlike the File-Restore, the names of the files being restored will not be displayed on the screen.

If the restore requires more than one tape or disk, you will be prompted to mount the next reel or pack.

7. When the Binary-Restore is completed, the TCL prompt will appear on your screen. Type:

T-UNLOAD and press RETURN

to rewind and unload the tape. When the tape stops moving, release the top tape hub's latch, and remove the tape reel. Store the tape in a safe place. (For more information on storing backup tapes, see Section 7.1.)

Restoring Data

8. You should be at the TCL prompt. Type:

BOOT and press RETURN.

The system will initialize, and the system startup options menu will appear.

9. Enter W

to select Warmstart. The system will warmstart and then resume normal operation.

10. If there were mismatches in Step 2 above, type:

VERIFY-SYSTEM and press RETURN.

If there are still mismatches, call the Ultimate Support Group.

Restoring Data

SUMMARY OF BINARY-RESTORE PROCEDURE

1. Make sure all users have logged off.
2. Log to SYSPROG and type VERIFY-SYSTEM and press RETURN. Note if there are any mismatches.
3. Type :WARMSTOP and press RETURN.
4. Mount the SYSGEN tape and boot your system.
5. Enter U at the System Startup Options Menu. At "(W)armstart Util from disc or (C)oldstart from tape," enter C.
6. Remove the SYSGEN tape, and load the Binary-Save tape from which you will restore.
7. At TCL, type RESTORE and press RETURN.
8. When the restore is completed, type T-UNLOAD. Then remove the tape.
9. At TCL, type BOOT and press RETURN.
10. At the System Startup Options menu, enter W for Warmstart.
11. If there were any mismatches in Step 2, type VERIFY-SYSTEM. If there are still mismatches, call the Ultimate Support Group.

Restoring Data

8.4 T-LOAD

The T-LOAD verb may be used to restore files that have been T-DUMPed.

1. Load the tape from which you want to load your file(s). See instructions in Section 4.
2. Use the T-LOAD verb to load your file(s): T-LOAD is a RECALL verb, and its general form is as follows:

```
T-LOAD {DICT} filename {item-list} {selection-criteria}
      {HEADER "name"} {(options)}
```

The filename may be preceded by the DICT modifier to load dictionary data. File definition items (such as D/CODE=D) will not be loaded.

The filename is the name of the source file to be loaded, or copied, onto the disk.

As explained in the Recall manual, the item-list and selection criteria select a sub-set of the items in the specified file which are to be written to disk. If the item-list and selection-criteria are omitted, then all items in the file will be written to disk.

The HEADER allows a "name" to be included in the label at the start of the file.

Options:

- (I) Inhibits listing to the terminal of items loaded.
- (O) Enables overwrite of items in the file with item-ids corresponding to the item-ids of items in the disk file.

As in other Recall statements, each item-id must be enclosed in double quotes (").

3. Unload the tape or disk. See instructions in Section 4.

Restoring Data

SUMMARY OF T-LOAD PROCEDURE

1. Load the tape from which you will load your files.
2. Type T-LOAD {DICT} filename {item-list}
 {selection-criteria} {HEADER "name"}
 {(options)}
3. Unload the tape or disk, and store it in a safe place.

Restoring Data

8.5 Selective-Restore

The Selective-Restore allows you to restore data into individual files or items from a File-Save or Account-Save tape or disk.

NOTE: Selective-Restores may be started from any tape of a multi-reel File-Save, ALL-UPDATE-SAVE, OR PART-UPDATE-SAVE. To save time in searching the tape, check the File-Stats listing to determine on which reel the file's data starts. Then mount that reel. A Selective-Restore may be started at any place on any reel of the File-Save tape.

1. Log on to the account that contains the file to be restored.
2. Load the save tape or disk. See instructions in Section 4.
3. Type:

```
SEL-RESTORE {DICT} filename {item-list} {(options)}
```

and press RETURN.

The filename may be preceded by the DICT modifier to restore dictionary data. File definition items (such as D/CODE=D) will not be restored.

The filename is the name of the file in which the restored items will be placed. This filename must exist on the account from which the restore is run.

The item-list selects a sub-set of the items within the specified file which are to be restored. You may enter an asterisk (*), instead of an item-list, to specify that all items within the file be restored.

The following screen will be displayed.

```
-----  
| Account name on tape? |  
-----
```

Enter the name of the account under which the file was saved on tape.

The following screen is displayed.

Restoring Data

Account name on tape?

File name?

Enter the name of the file as it appears on the tape, or press RETURN to indicate that the account Master Dictionary (MD) should be restored. The filename may be of the form filename, DICT filename, or filename,dataname.

As the tape is searched, the filenames on it are printed, along with the file numbers.

Options

- (A) Indicates that the tape is already positioned at the desired account. The prompt "Account name on tape" will not appear. This option may not be used if you specify that the account MD is to be restored.
- (B) Used to selectively restore BASIC object code files, and save-lists in a pointer file.
- (C) This option has effect when the N option is used. It causes every item before the next end-of-file to be a candidate for restore. This ensures that data can be restored even if a D-pointer is damaged on the tape.
- (I) The item-ids of the restored items will not be printed.
- (N) The file is to be identified on tape by its file number, instead of filename. The file number may be obtained from a listing of the STAT-FILE when the tape was created. If this option is used, the prompt "File name" will be replaced with the prompt "File #."
- (O) Overlay items already on the file.
- (S) Skips forward spacing of the tape. This option is used when at the beginning of the second or later reels of a File-Save tape.

4. Unload the tape or disk. See instructions in Section 4.

Restoring Data

SUMMARY OF SELECTIVE-RESTORE PROCEDURE

1. Log on to the account that contains the file to be restored.
2. Load the save tape or disk.
3. Type SEL-RESTORE {DICT} filename {item-list} {(options)} and press RETURN.
4. Enter the account name on tape.
5. Enter the filename (or file number, if using the N option), on tape. The Selective-Restore will begin.
6. When the restore is complete, unload the tape or disk.

Restoring Data

8.6 Restore From Update-Saves and Transaction Logger

Use this procedure to restore your data from ALL-UPDATE-SAVES, PART-UPDATE-SAVES, and transaction loggings. You will start by restoring your data from the File-Save. Then you will be prompted to mount the Update-Save or transaction tapes.

NOTE: For instructions on restoring an account (via the ACCOUNT-RESTORE command) from an Update-Save tape, see Section 8.2.2.

1. Make sure all users are logged off the system. To do so, go to the TCL prompt, and type:

LISTUSERS and press RETURN.

The console (line 0) should be the only terminal logged on. If other users are logged on, make sure they log off before you continue.

2. After all users have logged off, go to port 0 (the console terminal). Type:

LOGTO SYSPROG and press RETURN.

Then press RETURN again to go to TCL. Type:

:WARMSTOP and press RETURN.

A message similar to the following will be displayed. The Remote Panel information is not displayed on the 1400 Series systems.

```
-----  
Memory Flushed!  
Remote Panel  
B @ 00B64 TSA @ 00820  
A =  
-----
```

This message means that the system has halted all processing, flushed memory, and has entered the "Remote Panel" state.

3. Use the instructions in Section 5 to boot your system. Be sure your SYS-GEN tape is mounted.
4. Locate the latest full File-Save tape, and the update-save

Restoring Data

and/or transaction logger tapes with which you will be restoring the system.

5. At the System Startup Options menu, enter F.

This initiates a complete File-Restore.

Information about your disc configuration will be displayed. A sample screen is shown below. The memory and communications lines are not displayed on the 1400 Series systems.

```
-----  
Disc Configuration  
  
chan    set name      #  of  
0400    123 TEST        1  1  
L 2000# time  date    ABS ULT REL XX  
  
Memory = 512KB  
00016 Comm. Lines  
Tape 0 attached Block size: 4000  
-----
```

In the next screen, you will be asked for your system serial number.

Restoring Data

```
Memory = 512KB  
00016 Comm. Lines  
Tape 0 attached Block size: 4000
```

```
System serial # is presently
```

```
Enter system serial # or <CR> to accept
```

Enter your System Serial Number

(i.e., the "TN," "NE," or "NB" number of the system). For example, enter TN1234. If the present serial number is shown, and is correct, press RETURN to accept it.

The screen shown below is displayed.

```
Memory = 512KB  
00016 Comm. Lines  
Tape 0 attached Block size: 4000
```

```
System serial # is presently TN1234
```

```
Enter system serial # or <CR> to accept
```

Press RETURN if the number is correct.

You may re-enter the correct number if you made a mistake. Press RETURN after you enter the correct number.

The following screen is displayed.

Restoring Data

```
Memory = 512KB
00016 Comm. Lines
Tape 0 attached Block size: 4000
```

```
System serial # is presently
```

```
Enter system serial # or <CR> to accept
```

```
Mount ABS tape and enter number of files to
skip, if any
```

Press RETURN.

(Your SYSGEN tape should already be mounted.) The following screen is displayed.

```
System serial # is presently
```

```
Enter system serial # or <CR> to accept
```

```
Mount ABS tape and enter number of files to
skip, if any
```

```
XX-XXX
XXXX-XXX
XXXX-XXX
XXXX-XXX
XXXX-XXXX
```

```
Spooler started
```

```
Mount DATA tape and press RETURN
```

6. Unload the SYSGEN tape. See instructions in Section 4.

7. Mount the first reel of the latest File-Save tape and bring

Restoring Data

it to load point. See instructions in Section 4.

Press RETURN.

The following screen is displayed.

```
Mount ABS tape and enter number of files to
skip, if any
```

```
XX-XXX
XXXX-XXX
XXXX-XXX
XXXX-XXX
XXXX-XXXX
```

```
Spooler started
```

```
Mount DATA tape and press RETURN
```

```
L 2000# time date DATA File-Save
Seq# of this data tape: 0 0 0 0
Is this the right tape (Y/N)?
```

Check the tape label displayed to verify that this is your most recent File-Save tape.

NOTE: If you are not sure how to check the tape label, refer to the topic System Sequencing Information under the heading "Update Save Procedures" in the System Management and Support Guide.

Enter Y and press RETURN.

The File-Restore will begin. Each filename on the tape will be listed on your screen. If this is a multi-reel File-Save, you will be prompted to mount the next reel. After you have loaded the tape, enter C to Continue at the "(C)ontinue/(Q)uit?" prompt. When all files on all the tapes have been restored, the following screen is displayed.

Restoring Data

```
-----  
| Update/transaction tapes (Y/N)? |  
-----
```

If you are restoring from an ALL-UPDATE-SAVE, mount the latest Update-Save tape. Then enter Y and press RETURN. The following screen will be displayed.

```
-----  
| Mount DATA tape and press RETURN |  
| L 2000# time date DATA All-Update-Save |  
| Seq# of this data tape: |  
| Seq# of last data tape: |  
| Is this the right tape (Y/N)? |  
-----
```

Check the label displayed to verify that this is the correct tape. Then enter Y and press RETURN.

If this is a multi-reel Update-Save, the following screen will be displayed.

```
-----  
| Mount reel #2 |  
| (C)ontinue/(Q)uit? |  
-----
```

Mount the next reel. When ready, enter C. Continue mounting the reels as prompted. When all of the Update-Save reels have been loaded, enter N and press RETURN at the "Update/transaction tapes (Y/N)?" prompt.

If you are restoring from a PART-UPDATE-SAVE, you will have to load every Update-Save tape since the last full File-Save, in the same sequence in which the tapes were made. Mount the first Update-Save tape made after the last full File-Save. Then enter Y and press RETURN. The following screen will be displayed.

Restoring Data

```
Mount DATA tape and press RETURN
L 2000# time date DATA Part-Update-Save
Seq# of this data tape:
Seq# of last data tape:
Is this the right tape (Y/N)?
```

Check the label displayed to verify that this is the correct tape. Then enter Y and press RETURN.

If this is a multi-reel Update-Save, the following screen will be displayed.

```
Mount reel #2
(C)ontinue/(Q)uit?
```

Mount the next reel. When ready, enter C. Continue mounting the reels as prompted. When all of the Update-Save reels have been loaded, enter N and press RETURN at the "Update/transaction tapes (Y/N)?" prompt.

If you are restoring from a transaction tape, you will have to load every transaction tape since the last full File-Save, ALL-UPDATE-SAVE, or PART-UPDATE-SAVE in the same sequence in which the tapes were made. Mount REEL #1 of the first transaction session tape set made after the last full File-Save or Update-Save. Then enter Y and press RETURN. The following screen will be displayed.

```
Mount DATA tape and press RETURN
L 2000# time date DATA Transaction
Seq# of this data tape:
continued from tape:
Seq# of last data tape:
Is this the right tape (Y/N)?
```

Restoring Data

Check the label displayed to verify that this is the correct tape. Then enter Y and press RETURN.

After the end of REEL #1 is reached, the system will automatically unload the tape.

The following screen will be displayed.

```
-----  
Mount reel #2  
(C)ontinue/(Q)uit?  
-----
```

Mount the next reel in the same transaction session set. Then enter C to continue. After all reels of the transaction session set have been loaded, you will be prompted with "Update/transaction tapes (Y/N)?" If there is another transaction tape set, mount reel #1 of that set. Then enter Y and press RETURN. You will be prompted to mount the next reel. Then enter C to Continue at the "(C)ontinue/(Q)uit?" prompt. When all of the transaction reels have been loaded, enter N and press RETURN at the "Update/transaction tapes (Y/N)?" prompt.

NOTE: If you are restoring from both Update-Saves and transaction tapes, follow the procedures for restoring the ALL-UPDATE-SAVE or PART-UPDATE-SAVE tapes. Once the Update-Saves have been loaded, begin loading the transaction tapes.

Once all update/transaction tapes have been loaded, the following screen will be displayed.

Restoring Data

```
Update/transaction tapes (Y/N)? N
Saving Monitor
Linking workspace for line 0

      date      time      Logon Please:

<<< Welcome to the Ultimate Computer System >>>
<<< Copyright      date      The Ultimate Corp. >>>
<<<      time      Release XX Rev XX      date      >>>

This is the Cold-Start Procedure
Enter <CR> to continue
```

Press RETURN.

The following screen is displayed.

```
      date      time      Logon Please:

<<< Welcome to the Ultimate Computer System >>>
<<< Copyright      date      The Ultimate Corp. >>>
<<<      time      Release XX Rev XX      date      >>>

This is the Cold-Start Procedure
Enter <CR> to continue

Linking secondary TCL workspaces
X additional task workspaces initialized

      time      date

Time =
```

Restoring Data

Enter the time in military format (HH:MM:SS).

For example, enter 5PM as 17:00:00. The following screen is displayed.

```
This is the Cold-Start Procedure
Enter <CR> to continue

Linking secondary TCL workspaces

X additional task workspaces initialized

time          date

Time = 17:00:00
17:00:00      date
Date =
```

Enter the date in the following format: MM/DD/YY.

For example, enter February 3, 1986 as 02/03/86. The following screen is displayed.

```
This is the Cold-Start Procedure
Enter <CR> to continue

Linking secondary TCL workspaces

X additional task workspaces initialized

time          date

Time = 17:00:00
17:00:00      date
Date = 02/03/86
17:00:00      03 FEB 1986
```

Restoring Data

The system will display several messages. If there are any error messages (i.e. "Ultimate system software does not verify"), call the Ultimate Support Group immediately.

The following screen will be displayed.

```
-----  
|                                     |  
|   date       time       Logon please:   |  
|                                     |  
|-----|
```

8. You may now log on.

Restoring Data

SUMMARY OF THE FILE-RESTORE WITH UPDATE/TRANSACTION TAPES

1. At TCL on the SYSPROG account, enter :WARMSTOP to warmstop your system.
2. Boot your system and make sure that the SYSGEN tape is mounted.
3. Locate your File-Save tape.
4. Enter F at the System Startup Options menu.
5. Enter your system serial number.
6. Press RETURN at "Mount ABS tape."
7. At "Mount data tape," unload the SYSGEN tape.
8. Mount the first reel of the File-Save, and bring it to load point.
9. Press RETURN.
10. Verify the tape or disk label, and enter Y and press RETURN.
11. At "Update/transaction tapes?" mount the first reel of the update or transaction tapes. Then enter Y and press RETURN. If you are using a multi-reel set, you will be prompted to mount the next reel. Then enter C at the "(C)ontinue/(Q)uit?" prompt. When all of the reels have been loaded, enter N and press RETURN at "Update/transaction tapes (Y/N)?".
12. Press RETURN at "This is the Cold-Start Procedure."
13. Enter the time and date in military format.
14. Check error messages.
15. Log onto the system.

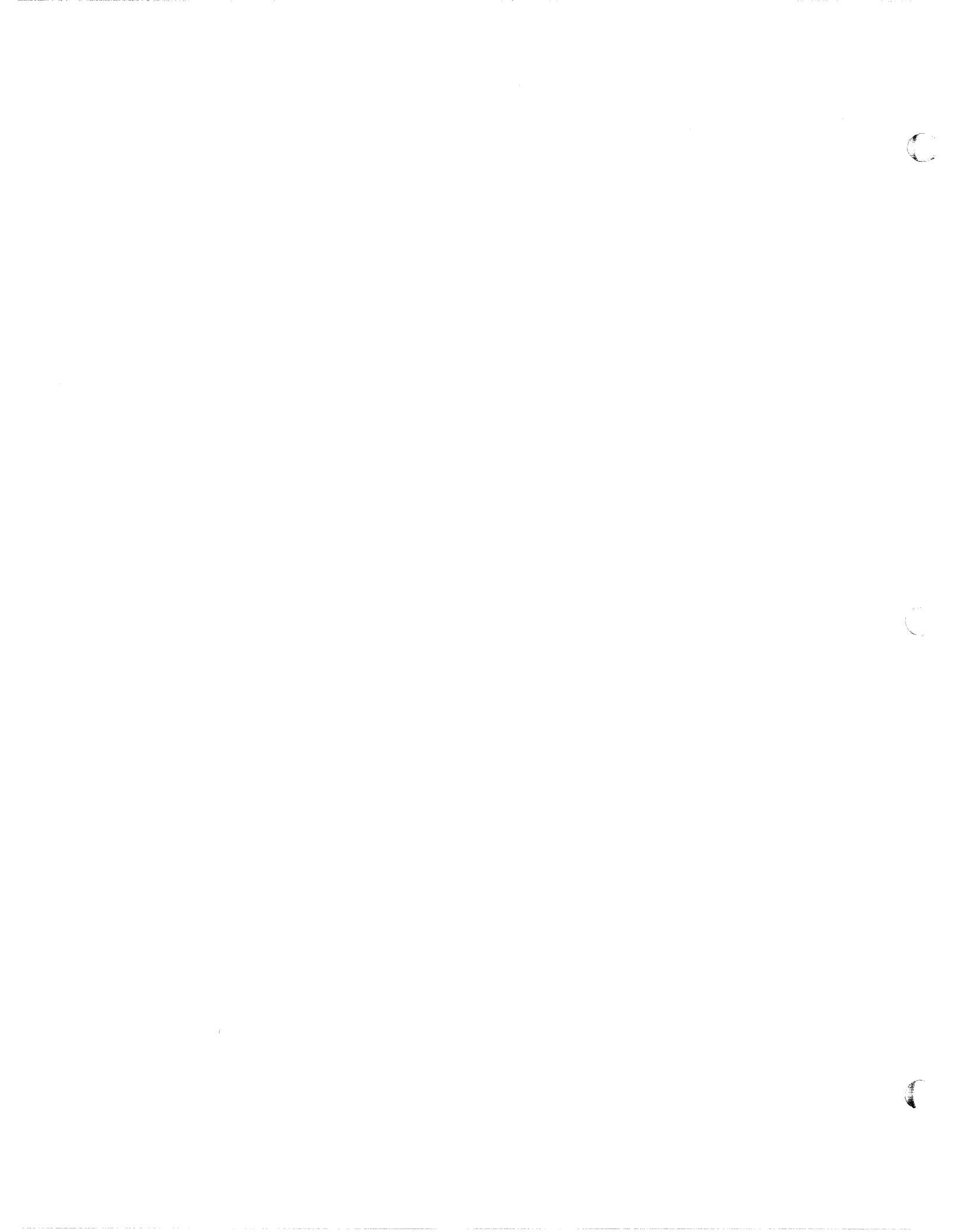

Maintenance

9 MAINTENANCE

The steps in this section should be performed routinely to ensure that your Ultimate system runs smoothly and efficiently. Ultimate strongly advises that you follow all daily, weekly, monthly, and semi-monthly procedures.

9.1 Daily

9.1.1 Back Up Your Data

Ultimate strongly recommends that you back up your data at the end of each work day. Failure to do so could result in considerable data loss if a system failure occurs. Such a failure (without a backup) would require the re-entry of all data, which may be difficult to retrace.

Note that full File-Saves should be done at least once each week.

For more information on backup methods, see Section 7.

9.1.2 Check File Statistics Report

Each time you perform a File-Save, you should also generate a file statistics report. This report may also be generated at any time by typing LIST-FILE-STATS and pressing RETURN at TCL.

The file stats report lists one item for each D-pointer saved on the File-Save tape. The report also adds security data by providing a list of file Base, Modulo, and Separation parameters, and by recording the order of the files on a File-Save tape. The information on the file stats report is only updated when a File-Save is performed. If you want a current file stat report, you will have to do it immediately after a File-Save.

The report is broken down by account, with a line of information generated for each file in the account, that includes:

1. total and average item size
2. total and average number of items per group
3. use of file space
4. actual data stored, and "pad" space used in the file

A total line is generated for each account, showing the total:

1. items
2. bytes (characters)
3. frames (includes linked)
4. Group Format Errors (GFEs)



Maintenance

The file stats report is cleared after every File-Restore, because the data is no longer applicable. The report is regenerated with every File-Save.

Check the file stats report at the end of every File-Save. Pay particular attention to the total line for each account, which shows the total number of Group Format Errors (GFEs).

IMPORTANT: If any GFEs are indicated on the file stats report, they must be corrected immediately! Refer to Section 11.3 of this manual, and call the Ultimate Support Group. Do not do any further processing until the GFEs have been corrected.

9.1.3 Verify-System

The verify-system procedure ensures that the system software is correct.

The verify-system generates a checksum for every frame of software, from 1 to 399 and from 600 to 1023. These check-sums are compared with those in the ERRMSG file, in an item named "CHECK-SUM." This item contains the correct check-sum for all the system software frames. Each line in the item contains a check-sum for one frame of code, optionally followed by one or more hexadecimal limits. If the limits are present, the check-sum is generated only for bytes within the limits. If no limits are present, the check-sum is generated for bytes 0--X'1FF.' This is done because some frames contain tables that change from time to time, such as the system overflow table. Table entries are not check-summed, only assembly code is check-summed.

1. Log to the SYSPROG account, and go to TCL.

2. Type:

VERIFY-SYSTEM and press RETURN.

If all the program frames verify, the following message is displayed:

[341] Ultimate System Software Verified

If a frame generates a check-sum that does not match the check-sum for that frame in the "CHECK-SUM" item, then the FID of the frame, the generated check-sum, and the stored check-sum from the item are printed, and the following message is displayed:

[342] Ultimate system software does not verify!

Maintenance

If this message is displayed, your system has mismatches. See Section 11.8 for causes and possible solutions for mismatches.

9.1.4 List-System-Errors

The List-System-Errors procedure lists disk errors.

1. Log on to the SYSPROG account, and go to TCL.
2. Type:

`LIST-SYSTEM-ERRORS` and press RETURN.

The following screen is displayed.

```
>LIST-SYSTEM-ERRORS
To the Printer (Y=<CR>/N)?
```

Enter Y and press RETURN (or press RETURN only)

for a printout of the errors, or enter N and press RETURN to display the errors on the terminal.

The following screen is displayed.

```
>LIST-SYSTEM-ERRORS
To the Printer (Y=<CR>/N)?
System Error listing explanation (Y/N=<CR>)?
```

Enter N and press RETURN (or press RETURN only)

if you don't want a printout explaining all possible system errors, or enter Y and press RETURN to print the document.

If you have never printed this document before, Ultimate suggests you enter Y to print it now. If you already have a copy of this document, you may enter N to bypass it.

Maintenance

The following screen is displayed.

```
>LIST-SYSTEM-ERRORS
To the Printer (Y=<CR>/N)?
System Error listing explanation (Y/N=<CR>)?
Would you like the list sorted (Y/N)?
```

Enter Y and press RETURN

to sort the list by date and time, or enter N and press RETURN if you don't want the list sorted.

The system errors will be listed. If there are no errors, the following message will be displayed:

```
[401] No items present.
```

If errors are listed, refer to the System Error Listing Explanation. Recurring errors should be reported to the Ultimate Support Group.

9.1.5 Check Print Overflow Table

The POVF verb is used to check the system overflow table, which displays the amount of disk space available on the system.

1. From TCL, type:

POVF and press RETURN.

You may also specify the (P) option to print the overflow table on the printer.

The overflow table will be displayed. The following is an example of an overflow table.

Maintenance

```
>POVF
```

```
          3936 ( 823)
5549- 5551 :          3 6746- 6746 :          1
6748- 7160 :          431 7254- 7258 :          2
23054- 23289 :          236 26000- 148159 : 122159
```

```
Total number of contiguous frames : 123655
```

```
>
```

The first line of output is the FID of the first frame in linked overflow, followed by the number of frames in the linked chain. The next lines describe blocks of contiguous overflow, and have the following format:

m - n : p m - n : p

m = the first frame of a contiguous block

n = the last frame of the block

p = the number of frames in the block

The total number of frames contained in all the contiguous overflow is then displayed:

Total number of contiguous frames :

If you have an SMD Disk Drive, this number should be greater than 50,000 frames. If it is not, call the Ultimate Support Group.

If you have a CMD Disk Drive, this number should be greater than 16,000 frames. If it is not, call the Ultimate Support Group.

If you have a 1400 WREN II Disk Drive, this number should be greater than 19,000 frames. If it is not, call the Ultimate Support Group.

If you have a 1400 WREN III Disk Drive, this number should be greater than 38,000 frames. If it is not, call the Ultimate Support Group.

1.1.1 Clean Tape Heads (For GCR Tape Drives Only)

If you have a GCR tape drive (6250 bpi), you should clean the

Maintenance

tape heads every day.

Refer to Section 4 for instructions.

Maintenance

9.2 Weekly

9.2.1 File-Save

If your daily back-up method is one other than the File-Save, then you should perform a full File-Save at least once each week. Note that if your daily method is the Update-Save, each Update-Save tape should be associated with a full File-Save tape.

Refer to Section 7.2 for instructions.

9.2.2 Clean Tape Heads

If your system is equipped with a tape drive, you should clean the tape heads once a week. (Note that GCR tape drives should be cleaned daily.)

Follow the procedures in Section 4 to clean the tape drive.

Maintenance

9.3 Monthly

9.3.1 File-Restore

You should perform a full File-Restore approximately once every 4 to 6 weeks, or as needed, to repair any fragmented disk space. See Section 8.1 for instructions and more information.

9.3.2 Clear ACC File

You should check and clear, if necessary, the accounting history items in the accounting history file for specific users to avoid overflowing them.

The point of overflow is determined by the amount of activity of each user (approximately 1000 logon/logoffs are allowed). If you do not clear the ACC file before it overflows, you may experience abort errors when attempting to log on.

1. From TCL, type:

LOGTO SYSPROG and press RETURN.

Then press RETURN again to go to TCL.

2. Type:

SORT ACC WITH NAME LPTR and press RETURN.

This will produce a list of users that are logged on.

3. Type:

SELECT ACC WITH NO NAME and press RETURN.

This selects updated items only.

WARNING: If you accidentally pressed an extra RETURN, do not continue to step 4. If you do, all your accounting records will be deleted. Instead, you should repeat step 3 before you go to step 4.

4. Type:

DELETE ACC and press RETURN.

The ACC file will be cleared. Refer to the System Support Manual for more information on the ACC file.

Maintenance

9.4 Semi-Monthly

9.4.1 Format Disk Drives

You should format your disk drives approximately every 90 days or as needed. Follow the procedures in Section 6.3.

SUMMARY OF MAINTENANCE ITEMS

Daily

1. Back up your data.
2. Create and check the File Stats Report for GFES. If GFES appear, correct them or call Ultimate immediately.
3. From SYSPROG, run a VERIFY-SYSTEM. If the system does not verify, see Section 11.8.
4. From SYSPROG, run a LIST-SYSTEM-ERRORS. If errors are present, check the System Error Listing Explanation, or call Ultimate.
5. Check the Print Overflow Table (POVF).
6. If you have a GCR tape drive, clean the tape heads.

Weekly

1. If you have a tape drive system (other than a GCR), clean the tape heads and vacuum chambers.
2. If your daily backup method is one other than a File-Save, then perform a full File-Save.

Monthly

1. Perform a full File-Restore.
2. Clear the ACC file.

Semi-Monthly

1. Format your disk drives.

Adding Equipment

10 ADDING EQUIPMENT

10.1 Adding Ports

Whenever you add ports to your system, you must perform a full File-Restore so that the system will recognize the ports. Perform the File-Restore from the latest File-Save. If you do not have the latest File-Save, you must do a File-Save first.

Refer to Section 7.2 for instructions on performing a File-Save, and Section 8.1 for instructions on performing a full File-Restore.

NOTE: If you are adding CRTs, refer to Appendix C for configurations of CRTs supported by Ultimate. If you are adding printers, refer to Appendix D for configurations of printers supported by Ultimate. If adding parallel printers, see Section 10.3.

10.2 Adding Disk Drives

Whenever you add disk drives to your system, you must perform a full File-Restore so that the system will recognize the drives. Perform the File-Restore from the latest File-Save. If you do not have the latest File-Save, you must do a File-Save first.

Refer to Section 7.2 for instructions on performing a File-Save, and Section 8.1 for instructions on performing a full File-Restore.

10.3 Adding Tape Drives and Parallel Printers

Whenever you add tape drives or parallel (not serial) printers to your system, you must perform a Coldstart so that the system will recognize them.

Refer to Section 6.2 for instructions on performing a Coldstart.

10.4 Adding Communications Boards

Whenever you add communications boards to your system, you must perform a full File-Restore so that the system will recognize them. Perform the File-Restore from the latest File-Save. If you do not have the latest File-Save, you must do a File-Save first.

Refer to Section 7.2 for instructions on performing a File-Save, and Section 8.1 for instructions on performing a full File-Restore.

Adding Equipment

SUMMARY OF PROCEDURES WHEN ADDING EQUIPMENT

Adding Ports, Disk Drives, Communications Boards

1. Perform a File-Save.
2. Perform a full File-Restore.

Adding Tape Drives and Parallel Printers

1. Perform a Coldstart.

Troubleshooting

11 TROUBLESHOOTING

11.1 General Procedures

These procedures apply to all types of problems:

1. Whenever you encounter any type of error or problem, always write down all messages and prompts that appear on your screen and on line 0 (the console). Troubleshooting will be very difficult without this information.
2. Whenever possible, leave your system in its failed state until the service organization responds to your call. Otherwise, valuable diagnostic information may be lost.
3. Whenever you encounter an error or problem, do not try to continue processing until the problem has been corrected. In many cases, processing under error conditions may create more errors.
4. Keep a log of all problems on your system so that recurring problems may be tracked. Make copies of the log sheet at the end of this section, and use them to track the history of your system.
5. If you have a problem or question about your hardware or operating system that you can't solve, call the Ultimate Support Group for assistance.
6. If you have a problem with your application software, call your application software dealer.
7. Before calling the Ultimate Support Group, be prepared to answer the following questions:
 - a. What is your system number (the TN, NB, NE, or BV number)?
 - b. What is the nature of your problem?
 - c. What software release are you on?
 - d. When did you notice the problem? Has this been a recurring problem?
 - e. Have you recently made any hardware replacements or upgrades?
 - f. Are you upgrading to a new release?
 - g. Is this a new installation?
8. Before turning your system over to a customer engineer for Operations and Maintenance

Troubleshooting

service, make sure you :WARMSTOP the system first! See Section 3 for instructions.

9. When sending correspondence to the Ultimate Corp., be sure to include your system number (the TN, NE or NB number).

Troubleshooting

11.2 Calling The Ultimate Support Group

The telephone number for the Ultimate Support Group is (201) 887-2721. This number should be used for technical questions and problems only. Calls cannot be transferred to other departments.

Questions regarding shipments or billings should be directed to the Administration department, at (201) 887-9222.

The Ultimate Support Group works on a call-back system, meaning that when you place a call, the call is entered into Ultimate's on-line support system, and the next available support technician will call you.

Ultimate's software support is available in the continental U.S. from 8am to 8pm, your local time. Tutorial or question-type calls after 5pm will be deferred until the next working day. All service calls received after 8pm (your local time) will be deferred until the next working day, unless your system is covered by an extended maintenance contract.

Technical support is available outside the normal hours on a contract basis only. Extended maintenance is available for second and third shifts, Saturdays and/or Sundays, or 24 hours per day, seven days per week.

For information on pricing and arrangements for extended maintenance, contact the Administration group at (201) 887-9222.

Troubleshooting

11.3 Group Format Errors (GFEs)

A Group Format Error (GFE) may occur when either reading or writing an item to or from disk. The GFE indicates that the group in which the item is located has been incorrectly or incompletely updated. Some or all of the data in that group may be destroyed or erroneous. The frames in that group must be corrected to restore database integrity.

When a GFE message is displayed, always write down all data in the message. This data is vital to correcting the GFE. Then call the Ultimate Support Group.

Group Format Errors (GFEs) should always be corrected as soon as they are discovered. If a file containing GFEs has records written against it, you will cause more GFEs. Eventually, they may cross into other files and even into other accounts.

WARNING: Unattended GFEs can eventually cause loss of data!

The following are types of GFEs and some possible causes:

1. The most common type of GFE is a bad forward or backward frame link. It can be caused by:
 - a. having to do a Warmstart because of a system hang while users were logged on.
 - b. power losses.
 - c. system hangs.
 - d. the system going down without being :WARMSTOPped first.
 - e. problems with the spooler when using the SP-KILL command.
 - f. starting the spooler while the spooler is still active.
 - g. memory problems or other hardware problems.
2. Another type of GFE is one with a bad count field. Each item in a group is made up of a count field, a key, and the data. The count field is used as a pointer to the end of the item. The end of the item must be an attribute mark followed by a segment mark. If the count field does not point to this pattern, then a Group Format Error is generated. (For more information on groups and count fields, see the System Management and Support Guide.) This can be caused by:
 - a. the system going down during processing.

Troubleshooting

b. a hardware failure.

All GFES may cause a loss of data. The amount of data lost will depend on the type and number of GFES.

Ultimate recommends that when you do a File-Save, you select 1 on the SYSPROG Main Menu. This selects File-Save with automatic GFE fixer. The automatic GFE fixer has the ability to correct 80% of the types of GFES. If you are still having GFE problems, type:

FIX-FILE-ERRORS filename and press RETURN.

This loads the data removed to the TSYM file. After fixing GFES, you should type:

COUNT filename and press RETURN.

Any existing GFES will be displayed. If you are still having problems, call Ultimate.

When a GFE is corrected, some of the data in the affected file may be lost. So after the GFE is corrected, you should Selective-Restore the file from a previous File-Save.

Once your GFES have been corrected, it is highly recommended that you do a File-Save to determine if there are more GFES. In any case, if there were many GFES or several files affected, you must do a File-Restore to ensure that your system is back to a clean base.

CAUTION: Never use the DELETE-FILE or CLEAR-FILE commands on a file that contains a GFE. If you do, you will not be able to determine the cause of the GFE, and you will probably still have GFES.

Troubleshooting

11.4 Aborts

When an abort message is displayed, always write down all data in the message. This data is vital to correcting your problem.

The following are possible causes and solutions for aborts. If you need assistance, call the Ultimate Support Group.

1. The data that the system is trying to manipulate may be corrupted. Try to determine which item was being accessed when the abort occurred, and then check that item for errors.
2. The abort may have been caused because the WORKSPACE for the line was blown, especially if the process being run works on another line. Simply run the LINK-WS verb, as instructed below.

Work space links should be particularly suspect if a program or process aborts on one channel, but works correctly on others. The workspace may be (re)linked on a live system using the LINK-WS verb on the SYSPROG account. But first, be sure the affected line is logged off.

Log on to SYSPROG, then press RETURN to go to TCL. At TCL, type:

```
LINK-WS {(n{-m})} and press RETURN.
```

If the (n) or (n-m) is omitted, the workspace of all lines will be relinked, except those of lines logged on and that of the spooler process. The parenthetical specification may be used to limit the relinking process to lines n, or n through m only. (The affected lines are given in the abort message.)

As the linkage proceeds, the line number of the process whose workspace is currently being linked is displayed on the terminal. If the line is logged on, the messages "ON!" and "THE WORK-SPACE IS NOT RELINKED!" are displayed.

The spooler's workspace can be linked via a COLDSTART. However, internally the spooler's workspace is not used in a manner that can cause problems if its links are not correct. Therefore, this is not necessary.

3. Consult the Aborts Definition List to see if it contains your abort message.
4. Your system software may not verify. Use the VERIFY-SYSTEM verb to determine if there are any mismatches. It is possible that a mismatch caused the abort. If this is the

Troubleshooting

case, try to find out why the mismatch occurred. If there are mismatches, the ABS will have to be reloaded via a Coldstart (see Section 6.2).

5. Have there been any recent hardware problems or hardware upgrades to the system? The hardware replacement may not have corrected the problem for which it was intended, or the upgrade may not have been installed properly.
6. If the message "!ERR" is displayed, then the abort may be caused by a bad board. Call the Ultimate Support Group.
7. The process currently active sometimes cannot be ENDED from the System Debugger prompt (!). When this happens, if you are on Release 170U or later, then type G4.1 and the process will go to the "Logon Please" prompt. (If you are on a 1400 Series system, type G4.2) Log on and then log off again. This will ensure that all registers will be properly set, and that any overflow frames the prior process may have been using will be released back to overflow.

WARNING: Do not attempt the G4.1 command if you are on a release prior to 170U. Otherwise, you may have problems with your secondary workspace.

8. If you abort with an asterisk (*) prompt, you have an application program problem. Call your application software dealer for assistance.

Troubleshooting

11.5 System Hangs

System hangs can occur on a single line, on several lines, or on a total system. There are many different causes of system hangs, so they are difficult to troubleshoot. You should always call the Ultimate Support Group for all system hangs. However, there are some things you can check first.

11.5.1 System

1. Check for error messages on all of your CRTs. If there are any messages, write them down.
2. Are there ampersands (&) on any of your screens? If so, you may have a disk error.
3. Are all of your terminals hung? Check each terminal, not just those in the computer room.
4. Check your disk drives and system panel to see if any CHECK lights are on.
5. Call the Ultimate Support Group before attempting to boot your system.

11.5.2 Terminals

1. Check your communications cables. You may have a CRT cable connected to the black communications cable, but not connected to a CRT. This is known as an "unterminated" cable. Either connect the cable to a CRT, or disconnect the CRT cable from the black communications cable.
2. Are ampersands (&) being displayed on your terminal? If so, you may have disk errors.
3. The LOCK table is full, or the File-Save process has a lock on a file that you are also trying to access from the hung line. Refer to the BASIC Manual, the System Commands Guide, and the System Management and Support Guide for information on group and item locks. Call the Ultimate Support Group for further assistance.
4. If you are working on a modem line and you can't get a connection, press CTRL BREAK.
5. If your terminal has recently been installed, check that cables, switch settings, and configuration options to make sure it was installed correctly.

11.5.3 Hangs During a File-Save

If you experience a hang during the File-Save process, it may

Troubleshooting

be caused by hardware, software, or media. In most cases, only the File-Save process is in a halted state, and not the entire system. If this is the case, do not end the File-Save process. Write down the name of the account and file, and call the Ultimate Support Group.

11.5.3.1 Disk Errors

1. The File-Save process can halt if it encounters a "hard disk error." This means that a portion of the disk cannot have data written to or read from. This is usually indicated by ampersands (&) displayed on your terminal.

To determine if there are any errors, log to the SYSPROG account and go to TCL. Type:

LIST-SYSTEM-ERRORS and press RETURN

for a complete error report, or type:

SYSTEM-ERROR-SUMMARY and press RETURN

for a summary of errors.

List the errors to the printer, then check the listing to determine if there are any errors present.

If you must continue the File-Save before attempting to correct the disk errors, then delete (FD) the file (or the pointer to the file) causing the error before doing the File-Save.

There are two methods of recovering from a disk error:

- a. Assign an alternate track on the disk. Each disk has an Alternate Track Table that is a record of tracks that have been assigned alternates because of excessive errors. Each entry in the table has the cylinder number of the bad track, the track's head number, and the alternate cylinder that contains the track's relocated data. For information on assigning alternate tracks, refer to System Management and Support Guide.
- b. Reformat your disk. You should reformat your disk only if you have a recent File-Save from which to restore your data after the reformat. If you reformat your disk, you may have to manually flag the bad track. (The format process will prompt you for this option.)

If you deleted the file causing the error prior to the File-Save, then you must do a File-Restore. Then create the file you deleted, and SEL-RESTORE it from a previous File-Save tape.

Troubleshooting

For information on formatting your disk, refer to Section 6.3 of this manual, and to your System Management and Support Guide.

11.5.3.2 Tape Errors

1. If percent signs (%) have been displayed and the File-Save process does not continue after you respond to the "(C)ontinue or (Q)uit" message, you may have a bad spot on the tape. Mount another tape and retry the File-Save.
2. You may have lost an interrupt during the File-Save. Press the tape drive's ON/OFF LINE button twice.

11.5.3.3 Checking a Tape For Parity Errors

You may use the following procedure to determine if a tape has parity errors before using it to back up your data (see Sections 7 and 8 for backup and restore methods).

This procedure involves doing a selective restore on an account and file that does not exist. This forces the system to read all of the tape(s), thereby checking the tape(s) for parity errors. Parity errors are signalled by percent (%) signs on your terminal.

1. Mount Reel #1 of your File-Save tape (or the tape you will use for backup). Make sure the tape is on-line.
2. At TCL, type:

LOGTO SYSPROG and press RETURN.

Then press RETURN again to go to TCL. At TCL, type:

T-ATT n and press RETURN.

Replace "n" with the number of the tape drive on which the tape is mounted. Then, at TCL, type:

SEL-RESTORE SYSPROG-PL * and press RETURN.

You will be prompted:

Account name on tape?

Type a name that you know does not exist on the tape. For example, type TEST-ACCOUNT and press RETURN. Next, you will see the following prompt:

Filename on tape?

Troubleshooting

Again, type a name that does not exist on the tape. For example, type TEST-FILE and press RETURN.

3. The system will begin reading the tape for the account and filenames you entered. If the tape is one reel of a multiple-reel set, then you will be prompted to enter Reel #2, then Reel #3, etc., until all reels have been mounted. Of course, the system will not find the account and file names so, when all reels have been mounted, you will see the message:

0 items restored

If you see percent (%) signs on the terminal at any point during this procedure, then your tape(s) contains parity errors, and should not be used. If the entire procedure runs without displaying percent (%) signs, then your tape(s) does not contain parity errors, and may be used to back up your data.

11.5.3.4 Lock Errors

1. If the total system is not hung, and if there are no disk or tape errors, then the hang was probably caused by locks. Use the WHAT, WHERE, or LIST-LOCKS verbs to determine if you have a lock problem. Also, if you are on a release prior to 130 and you press CTRL BREAK and the address is 48.xxx, then you have a lock problem. If you are on release 130 or later and you press CTRL BREAK and the address is 667.xxx, then you have a lock problem.

The File-Save process LOCKS a group while it is being saved. If a BASIC program leaves a lock on that group set, or if the LOCK table is full, then the File-Save process will definitely hang. End out of the BASIC program, and call Ultimate.

NOTE: If you try to clear the locks, subsequent updates may contain errors.

If the LOCK table continually becomes full, have your application software vendor check your programs to make sure each process is releasing the LOCKS being set.

Troubleshooting

11.6 Printer Problems

The following are possible causes and solutions for printer problems. If you need assistance, call the Ultimate Support Group.

1. Is the printer on-line? Make sure the ON-LINE button is lit.
2. Is the printer loaded with paper?
3. Are you assigned to the correct printer? At TCL, type SP-ASSIGN ? and press RETURN to determine to which printer you are assigned. Type SP-LISTLPTR and press RETURN for a listing of printers installed on your system.
4. Is the printer connected to the CPU or to a port?
5. Has this printer ever worked before? If not, it may not have been installed correctly. Check the printer's cabling and switch settings. Refer to Appendix D for options and switch settings of printers supported by Ultimate.
6. Was this printer recently added to your system? If yes, see Section 10 on Adding Equipment.
7. Is there sufficient voltage for the printer? Insufficient voltage can cause the printer to stop in the middle of a job or not print at all. If all the lights on the printer remain solid and the printer cannot be taken off-line, then the printer's power cord should be put on another circuit.

Troubleshooting

11.7 System Errors

Follow the instructions in Section 9.1.4 to LIST-SYSTEM-ERRORS. If you don't have a copy of the System Errors Listing Explanation, enter Y at the prompt to print a copy. If system errors are listed, refer to that document for information on the errors.

Troubleshooting

11.8 Mismatches

A mismatch occurs when the check-sum of the actual frame on the disk doesn't match the predetermined check-sum item in the ERRMSG file.

Use the following steps to get a list of your system's mismatches.

1. Log to SYSPROG, then press RETURN to go to TCL.
2. At the TCL (>) prompt, type:

`VERIFY-SYSTEM` and press RETURN.

The following screen is a sample of what might be displayed.

```
>VERIFY-SYSTEM
034 F7BE F89E
103 0D49 0D39
308 0200 E491
[342] ***Ultimate system software does not verify!***
      There are 3 frames with mismatches.
```

The following are possible causes and solutions for mismatch problems.

1. Are you booting the system with the wrong release tape? If you are, reboot with the correct tape, or upgrade to the new release.
2. Was your operating system properly upgraded? If the mismatches accompanied an upgrade, you should go over your upgrade instructions to see if you followed them correctly. If you find a mistake, all or part of the upgrade procedure may need to be repeated.
3. Did you add or delete any ABS frames? Either the frames or their checksum(s) may need to be reloaded in the ERRMSG file.
4. Do you have a hardware failure? Mismatches that occur consistently and cannot be attributed to software are probably hardware related.

Troubleshooting

If your mismatch was not caused by booting the system with the wrong release tape, or by problems during the upgrade procedure, you should :WARMSTOP the system. Then follow the procedure in Section 6.2 to Coldstart the system. Run the VERIFY-SYSTEM procedure again. If the system still does not verify, call Ultimate.

Troubleshooting

11.9 Traps

Traps are a set of fixed locations used by the CPU to display specific STATUS words when certain hardware error conditions occur, or when special software instructions are executed.

When a trap message is displayed, always write down all Data in the message. This data is vital to correcting the problem. Then call the Ultimate Support Group.

NOTE: Always call the Ultimate Support Group first, even if you suspect a hardware problem. Normally, you should not call Honeywell to replace hardware. You may only call Honeywell directly if you're certain that the problem is caused by hardware.

Troubleshooting

11.10 Debugger for the 1400 Series Systems

The panel is a debugging feature that will allow troubleshooting of the 1400 Series' problems.

When a message is displayed, always write down all data in the message. This data is vital to correcting the problem. Then call the Ultimate Support Group.

NOTE: Always call the Ultimate Support Group first, even if you suspect a hardware problem. Normally, you should not call Honeywell to replace hardware. You may only call Honeywell directly if you're certain that the problem is caused by hardware.

Troubleshooting

11.11 HPP Errors

HPP errors do not apply to the 1400 Series systems.

HPP errors may be generated when the High Performance Processor (HPP) is interacting with memory or with the CPU.

When an HPP message is displayed, always write down all data in the message. This data is vital to correcting your problem.

HPP errors are displayed via the remote panel. The remote panel processor is a troubleshooting aid to help diagnose problems. The panel simulates some of the functions of a full control panel on the Honeywell Level-6 or DPS 6 computers. The remote panel is invoked under certain error conditions. When invoked, all normal processing is suspended as though the STEP button on a full control panel were pressed. The following screen is an example of what may be displayed.

```
-----  
HPP Error 8002 @ XXXXX  
TSA @ 82C  
TSA = XXXX XXXX XXXX XXXX XXXX XXXX XXXX XXXX  
Dregs(1-7) XXXX XXXX XXXX XXXX XXXX XXXX XXXX  
Bregs(1-7) XXXXX XXXXX XXXXX XXXXX XXXXX XXXXX XXXXX  
V-regs(0-7) XXXXX XXXXX XXXXX XXXXX XXXXX XXXXX XXXXX XXXXX  
V-regs(8-15) XXXXX XXXXX XXXXX XXXXX XXXXX XXXXX XXXXX XXXXX  
PCTR = XXXX LINK = XXXX WREQ = XXXX  
ADDRA = XXXXX ADDR B = XXXXX AD RP = XXXXX SYND = XXXXX  
-----
```

If an HPP error occurs in your system, the Xs shown above will be replaced by numbers. Write down the numbers, and leave them displayed on your screen. Then call the Ultimate Support Group.

Troubleshooting

11.12 Power Failures

There are many different causes of power failures. The following are possible causes and solutions. If you need assistance, call the Ultimate Support Group.

Occasional power fluctuations may cause your system to hang. Constant system hangs caused by power fluctuations can cause extreme damage to both hardware (for example, boards going bad) and software (for example, data corruption and GFES).

If power is a constant problem in your business environment, identify the types of power problems you are having, and install an appropriate device to correct the problem. Available devices include power conditioners, uninterruptable power supplies, and battery backup units.

11.12.1 Power Failure Recoveries

The most critical step in recovering from a power failure is to make sure memory is flushed to disk. If your system is equipped with a battery backup unit, then the system should flush memory and execute an auto-warmstart when power is returned. If your system is not equipped with this device, then you must perform a Coldstart (see Section 6.2). If you do not perform a Coldstart, you will have a greater probability of Group Format Errors.

Power Conditioners

Power conditioners are designed to prevent the most common forms of electrical disturbances (noise and surges) from reaching your computer. These disturbances account for 95 percent of the electrical problems affecting computers.

Although a power conditioner does not regulate, it will provide a degree of "ride-through." That is, in the case of momentary power dips that cause the lights to flicker, the power conditioner will maintain voltage to the system and prevent a power failure.

See your Site Preparation Guide for more information on power conditioners.

Uninterruptable Power Supply (UPS)

The primary purpose of the UPS is to maintain power to the system if the main power source fails. Its batteries, from which the system draws power, can keep a system up from 10 minutes to over an hour. If power is restarted within that time, the system should execute an auto-warmstart, meaning that it will bring itself back up.

Troubleshooting

Although the UPS does provide isolation from certain types of power disturbances, it does not provide total protection. The UPS is primarily for systems in areas subject to frequent or prolonged power losses.

If you have a power failure and you do not have a UPS, or if the UPS did not auto-warmstart, then perform a Coldstart to reduce the possibility of data corruption. See Section 6.2 for instructions on the Coldstart procedure.

Battery Backup

NOTE: This is not available on 1400 Series systems.

If your system is equipped with a battery backup and a power failure occurs, the battery will provide power to memory for approximately 30 minutes. If power is restarted within that time, the system should execute an auto-warmstart, meaning that it will bring itself back up.

NOTE: For all Honeywell systems except those with System Control Facility (SCF), the panel security key must be in the LOCK position for the Battery Backup Unit to work. Turn the key counterclockwise to LOCK the panel. (Note that the key must be in the UNLOCK position to boot the system.)

If you have a power failure and you do not have a battery backup, or if the battery backup did not auto-warmstart, then perform a Coldstart to reduce the possibility of data corruption. See Section 6.2 for instructions on the Coldstart procedure.

Troubleshooting

11.13 Creating a Memory Dump on 6000 and 7000 Series systems.

NOTE: Refer to Section 11.13.3 if you have a 1400 Series system.

If an Ultimate Technical Support Representative asks you to send a memory dump, then follow this procedure to dump the contents of your system's memory to tape.

The methods for creating a memory dump vary for different systems. Follow the method that applies to your system.

NOTE: It is not possible to create a memory dump on a 6000, 6200, or other system with only cartridge tape capability.

11.13.1 System With Full Control Panel

1. Mount a tape (with a write ring attached) on tape drive 0, and put it on-line.
2. Unlock the panel (turn the panel security key clockwise). Then press the following buttons on the panel.

S (STEP)
CLR (CLEAR)
E0 (On the panel keypad)

Then press:

C (CHANGE)
S (STEP)
0081C (On the panel keypad)

The panel's LED should display the following:

E0 0081C

Then press the following two buttons.

R (READY)
E (EXECUTE)

3. The contents of memory should now be dumped to the tape. This process will simultaneously flush memory to disk.

If the tape does not move, then repeat Step 2. If the tape still does not move, then press the following two buttons to simply flush memory in your system. Then call Ultimate.

S (STEP)
CLR (CLEAR)

Troubleshooting

R (READY)
E (EXECUTE)

4. Once memory has been dumped to tape, unload and remove the tape. Then turn the panel security key counterclockwise, back to the lock position.
5. Send the tape to the following address (please do not send a memory dump until you have spoken with someone from Ultimate Technical Support):

The Ultimate Corp.
717 Ridgedale Avenue
East Hanover, NJ 07936
Attn: Memory Dumps

11.13.2 6400 System With SCF and Reel Tape Drive

1. Mount a tape (with a write ring attached) on tape drive 0, and put it on-line.
2. On the keyboard of the console terminal, press the following keys.

ESC ESC # # # and press RETURN.

(Press the ESC key twice, press the # key three times, and then press RETURN.)

This will put the SCF console into maintenance mode.

3. On the SCF console, press the following buttons.

H (HALT)
^ (SHIFT 6 to clear)
S (SELECT)
E0 (select the E0 register)
M (MODIFY)
0081C (enter 0081C into the selected register)
G (GO)
X (EXECUTE)

4. The contents of memory should now be dumped to the tape. This process will simultaneously flush memory to disk. If the tape does not move, then press the following buttons.

H (HALT)
^ (SHIFT 6 to clear)
G (GO)
X (EXECUTE)

5. Once memory has been dumped to tape, unload and remove the tape.

Troubleshooting

6. Send the tape to the following address (please do not send a memory dump until you have spoken with someone from Ultimate Technical Support):

The Ultimate Corp.
717 Ridgedale Avenue
East Hanover, NJ 07936
Attn: Memory Dumps

11.13.3 1400 Series Systems

1. Insert a 1/4" tape (with a write ring attached) into the tape drive. Raise the tape lever to the vertical position to put the tape on line.
2. Make sure you are in the 1400 system facility panel. If you are not, pressing the STANDBY button will enter you into the panel.
3. Enter FD to flush the memory to the disk.

The following screen will be displayed.

```
-----  
| ULT1400 Virtual Memory Flushed |  
-----
```

4. Enter FT to flush the memory to the tape.

The following screen will be displayed.

```
-----  
| ULT1400 Memory Address X000XXXXX |  
-----
```

5. Once the memory has been flushed, lower the tape lever to the horizontal position and remove the cartridge from the tape drive.
6. Send the tape to the following address (please do not send a memory dump until you have spoken with someone from Ultimate Technical Support):

Troubleshooting

The Ultimate Corp.
717 Ridgedale Avenue
East Hanover, NJ 07936
Attn: Memory Dumps

ULTIMATE SITE LOG

SYSTEM NUMBER -

Date	Reported by	Repaired by	Time Reported	Start Time	Stop Time
------	-------------	-------------	---------------	------------	-----------

Symptom/Problem

Solution

Troubleshooting

NOTES

Glossary

APPENDIX A: GLOSSARY

Abort	A system error identified by an abort error message.
ACC File	An accounting history file that keeps track of the time and date of each logon, and the location of each terminal. This file should be cleared periodically.
Account-Restore	A method of restoring files from a single account, rather than restoring the entire system. An account-restore may be done from a file-save or account-save tape.
Account-Save	A method of backing up files from a particular account, rather than backing up the entire system.
ALL-UPDATE-SAVE	A backup method that allows you to save only those file groups that have been changed since the last File-Save. To restore the system from this backup method, only the most recent full File-Save tape and the most recent ALL-UPDATE-SAVE tape are required.
Alternate Track Table	A record of tracks that have been assigned alternates because of excessive errors.
Backups	Tapes or disks containing copies of your files. Backups are used to restore your files in case they become lost or destroyed.
Battery Backup Unit (BBU)	A unit that will provide power to memory for approximately 30 minutes in the event of a power failure. If power is restarted within that time, the system will bring itself back up.
Binary-Restore	A method of restoring files backed up with the binary save method.
Binary-Save	An alternate, but not recommended, method of backing up your files. This method saves all files as is, and does not check for errors.
Boot	To initialize or start up a system after it has been powered up.
Boot Options	A series of choices for different types of booting. See System Startup Options.
Baud Rate	Speed of transmission.

Glossary

Charge Units	Numbers that represent computer usage.
CMD Drive	Cartridge Modulo Disc. The smaller of two drive types, it holds 67 megabytes of data. A 13 megabyte removable disc cartridge must be in the drive to be able to use the 67 mb fixed disc. The CMD disk is not used by the operating system. It is used as a back-up drive.
Coldstart	A procedure used to load the MONITOR code into memory, and all virtual system software from the SYS-GEN onto your system. This method does not load your files. A Coldstart is normally required if your system fails, or if any maintenance has been performed on your system.
Connect Time	Amount of time spent on the computer.
Diagnostics Monitor	Used primarily to format disks, and may also be used by experienced or support personnel to diagnose problems.
File-Restore	Used to perform a complete restore of system files and customer files. The restore is done from the most recent file-save.
File-Save	Used to back up your entire system. This procedure is recommended daily.
File-Stats	Statistics about your files, generated after each file-save. This report will indicate any Group Format Errors (GFEs) present in your system.
Group Format Errors (GFEs)	An error condition that indicates errors in the format of a virtual storage frame of a file. If your system contains GFEs, call Ultimate immediately.
Hang	An error condition caused by various reasons, usually characterized by one or more lines (or the total system) appearing to "freeze."
HPP Errors	An error condition that normally appears on the Remote Panel processor.
Line-Printer Pages	The number of pages printed during each log-on session.

Glossary

- Offline Monitor Used to make disk-to-disk copies.
- PART-UPDATE-SAVE A backup method that allows you to save only those file groups that have been changed since the last Update-Save or File-Save. To restore the system from this backup method, the most recent full File-Save tape and every subsequent PART-UPDATE-SAVE tape are required.
- Power Conditioner A unit designed to prevent common electrical disturbances from reaching your computer.
- Print Overflow Table (POVF) A pool of available space that contains portions of the file area not allocated to the files.
- Remote Panel A troubleshooting aid designed to help diagnose problems. The remote panel is invoked under certain error conditions.
- Selective Restore A method of restoring individual files or items from a file-save or account-save tape or disk.
- SMD Drive Storage Modulo Disc. It holds 256 megabytes of data. It is a standalone unit that holds a 10-platter removable disc pack.
- System Startup Options A series of choices for different types of booting. See Boot Options.
- T-DUMP A method of copying single files or individual items from disk to tape.
- T-LOAD A method of restoring files or items that have been T-DUMPed.
- Transaction Logger A backup method that records disk file updates on magnetic tape as the updates are made. In the event of a system failure, the tape can be used in conjunction with a File-Save tape to restore all files to their state at the time of the failure.
- Traps A set of fixed locations used by the CPU to display specific STATUS words when certain hardware error conditions occur, or when special software instructions are executed.
- Uninterruptable Power Supply A unit that can maintain power to your system for 10 minutes to an hour in the event

Glossary

- (UPS) of a power failure. If power is restarted within that time, the system will bring itself back up.
- Update-Save A backup method that allows you to save only those file groups that have been changed since the last File-Save.
- Util See Utilities Monitor.
- Utilities Monitor Used for Binary-Saves and Restores.
- Warmstart Used to restart a system that was brought down in a controlled manner, and resumes program execution. Is normally used on a system that was Warmstopped.
- Warmstop Used to bring the system down in a controlled manner, insuring data integrity. A system that was Warmstopped may be Warmstarted.

Panel Layouts

APPENDIX B: PANEL LAYOUTS

The next few pages contain illustrations of your hardware, including control, disk drive, and tape drive panels.

<u>Figure</u>	<u>Description</u>
1	Full Control Panel
2	Basic Control Panel
3	EMD Drive
4	FSD Drive
4A	FSD Drive Control Panel
5	SMD Drive
6	CMD Drive
7	Tape Drive
8	GCR Tape Drive
9	1400 Series System
10	1400 Series System Control Panel
11	GCR Tape Drive Panel (For use with 1400 Series systems)

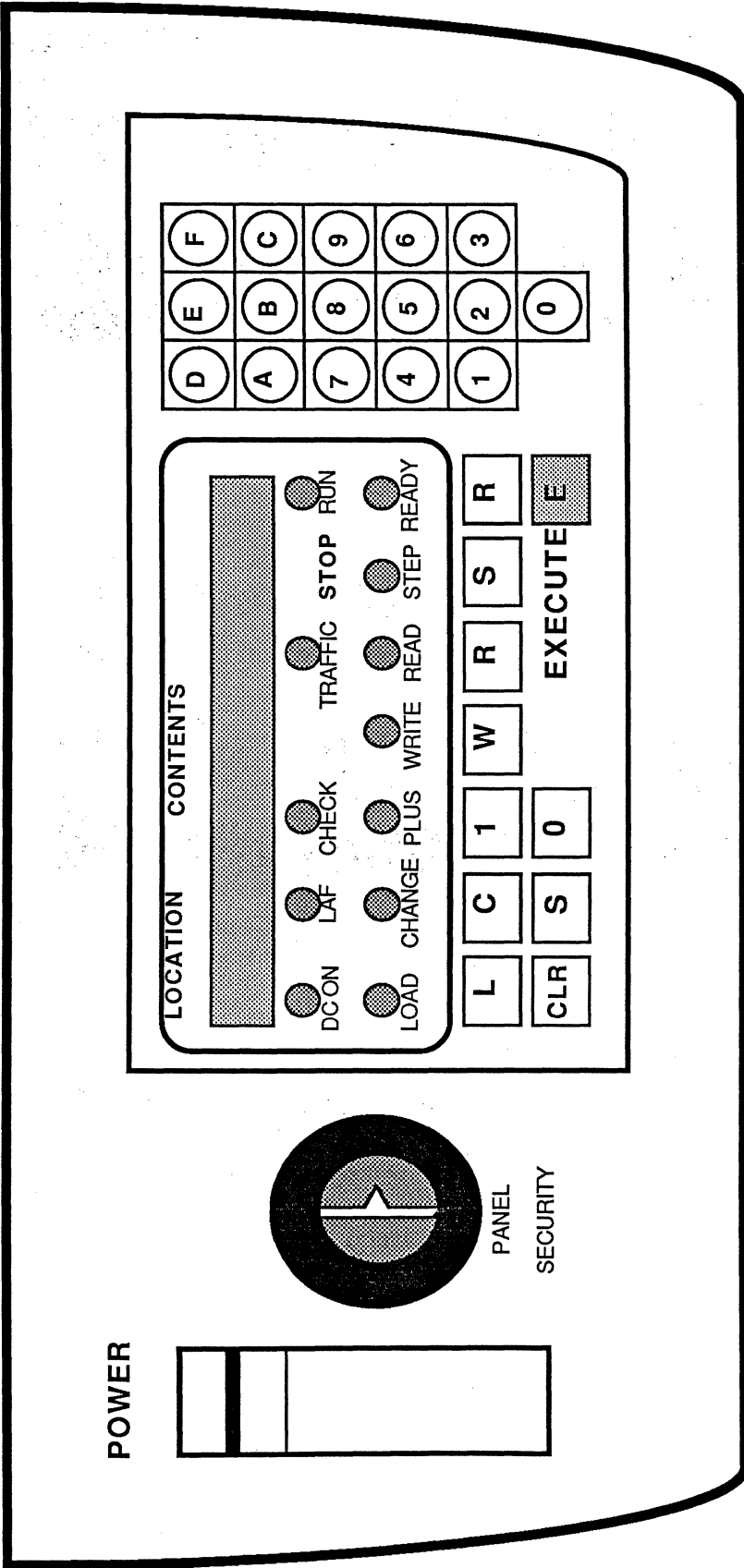

LEVEL 6 FULL CONTROL PANEL

Figure 1

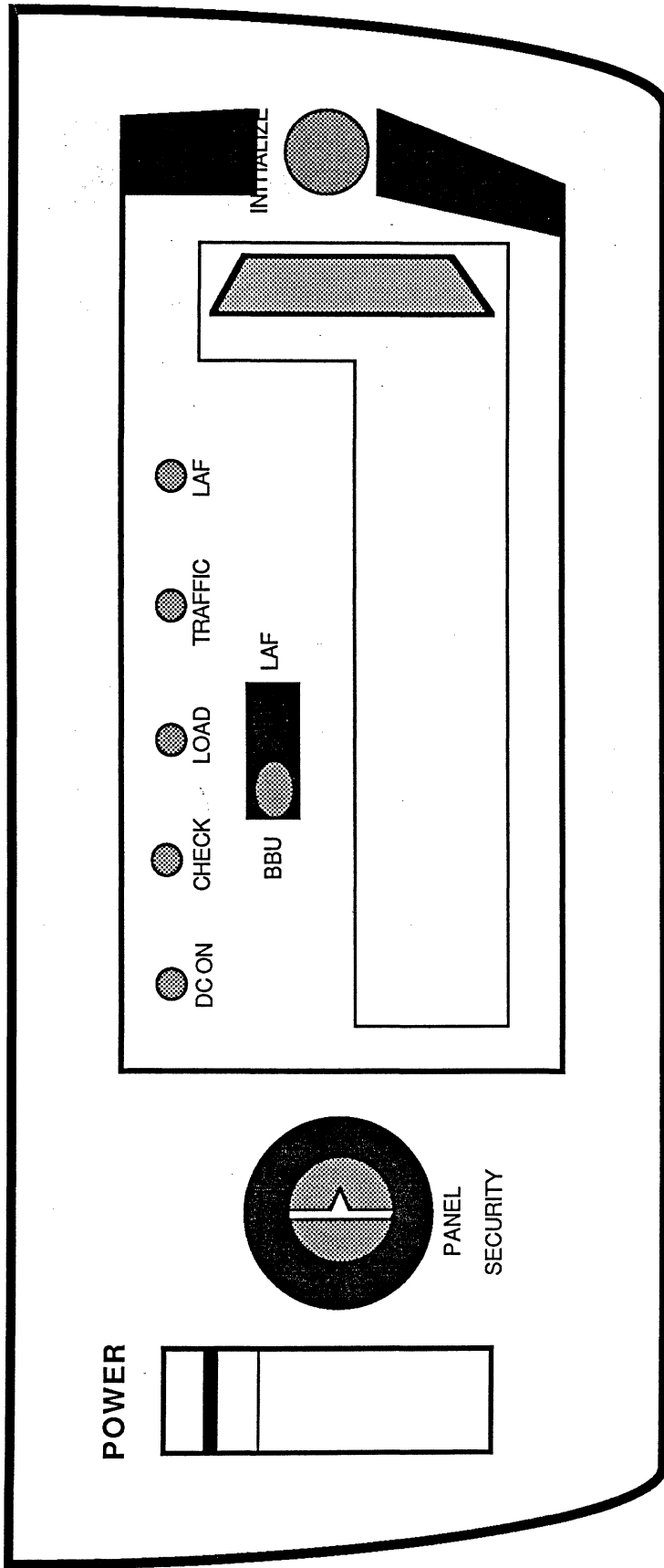

LEVEL 6

BASIC CONTROL PANEL

Figure 2

With Front Door Closed

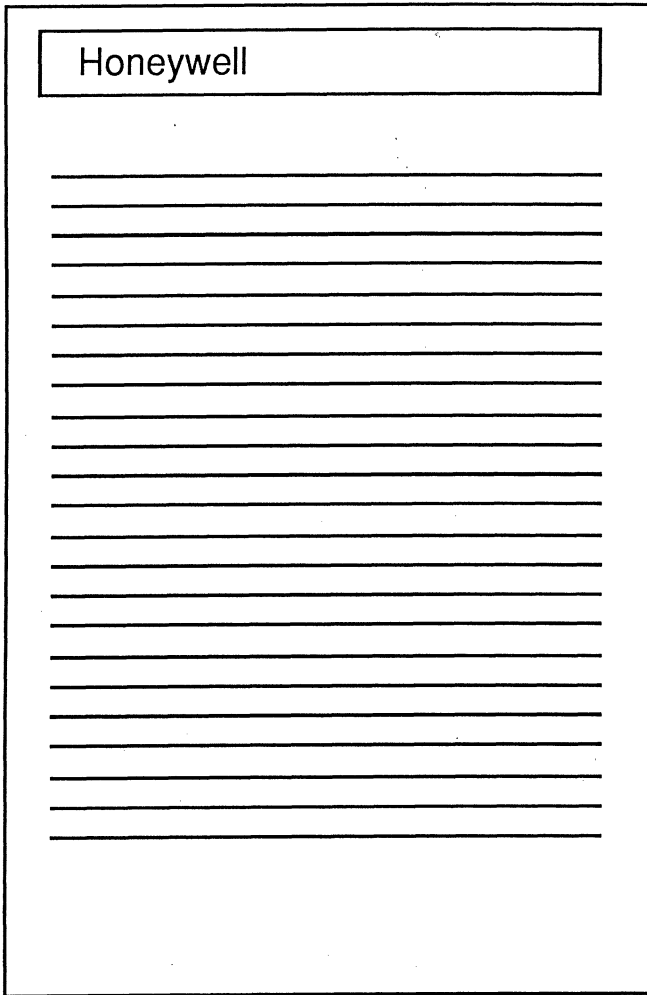

With Front Door Open

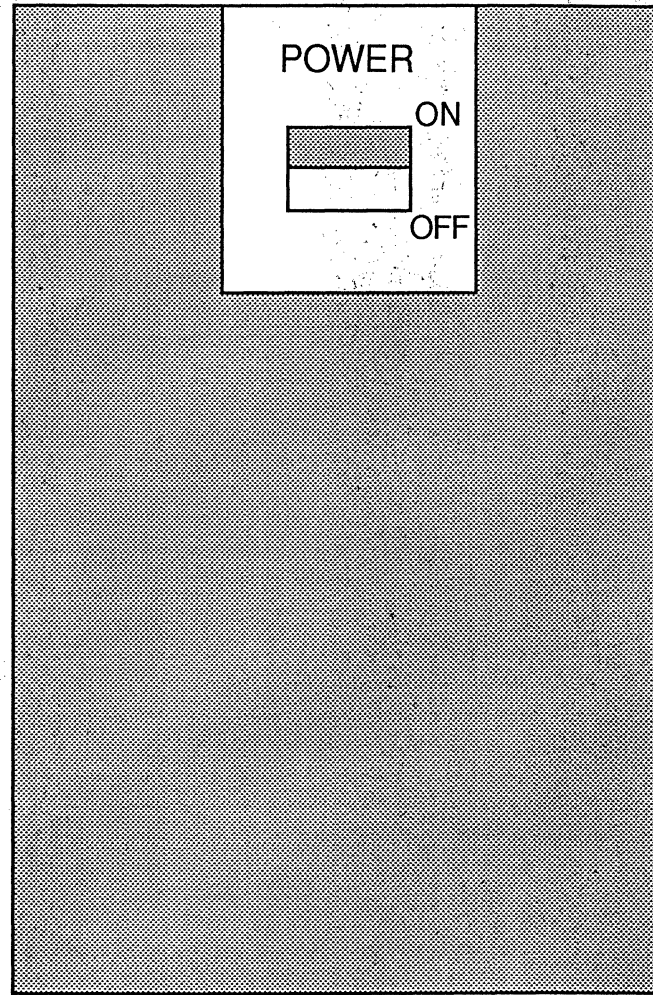

Eight-Inch Module Disk (EMD)

Figure 3

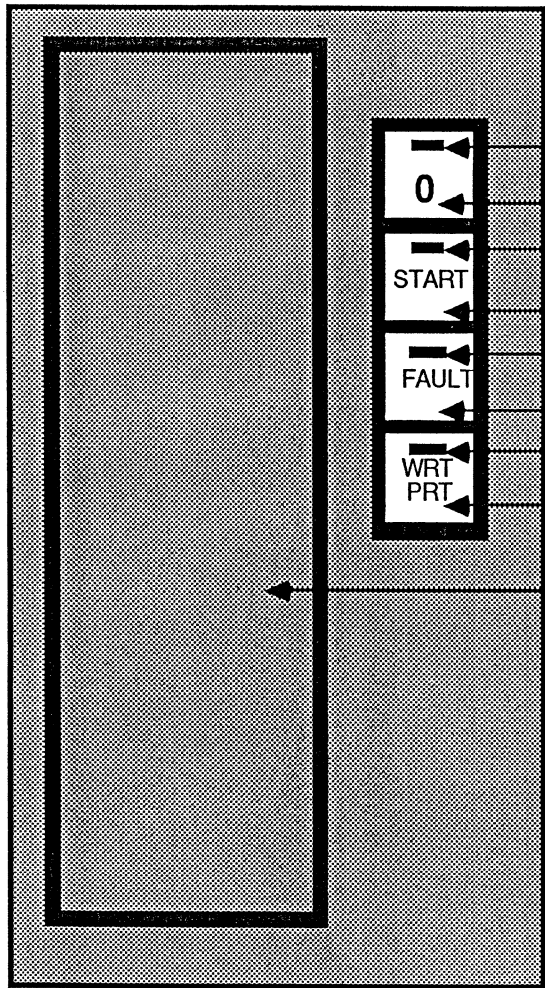

- Device Select Indicator
- Logic Address Plug
- Ready Indicator
- Start Button
- Fault Indicator
- Fault Clear Button
- Write Protect Indicator
- Write Protect Button
- Filter Cover

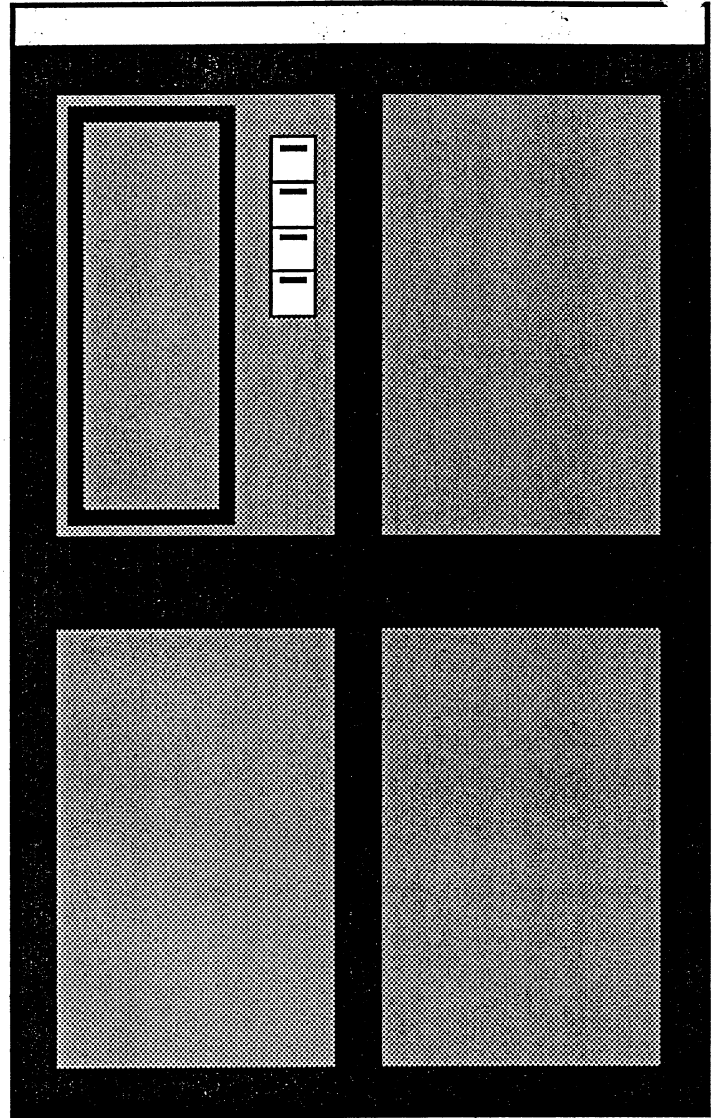

FIXED STORAGE DEVICE (FSD)

Figure 4

FSD DRIVE OPERATION CONTROL PANEL

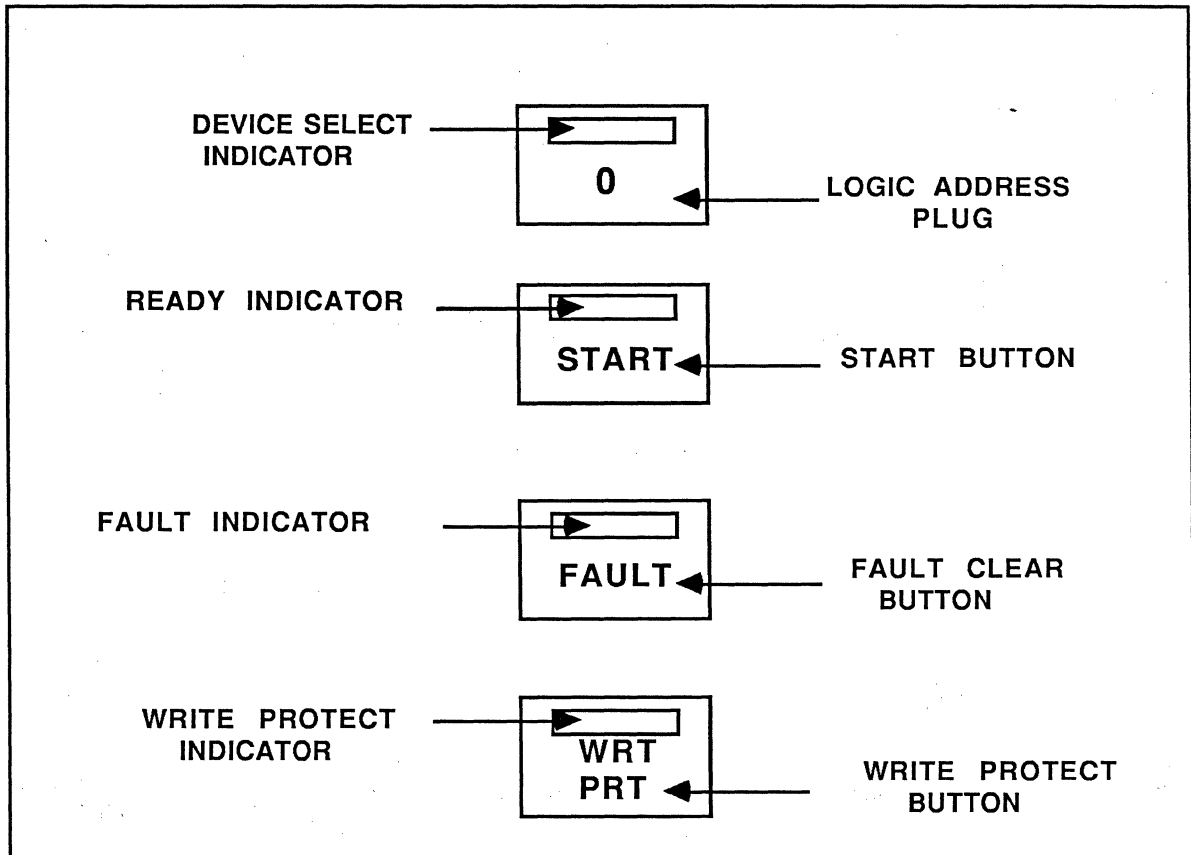

Logic Address Plug/ Select Indicator

Establishes the logical address of the device. When the select light is lit, it indicates activity from the controller. Each device must have a different plug number (numbers 0 through 3 are supplied with the unit). A single drive subsystem must use Plug 0 only.

START Button/ READY Indicator

Press the START button to power up the unit. The READY indicator flashes until the drive is powered up. Then it remains lit. Press the START button again to power down the drive. The READY indicator will flash until the unit is powered down.

FAULT Clear Button/ FAULT Indicator

The FAULT indicator lights if a fault exists within the disk drive. It is turned off by pressing the FAULT clear button, by a fault clear command, or by powering up the disk drive.

WRITE PROTECT Button/ WRITE PROTECT Indicator

Press the WRT PRT button to prevent data from being written to the disk. The WRITE PROTECT indicator will light. Press the button again to disable write protection, allowing data to be written to disk.

Figure 4A

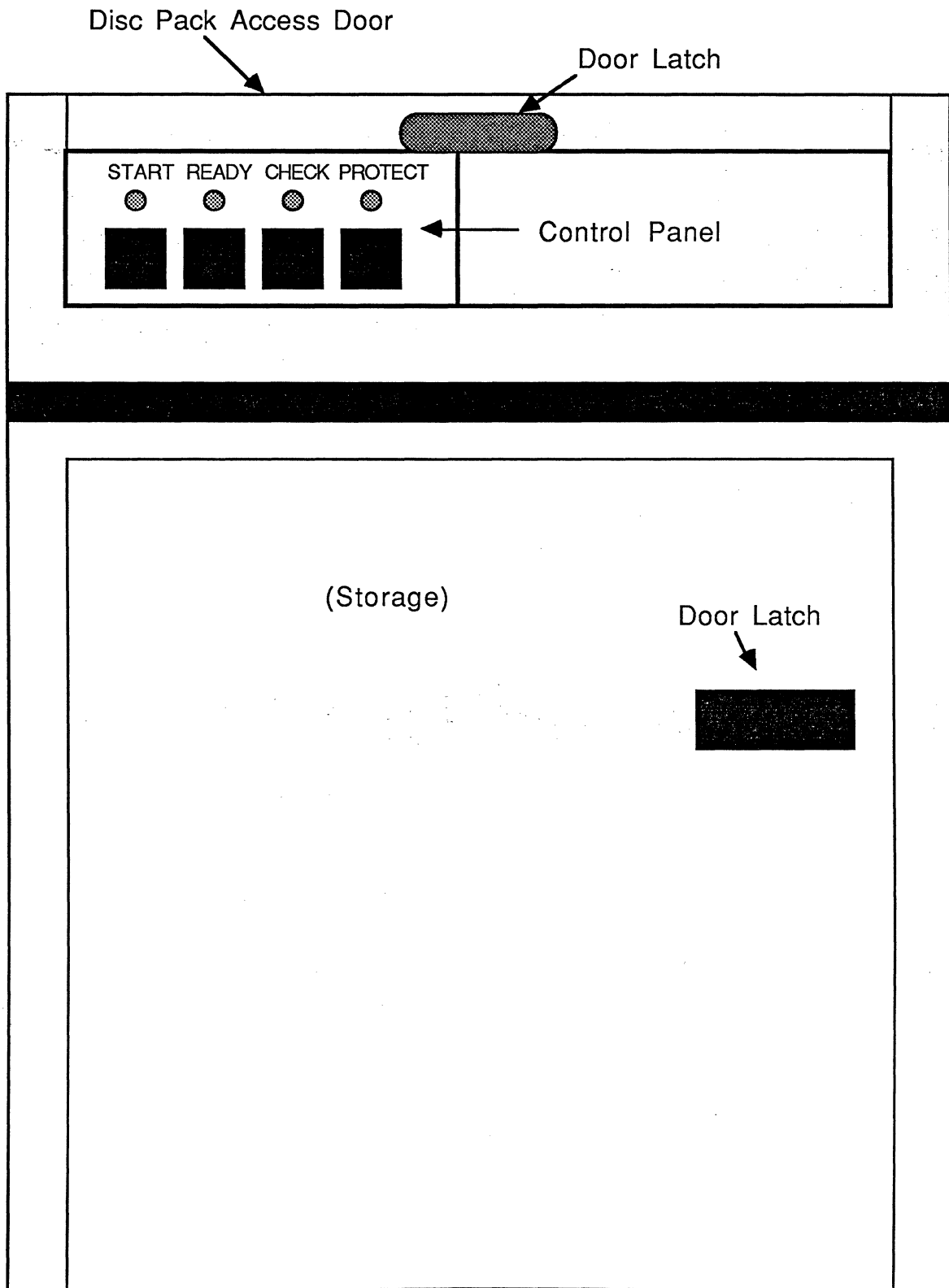

SMD DISC DRIVE

Figure 5

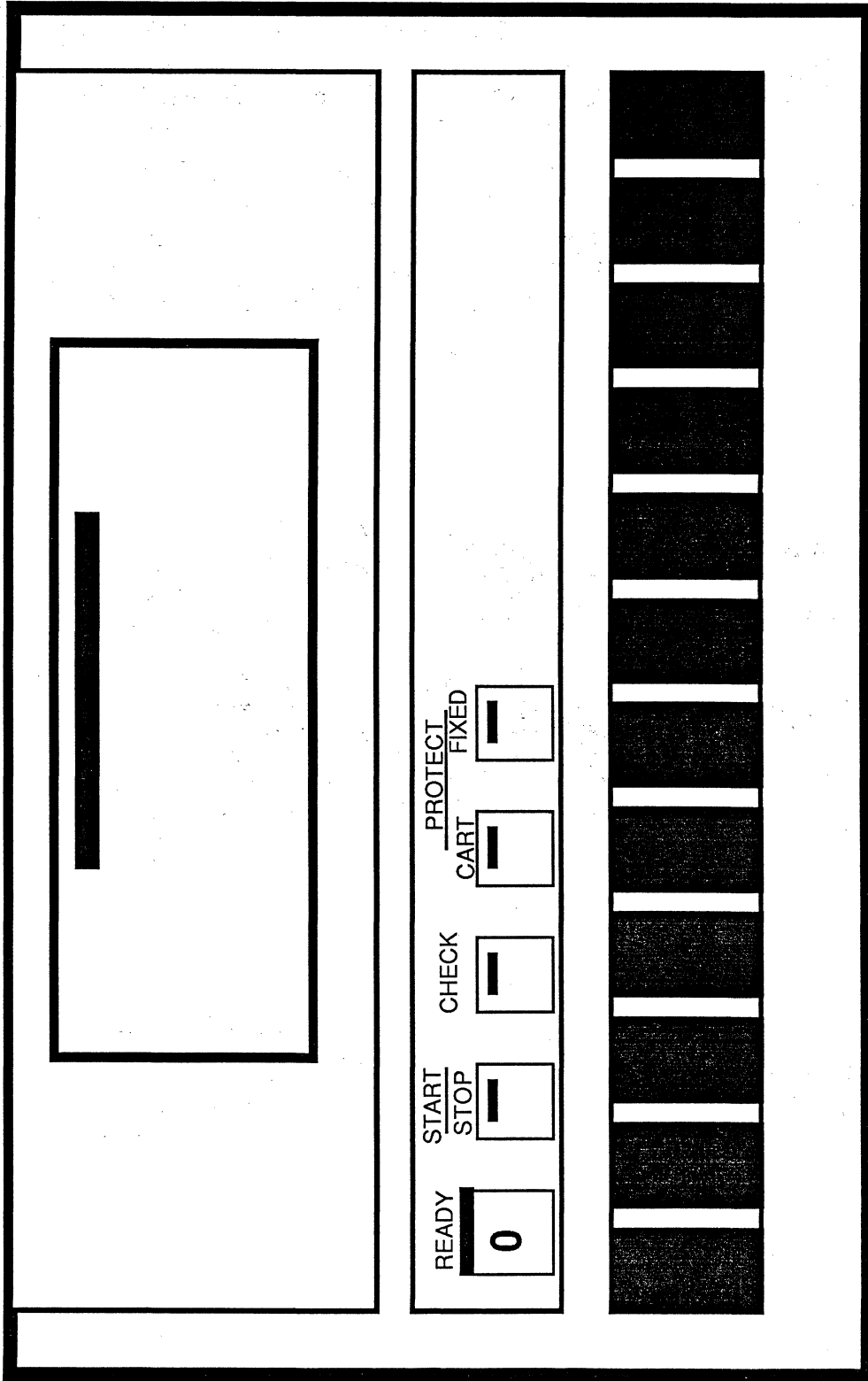

CMD DISC DRIVE

Figure 6

TAPE DRIVE

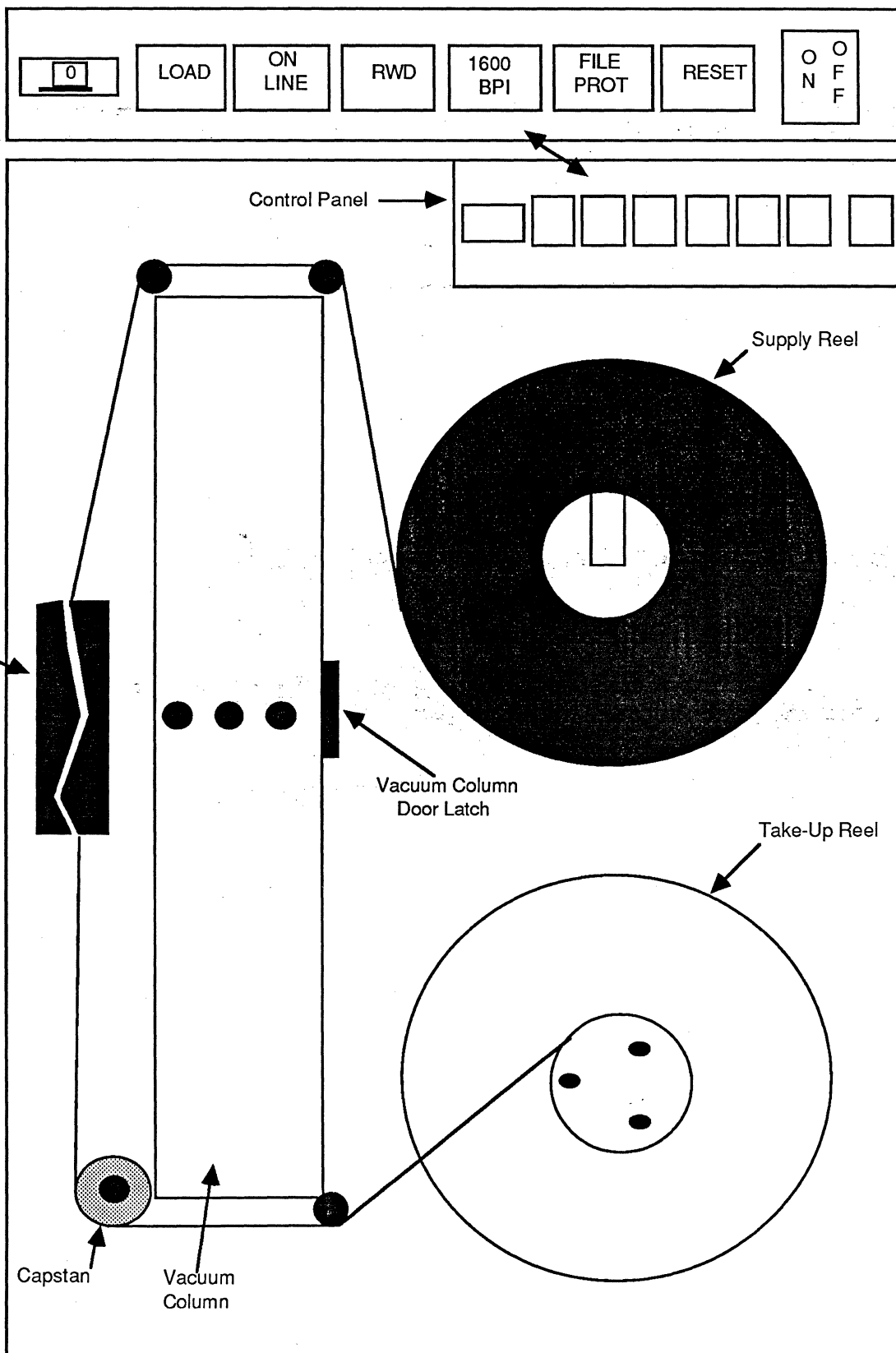
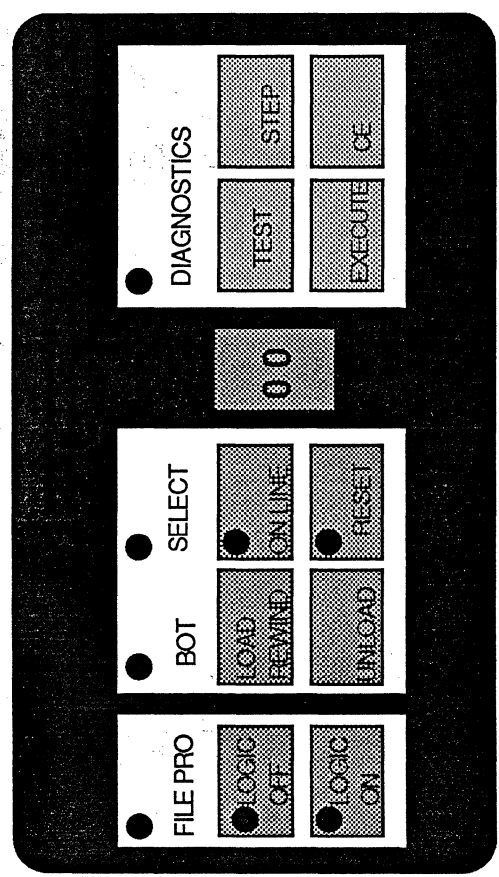
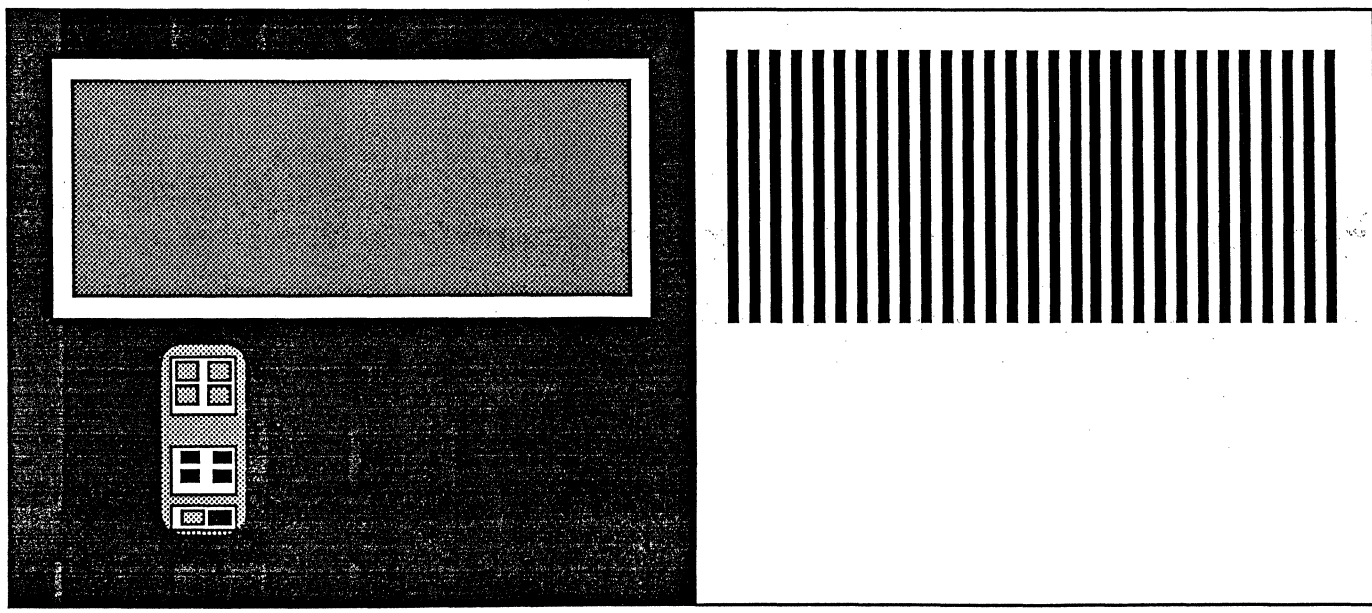
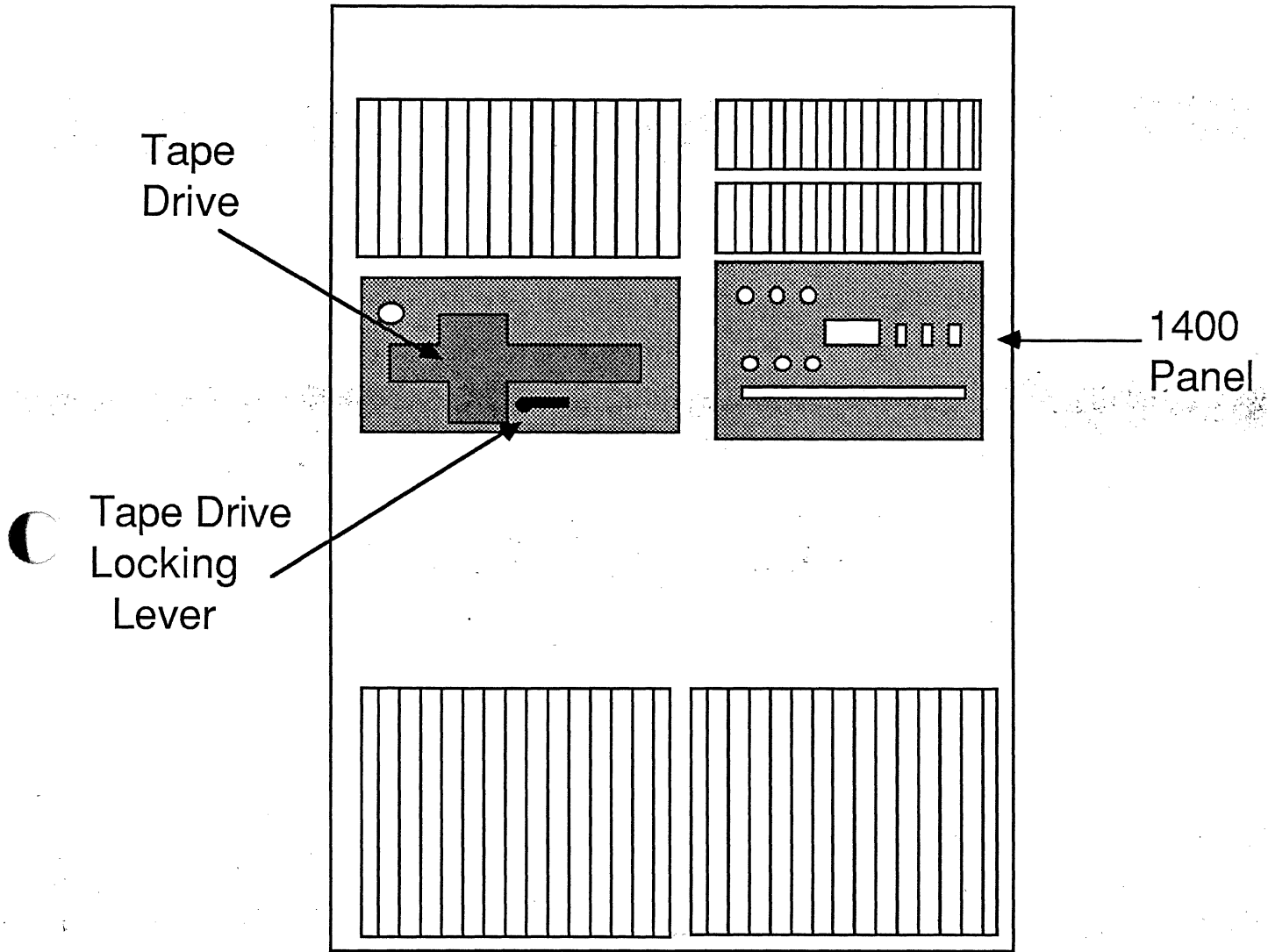

Figure 7



GCR TAPE DRIVE

Figure 8



1400 Series System

Figure 9

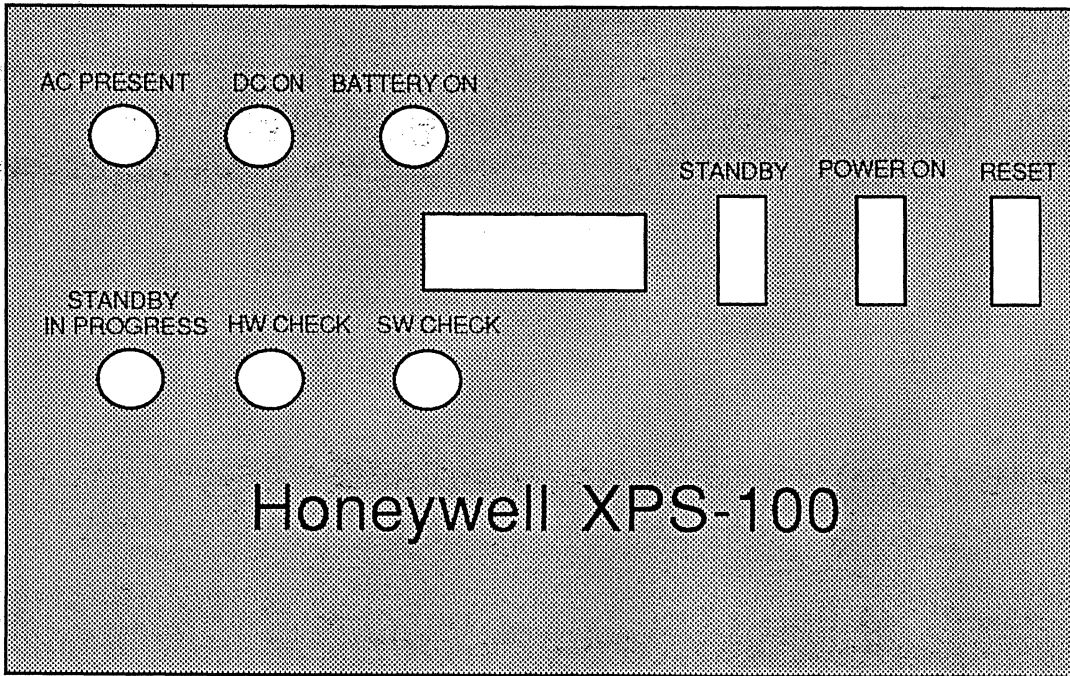

1400 Series System Panel

Figure 10

GCR TAPE DRIVE PANEL

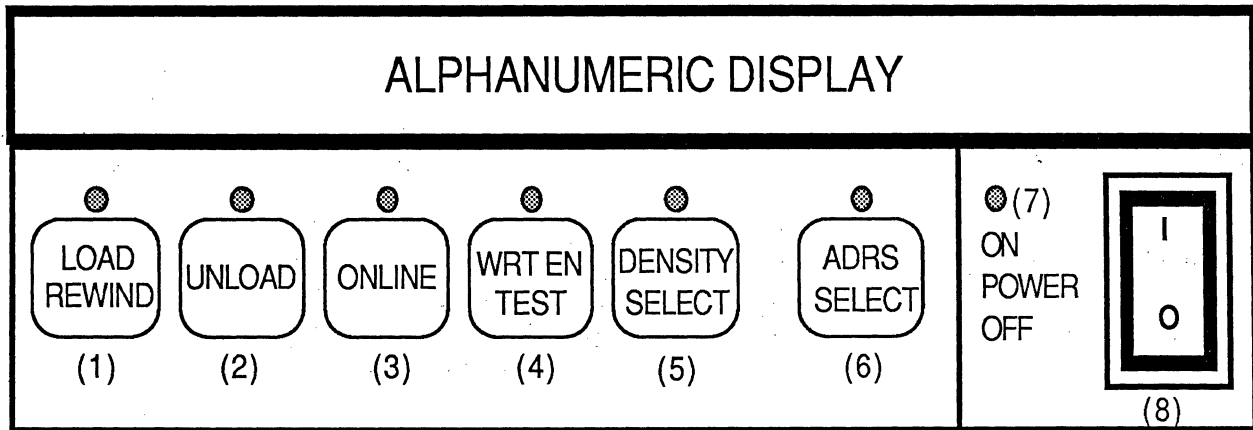

DESCRIPTION

FUNCTION

POWER	The power switch (8) turns the tape drive on and off. The power indicator (7) remains lit as long as the unit is powered on.
LOAD REWIND	The Load/Rewind switch (1) starts the load operation of a newly inserted tape. It also rewinds a tape that is loaded and off BOT. The display flashes "LOADING" until the tape is at BOT, then it will remain lit until taken off BOT.
UNLOAD	The Unload switch (2) unloads a tape from any point providing the tape unit is off-line. The display flashes "UNLOAD'G" during an unload operation.
ONLINE	The On-line switch (3) places the tape drive on-line if off-line and vice-versa. The display shows "ONLINE" if the tape drive is on-line. The tape drive must be off-line to respond to the other switches.
WRT EN TEST	The Write Enable/Test indicator (4) is lit when a tape with a write ring installed is loaded in the tape drive. This switch is used to place the unit in a diagnostic mode.
DENSITY SELECT	The Density switch (5) is used to select between 1600 bpi and 6250 bpi, for writing, at load point. 3200 bpi is not supported. The tape drive will select the proper density during read operations without being pre-set.
ADRS SELECT	The Address Select switch (6) is not used and will not function.
ALPHANUMERIC DISPLAY	The Alphanumeric Display is an eight character display that provides information to the operator.

Figure 11

CRT Configurations

APPENDIX C: CRT CONFIGURATIONS

NOTE: Refer to the Site Preparation Guide for information on Interface Cable Specifications.

ADDS 2020 TERMINAL

The ADDS 2020 terminal has the following general features:

1. 80 or 132 column mode
2. Programmable function keys
3. Bi-directional aux port

This terminal operates in the Viewpoint mode, with a term type of K for releases 180 and later, and with a term type of V for releases prior to 180.

SETUP MODE

To enter the setup mode, press and hold the SHIFT key and press the SETUP key. A menu of options will be displayed. Use the arrow keys and the ENTER key to get to the option you wish to change.

NOTE: The following settings are recommended by Ultimate. Other options may be set later via software. Refer to your ADDS 2020 manual for the correct escape sequences.

COMM

MODE	FDX	BAUD RATE	9600
PARITY	NONE	PARITY CHECK	NO
DATA BITS	8	STOP BITS	1
X-ON/X-OFF	DC1/DC3	PACE	00
TERMINATOR	US/CR		

AUX

PRINTER	SERIAL	BAUD RATE	9600
PARITY	SPACE	PARITY CHECK	NO
STOP BITS	1	X-ON/X-OFF	DC1/DC3
AUX ECHO	NO	PACE	00

KEYBOARD

CASE SELECT	UPPER/LOWER	SPACE CHAR	NON DESTRUCTIVE
KEY CLICK	NO	MARGIN BELL	NO
MENUS	U.S.	KEYBOARD	U.S.

CRT Configurations

SCREEN

SCREEN TIMEOUT	YES	AUTO WRAP	YES
AUTO SCROLL	YES	SCROLL	JUMP
CURSOR HOME	UPPER LEFT	COLUMNS	80
CURSOR	BLOCK	CURSOR BLINK	YES
FORE/BACK	WHT/BLK	PROTECT	HLFINT
DISPLAY TEST	YES		

MODE

TERMINAL	VIEWPOINT	MODE	ENHANCED
PROGRAM KEYS	USER DEPENDENT*		

TABS

User defined for applications. No Ultimate setting.

FUNCTION

Function keys 1-6 and shifted 1-6 are not to be changed. All other function keys are USER definable.

BELL

User defined. No Ultimate setting.

OPTIONS

Not changeable. Hardware set.

NOTE: In the MODE setup, the program keys option may be changed to Terminal Dependent if you wish to have the function keys revert to the default codes at power up. If the program keys are not to be changed, the User Dependent option should be used.

ADDED PRINT @(-n) FUNCTIONS

The following PRINT @(-n) have been added for the ADDS 2020.

@(-70) = 80 column screen display
@(-71) = 132 column screen display

CRT Configurations

VIEWPOINT/60 TERMINAL

SWITCH SETTINGS

To set up the Viewpoint/60 terminal, you must first enter its setup mode by pressing the SHIFT-HOME keys. The STATUS line will then be displayed on the bottom of the terminal.

Example of status line:

Bank 1 Bank 2 Bank 3 Bank 4
SETUP 1=01110111 2=11010001 3=00000000 4=00000000 VP/60

The cursor will be set to bank 1. To move the cursor you must use the cursor control arrows. The UP ARROW will change the status to 1. The LINE-FEED (DOWN ARROW) will change the status to 0. After a selection is made, you must move the cursor to the right or left with the cursor control arrows.

To leave the SET-UP mode, press the HOME key to save your new options. Press the (ESC)ape key to exit from the SET-UP mode without saving new options.

The settings for each switch bank appear on the next two pages.

NOTE: Settings with an asterisk (*) next to them are the recommended settings.

NOTE: 0 = OFF
1 = ON

CRT Configurations

Bank number 1

Switch positions 1 through 4 are for the EIA PORT
 Switch positions 5 through 8 are for the AUX PORT

Baud Rates Bit Settings

110	0000
150	0001
300	0010
1200	0011
1800	0100
2400	0101
4800	0110
9600*	0111*
19200	1000

Bank number 2

Position	Function	Choice		Selection	
		1	Setting	2	Setting
1	Duplex	Half	0	Full	1*
2	Video Presentation	Drk Lht	0	Lht Drk	1*
3	Video Highlight	Half	0*	Full	1
4	Auto Scroll	Disable	0	Enable	1*
5	Auto Line Feed	Disable	0*	Enable	1
6	Display Parity err.	Disable	0*	Enable	1
7	Parity High Bit	Odd	00	Mark	10
8	Parity Low Bit	Even	01**	Space	11

** If you have a DEC 1000/2000 system and are on Rev 110 or later, the terminals should be set for SPACE parity.

CRT Configurations

Bank number 3

Position	Function	Selection			
		Choice 1	Setting	Choice 2	Setting
1	Screen Refresh Rate	60Hz	0*	50Hz	1
2	Cursor Suppress	Visual	0*	Suppressed	1
3	Cursor Format 1	Block	0*	Underline	1
4	Cursor Format 2	Blink	0*	Steady	1
5,6	Character Case	Upper	00*	Up Only	10
		Lower	01	---	11
7,8	Line Terminator	Cr	00*	Cr EOT	10
		Cr ETX	01	No Term.	11

Bank number 4 should be left at all zeroes.

The Viewpoint/60 controls the communication flow to the AUX-PORT by using X/ON-X/OFF and data terminal ready (DTR, pin 20) from the printer. When the terminal's AUX-PORT detects DTR dropped by the printer, it will then send an X/OFF character to the system. This will stop data from going to the printer and overrunning its buffer. When DTR is raised, then the terminal sends an X/ON signal to the computer and then the computer continues sending data.

CRT Configurations

VIEWPOINT/60+ TERMINAL

SETUP MODE

To enter the setup mode, press and hold the SHIFT and HOME keys, then release both. The following menu will appear.

MAIN SETUP MENU

==== PLEASE SELECT ONE OF THE FOLLOWING ====

- "C" - adjust contrast
- "F" - program function keys
- "T" - set tab stops
- "P" - select parameters
- "D" - install default values
- "I" - install power up values
- "E" - exit setup menu

Enter C to adjust the contrast of the screen. The following menu will appear:

CONTRAST

- ARROW UP - increase contrast
- ARROW DOWN - decrease contrast
- HOME - save contrast
- RESET - abort

NORMAL HALF INTENSITY NORMAL | REVERSE | | REVERSE HALF |
| INTENSITY |

Press the UP ARROW to increase intensity. Press the DOWN ARROW to decrease intensity, and press HOME to save it and return to the MAIN SETUP MENU. Press RESET to return to the MAIN SETUP MENU.

To program the function keys, enter F at the MAIN SETUP MENU.

CRT Configurations

The following screen will appear:

<u>FUNCTION KEYS</u>		
<u>OPERATING KEYS</u>		<u>DESTINATION</u>
ARROWS	- cursor movement	0 = AUX
Fn	- function key to edit	1 = LOCAL
RESET	- abort	2 = EIA
ENTER	- exit & update	3 = LOCAL & EIA
HOME	- exit, update & save for power up	

<u>EDITING Fx</u>		
DESTINATION	LINK	LINK KEY
X	X	Fx

Enter the key you want to edit. It should appear in the heading EDITING Fx. Then enter the characters that you want the function key to represent. Use the ARROWS to move from editing line to DESTINATION, to LINK, or LINK KEY. DESTINATION is the port to which the terminal is going to send the function key values (ex. 0=AUX , 2=EIA, EIA is to the system). LINK allows you to link one function key to another.

Tab stops are not recognized by the system and it is recommended that you do not use them.

To change parameters, enter P. The following menu will appear:

CRT Configurations

PARAMETERS

F Duplex
7 EIA baud rate = 9600
7 AUX baud rate = 9600
1 Parity Type = EVEN ** see note
0 Line terminator
0 Language
0 Case select
Y Parity check
Y X-ON/X-OFF
N Refresh rate 50Hz
N Key click
Y Cursor blink
Y Cursor block
N Cursor suppress
N Cursor home upper left
N Half intensity background
Y Dark background
Y Auto scroll
N Auto line feed
N Tagged attributes
N Regent 40 mode

2nd PAGE xxxxxxxxxx

OPERATING KEYS

ARROWS - cursor movement
RESET - abort
ENTER - exit & update
HOME - exit & update &
save for power up

The ARROW keys will move you to each parameter. As you reach each parameter, the options for that parameter will appear on the upper right side of the screen. If you wish to change one, just move to that parameter and enter the option. The HOME key will save all the parameters once they are set, so you do not have to reset them.

** On DEC-based systems, parity should be set to SPACE = 0

CRT Configurations

VIEWPOINT PLUS TERMINALS

Terminal features and operating parameters are selected via the keyboard and are stored in a non-volatile memory. This allows the terminal to be turned off and on while retaining the selected options.

SETUP MODE

To enter the setup mode press and hold the CTRL and TAB keys, then release both. The following menu will appear.

<u>SETUP MENU</u>		
1 Terminal mode	<u>MODES</u>	<u>PARITY</u>
8 Baud rate	0 = A1	0 = Odd
1 Parity	1 = A2	1 = Even
N Display parity error	2 = 3A	2 = Marking
Y Full duplex	3 = 3A+	3 = Spacing
Y Auto scroll		
N Auto line feed		<u>LANGUAGE SELECTION</u>
N Light background	<u>BAUD RATES</u>	0 = United States
N Underline cursor	0 = 110	1 = France
N Blinking cursor	1 = 150	2 = Germany/Switz.
N Keyclick	2 = 300	3 = Sweden/Finland
N Bell on 73rd column	3 = 600	4 = Denmark/Norway
N 50 Hz operation	4 = 1200	5 = Spain/Portugal
O Language	5 = 1800	6 = United Kingdom
N Keycap option	6 = 2400	
N Disable CTRL-Z (3A/3A+)	7 = 4800	Cursor up/dn select
N Space advance (3A only)	8 = 9600	Enter param. change
N Programmable funct. keys	9 = 19200	HOME saves/exit
		ESC exit without
		saving changes
		CTRL-UP & DOWN to
		change contrast

To change a parameter, move the cursor up or down to the parameter and enter your option. If you want the changes to take effect for the duration of one session, press the ENTER key. The options will only be used until you power off the terminal. To save the options, press the HOME key. The ESC key is for exiting the setup menu without resetting the options. The CTRL-UP & DOWN keys are used for adjusting the contrast of the terminal.

CRT Configurations

VIEWPOINT 1010 TERMINAL

This terminal operates in the Viewpoint mode with a term type of V.

INTERFACE CABLE

Refer to the specifications in the Site Preparation Guide. The aux port is configured as an IBM PC compatible parallel printer port.

SETUP MODE

To enter the setup mode, press and hold the CONTROL and F1 keys, then release both. The following menu will appear on the screen. The settings below are recommended by Ultimate.

SETUP MENU

	<u>MODES</u>	<u>PARITY</u>	<u>PRINT LOCAL</u>
1 Term mode	0=A1	0=ODD	0=INHIBIT
8 Baud	1 A2	1 EVEN	1 CR/LF
3 Parity	2 3A	2 MRK	2 CR
N Display parity	3 3A+	3 SPC	3 NONE
Y Full dup			
Y Auto scroll			
N Auto line feed	<u>SCRN FORMAT</u>	<u>LANGUAGE</u>	
N Light background *	0=Normal	0=US	
Y Line cursor *	1 SS/24 LINES	1 FR	
N Blink cursor *	2 JS/25 LINES	2 GEP/SWS	
N Keyclick *		3 SWE/FIN	
Y CRT saver *	<u>BAUD</u>	4 DEN/NOR	
N 50 Hz	0 110	5 SPN/POR	
0 Language	1 150	6 UK	
N Disable CTRL-Z(3A/+ONLY)	2 300		
N Space advance(3A ONLY)	3 600		
0 Screen format	4 1200		
N XON/XOFF	5 1800		
0 Print local	6 2400		
	7 4800		
	8 9600		
	9 19200		

UP/DOWN TO SELECT
HOME - EXITS & SAVES
ESC - EXITS NO SAVE

* Set to User preference.

CRT Configurations

WYSE WY-50 TERMINAL

The WYSE terminal has a screen width of 80 or 132 columns, and split screen capabilities. Terminal features and operating parameters are selected via the keyboard and are stored in a non-volatile memory. This allows the terminal to be turned off and on while retaining the selected options.

SETUP MODE

To enter the setup mode, press the SHIFT and SETUP keys, then release both. A status line should appear at the top and bottom of the screen.

Example:

Top of screen:

Cursor-keys: select fields SPACE: changes FUNCT: F-Keys ESC:
Default

Bottom of screen:

HANDSHAKE=NONE SCREEN=80 CURSOR=BLOCK BLINK?=ON MODE=FDX

This is level one of five levels. All parameter fields are dim, except the far left field in the bottom row, which is normal intensity. Normal intensity indicates the active field. Changes may be made to active fields.

Press the SPACEBAR to change the parameter in the active field. Press the RIGHT ARROW key to activate the next field to the right, and press the LEFT ARROW key to activate the next field to the left. The UP ARROW key moves the fields up one level and the DOWN ARROW key moves the fields down one level.

Settings for each field level appear on the next few pages.

NOTE: An asterisk (*) indicates the recommended setting. If there is no asterisk, set the option at your preference.

CRT Configurations

Field level 1

HANDSHAKE = NONE SCREEN = 80 CURSOR = BLOCK BLINK? = ON
MODE = FDX

PARAMETER

SELECTIONS

Handshake
(protocol)

* None (default)
X-on X-off
DTR
Both (X-on/off and DTR)

Screen
(column/color)

* 80 (default)
132
80 Rev
132 Rev

Cursor

Block (default)
Line

Blink?

On (default)
Off

Mode

* FDX (default)
Block
HDX
H-BLK

CRT Configurations

Field level 2

DATA BIT=8 STOP BIT=1 PARITY BIT=NONE MODEM PORT BAUD RATE=9600

PARAMETER	SELECTIONS
DATA BIT	* 8 (DEFAULT) 7
STOP BIT	* 1 (DEFAULT) 2
PARITY BIT	* None (default) Odd Even Mark
Modem Port Baud Rate	* 9600 (default)

Field Level 3

BLK END=US/CR AUTO NL=ON CR=CR AUTO SCRL=ON AUX BAUD RATE=9600

PARAMETER	SELECTION
BLK END	* US/CR (default) CRLF/ETX
AUTO NL	* ON (default) Off
CR	* CR (default) CR, LF
AUTO SCRL	* On (default) Off
AUX BAUD R	9600

CRT Configurations

Field Level 4

SCRL=JUMP STATUS=ON S.SAVER=OFF PROT=DIM TEST=OFF

PARAMETER	SELECTION
SCRL (scrolling type)	* Jump (default) SM-1 SM-2 SM-3 SM-4 SM-8
STATUS	* On (default) Off
S.SAVER (shuts off screen)	Off (default) On
PROT (display protect attribute)	Dim (default) Rev Norm
TEST (self test)	* Off (default) On

CRT Configurations

Field Level 5

KEYS?=US/UK RET/ENTER=CR/CR COMPATIBLE MODE=WY50 ENHANCE= OFF

PARAMETER	SELECTION
KEYS? (require special ROMs)	* US/UK (default) German French Spanish Danish
RET/ENTER	* CR/CR (default) CRLF/TAB
COMPATIBLE MODE	WY50 (default) TVI910 TVI920 TVI925 * ADDSVP HZ1500
ENHANCE (ADDS-VP, HZ1500 CODE)	Off (default) * On

NOTE: The KEY CLICK status is also saved with the setup. The KEY CLICK may be turned on or off by pressing and holding the SHIFT and ENTER keys, then releasing both.

SAVE SETUP CHANGES

Press and hold the SHIFT and SETUP keys, and release both. The top row should look like the example below, with "Save changes for power-on?" flashing on and off.

Example:

Save changes for power-on? Y:yes (no F-keys) A:F-keys also others:no

If you press Y, all changes except those made to the function keys are saved for the next power-on. If you press A, all changes are saved. If you press any key other than Y or A, the terminal will operate with the current parameter changes,

CRT Configurations

but will not save them when power is turned off.

After you make your selections, the screen will go blank for a second and then return to its operating mode.

WYSE-60 TERMINAL

The WYSE 60 terminal has the following general features:

1. 80 or 132 column mode
2. 24 or 42 lines per screen
3. Programmable function keys
4. Bi-directional aux port which can be used as a modem port to another system

This terminal operates in a WYSE-60 mode, instead of a compatible mode. This may cause a problem with programs that have hard-coded screen functions. To eliminate this problem, use the Ultimate @ Function Negative Values for these features (i.e. PRINT @(-1) TO CLEAR SCREEN). Refer to the next page, and the "BASIC Statements and Functions" section of your BASIC manual for a list of @ functions.

SETUP MODE

To enter the setup mode, press and hold the SHIFT and SETUP keys. A menu of screen options will be displayed. Select the option you wish to change by using the function keys across the top of the keyboard.

NOTE: The following settings are recommended by Ultimate. Other options may be set later via software. See your WYSE-60 manual for escape sequences.

F1 DISPLAY

COLUMNS=80	STATUS LINE=STANDARD	BACKGROUND=DARK
LINES=24	SCRL=JUMP	SCRN SAVER=ON
PAGE LENGTH= 1xLINES	CURSOR=BLINK BLOCK	MONITOR=OFF
ATTRIBUTE=CHAR	TVI955=NO SPACE	

F2 GENERAL

PERSONALITY=WY60	ENHANCE=ON	FONT LOAD=ON
COMM MODE=FULL		
DUPLEX	END OF LINE WRAP=ON	SEND ACK=ON
DATA/PRINTER=		
MODEM/AUX	TEST=OFF	PAGE EDIT=OFF
MARGIN BELL=OFF	LABELS=ON	SAVE LABELS=ON

CRT Configurations

F3 KEYBOARD

KEY CLICK=ON	KEY LOCK=REV	KEY REPEAT=ON
RETURN=CR	ENTER=CR	CORNER KEY=HOLD
XMT LIMIT=NONE	FKEY LIMIT=NONE	BREAK=250ms
WYSEWORD=OFF	LANGUAGE=US	

F4 MODEM

BAUD RATE=9600	DATA BIT=8	RCV HANDSHAKE =
		X-ON/X-OFF
PARITY=NONE	STOP BIT=1	XMT HANDSHAKE =
		X-ON/X-OFF
		XPC HANDSHAKE=ON

F5 AUX

BAUD RATE=9600	DATA BIT=8	RCV HANDSHAKE =
		X-ON/X-OFF
PARITY=NONE	STOP BIT=1	XMT HANDSHAKE =
		X-ON/X-OFF
		XPC HANDSHAKE=ON

F6 IBM

NULL=ON	SEND PAGE=LINE
---------	----------------

F7 ASCII

BLOCK END=US/CR	AUTO SCRL=ON	WPRT INTENSITY=DIM
VP60 BLK END=NONE	AUTO PAGE=OFF	WPRT REVERSE=OFF
RCVD CR=CR		WPRT UNDERLINE=OFF

F8 (FUNCTION KEYS) and F9 (FUNCTION KEY LABELS) are user-defined. The settings above are recommended by Ultimate. Your software house or dealer may suggest other settings, depending on your application.

ADDED PRINT @(-N) FUNCTIONS

The following PRINT @(-n) have been added for the WYSE-60:

- @(-70) = 80 column screen display
- @(-71) = 132 column screen display
- @(-72) = 24 line mode
- @(-73) = 42 line mode

HONEYWELL-BASED CHIRON SYSTEMS

The following information is for Chiron systems with the SCF PORT 0. These systems include the Honeywell-based 6200 and 6400. The 6000 systems will run with the Wyse terminals if the CPU has a part number greater than BXCSS11A-009 (this

CRT Configurations

information should be available from Honeywell). All 6000 systems shipped recently will have the correct CPU.

HANDSHAKE = NONE

DATA BIT = 7

STOP BIT = 1

PARITY = EVEN

CRT Configurations

WYSE-85 TERMINAL

SETUP

The set-up mode is entered by pressing the SET-UP key, located in the upper left hand corner of the keyboard.

Upon entering the setup mode, a status line should appear both at the top and bottom of the screen. The status line at the top left corner of the screen displays the name of the set-up level currently being monitored. The rest of this status line displays the valid keyboard responses, followed by the action taken when that key is entered. In all levels, the keyboard responses are single key commands.

Example:

The status line for the DIRECTORY level (1st level) is:

```
LEVEL NAME  SETUP-Exit  ENTER-Select  < > New field  ^ v New  
level
```

Press the SETUP key to exit the set-up mode.

Press the ENTER key to select the next parameter in the active field. The active field is displayed in reverse video on the bottom status line.

Press the LEFT-ARROW or the RIGHT-ARROW keys to change the active field.

Press the UP-ARROW and DOWN-ARROW keys to select the next and previous levels, respectively.

The status line at the bottom of the screen displays the parameters that can be monitored in this level.

NOTE: This terminal will not send a control underscore to the system because the terminal that it emulates does not send that character.

CRT Configurations

SETTING UP THE WYSE-85 ON REV 150 AND ABOVE

If you are on Rev 150 or above, the Wyse-85 terminal may be set up by entering TERM-INIT from TCL on SYSPROG. You will be prompted for the terminal type, which is "Y" for this terminal. After using this utility, three parameters must be set up from the keyboard set-up mode. They are Handshake, Xmt limit and Fkey limit. Follow the steps below to set up these parameters.

1. Press the SET-UP key to enter the set-up mode.
2. Press the DOWN-ARROW key until you reach the Communications-2 level.
3. The active field will be the HANDSHAKE field.
4. Press the ENTER key until this field changes to <Both>.
5. Press the LEFT-ARROW to change the active field to XMT LIMIT.
6. Press the ENTER key until this field changes to <150 cps>.
7. Press the DOWN-ARROW until you reach the Send level.
8. Press the RIGHT-ARROW to change the active field to Fkey XMT.
9. Press the ENTER key until this field changes to <150 cps>.
10. Press the SET-UP key to return to the Directory level.
11. Press the RIGHT-ARROW to select the SAVE field.
12. Press the ENTER key to save all changes into memory.

CRT Configurations

SETTING UP THE WYSE-85 MANUALLY FOR ALL RELEASES

Below is a list of the proper setups for each of the setup levels.

LEVEL NAME: DISPLAY-1

Columns:80 Controls:Interpret Autowrap:ON Scroll:Jump
Screen:Dark Rows:24

LEVEL NAME: DISPLAY-2

Cursor: Blinking Block CRT Saver:ON Width Change Clear:OFF
Status Line:ON

LEVEL NAME: GENERAL-1

Mode:VT200 7 bit Pound:# Fkey Lock:OFF Feature Lock:OFF
Newline:OFF Local:OFF

LEVEL NAME: GENERAL-2

Keypad:Numeric Cursor Keys:Normal Transfer Term:Cursor
Test:OFF

LEVEL NAME: COMMUNICATIONS-1

Transmit:9600 Receive:9600 Data Bits:8 Parity:None Parity
Check:OFF Echo:OFF

LEVEL NAME: COMMUNICATIONS-2

Handshake:Both Stop Bits:1 Port:EIA data Disconnect:2 sec Xmt
Limit:150 cps

LEVEL NAME: PRINTER-1

Speed:9600 Data Bits:8 Parity:None Stop Bits:1 Handshake:Both
Terminator:None

LEVEL NAME: PRINTER-1

Print:Full Screen Print:ASCII Print Mode:Normal PR
Receive:OFF

LEVEL NAME: KEYBOARD-1

Lock:Caps Keyrepeat:ON Keyclick:OFF Margin bell:OFF Warning
Bell:ON Break:ON

LEVEL NAME: KEYBOARD-2

Answerback:OFF Compose:ON X:BS/DEL Keyboard:N. American
Keys:Typewriter

LEVEL NAME: SEND

Fkeys:Remote Fkey Xmt:150 cps Send:All Send Area: Full Screen
Send Term: None

Printer Configurations

		(connect)	
		/	
	GND .		
	GND .		
		DATA	
		\	
		(connect)	
		/	
	E2 .		
C-9	REQ TO SEND - BSY	. . . IONL	
		BSY .--.	
		. . . NBSY	
	DTR - BSY	BSY .--.	
		. . . NBSY	
		NTO . .	
		. . . TOB	
	DATA TRANSMIT - TOB	TOB .--.	
		. . . NTO	
	REVERSE CHANNEL - NBSY	NBSY .--.	
		. . . BSY	
C-11	BAUD RATE SELECT - 9.6K	EXT . .	
		. . . 75	
		150 . .	
		. . . 300	
		600 . .	
		. . . 1.2k	
		2.4k . .	
		. . . 4.8k	
		9.6k .--.	
		. . . 19.2k	
F-4	PARITY	PARITY .--.ENABLE(remove	
		. . . 64 for LSI)	
		.--. 128	
		8 . . . BITS	
		.--. 256	
		.--. 512	
		. . . ODD	
		PARITY	
H-10	BAFL - HYS	HYS .	
		\	
		(connect)	
		/	
		. . . NO HYS	
K-4	PROGRAM X-MIT	ON-ACK	OFF-NACK
	CHARACTER	8 .--.	8 .--.
		1 . .	1 . .

Printer Configurations

7	.--.	7	.--.
2	.--.	2	. . .
6	.--.	6	.--.
3	.--.	3	.--.
5	. . .	5	. . .
4	.--.	4	.--.

Printer Configurations

DEC LETTERPRINTER 210

The Letterprinter 210 is a dot-matrix serial printer with logic-seeking, bidirectional print. It can print at a maximum speed of 240 characters/second in Draft Quality Mode, and at 40 characters/second in Letter Quality Mode. The Letterprinter 210 can be used on the entire Ultimate product line.

SWITCH SETTINGS

Switch banks are located at the back of the printer, along the bottom. There are two banks of switches. They must be set before powering on the printer. Following are the standard switch settings for Ultimate systems.

ULTIMATE PC

Switch Bank A

1 OFF
2 OFF
3 OFF
4 OFF
5 ON
6 ON
7 ON
8 ON

Switch Bank B

1 ON
2 OFF
3 ON
4 ON
5 OFF
6 OFF
7 ON
8 OFF

DEC AND HONEYWELL SYSTEMS

Switch Bank A

1 OFF
2 OFF
3 OFF
4 OFF
5 ON
6 ON
7 ON
8 OFF

Switch Bank B

1 ON
2 OFF
3 ON
4 ON
5 OFF
6 OFF
7 ON
8 OFF

Printer Configurations

Switch Bank A

1 Speed Control Line	OFF	Restraint mode			
	ON	Speed Control mode			
2 Modem Control	OFF	No Modem Control			
	ON	Modem Control			
3/4 Paper Fault	OFF/OFF	XOFF Sent			
	ON/OFF	Break Sent			
	OFF/ON	Drop DTR			
	ON/ON	Do Not Connect			
5 End of Transmission	OFF	Disconnect on EOT			
	ON	Ignore EOT			
6 XON/XOFF	OFF	Disable XON/XOFF			
	ON	Enable XON/XOFF			
7 Error Processing	OFF	Print Substitute Char.			
	ON	Print as Received			
8 Store Features	Move off, then on, to store settings in memory.				

SWITCH BANK B

BAUD RATE	1	2	3	4	5
50	OFF	OFF	OFF	OFF	OFF
75	ON	OFF	OFF	OFF	OFF
110	OFF	ON	OFF	OFF	OFF
134.5	ON	ON	OFF	OFF	OFF
150	OFF	OFF	ON	OFF	OFF
200	ON	OFF	ON	OFF	OFF
300	OFF	ON	ON	OFF	OFF
600	ON	ON	ON	OFF	OFF
1200	OFF	OFF	OFF	ON	OFF
1800	ON	OFF	OFF	ON	OFF
2400	OFF	ON	OFF	ON	OFF
4800	ON	ON	OFF	ON	OFF
7200	OFF	OFF	ON	ON	OFF
9600	ON	OFF	ON	ON	OFF

Printer Configurations

IGP-10 BOARD

The Intelligent Graphics Processor (IGP-10) is an optional board that is used with the P-Series Printronix printers. It can be used in a serial printer, where it takes the place of the data comm board, or in a parallel printer, where it occupies the empty slot. The IGP board allows you to design and print forms, logos, seven types of bar codes, and alphanumeric data. The IGP board allows compressed print of 10, 13, 15, and 17 characters per inch and expanded print of 1 to 99 times the standard size. The IGP board has vertical line spacing of 6, 8, 9, or 10 lines per inch. The reverse print command causes the printer to print white-on-black, and works with standard and expanded characters, logos, and forms. The reverse print command does not work with bar codes or compressed print.

The jumpers on the A and B logic boards must be changed before the IGP board is installed. Refer to the configuration for Printronix A and B Logic Boards in the beginning of this appendix for the correct jumpering. The following is a list of the switch settings for the IGP-10 board.

SERIAL SWITCH SETTINGS

Switch B2

<u>Sw #</u>	<u>Open/Closed</u>	<u>Function</u>
1	Closed	Enable DTR
2	Closed	Enable RTS
3	Open	Control Character Selection (CTRL C)
4	Open	Control Character Selection (CTRL C)
5	Open	N/A
6	Open	Select P-Series Control Codes
7	Open	N/A
8	Open	Forms Length Selector Option

Switch B3

<u>Sw #</u>	<u>Open/Closed</u>	<u>Function</u>
1	Open/Closed	Serial Interface/Parallel Interface
2	Closed	Select Internal Baud Rate Clock
3	Open	External Clock (Ignored, Internal Clock Used)
4	Open	External Timing (Ignored, Internal Clock Used)
5	Open	N/A
6	Open	N/A
7	Open	N/A
8	Open	N/A

Printer Configurations

Switch D1

<u>Sw #</u>	<u>Open/Closed</u>	<u>Function</u>
-------------	--------------------	-----------------

1	Closed	Baud Rate * 9600 Baud
2	Open	Baud Rate * " "
3	Closed	Baud Rate * " "
4	Closed	Baud Rate * " "
5	Open/Closed	Select 8 Bit Interface (open/DEC, closed/Honeywell)
6	Open	Even Parity
7	Open/Closed	Enable/Disable Parity (open/DEC, closed/Honeywell)
8	Closed	2 Stop Bits

Switch D2

<u>Sw #</u>	<u>Open/Closed</u>	<u>Function</u>
-------------	--------------------	-----------------

1	Open	High True Logic (DTR/RTS)
2	Open	Enable Sense of Data Bit 8
3	Open	High True (data strobe)
4	Open	Enable Sense of PI Line
5	Open	CR will not cause Paper Advance
6	Open	Auto-Line Feed Disable
7	Open	Test
8	Open	N/A

Parallel Switch Settings

Switch B2 1-8 open
Switch B3 1 closed, 2-8 open
Switch D1 1-7 open, 8 closed
Switch D2 1-8 closed

Serial/Parallel Interface Jumpers

Jumper location A9 for Serial Interface
Jumper location A10 for Parallel Interface

Printer Configurations

* Alternate Baud Rates

<u>Baud Rate</u>	<u>Sw 1</u>	<u>Sw 2</u>	<u>Sw 3</u>	<u>Sw 4</u>
50	Closed	Open	Open	Open
75	Open	Closed	Open	Open
110	Closed	Closed	Open	Open
134.5	Open	Open	Closed	Open
150	Closed	Open	Closed	Open
300	Open	Closed	Closed	Open
600	Closed	Closed	Closed	Open
1200	Open	Open	Open	Closed
1800	Closed	Open	Open	Closed
2000	Open	Closed	Open	Closed
2400	Closed	Closed	Open	Closed
4800	Open	Open	Closed	Closed
9600	Closed	Open	Closed	Closed
19.2K	Open	Closed	Closed	Closed
38.4K	Closed	Closed	Closed	Closed

Printer Configurations

NEC 3500 LETTER QUALITY PRINTER

SWITCH SETTINGS

The following switch settings should be used for the NEC 3500 35cps printer. The switch settings are located on the logic board inside the rear of the printer. There are three sets of 8 dip switches each. The diagram below shows the order of these switches.



NOTE: 0 = OFF
1 = ON

The following is a description of each switch setting.

SW1

1	SPEED	ON	(1200 BAUD)
2	SPEED	ON	
3	LOCAL LF	OFF	
4	AUTO CR	ON	
5	PARITY ENABLE/DISABLE	OFF	for DEC systems, ON for HONEYWELL
6	PARITY EVEN/ODD	ON	
7	X/ON	ON	
8	CUT SHEET GUIDE	OFF	

SW2

1	10/12/15 CPI DEFAULT	OFF	
2		OFF	
3	LF/FF	OFF	(FF)
4	PAPER OUT DETECT	OFF	
5	8/6 LPI DEFAULT	OFF	
6	PS/STD DEFAULT	OFF	
7	TEST	ON	
8	REMOTE/LOCAL DEFAULT	ON	

SW3

1	NOT USED	OFF	
2	" "	OFF	
3	" "	OFF	
4	" "	OFF	
5	DATA SET READY	ON	

Printer Configurations

6	DTR=RVC	ON
7	RVC=-12	OFF
8	HAMMER DISABLE	OFF

Printer Configurations

NEC 5500 SPINWRITER

SWITCH SETTINGS

NOTE: ON is the UP position and OFF is the DOWN position.
The "*" indicates the normal switch settings for use
with ULTIMATE systems.

Printer Interface Logic Board

The printer cover must be removed. The switches are located on the board in the rear of the printer. Only the first 4 switches are set:

SW.	ON	OFF
1	Keyboard Enabled (KSR)	* Keyboard Disabled (RD)
2	* Driver Lock Normal	Driver Lock
3	Carrier Detect Enabled	* Carrier Detect Disabled
4	Hammer Driver Enabled	* Hammer Driver Disabled

Printer Control Panel Board

To locate the switch, lift the printer lid and look behind the Front Panel Cover on the top left side.

SW.	ON	OFF
1	Auto Carriage Return	* Auto Carriage Return Disabled
2	* Clear Individual Tab Stops	Clear All Tab Stops
3	Break Enabled	* Console Interrupt Enabled
4	* XON/XOFF Protocol	ETX/ACK Protocol
5	Reverse Channel High	* Reverse Channel Low
6	RESERVED...MUST BE OFF	* RESERVED...MUST BE OFF
7	* ON Baud Rate See Table 1	
8	* ON Baud Rate See Table 1	

Front Panel Rocker Switch Settings

TEST	Down	SPEED	High
DUPLEX	Full	PARITY	Even - Honeywell Systems Mark - DEC-based Systems

The balance of the rocker switches are set according to individual specifications.

Printer Configurations

TABLE 1

7	8	L	M	H
OFF	OFF	110	150	300
OFF	ON	110	200	300
ON	OFF	110	300	600
ON	ON	110	300	1200

Switches 7 and 8 on the Panel Control Board set the baud rates that can be selected by the Panel Rocker Switch, labeled L M H.

Printer Configurations

PRINTRONIX A AND B LOGIC BOARDS

JUMPERS

The following jumpers are required on the Printronix printer to properly interface with the Ultimate systems.

I M P O R T A N T ! ! !

On the "A" logic board of all model printers, chip location "3A" must contain a 1K ohm resistor pack, and location "2A" must be left empty.

Printer Speed	Logic Bd.	Chip Loc.	Jumper	Comments	
P-150	A-2	8K	4-11	Note 1	
		8K	5-10	Note 1	
		9K	7-8		
		9K	2-13	Note 2	
	A-4	See A-2			
	A-6	See A-2			
	B-5	8K	4-11	Note 2	
		9K	4-11		
		B-7	8K	6-9	
			8K	4-11	Note 2
9K	3-12				
9K	7-8				
B-9	See B-7				
P-300	A-1	8K	4-11	Note 1	
		8K	5-10	Note 1 & 3	
		9K	2-13	Note 2	
	A-2	See A-1			
	A-4	8K	4-11	Note 1	
		8K	5-10	Note 1 & 3	
		9K	2-13	Note 2	
		9K	4-11		
	A-6	See A-4			

Printer Configurations

Printer Speed	Logic Bd.	Chip Loc.	Jumper Pins	Comments
P-300	B-4	8K	6-9	Note 2
		8K	4-11	
	B-5	8K	6-9	Note 2
		8K	4-11	
		9K	6-9	
	B-7	8K	6-9	Note 2
		8K	4-11	
		9K	4-11	
		9K	6-9	
		9K	7-8	
	B-9	8K	6-9	Note 2
		8K	4-11	
9K		4-11		
9K		6-9		
9K		7-8		
P-600	A-4	8K	4-11	Note 1
		8K	5-10	Note 1 & 3
		8K	1-14	Note 5
		9K	2-13	Note 2
	A-6	See A-4		
	B-7	8K	4-11	Note 2
		8K	5-10	
		8K	6-9	
		9K	4-11	
		9K	6-9	
B-9	See B-7			

- Note 1 Remove if using IGP board
- Note 2 Install if using IGP board
- Note 3 Release 10 only
- Note 4 Install if using A-1 through A-5 logics
- Note 5 Phase Fire printer only

Printer Configurations

PRINTRONIX MVP

The MVP printer is a dot matrix line printer with 5 printing modes. The printing modes are Correspondence Print at 10 characters/inch, Data Processing Print at 10 characters/inch, Compressed Print at 12.5 characters/inch, Condensed Print at 16.7 characters/inch, and Plot Mode.

CONFIGURATION OPTIONS

The following are the standard internal settings for the MVP Printronix printer on Ultimate systems. For a description of each switch setting, consult the MVP Printer manual. You can select the printer configuration options shown below with the ADDR and DATA panel switches located directly on the right front of the printer. You must raise the front cover to see these switches. Also note the digital display to the left of the panel.

To change the parameters, follow these steps:

1. Insure that the RDY light is blinking. (If not, press the RDY switch).
2. Press the 2nd-Func key.
3. Increment the left side of the digital display by pressing the ADDR switch (the left counter will increment rapidly). Stop at the desired selection.
4. When the desired configuration parameter is reached, place the printer into configuration mode by holding the DATA key and quickly pressing and releasing the MODE key.
5. Step through the right side of the digital counter by pressing the DATA key. Once the desired selection is reached, press the 2nd-FUNC key.

20.1	21.0	22.0	23.0	24.0	25.0	26.0	27.0	28.0	29.0
30.0	31.0	32.0	33.0	34.0	35.0	36.0	37.0	38.0	39.0
40.0	41.0	42.0	43.0	44.0	45.0	46.0	47.0	48.0	49.0
50.1	51.0	52.0	53.0	54.0	55.0	56.0	57.0	58.0	59.0
60.1	61.0	62.0	63.1	64.0	65.0	66.0	67.0	68.0	69.0
70.1	71.0	72.9	73.0	74.0	75.0	76.1	77.0	78.2	79.1
80.0	81.0	82.17	83.19	84.11	85.0	86.C	87.8	88.1	89.0
90.0	91.0	92.0	93.0	94.0	95.0	96.0	97.0	98.0	99.0

Printer Configurations

Below is a brief description of the major switch settings.

Feature	Options	Comments
Programming standard	20.1	P-Series
Perforation skip	50.1	Disable perf. skip
Forms length (power on)	52.0	Enable 11 inches
Interface type	70.1	RS232 with XON/XOFF
Baud rate	71.0	9600 baud (see note)
Word length	72.1	7 bits even parity
	72.9	(DEC only) 7 bits no parity
Xmit polarity	73.0	Normal
Request to send	74.0	On if buffer not full
Clear to send	75.0	Disable
Data set ready	76.1	On to receive
Reverse channel	77.0	Disable
Data terminal ready	78.2	Always on
XON level	79.1	25% of buffer
XOFF level	80.0	75% of buffer

To print a configuration sheet:

1. Ensure the RDY light is blinking.
2. Press the 2nd-Func key.
3. Press the ADDR key until the first two digits are zeros.
4. Press the DATA key until the last digit is a one. The display should now show 00.1
5. Press the 2nd-Func key. The printer should now start printing a configuration sheet.

Printer Configurations

PRINTRONIX COMPRESS PRINT MODE

There are two methods of achieving compressed print on the Printronix printers. They are the installation of a A7-B10 logic board combination or the installation of an IGP board. Each method has distinct advantages.

A7-B10 LOGIC BOARDS

The A7-B10 logic board combination has printing of 10, 13.3 or 16.7 characters per inch. The character size is software-selectable, with a switch for default setup. For example, if the switch is set at 10 and you software-select 16.7 characters/inch, the printer will return to 10 characters/inch when done with your job. The A7-B10 combination also has a Draft Mode. This will allow the 300 to print at 400 lines per minute, and the 600 at 800 lines per minute, although the print quality is not as good.

IGP-10 BOARD

The use of an IGP-10 board is another way of achieving compressed print. This board will work on a parallel or serial printer. In a parallel printer, it goes in the empty card slot. In the serial printer, it replaces the data comm board. This board features 10, 13.3, 15 or 17 characters per inch, bar code, reverse printing, and enlarged print from a maximum of 9.9 inches, decreasing in 1/10 inch increments. This is totally software-selectable, with no default switch settings.

Index

INDEX

1/2" reel tapes	4-7
1/4" cartridge tapes	4-7
1400 series, creating memory dump	11-23
1400 series, debugger	11-17
1400 series, diagnostics monitor	6-30
1400 series, powering off	3-3
1400 series, powering on	2-3
1400 series, tape drives	4-7
6000 and 7000 series, creating memory dump	11-20
6000 and 7000 series, diagnostics monitor	6-9
6000 and 7000 series, powering off	3-1
6000 and 7000 series, powering on	2-1
:WARMSTOP	5-2, 5-5, 5-7, 6-2, 6-30, 7-10, 7-14, 8-18, A-4
Aborts	11-6, A-1
ACC file	1-3, A-1
ACC file, clearing	9-7
Account-Restore	8-10, A-1
Account-Restore, summary	8-16, 8-17
Account-Save	7-7, A-1
Account-Save, summary	7-9
Accounting history file	1-3, A-1
Adding equipment	10-1
Adding equipment, summary	10-1
Adding ports	10-1
ALL-UPDATE-SAVE	7-22, A-1
ALL-UPDATE-SAVE, restoring from	8-27
ALL-UPDATE-SAVE, summary	7-24
Alternate track table	11-9, A-1
Alternate tracks, assigning	11-9
Ampersands	11-8
Assigning alternate tracks	11-9
Backing up	7-1
Backup tapes, labeling	7-1
Backup tapes, organizing	7-1
Backup tapes, rotating	7-2
Basic control panel, booting	5-3, B-3
Basic control panel, initializing	5-3, B-3
Battery backup unit (BBU)	11-18, A-1
Baud rate	A-1
Binary-Restore	7-10, 8-18, A-1
Binary-Restore, summary	8-21
Binary-Save	7-10, A-1
Binary-Save, summary	7-13
Boot	6-1, 6-3, A-1
Boot options	6-1, A-1
Booting	5-1
Calling Ultimate Support	11-3
Cartridge Module Disk	4-1
Cartridge tapes, loading	4-7
Cartridge tapes, unloading	4-7
Charge units	1-4, A-2

Index

Checking tape for parity errors	11-10
Check-sum	9-2
Cleaning GCR tape heads	4-5, 9-5
Cleaning tape drive	4-5, 9-6
Clear ACC file	9-7
CMD drive	2-1, 3-2, 4-1, 9-5, A-2, B-8
CMD drive, cycling down	3-2, 4-3
CMD drive, cycling up	4-3
CMD drive, installing disk pack	4-4
CMD drive, removing disk pack	4-4
Coldstart	5-2, 5-3, 5-7, 6-1, 6-3, 11-6, 11-18, A-2
Coldstart, summary	6-8
CONFIG	7-15
Connect time	1-4, A-2
Creating memory dumps	11-20
CRT configurations	C-1
Daily maintenance	9-1
Data, restoring	8-1
Debugger, 1400 series	11-17
Diagnostics monitor, 1400 series	6-30
Diagnostics monitor, 6000 and 7000 series	6-1, 6-9, A-2
Disk drive procedures	4-1
Disk drive, cycling up	2-1
Disk errors	9-3, 11-9
Disk, formatting	6-9, 6-18, 9-8
Disk, formatting, summary	6-28, 6-29
Disk, reformatting	6-9, 6-18, 11-8
Disk-to-disk copy	7-14
Disk-to-disk copy, summary	7-19
D-RDLBL	7-15
Dumping memory to tape	11-20, 11-23
DX files and pointers	7-28
Eight-Inch Module Drive (EMD)	4-1
EMD drive, powering off	3-1, 4-1
EMD drive, powering on	3-1, 4-1
Equipment, adding	10-1
Equipment, adding, summary	10-1
Equipment, checking	1-1
FCC Warning	P-4
File-Restore	6-2, 6-30, 8-1, 9-7, A-2
File-Restore with update/transaction tapes	8-27
File-Restore with update/transaction tapes, summary	8-38
File-Restore, summary	8-9
File-Save	7-3, 9-1, 11-5, 11-8, A-2
File-Save, summary	7-6
File-Save, weekly	9-6
File-Save, incremental	7-22
File-Stats	9-1, A-2
File-Stats, checking	9-1
Fixed Storage Device	4-1
Formatting a disk	6-9, 6-18, 9-8
Formatting a disk, summary	6-28, 6-29
FSD drive	2-1, 4-1, B-5, B-6

Index

FSD drive, powering off	3-1, 4-1, B-5, B-6
FSD drive, powering on	3-1, 4-1, B-5, B-6
Full control panel, booting	5-1, B-2
Full control panel, initializing	5-1, B-2
GCR tape heads, cleaning	4-5, 9-5, B-10
Getting Started Checklist	1-12
Group Format Errors	6-2, 9-1, 11-4, 11-18, A-2
Hangs, during File-Save	11-8
Hangs, system	11-8, A-2
Hangs, terminal	11-8
HPP errors	11-18, A-2
Incremental File-Saves	7-22
Incremental File-Saves, restoring from	8-27
Incremental File-Saves, restoring from, summary	8-38
Initializing	5-1
Labeling backup tapes	7-1
Line-printer pages	1-4, A-2
LINK-WS	11-6
List-system-errors	9-3, 11-9, 11-13
Loading UltiWord	1-4
Loading WP	1-4
Locks	11-8, 11-11
Log, troubleshooting	11-1, 11-23
Maintenance	9-1
Maintenance, daily	9-1
Maintenance, monthly	9-7
Maintenance, semi-monthly	9-8
Maintenance, summary	9-8
Maintenance, weekly	9-6
Memory dump, creating for 1400 systems	11-23
Memory dump, creating for 6000 and 7000 systems	11-20
Mismatches	11-14
Monthly maintenance	9-7
Offline monitor	6-2, 6-30, A-3
Organizing backup tapes	7-1
Parity errors, checking for	11-10
PART-UPDATE-SAVE	7-22, 7-25, A-3
PART-UPDATE-SAVE, restoring from	8-27
PART-UPDATE-SAVE, restoring from, summary	8-38
PART-UPDATE-SAVE, summary	7-27
Percent signs	11-10
Ports, adding	10-1
POVF	9-4, A-3
Power conditioners	11-19, A-3
Power failures	11-19
Powering off	3-1
Powering on	2-1
Print overflow table	9-4, A-3
Printer problems	11-12
Printers	1-2
Printers, baud rate	1-3
Printers, configurations	D-1
Printers, location	1-2

Index

Reallocation modulo and separation	8-5
Reel tapes, loading	4-7
Reel tapes, unloading	4-8
Reformatting disk	11-9
Remote panel	3-1, 7-11, 7-15, 8-18, 11-19, A-3
Restoring data	8-1
Restoring from incremental file-saves	8-27
Restoring from incremental file-saves, summary	8-38
Restoring from transaction logger	8-27
Restoring from transaction logger, summary	8-38
Restoring from update-saves	8-27
Restoring from update-saves, summary	8-38
Rotating backup tapes	7-2
SCF, booting	5-5
SCF, initializing	5-5
Sel-Restore	8-24
Selective-Restore	8-24, A-3
Selective-Restore, summary	8-26
Semi-monthly maintenance	9-8
SET-BAUD verb	1-2
Site log	11-25
SMD drive	2-1, 3-2, 4-1, 9-5, A-3, B-7
SMD drive, cycling down	3-2, 4-2
SMD drive, cycling up	4-2
SMD drive, installing disk pack	4-2
SMD drive, removing disk pack	4-3
SP-ASSIGN	1-2, 11-10
SP-LISTLPTR	1-3, 11-10
Storage Module Disk	4-1
System control facility, booting	5-5
System control facility, initializing	5-5
System errors	9-3, 11-9, 11-12
System errors, listing	9-3, 11-9, 11-12
System hangs	11-8
System Startup Options	6-1, A-3
T-DUMP	7-20, A-3
T-DUMP, summary	7-21
T-LOAD	8-22, A-3
T-LOAD, summary	8-23
Tape, checking for parity errors	11-10
Tape, dumping memory to	11-20, 11-23
Tape drive procedures	4-4, B-9, B-10
Tape drive, cleaning	4-5, 9-5
Tape drive, loading	2-2, 4-4
Tape drive, unloading	3-2, 4-4
Tape errors	11-10
Tape handling	4-5
Tape heads, cleaning	4-5, 9-6
Tape heads, cleaning GCR	4-5, 9-5
Terminal hangs	11-8
Terminals	1-1
Terminals, baud rate	1-2
Terminals, configurations	C-1

Index

Terminals, location	1-2
Transaction, definition	7-28
Transaction logger	7-28, A-3
Transaction logger, restoring from	8-27
Transaction logger, restoring from, summary	8-38
Transaction logger, summary	7-32
Transaction logger, with update-saves	7-33
Transaction logging session	7-28
Transaction session tape set	7-28
Traps	11-16, A-3
Troubleshooting	11-1
Troubleshooting log	11-1, 11-25
Troubleshooting, general	11-1
Ultimate Support, calling	11-3
UltiWord, loading	1-4
Uninterruptable power supply (UPS)	11-19, A-3
Update-Saves	7-22, A-4
Update-Saves, restoring from	8-27
Update-Saves, restoring from, summary	8-38
Update-Saves, summary	7-24, 7-27
Update-Saves, with transaction logger	7-33
Utilities monitor	6-2, 6-30, A-4
Verify-system	9-2, 11-14
Warmstart	5-2, 5-3, 5-7, 6-2, 6-30, 11-4, A-4
Warmstart from options menu	6-30
Warmstart from options menu, summary	6-32
Warmstart from TCL	6-31
Warmstart from TCL, summary	6-33
Warmstart, summary	6-32, 6-33
Weekly maintenance	9-6
WHO verb	1-2
Workspace	11-6
WP, loading	1-4
WREN tape drives	4-5



ULT

THE ULTIMATE CORP.

717 RIDGEDALE AVENUE, EAST HANOVER, NEW JERSEY 07936

(201) 887-9222 TWX 710-996-5862 Telecopier (201) 887-6139

ID: COMM-12
DIST: DLR
RE: HAYES SMARTMODEM 1200
DATE: 07/10/86

This Tech Tip explains how the Hayes Smartmodem 1200 may be used with Ultimate systems.

The Hayes Smartmodem 1200 is an auto-dial modem that can be used to auto-dial either from the keyboard of a CRT or through software on a computer system. It is capable of detecting the baud rate being used, and thus does not require a modem baud rate setting. However, it is capable only of 300 and 1200 baud.

SWITCH SETTINGS

To use the Hayes Smartmodem 1200, the following switch settings are required. The switches can be accessed by removing the front cover of the modem, where the red indicator lights are located. Note that the older style Hayes Smartmodems have only 8 switches. On those modems, only the first 8 switches apply.

UP=ON
DOWN=OFF

! 1 ! 2 ! 3 ! 4 ! 5 ! 6 ! 7 ! 8 ! 9 ! 10 !
!DOWN!DOWN! UP !DOWN! UP !DOWN! UP !DOWN! UP ! UP !

Switch	direction	Function
1	down	Forces DTR high
2	down	Does not send command results out
3	up	Results will not be sent to computer
4	down	Does not echo commands to computer
5	up	Automatically answers incoming calls
6	down	Forces carrier detect true
7	up	Setting for connection to RJ1 jack
8	down	Enables command recognition
9	up	Compatible with Bell 103/212a modems
10	up	Modem reset when turned on

When hooking up this modem directly to a Honeywell-based Ultimate, Switch 1 should be UP, to allow DTR to be raised and lowered to insure disconnection when using UtiLink communications. Also, the modem will only read switches optioned upon power on. Once the modem is optioned, it must be powered off and then on.

SECRET
The following information is being furnished to you for your information only. It is not to be disseminated outside your organization.

SECRET

- 1. [Illegible]
- 2. [Illegible]
- 3. [Illegible]
- 4. [Illegible]
- 5. [Illegible]
- 6. [Illegible]
- 7. [Illegible]
- 8. [Illegible]
- 9. [Illegible]
- 10. [Illegible]
- 11. [Illegible]
- 12. [Illegible]
- 13. [Illegible]
- 14. [Illegible]
- 15. [Illegible]
- 16. [Illegible]
- 17. [Illegible]
- 18. [Illegible]
- 19. [Illegible]
- 20. [Illegible]
- 21. [Illegible]
- 22. [Illegible]
- 23. [Illegible]
- 24. [Illegible]
- 25. [Illegible]
- 26. [Illegible]
- 27. [Illegible]
- 28. [Illegible]
- 29. [Illegible]
- 30. [Illegible]
- 31. [Illegible]
- 32. [Illegible]
- 33. [Illegible]
- 34. [Illegible]
- 35. [Illegible]
- 36. [Illegible]
- 37. [Illegible]
- 38. [Illegible]
- 39. [Illegible]
- 40. [Illegible]
- 41. [Illegible]
- 42. [Illegible]
- 43. [Illegible]
- 44. [Illegible]
- 45. [Illegible]
- 46. [Illegible]
- 47. [Illegible]
- 48. [Illegible]
- 49. [Illegible]
- 50. [Illegible]

SECRET

The following information is being furnished to you for your information only. It is not to be disseminated outside your organization.

SECRET

The following information is being furnished to you for your information only. It is not to be disseminated outside your organization.

SECRET

SECRET

CABLING

When hooking up a Hayes Smartmodem 1200 to an Ultimate system, use a modem cable as noted on Page 1 of Tech Tip CRT-2 (the "W03" cable). When using this modem on a CRT, you must use the following cabling specification:

CRT	MODEM
1 -----	1
2 -----	2
3 -----	3
4 --!	
5 --!	
6 -----	6
7 -----	7
8 -----	8
13-----	13
15-----	15
17-----	17
20-----	20
22-----	22

OPERATIONAL COMMANDS

Below is a condensed list of some of the commands you may use with the Hayes Smartmodem 1200. For more information, refer to the Hayes Smartmodem 1200 documentation.

- AT Puts the modem at attention to receive the next command. All commands must be preceded with this command, except the +++ command.
- A/ Repeat the last command entered. This command is very useful when you're attempting to auto-dial and the line is busy or doesn't connect.
- D Auto-dial the following number.
- +++ Switch from on-line to command mode.
- O Switch from command to on-line mode.
- L1 Sets the speaker to low volume.
- M Toggles the speaker on and off.

(OVER)

His statement is that the...

His statement is that the...

His statement is that the...

His statement is that the...

His statement is that the...

His statement is that the...

His statement is that the...

His statement is that the...

His statement is that the...

His statement is that the...

His statement is that the...

His statement is that the...

His statement is that the...

- P Indicates a pulse (rotary) phone. A "T" or "P" must precede all phone numbers.
- T Indicates a touch-tone phone. A "T" or "P" must precede all phone numbers.
- Z This is the software reset command.
- H This is a toggle that enables or disables the phone jack, and enables or disables the line jack.
- HO Disconnect command.

, A comma indicates a delay (see example below).

Example of auto-dial sequence

ATDT(,8876069

This command begins with AT for attention. The D means to auto-dial the following number. The T indicates that a touch-tone phone will be used. In this example, a 9 must first be entered to dial out of the building, so the 9 is followed by a comma. The comma specifies a delay so that the 9 has time to acquire an outside line. Then the number to be dialed (8876069) is entered.

Example of disconnect sequence

+++ATHO

The +++ means to switch to command mode, the AT means "attention, a command is coming," and then the command to disconnect (HO) follows. Note that when using the +++ command, you should pause for 3 seconds before issuing the next command.

For more information on other Hayes Smartmodem features, refer to the Hayes Smartmodem documentation.



[The following text is extremely faint and illegible due to low contrast and scan quality. It appears to be a list or a series of entries, possibly containing names and dates, but the specific content cannot be transcribed accurately.]