

**WANG**

5103

## **OFFICE INFORMATION SYSTEMS**

### **Models:**

**OIS 140 (Model 6540)**

**OIS 145 (Model 6545)**

**Customer Engineering  
Product Maintenance Manual**

**741-0664**

## PREFACE

The purpose of this manual is to provide the Wang-trained Customer Engineer (CE) with instructions to operate, troubleshoot and repair Wang Office Information Systems 140 (Model 6540) and 145 (Model 6545).

Third Edition (July 1984)

This reprint of Document 729-0664-A is identified by a new converted document number (741-0664) and incorporates the following: Document 729-0664, Addendums 729-0664-1 through 729-0664-6, Product Service Notices (PSN's) 729-0986 and 729-1111, and Publication Update Bulletin (PUB) 729-0664-A1. The material in this document may be used only for the purpose stated in the Preface. Updates and/or changes to this document will be published as PUB's or subsequent editions.

This document is the property of Wang Laboratories, Inc. All information contained herein is considered company proprietary and its use is restricted to assisting the Wang-trained CE in servicing this Wang product. Reproduction of all or any part of this document is prohibited without the prior consent of Wang Laboratories, Inc.

© Copyright WANG Labs., Inc. 1982, 1984

TABLE OF CONTENTS

	<u>PAGE</u>
LIST OF TABLES	v
LIST OF ILLUSTRATIONS	vi
CHAPTER 1 INTRODUCTION	
1.1 SCOPE AND PURPOSE	1-1
1.2 ORGANIZATION	1-2
1.3 RELATED DOCUMENTATION	1-3
1.4 TOOLS AND EQUIPMENT	1-4
1.4.1 RECOMMENDED TEST EQUIPMENT / TOOL LIST	1-4
1.4.2 SPECIAL TOOLS AND EQUIPMENT	1-4
1.4.3 SOFTWARE TOOLS	1-4
CHAPTER 2 SYSTEM DESCRIPTION	
2.1 GENERAL DESCRIPTION OF OIS 140/145	2-1
2.2 MASTER UNIT SPECIFICATIONS	2-4
2.3 STANDARD/OPTIONAL DISK DRIVES	2-9
2.3.1 STANDARD DISK DRIVE - OIS 140	2-9
2.3.2 STANDARD DISK DRIVE - OIS 145	2-10
2.3.3 HAWK DISK DRIVE	2-11
2.4 OPTIONAL PERIPHERALS	2-14
2.5 ENVIRONMENTAL CHARACTERISTICS	2-14
CHAPTER 3 INSTALLATION	
3.1 INTRODUCTION	3-1
3.2 CHECKLIST FOR SITE PREPARATION	3-2
3.3 UNPACKING & INITIAL INSPECTION	3-4
3.3.1 UNPACKING THE MASTER PROCESSOR	3-4
3.3.2 UNPACKING THE CRT WORKSTATION	3-5
3.3.3 UNPACKING THE PHOENIX DISK DRIVE	3-6
3.3.4 UNPACKING THE 300 MEG SMD DISK DRIVE	3-7
3.3.5 UNPACKING THE HAWK DISK DRIVE	3-8
3.3.6 INSPECTING THE MASTER PROCESSOR	3-9
3.3.7 INSPECTING THE CRT WORKSTATION	3-11
3.3.8 INSPECTING THE PHOENIX DISK DRIVE	3-11
3.3.9 INSPECTING THE 300 MEG SMD DISK DRIVE	3-12
3.3.10 INSPECTING THE HAWK DISK DRIVE	3-13
3.4 SYSTEM INTERCONNECTIONS	3-14
3.4.1 CABLING	3-14
3.4.2 ELECTRICAL POWER	3-17
3.5 INITIAL SETUP, CHECKS, AND ADJUSTMENTS	3-18
3.5.1 INITIAL CHECKS AND ADJUSTMENTS FOR THE MASTER PROCESSOR	3-18
3.5.2 INITIAL CHECKS AND ADJUSTMENTS FOR THE CRT WORKSTATION	3-19
3.5.3 INITIAL CHECKS AND ADJUSTMENTS FOR THE PHOENIX DISK DRIVE	3-20
3.5.4 INITIAL CHECKS AND ADJUSTMENTS FOR THE SMD-300 DISK DRIVE	3-21
3.5.4.1 INITIAL CHECKS AND ADJUSTMENTS FOR THE 80 MEG SMD DRIVE	3-22a
3.5.5 INITIAL CHECKS AND ADJUSTMENTS FOR THE HAWK DISK DRIVE	3-23

TABLE OF CONTENTS (continued)

	<u>PAGE</u>
3.6 POWER-UP PROCEDURE	3-25
3.7 MASTER UNIT POWER-UP DIAGNOSTIC	3-25
3.8 POWER-DOWN PROCEDURE	3-26
3.9 SOFTWARE INSTALLATION	3-26
3.10 SYSTEM CHECKOUT	3-27
3.11 FINAL WORD PROCESSING CHECK	3-28
3.12 DETAILED PROCEDURES	3-29
3.12.1 MASTER PROCESSOR SWITCH SETTINGS	3-29
3.12.2 SWITCH SETTINGS FOR THE PHOENIX DRIVE	3-31
3.12.3 SWITCH SETTINGS FOR THE SMD-300 DRIVE	3-33
3.12.4 SWITCH SETTINGS FOR THE HAWK DRIVE	3-34
3.12.5 VOLTAGE ADJUSTMENTS FOR THE MASTER PROCESSOR	3-35
3.12.6 INSTALLATION OF THE LOGICAL ADDRESS PLUGS	3-37
3.12.7 CHECKING THE BOARD E-REV LEVELS	3-38
 CHAPTER 4 CONTROLS AND INDICATORS	
4.1 INTRODUCTION	4-1
4.2 MASTER-PROCESSOR CONTROLS AND INDICATORS	4-2
4.2.1 MASTER-PROCESSOR FRONT PANEL	4-2
4.2.2 MASTER PROCESSOR INTERNAL CONTROLS AND INDICATORS	4-4
4.2.2.1 7501 CPU/MEMORY BOARD	4-4
4.2.2.2 7502 - 10 MEG/FLOPPY CONTROLLER BOARD	4-6
4.2.2.3 7506 CMD/SMD "B" CONTROLLER BOARD	4-7
4.2.2.4 VOLTAGE-SELECTOR SWITCH	4-9
4.3 PHOENIX DISK UNIT	4-10
4.4 300 MEG SMD UNIT	4-13
4.5 CRT WORKSTATION	4-16
 CHAPTER 5 MAINTENANCE	
5.1 GENERAL	5-1
5.2 MATERIALS REQUIRED	5-1
5.3 PM SCHEDULES FOR THE MASTER PROCESSOR	5-2
5.4 DETAILED PROCEDURES	5-2
5.4.1 EQUIPMENT OPERATIONAL CHECK	5-2
5.4.2 CLEANING	5-2
5.4.3 INSPECTION	5-3
5.4.4 ALIGNMENTS/ADJUSTMENTS	5-4
 CHAPTER 6 TROUBLESHOOTING	
6.1 GENERAL	6-1
6.2 LEVEL OF REPAIR	6-2
6.3 TROUBLESHOOTING AIDS FOR THE MASTER PROCESSOR	6-2
6.3.1 POWER-UP (PROM) DIAGNOSTIC	6-2
6.3.2 OPERATING SYSTEM ERROR MESSAGES	6-2
6.3.3 MASTER DIAGNOSTIC MONITOR	6-3
6.3.4 SYSEX40 AND SYSEX40X	6-3
6.3.5 SOFTWARE PROCEDURES	6-3
6.4 TROUBLESHOOTING FLOWCHARTS	6-4

TABLE OF CONTENTS (continued)

	<u>PAGE</u>
CHAPTER 7 REPAIR	
7.1 GENERAL	7-1
7.2 TABLE OF FIELD-REPLACEABLE ITEMS	7-1
7.3 REMOVAL/REPLACEMENT PROCEDURES FOR THE MASTER PROCESSOR	7-2
7.3.1 TOP COVER REMOVAL/REPLACEMENT PROCEDURE	7-2
7.3.2 FRONT PANELS REMOVAL/REPLACEMENT PROCEDURES	7-3
7.3.3 PCB REMOVAL/REPLACEMENT PROCEDURES	7-5
7.3.4 DISKETTE DRIVE REMOVAL/REPLACEMENT PROCEDURE	7-5
7.3.5 POWER CHASSIS REMOVAL/REPLACEMENT PROCEDURES	7-7
7.3.6 MOTHERBOARD REMOVAL/REPLACEMENT PROCEDURES	7-7
7.3.7 REMOVING/REPLACING THE FAN MUFFINS	7-8
7.3.8 REMOVING/REPLACING THE SERIAL CONNECTOR PLATES	7-8
7.4 REMOVAL/REPLACEMENT PROCEDURES FOR OIS 140/145 PERIPHERALS	7-9
CHAPTER 8 THEORY OF OPERATION	
8.1 GENERAL	8-1
8.2 THE CPU/MEMORY BOARD	8-1
8.3 MEMORY-MAPPED I/O DEVICE ADDRESSES	8-3
8.4 MASTER UNIT DATA FLOW	8-4
8.5 AUTOMATIC STATUS OPERATION (ASOP)	8-5
8.6 THE DATA LINK CONTROLLER	8-6
8.7 THE DISK DRIVE CONTROLLERS	8-7
8.7.1 THE SMD CONTROLLER	8-7
8.7.2 THE 10 MEG/FLOPPY CONTROLLER	8-9
8.7.3 FLOPPY DISK FORMAT	8-9
APPENDIX A MASTER DIAGNOSTICS MONITOR	A-1
APPENDIX B SYSTEM ERROR MESSAGES	B-1
APPENDIX C SOFTWARE INSTALLATION PROCEDURES	C-1
APPENDIX D OIS 140-CLASS POWER-UP (PROM) DIAGNOSTIC	D-1
APPENDIX E OIS 140-CLASS EXTENDED MEMORY POWER-UP DIAGNOSTIC	E-1
APPENDIX F FINAL WORD PROCESSING CHECK	F-1
APPENDIX G ILLUSTRATED PARTS BREAKDOWN	G-1
APPENDIX H SCHEMATICS	H-1

LIST OF TABLES

TABLE 3-1 SITE PREPARATION CHECKLIST	3-2
TABLE 3-2 ELECTRICAL AND ENVIRONMENTAL REQUIREMENTS	3-3
TABLE 4-1 OIS 140/145 CONTROLS AND INDICATORS	4-1
TABLE 4-2 MASTER PROCESSOR FRONT-PANEL CONTROLS AND INDICATORS	4-3
TABLE 4-3 MASTER PROCESSOR INTERNAL CONTROLS AND INDICATORS	4-5
TABLE 4-4 MASTER PROCESSOR INTERNAL CONTROLS AND INDICATORS	4-7
TABLE 4-5 PHOENIX CMD CONTROLS AND INDICATORS	4-11
TABLE 4-6 300 MEG SMD CONTROLS AND INDICATORS	4-14
TABLE 4-7 WORKSTATION CONTROLS AND INDICATORS	4-16
TABLE 7-1 FIELD-REPLACEABLE ITEMS	7-1

LIST OF ILLUSTRATIONS

	<u>PAGE</u>
FIGURE 2-1	2-5
FIGURE 2-2	2-6
FIGURE 2-3	2-8
FIGURE 2-4	2-12
FIGURE 2-5	2-12
FIGURE 2-6	2-13
FIGURE 3-1	3-4
FIGURE 3-2	3-5
FIGURE 3-3	3-6
FIGURE 3-4	3-7
FIGURE 3-5	3-8
FIGURE 3-6	3-9
FIGURE 3-7	3-10
FIGURE 3-8	3-12
FIGURE 3-9	3-13
FIGURE 3-10	3-15
FIGURE 3-11	3-16
FIGURE 3-12	3-19
FIGURE 3-13	3-21
FIGURE 3-14	3-22
FIGURE 3-14a	3-22a
FIGURE 3-14b	3-22b
FIGURE 3-15	3-24
FIGURE 3-16	3-24
FIGURE 3-17	3-26
FIGURE 3-18	3-29
FIGURE 3-19	3-30
FIGURE 3-20	3-31
FIGURE 3-21	3-32
FIGURE 3-22	3-33
FIGURE 3-23	3-34
FIGURE 3-24	3-36
FIGURE 3-25	3-37
FIGURE 3-26	3-38
FIGURE 4-1	4-2
FIGURE 4-2	4-4
FIGURE 4-3	4-6
FIGURE 4-4	4-8
FIGURE 4-5	4-9
FIGURE 4-6	4-10
FIGURE 4-7	4-13
FIGURE 4-8	4-16
FIGURE 5-1	5-5
FIGURE 6-1	6-4
FIGURE 7-1	7-2
FIGURE 7-2	7-3
FIGURE 7-3	7-4
FIGURE 7-4	7-6
FIGURE 8-1	8-2
FIGURE 8-2	8-8

**CHAPTER**

**1**

**INTRO-  
DUCTION**

CHAPTER 1INTRODUCTION1.1 SCOPE AND PURPOSE

This publication concerns the Office Information Systems 140 and 145, (OIS 140/145) and provides field personnel with the information necessary to:

- A. Understand the functions of the principle parts of the system and all the relationships and interactions among these parts
- B. Unpack and install the system
- C. Perform preventive maintenance procedures
- D. Perform diagnostic tests
- E. Analyze failure indications
- F. Replace failed assemblies

A block-level description of the printed circuit boards internal to the Master Unit is presented in Chapter 8, "Theory of Operation". This document also serves as a reference to those publications necessary for the installation and maintenance of optional peripherals and accessories.

This manual is written for Customer Engineering personnel with a background in WANG word processing. Familiarity with OIS 140 and 145 systems and the HAWK, Phoenix, and 300 Meg SMD disk drives is essential for effective use of this manual.



## 1.2 ORGANIZATION

This manual describes the 140 and 145 Office Information Systems. Throughout this manual, all statements pertaining to both the OIS 140 and 145 systems will be identified as such by references to the collective 'OIS 140/145 System'. In cases where the two systems differ, the references will be qualified to explicitly indicate one system apart from the other. That is to say, whenever the phrase 'OIS 140' or 'OIS 145' stands alone, the ensuing statement applies to that system only.

The OIS 145 is essentially the same as the OIS 140 System, with the exception of the System Disk. The 145 is equipped with a 300 Megabyte Storage Module Drive (300 Meg SMD) as its System Disk, while the 140 System contains a 96 Meg 'Phoenix' Cartridge Module Drive (96 Meg CMD), sold in three different storage capacities.

In accordance with the stated scope and purpose, this manual is arranged into 8 chapters:

CHAPTER 1	INTRODUCTION
CHAPTER 2	SYSTEM DESCRIPTION
CHAPTER 3	INSTALLATION
CHAPTER 4	CONTROLS AND INDICATORS
CHAPTER 5	MAINTENANCE
CHAPTER 6	TROUBLESHOOTING
CHAPTER 7	REPAIR
CHAPTER 8	THEORY OF OPERATION

This manual is further organized and arranged so that all information pertaining to a task or subject is complete on a single page. Obviously, more than one page is required for complicated and difficult subjects. In these instances, all the information written at "page level" is presented on that page; references are given for further details. The referenced material is also organized in the same fashion.

That is to say: when the CE has completed a page, he/she has completed the task described on that page; there is no more to be done. If the CE is not familiar with, or needs detailed information about, some item on that page he/she is referenced to a page which details that item (the details also being complete on one page). This arrangement allows the experienced CE to quickly run through all the steps in a task without being slowed by details with which he/she is already familiar. At the same time, all the details needed by a CE less familiar with the product are also available.

In order to reduce endless paging back-and-forth, the manual is arranged so that once the CE has gone to the detailed portion of the manual, he/she can remain there and proceed from one detailed page to another. Of course, if the CE only needed additional information on one item, he/she is better advised to return to the "higher level" procedures and continue from there.

1.3 RELATED DOCUMENTATIONMISCELLANEOUS

Systems Installation Guide for VS, 2200, WP/OIS Systems	(729-0907)
Site Preparation Guide	(700-5978)
OIS Supervisor Procedures Manual	(700-5562C)
OIS Supervisor Quick Reference Guide	(700-5741C)

CRT WORKSTATION (Models 5536-2,-3,-4)

Models 5536-1/-2/-3/-4 Workstations, WPNL No.81.	(729-0522)
Model 5536 Series Workstation PMM	(729-0522A)

PHOENIX CMD DISK DRIVE (Model 6580)

CDC CMD Hardware Maintenance Manual	(729-0198A)
Wang Cartridge Module Disk Drive Manual	(729-0199)
Cartridge Module Drive (Block Point 4) Manual	(729-1063)
Wang CMD Addendum 2	(729-0199-2)

CDC SMD DISK DRIVES (80 MB, 300 MB)

CDC OEM Service Manual	(729-0210)
CDC SMD Hardware Maintenance Manual	(729-0221)
CDC SMD Hardware Reference Manual	(729-0222)

HAWK CDC DISK DRIVE (Model 6560)

CDC HAWK Field Maintenance Manual	(729-0884)
Wang/CDC HAWK Disk Drive Manual	(729-0181)

SHUGART FLOPPY DISKETTE DRIVE (Model SA901)

Shugart Disk System, Service Bulletin No. 46.2	(729-0115)
PSN-2 Shugart SA901	(729-0122)

OPTIONAL PERIPHERALS

Product Maintenance Manual: Wang Daisy Printers	(729-0372A)
Archiving Workstation - Service Information, WPNL #77	(729-0521)
Mag-Card Reader for WPS, WPNL #78	(729-0545)
Model 61/62 Matrix Printer Maintenance Manual	(729-0339)
Model 44, 48 Phototypesetter	(729-0465)
Image Printer Maintenance Manual	(729-0447)
Model 5538 Twin Sheet Feeder (TSF) Installation & Adjustment Manual	(729-0549)
Envelope Feeder (EF) Product Maintenance Manual	(729-0873)
WISE Model 6550-1 PMM	(729-0906)
TCB-1 TC Controller Self Study Workbook	(729-1057)

1.4 TOOLS AND EQUIPMENT1.4.1 RECOMMENDED TEST EQUIPMENT / TOOL LIST

OIS installation, repair, and maintenance procedures can be performed using the following tools and test equipment:

- A. Customer Engineering Standard Tool Kit (WLI P/N 726-9401) containing the following :
1. Allen Wrench (Hex Key) Set.
  2. Small Slotted Screwdriver (insulated shaft) (WL #726-9406) - for voltage adjustments.
  3. Medium Phillips Screwdriver (WL #726-9407).
  4. Medium Slotted Screwdriver (WL #726-9408).
  5. Handle and Assorted Nutdrivers (WL #726-9478, 726-9459 through 9477).
  6. Diagonal cutters (WL #726-9416)
- B. Digital Voltmeter - (e.g. FLUKE Model 8022A, WL #727-0119).
- C. Oscilloscope with two X1 probes and/or two X10 probes.  
(e.g. Phillips Model 3262, WL# 727-0054, probes - WL# 726-9689;  
Tektronix Model 465B, WL# 727-0001, probes - WL# 726-9690.)
- D. Alcohol Pads (WL #660-0130).
- E. Hypot/DC ESD Tester (WL #727-0144) (WL #727-0146 for 230 VAC, 50 Hz).
- F. AC Outlet Impedence Tester (WL #727-0143).
- G. Dry Air (WL #726-5816).
- H. Media Solution (WL #726-8018).

1.4.2 SPECIAL TOOLS AND EQUIPMENT

Special tools and equipment for the Phoenix, Hawk, 300 Meg SMD, and Shugart drives are presented in the associated manuals outlined in section 1.3.

1.4.3 SOFTWARE TOOLS

Software diskettes and documents referenced in this manual are:

<u>TITLE</u>	<u>DISKETTE/DOCUMENT</u>
OIS 140-Class Power Up (PROM)	(702-0042D)
OIS 140 Extended Memory Power Up (PROM)	(702-0123B)
SYSEX40	(702-0117)
SYSEX40X	(702-0135)
OIS 140-Class Master Monitor	(702-0057D)
OIS Online Device Monitor	(702-0174)
OIS Online Printer Part I	(702-0176A, Rev 2422)
OIS Online Printer Part II	(702-0149, Rev 21A0)

**CHAPTER**  
**2**  
**SYSTEM**  
**DESCRIP-**  
**TION**

CHAPTER 2SYSTEM DESCRIPTION2.1 GENERAL DESCRIPTION OF OIS 140/145

The OIS 140 and the closely-related OIS 145 are two of the continuing series of versatile text processors in Wang Laboratories Office Information Systems (OIS) "family". Masterprocessing and data-storage equipment form the core of these OIS systems; user devices are clustered around this core. Extensive options provide system configurations that are versatile and expandable.

The OIS 140 and 145 systems are the largest text processors in the OIS line. These CRT/disk-based processors are designed for users with large volumes of data input, output or storage requirements. The OIS System 140 is available in three different models (6540-1, 6540-2, and 6540-3). The basic configuration includes one master processor unit possessing a single diskette drive for off-line storage, one or more peripheral devices (workstations, printers, phototypesetters, etc.), and one or more hard disk storage devices (one of which is designated "System Disk"). The customer has three different choices for the size of his System Disk, available through configuration modifications on the unformatted 96 Meg CMD (Phoenix). These choices are reflected in the three different Model numbers of the OIS 140 System:

<u>SYSTEM</u>	<u>MODEL NUMBER</u>	<u>SYSTEM DISK (formatted capacity)</u>
OIS 140-1	6540-1	26.8 Meg
OIS 140-2	6540-2	53.6 Meg
OIS 140-3	6540-3	80.4 Meg

The OIS 145 is essentially the same as the OIS 140 System, with the exception of the System Disk. The 145 is equipped with a 300 Megabyte Storage Module Drive (300 Meg SMD) as its System Disk (formatted capacity = 275 Meg). In fact, up to three 300 Meg SMD units may be attached to the OIS 145, making the total system capable of storing over 334,000 pages of text. An additional 10 Meg HAWK drive is automatically sold with the system for information backup purposes.

Both the 140 and 145 systems utilize standard OIS architecture and software. Both may be expanded to include up to 32 peripherals (maximum of 24 workstations) in many different combinations. The diagrams on the next two pages outline the basic configuration, standard and optional software, and available peripherals for each system.

## -----NOTE-----

Throughout the remainder of this manual, statements applicable to both the OIS 140 and 145 systems will be identified as such by references to the 'OIS 140/145 System'. In cases where the two systems differ, the references will be qualified to explicitly indicate one system apart from the other.

# OFFICE INFORMATION SYSTEM 140

## Models 140-1, 140-2, 140-3

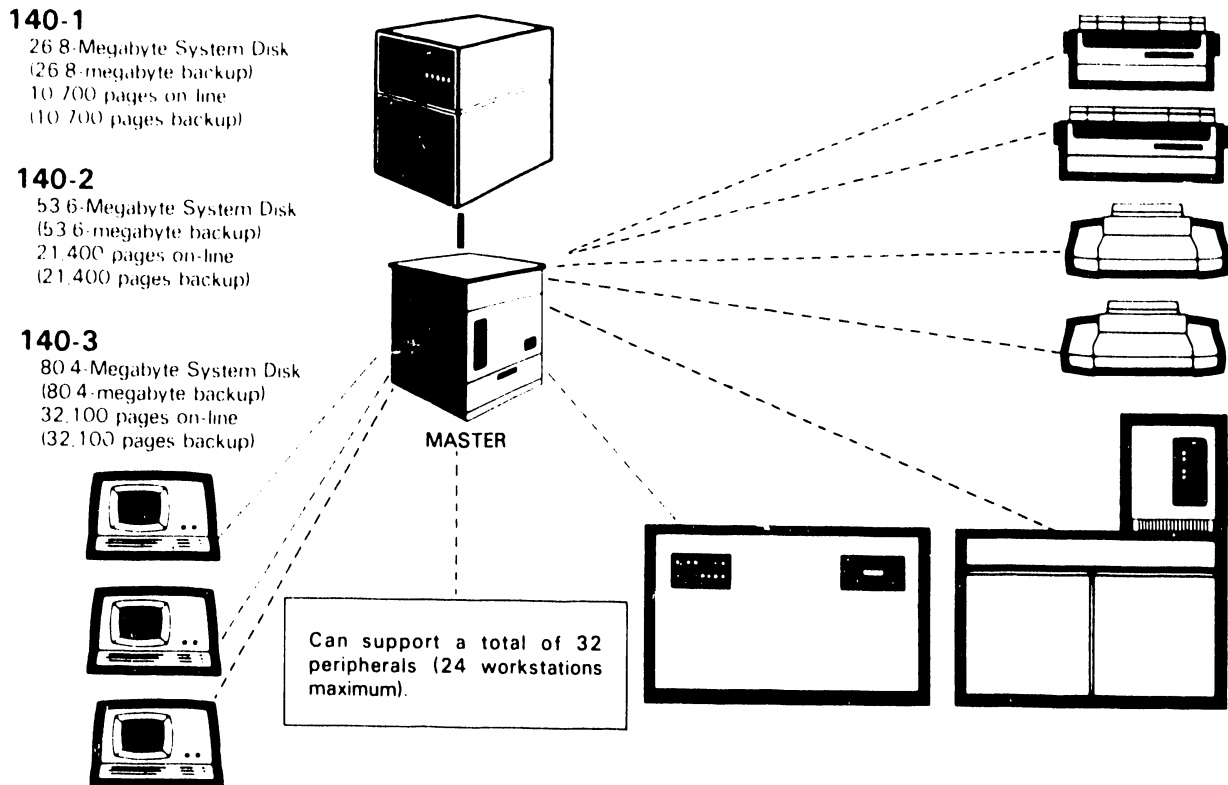

### Basic Configuration:

- 1 System Master and Archive Diskette
- 1 System Disk (26.8, 53.6, or 80.4 Megabytes)

### Standard Software:

- Math Support Package
- Sort
- System Security
- Advanced Functions

### Optional Software:

- Office BASIC
- List Processing

### Optional Peripherals:

- Archiving Workstation (48K or 64K)
- Mag Card Reader
- Numeric Keypad
- Phototypesetter
- Phototypesetter Input Option
- Papertape Punch for Telex
- Telecommunications
- Twin Sheet Feeder
- 26.8, 53.6, or 80.4-Megabyte Disk (13.4-Megabyte removable cartridge)
- (2) 10-Megabyte Disks (5-Megabyte removable cartridge)
- WISE (Wang Inter-System Exchange)
- Workstation (32K, 48K, or 64K)
- Envelope Feeder
- MAILWAY™
- Optical Character Recognition Interface
- Bidirectional Forms Tractor
- Multilingual Support Package

### Printers:

- 35-CPS Daisy
- 35-CPS Wide Carriage Daisy
- 120-CPS Matrix Printer
- 200-CPS Matrix Printer
- 425-LPM Line Printer
- Intelligent Image Printer
- Twin-Head Daisy

### Accessories:

- Workstation Table
- General Work Table
- Line Printer Stand
- Additional Cable Lengths (2000' Max.)

MAILWAY™ is a trademark of Wang Laboratories, Inc.

# OFFICE INFORMATION SYSTEM 145

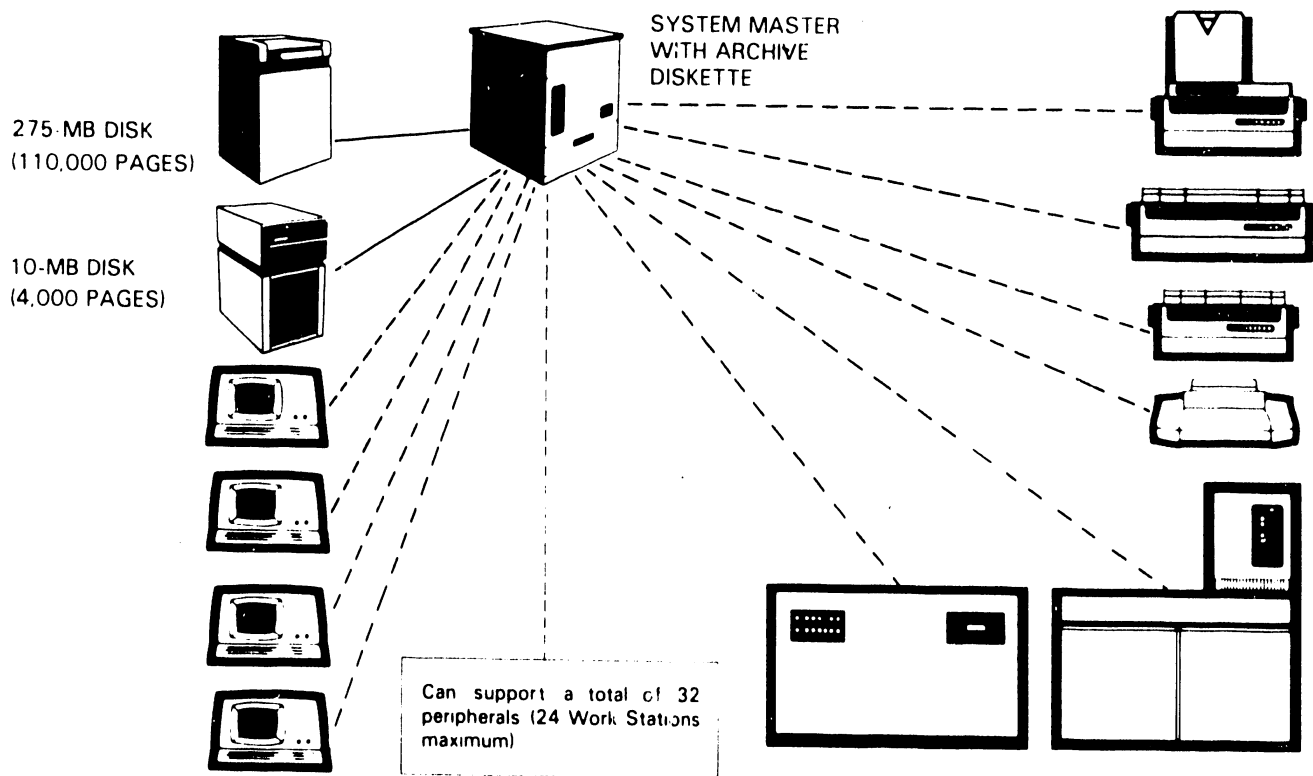

## Basic Configuration

- 1 275-Megabyte Disk
- 1 10-Megabyte Disk
- 1 Archive Diskette

## Standard Software

- Math Support Package
- Sort
- System Security
- Advanced Functions

## Optional Software

- Office Basic
- List Processing

## Optional Peripherals

- Archiving Workstation
- Bidirectional Forms Tractor
- 1 10-MB Disk
- 1 or 2 275-MB Disk
- Envelope Feeder
- Mag Card Reader
- MAILWAY™
- Numeric Keypad
- Optical Character Recognition Interface
- Phototypesetter 5548Z
- Phototypesetter Input Option
- Twin Sheet Feeder
- WISE (Wang Inter-System Exchange)
- Workstation with Communications

## Printers

- 35-CPS Daisy
- 35-CPS Wide Carriage Daisy
- Twin-Head Daisy Printer
- 120-CPS Matrix Printer
- 200-CPS Matrix Printer
- 425-LPM Line Printer
- Intelligent Image Printer

## Accessories

- Workstation Table
- General Work Table
- Line Printer Stand
- Additional Cable Lengths  
(2000' Max.)

2.2 MASTER UNIT SPECIFICATIONS

A Z-80 based Master CPU is a standard hardware feature of the OIS 140/145. Operating at 4 MHz, it provides this system with a faster transfer rate than previous processing systems. Included on the same circuit board as the Master CPU is a programmable Counter Timer Circuit (CTC), 3K of PROM, 1K of address space devoted to Memory Mapped I/O, and 60K of RAM. If the Extended Memory option is purchased, an additional 3K of PROM and 60K of RAM is available to the customer.

Other features of the Master Unit include thirty-two slave channels and I/O ports, nine Printed Circuit Assemblies (PCAs), a Power Supply Assembly, Front Panel Assembly, and Shugart Floppy Diskette Drive. Refer to Chapter 8, "Theory of Operation", for a block diagram discussion of the PCAs in the Master CPU.

Following is a list of printed circuit boards and chassis assemblies used in the OIS 140/145 Master Unit:

<u>BOARD/CHASSIS #</u>	<u>NAME</u>
210-7501-A	64K CPU/Memory Board
210-7502	Floppy/10 Meg Controller Board
210-7503	Data Link Controller Board
210-7504-A	Data Buffer Board
210-7505	SMD Disk Controller Board #1 (A)
210-7506	SMD Disk Controller Board #2 (B)
210-7507	Motherboard
210-7508	Regulator Board
210-7518	Front Panel PCB
270-0599	Motherboard Chassis
270-0601	Power Supply Chassis (60 Hz)
270-0601-1	Power Supply Chassis (50 Hz)



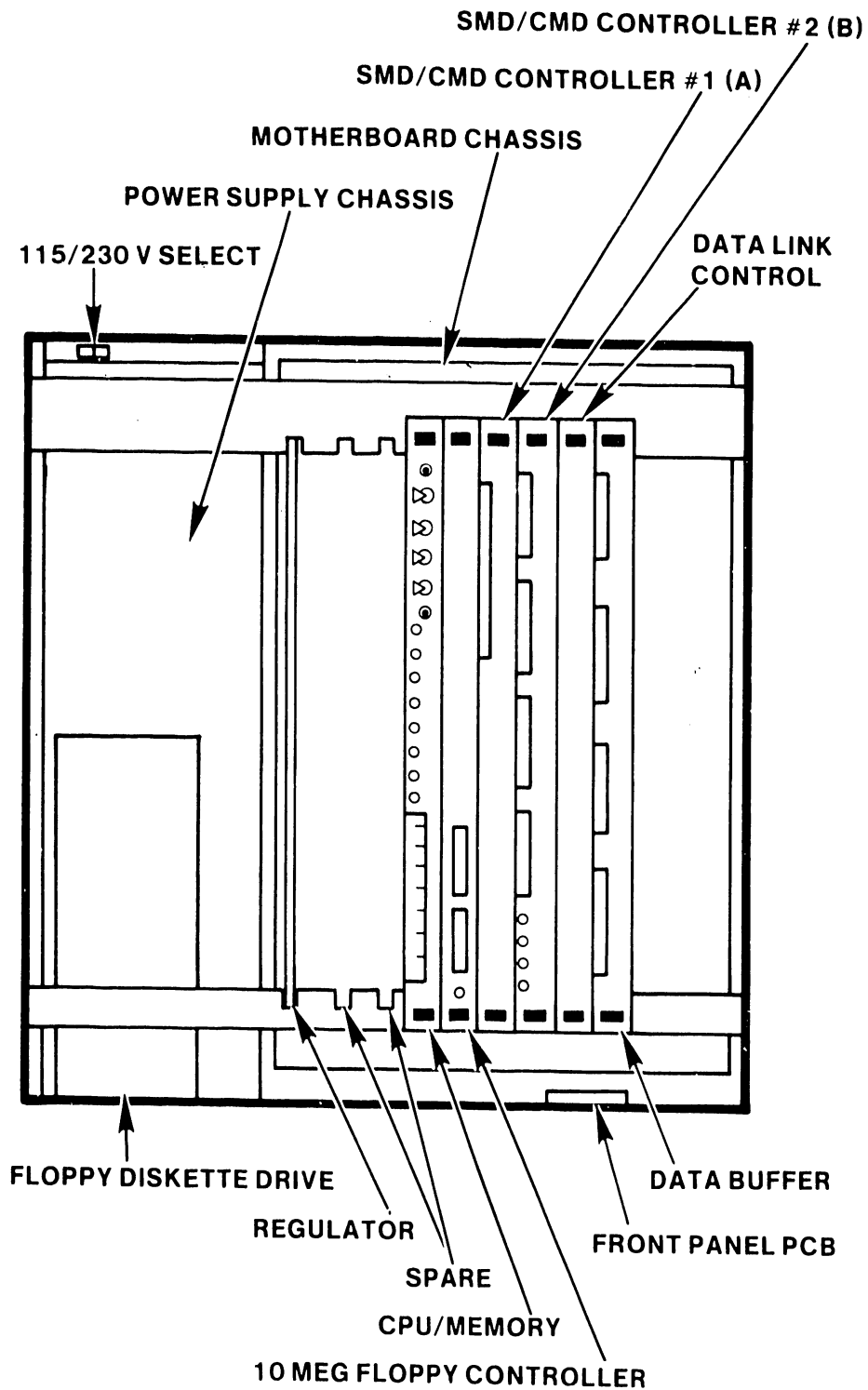

FIGURE 2-1 MASTER UNIT MAJOR COMPONENT LOCATIONS

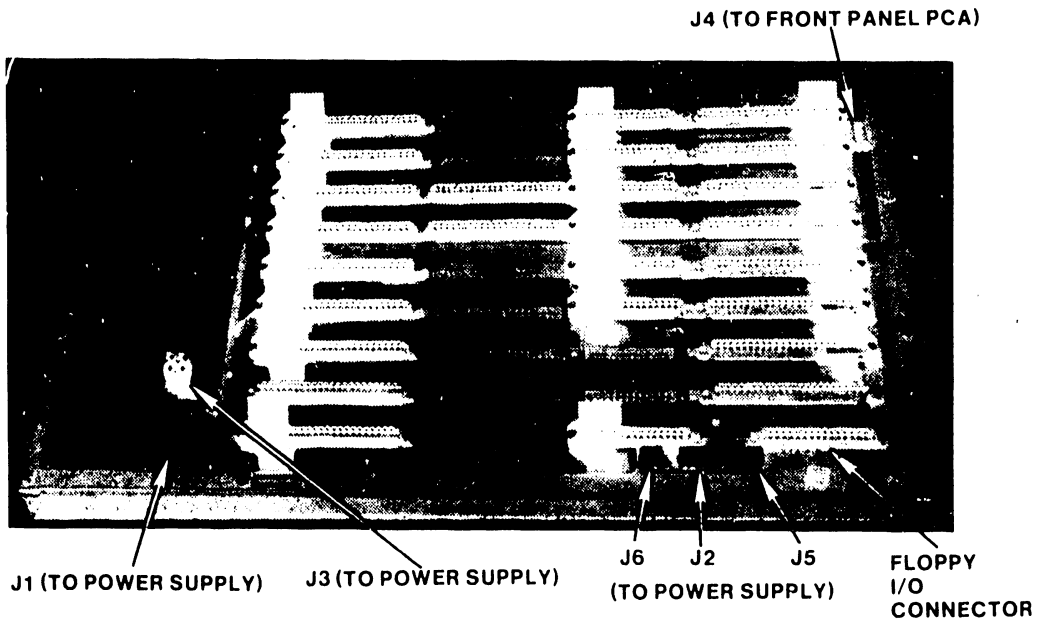

FIGURE 2-2 210-7507 MOTHERBOARD PCB AND CONNECTOR LOCATIONS

Following are the electrical and physical specifications for the Master Unit and Diskette Drive:

Master Unit:	<u>Domestic</u>	<u>International</u>
Height	30 Inches	(76.2 cm)
Width	24 Inches	(60.9 cm)
Depth	30 Inches	(76.2 cm)
Power Requirements	115VAC + 10%	(230VAC + 10%)
	60 Hz + 1 Hz	(50 Hz + 1 Hz)
	4A @ 115VAC	3A @ 230 VAC
Power Consumed	500 Watts	
Heat Dissipated	1700BTU/Hr	

Diskette Drive: (See fig. 2-3)

Height	12.75 Inches	(32.4 cm)
Width	6.0 Inches	(15.3 cm)
Depth	16.5 inches	(42 cm)

Diskette Drive characteristics:

Diskette Capacity	315,392 Characters
Rotational Speed	360 RPM
Rotational Period	166.72 msec
Average Access Time	424 msec
Average Latency	83 msec
Data Transfer Rate	31,250 Bytes/sec.
Bit Cell Time	4 usec
Track to Track	
Access Time	10 msec
Head Settling Time	10 msec
Sectors per Track	16
No. of Tracks	77
Total Sectors	1232
Sector Mark Duration	400 usec + 200 usec
Index Mark Duration	400 usec + 200 usec
Direction Select Pulse	
Duration	1 usec minimum
Time Between Head Load and Valid Data	50 msec
Time Between Head Load and step	30 msec

Refer to Service Bulletins 46.2 (729-0115), 46.3 (729-0116), and 46.3A (729-0117) for additional information on the Floppy Diskette.

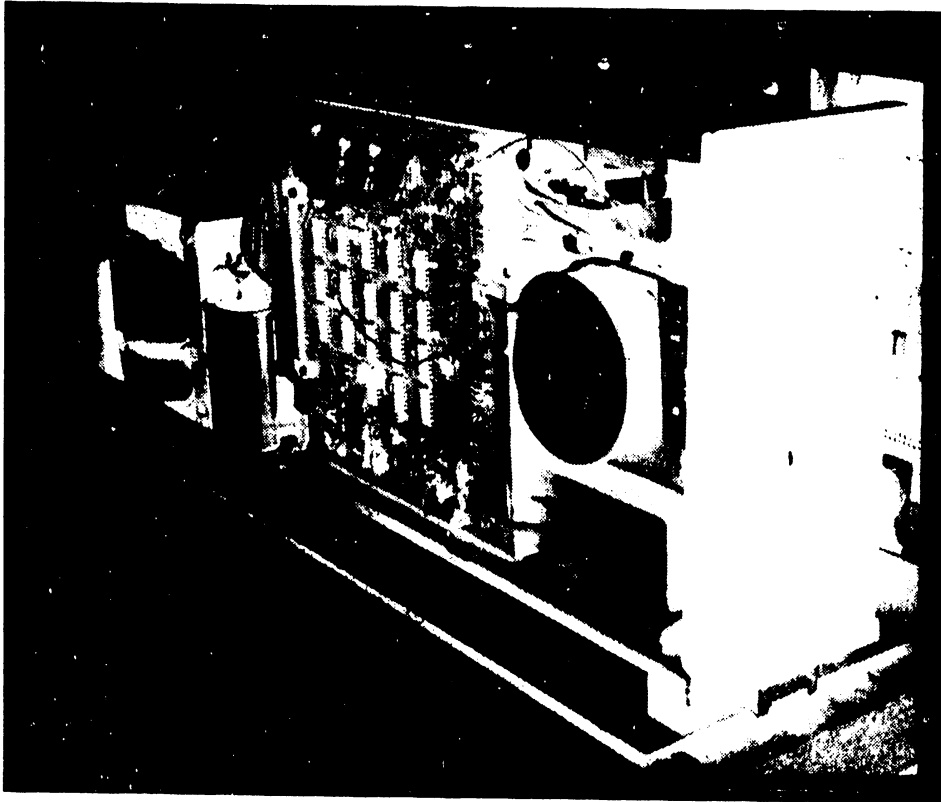

FIGURE 2-3 SHUGART DRIVE MOUNTED ON POWER CHASSIS

### 2.3 STANDARD/OPTIONAL DISK DRIVES

Two types of disk drives are available to the OIS 140; the Phoenix (6580) Cartridge Module Drive (CMD) standard to the system, and the HAWK (6560) 10 Mbyte Drive (optional). The number of drives on-line depends upon the needs of the end user. Because one Phoenix Drive is standard on the OIS 140, one Phoenix and two Hawk drives may be added to the system. Therefore, the OIS 140 can support a maximum of four drive units providing the user with up to 180 Mbytes (depending on model) of formatted storage. If an additional Phoenix is to be added to the standard system, it must be configured to the same capacity as the original Phoenix.

Two types of disk drives are available to the OIS 145; a 275 Mbyte Storage Module Drive (SMD), (Model 6565), and the HAWK (6560) 10 Mbyte Drive; one of each is sold standard with the system. The SMD unit has an unformatted capacity of 300 Mbytes, and a formatted capacity of 275 Mbytes. For this reason, the unit is often referred to as an 300 Meg SMD. Up to three 300 Meg SMD units may be attached to a 145 System along with two (2) 10-Meg HAWKS. These three SMD units and two CMD HAWK units comprise the maximum configuration for the 145, providing over 840 Mbytes of total formatted storage.

#### 2.3.1 STANDARD DISK DRIVE - OIS 140

As previously stated, the Phoenix (6580) Cartridge Module Drive (CMD) is the standard storage device for the OIS 140 (See Fig. 2-4). The Phoenix CMD is a high performance, random access, mass storage device available in three versions. After formatting, the Model 1 (6580-1) stores a maximum of 26.8 Mbytes, the Model 2 (6580-2) stores a maximum of 53.6 Mbytes, and the Model 3 (6580-3) stores a maximum of 80.4 Mbytes.

A linear positioner, a density of 384 Tracks per Inch (TPI), and a 30 msec average access time give the Phoenix CMD a 9.67 MHz transfer rate.

Following are the electrical/physical characteristics of the Phoenix CMD:

Phoenix Specifications:	<u>Domestic</u>	<u>International</u>
Height	10.5 Inches	(264 mm)
Width	19.0 Inches	(483 mm)
Depth	31.75 Inches	(806 mm)
Weight	170 lbs	(77.1 Kg)
Power Requirements*	115 VAC + 10% 60Hz + 1 Hz	(230VAC + 10% (50Hz + 1 Hz)
	8.2A @ 120 VAC	(4A @ 230 VAC)
	.950 KWH	

Phoenix Data Capacity (formatted):

Model 1 (6580-1)	26,836,992 bytes
Model 2 (6580-2)	53,675,984 bytes
Model 3 (6580-3)	80,510,976 bytes

\* A separate, 20A (10A Int'l) dedicated line should be provided for the Phoenix.

Phoenix Specifications - continued

Track Density	384 TPI
Maximum Positioning Time	55 ms
Track-to-track Positioning Time	6 ms
Average Access Time	30 ms
Spindle Speed	3600 rpm (+2.5%,-3.5%)
Avg. Latency Time	8.33 ms @ 3600 rpm

-----NOTE-----

Refer to the Wang Cartridge Module Disk Drive Manual (729-0199, 729-0199-1, 729-0199-2) and the Control Data Cartridge Module Hardware Maintenance Manual (729-0198A) for a detailed description of the Phoenix CMD.

-----

2.3.2 STANDARD DISK DRIVE - OIS 145

The 300 megabyte Storage Module Drive unit (300 Meg SMD, Model 6565) is the standard storage device for the OIS 145 System (see Fig. 2-6). The 300 Meg SMD is a high speed, random access, mass storage device having a formatted capacity of 275 megabytes. Like the Phoenix, the 300 Meg SMD has a density of 384 Tracks per Inch (TPI), a 30 msec average access time, and a 9.67 MHz transfer rate.

Following are the electrical and physical characteristics of the 300 megabyte Storage Module Drive:

300 Meg SMD Specifications:

	<u>Domestic</u>	<u>International</u>
Height	36 Inches	(920 mm)
Width	36 Inches	(914 mm)
Depth	23 Inches	(584 mm)
Weight	550 lbs	(252 Kg)
Power Requirements*	208 VAC $\pm$ 10%, 230 VAC $\pm$ 10% 60Hz $\pm$ 1Hz 8.0A @ 208 VAC 1300 Watts	(220 VAC $\pm$ 10%), (240 VAC $\pm$ 10%) (50Hz $\pm$ 1 Hz) (9.5A @ 220 VAC)

300 Meg SMD Characteristics:

Track Density	384 TPI
Maximum Positioning Time	55 ms
Track-to-track Positioning Time	6 ms
Average Access Time	30 ms
Spindle Speed	3600 rpm (+2.5%,-3.5%)
Avg. Latency Time	8.33 ms @ 3600 rpm

Data Capacity: 300 Mbytes (unformatted)  
275 Mbytes (formatted)

\* A separate, 20A dedicated line should be provided for the 300 Meg SMD.

## -----NOTE-----

Refer to the CDC SMD Hardware Reference Manual (729-0222) and the CDC Hardware Maintenance Manual (729-0221) for a detailed description of the 300 Meg SMD.

2.3.3 HAWK DISK DRIVE

Available as an option to the OIS 140 and standard on the 145 is the HAWK (6560) 10 Mbyte Cartridge Disk Drive (see Fig. 2-5). The OIS 140/145 can support a maximum of two HAWK drives; however, the HAWK Drive should not stand alone as the only storage device in an OIS 140/145 System.

Following are the electrical and physical characteristics of the HAWK Cartridge Disk Drive:

HAWK Specifications:	<u>Domestic</u>	<u>International</u>
Height	10.3 Inches	(262 mm)
Width	18.9 Inches	(480 mm)
Depth	30.6 Inches	(778 mm)
Weight	150 lbs.	(68.2 kg)
Power Requirements	115VAC + 10%	(230VAC + 10%)
	60Hz + 1Hz	(50Hz + 1 Hz)
	4.6A @ 120 VAC	(2.5A @ 230 VAC)
	310 Watts	

## HAWK Characteristics:

Track Density	200 TPI
Access Time	60 msec
Average Access Time	35 msec + 1 msec
Spindle Speed	2400 RPM (+ 48 RPM) at + 0.5 -1.0 Hz of input freq. and + 10%, -15% of input voltage.
Avg. Latency Time	12.5 msec (@ 2400 RPM)
Nominal Recording Bit Rate	2.5 MHz
Data Capacity (unformatted)	10 Mbytes

Refer to the Wang/CDC HAWK Disk Drive Manual (729-0181) for additional details.

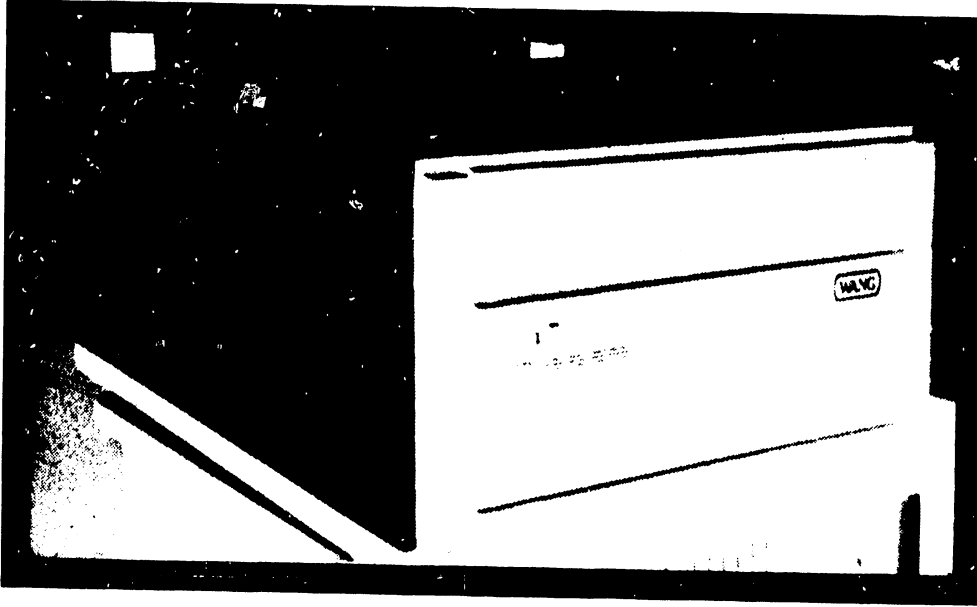

FIGURE 2-4 PHOENIX CMD

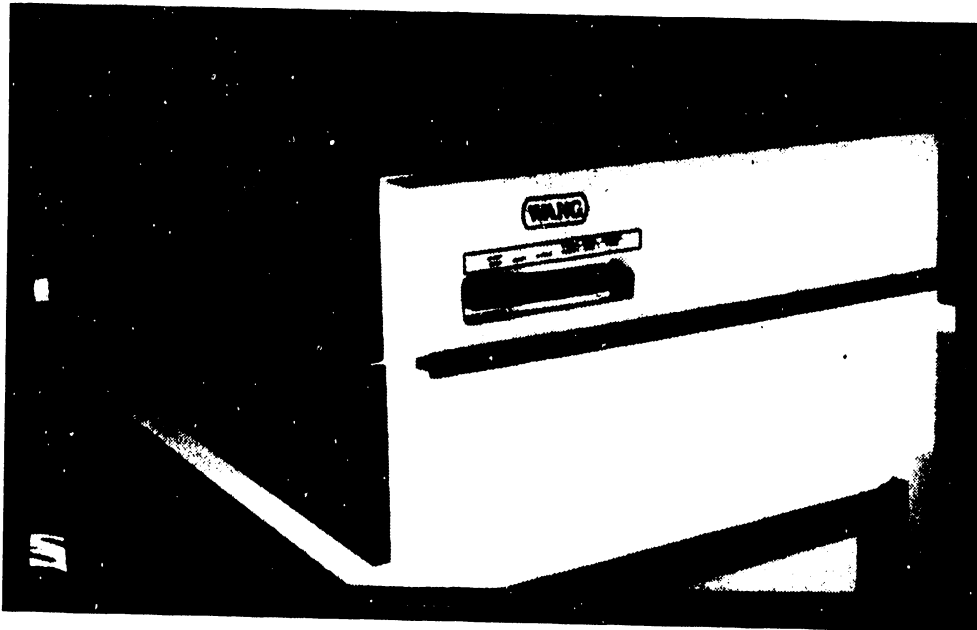
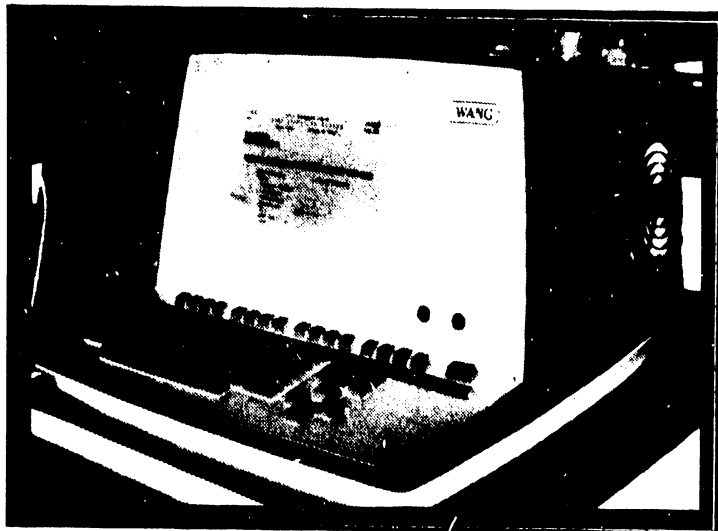
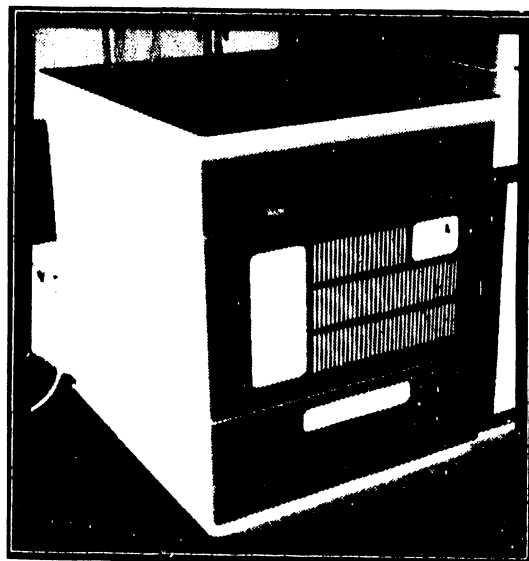

FIGURE 2-5 HAWK DISK DRIVE





CRT WORKSTATION



MASTER PROCESSOR



300 MEG SMD

FIGURE 2-6 300 MEG SMD DISK DRIVE, MASTER PROCESSOR,  
AND CRT WORKSTATION

## 2.4 OPTIONAL PERIPHERALS

The basic OIS 140/145 consists of a Master Unit and a System Disk. However, to communicate with the system, peripheral devices such as CRT/Workstations and printers are necessary additions.

Most peripherals available to the system are standard Wang products. These include the Model 5536-2, -3, and -4 CRT/Workstations with 32K, 48K, and 64K of memory, respectively, the 6521 Line Printer with 16K memory, and the 6581W Daisy Printer with 16K memory. A more complete list is provided on pages 2-2 and 2-3.

## 2.5 ENVIRONMENTAL CHARACTERISTICS

The operating environment is an important consideration when installing a processing system. Although the OIS 140/145 is designed to operate efficiently under less-than-ideal conditions, a dust-free, temperature-controlled environment is recommended.

Adhering to the following system environmental specifications will ensure that maximum operating efficiency is maintained:

- |                         |                             |
|-------------------------|-----------------------------|
| 1. Relative Humidity    | 40% to 60% (non-condensing) |
| 2. Ambient Temperature  | 60°F (15°C) to 80°F (28°C)  |
| 3. Temperature Gradient | 12°F/Hr (6.7°C/Hr)          |
| 4. Max. Wet Bulb Temp.  | 75°F (24.5°C)               |
| 5. Maximum Altitude **  | 10,000 ft (3048m)           |

\*\* Tape drives above 4000 ft (1200m) and disk drives (removable disks) above 6500 ft (1960m) require high altitude options.

**CHAPTER**

**3**

**INSTAL-**

**LATION**

CHAPTER 3  
INSTALLATION

3.1 INTRODUCTION

The configuration addressed in this manual is a minimum configuration and is comprised of a Master Processor with single diskette drive, CRT workstation, and a System Disk. A Model 6580 Phoenix CMD serves as System Disk for the OIS 140 System; a Model 6565 300 Meg SMD, for the OIS 145 System. System control is accomplished at the CRT workstation, while "off-line" data storage is provided by the diskette drive. Since the Model 6560 HAWK Disk Drive is a standard component in OIS 145 Systems, it is considered part of the minimum configuration, and so is addressed in this chapter.

This chapter sets forth a checklist for site preparation and the information necessary to unpack, inspect, make initial adjustments, and power-up the basic system. Specifically, this chapter provides:

<u>ITEM</u>	<u>SECTION</u>
Checklist for site preparation	3.2
Unpacking & initial inspection	3.3
System Interconnections	3.4
Initial Setup, checks, and adjustments	3.5
Power-up Procedure	3.6
Master Unit Power-up Diagnostic	3.7
Power-down procedure	3.8
Software Installation	3.9
System Checkout	3.10
Final Word Processing Check	3.11
Detailed Procedures	3.12

3.2 CHECKLIST FOR SITE PREPARATION

Proper location and site preparation are important for overall operating efficiency. Ideally, the area should be easily accessible, relatively dust free, and temperature and humidity controlled. An adequate number of dedicated, regulated, noise-free AC power outlets should be provided to minimize electromagnetic interference. Additional information is provided in the Systems Installation Guide (729-0907), and the Site Preparation Guide (700-5978).

Selection and preparation of the site should already be completed. The purpose of this checklist in Table 3-1 is to highlight key items, and thereby promote the best operating environment.

TABLE 3-1. SITE PREPARATION CHECKLIST

ITEM	NOTES
Location	Master Processor near the primary user; devices may be as much as 2000 feet from the Master Processor, if necessary.
Space	Easy access by user and service personnel.
Storage	For manuals, materials (ribbon, paper, spare disks), etc.
Environment	An air-conditioned and humidity-controlled environment is recommended (see Table 3-2).
Power Circuits	(1) Separate, noise-free, 3-wire, 20 amp dedicated lines (properly installed in rigid metal conduits that are correctly joined to junction boxes).  (2) Branch circuits protected by circuit breakers suitable for motor load application (see Table 3-2).
Grounding	Extremely important that the CPU and all disks be connected to a Grounding Conductor, which is securely attached to the ground bus in the service panel. The Grounding Conductor is green, green with yellow stripe, or bare. In addition, all outlets used by the system peripherals must be properly grounded.
Dust Free	No noticeable accumulation of dust in a 24-hour period.
Static Electricity	Preferably non-static floor materials.
Access	All doorways and corridors wide enough to allow passage of the system, and sufficient elevator weight-capacity (if used).

TABLE 3-2 ELECTRICAL AND ENVIRONMENTAL REQUIREMENTS \*

DEVICE	VOLTAGE REQUIREMENTS	AMPS	BTU/HR (max.)
<b>MASTER UNIT</b>			
Domestic	115 VAC $\pm$ 10% (60 Hz $\pm$ 1 Hz)	4A	1700
International	230 VAC $\pm$ 10% (50 Hz $\pm$ 1 Hz)	3A	
<b>96 MEG CMD</b>			
Domestic	115 VAC $\pm$ 10% (60 Hz $\pm$ 1 Hz)	8.2A	3000
International	230 VAC $\pm$ 10% (50 Hz $\pm$ 1 Hz)	4A	
<b>300 Meg SMD</b>			
Domestic	208 VAC (+14.6, -29)	8.0A	4200
	230 VAC (+16.0, -13) (60 Hz $\pm$ 1 Hz)	7.2A	
International	220 VAC (+15.0, -25)	9.5A	
	240 VAC (+17.0, -27) (50 Hz $\pm$ 1 Hz)	8.7A	
<b>5536-2/-3/-4 CRT/WS</b>			
Domestic	115 VAC $\pm$ 10% (60 Hz $\pm$ 1 Hz)	2.5A	480
International	230 VAC $\pm$ 10% (50 Hz $\pm$ 1 Hz)	1.5A	

## SYSTEM ENVIRONMENTAL SPECIFICATIONS

1. Relative Humidity 40% to 60% (non-condensing)
2. Ambient Temperature 60°F (15°C) to 80°F (28°C)
3. Temperature Gradient 12°F/Hr (6.7°C/Hr)
4. Max. Wet Bulb Temp. 75°F (24.5°C)
5. Maximum Altitude \*\* 10,000 ft (3048m)

\* All AC outlets used by the system and peripherals must be checked with the AC Outlet Impedance Tester (WL #727-0143) for proper polarity and grounding quality.

## -----CAUTION-----

The AC Outlet Impedance Tester, when used on circuits employing a GFI, will cause the GFI to trip. In environments containing extremely important equipment, such as life support equipment, tripping a GFI could spell disaster.

\*\* Tape drives above 4000 ft (1200m) and disk drives (removable disks) above 6500 ft (1960m) require high altitude options.

### 3.3 UNPACKING & INITIAL INSPECTION

#### 3.3.1 UNPACKING THE MASTER PROCESSOR

----- CAUTION -----

Inspect the shipping cartons and report any damage to the carrier. Do not proceed with unpacking until certain that this will not void any claims to the carrier.

-----

Unpacking procedures for the Master Processor comprise 6 steps:

- A. Using diagonal cutters (or other suitable tool), cut the two plastic straps securing the shipping carton.
- B. Remove the the carton's top cover and the cushion assembly that protects the top of the Master Unit
- C. Slide the square cardboard tube off of the unit. (tube should not be stapled to pallet.)
- D. Remove the plastic bag surrounding the unit.
- E. Remove the four shipping brackets that secure the CPU to its pallet, using the appropriate size nut driver.
- F. The Master Unit is now ready to be lifted from the pallet and placed in its assigned location.

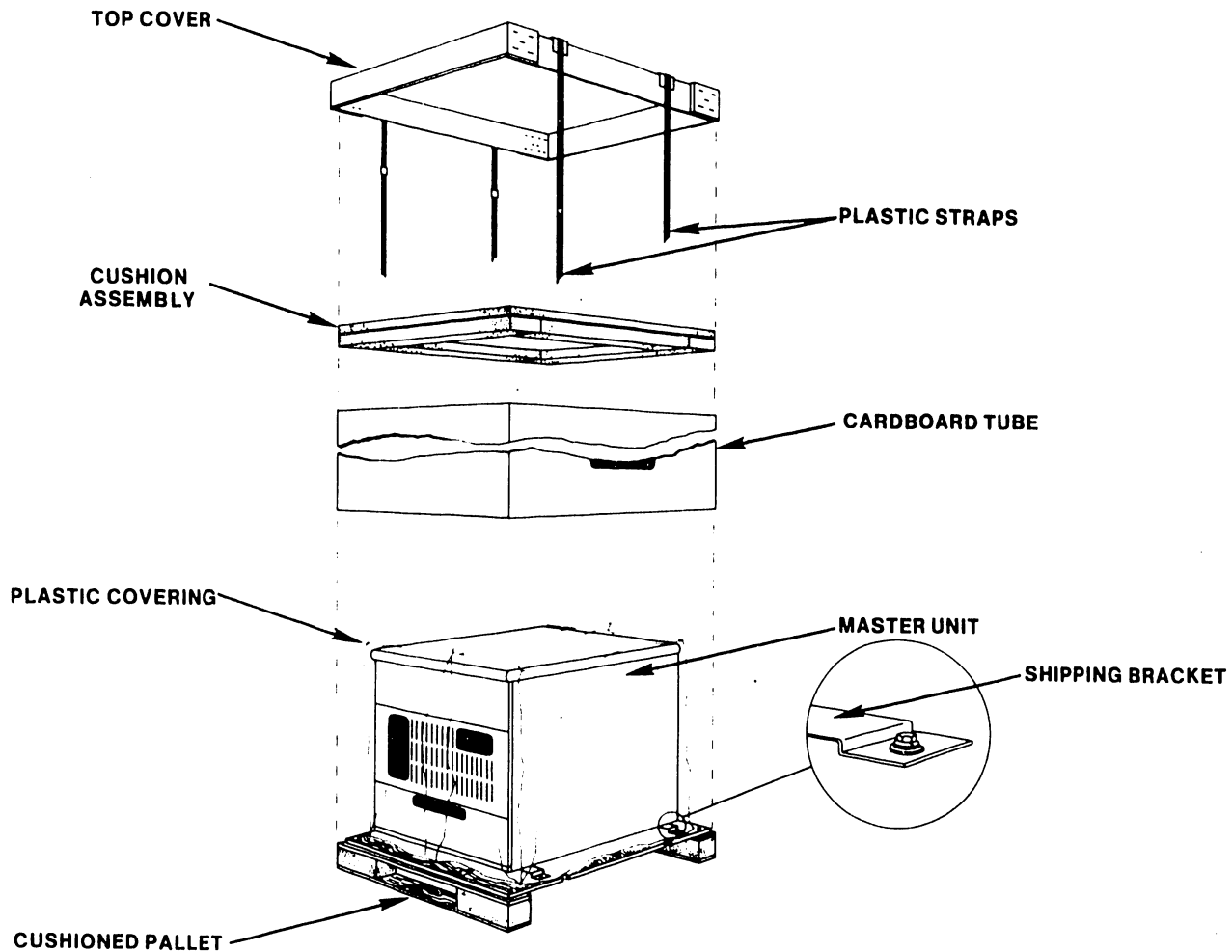

FIGURE 3-1 PACKAGING FOR THE MASTER PROCESSOR

### 3.3.2 UNPACKING THE CRT WORKSTATION

----- CAUTION -----

Inspect the shipping cartons and report any damage to the carrier. Do not proceed with unpacking until certain that this will not void any claims to the carrier.

-----

Unpacking the CRT workstation follows standard procedures for "foam in place" packaging:

- A. Cut the sealing tape and open the top of the shipping carton
- B. Remove the foam padding at the top and sides of the CRT workstation
- C. Carefully, lift the CRT workstation clear of the shipping carton and place it in its designated location.

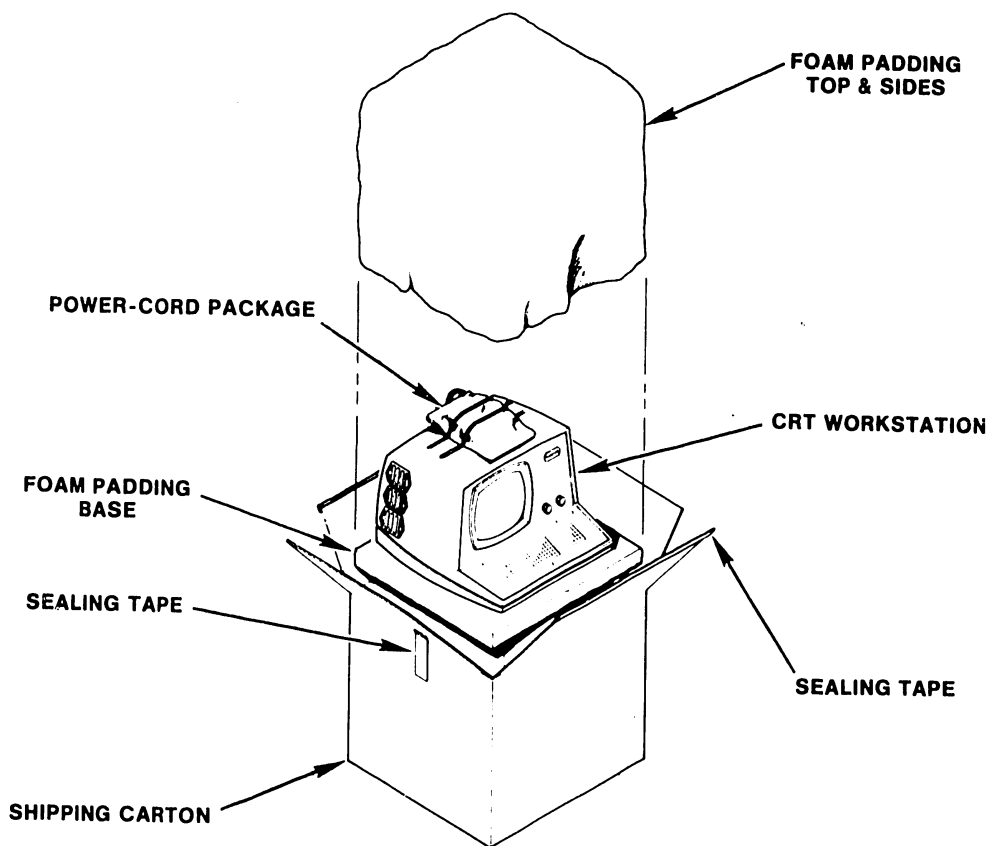

FIGURE 3-2 PACKAGING FOR THE CRT WORKSTATION



3.3.3 UNPACKING THE PHOENIX DISK DRIVE

----- CAUTION -----  
Inspect the shipping cartons and report any damage to the carrier. Do not proceed with unpacking until certain that this will not void any claims to the carrier.  
-----

Unpacking procedures for the Phoenix disk unit comprise 5 steps:

- A. Using diagonal cutters (or other suitable tool), cut the two steel straps securing the shipping carton.
- B. Open the top of the cardboard carton and remove Instapak that surrounds the drive. Take care not to lose or dispose of the hardware package shipped internally on top of the unit.
- C. Remove the staples that secure the cardboard carton to the wooden pallet, then lift off the carton.
- D. With the disk drive exposed, remove the four short metal hold-down brackets that secure the disk to the wooden support base.
- E. Prior to removing the Phoenix from the wooden pallet, raise one end of the drive at a time just enough to install the round white rubber mounts supplied with the associated hardware. The disk is now ready to mount on its stand.

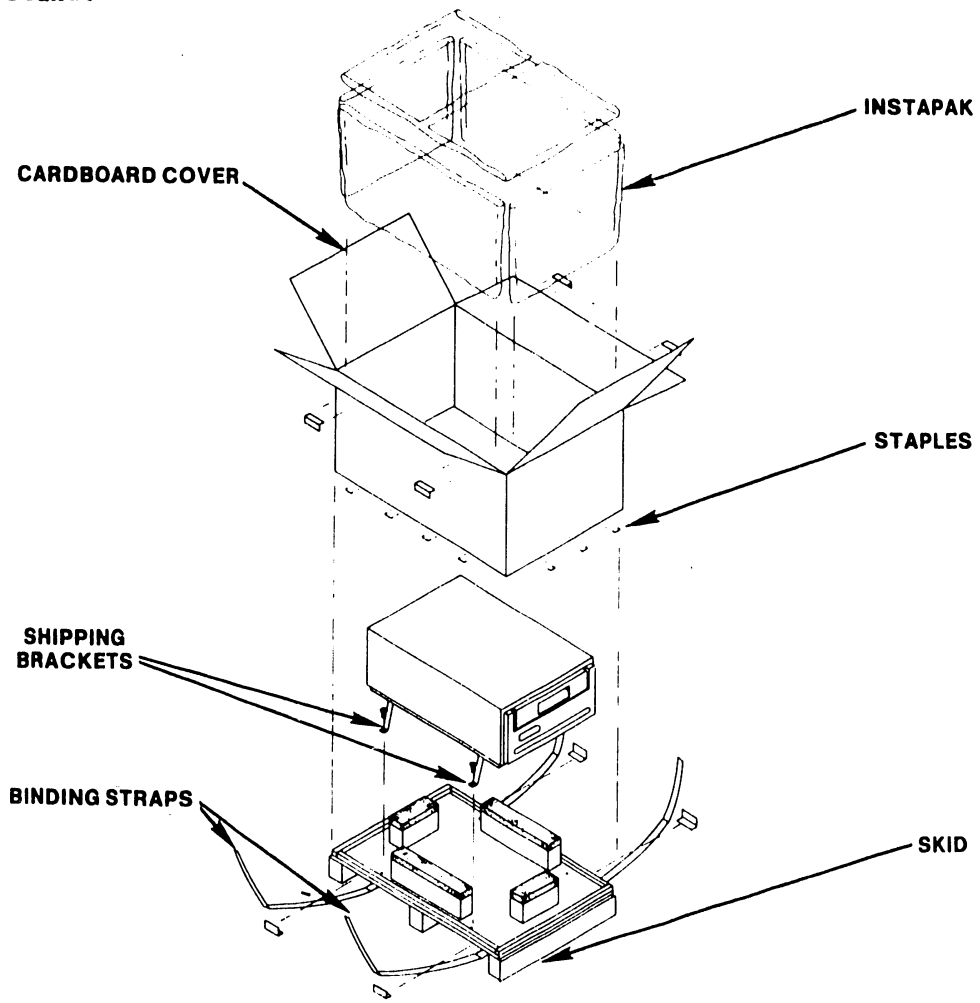

FIGURE 3-3 PACKAGING FOR THE PHOENIX DISK DRIVE

### 3.3.4 UNPACKING THE 300 MEG SMD DISK DRIVE

----- CAUTION -----

Inspect the shipping cartons and report any damage to the carrier. Do not proceed with unpacking until certain that this will not void any claims to the carrier.

-----

Unpacking procedures for the 300 Meg SMD disk unit comprise 5 steps:

- A. Using diagonal cutters (or other suitable tool), cut the two straps securing the shipping carton.
- B. Remove the the carton's top cover and the cushion assembly that protects the top of the Master Unit.
- C. Cut the inner straps that secure the unit to its pallet, then remove the protective plastic covering.
- D. Unbolt the shipping brackets and remove the middle and end cushion assemblies from the wooden pallet as shown in the figure below.
- E. Raise the four leveling legs as high as possible and slowly roll the unit down off the pallet. The disk is now ready to be placed in its assigned location.

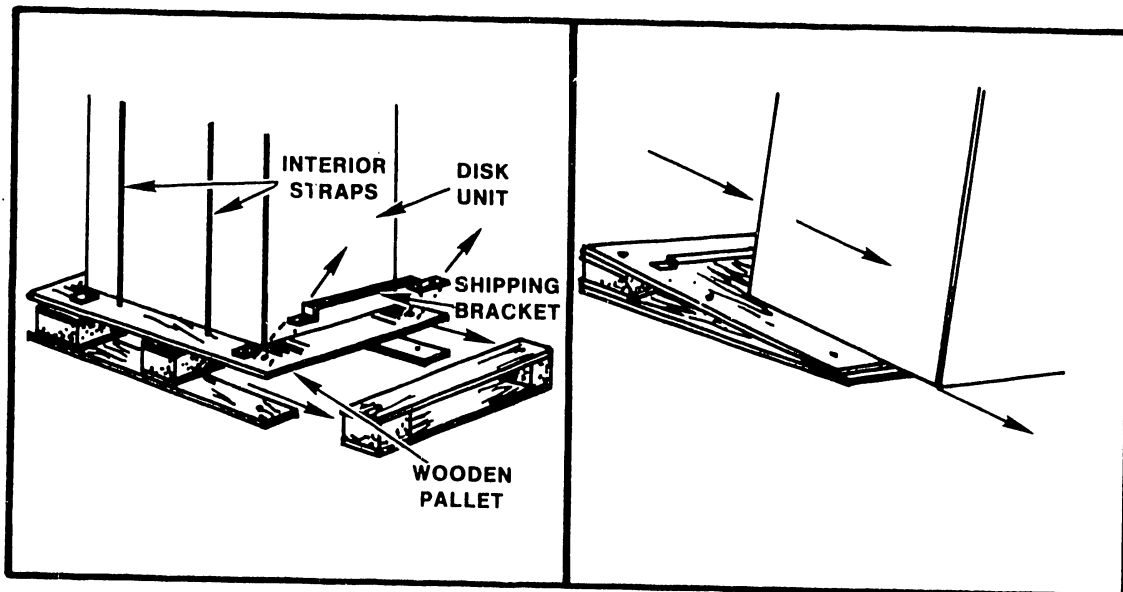

FIGURE 3-4 PACKAGING FOR THE 300 MEG SMD DISK DRIVE

3.3.5 UNPACKING THE HAWK DISK DRIVE

-----CAUTION-----  
Inspect the shipping cartons and report any damage to the carrier. Do not proceed with unpacking until certain that this will not void any claims to the carrier.  
-----

The HAWK disk unit is strapped to a cushioned pallet for shipping. A corrugated shipping carton covers the unit and is also strapped down.

Unpacking procedures comprise 6 steps:

- A. Using diagonal cutters (or other suitable tool), cut the steel straps securing the shipping carton.
- B. Using a slotted screwdriver, remove the staples which attach the carton to the pallet and lift off the carton.
- C. Remove any packing material.
- D. Cut the steel straps securing the HAWK disk unit.
- E. Carefully, lift the HAWK disk unit clear of the pallet and place it on the mounting cabinet.
- F. Thoroughly clean the unit of all particles of shipping dust.

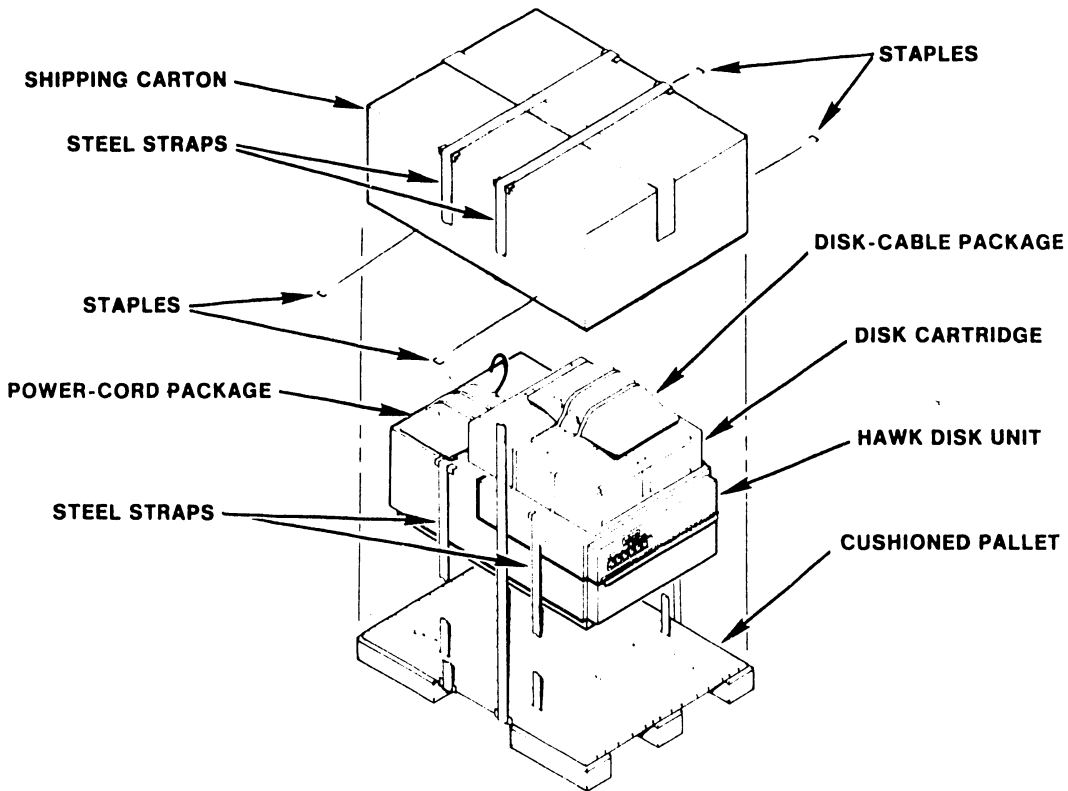

FIGURE 3-5 PACKAGING FOR THE HAWK DISK UNIT

### 3.3.6 INSPECTING THE MASTER PROCESSOR

- A. Ensure that the power-on switch is in the OFF position.
- B. Remove the top cover and front panels per Sections 7.3.1 and 7.3.2.
- C. Ensure that all connections from the motherboard to the power supply chassis, front panel, and diskette drive are secure and properly oriented per sections 7.3.2 and 7.3.4 (see Figure 3-6).
- D. Inspect the inside of the Master Unit, the motherboard, and the power supply chassis for wire clippings, metal shavings, etc.
- E. Clean as necessary.
- F. Ensure that the two screws located on top of the large capacitor on the power supply chassis are sufficiently tight (see Figure 3-7).
- G. Set the voltage selector switch to the correct position (see Figure 3-7). Check fuse to ensure value is correct for line voltage selected. (115 VAC - 4A SLO-BLO, WL# 360-1040-SB; 230 VAC - 3A SLO-BLO, WL# 360-1031-SB.)
- H. Check and properly seat all PCAs and connectors per section 7.3.3.
- I. Complete, sign, and mail the shipping card enclosed with the unit.
- J. The top cover and front panels need not be replaced until the system installation and checkout is complete.

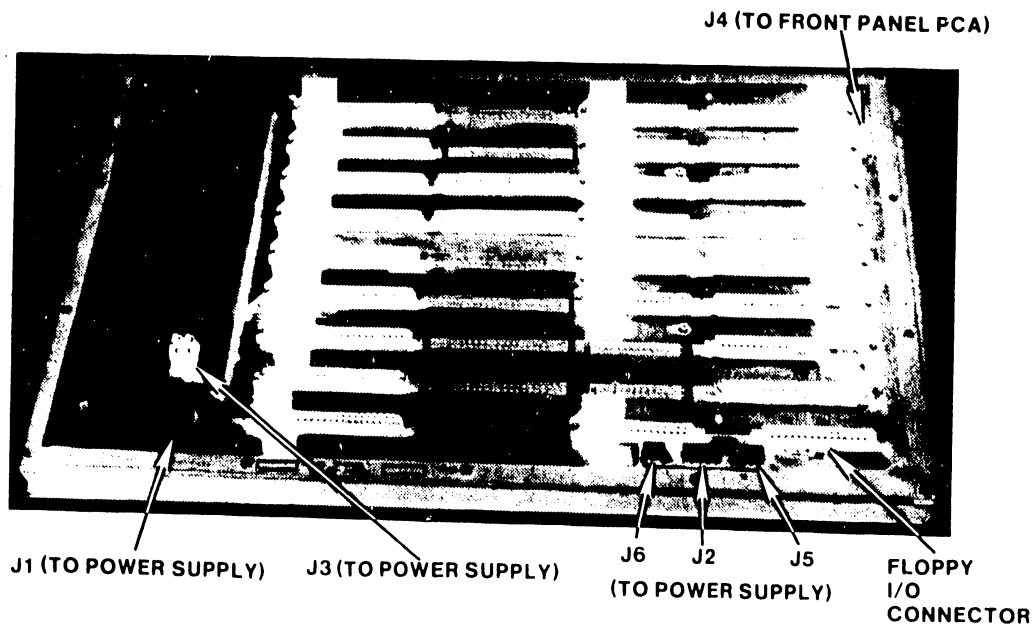

FIGURE 3-6 MOTHERBOARD CONNECTIONS

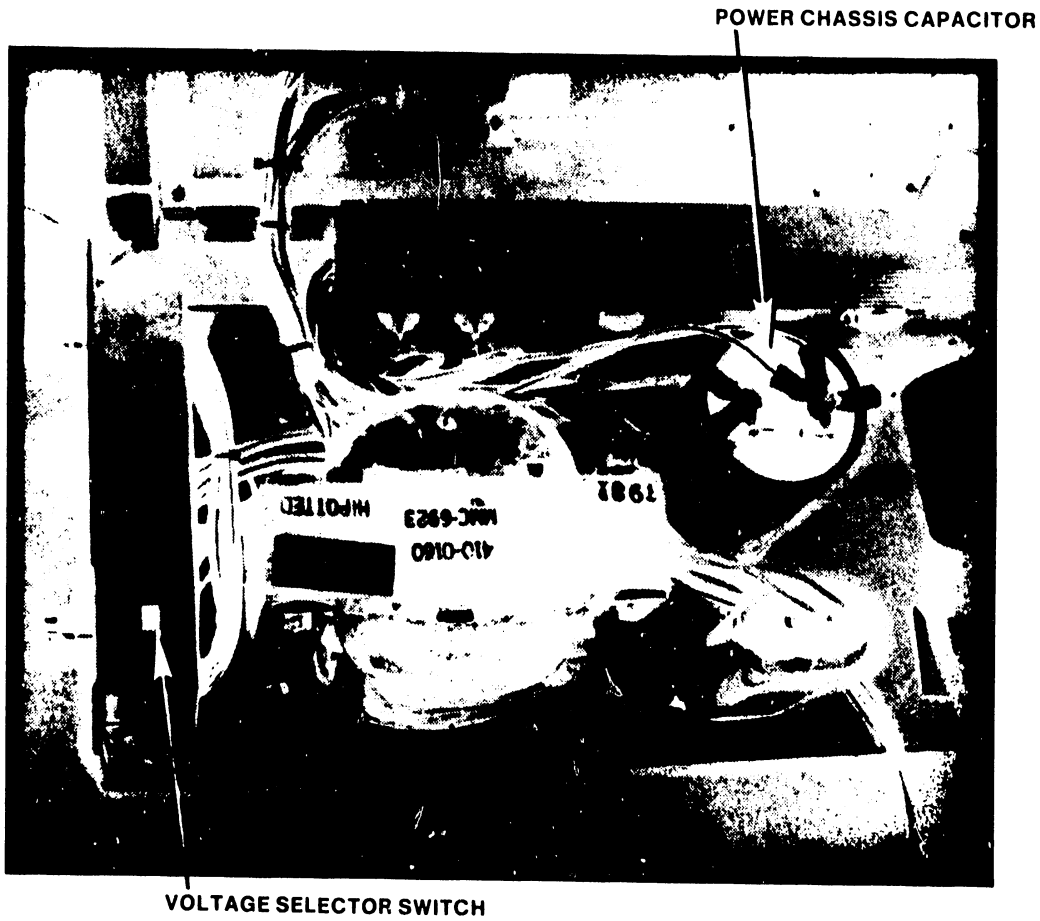

FIGURE 3-7 POWER CHASSIS CAPACITOR CONNECTIONS AND  
115/230 VOLTAGE-SELECT SWITCH

### 3.3.7 INSPECTING THE CRT WORKSTATION

These procedures are detailed in Models 5536-1/-2/-3/-4 Workstations, WPNL No.81 (729-0522) and Model 5536 Series Workstation PMM (729-0522A).

Inspection requires:

- A. Removing the keyboard and main covers.
- B. Inspecting for wire clippings, metal shavings, etc.
- C. Setting the switches
- D. Completion and mailing of the shipping card

The covers need not be replaced until the Initial Checks and Adjustments have been completed.

### 3.3.8 INSPECTING THE PHOENIX DISK DRIVE

The following procedures are detailed in the Wang Cartridge Module Disk Drive Manual (729-0199), and CMD Block Point Four Manual (729-1063):

- A. Remove the top dust cover and inspect various items such as circuit boards, carriage assembly, and read/write heads for shipping damage.
- B. Remove the Electronic Module Securing Screws.
- C. Move the Head Carriage Locking Tool from the 'shipping' position to the 'operating' position.
- D. Loosen the Deck Hold Down Bolts and ensure that the Rear Shipping Bolt and spacer are in position before attempting to raise the deck assembly.
- E. Check that the unit is clean inside. Raise the base deck assembly to inspect inside the base pan. Note that the Electronic Module must be in maintenance position to open the deck (not applicable to Block Four units).
- F. Check/perform the inspection of the following items:
  - 1. Power supply is securely tightened.
  - 2. Check the unit for any shipping or packing material that may be in the cartridge receiver area.
  - 3. Inspect top of unit for loose wires or damaged components.
  - 4. Check the connectors on the bottom of the Electronics Module while the Deck Base is raised.
  - 5. Check the Deck Lowered Switch Interlock located under the Electronic Module.
- G. Lower the base deck assembly and restore the Electronics Module to its normal position per Section 2.6 of the Wang CMD Disk Drive Manual. Take care not to pinch any cables while lowering the assembly.
- H. Tighten the Deck Hold Down Bolts, remove the Rear Shipping Bolt and spacer.
- I. When the procedure outlined in Section 2.6 has been completed, restore the top dust cover and complete, sign, and mail the shipping card.

3.3.9 INSPECTING THE 300 MEG SMD DISK DRIVE

The following inspection procedures are detailed in the CDC SMD Hardware Maintenance Manual (729-0221):

1. Inspect drive for possible shipping damage. Any claim for this type of damage should be filed promptly with the transporter involved. If a claim is to be filed, save the original shipping materials.
2. Ensure that all shipping hardware, e.g. shipping bolts, head clamp, etc., have been removed per chapter 1 of the manual cited above.
3. Verify that all logic cards are firmly seated in logic chassis and power supply.
4. Verify that all connectors are firmly seated.
5. Verify that the control panel is firmly seated in its shroud.
6. Verify that all cabling is intact and that there are no broken or damaged wires.
7. Check entire drive for presence of foreign material which could cause an electrical short.
8. Check actuator and pack area for presence of material which could obstruct movement of carriage and heads.
9. Complete, sign, and mail the shipping card.

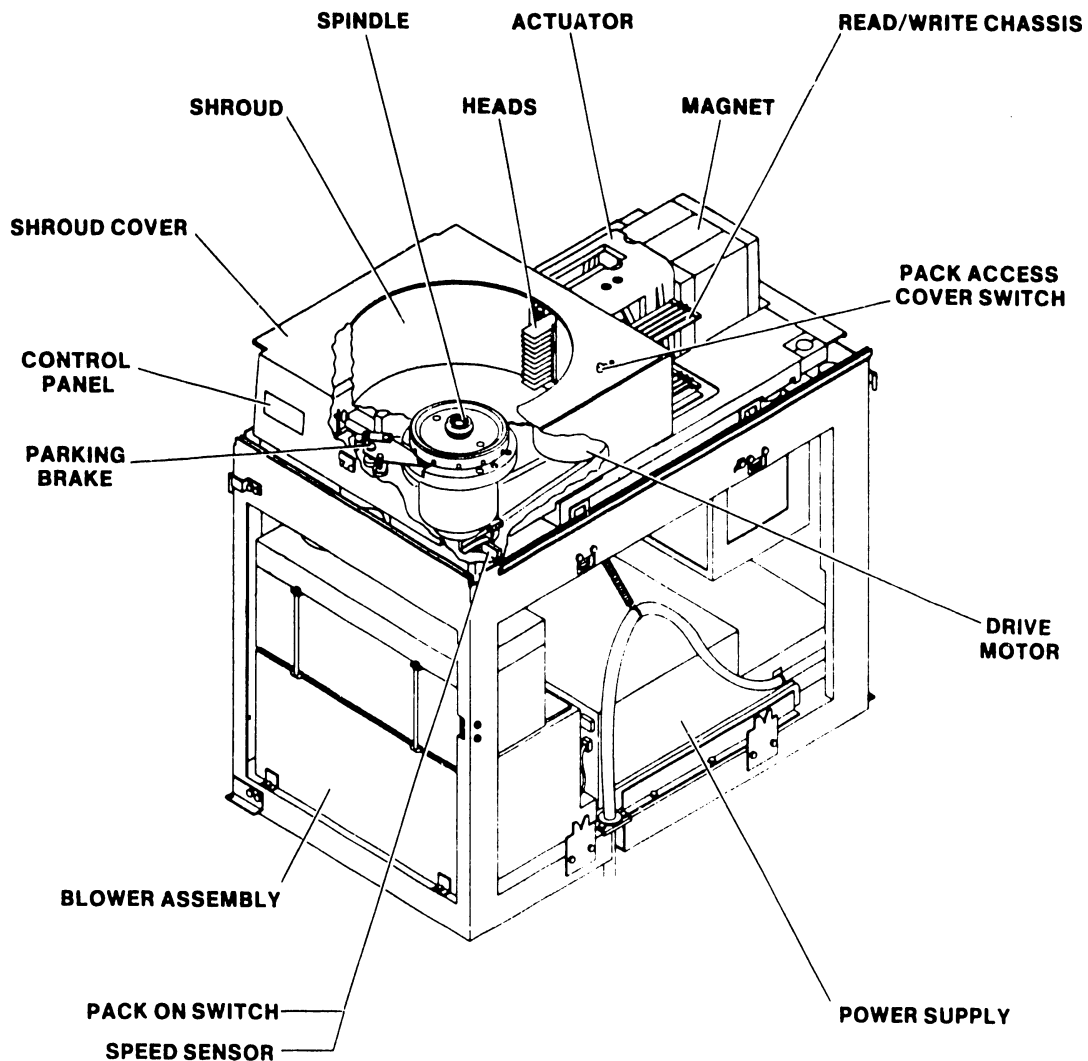

FIGURE 3-8 300 MEG SMD DETAILED LOCATIONS

### 3.3.10 INSPECTING THE HAWK DISK DRIVE

The following procedures are detailed in the Wang/CDC HAWK Disk Drive Manual (729-0181); refer to this document for further information unless directed otherwise.

- A. Remove the electronics cover.
- B. Remove the carriage lock pin.
- C. Remove the card-cage cover.
- D. Verify that all logic cards are firmly seated.
- E. Set the option switches per Section 3.12.4.
- F. Ensure that the ground straps are properly installed.
- G. Complete and mail the shipping card.
- H. The electronics covers need not be replaced until the Initial Checks and Adjustments have been completed.

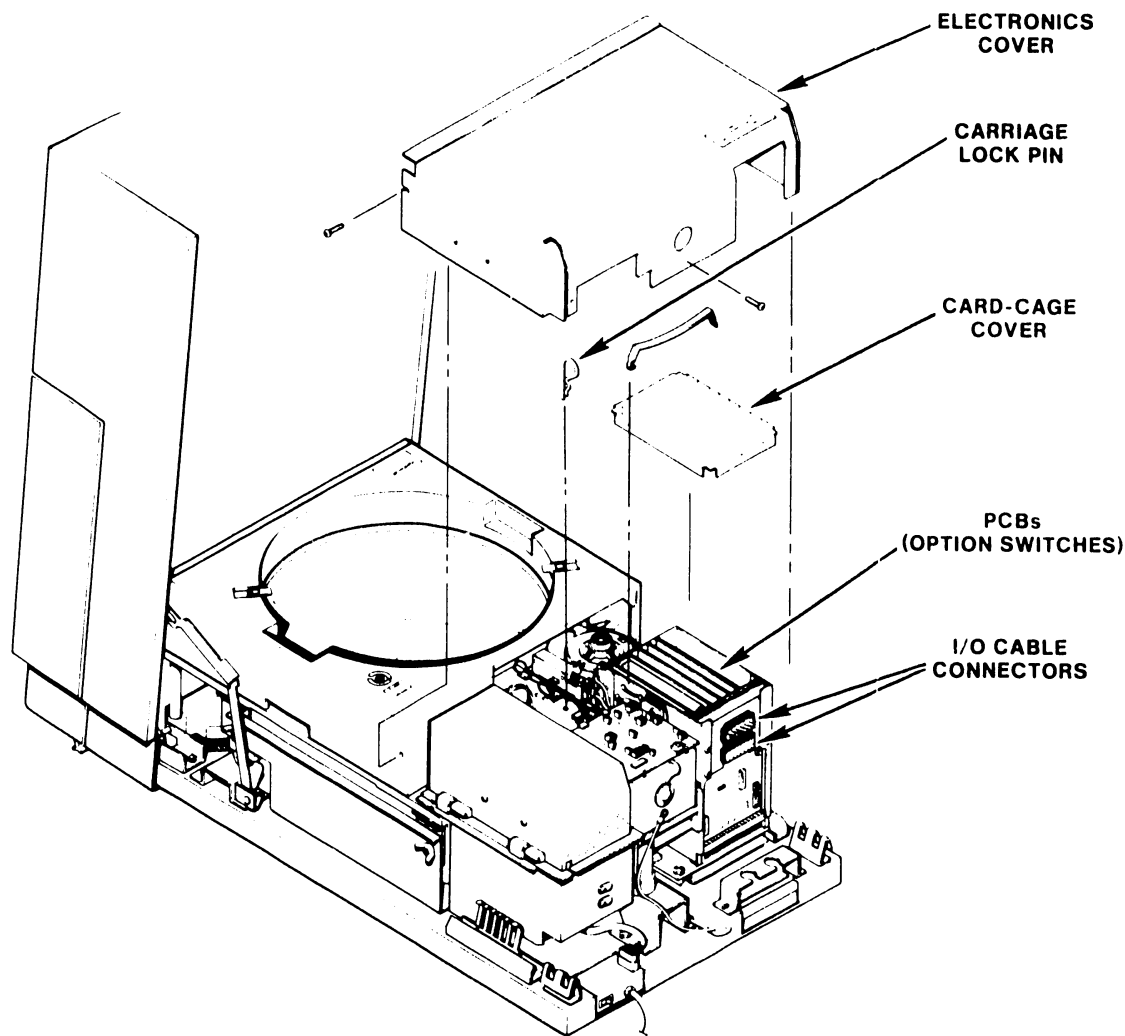

FIGURE 3-9 INSPECTING THE HAWK DISK UNIT



### 3.4 SYSTEM INTERCONNECTIONS

#### 3.4.1 CABLING

The Master Unit is connected to its various peripherals as follows:

- A. Connect all slave devices to the serial connector plates (279-0358) at the rear of the Master Unit. A CRT/Workstation should be close to the master processor to serve as a 'system console' for running Master Monitor Diagnostics and the like.

Be sure to number the coaxial cables at both ends, master and slave.  
Slave devices can be located up to 2000 feet from the Master Unit.

- B. Connect the four ribbon cables from the serial connector plates to the top of the 7504 DATA BUFFER board (See Fig. 3-10). The ribbon cable from adapter plate number one plugs into the J<sub>1</sub> connector, from plate number two, into the J<sub>2</sub> connector, and so on.
- C. The cables from the #1 HAWK drive, Phoenix CMDs, (or 300 Meg SMDs) are inserted through clamps at the rear of the main chassis. The J<sub>1</sub> and J<sub>2</sub> plugs of the HAWK cable are inserted into the J<sub>1</sub> and J<sub>2</sub> connectors, respectively, of the 210-7502 PCB. The CMD/SMD "A" cable is plugged into the 7505 board and the CMD/SMD "B" cables are plugged into Ports 0 through 3 (Connectors J1 through J4) of the 7506 board.

-----NOTE-----

Ports 0 through 3 are interchangeable, i.e. any Phoenix (or 300 Meg SMD) drive may be connected to any of the four ports, as long as each drive-type definition switch is set to the appropriate state. For OIS 140/145 Systems employing more than one Phoenix (or 300 Meg SMD), it is recommended that all the drive-type definition switches be set identically. In this way, all four ports may be interchanged at will during troubleshooting without having to modify the drive-type definition switches. See Section 3.12.1 for instructions on how to set the drive-type definition switches.

-----

The CMD/SMD "A" and "B" cables, and the HAWK cables are copper clad for shielding purposes. To ensure proper contact with the main chassis, all drive cables must be mounted as follows:

1. Slide plastic sleeve over ground clips ensuring that the copper shield is in contact with the clips. (See Fig. 3-11.)
2. Push cable into clamp until plastic sleeve of cable touches the cable clamp ground clips.
3. Tighten clamps to ensure good contact, do not overtighten as this could damage drive cable.

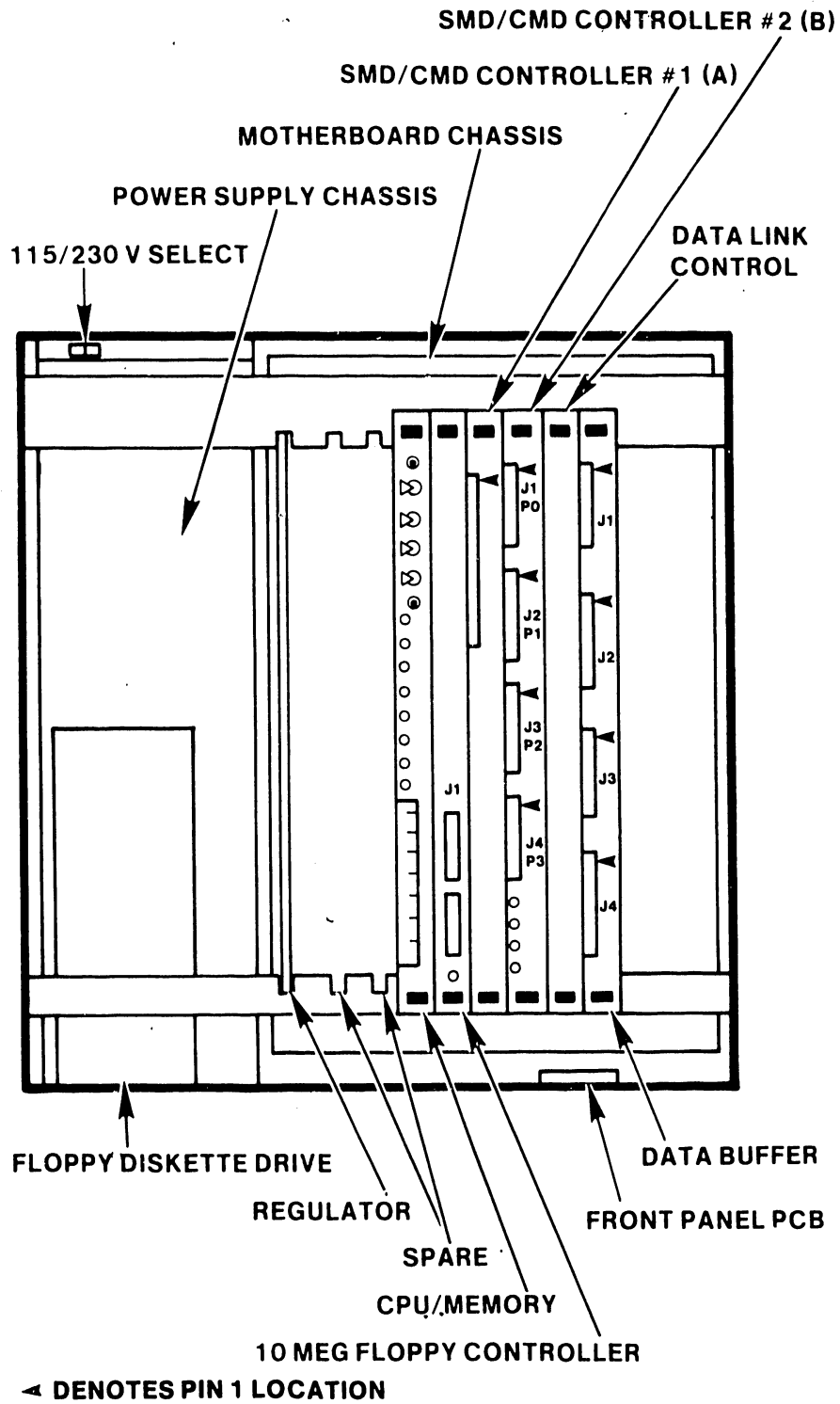

FIGURE 3-10 MASTER UNIT DETAILED LOCATIONS

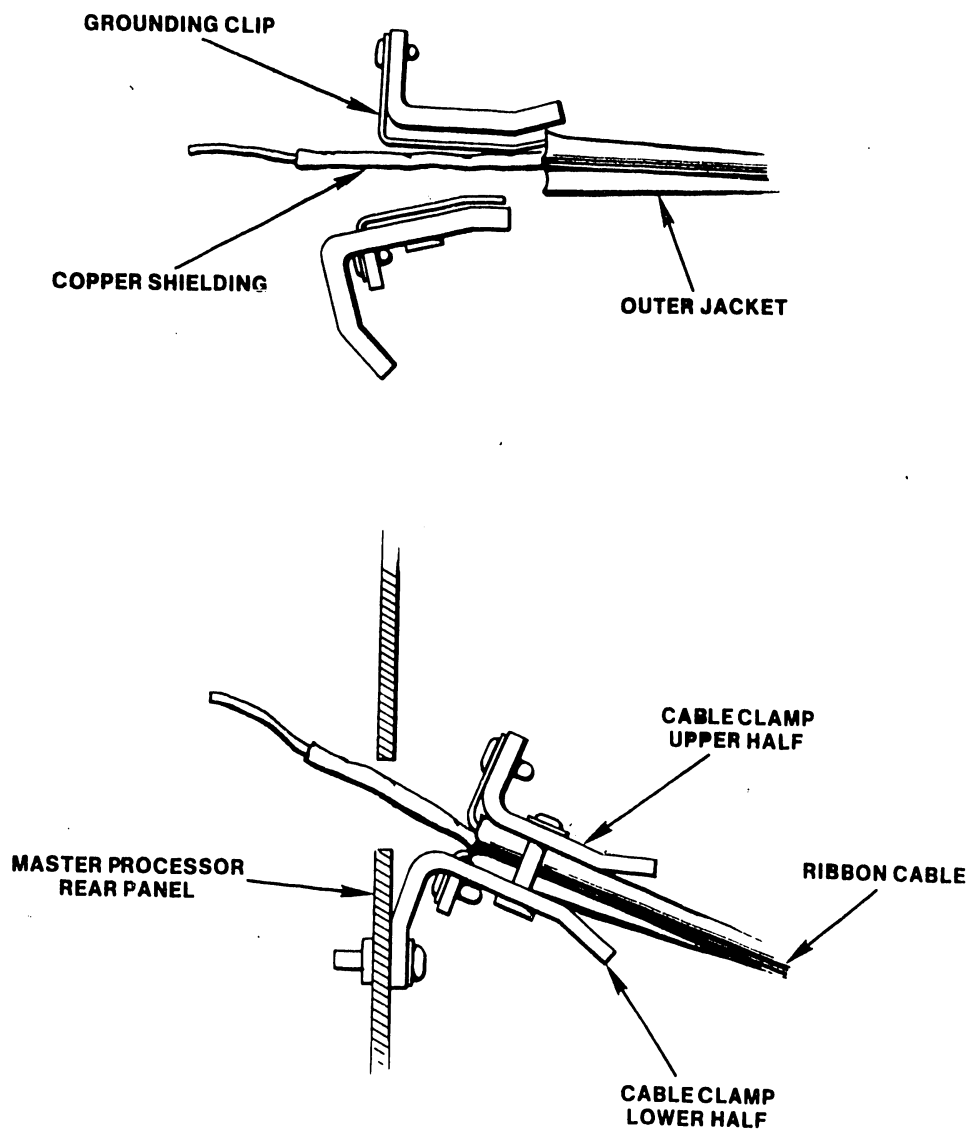

FIGURE 3-11 MASTER UNIT DISK CABLE CLAMP

3.4.2 ELECTRICAL POWER

## -----WARNING-----

It is extremely important that all system equipment and all outlets are properly grounded: The Master Unit and all disks must be connected to a Grounding Conductor which is securely attached to the ground bus in the service panel. "The Grounding Conductor shall be...green...or green with yellow stripes, unless it is bare." -- National Electrical Code, Article 210, National Fire Protection Association.

All AC outlets used by the system and peripherals must first be checked with the AC Outlet Impedance Tester (WL #727-0143) for proper polarity and grounding quality.

- 
- A. Ensure that all equipment power switches are positioned "OFF" and the Master Processor Voltage Selector switch is positioned correctly (see Figure 3-7).
  - B. Plug the Master Processor power cable into the outlet provided.
  - C. Plug all disk drive power cables into the outlets provided.
  - D. Plug the CRT Workstation power cable into the outlet provided.

3.5 INITIAL SETUP, CHECKS, AND ADJUSTMENTS

3.5.1 INITIAL CHECKS AND ADJUSTMENTS FOR THE MASTER PROCESSOR

-----WARNING-----

Do not touch the heat sink: serious injury could result.  
The heat sink reaches very high temperatures when the unit  
is running and the top cover is removed.

- 
- A. If applicable, remove the top cover. (See Section 7.3.1.)
  - B. Check the PC board E-revision level. (See Section 3.12.7)
  - C. Properly set all switches. (See Section 3.12.1)
  - D. Position the power switch to "ON".

-----CAUTION-----

Avoid touching bare leads and causing a short circuit:  
very little clearance is provided for these adjustments.

- 
- E. Adjust the voltages on the CPU/MEM board. (See Section 3.12.5)
  - F. Test the diagnostic LEDs. (See Section 3.12.5)
  - G. Replace the top cover. (See Section 7.3.1.)

### 3.5.2 INITIAL CHECKS AND ADJUSTMENTS FOR THE CRT WORKSTATION

These procedures are detailed in Models 5536-1/-2/-3/-4 Workstations, WPNL No.81 (729-0522).

Initial checks and adjustments comprise the following steps.

- A. Turn power ON and adjust voltages
- B. Turn power OFF and connect video cable
- C. Connect fan
- D. Connect brightness/contrast cable
- E. Replace covers
- F. Ensure free rotation of the fan blades
- G. Tighten all screws

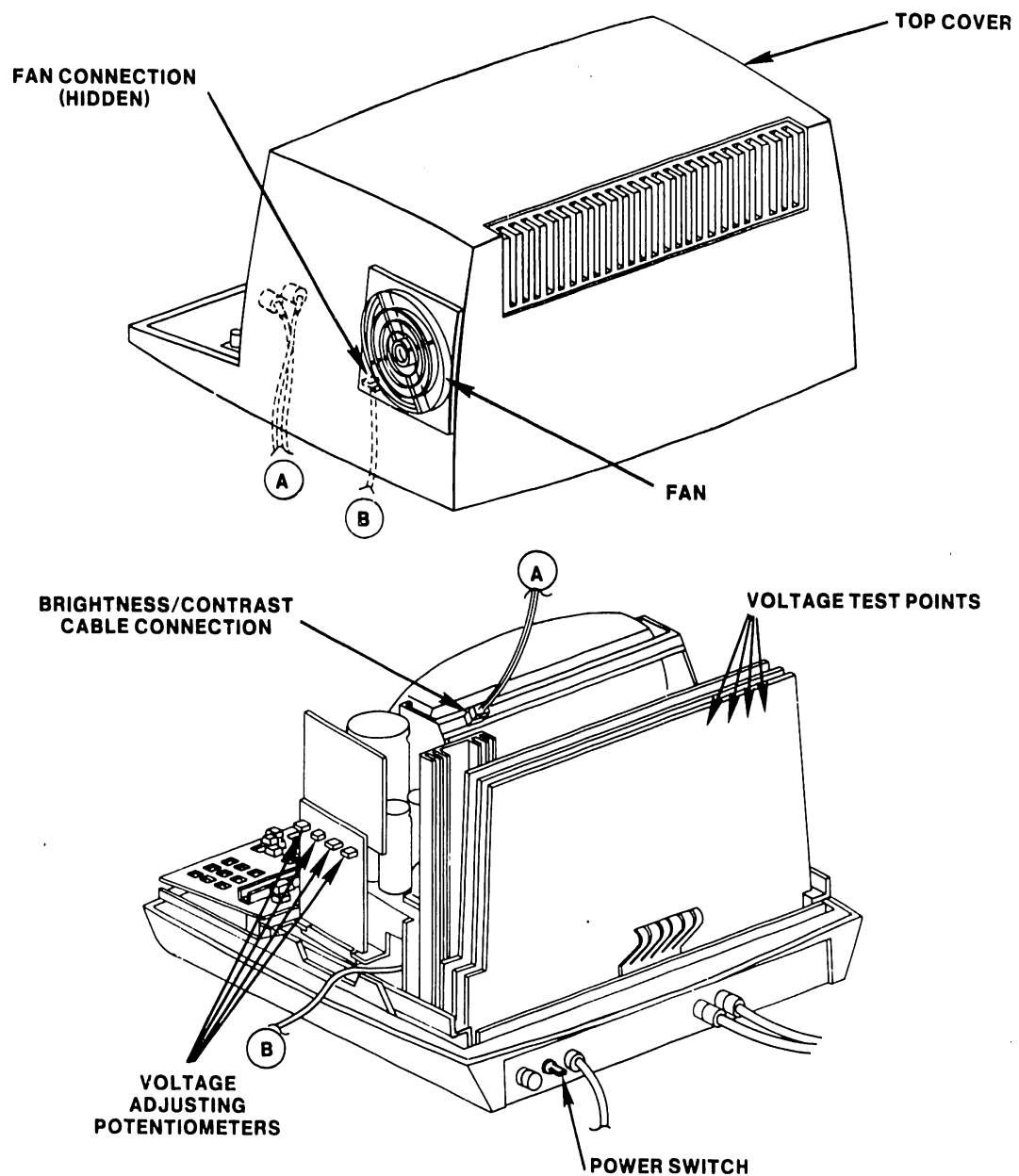

FIGURE 3-12 CRT WORKSTATION CHECKS AND ADJUSTMENTS

3.5.3 INITIAL CHECKS AND ADJUSTMENTS FOR THE PHOENIX DISK DRIVE

The following procedures are detailed in the Wang Cartridge Module Disk Drive Manual (729-0199):

- A. Ensure that the Carriage Locking Pin is in the 'operating' position.
- B. Verify the following cable connections:
  - 1. "A" Cable to the J1 connector of the I/O board.
  - 2. "B" Cable to the J3 connector of the Control MUX PCB.
  - 3. Terminator to the J2 connector of the I/O board of last drive in chain.
  - 4. If daisy chained, "A" Cable from J1 connector of the I/O board, to J2 connector of the I/O board on "upstream"\* drive.

-----NOTE-----

As viewed from the component side, positioned in the electronics module, the I/O board shows two large connectors. Connector J1 is to the left of J2. On both connectors, pin 1 is located in the upper-left corner.

The J3 connector of the Control MUX PCB, when viewed in the same manner locates pin 1 in the upper-left corner.

-----

- C. Make proper switch settings on Servo Coarse PCB. (See Section 3.12.2.)
- D. Make proper switch settings on Control MUX PCB. (See Section 3.12.2.)
- E. Check/perform Logical Address Plug Installation. (See Section 3.12.6.)
- F. Power up and perform voltage checks.
- G. Verify/perform correct head alignment.
- H. Perform the Heads Loaded Switch Adjustment.
- I. Perform the Spin Speed Sensor Test.
- J. Perform the Velocity Gain Adjustment.

\* In daisy chain, upstream drive is next drive closer to Master Processor.

### 3.5.4 INITIAL CHECKS AND ADJUSTMENTS FOR THE SMD-300 DISK DRIVE

The following procedures are detailed in the CDC SMD Hardware Maintenance Manual (729-0221):

- A. Ensure that the SMD unit is properly grounded according to the Daisy Chain Grounding scheme outlined on page 1-11 of the manual cited above.
- B. Verify the following cable connections on the SMD I/O connector panel (see Figures 3-13, 3-14):
  1. "B" Cable to connector IJ2.
  2. "A" Cable to connector IJ3.
  3. Terminator to connector IJ4 of last drive in chain.
  4. If daisy chained, "A" Cable from connector IJ3 to connector IJ4 on "upstream"\* drive.
- C. Make the proper sector switch settings on the LTV card, in logic chassis position A06. (See Section 3.12.3.)
- D. Check/perform Logical Address Plug installation. (See Section 3.12.6.)
- E. Power up and perform voltage check.
- F. Perform Servo System Test and Adjustment and Head Alignment procedures.

\* In daisy chain, upstream drive is next drive closer to Master Processor.

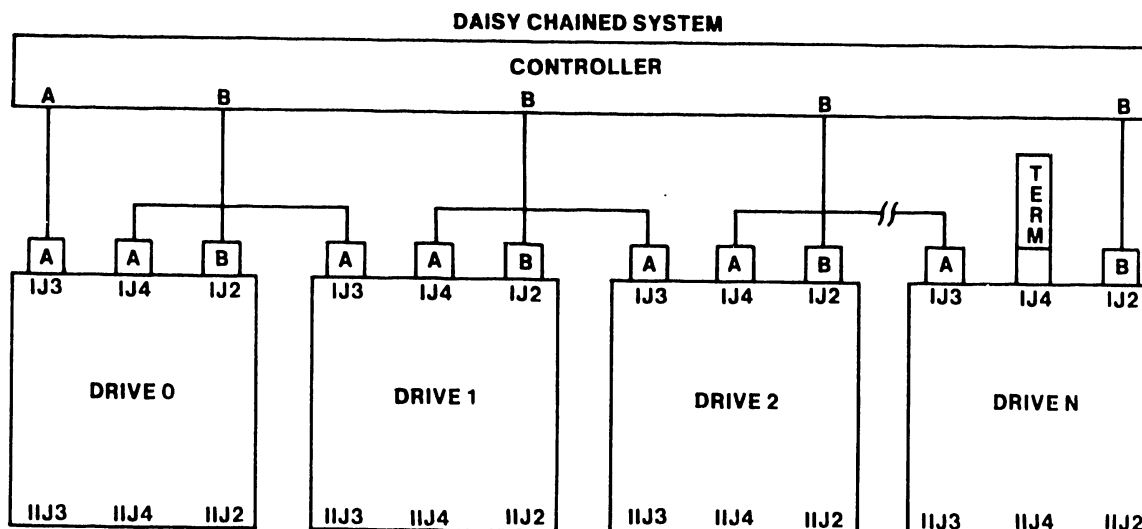
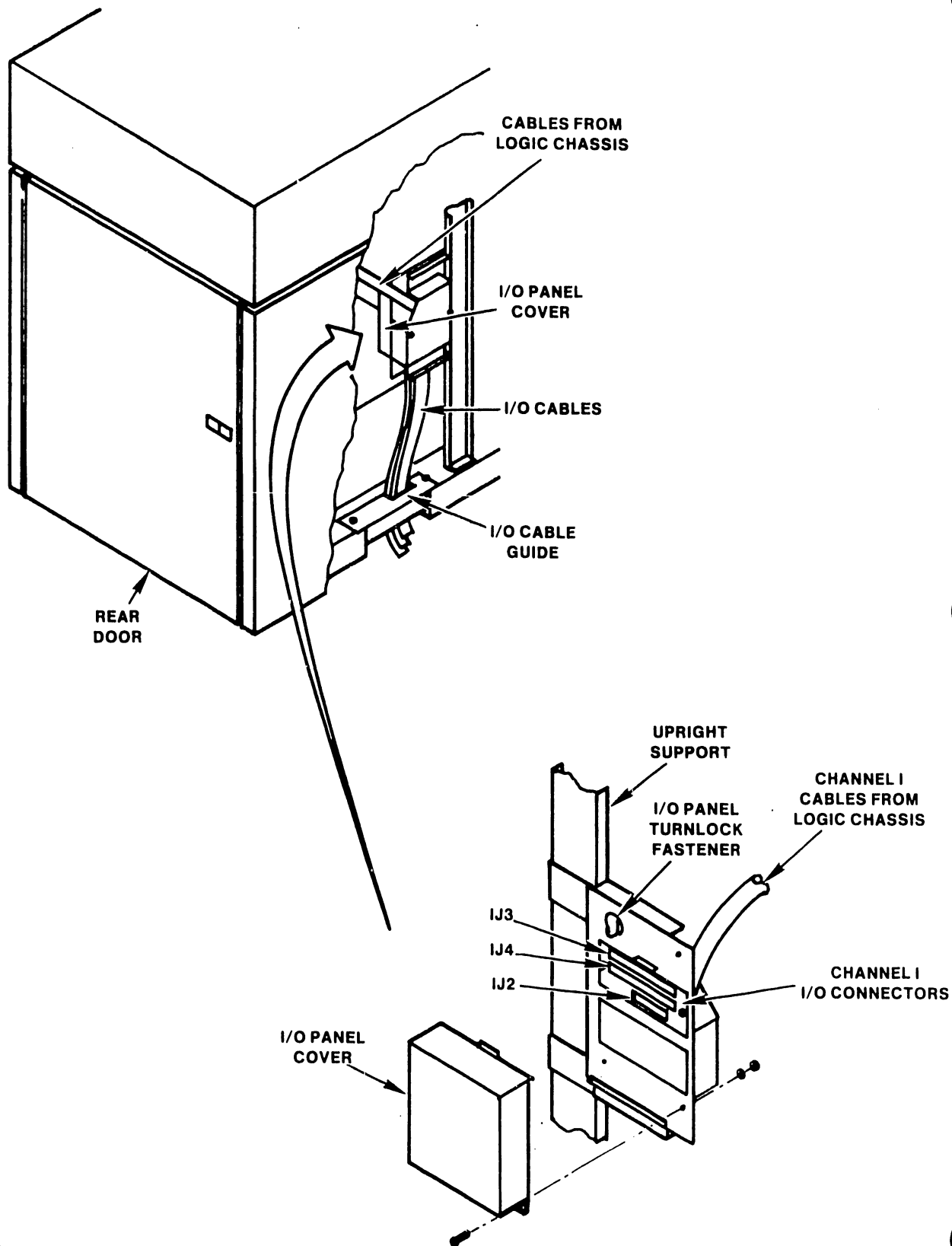

FIGURE 3-13 300 MEG SMD CABLE CONFIGURATIONS





**Note:** CONNECTOR PINS ARE LABELED. PIN #1 IS LOCATED AT THE BOTTOM LEFT OF EACH CONNECTOR, AS VIEWED FROM THIS ANGLE

FIGURE 3-14 300 MEG SMD I/O CONNECTOR PANEL

### 3.5.4.1 INITIAL CHECKS AND ADJUSTMENTS FOR THE 80 MEG SMD DRIVE

The following procedures are detailed in the CDC OEM Service Manual (729-0210):

- A. Verify the following cable connections on the SMD I/O connector panel (see Figures 3-14a, 3-14b):
  1. "B" Cable to connector IJ2.
  2. "A" Cable to connector IJ3.
  3. Terminator to connector IJ4 of last drive in chain.
  4. If daisy chained, "A" Cable from connector IJ3 to connector IJ4 on "upstream"\* drive.
- B. Make the proper sector switch settings on the LTV card, in logic chassis position B08. (See Section 3.12.3.)
- C. Check/perform Logical Address Plug installation. (See Section 3.12.6.)
- D. Power up and perform voltage check.
- E. Perform Servo System Test and Adjustment and Head Alignment procedures.

\* In daisy chain, upstream drive is next drive closer to Master Processor.

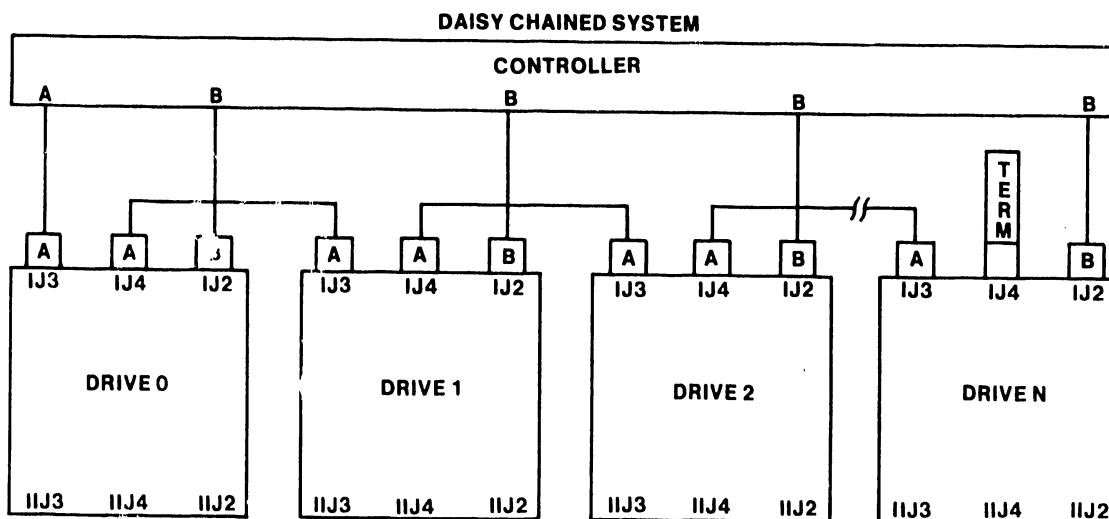

FIGURE 3-14a 80 MEG SMD CABLE CONFIGURATIONS

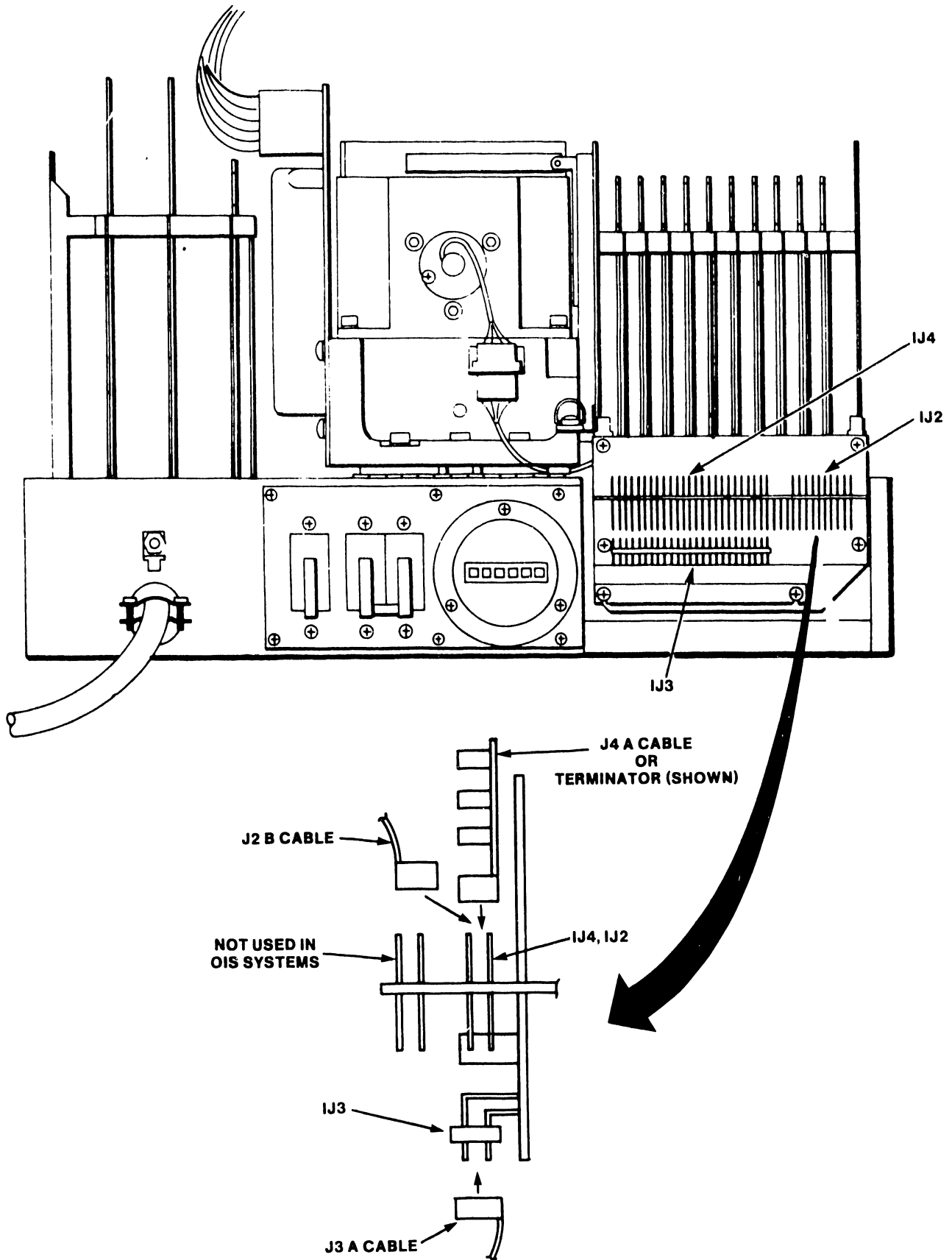

FIGURE 3-14b 80 MEG SMD I/O CONNECTOR PANEL

### 3.5.5 INITIAL CHECKS AND ADJUSTMENTS FOR THE HAWK DISK DRIVE

The following procedures are detailed in the Wang/CDC HAWK Disk Drive Manual (729-0181); refer to this document for further information unless directed otherwise.

-----CAUTION-----

Stop the unit immediately if a pinging or scratching sound (caused by head-to-disk contact) is heard and persists. Also, keep the access door closed to prevent unnecessary entry of atmospheric dust in order to obtain maximum performance and reliability.

-----

- A. Ground the I/O ribbon cable at the rear of the HAWK unit (see Fig. 3-14).
  1. Tilt the top cover forward to access the I/O board at the rear of the unit.
  2. Feed the cable under the cable clamp, located just below the I/O board.
  3. Ensure that the bare shield is in contact with the clamp.
  4. Tighten the screws evenly, ensuring good electrical contact between the clamp and copper shield.
  
- B. Connect the ribbon cable to the Winchester I/O board at the rear of the unit (see Fig. 3-15).
  1. Plug the ribbon cable from the Master Processor into the upper (male) connector on the Winchester I/O board. If there is only one HAWK in the system configuration, this ribbon cable should include a terminator at its connector, as shown in Figure 3-14.
  2. If a second HAWK is to be included in the system, plug the 'daisy chain' ribbon cable into the lower (female) connector on the Winchester I/O board as shown in Figure 3-15. The other end of the 'daisy chain' cable should include a terminator and be connected to the upper (male) connector of the 'downstream'\* HAWK.
  3. Evenly tighten the securing screws on all connectors.
  
- C. Ensure that the HAWK option switches have been set correctly. (See Section 3.12.4.)
  
- D. Power up the HAWK unit(s).
  
- E. Install the Cartridge Module(s).
  
- F. Perform compatibility alignments as outlined in Section 3 of the manual cited above.
  
- G. Replace all covers.

\* Downstream HAWK is unit furthest from Master Processor in daisy chain.

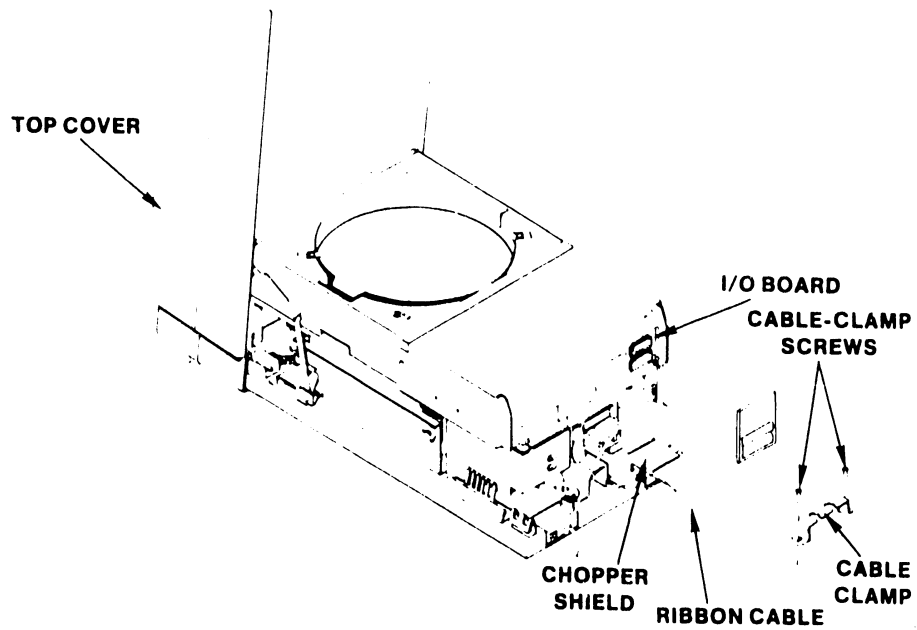

FIGURE 3-15 GROUNDING THE HAWK I/O RIBBON CABLE(S)

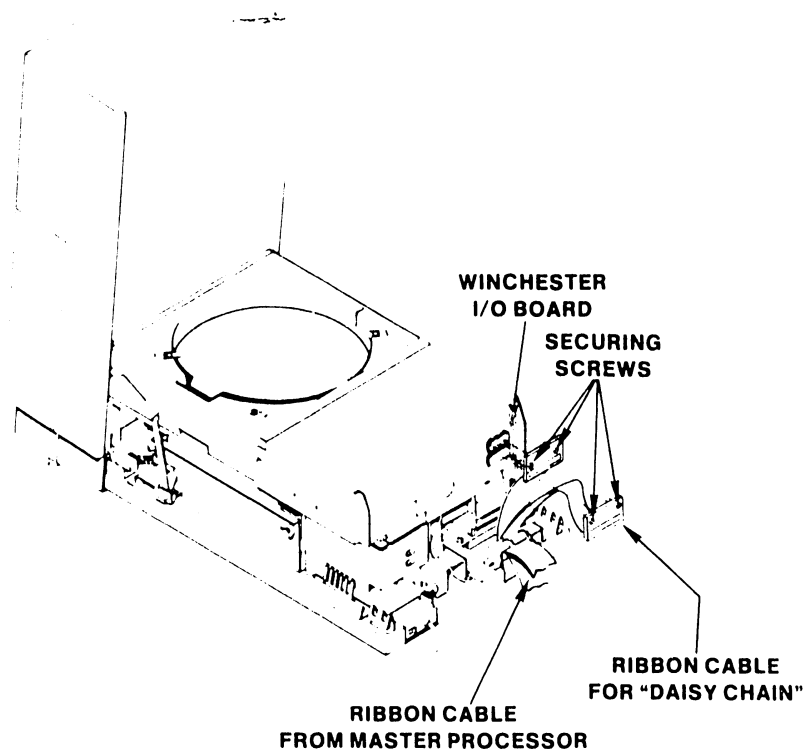

FIGURE 3-16 CONNECTING THE HAWK I/O RIBBON CABLE(S)

### 3.6 POWER-UP PROCEDURE

Power is applied to the system upon completion of all installation checks and adjustments. The power switches for the HAWK, Phoenix, and 300 Meg SMD drives are located at the rear of each unit. The START/STOP switches for these drives are located on the front panel of each unit. To minimize risk of damage to the system, follow the power-up procedure outlined below:

- A. Position the Disk Select Switch on the Master Processor to indicate the location of the System Disk.
- B. Position the power switch on the Master Processor to ON.
- C. Position the power switches on all the disk units to "ON" and ensure that the blower motors start. (This is the "standby mode".)

-----CAUTION-----

Do not power-up (or down) any optional drive unit if the system has been IPLed and is operating. Do not activate any drive units simultaneously; allow an interval of at least one minute to avoid overloading circuits. Wait a minimum of 5 minutes (30 minutes if room temperature was below 40°F during shutdown) for the equipment to stabilize before proceeding to activate the disk units.

- D. If the optional disk unit is required, activate the unit by pressing the START/STOP pushbutton. (Note that the optional drive may be left in the standby mode if not required for daily operation; when required, activate and mount volume(s) using Disk Control.)
- E. Activate the System Disk unit by pressing its START/STOP pushbutton.
- F. Power-up all workstations and devices to be used.
- G. Press RESET on the Master Processor.
- H. Enter correct date and time when the IPL menu is displayed.

### 3.7 MASTER UNIT POWER-UP DIAGNOSTIC

The Power-Up Diagnostic begins whenever the Master Unit is powered up, IPL'ed, or Reset and the system disk reaches operating speed. The diagnostics take approximately 15 seconds to complete.

Once the Power-Up diagnostic begins, the Power LED starts to flash. If all tests pass, the Power LED ceases flashing and goes to a steady-on state and the DATE/TIME screen is displayed on the CRT. If an error occurs, an error code is displayed on the Front Panel Error LEDs of the Master Unit and the Power LED continues flashing (See Fig. 3-17). For detailed information concerning the OIS 140/145 Power-Up Diagnostic and its associated error codes, refer to Appendix D for the standard 64K CPU, and Appendix E for the 128K CPU.

3.8 POWER-DOWN PROCEDURE

- A. Power down all system devices (excluding the Master Processor and disk units).
- B. Press RESET on the Master Processor.
- C. Press START/STOP pushbutton on the optional disk unit (if used).
- D. Press START/STOP pushbutton on the System Disk unit.

-----NOTE-----

It is recommended that the drive units be left in standby mode (AC power only, and the blower motors running). This will keep the drive units stabilized and reduce contaminants.

-----

- F. Position the power switches on all disk units to OFF.
- G. Position the power switches on the Master Processor to OFF.

3.9 SOFTWARE INSTALLATION

Refer to Appendix C, SOFTWARE INSTALLATION PROCEDURES, for detailed information concerning software installation and updates procedures.

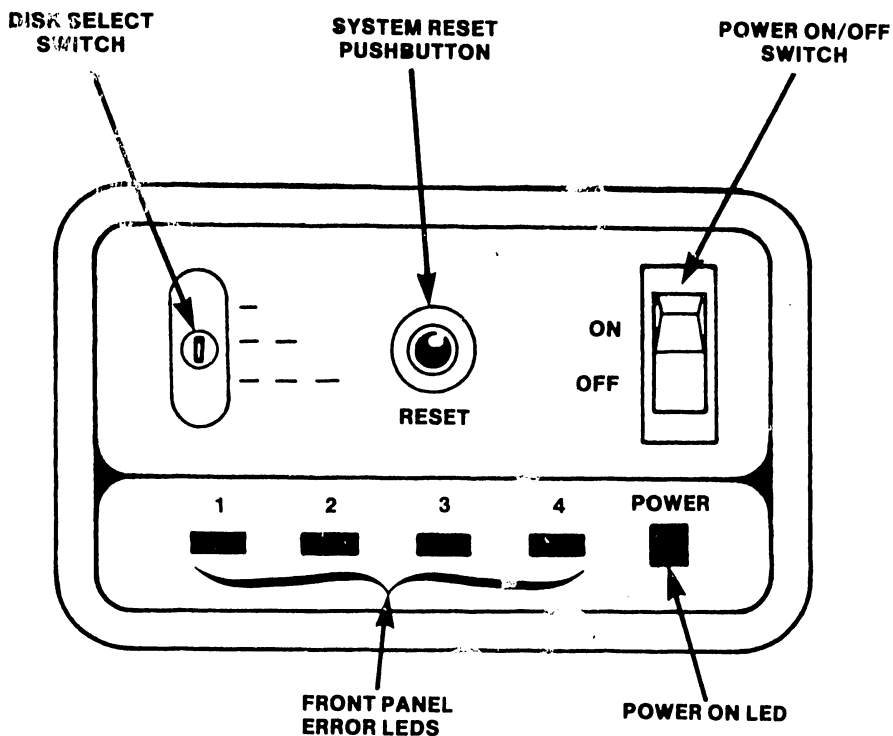

FIGURE 3-17 MASTER UNIT FRONT CONTROL PANEL

### 3.10 SYSTEM CHECKOUT

System checkout is complete when the items on the following checklist have been accomplished:

- A. Verify correct switch settings for all devices. (See Section 3.12)
- B. Verify correct head alignment for all disk drives.
- C. Set switches on the CMD/SMD "B" CONTROLLER board for the maximum storage capacity. (See Section 3.12.1)
- D. Configure the U33 jumper-pack on the Phoenix CONTROL MUX PCB for the maximum storage capacity. (See Section 3.12.2)
- E. Exercise the system for a minimum of four hours, using SYSEX40, if available.
- F. Exercise the Master Diagnostics Monitor for at least ten passes of each diagnostic program. (See Appendix A.)
- G. Reset the switches in the Master Processor and Phoenix to the purchased configurations. (See Section 3.12)
- H. Format and initialize the System Disk. (See Appendix C.)
- I. Load software packages. (See Appendix C.)
- J. Format and initialize all remaining volumes.
- K. Run the Single Channel Diagnostic Monitor for all devices (or on-line diagnostic, if available).
- L. Verify static immunity for all system components by Hypot testing to 2500 V. (Refer to Chapter 5 of the Systems Installation Guide, WL# 729-0907.)
- M. Adjust printers for best print quality.
- N. Perform final Word Processing Check. (See Section 3.11)
- O. Reinitialize the System Disk. (See Appendix C.)



3.11 FINAL WORD PROCESSING CHECK

Assign a library to each workstation. The libraries should be equally divided among the volumes available to the system. Each workstation should run the glossary listed in Appendix F. This glossary will:

- A. Create a New Document
- B. Edit a Document by:
  - 1. supercopying text from another document
  - 2. super global replace words contained within the text
  - 3. deleting words within the text
- C. File document to archive diskette
- D. Retrieve document from archive diskette
- E. Delete document from archive diskette
- F. Delete document from library
- G. Start process all over again

Only archiving workstations and one standard workstation using the central archive drive, can perform steps C, D, and E simultaneously. This checkout should be run over night. Upon completion of this test, documents should be queued to every printer and printed out. At least 2 documents should be printed per printer.

Upon completion of this Final Check-Out, all volumes should be reinitialized and software reloaded. Because loading of the software at this time should be suited to the customer and with purchased software options, the proper loading of the software is the responsibility of the Marketing Support Representative.

3.12 DETAILED PROCEDURES

3.12.1 MASTER PROCESSOR SWITCH SETTINGS

Internal switches of the Master Processor comprise:

<u>SWITCH</u>	<u>LOCATION</u>
Diagnostic switches	CPU/MEM board
Voltage Selector switch	Rear of power supply
Drive Type Definition switch	SMD/CMD Controller "B"
Options switch	CPU/MEM board

- A. Verify that the Voltage Selector switch has been set to the correct position (see Figure 3-7).
- B. Position all the Diagnostic switches on the CPU/MEM board to OFF (toward the component side of the board). The function of this group of switches is discussed in Appendices D and E.
- C. Position the switchpacks SW1 and SW2 on the CPU/MEM board as follows:

<u>SWITCHPACK</u>	<u>SWITCH</u>	<u>POSITION</u>
SW1	ALL	OFF
SW2	1,2,4,5,6,7,8	OFF
SW2	3	ON if BASIC purchased OFF if BASIC not purchased

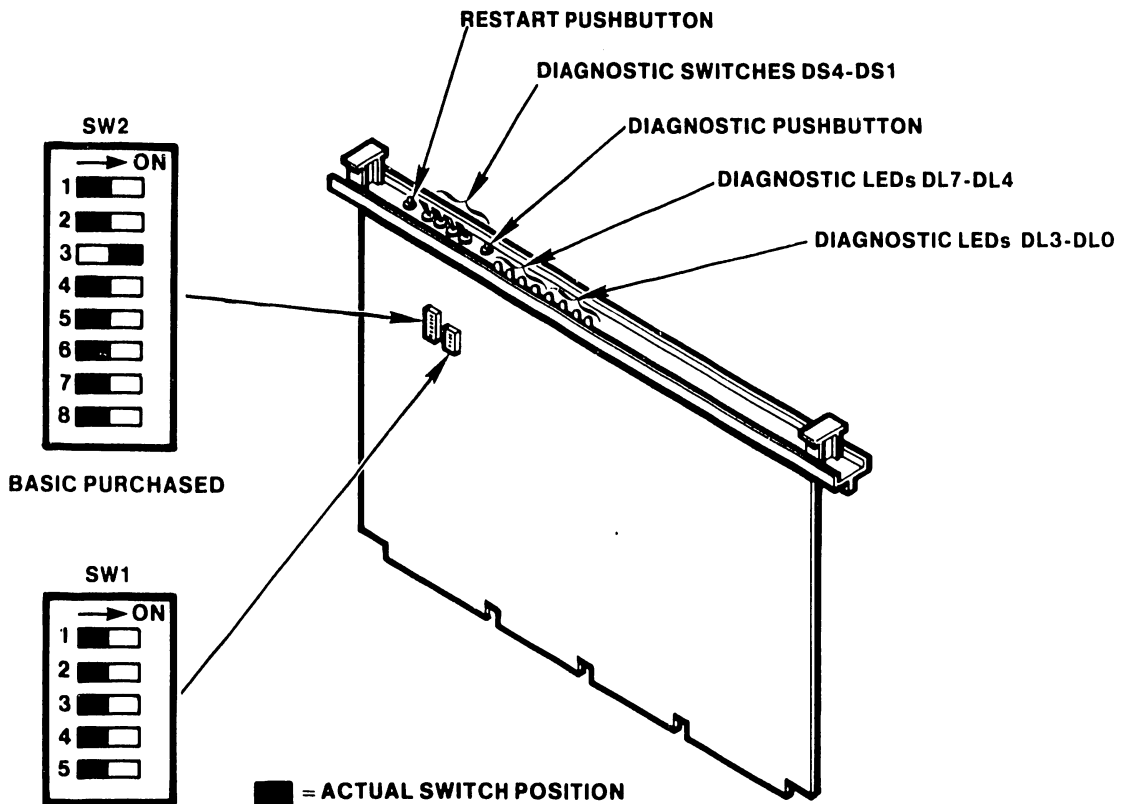

FIGURE 3-18 CPU/MEM DIAGNOSTIC AND OPTION SWITCHES

D. Position the Drive Type Definition switches on the 7506 SMD/CMD "B" CONTROLLER board as shown below:

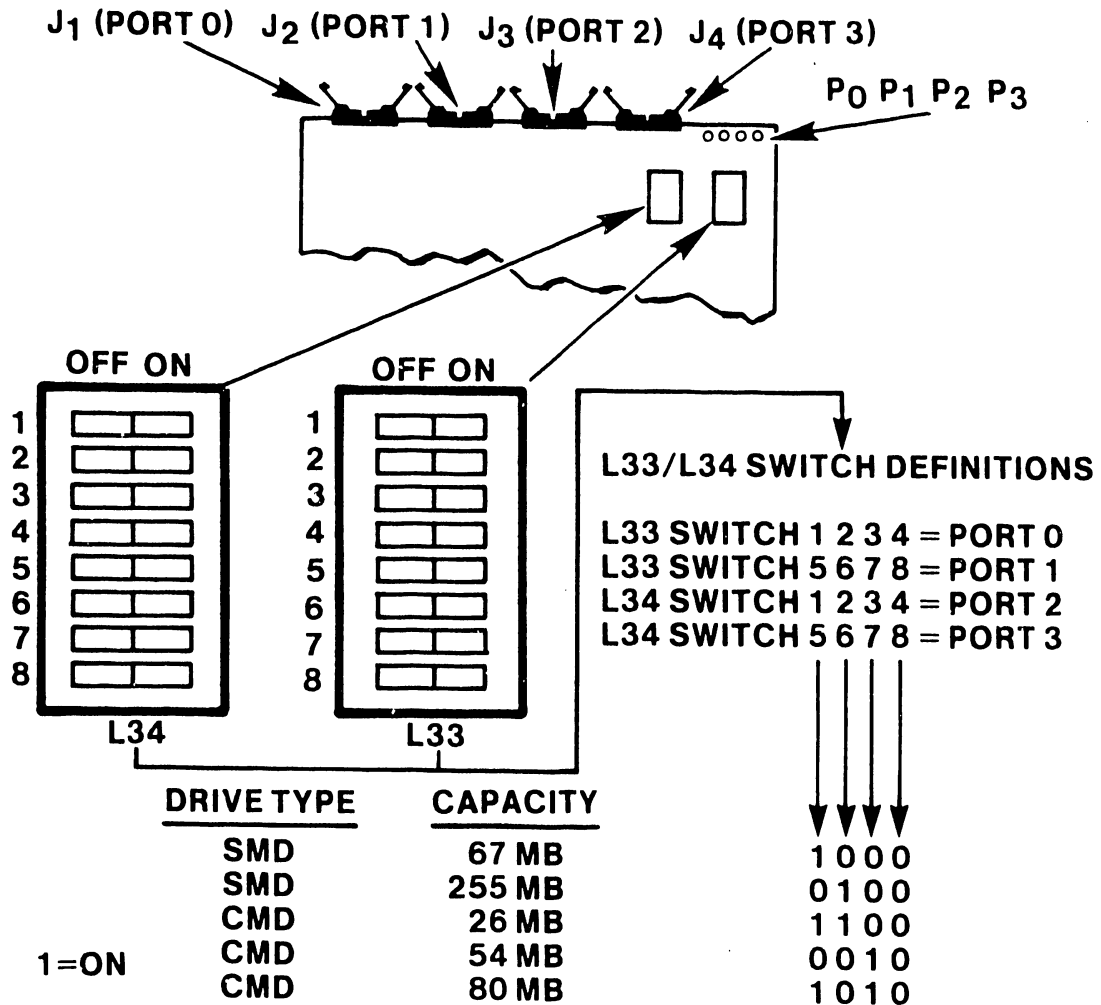

FIGURE 3-19 SWITCH SETTINGS FOR THE SMD/CMD "B" CONTROLLER

### 3.12.2 SWITCH SETTINGS FOR THE PHOENIX DRIVE

This section discusses only the internal Phoenix Drive switch settings unique to OIS 140 Systems. Additional switch settings are necessary for successful operation of the Phoenix Drive and may be obtained from the Wang CMD Disk Drive Manual (729-0199). Phoenix switch settings unique to OIS 140 Systems comprise:

1. Switchpack S1 on the SERVO-COARSE PCB (726-5780)
  2. Switchpack S2 and jumper-pack U33 on the CONTROL MUX PCB (726-5779)
- A. Set the Sector Pulse switches (Switchpack S1) on the SERVO-COARSE PCB as shown in Figure 3-20.
- B. Set the Switch pack S2 and jumper-pack U33 on the CONTROL MUX PCB as shown in Figure 3-21. (One need not cut the jumper to create an open jumper; simply bend the associated pin out of its socket. In the event a pin breaks, the jumper-pack may be rotated 180 degrees, replaced in its socket, and will still function correctly. For reorder purposes, this jumper-pack has WLI No. 726-5889.

#### SERVO-COARSE PCB WLI NO. 726-5780

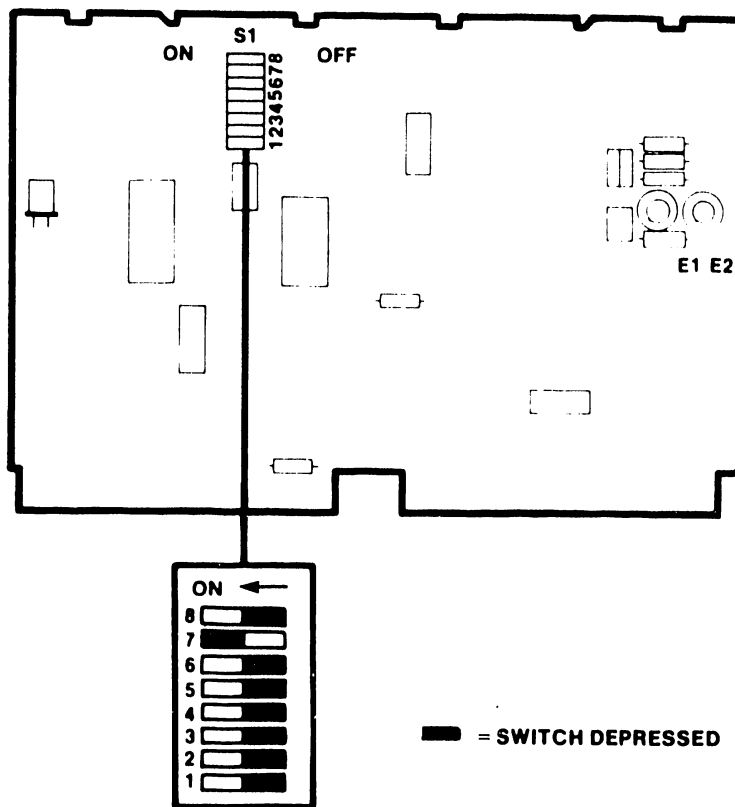

FIGURE 3-20 PHOENIX SWITCH SETTINGS FOR SERVO-COARSE PCB

## CONTROL MUX PCB WLI No 726-5779

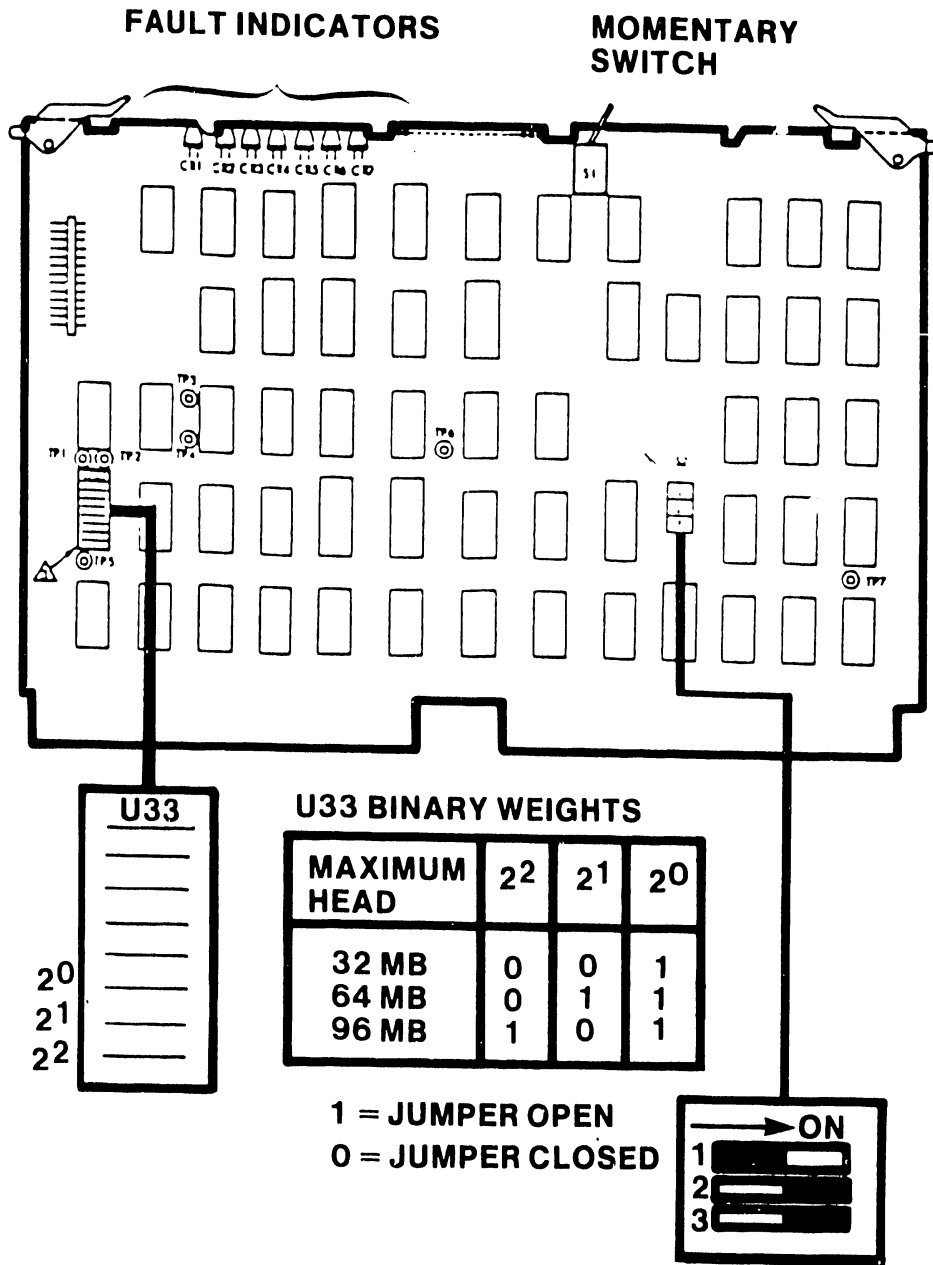

FIGURE 3-21 PHOENIX SWITCH SETTINGS FOR CONTROL MUX PCB

3.12.3 SWITCH SETTINGS FOR THE SMD-300 DRIVE

This section discusses only the internal 300 Meg SMD Drive switch settings unique to OIS 145 Systems. Additional switch settings are necessary for successful operation of the 300 Meg SMD Drive and may be obtained from the CDC SMD Hardware Maintenance Manual (729-0221). 300 Meg SMD switch settings unique to OIS 145 Systems affect the LTV printed circuit card located in chassis locatic. A06. Figure 3-22 below depicts these settings:

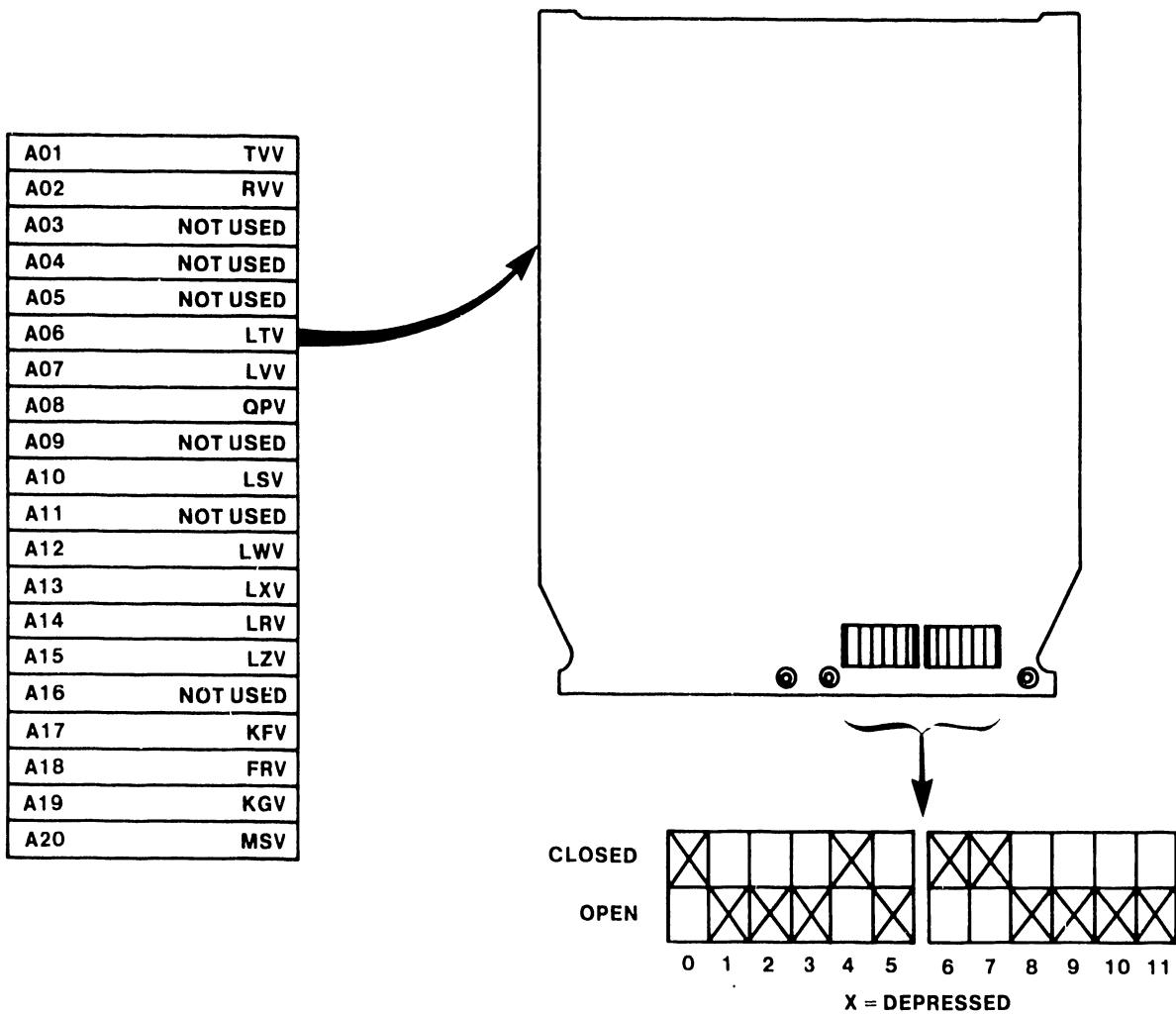

FIGURE 3-22 300 MEG SMD SECTOR SWITCH SETTINGS

3.12.4 SWITCH SETTINGS FOR THE HAWK DRIVE

This section discusses the internal switch settings for the HAWK Disk Drive, which are unique to OIS 140/145 Systems. Additional switch settings are necessary for successful operation of the HAWK Disk Drive and may be obtained from the Wang/CDC HAWK Disk Drive Manual (729-0181). The HAWK switch settings unique to OIS 140/145 Systems affect the Winchester I/O board located in the rear of the HAWK unit. Figure 3-23 below depicts these settings. Banks 1 through 4 on switch-packs S1 and S2 identify the drive unit number. For HAWK Unit 1, Bank 1 on both switch-packs should be 'ON', Banks 2, 3, and 4 should be 'OFF'. For HAWK Unit 2 (if present), Bank 2 should be 'ON', 1, 3, and 4, 'OFF'. Set switch-packs S3, S4, and S5 according to the diagram below.

NOTE: SWITCH SETTINGS SHOWN WOULD SELECT UNIT AS NUMBER 1

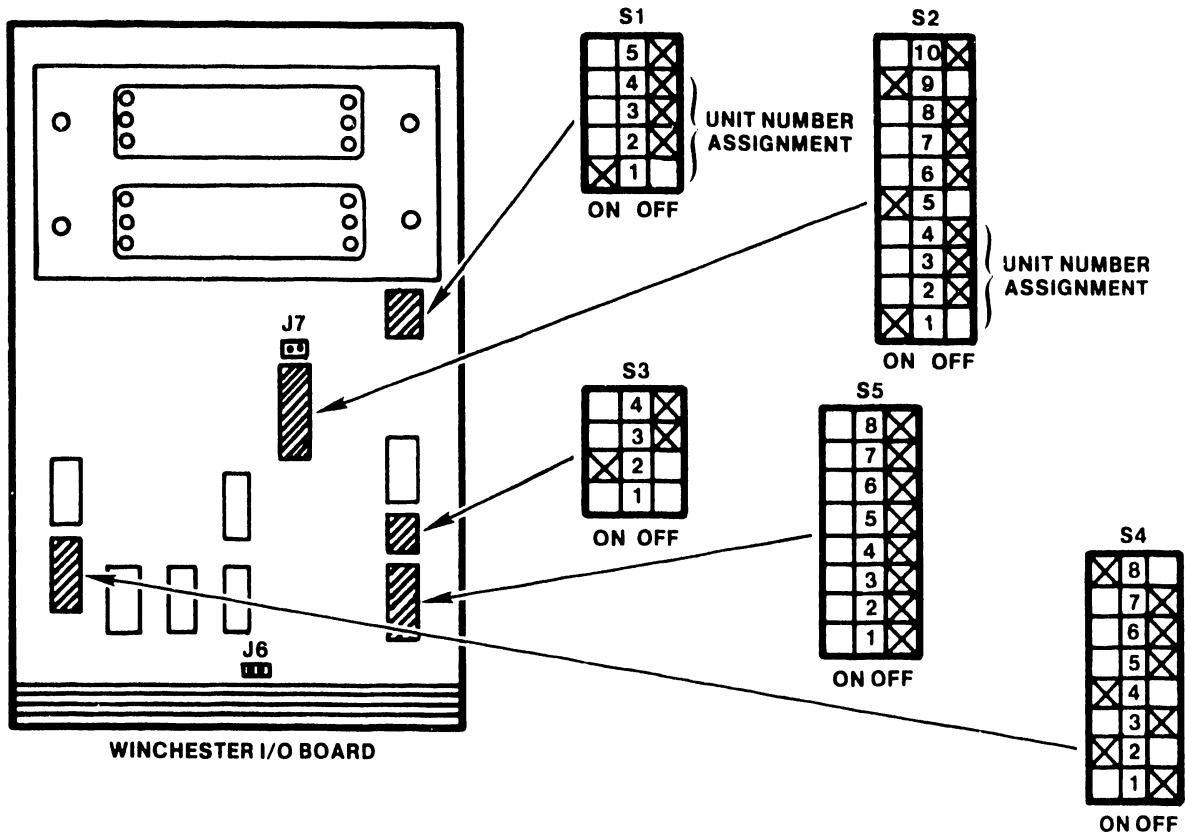

FIGURE 3-23 HAWK SWITCH SETTINGS

### 3.12.5 VOLTAGE ADJUSTMENTS FOR THE MASTER PROCESSOR

It is important that the following voltage-check procedures be performed to eliminate component failures due to improperly adjusted supply voltages.

- A. Ensure that all PCBs are properly seated.
- B. Plug in the main power cable from the Master Unit and turn the Master Unit Power switch ON.
- C. Using a DVM, measure the DC voltages at the test points on the CPU/MEM board using the GND point as a reference. These test points are located on the CPU/MEM board and are labeled +5V<sub>1</sub>, +5V<sub>2</sub>, -5V, +12V, -12V, +24V, respectively. (See Fig. 3-24.)
- D. Adjust specific voltages as necessary by trimming the related potentiometers located on the Power Regulator Board (210-7508), a +2% variation is allowed. There is no adjustment for The -12V supply. This voltage should not be lower than -11.7 VDC. Replace regulator board if voltage is not within limits. (See Fig. 3-24.)
- E. Check the system clock, Oz, on the CPU/MEM board with an oscilloscope or DVM. To check with an oscilloscope, set the Volts/Div. to 2V and the SEC/DIV to .1 usec. The resulting display should have a pulse width of 0.25 usec. A reading of approximately +1.9 VDC should be obtained when using a DVM. (See Figure 3-24.)
- F. Engage the Diagnostic Pushbutton (DPB) on the CPU/MEM board. While keeping the DPB engaged, push the Reset (IPL) button on the front panel on the Master Unit. Engaging both pushbuttons in the above sequence causes all diagnostic LEDs on the CPU/MEM board and front panel to light, replace any board having an unlit LED. (See Fig. 3-17, 3-18.)
- G. Turn the Master Unit Power switch OFF.



Test Point	Limits (Vdc)		Adjustment
+ 24	+ 23.5	+ 24.5	+ pot.
- 5	- 4.9	- 5.1	- pot.
- 12	- 11.7	- 12.3	none
+ 12	+ 11.75	+ 12.25	+ pot.
+ 5V1	+ 4.9	+ 5.1	+ 5V1 pot.
+ 5V2	+ 4.9	+ 5.1	+ 5V2 pot.

USING DVM, MEASURE DC VOLTAGES AT TEST POINTS ON CPU/MEM BOARD USING GND POINT AS A REFERENCE. THESE TEST POINTS ARE LOCATED ON THE 210-7501 BOARD AND ARE LABELED +5V1, +5V2, -5V, +12V, -12V, +24V

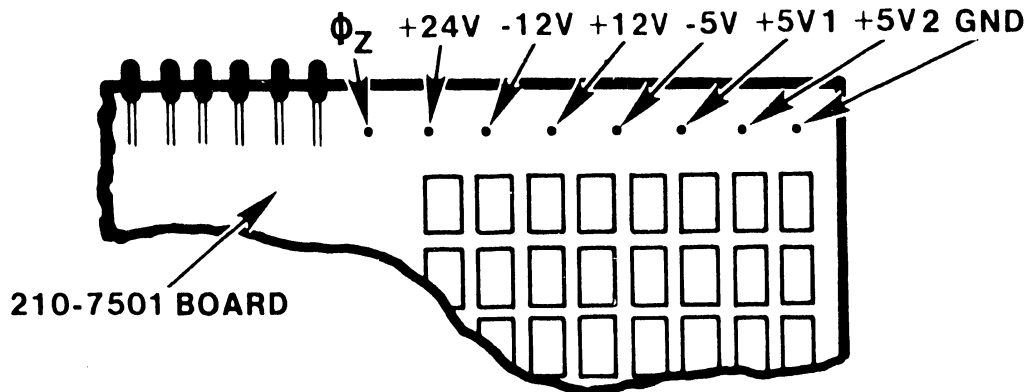

ADJUST VOLTAGES AS NECESSARY BY TRIMMING RELATED POTENTIOMETERS LOCATED ON POWER REGULATOR BOARD 210-7508. A  $\pm 2\%$  VARIATION IS ALLOWED

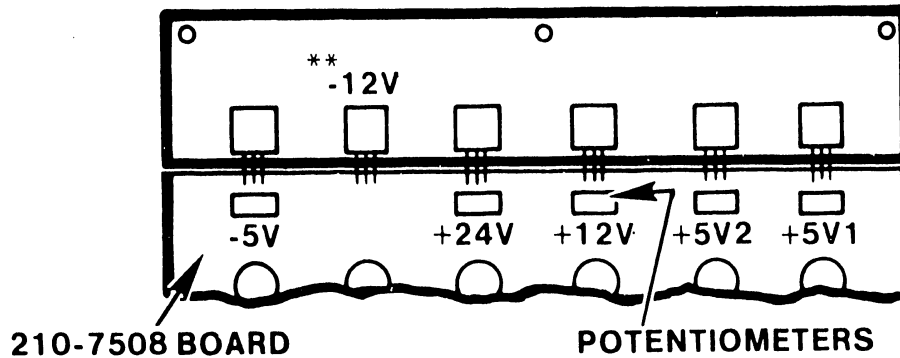

**\*\* -12V IS NOT ADJUSTABLE**

FIGURE 3-24 VOLTAGE TEST AND ADJUSTMENT LOCATIONS

### 3.12.6 INSTALLATION OF THE LOGICAL ADDRESS PLUGS

If more than one Phoenix or 300 Meg SMD drive is present in an OIS 140/145 System, and the drives are in a daisy-chained configuration, it becomes necessary to assign each drive a logical address, in order for the Master Processor to identify the individual drives. This is accomplished through the use of binary-coded Logical Address Plugs inserted into the front control panel of each disk unit. Plug 0 should be installed on the disk unit which serves as the System Disk. Extra plugs for the Phoenix may be ordered using WLI # 726-6550 (contains plugs 1-7), and WLI # 726-6848 (plug 0 only). Extra plugs for the 300 Meg SMD may be ordered using WLI # 726-6849. Note that only plugs with numbers 0 through 3 are valid addresses on the OIS System.

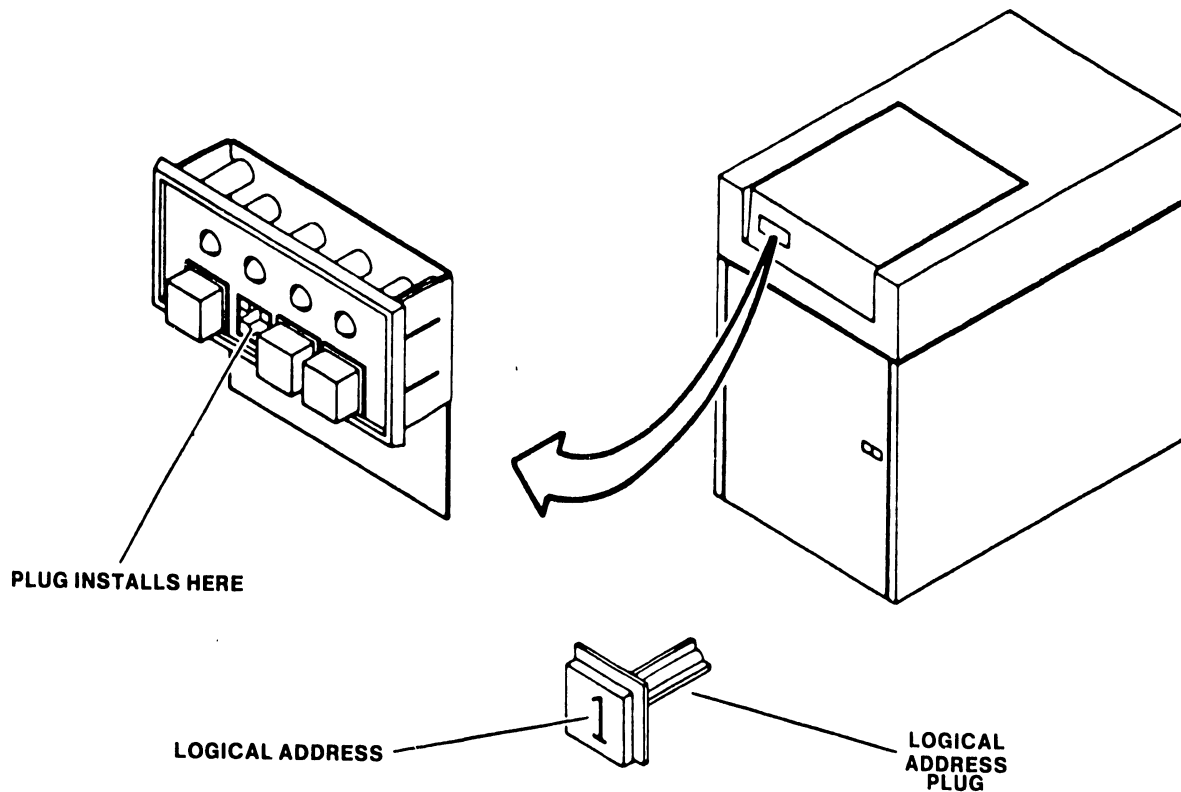

FIGURE 3-25 LOGICAL ADDRESS PLUG FOR THE 300 MEG SMD

3.12.7 CHECKING THE BOARD E-REV LEVELS

The E-revision level is noted on a sticker affixed to the non-component side of each PC board. Note that occasionally the E-revision level is only scratched into the board in the spot where the sticker should be affixed.

- A. Remove the PCB retainers.
- B. Remove the PCB by pulling up on the board handles.
- C. Verify that the board E-revision levels are at or above those listed in Figure 3-26 below.

Board	Revision
7501 CPU & MEMORY	3
7502 10 MEG FLOPPY CNTRL	4
7503 DATA LINK CONTROL	9
7504 DATA BUFFER	1
7505 SMD CONTROLLER A (140/145)	6
7506 SMD CONTROLLER B (140/145)	6
7507 MOTHERBOARD (140/145)	2
7508 REGULATOR (140/145)	3
7650 DISK I/O A (105/115)	6
7653 DISK I/O B (105/115)	5
7887 REGULATOR	3
7649 MOTHERBOARD	0
3025 CPU & MEMORY 128K ASSY	
7684 MOTHER 128K	3
7685 DAUGHTER 128K	2
3014 TCB-1 ASSY	
7762 MOTHER TC	2
7763 DAUGHTER TC	4

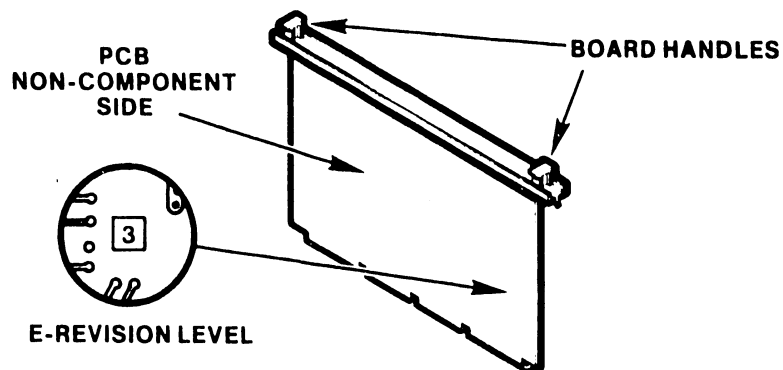

FIGURE 3-26 E-REVISION LEVELS

**CHAPTER**

**4**

**CONTROLS**

**AND**

**INDICA-**

**TORS**

CHAPTER 4CONTROLS AND INDICATORS4.1 INTRODUCTION

This chapter describes the main switches, controls, and indicators for the OIS-140/145 Master Processor. Controls and indicators for the CRT workstation, Phoenix, and 300 Meg SMD disk units are referenced.

TABLE 4-1 OIS 140/145 CONTROLS AND INDICATORS

<u>NAME</u>	<u>SECTION</u>
Power Switch	4.2.1
Front (Operator) Panel	4.2.1
Option Switches	4.2.2.1
Diagnostic Switches	4.2.2.1
Diagnostic LEDs	4.2.2.1
10 Meg/Floppy Disk Activity LED	4.2.2.2
CMD/SMD Drive Type Definition switches	4.2.2.3
CMD/SMD Disk Activity LEDs	4.2.2.3
Voltage Selector Switch	4.2.2.4
Phoenix CMD controls and indicators	4.3
300 Meg SMD controls and indicators	4.4
CRT workstation controls and indicators	4.5

4.2 MASTER-PROCESSOR CONTROLS AND INDICATORS

Controls and indicators for the Master Processor are located on the front panel, the PCBs, and at the rear of the power supply chassis.

4.2.1 MASTER-PROCESSOR FRONT PANEL

The locations of front-panel controls and indicators are called out in Figure 4-1. Their functions and settings are described in the associated Table 4-2.

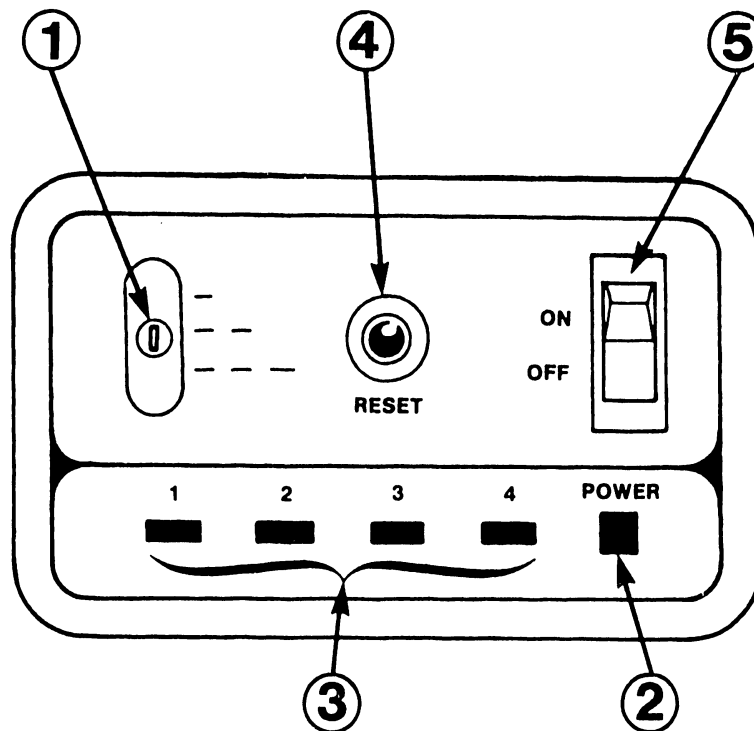

FIGURE 4-1 MASTER PROCESSOR FRONT-PANEL CONTROLS AND INDICATORS

TABLE 4-2 MASTER PROCESSOR FRONT-PANEL CONTROLS AND INDICATORS

ITEM	NAME	TYPE AND FUNCTION
1	DISK-SELECT	<p>Three-position toggle switch. Set to System Disk where IPL program is located. IPL program is normally located on the CMD/SMD with Logical Address Plug '0'.</p> <p>UP (-) = Floppy diskette  MIDDLE (--) = Hawk disk unit  DOWN (---) = Phoenix CMD or 300 Meg SMD</p>
2	POWER LED	<p>Indicates AC power applied to Master processor. Flashes during power-up diagnostics and when an error condition is detected. Steadily illuminated while the system is operational.</p>
3	ERROR LEDs 1, 2, 3, 4	<p>Error lights; indicate type of error detected during power-up diagnostics. LED 1 indicates a fatal error. LEDs 2, 3, and 4 indicate errors which are correctable by the operator. Refer to Appendices D and E for error descriptions.</p>
4	RESET	<p>Red pushbutton; IPL's system by forcing system to address 0000H.</p>
5	POWER-ON SWITCH	<p>Rocker-type switch; Energizes Master Unit and forces system into Power-up diagnostics.</p>

4.2.2 MASTER PROCESSOR INTERNAL CONTROLS AND INDICATORS

4.2.2.1 7501 CPU/MEMORY BOARD

Internal controls and indicators located on the 7501-board comprise those used for diagnostics and those used for options. The locations of the controls and indicators are called out in Figure 4-2, their function and use, in Table 4-3.

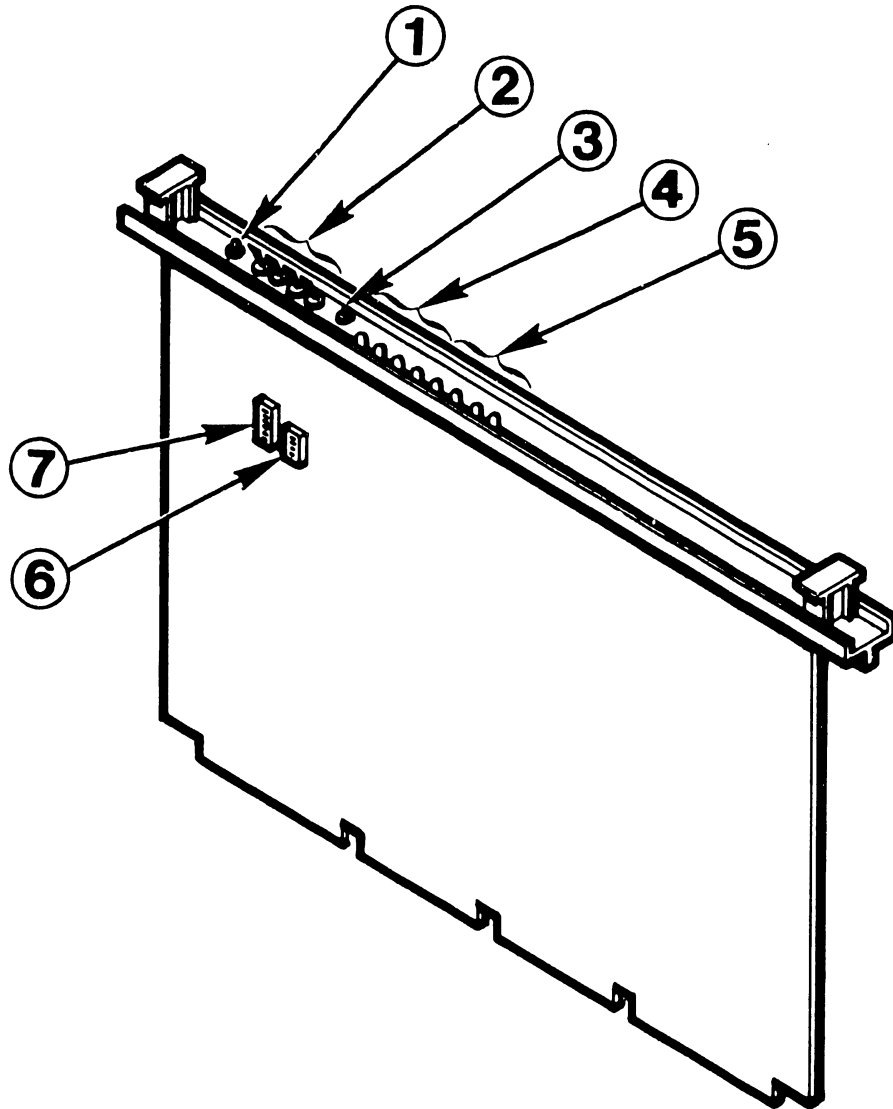

FIGURE 4-2 MASTER PROCESSOR INTERNAL CONTROLS AND INDICATORS  
7501 CPU/MEMORY BOARD



TABLE 4-3 MASTER PROCESSOR INTERNAL CONTROLS AND INDICATORS  
7501 CPU/MEMORY BOARD

ITEM	NAME	TYPE AND FUNCTION
1	RST	Restart pushbutton; forces system to trap at address 0066H; same effect as non-maskable interrupt.
2	DS4, DS3, DS2, DS1	Diagnostic switches; used to start diagnostic programs at particular locations. All switches should be positioned OFF for normal operation. Appendices D and E contain information concerning their use.
3	DPB	Diagnostic pushbutton; initializes requested diagnostic programs.
4	DL7-DL4	Diagnostic LEDs; display fatal "detailed error code" during power-up diagnostics. The detailed error codes do not apply if the error is not fatal. (See Appendices D and E.)
5	DL3-DL0	Diagnostic LEDs; display the test number being executed during power-up diagnostics. Also used to display Extended Error information. (See Appendices D and E.)
6	SW1	Option switches; 5-bank DIP switch. For future use. Position all switches to OFF.
7	SW2	Option switches; 8-bank DIP switch.  BASTC purchased, position switch 3 ON BAS not purchased, position switch 3 OFF  Position switches 1, 2, 4, 5, 6, 7, and 8 OFF.

4.2.2.2 7502 - 10 MEG/FLOPPY CONTROLLER BOARD

The activity LED indicates activity on either a Hawk disk drive or on the Shugart floppy diskette drive.

ITEM 1 10 Meg/Floppy Disk Activity LED

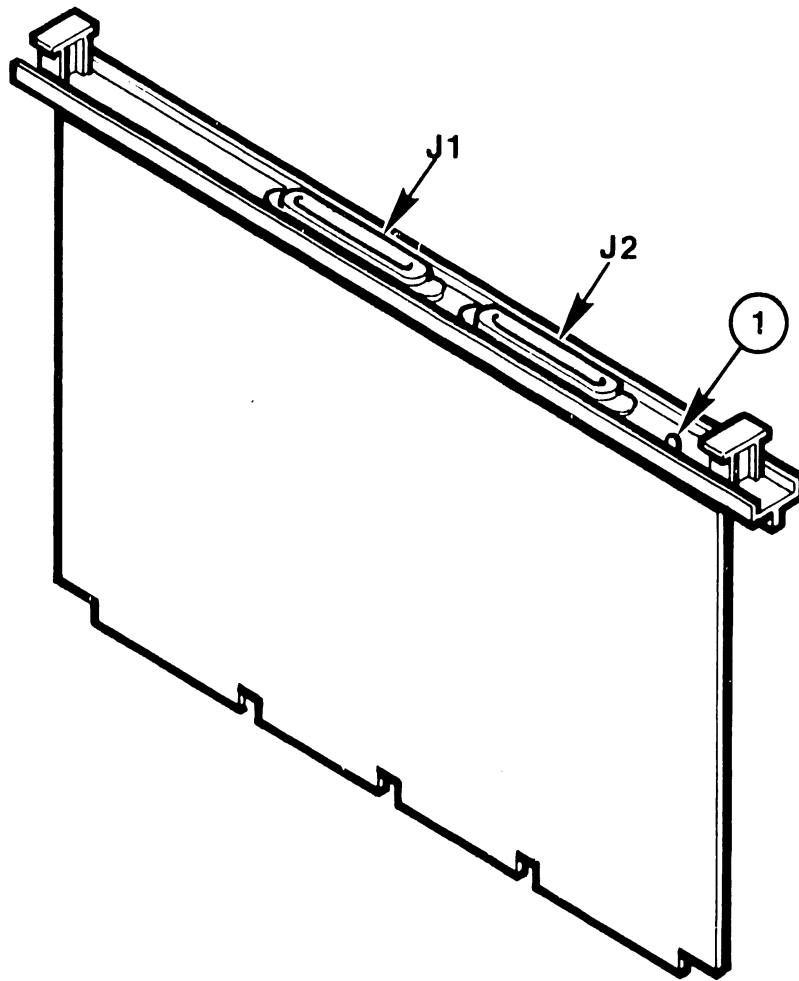

FIGURE 4-3 MASTER PROCESSOR INTERNAL CONTROLS AND INDICATORS  
7502 - 10 MEG/FLOPPY CONTROLLER BOARD

#### 4.2.2.3 7506 CMD/SMD "B" CONTROLLER BOARD

Internal switches and indicators located on the 7506 board comprise two 8-bank DIP switches used to define drive storage capacity and four LEDs to indicate drive activity. The locations of the switches and indicators are called out in Figure 4-4, their function and use, in Table 4-4.

TABLE 4-4 MASTER PROCESSOR INTERNAL CONTROLS AND INDICATORS  
7506 CMD/SMD "B" CONTROLLER BOARD

ITEM	NAME	TYPE AND FUNCTION
1	SW1	Drive-type Definition switch (L33); 8-bank DIP switch. Used to define the type and storage capacity of CMD/SMD connected to each port of the 7506 board. Switches 1 - 4 reference Port 0, switches 5 - 8 reference Port 1. Refer to Figure 4-4 for details.
2	SW2	Drive-type Definition switch (L34); 8-bank DIP switch. Used to define the type and storage capacity of CMD/SMD connected to each port of the 7506 board. Switches 1 - 4 reference Port 2, switches 5 - 8 reference Port 3. Refer to Figure 4-4 for details.
3	P0 - P3	These LEDs indicate read, write, or seek activity on the associated disk unit (P0 corresponds to the disk connected to Port 0, P1 to Port 1, etc.).

-----NOTE-----

Ports 0 through 3 are interchangeable, i.e. any Phoenix (or 300 Meg SMD) drive may be connected to any of the four ports, as long as the associated drive-type definition switch is set to the appropriate state. For OIS 140/145 Systems employing multiple CMD or SMD drives, it is recommended that all the drive-type definition switches be set identically. In this way, all four ports may be interchanged at will during troubleshooting without having to modify the drive-type definition switches. (This recommendation assumes that all the CMD/SMD units in the particular system have identical storage capacity.)

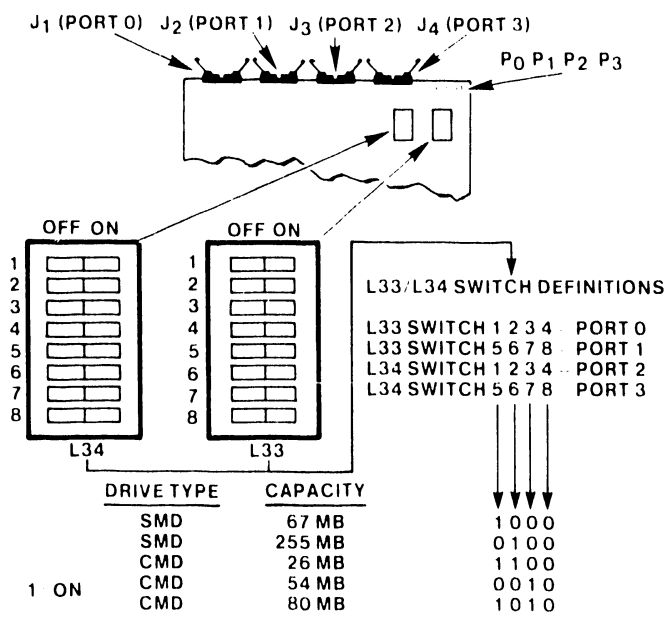
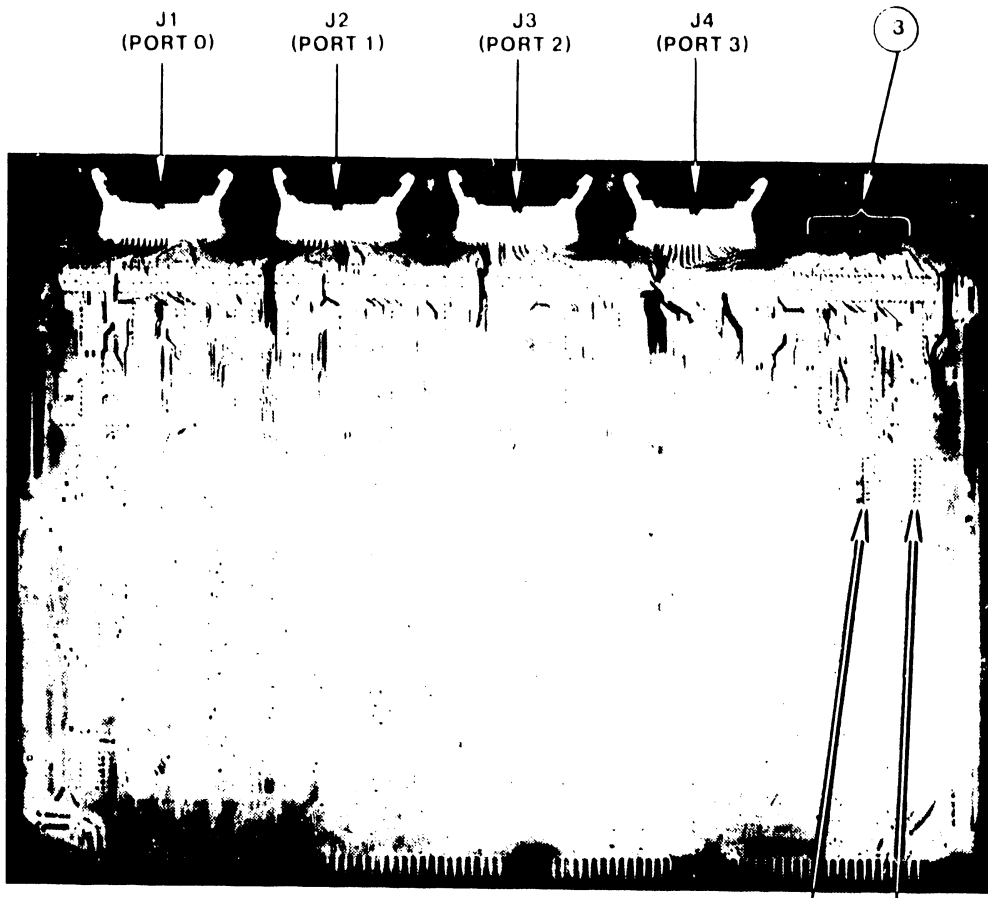
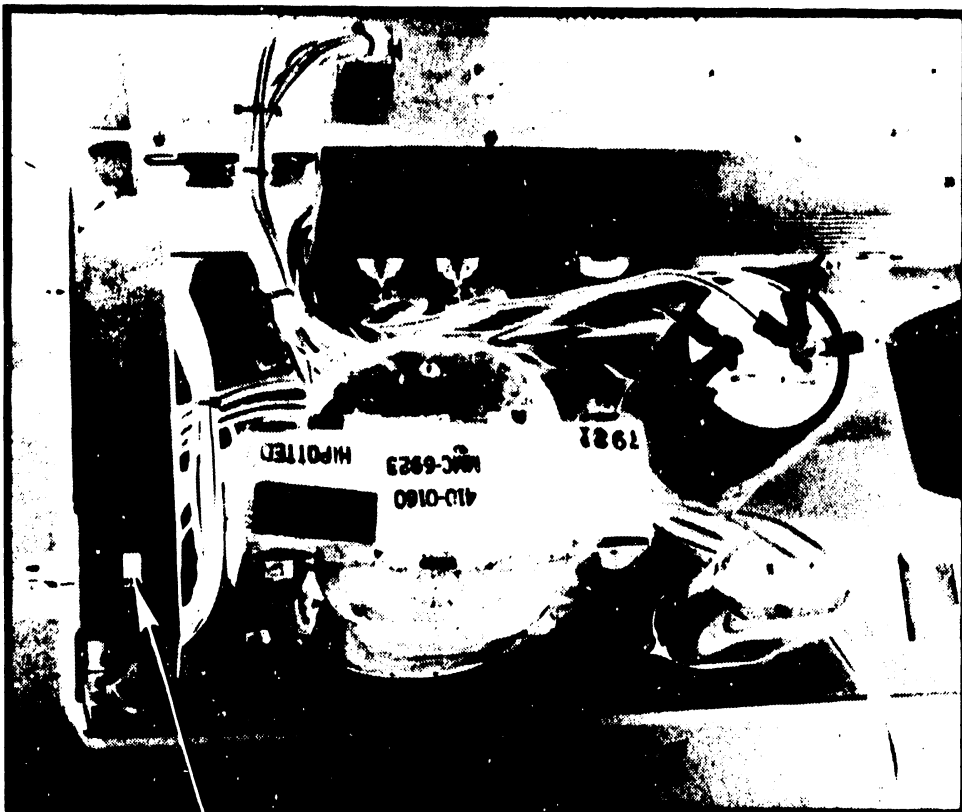

FIGURE 4-4 MASTER PROCESSOR INTERNAL CONTROLS AND INDICATORS  
7506 CMD/SMD "B" CONTROLLER BOARD

#### 4.2.2.4 VOLTAGE-SELECTOR SWITCH

The voltage-selector switch, located at the rear of the power-supply chassis, is used to select 115 Vac or 230 Vac according to the line voltage available. Changes in operating frequency (50/60 Hz) require a complete change of power supply and floppy diskette. The part numbers necessary to make such a change may be found in the IPB of Appendix G.



VOLTAGE SELECTOR SWITCH

FIGURE 4-5 MASTER PROCESSOR INTERNAL CONTROLS AND INDICATORS  
POWER SUPPLY CHASSIS

4.3 PHOENIX DISK UNIT

Operator controls and indicators for the Phoenix disk unit are described in the Wang Cartridge Module Disk Drive Manual (729-0199); refer to this document for further information. The locations of the controls and indicators are called out in Figure 4-6, their function and use, in Table 4-5.

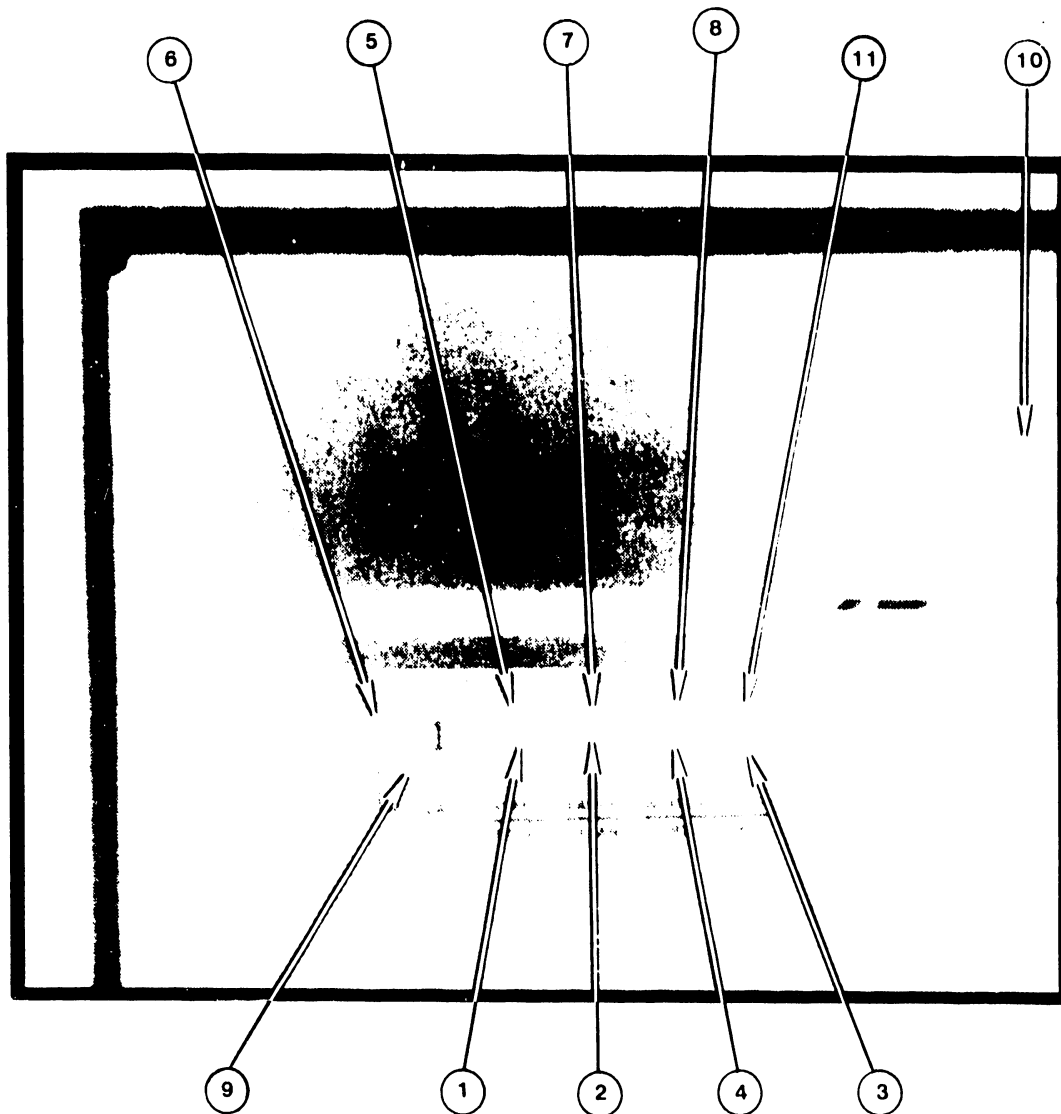

FIGURE 4-6 PHOENIX CMD CONTROLS AND INDICATORS

TABLE 4-5 PHOENIX CMD CONTROLS AND INDICATORS

ITEM	NAME	FUNCTION
1	START/STOP SWITCH	<p>Energizes spindle motor and initiates the first seek mode, provided the following conditions are met:</p> <ol style="list-style-type: none"> <li>1) The AC circuit breaker is ON.</li> <li>2) The disk cartridge loading door is closed and latched with cartridge in place. (Deck in lowered position)</li> <li>3) FAULT indicator LED is OFF.</li> <li>4) Ground on HOLD line for LOCAL start mode.</li> </ol> <p>Releasing the switch when the drive is in powered-up state (disk pack spinning) initiates power-down sequence.</p>
2	FAULT SWITCH	<p>Clears certain fault conditions when operated. Start/Stop switch may have to be released to clear some fault indicators.</p>
3	PROTECT FIXED SWITCH	<p>Disables write driver for fixed media; disabled in Wang Systems.</p>
4	PROTECT CARTRIDGE SWITCH	<p>Disables write driver for removable cartridge; disabled in Wang Systems.</p>
5	START/STOP INDICATOR LED	<p>Located within the START/STOP switch, lights when the START/STOP switch is activated, turns off when switch is released. Not all units have a START indicator.</p>
6	READY INDICATOR LED	<p>When lit this LED indicates unit ready status. The READY indicator is lit whenever unit is up to speed, heads are loaded, and no fault requiring manual intervention exists within the unit. The READY light will blink throughout the spindle start and stop procedure.</p>

TABLE 4-5 (continued)

ITEM	NAME	FUNCTION
7	FAULT INDICATOR LED	Located on the FAULT switch*. Indicates a fault condition when lit. Turns OFF when the fault condition is cleared by operating the FAULT switch.
8	PROTECT CARTRIDGE INDICATOR LED	Indicates that the removable volume cartridge of the drive is write protected.
9	LOGICAL ADDRESS PLUG	Plastic plug; generates the logical unit address when inserted into the socket. This is done by closing the coded switch contacts in the Logical Address socket. The plug is marked (0, 1, 2, 3 ...) to represent the unit number selected.
10	DISK PACK ACCESS DOOR LATCH	The Disk Pack Access Door is opened by lifting the latch located under the lip of the access door. The latch will not open the door until after the spindle motor has stopped rotating and the START/STOP switch is in the OFF position. This causes the interlock solenoid to release the catch. In the event of an AC power loss, the interlock solenoid will not release the catch. This is done to prevent damage to the cartridge.
11	PROTECT FIXED INDICATOR LED	Indicates that the fixed volume media of the drive is write protected.

\* Does not indicate Seek error.



## 4.4 300 MEG SMD UNIT

Operator controls and indicators for the 300 Meg SMD are described in the CDC SMD Hardware Maintenance Manual (729-0221); refer to this document for further information. The locations of the controls and indicators are called out in Figure 4-7, their function and use, in Table 4-6.

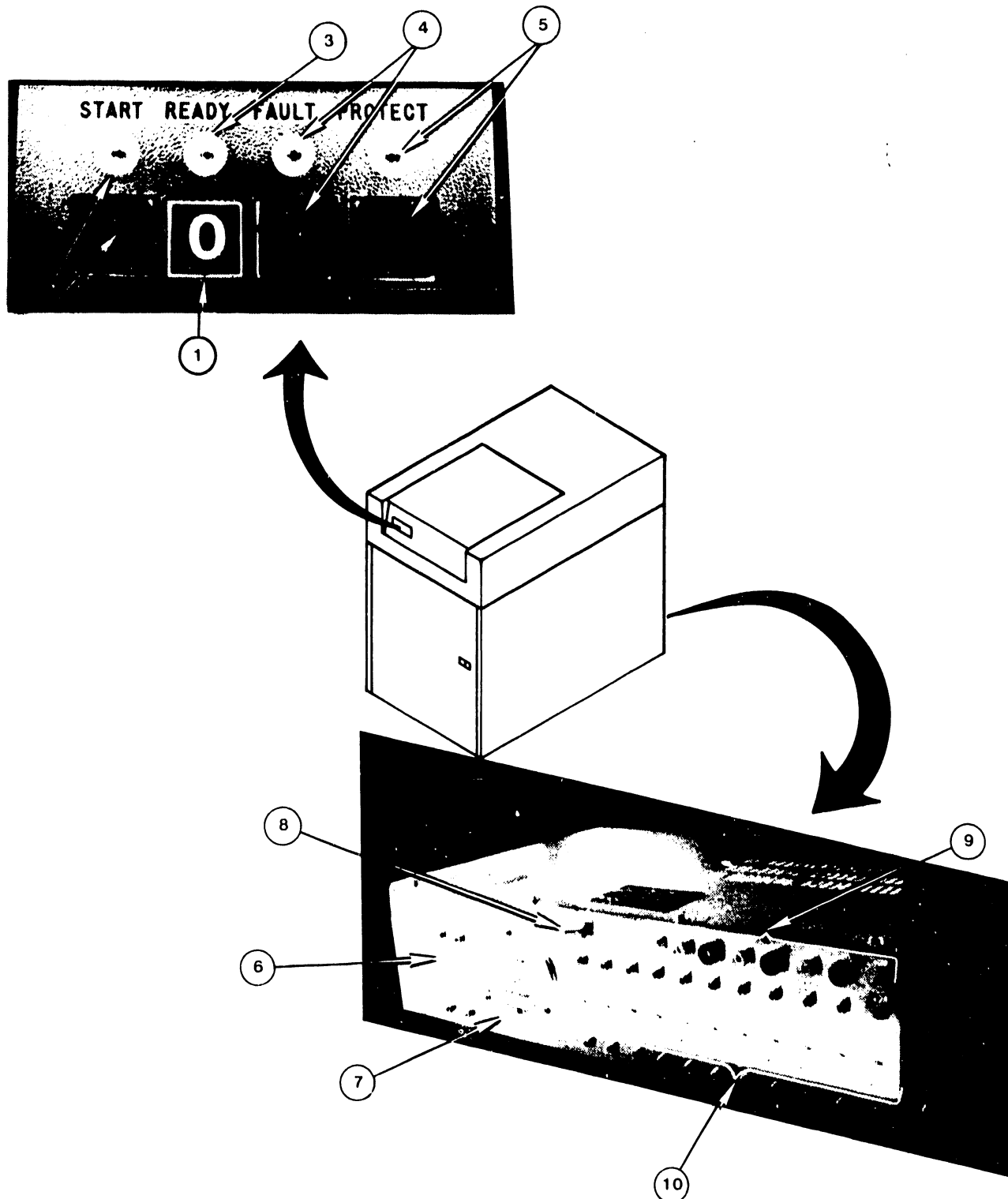

FIGURE 4-7 300 MEG SMD CONTROLS AND INDICATORS

TABLE 4-6 300 MEG SMD CONTROLS AND INDICATORS

ITEM	NAME	FUNCTION
1	LOGICAL ADDRESS PLUG	Determines logical address of drive. In OIS 145 Systems, this address may be 0, 1, or 2 (a maximum of 3 SMDs are allowed). 'Zero' plug must reside on System Disk.
2	START SWITCH/ INDICATOR	<p>Pressing button when drive is in power-off condition (disk pack not spinning) lights indicator and starts power-on sequence, provided the following conditions are met:</p> <ol style="list-style-type: none"> <li>1. Disk pack is installed</li> <li>2. Pack access cover is closed</li> <li>3. All power supply circuit breakers are on</li> </ol> <p>Pressing the indicator when drive is in power-on condition (disk pack spinning), extinguishes indicator and starts power-off sequence.</p>
3	READY INDICATOR	Lights when unit is up to speed, the heads are loaded, and no fault conditions exist.
4	FAULT SWITCH/ INDICATOR	<p>Lights if a fault condition exists within the drive. It is extinguished by either of the following:</p> <ol style="list-style-type: none"> <li>1. Pressing fault switch on indicator control panel</li> <li>2. Maintenance Fault Clear switch on fault card in logic chassis location A17</li> </ol>
5	WRITE PROTECT SWITCH/INDICATOR	Pressing switch lights indicator and disables the driver write circuits, preventing data from being written on the pack. Pressing the switch to extinguish the indicator removes the disable from the write circuits.
6	MAIN AC CIRCUIT BREAKER	Controls application of site AC power to drive. Closing this breaker applies power to blower and elapsed time meter.

TABLE 4-6 (continued)

NAME	FUNCTION
7 HOURS ELAPSED TIME METER	Records accumulated AC power-on time. Meter starts when Main AC Circuit Breaker is closed.
8 LOCAL/REMOTE SWITCH	Controls whether drive can be powered-up from drive, (LOCAL) or controller (REMOTE). The OIS System uses the LOCAL position, and drive power-on sequence starts when START switch is pressed.
9 GRD, +46, -46, +9.7, -9.7, +20 -20, +28 TEST POINTS	Provide means of checking the associated DC voltages.
10 +20V, MOTOR, +46, -46, +9.7, -9.7, +20, -20, +28 SWITCHES	Control application of associated voltages to drive and also provide overload protection.

4.5 CRT WORKSTATION

The CRT workstation is described in Models 5536-1/-2/-3/-4 Workstations, WPNL No.81 (729-0522). For more information on these controls and indicators, and the internal controls, refer to this WPNL.

TABLE 4-7 WORKSTATION CONTROLS AND INDICATORS

ITEM	NAME	TYPE AND FUNCTION
①	DISPLAY	CRT screen; displays input and output data.
②	CONTRAST	Potentiometer; adjusts contrast of "highlights".
③	BRIGHTNESS	Potentiometer; adjusts brightness of display.
④	KEYBOARD	"Typewriter" keys; input data.
⑤	CONNECTORS	BNC & TNC connectors; connects Master Processor.
⑥	POWER SWITCH	Toggle switch; energizes the workstation.
⑦	FUSE	2.5A Slow-Blow fuse; protection for all circuits.
⑧	TONE	Potentiometer; adjusts volume of "beep".
⑨	CLICKER	Potentiometer; adjusts volume of "clicker".

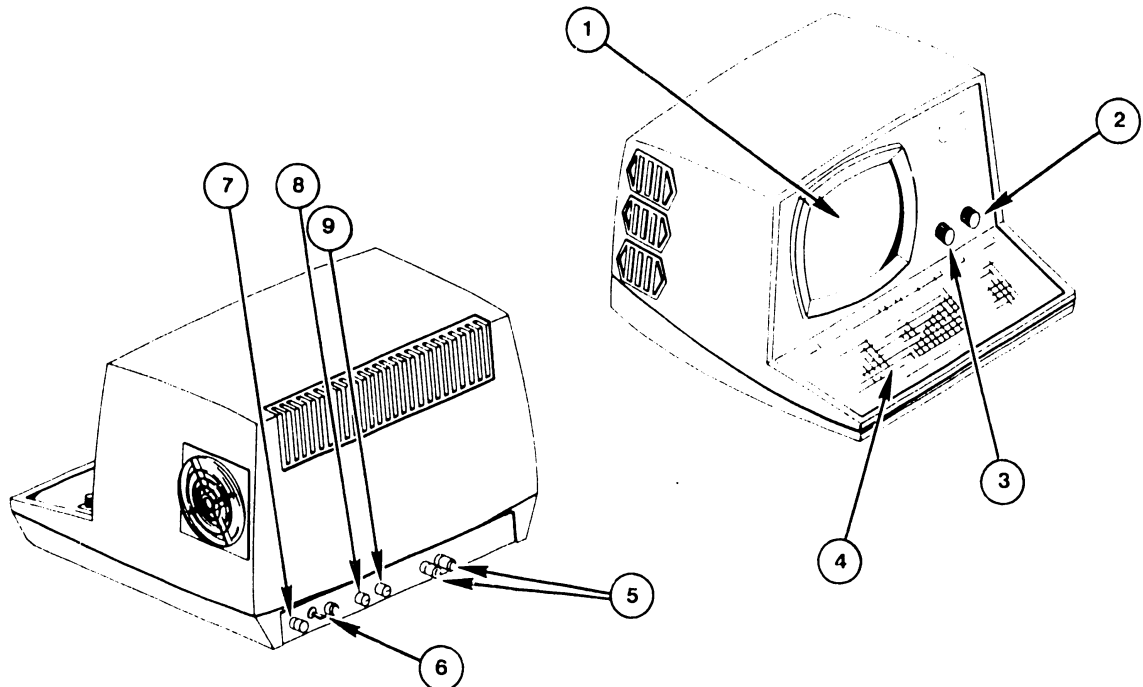

FIGURE 4-8 CRT WORKSTATION CONTROLS AND INDICATORS

**CHAPTER**

**5**

**MAINT-  
ENANCE**

CHAPTER 5MAINTENANCE5.1 GENERAL

This chapter contains a preventive maintenance schedule along with required materials and detailed maintenance procedures for the OIS 140/145 Master Unit. Proper and timely implementation of the information contained in this chapter is necessary to ensure maximum operating efficiency of the OIS 140/145 System.

Preventive maintenance procedures for the system's disk drives and CRT workstations do not fall within the scope of this manual. PM schedules and procedures for these peripheral devices may be found in the following documents:

A. PHOENIX CMD:

PM schedules and procedures for the Phoenix drive can be found in Chapter 6 of the CDC CMD Hardware Maintenance Manual (729-0198A).

B. 300 MEG SMD DRIVE:

PM schedules and procedures for the 300 Meg SMD drive are found in chapter 2 of the CDC SMD Hardware Maintenance Manual (729-0221).

C. HAWK DRIVE:

PM schedules and procedures for the HAWK drive are found in section 4 of the Wang/CDC HAWK Disk Drive Manual (729-0181).

D. CRT/WORKSTATION: (5536-2,-3,-4)

For information on maintenance procedures for the CRT workstation consult section 4 of Word Processing Newsletter No. 81 (729-0522).

5.2 MATERIALS REQUIRED

Materials required to perform a thorough and efficient job of preventive maintenance on OIS 140/145 Systems include:

1. Cleaning agents for use on the system cabinetry and special cleaning agents for use on heads, contacts, etc.
2. Dusting tools and aids such as assorted brushes, swabs, a vacuum, and aerosol can filled with compressed air.
3. Materials for cleaning electrical contacts.
4. Touchup paints.

- 5. CE tool kit.
- 6. Oscilloscope.
- 7. Diagnostics --
  - OIS 140-Class Power Up (PROM) (702-0042D)
  - OIS 140 Extended Memory Power Up (PROM) (702-0123B)
  - SYSEX40 (702-0117)
  - SYSEX40X (702-0135)
  - OIS 140-Class Master Monitor (702-0057D)
  - OIS Online Device Monitor (702-0174)
  - OIS Online Printer Part I (702-0176A, Rev 2422)
  - OIS Online Printer Part II (702-0149, Rev 21A0)
- 8. Manuals --
  - OIS 140/145 Product Maintenance Manual (729-0664A),
  - CDC CMD Hardware Maintenance Manual (729-0198A),
  - CDC SMD Hardware Maintenance Manual (729-0221),
  - Cartride Module Drive (Block Point 4) (729-1063)
  - Wang/CDC HAWK Disk Drive Manual (729-0181),
  - CDC Hawk Field Maintenance Manual (729-0884)
  - Word Processing Newsletter No. 81 (729-0522)

5.3 PM SCHEDULES FOR THE MASTER PROCESSOR

<u>ACTION / FREQUENCY</u>	<u>WEEKLY</u>	<u>6 MONTHS</u>	<u>12 MONTHS</u>	<u>SECTION</u>
Equipment operational check (IPL)	X			5.4.1
Clean exterior		X		5.4.2
Clean interior		X		5.4.2
Inspect		X		5.4.3
Align/Adjust		X		5.4.4
Diagnostic check		X		
Clean contacts and connectors			X	5.4.2
Apply ECN's			X	
Replace parts			X	
Repair scratches and blemishes			X	

5.4 DETAILED PROCEDURES

5.4.1 EQUIPMENT OPERATIONAL CHECK

It is recommended that the customer perform an equipment operational test at least once weekly. This test constitutes running the Power-Up Diagnostic and checking the front panel Diagnostic LEDs for possible error codes. The test takes approximately 15 seconds to complete and is activated when the customer re-IPL's the system.

5.4.2 CLEANING

A. Exterior:

1. Remove excess dust and debris from exterior with cloth and vacuum.
2. Apply general cleaning agent to soft cloth or towel and wipe case clean.

- B. Interior:
  - 1. Remove top cover, dust, then vacuum dust and debris from interior.
  - 2. Clean fan blades with cloth and cleaning agent.
- C. Contacts and Connectors:
  - 1. Remove all PCB assemblies and clean contacts if necessary, also brush and vacuum dust accumulated on PCBs.
  - 2. Clean PCB and I/O cable connector.
- D. Shugart Floppy:
  - 1. Using brush and vacuum cleaner, remove dust and debris from drive.
  - 2. Inspect the head load pad and head for dirt and/or damage. The head should be cleaned if it has an oxide build-up that is visible to the naked eye. Cleaning methods and materials other than those listed can permanently damage the head and should be avoided.
    - a. Lightly dampen a piece of clean, lintless tissue with isopropyl alcohol (use sparingly).
    - b. Lift the load arm off the head, being careful not to touch the load button (see Fig. 5-1). Note: Do not bend back the head load arm more than 90°.
    - c. Gently wipe the head with the moistened portion of the tissue.
    - d. After the alcohol has evaporated, gently polish the head with a clean, dry piece of lintless tissue.
    - e. Carefully lower the load arm onto the head. DO NOT let it snap back.

#### 5.4.3 INSPECTION

- A. Inspect for loose, missing, or damaged parts.
  - 1. Replace, if part on hand.
  - 2. Order for next PM, or call.
- B. Check PCB E-Rev, and PROM Rev levels.
  - 1. Update, if parts available.
  - 2. Order parts for update on next PM, or call.
- C. Check PCB and I/O cable security.
- D. Clean and check fan operation.
- E. Inspect covers for scratches or blemishes.
- F. Check controller address switch setting for correctness.



- G. Inspect the Shugart floppy disk drive as follows:
1. Check for and correct any loose connections.
  2. Check for excessive noise from spindle or head movement motors.
  3. Inspect drive belt for worn, frayed, or weak spots.
- NOTE: Hands and fingers should be clean, free of oil and grease when handling drive.
4. Check spindle lock nut for tightness. Do not take apart spindle and lubricate it.

5.4.4 ALIGNMENTS/ADJUSTMENTS

A. Mechanical: None required.

B. Voltage:

Adjust voltages per section 3.12.5 and Figure 3-24, using test points located on CPU/MEM board and adjusting potentiometers located on the Power Supply Regulator board.

-----CAUTION-----

Avoid touching bare leads and causing a short circuit: very little clearance is provided for these adjustments. If possible, insulate the shank of the adjusting screwdriver or use an insulated alignment tool. All PCBs must be inserted and the system drive connected for these adjustments.

-----

C. Shugart Floppy:

Check and/or replace worn read/write head load pad buttons to prevent excessive wear on the diskette (see Fig. 5-1).

1. To remove the button, hold the load arm out away from the head (not more than 90°), squeeze the locking tabs together with a pair of needle-nosed pliers and press forward.
2. To install the button, press the button into the head load arm and it will snap into place.
3. Check integrity of floppy door and door locking mechanism. Adjust as necessary.

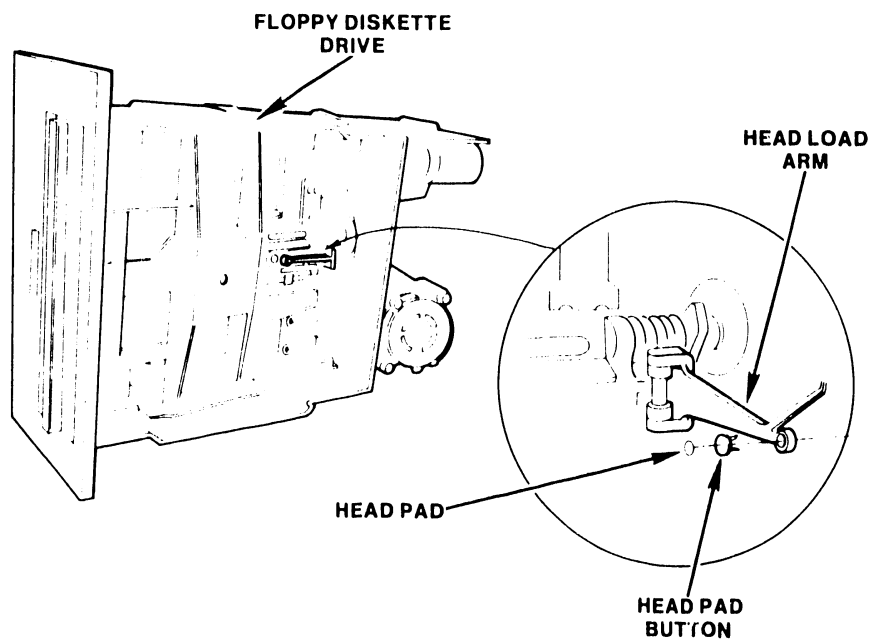

FIGURE 5-1 CHECKING/REPLACING THE DISKETTE DRIVE HEAD PAD

**CHAPTER**

**6**

**TROUBLE-  
SHOOTING**

CHAPTER 6TROUBLESHOOTING6.1 GENERAL

Efficient troubleshooting depends primarily upon three factors:

1. Knowledge of design, operation, and potential malfunctions of the equipment.
2. "Common-sense" reasoning.
3. Proper test equipment and knowledge of its application.

Item 1 has been discussed in the preceding chapters and, most especially, in the OIS training course. For greatest proficiency, however, this knowledge must be supplemented by practical experience. Item 2 is a prime ingredient which makes the difference between first-rate Field Service and that which is just mediocre. Item 3 is also important, but it should be remembered that many problems can be resolved using very simple test equipment, or, in many cases, no test equipment at all.

The proficient Field Service Technician evaluates all the evidence available; he/she then proceeds from the most obvious to the less obvious causes until the disorder is located. There are 3 methods for collecting the necessary evidence -- observation of the equipment, diagnostic aids, and test measurements.

Fortunately, observation usually provides enough information to allow the trouble to be isolated at least to a unit of equipment. The value of observation cannot be overstressed: often simple observations will identify the trouble at once; resulting in a quick service call without involved investigation at the customer's site. For example, the distinctive smell of melted transformer wax, varnish, or other component odors is familiar to the experienced technician and may pinpoint the defective component as well as the unit of equipment.

Extensive diagnostic aids are provided for the OIS systems. Fault-lights, diagnostic switches, and semi-automated tests furnish the Field Service Technician with detailed evidence. PROM-based diagnostics are exercised whenever the system is powered-on or IPLed. These usually provide sufficiently detailed evidence to isolate the trouble to a field-replaceable unit. More evidence, if needed, is available via the Master Monitor Diagnostic and Online Device Monitor.

Sometimes measurements are needed to make adjustments or actually test the defective component. Extensive diagnostic measurements at the customer's site, however, should be kept to a minimum.

1. Obtain the customer's full story of the complaint.
2. Observe the equipment, cabling, panel indicators, cabinetry, and CRT-screen for obvious indications (CRT prompts, poor power-plug connection, etc.).
3. Check all controls and switches.

4. Analyze the evidence from all sources to localize the trouble to an item of equipment (Master Processor, workstation, disk drive unit, etc.).
5. Utilize the diagnostic aids to further localize the trouble to a replaceable assembly.

## 6.2 LEVEL OF REPAIR

Repair of the OIS 140/145 is at the "board-replacement-level"; i.e., only major assemblies will be replaced at the customer's site. Those assemblies designed for field replacement are listed in Table 7-1.

## 6.3 TROUBLESHOOTING AIDS FOR THE MASTER PROCESSOR

### 6.3.1 PCWER-UP (PROM) DIAGNOSTIC

The Power-up diagnostic resides in PROM and checks the system integrity each time the Master Processor is powered-up or reset. This diagnostic takes approximately 15 seconds to complete. The primary use of this Power-Up diagnostic at the field level is for the isolation of board failures within the OIS Master Unit. Fault isolation is accomplished through the use of error codes displayed on the Master Unit's front panel LEDs. These error codes are either termed "non-fatal", indicating faulty operating conditions, or "fatal", indicating faulty circuit boards. Corrections or repairs, if required, may be performed by Customer Engineering personnel.

This diagnostic also provides both Detailed and Expanded Error information via error codes displayed on the eight LED indicators present on the CPU/MEM board. This additional error information can be used in the field to aid in the isolation of those problems that are not readily resolved by direct replacement of suspected faulty board(s).

Fault isolation beyond board level is possible in the case of the CPU/MEM board. With the use of diagnostic switches on the top of this board, Expanded Error information is available to correct CPU/MEM board problems by isolating faulty memory chips.

A complete guide for the proper use of the OIS 140-Class Power-Up Diagnostic is presented in Appendix D. This Appendix discusses the 64K CPU version, while Appendix E describes the differences associated with the 128K Extended Memory Power-Up Diagnostic.

### 6.3.2 OPERATING SYSTEM ERROR MESSAGES

The Operating System will display 4 types of error messages on the CRT screen:

1. Screen Package DEBUG error messages
2. Word Processing Error Handler messages
3. Request Control Block (RCB) error messages.
4. Additional error and warning messages.

These CRT error messages are explained in detail in Appendix B.

### 6.3.3 MASTER DIAGNOSTIC MONITOR

The OIS 140-Class Master Diagnostic Monitor (702-0057D) is completely contained on a single floppy diskette. General use of this diagnostic at the field level is anticipated for situations where the PROM-based Power-Up Diagnostics fail to isolate a board or assembly failure; this is especially true in the case of a suspected intermittent failure. In addition, this diagnostic can be used for confidence testing, quickly establishing that all device components operate properly. Test routines included in the Master Diagnostics Monitor are:

MASTER LOWER RAM TEST	Z80 INSTRUCTION TEST
MASTER UPPER RAM TEST	FIELD TEST UNIT SIMULATOR
MASTER DATA LINK	SLAVE DATA LINK EXERCISER
10-MEG DISK CONTROL	I/D MODE EXERCISER
SLAVE LOWER RAM TEST	WINCHESTER CONTROLLER
CMD/SMD DISK CONTROL	

Once the Master Diagnostic Monitor diskette is IPLed via the Master Processor floppy diskette drive, the operator can select, execute, control, and monitor desired combinations of the test programs listed above.

Appendix A presents a complete guide for the software-related tasks required to perform the OIS 140-Class Master Diagnostics Monitor package.

### 6.3.4 SYSEX40 AND SYSEX40X

SYSEX40 (702-0117) and SYSEX40X (702-0132) are diskette-based system exercisers which allow simultaneous exercising of each major logic board in the master processor plus some logic in attached slaves. SYSEX40 is used on systems with the standard 64K CPU memory while SYSEX40X is used with the 128K CPU memory option. Both generate a large amount of random activity on selected disk drives. They are very useful for system checkout, as slave memory may be used to perform some of the read, write, or random read operations.

### 6.3.5 SOFTWARE PROCEDURES

Appendix C presents a complete guide for the software-related tasks required to perform the OIS 140/145 Software Initialization and Post-Installation Software updates.

Software Installation is normally a Customer Service Representative function. The procedure is included in this manual for cases where it has been determined that Customer Engineering should perform this task.

6.4 TROUBLESHOOTING FLOWCHARTS

The troubleshooting flowcharts provided on the following pages are intended to aid in the systematic investigation, diagnosis, and repair of failures common to all OIS 140/145 Master Processors.

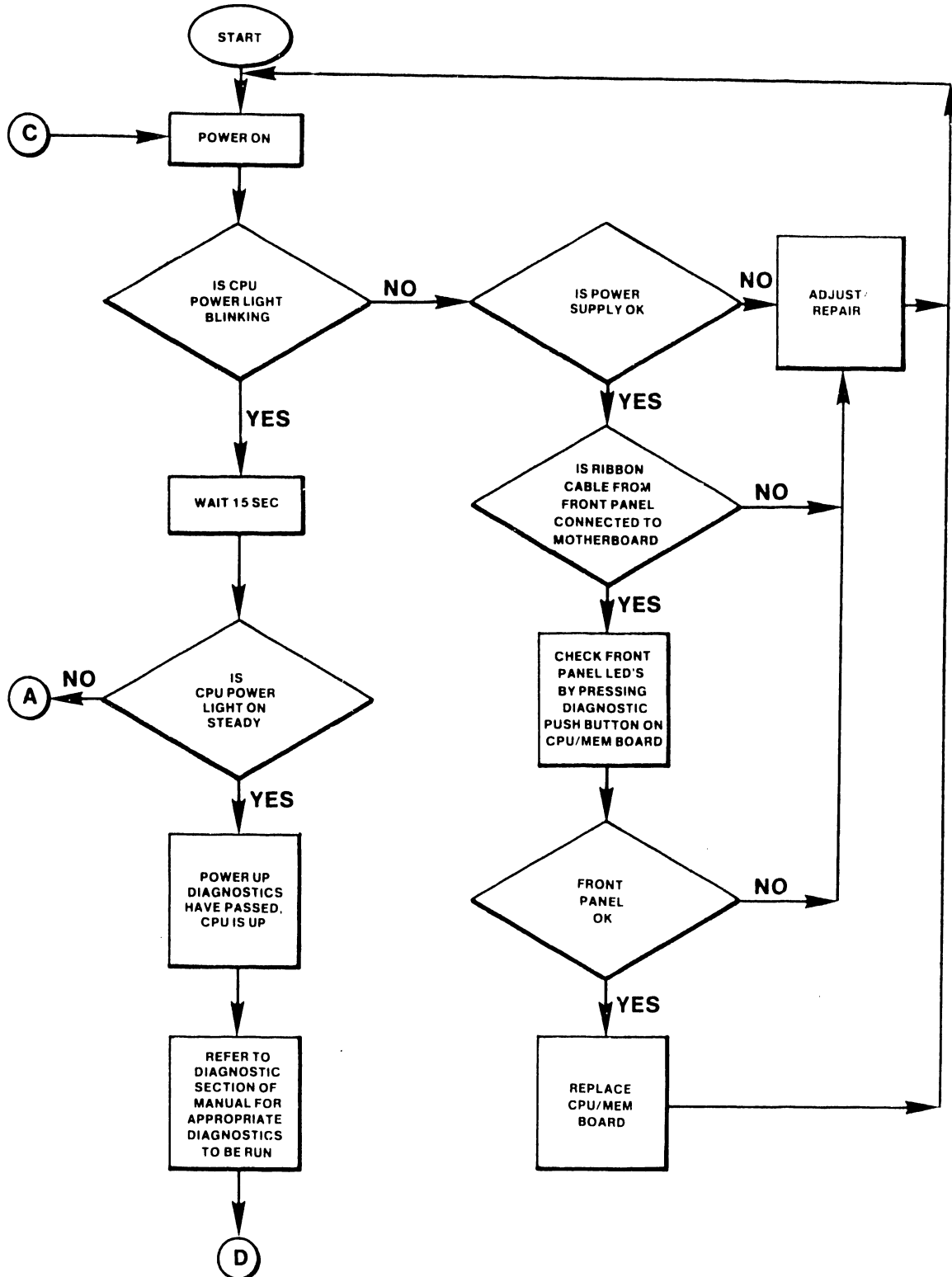

FIGURE 6-1 TROUBLESHOOTING FLOWCHART FOR MASTER UNIT COMMON FAILURES

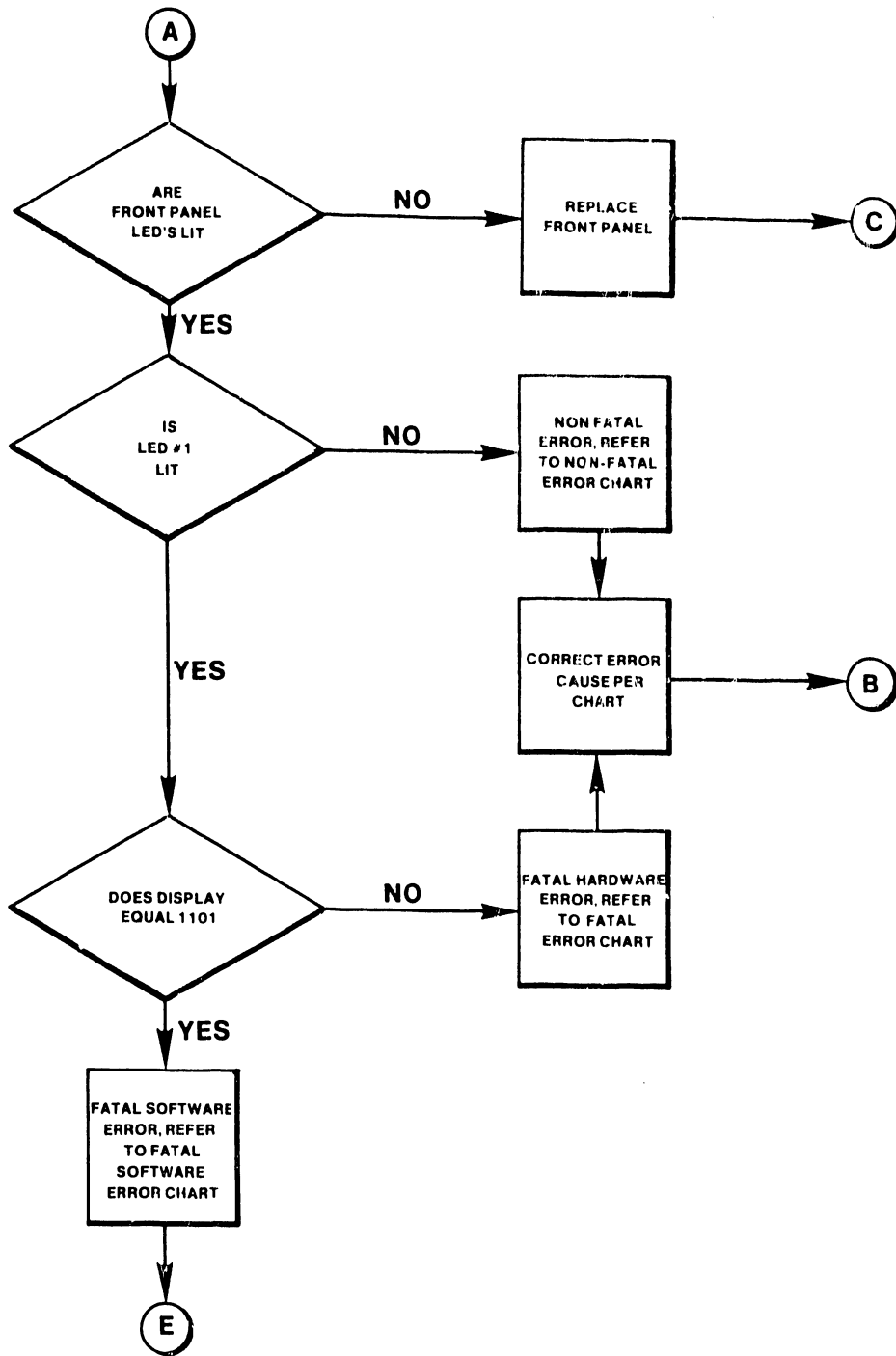

FIGURE 6-1 continued



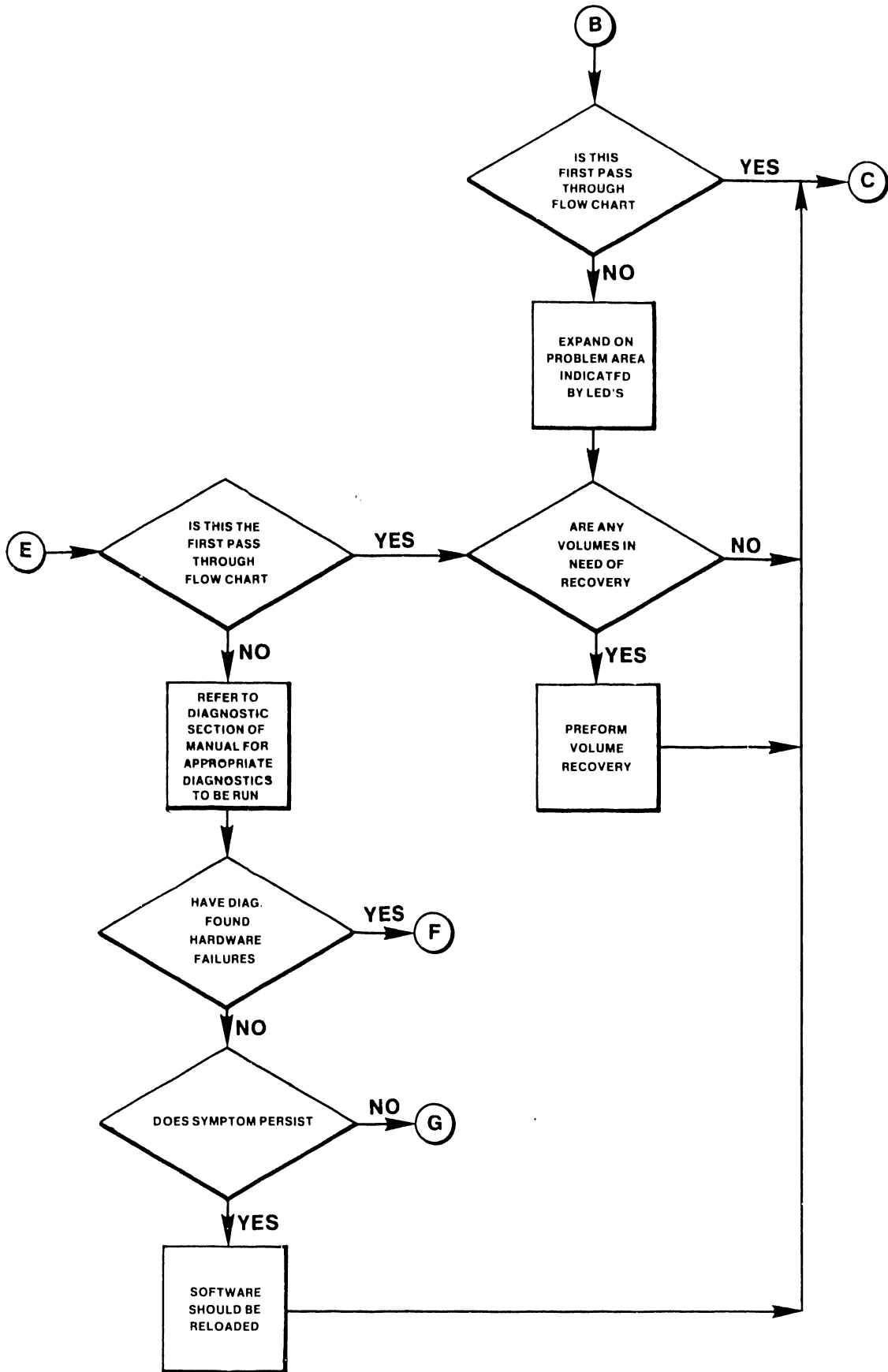

FIGURE 6-1 continued

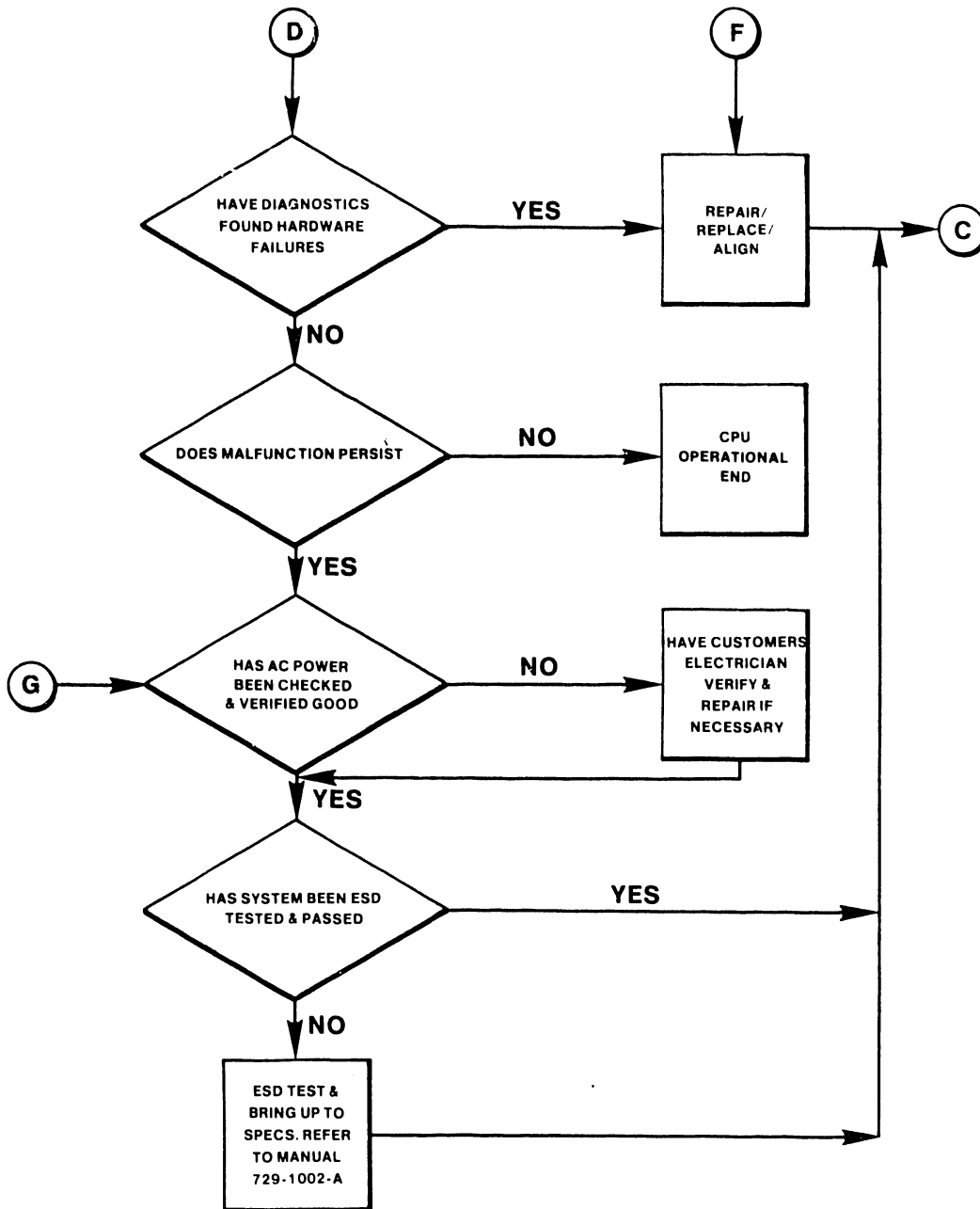

FIGURE 6-1 continued

**CHAPTER**

**7**

**REPAIR**

CHAPTER 7REPAIR7.1 GENERAL

This chapter provides the information necessary to remove and replace OIS 140/145 parts and assemblies. In general, most parts and assemblies are accessed with the top cover and front panels of the Master Processor removed. Thus procedures for removing and replacing these items are discussed first and are subsequently referenced by most of the following repair procedures.

7.2 TABLE OF FIELD-REPLACEABLE ITEMS

TABLE 7-1 FIELD-REPLACEABLE ITEMS

NAME	WLI PART NUMBER
PCA CPU & (64K) MEMORY	210-7501-A
PCA 10 MEG/FLOPPY CNTLR	210-7502
PCA DATA LINK CONTROL	210-7503
PCA DATA BUFFER	210-7504-A
PCA SMD CONTROLLER #1	210-7505
PCA SMD CONTROLLER #2	210-7506
PCA REGULATOR	210-7508
CABLE SMD B 15'	220-3033-18
CABLE SMD A 15'	220-3041-6
FLOPPY DISK DRIVE (60 Hz)	278-4003-M
FLOPPY DISK DRIVE (50 Hz)	278-4003-1M*
FUSE 3 AMP 250V	360-1031-SB
FUSE 4 AMP 250	360-1040-SB
FAN MUFFIN	400-1003
FLOPPY DOOR LOCK KIT	725-0053-93
CABLE 10 MEG CHAIN DRIVE 1	220-0169-1
CABLE 10 MEG CHAIN DRIVE 2	220-0187-1
CABLE 10 MEG	220-0236
FLOPPY DISK CABLE	220-3011
FRONT PANEL RIBBON CABLE	220-3020
30 PR FLAT A CABLE	220-3031-1
26 COND SHIELDED FLAT CABLE	220-3033-19
MOTHERBOARD ASSEMBLY	270-0599
HEAT SINK ASSEMBLY	270-0600
POWER SUPPLY CHASSIS (60 Hz)	270-0601
POWER SUPPLY CHASSIS (50 Hz)	270-0601-1*
FRONT PANEL ASSEMBLY	270-0605
SERIAL CONNECTOR PLATE	279-0358

\* International only

### 7.3 REMOVAL/REPLACEMENT PROCEDURES FOR THE MASTER PROCESSOR

The physical layout of the OIS 140/145 Master Unit chassis allows the field technician easy access to all major parts and assemblies internal to the Master Unit. This easy access simplifies removal and replacement of major parts and assemblies in comparison to previous systems. The following sections describe the procedures to be used to remove and replace major parts and assemblies.

-----CAUTION-----  
DISCONNECT AC POWER CORD BEFORE REMOVING ANY PCBs OR INTERNAL ASSEMBLIES.  
-----

#### 7.3.1 TOP COVER REMOVAL/REPLACEMENT PROCEDURE

The top cover of the OIS 140 Master Unit is removed as follows (See Fig. 7-1):

- A. Remove the machine screw at the rear of the main chassis. This screw is used to secure the top cover to the main chassis.
- B. Push the cover to the rear of the unit to disengage the tab on the front edge of the cover from the front of the main chassis.
- C. Lift the cover up and away from the main chassis.

Reinstall the top cover by aligning the guides to the top cover with the main chassis, then perform the above procedure in reverse order.

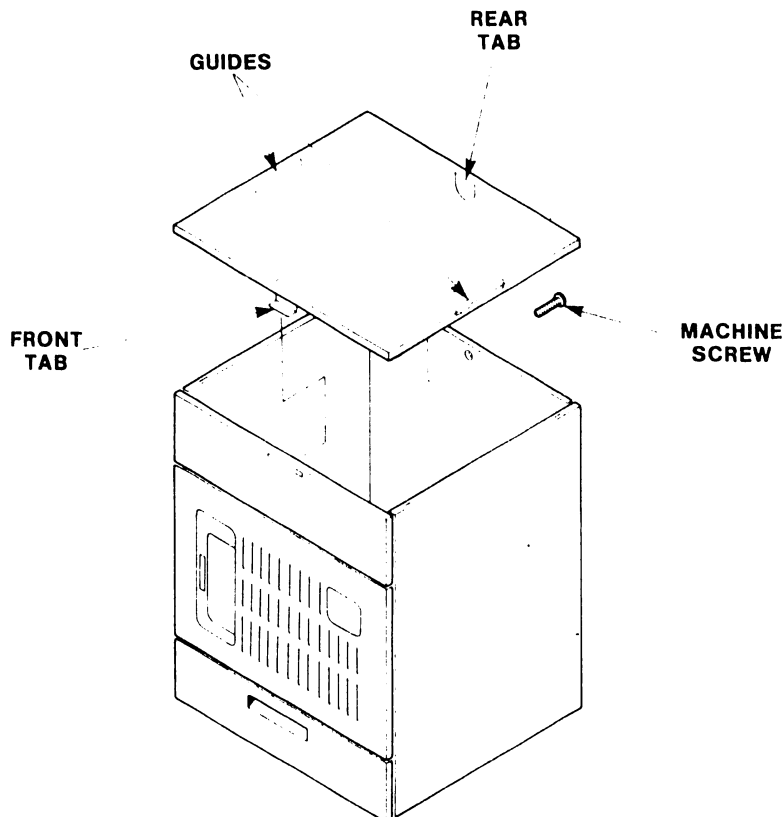

FIGURE 7-1 MASTER UNIT TOP COVER REMOVAL

### 7.3.2 FRONT PANELS REMOVAL/REPLACEMENT PROCEDURES

Two panels and a storage drawer are located on the front of the Master Unit. The panels consist of a small upper front panel and a larger lower front panel on which the control panel PCB is mounted. The upper panel is removed as follows (See Figs. 7-2, 7-3):

- A. Lift the panel upward disengaging the four tabs mounted on it from the slots located on the chassis.
- B. Pull the panel away from the unit.
- C. Reinstall the upper panel by reversing the above procedure.

The lower front panel is removed as follows:

- A. Disconnect the AC Molex connector, then the Front Panel ribbon cable at the motherboard. Note the orientation of both connectors.
- B. The lower front panel is then removed and replaced in the same manner as the upper front panel. Ensure that both cables are re-connected.

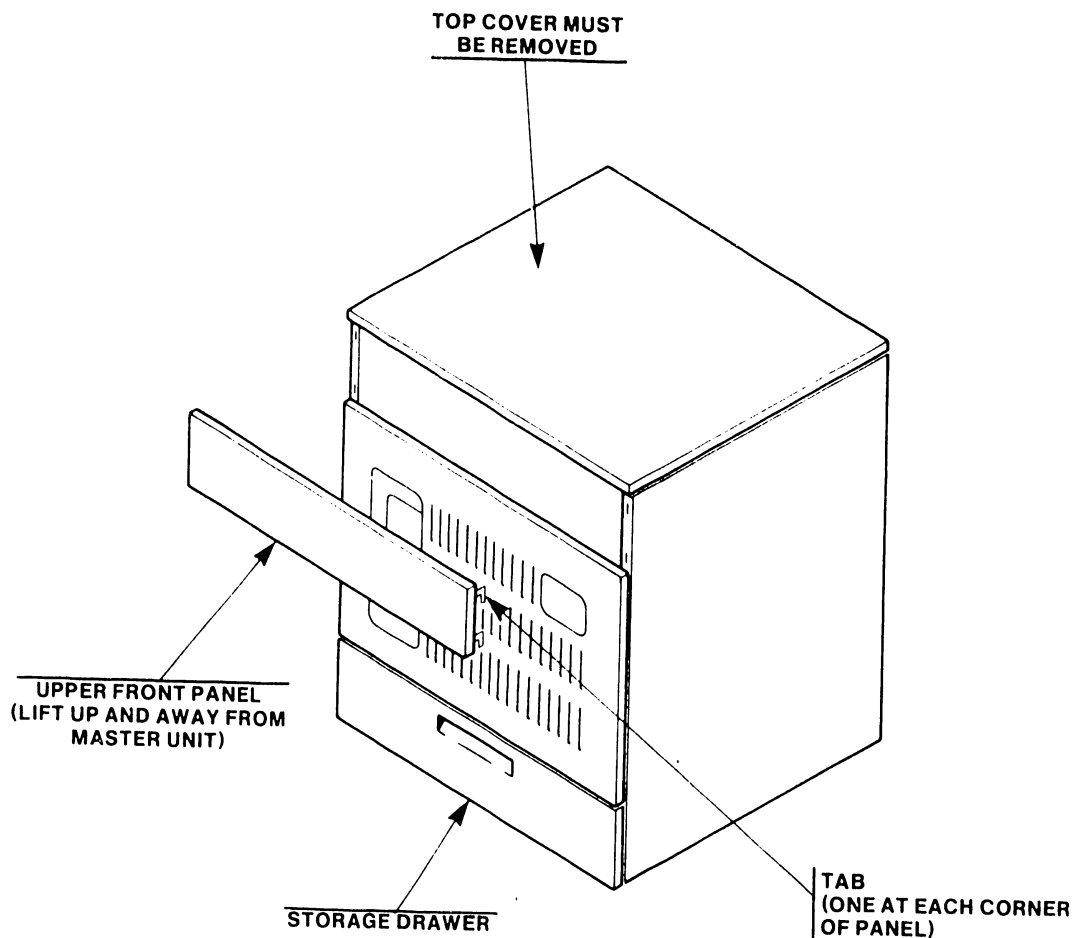

FIGURE 7-2 REMOVING MASTER UNIT UPPER FRONT PANEL

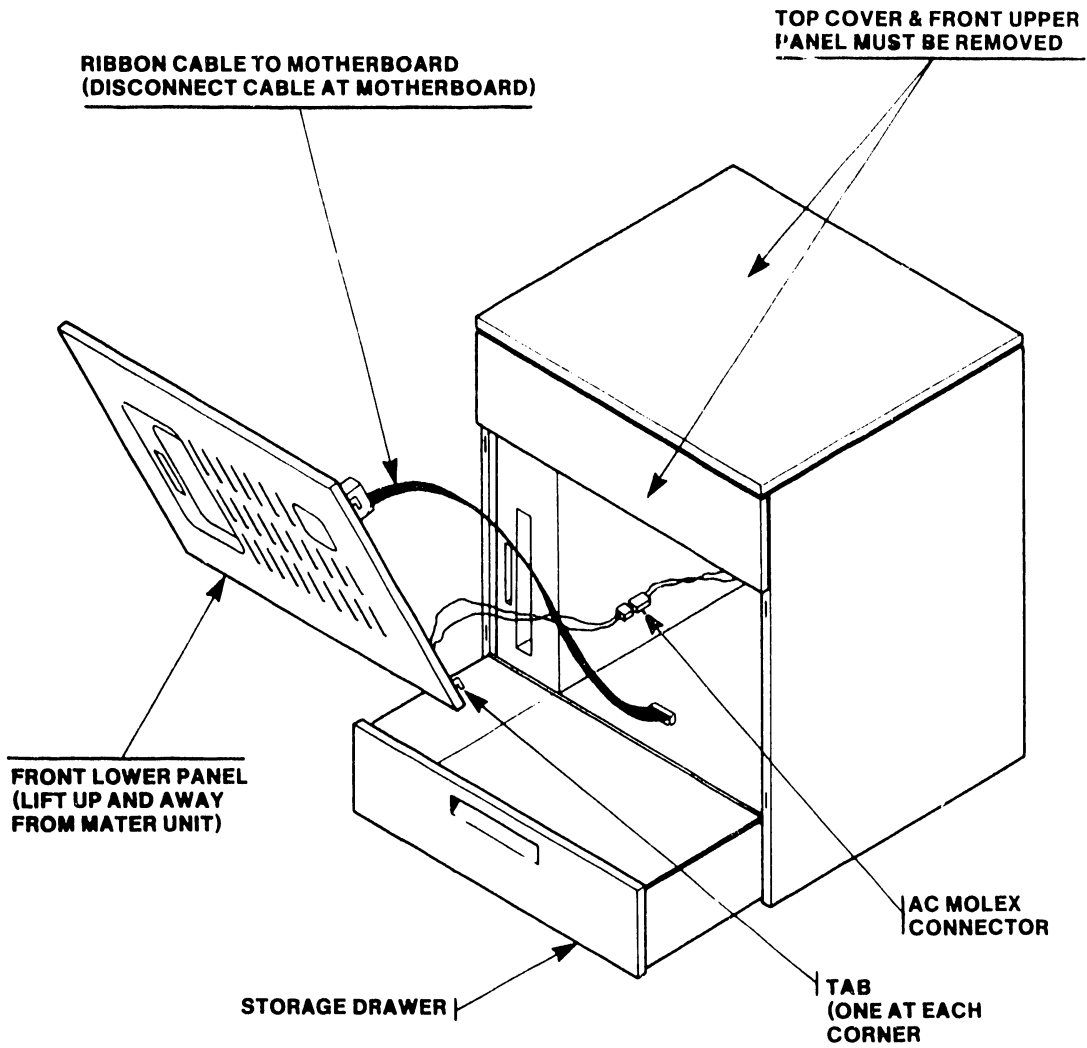

FIGURE 7-3 REMOVING MASTER UNIT LOWER FRONT PANEL

7.3.3 PCB REMOVAL/REPLACEMENT PROCEDURES

ITEM	WLI PART NUMBER
PCA CPU & (64K) MEMORY	210-7501-A
PCA 10 MEG/FLOPPY CNTLR	210-7502
PCA DATA LINK CONTROL	210-7503
PCA DATA BUFFER	210-7504-A
PCA SMD CONTROLLER #1	210-7505
PCA SMD CONTROLLER #2	210-7506
PCA REGULATOR	210-7508

These seven PCBs are secured by two board retainers. Each retainer is secured by a single Phillips screw and a tab. PCB removal has been greatly simplified in comparison with previous systems. To remove a PCB, perform the following procedures:

- A. Disconnect AC power.
- B. Remove the top cover per section 7.3.1.
- C. Remove the two board retainers (each secured by a Phillips screw and a Tab).
- D. Ensure that all cables are disconnected from the PCBs to be removed.
- E. Grasp the black handles mounted on the PCA faceplate and lift with a slow steady force.

To reinstall or replace a PCB, insert the PCB into the Master Unit using the plastic card guides on the motherboard to keep the PCB aligned with its connectors. Once the PCB is properly aligned, use a steady downward pressure to seat the PCB securely in place (see Fig. 2-1).

7.3.4 DISKETTE DRIVE REMOVAL/REPLACEMENT PROCEDURE \*\*

The top cover and front panels of the Master Unit must be removed in order to remove the diskette drive.

Remove and replace the diskette drive as follows (See Fig. 7-4):

- A. After noting its orientation, disconnect the Floppy I/O cable from motherboard.
- B. Disconnect AC power cord from rear of drive.
- C. Pull storage drawer located beneath lower front panel part-way out, insert hand into drawer under drive and remove wing screw securing drive to main and power chassis.
- D. Use appropriate-sized nut driver to remove the two bolts that secure the floppy drive mounting bracket to the top of the floppy drive.
- E. Pull drive forward and out of chassis.
- F. To reinstall drive, reverse the above procedure. See Figure 7-4 for orientation of Floppy I/O cable.

\*\* NOTE: OIS systems require Door Lock Kit be installed on all floppy drives. refer to PSN-2 Shugart SA901 (729-0122) for removal/replacement procedure.



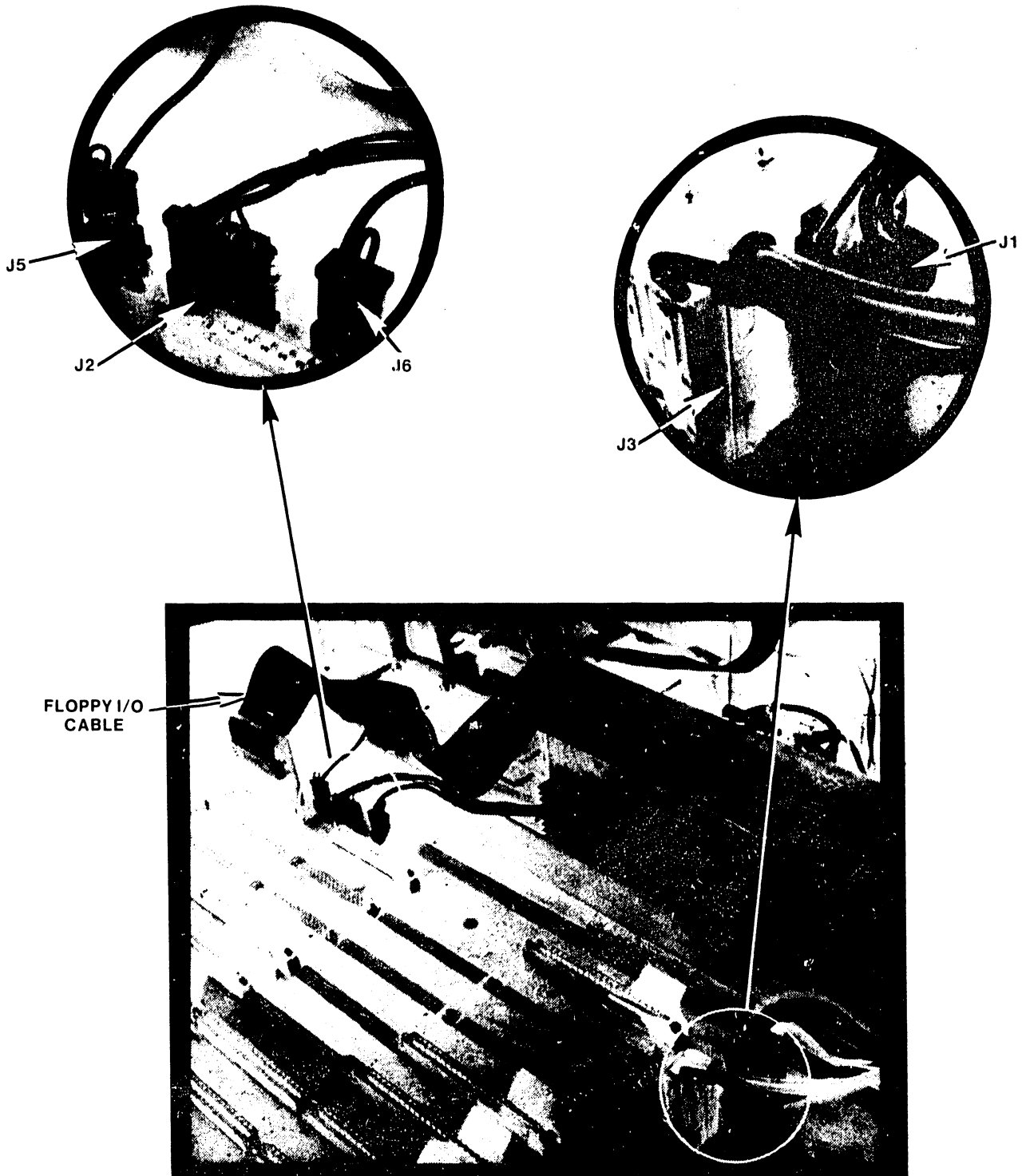

FIGURE 7-4 DISKETTE DRIVE, POWER CHASSIS, AND MOTHERBOARD CONNECTIONS

### 7.3.5 POWER CHASSIS REMOVAL/REPLACEMENT PROCEDURES

Before removing the power chassis, unplug the main AC power cord. Remove the diskette drive as described in section 7.3.3. Once the drive is removed proceed as follows (See Fig. 7-4):

- A. Disconnect the five (J<sub>1</sub>, J<sub>2</sub>, J<sub>3</sub>, J<sub>5</sub>, J<sub>6</sub>) connectors from the power chassis to the motherboard. Remove these connectors by pulling them straight up, do not move them from side-to-side as this could damage the connectors.
- B. Using a 7/16<sup>ths</sup> inch nut driver, remove the two bolts at the front of the power chassis.
- C. Using a Philips screwdriver, remove the two screws securing the power chassis to the rear of the main chassis.
- D. Disconnect the fan leads at the rear of the power chassis.
- E. Pull the power chassis forward and out of the main chassis. Keep the AC power cord from tangling in rear of main chassis.

To reinstall or replace the power chassis, reverse the above procedure. When placing the power chassis into the main chassis feed the AC power cord through the back of the main chassis and align the fuse holder at the rear of the power chassis with the appropriate hole in the main chassis.

### 7.3.6 MOTHERBOARD REMOVAL/REPLACEMENT PROCEDURES

The motherboard for the OIS 140 is removed and replaced or reinstalled as follows (See Fig. 7-4):

- A. Remove all data buffer and disk drive cables from PCBs. Note location of cables to aid in reinstallation.
- B. Remove all PCBs mounted on the motherboard per Section 7.3.3.
- C. Remove the five connectors coming from the power chassis (Section 7.3.5, Step A)
- D. Using a 7/16<sup>ths</sup> nut driver, remove the two bolts at the front of the motherboard.
- E. Grasp the front of the motherboard and lift upward slightly.
- F. Pull motherboard out from Master Unit while moving board from side-to-side (requires firm steady pressure). This is done to disengage the two tabs at the rear of the motherboard from the two slots on the main chassis.

To reinstall or replace the motherboard, reverse the above procedure. Ensure that all connections are correct and are firmly in place.

7.3.7 REMOVING/REPLACING THE FAN MUFFINS

Both Master Unit fan muffins may be removed using the following procedure:

- A. Disconnect AC power.
- B. Remove the top cover per section 7.3.1.
- C. Disconnect the fan AC power lead from the top of the fan assembly.
- D. Remove the four Phillips screws and nuts that secure the fan muffin to the Master Unit rear panel.
- E. Remove the fan.

To replace the fan:

- A. Align fan, fan guard, and screw holes.
- B. Install and finger-tighten the four Phillips screws and nuts.
- C. Tighten the screws with a Phillips screwdriver.
- D. Connect the fan AC power lead at the top of the fan assembly.
- E. Replace the top cover per section 7.3.1.

7.3.8 REMOVING/REPLACING THE SERIAL CONNECTOR PLATES

Each serial connector plate may be removed as follows:

- A. Disconnect the dual coaxial cables from the serial connector plate.
- B. Disconnect the ribbon cable from the Data Buffer board.
- C. Remove the four Phillips screws that connect the serial connector plate to the back panel (two at the top and two at the bottom).
- D. Remove the serial connector plate.

To replace:

- A. Insert the serial connector plate and align the screw holes.
- B. Finger-tighten all four Phillips screws (two at the top, two at the bottom).
- C. Tighten the screws with a Phillips screwdriver. Ensure that the serial connector plate makes good contact with the chassis so that the coaxial cables will be properly grounded.
- D. Connect the ribbon cable to the Data Buffer board per section 3.4.1.
- E. Connect the dual coaxial cables to the serial connector plate.

#### 7.4 REMOVAL/REPLACEMENT PROCEDURES FOR OIS 140/145 PERIPHERALS

A detailed discussion of removal/replacement procedures for all OIS 140/145 peripheral devices is beyond the scope of this manual. However, the following paragraphs provide document re-order numbers and specific chapters containing removal/replacement procedures for 140/145 disk drives and CRT workstations:

A. PHOENIX CMD:

Removal/replacement procedures for the Phoenix drive can be found in Chapter 6 of the CDC CMD Hardware Maintenance Manual (729-0198A).

B. 300 MEG SMD DRIVE:

Removal/replacement procedures for the 300 Meg SMD drive are found in chapter 2 of the CDC SMD Hardware Maintenance Manual (729-0221).

C. HAWK DRIVE:

Removal/replacement procedures for the HAWK drive are found in section 4 of the Wang/CDC HAWK Disk Drive Manual (729-0181).

D. CRT/WORKSTATION: (5536-2,-3,-4)

For information on removal/replacement procedures for the CRT workstation consult section 4 of Word Processing Newsletter No. 81 (729-0522).

**CHAPTER**

**8**

**THEORY**

**OF**

**OPERA-**

**TION**

CHAPTER 8THEORY OF OPERATION8.1 GENERAL

The Master CPU can be functionally divided into four components; the CPU/MEMORY board, TEN MEG/FLOPPY CONTROLLER, SMD CONTROLLER, and the DATA LINK CONTROLLER. The SMD Control Logic resides on two boards, SMD CONTROLLER "A" (#1), and SMD CONTROLLER "B" (#2). Similarly, the Data Link Control Logic also consists of two boards - the DATA LINK CONTROL board and the DATA BUFFER board. Figure 8-1 presents a simplified block diagram of the OIS 140/145 Master Unit.

8.2 THE CPU/MEMORY BOARD

The heart of the Master Unit is its 7501 CPU/MEMORY board; which includes a Z80A Microprocessor operating at 4 Megahertz. In addition to the Z80A and its associated timing and control logic, this board contains:

1. 3K of PROM
2. 1K of Memory-Mapped I/O allocations
3. a Counter/Timer Circuit (CTC)
4. parity generation and checking
5. a priority interrupt structure
6. 60K of RAM memory (expandable to 120K with Expanded Memory option).

The PROM portion of memory occupies the bottom 3K of addressable locations, 0000 to 0BFF Hex. The first 1K of PROM contains the "Bootstrap Loader" program while the remaining 2K contains the "Power-up Diagnostics". At power-up, the Bootstrap Loader gains program control briefly before passing it on to the Power-up Diagnostics. The diagnostics then test all basic system functions before allowing the system to proceed any further. If not satisfied with the state of the system, the Power-up Diagnostic program posts error codes on the Master Unit front panel indicators and the CPU/Memory board's diagnostic LEDs. The power-on light on the unit's front panel is set flashing and the system remains in this state until corrective measures are taken. When the Power-up Diagnostics program has determined the system to be operational, Z80A program control is passed back to the Bootstrap Loader program which then commences to Initial Program Load (IPL) the system.

The CPU/MEMORY board contains 64K bytes of Dynamic RAM memory, which must be continually refreshed in order to maintain its data. The Z80A provides a refresh pulse to serve this purpose. Because the PROM and Memory-Mapped I/O take up the lower 4K of memory addresses, only the upper 60K of RAM is addressable by the Z80A CPU. This 60K of RAM is referred to as "Master Memory". When the system is IPL'ed, the system operating software is loaded into Master Memory from the System Disk. The System Disk may reside in any one of three drives (floppy, Hawk, or SMD/CMD); its location is revealed to the CPU via the three-position switch on the Master Unit's front panel.

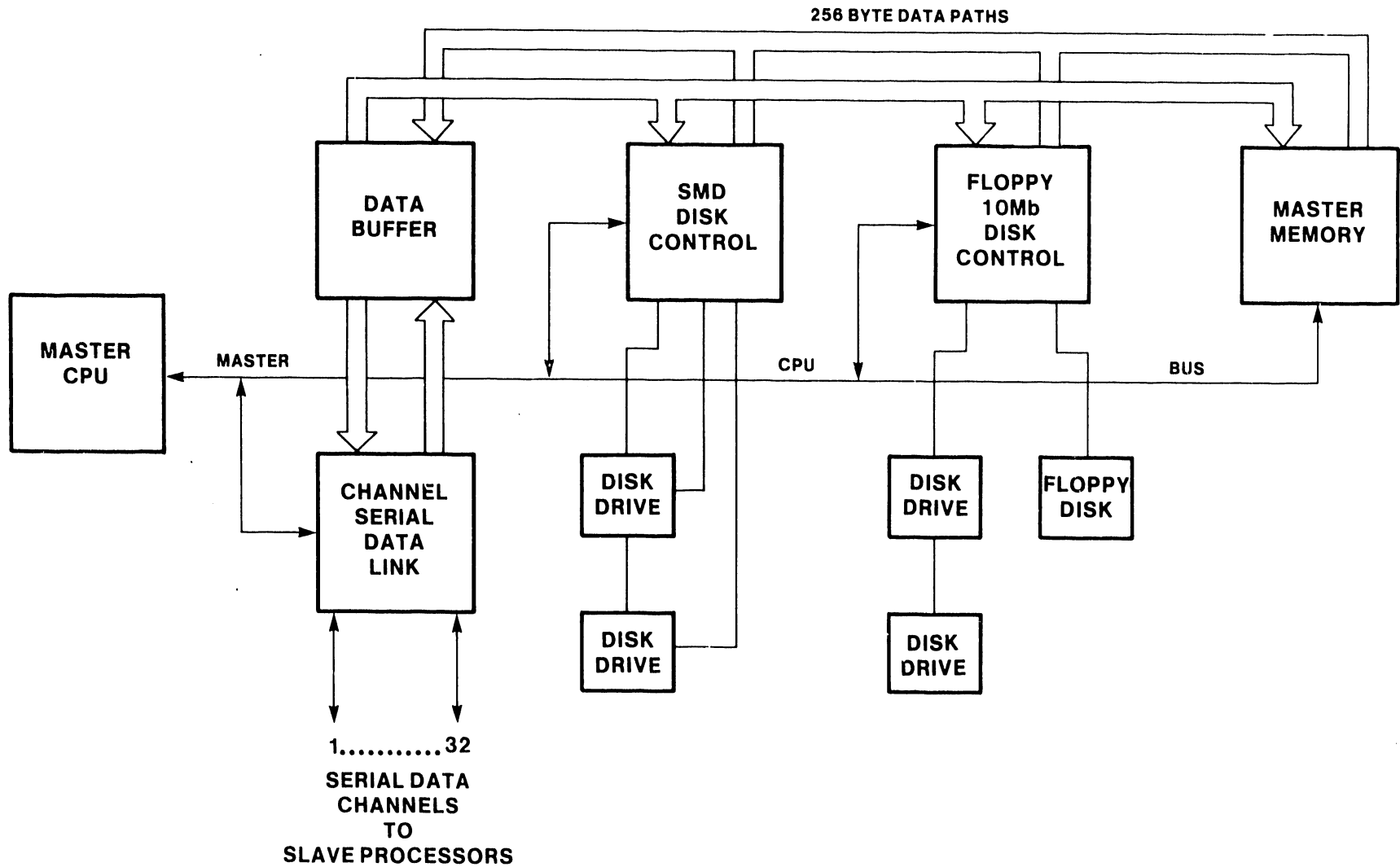

FIGURE 8-1 OIS 140/145 SYSTEM SIMPLIFIED BLOCK DIAGRAM

The CPU/MEMORY logic uses a Memory-Mapped I/O technique (MMI/O) to transfer all I/O commands. In MMI/O, I/O devices pose as memory devices, and as long as they respond like memory devices, the CPU can not tell the difference. By using MMI/O, one is able to take advantage of the larger Z80A instruction set that references memory address space. It permits direct arithmetic and logical operations on port data as well as transfers between any of the Z80A internal registers and the I/O port. Conventional I/O interfacing methods do not offer this versatility. Blocks of memory addresses are assigned to each of the system I/O devices and when specific locations are addressed they are decoded into commands on the associated device controllers. In the OIS 140/145 systems, memory address locations 0C00 to 0FFF Hex are reserved for Memory-Mapped I/O, sandwiched between 3K of PROM (0000 to 0BFF Hex) and 60K of RAM (1000 to FFFF Hex). Although 1000 bytes are available for this purpose, only 256 bytes are needed at present.

### 8.3 MEMORY-MAPPED I/O DEVICE ADDRESSES

The I/O devices referred to are the TEN MEG/FLOPPY CONTROLLER, SMD CONTROLLER, DATA LINK CONTROLLER, and the CPU/MEMORY board itself. Each is assigned MMI/O address space according to the following table:

<u>DEVICE TYPE</u>	<u>DEVICE NUMBER</u>	<u>ADDRESS SPACE (Hex)</u>
CPU/MEM BOARD	0	0C00 to 0C3F
10 MEG/FLOPPY CONT.	1	0C40 to 0C7F
SMD CONTROLLER BD.	2	0C80 to 0CBF
DATA LINK CONT. BD.	3	0CC0 to 0CFF

The Master CPU's Z-80A is designed with an address bus of 16 bits for address selection ( $A_{15}$ - $A_0$ ). These address bits break down as follows for I/O operations:

1. Address bits  $A_{15}$ - $A_{12}$  are used to select either a RAM memory bank or PROM.
2. Address bits  $A_{11}$ - $A_{10}$  are used to select one of the four 1K memory locations within PROM. (The fourth 1K of PROM is Memory Mapped In/Out (MMI/O).
3. Address bits  $A_9$ - $A_6$  are used for Device selection (MCPUs, 10 Megabyte and Floppy Disk controller, Data Link Control or SMD disk controller). See table above.
4. Address bits  $A_5$ - $A_0$  are used for one of sixty-four command selections.



For example, when the CPU Address Bus holds address (OCCO<sub>H</sub> = 0000 1100 1100 0000), an OCCO MMI/O command is generated on device 03, the DATA LINK CONTROLLER Board, as follows:

A <sub>15</sub> - A <sub>12</sub>	A <sub>11</sub> - A <sub>10</sub>	A <sub>9</sub> - A <sub>6</sub>	A <sub>5</sub> - A <sub>0</sub>
0 0 0 0	1 1	0 0 1 1	0 0 0 0 0 0
1 of 16 MEMORY BANK SELECTIONS	1 of 4 PROM SELECTIONS	1 of 16 DEVICE SELECTIONS	1 of 64 COMMAND SELECTIONS
0000 SELECTS PROM	11 SELECTS MMI/O	0011 SELECTS DATA LINK CONTROLLER	000000 SELECTS 1-BYTE STATUS COMMAND

#### 8.4 MASTER UNIT DATA FLOW

Data Flow in the OIS 140/145 system can be divided into eight functional categories:

1. DISK WRITE TO MASTER MEMORY

256-Byte Sectors are read from a Disk and written into Master 'RAM' Memory, a sector at a time. This is how the Initial Program Load, (IPL) is accomplished.

2. DISK READ FROM MASTER MEMORY

256 Byte 'Pages' are read from Master 'RAM' Memory and written to the Disk, a Sector at a time. This is how Volume Label information is written to the disk.

3. INPUT SLAVE STATUS

The Master CPU commands a specified 'Slave' Work Station or Printer to send its current status to the CPU. The 4 status conditions are:

- a. Power On (PO) - Slave power on or off.
- b. Memory Parity Error (MPE) - A parity error occurred in the Slave's memory.
- c. Channel Parity Error (CPE) - The slave data channel logic detected a parity error on one or more of the previously received characters.
- d. Initial Program Load State (IPL) - The slave device has been powered on but is not running because it:
  1. is waiting for an "IPL" from the Master.
  2. is waiting on a RESTART command from the Master.
  3. has had a hard failure.

## 4. SLAVE RESTART

The Master CPU commands a specified 'Slave' Work Station or Printer to do a 'Restart' due to a reported error from that unit or because that unit was just powered up.

## 5. ONE-BYTE WRITE

The Master CPU sends a 1 Byte Function Code, Slave Code, Drive Status or Function Release to a specific address in the selected slave's memory.

## 6. ONE-BYTE READ

The Master CPU commands a Slave to send it a One Byte Function code, Data Address (2 Bytes), or Slave Code from a specified address in that Slave's memory.

## 7. BLOCK WRITE TO SLAVE

A 256 Byte Sector is read from a Disk sector specified by the CPU and written to a specified page of a selected Slave Memory under Master CPU control.

## 8. BLOCK READ FROM SLAVE

A 256 Byte 'Page' is read from a selected Slave Memory and written to a specified disk sector under Master CPU control.

### 8.5 AUTOMATIC STATUS OPERATION (ASOP)

The OIS 140/145 System data link expands on the basic slave protocol by performing an Automatic Status Operation (ASOP) after each transfer operation except for the STATUS transfer command. The ASOP automatic slave STATUS read always reflects the slave's evaluation of the last transfer command. This relieves the Master software of the task of queuing a STATUS request following each command while other requests for the data link are backed up.

In addition, the received slave status error type bits are OR'ed together and presented in the master status word allowing the controlling software to see the result of each transfer as seen at both ends of the cable, by just examining one location.

## 8.6 THE DATA LINK CONTROLLER

The DATA LINK CONTROL board (210-7503) combined with the DATA BUFFER board (210-7504) provide the interface between the Master CPU and all peripheral devices. Together the two boards are referred to as the CHANNEL SERIAL DATA LINK (CSDL). The CSDL logic can be divided into five functional blocks, one of which is the 7504 DATA BUFFER. The other four blocks, located on the DATA LINK CONTROL board, are:

1. Master CPU (MCPU) command and Status interface
2. Slave channel selection logic
3. Serial data transmitting and receiving logic
4. Line protocol command transmission and timing logic

The DATA LINK CONTROL board provides the communication interface between the Master CPU and slave devices such as workstations and printers. It interprets and executes CPU MMI/O commands to control the flow and direction of communications between the master and its slaves. In addition, it resolves conflicting line use requests and provides the necessary control signals to the DATA BUFFER board.

The 7504 DATA BUFFER board serves as an intermediate storage area for data transfers between Master Memory and slave devices. It contains 256 bytes of Static RAM FIFO in addition to a 32 channel coaxial transmitter/receiver section. The data transfer is set up by a few commands from the CPU to the DATA LINK CONTROL board and one of the Disk Drive Controller boards. Then the hardware on the respective boards execute the transfer, leaving the CPU free to perform other tasks as needed. Four different types of data transfer involve the Data Buffer board. They are:

1. Block Read from Slave
2. Block Write to Slave
3. Disk Read from Master Memory (DMA READ)
4. Disk Write to Master Memory (DMA WRITE)

The DATA BUFFER board services a maximum of 32 lines, 24 of which may be CRT workstations. Each line (or channel) is a coaxial cable pair that can be up to 2000 feet long. The 32 channels are labeled CH01 through CH32 with CH00 (Channel Zero) being reserved for Master Memory. The CSDL logic remains in the transmit state except when actually receiving data from a selected slave. All slaves remain in the receive state except when individually selected and commanded by the master to transmit.

The CSDL logic (DATA BUFFER plus DATA LINK CONTROL board) is the only controller capable of executing a DMA block transfer. A DMA block is 256 bytes of data to be transferred between Master Memory and the DATA BUFFER (in either direction). The DMA transfer is initiated by the Z80A CPU when it issues a string of MMI/O commands to the DATA LINK CONTROL board. This board decodes these commands into either a Block Read from Master Memory, or a Block Write to Master Memory. The DATA LINK CONTROL board then generates a CBUSREQ signal which causes the Z80A on the CPU/MEM board

to enter a WAIT state. In addition, the CPU Address, Data, and Control Busses are tri-stated so that the DMA transfer logic can use the busses to access Master Memory. The DATA LINK CONTROLLER then provides the proper address and control signals to execute the transfer.

## 8.7 THE DISK DRIVE CONTROLLERS

The 7502 TEN MEG/FLOPPY DISK CONTROLLER interfaces the OIS Master to a 300 kilobyte Shugart type Floppy Diskette drive and one or two 10 Megabyte HAWK hard disk drives. The 7505/7506 SMD DISK CONTROLLER interfaces the OIS Master to up to four CMD or SMD hard disk drives, in any combination. The CMD/SMD drives range from 26.8 to 275 Megabyte capacity and are generally used to store the system operating software as well as all active document files. The floppy diskette drive is used for archiving and for loading diagnostics and operating software into the system.

All disk operations are controlled by a series of MMI/O commands issued by the MCPU and all the data transfers occur in 256 byte blocks between the DATA BUFFER and the particular disk controller. When writing to a disk, a disk controller converts the parallel data from the DATA BUFFER to serial data for transfer to the disk drive. Similarly, when reading from a disk, the controller will convert the serial data obtained into parallel data to be supplied to the DATA BUFFER.

### 8.7.1 THE SMD CONTROLLER

The 7505/7506 SMD CONTROLLER serves as an interpreter between the MCPU and the disk drive. It consists of two boards, SMD CONTROLLER BOARD "A" (210-7505), and SMD CONTROLLER BOARD "B" (210-7506). A maximum of four disk drives in any combination of SMD's and CMD's may be operated through these boards. The 7505/7506 SMD CONTROLLER contains the electronics necessary to position, read, and write the disk in a format suitable for the system operating software.

Figure 8-2 presents a simplified block diagram of the 7505/7506 SMD CONTROLLER. There are four major functional interfaces to this controller. The "A" Cable Interface daisy chains to all connected drives and handles command/status information between the controller and the drives. Under control of the 7505 board, it provides the signals necessary to select and address one out of several thousand sectors available on each drive. The "B" Cable Interface handles the read data, write data, synchronizing clocks, and format information for each disk drive up to a maximum of four. The Data Buffer Interface extracts parallel data from the DATA BUFFER during disk writes, and loads parallel data into the DATA BUFFER during disk reads. Lastly, the Master CPU Interface allows the CPU to check drive and controller status and diagnose errors and faults through MMI/O commands. The collection of logic blocks between the four interface blocks converts parallel data to serial and serial to parallel at a 9.67 MHz serial rate. It also generates and checks a 35 bit error check character, performs header writing and checking, write check/read compare tests, and other functions necessary to position and control the disk drives.

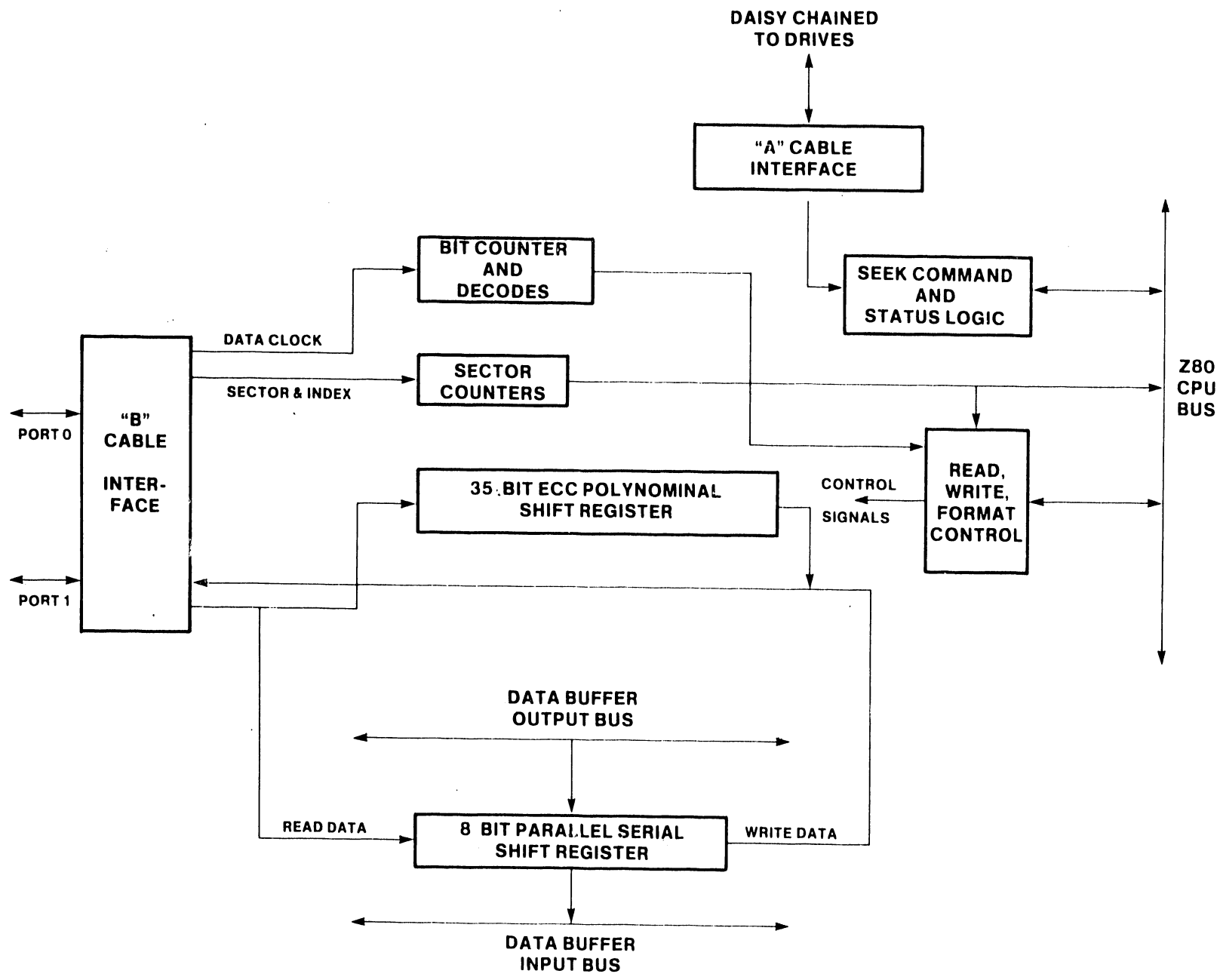

FIGURE 8-2 7505/7506 SMD CONTROLLER SIMPLIFIED BLOCK DIAGRAM

8-8

### 8.7.2 THE 10 MEG/FLOPPY CONTROLLER

The 10-Megabyte (Hard Disk Drive) and Floppy disk controller board 7502 is the interface between the MCPU and the selected disk drive (Floppy or 10 Megabyte/Hard Disk drives). Both the Floppy and Hard Disk Drives are controlled by a series of Memory Mapped Input/Output (MMI/O) commands issued by the MCPU which permits the selected disk to read or write data to or from any selected bank of memory. The data transfers are always via the Processor Communication Channel (DMA). The commands for both the floppy and hard disk drives are general enough to permit both types of drives to operate with the 7502 controller.

The operating commands controlled by the disk controller and performed by the disk drives are the "READ", "WRITE" and "FORMAT" operations. The Read and Write operations are 256-byte transfers from a selected disk to a selected slave or master memory bank or from a selected slave or master memory bank to a selected disk. The Format is an operation that prepares the disk by loading the preamble and identifying each sector with the Header bytes for a specific Track and Sector address for the controller to identify.

The time required to transfer data internally to or from the disk drives depends on the type of disk drive selected. The Hard disk can Read and Write data at ten times the rate of the Floppy drive. This situation requires the controller to be capable of processing the data at a higher rate. The A and B clock generator is designed to operate at these two rates; generating clocks that will fill the requirements.

The 10 Meg/Floppy controller board is addressed as DEVICE TYPE 01 and will use PROM Memory Mapped I/O addresses 0C40<sub>H</sub> to 0C7F<sub>H</sub> for operating commands. The controller board will always be attached to a Floppy drive. In addition the controller will support a maximum of two 10-megabyte CDC HAWK (Model 6560) disk drives.

### 8.7.3 FLOPPY DISK FORMAT

The single floppy disk has 77 tracks (cylinders) and each track is divided into 32 equal sector marks. The present specifications require a sector to be 256 data bytes long, therefore, it was necessary to use two sector marks for each 256-byte formatted sector. Each track is divided then into 16 sectors allowing a time of 10.42 ms for each sector to be written into or read from. The following diagram illustrates the sector organization.

FLOPPY DISK SECTOR FORMAT

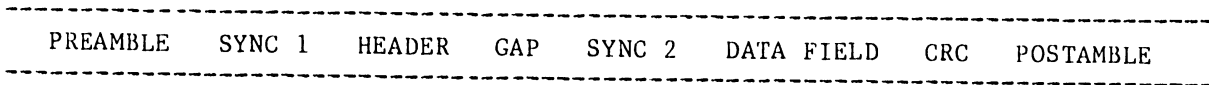

PREAMBLE

This field is created during a format operation. It starts at the leading edge of the sector mark and consists of 20 bytes. The first nineteen bytes are 0 (all clock bits), the first 6 bits of the twentieth byte are 0 and the last two bits are two ones '11'.

This field is used to switch the head to read the SYNC 1 character during WRITE, READ and READ/VERIFY operations.

SYNC 1

This field is contained in the PREAMBLE. It consists of two bits (11). The interface detects a (11) and prepares to read the header.

HEADER

This section contains information identifying the sector as track and actual sector address (one byte each). It is created as a result of the FORMAT command. It is read and compared for WRITE and READ operations.

The following diagram describes the 16 bits of the header:

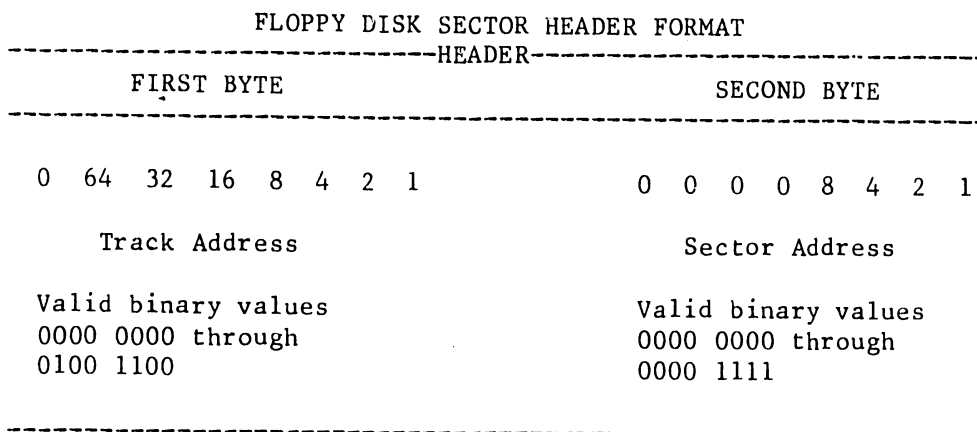

GAP

The gap is composed of all clock bits (zeros) but for the last two bits which are '11'. This field serves as a preamble to the data field. The gap is used as a delay for header comparison time and allow for switching of the heads in the case of a write command.

SYNC 2

The SYNC 2 character is the last 2 bits of the GAP (11). These bits are created during a Write operation. For Read operation, these bits designate the start of the data field.

## DATA FIELD

This field contains 256 bytes of data.

## CRC

(Cyclic Redundancy Check) - This check is a two byte character created from the SYNC 2 character and the 256 bytes of the data field.

## POSTAMBLE

This section is composed of all clock (zero) bits.

## DISKETTE SECTOR TIMING AND SIZE

FIELD	LENGTH	APPROXIMATE BYTES
PREAMBLE & SYNC 1	640us	20
HEADER 1	32us	1
HEADER 2	32us	1
GAP & SYNC 2	640us	20
DATA FIELD	8192us	256
CRC 1	32us	1
CRC 2	32us	1
POSTAMBLE	820us	25
TOTAL	10420us	325



**APPENDIX**

**A**

**MASTER**

**DIAG-**

**NOSTICS**

**MONITOR**

APPENDIX AMASTER DIAGNOSTICS MONITORA.1 INTRODUCTION

This appendix presents a quick reference guide for the software-related tasks required to perform the OIS-140/145 Master Diagnostics Monitor package.

General use of these diagnostic test programs at the field level is anticipated for situations where the PROM-based Power-Up Diagnostics fail to identify/isolate a board/assembly failure; this is especially true in the case of a suspected intermittent failure.

In addition, these diagnostic test programs can be used for confidence testing, quickly establishing that all device components operate properly.

## -----NOTE-----

The information contained within this appendix is based on Release 2242 of the Master Monitor. Later releases may contain changes that are not reflected here. Refer to the documentation accompanying the monitor package for complete detailed instructions and error code interpretation.

A.2 GENERAL DESCRIPTION

This package is completely contained on a single floppy diskette. In addition to the monitor, the following diagnostic test programs are supplied on the diskette:

MASTER LOWER RAM TEST	Z80 INSTRUCTION TEST
MASTER UPPER RAM TEST	FIELD TEST UNIT SIMULATOR
MASTER DATA LINK	SLAVE DATA LINK EXERCISER
10-MEG DISK CONTROL	I/D MODE EXERCISER
SLAVE LOWER RAM TEST	WINCHESTER CONTROLLER
CMD/SMD DISK CONTROL	

Once the Master Diagnostic Monitor diskette is IPLed via the Master Processor floppy diskette drive, the operator can select, execute, control, and monitor desired combinations of the test programs listed above.

Operation of the diagnostic test programs on this diskette requires, as a minimum, that the following equipment be on-line.

- \* The Master Processor
- \* One operable (32k or greater) workstation (to be used as the Test Display Console (TDC)).
- \* One other serial device.

A.3 MASTER MONITOR COMMANDSA.3.1 OVERVIEW

The diagnostic test programs are selected at the PROGRAM SELECTION MENU (see A.4.3). Testing begins with an EXECUTE command causing the selected diagnostic programs to run automatically in the order listed on the PROGRAM SELECTION MENU. This test sequence repeats automatically until the operator ends the test cycle.

The Stop On Error function (automatically enabled after EXECUTE) will cause the program sequence to halt on the first error detected.

During testing, the test program and the test routine in progress and other data are presented on the current RUN-TIME MENU.

Testing can be controlled via TDC key entries at anytime during run-time operation. The following types of test control are provided:

<u>PROGRAM FUNCTION</u>	<u>FUNCTION KEY</u>
Pause	FORMAT
Loop on program	DECTAB
Loop on routine	PAGE
Stop on error	CENTER
Loop on error	INDENT
Loop on next error	MERGE
Display Error Log	COMMAND
Clear all settings	STOP

The test program in progress is ended with the CANCEL command. CANCEL also ends the test sequence and causes the PROGRAM SELECT MENU to be re-displayed after a short delay.

### A.3.2 PROGRAM SELECTION MENU FUNCTIONS

The uses of the individual diagnostic test programs are described below:

1. MASTER LOWER RAM - Tests Master Memory including data and address busses, and parity circuitry. Both Addressing and data faults are detected. The memory that is not occupied by the monitor and this diagnostic will be tested. The Lower Ram diagnostic tests memory locations 1000 to 8FFF.
2. MASTER UPPER RAM - Used to check master memory address and data functions, as well as parity circuitry. This program should be selected whenever one of the MASTER DATA LINK test programs is selected. The Upper Ram diagnostic tests memory locations 6000 to FFFF.
3. MASTER DATA LINK - Used to check the performance of the Data Link Controller and Data Buffer boards (7503 and 7504). Also included are tests of the channel select logic and all channel drivers to on-line devices.
4. 10-MEG/FLOPPY DISK CONTROL - This diagnostic locates faults in the 10-MEG/Floppy Controller board (7502) and the HAWK Disk Drive(s).

----- NOTE -----  
 This diagnostic does not perform a comprehensive media test.  
 -----

5. SLAVE LOWER RAM - Used to isolate faults in the data link and/or lower 12k of RAM of an on-line device.
6. CMD/SMD DISK CONTROL - Used to check SMD/CMD Controller and attached SMD/CMD disk drives.

----- NOTE -----  
 This diagnostic does not perform a comprehensive media test.  
 -----

7. Z80 INSTRUCTION SET - Used to verify the correct execution of all Z-80 CPU chip instructions on the Master CPU board.
8. FIELD TEST UNIT SIMULATOR - This program is not a diagnostic, but will display an error message on the occurrence of a disk drive error. This program is used to simulate the Hardware Field Test Unit; thus, allowing disk drive alignment and adjustments to be performed.
9. SLAVE DATA LINK EXERCISER - Designed to test Slave Data Link functions including Status, Restart, Byte Read, Byte Write, Block Read, and Block Write. The lower 12K of slave memory is tested for data faults, and all of the slave memory can be tested for addressing faults. Addressing of both the slave CPU and the Slave Data Link is tested.
10. WINCHESTER DISK CONTROLLER - This program is only used to test OIS 105/115 systems. It verifies the correct operation of the two Winchester Controller boards in these systems, and the attached Winchester drive.

----- NOTE -----  
 This diagnostic does not perform a comprehensive media test.  
 -----

-----NOTE-----

Along with the programs on the preceding page, ten additional programs are made available when running on an expanded memory master. These ten programs are identical to the ten listed on the preceding page, except that they run in the second 64K of master memory, known as D space (D Sp). The ten on the preceding page run in the first 64K of memory, known as I space.

The D space programs are listed below:

11. MASTER LOWER RAM - D SPACE
12. MASTER UPPER RAM - D SPACE
13. MASTER DATA LINK - D SPACE
14. 10 MEG/FLOPPY DISK CONTROL - D SPACE
15. SLAVE LOWER RAM - D SPACE
16. SMD/CMD DISK CONTROLLER - D SPACE
17. Z80 INSTRUCTION TEST - D SPACE
18. FTU SIMULATOR - D SPACE
19. SLAVE DATA LINK EXERCISER - D SPACE
20. WINCHESTER CONTROLLER - D SPACE

One more program exists to test the operation of the Extended Memory Master. Its description follows:

21. I/D MODE EXERCISER - Used only with OIS Expanded Memory Master, this diagnostic tests the 7684/7685 128K CPU/MEMORY boards, specifically the circuitry responsible for I/D mode functions. This includes total verification of 2K of firmware located on the 7685 board.
-

### A.3.3 RUN-TIME CONTROLS

These commands are entered in the form of single-key entries to configure testing.

1. Pause (FORMAT) - Press FORMAT to interrupt the diagnostic program in progress. If the Monitor is between programs when FORMAT is keyed, the next program will come up in the Pause state. A second FORMAT key closure will restart the program from the interruption point.
2. Loop On Program (DECTAB) - DECTAB causes the diagnostic program in progress to be repeated continuously until the next DECTAB key closure. The number of loops performed is recorded by the Program Loop Counter. This counter is reset when the loop is exited.
3. Loop On Routine (PAGE) - PAGE causes the diagnostic program routine in progress to be repeated continuously until the next PAGE key closure. The number of loops performed is recorded by the Routine Loop Counter. This counter is reset when the loop is exited.
4. Stop On Error (CENTER) - CENTER causes the diagnostic program to stop when a hardware failure is detected. Testing is resumed when CENTER is re-keyed, and will not stop again on any subsequent failures (unless CENTER is selected again).
5. Loop On Error (INDENT) - INDENT causes a segment of the test routine in progress to loop when a hardware failure is detected. The segment repeated consists of all test routine code necessary to generate, detect, and report the error.

Non-intermittent errors are reported at a constant rate. If the error is intermittent, any remaining test routine code following the point of termination is performed, then the test routine begins again. Thus, the entire test routine is executed repeatedly until an error is detected (causing segment looping) or until the error loop is deselected with an INDENT key closure.

Deselection causes the diagnostic program:

- A. to continue from the interruption point, and
  - B. to not loop on any subsequent failure (until INDENT is selected again), and
  - C. to clear the Error Loop Counter.
6. Scope Loop (MERGE) - MERGE causes the same response as Loop On Error except that error reporting is disabled after the first error is detected. This feature is convenient when the error is to be traced with an oscilloscope as the time required to format and display error information may be very long compared to the time required to generate and test for the error.
  7. Clear All Settings (STOP) - Press STOP to reset all diagnostic control commands currently set (e.g., stop looping if looping, or resume testing if halted).
  8. Error Log (COMMAND) - COMMAND causes the error log to be displayed on the TDC screen in place of the Run-Time menu. The error log screen shows the most recent errors, up to the time when the command is invoked. See section A.3.5 for more details.

A.3.4 CURRENT TEST DESCRIPTOR MESSAGES

In addition to the RUN-TIME control commands described in A.3.3, the RUN-TIME MENU displays the following user prompts and messages

PROGRAM = Name of test program currently in progress.

TEST(RTN) = Name of test routine currently in progress.

ERROR CODE = Identifies the last hardware failure. (See Sect. A.5.)

ERROR COUNT = A cumulative count (decimal) of detected errors since returning to the PROGRAM SELECTION MENU or IPLing.

PROGRAM STATUS = Status of the current test program (Test in Progress, Program Pause, Stop On Error, etc.).

PROGRAM LOOP COUNT = The number of consecutive loops (decimal) which have occurred during a current Loop On Program function.

PROGRAM SET LOOP COUNT = A cumulative count (decimal) of the loops made through the selected program(s) set since returning to the PROGRAM SELECTION MENU or IPLing.

ROUTINE LOOP COUNT= The number of consecutive loops (decimal) which have been made during a current Loop On Routine function.

ERROR MESSAGES = English language descriptions and commands associated with the test routine currently in progress.

For details concerning error messages and user prompts see the individual diagnostic programs described in Section A.5.





A.4 DISKETTE LOAD/UNLOAD PROCEDURES

A.4.1 DISKETTE LOAD PROCEDURE

1. Position the Master Processor DISK-SELECT switch to "-" (up = floppy drive).
2. Insert the Master Diagnostic Monitor diskette into the Master Processor floppy drive.

----- CAUTION -----

Leave the diagnostic diskette in the drive for the entire test duration.

-----

3. Press the Master Processor RESET switch.

----- NOTE -----

At this time the PROM-based Power-Up Diagnostics are performed, and are followed by Monitor status checks of the system's devices and an initial Monitor test of each device's memory.

-----

4. To terminate a test program at any time, press CANCEL and do the A.4.2 Diagnostic Diskette Removal procedure.

A.4.2 DISKETTE REMOVAL PROCEDURE

Perform the following steps to discontinue testing and to enable normal system operation conditions:

1. Once testing is completed, set the Master Processor DISK-SELECT switch to the desired position.
2. Press and hold the Master Processor RESET pushbutton until the Master Diagnostic Monitor diskette is removed from the floppy drive.
3. The Master Diagnostic Monitor is now completed.
4. Return the system to desired operating conditions.

### A.4.3 PROGRAM SELECT MENU

With this screen displayed perform the following steps for program selection:

1. Select the diagnostic program(s) to be run by positioning the cursor (using the spacebar= down, backspace = up, or the North/South arrows) and selecting/deselecting using the INSERT/DELETE keys.
2. With the desired program(s) selected, press EXECUTE.
3. The next screen displayed will indicate the first program selected (see the PROGRAM = prompt on the TDC display).

----- NOTE -----

The CENTER = STOP ON ERROR test command is selected by default upon entering the first test program and remains in force until the first error is detected or the CENTER command is reset. Thus, program execution is automatically halted at the detection of the first error unless this function is reset.

4. Whenever end of testing is desired, press CANCEL to return to the PROGRAM SELECT MENU and then do the A.4.2 Diskette Removal procedure.

=====

140 MASTER RESIDENT DIAGNOSTIC MONITOR REV: X.X

POSITION CURSOR ON TEST YOU WANT SELECTED  
AND USE INSERT OR DELETE TO SELECT/DESELECT A TEST.  
USE EXECUTE TO START TESTS.

TEST NAME	TEST NAME
— MASTER UPPER RAM TST	REV. XXX
— MASTER DATA LINK	REV. XXX
— 10-MEG DISK CONTROL	REV. XXX
— SLAVE LOWER RAM TST	REV. XXX
— CMD/SMD DISK CONTROL	REV. XXX
— Z80 INSTRUCTION TST	REV. XXX
— SLAVE DATA LINK EX	REV. XXX
— FTU SIMULATOR	REV. XXX
— WINCHESTER CONTRL	REV. XXX

=====

----- NOTE -----

If an Extended Memory Master is being tested, the D-space counterparts of the above tests will appear as choices, along with the I/D Mode Exerciser, on the right side of the screen.

A.5 ERROR CODES

This section presents the diagnostic program error codes for detected faults for each of the pertinent OIS-140/145 diagnostic program routines. The error codes are presented as a two-character hexadecimal number. Error Codes for the following test programs are presented in this section:

<u>DIAGNOSTIC TEST</u>	<u>SECTION</u>
MASTER LOWER/UPPER RAM	A.5.1
MASTER DATA LINK	A.5.2
10 MEG DISK CONTROL	A.5.3
SLAVE LOWER RAM TEST	A.5.4
CMD/SMD DISK CONTROL	A.5.5
Z80 INSTRUCTION TEST	A.5.6
SLAVE DATA LINK EXERCISER	A.5.7
I/D MODE EXERCISER	A.5.8

## -----NOTE-----

For systems employing Extended Memory, error code interpretation is the same whether the diagnostic is running in I space or D space.

### A.5.1 MASTER UPPER/LOWER RAM

The following information is intended as a guide in interpreting and making use of the error messages for the MASTER UPPER and MASTER LOWER RAM Diagnostics. The suggested repair actions provided are meant for use in burn-in or at a customers site, not for board repair.

It is more economical to repair a unit by replacing a faulty memory chip than to replace the entire memory board. In cases where it is likely that the fault is with a single memory chip, enough information will be supplied to isolate that chip. In some cases it should be replaced, in others it should be checked for proper insertion (no bent pins that fail to make contact with socket).

All error messages with the exception of parity errors will begin in this form:

(type of error) at (loc.)  
 Rec. data = xx Exp. data = yy Xor data = zz

The important details of this message are the (loc.), the address at which the fault was detected, and the Xor data, which represents the discrepancy between the received and expected data, i.e. the failing chip. From the address received in the message, the operator must determine which bank of memory chips contains the fault. To aid in this task, a table of address boundaries has been provided.

<u>Bank #</u>	<u>Address Range</u>
0	1000-4FFF
1	5000-8FFF
2	9000-CFFF
3	D000-FFFF

-----NOTE-----

With Extended Memory systems, the operator should note whether the Master Upper/Lower RAM test is running in I-space or D-space. If in I-space, the faulty chip is located on the 7684A CPU motherboard; if in D-space, the chip is located on the 7685A daughterboard.

-----

Once the bank has been located, the failing chip must be identified. This is accomplished with the Xor data. If in the case of a 1-bit data error, where we wrote 'FF' to a location and read back '7F', the Xor data would equal '80' hex. This indicates that the failing chip is at bit D07, which can usually be located through markings on the PC board.

In the case of addressing errors, the failing address line or lines are identified in hex., along with what the problem appears to be, two shorted address lines, an address line stuck high or low, or an open address line. In many cases these faults cannot be repaired by replacing a single memory chip. The one exception to this is the open address line. The open address line looks just like a stuck address lines except that the Xor data contains only one bit, i.e. only one chip is being affected.

As mentioned before, parity errors do not follow this message format. The message form for parity errors will be:

Parity error occurred while testing memory from X000 to XFFF.

Note: In reference to the following table, the first error message received is always the most important one.

ERROR CODE	ERROR TYPE	SUGGESTED FIELD REPAIR
01	Data error	Replace memory chip(s) Replace memory board
02	Addressing error	For address shorts or stucks, replace memory board. For open address lines, and parity chip open address lines, check for faulty chip insertion, try replacing chip.
04	Parity error	Replace parity chip in appropriate bank.
05	Bank address error	If the Xor data = FF, the problem is affecting the entire bank, replace CPU bd. If the Xor is not FF, it might be the memory board, try replacing chips.
06	Parity chip open address line	Check parity chip of bank specified for proper insertion, try replacing it.
07	Parity	
08	generator	
09	errors	Replace CPU board.

A.5.2 MASTER DATA LINK

The error codes for the MASTER DATA LINK Diagnostic are listed below:

TEST	SCREEN NAME	ERROR CODE	FAILING MODULE
11	D-LINK R/W TEST	01,02,03,04	7503
12	OCDO IF AND DIAG	05,06	7503
13	OCCE/OCC1 LGO CHK	07	7503
14	OCDO BLK BSY CHK	08,09,0A,0B	7503, 7504
15	OCCE MSTR AND LGO	07,16,17 18,19	7503, 7504
16	OCCO VLDST TCG CMDT	12,13	7503, 7504
17	OCCE STXD STATUS BIT, BIT 7	14,15	7503, 7504
18	NDTO PULSE WIDTH	0D	7503, 7504
19	DLNB INTERRUPT	0C,29	7503
1A	OCCO OP COMP CHK	0F,10,11	7503, 7504
1B	DIAG MODE CMND	1A, 1B	7503
1C	DIAG MODE ADRS	1C	7503
1D/ 1E	DIAG MODE BLK XFER (1D), DIAG MODE XFER BAD PARITY (1E)	20,21,22 23,24,25 26,27,28	7503, 7504
1F	DIAG MODE BOSS	1D,1E,1F	7503,7504
20	MSTR-D BUFF TEST	2A,2B,36 37,38,39 3A,3B,3C,3D	7503, 7504
21	D-BUFF ADR TEST	38,39,3F,3F	7503, 7504
22	D-BUFF DATA TEST	38,39,40,41	7503, 7504
23	D-BUFF PARITY TEST	38,39,42	7503, 7504

TEST	SCREEN NAME	ERROR CODE	FAILING MODULE
24	RST: BK RD/WT TST	3D,44,45,46 47,48,49,50	7503, 7504
25	BK RD/WT	4A,4B,4C, 4D,4E	7503, 7504
26	BK RD/WT LOGIC	4A,4C,4D,4F	7503, 7504
27	BK ADR LOGIC	4A,4C,4D,4F	7503, 7504
28	SELCT LOGIC TEST	4A,4C,4D, 4F,51,56	7503, 7504
29	SELCT MUX TEST	38,39,52, 53,54,55	7503, 7504
2A	BYT NDTO BIT TST	57,58	7503, 7504
2B	BYTE READ TEST	4F,59,5A	7503, 7504
2C	BYTE WRITE TEST	4A,5B,5C	7503, 7504
2D	DATA XFER XRCISER	2D,56,59,5B, 5E,5F,60,61, 62,67,68,69	7503, 7504

A.5.3 10 MEG DISK CONTROLLER

The error codes for the 10-MEG DISK CONTROL Diagnostic are listed below:

TEST	SCREEN NAME	ERROR CODE	FAILING MODULE
00	STATIC REGISTER	01	7502
02	STATUS REG INTEG	01,02	7502
04	CONFIGURATION	00	7502
06	SECTOR REG. CHNG	01	7502, Drive
08	SECTOR REG. VAL.	01,02,04	7502, Drive
0A	ROT'L PERIOD	01,02	Drive Motor
0C	SECTOR PUL INTR	01,02,03	7502
0E	FIRST RESTORE	01,02,03, 04,05,06	7502, Drive
10	SEEK INTERRUPT	01,02,03, 04,05,06, 07,08,09	7502, Drive
12	CYLINDER ADRS	01,02,03, 04,05	7502, Drive
14	SEQ. FWD. SEEK	01,02,03,04, 05,06,07	7502, Drive
16	SEQ. BKD. SEEK	01,02,03, 04,05,08	7502, Drive
18	HEAD SELECT	01	7502, Drive
1A	READ DECODE	01,02,03, 04,05	7502
1C	FIRST READ	01,02,03	7502
1E	READ INTERRUPT	01,02	7502
20	FORMAT DECODE	01,02,03	7502
22	FIRST FORMAT	01,02,03	7502
24	FORMAT INTERRUPT	01	7502



TEST	SCREEN NAME	ERROR CODE	FAILING MODULE
26	HDR CHK ERR T1	01	7502
28	HDR CHK ERR T2	01	7502
2A	HDR CHK ERR T3	01	7502
2C	HEAD ADDRESSING	01,04 02,03	Drive 7502, Drive
2E	WRITE DECODE	01,02,03	7502
30	FIRST WRITE	01,02,03	7502
32	WRITE INTERRUPT	01	7502
34	WRITE ALL F'S	01	7502
36	WRITE ALL O'S	01	7502
38	WRITE INCR'L PAT	01	7502
3A	PARITY CHECK	01, 02	7502
3C	WRITE FLT O'S	01	7502
3E	WRITE FLT 1'S	01	7502
40	DB INP CTR CLR	01	7502
42	DB OUTPT CTR CLR	01	7502
44	CRC T1 (GOOD CRC)	01	7502
46	CRC T2 (BAD CRC)	01,02	7502
48	OVERLAPPING SEEKS	01,02,04	7502

A.5.4 SLAVE LOWER RAM TEST

The error codes for the SLAVE LOWER RAM are listed below:

TEST	SCREEN NAME	ERROR CODE	FAILING MODULE
01	GET SLAVE STATUS	01	7503 or device
02	SLAVE RESTART	02	coax
		04	coax
		05	coax or device
03	DATA BUS TEST	05	coax or device
04	PARITY GEN	06	7503, 7504, or device
05	BANK ADDRESS	0A	7503 or 7504
		08	7503 or 7504
06	ADDRESS BUS	08	7503 or 7504
		0B	7503 or 7504
07	ADRESS LINE	05	7503 or 7504
		07	7503 or 7504
08	DMA/CPU ADDRESS	05	7503 or 7504
		07	7503 or 7504
		08	7503 or 7504
09	MOVING INVRSN	05	7503 or 7504
0A	MEMORY PARITY	06	7503 or 7504
0B	BLOCK WT/BYTE RD	08	7503 or 7504
		09	7503 or 7504
0C	BLCK WT/BLCK RD	05	7503 or 7504
		09	7503 or 7504
0D	REFRESH TST	05	7503 or 7504
		09	7503 or 7504

A.5.5 CMD/SMD DISK CONTROLLER

The following table presents the complete set of error messages for the CMD/SMD DISK CONTROLLER diagnostic.

TEST	SCREEN NAME	ERROR CODES	FAILING MODULE
01	CUBSY TIMEOUT	1,2,4	7505
02	CONFIGURATION	1,2,7,8,9 4,5,6	7505 7506
04	CLEAR ERROR REG	1,2,5,7,9	7506, DRIVE
06	CNTRL UNIT INPT	4,01,02	7505
08	SEEK INTERRUPT	2,4,5,6,7,8	7505,DRIVE
0A	SEQ FWD SEEK	1,2,4,5,6,7,8	7505,7506 DRIVE
0C	SEQ BKWD SEEK	1,2,4,5,6,9,A,B	DRIVE
0E	SECTOR REG. CHANGE	1	7506, DRIVE
10	SECTOR REG. VAL.	1,2,4	7506, OR DRIVE SWITCHES SET WRONG
12	ROT'L PERIOD	1	DRIVE MOTOR
14	FIRST READ	4,5,6	
16	READ RESET	1,2	
18	TAG 3 (READ)	1,2,4,5 7,9,A 6	7505 7505, DRIVE
1A	SCTR ADFS/CMPRTR	1,2,4,5	7506
1C	READ CONTROL	1,2,4	7506
1E	OFFSET SIGNALS	1,2,4,5,6,7,8,9 A,B,C,D,E	7505
20	FIRST FORMAT	1,2	7506
22	FORMA SIGNALS	1,2,3,4,5 6,8,9,A	7505,7506, DRIVE 7506, DRIVE
24	HDR CHK PRP T1	1 2,4	7506 7505,7506, DRIVE

TEST	SCREEN NAMES	ERROR CODES	FAILING MODULE
26	HDR CHK PRR T2	1,2	7506
28	HRD CHK ERR T3	1,2	7506
2A	CONFIG/HEAD ADRS		
2C	FMT CYL, X'0336'	1	7506, DRIVE, PACK
2E	FIRST WRITE	1,2	
30	TAG 3 (WRITE)	1,2,4,5, 6,7,8,9,A	7505 7505, DRIVE
32	WRITE CONTROL	1,2,4	7506
34	READ END	1 2,4,5	7506
36	HDR CLK NOISE	1	7505
38	HEADER INTEGRITY	1	7505, DRIVE
3A	WRITE ALL F's	1,4 2	7506 7505,DRIVE,PACK
3C	WRITE ALL O's	1,4 2	7506 7506,DRIVE,PACK
3E	WRITE INCR'L PAT	1,4 2	7506 7506,DRIVE,PACK
40	PARITY CHECK	1,2	7506
42	WRITE-CHK F's	1 2,4	7505 7506
44	WRITE-CHK FLT O	1,2	7506
48	WRITE-CHK O's	7506 4	
4A	WRITE-CHK INCR'L	2	7506
4C	CLR MSK/ADR (WR)	1 2	7506 7505,7506
4E	CLR MSK/ADR (RD)	1 2	7506 7505,7506
50	DIAG RD FRC FCC	1,2,4,5	7505,7506

TEST	SCREEN NAMES	ERROR CODES	FAILING MODULE
52	ECC 1-BIT DETECT	1,2,4	7506
54	ECC ADRS CTR T1	1,2	7505
56	ECC ADRS CTR T2	1	7505
58	ECC ADRS CTR T3	1	7505
5A	ECC ADRS CTR T4	1,2	7505
5C	ECC ADRS FLT 1,0	1,2,4,5,6	7505,7506
5E	ECC MULT BIT ERR	1,2,4,5,6,7	7506,7505
60	DB INP CTR CLR	1	7506
62	DB OUTPT CTR CLR	1	7506
64	OVERLAPPING SEEK	1,2,4	DRIVE,7505

A.5.6 Z80 INSTRUCTION TEST

The following table describes a list of error codes for the Z80 CPU INSTRUCTION TEST Diagnostic. Each error code denotes a faulty 7501 CPU board.

ERROR CODE	DESCRIPTION
01	AND, OR, XOR COMMAND FAILURE
02	ACCUMULATOR FAILURE
04	8-BIT REGISTER FAILURE
05	RL RR COMMAND FAILURE
06	RLC RRC COMMAND FAILURE
07	SLA SRA COMMAND FAILURE
08	SRL COMMAND FAILURE
09	RLD RRD COMMAND FAILURE
0A	HL, BC, DE REGISTER FAILURE
0B	EX DE, HL OR EXX COMMAND FAILURE
0C	IX, IY, OR SP REGISTER FAILURE
0D	PUSH OR POP ERROR
0E	CCF OR SCF COMMAND FAILURE
0F	8-BIT ADC COMMAND FAILURE
10	16-BIT ADC COMMAND FAILURE
11	8-BIT ADD COMMAND FAILURE
12	16-BIT ADD COMMAND FAILURE
13	SUBTRACT CMD FAILURE
14	DAA COMMAND FAILURE
15	BIT TEST FAILING
16	RES CMD FAILURE
17	SET CMD FAILURE
18	CPI CMD FAILURE
19	CPD CMD FAILURE
1A	CPDR CMD FAILURE
1B	CPDR CMD FAILURE
1C	CPDR CMD FAILURE
1D	LDI CMD FAILURE
1E	LDD CND FAILURE
1F	LDIR CMD FAILURE
20	LDDR CMD FAILURE
21	CALL OR RET CMD FAILURE
	INDEXED ADDRESSING FAILURE

A.5.7 SLAVE DATA LINK EXERCISER

This section presents a list of error codes and a summary of the error messages reported in the SLAVE DATA LINK EXERCISER.

TEST	SCREEN NAME	ERROR CODE	DESCRIPTION
01	GET SLAVE STATUS	01	Bad Status Returns on Hardware Status Request.
		0D	Device Type Changing.
		0E	Intermittent NDT0 returned on -Hardware Status Request-.
		0F	No slave on line for -Hardware Status Request-.
02	SLAVE RESTART	02	Bad status Returned on -Slave Restart-.
		10	Bad Status Returned on -Byte Read-.
		11	Bad Status Returned on -Byte Write-.
		12	Restart is not executing the program loaded.
		13	Restart is working intermittently.
03	DATA BUS/PARITY	05	Data Error.
		06	Parity Error.
04	ADDRESS LINE	0B	Slave CPU addressing Error.
		11	Bad Status Returned on -Byte Write-.
		02	Bad status returned on -Slave Restart-.
		05	Data error.
		06	Parity error.
		11	Bad status returned on -Byte Write-.
		0B	Slave CPU addressing error.
05	BYTE LOW ADDRESS	02	Bad Status Returned on -Slave Restart-.
		05	Data Error.
		10	Bad Status Returned on -Byte Read-.
		11	Bad Status Returned on -Byte Write-.
06	BYTE HIGH ADDRESS	02	Bad Status Returned on -Slave Restart-.
		05	Data Error.
		10	Bad Status Returned on -Byte Read-.
		11	Bad Status Returned on -Byte Write-.
07	DMA/CPU ADDRESS TEST	05	Data Error.
		07	Slave CPU Address Lines and DMA Address line did not meet at location XXXX Bad Status Returned on -Byte Write-.
08	MOV-INVRSN/PARITY	05	Data Error.
		11	Bad Status Returned on -Byte Write-.
		10	Bad status returned on -Byte Read-.

TEST	SCREEN NAME	ERROR CODE	DESCRIPTION
09	BLOCK WRT/BYTE READ	05	Data Error.
		08	Bad Status returned on byte transfer.
		09	Bad Status returned on Block Transfer.
0B	BLOCK LOW ADDRESS	02	Bad Status returned on -Slave Restart-.
		11	Bad Status returned on -Byte Write-.
		18	Bad Status on Block Transfer to Data Buffer.
		19	Bad Status on Block Transfer from Data Buffer.
		1A	Data error on block transfer.
0C	BLOCK HIGH ADDRESS	02	Bad Status returned on -Slave Restart-.
		18	Bad Status on Block Transfer to Data Buffer.
		19	Bad Status on Block Transfer from Data Buffer.
		1A	Data Error on Block Transfer Operation.
0D	CPE Test	14	CPE bit not set after receiving bad parity byte.
		15	Slave did not terminate the data Xfer at the point of bad parity data.
		16	Data Error on Xfer of block with single byte of bad parity data: at byte XX.
		17	Data Error on Xfer of single byte of bad parity data; CPE failed to inhibit slave memory write at XX.
0E	Refresh Test	05	Data Error.
		09	Refresh Error while attempting to write a block of data to the slave.
		0A	Refresh Error while attempting to read a block of data from the slave.
0F	Power on Test	01	Bad status return on -Hardware Status Request-.
		1B	Power-on bit not set.
		1C	IPL bit not set.
		1D	CPE bit not reset.
		1E	MPE bit not reset.
		1F	Didn't receive bad parity from slave.
		11	Bad status return after -Byte Write-.
		0F	No slave on line.
		20	Could not detect bad parity. MPE bit not set.
21	Restart didn't reset slave bad parity.		



A.5.8 I/D MODE EXERCISER

Error codes for the I/D MODE EXERCISER used with expanded Memory CPU/MEM boards are presented in the two tables that follow. Replace the CPU/MEM board if failure is indicated.

ERROR CODE	DESCRIPTION
<u>I TO D DMA TEST</u>	
01	BAD DMA Transfer from I space page A0 to D space page B0
02	BAD DMA Transfer from D space page B0 to I space page C0
<u>NON MEMORY ACCESS INSTRUCTION</u>	
03	NMI DID NOT OCCUR AFTER OCOE.
04	JP (C3) INSTRUCTION DID NOT EXECUTE.
05	JP NZ (C2) EXECUTED WITH Z SET.
06	JP M (FA) EXECUTED WITH S SET.
07	JP C (DA) EXECUTED WITH C RESET.
08	JP Z (CA) NOT EXECUTED WITH Z SET.
09	JP P (F2) NOT EXECUTED WITH S SET.
0A	JP NC (D2) NOT EXECUTED WITH C RESET.
0B	JP Z (CA) EXECUTED WITH Z RESET.
0C	JP P (F2) EXECUTED WITH S RESET.
0D	JP NC (D2) EXECUTED WITH C SET.
0E	JP NZ (C2) NOT EXECUTED WITH Z RESET.
0F	JP M (FA) NOT EXECUTED WITH S RESET.
10	JP C (DA) NOT EXECUTED WITH C RESET.
11	JR (18) NO EXECUTED.
12	JP PO (E2) EXECUTED WITH P/V RESET.
13	JP PE (EA) NOT EXECUTED WITH P/V SET.
14	JP PE (EA) EXECUTED WITH P/V SET.
15	JP PO (E2) NOT EXECUTED WITH P/V RESET.
16	JR NZ (20) EXECUTED WITH Z SET.
17	JR Z (28) NOT EXECUTED WITH P/V RESET.
18	JR Z (28) EXECUTED WITH Z RESET.
19	JR NZ (20) NOT EXECUTED WITH Z RESET.
1A	JR NC EXECUTING WITH C SET
1B	JR C NOT EXECUTING WITH C SET
1C	JR C EXECUTING WITH C RESET
1D	JR NC NOT EXECUTING WITH C RESET
1E	DJNZ NOT EXECUTING CORRECTLY.
Note:	Z= Zero Flag C= Carry Flag S= Sign Flag P/V= Parity/Overflow Flag

---

CODE	FAILED INSTRUCTION	CODE	FAILED INSTRUCTION
------	--------------------	------	--------------------

---

MEMORY ACCESS INSTRUCTIONS

1F	PUSH AF	20	PUSH BC
21	PUSH DE	22	PUSH HL
23	PUSH IX	24	PUSH IY
25	JP (HL)	26	JP (IX)
27	JP (IY)	28	CALL NZ
29	CALL M	2A	CALL C
2B	CALL P	2C	CALL Z
2D	CALL NC	2E	CALL Z
2F	CALL P	30	CALL NC
31	CALL M	32	CALL NZ
35	CALL PE	36	CALL PE
37	CALL PO	38	LD (BC) ,A
39	LD (DE) ,A	3A	LD (HL) ,A
3B	LD (HL) ,B	3C	LD (HL) ,C
3D	LD (HL) ,D	3E	LD (HL) ,E
3F	LD (HL) ,H	40	LD (HL) ,L
41	LD (HL) ,NN	42	LD (IX) ,A
43	LD (IX) ,B	44	LD (IX) ,C
45	LD (IX) ,D	46	LD (IX) ,E
47	LD (IX) ,H	48	LD (IX) ,L
49	LD (IX) ,NN	4A	LD (IY) ,A
4B	LD (IY) ,B	4C	LD (IY) ,C
4D	LD (IY) ,D	4E	LD (IY) ,E
4F	LD (IY) ,H	50	LD (IY) ,L
51	LD (IY) ,NN	52	LD (NN) ,A
53	LD (NN) ,BC	54	LD (NN) ,DE
55	LD (NN) ,HL	56	LD (NN) ,IX
57	LD (NN) ,IY	58	LD (NN) ,SP
59	RETN	5A	RETI
5B	RET Z	5C	RET NZ
5D	RET C	5E	RET NC
5F	RET M	60	RET P
61	RET PE	62	RET PO

---

**APPENDIX**

**B**

**SYSTEM**

**ERROR**

**MESSAGES**

APPENDIX B  
SYSTEM ERROR MESSAGES

B.1 INTRODUCTION

The OIS Operating System presents error messages on the CRT in one of the following 4 types:

1. Screen Package DEBUG error messages. (Table B-1.)
2. Word Processing Error Handler messages. (Table B-2.)
3. Request Control Block (RCB) error messages. (Table B-3.)
4. Additional error and warning messages. (Table B-4.)

B.2 SCREEN PACKAGE DEBUG ERROR MESSAGES

----- NOTE -----  
At present, these error messages are being revised.  
-----

TABLE B-1. SCREEN PACKAGE DEBUG ERROR MESSAGES

ERROR CODE	MEANING
A	Message row invalid
B	Message column invalid
C	Message will not fit on the screen
D	Buffer data larger than display area
E	<u>Msgnr</u> * does not start with <u>stx</u> **
F	Invalid character in <u>msgnr</u> message
G	Invalid character in buffer area
H	Cannot load message module
I	Screen clear request invalid
J	Invalid Link Table
K	Invalid offset or choice pointer value
L	More than 16 error messages (stack overflow)
M	Invalid date mask

\* Message number

\*\* Start of message text flag

B.3 WORD PROCESSING ERROR HANDLER MESSAGES

Table B-2 explains the messages and suggested methods for recovery.

TABLE B-2. ERROR HANDLER MESSAGES

ERROR MESSAGE	MEANING
<b>File access conflict</b>	A workstation is tying up a file which is necessary to Word Processing. Since this may be only a momentary problem, first simply retry the whole operation from scratch. Request that all the workstations return to the main WP menu and retry the operation. If that fails, try entering SHIFT-CANCEL at each workstation. (If it is possible to isolate the workstation which is tying up the file, then it may be necessary to IPL only that workstation.) Only as a last resort should the Master Processor be IPLed.
<b>Master Processor overload</b>	This message indicates that there are too many files open. Try the same procedure indicated for a "File access conflict".
<b>Lock-out on shared files</b>	This is similar to "file access conflict". The same procedure is recommended.
<b>File not found on volume</b>	A file necessary to Word Processing is missing. If it is one which is copied to the WPS during installation, it may be possible to retrieve it from the Installation Disk. If it is a document, check to see if the volume for that library has been changed. Otherwise this should be considered a software error.
<b>Volume not found</b>	Word Processing is expecting a particular volume to be mounted, and cannot find it. (In most cases the volume name will be contained within the file name displayed.) Check all the drives to be sure that the correct volumes are mounted, then retry the operation.
<b>No disk in drive</b>	This indicates almost the same problem as above, although it refers to operations usually performed on floppy disks. Check all the drives to be sure that the disks are mounted properly.
<b>System residence volume space exhausted</b>	The "system" volume is full of files. Archiving documents from libraries found on the system volume will remedy this.

TABLE B-2 (continued). ERROR HANDLER MESSAGES

ERROR MESSAGE	MEANING
Volume space exhausted	This is the same problem as above, but the disk is not the "System" volume. If the volume is a floppy disk, it will be necessary to delete documents (files); otherwise the procedures described above are recommended.
Drive not ready	Ensure that all the drives are powered up properly.
Drive write protected	Check to see that the buttons on the front panel of the regular disk drives are not set to "write protect", and that the write-enabling tab is in place on any floppy disks being used.
Data transmission error	This indicates a true hardware error.
Disk format error	This could be either a software or a hardware error.
Equipment malfunction	This indicates a true hardware error.
Slave parity error	A parity error occurred when writing to the workstation memory. This is a hardware error.
Data link	A parity error occurred when writing to the workstation memory. This is a hardware error.
Parameter error	This is a programming error.
Drive dropped ready	Ensure that the disks are correctly powered-up and that the Fault light (on disk drive) is not on.
All others	Consider to be fatal errors.

B.4 REQUEST CONTROL BLOCK ERROR MESSAGES

If the error is so disabling that the Word Processing Error Handler cannot be invoked, then the following message format is displayed on the CRT screen.

```
----- NOTE -----
Copy the message before touching any key: touching any key
causes the message to be erased.
-----
```

```
Fatal I/O Error   RCB=(xxyy0000  00000000  00zz0000  00000000)  Press Any Key

      Request Code           Hardware Error Code if status code = X'08'.
                Status Code
```

The error message while in WP Mode has the form:

```
*** xx  *** yy zz, or      System error codes : xxyyzz
```

Explanations of these codes are presented in Tables B-3, 4, and 5.

TABLE B-3. REQUEST CODES

CODE xx	MEANING
00	OPEN--open file
01	READ--read sectors from a file
02	WRITE--write sectors to a file
03	CATALOG--change name of a file
04	CLOSE--terminates access to a file
05	OPEN CAT--provides scratch file containing information of a chosen subtree of a catalog
06	READ-LOCK--read lock sectors from a file opened with shared access
07	SET-EOF--reset the end of a file opened for read/write access
08	REOPEN--access to a file which is open may be changed without closing-read only-read/write-shared
09	OPEN-DC--open drive for direct control
0A	DIRECT I/O--enables slave to perform any physical operation on the disk*
0B	LOCK--locks sectors from a file open with shared access so a write operation can be performed*
0C	GET-FILE-NAME--allows sequential stepping through names of files on a volume
0D	FILE-LOCK--locks the entire file for exclusive use by the requesting slave*
0E	FILE-UNLOCK--unlocks the file from exclusive use*
0F	ASSIGN-PASSWORD--used to place/replace or remove passwords on nodes of the catalog
10	OPEN-DCS (Model 40 & XMM only)**--slave direct access to the memory of another slave as well as control of the slave

\* Receives no hardware I/O error

\*\* Model 40 includes OIS-105, OIS-115, OIS-125A, OIS-130A, OIS-140, and OIS-145. XMM refers to Extended Memory Master.

TABLE B-4. STATUS CODES

CODE yy	MEANING
01	Reference Number not valid, or Name node not found on volume.
02	Buffer not on page boundary, or Name string indicates a file-Access conflict, or Address drive is not available, or End of catalog.
03	File not open with write access, read/write access, shared access, or Volume not mounted, or No disk in drive, or Slave not open for direct control, or RN not for direct control disk, or Slave not available.
04	Invalid file segment specified (out of bounds), or Name string format error, or Insufficient space on volume to increase file size to that request, or Password string format error.
05	Lock-out (shared files only), or Tree structure error, or File not open for shared read/write access.
06	Segment not previously lock (shared file only), or Buffer not on page boundary, or Password incorerect or not provided.
07	Volume name is incorrect, or Master processor overloaded, or Invalid new password.
08	Permanent I/O error.
09	Invalid request option specified.
0A	Catalog damaged.
0B	VAU Map damaged.
0C	Insufficient space on volume to create file prologue sector.
0D*	System not found (WISE systems only).
0E*	File source connection broken (External File Source software option only).
80	Successful.
81	Successful, less than requested sectors read/written (System Residence Volume space exhausted, end-of-file encountered).

TABLE B-5. HARDWARE ERROR CODES

CODE zz	MEANING
01	Drive not ready
02	Drive is write protected
03	CRC or non-correctable ECC error
04	Format error/header error
05	Equipment malfunction error
06	Parity error (reading slave memory)
07	Data-link error (writing slave memory)
08	Programming error
09	Drive dropped power during operation
0A	Slave not available
0B	Slave dropped power during operation or Master Data Link error
0C	Write-check compare error (Model 40 & XMM only)**

\* Applies to Operation Systems 4.4, 5.1, or above.

\*\* Model 40 includes OIS-105, OIS-115, OIS-125A, OIS-130A, OIS-140, and OIS-145. XMM refers to Extended Memory Master.



B.5 ADDITIONAL ERROR AND WARNING MESSAGES

Table B-6 includes some of the ERROR and WARNING messages the operator will encounter during the DOS software implementation and operations contained in this document.

TABLE B-6. ADDITIONAL ERROR AND WARNING MESSAGES

ERROR MESSAGE	MEANING
Access Conflict, Input File	Displayed next to the file name if the file is in use during during a Copy Mode. These file names should be noted and the file copied later.
Answer all Questions	Before the system will accept the EXECUTE command, all fields on the menu must be completed.
Cannot Make Copy-- Insufficient Space	The Volume is full, delete files to continue.
Cannot Read Catalog File	The system cannot access the catalog file; the system disk is full. Archive or delete documents/files from the system.
Cannot Read Print Job File	The system cannot print the file because it has been deleted or it is in use.
Cannot Reserve Requested Drive	The drive is being accessed from another workstation and it is not available for mounting or dismounting a disk at this time.
Catalog Damaged	The system disk has been damaged and cannot be cataloged. Try Volume Recovery procedures through the Volume Utilities.
Could Not Cancel Active Job	The job is being processed at another device.
Disk I/O Error	Indicates a system error. Reset the system.
Drive is Not Available	Indicates that the drive is in use and cannot be accessed at this time.
Error Found When Opening Catalog	The Input Name String has been entered incorrectly. Reenter it, using the correct syntax.
Error Initializing Disk	Indicates a Format error, or a bad sector on the disk. Try the process again, if the same message appears, try another disk.

TABLE B-6 (continued). ADDITIONAL ERROR AND WARNING MESSAGES

ERROR MESSAGE	MEANING
<b>File Not Found</b>	The system has searched and has not found the named file on the Volume. Check to see that the name string has been entered correctly and that it's Volume is logically mounted.
<b>Invalid Character in Field</b>	Letters and Numbers Only Volume names, library names and passwords cannot contain any symbol other than uppercase letters, lower case letters or numbers 0-9.
<b>Invalid Key, Ignored</b>	A typographical error or illegal response has been entered. Reenter and press EXECUTE.
<b>Invalid Page</b>	The Print Thru Page number entered in the Print Document field does not exist in the document; this number cannot be higher than the last page of the document.
<b>Invalid Partial File Name</b>	The input name has been entered incorrectly. Check that it is in the correct DOS name string syntax and that it is a partial file name (volume and/or library only).
<b>Named Mode Not Found on Volume</b>	Indicates that the file has been deleted, the file name entered incorrectly, or the wrong volume has been accessed.
<b>Name String Format Error</b>	The name string has not been entered in the correct name string syntax: VOLUME1:DOCUMENT.A.12.34.
<b>No Disk in Drive</b>	The system does not recognize any volume at the designated address. Check to see if disk is mounted.
<b>Prototype Document</b>	This message means that the library prototype does not exist. It can be created using the Create Library Function.
<b>Password Error</b>	An error was made entering the password. Try again, or check that the Volume being requested is correct.
<b>Unable to Rename File</b>	Error in the Input Name String such as the wrong number of nodes or an illegal character.
<b>Volume Not Mounted</b>	Volume cannot be accessed until it is logically mounted. Mount the volume using the Volume Utility Mount/Dismount function.

**APPENDIX**

**C**

**SOFTWARE**

**INSTALLATION**

**PROCEDURES**

APPENDIX CSOFTWARE INSTALLATION PROCEDURESC.1 INTRODUCTION

This appendix presents a complete guide for the software-related tasks required to perform the OIS 140/145 Software Initialization (Section C.2) and the Post-Installation Software Updates Procedures (Section C.3) .

To properly utilize this appendix, address Section C.2 when performing system start-up during site installation.

Section C.3 provides the step-by-step procedures required to up-date or add on software to a previously installed system.

Further information on Software Loading and Operation is available in the OIS Supervisor Procedures Manual (700-5562C).

C.2 SOFTWARE INITIALIZATION AND INSTALLATION PROCEDURE

The procedures in Section C.2 provide a complete guide for performing software-related tasks during an initial installation of the OIS-140/145 systems. This section is divided into three areas:

C.2.1 System Disk Initialization (Screens 1 through 14)

C.2.2 System Configuration (Screens 15 through 18)

C.2.3 Software Installation (Screens 19 through 27)

----- NOTE -----

Software Installation is normally a Customer Support Analyst function. The procedure is provided here for cases where it has been determined that Customer Engineering should perform this task.

-----

C.2 SYSTEM DISK INITIALIZATION PROCEDURE

This procedure formats the system disk and loads the "STARTER" DOS system and "SYSTEM GENERATION" software packages.

C.2.1 SCREEN 1

1. Ensure that the switch settings on the CPU/MEM board conform to the configuration desired:  
    Position 3 of SW2 ON if BASIC is to be installed.  
    Position 4 of SW2 ON if the ALLIANCE software option is used.
2. Ensure that the switch settings on the 7506-board (SMD/CMD Controller "B") conform to the configuration desired (See section 3.12.1).
3. Perform the system Power-Up procedure described in section 3.6 of this manual.
4. Position the Master Processor DISK-SELECT switch to "-" (up=floppy drive).
5. Insert the STARTER diskette into the Master Processor diskette drive.
6. Press the Master Processor RESET pushbutton to access SCREEN 1.

```
=====
Unit XX                Office Information System                Type XXX
                   I N I T I A L P R O G R A M L O A D
                   Release X.X   System is "STARTER"

Enter Date and Time, Press EXECUTE

Enter Date:  mm/dd/yy:  __/__/__
Enter time:   hh:mm   :  __:__
=====
```

SCREEN 1

7. At the workstation, enter the Date on SCREEN 1 and press RETURN.
8. Enter the Time and press EXECUTE twice to access the next screen. (CANCEL would terminate this installation procedure.) After a short delay SCREEN 2 will appear on the Workstation CRT.

C.2.1 SCREEN 2

1. Select 'System Generation' (using the spacebar) at SCREEN 2.
2. Press EXECUTE to access SCREEN 3.

```
=====
| 02/18/81                               Office Information System          11:01:39
| Unit XX                               D I S K O P E R A T I N G S Y S T E M      Type XXX
|                                     Release X.X      System is "STARTER"
|
| Press EXECUTE to
| Select Indicated Choice
|
|      X System Generation           _ Control Functions
|
=====
```

SCREEN 2

C.2.1 SCREEN 3

```
=====
Office Information System - System Generation
SYSGEN FUNCTION SELECTION

Select Function and Disk Type
Press EXECUTE or CANCEL

      X Initialize System Disk           _ Hawk-5
      _ Update System software         _ Hawk-2
      _ Configure System                _ Winc-3
                                          _ Winc-4
                                          _ Winc-8
                                          _ Winc-20
                                          _ Winc-40
                                          _ CMD-32
                                          _ CMD-64
                                          X CMD-96
                                          _ SMD-80
                                          _ SMD-300
=====
```

SCREEN 3

1. Select 'Initialize System Disk' and press RETURN at SCREEN 3. Notice that the cursor moves to the right-hand column.

----- NOTE -----  
In step 2, select one of the following for OIS 140/145:

CMD-32 for OIS 140-1  
CMD-64 for OIS 140-2  
CMD-96 for OIS 140-3  
SMD-300 for OIS 145

2. Select the appropriate system disk drive (using the space bar) and press EXECUTE.

----- NOTE -----  
If this system has not been initialized previously, SCREEN 4 will appear on the CRT, proceed with C.2.1, SCREEN 4.  
If this system has been initialized previously, SCREEN 9 will appear; in this case, proceed with C.2.1, SCREEN 9.

## C.2.1 SCREEN 4

```

=====
Office Information System - System Generation
  I N I T I A L I Z E   S Y S T E M   D I S K

Fill in all fields
Press EXECUTE or CANCEL

Initialize xxxxxx Disk on Drive nn

Formatting is Required

New Volume Name: _____
New Password:   _____
New Sectors Per VAU: _____
=====

```

## SCREEN 4

1. For xxxxxxxx, the system will enter the name of the disk selected on the previous menu. For Disk on Drive nn, the system will enter the disk hardware address. (In this example xxxxxxxx = CMD-96, nn = 50.)\*\*
2. With SCREEN 4 on the CRT, Enter the volume name, up to eight alphanumeric characters. Press RETURN.
3. Enter a password in the appropriate field and press RETURN.

----- NOTE -----

In step 4, suggested VAU's (Volume Allocation Units) are as follows:

32 for CMD-32  
 32 for CMD-64  
 64 for CMD-96  
 64 for SMD-300

4. Fill in the appropriate New Sectors Per VAU.
5. Press EXECUTE and note that SCREEN 5 appears on the CRT.

\*\* NOTE: For drive addresses, i.e. nn = 50, the first digit is the value of the port setting on the 7506 board, and the second digit is the LAP (Logical Address Plug) number of the drive.



C.2.1 SCREEN 5

1. With SCREEN 5 displayed on the CRT, press EXECUTE. SCREEN 6 will appear on the CRT and Formatting will begin automatically.

=====  
Office Information System-System Generation  
I N I T I A L I Z E S Y S T E M D I S K

Press EXECUTE to  
\*\*\*BEGIN INITIALIZATION\*\*\*

Initialize CMD-96 Disk on Drive 50  
Formatting is Required

New Volume Name: VOL1

New Sectors Per VAU: 64

=====  
SCREEN 5

## C.2.1 SCREEN 6

1. SCREEN 6 (Formatting) will continue for anywhere from 10 to 105 minutes (depending on system model). This time will increase dramatically if retries are performed by the Disk Unit. At the conclusion of Formatting, SCREEN 7 will automatically appear.

----- NOTE -----  
 It's possible that at the end of Formatting, the CRT screen will display the following to indicate that bad sectors were found:

Disk Contains XX Bad Sector(s)  
 Press EXECUTE to continue

XX indicates the number of bad sectors. The sector(s) could have either a SOFT or a HARD (damaged surface) error. EXECUTE must be pressed at this time as an acknowledgement before the procedure may continue. With EXECUTE as an acknowledgement, the system will flag the bad sector(s); indicating that they are not to be used, insuring that they will not effect normal disk operation.

If the number of bad sectors exceeds 85, the following prompt will be displayed:

Too Many Bad Sectors, Unable to continue  
 please press cancel

The Initialization Procedure should then be canceled and the source of the problem located and repaired.

-----

=====  
 Office Information System-System Generation  
 I N I T I A L I Z E S Y S T E M D I S K

INITIALIZATION IN PROGRESS  
 (Formatting)

Initialize CMD-96 Disk on Drive 50  
 Formatting is Required

New Volume Name: VOL1

New Sectors Per VAU: 64

=====

SCREEN 6

C.2.1 SCREEN 7

1. When SCREEN 7 automatically replaces SCREEN 6 (after Formatting is complete), the word 'Formatting' will be sequentially replaced by 'Initializing Catalog', then 'Installing Master', and finally 'Installing Device Software'.

----- NOTE -----

All three operations combined will last approximately 2-1/2 minutes, after which SCREEN 8 will automatically replace SCREEN 7.

-----

Office Information System-System Generation  
I N I T I A L I Z E S Y S T E M D I S K

INITIALIZATION IN PROGRESS  
(Initializing Catalog) ...(Installing Master)  
...(Installing Device Software)

Initialize CMD-96 Disk on Drive 50  
Formatting is Required

New Volume Name: VOL1

New Sectors Per VAU: 64

=====

SCREEN 7

C.2.1 SCREEN 8

1. When SCREEN 8 appears, press CANCEL (SCREEN 15 will appear on the CRT). Continue by performing the C.2.2, System Configuration Procedure

```
=====
Office Information System-System Generation
I N I T I A L I Z E   S Y S T E M   D I S K
```

```
Initialization Complete
Please Press CANCEL
```

```
Initialize CMD-96 Disk on Drive 50
Formatting is Required
```

```
New Volume Name: VOL1
```

```
New Sectors Per VAU: 64
```

```
=====
SCREEN 8
```

C.2.1 SCREEN 9

----- NOTE -----

SCREEN 9 will appear if this system has been initialized in the past (e.g., at the factory), a password will have already been entered. Thus, the password is requested before the System Disk Initialization Procedure may continue. Manufacturing and shipping use the volume name 'VOL1' and the password (voll) when initializing system disks.

1. Enter the required password and press EXECUTE. SCREEN 10 will appear on the CRT.

=====  
Office Information System-System Generation  
I N I T I A L I Z E S Y S T E M D I S K

Press EXECUTE to Continue  
or CANCEL for Previous Menu

VOLUME "VOL1" on Drive 50

Password Required \_\_\_\_\_

=====  
SCREEN 9

## C.2.1 SCREEN 10

1. Since the disk has been previously initialized, the existing volume name, password, and sectors per VAU are displayed. These may be modified if so desired. Press RETURN until the cursor is positioned in the right hand field.

## ----- NOTE -----

Suggested sectors per VAU are as follows:

32 for CMD-32  
 32 for CMD-64  
 64 for CMD-96  
 64 for SMD-300

2. If during the previous step, the VAU size was modified, reformatting is required. Select Format and Initialize using the spacebar. If circumstances dictate, select 'Reinitialize' instead.
3. Press EXECUTE and note that SCREEN 11 appears on the CRT.

```
=====
Office Information System-System Generation
I N I T I A L I Z E   S Y S T E M   D I S K
=====
```

Fill in all fields  
 Press EXECUTE or CANCEL

Initialize CMD-96 Disk on Drive 50  
 Disk has Volume Name: VOL1

Initialization Operation

New Volume Name: VOL1

X Format and Initialize  
 \_ Reinitialize

New Password: voll

New Sectors Per VAU: 64

```
=====
SCREEN 10
=====
```

C.2.1 SCREEN 11

1. With SCREEN 11 displayed on the CRT, press EXECUTE. SCREEN 12 will appear on the CRT and Formatting will begin automatically.

```
=====
Office Information System-System Generation
  I N I T I A L I Z E   S Y S T E M   D I S K

Press EXECUTE to
***BEGIN INITIALIZATION***

Initialize CMD-96 Disk on Drive 50
Disk has Volume Name: VOL1

New Volume Name: VOL1

New Sectors Per VAU: 64

Initialization Operation
  X Format and Initialize
  _ Reinitialize
=====
```

SCREEN 11

## C.2.1 SCREEN 12

1. SCREEN 12 (Formatting) will continue for anywhere from 10 to 105 minutes (depending on system model). This time will increase dramatically if retries are performed by the Disk Unit. At the conclusion of Formatting, SCREEN 13 will automatically appear.

## ----- NOTE -----

It's possible that at the end of Formatting, the CRT screen will display the following to indicate that bad sectors were found:

Disk Contains XX Bad Sector(s)  
Press EXECUTE to continue

XX indicates the number of bad sectors. The sector(s) could have either a SOFT or a HARD (damaged surface) error. EXECUTE must be pressed at this time as an acknowledgement before the procedure may continue. With EXECUTE as an acknowledgement, the system will flag the bad sector(s); indicating that they are not to be used, insuring that they will not effect normal disk operation.

If the number of bad sectors exceeds 85, the following prompt will be displayed:

Too Many Bad Sectors, Unable to continue  
please press cancel

The Initialization Procedure should then be canceled and the source of the problem located and repaired.

Office Information System-System Generation  
I N I T I A L I Z E S Y S T E M D I S K

INITIALIZATION IN PROGRESS  
(Formatting)

Initialize CMD-96 Disk on Drive 50  
Disk has Volume Name: VOL1

New Volume Name: VOL1

Initialization Operation

Format and Initialize  
 Reinitialize

New Sectors Per VAU: 64

=====

SCREEN 12



C.2.1 SCREEN 13

1. When SCREEN 13 automatically replaces SCREEN 12 , the word 'Formatting' will be sequentially replaced by 'Initializing Catalog', then 'Installing Master', and finally 'Installing Device Software'.

----- NOTE -----

All three operations combined will last approximately 2-1/2 minutes, after which SCREEN 14 will automatically replace SCREEN 13.

-----

=====  
Office Information System-System Generation  
I N I T I A L I Z E S Y S T E M D I S K

INITIALIZATION IN PROGRESS  
(Initializing Catalog) ...(Installing Master)  
...(Installing Device Software)

Initialize CMD-96 Disk on Drive 50  
Disk has Volume Name: VOL1

Initialization Operation

New Volume Name: VOL1

Format and Initialize  
 Reinitialize

New Sectors Per VAU: 64

=====  
SCREEN 13

C.2.1 SCREEN 14

1. When SCREEN 14 appears, press CANCEL (SCREEN 15 will appear on the CRT). Continue by performing C.2.2, System Configuration Procedure

```
=====
Office Information System-System Generation
INITIALIZE SYSTEM DISK

Initialization Complete
Please Press CANCEL

Initialize CMD-96 Disk on Drive 50
Disk has Volume Name: VOL1

New Volume Name: VOL1

New Sectors Per VAU: 64

Initialization Operation
X Format and Initialize
_ Reinitialize
=====
```

SCREEN 14

C.2.2 SYSTEM CONFIGURATION PROCEDURE

This procedure enters system hardware configuration information onto the system disk.

C.2.2 SCREEN 15

1. With SCREEN 15 on the CRT as a result of completing the C.2.1, System Disk Initialization Procedure, select 'Configure System' using the spacebar and press RETURN.
2. Identify the appropriate system drive model (must be the same as the one selected in C.2.1, SCREEN 3 of the System Disk Initialization Procedure) using the spacebar and press EXECUTE. SCREEN 16 will appear on the CRT.

```
=====
Office Information System-System Generation
SYSGEN FUNCTION SELECTION

Select Function and Disk Type
Press EXECUTE or CANCEL

- Initialize System Disk
- Update System software
X Configure System

- Hawk-5
- Hawk-2
- Winc-3
- Winc-4
- Winc-8
- Winc-20
- Winc-40
- CMD-32
- CMD-64
X CMD-96
- SMD-80
- SMD-300
=====
```

SCREEN 15

C.2.2 SCREEN 16

1. With SCREEN 16 displayed on the CRT, enter the password (same as the one used during C.2.1, SCREEN 4 or C.2.1, SCREEN 10 of the System Disk Initialization Procedure) and press EXECUTE. SCREEN 17 will appear.

Office Information System-System Generation  
C O N F I G U R E S Y S T E M

Press EXECUTE to Continue  
or CANCEL for Previous Menu

VOLUME "VOL1" on Drive 50

Password Required: \_\_\_\_\_

SCREEN 16

C.2.2 SCREEN 17

1. Make selections as explained below and press EXECUTE. SCREEN 18 will appear.

Enter the number of disk drives (of each type) to be supported by the system.

- a. Floppy drive should be 1.
- b. Hawk Units\* may be 0, 1 or 2.
- c. SM may be 1, 2, 3. This digit indicates the number of CMD or SMD units which are supported by the operating system.

Devices - Set for the total number of devices supported by the system (example 140/145 = 32 devices).

Non-Wise Devices - On systems not using WISE, this number should be the same as that set for "Devices". On systems using WISE, if the WISE box is on port 1, this number should be 1 less than the number set for "Devices"; if the WISE box is on port 2, it should be 2 less than the number set for "Devices".

External File Source - This must be set as "Supported" for all systems using WISE, 3270, or RCF (Remote cluster facility). Set this selection as "Not Supported" for all other systems.

Extended Memory Master - This must be set as "Supported" for all systems containing the Extended Memory Option (128K). Set this selection as "Not Supported" for systems with the 64K master.

\* Note that a unit is different from a drive in that a unit may contain one or more drives (volumes). A Hawk Disk Unit contains two Hawk drives. A CMD Disk Unit contains two CMD drives, and an SMD Disk Unit contains one SMD drive.

```

=====
                                Office Information System-System Generation
                                C O N F I G U R E   S Y S T E M

Modify Configuration
Press EXECUTE or CANCEL

Configure CMD-96 Disk on Drive 50   Software Release X.X
Disk has Volume Name: VOL1          Last IPLed on: 03/05/81

Floppy Drives: 1                    Devices (Dec): 32
Hawk Units : 2                      Non-WISE Devices (Dec): 32
SM/Winc Units: 4
External File Source                Extended Memory Master

  X Non-Supported                    X Non-Supported
    Supported                          Supported
=====

```

C.2.2 SCREEN 18

1. With SCREEN 18 on the CRT, press EXECUTE again. When the operation is complete, the message 'New Configuration Written to Disk' will appear on the screen. press CANCEL to return to the main menu.
2. On the Master Processor set the Disk Select switch to the bottom "---" position.
3. Press the Master Processor RESET pushbutton while removing the STARTER diskette from the floppy disk drive. Once the diskette is removed, release the RESET pushbutton. SCREEN 19 will appear on the CRT, after the system has been initialized from the System Disk.
4. The system is now ready for installation of software. Proceed to C.2.3, Software Installation.

## -----NOTE-----

The following screen shows a system configuration of one floppy, zero Hawks, and two CMD units, with 128K Extended Memory and a WISE unit on port 3.

```

=====
Office Information System-System Generation
  C O N F I G U R E   S Y S T E M

Modify Configuration
Press EXECUTE to write to disk

Configure CMD-96 Disk on Drive 50   Software Release X.X
Disk has Volume Name: VOL1         Last IPLed on: 03/05/81
Floppy Drives: 1                   Devices (Dec): 32
Hawk Units : 0                     Non-WISE Devices (Dec): 29
SM/Winc Units: 2
External File Source                Extended Memory Master

    Non-Supported                  Non-Supported
  X Supported                   X Supported
=====

```

SCREEN 18

C.2.3 SOFTWARE INSTALLATION PROCEDURE

This procedure is used to enter software packages onto the system disk. The software packages are distributed on separate floppy diskettes.

If installation of software is required, perform the following procedure (having completed the C.2.1, System Disk Initialization and C.2.2, System Configuration Procedures).

C.2.3 SCREEN 19

1. With SCREEN 19 on the Workstation CRT as the result of IPL'ing from the System Disk, enter the Date and press RETURN.
2. Enter Time and press EXECUTE twice. SCREEN 20 will appear on the CRT.

```
=====
Unit XX                Office Information System                Type XXX
                   I N I T I A L  P R O G R A M  L O A D
                   Release X.X      System is "VOL1"

Fill in fields,
Then press EXECUTE

Enter Date:  mm/dd/yy:  __/__/__
Enter time:   hh:mm   :  __:__
=====
```

SCREEN 19

C.2.3 SCREEN 20

1. With SCREEN 20 on the CRT, press EXECUTE. SCREEN 21 will appear.

```
=====
02/18/81          Office Information System          11:17:07
Unit XX          D I S K O P E R A T I N G S Y S T E M      Type XXX
                  Release X.X          System is "VOL1"
```

```
Press EXECUTE to
Select Indicated Choice
```

```
      X Control Functions
```

```
=====
SCREEN 20
```



C.2.3 SCREEN 21

1. With SCREEN 21 on the CRT, select 'Install Software Package' and press EXECUTE. SCREEN 22 will appear.

```
=====
| 02/18/81                Office Information System                11:18:25 |
| Unit XX                 D I S K O P E R A T I N G S Y S T E M   Type XXX |
|                          Release X.X           System is "VOL1" |
|                                                                    |
| Press EXECUTE to                                               |
| Select Indicated Choice                                         |
|                                                                    |
| Control Functions:  _ Queue Control                             |
|                    _ Device Control                            |
|                    _ Disk Control                              |
|                    _ Message Control                           |
|                                                                    |
|                    X Install Software Package                    |
|                                                                    |
|=====
```

SCREEN 21

C.2.3 SCREEN 22----- CAUTION -----

- BEFORE PROCEEDING TO LOAD ANY SOFTWARE DISKETTES INTO THE SYSTEM, READ ALL MATERIAL IN THE RELEASE DOCUMENTATION ACCOMPANYING THE DISKETTES.
- 
1. With SCREEN 22 on the CRT, mount the appropriate diskette (according to the sequence presented in the release documentation) into the Master Processor floppy disk drive.
  2. Press EXECUTE to start the diskette installation process. Type in Destination Volume if different. When prompted, press EXECUTE again. SCREEN 23 will appear. (Some utilities packages will display a selection menu like SCREEN 22A.)

```
=====
Office Information System
  I N S T A L L   S O F T W A R E   P A C K A G E

Mount Installation Disk in
Drive 01 and Press EXECUTE

Destination Volume: "VOL1"
=====
```

SCREEN 22

C.2.3 SCREEN 22A

1. With SCREEN 22A on the CRT or some other similar menu depending on the utility being installed, select each of the entries this system is to support. Use the INSERT key for selection, and the DELETE key for deselection. Then press EXECUTE. Answer all prompts if any occur. SCREEN 23 will appear.

```
=====
Office Information System
  S O F T W A R E   S E L E C T I O N   O P T I O N

Make Software Selection
Press EXECUTE to Begin

      X Library Catalog
      X Document Compare
      X Document Recover
      X Duplicate Diskette
      X Recover Diskette
      X Sort Document
=====
```

SCREEN 22A

C.2.3 SCREEN 23

## ----- NOTE -----

The 'Package ID' of the diskette currently being installed will be displayed automatically on SCREENS 23 and 24.

-----

1. With diskette installation in progress, SCREEN 23 will be present until the installation of the current package is complete. When each diskette installation is completed, SCREEN 24 will automatically appear on the CRT.

```
=====
Office Information System
INSTALL SOFTWARE PACKAGE
=====
```

```
Installation in Progress
```

```
Destination Volume: "VOL1"
Package ID: SP000012
```

```
=====
SCREEN 23
```

C.2.3 SCREEN 24

1. If there are more software packages (diskettes) to install when SCREEN 24 appears, press EXECUTE and return to C.2.3, SCREEN 22 where you will repeat the procedure and install another package. If, however, the last package has been installed, press CANCEL (SCREEN 25 will appear). Proceed with C.2.3, SCREEN 25.

```
=====
Office Information System
INSTALL SOFTWARE PACKAGE

Press EXECUTE to Run Again
or CANCEL to Terminate

Destination Volume: "VOL1"
Package ID: SP000012
=====
```

SCREEN 24

C.2.3 SCREEN 25

1. With SCREEN 25 on the CRT, first remove diskette and then press EXECUTE. SCREEN 26 will appear on the CRT.

```
=====
|
|                               Office Information System
|                               I N S T A L L   S O F T W A R E   P A C K A G E
|
| Remove Installation Disk From
| Drive 01 and Press EXECUTE
|
|
| Destination Volume: "VOL1"
| Package ID:  SP000012
|
|=====
```

SCREEN 25

C.2.3 SCREEN 26

1. With SCREEN 26 on the CRT, press CANCEL. The main DOS menu (SCREEN 27) will appear.

```
=====
| 02/18/81                Office Information System                11:24:31
| Unit XX                 D I S K O P E R A T I N G S Y S T E M   Type XXX
|                          Release X.X           System is "VOL1"
|
| Press EXECUTE to
| Select Indicated Choice
|
| Control Functions:  X Queue Control
|                   _ Device Control
|                   _ Disk Control
|                   _ Message Control
|
|                   _ Install Software Package
|
=====
```

SCREEN 26

C.2.3 SCREEN 27

1. With the main DOS menu displayed, Software Initialization is complete.

----- NOTE -----  
 The DOS menu will only display the names of the software packages that have been installed in this section.  
 -----

2. The Customer Support Analyst and/or the customer will now be able to initialize other volumes using Volume Utilities.

----- NOTE -----  
 For information on operating the Disk Operating System functions, refer to Word Processing Newsletter 76 or 76.1.  
 -----

```

=====
02/18/81                Office Information System                11:30:02
Unit XX                 D I S K O P E R A T I N G S Y S T E M   Type XXX
                        Release X.X          System is "VOL1"

Press EXECUTF to
Select Indicated Choice

      _ Word Processing                _ Control Functions
      _ Supervisory Utilities
      _ Volume Utilities
      _ File Utilities
      _ Basic .
      .
      .
      .
=====
  
```

SCREEN 27



C.3 POST-INSTALLATION SOFTWARE UPDATES

The procedures in Section C.3 provide a complete guide for performing software-related tasks during software modification of the OIS 140/145 systems. This section is divided into three areas:

C.3.1 Updating System Software (Screens 28 through 34)

C.3.2 System Re-Configuration (Screens 35 through 40)

C.3.3 Updating Software Packages (Screens 41 through 49)

In one case, a new STARTER will be installed (Updating System Software) and the system will be re-configured (System Re-Configuration), if the Hardware configuration has changed. In the other case, where a new STARTER is not involved; the software resident within the system is IPL'd to control updating (Updating Software Packages).

In either case, installation of updated software is normally a Customer Support Analyst function. Customer Engineering should carry out such procedures only if a need is specifically indicated.

When software packages are available to update a customer's system and a new STARTER package release is not involved, perform the procedure under paragraph C.3.3 (Updating Software Packages) in this section. In this case, IPL from the system drive to obtain C.3.3, SCREEN 41.

C.3.1 UPDATING SYSTEM SOFTWARE

Perform the following procedure when software updating includes the reinstallation of new Operating System Software. This procedure will require the reinstallation of all Wang System Software

C.3.1 SCREEN 28

## ----- NOTE -----

Word Processing documents and/or files are not normally affected by this procedure, therefore they do not need to be archived. However, read the Release Documentation distributed with the software for restrictions, and use your own discretion when especially important documents or files may be involved. This procedure is not recommended except for unique circumstances.

1. Position the Master Processor DISK-SELECT switch to "-" (up=floppy drive).
2. Insert the STARTER diskette into the Master Processor diskette drive.
3. Press the Master Processor RESET pushbutton to access SCREEN 28.

## ----- CAUTION -----

FOLLOW THE STEP-BY-STEP PROCEDURES IN THIS APPENDIX:  
 IGNORE PROMPTS ON THE CRT SCREEN. Make keyboard entries to fill in requested information and make appropriate selections only as directed by this procedure.

4. Enter the Date and press RETURN.
5. Enter Time and press EXECUTE twice to access the next screen. (CANCEL would terminate this software updating procedure.) After a short delay, SCREEN 29 will appear on the Workstation CRT.

```

=====
Unit XX                Office Information System                Type XXX
      I N I T I A L  P R O G R A M  L O A D
      Release X.X      System is "STARTER"
=====

```

Fill in fields,  
 Then press EXECUTE

Enter Date: mm/dd/yy: \_\_/\_\_/\_\_

Enter time: hh:mm : \_\_:\_\_

=====

SCREEN 28

C.3.1 SCREEN 29

1. Select 'System Generation' at SCREEN 29.
2. Press EXECUTE to access SCREEN 30.

```
=====
| 02/18/81                Office Information System                11:33:51
| Unit XX                 D I S K O P E R A T I N G   S Y S T E M   Type XXX
|                          Release X.X           System is "STARTER"
|
| Press EXECUTE to
| Select Indicated Choice
|
|      X System Generation           _ Control Functions
|
=====
```

SCREEN 29

## C.3.1 SCREEN 30

1. With SCREEN 30 on the CRT, select 'Update System Software' (using the spacebar) and press RETURN.

----- NOTE -----  
 In step 2, select the drive as follows:

CMD-32 for OIS 140-1  
 CMD-64 for OIS 140-2  
 CMD-96 for OIS 140-3  
 SMD-300 for OIS 145

2. Select the appropriate system disk drive (using the space bar) and press EXECUTE. SCREEN 31 will appear on the CRT.

```

=====
                Office Information System-System Generation
                S Y S G E N F U N C T I O N S E L E C T I O N

Select Function and Disk Type
Press EXECUTE or CANCEL

      _ Initialize System Disk
      X Update System software
      _ Configure System

                                _ Hawk-5
                                _ Hawk-2
                                _ Winc-3
                                _ Winc-4
                                _ Winc-8
                                _ Winc-20
                                _ Winc-40
                                _ CMD-32
                                _ CMD-64
                                X CMD-96
                                _ SMD-80
                                _ SMD-300
=====
  
```

SCREEN 30

C.3.1 SCREEN 31

1. Enter the required password and press EXECUTE. SCREEN 32 will appear on the CRT.

Office Information System-System Generation  
I N I T I A L I Z E S Y S T E M D I S K

Press EXECUTE to Continue  
or CANCEL for Previous Menu

VOLUME "VOL1" on Drive 50

Password Required \_\_\_\_\_

SCREEN 31

C.3.1 SCREEN 32

1. With SCREEN 32 displayed on the CRT, press EXECUTE. SCREEN 33 will appear on the CRT and updating will begin automatically.

Office Information System-System Generation  
UPDATE SYSTEM SOFTWARE

Press EXECUTE to  
\*\*\*BEGIN UPDATING\*\*\*

Updating CMD-96 Disk on Drive 50  
Disk has Volume Name: "VOL1"

SCREEN 32

C.3.1 SCREEN 33

1. 'Installing Master' then 'Installing Device Software' will appear on SCREEN 33 as updating takes place.

----- NOTE -----

At the end of updating, SCREEN 34 will automatically replace SCREEN 33.  
-----

=====

Office Information System-System Generation  
U P D A T E S Y S T E M S O F T W A R E

UPDATE IN PROGRESS

(Installing Master) ...(Installing Device Software)

Updating CMD-96 Disk on Drive 50  
Disk has Volume Name: "VOL1"

=====

SCREEN 33

C.3.1 SCREEN 34

1. When SCREEN 34 appears, press CANCEL (SCREEN 35 will appear on the CRT).
2. With SCREEN 35 on the CRT, this Updating System Software Procedure is completed.
3. Continue by performing the C.3.2, System Re-Configuration Procedure, if the Hardware Configuration has changed. Otherwise continue with Section C.2.3..

```
=====
Office Information System-System Generation
UPDATE SYSTEM SOFTWARE
=====
```

```
Update Complete
Please Press CANCEL
```

```
Updating CMD-96 Disk on Drive 50
Disk has Volume Name: "VOL1"
```

```
=====
SCREEN 34
```



C.3.2 SYSTEM RE-CONFIGURATION

Perform the following procedure only if the disk has been formatted, and loaded with new operating software; or if the hardware configuration has changed.

----- NOTE -----  
Reconfiguration is not required after updating unless updating included the addition of a WISE option or an optional drive  
-----

C.3.2 SCREEN 35

1. IPL the System from the STARTER diskette, and select System Generation. With SCREEN 35 on the CRT, select 'Configure System' and press RETURN.
2. Select the appropriate system drive model (the same as the one selected in C.3.1, SCREEN 30) and press EXECUTE. SCREEN 36 will appear on the CRT.

```
=====
Office Information System-System Generation
SYSGENFUNCTIONSELECTION

Select Function and Disk Type
Press EXECUTE or CANCEL

      _ Initialize System Disk
      _ Update System software
      X Configure System

                                     _ Hawk-5
                                     _ Hawk-2
                                     _ Winc-3
                                     _ Winc-4
                                     _ Winc-8
                                     _ Winc-20
                                     _ Winc-40
                                     _ CMD-32
                                     _ CMD-64
                                     X CMD-96
                                     _ SMD-80
                                     _ SMD-300
=====
```

SCREEN 35

C.3.2 SCREEN 36

1. Enter the password (the same one used in C.3.1, SCREEN 31) and press EXECUTE. SCREEN 37 will appear.

=====  
Office Information System-System Generation  
C O N F I G U R E S Y S T E M

Press EXECUTE to Continue  
or CANCEL for Previous Menu

VOLUME "VOL1" on Drive 50

Password required \_\_\_\_\_

=====  
SCREEN 36

C.3.2 SCREEN 37

1. Change the information on SCREEN 37 to reflect the configuration of the system and press EXECUTE, press EXECUTE, then press CANCEL. SCREEN 38 will appear on the CRT.

```
=====
                                Office Information System-System Generation
                                C O N F I G U R E   S Y S T E M

Modify Configuration
Press EXECUTE or CANCEL

Configure CMD-96 Disk on Drive 50   Software Release X.X
Disk has Volume Name: VOL1          Last IPLed on: 12/30/80
Floppy Drives: 1                    Devices (Dec): 32
Hawk Units : 2                      Non-WISE Devices (Dec): 32
SM/Winc Units: 4

External File Source                 Extended Memory Master

   X  Non-Supported                  X  Non-Supported
      Supported                        Supported
=====
```

SCREEN 37

## C.3.2 SCREEN 38

1. With SCREEN 38 on the CRT, System Re-configuration is complete.
2. On the Master Processor set the DISK SELECT switch to the "-- --" (bottom=CMD/SMD) position.
3. Press and hold the Master Processor RESET pushbutton while removing the STARTER diskette from the floppy disk drive. Once the diskette is released from the drive, release the RESET pushbutton. SCREEN 39 will appear on the CRT.
4. The system is now ready for updating of other software packages.
5. Proceed to C.3.3, Updating Software Packages.

```

=====
                Office Information System-System Generation
                SYSGEN FUNCTION SELECTION

Select Function and Disk Type
Press EXECUTE or CANCEL

      _ Initialize System Disk
      _ Update System software
      _ Configure System

                                     _ Hawk-5
                                     _ Hawk-2
                                     _ Winc-3
                                     _ Winc-4
                                     _ Winc-8
                                     _ Winc-20
                                     _ Winc-40
                                     _ CMD-32
                                     _ CMD-64
                                     _ CMD-96
                                     _ SMD-80
                                     _ SMD-300
=====

```

SCREEN 38

C.3.3 UPDATING SOFTWARE PACKAGES

Perform the following procedure to update software packages. This procedure can be entered in two ways:

1. By performing the UPDATE SYSTEM SOFTWARE procedure (C.3.1 ) in this section, Or,
2. By simply IPLing from the system disk for the case when the STARTER was not updated.

C.3.3 SCREEN 39

1. With SCREEN 39 on the CRT, enter Date and press RETURN.
2. Enter Time and press EXECUTE twice. SCREEN 40 will appear on the CRT.

```
=====
Unit XX                               Office Information System           Type XXX
                                I N I T I A L P R O G R A M L O A D
                                Release X.X   System is "VOL1"

Fill in fields,
Then press EXECUTE

Enter Date:  mm/dd/yy:  __/__/__
Enter time:   hh:mm   :  __:__
=====
```

SCREEN 39

C.3.3 SCREEN 40

1. With SCREEN 40 displayed, press EXECUTE. SCREEN 41 will appear.

```
=====
02/18/81          Office Information System          11:40:26
Unit XX          D I S K O P E R A T I N G S Y S T E M  Type XXX
                  Release X.X          System is "VOL1"

Press EXECUTE to
Select Indicated Choice

          . . . .
          . . . .
          . . . .
          . . . .
          . . . .

          X Control Functions
=====
```

SCREEN 40

C.3.3 SCREEN 41

1. At SCREEN 41, select 'Install Software Package'.
2. Press EXECUTE, SCREEN 42 will appear.

```
=====
| 02/18/81                Office Information System                11:41:39
| Unit XX                 D I S K O P E R A T I N G S Y S T E M   Type XXX
|                          Release X.X           System is "VOL1"
|
| Press EXECUTE to
| Select Indicated Choice
|
| Control Functions:  _ Queue Control
|                    _ Device Control
|                    _ Disk Control
|                    _ Message Control
|
|                    X Install Software Package
|
=====
```

SCREEN 41

C.2.3 SCREEN 42----- CAUTION -----

BEFORE PROCEEDING TO LOAD ANY SOFTWARE DISKETTES INTO THE SYSTEM, READ ALL MATERIAL IN THE RELEASE DOCUMENTATION ACCOMPANYING THE DISKETTES.

-----

1. With SCREEN 42 on the CRT, mount the appropriate diskette (according to the sequence presented in the release documentation) into the Master Processor floppy disk drive.
2. Press EXECUTE to start the diskette installation process. Type in Destination Volume if different. When prompted, press EXECUTE again. SCREEN 43 will appear. (Some utilities packages will display a selection menu like SCREEN 42A.)



```
=====
Office Information System
INSTALL SOFTWARE PACKAGE

Mount Installation Disk in
Drive 01 and Press EXECUTE

Destination Volume: "VOL1"
=====
```

SCREEN 42

C.3.3 SCREEN 42A

1. With SCREEN 42A on the CRT or some other similiar menu depending on the utility being installed, select each of the entries this system is to support. Use the INSERT key for selection and the delete key for deselection. Then press EXECUTE. Answer all prompts if any occur. SCREEN 43 will then appear.

```
=====
Office Information System
SOFTWARE SELECTION OPTION

Make Software Selection
Press EXECUTE to Begin

X Library Catalog
X Document Compare
X Document Recover
X Duplicate Diskette
X Recover Diskette
X Sort Document
=====
```

SCREEN 42A

C.3.3 SCREEN 43

----- NOTE -----

The 'Package ID' of the diskette currently being updated will be displayed automatically on SCREENS 43 and 44.

-----

1. With installation in progress, SCREEN 43 will be present until the update of the current package is complete. When each diskette installation is completed, SCREEN 44 will appear on the CRT.

```
=====
Office Information System
INSTALL SOFTWARE PACKAGE

Installation in Progress

Destination Volume: "VOL1"
Package ID: SP000012
=====
```

SCREEN 43



C.3.3 SCREEN 45

1. With SCREEN 45 on the CRT, first remove diskette (DO NOT RESET) and then press EXECUTE. SCREEN 46 will appear on the CRT.

Office Information System  
I N S T A L L S O F T W A R E P A C K A G E

Remove Installation Disk From  
Drive 01 and Press EXECUTE

Destination Volume: "VOL1"  
Package ID: SP000012

SCREEN 45

C.3.3 SCREEN 46

1. With SCREEN 46 on the CRT, press CANCEL. The main DOS menu (SCREEN 47) will appear.

```
=====
| 02/18/81                Office Information System                11:44:09 |
| Unit XX                D I S K C P E R A T I N G S Y S T E M    Type XXX |
|                        Release X.X                System is "VOL1" |
|                                                                    |
| Press EXECUTE to                                               |
| Select Indicated Choice                                         |
|                                                                    |
| Control Functions:  X Queue Control                            |
|                   - Device Control                             |
|                   - Disk Control                              |
|                   - Message Control                           |
|                   - Install Software Package                  |
|                                                                    |
|=====
```

SCREEN 46

C.3.3 SCREEN 47

1. With SCREEN 47 displayed, Software Updating is complete.

## ----- NOTE -----

The DOS menu will display the software packages that have been installed by this section (C.3.3) and also those previously installed during the original Software Initialization procedure.

2. The Customer Support Analyst and/or the customer will now be able to initialize other volumes using Volume Utilities (if required).

```

=====
02/18/81                Office Information System                11:45:57
Unit XX                 D I S K O P E R A T I N G S Y S T E M   Type XXX
                        Release X.X          System is "VOL1"

Press EXECUTE to
Select Indicated Choice

      x Word Processing                _ Control Functions
      _ Supervisory Utilities
      _ Volume Utilities
      _ File Utilities
      _ Basic
      _ Demonstration
      .
      .
=====

```

SCREEN 47

**APPENDIX**

**D**

**OIS 140 - CLASS**

**POWER-UP (PROM)**

**DIAGNOSTIC**

APPENDIX DOIS 140-CLASS POWER-UP (PROM) DIAGNOSTICD.1 INTRODUCTION

This appendix contains the complete guide for the proper use of the PROM-based OIS 140-Class Power-Up Diagnostic (Revision 5.0 at this printing). This Appendix discusses the 64K CPU version, with Appendix E describing the differences associated with the 128K Extended Memory Power-Up Diagnostic. The diagnostic is automatically initiated when the system is powered up or alternatively, when the front panel RESET button is depressed.

The primary use of this Power-Up diagnostic at the field level is for the isolation of board failures within the OIS Master Unit. Fault isolation is accomplished through the use of error codes displayed on the Master Unit's front panel LEDs. These error codes are either termed "non-fatal", indicating faulty operating conditions, or "fatal", indicating faulty circuit boards. Corrections or repairs, if required, may be performed by Customer Engineering personnel.

This diagnostic also provides both Detailed and Expanded Error information via error codes displayed on the eight LED indicators present on the CPU/MEM board. This additional error information can be used in the field to aid in the isolation of those problems that are not readily resolved by direct replacement of suspected faulty board(s).

Fault isolation beyond board level is possible in the case of the CPU/MEM board. With the use of diagnostic switches on the top of this board, Expanded Error information is available to correct CPU/MEM board problems by isolating faulty memory chips.

## -----NOTE-----

It should be noted that passing the Power-Up Diagnostic DOES NOT NECESSARILY MEAN the Master Unit is trouble-free. For example, write operations are not performed by the Power-Up Diagnostic, in order to avoid damaging customer documents on system disk. Thus, the system will still pass the Power-Up Diagnostic test even though write circuitry in either the disk drive or the disk controller may be faulty.

D.2 CONFIGURATION REQUIREMENTS

This diagnostic program verifies correct operation of the OIS 140-Class\*\* Operating System as well as correct operation of the following types of OIS-140-Class Master Unit PCBs:

7501	E Rev. 3	CPU/MEMORY
7502	E Rev. 4	10 MEG/FLOPPY CONTROLLER
7503/7504	E Rev. 5/1	DATA LINK CONTROLLER
7505/7506	E Rev. 6/6	SMD/CMD CONTROLLER
7650/7653	E Rev. 2/1	WINCHESTER CONTROLLER

\*\* Masters in the 140-Class include Models 105, 115, 125A, 130A, 130B/E, 140, and 145.



In order to operate the Power-Up Diagnostics, the following conditions must be met:

- a. One slave (of any type except WISE) must be connected and powered on (if not available, the test will hang with appropriate error code).
- b. The System Disk must be on line and READY (if not, the test will hang with appropriate error code).
- c. The Initial Bootstrap Chip (IBC) must be present in the 7501 CPU/MEM board.
- d. The System Disk must already be designated by the three-level Disk Select Switch on the front panel BEFORE powering-up or resetting the Master. The switch designates the System Disk to both the Power-Up Diagnostic and Operating System Software.

### D.3 MAJOR CHARACTERISTICS

The major characteristics of the OIS 140-Class Power-Up Diagnostic are as follows:

1. The Diagnostic is PROM-loaded, residing in two 1K 2708 EPROMs found on the CPU/MEM board (memory locations 0400 to 0BFF).  
PROM 1 (L101), 378-2666R5  
PROM 2 (L102), 378-2667R5
2. The program is written in Z80 Assembly Language and attains control whenever the system is powered on or reset.
3. At the beginning of the test, the program controls the following events:
  - a. It erases all four diagnostic LEDs on the front panel (they are automatically turned on by reset or power on).
  - b. It sets a hardware register bit (X'0COB') to direct any parity error to the diagnostic parity handler.
4. The test reads only the IPL sector data (Track 0, Sector 1) from the System Disk. The System Disk is selected by the three-level pointer switch on the front panel as follows:  
Level - : diskette  
Level -- : 10 Meg disk drive (Model 6560)  
Level --- : 80 Meg, 300 Meg SMD disk drive (Model 6565),  
32-, 64-, or 96-Meg CMD disk drive (Model 6580).

During the test, no disk write operations take place.

5. In the event of an error, a four bit error code will be displayed on the front panel.
6. If the System Disk is not on line ( i.e., not powered up or not up to speed), the test will hang in a loop and display an error code on the front panel. When the disk comes on line the error code is erased and the test continues.
7. The OIS 140/145 may include up to 32 peripherals (slaves). The test will IPL the first slave encountered while scanning through all the channels from 1 to 32. If there is no slave powered on, the test will hang in a loop and display an error code on the front panel. When one of the channels comes on line, the error code is erased and the test continues.
8. If an error condition causes the system to halt, it may still be IPLed with the OIS 140 Master Monitor diskette (see section D.12 for instructions).

#### D.4 USER INTERFACE

The Power-Up Diagnostic is initiated when the user powers up the system via the front panel ON/OFF switch (1/0 on some OIS 140-Class Masters). Alternatively, if the system is already powered up, the user may press the front panel RESET button to re-IPL the system and initiate the diagnostic test.

There are two sets of LEDs used for diagnostic purposes. Four of these are located on the Master Unit's front panel, while the remaining eight reside on the 7501 CPU/MEM board. The four front panel LEDs indicate that either a fatal or non-fatal error has occurred, according to the error codes explained in Table D-1, Section D.6. The front panel LED labeled POWER is used to indicate that the Power-Up Diagnostic is executing (blinking mode), or that the system software is executing (solid-on mode). Figures D-1 and D-2 show the OIS 140-Class front panel controls and indicators.

The eight LEDs residing on the CPU/MEM board provide Detailed Error information when a fatal error has occurred (figure D-3). LEDs DL3 through DL0 indicate the number of the last test in process when the fault was encountered. (Section D.7 lists and numbers the various tests comprising the Power-Up Diagnostic.) All eight LEDs, when read together, provide the two-digit Hex code for Detailed Error analysis. Detailed Error codes are explained in sections D.8 and D.9.

There are four switches and two push buttons on the CPU/MEM board that are used for diagnostics. These controls are used to obtain Expanded Error information (section D.10), or perform special diagnostic functions as explained in section D.12.

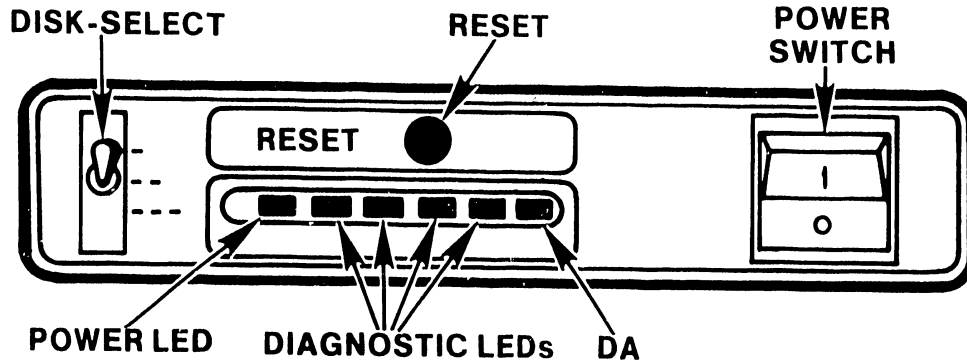

Figure D-1 Front Panel Controls -- OIS 105, 115, 125A, 130A/B/C

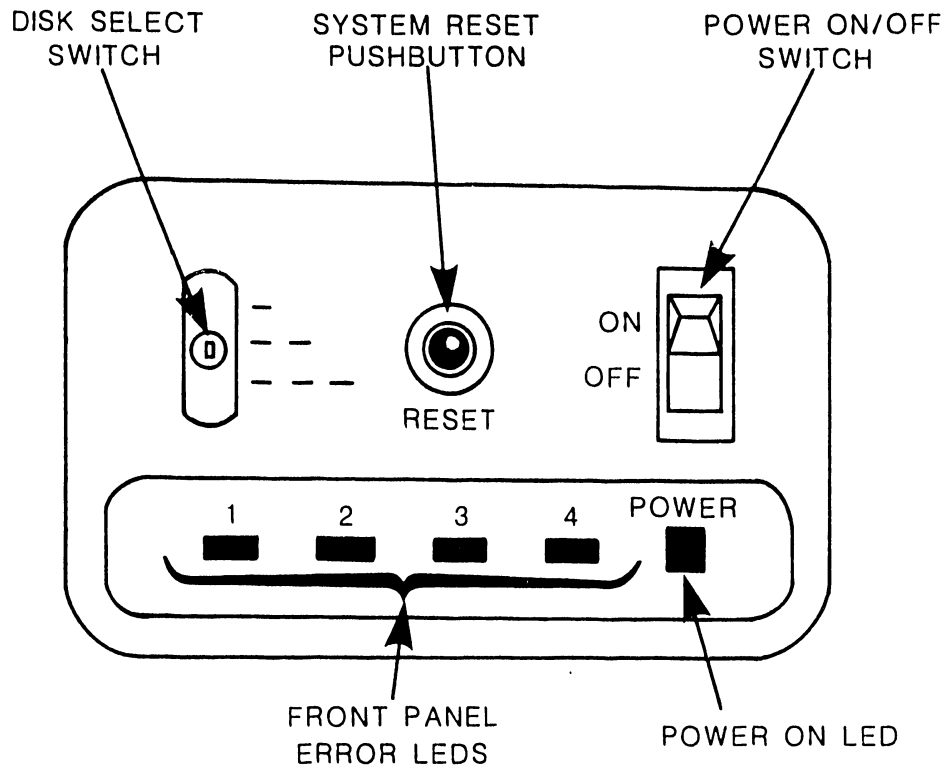

Figure D-2 Front Panel Controls -- OIS 140/145

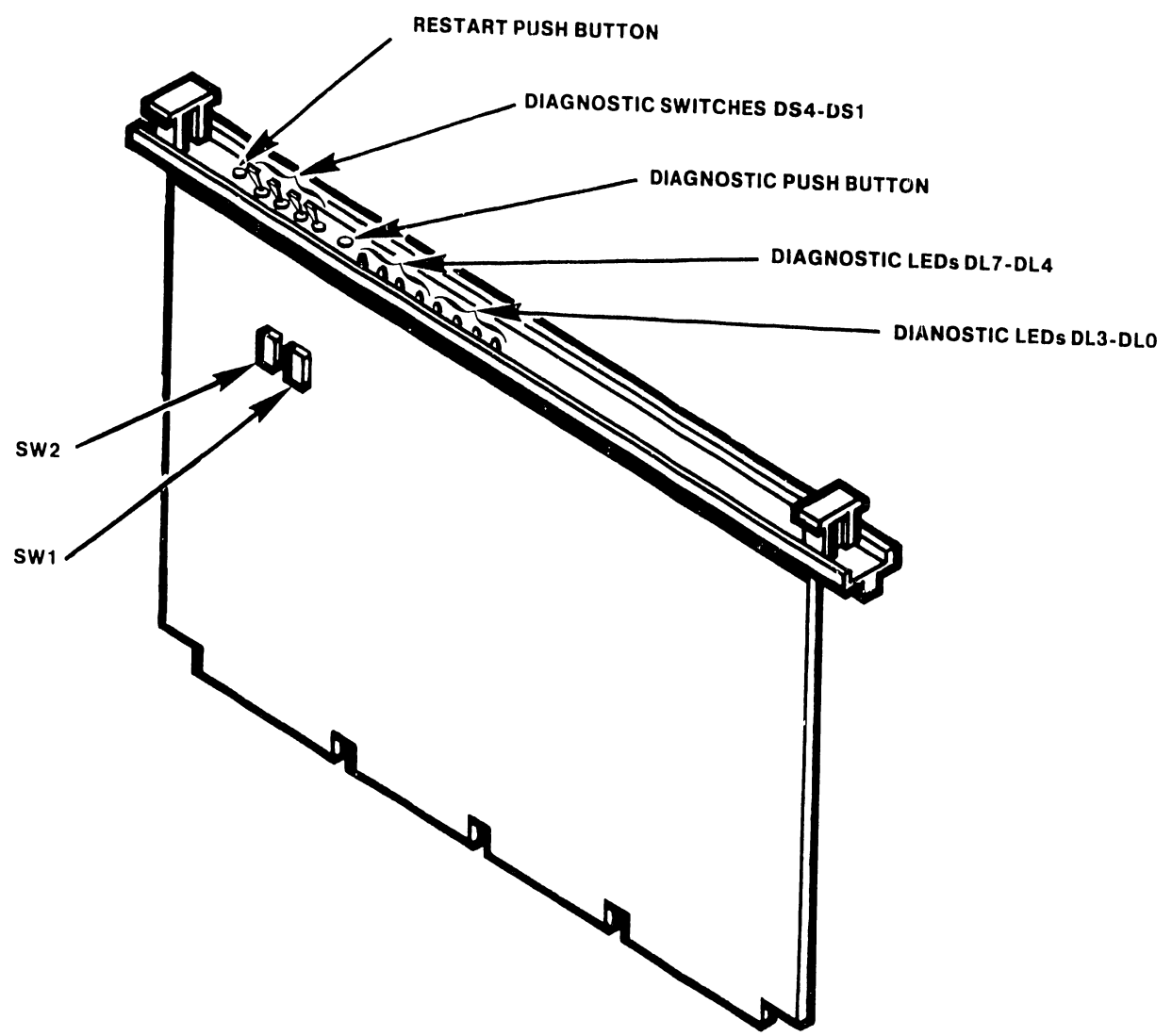

Figure D-3 CPU/MEM Board Diagnostic Controls and indicators

D.5 OPERATING PROCEDURE

The Power-up (PROM) diagnostics start whenever the Master Processor is powered-up or reset and take approximately 15 seconds to be performed.

1. Press RESET on the Master Processor Front Panel. If the system is powered-down, simply set the power switch to 1 (ON).
2. The Power LED will blink while the diagnostics are running.
  - A. When all tests pass, the Power LED stops blinking (goes to steady-on) and the IPL menu is displayed at the CRT workstation.
  - B. If an error is detected, the Power LED will continue to blink while the Front Panel LEDs display an error code. See sections D.6 through D.10 for error code interpretation. Take action as specified.
3. Enter correct Date and Time when the IPL menu is displayed.

D.6 MASTER UNIT FRONT PANEL ERROR CODES

Table D-1 explains the error codes displayed by the four front panel diagnostic LEDs. There are two major types of errors: non-fatal and fatal. Non-fatal errors are operator correctable, while fatal errors, which may be either hardware or software faults, require system servicing. Fatal errors are distinguishable by the presence of front panel LED #1 in the "on" state.

TABLE D-1 FRONT PANEL ERROR INDICATIONS

LED ERROR CODE				PROBLEM
1	2	3	4	
-----				
NON-FATAL ERROR INDICATIONS				
0	0	0	1	No external devices on line: ... Turn on a workstation.
0	0	1	0	Floppy diskette not on line: ... Check position of Disk Select Switch, insert a diskette, or close floppy door.
0	0	1	1	System CMD, SMD, or Winchester not on line: ... Check ready light on drive.
0	1	0	0	HAWK 10-Meg disk unit not on line: ... Check ready light on HAWK.
0	1	0	1	Run-time error: ... Record CPU/MEM LED status and Re-IPL.

TABLE D-1 FRONT PANEL ERROR INDICATIONS  
(continued)

LED ERROR CODE				PROBLEM
1	2	3	4	
FATAL ERROR INDICATIONS				
1	0	0	0	7501 CPU/MEM board: ... Check CPU/MEM LEDs and Table D-3.
1	0	0	1	7503 DATA LINK CONTROL board or 7504 DATA BUFFER board: ... Replace. (see Table D-4)
1	0	1	0	7502 10-MEG/FLOPPY CONTROLLER board: ... Replace. (see Table D-5)
1	1	0	0	7505/7506 SMD/CMD CONTROLLER board(s) or 7650/7653 WINCHESTER CONTROLLER board(s): ... Replace. (see Table D-6)
1	1	0	1	Software error: ... Check CPU/MEM LEDs and Table D-7.

D.7 DIAGNOSTIC TEST NUMBER IDENTIFICATION

The Diagnostic LEDs DL3 through DLO on the top of the CPU/MEM board display the Power-Up Diagnostic test number currently in process. Table D-2 identifies the various tests comprising this diagnostic.

TABLE D-2 TEST IDENTIFICATION AND DESCRIPTIONS

CPU/MEM BOARD LED INDICATORS				TEST NUMBER	TEST NAME
DL3	DL2	DL1	DLO		
0	0	0	0	0	Data Bus/Parity Gen/Marching 1's and 0's
0	0	0	1	1	Not Used
0	0	1	0	2	Not Used
0	0	1	1	3	Not Used
0	1	0	0	4	Interrupt structure
0	1	0	1	5	CTC Timing/Priority
0	1	1	0	6	Data Link Function
0	1	1	1	7	Diskette Controller
1	0	0	0	8	10-Meg Controller
1	0	0	1	9	SMD/CMD Controller
1	1	1	0	E	Winchester Controller

The normal sequence of test execution is 00, 04, 05, and 06. Note that test 06 will be skipped if a WISE is the only slave on-line. Only one of tests 07, 08, 09, or 0E will be executed next, depending on which drive is selected by the three-level front panel Disk Select switch. If the Winchester Drive is present (not applicable to OIS 140/145) and it is not the System Disk, it will be initialized and positioned at sector 00 before passing execution to the Initial Bootstrap Chip.

D.8 DETAILED HARDWARE ERROR CODES

The Diagnostic LEDs DL7 through DL0 on the top of the CPU/MEM board display detailed hardware error code when a fatal error has occurred. Tables D-3 through D-6 decipher these codes. Each table corresponds to one of four hardware Front Panel Error Codes, presenting detailed error information for that particular code.

TABLE D-3 CPU/MEM ERRORS  
(FRONT PANEL ERROR = 1000)

HEX	DL7-DL4	DL3-DL0	PROBLEM
10*	0001	0000	Data Bus Error
20	0010	0000	MPE bit (OC06) does not flag bad parity
30	0011	0000	NMI does not flag parity errors
40*	0100	0000	MAIN MEMORY PARITY ERROR
50*	0101	0000	Memory error: first read of a READ/WRITE/READ sequence
65	0110	0101	CTC Time Out Occurred
75*	0111	0101	CTC Priority Error
80*	1000	0000	Memory error: second read of a READ/WRITE/READ sequence
94*	1001	0100	Incorrect interrupt vector generated by OCOF
A4	1010	0100	No interrupts generated by OCOF
B4*	1011	0100	Incorrect number of interrupts generated by OCOF
C0	1100	0000	ILLEGAL PROM ADDRESS ERROR

\* Error codes notated with asterisks refer to those codes that may be expanded using Diagnostic Switch DS2 on the CPU/MEM board. (See paragraph D.10 for details concerning expanded error information.)

TABLE D-4 DATA LINK CONTROL ERRORS  
(FRONT PANEL ERROR = 1001)

HEX	DL7-DL4	DL3-DL0	PROBLEM
16*	0001	0110	Read/Write Control Registers Error
26	0010	0110	Not used
36	0011	0110	CANNOT SELECT A SLAVE
46	0100	0110	CANNOT IPL A SLAVE
56	0101	0110	ONE BYTE SLAVE READ ERROR
66	0110	0110	Not used
76*	0111	0110	DATA LINK BUSY TIME OUT DOING BLOCK TRANSFER
86*	1000	0110	DATA LINK BUSY INT DID NOT OCCUR DOING BLOCK TRANSFER
96*	1001	0110	DATA LINK DATA BUFFER PARITY ERROR ON BLOCK TRANSFER
A6*	1010	0110	Incorrect Data found after Block Transfer

TABLE D-5 10-MEG/FLOPPY ERRORS  
(FRONT PANEL ERROR = 1010)

HEX	DL7-DL4	DL3-DL0	PROBLEM
17*	0001	0111	READ/WRITE Control Register Error (Floppy)
27	0010	0111	IPL from Floppy Status Error
47	0100	0111	Floppy: Cannot find track 00
77	0111	0111	No Sector Pulse Interrupt
97	1001	0111	Sector Counter Never Indicates Sector 00
18*	0001	1000	READ/WRITE Control Register Error (10-Meg)
38	0011	1000	Drive Select Register Error
48	0100	1000	10-MEG: Drive Does Not Restore
58	0101	1000	Restore Takes Greater Than 500 Milliseconds
68	0110	1000	No Interrupt On Seek Complete.
78	0111	1000	No Sector Pulse Interrupt.
88	1000	1000	IPL from 10-MEG Status Error.
98	1001	1000	Sector counter never indicates sector 00



TABLE D-6 SMD/CMD OR WINCHESTER CONTROLLER ERRORS  
(FRONT PANEL ERROR = 1100)

HEX	DL7-DL4	DL3-DL0	PROBLEM
SMD/CMD CONTROLLER			
19*	0001	1001	READ/WRITE CONTROL REGISTER ERROR
29	0010	1001	Seek Operation Failed To Cause Interrupt
39	0011	1001	Seek Operation Returned Bad Status
49	0100	1001	Incorrect Interrupt Vector On Seek
59	0101	1001	Read Operation Failed To Cause Interrupt
69	0110	1001	Read IPL Sector Returned Bad Status (includes an ECC error)
WINCHESTER CONTROLLER			
1E*	0001	1110	READ/WRITE CONTROL REGISTER ERROR
2E	0010	1110	DRIVE DOES NOT BECOME READY
3E	0011	1110	NO SEEK INTERRUPT ON RTZ
4E	0100	1110	TKO NOT SET AFTER RTZ
5E	0101	1110	TIMEOUT ON IPL READ
6E	0110	1110	STATUS ERROR ON IPL READ
7E	0111	1110	CANNOT FIND SECTOR ZERO
8E	1000	1110	READ/SELECT FORCED READ ERROR

## D.9 DETAILED SOFTWARE ERROR CODES

When the four front panel LEDs indicate a fatal software error, additional information concerning the error may be obtained by analyzing DL7 through DL0 on the CPU/MEM board, according to the table that follows:

TABLE D-7 DETAILED SOFTWARE ERROR CODES  
(FRONT PANEL ERROR = 1101)

HEX	DL7-DL4	DL3-DL0	PROBLEM
E0	1110	0000	IPLed Disk has an invalid Volume Label
E1	1110	0001	IPLed Disk is not a System Disk
E2	1110	0010	Bad Configuration: too little Master Memory
E3	1110	0011	Bad Configuration: IPLed Disk excluded
E4	1110	0100	Insufficient Memory for Control Blocks TCB
E5	1110	0101	Insufficient Memory for Control Blocks VCB
E6	1110	0110	Insufficient Memory for Control Blocks DCB
E7	1110	0111	Insufficient Memory for Control Blocks FCB
E8	1110	1000	Bad Configuration: Unsupported Disk Type
E9	1110	1001	Insufficient Memory for Buffers (VAU Map)
EA	1110	1010	Insufficient Memory for Buffers (Catalog)
EB	1110	1011	Incorrect PROM Revision Installed
EC	1110	1100	Unsupported Timer Interval
ED	1110	1101	Cannot Mount System Disk
FA	1111	1010	Invalid IPL Sector Hash Code
FB	1111	1011	Error Reading Master or Volume Label
FC	1111	1100	Hard Debug
FD	1111	1101	Soft Debug
FE	1111	1110	Restart Button Depressed
FF	1111	1111	Parity Error

## D.10 EXPANDED HARDWARE ERROR INFORMATION

The detailed hardware error codes marked with an asterisk in Tables D-3 through D-6 can be expanded by positioning Diagnostic Switch DS2 on the CPU/MEM board to its opposite position. Valid additional information exists at the CPU/MEM board LEDs for error codes marked with an asterisk after DS2 has been toggled. The first change of the position of DS2 will cause the first byte of additional error information to be presented at the CPU/MEM board LEDs. Record the data displayed at the LEDs, then toggle DS2 a second time to obtain the second byte of expanded hardware error information.

For the detailed hardware error codes 10, 40, 50, and 80, (See Table D-3) the first byte of information is the high byte of the memory location in error. The second byte of information is the exclusive-or (XOR) of the data read with the data written. Refer to Section D.11 to use these error codes to locate and replace faulty memory chip(s).

For errors 94 and B4 the first byte of information displayed is hexadecimal B0 (x'B0'). The second byte of expanded information for error 94 is the XOR of the low byte interrupt vector received and the one expected. The second byte of error B4 is the number of interrupts that were generated.

The first byte for error 75 is not applicable, the second byte is the XOR of the CTC channel expected to interrupt and the one that did the interrupting.

The first byte for errors 76, 86, 96, and A6, is not applicable. The second byte for each of these errors is the slave selected during the block transfer. Slave select value 00 implies the operation was master to master. Non-zero implies master to slave.

The first byte for errors 16, 17, 18, 19, and 1E (the READ/WRITE Register Test errors) has the low order byte of the Memory Mapped I/O (MMIO) location in error.

TABLE D-8 EXPANDED HARDWARE ERROR CODES

HEX	DL7-DL4	DL3-DL0	FIRST BYTE	SECOND BYTE
** 10	0001	0000	High Byte of Bad Mem Loc.	XOR of data read and data written
** 40	0100	0000	"	"
** 50	0101	0000	"	"
** 80	1000	0000	"	"
94	1001	0100	x'B0'	XOR INTERRUPT
B4	1011	0100	x'B0'	Number of Interrupts
75	0111	0101	N/A	XOR CTC Channel Number
76	0111	0110	N/A	Slave Selected During block Transfer
86	1000	0110	N/A	"
96	1001	0110	N/A	"
A6	1010	0110	N/A	"
16	0001	0110	LO BYTE MMIO	N/A
17	0001	0111	"	N/A
18	0001	1000	"	N/A
19	0001	1001	"	N/A
1E	0001	1110	"	N/A

\*\* See Section D.11 for isolation of faulty memory chips.

D.11 ISOLATION OF FAULTY MEMORY CHIPS

Additional memory error information is available via the CPU/MEM board LEDs. If any of the error codes listed below occur, it may be possible to correct the problem by replacing a memory chip. There are two bytes of additional error information associated with these memory error codes. (Refer to section D.10 for instructions on obtaining expanded error information.) The first byte of information is the high byte of the location where the error occurred. The second byte is the exclusive or of the data written to that location and the data subsequently read from the location.

DETAILED ERROR CODES (FRONT PANEL ERROR = 1000)

10, 40, 50, 80

Use the two bytes of expanded error information in conjunction with the table below in order to locate the faulty memory chip.

TABLE D-9 MEMORY CHIP ISOLATION

SECOND BYTE	FIRST BYTE			
	10-4F	50-8F	90-CF	D0-FF
00	L01	L19	L35	L52
01	L09	L27	L43	L60
02	L08	L26	L42	L59
04	L07	L25	L41	L58
08	L06	L24	L40	L57
10	L05	L23	L39	L56
20	L04	L22	L38	L55
40	L03	L21	L37	L54
80	L02	L20	L36	L53

D.12 SPECIAL DIAGNOSTIC FUNCTIONSD.12.1 BOOTING A DIAGNOSTIC DISKETTE AFTER A FATAL ERROR

If, during execution of the power-up, a fatal error is detected, it is still possible to IPL a diskette-based diagnostic such as the OIS 140-class Master Monitor Diagnostic package (WLI No. 702-0057).

1. Set the CPU/MEM board Diagnostic Switches to hexadecimal 'D' (i.e., DS4, DS3, and DS1 to 'ON', and DS2 to 'OFF').
2. Press the CPU/MEM Diagnostic Push Button (DPB). See figure D-3.

This will cause the Power-Up Diagnostic PROM to pass control to the Initial Bootstrap Chip and attempt to boot up the selected diskette.

### D.12.2 LAMP TEST EXECUTION

Perform the following procedure to test all Front Panel and CPU/MEM Board LEDs.

1. Set the CPU/MEM Diagnostic Switches to the OFF position.
2. Press and hold the Diagnostic Push Button (DPB) on the CPU/MEM board.
3. Press and release the Front Panel RESET switch.

This should cause all of the Diagnostic LEDs (except DA on Systems with Winchester System Disks) to light. To continue with the diagnostic just release the DPB.

### D.12.3 CPU/MEMORY BOARD TEST AND LOOP MODE

There is an option to continuously run only the CPU/MEM board diagnostic tests. To select this function perform the following procedure:

1. Set the four CPU/MEM board diagnostic switches to the 'ON' state.
2. Press and hold the CPU/MEM board Diagnostic Push Button (DPB).
3. Press and release the Front Panel RESET button, then release the DPB.

This action will set a flag directing the diagnostic to execute only CPU/MEM board functions in a continuous loop. Errors will be reported in the usual manner. To exit this mode and execute a normal Power-Up, simply reset the system via the Front Panel RESET button.

### D.13 REFERENCE

At the time of this printing the OIS 140-Class Power-Up Diagnostic exists at the Revision 5161 level. Should this level change, as it often does, the latest version of the Power-Up Diagnostic documentation may be obtained by ordering WLI Number 702-0042 from the Diagnostic Distribution Group.

**APPENDIX**

**E**

**OIS 140-CLASS**

**EXTENDED**

**MEMORY**

**POWER-UP**

**DIAGNOSTICS**

APPENDIX EOIS 140-CLASS EXTENDED MEMORY POWER-UP DIAGNOSTICE.1 INTRODUCTION

This appendix is designed to serve as a supplement to Appendix D, outlining the differences between the normal power-up diagnostic and its Extended Memory counterpart. For the most part, Appendix D is directly applicable to Extended Memory systems. The exceptions are explicitly stated in the paragraphs that follow. The addition of the 7684/7685 Mother/Daughterboard set affects the normal 140-Class Power-Up Diagnostic in the following ways:

1. An additional code has been included in the set of front panel error codes, in order to indicate occurrence of a fatal error in the 7685A Daughterboard.
2. An additional set of detailed error codes associated with the daughterboard has been included.
3. Additional extended (two-byte) error information has been included, in order to isolate faulty Daughterboard memory chips.
4. Three additional test modules have been included to test Daughterboard circuitry.

E.2 CONFIGURATION REQUIREMENTS

This diagnostic program verifies correct operation of the OIS 140-Class\*\* Operating System as well as correct operation of the following types of OIS 140-Class Master Unit PCBs:

7684A/7685A	E Rev. 1/1	CPU/MEMORY (MOTHER/DAUGHTER)
7502	E Rev. 4	10 MEG/FLOPPY CONTROLLER
7503/7504	E Rev. 5/1	DATA LINK CONTROLLER
7505/7506	E Rev. 6/6	SMD/CMD CONTROLLER
7650/7653	E Rev. 2/1	WINCHESTER CONTROLLER

\*\* Masters in the 140-Class include Models 105, 115, 125A, 130A, 130B/E, 140, and 145.

E.3 PROM SPECIFICATIONS

	PCB	LOCATION	TYPE	WLI No.
PROM 1	7684A	L110	2716 EPROM	378-5002R2
PROM 2	7684A	L111	2716 EPROM	378-5003R2

#### E.4 128K EXTENDED MEMORY CHARACTERISTICS

The 128K Extended Memory (EM-OIS) is a two board option providing additional memory for OIS 140-Class systems. The option is available for Office Information Systems 140/145, as well as models 105/115/125A/130A/130B/130C. The option adds 60K of user RAM memory to the existing 60K user RAM. An OIS system with this option has 120K of user RAM, 2K of non-user RAM, and 6K of ROM for the Initial Bootstrap and Power-up diagnostics.

The option is installed by removing the existing 7501 CPU/MEMORY board and replacing it with the new two board combination of CPU/Memory and Extended Memory. The option is a piggyback arrangement of motherboard (210-7684A) and daughterboard (210-7685A) maintained as a unit (P/N 212-3025). It plugs into the single (4 section) connector where the previous CPU/MEMORY board was installed.

This 128K memory option allows future software enhancements of all OIS 140-Class systems. It is normally required when an OIS System is connected in a Wang Inter-System Exchange (WISE) network operating with Level 2 software. The WISE network, an intelligent interconnection system, functions as a high speed communication path between OIS systems. The WISE unit is a self-contained assembly with a single CPU and Memory board and up to four Data Link boards (1 per channel). It connects as a slave unit for a designated OIS Master. The EM-OIS 128K option increases the number of files than can be opened concurrently in a WISE network.

##### E.4.1 INSTALLATION

To install the EM-OIS 128K option on any OIS 140-Class system;

- Turn off all power
- Remove the top cover of the cabinet
- Remove the existing 7501 CPU/Memory board
- Plug new piggyback combination (212-3025) into same location
- Return power to the system
- Reconfigure for "supported Extended Memory Master" using starter diskette

In OIS systems, both the Initial Bootstrap and the Power-up diagnostics are PROM resident. Returning power to the system resets the system, bootstraps it, and runs the diagnostics. The power-up diagnostic takes about 7 seconds to run if successful. It stops and displays error codes for any failed module or memory chip.

##### E.4.2 MODIFIED HARDWARE

The mother/daughter board combination has a memory address space of 64K, shared by two banks of memory. An address space of 3k is shared by 6K of Erasable PROM (EPROM). An address space of 60K is shared by 60K of RAM Instruction (I) memory and 60K of RAM Data (D) memory. Memory Mapped I/O (MMIO) uses 1K of unshared RAM. The 128K option boards retain circuits for parity generation and checking and Input and Output (I/O) decoding. The option boards also retain the Counter Timer Circuit (CTC) and the priority interrupt (INT) structure.



The hardware design provides five software-controlled memory modes for the operating system. These modes are as follows:

- Mode 1 Instruction (or I) space
- Mode 2 Instruction/Data (or I/D) space
- Mode 3 Data (or D) space
- Mode 4 DMA transfers
- Mode 5 Data/Instruction (or D/I) space.

The five memory modes are described below.

1. MODE 1 is defined as Instruction, or I, space. In Mode 1, the system functions as a normal 140 class master ignoring the additional memory. It is the default mode after Reset or Power-up. Mode 1 loads all IPL code into Instruction (I) memory at power up time. After the IPL loading, software selects any of the five memory modes.

2. MODE 2 is defined as I/D space, an Instruction/Data memory organization. This mode is the most powerful because it enables the additional 60K of RAM and its control circuitry. Mode 2 is selected only after the IPL code is loaded into (I) memory. It is initialized when an OIS 140 class system is in a WISE network with Level 2 software.

Two 60K banks of memory are active in the system with Mode 2. One array, or bank, is Instruction RAM (I space), and the second is Data RAM (D space). The memory banks share the same addressing space. Because they share address space, the bottom 4K of memory address space is masked. This space is used as addresses for 3K of ROM and 1K for Memory Mapped IN/OUT (MMIO)

Ideally, all instruction code is loaded into (I) space, while Stacks, Tables and File Control Blocks (FCBs) reside in (D) space.

The control circuitry, located on the daughterboard, does an OPCODE DECODE when the system is in the I/D mode. this decoding technique is a steering mechanism for memory, allowing convenient alternate addressing between the two 60K memory banks of RAM.

3. MODE 3 is defined as Data, or D, space. It is similar to Mode 1 except that the additional 60K of memory (D) space is the only memory array accessed by the system. This mode is useful for diagnostics.

4. MODE 4 is defined as DMA transfer space. The modified CPU is designed for software-controlled DMA transfers between data buffers and either (I) or (D) space. Software directs the normal flow of the Master Memory/Data Buffer transfers to I space by clearing bit 2 of the Program Control Register (PCR). DMA transfers to or from D space are enabled when bit 2 of the PCR is set.

5. MODE 5 is defined as D/I space. It is the opposite of Mode 2 and follows the same conventions as Mode 2 except that memory is structured in a (D/I) configuration.

Memory organization is software-controlled through the PCR. Software selects the memory mode operation by controlling four bits in the PCR.

E.5 MASTER UNIT FRONT PANEL ERROR CODES

Table E-1 explains the error codes displayed by the four front panel diagnostic LEDs. Note that this table differs from Table D-1 due to the addition of error code 1110, which indicates a fatal error involving the 7685A CPU/MEM Daughterboard.

TABLE E-1 FRONT PANEL ERROR INDICATIONS

LED ERROR CODE				PROBLEM
1	2	3	4	
-----				
NON-FATAL ERROR INDICATIONS				
0	0	0	1	No external devices on line: ... Turn on a workstation.
0	0	1	0	Floppy diskette not on line: ... Check position of Disk Select Switch, insert a diskette, or close floppy door.
0	0	1	1	System CMD, SMD, or Winchester not on line: ... Check ready light on drive.
0	1	0	0	HAWK 10-Meg disk unit not on line: ... Check ready light on HAWK.
0	1	0	1	Run-time error: ... Record CPU/MEM LED status and Re-IPL.
-----				
FATAL ERROR INDICATIONS				
1	0	0	0	7684 CPU/MEM board: ... Check CPU/MEM LEDs and section E.7.
1	0	0	1	7503 DATA LINK CONTROL board or 7504 DATA BUFFER board: ... Replace. (See Table D-4.)
1	0	1	0	7502 10-MEG/FLOPPY CONTROLLER board: ... Replace. (See Table D-5.)
1	1	0	0	7505/7506 SMD/CMD CONTROLLER board(s) or 7650/7653 WINCHESTER CONTROLLER board(s): ... Replace. (See Table D-6.)
1	1	0	1	Software error: ... Check CPU/MEM LEDs and Table D-7.
1	1	1	0	7685 EXPANDED MEMORY DAUGHTERBOARD: ... See section E.7
-----				

## E.6 DIAGNOSTIC TEST NUMBER IDENTIFICATION

The Diagnostic LEDs DL3 through DLO on the top of the CPU/MEM board display the Power-Up Diagnostic test number currently in process. Table E-2 identifies the various tests comprising this diagnostic.

TABLE E-2 TEST IDENTIFICATION AND DESCRIPTIONS

CPU/MEM BOARD				TEST NUMBER	TEST NAME
LED INDICATORS					
DL3	DL2	DL1	DLO		
0	0	0	0	00	Data Bus/Parity Gen/Marching 1's and 0's
0	0	0	1	01	Not Used
0	0	1	0	02	Not Used
0	0	1	1	03	Not Used
0	1	0	0	04	Interrupt structure
0	1	0	1	05	CTC Timing/Priority
0	1	1	0	06	Data Link Function
1	0	1	0	0A	Test 00 applied to Daughterboard
1	0	1	1	0B	ROM Decoding Tests (Daughterboard)
1	1	0	0	0C	I/D Interrupt Structure (Test 04 in I/D mode)
0	1	1	1	07	Diskette Controller
1	0	0	0	08	10-Meg Controller
1	0	0	1	09	SMD/CMD Controller
1	1	1	0	0E	Winchester Controller

The normal sequence of test execution is 00, 04, 05, and 06. Note that Test 06 will be skipped if a WISE is the only slave on-line. After Test 06 is completed, Tests 0A through 0C will be executed if and only if the 7685 Expanded Memory board is present. Only one of Tests 07, 08, 09, or 0E will be executed next, depending on which drive is selected by the three-level front panel Disk Select switch. If the Winchester Drive is present (not applicable to OIS 140/145) and it is not the System Disk, it will be initialized and positioned at sector 00 before passing execution to the Initial Bootstrap Chip.

## E.7 DETAILED ERROR CODES

Tables D-4 through D-7 in the preceding appendix are still applicable to Expanded Memory operation. The Expanded Memory Power-Up Diagnostic provides an additional set of detailed error codes which are associated with the 7684 Motherboard and the 7685 Daughterboard. These are presented in Tables E-3 and E-4 on the next two pages.

TABLE E-3 128K MOTHER MODULE  
(FRONT PANEL ERROR = 1000)

HEX	DL7-DL4	DL3-DL0	PROBLEM
10*	0001	0000	Data Bus Error
20	0010	0000	MPE bit (0C06) does not flag bad parity
30	0011	0000	NMI does not flag parity errors
40*	0100	0000	MAIN MEMORY PARITY ERROR
50*	0101	0000	Memory error: first read of a READ/WRITE/READ sequence
65	0110	0101	CTC time out occurred
75	0111	0101	CTC priority error
80*	1000	0000	Memory error: second read of a READ/WRITE/READ sequence
94	1001	0100	Incorrect interrupt vector generated by 0C0F
A4	1010	0100	No interrupts generated by 0C0F
B4	1011	0100	Incorrect number of interrupts generated by 0C0F
C0	1100	0000	ILLEGAL PROM ADDRESS ERROR

\* See section E.8 for Expanded Error Code information.

TABLE E-4 120K DAUGHTER MODULE  
(FRONT PANEL ERROR = 1110)

HEX	DL7-DL4	DL3-DL0	PROBLEM
1A	0001	1010	Can not access other side of PROMs
2A	0010	1010	D Space not being accessed
3A	0011	1010	No NMI generated after parity error, or 0C22
4A*	0100	1010	Data Bus Error
5A	0101	1010	MPE Bit not set on parity error
6A*	0110	1010	Parity error on Daughterboard
7A	0111	1010	Illegal PROM address error
8A*	1000	1010	Memory error on first READ of READ/WRITE/READ
9A*	1001	1010	Memory error on second READ of READ/WRITE/READ
1B	0001	1011	IPA Bit not set after 0C22 WRITE
2B	0010	1011	Table ROM Checksum error ROM 1
3B	0011	1011	Table ROM Checksum error ROM 2
4B	0100	1011	No NMI when illegal PROM address is generated
5B	0101	1011	I/D problem, page 0, PROM 1 (CB Instruction)
6B	0110	1011	I/D problem, page 1, PROM 1 (ED Instruction)
7B	0111	1011	I/D problem, page 2, PROM 1 (DD Instruction)
8B	1000	1011	I/D problem, page 3, PROM 1 (FD Instruction)
9B	1001	1011	D/I Mode not reflected in 0C20
AB	1010	1011	D/I does not execute MRD from I Space
BB	1011	1011	DMA BLOCK XFER from I to D bad
CB	1100	1011	DMA BLOCK XFER from D to I bad
DB	1101	1011	M1 from D Space while in I/D Mode
EB	1110	1011	Can not return to continue PUP
1C*	0001	1100	Incorrect interrupt vector generated
2C	0010	1100	No interrupts occurred
3C*	0011	1100	Incorrect number of interrupts occurred

\* See section E.8 for Expanded Error Code information.

#### E.8 EXPANDED HARDWARE ERROR INFORMATION

The detailed hardware error codes marked with an asterisk in Tables E-3 and E-4, can be expanded by positioning Diagnostic Switch DS2 on the CPU/MEM board to its opposite position. Valid additional information exists at the CPU/MEM board LEDs for error codes marked with an asterisk after DS2 has been toggled. The first change of the position of DS2 will cause the first byte of additional error information to be presented at the CPU/MEM board LEDs. Record the data displayed at the LEDs, then toggle DS2 a second time to obtain the second byte of expanded hardware error information. See Section D-10 for additional information.

TABLE E-5 EXPANDED HARDWARE ERROR CODES

HEX	DL7-DL4	DL3-DL0	FIRST BYTE	SECOND BYTE
10	0001	0000	High Byte of Bad Mem Loc.	XOR of data read and data written
40	0100	0000	"	"
50	0101	0000	"	"
80	1000	0000	"	"
4A			High Byte of Bad Mem Loc.	XOR of data read and data written
6A			"	"
8A			"	"
9A			"	"
1C			x'B0'	XOR INTERRUPT
3C			x'Bo'	Number of Interrupts

#### E.9 ISOLATION OF FAULTY MEMORY CHIPS

Additional memory error information is available via the CPU/MEM board LEDs. If any of the error codes listed below occur, it may be possible to correct the problem by replacing a memory chip. There are two bytes of additional error information associated with these memory error codes. (Refer to section E.8 for instructions on obtaining expanded error information.) The first byte of information is the high byte of the location where the error occurred. The second byte is the exclusive or of the data written to that location and the data subsequently read from the location.

#### DETAILED ERROR CODES (FRONT PANEL ERROR = 1000)

10, 40, 50, 80

#### DETAILED ERROR CODES (FRONT PANEL ERROR = 1110)

4A, 6A, 8A, 9A

Use the two bytes of expanded error information in conjunction with the tables E-5 and E-6 in order to locate the faulty memory chip.

TABLE E-6 MEMORY CHIP ISOLATION  
FRONT PANEL = 1000 (7684 PCB)

SECOND BYTE	FIRST BYTE			
	10-4F	50-8F	90-CF	D0-FF
00	L09	L30	L50	L69
01	L08	L29	L49	L68
02	L07	L28	L48	L67
04	L06	L27	L47	L66
08	L05	L26	L46	L65
10	L04	L25	L45	L64
20	L03	L24	L44	L63
40	L02	L23	L43	L62
80	L01	L22	L42	L61

TABLE E-7 MEMORY CHIP ISOLATION  
FRONT PANEL = 1110 (7685 PCB)

SECOND BYTE	FIRST BYTE			
	10-4F	50-8F	90-CF	D0-FF
00	L07	L24	L41	L58
01	L15	L32	L49	L66
02	L14	L31	L48	L65
04	L13	L30	L47	L64
08	L12	L29	L46	L63
10	L11	L28	L45	L62
20	L10	L27	L44	L61
40	L09	L26	L43	L60
80	L08	L25	L42	L59

#### E.10 REFERENCE

At the time of this printing the OIS 140-Class Extended Memory Power-Up Diagnostic exists at the Revision 5161 level. Should this level change, as it often does, the latest documentation on the Power-Up Diagnostic may be obtained by ordering WLI Number 702-0123 from the Diagnostic Distribution Group.

**APPENDIX**

**F**

**FINAL**

**WORD**

**PROCES-**

**SING**

**CHECK**



APPENDIX F  
FINAL WORD PROCESSING CHECK

F.1 DESCRIPTION

Final Word Processing Checkout for an OIS system consists of the following items:

Select Word Processing	Delete words in the text
Create a New Document	Insert words into the text
Select Edit a Document	File to archive diskette
Create text	Retrieve from archive diskette
Globally replace words in the text	Delete from archive diskette

This sequence of tests is to be run overnight on all workstations. After running these tests overnight, a document is to be queued to the printers, printed, and the document deleted from library.

A Glossary of the Final Word Processing Checkout has been prepared and this Glossary is included in this appendix. The glossary accounts for differences in tests for standard and archiving workstations. It is suggested that the Field Service Technician archive this Glossary onto his own diskette in order to expedite checkout of OIS systems.

The Final Word Processing Checkout glossary is exercised as follows:

1. Retrieve glossary from diskette (or enter the glossary on the keyboard).
2. Mount initialized diskettes in all archiving workstations and the central archiver.
3. Attach the glossary to all workstations.
4. Exercise Glossary "1" on all archiving workstations and one standard workstation (to test the central archiver).
5. Exercise Glossary "2" on all standard workstations.
6. Cancel the glossary when finished; the glossary will loop upon itself until cancelled.

F.2 GLOSSARY OF FINAL WORD PROCESSING CHECKOUT

----- Page 1 of Glossary -----  
(1)

(-RETURN-)(-PROMPT-)Enter Library(-EXECUTE-)(-1-KEY-)(-PROMPT-)(-EXECUTE-)  
(-GO-TO-GL-)A

----- Page 2 of Glossary -----  
(A)

(-GL-)a  
(-GL-)b  
(-GO-TO-GL-)A

----- Page 3 of Glossary -----  
(2)

(-RETURN-)(-PROMPT-)Enter Library(-EXECUTE-)(-1-KEY-)(-PROMPT-)(-EXECUTE-)  
(-GO-TO-GL-)B

(B)

(-GL-)a  
(-GL-)c  
(-GO-TO-GL-)B

(a)

(-EXECUTE-)Test Document(-EXECUTE-)  
This is a test. This is only a test.(-RETURN-)  
(-GO-TO-PAGE-)(-NORTH-)(-COPY-)(-GO-TO-PAGE-)(-SOUTH-)(-EXECUTE-)(-EXECUTE-)  
(-GO-TO-PAGE-)(-NORTH-)(-COPY-)(-GO-TO-PAGE-)(-SOUTH-)(-EXECUTE-)(-EXECUTE-)  
(-GO-TO-PAGE-)(-NORTH-)(-COPY-)(-GO-TO-PAGE-)(-SOUTH-)(-EXECUTE-)(-EXECUTE-)  
(-GO-TO-PAGE-)(-NORTH-)(-COPY-)(-GO-TO-PAGE-)(-SOUTH-)(-EXECUTE-)(-EXECUTE-)  
(-GO-TO-PAGE-)(-NORTH-)(-COPY-)(-GO-TO-PAGE-)(-SOUTH-)(-EXECUTE-)(-EXECUTE-)  
(-GO-TO-PAGE-)(-SOUTH-)(-PAGE-)  
(-GO-TO-PAGE-)1(-EXECUTE-)(-COPY-)(-GO-TO-PAGE-)99(-EXECUTE-)(-EXECUTE-)(-EXECUT  
E-)  
(-GO-TO-PAGE-)1(-EXECUTE-)(-SEARCH-)test(-CANCEL-)  
(-GLOBL-REPLC-)(-EAST-)(-EAST-)(-EAST-)(-EXECUTE-)  
TEST OF REPLACE(-EXECUTE-)(-GLOBL-REPLC-)  
(-GO-TO-PAGE-)1(-EXECUTE-)  
(-SOUTH-)(-SOUTH-)(-SOUTH-)(-SOUTH-)(-SOUTH-)  
(-DELETE-)(-SOUTH-)(-SOUTH-)(-SOUTH-)(-SOUTH-)(-SOUTH-)(-RETURN-)(-EXECUTE-)  
(-INSERT-)  
This is a test INSERT(-RETURN-)  
This is a test INSERT(-RETURN-)  
This is a test INSERT(-RETURN-)  
This is a test INSERT(-RETURN-)  
This is a test INSERT(-RETURN-)  
(-EXECUTE-)  
(-CANCEL-)(-EXECUTE-)

(b)

(-EXECUTE-)  
(-EXECUTE-)(-EXECUTE-)(-EXECUTE-)(-EXECUTE-)(-EXECUTE-)  
(-EXECUTE-)(-EXECUTE-)(-EXECUTE-)(-EXECUTE-)  
(-EXECUTE-)(-EXECUTE-)(-EXECUTE-)(-EXECUTE-)  
(-EXECUTE-)(-EXECUTE-)(-EXECUTE-)  
(-CANCEL-)

(c)

(-EXECUTE-)  
(-EXECUTE-)(-EXECUTE-)(-EXECUTE-)  
(-CANCEL-)

**APPENDIX**  
**G**  
**ILLUSTRATED**  
**PARTS**  
**BREAKDOWN**

APPENDIX GILLUSTRATED PARTS BREAKDOWN

The Illustrated Parts Breakdown for the OIS 140/145 Master Unit is presented in this appendix as follows:

TABLE G-1 IPB INDEX

DESCRIPTION	ILLUSTRATION	PARTS LIST
Master Unit Overview	Figure G-1	-----
Rear Panel Assembly	Figure G-2	Table G-2
Frames Assembly	Figure G-3	Table G-3
Rack-Mounted Sub Assembly	Figure G-4	Table G-4
Control Panel Assembly	Figure G-5	Table G-5
Motherboard Assembly	Figure G-6	Table G-6
Chassis Assembly	Figure G-7	Table G-7

POWER SUPPLY CHASSIS 60Hz  
270-0601

POWER SUPPLY CHASSIS 50Hz  
270-0601-1

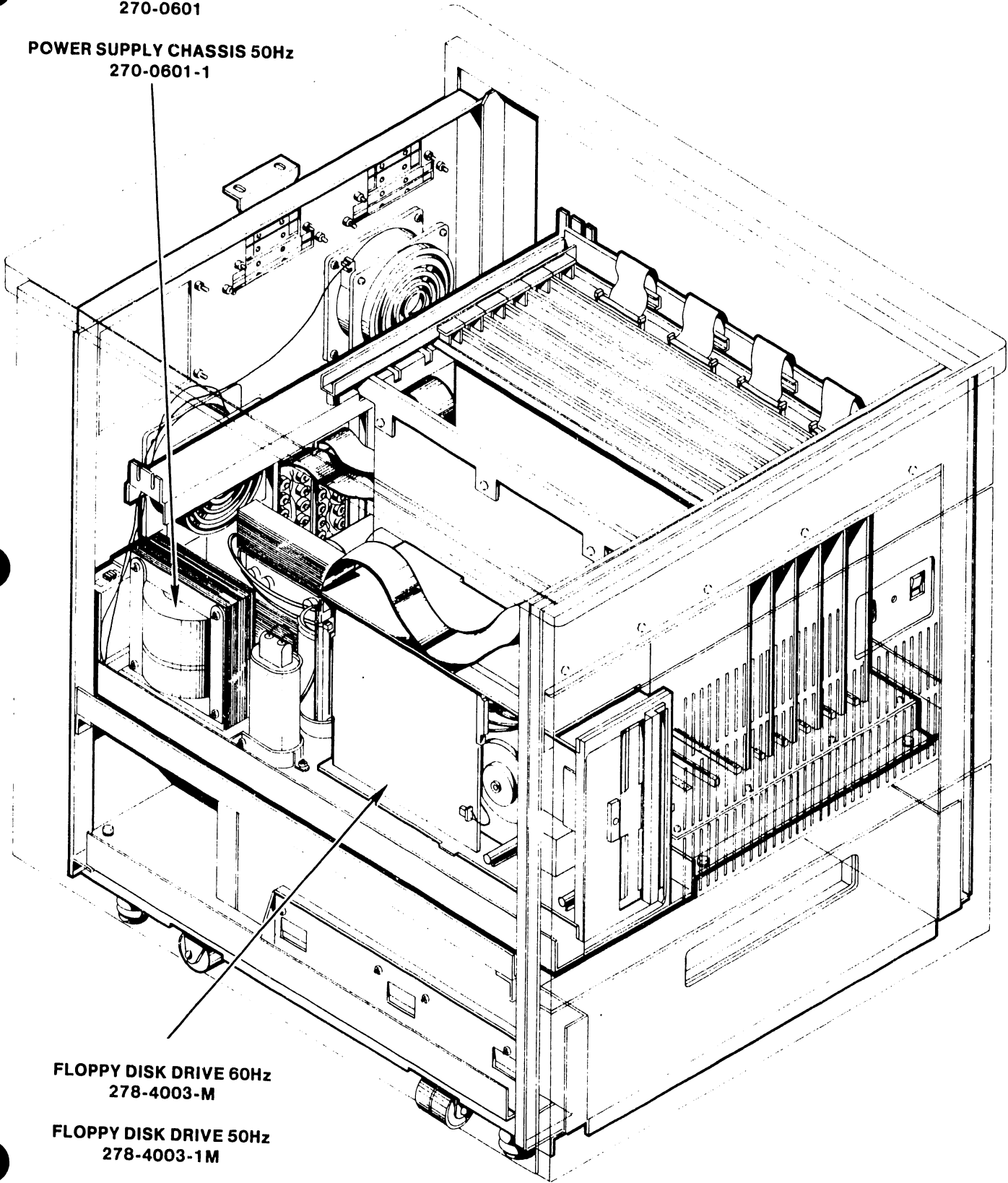

FLOPPY DISK DRIVE 60Hz  
278-4003-M

FLOPPY DISK DRIVE 50Hz  
278-4003-1M

FIGURE G-1 MASTER UNIT OVERVIEW

TABLE G-2 REAR PANEL ASSEMBLY

ITEM	PART NO.	DESCRIPTION
1	451-2277	REAR PANEL COVER
2	458-0784	WIDE CABLE CLAMP RETAINER
3	458-0782	WIDE RIBBON RETAINER
4	458-0785	CABLE CLAMP RETAINER
5	458-0783	NARROW RIBBON RETAINER
6 *	458-0787	NARROW CABLE CLAMP GROUND STRAP
7 *	458-0786	WIDE CABLE CLAMP GROUND STRAP
8 *	400-1003	TUBEAXIAL FAN
9 *	449-0101	FAN GUARD
10 *	652-0032	6-32 LOCK-NUT KEPS
11 *	650-3160	6-32 1/2 PAN HD PHILP SCREW
12 *	279-0358	SERIAL CONNECTOR PLATE ASSY
13 *	452-2618	CLAMP, CABLE
14 *	654-1011	GROUND LUG, 3/8 INCH
15 *	350-1036	BNC BULKHEAD CONNECTOR
16 *	350-2078	TNC BULKHEAD CONNECTOR
17	451-2290	COVER PLATE, REAR
18 *	650-4240	8-32 x 3/4 PAN HD. PHIL SCREW

\* Indicates Part Is Stocked

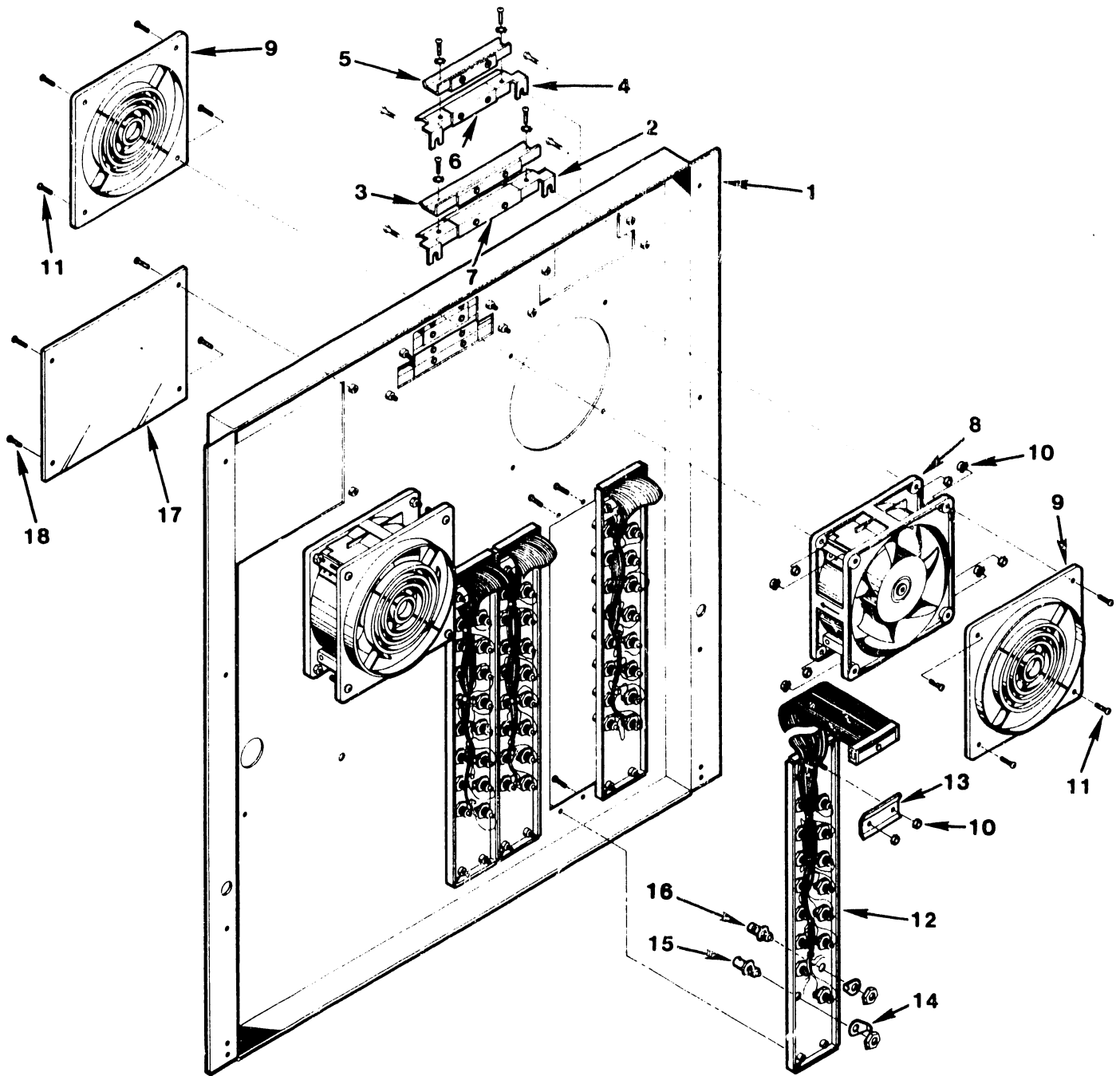

**FIGURE G-2 REAR PANEL ASSEMBLY**

TABLE G-3 FRAMES ASSEMBLY

ITEM	PART NO.	DESCRIPTION
1	451-2277	REAR PANEL COVER
2 *	451-0144	TABLE TOP
3	451-4874	BRACKET GUIDE, TOP
4 *	650-3160	6-32 X 1/2 PAN HD. EL. SCREW
5	451-4872	BRACKET LOCATOR, TOP
6	452-2628	FACE PLATE CLAMP
7	651-4120	8-32 X 3/8 PAN HD. PHIL. SCREW
8	451-4871	REAR FACE PLATE GUIDE
9	478-0571	SPACER, FACE PLATE
10	452-2629	STUD, FACE PLATE CLAMP
11	451-3089	FRONT PANEL (TOP)
12	458-0749	RH SIDE WELDMENT
13	451-4882	BRACKET DAGGER, RH
14	451-3091	FRONT PANEL (MIDDLE)
15	451-3093	FRONT PANEL (BOTTOM)
16 *	652-0032	6-32 LOCK-NUT KEPS
17	451-4881	BRACKET DAGGER, LH
18	458-0750	LH SIDE WELDMENT
19 *	400-1003	TUBEAXIAL FAN
20	451-4873	BRACKET STOP, TOP

\* Indicates Part Is Stocked



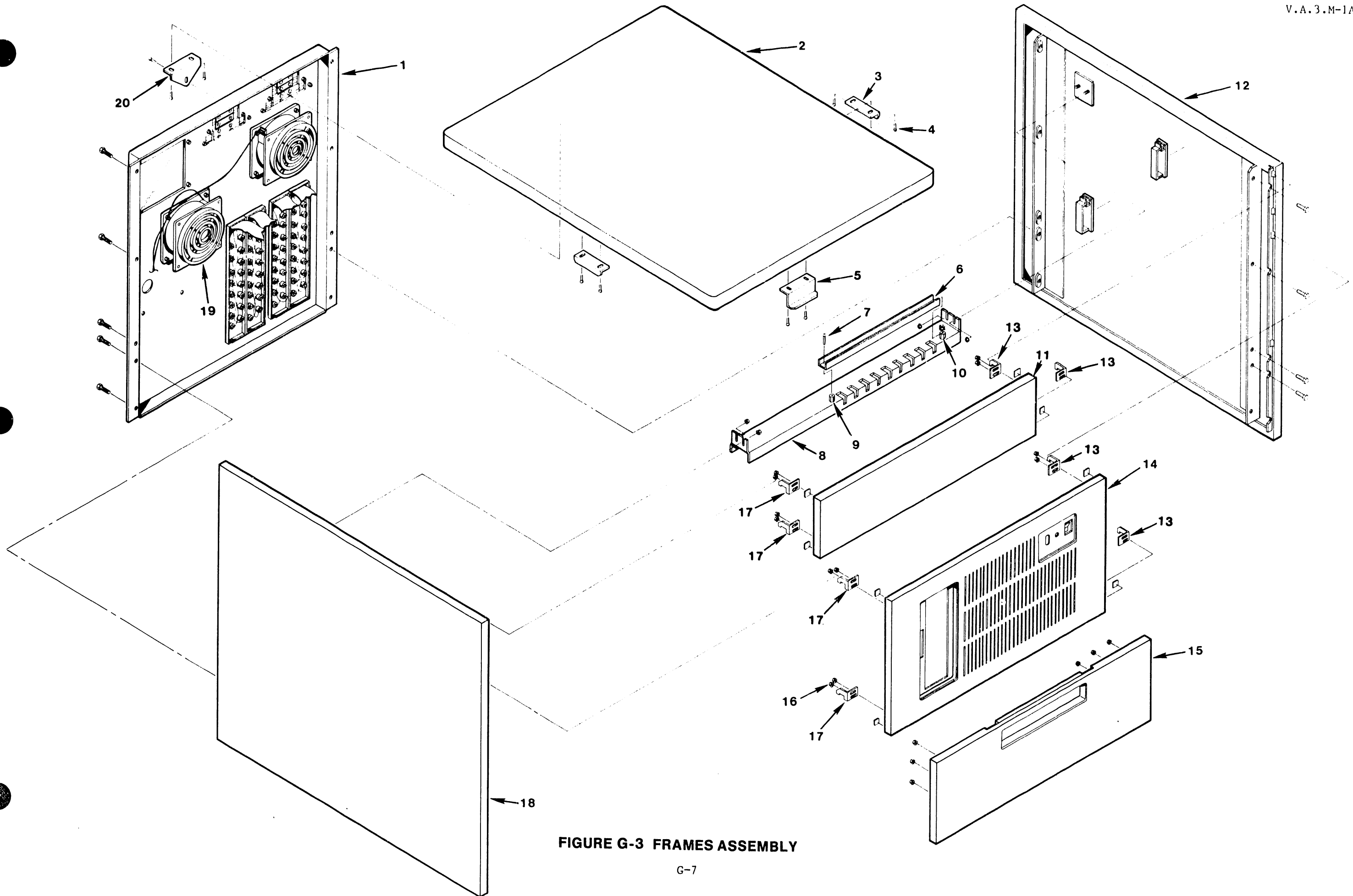

FIGURE G-3 FRAMES ASSEMBLY

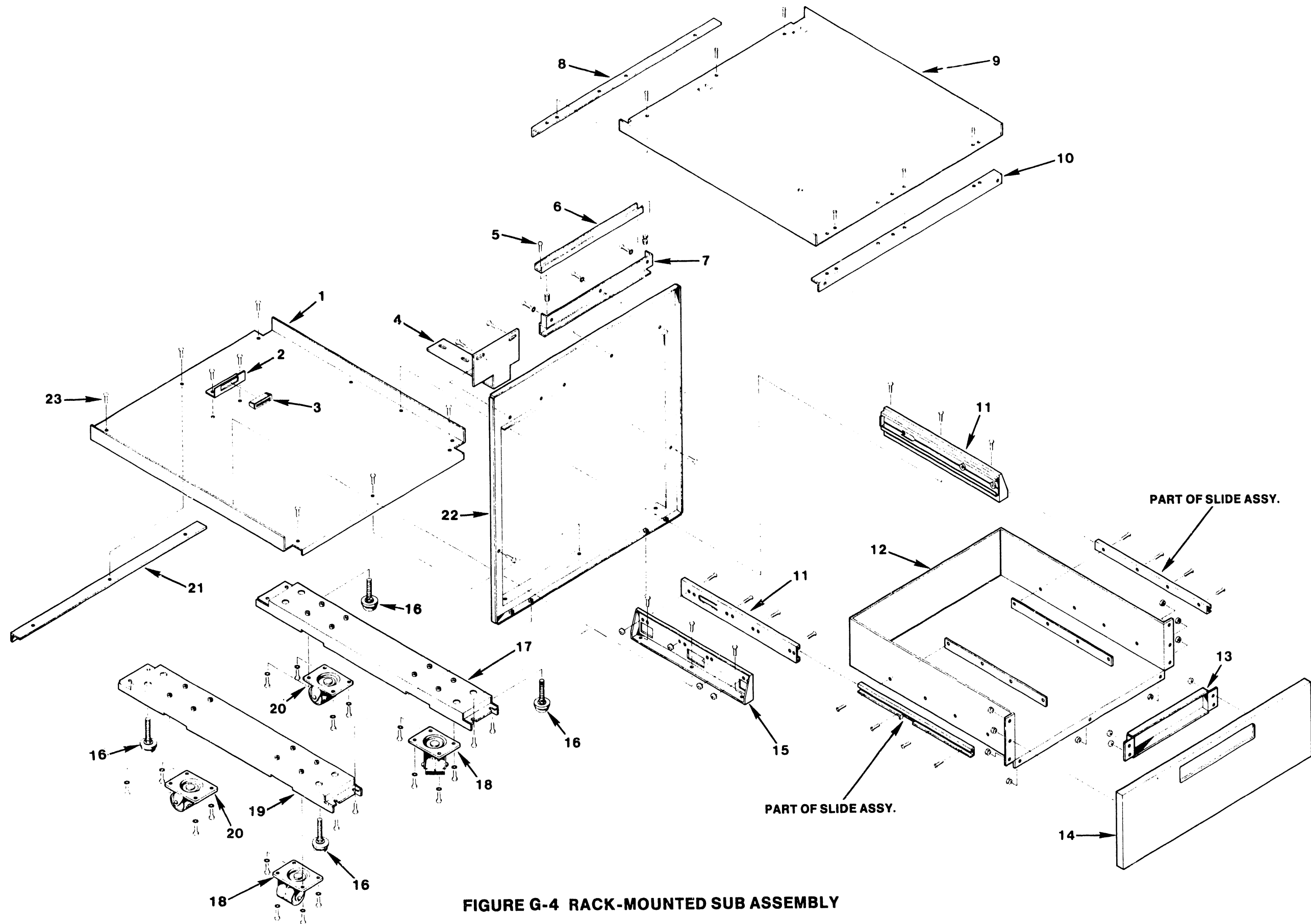

FIGURE G-4 RACK-MOUNTED SUB ASSEMBLY

TABLE G-4 RACK MOUNTED SUB-ASSEMBLY

ITEM	PART NO.	DESCRIPTION
1	458-0752	CABINET BOTTOM WELDMENT
2	451-4581	MAGNET CATCH BRACKET
3	655-0017	MAGNET CATCH
4	451-4885	FLOPPY SUPPORT BRACKET
5 *	650-3160	6-32 X 1/2 PAN HD. PHIL SCREW
6	452-2628	FACE PLATE CLAMP
7	451-4875	FRONT FACE PLATE GUIDE
8	451-4883	REAR BRACKET
9	458-0754	MOTHERBOARD FRAME WELDMENT
10	451-4870	FRONT BRACKET
11	451-1947	SLIDE ASSEMBLY
12	451-6000	DRAWER
13	451-2273	COVER, DRAWER OPENING
14	451-3093	FRONT PANEL (BOTTOM)
15	451-4878	SLIDE BRACKET
16 *	655-0016	LEVELING GUIDES
17	451-4880	BRACKET LEVELER, R.H.
18 *	655-0020	SWIVEL CASTOR
19	451-4879	BRACKET LEVELER, L.H.
20	655-0190	NONSWIVEL CASTOR
21	451-4877	BOTTOM REAR BRACKET
22	458-0748	FRONT SUPPORT
23	650-9024	SCRS/16-18 3/4 HEX HD SCREW

\* Indicates Part Is Stocked

TABLE G-5 CONTROL PANEL ASSEMBLY

ITEM	PART NO.	DESCRIPTION
---	*	
1	*	OIS 140 FRONT CONTROL PANEL ASSY
2	*	PCA 140 FRONT PANEL BOARD
3	*	SPDT TOGGLE SWITCH
4	*	RESET PUSH BUTTON
5	*	RED RECTANGULAR LED CM4-264
6	*	SWITCH COVER
7	*	4-40 LOCK-NUT KEPS
8	*	SPACER, 6-32
9	*	CONTROL PANEL BRACKET WELDMENT
10	*	ROCKER SWITCH, SPST
11	*	FRONT PANEL SILK SCREEN
12	*	FRONT PANEL SWITCH CABLE ASSY
13	*	6-32 x 1/4 PAN HD. PHIL. SCREW
14	*	WASHER
15	*	FRONT PANEL (MIDDLE)
16	*	14 PIN RIBBON CABLE
		FRONT PANEL FLOPPY WELDMENT

\* Indicates Part is Stocked

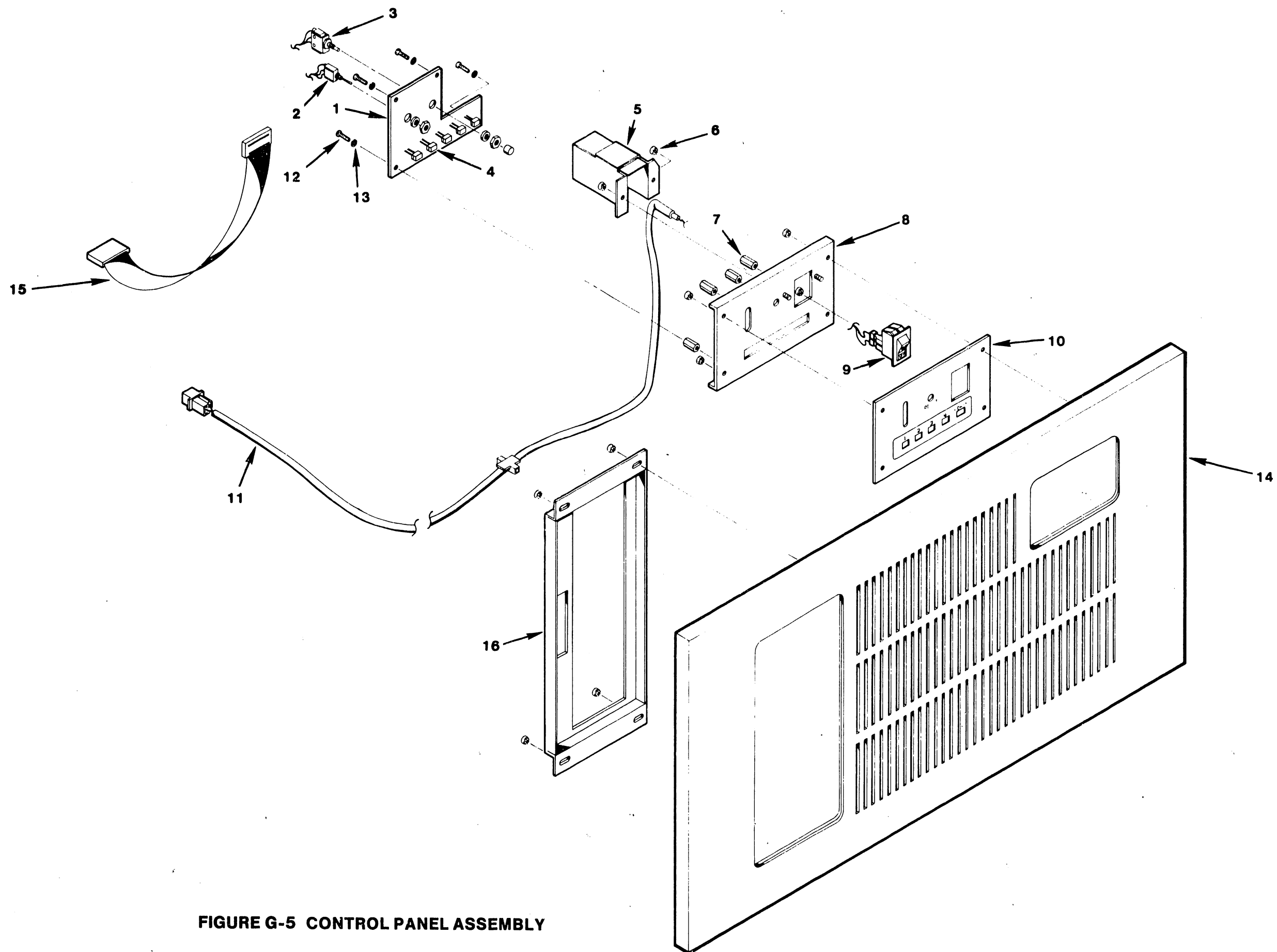

FIGURE G-5 CONTROL PANEL ASSEMBLY

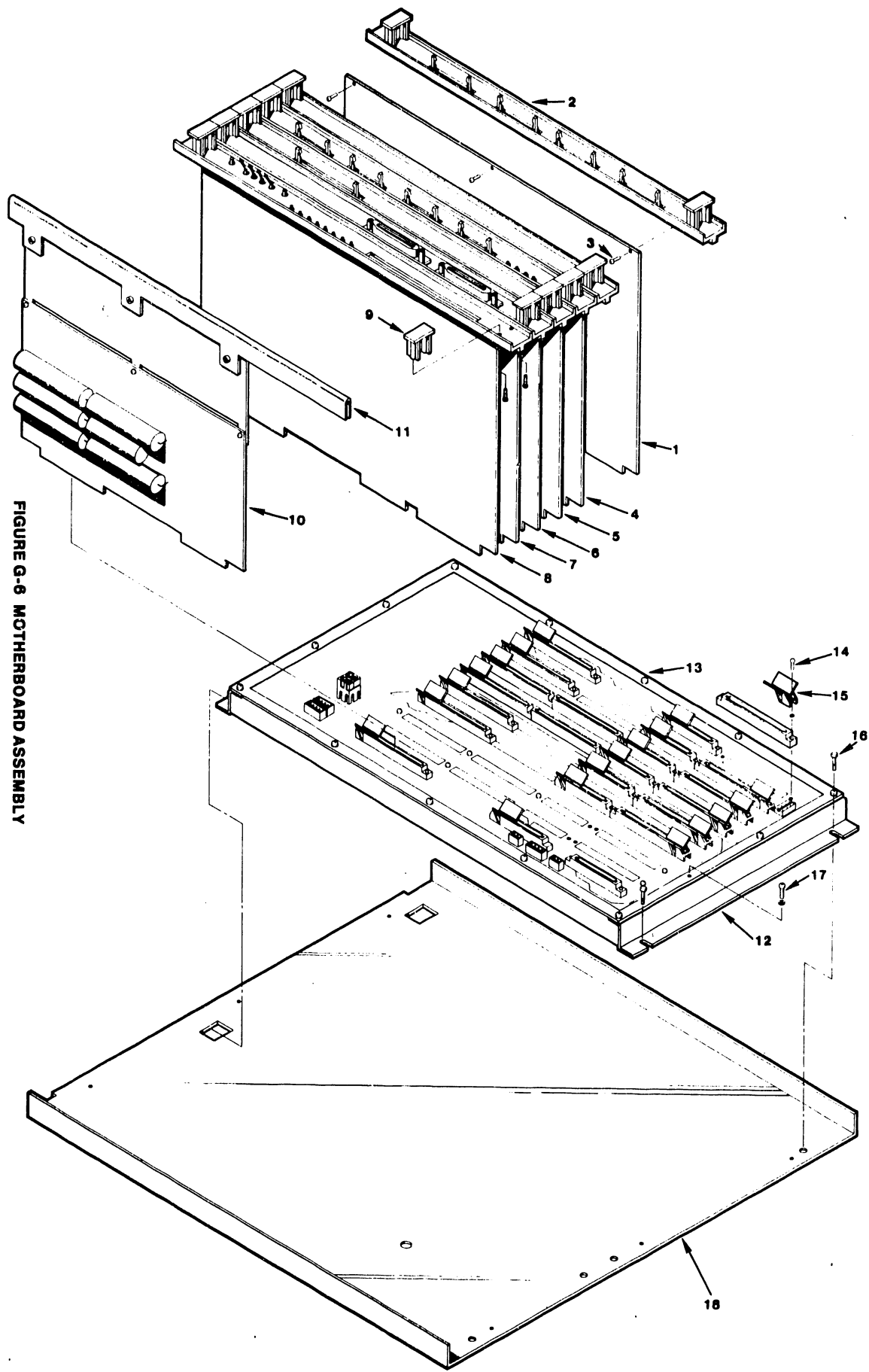

FIGURE G-6 MOTHERBOARD ASSEMBLY

TABLE G-6 MOTHERBOARD ASSEMBLY

ITEM	PART NO.	DESCRIPTION
1 *	210-7504-A	PCA DATA BUFFER
2	452-2095-23	FACE PLATE, 7504 BOARD
3 *	650-2120	4-40 X 3/8 PAN HD SCREW
4 *	210-7503	PCA DATA LINK CONTROL
5 *	210-7506	PCA CMD/SMD CONTROLLER "B"
6 *	210-7505	PCA CMD/SMD CONTROLLER "A"
7 *	210-7502	PCA 10 MEG/FLOPPY CONTROLLER
8 *	210-7501-A	PCA CPU & MEMORY
9	449-0247	FACE PLATE HANDLE
10 *	210-7508	PCA 140 REGULATOR
11	452-2095-40	REGULATOR FACE PLATE
12 *	270-0599	MOTHERBOARD CHASSIS ASSY
13 *	210-7507	PCA MOTHERBOARD
14 *	650-2200	4-40 X 5/8 PAN HD PHIL SCREW
15 *	449-0253	PC CARD GUIDE
16	652-0053	1/4 X 7/16 HEX NUT HD SCREW
17 *	650-3120	6-32 X 3/8 PAN HD PHIL SCREW
18	458-0754	MOTHERBOARD FRAME WLDMT

\* Indicates Part Is Stocked

TABLE G-7 CHASSIS ASSEMBLY

ITEM	PART NO.	DESCRIPTION
1 *	270-0601	POWER SUPPLY CHASSIS ASSY 60 HZ
	270-0601-1	POWER SUPPLY CHASSIS ASSY 50 HZ
2	420-1022	AC CORD
3	654-1214	GROMMET, HEYCO 6P3-4
4 *	380-5001	VARISTOR, 250V
5 *	410-2005	LINE FILTER
6	300-9024	CAPACITOR BOOT
7 *	300-3203	CAPACITOR, 4 UF, 660 VAC
8	300-9026	CAPACITOR CLAMP, OVAL
9 *	300-3087	CAPACITOR, 161K UF 10V
10 *	300-9006	CAPACITOR CLAMP, 2 1/2 INCH.
11 *	270-0600	HEATSINK ASSEMBLY
12	270-3149	HEATSINK HARNESS ASSY
13	220-1365	115 VAC CABLE
14	420-1021	FLOPPY DISK POWER CORD ASSY
15	451-2274	FILTER COVER
16 *	420-1005	ROTRON FAN CORD
17 *	360-9002	HEX NUT
18 *	360-9003	LOCK WASHER
19 *	360-0000	FUSE HOLDER
20 *	360-1040-SB	4.0 AMP FUSE, 3AG, SB (125 VAC PWR)
	360-1031-SB	3.0 AMP FUSE, 3AG, SB (250 VAC PWR)
21	270-3150	TRANSFORMER/HARNESS ASSY 60 HZ
	270-3151	TRANSFORMER/HARNESS ASSY 50 HZ
22 *	220-3011	FLOPPY DISK CABLE ASSY
23 *	278-4003-M	FLOPPY DISK DRIVE ASSY, 60 HZ
	278-4003-1M	FLOPPY DISK DRIVE ASSY, 50 HZ
24	458-0754	MOTHERBOARD FRAME WELDMENT

\* Indicates Part Is Stocked



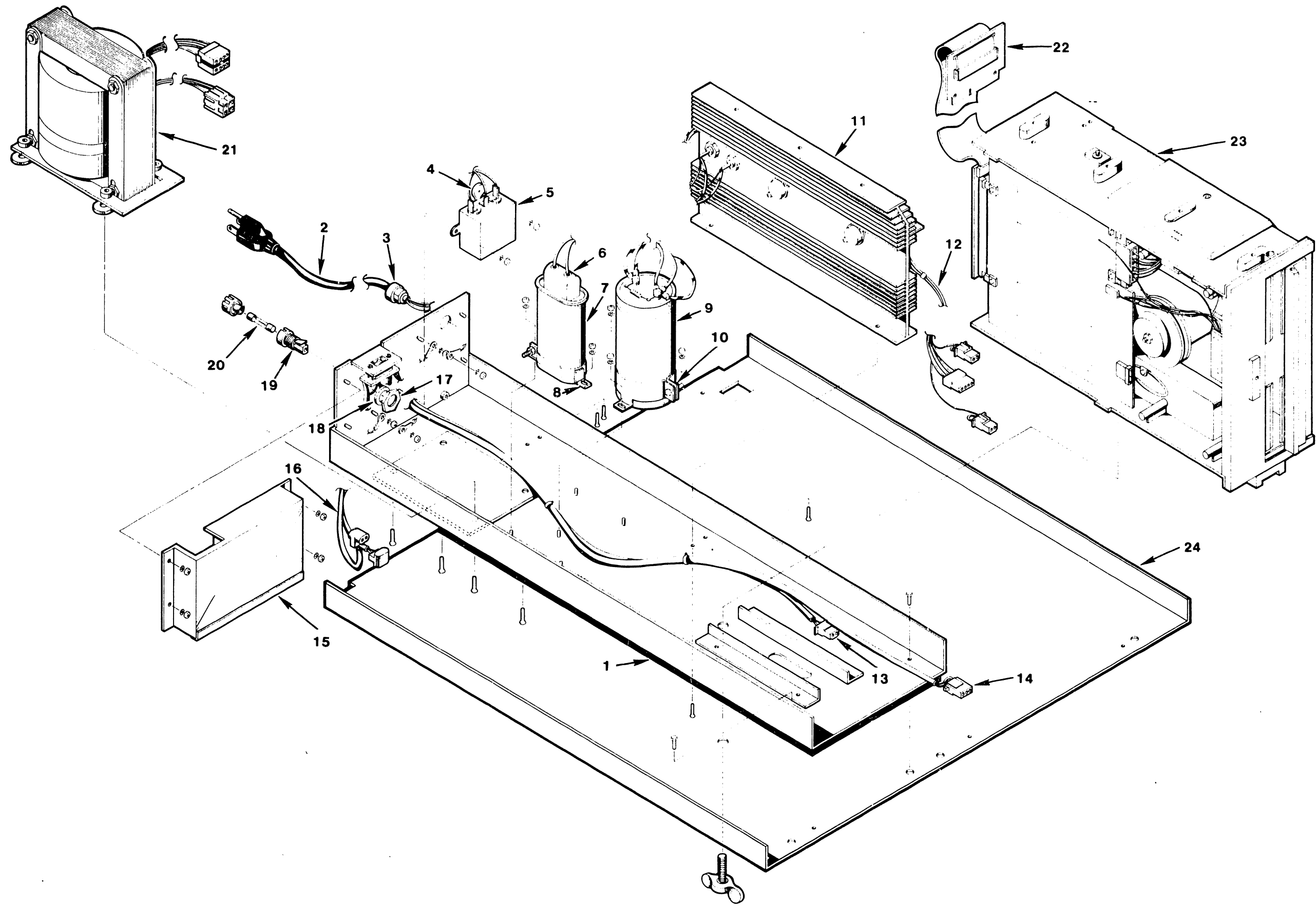

FIGURE G-7 CHASSIS ASSEMBLY

**APPENDIX**

**H**

**SCHE-**

**MATICS**

APPENDIX H  
SCHEMATICS

This appendix provides electrical schematics for the following printed circuit boards:

WLI #	DESCRIPTION	# PAGES
210-7501	CPU/MEMORY	6
210-7502	10 MEG/FLOPPY CONTROLLER	6
210-7503	DATA LINK CONTROLLER	8
210-7504	DATA BUFFER	7
210-7505	CMD/SMD CONTROLLER "A"	6
210-7506	CMD/SMD CONTROLLER "B"	8
210-7507	MOTHERBOARD	4
210-7507-900	INTERCONNECTION DIAGRAM	1
210-7508	POWER SUPPLY REGULATOR	3
210-7684	128K EXTENDED MEM CPU	9
210-7685	128K EXTENDED MEM DAUGHTER	4

THIS DRAWING AND THE DATA SHOWN THERE ON ARE THE CONFIDENTIAL PROPERTY OF AND ARE PROPRIETARY TO WANG LABORATORIES, INC. THIS DRAWING AND THE DATA SHOWN THEREIN MAY NOT BE MADE PUBLIC WITHOUT THE WRITTEN CONSENT OF WANG LABORATORIES, INC. IF FOR ANY REASON THIS DRAWING IS PERMITTED BY WANG TO LEAVE THE PHYSICAL CUSTODY OF THE COMPANY, IT IS RETURNABLE UPON THE DEMAND OF WANG LABORATORIES, INC.

DO NOT SCALE

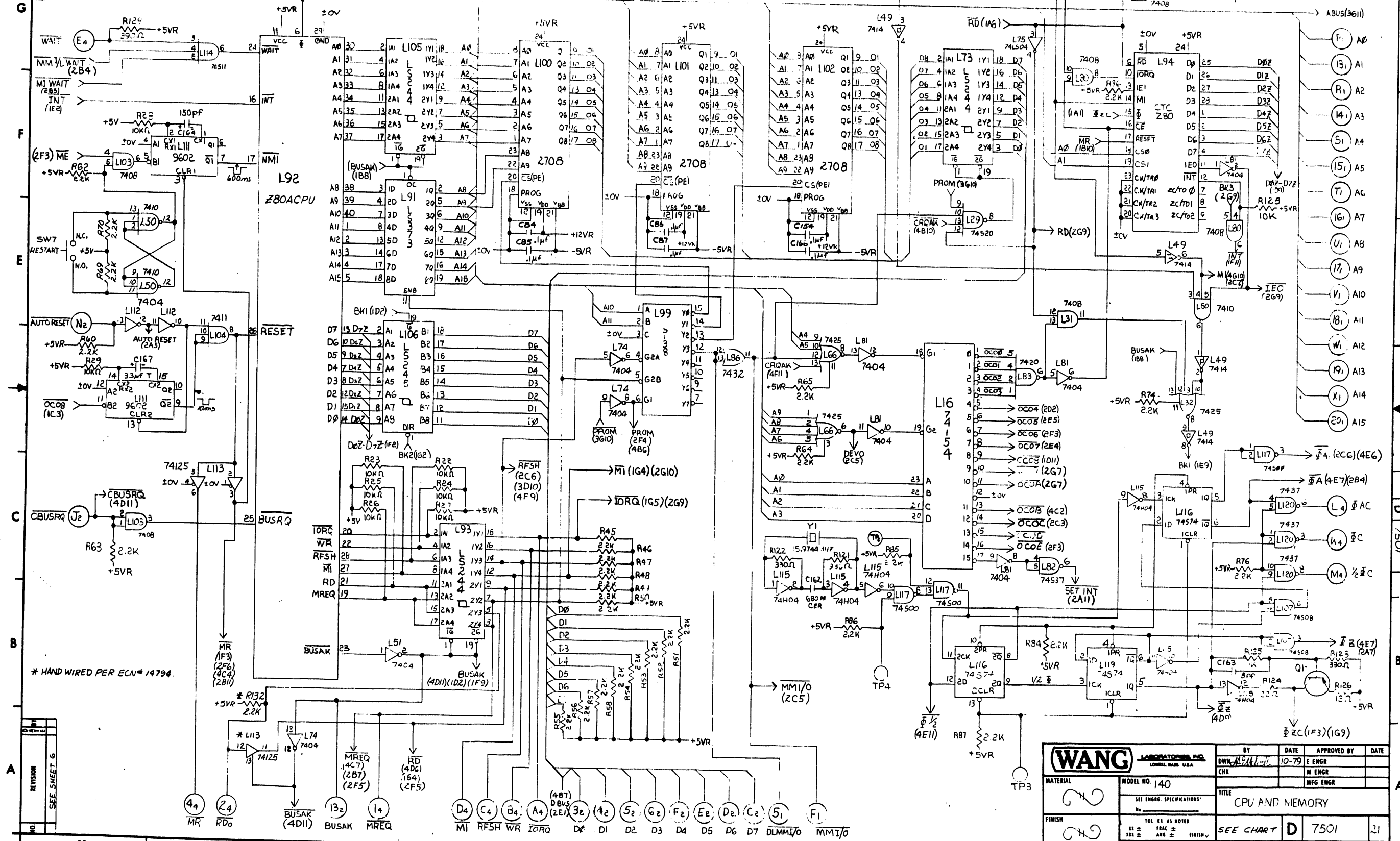

REV	DESCRIPTION
1	ISSUED
2	REVISED
3	REVISED
4	REVISED
5	REVISED
6	REVISED
7	REVISED
8	REVISED
9	REVISED
10	REVISED
11	REVISED

<b>WANG</b> LABORATORIES, INC. LOWELL, MASS. U.S.A.		BY DWN	DATE 10-79	APPROVED BY E ENGR	DATE
MATERIAL	MODEL NO. 140	CHK		MFG ENGR	
SEE ENGR. SPECIFICATIONS		TITLE CPU AND MEMORY			
FINISH		SEE CHART		D	7501
101 EX AS NOTED		SCALE		1	OF 6
11 ± FRAC ±		WANG PART NUMBER		SIZE	DRAWING NUMBER
33 ± ANG ±					REV
SCALE					

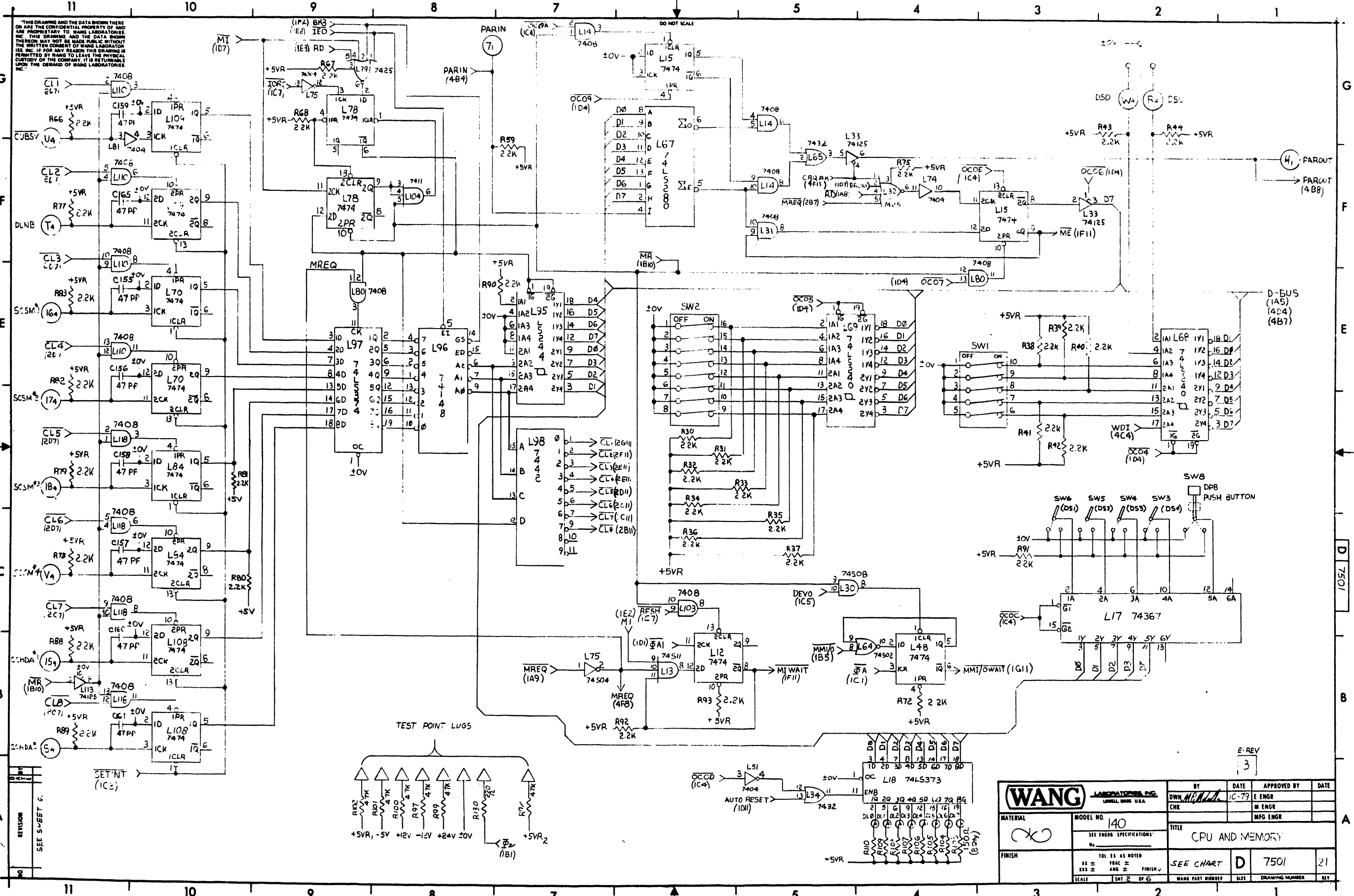

THIS DRAWING AND THE DATA SHOWN THERE ON ARE THE CONFIDENTIAL PROPERTY OF WANG LABORATORIES, INC. THIS DRAWING AND THE DATA SHOWN THEREON MAY NOT BE MADE PUBLIC WITHOUT THE WRITTEN CONSENT OF WANG LABORATORIES, INC. IF FOR ANY REASON THIS DRAWING IS PERMITTED BY WANG TO LEAVE THE PHYSICAL CUSTODY OF THE COMPANY, IT IS RETURNABLE UPON THE DEMAND OF WANG LABORATORIES, INC.

REVISION	SEE SHEET G.
NO.	

<b>WANG</b> LABORATORIES, INC. LOWELL, MASS. U.S.A.		BY DWN CHK	DATE 10-79	APPROVED BY E ENGR M ENGR MFG ENGR	DATE
MATERIAL	MODEL NO. 140 SEE ENGR. SPECIFICATIONS	TITLE CPU AND MEMORY			
FINISH	TOL. EX. AS NOTED XX ± XXX ± SCALE	SEE CHART	D	7501	21
SCALE SHT 2 OF 6		WANG PART NUMBER	SIZE	DRAWING NUMBER	REV

E-REV  
3

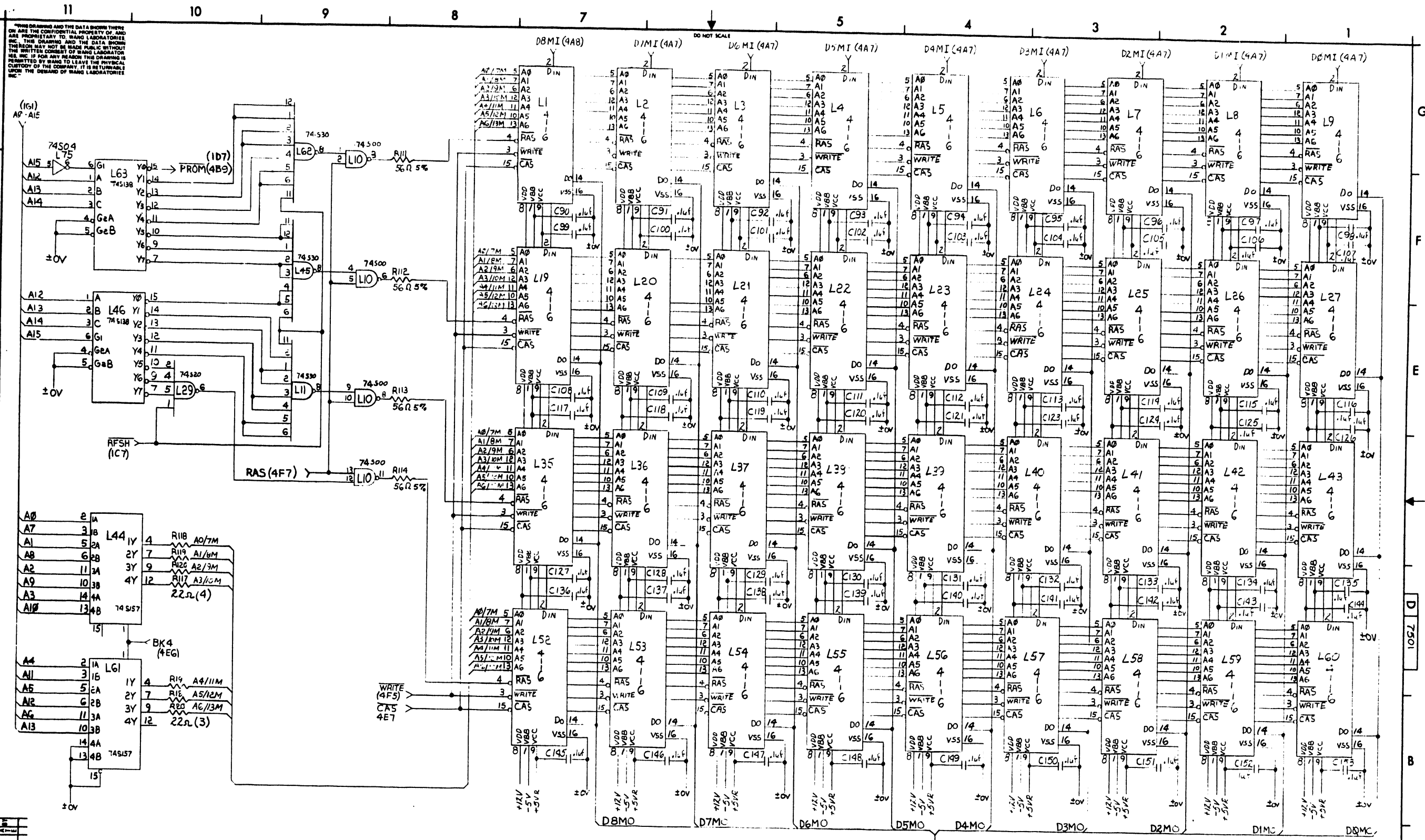

THIS DRAWING AND THE DATA SHOWN THERE ON ARE THE CONFIDENTIAL PROPERTY OF, AND ARE PROPRIETARY TO WANG LABORATORIES, INC. THIS DRAWING AND THE DATA SHOWN THEREIN MAY NOT BE MADE PUBLIC WITHOUT THE WRITTEN CONSENT OF WANG LABORATORIES, INC. IF FOR ANY REASON THIS DRAWING IS PERMITTED BY WANG TO LEAVE THE PHYSICAL CUSTODY OF THE COMPANY, IT IS RETURNABLE UPON THE DEMAND OF WANG LABORATORIES, INC.

NO.	REVISION
	SEE SHEET G

<b>WANG</b> LABORATORIES, INC. LOWELL, MASS. U.S.A.		BY	DATE	APPROVED BY	DATE
		DWN. <i>AD. Mal...</i> CHE	10-79	E ENGR	
MATERIAL		MODEL NO. 140		TITLE	
FINISH		SEE ENGR SPECIFICATIONS		CPU AND MEMORY	
SCALE 1:1		SEE CHART D		SIZE 7501	
DRAWING NUMBER		WANG PART NUMBER		REV	

D8MO - D8MO (4A5)

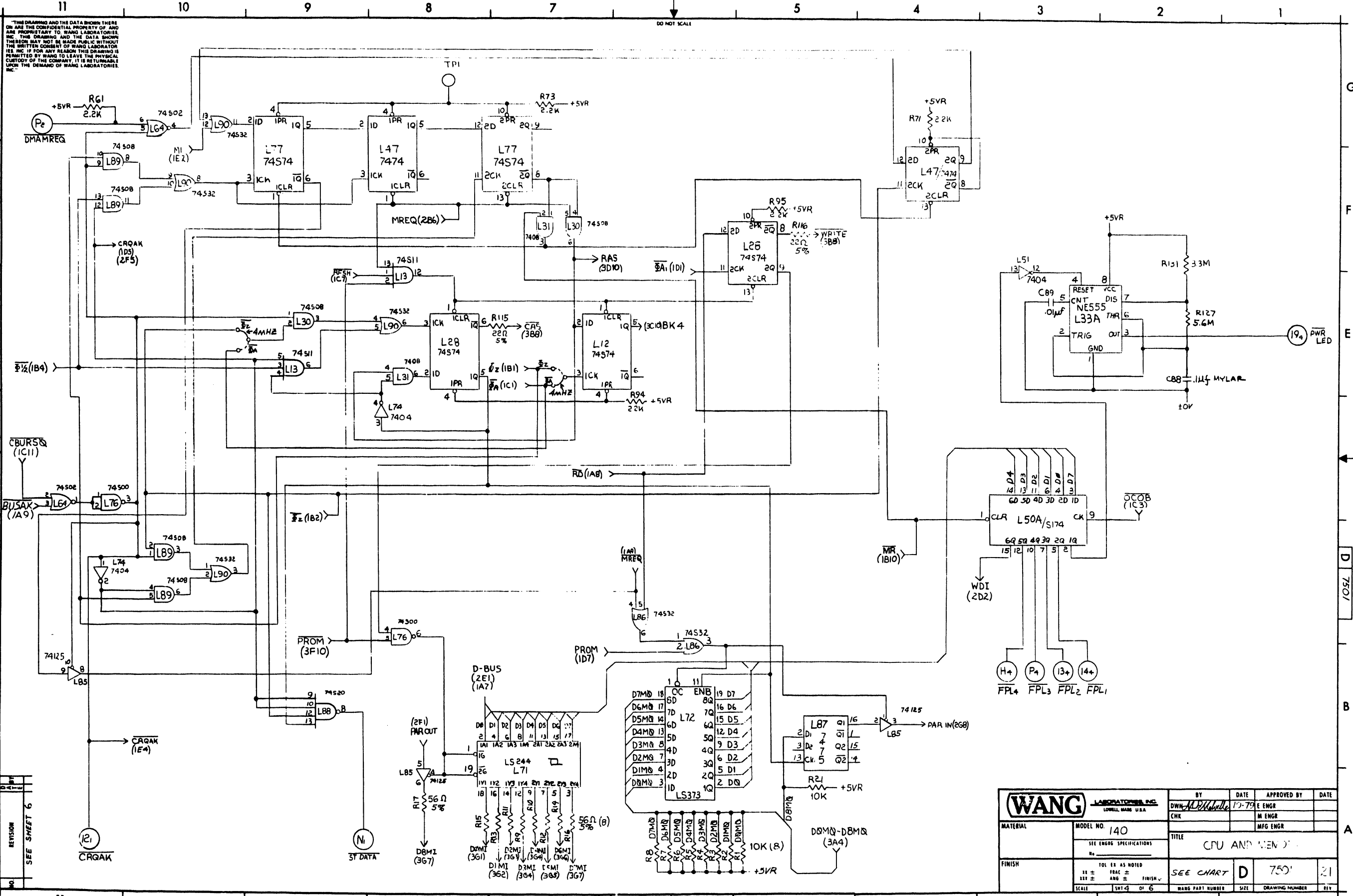

THIS DRAWING AND THE DATA SHOWN THERE ON ARE THE CONFIDENTIAL PROPERTY OF WANG LABORATORIES, INC. THIS DRAWING AND THE DATA SHOWN THEREON MAY NOT BE MADE PUBLIC WITHOUT THE WRITTEN CONSENT OF WANG LABORATORIES, INC. IF FOR ANY REASON THIS DRAWING IS PERMITTED BY WANG TO LEAVE THE PHYSICAL CUSTODY OF THE COMPANY, IT IS RETURNABLE UPON THE DEMAND OF WANG LABORATORIES, INC.

REVISION	DATE	BY	APPROVED BY
1			

SEE SHEET 6

<b>WANG</b> LABORATORIES, INC. LOWELL, MASS. U.S.A.		BY DWN	DATE 10-79	APPROVED BY E ENGR	DATE
MODEL NO. 140		TITLE CPU AND MEM.		MFG ENGR	
SEE ENGR SPECIFICATIONS		FINISH SEE CHART		SCALE 1:1	
MATERIAL		SIZE D		DRAWING NUMBER 7501	
FINISH		WANG PART NUMBER		REV 21	

THIS DRAWING AND THE DATA SHOWN THERE ON ARE THE CONFIDENTIAL PROPERTY OF AND ARE PROPRIETARY TO WANG LABORATORIES, INC. THIS DRAWING AND THE DATA SHOWN THEREON MAY NOT BE MADE PUBLIC WITHOUT THE WRITTEN CONSENT OF WANG LABORATORIES, INC. IF FOR ANY REASON THIS DRAWING IS PERMITTED BY WANG TO LEAVE THE PHYSICAL CUSTODY OF THE COMPANY IT IS RETURNABLE UPON THE DEMAND OF WANG LABORATORIES, INC.

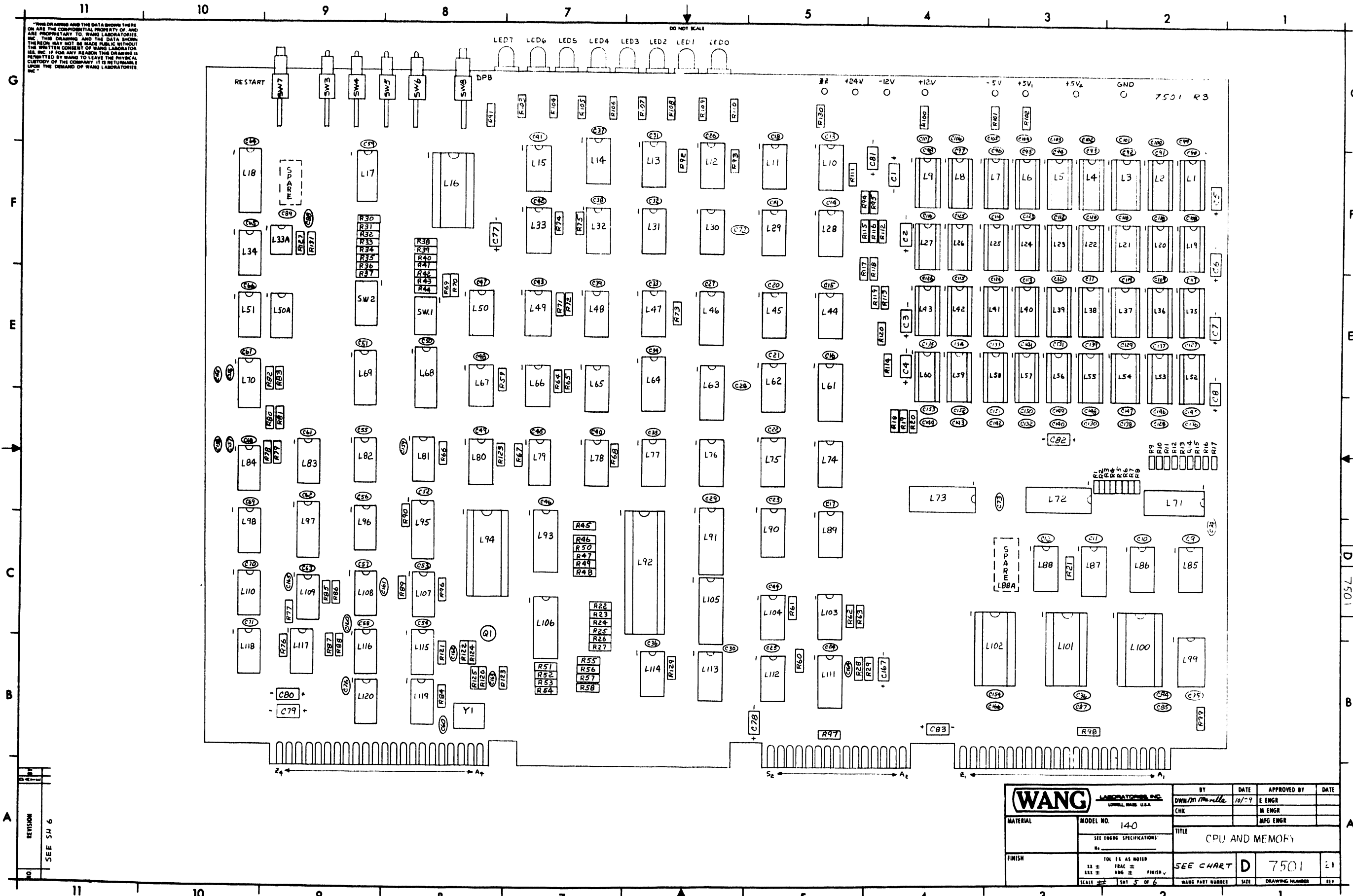

NO.	REVISION

SEE SH 6

<b>WANG</b> LABORATORIES, INC. LYNN, MASS. U.S.A.		BY DWN/M. Manilla	DATE 10/79	APPROVED BY E ENGR	DATE
MATERIAL	MODEL NO. 140	TITLE CPU AND MEMORY			
FINISH	SEE ENGR SPECIFICATIONS	SEE CHART	D	7501	21
SCALE 1:1		SHEET 5 OF 6		WANG PART NUMBER	SIZE



THIS DRAWING AND THE DATA SHOWN THEREON ARE THE CONFIDENTIAL PROPERTY OF AND ARE PROPRIETARY TO WANG LABORATORIES INC. THIS DRAWING AND THE DATA SHOWN THEREON MAY NOT BE MADE PUBLIC WITHOUT THE WRITTEN CONSENT OF WANG LABORATORIES INC. IF FOR ANY REASON THIS DRAWING IS PERMITTED BY WANG TO LEAVE THE PHYSICAL CUSTODY OF THE COMPANY, IT IS RETURNABLE UPON THE DEMAND OF WANG LABORATORIES INC.

COMPONENT	TYPE	W.L. I #
Q1	SPS6551	375-1050
SW1	SWITCH, 5 POS	325-1501
SW2	SWITCH, 8 POS.	325-1503
SW3-6	SWITCH, TOG	325-0040
SW7,8	SWITCH, P.B.	325-0041

COMPONENT	TYPE	W.L. I #
RI-8, 21, 29, 128	10% 1/4W 10% 1	330-4010
R9-17, 114	560 1/4W 5% 1	330-1057
RI6-1, 111, 120, 124	220 1/4W 5% 1	330-1023
R33, 56, 132	20K 1/4W 10% 1	330-3022
R47, 102	47K 1/4W 5% 1	330-3047
R103, 110	150K 1/4W 10% 1	330-2015
R121, 123	3300 1/4W 10% 1	330-2033
R125	1K 1/4W 10% 1	330-3010
R126	12K 1/4W 10% 1	330-1012
R127	560K 1/4W 10% 1	330-6056
R129	390K 1/4W 10% 1	330-2039
R130	220K 1/4W 10% 1	330-2022
R131	3.3MR 1/4W 10% 1	330-6033

CI-8, 77-83	15uf 20V	300-4022
C9-76	.047uf 50V	300-1966
CB4-87, 90, 121, 123-154, 166	.1uf 50V	300-1930
CB8	.1uf, 50V (M)	300-2213
CB7	.01uf, 25V	300-1903
CI55-161, 165	47Pf 500V	300-1047
C162	680Pf 500V	300-1168
C163	18 Pf, 500V	300-1018
C164	150Pf 500V	300-1150
C167	3.3uf 15V (T)	300-4016
LEDO-7	MV5024 (RED)	370-0026
Y1	15.9744 Mhz	321-0022

LOCATION	TYPE	SPARE
L30	74508	1
L33, L85	74125	2, 1
L34, L65	7432	3, 2
L48	74LS74	1
L49, L87	7474	2, 1
L51	7407	3
L64	74502	1
L75	74504	2
L76, L117	74500	2, 1
L79	7425	1
L82	74537	3
L88	74520	1
L103	7408	1
L107	74508	2
L112	7404	4
L114	74511	2
L119	74574	1
L120	7437	1

LOCATION	W.L. PART NO.	TYPE
L1-5, 19, 27, 35, 43, 52, 60	376-9002	16 PIN SKT
L16, 100-102	376-9003	24 PIN SKT
L92	376-9011	40 PIN SKT
L94	376-9015	28 PIN SKT

LOCATION	W.L. PART NO.	TYPE
L1-9, 19-27, 35-43, 52-60	SEE CHART	MK4116
L10, 76, 117	376-0228	74500
L11, 45, 62	376-0198	74530
L12, 28, 48, 77, 116, 119	376-0202	74514
L13, 114	376-0237	74511
L14, 31, 80, 103, 110, 118	376-0081	7408
L15, 47, 70, 78, 84, 108, 109	376-0006	7474
L16	376-0090	74154
L17	376-0176	74367
L18, 72, 91	376-0310	74LS373
L29, 88	376-0230	74520
L30, 89, 107	376-0200	74508
L32, 66, 79	376-0092	7425
L33, 85, 113	376-0324	74125
L33A	376-0126	NE555
L34, 65, 86	376-0093	7432
L44, 61	376-0217	74LS157
L46, 63, 99	376-0298	74LS138
L49	376-0137	7414
L50	376-0003	7410
L50A	376-0247	74LS174
L51, 74, 81, 112	376-0010	7404
L64	376-0117	74502
L67	376-0242	74LS280
L68, 69	376-0297	74LS240
L71, 73, 93, 95, 105	376-0288	74LS244
L75	376-0197	74504
L82	376-0296	74537
L83	376-0004	7420
L87	376-0013	7475
L90	376-0205	74532
L92	SEE CHART	Z80ACPU
L94	SEE CHART	Z80A-CTC
L96	376-0171	7414A
L97	376-0286	74LS374
L98	376-0008	7442
L100-102	SEE CHART	2708
L104	376-0194	7411
L106	376-0285	74LS245
L111	376-0104	9602
L115	376-0045	74HO4
L120	376-0068	7437

210	209	377-0345	377-0346	377-0371	378-3048-R4	378-2666-R5	378-2667-R5
7501-A	7501	377-0345	377-0371	378-2492-R1	378-2493-R1	378-2494-R1	
7501	7501	377-0345	377-0371	378-2495-R1	378-2496-R1	378-2497-R1	
7501	7501	377-0345	377-0371	378-3047-R5		378-2497-R1	

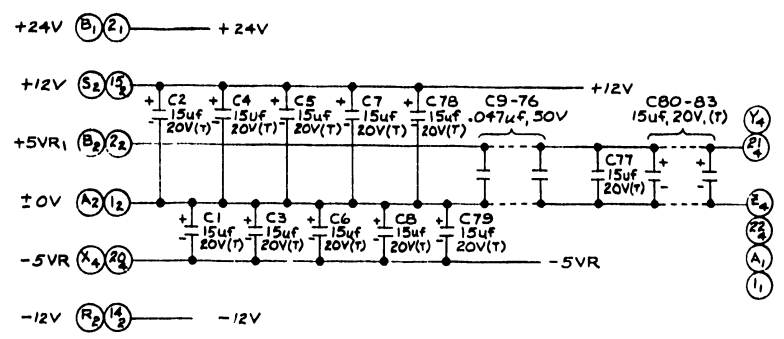
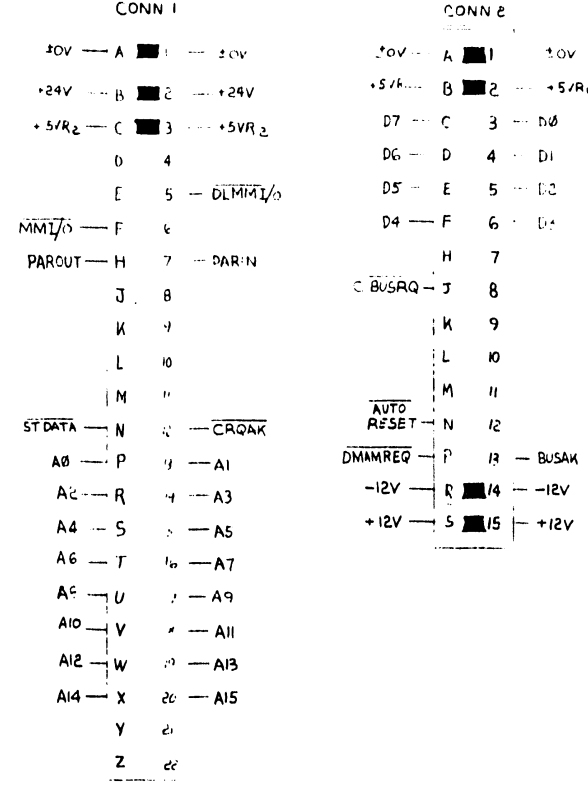

MNEMONIC	COORD.
AQ-AIS	(1F1)
AUTO RESET	(1E11)
BUSAK	(1A9)
CBUSRQ	(1C11)
CRQAK	(4A11)
CUBSY	(4G11)
DO-D7	(1A7)
DLMMI/O	(1A5)
DLNB	(4F11)
DMAMREQ	(4G11)
DSD	(4G2)
DSU	(4G2)
FPLI-FPL4	(4B3)
BAC	(1C1)
BC	(1C1)
1/2 BC	(1C1)

MNEMONIC	COORD.
TORG	(1A7)
MI	(1AB)
MMI/O	(1A5)
MR	(1A10)
MREQ	(1A9)
PARIN	(4G8)
PAROUT	(4F1)
PWR LED	(4E1)
RDS	(1A10)
RFSH	(1AB)
SCHDA1, SCHDA2	(4B11)
SCSM1-SCSM4	(4D11)
STDATA	(4A9)
WAIT	(1G11)
WR	(1AB)

**WANG LABORATORIES INC.**  
LOWELL, MASS. U.S.A.

BY: D.W. DEWITT DATE: 10-79 APPROVED BY: PEP DATE: 10-79  
CHK: RL M ENGR

MATERIAL: SEE ENGR SPECIFICATIONS MODEL NO: 140 TITLE: CPU AND MEMORY

FINISH: 101 EE AS NOTED SCALE: 1:1 WANG PART NUMBER: D SIZE: 7501 DRAWING NUMBER: 21

THIS DRAWING AND THE DATA SHOWN THERE ON ARE THE CONFIDENTIAL PROPERTY OF AND ARE PROPRIETARY TO WANG LABORATORIES, INC. THE DRAWING AND THE DATA SHOWN THEREIN MAY NOT BE REPRODUCED OR TRANSMITTED IN ANY FORM OR BY ANY MEANS, ELECTRONIC OR MECHANICAL, INCLUDING PHOTOCOPYING, RECORDING, OR BY ANY INFORMATION STORAGE AND RETRIEVAL SYSTEM, WITHOUT THE WRITTEN CONSENT OF WANG LABORATORIES, INC. IF FOR ANY REASON THIS DRAWING IS PERMITTED BY WANG TO LEAVE THE PHYSICAL POSSESSION OF THE COMPANY, IT IS RETURNABLE UPON THE DEMAND OF WANG LABORATORIES, INC.

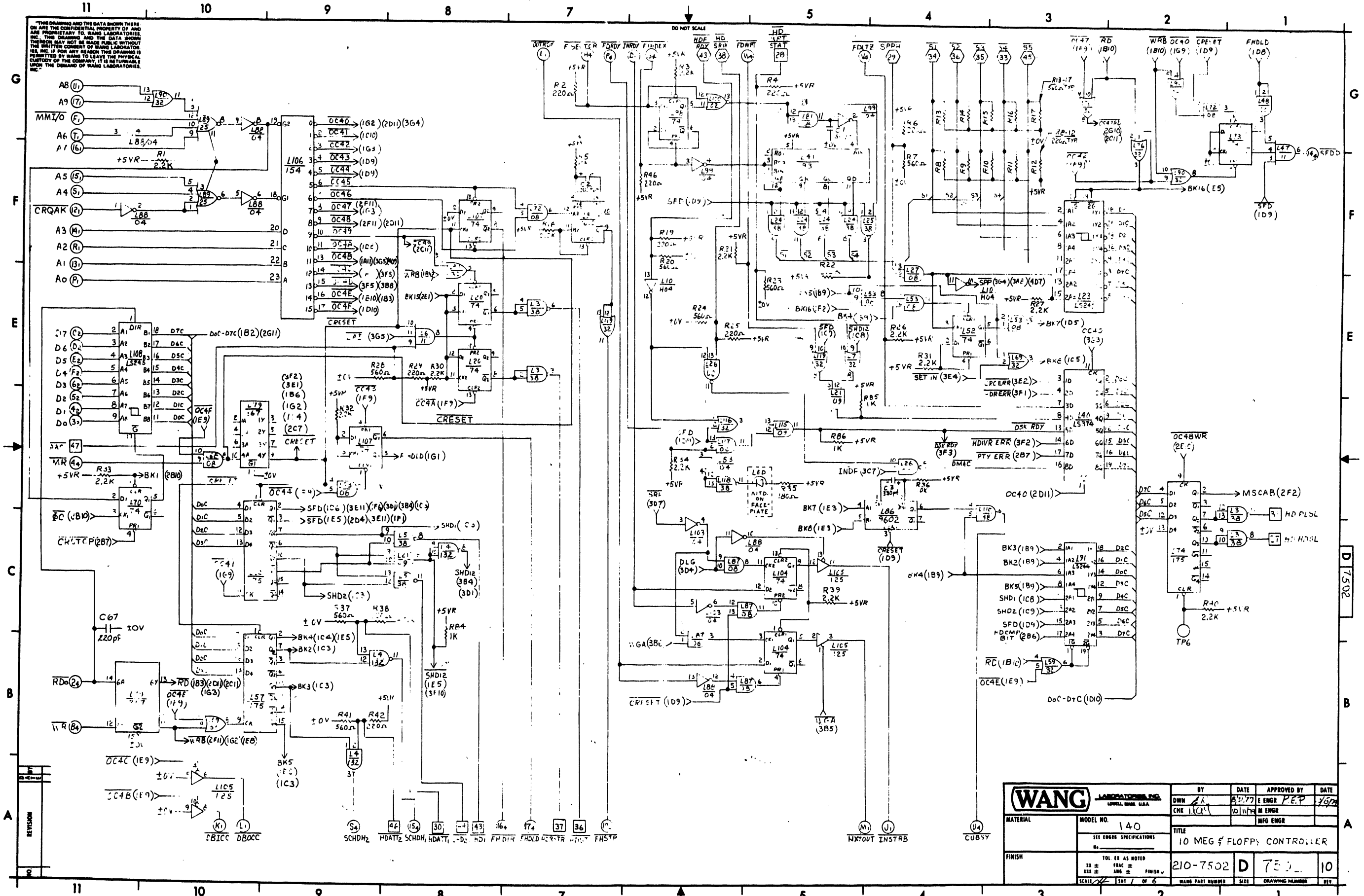

<b>WANG</b> LABORATORIES, INC. LOWELL, MASS. U.S.A.		BY DWN	DATE 8/27/77	APPROVED BY ENGR P.E.P.	DATE 3/6/78
MATERIAL		CHK 1/0/78	DATE 10/17/78	APPROVED BY MFG ENGR	
MODEL NO. 140		TITLE 10 MEG FLOPPY CONTROLLER			
FINISH		SCALE 1/1			
TOL. EX. AS NOTED		DRAWING NUMBER 210-7502			
FRAC. ±		SIZE D			
ANG. ±		REV. 7502			
FINISH ±		DATE 10			
SCALE 1/1		PAGE PART NUMBER 1 OF 6			

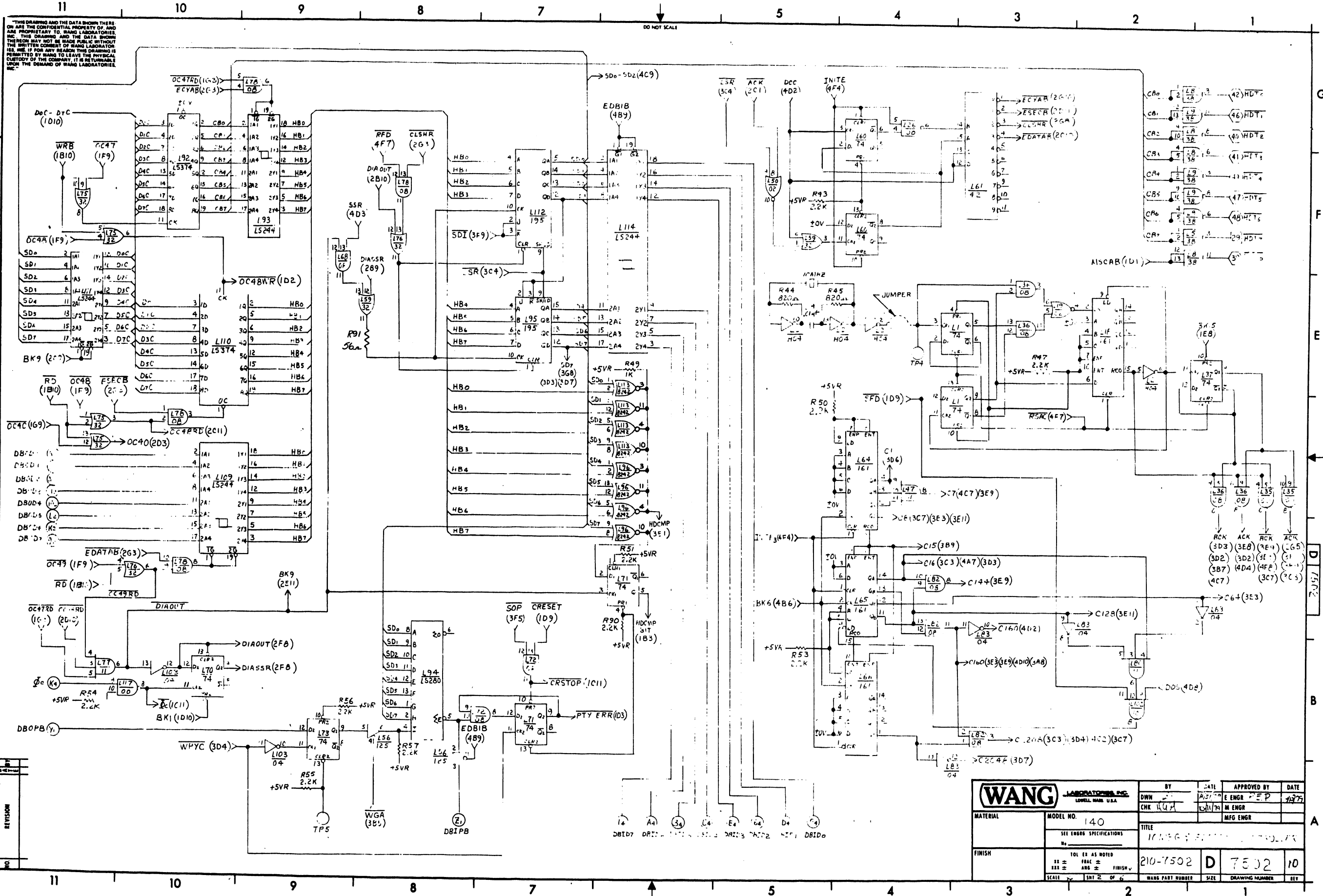

THIS DRAWING AND THE DATA SHOWN THERE ON ARE THE CONFIDENTIAL PROPERTY OF, AND ARE PROPRIETARY TO, WANG LABORATORIES, INC. THIS DRAWING AND THE DATA SHOWN THEREIN MAY NOT BE MADE PUBLIC WITHOUT THE WRITTEN CONSENT OF WANG LABORATORIES, INC. IF FOR ANY REASON THIS DRAWING IS PERMITTED BY WANG TO LEAVE THE PHYSICAL CUSTODY OF THE COMPANY, IT IS RETURNABLE UPON THE DEMAND OF WANG LABORATORIES, INC.

DO NOT SCALE

<b>WANG LABORATORIES, INC.</b> LOWELL, MASS. U.S.A.		BY DWN	DATE 1/27/75	APPROVED BY E ENGR	DATE 1/27/75
MATERIAL		CHK HGH	DATE 1/27/75	MFG ENGR	
MODEL NO. 140		TITLE 10-100-0000-0000-0000-0000			
SEE ENGR SPECIFICATIONS					
FINISH					
TOLERANCES AS NOTED					
XXX ± ANG ± FINISH					
SCALE		210-7502		D 7502 10	
		WANG PART NUMBER		SIZE DRAWING NUMBER REV	



THIS DRAWING AND THE DATA SHOWN THERE ON ARE THE CONFIDENTIAL PROPERTY OF, AND ARE PROPRIETARY TO WANG LABORATORIES, INC. THIS DRAWING AND THE DATA SHOWN THEREON MAY NOT BE MADE PUBLIC WITHOUT THE WRITTEN CONSENT OF WANG LABORATORIES, INC. IF FOR ANY REASON THIS DRAWING IS PERMITTED BY WANG TO LEAVE THE PHYSICAL CUSTODY OF THE COMPANY, IT IS RETURNABLE UPON THE DEMAND OF WANG LABORATORIES, INC.

DO NOT SCALE

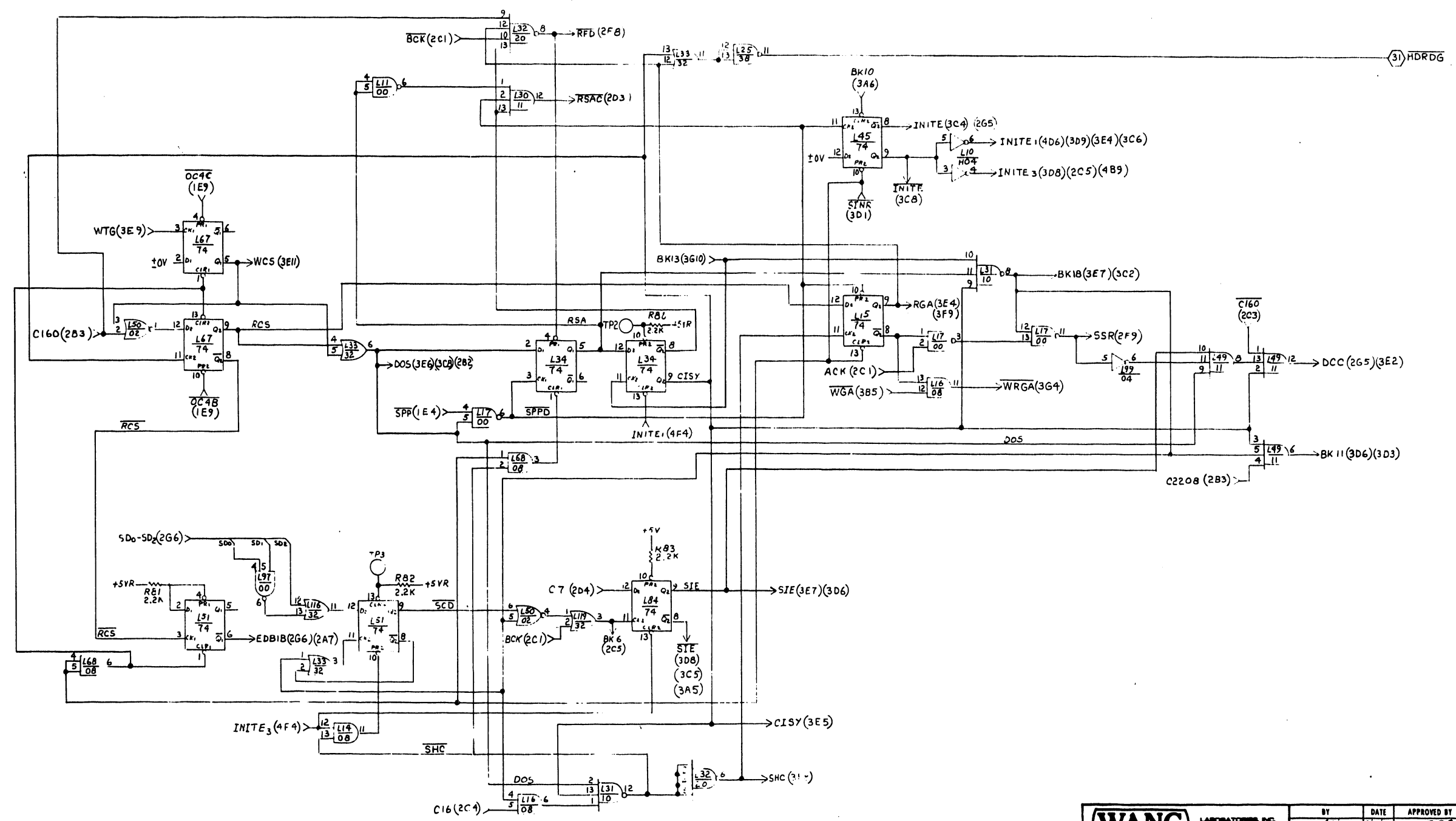

REVISION	
1	
2	

<b>WANG</b> LABORATORIES, INC. LOWELL, MASS. U.S.A.		BY DWH	DATE 8/31/79	APPROVED BY E ENGR P.E.P.	DATE 10/27/79
MATERIAL	MODEL NO. 140	CHK WQR	DATE 10/11/79	APPROVED BY MFG ENGR	
SEE ENGR SPECIFICATIONS		TITLE 16 MEG & FLOW CONTROL			
FINISH	101 ± AS NOTED	216-7500	D	7502	10
	SCALE SHT 4 OF 6	WANG PART NUMBER	SIZE	DRAWING NUMBER	REV

"THIS DRAWING AND THE DATA SHOWN THERE ON ARE THE CONFIDENTIAL PROPERTY OF, AND ARE PROPRIETARY TO, WANG LABORATORIES, INC. THE DRAWINGS AND THE DATA SHOWN THEREIN MAY NOT BE MADE PUBLIC WITHOUT THE WRITTEN CONSENT OF WANG LABORATORIES, INC. IF FOR ANY REASON THIS DRAWING IS PERMITTED BY WANG TO LEAVE THE PHYSICAL CUSTODY OF THE COMPANY, IT IS RETURNABLE UPON THE DEMAND OF WANG LABORATORIES, INC."

DO NOT SCALE

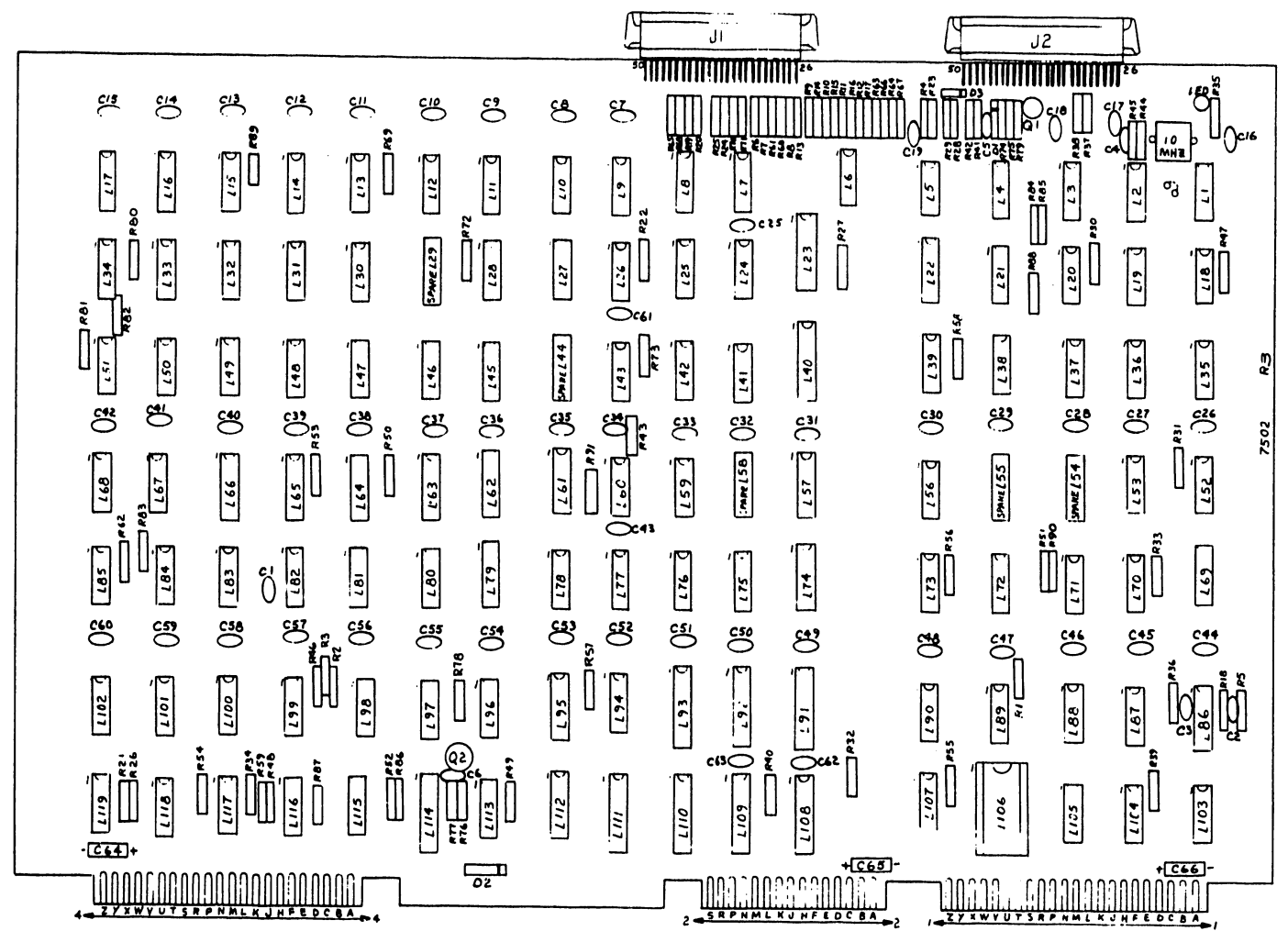

COMPONENT LAYOUT

REV	DATE	BY	CHK
1			
2			

<b>WANG</b> LABORATORIES, INC. LOWELL, MASS. U.S.A.		BY DWN CA	DATE 8/31/79	APPROVED BY E ENGR YEP	DATE 10/8/79
MATERIAL	MODEL NO. 140 SEE ENGR SPECIFICATIONS	CHK VGA		MFG ENGR	
FINISH	TOL EE AS NOTED XX ± ISAC ± XXX ± ANG ± FINISH	TITLE 10MEG FLOPPY CONTROLLER			
SCALE 1/2	SHT 5 OF 6	WANG PART NUMBER 210-7502	SIZE D	DRAWING NUMBER 7502	REV. 10

THIS DRAWING AND THE DATA SHOWN THERE ON ARE THE CONFIDENTIAL PROPERTY OF AND ARE PROPRIETARY TO WANG LABORATORIES, INC. THE DRAWING AND THE DATA SHOWN THEREIN MAY NOT BE MADE PUBLIC WITHOUT THE WRITTEN CONSENT OF WANG LABORATORIES, INC. IF FOR ANY REASON THIS DRAWING IS PERMITTED BY WANG TO LEAVE THE PHYSICAL CUSTODY OF THE COMPANY, IT IS RETURNABLE UPON THE DEMAND OF WANG LABORATORIES, INC.

LOCATION	TYPE	PART NO.
L1,12,15,20,28,34,37,39,42,45,51,52,60,62,67,70,73,84,98,104,107,71	7474	376-0006
L2,10	74H04	376-0045
L3,5,8,9,24,25,118	7438	376-0128
L11,17,26,35,48,97,117	7400	376-0002
L6,30,47,49,77,80,101	7411	376-0194
L7,33,38,59,69,75,76,90,116,119	7432	376-0093
L13,32	7420	376-0004
L14,16,27,36,43,53,68,72,78,81,82,87	7408	376-0081
L18,64,65,66	74161	376-0094
L19,50,100	7402	376-0016
L22,57,74	74175	376-0119
L23	74LS240	376-0297
L31,46,63,102	7410	376-0003
L40,92,110	74LS374	376-0286
L41	7493	376-0011
L56,105	74125	376-0324
L61	7442	376-0008
L91,93,109,111,114	74LS244	376-0288
L79	74367	376-0176
L83,88,103,99	7404	376-0010
L85	9401	376-0440
L86	9602	376-0104
L89	7425	376-0092
L94	74LS280	376-0242
L95,112	74195	376-0097
L96,113	8242	376-0040
L106	74154	376-0090
L108	74LS245	376-0285
L29	SPARE	
L44	SPARE	
L54	SPARE	
L55	SPARE	
L58	SPARE	
L21,115	7409	376-0085
L9	74132	376-0266

COMPONENT	PART NO.	TYPE
R1,13,18,21,22,27,30-34,39,40,43,45,51,53-58,69,72,79,77,80,81,82,83,89,90	330-3022	2.2K 1/4W, 10%
R2,4,6,8-12,19,25,29,38,42,61,63,64,65,70,76	330-2022	220Ω 1/4W, 10%
R5,36,62	330-4010	10K 1/4W, 10%
R7,13-17,20,23,24,28,37,41,60,67,68,71,66,87,88,52	330-2056	560Ω 1/4W, 10%
R35	330-2018	180Ω 1/4W, 10%
R44,45	330-2082	820Ω 1/4W, 10%
R47,57,78,79,81,85,86	330-3010	1K 1/4W, 10%
R59,48	330-2010	100Ω 1/4W, 10%
R91	330-1056	56Ω 1/4W, 10%
C2	300-1911	.0068μF, 100V
C1	300-1560	560pF, 50V
C3	300-1330	330pF, 50V
C4	300-1903	.047μF, 251
C5,6	300-1901	.1μF
C7-63	300-1966	.1μF, 50V
C66	300-4032	10μF, 35V, 10%(T)
C64,65	300-4022	15μF, 20V, 7A
C67	300-1220	220pF, CER
Q1,2	375-9001	TRANSIPAD LGE
Q1,2	375-1009	2N2270
LED 1	370-0026	AV5024 RED
D1,2	580-2120	ZEN INT59A
D3	380-4000	EM403
XTAL	321-0008	10MHZ
J1, J2	350-1045	50 PIN CONN

MNEMONIC	COORD.
A0-A9	1F11
AAC	1D11
CRQAK	1F11
CUBSY	1A4
D0-D7	1D11
SBICC	1A10
DBID0-DBID7	2A6
DBIPB	2A8
DBOCC	1A10
DBOD0-DBOD7	2D11
DBOPB	2B11
FDLT2	1G5
FDRCK	3G11
FDRDD	3F11
FDRDY	1G7
FDWCD	3D1
FDWRG/ERGT	3B1
FHDIR	1A7
FHDL	1A7
FHSTP	1A7
FINDEX	3G
FV. 11	3G
F SECTOR	1G7
HDATT1	1A8
HDATT2	1A8
HDHDSL	1C1
HDPLSL	1D1
HDRCK	3F11

MNEMONIC	COORD.
HDRDD	3F11
HDRSTR	1A7
HDRDG	4F1
HDSRW	1G6
HDST	1A7
HDT0-HDT8	2G1
HDWCD	3D1
HDWRT/ERGT	3A5
HD WRT STAT	1G5
INRDY	1G6
INSTRB	1A4
φc	2B11
LAI	3G5
MM I/O	1G11
MR	1D11
MXT OUT	1A4
OUT RDY	1G7
RD0	1E11
S1-S5	1G4
SCHDH1	1A8
SCHDH2	1A7
SFDD	1G1
SHD1	1A8
SHD2	1A8
SIE	3G6
SPPH	1G4
WCE	3G6
WR	1B11

LOCATION	TYPE	SPARES
L2	74H04	2
L4	74132	1
L5	7438	1
L7	7432	1
L19	7402	3
L25	7438	1
L35	7400	2
L50	7402	1
L52	7474	1
L56	74125	2
L69	7432	3
L79	74367	2
L83	7404	1
L100	7402	1
L103	7404	1
L118	7438	2

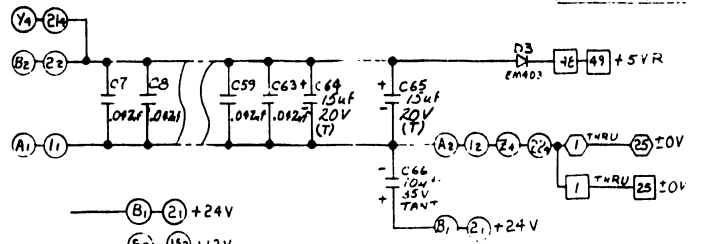

BREAK	FROM	TO
1	1D10	2B10
2	1C3	1B4
3	1C3	1B9
4	1B9	1C4, 1E5
5	1B9	1C3, 1E5
6	4B6	2C5
7	1E3	1D5
8	1E3	1C5
9	2C9	2E11
10	3A6	4F5
11	4D2	303, 3D6
12	321	3F8
13	4E6	3G10
14	3C4	3E10
15	1E8	2E1
16	1F2	1E5

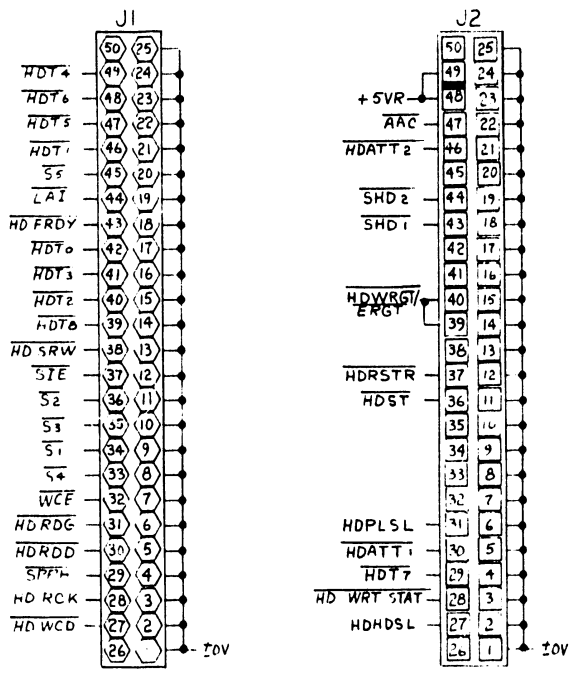
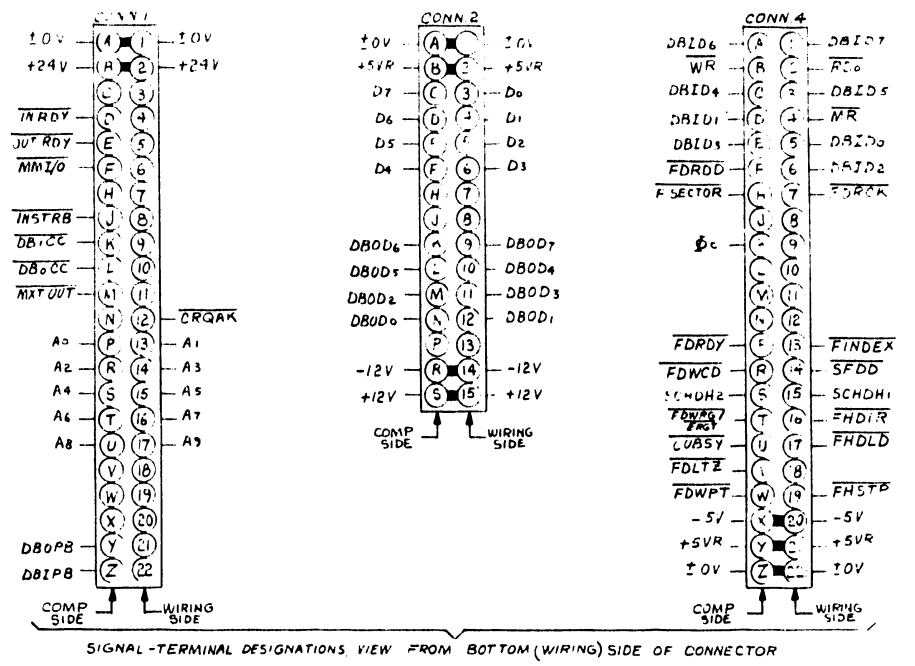

NO.	REVISION	DATE	BY	APPROVED BY
1	ORIGINATED PER			
2	DWR REG. 17			
3	REVISED PER			
4	ECN # 1055			
5	APP'D: 11-11-79			
6	REVISED PER			
7	ECN # 1170			
8	APP'D: 11-11-79			
9	REVISED PER			
10	ECN # 12675			
11	APP'D: 11-11-79			
12	REVISED PER			
13	ECN # 13920			
14	APP'D: 11-11-79			
15	REVISED PER			
16	ECN # 15186			
17	APP'D: 11-11-79			
18	REVISED PER			
19	ECN # 20150			
20	APP'D: 11-11-79			
21	REVISED PER			
22	ECN # 22175			
23	APP'D: 11-11-79			
24	REVISED PER			
25	ECN # 22175			
26	APP'D: 11-11-79			

**WANG** LABORATORIES, INC. LOWELL, MASS. U.S.A.

BY: DWN DATE: 11/11/79 APPROVED BY: E ENGR P.E.P. DATE: 11/11/79

MODEL NO. 140 TITLE: 10MEG 8 FLOPPY CONTROLLER

FINISH: 210-7502 D 7502 10

SCALE: 1/8" = 1" INT. 6 OF 6 WANG PART NUMBER: 7502 DRAWING NUMBER: 10

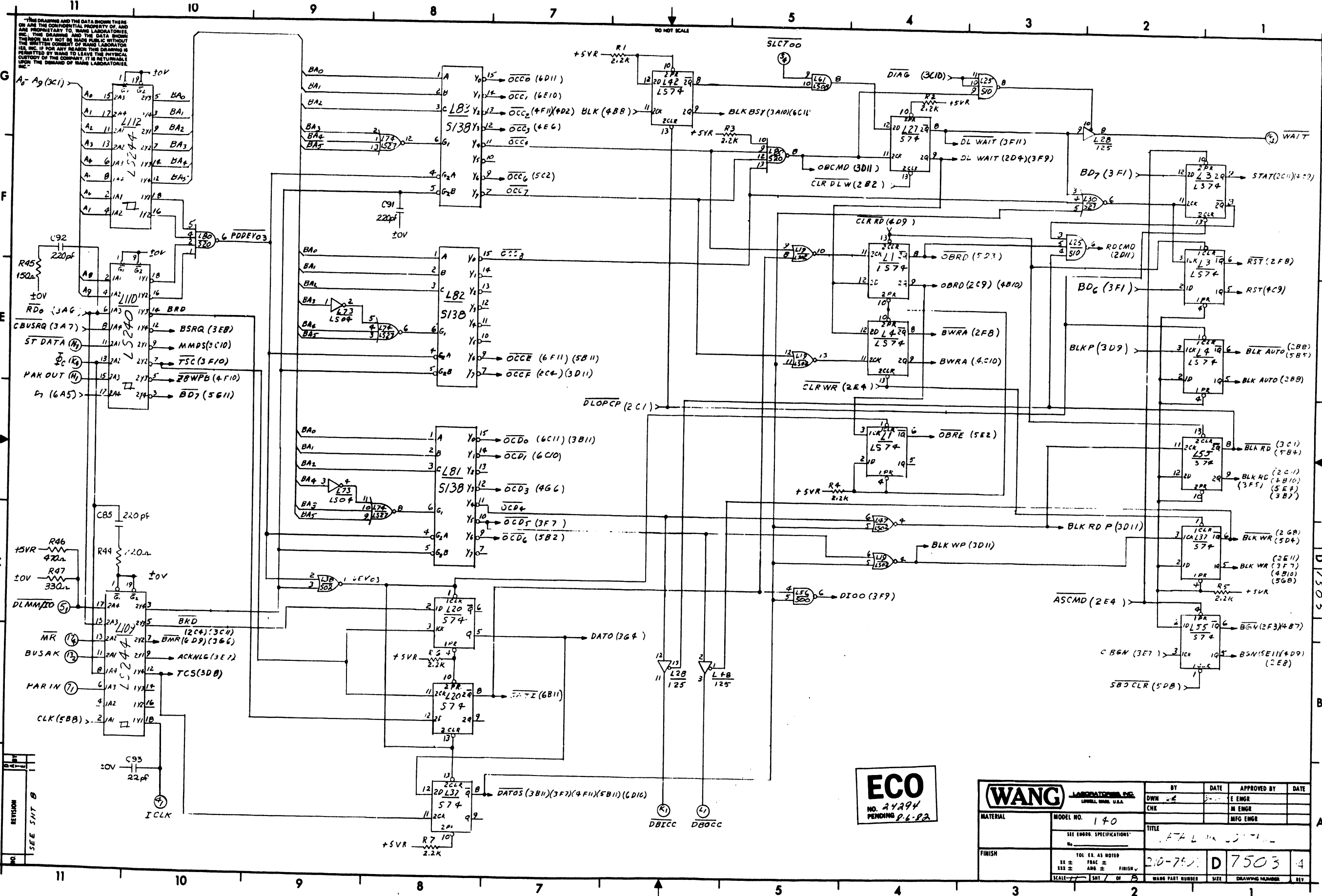

THE DRAWING AND THE DATA SHOWN THERE ON ARE THE CONFIDENTIAL PROPERTY OF, AND ARE PROPRIETARY TO, WANG LABORATORIES INC. THE DRAWING AND THE DATA SHOWN THEREON MAY NOT BE REPRODUCED OR TRANSMITTED IN ANY FORM OR BY ANY MEANS, ELECTRONIC OR MECHANICAL, INCLUDING PHOTOCOPYING, RECORDING, OR BY ANY INFORMATION STORAGE AND RETRIEVAL SYSTEM, WITHOUT THE WRITTEN CONSENT OF WANG LABORATORIES INC. IF FOR ANY REASON THIS DRAWING IS REPRODUCED OR TRANSMITTED IN ANY FORM OR BY ANY MEANS, WITHOUT THE WRITTEN CONSENT OF WANG LABORATORIES INC., IT IS RETURNABLE TO THE COMPANY, AT THE ADDRESS SHOWN BELOW, AT THE RISK OF THE REPRODUCER.

REV	DESCRIPTION
1	ISSUE
2	SEE SHEET B

**ECO**  
NO. 24294  
PENDING P. 6-82

<b>WANG</b> LABORATORIES INC. SPRING HOUSE, PA. U.S.A.		BY: <i>[Signature]</i>	DATE: 5-7-72	APPROVED BY: <i>[Signature]</i>	DATE:
MATERIAL:	MODEL NO. 140	CHK: <i>[Signature]</i>		M ENGR:	
SEE ENGR SPECIFICATIONS		TITLE: <i>[Signature]</i>			
FINISH:	TOL. EX. AS NOTED	210-7503		D7503	4
	SCALE: 1/8" = 1"	SHEET 1 OF 2		DRAWING NUMBER:	REV:



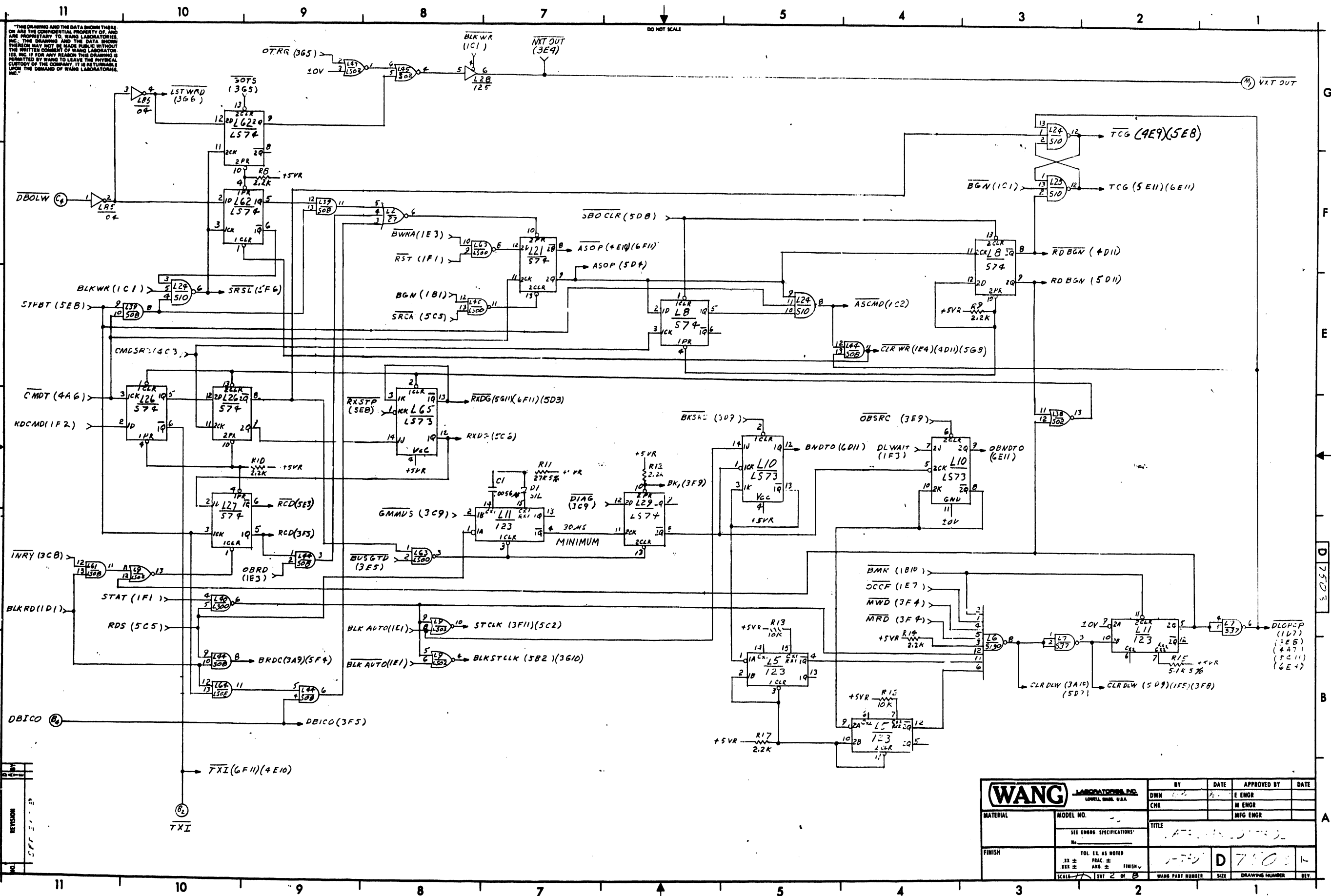

THIS DRAWING AND THE DATA SHOWN THEREON ARE THE CONFIDENTIAL PROPERTY OF, AND ARE PROPRIETARY TO, WANG LABORATORIES, INC. THE DRAWING AND THE DATA SHOWN THEREON MAY NOT BE MADE PUBLIC WITHOUT THE WRITTEN CONSENT OF WANG LABORATORIES, INC. IF FOR ANY REASON THIS DRAWING IS PERMITTED BY WANG TO LEAVE THE PHYSICAL CUSTODY OF THE COMPANY, IT IS HEREBY RETURNABLE UPON THE DEMAND OF WANG LABORATORIES, INC.

REV.	DESCRIPTION
1	REVISED
2	REVISED

WANG LABORATORIES, INC. LOWELL, MASS. U.S.A.		BY	DATE	APPROVED BY	DATE
MATERIAL	MODEL NO.	DWN	7-1-68	E ENGR	
SEE ENGR. SPECIFICATIONS		CHK		M ENGR	
FINISH		TITLE		MFG ENGR	
TOL. EX. AS NOTED		D 7503-14		SCALE 1/8" = 1"	
XX ±		D 7503-14		WANG PART NUMBER	
XXX ±		D 7503-14		SIZE	
FINISH		D 7503-14		DRAWING NUMBER	
SCALE		D 7503-14		DRAWING NUMBER	
SCALE		D 7503-14		DRAWING NUMBER	
SCALE		D 7503-14		DRAWING NUMBER	
SCALE		D 7503-14		DRAWING NUMBER	

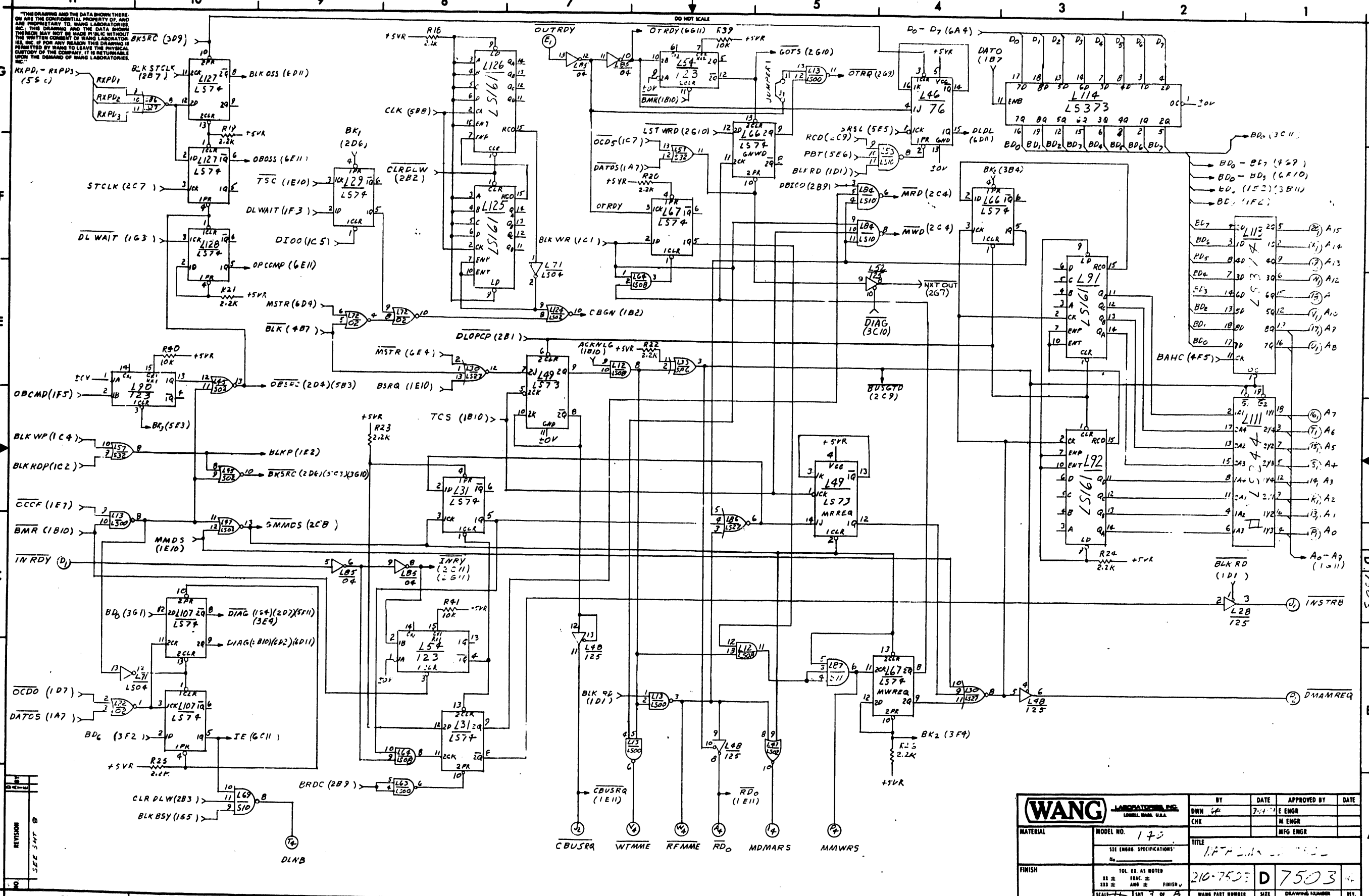

THIS DRAWING AND THE DATA SHOWN THERE ON ARE THE CONFIDENTIAL PROPERTY OF AND ARE PROPRIETARY TO WANG LABORATORIES, INC. THIS DRAWING AND THE DATA SHOWN THEREIN MAY NOT BE REPRODUCED OR TRANSMITTED IN ANY FORM OR BY ANY MEANS WITHOUT THE WRITTEN CONSENT OF WANG LABORATORIES, INC. IF FOR ANY REASON THIS DRAWING IS PERMITTED BY WANG TO LEAVE THE PHYSICAL POSSESSION OF THE COMPANY, IT IS RETURNABLE UPON THE DEMAND OF WANG LABORATORIES, INC.

REV	DESCRIPTION	DATE
1	SEE SMT B	

<b>WANG</b> LABORATORIES, INC. LOWELL, MASS. U.S.A.		BY DWN	DATE 7-7-73	APPROVED BY E ENGR	DATE
MATERIAL		CHK		M ENGR	
MODEL NO. 173		TITLE DATA BUS		MFG ENGR	
FINISH		TOL. EX. AS NOTED		SCALE: 1/8" = 1"	
210-7503		SIZE D 7503		DRAWING NUMBER	

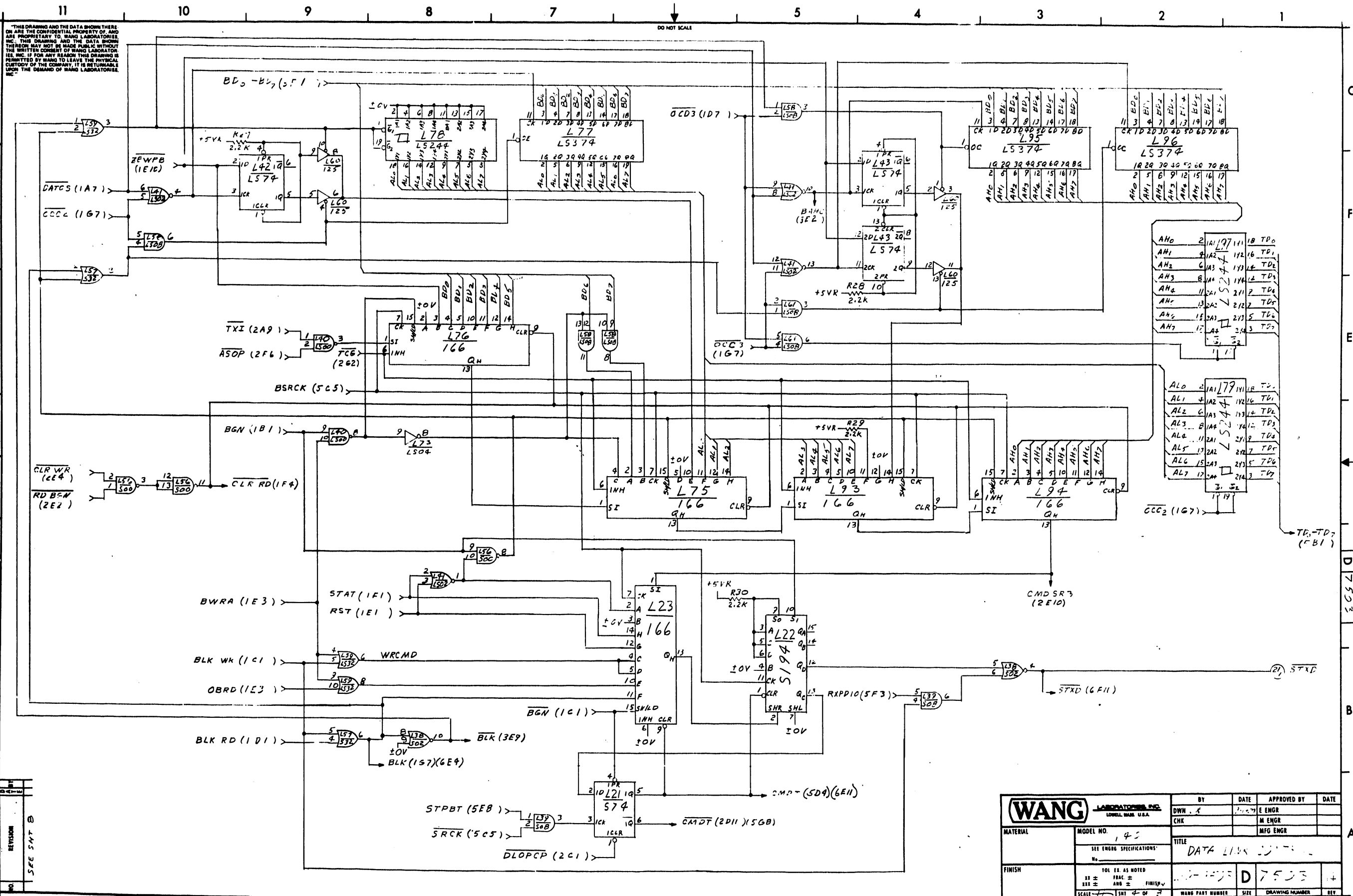

<b>WANG</b> LABORATORIES, INC. LOWELL, MASS. U.S.A.		BY DWN. X	DATE 7-1-77	APPROVED BY E ENGR	DATE
MATERIAL	MODEL NO. 145	CHK		MFG ENGR	
SEE ENGR SPECIFICATIONS		TITLE DATA LINK UNIT			
FINISH TOL. EX. AS NOTED SEE ENGR SPECIFICATIONS		SCALE 1:1		DRAWING NUMBER D 7533	
SCALE		WANG PART NUMBER		SIZE	



"THIS DRAWING AND THE DATA SHOWN THERE ON ARE THE CONFIDENTIAL PROPERTY OF, AND ARE PROPRIETARY TO WANG LABORATORIES, INC. THIS DRAWING AND THE DATA SHOWN THEREON MAY NOT BE MADE PUBLIC WITHOUT THE WRITTEN CONSENT OF WANG LABORATORIES, INC. IF FOR ANY REASON THIS DRAWING IS PERMITTED BY WANG TO LEAVE THE PHYSICAL CUSTODY OF THE COMPANY, IT IS RETURNABLE UPON THE DEMAND OF WANG LABORATORIES, INC."

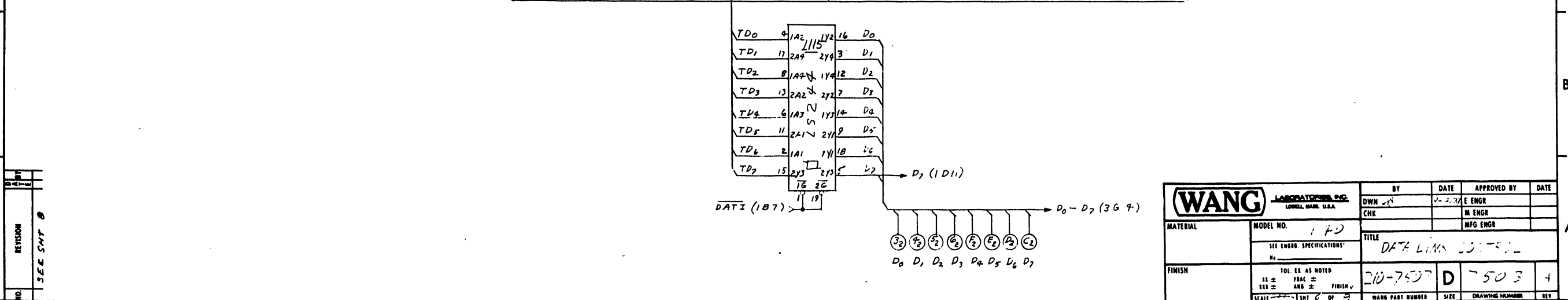
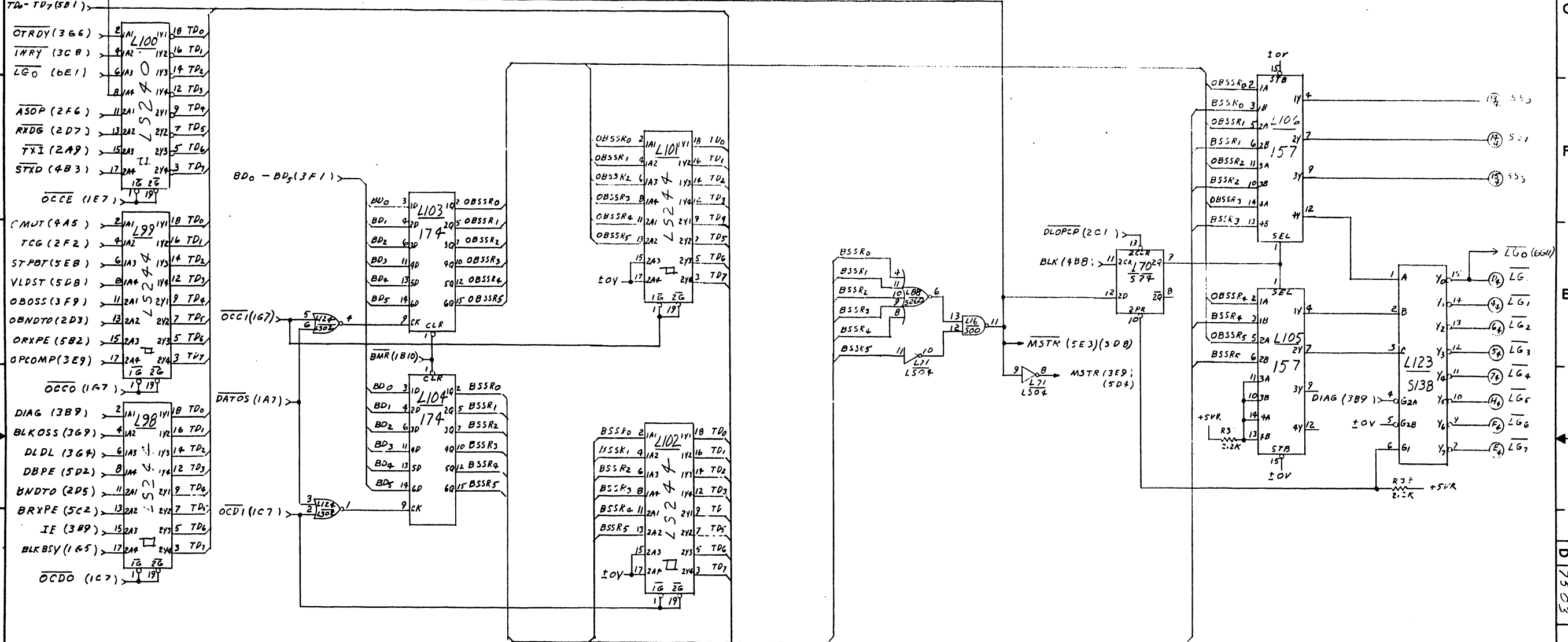

REV	DATE	BY	CHK

<b>WANG</b> LABORATORIES, INC. LOWELL, MASS. U.S.A.		BY	DATE	APPROVED BY	DATE
MATERIAL	MODEL NO. 170	DWN	2-2-70	E ENGR	
FINISH	SEE ENGR. SPECIFICATIONS	CHK		M ENGR	
TITLE		DATA LINK CONTROL			
TOL. EX. AS NOTED		210-7503 D 7503 4			
SCALE 1:1		WANG PART NUMBER SIZE DRAWING NUMBER SET			

D 7503

"THIS DRAWING AND THE DATA SHOWN THERE ON ARE THE CONFIDENTIAL PROPERTY OF AND ARE PROPRIETARY TO WANG LABORATORIES, INC. THIS DRAWING AND THE DATA SHOWN THEREIN MAY NOT BE MADE PUBLIC WITHOUT THE WRITTEN CONSENT OF WANG LABORATORIES, INC. IF FOR ANY REASON THIS DRAWING IS PERMITTED BY WANG TO LEAVE THE PHYSICAL CUSTODY OF THE COMPANY, IT IS RETURNABLE UPON THE DEMAND OF WANG LABORATORIES, INC."

DO NOT SCALE

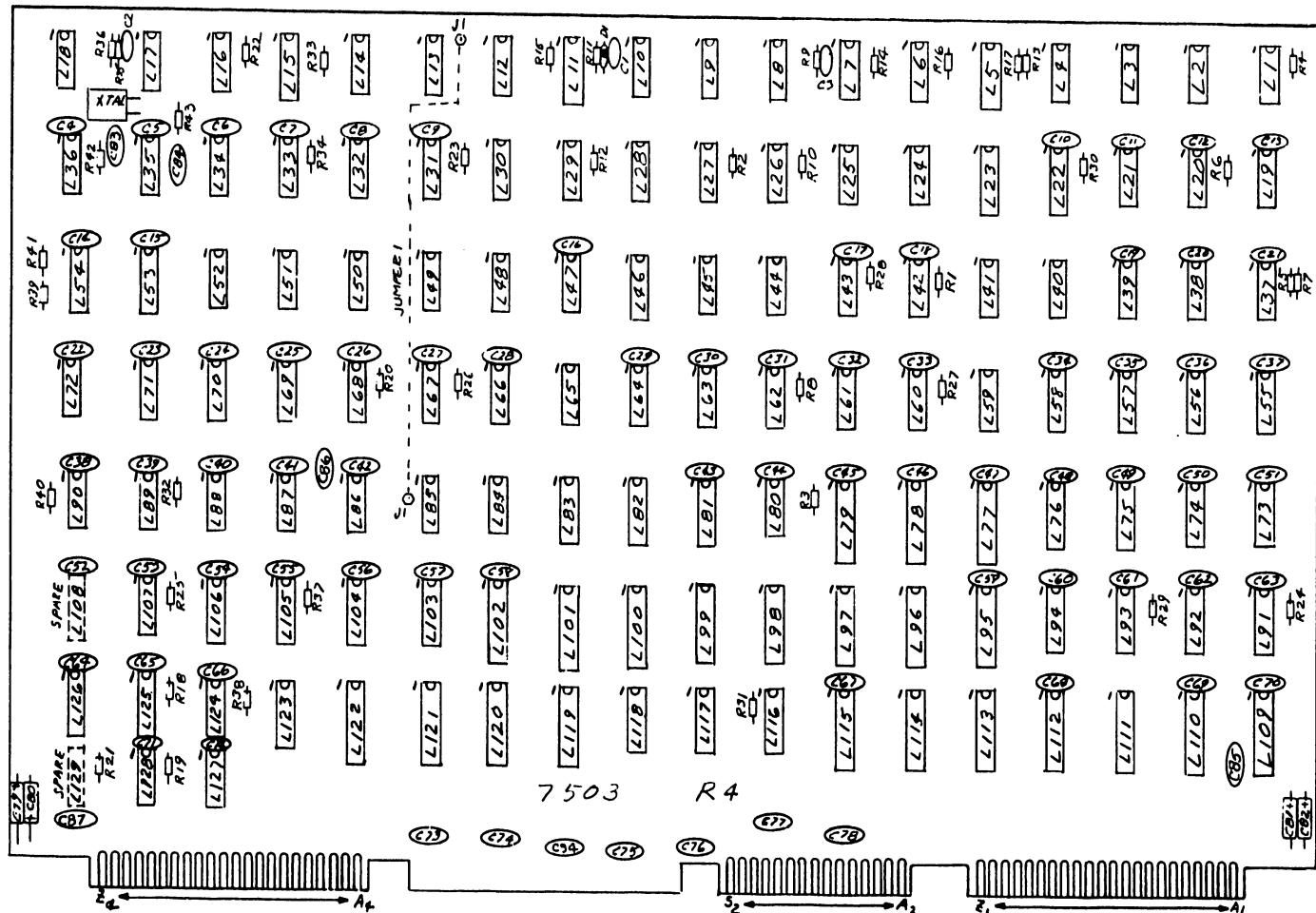

NO.	REVISION	DATE	BY
	SEE SHIP		

<b>WANG</b> LABORATORIES, INC. LOWELL, MASS. U.S.A.		BY DWN	DATE 2-11-77	APPROVED BY E ENGR	DATE
MATERIAL	MODEL NO. 140	CHE		M ENGR	
	SEE ENGR SPECIFICATIONS			MFG ENGR	
FINISH	TOL. EX. AS NOTED XX ± FRAC ± XXX ± ANG ± FINISH	TITLE DATA LINK CONTASL			
	SCALE 1:1	WANG PART NUMBER 210-7503	SIZE D	DRAWING NUMBER 7503	SHEET 14

THIS DRAWING AND THE DATA SHOWN THEREON ARE THE CONFIDENTIAL PROPERTY OF, AND ARE PROPRIETARY TO, WANG LABORATORIES, INC. THIS DRAWING AND THE DATA SHOWN THEREON MAY NOT BE MADE PUBLIC WITHOUT THE WRITTEN CONSENT OF WANG LABORATORIES, INC. IF FOR ANY REASON THIS DRAWING IS PERMITTED BY WANG TO LEAVE THE PHYSICAL CUSTODY OF THE COMPANY, IT IS RETURNABLE UPON THE DEMAND OF WANG LABORATORIES, INC.

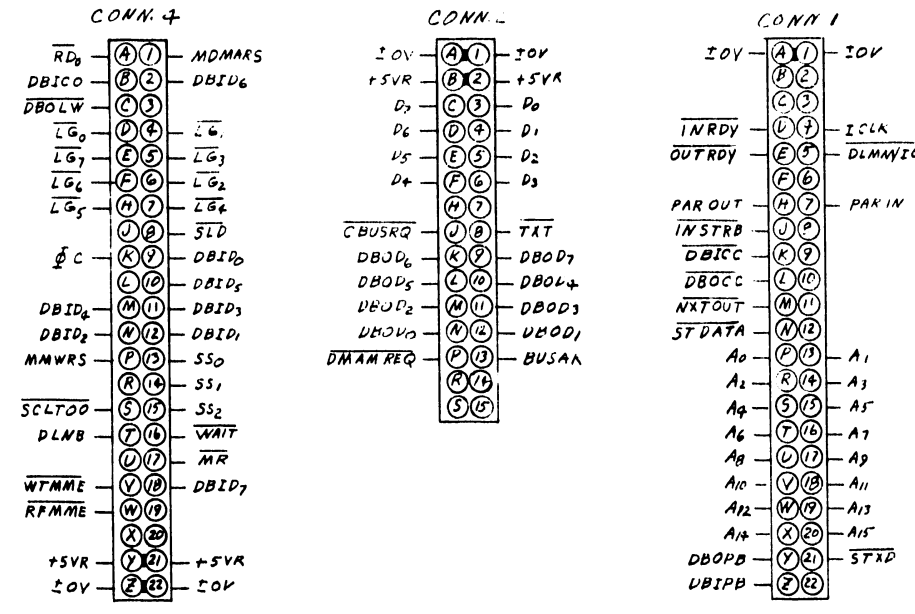

SIGNAL-TERMINAL DESIGNATIONS, VIEW FROM BOTTOM (WIRING) SIDE OF CONNECTOR

I.C. TYPE	LOC.	SPARES
74LS00	L34	1
	L63	1
7402	L72	1
	L7	1
74LS02	L17	1
	L121	1
74LS04	L73	3
74LS08	L12	1
	L64	1
74S10	L53	2
74S11	L87	1
74S20	L80	1
7427	L2	2
74LS32	L59	1
74S37	L7	2
74LS17	L89	1
7426	L46	1
74123	L90	1
74125	L52	1

COMPONENT	WRANG PART NO.	TYPE
R46	330-2047	470Ω 1/4W 10%
R1-10, 12, 14, 17-34, 37, 38	330-3022	2.2K 1/4W 10%
R11	330-4028	27K 1/4W 5%
R15	330-3052	5.1K 1/4W 5%
R16, 39, 40, 41, 13	330-4010	10K 1/4W 10%
R35, 36, 47	330-2033	330Ω 1/4W 10%
R43, 44	330-2022	220Ω 1/4W 10%
R42	330-1022	22Ω 1/4W 10%
R45	330-2015	150Ω 1/4W 10%
C3-78, 84, 87, 94	300-1966	.042μF 50V 20% CER
C79-82, 88, 89	300-4022	15μF 20V (T)
C83, 85, 91, 92	300-1220	220pF 500V CER
C86	300-1082	82pF 500V 10% C
C1	300-1915	.0056μF 500V CER
C90	300-1930	.1μF 50V CER
C2	300-1150	150pF 500V CER
D1	380-1001	51L DO35
XTAL	321-0018	17.1 MHE
C93	300-1022	22pF

I.C. LOCATION	WL PART No	TYPE
L1, 3, 4, 29, 36	376-0155	74LS74
L2	376-0125	7427
L5, 11, 54, 90	376-0080	74123
L6	376-0198	74S30
L7	376-0286	74S77
L8, 20, 21, 26, 27, 32, 37, 50, 55, 68, 70	376-0202	74S74
L9, 12, 41, 42, 124	376-0208	74LS02
L10, 36, 49, 65, 35	376-0304	74LS73
L12, 50, 61, 64	376-0153	74LS08
L13, 34, 40, 63	376-0207	74LS00
L14	376-0102	74164
L15, 22	376-0221	74S194
L16, 56	376-0228	74S00
L17	376-0045	74HC04
L18	376-0184	74S51
L23, 75, 76, 93, 94	376-0109	74166
L24, 25, 69	376-0238	74S10
L28, 48, 52, 60	376-0224	74125
L30, 74, 86	376-0245	74LS27
L33	376-0271	74S86
L85	376-0010	7404
L38, 45, 51	376-0199	74S02
L39, 44	376-0200	74S08
L46	376-0007	7476
L108, 129		SPARE
L57	376-0205	74S32
L59	376-0211	74LS72
L71, 73	376-0180	74LS04
L72	376-0016	7402
L77, 85, 96, 113, 119-122	376-0286	74LS374
L78, 79, 97, 98, 99, 101, 102, 109, 111, 112, 115	376-0288	74LS244
L80	376-0230	74S20
L81, 82, 83	376-0292	74S138
L84, 53	376-0207	74LS10
L87	376-0237	74S11
L88	376-0206	74S260
L91, 92, 125, 126	376-0233	74LS161
L100, 110	376-0297	74LS240
L103, 104	376-0098	74174
L105, 106	376-0082	74157
L116, 117, 118	376-0221	74S194
L123	376-0298	74S138
L114	376-0310	74LS373

MNEMONIC	COORDINATE
A0-A15	3E1
BUSAK	1B11
BUSRQ	3A7
D0-D7	6A5
DBICC	1A5
DBID0	2B11
DBID0-DBID7	5G1
DBIPB	5F1
DBOCC	1A1
DBOD0-DBOD7	5G3
DBOLW	2F1
DBOPB	5G7
DLNB	3A9
DLMMREQ	1C11
DMAMREQ	3B1
ICLK	1A10
INRDY	3C11
INSTRB	3C1
LG0-LG7	6E1
MDMARS	3A5
MMWRS	3A5
MR	1B11
NXTOUT	2G1
OUTRDY	3G7
PAR IN	1B11
PAR OUT	1E11
RDO	3A6
RFMME	3A6
SCLTDO	1G5
SLD	5A11
SS0, SS1, SS2	6F1
STDATA	1E11
STXP	4B1
TXI	2A10
WAIT	1G1
WTMME	3A6
YC	1E11

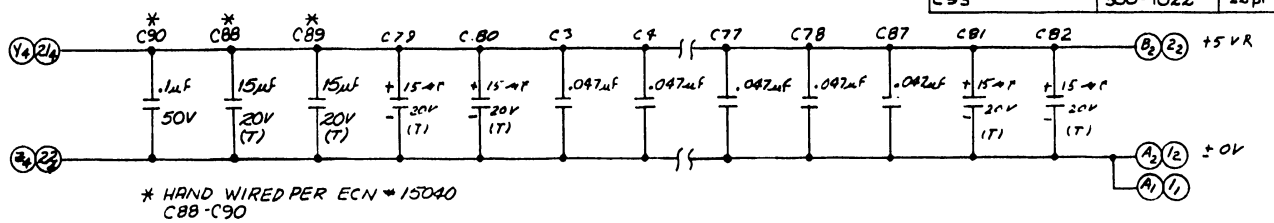

\* HAND WIRED PER ECN # 15040  
C88-C90

E-REV.  
9

NO.	REVISION	DATE	BY	APP'D.
1	DRG. REC.	9-11-79	9-11-79	
2	DWG. # ECN # 12025	9-17-79	9-17-79	
3	REVISED PER ECN # 12025	9-17-79	9-17-79	
4	REVISED PER ECN # 12025	9-17-79	9-17-79	
5	REVISED PER ECN # 12025	9-17-79	9-17-79	
6	REVISED PER ECN # 12025	9-17-79	9-17-79	
7	REVISED PER ECN # 12025	9-17-79	9-17-79	
8	REVISED PER ECN # 12025	9-17-79	9-17-79	
9	REVISED PER ECN # 12025	9-17-79	9-17-79	
10	REVISED PER ECN # 12025	9-17-79	9-17-79	
11	REVISED PER ECN # 12025	9-17-79	9-17-79	
12	REVISED PER ECN # 12025	9-17-79	9-17-79	
13	REVISED PER ECN # 12025	9-17-79	9-17-79	
14	REVISED PER ECN # 12025	9-17-79	9-17-79	
15	REVISED PER ECN # 12025	9-17-79	9-17-79	
16	REVISED PER ECN # 12025	9-17-79	9-17-79	
17	REVISED PER ECN # 12025	9-17-79	9-17-79	
18	REVISED PER ECN # 12025	9-17-79	9-17-79	
19	REVISED PER ECN # 12025	9-17-79	9-17-79	
20	REVISED PER ECN # 12025	9-17-79	9-17-79	
21	REVISED PER ECN # 12025	9-17-79	9-17-79	
22	REVISED PER ECN # 12025	9-17-79	9-17-79	
23	REVISED PER ECN # 12025	9-17-79	9-17-79	
24	REVISED PER ECN # 12025	9-17-79	9-17-79	
25	REVISED PER ECN # 12025	9-17-79	9-17-79	
26	REVISED PER ECN # 12025	9-17-79	9-17-79	
27	REVISED PER ECN # 12025	9-17-79	9-17-79	
28	REVISED PER ECN # 12025	9-17-79	9-17-79	
29	REVISED PER ECN # 12025	9-17-79	9-17-79	
30	REVISED PER ECN # 12025	9-17-79	9-17-79	
31	REVISED PER ECN # 12025	9-17-79	9-17-79	
32	REVISED PER ECN # 12025	9-17-79	9-17-79	
33	REVISED PER ECN # 12025	9-17-79	9-17-79	
34	REVISED PER ECN # 12025	9-17-79	9-17-79	
35	REVISED PER ECN # 12025	9-17-79	9-17-79	
36	REVISED PER ECN # 12025	9-17-79	9-17-79	
37	REVISED PER ECN # 12025	9-17-79	9-17-79	
38	REVISED PER ECN # 12025	9-17-79	9-17-79	
39	REVISED PER ECN # 12025	9-17-79	9-17-79	
40	REVISED PER ECN # 12025	9-17-79	9-17-79	
41	REVISED PER ECN # 12025	9-17-79	9-17-79	
42	REVISED PER ECN # 12025	9-17-79	9-17-79	
43	REVISED PER ECN # 12025	9-17-79	9-17-79	
44	REVISED PER ECN # 12025	9-17-79	9-17-79	
45	REVISED PER ECN # 12025	9-17-79	9-17-79	
46	REVISED PER ECN # 12025	9-17-79	9-17-79	
47	REVISED PER ECN # 12025	9-17-79	9-17-79	
48	REVISED PER ECN # 12025	9-17-79	9-17-79	
49	REVISED PER ECN # 12025	9-17-79	9-17-79	
50	REVISED PER ECN # 12025	9-17-79	9-17-79	
51	REVISED PER ECN # 12025	9-17-79	9-17-79	
52	REVISED PER ECN # 12025	9-17-79	9-17-79	
53	REVISED PER ECN # 12025	9-17-79	9-17-79	
54	REVISED PER ECN # 12025	9-17-79	9-17-79	
55	REVISED PER ECN # 12025	9-17-79	9-17-79	
56	REVISED PER ECN # 12025	9-17-79	9-17-79	
57	REVISED PER ECN # 12025	9-17-79	9-17-79	
58	REVISED PER ECN # 12025	9-17-79	9-17-79	
59	REVISED PER ECN # 12025	9-17-79	9-17-79	
60	REVISED PER ECN # 12025	9-17-79	9-17-79	
61	REVISED PER ECN # 12025	9-17-79	9-17-79	
62	REVISED PER ECN # 12025	9-17-79	9-17-79	
63	REVISED PER ECN # 12025	9-17-79	9-17-79	
64	REVISED PER ECN # 12025	9-17-79	9-17-79	
65	REVISED PER ECN # 12025	9-17-79	9-17-79	
66	REVISED PER ECN # 12025	9-17-79	9-17-79	
67	REVISED PER ECN # 12025	9-17-79	9-17-79	
68	REVISED PER ECN # 12025	9-17-79	9-17-79	
69	REVISED PER ECN # 12025	9-17-79	9-17-79	
70	REVISED PER ECN # 12025	9-17-79	9-17-79	
71	REVISED PER ECN # 12025	9-17-79	9-17-79	
72	REVISED PER ECN # 12025	9-17-79	9-17-79	
73	REVISED PER ECN # 12025	9-17-79	9-17-79	
74	REVISED PER ECN # 12025	9-17-79	9-17-79	
75	REVISED PER ECN # 12025	9-17-79	9-17-79	
76	REVISED PER ECN # 12025	9-17-79	9-17-79	
77	REVISED PER ECN # 12025	9-17-79	9-17-79	
78	REVISED PER ECN # 12025	9-17-79	9-17-79	
79	REVISED PER ECN # 12025	9-17-79	9-17-79	
80	REVISED PER ECN # 12025	9-17-79	9-17-79	
81	REVISED PER ECN # 12025	9-17-79	9-17-79	
82	REVISED PER ECN # 12025	9-17-79	9-17-79	
83	REVISED PER ECN # 12025	9-17-79	9-17-79	
84	REVISED PER ECN # 12025	9-17-79	9-17-79	
85	REVISED PER ECN # 12025	9-17-79	9-17-79	
86	REVISED PER ECN # 12025	9-17-79	9-17-79	
87	REVISED PER ECN # 12025	9-17-79	9-17-79	
88	REVISED PER ECN # 12025	9-17-79	9-17-79	
89	REVISED PER ECN # 12025	9-17-79	9-17-79	
90	REVISED PER ECN # 12025	9-17-79	9-17-79	
91	REVISED PER ECN # 12025	9-17-79	9-17-79	
92	REVISED PER ECN # 12025	9-17-79	9-17-79	
93	REVISED PER ECN # 12025	9-17-79	9-17-79	
94	REVISED PER ECN # 12025	9-17-79	9-17-79	
95	REVISED PER ECN # 12025	9-17-79	9-17-79	
96	REVISED PER ECN # 12025	9-17-79	9-17-79	
97	REVISED PER ECN # 12025	9-17-79	9-17-79	
98	REVISED PER ECN # 12025	9-17-79	9-17-79	
99	REVISED PER ECN # 12025	9-17-79	9-17-79	
100	REVISED PER ECN # 12025	9-17-79	9-17-79	

<b>WANG</b> LABORATORIES, INC. LOWELL, MASS. U.S.A.		BY	DATE	APPROVED BY	DATE
		DWN	9-17-79	E ENGR A. DESKUR	10-15-79
MATERIAL		MODEL NO.	TITLE		
FINISH		SIT ENGR SPECIFICATIONS	DATA CONT-2		
TOL EX AS NOTED		FRAC ±	210-7503	D	15 2 14
ANG ±		FINISH	WANG PART NUMBER	SIZE	DRAWING NUMBER
SCALE		SMT # OF			

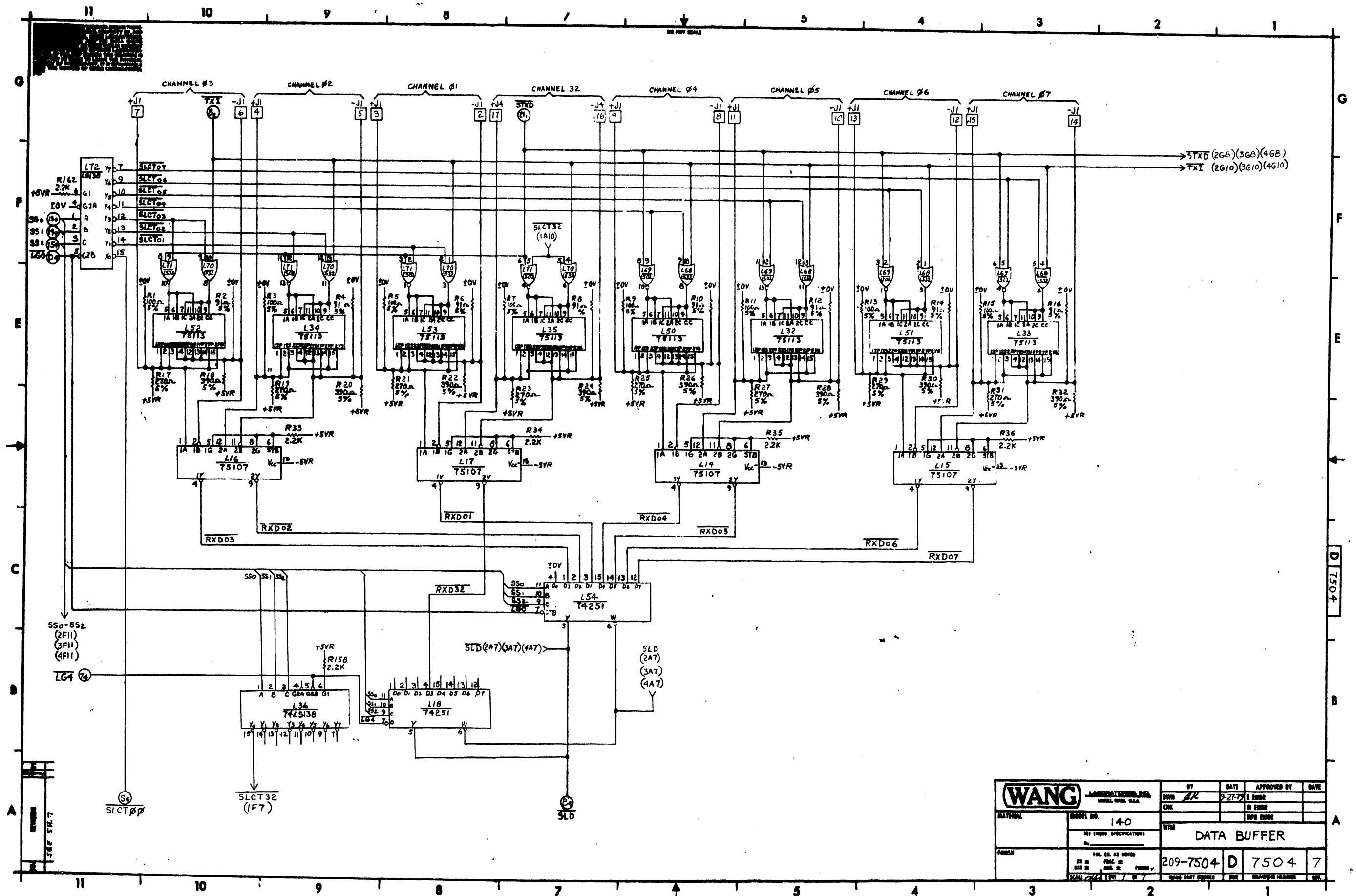

<b>WANG</b> LABORATORIES, INC. MODEL NO. 140		BY: <i>[Signature]</i>	DATE: 8-27-77	APPROVED BY: E. E. EHRH	DATE:
MATERIAL: SEE ENG. SPECIFICATIONS		TITLE: DATA BUFFER		INFO CODE:	
PART: 209-7504		D 7504		7	
SCALE: 1/8" = 1"		SHEET: 1 OF 7		CHANGED NUMBER:	



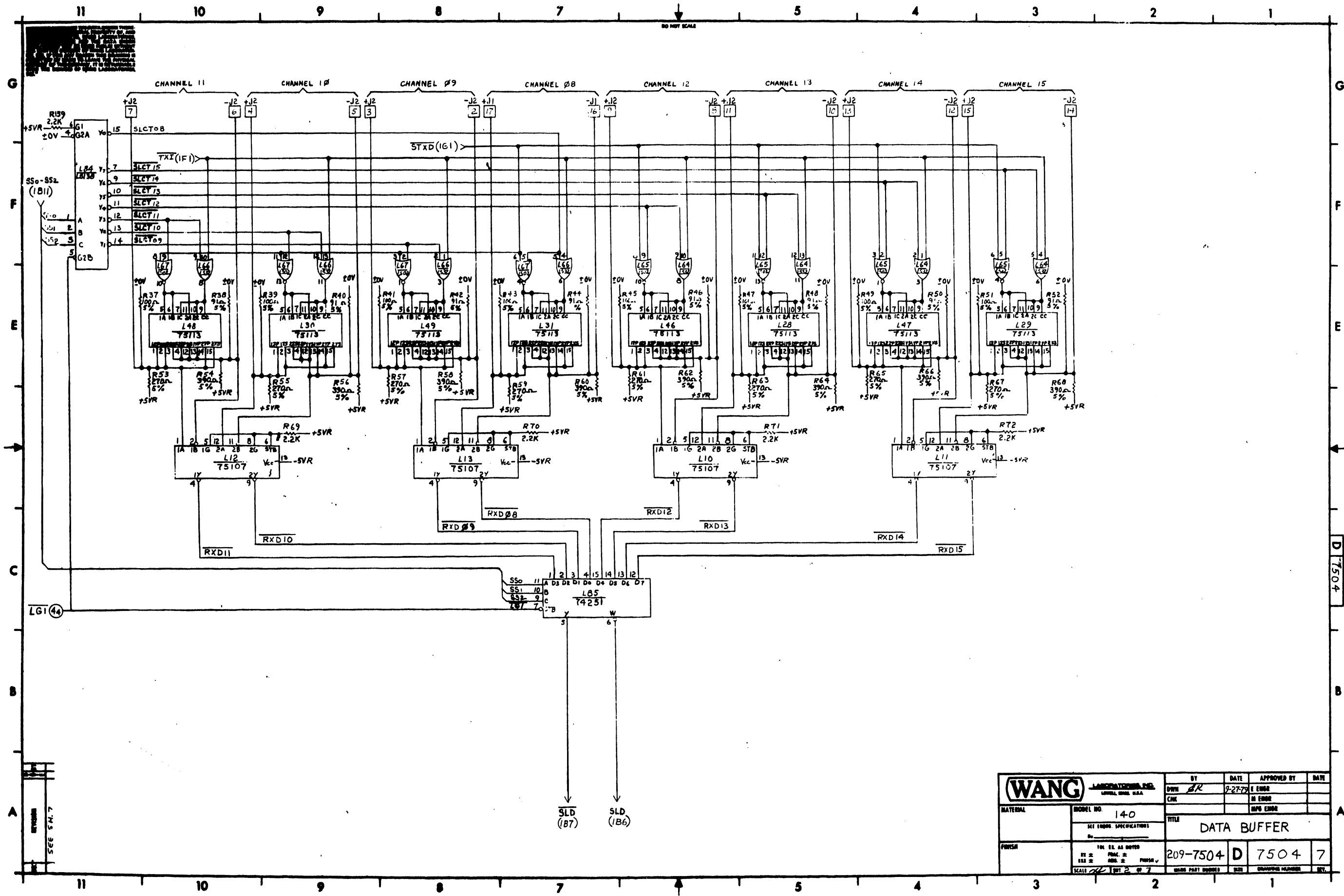

<b>WANG</b> LABORATORIES, INC. LINDEN, NEW JERSEY, U.S.A.		BY	DATE	APPROVED BY	DATE
		DWN CNE	AR 9-27-73	E ENDR M ENDR MFO ENDR	
MATERIAL	MODEL NO. 140 SEE LEGEND SPECIFICATIONS	TITLE DATA BUFFER			
FORN	FOR ALL AS NOTED REV. 2 REV. 3 SCALE 1/8" = 1" PART 2 OF 7	209-7504	D	7504	7

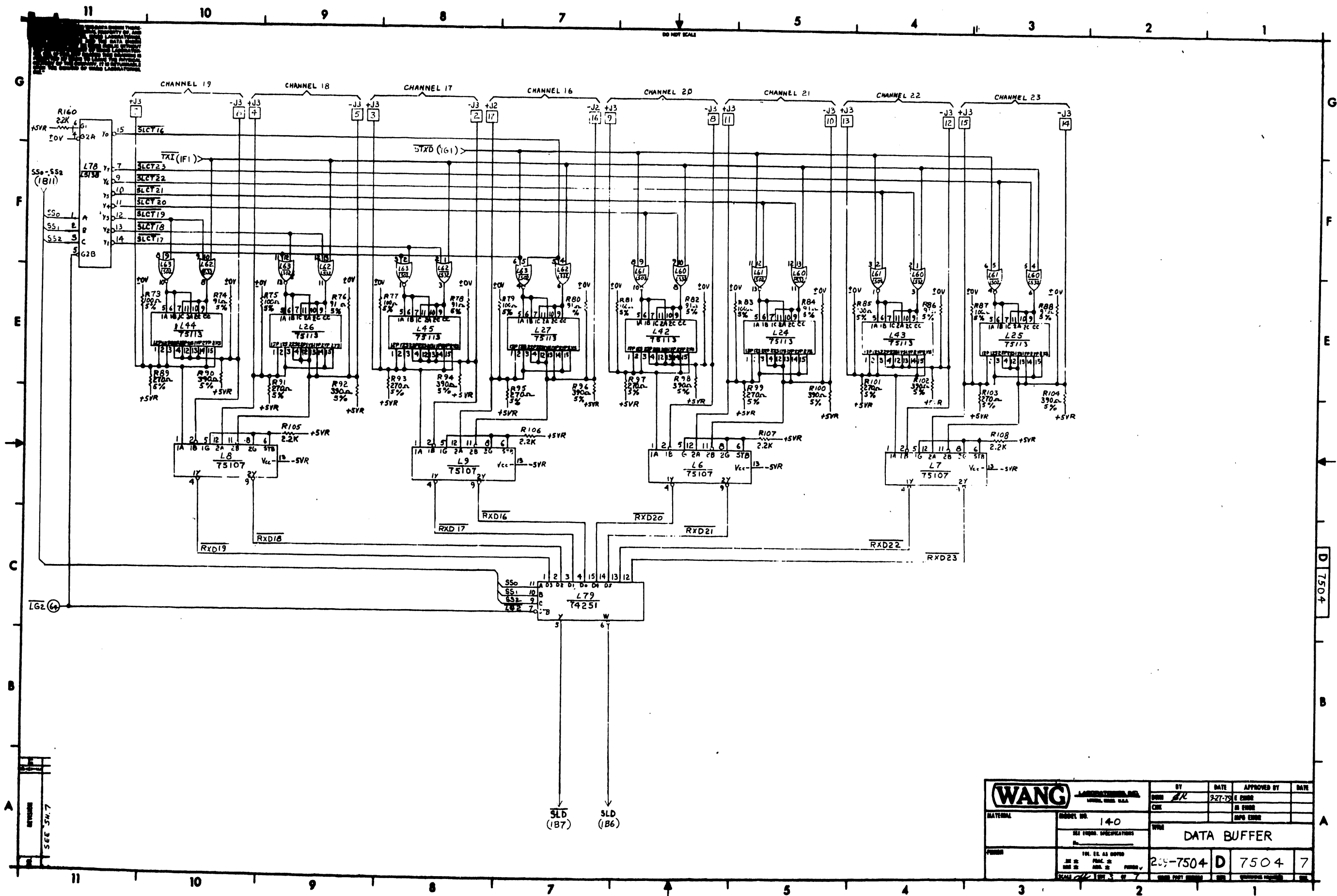

THIS DOCUMENT IS THE PROPERTY OF WANG LABORATORIES, INC. IT IS TO BE KEPT IN CONFIDENTIALITY AND IS NOT TO BE REPRODUCED OR TRANSMITTED IN ANY FORM OR BY ANY MEANS, ELECTRONIC OR MECHANICAL, INCLUDING PHOTOCOPYING, RECORDING, OR BY ANY INFORMATION STORAGE AND RETRIEVAL SYSTEM.

<b>WANG</b> LABORATORIES, INC. WALTHAM, MASS. U.S.A.		BY: <i>AK</i>	DATE: 3-27-75	APPROVED BY:	DATE:
MATERIAL:	PRODUCT NO. 140	CHK:	IN CODE:	IN CODE:	IN CODE:
SEE FIGS. OPERATIONS:		TITLE: DATA BUFFER			
PART NO. 205-7504 D		REV. 7504		7	

D 7504

SEE SH. 7



THIS DRAWING AND THE DATA SHOWN THERE ON ARE THE CONFIDENTIAL PROPERTY OF WANG LABORATORIES, INC. THIS DRAWING AND THE DATA SHOWN THEREON MAY NOT BE MADE PUBLIC WITHOUT THE WRITTEN CONSENT OF WANG LABORATORIES, INC. IF FOR ANY REASON THIS DRAWING IS PERMITTED BY WANG TO LEAVE THE PHYSICAL CUSTODY OF THE COMPANY, IT IS RETURNABLE UPON THE DEMAND OF WANG LABORATORIES, INC.

DO NOT SCALE

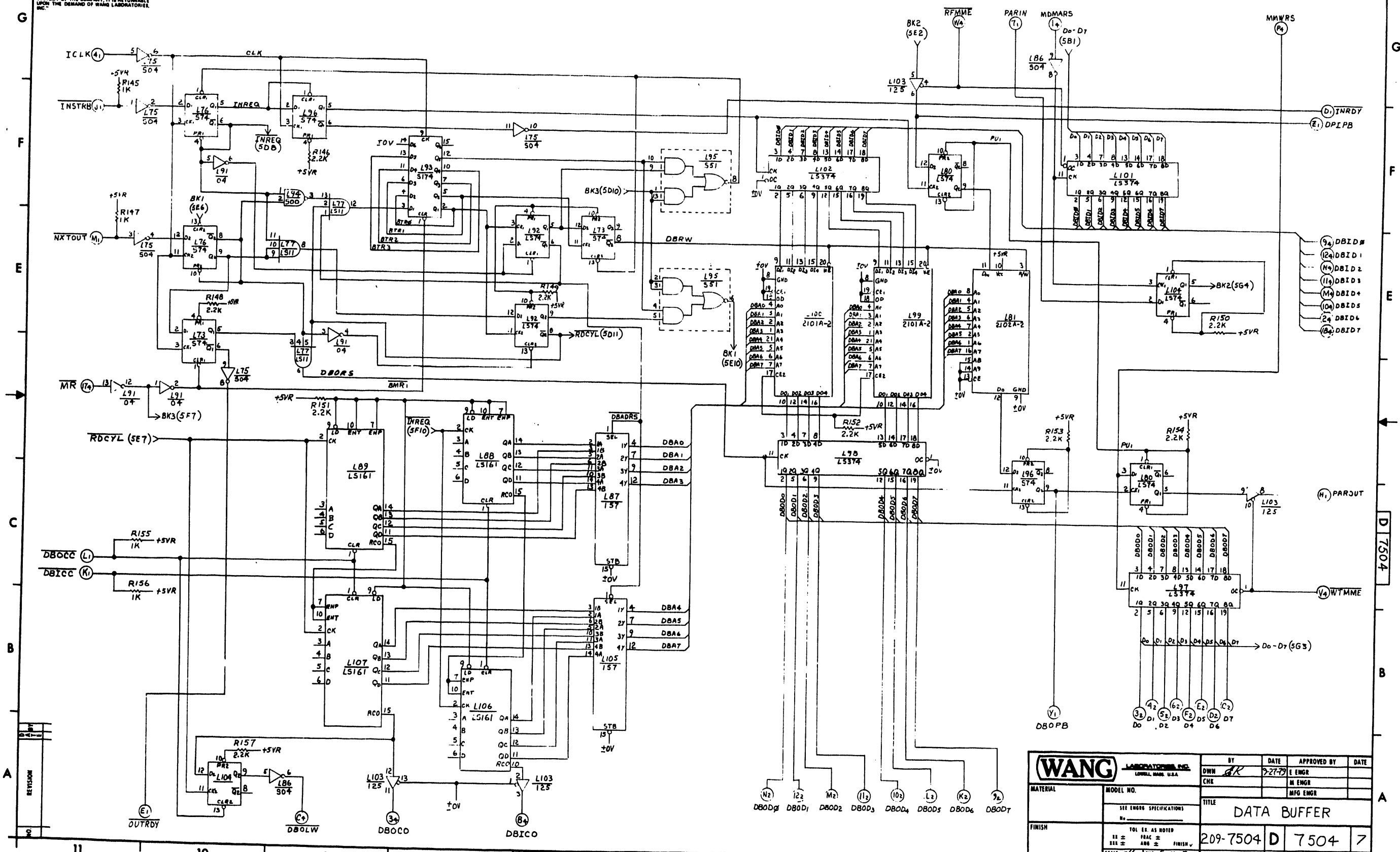

<b>WANG</b> LABORATORIES, INC. LOWELL, MASS. U.S.A.		BY DWN BR	DATE 7-27-75	APPROVED BY E ENGR	DATE
MATERIAL	MODEL NO.	CHK	M ENGR	MFG ENGR	
SEE ENGR SPECIFICATIONS		TITLE DATA BUFFER			
FINISH		209-7504 D 7504		7	
SCALE 1/8" = 1"		SHEET 5 OF 7		WANG PART NUMBER	

THE DRAWING AND THE DATA SHOWN THEREON ARE THE CONFIDENTIAL PROPERTY OF, AND ARE PROPRIETARY TO, WANG LABORATORIES, INC. THIS DRAWING AND THE DATA SHOWN THEREON MAY NOT BE MADE PUBLIC WITHOUT THE WRITTEN CONSENT OF WANG LABORATORIES, INC. IF FOR ANY REASON THIS DRAWING IS PERMITTED BY WANG TO LEAVE THE PHYSICAL CUSTODY OF THE COMPANY, IT IS RETURNABLE TO THE DEMAND OF WANG LABORATORIES, INC.

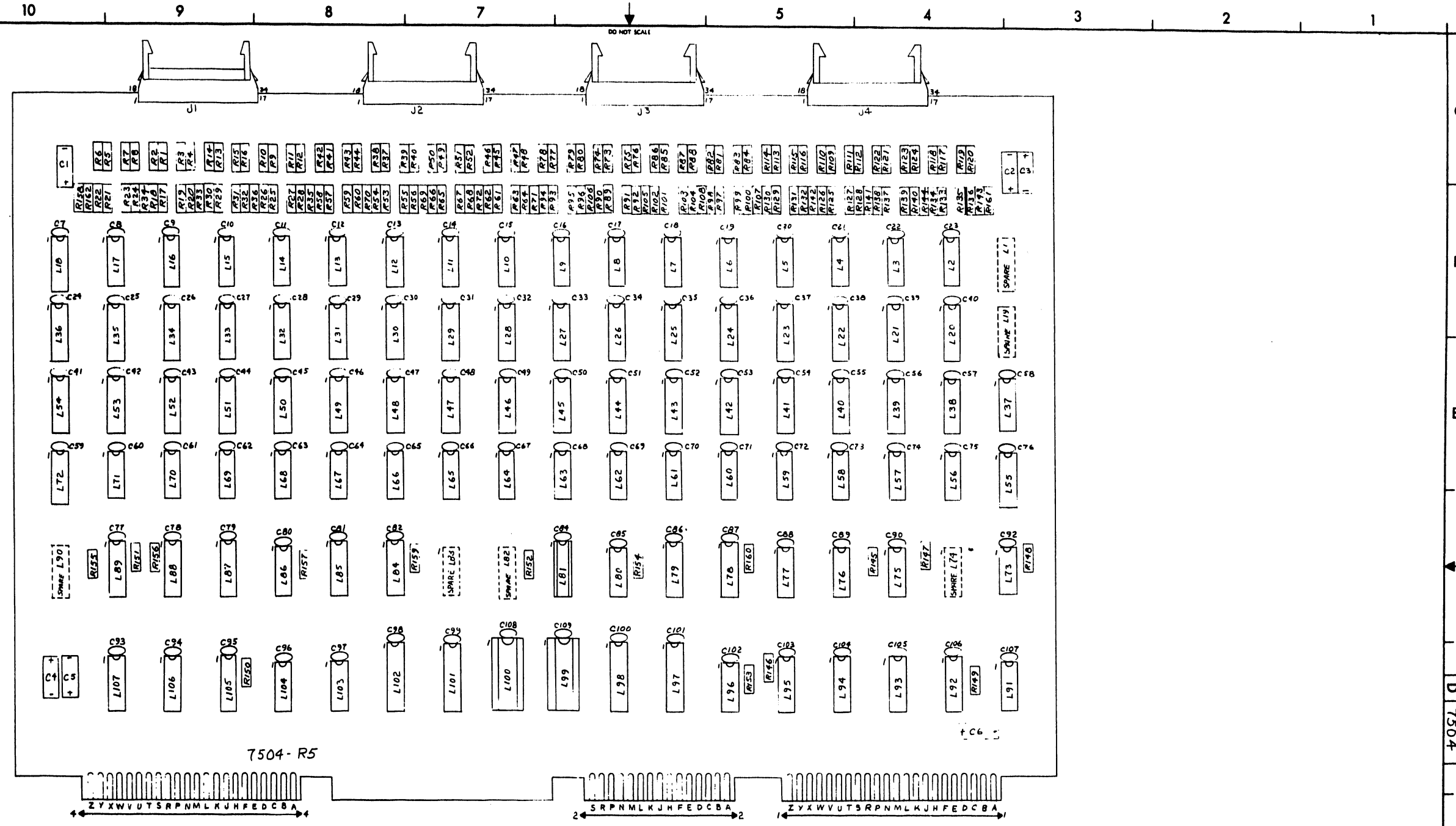

COMPONENT LAYOUT

<b>(WANG)</b> LABORATORIES, INC. LONDON, MASS. U.S.A.		BY	DATE	APPROVED BY	DATE
		DWN <i>AK</i>	9-27-79	E ENGR	
MATERIAL		CHK		M ENGR	
				MFG ENGR	
MODEL NO. 140		TITLE			
SEE ENGR SPECIFICATIONS		DATA BUFFER			
FINISH		209-7504 D		7504	7
SCALE 1/8" = 1"		WANG PART NUMBER		SIZE	DRAWING NUMBER

THIS DRAWING AND THE DATA SHOWN THERE ON ARE THE CONFIDENTIAL PROPERTY OF AND ARE PROPRIETARY TO WANG LABORATORIES, INC. THIS DRAWING AND THE DATA SHOWN THEREIN MAY NOT BE MADE PUBLIC WITHOUT THE WRITTEN CONSENT OF WANG LABORATORIES, INC. IF FOR ANY REASON THIS DRAWING IS PERMITTED BY WANG TO LEAVE THE PHYSICAL CUSTODY OF THE COMPANY, IT IS RETURNABLE UPON THE DEMAND OF WANG LABORATORIES, INC.

DO NOT SCALE

COMPONENT	W.L. PART NO.	TYPE
R1, 3, 5, 7, 9, 11, 13, 15, 37, 39, 41, 43, 45, 47, 49, 51, 73, 75, 77, 79, 81, 83, 85, 87, 109, 111, 113, 115, 117, 119, 121, 123	330-2011	100Ω 5% 1/4W
R2, 4, 6, 8, 10, 12, 14, 16, 38, 40, 42, 44, 46, 48, 50, 52, 74, 76, 78, 80, 82, 84, 86, 88, 110, 112, 114, 116, 118, 120, 122, 124	330-1092	91Ω 5% 1/4W
R17, 19, 21, 23, 25, 27, 29, 31, 53, 55, 57, 59, 61, 63, 65, 67, 89, 91, 93, 95, 97, 99, 101, 103, 125, 127, 129, 131, 133, 135, 137, 139	330-2028	270Ω 5% 1/4W
R18, 20, 22, 24, 26, 28, 30, 32, 34, 36, 38, 40, 62, 64, 66, 68, 90, 92, 94, 96, 98, 100, 102, 104, 126, 128, 130, 132, 134, 136, 138, 140	330-2040	390Ω 5% 1/4W
R33, 34, 35, 36, 69, 70, 71, 72, 105, 106, 107, 108, 141, 142, 143, 144, 146, 148, 149, 150, 151, 152, 153, 154, 157, 158, 159, 160, 161, 162	330-3022	2.2K 10% 1/4W
R145, 147, 155, 156		1K 10% 1/4W
C1-6	300-4022	15μF 20V(T)
C7-82, 84, 90, 92-107	300-1900	.05μF 12V
C108, 109	300-1930	.14μF 50V
J1, 2, 3, 4	350-0429	34 PIN
LB1	376-9002	16 PIN SKT
L99, 100	376-9010	22 PIN SKT

LOCATION	W.L. PART NO.	TYPE
L2-17	376-0146	75107
L18, 37, 54, 79, 85	376-0272	74251
L20-35, 38-53	376-0256	75113
L36, 55, 72, 76, 84	376-0294	74LS13B
L56, 58, 60, 62, 64, 66, 68, 70	376-0211	74LS32
L57, 59, 61, 63, 65, 67, 69, 71	376-0208	74LS02
L73, 76, 96	376-0202	74574
L86	376-0197	74504
L77	376-0225	74LS11
L81	377-0363	2102A-2
L87, 105	376-0082	74157
L88, 89, 106, 107	376-0233	74LS161
L91	376-0010	7404
L92, 104, 80	376-0155	74LS74
L93	376-0247	745174
L94	376-0228	74500
L95	376-0184	74551
L97, 98, 101, 102	376-0286	74LS374
L99, 100	377-0367	2101A-2
L103	376-0324	74125
L75	376-0045	74H04
L1, 19, 74, 82, 83, 90	SPARES	

LOCATION	TYPE	SPARES
L75	74H04	1
L86	74504	4
L91	7404	2
L94	74500	3

MNEMONIC	COORDINATE
Do-D7	5B2
DBICC	5C11
DBICO	5A7
DBID0-DBID7	5E1
DBOCC	5C11
DBOCO	5A8
DBOD0-DBOD7	5A5
DBOLW	5A9
DBOPB	5A3
DPIPB	5F1
ICLK	5G11
INRDY	5F1
INSTRB	5F11
LG0	1F11
LG1	2C11
LG2	3C11
LG3	4C11
LG4	1B11
MMWRS	5G1
MDMARS	5G3
MR	5D11
NXTOUT	5E11
OUTRDY	5A10
PARIN	5G4
PAROUT	5C1
RFMME	5G4
SLCT00	1A11
SLCT32	1A10
SLD	1A7
SS0-SS2	1F11
STXD	1G7
TXI	1G10
WTMME	5C1
CHAN. 1-7, 32	1G3-10
CHAN. 8-15	2G3-10
CHAN. 16-23	3G3-10
CHAN. 24-31	4G3-10

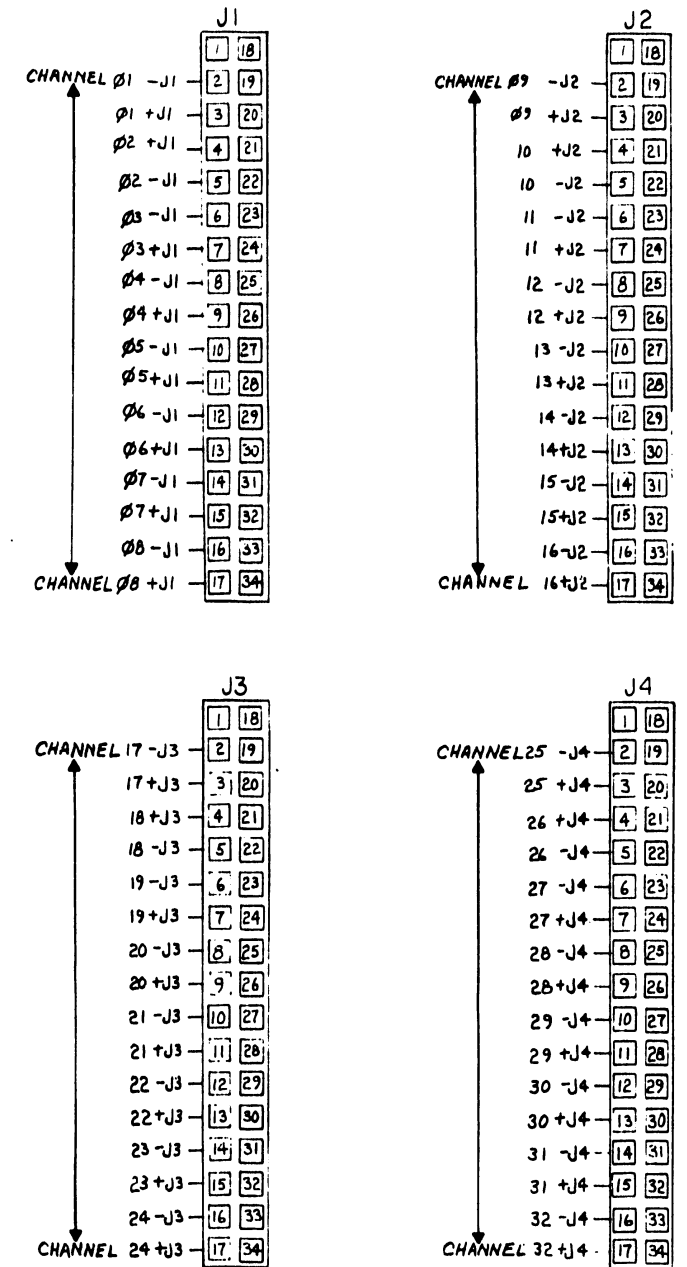
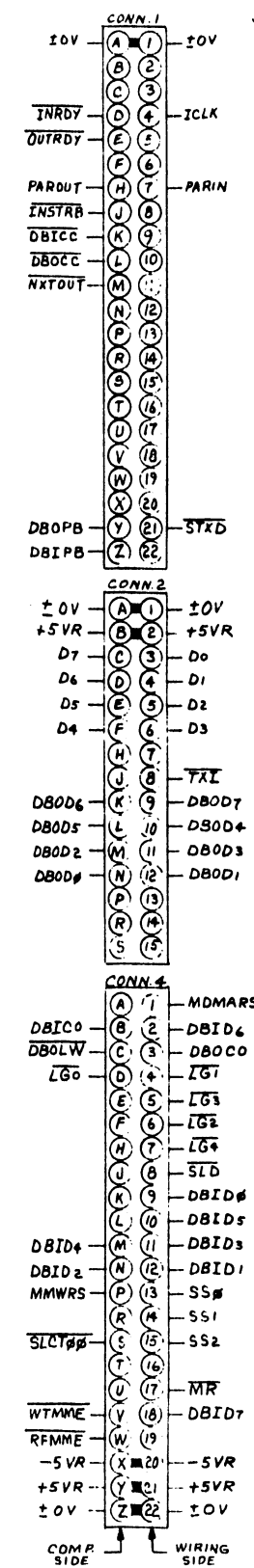
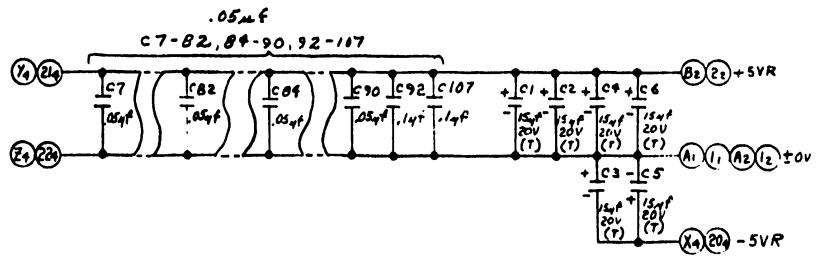

NO.	REVISION	DATE	BY	APPROVED BY
1	ORIGINATED PER DWK/ELB	11-15-79		
2	REVISED PER ECN #11726, 11714	11-15-79		
3	REVISED PER ECN #12138	11-15-79		
4	REVISED PER ECN #12139	11-15-79		
5	REVISED PER ECN #12177	11-15-79		
6	REVISED PER ECN #13275	11-15-79		
7	REVISED PER ECN #13953	11-15-79		
8	REVISED PER ECN #15091	11-15-79		
9	REVISED PER ECN #15092	11-15-79		
10	REVISED PER ECN #15093	11-15-79		

<b>WANG</b> LABORATORIES, INC. LOWELL, MASS. U.S.A.		BY DWN	DATE 9-27-79	APPROVED BY E ENGR A. DES KURH-1578	DATE 10-15-79
MATERIAL	MODEL NO. 140	TITLE DATA BUFFER			
FINISH	SCALE 1:1	209-7504	D	7504	7
TOL. EX. AS NOTED		SCALE 1:1		WANG PART NUMBER	

THIS DRAWING AND THE DATA SHOWN THEREON ARE THE CONFIDENTIAL PROPERTY OF WANG LABORATORIES, INC. AND ARE NOT TO BE REPRODUCED OR TRANSMITTED IN ANY FORM OR BY ANY MEANS, ELECTRONIC OR MECHANICAL, INCLUDING PHOTOCOPYING, RECORDING, OR BY ANY INFORMATION STORAGE AND RETRIEVAL SYSTEM, WITHOUT THE WRITTEN CONSENT OF WANG LABORATORIES, INC. IF FOR ANY REASON THIS DRAWING IS PERMITTED BY WANG TO LEAVE THE PHYSICAL POSSESSION OF THE COMPANY, IT IS RETURNABLE UPON THE DEMAND OF WANG LABORATORIES, INC.

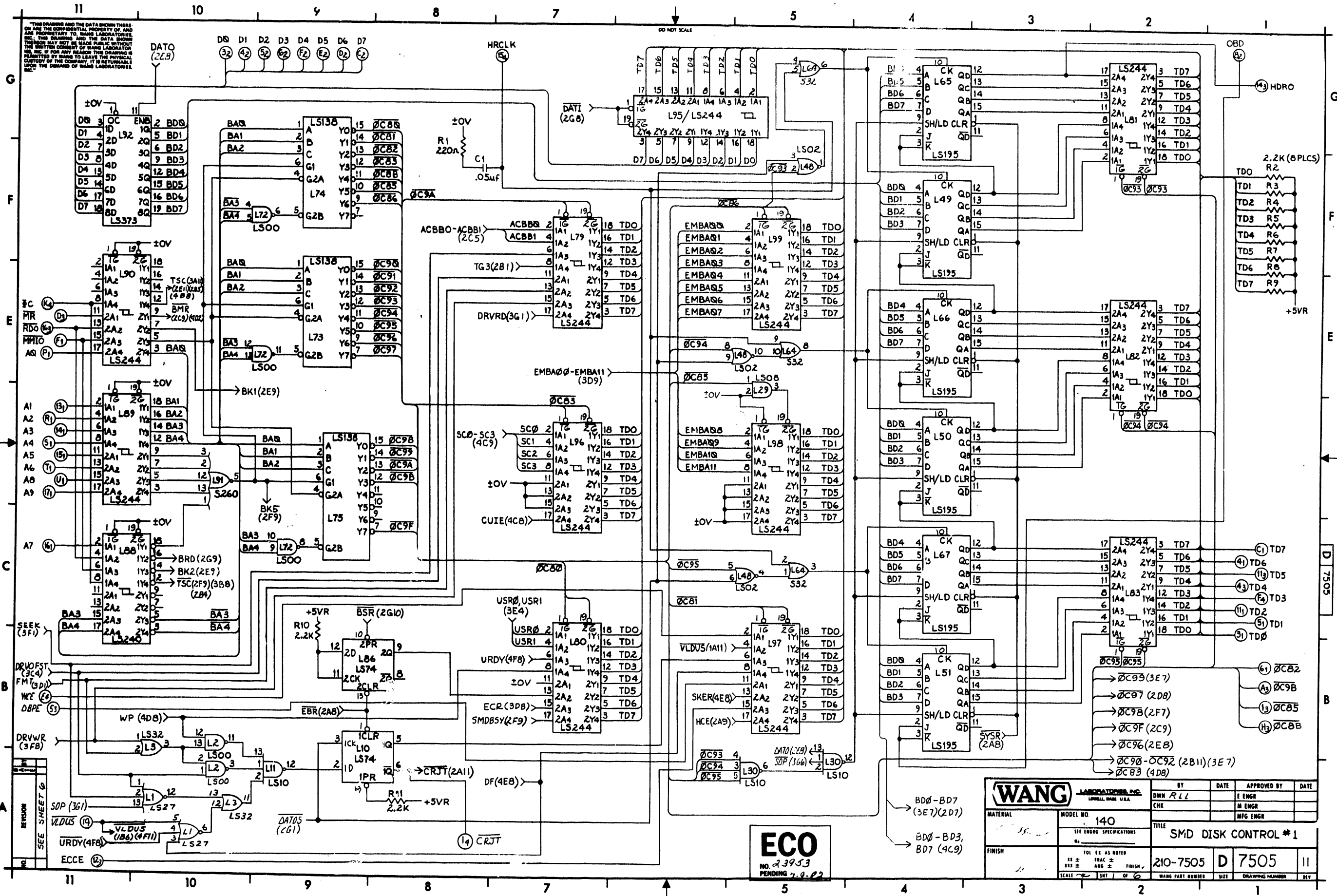

REVISION SHEET

NO.	DESCRIPTION	DATE
1	ASSEMBLED	7-9-62

**ECO**  
NO. 23953  
PENDING 7-9-62

<b>WANG</b> LABORATORIES, INC. LOWELL, MASS. U.S.A.		BY	DATE	APPROVED BY	DATE
MATERIAL	MODEL NO. 140	DWN RLL		E ENGR	
FINISH	SEE ENGR SPECIFICATIONS	CHK		M ENGR	
TITLE: SMD DISK CONTROL #1		WANG PART NUMBER: 210-7505			
SCALE: 101 EX AS NOTED		SIZE: D 7505		REV: 11	

THIS DRAWING AND THE DATA SHOWN THERE ON ARE THE CONFIDENTIAL PROPERTY OF WANG LABORATORIES, INC. AND ARE PROPRIETARY TO WANG LABORATORIES, INC. THIS DRAWING AND THE DATA SHOWN THEREIN MAY NOT BE MADE PUBLIC WITHOUT THE WRITTEN CONSENT OF WANG LABORATORIES, INC. IF FOR ANY REASON THIS DRAWING IS PERMITTED BY WANG TO LEAVE THE PHYSICAL POSSESSION OF THE COMPANY, IT IS RETURNABLE UPON THE DEMAND OF WANG LABORATORIES, INC.

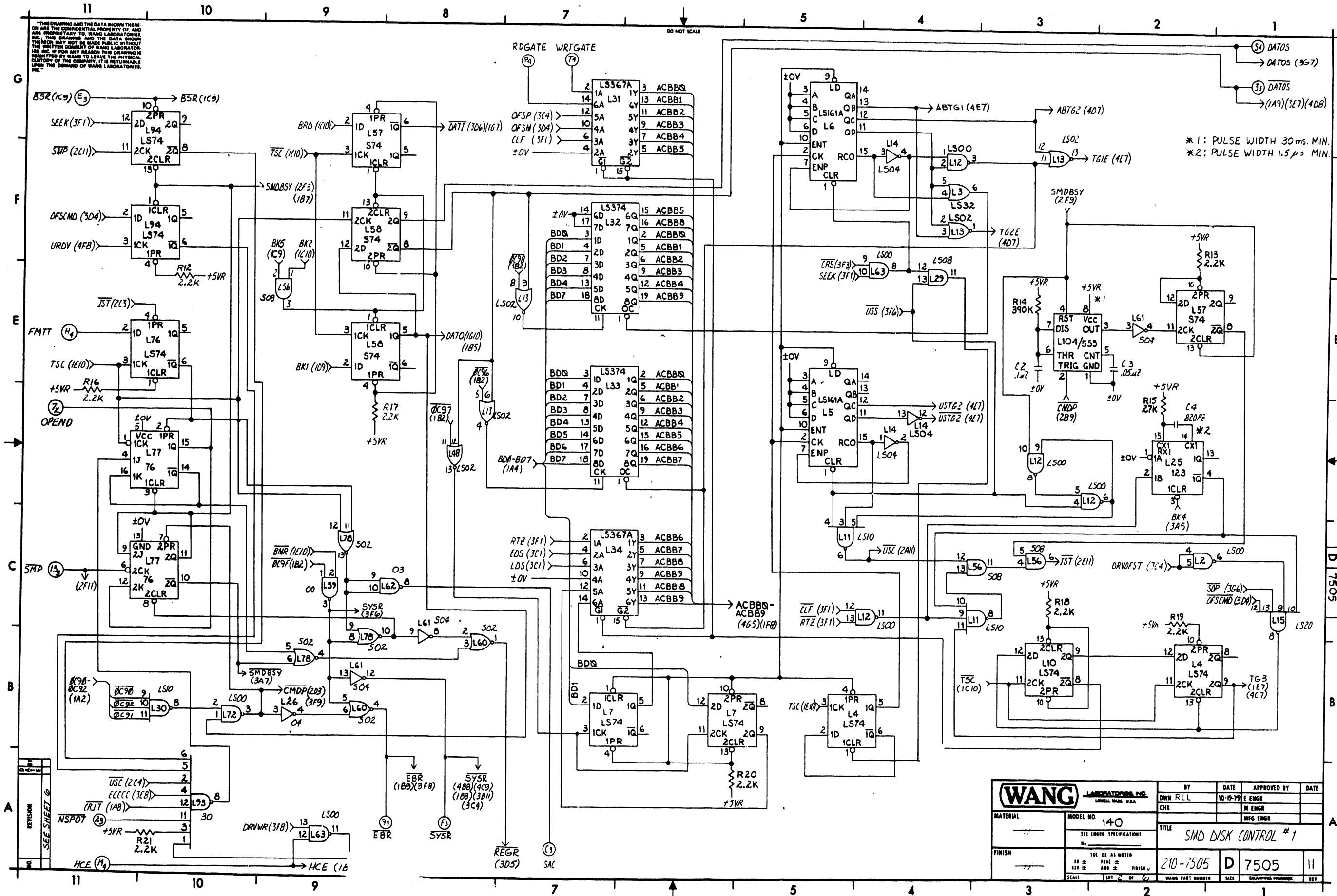

\* 1: PULSE WIDTH 30ms. MIN.  
\* 2: PULSE WIDTH 1.5μs MIN.

<b>WANG</b> LABORATORIES, INC. LOWELL, MASS. U.S.A.		BY DWN RLL	DATE 10-19-79	APPROVED BY E ENGR	DATE
MATERIAL	MODEL NO. 140	CHE		M ENGR	
FINISH	SEE ENGR SPECIFICATIONS	TITLE SMD DISK CONTROL #1		MFG ENGR	
101 IS AS NOTED 11AC ± 11P ± 11T ± 11V ± 11W ± 11X ± 11Y ± 11Z ±		SCALE 1:1	SHT 2 OF 6	210-7505	D 7505 11



THIS DRAWING AND THE DATA THEREON ARE THE CONFIDENTIAL PROPERTY OF, AND ARE PROPRIETARY TO, WANG LABORATORIES, INC. THIS DRAWING AND THE DATA THEREON MAY NOT BE MADE PUBLIC WITHOUT THE WRITTEN CONSENT OF WANG LABORATORIES, INC. IF FOR ANY REASON THIS DRAWING IS PERMITTED BY WANG TO LEAVE THE PHYSICAL CUSTODY OF THE COMPANY, IT IS RETURNABLE UPON THE DEMAND OF WANG LABORATORIES, INC.

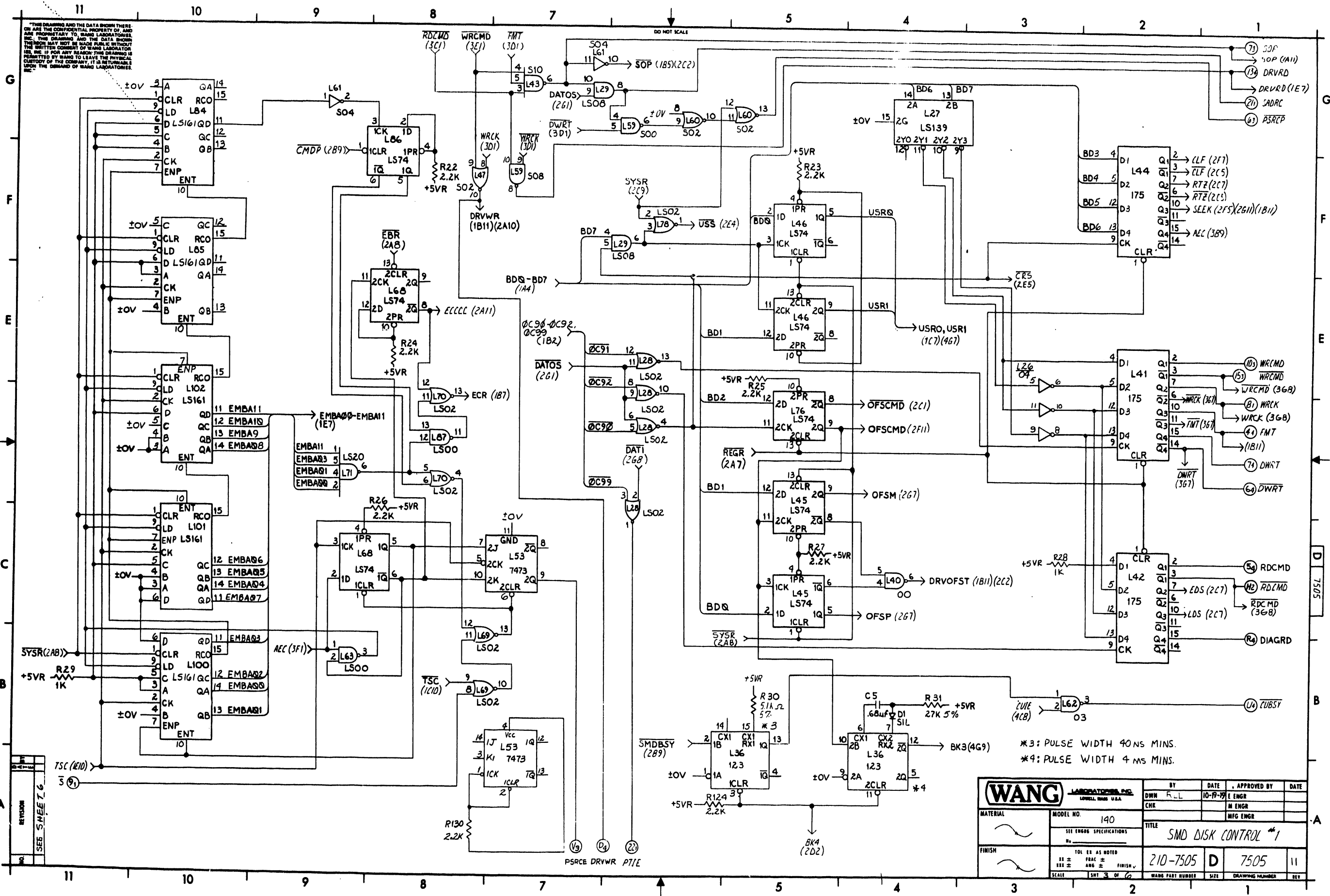

REV	DESCRIPTION
1	ISSUED

<b>WANG</b> LABORATORIES, INC. SPRING HOUSE, PA. U.S.A.		BY: R.L.	DATE: 10-19-75	APPROVED BY: E ENGR	DATE:
MATERIAL:	MODEL NO. 140	CHK:		M ENGR:	
SEE ENGR SPECIFICATIONS		TITLE: SMD DISK CONTROL #1			
FINISH:	TOL AS NOTED	210-7505	D	7505	11
SCALE: 1:1	SMT 3 OF 6	WANG PART NUMBER:	SIZE:	DRAWING NUMBER:	REV:

\*3: PULSE WIDTH 40 NS MINS.  
\*4: PULSE WIDTH 4 MS MINS.

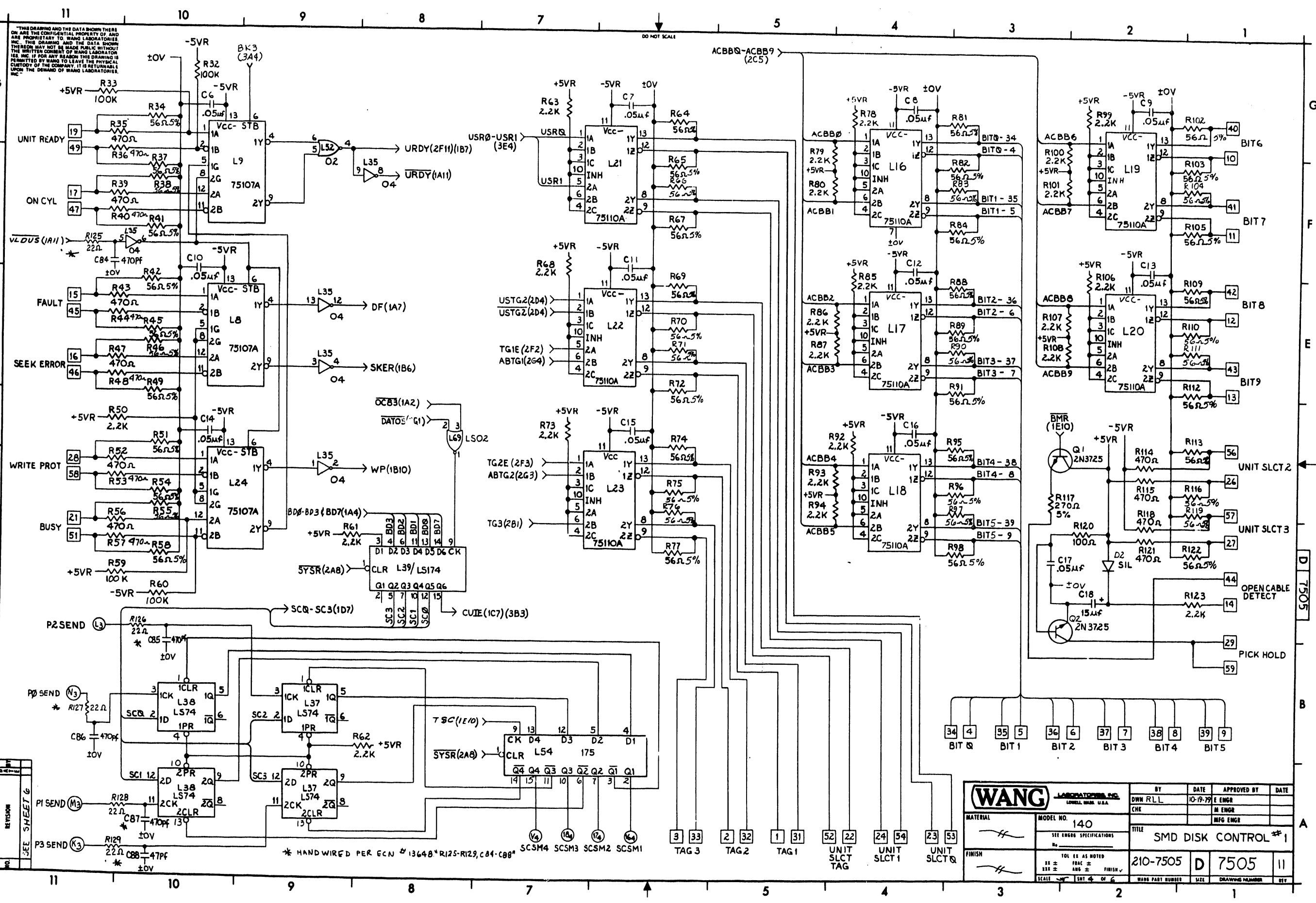

THIS DRAWING AND THE DATA SHOWN THEREON ARE THE CONFIDENTIAL PROPERTY OF AND ARE PROMISED TO WANG LABORATORIES, INC. THIS DRAWING AND THE DATA SHOWN THEREON MAY NOT BE MADE PUBLIC WITHOUT THE WRITTEN CONSENT OF WANG LABORATORIES, INC. IF FOR ANY REASON THIS DRAWING IS PERMITTED BY WANG TO LEAVE THE PHYSICAL CUSTODY OF THE COMPANY, IT IS RETURNABLE UPON THE DEMAND OF WANG LABORATORIES, INC.

DO NOT SCALE

REVISION	DATE	BY	APPROVED BY

<b>WANG</b> LABORATORIES, INC. LOWELL, MASS. U.S.A.		BY	DATE	APPROVED BY	DATE
		OWN R.L.L.	10-19-79	E ENGR	
MATERIAL		CHE	IN ENGR	MFG ENGR	
MODEL NO. 140		TITLE			
SEE ENGR SPECIFICATIONS		SMD DISK CONTROL #1			
FINISH		TOL EX AS NOTED	210-7505	D	7505
SCALE		1:1	SIZE		

\* HAND WIRED PER ECN # 13648 \* R125-R129, C84-C88

THE DRAWING AND THE DATA SHOWN THEREON ARE THE CONFIDENTIAL PROPERTY OF, AND ARE PROPRIETARY TO, WANG LABORATORIES, INC. THE DRAWING AND THE DATA SHOWN THEREON MAY NOT BE MADE PUBLIC WITHOUT THE WRITTEN CONSENT OF WANG LABORATORIES, INC. IF FOR ANY REASON THIS DRAWING IS REPRODUCED BY ANY OTHER PARTY, THE REPRODUCED COPY OF THIS DRAWING IS RETURNABLE TO WANG LABORATORIES, INC. UPON THE DEMAND OF WANG LABORATORIES, INC.

DO NOT SCALE

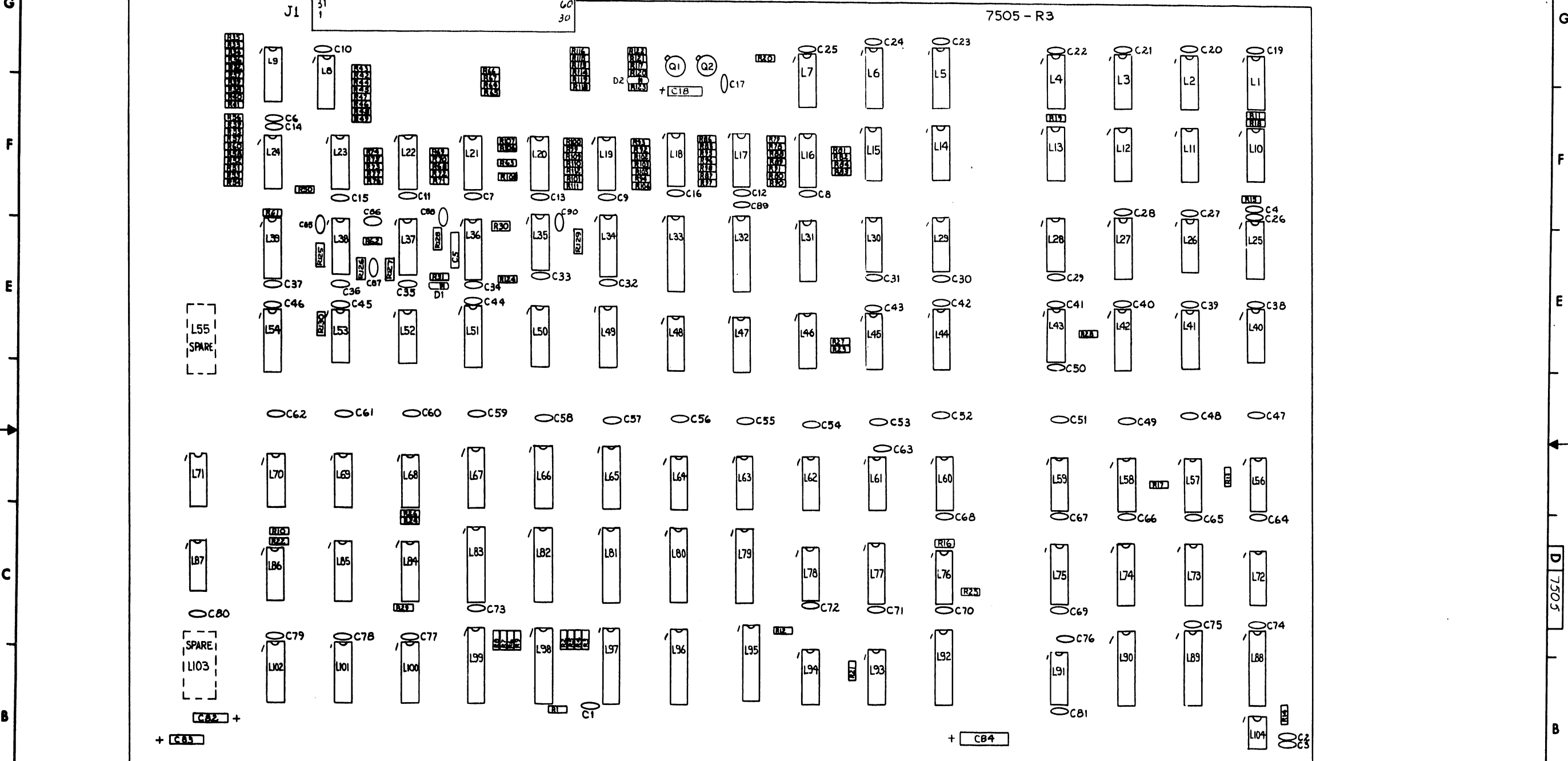

SEE SHEET 6

<b>WANG</b> LABORATORIES, INC. LOWELL, MASS. U.S.A.		BY DWN	DATE 07.07.70	APPROVED BY E ENGR	DATE
MATERIAL		CHK		MFG ENGR	
FINISH		TITLE SMD DISK CONTROL #1			
MODEL NO. 140 SEE ENGR SPECIFICATIONS No.		PART NO. 210-7505 SIZE D 7505		REV. 11	
TOL. EX. AS NOTED XX ±    FRAC ± XXX ±    ANG ±    FINISH ✓ SCALE 1/8" = 1"		WANG PART NUMBER SIZE DRAWING NUMBER		REV.	

THIS DRAWING AND THE DATA SHOWN THERE ARE THE CONFIDENTIAL PROPERTY OF AND ARE PROPRIETARY TO WANG LABORATORIES, INC. THIS DRAWING AND THE DATA SHOWN THEREIN MAY NOT BE REPRODUCED, COPIED, OR IN ANY MANNER DISCLOSED TO ANY OTHER PERSON WITHOUT THE WRITTEN CONSENT OF WANG LABORATORIES, INC. IF FOR ANY REASON THIS DRAWING IS USED IN THE COURSE OF EMPLOYMENT, IT IS HEREBY RETURNED TO WANG LABORATORIES, INC. UPON THE DEMAND OF WANG LABORATORIES, INC.

I. C. LOCATION	TYPE	W. L. NO.
L1	74LS27	376-0245
L2,12,63,72,87	74LS00	376-0207
L3	74LS32	376-0211
L4,7,10,37,38,45,46,68,76,86,94	74LS74	376-0155
L53	7473	376-0005
L8,9,24	75107A	376-0146
L11,30	74LS10	376-0209
L13,28,48,69,70,78	74LS02	376-0208
L14	74LS04	376-0180
L15,71	74LS20	376-0210
L16-23	75110A	376-0255
L25,36	74123	376-0080
L26,35	7404	376-0010
L27	74LS139	376-0226
L29	74LS08	376-0153
L31,34	74LS367A	376-0192
L32,33	74LS374	376-0286
L39	74LS174	376-0159
L40	7400	376-0002
L41,42,44,54	74175	376-0119
L43	74S10	376-0238
L47,60	74S02	376-0199
L49-51,65-67	74LS195	376-0248
L52	7402	376-0016
L56	74S08	376-0200
L57,58	74S74	376-0202
L59	74S00	376-0228
L61	74S04	376-0197
L62	7403	376-0028
L64	74S32	376-0205
L73-75	74LS138	376-0294
L77	7476	376-0007
L79-83,89,90,95-99	74LS244	376-0288
L5,6,84,85,100-102	74LS161A	376-0233
L88	74LS240	376-0297
L91	74S260	376-0206
L92	74LS373	376-0310
L93	7430	376-0031
L104	NE555	376-0126

COMPONENT	TYPE	W. L. NO.
R1	220R 1/4W 10%	330-2022
R2-13,16-27,50,61-63,68,73,78-80,85-87,92-94,99-101,106-108,123,124,130	2.2K 1/4W 10%	330-3022
R14	390K 1/4W 10%	330-5039
R15,31	27K 1/4W 5%	330-4028
R28,29	1K 1/4W 10%	330-3010
R30	5.1K 1/4W 5%	330-3052
R32,33,59,60	100K 1/4W 10%	330-5010
R34,37,38,41,42,45,46,49,51,54,55,58,64-67,69-72,74-77,81-84,88-91,95-98,102-105,109-113,116,119,122	56R 1/4W 5%	330-1057
R35,36,39,40,43,44,47,48,52,53,56,57,114,115,118,121	470R 1/4W 10%	330-2047
R117	270R 1/4W 5%	330-2028
R120	100R 1/4W 10%	330-2010
R125-129	22R 1/4W 10%	330-1022
C1,6-17,19-81,89	.047µF 50V	300-1966
C2	.1µF 50V	300-1930
C3	.01µF 25V	300-1903
C4	820Pf 50V	300-1820
C5	.68µF 35V (T)	300-4011
C18,82,83,84	15µF 20V (T)	300-4022
C85-88,90	470Pf 50V	300-1470
D1,2	51L	380-1001
Q1,2	2N3725	375-1027
J1	60 PIN	350-0057

I. C. LOCATION	TYPE	SPARES
L1	74LS27	1
L52	7402	3
L3	74LS32	1
L14	74LS04	3
L15	74LS20	1
L26	7404	2
L40	7400	3
L43	74S10	2
L47	74S02	3
L55,103	SPARE	
L56	74S08	1
L59	74S00	1
L61	74S04	1
L62	7403	2
L64	74S32	1
L69	74LS02	1
L70	74LS02	2
L71	74LS20	1
L35	7404	1
L2		1
L63	74LS00	1
L87		3

MNEMONIC	COORD.
AB-A9	(1D11)
BIT 0 - BIT9	(4B2)(4F)
BSR	(2G11)
BUSY	(4C11)
CRJF	(A8)
CUBSY	(3B1)
DQ-D7	(1G9)
DATOS	(2G1)
DBPE	(1B1)
DIAGRD	(3B1)
DRVRD	(3G1)
DRVWR	(3A7)
DWRT	(3D1)
DWRT	(3D1)
EBR	(2A8)
ECCE	(1A11)
FMT	(3D1)
FMTT	(2E11)
FAULT	(4E11)
HCE	(2A11)
HDRO	(1G1)
HRCLK	(1G7)
MMIO	(1E11)
MR	(1E11)
N5POT	(2A11)
OBD	(1G1)
PCB2	(1B1)
PCB5	(1B1)
PCB8	(1B1)
ONCYL	(4F11)
OPEN CABLE DETECT	(4C1)
OPEND	(2D11)
PB SEND, PZ SEND	(4B11)
PICKHOLD	(4B1)
PSRCE	(3A7)
PSRCP	(3G1)
PTIE	(3A6)
RDO	(1E11)
RDCMD	(3C1)
RDGATE	(2G7)
S	(3A11)
SAC	(2A7)
SACRC	(3G1)
SCSM1 - SCSM4	(4A7)
SEEK ERROR	(4E11)
SOP	(2C11)
SOP	(3G1)
STEP	(2A8)
TAG1 - TAG3	(4A5)
TD0-TD7	(1C1)
UNIT READY	(4G11)
UNIT SLCT 0 - UNIT SLCT3	(4A4)(4C1)
UNIT SLCT TAG	(4A4)
VLDJ5	(1A11)
WC	(1E11)
RDCMD	(3C1)
PI SEND, P3 SEND	(4A11)

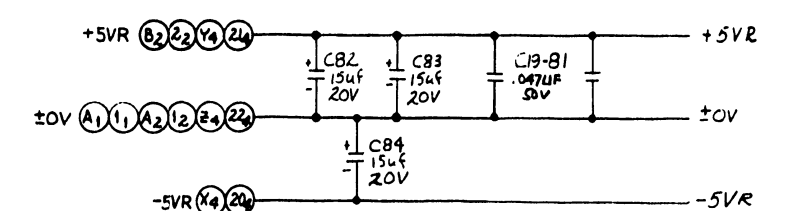
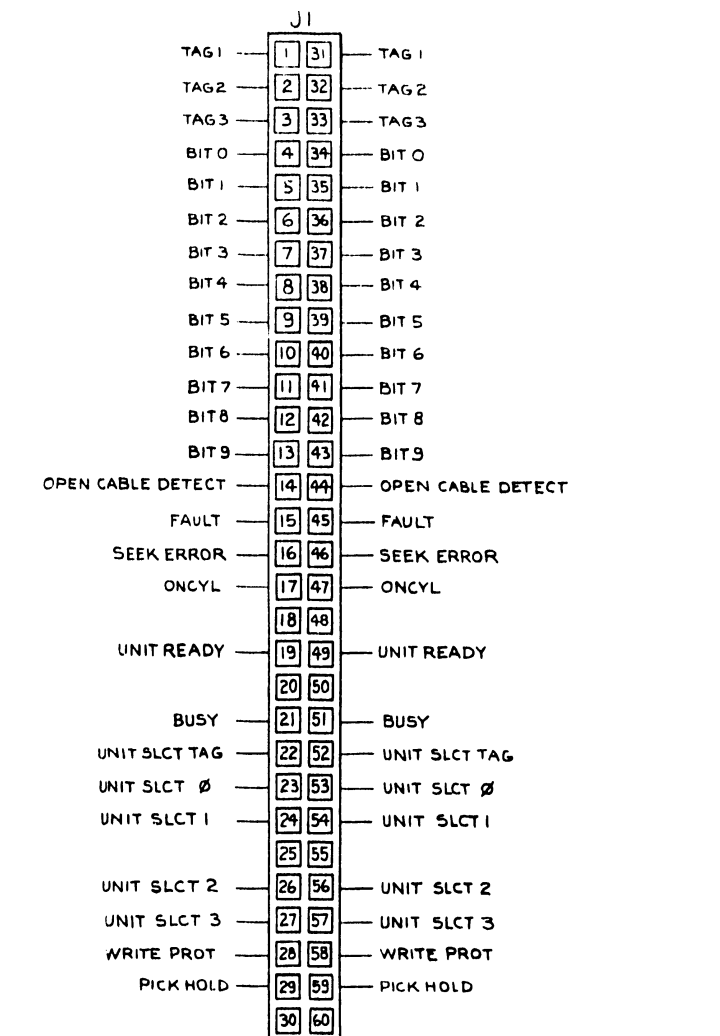
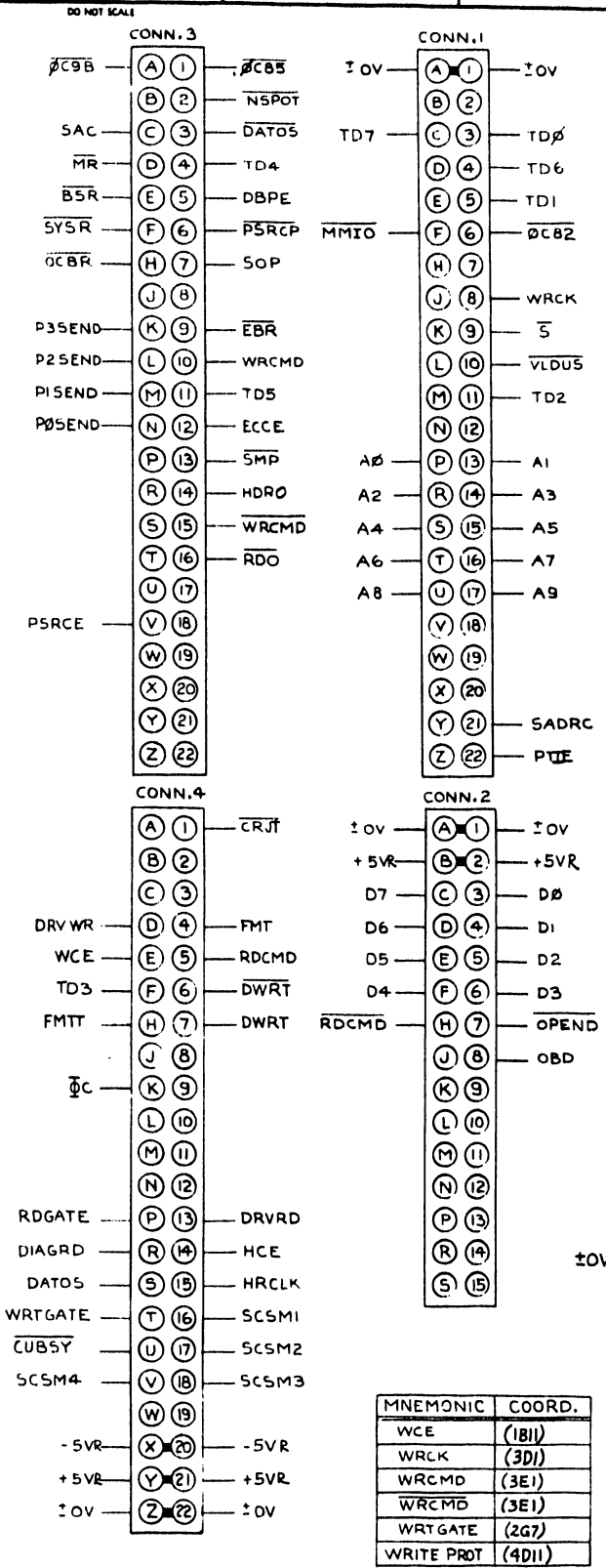

MNEMONIC	COORD.
WCE	(1B1)
WRCK	(3D1)
WRCMD	(3E1)
WRCMD	(3E1)
WRTGATE	(2G7)
WRITE PROT	(4D11)

E-REV 6

REVISED PER	DATE	BY	APPROVED BY	DATE
1	10-27-79	WLL		
2	11-11-79	WLL		
3	11-11-79	WLL		
4	11-11-79	WLL		
5	11-11-79	WLL		
6	11-11-79	WLL		
7	11-11-79	WLL		
8	11-11-79	WLL		
9	11-11-79	WLL		
10	11-11-79	WLL		
11	11-11-79	WLL		
12	11-11-79	WLL		
13	11-11-79	WLL		
14	11-11-79	WLL		
15	11-11-79	WLL		
16	11-11-79	WLL		
17	11-11-79	WLL		
18	11-11-79	WLL		
19	11-11-79	WLL		
20	11-11-79	WLL		
21	11-11-79	WLL		
22	11-11-79	WLL		
23	11-11-79	WLL		
24	11-11-79	WLL		
25	11-11-79	WLL		
26	11-11-79	WLL		
27	11-11-79	WLL		
28	11-11-79	WLL		
29	11-11-79	WLL		
30	11-11-79	WLL		
31	11-11-79	WLL		
32	11-11-79	WLL		
33	11-11-79	WLL		
34	11-11-79	WLL		
35	11-11-79	WLL		
36	11-11-79	WLL		
37	11-11-79	WLL		
38	11-11-79	WLL		
39	11-11-79	WLL		
40	11-11-79	WLL		
41	11-11-79	WLL		
42	11-11-79	WLL		
43	11-11-79	WLL		
44	11-11-79	WLL		
45	11-11-79	WLL		
46	11-11-79	WLL		
47	11-11-79	WLL		
48	11-11-79	WLL		
49	11-11-79	WLL		
50	11-11-79	WLL		
51	11-11-79	WLL		
52	11-11-79	WLL		
53	11-11-79	WLL		
54	11-11-79	WLL		
55	11-11-79	WLL		
56	11-11-79	WLL		
57	11-11-79	WLL		
58	11-11-79	WLL		
59	11-11-79	WLL		
60	11-11-79	WLL		
61	11-11-79	WLL		
62	11-11-79	WLL		
63	11-11-79	WLL		
64	11-11-79	WLL		
65	11-11-79	WLL		
66	11-11-79	WLL		
67	11-11-79	WLL		
68	11-11-79	WLL		
69	11-11-79	WLL		
70	11-11-79	WLL		
71	11-11-79	WLL		
72	11-11-79	WLL		
73	11-11-79	WLL		
74	11-11-79	WLL		
75	11-11-79	WLL		
76	11-11-79	WLL		
77	11-11-79	WLL		
78	11-11-79	WLL		
79	11-11-79	WLL		
80	11-11-79	WLL		
81	11-11-79	WLL		
82	11-11-79	WLL		
83	11-11-79	WLL		
84	11-11-79	WLL		
85	11-11-79	WLL		
86	11-11-79	WLL		
87	11-11-79	WLL		
88	11-11-79	WLL		
89	11-11-79	WLL		
90	11-11-79	WLL		
91	11-11-79	WLL		
92	11-11-79	WLL		
93	11-11-79	WLL		
94	11-11-79	WLL		
95	11-11-79	WLL		
96	11-11-79	WLL		
97	11-11-79	WLL		
98	11-11-79	WLL		
99	11-11-79	WLL		
100	11-11-79	WLL		

<b>WANG</b> LABORATORIES, INC. LOCAL MADE U.S.A.		BY: DWN	DATE: 10-12-79	APPROVED BY: E ENGR. MARTELLO	DATE: 10-29-79
MATERIAL:	MODEL NO: 140	CHE: 10/14	10/31/79	M ENGR:	INFO ENGR:
SEE ENGR SPECIFICATIONS		TITLE: SMD DISK CONTROL #1			
FINISH:	101 EE AS NOTED	210-7505	D	7505	11
SCALE: 1/8" = 1"		SHEET 6 OF 6		WANG PART NUMBER	SIZE

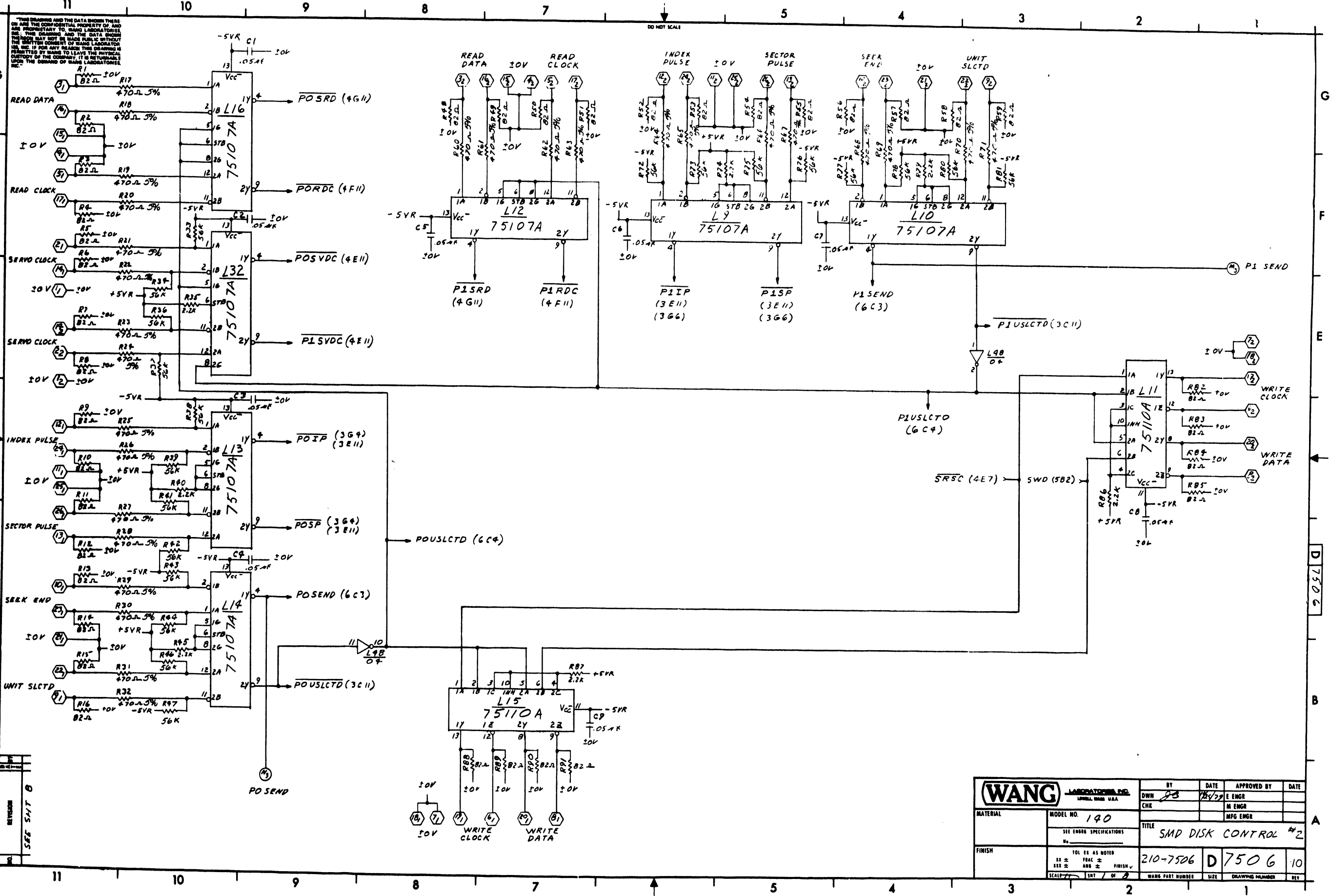

<b>(WANG) LABORATORIES, INC.</b> LIVELY, MASS. U.S.A.		BY	DATE	APPROVED BY	DATE
		DWN	12/22	E ENGR	
MATERIAL		MODEL NO.	190		
		SEE ENGR SPECIFICATIONS			
FINISH		TOL EE AS NOTED			
		XX ±    FRAC ±    FINISH ±			
SCALE		210-7506	D7506	10	
SCALE		1/2	1	1	

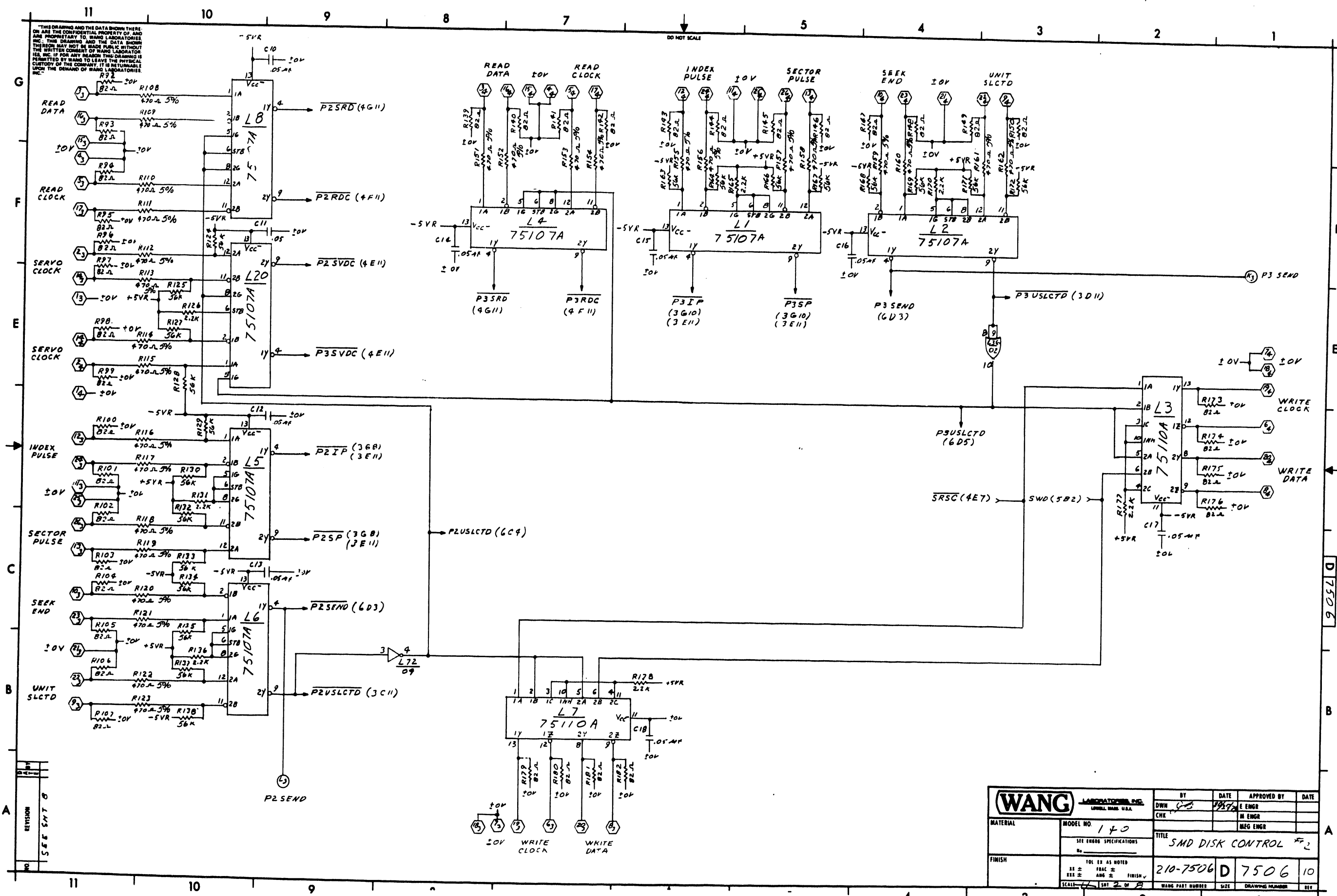

THIS DRAWING AND THE DATA SHOWN THERE ON ARE THE CONFIDENTIAL PROPERTY OF WANG LABORATORIES, INC. THIS DRAWING AND THE DATA SHOWN THEREON MAY NOT BE MADE PUBLIC WITHOUT THE WRITTEN CONSENT OF WANG LABORATORIES, INC. IF FOR ANY REASON THIS DRAWING IS PERMITTED BY WANG TO LEAVE THE PHYSICAL CUSTODY OF THE COMPANY, IT IS RETURNABLE UPON THE DEMAND OF WANG LABORATORIES, INC.

REV	DATE	BY	CHK

SEE SMT 8

<b>WANG</b> LABORATORIES, INC. LITTLE ROCK, ARK. U.S.A.		BY	DATE	APPROVED BY	DATE
MATERIAL		DWN	9/27/72	E ENGR	
MODEL NO. 140		CHK		M ENGR	
SEE ENGR SPECIFICATIONS		TITLE		MFG ENGR	
NO.		SMD DISK CONTROL #2			
FINISH		210-7506	D	7506	10
SCALE: 1/8" = 1" (SEE SMT 8)		WANG PART NUMBER	SIZE	DRAWING NUMBER	REV

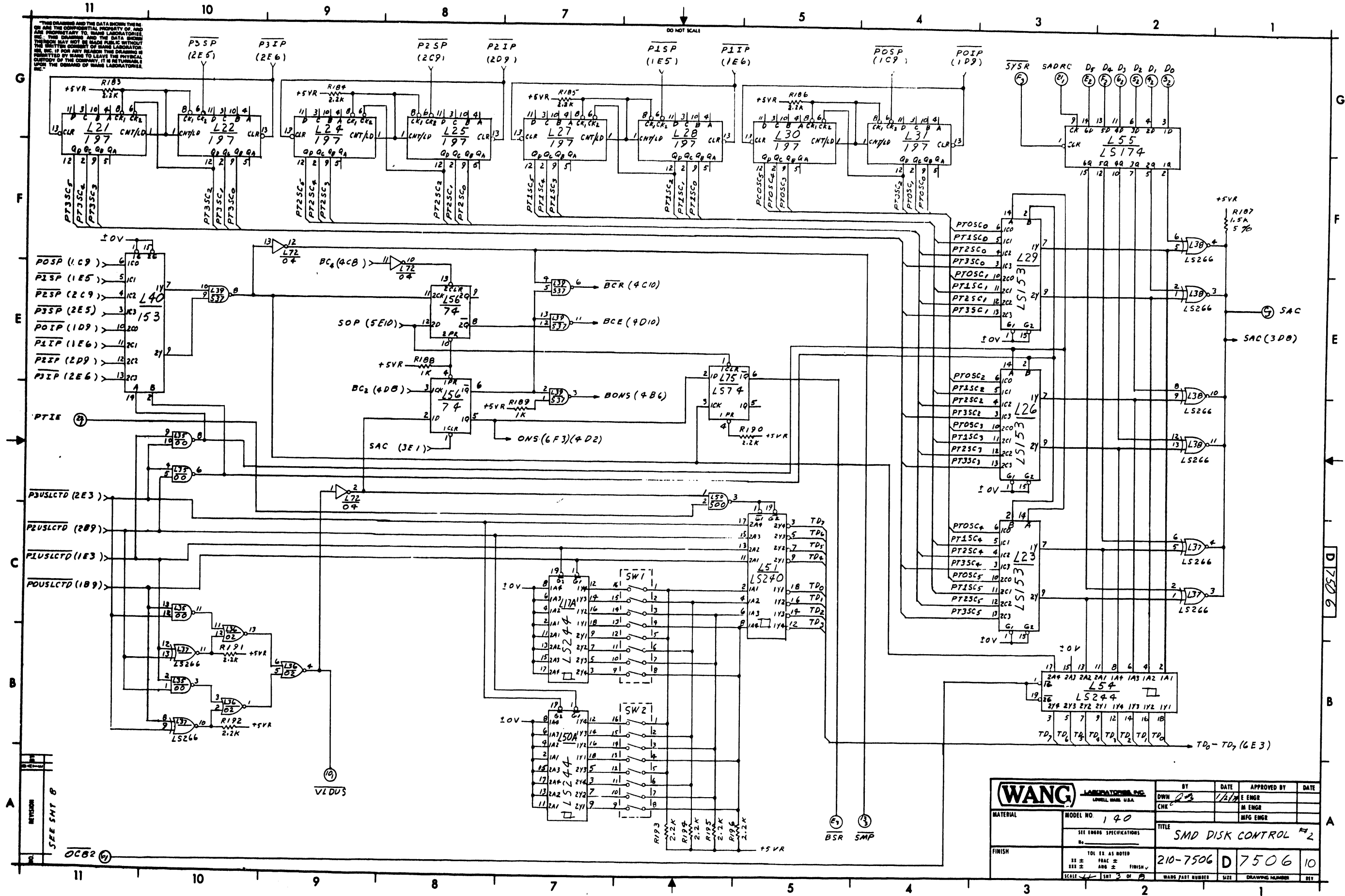

<b>WANG</b> LABORATORIES INC. LOWELL, MASS. U.S.A.		BY DWH	DATE 1/27	APPROVED BY M ENGR	DATE
MATERIAL		CHK		MFG ENGR	
FINISH		TITLE SMD DISK CONTROL #2			
SCALE 1:1		210-7506		D 7506 10	
SHEET 3 OF 3		WANG PART NUMBER		SIZE	

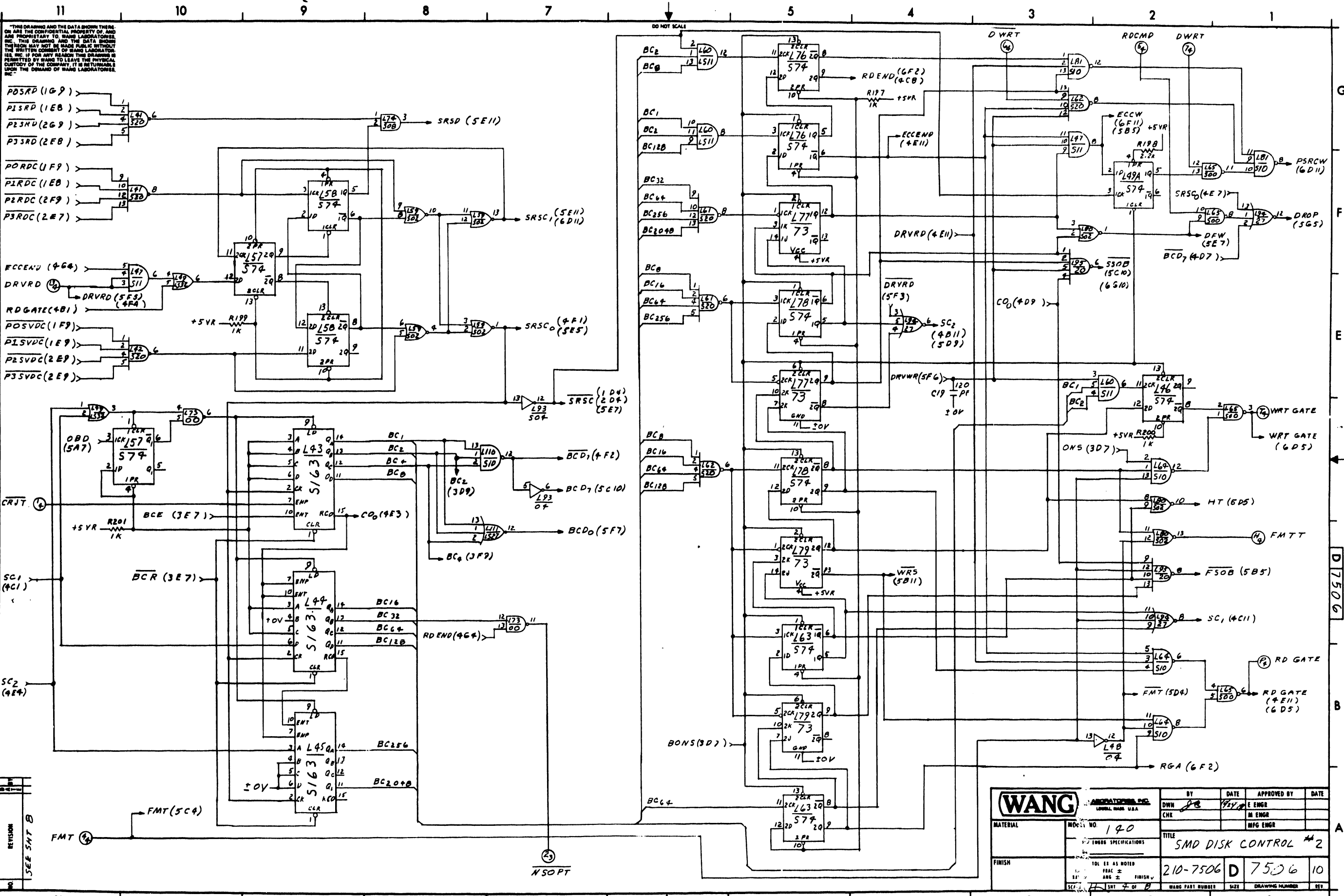

THIS DRAWING AND THE DATA SHOWN THEREON ARE THE CONFIDENTIAL PROPERTY OF, AND ARE PROPRIETARY TO, WANG LABORATORIES, INC. THIS DRAWING AND THE DATA SHOWN THEREON MAY NOT BE MADE PUBLIC WITHOUT THE WRITTEN CONSENT OF WANG LABORATORIES, INC. IF FOR ANY REASON THIS DRAWING IS PERMITTED BY WANG TO LEAVE THE PHYSICAL CUSTODY OF THE COMPANY, IT IS HEREBY RELEASED TO THE DEMAND OF WANG LABORATORIES, INC.

REVISION  
 1  
 SEE SHT B

<b>WANG</b>		BY	DATE	APPROVED BY	DATE
MATERIAL		DWN	8/28	E ENGR	
FINISH		CHK		M ENGR	
				MFG ENGR	
MOD. NO. 140		TITLE			
210-7506		SMD DISK CONTROL #2			
D 7506		210-7506 D 7506 10			

NSOPT



THIS DRAWING AND THE DATA SHOWN THEREON ARE THE CONFIDENTIAL PROPERTY OF AND ARE PROPRIETARY TO WANG LABORATORIES, INC. THIS DRAWING AND THE DATA SHOWN THEREON SHALL NOT BE MADE PUBLIC WITHOUT THE WRITTEN CONSENT OF WANG LABORATORIES, INC. IF FOR ANY REASON THIS DRAWING IS REPRODUCED OR COPIED IN WHOLE OR IN PART BY ANY OTHER PARTY, IT IS RETURNABLE TO THE DEMAND OF WANG LABORATORIES, INC.

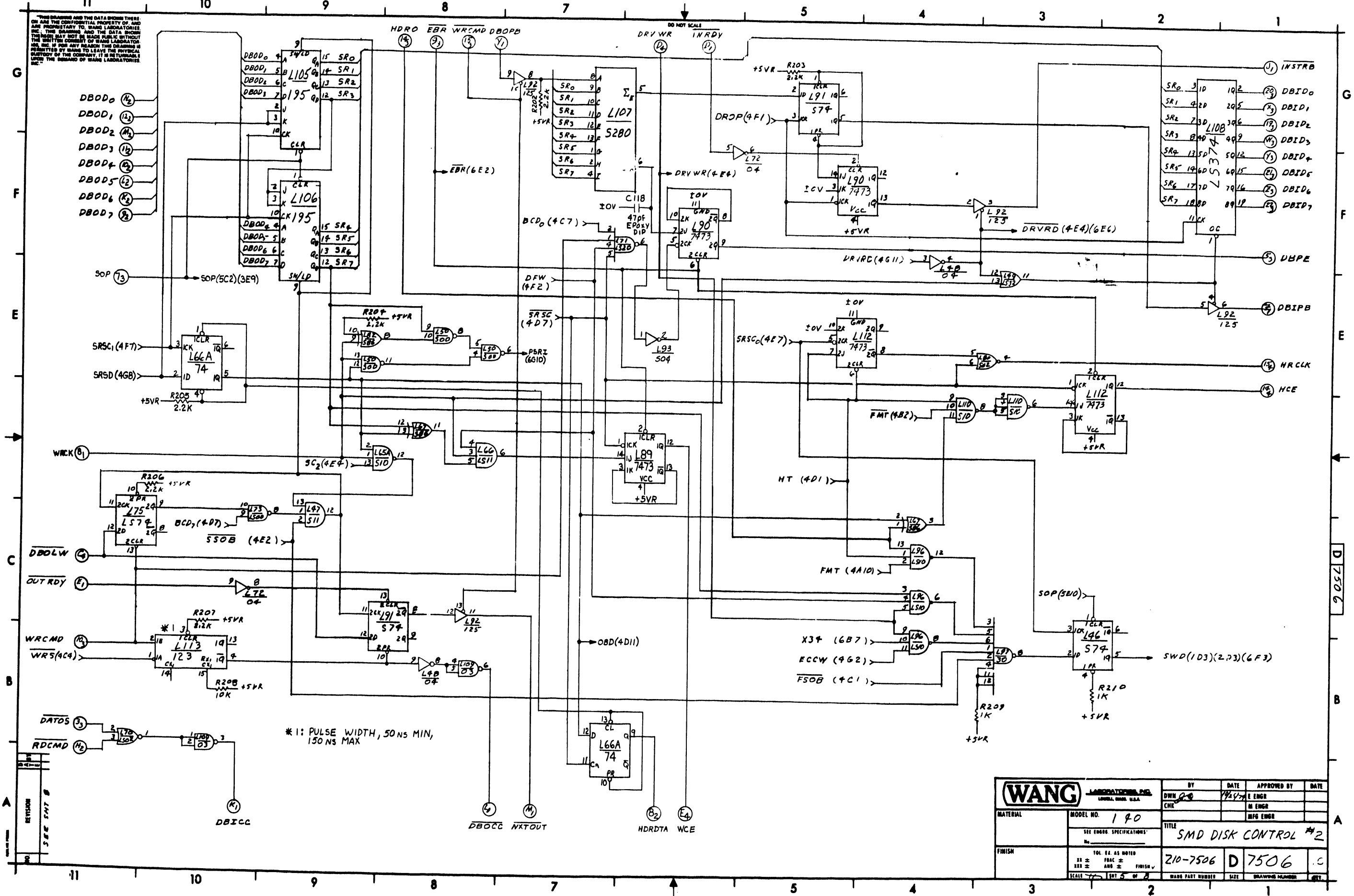

\* 1: PULSE WIDTH, 50 NS MIN, 150 NS MAX

<b>WANG</b> LABORATORIES, INC. LOWELL, MASS. U.S.A.		BY DWN	DATE 7/2/74	APPROVED BY E ENGR	DATE
MATERIAL		CHK		M ENGR	
FINISH				MFG ENGR	
MODEL NO. 190		TITLE SMD DISK CONTROL #2			
SEE ENGR. SPECIFICATIONS		210-7506 D 7506 .C			
SCALE 1/8" = 1"		WANG PART NUMBER SIZE DRAWING NUMBER			

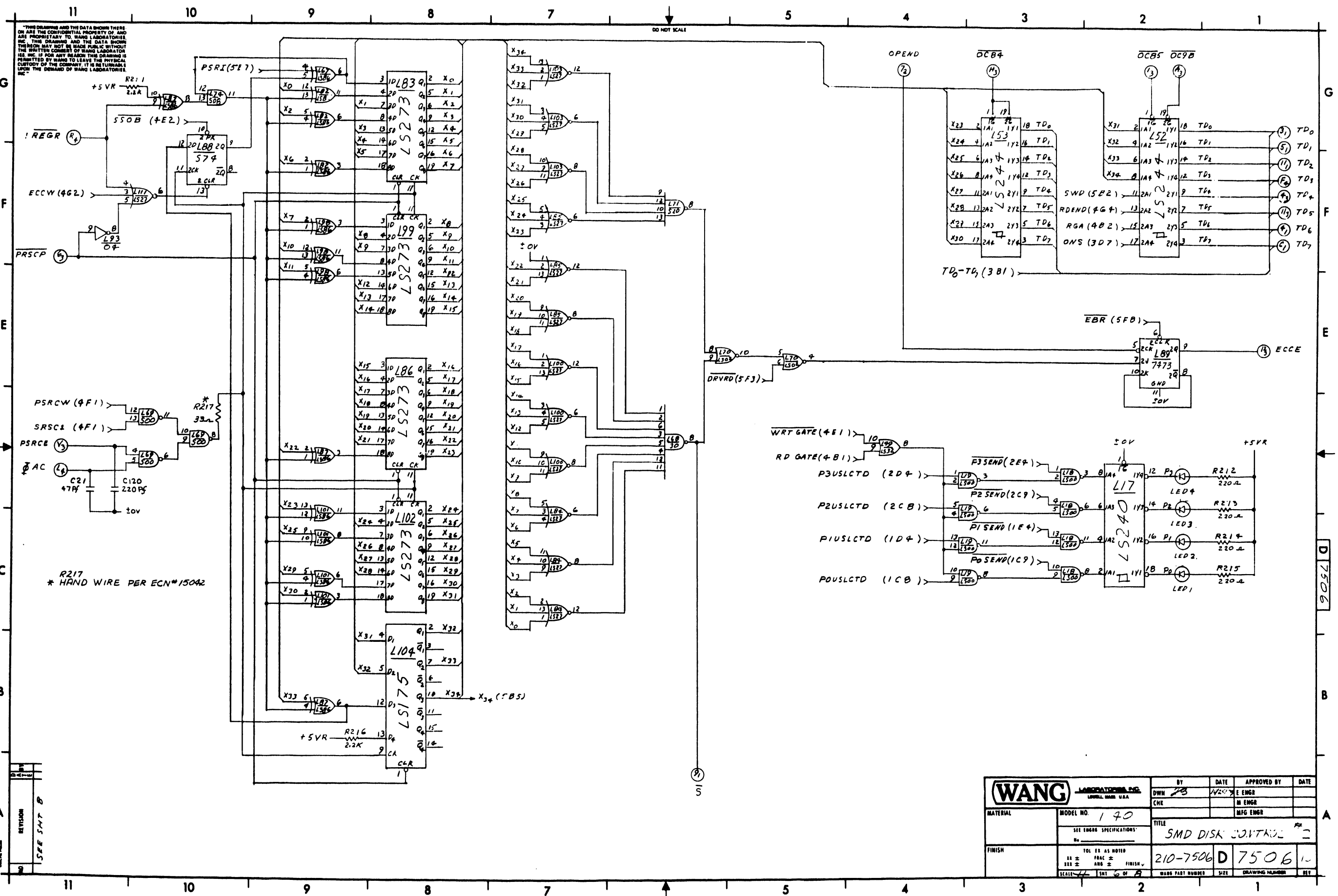

THIS DRAWING AND THE DATA SHOWN THERE ON ARE THE CONFIDENTIAL PROPERTY OF AND ARE PROPRIETARY TO WANG LABORATORIES, INC. THIS DRAWING AND THE DATA SHOWN THEREIN MAY NOT BE MADE PUBLIC WITHOUT THE WRITTEN CONSENT OF WANG LABORATORIES, INC. IF FOR ANY REASON THIS DRAWING IS PERMITTED BY WANG TO LEAVE THE PHYSICAL CUSTODY OF THE COMPANY, IT IS RETURNABLE UPON THE DEMAND OF WANG LABORATORIES, INC.

R217  
\* HAND WIRE PER ECN#15042

<b>WANG</b> LABORATORIES, INC. LINDEN, MASS. U.S.A.		BY DWN	DATE 12/20/68	APPROVED BY E ENGR	DATE
MATERIAL	MODEL NO. 170	CHE		MFG ENGR	
SEE ENGR SPECIFICATIONS		TITLE SMD DISK CONTROL			
FINISH	TOI AS NOTED 11 ± FRC ± 12 ± FRC ± 13 ± FRC ±	210-7506 D 7506 1-		DRAWING NUMBER	
SCALE 1/16" = 1"		SHEET 6 OF 8		WANG PART NUMBER SIZE DRAWING NUMBER	

11 10 9 8 7 5 4 3 2 1

THIS DRAWING AND THE DATA SHOWN THERE ON ARE THE CONFIDENTIAL PROPERTY OF, AND ARE PROPRIETARY TO, WANG LABORATORIES, INC. THIS DRAWING AND THE DATA SHOWN HEREIN MAY NOT BE MADE PUBLIC WITHOUT THE WRITTEN CONSENT OF WANG LABORATORIES, INC. IF FOR ANY REASON THIS DRAWING IS REPRODUCED OR COPIED IN ANY MANNER WITHOUT THE DEMAND OF WANG LABORATORIES, INC.

DO NOT SCALE

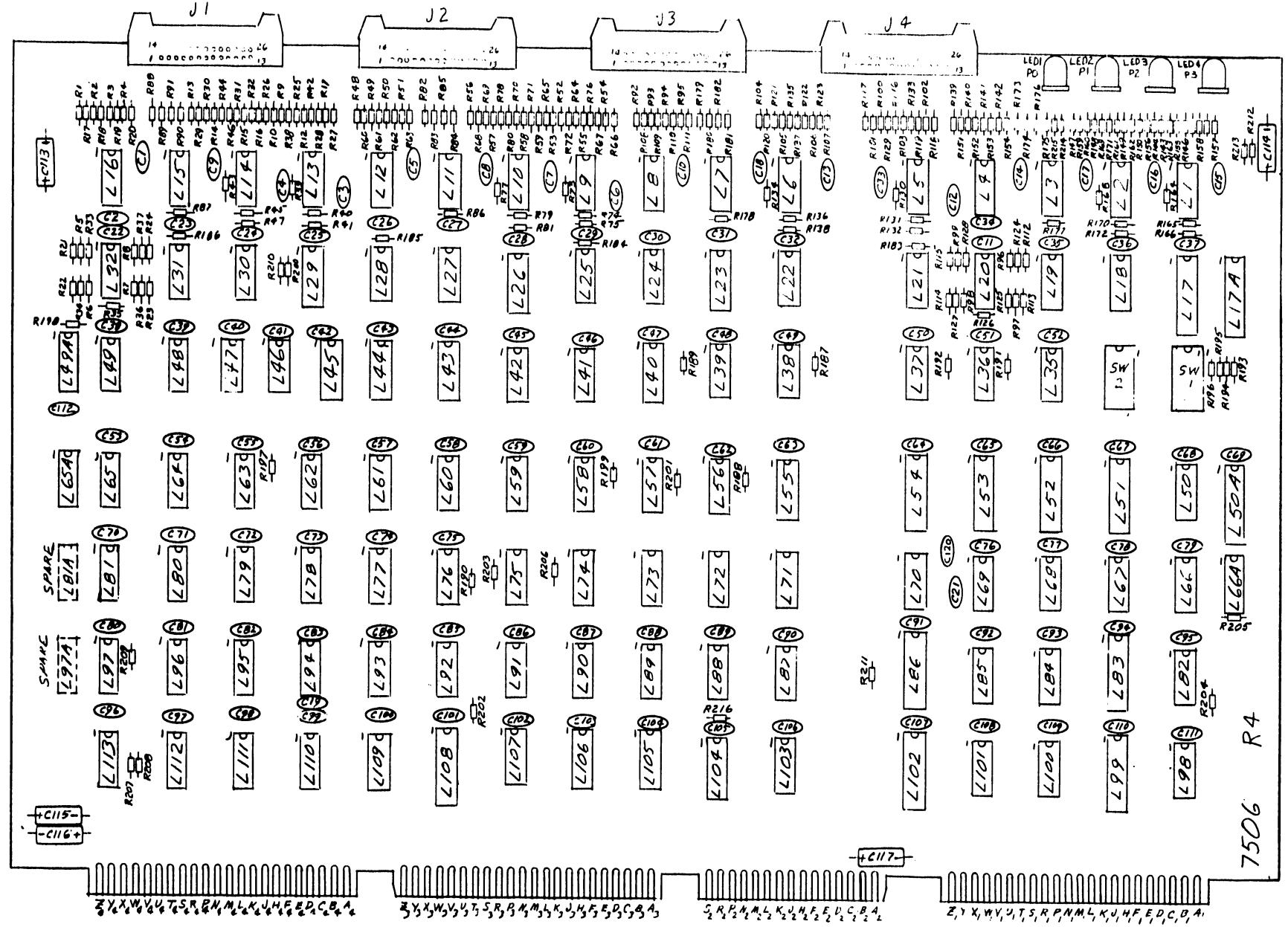

7506 R4

NO.	REVISION
	SEE SHT 0

<b>WANG</b> LABORATORIES, INC. SMALL SIGNAL U.S.A.		BY	DATE	APPROVED BY	DATE
MATERIAL	MODEL NO. 140	DWN	02/78	E ENGR	
	SEE ENGR SPECIFICATIONS	CHK		M ENGR	
FINISH	TOL EN AS NOTED			MFG ENGR	
	FRAC ±				
	ANG ±				
	FINISH				
SCALE 1/1	SHEET 7 OF 8	WANG PART NUMBER	210-7506	SIZE	D 7506
		DRAWING NUMBER			

7506

11 10 9 8 7 5 4 3 2 1

THIS DRAWING AND THE DATA SHOWN THERE ON AND THE PROPRIETARY PROPERTY OF AND ARE PROPRIETARY TO WANG LABORATORIES, INC. THE DRAWING AND THE DATA SHOWN THEREON MAY NOT BE MADE PUBLIC WITHOUT THE WRITTEN CONSENT OF WANG LABORATORIES, INC. NO USE, IN WHOLE OR IN PART, IS PERMITTED BY WANG TO LEAVE THE PHYSICAL PROPERTY OF THIS COMPANY. IT IS RETURNABLE UPON THE DEMAND OF WANG LABORATORIES, INC.

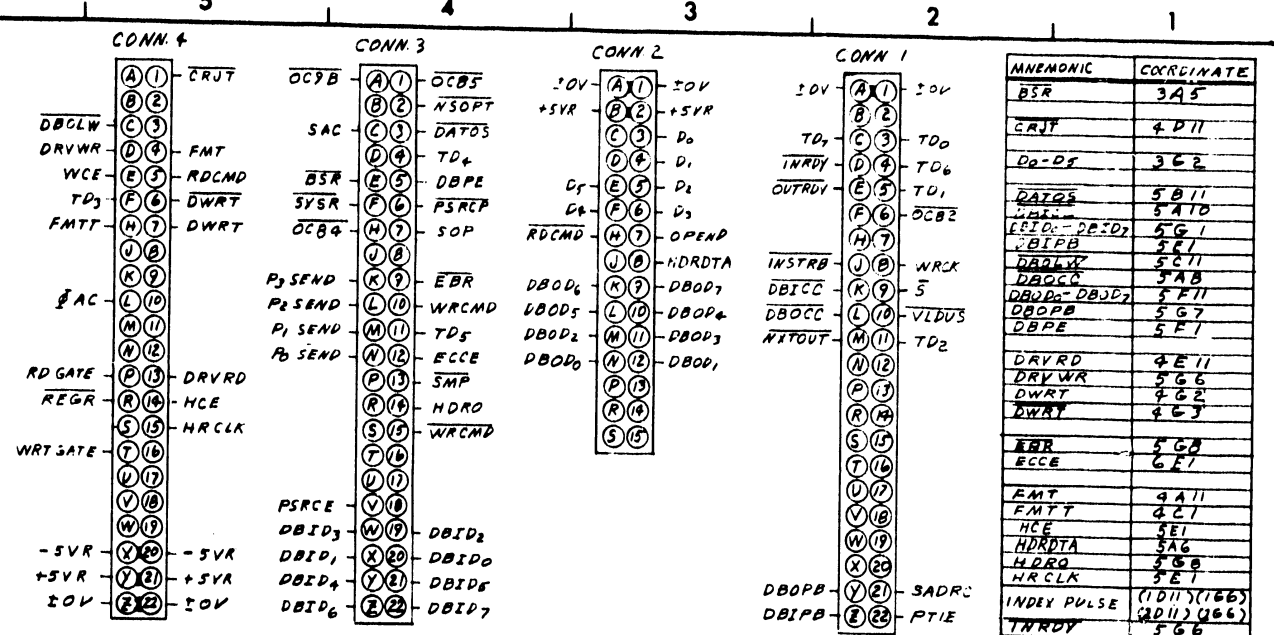
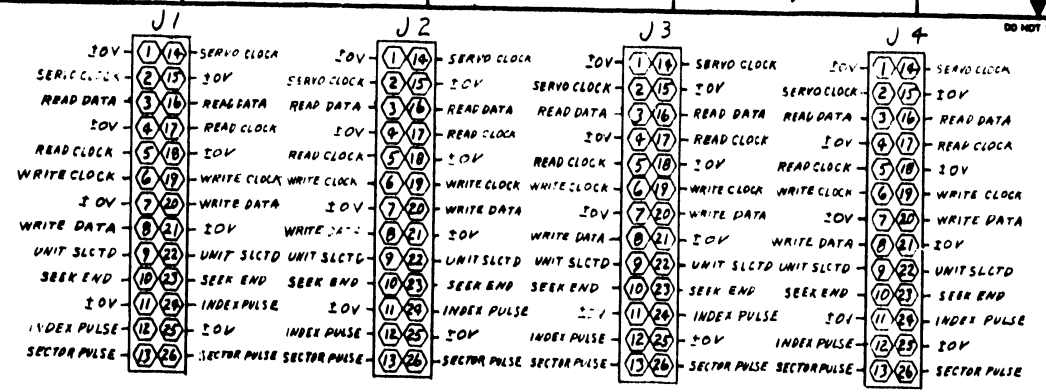

I.C. TYPE	LOC	SPARES
7400	L73	1
74500	L69	1
74LS02	L70	1
7403	L109	2
7404	L48	1
74504	L93	2
74508	L74	1
74510	L81	1
74510	L65A	2
74LS11	L66	2
74520	L42	1
74LS27	L11	1
74574	L49A	1
	L80	1
74586	L67	1
74LS86	L87	1
74123	L113	1
74LS240	L17	1

I.C. LOCATION	W.L. PART NO.	TYPE
L1,2,4,5,6,8,9,12,13,14,16,20,32	376-0196	75107A
L3,7,11,15	376-0289	75110A
L12A,50A,52,53,54	376-0288	74LS244
L17,57	376-0287	74LS240
L18,19	376-0287	74LS240
L21,22,24,25,27,28,30,31	376-0287	74LS240
L23,24,29	376-0156	74LS153
L35,73	376-0002	7400
L36	376-0016	7402
L37,38	376-0148	74LS266
L39	376-0286	74LS37
L40	376-0286	74LS37
L41,43,61,62	376-0048	74LS13
L43,44,45	376-0287	74LS240
L46,48,51,53,55,63,76,78,81,91	376-0282	74LS74
L47	376-0237	74LS11
L48,72	376-0211	7409
L49	376-0211	74LS32
L30,65,69	376-0235	74LS00
L55	376-0189	74LS174
L59,80	376-0189	74LS2
L60,66	376-0235	74LS37
L63,65A,B1,110	376-0238	74LS10
L66A	376-0006	7474
L67	376-0271	74586
L68,97	376-0231	7430
L70	376-0208	74LS02
L74	376-0200	74LS08
L75	376-0189	74LS74
L77,79,89,90,112	376-0005	7473
L81A,97A		SPARE
L82,83,98,101	376-0231	74LS86
L83,86,99,102	376-0302	74LS273
L88,85,109,103,111	376-0249	74LS27
L92	376-0234	74125
L93	376-0189	74LS04
L94	376-0125	7427
L95	376-0009	7420
L96	376-0209	74LS10
L104	376-0160	74LS175
L105,106	376-0097	74193
L107	376-0246	74LS280
L108	376-0286	74LS374
L109	376-0028	7403
L113	376-0080	74123
L71	376-0210	74LS20

COMPONENT	W.L. PART NO.	TYPE
R1-16,48-59,82-85,88-103,139-150,173-176,179-182	330-1082	82-2 1/2 W 10%
R17-32,60-71,108-123,151-162	330-2048	40A 1/4 W 5%
R33,35,36-39,41-44,46,47,72,73,75-78,80,81,124,125,127-129,132-135,137,138,163,164,166-169,171,172	330-4056	56K 1/4 W 10%
R35,40,43,74,79,126,131,136,165,170,183-186,190-196,198,202-205,207,210,216,173,178	330-3022	2.2K 1/4 W 10%
R187	330-3016	1.5K 1/4 W 5%
R188,189,197,199,200,201,209,210	330-3010	1K 1/4 W 5%
R208	330-4010	10K 1/4 W 10%
R212-215	330-2022	220A 1/4 W 10%
R217	330-1033	330 1/4 W 10%
C1-18,22-112	300-1900	.0547 12V (CE)
C19	300-1120	180PF (CE)
C119,120	300-1220	220PF 50V (CE)
C21	300-1047	47PF 50V (CE)
C113-117	300-4022	154R 20V (T)
C118	300-2602	47PF 50V 10% (CE)
LED1-4	370-0026	LED RED
J1,2,3,4	350-0058	26 PIN CONN
SW1,2	325-1503	9 BANK ROC. SW
SW1,2	325-9047	SW COOPER

MNEMONIC	COORDINATE
TD0-TD2	6 F 1
UNIT SLCTD	(1811) (183) (2811) (283)
VLDUS	3 A 9
WCE	5 A 6
WRCK	5 D 11
WRCMD	3 A 7
WRCP	3 B 11
WRCPD	5 B 9
WRITE CLOCK	(1A7) (1D1) (2A7) (2D1)
WRITE DATA	(1A7) (1D1) (1A7) (2D1)
WRT GATE	1 D 1
AC	6 D 11

MNEMONIC	COORDINATE
BSR	3 A 5
CRJT	4 D 11
DO-DS	3 E 2
DATGS	5 B 11
DBALW	5 A 10
DBIPB	5 G 1
DBIPB	5 E 1
DBALW	5 C 11
DBOCC	3 A 8
DBOCC-DBOCC	5 F 11
DBOPB	5 G 7
DBPE	5 F 7
DRYRD	4 E 11
DRVWR	5 G 6
DWRT	4 G 2
DWRT	4 G 3
EBR	5 G 8
ECCE	6 E 7
FMT	4 A 11
FMTT	4 C 1
HCE	5 E 1
HDRDTA	5 A 6
HDRD	5 B 8
HRCLK	5 E 1
INDEX PULSE	(1011) (166) (2D11) (266)
INRDY	5 G 6
INSTAB	5 G 1
NSOPT	4 A 7
OUTOUT	4 A 7
OCB2	6 G 2
OCB2	3 A 11
OCB2	6 G 3
OCB2	6 G 2
OPEND	6 G 4
OUTRDY	5 C 11
P2 SEND	1 A 9
P1 SEND	1 F 1
P2 SEND	2 A 9
P3 SEND	2 F 1
PSRCE	6 D 11
PSRCP	6 F 11
PTIE	3 D 11
RDCMD	4 G 2
RDCMD	5 A 11
RDCMD	4 B 7
READ CLOCK	(1F11) (1G7) (2F11) (2G7)
READ DATA	(1G11) (1G8) (2G11) (2G8)
REGR	6 G 1
S	6 A E
SAC	3 E 1
SADRC	3 G 3
SECTOR PULSE	(1C11) (1G5) (2C11) (2G5)
SEEK END	(1C11) (1G4) (2C11) (2G4)
SERVO CLOCK	(1F11) (1E11) (2F11) (2E11)
SMP	3 A 4
SOP	3 E 11
SVSR	3 G 5

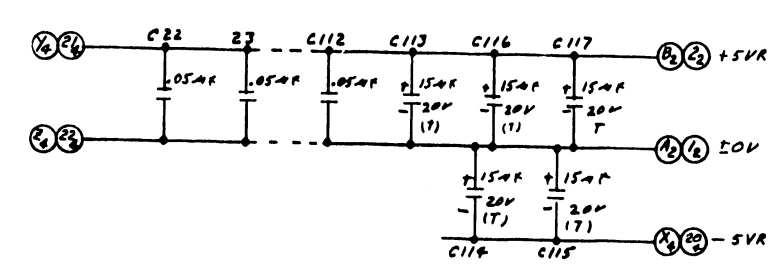

REV	DATE	BY	DESCRIPTION
1	11-11-77	...	...
2	11-11-77	...	...
3	11-11-77	...	...
4	11-11-77	...	...
5	11-11-77	...	...
6	11-11-77	...	...
7	11-11-77	...	...
8	11-11-77	...	...
9	11-11-77	...	...
10	11-11-77	...	...
11	11-11-77	...	...

<b>WANG</b> LABORATORIES, INC. LOCAL WANG USA		BY: <i>...</i>	DATE: 11/11/77	APPROVED BY: E ENGR A. DESKUR	DATE: 11/30/77
MATERIAL:	MODEL NO. 140	CNK: <i>...</i>	10/30/77	M ENGR	MFG ENGR
SEE ENGR SPECIFICATIONS		TITLE: SMD DISK CONTROL #2			
FINISH: 10% OR AS NOTED		210-7506 D		7506 10	
SCALE: 1:1		SHEET 8 OF 8		DRAWING NUMBER	

THIS DRAWING AND THE DATA SHOWN THERE ON ARE THE CONFIDENTIAL PROPERTY OF AND ARE PROPRIETARY TO WANG LABORATORIES, INC. THIS DRAWING AND THE DATA SHOWN THEREIN MAY NOT BE MADE PUBLIC WITHOUT THE WRITTEN CONSENT OF WANG LABORATORIES, INC. IF FOR ANY REASON THIS DRAWING IS PERMITTED BY WANG TO LEAVE THE PHYSICAL CUSTODY OF THE COMPANY, IT IS RETURNABLE UPON THE DEMAND OF WANG LABORATORIES, INC.

DO NOT SCALE

SIGNAL	DATA LINK DRIVER	DATA LINK CONTROLLER	SMD DRIVER	FLOPPY I/O	CPU/MEMORY	SPARE	SPARE	SPARE	FLOPPY RESOURCE	
	P1, P2, P3, P4, P5, P6, P7, P8, P9, P10, P11, P12, P13, P14, P15, P16, P17, P18, P19, P20, P21, P22, P23, P24, P25, P26, P27, P28, P29, P30, P31, P32, P33, P34, P35, P36, P37, P38, P39, P40, P41, P42, P43, P44, P45, P46, P47, P48, P49, P50, P51, P52, P53, P54, P55, P56, P57, P58, P59, P60, P61, P62, P63, P64, P65, P66, P67, P68, P69, P70, P71, P72, P73, P74, P75, P76, P77, P78, P79, P80, P81, P82, P83, P84, P85, P86, P87, P88, P89, P90, P91, P92, P93, P94, P95, P96, P97, P98, P99, P100, P101, P102, P103, P104, P105, P106, P107, P108, P109, P110, P111, P112, P113, P114, P115, P116, P117, P118, P119, P120, P121, P122, P123, P124, P125, P126, P127, P128, P129, P130, P131, P132, P133, P134, P135, P136, P137, P138, P139, P140, P141, P142, P143, P144, P145, P146, P147, P148, P149, P150, P151, P152, P153, P154, P155, P156, P157, P158, P159, P160, P161, P162, P163, P164, P165, P166, P167, P168, P169, P170, P171, P172, P173, P174, P175, P176, P177, P178, P179, P180, P181, P182, P183, P184, P185, P186, P187, P188, P189, P190, P191, P192, P193, P194, P195, P196, P197, P198, P199, P200, P201, P202, P203, P204, P205, P206, P207, P208, P209, P210, P211, P212, P213, P214, P215, P216, P217, P218, P219, P220, P221, P222, P223, P224, P225, P226, P227, P228, P229, P230, P231, P232, P233, P234, P235, P236, P237, P238, P239, P240, P241, P242, P243, P244, P245, P246, P247, P248, P249, P250, P251, P252, P253, P254, P255, P256, P257, P258, P259, P260, P261, P262, P263, P264, P265, P266, P267, P268, P269, P270, P271, P272, P273, P274, P275, P276, P277, P278, P279, P280, P281, P282, P283, P284, P285, P286, P287, P288, P289, P290, P291, P292, P293, P294, P295, P296, P297, P298, P299, P300, P301, P302, P303, P304, P305, P306, P307, P308, P309, P310, P311, P312, P313, P314, P315, P316, P317, P318, P319, P320, P321, P322, P323, P324, P325, P326, P327, P328, P329, P330, P331, P332, P333, P334, P335, P336, P337, P338, P339, P340, P341, P342, P343, P344, P345, P346, P347, P348, P349, P350, P351, P352, P353, P354, P355, P356, P357, P358, P359, P360, P361, P362, P363, P364, P365, P366, P367, P368, P369, P370, P371, P372, P373, P374, P375, P376, P377, P378, P379, P380, P381, P382, P383, P384, P385, P386, P387, P388, P389, P390, P391, P392, P393, P394, P395, P396, P397, P398, P399, P400, P401, P402, P403, P404, P405, P406, P407, P408, P409, P410, P411, P412, P413, P414, P415, P416, P417, P418, P419, P420, P421, P422, P423, P424, P425, P426, P427, P428, P429, P430, P431, P432, P433, P434, P435, P436, P437, P438, P439, P440, P441, P442, P443, P444, P445, P446, P447, P448, P449, P450, P451, P452, P453, P454, P455, P456, P457, P458, P459, P460, P461, P462, P463, P464, P465, P466, P467, P468, P469, P470, P471, P472, P473, P474, P475, P476, P477, P478, P479, P480, P481, P482, P483, P484, P485, P486, P487, P488, P489, P490, P491, P492, P493, P494, P495, P496, P497, P498, P499, P500, P501, P502, P503, P504, P505, P506, P507, P508, P509, P510, P511, P512, P513, P514, P515, P516, P517, P518, P519, P520, P521, P522, P523, P524, P525, P526, P527, P528, P529, P530, P531, P532, P533, P534, P535, P536, P537, P538, P539, P540, P541, P542, P543, P544, P545, P546, P547, P548, P549, P550, P551, P552, P553, P554, P555, P556, P557, P558, P559, P560, P561, P562, P563, P564, P565, P566, P567, P568, P569, P570, P571, P572, P573, P574, P575, P576, P577, P578, P579, P580, P581, P582, P583, P584, P585, P586, P587, P588, P589, P590, P591, P592, P593, P594, P595, P596, P597, P598, P599, P600, P601, P602, P603, P604, P605, P606, P607, P608, P609, P610, P611, P612, P613, P614, P615, P616, P617, P618, P619, P620, P621, P622, P623, P624, P625, P626, P627, P628, P629, P630, P631, P632, P633, P634, P635, P636, P637, P638, P639, P640, P641, P642, P643, P644, P645, P646, P647, P648, P649, P650, P651, P652, P653, P654, P655, P656, P657, P658, P659, P660, P661, P662, P663, P664, P665, P666, P667, P668, P669, P670, P671, P672, P673, P674, P675, P676, P677, P678, P679, P680, P681, P682, P683, P684, P685, P686, P687, P688, P689, P690, P691, P692, P693, P694, P695, P696, P697, P698, P699, P700, P701, P702, P703, P704, P705, P706, P707, P708, P709, P710, P711, P712, P713, P714, P715, P716, P717, P718, P719, P720, P721, P722, P723, P724, P725, P726, P727, P728, P729, P730, P731, P732, P733, P734, P735, P736, P737, P738, P739, P740, P741, P742, P743, P744, P745, P746, P747, P748, P749, P750, P751, P752, P753, P754, P755, P756, P757, P758, P759, P760, P761, P762, P763, P764, P765, P766, P767, P768, P769, P770, P771, P772, P773, P774, P775, P776, P777, P778, P779, P780, P781, P782, P783, P784, P785, P786, P787, P788, P789, P790, P791, P792, P793, P794, P795, P796, P797, P798, P799, P800, P801, P802, P803, P804, P805, P806, P807, P808, P809, P810, P811, P812, P813, P814, P815, P816, P817, P818, P819, P820, P821, P822, P823, P824, P825, P826, P827, P828, P829, P830, P831, P832, P833, P834, P835, P836, P837, P838, P839, P840, P841, P842, P843, P844, P845, P846, P847, P848, P849, P850, P851, P852, P853, P854, P855, P856, P857, P858, P859, P860, P861, P862, P863, P864, P865, P866, P867, P868, P869, P870, P871, P872, P873, P874, P875, P876, P877, P878, P879, P880, P881, P882, P883, P884, P885, P886, P887, P888, P889, P890, P891, P892, P893, P894, P895, P896, P897, P898, P899, P900, P901, P902, P903, P904, P905, P906, P907, P908, P909, P910, P911, P912, P913, P914, P915, P916, P917, P918, P919, P920, P921, P922, P923, P924, P925, P926, P927, P928, P929, P930, P931, P932, P933, P934, P935, P936, P937, P938, P939, P940, P941, P942, P943, P944, P945, P946, P947, P948, P949, P950, P951, P952, P953, P954, P955, P956, P957, P958, P959, P960, P961, P962, P963, P964, P965, P966, P967, P968, P969, P970, P971, P972, P973, P974, P975, P976, P977, P978, P979, P980, P981, P982, P983, P984, P985, P986, P987, P988, P989, P990, P991, P992, P993, P994, P995, P996, P997, P998, P999, P1000									
A0										
A1	R1	R1	R1	R1	R1					
A2	R1	R1	R1	R1	R1					
A3	R1	R1	R1	R1	R1					
A4	S1	S1	S1	S1	S1					
A5	T1	T1	T1	T1	T1					
A6	U1	U1	U1	U1	U1					
A7	U1	U1	U1	U1	U1					
A8	U1	U1	U1	U1	U1					
A9	V1	V1	V1	V1	V1					
A10	V1	V1	V1	V1	V1					
A11	W1	W1	W1	W1	W1					
A12	W1	W1	W1	W1	W1					
A13	X1	X1	X1	X1	X1					
A14	X1	X1	X1	X1	X1					
A15	X1	X1	X1	X1	X1					
A16										
A17										
A18										
A19										
A20										
A21										
A22										
A23										
A24										
A25										
A26										
A27										
A28										
A29										
A30										
A31										
A32										
A33										
A34										
A35										
A36										
A37										
A38										
A39										
A40										
A41										
A42										
A43										
A44										
A45										
A46										
A47										
A48										
A49										
A50										
A51										
A52										
A53										
A54										
A55										
A56										
A57										
A58										
A59										
A60										
A61										
A62										
A63										
A64										
A65										
A66										
A67										
A68										
A69										
A70										
A71										
A72										
A73										
A74										
A75										
A76										
A77										
A78										
A79										
A80										
A81										
A82										
A83										
A84										
A85										
A86										
A87										
A88										
A89										
A90										
A91										
A92										
A93										
A94										
A95										
A96										
A97										
A98										
A99										
A100										

SECTION  
SHEET 4

 MODEL NO. 140 TITLE MOTHERBOARD PART NO. 210-7507 DATE 12-79 DRAWN BY CHECKED BY MFG ENGR DATE APPROVED BY DATE MFG ENGR DATE PART NUMBER SIZE DRAWING NUMBER REV	BY	DATE	APPROVED BY	DATE
	CHK			
	TITLE			
	210-7507	D	7507	5





11 10 9 8 7 6 5 4 3 2 1

DO NOT SCALE

THIS DRAWING AND THE DATA SHOWN THERE ON ARE THE CONFIDENTIAL PROPERTY OF AND ARE PROPRIETARY TO WANG LABORATORIES, INC. NO PART OF THIS DRAWING OR THE DATA SHOWN THEREIN MAY BE REPRODUCED OR TRANSMITTED IN ANY FORM OR BY ANY MEANS, ELECTRONIC OR MECHANICAL, INCLUDING PHOTOCOPYING, RECORDING, OR BY ANY INFORMATION STORAGE AND RETRIEVAL SYSTEM, WITHOUT THE WRITTEN CONSENT OF WANG LABORATORIES, INC. IF FOR ANY REASON THIS DRAWING IS PERMITTED BY WANG TO LEAVE THE PHYSICAL CUSTODY OF THE COMPANY, IT IS IRREVOCABLY AND EXCLUSIVELY THE PROPERTY OF WANG LABORATORIES, INC.

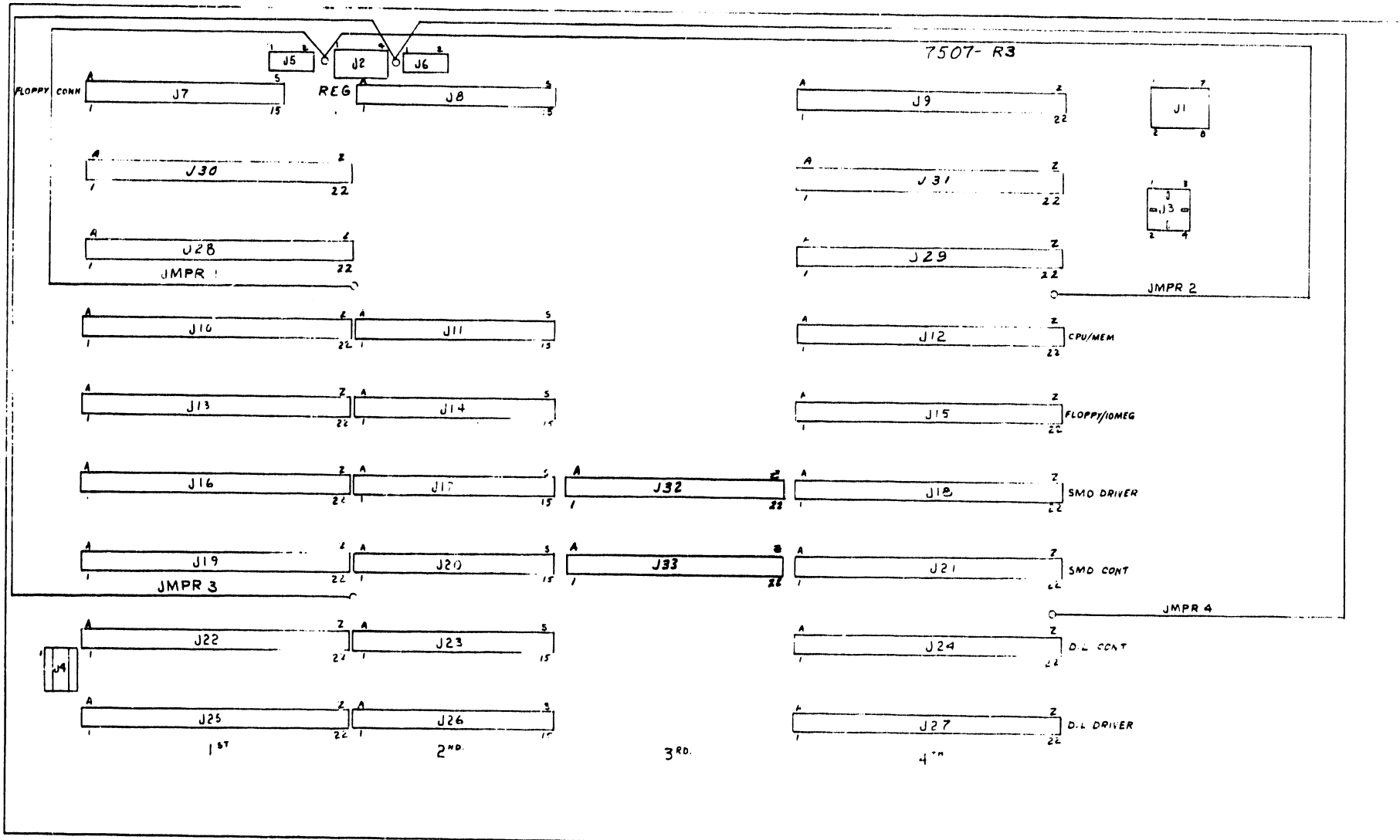

COMPONENT	W.L. PART NO.	TYPE
J1	654-1190	8 POS. PIN HEADER
J2	654-1194	4 POS. PC HEADER
J4	376-9212	14 PIN CAMBION
J5,6	654-1198	2 POS. PIN HEADER
J9,10,21,15,16,18,19,21,22,24,25,27,28-31	350-0021	44 PIN CONN.
J7,8,11,14,17,20,23,26	350-0011	30 PIN CONN.
J32,33	350-0039	44 PIN CONN.
.13	654-3001	4 MALE CONTACT
	654-2073	CONN. HOUSING

COMPONENT LAYOUT

E-REV  
2

REV	DATE	BY	DESCRIPTION
1	10-2-77	W.P.	INITIAL PER
2	10-2-77	W.P.	CHK. E.S.
3	10-2-77	W.P.	REVISED PER
4	10-2-77	W.P.	REVISED PER
5	10-2-77	W.P.	REVISED PER
6	10-2-77	W.P.	REVISED PER
7	10-2-77	W.P.	REVISED PER
8	10-2-77	W.P.	REVISED PER
9	10-2-77	W.P.	REVISED PER
10	10-2-77	W.P.	REVISED PER

<b>WANG</b> LABORATORIES, INC. LOWELL, MASS. U.S.A.		BY DWN	DATE 10-2-77	APPROVED BY E. ENGR. T.E.P.	DATE 10/2/77
MATERIAL	MODEL NO. 140	TITLE MOTHERBOARD			
FINISH	SEE ENGR. SPECIFICATIONS	MFG ENGR			
TOL. EX. AS NOTED		210-7507	D	7507	5
SCALE: 1/8" = 1"		SHEET 4 OF 4		WANG PART NUMBER	SIZE DRAWING NUMBER



THIS DRAWING AND THE DATA SHOWN THERE ON ARE THE CONFIDENTIAL PROPERTY OF AND ARE PROPRIETARY TO WANG LABORATORIES, INC. THE DRAWING AND THE DATA SHOWN THEREIN MAY NOT BE MADE PUBLIC WITHOUT THE WRITTEN CONSENT OF WANG LABORATORIES, INC. IF FOR ANY REASON THIS DRAWING IS PERMITTED BY WANG TO LEAVE THE PHYSICAL POSSESSION OF THE COMPANY, IT IS RETURNABLE UPON THE DEMAND OF WANG LABORATORIES, INC.

DO NOT SCALE

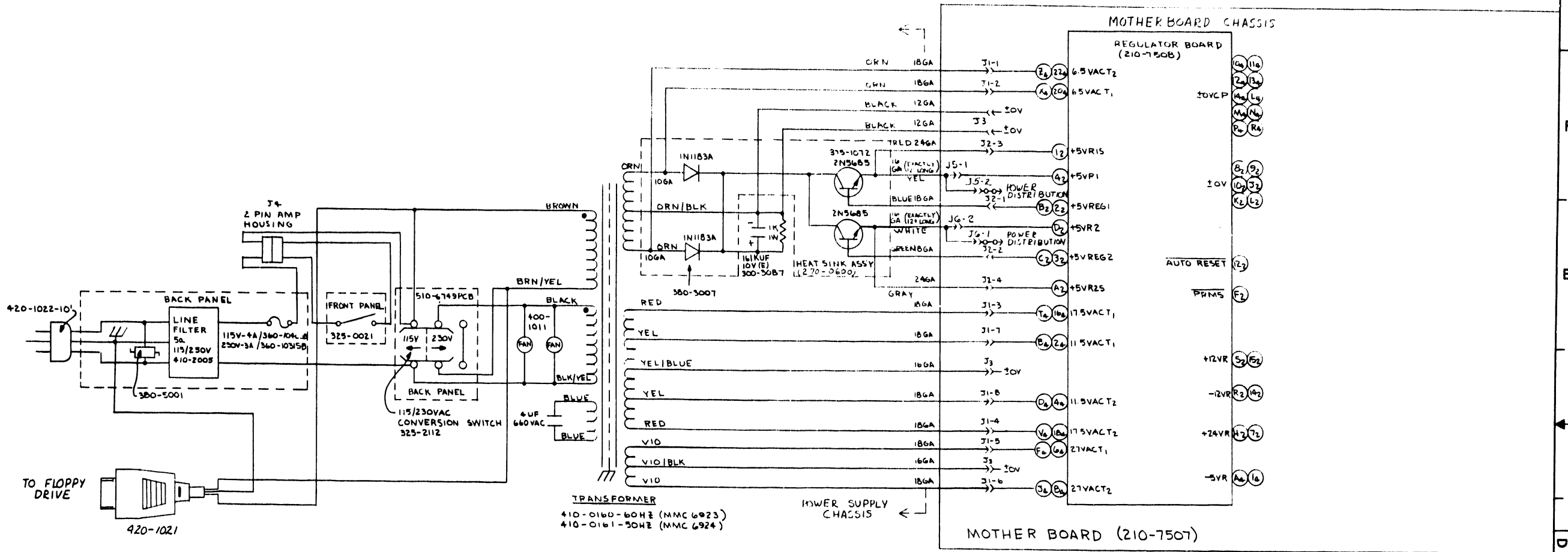

**CHASSIS ASSEMBLIES:**  
 MOTHERBOARD - 270-0599  
 POWER SUPPLIES -  
 60 HZ - 270-0601  
 50 HZ - 270-0601-1

**CONNECTORS**  
 J1 - 8 PIN HOUSING - 654-1189  
 8 PIN HEADER - 654-1190  
 J2 - 4 PIN HOUSING - 654-1195  
 4 PIN HEADER - 654-1194  
 J3 - HOUSING - 654-2073  
 PC PIN - 654-3001  
 CONTACT - 654-3000R  
 J4 - 2 PIN HOUSING - 654-1147  
 SOCKET HOUSING (2 PIN) - 654-1148  
 J5, J6 - 2 PIN HEADER - 654-1198  
 SOCKET HOUSING (2 PIN) - 654-1148

REV	DATE	BY	CHKD	APP'D	DESCRIPTION
0	6-21-75	DWR			ORIGINATED PER DWR #E692
1	8-15-75	WJ			REVISED PER APPR. #1192.3
2	11-11-80	WJ			REVISED PER ECN #1198

<b>WANG</b> LABORATORIES, INC. LOWELL, MASS. U.S.A.		BY DWN L.D.B.	DATE 6-27-75	APPROVED BY E ENGR	DATE 7-3-75
MATERIAL —  —	MODEL NO 140 SEE ENGR SPECIFICATIONS	CHK 67	M ENGR	MFG ENGR	
FINISH —  —	TOL. AS NOTED ± .001 ± .002 ± .005 ± .010 ± .020 ± .050 ± .100 ± .200 ± .500 ± 1.000 ±	TITLE 140PS INTERCONNECTION SCHEMATIC		SCALE D 7507-900 2	
SCALE: —  — SMT / DT /		WANG PART NUMBER		SIZE	DRAWING NUMBER

D 7507-900

A

"THIS DRAWING AND THE DATA SHOWN THERE ON ARE THE CONFIDENTIAL PROPERTY OF AND ARE PROPRIETARY TO WANG LABORATORIES, INC. THIS DRAWING AND THE DATA SHOWN THEREIN MAY NOT BE MADE PUBLIC WITHOUT THE WRITTEN CONSENT OF WANG LABORATORIES, INC. IF FOR ANY REASON THIS DRAWING IS PRINTED BY WANG TO LEAVE THE PHYSICAL CUSTODY OF THE COMPANY, IT IS RETURNABLE UPON THE DEMAND OF WANG LABORATORIES, INC."

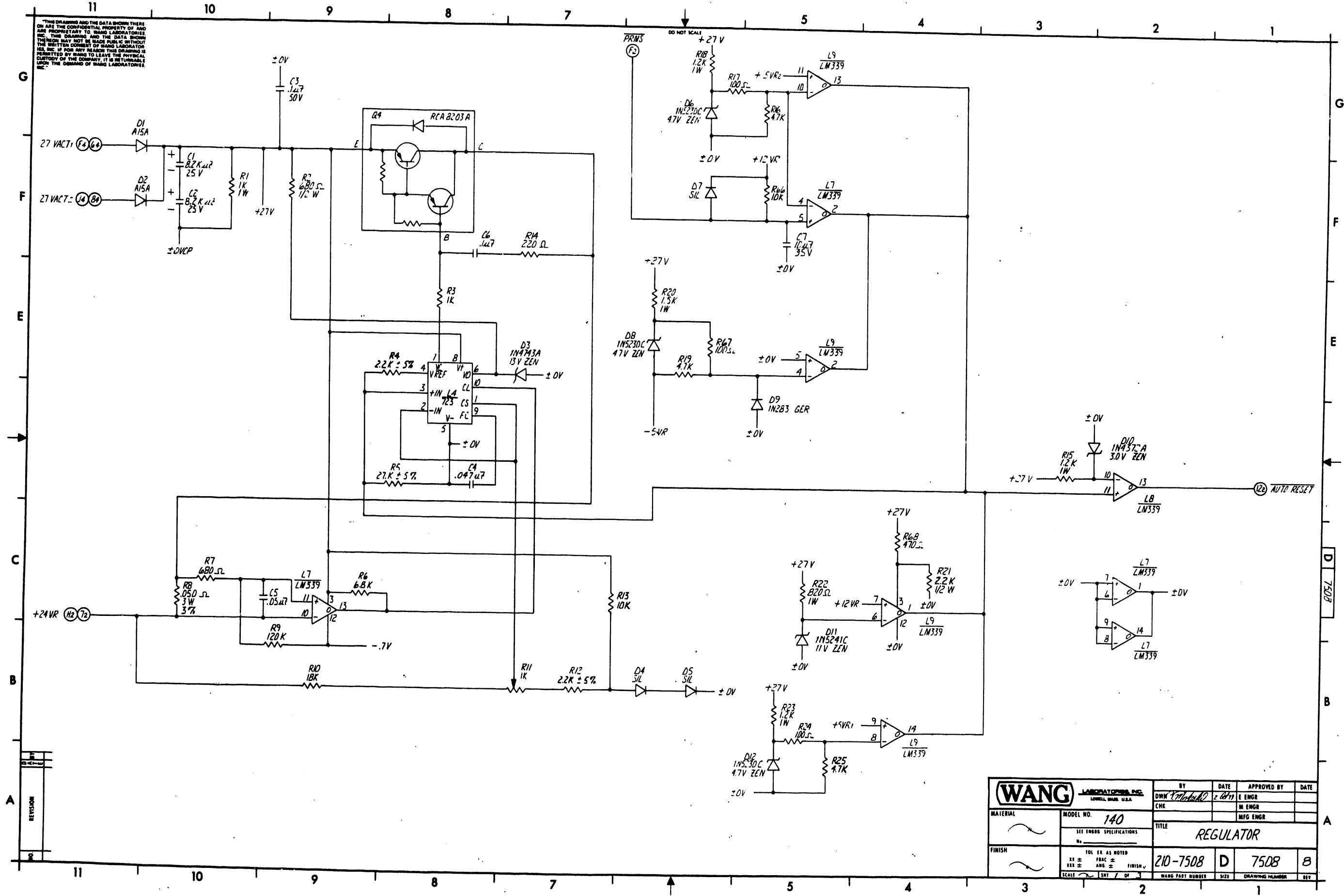

REV	DATE	DESCRIPTION
1		REVISED

<b>WANG</b> LABORATORIES, INC. LOWELL, MASS. U.S.A.		BY DWN	DATE 2/27/71	APPROVED BY E ENGR	DATE
MATERIAL	MODEL NO. 140	CHK		M ENGR	
	SEE ENGR SPECIFICATIONS			MFG ENGR	
FINISH	TOL. IS AS NOTED	TITLE REGULATOR			
	SEE ENGR SPECIFICATIONS	210-7508		D	7508
	SCALE 1/8" = 1"	WANG PART NUMBER		SIZE	DRAWING NUMBER
					REV B

"THIS DRAWING AND THE DATA SHOWN THERE ON ARE THE CONFIDENTIAL PROPERTY OF AND ARE PROPRIETARY TO WANG LABORATORIES, INC. THIS DRAWING AND THE DATA CONTAINED HEREIN MAY NOT BE MADE PUBLIC WITHOUT THE WRITTEN CONSENT OF WANG LABORATORIES, INC. IF FOR ANY REASON THIS DRAWING IS PERMITTED BY WANG TO LEAVE THE PHYSICAL CUSTODY OF THE COMPANY, IT IS RETURNABLE UPON THE DEMAND OF WANG LABORATORIES, INC."

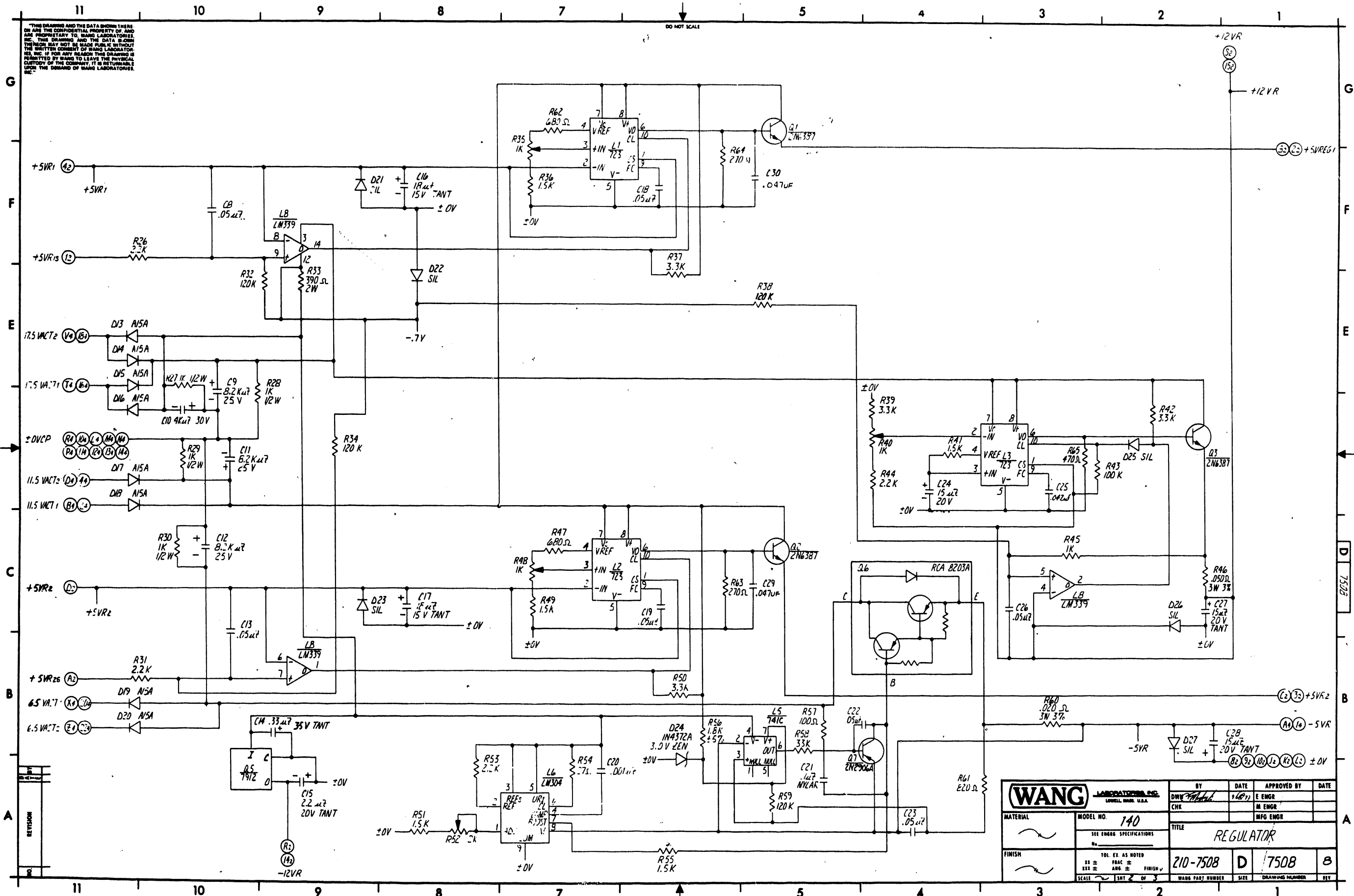

<b>WANG</b> LABORATORIES, INC. LOWELL, MASS. U.S.A.		BY DW	DATE 9/6/77	APPROVED BY E ENGR	DATE
MATERIAL	MODEL NO. 140	CHK		M ENGR	
	SEE ENGR SPECIFICATIONS			INFO ENGR	
FINISH	TOL. EX. AS NOTED	TITLE REGULATOR		SCALE 1:1	SIZE D 7508
	XX ± FAC ±			WANG PART NUMBER	REV B
	XXX ± ANG ±				
	SCALE SMT 2 OF 3				

THIS DRAWING AND THE DATA SHOWN THERE ON ARE THE CONFIDENTIAL PROPERTY OF AND ARE PROPRIETARY TO WANG LABORATORIES, INC. THIS DRAWING AND THE DATA SHOWN THEREON MAY NOT BE REPRODUCED OR TRANSMITTED IN ANY FORM OR BY ANY MEANS, ELECTRONIC OR MECHANICAL, INCLUDING PHOTOCOPYING, RECORDING, OR BY ANY INFORMATION STORAGE AND RETRIEVAL SYSTEM, WITHOUT THE WRITTEN CONSENT OF WANG LABORATORIES, INC. IF FOR ANY REASON THIS DRAWING IS PERMITTED BY WANG TO LEAVE THE PHYSICAL CUSTODY OF THE COMPANY, IT IS RETURNABLE UPON THE DEMAND OF WANG LABORATORIES, INC.

DO NOT SCALE

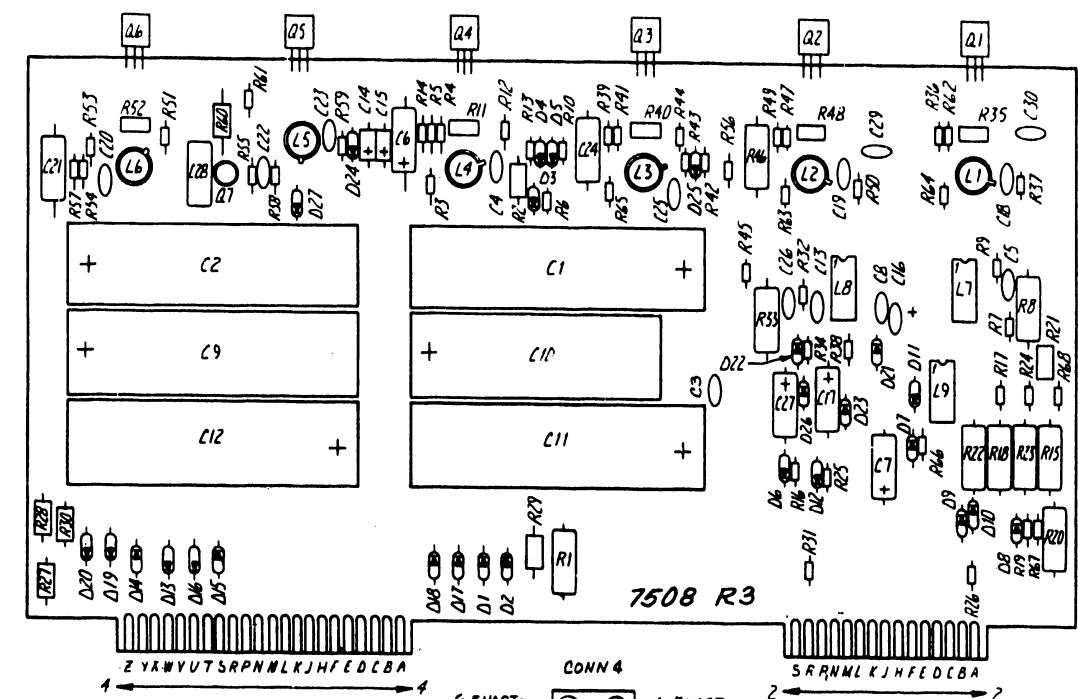

I.C. LOCATION	TYPE	W.L. NO.
L1, 2, 3, 4	723	376-0066
L5	741C	376-0074
L6	LM304	376-0134
L7, 8, 9	LM339	376-0240

COMPONENT	TYPE	W.L. PART NO.
C1, 2, 9, 11, 12	8.2K $\mu$ 2 25V ELEC.	300-306B
C3	.1 $\mu$ 2 50V CER.	300-193D
C4 5, 8, 13, 18, 19, 22, 23, 25 26, 29, 30	.047 $\mu$ F CER	300-1966
C6 21	.1 $\mu$ 2 50V MYLAR	300-2213
C7	10 $\mu$ 2 35V TANT.	300-4032
C10	4K $\mu$ 2 30V ELEC.	300-308D
C14	.33 $\mu$ 2 35V TANT.	300-400B
C15	2.2 $\mu$ 2 20V TANT.	300-4014
C16, 17	18 $\mu$ 2 15V TANT.	300-4018
C20	.001 $\mu$ 2 500V CER	300-1906
C24, 27, 28	15 $\mu$ 2 20V TANT.	300-4022
D1, 2, 13, 14, 15, 16, 17, 18, 19, 21	AISA RECTIFIER	380-3008
D3	1N4743 ZEN.	380-2113
D4 5, 7, 21, 22, 23, 25, 26, 27	SIL. DIODE	380-1001
D6, 8, 12	1N5230C ZEN.	380-2048
D9	1N283 GER.	380-0001
D10, 24	1N4372A ZEN.	380-2129
D11	1N5241C ZEN.	380-2111
R1	1K 10% 1W	332-3010
R2	680 $\Omega$ 10% 1/2W	331-206B
R3, 45	1K 10% 1/4W	330-3010
R4 12	2.2K 5% 1/4W	330-3023
R26, 31, 44, 53	2.2K 10% 1/4W	330-3022
R5	2.7K 5% 1/4W	330-3028
R6	6.8K 10% 1/4W	330-3068
R7, 47, 62	680 $\Omega$ 10% 1/4W	330-306E
R8, 46	.050 $\Omega$ 3% 3W	334-0033
R9, 32, 34, 38, 39	120K 1/4W	330-5012
R10	18K 1/4W 5%	330-4019

COMPONENT	TYPE	W.L. NO.
R11, 35, 40, 48	1K VAR	336-1014
R13, 66	10K 10% 1/4W	330-4010
R14	220 $\Omega$ 10% 1/4W	330-2022
R15, 18, 23	1.2K 10% 1W	332-3012
R16, 19, 25	4.7K 10% 1/4W	330-3047
R17, 24, 57, 67	100 $\Omega$ 10% 1/4W	330-2010
R20	1.5K 10% 1W	332-3015
R21	2.2K 10% 1/2W	331-3022
R22	820 $\Omega$ 10% 1W	332-2082
R27, 28, 29, 30	1K 10% 1/2W	331-3010
R33	390 $\Omega$ 10% 2W	337-2039
R36, 41, 49, 51, 55	1.5K 10% 1/4W	330-3015
R37, 39, 42, 50	3.3K 10% 1/4W	330-3033
R43	100K 10% 1/4W	330-5010
R52	2K VAR	336-1022
R54	27 $\Omega$ 10% 1/4W	330-1027
R56	1.8K 5% 1/4W	330-3019
R58	33K 10% 1/4W	330-4033
R60	.020 $\Omega$ 3% 3W	334-0032
R61	820 $\Omega$ 10% 1/4W	330-2082
R63, 64	270 $\Omega$ 10% 1/4W	330-2027
R65 6E	470 $\Omega$ 10% 1/4W	331-3047
Q1, 2, 3	2N6387	375-1052
Q4, 6	RIA B203A	375-1053
Q5	7912 I.C. REG.	374-0013
Q7	2N2906A	375-1017
L1-L6	INSULATOR	375-9016
Q7	TRANSIPAD 70-19	375-9014

MNEMONIC	COORDINATE
AUTO RESET	D1
PRMS	166
27 VACT1	1F11
27 VACT2	1F11
+24V R	1C11
17.5 VACT1	2E11
17.5 VACT2	2E11
+12V R	2G1
11.5 VACT1	2D11
11.5 VACT2	2D11
6.5 VACT1	2B11
6.5 VACT2	2B11
+5VREG1	2F1
+5VREG2	2B1
+5VRS15	2F11
+5VRS25	2B11
+5VRS1	2F11
+5VRS2	2C11
$\pm$ OVCP	2D11
-5V R	2B1
-12V R	2A9

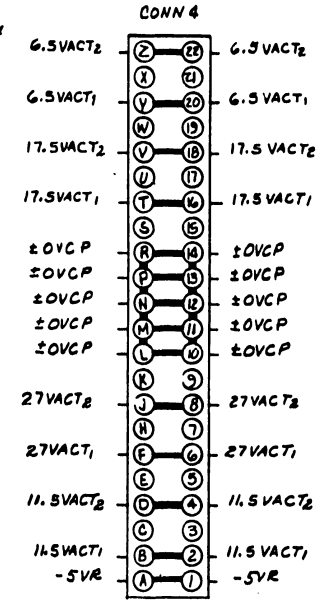
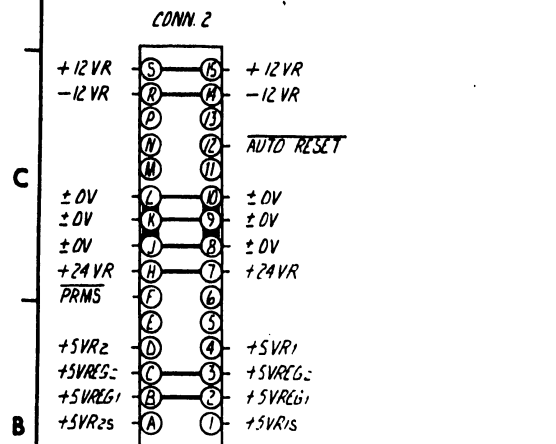

NO.	DATE	REVISION	BY	CHKD	APP'D	REVISED PER	REVISED BY	REVISED DATE
1	11/14/77	1				INITIAL		
2	11/19/77	2				ECN # 15989		
3	12/27/77	3				APP'D: P. J. J. 11/26/77		
4	1/15/78	4				REVISED PER		
5	1/15/78	5				APP'D: S. J. 11/26/77		
6	1/15/78	6				REVISED PER		
7	1/15/78	7				APP'D: S. J. 11/26/77		
8	1/15/78	8				REVISED PER		
9	1/15/78	9				APP'D: S. J. 11/26/77		
10	1/15/78	10				REVISED PER		
11	1/15/78	11				APP'D: S. J. 11/26/77		

WANG LABORATORIES, INC. LOWELL, MASS. U.S.A.

BY: [Signature] DATE: 1/15/78 APPROVED BY: P.F.P. DATE: 1/15/78

CHKD: [Signature] MFG ENGR:

MATERIAL: SEE ENGR SPECIFICATIONS MODEL NO. 140

TITLE: REGULATOR

FINISH: TOU 12 AS NOTED

SCALE: 1:1

210-7508 D 7508 B

WANG PART NUMBER SIZE DRAWING NUMBER REV.

E-REV 3

"THIS DRAWING AND THE DATA SHOWN THERE ON ARE THE CONFIDENTIAL PROPERTY OF AND ARE PROPRIETARY TO WANG LABORATORIES INC. THIS DRAWING AND THE DATA SHOWN THEREON MAY NOT BE MADE PUBLIC WITHOUT THE WRITTEN CONSENT OF WANG LABORATORIES INC. IF FOR ANY REASON THIS DRAWING IS PERMITTED BY WANG TO LEAVE THE PHYSICAL CUSTODY OF THE COMPANY, IT IS RETURNABLE UPON THE DEMAND OF WANG LABORATORIES INC."

DO NOT SCALE

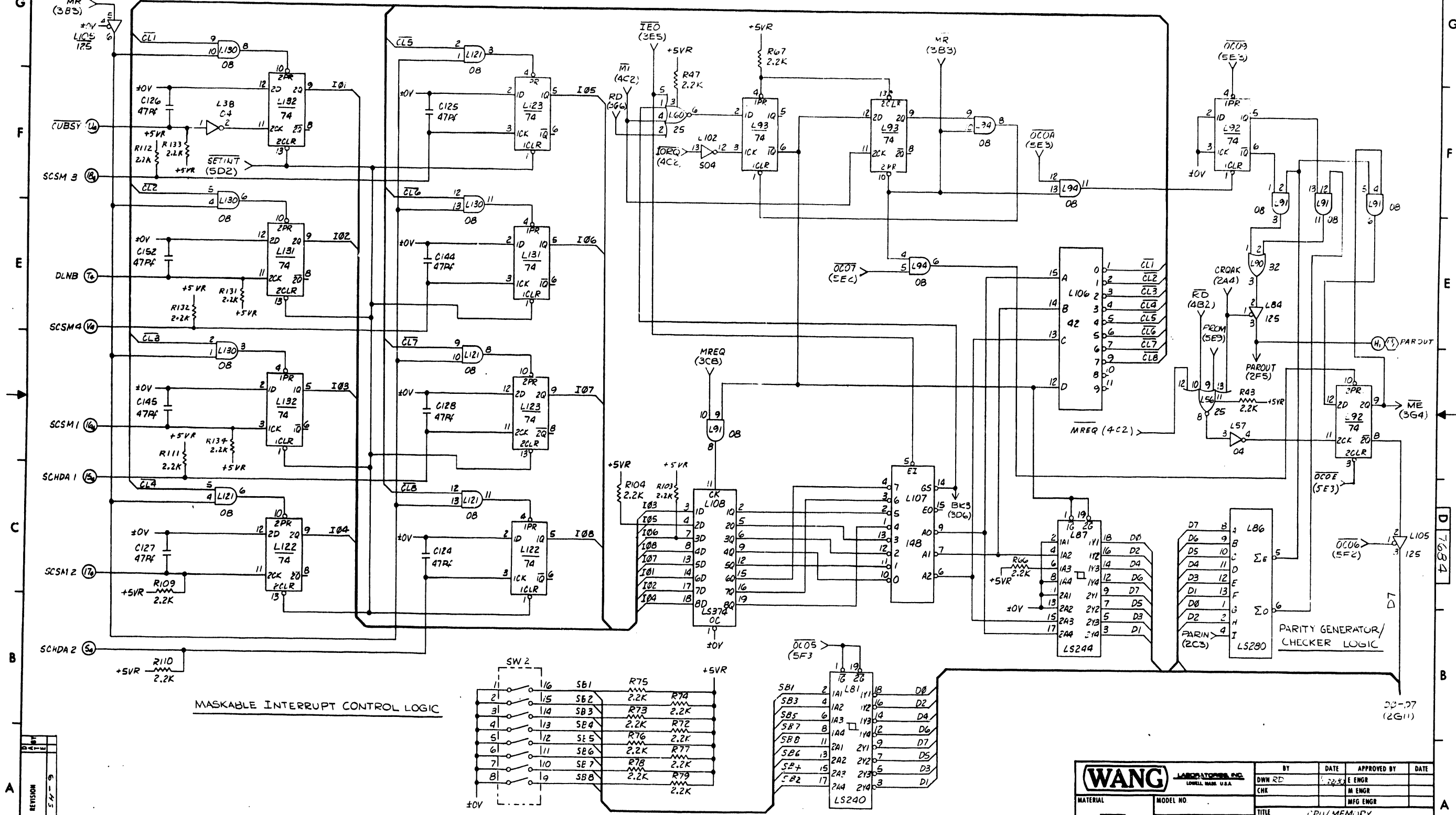

MASKABLE INTERRUPT CONTROL LOGIC

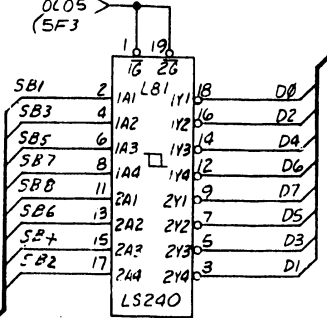
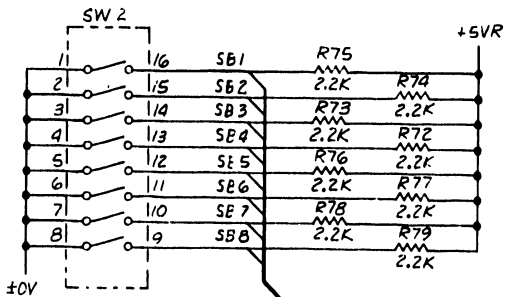

<b>WANG</b> LABORATORIES INC. LOWELL, MASS. U.S.A.		BY	DATE	APPROVED BY	DATE
MATERIAL		DWN RD	2/28/68	E ENGR	
MODEL NO.		CHK		M ENGR	
SEE ENGR SPECIFICATIONS		TITLE CPU/MEMORY			
FINISH		SEE CHAS D 7684 13			
SCALE		WANG PART NUMBER SIZE DRAWING NUMBER REV			

REV	DATE	BY	DESCRIPTION
1			SEE EN-9

THIS DRAWING AND THE DATA SHOWN THEREON ARE THE CONFIDENTIAL PROPERTY OF, AND ARE PROPRIETARY TO WANG LABORATORIES, INC. THIS DRAWING AND THE DATA SHOWN THEREON MAY NOT BE MADE PUBLIC WITHOUT THE WRITTEN CONSENT OF WANG LABORATORIES, INC. IF FOR ANY REASON THIS DRAWING IS PERMITTED BY WANG TO LEAVE THE PHYSICAL CUSTODY OF THE COMPANY, IT IS RETURNABLE UPON THE DEMAND OF WANG LABORATORIES, INC.

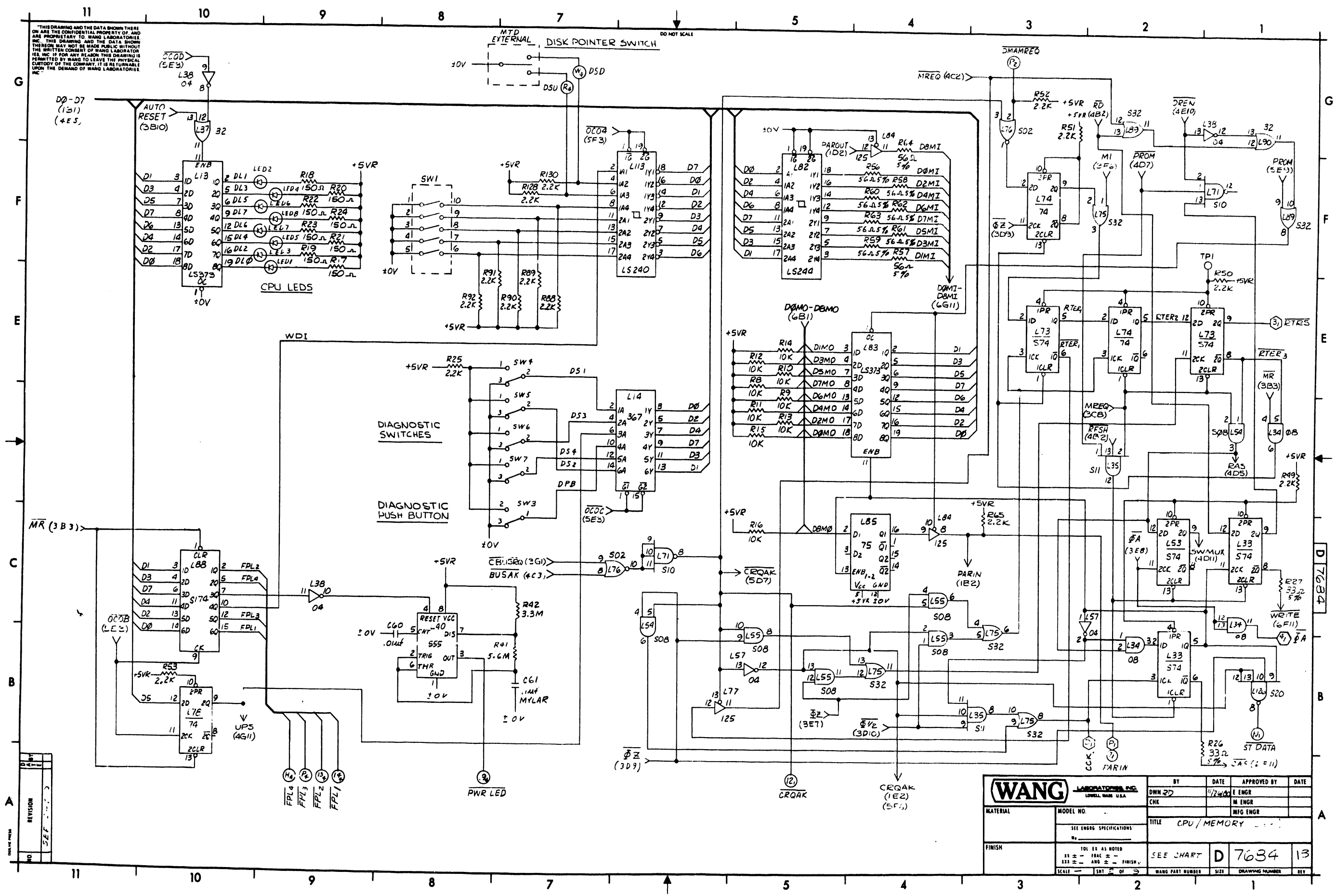

<b>WANG</b> LABORATORIES, INC. LONDON, MASS. U.S.A.		BY	DATE	APPROVED BY	DATE
MATERIAL		DWN 27	11/24/64	E ENGR	
MODEL NO.		CHK		M ENGR	
SEE ENG'G SPECIFICATIONS		TITLE		MFG ENGR	
FINISH		SEE CHART			
SCALE		D 7634			
SCALE		13			

THIS DRAWING AND THE DATA SHOWN THERE ON ARE THE CONFIDENTIAL PROPERTY OF AND ARE PROPRIETARY TO WANG LABORATORIES, INC. THIS DRAWING AND THE DATA SHOWN THEREON MAY NOT BE MADE PUBLIC WITHOUT THE WRITTEN CONSENT OF WANG LABORATORIES, INC. IF FOR ANY REASON THIS DRAWING IS PERMITTED BY WANG TO LEAVE THE PHYSICAL CUSTODY OF THE COMPANY, IT IS RETURNABLE UPON THE DEMAND OF WANG LABORATORIES, INC.

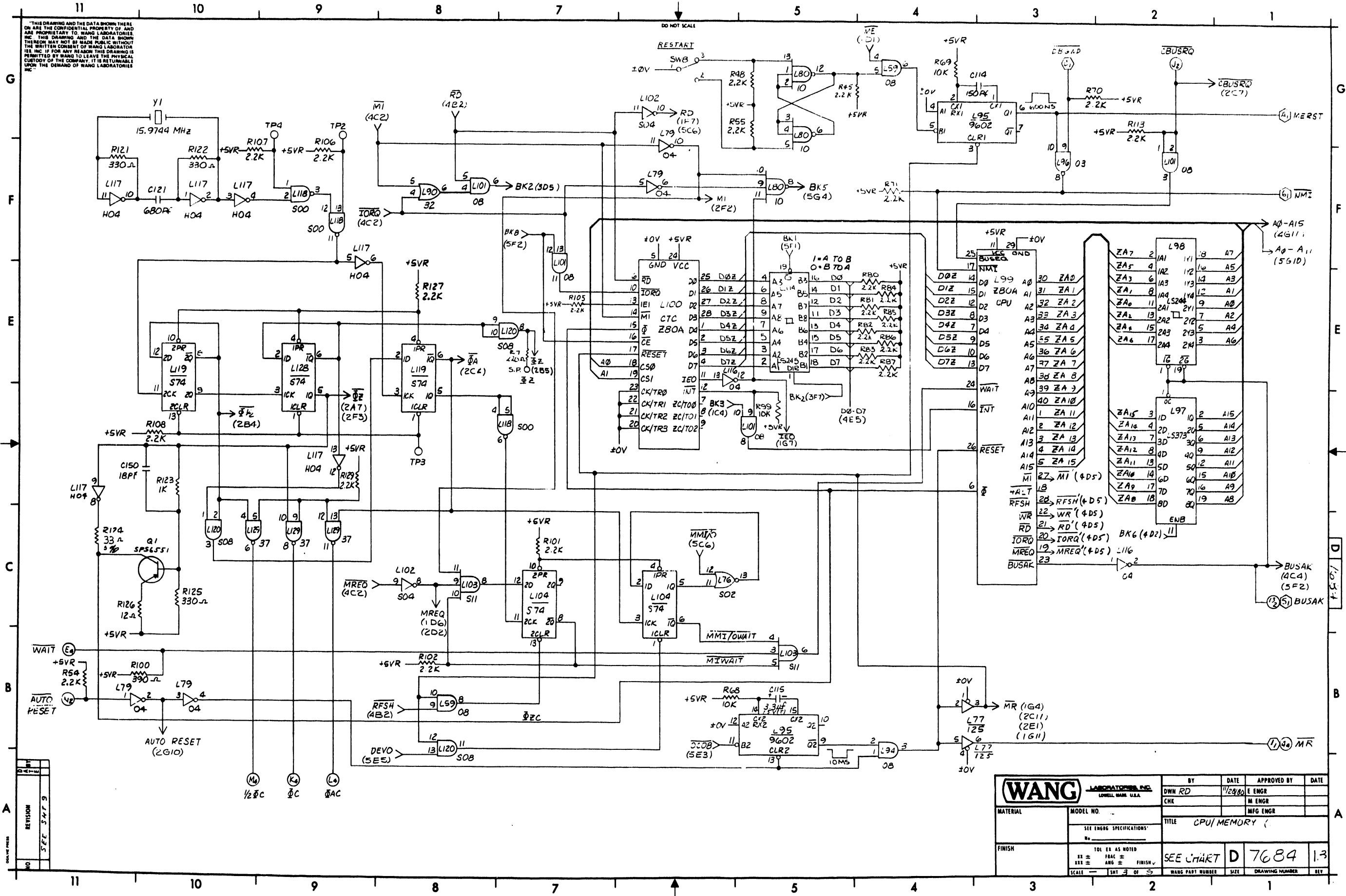

<b>WANG</b> LABORATORIES, INC. LOWELL, MASS. U.S.A.		BY DWN RD	DATE 11/23/60	APPROVED BY E ENGR	DATE
MATERIAL		CHK		M ENGR	
MODEL NO.		MFG ENGR		TITLE CPU/MEMORY	
SEE ENGR SPECIFICATIONS No.		TOL EX AS NOTED		SEE CHART D 7684 1.3	
FINISH		SCALE		WANG PART NUMBER	
		SIZE		DRAWING NUMBER	
		SMT # OF		REV	

THIS DRAWING AND THE DATA SHOWN THERE ON ARE THE CONFIDENTIAL PROPERTY OF AND ARE PROPRIETARY TO WANG LABORATORIES, INC. THIS DRAWING AND THE DATA SHOWN THEREON MAY NOT BE REPRODUCED WITHOUT THE WRITTEN CONSENT OF WANG LABORATORIES, INC. IF FOR ANY REASON THIS DRAWING IS PERMITTED BY WANG TO LEAVE THE PHYSICAL CUSTODY OF THE COMPANY, IT IS RETURNABLE UPON THE DEMAND OF WANG LABORATORIES, INC.

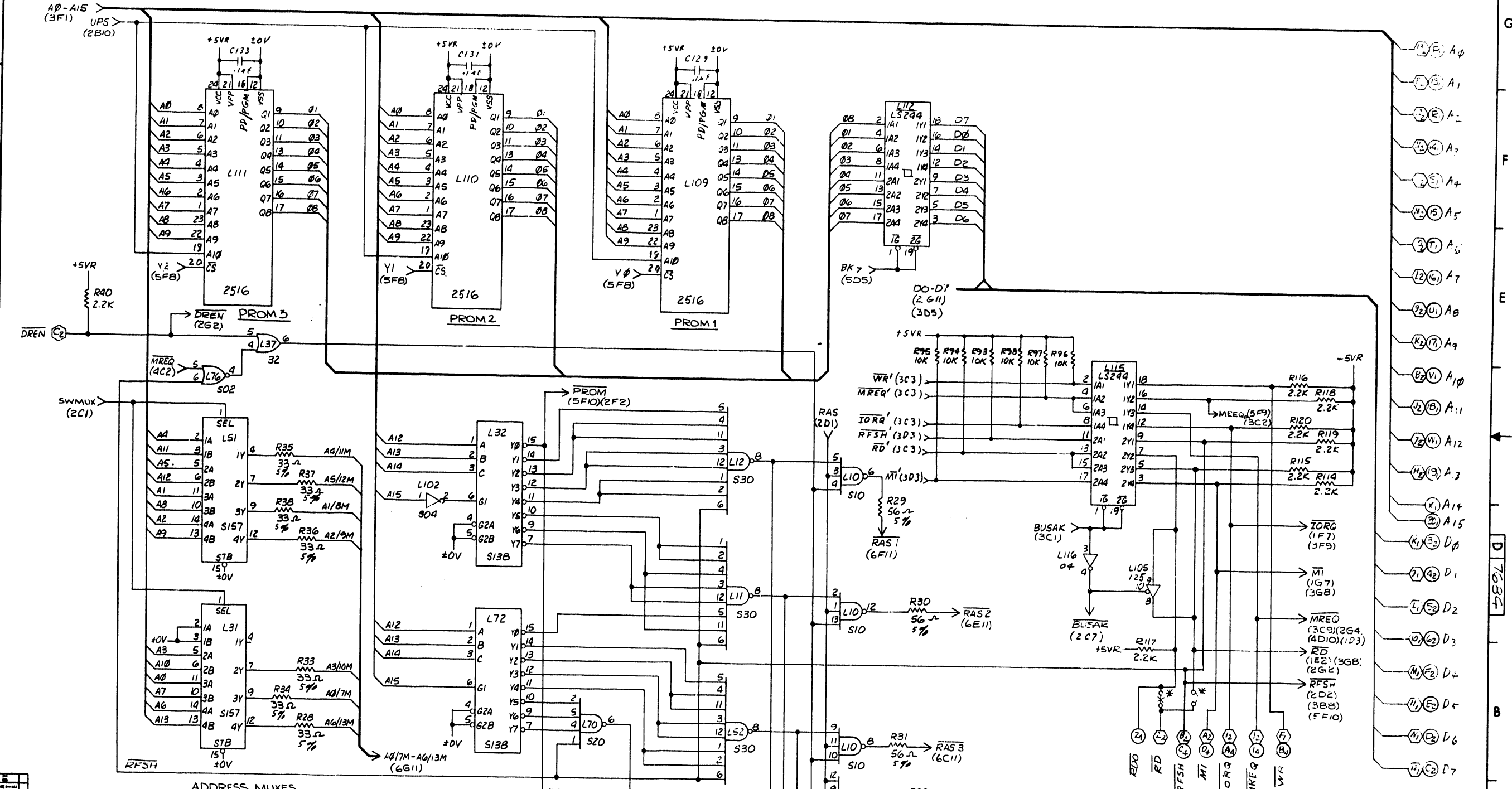

REV	DESCRIPTION
1	SEE SHTS

<b>WANG</b> LABORATORIES, INC. LOWELL, MASS. U.S.A.		BY DWN RD	DATE 11/29/80	APPROVED BY E ENGR	DATE
MATERIAL		CHK		M ENGR	
MODEL NO. SEE ENGR SPECIFICATIONS		TITLE CPU/MEMORY			
FINISH TOL EX AS NOTED ALL ± - - - - - FINISH		SEE CHART		D 7684	13
SCALE - - - - - SHT 4 OF 9		WANG PART NUMBER		SIZE	DRAWING NUMBER

\* ADD JUMPER AND CUT ETCH PER ECO # 21314.



THIS DRAWING AND THE DATA SHOWN THEREON ARE THE CONFIDENTIAL PROPERTY OF, AND ARE PROPRIETARY TO WANG LABORATORIES, INC. THIS DRAWING AND THE DATA SHOWN THEREON MAY NOT BE MADE PUBLIC WITHOUT THE WRITTEN CONSENT OF WANG LABORATORIES, INC. IF FOR ANY REASON THIS DRAWING IS PERMITTED BY WANG TO LEAVE THE PHYSICAL POSSESSION OF THE COMPANY, IT IS RETURNABLE UPON THE DEMAND OF WANG LABORATORIES, INC.

DO NOT SCALE

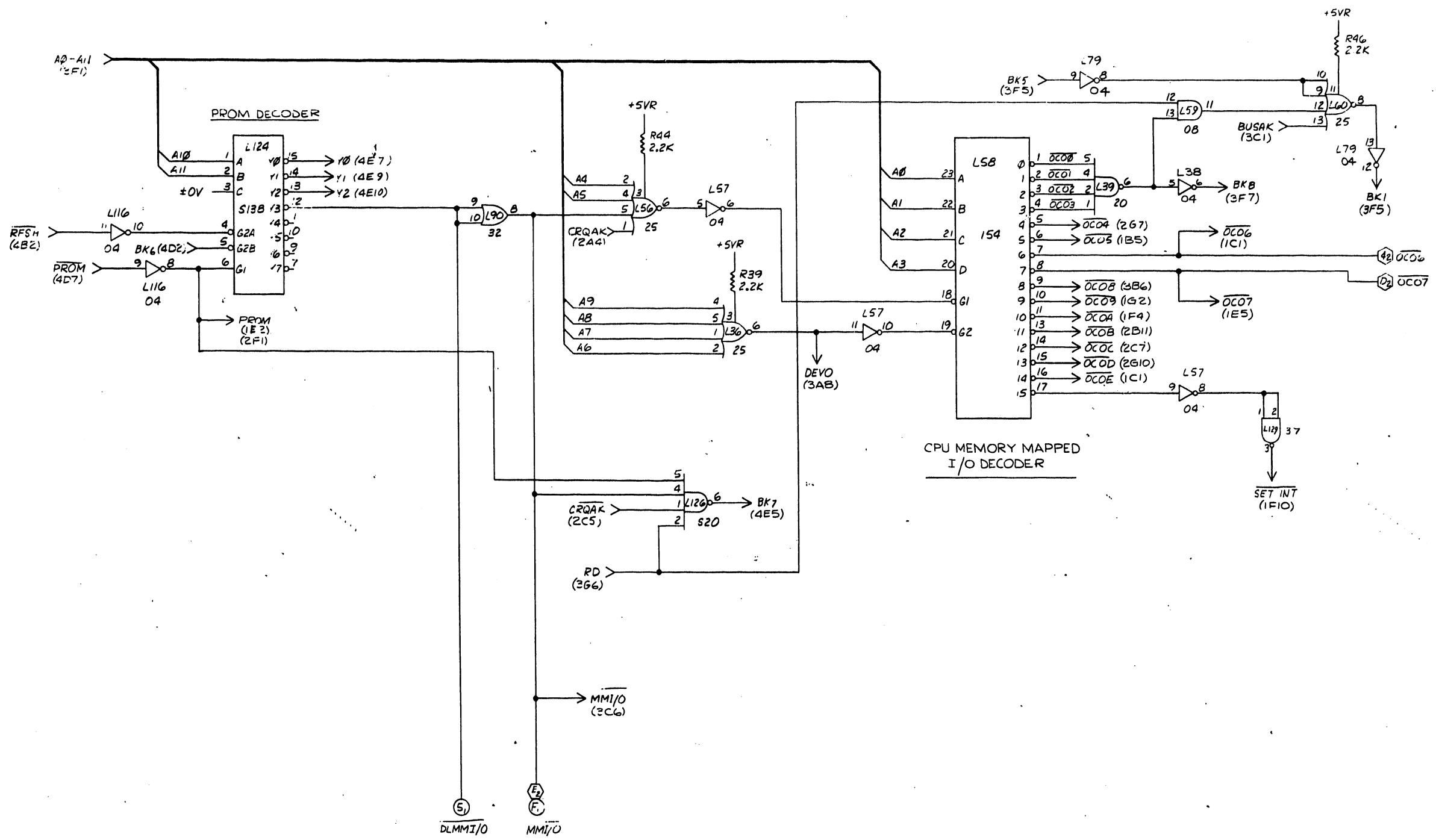

REV	DATE
1	11/27/73
2	12/11/73
3	1/10/74
4	2/1/74
5	2/1/74
6	2/1/74
7	2/1/74
8	2/1/74
9	2/1/74
10	2/1/74
11	2/1/74

<b>WANG</b> LABORATORIES, INC. LOWELL, MASS. U.S.A.		BY	DATE	APPROVED BY	DATE
MATERIAL		DWN RD	11/27/73	E ENGR	
MODEL NO. 22		CHK		M ENGR	
SEE ENGR. SPECIFICATIONS		TITLE		MFG ENGR	
FINISH		CPU/MEMORY			
TOL. AS NOTED		SEE CHART, D		7684	13
SCALE - SHT. 5 OF 5		WANG PART NUMBER		SIZE	DRAWING NUMBER

D 7684

THIS DRAWING AND THE DATA SHOWN THEREON ARE THE CONFIDENTIAL PROPERTY OF AND ARE PROPRIETARY TO WANG LABORATORIES, INC. THIS DRAWING AND THE DATA SHOWN THEREON MAY NOT BE MADE PUBLIC WITHOUT THE WRITTEN CONSENT OF WANG LABORATORIES, INC. IF FOR ANY REASON THIS DRAWING IS PERMITTED BY WANG TO LEAVE THE PHYSICAL CUSTODY OF THE COMPANY, IT IS RETURNABLE UPON THE DEMAND OF WANG LABORATORIES, INC.

DO NOT SCALE

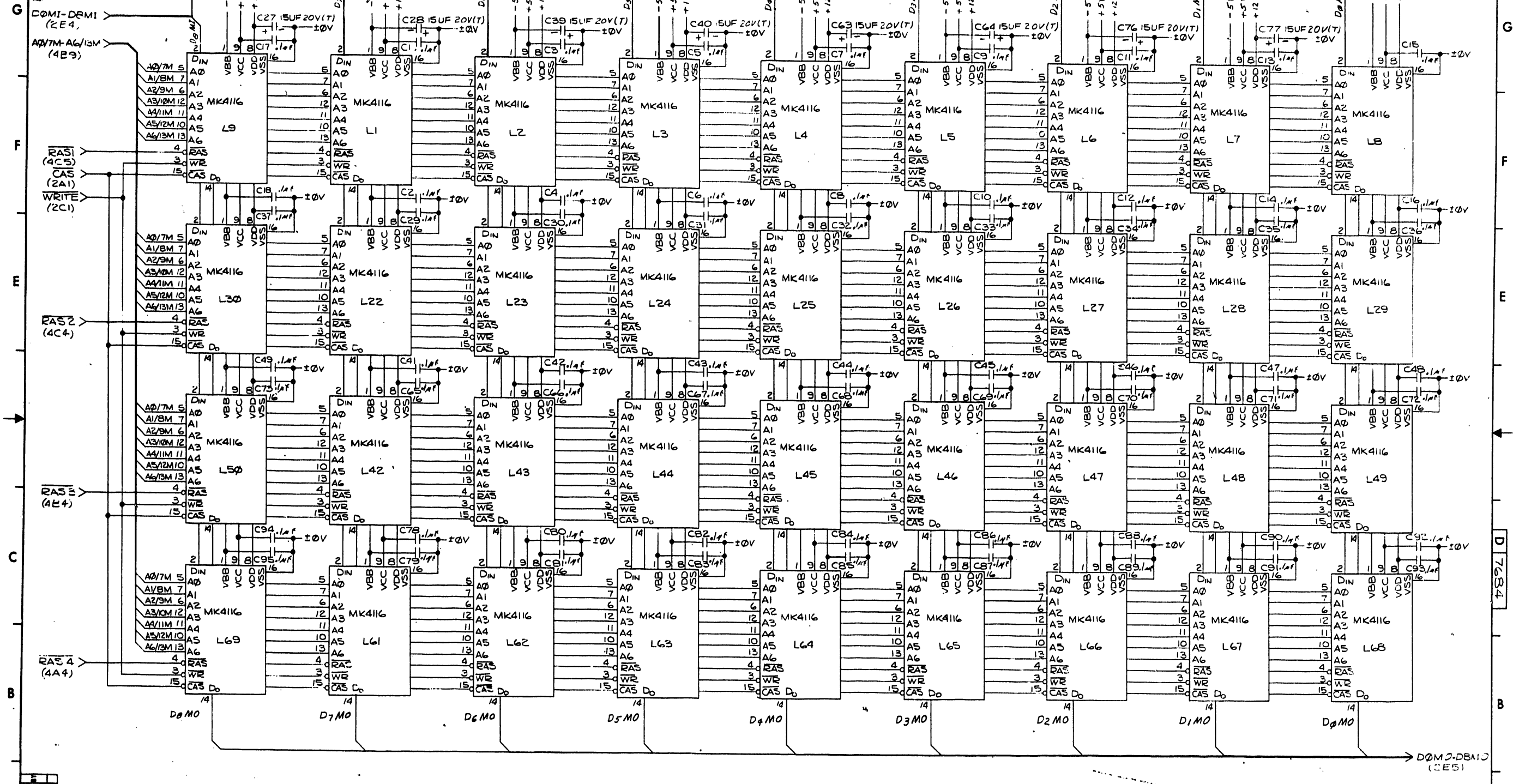

NO	REVISION
1	SEE SHEET 3

<b>WANG</b> LABORATORIES, INC. LOWELL, MASS. U.S.A.		BY DWN JP	DATE 11/23/69	APPROVED BY E ENGR	DATE
MATERIAL		CHK		M ENGR	
MODEL NO.		TITLE CPU/MEMORY			
FINISH		SEE SHEET D 7684 13			
TOL IS AS NOTED		WANG PART NUMBER			
SCALE		SHEET NUMBER			

11 10 9 8 7 5 4 3 2 1

THIS DRAWING AND THE DATA SHOWN THEREON ARE THE CONFIDENTIAL PROPERTY OF AND ARE PROPRIETARY TO WANG LABORATORIES, INC. THIS DRAWING AND THE DATA SHOWN THEREON MAY NOT BE REPRODUCED WITHOUT THE WRITTEN CONSENT OF WANG LABORATORIES, INC. IF FOR ANY REASON THIS DRAWING IS PERMITTED BY WANG TO LEAVE THE PHYSICAL CUSTODY OF THE COMPANY IT IS RETURNABLE UPON THE DEMAND OF WANG LABORATORIES, INC.

SWITCHES SW3-SW8 MOUNT ON FAR SIDE

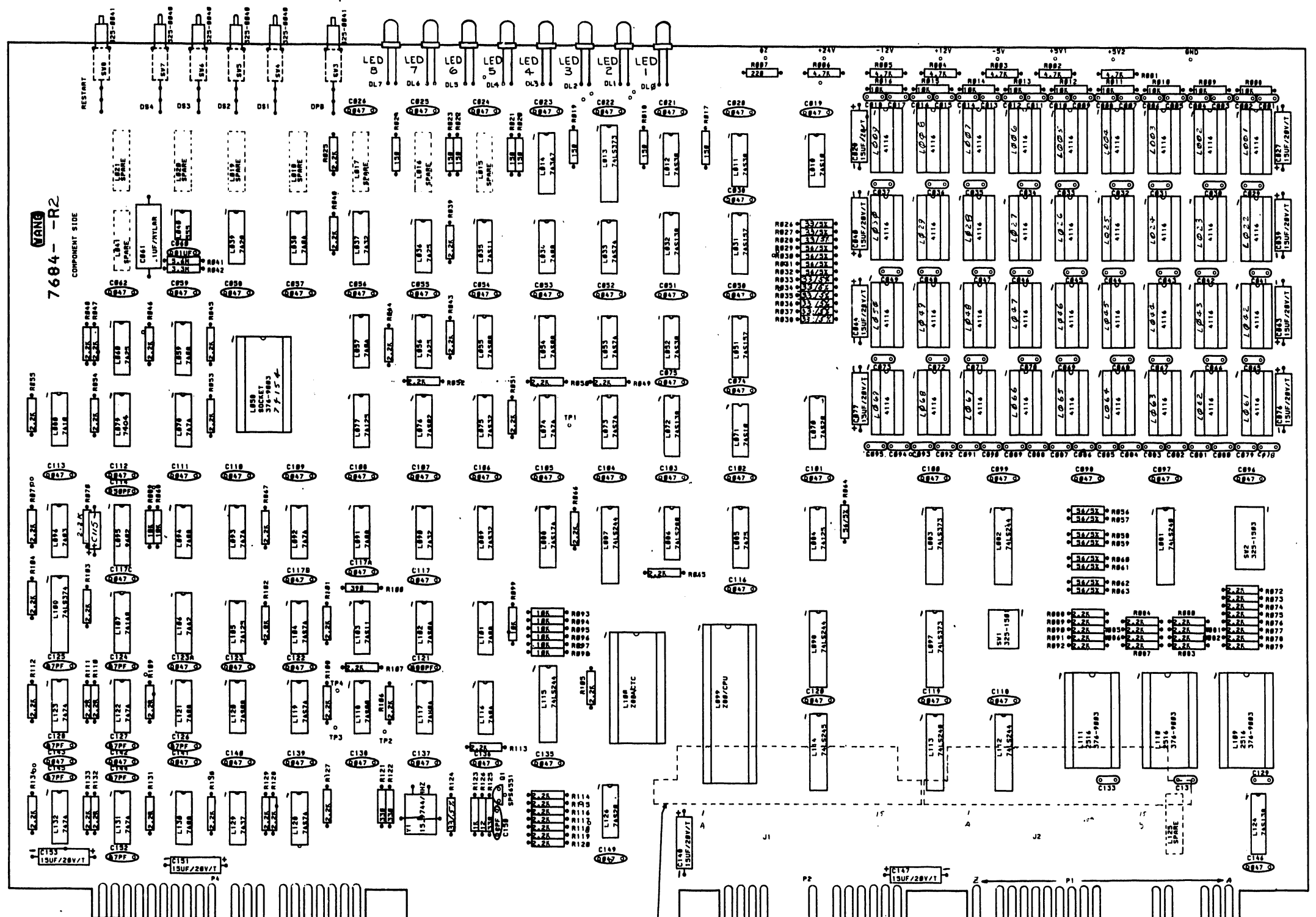

7684-R2  
COMPONENT SIDE

CONN. 350-0009  
2 PLACES  
MOUNT FAR SIDE

NO.	REVISION

<b>WANG</b> LABORATORIES, INC. LOWELL, MASS. U.S.A.	BY	DATE	APPROVED BY	DATE
	CHK			
MATERIAL	MODEL NO.	TITLE		
		CPU/MEMORY (64K)		
FINISH		SEE CHART	D	7684

D 7684

A

11 10 9 8 7 5 4 3 2 1

DO NOT SCALE

"THIS DRAWING AND THE DATA SHOWN THEREON ARE THE CONFIDENTIAL PROPERTY OF, AND ARE PROPRIETARY TO, WANG LABORATORIES, INC. THIS DRAWING AND THE DATA SHOWN THEREON MAY NOT BE MADE PUBLIC WITHOUT THE WRITTEN CONSENT OF WANG LABORATORIES, INC. IF FOR ANY REASON THIS DRAWING IS PERMITTED BY WANG TO LEAVE THE PHYSICAL CUSTODY OF THE COMPANY, IT IS RETURNABLE UPON THE DEMAND OF WANG LABORATORIES, INC."

210 • 209 • 377 OR 378							
210	209	L1-9, 23-30, 42-50, 61-69	L109	L99	L100	L110	L111
7684-A	7684	377-0345	378-5001-R6	377-0368	377-0371	378-5002-R2	378-5003-R2

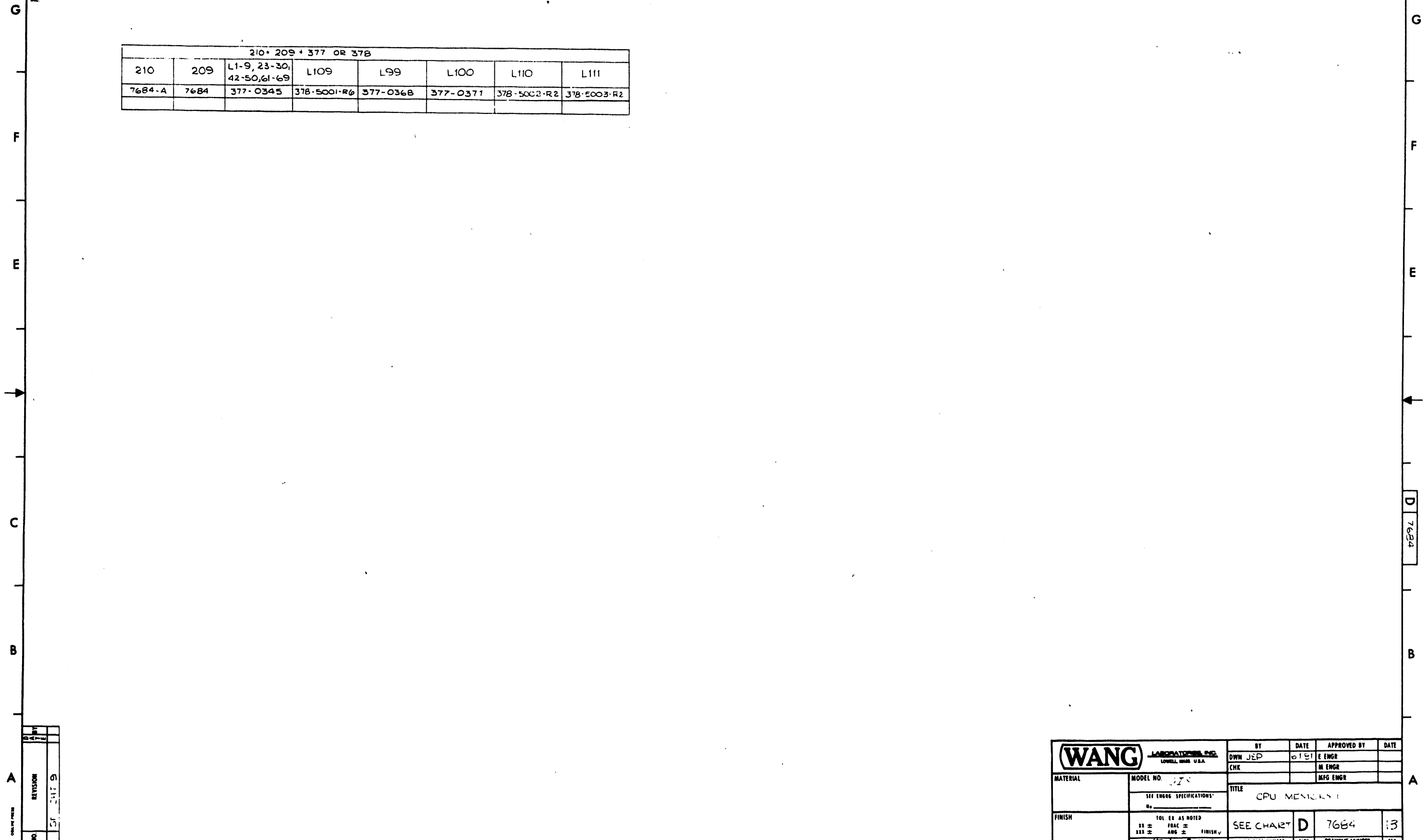

REV	DATE	BY	DESCRIPTION
1	01-11-69	JEP	INITIALS

<b>WANG</b> LABORATORIES, INC. LOWELL, MASS. U.S.A.		BY DWN JEP	DATE 01-11-69	APPROVED BY E ENGR	DATE
MATERIAL		CHK		M ENGR	
MODEL NO. 210		TITLE CPU MEMORIES I			
FINISH		SEE CHART D		7684	13
SCALE 1/8" = 1"		WANG PART NUMBER		SIZE	DRAWING NUMBER

11 10 9 8 7 5 4 3 2 1

THIS DRAWING AND THE DATA SHOWN THERE ON ARE THE CONFIDENTIAL PROPERTY OF AND ARE PROPRIETARY TO WANG LABORATORIES INC. THIS DRAWING AND THE DATA SHOWN THEREON MAY NOT BE MADE PUBLIC WITHOUT THE WRITTEN CONSENT OF WANG LABORATORIES INC. IF FOR ANY REASON THIS DRAWING IS PERMITTED BY WANG TO LEAVE THE PHYSICAL CUSTODY OF THE COMPANY, IT IS RETURNABLE UPON THE DEMAND OF WANG LABORATORIES INC.

DO NOT SCALE

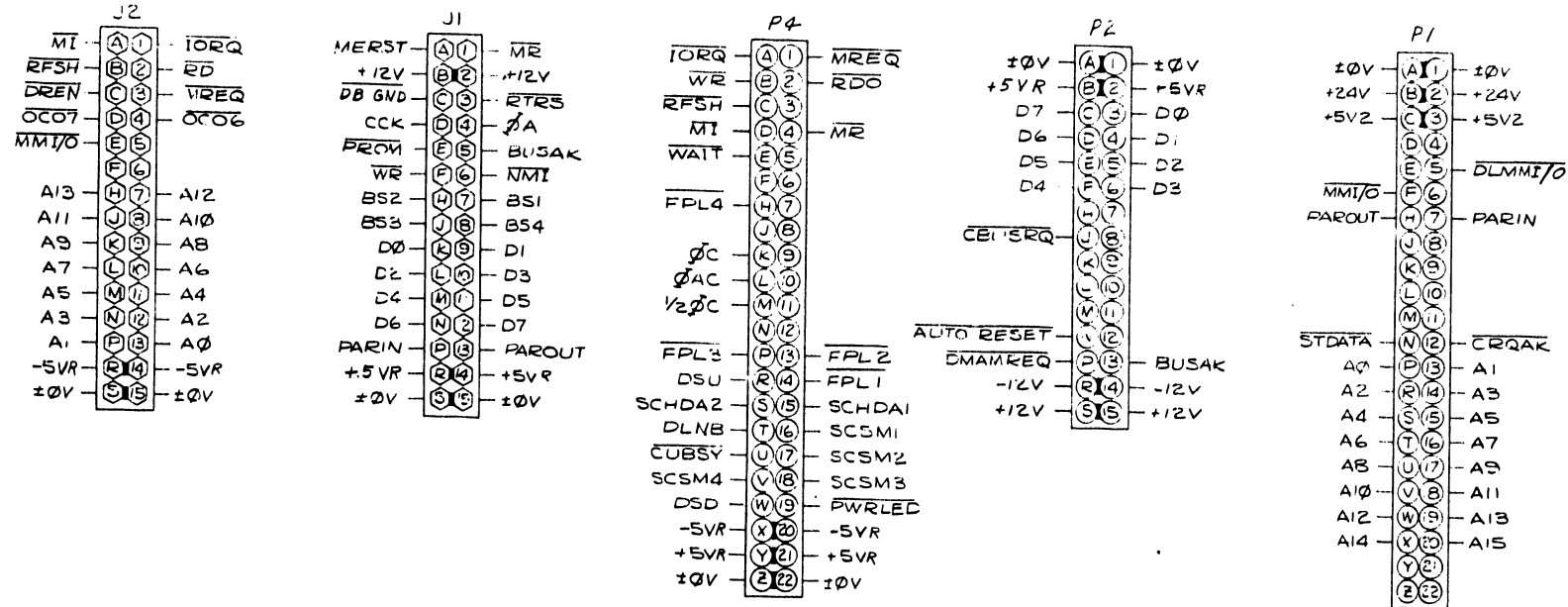

I.C. TYPE	LOC	SPARES
74500	L11B	1
7403	L76	3
7404	L38	1
	L116	1
74504	L102	2
7408	L34	1
	L59	1
7450B	L54	2
	L120	1
74570	L77	1
74571	L35	1
	L103	1
7420	L39	1
7425	L36	1
7432	L37	2
74532	L89	2
7474	L78	1
74574	L53	1
	L108	1
7475	L85	1
74725	L77	1
	L84	1
	L105	1

MNEMONICS	LOC
A0-A15	4E1
AUTO RESET	3B11
BS1	4A6
BS2	4A6
BS3	4A6
BS4	4A7
BUSAK	3C1
CBUSEQ	3G2
CK	2B2
CRQAK	2A5
CUBSY	1F11
DBGND	3G3
DX-D7	4C1
DLNB	1E11
DLMMI/O	5B7
DMAMREQ	2G7
DREN	4E11
DSD	2G7
DSU	2G7
FDLI	2A9
FPL2	2A9
FPL3	2A9
FPL4	2A9
TORQ	4B2
MERST	3G1
MI	4B5
VMI/O	5B7
MR	3B1
MREQ	4B2
NMI	3F1
OCOG	5F1
OCOT	5E1
PARIN	2B2
PAROUT	1E1
PROM	4A7
PWRLED	2A8
RD	4B3
RDO	4B3
RFSH	4B5
RTRS	2E1
SCHDA1	1C11
SCHDA2	1B11
SCSM1	1D11
SCSM2	1C11
SCSM3	1F11
SCSM4	1E11
STDATA	2E1
WAIT	3B11
WR	4B2
QA	2B1
QC	3A9
QAC	3A9
V2QC	3A10

COMPONENT	W.L. PART NO.	TYPE
R1-6	370-3047	4.7K 1/4W 10%
R7	370-2022	220Ω 1/4W 10%
R8-16, 6B, 69, 93-99	370-4010	10K 1/4W 10%
R17-24	370-2015	150Ω 1/4W 10%
R25, 39, 40, 43-55, 65-67, 70-92, 101-120, 127-134	370-3022	2.2K 1/4W 10%
R26-28, 37-38, 124	370-1034	33Ω 1/4W 5%
R41	370-4076	5.6M 1/4W 10%
R42	370-6033	3.3M 1/4W 10%
R29-32, 56-64	370-1077	26Ω 1/4W 5%
R100	370-2039	370Ω 1/4W 10%
R121, 122, 125	370-2033	370Ω 1/4W 10%
R123	370-3010	1K 1/4W 10%
R124	370-1012	12Ω 1/4W 10%
C1-18, 29-37, 41-49, 65-73, 78-95, 129, 131, 133	300-1930	.1μF 50V
C19-26, 30, 50-59, 62, 74, 75, 96-113, 116-120, 117A, 117B, 117C, 122, 123, 123A, 135-143, 144, 149	300-1966	.047μF 50V
C27, 28, 39, 40, 63, 64, 76, 77, 147, 148, 151, 153	300-4022	15μF 20V (T)
C60	300-1903	.01μF 25V
C61	300-2373	.1μF 50V MYLAR
C114	300-1750	150PF 500V
C115	300-4016	3.3μF 15V (T)
C121	300-1680	500PF 500V
C129-128, 144, 145, 152	300-1047	47PF 500V
C150	300-1018	18PF
LED1-B	370-0026	MV5024 (RED)
V1	370-0022	15.9744 MHz
SW1	325-1507	SP5T, 5 POS
SW2	325-1503	SP5T, 5 POS
SW3-B	325-0041	SPDT, MOM, 90°
SW4-7	325-0040	SPDT, 704, 90°
Q1	375-1050	SP5 6551
J112	350-0009	CONN. 90°

I.C. LOCATION	W.L. PART NO.	TYPE
L1-9, 22-30, 42-50, 61-69	SEE CHART	MK4116
L10, 71	376-0238	74570
L11, 12, 52	376-0198	74530
L13, 83, 97	376-0310	74LS373
L14	376-0176	74367
L15-21, 41, 125		SPARE
L31, 57	376-0217	745157
L32, 72, 124	376-0288	74LS13B
L33, 53, 73, 104, 119, 128	376-0202	74574
L34, 59, 74, 101, 121, 130	376-0081	7408
L35, 103	376-0237	74511
L36, 56, 60	376-0092	7425
L37, 20	376-0093	7432
L38, 57, 116	376-0010	7404
L39	376-0004	7420
L40	376-0126	555
L54, 55, 120	376-0200	7450B
L58	376-0230	74LS4
L70, 126	376-0230	74520
L74, 78, 92, 93, 121, 123, 131, 132	376-0006	7474
L75, 89	376-0205	74532
L76	376-0199	74502
L77, 84, 105	376-0324	74125
L79	376-0010	7404
L80	376-0003	7410
L81, 113	376-0297	74LS240
L82, 87, 98, 112, 115	376-0288	74LS244
L84	376-0242	74LS280
L88	376-0247	74574
L95	376-0104	9602
L96	376-0028	7403
L99	SEE CHART	280A-CPU
L100	SEE CHART	280-CTC
L102	376-0197	74504
L106	376-0008	7442
L107	376-0171	74148
L108	376-0286	74LS374
L109-111	SEE CHART	2516
L114	376-0285	74LS245
L117	376-0043	74H04
L118	376-0228	74500
L129	376-0068	7437
L85	376-0013	7475
L1-9, 22-30, 42-50, 61-69	376-9002	SKT, 16 PIN
L79	376-9011	SKT, 40 PIN
L100	376-9015	SKT, 28 PIN
L58, 109-111	376-7003	SKT, 24 PIN

REVISION	DATE	BY	DESCRIPTION
1	11-22-80	JT	ORIG DES
2	12-22-80	JT	SWAP RE 9.2
3	1-11-81	JT	APP. 1.1.1
4	1-11-81	JT	REVISED PER ECO #18767
5	2-11-81	JT	REVISED PER ECO #18767
6	3-11-81	JT	REVISED PER ECO #18767
7	4-11-81	JT	REVISED PER ECO #18767
8	5-11-81	JT	REVISED PER ECO #18767
9	6-11-81	JT	REVISED PER ECO #18767
10	7-11-81	JT	REVISED PER ECO #18767
11	8-11-81	JT	REVISED PER ECO #18767
12	9-11-81	JT	REVISED PER ECO #18767
13	10-11-81	JT	REVISED PER ECO #18767
14	11-11-81	JT	REVISED PER ECO #18767

<b>WANG</b> LABORATORIES INC. LOWELL, MASS. U.S.A.		BY	DATE	APPROVED BY	DATE
MATERIAL		DWN-T	1/22/80	E ENGR	7/5/80
MODEL NO.		CHK 11/4	SUN	M ENGR	
SEE ENGR SPECIFICATIONS		TITLE CPU, MEMORY (			
FINISH		101 EX AS NOTED		SEE CHART	D 7684
SCALE		1:1	1:1	WANG PART NUMBER	SIZE
				DRAWING NUMBER	REV

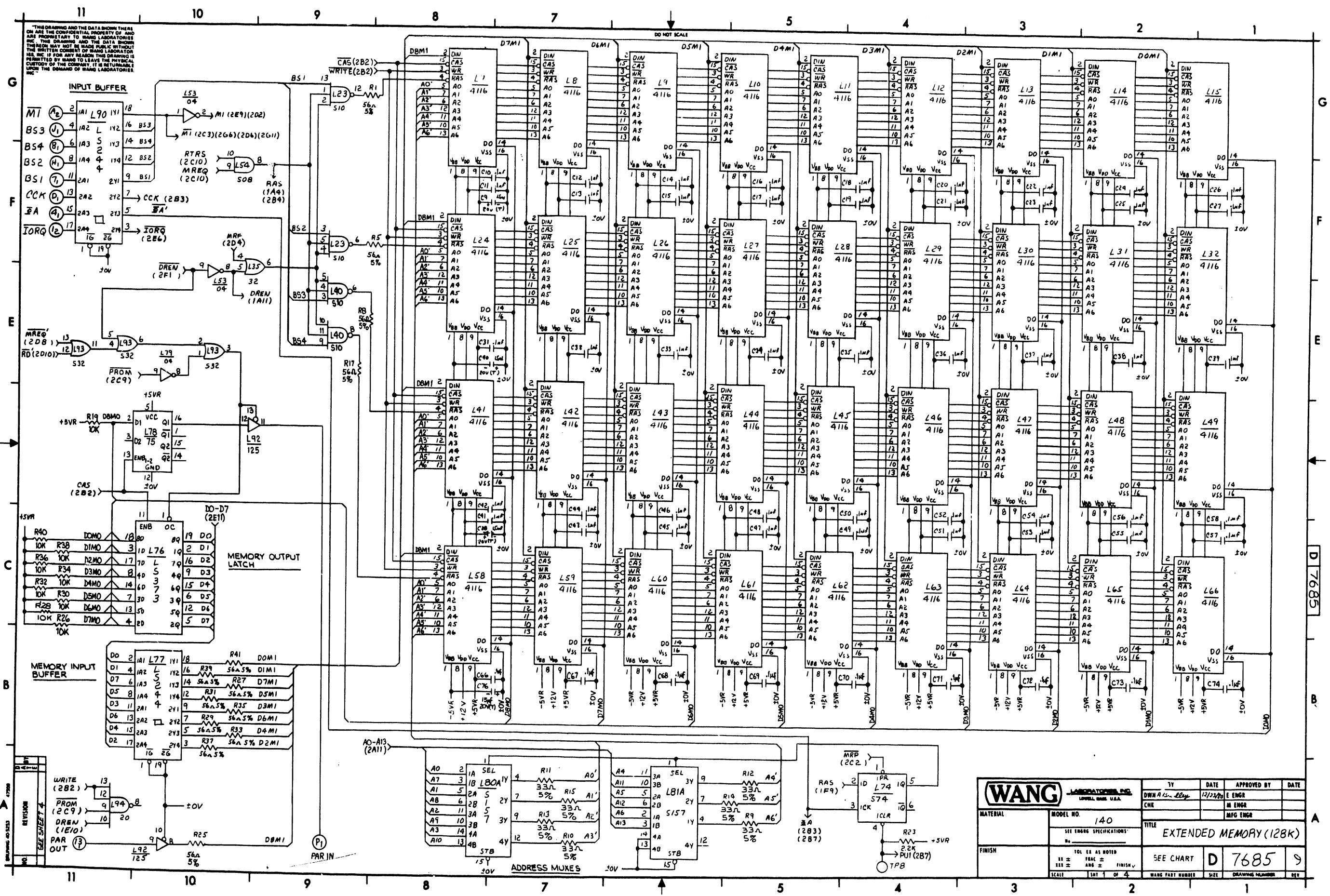

<b>WANG</b> LABORATORIES, INC. LOWELL, MASS. U.S.A.		3Y	DATE	APPROVED BY	DATE
MATERIAL	MODEL NO. 140	CHK	DWN A 12/23/70	E ENGR	
SEE ENGR SPECIFICATIONS		TITLE		EXTENDED MEMORY (128K)	
FINISH		SEE CHART		D 7685 9	
SCALE		WANG PART NUMBER		SIZE	

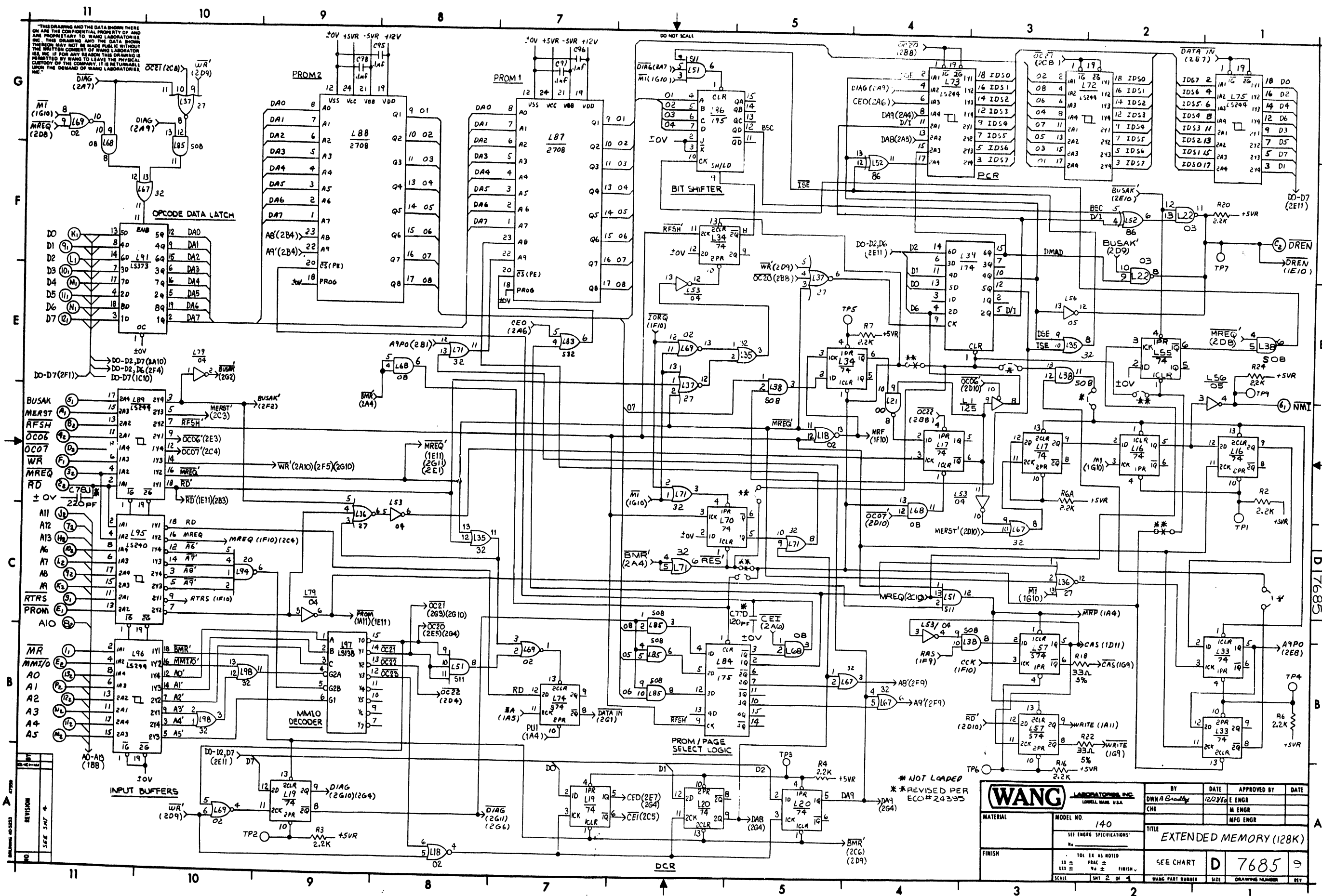

THIS DRAWING AND THE DATA SHOWN THERE ON ARE THE CONFIDENTIAL PROPERTY OF AND ARE PROPRIETARY TO WANG LABORATORIES, INC. THIS DRAWING AND THE DATA SHOWN THEREIN MAY NOT BE REPRODUCED OR TRANSMITTED IN ANY FORM OR BY ANY MEANS WITHOUT THE WRITTEN CONSENT OF WANG LABORATORIES, INC. IF FOR ANY REASON THIS DRAWING IS PERMITTED BY WANG TO LEAVE THE PHYSICAL CUSTODY OF THE COMPANY, IT IS RETURNABLE UPON THE DEMAND OF WANG LABORATORIES, INC.

REVISION	SEE 347 +
DATE	
BY	
CHK	
DATE	
BY	
CHK	
DATE	
BY	
CHK	
DATE	

<b>WANG</b> LABORATORIES, INC. LOWELL, MASS. U.S.A.		BY	DATE	APPROVED BY	DATE
MODEL NO. 140		DWN A Bradley	12/23/68	E ENGR	
SEE ENGR SPECIFICATIONS		CHK		M ENGR	
TITLE		EXTENDED MEMORY (128K)			
FINISH		SEE CHART	D	7685	9
SCALE		WANG PART NUMBER SIZE DRAWING NUMBER DTY			

\* NOT LOADED  
\* REVISED PER ECO# 24395

THE DRAWING AND THE DATA SHOWN THERE ON ARE THE CONFIDENTIAL PROPERTY OF, AND ARE PROPRIETARY TO, WANG LABORATORIES, INC. THIS DRAWING AND THE DATA SHOWN THEREIN MAY NOT BE MADE PUBLIC WITHOUT THE WRITTEN CONSENT OF WANG LABORATORIES, INC. IF FOR ANY REASON THIS DRAWING IS PERMITTED BY WANG TO LEAVE THE PHYSICAL CUSTODY OF THE COMPANY, IT IS RETURNABLE UPON THE DEMAND OF WANG LABORATORIES, INC.

7685 R3

DO NOT SCALE

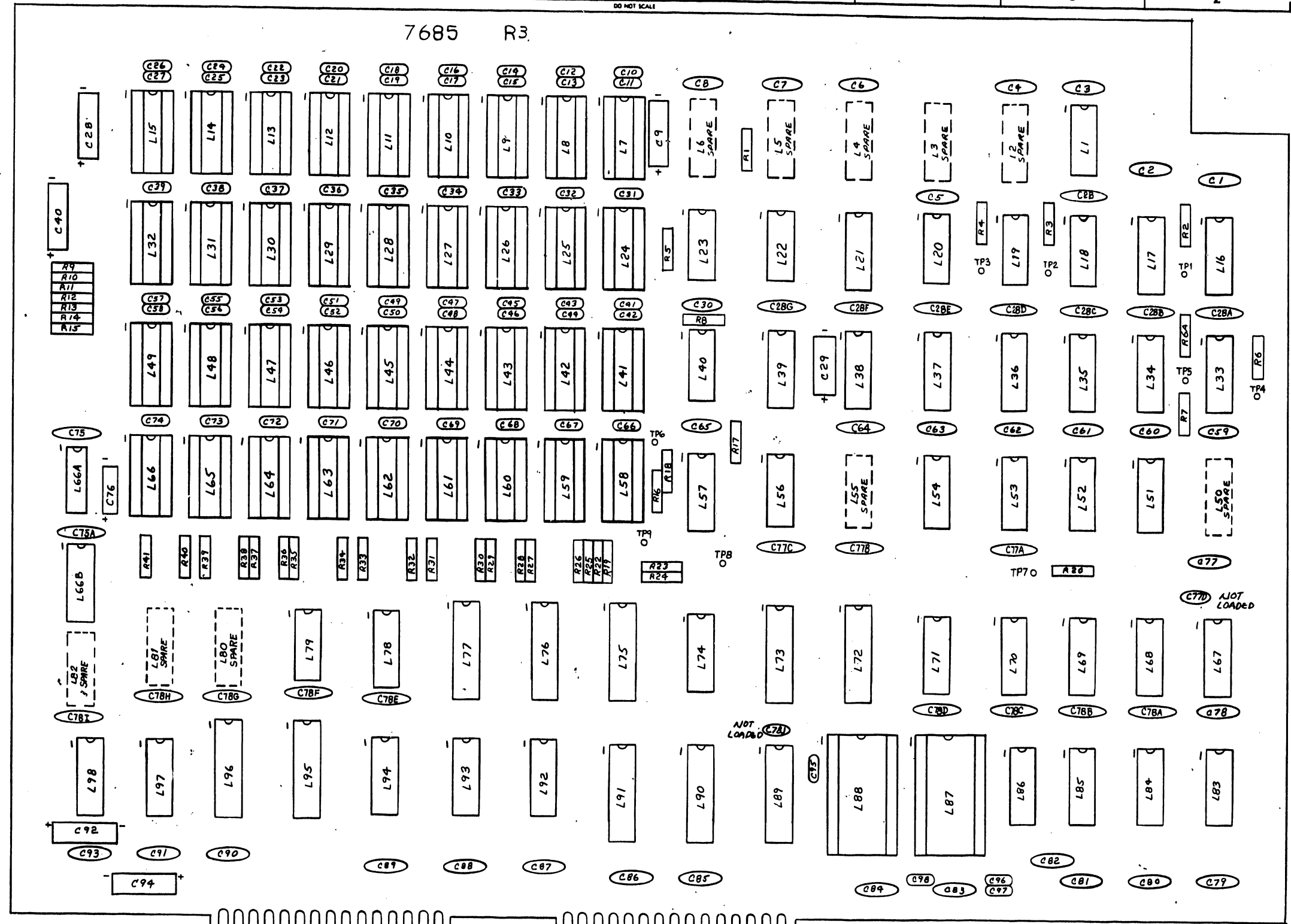

G  
F  
E  
C  
B  
A

G  
F  
E  
D  
B  
A

REVISION	DATE	BY
SEE SHIP		

<b>WANG</b> LABORATORIES, INC. LITTLETON, COLORADO, U.S.A.		BY DWN R. B...	DATE 3-2-81	APPROVED BY E ENGR	DATE
MATERIAL	MODEL NO. 140	CHK		MFG ENGR	
SEE ENGR SPECIFICATIONS		TITLE EXTENDED MEMORY (128K)			
FINISH	TOL ER AS NOTED	SEE CHART	D	7685	9
SCALE 1/8" = 1"		WANG PART NUMBER		SET	DRAWING NUMBER

D 7685

A



THIS DRAWING AND THE DATA SHOWN THERE ON ARE THE CONFIDENTIAL PROPERTY OF AND ARE PROPRIETARY TO WANG LABORATORIES, INC. THIS DRAWING AND THE DATA SHOWN THEREIN MAY NOT BE REPRODUCED OR TRANSMITTED IN ANY FORM OR BY ANY MEANS, ELECTRONIC OR MECHANICAL, INCLUDING PHOTOCOPYING, RECORDING, OR BY ANY INFORMATION STORAGE AND RETRIEVAL SYSTEM, WITHOUT THE WRITTEN CONSENT OF WANG LABORATORIES, INC. IF FOR ANY REASON THIS DRAWING IS PERMITTED BY WANG TO LEAVE THE PHYSICAL CUSTODY OF THE COMPANY, IT IS RETURNABLE UPON THE DEMAND OF WANG LABORATORIES, INC.

I.C. LOCATION	TYPE	WL PART NO.
L1, 92	74125	376-0324
L2-6, 50, 82, 80, 81	SPARE	
L7-15, 24-32, 41-49, 58-66	MK4116	SEE CHART
L16, 17, 19, 20, 33, 34, 70	7474	376-0006
L18, 69	7402	376-0016
L21	7400	376-0002
L22	7403	376-0028
L23, 40	74510	376-0238
L35, 67, 71, 98	7432	376-0093
L36, 37	7427	376-0125
L68	7408	376-0081
L39	74174	376-0098
L51	74511	376-0237
L52	7486	376-0036
L53, 79	7404	376-0010
L54, 85, 38	74508	376-0200
L56	7405	376-0029
L57, 74	74574	376-0202
L72, 73, 75, 77, 89, 90, 96	74LS244	376-0288
L76, 91	74LS373	376-0310
L78	7475	376-0013
L66A, 66B	745157	376-0217
L83, 93	74532	376-0205
L84	74175	376-0119
L86	74195	376-0097
L87, 88	TMS2708	SEE CHART
L94	7420	376-0004
L95	74LS240	376-0297
L97	74LS138	376-0294
L7-15, 24-32, 41-49, 58-66	16 PIN SKT.	376-9002
L87, 88	24 PIN SKT.	376-9003

COMPONENT	TYPE	WL PART NO.
R1, 5, 8, 17, 25, 27, 29, 31, 33, 35, 37, 39, 41	56Ω 1/4W 5%	330-1057
R2-4, 6, 6A, 7, 4, 20, 23, 24	2.2K 1/4W 10%	330-3022
R9-15, 18, 22	33Ω 1/4W 5%	330-1034
R19, 26, 28, 30, 32, 34, 36, 38, 40	10K 1/4W 10%	330-4010
C1-8, 28, 28A-28C, 30, 59-65, 75, 75A, 77, 77A-77C, 78, 78A-78I, 79-91, 93	.047μF, 50V	300-1966
C10-27, 31-39, 41-58, 66-74, 95-98	.1μF 50V	300-1930
C9, 29, 29, 40, 76, 92, 94	15μF 20V(T)	300-4022
C77D	120PF	NOT LOADED
C78J	220PF 500V	NOT LOADED

TYPE	I.C. LOCATION	SPARES
7400	L21	3
7402	L18	2
7403	L22	2
74804	L79	3
7405	L56	4
74508	L84	3
74510	L23	1
	L40	1
7474	L70	1
	L55	1
7486	L52	2
7427	L36	1
7432	L98	2
74532	L83	3
	L93	1
7475	L78	1
74125	L1	3
	L92	2

MNEMONICS	COORD.
AO-A5	2B11
A6-A13	2C11
BS1-BS4	1F11
BUSAK	2D11
CCK	1F11
DREN	2F11
DO-D7	2F11
ORA	1F11
IORQ	1F11
MERST	2D11
MMT/G	2B11
MR	2B11
MREG	2D11
MT	1G11
NMT	2E11
OCOC	2D11
OCOT	2D11
PAR IN	1A9
PAR OUT	1A11
PROM	2C11
RD	2D11
RFSH	2D11
RTRS	2C11
WR	2D11

210 = 209 + 377 OR 378				
210	209	L7-15, 24-32, 41-49, 58-66	L87	L88
7685-A	7685	377-0345	378-3064	378-3065

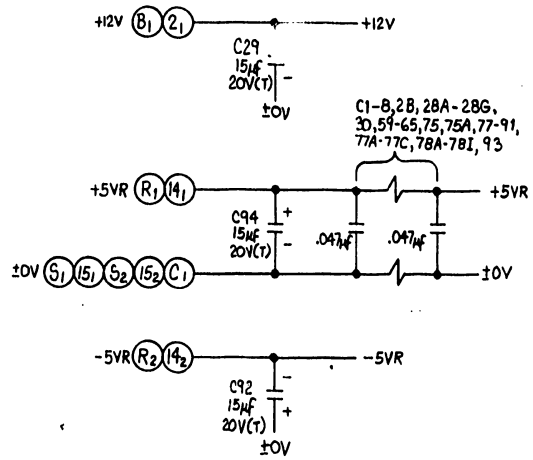
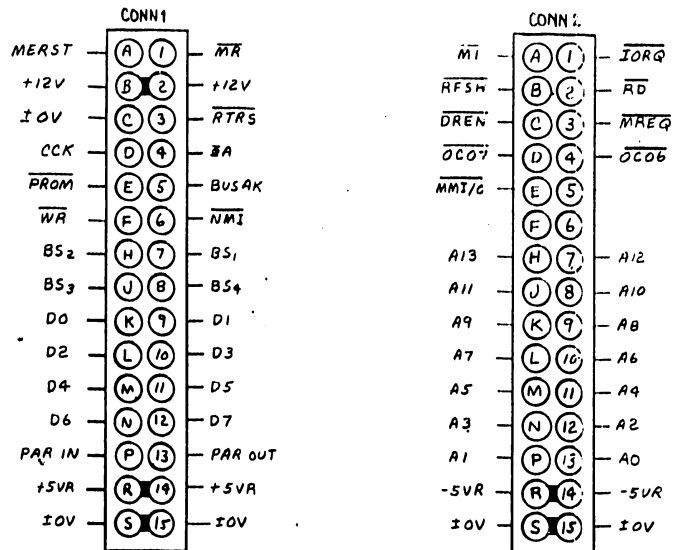

E REV  
5

REV	DATE	BY	CHK'D	APP'D	DESCRIPTION
1	1-23-81				ORIGINAL PER DMR # E-93
2	1-23-81				APP'D: M/COMP/11
3	1-23-81				REVISED PER ECO # 177
4	1-23-81				APP'D: M/COMP/11
5	1-23-81				REVISED PER ECO # 183
6	1-23-81				APP'D: M/COMP/11
7	1-23-81				REVISED PER ECO # 192
8	1-23-81				APP'D: M/COMP/11
9	1-23-81				REVISED PER ECO # 203
10	1-23-81				APP'D: M/COMP/11
11	1-23-81				REVISED PER ECO # 210
12	1-23-81				APP'D: M/COMP/11
13	1-23-81				REVISED PER ECO # 219
14	1-23-81				APP'D: M/COMP/11
15	1-23-81				REVISED PER ECO # 243
16	1-23-81				APP'D: M/COMP/11
17	1-23-81				REVISED PER ECO # 243
18	1-23-81				APP'D: M/COMP/11
19	1-23-81				REVISED PER ECO # 243
20	1-23-81				APP'D: M/COMP/11

<b>WANG</b> LABORATORIES, INC. LOWELL, MASS. U.S.A.		BY DWN A. Bradley	DATE 2-13-81	APPROVED BY E. ENGR. 2	DATE 2/1/81
MATERIAL		MODEL NO. 140		TITLE EXTENDED MEMORY (128K)	
FINISH		SCALE 1:1		SEE CHART	
DRAWING NO. 4752		SIZE D		DRAWING NUMBER 7685	
REVISED PER ECO # 243		MFG ENGR		WANG PART NUMBER	

**END**