

➔  **Solar Water Heaters in Nepal (SKAT, 1979, 142 p.)**

 **(introduction...)**

 **ACKNOWLEDGEMENTS**

 **INTRODUCTION**

 **FOREWORD**

 **PART I INSTALLATION**

 **1. PRINCIPLES**

 **2. INSTALLATION OF A SOLAR WATER HEATER SYSTEM**

 **3. PASSIVE SYSTEMS**

 **4. PUMPED CIRCULATION SYSTEMS**

 **PART II SOLAR WATER HEATER APPLIANCES MADE BY MECHANICAL TRAINING CENTRE**

 **5. SOLAR WATER HEATERS MADE BY MECHANICAL TRAINING CENTRE**

 **PART III SOLAR WATER HEATER APPLIANCES OTHER DESIGNS**

 **6. SOLAR WATER HEATER APPLIANCES/OTHER DESIGNS**

 **PART IV EXAMPLES OF COST CALCULATION**

 **7. EXAMPLES OF COST CALCULATION**







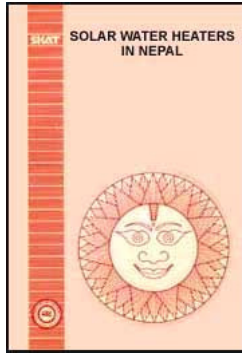

 **PART V ANNEX**

 **8. ANNEX**





 **Solar Water Heaters in Nepal (SKAT, 1979, 142 p.)**

- ➔  **(introduction...)**
-  **ACKNOWLEDGEMENTS**
-  **INTRODUCTION**
-  **FOREWORD**
-  **PART I INSTALLATION**
-  **PART II SOLAR WATER HEATER APPLIANCES MADE BY MECHANICAL TRAINING CENTRE**
-  **PART III SOLAR WATER HEATER APPLIANCES OTHER DESIGNS**
-  **PART IV EXAMPLES OF COST CALCULATION**
-  **PART V ANNEX**

Manufacture & Installation



[Home](#) > [ar.cn.de.en.es.fr.id.it.ph.po.ru.sw](#)

 **Solar Water Heaters in Nepal (SKAT, 1979, 142 p.)**

-  **(introduction...)**
- ➔  **ACKNOWLEDGEMENTS**
-  **INTRODUCTION**
-  **FOREWORD**
-  **PART I INSTALLATION**
-  **PART II SOLAR WATER HEATER APPLIANCES MADE BY MECHANICAL TRAINING CENTRE**

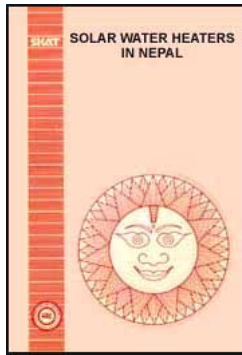

- PART III SOLAR WATER HEATER APPLIANCES OTHER DESIGNS**
- PART IV EXAMPLES OF COST CALCULATION**
- PART V ANNEX**

ACKNOWLEDGEMENTS

The Mechanical Training Centre (MTC) is a vocational training centre run jointly by His Majesty's Government of Nepal and the Government of Switzerland through the Council for Technical Education and Vocational Training (Nepal) and Helvetas Nepal.

SKAT, Swiss Center for Appropriate Technology, is a documentation centre and consultancy group which is engaged in promoting Appropriate Technology in the Third World. Its mail - order bookshop with more than 1200 publications in stock and its publishing help to fulfill this aim.

First Edition 1979

Second Edition 1990, revised and expanded, co-published by MTC and SKAT

Authors Andreas Bachmann & Heinz Waldvoel

Editor MTC (Mechanical Training Centre, Balaju, Kathmandu/Nepal)

Publishers MTC, Balaju, Kathmandu/Nepal SKAT, St Gallen/Switzerland

Copyright Material of this publication may be freely quoted, translated or otherwise used.
Acknowledgement is requested.

Comments Questions and comments are welcome at MTC

Distributors in Nepal: Mechanical Training Centre P.O. Box 4897 Kathmandu / Nepal
outside Nepal: SKAT, Varnbuelstrasse 14 CH-9000 St. Gallen/Switzerland
and
KODIS, Wartstrasse 6 CH-8400 Winterthur/Switzerland

ISBN 3 908001 11 0

Front cover designed by Mr. Sapta Raj Shakya
Printed in Nepal at SAHAYOGI PRESS, Tripureshwar, Kathmandu



[Home](#) > [ar.cn.de.en.es.fr.id.it.ph.po.ru.sw](#)

 **Solar Water Heaters in Nepal (SKAT, 1979, 142 p.)**

 **(introduction...)**

 **ACKNOWLEDGEMENTS**

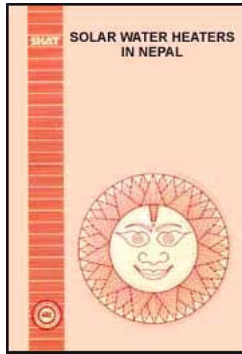

- ➔ **INTRODUCTION**
- 📄 **FOREWORD**
- 📁 **PART I INSTALLATION**
- 📁 **PART II SOLAR WATER HEATER APPLIANCES MADE BY MECHANICAL TRAINING CENTRE**
- 📁 **PART III SOLAR WATER HEATER APPLIANCES OTHER DESIGNS**
- 📁 **PART IV EXAMPLES OF COST CALCULATION**
- 📁 **PART V ANNEX**

INTRODUCTION

Solar water heaters were developed some two hundred years ago. The first known flat plate collector was made by H. B. de Sausurre, a Swiss, in the second half of the 18th century. However, little interest was shown in such devices until the world-wide oil crisis of 1973. This crisis promoted new interest in alternative energy sources. As a result, solar energy has, received increased attention and many countries are taking a keen interest in new developments.

It is understood that achievements in science and technology cannot always simply be transferred from one country to another. They must usually be somewhat changed and adapted to suit local conditions and constraints on production. It is known, for example, that copper has the best characteristics for solar heaters, and that aluminium has considerable potential. However, in many countries these materials may be too costly, too difficult to work with, or not available in local markets.

In Nepal, attention was given from the beginning to the use of locally available materials. This resulted in simple working techniques and in designs which favoured the modular

system. The combination of product manufacture and installation by the same enterprise proved to be a satisfactory approach. Nowadays, solar water heaters are manufactured in several workshops which, with increasing demand, are gradually upgrading to real small-scale industries.

Performance: Solar water heaters are one of the best known applications for the direct use of the sun's energy. Simple solar water heaters require almost no attention; they work automatically and provide hot water without any special care.

Design: Solar water heaters have been designed to suit local conditions. "Passive Systems,, were tested first. These systems, which have collecting surfaces connected to a separate hot water storage, tank, circulate water by thermosiphon (convection) effect. This proved to be the most popular design. Another type, the flat tank collector, was also developed. This simple one-piece unit can be a satisfactory alternative to more complex systems. It does not keep water hot overnight, but hot water is available from late morning until after sunset. These are the two most commonly used systems in Nepal. The manufacture and installation of pumped systems and systems incorporating anti-freeze protection is as yet untried, but is technically feasible.

Size: The size of solar water heaters depends on the daily hot water requirements. In general one person may require approx. 25 to 40 liters of hot water at approx. 55° to 60° Centigrades per day (for domestic bathing only, without laundry and not in hotels). For a small family a circulation system with a hot water storage capacity of approx. 120 liters may be sufficient. A flat tank collector of 60 or 90 liters may be appropriate for a few persons where the demand is limited. Selection of size would also depend on availability of standard products. Prizes vary with the heater size and with the installation charges. Installation is simplest when the system is incorporated in the initial planning of the construction of a new house. This allows the architect to incorporate the heater into the plan, both esthetically and economically.

A. Bachmann H. Waldvogel

[Home](#) > [ar.cn.de.en.es.fr.id.it.ph.po.ru.sw](#)

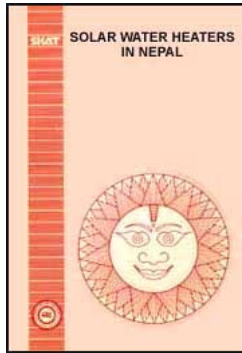
**📖 Solar Water Heaters in Nepal (SKAT, 1979, 142 p.)**

📄 *(introduction...)*

📄 **ACKNOWLEDGEMENTS**

📄 **INTRODUCTION**

➔ 📄 **FOREWORD**

📄 **PART I INSTALLATION**

📄 **PART II SOLAR WATER HEATER APPLIANCES MADE BY MECHANICAL TRAINING CENTRE**

📄 **PART III SOLAR WATER HEATER APPLIANCES OTHER DESIGNS**

📄 **PART IV EXAMPLES OF COST CALCULATION**

📄 **PART V ANNEX**

FOREWORD

The first pilot solar water heater at Balaju Yantra Shala (BYS) Plumbing Division was made in autumn 1974. It was constructed from an old electric hot water tank and a small, self-made collector. After considerable experiment, improved solar water heaters were supplied to the boarding school at Budhanilkantha. For BYS this was the beginning of a challenging development.

The development of solar water heaters received further support at the newly established sanitary section of the Mechanical Training Centre in Balaju. This work, like that of BYS,

was supported by Helvetas. (Both BYS and MTC were initiated by agreements between His Majesty's Government of Nepal and HELVETAS, Switzerland.)

In this manner, through improvements in design, manufacturing and installation and through a combination of the efforts of a private company and a technical school, the efficiency and performance of solar collectors and hot water storage tanks was much improved. Today, these installations are a common sight in Nepal and in neighbouring countries.

This second edition includes the latest developments made at MTC. The basics of "pumped circulation systems" have been added, and has with thanks much valuable information from "Solaranlagen" by Mr. H. R. Schmidli.

Much information on solar energy technology was generously made available by the late Rev. B. R. Saubolle, S. J. whose pioneering work in this field began as early as 1968. Thanks largely to his efforts, the utilization of solar energy has become a promising reality in Nepal, India and Africa.

We acknowledge with thanks the support given for the production of this book by Mr. Laxmi Bahadur Manandhar, Principal of MTC and Mr. Andres Wiederkehr at Helvetas in Zuerich. Thanks are also due to Mr. Ram Kumar Thapa, office assistant, Mr. Purna Man Shrestha, Head of Printing Section to Mr. Ram Prasad Shah, Draftsman and to Mr. Nick Gregory for checking the English language. We gratefully acknowledge the contribution of HELVETAS (Swiss Association for Development and Cooperation), whose support made this edition possible.

**Ben Dolf/Programme Director
Helvetas Nepal
Patrick Leu / Co-Principal
MTC, Balaju**



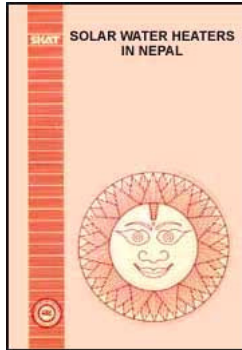

[Home](#) > [ar.cn.de.en.es.fr.id.it.ph.po.ru.sw](#)



Solar Water Heaters in Nepal (SKAT, 1979, 142 p.)

PART I INSTALLATION

-  1. PRINCIPLES
-  2. INSTALLATION OF A SOLAR WATER HEATER SYSTEM
-  3. PASSIVE SYSTEMS
-  4. PUMPED CIRCULATION SYSTEMS

Solar Water Heaters in Nepal (SKAT, 1979, 142 p.)

PART I INSTALLATION

1. PRINCIPLES

For systems with natural circulation (i.e. by convection or thermo-siphon) in non-freezing areas, with some basic information on anti-freeze protection and pumped circulation systems.

Typical solar heating systems collect the sun's energy with rooftop arrays of piping and net metal sheets, painted black to absorb as much radiation as possible. They are encased in glass or plastic and angled towards south to catch maximum sunshine. The collectors act as miniature greenhouses, trapping heat under their glass plates. Because solar

radiation is so diffuse, the collectors must have a large area.

Solar water heaters can be made in various sizes depending on requirements. They give enough hot water for cooking, showers and washing. They can be used as pre-heaters for existing electric water heaters. SWH should be automatic and self-regulating and be designed to refill as they are used.

The hottest water in the heating system is always served automatically, and if a steady water supply to the heater is maintained at all times, there is no inconvenience of having to replace it manually.

The SWH is a very economical way to supply hot water. Since the sun does not send a monthly bill for services costs are nominal. Compared to fuel charges for firewood, gas, kerosene, etc., the SWH is so economical that it will pay for itself within a few years.

1.1 HOT WATER INSTALLATION

Basics -the plumbing for hot water is in principle the same as for cold, but there are certain additional factors that apply to hot water systems, and these must be taken in account (e.g. length and diameter of pipes, insulation, safety devices, etc.).

Layout of pipelines -connection of hot water storage tank and collectors to be of shortest possible distance.

-Pipes should not be exposed to the weather if possible. (keep pipes inside the house where possible).

-All connections must be of good quality.

-Adequate spacing must be left for insulation (insulation thickness: 30 to 50 mm).

-Air valves and drainage valves must be in accessible places.

-Layout must allow complete drainage of the entire system.

Diameter-pipe diameter depends on different factors, such as:

- Consumption/time unit**
- Total quantity/time**
- Length**
- Materials, etc.**

To ensure trouble-free functioning there must be a safety device for the release of over-pressure due to the increase of volume by heating. This is normally a safety valve and a non-return valve (check), or a non-return valve and a vent pipe.

Note: In a low pressure system using a separate feed tank (as in installation example No. 6), over pressure safety devices are not required. If 100 liters of water are heated from 10 to 70 Centigrade the volume will increase by 1.08 liters!

Distribution systems -a choice of different systems is available. One should choose the system best suited to the individual circumstances. For large buildings a central hot water system, having well insulated pipes, may be best.

For smaller installations, the single pipe system (one pipe for one tap) is usually preferable. For solar heater water with thermo-siphon circulation this is the best solution.

Note: It is important to have several separate pipes from the heater to the taps to reduce heat losses (smaller pipes) and to give a convenient and fast supply of hot water to the user, with a maximum delay of about 10 to 20 seconds. Pipes concealed in cement or in brickwork must be protected against heat loss with a corrosion-free bandage of at least 5

mm thickness.

1.2 HOT WATER STORAGE TANKS

All hot water storage tanks must be well insulated to keep the water hot during the night. Heat loss depends on many factors (ambient temperature, wind, season, etc.) and will be approximately 0.5 to 1 Centigrade per hour during the night. Experience shows that a minimum thickness of insulation of 100 mm should be maintained.

There are several different sizes of tanks available. All tanks must have connections for cold water inlet and hot water outlet as well as two connections for circulation pipes. These hot water storage tanks can easily be fitted to a stand. An electric element can be inserted, even after the installation, as there is a flange for this purpose. The flange at the bottom serves also for cleaning and maintenance of the tank.

These hot water storage tanks are made for low pressure use only. They can withstand a pressure of approx. 30 meters head. It is important to select correct connections to guarantee trouble-free functioning (as shown in the drawings).

Shape -two important factors influence the shape of a tank: -The smaller the diameter the less the tension (because of pressure from the inside) -The larger the outer surface of the tank proportion to its volume, the greater the heat losses.

Suitable proportions are as follows:

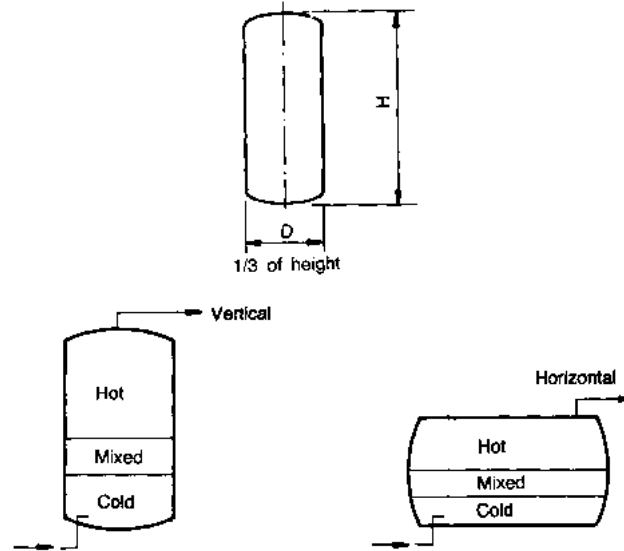
**FIGURE**

Types -there are vertical and horizontal types available. For solar hot water systems with thermo-siphon circulation the vertical position is essential for proper circulation and hot water availability.

Hot water availability: A vertical hot water storage tank will provide more liters of hot water (having a smaller volume of mixed water)

Cold inlet and hot outlet - these pipes must be welded to the hot water storage tanks by the manufacturer so that the incoming cold water will not mix with the hot water inside the storage tank (by fitting a baffle plate or by a tee on to the cold inlet). It is important to follow the rules for installation of the hot water storage tank (as shown in the tables) so

as to guarantee satisfactory hot water supply.

Sizes of hot water storage tanks - must be of adequate size to fulfill maximum requirement of hot water per day, or per heating time cycle.

Because of the intermittent availability of solar energy a large insulated storage tank is required, with a lagging of 100 mm. It is poor planning to install and undersized tank, no matter what heating medium is used: Sun, gas, oil, electricity. A well insulated storage tank keeps the water hot during the night. The storage tank and the circulation pipes must have a weatherproof cover when exposed to outside climate.

If an all-solar system is to be installed, then a tank with a capacity of between two and two-and-a-half times the daily consumption is suggested, owing to the intermittent nature of the solar energy received.

To estimate the daily usage, a figure of approximately 25 to 40 liters of hot water per person may be used.

Once the decision has been made on the type of energy-system, i. e. all-solar or solar with auxiliary boosting circulation of flat tank collector, then the tank capacity and collector area must be decided. These are determined by the daily requirement of hot water. Count approximately 50 liters of hot water per day for one collector surface of 1.m².

Quality and maintenance - corrosion of pipes and tanks is greater with hot water. The water should not be heated above 60 to 65 Centigrade. PE or PVC plastic pipes are easily damaged by hot water, and their use should be avoided. Heat, causes pipes to expand, thus increasing the length of the pipeline. It is therefore necessary to take proper precautions to allow for constant expansion and contraction due to changes in temperature.

Nowadays solar water heater systems are often made of galvanized M. S. Sheet metal, and are therefore protected from rusting. If the galvanized layer is damaged, or after several years of service, they may have to be painted with a good paint. The collectors and the hot water storage tanks require cleaning and painting before rust takes hold and causes damage.

1.3 CONNECTION OF COLLECTORS TO HOT WATER STORAGE TANKS

Hot water storage tanks have to be connected to collectors as follows:

Capacity of Hot Water storage tank	Number of Collectors	Circulation Pipes	
		riser	down-comer
100 Itr	1	1"	1"
125 Itr	1 to 2	1"	1"
150 Itr	2 to 3	1"	1"
200 Itr	2 to 3	1"	1"

Note:

- 1) Surface of a standard collector is approximately 1.4 m².**
- 2) Per m² of such a collector count approximately 50 Itr. of hot water at 50 K (say from 10 to 60 Centigrade)**

At each connection between the collector and the hot water storage tank there has to be a union to allow the disconnection of the collector and also the disconnection of the hot water storage tank from the pipelines.

The pipes between the hot water storage tank and the collectors must be free of any

obstructions, and it is advisable to check this by blowing through these pipes before connecting them.

1.4 COLLECTORS AND CIRCULATION PIPES

For proper functioning it is most important to have gradients in pipelines and collector installations. The upper edge (upper head) of the collectors have to be slightly inclined to prevent the trapping of air bubbles in the 1" circulation pipes. The side of the collector connected to the hot water storage tank should be approximately, 1 to 3 cm higher than the closed end of the 0 1" end pipe. In case of multiple connections between collectors, where a collector is connected on both sides, the upper head should be slightly inclined towards one side to allow air bubbles to pass through the collector into the hot water storage tank in thermo-siphon systems (or to air valves, in pumped systems).

The side of the collector closed with a 1" cap can be opened for flushing and cleaning the collector. In the lower head sludge, sand and dirt may accumulate, and in the upper head air bubbles may accumulate.

1.5 CONNECTION TO DRINKING WATER MAINS

Water heaters may be connected to the drinking water main line only if the following points are fulfilled and where sufficient pressure from the supply side is available. (As with any hot water tank connection, it is essential to have sufficient water pressure available, either from the mains or from a roof tank).

Diameter - the cold water inlet pipe to a hot water storage tank should never be smaller, in diameter than the hot water outlet pipe. In pressure systems a 0 1/2" pipe is in most of the cases sufficient, but in systems with less than 10 m head, when measured with a pressure gauge, or with greater supply demands, it is better to use a 0 3/4" or 0 1" pipe.

Cold water inlet and stop valve - the cold inlet in water heaters, has to be at the bottom of the tank. It is essential to have a baffle plate, a tee or elbow fitted inside the tank by the manufacturer. This is to avoid direct mixing of cold water with hot water, i.e. to guarantee satisfactory hot water supply.

The branch from the roof tank or from the main cold water supply pipeline should have a stop valve, fitted near the hot water storage tank. This is required for any maintenance work, which can then be done without disturbance to the cold water supply.

Hot water pipeline -in cases where the water supply pressure is low, the hot water pipe should always be installed with a downward flow. Should piping with a U-bend be unavoidable, install at the lowest point of the piping a riser of suitable length with a tap at the top end of the riser, so that air can be let out (or install a vent pipe or a air release valve).

Non-return valve -a non return valve is needed to prevent a back flow of hot water into the cold water pipeline. A good alternative solution for low pressure is a separate line from the roof tank to the water heater, not requiring a check valve, but eliminating the possibility of back flow into the cold water pipeline.

Note: When fitted with an electric booster, a safety valve has to be installed between tank and none return valve.

Pressure reduction - if the head is greater than 30 meters or even less, depending on the manufacturer's instructions) a pressure reducing valve, or a pressure reducing feed tank (with ball valve) has to be used.

Safety valve -a safety valve or vent pipes are required to protect the water heaters and other apparatus from over-pressure. A safety valve has to be installed between the non-return valve and the water heater.

Caution -there must never be any other stop valve between the non-return valve and the water heater, to guarantee the functioning of the safety valve.

For small heaters one safety valve of 1/2" is sufficient up to 7 kWh or 6000 kcal/h. For bigger heaters one 3/4" or two 1/2" safety valves may be used.

The working pressure of the safety valve must be adjusted to approx. 0.5 to 1 kg/cm² (5 to 10 m head) above normal working pressure of the installation.

Example: the working head is 15 m, the safety valve shall be set at 25 meters (15 m + 10 m).

Note: Because of pressure release, a drain from the safety valve is needed. Direct connection to the drainage system is not permissible, such drains must pass through a siphon, and the inlet funnel must have a spacing of at least 2 cm. The safety fixtures must remain easily accessible.

Drainage -for ease of maintenance the system must have the facility for complete drainage. A tee with a valve and/or plug has to be fitted in the cold water pipeline, between the non-return valve and the water heater.

Disconnection -water heaters, like all other fixed appliances to the pipe systems, are to be connected with unions, to ensure easy connection and removal.

1.6 ELECTRIC BOOSTING

In places with electricity available people may wish to have electric boosters incorporated. Such arrangements are a convenient upgrading of such a system, providing heating of water during cloudy days and where a greater amount of hot water is needed.

When deciding on production of hot water storage tanks there are some questions to be answered, such as costs of production (simple or advanced modules, with one or two flanges) and requirements for boosting (on a regular basis, or on a few, exceptional days only).

Solution 1 (regular basis, electricity always "ON"):

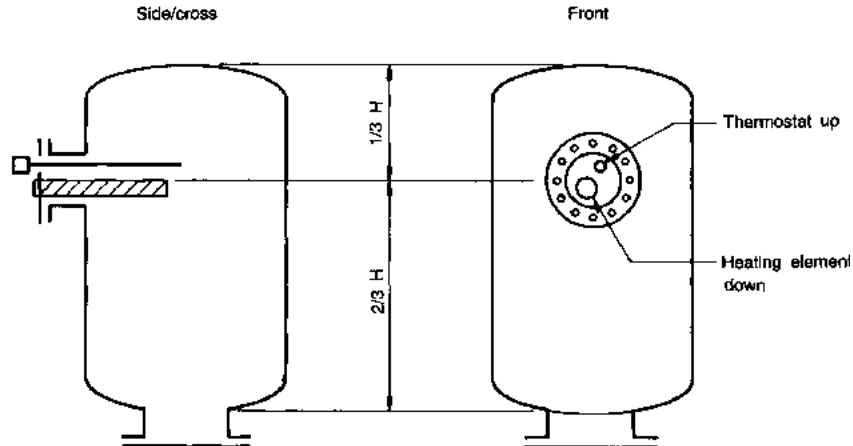

Fix thermostat and heating element in diagonal alignment

This system as shown above, will always provide hot water ($1/3$ of total content), heated either by solar energy or electricity).

Solution 2 (exceptional boosting only -by hand switching)

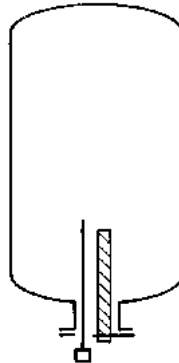
**FIGURE**

The above system may be considered, where additional hot water requirements are on exceptional occasions only. It is less costly, but also provides less comfort.

Where solar water heaters are connected to electricity earthing is essential. The electric heating element must be connected to the installation according to the regulations. The thermostat should be adjusted to switch off at approximately 50 Centigrade. The operation of the thermostat should be checked regularly.

1.7 COMBINATION OF SOLAR-AND WOOD STOVE-HEATER

A very satisfactory arrangement in rural areas is to combine solar collectors and the ordinary, wood-fired cooking stove, so that they supply the same hot water storage, tank, (see illustration). The system automatically adjusts itself, to whichever input is operating at the time. If desired, a electric booster can be installed near the top of the hot water storage tank. This avoids unnecessary lighting of the stove to provide additional hot water during the summer months.

To prevent circulation through the collectors when the stove is operating at night, the pipes from the stove and collectors should be connected to a tee (branch) at the hot water storage tank. Separate connections may be used if more convenient.

1.8 PRINCIPLES OF HOT WATER STORAGE TANK CONNECTIONS

Note: All water heaters installed must have a pressure release possibility with a safety valve or by an air pipe.

Caution: The max. head for water heaters is given by the factory, indicated on the water heaters. (Normally for max 30 m head)

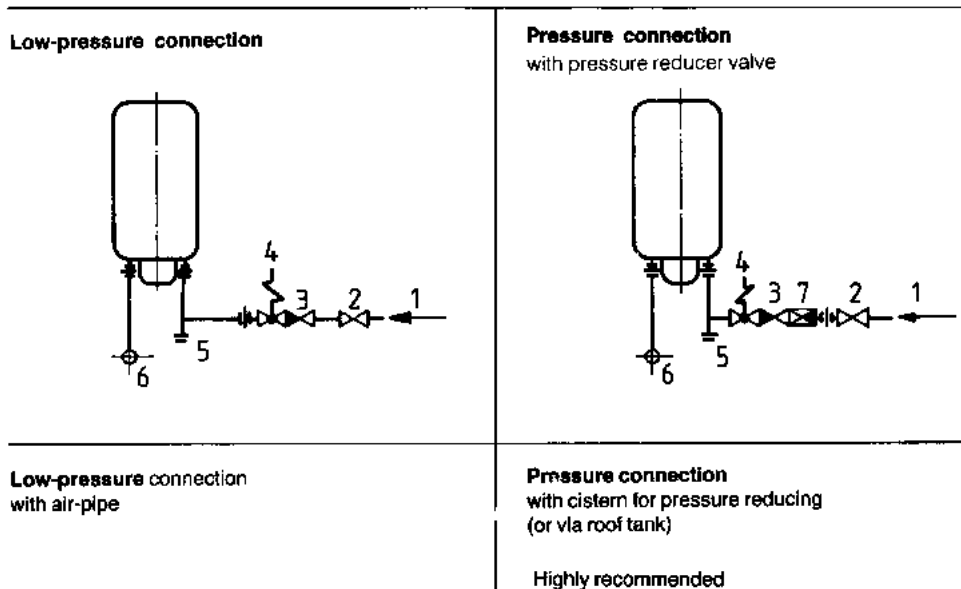

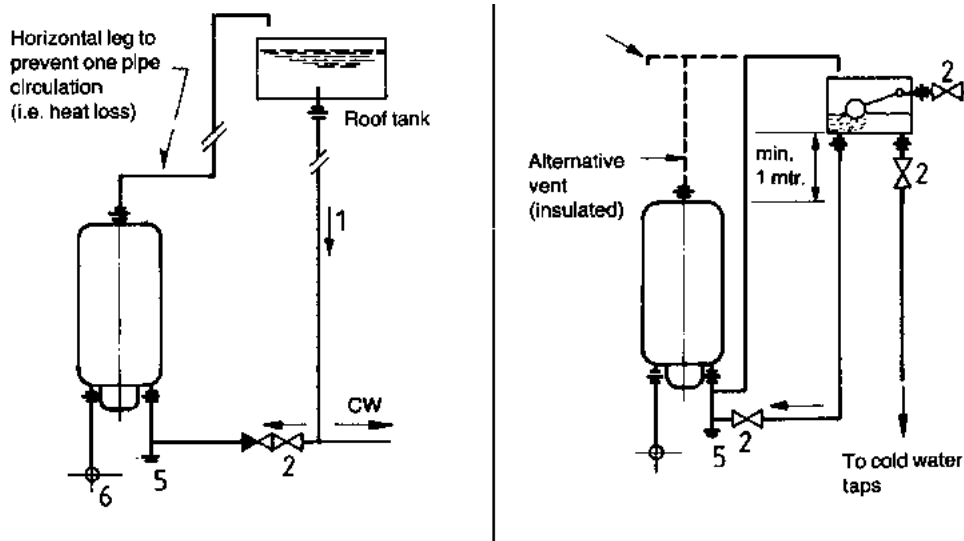

FIGURE

- 1 Feed pipe
- 2 Main valve
- 3 Non return valve
- 4 Safety valve
- 5 Drain
- 6 Hot water tap
- 7 Pressure reducer valve

1.9 HOT WATER DISTRIBUTION SYSTEMS

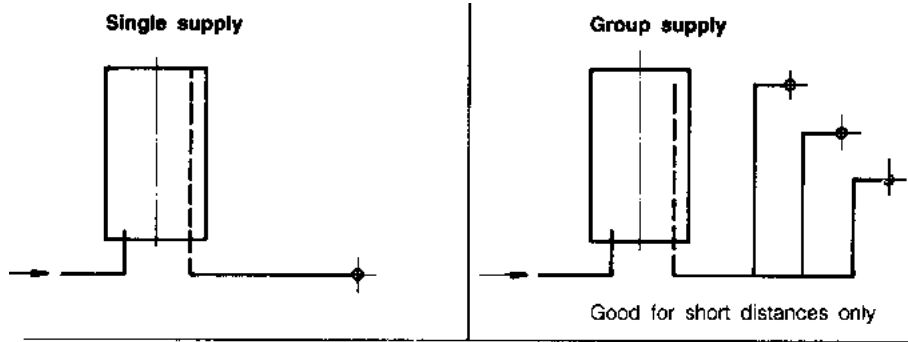

Single tap system (effective system; hot water is fastly available)

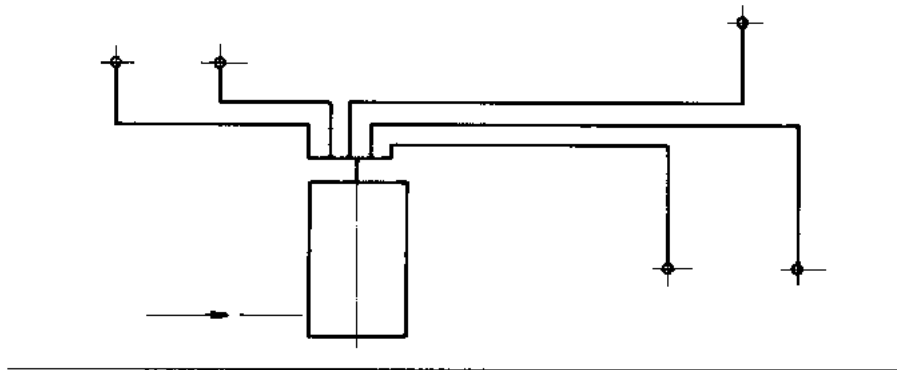

Here insulation is a must

Circulation pipes of
solar water heaters



Central plants



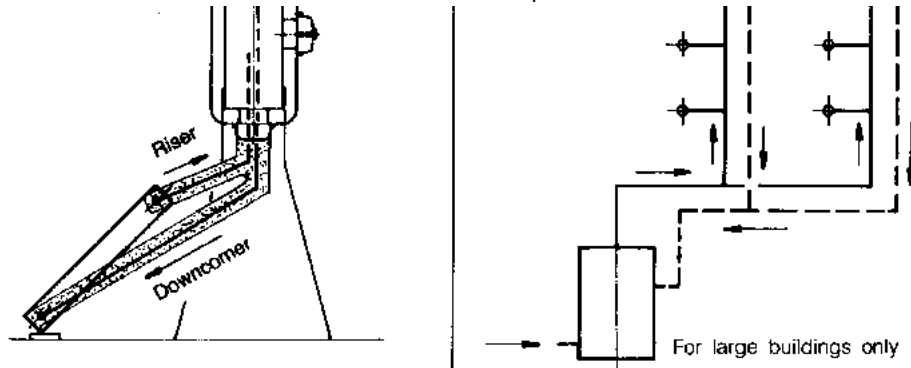

FIGURE

1.10 GUIDING PRINCIPLES FOR HOT WATER REQUIREMENTS

Purpose	Medium consumption day	Maximum consumption day
	Liter / person	Liter / person
	at 60 -65 °C	at 60 -65 °C
Modest domestic	20 -40	30 -60
Comfortable standard	40 -60	60 -90
High standard	60-120	90-180
Children hostel	40 -60	60 -80
Hospital (town)	70 - 100	100 -150
Hostel (luxury)	upto 200	upto 300

Consumption	Quantity	Temperature °C
	in Itrs.	

Bathtub	150 - 200	40
Shower (ca. 5-6 min.)	40 - 60	40
	(20-30)	
Bidet (for 1 filling)	25	40
Washbasin (1 filling)	6 - 8	40
Kitchen (1 filling)	25 - 30	50 -60
Dish washing machine	15 - 25	55

GUIDING PRINCIPLES FOR WATER REQUIREMENTS

Purpose	Unit	Requirement		
		Consumer/Time	Min.	Medium
Domestic Purposes:				
Drinking, cooking, cleaning	Person day	50	80	120
Laundry (washing)	Person day	10	20	40
Bathing, douche	Person day	50	100	180
WC-cistern, flush	Person day	40	50	60
Cleaning of a car	Car	150	250	4000
Domestic Buildings:				
Modest conditions	Inhabitant day	100	150	200
Medium comfort	Inhabitant day	150	200	300
Higher standard	Inhabitant day	250	400	600

Public:				
Schools	Student day	10	12	15
Hospitals	Patient day	300	450	600
Bathing establishment	500-600 bath	500	550	600
Restaurants (for meals)	Guest day	60	100	150
Barracks (army)	Man day	50	100	150
Covered market	m ² day	3	4	5
Slaughter houses	Cattle/big	400	450	5000
Slaughter houses	Livestock, small	300	350	400
Wash institution	Kg (dry wash)	50	60	70
Open yard (grass field)	m ² surface	1	1.5	2
Road sprinklers	m ² surface	1	1.25	1.5
Car workshop	Employee day	30	40	50
Bakery (bread)	Employee day	120	130	140
Hair-dresser	Employee day	160	170	180
Photo-studio	Employee day	280	300	320
Administration-building	Employee day	30	40	50
Industries:				
Brewery				
(without cooling)	100 ltr. beer	600	700	800
(with cooling)	100 ltr. beer	1400	1700	2000

Dairy	100 Itr. milk	400	500	600
Paper factory	kg, fine paper	1500	2200	3000
Farming Purposes:				
Horses	1 pc. day	60	70	80
Cows	1 pc. day	60	65	70
Young cattle	1 pc. day	40	45	50
Pig	1 pc. day	15	20	25
Sheep/goats	1 pc. day	5	6	7

*** According to international standards**

2. INSTALLATION OF A SOLAR WATER HEATER SYSTEM

For the best performance of a solar water heater system the basic rules of installation should be strictly followed. The heaters should be installed only when the rules have been properly understood and solutions determined only after studying the instructions.

The proper situation of collectors is determined by the hours of sunshine available. Care must be taken that shading of them does not occur at any time of the day during any seasons of the year.

Having decided on the dimensions of the system, it is necessary to plan the layout of the installation. The cold water supply tank (roof tank) has always to be higher than the SWH system. If the thermo-siphon system is chosen, it is necessary to mount the collectors below the hot water storage tank (because of the functioning of natural circulation). It is recommended to keep sufficient spacing between the riser (upper head, of collector) and the bottom of the hot water storage, tank (min. 150 mm spacing).

It is recommended to keep easy access to collectors and the solar system. For example to keep a space between groups of collectors for maintenance and repairs.

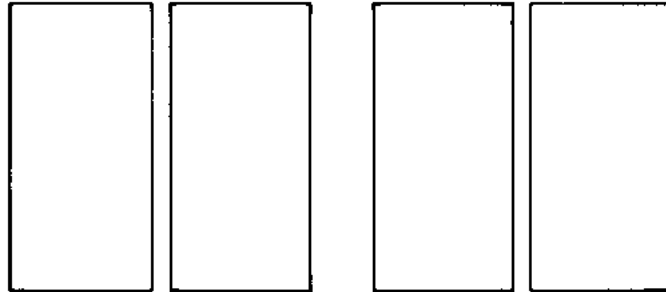

Keep space between groups of collectors for maintenance and repair

2.1 PLAZING AND PREPARATION

After the collectors have been unpacked, the blackened collector plate has to be cleaned as follows:

- Clean off dust and dirt with a dry rag.**
- Remove all traces of oil or dirt with clean, dry rag.**
- Clean the glass of dust and dirt.**

If a glass cracks or breaks it must be replaced immediately. The collector front has to be covered until the broken glass is replaced. Water or humidity will damage the insulation. Before new glass is fitted, clean the plate with a dry rag. Glass can easily be replaced on collectors already installed, provided the site is easily accessible.

2.2 INSTALLATION ON THE ROOF

Arrangement of collectors as an awning over windows or placed directly on roofs can be suitable.

Note: Keep in mind that for thermo-siphon systems the hot water storage tank has to be mounted above the collectors, e.g. in the roof space or on the roof itself.

The roof of any ordinary house will be able to support the weight of a domestic SWH without problem.

On houses with sloping roofs, it is suggested that a roof window is fitted above the collectors for easy access for cleaning and repairs.

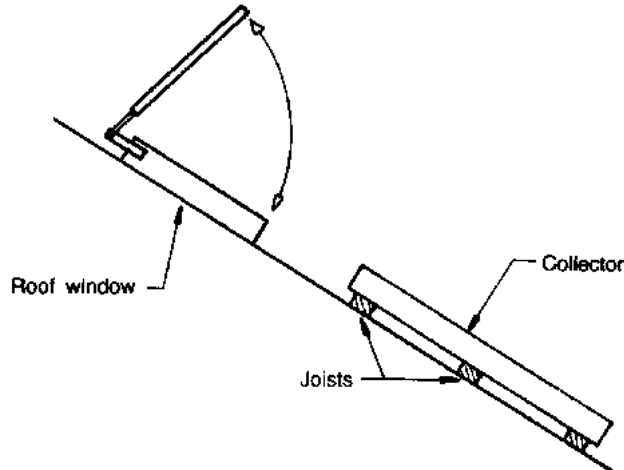

FIGURE

2.3 INSTALLATION ON THE GROUND

If the solar system is to be placed near floor level, then the collectors must be mounted on

the ground. It is recommended that collectors are placed far enough from the house wall to prevent rain water dropping from the roof onto the glass. In case of mounted rain gutters, a suitable distance should be kept so that bird droppings are not deposited on the glass. It should be realized that ground mounted collectors are subject to easy breakage from stones, and may possibly be shaded during part of the day.

2.4 HAIL SCREENS / VANDALISM

In parts of Nepal very severe hailstorms sometimes occur. Sometimes glass covers are also subject to vandalism. In such places protection could be provided in the form of galvanized wire netting (say approximately 1 mm thick, 13 mm + holes). The net to be fitted on a light frame, about 80 mm above the collector surface. Owing to the reduction in solar transmission of from 12 to 15 percent, which is caused by the net, a corresponding increase in collector area may be necessary.

2.5 ANGLE AND DIRECTION OF COLLECTORS

Direction - the solar collectors have to be exposed with the glass front directly facing south in the northern hemisphere (and due north in the southern hemisphere). Deviation from this direction may be up to 15 to 20 degrees to either side. It is preferable to have the deviation, if any, slightly towards the west, as the sun shines brighter in the afternoon than in the early morning (fog).

Angle -the angle of inclination of the collector to the horizontal should be 5 to 10 degrees more than the latitude of the location, with a minimum of 17°.

Example: The latitude of Kathmandu is 27°. $27^\circ + 10^\circ = 37^\circ$, so 37° is the recommended angle of installation (measured from the horizontal).

Note: The drawings provided correspond nearly to this geographical latitude of

Kathmandu. Where solar water heaters are fitted, at, a different latitude, necessary adjustments of angle and measurements have to be made.

It is understood that compromises may be required for both angle and direction. Slight changes may not have much negative effect. If required, one or more additional collector(s) may be fitted, in order to provide the heating requirements. The following tables show the influences on changes.

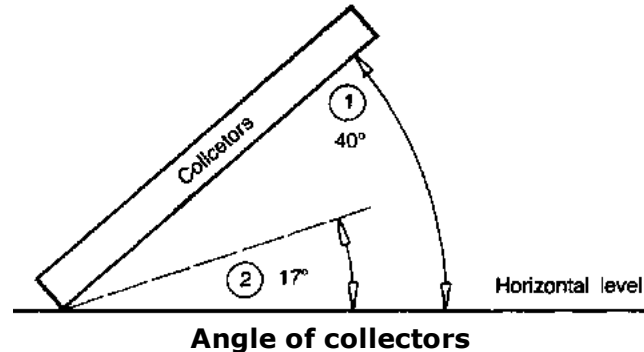

Note:

- 1) Angle of flat tank collectors should not be above 40°
- 2) Angle of thermosiphon systems should not be below 17°

Correcting Factors (Angle)

	Horizontal					Vertical				
Angle of collectors	0.°	10°	20°	30°	40°	50°	60°	70°	80°	90°
Correctina factors	0.77	0.85	0.92	0.97	1	1	0.98	0.93	0.85	0.75

(Source of tables: "Solaranlagen", by H.R. Schmidli, Switzerland)

Example: At a site, collectors are to be fitted at an angle of 40° , however, the angle of the roof is only 20° . Will the system work with the same numbers of collectors? When checking on the above table it shows, at 20° the factor 0.92, i.e. a reduction of 0.08, or of 8 percent. This system will work very well, despite of a slight change of angle.

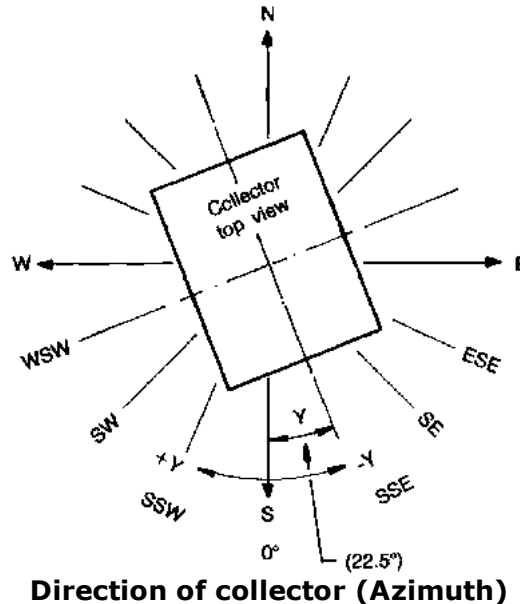

**Correcting Factors (Direction)
Collectors set at proper angle.**

	W	WSW	SW	SSW	S	SSE	SE	ESE	E
Deviation from south direction	90°	67.5	45°	22.5	0°	22.5	45°	67.5	90°
Correcting factor	0.75	0.85	0.95	1	1	1	0.9	0.88	0.7

(Source of tables: "Solaranlagen", by H.R. Schmidli, Switzerland)

Example 1: The direction measured at a site is 45° towards the east, but angle is maintained at required 40°. Reading in above table -SW, 45° shows correcting factor of 0.95. This is a negligible change and the system will work satisfactorily.

Example 2: At a site three collectors are to be fitted at an angle of 20°, and at a direction west-south-west (67.5°). Reading at charts, correcting factors, shows:

angle	0.92	=0.08
direction	0.85	=0.15
	reduced efficiency	=0.23

At the same site the system required a hail screen, which further reduces the solar energy input.

reduced efficiency (as above)	23%
hail screen reduction	15%
total reduction	38%

In this case one more collector will be required to meet the heating requirement, since the reduction exceeds acceptable limits.

2.6 INSTALLATION IN FREEZING CLIMATE

Solar water heaters fitted in sub-zero temperature climates have, to be fitted with an "indirect system", having a heat exchanger fitted in the hot water storage tank. Collectors exposed to cold climate require an anti-freeze mixture of water and glycol.

Solar collector systems require a liquid for heat transfer equal to the volume of water. This liquid would ideally be non-toxic and non-corrosive, would not freeze or boil and still be a good heat transfer medium. As there is no product to meet these requirements to the maximal extent, a compromise through a combination of the various requirements has to be made. Glycol/water mixtures, with corrosion reducing additions are commercially available. Specific data are available from the manufacturers.

Note: Ordinary rubber and plastics are not resistant against corrosion caused by such mixtures (pipes, washers, etc.).

Water piping in houses -to secure regular water supply and avoid damage, pipelines fitted in places with sub-zero temperatures require special attention. Security can be partly achieved by proper installation. However, when systems inside the buildings are left without room heating they need to be drained.

The following requirements should be noted

-Supply line from mains to be underground (1 meter deep) with pipelines placed inside the building.

-Main valve to be inside the house, having a drain valve at the lowest point. The drain valve has to be operated before freezing conditions occur, and to be left open until the system is refilled.

-All pipes to be fitted, with constant slope towards tanks at the lowest point. It is unwise to have any U-bend fitted, since, drainage is then not possible. Proper ventilation is also required to guarantee a thorough drainage (top-most valve or ventilation pipe).

-Pipelines not be concealed in outer walls (to reduce cooling effect).

-Consider whether pipelines could be fitted on walls or in ducts (keeping distance from walls by means of clamps) with insulation added where required.

-Pipelines not to pass through shafts, chimneys, etc., and to remain accessible as much as possible.

-Hot water tanks to be fitted inside the house, with easy draining facility.

-Pipelines and valves exposed to outside temperatures (pump line, pipeline in roof, vent pipe) probably require good pipe insulation.

-The use of G. 1. pipes in the house is recommended since they can be thawed by flame heat. (HDPE pipes have the advantage as they will not crack in normal circumstances, but if they freeze they cannot be thawed by flame heat).

-Water storage tanks and pipelines may require lagging to prevent freezing of the water, especially when fitted in cold roofs. The insulation has to be of inorganic and anti-corrosive materials.

2.7 VENTILATION

Air locks are the main cause of non-functioning solar water heater installations. Pipes should

be fitted with a slight gradient towards the vent pipe as this enables air to escape. There should be no U-bend in the system.

The installation of hot water systems requires attention also to the expansion of heated water as well as air escape.

In installations with roof tanks (low pressure) this can be achieved by having a vent pipe.

Note: That such pipes should preferably have a "horizontal leg" of min. 500 mm. This to avoid a "one pipe circulation". A vent pipe releases air from the system, and breaks a possible vacuum caused in pipelines when water is drawn from a tap. A vent pipe requires careful lagging to provide good insulation against heat losses.

Air release valve -these are small valves which release air bubbles in a system. They replace vent pipes, but make a safety release of heated, expanded water necessary (i.e. fitting of safety valves).

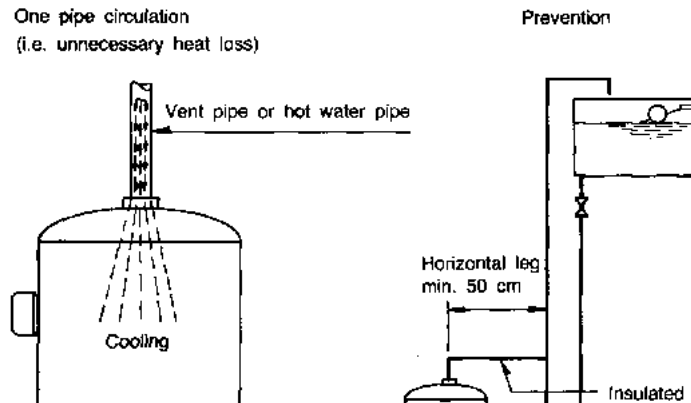

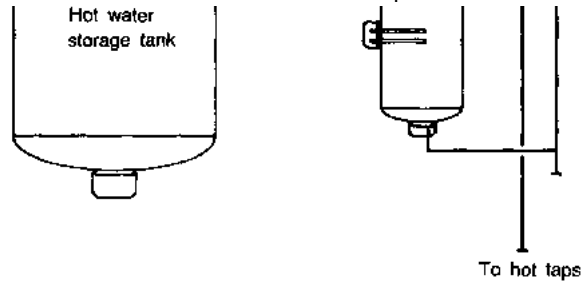

Automatic Air-Release Valve

Closed

Open

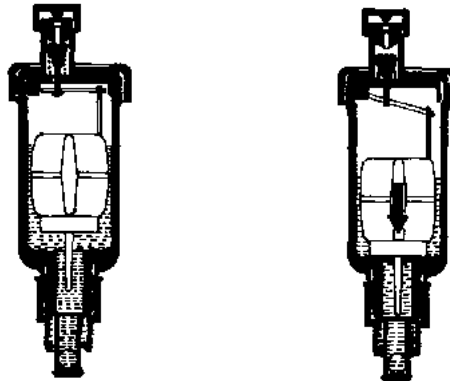

FIGURE

Air release valves on thermo-siphon circulation systems can be fixed directly on to the hot water storage tanks.

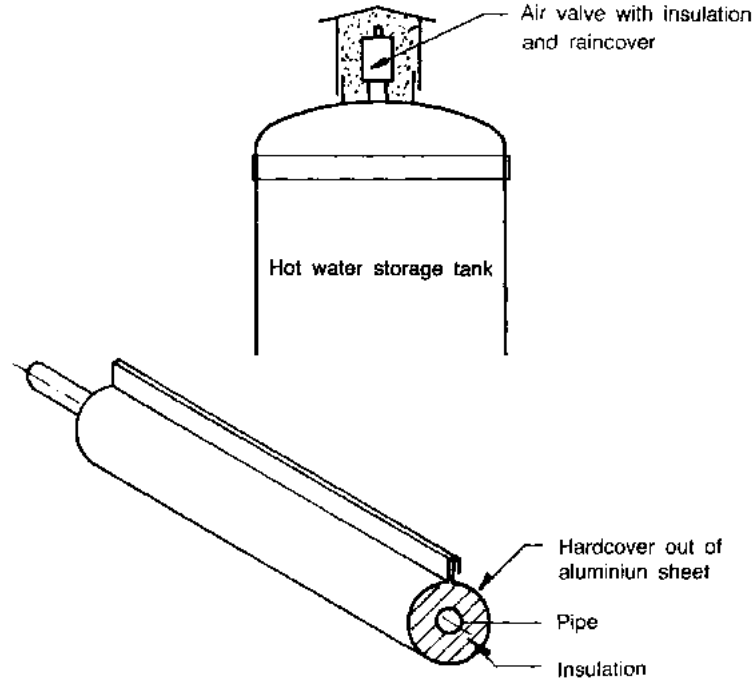

FIGURE

2.8 INSULATION

The transformation of one form of energy to another always entails losses. With hot water systems this is experienced as a heat loss between the source of energy (e.g. the sun) and the storage tank, and again between the tank and the taps.

In proper installations these losses are minimized by having short pipelines, adequate

insulation, etc. Therefore the storage tank and the distribution pipelines have to be well insulated. It is recommended that pipelines are placed, as far as possible, within the building and not on the outside. Depending on the quality of the insulation, heat loss through distribution pipelines may be from 10 to 15 percent (or more)!.

The money invested in captured solar energy should be carefully handled by providing adequate insulation. Even more important than a little more or less lagging applied to pipes is the comprehensiveness of insulation:

- No heat bridges (heat transfers at clamps)**
- Pipes passing through walls, ceilings, etc., are also to be properly insulated**
- All parts are to be insulated, such as unions, valves, etc.**

The insulation has to be water tight and ultra violet resistant!

Note: A wet insulation has reduced efficiency and may even accelerate heat losses.

Weatherproof protection of insulation material can be made with sheet metal pipes of sufficient diameter.

Example of pipe insulation with aluminium cover

A main difficulty exists in making bends, and probably a square pipe is easier to arrange for change in direction.

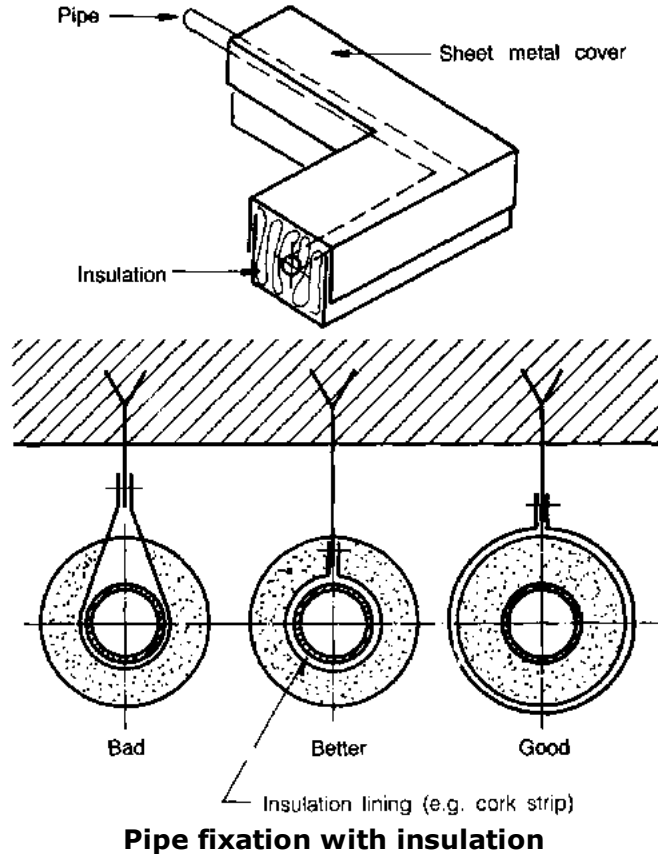

Pipe fixation with insulation

3. PASSIVE SYSTEMS

Two types are available:

3.1 THERMOSIPHON

Thermo-siphon Circulation System

The complete SWH thermo-siphon circulation system may be divided into three separate sections:

- The flat plate collector (absorber).**
- The circulation piping.**
- The hot water storage tank (boiler).**

Such installations involve more labour and require more materials, however, they provide more comfort, as the water remains hot throughout the night. The circulation pipes from and to the hot water storage tank and collectors have to be insulated and, where exposed to weather, protected with weatherproof covering, (e.g. aluminium or galv. sheets).

Flat Tank Collector (Solar absorber) -is a simple flat plate heat exchanger, which absorbs radiant energy from the sun and transfers the energy to the water within it.

The Circulating Piping

In this section the natural circulation (thermo-siphon) is mentioned. Natural circulation is suitable for domestic application, because of its simplicity and reduced requirements for maintenance.

It has the advantage that it functions only when the solar energy input is sufficient to heat the water in the collector to a temperature above that of the water in the bottom of the hot water storage tank.

This thermo-siphon circulation occurs because of the variation of water density with its temperature. With the heating of the water in the collector, the warm water rises, and since it is connected in a riser pipe to the hot water storage tank and a down-comer pipe again to the collector, it is replaced by the cooler, heavier cold water from the bottom of the hot water storage tank. It is therefore necessary to place the collectors below the hot water storage tank and to insulate both connecting circulation pipes.

Filling and Bleeding of a Solar Heater Unit

After all connections between the collector and the hot water storage tank are correctly made, the tank itself has to be connected to the main cold water supply, and the hot water circuit connected to the house.

When this has been done, one or more hot water taps should be opened, and then the main stop valve to the hot water storage tank completely opened. The hot water storage tank will slowly fill with water and air will be driven out of the piped system.

Bleeding of Collectors

To bleed the upper head of the collector proceed as follows:

- Close main cold inlet valve to the hot water storage tank.**
- Open upper 1" cap on collector.**
- Open main valve and flush.**
- Open hot water tap completely.**
- Close main valve till water is flowing slowly.**

-Close 1" cap while water is flowing through the hot water storage tank. This prevents the forming of an air pocket in the collector.

-Open main valve completely, tighten 1" cap.

-Close hot water tap and check under pressure for leaks.

Checking of Operation

After thirty minutes on a sunny day, the riser (circulation pipe from collector to hot water storage tank) should be hot. This shows that the collectors are working. The riser should not be hotter than 50 (or maximum 65 Centigrade). If the riser stays warm but does not get hot, this is a sign that the flow of the thermo-siphon is too fast. In this case a regulator-tee (circulation flow regulator) or valve in the circulation pipe may be required to slow the flow down.

If the riser is too hot, the flow is too slow Check for obstructions in all pipes of the collector circuit.

If the riser and down-comer are hot, this might be for two reasons: Either the hot water storage tank is completely filled with hot water and the circulation has almost stopped -as might be the case after several hours of sunshine, or the flow in the collectors has completely stopped because of an obstruction in the pipes. The flow in the collectors' circuit is very sensitive, even a small air bubble is sufficient to stop it!

Each m² of collector area, should heat approximately 8 liters of cold water (starting with cold water of approximately 15 to 20 Centigrade) to a temperature of 50 to 65 Centigrade during one hour's full sunshine.

The temperature depends on many factors: Time of the day, season, wind, ambient

temperature, temperature of cold water, angle and direction of the collector, etc. Generally speaking, the pipes in the collector circuit should be of the maximum recommended diameter. They can easily be throttled, if necessary as follows:

-Close the regulator tee or valve slightly

If there is no such possibility of regulation:

-Close the main inlet valve, open union in hot pipe (circulation pipe between collector and storage tank) insert into union recess a washer (preferably of brass) with a hole of smaller diameter than that of the inside pipe diameter.

The washer will work as a speed flow regulator and reduce the velocity of flow in the collector/hot water storage tank circuit. The correct diameter of the hole must be found by trial and error; but it should not be smaller than 0,8 mm (Smaller holes or smaller pipes will become clogged by lime deposits). After this is done, the main stop valve can be opened, the union tightened and checks be made for possible leaks.

Regulating Device in Circulation Pipes

Regulating devices are often fitted to thermo-siphon circulation systems. These reduce the speed of flow through the system, water remain longer in the collector and is therefore heated to a higher temperature. The disadvantages of this system are reduced efficiency of the collector due to high collector temperature (heat loss to surrounding colder air).

To achieve such regulation a gate valve can be fitted, however, experience shows that someone will open the valve at some time and the regulation is then gone. A metal washer, preferably made of brass, inserted in a union might be a better solution.

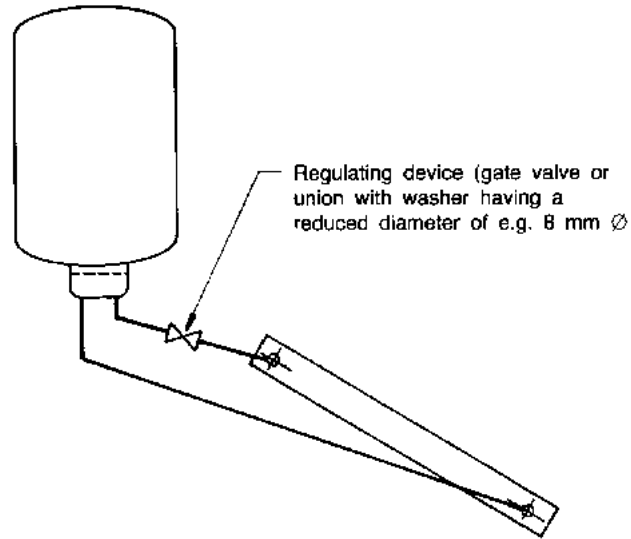

FIGURE

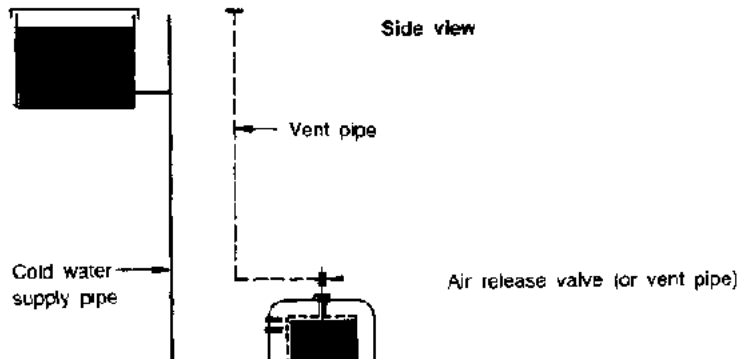

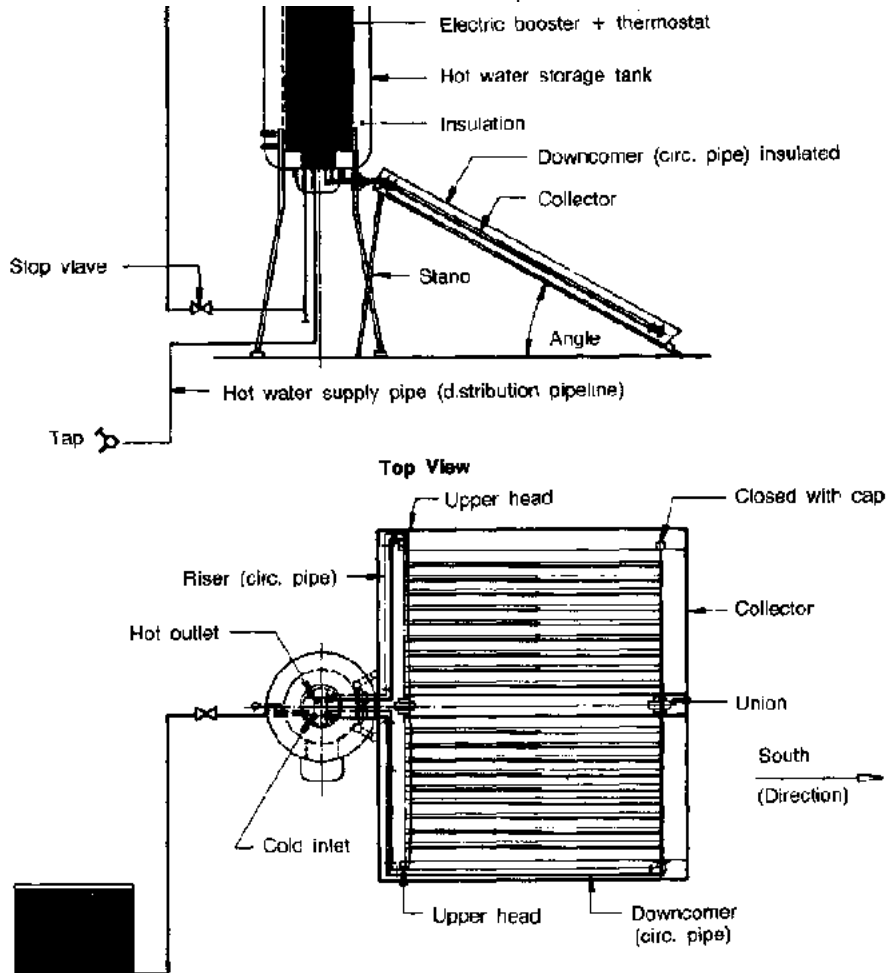

20/10/2011

Solar Water Heaters in Nepal (SKAT, 19...

SOLAR WATER HEATER / THERMOSIPHON SYSTEM

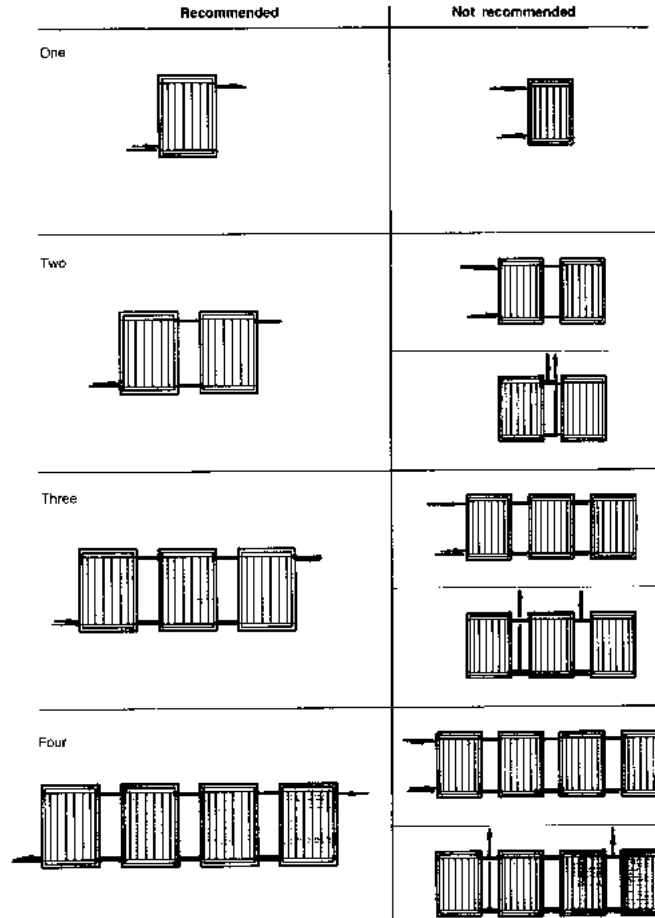

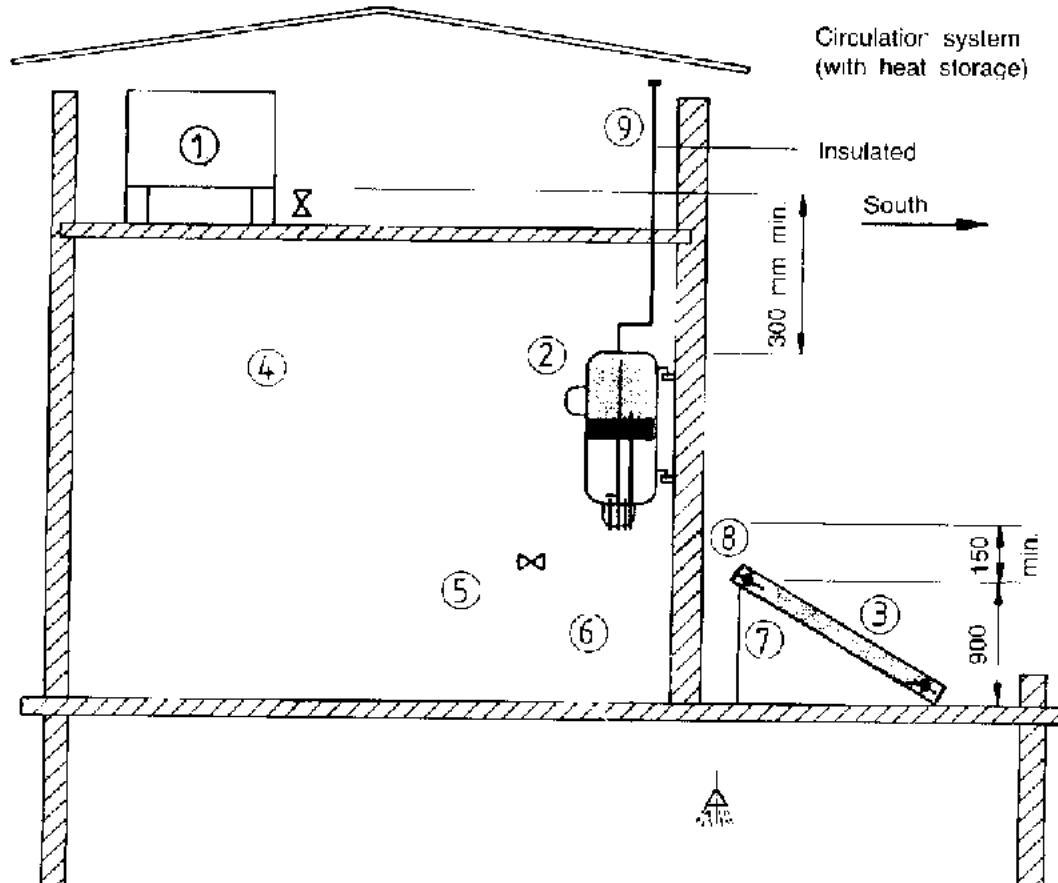
CONNECTION OF COLLECTORS / THERMOSIPHON SYSTEM

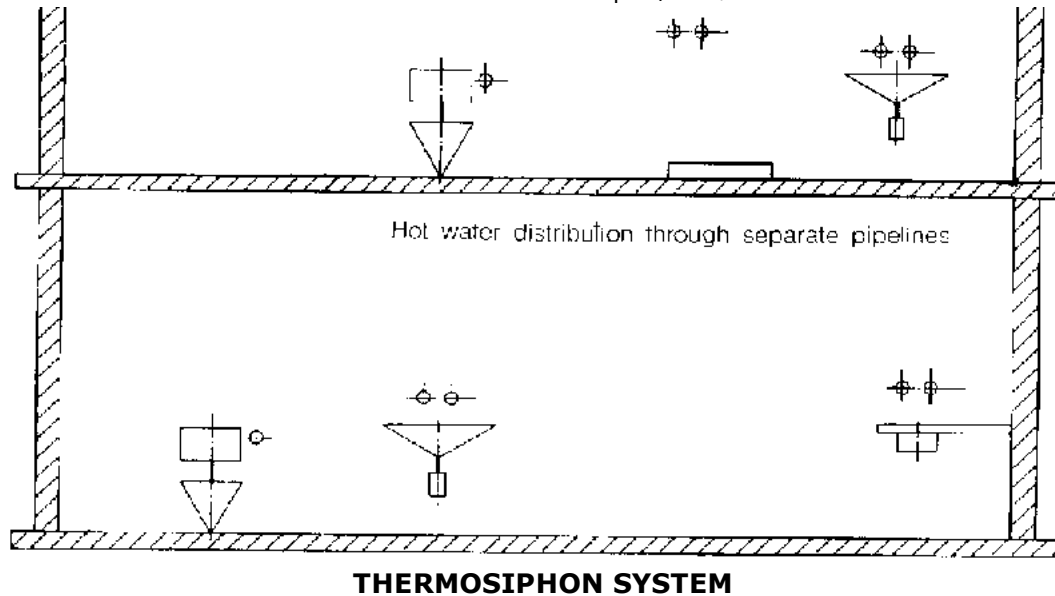

Installation example No. 1

-Roof tank with separate cold water pipeline to the SWH -system this does not require any special valve.

- 1 Coldwater storage tank**
- 2 Hotwater storage tank**
- 3 Collector**
- 4 Coldwater pipeline**
- 5 Coldwater to hot tank**

- 6 Hotwater to the taps**
- 7 Circulation pipe to collector**
- 8 Circulation pipe to hot tank**
- 9 Vent pipe**

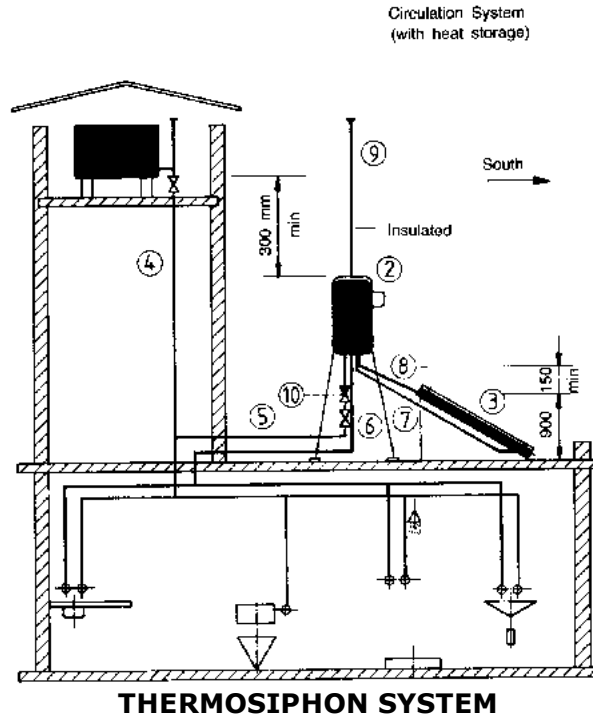

Installation example No. 2

- Roof tank with branch in main, cold water pipeline to the SWH-system**
- Requires one non return valve**

- 1 Coldwater storage tank**
- 2 Hotwater storage tank**
- 3 Collector**
- 4 Coldwater pipeline**
- 5 Coldwater to hot tank**
- 6 Hotwater to the taps**
- 7 Circulation pipe to collector**
- 8 Circulation pipe to hot tank**
- 9 Vent pipe insulated**
- 10 Check valve (non return valve)**

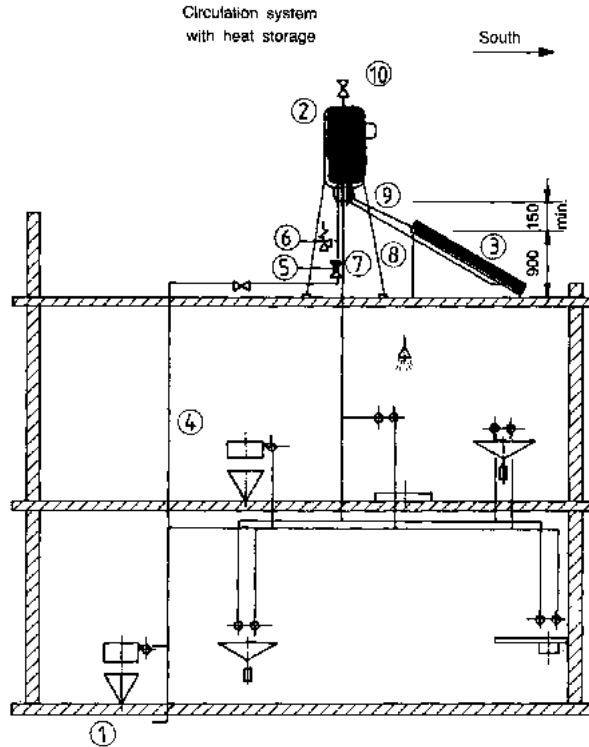

THERMOSIPHON SYSTEM

Installation example No. 3

- Town supply (24 hours/day) with low-pressure conditions
- Requires one none return and safety valve

- 1 Coldwater townsupply**
- 2 Hotwater storage tank**
- 3 Collector**
- 4 Coldwater to hot tank**
- 5 Check valve (non return valve)**
- 6 Safety valve**
- 7 Hotwater to the taps**
- 8 Circulation pipe to collector**
- 9 Circulation pipe to hot tank**
- 10 Air valve**

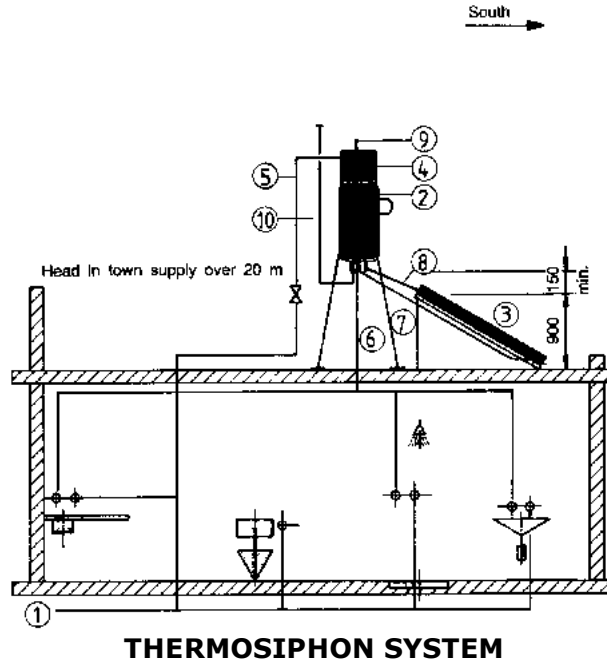

Installation example No. 4

- Town supply (24 hours day) with pressure over 2 kg/cm² (20 m.head)
- Requires one feed tank with ball valve

- 1 Coldwater townsupply
- 2 Hotwater storage tank
- 3 Collector

- 4 Feed cistern (pressure reduced)**
- 5 Coldwater supply to boiler head more than 20 m.**
- 6 Hotwater to the taps**
- 7 Circulation pipe to collector**
- 8 Circulation pipe to boiler**
- 9 Vent pipe**
- 10 Coldwater to boiler (of reduced pressure)**

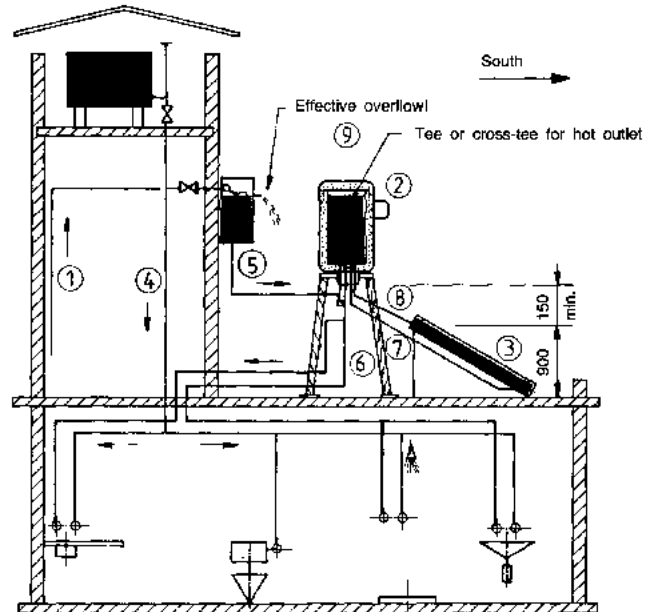
**THERMOSIPHON SYSTEM**

Installation example No. 5

- Open hotwater storage tank (cover not welded)**
- Adaption of existing container**
- Requires one feed tank with ball valve**

- 1 Coldwater supply from roof tank or town**
- 2 Hotwater storage tank open container (oil drum)**
- 3 Collector**
- 4 Coldwater line**
- 5 Coldwater to the boiler**
- 6 Hotwater to the taps**
- 7 Circulation pipe to collector**
- 8 Circulation pipe to boiler**
- 9 Vent-pipe**
- 10 Feed-cistern, with ball-valve**

Note: Levels from boiler and feed-cistern (top most) have to be the same.

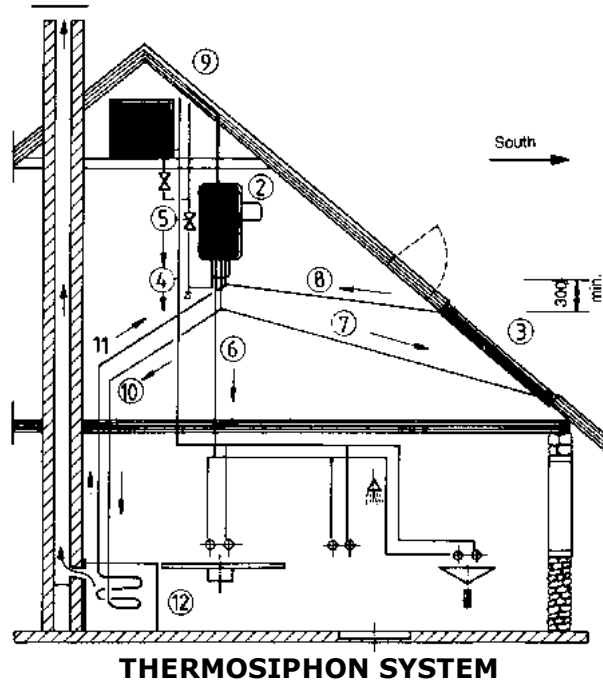

Installation example No. 6

-Combination of solar and stove heater

- 1 Coldwater storage tank**
- 2 Hotwater storage tank**
- 3 Collector**
- 4 Coldwater line**

- 5 Coldwater to the boiler**
- 6 Hotwater to the taps**
- 7 Circulation pipe to collector**
- 8 Circulation pipe to boiler**
- 9 Vent-pipe**
- 10 Circulation pipe to the combustion cooker**
- 11 Circulation pipe to boiler**
- 12 Slow combustion heater**

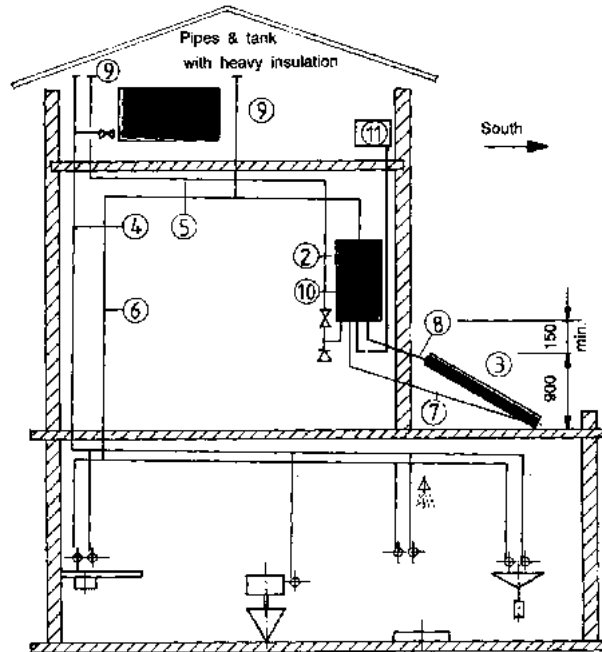

THERMOSIPHON SYSTEM / ANTI-FREEZE

Installation example No. 7

- System with anti-freeze mixture**
- Special hotwater tank with heat exchanger**

- 1 Coldwater storage tank**
- 2 Hotwater storage tank**
- 3 Collector**
- 4 Coldwater pipeline**
- 5 Coldwater to hot tank**
- 6 Hotwater to the taps**
- 7 Circulation pipe to collector**
- 8 Circulation pipe to hot tank**
- 9 Vent pipes, insulated**
- 10 Heat exchanger**
- 11 Cistern, for top-up and expansion, containing anti-freeze and anti-corrosion fluid**

3.2 FLAT TANK COLLECTOR SYSTEMS

The flat tank collector (FTC) is a high performance solar water heater, which produces hot water efficiently with solar energy. It combines the principle of a heating box using the greenhouse effect with a heat absorbing flat tank collector and it is a single unit for installation at the site.

The flat tank collector system is a one-piece unit. It gives cheaper water during most hours of the day. The installation is quite simple: the pipes have not to be insulated, there are no circulation pipes and no separate hot water storage tank. Possible types of installation are shown in the tables.

The FTC gives hot water for warm bathing, washing and for the kitchen or anything else that requires hot water. It should be noted however, that when using a FTC for bathing, or for a hot water supply round the clock, it has to be connected to a electric hot water storage tank or to another suitable means of heating to provide additional warmth.

One can expect hot water from an FTC from around 11 O'clock in the morning till 7 O'clock in the evening (in summer till 10 O'clock). That depends mainly on the hours of sunshine and the outside temperature after sunset.

This one-piece unit serves very well where hot water is not required in the early morning. This cheaper, yet efficient solar water heater provides enough water for a small family.

Solar preheater -the solar preheater can be connected to an existing hot water storage tank to which it is impractical or inconvenient to attach collectors directly. This may occur when the existing system is fixed in such a way that it is difficult to install collectors below it. The existing system can be converted in the manner shown in the examples in the tables.

EXAMPLE OF FLAT TANK COLLECTORS

Max. permitted head = 10 m

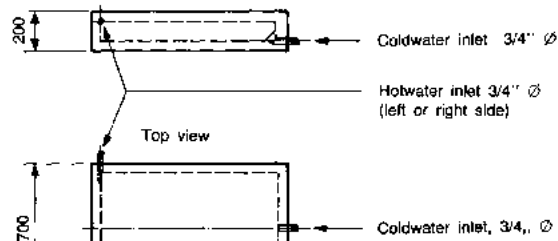

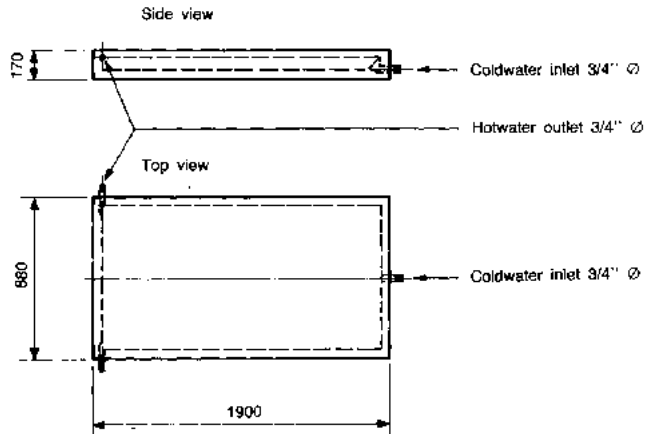
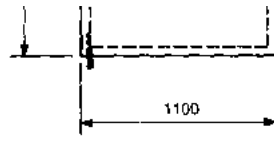

Flat tank collector (60 Itr. ;90 Itr.)

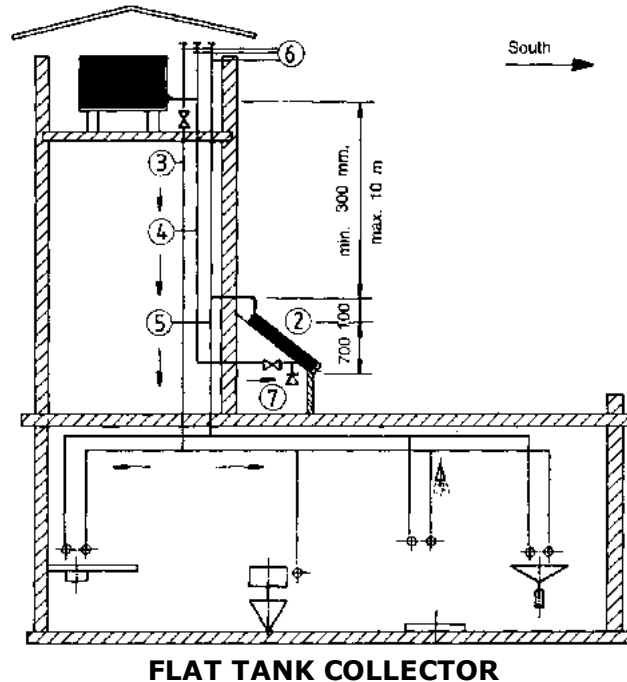

Installation example No. 8

-Roof tank with separate cold water pipeline to the flat tank collector. This does not require special valves.

1 Coldwater storage tank

2 Collector

3 Coldwater line

- 4 Coldwater to flat tank collector**
- 5 Hotwater to the taps**
- 6 Vent pipes**
- 7 Drain plug**

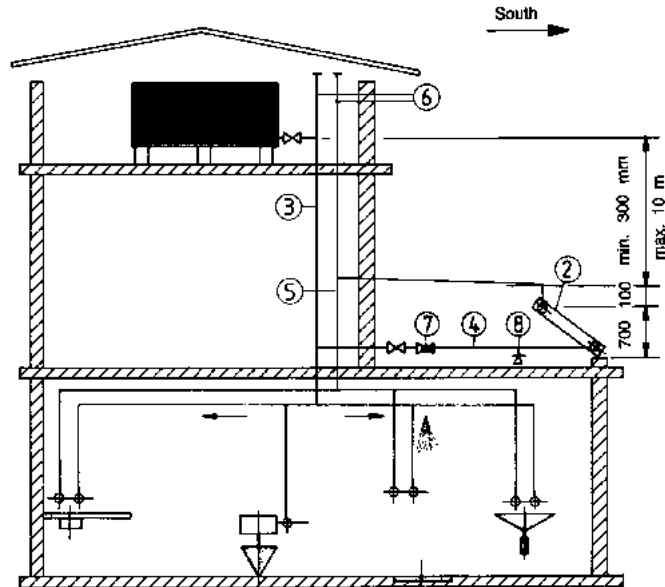

FLAT TANK COLLECTOR

Installation example No. 9

- Roof tank with branch in the main cold water pipeline to the flat tank collector
- Requires one non-return valve

20/10/2011

Solar Water Heaters in Nepal (SKAT, 19...

- 1 Coldwater storage tank**
- 2 Flat tank collector**
- 3 Coldwater line**
- 4 Coldwater to flat tank**
- 5 Hotwater to the taps**
- 6 Vent pipes**
- 7 Check (non return valve)**
- 8 Drain plug**

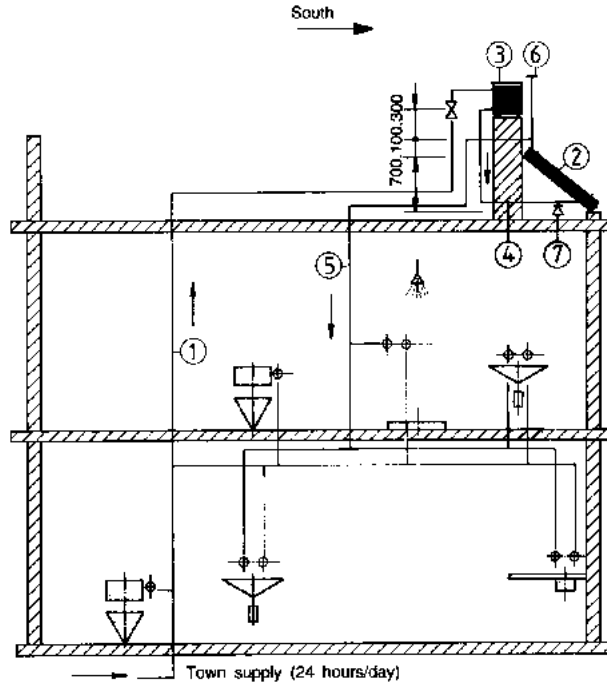

FLAT TANK COLLECTOR

Installation example No. 10

- Town supply (24 hours/day) with high or low pressure
- Requires one feed tank with ball valve

1 Coldwater town supply

- 2 Flat tank collector**
- 3 Feed cistern (with ball valves)**
- 4 Coldwater to flat tank collector**
- 5 Hotwater to taps**
- 6 Vent pipe**
- 7 Drain plug**

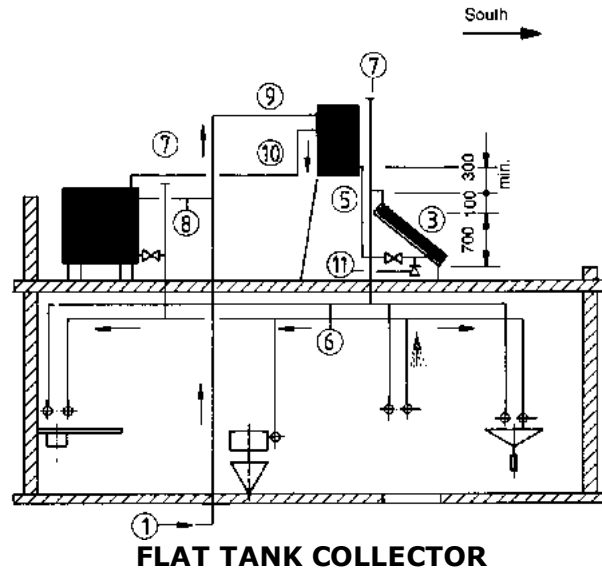

Installation example No. 11

-Fixing of flat tank collector without raising of existing roof tank

- 1 Coldwater supply**
- 2 Coldwater storage tank (existing)**
- 3 Flat tank collector**
- 4 Cold water storage tank (Additional, capacity CA. 80 Itr)**
- 5 Coldwater to flat tank collector**
- 6 Hotwater to the taps**
- 7 Vent pipes**
- 8 Tank filling line (disconnected)**
- 9 Extended tank filling line**
- 10 Overflow too main coldwater tank**
- 11 Drain plug**

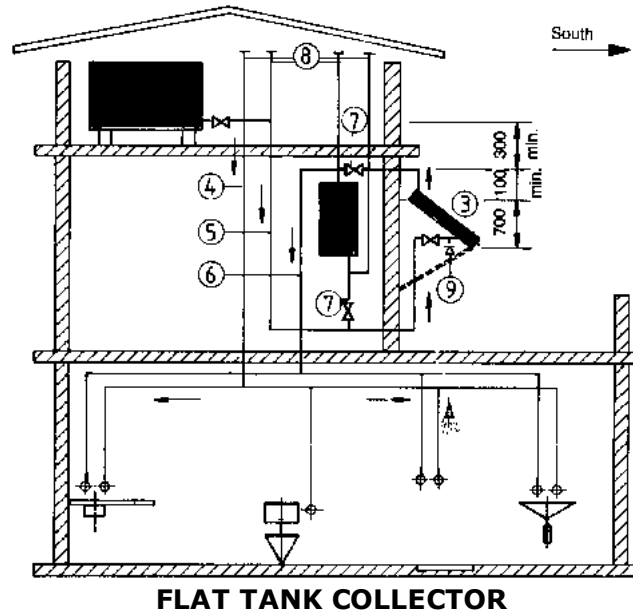

Installation example No. 12

-Preheater before electric water heater. This increases the hot water capacity, reduces the electricity consumption.

- 1 Cold water storage tank**
- 2 Electro or gas boiler**
- 3 Flat tank collector**
- 4 Cold water line**
- 5 Cold water line to flat tank collector (and electro or gas boiler)**

6 Hotwater to the taps

7 By-passes (for electro boiler use only)

8 Vent pipes

9 Drain plug

4. PUMPED CIRCULATION SYSTEMS

Wherever possible, thermo-siphon (natural) circulation is recommended. Good reasons for this are lower costs and reliable operation. This is especially valid for smaller sizes and where site situations are favorable.

The information provided herewith is made to outline basic principles. However, when making such systems a thorough design planning and reading of other relevant tables (friction loss) is required, and a list of suppliers should be consulted (valves, pumps, anti-freeze mixtures, etc.). Pumped circulation systems might be required:

- When collectors are above hot water storage tank (incl. swimming pools)**
- For larger plants**
- For heat exchanger (in freezing areas)**

Such systems require more attention in many respects, since they are more demanding in design planning and material utilization.

Several important factors are to be considered:

- Collector arrangements**
- Aeration system**
- Pump / Bypass**
- Temperature control**
- Valves, drainage**

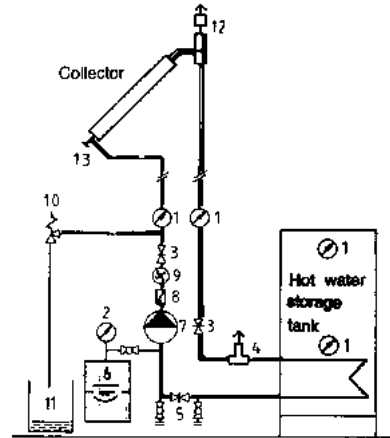
**FIGURE**

EXAMPLE: Scheme of functioning of a pumped system for domestic solar water heating

- 1 Thermometer**
- 2 Pressure gauge**
- 3 Stop valve**
- 4 Air valve**
- 5 Filling and drainage**
- 6 Expansion vessel**
- 7 Circulation pump**
- 8 Non return valve**
- 9 Flow control**
- 10 Safety valve**
- 11 Safety vessel**
- 12 Air vessel and aeration**

13 Drain plug

4.1 CIRCUITS

Direct Circuits

Principle of direct connection (or by means of a heat exchanger)

Advantages:

- Simple, economical**

Disadvantages:

- At "switch-On" of pump, cold water, is flowing into the hot water storage tank (or through the heat exchanger).**
- Reduced heat efficiency of collectors**
- Risk of blocking-up through calcifying**

Applications:

- For domestic, smaller hot water requirements.**

Simple anti-freeze system with circulation pipe

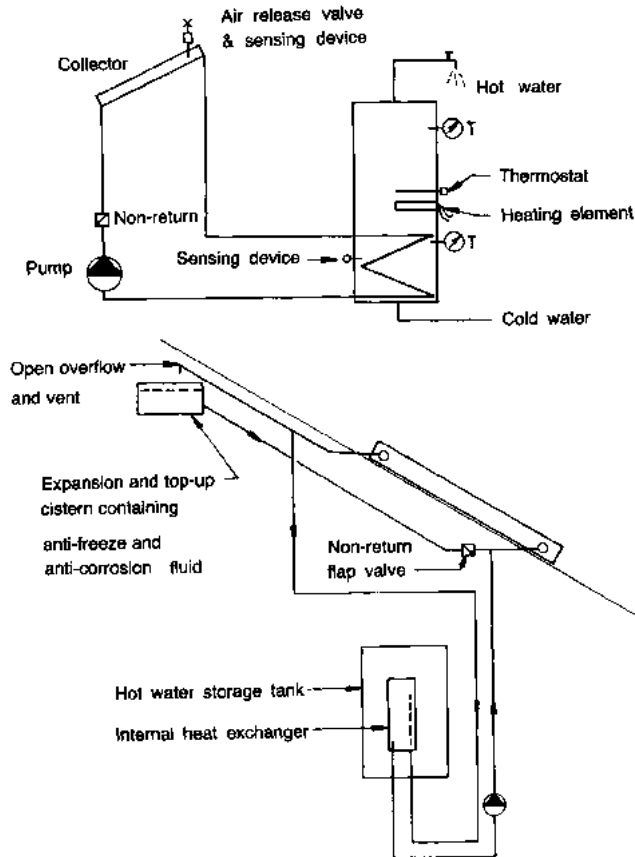

FIGURE

External Heat Exchanger

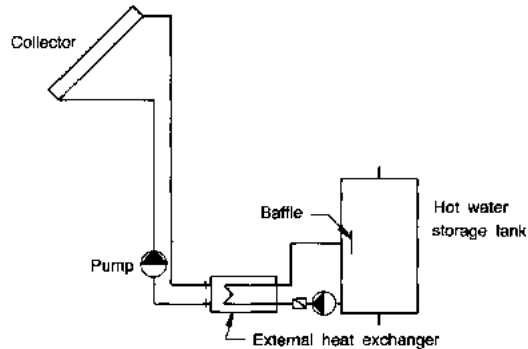

(Principle, showing system, but not complete requirements, e.g. electricity, etc.)

Advantages:

- No heat losses, when pump is switched on
- Variable sizes, of heat exchangers
- High output of heat exchanger
- Adaptable to all types of hot water storage tanks (e.g. existing boiler, with improved insulation and incorporating baffle plates).

Disadvantages:

- Larger investment
- Requires two pumps
- Larger heat losses in pipes

Applications: -Medium and larger hot water requirements

(such systems might be available from McMaster Carr, Supply Company, P.O. Box 4355, Chicago/Illinois).

Collector Circuit Connection for Swimming Pool Heating

For swimming pool solar heating systems, a simple circuit system can be made. The thermostat fitted, on the collector is to have the reading of the required water temperature in the swimming pool. Such switches are not recommended for other solar heated systems. Additional precautions are required against corrosion in collectors, since the water is quite aggressive (use of low temperature collectors, possibly made of plastics).

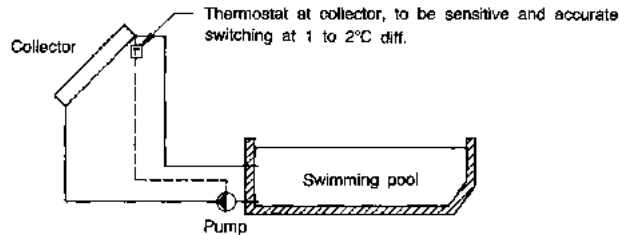

Principle, showing system without details

Adequate swimming pool heating can be achieved by having low temperature collectors directly connected to the filter circulation. The full volume flow will be pumped through the collectors, whenever sufficient solar radiation is available. Note that such systems require higher corrosion resistance of collectors and pipe works.

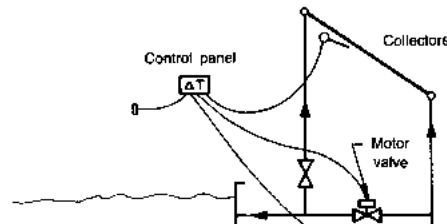

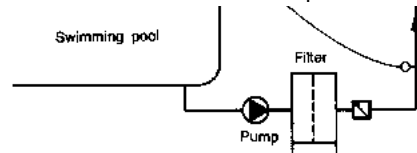

Refined circuit

Collector Arrangements - pumped circulation systems can have a variety of connecting arrangements, as the water will be forced through the collectors by a pump.

Parallel Circuit

- Advantages:**
- Less friction loss in plant
- Disadvantages:**
- More pipelines
 - Collector circuits have to be flow regulated

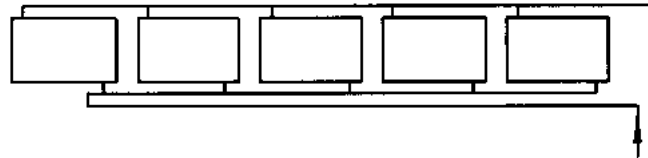

Serial Circuit:

- Advantages:**
- Less pipelines
 - No problems with flow regulations
- Disadvantages:**
- Higher friction losses

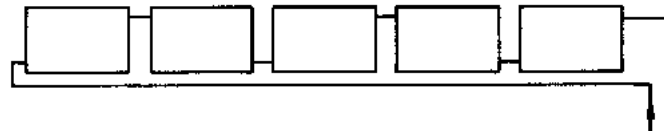

Refined circuit

Parallel and Serial Circuit (for larger installations)

The advantages and disadvantages must to be balanced by consideration of site specifications in order to achieve optimized solutions.

Note: System requires numerous air release points, easier access is provided when collectors are installed on flat roofs.

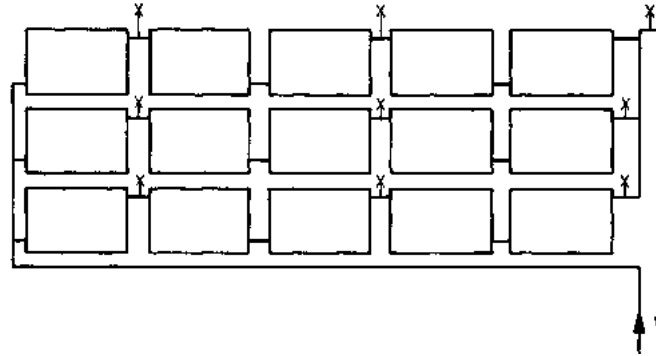

FIGURE

Aeration Systems

It is essential that collector circuits are fitted with air valves wherever necessary. The major problem in solar systems is the blockage of water circulation by air bubbles. Therefore all U-bends (for example highest points at collectors) require an air valve.

- 1 Automatic air valve**
- 2 Drain (valve or plug)**
- 3 Hand-operated air valve**

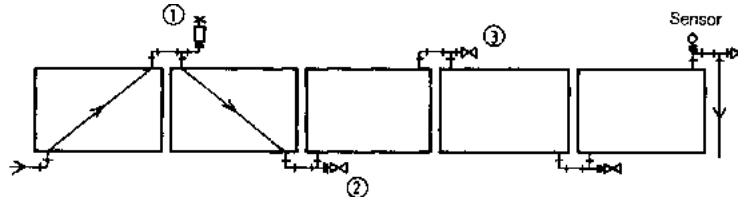

FIGURE

Examples of properly placed air valves

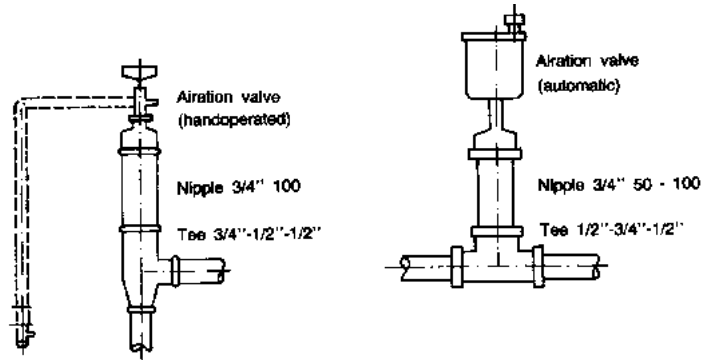

Wrong installation of air release valves

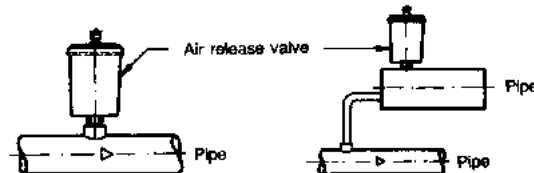

FIGURE**4.3 PUMPS**

When buying or installing a pump, consider the following: Pumps have to be of good quality. They have to withstand hot water temperatures (up to 130°C) and to be resistant against corrosion from anti-freeze mixtures.

The temperature difference of inlet and outlet of collector should be approximately 10-15° C. Having 4 m² collector surface, for example, requires a circulation of 160 to 200 liters per hour.

A pump of 15 to 20 Watts is normally sufficient. However, available pumps are often too powerful, and need a regulating device. Thermometers should be fitted for easy readings and adjustment.

Pumps have to be regulated by thermo-switches. They have to run when the temperature in collectors is higher (10 K) than the temperature in the hot water storage tank.

Note: When using a circulation pump run from batteries (charged by solar panels) it is recommended to use differential thermostats working on Bi-metal principles, and therefore not using electricity for functioning. Manufactured by Danfoss.

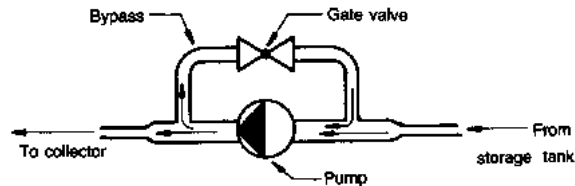
**FIGURE**

4.4 TEMPERATURE CONTROL

The pump needs to run when the temperature in the collector is higher than that in the hot water storage tank. The difference should be 10 K.

Differential thermostat - most of these require a little electricity to operate, which is acceptable when the pump is run by electricity from the mains. However, in cases where pumps run from solar panels (direct or from batteries) it is important not to consume more electricity. There are differential thermostats available which work on Bi-metal principles, not consuming electricity (Danfoss, Type RT).

Control panels - manufacturers of pumps often also provide control panels for temperature regulation, pump switching including gauges, etc. they may be fitted in larger plants and also where multiple switches are required.

4.5 PLACEMENT OF TEMPERATURE SENSING DEVICES

The sensing devices for temperature regulation (for pump switching) have to be placed properly.

Collector -to be fitted at the highest place and at the exit of the collector. The best systems are dip-sensing devices, which project into the collector exit.

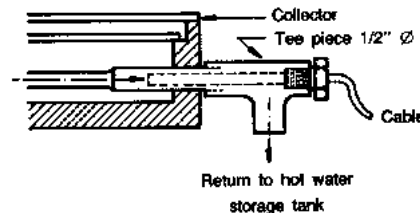

Upper edge of collector

Hot Water Storage Tank - dip sensing devices are best for sensing of the temperature in hot water storage tanks preferably alternatively, a clip-sensing device can be fitted to the outside of the metal container, but are not very accurate.

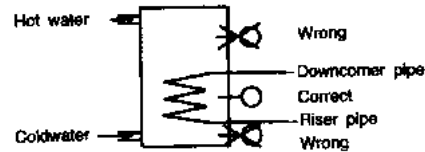

Correct placement of sensing device

It is important to have the sensing device fitted at the height of the heat exchanger.

Collector circuit connection with differential thermostatic switching, connected to circulation pump:

- 1 Collector**
- 2 Hot water storage tank/heat exchanger**
- 3 Circulation pump**
- 4 Differential thermostatic switch**
- 5 Collector sensing device**
- 6 Hot water storage tank sensing device**

4.6 VALVES

The efficient functioning of a solar water heater system depends greatly on proper installation and the use of appropriate valves.

The following functions must be possible:

- Complete filling and draining of a system (valves, drain plugs)
- Ventilation to release air, by means of vent pipes or air release valves (manual or automatic types), to completely remove any air blockages.
- Release of over pressure by means of a safety valve.
- Maintain required volume of liquid for circulation.

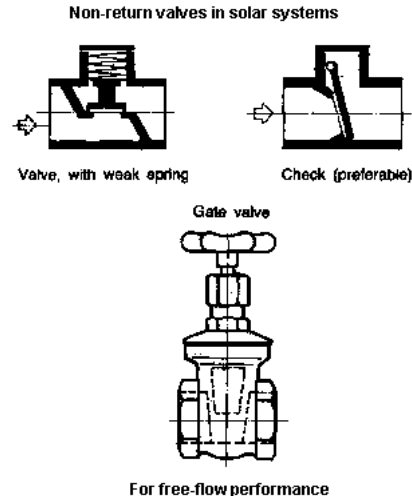
**FIGURE**

Valves must be of "free flow" type and be heat resistant. Valves, air valves, drain plugs,

vent pipes must remain operational in freezing climates and have adequate insulation.



[Home](#) > [ar.cn.de.en.es.fr.id.it.ph.po.ru.sw](#)

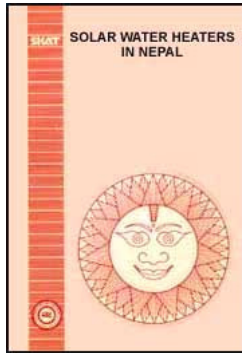

- 📖 **Solar Water Heaters in Nepal (SKAT, 1979, 142 p.)**
 - 📄 **PART II SOLAR WATER HEATER APPLIANCES MADE BY MECHANICAL TRAINING CENTRE**
 - 📄 **5. SOLAR WATER HEATERS MADE BY MECHANICAL TRAINING CENTRE**

Solar Water Heaters in Nepal (SKAT, 1979, 142 p.)

PART II SOLAR WATER HEATER APPLIANCES MADE BY MECHANICAL TRAINING CENTRE

5. SOLAR WATER HEATERS MADE BY MECHANICAL TRAINING CENTRE

5.1 HOTWATER STORAGE, TANK 100 LTR (SE 100)

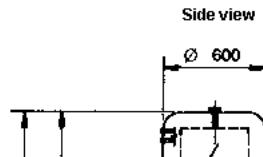

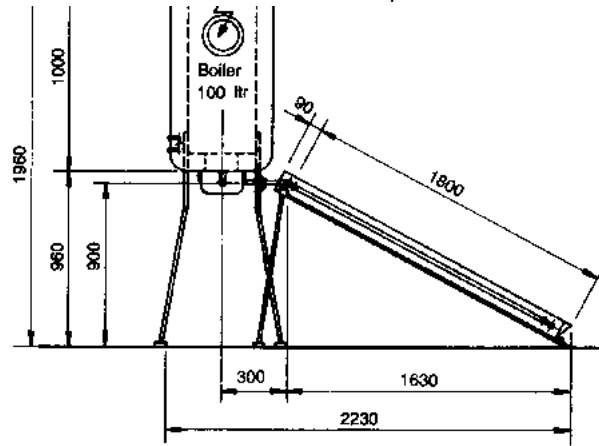

Top view

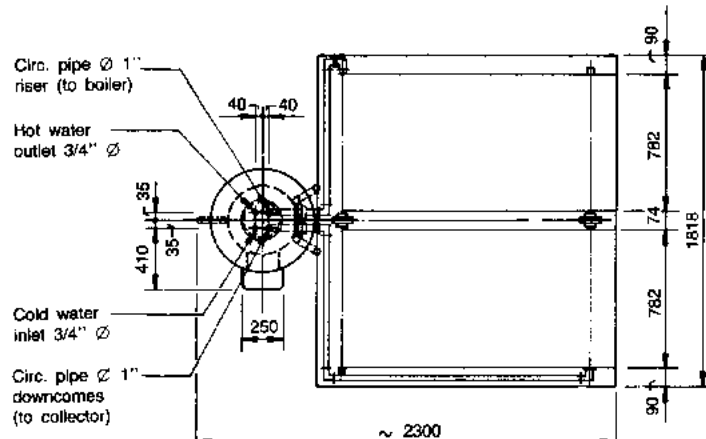

FIGURE

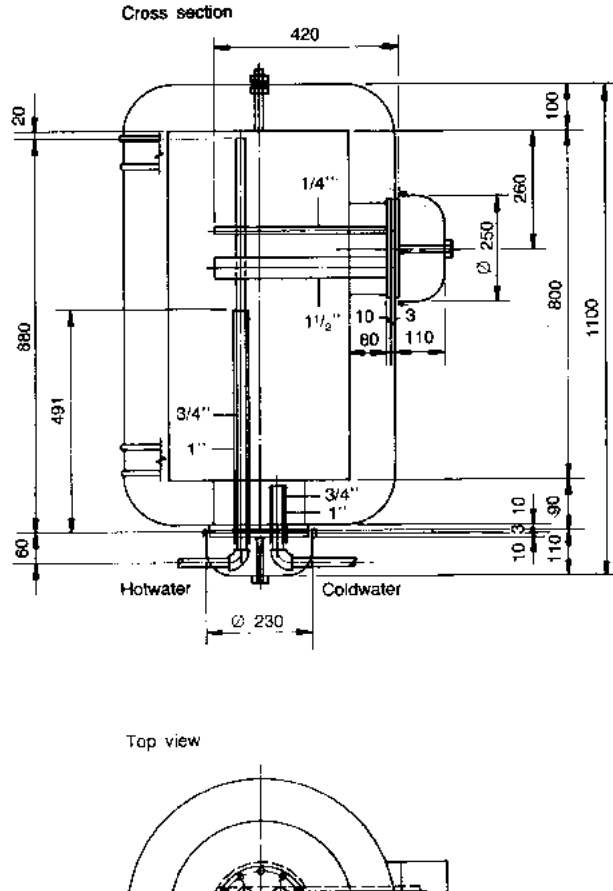

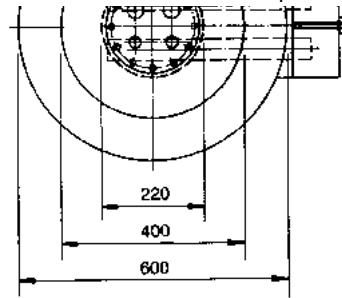

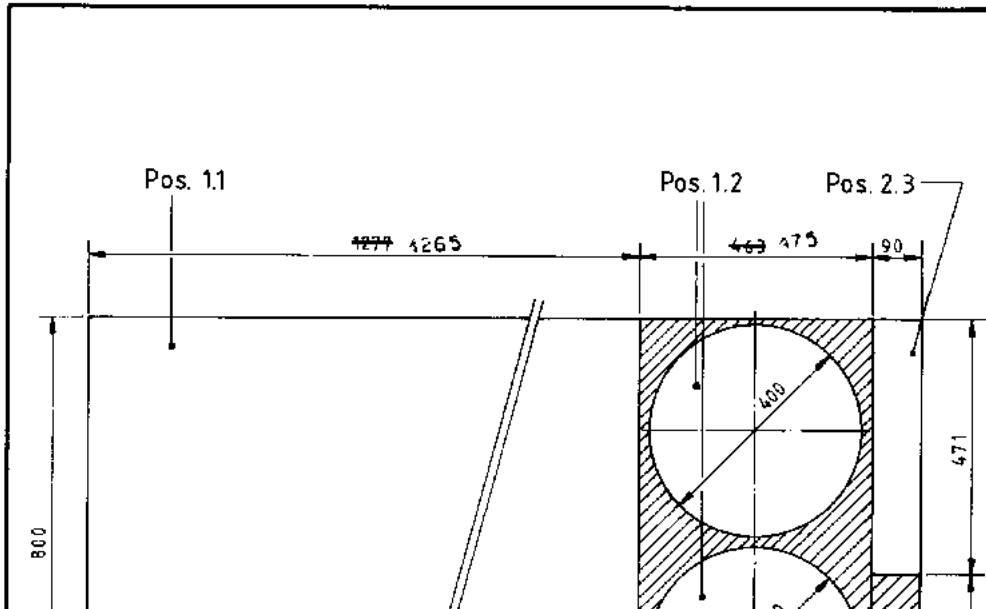

FIGURE

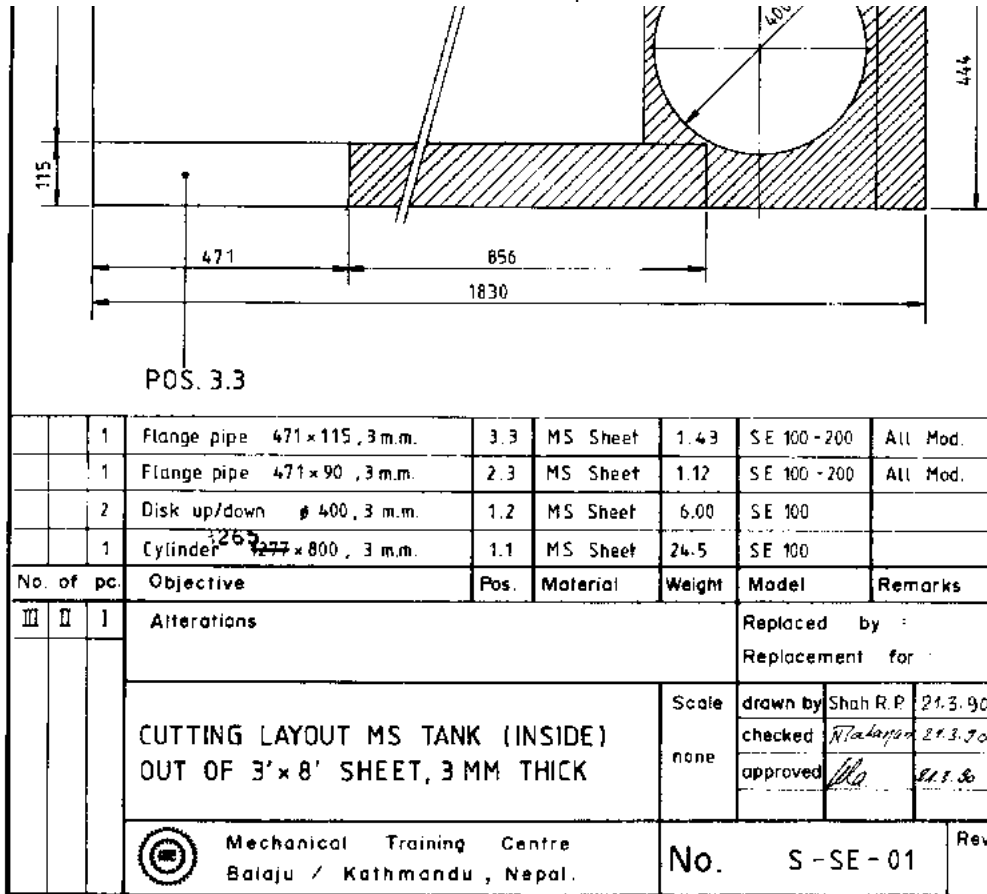

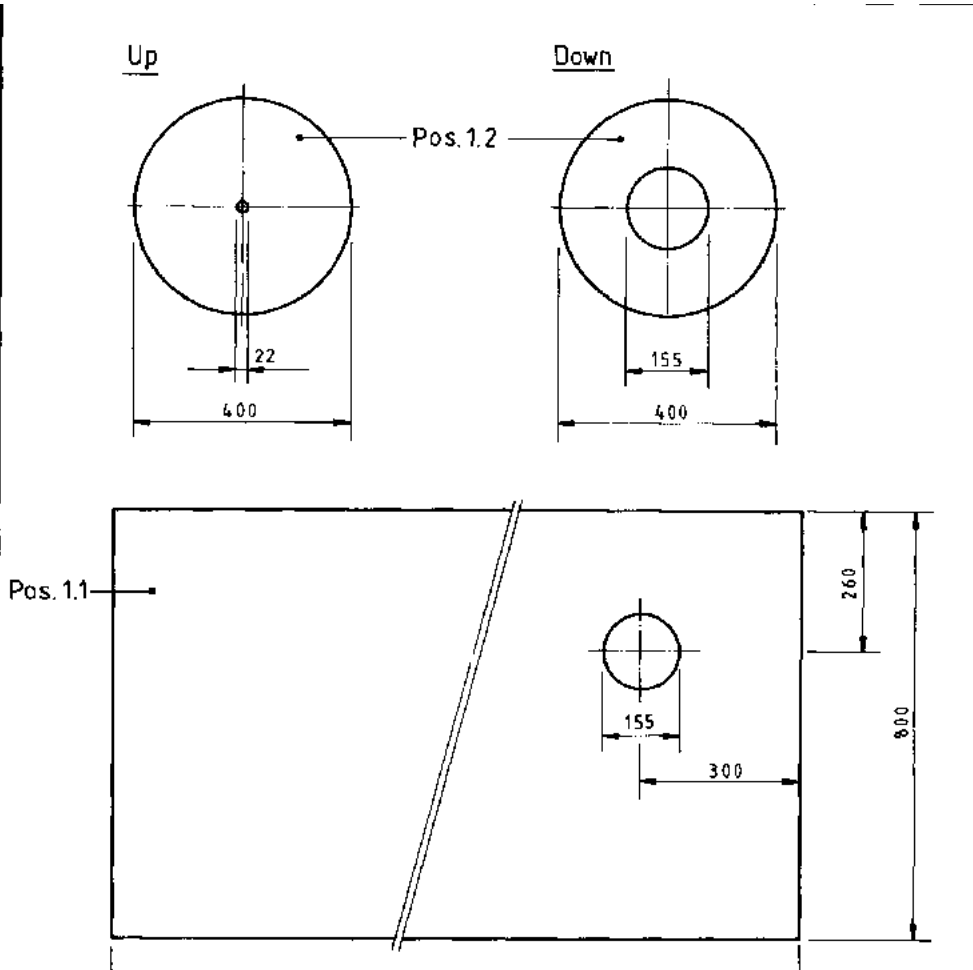

FIGURE

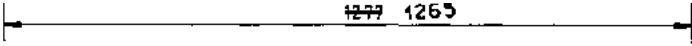

							
	2	Disk up / down ϕ 400, 3 mm	1.2	MS Sheet	6.0	SE 100	
	1	Cylinder 1277 ¹²⁶⁵ x 800, 3 mm	1.1	MS Sheet	24.5	SE 100	
No. of pc.	Objective		Pos.	Material	Weight	Model	Remarks
III	II	I	Alterations			Replaced by : Replacement for :	
CUTTING SIZE MS TANK					Scale	drawn by	Shah R.P. 21.3.90
					none	checked	N. Khatiwada 21.3.90
						approved	<i>[Signature]</i> 21.3.90
 Mechanical Training Centre Balaju / Kathmandu, Nepal					No. S-SE-02		Rev

FIGURE

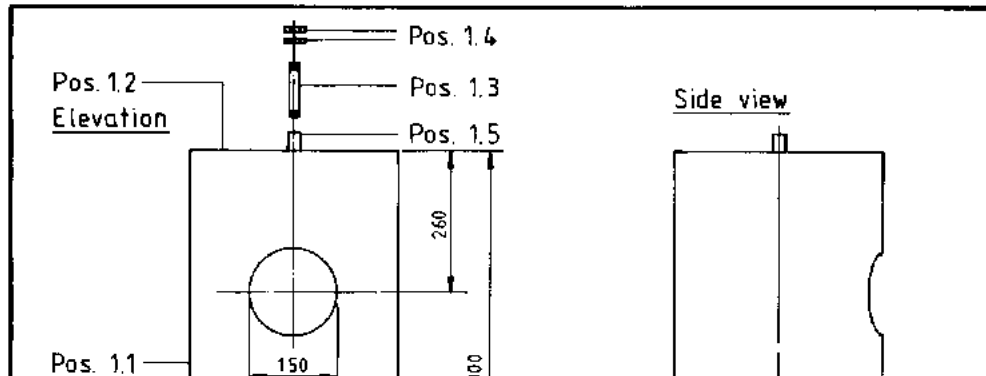

Pos. 1.2
Top view

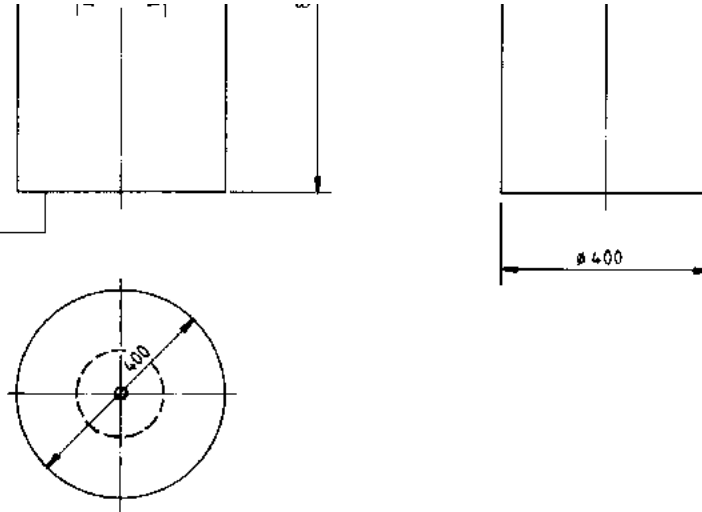

		1	Socket 1/2"	1.5	M.S.		SE 100-200	All Mod.	
		2	Hexagon nut 1/2"	1.4	G.I.		SE 100-200	All Mod.	
		1	Pipe 1/2" 100mm	1.3	G.I.		SE 100-200	All Mod.	
		2	Disk up/down ϕ 400, 3mm	1.2	M.S. Sheet	6.0	SE 100		
		1	Cylinder ¹²⁶² 1277 x 800, 3mm	1.1	M.S. Sheet	24.5	SE 100		
No. of	pc	Object			Pos.	Material	Weight	Model	Remarks
III	II	Alterations					Replaced by :		
							Replacement for :		
						Scale	drawn by	Shah R.P. 21-3-90	
							checked	Nishanin 22.3.90	

MS TANK (INSIDE)		none		
		approved	<i>Ma.</i>	<i>U.S. G.</i>
	Mechanical Training Centre Balaju / Kathmandu , Nepal .	No.	S - SE - 03	Rev.

FIGURE

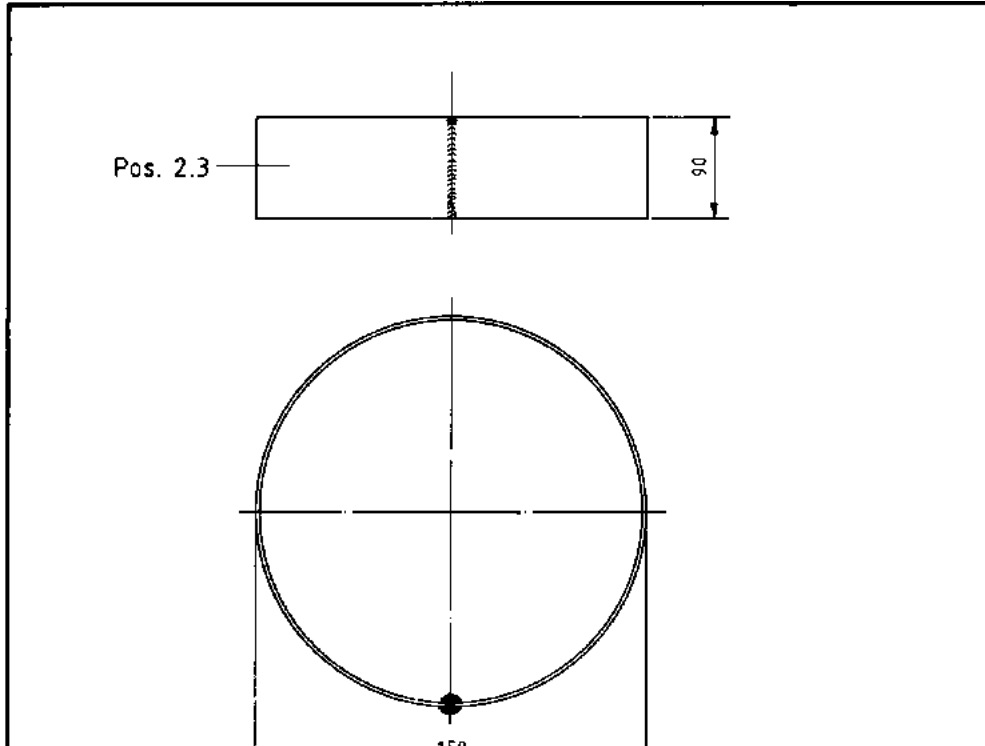

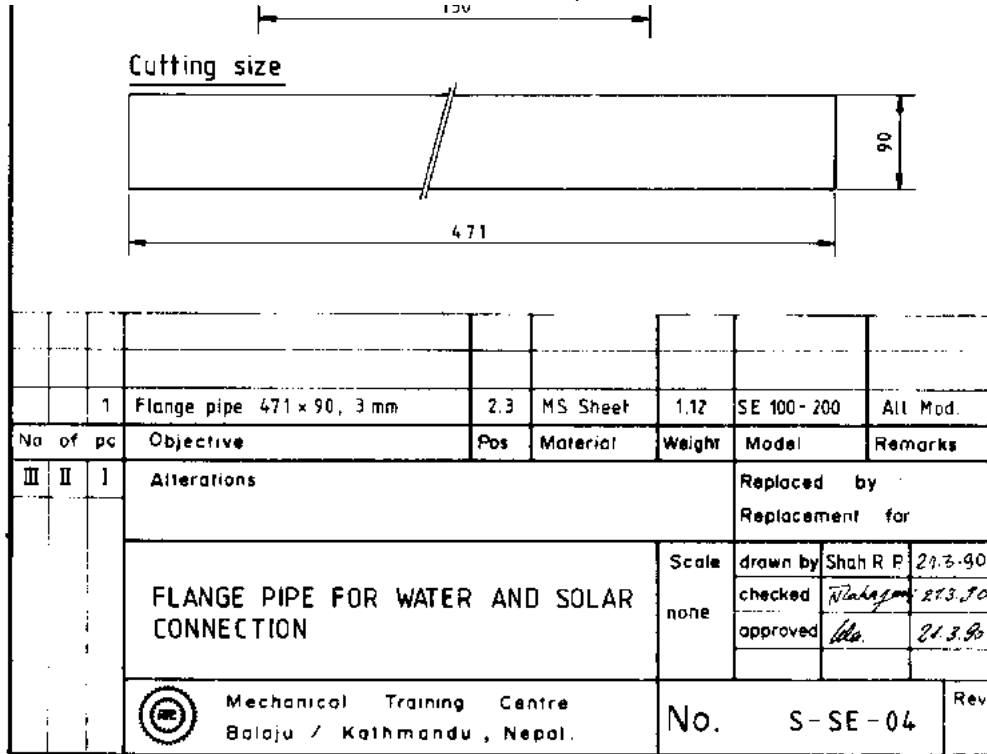

FIGURE

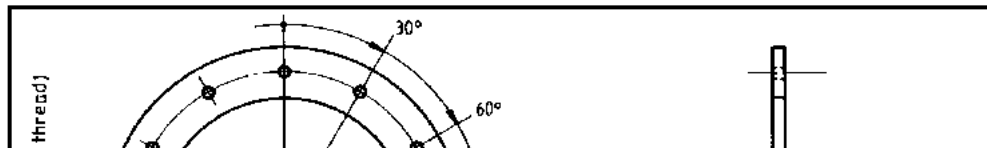

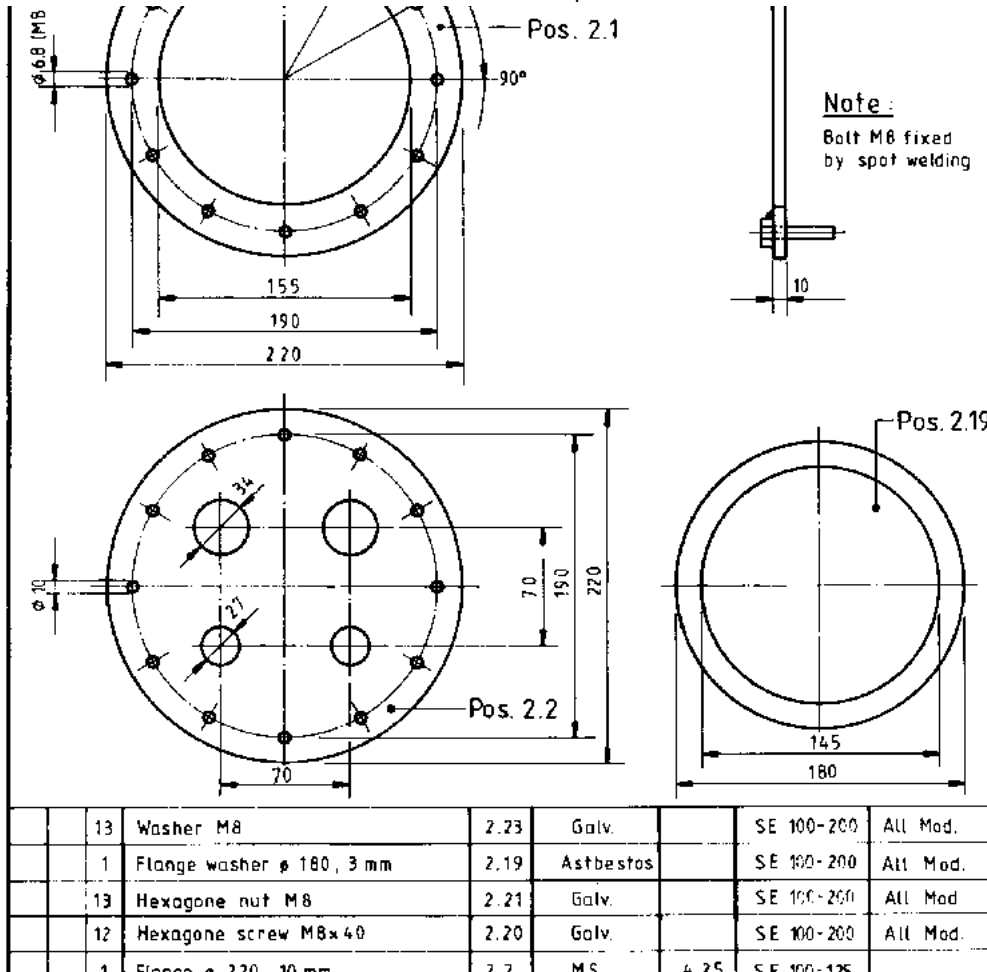

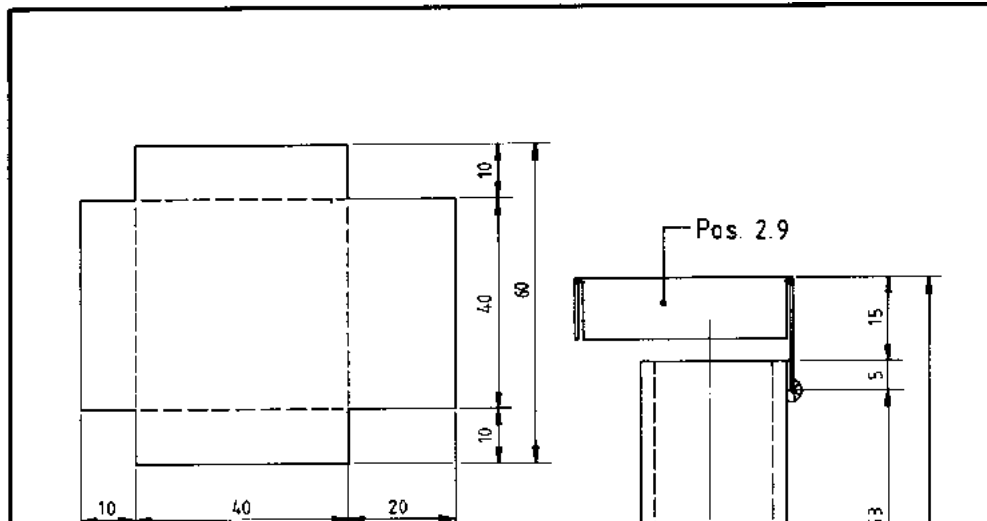

		1	Flangering ϕ 220, 10mm	2.1	MS	4.25	SE 100-200	All Mod.		
No. of pc.	Object			Pos.	Material	Weight	Model	Remarks		
III	II	I	Alterations				Replaced by :			
			FLANGE WITH WATER AND SOLAR CONNECTIONS				Scale	drawn by Shah R. P.	21.5.90	
								checked	<i>N. K. J. P.</i>	21.8.90
								approved	<i>Ma</i>	21.8.90
			 Mechanical Training Centre Balaju / Kathmandu , Nepal.			No. S-SE-05		Rev.		

FIGURE

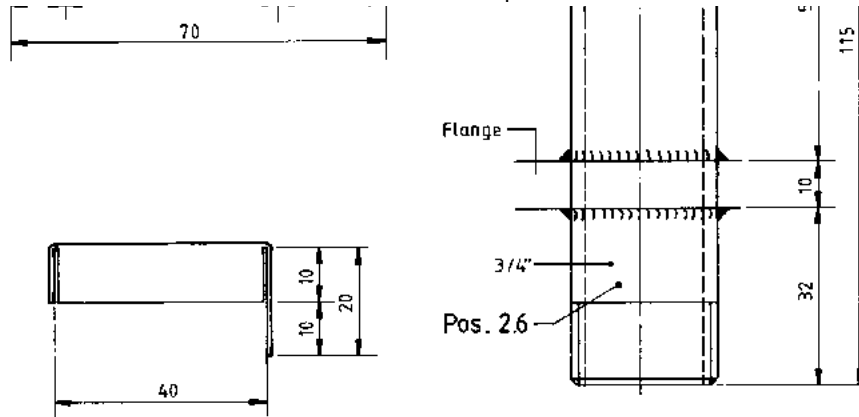



		1	G. I. Pipe 3/4" x 100 mm	2.6	G. I pipe				
		1	Baffel plate 70 x 60, 18 g	2.9	G. I sheet				
No. of pc	Object			Pos	Material	Weight	Model	Remarks	
III	II	I	Alterations				Replaced by : Replacement for :		
COLD WATER CONNECTIONS WITH BAFFEL PLATE						Scale	drawn by	Shah R.P.	21.3.90
						none	checked	<i>Shah R.P.</i>	21.3.90
							approved	<i>Shah R.P.</i>	21.3.90
 Mechanical Training Centre Balaju / Kathmandu , Nepal.						No. S-SE-06		Rev.	

FIGURE

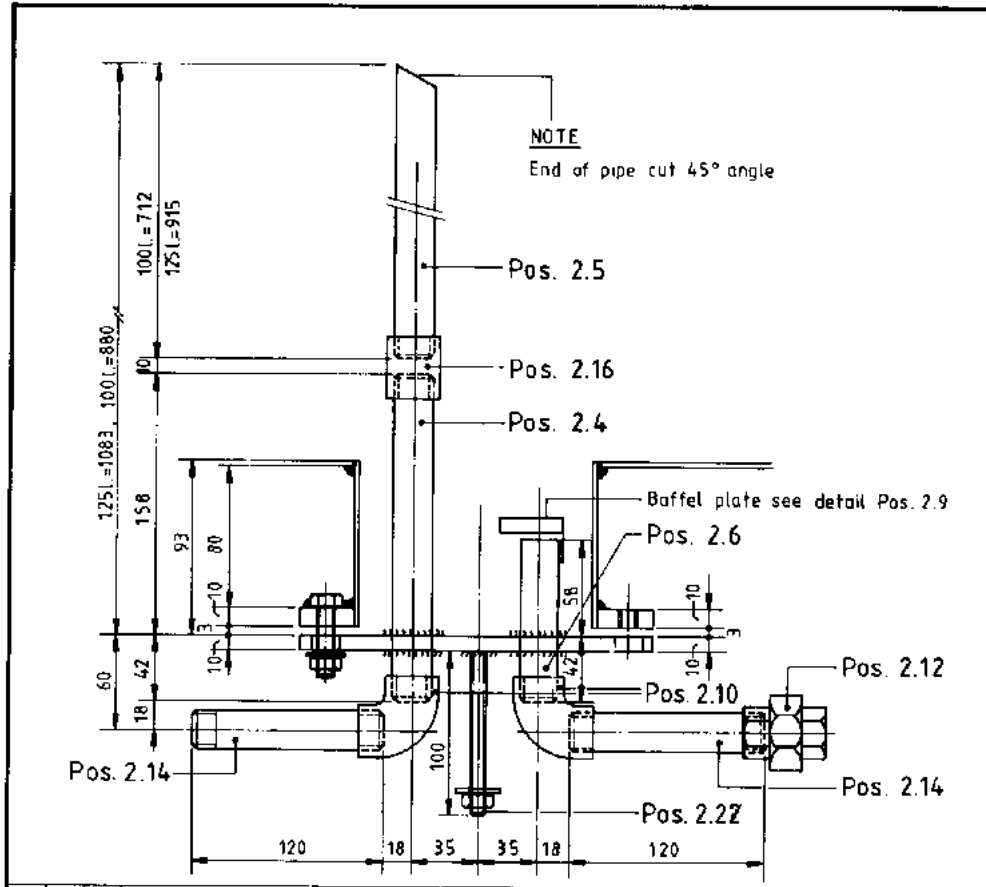

		2	G. I. Elbow 3/4"	2.10		SE 100-125		
		1	G. I. Pipe 3/4", 100 mm	2.6	G. I. class A	SE 100-125		
		1	G. I. Pipe 3/4", 100L=712 125L=915	2.5	G. I. class A	SE 100-125	Check capacity	
		1	G. I. Pipe 3/4", 200 mm	2.4	G. I. class A	SE 100-125	of tank!!	
		2	G. I. Union 3/4"	2.12		SE 100-125		
		2	G. I. Nipple 3/4", 120 m	2.14	G. I. class A	SE 100-125		
		1	G. I. Socket 3/4"	2.16		SE 100-125		
		1	Threaded rod w. nut M8 x 100 mm	2.22	Galv.	SE 100-125		
No. of pc		Object		Pos.	Material	Weight	Model	Remarks
III	II	I	Alterations			Replaced by : Replacement for :		
FLANGE, HOT AND COLD WATER CONNECTIONS					Scale none	drawn by	Shah R.P.	21.3.90
						checked	<i>N. B. Joshi</i>	22.3.90
						approved	<i>Ma.</i>	21.3.90
 Mechanical Training Centre Balaju / Kathmandu , Nepal.					No. S-SE-07		Rev.	

FIGURE

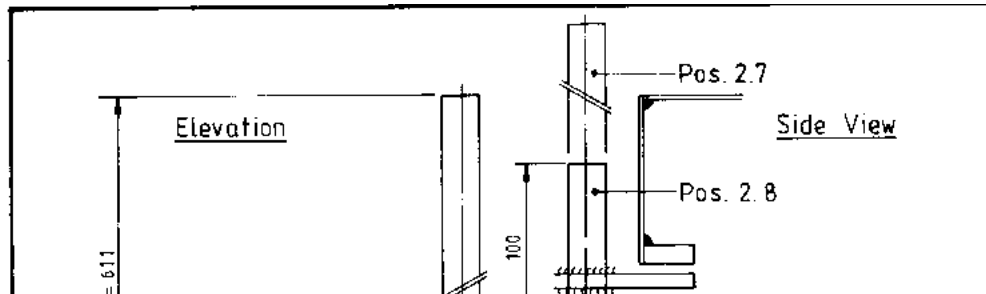

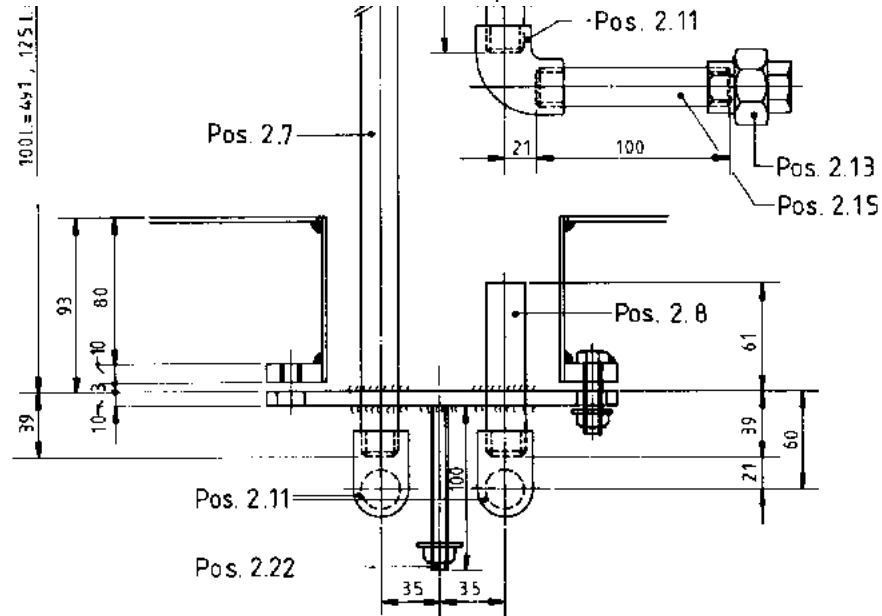

	2	G. I. Elbow 1"	2.11	G. I.		S E 100-125		
	1	G. I. Pipe 1", 100L=530, 125L=650	2.7	G. I. Class A		S E 100-125	Check capacity	
	1	G. I. Pipe 1", 100 mm	2.8	G. I. Class A		S E 100-125	of tank.	
	2	G. I Union 1"	2.13			S E 100-125		
	2	G. I Nipple 1", 100 mm	2.15	G. I. Class A		S E 100-125		
	1	Threaded rod w. nut M8 x 100 mm	2.22	Galv.		S E 100-125		
	N° of pc.	Object	Pos.	Material	Weight	Model	Remarks	
III	II	I	Alterations				Replaced by: Replacement for:	

FLANGE, SOLAR WATER CONNECTIONS	Scale	drawn by	Shah R P	24.3.90
	none	checked	<i>Raj...</i>	21.2.90
		approved	<i>...</i>	21.3.90
 Mechanical Training Centre Balaju/Kathmandu, Nepal	N^o. S-SE-08			Rev.

FIGURE

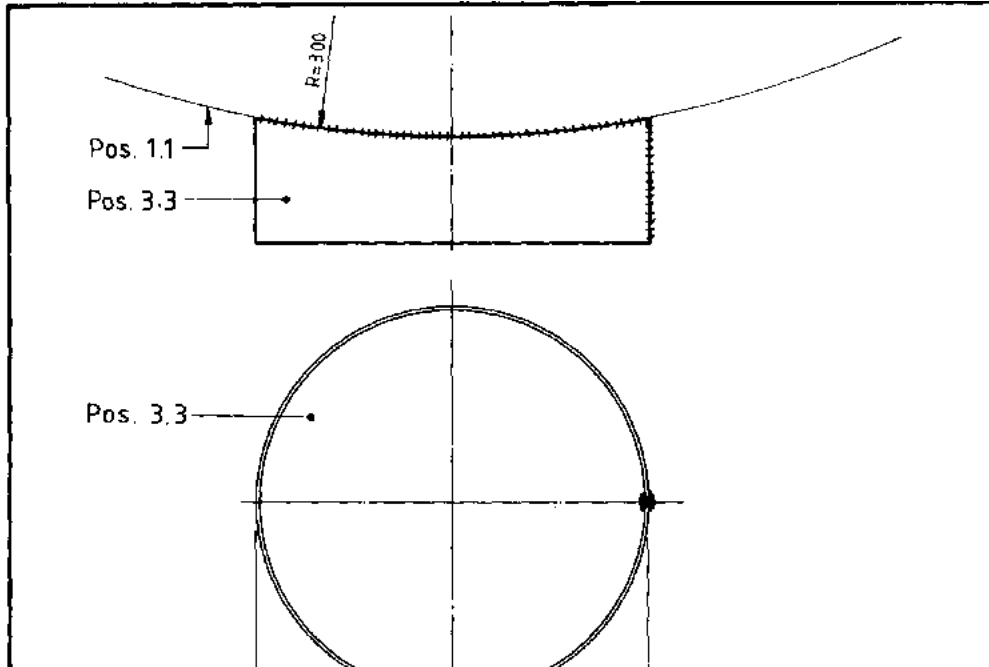

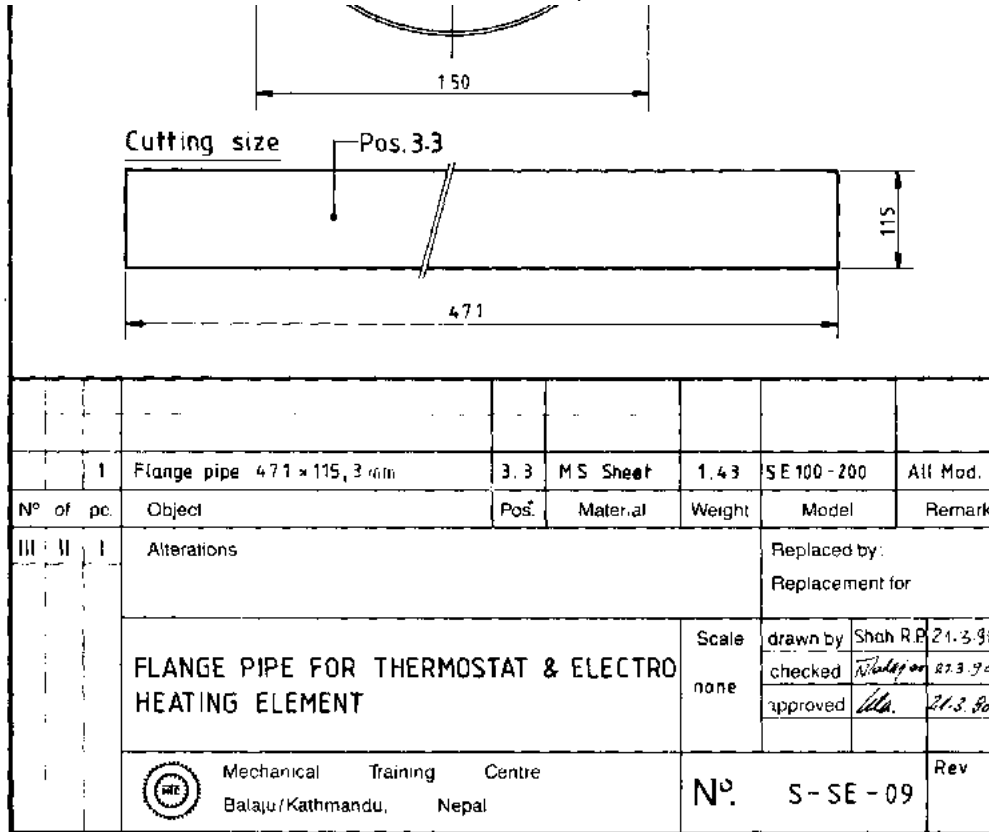

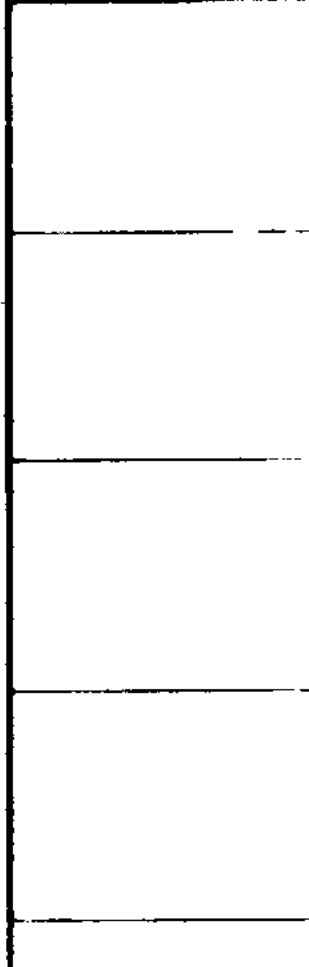

FIGURE

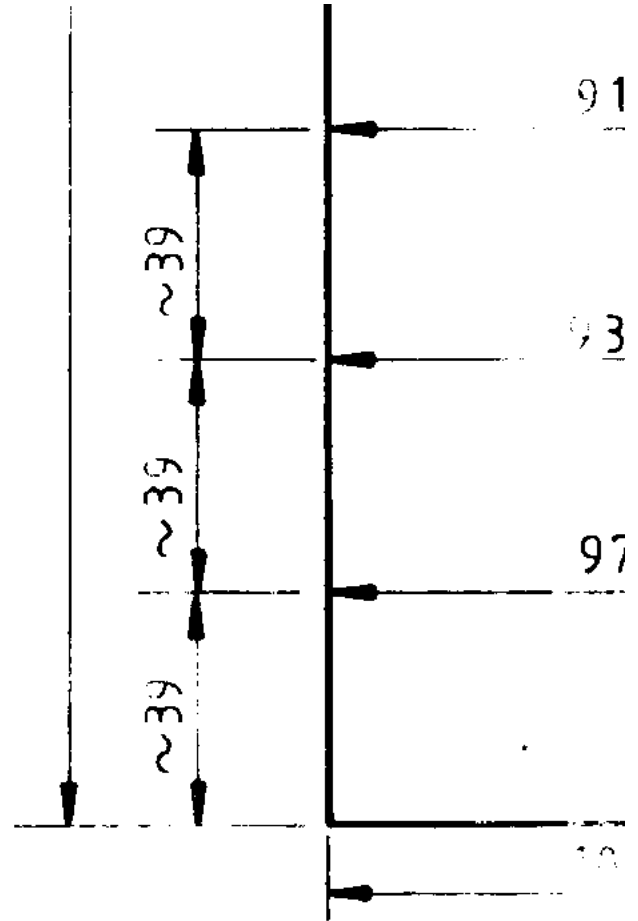

471



		1	Flange pipe 471 × 115 , 3 m. m.	3
		N ^o of pc.	Object	Pc
III	II	I	Alterations	
<p>SIDE FLANGE PIPE CUTTING SI THERMOSTAT & ELECTRO HEAT (DEVELOPMENT)</p>				
			Mechanical	Electrical



FIGURE

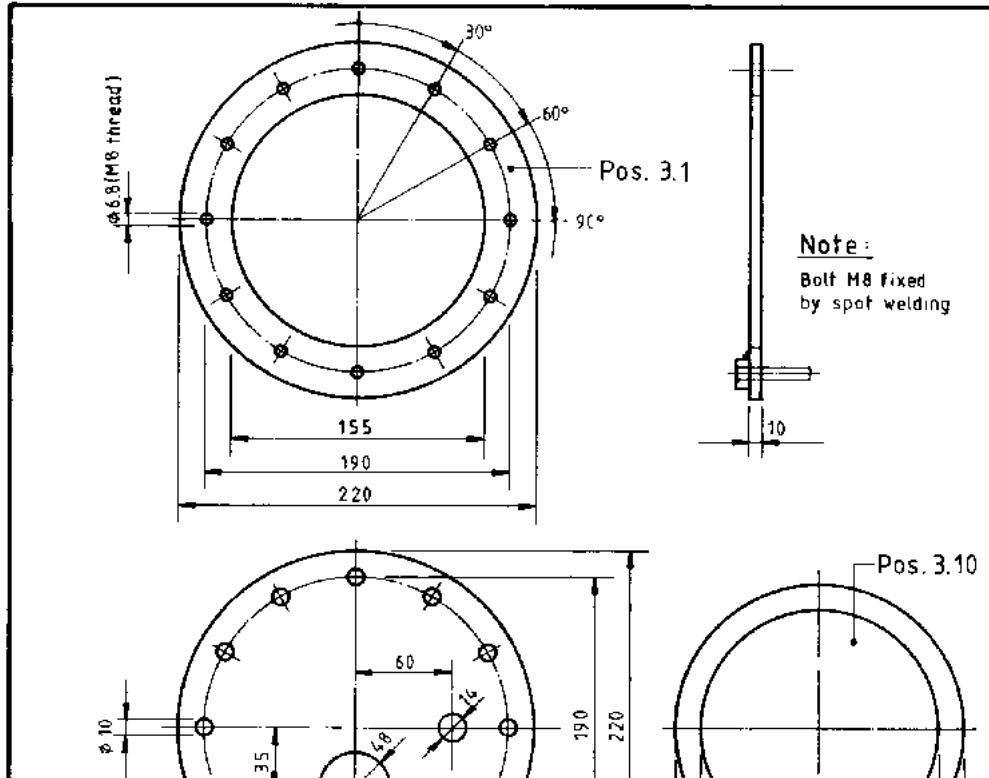

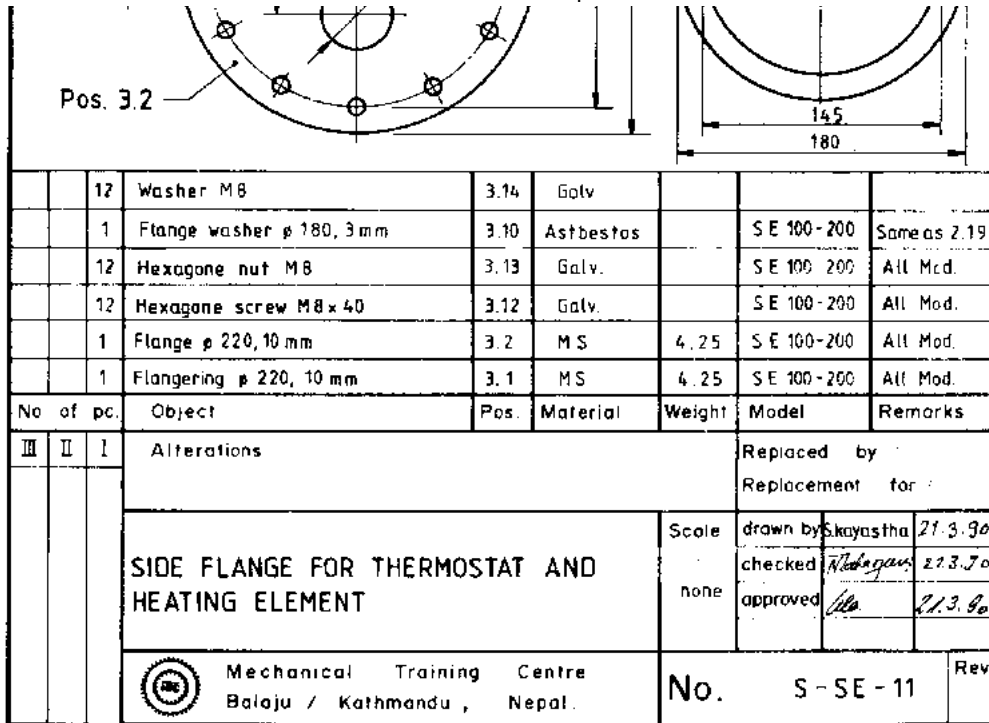

FIGURE

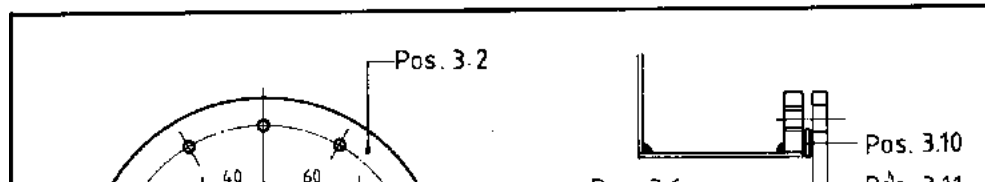

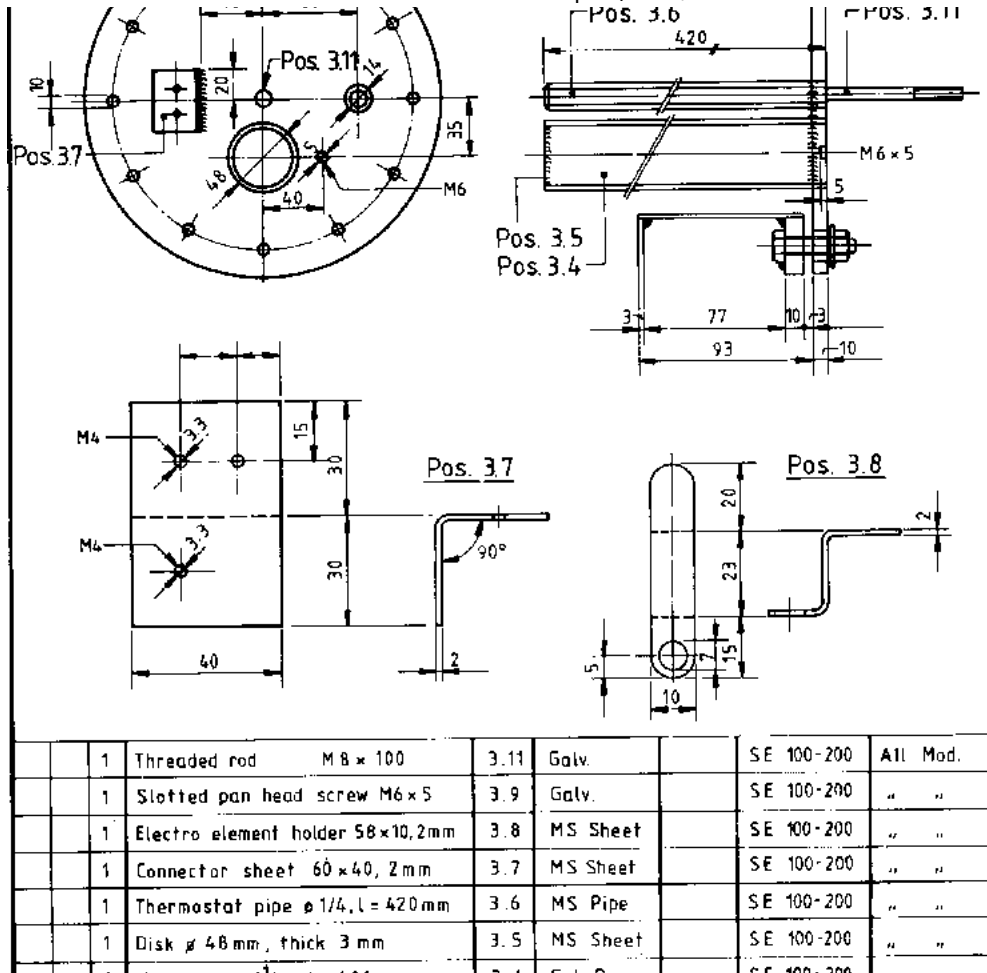

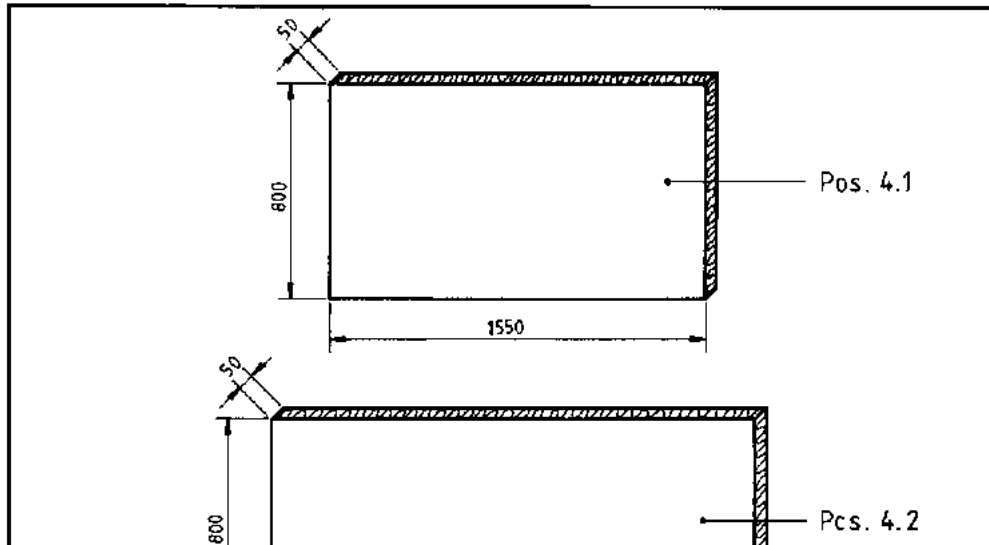

1			Heatpipe ϕ 1 1/2", L = 420 mm	3.4	u. l. pipe	3.1. 100. 200	11	11	
No. of pc.			Object	Pos.	Material	Weight	Model	Remarks	
III	II	I	Alterations				Replaced by :		
							Replacement for :		
			SIDE FLANGE FOR THERMOSTAT AND ELECTRO HEATING ELEMENT				Scale	drawn by Shah R.P 21.3.90	
							none	checked <i>W. Balaju</i> 21.3.90	
								approved <i>Wb.</i> 21.3.90	
			 Mechanical Training Centre Balaju / Kathmandu, Nepal.				No.	S - SE - 12	Rev.

FIGURE

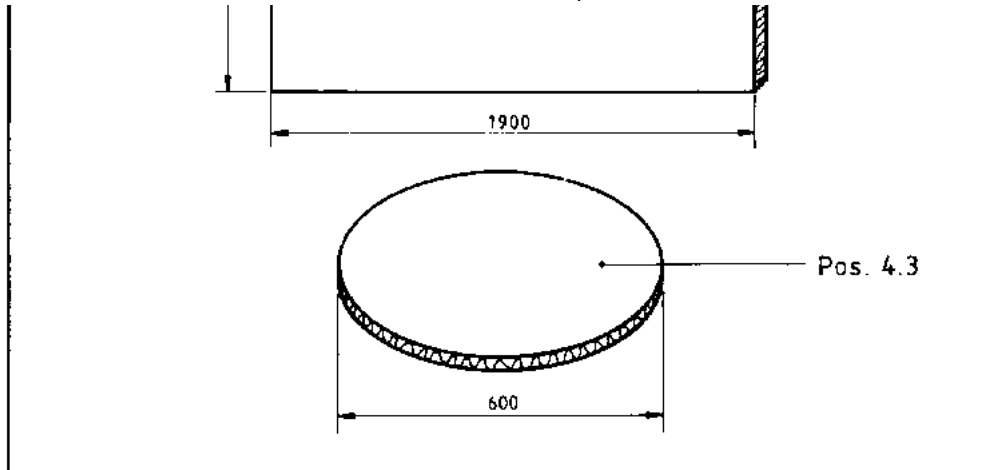



		1	Insulation 1550×800×50	4.1	Fibre glass		SE 100	1.12m ²	
		1	Insulation 1900×800×50	4.2	..		SE 100	1.44m ²	
		4	Insulation disks 600 ² ×50	4.3	..		SE 100-125	1.44m ²	
		1	Pe bag 1900×1000	4.4	Pe		SE 100		
No. of oc.		Object			Pos.	Material	Weight	Model	Remarks
III	II	I	Alterations from 1400 to 1550, from 1800 to 1900				Replaced by : Replacement for :		
		INSULATION MAT SIZES				Scale	drawn by	S.kayastha	21.3.90
						none	checked	N. K. G. P.	22.3.90
							approved	llla.	22.3.90
		 Mechanical Training Centre Balaju / Kathmandu , Nepal.				No.	S - SE - 13		Rev.

FIGURE

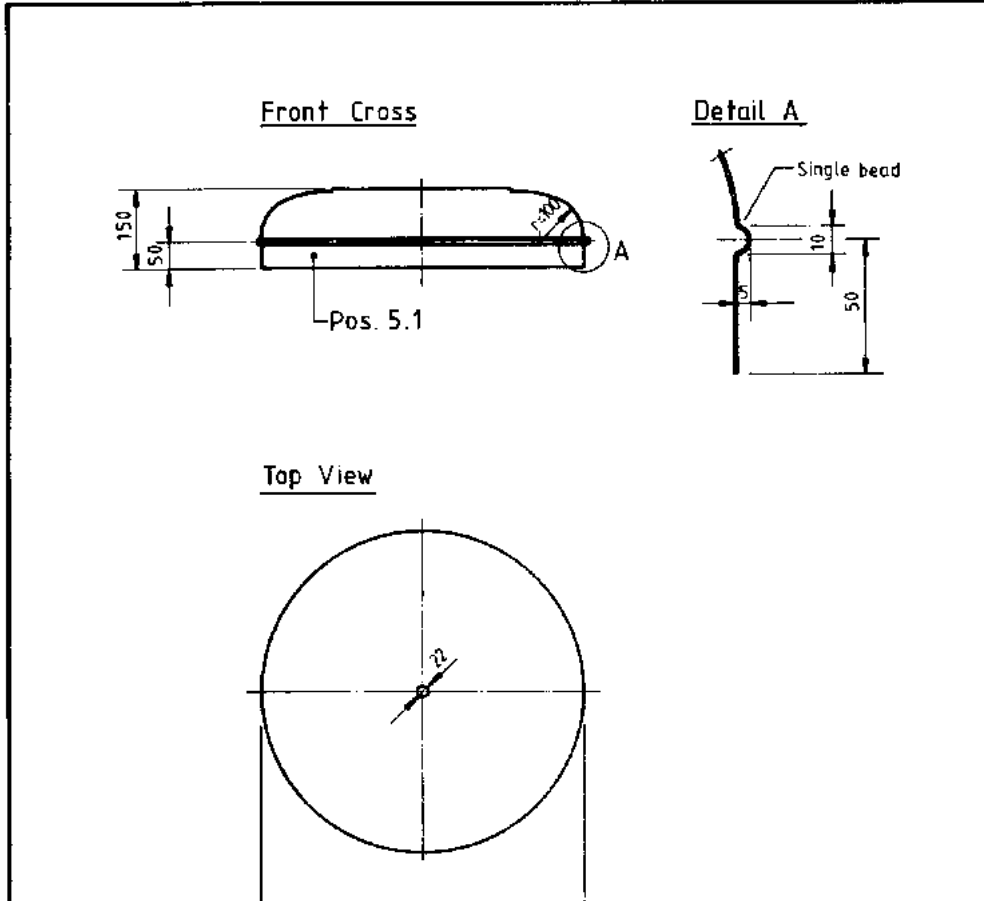

600						
No. of pc.	Object	Pos.	Material	Weight	Model	Remarks
1	Alu. cover ϕ 600 mm, up	5.1	Al.		SE 100-125	
III	Alterations from 25 to 22				Replaced by Replacement for :	
ALU. COVER UP (PREFABRICATED PART)				Scale none	drawn by Shah R.P.	21.3.90
					checked <i>N. Mahajan</i>	21.3.90
					approved <i>Ma.</i>	21.3.90
 Mechanical Training Centre Balaju / Kathmandu, Nepal.				No. S-SE-14		Rev.

FIGURE

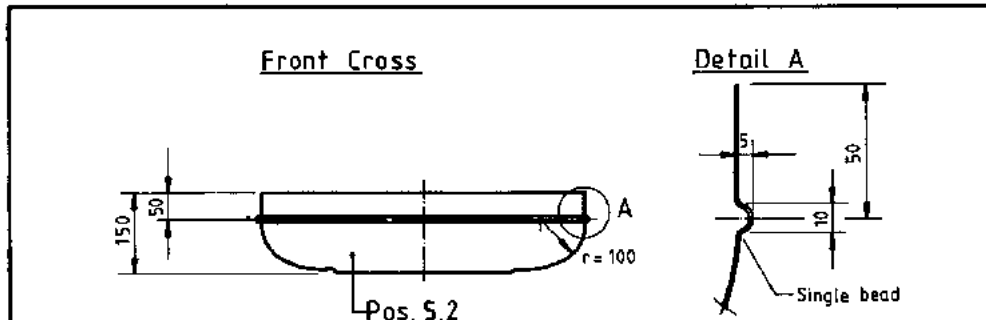

Top View

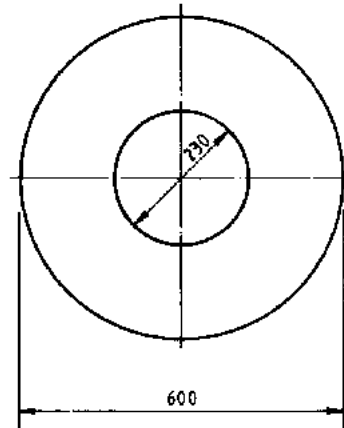

		1	Alu. cover ϕ 600mm, down	5.2	Alu.		SE 100-125
No. of pc.			Object	Pos.	Material	Weight	Model
III	II	1	Alterations from 250 to 230			Replaced by :	
						Replacement for :	

ALU. COVER DOWN (PREFABRICATED PART)	Scale	drawn by	Shah R.P.	27.3.90
	none	checked	<i>Wakajira</i>	21.3.90
		approved	<i>W</i>	21.3.90
 Mechanical Training Centre Balaju / Kathmandu, Nepal.	No.	S-SE-15		Rev.

FIGURE

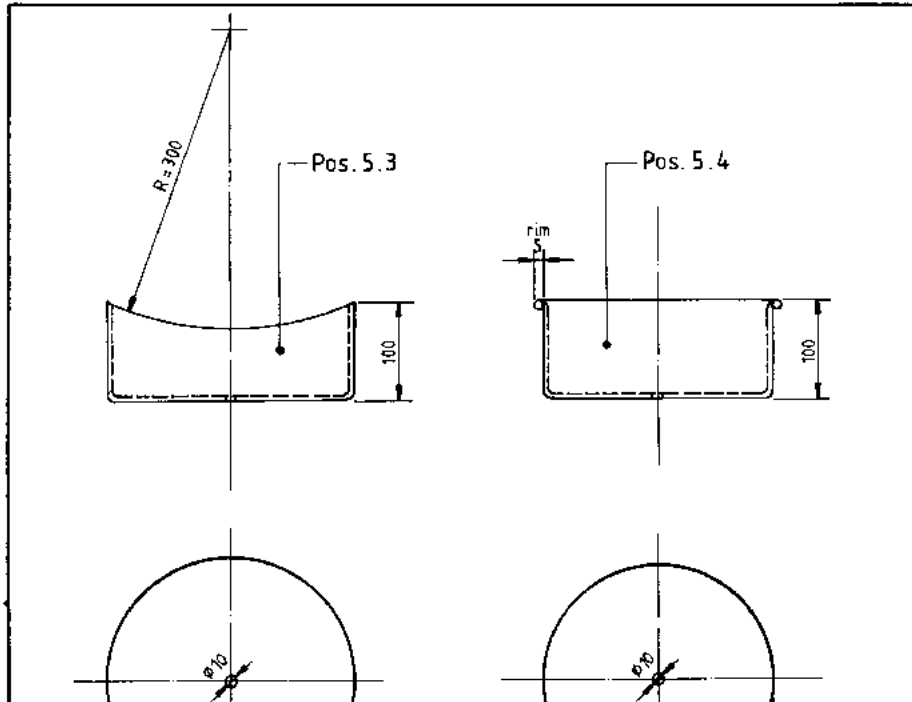

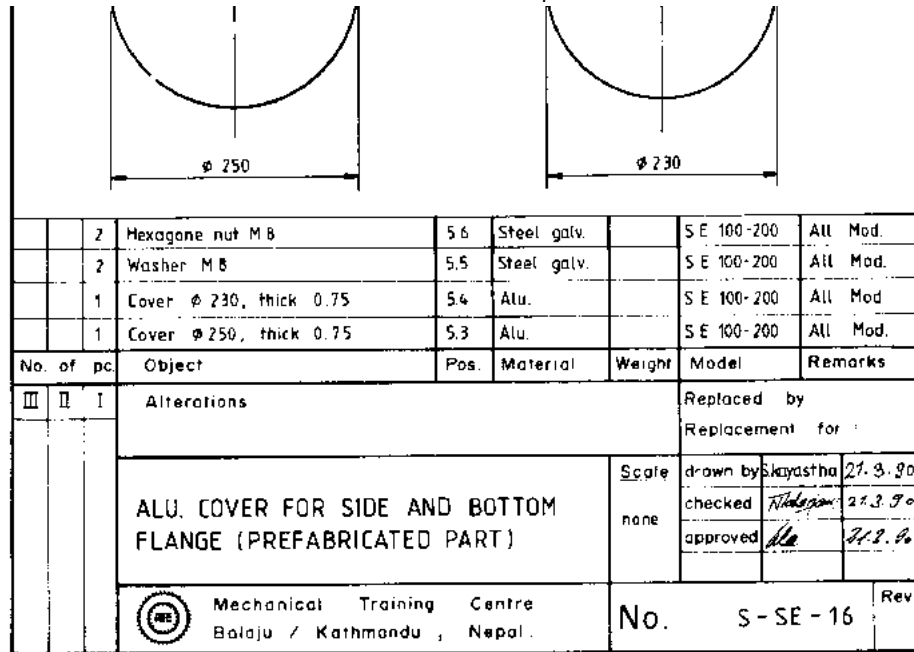

FIGURE

Note :

- Conical cutting
- Opening for side flange according to situation
- Options left, middle, right side

1885

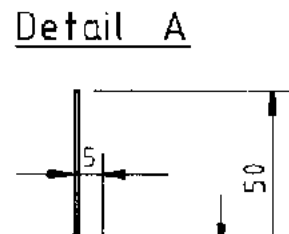
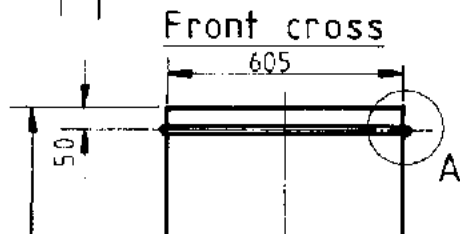
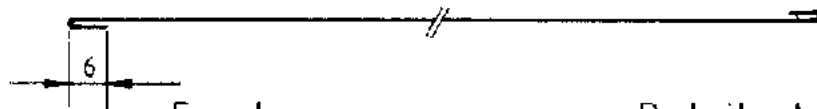
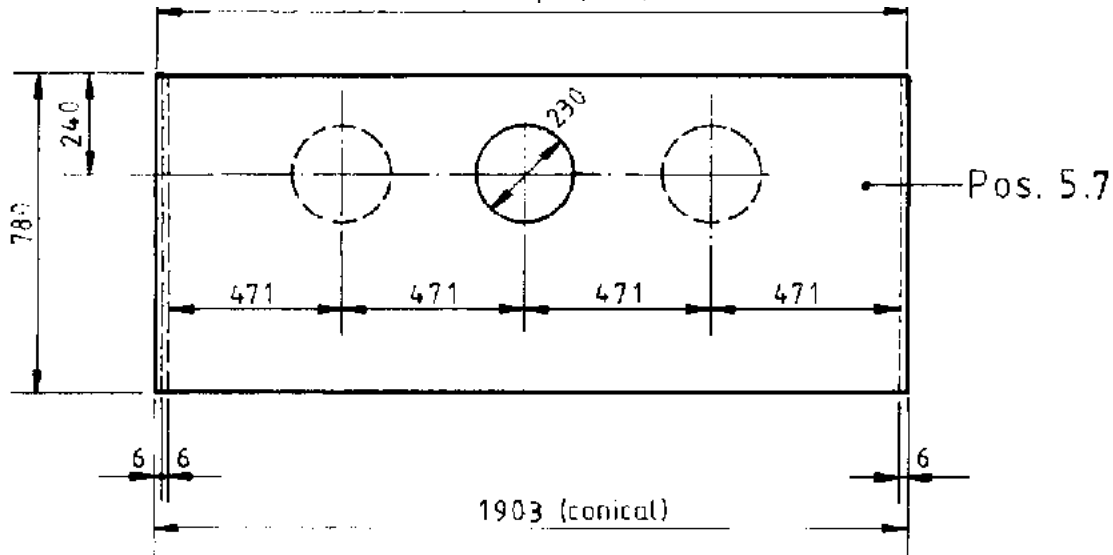

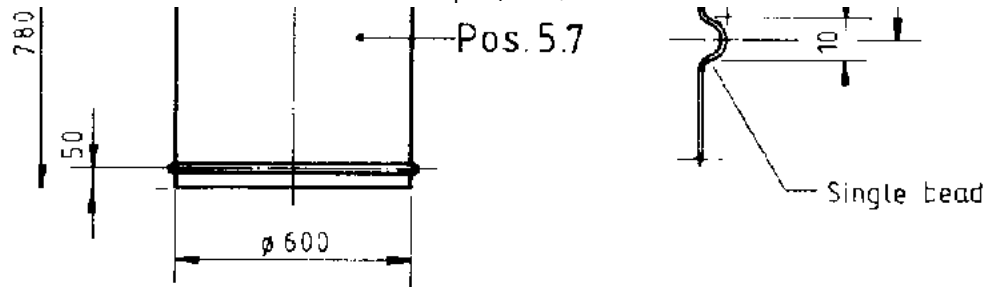

No	of	pc.	Object	Pos.	Material	Weight	Model	Remarks	
	1		Outside cutting 1903 × 780, 24 g.	5.7	G. I Sheet	6.66	SE 100		
III	II	I	Alterations					Replaced by : Replacement for :	
G. I. SHEET CYLINDER						Scale	drawn by	Shah R P	21.3
						none	checked	<i>N. K. Sharma</i>	21.3
							approved	<i>alla</i>	21.3
Mechanical Training Centre Balaju / Kathmandu , Nepal.						No. S - SE - 17			

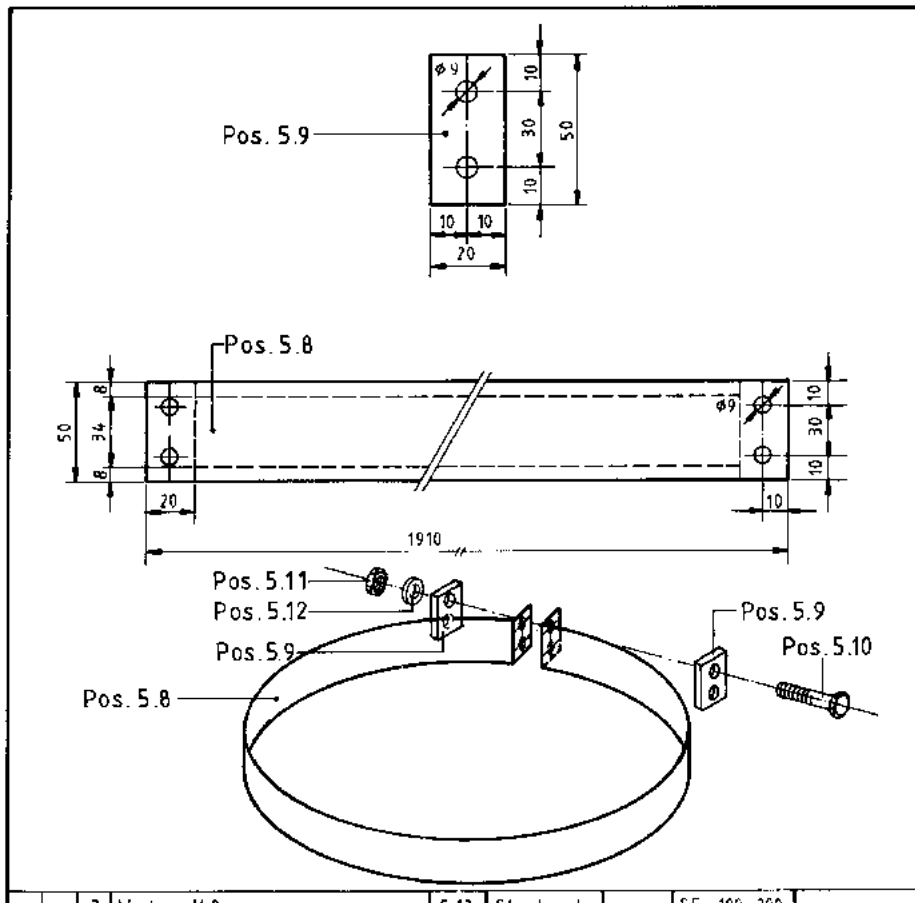
FIGURE

		4	wasner m b	5.10	Steel galv.		SE 100-200		
		2	Hexagone nut M8	5.11	Steel galv.		SE 100-200		
		2	Hexagone screws M8x25	5.10	Steel galv.		SE 100-200		
		4	Screw plates 50x20x3mm	5.9	M S- flat	0.094	SE 100-200		
		2	Cover belt 1910x50mm , 24gauge.	5.8	G.I. Sheet		SE 100-200		
No. of pc	Object			Pos.	Material	Weight	Model	Remarks	
III	II	I	Alterations				Replaced by :		
			COVER BELTS, SCREW PLATES				Scale	drawn by S.kayastha 21.3.90	
							none	checked	M. Nepal 21.3.90
								approved	He 26.5.90
 Mechanical Training Centre Balaju / Kathmandu , Nepal.					No. S-SE-18		Rev.		

FIGURE

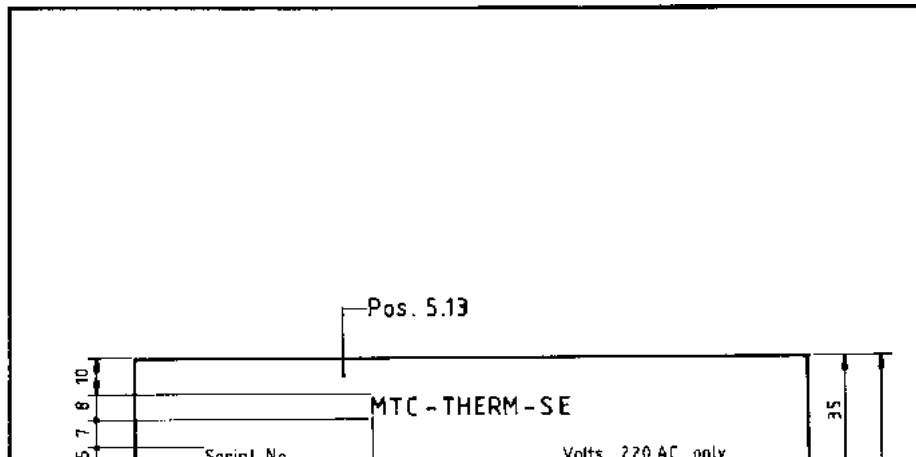

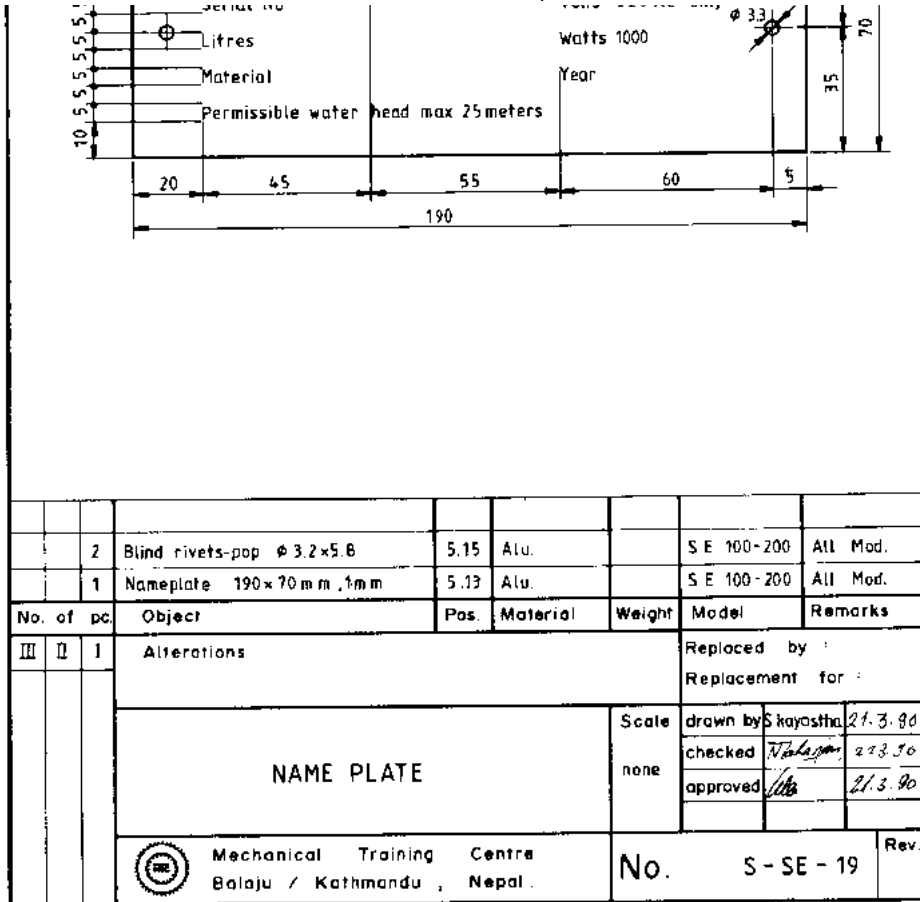

FIGURE

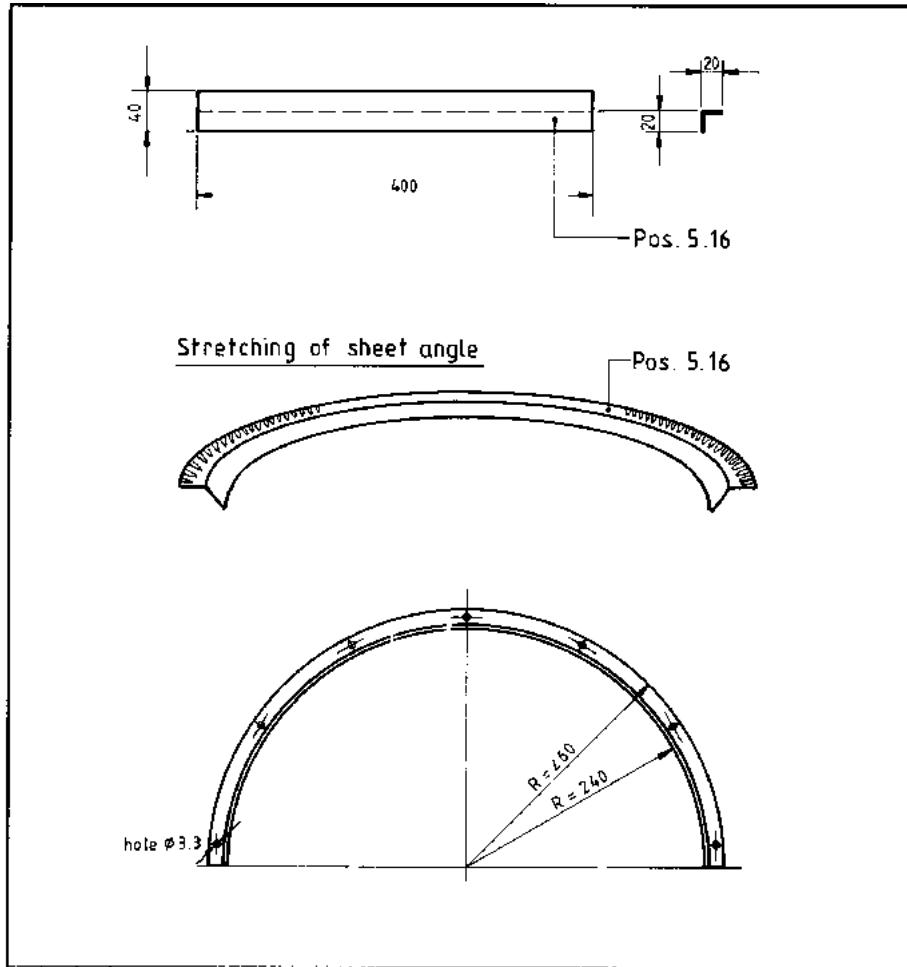

		7	Blind rivets-pop \varnothing 3.2x5.8	5.15	Alu.		SE 100-200	All Mod.		
		1	Sheet angle 400x40, 20 gauge	5.16	G I Sheet		S E 100-200	All Mod.		
No. of pc	Object		Pos	Material	Weight	Model	Remarks			
III	II	I	Alterations			Replaced by Replacement for :				
			WATER SHILD FOR SIDE FLANGE			Scale	drawn by	Shah R.P.	21.3.00	
						none	checked	<i>M. Balaju</i>	21.3.96	
							approved	<i>Shah</i>	21.3.96	
			 Mechanical Training Centre Balaju / Kathmandu, Nepal.			No.	S-SE-20		Rev.	

FIGURE

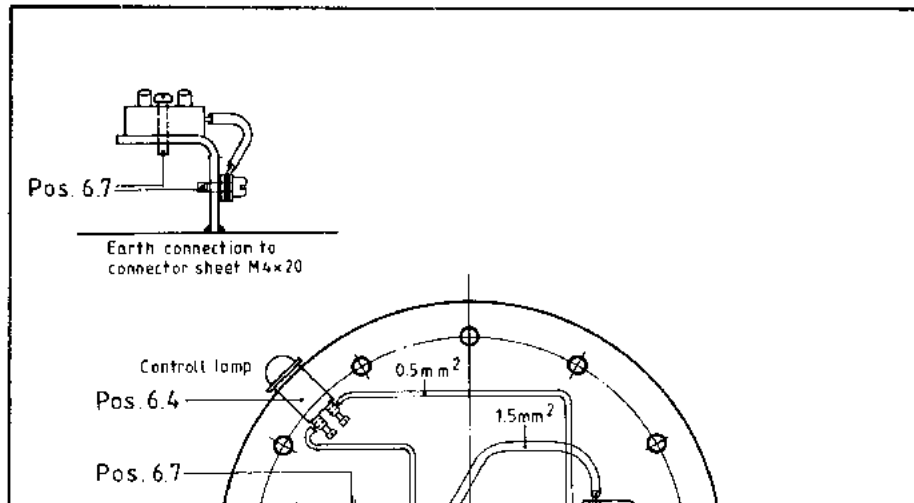

Solar Water Heaters in Nepal (SKAT, 19...

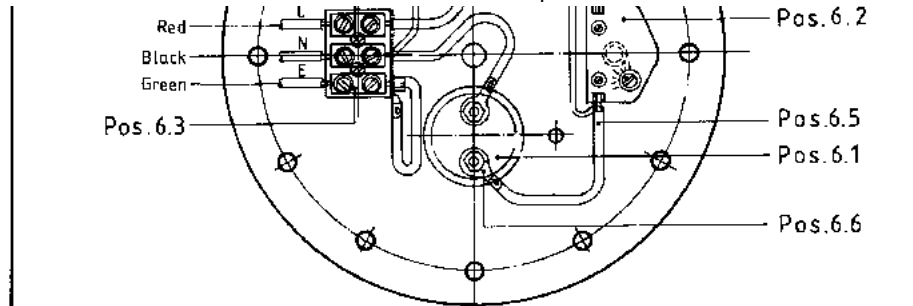



	3	Slotted pen head screw M4x20mm	6.7	Galv.					
	3	Cable shoes	6.6						
		Wire 1.5mm ² , 0.4m	6.5	Cu.		Heat proof			
	1	Control lamp	6.4						
	1	Connector	6.3						
	1	Thermostat, L=280mm, Ø8mm	6.2			230V, 20A			
	1	Heating element, L=280, Ø37	6.1			1000W/230V			
No of pc.		Object	Pos.	Material	Weight	Model	Remarks		
1	1	Alterations				Replaced by : Replacement for :			
		Electric heating/thermostat connection			Scale	drawn by	Skayastha	26.3.90	
					none	checked	<i>He</i>		26.3.90
						approved	<i>He</i>		26.3.90
Mechanical Training Centre Balaju / Kathmandu , Nepal.				No. S-SE-21		Rev			

FIGURE

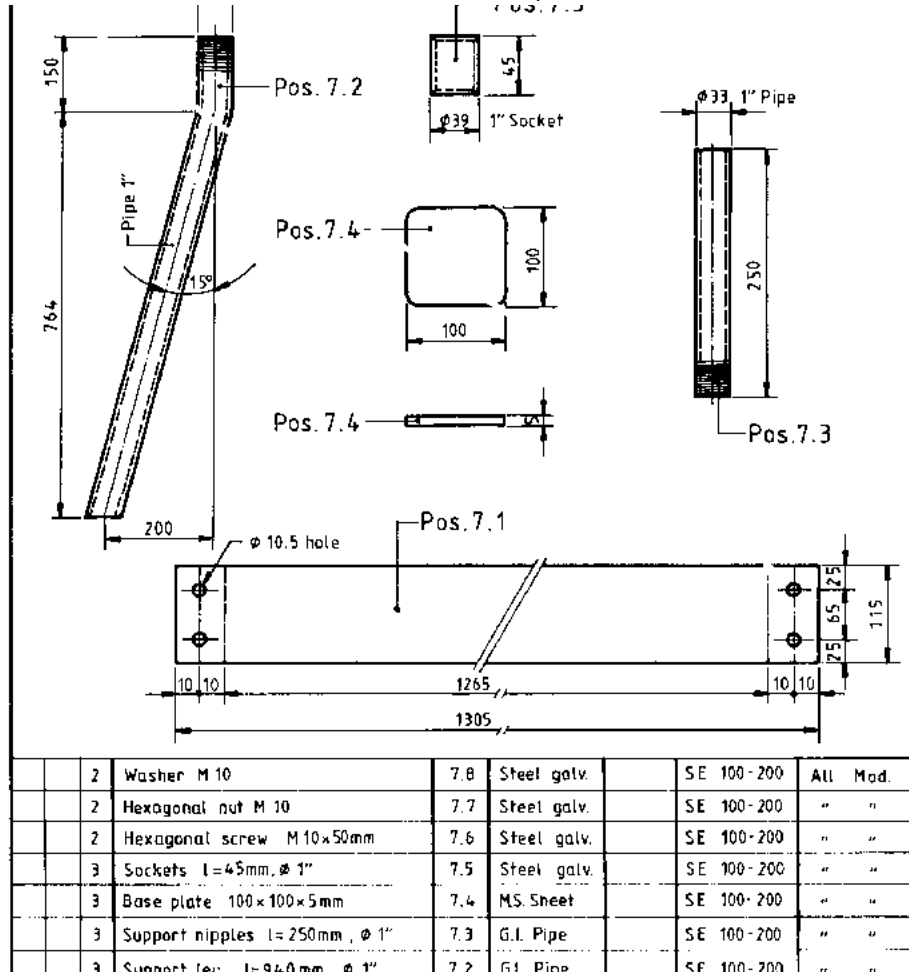

Doc 7 5



		1	Belt 1305x115x3mm	7.1	MS Sheet	SE 100-125			
No. of pc.	Object			Pos	Material	Weight	Model	Remarks	
III	II	I	Alterations Pos 7.2 from 1000 to 940				Replaced by Replacement for :		
			BOILER STAND			Scale	drawn by Skayastha	21.3.90	
						none	checked	<i>Mohy</i>	21.3.90
							approved	<i>kl</i>	21.3.90
 Mechanical Training Centre Balaju / Kathmandu , Nepal.					No. S-SE-22		Rev.		

FIGURE

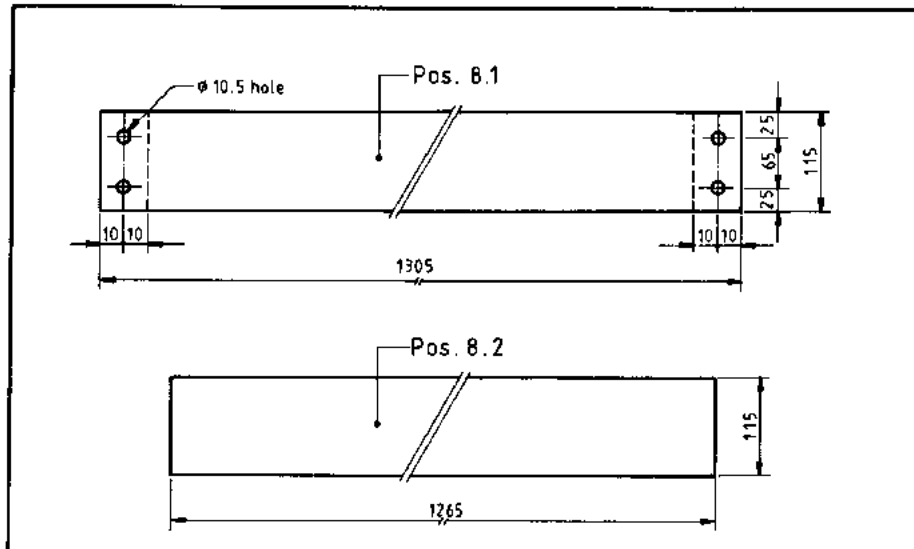

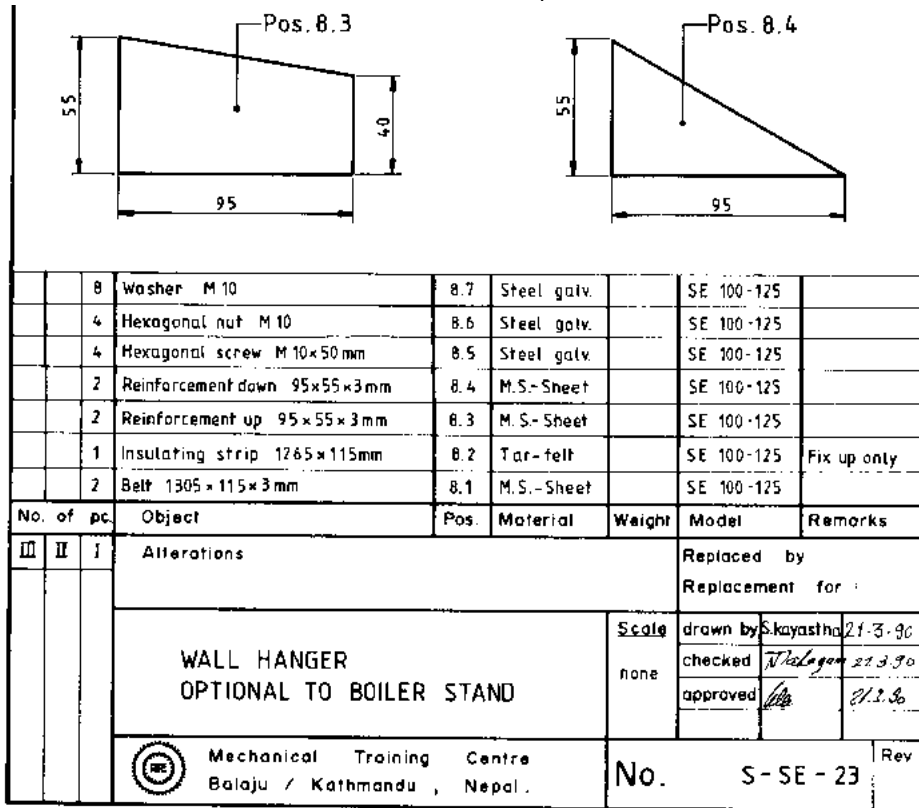

FIGURE

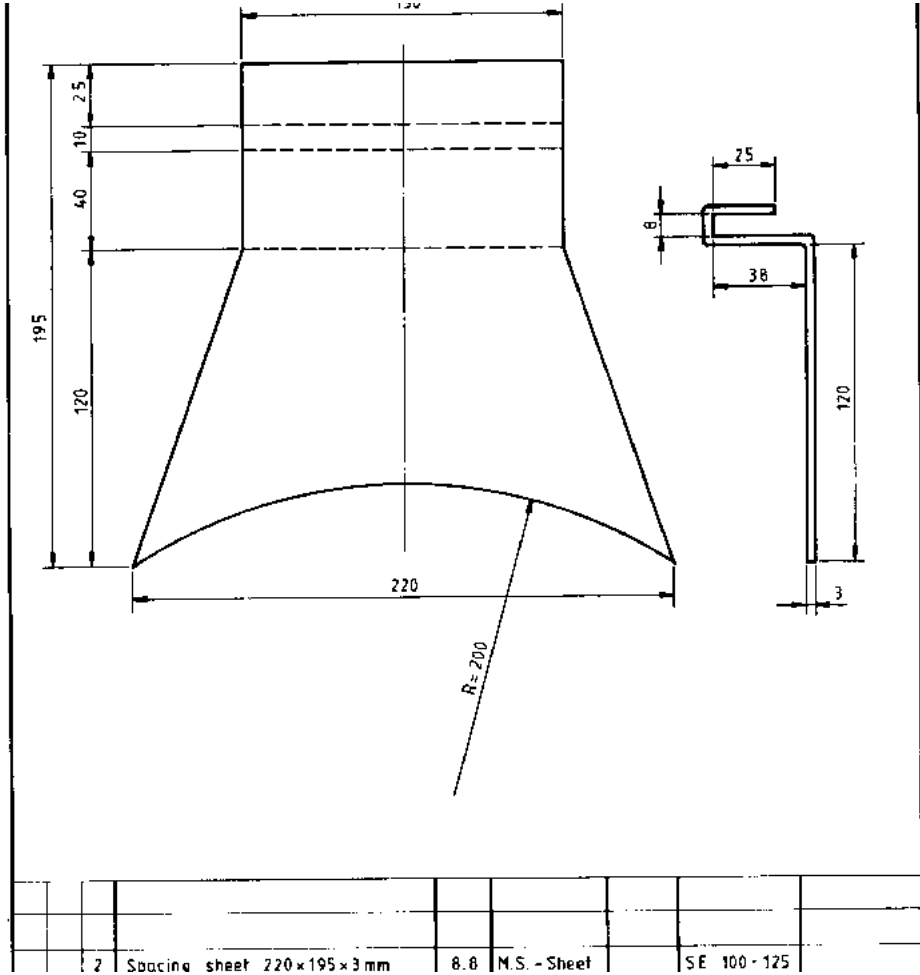

2	Spacing sheet	220 × 195 × 3 mm	8.8	M.S. - Sheet	SE 100 - 125
---	---------------	------------------	-----	--------------	--------------

No. of pc			Object	Pos	Material	Weight	Model	Remarks				
III	II	I	Alterations				Replaced by Replacement for :					
			WALL HANGER OPTIONAL TO BOILER STAND				Scale	drawn by Skayastha	21.3.90			
							none	checked	Maharjan	21.3.90		
								approved	JK	21.3.90		
			 Mechanical Training Centre Bhatju / Kathmandu, Nepal.				No.	S-SE-24	Rev.			

FIGURE

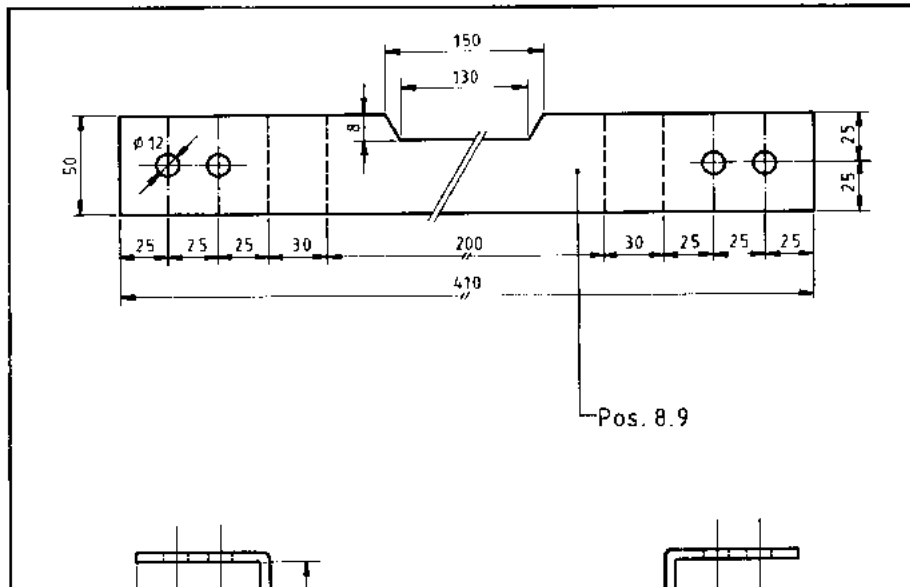

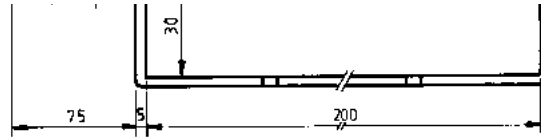

		4	Square head wood screw 100x10	8.11	Steel galv.		SE 100-125				
		4	Wall plugs S12	8.10	Nylon		SE 100-125	(Dowel)			
		2	M.S. Flat 40x50x5mm	8.9	M.S.	0.8	SE 100-125				
No. of pc.			Object	Pos.	Material	Weight	Model	Remarks			
III	II	I	Alterations				Replaced by Replacement for				
			<p>WALL SUPPORT, HANGER OPTIONAL TO BOILER STAND</p>				Scale	drawn by	Skayastha 21.3.90		
							none	checked	Thakur 21.3.90		
								approved	21.2.90		
				Mechanical Training Centre Balaju / Kathmandu, Nepal.			No. S-SE-25		Rev		

FIGURE

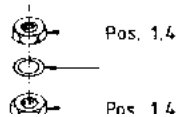

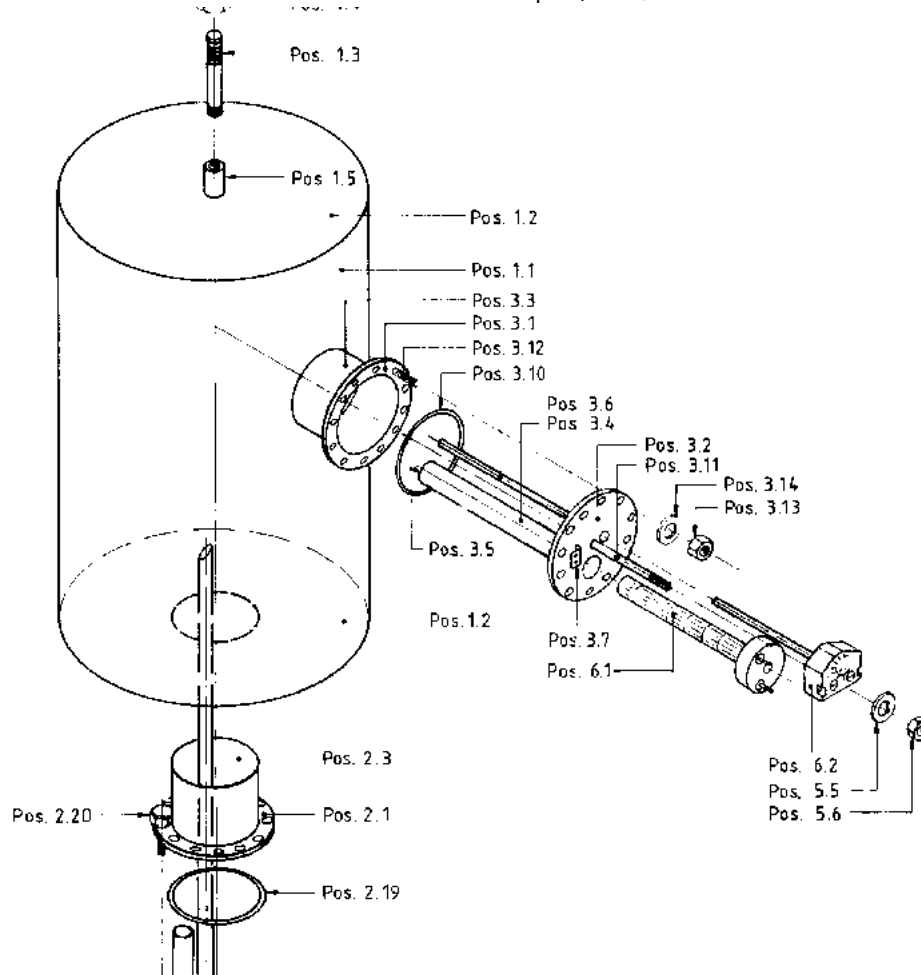

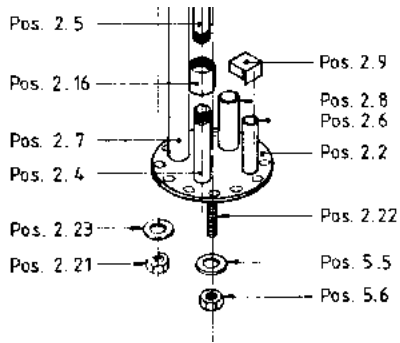

MS-tank, flanges w. water, solar and electro connections

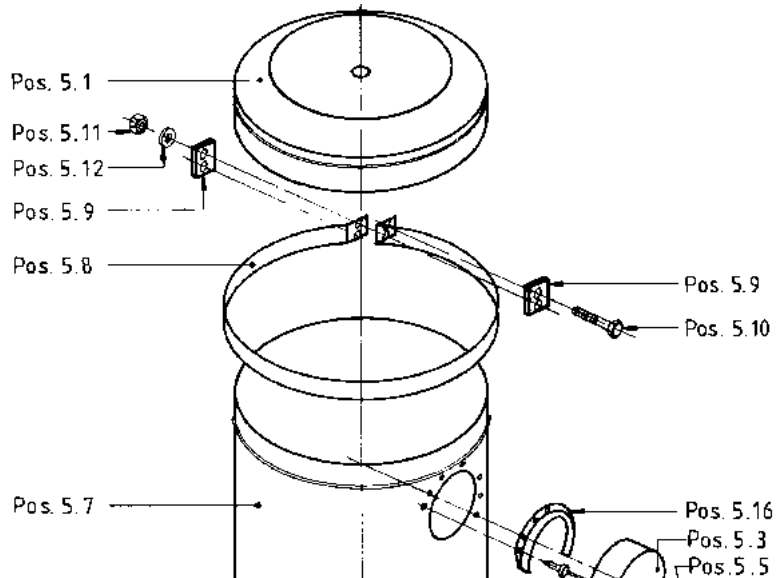

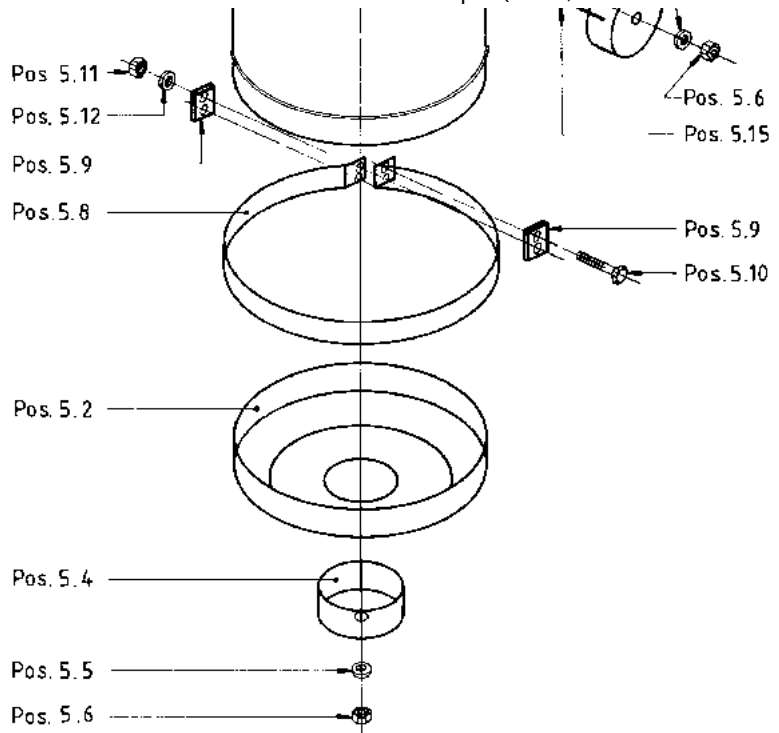

Outside sheet cylinder



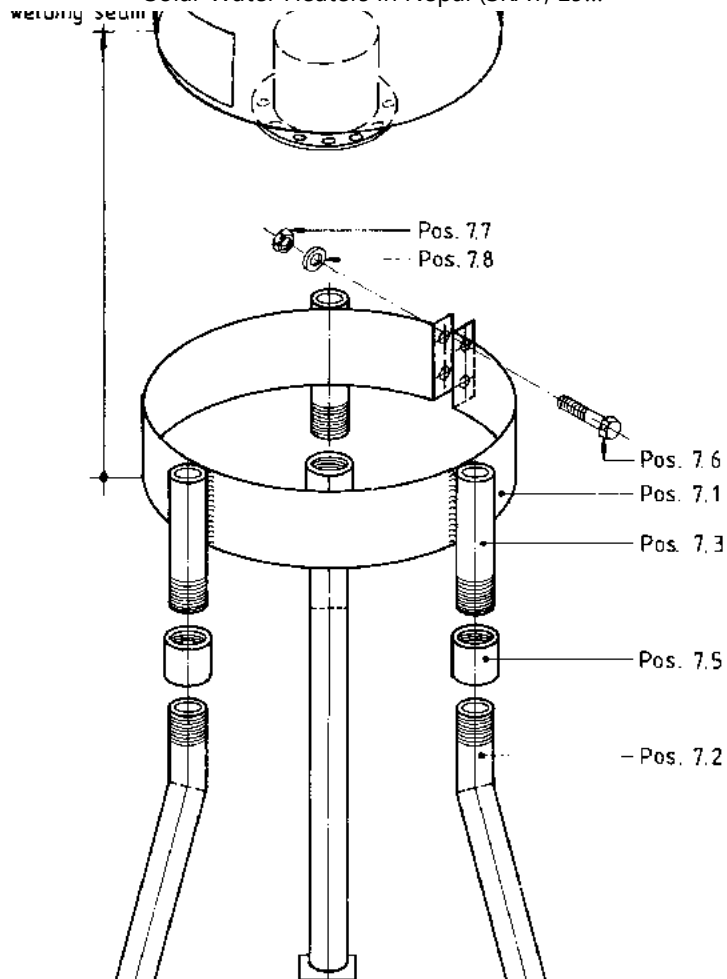

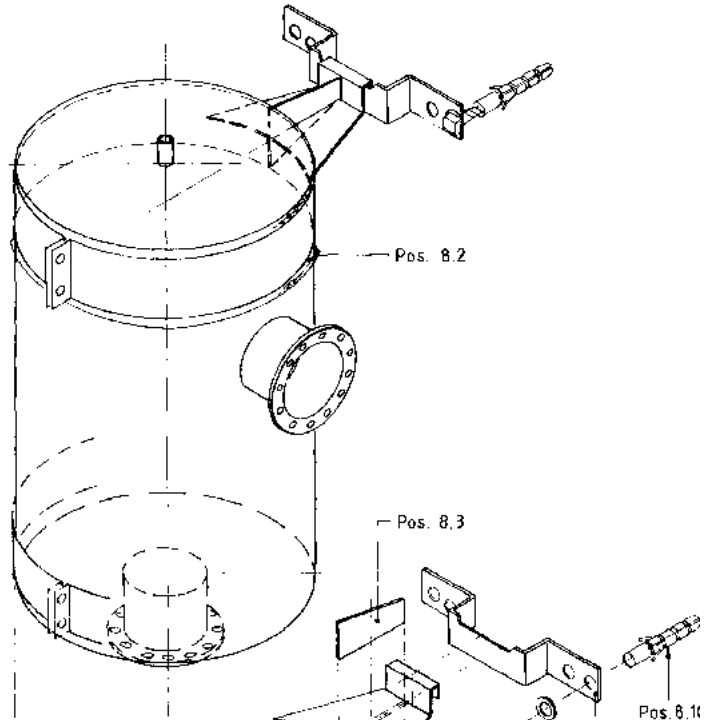
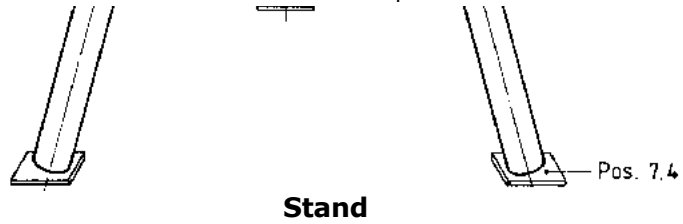

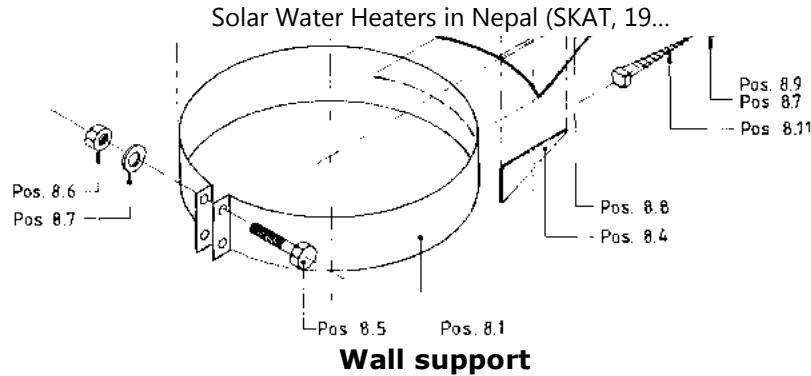

5.2 SOLAR COLLECTOR (SE-85)

Solar collector, MTC-SC-85

Dates:

Collector effective area	1.22 m ²
Weight	47 kg
Contain of water	3.9 ltr.
Test pressure	10 bar
Working pressure	5 bar
Overall size	782 x 1300 x 110 mm
Absorber	36 alu. fins 0.5
Absorber surface	black colour paint
Collector box/frame	galvanized steel sheet 24 gauge, 0.56

Collector box inside/outside 1 coat red oxide, 1 coat dark brown

20/10/2011

Cover

Insulation

Solar Water Heaters in Nepal (SKAT, 19...

single glass 4 mm

50 mm fibreglass

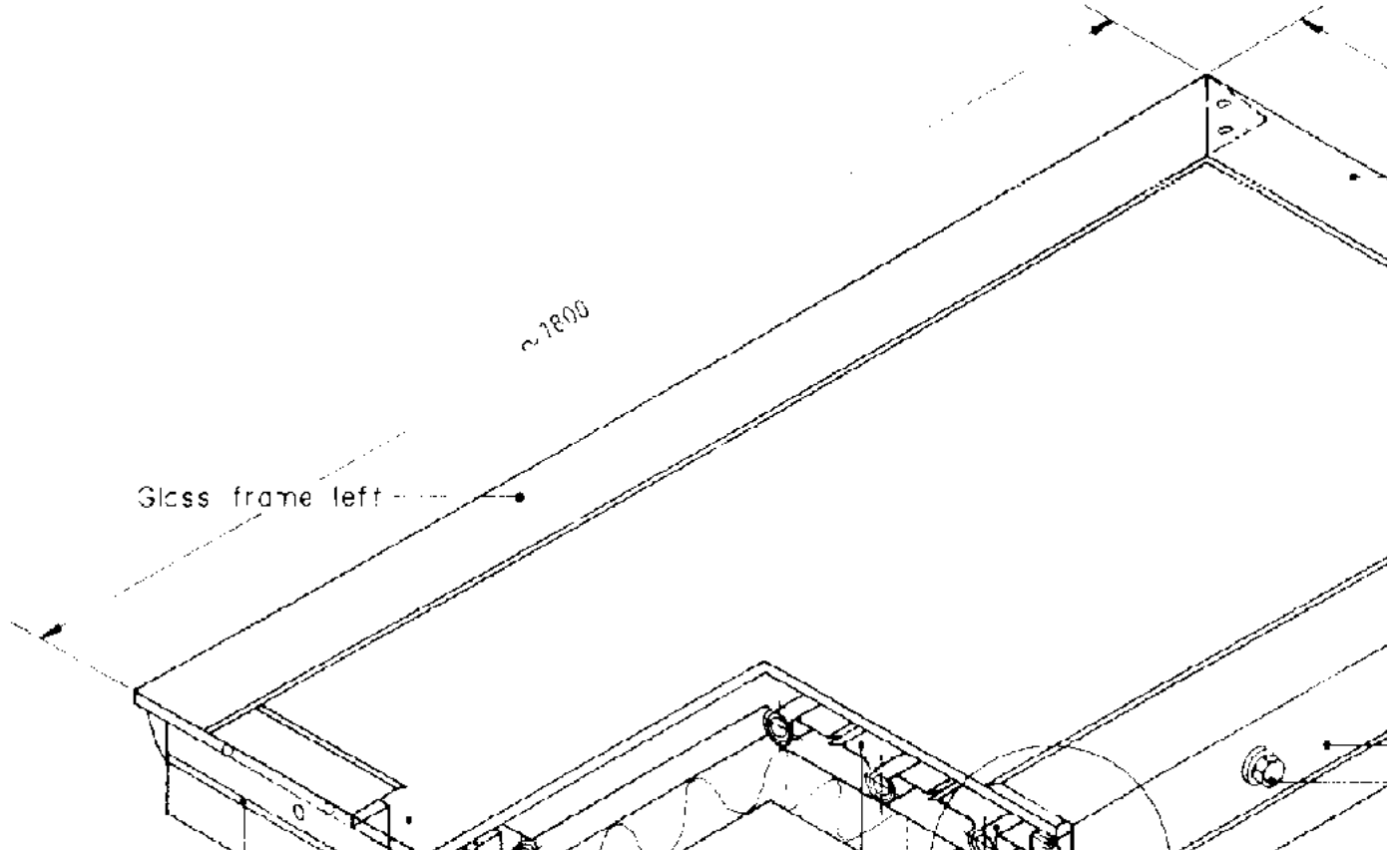

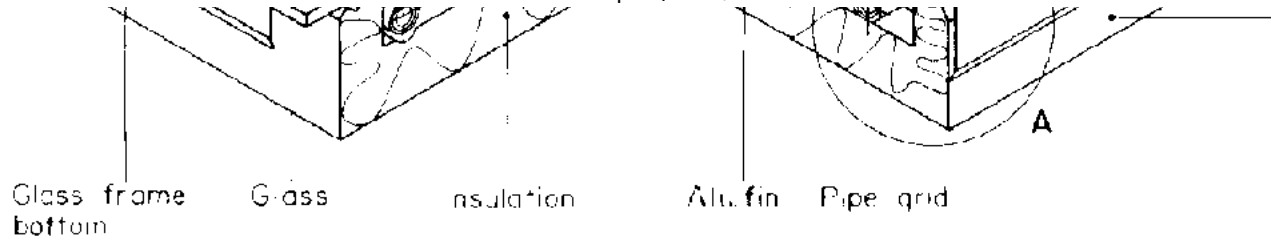

Detail A

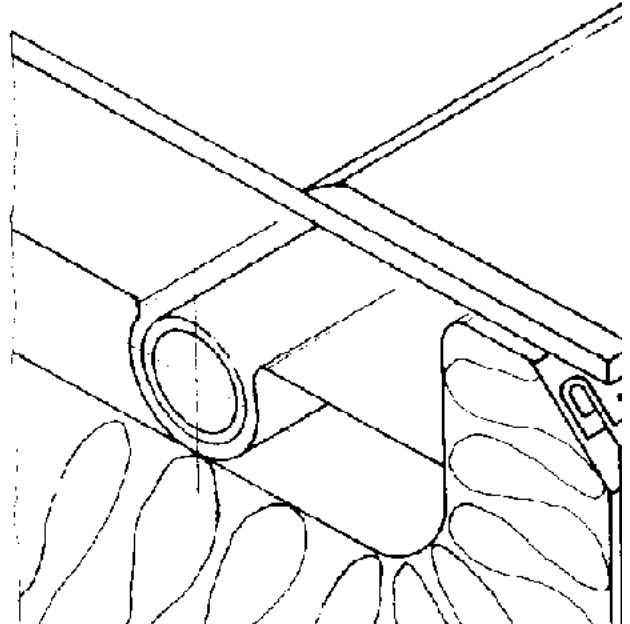

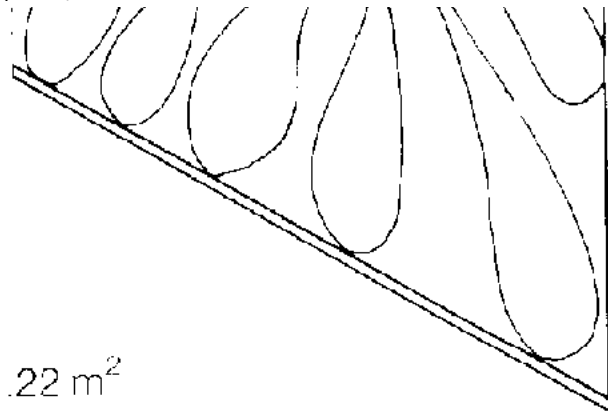



Solar collector, MTC-SC-85

Dates :

Collector effective area	1.22 m ²
Weight	47 kg
Contain of water	3.9 ltr.
Test pressure	10 bar
Working pressure	5 bar
Overall size	782 × 1800 × 110 mm
Absorber	36 alu. fins 0.5
Absorber surface	black clour paint
Collector box/frame	galvanized stee sheet 24 gauge, (
Collector box inside/outside	1 coat red oxyde, 1 coat dark brow
Cover	single glass 4 mm
Insulation	50 mm fibreglass

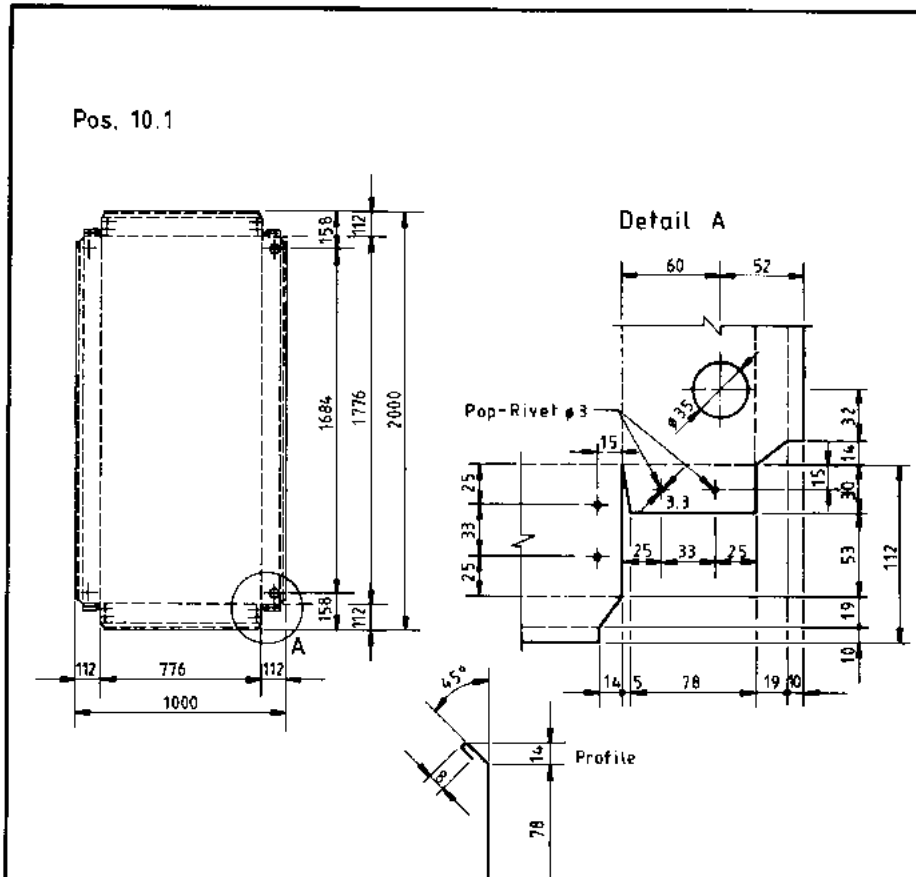
FIGURE



No. of pc.	Object	Pos.	Material	Weight	Model	Remarks		
8	Pop-rivets # 3	10.14	Copper					
1	Collector box 1000x2000mm, 24 g.	10.1	G. I. Sheet					
III	Alterations				Replaced by :			
II	COLLECTOR BOX				Replacement for :			
I					Scale	drawn by	<i>ES</i>	22.4.90
					none	checked	<i>TR</i>	22.4.90
			approved	<i>ide</i>	22.4.90			
 Mechanical Training Centre Balaju / Kathmandu , Nepal .				No. S-SC-01		Rev.		

FIGURE

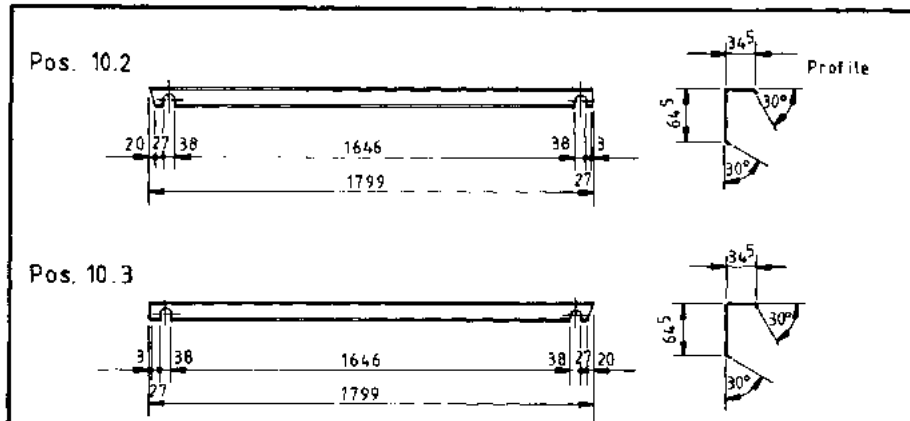

Pos. 10.2+10.3

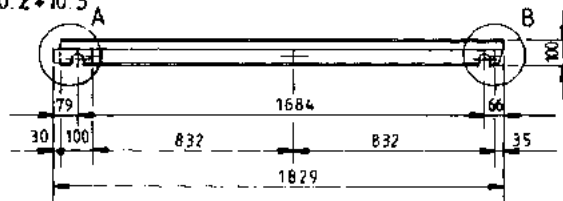

Detail A

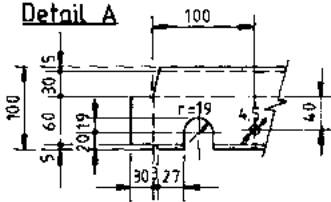

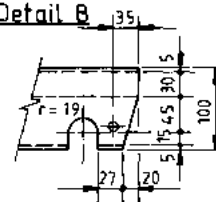

Detail B

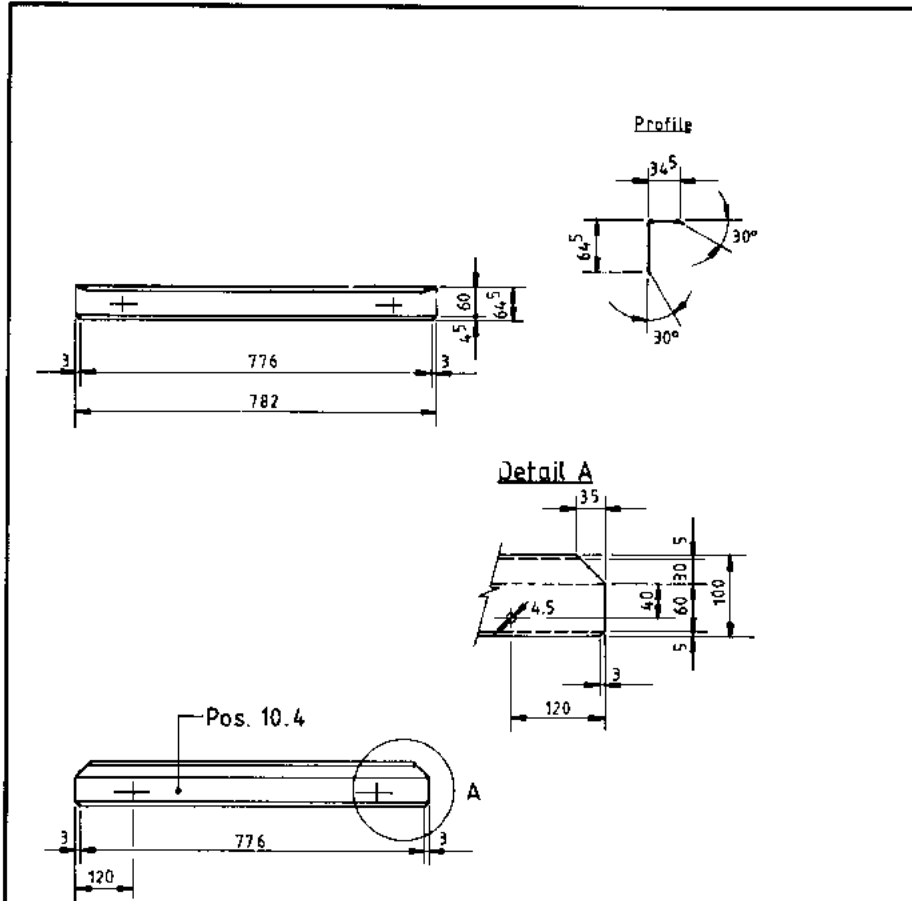

	1	Frame right 1829 x 100, 24 g.	10.3	G. I.-Sheet			
	1	Frame left 1829 x 100, 24 g.	10.2	G. I.-Sheet			
No. of pc	Object		Pos.	Material	Weight	Model	Remarks
III	II	I	Alterations			Replaced by :	
						Replacement for :	
			GLASS FRAME LEFT/RIGHT SIDE			Scale	drawn by <i>SKA</i> 22.4.90
						none	checked <i>N. Khatiwada</i> 22.4.90
							approved <i>Ala.</i> 22.4.90
 Mechanical Training Centre Balaju / Kathmandu, Nepal.				No. S-SC-02		Rev	

FIGURE



		1	Frame top 782x100mm, 24 g.	10.4	G.I. Sheet			
No. of pc.	Object			Pos.	Material	Weight	Model	Remarks
III	II	I	Alterations			Replaced by : Replacement for :		
			GLASS FRAME TOP			Scale	drawn by	<i>B. Saha</i> 21.4.90
						none	checked	<i>N. Kalyan</i> 22.4.90
							approved	<i>Ala</i> 22.4.90
			 Mechanical Training Centre Balaju / Kathmandu , Nepal.			No. S-SC-03		Rev.

FIGURE

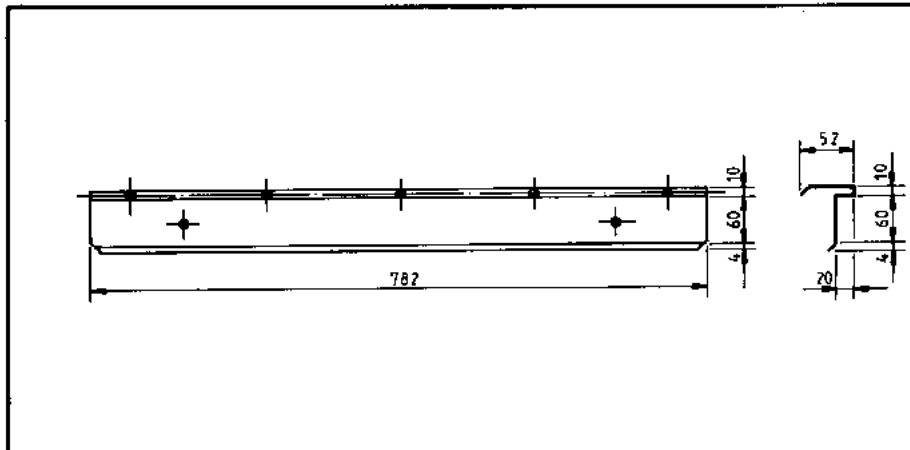

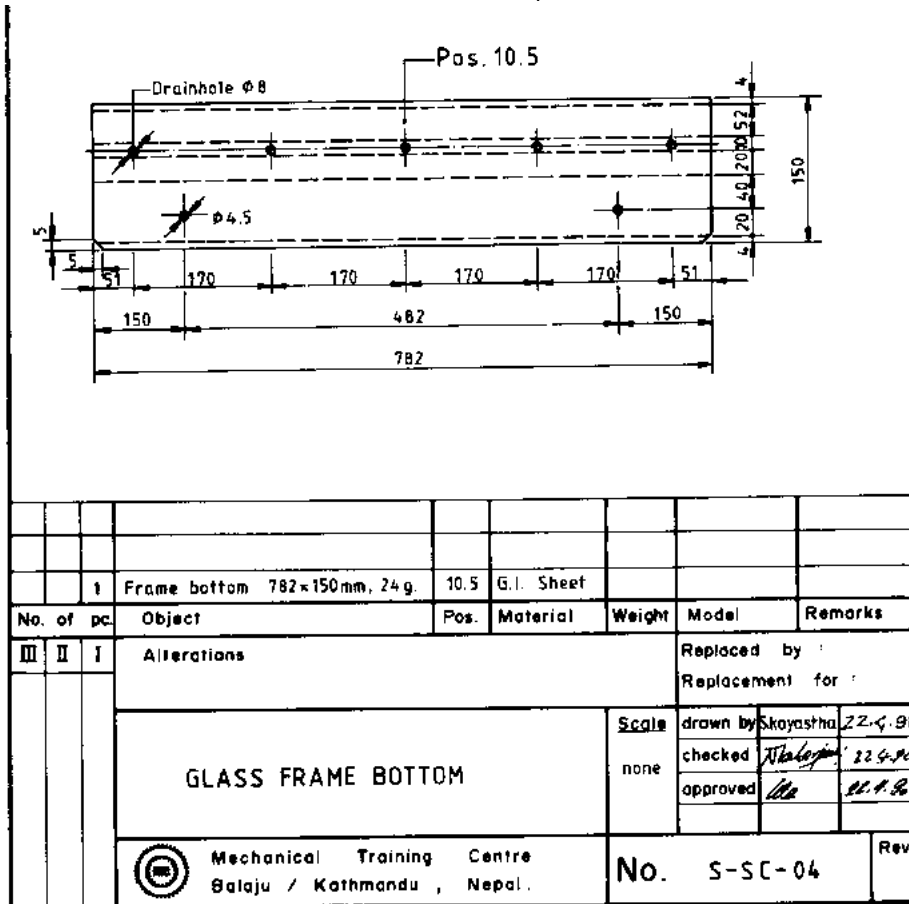

FIGURE

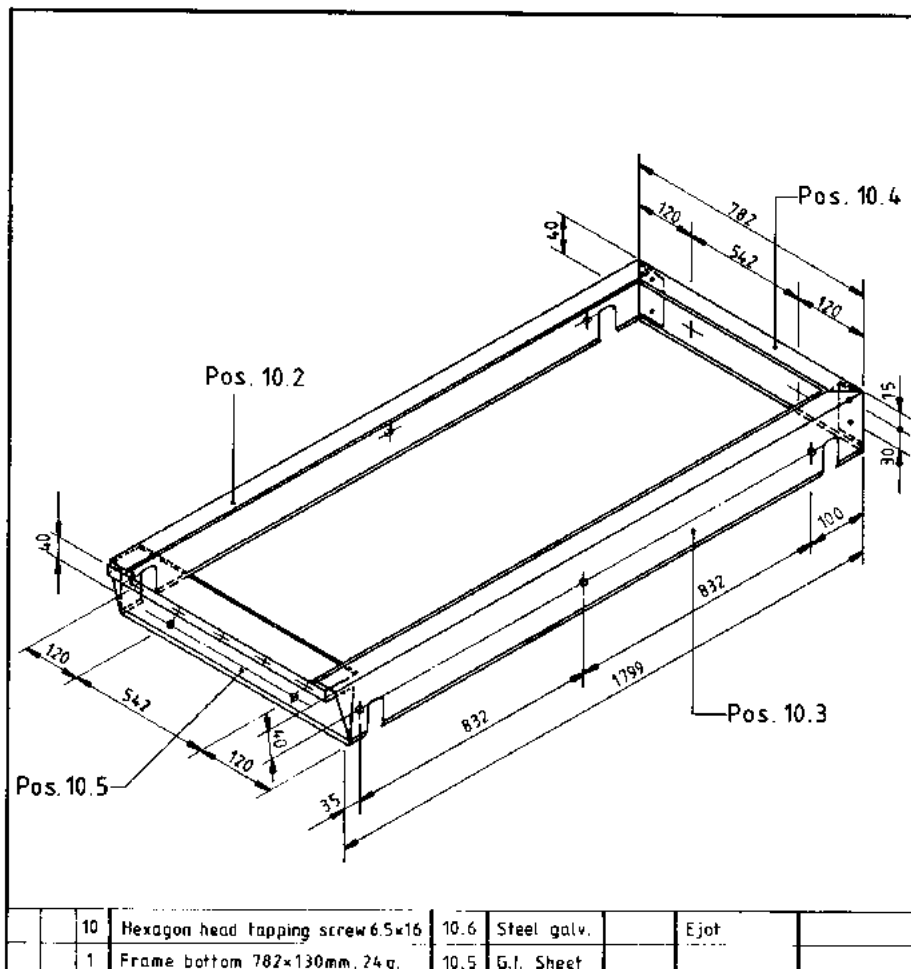

		1	Frame top 782×100 mm, 24 g.	10.4	G.I. Sheet			
		1	Frame right 1829×100 mm, 24 g.	10.3	G.I. Sheet			
		1	Frame left 1829×100 mm, 24 g.	10.2	G.I. Sheet			
No. of pc.		Object	Pos.	Material	Weight	Model	Remarks	
III	II	I	Alterations			Replaced by :		
			GLASS FRAME (ASSEMBLY)			Scale	drawn by	22.4.90
						none	checked	21.9.97
							approved	22.4.96
		 Mechanical Training Centre Balaju / Kathmandu, Nepal.			No.	S-SC-05	Rev.	

FIGURE

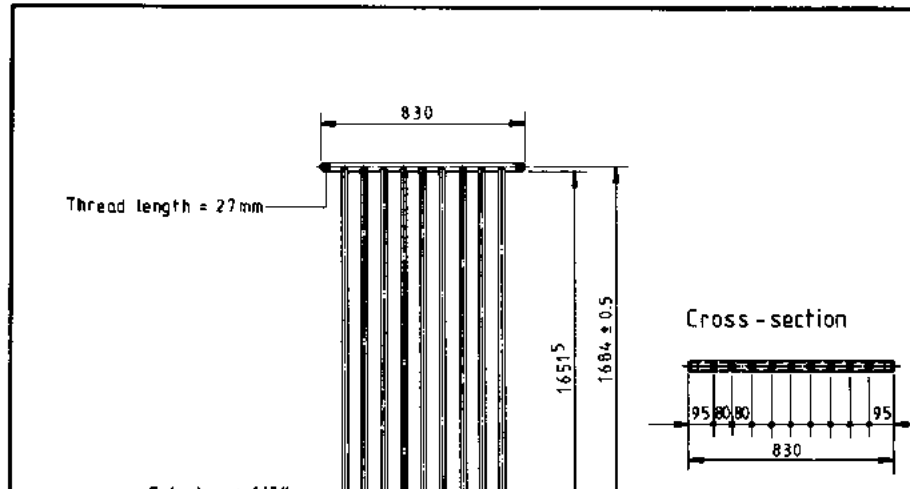

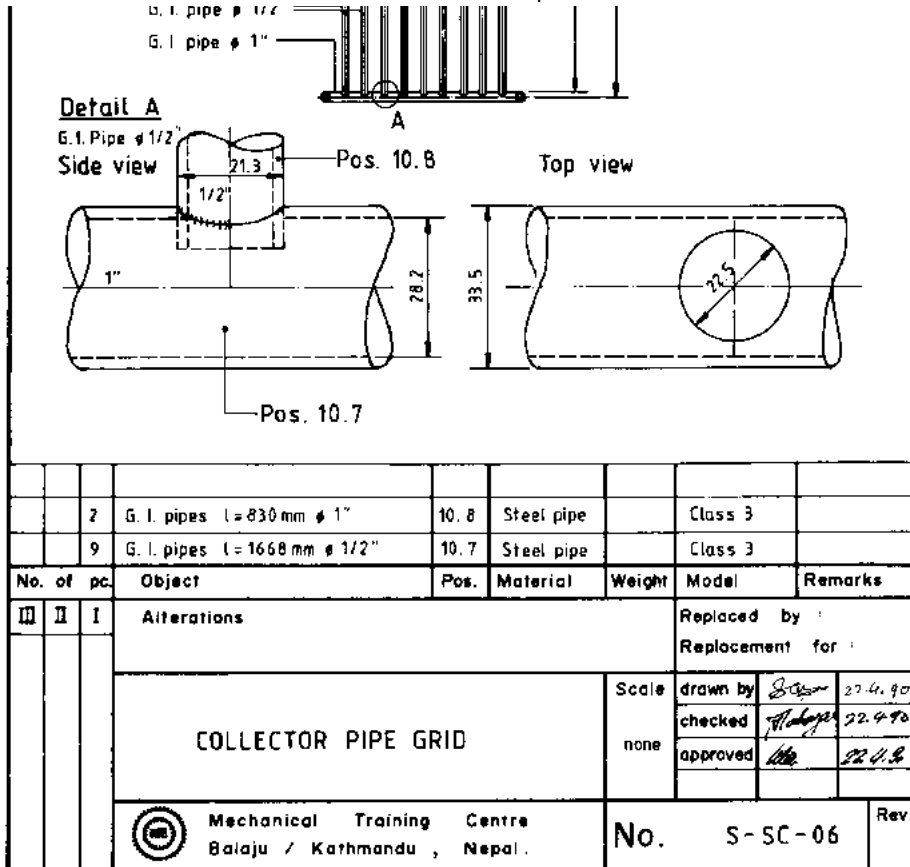

FIGURE

Pos. 10.9

Top view

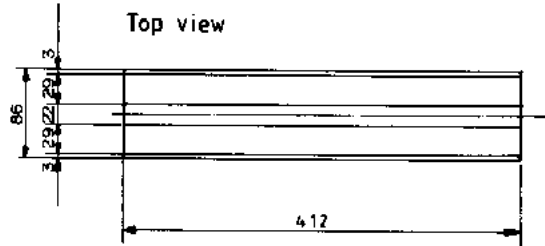

Front view

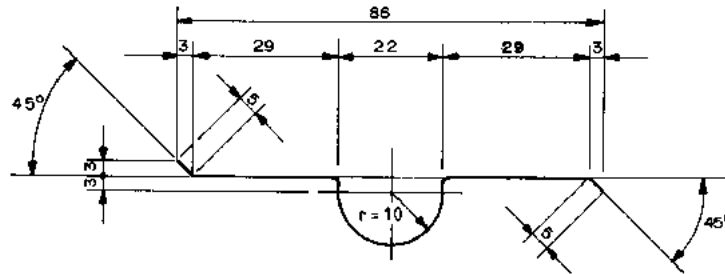

72	Crescent rings 27.7 x 21.7	10 10	Spring steel	Shaft d 7.4
----	----------------------------	-------	--------------	-------------

		36	Alu. fins 412 x 120 mm, 26 g.	10.9	Alu			
No. of pc		Object		Pos.	Material	Weight	Model	Remarks
III	II	I	Alterations			Replaced by Replacement for:		
ALU. FIN					Scale	drawn by	Shoh R.P.	22.4.90
					none	checked	<i>[Signature]</i>	22.4.90
						approved	<i>[Signature]</i>	22.4.90
		 Mechanical Training Centre Balaju / Kathmandu, Nepal		No. S-SC-07		Rev		

FIGURE

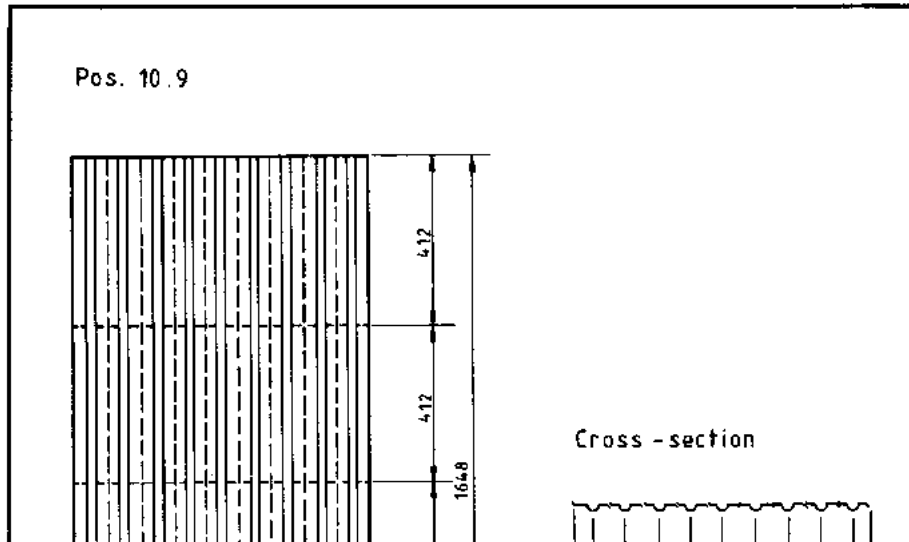

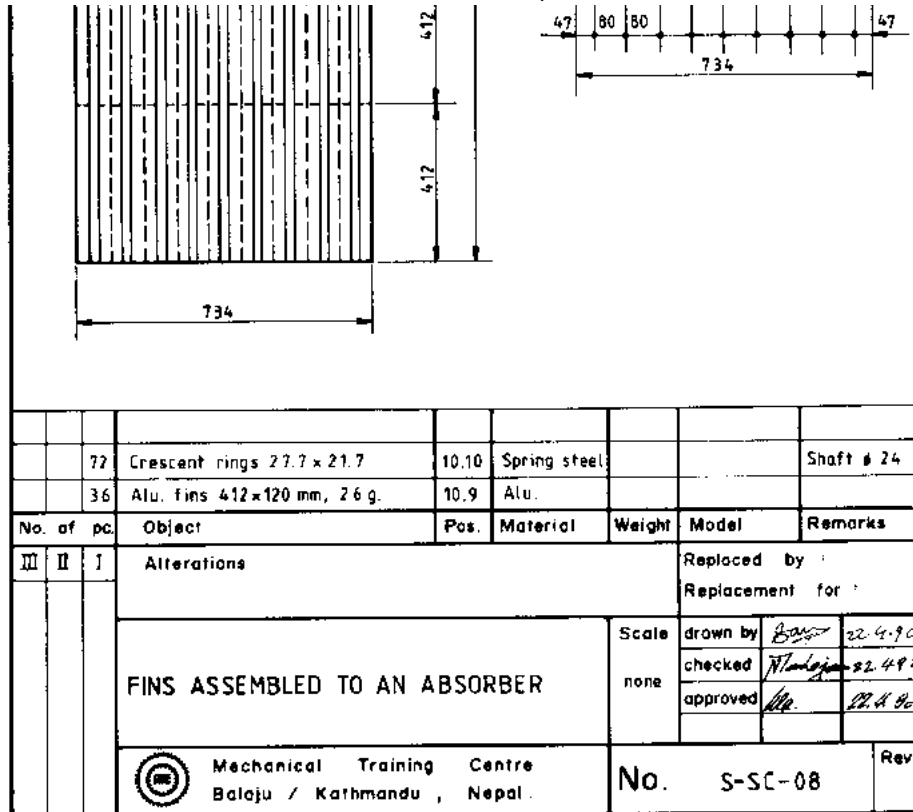

FIGURE

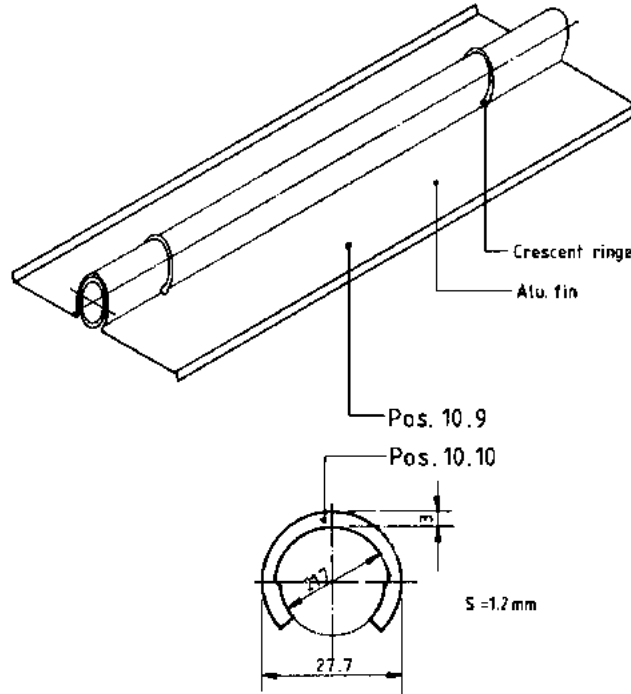

	72	Crescent rings	27.7 × 21.7	10.10	Spring steel	Shaft ø 24
	36	Alu. fins	400 × 108 mm, 26 g.	10.9	Alu.	

No. of pc.			Object	Pos.	Material	Weight	Model	Remarks	
III	II	I	Alterations					Replaced by : Replacement for :	
			FIN FIXING TO 1/2" GI - PIPE			Scale none	drawn by	B. P. P.	22.4.90
		checked					M. P. P.	22.4.90	
		approved					M. P. P.	22.4.90	
 Mechanical Training Centre Balaju / Kathmandu , Nepal.						No. S-SC-09		Rev.	

FIGURE

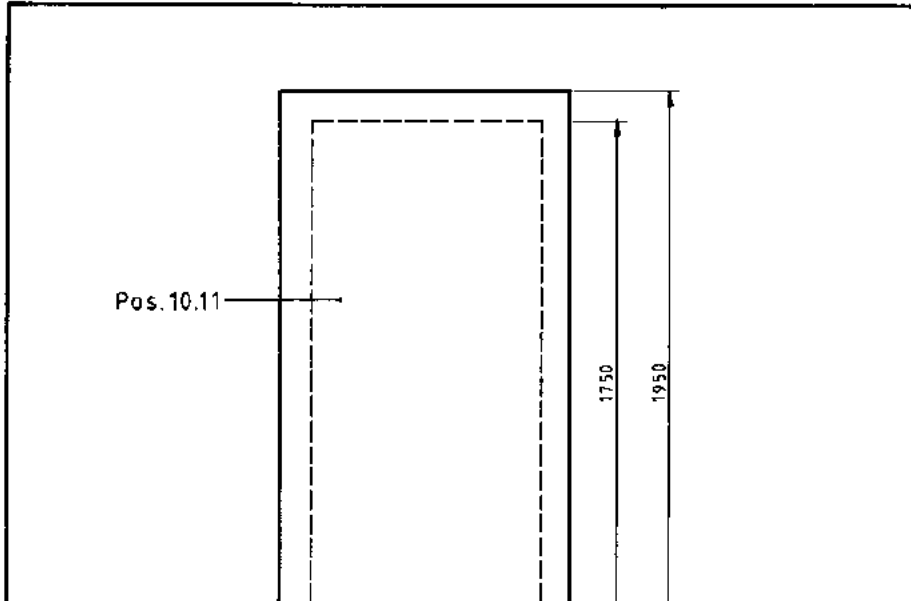

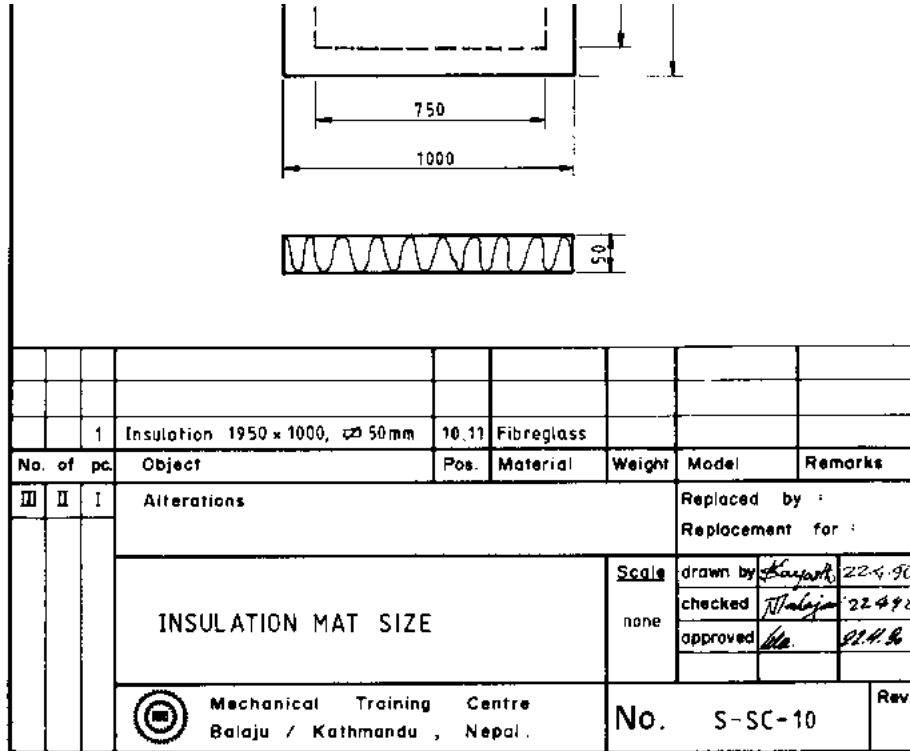

FIGURE



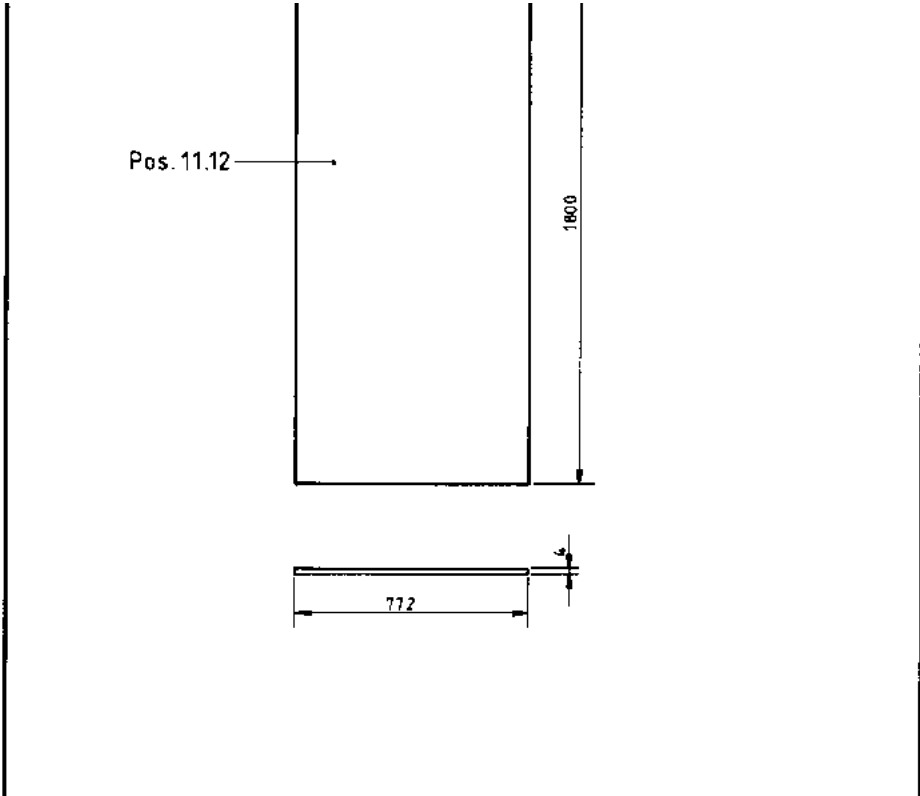

	1	U Profile	l = 5.3 m.	10.13	Rubber		U-channel	See assembly drawing.
	1	Glass	1800 × 772 × 4 mm	10.12	Glass			
No. of pc		Object		Pos.	Material	Weight	Model	Remarks
III	II	I	Alterations				Replaced by :	

GLASING	Scale none	Replacement for :	
		drawn by	<i>S. K. M.</i> 22.9.90
		checked	<i>T. K. P.</i> 22.9.90
		approved	<i>M. K.</i> 27.9.90
 Mechanical Training Centre Balaju / Kathmandu , Nepal.		No. S-SC-11	Rev.

FIGURE

5.3 SUPPORT FOR TWO COLLECTORS

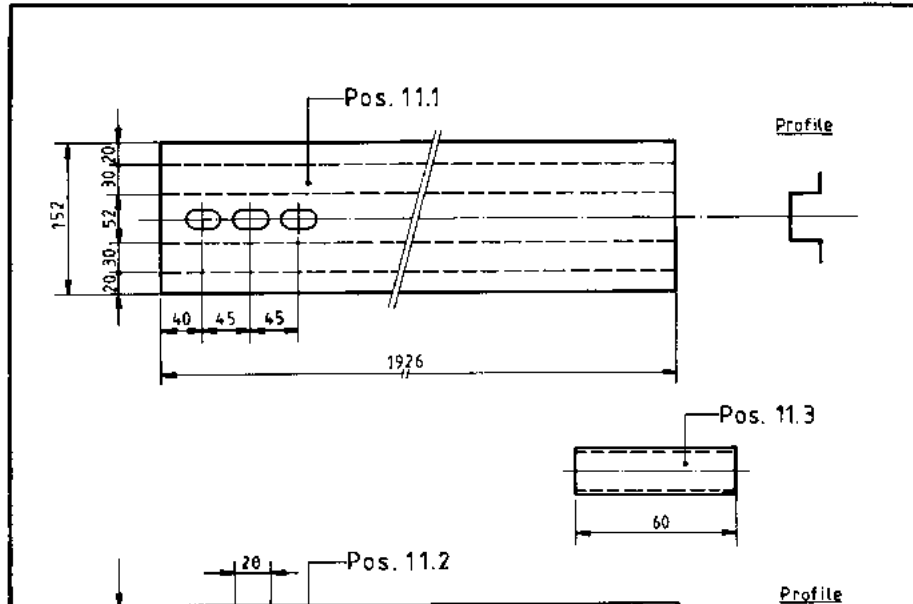

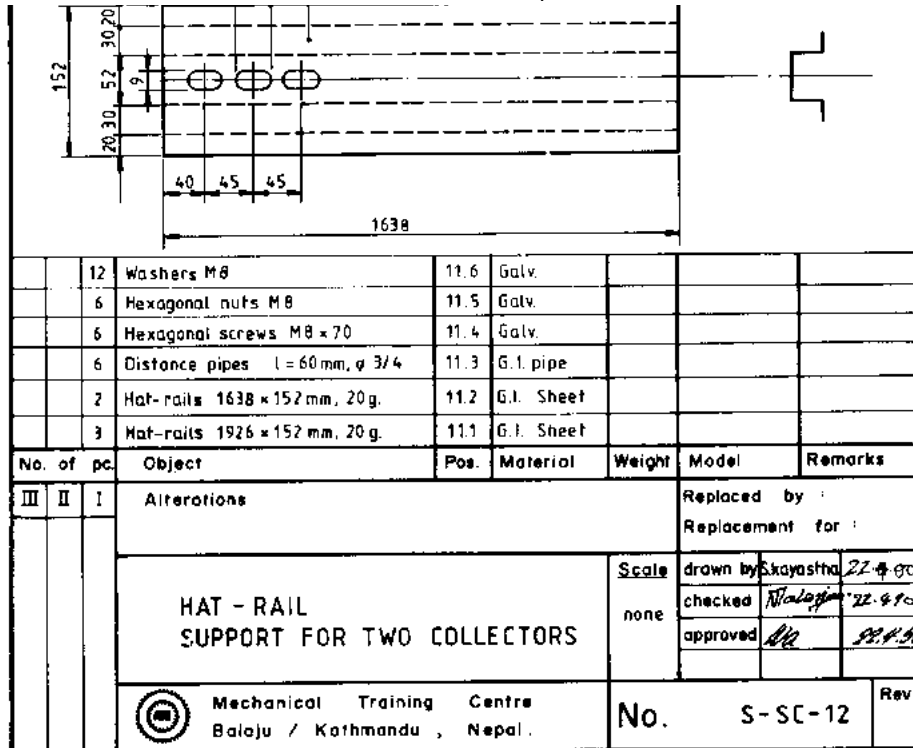

FIGURE



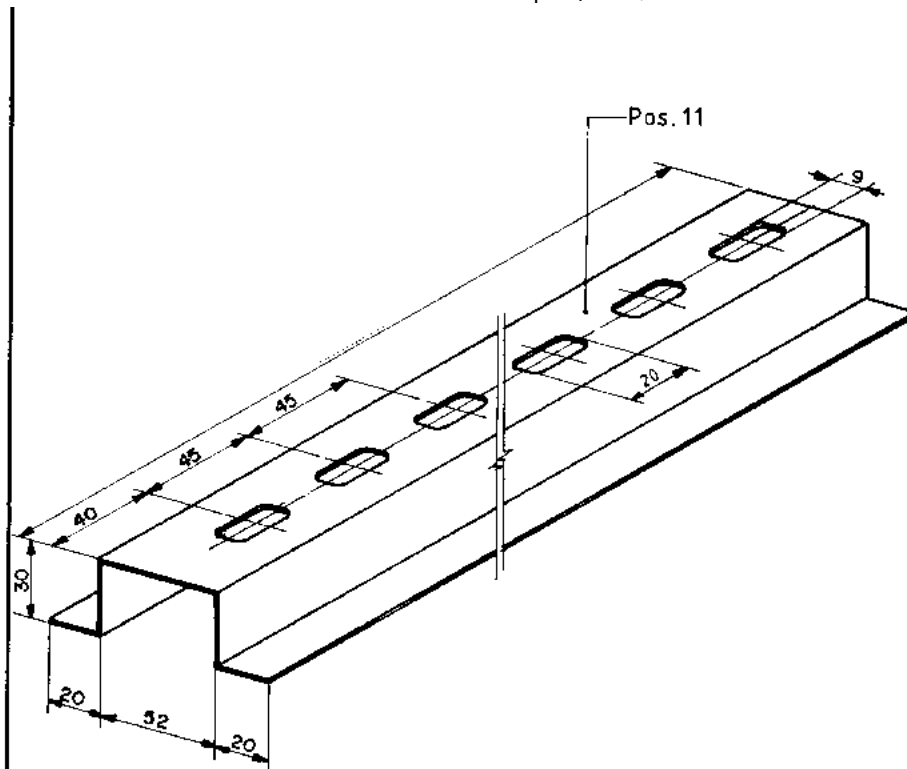

No. of pc	Object	Pos.	Material	Weight	Model	Remarks
	Top hat rail 152 x , 20g.	11	G.I. Sheet		SC - 86	
III	Alterations				Replaced by	

HAT - RAIL		Replacement for	
		Scale	drawn by Shah R.P. 22.4.90
		none	checked <i>[Signature]</i> 22.4.90
approved <i>[Signature]</i> 22.4.90			
 Mechanical Training Centre Balaju / Kathmandu, Nepal.	No. S-SC-13		Rev

FIGURE

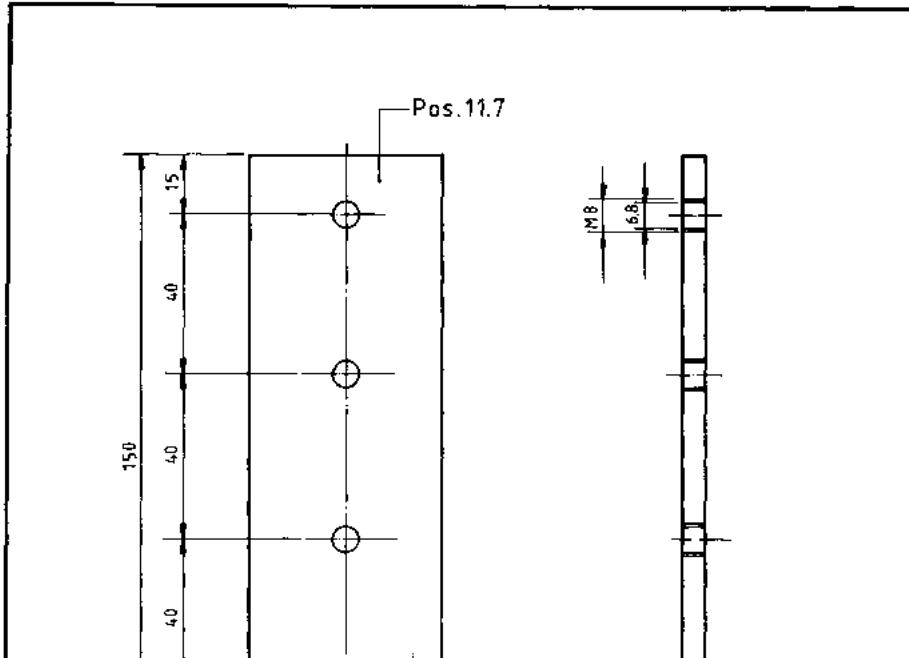

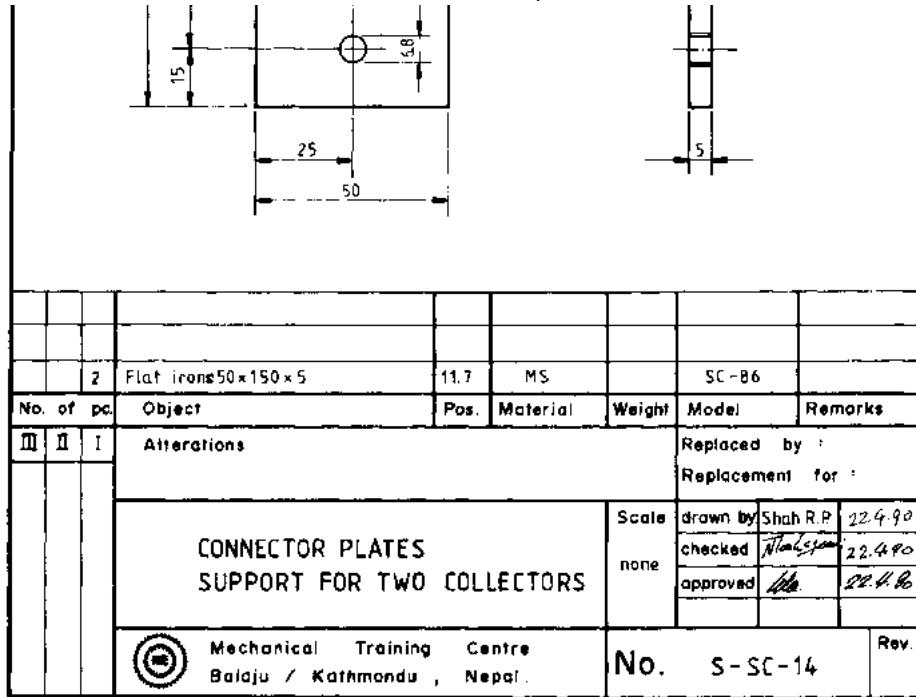

FIGURE

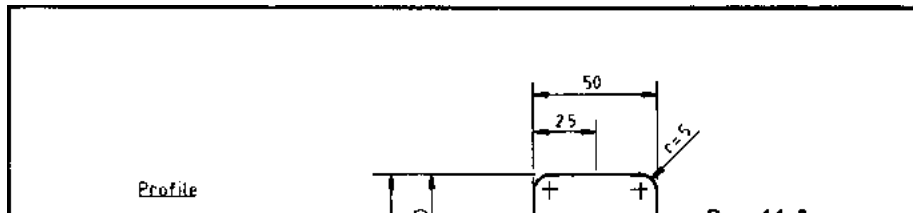

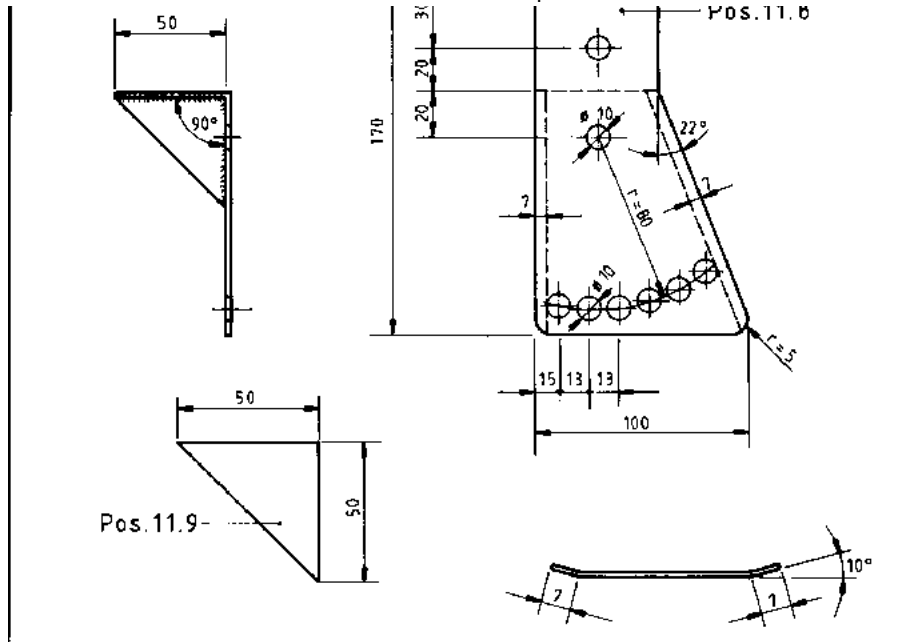

			4	Washers M8	11.12	Galv.			
			4	Hexagonal nuts M8	11.11	Galv.			
			4	Hexagonal screws M 8x20	11.10	Galv.			
			2	Reinforcem. triangles 50x50, 3mm	11.9	M. S. Sheet			
			2	Support sheets 100x170, 3mm	11.8	M. S. Sheet			
No. of	pc.	Object	Pos.	Material	Weight	Model	Remarks		
III	II	I	Alterations				Replaced by :		
							Replacement for :		
					Scale	drawn by	<i>[Signature]</i>	22.4.90	

ADJUSTABLE SUPPORT SHEET FOR TWO COLLECTORS	none	checked <i>N. K. K. K.</i>	22.9.90
		approved <i>N. K. K. K.</i>	22.8.90
 Mechanical Training Centre Balaju / Kathmandu , Nepal.	No. S-SC-15	Rev.	

FIGURE

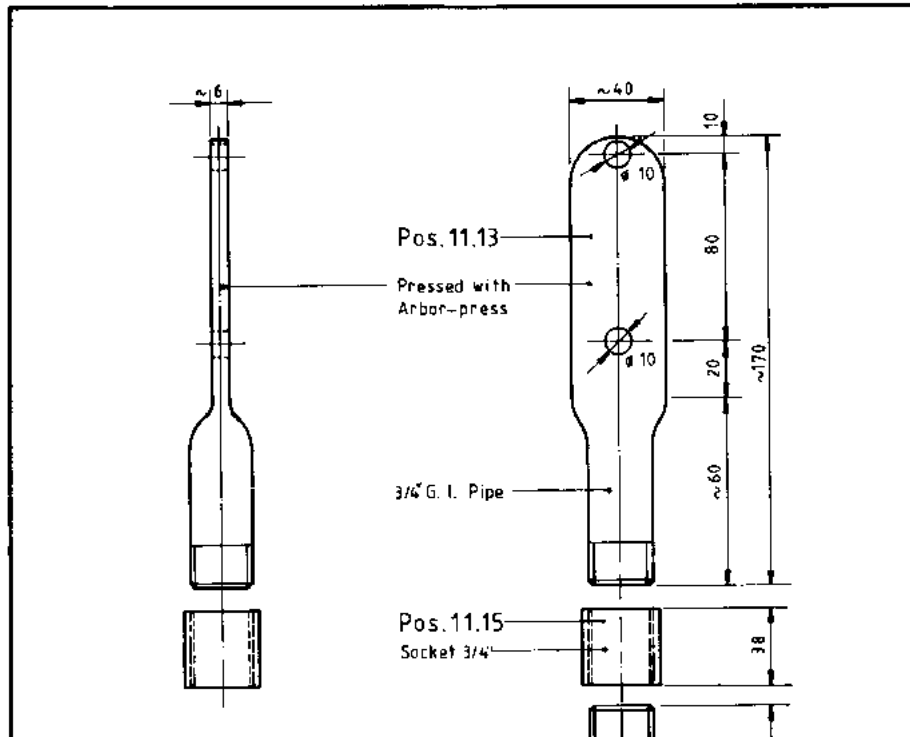

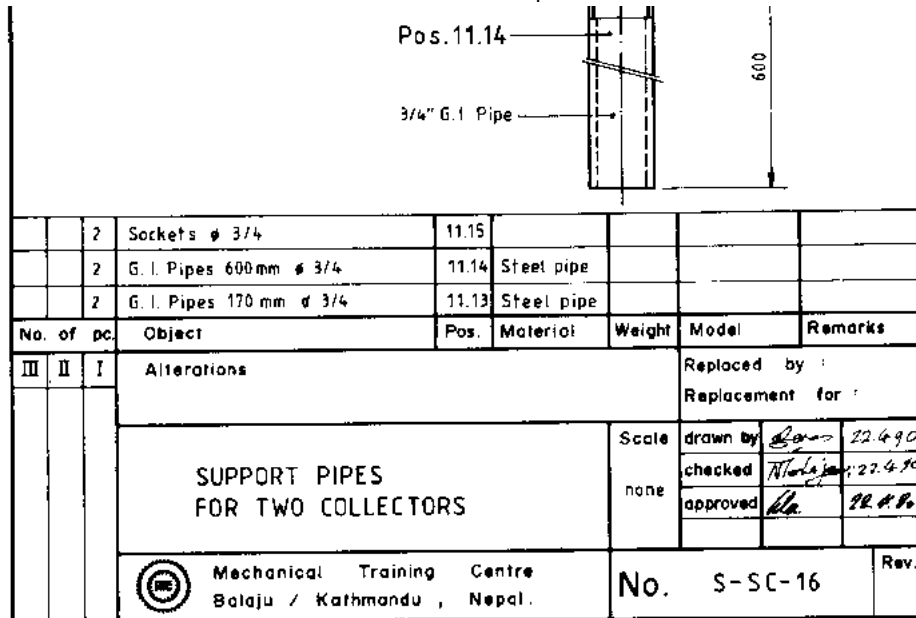

FIGURE

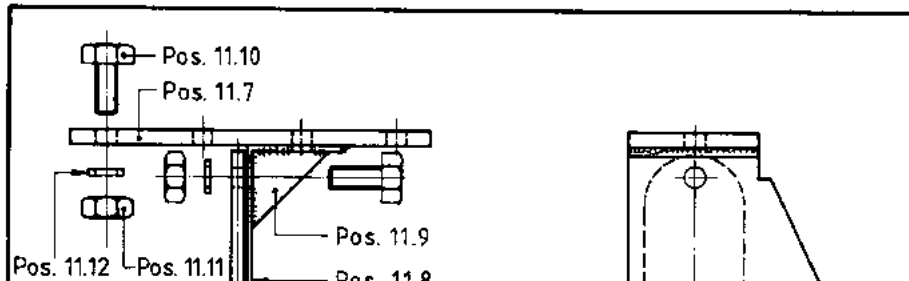

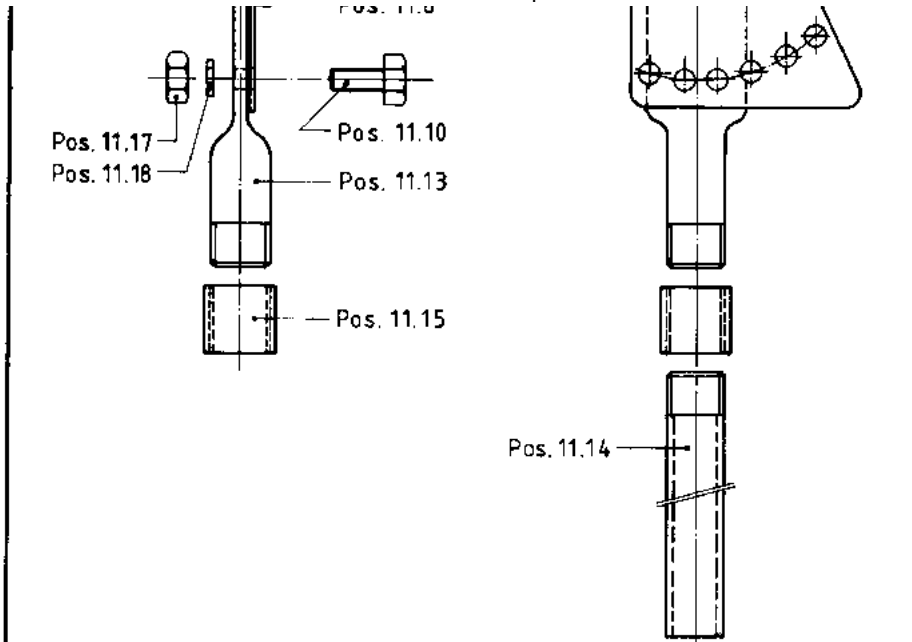



	4	Washers M8	11.18					
	4	Hexagonal nuts M8	11.17					
	4	Hexagonal screws M 8x20	11.16					
No. of	pc.	Object	Pos.	Material	Weight	Model	Remarks	
III	II	I	Alterations				Replaced by :	
							Replacement for :	
SUPPORT PIPES FOR TWO COLLECTORS					Scale	drawn by	22.4.90	
					none	checked	22.9.90	
					approved		22.11.90	

	Mechanical Training Centre Balaju / Kathmandu , Nepal.	No. S-SC-17	Rev.

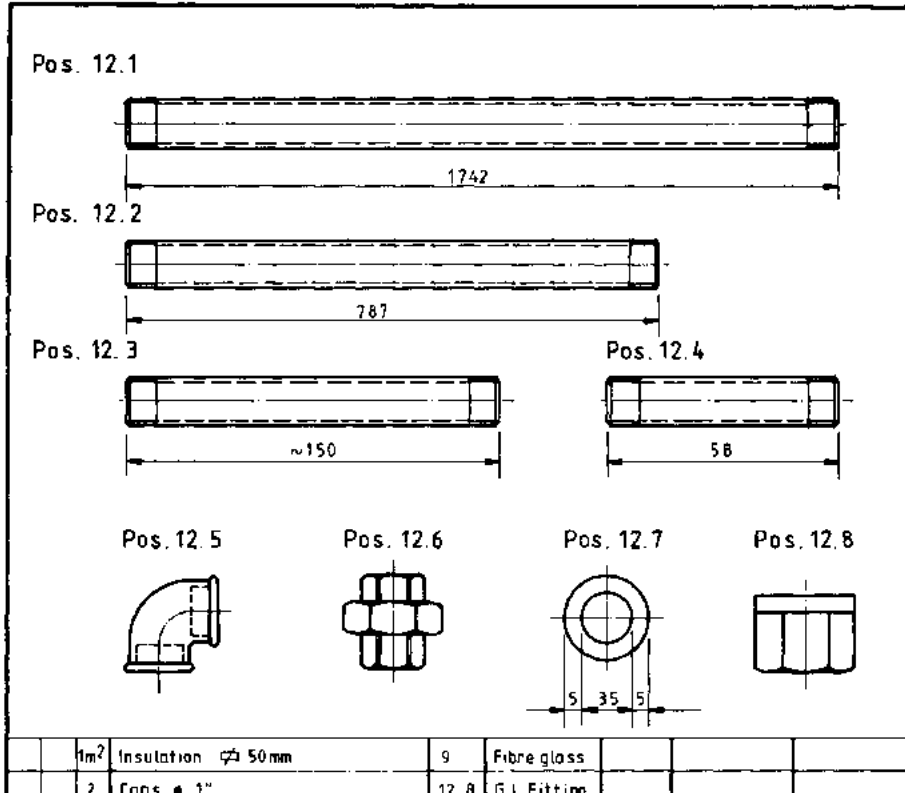
FIGURE



		2	Washers 35/45	12.7	Asbestos					
		2	Unions # 1"	12.6	G.I. Fitting					
		6	Elbows # 1	12.5	G.I. Fitting					
		1	G.I. Pipe l = 58 , # 1"	12.4	Steel pipe					
		2	G.I. Pipes l = 150 , # 1"	12.3	Steel pipe					
		2	G.I. Pipes l = 787 , # 1"	12.2	Steel pipe					
		1	G.I. Pipe l = 1742 , # 1"	12.1	Steel pipe		Class 3			
No. of	pc.	Object		Pos.	Material	Weight	Model	Remarks		
III	II	I	Alterations				Replaced by :			
			CIRCULATION GI - PIPES				Replacement for :			
							Scale	drawn by	<i>[Signature]</i>	22.4.90
							none	checked	<i>[Signature]</i>	22.4.90
				approved	<i>[Signature]</i>	22.4.90				
 Mechanical Training Centre Balaju / Kathmandu , Nepal.					No.	S-SC-18		Rev.		

FIGURE

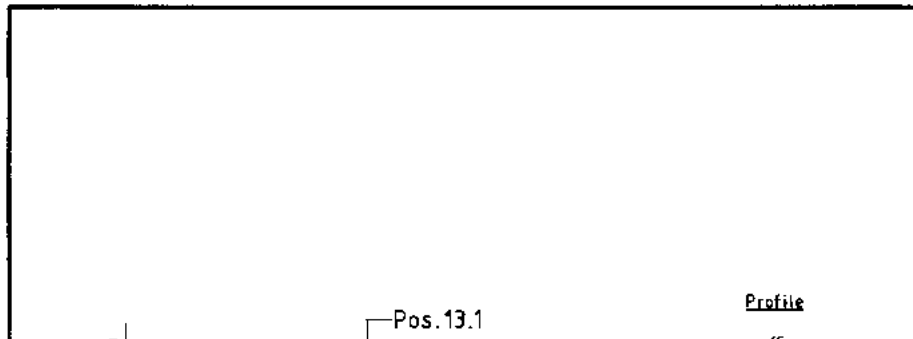

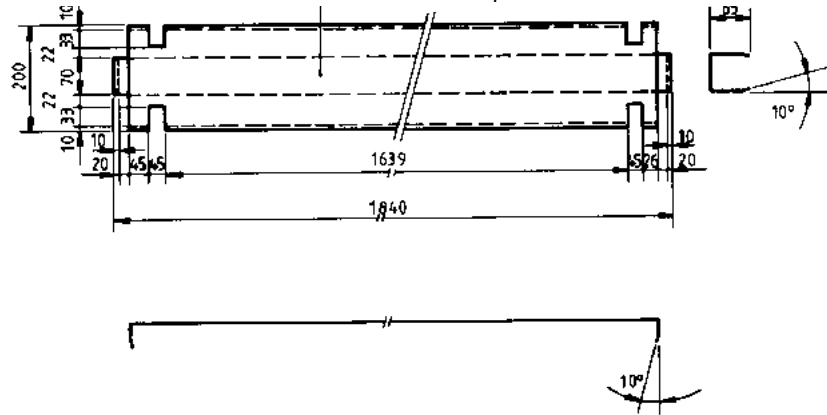

		1	Middle panel 1840 x 200 mm, 24 g.	13.1	G.I. Sheet				
No. of	pc	Object	Pos.	Material	Weight	Model	Remarks		
III	II	I	Alterations				Replaced by :		
							Replacement for :		
			MIDDLE PANEL FOR TWO AND MORE COLLECTORS				Scale	drawn by Skayastha 22.4.90	
							none	checked	<i>H. N. Singh</i> 22.11.0
								approved	<i>Me</i> 22.11.0
			Mechanical Training Centre					Rev.	

FIGURE

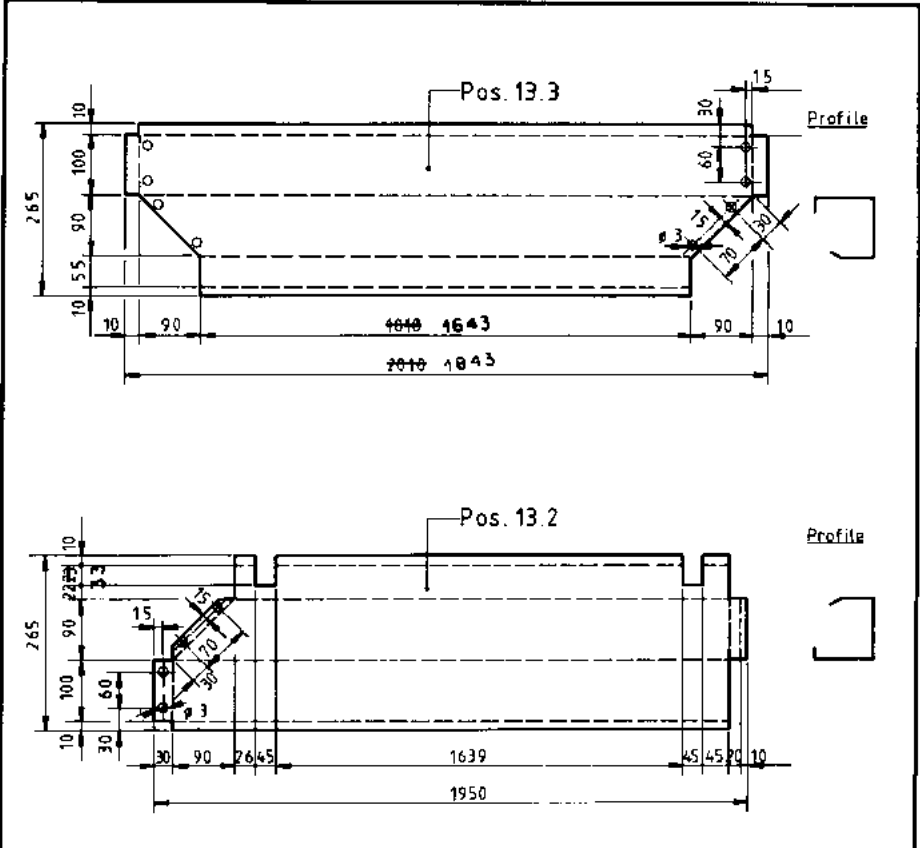

		8	Pan head tapping screws 3.5x9.5		Galv.					
		1	Top panel 2040 x 265mm, 24g.	13.3	G.I. Sheet					
		2	Side panels 1950 x 265mm, 24g.	13.2	G.I. Sheet					
No. of pc.		Object			Pos.	Material	Weight	Model	Remarks	
III	II	I	Alterations				Replaced by :			
			SIDE AND TOP PANELS FOR MULTIPLE COLLECTORS				Scale	drawn by	S.kayastha 22.4.90	
							none	checked	<i>Thakur</i>	22.4.90
							approved	<i>Alka</i>	22.4.90	
 Mechanical Training Centre Balaju / Kathmandu , Nepal.					No. S-SC-20			Rev.		

FIGURE

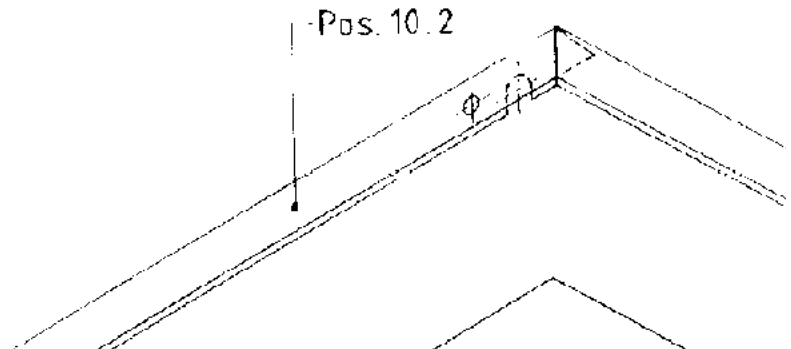

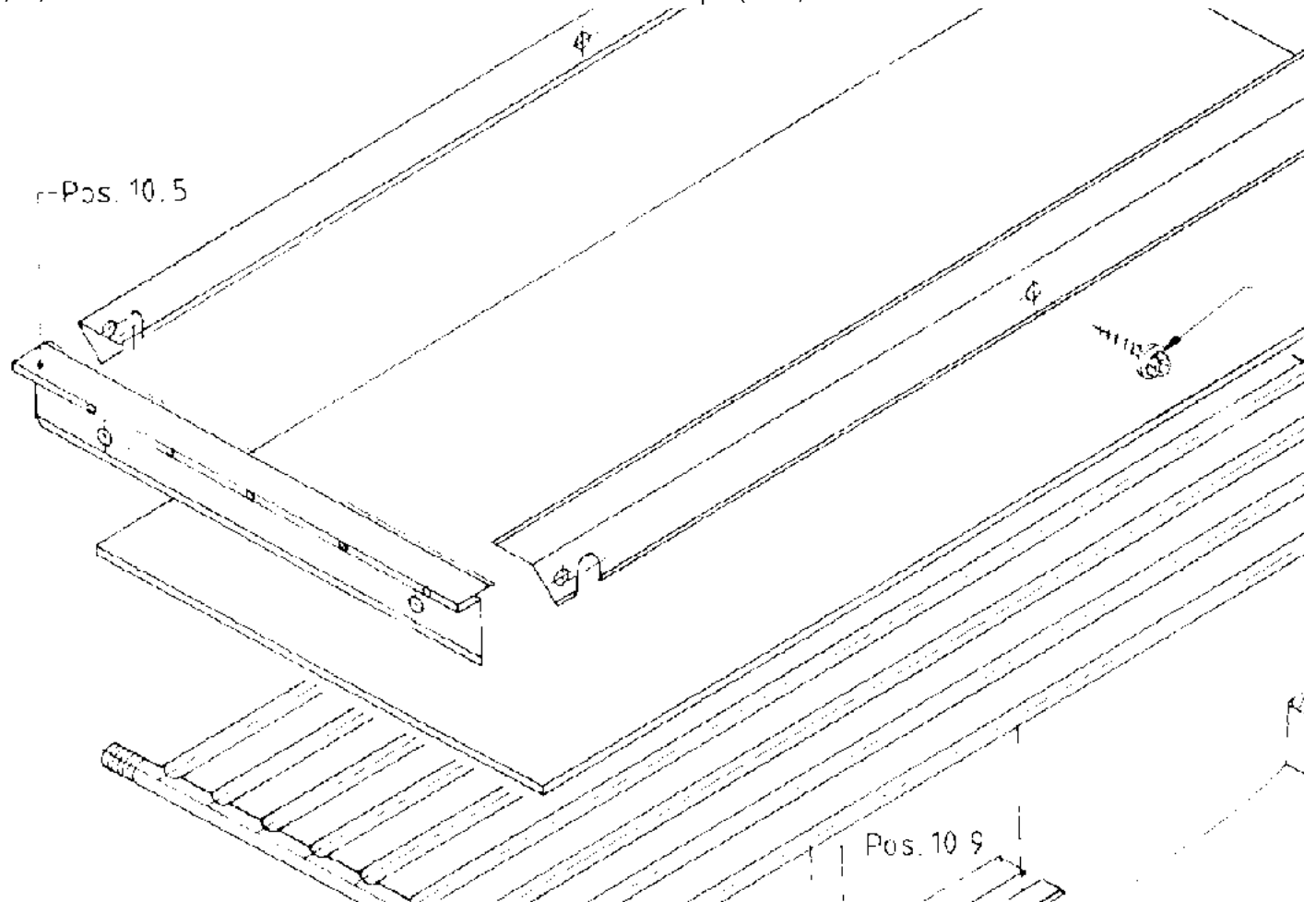

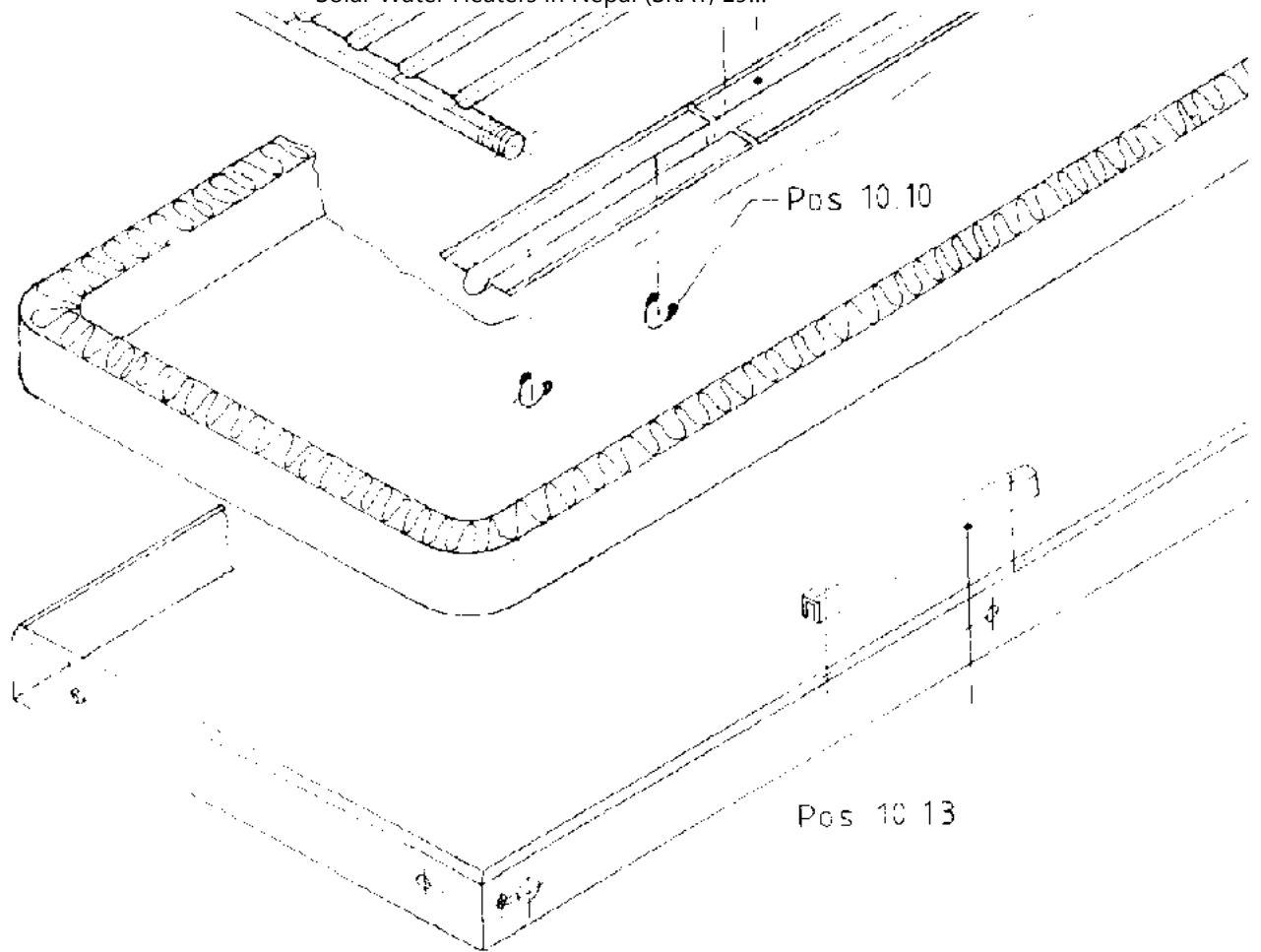

Assembly of collector

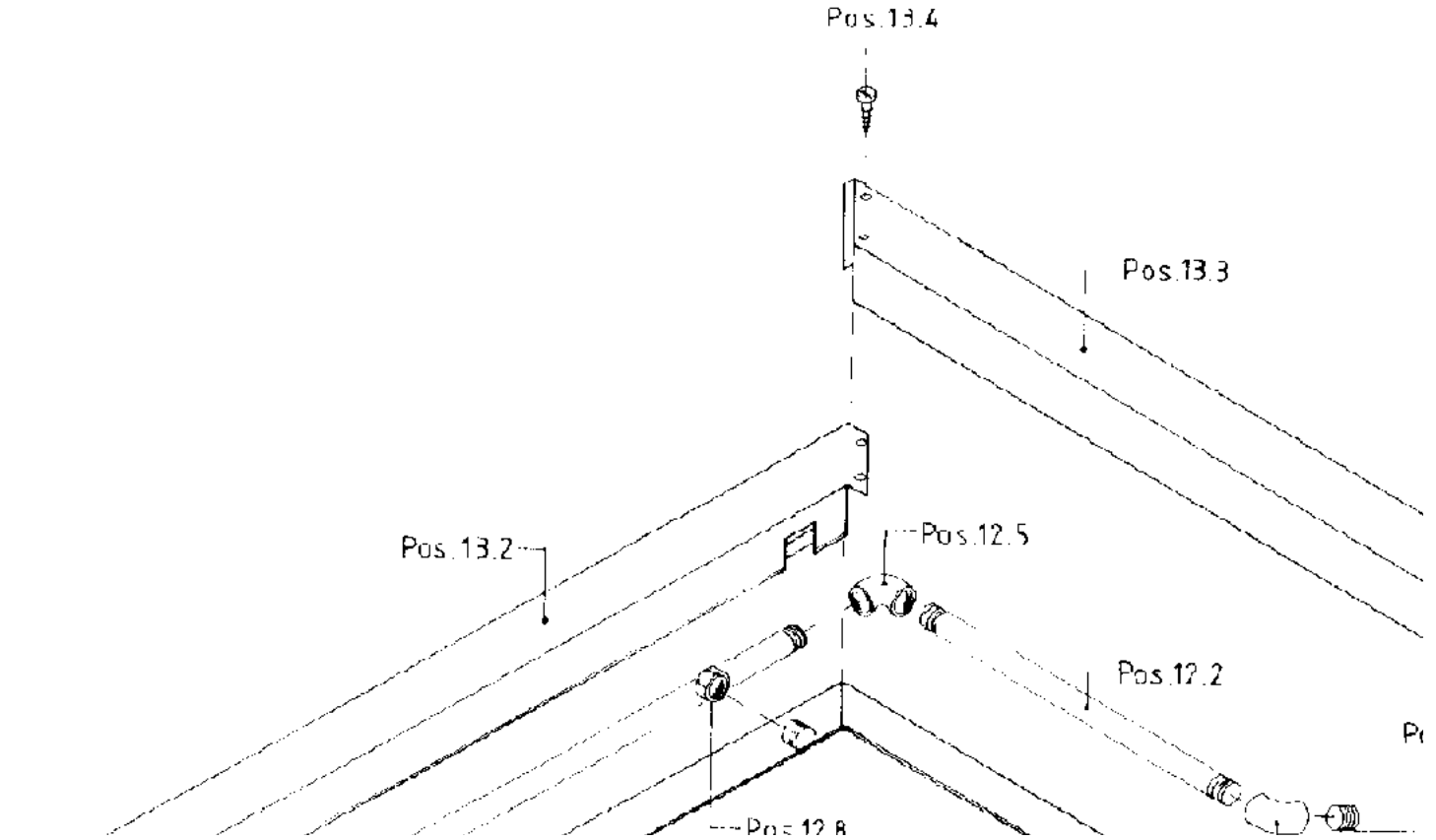

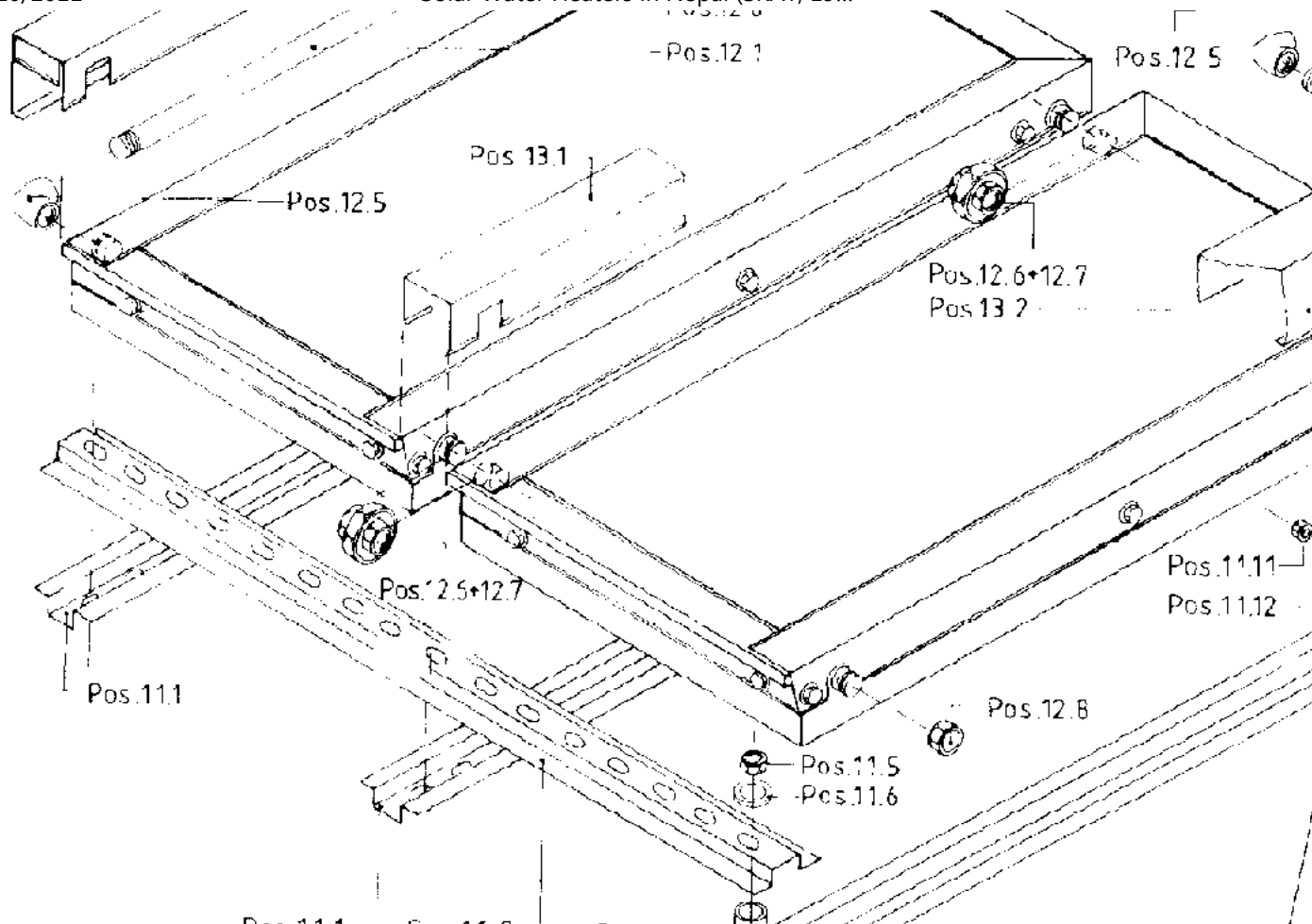

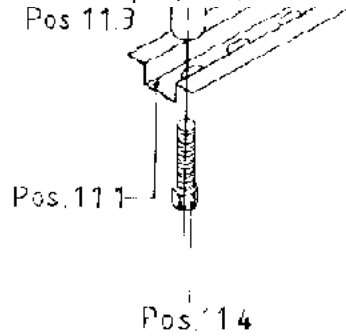

Support, pipes and panels

5.4 WELDING JIG FOR PIPE GRID

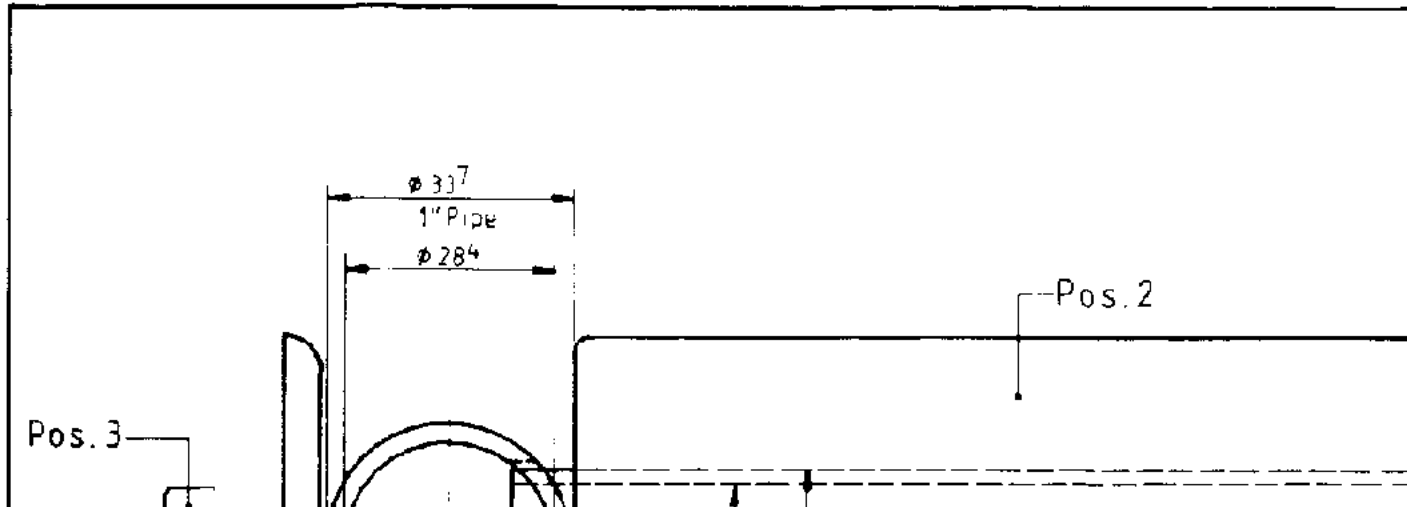

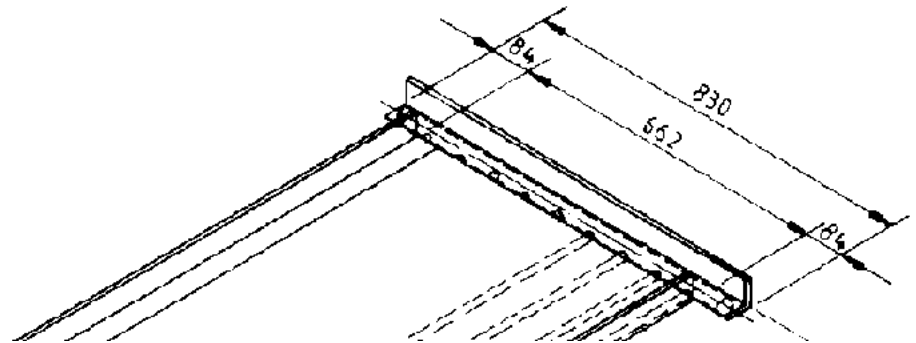
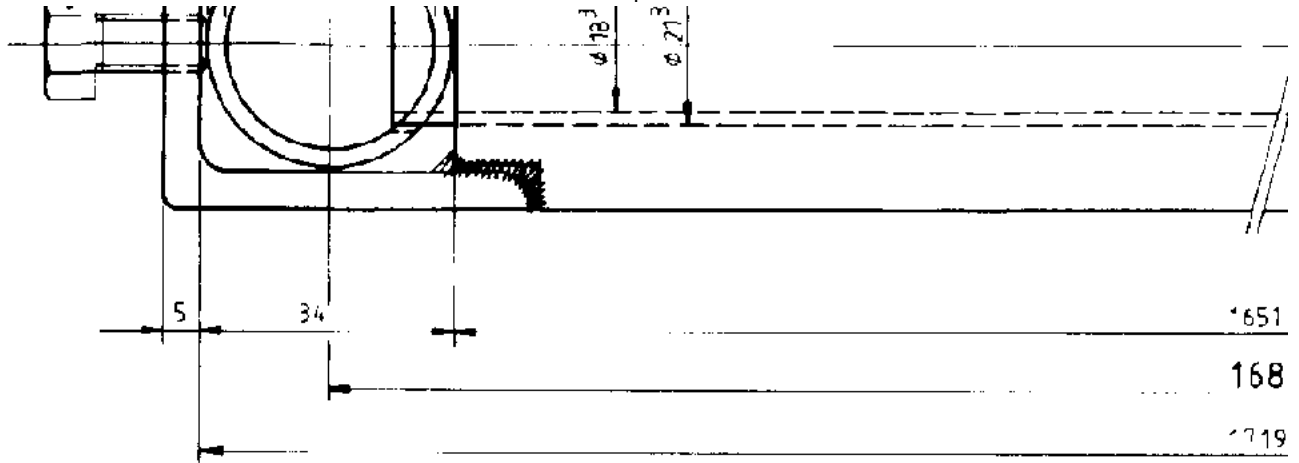

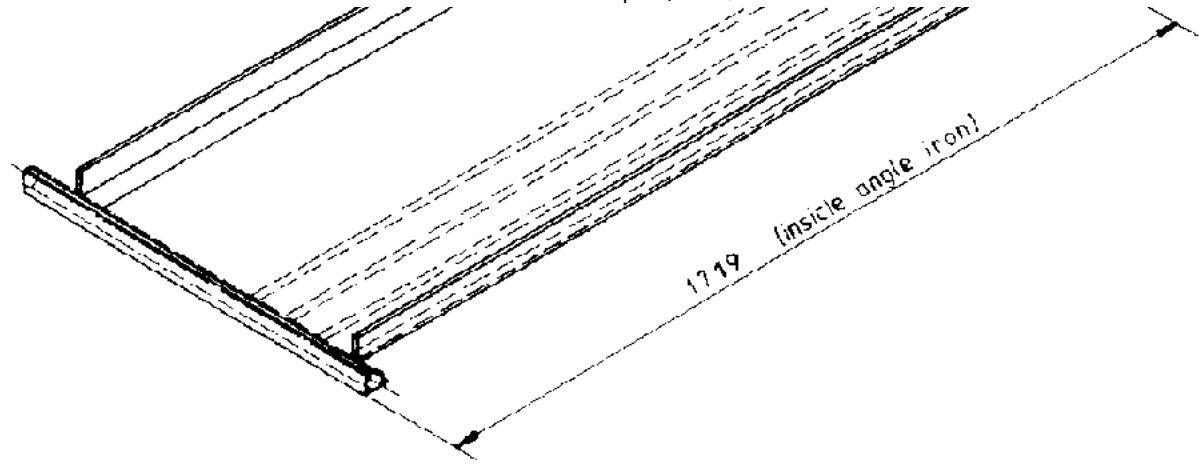

FIGURE

5.5 ARBOR PRESS TOOL FOR ABSORBER SHEET

SECTION A—A

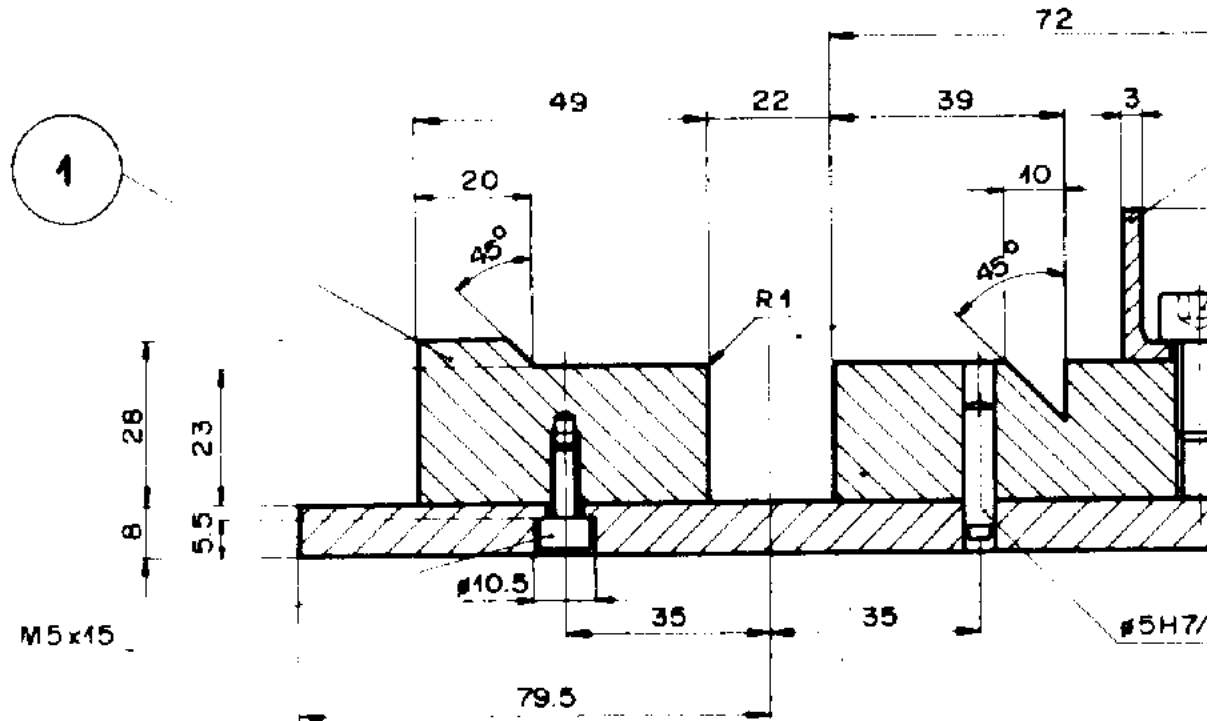

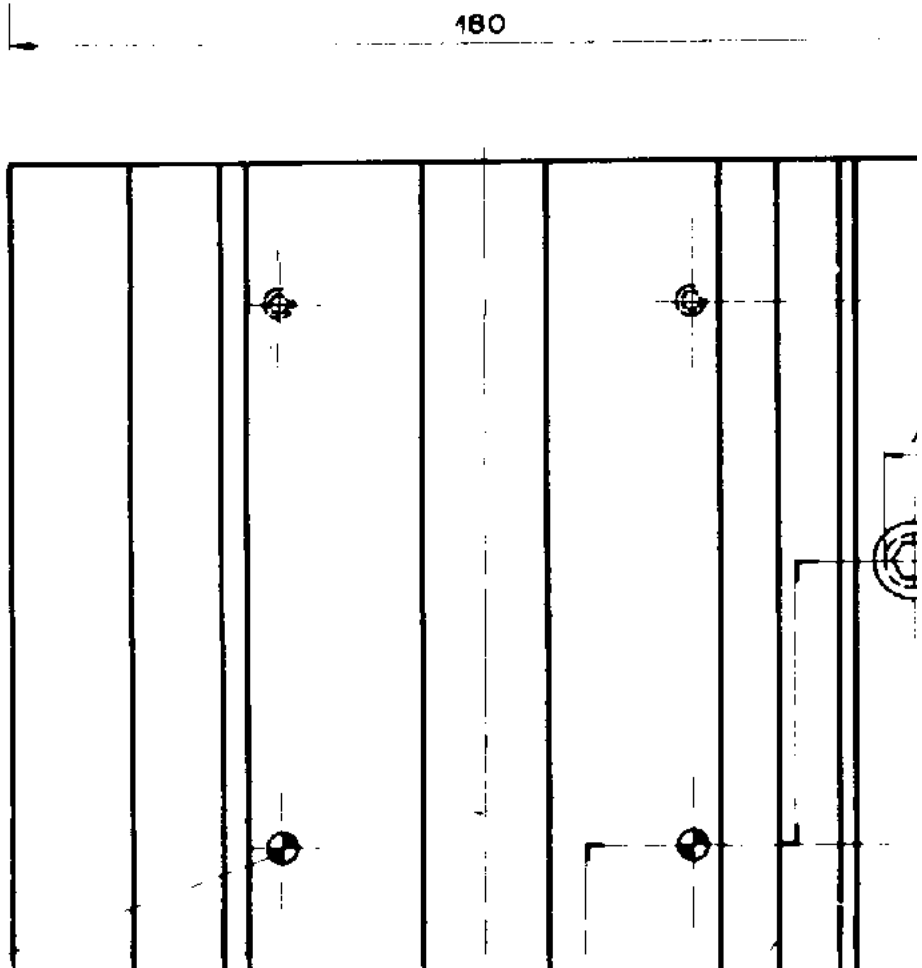

16

A ↑

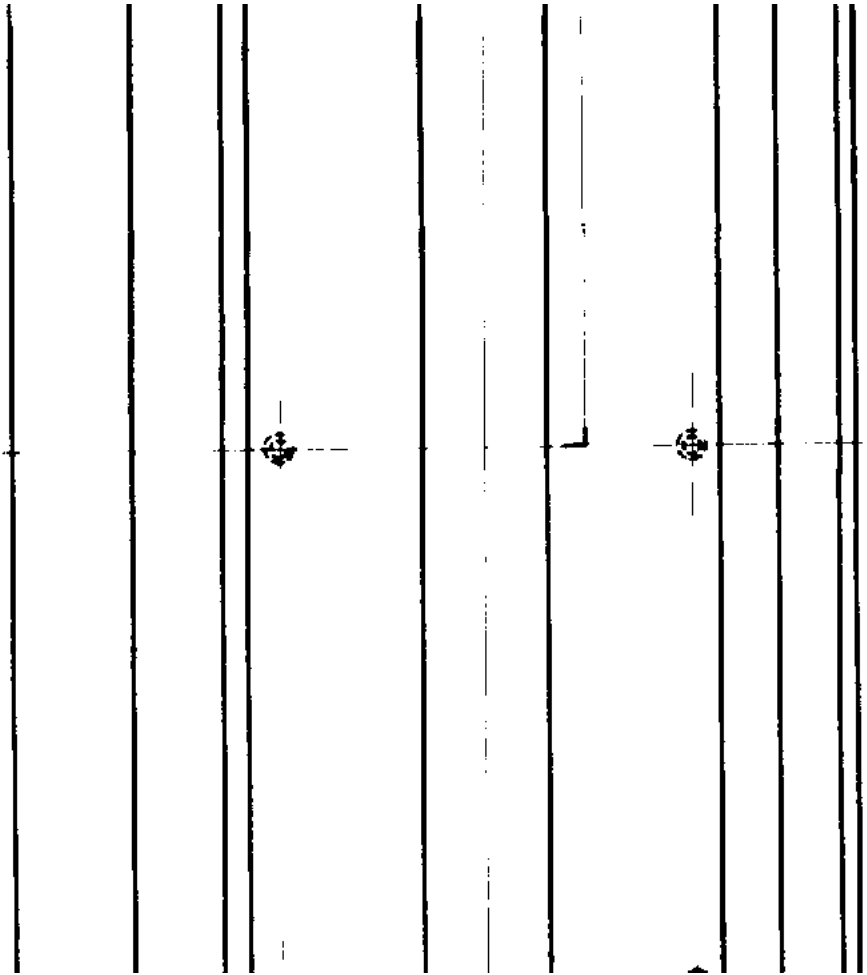

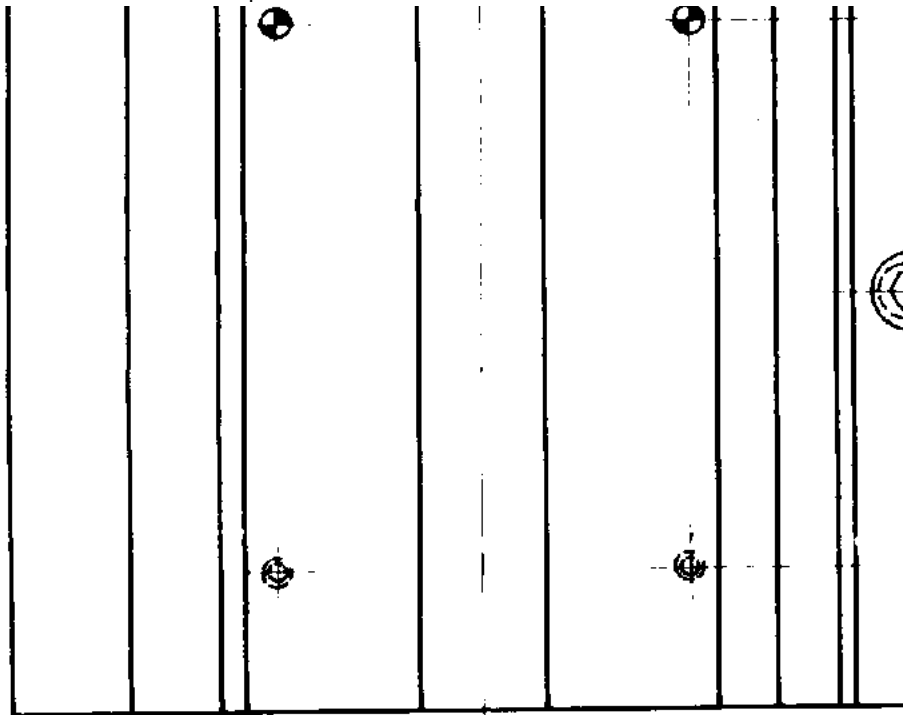

Component Profile

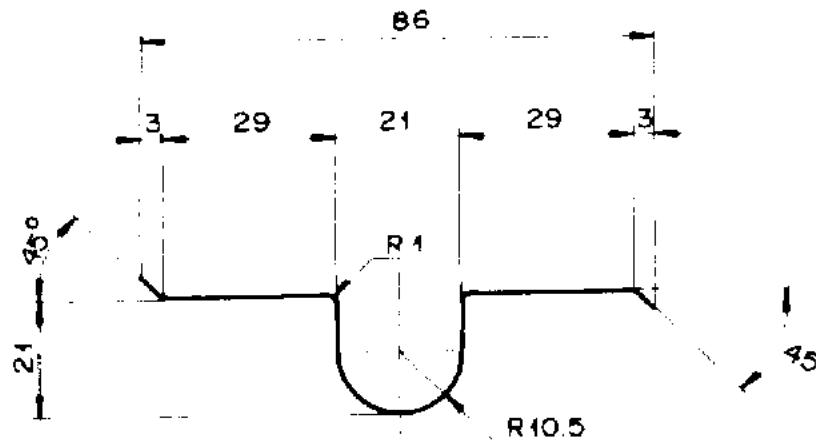

Material - Alu fins 412 x 120 x 26 g

FIGURE

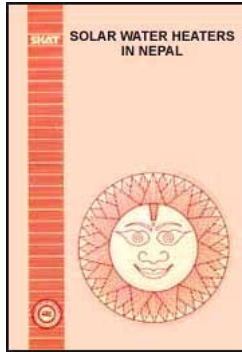

 **Solar Water Heaters in Nepal (SKAT, 1979, 142 p.)**

  **PART III SOLAR WATER HEATER APPLIANCES OTHER DESIGNS**

 **6. SOLAR WATER HEATER APPLIANCES/OTHER DESIGNS**

Solar Water Heaters in Nepal (SKAT, 1979, 142 p.)

PART III SOLAR WATER HEATER APPLIANCES OTHER DESIGNS

6. SOLAR WATER HEATER APPLIANCES/OTHER DESIGNS

6.1 STAND FOR HOT WATER STORAGE TANK

Front/cross

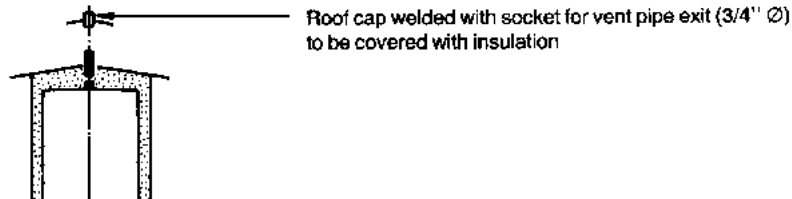

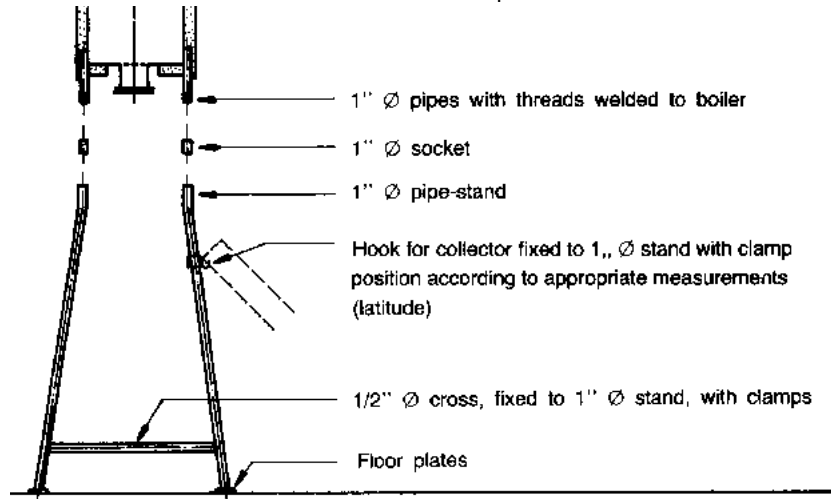

Top view

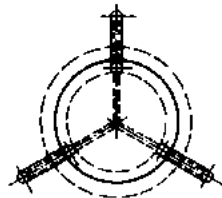

FIGURE

6.2 SOLAR HOT WATER STORAGE TANK

Cross section

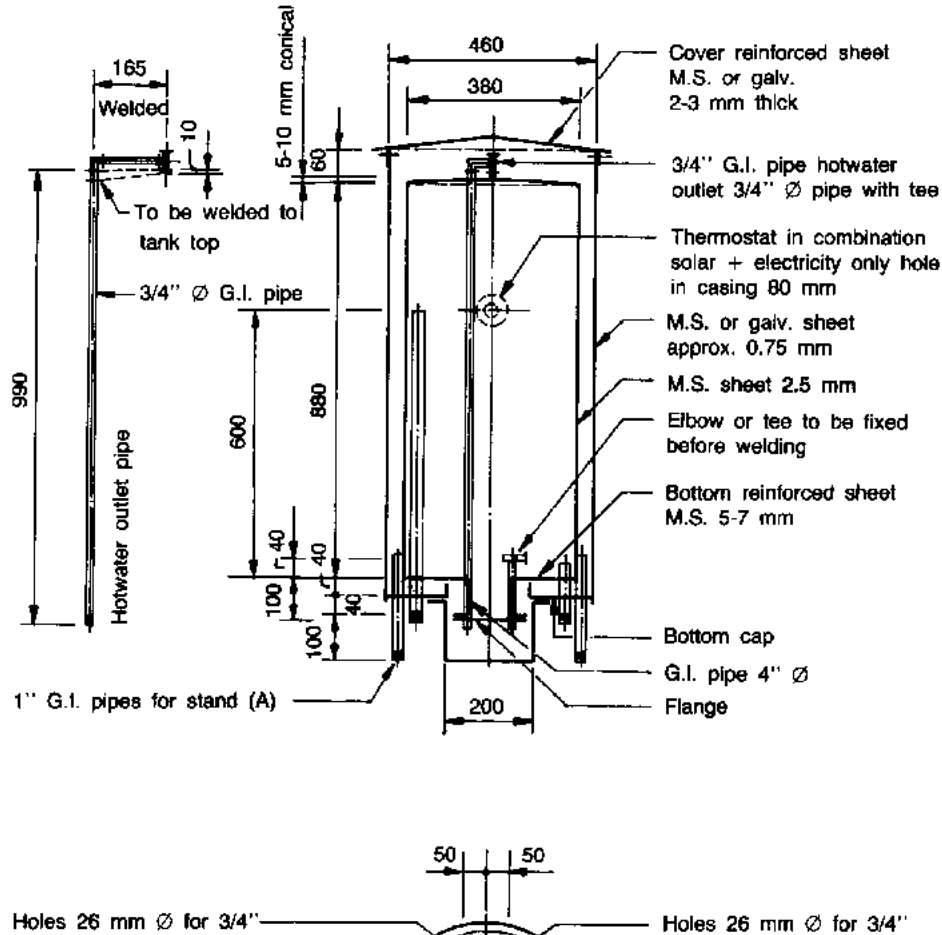

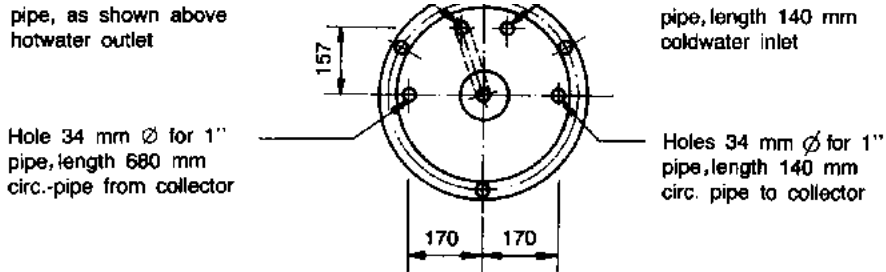

100 ltr. Capacity (for simple make)

Note: To further reduce heat losses the thickness of insulation can be increased.

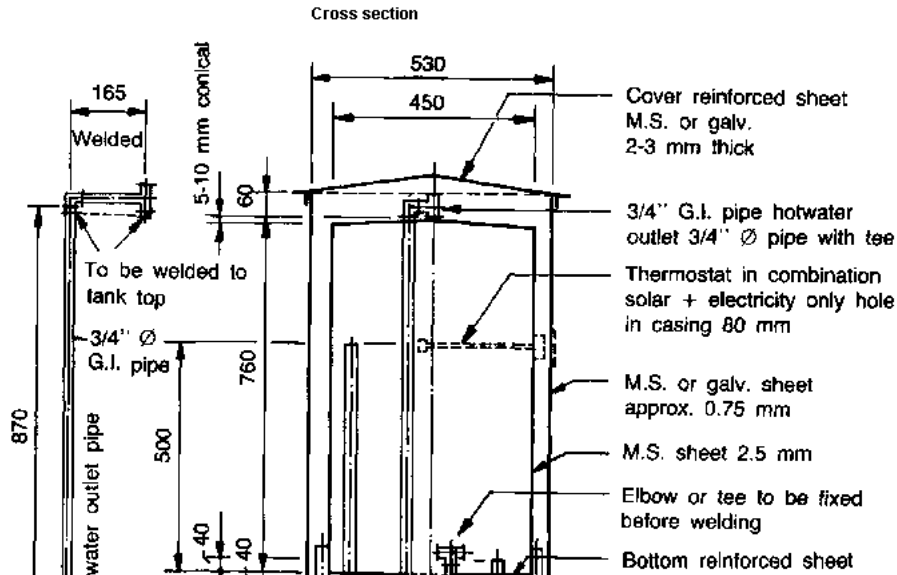

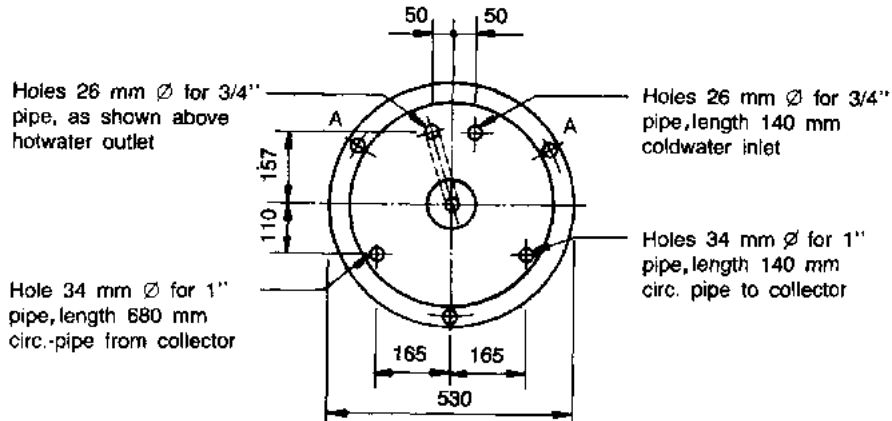
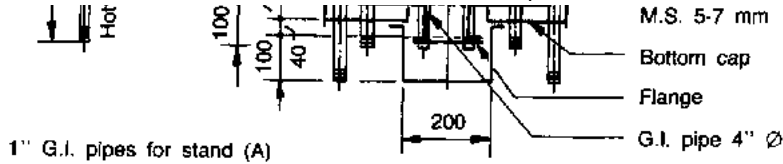

Note: To further reduce heat losses the thickness of insulation can be increased.

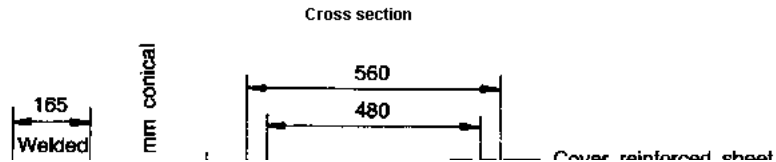

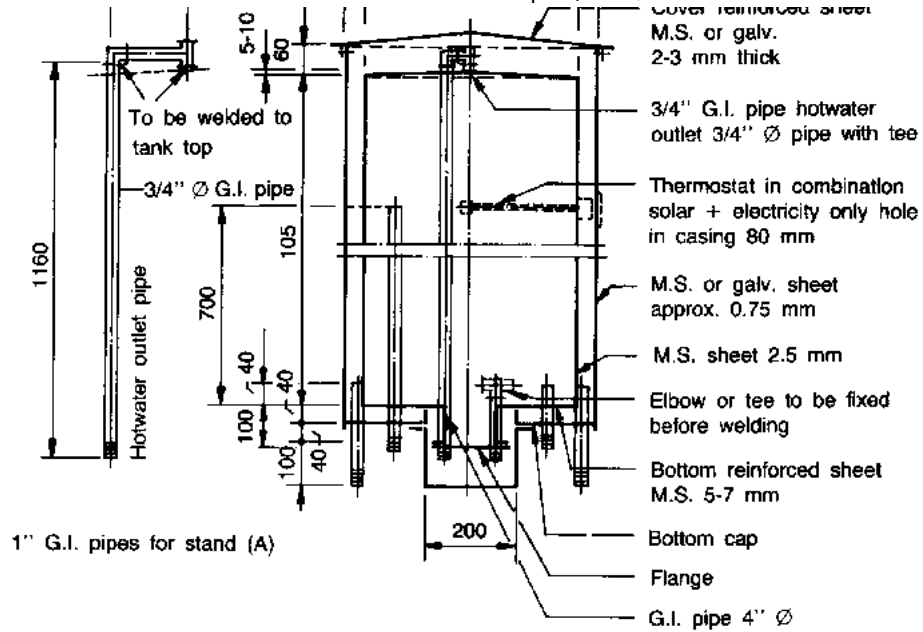

1" G.I. pipes for stand (A)

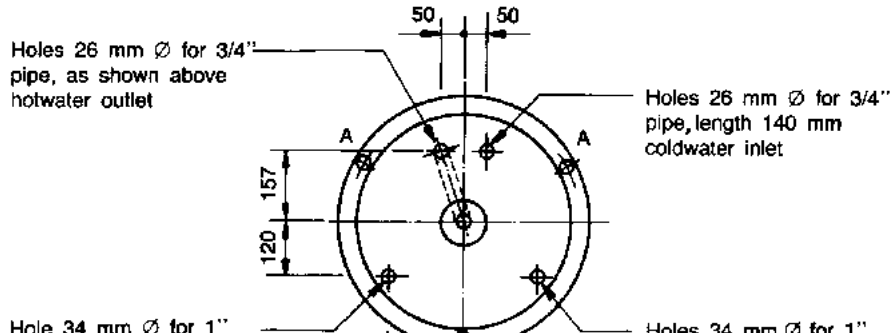

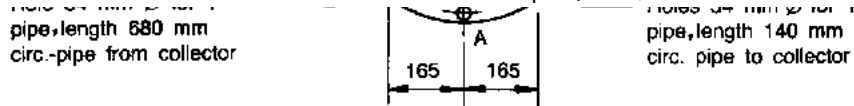

200 ltr. Capacity (for simple make)

Note: To further reduce heat losses the thickness of insulation can be increased.

FLANGES FOR SOLAR HOT WATER STORAGE TANKS

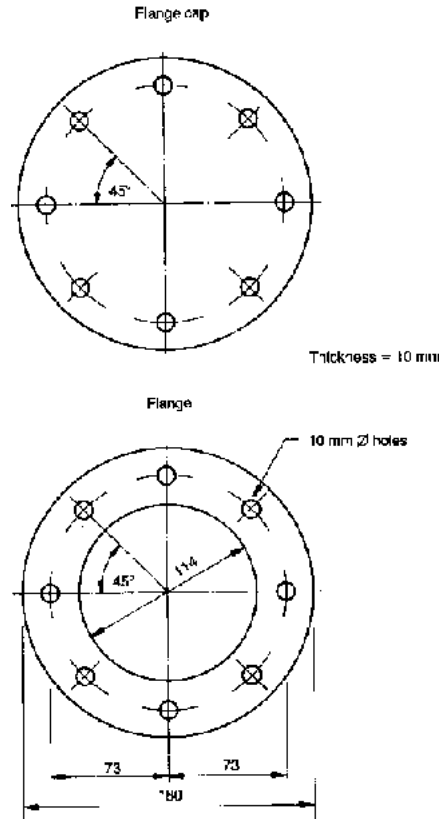
**FIGURE**

6.3 HOT WATER STORAGE TANK WITH HEAT EXCHANGER

Circulation to work with thermosiphon system can also be connected to a wood stove heat exchanger

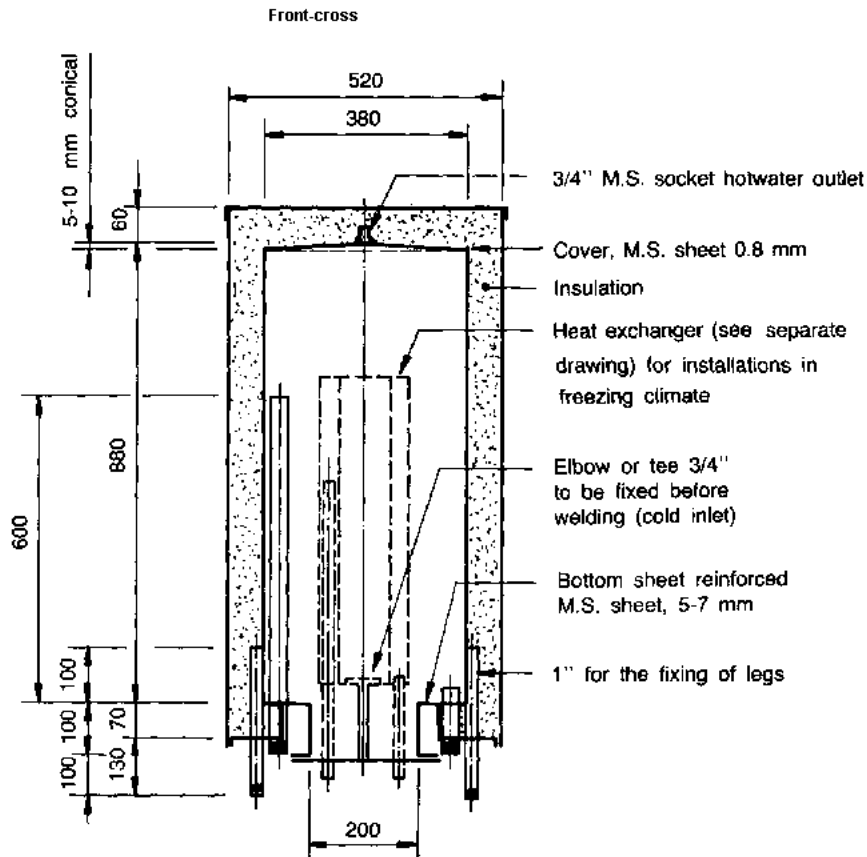

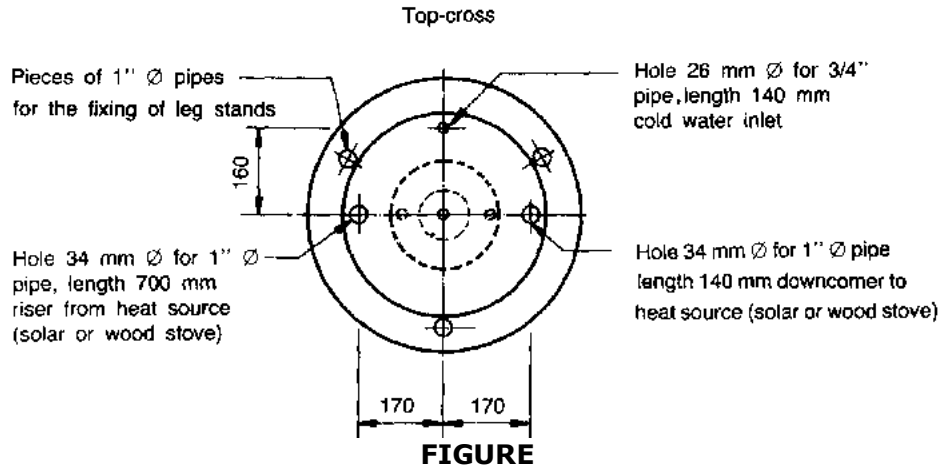

HEAT EXCHANGER FOR HOT WATER STORAGE TANK

To fit inside special hot water storage tank.

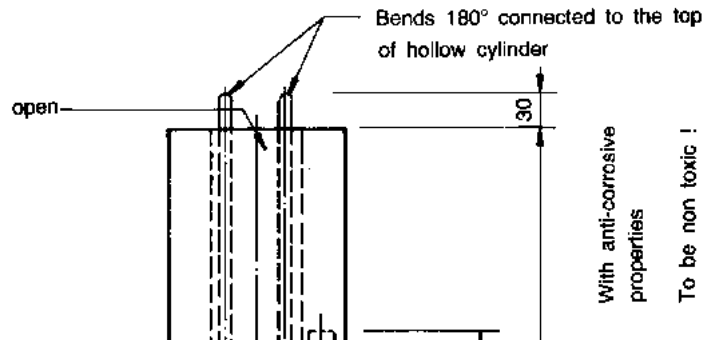

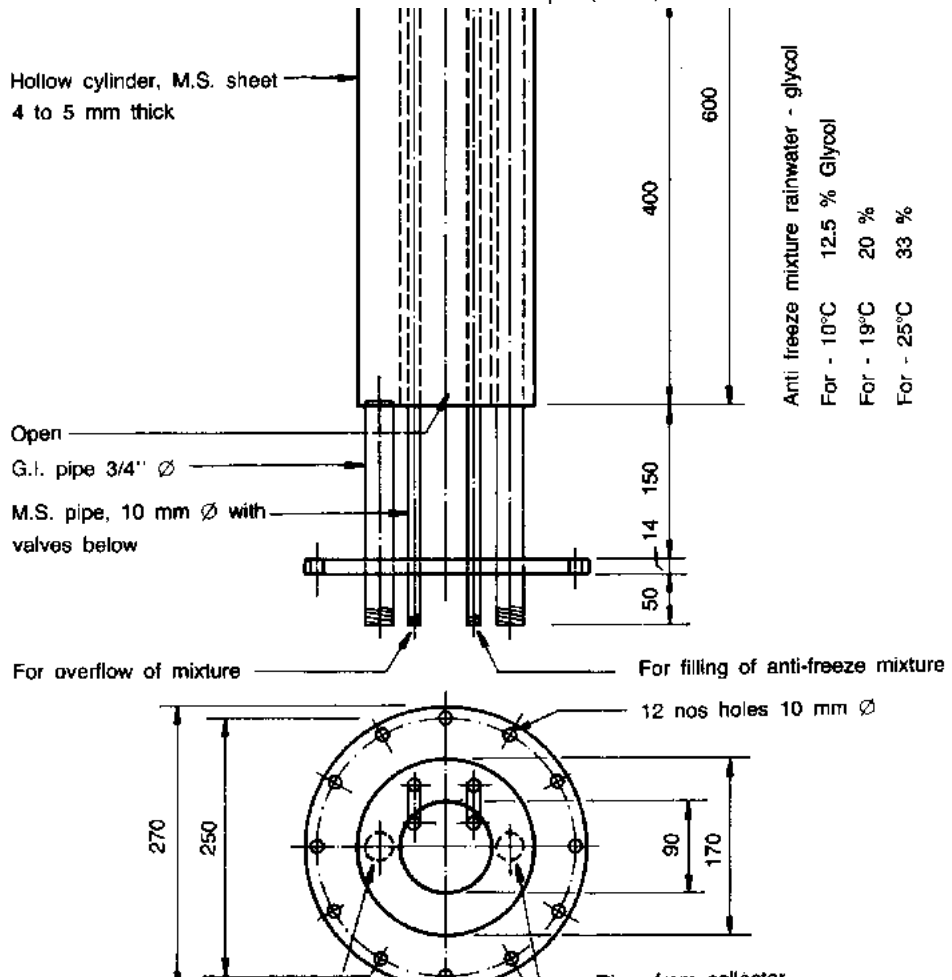

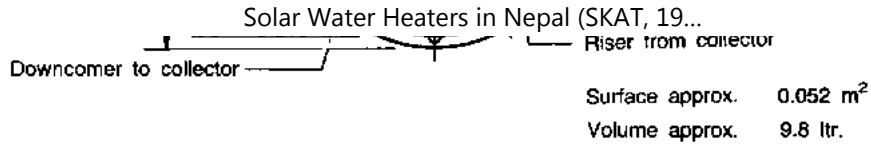

FIGURE

6.4 FLAT TANK COLLECTOR, 60 Itr. Box

Materials: GI-sheet 22 gauge (0.75), corner double seam or riveted and soldered painting one coat red oxide and one coat enamel paint.

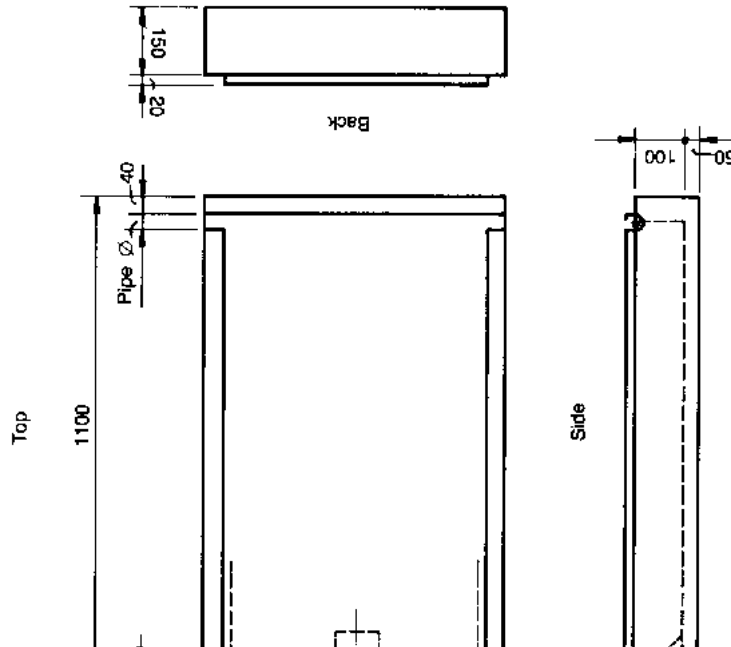

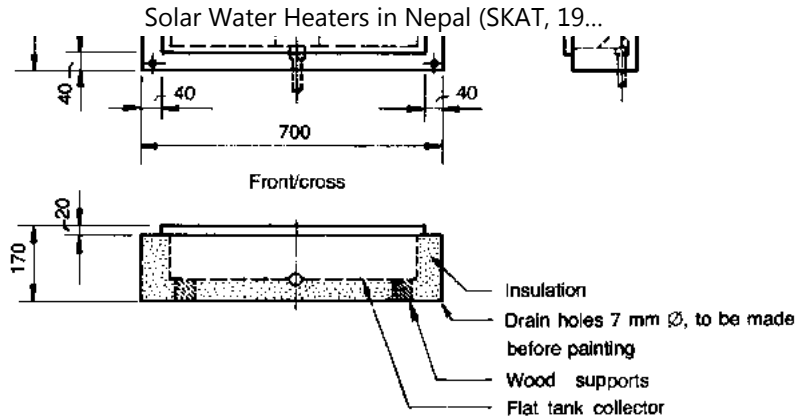
**FIGURE****FLAT TANK COLLECTOR, 60 Itr. COVER FRAME**

Materials: GI-sheet 22 gauge (0.75), corner double seam or riveted and soldered, painting one coat red oxyde and one coat enamel paint.

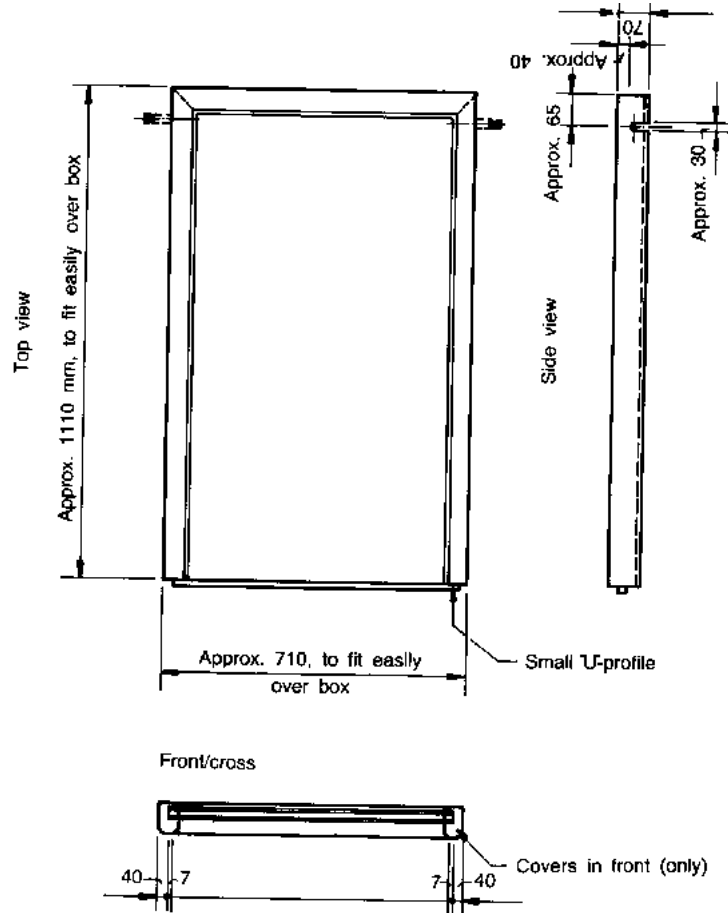

FIGURE

FLAT TANK COLLECTOR, 60 Itr. MS-TANK

Materials: M.S. sheet, 3 mm welded

Inside: Non-toxic paintings

Outside: Painting

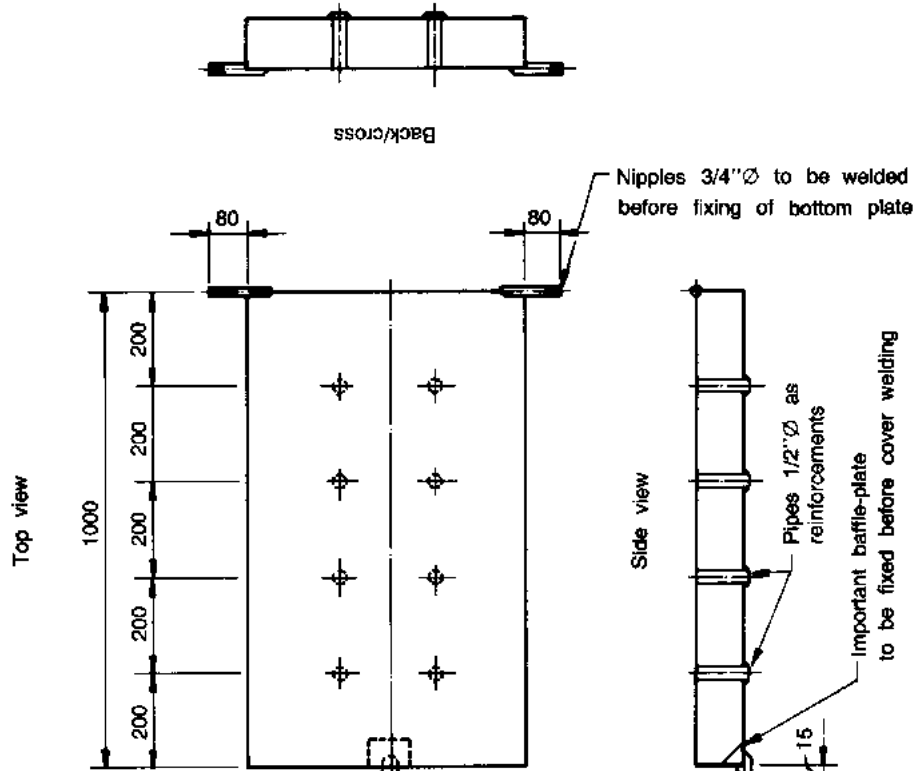

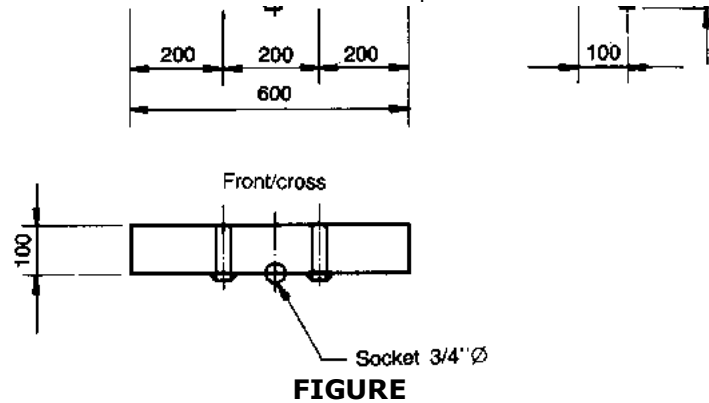

SIMPLE MAKING OF PROFILES (ABSORBER PLATES)

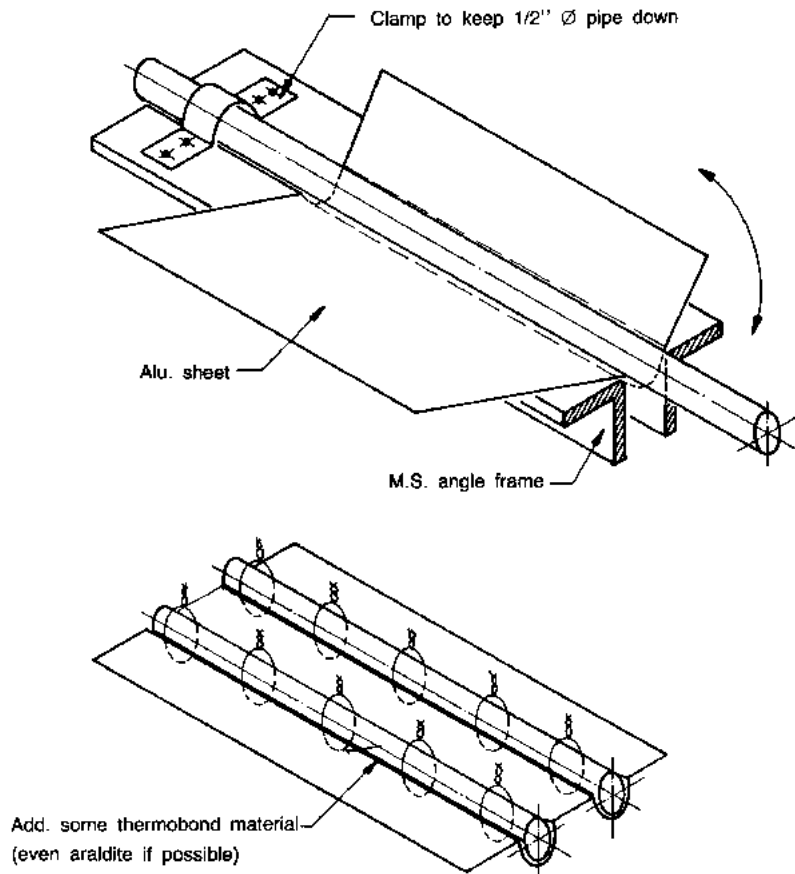

FIGURE

HARD COVER OVER WELL INSULATED PIPES

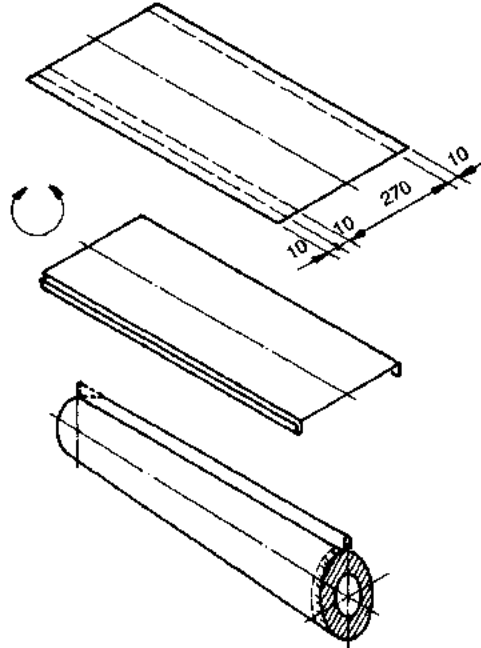

1 Marking of lines for bending

2 Bending by turning to pipe

3 Fix insulation material on pipe
fix hardcover over it

Do not close the seam perfectly
so it can be removed easily



4 End cap for the lower pipe end to
be fitted in side

FIGURE



[Home](#) > [ar.cn.de.en.es.fr.id.it.ph.po.ru.sw](#)

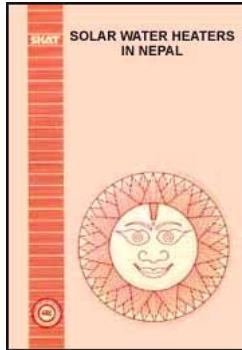

Solar Water Heaters in Nepal (SKAT, 1979, 142 p.)

PART IV EXAMPLES OF COST CALCULATION

7. EXAMPLES OF COST CALCULATION

Solar Water Heaters in Nepal (SKAT, 1979, 142 p.)

PART IV EXAMPLES OF COST CALCULATION

7. EXAMPLES OF COST CALCULATION

7.1 SOLAR SYSTEM

One hotwater storage tank 100ltr.

Two solar collectors SC-85

Pos.	Article	Qty.	Rate	Amount
	Summarv material			

1-8	Material cost for hot water storage tank 100 Itr. net	1		
10-13	Material cost for two solar collectors SC-85 and accessories, net	2		
	Sub total			
	Summary working hrs., labour charge			
1-8	Hotwater storage tank 100 Itr. working hrs., and labour cost	163 hrs.		
10-13	Two solar collector SC-85 and accessories			
	Working hrs., and labour cost	173 hrs.		
	Sub total			
	Overhead on material %			
	Overhead on labour charge %			
	Transportation charge			
1-13	Total cost of one solar system one hotwater storage tank 100 Itr. two solar collectros SC-85			

7.2 HOTWATER STORAGE TANK 100 LTR.

Pos.	Article		Qty.	Rate	Amount
1	MS-tank 100 ltr. (inside)				
1.1	Cylinder MS-sheet 3 mm				
	1277 x 800 mm				
	1.021 m ² + 10%*		1.23 m ²		
1.2	Disk up/down MS-sheet 3 mm				
	400 x 400 mm				
	0.16 m ² + 10% = 1.76 m ² x 2		0.352 m ²		
1.3	G.I. pipe (vent)	1/2"	0.1 m		
1.4	G.I. hexagon nuts	1/2"	2 pcs.		
1.5	G.I. socket	1/2"	1 pc.		
1.6	G.I. cap	1/2"	1 pc.		
1.7	Red. Socket	1 /2" - 3/8"	1 pc.		
1.8	Welding rods 0 3 mm		40 pcs.		
1.9	Tar-paint (2-coats)		1.2 Itr.		
1.10	Cement (inside lining, corrosion production)		5 kg		
1.11	Electric charge				
1.12	Tool and machine charge				
1	Material cost for MS-tank 100 ltr. net				

1	Working hrs. and Labour charge for				
	cutting, rolling, welding, pressure				
	testing, painting and cement coating		24 hrs.		
2	Flange with water and solar connection				
2.1	Flangering MS	10 mm			
	outside 220, inside 155		4.25 kg		
2.2	Flange MS 10 mm	220 mm	4.25 kg		
2.3	Flange pipe MS-sheet 3 mm				
	471 x 90 mm = 0.042 m ² + 10%		0.046 m ²		
2.4	G.I. pipe (hot water)	3/4"	0.2 m		
2.5	G.I. pipe (hot water)	3/4"	0.712 m		
2.6	G.I. pipe (cold water)	3/4"	0.1 m		
2.7	G.I. pipe (solar inlet warm)	1 "	0.53 m		
2.8	G.I. pipe (solar outlet cold)	1 "	0.1 m		
2.9	Baffle plate G.I. sheet 18 gauge				
	60 x 70 mm		0.0046 m ²		
2.10	G.I. elbows	3/4"	2 pcs.		
2.11	G .I. elbows	1 "	2 pcs.		

2.12	G.I. unions	3/4"	2 pcs.		
2.13	G.I. unions	1 "	2 pcs.		
2.14	Nipple 2 x 120 mm	3/4"	0.24 m		
2.15	Nipple 2 x 100 mm	1 "	0.2 m		
2.16	G.I. socket	3/4"	1 pc.		
2.17	Steam packing washers for union	3/4"	2 pcs.		
2.18	Steam packing washers for union	1 "	2 pcs.		
2.19	Steam packing washer 3 mm				
	180 outside, 145 inside				
	180 mm ² = 0.032 m ² + 10%		0.035 m ²		
2.20	Hexagon screws, galv.	M8 x 40	12 pcs.		
2.21	Hexagon nuts, galv.	M8	12 pcs.		
2.22	Threaded rod, galv. L= 100 mm	M8	1 pc.		
2.23	Washers, galv.	M8	12 pcs.		
2.24	Red oxyde paint		0.1 ltr.		
2.25	Welding rods 0 3 mm	5 pcs.			
2.26	Electric charge				
2.27	Tool and machine charge				
2.28	Oxygen and gas				
2	Material cost for flange with water and solar connection, net				
2	Working furs. and labour charge for gas cutting, filina, drilling.		32 hrs.		

3	preparation of pipes, welding and assembling Side flange for thermostat and electro heating element				
3.1	Flangeringg MS 10 mm				
	220 outside, 0 155 mm inside		4.25 kg		
3.2	Flange, MS 10 mm 0 220 mm		4.25 kg		
3.3	Flange pipe, MS-sheet 3 mm				
	0 150 mm, length 90 mm				
	471 x 115 mm				
	0.054 m ² + 10%		0.059 m ²		
3.4	G.I. pipe	1½ "	0.42 m		
3.5	Disk MS-sheet 3 mm				
	48 x 48 mm		0.002 m ²		
3.6	MS-pipe	1/4"	0.42 m		
3.7	Connectorr sheet 2 mm				
	60 x 40 mm		0.0024 m ²		
3.8	Electro element holder 2 mm				
	58 x 10 mm		0.0006 m ²		
3.9	Slotted pan head screw	M6 x 5	1 pc.		
3.10	Steam packing washer 3 mm				

3.10	Steam packing washer 3 mm				
	180 outside, 0 145 inside				
	180 mm ² = 0.034 m ² + 10%		0.038 m ²		
3.11	Threaded rod + nut	M8 x 100	1		
3.12	Hexagon screws, galv.	M8 x 40	12 pcs.		
3.13	Hexagon nuts, galv.	M8	12 pcs.		
3.14	Washers, galv.	M8	12 pcs.		
3.15	Welding rod 3 mm		5 pcs.		
3.16	Electric charge				
3.17	Tool and machine charge				
3.18	Oxygen and gas				
3.19	Red oxyde paint		0.1 ltr.		
3	Material cost for one side flange for thermostat and electro heating element, net				
3	Working furs. and labour charge for gas cutting, filing, drilling, preparation of pipes, welding and assembling		24 hrs.		
4	Insulationn 100 mm (for tank 100 ltr.)				
4.1	Fibreglasss insulation 50 mm				
	First layer				
	1550 x 800		1.24 m ²		
4.2	Second layer				

4.2	Second layer				
	1900 x 800		1.52 m ²		
4.3	Top and bottom				
	600 x 600 = 0.36 m ² x 4		1.44 m ²		
4.4	Pe-bag 1900 x 1000 mm		1		
4	Material cost for insulation 100 mm thick for one 100 ltr. hotwater storage tank, net				
4	Working furs. and labour charge for				
	cutting, fixing of the insulation		8 hrs.		
5	Outside cover, (for tank 100 ltr.)				
5.1	Alu. cover up, prefabricated				
	600 mm.		1 pc.		
5.2	Alu. cover down, prefabricated				
	600 mm		1 pc.		
5.3	Alu. cover for side flange				
	(250 mm), prefabricated 10"		1 pc.		
5.4	Alu. cover for bottom flange				
	(230 mm), prefabricated 0 9"		1 pc.		
5.5	Washers, galv.	M8	2 pcs.		
5.6	Hexagon nuts	M8	2 pcs.		
5.7	G.I. sheet, cylinder 24 gauge				
	1000 x 780 mm				

	1900 x 700 mm				
	1.48 m ² + 10%			1.59 m ²	
5.8	Cover belts, G.I. sheet 24 gauge				
	(2 pieces)				
	50 x 1910 mm				
	0.095 m ² + 10% = 0.1 x 2			0.2 m ²	
5.9	Screw plates, 4 pieces				
	size: 50x20 x 3 mm				
	MS-flat 0.08 m (1.8 kg/m)			0.094 kg	
5.10	Hexagon screws, galv.	M8 x 25	4 pcs.		
5.11	Hexagon nuts, galv.	M8	4 pcs.		
5.12	Washers, galv.	M8	4 pcs.		
5.13	Nameplate alu.	190 x 70 mm	1 pc.		
5.14	Soldering mat. Tin	40/60	0.05 kg		
5.15	Pop rivets alu.	3	30 pcs.		
5.16	G. I. sheet watershild 20 gauge				
	400 x 40 mm				
	0.016 + 10%			0.017 m ²	
5.17	Red oxide paint			1.5 ltr.	
5.18	White paint.enamel			1.0 ltr	

5.19	Blue paint, enamel		0.2 ltr		
5.20	Thiner		1.0 ltr		
5.21	Tool and machine charge				
5.22	Electric charge/gas				
5	Material cost for G. I. outside cover for one hotwater storage tank 100 ltr., net				
5	Working furs. and labour charge for cutting, of alu. covers and G.I. sheets, folding, bending, assembling and painting		35 hrs.		
6	Electric heating/thermostat				
6.1	Heating element removable L = 280 mm, 37 mm, 230 V		1 pc.		
6.2	Thermostaat, L = 280 mm, 8 mm 230 V, 20 A range 30 -80°C		1 pc.		
6.3	Connectorr		1 pc.		
6.4	Control lamp		1 pc.		
6.5	Wiring		1		
6.6	Cable shoes		3 pcs.		

6.7	Slotted pan head screws	M4 x 20	3 pcs.		
6	Material cost for electro heating/thermostat ,net				
6	Working furs. and labour charge for fixing of heating element, thermostat, wiring and testing		5 hrs.		
7	Boiler stand SE 100 ltr.				
7.1	Belt for boiler stand, MS 3 mm 1305 x 115 mm 0.15 m ² + 10%		0.165 m ²		
7.2	G.I. pipe, support legs (3 pcs.) 1" length 1000 mm x 3		3 m		
7.3	G.I. pipe, support nipples (3 pcs.) 1 " length 250 mm x 3		0.75 m		
7.4	Baseplate MS-sheet 100 x 100 mm 0.01 m ² + 10%		5 mm		
7.5	GI socketss	1"	3 pcs.		

7.6	Hexagon screws, galv.	M10 x 50mm	2 pcs		
7.7	Hexagon nuts, galv.	M10	2 pcs.		
7.8	Washers, galv	M10	2 pcs		
7.9	Welding rods 3 mm		3 pcs		
7.10	Red oxyde paint		0.3 ltr.		
7.11	Electric charge				
7.12	Tool and machine charge				
7	Material cost for one boiler				
	stand, net				
7	Working furs. and labour charge for				
	cutting, drilling, rolling, thread				
	cutting, welding, painting, and assembling		14 hrs.		
8	Wall-hangeers 100 ltr.				
8.1	Belt for boiler wall-hangers				
	MS 3 mm (2 pcs.)				
	1305 x 115 mm				
	$0.15 \times 2 + 10\% \times 2$		0.33 m ²		
8.2	Insulatingg strip, tarfelt				
	1265 x 115 mm (up only)		0.145 m ²		
8.3	Reinforcement up. MS-sheet 3 mm				

	95 x 55 mm (2 pcs.)				
	0.0052 m ² + 10% x 2		0.002 m ²		
8.4	Reinforcement down, MS-sheet 3 mm				
	95 x 55 mm (2 pcs.)				
	0.0052 m ² + 10% x 2		0.002 m ²		
8.5	Hexagon screws, galv.	M10 x 50 mm	4 pcs.		
8.6	Hexagon nuts, galv.	M10	4 pcs.		
8.7	Washers, galv.	M10	8 pcs.		
8.8	Spacing sheets, MS 3 mm				
	220 x 195 mm (2 pcs.)				
	0.043 + 10% x 2		0.094 m ²		
8.9	Hangers, MS-flat				
	410 x 50 x 5 mm (2 pcs.)				
	L = 0.41 m (1.96 kg/m)		0.8 kg		
8.10	Wall plugs, Mod. Fischer S12				
	(plastic dowel 0 12 mm)		4 pcs.		
8.11	Square head wood screws, galv.				
	100 x 10 mm, (4" x 3/8")		4 pcs.		
8.12	Welding rods 0 3 mm		3 pcs.		
8.13	Red oxvde paint		0. 3		

					Itr.
8.14	Electric charge				
8.15	Tool and machine charge				
8	Material cost for two wall hangers				
	net				
8	Working furs. and labour charge for				
	cutting, drilling, rolling, welding,				
	painting and assembling			21 hrs.	

7.3 Hotwater storage tank 100 Itr.,SUMMARY

Pos.	Article	Qty.	Rate	Amount
	Summary Material			
1.	MS-tank 100 Itr. (inside)	1		
2.	Flange with water and solar connection	1		
3.	Side flange for thermostat and electro heating element	1		
4.	Insulation, 100 mm (tank 100 Itr.)	1		
5.	Outside cover (tank 100 Itr.)	1		
6.	Electro heating/thermostat	1		
7.	Boiler stand	1		
8.	Wall hangers (optional to boiler stand)		1	
1-8	Material cost for hotwater storage tank 100 Itr. net			

1-8	Material cost for hotwater storage tank 100 ltr. (net)			
	Working hrs., labour charge			
1.	MS-tank 100 ltr. (inside)	24 hrs.		
2.	Flange with water and solar connection	32 hrs.		
3.	Side flange for thermostat and electro heating element	24 hrs.		
4.	Insulation 100 mm (tank 100 ltr.)	8 hrs.		
5.	Outside cover (tank 100 ltr.)	35 hrs.		
6.	Electro heating/thermostat	5 hrs.		
7.	Boiler stand	14 hrs.		
8.	Wall hangers (optional to boiler stand)	21 hrs.		
1-8	Working hrs., labour charge total			
	Overhead on materials, %			
	Overhead on labour charge, %			
	Transportation charge			
	Total cost of one hotwater storage tank 100 ltr.			

EXAMPLES OF COST CALCULATION

7.4 SOLAR COLLECTOR SC-85

Pos.	Article		Oty.	Rate	Amount
10	Solar collector SC-85				

	Size: 1810x 790x 110 mm,			
	effective area 1.2 m ²			
	Weight: 47 kg			
10.1	Collector box 24 gauge G. I. sheet			
	1000 x 2000 mm			
	2m ² + 10%*		2.2 m ²	
10.2	Frame left 24 gauge G. I. sheet			
	1829 x 100 mm			
	0.182 m ² + 10%		0.2 m ²	
10.3	Frame right 24 gauge G. I. sheet			
	1829 x 100 mm			
	0.182 m ² + 10%		0.2 m ²	
10.4	Frame top 24 gauge G. I. sheet			
	782 x 100 mm			
	0.078 m ² + 10%		0.086m ²	
10.5	Frame bottom	24 gauge G. I. sheet		
	782 x 150 mm			
	1.17 m ² + 10%	1.3 m ²		
10.6	Hexagon head tapping			
	screws w. metal and rubber			
	washer 6.5 x 16		10 pcs.	
10.7	G.I. pipes 1/2"			
	length = 1668 mm,	9 pcs.	15.012 m	

10.8	G.I. pipes 1 /2"				
	length = 830 mm,	2 pcs.	1.66 m		
10.9	Alu. fins 26 gauge Alu. sheet				
	412 x 120 mm 36 pcs.				
	1.78 m ² + 10%		1.95 m ²		
10.10	Crescent rings 27.7 x 21.7 mm		72 pcs.		
10.11	Insulation fibreglass	50 mm			
	1950 x 1000 mm				
	1.95 m ²		2 m ²		
10.12	Glass, 4 mm thick				
	1800 x 772 mm		1.39 m ²		
10.13	Rubberseal,				
	U-channel		5.3 m		
10.14	Pop-rivets copper 3.2		8 pcs.		
10.15	Soldering mat. tin 40/60		0.05 kg		
10.16	Black board paint		0.5 ltr.		
10.17	Red oxyde		1.0 ltr.		
10.18	Brown No. 403 or dark green No. 212				
	enamel paint		1.0 ltr.		
10.19	Thinner		0.5 ltr.		
10.20	Tool and machine charge				
10.21	Electric charge				

10	Mat. cost for one collector type SC-85, net				
10	Working hrs., and labour charge for one collector type SC-85 marking, cutting, folding, pressing, welding, soldering, testing, painting and assembling.		53 hrs.		
11	Support for two collectors SC-85				
11.1	Hat rails, (G.I. sheets 20 gauge 1926 x 152 mm (3 pcs.) 0.292 m ² + 10% = 0.32 x 3		1.0 m ²		
11.2	Hat rails, G.I. sheets 20 gauge 1638 x,52 mm (2 pcs.) 0.248 m ² + 10% = 0.273 x 2		0.55 m ²		
11.3	Distance pipes (6 pcs.) G.I. pipe 3/4" L= 60 mm x 6		0.36 m		
11.4	Hexagon screws, galv.	M8 x 70	6 pcs.		
11.5	Hexagon nuts, galv.	M8	6 pcs.		
11.6	Washers, galv.	M8	12 pcs.		
11.7	Flat iron (2 pcs.) size: 50 x 150 x 5 mm				

	MS-flat 0.3 m (1.96 kg/m)		0.6 kg		
11.8	Support sheets	3 mm			
	100 x 170 mm	(2 pcs.)			
	0.017 m ² + 10%		0.019 m ²		
11.9	Reinforcement triangle sheet, 3 mm				
	50 x 50 mm (2 pcs.)				
0.25	m ² + 10%		0.0027m ²		
11.10	Hexagon screws, galv.	M8 x 20	4 pcs.		
11.11	Hexagon nuts, galv.	M8	4 pcs.		
11.12	Washers, galv.	M8	4 pcs.		
11.13	G.I. pipes	(2 pcs.)			
	L = 600 mm	3/4"	1.2 m		
11.14	G.I. pipes	(2 pcs.)			
	L = 170 mm	3/4"	0.34 m		
11.15	G.I. sockets	3/4"	2 pcs.		
11.16	Hexagon screws, galv.	M8 x 20	4 pcs.		
11.17	Hexagon nuts, galv.	M8	4 pcs.		
11.18	Washers, galv.	M8	4 pcs.		
11.19	Red oxyde paint		0.2 llr.		
11.20	Dark brown paint		0.2 ltr.		
11.21	Tool and machine charge				
11.22	Electric charge				

11	Mat. cost support for two collectors SC-85			
11	Working hrs., and labour charge support for two collectors SC-85 marking, cutting, punching, folding, thread cutting, painting and assembling		42 hrs.	
12	Circulation G.I. pipes for two collectors SC-85			
12.1	G.I. pipe 1742 mm 1 "		1.742 m	
12.2	G.I. pipes(2 pcs.) L = 787 mm 1 "		1.574 m	
12.3	G.I.pipes (2 pcs.) L= 150 mm 1"		0.3 m	
12.4	G.I. pipes 58 mm 1 "		0.058	
12.5	G.I. elbows 1 "		6 pcs.	
12.6	G.I. unions 1"		2 pcs.	
12.7	Steam packing washers for union 1"		2 pcs.	
12.8	G.I. caps 1 "		2 pcs.	
12.9	Fibreglass insulation 50 mm 1.0 m ²			

12.10	Red oxyde paint		0.3 ltr.		
12.11	Tool and machine charge				
12	Mat. cost circulation pipes for two collectors SC-85				
12	Working hrs., and labour charge, circulation pipes for two collectors SC-85 marking, cutting, thread cutting, painting and assembling		14 hrs.		
13	Panels for two collectors SC-85				
13.1	Middle panel 24 gauge 1840 x 200 mm				
0.368	m ² + 10%		0.4 m ²		
13.2	Side panel 24 gauge 1950 x 265 mm (2 pcs.)				
	0.516 m ² + 10% x 2		1.14 m ²		
13.3	Top panel 24 gauge 2018 x 265 mm				
	0.534 m ² + 10%		0.59 m ²		

13.4	Pan head tapping screws, galv. 3.5 x 95		8 pcs		
13.5	Red oxyde paint		1.0 ltr.		
13.6	Dark brown paint.		1.0 ltr.		
13.7	Tool and machine charge				
13	Mat. cost panels for two collectors SC-85				
13	Working hrs., and labour charge panels for two collectors marking, cutting, folding, drilling painting, assembling				
			11 hrs.		

7.5 SOLAR COLLECTOR SC-85, SUMMARY

Pos.	Article	Qty.	Rate	Amount
	Summary Material			
10	Material cost for two collectors SC-35	1 set		
11	Support for two collectors SC-85	1		
12	Circulation G. I. pipes for two collectors SC-85	1		
13	Panels for two collectors SC-35	1		
10-13	Material cost for two solar collectors SC-85 and accessories net			

	SC-85 and accessories, incl			
	Working hrs., labour charge			
10	Solar collector SC-85			
	two pieces (2 x 53 hrs.)	106 hrs.		
11	Support for two collectors SC-85	42 hrs.		
12	Circulation G. I. pipes for two			
	collectors SC-85	14 hrs.		
13	Panels for two collectors SC-85	11 hrs.		
10-13	Working hrs., labour charge total	173 hrs.		
	Overhead on materials, %			
	Overhead on labour charge %			
	Transportation charge			
	Total cost for two solar collectors SC-85			
	and accessories			



[Home](#) > [ar.cn.de.en.es.fr.id.it.ph.po.ru.sw](#)

Solar Water Heaters in Nepal (SKAT, 1979, 142 p.)

PART V ANNEX

8. ANNEX

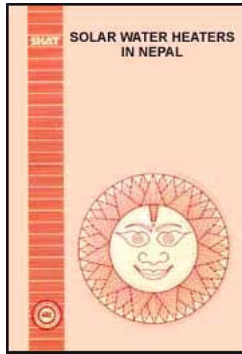

Solar Water Heaters in Nepal (SKAT, 1979, 142 p.)

PART V ANNEX

8. ANNEX

8.1 CHECKLIST FOR SOLAR WATER INSTALLATIONS

- 1) Careful site selection. Check for full sunshine throughout the year.**
- 2) Structure to hold weight of system.**
- 3) Water supply: Sufficient quantity and pressure (head).**
- 4) Continued accessibility of installation (collectors, tank) for maintenance and repairs.**
- 5) Cold connection to supply pipeline to prevent return of hot water into cold water pipeline, (e.g. non-return valve or separate pipeline from feed or roof tank).**

- 6) Safety valve or vent pipe for over pressure release (due to expansion of hot water).**
- 7) Ventilation of system: Requires gradient in circulation pipes and an air release valve or a vent pipe on top of the hot water storage tank.**
- 8) Slopes in pipelines, to avoid blockages of flow through air bubbles. Avoid U-bend installations (especially in low-pressure supply systems).**
- 9) Insulation requirements for hot water storage tank, circulation pipes and for hot water pipelines.**
- 10) Drainage facility (tap, cap) for drainage of entire system.**

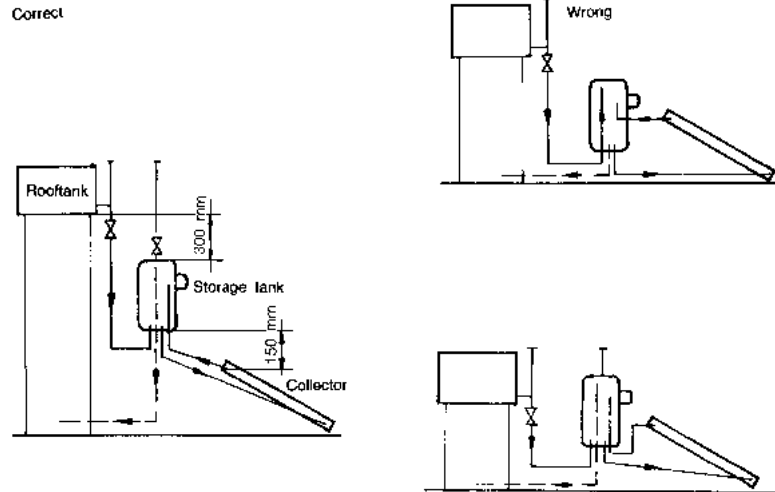

Four common installation mistakes

1st mistake: Distance between storage tank and collector is too small-circulation can reverse during the night, which means great heat loss!

2nd mistake: Cold-and hot water pipe connections are mixed up-cold-and hot water layer are disturbed which results in low water temperature!

3rd mistake: U-bent in collector circuit-air accumulates and interrupts the circulation, which means no heating at all!

4th mistake: Distance between rooftank and storage tank is too small-below a certain level in the rooftank the storage tank is not refilled, which means hot water doesn't flow!

8.2 LEAFLET SOLAR SYSTEM

The natural circulation system is driven by one fundamental principle: hot water is lighter than cold water and tends therefore to rise.

The figures to the side show, how the system cleverly uses this principle to avoid any moving parts except the water.

The sun heats the water in the collector, which starts to rise and accumulate at the top of the storage tank. It is replaced by cold water from the bottom of the tank.

As long as the collector water is hotter than the storage tank water, it keeps circulating. Hot and cold water in the storage tank will not mix. Always the hottest water is the top layer. Therefore during night, when the collector is cold, the circulation will not reverse. Never the hot water can sink down to the cold collector.

If hot water is consumed it is always the hottest water in the storage tank, as the hot outlet is at the very top. The consumption is replaced by cold water from the rooftank.

This water has to enter at the bottom of the storage tank so it will not disturb the hot and cold water layers.

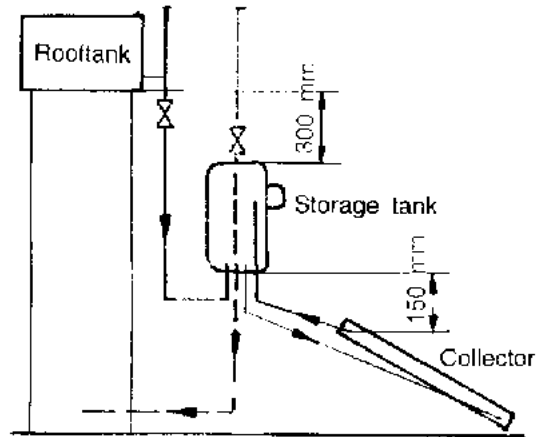

FIGURE

Essentials

-Storage tank has to be higher up than the collectors, the roof tank has to be higher up than the storage tank.

-Heating circuit: Cold water leaves the storage tank at the bottom and enters the collector at the bottom. Hot water leaves the collector at the top and enters the storage tank at about 2/3 in high.

-Consumer circuit: Hot water leaves the storage tank at the top and is replaced by cold water from the roof tank entering at the bottom.

Solar collector, MTC-SC-85**Datas:**

Vertical pipe type and overall size 1810 x 1 10 mm

Collector effective area 1.22 m²

Weight 47 kg (empty)

Contain of water 3.9 ltr.

Test pressure 10 bar

Working pressure 5 bar

Absorber 36 fins alu. sheet 0.5

Absorber surface Black colour paint

Collector box / frame Galvanized steel sheet 0.55

Collector box inside / outside 1 coat painted

Cover Single glass 4 mm

Insulation back/side 50 mm fibreglass

THREADS AND FORMULAS**8.3 SHEET-METAL AND STEEL PIPES****Drill diameter for**

For metric threads			For whitworth threads		
Thread size	Through hole	Threaded hole	Thread size	Through hole	Threaded hole
M3	3.6	2.5	1/4"	7.4	5.0
M4	4.8	3.2	5/16"	8.5	6.1

Model	Area (m ²)	Volume (liters)	Height (m)	Volume (liters)	Volume (liters)
M5	5.8	4.2	3/8"	11.5	7.7
M6	7.0	5.0	7/16"	13.0	9.25
M8	9.5	6.7	1/2"	15.0	10.25
M10	11.5	8.4	5/8"	18.0	13.25
M12	14.0	10.0	3/4"	22.0	16.25

Circle and cylinder

$$A = \pi/4 D^2$$

$$\text{Area} = \pi/4 \times \text{Diameter} \times \text{Diameter}$$

$$C = \pi r^2 = 0.785 D^2$$

$$C = \pi D$$

$$\begin{aligned} \text{Circumference} &= \pi \times \text{Diameter} \\ &= 3.142 D \\ &= 2 \pi r \end{aligned}$$

$$V = A \times h$$

$$V = A_0 \times h$$

$$V = \pi/4 \times D^2 \times h$$

Lateral area of the cylinder

$$A_l = \pi \times D \times h$$

Circle

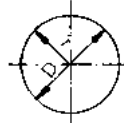

Cylinder

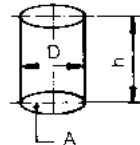

FIGURE

8.4 STEEL DIMENSIONS AND WEIGHT

MS-flat

Width mm	Thickness mm								
	3	4	5	6	7	8	10	12	14
10	0,236	0,314	0,393	0,471+	0 550+	0,628+			
12	0,283	0,377	0,471	0,565	0 659 +	0,754	0,942 +		
15	0,353	0,471	0,589	0,707	0,824 +	0,942	1,18	1,41 +	
16	0,377	0,502	0,628	0,754	0,879 +	1,00	1,26	1,51 +	
18	0,424	0,565	0,707	0,848	0,989 +	1,13	1,41	1,70 +	1,98 +

20	0,471	0,628	0,785	0,942	1,10	1,26	1,57	1,88	22,20
22	0,518 +	0,691	0,864	1,04	1,21	1,38	1,73	2,07	22,42+
24	0,565 +	0,754 +	0,942+	1,13+	1,32+	1,51 +	1,88+	2,26+	2,64+
25	0,589	0,785	0,981	1,18	1,37	1,57	1,96	2 36	2,75
27	0,636 +	0,848 +	1,06	1,27 +	1,48 +	1,70 +	2,12 +	2 54 +	2,97 +
28	0,659 +	0,879 +	1,10 +	1,32 +	1,54 +	1,76 +	2,20 +	2,64 +	3,08 +
30	0,707	0,942	1,18	1,41	1,65	1,88	2,36	2,83	33,30+
32	0,754 +	1,00 +	1,26 +	1,51 +	1,76 +	2,01 +	2,51 +	3,01 +	3,52 +
35	0,824	1,10	1,37	1,65	1,92	2,20	2,75	3,30	33,85 +
40	0,942	1,26	1,57	1,88	2,20	2,51	3,14	3,77	44,40 +
45	1,06	1,41	1,77	2,12	2,47	2,83	3,53	4,24	44,95 +
50	1,18	1,57	1,96	2,36	2,75	3,14	3,93	4 71	5,50+
55	1,30	1,73	2,16	2,59	3,02	3,45	4,32	518	66,04 +
60	1,41	1,88	2,36	2,83	3,30	3,77	4,71	5,65	66,59 +
65	1,53	2,04	2,55	3,06	3,57	4,08	5,10	6,12	77,14

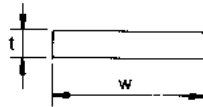
**FIGURE**

Round bar

d	cm ²	kg/m	d	cm ²	kg/m
5 +	0,196	0,154	9	0,636	0,499
5,5	0,238	0,187	9,5+	0,709	0,556
6	0,283	0,222	10	0,785	0,617
6,5 +	0,332	0,260	10,5 +	0,866	0,680
7	0,385	0,302	11	0,950	0,746
7,5 +	0,442	0,347	11,5	1,04	0,815
	0,503	0,395	12	1,13	0,888
8,5 +	0,568	0,445	12,5 +	1,23	0,963

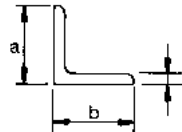
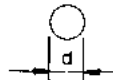
**FIGURE****Angle iron**

Size	Thickness	Weight / m	Size	Thickness	Weight / m

Size	a x b	Thickness	cm ²	kg/m	Size	a x b	Thickness	cm ²	kg/m
15	15	3	0,82	0,640	40	40	3 +	2,35	1,84
				40	40	4	3,08	2242	
20	20	3	1,12	0,880	40	40	5	3,79	297
20	20	4	1,45	1,14	40	40	6	4,48	3,52
					40	40	7 +	5,13	4,03
25	25	3	1,42	1,12	40	40	8	580	4 55
25	25	4	1,85	1,45					
25	25	5 +	2,26	1,77	45	45	3 +	2,66	2,09
					45	45	4	3,49	22,74
30	30	3	1,74	1,36	45	45	5	4,30	3,38
30	30	4	2,27	1,78	45	45	6	509	4 00
30	30	5	2,78	2,18	45	45	7	586	4 60
30	30	6	3,27	2,57					
					50	50	4+	3,89	33,06
35	35	3+	2,04	1,60	50	50	5	4,80	3,77
35	35	3,5+	2,33	1,87	50	50	6	5,69	4,47
35	35	4	2,67	2,10	50	50	7	6 56	515
35	35	4,5	2,93	2,30	50	50	8	7,41	582
35	35	5	3,28	2,57	50	50	9	824	647
35	35	6	3,87	3,04					

8.5 SHEET-METAL

Conversion table for sheet thickness

Thickness in ISWG	Thickness in mm	Thickness in ISWG	Thickness in mm
30	0.314	19	1.015
29	0.345	18	1.218
28	0.376	17	1.422
27	0.416	16	1.625
26	0.457	15	1.828
25	0.507	14	2.040
24	0.558	13	2.337
23	0.609	12	2.641
22	0.711	11	2.946
21	0.812	10	3.250
20	0.914		

**FIGURE****Steel sheet**

Plate thickness	Weight kg/m²	size of plate	
		100 x 2000 mm	1250 x 2500 mm
in mm		weight in ka	

0.5	4	8	12.5
0.62	5	10	16
0.75	6	12	19
0.87	7	14	22
1	8	16	25
1.25	10	20	31
1.5	12	24	38
1.75	14	28	44
2	16	32	50
2.5	20	40	63
3	24	48	75
3.5	28	56+	88+
4	32	64	100
5	40	80	125
6	48	96	150
7	56	112	175
8	64	128	200
9	72	144+	225+
10	80	160	250

Alu. sheet

Plate	Weight	Size of plate
thickness	kg/m ²	1000 x 2000 mm

	in mm	weight in kg
0.5	1.35	5.4
0.75	1.62	-
0.80	2.18	-

Copper sheet

0.5	4.45	8.9
0.55	4.90	9.8
0.6	5.35	10.70
0.7	6.25	12.5

8.6 ADDRESSES OF SUPPLIERS

- 1) Air vent valve "TACO" TACO Armaturen AG
(also heat exchangers, Buckhauserstrasse 40
solar modules, etc.! Postfach 1381
CH-8048 Zurich/Switzerland)
- 2) Differential-Thermostat W. Kuster AG
type "RT" (Bimetal- Parkstrasse 6
switching) DANFOSS) 4402 Frenkendorf/Switzerland
- 3) 12 V/DC circulation R. Brun
pump ARWA vortex Alternative Energy Technologies
(and other solar 95 Ruefa
appliances) CH-7015 Tamins Switzerland

SOLAR WATER HEATERS FURTHER READINGS:

1) Guidelines for the cost-effective design of solar water heating collectors

by A W K McGregor, Senior Lecturer

Dept. of Mechanical Engineering

Napier College, Colinton Road

Edinburgh EH10 5DT, Scotland, U.K.

2) Solaranlagen

von H. R. Schmidli, Berufsschullehrer,

erhaeltlich: SSIV, Postfach, Ch-8023 Zuerich, Switzerland

3) Le chauffe-eau solaire

de Thierry Cabirol et al.

EDISUD, La Calade, F-13090 Aix-en Provence, France

4) Agua caliente solar (Original: practical solar heating)

1978: Kevin McCartney -Prism Press, Chalmington, Dorchester

1980: H. Blume Ediciones, Rosario, 17, Madrid -5, Spain

5) Plumbing, hot water supply and heating systems

by F. Hall (1986)

Longman Scientific & Technical, Longman House,

Burnt Mill, Harlow, Essex CM20 2JE, England, U.K.

6) Plumbing and heating

by F. Hall (1980)

The Macmillan Press, Ltd, London and Basingstoke

20/10/2011

Solar Water Heaters in Nepal (SKAT, 19...

**7) Drinking water installations and drainage requirements in Nepal
by A. Bachmann and H. Waldvogel
a publication by MTC-Nepal and Skat-Switzerland
SKAT, Varnbuelstrasse 14, CH-9000 St. Gallen, Switzerland**

