

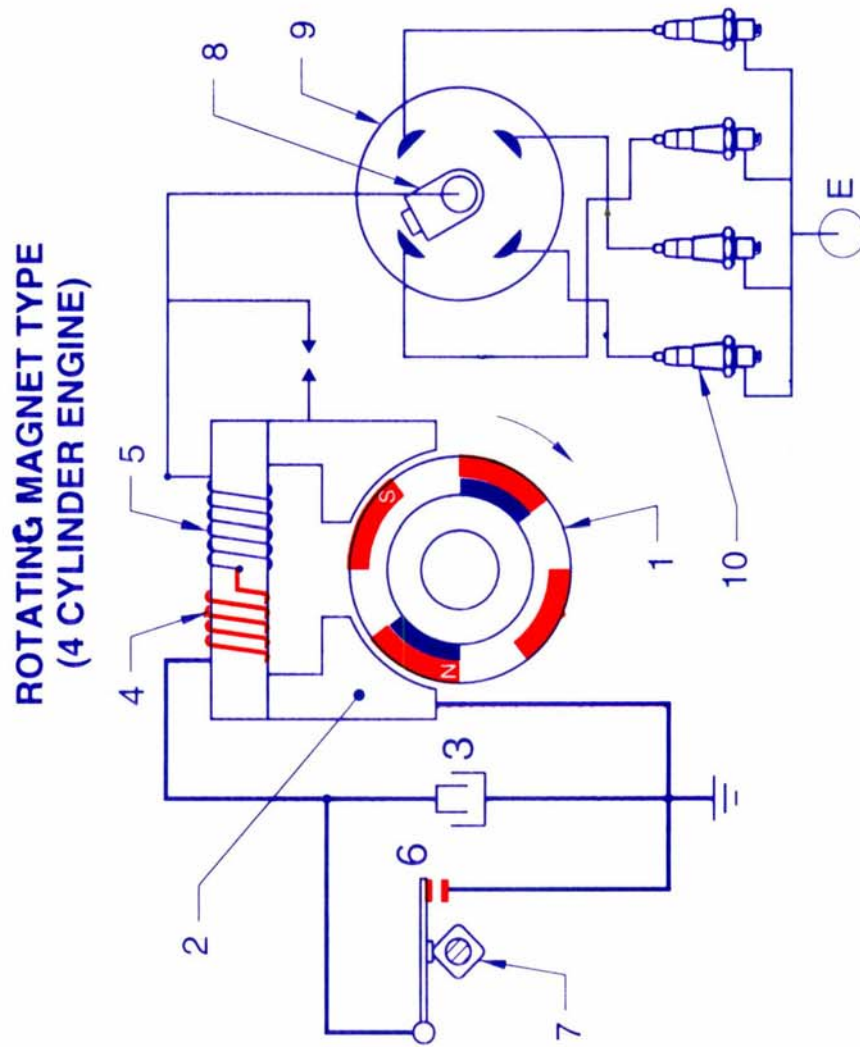

MAGNETO IGNITION SYSTEM (4 CYLINDER ENGINE)





MAGNETO IGNITION SYSTEM (SINGLE CYLINDER ENGINE)

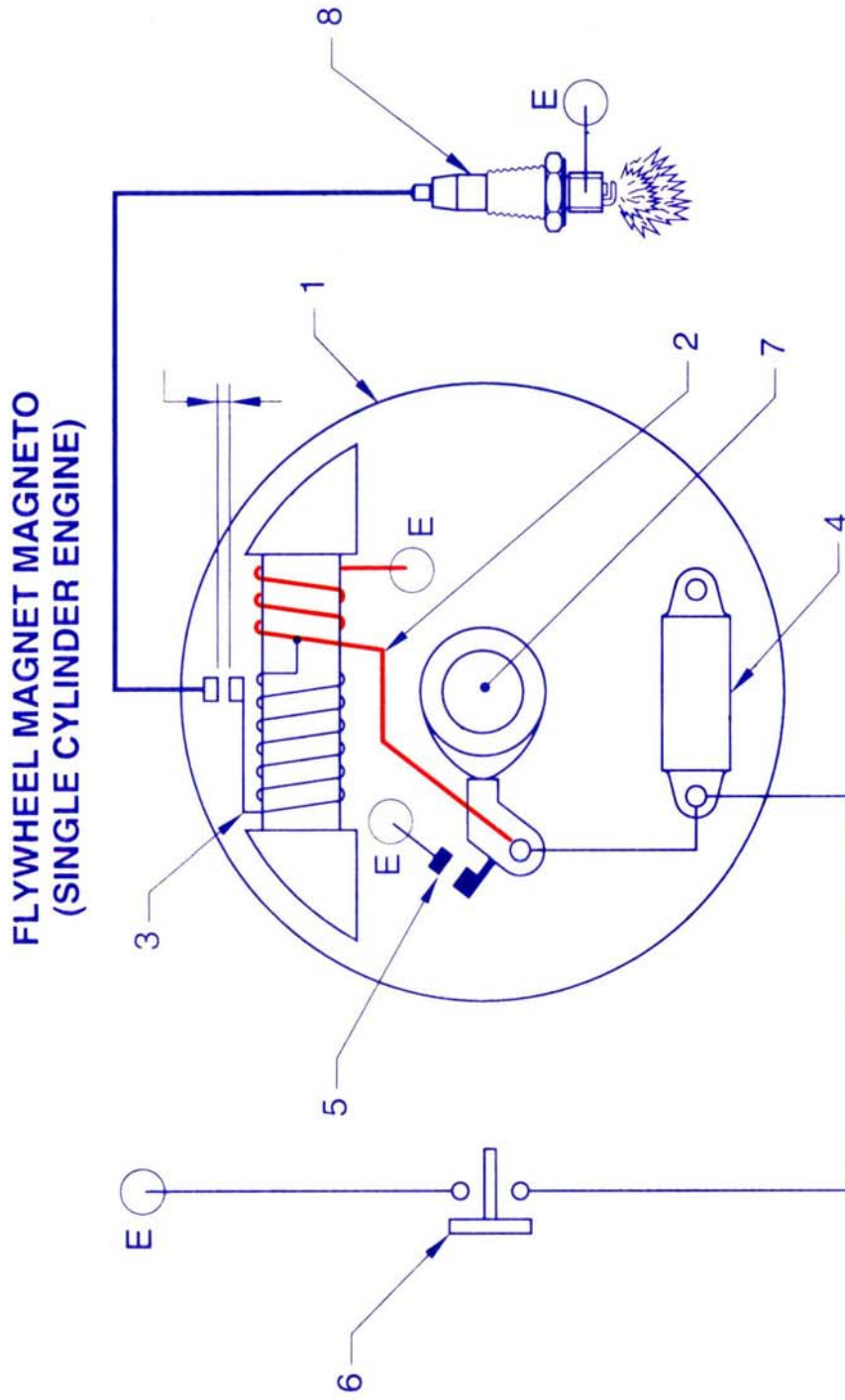



ANTI-DAZZLING ARRANGEMENT

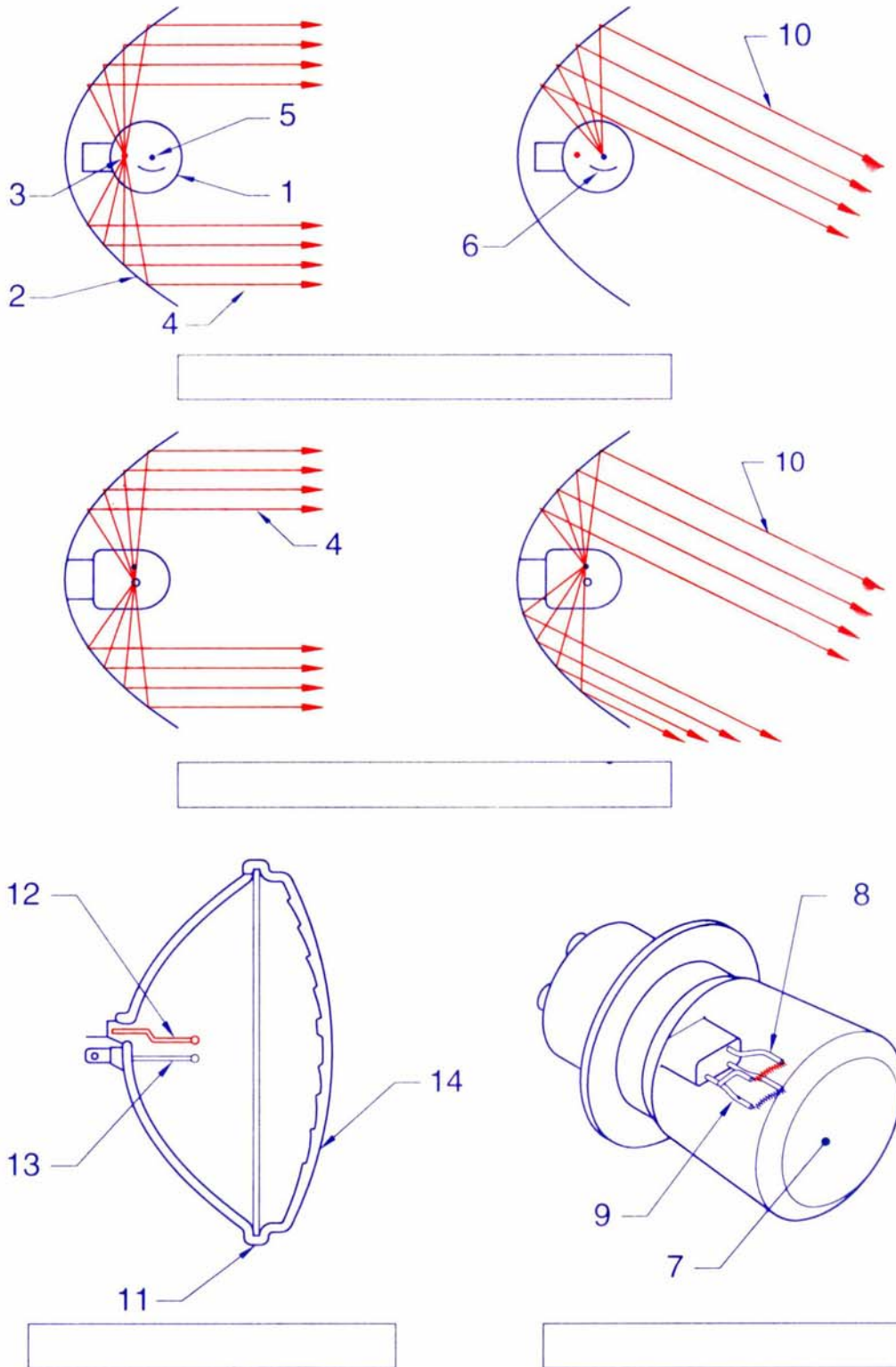



WIRING DIAGRAM OF RELAY TYPE HORN

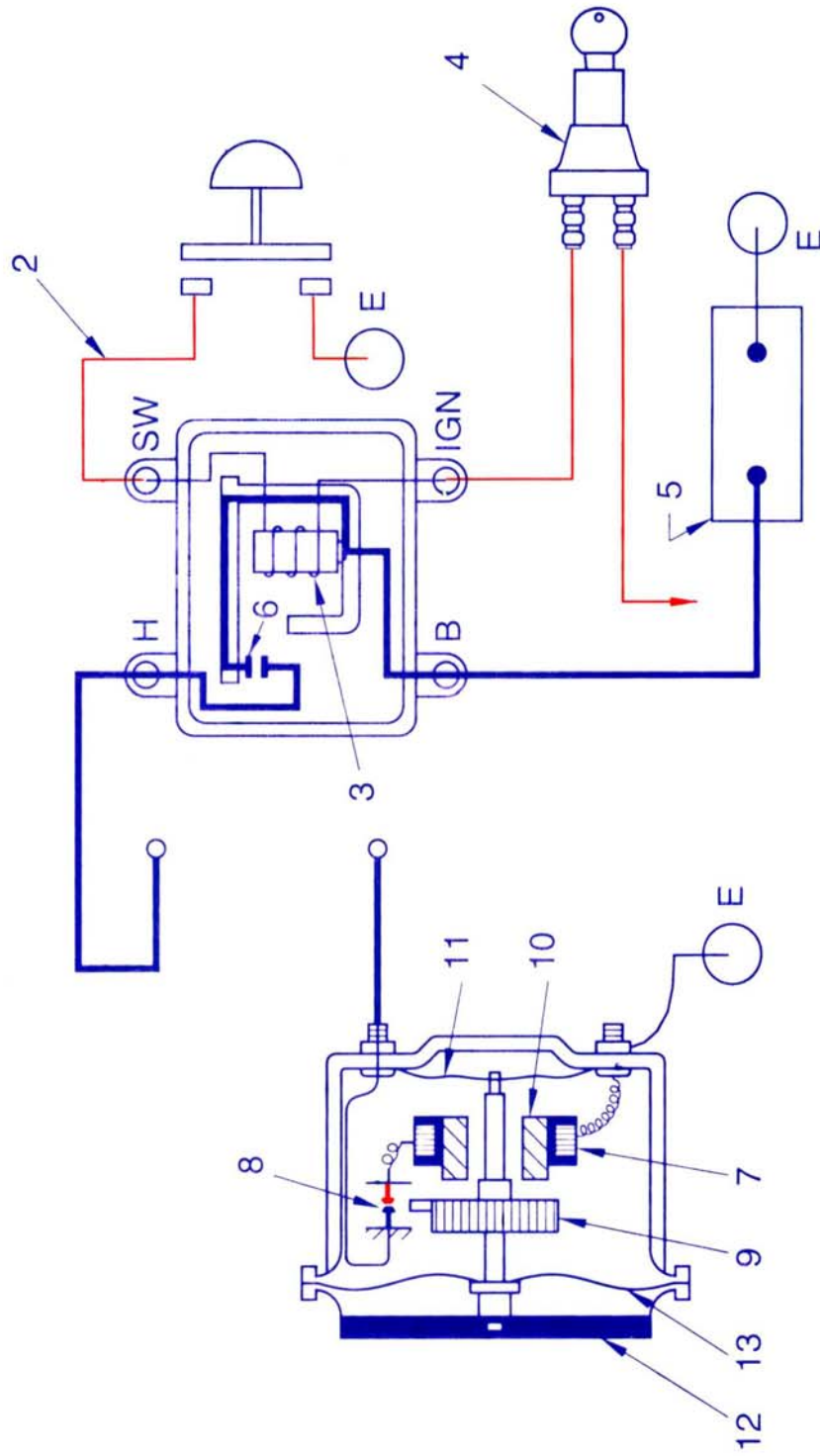



SELF STARTER WIRING CIRCUIT (PETROL ENGINE)

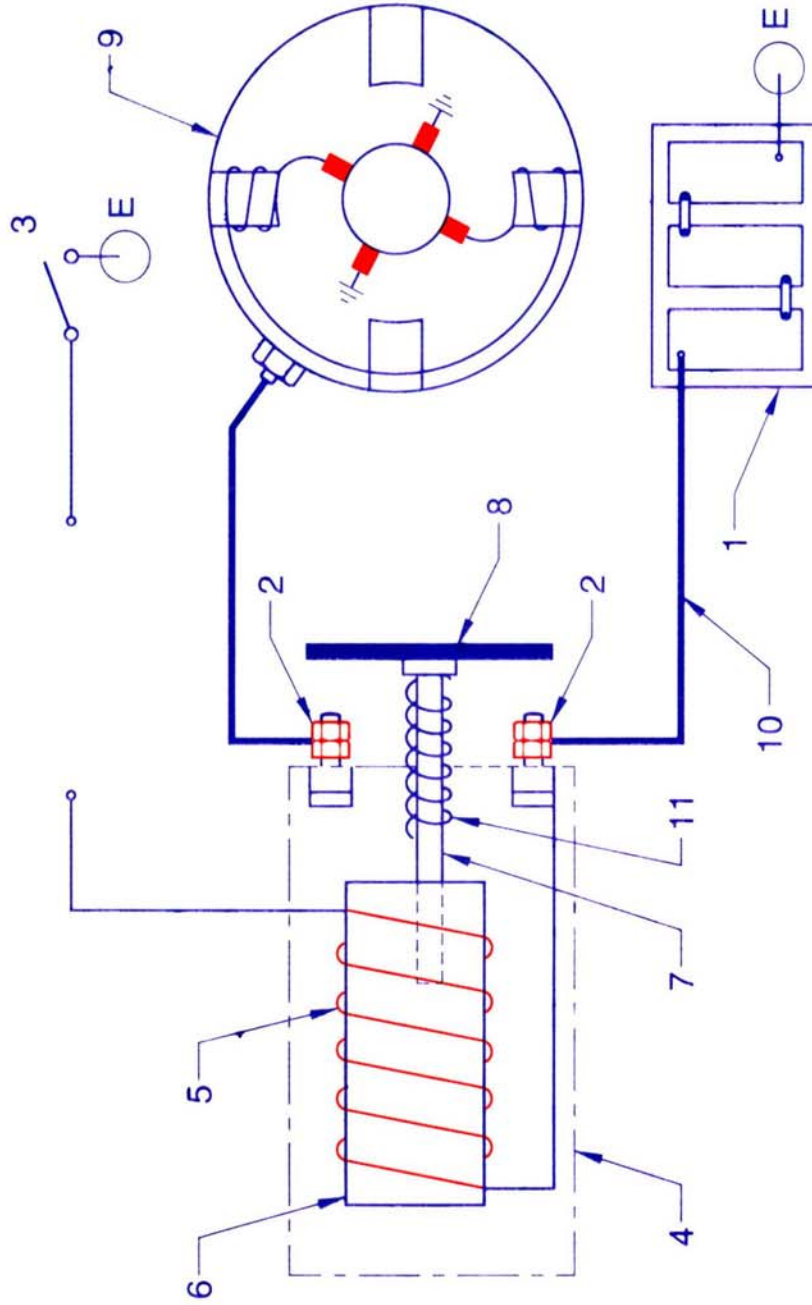



SELF STARTER WIRING CIRCUIT (DIESEL ENGINE)

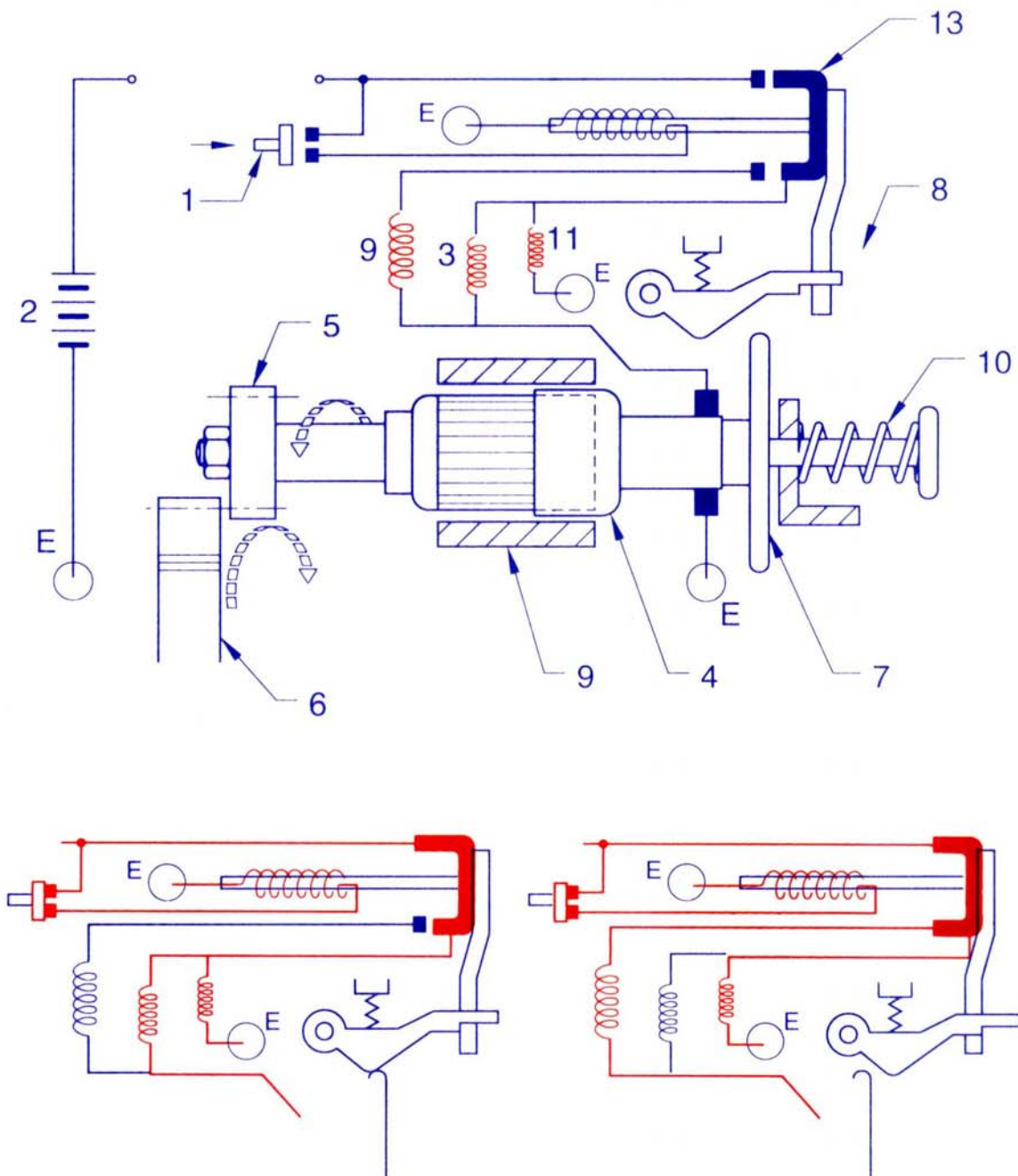



WIRING DIAGRAM OF A CHARGING CIRCUIT (VEHICLE)

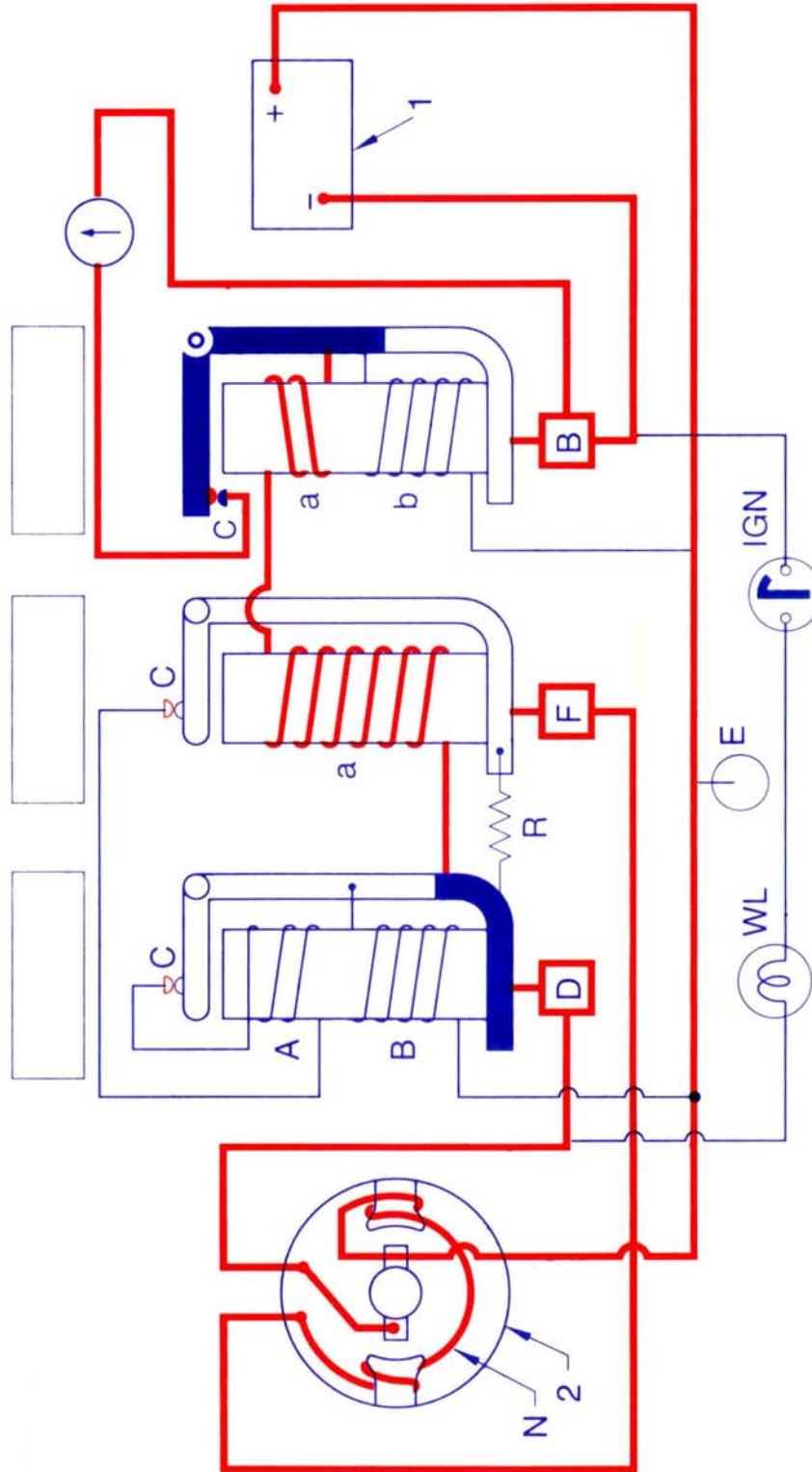



CIRCUIT DIAGRAM OF ALTERNATOR TESTING

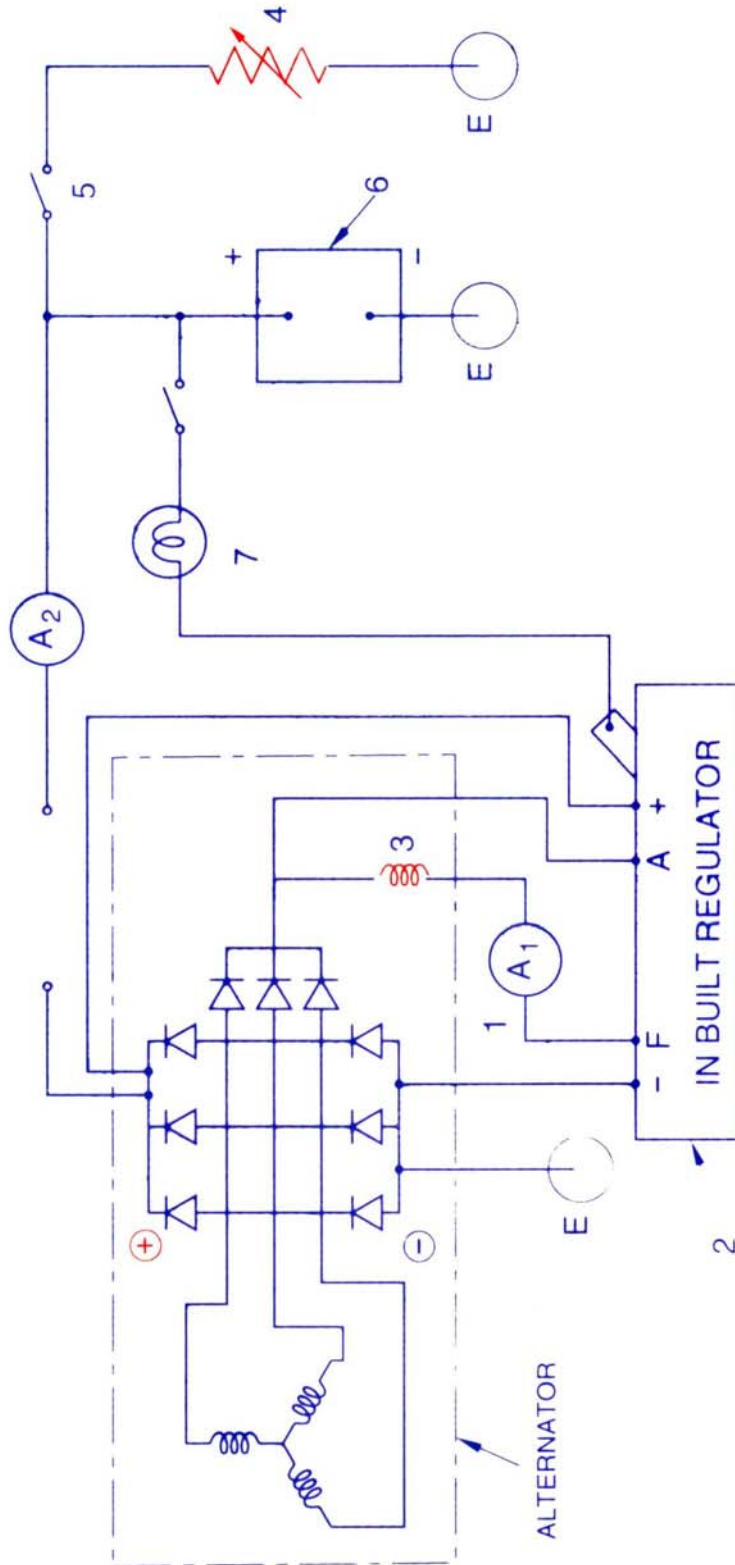



SYNCHRONISER UNIT AND ITS ACTION

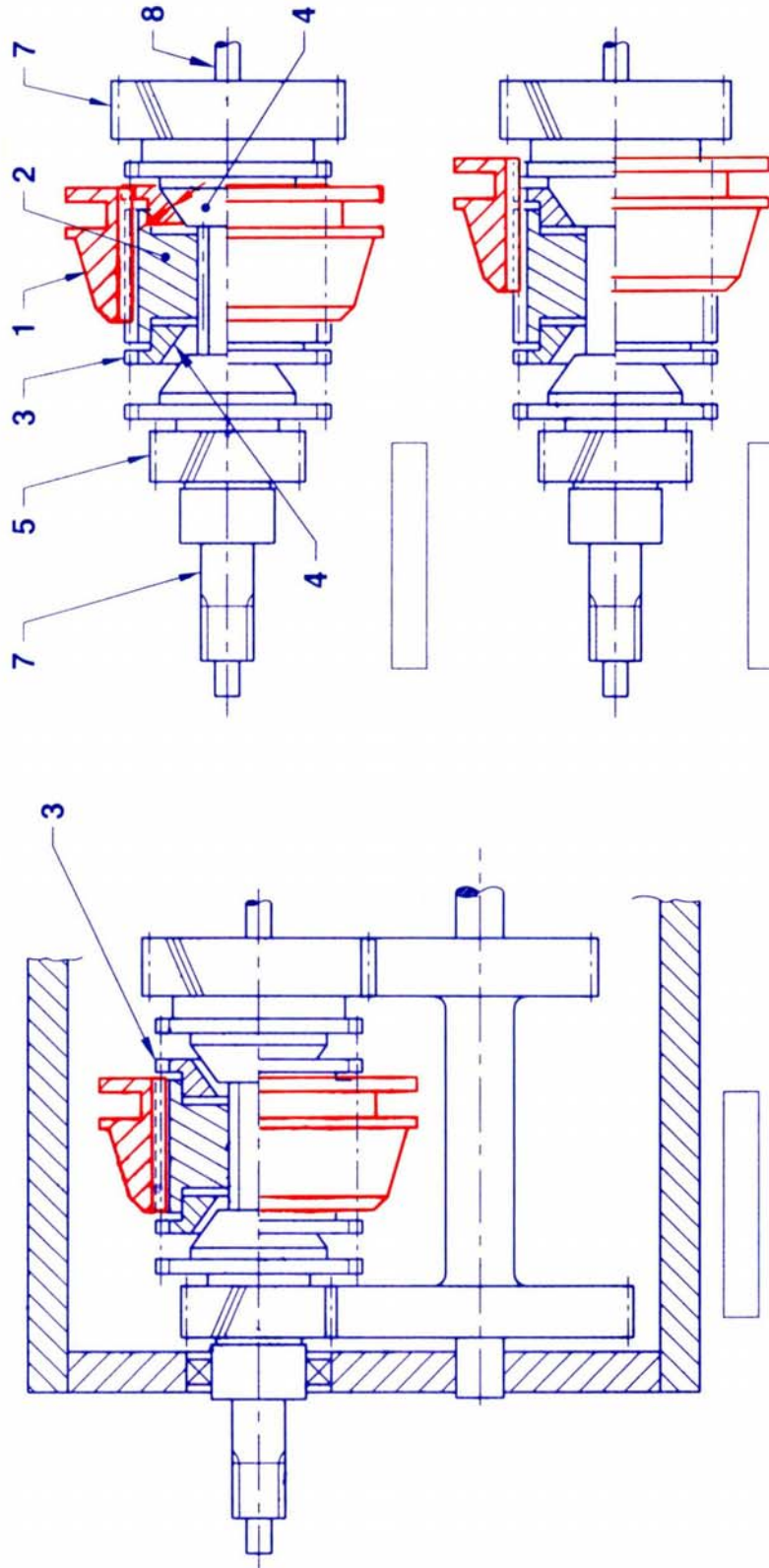



LAYOUT OF 4 WHEEL DRIVE

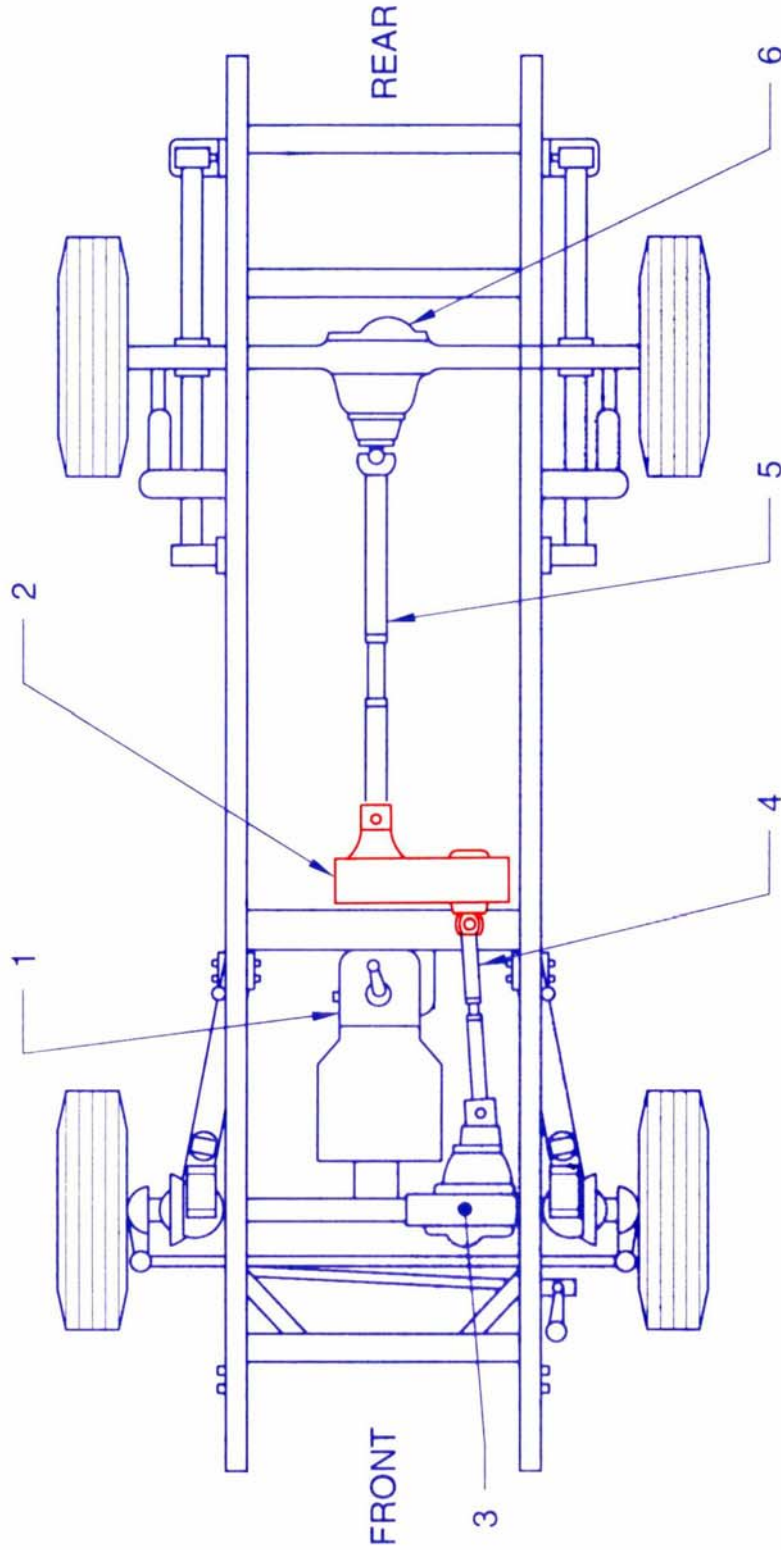



FOUR WHEEL DRIVE TRANSFER CASE (HIGH RANGE)

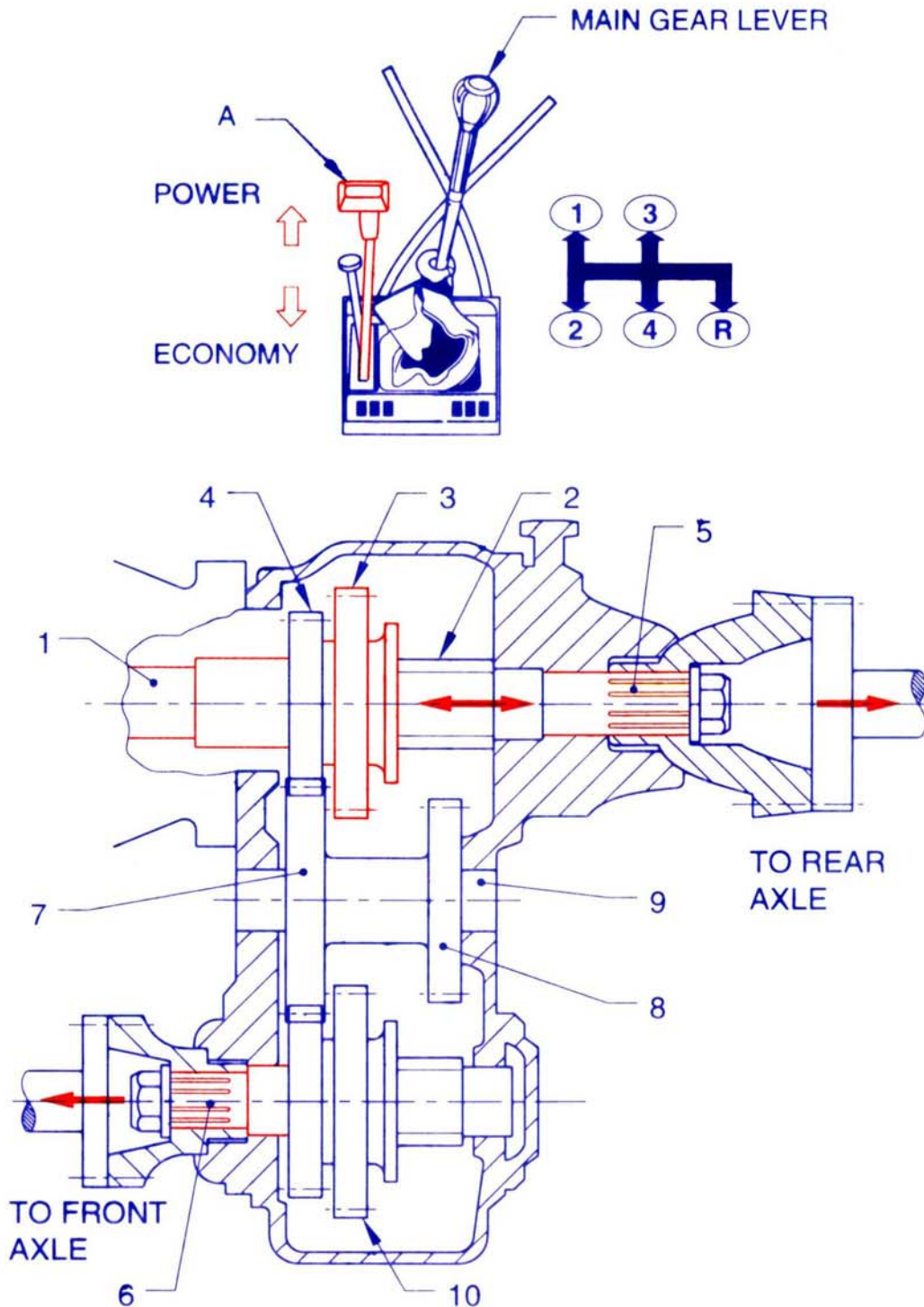



INDEPENDENT FRONT WHEEL SUSPENSION (MACPHERSON & COIL SPRING)

MACPHERSON STURT TYPE SUSPENSION

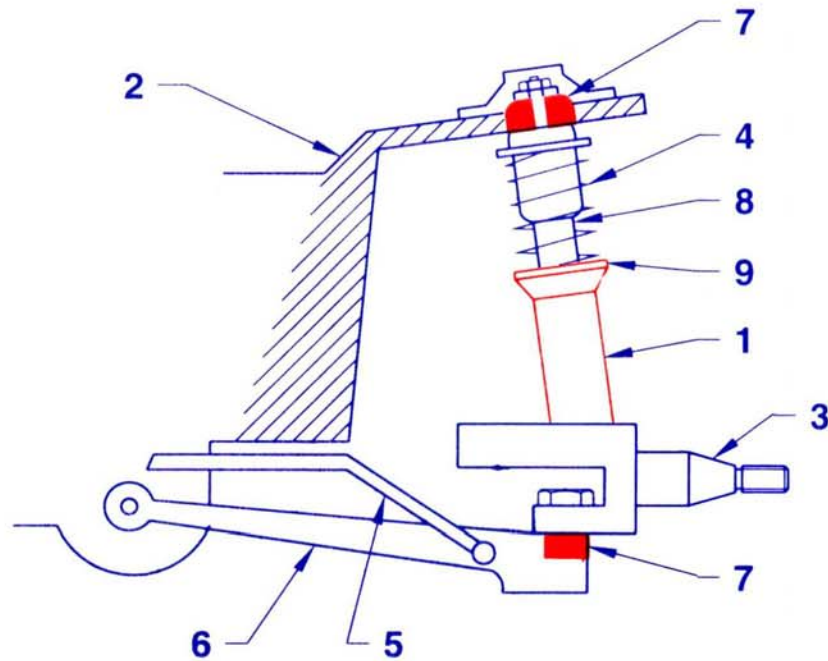

COIL SPRING SUSPENSION

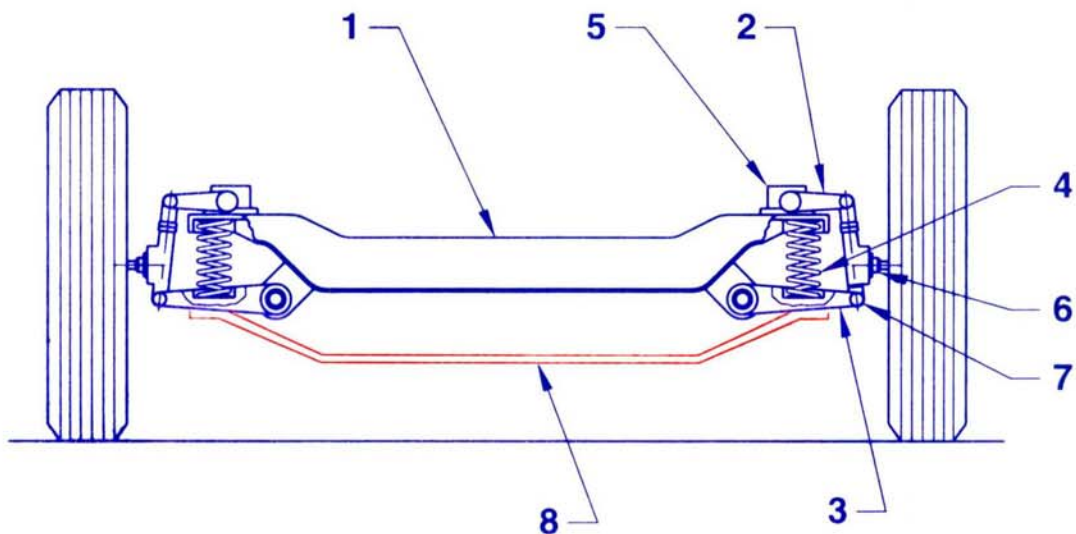



VALVE TIMING DIAGRAM (4 STROKE CYCLE DIESEL ENGINE)

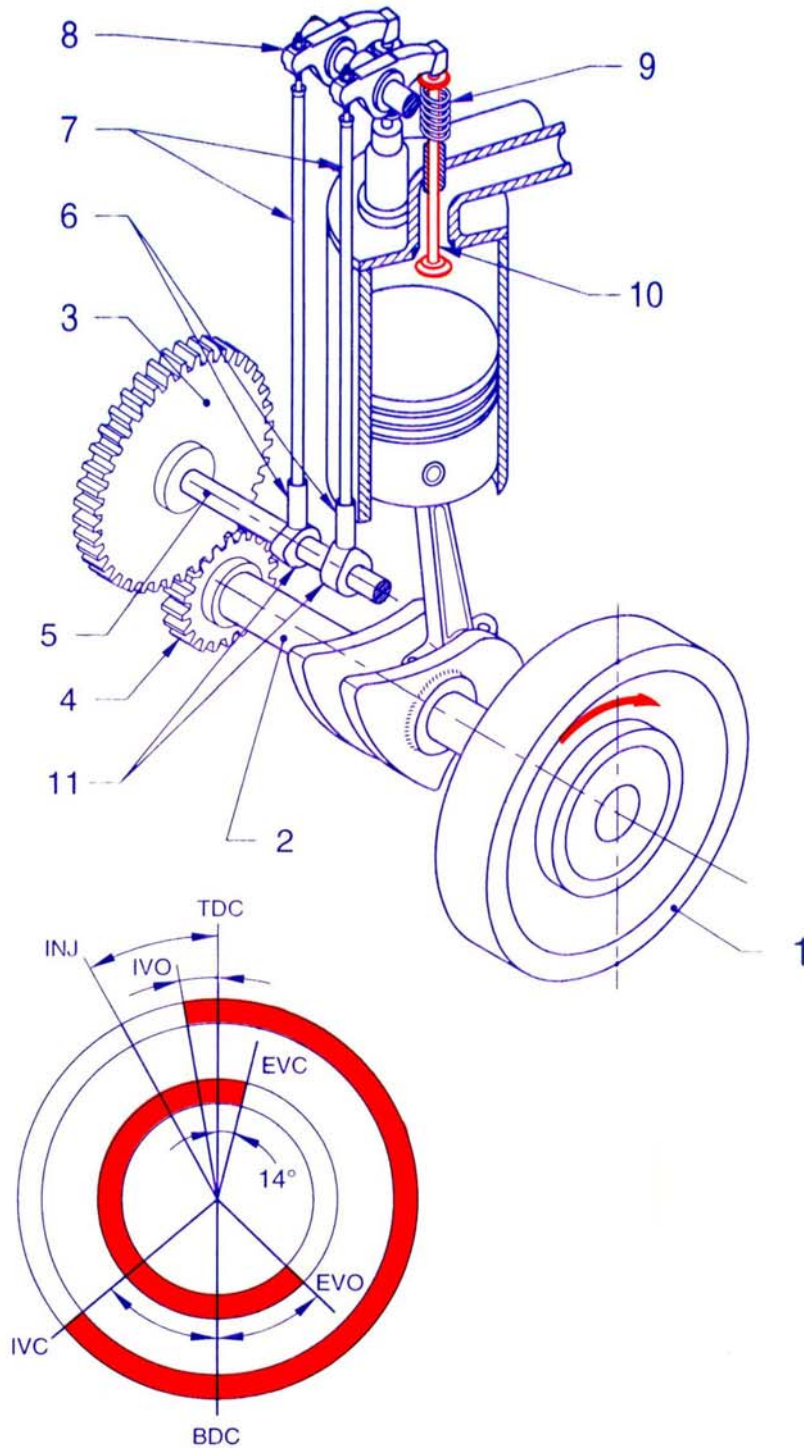



CRANKCASE VENTILATION

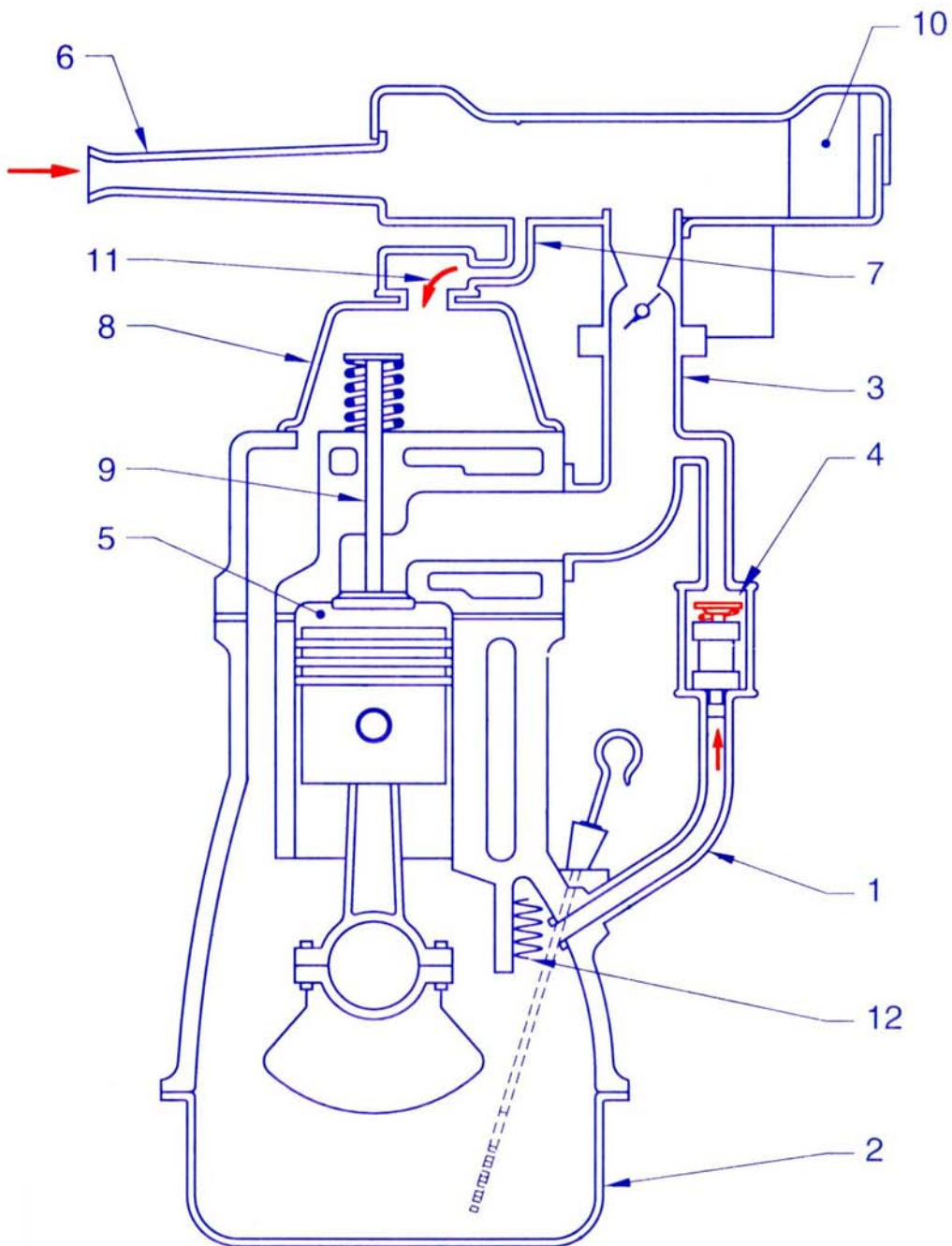



COMPARISON OF FUNCTION MULTI HOLE AND PINTLE NOZZLES

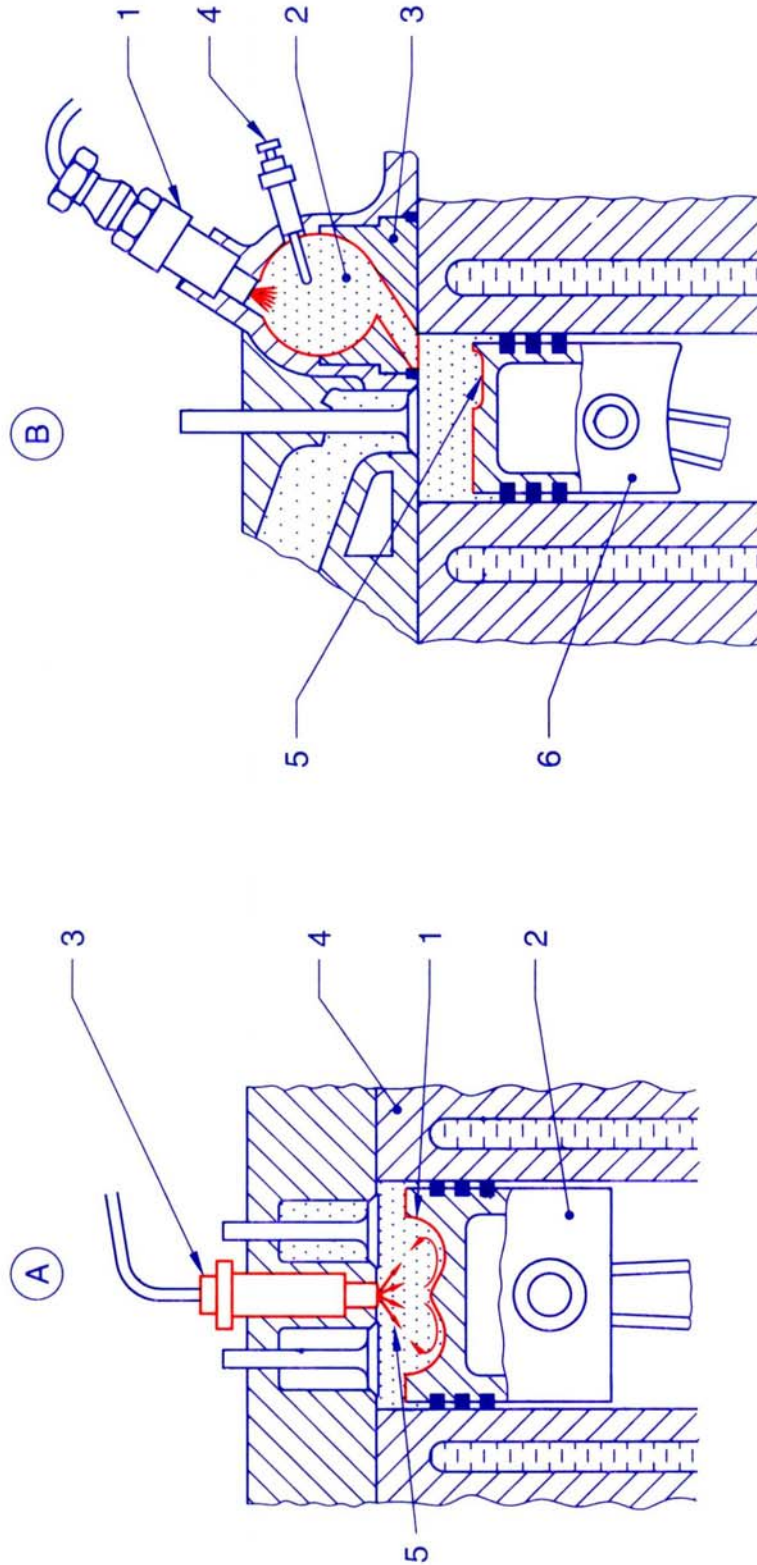



FUEL FEED SYSTEM (DIESEL INLINE JERK PUMP)

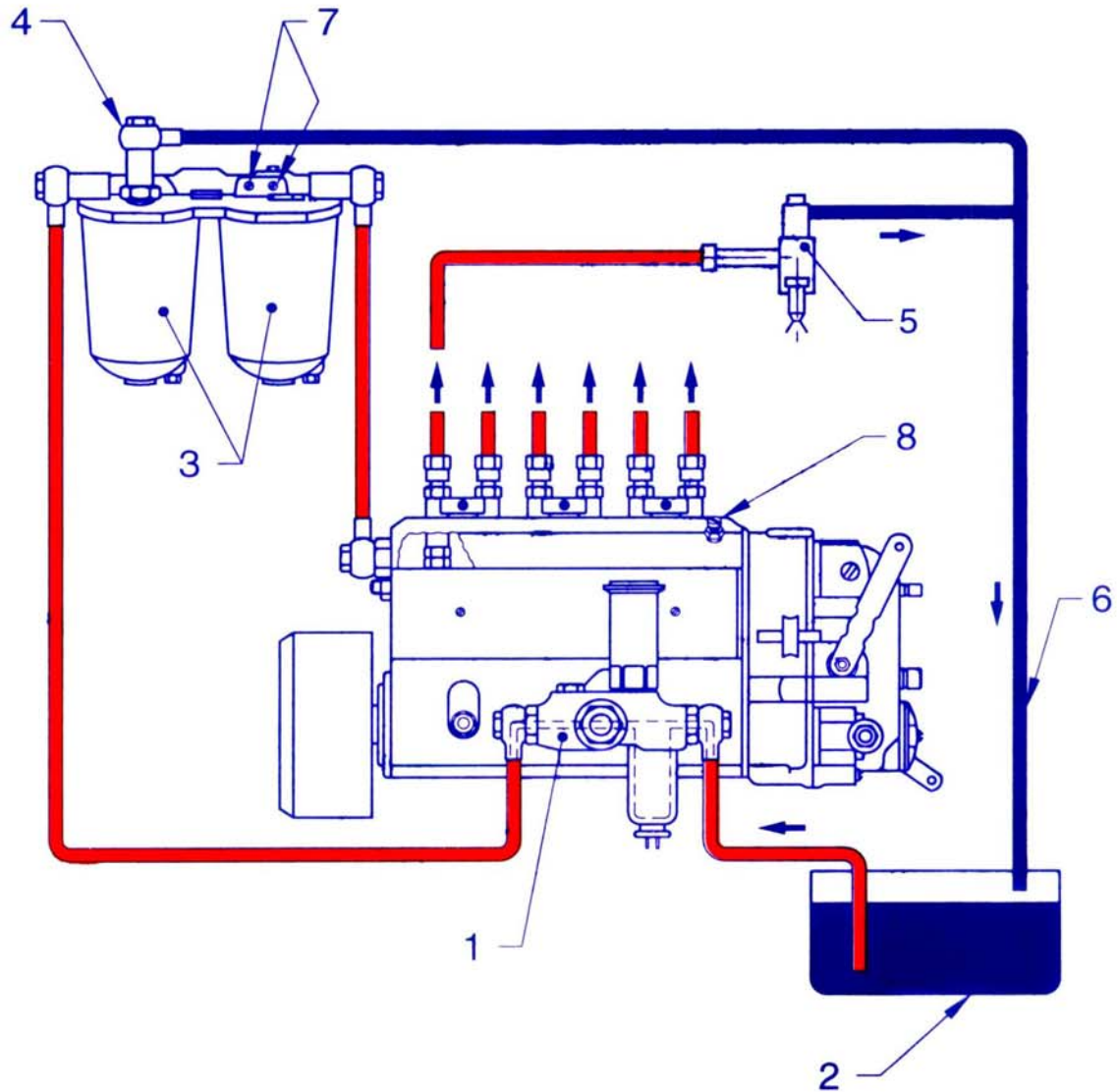



FUEL INJECTION PUMP

(A) FUEL DELIVERY POSITION

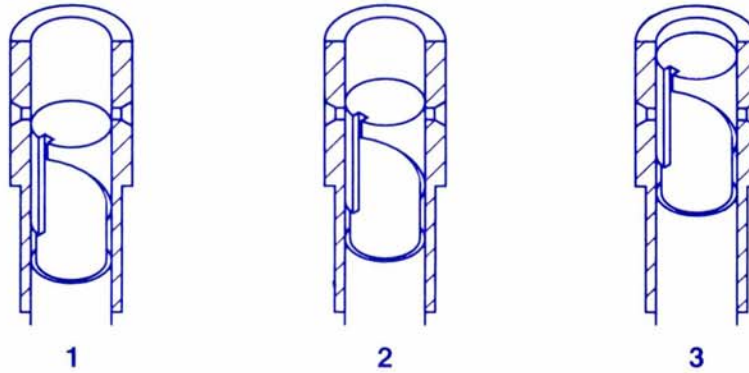

(B) ARRANGEMENT OF PLUNGER & BARREL

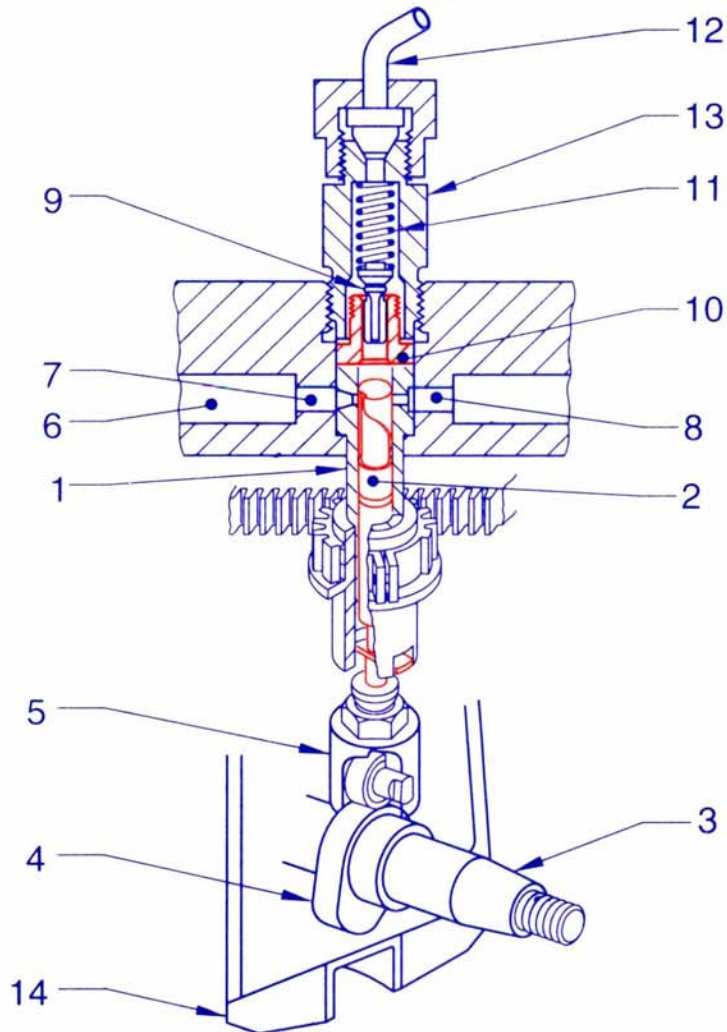



DIESEL ENGINE FUEL FILTER

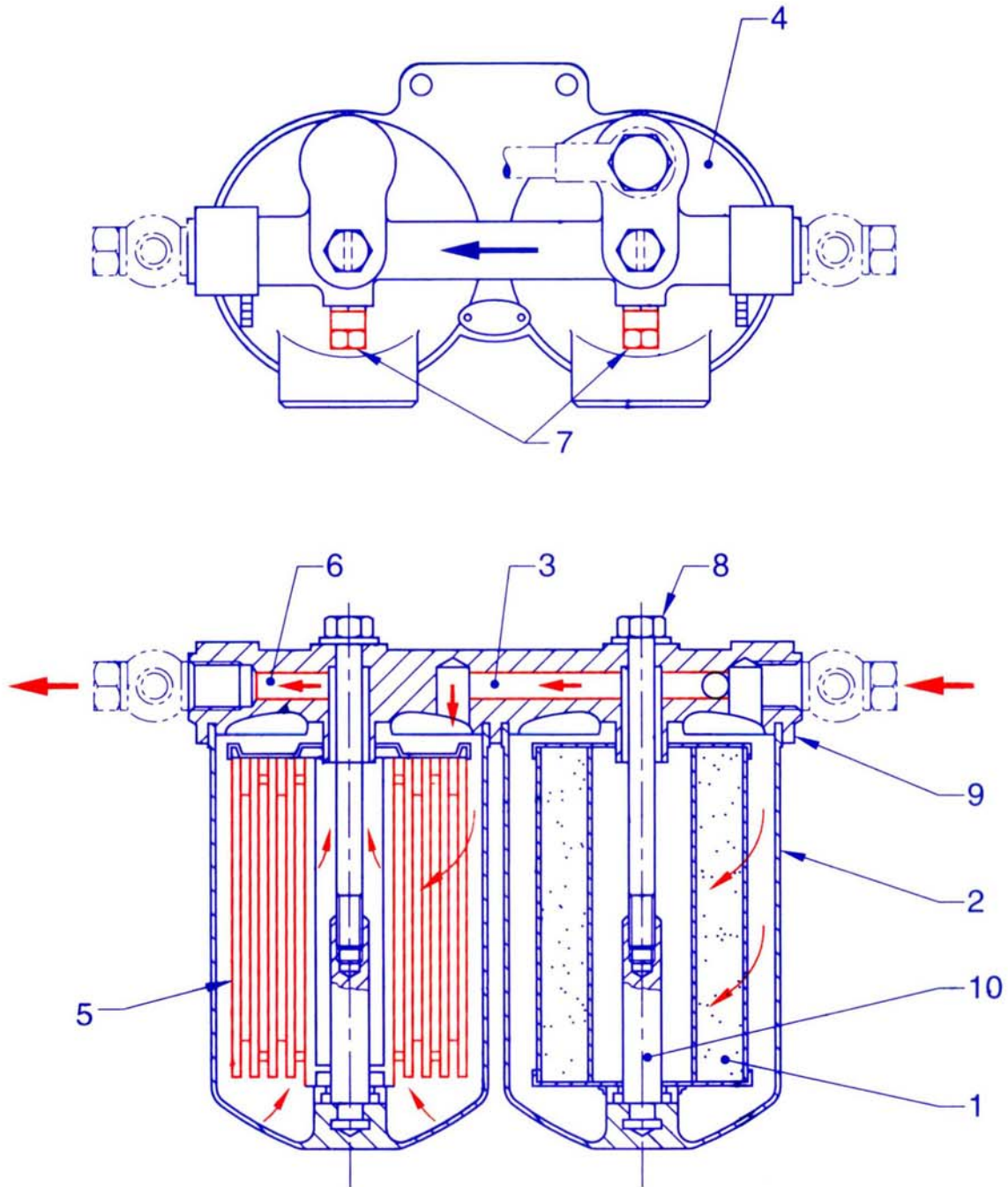



TYPES OF STUBAXLE MOUNTINGS (CONVENTIONAL FRONT AXLE)

ELLIOT TYPE

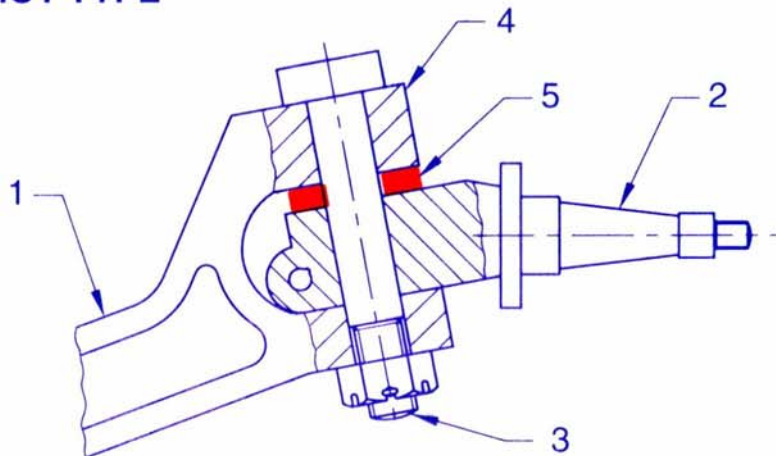

REVERSED ELLIOT TYPE

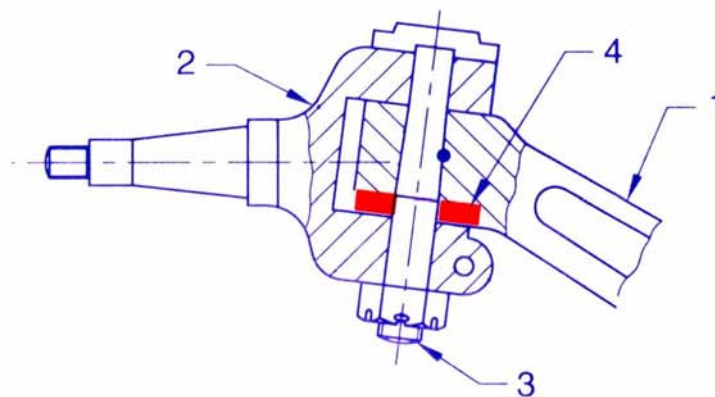

LEMOIN TYPE

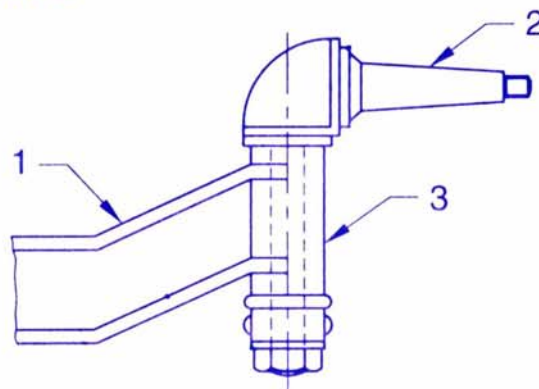



STEERING LINKAGES LIGHT MOTOR VEHICLE

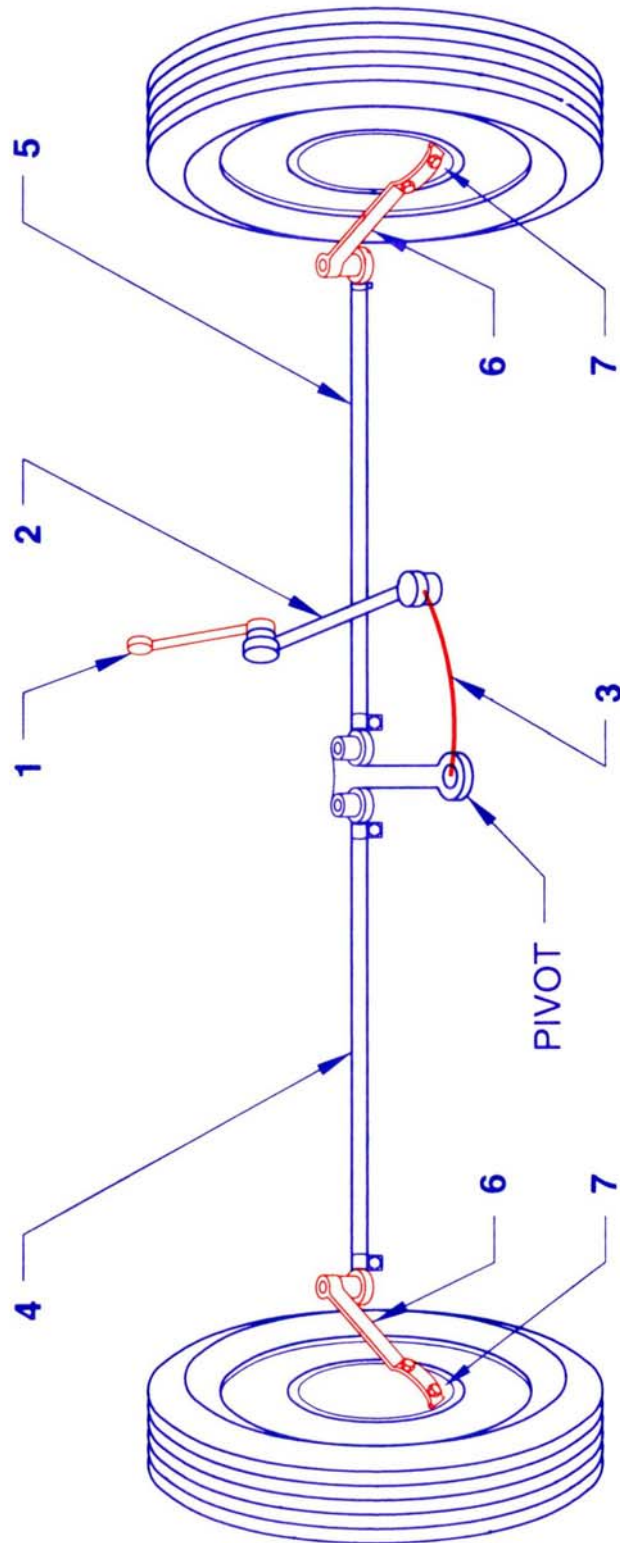



STEERING GEAR BOX RACK & PINION STEERING

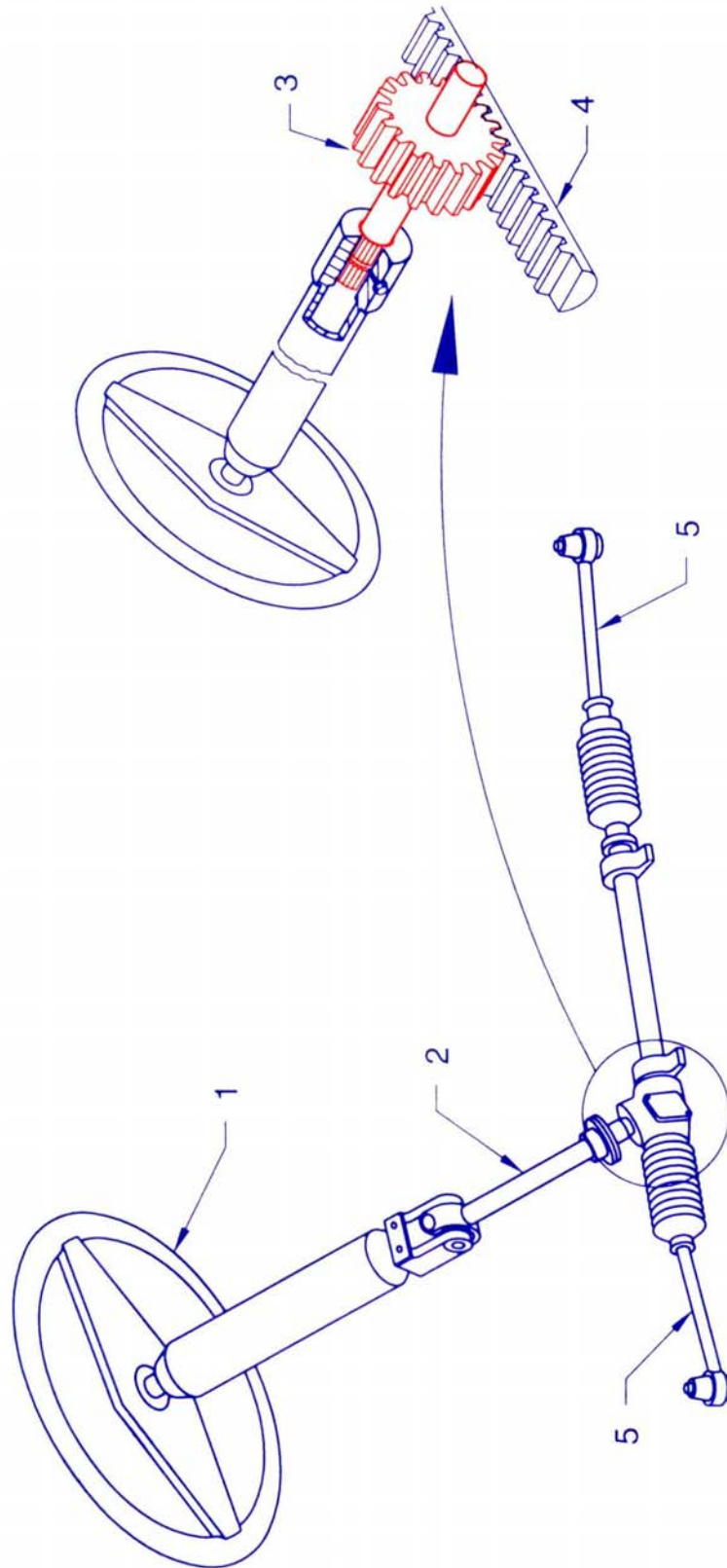



TANDEM MASTER CYLINDER AND ITS FUNCTION

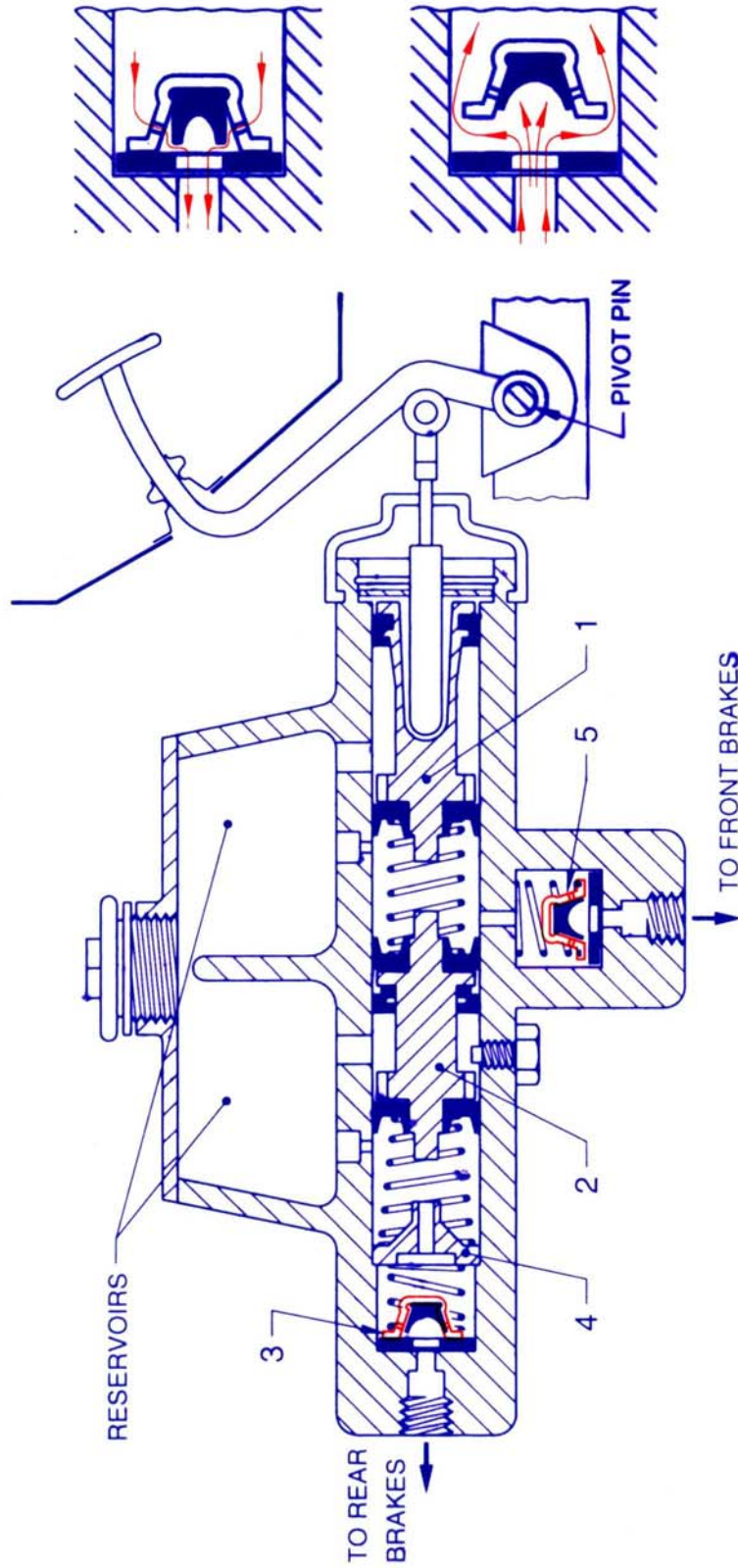



DIFFERENTIAL AND ITS ACTION

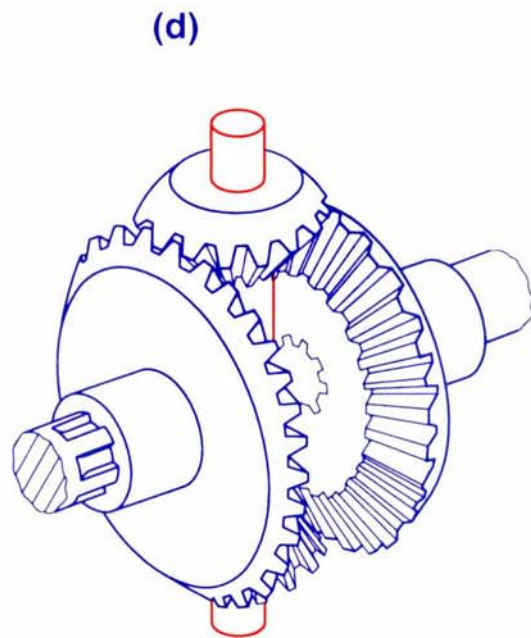
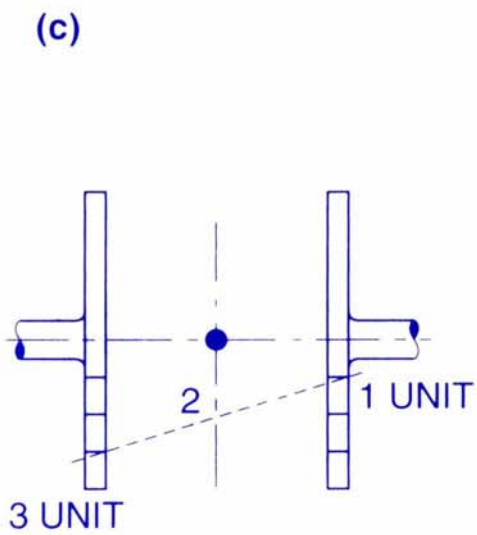
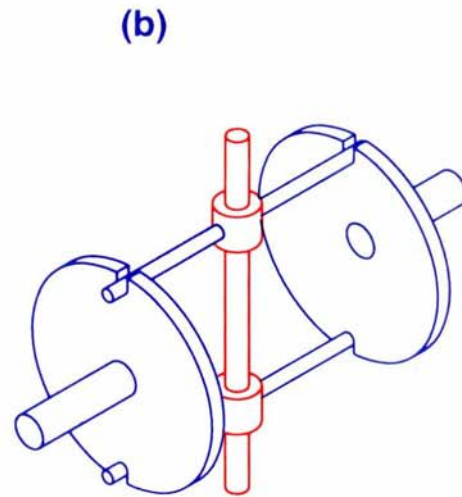
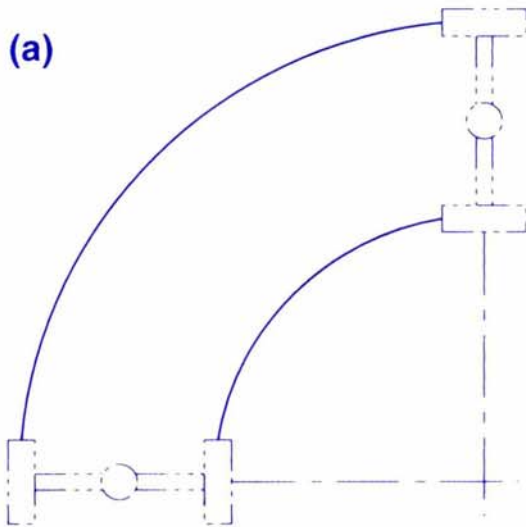



WHEEL CYLINDER AND ITS ACTION

