

# MECHANIC DIESEL TRANSPARENCIES



**CIM** CENTRAL INSTRUCTIONAL  
MEDIA INSTITUTE, MADRAS  
AN INDO - GERMAN PROJECT



**Directorate General of Employment & Training, Ministry of Labour, Govt. of India.**

Developed by  
CENTRAL INSTRUCTIONAL MEDIA INSTITUTE  
in collaboration with DEUTSCHE GESELLSCHAFT FUER TECHNISCHE ZUSAMMENARBEIT (GTZ) Germany.  
P.O.Box 3142, 76, GST Road, Guindy, Madras - 600 032. Phone : 234 5256, 234 5257, Fax : (0091-44) 234 2791



# DIESEL FUEL FEED PUMP

A

DELIVERY AND SUCTION STROKE

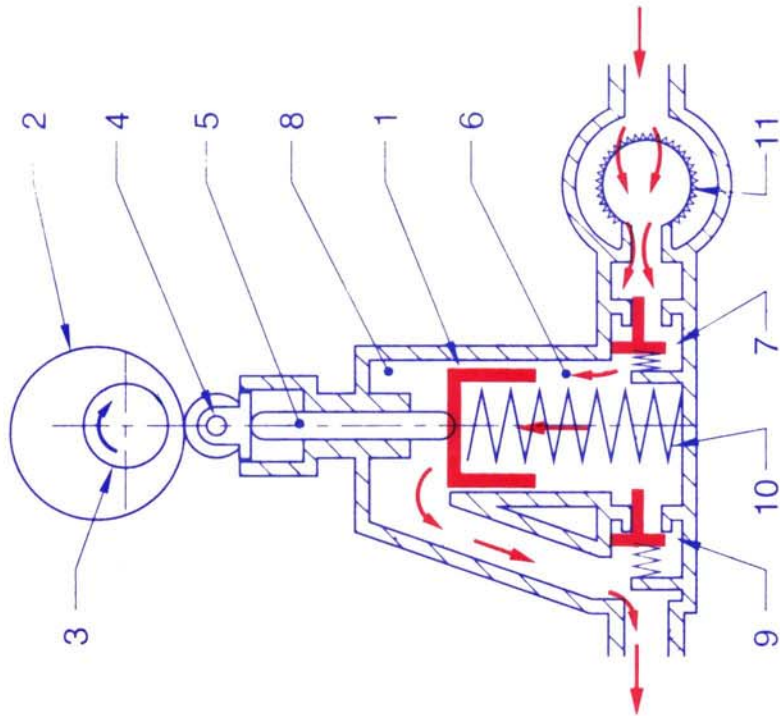

B

INTERMEDIATE STROKE / IDLING ACTION

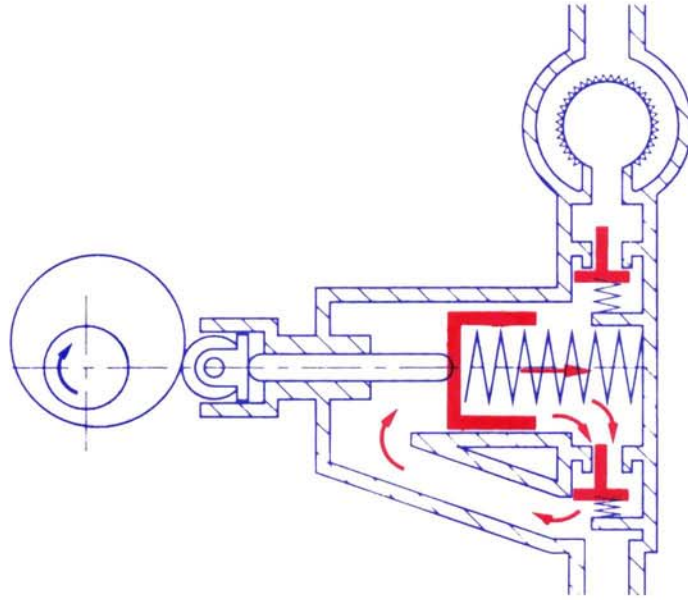



## VALVE TIMING DIAGRAM (4 STROKE CYCLE DIESEL ENGINE)

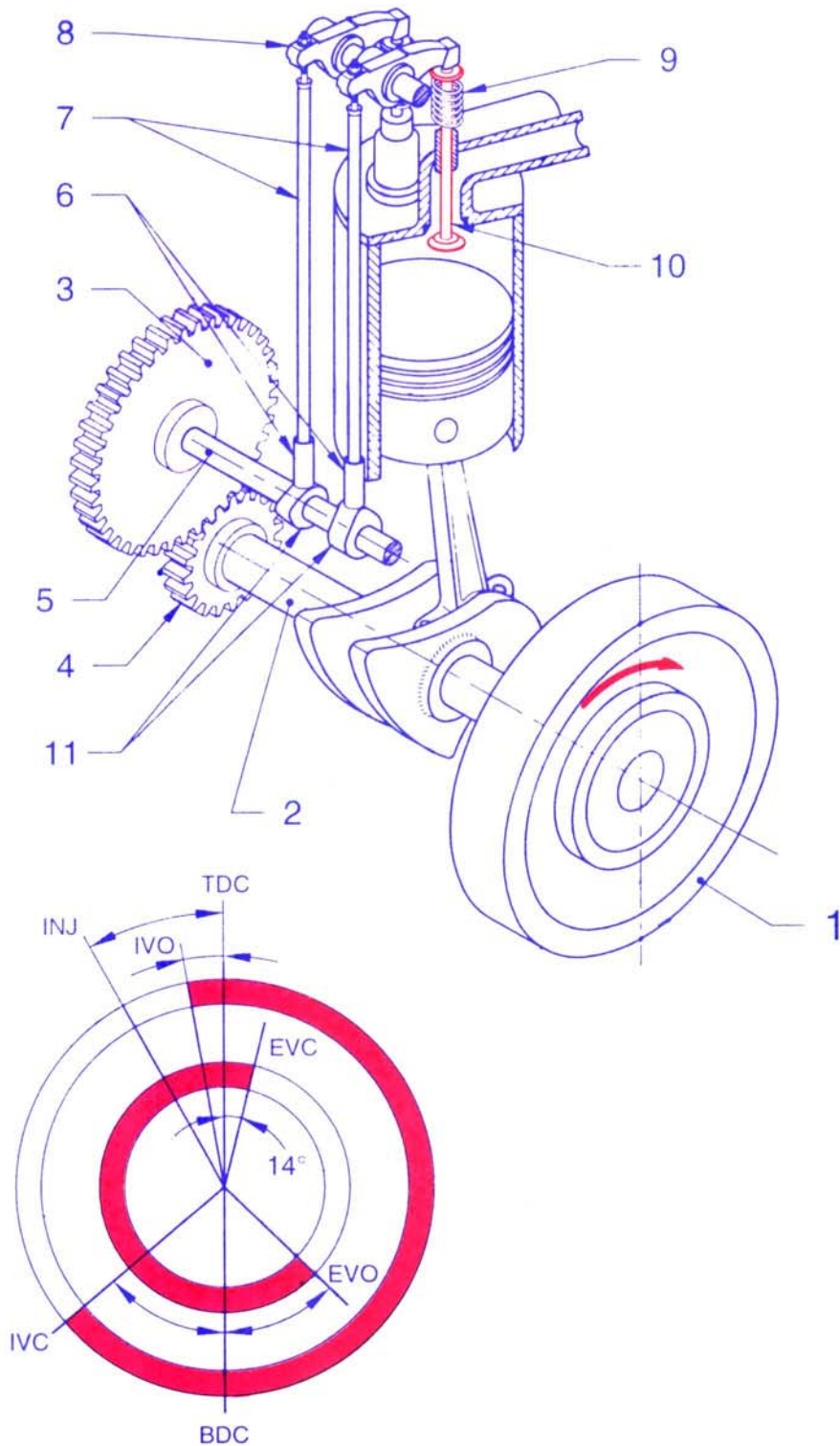



## VALVE TIMING DIAGRAM (2 STROKE CYCLE DIESEL ENGINE)

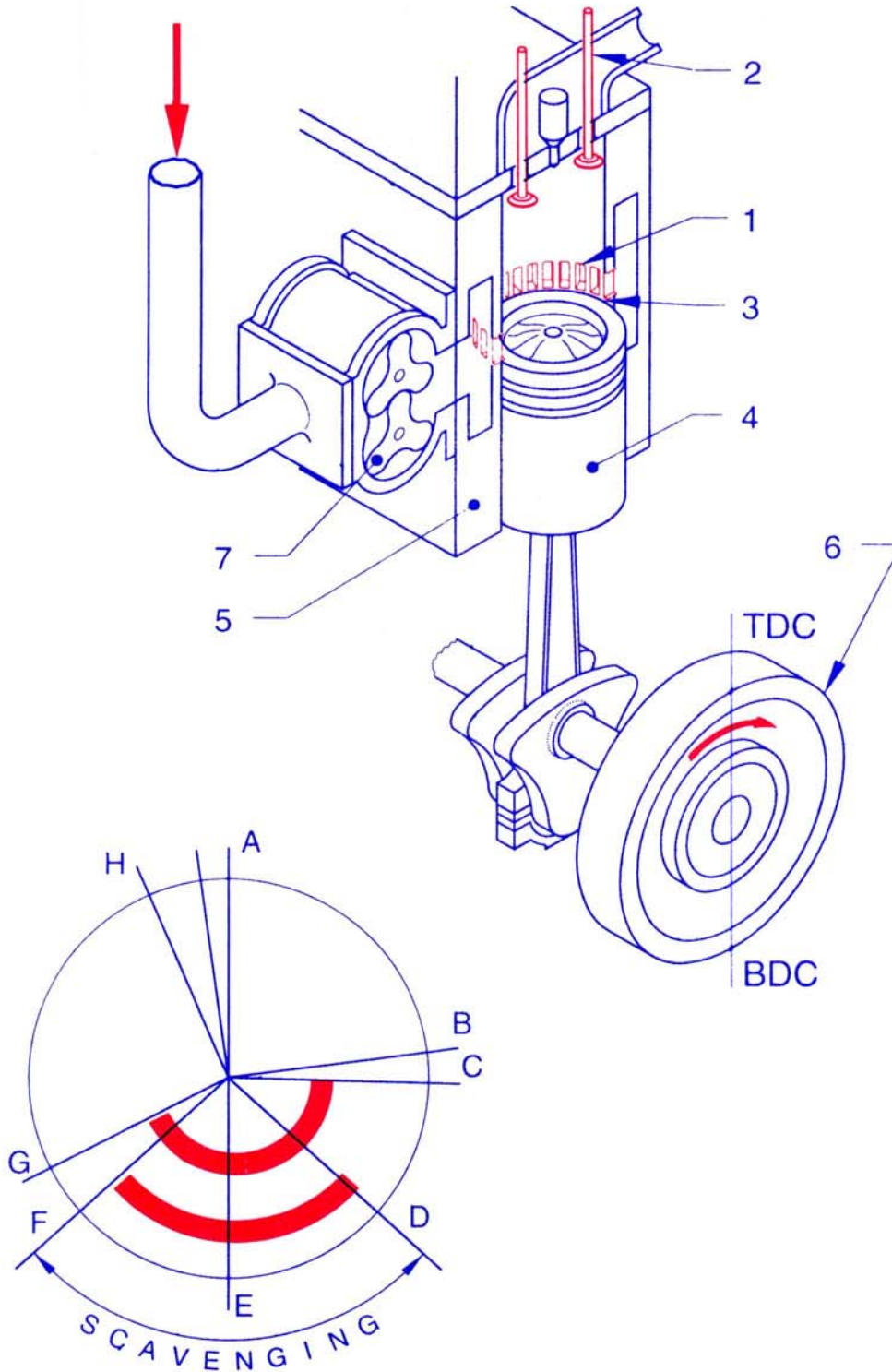





# DIESEL ENGINE LUBRICATION WITH OIL COOLER

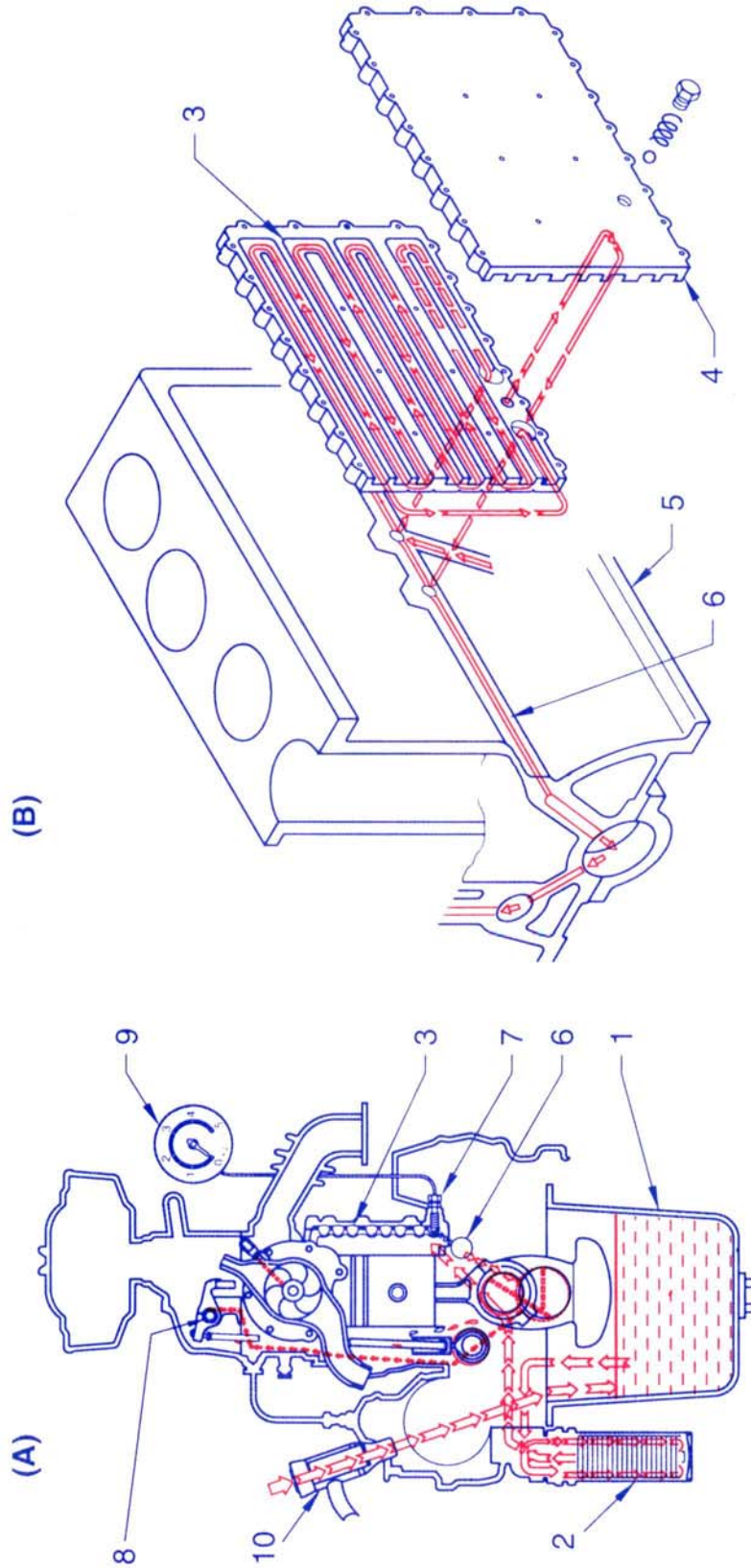



## DIESEL ENGINE LUBRICATION OIL FILTER (FULL FLOW)

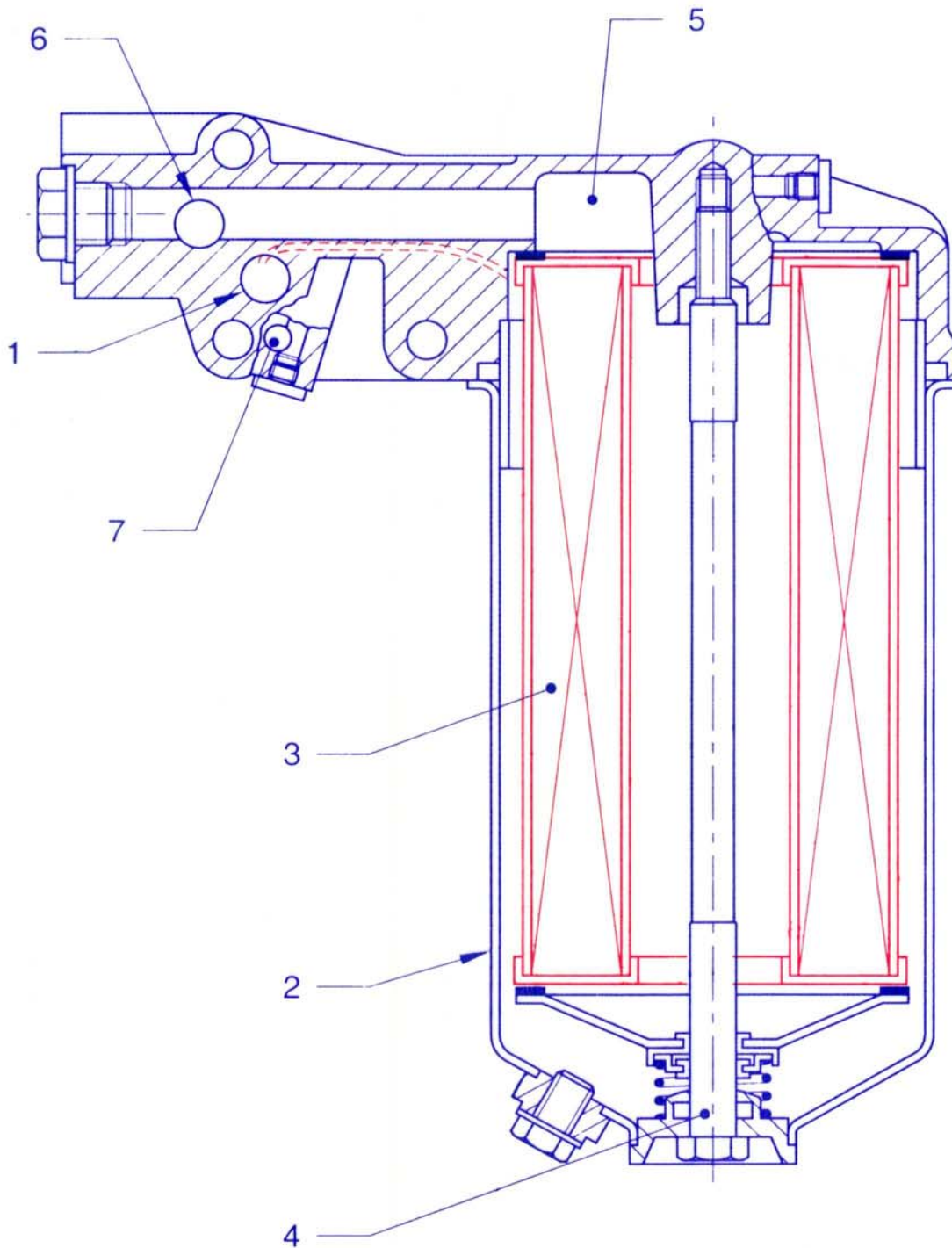



# GLOW PLUG ELECTRICAL CIRCUIT

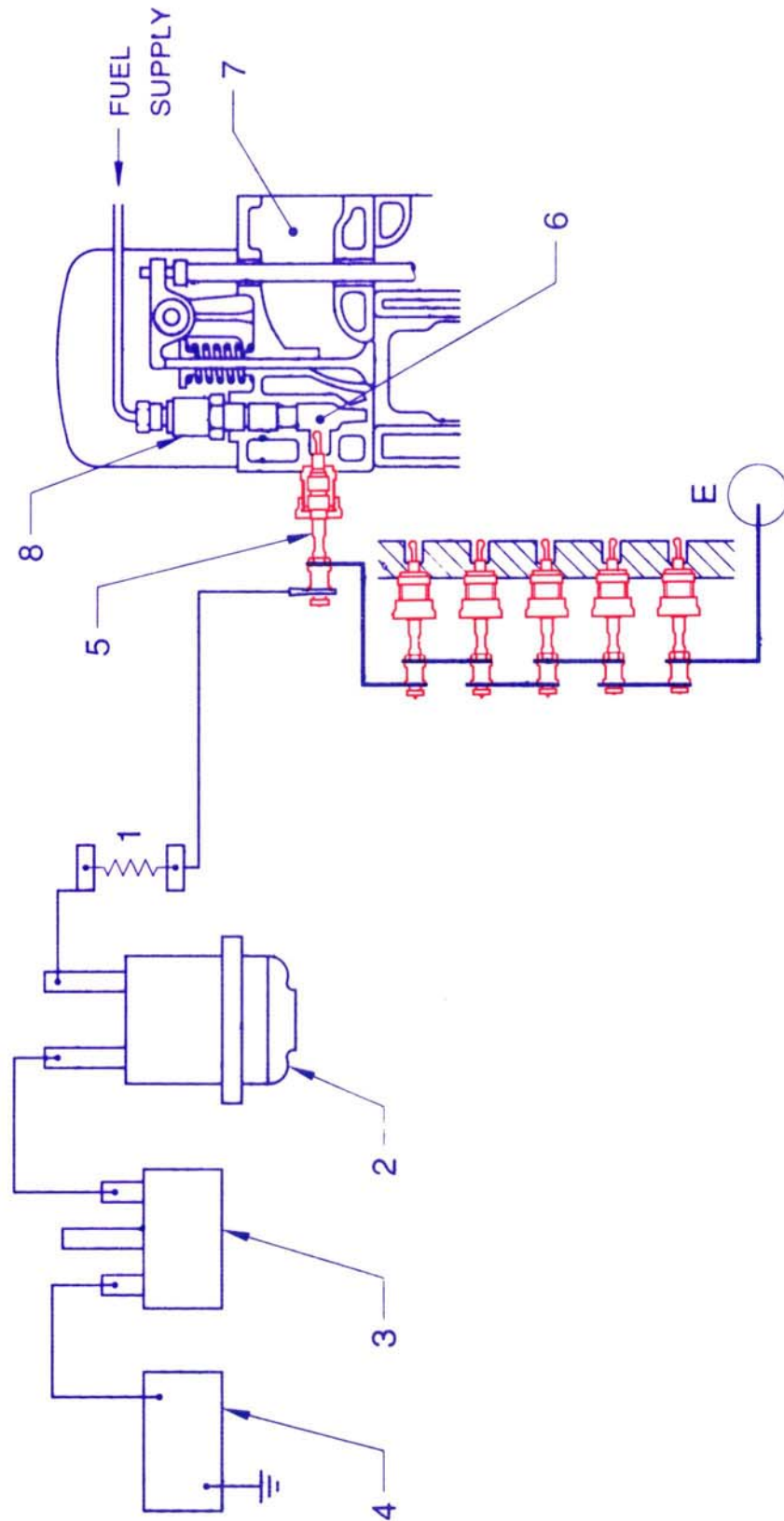



## CRANKCASE VENTILATION

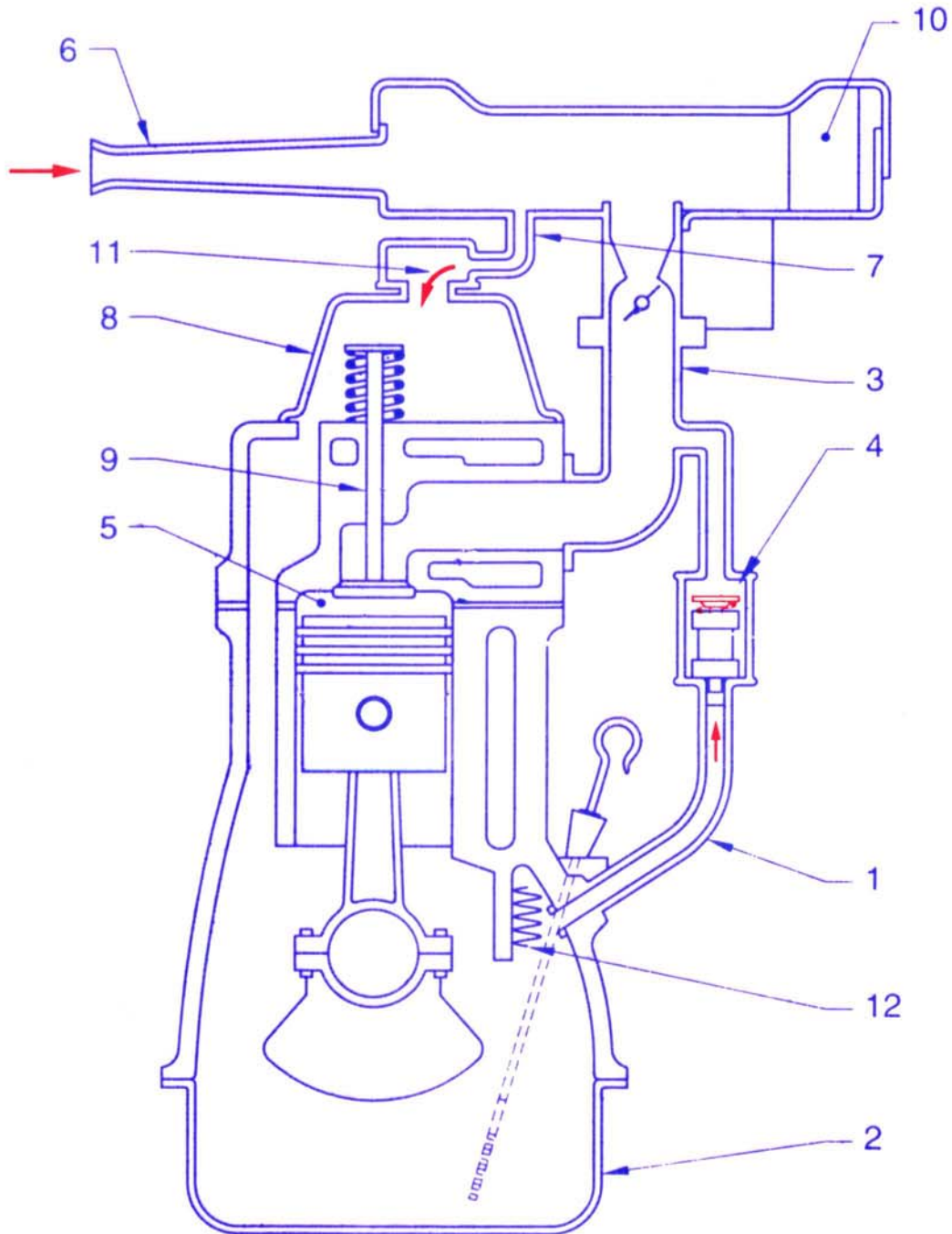





# SPARKING PLUG

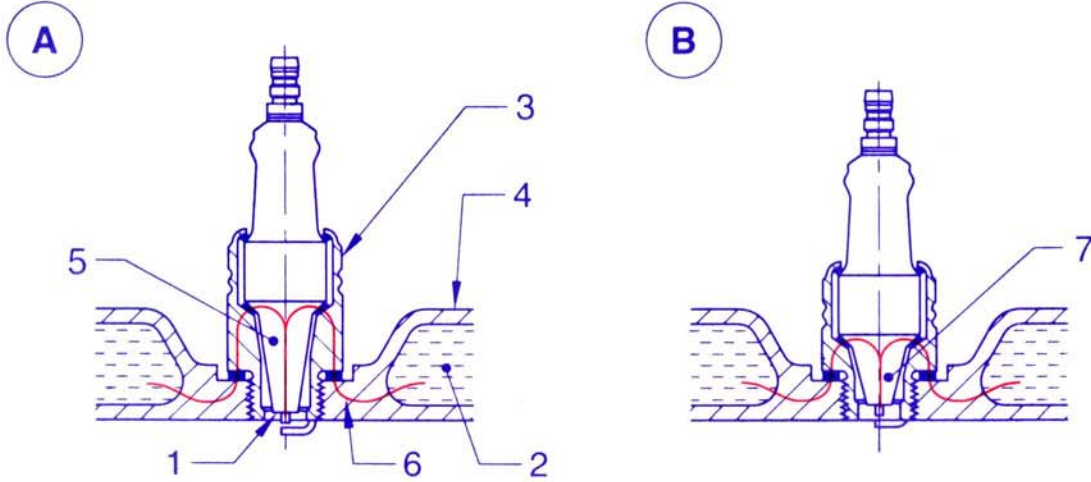

## INSTALLATION

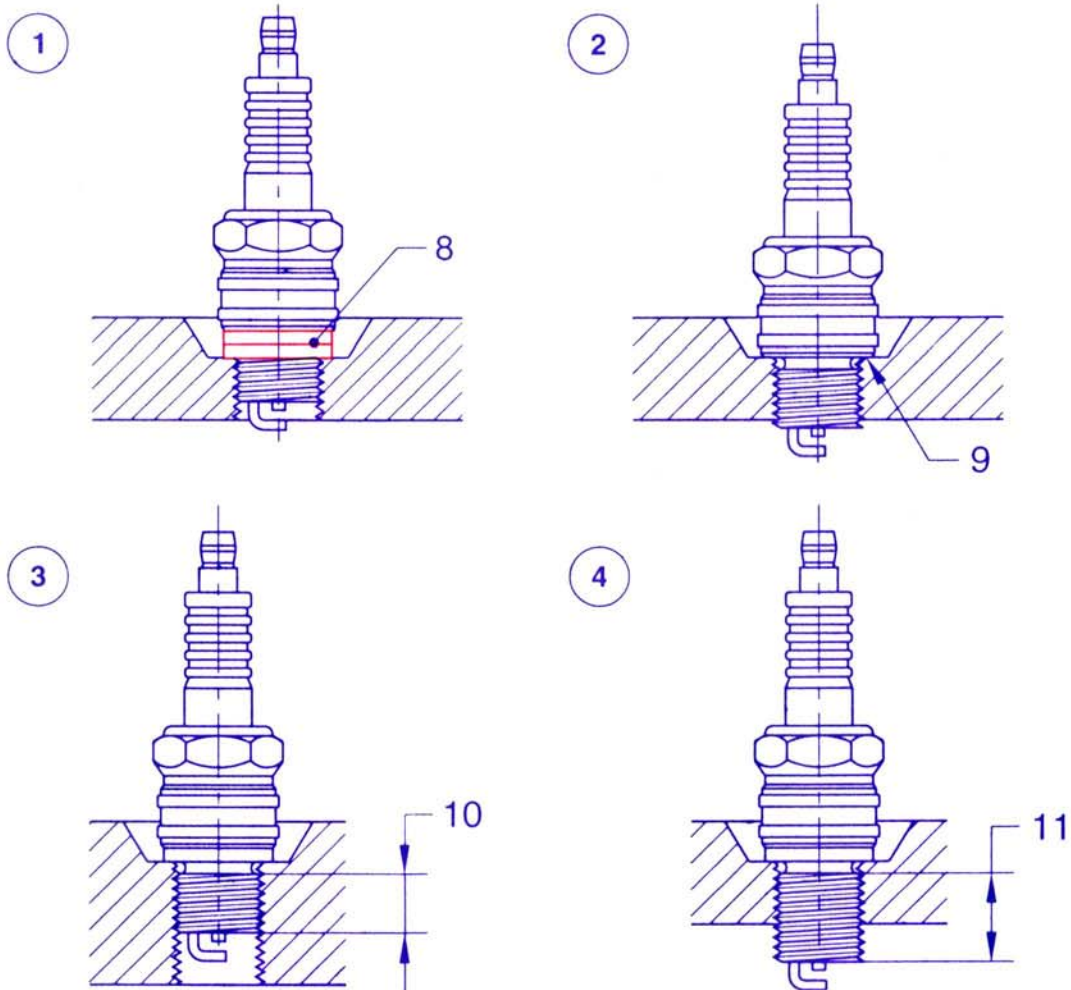



# CHEMICAL ACTION IN LEAD ACID BATTERY

## CHARGING

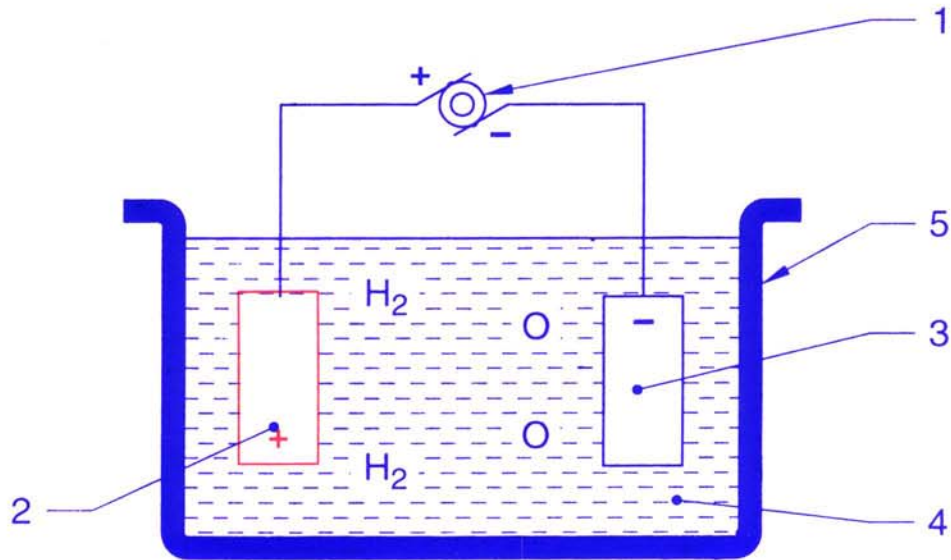

## DISCHARGING

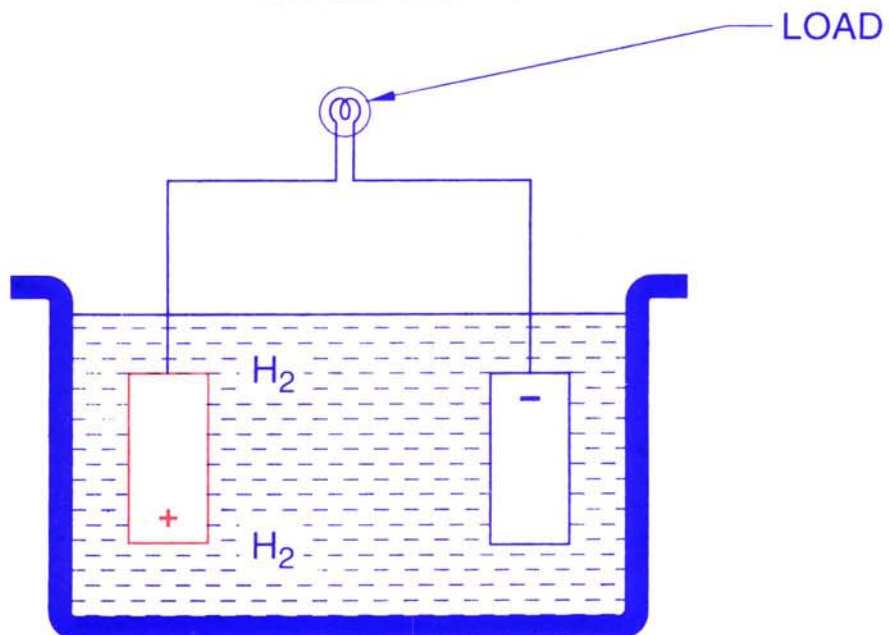



# MICROMETER READING

## MICROMETER GRADUATIONS

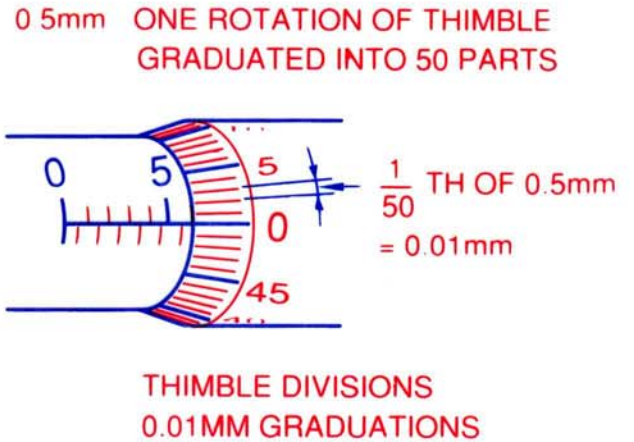
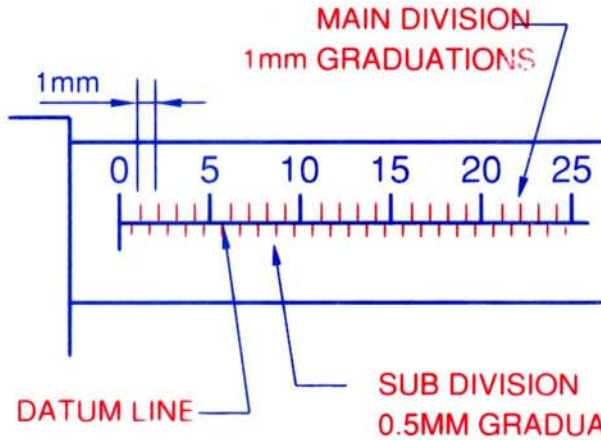

## MICROMETER READING

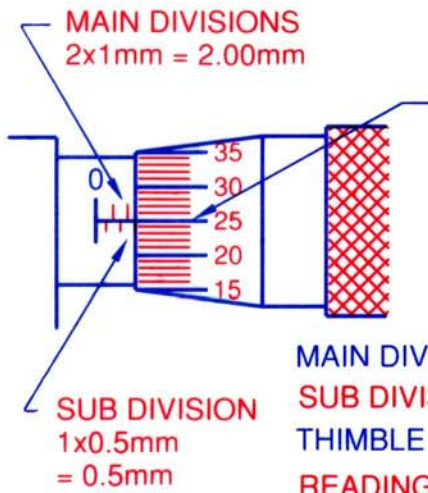

MAIN DIVISIONS = \_\_\_\_\_  
SUB DIVISION = \_\_\_\_\_  
THIMBLE DIVISIONS = \_\_\_\_\_  
READING = \_\_\_\_\_

Example

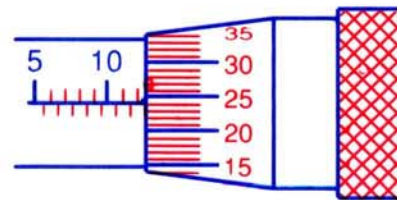

MAIN DIVISIONS = \_\_\_\_\_  
SUB DIVISION = \_\_\_\_\_  
THIMBLE DIVISIONS = \_\_\_\_\_  
READING = \_\_\_\_\_

ASSIGNMENTS:-

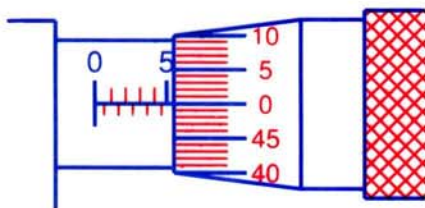

B READING

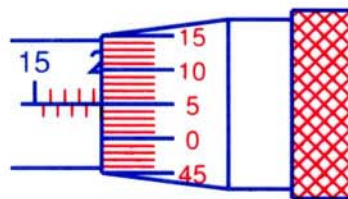

B READING

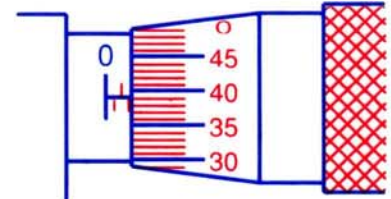

B READING



## MICROMETER PARTS AND GRADUATIONS

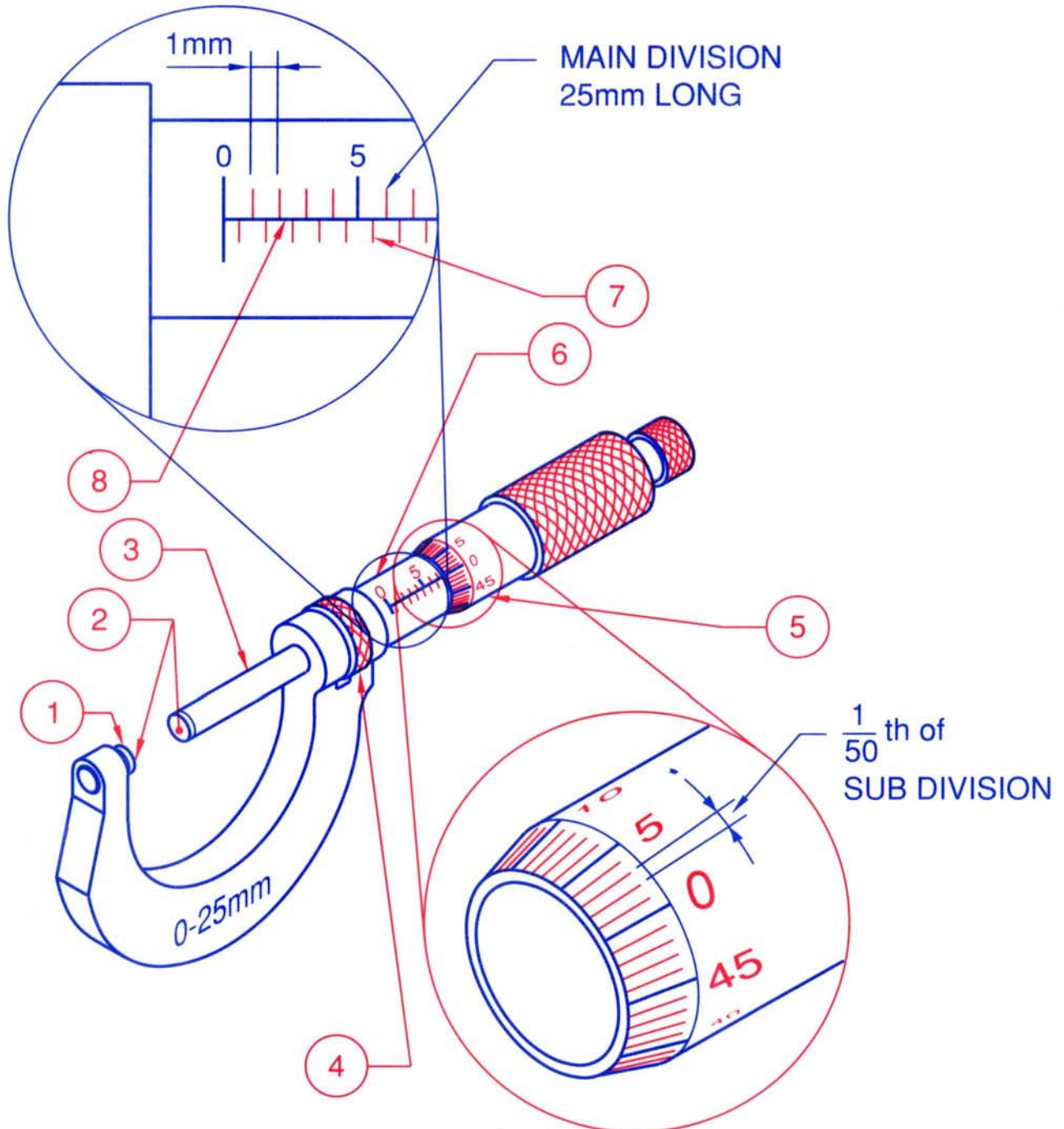

$$\text{LEAST COUNT} = \frac{1}{50} \text{ th of } 0.5\text{mm}$$

$$= \boxed{\phantom{000}}$$





## READING OF VERNIER CALIPER

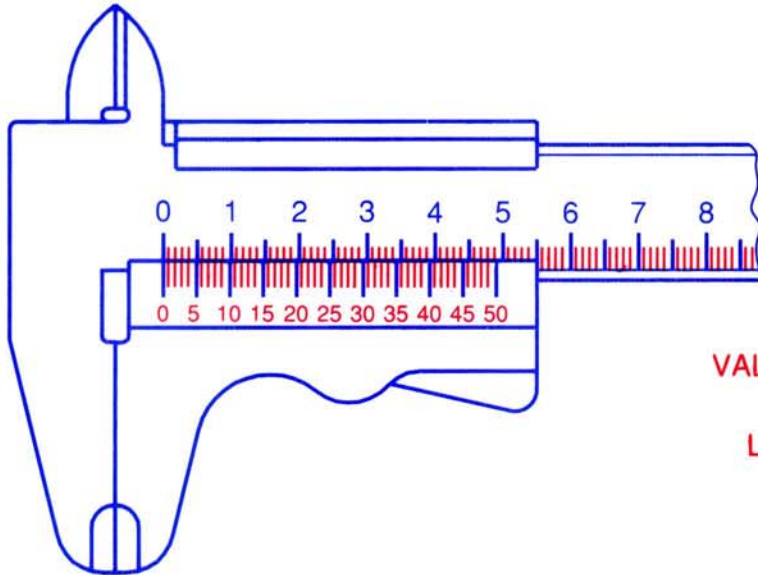

$$\text{VALUE OF 1 VSD} = \frac{49}{50} \text{ mm}$$

$$\text{LEAST COUNT} = 1 \text{ MD} - 1 \text{ VSD}$$

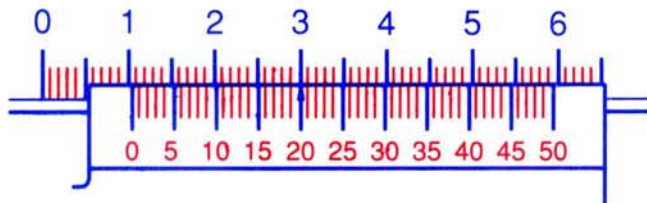

MAIN SCALE READING =

VALUE OF COINCIDING  
VERNIER DIVISION } =

READING =

### ASSIGNMENTS:-

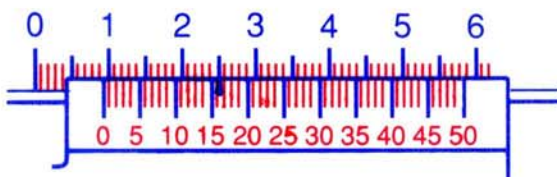

A READING



B READING

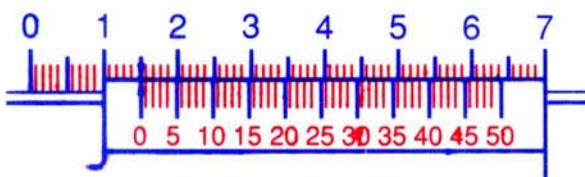

C READING

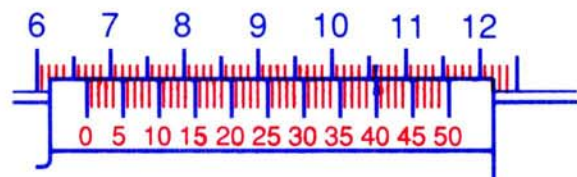

D READING



# VERNIER CALIPER PARTS AND PRINCIPLE

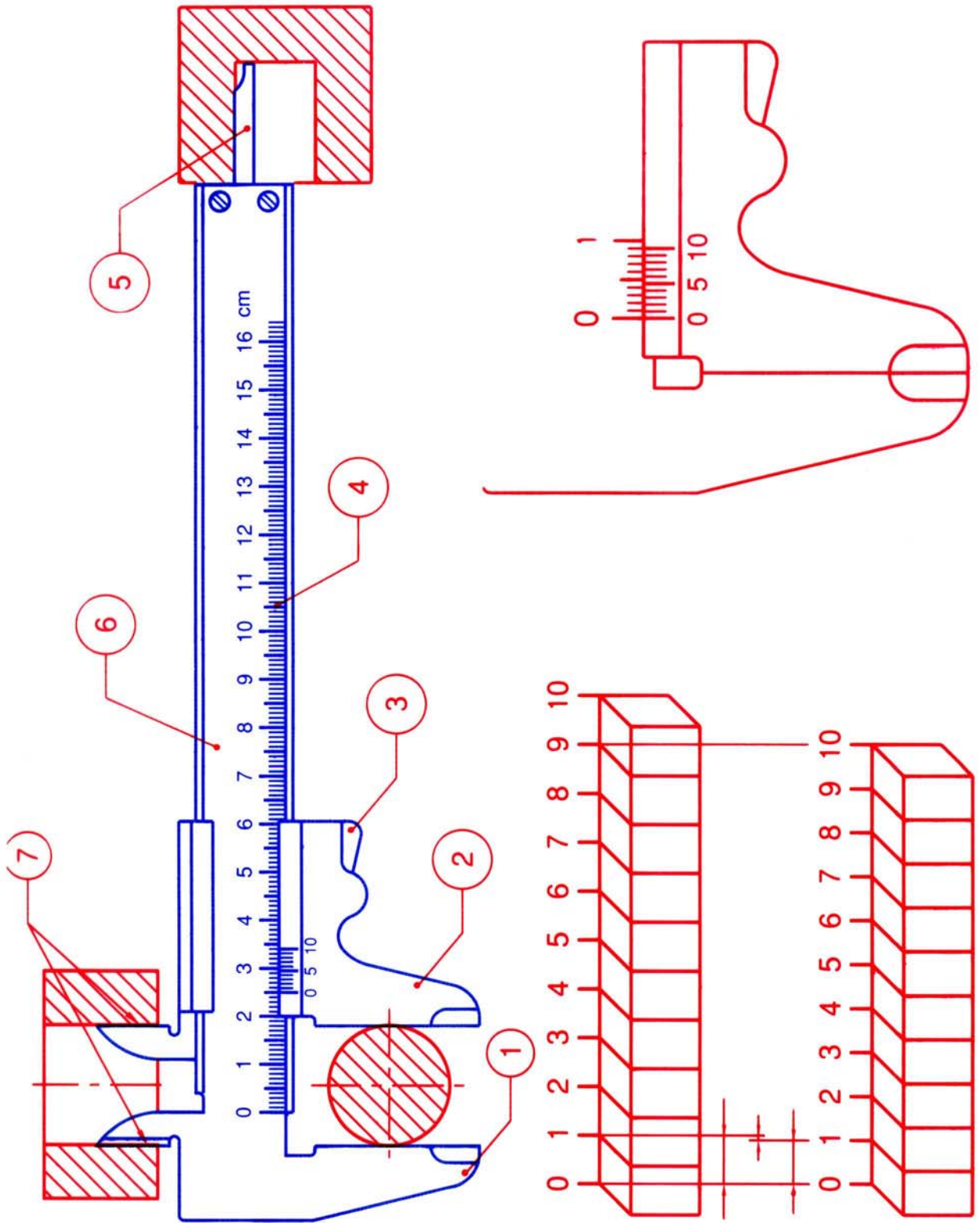



# COMBUSTION CHAMBERS

(A) INDIRECT INJECTION  
AERO FLOW CHAMBER

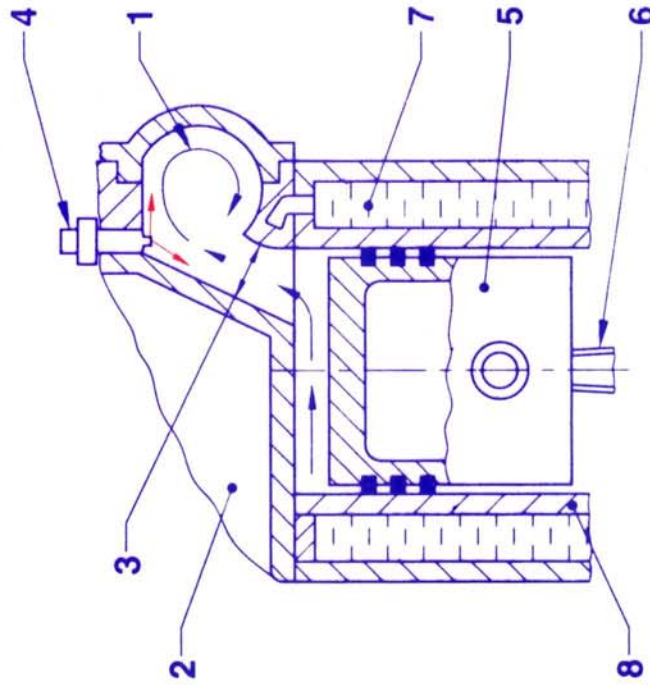

(B) DIRECT INJECTION  
OPEN COMBUSTION CHAMBER

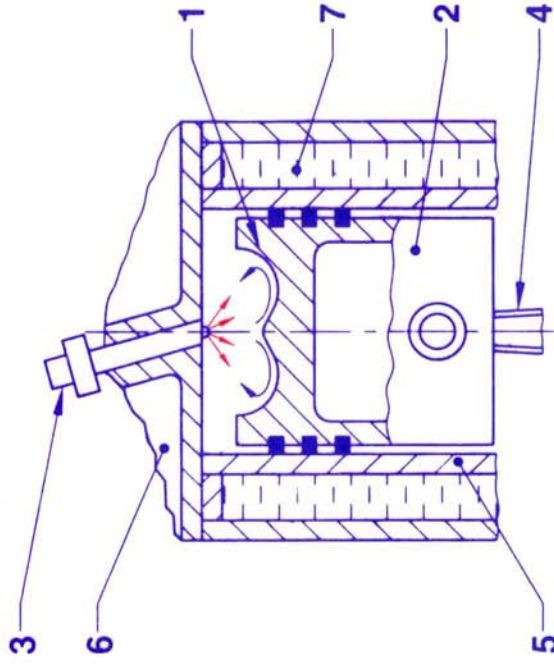





# TURBO-CHARGED ENGINE (TWO STROKE DIESEL)

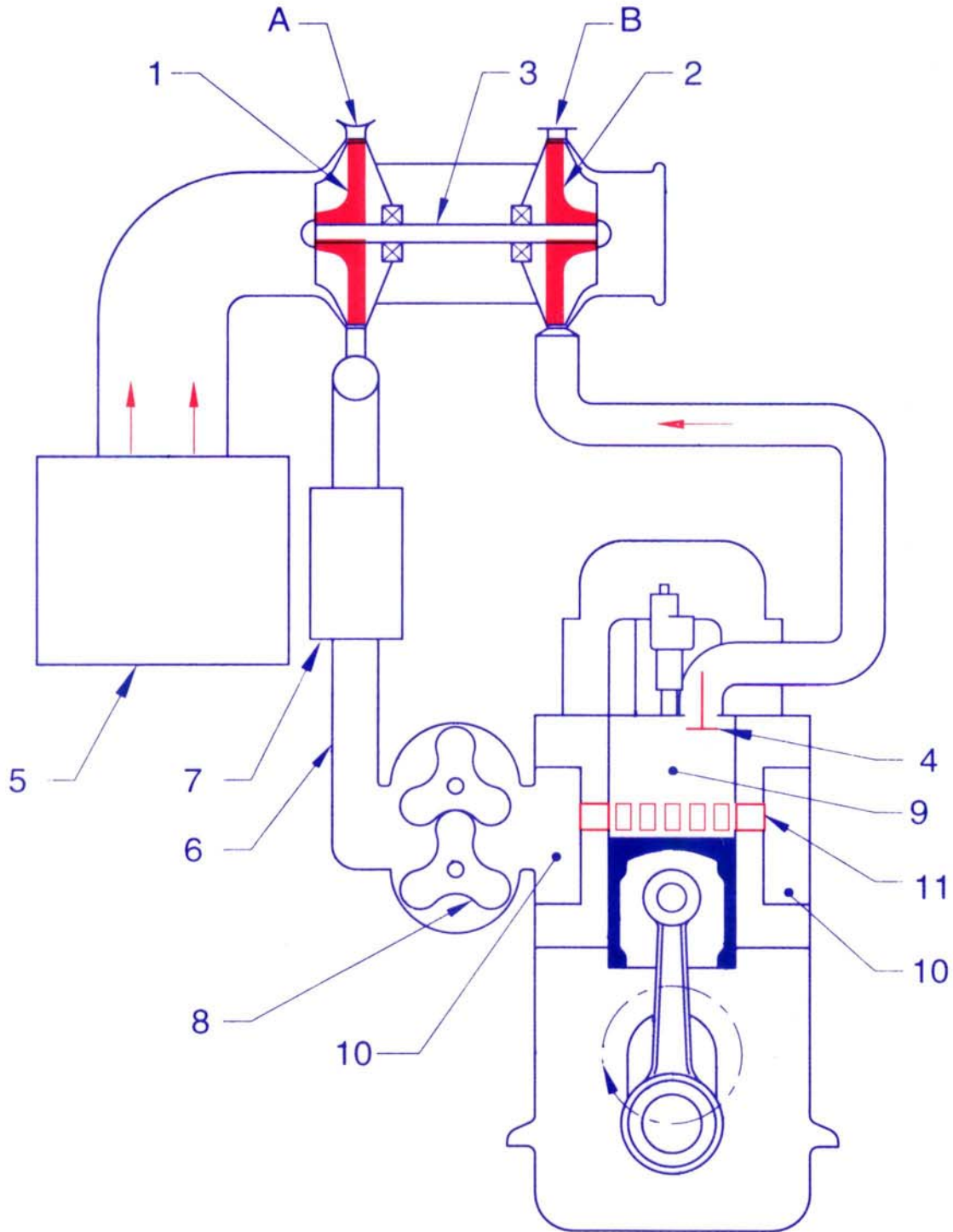





# UNIFLOW SCAVENGE

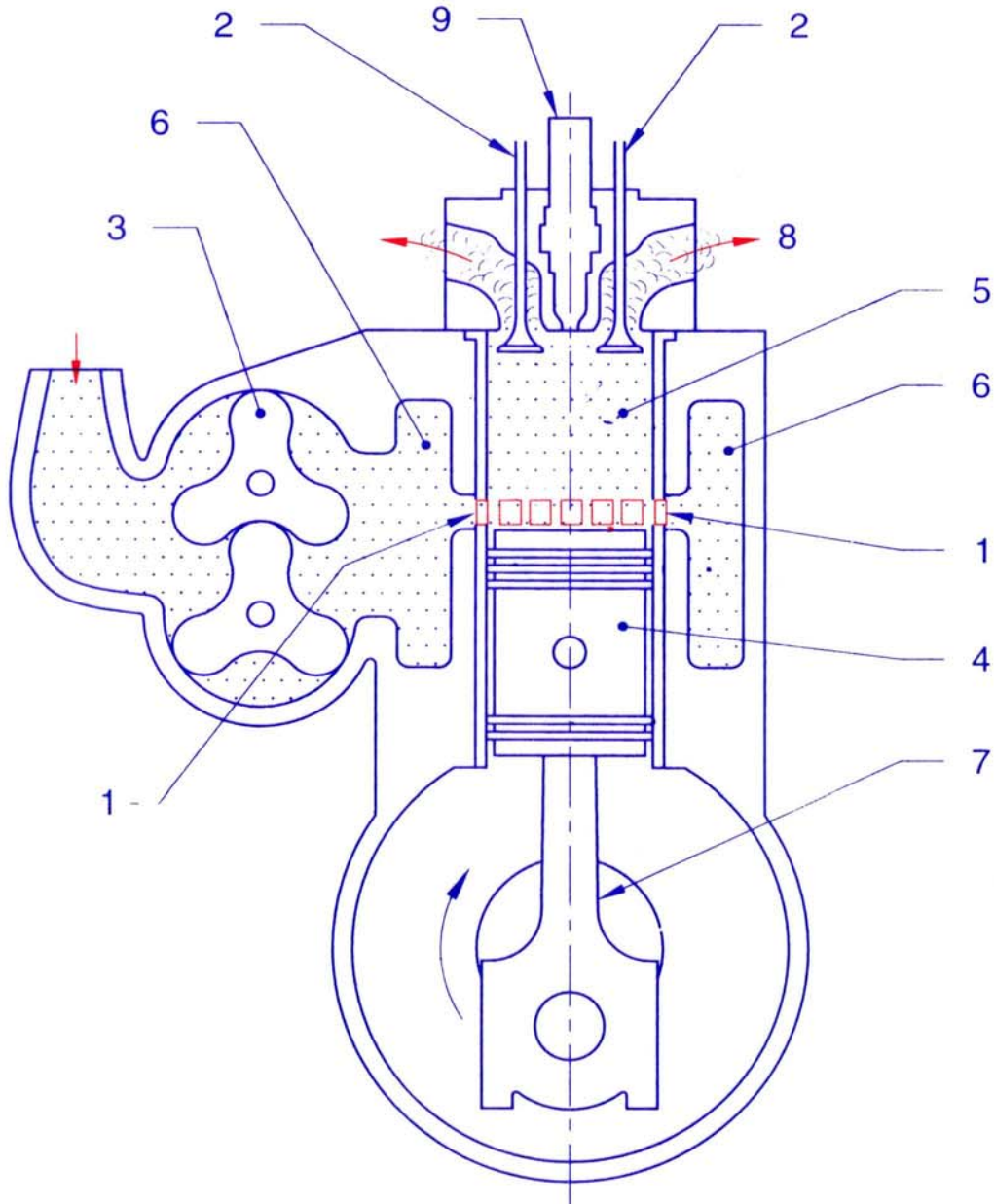



# SCAVENGING SYSTEM (DIESEL) LOOP SCAVENGE

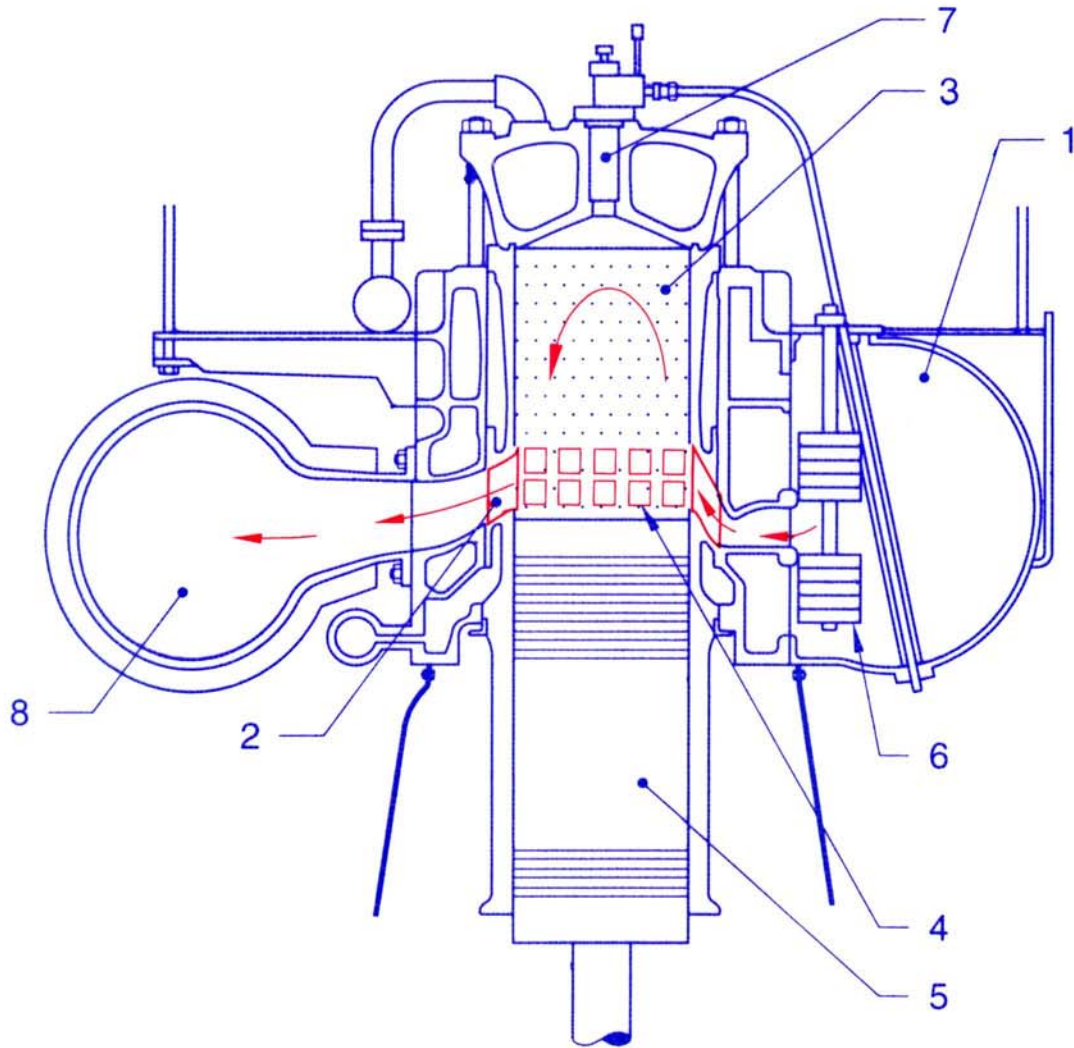



# PNEUMATIC GOVERNOR FUNCTION

MAXIMUM RATED SPEED

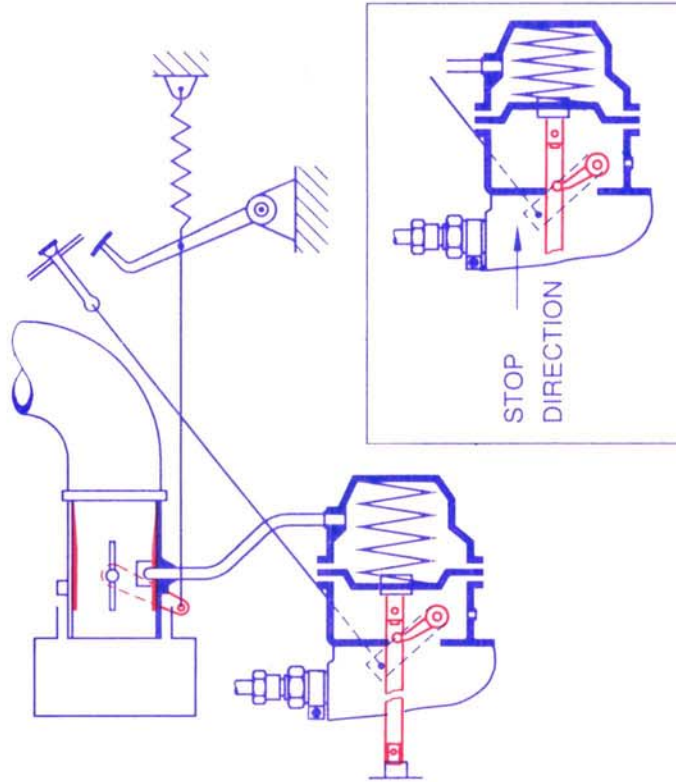

IDLING

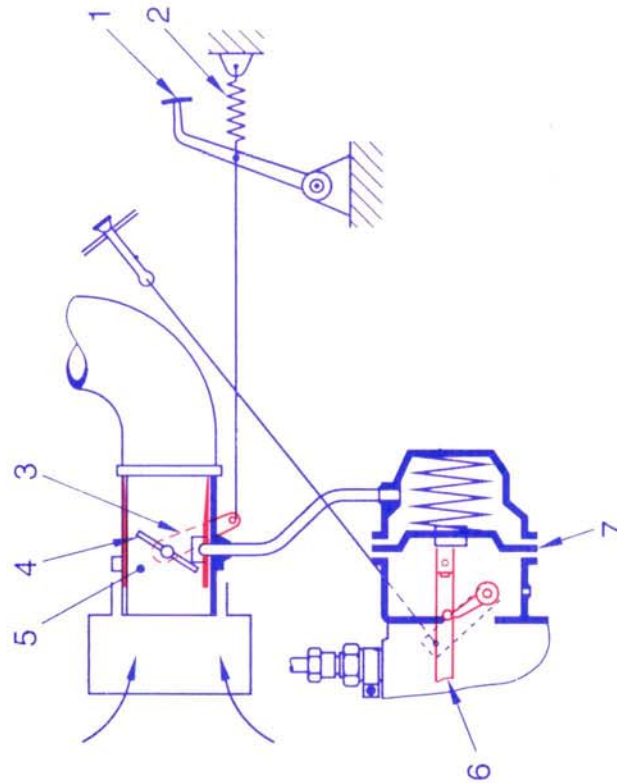









## FUEL FEED SYSTEM (DIESEL INLINE JERK PUMP)

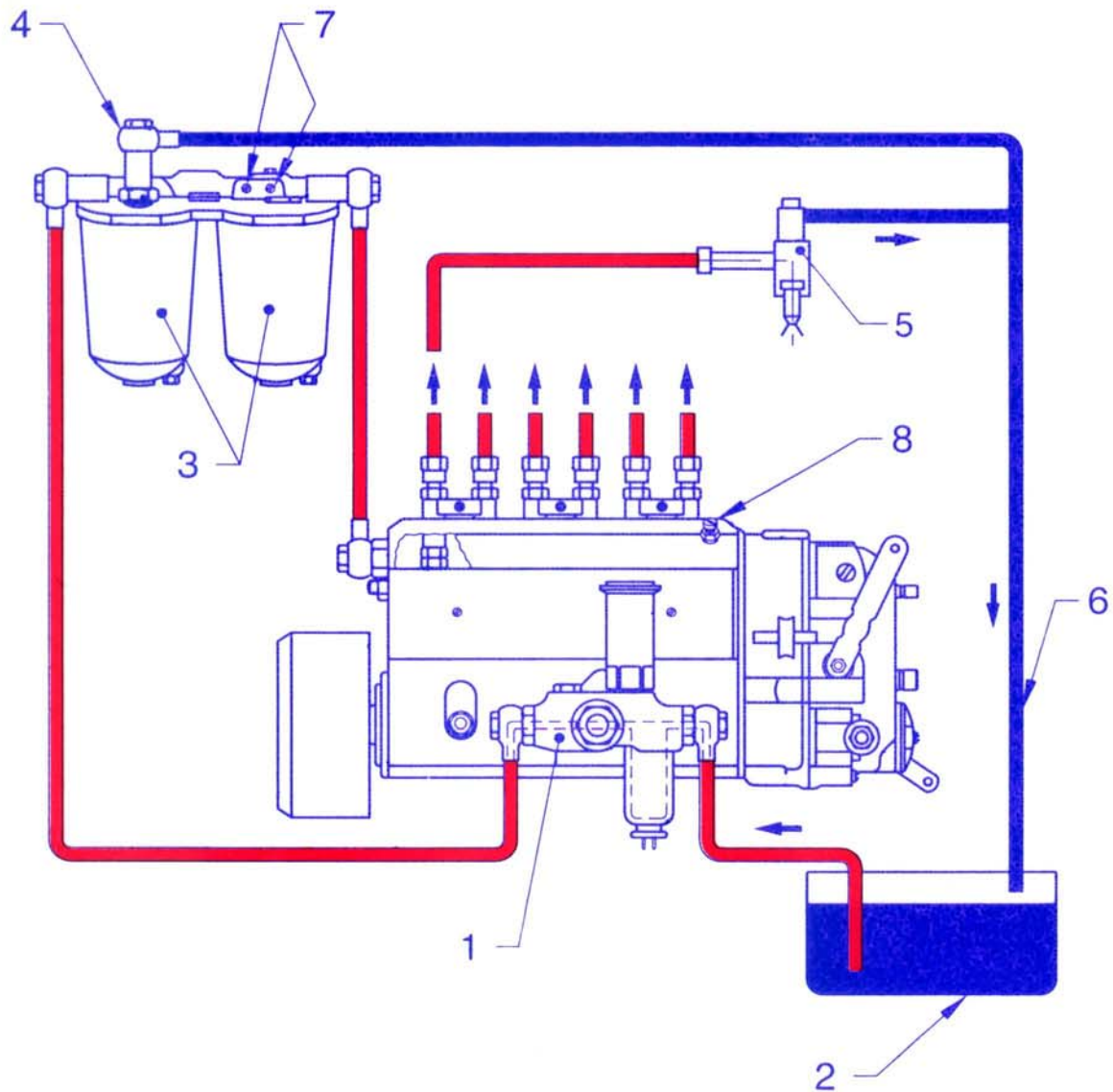



## DIESEL ENGINE FUEL FILTER

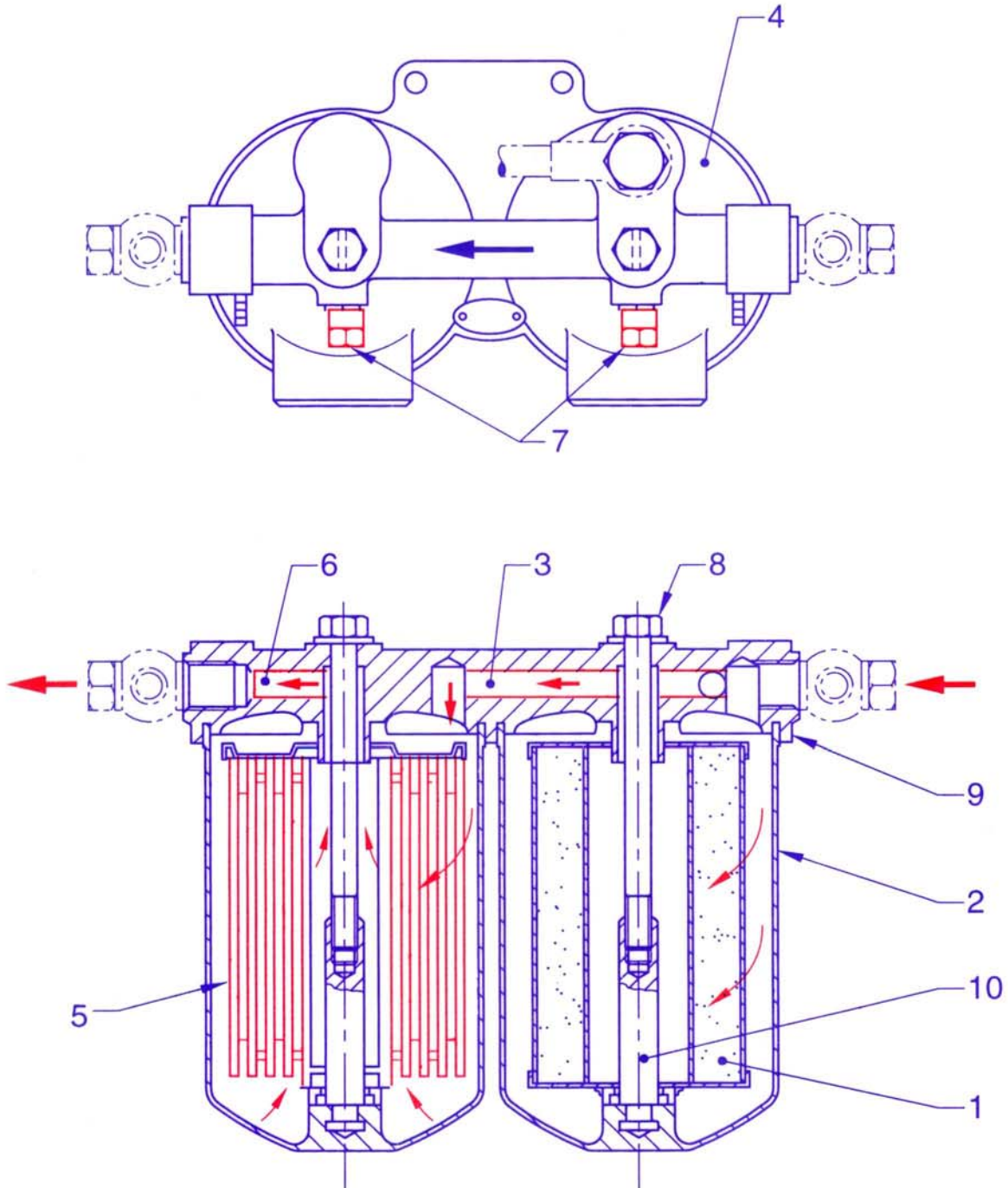



# COMPARISON OF FUNCTION MULTI HOLE AND PINTLE NOZZLES

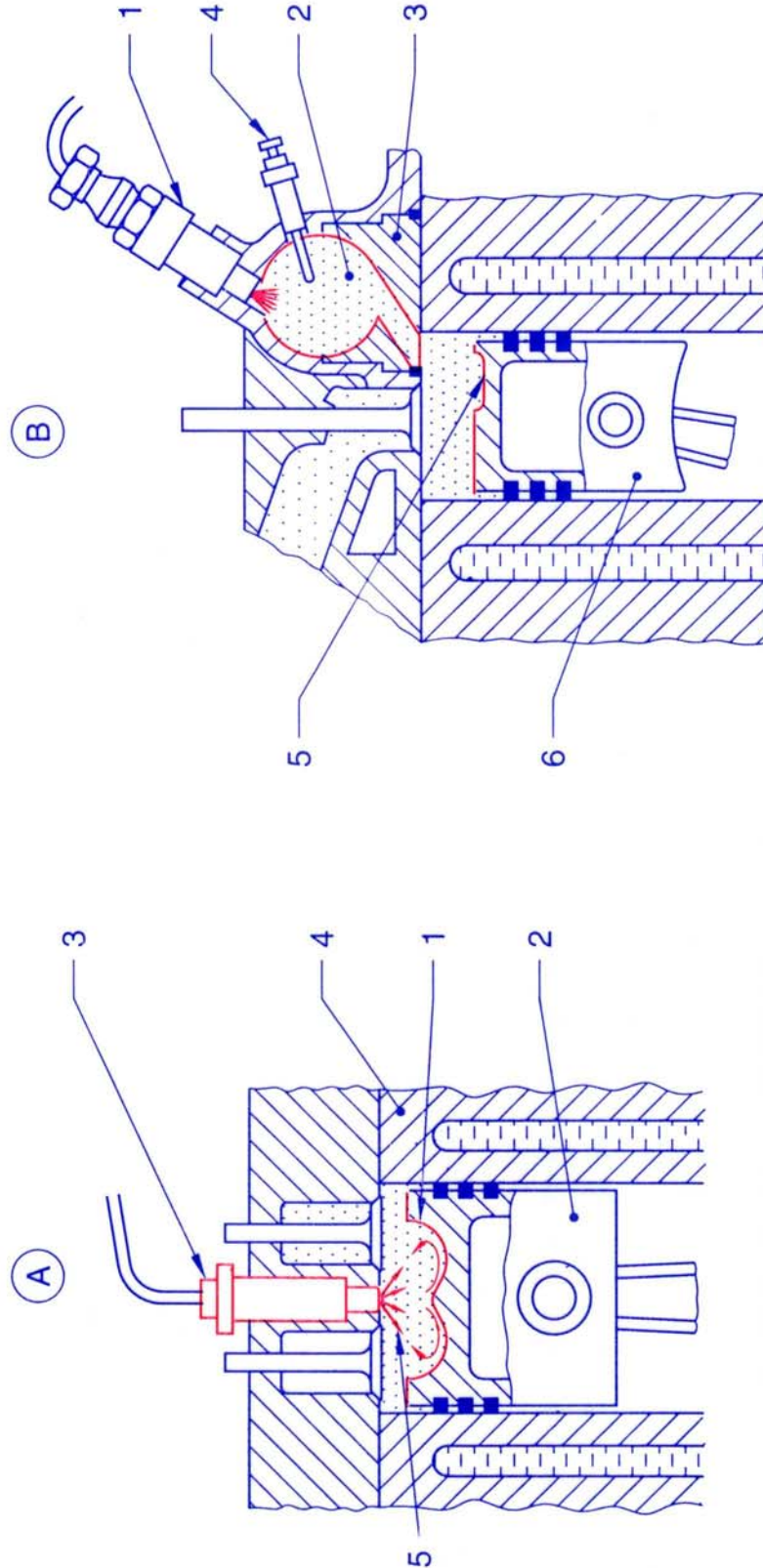





# FUEL INJECTION PUMP

(A) FUEL DELIVERY POSITION

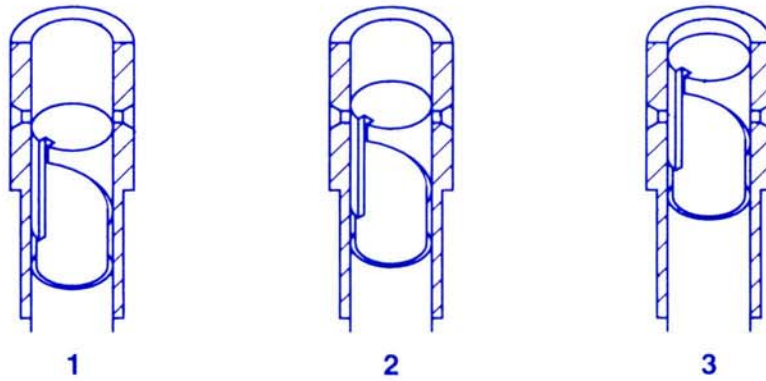

(B) ARRANGEMENT OF PLUNGER & BARREL

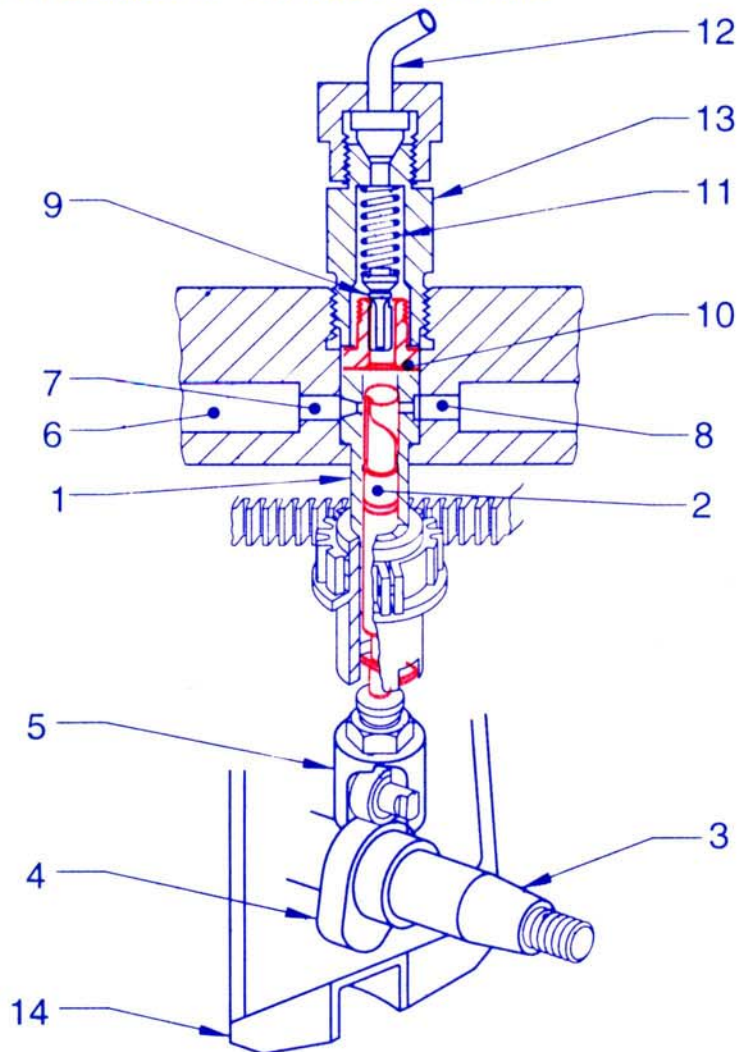



# PISTON RINGS ASSEMBLY

(A) COMPRESSION RINGS

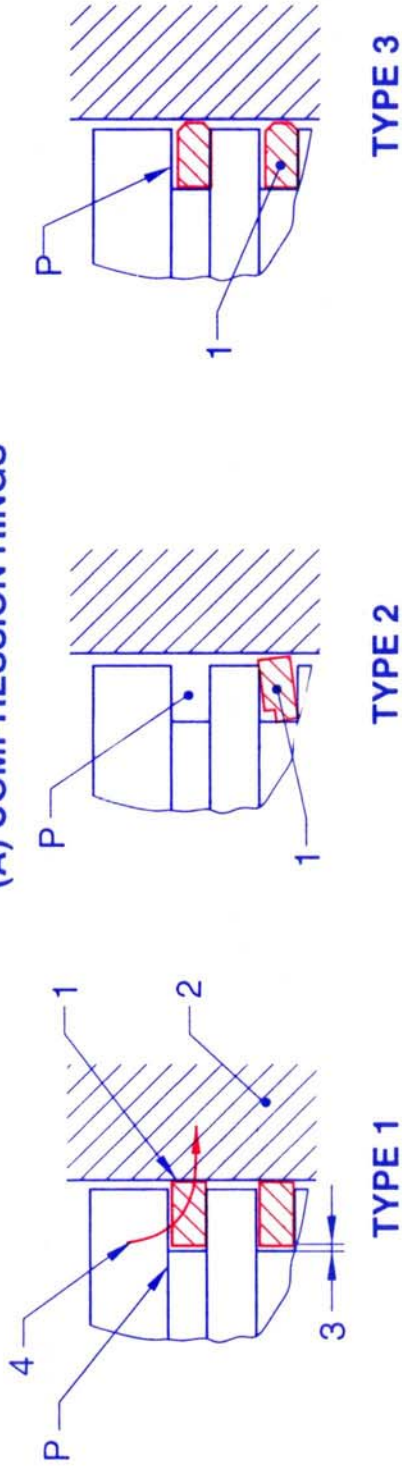

(B) OIL CONTROL RINGS

