

SMALL ENGINE

1. Fuel system
2. Ignition system
3. Speed control system
4. Valve mechanism
5. Crancshaft mechanism
6. Lubrication system
7. Cooling system
8. Starting system
9. Exhaust system



What this Instruction
Material wants:

- to be easy understandable
- to be job related
- to support the teacher in his work
- to create student activity

What this Instruction
Material does not want:

- to replace a book
- to substitute the teacher
- to teach unnecessary subject matter

Help to teach and learn
efficiently

- o This instructional material is developed by the Thai-German Teaching Aid Centre in cooperation with the Technical College Nongkhai.
- o The student should have preknowledge about the principle of 4-stroke internal combustion engine.
- o The Information, specially about maintenance and repair is based mainly on the Honda engines G 150 - G 200 and GX 120 - GX 160.
- o The teaching method, which should be used, is the "questioning technique". Please do not only lecture!



Small engine

Introduction

The Instructional Material Package (IMP) contents the following elements:

1. List of objectives
2. Information sheets
3. Task sheets
4. Job sheets
5. Teaching aids (Transparencies, models, e.g.)
6. Solutions

1. A list of objectives shows the teacher what the student should know after the lesson.
2. Information sheets show pictures with short explanations of the subject matter. These information sheets should be given to the student after the lesson as a summary. Information about repair and maintenance should be given briefly before starting the work prescribed in the Job sheets.
3. Task sheets help the teacher to check the learning progress. They should be used at the end of one period. It is necessary to discuss the solutions with the students. Please do not use them as a test.
4. The Job sheets are showing the student the right sequence of working steps. The Information sheets about maintenance and repair can be used like a manual during work.
5. Teaching aids make the subject matter better understandable and motivate the students.
6. Solutions for the task sheets



| | Page |
|---|------|
| Objectives | 1 |
| 1. Fuel System | 5 |
| 1.1 Components of fuel system | 5 |
| 1.2 Fuel tank | 5 |
| 1.3 Fuel filter | 6 |
| 1.4 Air filter | 6 |
| 1.4.1 Oil type | 6 |
| 1.4.2 Paper type | 7 |
| Task sheet | 8 |
| 1.5 Carburetter | 9 |
| 1.5.1 Principle of carburetter | 9 |
| 1.5.2 Types of carburetters | 9 |
| 1.5.3 Side draft carburetter | 9 |
| 1.5.4 Floating circuit | 10 |
| 1.5.5 Idle circuit | 11 |
| 1.5.6 Full throttle circuit | 12 |
| 1.5.7 Choke circuit | 13 |
| Task sheets | 14 |
| 1.6 Maintenance and repairs | 17 |
| 1.6.1 Fuel tank service | 17 |
| 1.6.2 Dry air filter service | 18 |
| 1.6.3 Wet air filter service | 18 |
| 1.6.4 Mounting and dismounting carburetter | 19 |
| 1.6.5 Float setting | 20 |
| 1.6.6 Idle mixture adjustment | 21 |
| 1.6.7 Idle speed setting | 21 |
| 1.6.8 Trouble shooting | 22 |
| Job sheets | 23 |
| 2. Ignition system | 29 |
| 2.1 Basic principle | 29 |
| 2.2 Contact point ignition system | 30 |
| 2.2.1 Components and their function | 30 |
| 2.2.2 Function of contact point ignition system | 31 |
| Task sheet | 32 |
| 2.3 Transistor ignition system | 33 |
| 2.3.1 Components and their function | 33 |
| 2.3.2 Function of transistor ignition system | 34 |
| 2.4 Capacitive discharge ignition system (CDI) | 35 |
| 2.4.1 Components and their function | 35 |
| 2.4.2 Function of the CDI ignition system | 36 |



| | Page |
|--|------|
| 2.5 Advantage of electronic ignition systems | 37 |
| Task sheets | 38 |
| 2.6 Maintenance and repair | 40 |
| 2.6.1 Assembling and disassembling | 40 |
| 2.6.2 Inspect, clean and adjust spark plug | 41 |
| 2.6.3 Inspect ignition coil | 42 |
| 2.6.4 Inspect CDI and transistor ignition system | 42 |
| 2.6.5 Inspect condenser | 43 |
| 2.6.6 Inspect and adjust contact points | 44 |
| 2.6.7 Adjust ignition timing | 44 |
| 2.6.8 Adjust gap between ignition coil and wheel | 46 |
| 2.6.9 Trouble shooting | 47 |
| Job sheets | 48 |
| 3. Governor (Speed control system) | 50 |
| 3.1 Task of governor | 50 |
| 3.2 Types and function of governor | 50 |
| 3.2.1 Pneumatic governor | |
| 3.2.2 Mechanical governor | |
| Task sheet | 52 |
| 3.3 Maintenance and repairs | 53 |
| 3.3.1 Adjustment of Pneumatic governor | |
| 3.3.2 Adjustment of Mechanical governor | |
| Job sheet | 54 |
| 4. Valve mechanism | 55 |
| 4.1 Task of valve mechanism | 55 |
| 4.2 Types and their function | 55 |
| 4.2.1 Overhead valve | |
| 4.2.2 Side valve | |
| Task sheet | 57 |
| 4.3 Compression reduction mechanism | 58 |
| 4.3.1 Purpose of compression reduction | |
| 4.3.2 Components and their function | |
| Task sheet | 59 |



| | Page |
|---|------|
| 4.4 Maintenance and repairs | 60 |
| 4.4.1 Assembling and disassembling | 60 |
| 4.4.2 Assembling the cylinder head | 61 |
| 4.4.3 Assembling and disassembling the valves | 62 |
| 4.4.4 Valve spring | 62 |
| 4.4.5 Valve (measure and check) | 63 |
| 4.4.6 Valve seat | 64 |
| 4.4.7 Valve guide | 65 |
| 4.4.8 Valve adjustment | 66 |
| Job sheets | 67 |
| 5. Crankshaft mechanism | 69 |
| 5.1 Components and their function | 69 |
| 5.1.1 Piston and piston rings | 69 |
| 5.1.2 Connecting rod and rod bearings | 70 |
| 5.1.3 Crankshaft | 70 |
| Task sheet | 71 |
| 5.2 Maintenance and repairs | 72 |
| 5.2.1 Testing compression | 72 |
| 5.2.2 Assembling and disassembling | 73 |
| 5.2.3 Inspecting the piston and piston rings | 76 |
| 5.2.4 Checking gudgeon pin and hole | 77 |
| 5.2.5 Checking crankshaft and bearing | 78 |
| 5.2.6 Checking the cylinder | 78 |
| 6. Lubrication system | 79 |
| 6.1 Task of the lubrication system | 79 |
| 6.2 Splash-type lubrication | 79 |
| 6.2.1 Components and their function | |
| Task sheet | 80 |
| 6.4 Maintenance | 81 |
| 6.4.1 Check and change oil | |
| Job sheet | 82 |
| 7. Cooling system | 83 |
| Task sheet | 84 |
| 7.1 Maintenance and repair | 85 |
| Job sheet | 86 |



Small engine

Content

| | Page |
|-----------------------------------|------|
| 8. Starting system | 87 |
| 8.1 Types of starting systems | 87 |
| 8.2 Maintenance and repairs | 87 |
| Job sheet | 89 |
| 9. Exhaust system | 90 |
| 9.1 Purpose of exhaust system | 90 |
| 9.2 Components and their function | 90 |
| Task sheet | 91 |

The student should be able to ...

Fuel system

1.1 Components of fuel system

1. Name various components and their functions of fuel system
2. Describe about fuel delivery from fuel tank to carburetter

1.2 Fuel tank

3. Tell components of fuel tank
4. Tell function of fuel tank

1.3 Fuel filter

5. Tell components of fuel filter
6. Tell functions of fuel filter

1.4 Air filter

7. Tell various types of air filter
8. Tell features and characteristics of the wet-type air filter
9. Explain principle of the wet-type air filter
10. Tell advantages and disadvantages of the wet-type air filter
11. Tell features and characteristics of the dry-type air filter
12. Explain principle of the dry-type air filter
13. Tell advantages and disadvantages of the dry-type air filter

1.5 Carburetter

14. Explain principle of carburetter
15. Tell various types of carburetter
16. Tell internal construction of the side draft carburetter
17. Tell functions and components of the floating circuit
18. Explain principle of the floating circuit
19. Tell functions and components of the idle circuit
20. Explain principle of idle circuit
21. Tell functions and components of full throttle circuit
22. Explain principle of full throttle circuit
23. Tell functions and components of choke unit
24. Explain principle of choke unit

1.6 Repair and maintenance

25. Inspect any leakage of the fuel tube
26. Clean fuel tank correctly
27. Clean air filter correctly
28. Dismantle and reassemble carburetter correctly
29. Inspect components of carburetter for wear
30. Set the float correctly
31. Adjust the idle mixture correctly
32. Adjust the idle speed correctly

2. Ignition system

2.1 Basic principle

1. Explain basic principle of ignition system used in small engines.
2. Tell various types of ignition system used in small engines

2.2 Contact breaker ignition system

3. Tell name and function of various parts of the contact breaker ignition system.
4. Explain principle of the contact breaker ignition system.

2.3 Capacitor discharge ignition system (CDI)

5. Tell name and function of various parts of the CDI system
6. Explain principle of the CDI system.
7. Tell advantages and disadvantages of the CDI system

2.4 Transistor ignition system

8. Tell name and function of various parts of the transistor ignition system.
9. Explain principle of transistor ignition system.
10. Tell advantages and disadvantages of the transistor ignition system.

2.5 Repair and maintenance

11. Remove and reassemble various parts of ignition system.
12. Check conditions of spark plug.
13. Clean and set electrode gap of spark plug correctly.
14. Check ignition coil correctly.
15. Check CDI and transistor ignition module correctly.
16. Check condenser correctly.
17. Set contacting point gap correctly.
18. Adjust ignition timing correctly.
19. Adjust clearance between ignition coil and magnetic fly-wheel correctly.

3. Speed control system

3.1 Governor

1. Tell the task of a governor

3.2 Types and function of governors

2. Tell various types of speed control systems.
3. Explain principle of pneumatic governor.
4. Explain principle of mechanical governor.

3.3 Repair and maintenance

5. Remove/refitting pneumatic and mechanical governor
6. Adjust pneumatic and mechanical governor

4. Valve mechanism

4.1 Functions of valve mechanism

1. Tell functions of valve mechanism.

4.2 Types and principle of valve mechanism

2. Tell various arrangements of valve.
3. Explain principle of overhead valve engine.
4. Tell advantages and disadvantages of the overhead valve engine.
5. Explain principle of side valve engine.
6. Tell advantages and disadvantages of side valve engine.

4.3 Compression-reduction mechanism

7. Tell purpose of compression-reduction mechanism
8. Tell various parts of compression-reduction mechanism.
9. Tell function of various parts of compression-reduction mechanism.
10. Explain principle of compression-reduction mechanism.

4.4 Repair and maintenance

11. Remove-reassemble cylinder head.
12. Remove-reassemble valves.
13. Measure length of valve spring.
14. Check squareness of valve spring.
15. Check strength of valve spring.
16. Measure diameter of valve stem.
17. Check straightness of valve stem.
18. Check valve face, margin and valve stem.
19. Measure width of valve seat.
20. Use valve seat cutter correctly.
21. Grind valve correctly.
22. Measure bore of the valve guide.
23. Remove and refit valve guide.
24. Adjust valve clearance correctly.

5. Crankshaft mechanism

5.1 Components and functions

1. Tell various parts of crankshaft mechanism
2. Tell various types of piston rings.
3. Tell functions of piston rings.
4. Tell functions and components of piston, connecting rod and crankshaft.

5.2 Repair and maintenance

5. Test compression, and tell their specification.
6. Remove and reassemble crancshaft mechanism.
7. Inspect piston, crankshaft and cylinder.
8. Inspect thickness and clearances of piston rings.
9. Arrange piston ring ends.
10. Measure sizes of gudgeon pin, hole and small-end connecting rod.

6. Lubrication system

6.1 Tasks of the lubrication system

1. Tell the Tasks of the lubrication system
2. Tell various parts that need lubrication.

6.2 Splash-type lubrication

3. Tell various parts of the splash-type lubrication.
4. Explain principle of the splash-type lubrication.
5. Tell advantages and disadvantages of the splash-type lubrication.

6.4 Repair and maintenance

6. Check and change oil.

7. Cooling system

1. Tell tasks of the cooling system.
2. Explain principle of air cooling system.
3. Tell components of air cooling system

7.1 Repair and maintenance

4. To remove-reassemble various components of cooling system.
5. To clean blower blade and its cover.

8. Starting system

8.1 Types of starting system

1. Tell types of starting systems.

8.2 Components of starting system

2. Tell components of starting unit.
3. Tell functions of components of starting unit.

8.3 Repair and maintenance

4. To remove/reassemble components of the starting unit.
5. To repair the starting unit.

9. Exhaust system

9.1 Purpose of exhaust system

1. Tell purposes of the exhaust system.

9.2 Components of exhaust system

2. Tell components of the exhaust system.
3. Tell functions of the components of the exhaust system.

1 Fuel system

1.1 Components of fuel system

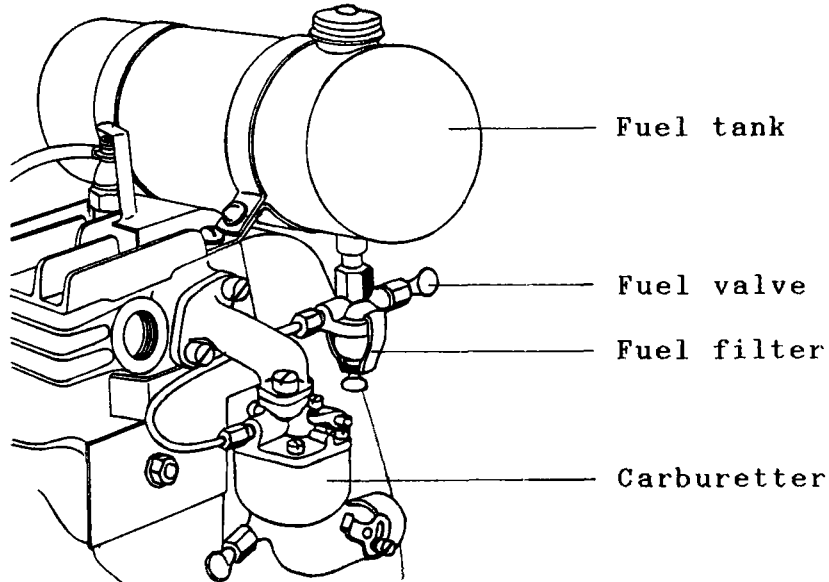

Fuel is delivered from the fuel tank into the carburetter by means of its gravity

1.2 Fuel tank

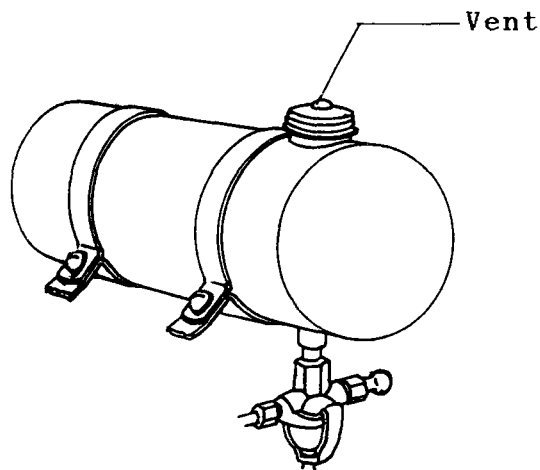

Vent : When fuel level decreases, air can enter into the fuel tank via the vent and fills up the decreased space of fuel.

1.3 Fuel filter

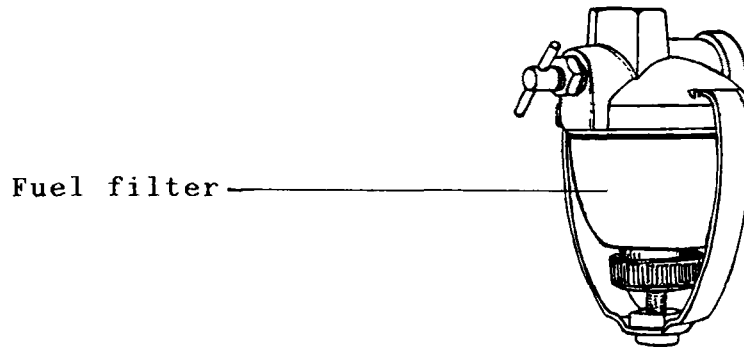

Fuel filter will trap impurities as contained in the fuel before the fuel is delivered into the carburettor.

1.4 Air filter

If unfiltered air is entering the combustion chamber, then both, cylinder and piston will be worn rapidly.

1.4.1 Oil bath- or wet-type

Oil will trap dust in the air.

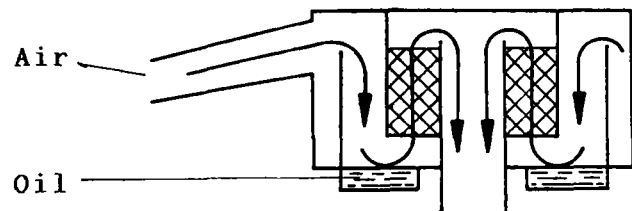
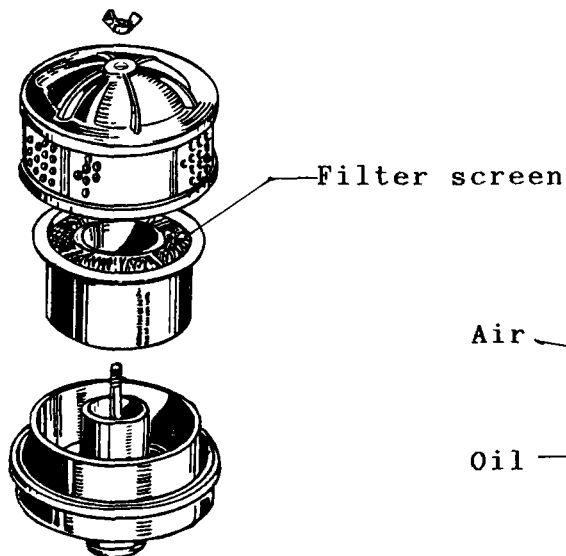

Filtered air to carburettor

Advantage : Filter screen can be washed by benzene

Disadvantage : dirty

1.4.2 Paper element type or dry type

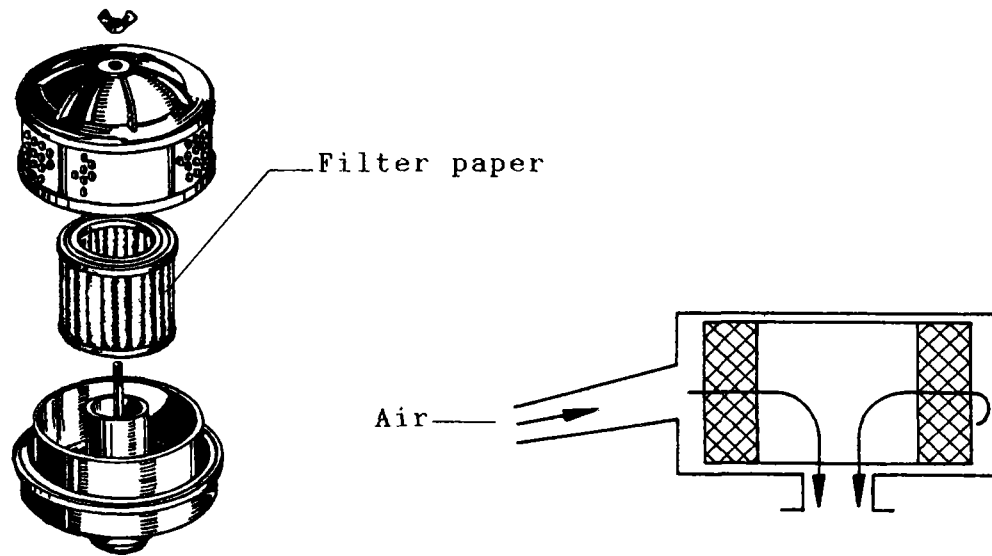

Filtered air to carburettor

Advantage : Easy to use and maintain, most use nowadays

Disadvantage : If the filter gets too dirty, it must be replaced.



1.1 to 1.4 Tank and Filters

Cross the correct statements!

- 1. Fuel from the fuel tank enters into the carburetter by means of its gravity.
- 2. In small engines, the fuel tank is mounted below the carburetter.
- 3. If the fuel tank vent is clogged, then the fuel cannot enter into the carburetter.
- 4. Fuel filter can trap water as contained in the fuel.
- ... 5. Engine without fuel filter will shorten life of its piston and piston rings.
- 6. Air filter can be classified, according to usage, into 2 types: wet and dry.
- 7. Wet type air filter uses oil to trap dust from intake air.
- 8. Clogged air filter will cause high fuel consumption.
- 9. Wet type air filter can be cleaned by benzene.
- 10. Nowadays, small engines employ the dry type air filter.

1.1 to 1.4 Tank and Filters

Cross the correct statements!

- 1. Fuel from the fuel tank enters into the carburetter by means of its gravity.
- 2. In small engines, the fuel tank is mounted below the carburetter.
- 3. If the fuel tank vent is clogged, then the fuel cannot enter into the carburetter.
- 4. Fuel filter can trap water as contained in the fuel.
- 5. Engine without fuel filter will shorten life of its piston and piston rings.
- 6. Air filter can be classified, according to usage, into 2 types: wet and dry.
- 7. Wet type air filter uses oil to trap dust from intake air.
- 8. Clogged air filter will cause high fuel consumption.
- 9. Wet type air filter can be cleaned by benzene.
- 10. Nowadays, small engines employ the dry type air filter.

1.5 Carburetter

1.5.1 Principle of carburetter

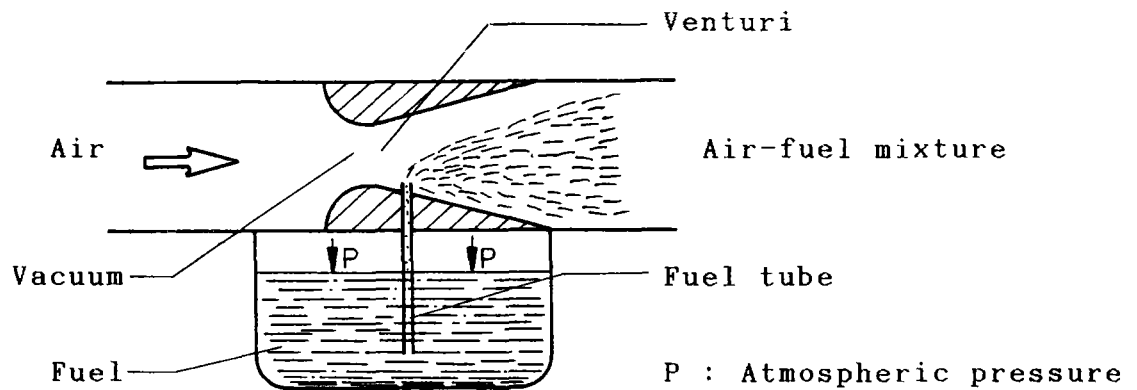

As air rushes through the venturi, it will develop partial vacuum in that area. At the same time, atmospheric pressure will push fuel up by the fuel tube to mix with the rushing air.

1.5.2 Types of carburetter

They can be classified into three types according to suction methods:

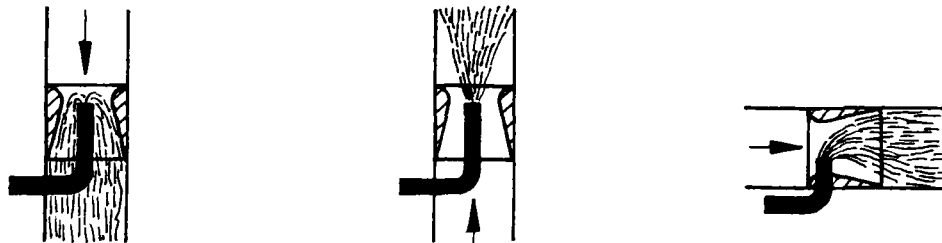

a) Down draft

b) Up draft

c) Side draft

Remark: Most small engines use the side draft carburetters, and next the up draft ones.

1.5.3 Side draft carburetter

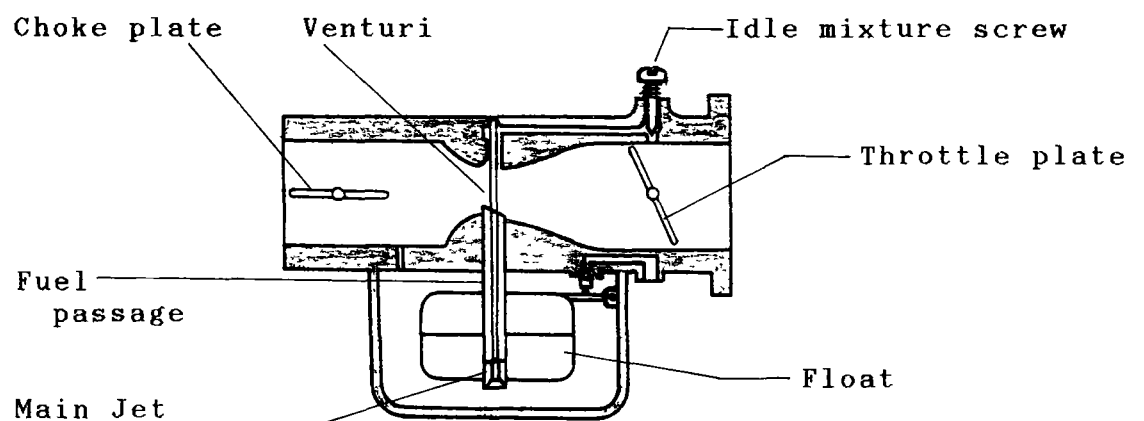

1.5.4 Floating circuit

Floating circuit is to control the amount of fuel entering the float chamber and maintain the fuel level in it.

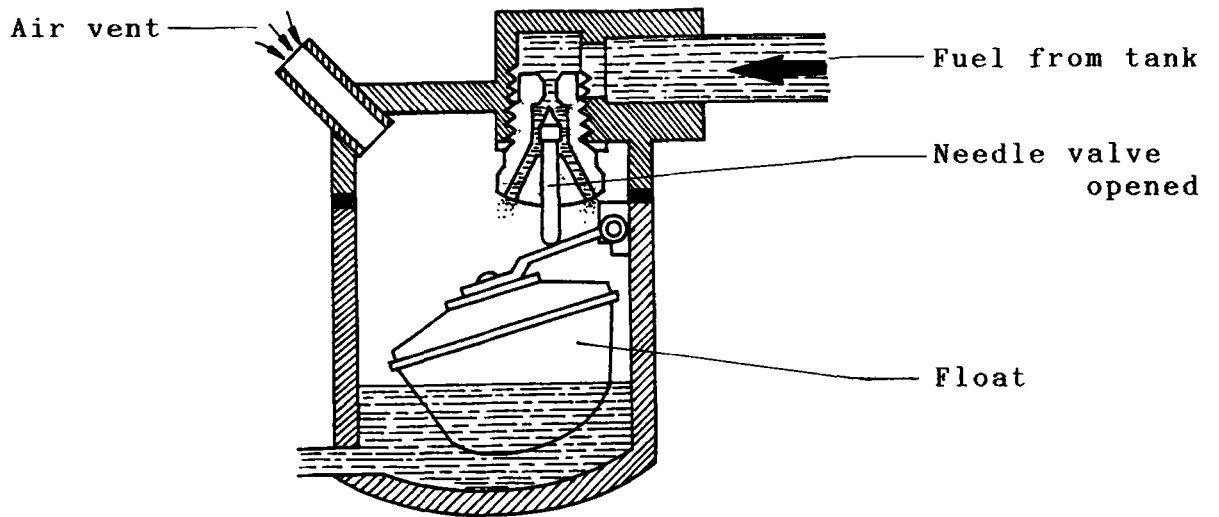

As the engine is running, a certain amount of fuel is used up causing the fuel level to decrease and thereby lowering the float which activates the needle valve to allow additional fuel to enter into the float chamber.

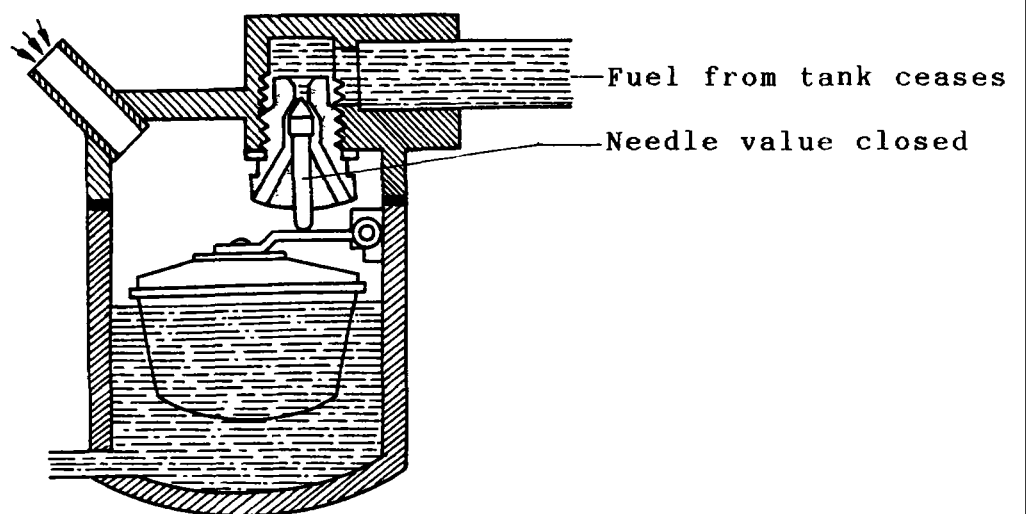

As additional fuel is entering into the float chamber, the float rises until a certain level the needle valve closes and fuel flow ceases. In this circumstance, the fuel level is maintained constantly.

1.5.5 Idle circuit

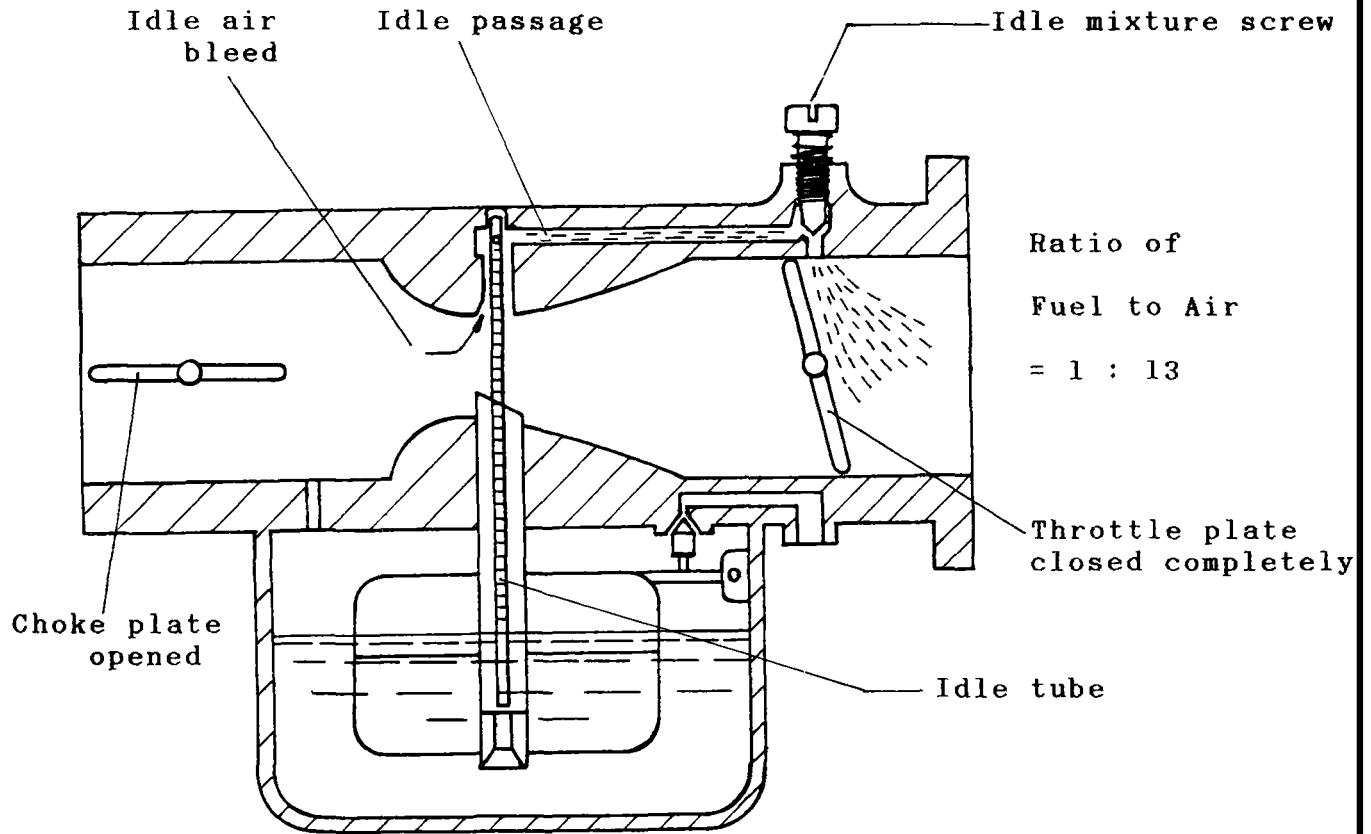

When the throttle plate closes completely, air is sucked via the idle air bleed and thereby sucks fuel from the float bowl to mix with it in the idle passage and comes out by the idle port.

Ratio of fuel to air can be adjusted by means of the idle mixture screw. Whereas the idle speed is adjusted by the idle speed screw.

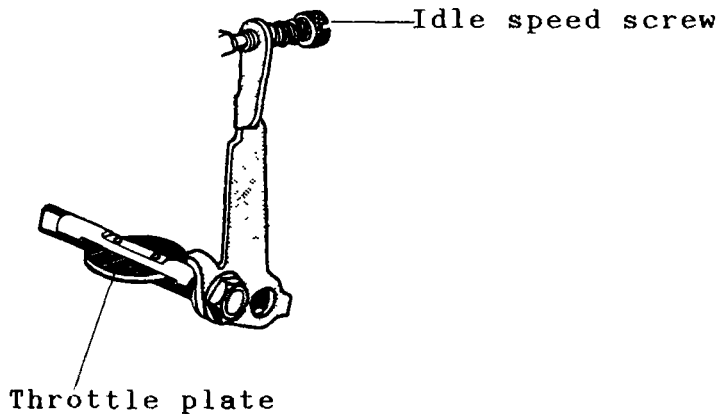

1.5.6 Full throttle circuit

Full throttle circuit is for distributing sufficient amount of air-fuel mixture to the required increasing engine speed.

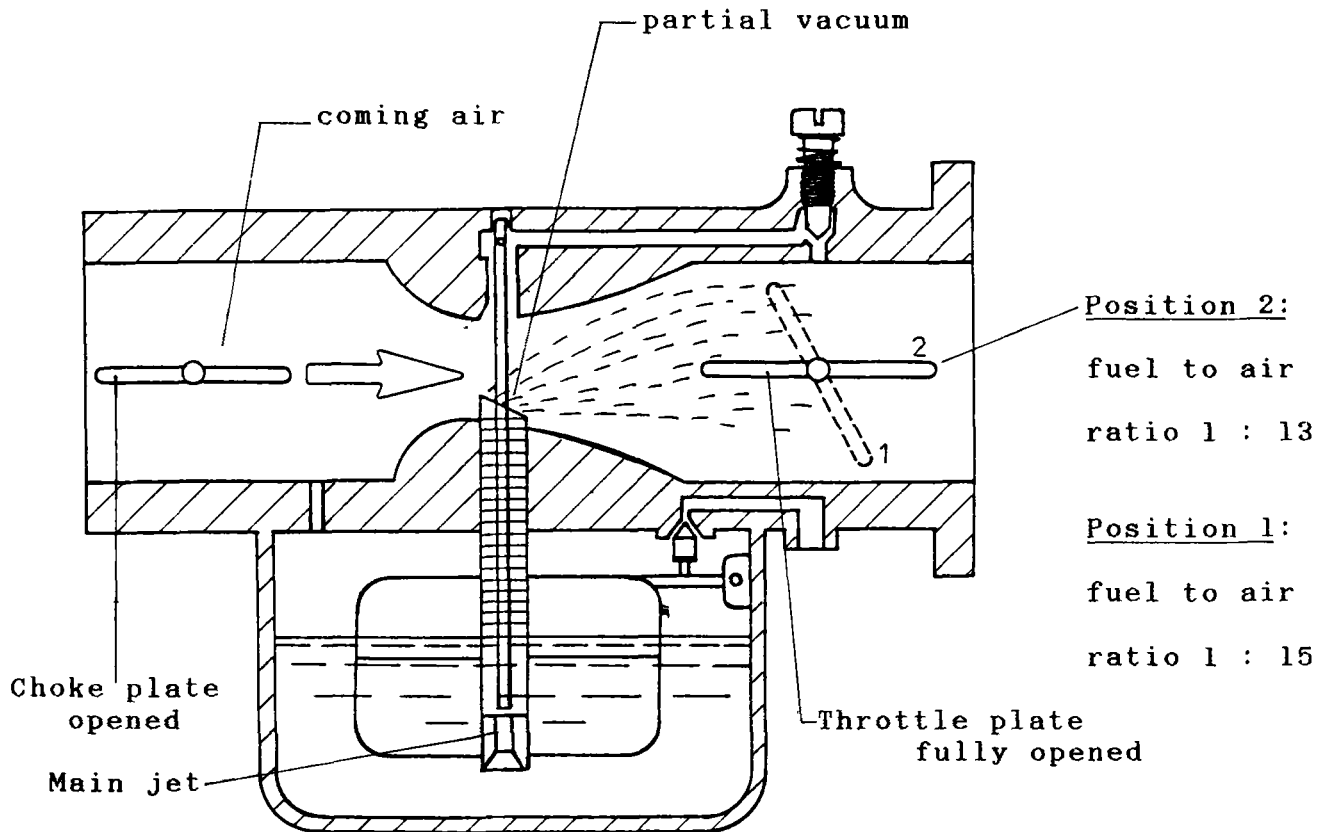

Pos. 1 : When the throttle plate opens, air rushes over the venturi increasing the partial vacuum in that area and thereby sucks fuel via the main jet - Engine speed is thus increasing.

Pos. 2 : When the throttle plate opens fully, more air rushes over the venturi, thus higher partial vacuum is developed. The fuel is sucked more than in the previous position, thus the engine is running at maximum speed.

1.5.7 Choke Circuit

Choke circuit provides richer fuel mixture than normal especially, during the start of the engine.

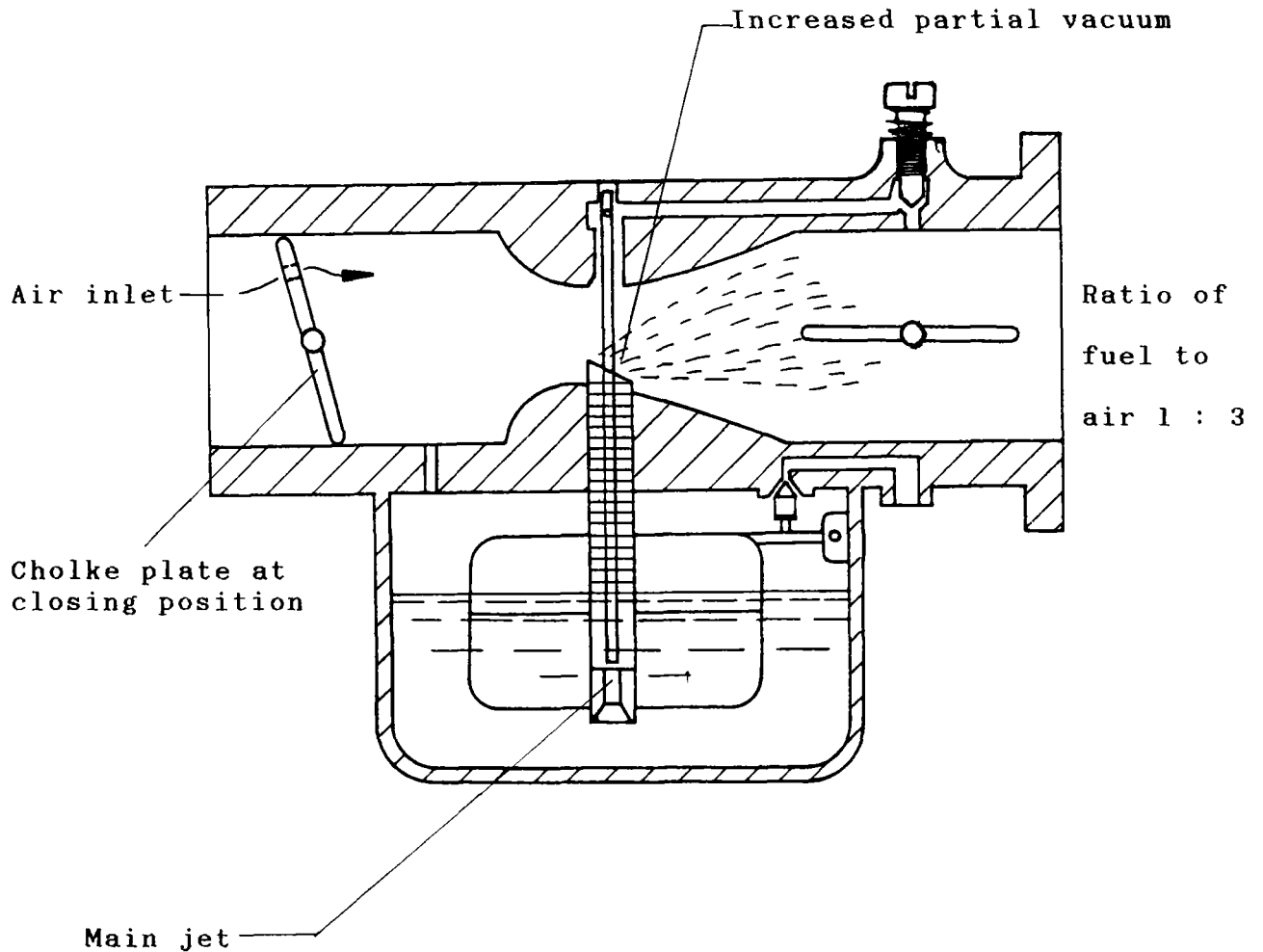

When the engine is started, its speed is still low. A small amount of air flows through the venturi and suck very limited amount of fuel. Increasing fuel is needed in this case by closing the choke plate which in turn increasing the partial vacuum over the venturi.

1.5 Carburettor (I)

1. Name the parts of the carburettor!

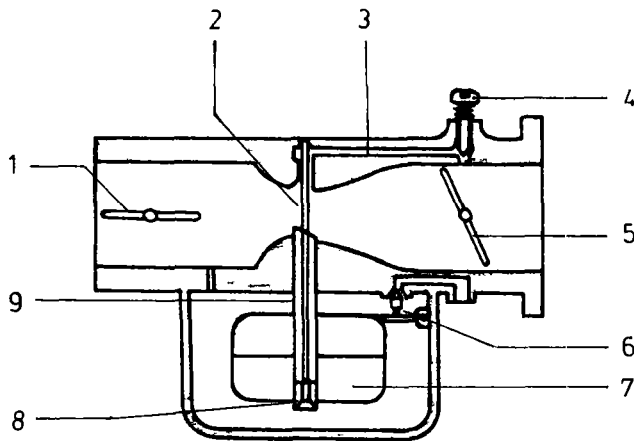

1. -----
2. -----
3. -----
4. -----
5. -----
6. -----
7. -----
8. -----
9. -----

2. As air is flowing through the venturi, the pressure at the venturi is -higher/lower- than the atmospheric pressure.
3. The pressure over the float chamber is -higher/lower- than the pressure at the main jet when air is flowing through the venturi.
4. Carburettors used in small engines can be classified, according to types of drafts, into __ types; i.e. -----.
5. The most used carburettor for small engines is -----.
6. The float circuit is for -----.
7. If the fuel level in the float chamber is dropped, the needle valve will -close/open-.
8. The fuel to air ratio of the idle circuit is about ___ : ___.
9. While the engine is idling, the throttle plate will be at -fully closing/fully opening- position.
10. The fuel to air ratio of the idle circuit can be adjusted by -----.

1.5 Carburettor (I)

1. Name the parts of the carburettor!

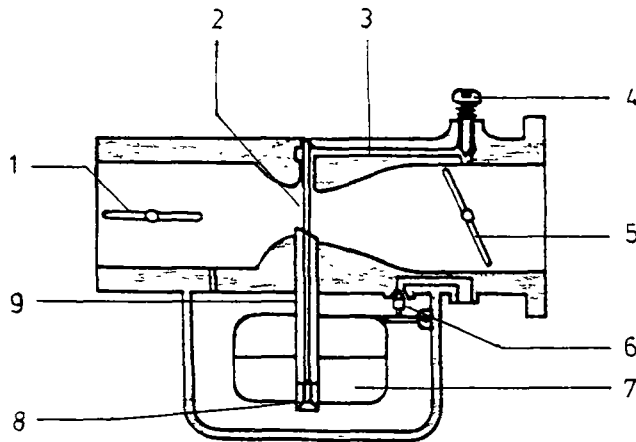

1. Choke plate
2. Venturi
3. Idle passage
4. Idle mixture screw
5. Throttle plate
6. Needle valve
7. Float
8. Main jet
9. Fuel passage

2. As air is flowing through the venturi, the pressure at the venturi is ~~higher~~/lower than the atmospheric pressure.
3. The pressure over the float chamber is ~~higher~~/lower than the pressure at the main jet when air is flowing through the venturi.
4. Carburettors used in small engines can be classified, according to types of drafts, into 3 types; i.e. down, up, side.
5. The most used carburettor for small engines is side draft.
6. The float circuit is for control the amount of fuel in the carburettor.
7. If the fuel level in the float chamber is dropped, the needle valve will ~~close~~/open.
8. The fuel to air ratio of the idle circuit is about 1 : 13.
9. While the engine is idling, the throttle plate will be at ~~fully closing~~/fully opening position.
10. The fuel to air ratio of the idle circuit can be adjusted by the idle mixture screw.

1.5 Carburettor (II)

Picture 1: If little fuel is needed by the cylinder, (idle run) what will be the position of the throttle plate? (make a sketch!)

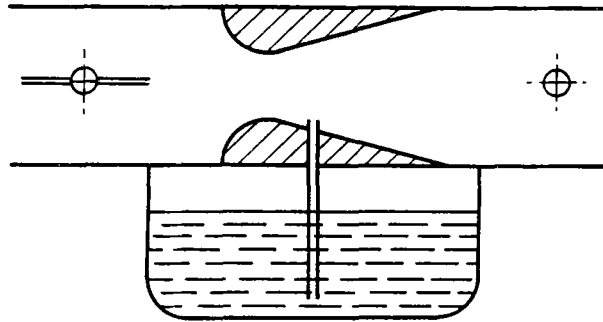

Picture 2: If more fuel is required by the cylinder, what will be the position of the throttle plate? (make a sketch!)

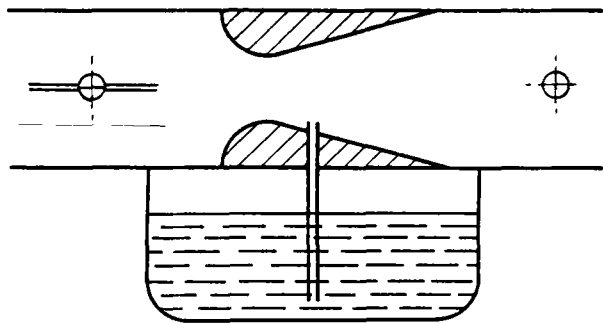

Picture 3: If maximum fuel is needed by the cylinder, what will be the positions of both, the choke plate and the throttle plate? (make a sketch!)

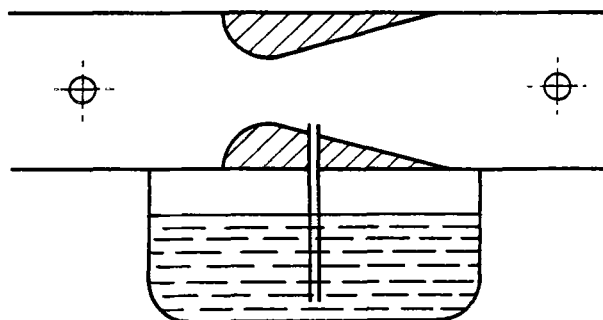

1.5 Carburettor (II)

Picture 1: If little fuel is needed by the cylinder, (idle run) what will be the position of the throttle plate? (make a sketch!)

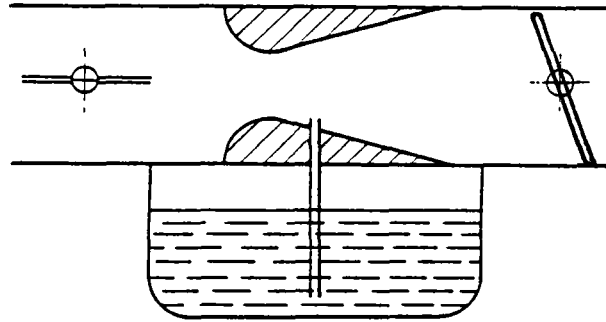

Picture 2: If more fuel is required by the cylinder, what will be the position of the throttle plate? (make a sketch!)

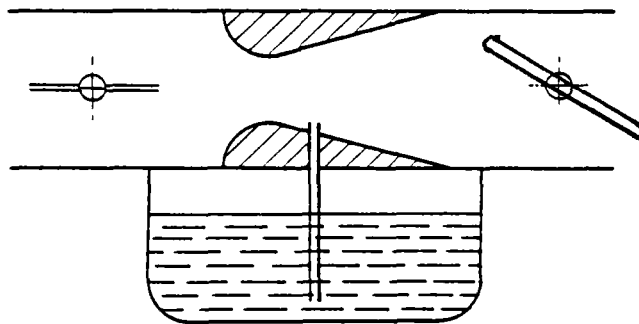

Picture 3: If maximum fuel is needed by the cylinder, what will be the positions of both, the choke plate and the throttle plate? (make a sketch!)

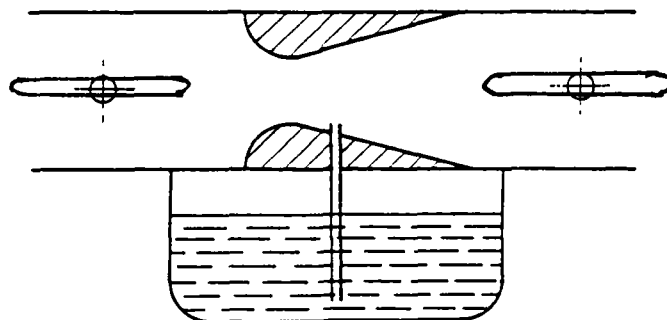



1.5 Carburettor (III)

Answer the following questions correctly!

1. In float setting, what will happen if the float is not set to the specified value ?

1.1 In case the float is too low : _____

1.2 In case the float is too high _____

2. What will happen if the idle mixture screw is not adjusted to the specified value?

2.1 In case it is higher than the given standard : _____

2.2 In case it is lower than the given standard : _____

3. How can the size of the main jet effect the fuel consumption rate ?

4. What will happen if the needle valve is worn ?

1.5 Carburettor (III)

Answer the following questions correctly!

1. In float setting, what will happen if the float is not set to the specified value ?

1.1 In case the float is too low : Fuel is overflowing

1.2 In case the float is too high: Insufficient fuel

2. What will happen if the idle mixture screw is not adjusted to the specified value?

2.1 In case it is higher than the given standard : idle speed is to high

2.2 In case it is lower than the given standard : idle speed is to low

3. How can the size of the main jet effect the fuel consumption rate ?

Big bore → high fuel consumption

Small bore → low fuel consumption

4. What will happen if the needle valve is worn ?

The carburettor will leak

1.6 Repair and maintenance

1.6.1 Servicing fuel tank

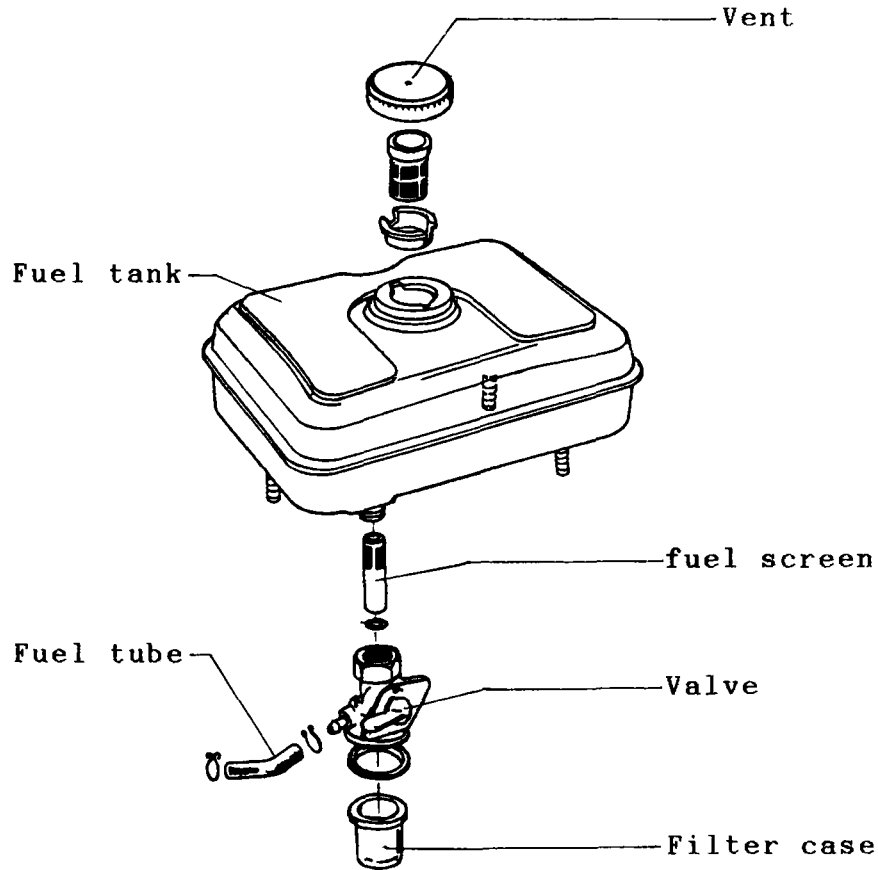

Caution : Fuel must be drained out completely prior removing the fuel tank.

| Components | Services |
|----------------|---|
| 1. Fuel cap | -Inspect the vent, it must be clean and clear. Use air gun to clean it. |
| 2. Fuel tank | -Inspect for any puncture of the fuel tank. Clean inside of the tank. |
| 3. Fuel screen | -Inspect for any blockage or wreckage. |
| 4. Valve | -Clean it. |
| 5. Fuel tube | -Inspect conditions like cracks. |
| 6. Filter cae | Clean the filter case in benzene. |

Caution : Be sure that no fuel leakage after reassemble.

1.6.2 Servicing dry-type air filter

- Filter paper type



- Tap the filter rim gently or brush the paper.
- Blow out dirt from inside the filter with an air gun.

- Filter sponge

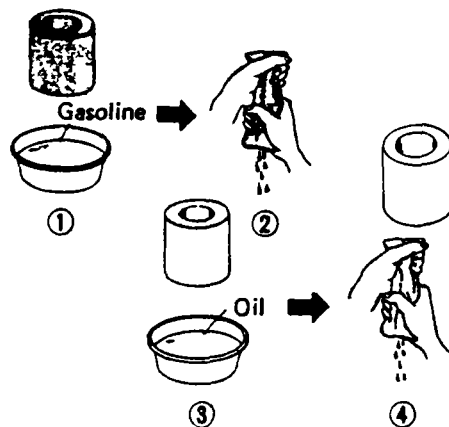

- Clean the filter sponge in benzene, squeeze out dirt.
- Dry the filter sponge by squeezing and waving it.
- Dip the filter sponge into the pan of oil and benzene mixture of 1 to 10 ratio.
- Squeeze the sponge until wet dry.

Precaution : Do not twist the filter sponge, otherwise it will be torn off. Replace the damaged or ruin sponge.

1.6.3 Servicing wet-type filter

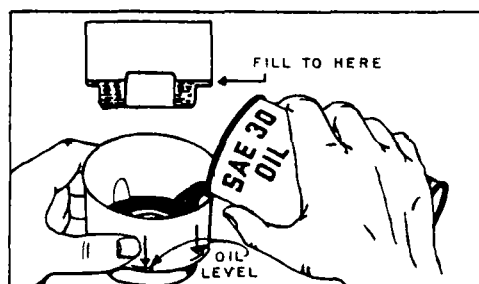

- Remove the filter and stir it in a fuel pan.
- Clean the filter inside and outside.
- Refil the oil upto the marked level.

Precaution : Use the correct oil and refill according to the manufacturer's manual.

1.6.4 Dismantling Reassembling carburetter

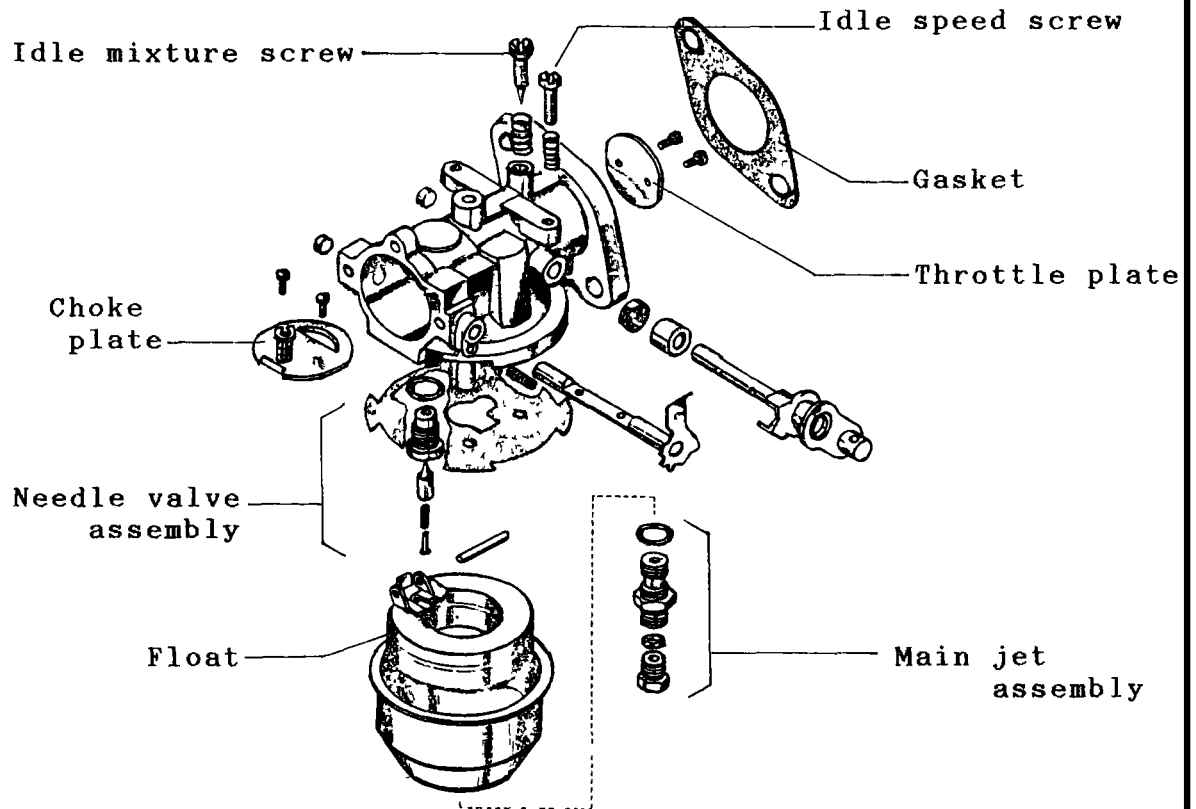

| Components | Services |
|-----------------------|---|
| 1. Float chamber | - Clean and blow with air gun |
| 2. Float | - Clean and blow with air gun |
| 3. Main jet | - Blow with air gun |
| 4. Needle | - Inspect for wear |
| 5. Idle mixture screw | - Inspect for wear or damage on cone and thread |
| 6. Carburetter body | - Clean and blow with air gun. |

Remarks: - In removing the carburetter assembly, unscrew and remove the float chamber, and drain out fuel residual.

- Before Inspection, clean all parts with benzene and brush, and blow until dry with air gun.

1.6.5 Float Setting

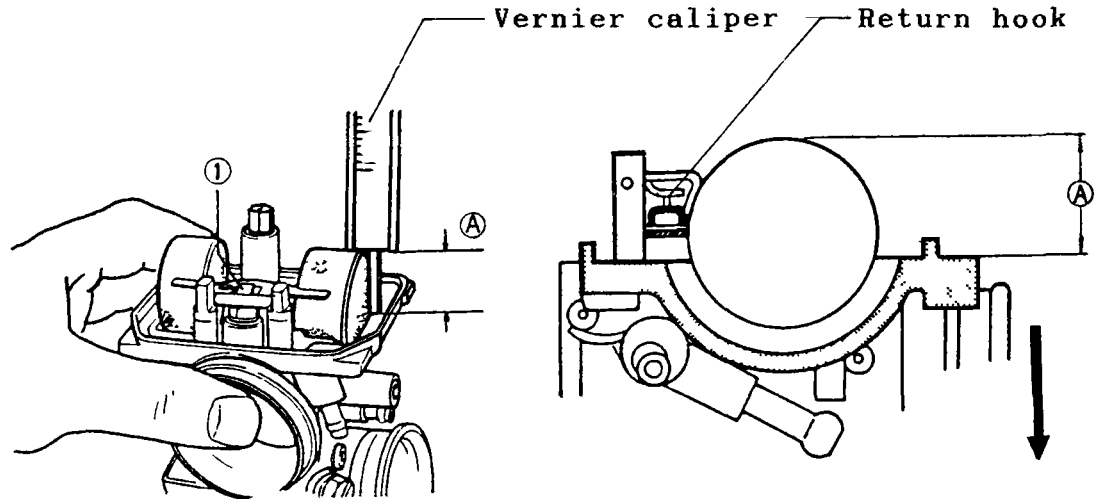

Measuring and setting:

With the float cover placed horizontally, lift the float slowly with a finger (until the return hook is just lifting the float). Measure the height of the float at this position and compare the obtained value with that given in the manual.

If the obtained value is outside the manual value, then resetting is needed.

Example:

| | | | |
|-------------------------------------|-------|--------|---------|
| Standard value for height of float: | HONDA | G 150 | 8.2 mm |
| | | G 200 | 8.0 mm |
| | | GX 120 | 13.7 mm |
| | | GX 160 | 13 mm |

1.6.6 Idle mixture adjustment

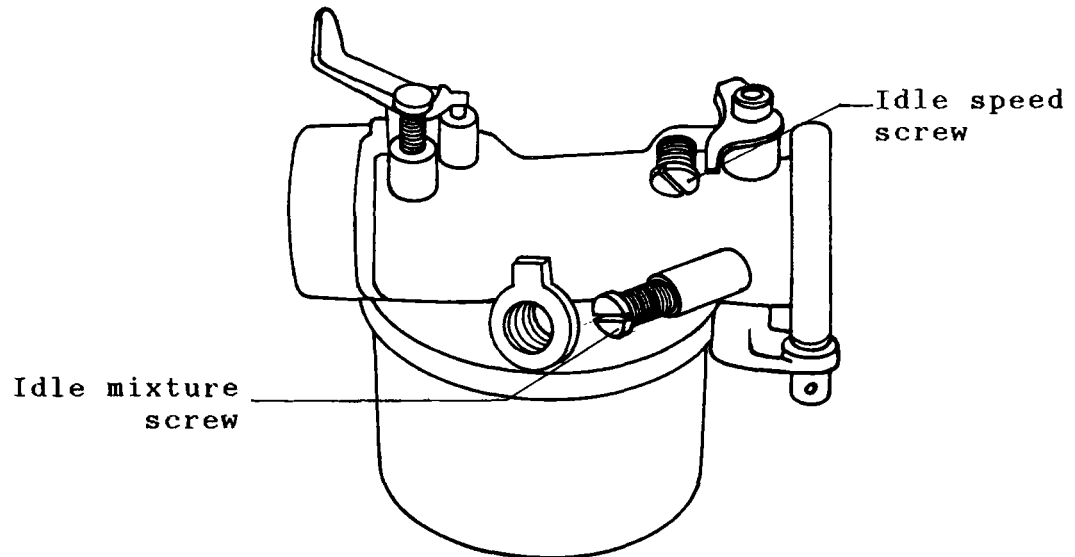

Screw in the idle mixture screw completely and then unscrew it for the specified number of turns as given in the manual.

| | | | |
|--|-------|---------|-------------|
| The specified number of turns of idle mixture screw: | HONDA | G 150 | 1 3/8 Turns |
| | | G 200 | 3 1/4 Turns |
| | | G x 120 | 2 5/8 Turns |
| | | G x 160 | 2 1/8 Turns |

Remark: If the specified number of turns is not known, then assumes for 1 1/2 to 2 turns or observe for the smoothest idling of the engine.

1.6.7 Idle speed setting

- Start the engine and allow it to idle.
- Adjust the idle speed screw inward or outward until the specified number of revolutions is obtained.

| | |
|-----------------------|---------------|
| Standard idling speed | 1,400 rev/min |
|-----------------------|---------------|

1.6.8 Fault diagnosis of engine as due to carburettor failure.

| Symptom | Causes | Remedy |
|--------------------------|---|--|
| 1. Wet spark plug | <ul style="list-style-type: none"> - Fuel flooded - Worn float needle or dirty | <ul style="list-style-type: none"> - adjust float level - Clean, replace |
| 2. Idle speed too high | <ul style="list-style-type: none"> - Incorrect idle speed - Clogged idle circuit - Clogged fuel tube of idle circuit | <ul style="list-style-type: none"> - Readjust idle mixture screw - Clean, blow with air gun |
| 3. Poor acceleration | <ul style="list-style-type: none"> - Clogged fast idle main jet - Fuel level is too low in the float chamber - Choke unit sticking | <ul style="list-style-type: none"> - Clean, blow with air gun - Readjust the float level - Dismantle, clean |
| 4. Engine will not start | <ul style="list-style-type: none"> - Float sticking, no fuel entering - Choke unit sticking - Fuel flooded | <ul style="list-style-type: none"> - Clean - Dismantle, clean - Readjust the float level |



1.2 to 1.4 Tank and Filters (I)

Tools: A set of wrenches, air gun with hose

Equipment: Benzen, Oil, Soft brush, cleaning pan, cloth

Manufacturer Model

Type of air cleaner

| Sequence of operations | Inspection |
|--|--|
| 1. Prepare tools and equipment | |
| 2. Close fuel valve and disconnect hoses. | - Condition of fuel valve <input type="checkbox"/> Normal <input type="checkbox"/> Damaged - Condition of hose <input type="checkbox"/> Normal <input type="checkbox"/> Damaged |
| 3. Remove fuel tank | |
| 4. Empty the fuel tank | - Condition of fuel <input type="checkbox"/> Normal <input type="checkbox"/> Deposited <input type="checkbox"/> Water contained <input type="checkbox"/> Others |
| 5. Remove fuel valve and fuel cap | - Condition of fuel cap <input type="checkbox"/> Normal <input type="checkbox"/> Blocked vent |
| 6. Clean fuel valve and fuel filter | - Condition of fuel filter <input type="checkbox"/> Normal <input type="checkbox"/> Clogged <input type="checkbox"/> Damaged |
| 7. Clean fuel tank with benzene | - Condition of fuel tank <input type="checkbox"/> Normal <input type="checkbox"/> Rusty <input type="checkbox"/> Leaked |
| 8. Reassemble those components in reverse order. | Remarks: ----- ----- |



1.2 to 1.4 Tank and Filters (II)

| Sequence of operations | Inspection |
|--|--|
| <p>Paper type air cleaner:</p> <ol style="list-style-type: none"> 1. Remove the air cleaner unit from the carburetter. 2. Remove the filter for inspection 3. Blow the filter from inside 4. Clean the air cleaner body with benzene 5. Reassemble the air cleaner | <p>- Condition of the filter</p> <p><input type="checkbox"/> Normal</p> <p><input type="checkbox"/> Dirty, clogged</p> <p><input type="checkbox"/> Damaged</p> <p><input type="checkbox"/> Others</p> <p>Remarks:</p> <p>.....</p> |
| <p>Sponge type air cleaner:</p> <ol style="list-style-type: none"> 1. Remove the air cleaner unit from carburetter. 2. Remove the filter for inspecting. 3. Clean the filter with benzene 4. Squeeze and wave the filter. 5. Dip the filter in the fuel oil mixture (1 : 10 ratio) 6. Reassemble the air cleaner | <p>- Condition of filter</p> <p><input type="checkbox"/> Normal</p> <p><input type="checkbox"/> Dirty, clogged</p> <p><input type="checkbox"/> Damaged</p> <p><input type="checkbox"/> Others</p> <p>Remarks:</p> <p>.....</p> |



1.2 to 1.4 Tank and Filters (III)

| Sequence of operations | Inspection |
|--|--|
| <p>Wet type air cleaner:</p> <ol style="list-style-type: none"> 1. Remove the air cleaner unit. 2. Remove the filter for inspecting 3. Clean the filter and the air cleaner body. 4. Refil oil into the air cleaner body upto the marked level. 5. Reassemble the filter and the air cleaner. 6. Clean and store tools and equipment used. | <p>- Condition of the filter</p> <ul style="list-style-type: none"> <input type="checkbox"/> Normal <input type="checkbox"/> Dirty, clogged <input type="checkbox"/> Damaged <input type="checkbox"/> Others <p>- Amount of refil oil</p> <p>..... ccm</p> <p>Oil number</p> <p>Remarks</p> <p>.....</p> |



1.5 Carburetter (I)

 Tools: A set of wrenches, air gun with hose

Equipment: Benzen, soft brush, cleaning pan, cloth

Manufacturer Model

Type of carburetter Model

Standard float height mm

Standard number of
 turns of idle mixture screw

Standard idling speed rev/min

Standard number of main jet

| Sequence of operation | Inspection |
|--|---|
| <p>1. Prepare tools and equipment.</p> <p>2. Remove air cleaner.</p> <p>3. Close fuel valve and disconnect hose.</p> <p>4. Remove carburetter and related linkage and spring.</p> <p>Remark : Memorize linkages before removing.</p> <p>5. Clean outside of carburetter.</p> <p>6. Remove carburetter cover and empty fuel residual.</p> <p>Caution : Gasket may be torn off</p> | <p>- Type of filter</p> <p>- Condition of leakage</p> <p><input type="checkbox"/> Nil <input type="checkbox"/> leaked</p> <p>- Condition of float chamber</p> <p><input type="checkbox"/> Normal <input type="checkbox"/> Dirty</p> <p>- Condition of fuel</p> <p><input type="checkbox"/> Normal <input type="checkbox"/> Di ty</p> <p><input type="checkbox"/> Water contained</p> <p><input type="checkbox"/> Others</p> |



1.5 Carburetter (II)

| Sequence of operations | Inspection |
|---|--|
| <p>7. Remove float and needle for inspection.</p> <p>8. Remove main jet assembly</p> <p>9. Remove idle mixture screw</p> <p>10. Clean all components with benzene and dry with air gun.</p> <p>11. Set the height of float according to the manual.</p> <p>12. Reassemble the carburetter in reverse order.</p> | <p>- Condition of float</p> <p><input type="checkbox"/> Normal</p> <p><input type="checkbox"/> Damaged</p> <p>- Condition of needle</p> <p><input type="checkbox"/> Normal <input type="checkbox"/> Dirty</p> <p><input type="checkbox"/> Worn <input type="checkbox"/> Others</p> <p>.....</p> <p>- Condition of main jet bore</p> <p><input type="checkbox"/> Normal <input type="checkbox"/> Blocked</p> <p><input type="checkbox"/> Worn</p> <p>Number of main jet</p> <p><input type="checkbox"/> Original main jet</p> <p><input type="checkbox"/> New main jet</p> <p>- Condition of idle mixture screw</p> <p><input type="checkbox"/> Normal <input type="checkbox"/> Dirty</p> <p><input type="checkbox"/> Worn <input type="checkbox"/> Others</p> <p>.....</p> <p>- Height of float</p> <p>Obtained value mm</p> <p><input type="checkbox"/> Normal</p> <p><input type="checkbox"/> Resetting</p> |



1.5 Carburettor (III)

| Sequence of operations | Inspection |
|---|--|
| 13. Adjust the idle mixture screw according to the manual as specified. | - Number of turns |
| 14. Start the engine and allow to idle. | - Performance of the engine <input type="checkbox"/> Normal <input type="checkbox"/> Abnormal |
| 15. Adjust the idle speed screw according to manual. | - Idling speed as specified rev/min |
| 16. Stop the engine | |
| 17. clean tools and equipment and store it. | |
| Remarks: | |

2. Ignition system

2.1 Basic principle

For small gasoline engines, magneto ignition system is generally used.

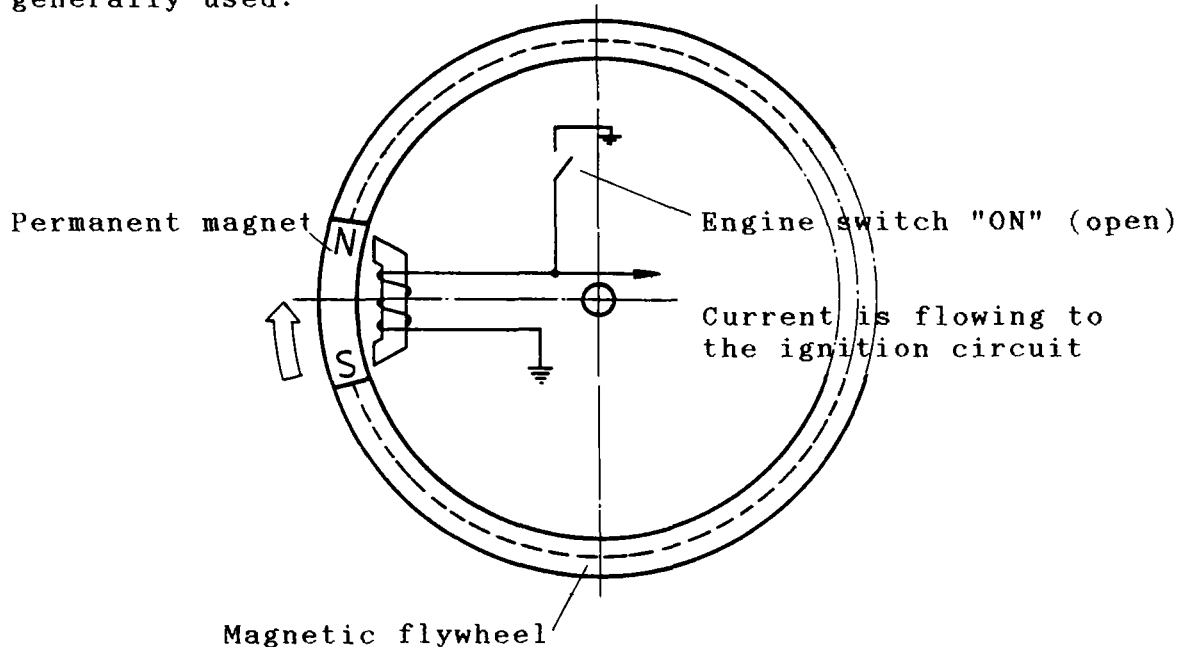

- The magnetic field of the permanent magnet, which rotates over the coil will generate current in the coil circuit.
- If the engine switch is at "OFF" position (closed), the generated current flows to the ground and cause no current flows in the ignition circuit.

Magneto ignition system can be classified into 3 types:

1. Contact point ignition system.
2. Transistor ignition system
3. Capacitive discharge ignition system.

On the following pages the function of these systems is shown.

2.2 Contact point ignition system

2.2.1 Components of contact point ignition system and their function

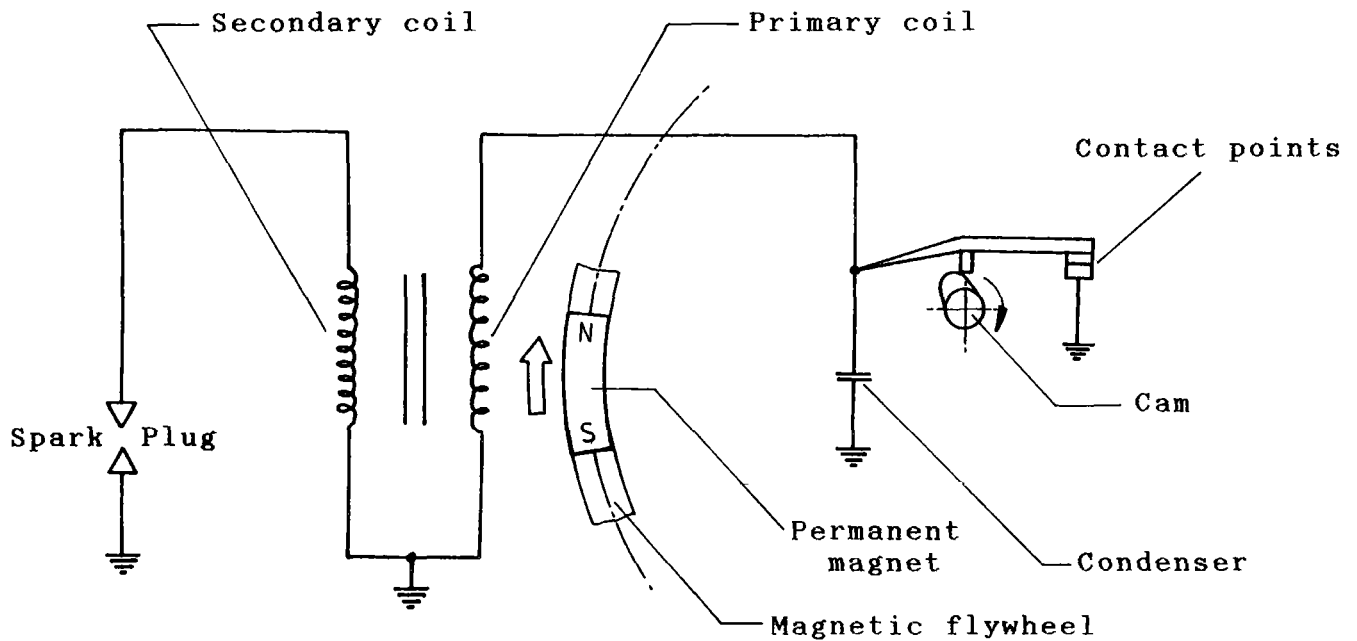

| Components | Functions |
|-----------------------|---|
| 1. Magnetic fly wheel | - makes the permanent magnet rotates around the coil and thereby produces the current in the ignition circuit |
| 2. Contact point | - switches on and off the current flowing from the primary coil |
| 3. Cam | - open/closes the contact point at correct timing. |
| 4. Condenser | - charges/discharges the current and to prevent arcing between the two contact points. |
| 5. Ignition coil | - converts low current voltage to high current voltage, sufficient for arcing the spark plug. |
| 6. Spark plug | - produces arcing and ignite the fuel mixture in cylinder. |

2.2.2 Function of contact point ignition system

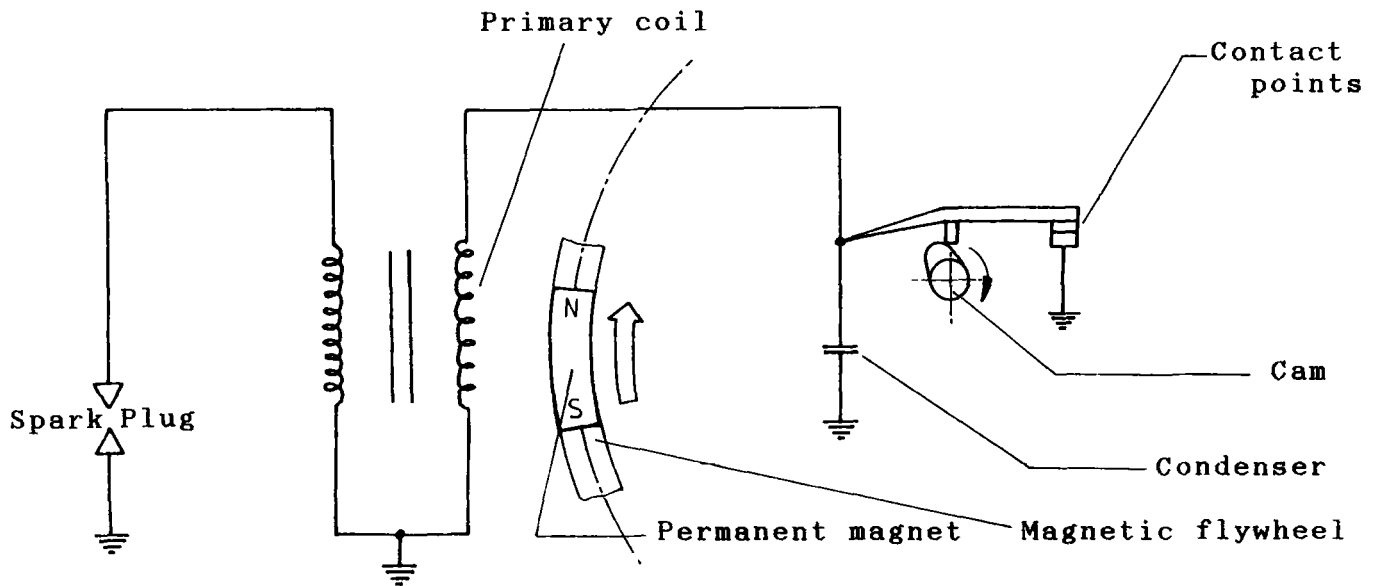

- When the engine is starting, the magnetic flywheel rotates causing the magnetic field of permanent magnet to cut the primary coil, and thereby generates current flowing in the primary coil. As the gap of contact point is closed, the generated current is flowing to the ground by the contact points.

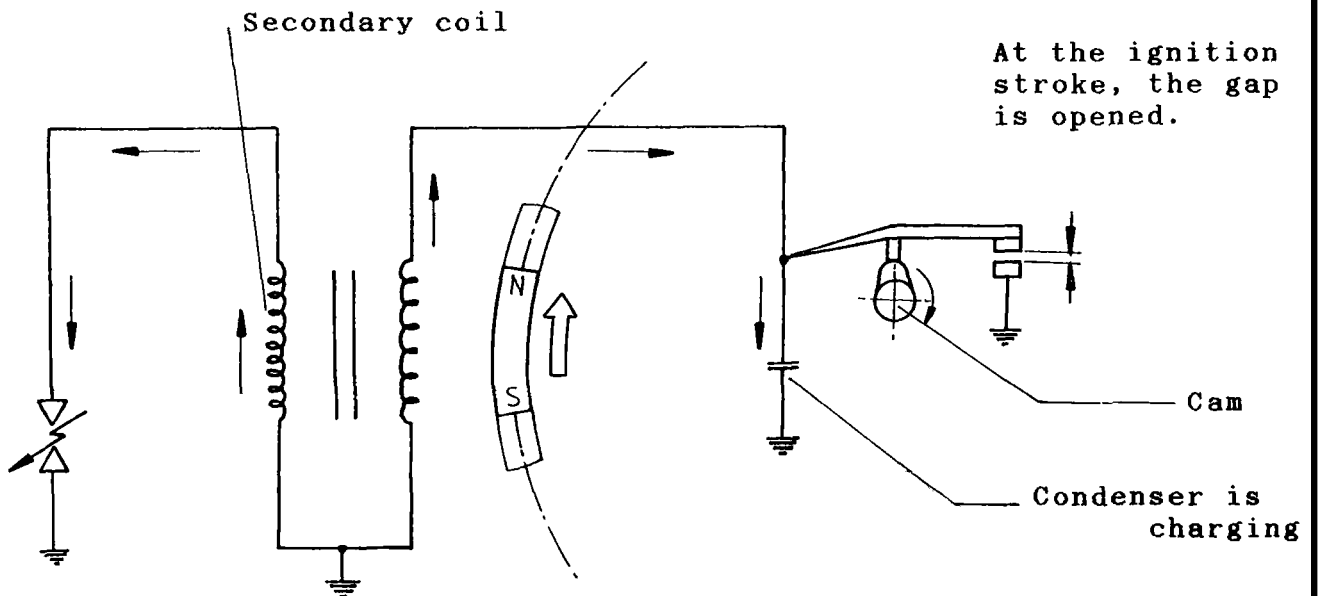

- At the ignition stroke, the cam mounted on the magnetic flywheel opens the gap of contact points. The current flowing to ground is impossible. The condenser is charging by the time the gap is opening. This will prevent arcing between contact points.
- A sudden interruption of current flowing in the primary coil causes the magnetic field to collapse and cut the secondary coil.
- Thus, the high current voltage is generated in the secondary coil and enable arcing between the electrodes of the spark plug.

2.2 Contact point ignition system

Complete the sentences or underline the correct options.

1. Ignition system generally used in small gasoline engine is
-battery/magneto type.
2. Current which flows in the ignition circuit is generated by
-----.
3. Magneto ignition system is classified into ----- types, they
are -----.
4. Please name all parts of the ignition system.

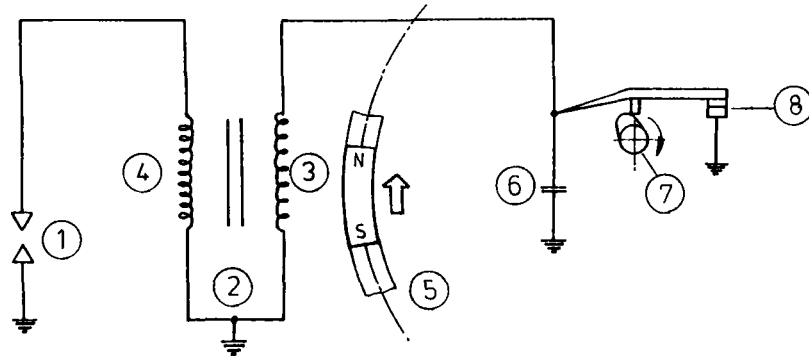

- | | |
|---------|---------|
| 1. | 5. |
| 2. | 6. |
| 3. | 7. |
| 4. | 8. |

5. Contact point is for -----.
6. The device that opens/closes the contact point is -----.
7. Condenser/Ignition coil is for converting low current voltage
to high current voltage.
8. The primary coil will be induced when the gap of contact point
is closed/opened.
9. When the current flowing in the primary coil is interrupted
suddenly, the magnetic field will -----.
10. The secondary coil shall generate high current voltage for the
spark plug when the gap of contact is beginning to open/close.

2 Contact point ignition system

Complete the sentences or underline the correct options.

1. Ignition system generally used in small gasoline engine is -battery/magneto type.
2. Current which flows in the ignition circuit is generated by magnetic flywheel .
3. Magneto ignition system is classified into 3 types, they are Contact point, Transistor and CDI .
4. Please name all parts of the ignition system.

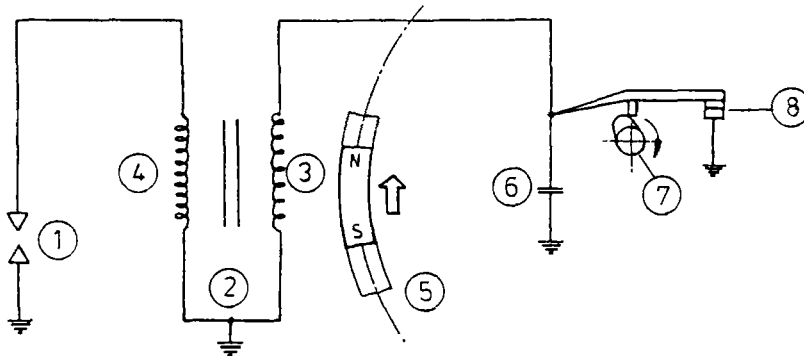

- | | |
|------------------------|----------------------|
| 1. Spark plug..... | 5. Magnetic flywheel |
| 2. Ignition coils..... | 6. Condenser..... |
| 3. Primary coil..... | 7. Cam..... |
| 4. Secondary coil.... | 8. Contact points... |

5. Contact point is for interrupting current flow in primary coil.
6. The device that opens/closes the contact point is the cam .
7. ~~Condenser~~/Ignition coil is for converting low current voltage to high current voltage.
8. The primary coil will be induced when the gap of contact point is closed/opened.
9. When the current flowing in the primary coil is interrupted suddenly, the magnetic field will collapse .
10. The secondary coil shall generate high current voltage for the spark plug when the gap of contact is beginning to open/close.

2.3 Transistor ignition system

2.3.1 Components of transistor ignition system and their function

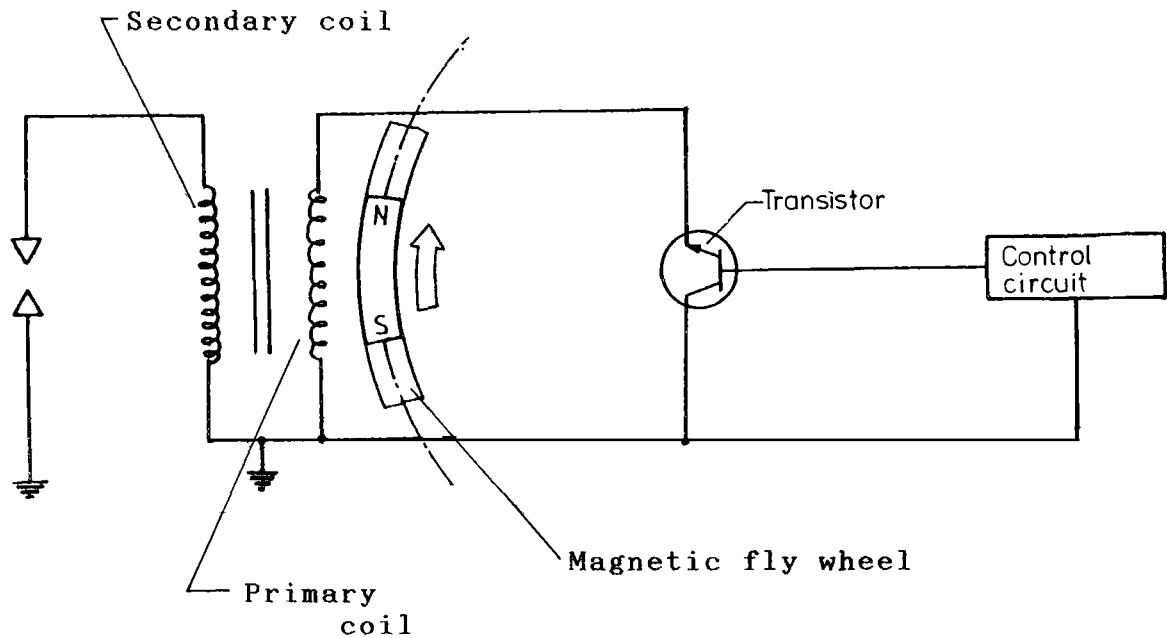

Transistor (TR)

- acts as on/off switch, like the contact points. But, a transistor can do the task contact-free.

Control circuit

- acts like the cam in opening-closing the contact points, it controls the opening/closing of the transistor.

2.3.2 Function of transistor ignition system

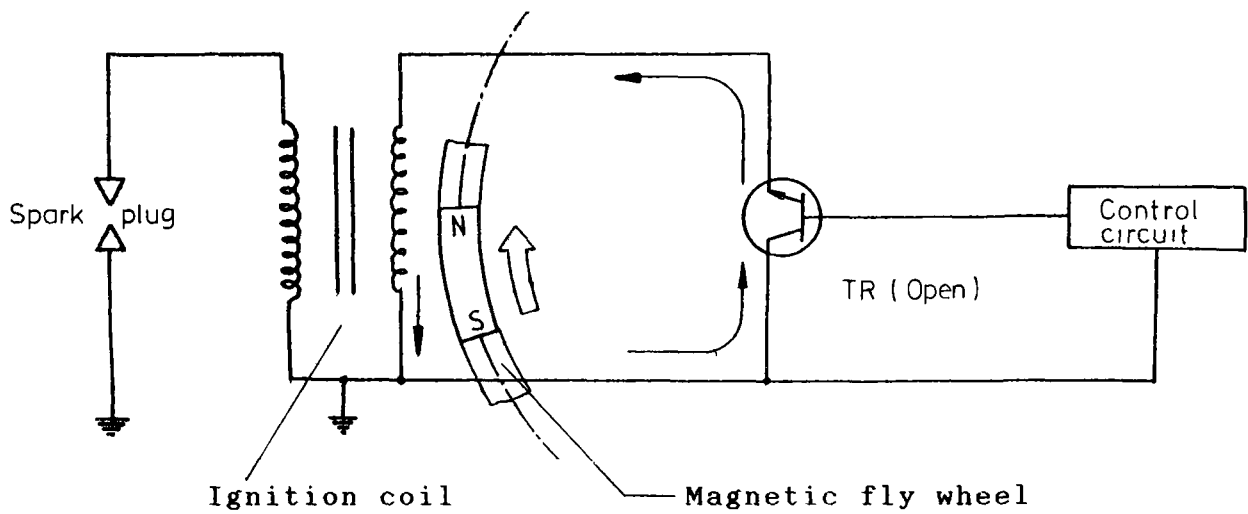

When starting the engine, magnetic fly wheel will rotate. As the magnetic field of permanent magnet is approaching the primary coil, current is induced and flowing through the transistor and thereby coming back to the primary coil, generating a magnetic field.

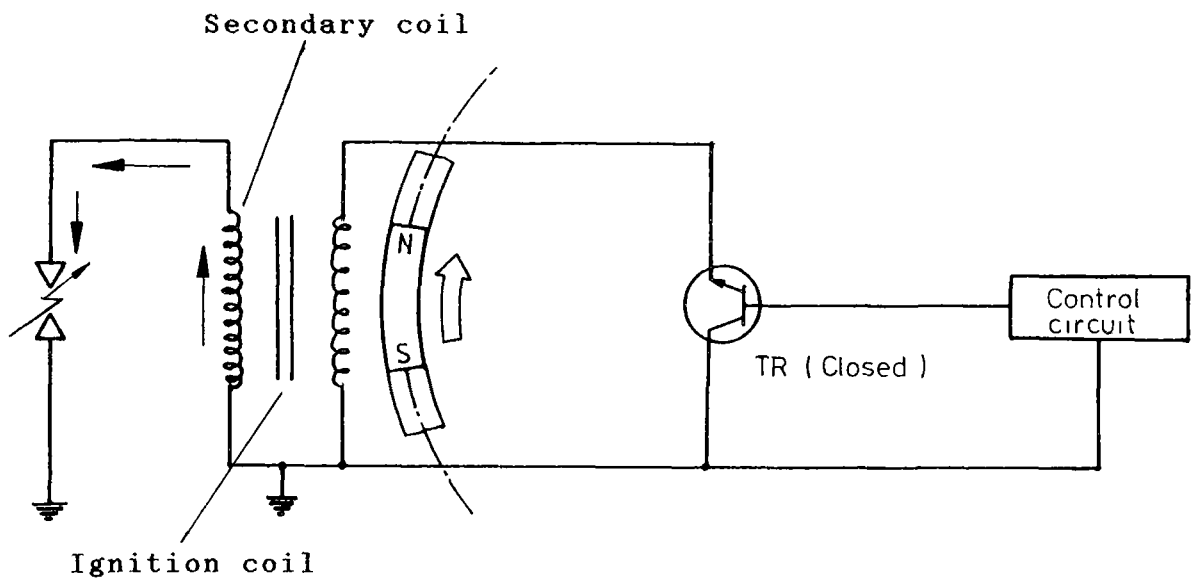

As the magnetic fly wheel turns until the ignition stroke, the induced voltage is increasing sufficiently for the control circuit to activate the Transistor to cut the flow of current to the primary coil. The magnetic field in the coil is, thus, collapsing and thereby inducing the high voltage current in the secondary coil, to flow to the spark plug.

2.4 Capacitive discharge ignition system (CDI)

2.4.1 Components of capacitive discharge ignition system and their function

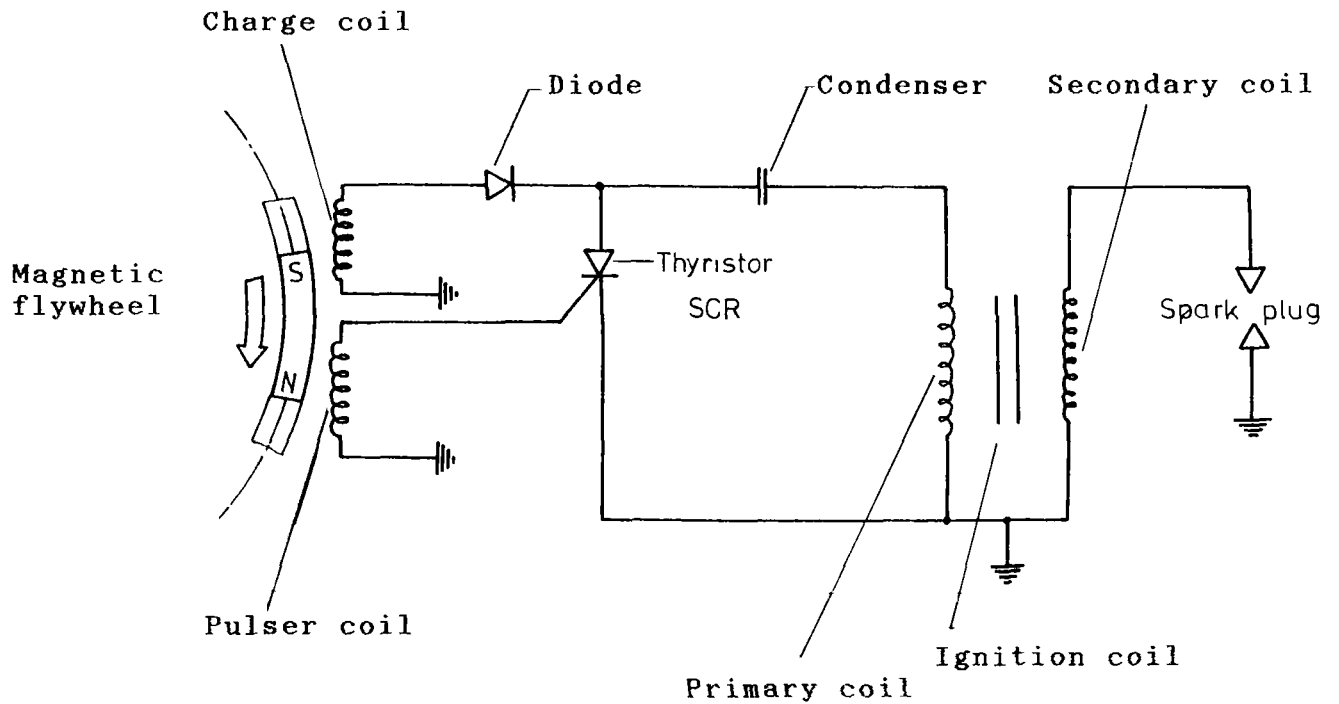

| Components | Functions |
|--|--|
| 1. Primary coil | - generates alternating current |
| 2. Diode | - converts alternating current to direct current |
| 3. Condenser | - charges and discharges current |
| 4. Thyristor or SCR SCR = Silicon Control Rectifier | - closes/opens the circuit, acts like the contact points of the contact point ignition system. The current can flow from A to K only when G is activated. |
| 5. Pulser coil | - generates a current to activate the SCR to open the circuit. |

2.4.2 Function of CDI ignition system

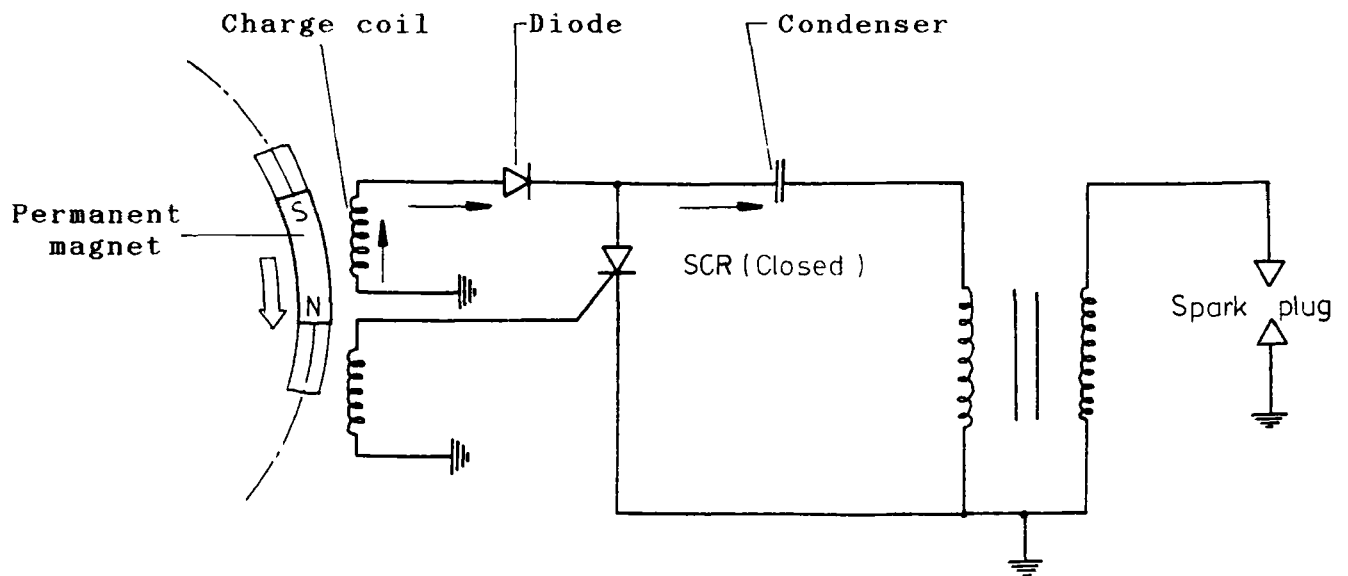

When starting the engine, the magnetic flywheel will rotate.

As the magnetic field of the permanent magnet cuts the charge coil, alternating current is induced and flows to the diode. The diode will rectify it into direct current and the condenser will store it.

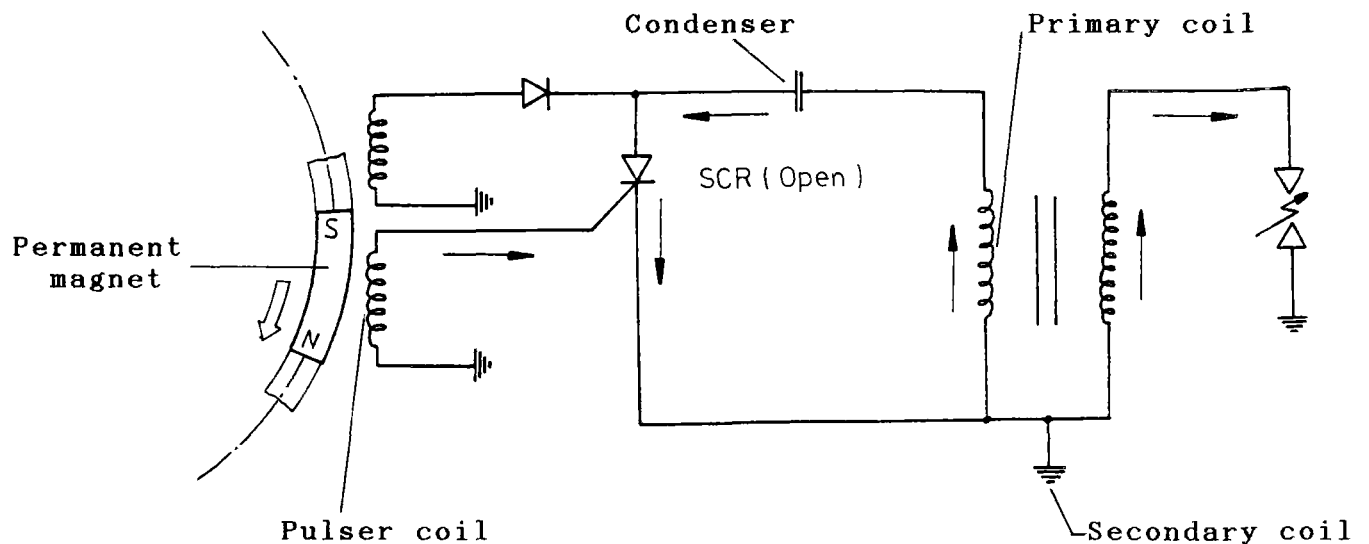

As the magnetic flywheel turns until the ignition stroke, its magnetic field cuts the pulser coil and current is generated.

The generated current will trig the SCR, causing the condenser to discharge its stored current to flow through SCR and through the primary coil to ground. This will induce the high current voltage in the secondary coil which flows to the spark plug causing arcing between the electrodes of the spark plug.

2.5 Advantages and disadvantages of CDI and transistor ignition systems

Advantages:

1. Reduced maintenance, no need of adjustment
2. Prolong life of a spark plug
3. No wearing of contact points
4. Easy starting, because higher ignition voltage
7. Constant high performance over the working life.

Disadvantages:

1. Expensive.
2. Electronic devices are not repairable.

2.3 and 2.4 Transistor and CDI ignition systems

Fill in the blanks and underline the correct answers.

1. Name various parts and complete the circuit diagramme of the transistor ignition system.

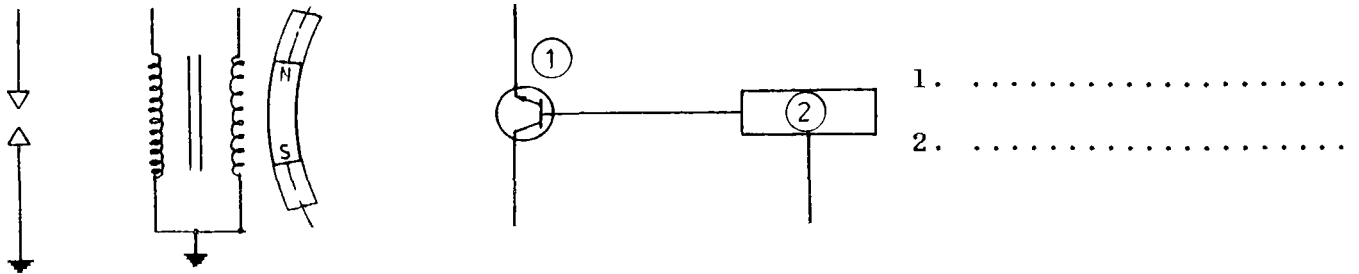

2. The Transistor is for
3. In a Transistor ignition system, the device which is equivalent to the cam is
4. The Control circuit will activate the Transistor to cut the current flow when the voltage is increasing/decreasing.
5. What happens, when the Transistor cuts the current flow to the primary coil?
6. Name the parts of the CDI system.

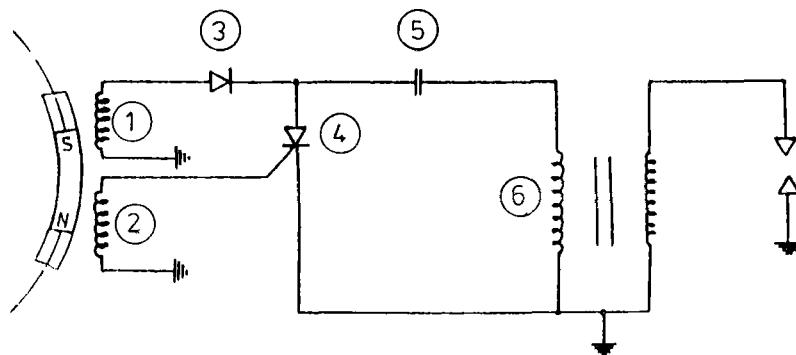

- | | |
|---------|---------|
| 1 | 4 |
| 2 | 5 |
| 3 | 6 |

2.3 and 2.4 Transistor and CDI ignition systems

Fill in the blanks and underline the correct answers.

1. Name various parts and complete the circuit diagramme of the transistor ignition system.

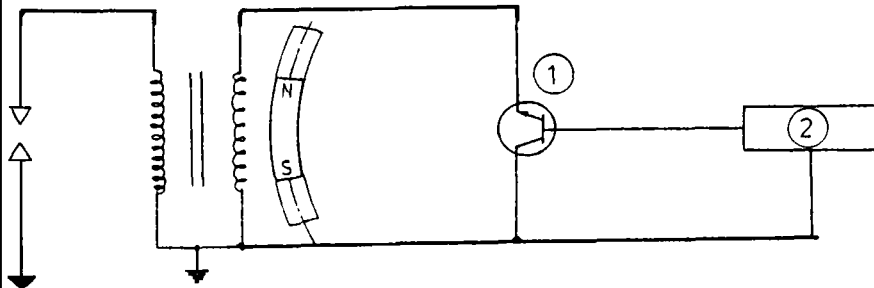

1. Transistor.....
2. Control unit.....

2. The Transistor is for opening / closing the current flow of primary coil
3. In a Transistor ignition system, the device which is equivalent to the cam is the Control unit.....
4. The Control circuit will activate the Transistor to cut the current flow when the voltage is increasing / decreasing.
5. What happens, when the Transistor cuts the current flow to the primary coil? The magnetic field is collapsing and generating high voltage in the secondary coil.....
6. Name the parts of the CDI system.

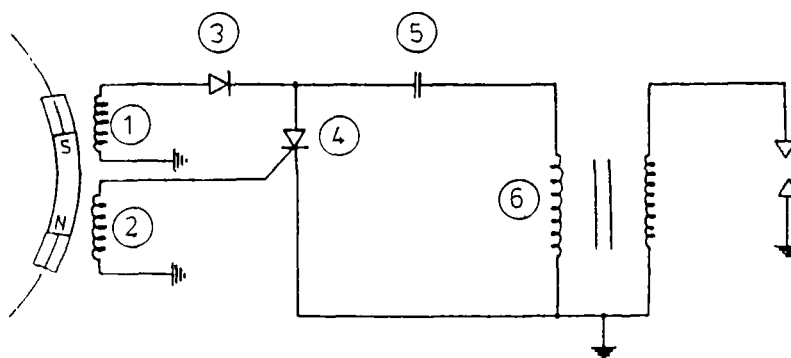

- 1 Charge coil..... 4 Thyristor (SRC)
2 Pulser coil..... 5 Condenser.....
3 Diode..... 6 Primary coil.....



- 7. The device in the CDI system, which performs the same function as the contact points is
- 8. The Pulser coil/Charge coil is producing the current that triggers the SCR to open the circuit.
- 9. From the circuit of item 6:
As the permanent magnet is moving past the coil 1,
-alternating/direct- current will be generated and flowing through the diode by which it is changed into -alternating/direct- current and storing in
- 10. When the SCR opens the circuit, the current as released by the condenser will flow through
- 11. High voltage current will flow to the spark plug when the magnetic wheel is cutting- the charge coil/the pulser coil.
- 12. Advantages of both the CDI and transistor ignition systems are:
1. 3.
2. 4.
- 13. Disadvantages of both the CDI and transistor ignition systems are:
1.
2.



- 7. The device in the CDI system, which performs the same function as the contact points is *the Transistor...*
- 8. The Pulser coil/~~Charge coil~~ is producing the current that triggers the SCR to open the circuit.
- 9. From the circuit of item 6:
As the permanent magnet is moving past the coil 1,
~~-alternating/direct-~~ current will be generated and flowing through the diode by which it is changed into ~~-alternating/direct-~~ current and storing in *the condenser.....*
- 10. When the SCR opens the circuit, the current as released by the condenser will flow through *the primary coil.....*
- 11. High voltage current will flow to the spark plug when the magnetic wheel is cutting- ~~the charge coil~~/the pulser coil.
- 12. Advantages of both the CDI and transistor ignition systems are:
 - 1. *Reduced maintenance...*
 - 2. *Longer live of spark plug*
 - 3. *No wearing of contact points*
 - 4. *Easy starting.....*
- 13. Disadvantages of both the CDI and transistor ignition systems are:
 - 1. *Expensive.....*
 - 2. *Electronic devices not repairable.....*

2.6 Maintenance and repair

2.6.1 Assemble and disassemble the ignition system

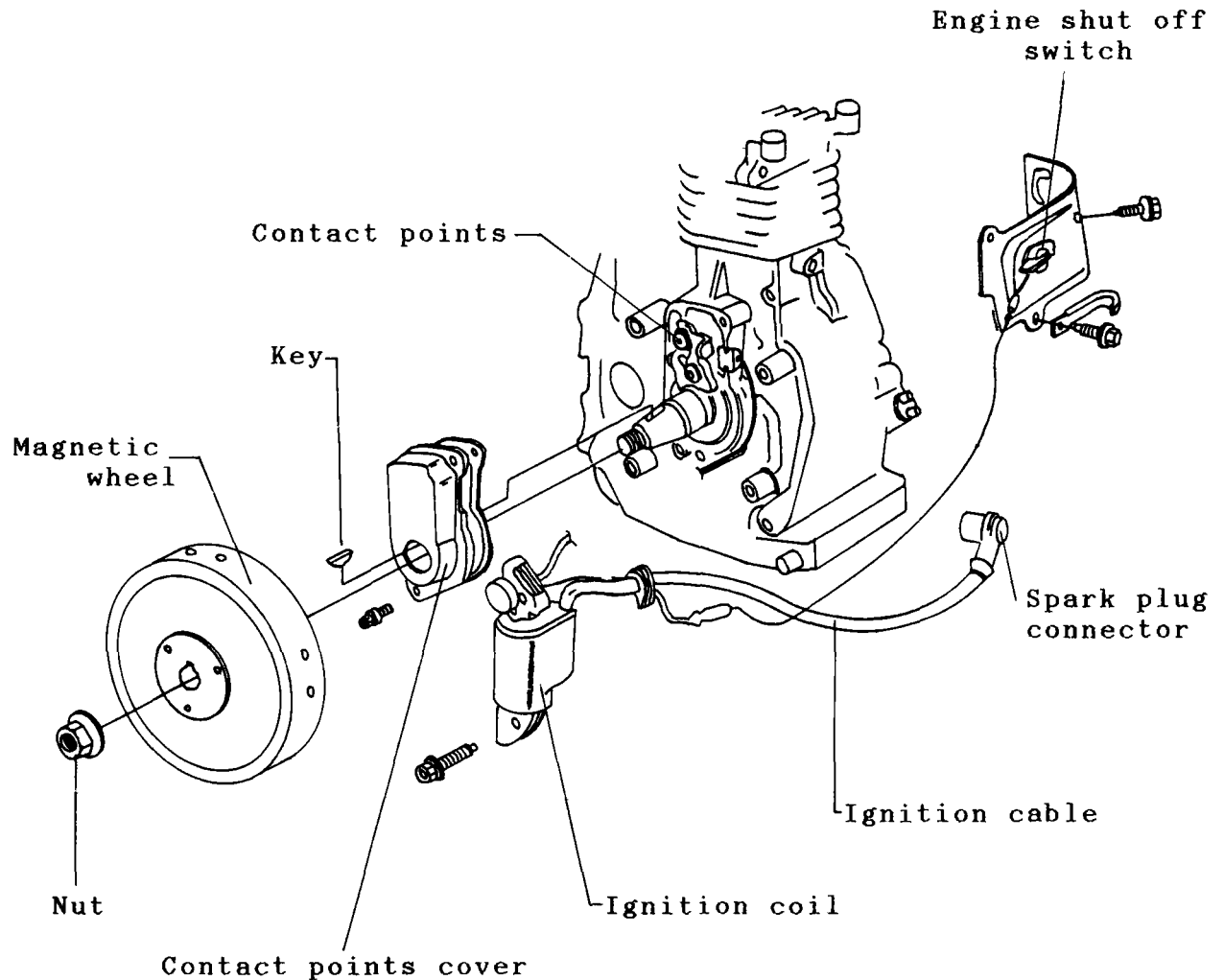

Removing: - Special tool should be used to remove the magnetic wheel.
 - Do not hammer the magnetic wheel, otherwise it will be damaged or spoiled.

Refitting: - Clean the magnetic wheel completely before refitting.

Remark: - The magnetic wheel nut must be tighten with a torque wrench at the correct torque according to the manufacture's manual.

- The specified torque = 6.0 - 7.0 kgm

2.6.2 Inspect, clean and adjust spark plugs

Inspecting conditions of a spark plug:

| Conditions of electrodes | Cause | Remedy |
|--------------------------|--|--|
| dry and light brown | - normal engine operation | |
| dry and black | - fuel mixture too rich - wrong heat range | - readjust the idle mixture screw - inspect choke and air filter - switch to hotter plug, e.g. from BP 7 ES to BP 6 ES |
| wet and black | - Oil leaking into the combustion chamber may be caused by worn piston rings or others | - inspect and repair piston rings, piston and cylinder |
| burned and eroded | - wrong heat range | - switch to colder plug, e.g. from BP 6 ES to BP 7 ES |
| white spot deposit | - additive deposits from leaded fuel | - switch to hotter plug |

Cleaning and adjusting a spark plug:

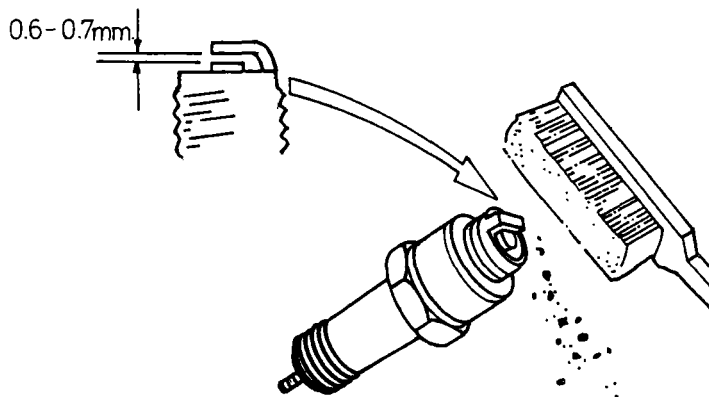

- clean the electrodes with a steel brush.
- adjust the spark plug gap according to manual

(Standard spark plug gap = 0.6 - 0.7 mm)

2.6.3 Inspect the ignition coil

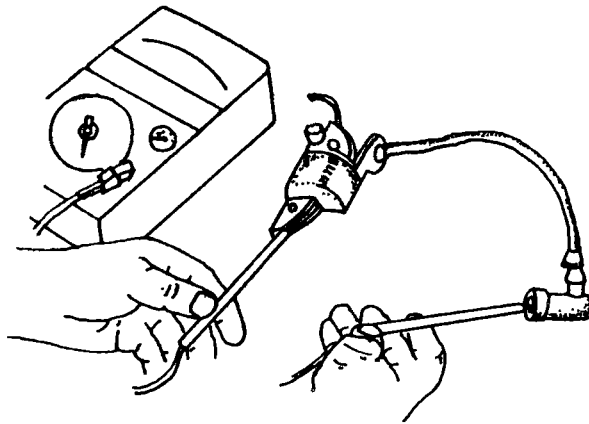

- disconnect the spark plug connector
- measure between the spark plug connector and the ignition coil base with an ohmmeter

standard resistance = 6.6 K Ω

| Condition of ignition coil | Causes |
|--|-------------------------|
| Resistance of the primary coil is too low | - short circuit in coil |
| Resistance of the primary coil is too high | - dirty coil |
| Resistance of the secondary coil is too low | - short circuit in coil |
| Resistance of the secondary coil is too high | - dirty terminal |

2.6.4 Inspect CDI and transistor ignition system

Primary coil:

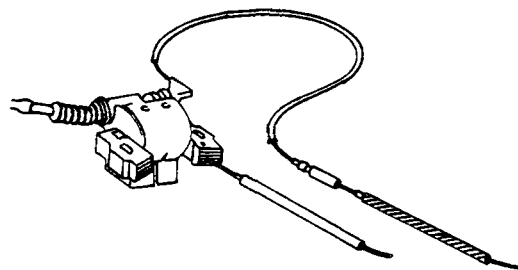

Use ohmmeter to check between the black cable (engine stop) and the core.

Standard resistance of primary coil:

| | | |
|---|--|---|
| I | | I |
| I | for HONDA Model GX 110, 120, 140, 160 = 1.2 - 0.2 Ω | I |
| I | | I |
| I | For HONDA Model GX 240, 340 = 0.7 - 0.9 Ω | I |
| I | | I |

Secondary coil:

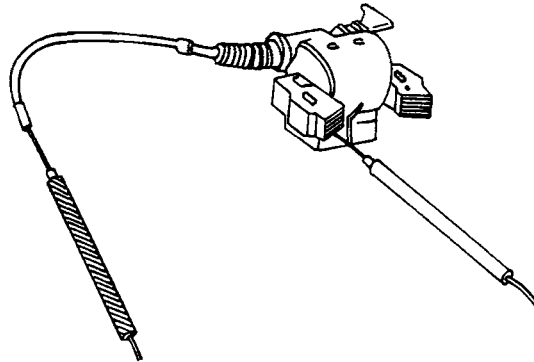

- Remove the spark plug lead
- Use ohmmeter to check between the spark plug lead and the core.

Standard resistance of secondary coil:

| | | | | | |
|---|-----------------------------|-------|-------|----|---|
| I | | | | | I |
| I | for HONDA Model GX 110, 140 | = 12 | - 2 | kΩ | I |
| I | | | | | I |
| I | for HONDA Model GX 120, 160 | = 6.5 | - 8 | kΩ | I |
| I | | | | | I |
| I | for HONDA Model GX 240, 340 | = 6.3 | - 7.7 | kΩ | I |
| I | | | | | I |

2.6.5 Inspect condenser

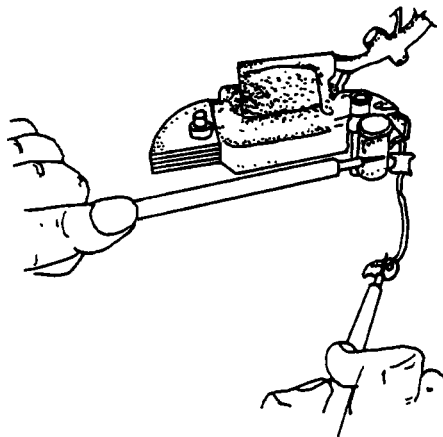

- measure the resistance of the condenser between positive and negative terminals
- if the indicator rises a little and falls back, the condenser is alright
- if the indicator does not rise or fall, it is damaged

Standard capacitive = 0.24 μF

Remark: If the contact points wear abnormally, then the condenser must be replaced.

| Conditions of condenser | Faults |
|-------------------------|-----------------------------|
| Too large capacitive | - Contact points are eroded |
| Too small capacitiv | - Contact points are eroded |

2.6.6 Inspect and adjust contact points

Conditions of contact points:

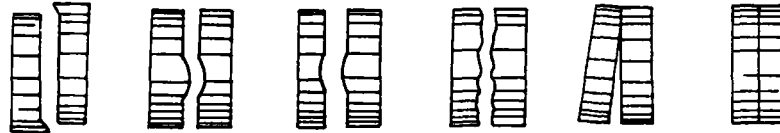

- Light gray contact points are normal.
- If burned, eroded or pitted, contact points must be replaced.
- If colour is normal and worn a little, then file them smooth.

Adjusting the contact points:

- Insufficient gap will cause contact points arcing and burning.
- Excessive gap will reduce the dwell angle of the contact points and thereby ceasing the ignition at high-speed.

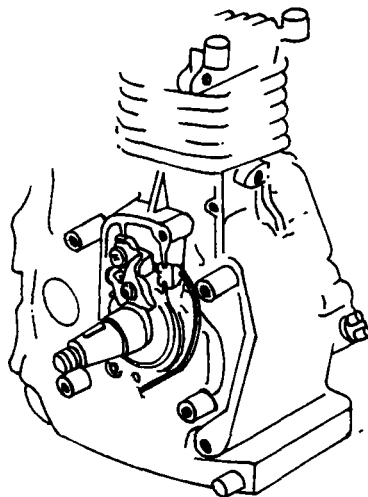

Operating steps:

- Turn the crank shaft until the cam opens the contact points fully.
- Measure the gap by using feeler gauge.
- Readjust the gap if it is not correct according to the manual.

(Standard contact point gap = 0.4 - 0.5 mm)

2.6.7 Adjust the ignition timing

| Ignition timing | Faults |
|----------------------|--|
| 1. Advanced ignition | <ul style="list-style-type: none"> - Engine is knocking - Engine runs back |
| 2. Retarded ignition | <ul style="list-style-type: none"> - Difficult to start - Engine lacks power - Engine is overheated |

Adjusting the ignition timing:

a) by using timing tester

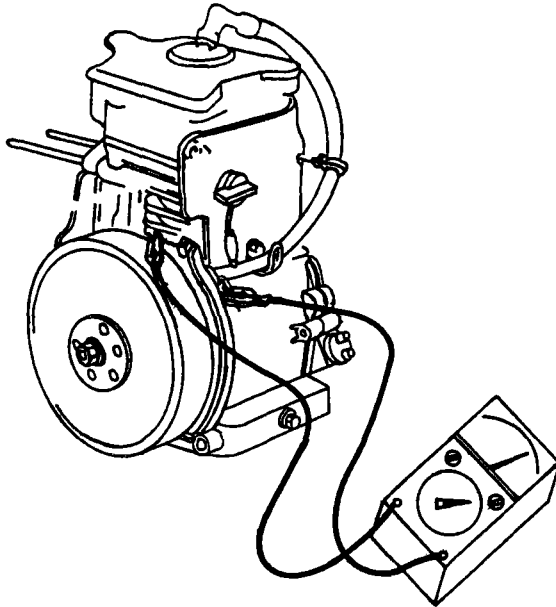

- Connect one lead of the timing tester to ground.
- Connect another lead of the timing tester to contact point terminal (ignition terminal of switch key)
- When the timing tester is switched on, sound should be heard if the contact points open, or vice versa.
- The position at which the contact points open, must be inlined with F, otherwise readjusting the ignition timing is needed.

b) by using special tool to identify the "F" mark

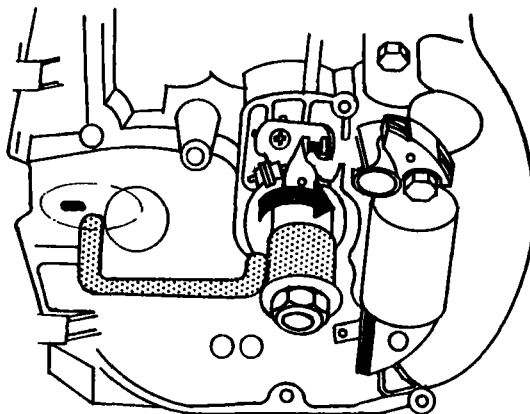

- Remove the magnetic wheel and the cover of contact points.
- Install the special tools to the crank shaft and tighten the nut.
- Turn the engine clockwise.
- At the position where the contact points open, the mark on the special tool must be inlined with the F mark.
- If it is out of inlined, then loosen the screw of the contact point base, and readjust it according to the mark.

c) Without using a special tool

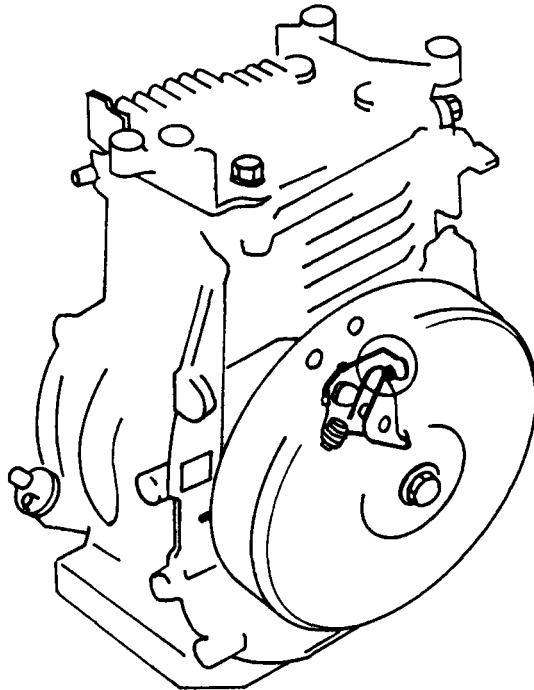

- Remove the magnetic wheel and the contact point cover, then reassemble the magnetic wheel temporarily to its position.
- Now the opening - closing of the contact points can be seen.
- Turn the magnetic wheel clockwise, at the point where the contact points are opening, the F mark on the magnetic wheel must be inlined with the mark of the engine.

2.6.8 Adjust gap between ignition coil and magnetic wheel

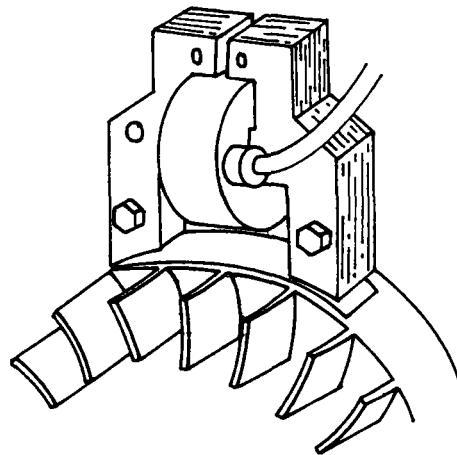

- Turn the engine until the permanent magnet is underneath the ignition coil
- Measure the gap by feeler gauge.

Standard gap = 0.4 - 0.2 mm.

If it is outside the standard value, then loosen the screw of the ignition coil and readjust the ignition coil up or down until the required gap is obtained.

2.6.9 Trouble shooting

| Fault | Possible causes | Remedy |
|--|---|--|
| Engine cranks normally, but will not start | <ol style="list-style-type: none"> 1. Low voltage circuit is broken. 2. Contact points sticking. 3. Burned contact points. 4. Incorrect ignition timing. 5. Damaged condenser. 6. Damaged ignition coil 7. 8. Fouled spark plug | <ul style="list-style-type: none"> - Inspect connections of ignition coil and contact points. - Readjust. - Clean or replace. - Inspect and readjust the ignition timing. - Replace the condenser. - Replace the ignition coil. - Inspect ignition coil and spark plug cable. - Clean and readjust or replace. |
| Engine lacks power | <ol style="list-style-type: none"> 1. Incorrect ignition timing | <ul style="list-style-type: none"> - Inspect and readjust the ignition timing. |
| Engine is overheated | <ol style="list-style-type: none"> 1. Retarded ignition timing | <ul style="list-style-type: none"> - Readjust the ignition timing. |
| Engine is back fired | <ol style="list-style-type: none"> 1. Incorrect ignition timing 2. Wrong heat range of spark plug | <ul style="list-style-type: none"> - Readjust the ignition timing. - Use correct heat range. |
| Engine is knocking or pinging | <ol style="list-style-type: none"> 1. Incorrect ignition timing 2. Incorrect contact point gap | <ul style="list-style-type: none"> - Readjust the ignition timing. - Readjust the contact points gap. |



Tools: A set of wrenches, special tool for removing magnetic fly-wheel, Torque wrench, Filler gauge, Ohmmeter, Smooth file, Timing tester, a special tool for setting the position F, Air gun with hose

Equipement: Steel brush, Brass brush, Cleaning pan, Cloth

Manufacturer: Model

Type of ignition system :

Standard torque for magnetic flywheel : Nm

Standard resistance of ignition coil :

Standard inspection for C.D.I and transistor module :

- Primary coil :

- Secondary coil :

Standard capacitive of condenser : μF

Standard gap between ignition coil and magnetic flywheel mm

Standard gap between contact points mm

| Sequence of operations | I | Inspection |
|---|---|---|
| 1. Prepare tools and equipment | I | Condition of spark plug. |
| 2. Remove spark plug. | I | <input type="checkbox"/> Normal <input type="checkbox"/> Damaged |
| 3. Clean spark plug. | I | <input type="checkbox"/> Use steel brush |
| 4. Check and adjust electrode. | I | Obtained electrode gap |
| 5. Remove starting unit. | I | <input type="checkbox"/> Normal |
| 6. Remove blower cover and other obstruction. | I | <input type="checkbox"/> To be readjusted |
| 7. Remove magnetic flywheel. | I | Use of tools. |
| | I | <input type="checkbox"/> Use special tools |
| | I | <input type="checkbox"/> Others |
| 8. Remove all parts of ignition system. | I | Conditions of general parts. |
| | I | <input type="checkbox"/> Perfect <input type="checkbox"/> Imperfect |



| Sequence of operations | I | Inspection |
|---|---|--|
| 9. Check ignition coil. | I | Obtained reading <input type="checkbox"/> Normal <input type="checkbox"/> Damaged |
| 10. Check CDI and transistor module. | I | Obtained reading <input type="checkbox"/> Primary coil <input type="checkbox"/> Secondary coil <input type="checkbox"/> Normal <input type="checkbox"/> Damaged |
| 11. Check condenser | I | Condition of condenser <input type="checkbox"/> Normal <input type="checkbox"/> Damaged |
| 12. Check contact points | I | Condition of contact points <input type="checkbox"/> Normal <input type="checkbox"/> Damaged |
| 13. Reassemble those parts in their reverse order. | I | Reassemble <input type="checkbox"/> Complete <input type="checkbox"/> Incomplete |
| 14. Adjust clearance between ignition coil and magnetic flywheel. | I | Standard clearance mm. |
| 15. Adjust gap of contact point. | I | Standard gap of contact points mm. |
| 16. Adjust ignition timing. | I | Ignition timing adjustment <input type="checkbox"/> Use timing tester <input type="checkbox"/> Others |
| 17. Reassemble all parts. | I | Reassemble of all parts. <input type="checkbox"/> Complete <input type="checkbox"/> Incomplete |
| 18. Clean and store tools-equipment. | I | <input type="checkbox"/> Complete <input type="checkbox"/> Incomplete |

Note :

.....

.....

.....

3. Speed control system

3.1 Task of governor

- to maintain constant engine speeds during running under varying loads.

3.2 Types and function of governor

Governors can be classified into 2 types:

3.2.1 Pneumatic governor

Constant engine speed is controlled by means of air flowing from the blower upon the blade of governor, which is connected to throttle plate mechanism.

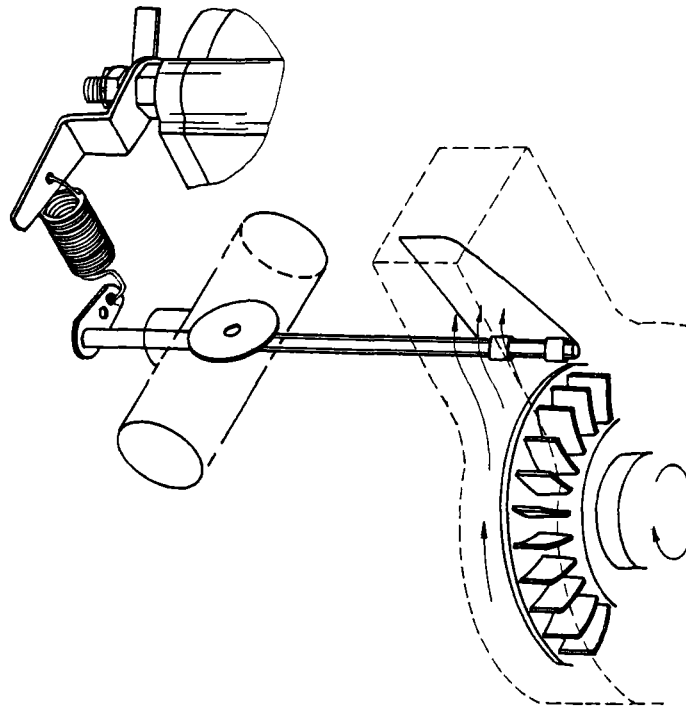

- As the engine speed increases, the flow of air is also increasing accordingly, and thereby turning the governor blade to turn the throttle plate in the direction to which the engine speed decreases until the throttle plate spring balances the force on the governor blade.
- When the engine is subjected to increasing load its speed will be decreasing. Thus, the air-force on the governor blade is also decreasing relatively, and surrendering to the force of throttle plate spring. Therefore, the engine speed will be maintained constant at every changing load.

3.2.2 Mechanical governor

This type of governor is operated by means of centrifugal force of the fly weights.

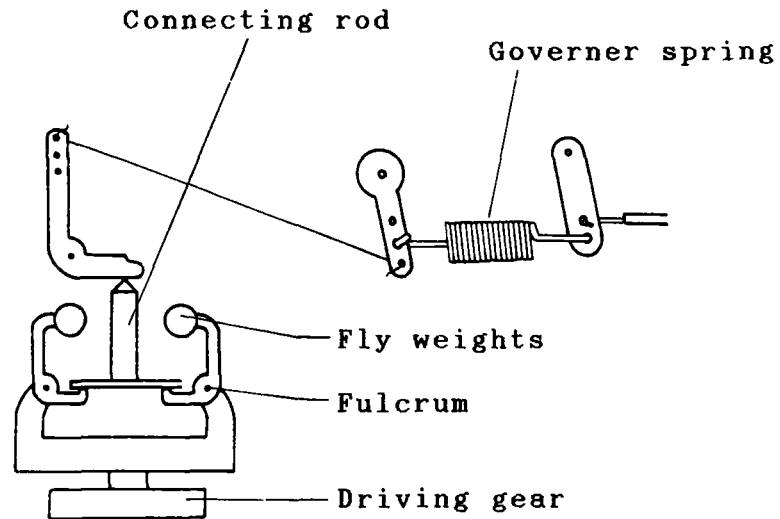

- As the engine speed decreases, the centrifugal forces of the flyweights are also decreasing, and thereby opens the linkage of the throttle plate further. Thus, the engine speed increases to match a particular load.

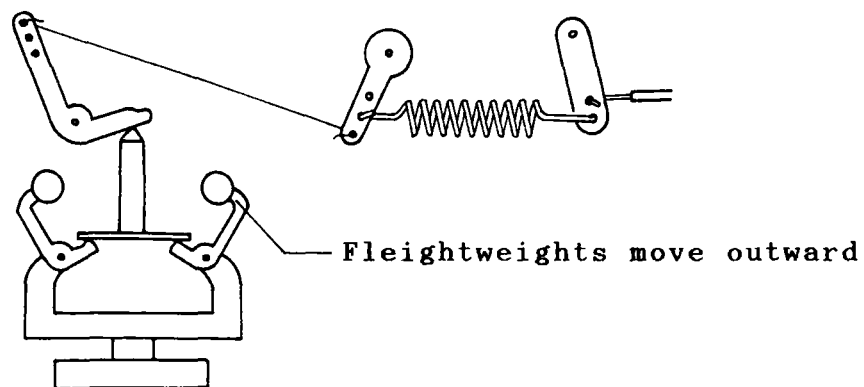

- As the engine speed increases, the fly weights move away further and thereby reducing the opening of the throttle plate. Thus, the engine speed is coming down. Therefore, the engine speed will be maintained constantly at every changing load.



Fill in the blanks and underline the correct answer.

1. Governor is for
2. Governor is classified into types, i.e.
.....
3. At the engine stops, the position of the throttle plate will be -fully opened/ fully closed-.
4. The tensioning force of spring will tend to -increase/decrease- the engine speed.
5. Governor that has fly weights is of the type.
6. As the engine speed is on the increase, the flyweights will be -retracted/expanded-.
7. When the centrifugal forces of the flyweights are reducing, the throttle plate will be progressively -opened/closed-.

Fill in the blanks and underline the correct answer.

1. Governor is for maintaining constant engine speed.....
2. Governor is classified into 2 types, i.e. Pneumatic
governor & Mechanical governor.....
3. At the engine stops, the position of the throttle plate will be ~~fully opened~~/ fully closed-.
4. The tensioning force of spring will tend to increase/~~decrease~~ the engine speed.
5. Governor that has fly weights is of the mechanical type.
6. As the engine speed is on the increase, the flyweights will be ~~retracted~~/expanded-.
7. When the centrifugal forces of the flyweights are reducing, the throttle plate will be progressively opened/~~closed~~-.

3.3 Repair and maintenance

3.3.1 Adjusting the pneumatic governor

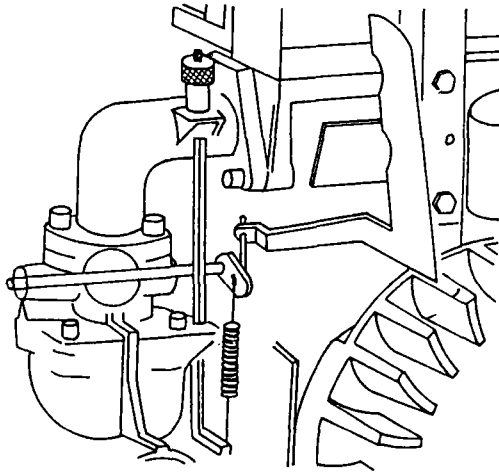

Sequence of operations:

1. Screw on the governor spring fully.
2. Start the engine.
3. Unscrew the governor spring gradually until the required engine speed is obtained.

Remark: - The further the screw is tightened the lower the engine speed.
 - The further the screw is loosened the higher the engine speed.

3.3.2 Adjusting the mechanical governor

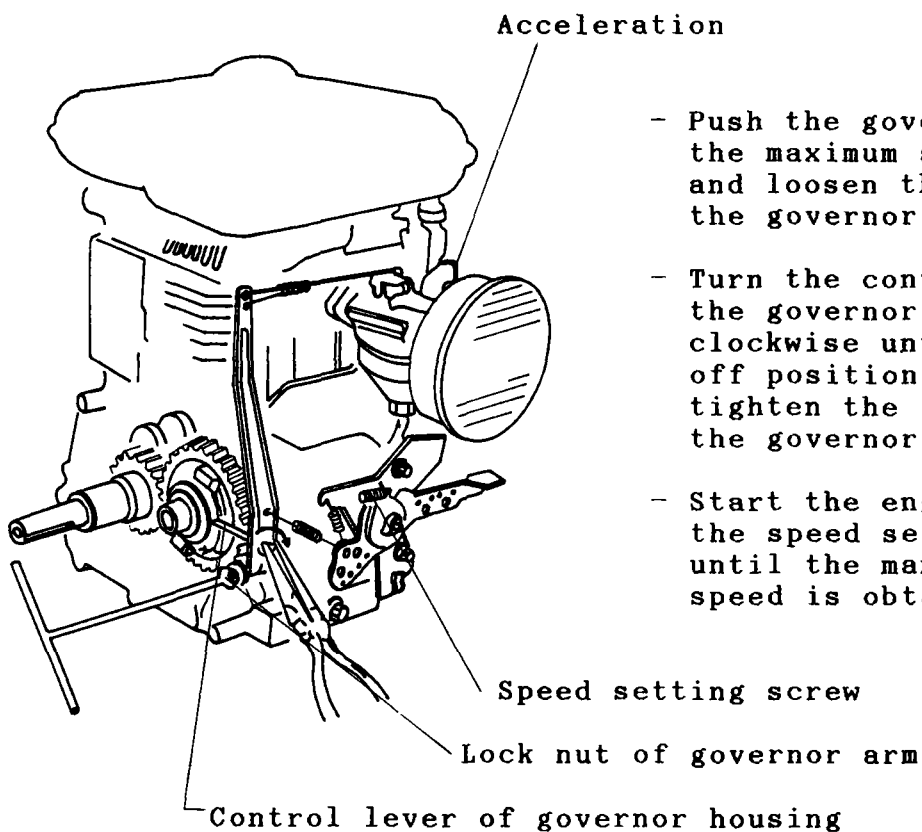

- Push the governor arm to the maximum speed position and loosen the lock nut of the governor arm.
- Turn the control lever of the governor housing clockwise until stop (shut off position), then tighten the lock nut of the governor arm.
- Start the engine; adjust the speed setting screw until the maximum engine speed is obtained.

 I Standard maximum speed 4000 rev/min. I
 I-----

Tools: a set of wrenches, air gun with hose
 Equipment: Benzene, oil can, cleaning tray, cloth

a) Pneumatic governor

Manufacturer Model

| Sequence of operations | Inspection |
|---|--|
| 1. Remove the blower cover. | - Condition of blower cover |
| 2. Remove the governor unit. Caution : Be aware of mixing up positions of governor mechanism | - Condition of governor spring Normal Weakened Others |
| 3. Reassemble in reverse order. | |

b) Mechanical governor

Manufacturer Model

| Sequence of operations | Inspection |
|--|---|
| 1. Remove carburettor and governor arm. Caution beware of benzene | - Tension of the throttle plate spring. Normal Weakened |
| 2. Remove governor unit from the carburettor. | - Straightness of the governor arm Normal Bent |
| 3. Reassemble in reverse order | |

Remember: The short end of the throttle plate spring is on the carburettor side.

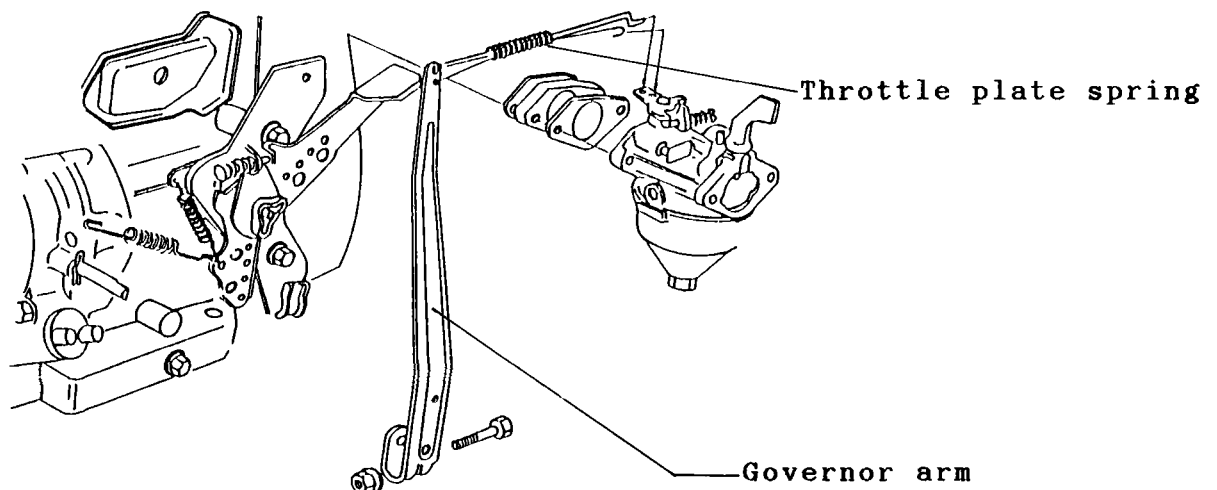

4. Valve mechanism

4.1 Task of valve mechanism

to open/close intake air-fuel mixture and exhaust gas in and out the cylinder, according to various strokes of engine.

4.2 Types and function

Valve mechanism is classified into 2 types:

4.2.1 Overhead valve

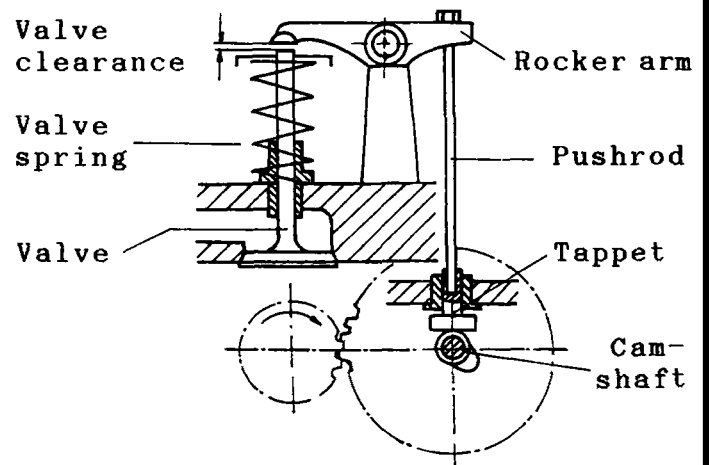
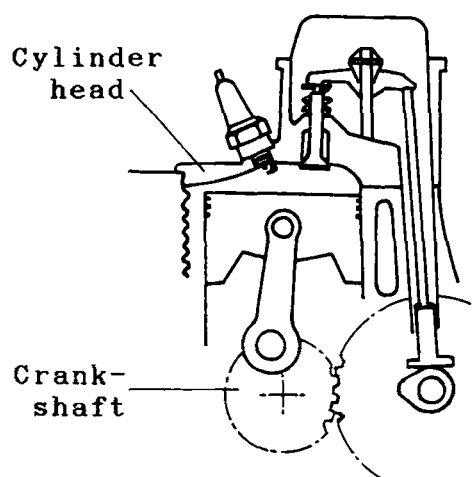

 Crankshaft speed : Camshaft speed = 2 : 1

As the camshaft is driven by the crankshaft gear, the tappet is left and thereby the push rod pushes the rocker arm. The valve is, thus, opened as the pushing force of the rocker arm prevails that of the spring. When the cam turns beyond its lift the valve is closed under the force of valve spring.

Opening/Closing of valves is timed according to various strokes of the engine.

| Advantages | I | Disadvantages |
|--------------------------------|---|--|
| 1. Low intake flow resistance. | I | - Complicated cylinder head. |
| 2. Improved engine power. | I | - Engine is tall. |
| 3. Valve servicing is easy. | I | - High number of parts of valve mechanism. |

4.2.2 Side Valve

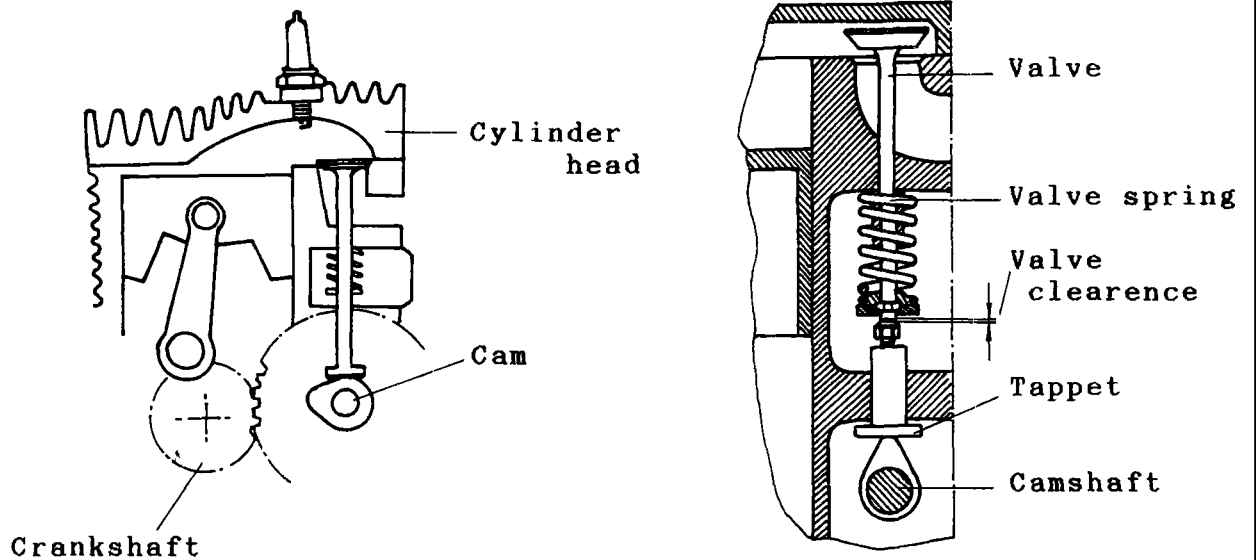

- As the camshaft is driven by the crankshaft gear, the valve is pushed to open by the cam via the tappet.

| Advantages | I | Disadvantages |
|--|---|--|
| | I | |
| | I | |
| | I | |
| 1. Valve arrangement is easy. | I | - High intake and exhaust flow resistance. |
| | I | |
| 2. Small number of parts of valve mechanism. | I | - Combustion chamber is not compact. |
| | I | |
| | I | - Inefficient engine power. |
| | I | |

Complete the statements.

1. Valve arrangement for 4 stroke small engines can be accomplished in ways, that is

2. Name various parts of the valve mechanism.

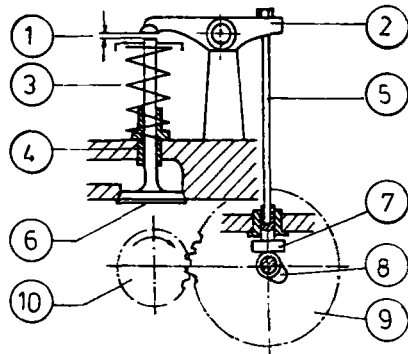

- 1
- 2
- 3
- 4
- 5
- 6.....
- 7
- 8
- 9
- 10

3. Crankshaft speed : camshaft speed = :

4. As the engine makes 1 complete turn, the intake valve will open and close for time whereas the exhaust valve does the same for time.

5. Both intake and exhaust valves can be opened or closed by means of

6. The advantages of the overhead valve engine are :

- 1.
- 2.
- 3.

7. The advantages of the side valve engine are :

- 1.
- 2.

Complete the statements.

1. Valve arrangement for 4 stroke small engines can be accomplished in 2 ways, that is Side valve and Overhead valve
2. Name various parts of the valve mechanism.

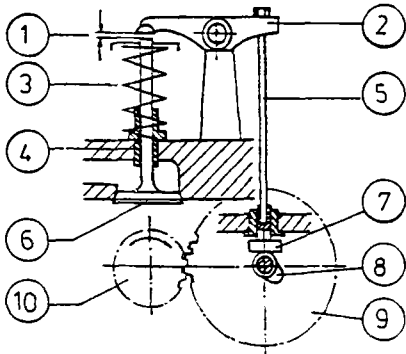

- | | | | |
|---|-----------------|----|--------------------------|
| 1 | Valve clearance | 6 | Valve |
| 2 | Rocker arm | 7 | Tappet |
| 3 | Valve spring | 8 | Cam |
| 4 | Valve guidance | 9 | Timing gear (cam) |
| 5 | Pushrod | 10 | Timing gear (crankshaft) |

3. Crankshaft speed : camshaft speed = 2 : 1
4. As the engine makes 1 complete turn, the intake valve will open and close for 1 time whereas the exhaust valve does the same for 1 time.
5. Both intake and exhaust valves can be opened or closed by means of cam, Tappet, Pushrod and Rocker arm.
6. The advantages of the overhead valve engine are :
 1. Low intake flow resistance
 2. Improved engine power
 3. Valve service is easy
7. The advantages of the side valve engine are :
 1. Valve arrangement is easy
 2. Small number of parts

4.3 Compression reduction mechanism

4.3.1 Purpose of compression reduction mechanism

To reduce compression in the cylinder during engine starting, thus, the power to start the engine is at minimum..

4.3.2 Components and function

This mechanism will open the exhaust valve during the starting string is pulled out.

a) When starting the engine

Counter weight plate

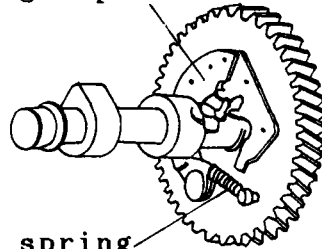

Retracting spring

When the engine is at rest, the counter weight plate is kept in its original position by means of the retracting spring.

Valve tappet

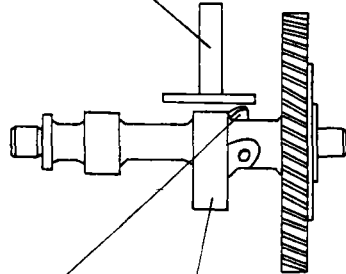

Compression reduction cam

Cam

The compression reduction cam is on its peak which is above the heel of the cam.

When the starting string is pulled out, the compression reduction cam will slightly raise the valve tappet to reduce compression. This arrangement will ease the start of the engine due to the engine can run fast.

b) During engine running

Valve tappet

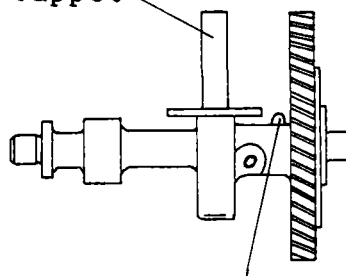

Compression reduction cam

When the engine is running at the speed of 800 rev/min, the counterweight plate is forced outward by the centrifugal force.

The compression reduction cam is thereby pulled down and away from the valve tappet.

4.3 Compression reduction mechanism

Complete the statements or underline the correct answers.

1. The purpose of compression-reduction is
2. Compression -reduction can be accomplished by -opening/closing- the valve.
3. Name various parts of the compression-reduction mechanism.

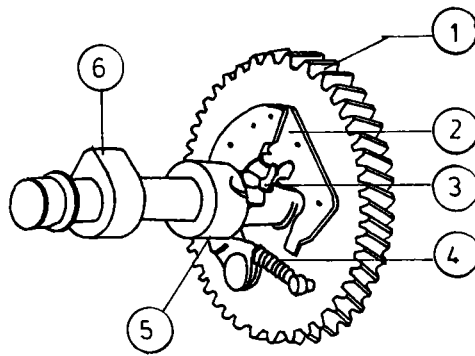

1.
2.
3.
4.
5.
6.

4. When the starting string is pulled, the will lift the tappet and the is opened to allow the exhaust gas to escape.
5. As the engine is running, the centrifugal force of the counterweights will be -increasing/decreasing- and causing them to -expand/retract.

4.3 Compression reduction mechanism

Complete the statements or underline the correct answers.

1. The purpose of compression-reduction is to reduce compression in the cylinder during engine start.
2. Compression -reduction can be accomplished by -opening/closing- the exhaust valve.
3. Name various parts of the compression-reduction mechanism.

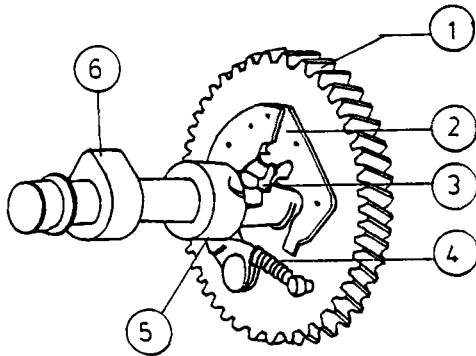

1. Timing gear
2. Counter weight plate
3. Compression reduction cam
4. Retracting spring
5. Cam for exhaust valve
6. Cam for intake valve

4. When the starting string is pulled, the compression redc. will lift the tappet and the exhaust valve is opened to allow the exhaust gas to escape.
5. As the engine is running, the centrifugal force of the counter-weights will be -increasing/decreasing- and causing them to -expand/retract.

4.4 Repair and maintenance

4.4.1 Removal and refitting of valve mechanism

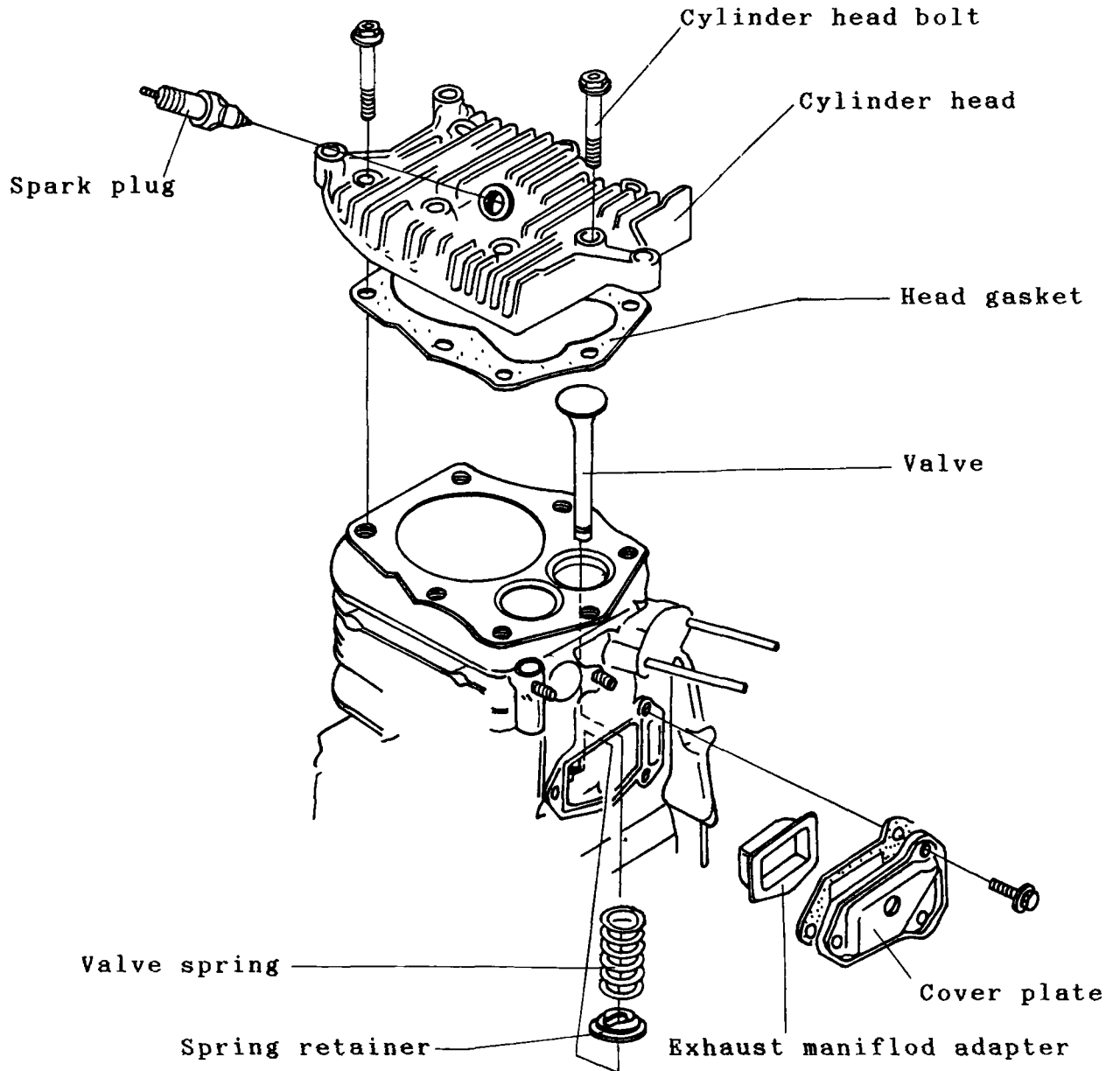

Remark : For valve mechanism removal, cylinder head and valves must be removed accordingly to the specified numbers and reassembled in their reverse order.

4.4.2 Removal/Reassemble of the cylinder head

a) Removing cylinder head

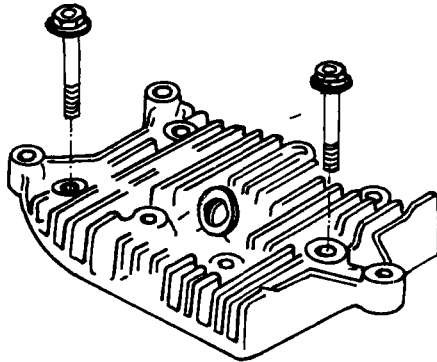

- Loosen all bolts in reverse order
- During loosening, gradual torque settings must be distributed over each bolt.

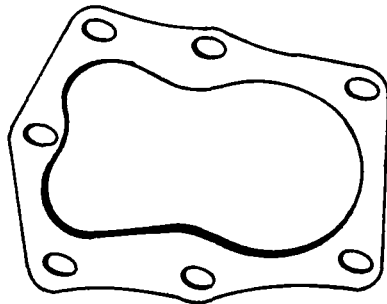

- Mating surface of the gasket, between the cylinder head and the cylinder block, must be cleaned and of no traces.

b) Cleaning cylinder head

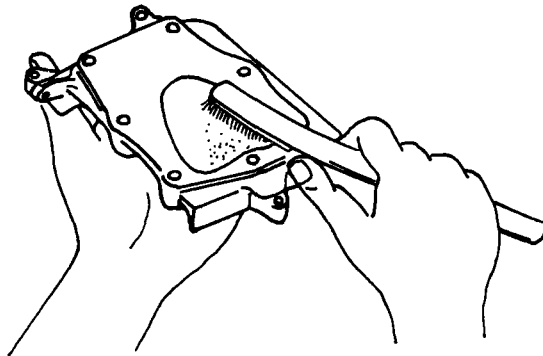

- Decarbonize the combustion chamber and clean with benzene and dry with air gun.

Remark:

In removing carbon deposits, a broken piece of saw blade which is ground unsharp may be used.

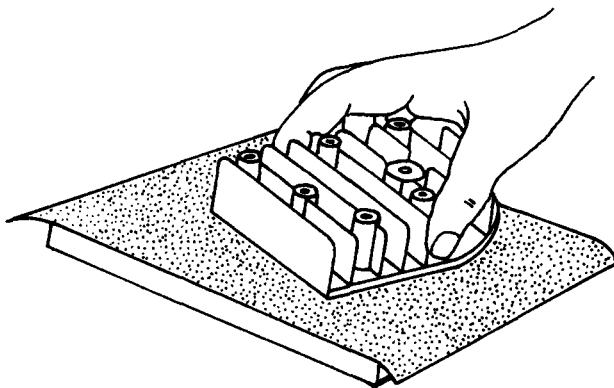

- In case, the cylinder head is distorted or bent, then grind its mating surface with fine grain sand paper (No. 400), which places on a smooth, flat surface level.

- Remarks:
- Contaminated dirt on fins of the cylinder head causes poor heat dissipation.
 - After scraping and cleaning the fins, the cylinder head must be cleaned with benzene and dried with air gun.

c) Refitting the cylinder head

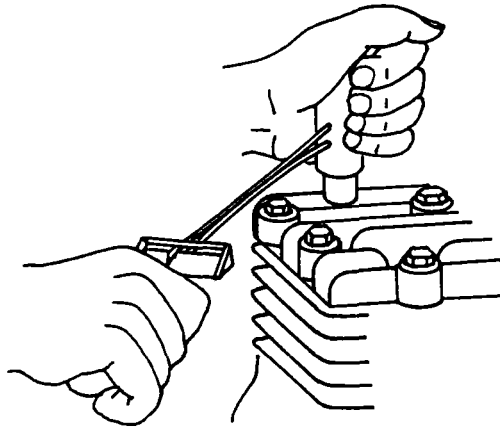

- Tighten the cylinder head bolts in their reverse sequence by using the torque wrench.
- The required tightening torque must be distributed gradually over successive settings.

Remark: Required tightening torque 24 - 26 Nm

4.4.3 Removal/Reassemble of the valves

Pliers for valve removal

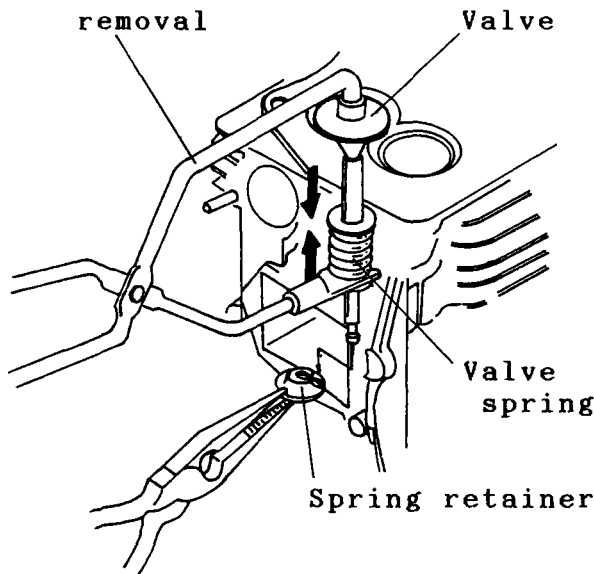

Removal:

Press the valve spring with pliers and remove the spring retainer, then release the pliers and remove valve and valve spring.

Reassemble:

Insert valve and valve spring, press the spring with pliers and insert the valve retainer.

Caution: Check, if the spring retainer is in the right position!

4.4.4 Valve spring

a) Measuring length of valve spring

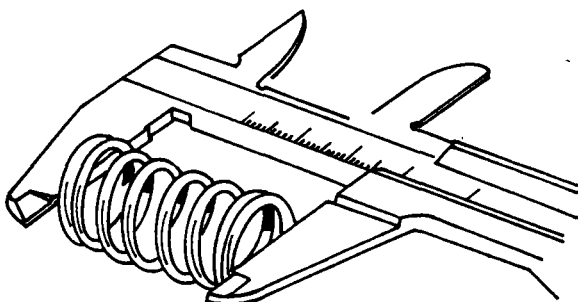

- If the length of spring is shorter than the specification then the spring is weakened.

Standard length 36.7 mm

Minimum length 35.2 mm

a) Checking squareness

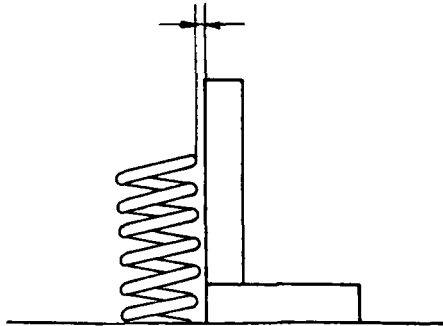

- Turn the spring around itself against the square and observe any deviation.

Remark: Deviation should not exceed 2 mm

c) Checking strength of spring

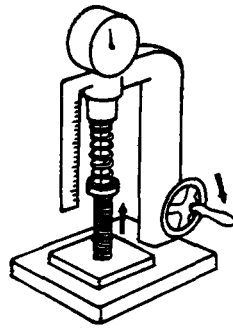

- Set the height of the tester to the specification and read the obtained value on the dial

4.4.5 Valve

a) Measuring diameter of valve stem

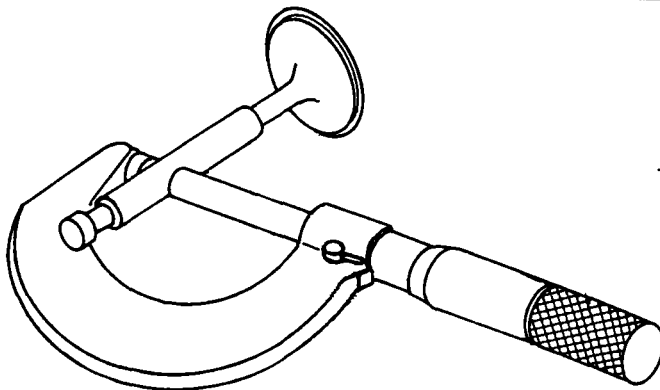

- Compare the obtained reading with that of the manual.

b) Checking straightness of the valve stem

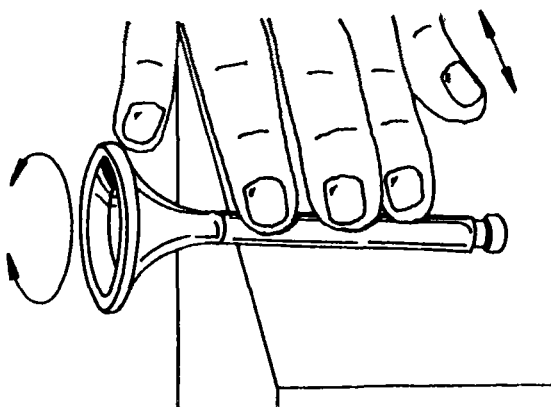

- Roll the valve stem over the surface level, notice for any bending. Replace if it is bent.

c) Checking valve face, margin, and valve stem

Valve margin ...

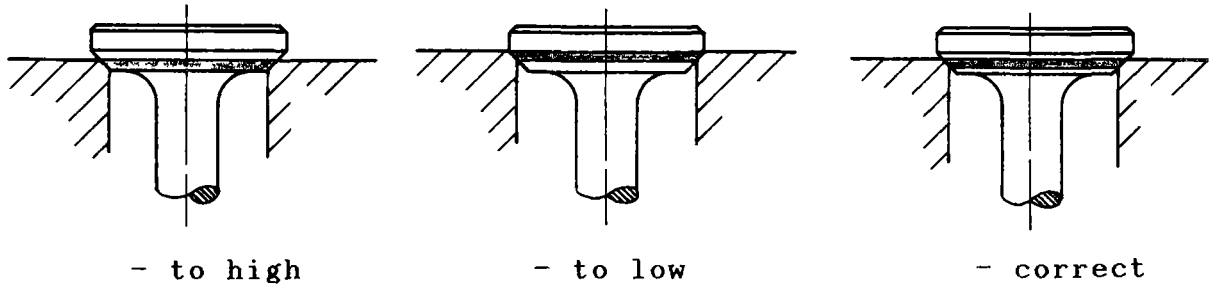

If valve foot is not smooth, then grind it with oil stone.

4.4.6 Valve seat

a) Measuring width of valve seat

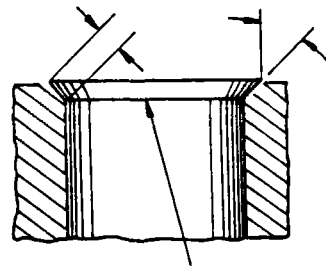

Valve seat

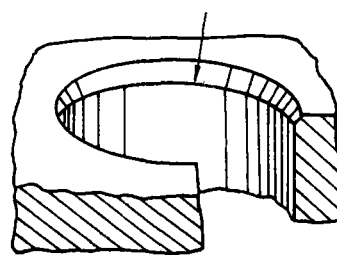

- Measure width of valve seat with vernier caliper.
- Recut the valve seat with the valve seat cutter, if its width is less than that of the specification.

a) Valve cutting

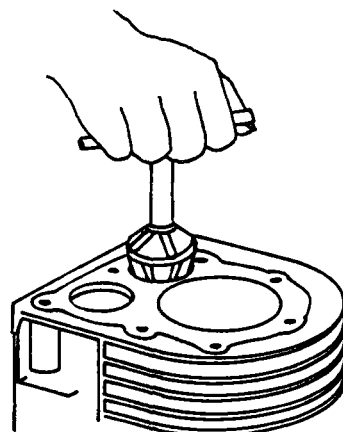

- cut the valve seat with 90 valve seat cutter.
- Recut the valve seat with the smooth cutter.
- Final cut with the 90 valve seat cutter.

b) Valve grinding

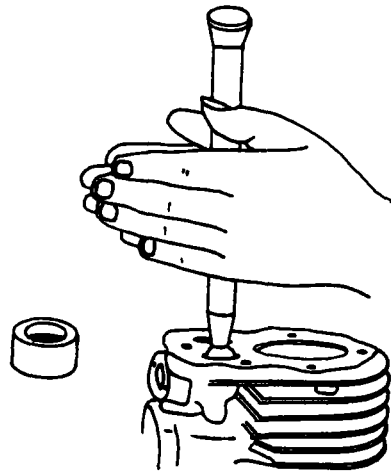

- Smear the valve seat lightly with carborundum paste.
- Hold the valve by the rubber of the grinding tool. Turn the grinding tool to rub the valve face against valve seat.
- Clean the ground valve seat and valve face.

4.4.7 Valve guide

a) Measuring bore of the valve guide

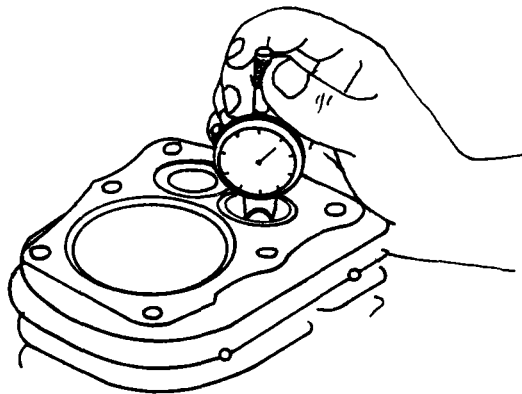

- Measure the bore with the dial indicator.
- Replace the valve guide if the obtained reading is beyond that of the specification.

b) Removing valve guide

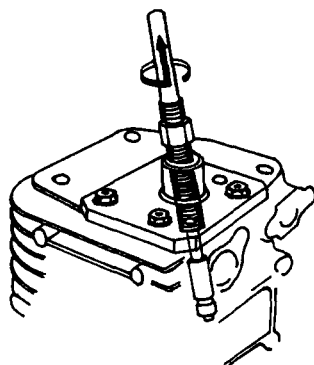

- Mount the special tool to the cylinder head by tightening 3 nuts.
- Screw in the valve guide extractor and screw on the nut underneath the valve guide.
- Unscrew the valve guide extractor until the valve guide is out.

c) Guide and its bore

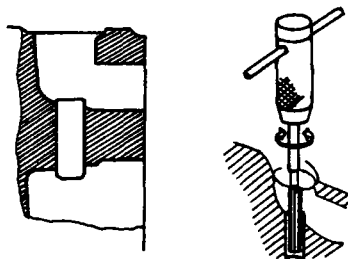

- Screw in the extractor to pull the valve guide.
- The valve guide must be pulled in and positioned correctly.
- Remove the nut and the extractor.

d) Reassembling valve guide

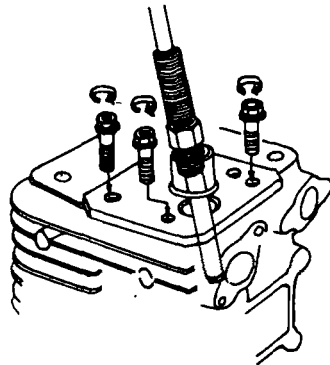

- Reverse the valve guide extractor.
- Fix the flange to the cylinder head and screw on the nut tightly.
- Insert the valve guide onto the extractor and hold it with the nut.
- Oil must be applied to the valve guide and its bore before reassembling.

4.4.8 Valve adjustment

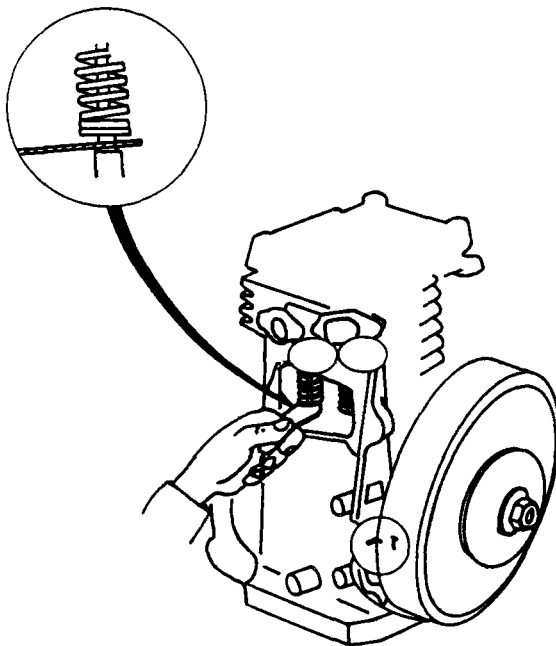

- Turn the engine until the piston is at the top of compression stroke.
- Measure the valve clearance by the feeler gauge.
- Adjust the valve clearance to the specification.

 Valve clearance specification 0.04-0.12 mm

- Excessive valve clearance : change valve or tappet
- Insufficient valve clearance : grind valve stem with oil stone.



Tools: a set of wrenches, Spark plug wrench, Torque wrench, Socket wrench and handle, Feeler gauge, Vernier caliper, Spring strength tester, dial indicator

Equipment: Benzene, Oil can, Cleaning pan, Cloth, Brass brush, Sand paper (400), broken saw blade, Oil stone

Manufacturer Model

Type of valve arrangement

Compression-reduction mechanism Yes No

Torque for cylinder head hold-down screwNm

Standard length of valve spring mm

Limited deviation of valve spring squareness mm

Standard strength of valve spring

Standard diameter of valve stem mm

Standard width of valve seat mm

Standard bore of valve guide mm

Standard valve clearance mm

| Sequence of operations | I | Inspection |
|---|---|--|
| 1. Prepare tools and equipment. | I | |
| 2. Close fuel valve and disconnect fuel hose. | I | |
| 3. Remove fuel tank. | I | |
| 4. Remove blower cover and any obstruction. | I | |
| 5. Remove cylinder head by loosening from the outmost screw toward center. | I | |
| 6. Remove head gasket. | I | - Condition of head gasket <input type="checkbox"/> Normal <input type="checkbox"/> Damaged |
| 7. Clean cylinder head. | I | - Condition of cylinder head |
| Remark: | I | <input type="checkbox"/> Normal <input type="checkbox"/> Dirty |
| If the cylinder head is bent or distorted, grind it with sand paper over the surface level. | I | <input type="checkbox"/> Cracked <input type="checkbox"/> Bent, disorted |



| Sequence of operation | I | Inspection |
|---|---|---|
| 8. Remove carburetter. | I | |
| 9. Remove side cover plate. | I | |
| 10. Remove valve springs. | I | |
| 11. Remove valves. | I | |
| 12. Clean valve unit and valve seats and arrange them in good order. | I | |
| 13. Check length of valve spring. | I | - Obtained reading mm. <input type="checkbox"/> Normal <input type="checkbox"/> Damaged |
| 14. Check squareness of valve spring. | I | - Obtained reading mm. <input type="checkbox"/> Normal <input type="checkbox"/> Damaged |
| 15. Check strength of valve spring. | I | - Correct to specification |
| 16. Measure diameter of valve | I | - Obtained reading mm. <input type="checkbox"/> Normal <input type="checkbox"/> Worn |
| 17. Check straightness of valve | I | <input type="checkbox"/> Normal <input type="checkbox"/> Distorted, bent |
| 18. Check valve face. | I | <input type="checkbox"/> Normal <input type="checkbox"/> Worn |
| 19. Check margin of valve seat. | I | - Obtained reading mm. <input type="checkbox"/> Normal <input type="checkbox"/> Worn |
| 20. Check width of valve seat. | I | - Obtained reading mm. <input type="checkbox"/> Normal <input type="checkbox"/> Worn |
| Remark: If excessive wear on valve seats, then recut the valve seats and regrind it. | I | |
| 21. Check bore of valve guide. | I | - Obtained reading mm. <input type="checkbox"/> Normal <input type="checkbox"/> Worn |
| Remark: If excessive wear on valve guides then remove and replace the valve guides by using the special tool. I | I | |
| 22. Reassemble all components in their reverse order. | I | Reassembling <input type="checkbox"/> Complete <input type="checkbox"/> Incomplete |
| 23. Adjust valve clearance. | I | - Standard valve clearance mm. |
| 24. Clean and store all tools and equipment. | I | Note: |

5. Crankshaft mechanism

5.1 Components and functions of crankshaft mechanism

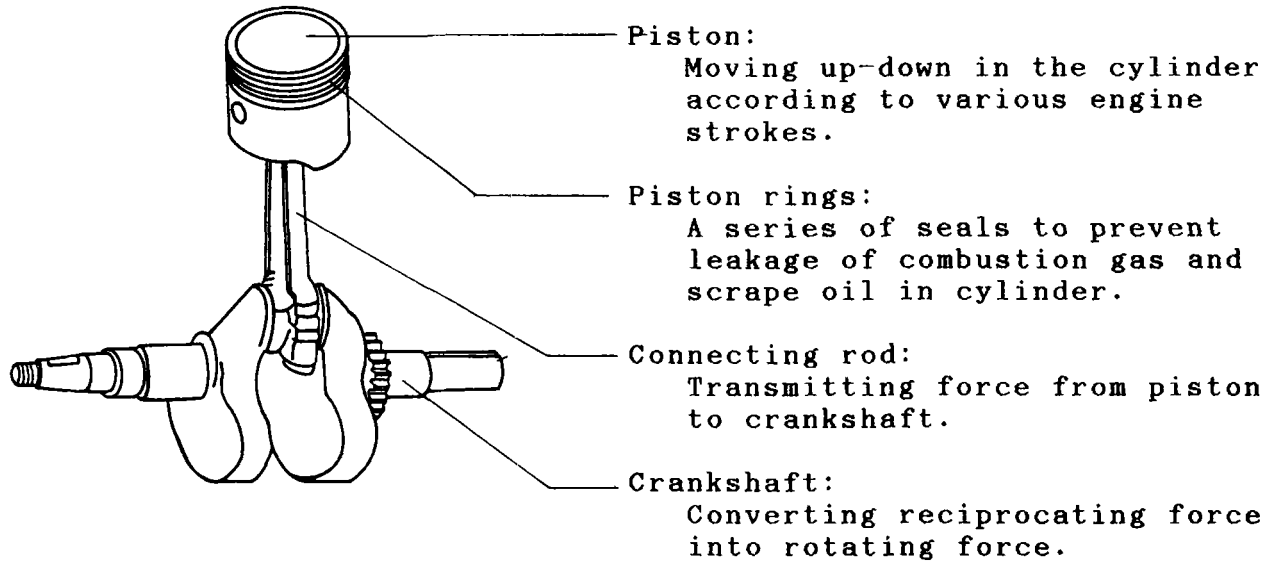

5.1.1 Piston and piston rings

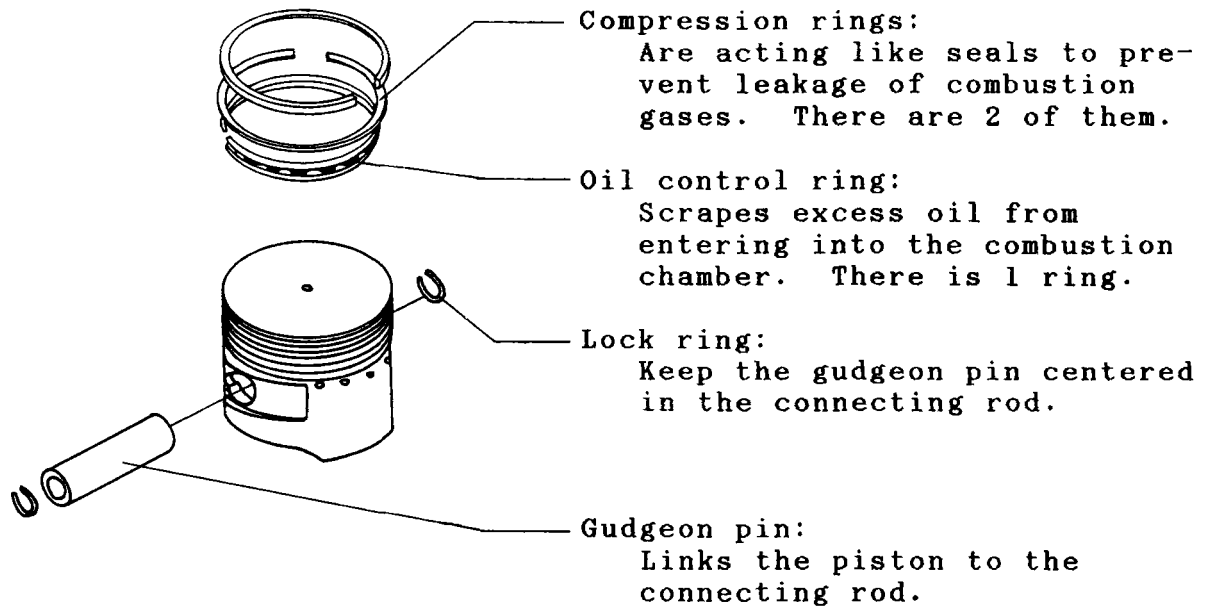

5.1.2 Connecting rod and connecting rod bearings

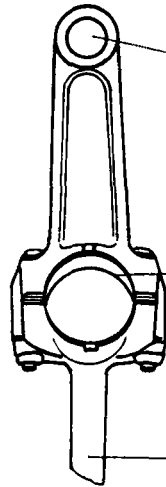

Small-end bearing:

The upper end of connecting rod has a bush bearing for connecting with the gudgeon pin.

Big-end bearing:

The lower end of connecting rod has bearing shells for connecting with the crankshaft.

Oil splasher

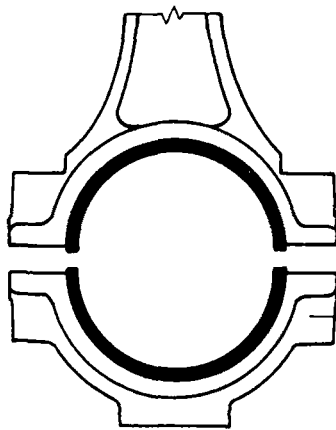

The big-end bearing shells split in two halves. The upper shell fixes with the connecting rod, the lower one with the connecting rod cap.

Connecting rod cap

Bearing shell

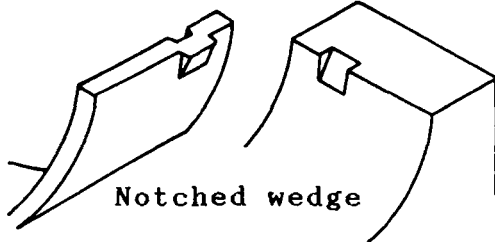

Notched wedge

The bearing shells are positioned by the notched wedges and grooves on the connecting rod and connecting rod cap.

5.1.3 Crankshaft

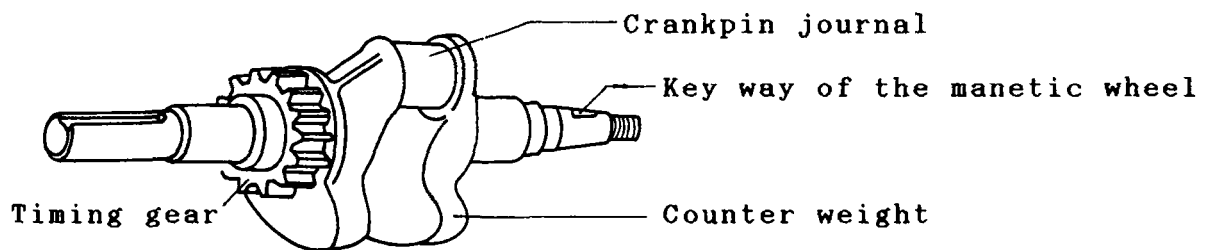

- Crankpin journal is for connecting with the connecting rod.
- Timing gear is for driving the camshaft.
- Key way is for connecting with the magnetic wheel.
- Counterweight is for damping the engine vibration.

1. Name the parts of the crankshaft mechanism.

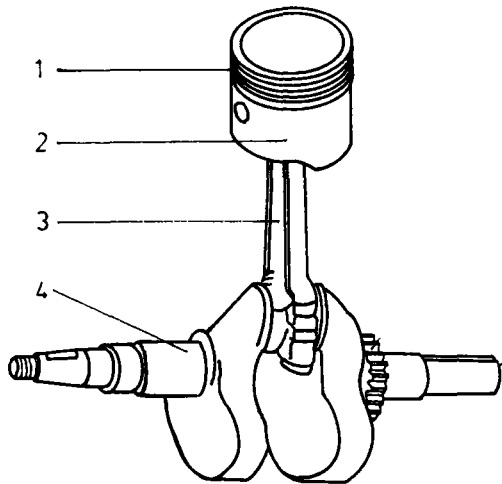

- 1.
- 2.
- 3.
- 4.

2. Make a cross in front of the correct statements

- ... 1. The part of the piston that bears the impact force mostly is the piston skirt.
- ... 2. Piston rings act as a series of seals to prevent leakage of combustion gases.
- ... 3. Compression rings and oil control ring are exchangeable.
- ... 4. Connecting rod transfers the force from piston to crankshaft.
- ... 5. Big-end bearing shells can be inserted to connecting rod with regardless of their positions.
- ... 6. Crankshaft converts reciprocating motion into rotary motion.
- ... 7. Timing gear of the crankshaft is for setting the ignition timing.

1. Name the parts of the crankshaft mechanism.

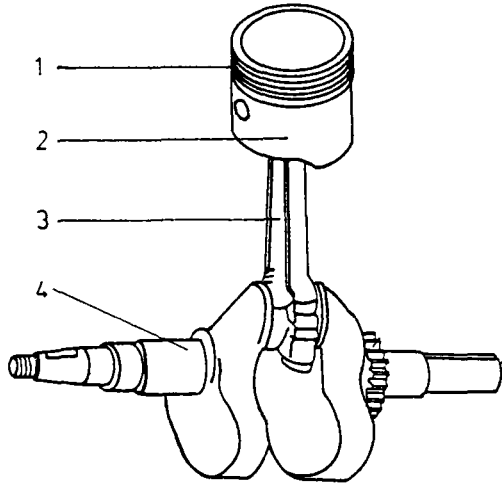

- 1. Piston rings.....
- 2. Piston.....
- 3. Connecting rod.....
- 4. Crankshaft.....

2. Make a cross in front of the correct statements

- ... 1. The part of the piston that bears the impact force mostly is the piston skirt.
- .X. 2. Piston rings act as a series of seals to prevent leakage of combustion gases.
- ... 3. Compression rings and oil control ring are exchangeable.
- .X. 4. Connecting rod transfers the force from piston to crankshaft.
- ... 5. Big-end bearing shells can be inserted to connecting rod with regardless of their positions.
- .X. 6. Crankshaft converts reciprocating motion into rotary motion.
- ... 7. Timing gear of the crankshaft is for setting the ignition timing.

5.2 Repair and maintenance

5.2.1 Testing the compression

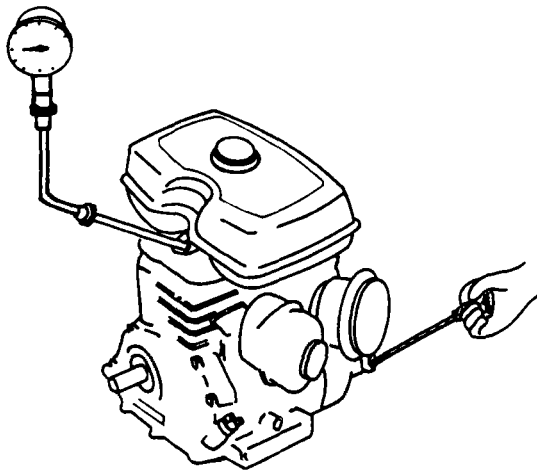

Sequence of operations:

- Remove the spark plug.
- Install the pressure gauge in the spark plug hole.
- Pull the string to crank the engine hardly for several times, and read the pressure.

 Standard minimum compression = 6 bar

 Caution:

- During spark plug removal, be aware of dust falling into the cylinder.
- Pressure gauge should be cleaned before installing.

5.2.1 Dismantling-Reassembling components of engine

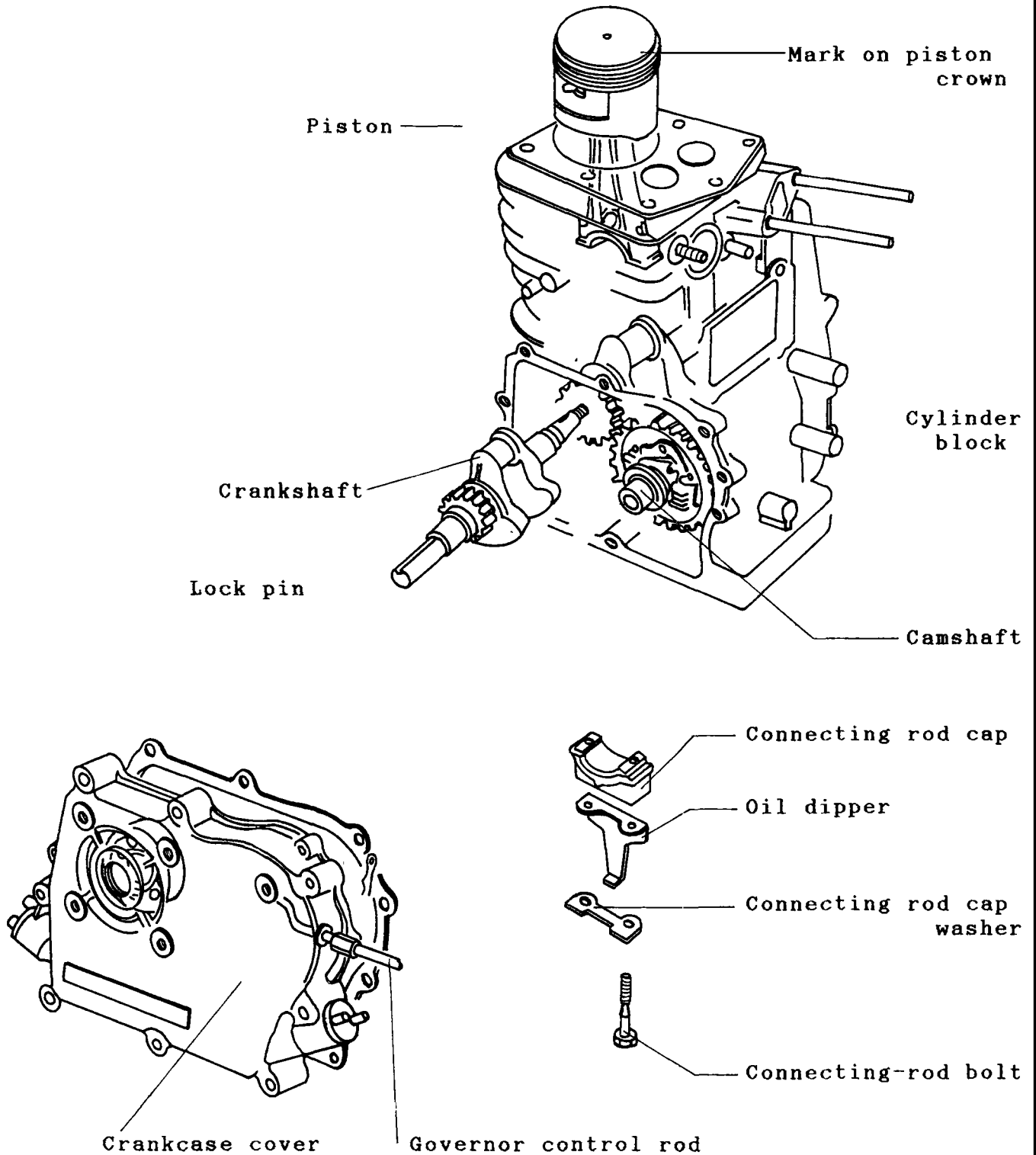

a) Crankcase cover

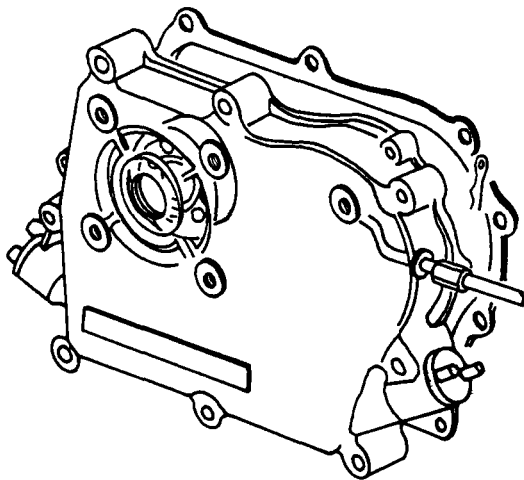

Removal:

1. Remove key on crankshaft if any.
2. Remove all screws of crankcase cover.
3. Tap the crankcase cover around gently with a plastic head hamer.
4. Remove the crankcase cover slowly.

Caution: Gasket may tear off and seal be damaged.

b) Camshaft

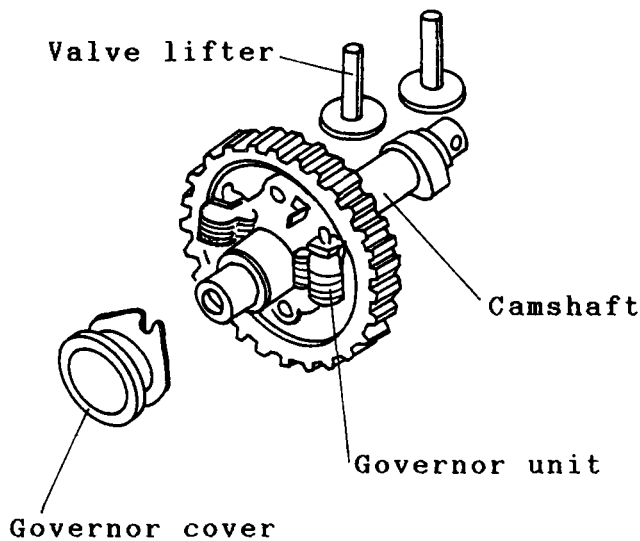

Removal:

1. Turn the crankshaft until the piston is at the top of the compression stroke.
2. Pull the camshaft assembly out.
3. Remove the valve lifters.

Remark: Governor unit is fixed to the camshaft assembly.

c) Connecting-rod cap

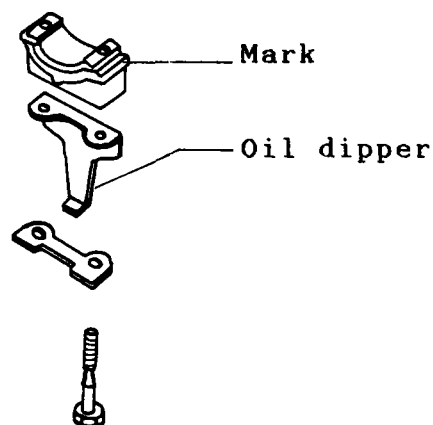

1. Make a mark onto the connecting-rod cap to prevent mixing up.
2. Unscrew the connecting rod bolts after flatten the cap washer.

Caution: position of oil dipper

3. Remove the connecting rod and cap.

 Standard torque 9 - 11 Nm

d) Piston unit

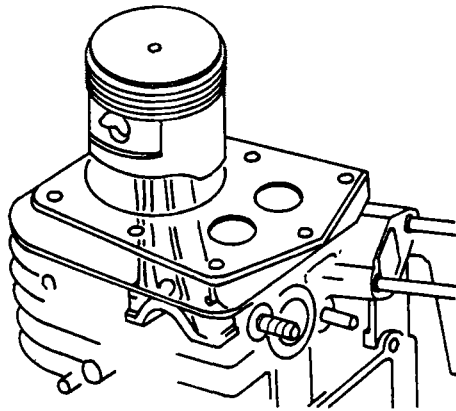

Removal:

Push the piston assembly upward

Reassemble:

The arrow mark must be directed toward the valves.

e) Crankshaft unit

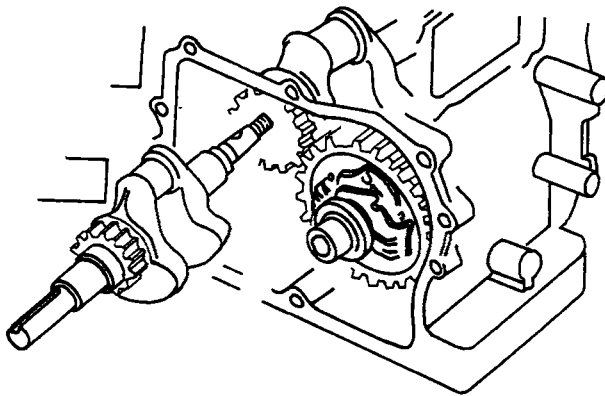

Caution: Do not drop the crankshaft.

f) Piston rings and gudgeon pin

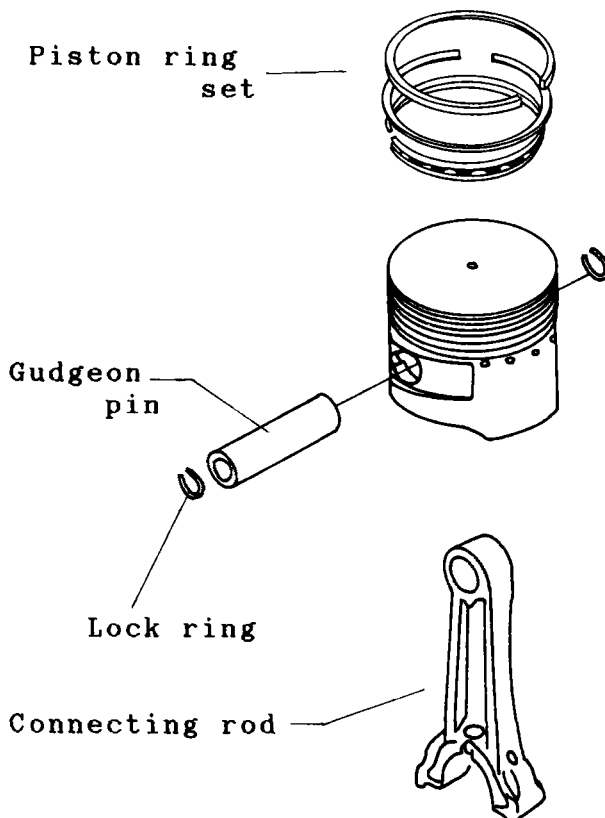

Removal:

1. Remove piston rings with a special tool.
2. Take out one of the lock ring.
3. Push out the gudgeon pin by hand or with hammer.

Remark: Remove piston rings before the gudgeon pin, otherwise, piston ring may brake

Reassembling:

Install piston Gudgeon pin rings in correct order and arrange their ends at 120 offset.

Mark

5.2.3 Inspecting the piston and piston rings

a) Measure diameter of the piston skirt

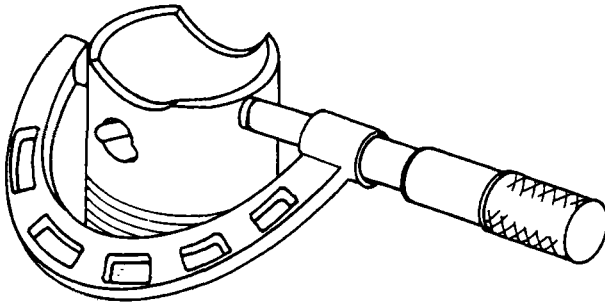

| Model | Nom. size | Limited size |
|-------|-----------|--------------|
| G150 | 64 mm | 68.88 mm |
| G200 | 67 mm | 66.88 mm |

b) Measure thickness of compression rings and oil control ring

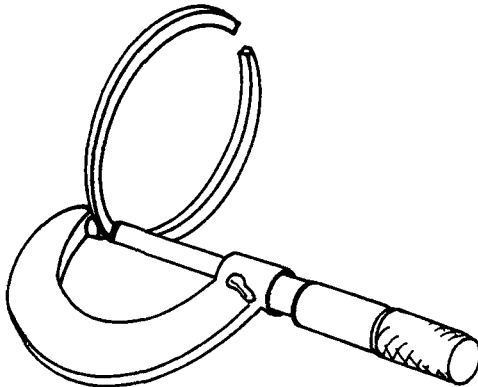

| Nominal size | Limited size |
|------------------------------|--------------|
| Top compression ring 2 mm | 1.87 mm |
| Second compr. ring 2mm | 1.87 mm |
| Oil control ring 2mm | 2.87 mm |

c) Measure side clearance of piston ring

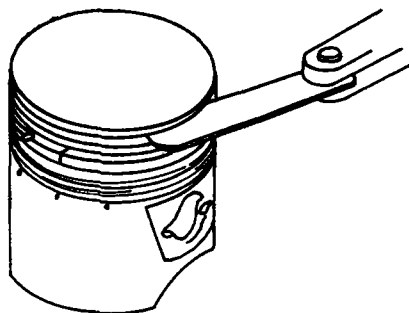

All piston rings must be installed correctly before measuring.

| Nominal size | Limited size |
|---------------------------|--------------|
| all rings 0.01-0.05 mm | 0.15 mm |

d) Check piston ring end gaps with feeler gauge

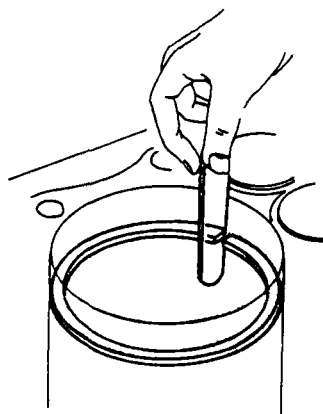

Insert all piston rings into the cylinder before measuring.

| Nominal size | Limited size |
|-------------------------|--------------|
| all rings 0.2-0.4 mm | 1 mm |

5.2.4 Checking gudgeon pin and gudgeon-pin hole

a) Check gudgeon-pin hole

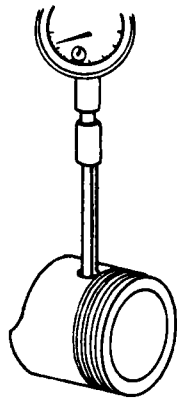

Inside micrometer

| Nominal size | Limited size |
|--------------|--------------|
| 15 mm | 15.04 mm |

b) Measure diameter of the gudgeon pin

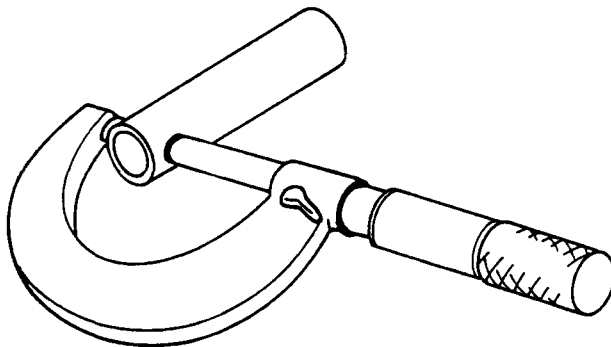

| Nominal size | Limited size |
|--------------|--------------|
| 15 mm | 14.954 mm |

c) Measure bore of the small-end connecting rod

Inside micrometer

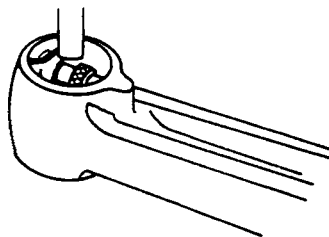

| Nominal size | Limited size |
|--------------|--------------|
| 15 mm | 15.07 mm |

5.2.5 Checking crankshaft and crankshaft bearings

a) Measure diameter of crankpin journal

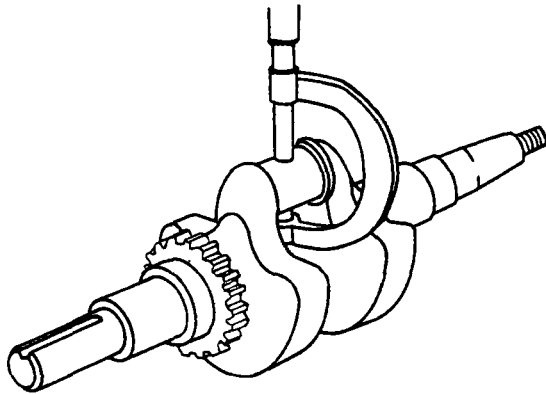

| Nominal size | Limited size |
|--------------|--------------|
| 26 mm | 25.917 mm |

- b) Inspect surface conditions of both, crankshaft and seals with eyes.
- c) Inspect condition of the big-end bearing shells with eyes for any sign of wear.
- d) Measure connecting rod side clearance with feeler gauge.

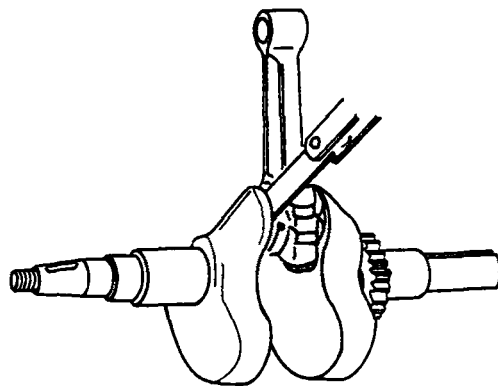

| Nominal size | Limited size |
|--------------|--------------|
| 0.1-0.8 mm | 1.2 mm |

Remark: Any parts of beyond the limited size it must be replaced.

5.2.6 Checking the cylinder

Measure diameter of cylinder with inside micrometer.

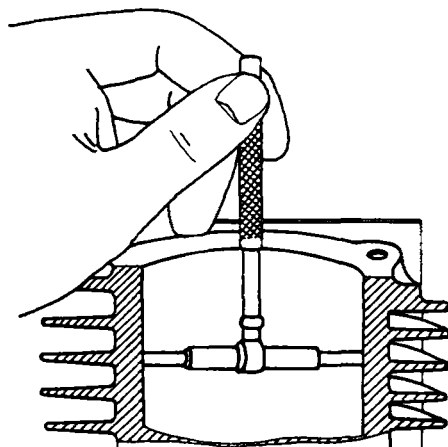

| Nominal size | Limited size |
|--------------|--------------|
| G150 64.0 mm | 64.165 mm |
| G200 67.0 mm | 67.165 mm |

Remark: Measuring should be carried out in several locations

6. Lubrication system

6.1 Tasks of the lubrication system

Lubrication system will supply oil to various moving parts of an engine, in order to ...

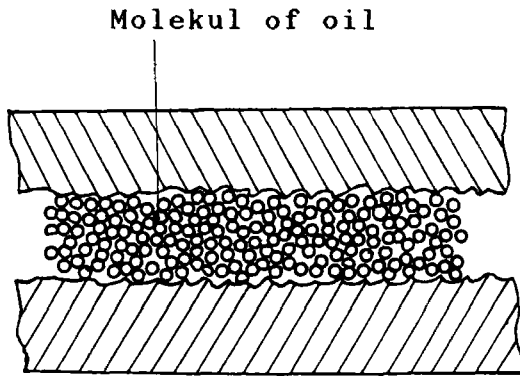

- reduce friction between moving parts,
- dissipate heat from various parts,
- absorb shock load between shaft and bush bearing,
- act like a sealing between piston rings and cylinder,
- act as cleaning agent.

6.2 Splash-type lubrication

This type of lubrication is mostly used in small engines, due to its simple construction and the simplest lubricating method.

6.2.1 Components and their function

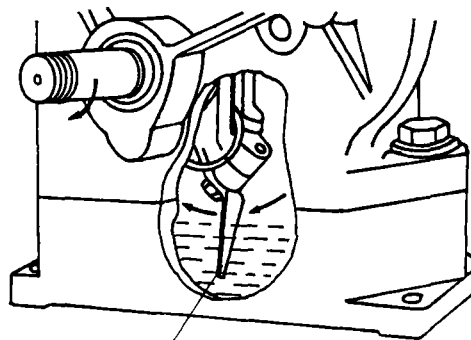

Oil dipper

- Oil dipper will splash oil from the sump during the downward rotation of the crankshaft, to the cylinder wall and other parts.

Advantage:

- Small number of parts and simple construction

Disadvantage:

- Insufficient lubrication may occur to various part in case there is inadequate amount of oil in the sump.



Complete the statements!

1. Lubrication means
2. The tasks of the lubrication systems are:
 1.
 2.
 3.
 4.
 5.
3. Parts of small engine which need lubrication are
4. Most used lubrication system in small engines is the type, because
5. Disadvantage of the lubrication system used in small engines:

.....

.....

Complete the statements!

1. Lubrication means *supply oil to the moving parts of the engine.*
2. The tasks of the lubrication systems are:
 1. *reduce friction between moving parts*
 2. *dissipate heat from various parts*
 3. *absorb shock load between shaft and bush bearing*
 4. *act like a sealing between piston rings and cylinder*
 5. *act as cleaning agent*
3. Parts of small engine which need lubrication are *crankshaft mechanism, valve mechanism and cylinder*
4. Most used lubrication system in small engines is the *splash* type, because *due simple construction*
5. Disadvantage of the lubrication system used in small engines:

Insufficient lubrication when there is inadequate amount of oil in the sump.

6.3 Repair and maintenance

Inspecting/changing oil:

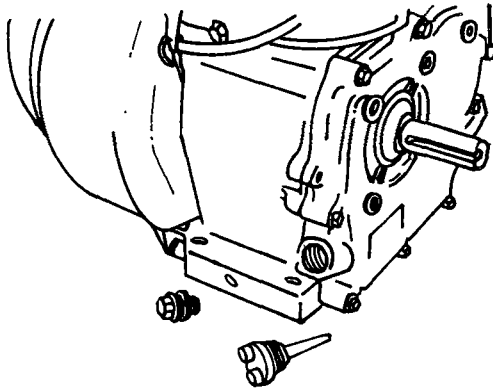

- Unscrew both the drain plug and oil refill screw plug to drain out old oil.
- Screw in the drain plug and refill with new oil upto the specified level.

Capacity of oil sump 0.7 litre

Drain plug

Oil refill
screw plug

Recommended oil: SAE 2100 W-30

- The engine must be in horizontal position when checking oil level.
- Close the screw plug tightly with the aid of screw driver.

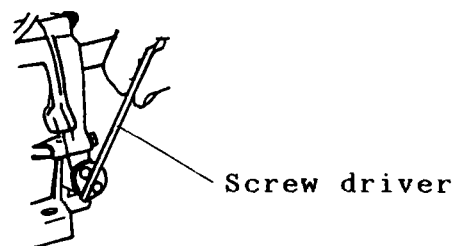
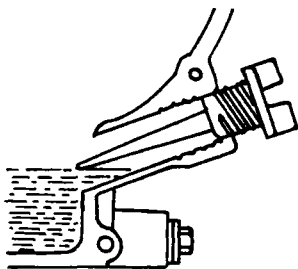



Tools: A set of wrenches

Equipment: Equipment tray, Cloth, Oil, Oil pan

Manufacturer Model

Oil grade

Capacity litre

| Sequence of operation | I | Inspection |
|--|---|---|
| | I | |
| | I | |
| | I | |
| 1. Prepare tools and equipment. | I | |
| | I | |
| 2. Run the engine for 5 minutes. | I | |
| | I | |
| 3. Stop the engine and drain oil. | I | - Condition of oil |
| | I | |
| 4. Refil new oil upto the specified level. | I | - Capacity of oil litre |
| | I | |
| | I | - Grade |
| | I | |
| 5. Start the engine and observe for oil leakage. | I | <input type="checkbox"/> Leakage <input type="checkbox"/> No leakage |
| | I | |
| | I | |
| 6. Stop the engine and recheck oil level. | I | - Oil level |
| | I | |
| | I | <input type="checkbox"/> Correct <input type="checkbox"/> Incorrect |
| | I | |
| 7. Clean and store tools and equipment. | I | - Tools |
| | I | |
| | I | <input type="checkbox"/> Complete <input type="checkbox"/> Incomplete |
| | I | |

Note :
.....
.....
.....

7. Cooling system

Air cooling system....

is the most used system in small engines because it is easy to place, light in weight, has a small number of parts and low production costs.

Its tasks are:

- to dissipate heat as generated by friction
- to control dissipating heat within certain range of working temperature for efficient engine performance

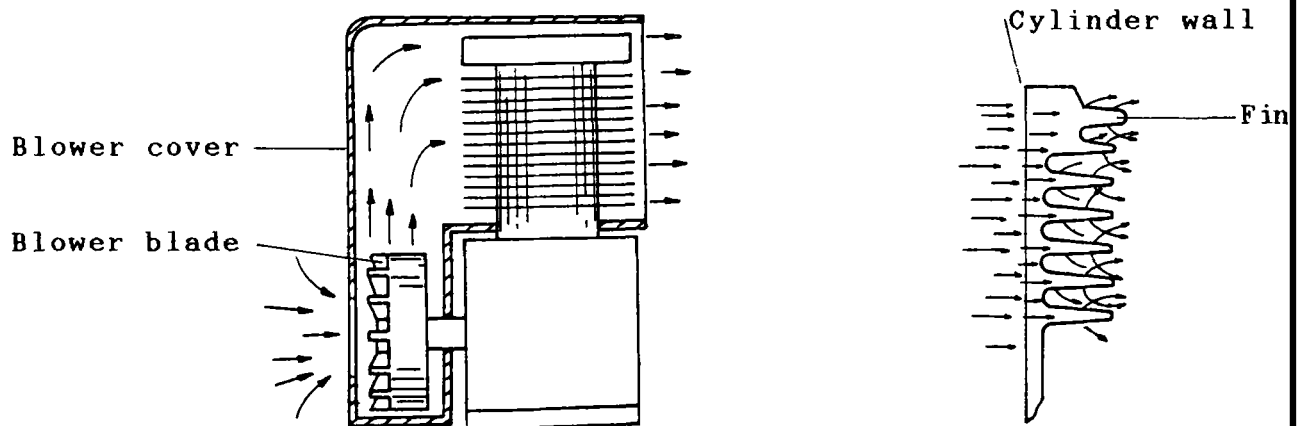

- The system uses air as a cooling medium to transfer heat from engine to surrounding air which has lower temperature.
- For engine with air cooling system, the exterior of cylinder will be in forms of fins and spaces which increases area of air contact.
- To be of efficient the blower cover is used to direct air blowing.
- As the engine runs, the blower blade attached on the flywheel will suck in cool air and blow it along the cover to cool down the cylinder wall.



Complete the statements!

1. The tasks of the cooling system are:
 1.
 2.
2. Small gasoline engines generally use cooling system, because
3. Small gasoline engines generally have their cylinder head and cylinder block made in the forms of
This is for
4. Components of cooling system of most small gasoline engines consist of
5. Blower cover is used for

Complete the statements!

1. The tasks of the cooling system are:

1. *To dissipate heat as generated by friction.....*
2. *To control temperature within a certain range...*

2. Small gasoline engines generally use *air*... cooling system, because *it is easy to place, light in weight, has a small number of parts and low production costs.*

3. Small gasoline engines generally have their cylinder head and cylinder block made in the forms of *fin and spaces*..... This is for *increasing the area of air contact*.....

4. Components of cooling system of most small gasoline engines consist of *lower, lower-cover and fin*.....

5. Blower cover is used ~~for~~ *to guide the air*.....

7.1 Repair and maintenance

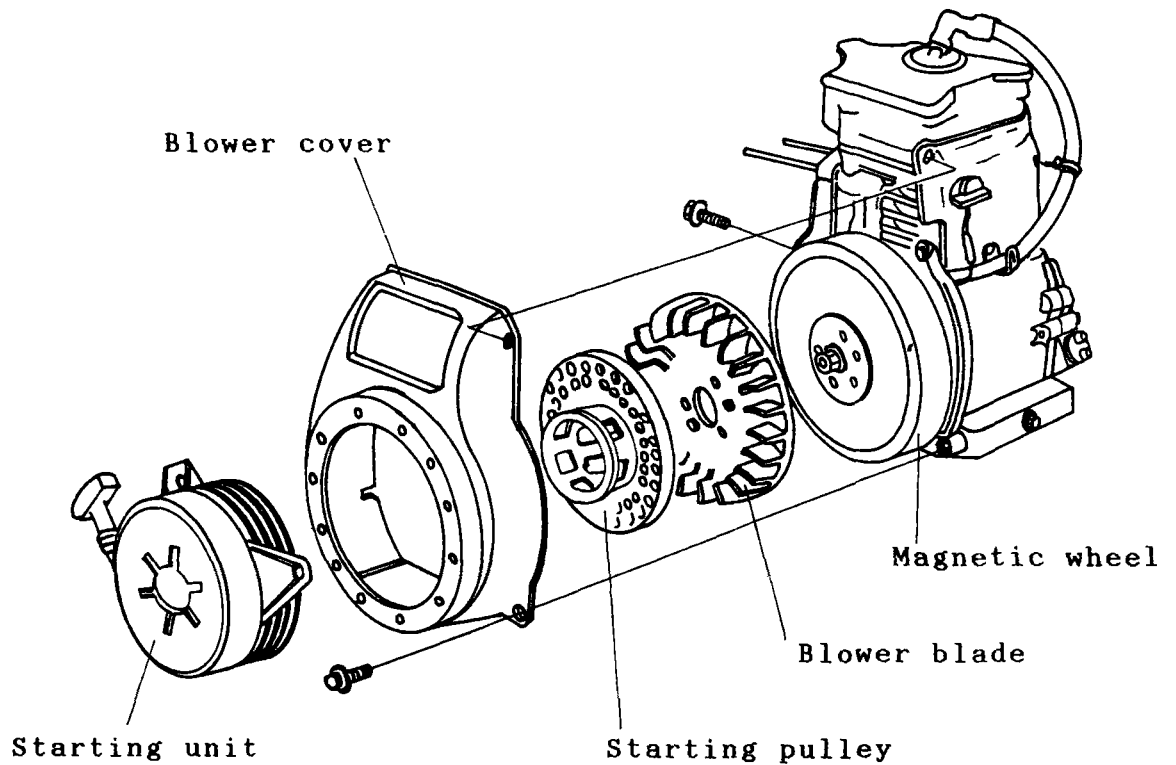

- The starting unit must be cleaned before assembling the blower cover.
- The blower blade must be fixed to the magnetic wheel at the correct position which is guided by the pilot pin of the magnetic wheel. Be aware of cracking the blower blade.



Tools: A set of wrenches

Equipement: Tray, cloth, benzene

Manufacturer..... Model

Type of cooling system

| Sequence of operations | I | Inspection |
|---|---|---|
| | I | |
| | I | |
| | I | |
| 1. Prepare tools and equipment. | I | |
| | I | |
| 2. Close fuel valve, disconnect fuel hose and remove fuel tank. | I | |
| | I | |
| | I | |
| 3. Remove starting unit. | I | |
| | I | |
| Remark: Notice the position of starting unit. | I | |
| | I | |
| 4. Remove blower cover. | I | - Condition of blower cover |
| | I | <input type="checkbox"/> Normal <input type="checkbox"/> Damaged |
| | I | |
| 5. Remove starting pulley. | I | |
| | I | |
| Remark: Notice the position of starting pulley. | I | |
| | I | |
| 6. Remove blower blade. | I | - Condition of blower blade |
| | I | <input type="checkbox"/> Normal <input type="checkbox"/> Damaged |
| | I | |
| 7. Clean blower blade, fins of cylinder head and cylinder block, and blowe cover. | I | |
| | I | |
| | I | |
| 8. Reassemble those components | I | |
| | I | |
| 9. Clean and store tools and equipment. | I | - Tools-equipment |
| | I | <input type="checkbox"/> Complete <input type="checkbox"/> Incomplete |
| | I | |
| | I | |

Note :
.....
.....

8. Starting system

8.1 Types of starting systems

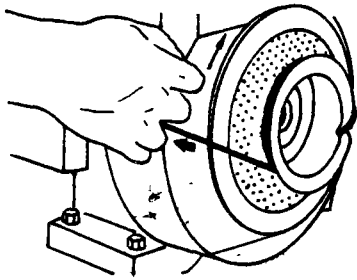

Conventional type

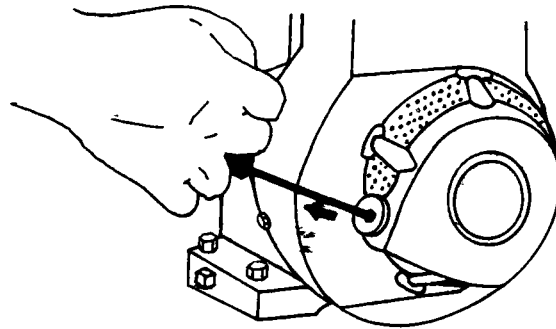

Built in starting unit

8.2 Repair and maintenance

a) Removal and reassemble starting unit

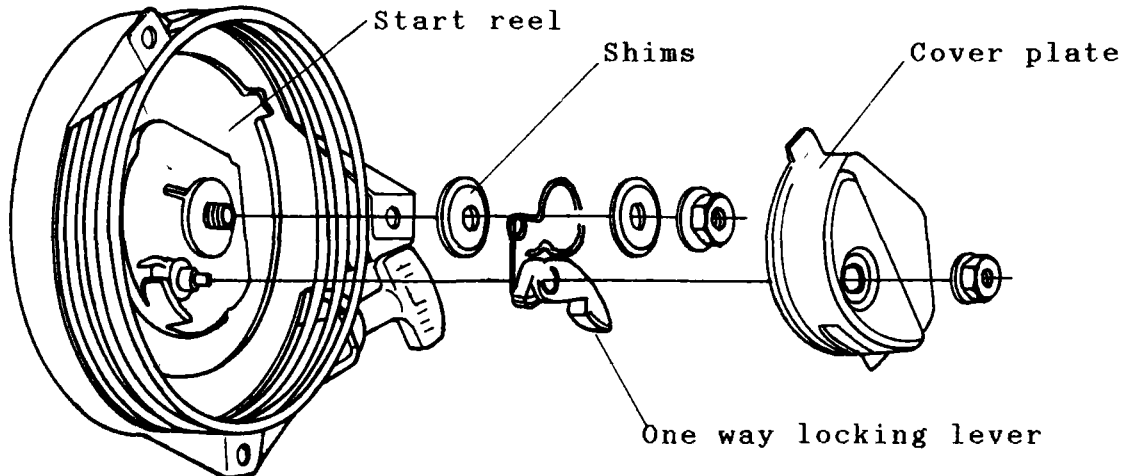

b) Assembling starting string

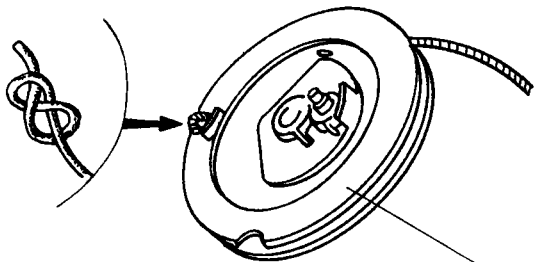

- Thread one end of the string through the hole of the start reel and make a knot.

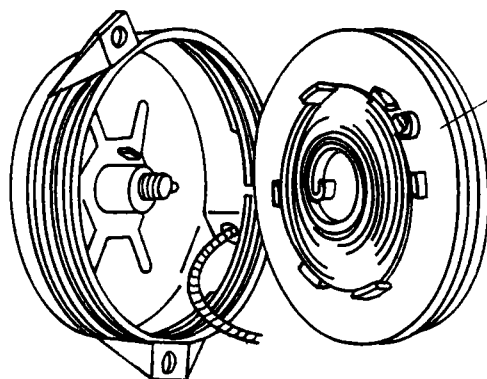

Start reel

- Wind the string on the start reel (in the direction of spring). Thread the other end of string through the spring housing. Refit the start reel to the spring housing.

Starting spring housing

Lock nut

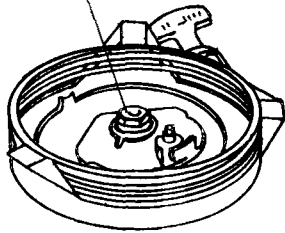

- Reassemble the spring plate and screw on the lock nut. Tighten it to the specified torque.

Spring plate

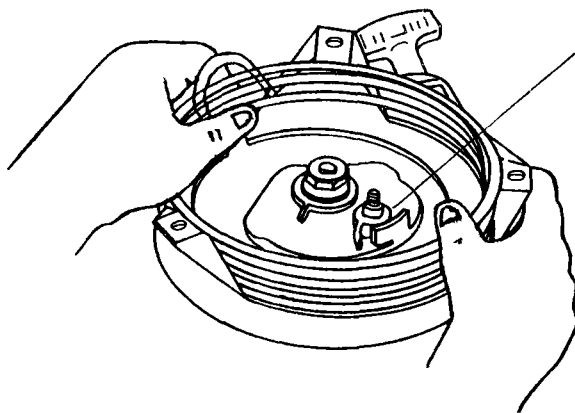

Notch of start reel

- Turn the start reel for about 1 1/2 turns to wind up the rest of string from the notch of the start reel.

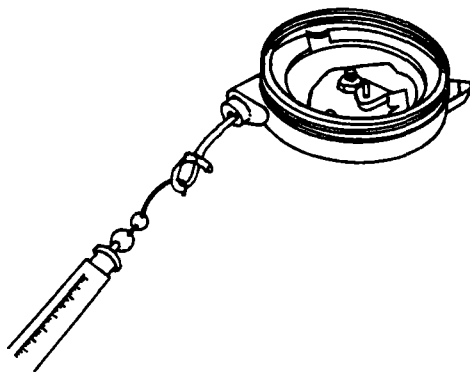

- Check tensioning of the starting string by using a spring scale. The reading should be about 0.6-1.4 kg. Adjustment of tension can be accomplished by tightening or loosening the start reel.

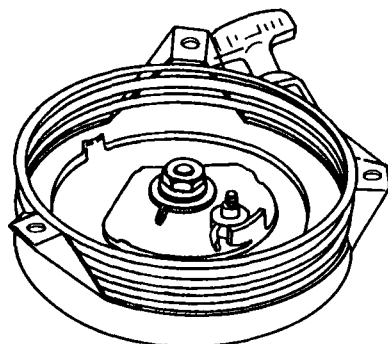

- Refit the handle to the starting string and tie it. Assemble the spring to the ratchet of the start reel. Inspect function of the ratchet.

- Reinstall the start reel cover.



Tools: A set of wrenches

Equipment: Tray, cloth, grease

Manufacturer Model

Type of starting system

| Sequence of operations | I | Inspection |
|--|---|-----------------------|
| | I | |
| | I | |
| | I | |
| 1. Prepare tools and equipment. | I | |
| | I | |
| 2. Remove starting unit from blower cover. | I | |
| | I | |
| 3. Dismantle components of starting unit. | I | - check/repalce parts |
| | I | |
| 4. Clean all parts of the starting unit. | I | - grease moving parts |
| | I | |
| 5. Reassemble components of the starting unit. | I | |
| | I | |
| 6. Refit the starting unit | I | - check performance |
| | I | |
| 7. Inspect its function | I | |
| | I | |
| 8. Clean and store tools and equipment. | I | |
| | I | |
| | I | |

Note :
.....
.....
.....

9. Exhaust system

9.1 Purposes of exhaust system

- a) To relief exhaust gas from the combustion chamber.
- b) To improve engine power.
- c) To reduce expanding noise of exhaust gas.

9.2 Components and their function

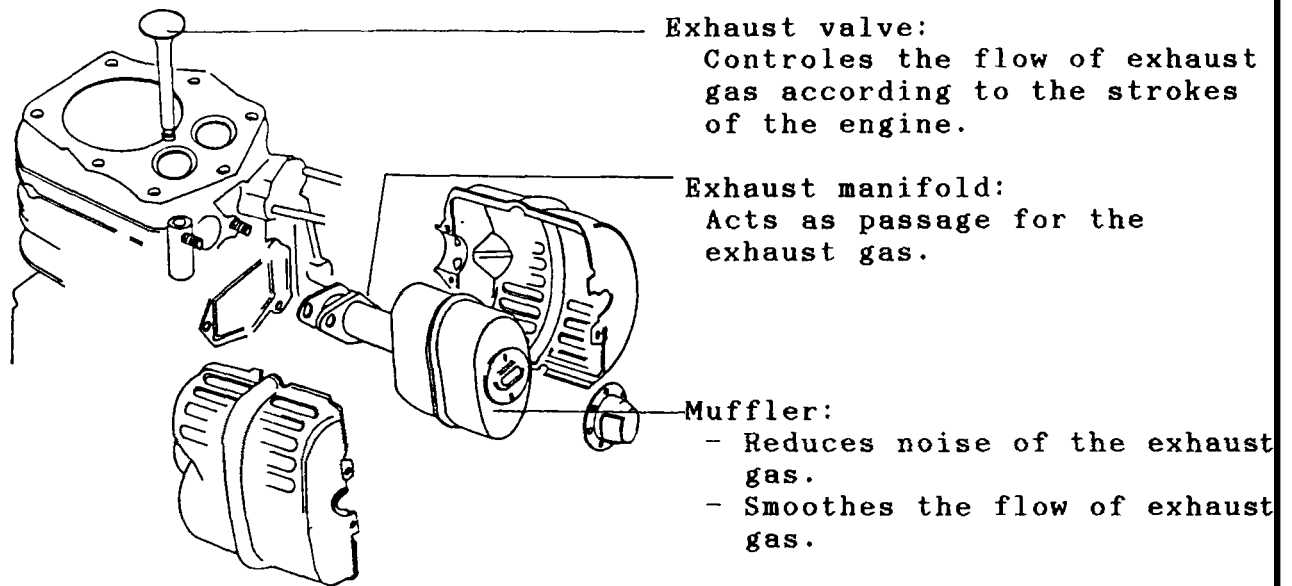

There are two kinds of mufflers:

a) Straight-through muffler

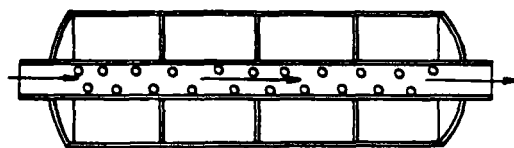

The exhaust gas flows like a stream both inside and outside the muffler, causing turbulence.

Hard flow of exhaust gas will reduce engine power.

b) Reverse-flow muffler

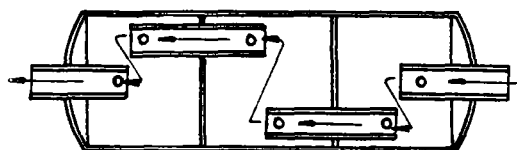

The exhaust gas will expand inside each compartment of the muffler as it flows. This will minimize the level of noise considerably when it comes out to the atmosphere.

Turbulence of exhaust gas is reduced, thus, noise is also reduced.

Complete the statements!

1. Purposes of exhaust system are :

- a)
- b)
- c)

2. Name various parts of the exhaust system.

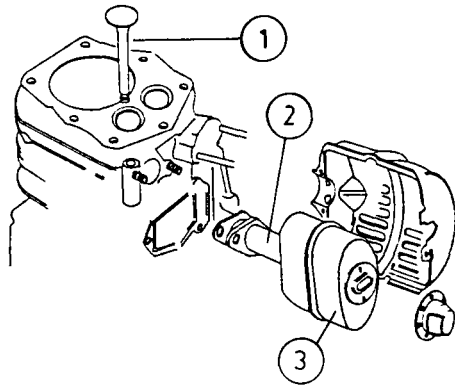

- 1.
- 2.
- 3.

3. The muflfer can reduce noise of exhaust gas, due to

.....

4. There are muffler-designs, which are

.....

5. Small gasoline engines generally use themuffler-type because

Complete the statements!

1. Purposes of exhaust system are :

- a) To relief exhaust gas from the combustion chamber
- b) To improve engine power
- c) To reduce expanding noise of exhaust gas

2. Name various parts of the exhaust system.

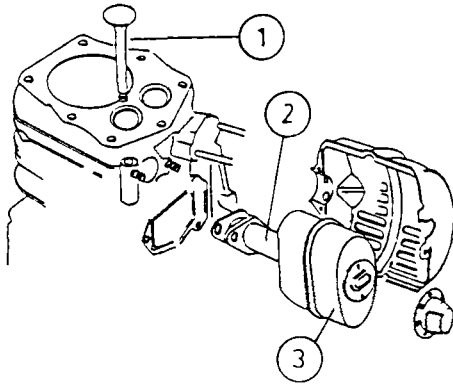

- 1. Exhaust valve
- 2. Exhaust manifold
- 3. Muffler

3. The muffler can reduce noise of exhaust gas, due to turbulence and expansion

4. There are 2 muffler-designs, which are Straight-through and Reverse-flow muffler

5. Small gasoline engines generally use the Reverse muffler-type, because noise is reduced and engine power improved.