

Mechanic Motor Vehicle 2nd Year – Transparencies

Table of Contents

Mechanic Motor Vehicle 2nd Year – Transparencies	1
<u>Magneto Ignition System (4 Cylinder Engine)</u>	1
<u>Magneto Ignition System (Single Cylinder Engine)</u>	2
<u>Anti-dazzling arrangement</u>	2
<u>Flasher unit and its circuit</u>	3
<u>Wiring Diagram of relay type horn</u>	4
<u>Self starter wiring circuit (Petrol Engine)</u>	5
<u>Self starter wiring circuit (Diesel Engine)</u>	6
<u>Wiring Diagram of a charging circuit (Vehicle)</u>	7
<u>Circuit Diagram of Alternator Testing</u>	8
<u>Synchroniser unit and its action</u>	8
<u>Layout of 4 Wheel Drive</u>	9
<u>Four wheel drive transfer case (High Range)</u>	10
<u>Independent front wheel suspension (Macpherson & Coil spring)</u>	11
<u>Valve Timing Diagram (4 Stroke Cycle Diesel Engine)</u>	12
<u>Crankcase Ventilation</u>	13
<u>Comparison of function Multi hole and Pintle nozzles</u>	13
<u>Fuel feed system (Diesel Inline Jerk Pump)</u>	15
<u>Fuel Injection Pump</u>	16
<u>Diesel Engine Fuel Filter</u>	17
<u>Types of Stub Axle mountings on front Axle</u>	18
<u>Steering linkages Light Motor Vehicle</u>	19
<u>Steering Gear Box Rack & Pinion Steering</u>	20
<u>Tandem Master Cylinder and its function</u>	20
<u>Differential and its action</u>	21
<u>Wheel Cylinder and its action</u>	22

Mechanic Motor Vehicle 2nd Year – Transparencies



CIMI

CENTRAL INSTRUCTIONAL
MEDIA INSTITUTE, CHENNAI



AN INDO – GERMAN PROJECT

Directorate General of Employment & Training, Ministry of Labour, Govt. of India.

Developed by

CENTRAL INSTRUCTIONAL MEDIA INSTITUTE

in collaboration with

DEUTSCHE GESELLSCHAFT FÜR TECHNISCHE ZUSAMMENARBEIT (GTZ) Germany.

P.O. Box 3142, 76, GST Road, Guindy, Chennai – 600 032.

Phone: 234 5256, 234 5257, Fax: (0091-44) 234 2791

Magneto Ignition System (4 Cylinder Engine)

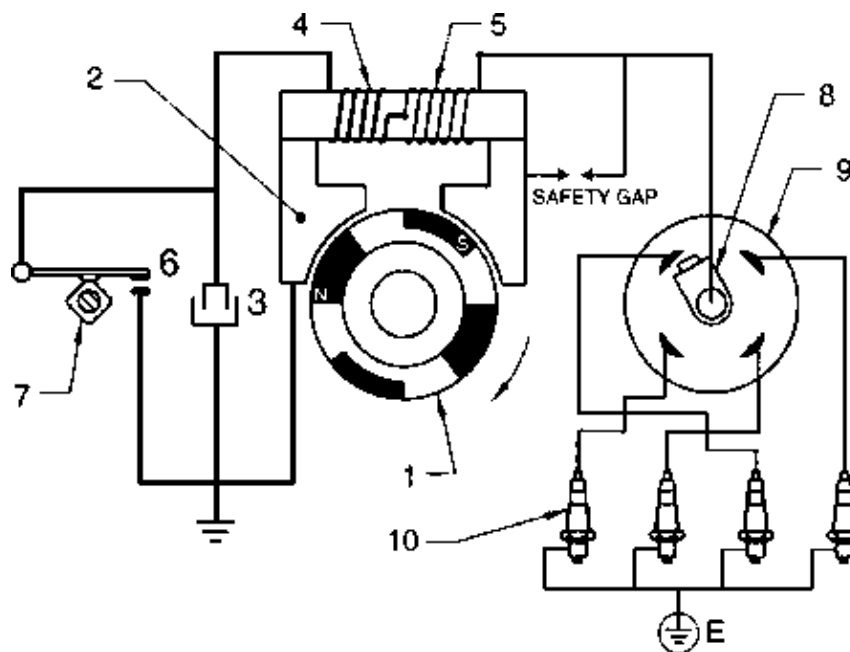

ROTATING MAGNET TYPE (4 CYLINDER ENGINE)

Function

The magnet (1) revolves whereas the Armature and pole pieces (2) remain stationary. In a base plate condenser (3) and Primary and Secondary coils (4 & 5) are mounted, The CB points (6) are also kept stationary. The Ignition cam (7) is attached to distributor shaft and it only rotates.

When the flywheel revolves, the magnet (1) also revolves. It generates current in the coil as its magnetic field cuts across the Ignition coil windings (4 & 5). This current flows through the primary coil (4) and gets earthed. When CB points (6) are separated by an Ignition cam (7) a h.t. current is generated in the secondary coil (5). The condenser (3) absorbs surge of primary current when CB points (6) open and prevents arcing also across the points. The h.t. current then passes on to the distributor Rotor Arm (8) and from the arm the current is delivered to spark plug (10) through segments in distributor cap (9) and discharged as a spark with high intensity across plug gap and finally earthed to complete its circuit. As the distributor shaft rotates at 1/2 speed of crankshaft rpm, one spark will be delivered at 180° of its revolution.

NOTE

Some tractors with 4 cylinder engine work with the rotating magnet type Magneto ignition System

Magneto Ignition System (Single Cylinder Engine)

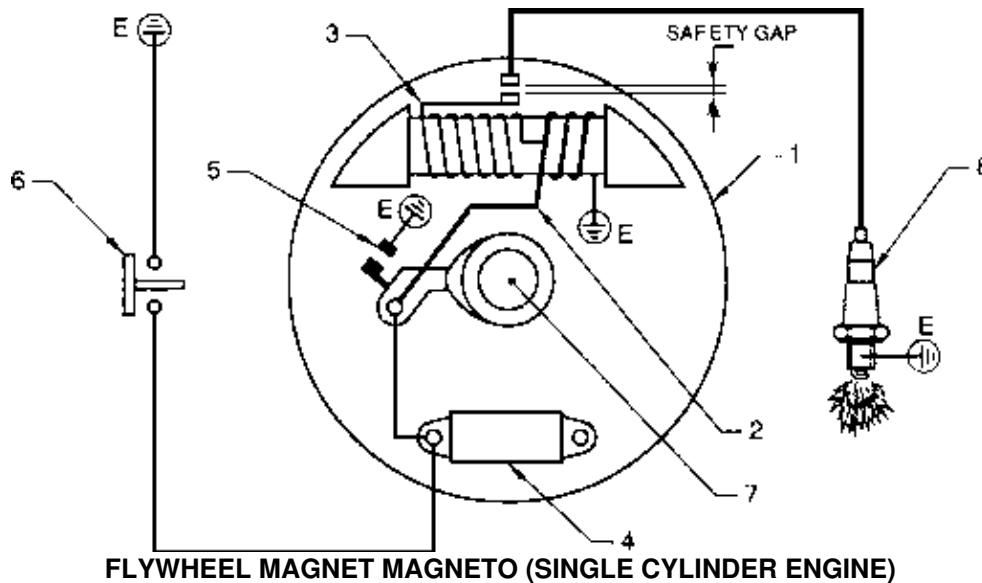

Function

This system is used in Motor cycles & Scooters. In this design flywheel (1) is attached with magnetic pole pieces and revolving as one unit with crank shaft. The primary winding (2). Secondary winding (3), condenser (4), CB points (5) are all fixed on a base plate on the engine housing. The Ignition cam (6) is attached to one end of the crankshaft and revolves with it.

When the flywheel revolves, magnetic pole pieces also revolve. The magnetic lines set up between N & S poles, cut the primary winding (2) generate LT current. The LT current flows then to condenser (4) and contact breaker points (5). When the points remain closed a magnetic field is set up around the primary winding (2). A switch (6) is provided in the primary circuit in series with CB points to earth the primary circuit. When the Ignition cam (7) opens the CB points (5) the surging current is absorbed by the condenser and thus prevents arcing. Due to break up of primary circuit, the magnetic field collapses and a heavy current (h.t) is induced at secondary winding (3) and it is delivered to the spark plug (8) and the h.t current jumps across plug points and finally earthed through engine block.

This cycle of operation is repeated and one spark per crank shaft revolution will be delivered in a Single cylinder 2 stroke engine.

The L.T current thus generated passes on through rectifiers for change of AC to DC and is supplied to lights, Battery, Horn and other circuits.

Anti-dazzling arrangement

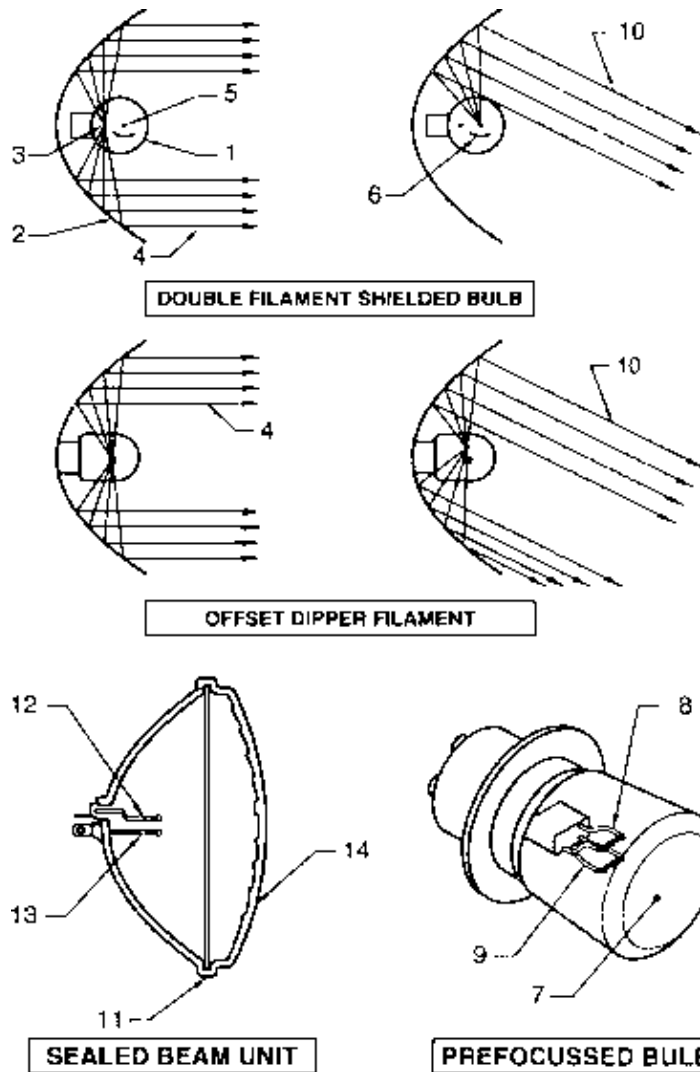

Function

In a car the effect of head light dazzle is being prevented by re-direction of light rays towards the ground. A double filament shielded bulb (1) is used. The Bulb (1) is fitted on the parabolic reflector (2) at the focal point (3) and the reflected rays (4) are indicated by straight line arrows. If another filament (5) is placed away from focal point (3) the light rays (10) are deflected towards the ground surface. The shield assists deflection of rays to wards ground. This beam is called dipped beam and operated by a dipper switch provided in instrument panel of the vehicle or at foot of drivers seat.

(A) By use of pre-focussed bulb (7) with dip and main beam (8 & 9) filaments

It can be fitted in the reflector to give a main beam (4) and also a dip beam to deflect the rays in a deflected path (10), when dazzling of head light rays come from opposite vehicles.

(B) By use of a Sealed Beam Unit (11)

There are two filaments (12) and (13) accurately positioned in the unit. A special type of lense (14) is provided which redirect the light rays in the deflected path (10).

Flasher unit and its circuit

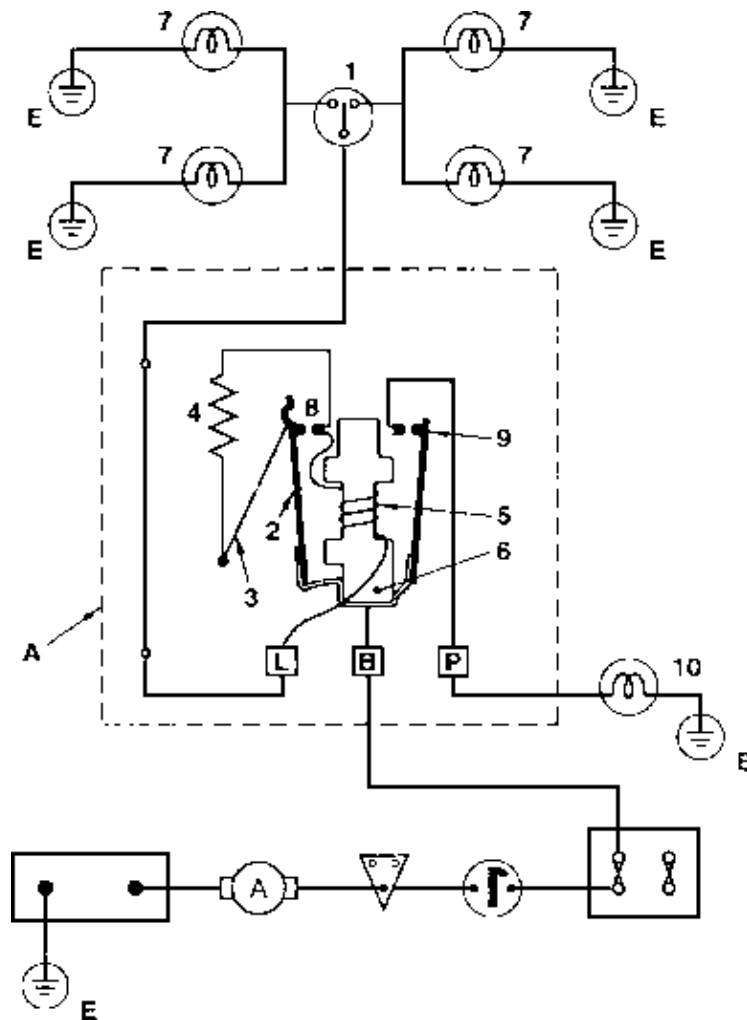

Function

The flasher unit (A) is provided between Battery and lamps. This is a sealed unit and mounted vertically in a place below the Bonnet of the car.

When the flasher switch (1) is operated to the right or left the battery current flows from terminal (B) through the main armature (2) actuating wire (3), Ballast resistor (4), Coil winding (5) on the Iron core (6) and to the flasher lamp filaments (7) and get earthed. The lamps (7) do not illuminate but ready to flash due to pre-heating of filaments.

Due to current flow, the actuating wire (3) is heated up and expands in its length. This action causes the lamp contacts (8) to close in the supply circuit of flasher lamps (7) and at the same time to keep the actuating wire (3) and Ballast resistor (4) out of circuit. Now full current flows, from terminal (B) to Terminal (L) along the closed contacts (8) and round the coil windings (5). The lamps (7) get now illuminated. At the same time, the pilot contacts (9) also close due to Electro-Magnetic action of the coil winding (5) and pilot lamps (10) are now lit. Now the current flows to the two lamps (7) of the same side through the main points (8) and they begin to flash at a regulation of 70-100 flashes per minute.

When the actuating wire (3) cools down, it breaks the contact; the current flow is cut out from the lamps (7) and points (8) reopen. Now reduced current flows to the coil (5) through Ballast resistor (4). The current is not sufficient enough to illuminate the lamps (7). Thus lighting signals are extinguished off. The pilot lamps also go off. The sequence of operation is repeated till indicator switch is returned to its off position.

Wiring Diagram of relay type horn

A. Function

In the starter wiring circuit, Battery (1) supplies current to solenoid switch terminals marked (2) through a starter button switch (3). The solenoid switch (4) is placed between the battery (1) and starter motor (9). When the current passes through a winding (5) in the solenoid switch, it gets a magnetic field around it and the soft Iron Core (6) becomes an Electro Magnet. This electro Magnet attracts the plunger (7) to force the contact disc (8) on one end to make contact with terminals (2) of the switch thus completing the circuit. Now a heavy current passes to the starting motor (9) through battery cables (10) from battery and the starter begins to revolve. When the switch is released the electro magnetic field collapses and the spring (11) moves plunger (7) and the contact disc (8) away from the terminals (2) thus electrical connection is open between the battery (1) and the starter motor (9). Now the self starter stops revolving.

Self starter wiring circuit (Diesel Engine)

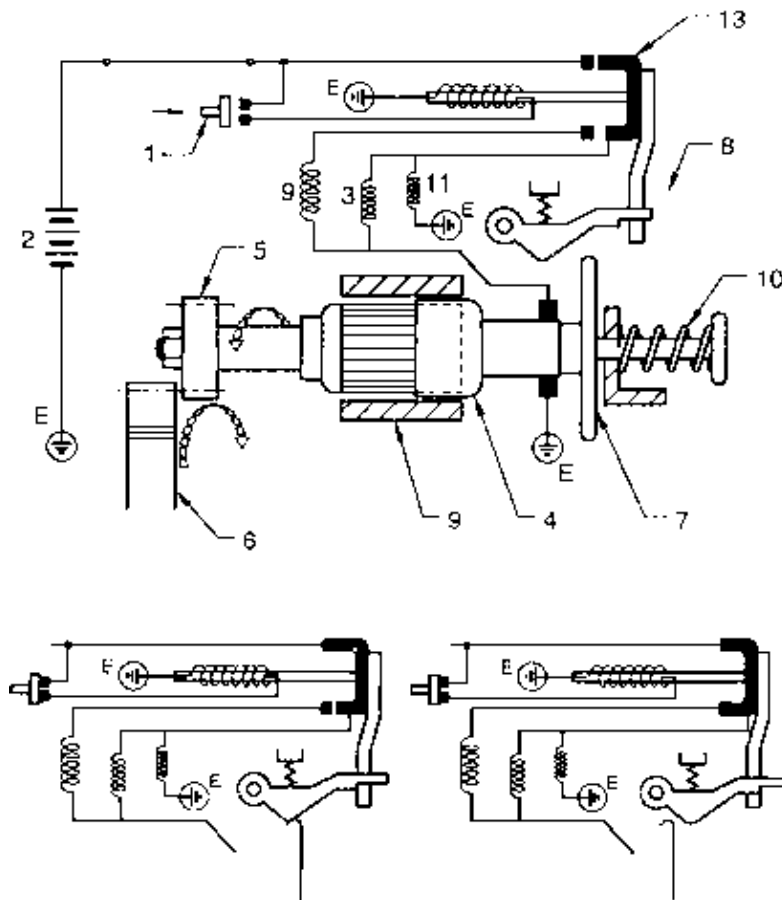

Function

In these type of axial starters, the pinion engagement is done by axial movement of complete armature assembly. The starter wiring circuit indicates two stages of operation.

A. First stage

When starter push contact (1) is pressed, the first set of contact on the solenoid close and a small current passes from Battery (2) through Auxiliary field windings (3) causing armature (4) to rotate slowly. Due to magnetic field set up in the windings, the armature (4) is drawn towards driving end of the machine and pinion (5) engages with the engine flywheel ring gear (6).

B. Second stage

As the armature nears the end, in its axial movement, a tripping plate (7) operates the Trigger (8) on the solenoid switch resulting on the second stage contacts to close and complete the circuit with main series winding (9).

Now the starter exerts its full torque to the engine. When the starter button (1) is released, the armature (4) is returned to its disengaged position by the coiled spring (10) on the armature plunger. The auxiliary shunt windings (11) in the circuit try to hold the pinion in mesh until the starter push button (1) is released.

Wiring Diagram of a charging circuit (Vehicle)

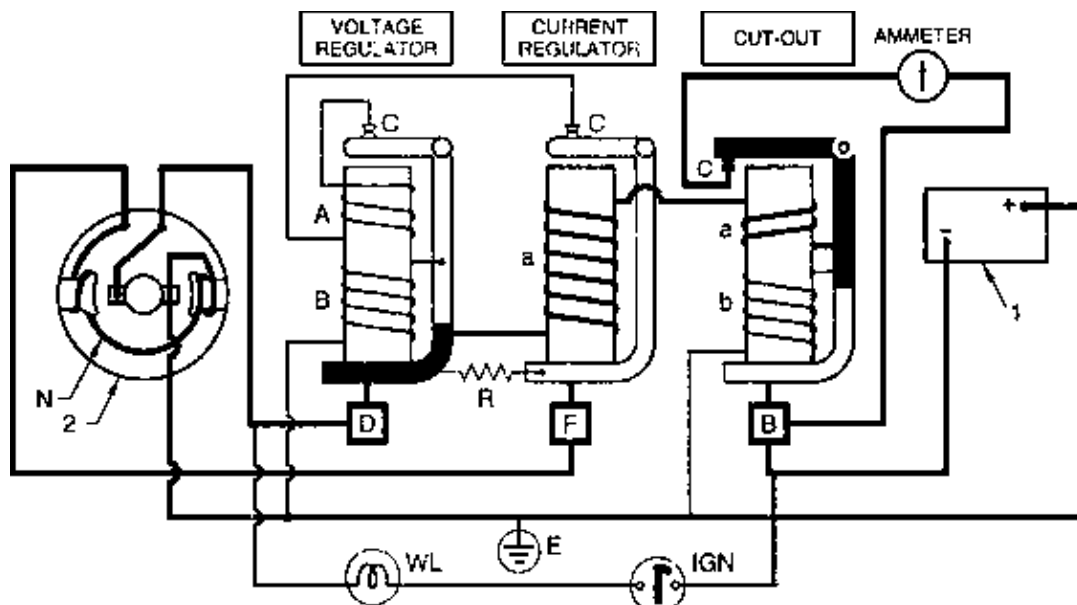

General

The vehicle charging circuit consists of a battery 12V (1) and a two brush dynamo (2) and a regulator unit and connecting wires,

The regulator unit contains a voltage regulator (I) current regulator (II) and a cutout relay III, all being mounted on a single base, with markings B–D–F for wire connections.

Function

A. At Slow speeds

The dynamo (2) produces less voltage and hence less current so it does not charge the battery (1).

B. At High speeds

The current produced is sufficiently of high value and flows into the series and shunt coils of voltage regulator, current regulator and cutout (A, a, b). The shunt coil in the cutout (b) produces a magnetic field which attracts the contacts (C) and when they are closed, current passes into the battery (1) via Ammeter and series coil (a). The cutout (III) does not allow reverse current from battery (1) to dynamo (2) when Battery is fully charged. Hence it is called Reverse current relay.

Dynamo output regulation

The function of regulator is to limit the output voltage/current of the dynamo. The current and voltage regulator contacts open when the current/voltage reaches a pre-set value causing a resistance (R) to be inserted to reduce the value of the current/voltage and contacts are closed again by spring action. With a Low Battery Voltage the current regulator (II) will

Circuit Diagram of Alternator Testing

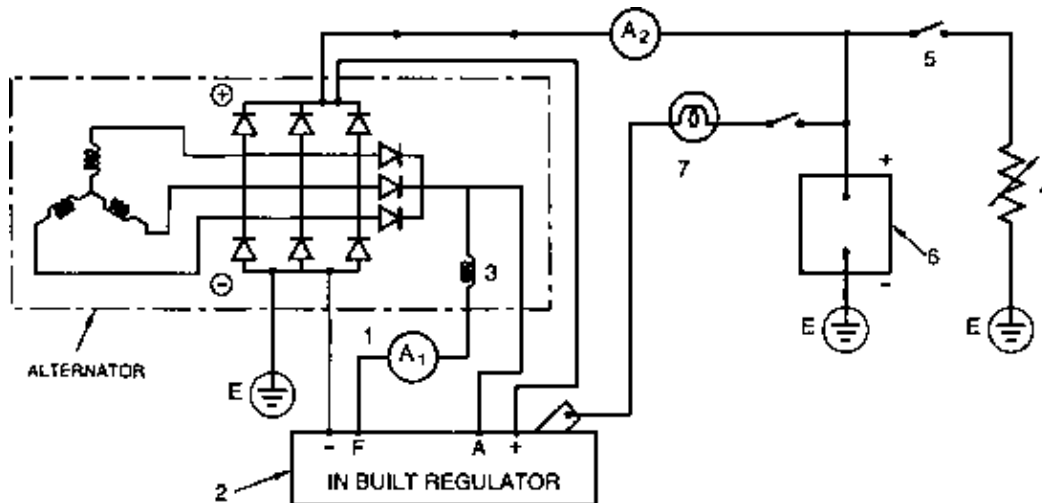

Bench Testing Method

The Bench Testing of an Alternator is described below.

Preliminaries

- 1 Mount alternator on test rig with cowl removed.
- 2 Connect the Test circuit wires as shown in the chart.
- 3 Use recommended size of wires. (Refer Vehicle Service Manual)

Test connections

- 1 Connect field ammeter (A_1)(1) between Field Terminal of regulator box (2) and field winding (3).
- 2 Connect a variable load of 60 Amps (4) in series with switch (5) and across the battery (6),

Alternator output test with an Voltmeter

- 1 Run alternator upto 6000 rpm
- 2 Adjust variable load (4) so that voltmeter will show 13.5 volts for 12V and 26.75 V for 24 V systems.
- 3 Ammeter (A_1)(1) should also record field current as below.

- a) 3 to 4 amps for 12 volt system
- b) 2 to 2.5 amps for 24 volt system

- 4 Test warning lamp (7) for its working or not. (Refer to fault finding chart for remedial action in the Vehicle Service Manual)

Synchroniser unit and its action

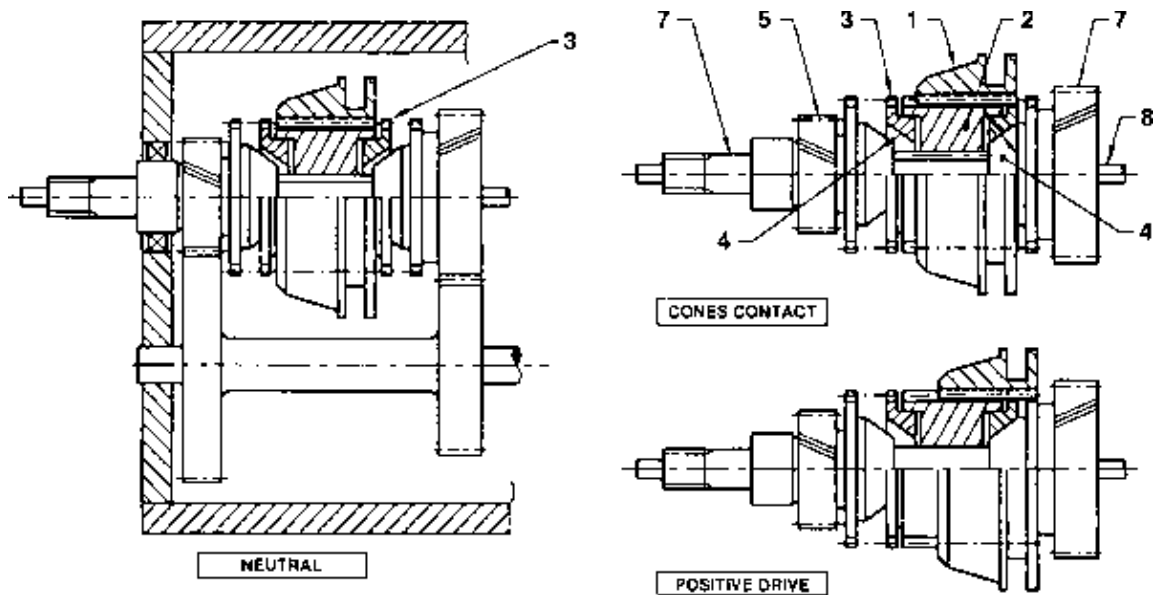

(A) Description of the unit

The synchroniser unit has a synchroniser sleeve (1), a centre hub (2), a set of blocking rays (3) with inside conical surfaces (4). The corresponding conical surfaces (4) are also made on the gear wheels (5) and (6) which are driven by clutch primary shaft (7) and gear box main shaft (8). These conical surfaces match with each other. Gears (5) & (6) rotate in mesh with gear box counter shaft gears in the gear box. But the hub (2) rotates at the main shaft speed, as it is splined to it. The synchroniser sleeve (1) can slide back and forth along the splines provided on the synchroniser hub.

(B) Working

The synchroniser unit is provided between top gear and second gear drive in the gear box when a gear change is made for the second gear the synchronising unit moves as a unit until the conical surfaces of blocking ring (3) and gear wheel (6) engage with each other. Now the speeds of gear box mainshaft and clutch primary shaft become equal. Further movement of the sleeve 1 engages the dog teeth of blocking ring (3) and gear wheel (6). At this stage both shafts are rotating at the same speed. Thus II gear drive is obtained without clashing of gears and double declutching. All the three stages of operation are shown in the figures.

Layout of 4 Wheel Drive

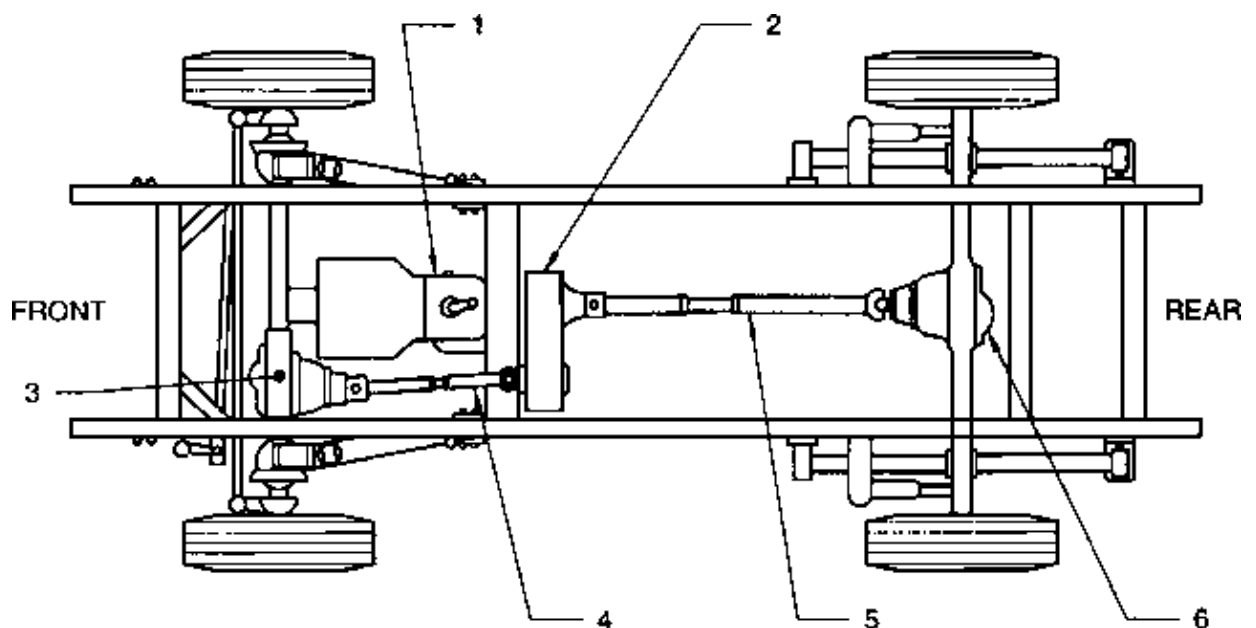

Power flow

The main transmission (1) is fitted with a transfer case (2) at its back. The transfer case (2) is an auxiliary transmission, connected to front differential (3) through a front drive (propeller) shaft (4) and to rear differential (6) through a rear drive shaft (5). By shifting to gears in the transfer case by a selector lever (A) the engine power is divided and transmitted to both front and rear differentials. High speed in transfer case provides a direct drive i.e. 1:1 ratio and low speed provides a ratio of 2:1.

These ratios help to drive the vehicle on rugged terrain, upgradients muddy and sandy roads without spinning of wheels.

Four wheel drive transfer case (High Range)

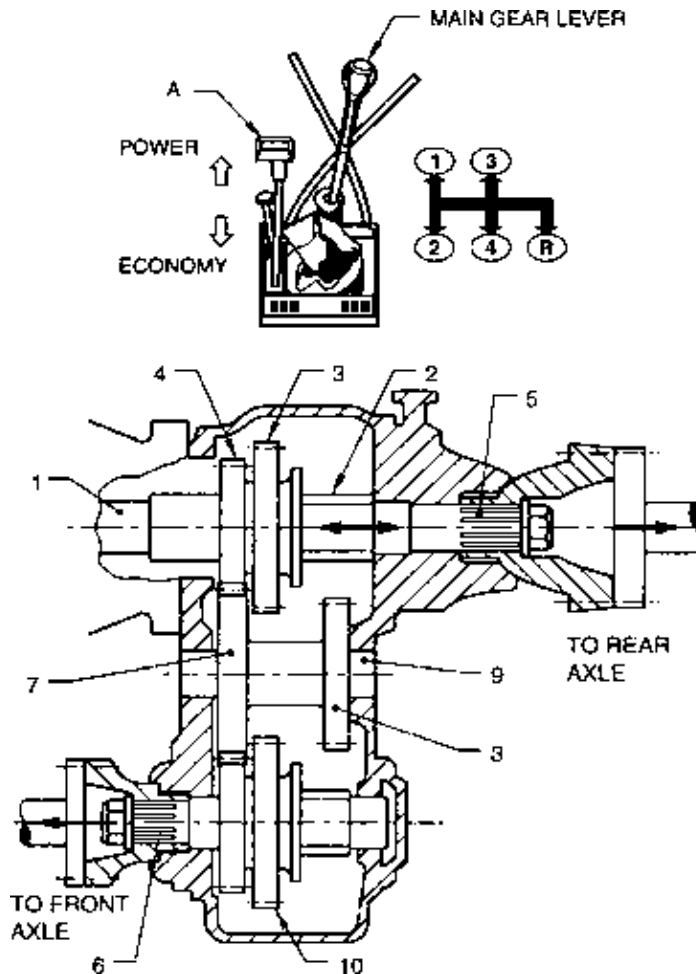

General

A gear lever is provided with 4 positions shaft for gear shift. In addition a transfer case selector (A) is provided on the left or right of drivers seat. The selector lever (A) can be placed either in high range (for economy) or Low range (for power). The figure shows high range drive through transfer case mechanism.

Power flow

When the selector lever (A) is shifted to engage high range drive position, the drive from the primary gear box shaft (1) goes to the main shaft (2). The main shaft sliding gear (3) engages with high range gear (4) and the power is transmitted to the rear wheels drive output shaft (5) directly and to the front wheel drive output shaft (6) through idler gear (7).

The four wheel drive mechanism provides necessary gear ratios to avoid spinning of road wheels on slippery surfaces.

Independent front wheel suspension (Macpherson & Coil spring)

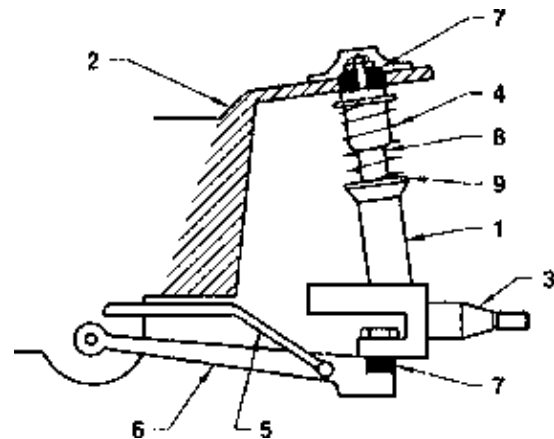

MACPHERSON STURT TYPE SUSPENSION

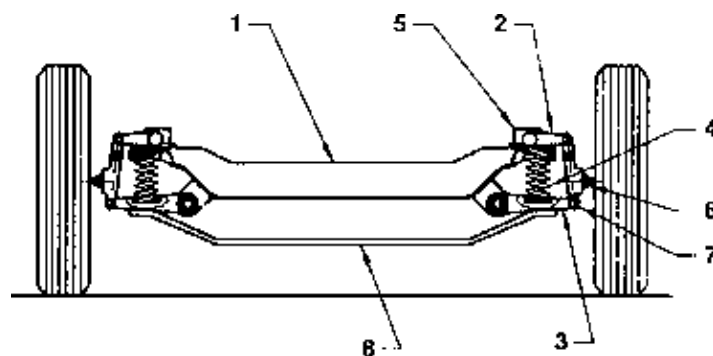

COIL SPRING SUSPENSION

A. Macpherson strut type suspension

This system is largely used for independent springing action of front wheels of a car. The working of it is described below.

Working

This type of suspension has no upper control arm. A strut (1) is mounted between the frame (2) and Stub axle (3). The road shocks (while driving a vehicle) received by front strut (1) is distributed through stub axle (3) and coil spring (4) and then to front suspension Arm (7) and finally are absorbed. A rubber pad (7) is provided to prevent road wheel shocks being transferred to the frame (2). The coil spring (4) reduces the effects of Road shocks due to bumps and Pot holes and a shock absorber (8) distributes it evenly to all members. A stabiliser bar (6) connects the two lower transverse members and prevent body rules on cornering.

B. Coil spring suspension

This system uses coil springs for spring action of front wheels and keeps the car stable on road during driving due to low centre gravity of the vehicle.

Working

A frame (1) is provided with two control arms (upper and lower) (2&3) with suitable swinging arrangement. A coil spring (4) and shock absorber (5) are placed between them. A steering knuckle (6) is pivoted at each end of the upper and lower control arms through Ball joints (7). These joints allow angular movement of steering knuckle and its linkages. When the vehicle is driven on pumps and pot holes, the wheel and tyre moves upward and also inwards. The inward movement drags the tyre sideways and causes rapid tyre wear. This tyre wear could be reduced by use of shorter and longer arms in the system. Shims are provided on the upper control arm for chamber adjustments.

A stabiliser bar (8) (called also Anti-Roll Bar) connecting both Lower Control Arms prevents the tendency of car body to roll outwards during vehicle cornering by offering resistance to twisting action.

Valve Timing Diagram (4 Stroke Cycle Diesel Engine)

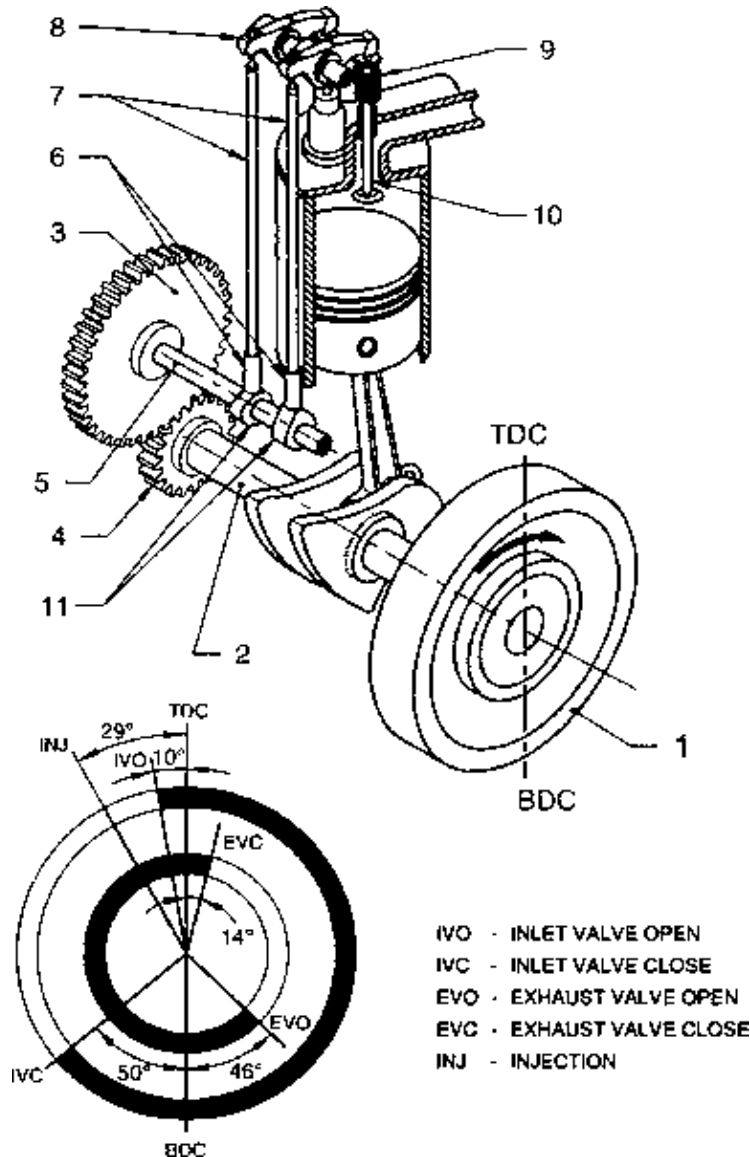

Valve timing

Valve timing is set and checked with reference to TDC and BDC marked on flywheel (1).

Checking Inlet valve opening

The valve timing angles are marked on the face of the flywheel (1). Hence rotate flywheel (1). The crankshaft (2) Timing gears (3 & 4) camshaft (5). Tappet (6) pushrod (7) and Rocker arm (8) and springs (9) will operate. Observe position of pushrod (7) and compression of springs (9). Feel the push rod for tightness and ensure the valve opening. Now the Inlet valve (10) is fully opened.

Now measure the distance on the flywheel (1) from TDC to the point of opening Inlet valve (9) by using a measuring tape. Convert, this flywheel distance into degrees of crankshaft revolution by using the formula

$$D = 2 \times 360 \times A \times R \text{ [Where A = Timing angle, R = Radius of flywheel]}$$

Result

If in the conversion you get 10° as the degrees marked on the flywheel, the Inlet valve opening is correct. Also check the timing gear marks for alignment. If they align, the timing is correct.

Crankcase Ventilation

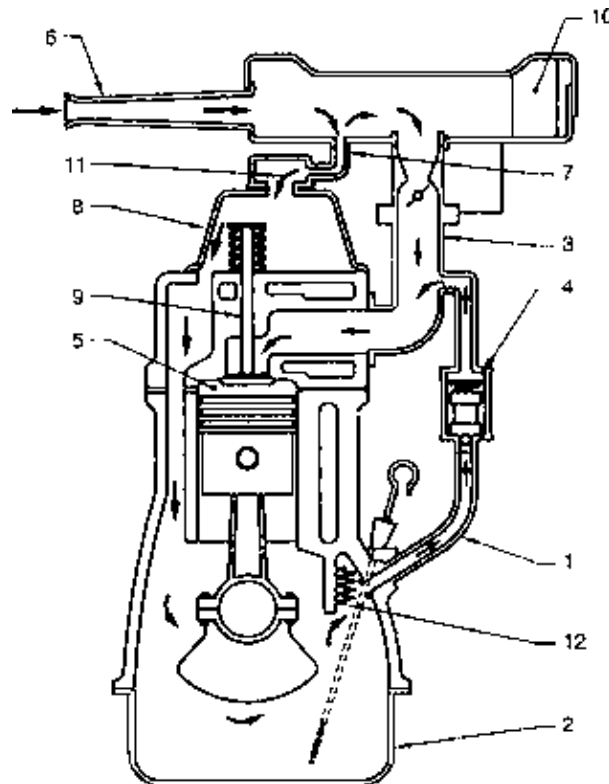

Function

In IC engines, products of combustion leak past the rings into the crankcase. These products are to be removed to reduce oil contamination, dilution, corrosion and other undesirable chemical effects. For removal of these products positive crankcase ventilation is used in engines.

As per MV Act all Motor Vehicle Engines are to be provided with P.C. Ventilation system and this is compulsory.

Working

Generally a Tube or Hose (1) connects the crankcase (2) to the Intake manifold (3) via a PCV valve (4). The crankcase gases are drawn into the Inlet manifold (3) by engine vacuum, then goes into the combustion chamber (5) with air fuel mixture and gets burnt up as a fuel. Clean Air is delivered to the engine through air entry tube (6) and also through a Breather pipe provided on the oil filler or A Tube or Hose (7) connecting the engine air filter to the crankcase or rocker cover (8). The PCV Valve (4) controls the flow of air through the crankcase (2) and prevents excess air admission during suction and acceleration of the vehicle. Also it protects engine against damage due to back firing.

Comparison of function Multi hole and Pintle nozzles

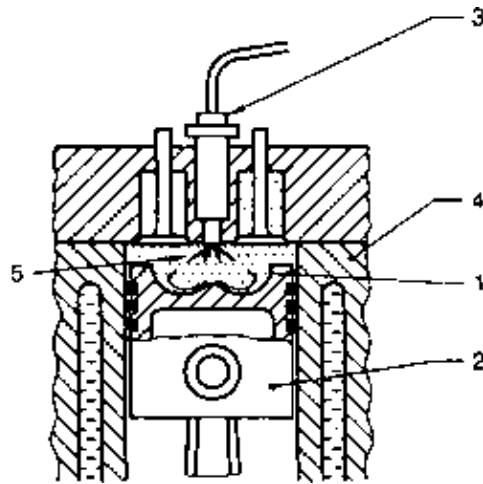

A. Multi-Hozzle Nozzle

Functional aspect

This nozzle works in conjunction with a Torroidal chamber.

The provision of torroidal chamber (1) on the top of the piston (2) provides a squish turbulence of air to enable fuel to mix with air fully.

The air in the cylinder (4) is compressed to a very high pressure. The fuel nozzle (3) has 4 spray (5) holes and fuel is sprayed at a very high pressure to penetrate into the highly compressed air. The fuel is ignited very quickly and combustion proceeds in the cylinder (4).

No heater or glow plug is necessary. Hence starting of engine is easy. The method is called direct injection in diesel engines. (D.I. Engines)

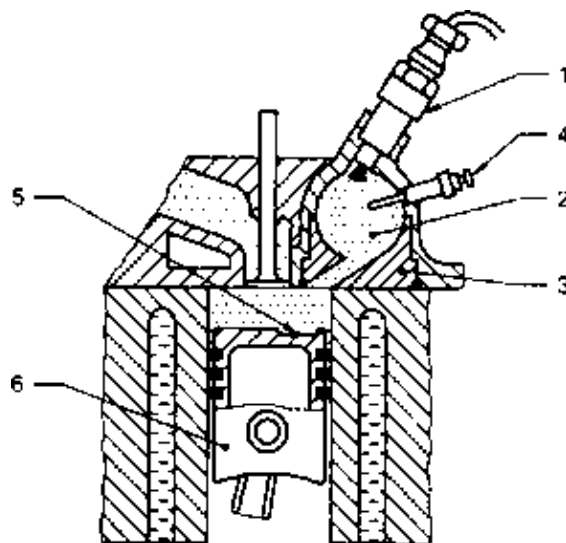

B. Pintle Nozzle Functional aspect

The pintle nozzle (1) works in conjunction with Pre-chamber (2) provided in the cylinder head (3).

The pintle nozzle (1) provides a conical spray of fuel at a low pressure on the compressed air in the pre-combustion chamber (2).

The pre-chamber provides good turbulence of air for mixing with fuel spray. Since the air in the pre-chamber (2) is not compressed to high pressure enough heat is not available for igniting the fuel. Hence a glow plug (4) to preheat the air is provided.

The combustion of fuel takes place in two stages, i.e first in the pre-combustion chamber (2) and it is continued in the spherical chamber (5) on the top of the piston. The burnt gas and unburnt fuel particles pass to the main chamber through passage in the pre-chamber (2). During this process further atomisation of fuel takes place and all fuel is burnt out. The combustion process is continued on the top of the piston (6).

This method is called Indirect Injection in diesel engine.

Fuel feed system (Diesel Inline Jerk Pump)

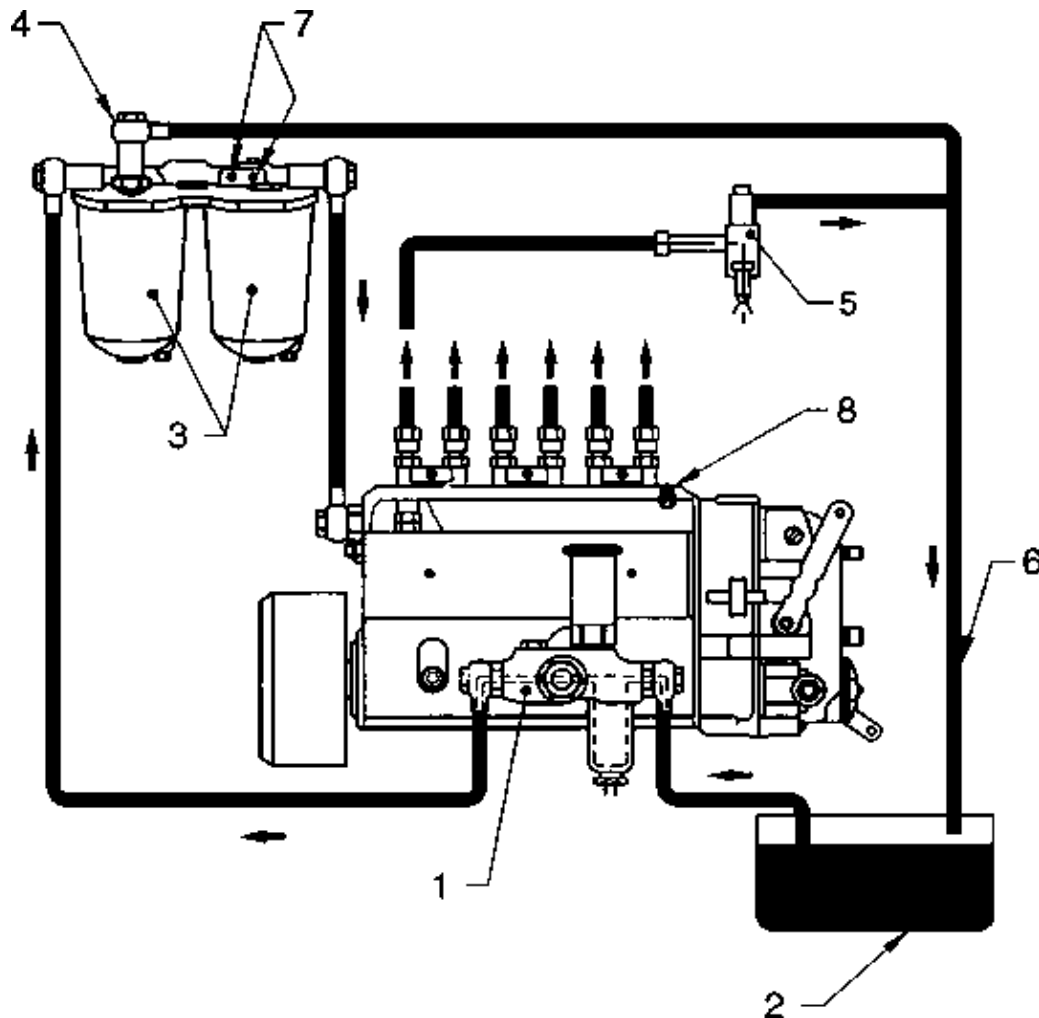

Fuel circulation

In a Motor Vehicle fitted with diesel engine, diesel fuel is drawn by the fuel feed pump (1) from the fuel tank (2). The fuel from the feed pump (1) is supplied to the fuel filters (3) under low pressure. From fuel filters (3) the fuel flows into the fuel Injection pump gallery. The excess fuel is sent back to the fuel tank through the overflow valve (4). From the fuel injection pump the fuel is supplied to the injectors (5) under high pressure. The excess fuel from the Injector Nozzle is delivered back to the fuel tank (2) through overflow pipe line (6).

For removing the air trapped in the pipe lines, bleeder screws (7) on the filter and Bleeder screws (8) on the F.I. Pump are provided and they are to be opened up and then closed tightly after exit of air from the fuel lines.

The system of removing air from the pipe lines is called bleeding or air venting.

Fuel Injection Pump

Fuel Delivery position



Position 1: The Plunger (2) is now at BDC – Fuel enters the Top of Plunger (2) from gallery (6).

No fuel is delivered now.



Position 2: Plunger (2) moves up in the Barrel, closing both the ports (7 & 8). The fuel is being pressurised by the moving plunger (2) during the movement to TDC.



Position 3: When the helix of the plunger uncovers the spill ports fuel delivery is complete. The pressure drops in the fuel line. But the plunger will continue to move upto TDC to complete its stroke.

NOTE: The height of helix determines the quantity of fuel delivered to the engine.

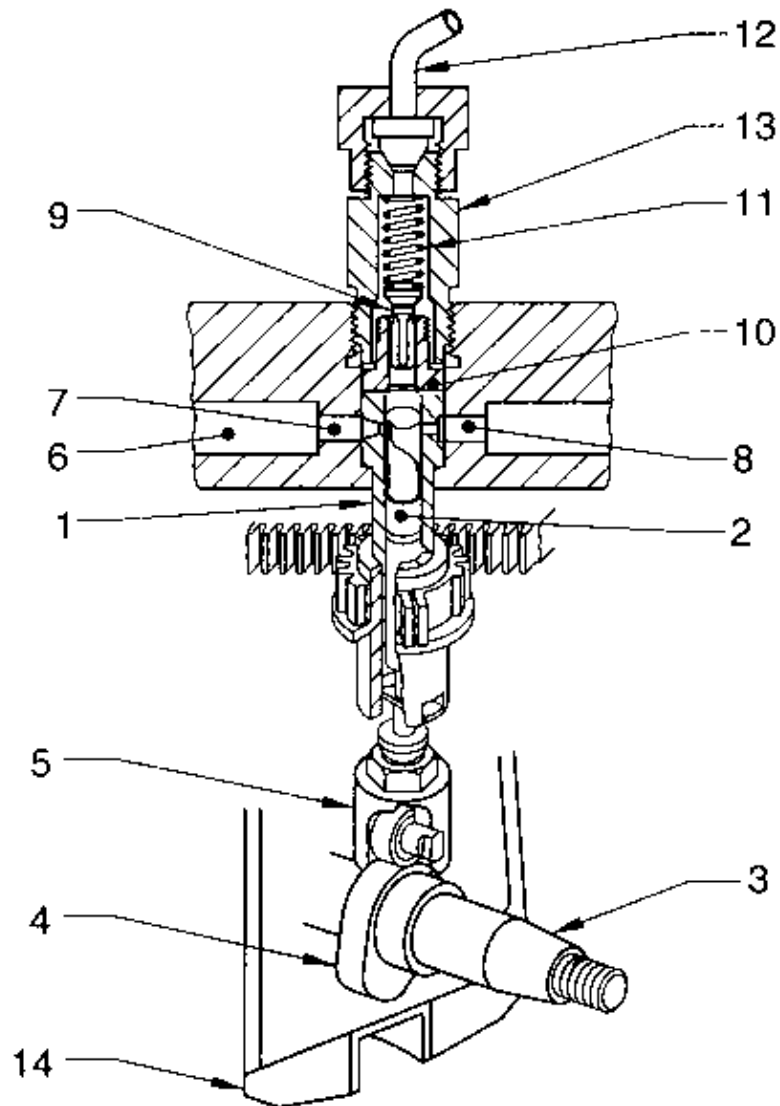

(B) ARRANGEMENT OF PLUNGER & BARREL

Working of F.I. Pump (Fig B)

The figure (B) indicates assembly of components of a Fuel Injection Pump.

This pump has a Barrel (1) and plunger (2) for each Engine Cylinder in a Multi-cylinder engine. The camshaft (3) is driven by the engine and a cam lobe (4) operates each plunger. When a lobe of a cam (4) comes up with roller tappet (5) under a plunger (2), the plunger (2) is lifted and its movement pressurises the Diesel entered from the gallery (6) through feed port (7). The pressure of fuel is raised to a high value when both ports Feed Port (7) and spill port (8) closed. This pressurised fuel lifts the delivery valve (9) off its seat (10) compressing the spring (11) and passes into the fuel out let pipe (12) and then delivered to the Injector nozzle by opening it. The Injection of fuel is stopped, when bottom of helix on the plunger uncovers the spill port (8). The fuel pressure in the pipe line drops. Due to this the delivery valve is seated first on its seat increasing the drop in the fuel pressure. The Injector Nozzle is closed abruptly without dribbling of fuel.

NOTE: The quantity of fuel delivered can be altered by rotating the plunger in the barrel. As plunger is rotated the effective stroke of the plunger is varied and the quantity of fuel delivered to the engine also varies.

Diesel Engine Fuel Filter

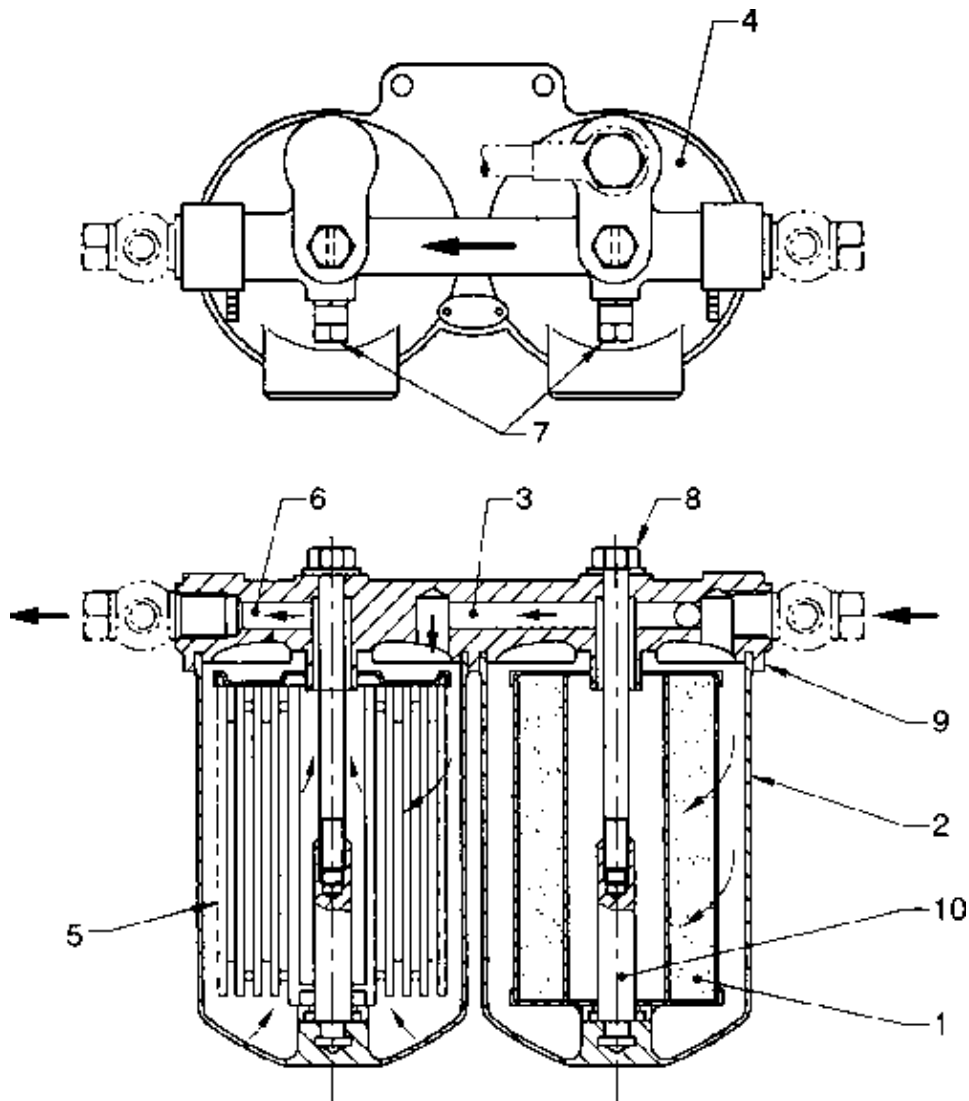

Function

In a Diesel Engine a number of fuel filters are used to clean the fuel free of contaminants to enable the fuel to pass through clearances of very highly precision finished parts like Elements and Nozzles.

Fuel flow

The fuel passes through cloth insert (1) in the Bowl (2) of the pre-filter. Then it passes through the drilled passage (3) in the top cover (4) and enters into Bowl of Micro filter. Then the fuel passes through paper insert (5) and comes out fully cleaned off impurities, dust and dirt and enters the outlet passage (6) provided in the top cover (4) and reaches the F.I. pump. Bleeding screws (7) are provided to remove air from the system (fuel lines). At the Inlet and outlet, Banjos, Banjo bolts with copper washers are provided for connection of fuel lines from lift pump and F.I. pump. The copper washers prevent leakage of fuel through Banjos.

Types of Stub Axle mountings on front Axle

Stub Axle mounting

The stub axle mountings on the Beam front axle conventional type are of 3 types. They are illustrated in the figures.

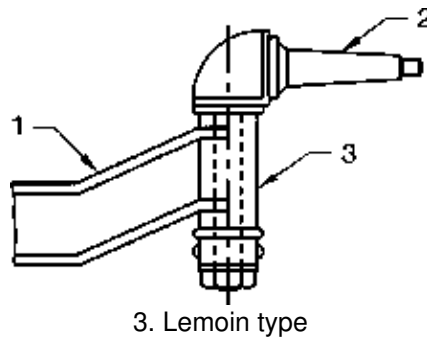
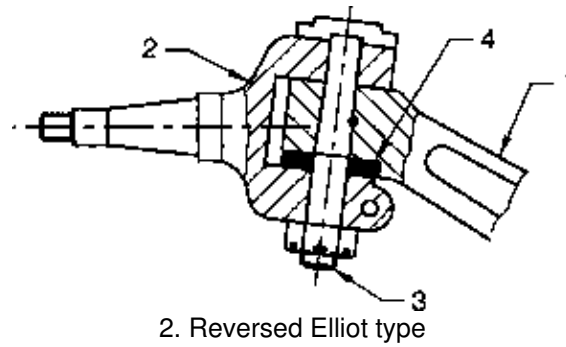
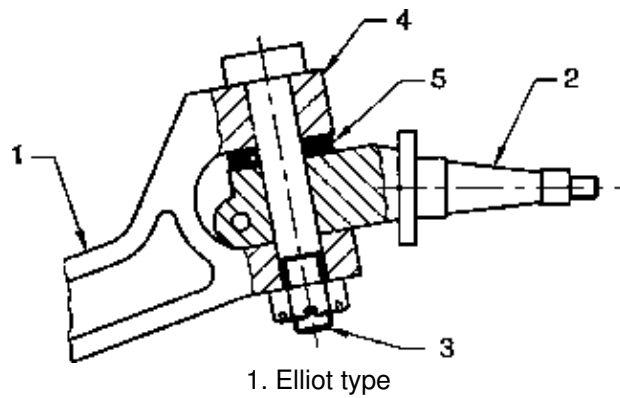

Out of the 3 types, Reversed Elliot type stub axle is largely used on commercial vehicle like Trucks and buses.

Elliot type

In this type the axle (1) is a single rigid 'I' shaped beam with a provision to fit the stub axle (2) at its two ends with king pins (3). The end of the axle (1) is Elliot shaped (forked with two eyes) (4). The stub axle (2) is mounted in between the two eyes with a thrust bearing (5) at the top end of the stub axle.

Reversed Elliot type

In this type Elliot shape is provided in the stub axle (2) The solid end of axle beam (1) is mounted in between the two eyes of the stub axle (2) with king Pins (3) with a thrust washer/bearing (4) at the bottom of the axle. It is commonly used in commercial vehicles.

Lemoin type

In this type the stub axle (2) is mounted on the top of the axle beam (1) with king pins (3).

Steering linkages Light Motor Vehicle

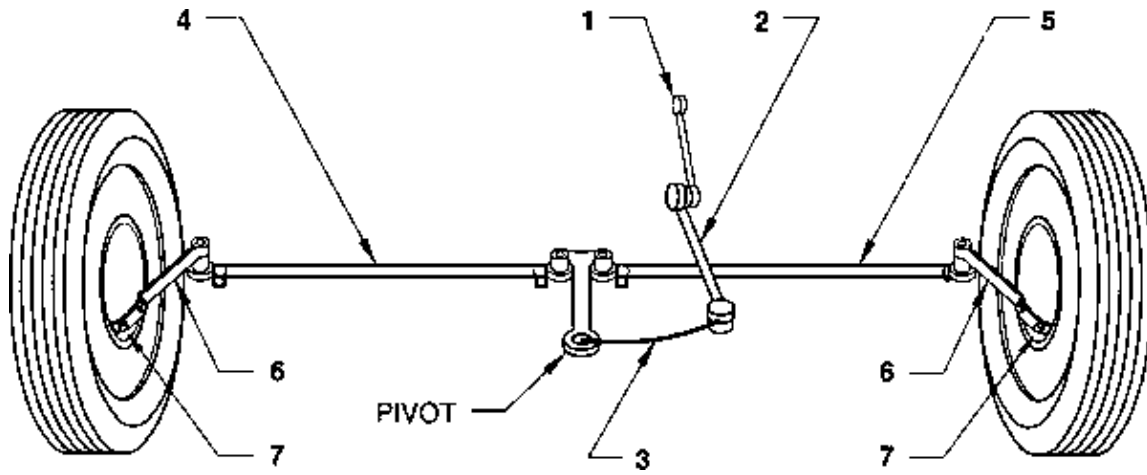

Working

The type of Steering Linkages used in LMVs is different from the Heavy Motor Vehicle Linkages. In the system shown in figure, one Bell Crank Lever and two tie Rods are used for steering operation in addition to other components. When Pitman Arm or Drop Arm (1) is turned by steering wheel it operates the Drag link (2). The Drag link moves the Bell crank (3) on its pivot. When Bell crank (3) moves, it actuates the Right and left Tie rods (4) and (5), which in turn operates the spindle steering arm (6) to turn the wheels. Sockets (7) are provided at all moving points so that turning of these Tie rods will be easy. These Sockets or Joints are to be lubricated with grease periodically.

Steering Gear Box Rack & Pinion Steering

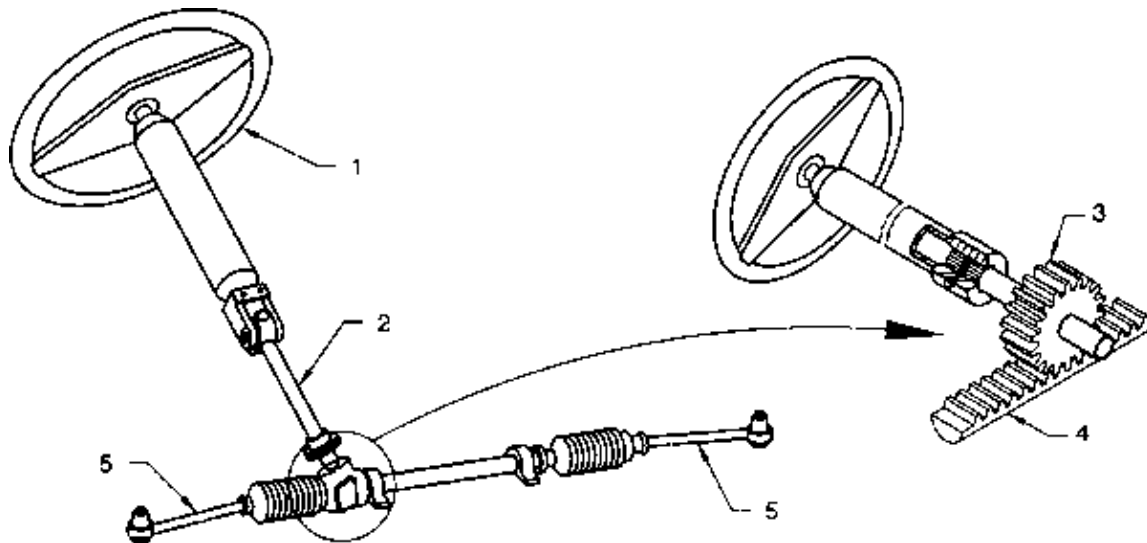

In some of the lighter cars, a Rack and Pinion steering mechanism is provided.

Function

When the steering wheel (1) is rotated the steering column (2) attached with a pinion (3) is also rotated. The pinion (3) is always in mesh with the Rack Teeth (4). This action makes the rack (4) to move either left or right. The Rack (4) is connected to tie rods which cause the wheels to turn for steering the vehicle on road. The steering adjustments are very simple and easy to carry out. The maintenance cost is also less.

Tandem Master Cylinder and its function

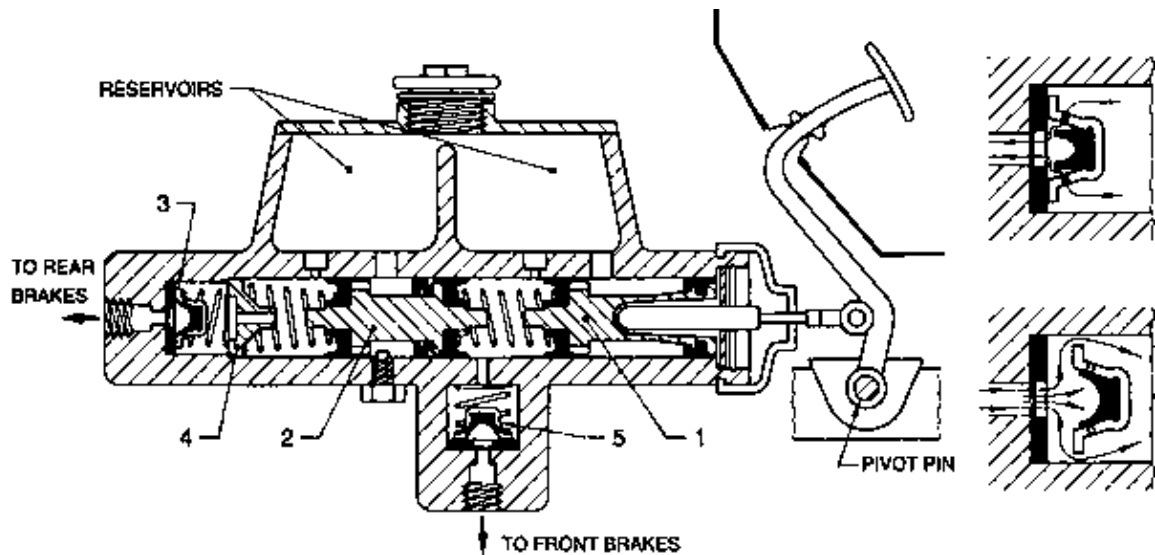

(a) Special points

The operation of this type of master cylinder is similar to that of ordinary master cylinder used in cars and other vehicles.

In this type two separate cylinders and reservoirs are provided in the same body there are two check-valves and two pistons for operation, one each for the front and rear brakes.

In this type, in the event of failure of one brake line (front or rear), the other continues to work and stops the vehicle.

(b) Failure of brakes

When the front brake fails, the primary piston (1) is forced forward till it contacts the secondary piston (2) Now, both the pistons move together in TANDEM.

Pressure is created on the secondary side and this forces the fluid through the check-value (3) to the rear brakes and the vehicle is stopped.

When the rear brake fails there is no pressure on the secondary side. The pedal effort pushes the primary position (1) which forces the secondary piston (2) to stop point (4). Further movement of the piston (1) builds up the fluid pressure which is transmitted to the front wheel cylinders through the check-valve (5) and the vehicle is stopped.

Differential and its action

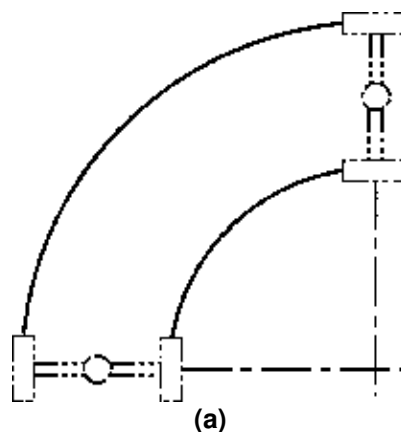

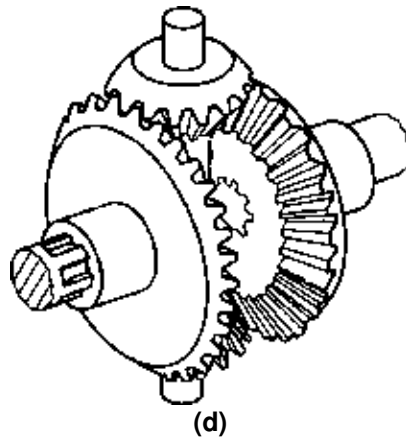
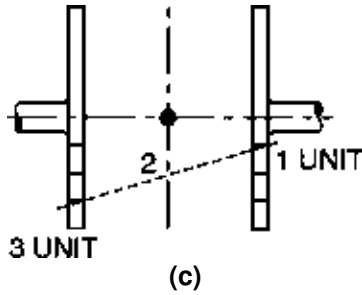
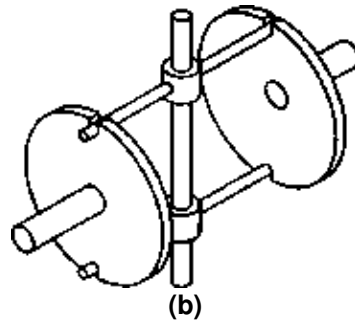

When the vehicle is moving straight, the power is transmitted from the pinion to the crown wheel and to the cage. The differential mechanism is mounted with in the cage and it also moves. When the spider cage is rotating the cross pin or (1) also rotates along with the star gears (2). The sun gears are pushed by the star gears, and power is transmitted to the axle shafts (4) During a straight line run the star gear (3) do not rotate on their axis.

When the vehicle makes a turn, the inner wheel has more grip on the road than the outer wheel. So the respective inner sun gear (3) offers more resistance. At that time, the star gears (2) rotate on their own axis and move the inner sun gear slowly and allow the outer sun gear to rotate faster. So the outer wheel travels more distance in the same time. This is also shown in the Figure (d).

Wheel Cylinder and its action

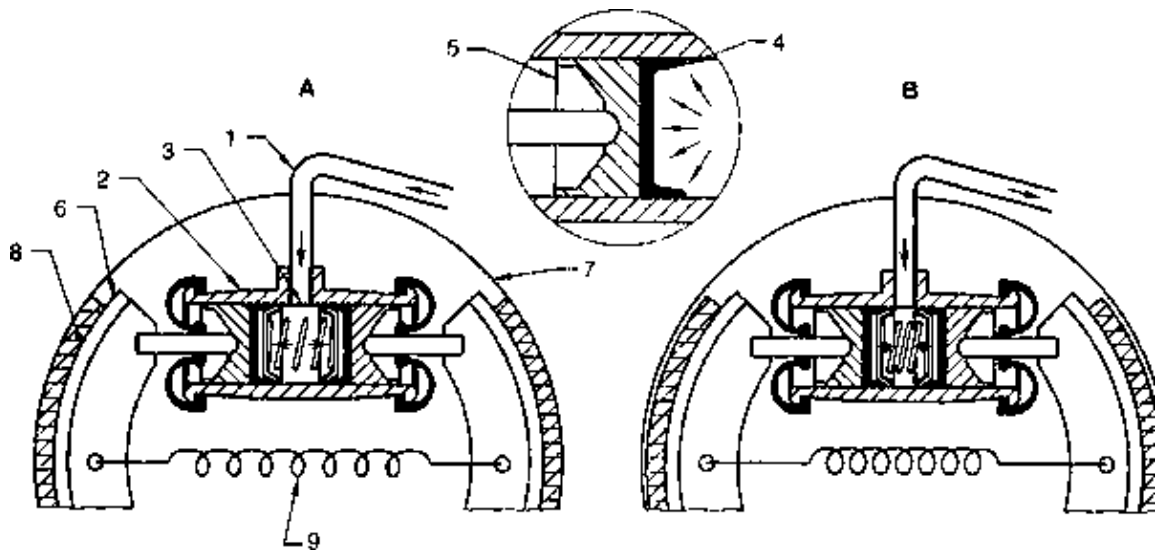

a) Brake application

The pressurized brake fluid coming from master cylinder pipeline (1) enters the wheel cylinder (2) through the entry port (3). This fluid exerts pressure on rubber cups (4) in the direction shown. Now the flanged edges of the cups are pressed tight against wheel cylinder bore. This action prevents leakage of fluid and also entry of air in the system. The pistons (5) move outwards and forces the brake shoes (6) against the brake drum (7). The friction between the brake shoe lining (8) and the brake drum (7), stops the rotation of brake drum (7). Now the vehicle is stopped.

b) Brake release

When brakes are released, the brake shoes (6) come to original position with the help of retracting spring (9). this action pushes the wheel cylinder pistons (5) inside the cylinder and the pressurized fluid returns back to master cylinder by lifting the check valve off its seat.

