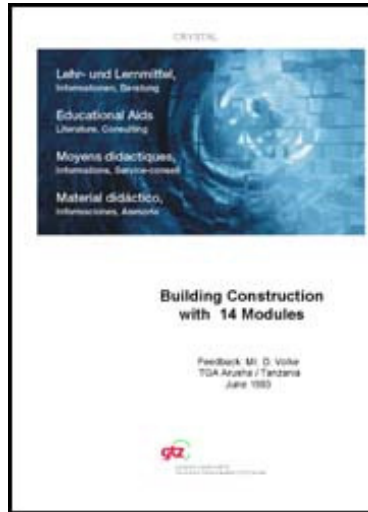

[Home page](#) | [Help](#) | [Clear](#)[English](#) | [French](#) | [Spanish](#) | [German](#)[Search](#) | [Subjects](#) | [Titles A-Z](#) | [Courses](#) | [Illustrations](#) | [Topics](#) | [e-Course builder](#)[Contract TOC](#)[Expand Document](#)[Contract Chapter](#)[Add to e-Course](#)[Preferences](#)

Printable version

Export document
as HTML file [Help](#)

Export document
as PDF file

Building Construction with 14 Modules (TCA; 1983; 618 pages)

1. ARCHITECTURAL DRAWING I

1.1 AIMS AND PURPOSE OF ARCHITECTURAL DRAWINGS

1.1.1 CONTENTS OF ARCHITECTURAL DRAWINGS

1.2 DRAWING EQUIPMENT

1.2.1 PENCILS

1.2.2 DRAWING PENS

1.2.3 COMPASSES

1.2.4 DRAWING BOARDS

1.2.5 T-SQUARES

1.2.6 SET SQUARES

1.2.7 PROTRACTORS

1.2.8 SCALES

1.2.9 FRENCH CURVES

1.2.10 TEMPLATES

1.2.11 DRAWING PINS AND OTHER FIXINGS

1.2.12 MINOR ITEMS OF EQUIPMENT

1.2.13 PRINTING PAPERS

1.2.14 TRACING PAPER, CLOTH AND FILM

 **1.2.15 BACKING SHEETS**

 **1.2.16 DRAWING PAPERS**

 **1.2.17 CARTRIDGE**

 **1.2.18 HANDMADE AND MOULDMADE PAPERS**

 **1.2.19 PLASTIC-COATED CARD**

 **1.3 LETTERING**

 **1.3.1 PRINCIPLE OF LETTERING**

 **1.3.2 FREEHAND LETTERING**

 **1.3.3 TYPES OF LETTERS**

 **1.3.3.1 The Roman Alphabet**

 **1.3.3.2 Sans Serif Letters**

 **1.3.3.3 Inclined Lettering**

 **1.3.3.4 Script Lettering**

 **1.3.3.5 Stencil Lettering**

 **1.3.3.6 Guided Pen Lettering**

 **1.3.3.7 Pressure-Transfer Lettering**

 **1.4 LINEWORK AND DIMENSIONING**

 **1.4.1 TYPES OF LINES**

 **1.4.2 PENCIL DRAWING**

 **1.4.3 INKING - IN**

 **1.4.4 BASIC RULES OF DIMENSIONING**

 **1.4.4.1 Types of Dimensions**

 **1.4.4.2 Placement of Dimensions**

 **1.5 ENLARGEMENT AND REDUCTION OF LINE DRAWINGS** **1.6 GEOMETRICAL CONSTRUCTIONS** **1.6.1 LINES AND ANGLES** **1.6.1.1 To bisect a straight line AB** **1.6.1.2 To divide a straight line AB into a given number of equal parts** **1.6.1.3 To divide a straight line AB into any ratio** **1.6.1.4 To construct an angle of 90°**  **1.6.1.5 To construct an angle of 45°**  **1.6.1.6 To construct an angle of 60°**  **1.6.1.7 To construct an angle of 30°**  **1.6.1.8 To bisect any given angle** **1.6.1.9 To construct an angle SIMILAR to a given angle** **1.6.1.10 To draw a line PARALLEL to a given line** **1.6.2 TRIANGLES** **1.6.2.1 To construct an EQUILATERAL triangle** **1.6.2.2 To construct a triangle with given BASE ANGLES and ALTITUDE** **1.6.2.3 To inscribe a circle in a given triangle ABC** **1.6.2.4 To circumscribe a triangle ABC** **1.6.3 CIRCLES** **1.6.3.1 Basic CIRCLE-Constructions** **1.6.3.2 To draw a tangent to a point A on the circumference of a circle centre O**

 **1.6.3.3 To draw an internal tangent to two circles of equal diameter**

 **1.6.3.4 To find the centre of a given circle arc**

 **1.6.3.5 To join two straight lines at RIGHT ANGLES to each other by an arc of given radius**

 **1.6.3.6 To draw a curve of given radius joining two circles**

 **1.6.3.7 To join two straight lines by two arcs of equal radius**

 **1.6.4 BASIC ARCH CONSTRUCTIONS**

 **2. ARCHITECTURAL DRAWING II**

 **2.1 TYPES OF PROJECTIONS**

 **2.2 ORTHOGRAPHIC PROJECTION**

 **2.2.1 CONSTRUCTION OF ORTHOGRAPHIC PROJECTION**

 **2.2.2 ELEVATIONS**

 **2.2.3 PLANS AND SECTIONS**

 **2.3 PICTORIAL DRAWING**

 **2.3.1 AXONOMETRIC PROJECTION**

 **2.3.2 ISOMETRIC PROJECTION**

 **2.3.3 DIMETRIC PROJECTION**

 **2.3.4 OBLIQUE PROJECTION**

 **2.3.4.1 Length of Receding Lines**























 **2.3.4.2 Construction of Oblique Drawings**

 **2.3.4.3 Rules of Oblique Drawing**























 **2.3.4.4 Scale of the Receding Lines**























 **2.3.4.5 Direction of Receding Lines**

 **2.3.4.6 Position of Axes** **2.4 PERSPECTIVE DRAWING** **2.4.1 PERSPECTIVE TERMS** **2.4.2 PHENOMENA OF PERSPECTIVE DRAWING** **2.4.3 SYSTEMS OF PERSPECTIVE DRAWINGS** **2.4.4 METHODS OF PERSPECTIVE DRAWINGS** **2.4.5 TWO-POINT PERSPECTIVE** **2.4.6 ONE-POINT PERSPECTIVE** **2.5 SHADES AND SHADOWS** **2.5.1 THE USE OF SHADOWS** **2.5.2 SHADES AND SHADOWS** **2.5.3 THE CONVENTIONAL DIRECTION OF LIGHT** **2.5.4 THE 45° DIRECTION** **2.5.5 THE TRUE DIRECTION OF LIGHT** **2.5.6 SHADOWS OF SOLIDS** **2.5.7 PLANES OF SHADOW** **2.5.8 PRINCIPLES OF SHADOW-CASTING** **2.6 DRAWING PRACTICE** **2.6.1 DRAWING SHEETS** **2.6.1.1 Sizes and Folds** **2.6.1.2 Layout and Identification** **2.6.2 LEVELS** **2.6.3 REFERENCING**

-  **2.6.4 ABBREVIATIONS**
-  **2.6.5 REPRESENTATION OF MATERIALS**
-  **2.6.6 GRAPHICAL SYMBOLS AND REPRESENTATION**
-  **2.6.7 HATCHING RULES**
-  **2.7 APPLICATION FOR BUILDING PERMIT**
 -  **2.7.1 PROCEDURE OF APPLYING FOR PERMISSION TO ERECT A BUILDING**
 -  **2.7.2 FORMULARS**
-  **4. CONTRACT PLANNING AND SITE ORGANISATION**
 -  **4.1 CONTRACT PLANNING**
 -  **4.1.1 BAR CHART**
 -  **4.1.2 NETWORK ANALYSIS**
 -  **4.1.3 THE OVERALL PROGRAMME**
 -  **4.1.3.1 Break down of job**
 -  **4.1.3.2 Quantities of work and time content**
 -  **4.1.3.3 Plant and Labour outputs**
 -  **4.1.3.4 Sequence and timing of operations**
 -  **4.1.3.5 The programme chart**
 -  **4.1.4 PLANNING CONSIDERATIONS**
 -  **4.1.4.1 Site conditions and access**
 -  **4.1.4.2 Nature of job**
 -  **4.1.4.3 Plant**
 -  **4.1.4.4 Scaffolding**

 **4.2 SITE ORGANIZATION** **4.2.1 PRELIMINARY WORK** **4.2.2 SITE PLANNING** **4.2.2.1 Period planning** **4.2.2.2 Weekly planning** **4.2.2.3 Progress control** **4.2.3 SITE LAYOUT** **5. FOUNDATIONS** **5.1 SOIL INVESTIGATIONS** **5.1.1 SITE EXPLORATION** **5.1.1.1 Trial holes** **5.1.1.2 Bore holes** **5.1.1.3 Sampling** **5.1.1.4 Tests** **5.1.1.5 Load or bearing test** **5.1.2 SOILS AND SOIL CHARACTERISTICS** **5.1.2.1 Rocks and soils** **5.1.2.2 Stresses and pressures** **5.2 EXCAVATIONS AND TIMBERING** **5.3 TYPES OF FOUNDATIONS** **5.3.1 CLASSIFICATION** **5.3.2 CHOICE OF FOUNDATION** **5.3.3 SPREAD FOUNDATIONS**

-  **5.3.3.1 Strip foundations**
-  **5.3.3.2 Deep strip foundations**
-  **5.3.3.3 Stepped foundations**
-  **5.3.3.4 Pad foundations**
-  **5.3.3.5 Raft foundations**
-  **5.3.4 PILE FOUNDATIONS**
 -  **5.3.4.1 Short bored pile foundations**
-  **5.3.5 PIER FOUNDATIONS**
-  **6. WALLS**
 -  **6.1 FUNCTION AND PROPERTIES OF WALLS**
 -  **6.2 THE BEHAVIOR OF THE WALL UNDER LOAD**
 -  **6.2.1 CALCULATION OF WALL THICKNESS**
 -  **6.3 TYPES OF WALLS**
 -  **6.4 STONEWORK**
 -  **6.4.1 BUILDING STONES**
 -  **6.4.2 STONEWORK THERMINOLOGY**
 -  **6.4.3 STONEWORK CLASSIFICATION**
 -  **6.4.4 RUBBLE WALLING**
 -  **6.4.5 ASHLAR WALLING**
 -  **6.4.5.1 Rules for ashlar work**
 -  **6.5 BRICK WORK**
 -  **6.5.1 BRICKWORK TERMINOLOGY**
 -  **6.5.2 MANUFACTURE OF CLAY BRICKS**

-  **6.5.2.1 Pressed Bricks**
-  **6.5.2.2 Wire cut bricks**
-  **6.5.2.3 Efflorescence**
-  **6.5.3 BRICK CLASSIFICATION**
-  **6.5.4 CALCIUM SILICATE BRICKS**
-  **6.5.5 CONCRETE BRICKS**
-  **6.5.6 MORTARS FOR BRICKWORK**
-  **6.5.7 DAMPNES PENETRATION**
-  **6.5.8 BRICKWORK BONDING**
 -  **6.5.8.1 Common bonds**
-  **6.5.9 METRIC MODULAR BRICKWORK**
-  **6.5.10 JUNCTIONS**
-  **6.5.11 QUOINS OR EXTERNAL ANGLES**
-  **6.5.12 PIERS**
 -  **6.5.12.1 Detached piers:**
 -  **6.5.12.2 Attached Piers (or Pilasters)**
 -  **6.5.12.3 Buttresses**
-  **6.6 BLOCKWORK**
 -  **6.6.1 CLAY BLOCKS**
 -  **6.6.2 PRECAST CONCRETE BLOCKS**
 -  **6.6.3 AERATED CONCRETE BLOCKS**
-  **6.7 CONCRETE WALLS**
 -  **6.7.1 GENERAL**



6.7.2 FOREWORK

6.7.3 PLAIN MONOLITHIC CONCRETE WALL

6.7.3.1 Dense concrete walls

6.7.3.2 Light-weight aggregate

6.7.3.3 No-fines concrete walls

6.7.3.4 Thickness of plain concrete walls

6.7.3.5 Shrinkage reinforcement

6.7.4 REINFORCED CONCRETE WALLS

6.7.4.1 In-Situ Cast external walls

6.7.4.2 Concrete Box Frames

6.7.4.3 Large precast panel structure

6.8 OPENINGS IN WALLS

6.8.1 HEAD

6.8.1.1 Lintels

6.8.1.2 Arches

6.8.2 JAMBS

6.8.3 SILLS AND THRESHOLDS

6.8.3.1 Sills

6.8.3.2 Thresholds

7. FLOORS

7.1 GENERAL

7.2 SOLID GROUND FLOORS





7.2.1 SITE CONCRETE



7.2.2 HARDCORE



7.2.3 WATERPROOF MEMBRANE



7.3 SUSPENDED TIMBER GROUND FLOOR



7.3.1 BUILDING REGULATIONS



7.3.2 LAY OUT



7.4 UPPER FLOORS



7.4.1 TYPES OF UPPER FLOORS



7.4.2 STRUCTURE OF UPPER FLOORS



7.4.3 SUSPENDED TIMBER UPPER FLOORS



7.4.3.1 Floor Joists



7.4.3.2 End Support of Floor Joists



7.4.3.3 Trimming



7.4.4 REINFORCED CONCRETE UPPER FLOORS



7.4.4.1 Monolithic Reinforced Concrete Upper Floors



7.4.4.2 Precast Concrete Upper Floors



7.4.4.3 Hollow Block and Waffle Floors



7.5 FLOOR FINISHES



7.5.1 JOINTLESS FLOOR FINISHES



7.5.1.1 The most common of these is the Cement/Sand Screed

























7.5.1.2 Granolithic Concrete Finishes



7.5.1.3 Terazzo



7.5.2 SLAB FLOORS FINISEHES

-  **7.5.3 SHEET FLOOR FINISHES**
-  **7.5.4 WOOD FLOOR FINISHES**
-  **8. OPEN FIREPLACES, CHIMNEYS AND FLUES**
 -  **8.1 FUNCTION OF FIREPLACES AND FLUES**
 -  **8.2 PRINCIPLES OF FIREPLACE DESIGN**
 -  **8.2.1 TRADITIONAL OPEN FIREPLACE**
 -  **8.2.2 IMPROVED SOLID FUEL APPLIANCES**
 -  **8.3 PRINCIPLES OF FLUE DESIGN**
 -  **8.4 CONSTRUCTION OF FLUE DESIGN**
 -  **8.4.1 NON-CONVECTOR OPEN FIRES**
 -  **8.4.2 CONVECTOR OPEN FIRES**
 -  **8.5 CONSTRUCTION OF CHIMNEYS**
-  **9. ROOFS**
 -  **9.1 FUNCTIONAL REQUIREMENTS**
 -  **9.1.1 STRENGTH AND STABILITY**
 -  **9.1.2 WEATHER RESISTANCE**
 -  **9.1.3 THERMAL INSULATION**
 -  **9.1.4 FIRE RESISTANCE**
 -  **9.1.5 SOUND INSULATION**
 -  **9.2 TYPES OF ROOF STRUCTURES**
 -  **9.2.1 FLAT AND PITCHED ROOFS**
 -  **9.2.2 STRUCTURE OF THE ROOF**
 -  **9.2.3 LONG AND SHORT SPAN ROOFS**

 **9.2 LONG AND SHORT OF A ROOF** **9.3 FLAT ROOFS** **9.3.1 PHYSICAL AND STRUCTURAL PROBLEMS** **9.3.2 STRUCTURE OF A FLAT ROOF** **9.3.3 THERMAL INSULATION MATERIAL** **9.3.4 SINGLE AND DOUBLE FLAT ROOF CONSTRUCTION** **9.3.5 PARAPET WALLS** **9.4 PITCHED ROOFS** **9.4.1 SHAPES OF PITCHED ROOFS IN TIMBER** **9.4.2 TERMS** **9.4.3 TYPES OF PITCHED ROOFS IN TIMBER (STRUCTURES)** **9.4.3.1 Mono-(single) pitched Roof** **9.4.3.2 Lean - to Roof** **9.4.3.3 Couple Roof** **9.4.3.4 Close couple Hoof** **9.4.3.5 Collar Roof** **9.4.3.6 Double or Purlin Roof** **9.4.3.7 Tripple or Trussed Roofs** **9.4.3.8 Trussed Rafters** **9.4.3.9 Hipped Roofs** **9.4.4 VALLEY** **9.4.5 EAVES TREATMENT** **9.4.6 OPENINGS IN TIMBER ROOFS** **9.5 ROOF COVERINGS**

9.5 ROOF COVERINGS **9.5.1 FUNCTION OF ROOF COVERINGS** **9.5.2 TYPES OF ROOF COVERINGS** **9.5.3 SUBSTRUCTURES** **9.5.4 CHOICE OF ROOF COVERINGS** **9.5.5 MATERIALS AND COVERING METHODS** **10. FRAMED STRUCTURES** **10.1 STRUCTURAL CONCEPT** **10.2 FUNCTIONAL REQUIREMENTS** **10.3 STRUCTURAL MATERIALS** **10.4 LAYOUT OF FRAMES** **10.5 BUILDING FRAMES** **10.5.1 FUNCTIONS OF BUILDING FRAME MEMBERS** **10.5.2 REINFORCED CONCRETE FRAMES** **10.5.2.1 Reinforced Concrete Beams** **10.5.2.2 Reinforced Concrete Columns** **10.5.2.3 Reinforced Concrete Slabs** **10.5.3 PRECAST CONCRETE FRAMES** **10.5.3.1 Methods of Connections** **10.5.4 STRUCTURAL STEELWORK FRAMES** **10.5.4.1 Structural Steel Frames** **10.5.4.2 Castellated Universal Sections** **10.5.4.3 Connections**



10.5.4.4 Structural Steel Connections



10.5.4.5 Frame Erection



10.5.4.6 Fire Protection of Steelwork



10.5.5 TIMBER FRAMES



10.5.5.1 Columns and Beams



10.5.5.2 Connections



10.5.5.3 Building frames in timber



10.5.5.4 Prefabrication



10.6 PORTAL FRAMES



10.6.1 THEORY



10.6.2 CONCRETE PORTAL FRAMES



10.6.3 STEEL PORTAL FRAMES



10.6.4 TIMBER PORTAL FRAMES



11. PROTECTION OF BUILDINGS



11.1 EXCLUSION OF WATER



11.1.1 PRECIPITATION



11.1.1.1 Roof Drainage



11.1.1.2 Flooding



11.1.1.3 Drought



11.1.2 DAMP RISING AND MOISTURE MIGRATION



























11.1.3 CONDENSATION



11.2 THERMAL INSULATION



11.2.1 DEFINITION

-  **11.2.1 DEFINITION**
-  **11.2.2 INSULATING MATERIALS**
-  **11.3 SOUND INSULATION**
 -  **11.3.1 DEFINITION**
 -  **11.3.2 SOUND INSULATION**
 -  **11.3.3 EXTERNAL NOISE**
-  **11.4 FIRE PROTECTION**
 -  **11.4.1 STRUCTURAL FIRE PROTECTION**
 -  **11.4.1.1 Fire Load**
 -  **11.4.1.2 Fire Resistance of Material**
 -  **11.4.1.3 Appropriate Types of Construction**
-  **12. FINISHING & FINISHES**
 -  **12.1 EXTERNAL WALL FINISHES**
 -  **12.1.1 EXTERNAL RENDERING**
 -  **12.1.2 CONCRETE FINISHES**
 -  **12.1.3 CLADDING**
 -  **12.1.3.1 CLADDINGS FIXED TO A STRUCTURAL BACKING**
 -  **12.1.3.2 CLADDINGS TO FRAMED STRUCTURES**
 -  **12.1.4 EXTERNAL PAINTS AND FINISHES**
 -  **12.2 INTERNAL WALL FINISHES**
 -  **12.2.1 PLASTERING**
 -  **12.2.2 OTHER INTERNAL WALL FINISHES**
 -  **12.2.3 PAINTING**
 -  **12.3 CEILING FINISHES**

 **12.3 CEILING FINISHES** **13. STAIRS** **13.1 INTRODUCTION** **13.2 DEFINITION OF TERMS** **13.3 TYPES OF STAIRS** **13.4 DESIGN OF STAIRS** **13.4.1 RISE - TREAD - PROPORTION** **13.4.2 SLOPE OR PITCH** **13.4.3 LANDINGS** **13.4.4 WIDTH** **13.4.5 WALKING LINE** **13.5 CONSTRUCTION OF STAIRS** **13.5.1 BRICK STAIRS** **13.5.2 STONE STAIRS** **13.5.3 CONCRETE STAIRS** **13.5.3.1 In Situ Cast R.C. Stairs** **13.5.3.2 Precast Concrete Stairs** **13.5.4 TIMBER STAIRS** **13.5.5 METAL STAIRS** **13.6 MISCELLANEOUS** **13.6.1 BALUSTRADES/HANDRAILS** **13.6.2 'SAMBA' STAIR, LADDERS, DISAPPEAR STAIRS, RAMPS** **13.6.3 ESCALATORS** **14 DOORS & WINDOWS**

 **14. DOORS & WINDOWS** **14.1 DOORS** **14.1.1 EXTERNAL DOORS** **14.1.2 INTERNAL DOORS** **14.1.3 PURPOSE MADE DOORS** **14.1.4 METHODS OF CONSTRUCTION** **14.1.4.1 Door terminology** **14.1.4.2 Panelled and glazed wood doors** **14.1.4.3 Flush doors** **14.1.4.4 Fire-check flush doors** **14.1.4.5 Matchboarded doors** **14.1.5 FRAMES AND LININGS** **14.1.5.1 Timber Door Frames** **14.1.5.2 Metal door frames** **14.1.5.3 Door linings** **14.1.6 SPECIAL DOORS** **14.2 WINDOWS, GLASS & GLAZING** **14.2.1 PRIMARY FUNCTIONS OF WINDOWS** **14.2.2 BUILDING REGULATIONS** **14.2.3 TRADITIONAL CASEMENT WINDOWS** **14.2.4 STANDARD WOOD CASEMENT WINDOWS** **14.2.5 STEEL CASEMENT WINDOWS** **14.2.6 BAY WINDOWS**

**14.2.7 SLIDING SASH WINDOWS** **14.2.7.1 Vertical sliding windows (also called double hung sash windows)** **14.2.7.2 Horizontal sliding windows** **14.2.8 PIVOT WINDOWS** **14.2.9 LOUVRES** **14.2.10 GLASS AND GLAZING** **14.2.10.1 Glass** **14.2.10.2 Glazing** **14.2.11 MOSQUITO SCREENING (FLY SCREENS)** **14.2.12 SUN-BREAKERS** **14.3 IRON MONGERY** **14.3.1 HINGES** **14.3.2 LOCKS AND LATCHES** **14.3.3 MISCELLANEOUS****2. ARCHITECTURAL DRAWING II**

AD II		ARCH. DRWNG
compiled: D. VOLKE		--- LECTURE ---
AUG. '83		
TCA	TECHNICAL COLLEGE ARUSHA CHUO CHA UFUNDI ARUSHA	CIVIL ENGINEER. DEPARTMENT

REFERENCES:

1. C. Leslie Martin
"ARCHITECTURAL GRAPHICS"
2. E. Neufert
"ARCHITECTS DATA"
3. Dahmlos/Witte
"Bauzeichnen"

2.1 TYPES OF PROJECTIONS

Drawings are a medium through which the draftsman or designer conveys his ideas and instructions to others. Therefore an understanding of all types of drawing is necessary in order to present informations in the clearest and most effective manner.

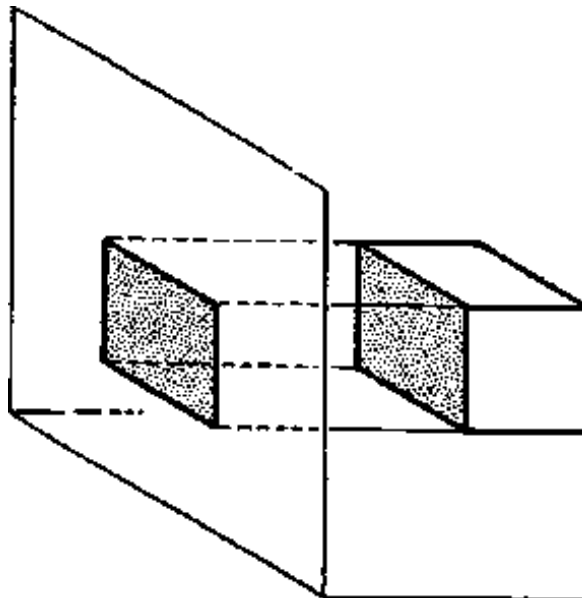

A ORTHOGRAPHIC PROJECTORS PERPENDICULAR TO PICTURE PLANE

The theory of any type of projection drawing assumes that the drawing can be made by locating the intersections of lines, which are called **PROJECTORS** from points on the object with a plane of projection called the **PICTURE PLANE**:

The lines connecting the points thus located on the picture plane make the projected drawing of the object. The three factors which determine the type of projection drawing are:

1. The relation of the object to the picture plane
2. The relation of the projectors to the picture plane, and
3. The relation of the projectors to each other.

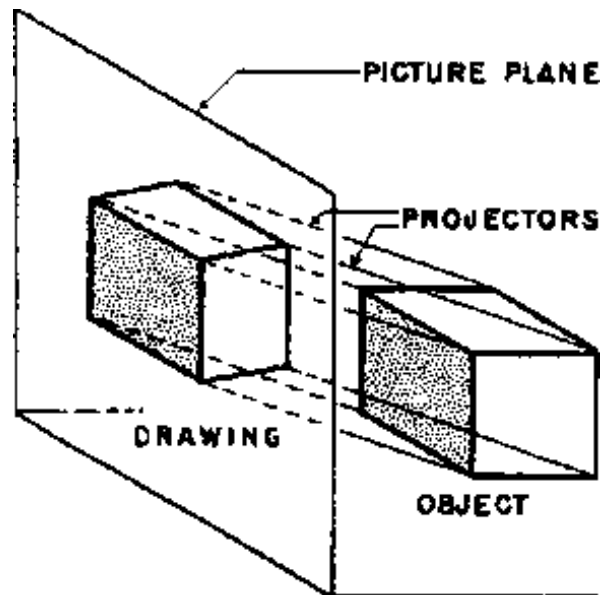

B OBLIQUE PARALLEL PROJECTORS OBLIQUE TO PICTURE PLANE

Various types of **ORTHOGRAPHIC** and **PERSPECTIVE PROJECTION** are obtained by changing the relation between the object and picture plane. In **OBLIQUE PROJECTION** the different types are obtained

by changing the relative positions of the object and picture plane and by changing the scale of the receding lines. Variations in pictural effect of any type of oblique drawing can also be secured by using different directions for the projectors.

In actual drawing the paper is the picture plane on which the drawing is constructed by drafting methods to conform to the assumed relations of the object, projectors, and picture plane.

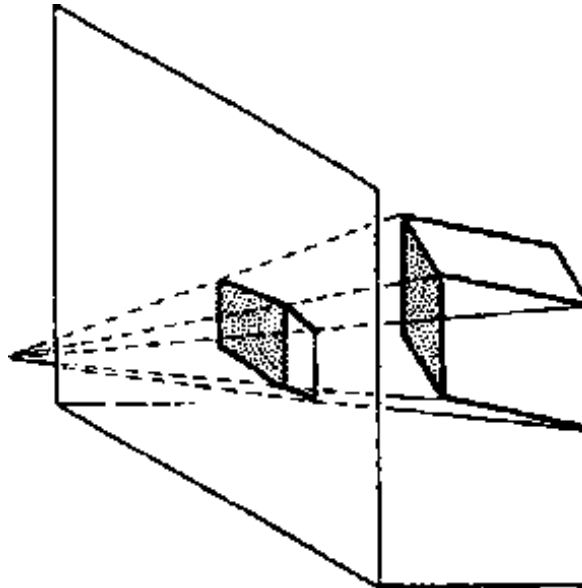











C PERSPECTIVE PROJECTORS CONVERGE TO A STATION POINT

PROJECTION DRAWING is the science of constructing drawings of different types by the most efficient and direct drafting methods.

CLASSIFICATION OF TYPES OF PROJECTION DRAWING

TYPE OF DRAWING			RELATION OF		
GENERAL	GRAPHIC	SPECIFIC	OBJECT TO	PROJECTORS	PROJECTORS

TYPE	DIAGRAM	CLASSIFICATION	PICTURE PL.	TO EACH OTHER	TO PICTURE PL.
ORTHOGRAPHIC AXONOMETRIC		MULTI - VIEW	PARALLEL ON ONE FACE	PARALLEL	PERPENDICULAR
		ISOMETRIC	OBLIQUE THREE AXES AT EQUAL ANGLES WITH PICTURE PLANE	PARALLEL	PERPENDICULAR
		DIMETRIC	OBLIQUE TWO AXES AT EQUAL ANGLES WITH PICTURE PLANE	PARALLEL	PERPENDICULAR
		TRIMETRIC	OBLIQUE ALL AXES DIFFERENT ANGLES WITH PICTURE PLANE	PARALLEL	PERPENDICULAR
OBLIQUE		CAVALIER PROJECTION	PARALLEL ON ONE FACE	PARALLEL	OBLIQUE 45°
		GENERAL OBLIQUE	PARALLEL ON ONE FACE	PARALLEL	OBLIQUE AT ANY ANGLE

		OBLIQUE	ONE FACE		ANY ANGLE
		CABINET PROJECTION	PARALLEL ON ONE FACE	PARALLEL	OBLIQUE AT 63° APPROX.
PERSPECTIVE		ONE-POINT PERSPECTIVE	PARALLEL ON ONE FACE	CONVERGE TO A POINT	VARIOUS ANGLES
		TWO-POINT PERSPECTIVE	OBLIQUE VERTICAL LINES PARALLEL TO PICTURE PLANE	CONVERGE TO A POINT	VARIOUS ANGLES
		THREE-POINT PERSPECTIVE	OBLIQUE ALL THREE AXES OBLIQUE TO PICTURE PLANE	CONVERGE TO A POINT	VARIOUS ANGLES

The most important types of projection are classified in the chart, typical examples of drawings of the four most widely used divisions of projection drawing are given in the figure.

Most of the objects drawn in architecture have three sets of planes and lines which are mutually perpendicular to each other.

PROJECTION DRAWING METHODS

A COMPARISON OF FOUR WIDELY USED TYPES OF DRAWING

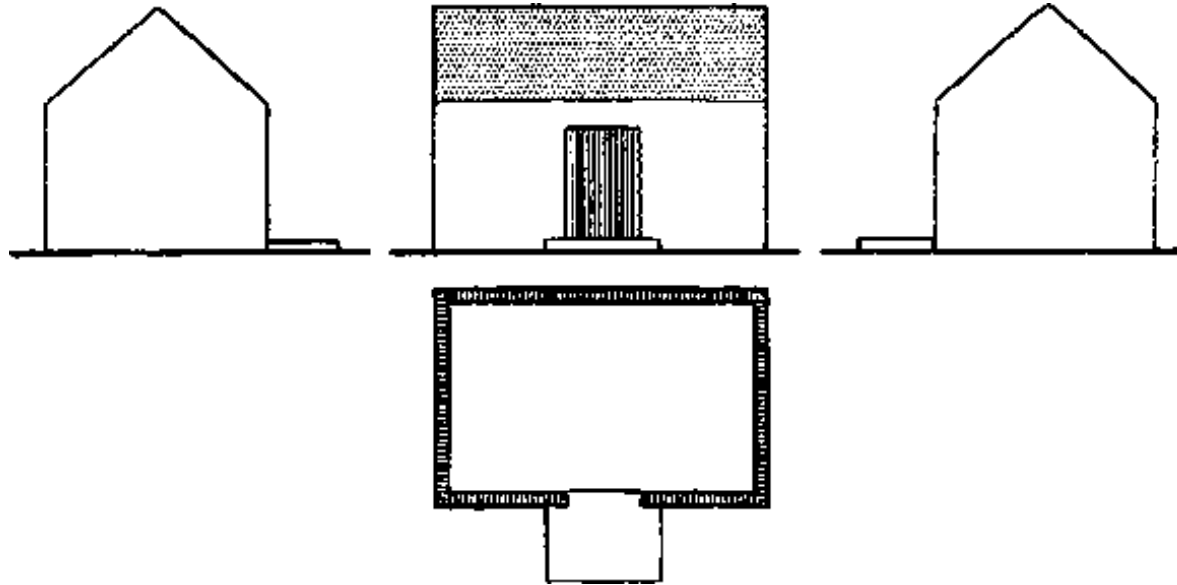

(A) MULTI-VIEW

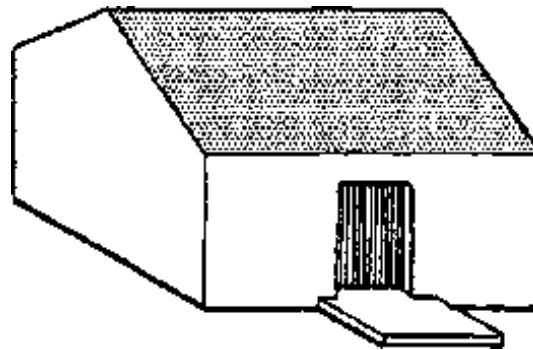

(B) OBLIQUE

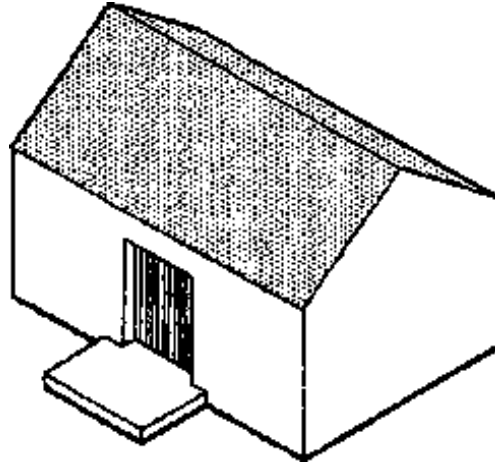

(C) ISOMETRIC

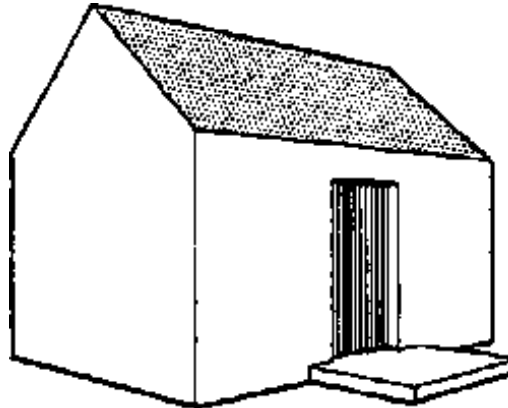

(D) PERSPECTIVE

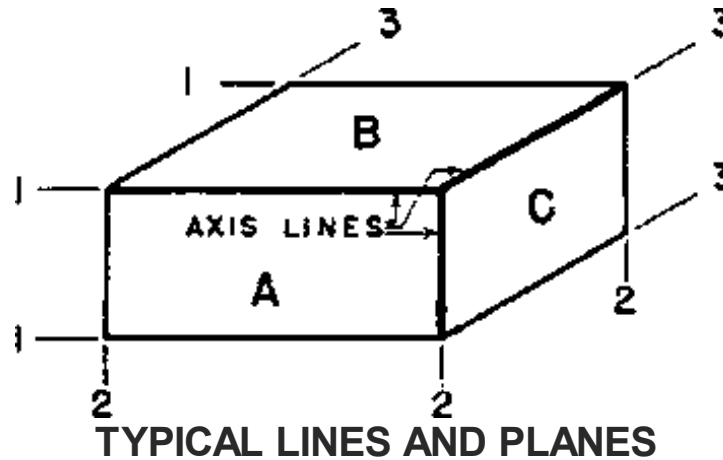

2.2 ORTHOGRAPHIC PROJECTION

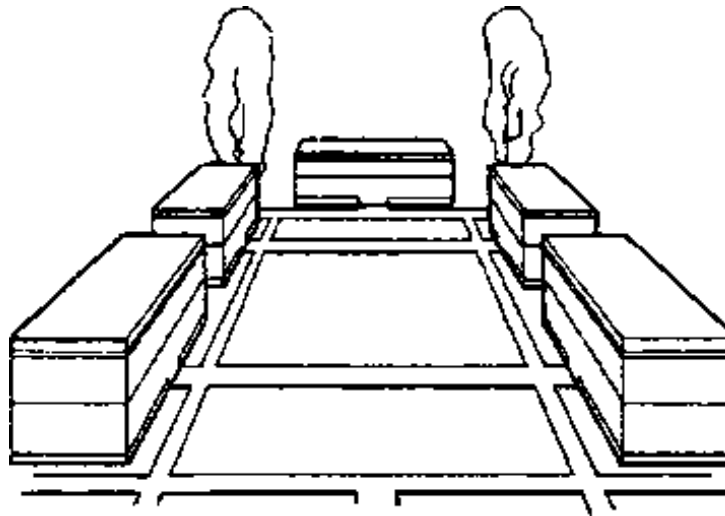

In any type of drawing those parts of the object which are parallel to the picture plane are shown in their **TRUE SHAPES**.

In **ORTHOGRAPHIC PROJECTION** where the projectors are parallel lines, all parts of the object which are parallel to the picture plane are shown in their correct **RELATIVE SIZES**, that is, at the same scale -

regardless of their distances from the picture plane.

Since only one set of planes of an object can be shown parallel to the picture plane in a single drawing, it is necessary to have a minimum number of three views of an object to give all of its sizes and shapes. These three basic views are obtained by looking in three mutually perpendicular directions, and these views are drawn on planes perpendicular to each of the three directions respectively.

The basic views, which are drawn true to scale, are taken at 90° to each other and when set on paper are said to be drawn in the principal planes.

At present there are two methods of relating the principal views to each other, namely FIRST-ANGLE PROJECTION (used in Europe) and THIRD ANGLE PROJECTION (used in Canada and U.S.A.)

These terms FIRST ANGLE and THIRD ANGLE have been derived from the mathematicians convention of annotating the four right angles which make up the 360° of a circle, the first being 0° to 90° and the third angle from 180° to 270° .

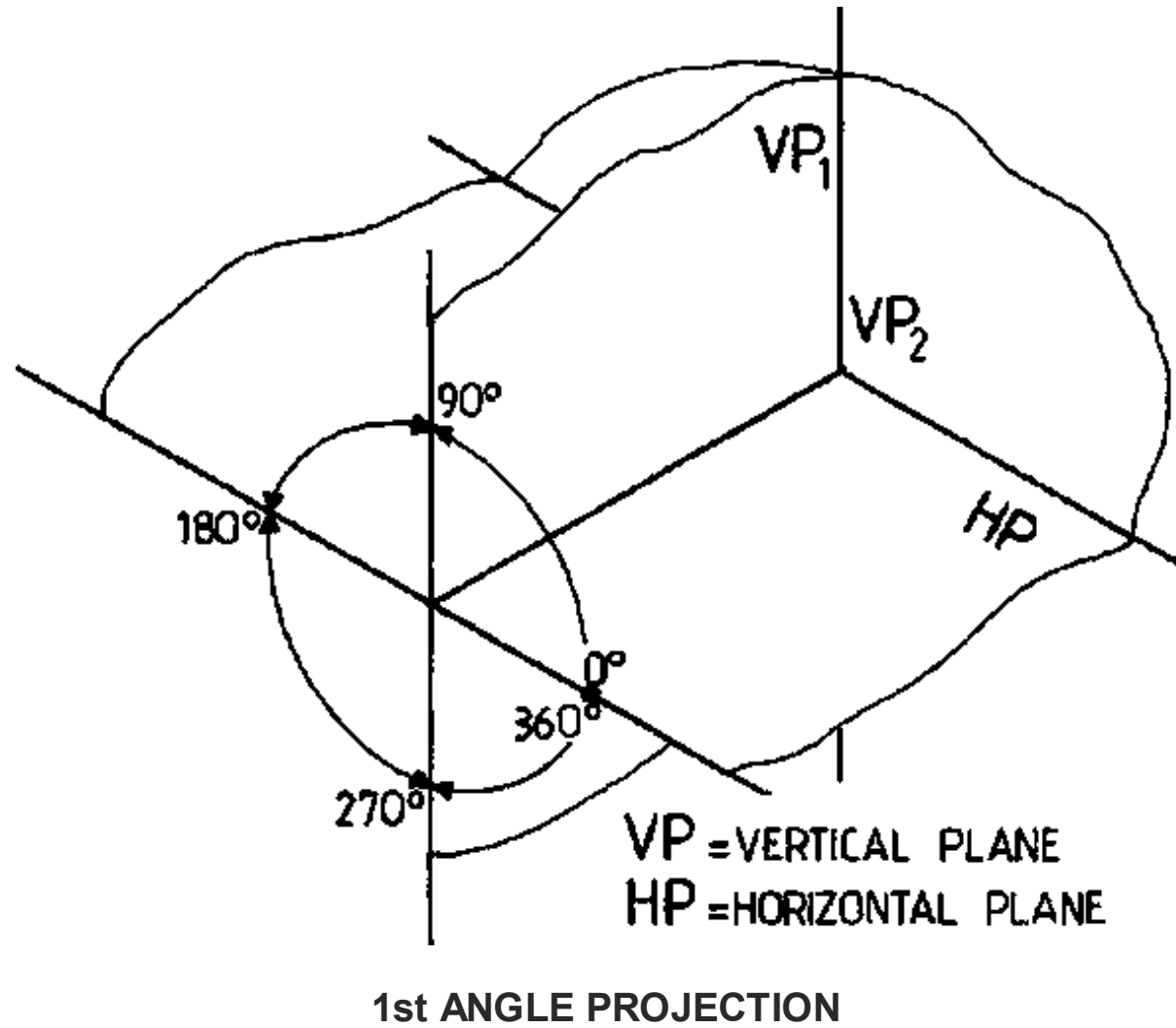

1. Projection of a Point (A)

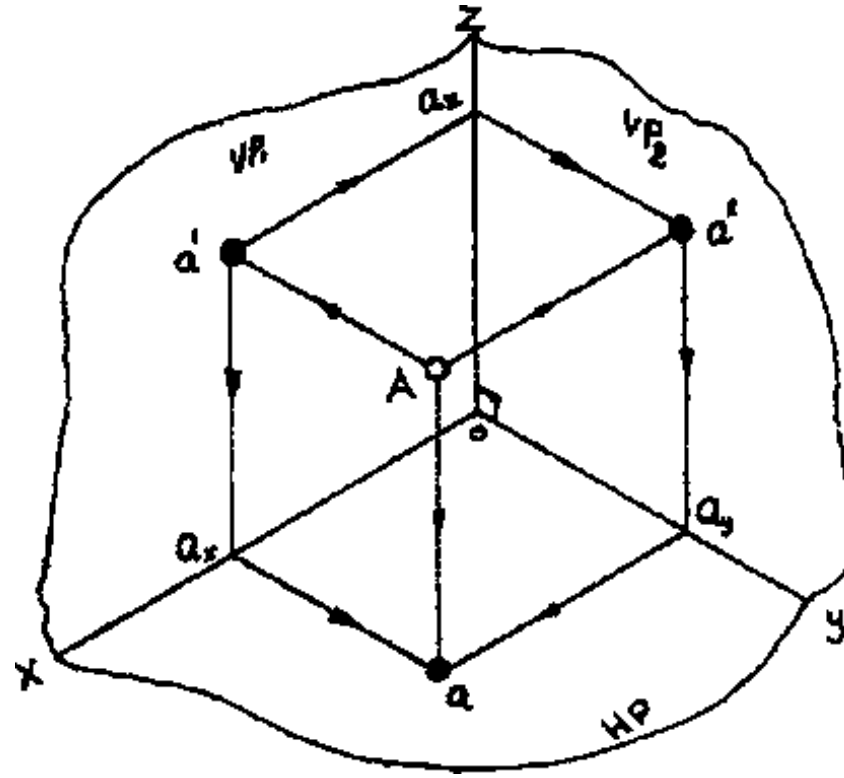

Orthographic projection of point A

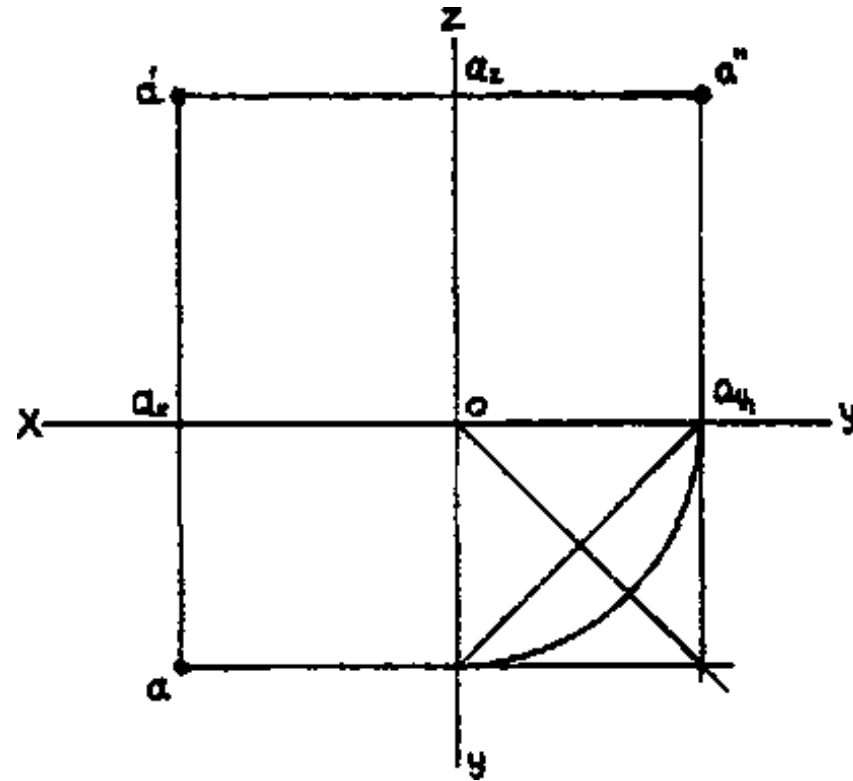

2. Projection of a line (AB)

(a) $AB \perp VP$

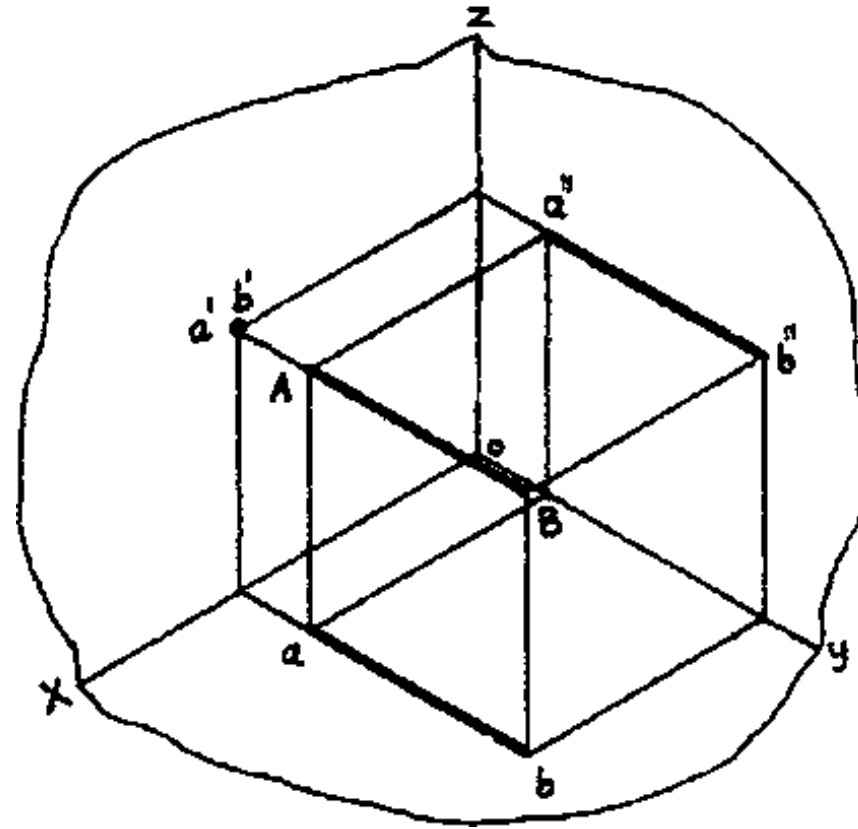

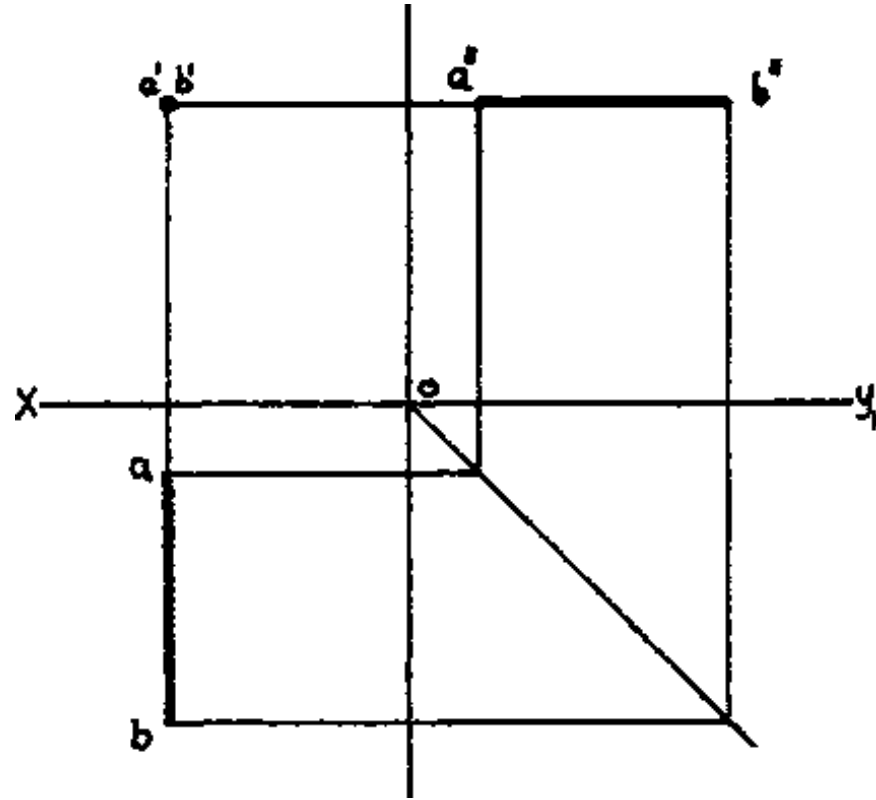

(b) AB NOT parallel to any plane

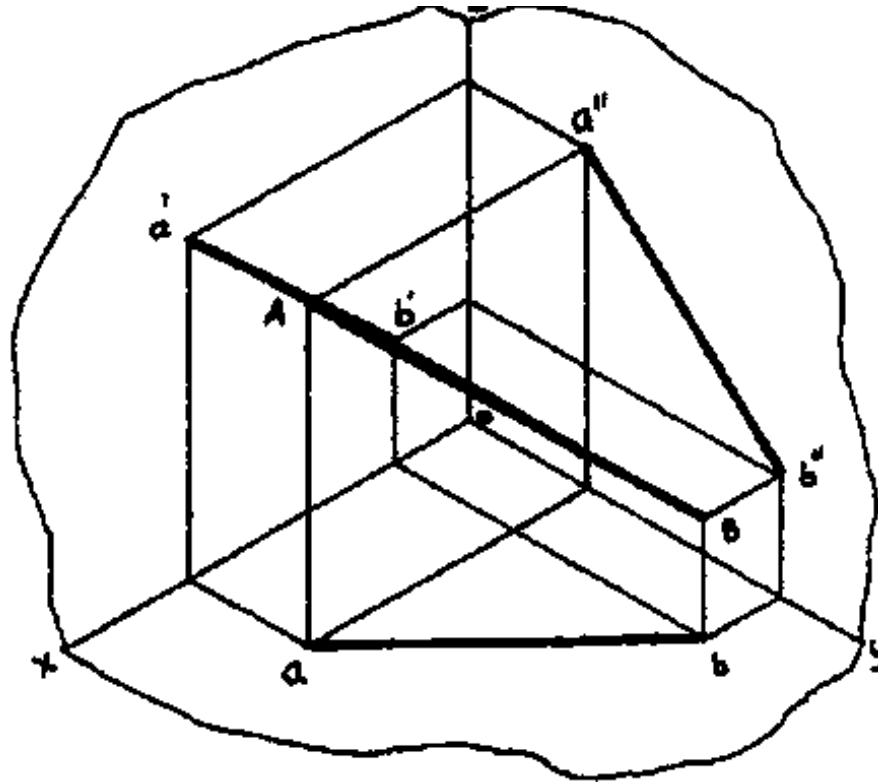

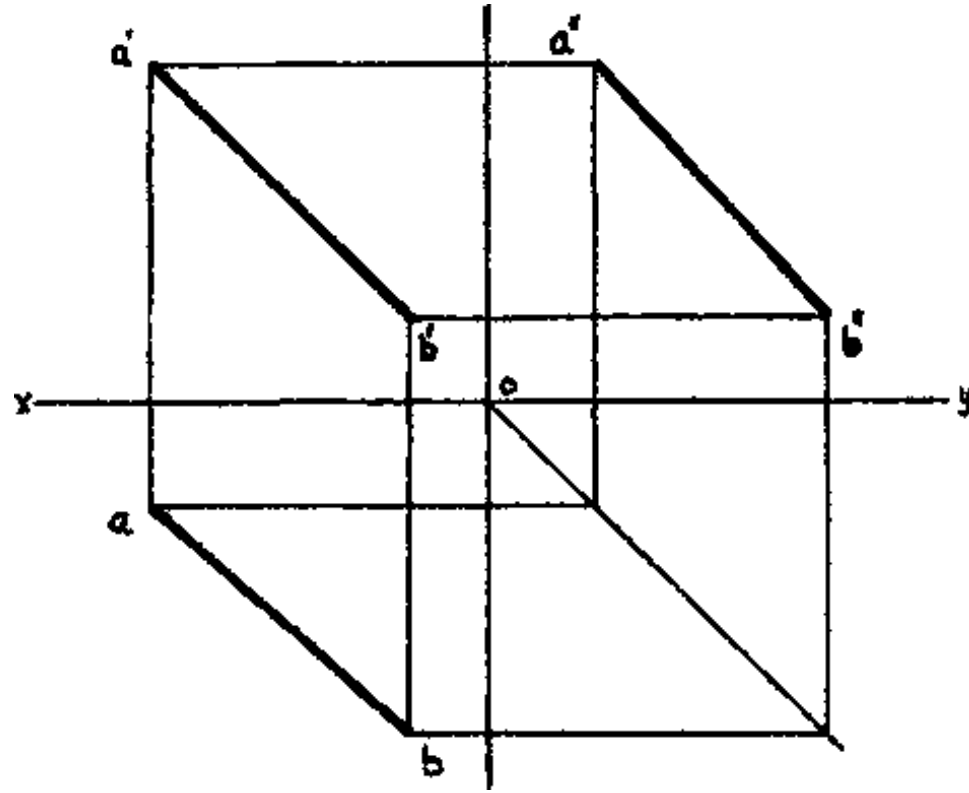

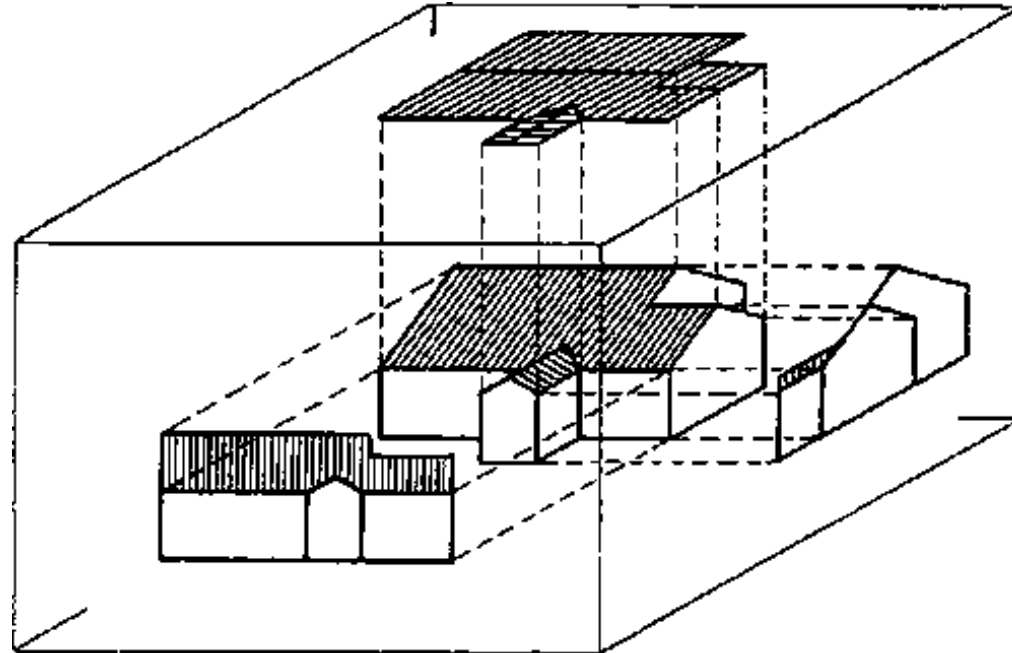

(A) PROJECTING ONTO THE GLASS BOX

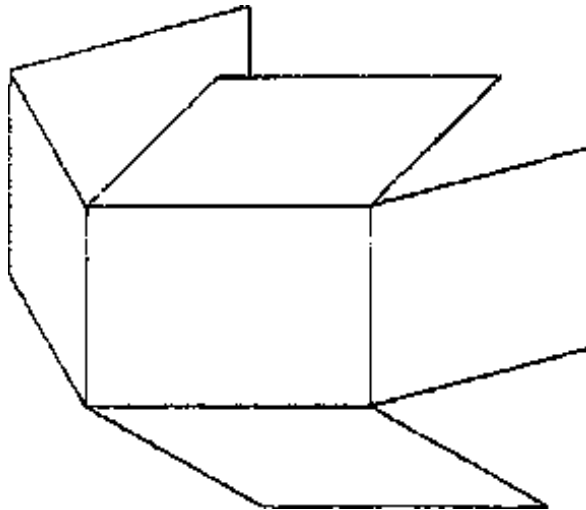

(B) REVOLVING PLANES OF THE GLASS BOX

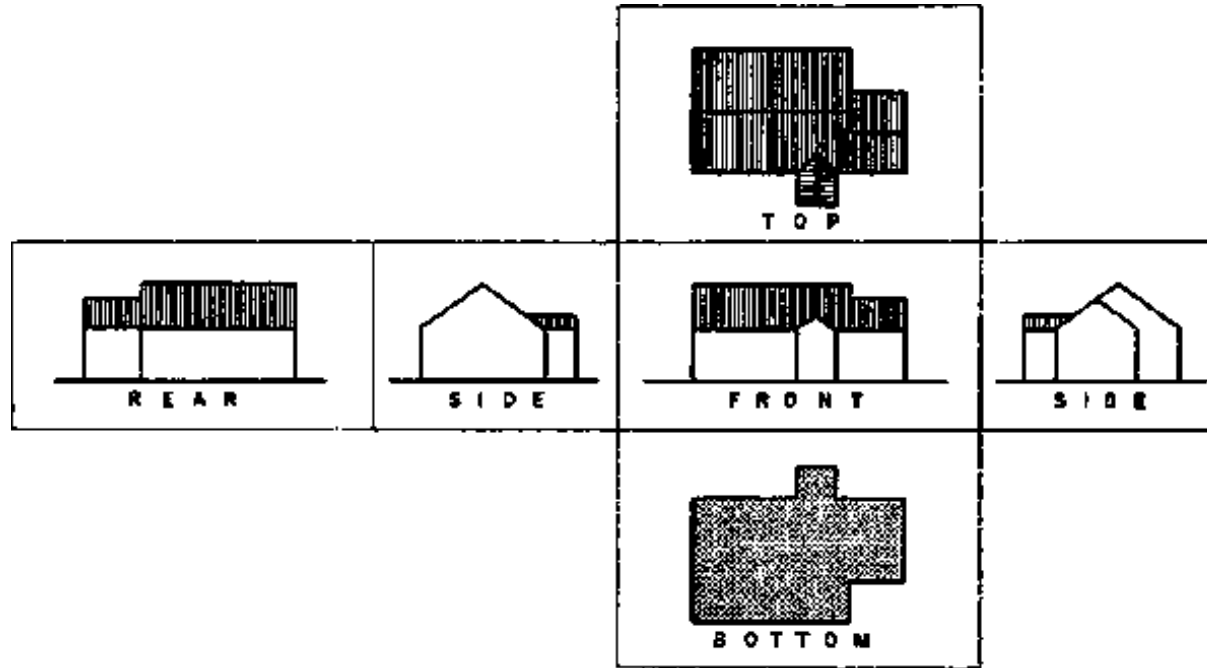

(C) ARRANGEMENT OF DRAWINGS FROM THE GLASS BOX

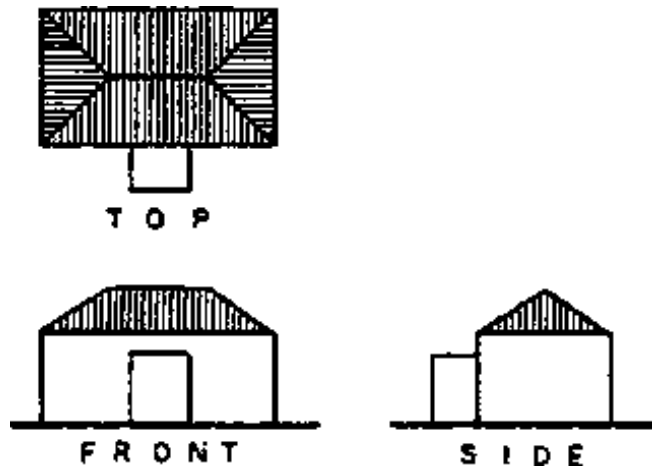

(D) ARCHITECTURAL ARRANGEMENTS

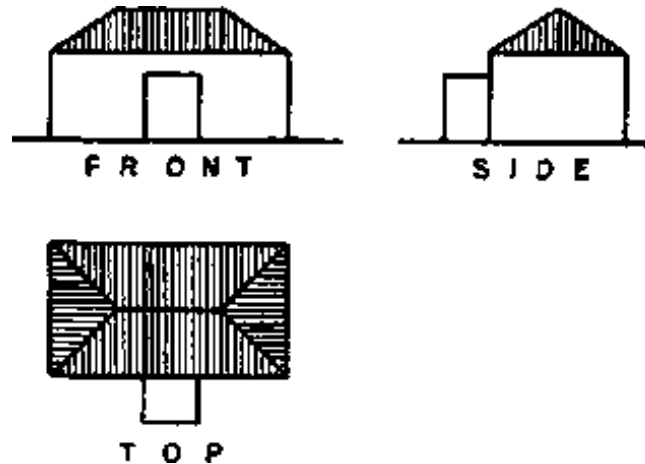

(E) ARCHITECTURAL ARRANGEMENTS

The planes provided by the transparent box - shape of the figure are not always adequate to give **TRUE SHAPE VIEWS** of all sides of a building. If a wall of the building is not parallel one of the typical planes and consequently one of the faces of the transparent box, its **TRUE SHAPE** will not be shown by any of the conventional elevations. Picture planes, which are added to the transparent box - shape in order to obtain true shape views of planes of the object not parallel to the original planes of the box, are called **AUXILIARY PLANES** (see figure A and D) and the projections made on these planes are called **AUXILIARY VIEWS**.

The true shape of any oblique surface, such as a slating roof or wall, can then be obtained by projecting onto an auxiliary plane parallel to the oblique surface.

AUXILIARY VIEWS

ELEVATION AUXILIARIES

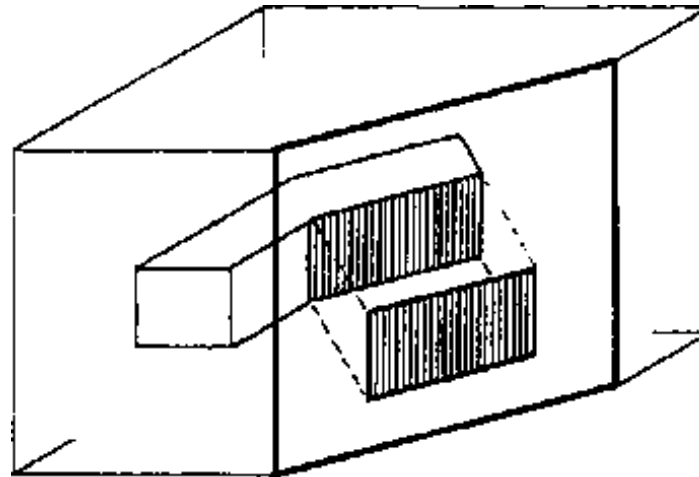

(A) VERTICAL AUXILIARY PLANE

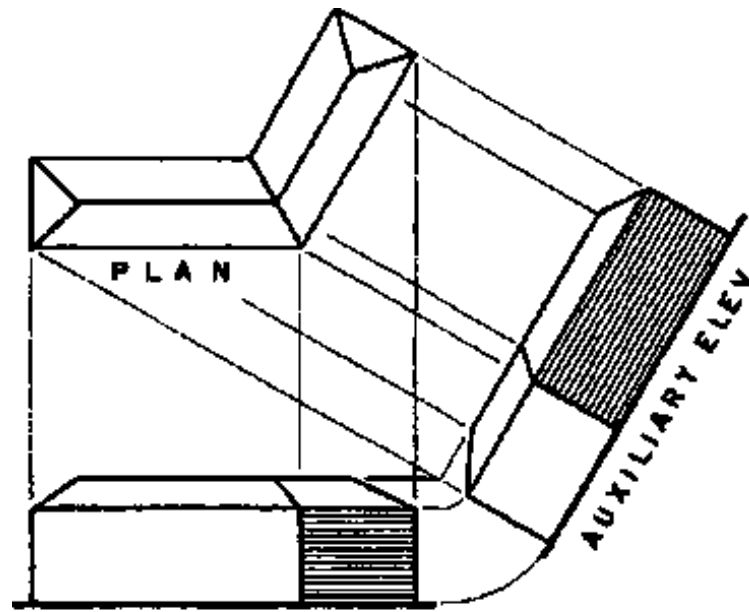

FRONT ELEV.
(B) COMPLETE AUXILIARY VIEW

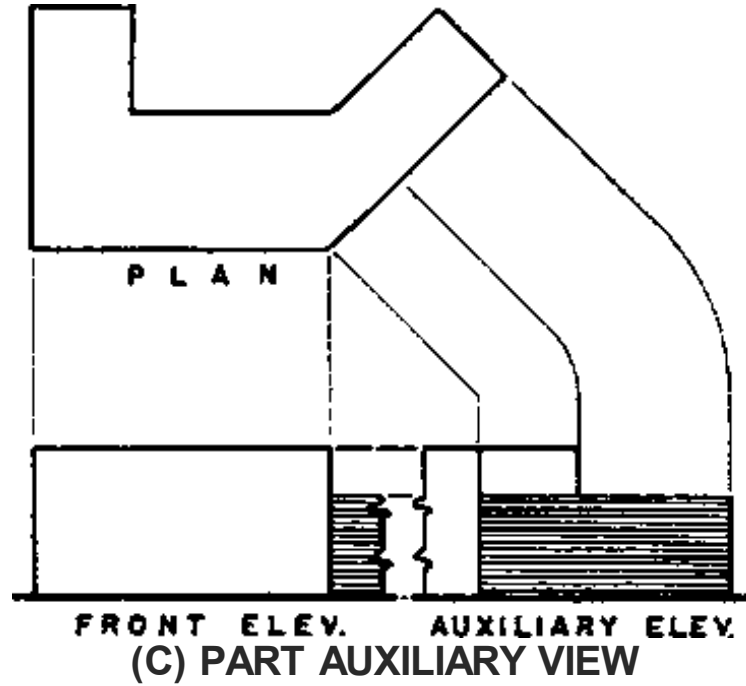

OBLIQUE PLANE AUXILIARIES

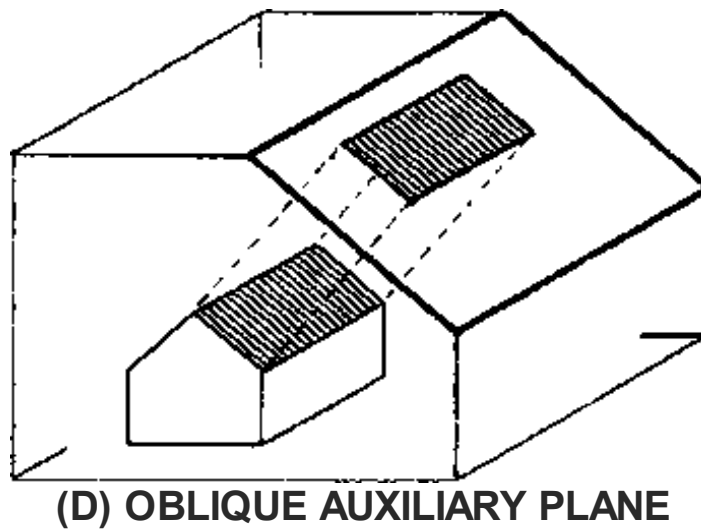

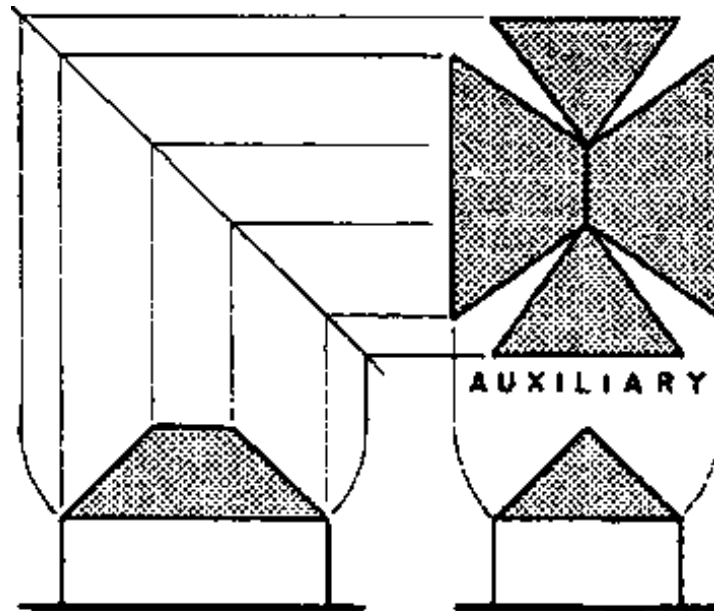
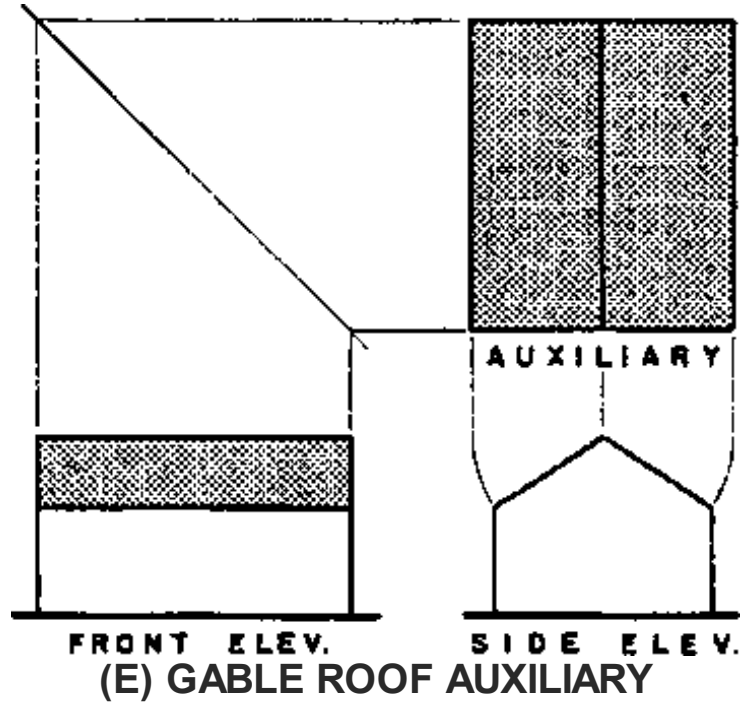

(F) HIP ROOF AUXILIARY**2.2.1 CONSTRUCTION OF ORTHOGRAPHIC PROJECTION**

In the **CONSTRUCTION** of orthographic projections, it should be kept in mind that all the different views must check. Drafting methods for the construction of orthographic projections are shown in the figure.

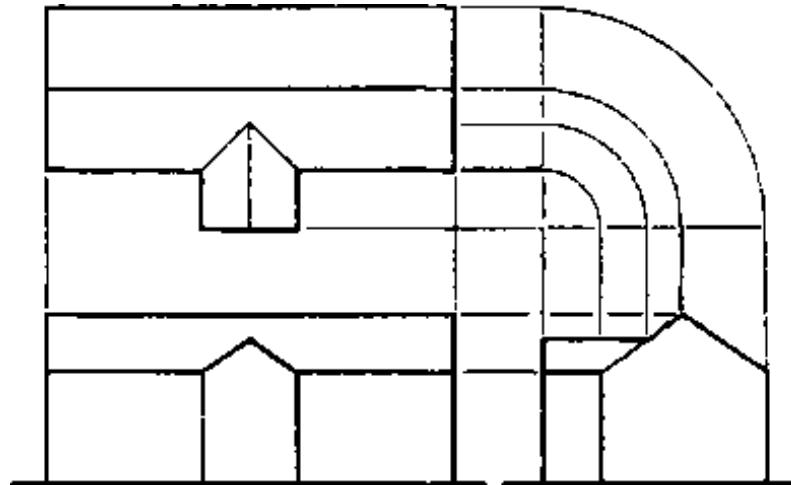
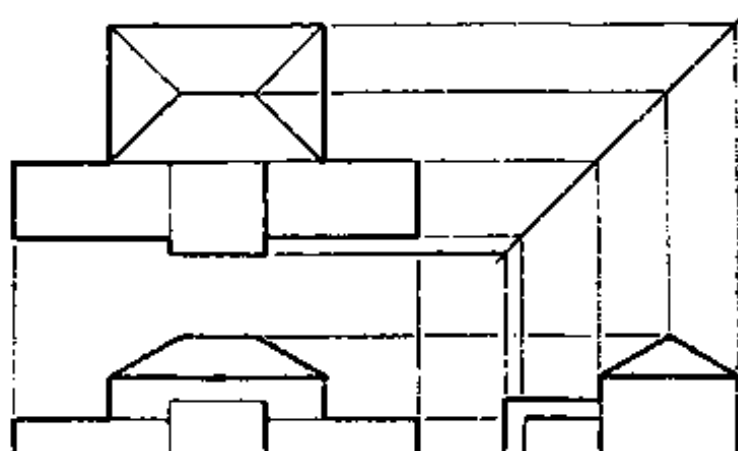
EQUAL DIVISIONS ON GEOMETRIC SHAPES**(A) TURNING MEASUREMENTS WITH CIRCULAR ARCS**



(B) TURNING MEASUREMENTS ON A 45° BISECTOR

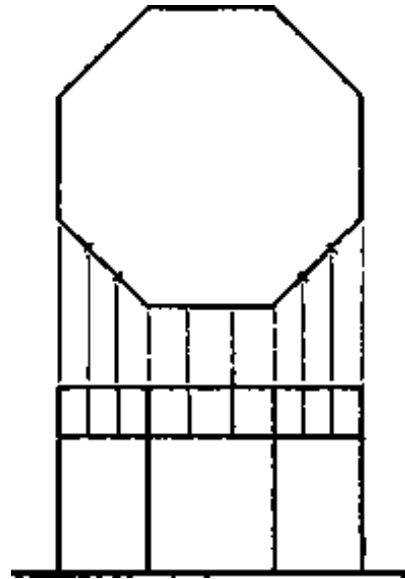

(C) OCTAGON

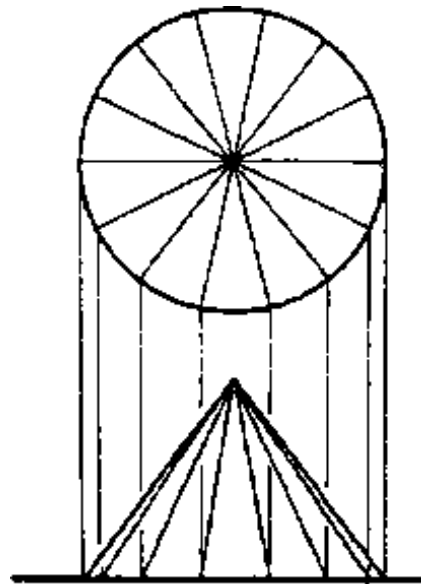

(D) CONE

(D) CONE

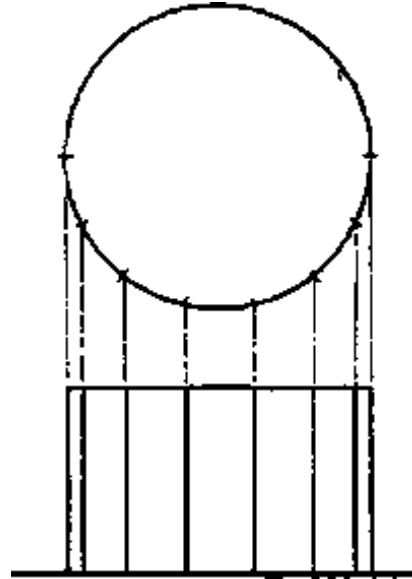

(E) CYLINDER

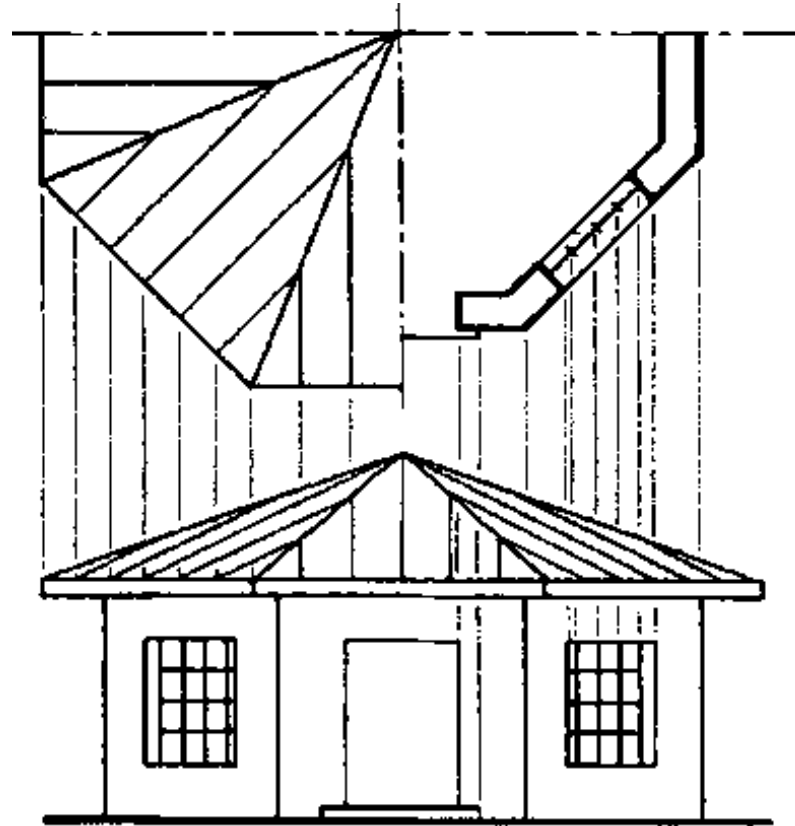

(F) OCTAGONAL BUILDING

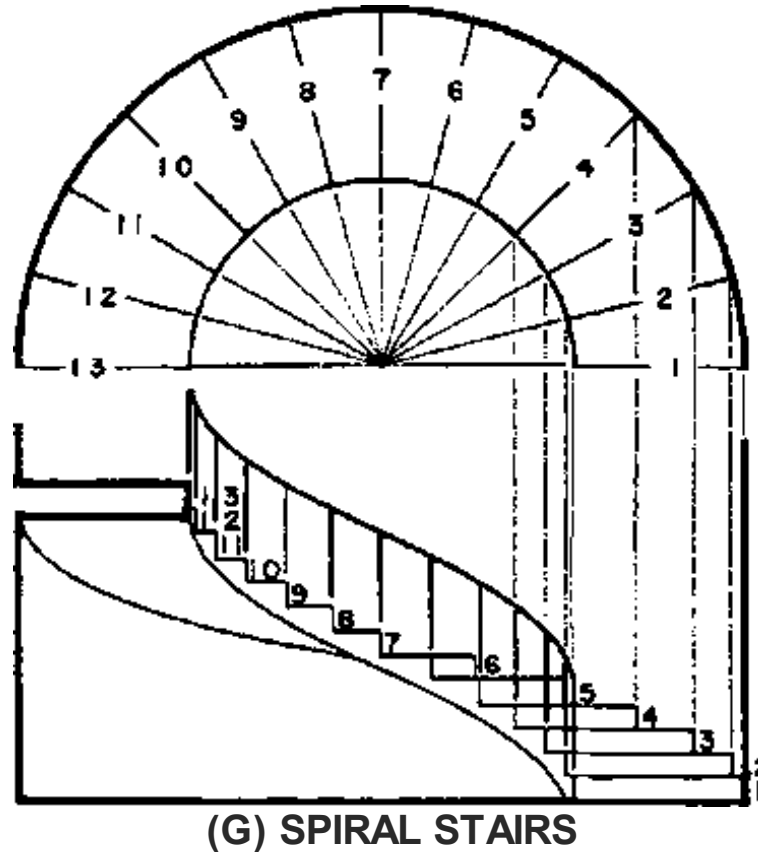

2.2.2 ELEVATIONS

The most common auxiliary views in architecture are ELEVATIONS. The drafting process by which an auxiliary elevation is made may vary in details of construction. However, in all cases the heights may be taken from any other elevation of the building and the horizontal dimensions from plan.

The figure shows two methods of making the auxiliary elevation from a front elevation and plan. In B the auxiliary drawing is made to show the entire building, as would usually be done in architectural drawing. In C only the part of the building parallel to the picture plane is shown in each elevation.

The front roof plane of E is shown by the front elevation to be a rectangle. The length of this roof area is shown in the front view and its true slant-height is shown in the side view. The rectangle made by using these two dimensions is the correct auxiliary view of the front roof plane.

In F all four planes of the simple hip roof are drawn in the auxiliary views. Such drawings are useful to show the true shapes and areas of the roof planes and the true lengths of lines in those planes. The slanting lines in the auxiliary view of F show the true length of the hips. The length of any straight line can be determined graphically by making an auxiliary view on any picture plane parallel to the line.

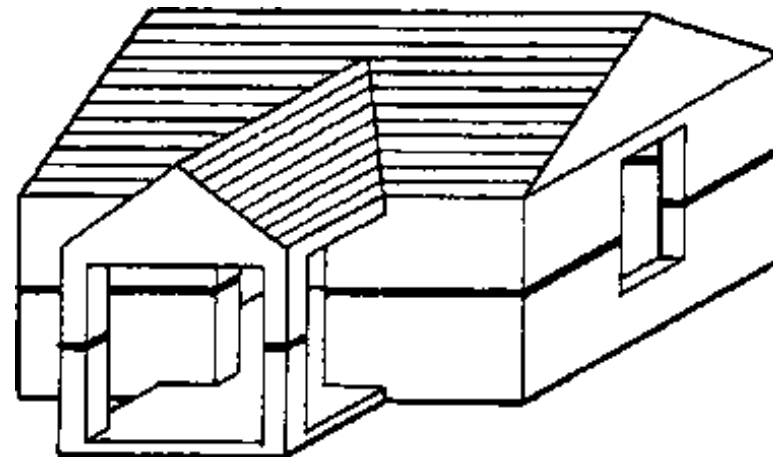

(A) POSITION OF PLANE

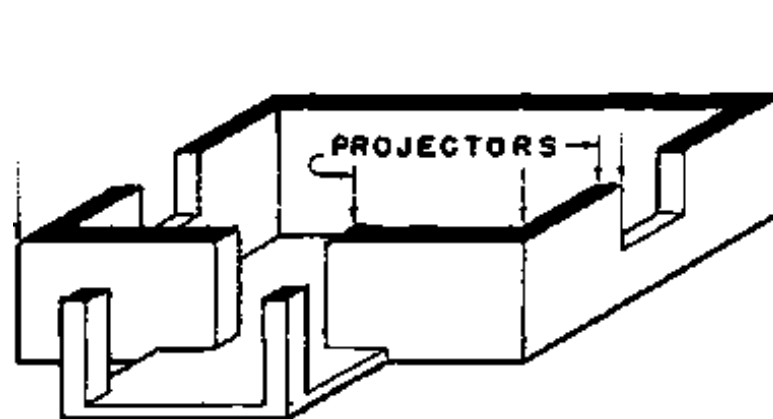

(B) TOP PART REMOVED



(C) PLAN OF REMAINDER

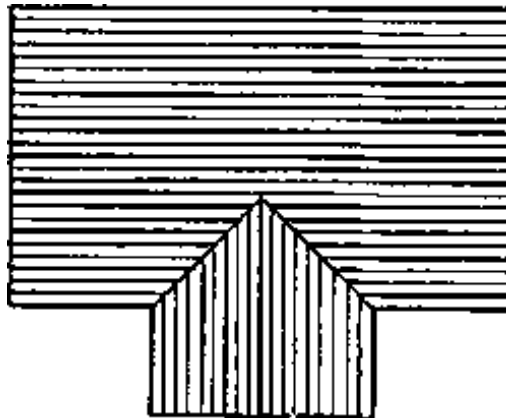

(D) ROOF PLAN





(E) FRAMING PLAN

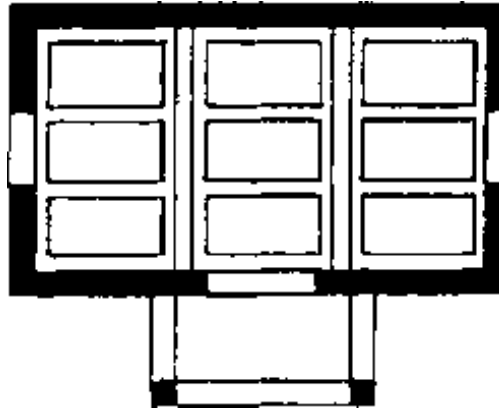

(F) REFLECTED PLAN

2.2.3 PLANS AND SECTIONS

In addition to the exterior views of building it is usually necessary to have one or more views made which CUT through the structure and shows the interior. These views are known as

1. **PLAN**, which is the term applied to any view on a **HORIZONTAL PICTURE PLANE** either from the exterior or cut through, and
2. **SECTION**, which is the name given to any view cutting through the building on a **VERTICAL PLANE**.

Both, the **ARCHITECTURAL PLAN** as well as the **ARCHITECTURAL SECTION** are demonstrated in the figure.

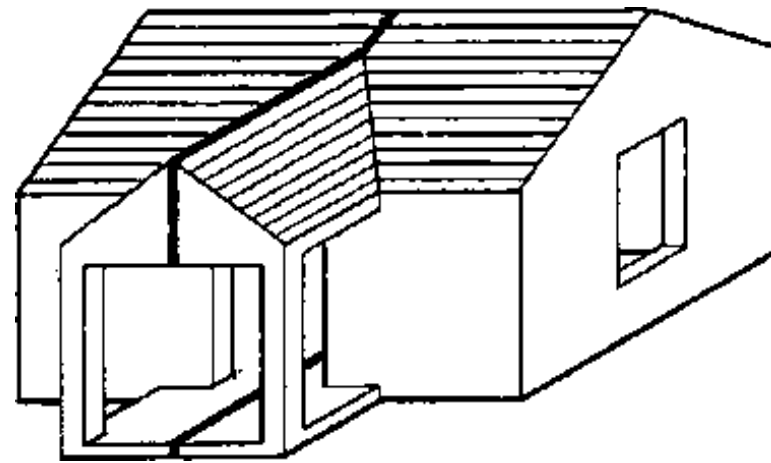

(A) POSITION OF PLANE

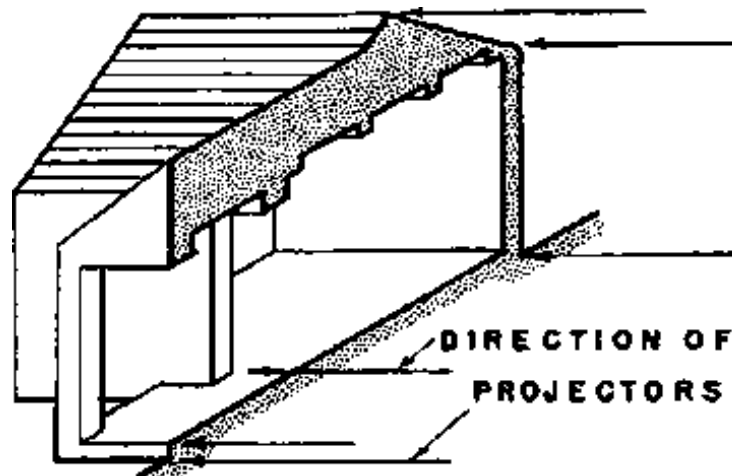

(B) RIGHT SIDE REMOVED

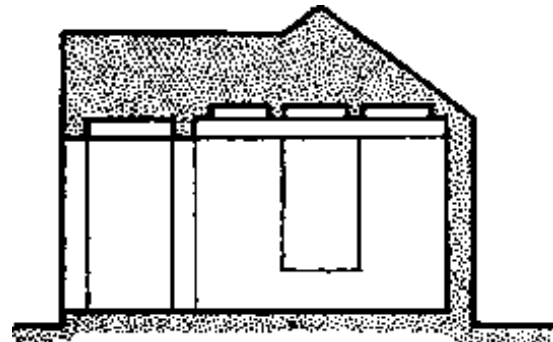

(C) SECTION OF REMAINDER

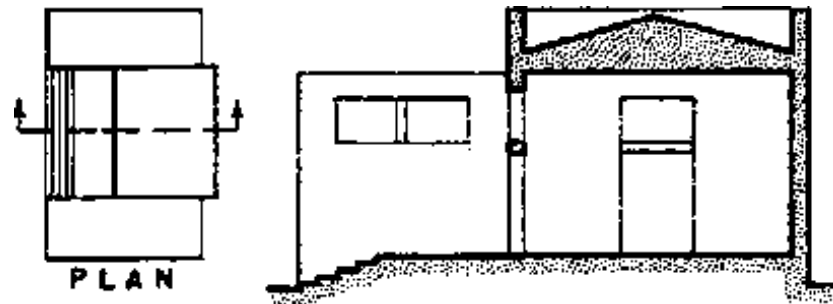

(D) TRANSVERSE SECTION

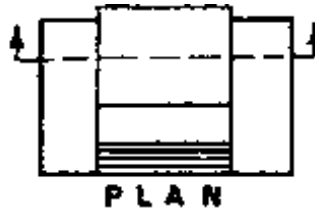

PLAN

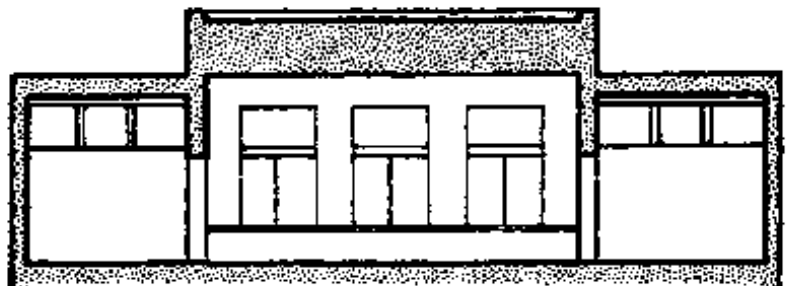

(E) LONGITUDINAL SECTION

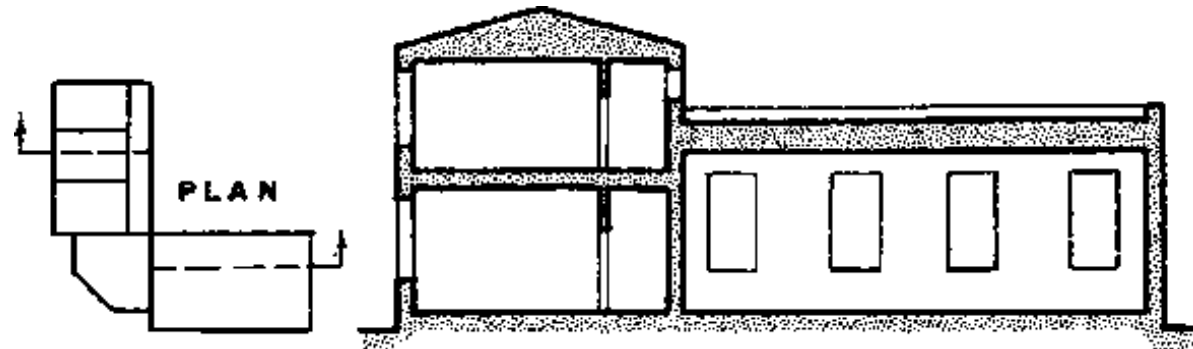

(F) OFFSET SECTION

2.3 PICTORIAL DRAWING

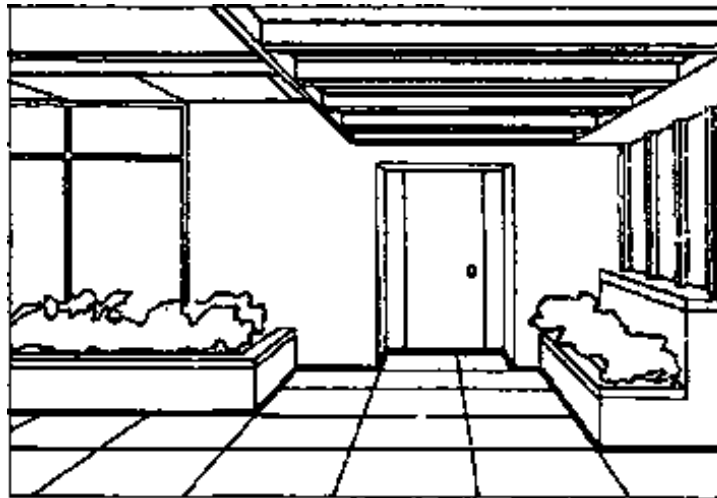

2.3.1 AXONOMETRIC PROJECTION

Axonometric and oblique drawings are similar in many respects. Both give views of the object which show all three typical sets of lines and planes in ONE drawing. Both are more easily understood than orthographic drawings because they show all three dimensions in one drawing and indicate the relations

of the various parts of the object to each other.

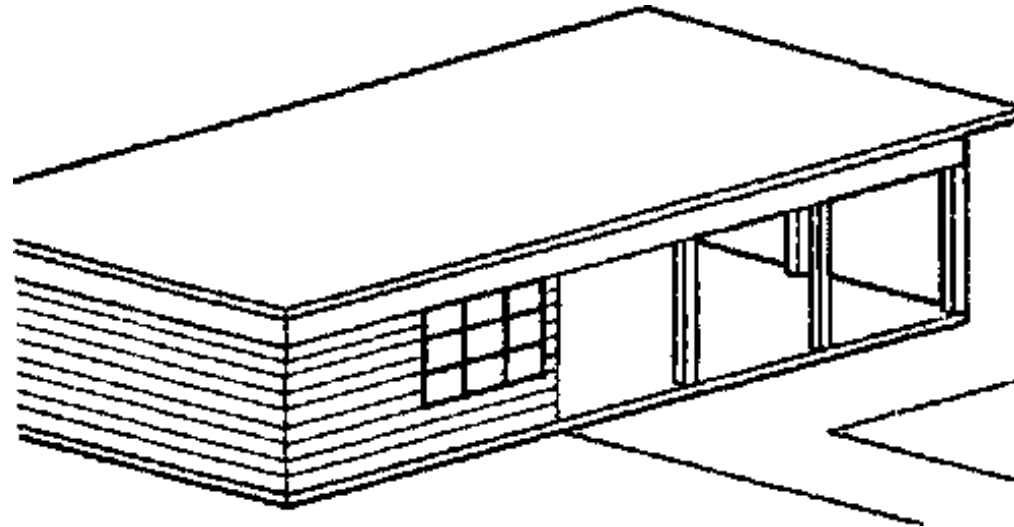

(A) AXONOMETRIC

In both axonomic and oblique drawings parallel lines in any direction are drawn parallel. This simplifies construction but causes the more distant parts of the object to appear to be too large. This pictorial defect is the principal criticism of these types of drawings.

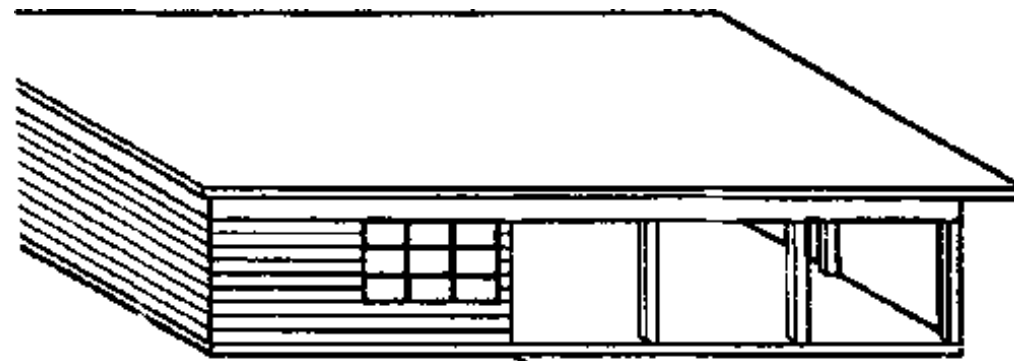

(B) OBLIQUE

The three typical sets of lines of the object are all measured to scale in axonometric and oblique

drawings. Therefore, most of the measuring can usually be done directly on the lines of the drawing itself, and it is practical to give dimensions on the drawings. Simplicity of construction is the chief advantage of these drawings over perspective drawing.

An **AXONOMETRIC** projection is an orthographic projection in which the object is tilted so that none of the three typical sets of planes, and consequently none of the axes at the intersections of these planes, are parallel to the picture plane.

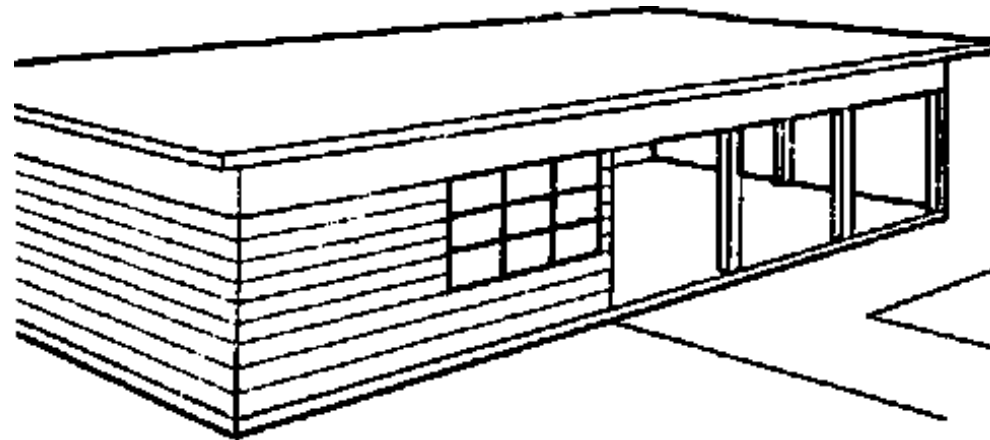

(C) PERSPECTIVE

Projectors from the object, perpendicular to the picture plane, locate points on the projected drawing of the object.

All axonometric projections may be divided into three classifications:

1. **ISOMETRIC** projections, in which all three of the axes make equal angles with the plane of projection,
2. **DIMETRIC** projections, in which two of the axes make equal angles with the plane of projection, and the third axis is at different angle,

3. TRIMETRIC projections, in which all three axes are at different angles with the picture plane.

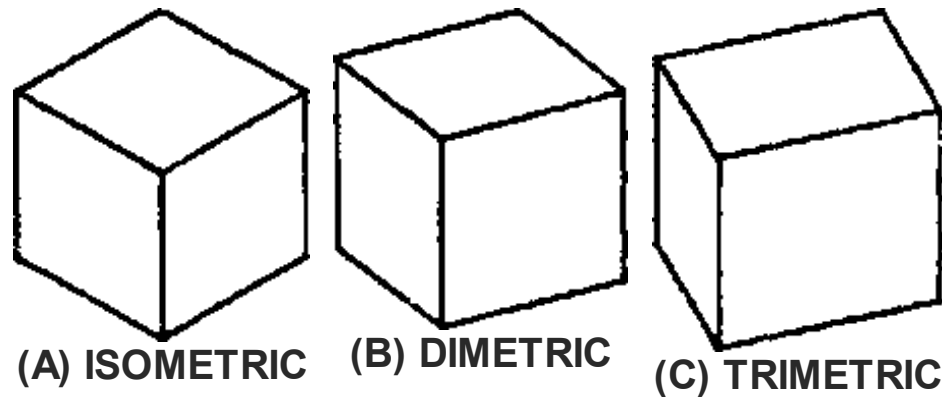

The axonometric drawings of a cube in the figure indicate the relation of the cube to the pictureplane in each case:

- In the isometric drawing all edges of the cube are represented as being of the same length because they are all turned at the same angle to the picture plane
- In the dimetric drawing of the cube two of the sets of edges are the same length and the third set a different length.
- In the trimetric drawing all three sets of edges of the cube are shown at different sizes, because the three sets of lines make different angles with the picture plane.

The relative sizes of the edges of the cube in the dimetric and trimetric drawing can be varied, but the relation in isometric drawing does not allow any variation.

2.3.2 ISOMETRIC PROJECTION

A scale is assumed for the object and the projected or foreshortened size drawing for that scale is shown in an isometric projection. The projected size of the axis lines is 0.816 of the actual length of the lines. An isometric drawing of an object is measured at any desired scale without considering the scale size of the object represented. The figure shows the difference in size between the isometric projection (B) made with the isometric scale and the isometric drawing (C) measured with the ordinary scale. Although isometric drawings are satisfactory for most practical purposes isometric projections sometimes have advantages.

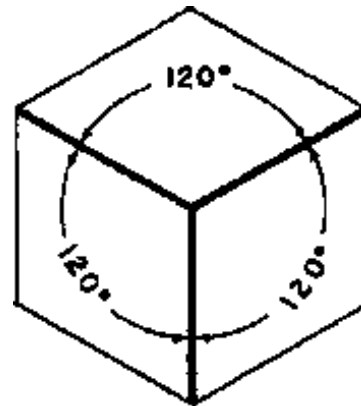

(A) ISOMETRIC AXES

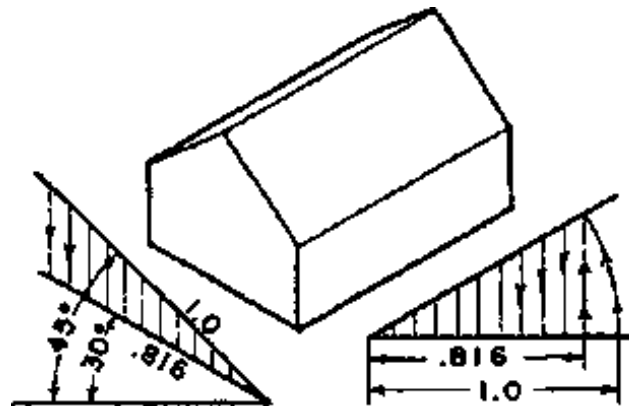

(B) ISOMETRIC PROJECTION

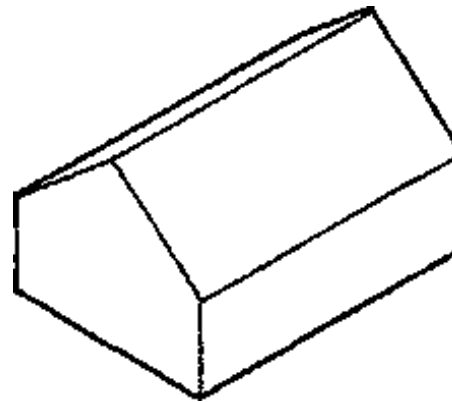

(C) ISOMETRIC DRAWING

Making an isometric drawing the angle between two adjacent axes of an isometric drawing is 120° . When one axis is vertical the other two are at 30° with the horizontal. To make an isometric drawing of a simple rectangular object: from a point selected for one of the front corners of the object draw the three axis lines and lay out on these lines their scale sizes. From the ends of the lines draw lines parallel to the axes to complete the drawing.

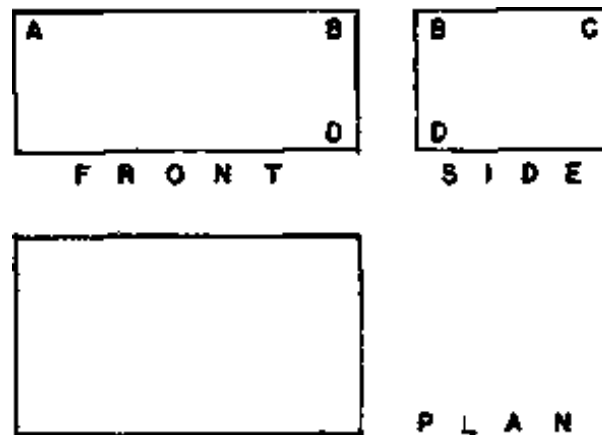

(A) MULTI-VIEW DRAWINGS

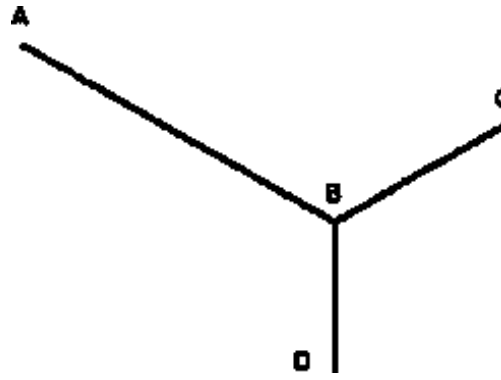

(B) AXES LOCATED

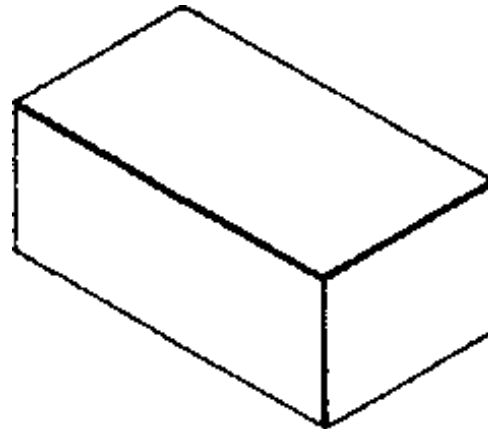

(C) OBJECT DRAWN

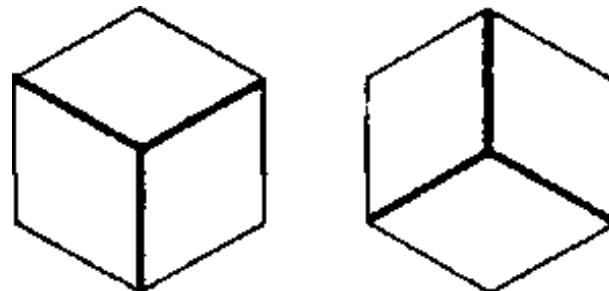

(A) ONE AXIS VERTICAL (B)

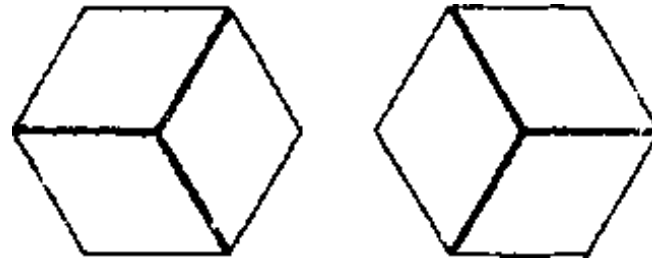

(C) ONE AXIS HORIZONTAL (D)

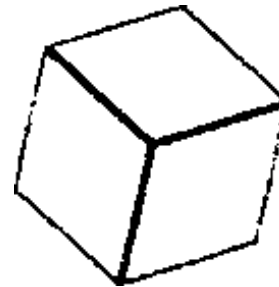

(E) INCLINED

Isometric Construction Methods:

- **Offset method**
- **Box method**
- **Section**

All steps are illustrated in the figure

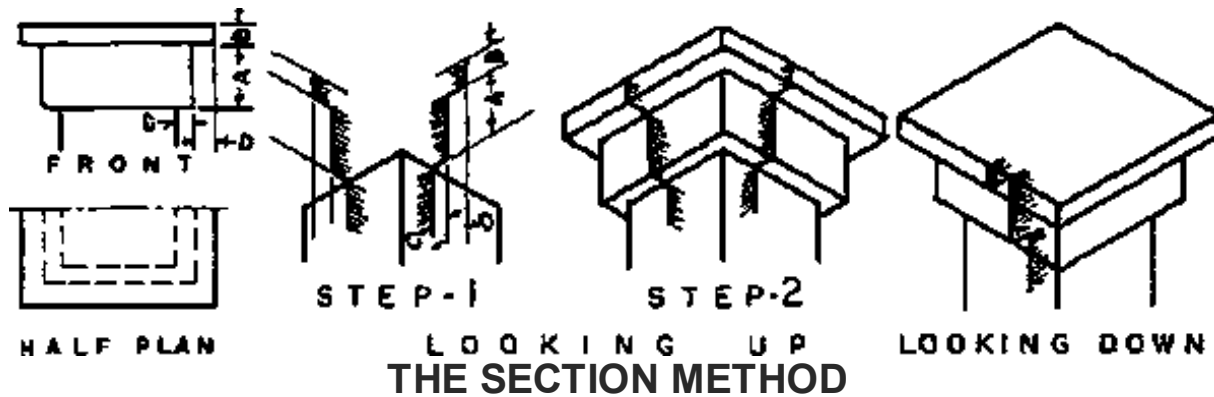
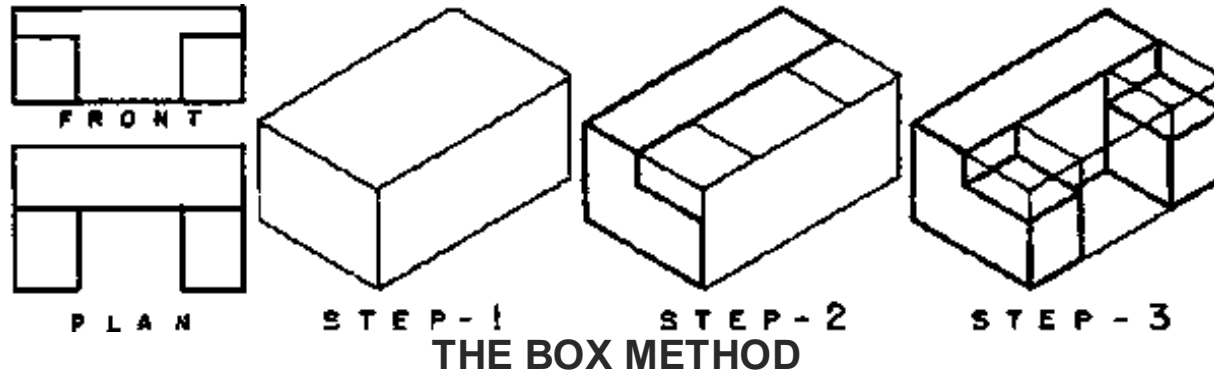
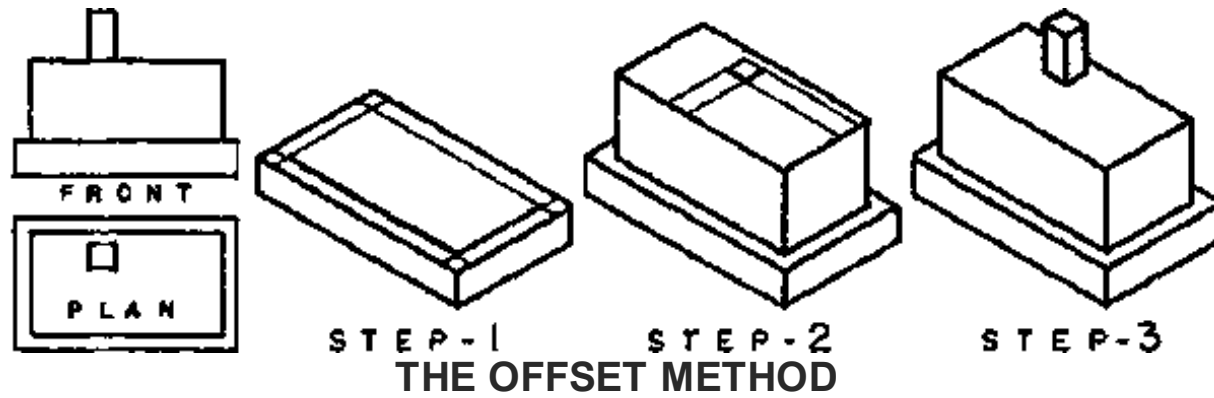

EXAMPLES

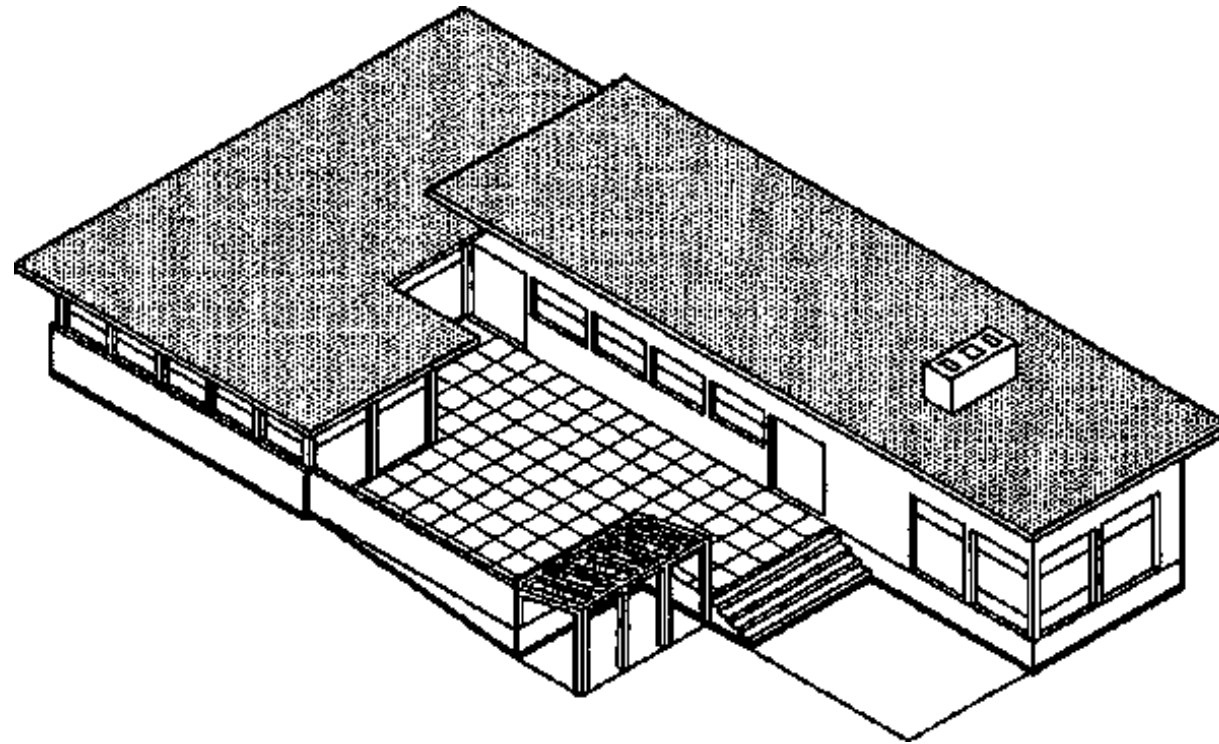

(A) EXTERIOR OF BUILDING

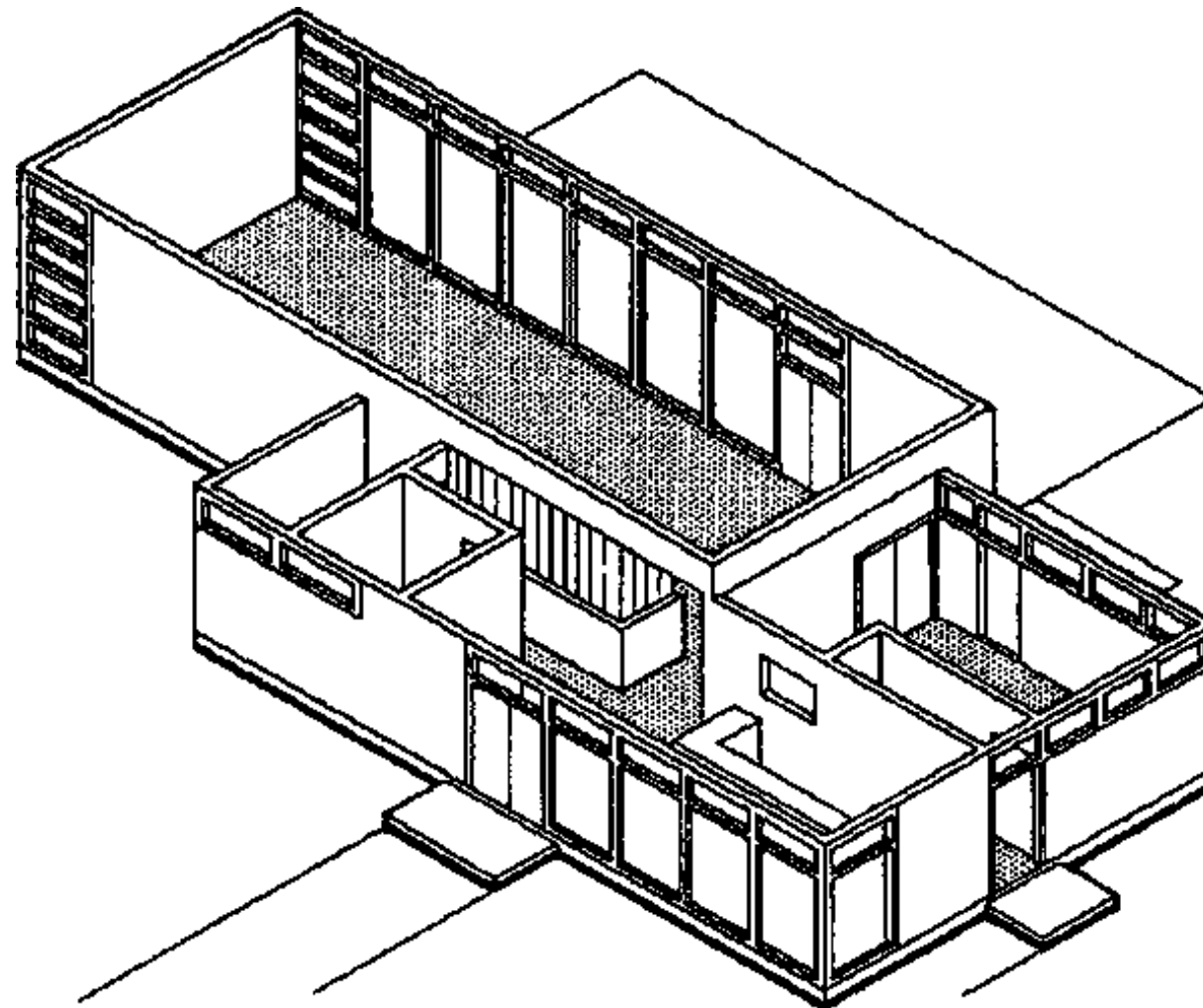

(B) VOLUMES BELOW CEILING

2.3.3 DIMETRIC PROJECTION

The figure shows a cube placed so that the top and bottom are horizontal and the two visible sides make equal angles with the picture plane. Imagine the cube to be rotated forward on a horizontal line which is

parallel to the picture plane, thus keeping the sides always at equal angles to the picture plane until the top is in a vertical position.

As the cube was rotated between these two positions the projections of its axes passed through all possible dimetric relations to each other. A few of the infinite number of possible dimetric positions obtained in this manner are illustrated in the figure. In these illustrations the two equal axes are turned to make equal angles with a horizontal line. If one of these equal axes is turned vertically then the axes to either side will be at different scales and at different angles with a horizontal line. Thus it is possible to use the same spacings of the axes that are shown in the left column of the figure and twist them to new positions with one of the two equal axes in a vertical position and get a new set of pictorial effects, such as are illustrated in the right column of the figure. Dimetric drawings can then be made with the angles and scales giving either a symmetrical or an unsymmetrical arrangement.

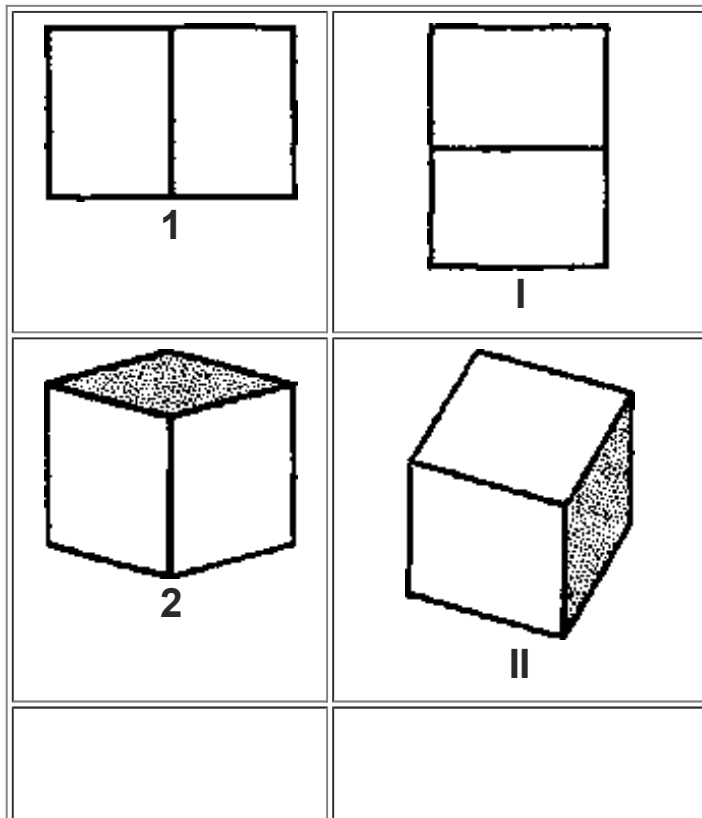

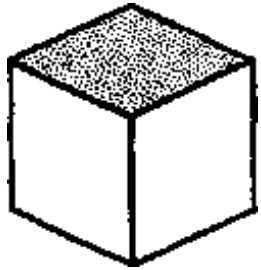

3

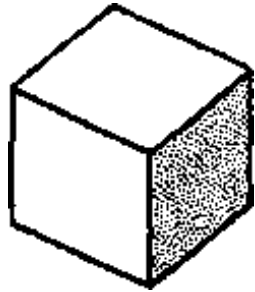

III

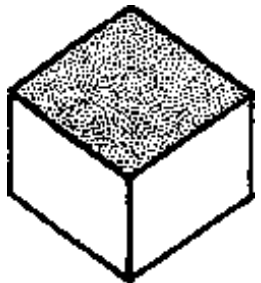

4

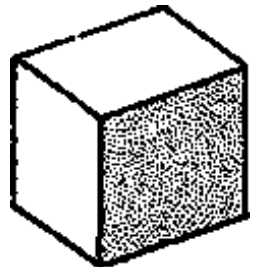

IV

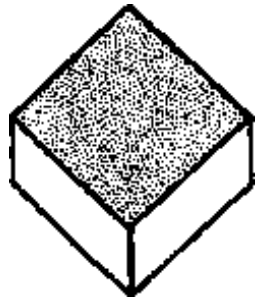

5

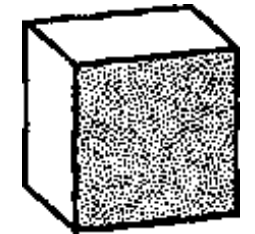

V

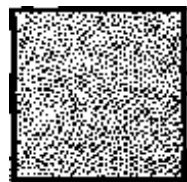

VI

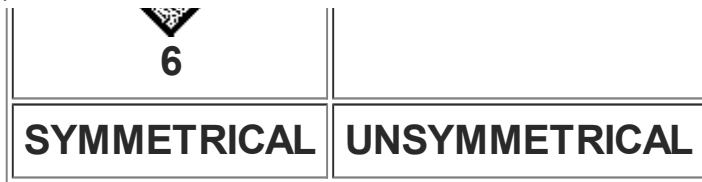

Isometric drawing is rigid and inflexible. There is only one possible view of the three typical planes which meet in any corner of the object because the axes must be equally spaced.

Because of its great variety of possible pictorial effects dimetric drawing overcomes the following faults and shortcomings of isometric drawings:

- 1) The lines of a hip roof and of equal projections of the near corner form parts of continuous vertical line in isometric drawing. This pictorial defect can be avoided in dimetric drawing by using the position of axes, which causes the two sides of the object to be turned at different angles to the picture plane.**
- 2) One of the three typical planes of the object can be emphasized in dimetric drawing by turning the object so that this plane is seen more directly and consequently occupies a greater proportionate area in the drawing. The emphasis on one plane and subordination of the other two can be in any desired ratio.**
- 3) Two of the planes of the object can be emphasized equally and the third subordinated. Thus, it is possible to subordinate the roof or floor area and emphasize the walls or to subordinate one wall. An example of subordination of roof areas and relatively increased importance of wall areas are shown in the figure. By showing less of the roof it is also possible to see more of the wall under an extending roof.**
- 4) The unpleasant effect of wall planes at 45° in isometric projection can be avoided in dimetric drawing.**

Dimetric drawing has the advantage of allowing the choice of a symmetrical or unsymmetrical view of the object and emphasis on one or two of the three planes. It permits variation in the pictorial effect obtained, while isometric drawing is rigid and inflexible.

A carefully chosen dimetric drawing usually gives the most pleasing results of any of the usable types of parallel line pictorial drawing. It ranks next to perspective in desirability for presentation work.

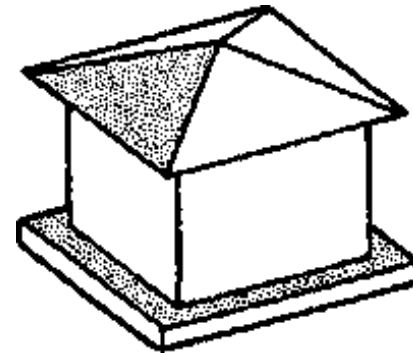
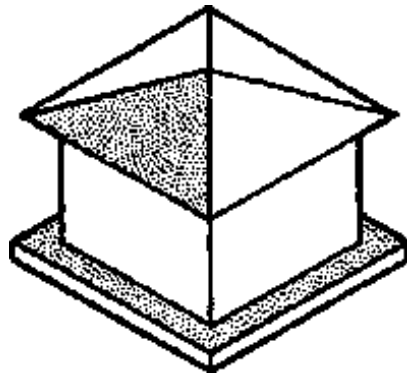

(A) NATURAL APPEARANCE OF CORNERS AND ROOF LINES

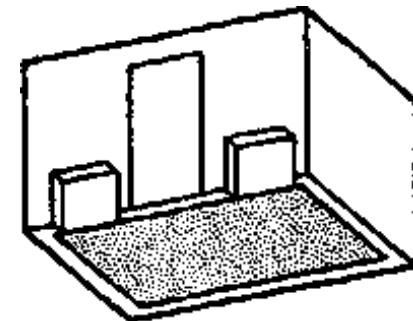
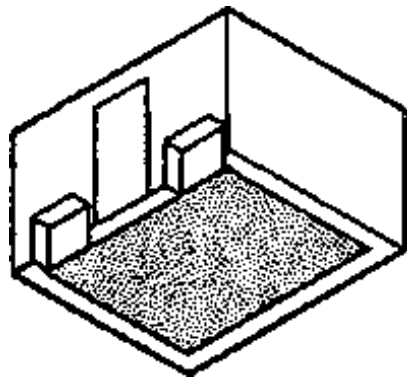

(B) EMPHASIS ON IMPORTANT WALL FLOOR AND ONE WALL SUBORDINATED

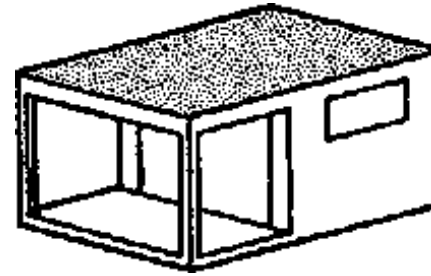
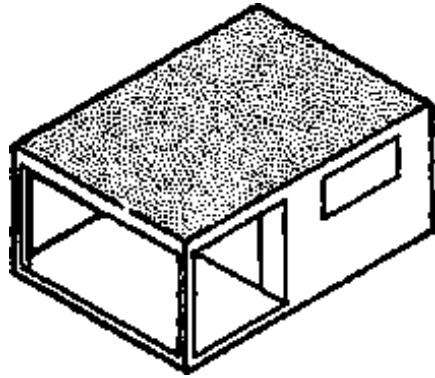

(C) EMPHASIS ON TWO WALLS ROOF AREA SUBORDINATED

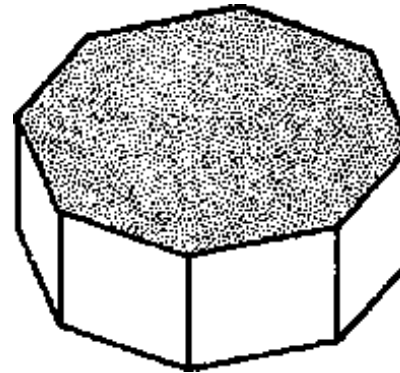
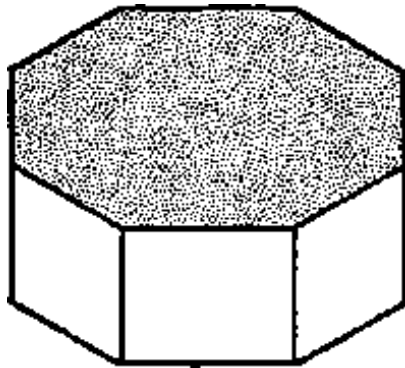

(D) CLEARER REPRESENTATION OF 45° WALL SURFACES

ISOMETRIC

DIMETRIC

DIMETRIC SCALES &. ANGLES

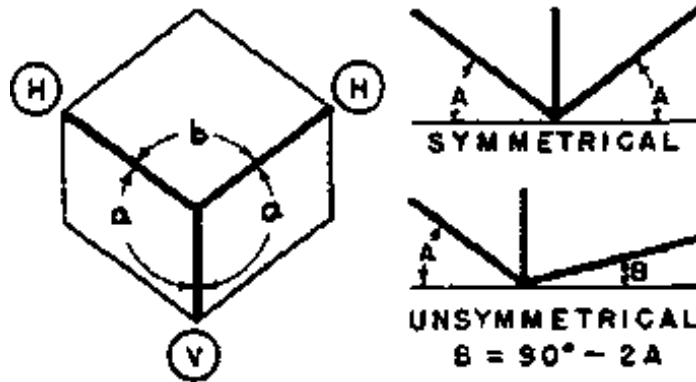

(A) THE RELATION OF SCALES AND ANGLES

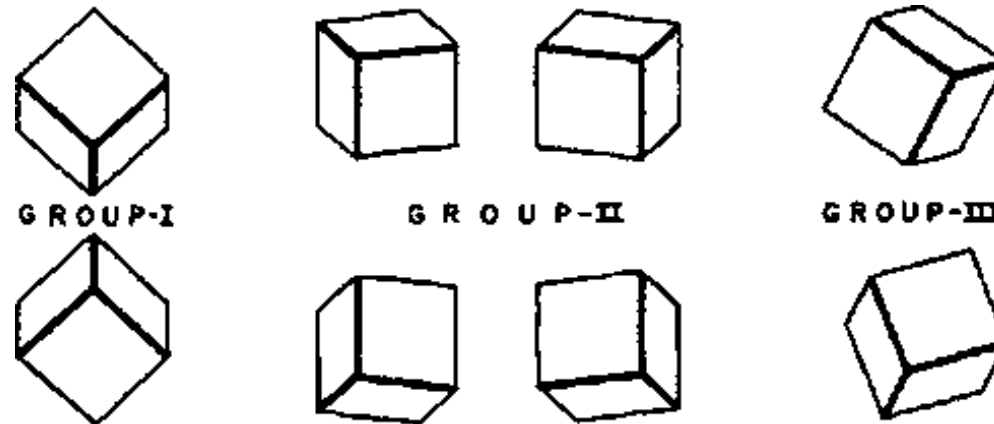

(B) POSITIONS OF THE AXES

(D) SIMPLE FRACTIONAL SCALE RELATIONS

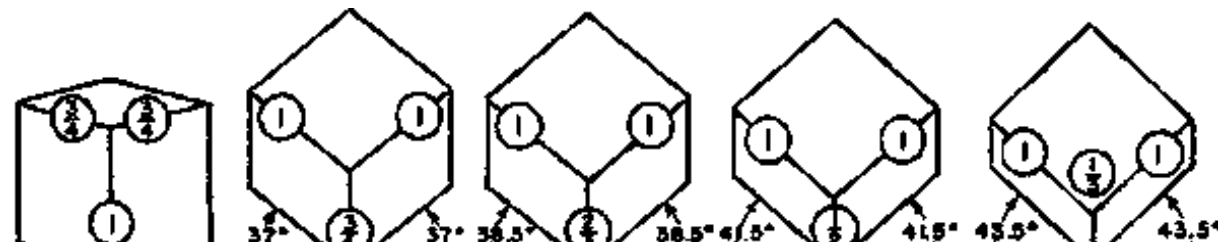

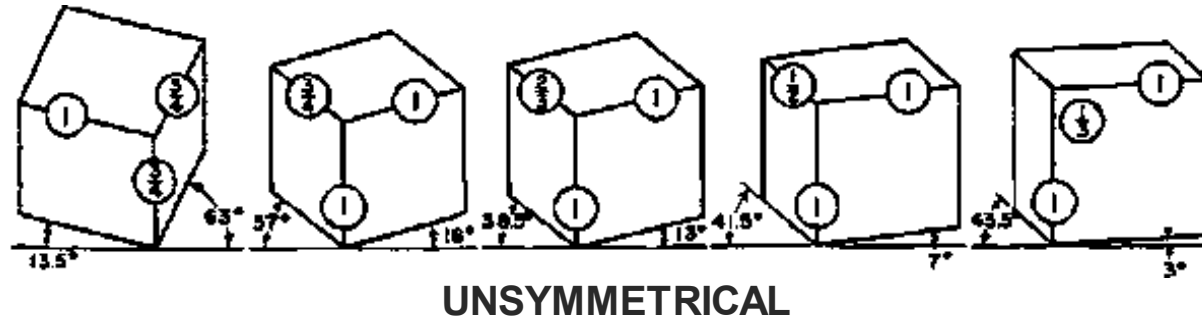

MAKING A DIMETRIC DRAWING

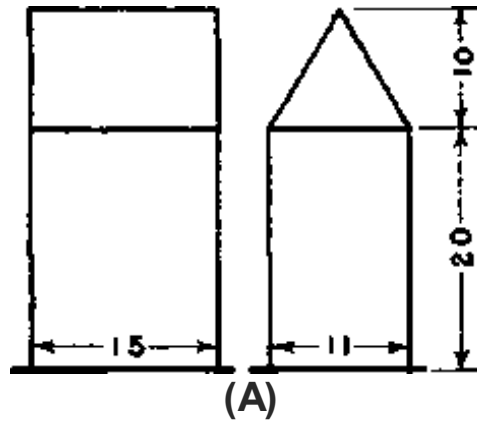

**STEP-1
SELECTED
SET-UP**

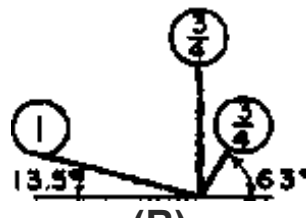

(B)

**STEP-2
MAIN
SIZES**

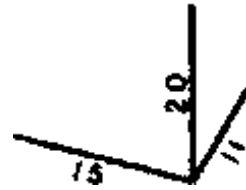

(C)

**STEP-3
BLOCK
SHAPE**



(D)



(E)

EXAMPLES

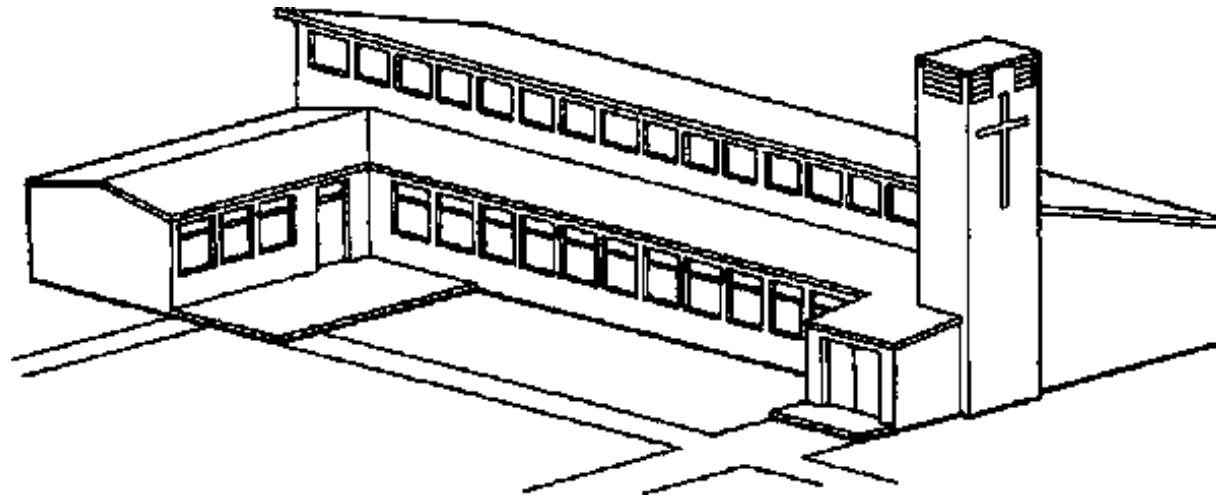

(A) A VILLAGE CHURCH

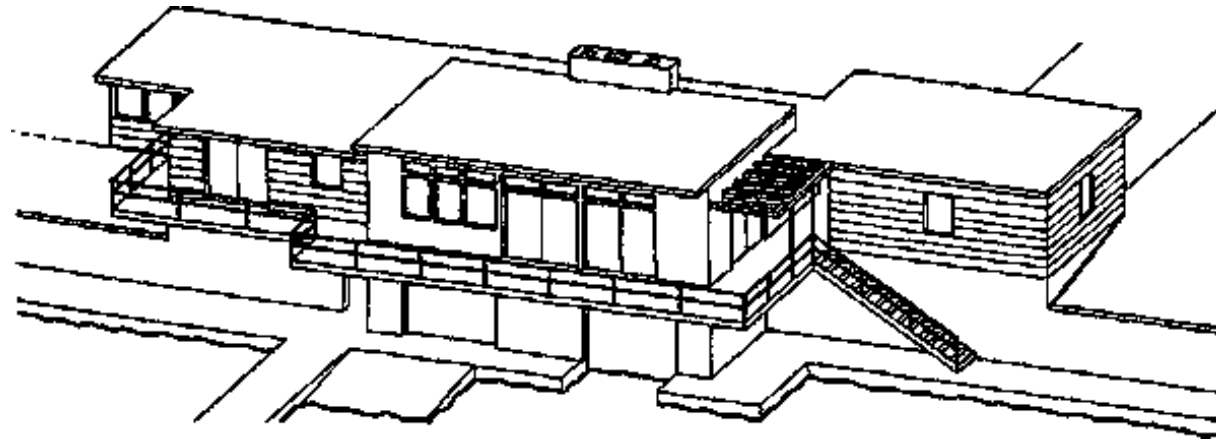

(B) A BOATHOUSE

2.3.4 OBLIQUE PROJECTION

In oblique projection the projectors are oblique to the picture plane and the object is usually turned with one of the typical planes parallel to the picture plan (see fig. A)

In axonometric projection the projectors are perpendicular to the picture plane and the object has all three typical planes oblique to the picture plane. Thus, both the relation of the object to the picture plane and the direction of the projectors in oblique drawing differ from those of axonometric drawing.

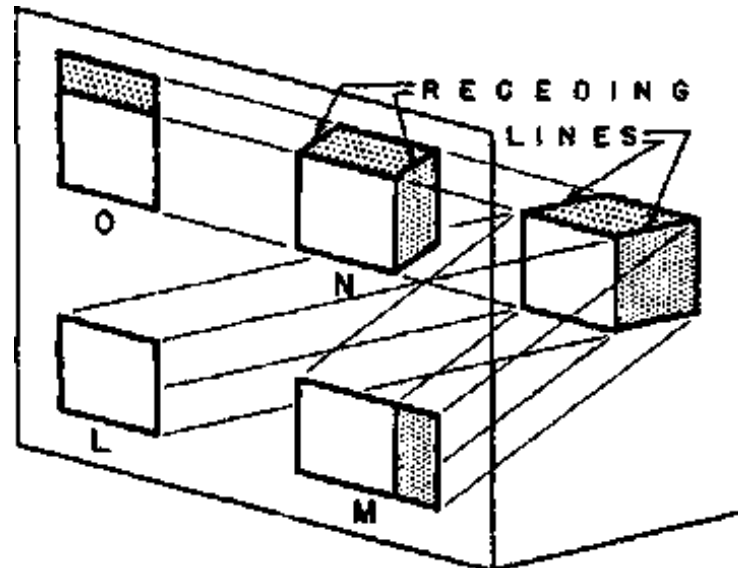

(A) PICTORIAL VIEW OF OBJECT AND DRAWINGS

Although the drawings M and O of figure A may be considered oblique drawings they are made with the projectors in planes parallel to one of the typical planes of the object and are neither good pictorial drawings nor characteristic oblique drawings. Drawing N shows the characteristic oblique drawing in which the projectors are oblique to the three typical planes of the object. Fig. B shows these drawings as they would appear from in front of the picture plane.

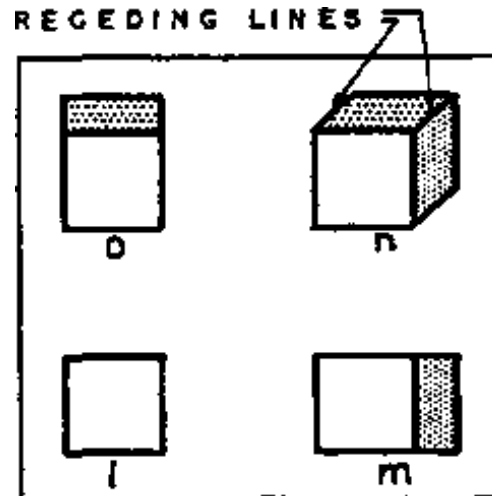

(B) DRAWINGS SEEN ON THE PICTURE PLANE

2.3.4.1 Length of Receding Lines

The angle of the projectors with the picture plane determines the length of the receding lines of an oblique drawing. If the projectors make an angle of 45° with the picture plane the receding lines will be projected in their true length.

From the end b of a given receding line a - b (fig. C) any number of projectors can be drawn making an angle of 45° with the picture plane. The intersections of these projectors with the picture plane will form a circle with the end 'a' of the line 'a-b' as a centre and the projectors will form a right cone with 'b' at the apex and 'a' at the centre of the base. The possible projections of the receding line 'a-b' radiate in all directions from the end 'a' of the line.

DIRECTION OF RECEDING LINES

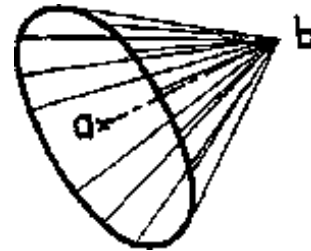

(C) PICTORIAL VIEW

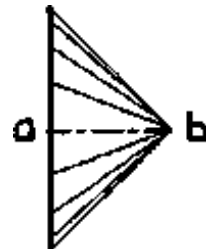

(D) SIDE VIEW

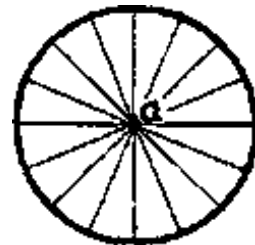

(E) FRONT VIEW

Therefore a line can be drawn at any angle from a (fig. E), to represent the receding line 'a-b' in an oblique drawing, and the projection of the line 'a-b' will be equal to the length of the line itself if the projectors make an angle of 45° with the picture plane. By varying the angle of the projectors with the picture plane the receding lines can be made larger or smaller than scale size.

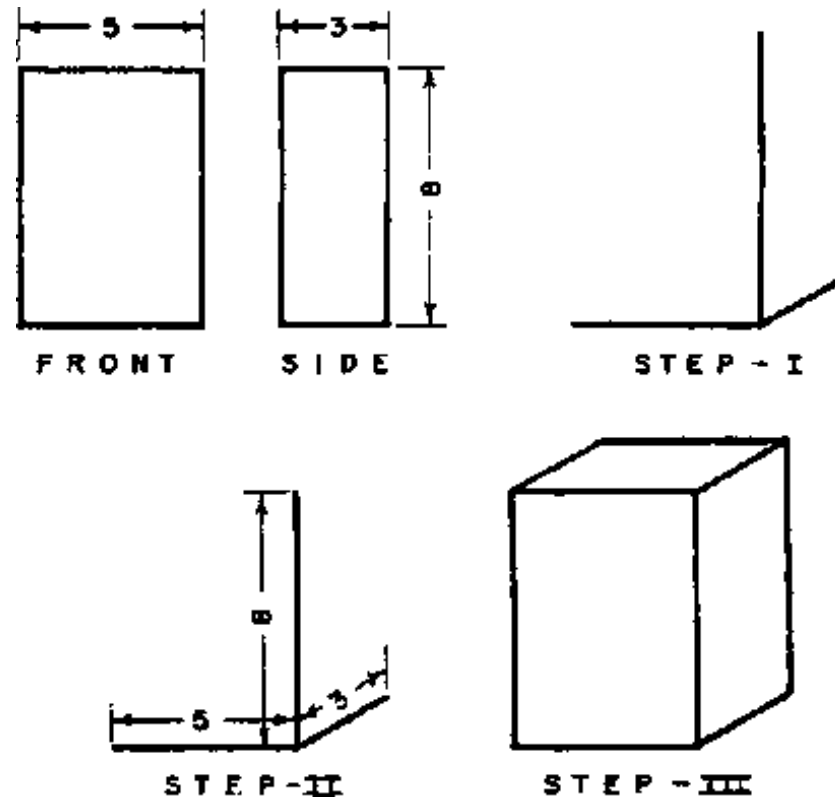

2.3.4.2 Construction of Oblique Drawings

The block shape shown in fig. A is drawn in oblique by proceeding as follows:

Step 1: Draw the horizontal and vertical axes and from their intersection lay out the receding axis at any desire angle.

Step 2: Lay out the dimensions of the object on the axis lines

Step 3: Draw lines from the measurements to complete the drawing.

Offset Method: The way of construction is illustrated in fig. B. Usually most measurements on an oblique drawing can be made on lines parallel to the axes. However, the planes of the object which are parallel to the picture plane appear in their true shapes and measurements can be made on them at any angle. Furthermore, any slanting lines which are parallel to the picture plane are drawn in their true directions and lengths.

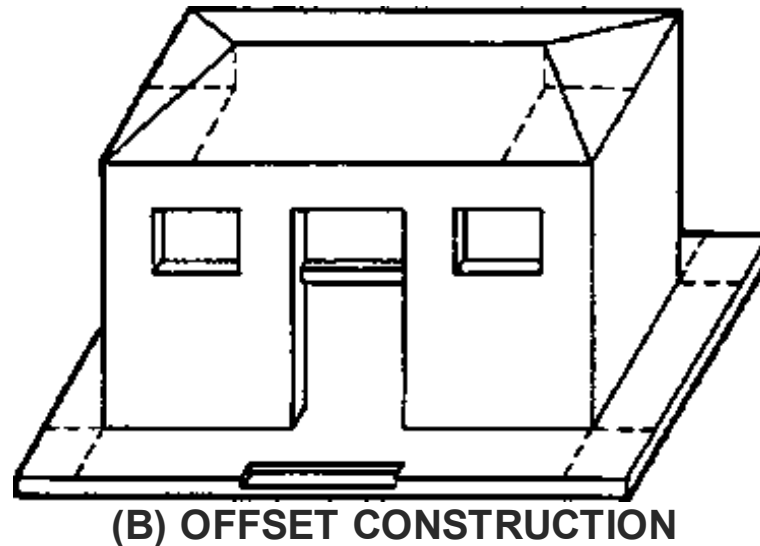

2.3.4.3 Rules of Oblique Drawing

There are two rules of oblique drawing which should be followed when it is practical to do so (see fig. C)

Rule 1: Turn the length of the object parallel to the picture plane

Rule 2: Turn the most complex or characteristic face of the object parallel to the picture plane

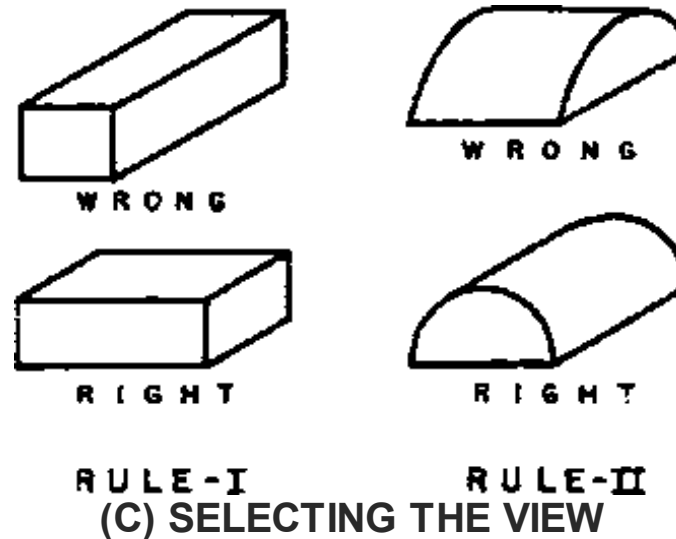

The purpose of the first rule is to decrease the appearance of distortion by making the receding lines represent the short dimension of the object.

The purpose of the second rule is to show the true shapes of characteristic forms of the object and simplify construction.

2.3.4.4 Scale of the Receding Lines

Since the projectors can be at any angle with the picture plane the receding lines of an oblique drawing can be drawn at any scale.

The four drawings of the cube in the figure show the effect of different scales for the receding lines on the proportions of the drawings.

- The receding lines of the **CAVALIER- PROJECTION** in which the same scale is used on all lines, appear to be too long.

- The **CABINET PROJECTION**, with half- scale on the receding lines, has gone too far in the other direction, making the receding lines appear too short and the object appear thin.

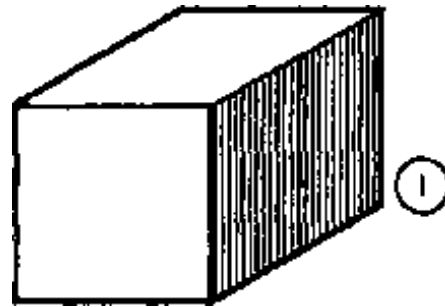

(A) CAVALIER PROJECTION TOO LONG

When the scale of the receding axis is made $\frac{3}{4}$ or $\frac{2}{3}$ of the scale of the horizontal and vertical axes the proportions of the drawings are better.

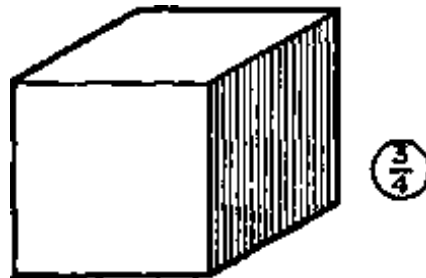

(B) IMPROVED PICTORIAL PROPORTIONS

Cavalier projection has the advantage of simplicity of construction. The use of $\frac{3}{4}$ or $\frac{2}{3}$ scale on the receding lines gives a better pictorial effect.

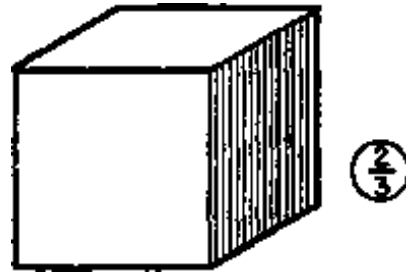

(C) IMPROVED PICTORIAL PROPORTIONS

One of these scales should be used when appearance is an important factor.

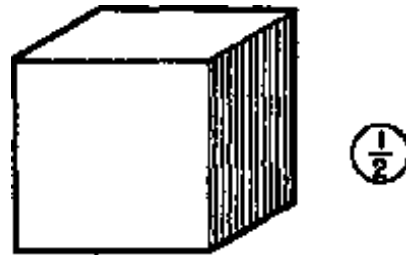

(D) CABINET PROJECTION TOO SHORT

2.3.4.5 Direction of Receding Lines

Since the receding axis of an oblique drawing can be drawn in any direction it is possible to secure a great variety of pictorial effects. The figure shows three variations of direction of the receding lines for an exterior and an interior.

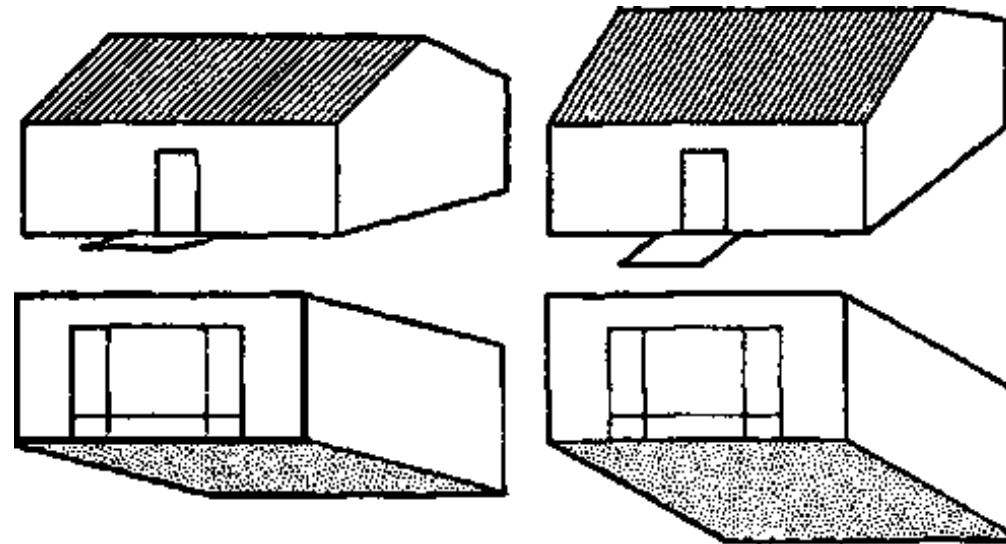

2.3.4.6 Position of Axes

In all the preceding illustrations of oblique drawing one axis has been horizontal and another vertical.

However, the axes may be turned in any position, if two of the three are kept at 90° with each other.

In A: One axis is vertical, another horizontal

In B: The oblique axis is horizontal

In C: None of the axes is vertical or horizontal

In D: The oblique axis is vertical





(A) ELEVATION PLANE TRUE SHAPE ELEVATION OBLIQUE

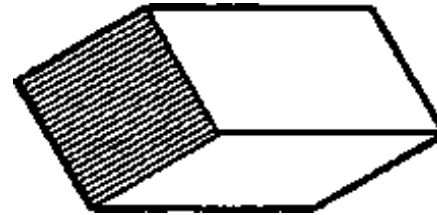

(B) END TRUE SHAPE RECEDING LINES HORIZONTAL

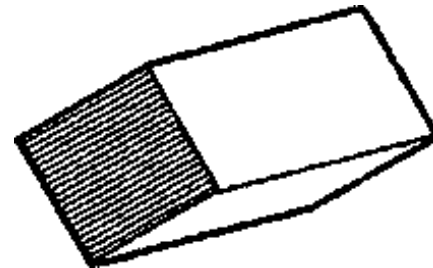

(C) INCLINED OBJECT ALL OF AXES OBLIQUE LINES

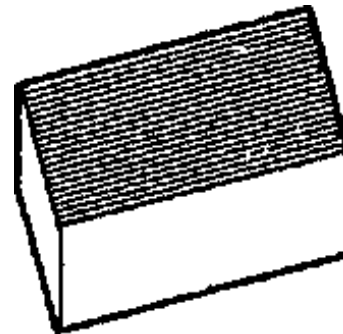

(D) PLAN PLANE TRUE SHAPE PLAN OBLIQUE

The **PLAN OBLIQUE** axis position, shown in D, is often used in drawing pictorial views in which it is advantageous to have the picture plane horizontal and parallel to the floor plane. This position of the axis allows all horizontal areas to appear in their true forms.

For either interior or exterior designs having horizontal, circular or other complex forms this arrangement of the axes is to be recommended for simplicity of construction and for clearest representation of the shapes. With the oblique axis vertical, the other axes must remain at 90° with each other but may be turned in any desired relation to the vertical axis. The oblique lines (vertical) should be drawn at $2/3$ or $3/4$ scale.

TRUE SHAPE PLANES ARE SHADED ON THIS PAGE

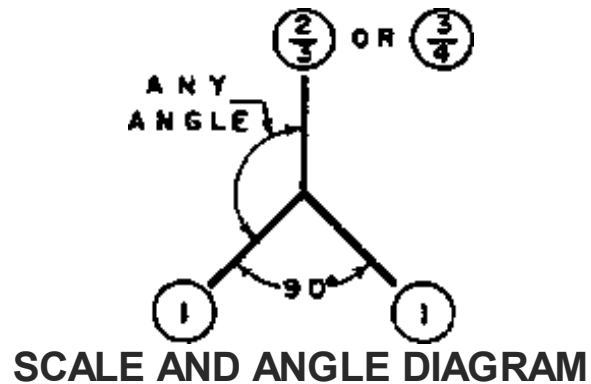

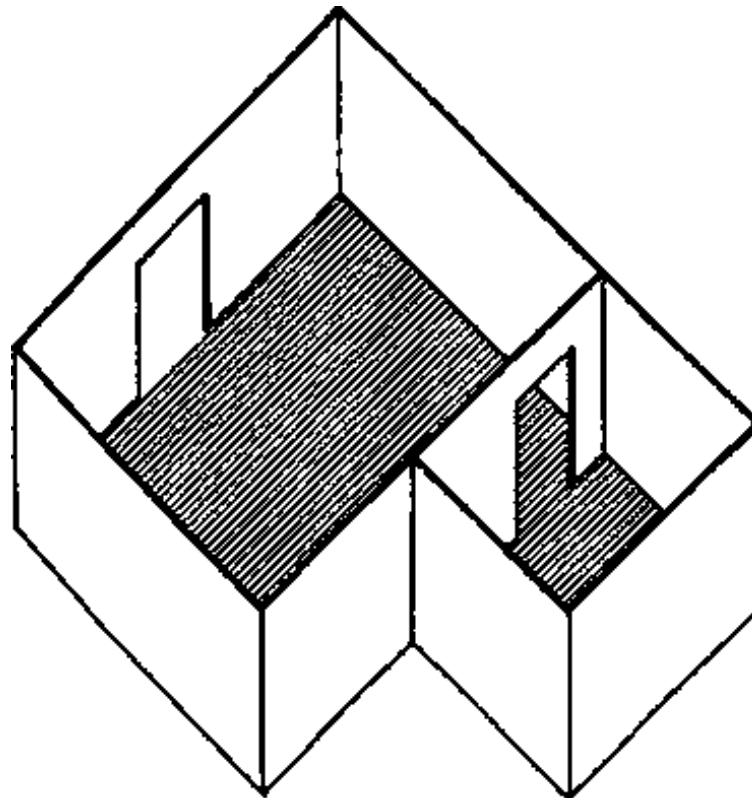

(A) ALL WALLS SHOWN

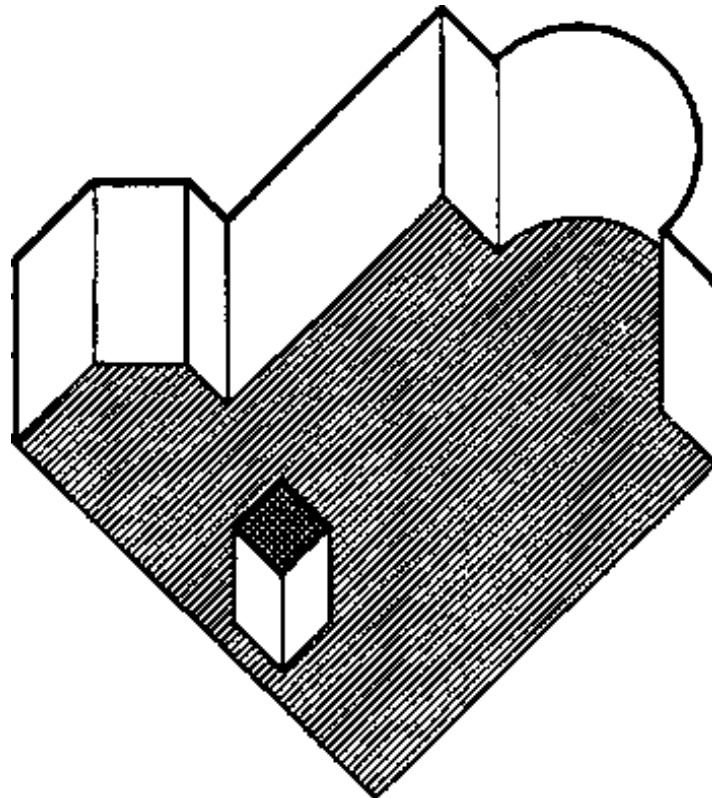

(B) NEAR WALLS OMITTED

EXAMPLES

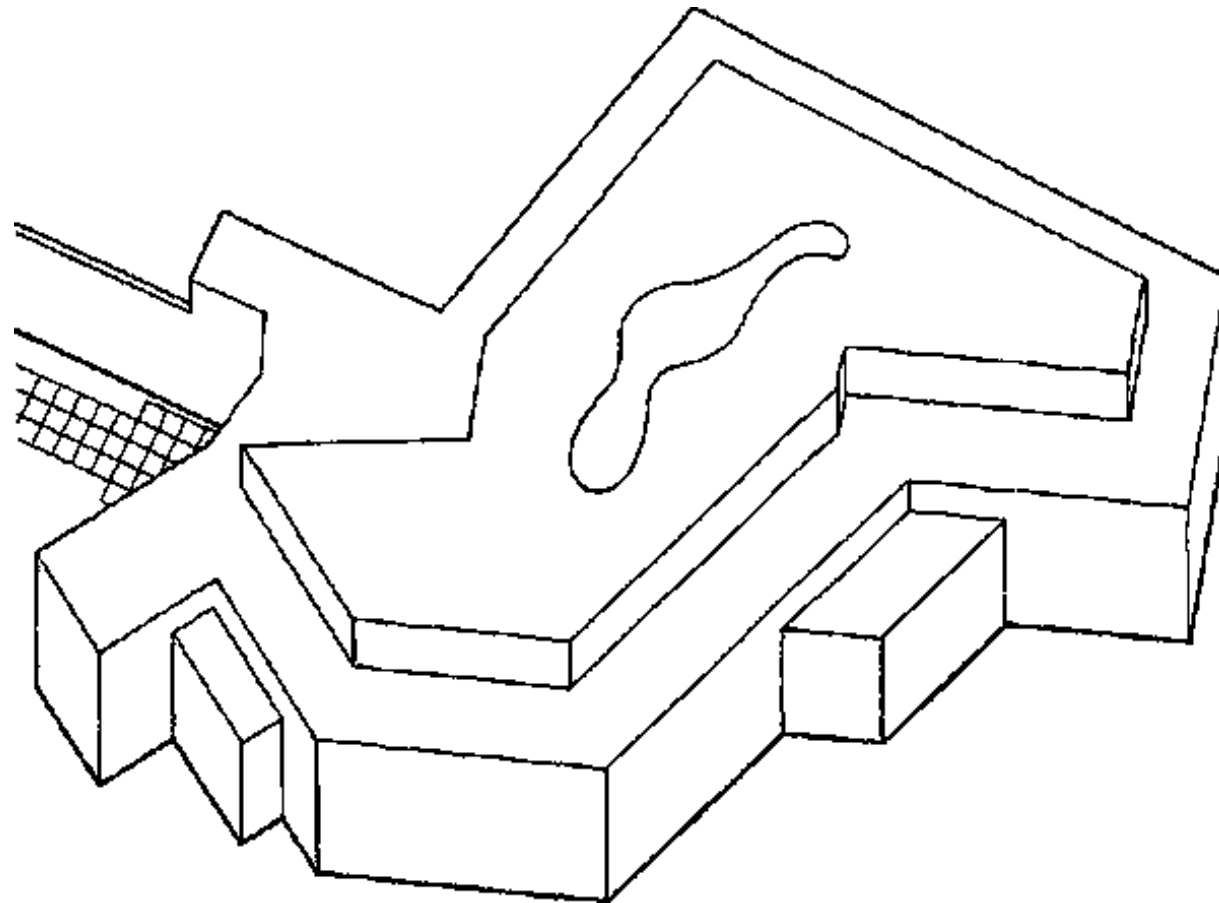

(A) PLAN OBLIQUE OF AN AQUARIU

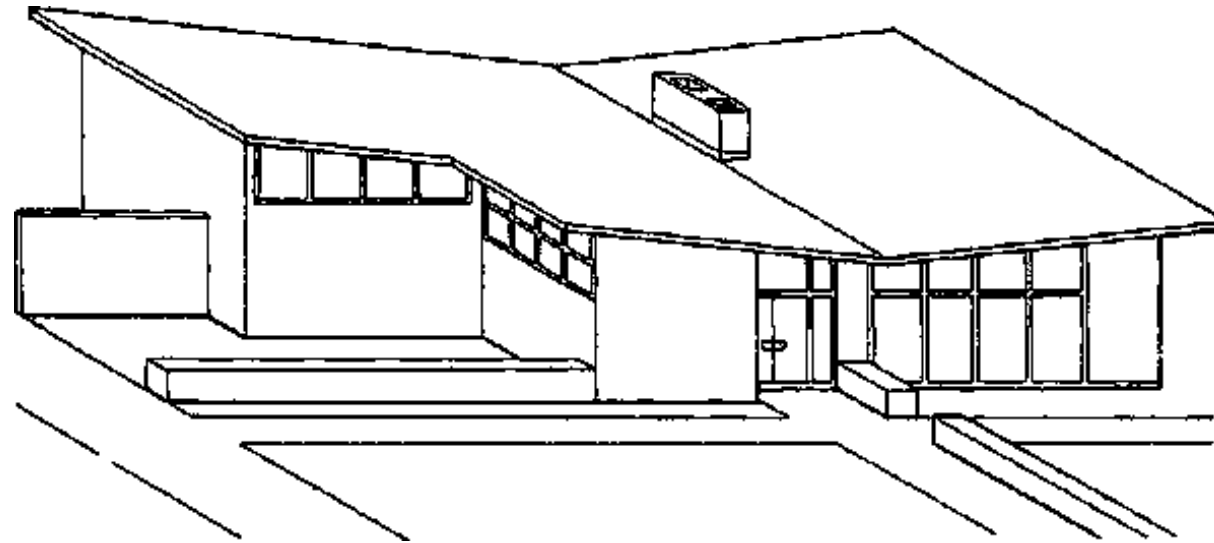

(B) ELEVATION OBLIQUE OF A RESTAURANT

2.4 PERSPECTIVE DRAWING

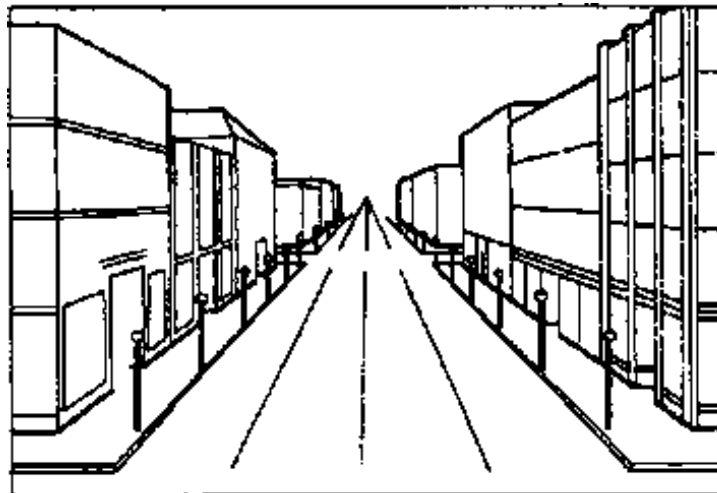

Perspective drawing is essential in the work of the architect and designer, because it is the only type of drawing which represents an object in the natural and pleasing way that it would actually appear to the eye. In all other types of pictorial drawing all parallel lines are drawn parallel and produce the unpleasant illusion of becoming farther apart on the more distant parts of the object.

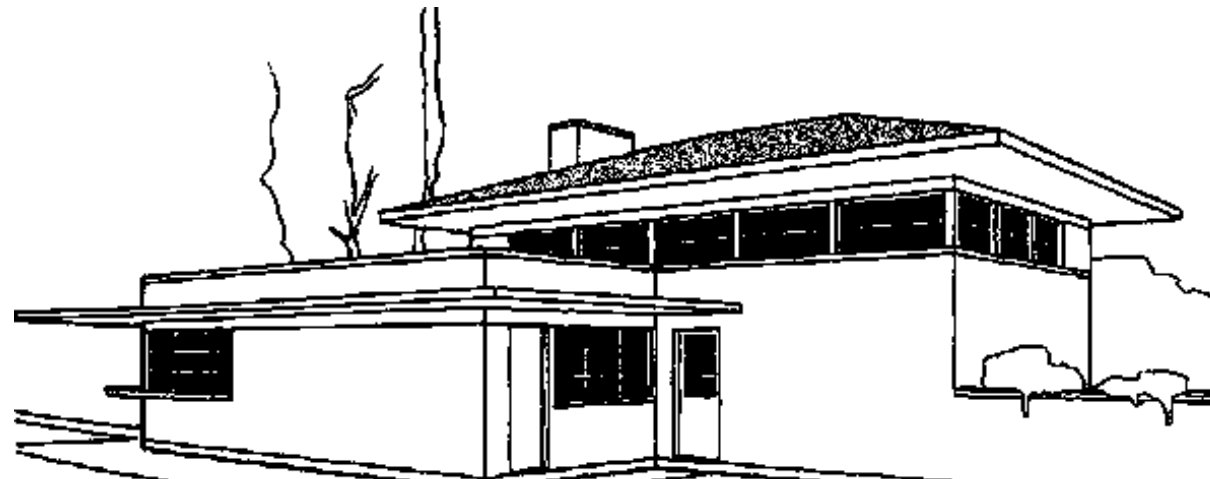
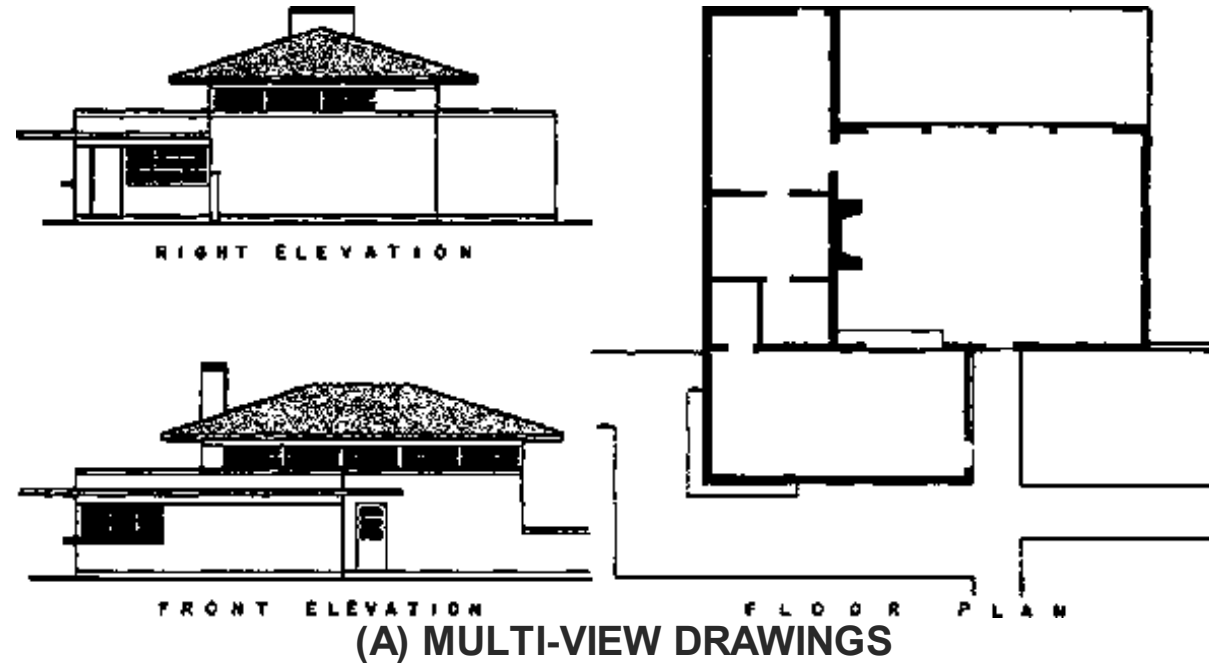

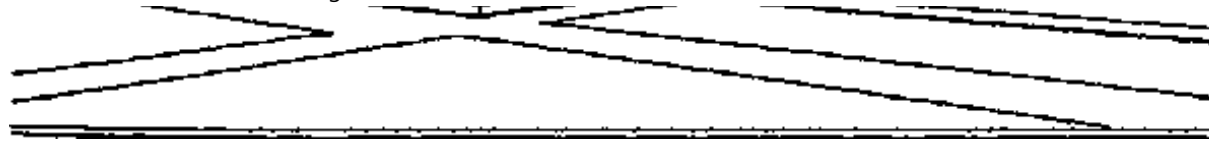

(B) PERSPECTIVE DRAWING

PERSPECTIVE is of value for:

1. drawings which can be easily understood by anyone,
2. an accurate method of studying and perfecting designs, and
3. explanatory sketches and drawings.

2.4.1 PERSPECTIVE TERMS

STAND POINT (S.P.) is the position of the observers eye and is assumed to be the position from which an object is seen.

PROJECTORS. In perspective drawing the projectors converge to a station point instead of being parallel as they are in all other types of drawings.

Perspective projectors are imaginary lines of sight from the eye of the observer to points on the object.

PICTURE PLANE (P.P.) is an imaginary plane which intersect the perspective projectors in order to give points through which the perspective drawing is made, as though drawn on the picture plane.

VANISHING POINT (V.P.) is a point at which lines, not parallel to the P.P. appear to meet on the horizon line.

CENTRE OF SIGHT is the point at which the line of sight meets the P.P. and should be as near as possible to the centre of the object.

GROUND PLAN (G.P.) is the horizontal plane on which the object rests.

GROUND LINE (G.L.) is the intersection of the ground plane and the picture plane.

HORIZON LINE (H.L.) is the line parallel to the ground line and passing through the centre of sight on **EYE LEVEL (E.L.)**.

2.4.2 PHENOMENA OF PERSPECTIVE DRAWING

- **Sizes.**

In a perspective drawing sizes are shown as they appear to the eye from the position of the station point, **NOT** as they actually are.

The converging projectors reduce the perspective sizes of distant objects causing them to appear to be smaller than identical objects nearer the picture plane.

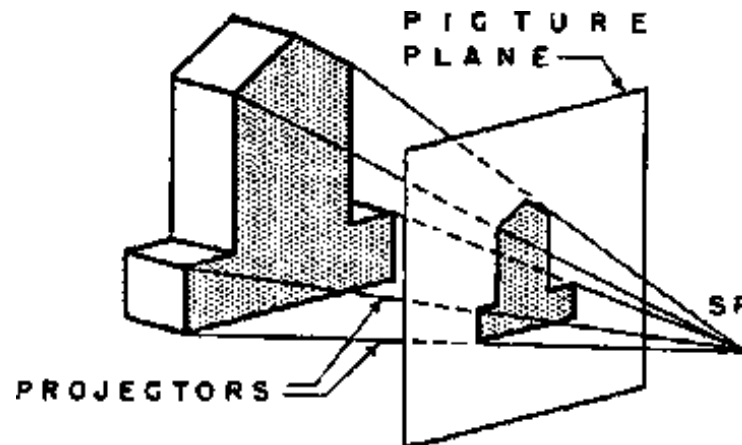

(A) CONVERGING PROJECTORS IN PERSPECTIVE

Objects in front of the picture plane are enlarged in the size by the projectors.

ONLY THE LINES IN THE PICTURE PLANE ARE DRAWN TO THEIR SCALE SIZES:**- Measurements.**

Since lines of equal length on the object may appear in an infinite variety of sizes in a perspective drawing, it is impossible to measure sizes directly on the drawing except in special cases. The determination of sizes, and especially of heights, is one of the most difficult features of making an perspective drawing.

Any lines of the object which lie in the picture plane can be measured to scale.

Parts of the object in front of the P.P. will be larger than scale size.

Parts of the object in the back of the P.P. will be smaller than scale size.

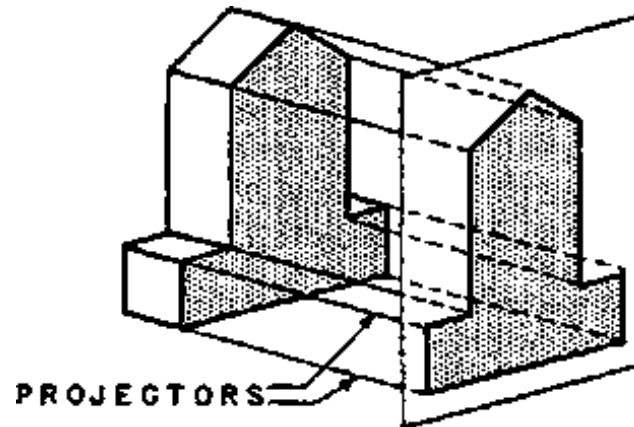

(B) PARALLEL PROJECTORS IN ALL OTHER DRAWING

The various methods of perspective drawing obtain this correction of sizes in different ways.

- Shapes.

In perspective drawing the object is represented as it appears to the eye. Areas and angles usually do

not appear in perspective as they really are.

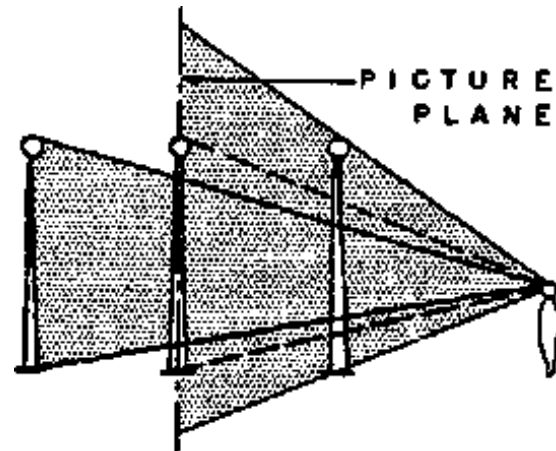

(C) EFFECT OF DISTANCE ON PERSPECTIVE

Rectangles and squares are often drawn as irregular quadrilaterals with four unequal sides and four unequal angles.

A right angle seldom appears as such in a perspective but is drawn as an acute or obtuse angle. A circle usually appears as an ellipse in perspective.

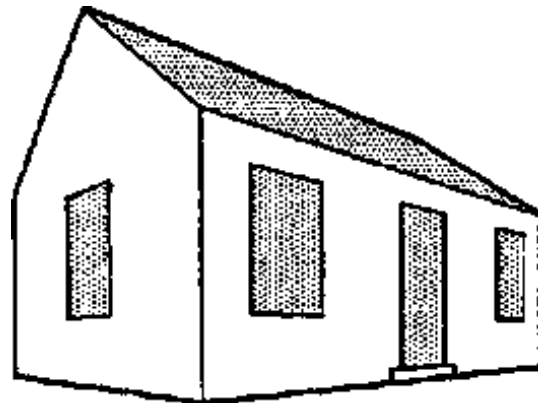

(D) VARIATIONS OF SIZE IN LINES AND AREAS

- Horizontal Surfaces.

The horizon is at the level of the station point in a perspective drawing. The eye looks up at things above the horizon and down on things below the horizon. Horizontal surfaces above the horizon (eye level) are visible from below and horizontal surfaces below the horizon are visible from above. Such as steps, are visible from above. Thus, both the ceiling and floor of a room may be seen in the same perspective drawing, if the horizon line is located at some position between the floor and ceiling.

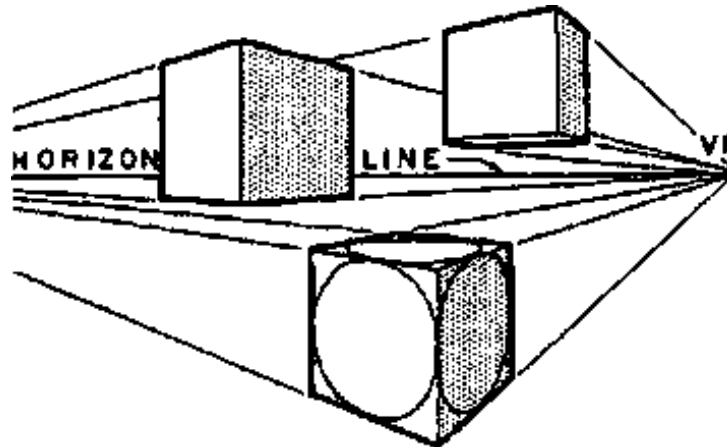

(A) APPEARANCE OF SHAPES OF AREAS AND MASSES

The size of a horizontal area in a perspective drawing depends on the distance and angle from which it is seen.





(B) HORIZONTAL AREAS IN PERSPECTIVE

With the area at a constant horizontal distance from the station point, at the level of the horizon, a given horizontal area appears as a line and increases in visible size with its distance above or below the horizon.

When the height of a horizontal or vertical area is constant, its visible size increases as it approaches the station point and diminishes as it recedes farther from the station point.

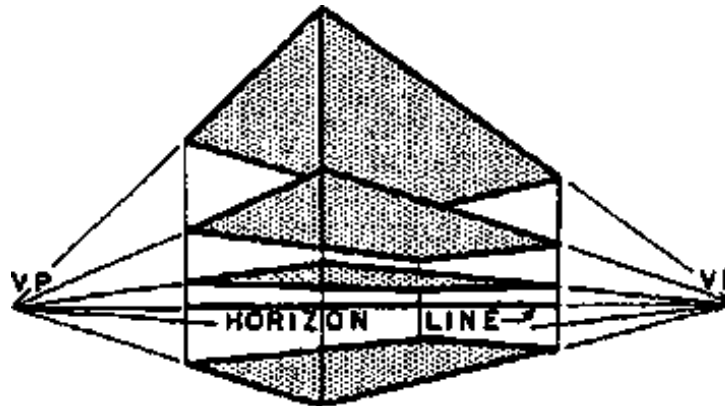

(C) EFFECT OF HEIGHT ON HORIZONTAL AREAS

Except that, whenever the line of vision passes through the plane of a surface the surface is always seen as a **LINE**. I.e.: any horizontal plane at the level of the horizon would always appear as a straight line.

- Lines Parallel to the Picture Plane.

These lines retain their true direction in perspective. Thus, horizontal and vertical lines parallel to the

picture plane remain respectively horizontal and vertical. Sets of parallel lines which are parallel to the picture plane remain parallel perspective just as they do in orthographic projection.

However, the length of the parallel lines in perspective varies with the distance from the picture plane, instead of being projected in actual size relations.

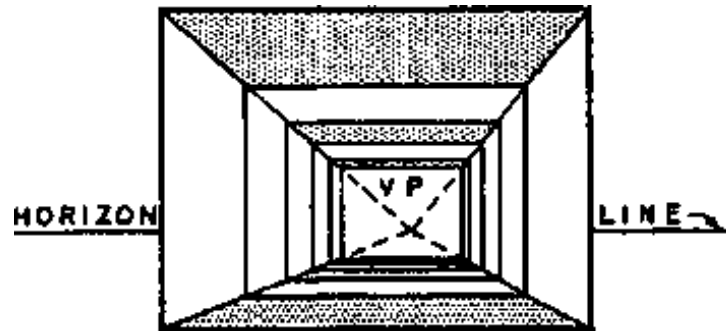

(D) EFFECT OF DISTANCE ON LINES AND AREAS

- Lines NOT Parallel to the Picture Plane.

In perspective each set of parallel lines which is not parallel to the picture plane converges to its vanishing point. The vanishing points of all sets of horizontal lines are located on the horizon, which is always on a level with the eye of the observer, the Station Point.

PERSPECTIVE SYSTEMS

PARALLEL OR ONE-POINT PERSPECTIVE SYSTEM

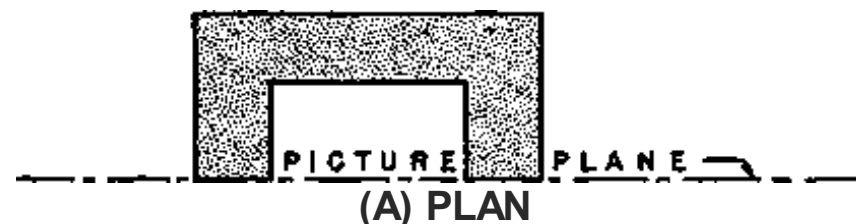

(A) PLAN

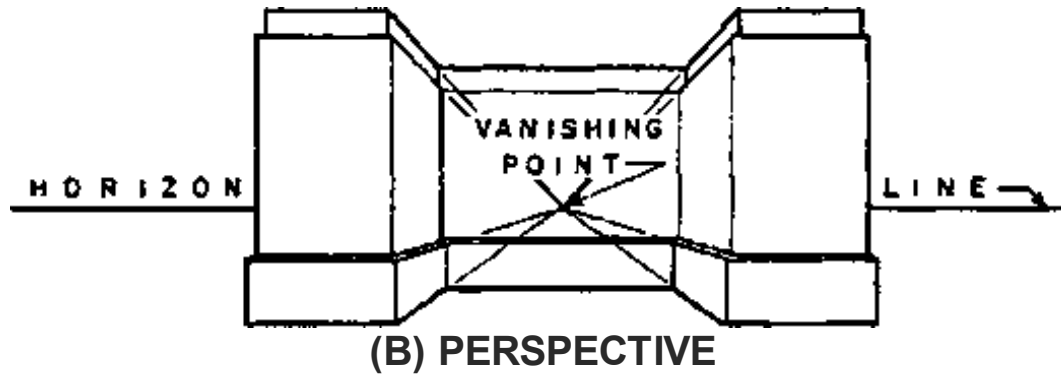

ANGULAR OR TWO-POINT PERSPECTIVE SYSTEM

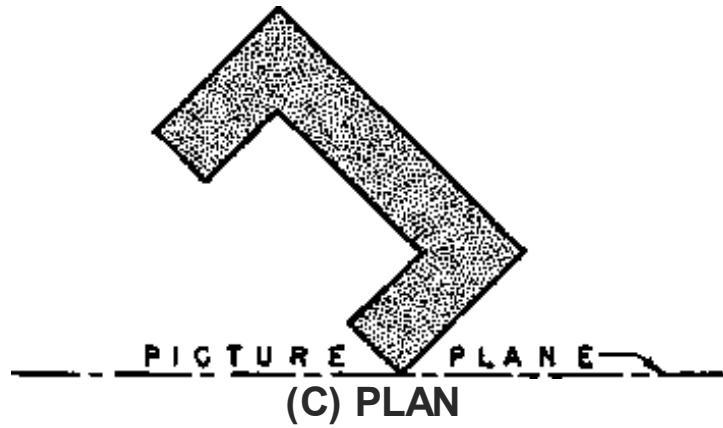

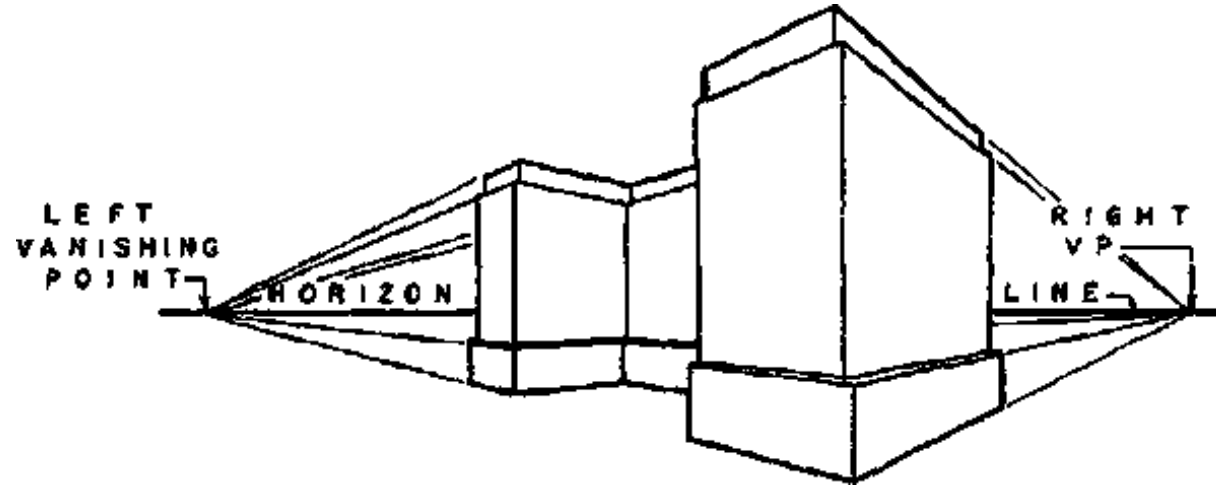

(D) PERSPECTIVE

OBLIQUE OR THREE-POINT PERSPECTIVE SYSTEM

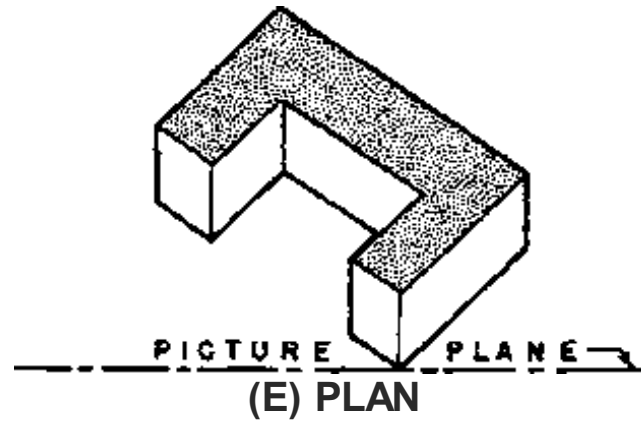

(E) PLAN

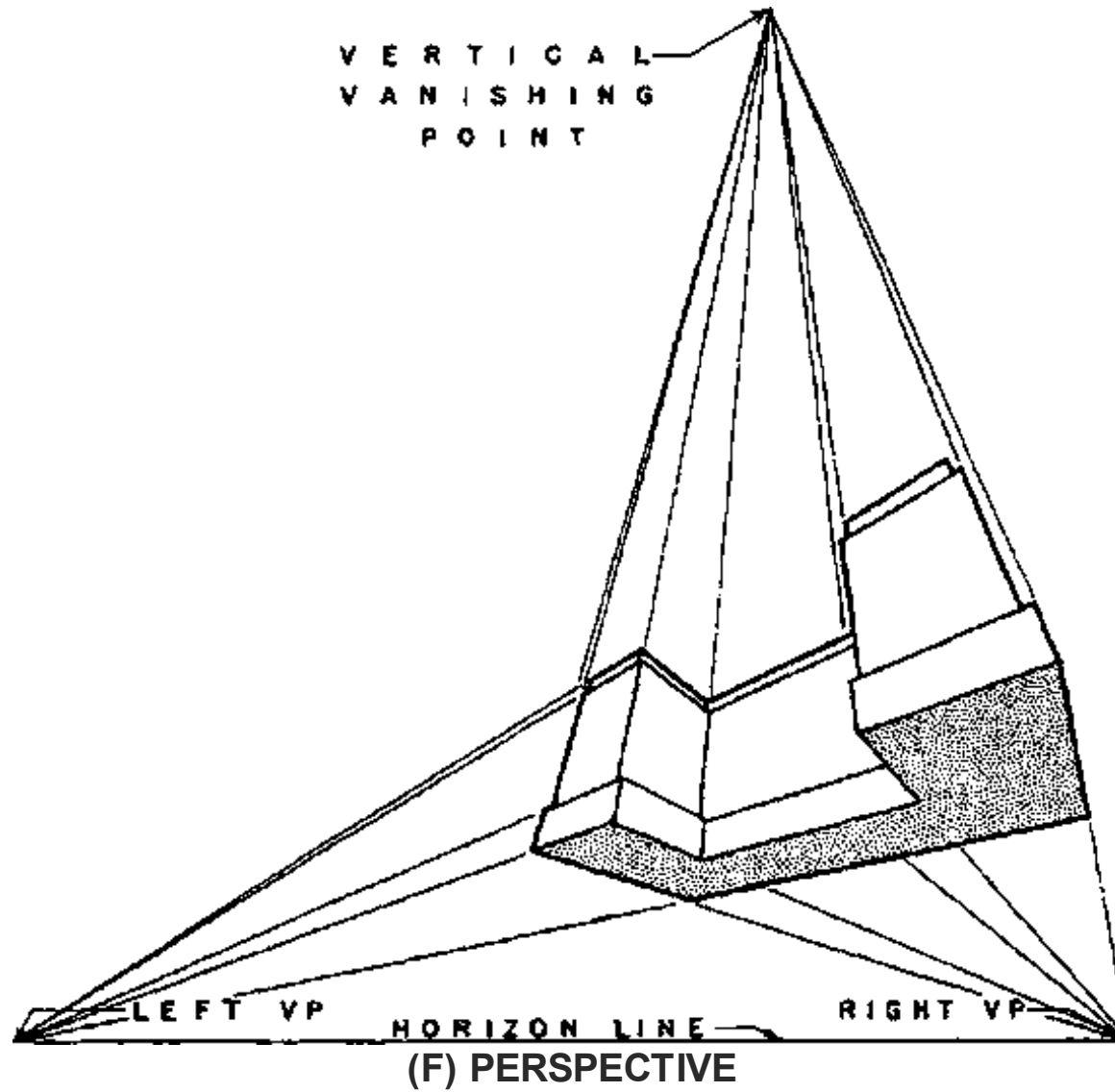

2.4.3 SYSTEMS OF PERSPECTIVE DRAWINGS

There are three systems of perspective drawing which are classified according to the relation between the object and the picture plane and the resulting number of vanishing points for the three sets of typical lines.

Most buildings have as important elements three sets of planes which are illustrated by a box.

One of these sets of planes is horizontal (top and bottom). The other two are vertical and at right angles to each other. These planes meet in the three sets of typical lines of which one set is vertical and the other two horizontal and at right angles to each other.

In the PARALLEL or ONE POINT perspective system one set of planes and two sets of lines of the object are parallel to the picture plane, Fig. A. Lines of these two sets remain respectively vertical and horizontal in perspective, Fig. B. The remaining set of horizontal lines is perpendicular to the picture plane and converges to a vanishing point.

In the ANGULAR or TWO POINT perspective system the object is turned with both sets of horizontal lines at an angle to the picture plane, as shown in the plan of Fig. C. There are, therefore, two vanishing points, one for each of these sets of horizontal lines, Fig. D. Since the vertical lines are parallel to the picture plane they remain vertical and parallel in the perspective.

In the OBLIQUE or THREE POINT perspective system the object is turned, or the picture plane tilted, so that none of the three sets of typical planes and lines of the object is parallel to the picture plane, plan Fig. E. Since all three sets of lines are at an angle to the picture plane, there are three sets of converging lines and three vanishing points, as shown in Fig. F.

The three vanishing points of the typical sets of lines are the only ones mentioned in this discussion of systems of perspective drawings. However, vanishing points of other sets of parallel lines are sometimes useful. Their location and use will be explained later.

2.4.4 METHODS OF PERSPECTIVE DRAWINGS

A perspective of an existing object can be sketched on a picture plane made of a sheet of glass in the following manner: Place the picture plane at arms length, keep the eye in one position, and draw lines to exactly cover the lines of the object as seen through the stationary picture plane (see fig.). A window glass makes an excellent picture plane for this purpose. Whenever the object is not conveniently located, when greater accuracy is required, or when there is no existing object but only the drawings of some proposed structure, it is necessary to use some other method of making the perspective. However, the various drafting methods of making perspective drawings are based on this method of sketching the perspective of an existing object on a transparent plane.

A perspective drawing is made by working out by one of the drafting methods the positions of the lines of the object as they would appear on a given picture plane from a given station point. Three of these mechanical methods of constructing perspective drawings:

- 1. the direct projection method**
- 2. the perspective plan method**
- 3. the common method.**

These methods are described in a general way in the following paragraphs and are explained in detail in the chapters on one- and two-point perspective.

THE DIRECT PROJECTION METHOD has the simplest theory of any method of perspective drawing. Plan and elevation views parallel to the picture plane showing the object, picture plane, and station point are first drawn the fig. The converging projectors are then traced to the picture plane in plan and elevation. Points on the perspective drawing are located from their heights, which are determined from the projectors in plan. The drawings are so arranged that the heights can be carried across horizontally with the T-square and the widths brought down vertically with the triangle to their positions in the

perspective from the intersections of the projectors with the picture plane.

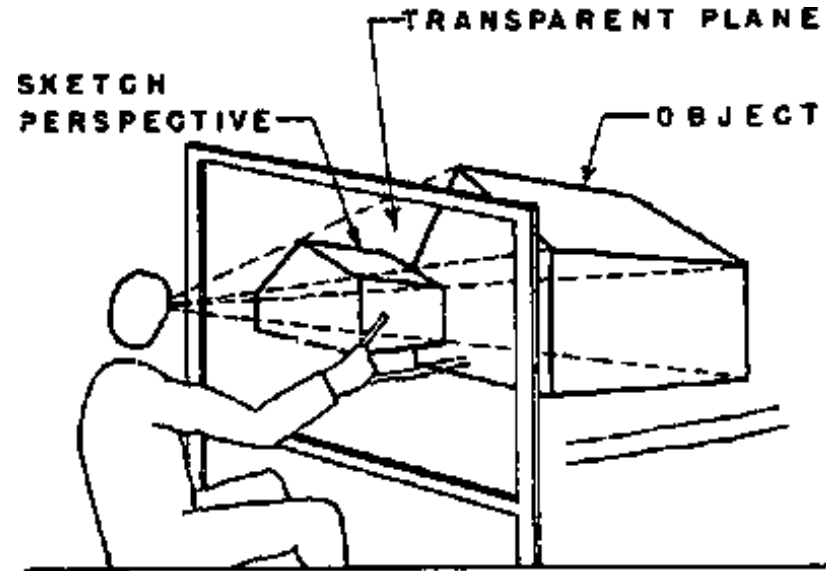

SKETCHING A PERSPECTIVE

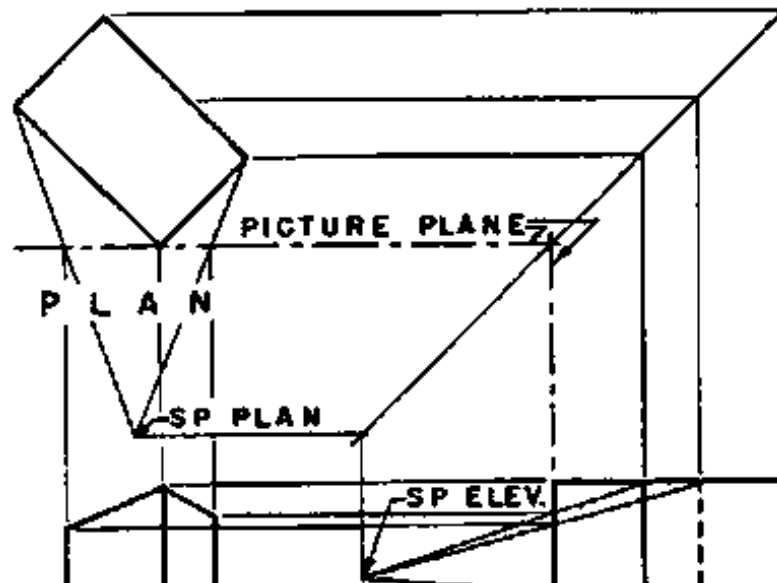



PERSPECTIVE ELEVATION
DIRECT PROJECTION METHOD

The direct projection method is a good method for one-point perspective because the auxiliary drawings used are the plan and elevations, or sections. These drawings are easily understood by the draftsman, and are often available at the correct scale. In two-point perspective one or two special drawings are required for the direct projection method. These drawings are auxiliary elevations or sections from a corner (parallel to the picture plane) and are more difficult to construct and understand than the ordinary elevations and sections. If this method is used without vanishing points very, slight inaccuracies will change the directions of short lines and produce a warped effect. This method requires a great deal of space on the drafting board and many construction lines. Although vanishing points are not required their use will simplify the construction and make the drawing more accurate.

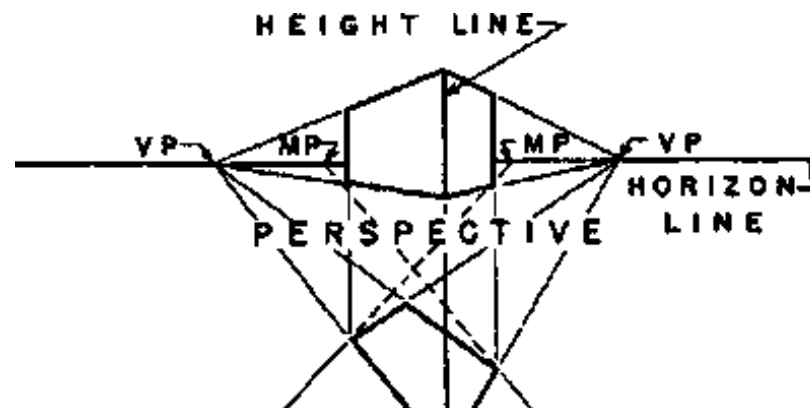
THE PERSPECTIVE PLAN METHOD allows the entire perspective to be constructed from measurements made in the picture plane and brought into correct perspective sizes and positions by tracing line to their vanishing points. The plan is first drawn in perspective. The vertical lines of the perspective drawing are then obtained by drawing vertically from the perspective plan. The scale heights are laid out on any convenient vertical line in the picture plane from which they can be traced by lines toward the vanishing points into their correct perspective positions.

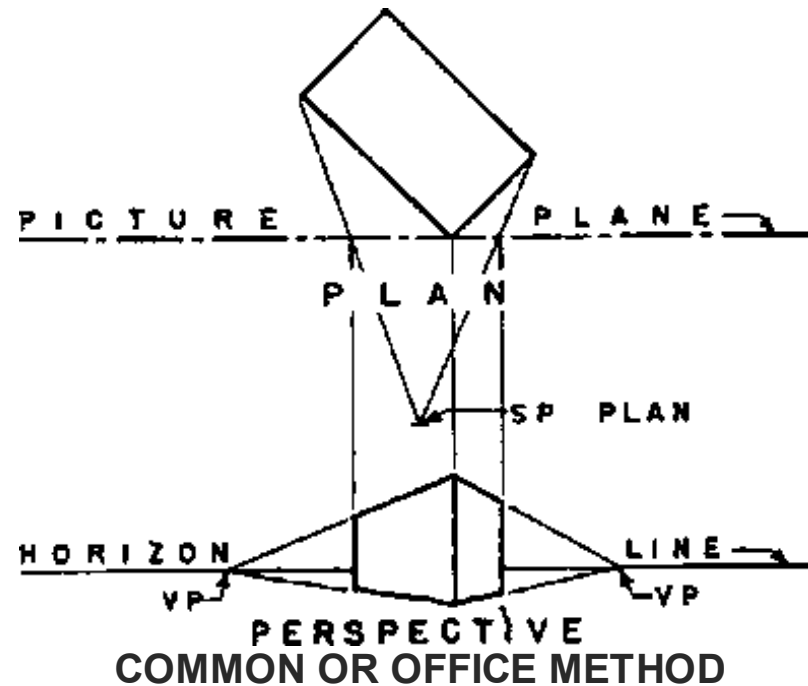



Since this method divides the construction into two steps, the construction lines are easier to trace to the perspective. In addition to the vanishing points of the sets of typical lines not parallel to the picture plane, the perspective plan method requires one or more measuring points to be used in drawing the perspective plan. A measuring point is the vanishing point for the set of parallel lines, which transfers scale measurements of horizontal dimensions from the horizontal measuring line to a base line of the perspective plan. The location and use of measuring points is explained under one- and two-point perspective.

The perspective plan can be drawn at any convenient height either above or below the perspective

The perspective plan can be drawn at any convenient height either above or below the perspective drawing. It can be placed on an important plane of the perspective, such as the floor of an interior or ground plane of an exterior. It is practical and sometimes very convenient to use more than one perspective plan for tall buildings. The perspective plan method requires less space on the drawing board than any other widely used method and is considered the best method by some expert draftsmen.

THE COMMON METHOD is also called the OFFICE METHOD and the MIXED METHOD. It combines the plan construction for horizontal spacing of vertical lines of the direct projection method and the height construction of the perspective plan method.(Fig.) It is widely used in offices and schools. One reason for its popularity is that plans and elevations which are available at the correct scale may be attached to the drawing board and used as auxiliary drawings from which the perspective is made.

CHOOSING A METHOD Each of these methods of making perspective drawings has advantages and disadvantages. Some problems are more easily solved by one method, some by another. This is partly due to the varying nature of designs, and partly because of the information furnished by available drawings of the object of which the perspective is to be made. All accomplish the same result - a true picture of the object from some chosen position.

2.4.5 TWO-POINT PERSPECTIVE

Two-point perspective is the most widely used of the three perspective systems. It is typical of the way in which buildings are usually seen and of photographs of buildings. It is, therefore, of greatest importance to the architect and draftsman. When only one kind of perspective is to be learned two-point perspective is in most cases the one.

THE COMMON METHOD. The most popular and most widely used method of two-point perspective is called the common method. In this method the plan of the object, picture plane, and station point is used to work out the horizontal spacing of points, and vertical lines for the perspective. The plan is turned with the line of the picture plane horizontal. It is convenient to have an elevation at one side of and below

the plan. From this elevation the heights can be carried across with the T-square to the construction for the correct heights for the perspective. Any elevation, or section, or part of either drawing which gives all of the heights necessary to construct the perspective drawing will serve for this purpose. Although it is not necessary to have an elevation or section included in the construction its use makes the construction more easily understood, decreases the chance of error in working out heights, and makes the checking of construction easier.

THE CONSTRUCTION OF A SIMPLE TWO-POINT PERSPECTIVE.

The construction by the common method has been divided into a series of steps, illustrated in fig. A, B, and C, These steps are typical of the procedure followed in this method of two-point perspective.

- THE AUXILIARY DRAWINGS are a plan and elevation. The plan of the object, picture plane, and station point is drawn with the picture plane line horizontal (fig. A). The elevation is drawn and the horizon line and ground line placed to suit it.

The horizon line is at the height of the eye of the observer. The ground line is drawn at the bottom of the elevation. The station point should be approximately on a line perpendicular to the picture plane through the center of the plan.

- THE VANISHING POINTS are located on the horizon line in the following manner (fig. B). From the station point SP lines are drawn parallel to the two typical sets of horizontal lines of the plan to meet the picture plane. From these intersections A and B vertical lines are drawn to the horizon to locate the two vanishing points, VL and VR. All of the horizontal lines of the object which are parallel to the line SP-B in plan vanish in VR in the perspective drawing. Likewise, all of the horizontal lines of the object which are parallel to the line SP-A in plan vanish in VL in the perspective drawing.

- MAKING THE PERSPECTIVE requires the use of a plan and elevation. The horizontal spacing of all points and vertical lines of the perspective drawing are obtained from the plan. This is done by drawing lines from the necessary points on the plan toward the station point to meet the picture plane, then

lines from the necessary points on the plan toward the station point to meet the picture plane, then drawing vertical lines from these intersections to the perspective (Fig. C).

Since the nearest corner of the wall is in the picture plane its height is laid out to scale by drawing

horizontal lines from the top and bottom of the wall in elevation to the line of the corner in the perspective. From these height measurements lines are drawn to VR to locate the top and bottom of the right side. Likewise, lines are drawn to VL to locate the top and bottom lines of the left side.

The illustrations of Fig. A, B, and C show the elementary principles of two - point perspective by the common method.

THE COMMON METHOD

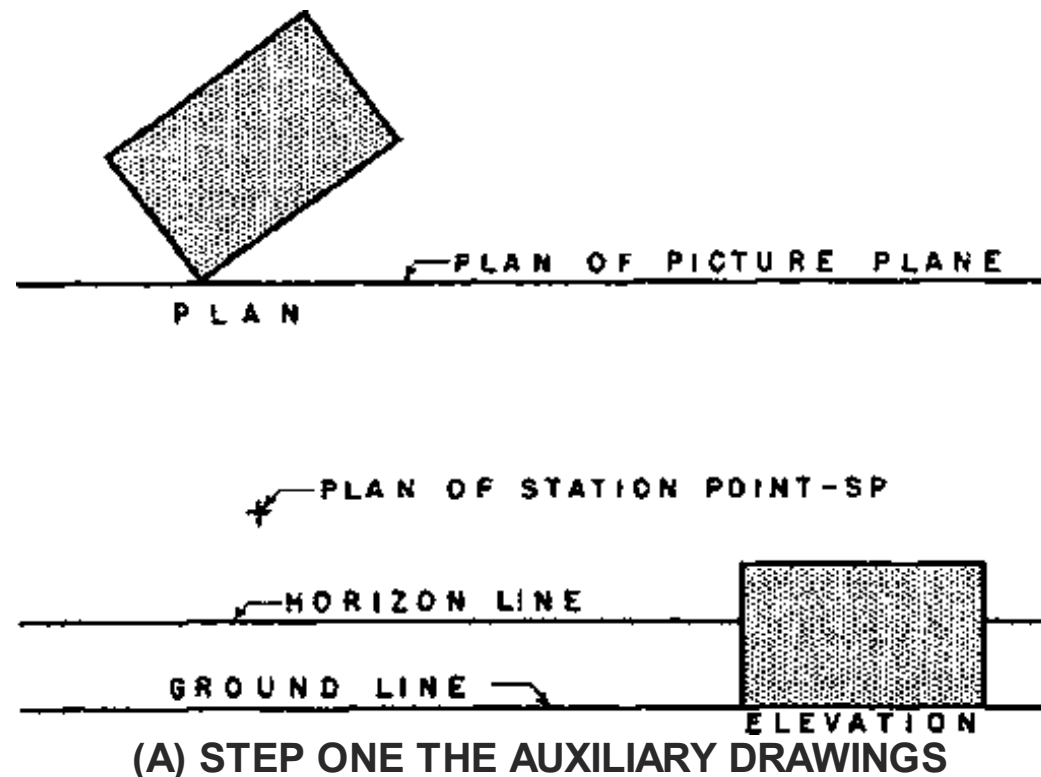

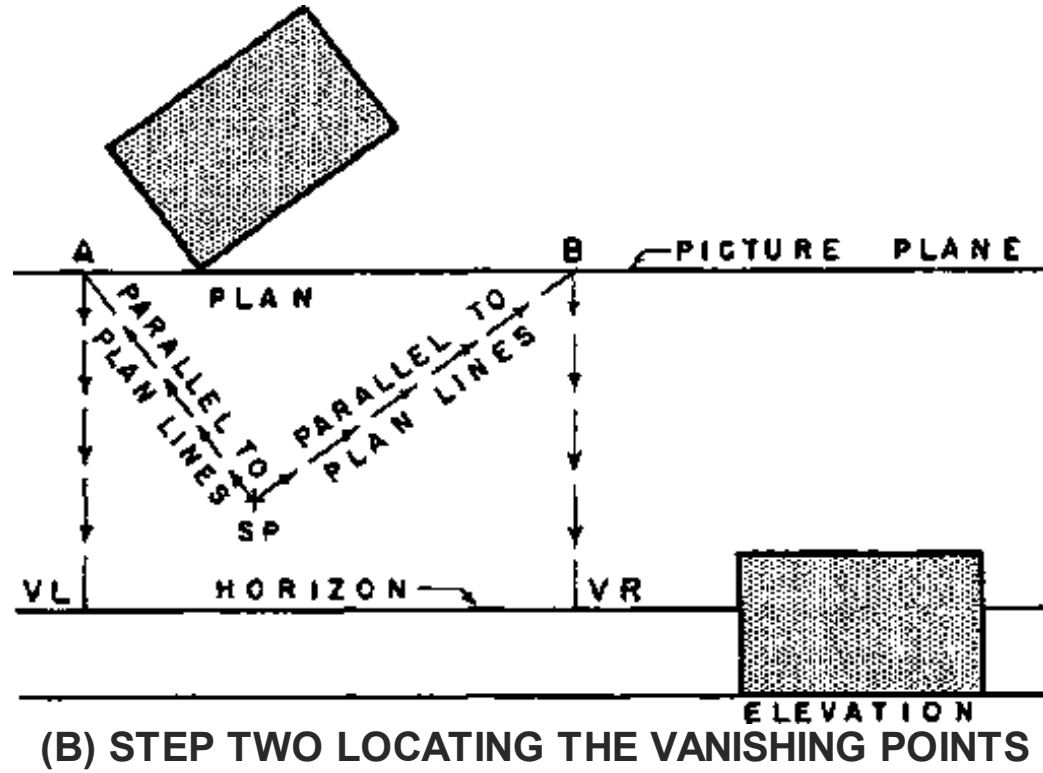

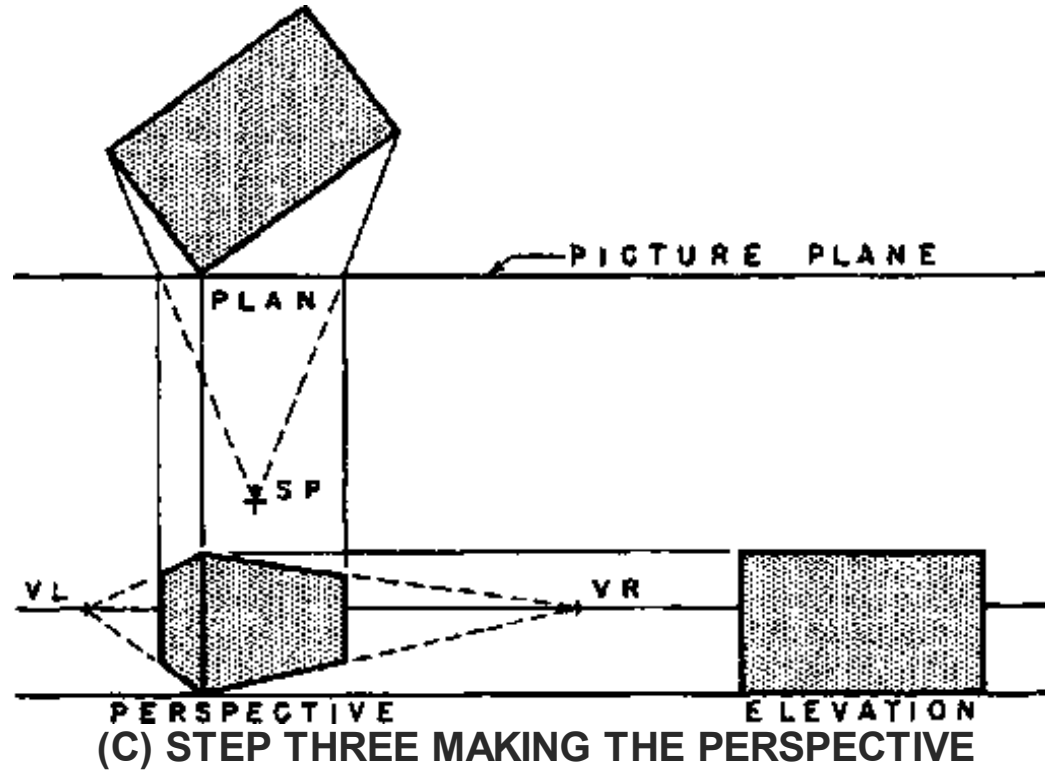

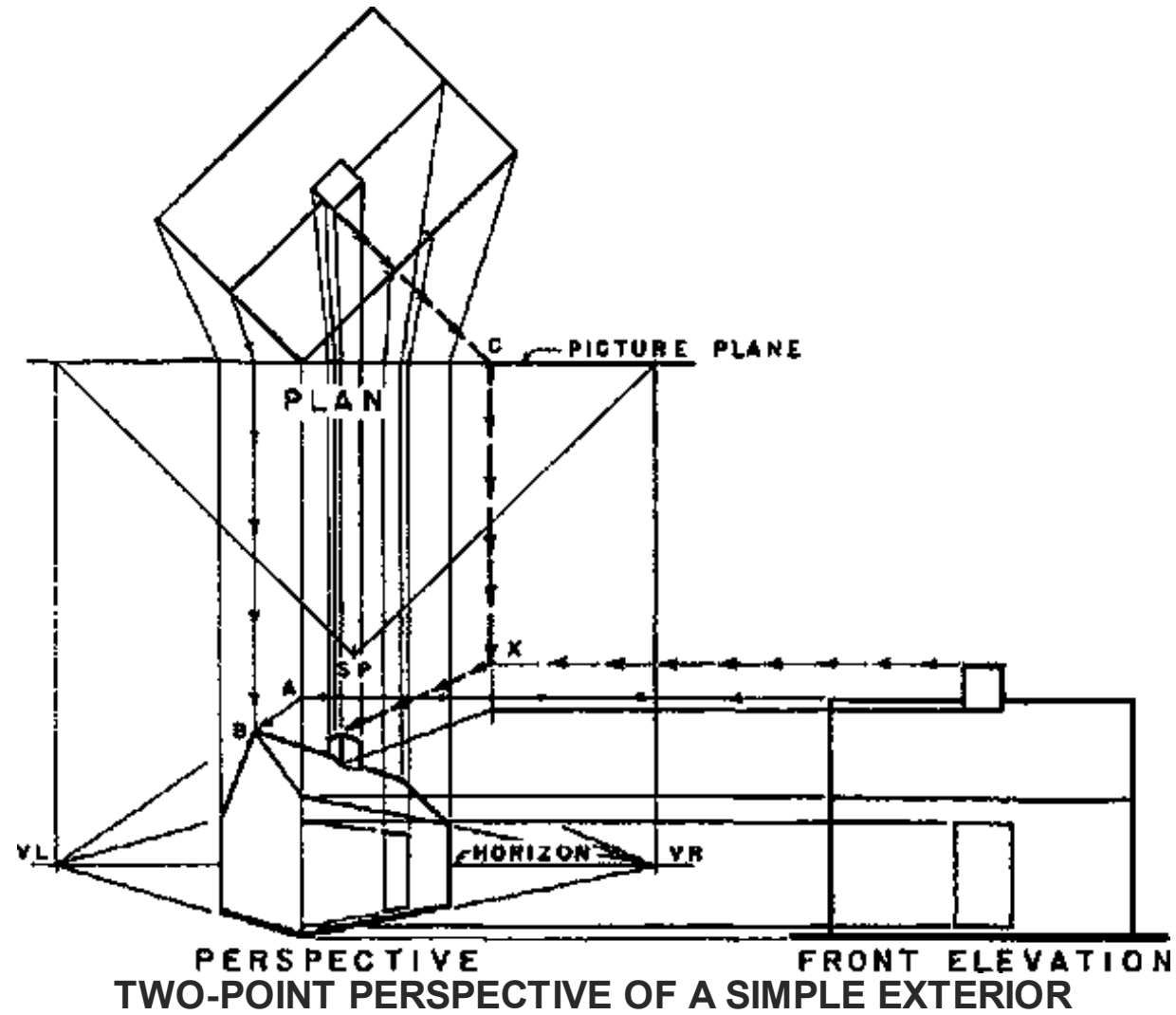

- THE DETERMINATION OF HEIGHTS.

Two important facts should be kept in mind while studying the following illustrations:

Two important facts should be kept in mind while studying the following illustrations:

- 1. All heights are laid out to scale in the picture plane only,**
- 2. Heights are carried from their scale sizes in the picture plane into correct perspective positions by tracing them along lines which vanish in the vanishing points and lead to the object where the heights are used.**

- THE LOCATION OF THE STATION POINT.

The pictorial effect obtained in a perspective drawing is determined by the position of the station point. Since it would be possible to have the eye of the observer in any one of an infinite number of positions in viewing an object it is possible to have an infinite number of different perspective drawings of the object.

The location of the station point can be varied in three ways:

- 1. distance from the object**
- 2. height**
- 3. angle of view.**

These variations and their effects on the perspective are discussed in the following paragraphs. The general theory applies to interiors as well as exteriors.

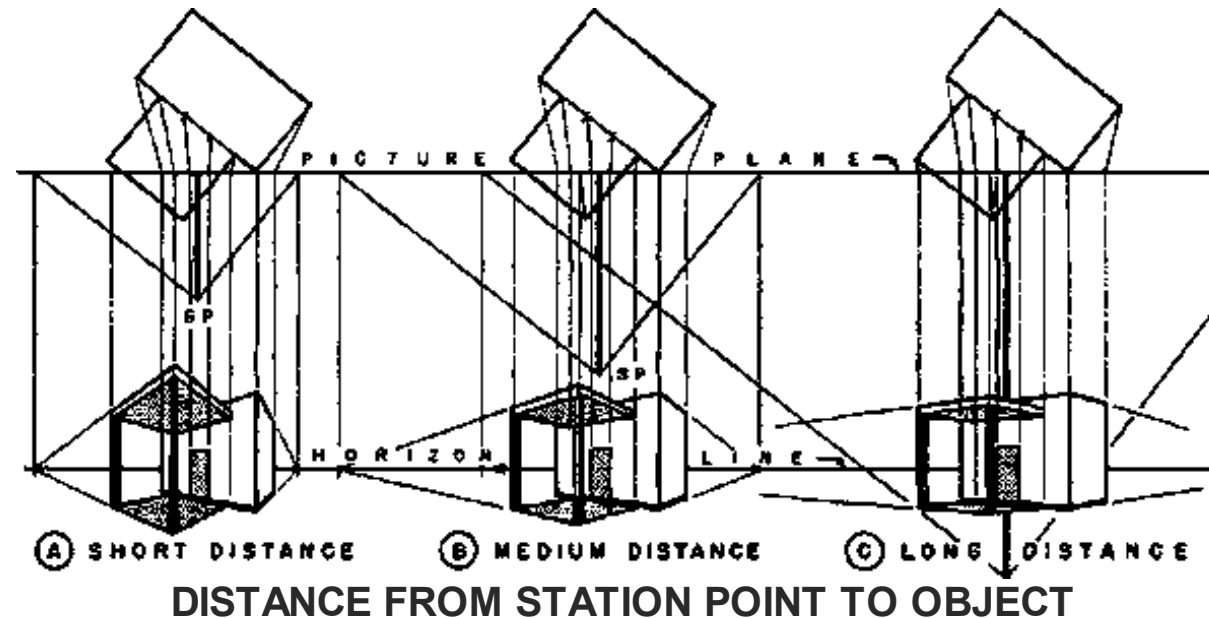

THE DISTANCE FROM THE STATION POINT TO THE OBJECT influences the pictorial effect and size of the perspective. When the station point is near the object the horizontal lines not parallel to the picture plane slant sharply (Fig. A). As the distance from the object is increased the horizontal lines flatten out and the perspective approaches the form of an elevation perpendicular to the picture plane in which all horizontal lines are parallel and horizontal (Fig. B and C). Parts of the object which are in front of the picture plane become smaller as the distance from the object to the station point increases, and parts behind the picture plane become larger. Both approach scale size as the distance increases and conversely, both vary more from scale size as the distance diminishes. When the station point is near the object the bottoms of horizontal surfaces above the horizon are large, as are the top surfaces of horizontal areas below the horizon. As the station point moves farther away these areas become smaller and disappear from view when the station point is at infinity (Fig. A, B, and C).

The maximum angle of vision of the eye is usually assumed to be 45° or 60° . This angle should include everything shown in the perspective. When the height of the object is greater than its width the height will determine the angle of vision. In one-point perspective the limit of vision is considered to be a cone of rays from the eye, thus avoiding the distorted effect sometimes found in the corners of one-point perspectives. To avoid excessive distortion in perspectives of spheres and circles, these shapes should be kept within a 30° cone of vision in any type of perspective.

As a practical consideration the farther the station point is located from the object, the greater the distance from the drawings to the various centers of converging lines. It is usually desired that these centers be in reach of the T-square for drawing lines and that they be on the area of the board. When the picture effect of the perspective is entirely satisfactory it is more convenient to keep all centers of converging lines on the board.

THE HEIGHT OF THE STATION POINT determines whether the object is seen from above, below, or from its own level in the perspective drawing. The relation of the station point, vanishing points, and horizon is constant for varying heights of the station point if the distance from the picture plane to the station point and the angle between the object and picture plane are constant. The perspective position of the station point is always on the horizon when the picture plane is vertical. The picture plane is almost always vertical in one- and two-point perspective. The vanishing points of horizontal lines are always found on the horizon. When the eye of the observer (SP) moves up or down, the horizon and VP's of the horizontal lines move with it. The distance from the horizon to the ground line is the height of the eye of the observer above or below the base of the building. Fig. A, B, and C uses the same position of the horizon, SP and VP's but uses three different distances to the ground line, so that the view in the center has the SP opposite the center of the object, while the other two have the SP above or below the object. The relation of the horizon and ground line then determines whether the perspective is a view from below (A), normal perspective (B) or an aerial view (C).

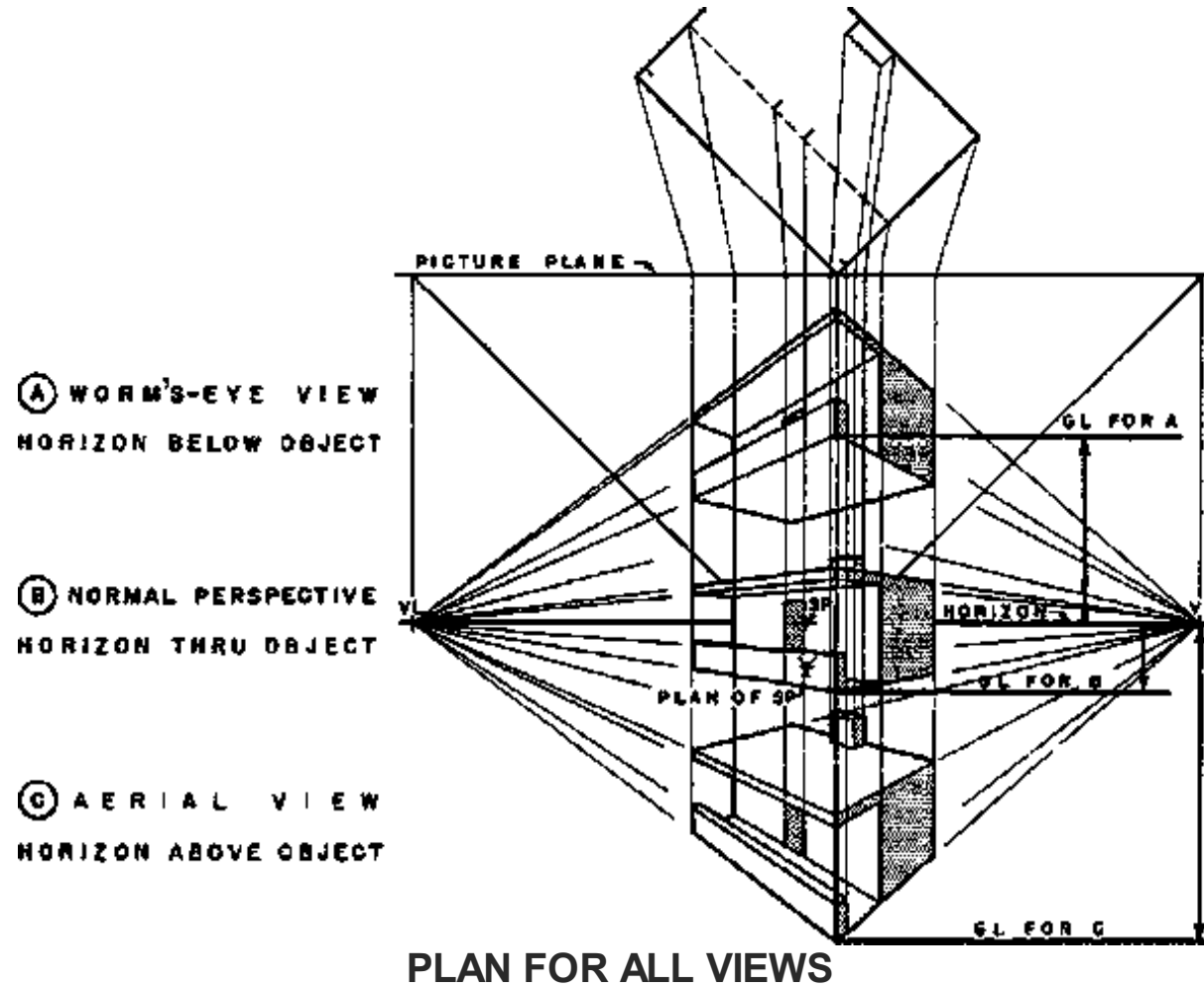

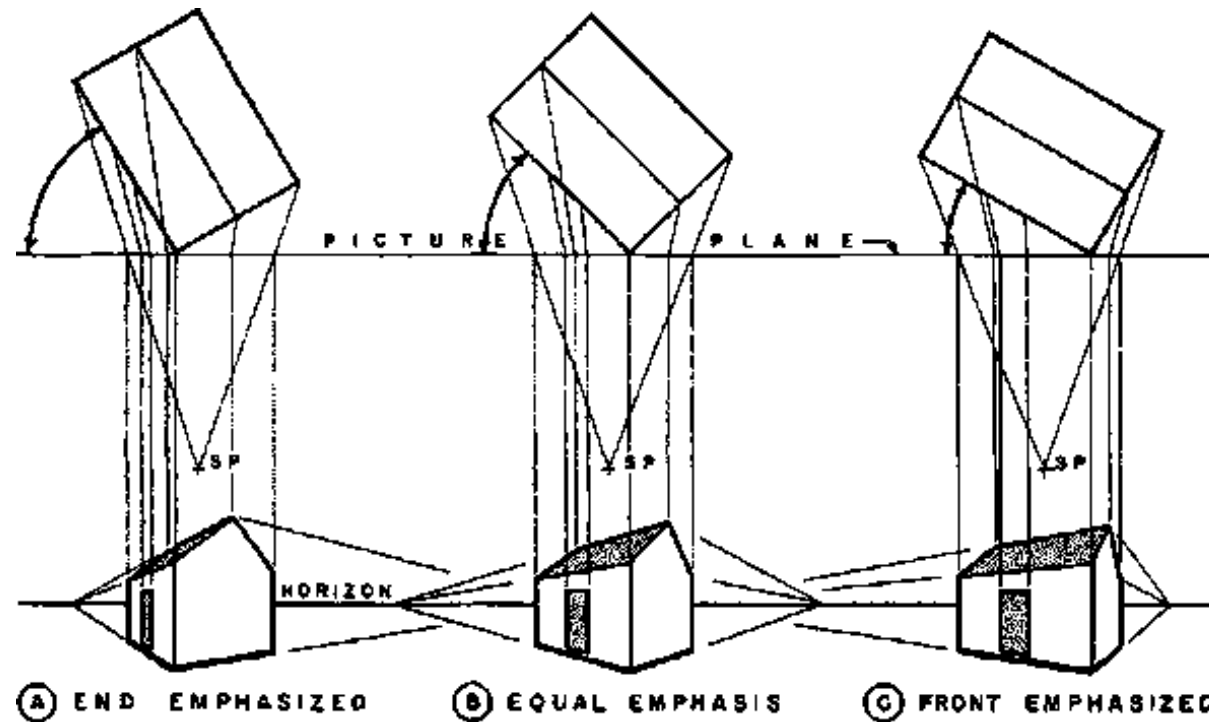

THE ANGLE OF VIEW determines which sides of the object are seen and their relative widths in the perspective. When a photographer takes a picture of a free standing building he walks around it to find the best position for his camera. The draftsman can get similar information in two dimensions from a plan of the building of which the perspective is to be made. He can choose a trial station point and, by turning a straight-edge on this point as a pivot, he can determine which wall areas will be visible in a perspective made from this point. Furthermore, he can determine the relative perspective widths and importance of these areas and whether there is any unfortunate alignment of corners in an irregular plan. From these observations he may be able to select a more satisfactory station point. The experienced draftsman develops the ability to visualize the perspective effect from different positions

around the plan of the object and thus choose the station point best suited to his purpose. The relative importance of the sides shown in the perspective has probably the area test influence on the angle of view. Ordinarily it is desirable to look more directly at the important side and less directly at the unimportant one. In most perspectives of exteriors the entrance to the building is considered as an essential. A reasonable amount of the entrance should be visible when the shape of the building does not allow all of it to be shown from the chosen direction. When a model of the proposed building is available it is very useful in selecting a station point. All three of the variables can be considered with a model. The figure shows three views of the same object from different angles.

Regardless of the angle from which the object is seen, the station point should always be located approximately on a line through the center of the plan and perpendicular to the picture plane. The perspective is distorted when the station point is located very far to one side of this line. It is a great temptation where the plan is set up and the correctly located station point does not give satisfactory results, to take the easy way out and push the station point to one side. However, such a procedure causes the perpendicular to the picture plane to be off center on the plan and perspective. It will, therefore, cause the perspective to be out of proportion.

THE POSITION OF THE PICTURE PLANE. The size of the perspective drawing obtained with a given object, given scale, and given relation between station point and object, can be varied by changing the position of the picture plane (fig. A, B, and C) The nearer the picture plane to the station point the smaller the perspective, the farther the picture plane from the station point the, larger the perspective. If all positions of the picture plane are parallel the resulting perspective drawings will be identical in all respects except size. The shifting of the position of the picture plane is a very helpful device for obtaining any size perspective desired. However, there are limits to its use. Extreme enlargements may be lacking in accuracy, while extreme reductions in size require space for the construction which is out of proportion to the size of the resulting perspective drawing. The most common position of the picture plane is through the nearest main corner of the object. Simplicity and directness of construction are the principal advantages of this location of the picture plane. However, similar advantages are secured by

having the picture plane pass through any visible corner of the object. Other positions of the picture plane can be used to increase or diminish the size of the drawing without greatly complicating the construction. The constructions for points in front of and behind the picture plane have been given in the preceding pages.

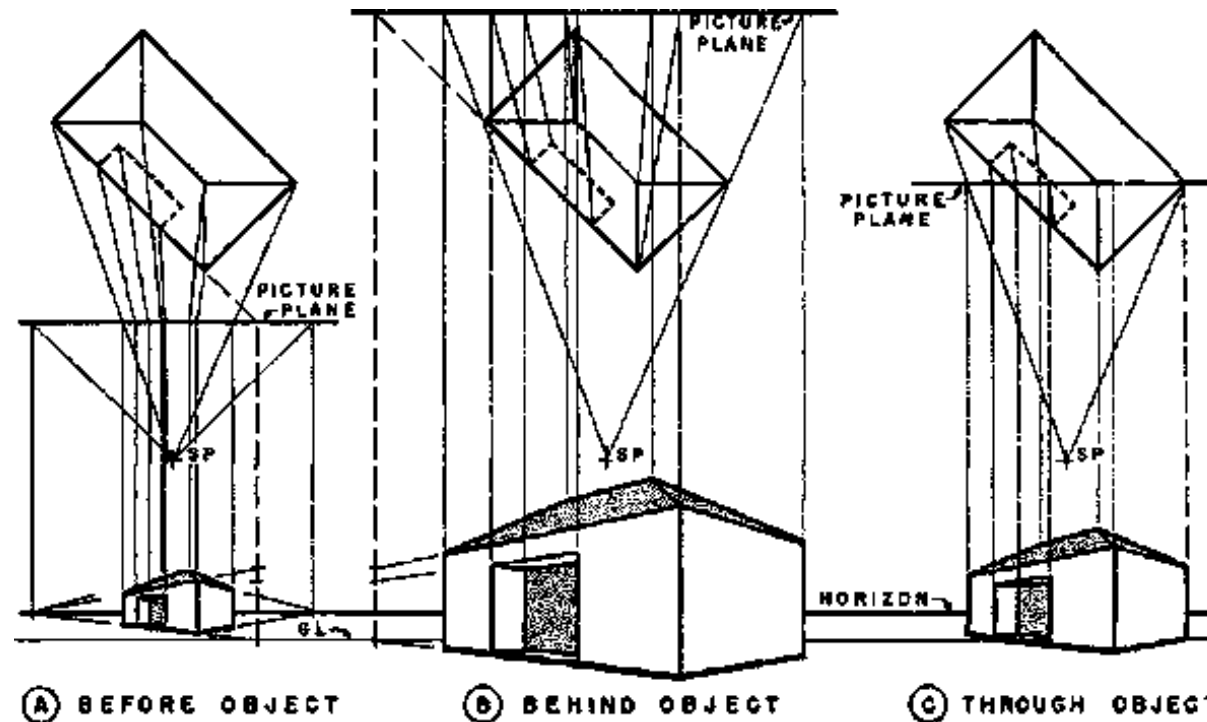

VARIATIONS OF THE PICTORIAL EFFECT IN PERSPECTIVE are obtained by changing the height, distance, and angle of view through manipulation of the station point. Variations in size of the perspective drawing can be obtained by change of scale of the auxiliary drawings, and by varying the position of the picture plane. An active imagination and the ability to visualize final results are as important to the draftsman as to the photographer in obtaining interesting pictures. The draftsman who understands the effect of the variables in perspective should be able to get the exact view that he wishes and make it the size best suited to his purpose.

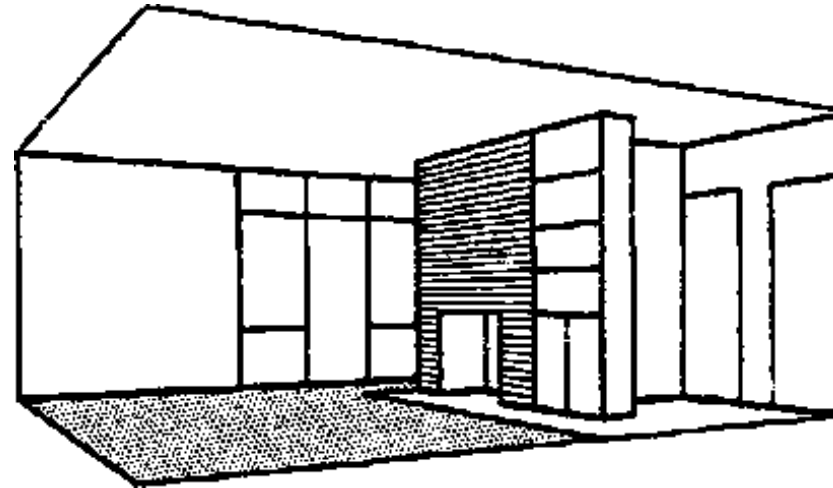

When several perspective studies are made from a given design and none of them looks well, the designer may be reluctantly forced to the conclusion that he has not designed a beautiful building. It is even more difficult for the draftsman to make a dramatic perspective of a mediocre design than for the photographer to make a glamorous photograph of a homely person. Furthermore, the architect must prove the design in the actual building, and there is a question of professional integrity involved.

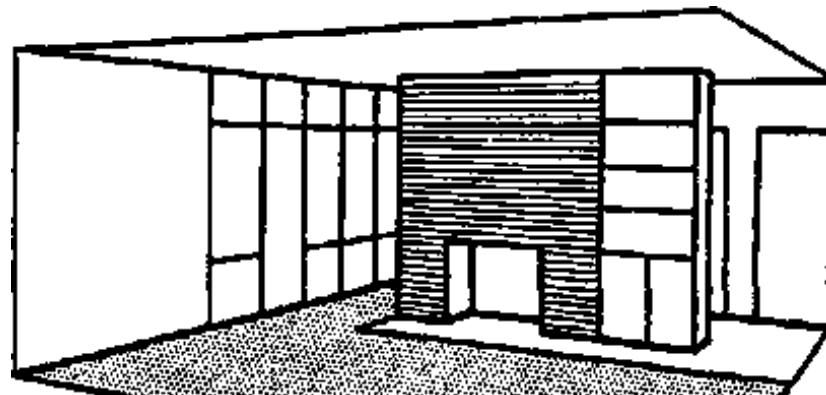



BLOCK STUDIES AT SMALL SCALE, which show only the masses and principal features of the object, can be made very quickly. They are of great value in choosing a station point for a larger and more detailed perspective drawing. They often save time because the large perspective can be made correctly the first time. With several possible variations considered in block form a better pictorial effect can be secured. These simple preliminary studies may be compared to the proofs furnished by a photographer. One of the proofs is selected for the final pictures or perspective.

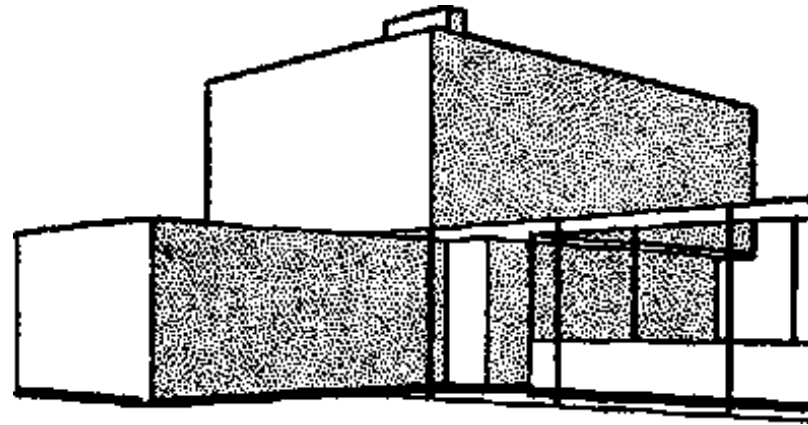

While the beginner in perspective drawing needs the information from a number of block studies, he is usually not as willing to make them as the expert draftsman who appreciates their value from experience. On these speedy drawings the designer feels free to try arrangements which he would be very unlikely to try for a single large perspective. There is, therefore, a psychological advantage in a number of block studies which leads to greater imaginative freedom, and often to more dramatic results. Freehand studies are used by many designers for ideas for perspectives.

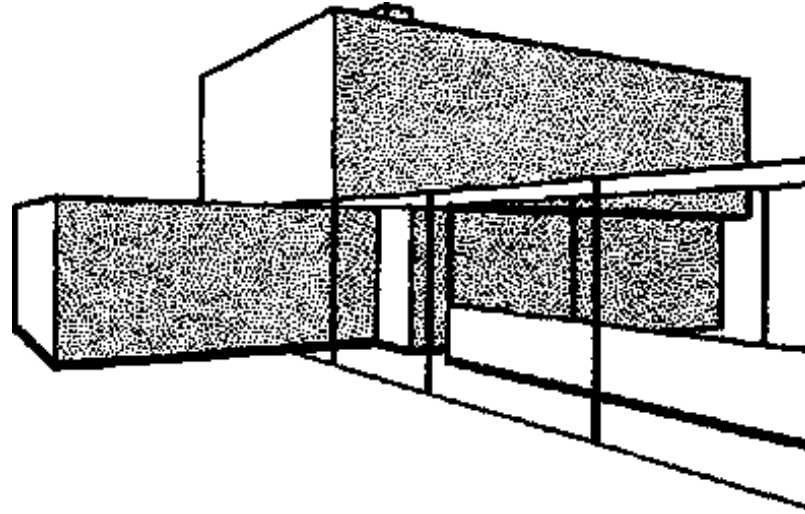

EXTERIOR BLOCK STUDIES

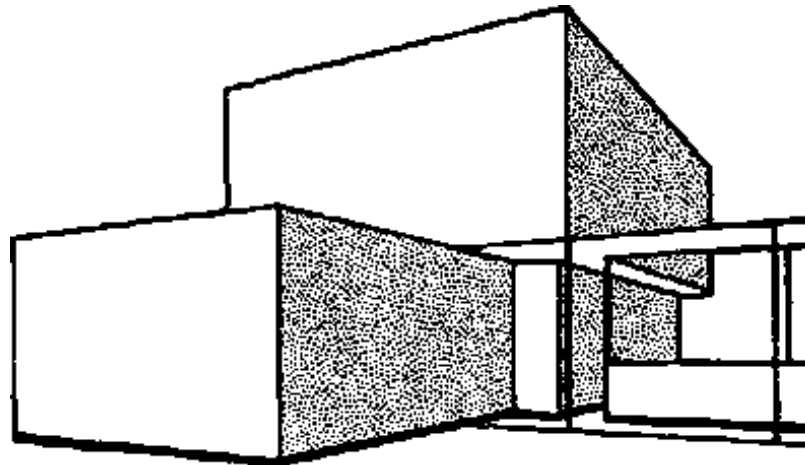

(A)

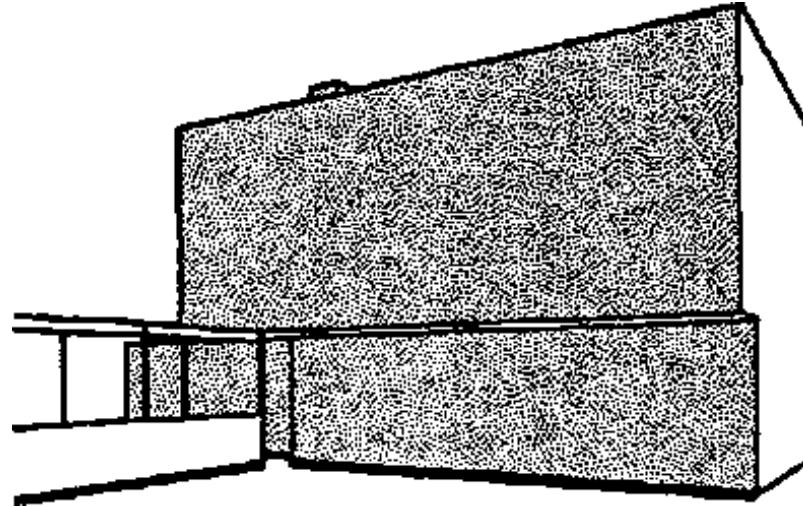

(B)

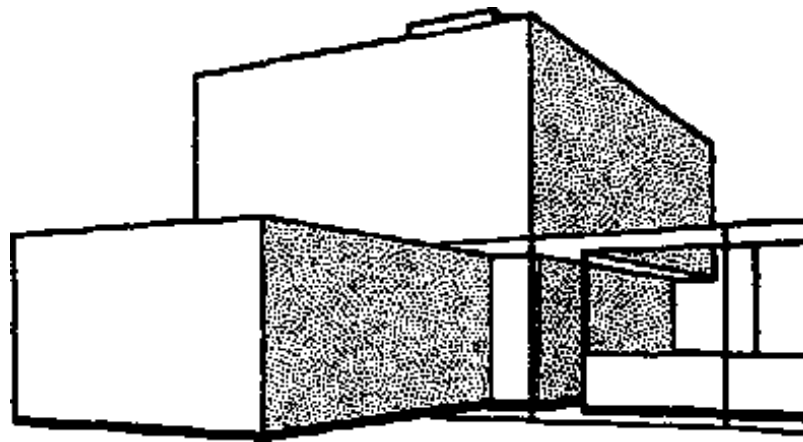

(C)

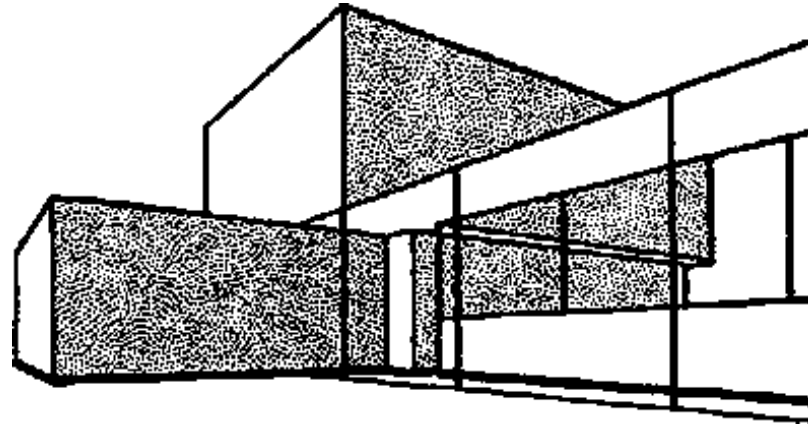

(D)

INTERIOR BLOCK STUDIES

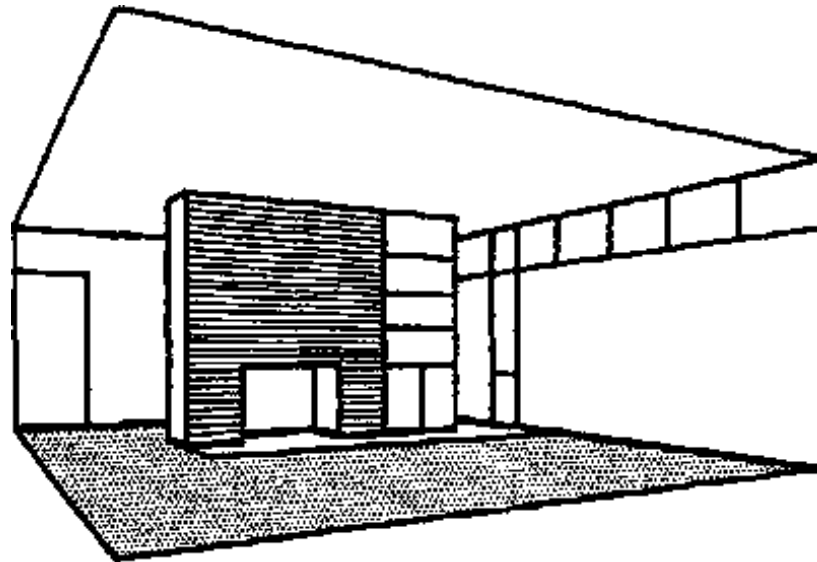

(A)

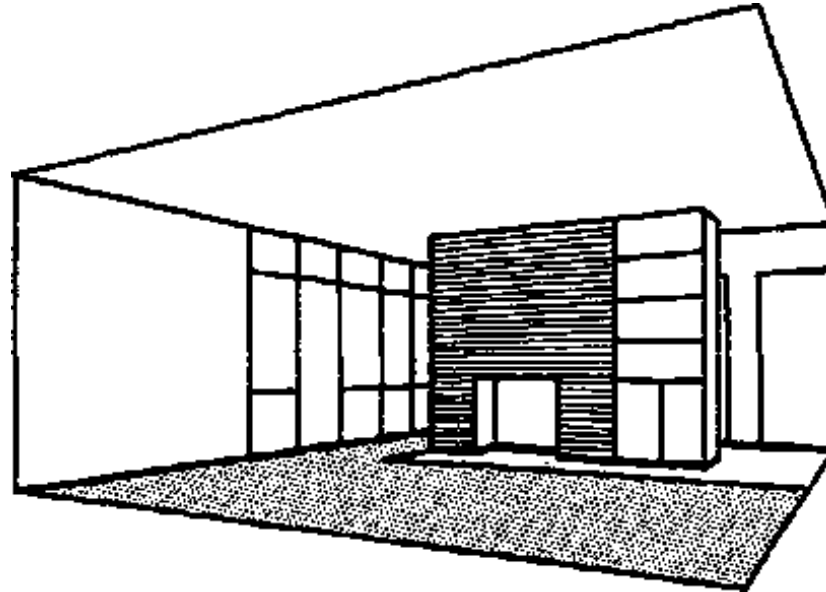

(B)

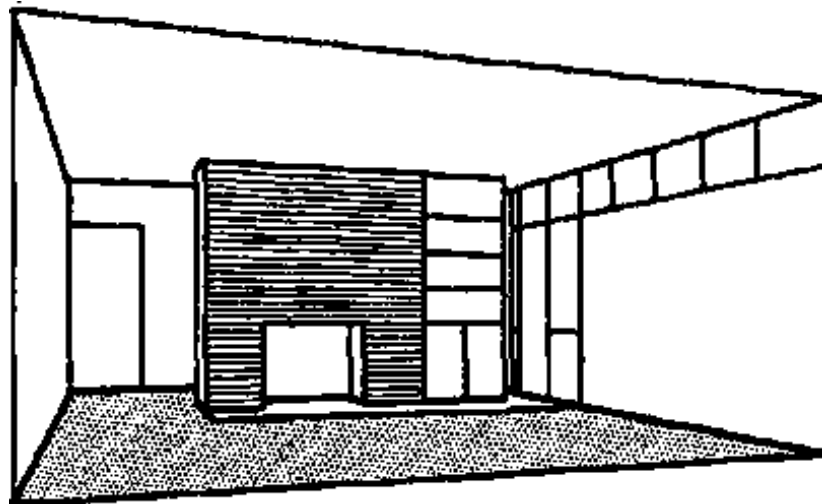

(C)

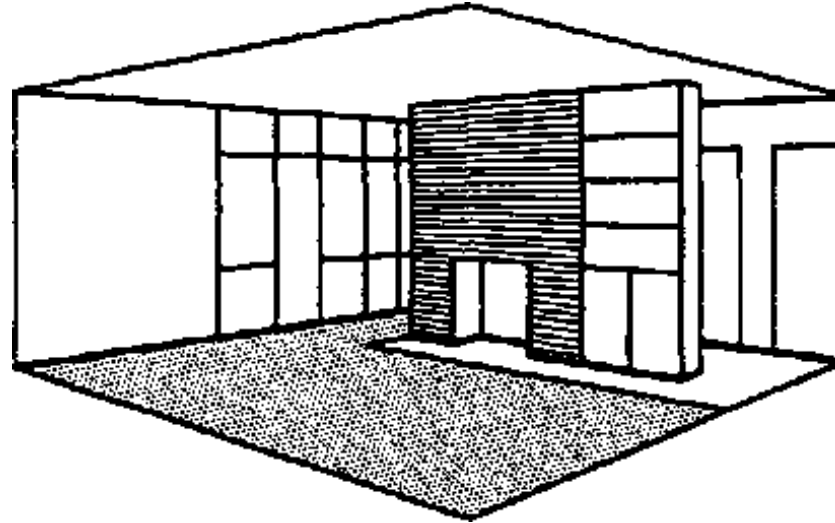

(D)

THE PERSPECTIVE PLAN METHOD

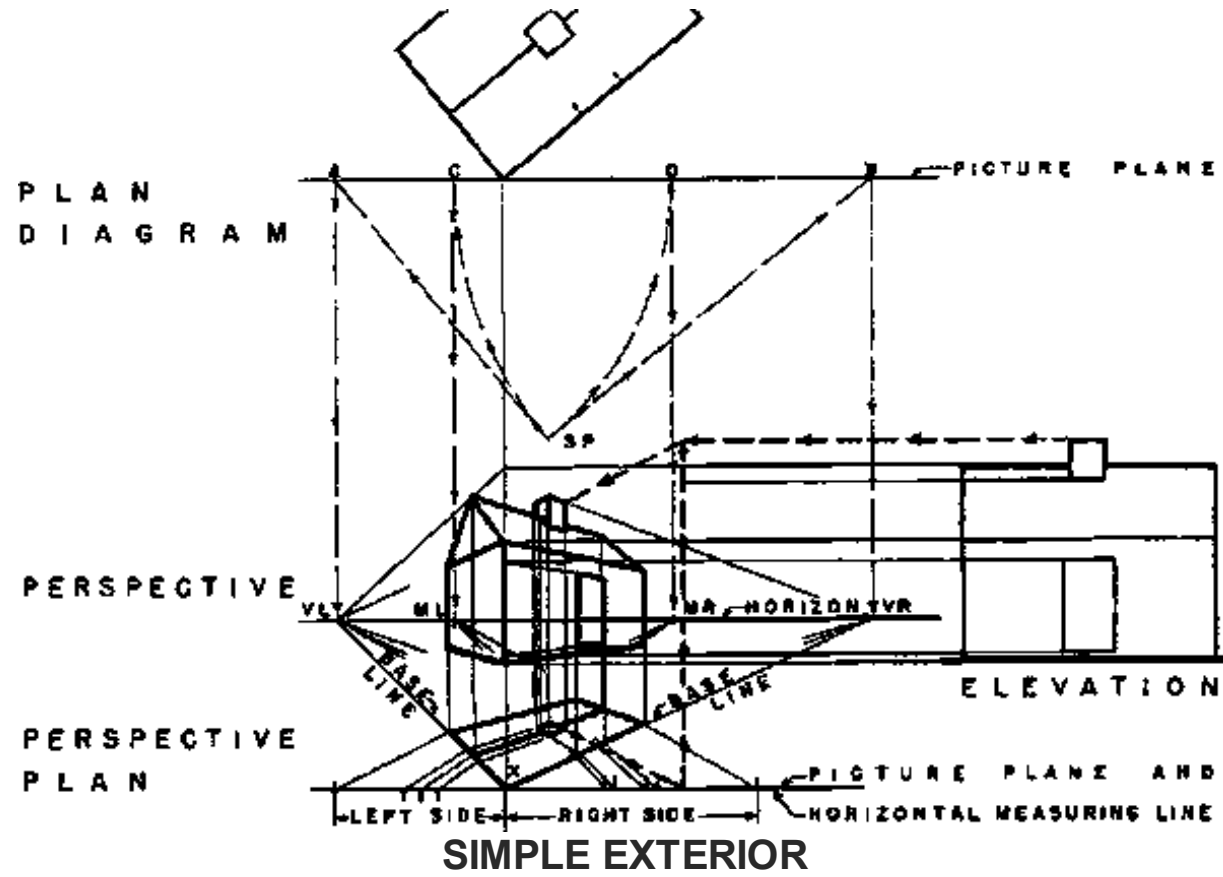

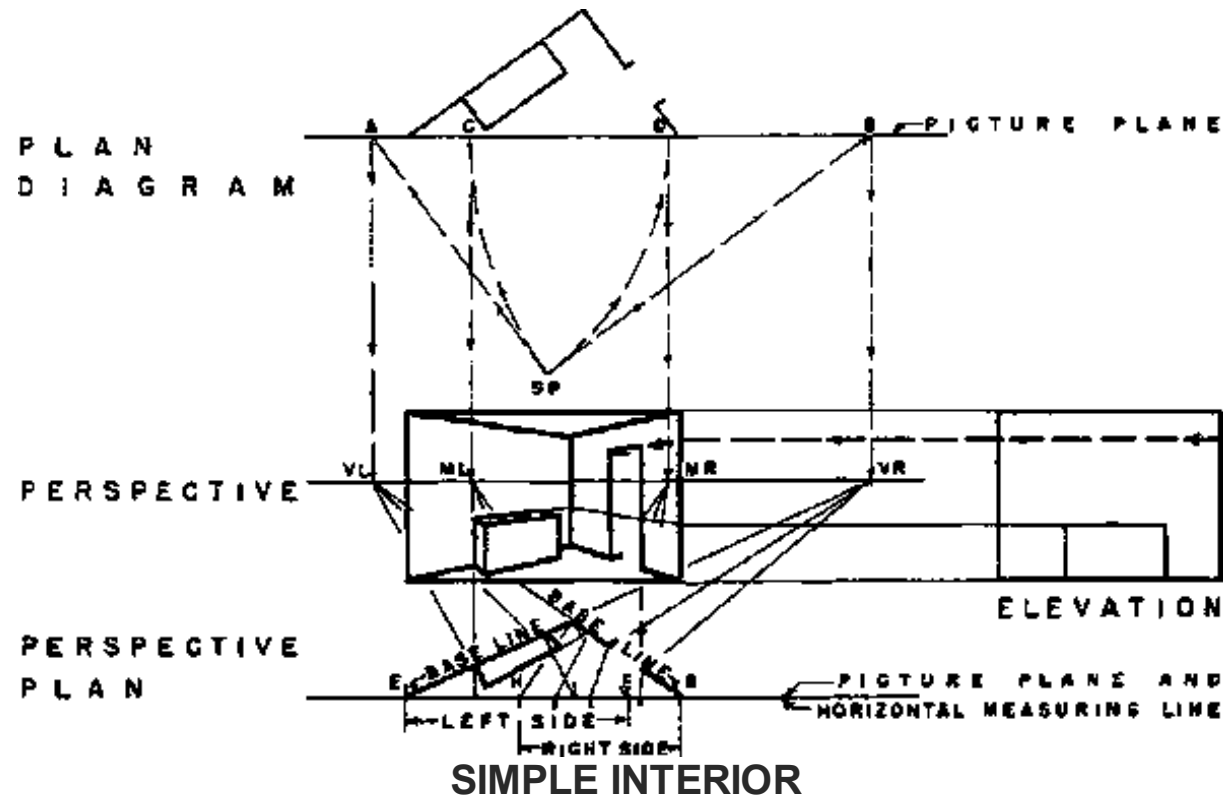

2.4.6 ONE-POINT PERSPECTIVE

The most striking and characteristic views of streets, landscape garden scenes, groups of buildings, single buildings, and parts of buildings both exterior and interior, often show them as they would appear in one-point perspective. One-point perspective is therefore important to the architect and draftsman, because it is frequently more suitable for the subject to be drawn or gives a more characteristic view than could be obtained with two - point perspective.

One-point perspective is so named because only one of the three typical sets of lines converges to a vanishing point. The remaining two sets of lines are parallel to the picture plane. Since lines which are parallel to the picture plane retain their true directions, the lines of each of these two sets remain parallel

in perspective. In most one-point perspectives the picture plane is vertical. The vertical lines and one set of horizontal lines of the object are parallel to the picture plane, and remain respectively vertical and horizontal in the perspective drawing. The remaining set of horizontal lines is perpendicular to the picture plane and converges to a vanishing point.

One-point perspective can be used appropriately and effectively whenever the object presents a good appearance with the line of the center of vision of the observer perpendicular to one set of planes of the object, and consequently parallel to one set of lines; that is, when the conditions under which the object is naturally seen are those of one-point perspective.

Typical subjects for one-point perspectives are shown in the illustrations of the figure.

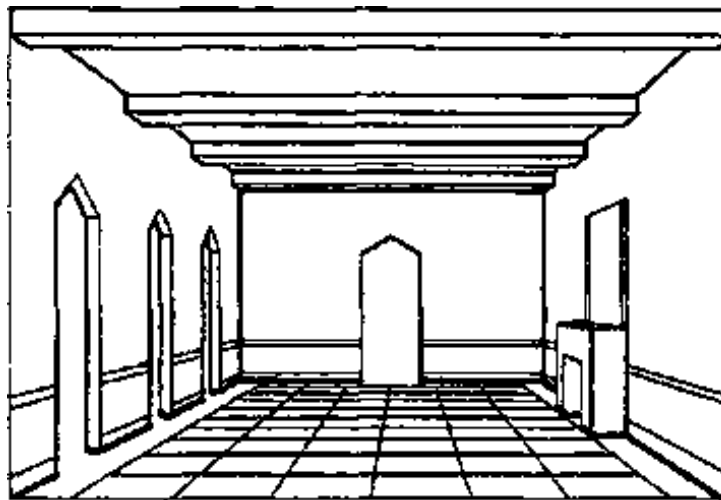

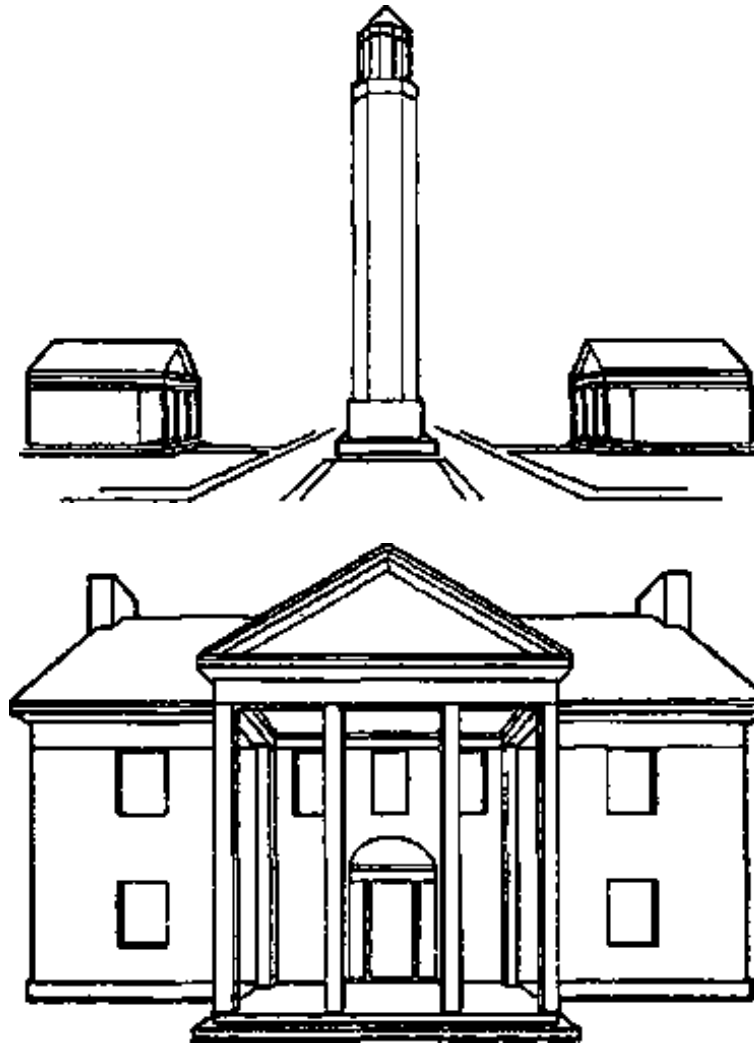

Although one-point perspective is not as widely used as two-point perspective it is extremely useful for both exterior and interior subjects and deserves the careful study and consideration of the person who

wishes to become proficient in perspective drawing. Some of the most striking photographs used in illustrations of architectural magazines are one-point perspective views. Since the photographer usually has a wide range of choice of views, the one-point perspective position is chosen in most cases because of its pictorial merits and not from necessity.

THE COMMON METHOD OF ONE-POINT PERSPECTIVE. The use of a plan showing the object, picture plane, and station point is required for the construction of the perspective drawing.

Step I of the figure shows the location of the plan and elevation as the first step in making the perspective. The elevation is in this example located below the station point of the plan and to the right of the edge of the plan to leave a clear area for the perspective drawing. The horizon has been located near the center of the height of the elevation.

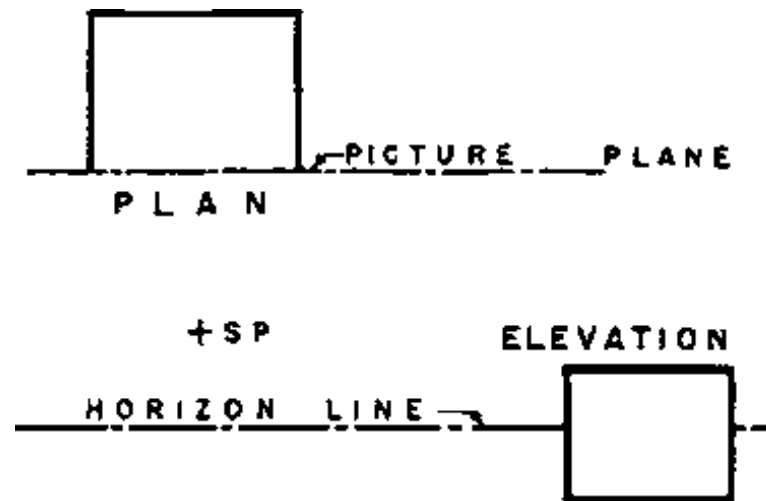

STEP I - ARRANGING THE AUXILIARY DRAWINGS

In Step II vertical lines are drawn from plan and horizontal lines from the elevation to give the intersection of walls, floor, and ceiling of the room with the picture plane. This line of intersection is at scale size since it lies in the picture plane. The vanishing point is located by drawing a vertical line from the plan of the station point to meet the horizon. When the position of one end of a line perpendicular to

the picture plane has been located in the perspective drawing the line can then be drawn through this point toward or away from the vanishing point.

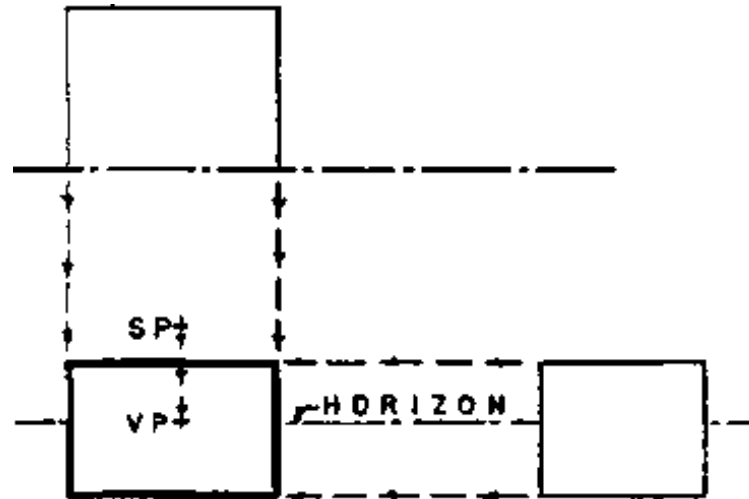

STEP II - LOCATING VP AND LINES IN PICTURE PLANE

Step III shows how the plan is used to determine the correct horizontal spacing of vertical lines for the perspective drawing. The projectors are drawn from the two rear corners of the plan toward the station point to meet the picture plane. From these intersections with the picture plane vertical lines are drawn to the perspective locating the two vertical corners at the rear of the room. The lines of the intersections of walls with floor and ceiling are drawn from the corners A, B, C, D toward the vanishing point to meet the rear corners of the room. Horizontal lines from the two rear corners complete the simple perspective.



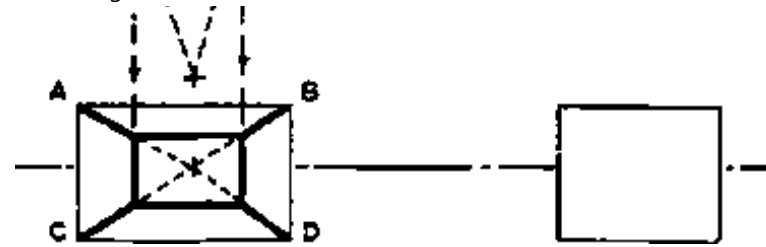

STEP III - DRAWING LINES NOT IN PICTURE PLANE

Step IV shows how lines can be traced around the walls and along the floor and ceiling from their correct scale positions on the lines in the picture plane.

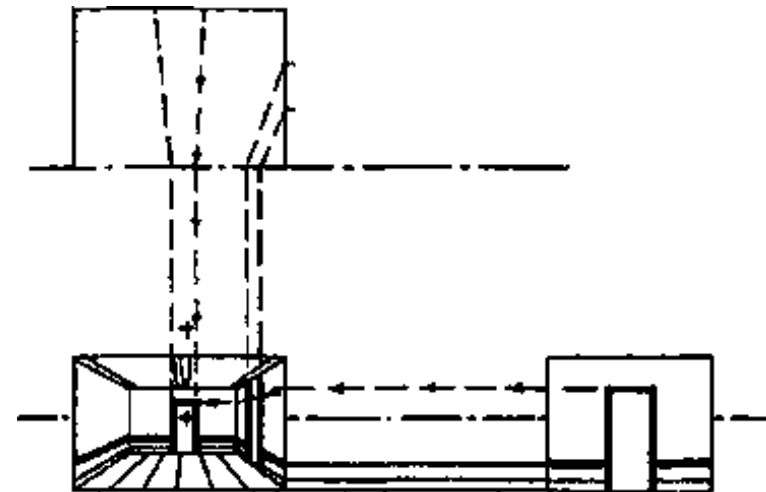

STEP IV - LINES ON WALLS CEILING AND FLOOR

Fig. A and B shows two methods of determining heights of objects which do not lie in or touch the wall surfaces or picture plane of a one-point perspective drawing. In these examples the freestanding objects are vertical lines which rest on the floor.

In each example there are two freestanding lines. The line object on the right of each example is behind the picture plane and the one on the left is in front of the picture plane. When the object is a solid, the method shown can be repeated as many times as necessary for different parts of the object to obtain a number of points which can be connected to make the drawing.

number of points which can be connected to make the drawing.

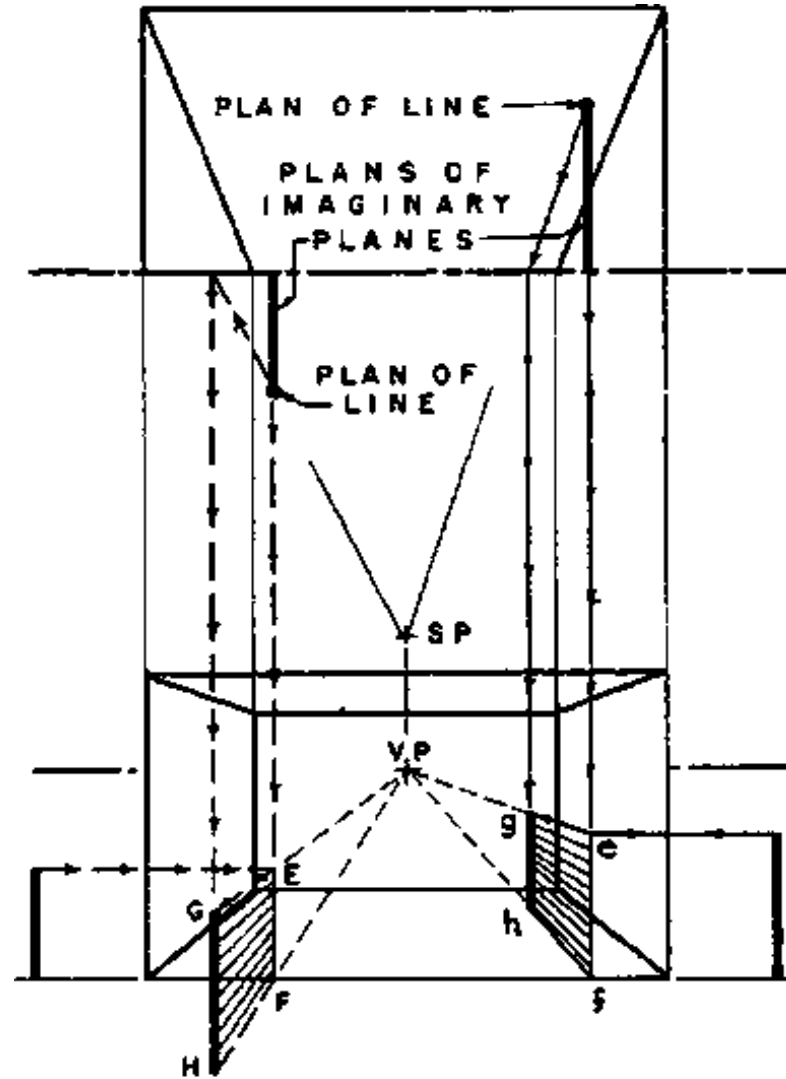

OBJECT BEFORE
PICTURE PLANE

OBJECT BEHIND
PICTURE PLANE

(A) DIRECT METHOD

IN THE DIRECT METHOD, Fig., an imaginary plane which is parallel to the side walls of the perspective drawing and perpendicular to the picture plane is extended through the point plan of the freestanding line to meet the picture plane in plan. The height of the line is laid out to scale on the line E-F of intersection of the imaginary plane and picture plane in the perspective drawing. The height is then traced directly along the imaginary plane by lines through the vanishing point and brought to correct perspective position at G-H as shown. This is the most convenient and simple method of determining most heights of freestanding objects. However, in the special case when the freestanding line is on a vertical through the vanishing point this method cannot be used, because the line from the vanishing point is a vertical line and will not intersect vertical lines brought down from plan to establish heights. Furthermore, the lines from the vanishing point must be at a sufficient angle, so that their intersections with vertical lines can be accurately located. Objects which are very near a vertical line through the vanishing point cannot be accurately located by this method.

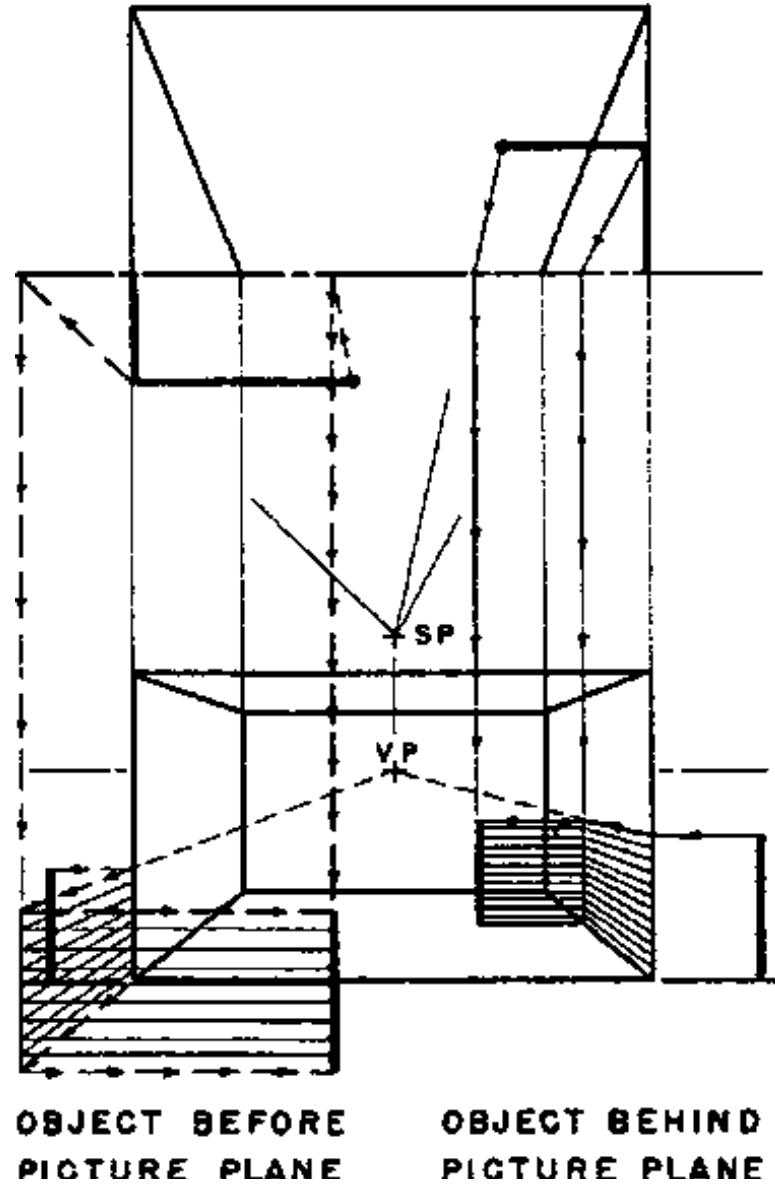

(B) INDIRECT METHOD

THE INDIRECT METHOD carries the heights along the walls or other planes perpendicular to the picture plane to the required distance, then along imaginary planes parallel to the picture plane to the correct perspective position. In the two examples of Fig. the wall serves as the plane perpendicular to the picture plane for the object behind the picture plan. An extension of the wall has been used for the object in front of the picture plane.

The three examples of one-point perspective by the common method (see figures) show the application of principles previously explained to more detailed subjects. An elevation or section has been drawn in each example in order to make the methods of determining heights as clear as possible. It is not necessary to draw the elevation or section as a part of the construction of a perspective by the common method.

The heights and widths of the parts of the object in the picture plane are drawn to scale size.

In the figure the ends of the projecting wings of the building lie in the picture plane and are drawn to scale size by dropping verticals from plan to meet horizontals from elevation. The top and bottom lines of the wings, which are perpendicular to the picture plane, are drawn to the vanishing point to meet the construction lines brought down from the junction of the wings and main building in plan. The indirect method is used to determine the height of the flagpole since it is too nearly on a vertical line through the vanishing point to use the direct method accurately. These construction lines are heavy dotted lines. The height of the roof is traced back into position by the direct method using an extension of the end wall to the picture plane for the height construction.

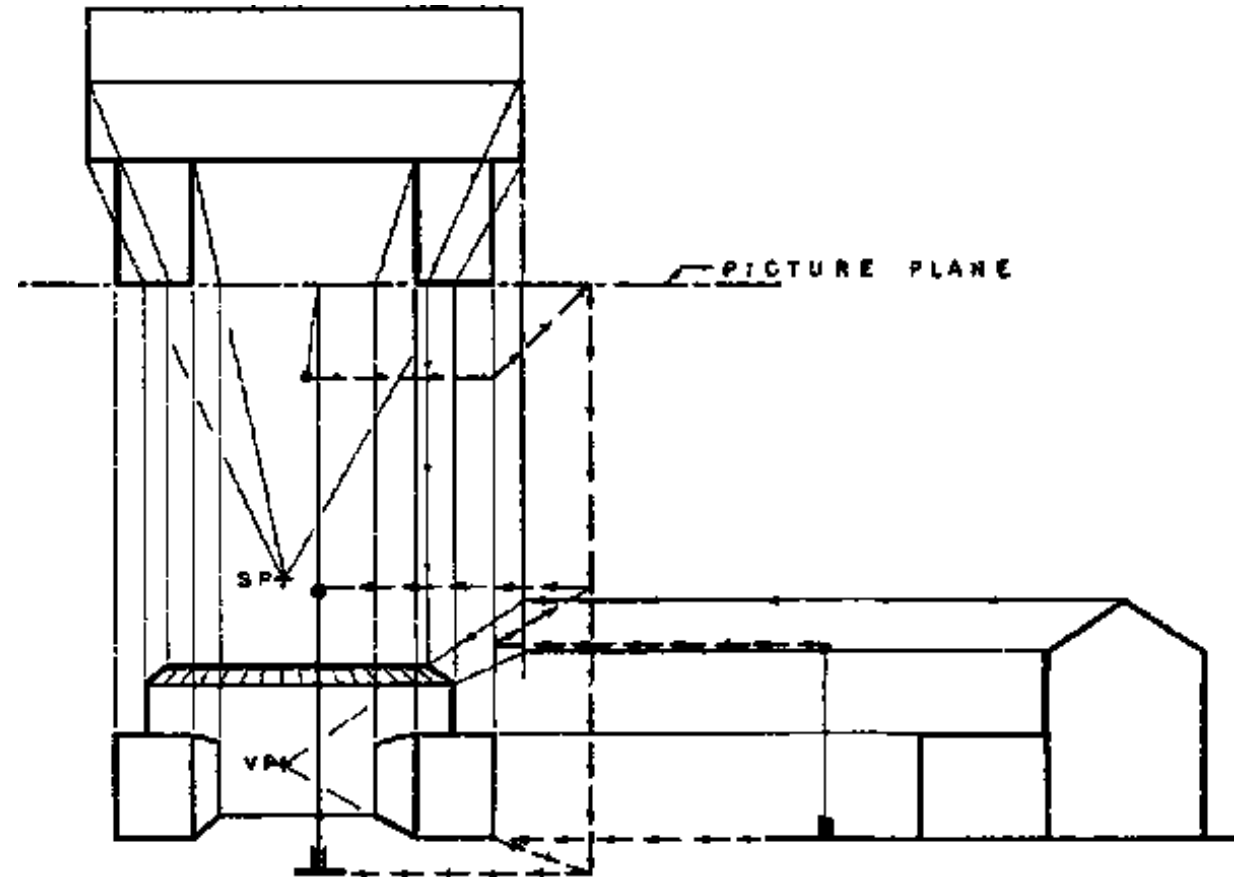

ELEMENTS OF ONE-POINT PERSPECTIVE - COMMON METHOD

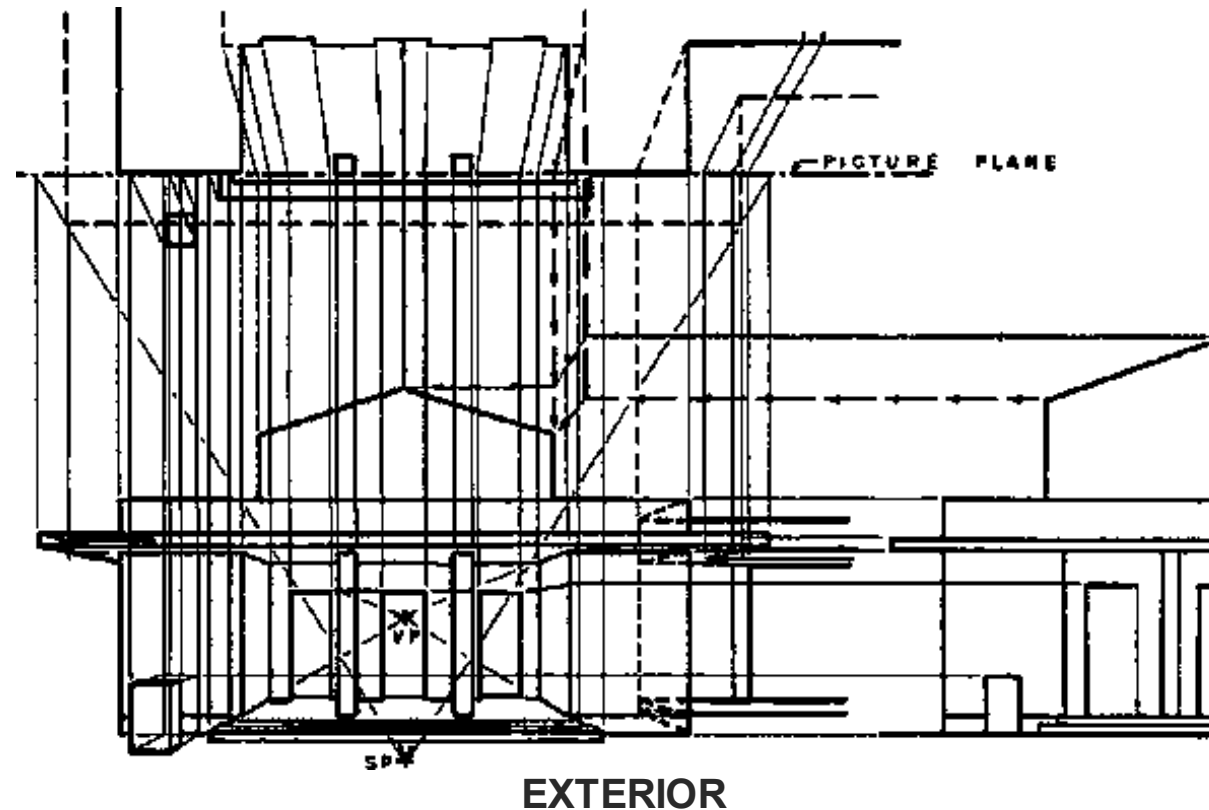

In the figure the lines made of short dots on the right side of the perspective show the construction of heights by tracing around hidden surfaces. The lines with longer dots and arrows in this example show the construction of a height, by the direct method, around one imaginary corner. The indirect method is used to determine the height of the highest point of the building.

The figure illustrates the tracing of heights around visible wall surfaces for the wainscoting, windows, and ceiling line. The height of the rectangular box is found by the indirect method, using an imaginary

and ceiling line. The height of the rectangular box is found by the indirect method, using an imaginary extension of a plane of the box to meet the wall. The lines of the sofa are projected directly from the scale profile (drawn in dotted lines) in the picture plane to position in the perspective drawing.

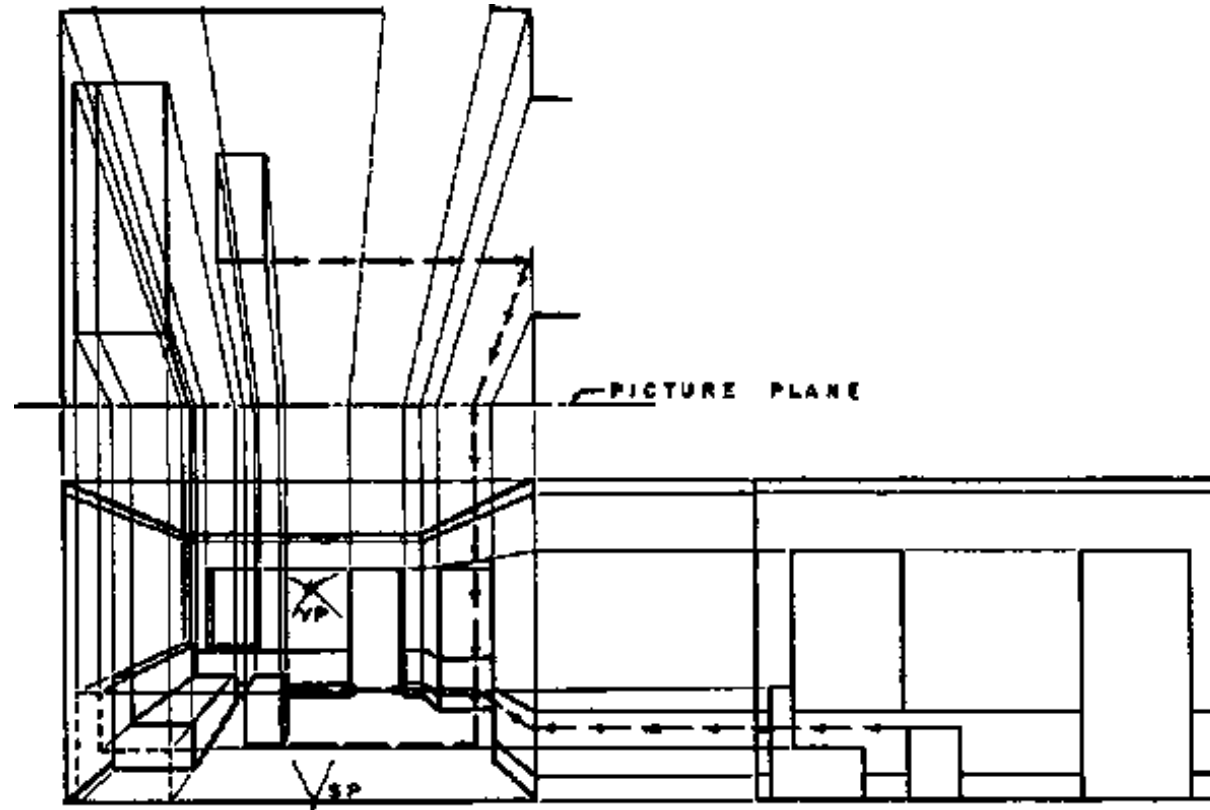

INTERIOR

VARIABLES



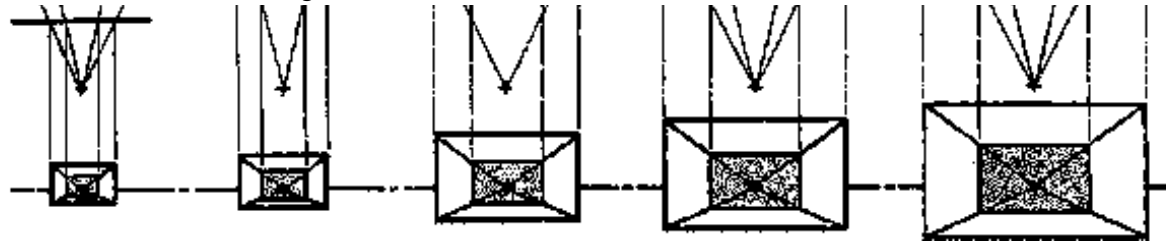

LOCATION OF THE PICTURE PLANE

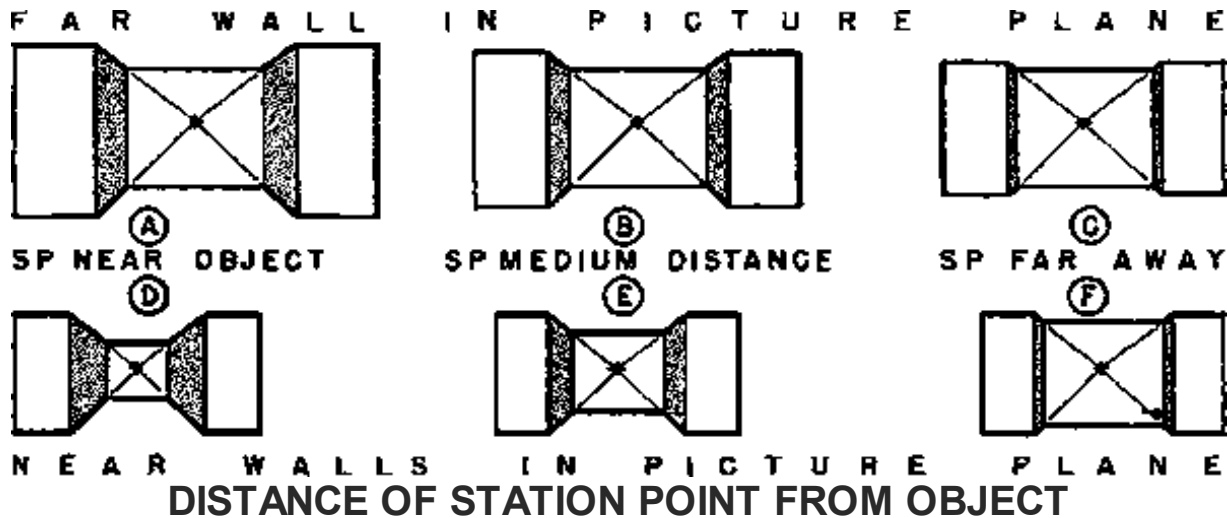

EXAMPLES

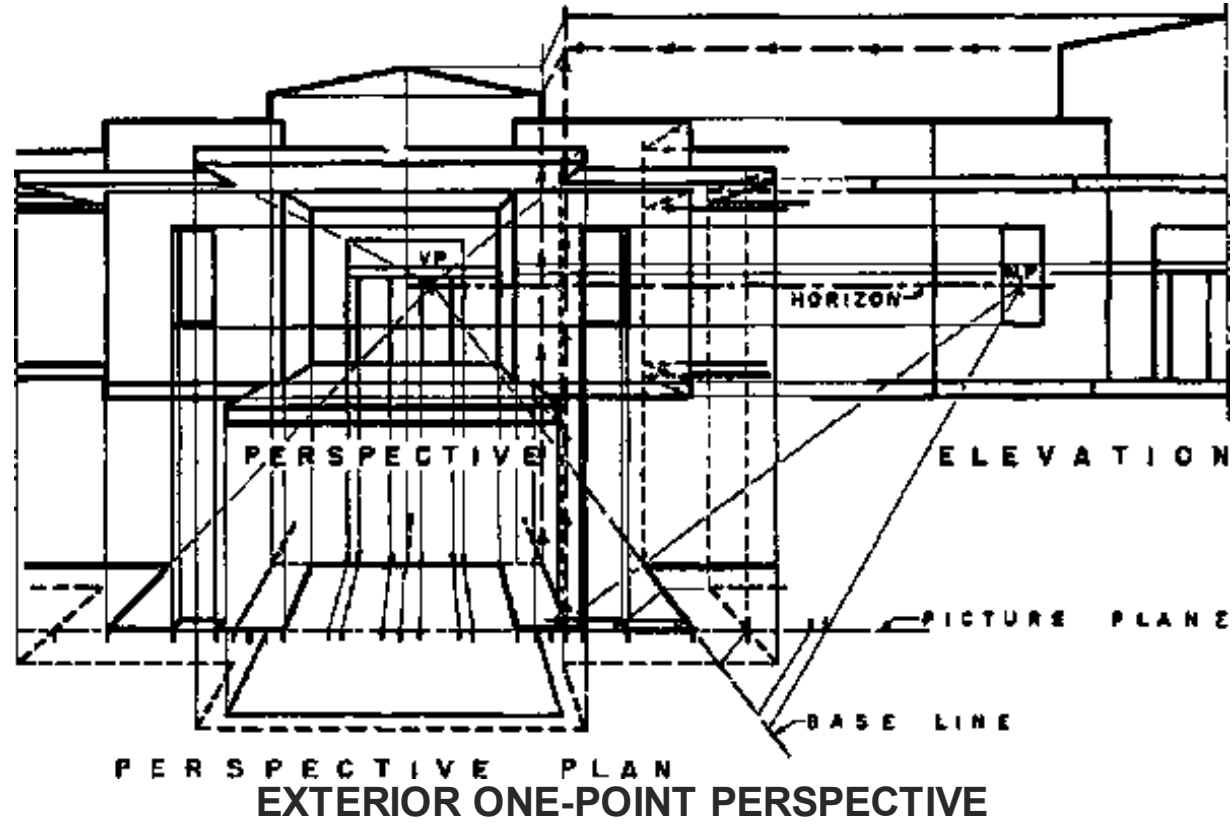

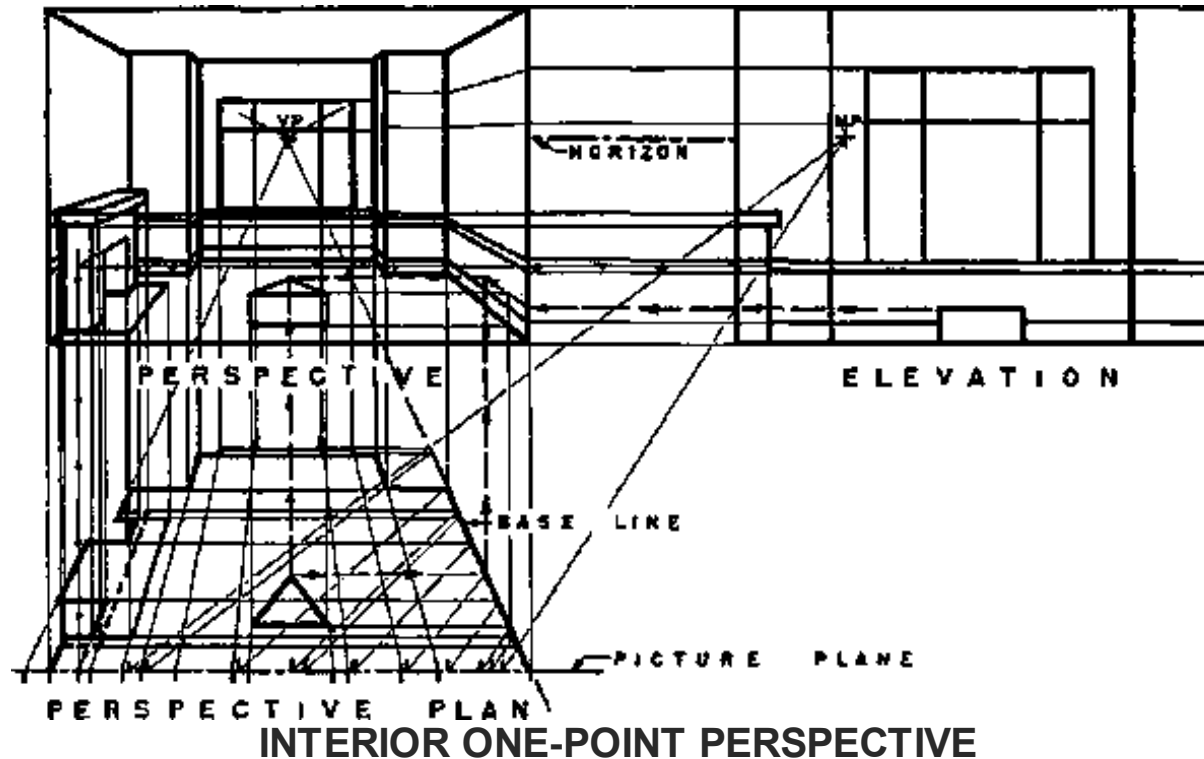

2.5 SHADES AND SHADOWS

Wherever there are buildings, clouds, trees, rocks, or other objects extending above the surface of land or water there are shadows when the sun shine. These shadows form an essential part of the pattern of a landscape, a piece of pottery, or a building. Since shadows are inevitably a part of any object which is to be placed in the light, their forms and masses must be considered in studying a design if that design is to be completely successful.

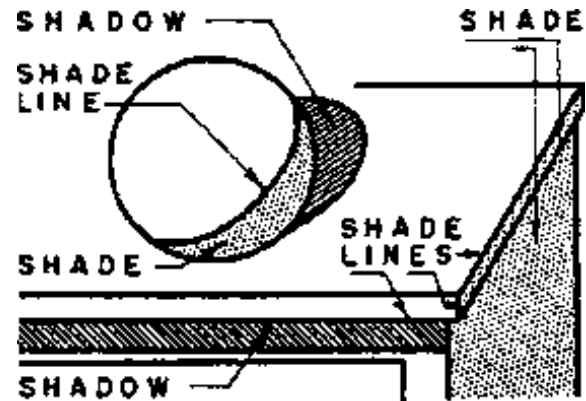

(A) DISTINCTION BETWEEN SHADE AND SHADOW

A knowledge of shadow shapes and of the methods by which they are correctly and accurately constructed on various types of drawings is an essential part of the training of any draftsman or designer of objects in three dimensions.

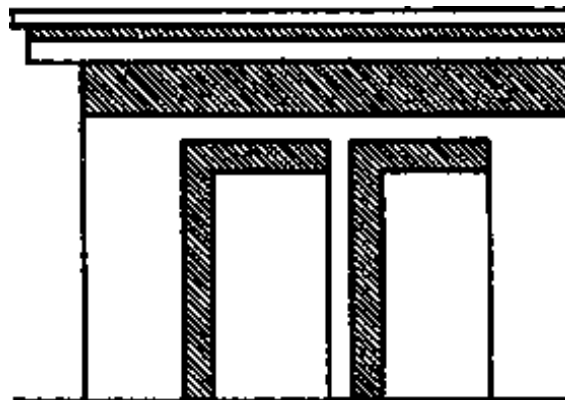

(B) SHADOW WIDTHS MAY EQUAL PROJECTIONS

2.5.1 THE USE OF SHADOWS

Shadows are especially useful in architectural drawing and design because they make the drawings more easily understood. The shades and shadows express the shapes of surfaces, showing whether they are curved or flat, slanting or vertical. In drawings shadows are especially valuable because they bring out the third dimension; the distance back, in what would otherwise be a two-dimension drawing. The lines and masses of shadows form an important part of an architectural design and should be a part of the studies made in the development of the design. When the correctly drawn shadows are unpleasant or disturbing there is something wrong with the design and it should be revised to produce a more harmonious effect.

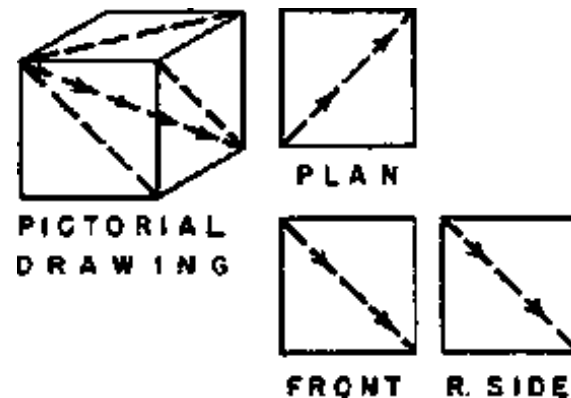

(C) THE CONVENTIONAL DIRECTION OF LIGHT

Shadows are almost indispensable on rendered presentation drawings. They add to the picture effect of drawings, making them much more easily understood by the client. The rendered shadows give even the designer a clearer conception of the appearance of the projected building and aid him in perfecting its design.



T H R U C U B E



**D R A F T I N G
C O N S T R U C T I O N
O F T H E T R U E
D I R E C T I O N**



(D) TRUE DIRECTION OF A CONVENTIONAL RAY

DEFINITION OF SHADOW TERMS

2.5.2 SHADES AND SHADOWS

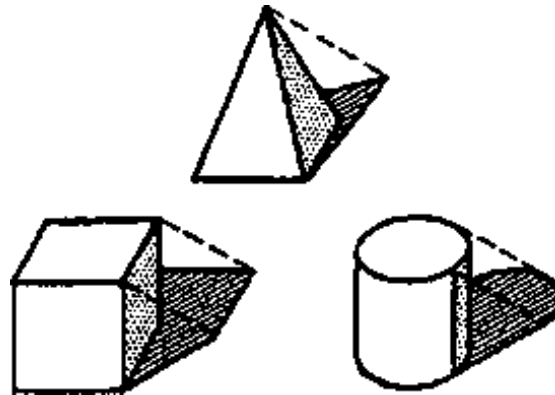

(I) THE SHADE LINES CAST SHADOW OUTLINES

A shade occurs when the shape of the object excludes the light rays from part of its surface (Fig. A) The lines between the areas of light and shade are called shade lines. On a curving surface, such as that of a sphere, the shade line is the line of tangency of light rays to the curving surface. On objects made up of plane surfaces a shade line is the edge where a surface in light meets a surface in shade. A shadow travels through the air from one object to another, or from one part of an object to another part of the same object.

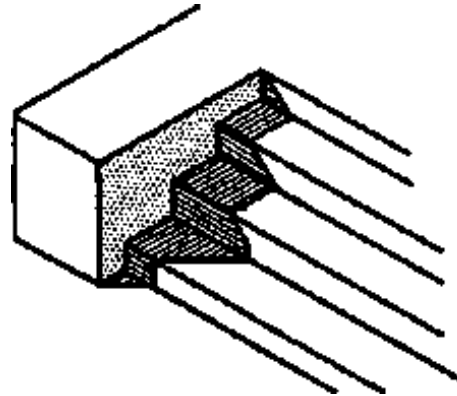

(II) SHADOW SEEN IN A PICTORIAL DRAWING

2.5.3 THE CONVENTIONAL DIRECTION OF LIGHT

In casting shadows it is necessary to assume a source and direction of light. The source of light is usually assumed to be the sun and the rays of light are considered to be parallel. The direction of light used in practically all shadow-casting gives shadow widths which are equal to the projections from wall surfaces of vertical and horizontal shade lines which are parallel to the picture plane and the wall. Characteristic examples of shadows which are equal to the projections making them are those of the cornice and window shown in fig. B.



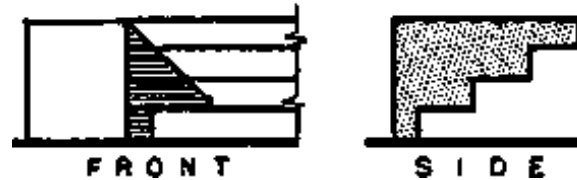

(III) SHADOW SEEN IN THE MULTI-VIEW DRAWINGS

If a cube is placed so that its sides are parallel to the three coordinate planes of elevation, plan, and side elevation, then its diagonal from the top left front corner to the lower right rear corner gives the conventional direction of light and the three views of the cube give the apparent directions of light in the three typical drawings (fig. C).

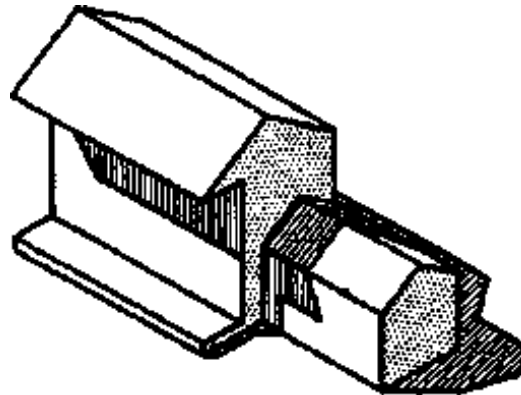

(IV) SIMPLE MODELS HELP TO EXPLAIN SHADOWS

2.5.4 THE 45° DIRECTION

Since the direction of light in front elevation, plan, and side elevation views is the diagonal of a square it is a 45° line in all three drawings. Therefore, shadows may be traced by using the 45° triangle on these drawings. A ray of light travels equally in three directions:

1. to the right
2. down, and

3. BACK,

as shown by edges of the cube.

The 45° triangle should be regarded as a tool for measuring equal distances in two directions, in front elevation down and to the right, in side elevation down and back, and in plan back and to the right. It is usually the most convenient way to measure shadow widths, but any means of measuring equal distances such as dividers, scale, or paper strips may be used if more convenient.

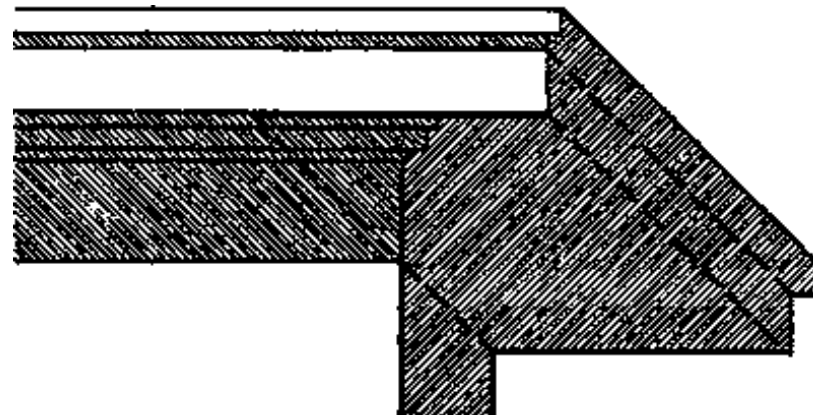

(A) LINES WHICH CAST SHADOWS

2.5.5 THE TRUE DIRECTION OF LIGHT

Since the light rays are at an angle to all the planes of projection the true direction of light is not seen in any of the multi-view drawings. In order to see the true direction of the conventional ray of light it is necessary to use an auxiliary plane perpendicular to plan and parallel to the direction of light. The true direction of a ray of light is represented by the diagonal of a cube, which is the diagonal of a rectangle, of which the short sides are edges of the cube and the long sides the diagonals of the top and bottom of the cube. The true direction of light may readily be constructed as shown in the bottom drawing of fig. D, and will be found useful in constructing some shadows.

and will be found useful in constructing some shadows.

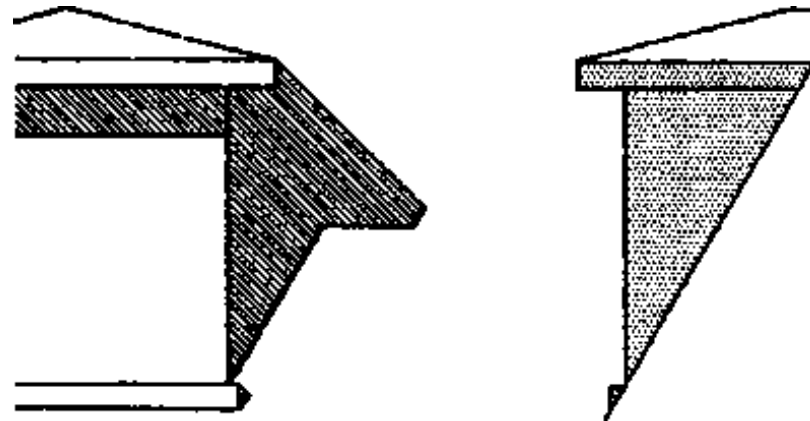

(B) SHADOWS OF PARALLEL LINES

2.5.6 SHADOWS OF SOLIDS

Architecture is made up of volumes and masses which are usually the shapes of the simple geometric solids used either singly or in combinations. Shadows on architectural drawings are the shadow of solids or of hollow masses.

The shadow of any solid is bounded by the shadows of the shade lines of the object.

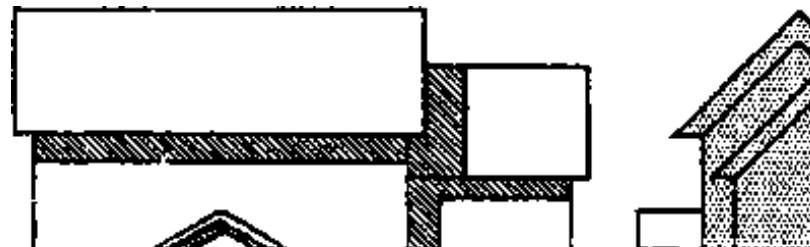



(C) SHADE LINES PARALLEL TO SURFACE RECEIVING SHADOW

Only those lines which mark the divisions between light and shade on an object can cast shadows.

Therefore, if the shade lines on the drawings of an object can be located by inspection, the shadows of these shade lines can then be determined to give the outline of the shadow of the object.

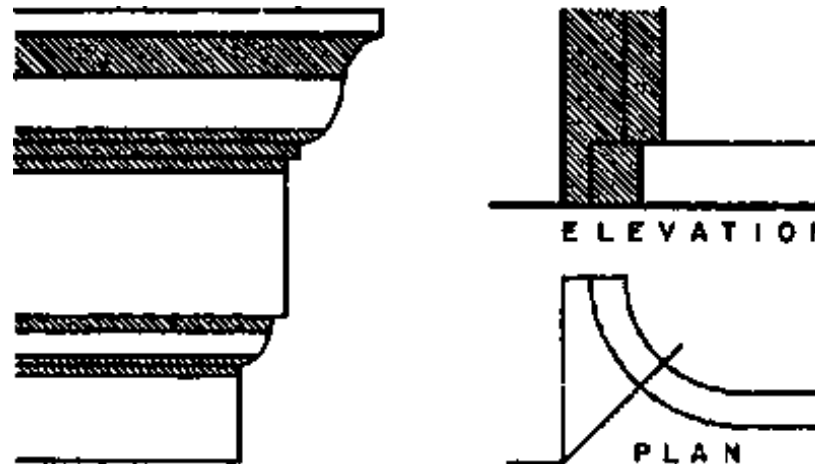

(D) SHADE LINES PARALLEL TO LINES IN SHADOW SURFACE

PRINCIPLES OF SHADES AND SHADOWS

2.5.7 PLANES OF SHADOW

The straight shade lines of an object make planes of shadow. Therefore the shadows of these straight lines are the intersections of their planes of shadow with the surfaces on which the shadows fall.

1. The position of the shade line
2. the location of the eye of the observer

3. the direction of light, and

4. the shape of the surface on which the plane of shadow ends are the factors which determine the shape of the shadow as shown on the drawing.

2.5.8 PRINCIPLES OF SHADOW-CASTING

A knowledge of some of the simple geometric and self-evident principles used in casting shadows will make the problems of working out shadows more easily understood. Several of these helpful principles are described in the numbered paragraphs, and illustrated on this and the following page. The use of a light and a simple model will help the reader to verify and understand these principles.

1 - A LINE IN SHADE OR SHADOW CANNOT CAST A SHADOW because light does not strike it. The lines of the moldings underneath the cornice in fig. A are entirely in shadow and do not cast shadows. When part of a line is a shade line in light and part of the line is in shadow, then only the part of the line which is in light will cast a shadow. The corner of the wall in fig. A is an example of a line which is partly in light and partly in shadow. By first determining which parts of the object are in shadow it is possible to locate the shadow of the object without wasting time finding the shadows of lines which do not make parts of the shadow outlines.

2 - SHADOWS OF PARALLEL LINES ARE PARALLEL when they fall on the same plane or on parallel planes (fig. B). This is true regardless of the relation of the parallel lines to the plane receiving the shadow and of the direction of the plane receiving the shadow. This principle can often be applied to problems to simplify the working out of shadows of parallel lines and to secure greater accuracy. In the case of slanting shadow lines such as those from the dormer onto the roof the direction can be determined most accurately from the longest shadow; then the others can be drawn parallel to it. When the direction of a shadow line is known the construction of the shadow is simplified.

3 - THE SHADOW IS PARALLEL TO THE LINE MAKING THE SHADOW

1. when the line is parallel to the plane receiving the shadow, or
2. the line is parallel to the straight lines in the surface receiving the shadow.

The shadows on the house of Fig. C illustrate the first condition. The shadow of the cornice onto the wall below, the shadow of the vertical corner of the wall onto the second wall surface and the shadow of the right edge of the main roof onto the parallel lower roof surface are all illustrations of this principle. The second condition is illustrated by the molding and the shadow of the vertical line onto a vertical cylinder in Fig. D.

4 - THE SHADOW OF ANY PLANE FIGURE ON A PARALLEL PLANE is identical in shape size, and direction with the figure. This relation is true regardless of the angle at which the area and the parallel plane are turned (fig.). When part of the shadow is behind the plane figure making the shadow, as in the center example, the visible part of the shadow is identical with the part of the figure which makes the shadow. When the plane figure is part of a solid, as in the case of the example of the block on the right of Fig. I, then the part of the shadow made by the end of the block follows this rule since it is parallel to the plane receiving the shadow.

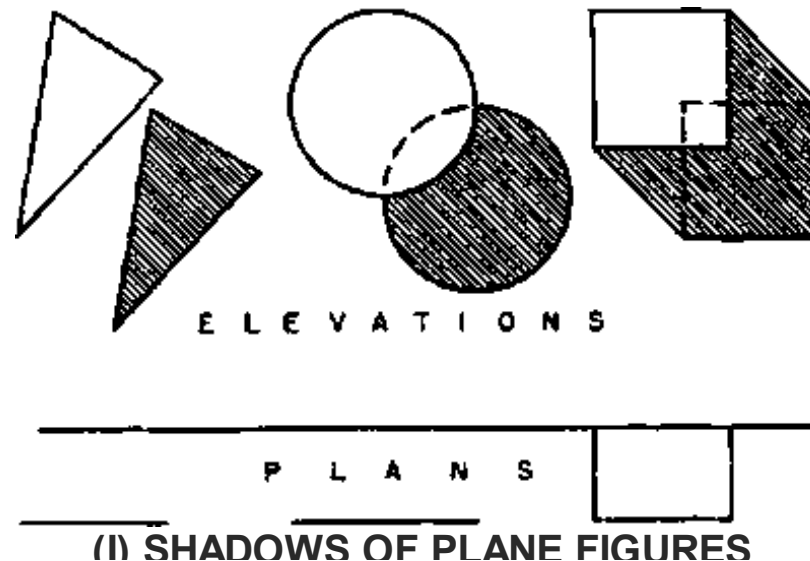

5 - A SHADOW IS VISIBLE only where it falls on a visible surface which is in light. The triangular shadow below the left edge of the dormer roof in Fig. II is visible because it falls on the main roof. There is no similar visible shadow at the left edge of the main roof because there is no visible surface receiving the shadow. The block at the left of Fig. II is set out from the wall so far that none of its shadow is visible in elevation. All of the shadow falls on the floor plane. The distance of the block on the right side is such that part of the shadow is visible in elevation and part in plan.

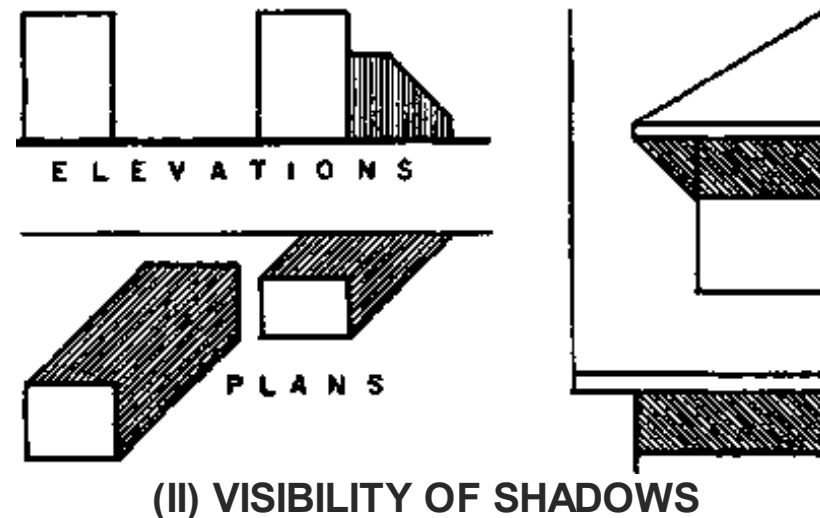

6 - ANY LINE ON A PLANE SURFACE APPEARS TO BE A STRAIGHT LINE WHEN THE OBSERVER LOOKS PARALLEL TO THE PLANE SURFACE. (Fig. III) Since the entire plane surface will be seen as a line when the observer looks parallel to the plane, then any line in the plane will appear to be straight. Objects, areas, and lines are shown in drawings as they would appear from a certain viewpoint.





7 - WHEN THE OBSERVER LOOKS AT THE END OF ANY STRAIGHT LINE, so that the line is seen as a point, then the shadow of the line will appear to be straight regardless of the shape of the surface receiving the shadow. The line makes a plane of shadow. Since the observer is looking parallel to the line he is also looking parallel to the plane of shadow made by the line and any line in the plane of shadow appears to be straight. The shadow line lies in the plane of shadow and therefore appears to be a straight line when seen parallel to the plane, as illustrated in the elevation of fig. IV. Any line seen in end view in elevation, plan, perspective, or any other drawing will cast a straight line shadow in that view where it is seen as a point. A simple model made of boxes and cans with either sunlight or a single artificial light will help the reader understand this type of shadow.

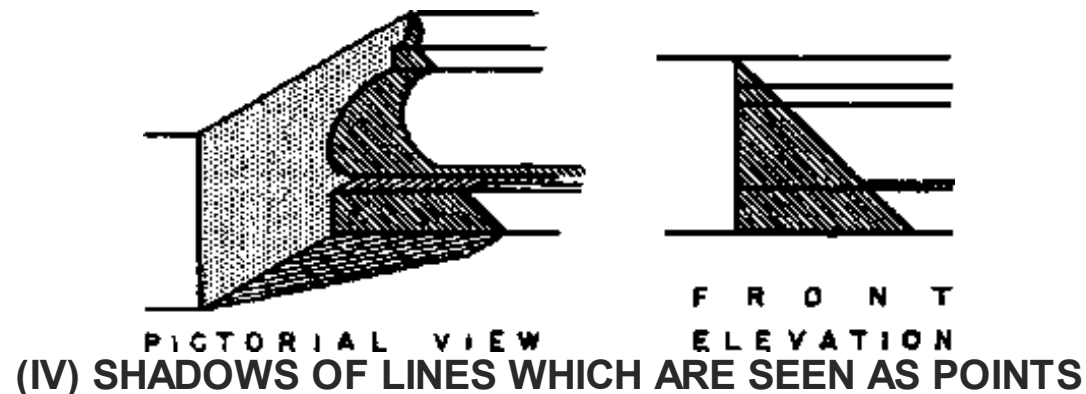

PRINCIPLES OF SHADES AND SHADOWS

2.6 DRAWING PRACTICE

The designer's language is the drawing. It formulates his statements clearly and is internationally readable; factually, by geometrical drawings; attractively, by perspectives. A drawing helps to present

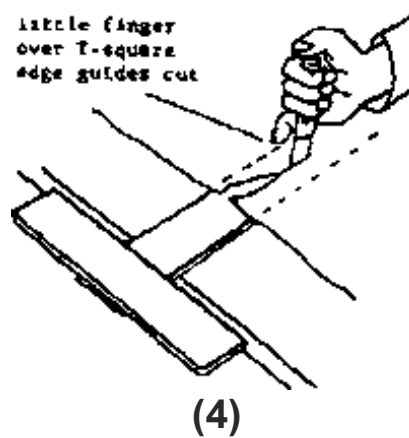
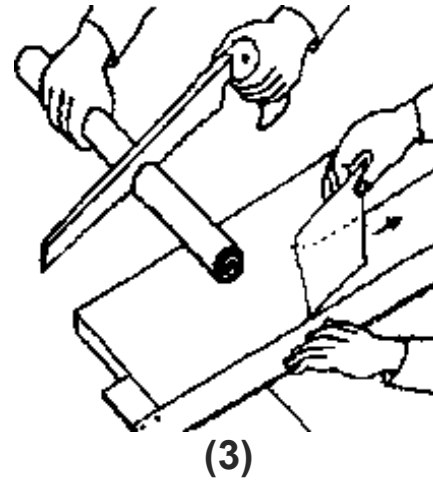

Sketch pads (A4 size) with 5 mm ($\frac{1}{4}$ in) squared paper are convenient for freehand designing to scale; for more exact sketches, mm squared paper with bold 10 mm and less bold 5 mm division lines, → (1),

(2). For sketching with soft pencil, thin transparent paper roll is cut to required sizes and single pieces torn off along T-square, → (3), or cut on T-square, → (4). Plans on good translucent, unglazed tracing paper in standard sizes, → p. 2, to be used with edge protection, → (5). For ink and water colour drawings, tracing

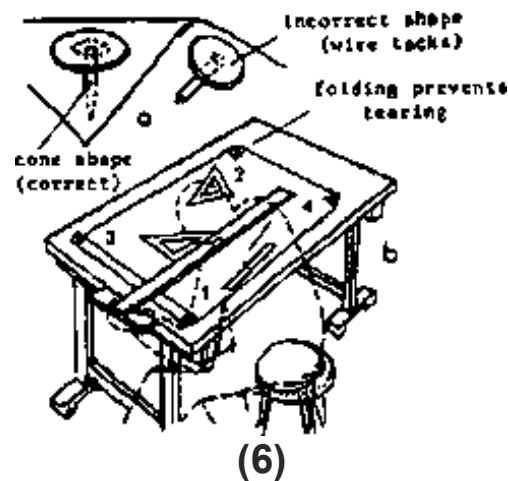
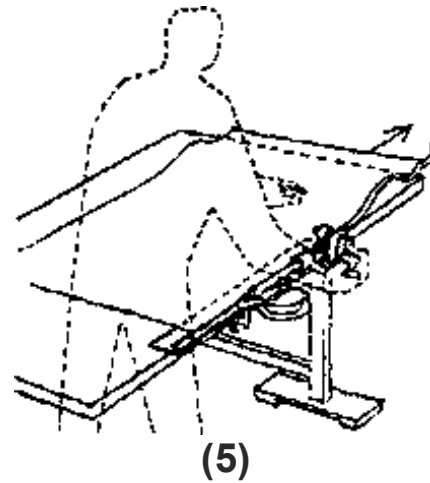

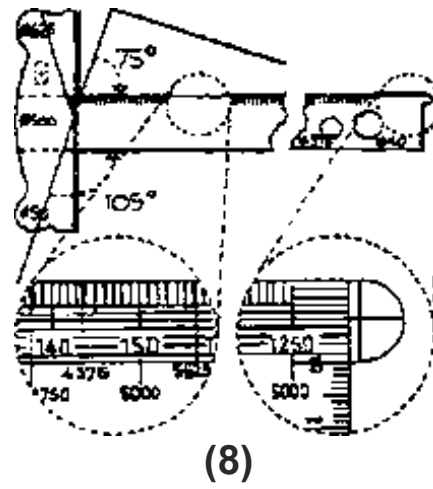
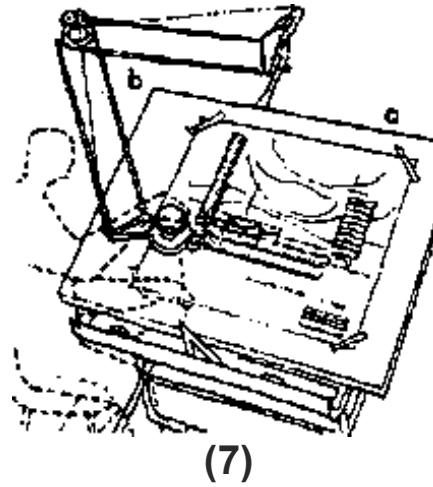

linen is best; for painting and perspectives, special papers. Fix paper to drawing board or table with clips

or drawing pins, not wire tacks which leave holes, → (6a). First, fold 20 mm ($\frac{1}{4}$ in) wide edge of the paper which later becomes the fastener hem and lifts T-square slightly off paper to avoid blurred lines (for same reason draw from top to bottom). Then fold remaining corners 2 and 4 of

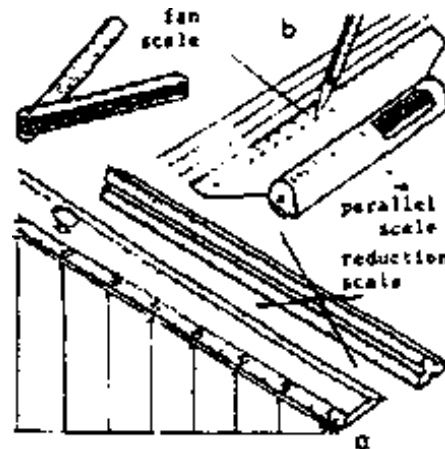

(9)

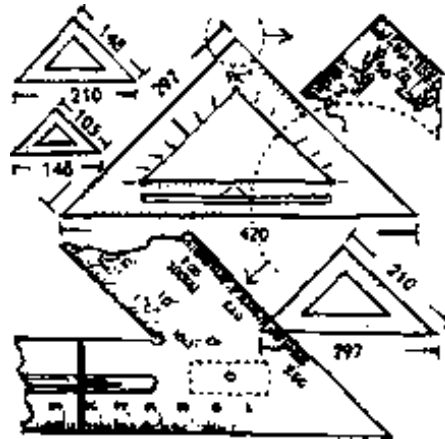

(10)

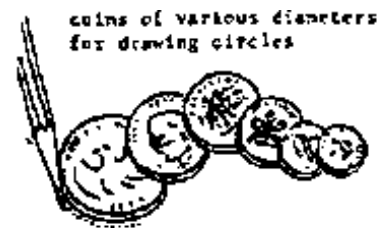

(11)



(12)

sheet, → (6b), pin corner in 1, smooth sheet in direction 2; after fixing this corner, repeat the action from corner 3 to 4. Instead of drawing pins. clips or adhesive tape may be used. → (7a). Mechanical drawing

equipment originally used only by engineers is finding its way into architects offices, → (7b). In addition to ordinary T-square, special (Patent Neufert) T-square, which makes it possible to apply various angles; has octameter and centimetre scale, → (8).

Scale with 1 mm divisions is best, $\frac{1}{2}$ mm markings are confusing. For sketching to scale and drawing lines at set distances, parallel rules or rolling parallel rules are useful, → (9b). Use of triangle rules is discouraged, → (9). Best set squares are transparent uncoloured plastic with mm division, sometimes degrees, → (10), (rigid or adjustable). Various aids to drawing circles and curves,

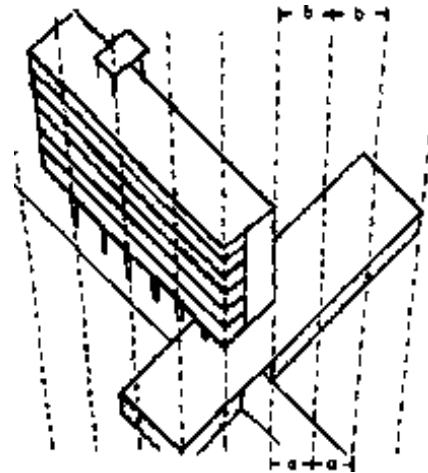

(13)

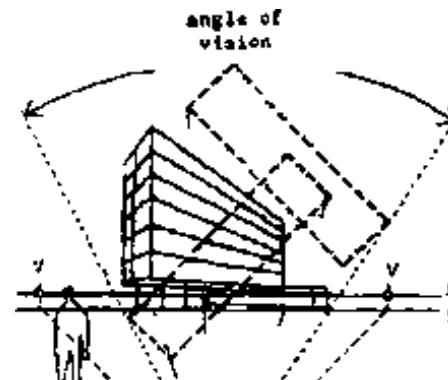



(14)

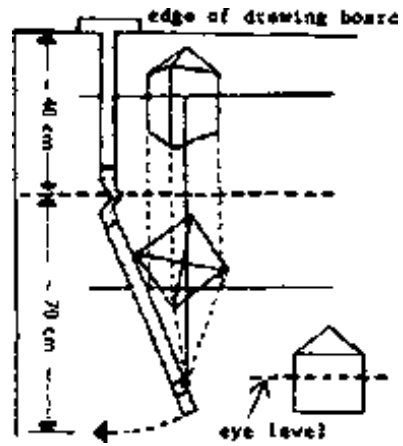

(15)

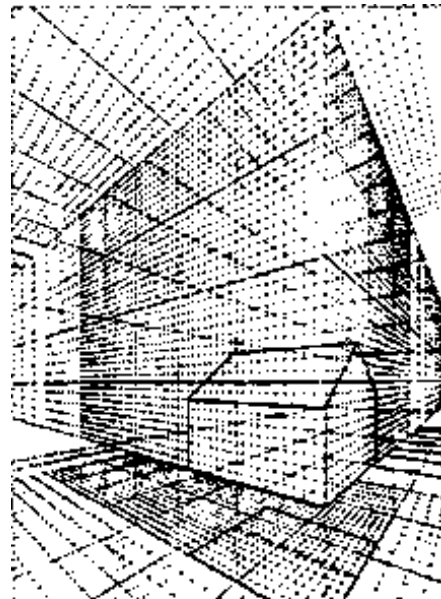

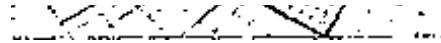

(16)

→ (11) (improvised) and (12) (manufactured). Perspectives and models clarify the ideas of the designer and usually convince better than words. Perspective should be constructed to give an exact picture of the real building. Isometric projections can replace perspective birds-eye view if they are drawn to sc.

1:500, → (13). Easy method to set up perspective, → (14). Perspective apparatus, → (15). Perspective screen which may also be used for interiors, → (16). Drawing tricks: fast and exact drawing of rectangular

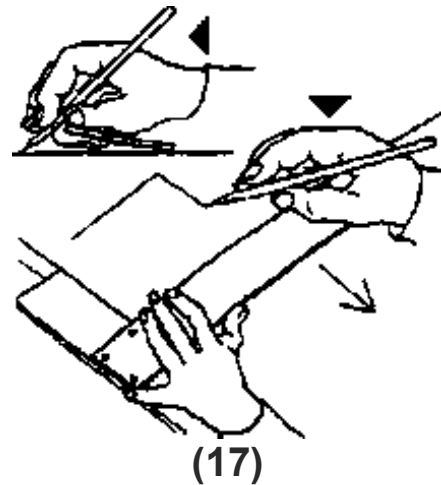

(17)

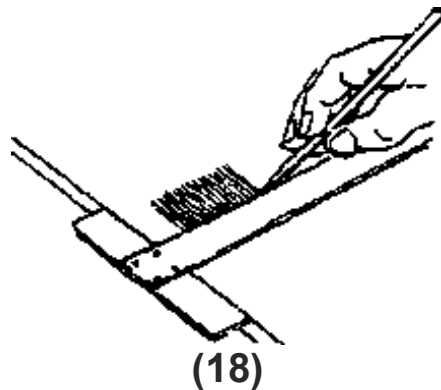

(18)

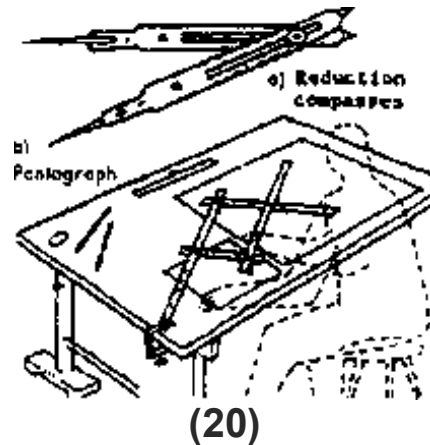
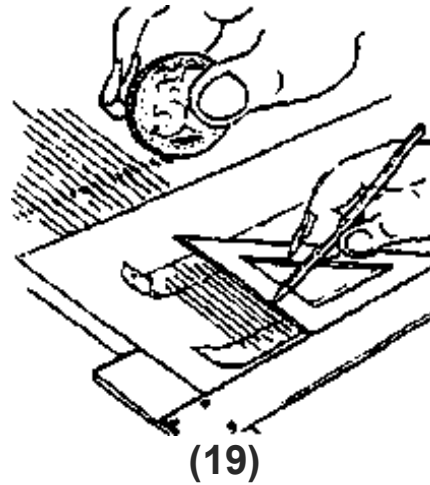

diagrams with T-square only, without set square, → (17); correct holding of T-square and much practice essential to success. Division of line into equal parts facilitated by putting a scale rule at slant, → (9).

Various aids, → (18), (19). Enlargement of drawings to scale through pantograph, → (20). Reduction compasses facilitate drawing of fixed lines in adjusted relation to original, → (20).

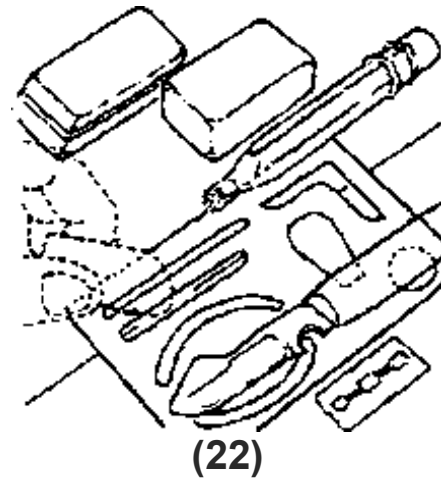
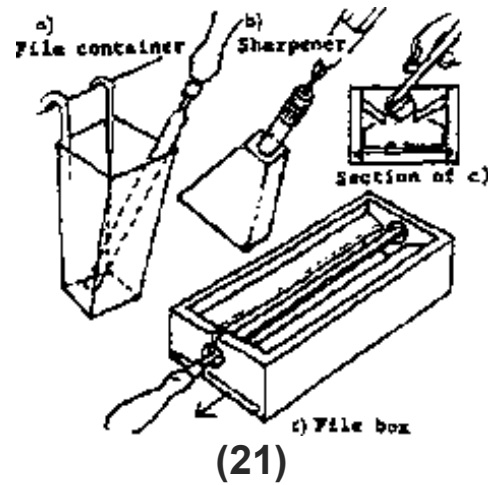

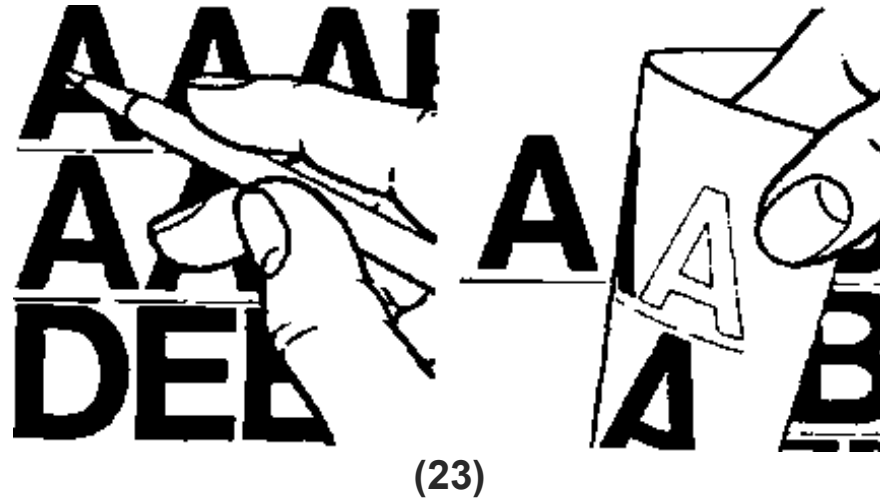

Retractable pencil suitable for 2 mm dia leads of all grades 6B-9H. When sharpening leads, graphite catcher essential, → (21). To erase indian ink; glass eraser, erasing knife or razor blade; to erase pencil lead: non-smearing india rubbers. In drawing with many lines use erasing shields, → (22). Lettering best unaided; for technical drawings stencil with pen or brush, or use instant dry transfer system such as 'Letraset' which also provides architectural symbols, → (23).

2.6.1 DRAWING SHEETS

2.6.1.1 Sizes and Folds

(→ BS 1192:1969)

Standard sizes

A0 841 × 1 189 mm
(33 $\frac{1}{8}$ × 46 $\frac{3}{4}$ in)

A1 594 × 841 mm
(23 $\frac{3}{8}$ × 33 $\frac{1}{8}$ in)

A2 420 × 594 mm
(16 $\frac{1}{2}$ × 23 $\frac{3}{8}$ in)

A3 297 × 420 mm
(11 $\frac{5}{8}$ × 16 $\frac{1}{2}$ in)

A4 210 × 297 mm
(8 $\frac{1}{4}$ × 11 $\frac{5}{8}$ in)

These sizes are all proportional, leading to simple reduction and enlargement and sheets may be easily folded for filing and dispatch. The relatively small sizes should lead to easier handling in the drawing office and on site. Keep the number of sizes to minimum, to facilitate binding and reference.

Original drawings and contact copies should both be of standard sizes, therefore trimming of sheets that makes them less than A sizes should be avoided.

Folding

Prints may be folded to A4 size quite easily from any larger A size.

When prints are to be filed it is necessary to fold them in such a way that the punch holes penetrate only one layer. Methods of folding, → (1) and p. 3.

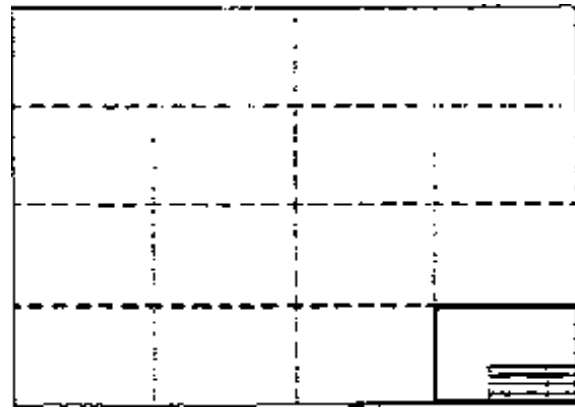

A0 (841 × 1189)

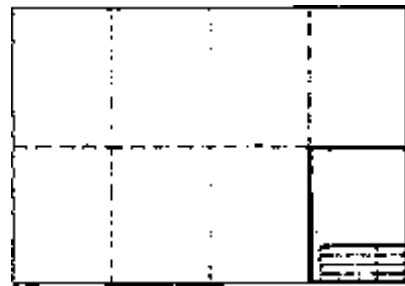

A1 (594 × 841)

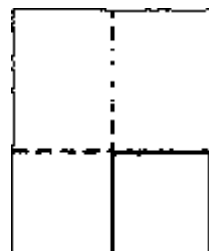



A2 (420 × 594)

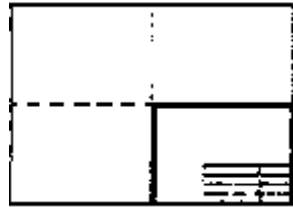
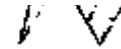

A2 (420 × 594)



A3 (297 × 420)



(1) Simple folding of drawings

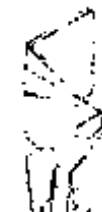
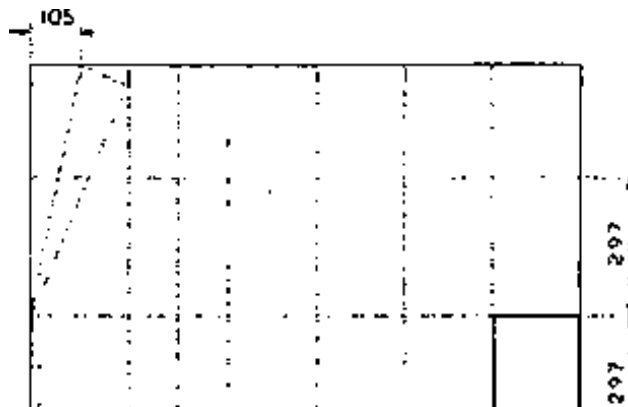

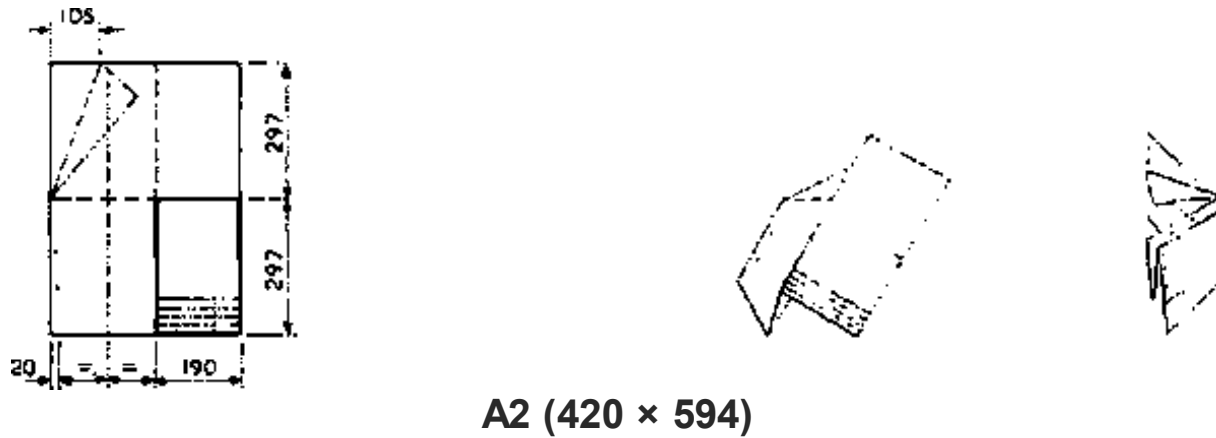
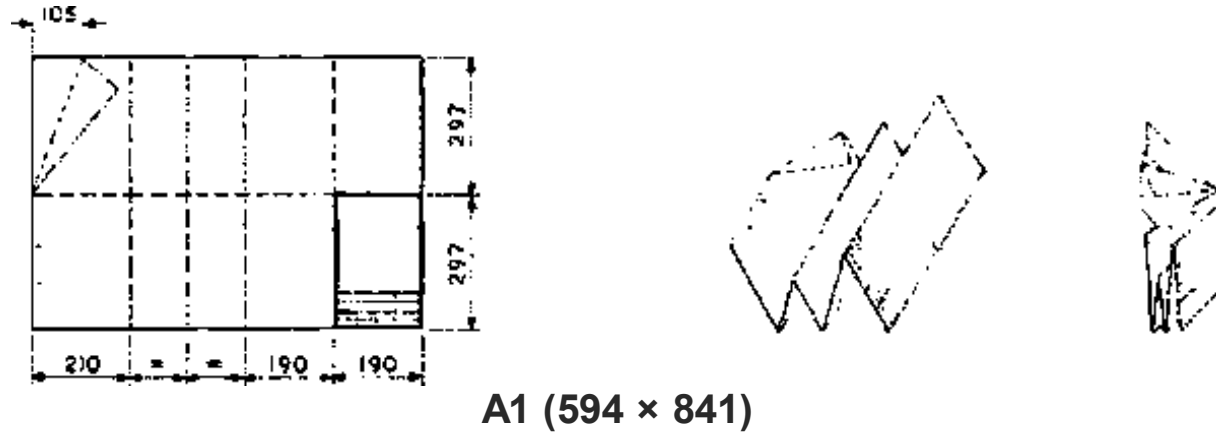
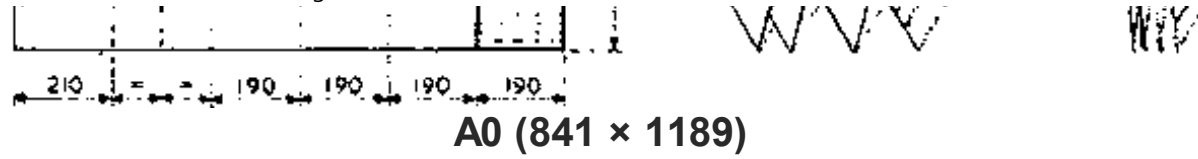

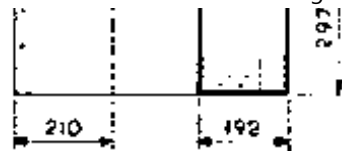

A2 (420 × 594)



A3 (297 × 420)

(1) Folding of drawings for filing

2.6.1.2 Layout and Identification

(→ BS 1192:1969)

Layout: every sheet should have filing margin, title and identification panel.

Filing margin: at left hand edge ≥ 20 mm ($\frac{7}{8}$ in) wide. Filing punch marks and fold marks printed as ticks at edges of sheet. Where microfilming likely, → BS 4210.

Title panel: place in bottom right hand corner of sheet to aid reference when prints are filed or folded, → (1), (2).

Include: job title; subject of drawing; scale; date of drawing; job number; SfB and UDC reference if appropriate; name of architect, etc. Panel may also give initials of person drawing, tracing and checking.

appropriate, name of architect, etc. and may also give initials of person drawing, tracing and checking sheet.

Revision suffix should be changed each time drawing is issued after revision.

Printed blank title panels or use of stencils, transfers or rubber stamps save time and labour.

Information panel: note nature and date of each revision, with architect's initials; start at bottom of panel and work upwards. When general notes included, start at top and work down.

Key: on large projects give key diagram showing continuous drawing sheets, with appropriate part blacked in on each relevant drawing.

Orientation: show north point on every plan. When practicable all plans should have same orientation, except for site location plan. For latter, draw with north at top of sheet to aid identification with Ordnance Survey maps.

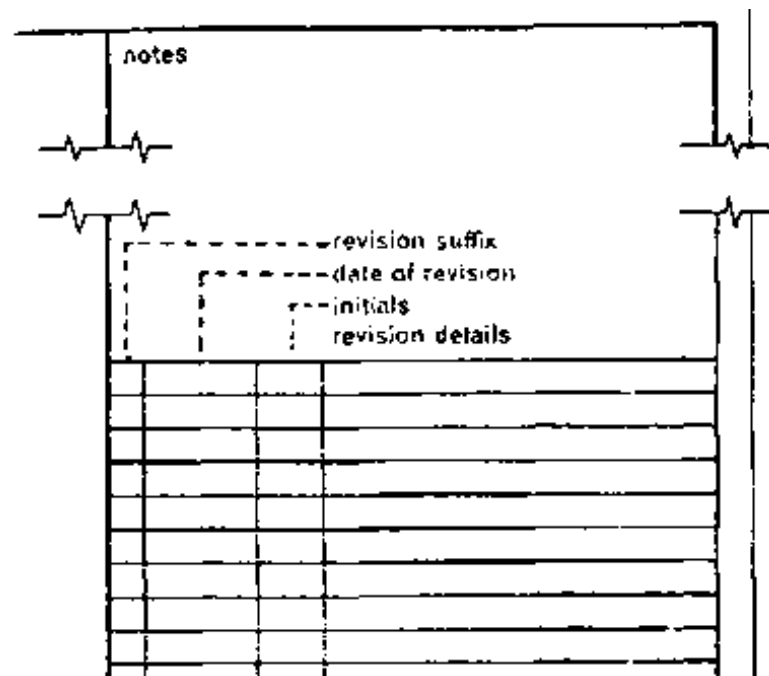

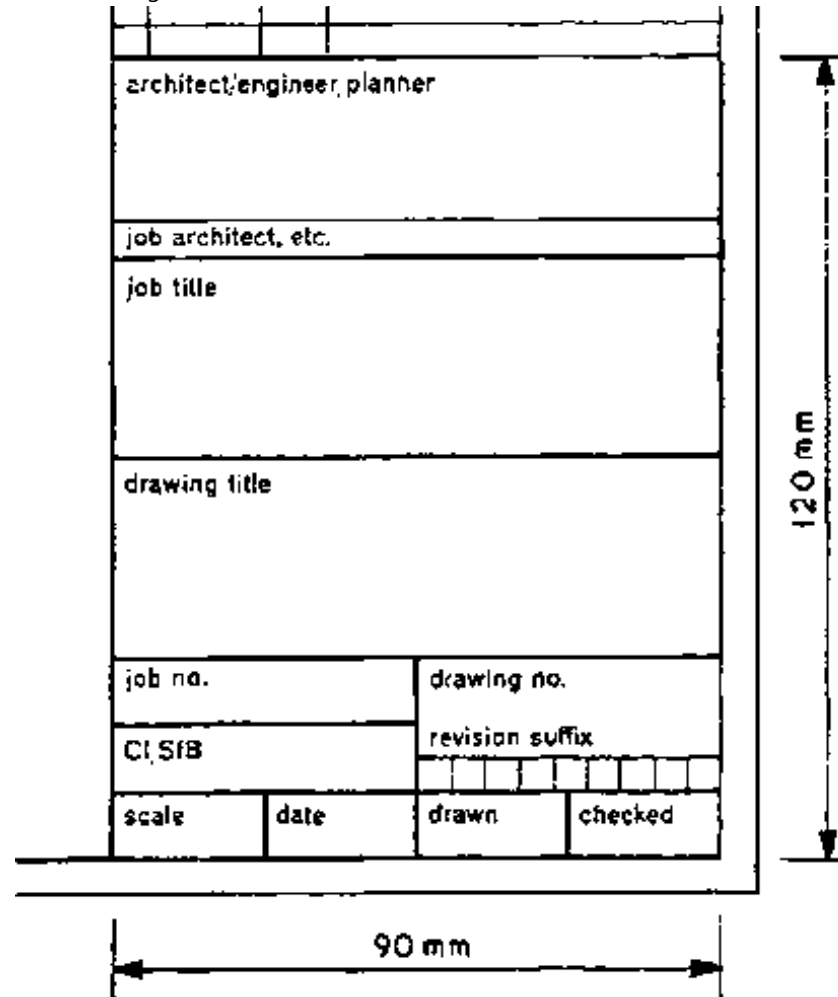

(1) Typical tide panels - vertical

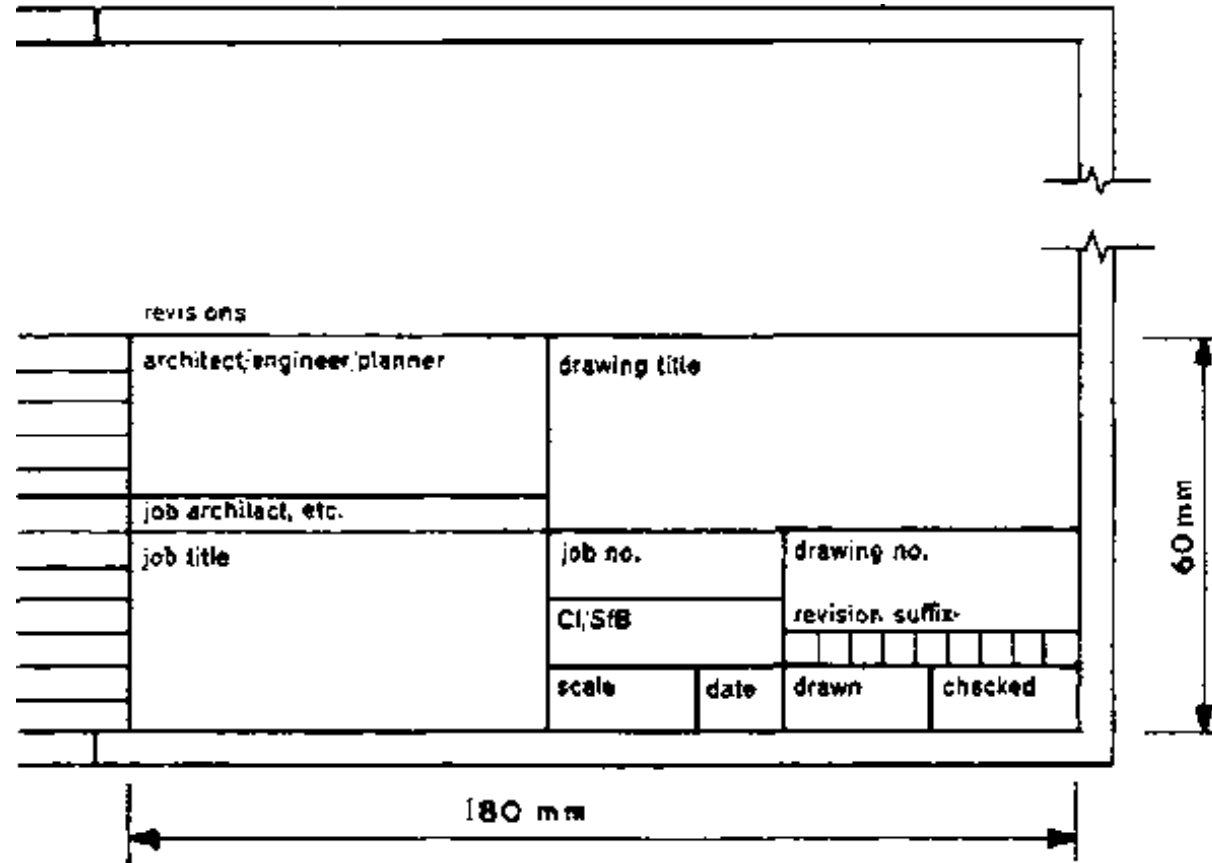

(2) Typical title panels - horizontal

TITLE PANEL

NOTES



REVISIONS

SUFF.	DATE	INICIALS	REVISION DETAILS

TCA	TECHNICAL COLLEGE CHUO CHA UFUNDI	ARUSHA
------------	--	---------------

JOB TITLE	DRWG. TITLE
JOB ARCHITECT	REVISION SUFFIX

CLIENT	JOB No.			DRWG No.					
SIGNATURE	SCALE	DATE	DRAWN	CHECKED					

2.6.2 LEVELS

Levels

(→ **BS 1192:1969**)

General

Levels record distance of a position above or below a defined datum.

Datum

A suitable fixed point should be taken as TBM (temporary bench mark) such that all other levels are positive (minus sign is easily misread). This datum should be clearly indicated or described on drawings, and all levels and vertical dimensions related to it. Vertical dimensions in metres to three decimal places (or in feet and decimals of a foot) above this datum. On large jobs, particularly, it is usually necessary to relate job datum to OS datum (OS levels at present in feet). State clearly whether Newlyn or Liverpool Ordnance Datum is used.

OS are preparing bench mark lists giving heights in metres to two places of decimals.

Levels on plan

It is important to differentiate on site layout drawings between existing levels and intended levels:

existing level:	× 58.210
intended level:	× 60.255

Exact position to which level applies should be indicated by 'X'

Finished floor levels should be indicated by letters FFL followed by figures of level:

FFL	12.335
-----	--------

Levels on section and elevation

Use same method as for levels on plan except that level should be projected beyond drawing with arrowhead indicating appropriate line, → (1).

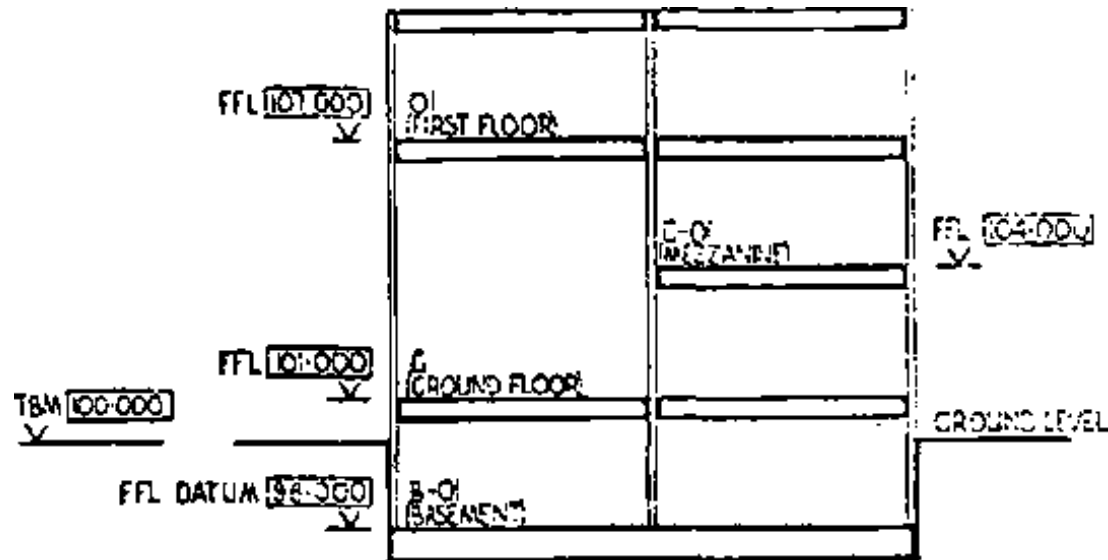

(1) Levels on section and elevation

2.6.3 REFERENCING

Referencing

Classification and coding of building components and elements shown on drawings may be achieved through use of SfB system (UK application known as CI/SfB; → 'Construction Indexing Manual', published by RIBA, for details of system and its tables).

SfB enables information contained within different kinds of documents, such as bills of quantity, drawings, specifications, texts, trade literature, etc, to be co-ordinated and correlated for maximum benefit of user.

SfB system is a facet system of alpha-numerical symbols forming three tables which may be used individually or in combination to indicate concepts and terms required. Three tables of SfB system cover building elements, components/products, and materials.

Each type of component or element shown on a drawing may be identified by appropriate SfB notation, e.g.:

concrete blocks	Ff2
concrete lintels	Gf2
aluminum sections	Hh4
hardwood sections	Hi3
manholes	(52)
external walls	(21)

windows	(31)
doors	(32)
radiators	(56)

Notations may be combined, e.g.:

external walls, concrete block	(21) Ff2
windows, aluminum	(31) Hh4
doors, hardwood	(32) Hi3

Number and length of component and element notations should be kept to minimum compatible with a rational system of identification for each particular job.

A specific component within any range may be identified by a suffix giving nominal sizes for length, width, height, etc:

concrete block Ff2 400 mm × 100 mm × 200 mm
Ff2 1 ft 4 in × 4 in × 8 in

Alternatively, where principles of modular coordination are applied, such a suffix may give nominal sizes for a component or element in multiples of 100 mm or 4 in (M), e.g.:

concrete block Ff2 4M × 1M × 2M

2.6.4 ABBREVIATIONS

(→ **BS 1192:1969**)

Aggregate	agg
Air brick	AB
Aluminum	al
Asbestos	abs
Asbestos cement	abs CT
Asphalt	asph
Bitumen	bit
Boarding	bdg
Brickwork	bwk
BS Universal beam	BSUB
BS Channel	BSC
BS equal angle	BSEA
BS unequal angle	BSUA
BS tee	BST
Bronze metal antique	BMA
Building	bldg
Cast iron	CI
Cement	ct

Chromium plate	CP
Cleaning eye	CE
Column	col
Concrete	conc
Convactor	conv
Copper	cu copp
Cupboard	cpd
Damp proof course	DPC
Damp proof membrane	DPM
Discharge pipe	DP
Drawing	dwg
Expanded metal lathing	EML
Foundation	fdn
Fresh air inlet	FAI
Glazed pipe	GP
Granolithic	grano
Hardcore	hc
Hardboard	hdt
Hardwood	hwc

Inspection chamber	IC
Insulation	insul
Invert	inv
Joist	jst
Lighting	ltg
Mild steel	MS
Pitch fibre	PF
Plasterboard	pbd
Polyvinyl acetate	PVA
Polyvinyl chloride	PVC
Radiator	rad
Rainwater head	RWH
Rainwater pipe	RWP
Reinforced concrete	RC
Rodding eye	RE
Satin chrome	SC
Sewers foul	FS
Sewers surface water	SWS
Satin anodised aluminum	SAA

Softwood	swd
Stainless steel	SS
Tongue and groove	T&G
Unglazed pipe	UGP
Vent pipe	VP
Wrought iron	WI

2.6.5 REPRESENTATION OF MATERIALS

(→ BS 1192:1969)

Table shows recommended methods of indicating materials on drawings. These methods should only be used where confusion is likely to occur in interpretation of drawings, but in all cases they should be accompanied by a descriptive note, stating type of material, thickness, etc. Existing and proposed work should be clearly indicated. Spacing of hatching lines should be adapted to scale of drawing and should not normally be used on small scale drawings.

Colouring is costly, laborious and conducive to error and consequently to be avoided. Hatching is preferable where it is necessary to show different materials.

Brick



Concrete

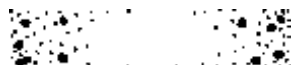











Earth

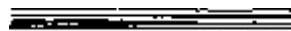
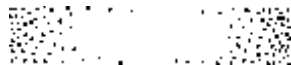

Fibre board



Fibre board	
Glass	
Hardcore	
Loose insulation	
Metal	
Partition block	
Plywood	
Screed	
Sheet membrane	
Stone	
Wood (unwrot)	
Wood (wrot)	

2.6.6 GRAPHICAL SYMBOLS AND REPRESENTATION

(→ BS 1192:1969)

A drawing is a symbolic representation of a real or imagined object. Aspects or parts of a drawing may themselves be symbolically represented. Symbols for this purpose are termed graphical symbols, use of which enables maximum information to be contained within the drawing, clearly and legibly, with minimum effort.

Types of symbols

Principal types used in building drawing practice are graphical. Many of these, as well as other kinds of symbols such as letters, numbers and signs, are covered by British Standards, of which the following are relevant:

BS 108 Graphical symbols for general electrical purposes (power and lighting).

BS 1553 Graphical symbols for engineering:
 Part 1 Pipes and valves
 Part 4 Heating and ventilating systems.

BS 1635 Graphical symbols for fire protection drawings.

BS 1991 Letter symbols, signs and abbreviations
 Part 1 General
 Part 4 Structures, materials and soil mechanics.

BS 3939 Graphical symbols for electrical power, telecommunications and electronics diagrams.

Graphical symbols









Building drawing practice requires use of graphical symbols on drawings which are additional to those covered in above British Standards. Examples of most commonly used graphical symbols are given below

GRAPHICAL SYMBOLS AND REPRESENTATION

Draughtsmanship

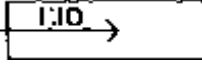
Description

Symbol

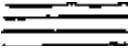
Description	Symbol
Centre to centre	c/c
Centre line	
Direction of view	
External	ext
Internal	int
North point	
Modular space	
Rise of stair	
Rise of ramp	
Bench mark	BM
Existing level on plan	
Existing level on section	
Finished floor level	FFL
Ground level	GL
Required level on plan	
Required level on section	
Temporary bench mark	TBM
Paved area	

Grass area



Planted area



New trees



Existing trees



Existing trees removed



2.6.7 HATCHING RULES

1. Draw **HATCHING LINES** preferably at 45 as thin lines with a spacing of - preferably - not less than 4 mm.

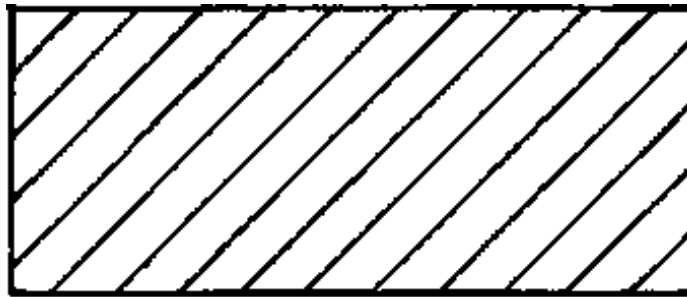

2. If two adjacent parts to be hatched, draw the **HATCHING LINES** in opposite directions.





3. Where more than two adjacent parts to be hatched, draw the HATCHING LINES of one area -preferably the smallest - closer together.

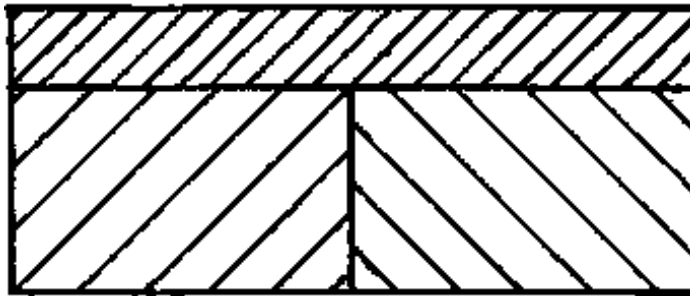

4. In order to simplify distinguishing between more than two adjacent parts, HATCHING LINES drawn at 60 and/or 30 may be used additionally.

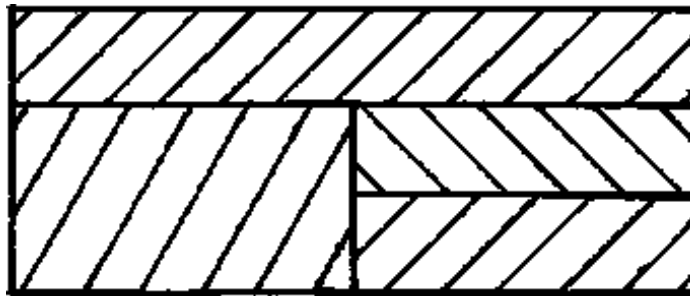

5. Large areas may be hatched along the borderline only.





6. If a part is drawn at such an angle that the **HATCHING LINES** become parallel to one edge of the part, the angle of hatching may be caused.



7. Interrupt **HATCHING LINES** to give space for dimensioning figures, words etc.

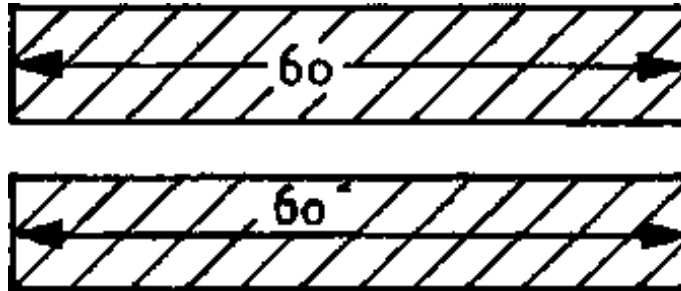

2.7 APPLICATION FOR BUILDING PERMIT

2.7.1 PROCEDURE OF APPLYING FOR PERMISSION TO ERECT A BUILDING

Application for and Allocation of a plot:

- a) **Request to the (District) Land Officer**
- b) **Land Officer submit all applications to the Urban Planning Committee**
- c) **Plots are allocated by the Urban Planning Committee**
- d) **Right of Occupancy of the plot is issued through the Land - Officer.**

Application for Permission to erect a Building

a) **Submission of the Application to the Town Council Authority The application includes:**

- **A properly filled Form of Application for Permission to erect a Building**
- **A properly filled Form of Application for Planning Consent.**
- **4 sets of drawings:**

Blockplan scale 1:2500 (better 1:1000)

Siteplan scale 1: 500

All floor plans scale 1: 100

Sections scale 1: 100

Elevations scale 1: 100

R.C. Details scale 1: 20 - 1: 5

- **Schedule of doors, windows, opening arrangements.**
- **Details of the Drainage system including septic tank and soakage, pit, inspection chambers, gully traps, vent, pipes, etc.**

b) Before submitting the Application to the Urban Planning Committee, forms and plans will be checked by:

- the Land Officier
- the Health Officier
- the Town Engineer
- the Town Planning Officier
- the Fire Master

In case the application does not comply with the technical requirements of the Authority the Application may be disapproved and send backs for amendments resubmission to the applicant. After the technical approval, the application will be submitted to the Urban Planning Committee. The Committee approves or disapproves the application and issues the Building Permit.

c) The Building Permit will be sent to the applicant together with one set of plans (with stamp and signature of the Authority) and one set of proceed sheets.

Form of Application for Permission to Erect a Building

**To, TOWN
DIRECTOR**

FOR OFFICE USE ONLY

**ARUSHA TOWN
COUNCIL**

Plan submitted.....

**P. O. Box 3013,
Arusha**

Registered No. of Plan.....

Date of Registration.....

.....19.....

I beg to submit herewith Plans, Sections and Elevations for

.....

(State here if New Building, Alteration or Addition or Sanitary Reconstruction)
to be used as

(Insert whether a Domestic Building or for what purpose the building will be used)
to be executed by me on Plot No

such plot having frontage to

I also submit the following proposed means of construction and other particulars:

External walls to be built of

Internal walls to be built of

Mortar in walls to be composed of

Dampcourse to be of

Foundations to be of Mortar in foundation composed of

Roof to be constructed of

Water supply from

Drainage to sewer/permeable cesspit/impermeable septic/tank (erase words which do not apply). In the of septic tanks state how the effluent will be disposed of

Material of drain pipes

Closet accommodation - (state type)

Indoor

.....

Outdoor

.....

Name of Architect or Draughtsman

Address of above

Name of Builder (if known)

Signature of Owner or Agent

Address of Owner or Agent

SUBMISSION OF PLANS

All Plans to be submitted to the

One set of Plans to be made on cloth (paper on cloth is not accepted)

AH Drawings to be signed by owner or his agent.

All Drawings to be accompanied by application form duly completed as required by the

All Drawings to be submitted in duplicate and to be of a quality approved by the

DRAWINGS REQUIRED

Scale 1:100 - Plans of each floor or level; having thickness of wall shown in figures. Section through Building (more than one if building is large or if required by Authority).

Scale 1:50 - Sections are required of Floors and Roofs, Verandas, and Balconies, Stairs, iron or steel Beams, Pillar and Principal Timbers, Pavements, Openings, etc.. on public Streets

Colours - The above drawings are to be coloured thus:

Brick, stone or concrete Red

Fire-proofing, damp-proofing or impervious floors of stables, closets, etc.	Thick black line
Work to be removed	Dotted line
Steel or iron	Blue lines, in skeleton
Work existing	Natural Colour

Scale 1:500 - Block plan as follows:

To show plot on which buildings are to be erected.

To show plots immediately adjoining and names of the proprietors thereof.

To show buildings, existing or proposed, on all these plots.

To show numbers of plots, names of streets, and township.

To indicate of what materials existing buildings are composed, i.e. bricks wood and iron, or stone, etc.

To show lines of drainage, giving size and fall of drains.

To show level and width of the street or streets upon which the proposed buildings will abut with reference to their ground-floor level.

2.7.2 FORMULARS

**for
office**

Date

**Application
No.**

Zone

Category

FORM A

.....
APPLICATION FOR PLANNING CONSENT

The Town and Country Planning Ordinance

(All development other than Use classes A (d), A (c) and A (f))

This form should be submitted in duplicate

To: The TOWN DIRECTOR

1. I hereby make application to the Area

Planning Committee for planning consent to the following development -

.....

2. Location and planning zone of proposed development

.....

3. Development (delete as necessary).

(a) Category I (Sub division and layout of land)

Number of plots proposed and proposed use of any buildings to be erected thereon

(b) Category II (Change of use of land or premises).

Number of buildings effected (if any) and changes of use proposed

(c) Category III (any building, engineering or mining work in, on under or over any land or premises)

(d) Previous use: purpose for which building or land was last used

**(e) Details of plot or land Area
acres/sq feet Frontage to road
feet. Width of street opposite
feet. Building line or set back adjoining building
..... feet.**

4. My interest in land is

5. I enclose three copies of plans illustrating the proposals

.....

Signature of Applicant

Address

P.O. Box 3013

Phone: 3631/1

ARUSHA TOWN COUNCIL

TOWN HALL

BUILDING PERMIT

The Township (Building) Rules 1930

Permission is hereby given to to erect a building as a on in accordance with the plan (No.) attached hereto and with all conditions imposed by the above Rules.

.....**107**.....

TOWN DIRECTOR

N. D.: Your attention is invited to the Electricity Rules, 1953, which require you to notify The Tanganyika Electric Supply Company, Limited, as well as the Electrical Engineer, General Post Office, before Commencing to erect a building; should the electric wires in the street be accessible from any portion of such building where erected or from the scaffolding required during its construction.

Building Rules 9 (6), This permit is subject to the fulfillment of the covenants entered into betweenlessee of the above mentioned plot and the Authority, concerning connection of the building (s) to the main sewerage system when this is applicable.

Building Rule 5 (6), (G. N. 45/1955). The prescribed number of occupants permitted to reside in the building to which this Permit refers is:

.....

(Note - Two children may be counted as one adult person)

**YOU ARE HEREBY WARNED THAT APPROVAL OF PLANS BY THE
 AUTHORITY DOES NOT IMPLY THAT ERECTION OF BUILDINGS IN
 ACCORDANCE WITH THESE PLANS WILL NECESSARILY BE IN
 ACCORDANCE WITH THE CONDITIONS OF THE RIGHT OF OCCUPANCY
 UNDER WHICH YOU HOLD THE LAND**

Building Construction with 14 Modules: 2. ARCHITECTURAL D...
UNDER WHICH YOU HOLD THE LAND

A

This form MUST be submitted in its proper sequence prior to any further work proceeding.

No. 1885

.....
.....

Date.....

Plot No.

Block No.

Area

**I hereby give notice that I intend commence the work approved in Plan No. on
..... 197**

Signed.....

TWO DAYS NOTICE REQUIRED

B

This form MUST be submitted in its proper sequence prior to any further work proceeding.

No. 1885

.....
.....

Date.....

Plot No.

Block No.

Area

I hereby give notice that the foundation trenches are now ready for inspection.

Plan No.

Before

Plan No.

Refers

Signed.....

TWO DAYS NOTICE REQUIRED

C

This form MUST be submitted in its proper sequence prior to any further work proceeding.

No. 1885

.....
.....

Date.....

Plot No.

Block No.

Area

I hereby give notice that the foundation concrete is now ready for inspection.

Plan No.

Refers

Signed.....

TWO DAYS NOTICE REQUIRED

D

This form MUST be submitted in its proper sequence prior to any further work proceeding.

No. 1885

.....
.....

Date.....

Plot No.

Block No.

Area

I hereby give notice that the ground floor concrete and damp proof course are ready for inspection.

Plan No.

Refers

Signed.....

TWO DAYS NOTICE REQUIRED

E

This form MUST be submitted in its proper sequence prior to any further work proceeding.

No. 1885

.....
.....

Date.....

Plot No.

Block No.

Area

I hereby give notice that the work of construction has now proceeded to wall plate level.

Plan No.

Refers

Signed.....

TWO DAYS NOTICE REQUIRED

F

This form MUST be submitted in its proper sequence prior to any further work proceeding.

No. 1885

Date.....

.....

.....

Plot No.

Block No.

Area

I hereby give notice that all the roofing timbers in the building re in position and are ready for examination.

Plan No.

Refers

Signed.....

TWO DAYS NOTICE REQUIRED

G

This form MUST be submitted in its proper sequence prior to any further work proceeding.

No. 1885

.....

Date.....

.....

Plot No.

Block No.

Area

I hereby give notice that the drainage and sanitary work are ready for testing.

Plan No.

Refers

Signed.....

TWO DAYS NOTICE REQUIRED

..

H

This form MUST be submitted in its proper sequence prior to any further work proceeding.

No. 1885

.....
.....

Date.....

Plot No.

Block No.

Area

I hereby give notice that the whole of the work has been completed and I hereby apply for a certificate of occupation in respect of the premises.

Plan No.

Refers

Signed.....

SEVEN DAYS NOTICE REQUIRED

Please provide your feedback

English | French | Spanish | German