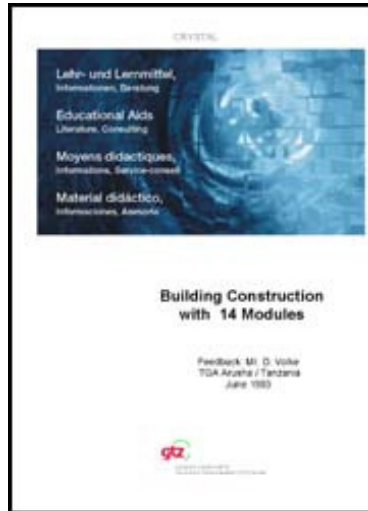

[Home page](#) | [Help](#) | [Clear](#)[English](#) | [French](#) | [Spanish](#) | [German](#)[Search](#) | [Subjects](#) | [Titles A-Z](#) | [Courses](#) | [Illustrations](#) | [Topics](#) | [e-Course builder](#)[Contract TOC](#)[Expand Document](#)[Contract Chapter](#)[Add to e-Course](#)[Preferences](#)

Printable version

Export document
as HTML file [Help](#)

Export document
as PDF file

Building Construction with 14 Modules (TCA; 1983; 618 pages)

1. ARCHITECTURAL DRAWING I

1.1 AIMS AND PURPOSE OF ARCHITECTURAL DRAWINGS

1.1.1 CONTENTS OF ARCHITECTURAL DRAWINGS

1.2 DRAWING EQUIPMENT

1.2.1 PENCILS

1.2.2 DRAWING PENS

1.2.3 COMPASSES

1.2.4 DRAWING BOARDS

1.2.5 T-SQUARES

1.2.6 SET SQUARES

1.2.7 PROTRACTORS

1.2.8 SCALES

1.2.9 FRENCH CURVES

1.2.10 TEMPLATES

1.2.11 DRAWING PINS AND OTHER FIXINGS

1.2.12 MINOR ITEMS OF EQUIPMENT

1.2.13 PRINTING PAPERS

1.2.14 TRACING PAPER, CLOTH AND FILM

 **1.2.15 BACKING SHEETS**

 **1.2.16 DRAWING PAPERS**

 **1.2.17 CARTRIDGE**

 **1.2.18 HANDMADE AND MOULDMADE PAPERS**

 **1.2.19 PLASTIC-COATED CARD**

 **1.3 LETTERING**

 **1.3.1 PRINCIPLE OF LETTERING**

 **1.3.2 FREEHAND LETTERING**

 **1.3.3 TYPES OF LETTERS**

 **1.3.3.1 The Roman Alphabet**

 **1.3.3.2 Sans Serif Letters**

 **1.3.3.3 Inclined Lettering**

 **1.3.3.4 Script Lettering**

 **1.3.3.5 Stencil Lettering**

 **1.3.3.6 Guided Pen Lettering**

 **1.3.3.7 Pressure-Transfer Lettering**

 **1.4 LINEWORK AND DIMENSIONING**

 **1.4.1 TYPES OF LINES**

 **1.4.2 PENCIL DRAWING**

 **1.4.3 INKING - IN**

 **1.4.4 BASIC RULES OF DIMENSIONING**

 **1.4.4.1 Types of Dimensions**

 **1.4.4.2 Placement of Dimensions**

 **1.5 ENLARGEMENT AND REDUCTION OF LINE DRAWINGS** **1.6 GEOMETRICAL CONSTRUCTIONS** **1.6.1 LINES AND ANGLES** **1.6.1.1 To bisect a straight line AB** **1.6.1.2 To divide a straight line AB into a given number of equal parts** **1.6.1.3 To divide a straight line AB into any ratio** **1.6.1.4 To construct an angle of 90°**  **1.6.1.5 To construct an angle of 45°**  **1.6.1.6 To construct an angle of 60°**  **1.6.1.7 To construct an angle of 30°**  **1.6.1.8 To bisect any given angle** **1.6.1.9 To construct an angle SIMILAR to a given angle** **1.6.1.10 To draw a line PARALLEL to a given line** **1.6.2 TRIANGLES** **1.6.2.1 To construct an EQUILATERAL triangle** **1.6.2.2 To construct a triangle with given BASE ANGLES and ALTITUDE** **1.6.2.3 To inscribe a circle in a given triangle ABC** **1.6.2.4 To circumscribe a triangle ABC** **1.6.3 CIRCLES** **1.6.3.1 Basic CIRCLE-Constructions** **1.6.3.2 To draw a tangent to a point A on the circumference of a circle centre O**

 **1.6.3.3 To draw an internal tangent to two circles of equal diameter**

 **1.6.3.4 To find the centre of a given circle arc**

 **1.6.3.5 To join two straight lines at RIGHT ANGLES to each other by an arc of given radius**

 **1.6.3.6 To draw a curve of given radius joining two circles**

 **1.6.3.7 To join two straight lines by two arcs of equal radius**

 **1.6.4 BASIC ARCH CONSTRUCTIONS**

 **2. ARCHITECTURAL DRAWING II**

 **2.1 TYPES OF PROJECTIONS**

 **2.2 ORTHOGRAPHIC PROJECTION**

 **2.2.1 CONSTRUCTION OF ORTHOGRAPHIC PROJECTION**

 **2.2.2 ELEVATIONS**

 **2.2.3 PLANS AND SECTIONS**

 **2.3 PICTORIAL DRAWING**

 **2.3.1 AXONOMETRIC PROJECTION**

 **2.3.2 ISOMETRIC PROJECTION**

 **2.3.3 DIMETRIC PROJECTION**

 **2.3.4 OBLIQUE PROJECTION**

 **2.3.4.1 Length of Receding Lines**























 **2.3.4.2 Construction of Oblique Drawings**

 **2.3.4.3 Rules of Oblique Drawing**























 **2.3.4.4 Scale of the Receding Lines**

 **2.3.4.5 Direction of Receding Lines**

 **2.3.4.6 Position of Axes** **2.4 PERSPECTIVE DRAWING** **2.4.1 PERSPECTIVE TERMS** **2.4.2 PHENOMENA OF PERSPECTIVE DRAWING** **2.4.3 SYSTEMS OF PERSPECTIVE DRAWINGS** **2.4.4 METHODS OF PERSPECTIVE DRAWINGS** **2.4.5 TWO-POINT PERSPECTIVE** **2.4.6 ONE-POINT PERSPECTIVE** **2.5 SHADES AND SHADOWS** **2.5.1 THE USE OF SHADOWS** **2.5.2 SHADES AND SHADOWS** **2.5.3 THE CONVENTIONAL DIRECTION OF LIGHT** **2.5.4 THE 45° DIRECTION** **2.5.5 THE TRUE DIRECTION OF LIGHT** **2.5.6 SHADOWS OF SOLIDS** **2.5.7 PLANES OF SHADOW** **2.5.8 PRINCIPLES OF SHADOW-CASTING** **2.6 DRAWING PRACTICE** **2.6.1 DRAWING SHEETS** **2.6.1.1 Sizes and Folds** **2.6.1.2 Layout and Identification** **2.6.2 LEVELS** **2.6.3 REFERENCING**

-  **2.6.4 ABBREVIATIONS**
-  **2.6.5 REPRESENTATION OF MATERIALS**
-  **2.6.6 GRAPHICAL SYMBOLS AND REPRESENTATION**
-  **2.6.7 HATCHING RULES**
-  **2.7 APPLICATION FOR BUILDING PERMIT**
 -  **2.7.1 PROCEDURE OF APPLYING FOR PERMISSION TO ERECT A BUILDING**
 -  **2.7.2 FORMULARS**
-  **4. CONTRACT PLANNING AND SITE ORGANISATION**
 -  **4.1 CONTRACT PLANNING**
 -  **4.1.1 BAR CHART**
 -  **4.1.2 NETWORK ANALYSIS**
 -  **4.1.3 THE OVERALL PROGRAMME**
 -  **4.1.3.1 Break down of job**
 -  **4.1.3.2 Quantities of work and time content**
 -  **4.1.3.3 Plant and Labour outputs**
 -  **4.1.3.4 Sequence and timing of operations**
 -  **4.1.3.5 The programme chart**
 -  **4.1.4 PLANNING CONSIDERATIONS**
 -  **4.1.4.1 Site conditions and access**
 -  **4.1.4.2 Nature of job**
 -  **4.1.4.3 Plant**
 -  **4.1.4.4 Scaffolding**

 **4.2 SITE ORGANIZATION** **4.2.1 PRELIMINARY WORK** **4.2.2 SITE PLANNING** **4.2.2.1 Period planning** **4.2.2.2 Weekly planning** **4.2.2.3 Progress control** **4.2.3 SITE LAYOUT** **5. FOUNDATIONS** **5.1 SOIL INVESTIGATIONS** **5.1.1 SITE EXPLORATION** **5.1.1.1 Trial holes** **5.1.1.2 Bore holes** **5.1.1.3 Sampling** **5.1.1.4 Tests** **5.1.1.5 Load or bearing test** **5.1.2 SOILS AND SOIL CHARACTERISTICS** **5.1.2.1 Rocks and soils** **5.1.2.2 Stresses and pressures** **5.2 EXCAVATIONS AND TIMBERING** **5.3 TYPES OF FOUNDATIONS** **5.3.1 CLASSIFICATION** **5.3.2 CHOICE OF FOUNDATION** **5.3.3 SPREAD FOUNDATIONS**

-  **5.3.3.1 Strip foundations**
-  **5.3.3.2 Deep strip foundations**
-  **5.3.3.3 Stepped foundations**
-  **5.3.3.4 Pad foundations**
-  **5.3.3.5 Raft foundations**
-  **5.3.4 PILE FOUNDATIONS**
 -  **5.3.4.1 Short bored pile foundations**
-  **5.3.5 PIER FOUNDATIONS**
-  **6. WALLS**
 -  **6.1 FUNCTION AND PROPERTIES OF WALLS**
 -  **6.2 THE BEHAVIOR OF THE WALL UNDER LOAD**
 -  **6.2.1 CALCULATION OF WALL THICKNESS**
 -  **6.3 TYPES OF WALLS**
 -  **6.4 STONEMWORK**
 -  **6.4.1 BUILDING STONES**
 -  **6.4.2 STONEMWORK THERMINOLOGY**
 -  **6.4.3 STONEMWORK CLASSIFICATION**
 -  **6.4.4 RUBBLE WALLING**
 -  **6.4.5 ASHLAR WALLING**
 -  **6.4.5.1 Rules for ashlar work**
 -  **6.5 BRICK WORK**
 -  **6.5.1 BRICKWORK TERMINOLOGY**
 -  **6.5.2 MANUFACTURE OF CLAY BRICKS**

 **6.5.2.1 Pressed Bricks**

 **6.5.2.2 Wire cut bricks**

 **6.5.2.3 Efflorescence**

 **6.5.3 BRICK CLASSIFICATION**

 **6.5.4 CALCIUM SILICATE BRICKS**

 **6.5.5 CONCRETE BRICKS**

 **6.5.6 MORTARS FOR BRICKWORK**

 **6.5.7 DAMPNES PENETRATION**

 **6.5.8 BRICKWORK BONDING**

 **6.5.8.1 Common bonds**

 **6.5.9 METRIC MODULAR BRICKWORK**

 **6.5.10 JUNCTIONS**

 **6.5.11 QUOINS OR EXTERNAL ANGLES**

 **6.5.12 PIERS**

 **6.5.12.1 Detached piers:**

 **6.5.12.2 Attached Piers (or Pilasters)**

 **6.5.12.3 Buttresses**

 **6.6 BLOCKWORK**

 **6.6.1 CLAY BLOCKS**

 **6.6.2 PRECAST CONCRETE BLOCKS**

 **6.6.3 AERATED CONCRETE BLOCKS**

 **6.7 CONCRETE WALLS**

 **6.7.1 GENERAL**



6.7.2 FOREWORK

6.7.3 PLAIN MONOLITHIC CONCRETE WALL

6.7.3.1 Dense concrete walls

6.7.3.2 Light-weight aggregate

6.7.3.3 No-fines concrete walls

6.7.3.4 Thickness of plain concrete walls

6.7.3.5 Shrinkage reinforcement

6.7.4 REINFORCED CONCRETE WALLS

6.7.4.1 In-Situ Cast external walls

6.7.4.2 Concrete Box Frames

6.7.4.3 Large precast panel structure

6.8 OPENINGS IN WALLS

6.8.1 HEAD

6.8.1.1 Lintels

6.8.1.2 Arches

6.8.2 JAMBS

6.8.3 SILLS AND THRESHOLDS

6.8.3.1 Sills





















6.8.3.2 Thresholds























7. FLOORS

7.1 GENERAL

7.2 SOLID GROUND FLOORS



-  **7.2.1 SITE CONCRETE**
-  **7.2.2 HARDCORE**
-  **7.2.3 WATERPROOF MEMBRANE**
-  **7.3 SUSPENDED TIMBER GROUND FLOOR**
 -  **7.3.1 BUILDING REGULATIONS**
 -  **7.3.2 LAY OUT**
-  **7.4 UPPER FLOORS**
 -  **7.4.1 TYPES OF UPPER FLOORS**
 -  **7.4.2 STRUCTURE OF UPPER FLOORS**
 -  **7.4.3 SUSPENDED TIMBER UPPER FLOORS**
 -  **7.4.3.1 Floor Joists**
 -  **7.4.3.2 End Support of Floor Joists**
 -  **7.4.3.3 Trimming**
 -  **7.4.4 REINFORCED CONCRETE UPPER FLOORS**
 -  **7.4.4.1 Monolithic Reinforced Concrete Upper Floors**
 -  **7.4.4.2 Precast Concrete Upper Floors**
 -  **7.4.4.3 Hollow Block and Waffle Floors**
-  **7.5 FLOOR FINISHES**
 -  **7.5.1 JOINTLESS FLOOR FINISHES**
 -  **7.5.1.1 The most common of these is the Cement/Sand Screed**
 -  **7.5.1.2 Granolithic Concrete Finishes**
 -  **7.5.1.3 Terazzo**
 -  **7.5.2 SLAB FLOORS FINISEHES**

-  **7.5.3 SHEET FLOOR FINISHES**
-  **7.5.4 WOOD FLOOR FINISHES**
-  **8. OPEN FIREPLACES, CHIMNEYS AND FLUES**
 -  **8.1 FUNCTION OF FIREPLACES AND FLUES**
 -  **8.2 PRINCIPLES OF FIREPLACE DESIGN**
 -  **8.2.1 TRADITIONAL OPEN FIREPLACE**
 -  **8.2.2 IMPROVED SOLID FUEL APPLIANCES**
 -  **8.3 PRINCIPLES OF FLUE DESIGN**
 -  **8.4 CONSTRUCTION OF FLUE DESIGN**
 -  **8.4.1 NON-CONVECTOR OPEN FIRES**
 -  **8.4.2 CONVECTOR OPEN FIRES**
 -  **8.5 CONSTRUCTION OF CHIMNEYS**
-  **9. ROOFS**
 -  **9.1 FUNCTIONAL REQUIREMENTS**
 -  **9.1.1 STRENGTH AND STABILITY**
 -  **9.1.2 WEATHER RESISTANCE**
 -  **9.1.3 THERMAL INSULATION**
 -  **9.1.4 FIRE RESISTANCE**
 -  **9.1.5 SOUND INSULATION**
 -  **9.2 TYPES OF ROOF STRUCTURES**
 -  **9.2.1 FLAT AND PITCHED ROOFS**
 -  **9.2.2 STRUCTURE OF THE ROOF**
 -  **9.2.3 LONG AND SHORT SPAN ROOFS**

 **9.2 LONG AND SHORT STRAIGHT ROOFS** **9.3 FLAT ROOFS** **9.3.1 PHYSICAL AND STRUCTURAL PROBLEMS** **9.3.2 STRUCTURE OF A FLAT ROOF** **9.3.3 THERMAL INSULATION MATERIAL** **9.3.4 SINGLE AND DOUBLE FLAT ROOF CONSTRUCTION** **9.3.5 PARAPET WALLS** **9.4 PITCHED ROOFS** **9.4.1 SHAPES OF PITCHED ROOFS IN TIMBER** **9.4.2 TERMS** **9.4.3 TYPES OF PITCHED ROOFS IN TIMBER (STRUCTURES)** **9.4.3.1 Mono-(single) pitched Roof** **9.4.3.2 Lean - to Roof** **9.4.3.3 Couple Roof** **9.4.3.4 Close couple Hoof** **9.4.3.5 Collar Roof** **9.4.3.6 Double or Purlin Roof** **9.4.3.7 Tripple or Trussed Roofs** **9.4.3.8 Trussed Rafters** **9.4.3.9 Hipped Roofs** **9.4.4 VALLEY** **9.4.5 EAVES TREATMENT** **9.4.6 OPENINGS IN TIMBER ROOFS** **9.5 ROOF COVERINGS**

9.5 ROOF COVERINGS

-  **9.5.1 FUNCTION OF ROOF COVERINGS**
-  **9.5.2 TYPES OF ROOF COVERINGS**
-  **9.5.3 SUBSTRUCTURES**
-  **9.5.4 CHOICE OF ROOF COVERINGS**
-  **9.5.5 MATERIALS AND COVERING METHODS**

 **10. FRAMED STRUCTURES**

-  **10.1 STRUCTURAL CONCEPT**
-  **10.2 FUNCTIONAL REQUIREMENTS**
-  **10.3 STRUCTURAL MATERIALS**
-  **10.4 LAYOUT OF FRAMES**
-  **10.5 BUILDING FRAMES**
 -  **10.5.1 FUNCTIONS OF BUILDING FRAME MEMBERS**
 -  **10.5.2 REINFORCED CONCRETE FRAMES**
 -  **10.5.2.1 Reinforced Concrete Beams**
 -  **10.5.2.2 Reinforced Concrete Columns**
 -  **10.5.2.3 Reinforced Concrete Slabs**
 -  **10.5.3 PRECAST CONCRETE FRAMES**
 -  **10.5.3.1 Methods of Connections**
 -  **10.5.4 STRUCTURAL STEELWORK FRAMES**
 -  **10.5.4.1 Structural Steel Frames**
 -  **10.5.4.2 Castellated Universal Sections**
 -  **10.5.4.3 Connections**
 - 



10.5.4.4 Structural Steel Connections



10.5.4.5 Frame Erection



10.5.4.6 Fire Protection of Steelwork



10.5.5 TIMBER FRAMES



10.5.5.1 Columns and Beams



10.5.5.2 Connections



10.5.5.3 Building frames in timber



10.5.5.4 Prefabrication



10.6 PORTAL FRAMES



10.6.1 THEORY



10.6.2 CONCRETE PORTAL FRAMES



10.6.3 STEEL PORTAL FRAMES



10.6.4 TIMBER PORTAL FRAMES



11. PROTECTION OF BUILDINGS



11.1 EXCLUSION OF WATER



11.1.1 PRECIPITATION



11.1.1.1 Roof Drainage



11.1.1.2 Flooding



11.1.1.3 Drought



11.1.2 DAMP RISING AND MOISTURE MIGRATION



























11.1.3 CONDENSATION



11.2 THERMAL INSULATION



11.2.1 DEFINITION

-  **11.2.1 DEFINITION**
-  **11.2.2 INSULATING MATERIALS**
-  **11.3 SOUND INSULATION**
 -  **11.3.1 DEFINITION**
 -  **11.3.2 SOUND INSULATION**
 -  **11.3.3 EXTERNAL NOISE**
-  **11.4 FIRE PROTECTION**
 -  **11.4.1 STRUCTURAL FIRE PROTECTION**
 -  **11.4.1.1 Fire Load**
 -  **11.4.1.2 Fire Resistance of Material**
 -  **11.4.1.3 Appropriate Types of Construction**
-  **12. FINISHING & FINISHES**
 -  **12.1 EXTERNAL WALL FINISHES**
 -  **12.1.1 EXTERNAL RENDERING**
 -  **12.1.2 CONCRETE FINISHES**
 -  **12.1.3 CLADDING**
 -  **12.1.3.1 CLADDINGS FIXED TO A STRUCTURAL BACKING**
 -  **12.1.3.2 CLADDINGS TO FRAMED STRUCTURES**
 -  **12.1.4 EXTERNAL PAINTS AND FINISHES**
 -  **12.2 INTERNAL WALL FINISHES**
 -  **12.2.1 PLASTERING**
 -  **12.2.2 OTHER INTERNAL WALL FINISHES**
 -  **12.2.3 PAINTING**
 -  **12.3 CEILING FINISHES**

 **12.3 CEILING FINISHES** **13. STAIRS** **13.1 INTRODUCTION** **13.2 DEFINITION OF TERMS** **13.3 TYPES OF STAIRS** **13.4 DESIGN OF STAIRS** **13.4.1 RISE - TREAD - PROPORTION** **13.4.2 SLOPE OR PITCH** **13.4.3 LANDINGS** **13.4.4 WIDTH** **13.4.5 WALKING LINE** **13.5 CONSTRUCTION OF STAIRS** **13.5.1 BRICK STAIRS** **13.5.2 STONE STAIRS** **13.5.3 CONCRETE STAIRS** **13.5.3.1 In Situ Cast R.C. Stairs** **13.5.3.2 Precast Concrete Stairs** **13.5.4 TIMBER STAIRS** **13.5.5 METAL STAIRS** **13.6 MISCELLANEOUS** **13.6.1 BALUSTRADES/HANDRAILS** **13.6.2 'SAMBA' STAIR, LADDERS, DISAPPEAR STAIRS, RAMPS** **13.6.3 ESCALATORS** **14 DOORS & WINDOWS**

 **14. DOORS & WINDOWS** **14.1 DOORS** **14.1.1 EXTERNAL DOORS** **14.1.2 INTERNAL DOORS** **14.1.3 PURPOSE MADE DOORS** **14.1.4 METHODS OF CONSTRUCTION** **14.1.4.1 Door terminology** **14.1.4.2 Panelled and glazed wood doors** **14.1.4.3 Flush doors** **14.1.4.4 Fire-check flush doors** **14.1.4.5 Matchboarded doors** **14.1.5 FRAMES AND LININGS** **14.1.5.1 Timber Door Frames** **14.1.5.2 Metal door frames** **14.1.5.3 Door linings** **14.1.6 SPECIAL DOORS** **14.2 WINDOWS, GLASS & GLAZING** **14.2.1 PRIMARY FUNCTIONS OF WINDOWS** **14.2.2 BUILDING REGULATIONS** **14.2.3 TRADITIONAL CASEMENT WINDOWS** **14.2.4 STANDARD WOOD CASEMENT WINDOWS** **14.2.5 STEEL CASEMENT WINDOWS** **14.2.6 BAY WINDOWS**

**14.2.7 SLIDING SASH WINDOWS** **14.2.7.1 Vertical sliding windows (also called double hung sash windows)** **14.2.7.2 Horizontal sliding windows** **14.2.8 PIVOT WINDOWS** **14.2.9 LOUVRES** **14.2.10 GLASS AND GLAZING** **14.2.10.1 Glass** **14.2.10.2 Glazing** **14.2.11 MOSQUITO SCREENING (FLY SCREENS)** **14.2.12 SUN-BREAKERS** **14.3 IRON MONGERY** **14.3.1 HINGES** **14.3.2 LOCKS AND LATCHES** **14.3.3 MISCELLANEOUS****4. CONTRACT PLANNING AND SITE ORGANISATION**

| | | |
|---------------------------|--|---------------------------------------|
| 4. CONTR. PLANNING | | BUILDING CONSTR. |
| compiled: D. VOLKE | | --- LECTURE --- |
| MAY '83 | | |
| TCA | TECHNICAL COLLEGE ARUSHA CHUO CHA UFUNDI ARUSHA | CIVIL ENGINEER. DEPARTMENT |

REFERENCES:

1. Jack Stroud Foster
MITCHELL'S BUILDING CONSTRUCTION
"Structure and Fabric"
Part 1 and 2

W. G. Nash
"Brickwork 3 "

R. Chudley
"Construction technology"
Volume 2 and 4

R. L. Fullerton
"Building Construction in Warm Climates"
Volume 1 and 2

Buildings, and consequently their construction, have become more and more complex and the proper management of a contract as well as the control of cost (on the part of the architect at design stage and the contractor during erection) are more than essential.

Because mechanisation of building operations and the use of expensive plant has increased, the contractor must obtain maximum use of the plant and speed the construction of the job in order to keep his costs to a minimum. The design/erection continuum must be seen as a production process from inception to completion and there must be a programme on which the job may be organized, against which performance may be assessed and within which control may be exercised.

Contract planning and site organization, together with general control are the construction aspects of production management which itself is a part of overall management in building.

PLANNING makes efficient and economical use of labour, machines and materials.

ORGANIZATION is the means of delegating tasks

CONTROL enables planning and organization to be effective.

4.1 CONTRACT PLANNING

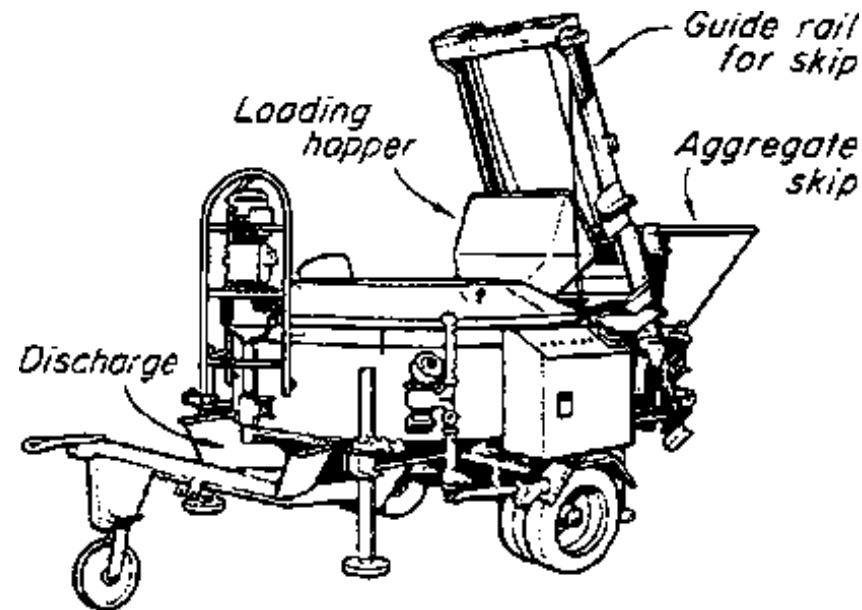

A Turbo-mixer

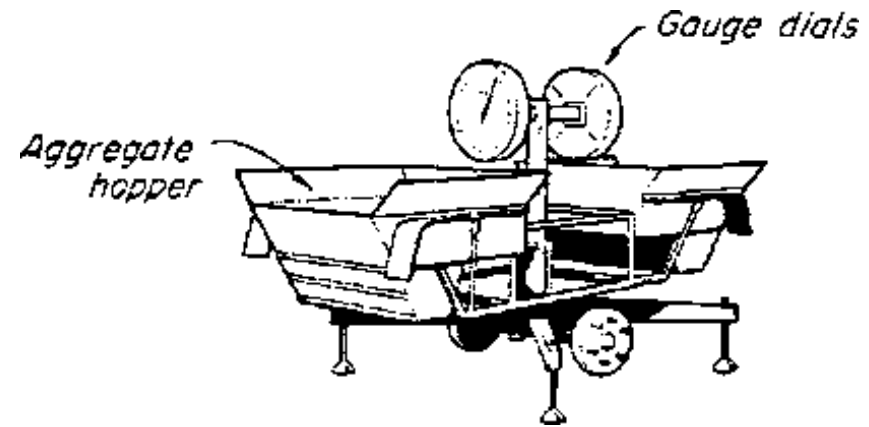

B Independent weightbatcher

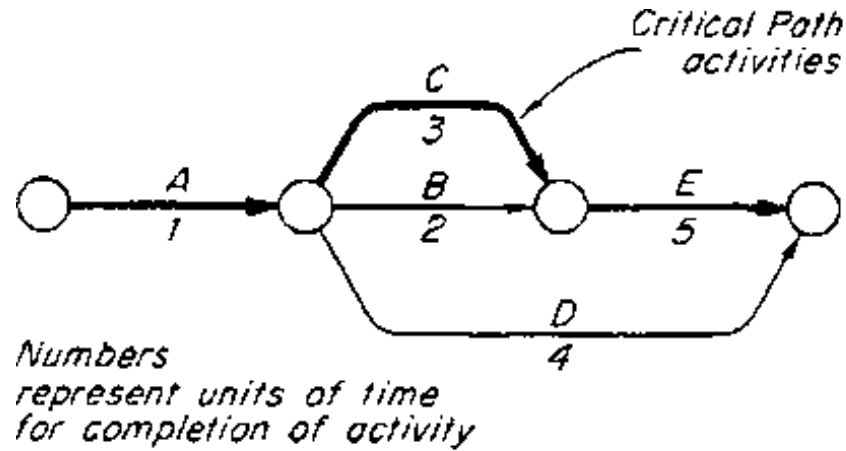

Dependencies:

E is dependent on activities C, B and A being completed
C and B are dependent on A being completed
D is dependent on A being completed

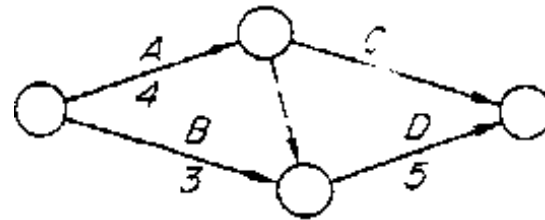

| | |
|---|---|
| A | 4 |
| B | 3 |
| C | 1 |
| D | 5 |

Duration

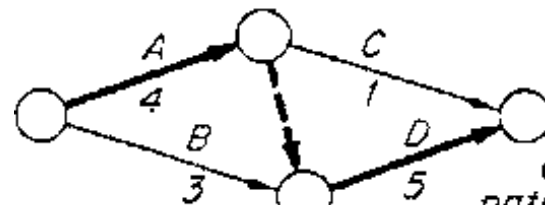

— shows the Critical Path – longest path through the network

Contract Planning involves working out a PLAN OF CAMPAIGN or PROGRAMME for the contract as a whole and assembling the necessary data.

Such a programme is to promote the flow of the various building operations during the course of erection, by planning in advance

- the times and sequences of all operations**
- the requirements in labour**
- the requirements in materials**
- the requirements in equipment.**

The BUILDING RESEARCH STATION DIGEST 91 states that such a programme should:

- a) show the quickest and cheapest method of carrying out the work consistent with the available resources of the builder.**
- b) by the proper phasing of operations with balanced labour gangs in all trades, ensure continuous productive work for all the operatives employed and reduce unproductive time to a minimum.**
- c) provide an assessment of the level of productivity in all trades**
- d) determine attendance dates, and periods for all subcontractor's work**
- e) provide information on material quantities and essential delivery dates, the quantity and capacity of the plant required and the periods it will be on site.**
- f) provide, at any time during the contract, a simple and rapid method of measuring progress for**

the builders information for the architect's periodical, for the valuation of work for accounting purposes.

If a builders tender is to be realistic, planning must start at the estimating stage.

The following considerations should be taken into account:

- use of the most economic methods for each operation**
- sequence and timing of the operations**
- resources at the contractors disposal**
- use of hand or mechanical methods, type of plant**
- space available and best positions for the various machines to be used.**
- the best methods of handling material and most suitable places on the site for the storage of materials and for the placing of hut**
- suitable points of access to the site for lorries and machines.**

4.1.1 BAR CHART

A typical site orientated control device is the GANTT CHART or BAR CHART which allows a fairly simple and easily read plan of operations to be made available to all site personnel against which may be plotted actual performances. However, this device only takes into account one of the resources - TIME - and unless further schedules of the resources needed for each operation are also available (adjacent at the BAR CHART) it does not inform on the critical relationships between the various activities nor does it

enable procedures involving a number of variables to be optimised since the complex interrelationships affecting the outcome of any plan (or alteration of plan) are not readily evident or quantifiable. (see fig.)

This can be achieved by means of a technique known as NETWORK ANALYSIS.

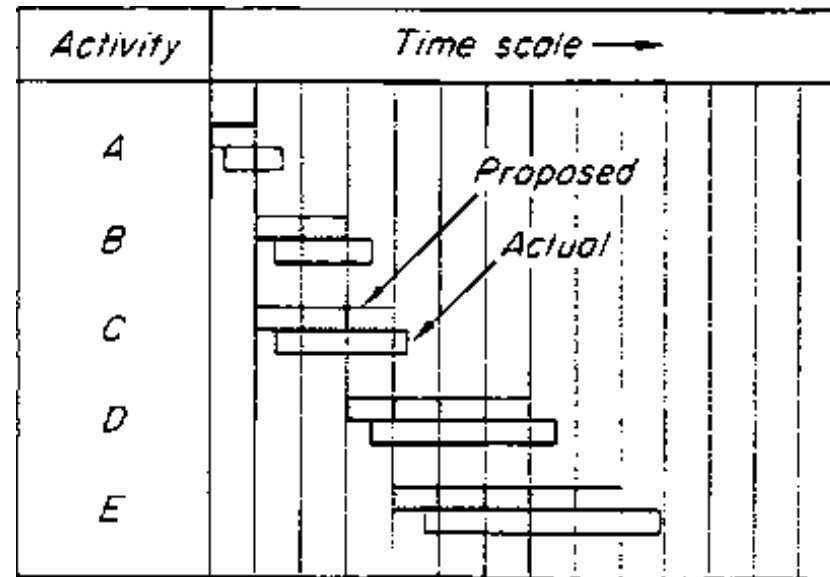

4.1.2 NETWORK ANALYSIS

The essential difference between analysing a production problem by NETWORK and LINEAR or PARALLEL LINEAR methods lies in the identification of the dependency between operation.

This approach leads to interrelated networks through which certain sequences can be seen to be 'critical' to the anticipated outcome in that they occupy the longest and irreducible time necessary to execute the project (or parts of the project) to which they are necessary.

The fig. shows this in a simple set of 5 interrelated activities A, B, C, D, E of time values 1,2,3,4 and 5 days.

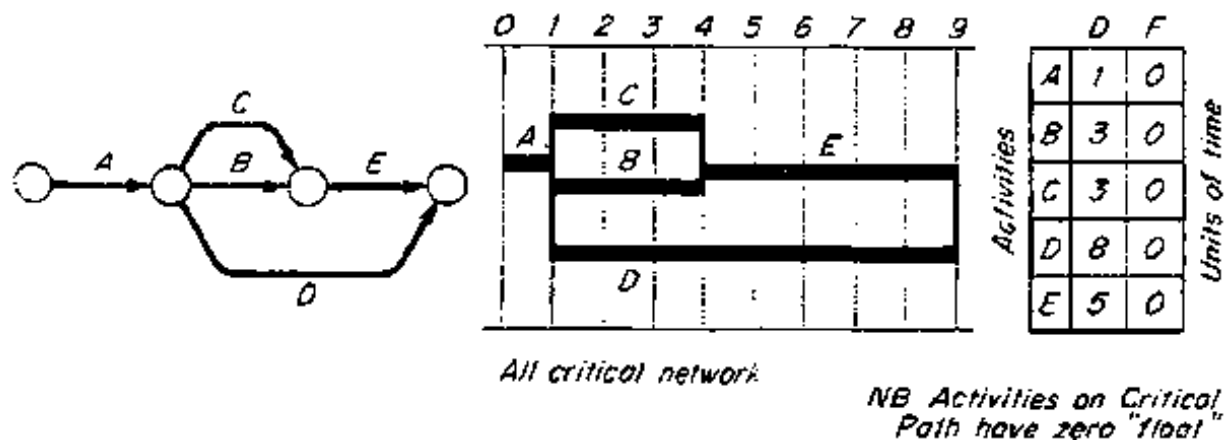
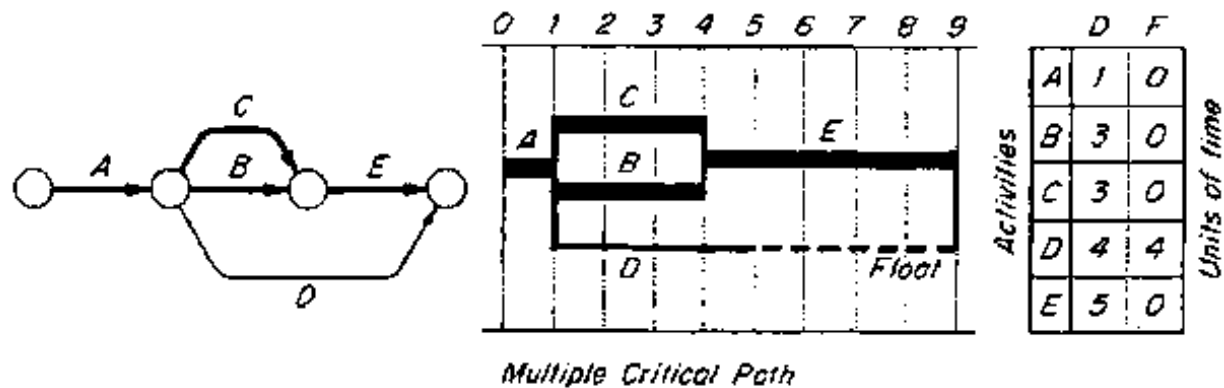
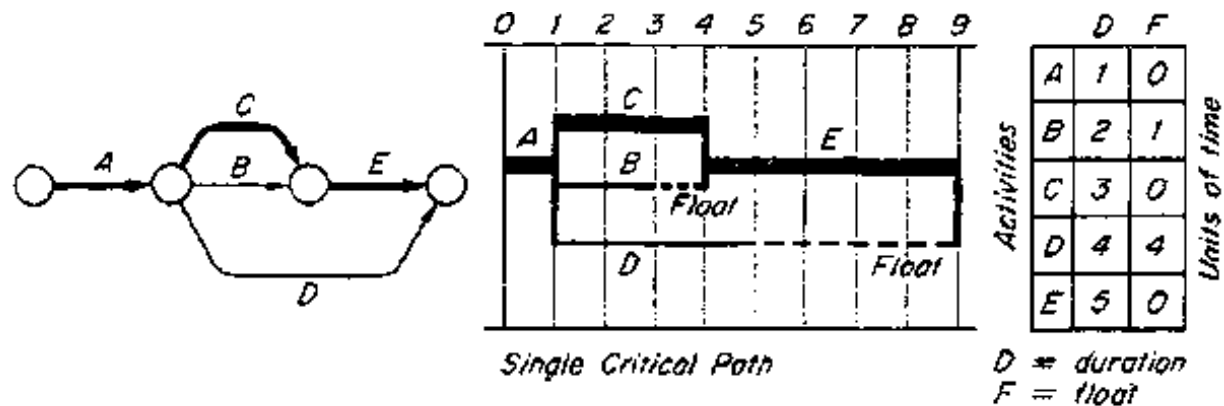

Network or Critical Path diagrams

The way how to prepare a NETWORK in the form of an ARROW DIAGRAM is described in the following:

1) Project to be broken down into a series of stages (or elements of work) called **ACTIVITIES** represented by **ARROWS** (Length not important).

Head of arrow = finish of activity

2) Any junctions of activities are called **EVENTS** represented by **CIRCLES**.

An event indicates the completion of one activity and the start of the next (except first and last!)

3) Example: 5 operations carried out continuously:



4) Each activity may be identified by the numbers of the beginning and end as follows:

Activity Identity

| | |
|----------|------------|
| A | 1-2 |
| B | 2-3 |
| C | 3-4 |
| D | 4-5 |
| E | 5-6 |

5) If these 5 operations had been started and finished at the same time, it is not convenient to show them as follows:

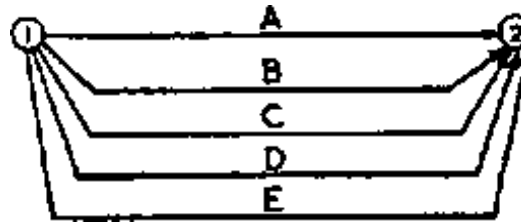

because each has the same identity.

Therefore, to give each a separate identity, DUMMY ACTIVITIES must be introduced (dotted lines)

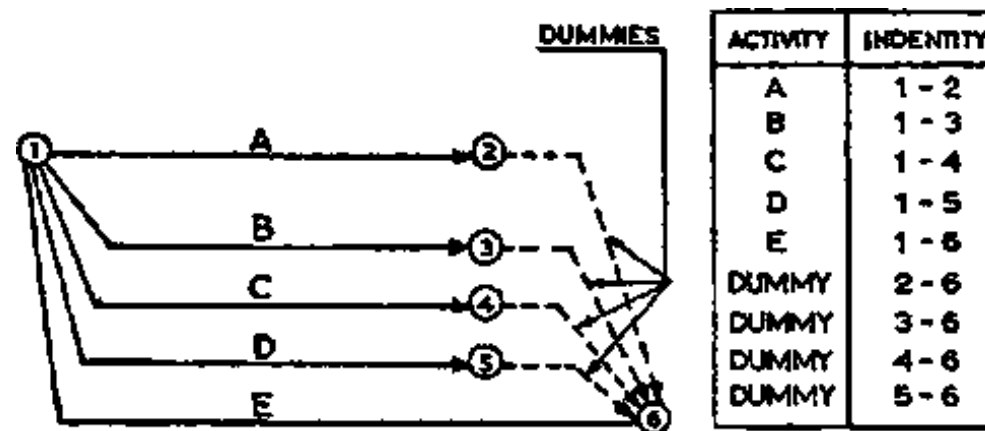

A dummy arrow has no duration and shows only the logical relationship which cannot be shown by activity arrows (no time, no resources, they have only transfer information from one event to another) Arrows should always be identified by ascending order of numbers (lower number: the tail, higher number: the head).

6) Which questions should be asked, when setting out an arrow diagram for a project?

- what controls the start of each activity?
- what controls its finish or end?
- what job or jobs must be done before the next activity can be started?

- d) what jobs must follow the activity?
e) what jobs can run concurrently?

7) Examples (should be thoroughly understood)

1 Activity X depends upon activity

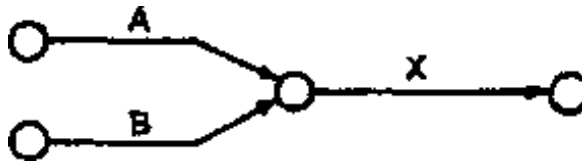

2 Activity X and Y depend upon activities A and B

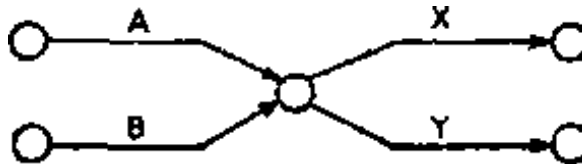

3 Activity X depends upon activities A and B and activity Y depends upon B only

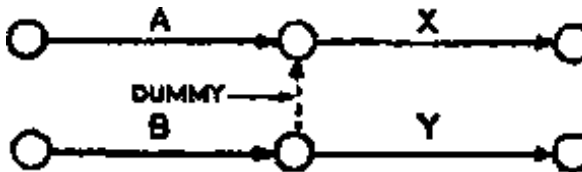

4 Activity Y depends upon activities A and B and activity X depends upon A only

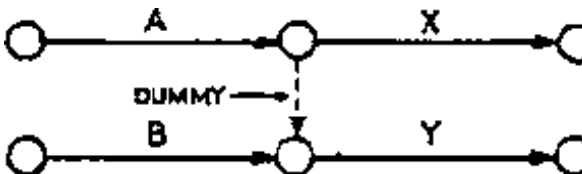

5 Activity X depends upon A and B and activity Y depends upon B and C

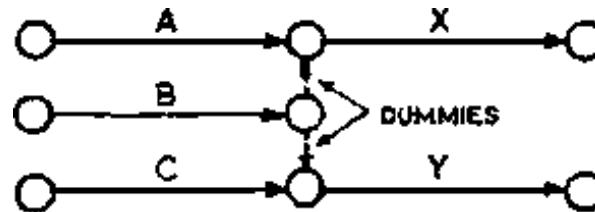

6 Activity X depends upon activities A and B, activity Z depends upon activities B and C and activity Y depends upon B only

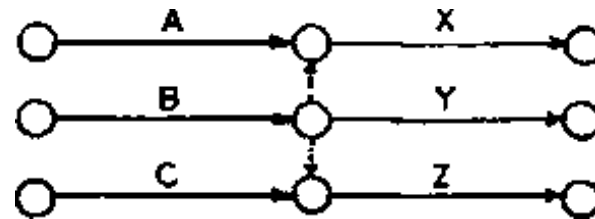

7 Activity Z depends upon activities A, B, C, activity X upon A only and activity Y upon A and B

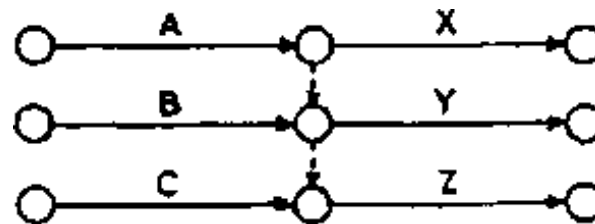

8 Activity Y depends upon activities A, B, C, activity X depends upon A only and activity Z depends upon activity C only

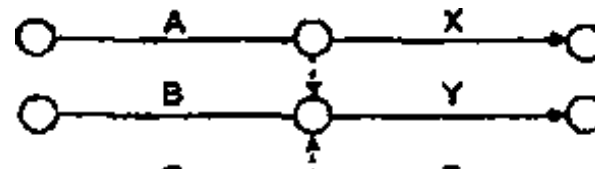



9 Activity X depends upon activity A, activity Y depends upon activities A and B and activity Z depends upon activities B and C

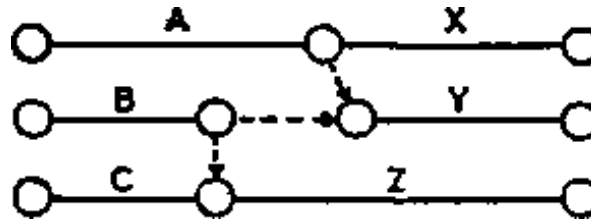

8) Example: Erecting a corner

Activities:

- 1 raise scaffold
- 2 deliver bricks from stack to scaffold
- 3 place mortar boards
- 4 mix mortar
- 5 deliver mortar to scaffold
- 6 build corner

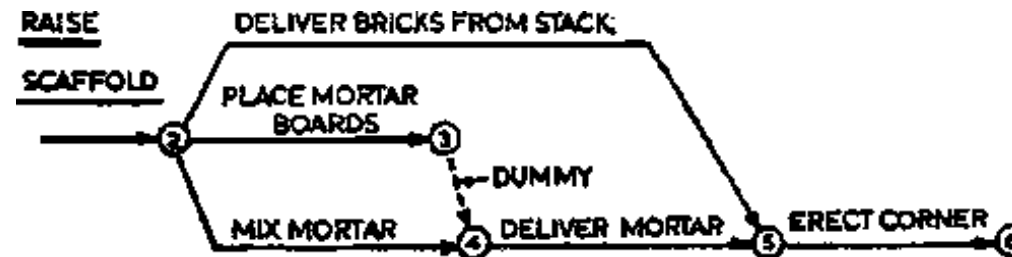

9) The time element

We have so far been concerned only with the placing of the activities in a logical order.

Now the time element has to be considered, and to be applied to the network, in order to obtain the **EVENT TIMES** and the **TOTAL PROJECT TIME**.

- The duration of the activities should be written under each arrow.

these items must be very carefully estimated

(according to the work content contained within each activity) otherwise the network would not be of any value.

10) Earliest starting times

When the durations of the activities have been entered, the times of starting and finishing the events can be calculated. The earliest times for starting and finishing activities can be found by adding the duration of each activity to the finishing time of the previous activity. Begin at 0 with the first activity and calculate each path separately. Where two or more paths meet at an event or node, the longer or longest total time must be taken as the earliest starting time to the next activity.

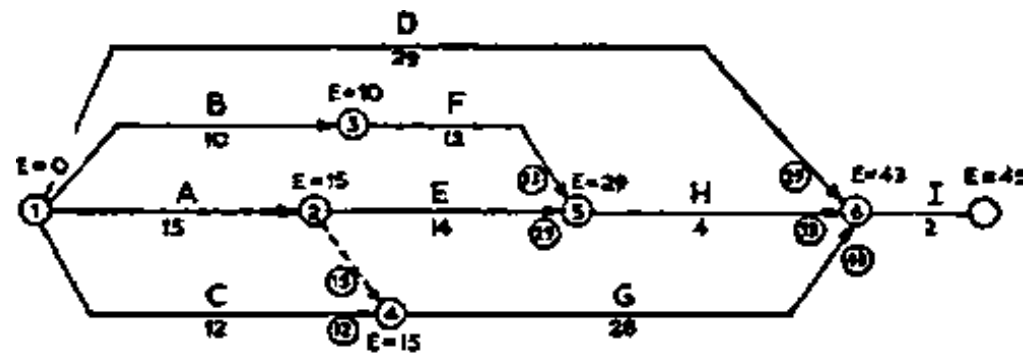

E = Earliest starting time

| | ACTIVITY | DURATION | START | FINISH |
|----------|------------|----------------|-----------|-----------|
| A | 1-2 | 15 days | 0 | 15 |
| B | 1-3 | 10 days | 0 | 10 |
| C | 1-4 | 12 days | 0 | 12 |
| D | 1-6 | 29 days | 0 | 29 |
| | 2-4 | dummy | 15 | 15 |
| E | 2-5 | 14 days | 15 | 29 |
| F | 3-5 | 13 days | 10 | 23 |
| G | 4-6 | 28 days | 15 | 43 |
| H | 5-6 | 4 days | 29 | 33 |
| I | 6-7 | 2 days | 43 | 45 |

11) Latest starting times

This is a similar analysis carried out only in a reverse direction, which means beginning at the last event time and working backwards by deducting the activity time from the end event time. Where two or more paths meet at an event, the shorter or shortest time is adopted for the calculation of the latest starting time. The total times for each path have been indicated by the figures in circles, and it will be seen that the highest figures have been taken in each case.

12) Latest finishing times

The times for each path have been shown in circles as before, but this time the lowest figure have been used in each case. It is most important that the dummy activity is taken into account when calculating the earliest starting and latest finishing times. These times could have been analysed as before, but in this case the calculating is started at the bottom of the table and the durations are deducted from the latest finishing times.

| | | | LATEST | |
|-------------------|----------|----------|--------|--------|
| | ACTIVITY | DURATION | START | FINISH |
| A | 1-2 | 15 days | 0 | 15 |
| B | 1-3 | 10 days | 16 | 26 |
| C | 1-4 | 12 days | 3 | 15 |
| D | 1-6 | 29 days | 14 | 43 |
| | 2-4 | dummy | 15 | 15 |
| E | 2-5 | 14 days | 25 | 39 |
| F | 3-5 | 13 days | 26 | 39 |
| G | 4-6 | 28 days | 15 | 43 |
| H | 5-6 | 4 days | 39 | 43 |
| I | 6-7 | 2 days | 43 | 45 |
| start here | | | | |

The two tables can now be combined as follows

| | ACTIVITY | DURATION | EARLIEST | | LATEST | |
|---|----------|----------|----------|--------|--------|--------|
| | | | START | FINISH | START | FINISH |
| A | 1-2 | 15 days | 0 | 15 | 0 | 15 |
| B | 1-3 | 10 days | 0 | 10 | 16 | 26 |
| C | 1-4 | 12 days | 0 | 12 | 3 | 15 |
| D | 1-6 | 29 days | 0 | 29 | | 43 |
| | 2-4 | dummy | 15 | 15 | 15 | 15 |
| E | 2-5 | 14 days | 15 | 29 | 25 | 39 |
| F | 3-5 | 13 days | 10 | 23 | 26 | 39 |
| G | 4-6 | 28 days | 15 | 43 | 15 | 43 |
| H | 5-6 | 4 days | 29 | 33 | 39 | 43 |
| I | 6-7 | 2 days | 43 | 45 | 43 | 45 |

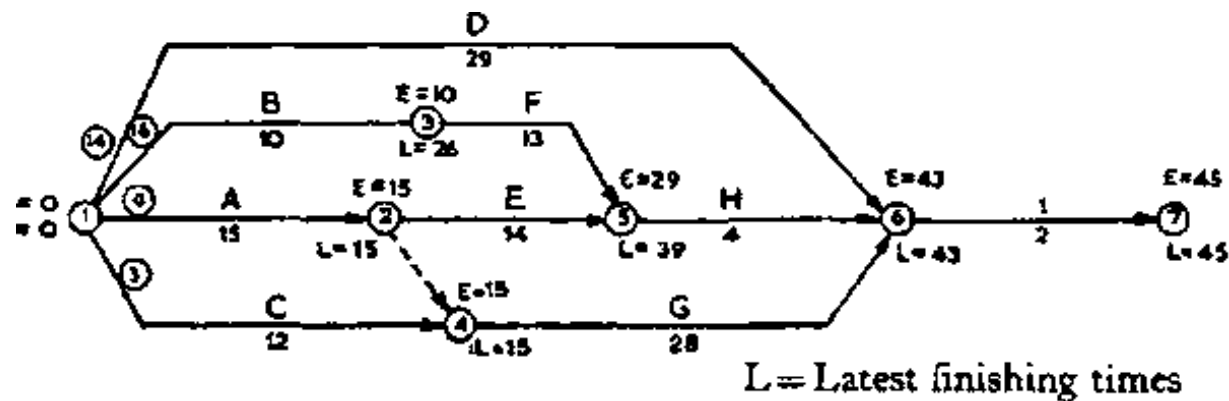

13) Floating times

From the diagrams and the analyses it will be seen that, if the earliest starting times are deducted from the latest finishing times, some activities have a greater length of time available for carrying out the activity than the work content requires. The spare time in each case is called the total float.

The total float for each activity is calculated as follows: Latest finishing time - earliest starting time - duration of the activity.

14) Critical path

Where there is a zero float against an activity, this activity will be a critical item. This means that such an item must not be delayed otherwise it will delay the whole project. These activities will form a continuous chain through the network, and this chain is called **CRITICAL PATH** in a network.

The critical path includes the dummy activity. All of the other activities have longer times than the durations need.

Besides **TIME** (as the main planner's parameter) other factors such as **COST**, **LABOUR** and **MATERIAL AVAILABILITY**, the **DEMAND** of other Projects under the planner's control will affect the final assessment of times to be ascribed to the constituent activities of network.

| | | | EARLIEST | | LATEST | | TOTAL |
|---|----------|----------|----------|--------|--------|--------|-------|
| | ACTIVITY | DURATION | START | FINISH | START | FINISH | FLOAT |
| A | 1-2 | 15 days | 0 | 15 | 0 | 15 | 0 |
| B | 1-3 | 10 days | 0 | 10 | 16 | 26 | 16 |

| | | | | | | | |
|---|-----|---------|----|----|----|----|----|
| C | 1-4 | 12 days | 0 | 12 | 3 | 15 | 3 |
| D | 1-6 | 29 days | 0 | 29 | 14 | 43 | 14 |
| | 2-4 | dummy | 15 | 15 | 15 | 15 | 0 |
| E | 2-5 | 14 days | 15 | 29 | 25 | 39 | 10 |
| F | 3-5 | 13 days | 10 | 23 | 26 | 39 | 16 |
| G | 4-6 | 28 days | 15 | 43 | 15 | 43 | 0 |
| H | 5-6 | 4 days | 29 | 33 | 39 | 43 | 10 |
| I | 6-7 | 2 days | 43 | 45 | 43 | 45 | 0 |

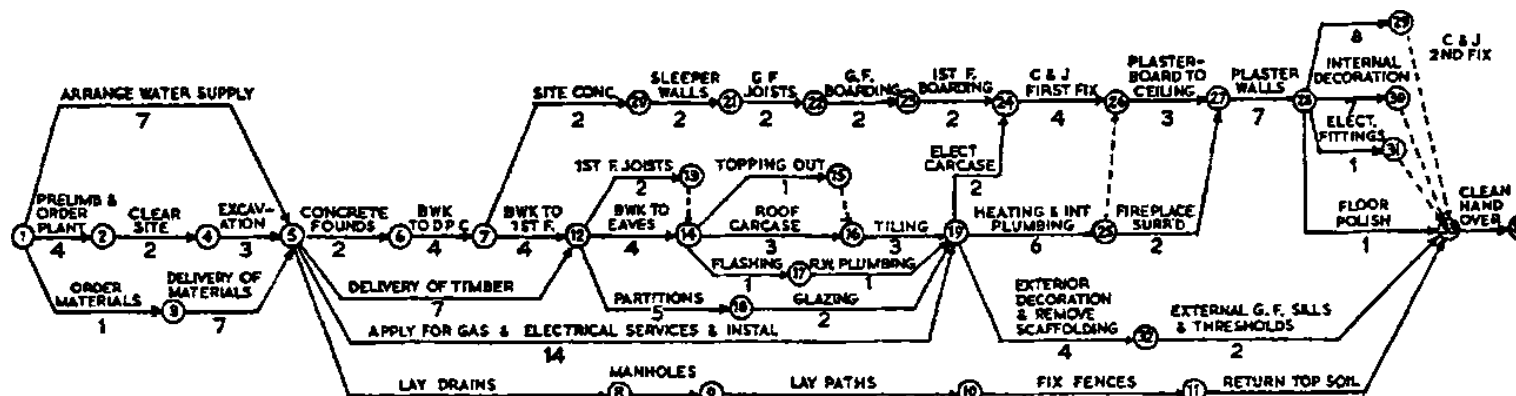
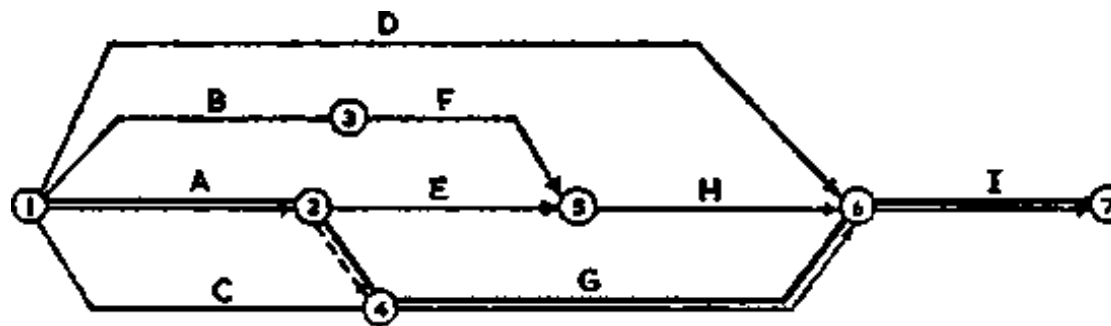

5 5 4 4 2

DURATION OF ACTIVITIES IN DAYS

| | | | EARLIEST | | LATEST | | TOTAL |
|-----------------------------|------|----------|----------|--------|--------|--------|-------|
| ACTIVITY | NO. | DURATION | START | FINISH | START | FINISH | FLOAT |
| Prelims and order plant | 1-2 | 4 days | 0 | 4 | 0 | 4 | 0* |
| Order material | 1-3 | 1 day | 0 | 1 | 1 | 2 | 1 |
| Arrange water supply | 1-5 | 7 days | 0 | 7 | 2 | 9 | 2 |
| Clear site | 2-4 | 2 days | 4 | 6 | 4 | 6 | 0* |
| Delivery of materials | 3-5 | 7 days | 1 | 8 | 2 | 9 | 1 |
| Excavation | 4-5 | 3 days | 6 | 9 | 6 | 9 | 0* |
| Concrete foundations | 5-6 | 2 days | 9 | 11 | 9 | 11 | 0* |
| Lay drains | 5-8 | 5 days | 9 | 14 | 32 | 37 | 23 |
| Delivery of timber | 5-12 | 7 days | 9 | 16 | 12 | 19 | 3 |
| Gas and electrical services | 5-19 | 14 days | 9 | 23 | 15 | 29 | 6 |
| Bwk up to d.p.c. | 6-7 | 4 days | 11 | 15 | 11 | 15 | 0* |
| Bwk to 1st floor level | 7-12 | 4 days | 15 | 19 | 15 | 19 | 0* |
| Site concrete | 7-20 | 2 days | 15 | 17 | 21 | 23 | 6 |
| Manholes | 8-9 | 5 days | 14 | 19 | 37 | 42 | 23 |
| Lay paths | 9-10 | 4 days | 19 | 23 | 42 | 47 | 23 |

| | | | | | | | |
|--------------------------------------|--------------|---------------|-----------|-----------|-----------|-----------|-----------|
| Fix fences | 10-11 | 4 days | 23 | 27 | 47 | 51 | 24 |
| Return top-soil | 11-33 | 2 days | 27 | 29 | 51 | 53 | 24 |
| 1st floor joists | 12-13 | 2 days | 19 | 21 | 25 | 27 | 6 |
| Bwk to eaves | 12-14 | 4 days | 19 | 23 | 19 | 23 | 0* |
| Partitions. | 12-18 | 5 days | 19 | 24 | 22 | 27 | 3 |
| Dummy | 13-14 | | 21 | 21 | 27 | 27 | 6 |
| Topping out | 14-15 | 1 day | 23 | 24 | 25 | 26 | 2 |
| Roof carcase | 14-16 | 3 days | 23 | 26 | 23 | 26 | 0* |
| Flashings | 14-17 | 1 day | 23 | 24 | 27 | 28 | 4 |
| Dummy | 15-16 | | 24 | 24 | 26 | 26 | 2 |
| Tiling | 16-19 | 3 days | 26 | 29 | 26 | 29 | 0* |
| R.W. plumbing | 17-19 | 1 day | 24 | 25 | 28 | 29 | 4 |
| Glazing | 18-19 | 2 days | 24 | 26 | 27 | 29 | 3 |
| Electrical carcase | 19-24 | 2 days | 29 | 31 | 29 | 31 | 0* |
| Heating and internal plumbing | 19-25 | 6 days | 29 | 35 | 29 | 35 | 0* |
| External decorate, etc. | 19-32 | 4 days | 29 | 33 | 47 | 51 | 18 |
| Sleeper walls | 20-21 | 2 days | 17 | 19 | 23 | 25 | 6 |
| G.F. floor joists | 21-22 | 2 days | 19 | 21 | 25 | 27 | 6 |

| | | | | | | | |
|--|--------------|---------------|-----------|-----------|-----------|-----------|-----------|
| G.F. floor boards | 22-23 | 2 days | 21 | 23 | 27 | 29 | 6 |
| 1st F. floor boards | 23-24 | 2 days | 23 | 25 | 29 | 31 | 6 |
| C & J 1st fixing | 24-26 | 4 days | 31 | 35 | 31 | 35 | 0* |
| Dummy | 25-26 | | 35 | 35 | 35 | 35 | 0* |
| Fireplace surround | 25-27 | 2 days | 35 | 37 | 36 | 38 | 1 |
| Plasterboard to ceilings | 26-27 | 3 days | 35 | 38 | 35 | 38 | 0* |
| Plaster to walls | 27-28 | 7 days | 38 | 45 | 38 | 45 | 0* |
| C & J 2nd fixing and fittings | 28-29 | 8 days | 45 | 53 | 45 | 53 | 0* |
| Internal decoration | 28-30 | 7 days | 45 | 52 | 46 | 53 | 1 |
| Electrical fittings | 28-31 | 1 day | 45 | 46 | 52 | 53 | 7 |
| Polish floors | 28-33 | 1 day | 45 | 46 | 52 | 53 | 7 |
| Dummy | 29-33 | | 53 | 53 | 53 | 53 | 0* |
| Dummy | 30-33 | | 52 | 52 | 53 | 53 | 1 |
| Dummy | 31-33 | | 46 | 46 | S3 | 53 | 7 |
| Ext. G.F. sills and thresholds | 32-33 | 2 days | 33 | 35 | 51 | 53 | 18 |
| Clean and hand over | 33-34 | 2 days | 53 | 55 | 53 | 55 | 0* |

15) Time/cost optimisation

This technique explores the possibilities of altering production time in order to optimise the costs.

In building work:

increased speed of production leads to increased cost (due to having to use more operatives, and/or machinery, or to pay high rates).

Any reduction of the activity times on the critical path will reduce the overall production time, but will probably reduce the 'float' on other activities to the point that they also become critical (case 1)
Activities A, B, C, D, E are given to be carried out in 'normal' times shown in column X. Activities A, C, and E are capable of being carried out by different means at 'crash' times for increased rates shown in column Y. It is then possible to define three basic outcomes from the application of these figures: normal cost programme (case 1) all 'crash' programme (case 5) best time/least cost programme (case 4)

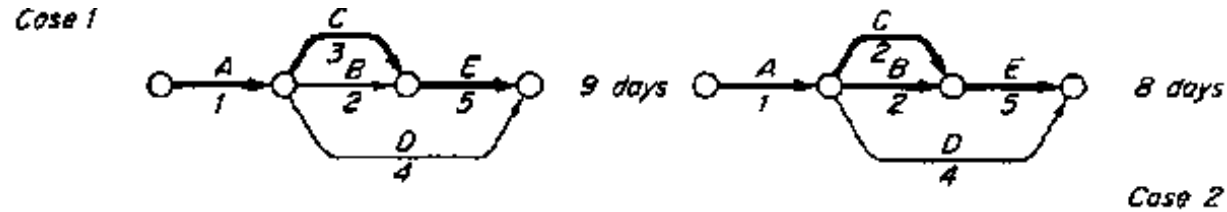

Cost data

| Activity | Dur'n | Cost | Dur'n | Cost | CC |
|----------|-------|------|-------|------|----|
| A | 1 | 120 | 1/2 | 200 | CC |
| B | 2 | 80 | 2 | 80 | |
| C | 3 | 100 | 2 | 150 | CC |
| D | 4 | 60 | 4 | 60 | |
| E | 5 | 200 | 3 | 300 | CC |

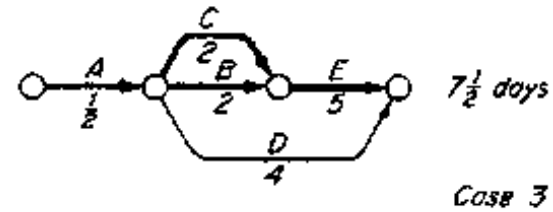

CC = crash costs

I.C. = rate of Indirect Costs - 70 00 per day

| Activity | Duration (days) | | | | |
|----------|-----------------|------|-------|------|-------|
| | 9 | 8 | 7 1/2 | 6 | 5 1/2 |
| A | 120 | 120 | 200 | 120 | 200 |
| B | 80 | 80 | 80 | 80 | 80 |
| C | 100 | 150 | 150 | 150 | 150 |
| D | 60 | 60 | 60 | 60 | 60 |
| E | 200 | 200 | 200 | 300 | 300 |
| I.C. | 630 | 560 | 525 | 420 | 385 |
| Totals | 1190 | 1170 | 1215 | 1130 | 1175 |

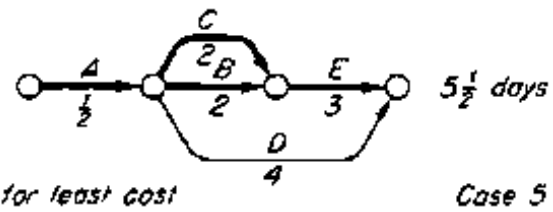
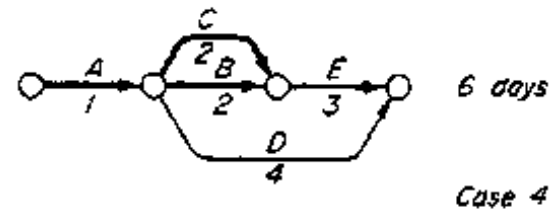

Summary of cases 1-5

Best time for least cost

Time-cost optimisation

16) Resource leveling and control This technique enables a planner to assess the requirements of various resources to serve any given network of activities and to utilise 'float' in uncritical activities to

~~various resources to serve any given network of activities and to determine that in identical activities to~~
optimise his use of resources or to reduce imbalances of resource demand.

- The technique ascribes the various resources to each activity and by comparison with established norms identifies excessive demands.
- It is possible to reposition activities requiring excessive use of resources and to balance the total requirements within the resources available or at least to reduce the time of excessive demand.
- The repositioning of certain activities will often render them critical when they are taken together with fixed waiting periods necessary to the planned use of resources.

This technique is illustrated in fig.

The network A (i) yields the scaled network in bar chart form A(ii) By allocating the resource units - RU's - for each activity, a resource loading diagram (A(iii)) can be prepared.

In this case it shows an executive demand of four RU's above the resource units normally available during the second and third days, due to activities B and D coming together.

B (i) shows the repositioning of activities B and D in the excess times available for their execution and a resulting 'leveling' of the loading diagram to bring the requirements for resources within the limits of normal availability as in B (ii).

This maneuver involves specific positioning of waiting periods B_1 and D_1 and examination of the resulting network at C shows that these constrains on the commencement of activities B_2 and D_2 leads to the former becoming critical and reduces the float of the latter to one day only.

The foregoing brief description of some of the uses of network analysis has been based on a simplified

description of the network involved. For further informations one of the many books dealing specially with these techniques should be consulted.

The most useful aspect of network analysis lies in exercising the logic used to set up the basic network of activities since the planner has a full knowledge of the practical consequences of any sequence of activities and the importance of their relationships. This aspect of a network approach to planning is illustrated in the method of presentation of the logic known as a Precedence Diagram. The fig. shows a typical network restated in this form which eliminates the need for dummy activities normally used in conventional networks to indicate dependency.

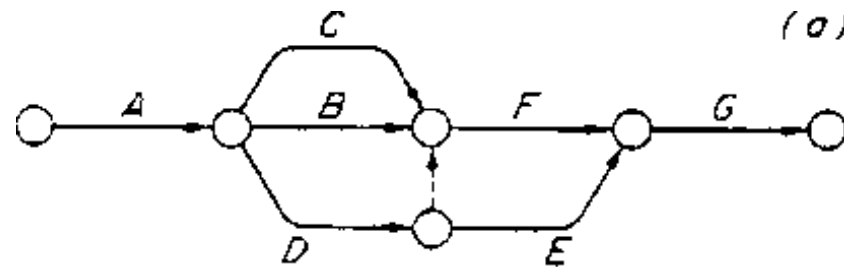

Dependencies:

C, B and D depend on A being completed

F depends on B, C and D being completed

E depends on D being completed

G depends on F and E being completed

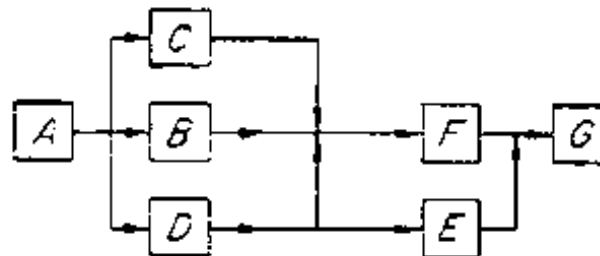

Precedence diagram

(b)

4.1.3 THE OVERALL PROGRAMME

On acceptance of the tender a **WORKING** or **OVERALL PROGRAMME** is prepared by the contractor's planning staff together with the plant engineers and the site agent or foreman for the job. This will be used as a guide for:

- **site activities**
- **detailed planning**
- **purchasing and delivering of materials**
- **coordination of sub-contractors and main contractors work**
- **assessing job progress**

At this point it is essential to have full information from the architect in the form of

- **site survey**
- **a full set of working drawings**
- **specifications**
- **bills of quantities and**
- **a full list of all nominated sub contractors.**

The preparation of the overall programme consists broadly of

- **breaking the job down into a series of basic operations involving only one trade.**
- **establishing the quantities of work in each operation and the time content of each in terms of men and machines.**
- **arranging the operations in a sequence and balancing the size of gangs to give a maximum**

continuity of work for each trade

- **breaking down a large job into phases so that several operations may proceed simultaneously.**

The programme is usually expressed in the form of a chart, covering

- **all main operations throughout the contract**
- **the phasing of the work**
- **the duration of each operation**

Together with this chart a written report or schedule has to be prepared including

- **the methods to be used**
- **a schedule of plants**
- **the labour requirements**
- **informations regarding site offices, storage huts, equipment, and small tolls.**

Besides the overall programme, showing the major operations and phasing of a job, a detailed short - term planning at regular intervals on the site is necessary:

- 1) a reasonably detailed programme is prepared at monthly intervals, to cover four weeks ahead,**
- 2) a detailed programme is prepared each week. This indicates in de tail the materials/labour requirement/ and operational methods to be used.**

4.1.3.1 Break down of job

Smaller jobs are commonly divided into the following stages:

- 1) foundations and walling up to DPC**
- 2) carcass to completion of roofing in**
- 3) finishes and all services**
- 4) drains and site works**

In large jobs and multi - storey work the break - down stages can be.

- 1) sub-structure, or foundation work**
- 2) frame, or basic structure**
- 3) cladding, infilling, weather - proofing etc.**
- 4) drains and site works.**

Each stage is planned separately first.

Compensation for any variations from the programme arising within the stages can be made by increasing the gang sizes to speed up certain operations or, at times when productivity is greater than that assumed at the planning stage, labour can be put on to isolated jobs which can be carried out at any time without interfering with the sequence of other operations.

4.1.3.2 Quantities of work and time content

In order to relate the various operations throughout the job a schedule of basic quantities has to be worked out from which the number of MAN HOURS and MACHINE HOURS required to complete the job can be obtained. (so-called LABOUR and PLANT standards.)

These standards in each case are established on the basis of information fed back from

- previous contracts or**
- work studies, having regard to the type of labour which will be available and the likely demand on plant.**

The work content for each operation is inserted on a schedule of basic operations which can be in the form of a series of DATA SHEETS.

These sheets form a detailed analysis of the complete work and give informations to all planning activities during the course of the contract.

4.1.3.3 Plant and Labour outputs

As soon as the probable availability of resources has been estimated, the outputs of men and machines must be evaluated, so that the times for elements of work can be determined. These LABOUR CONSTANTS must be realistic and allowances must be made for rests, bad weather, tea breaks and other interferences with normal output.

An element of work on site is 1,000m² of 1-brick internal walling. If the firm's estimated labour constant for this work is 1.50 men/h/m² then the number of men/h required for this work will be:

$$1,000\text{m}^2 \times 1.50 \text{ men/h/m}^2 = 1,500 \text{ men/h}$$

If 10 bricklayers are available in a gang, the time to be taken will be

$$\frac{1,500\text{men/h}}{10\text{men}} = 150\text{h}$$

If an 8 hour day is worked on site, this element will take 18 3/4 days to complete.

The following examples are typical of reasonable standard times for various operations, but these should be carefully checked and verified, and, if necessary, adjusted to suit any special conditions before applying them to actual work on site.

| Machine excavation | cbm/h |
|--|-----------------|
| Surface excavation not exceeding 300 mm deep 0.375 m³ bucket | 11 |
| Surface excavation not exceeding 300 mm deep 0.625 m² bucket | 21 |
| Surface excavation not exceeding 300 mm deep 0.375 m³ bucket | 12 |
| Surface excavation not exceeding 300 mm deep 0.625 m³ bucket | 24 |
| Excavate foundation trenches not exceeding 1.5 m deep 0.375 m³ bucket | 6 |
| Excavate foundation trenches not exceeding 1.5 m deep 0.625 m³ bucket | 12 |
| Excavate basements not exceeding 1.5 m deep 0.375 m³ bucket | 9 |
| Excavate basements not exceeding 1.5m deep 0.625 m³ bucket | 18 |
| Excavate basements exceeding 1.5 m and not exceeding 3 m 0.375 m³ bucket | 7 1/2 |
| Excavate basements exceeding 1.5 m and not exceeding 3 m 0.625 m³ bucket | 15 |
| Add for each additional 1.5 m depth | 1.25 |
| Excavate spoil from heap and load into barrow Wheel 20 m | 0.5 0.25 |
| Load excavated material into lorries | 0.6 |

| | | |
|---|---------------------------------|-------------------------------|
| Spread and level in layers not exceeding 300 mm thick | | 0.3 |
| Return fill and ram | | 0.85 |
| Level and ram bottoms | | 0.06/m2 |
| Planking and strutting excavations not exceeding 1.5 m deep: | | Hours per square metre |
| | poling boards and struts | 0.075 |
| | open boarding | 0.2 |
| | close boarding | 0.4 |
| excavations exceeding 1.5 m and not exceeding 3 m deep: | | |
| | open boarding | 0.3 |
| | close boarding | 0.8 |

| | |
|--------------------------------------|--------------|
| Hardcore filling | h/cbm |
| Filling in making up levels | 0.5 |
| Consolidated in 150 mm layers | 1.0 |

| | |
|--|--------------|
| Hand excavation | h/cbm |
| Surface excavation not exceeding 1.5 m deep | 2.0 |
| Add for each additional 1.5 m of depth | 0.75 |
| Excavate trenches not exceeding 1.5 m deep | 2.5 |

| | |
|---|------------|
| Add for each additional 1.5 m of depth | 1.0 |
| Excavate pits not exceeding 1.5 m deep | 3.0 |

| | |
|---|---------------|
| Concrete work | h/cbm |
| Mixing By hand for small quantities By machine allow 4 to 5 minutes per batch according to type of mixer | 4 to 6 |

| | |
|---|--------------|
| Transporting | h/cbm |
| By hand in barrows and wheel not exceeding 18 m or raise not exceeding 3 m | 1.5 |
| By machine plant and labour to suit required output and placing conditions | |

| | |
|---|--------------|
| Placing and compaction | h/cbm |
| Foundations in trenches over 300 mm thick | 0.5 |
| Foundations in trenches not exceeding 300 mm thick | 0.7 |
| Isolated pier holes | 1.0 |
| Beds over 300 mm thick | 0.75 |
| Beds over 150 mm thick not exceeding 300 mm thick | 1.0 |
| Beds not exceeding 150 mm thick | 1.25 |
| Add to the above for working around reinforcement | 1.0 |

| | |
|--------------------------|-----------------------|
| Surface treatment | h/square metre |
| Grading to falls | 0.3 |

| | |
|-------------------|-------------|
| Tamping | 0.2 |
| Trowelling | 0.25 |

Brickwork

(The following outputs are based on the ratio of 2 bricklayers to 1 labourer).

| | Men/h per unit |
|---|---------------------------|
| General brickwork in plasticised or gauged mortar 60 bricks | 1.0 |
| General brickwork in cement mortar 60 bricks | 1.1 |
| General brickwork overhand in gauged mortar 60 bricks | 1.1 |
| Walling curved on plan ex 15 m n.e. 22 m rad 60 bricks | 1.5 |
| Walling curved on plan ex 7.5 m n.e. 15 m rad 60 bricks | 1.66 |
| Walling curved on plan ex 4.5 m n.e. 7.5 m rad 60 bricks | 1.75 |
| Walling curved on plan exceeding 3 m rad | |
| Underpinning 60 bricks | 2.00 |
| Rough arches 60 bricks | 3.0 |
| Form cavity inc. laying wall ties, and keeping cavity clean per m2 | 0.25 |
| Rough cutting per m2 | 0.7 |

| | |
|---------------------------------------|-------------|
| Close cavity per m | 0.3 |
| Cut chase for small pipe per m | 0.6 |
| Eaves filling per m | 0.3 |
| Engineering bricks per 60 | 1.50 |

| Face brickwork | men/h per unit |
|---|---------------------------|
| General facing bricks per m2 | 1.25 |
| Fair faced walling/m2 | 1.10 |
| Rake out joints and point on completion per m2 | 0.75 |
| Fair straight cutting per lin. m. | 0.3 |
| Fair raking cutting per lin. m. | 0.4 |
| Fair curved cutting per lin. m. | 0.5 |

| Arches | men/h per unit |
|---|---------------------------|
| Soldier arches or brick lintels per m2 | 3.6 |
| Fair axed arches per m2 | 5.5 |
| Rubbed and gauged per m2 | 12.25 |

| Copings and sills | men/h per unit |
|--------------------------|---------------------------|
|--------------------------|---------------------------|

| | |
|--|-------------|
| Brick on edge coping including pointing per lin. M. | 0.4 |
| Two courses of tile creasing per lin. m. | 0.6 |
| Brick on edge per lin. m. | 0.75 |

| Partitions | men/h |
|--|--------------|
| Clinker, concrete and hollow clay 50 mm thick per m2 | 0.5 |
| Clinker, concrete and hollow clay 75 mm thick per m2 | 0.6 |
| Clinker, concrete and hollow clay 100 mm thick per m2 | 0.7 |
| Lightweight blocks 50 mm thick per m2 | 0.4 |
| Lightweight blocks 75 mm thick per m2 | 0.5 |
| Lightweight blocks 100 mm thick per m2 | 0.6 |
| Bonding to brickwork per lin. m | 0.2 |
| Rough cutting at irregular angles and soffits per lin. m. | 0.15 |

| Sundries | men/h |
|---|--------------|
| Bed plates and sills per lin. m. | 0.1 |
| Bed frame and point one side per lin. m. | 0.25 |
| Bed frame and point two sides per lin m | 0.35 |
| Rake out joints and point flashings per lin. m. | 0.3 |
| Cut groove for asphalt skirting and point per lin. m | 0.45 |

| | |
|--|-------------|
| Fix metal windows including cut and pin lugs to brickwork not exceeding 0.4 m2 each | 0.5 |
| Fix metal windows including cut and pin lugs to brickwork not exceeding 0.8 m2 each | 0.75 |
| Fix metal windows including cut and pin lugs to brickwork not exceeding 1.6 m2 each | 1.0 |
| Add for pointing one side per lin. m. | 0.08 |
| Air bricks each | 0.2 |
| Flue linings per lin. m. | 0.6 |
| Set chimney pot and flaunch each | 1.0 |

| | |
|--|--------------|
| Damp-proof courses | men/h |
| Two courses of slates horizontal per m2 | 0.9 |
| Two courses of slates vertical per m2 | 1.35 |
| Bituminous felt per m2 | 0.3 |

| | |
|---------------------------------------|---|
| Scaffolding | men/h per 100 m2 erect and dismantle |
| Putlog scaffold up to 6 m high | 25 |
| Putlog scaffold 6 to 9 m high | 30 |
| Putlog scaffold 9 to 18 m high | 35 |
| Putlog scaffold over 18 m high | 40 |

| | | | | |
|---|---------------|---------------|---------------|---------------|
| Independent scaffolds add 25 per cent to the above | | | | |
| Drainage | men/h | | | |
| Stoneware drain pipes | 100 mm | 150 mm | 225 mm | |
| Lay and joint 600 mm pipes per lin. m. | 0.45 | 0.6 | 0.75 | |
| Lay and joint 900 mm pipes per lin. m. | 0.35 | 0.45 | 0.6 | |
| Extra for bends each | 0.1 | 0.12 | 0.15 | |
| Extra for junctions each | 0.2 | 0.25 | 0.3 | |
| Gulleys each | 0.5 | 0.66 | - | |
| Interceptors each | 0.66 | 0.75 | - | |
| | | | | |
| Concrete drain pipes | 225 mm | 300 mm | 375 mm | 450 mm |
| Lay and joint per lin. m. | 0.8 | 0.9 | 1.1 | 1.25 |
| Extra for bends each | 0.2 | 0.25 | 0.3 | 0.35 |
| | | | | |
| Manholes | 100 mm | 150 mm | 225 mm | |
| Channels each | 0.2 | 0.3 | 0.4 | |
| Three-quarter section channels each | 0.3 | 0.5 | 0.7 | |
| Covers and frames bedding and fixing each | 0.75 | | | |

| | | | |
|------------------------|------------|--|--|
| | | | |
| Step irons each | 0.1 | | |

4.1.3.4 Sequence and timing of operations

In each stage into which a job may be divided, there will be one operation or a group of related operations governing the production time of the complete stage. This **KEY OPERATION** takes the longest time, when the time cycles of all the operations are based on the use of the optimum size of gang for each.

The largest of the key operations in each stage is termed the **MASTER OPERATION**. The speed of the master operation is governed by:

- the time, in which the work has to be completed
- the size of the gang or
- the amount of labour available(in which case the size of the gang which can be put on it will fix the time required to complete the operation)

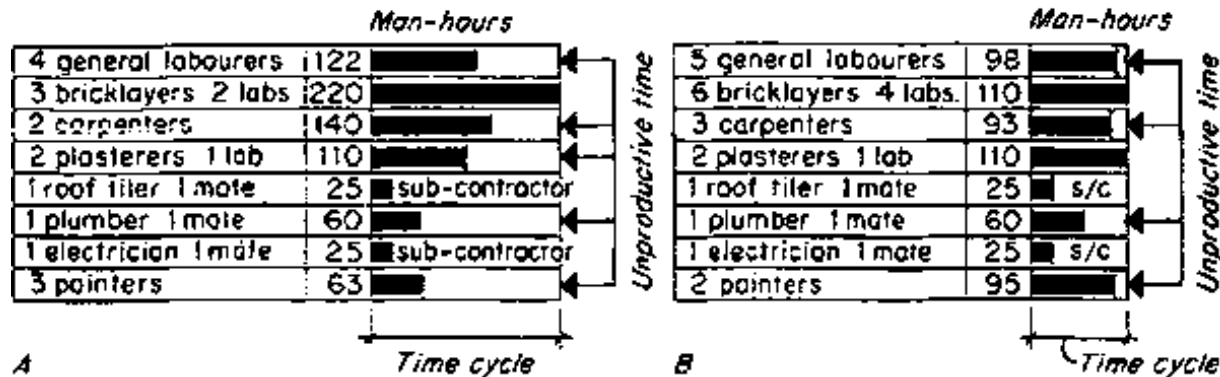
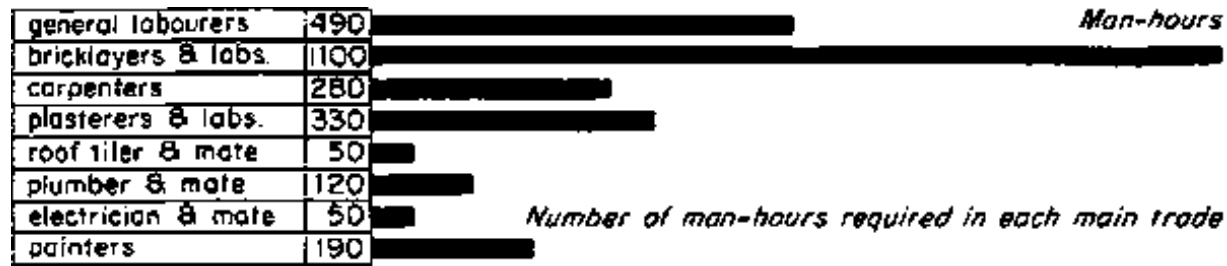

Number of man-hours required in each main trade

It is necessary to bring all other operations into phase with the master operation, in order to ensure continuity of productive work for each trade or gang and to minimize unproductive time.

The time cycles of the operations in each stage are brought into phase by adjusting the size of the gangs, so that the working time of each gang is (as far as possible) the same as that of the key operation. Figure illustrates the effect of the balancing of trade gangs.

4.1.3.5 The programme chart

The final step is to prepare a working schedule on the basis of the balanced production in each stage, from which programmes for the various stages are drawn up.

The stage programmes are combined to give the final overall programme. (A short interval may be left between the stages to provide for delays due to bad weather or other causes). A typical overall programme chart is shown in fig.

In addition to the data sheets and the overall programme, a SCHEDULE of CONTRACT INFORMATION is prepared giving

- the recommended labour force for each stage of the contract under trades**
- details regarding the sequence of operations given on the data sheets**
- details of equipment and methods of construction to be used.**
- full details concerning all sub contractors**

A site layout plan and a site preparation programme will also be prepared at this stage as well as the detailed programme for the first four week period of the contract. (ref. to 'site organisation')

OVERALL PROGRAMME

OFFICE & WAREHOUSE FOR A CLIENT & CO LTD

Job no: 123

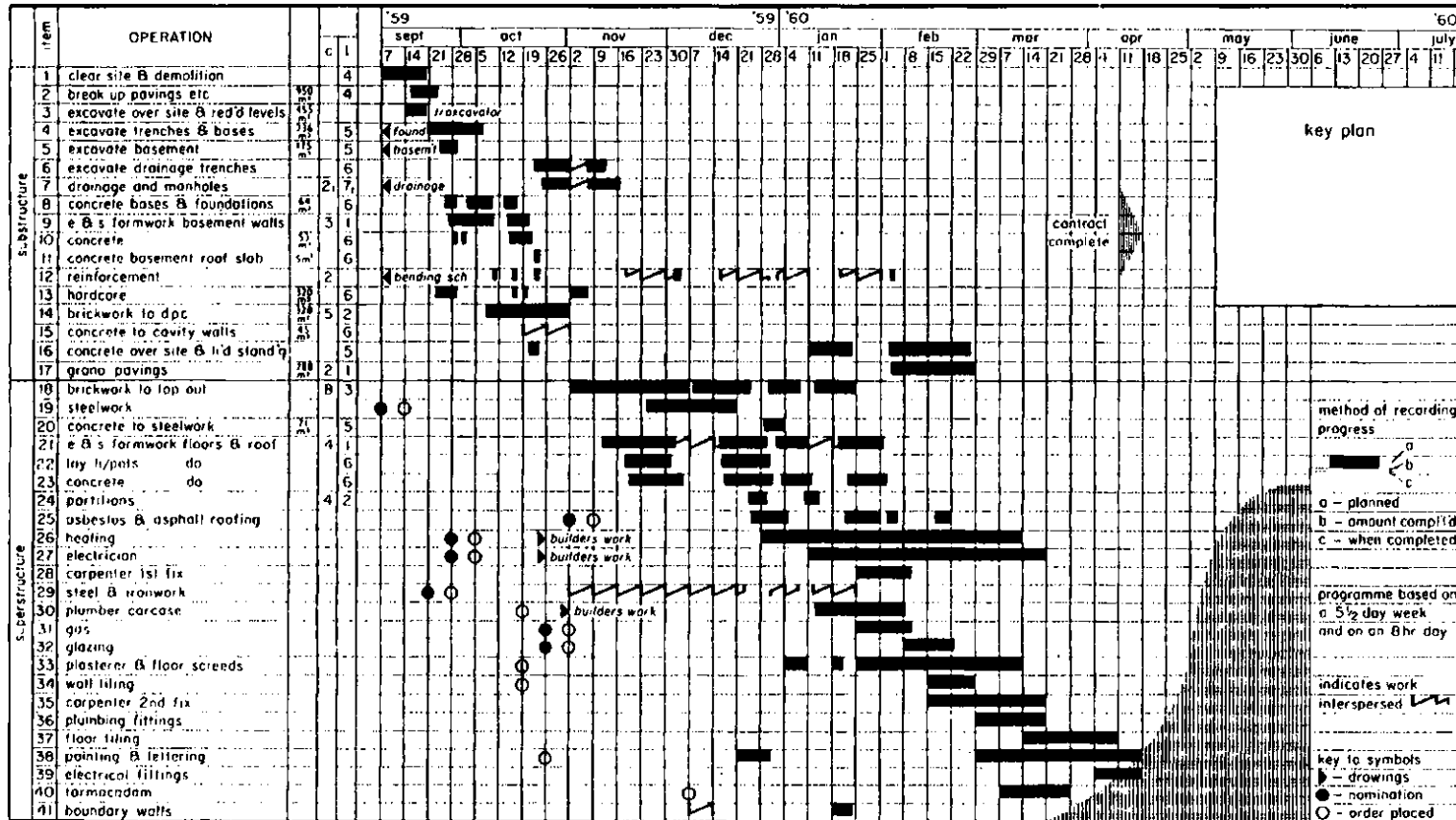

| | | | | | | | | | | | | | | | | | | | | | | | | | | | | | | | |
|-----------------------------|-------------|---|---|-----|-----|-----|-----|-----|-----|-----|-----|-----|-----|-----|-----|-----|-----|-----|-----|---|---|---|---|---|---|---|---|---|---|---|--|
| approximate labour strength | unskilled | 5 | 6 | 7 | 8 | 6 | 6 | 6 | 6 | 6 | 7 | 7 | 7 | 7 | 7 | 7 | 8 | 8 | 8 | 8 | 7 | 6 | 6 | 4 | 3 | 2 | 2 | 2 | 2 | 2 | |
| | carpenters | | | 3/1 | 3/1 | 3/1 | 3/1 | | | 4/1 | 4/1 | 4/1 | 4/1 | 4/1 | 4/1 | 4/1 | 3 | 3 | 3 | 3 | 4 | 4 | 4 | 4 | 4 | | | | | | |
| | bricklayers | | | | 5/3 | 5/3 | 5/3 | 5/3 | 6/3 | 6/3 | 6/3 | 5/2 | 5/2 | 5/2 | 5/2 | 4/1 | 2/1 | 2/1 | 2/1 | | | | | | | | | | | | |
| | drainlayers | | | | | | | | 1 | 1 | 1 | 1 | | | | | | | | | | | | | | | | | | | |

architect

contractor

engineer

OVERALL PROGRAMME

contract A Client & Co Ltd
 job no 123
 period 7-9-59 to 5-10-59

MONTHLY PERIOD PROGRAMME

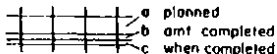
method of recording progress

| OPERATION | QNT | LAB | 7th sept | | | | | | | 14th sept | | | | | | | 21st sept | | | | | | | 28th sept | | | | | | | 5th oct | | | | | | |
|------------------------------------|-------------------|-----|---|----|---|---|---|---|----|-----------|----|---|---|---|---|----|-----------|----|---|---|---|---|----|-----------|----|---|---|---|---|----|---------|----|---|---|---|---|----|
| | | | M | Tu | W | T | F | S | Su | M | Tu | W | T | F | S | Su | M | Tu | W | T | F | S | Su | M | Tu | W | T | F | S | Su | M | Tu | W | T | F | S | Su |
| clear site | | 4 | [Gantt bars for clear site] | | | | | | | | | | | | | | | | | | | | | | | | | | | | | | | | | | |
| demolition | | 4 | [Gantt bars for demolition] | | | | | | | | | | | | | | | | | | | | | | | | | | | | | | | | | | |
| break up pavings | 950m ² | 2 | [Gantt bars for break up pavings] | | | | | | | | | | | | | | | | | | | | | | | | | | | | | | | | | | |
| excavate over site | 150m ³ | 2 | [Gantt bars for excavate over site] | | | | | | | | | | | | | | | | | | | | | | | | | | | | | | | | | | |
| excavate reduced levels | 192m ³ | 2 | [Gantt bars for excavate reduced levels] | | | | | | | | | | | | | | | | | | | | | | | | | | | | | | | | | | |
| excavate surface trenches & bases | 190m ³ | 2 | [Gantt bars for excavate surface trenches & bases] | | | | | | | | | | | | | | | | | | | | | | | | | | | | | | | | | | |
| do do | 46m ³ | 5 | [Gantt bars for do do] | | | | | | | | | | | | | | | | | | | | | | | | | | | | | | | | | | |
| excavate basement | 151m ³ | 2 | [Gantt bars for excavate basement] | | | | | | | | | | | | | | | | | | | | | | | | | | | | | | | | | | |
| excavate basement foundations | 23m ³ | 5 | [Gantt bars for excavate basement foundations] | | | | | | | | | | | | | | | | | | | | | | | | | | | | | | | | | | |
| blinding to trenches & bases | 11m ³ | 6 | [Gantt bars for blinding to trenches & bases] | | | | | | | | | | | | | | | | | | | | | | | | | | | | | | | | | | |
| concrete do do | 53m ³ | 6 | [Gantt bars for concrete do do] | | | | | | | | | | | | | | | | | | | | | | | | | | | | | | | | | | |
| make basement wall formwork | | 3/1 | [Gantt bars for make basement wall formwork] | | | | | | | | | | | | | | | | | | | | | | | | | | | | | | | | | | |
| erect do do | | 3/1 | [Gantt bars for erect do do] | | | | | | | | | | | | | | | | | | | | | | | | | | | | | | | | | | |
| make formwork to stairs, slab, etc | | 3/1 | [Gantt bars for make formwork to stairs, slab, etc] | | | | | | | | | | | | | | | | | | | | | | | | | | | | | | | | | | |
| blinding to basement foundations | 7m ³ | 6 | [Gantt bars for blinding to basement foundations] | | | | | | | | | | | | | | | | | | | | | | | | | | | | | | | | | | |
| concrete basement floor slab | 46m ³ | 6 | [Gantt bars for concrete basement floor slab] | | | | | | | | | | | | | | | | | | | | | | | | | | | | | | | | | | |
| brickwork to sump | | 1/1 | [Gantt bars for brickwork to sump] | | | | | | | | | | | | | | | | | | | | | | | | | | | | | | | | | | |
| reinforcement to basement walls | | 2 | [Gantt bars for reinforcement to basement walls] | | | | | | | | | | | | | | | | | | | | | | | | | | | | | | | | | | |
| hardcore to hardstanding | 320m ³ | 5 | [Gantt bars for hardcore to hardstanding] | | | | | | | | | | | | | | | | | | | | | | | | | | | | | | | | | | |
| brickwork to dpc | | 5/2 | [Gantt bars for brickwork to dpc] | | | | | | | | | | | | | | | | | | | | | | | | | | | | | | | | | | |

| LABOUR | | | | | | | | | | | | | | | | | | | | | | | | | | | | | | |
|-------------|--|--|---------------------------------|--|--|--|--|--|--|--|--|--|--|--|--|--|--|--|--|--|--|--|--|--|--|--|--|--|--|--|
| unskilled | | | [Labour values for unskilled] | | | | | | | | | | | | | | | | | | | | | | | | | | | |
| carpenters | | | [Labour values for carpenters] | | | | | | | | | | | | | | | | | | | | | | | | | | | |
| bricklayers | | | [Labour values for bricklayers] | | | | | | | | | | | | | | | | | | | | | | | | | | | |
| drivers | | | [Labour values for drivers] | | | | | | | | | | | | | | | | | | | | | | | | | | | |
| steelers | | | [Labour values for steelers] | | | | | | | | | | | | | | | | | | | | | | | | | | | |

MONTHLY PERIOD PROGRAMME

4.1.4 PLANNING CONSIDERATIONS

A number of factors which have a bearing on the decisions made during the contract planning stage are briefly considered here.

4.1.4.1 Site conditions and access

Site conditions will limit the type of plant that may be used:

- on wet sites it will be necessary to use tracked machines in the case of excavators and mobile cranes, and dempers for transport**
- sloping sites may make the use of rail mounted cranes unsuitable or uneconomical.**
- on confined sites there may be insufficient room for a mixer or mixing plant and it may be necessary to use truck mixed concrete.**
- Limitations of access may fix the maximum size of plant which can be brought on the site.**

4.1.4.2 Nature of job

The type of structure, the general form, size and detailing of the building will all have an effect upon the way in which the contract is planned.

The contractor has to consider the nature of the structure in relation to the site so that he can decide where best to place his equipment and materials. All plant should be so placed on the site that the structure can be erected without moving the plant until most of it is completed. Plant should also be so placed that it can be removed easily at the completion of the job. In some circumstances the contractor may request the adjustment of the structure in some way in order to permit the most efficient planning

may request the adjustment of the structure in some way, in order to permit the most efficient planning of the contract. It may be desirable to enlarge a lift shaft slightly in order that a climbing crane may be accommodated within it. OR: For certain parts designed originally as in situ cast work to be carried out as precast work in order fully to utilize a crane on the job etc.

4.1.4.3 Plant

The choice of the most suitable plant for any particular operation necessitates a consideration of the capabilities, limitations, and outputs of different types of plant.

- EXCAVATION can be carried out either mechanically by a number of different types of plant or by hand. The SPOIL can be transported in various types of vehicle and the length of haul to tip will vary with the job, so that many combinations of excavator and transporting machines are possible.

The method adopted for excavating operations will depend upon

- a) the type of excavation to be carried out
- b) the nature of the soil to be excavated
- c) the volume of soil to be excavated
- d) the length of haul to tip and the terrain over which the machinery has to dig and travel
- e) the type of plant available for the contractor

For small quantities, handexcavation is cheaper than mechanical excavation and the type of transport will depend on the distance to be hauled, the nature of the ground to be traversed and the cost of temporary roads, where necessary.

- HANDLING of structural units and materials in fabrication and erection can be carried out by crane or forklift truck.

If a crane is used the work must be planned round the crane. Consideration must be given to the quantity and nature of materials to be handled and whether or not there is sufficient to keep a crane fully occupied throughout the working day.

The careful timing of materials as near as possible to the point at which they will be used, together with the correct siting of hoisting plant, materials dumps and mixing plant in relation to the building and to each other is an important factor in planning for high productivity and for the reduction of double-handling.

- MIXING Type and size of concrete mixer are dictated to a large extent by the quality and quantity of concrete required.

When small to medium quantities (say up to 20 m³/day) are required a mixer together with hand loading of the aggregate skip, some form of weight batching and hand barrow delivery can be economical. When steady outputs of not less than 30m³ per day are required, complete mechanisation (with a mechanical scoop and gravity loading of the mixer skip, gravity fed bulk cement and - for delivery - a crane carrying a full batch skip or, alternatively, a pneumatic concrete placer) is best.

- CONTRACTORS MECHANICAL PLANT

In its widest sense 'contractors plant' implies the machinery, tools and other equipment used in the contractor's yard and workshop, and on the site.

The machines and power tools are divided into three classes according to their degree of mobility:

- fixed (operating from a fixed position on site)
- portable (being moved about by pulling, pushing or carrying by hand)
- mobile (moving from one place to another under their own power)

They may further be divided into classes according to their function.

The following figures show a collection of mechanical plant and power tools used on the building site only.

Excavator equipment

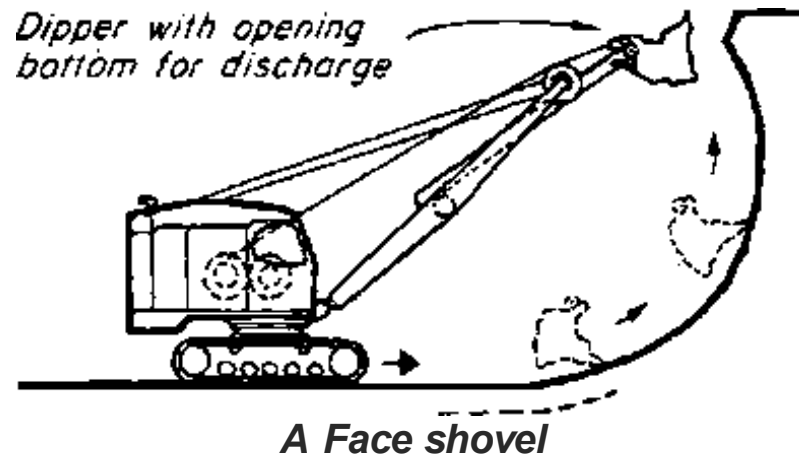

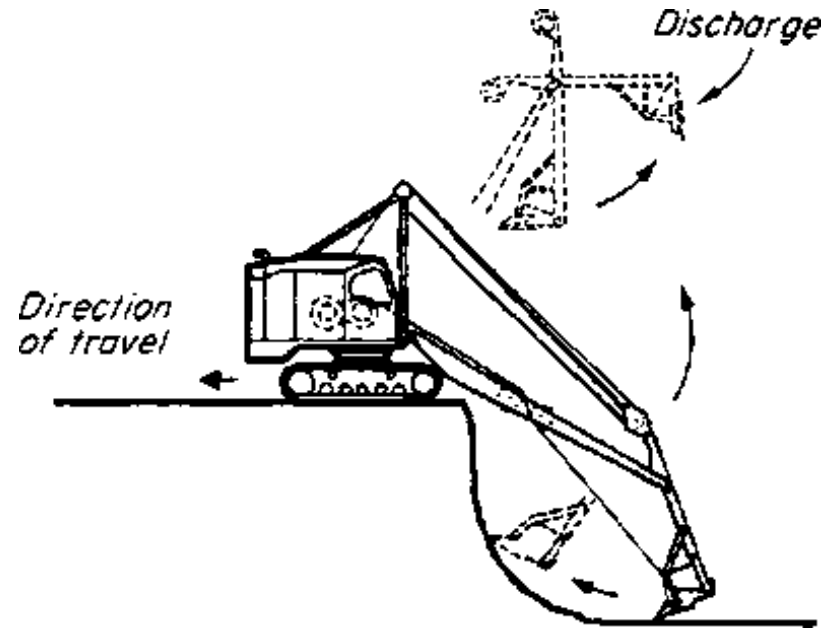

B Backacter

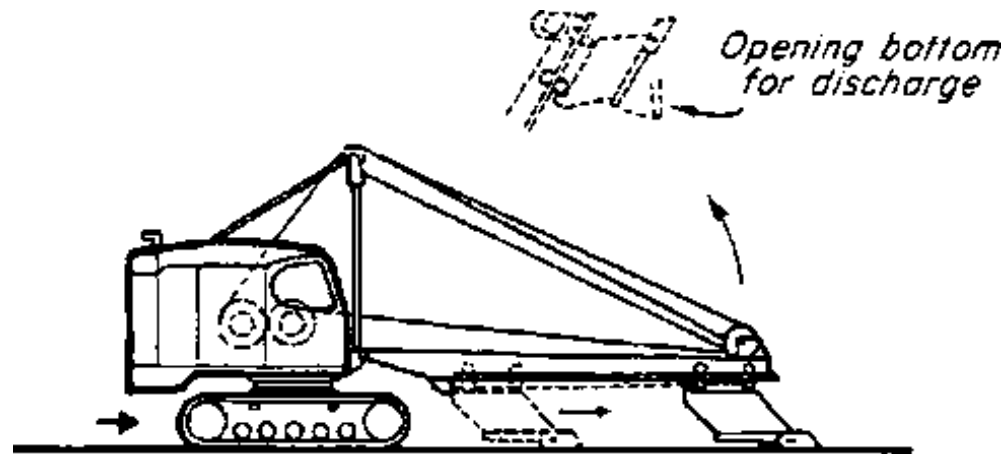

C Skimmer

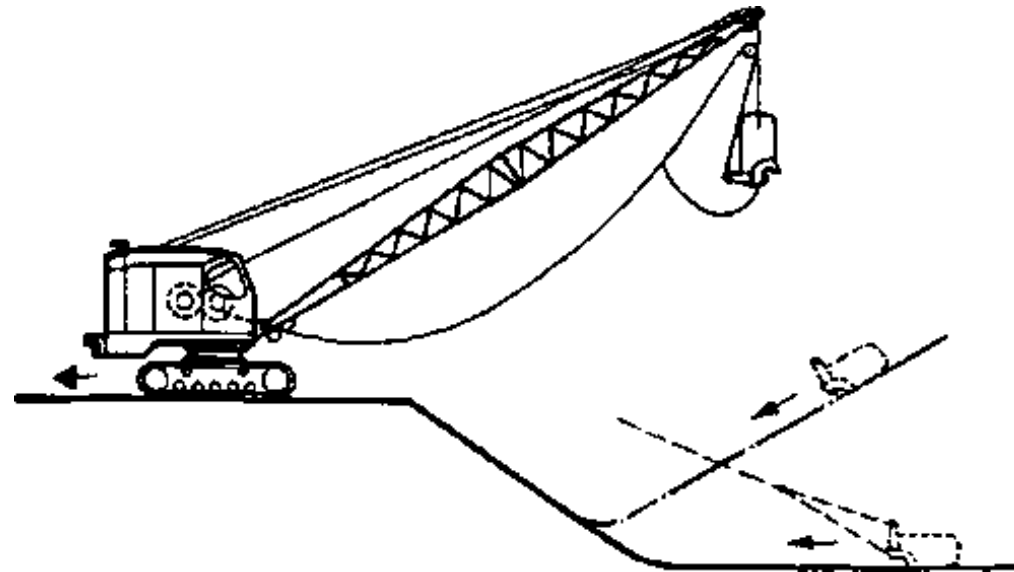

D Dragline

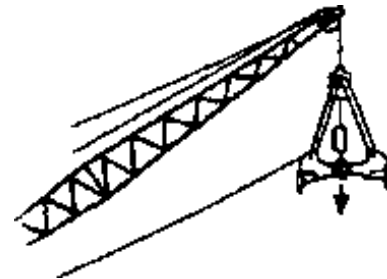

E Crane and grab

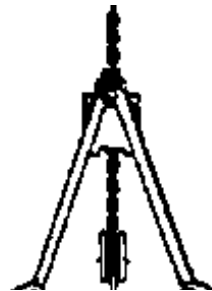



F Grab

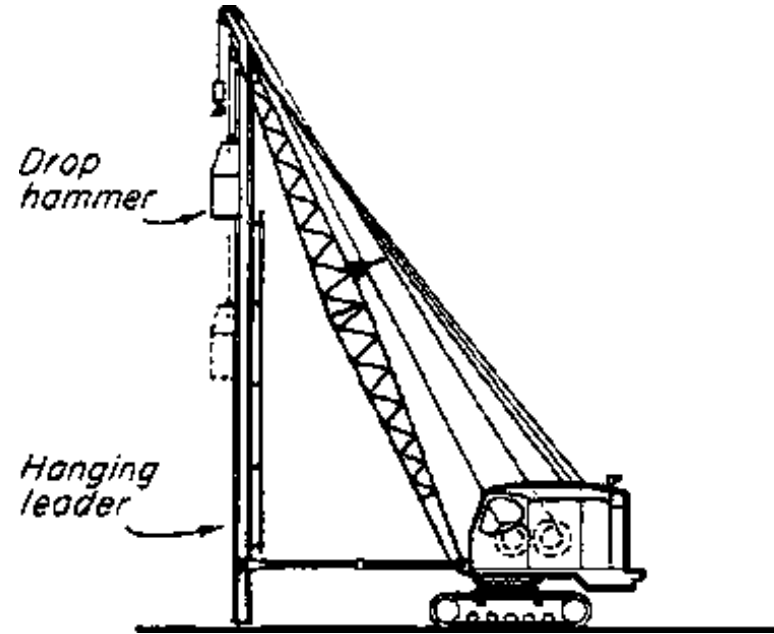

G Pile driver

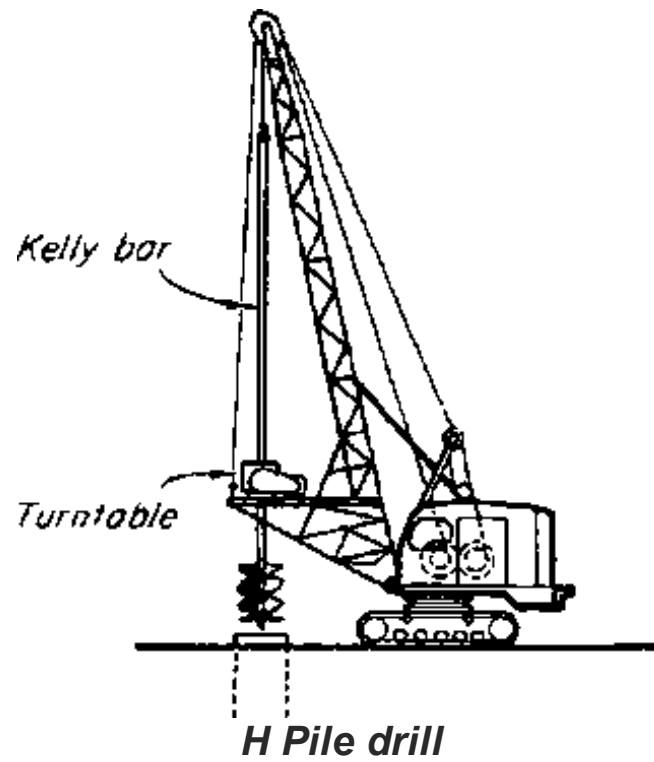

Tractor based equipment

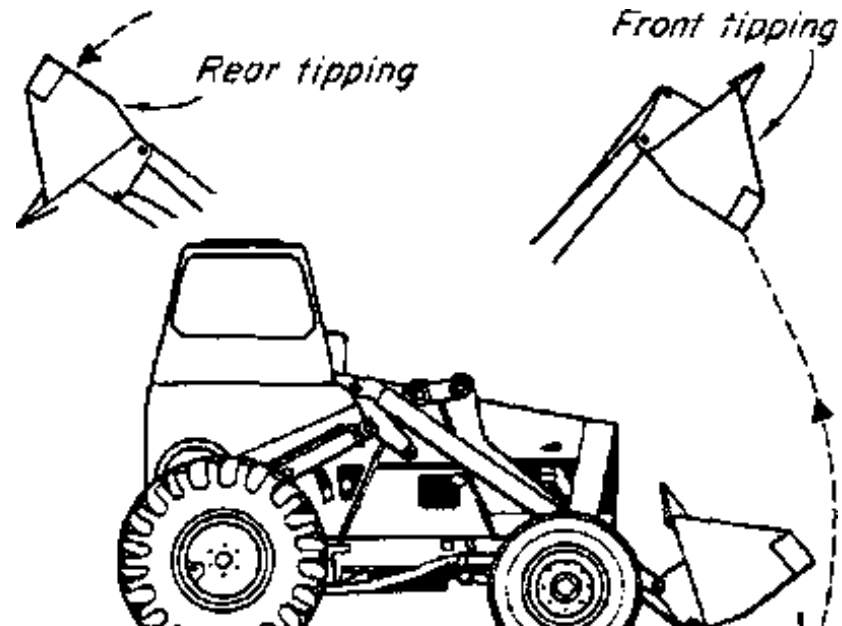
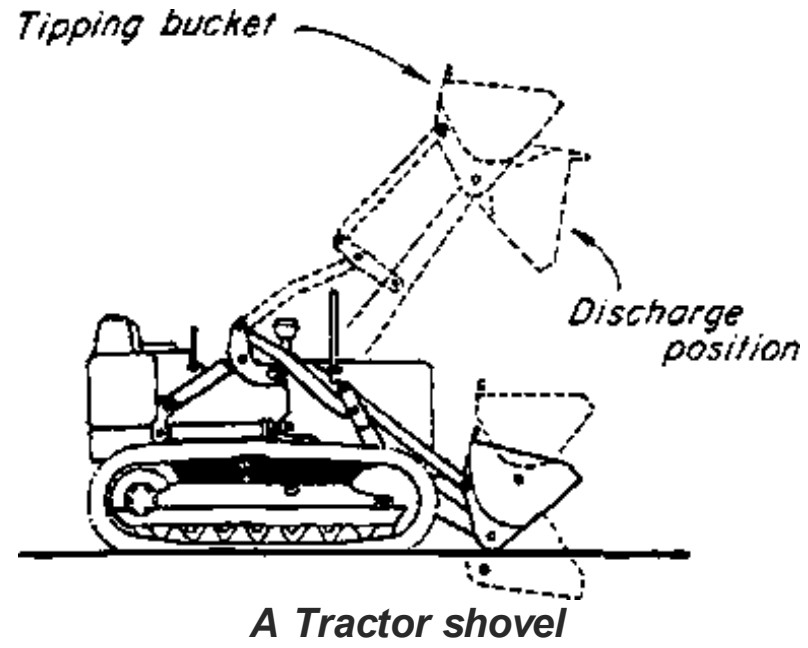

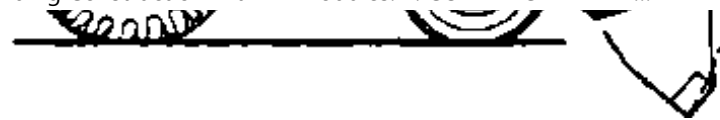

B Overloading shovel

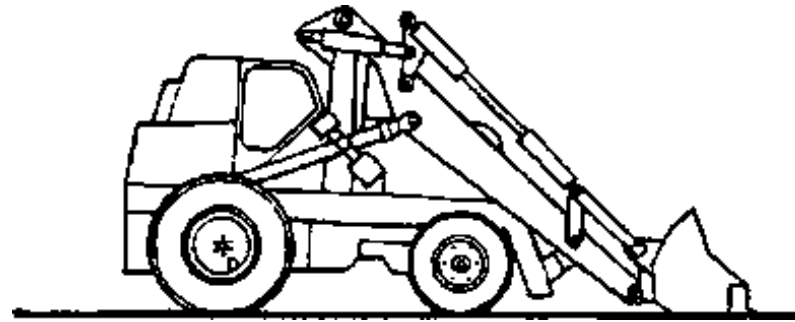

C Loading shovel

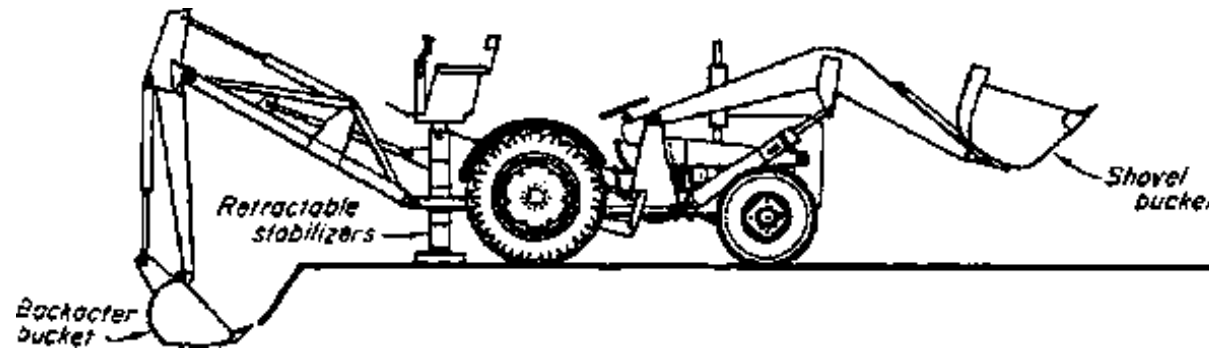

D Combined trench digger and loading shovel

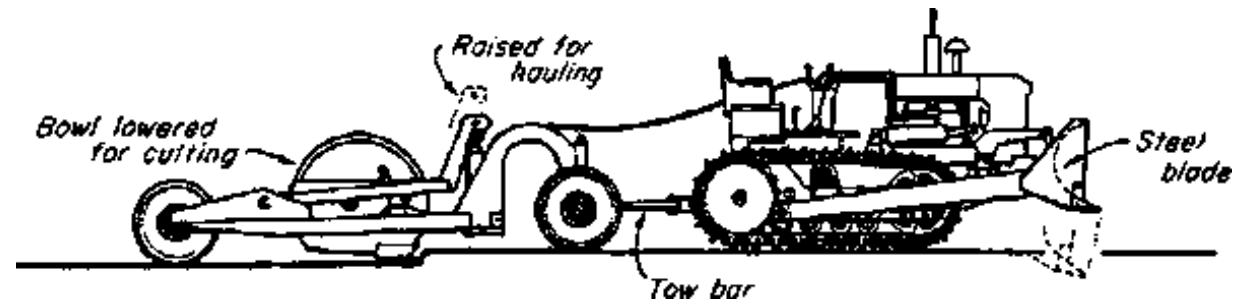

E Scraper, F Bulldozer

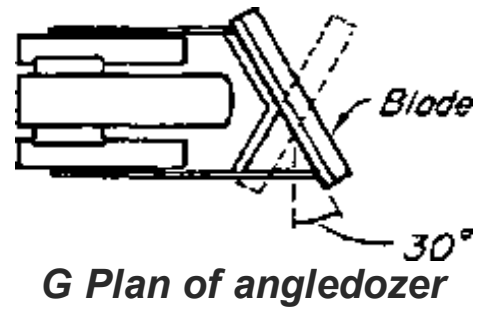

Cranes - relative amount of working areas and coverage

*All jibs shown are
the same length*

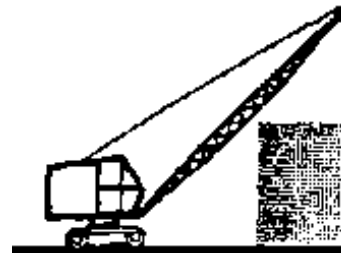

A Mobile Crane

Closer proximity to building, greater coverage

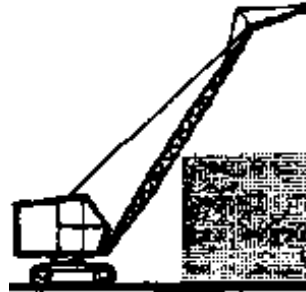

B With fly jib

Closer proximity to building, greater building height and coverage

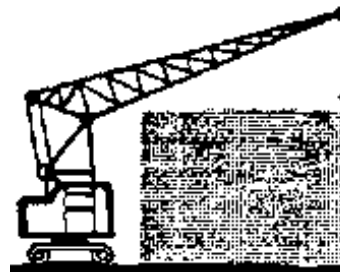

C High mounted jib

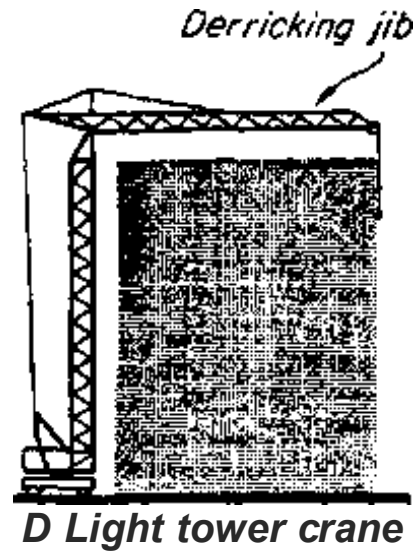

Derrick cranes

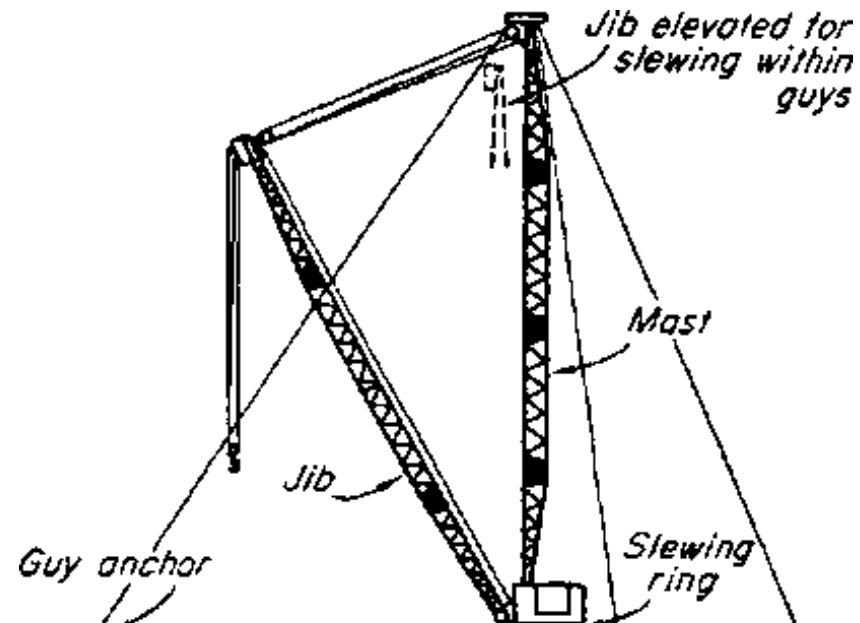

A Guy derrick

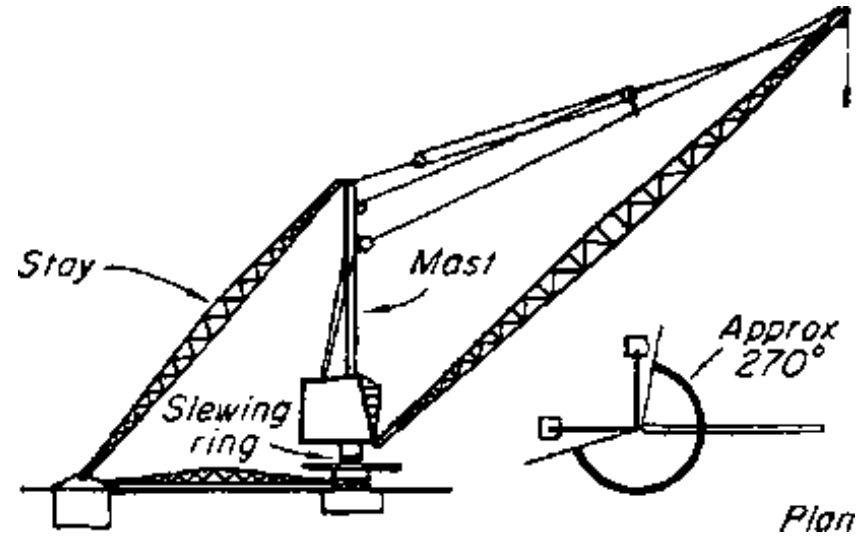

B Scotch derrick

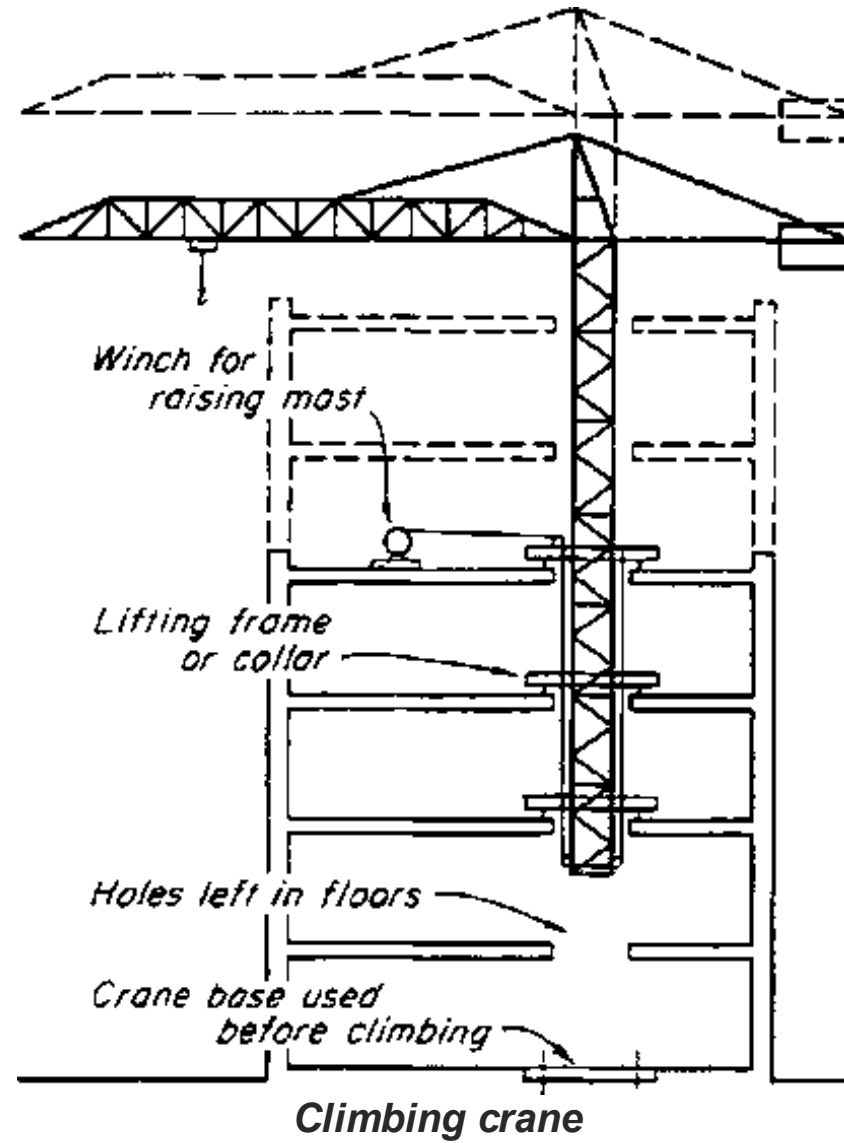

Mobile cranes

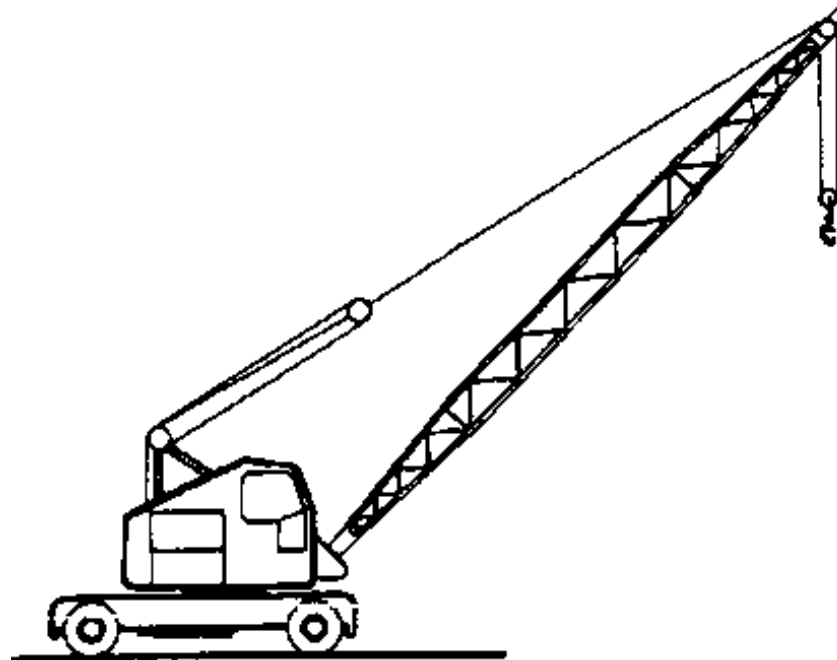

A Road mobile crane (tire mounted)

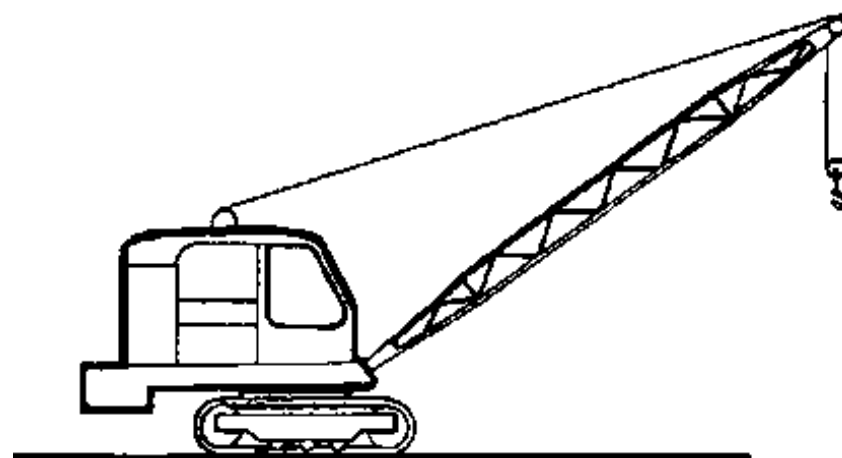

B Crane on crawler tracks

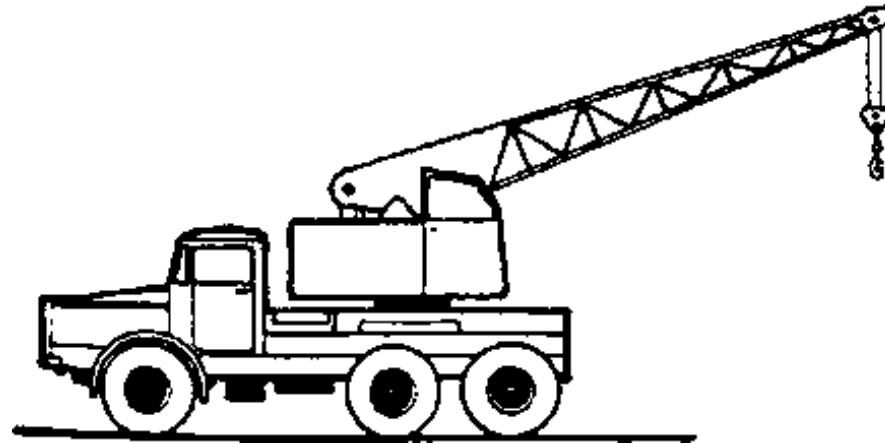

C Truck mounted crane

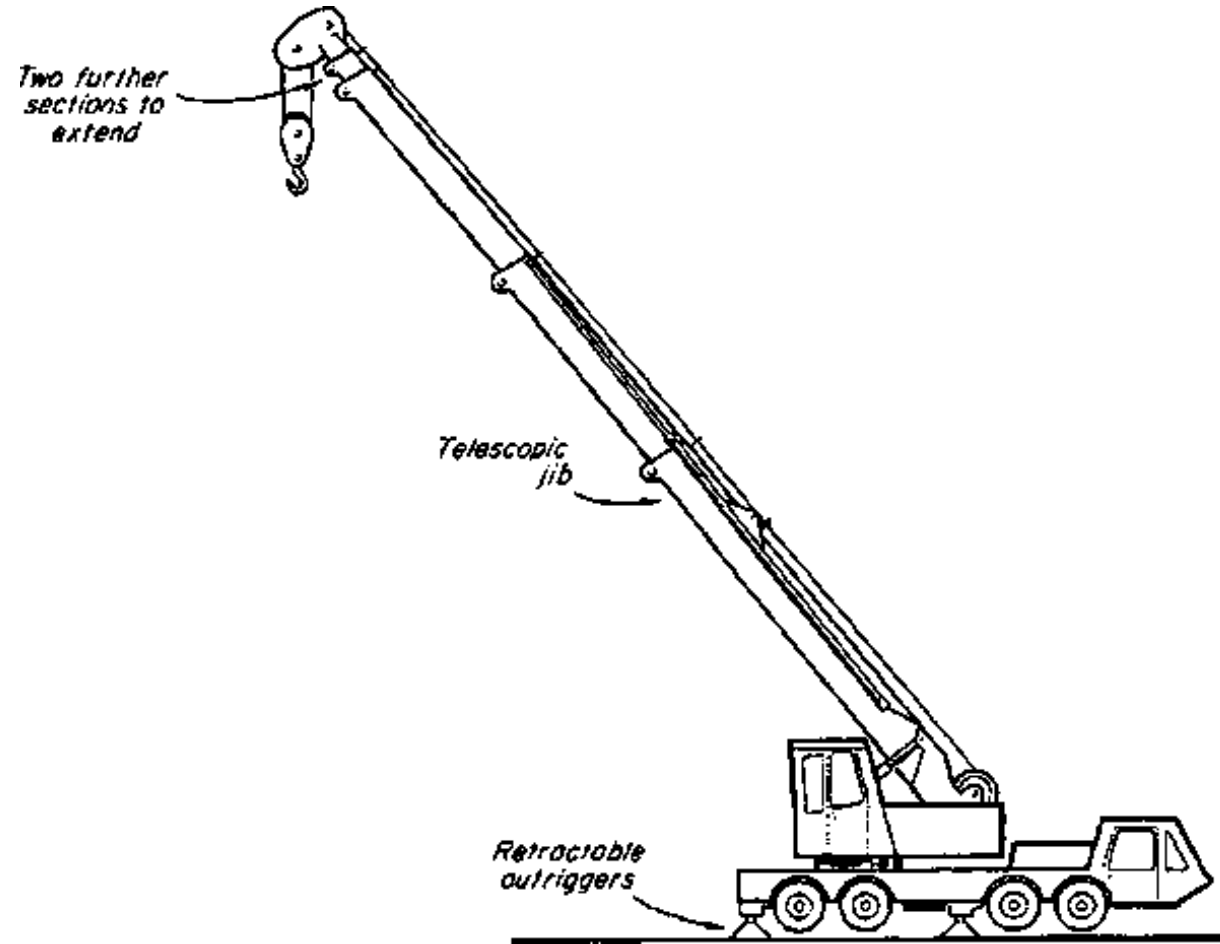

D Telescopic jib crane

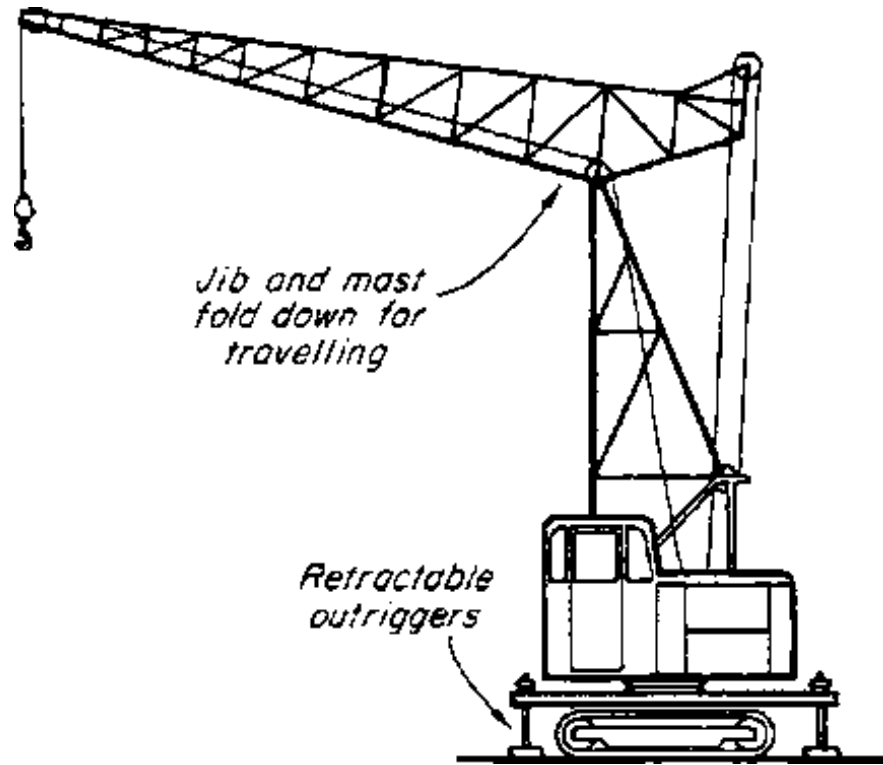

*Jib and mast
fold down for
travelling*

*Retractable
outriggers*

E High pivoted jib crane

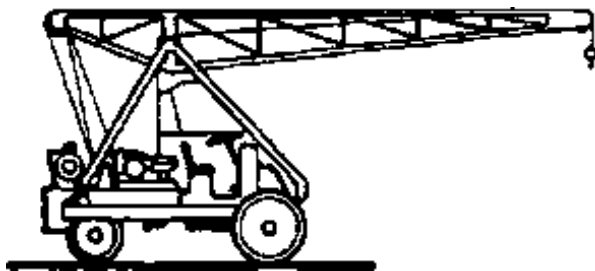

F Non-slewing jib crane

Derricking jib tower cranes

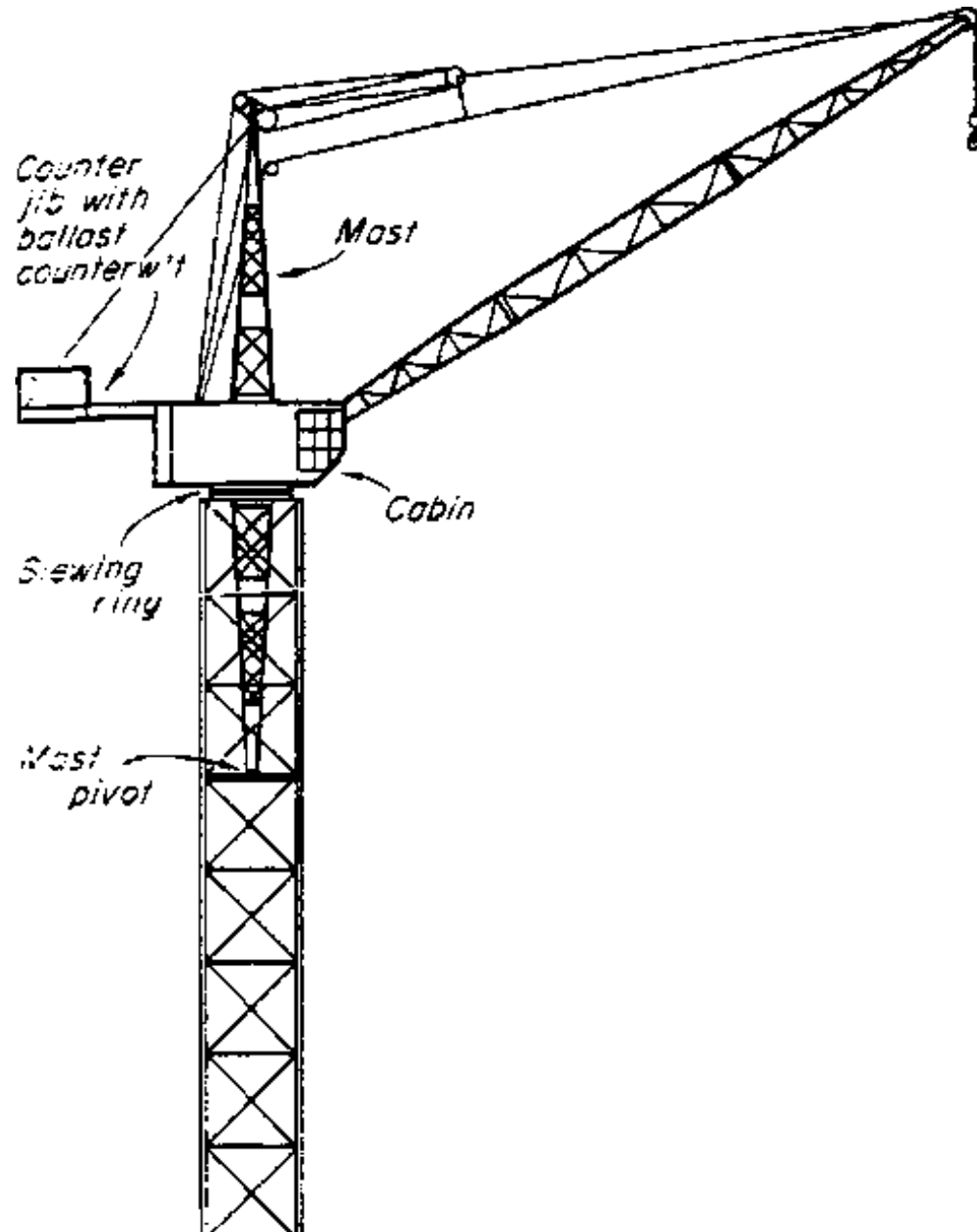



A Monotower derrick

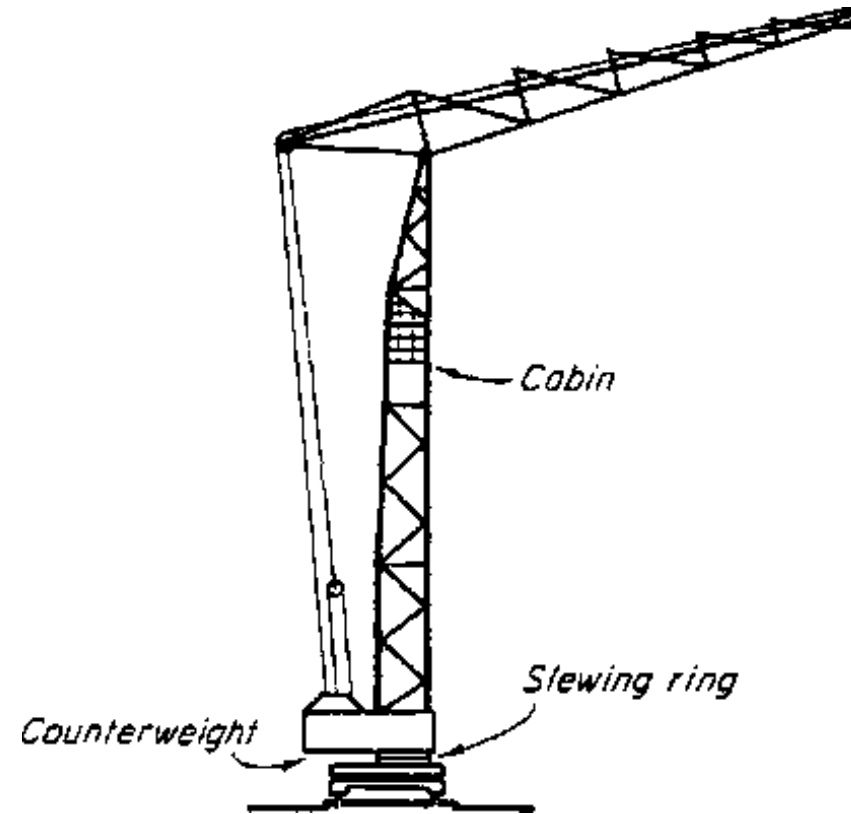

B Slewing mast crane with cantilever jib

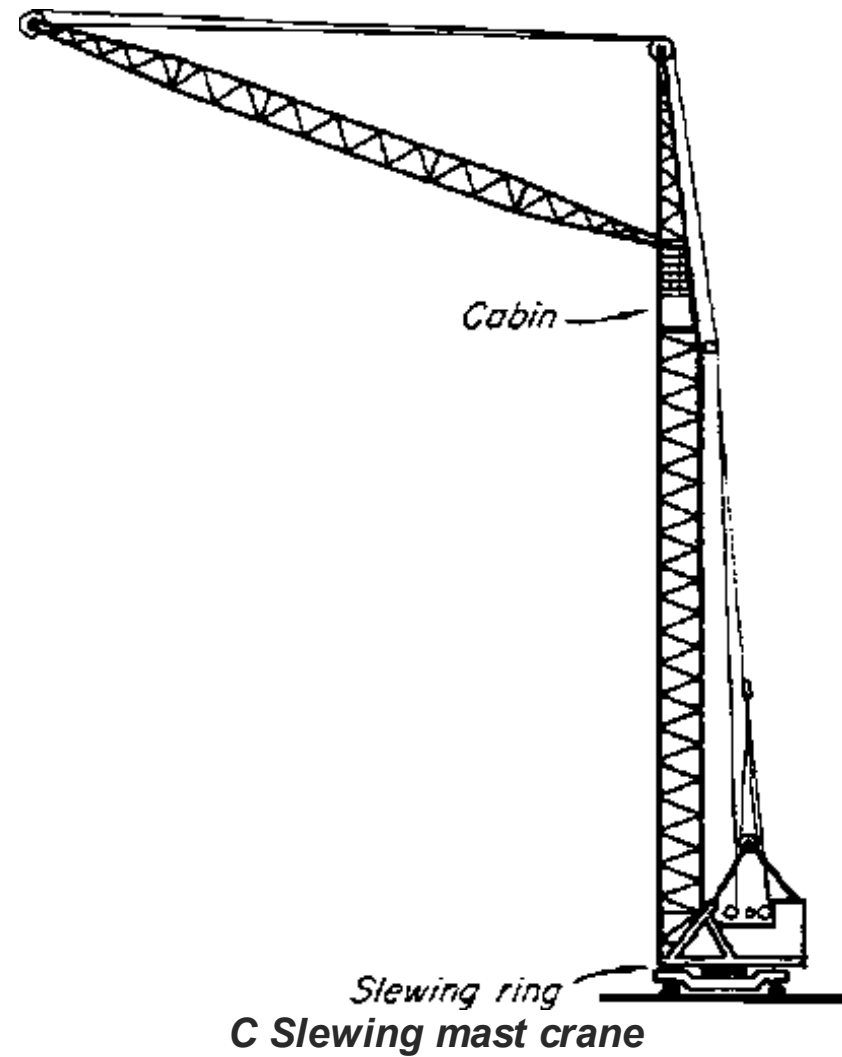

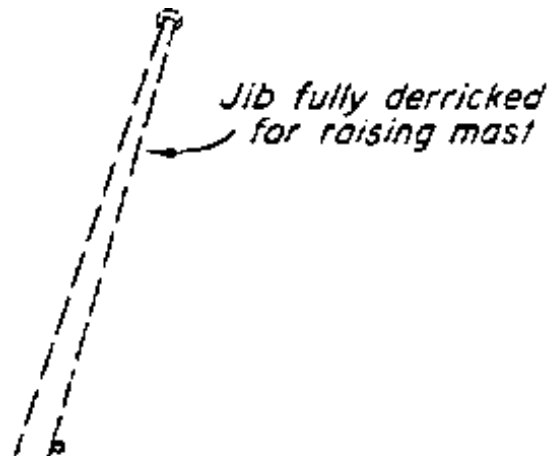
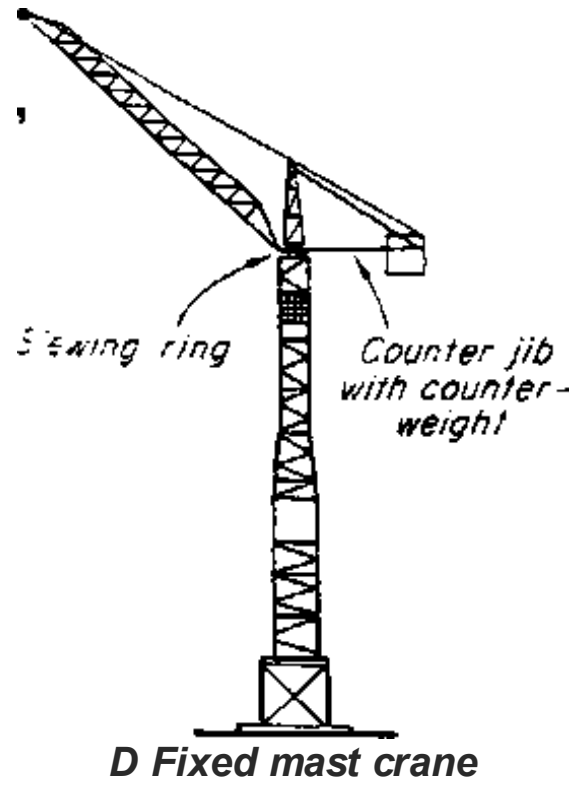

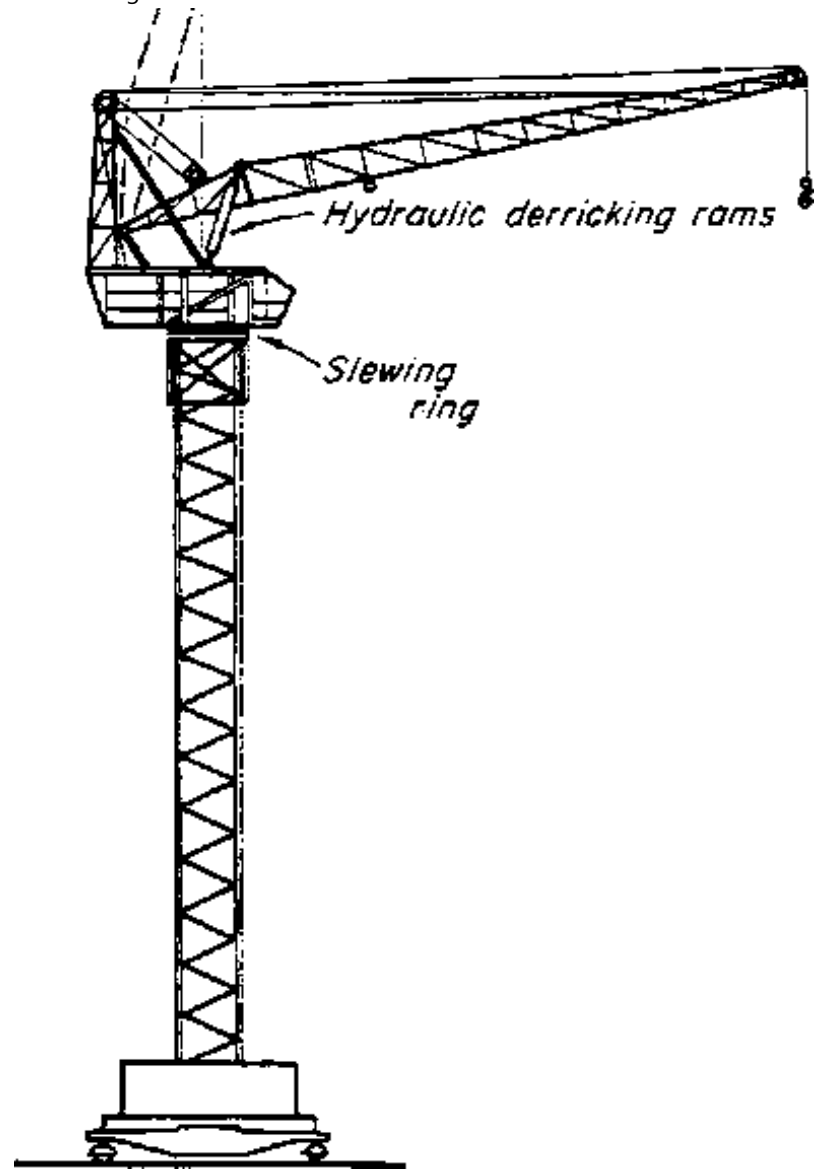

E Fixed mast hydraulic derricking crane

Horizontal jib tower cranes

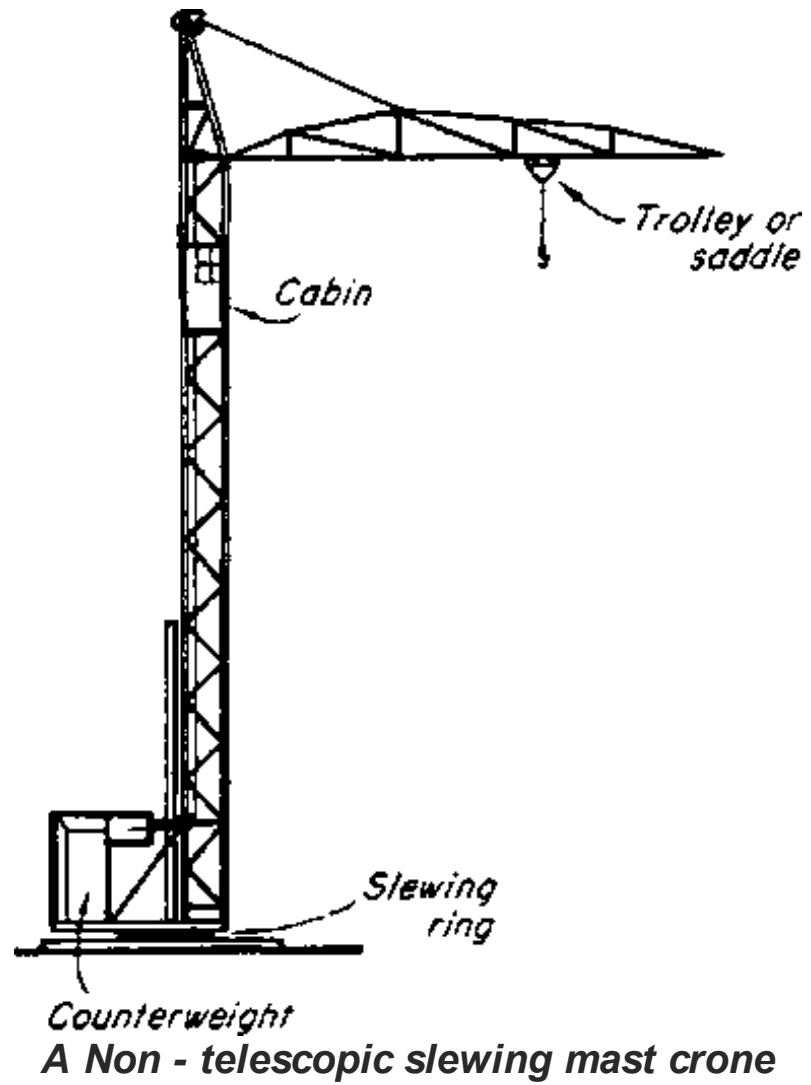

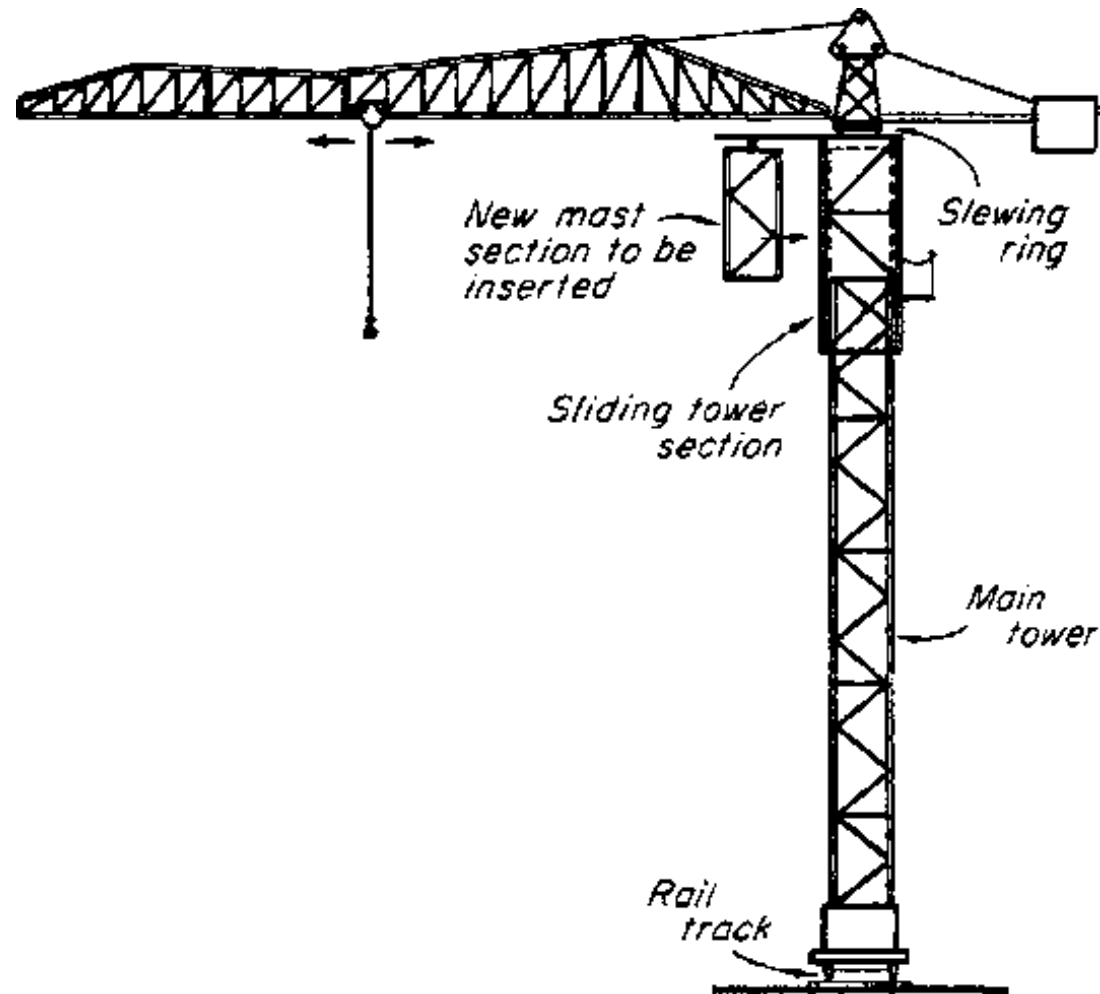

B Travelling crane with extending mast

Note: cranes such as A and B can be either stationary or travelling

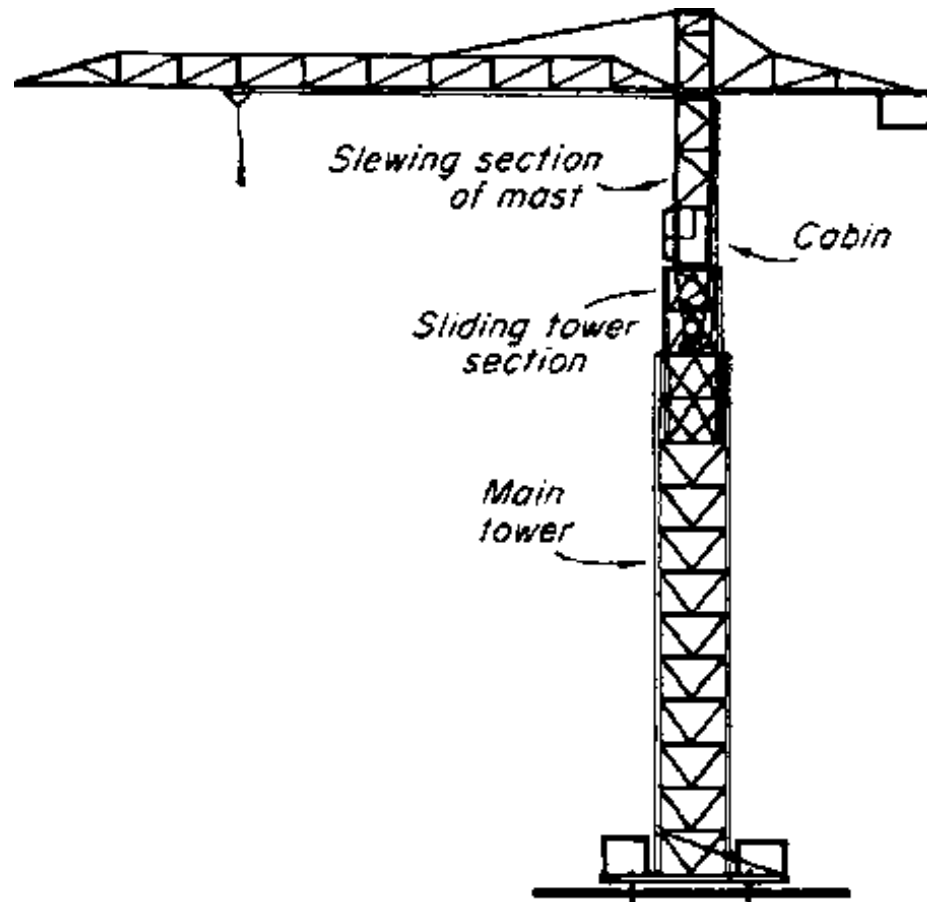

C Stationary crane with extending mast

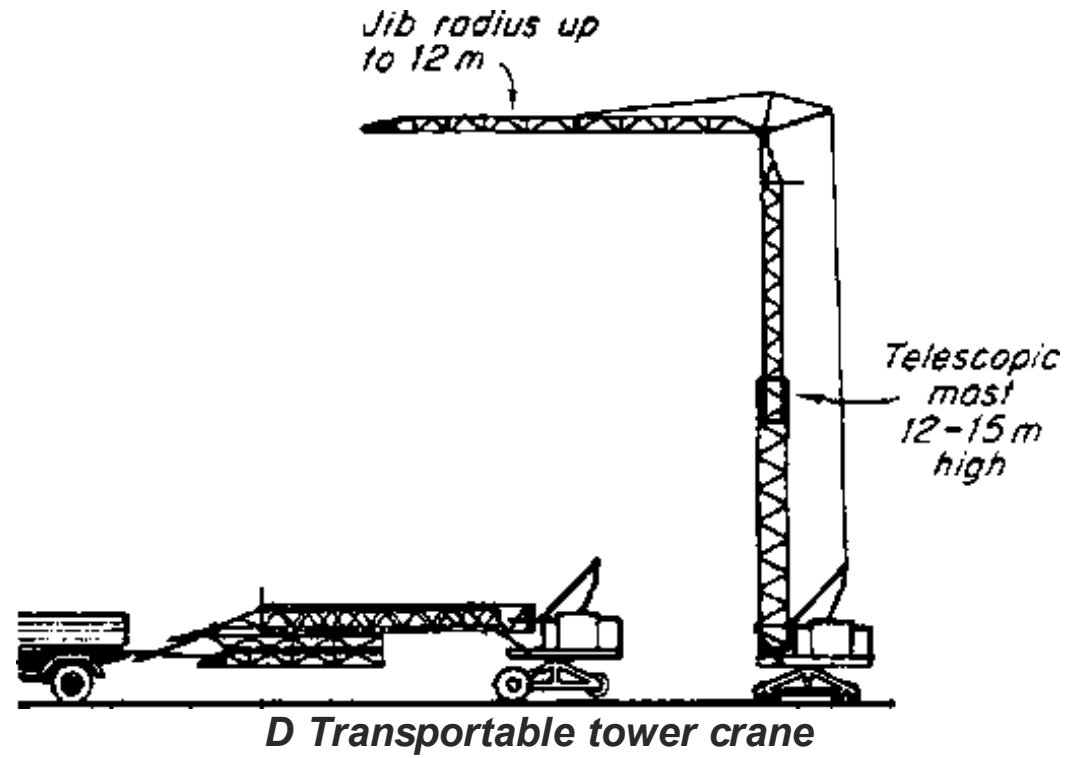

Hoists and elevators

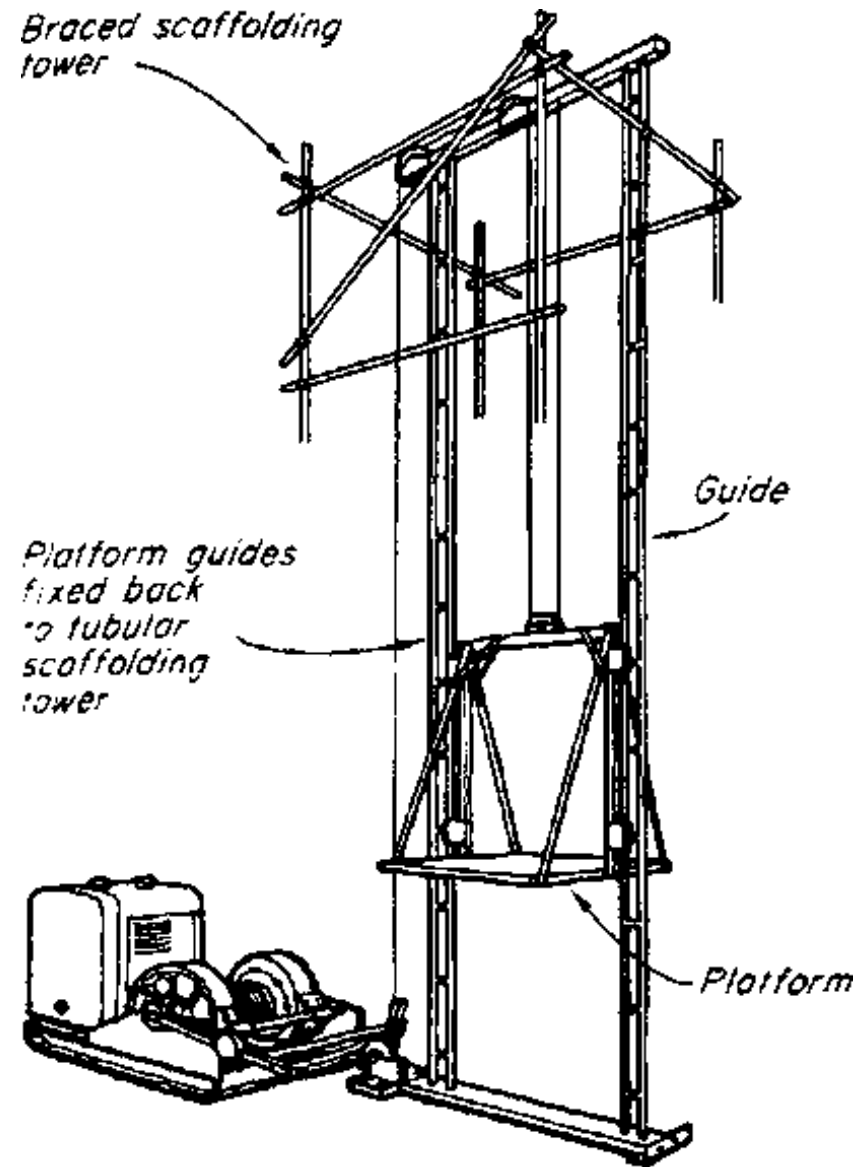

A High speed hoist

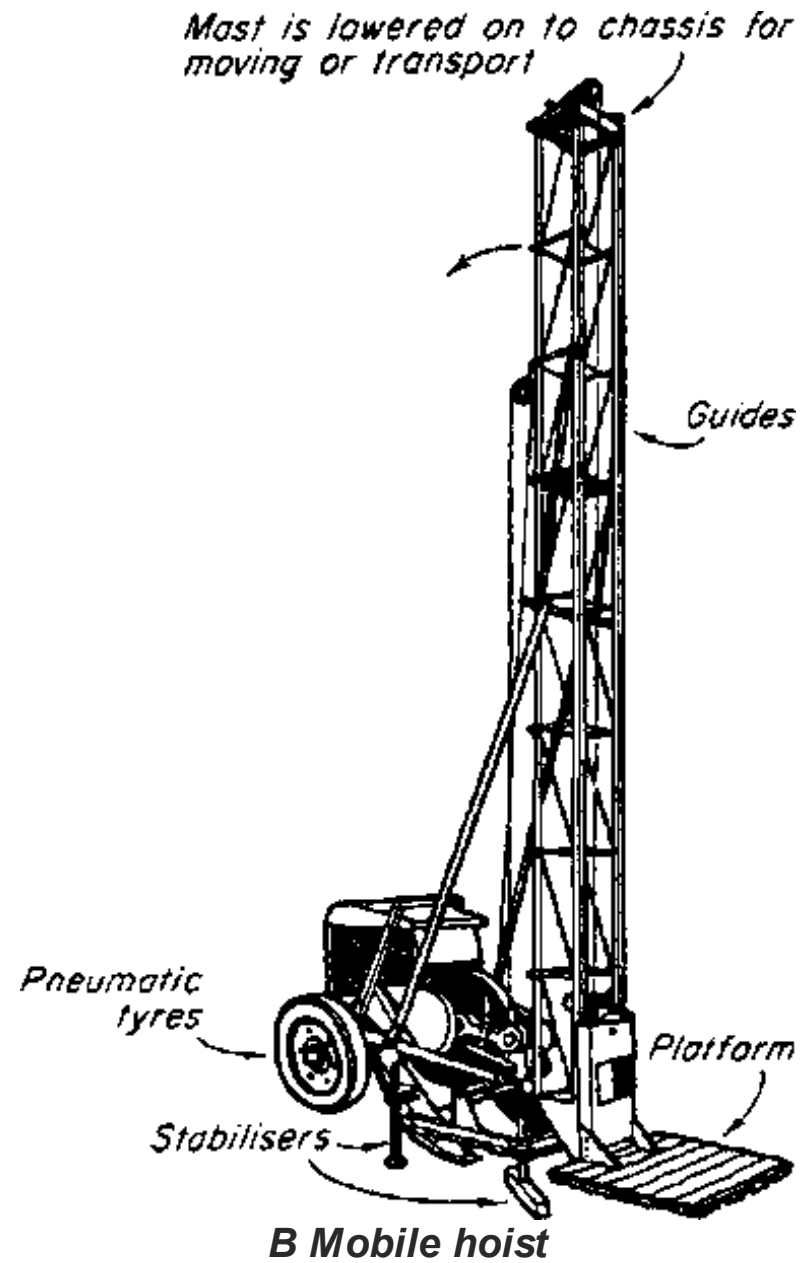

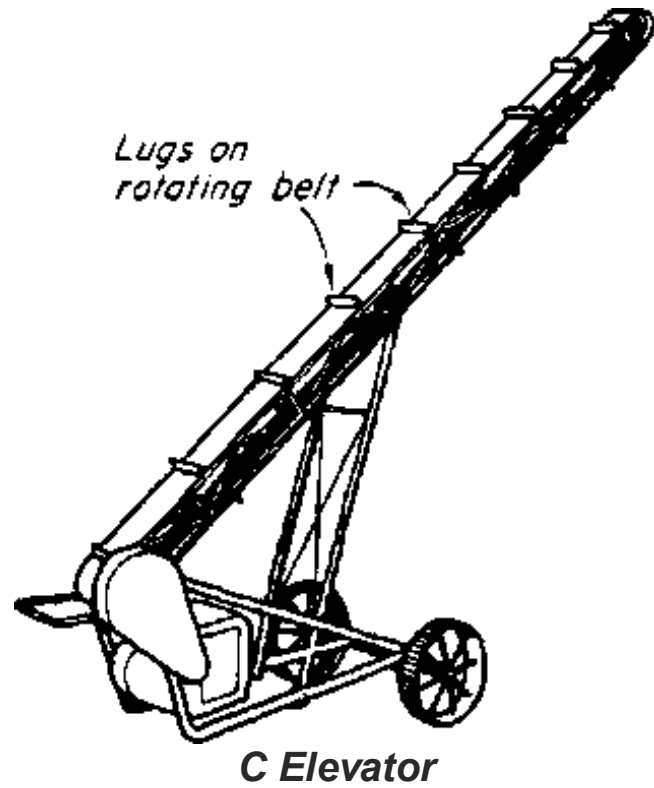

Transporting equipment

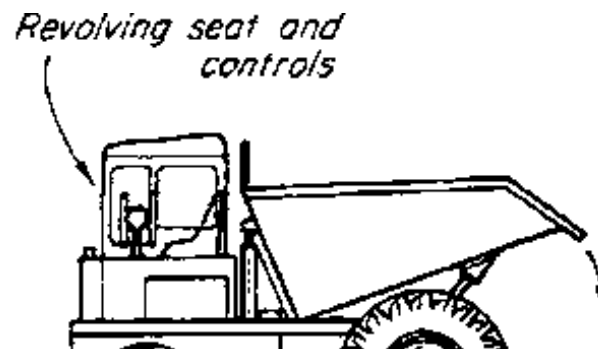



A Highway dumper

Tipping skip

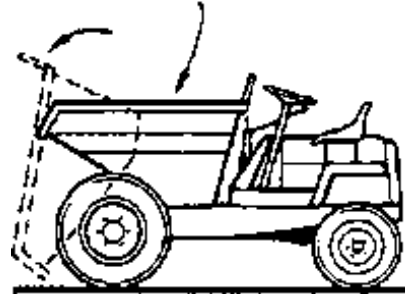

B Dumper

Tipping skip

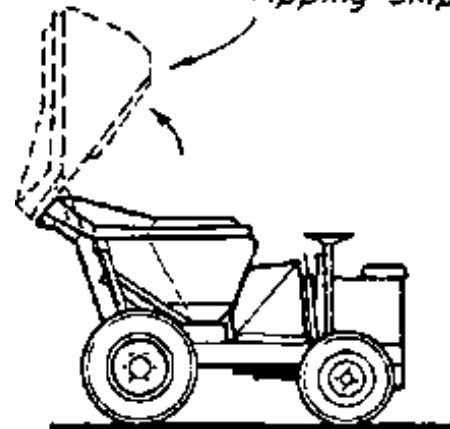

C High discharge dumper



D Powered barrow

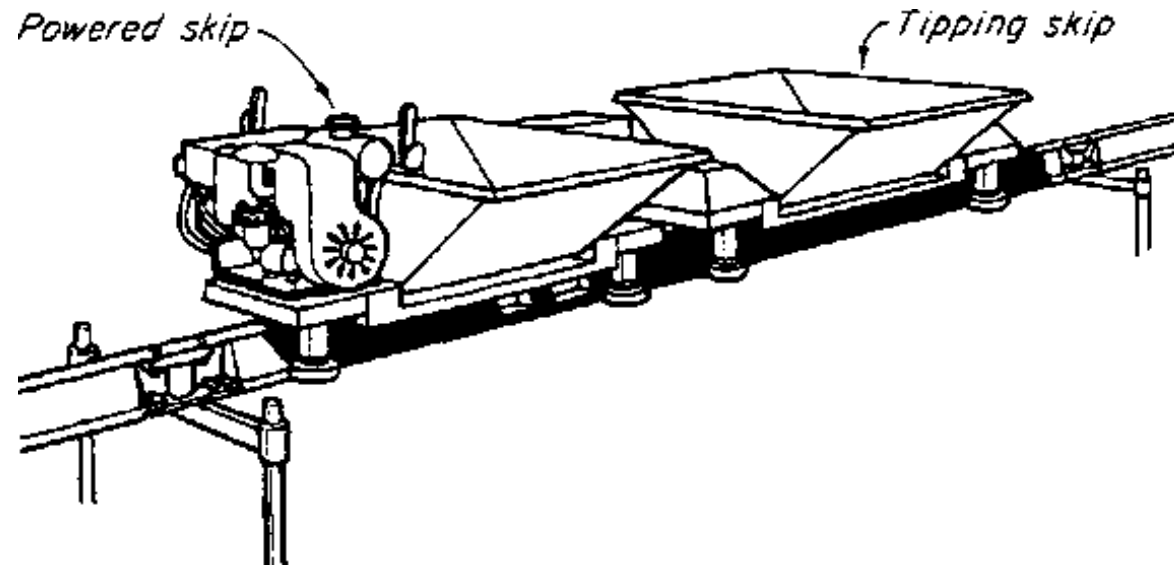

E Monorail transporter

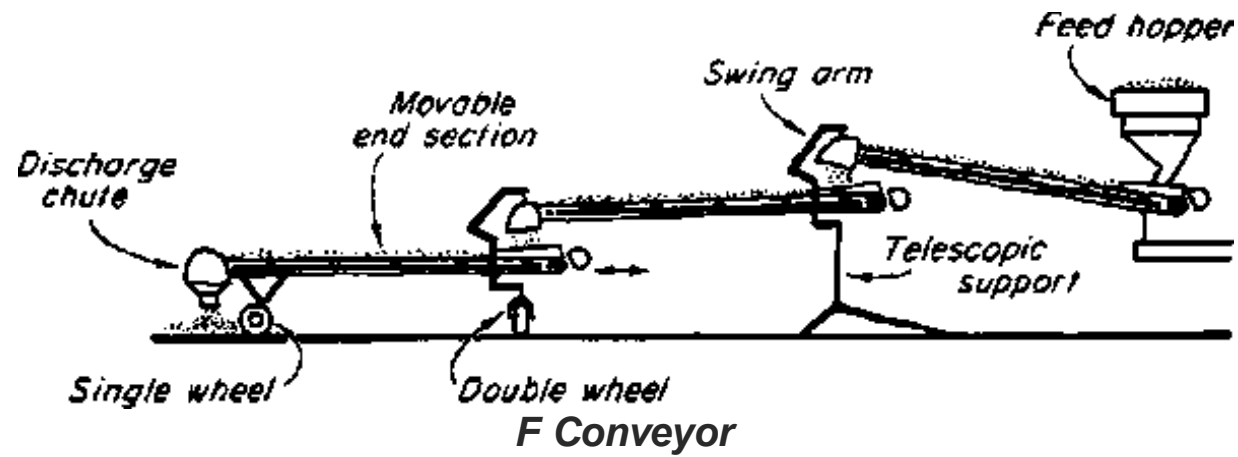

F Conveyor

Forklift trucks

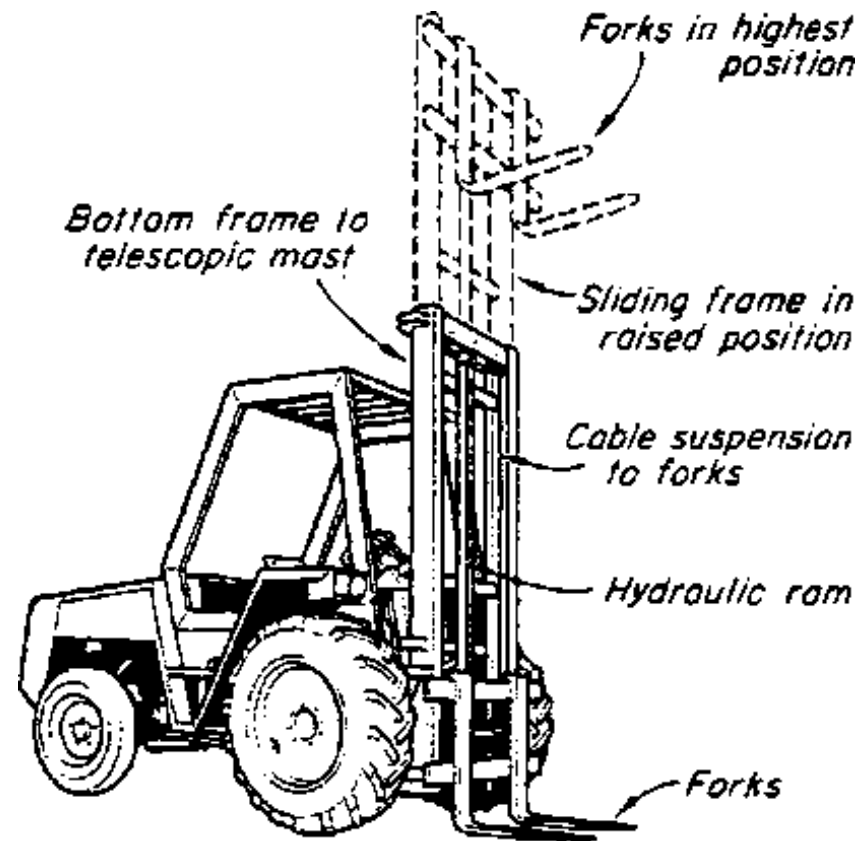

A Rough terrain forklift truck

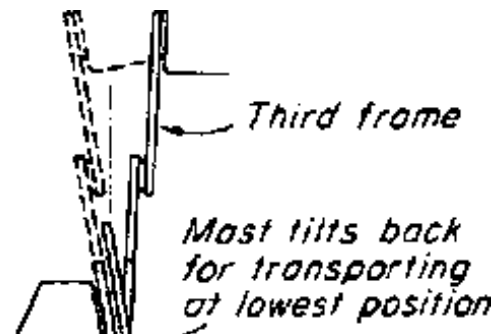

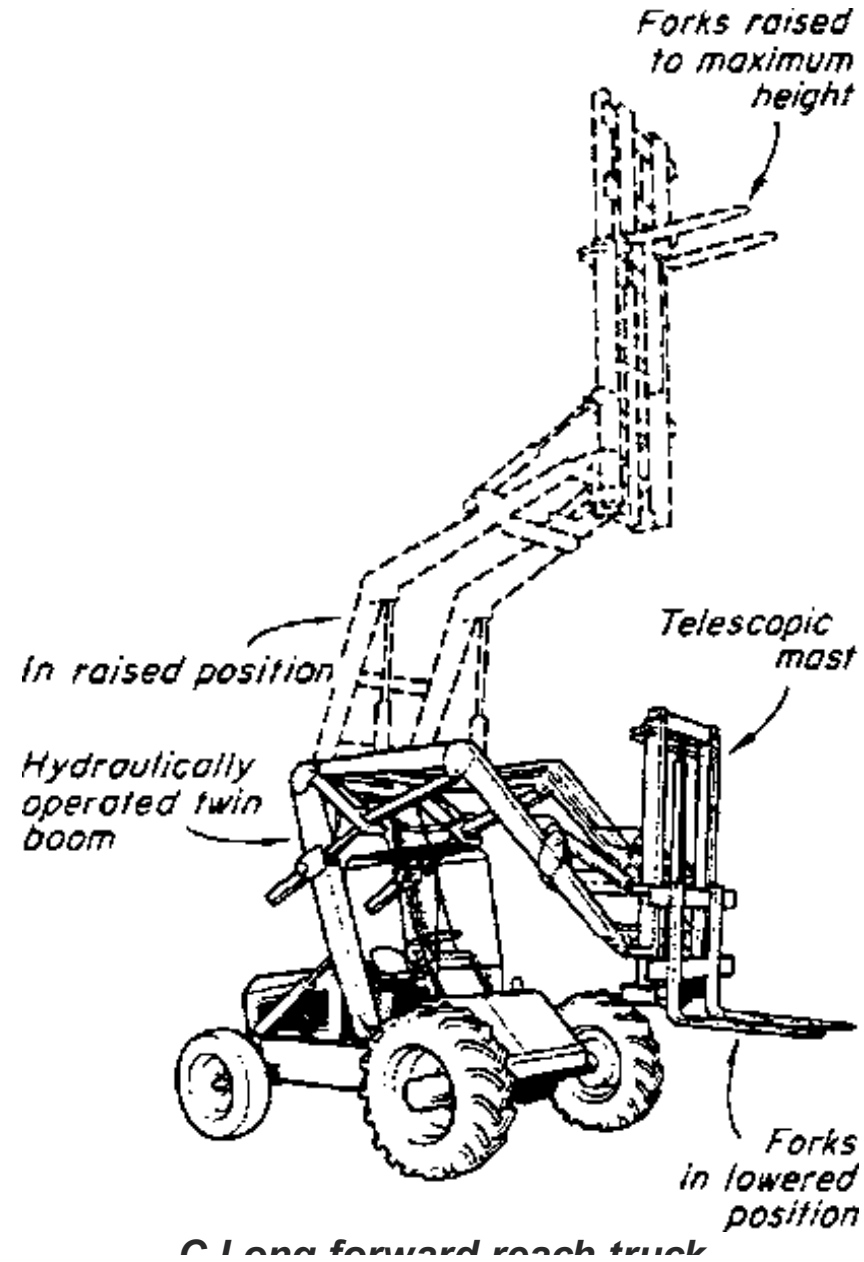

C Long forward reach truck

Concrete mixers

A Non-tilting drum mixer (reversing drum)

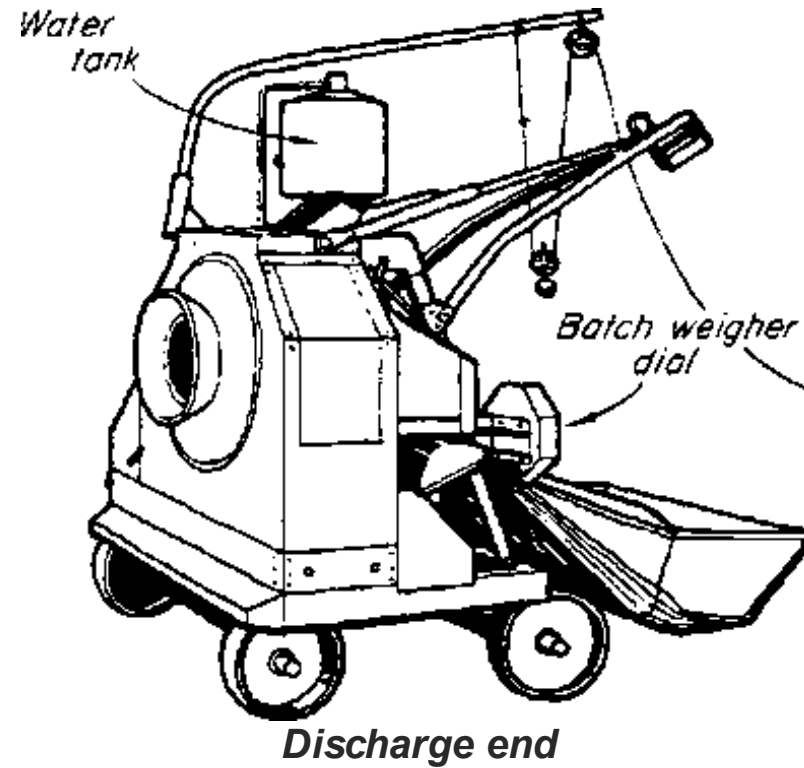

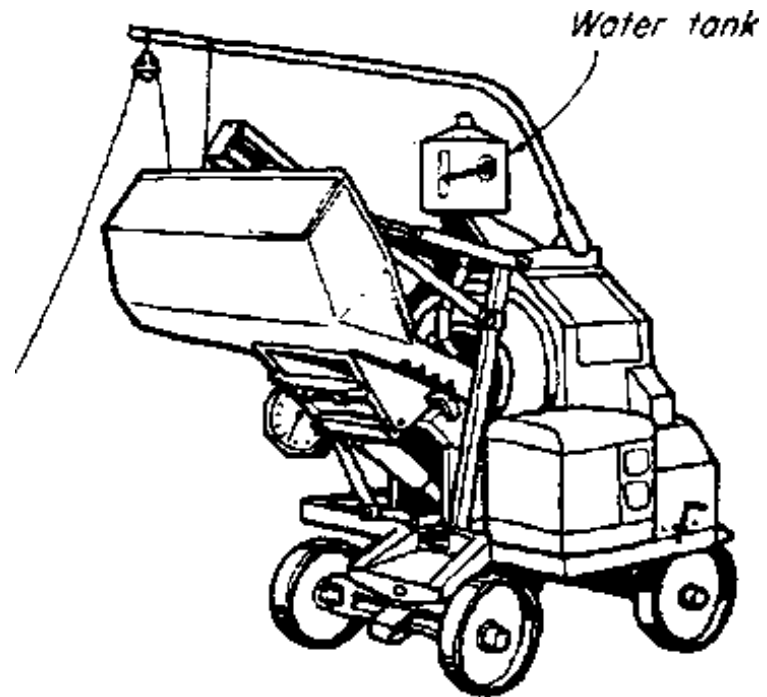

Loading of drum

B Tilting drum mixer

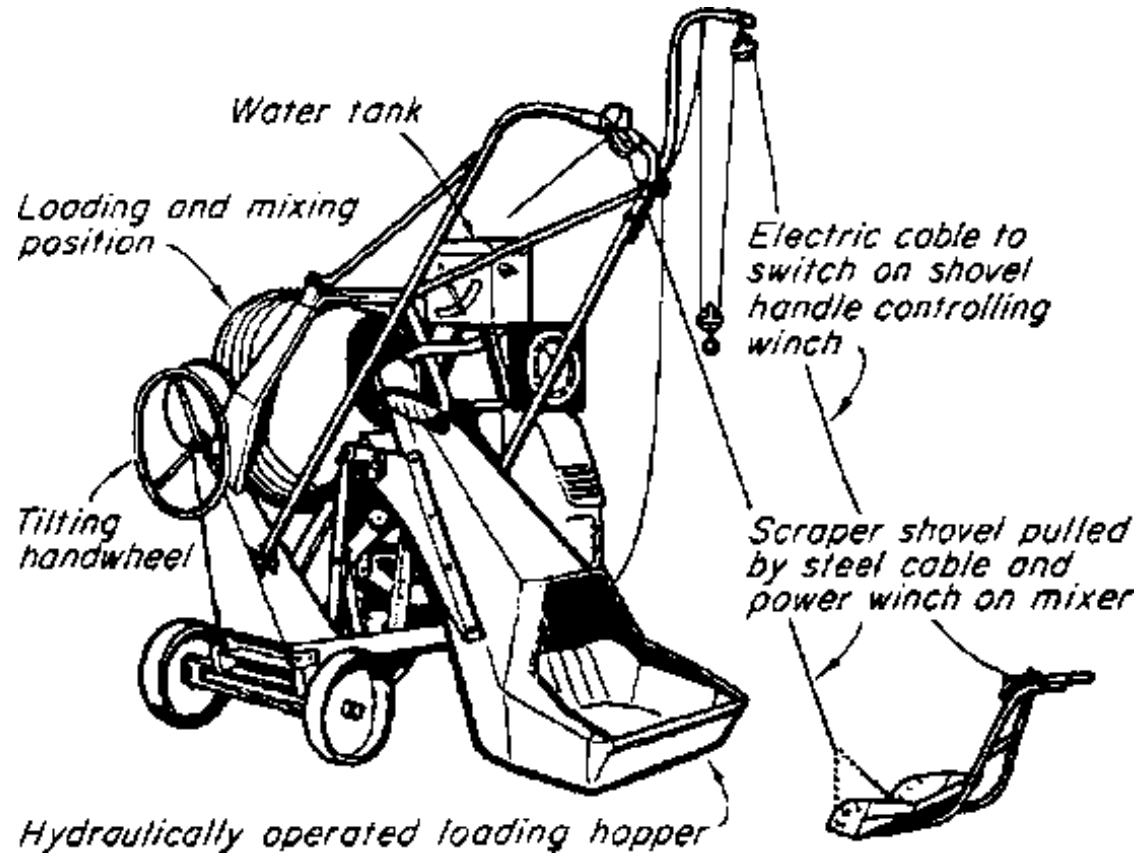

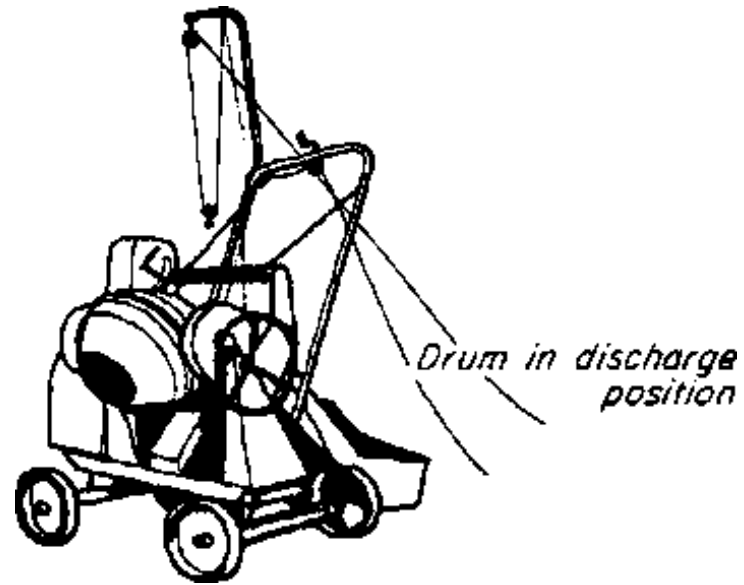

*Drum fixed
eccentrically to
tilting wheel*

*Loading and
mixing position*



C Small hand-fed tilting drum mixer

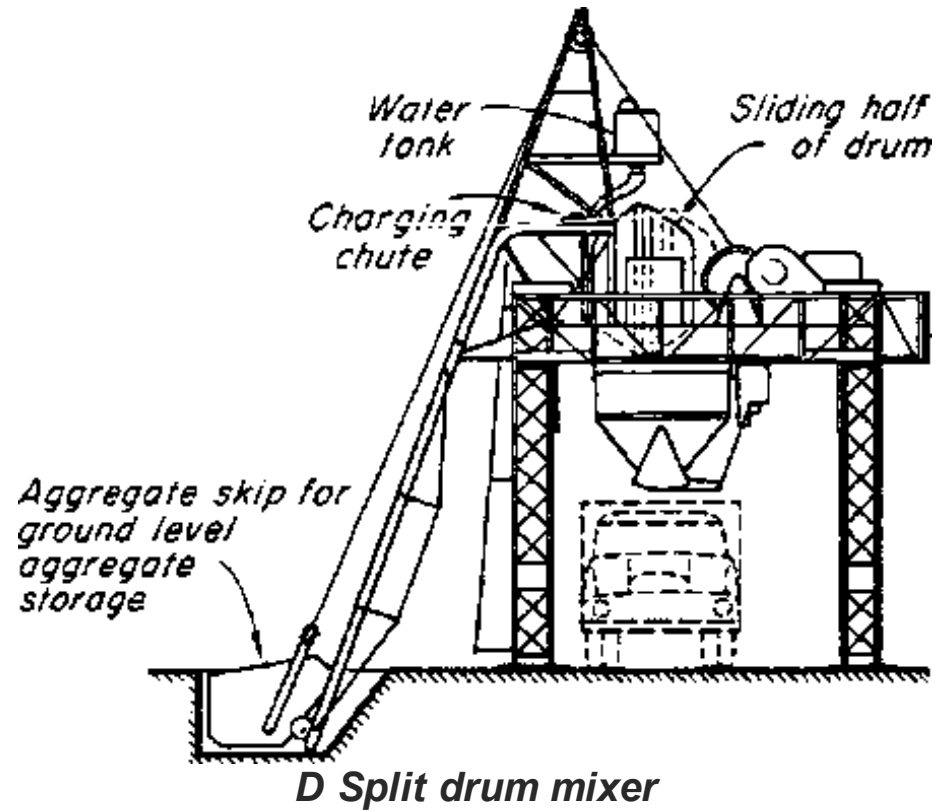

Concrete pumps and mixers

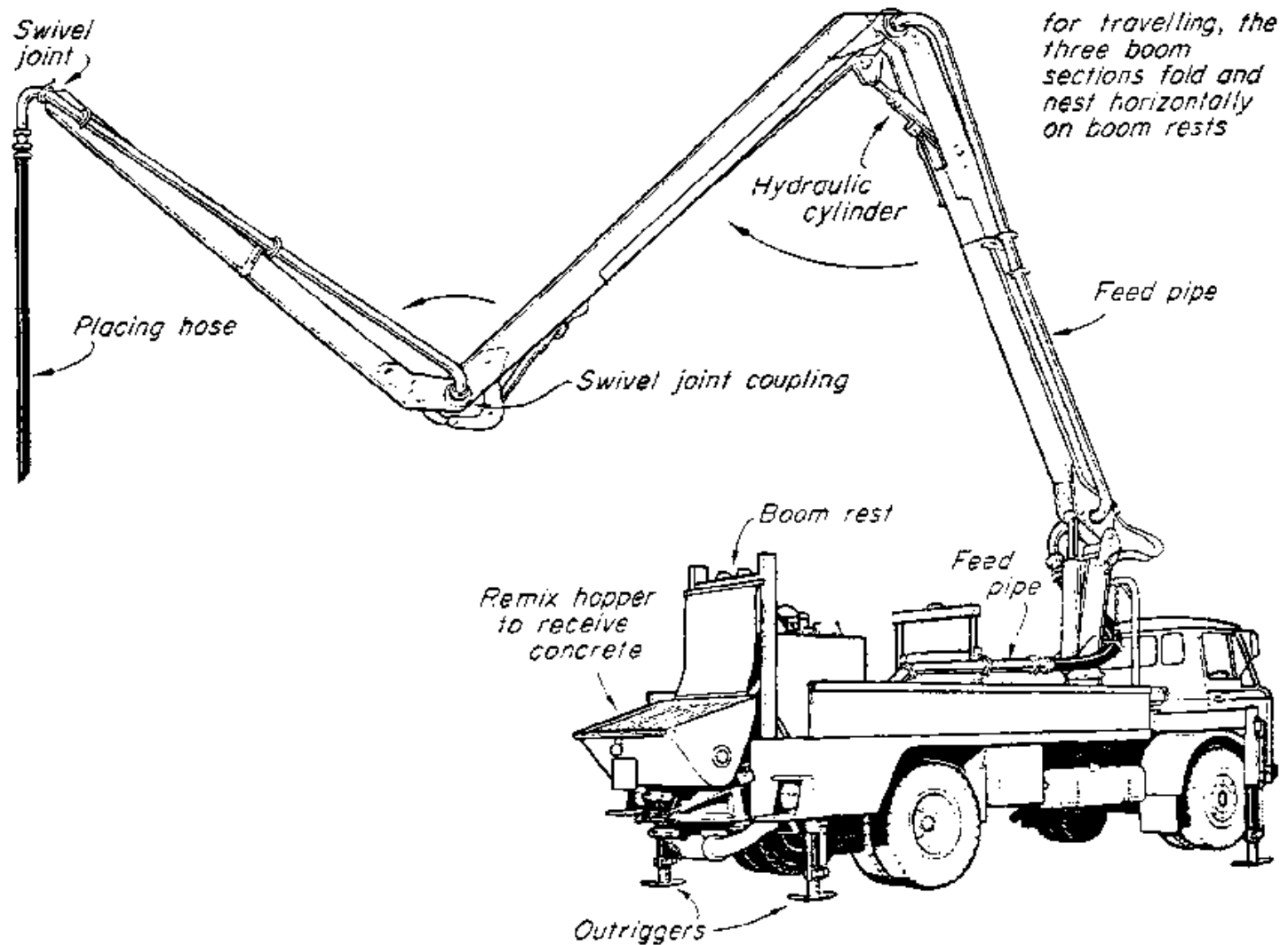

A. Mobile concrete pump

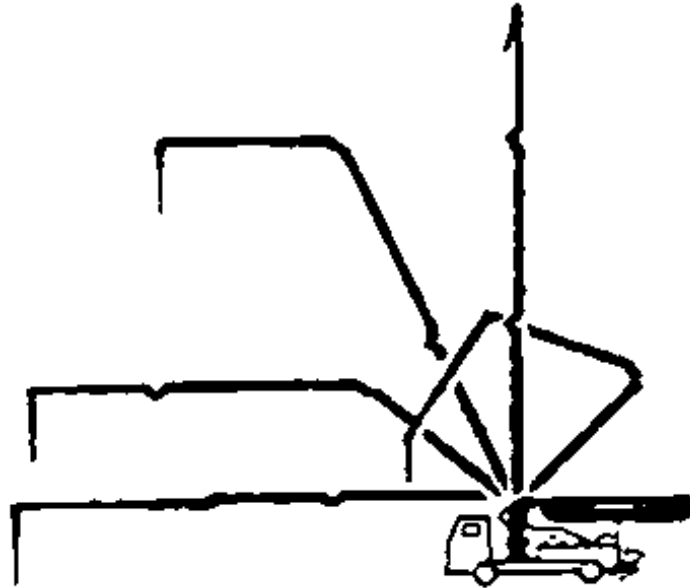

B. Various boom extensions

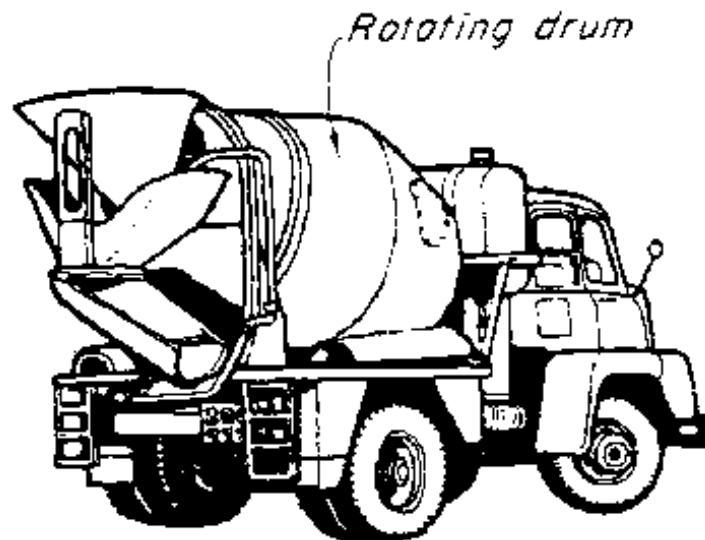

C. Truck mixer

Compressors and pumps

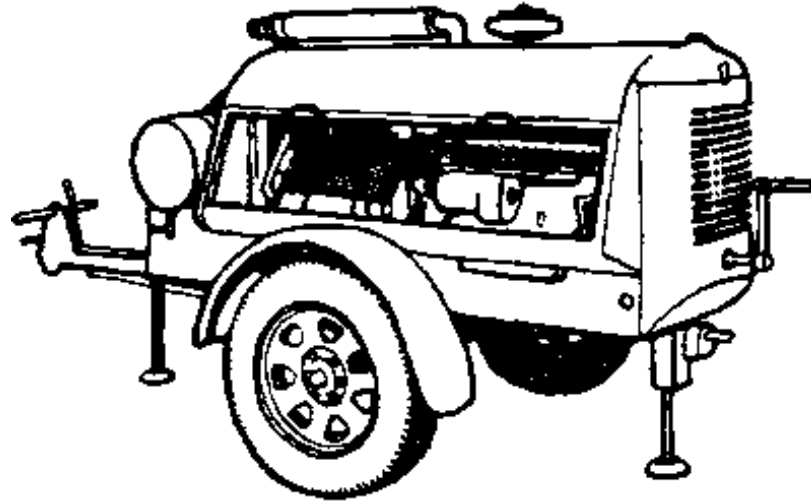

A. Compressor

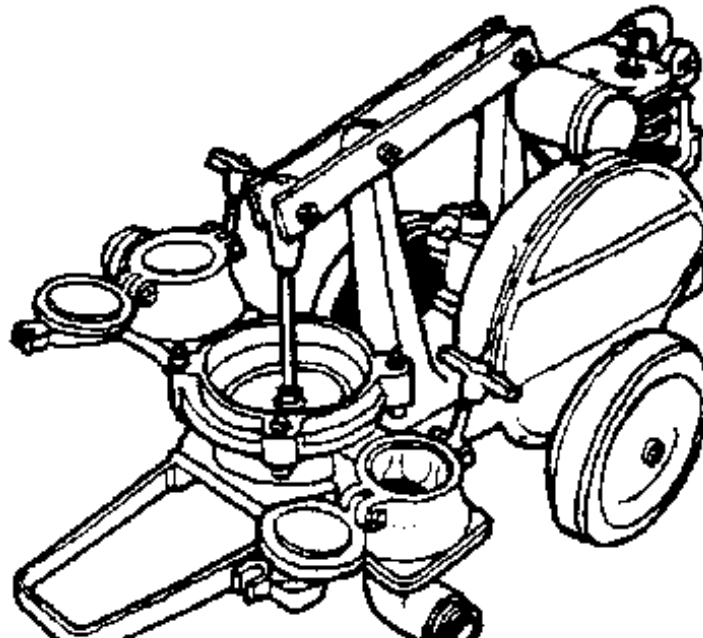

B. Single diaphragm pump

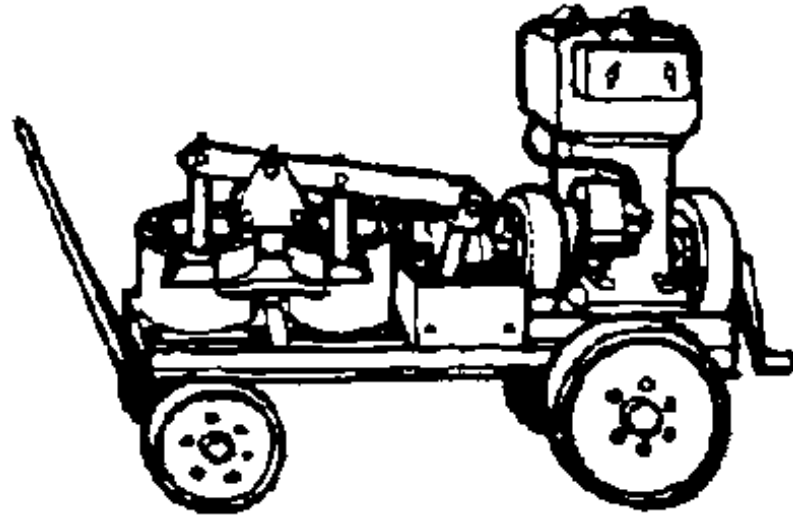

C. Double diaphragm pump

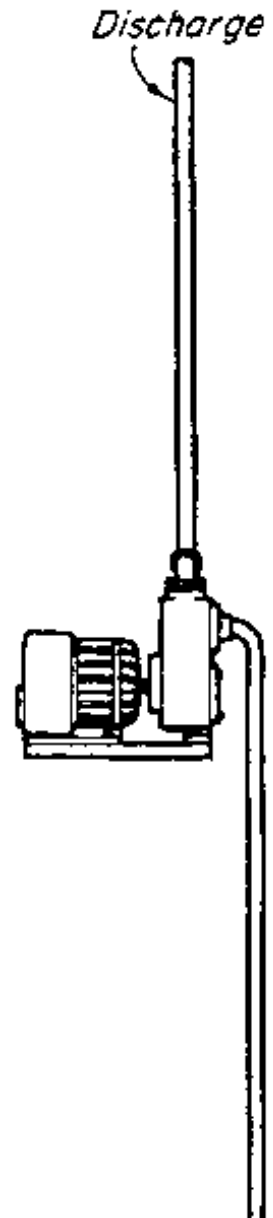



D. Centrifugal pump

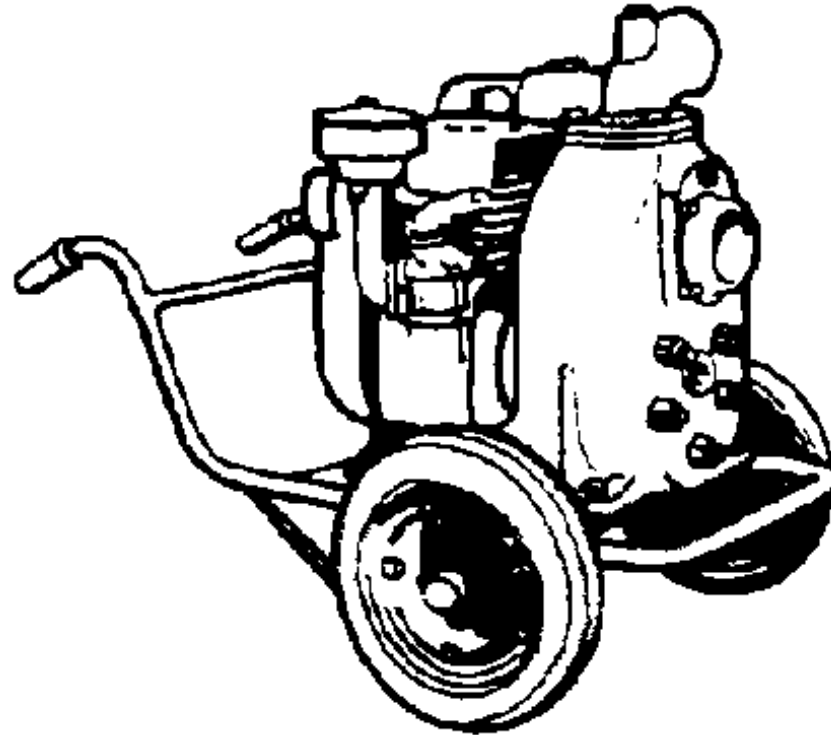

E. Mobile centrifugal pump





F. Submersible pump

POWER TOOLS

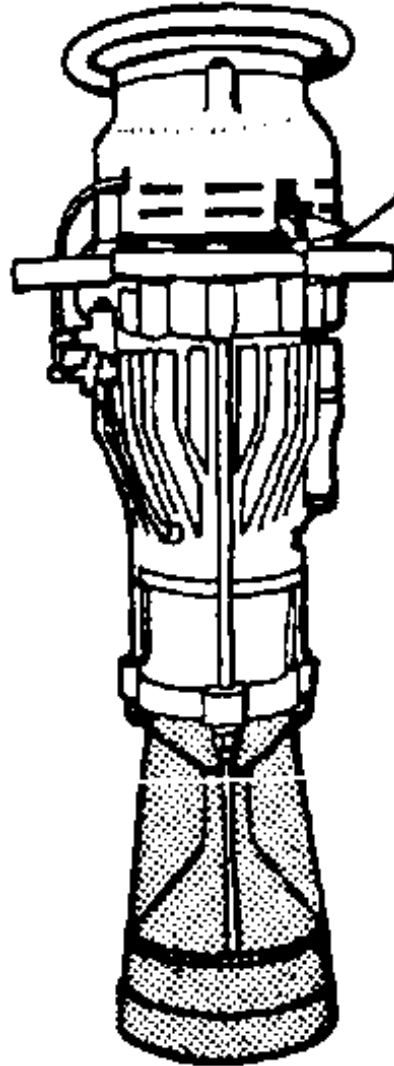

Rammer

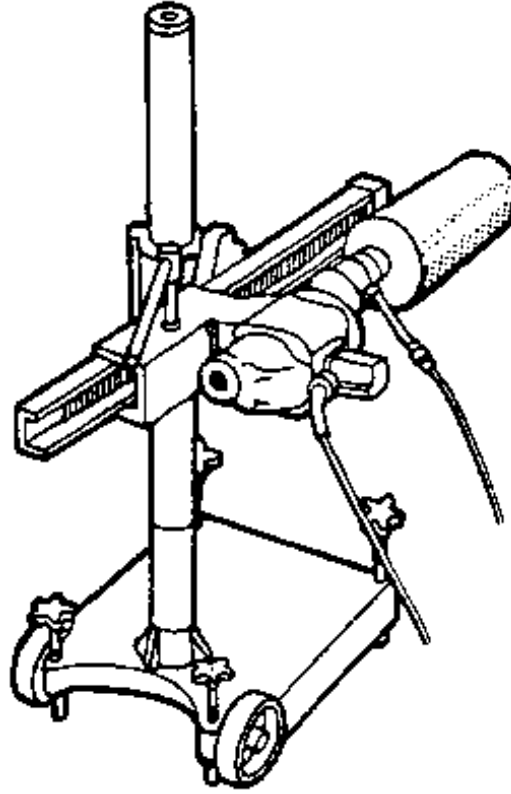

Rock drill

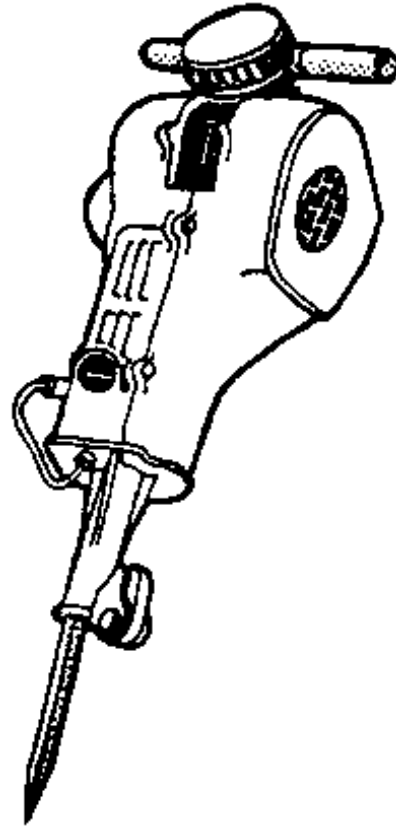

Pick

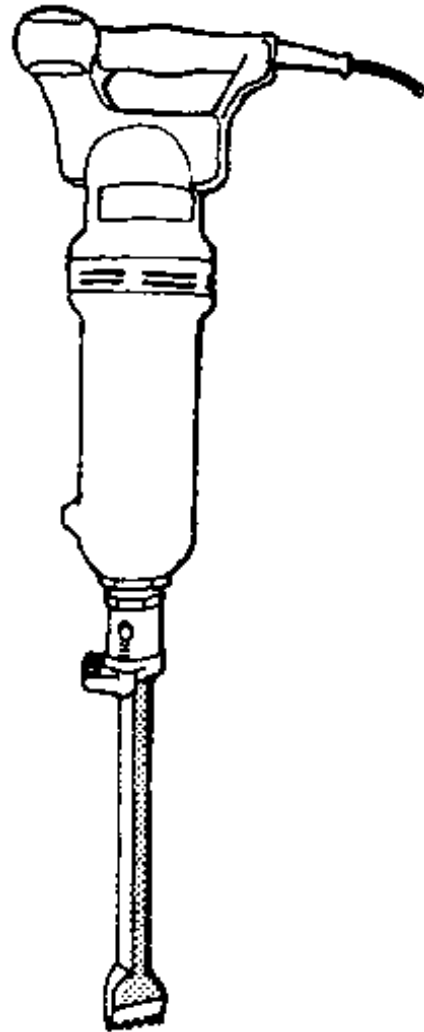

Hammer

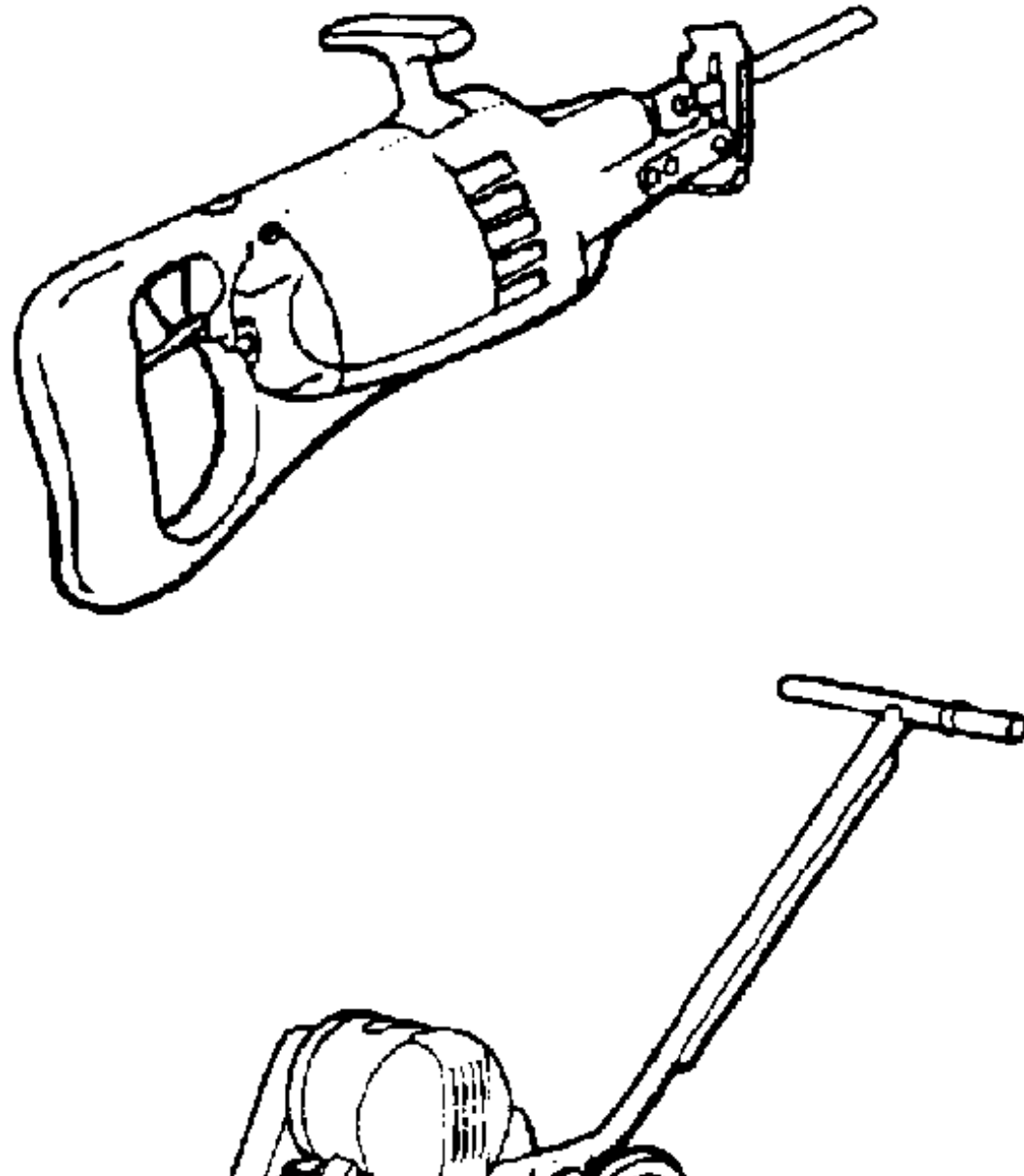



Metal disc

Power float

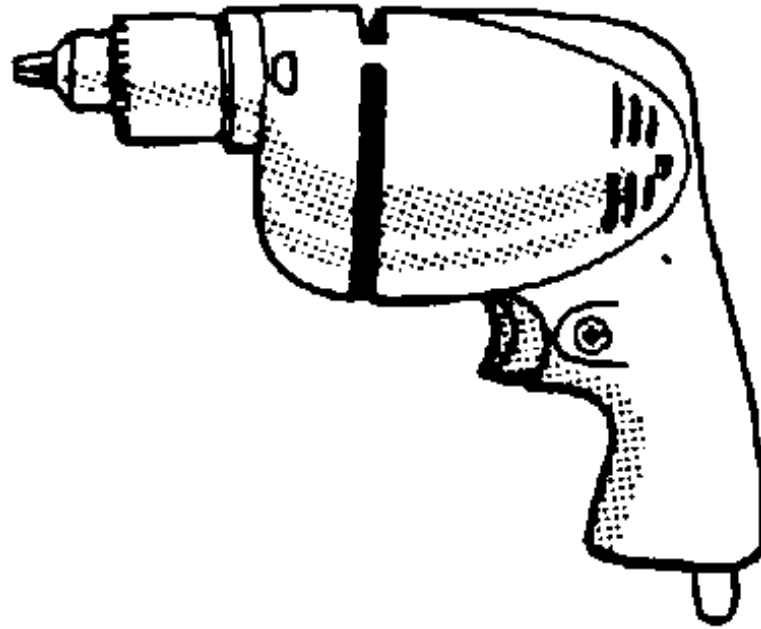

Rotary drill





Disc sander

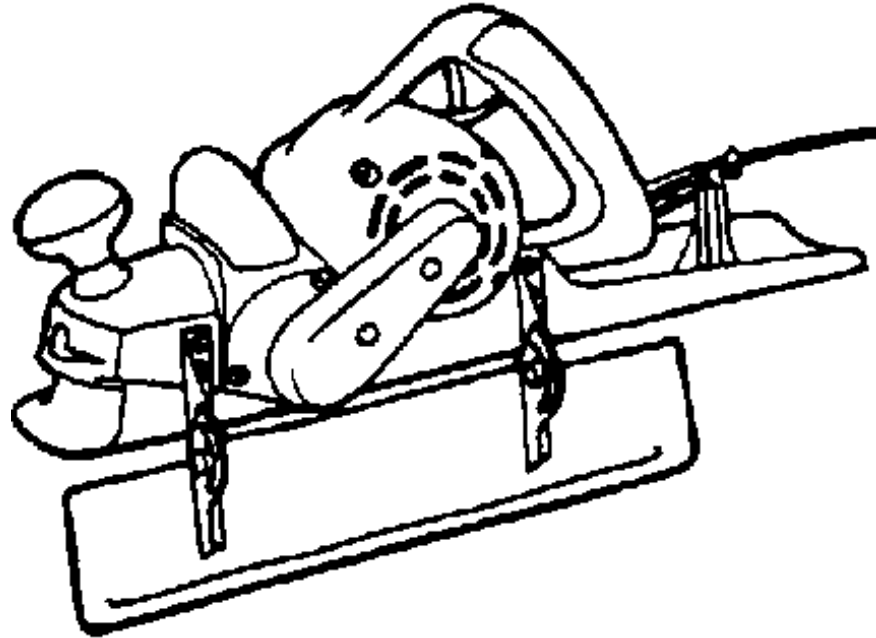

Planer

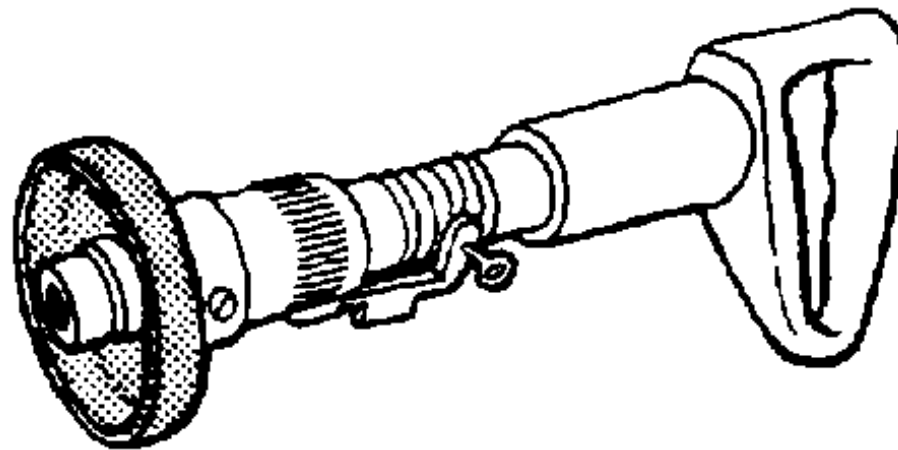

Cartridge hammer

~~Carriage Hammer~~

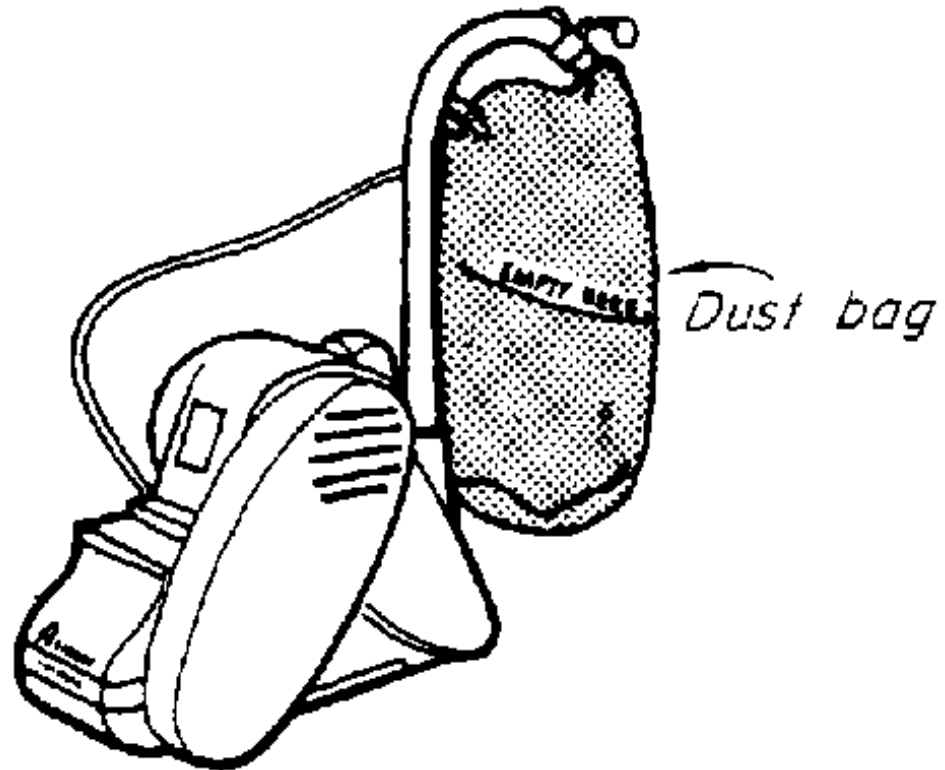

Drum sander

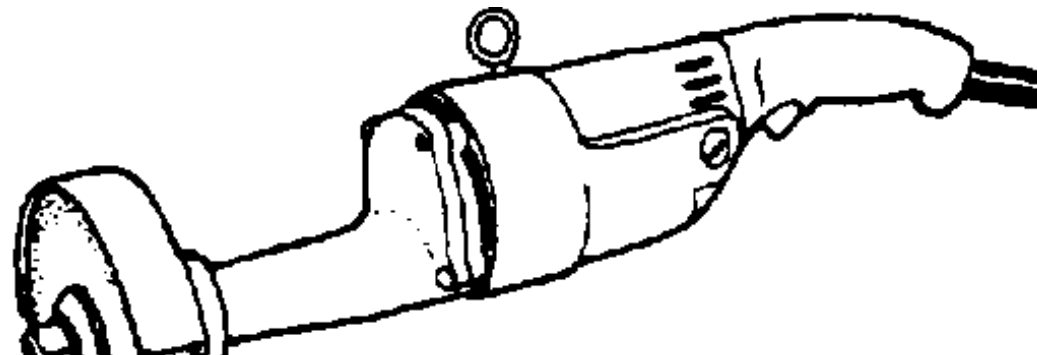



Hand grinder

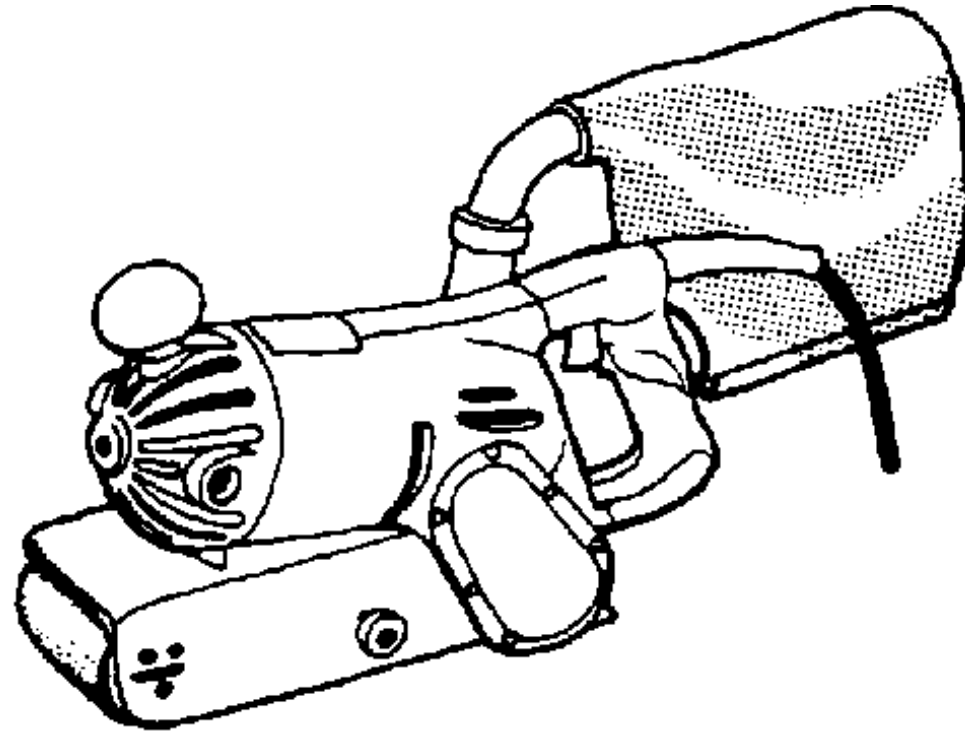

Belt sander

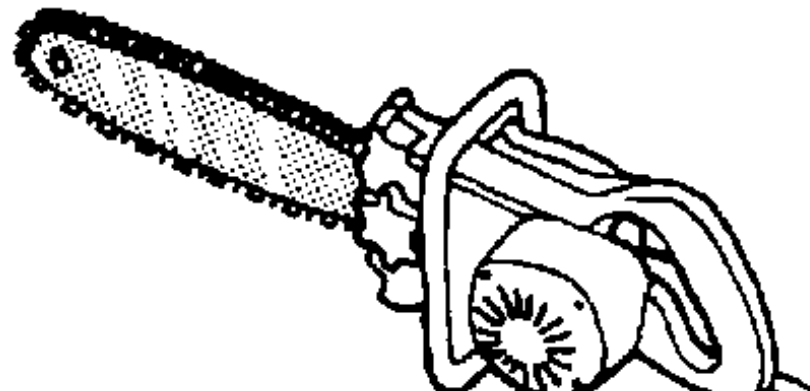



Chain saw

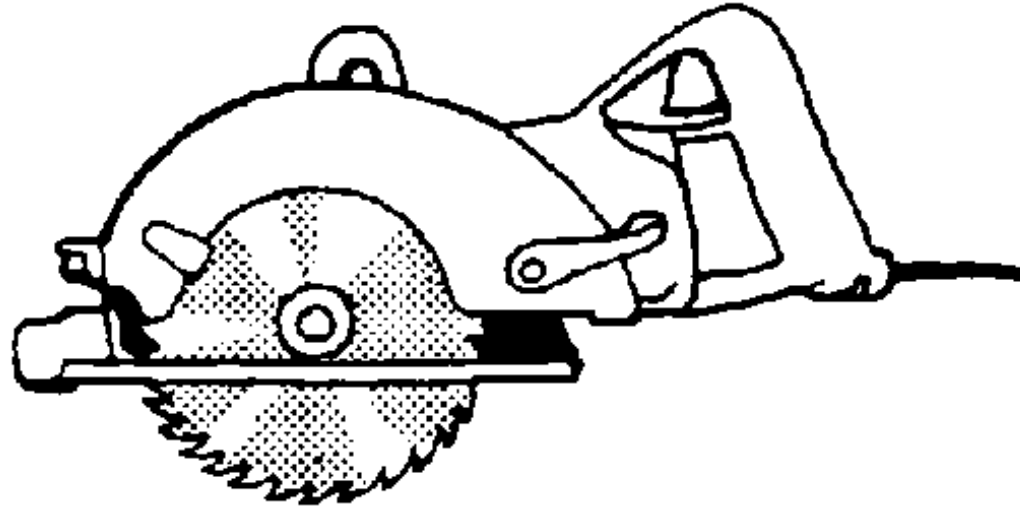

Circular saw

4.1.4.4 Scaffolding

A scaffold is a temporary structure from which persons can gain access to a place of work in order to carry out building operations, it includes any working platforms, ladders and guard rails. Baically there are two forms of scaffolding:

- 1) Putlog scaffolds.
- 2) Independent scaffolds.

wall under
construction

■ ■

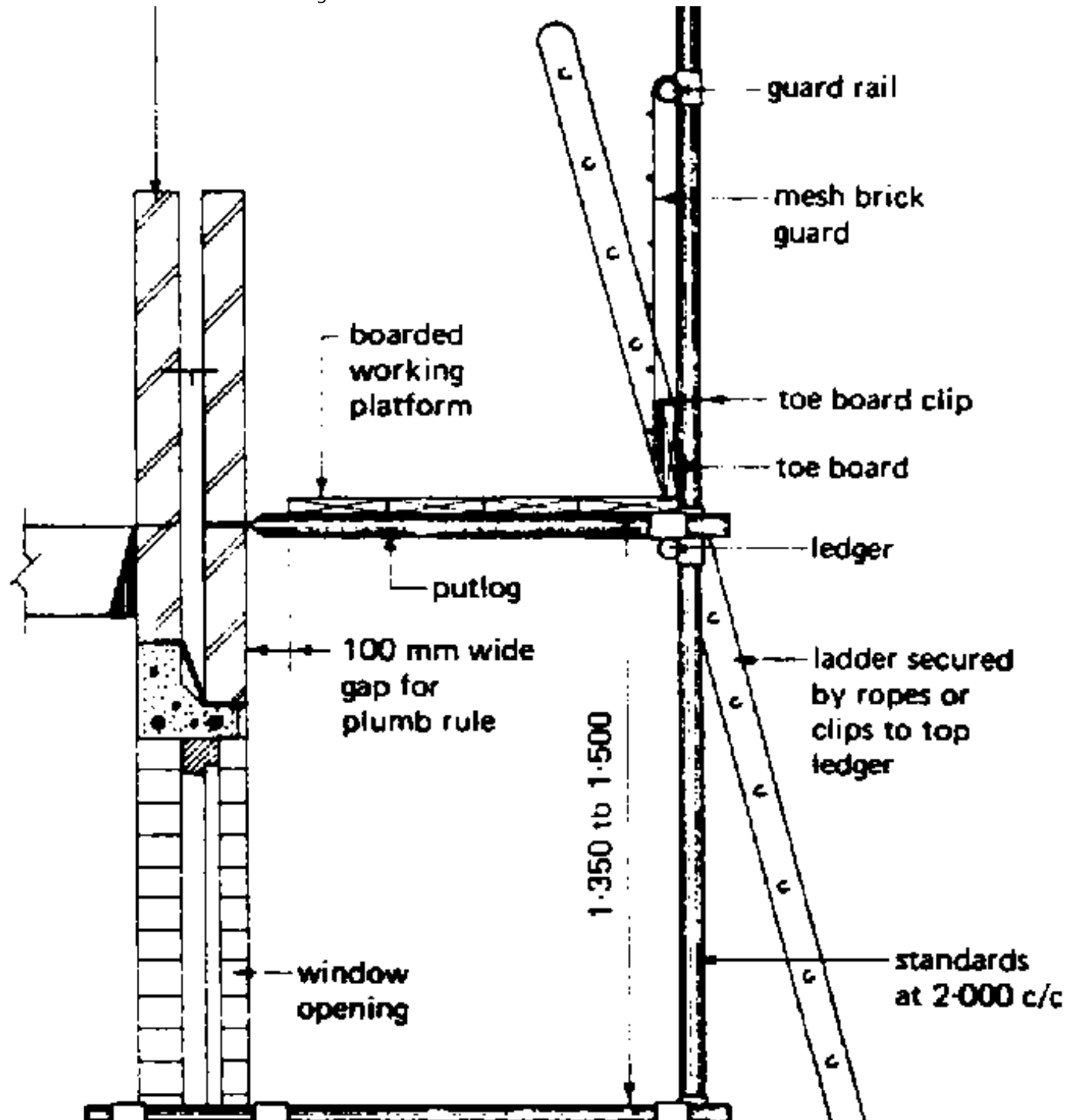

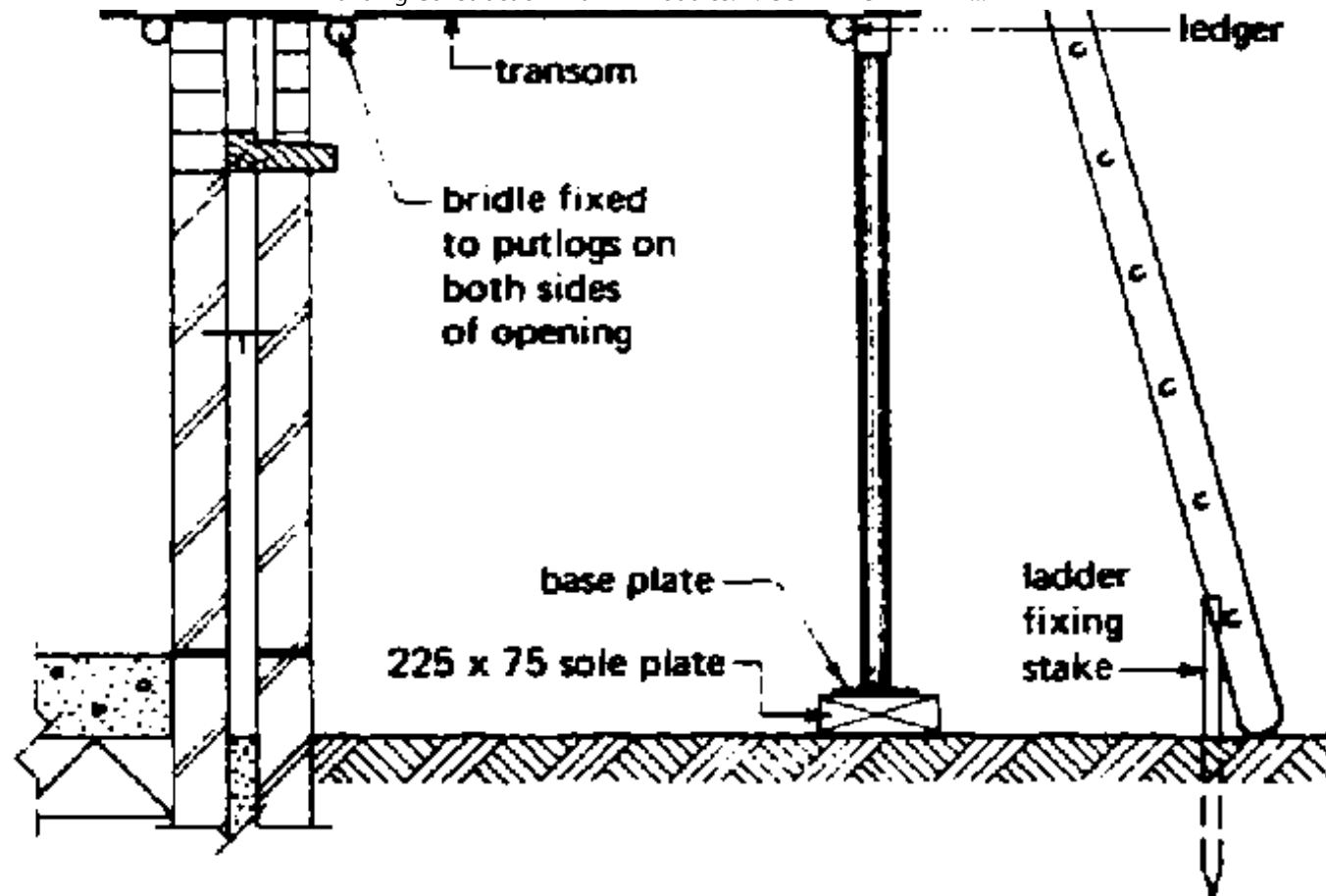

Typical tubular steel putlog scaffold

PUTLOG SCAFFOLDS This form of scaffolding consists of a single row of uprights or standards set away from the wall at a distance which will accommodate the required width of the working platform. The standards are joined together with horizontal members called ledgers and are tied to the building with cross members called putlogs. The scaffold is erected as the building rises and is mostly used for buildings of traditional brick construction (see Fig.).

INDEPENDENT SCAFFOLDS An independent scaffold has two rows of standards which are tied by cross members called transoms. This form of scaffold does not rely upon the building for support and is therefore suitable for use in conjunction with framed structures (see Fig.).

Every scaffold should be securely tied to the building at intervals of approximately 3.600 m vertically and 6.000 m horizontally. This can be achieved by using a horizontal tube called a bridle bearing on the inside of the wall and across a window opening with cross members connected to it (see Fig.);

alternatively a tube with a reveal pin in the opening can provide a connection point for the cross members (see Fig.). If suitable openings are not available then the scaffold should be strutted from the ground using raking tubes inclined towards the building.

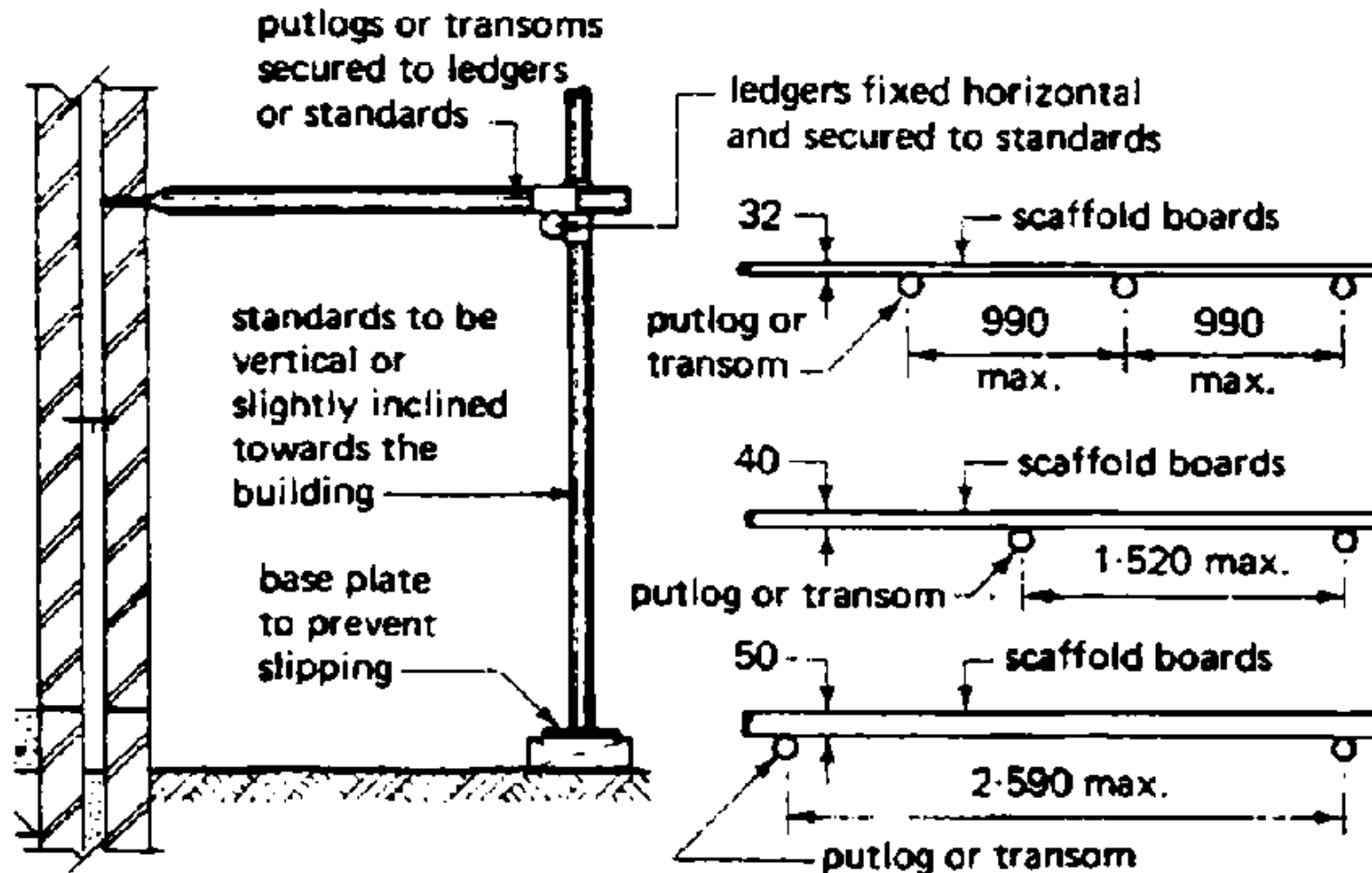

Scaffolds and Construction Regulations

Regulation 13 ~ Standards, putlogs and transoms

MATERIALS Scaffolding can be of:

- 1) Tubular steel
- 2) Tubular aluminium alloy
- 3) Timber

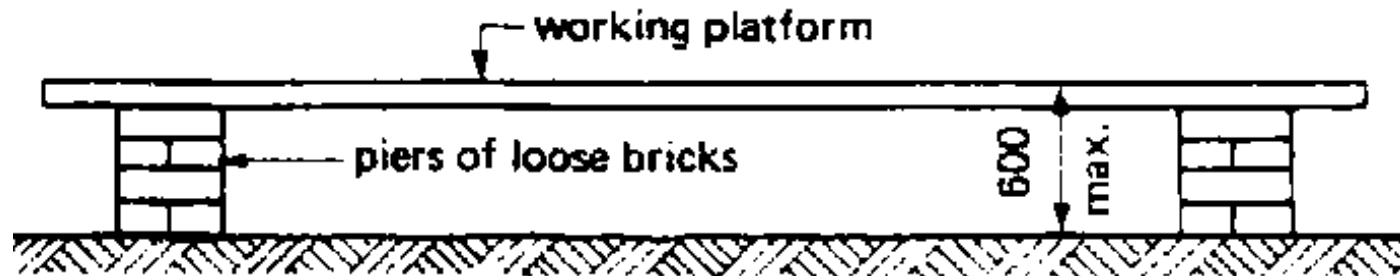

Regulation 15 ~ Stability of scaffolds

TUBULAR STEEL British Standard 1139 gives recommendations for both welded and seamless steel tubes of 48mm outside diameter with a nominal 38 mm bore diameter. Steel tubes can be obtained galvanised (to guard against corrosion); ungalvanised tubes will require special care such as painting, varnishing or an oil bath after use. Steel tubes are nearly three times heavier than comparable aluminium alloy tubes but are far stronger and since their deflection is approximately one third of aluminium alloy tubes, longer spans can be used.

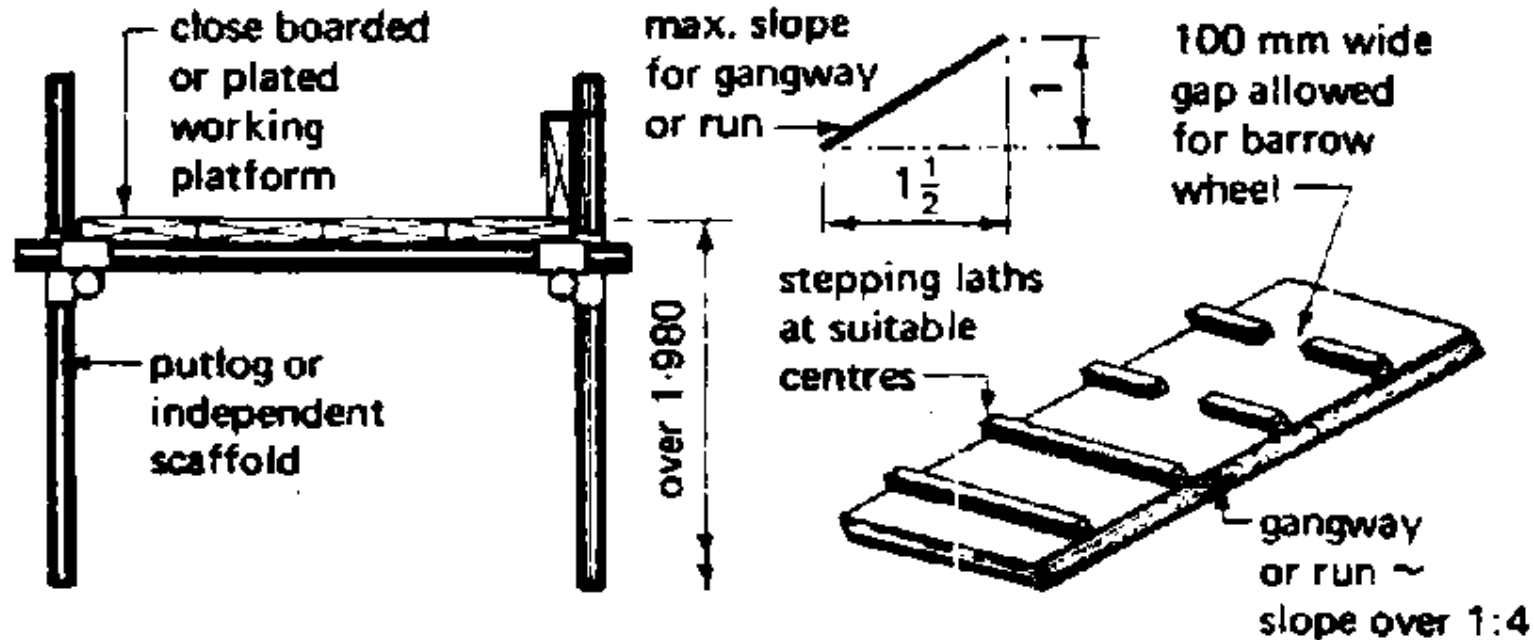

Regulation 24 ~ Platforms, gangways and runs

ALUMINIUM ALLOY Seamless tubes of aluminium alloy with a 48 mm outside diameter are specified in BS 1139 for metal scaffolding. No protective treatment is required unless they are to be used in contact with materials such as damp lime, wet cement and sea water, which can cause corrosion of the aluminium alloy tubes. A suitable protective treatment would be to coat the tubes with bitumastic paint before use.

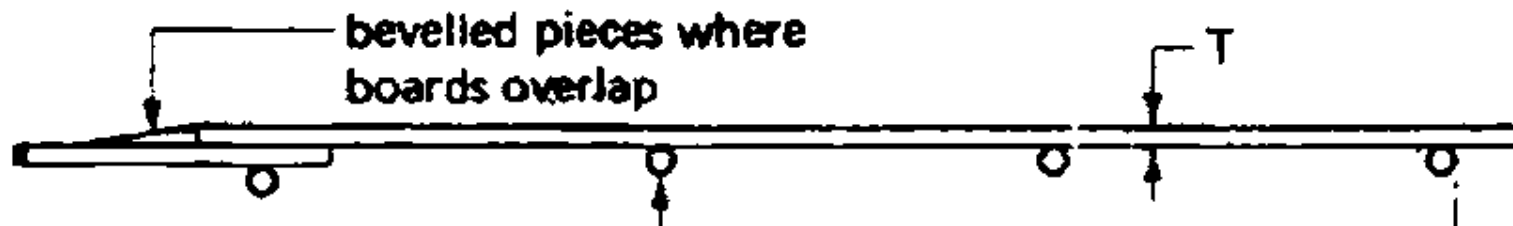

**NB platform to extend
600 mm beyond end
of working face
wherever practicable**

max. overhang $4 \times T$

**boards evenly supported on at
least 3 supports per board length**

Regulation 25 ~ Boards in working platforms

TIMBER The use of timber as a temporary structure in the form of a scaffold is now rarely encountered in this country, although it is still used extensively in other countries. The timber used is fir of structural quality in either putlog or independent format, the members being lashed together with wire or rope instead of the coupling fittings used with metal scaffolds.

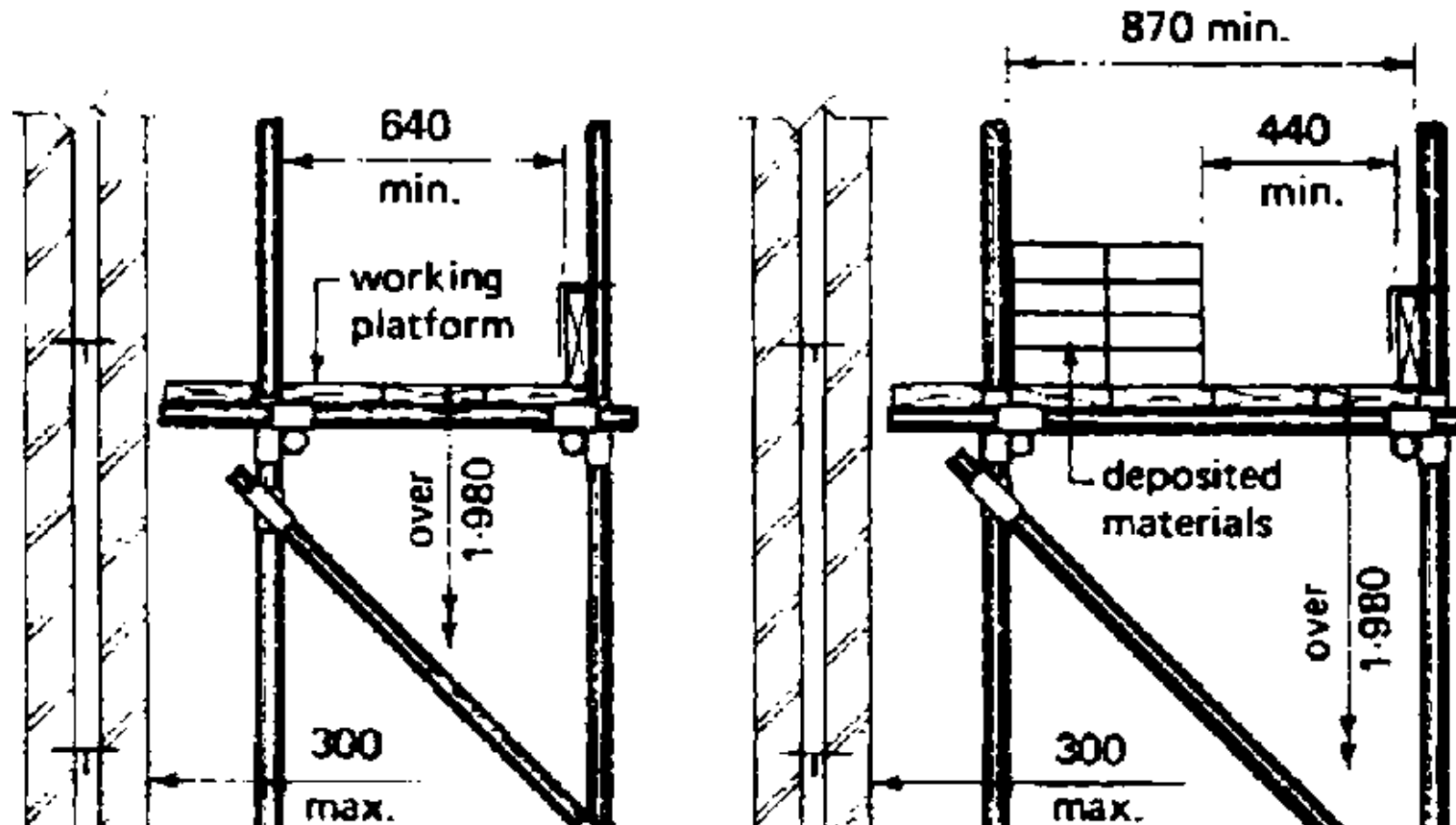

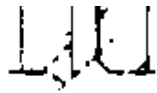

**clear passage way for
persons or materials**



deposit of materials



Regulation 26 ~ Widths of working platforms for putlog and independent scaffolds

SCAFFOLD BOARDS These are usually boards of softwood timber complying with the recommendations of BS 2482 used to form the working platform at the required level. They should be formed out of specified softwoods of 225 x 38 section and not exceeding 4.800 m in length. To prevent the ends from splitting they should be end bound with not less than 25 mm wide x 0.9 mm galvanised hoop iron extending at least 150 mm along each edge and fixed with a minimum of two fixings to each end. The strength of the boards should be such that they can support a uniformity distributed load of 6.7 kN/M² when supported at 1.200m centres.

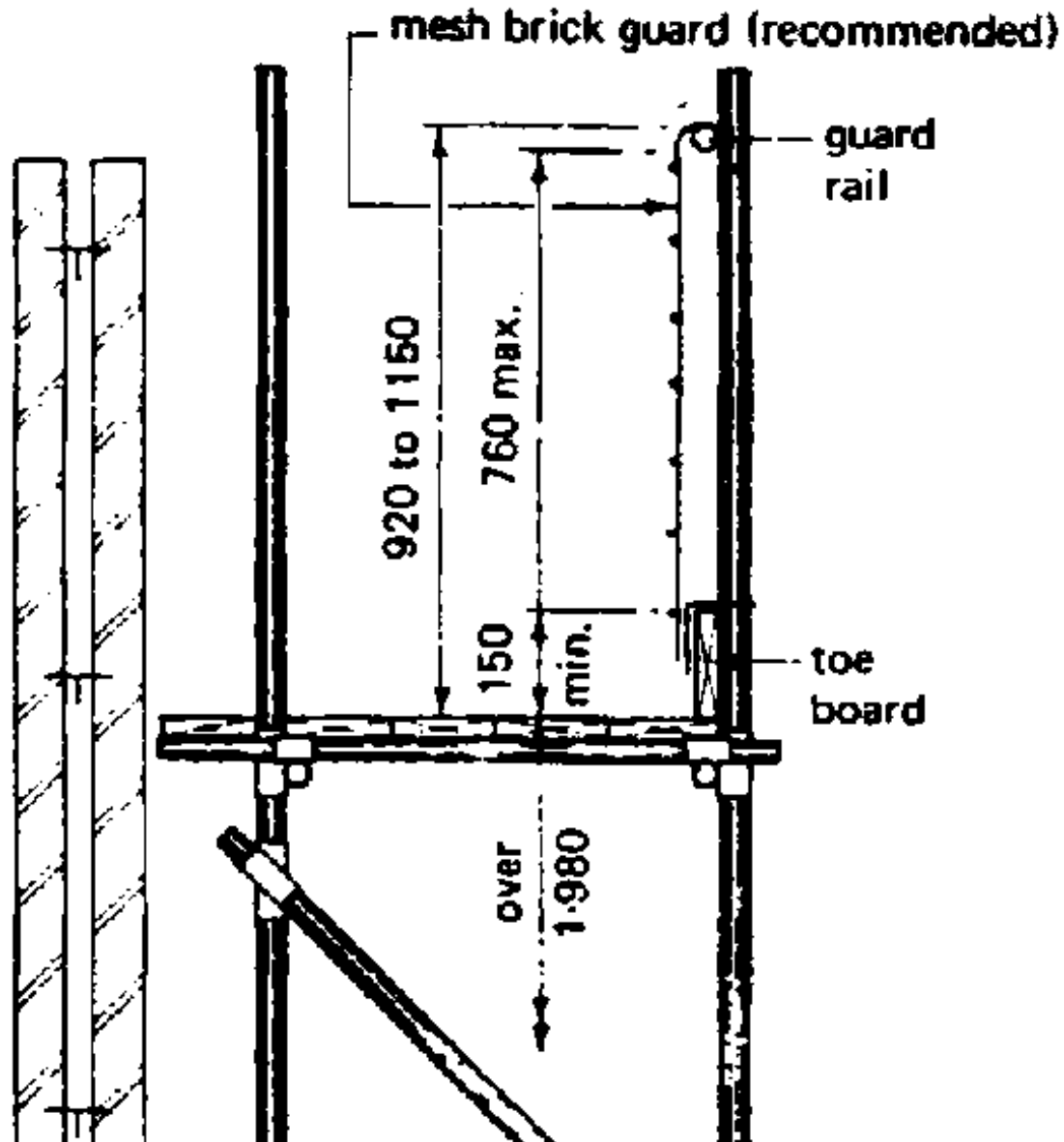

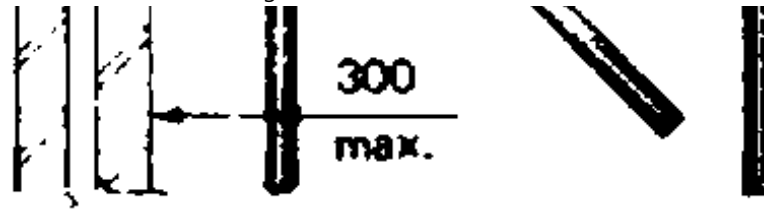

Regulation 28 ~ Guard rails and toe boards for putlog and independent scaffolds

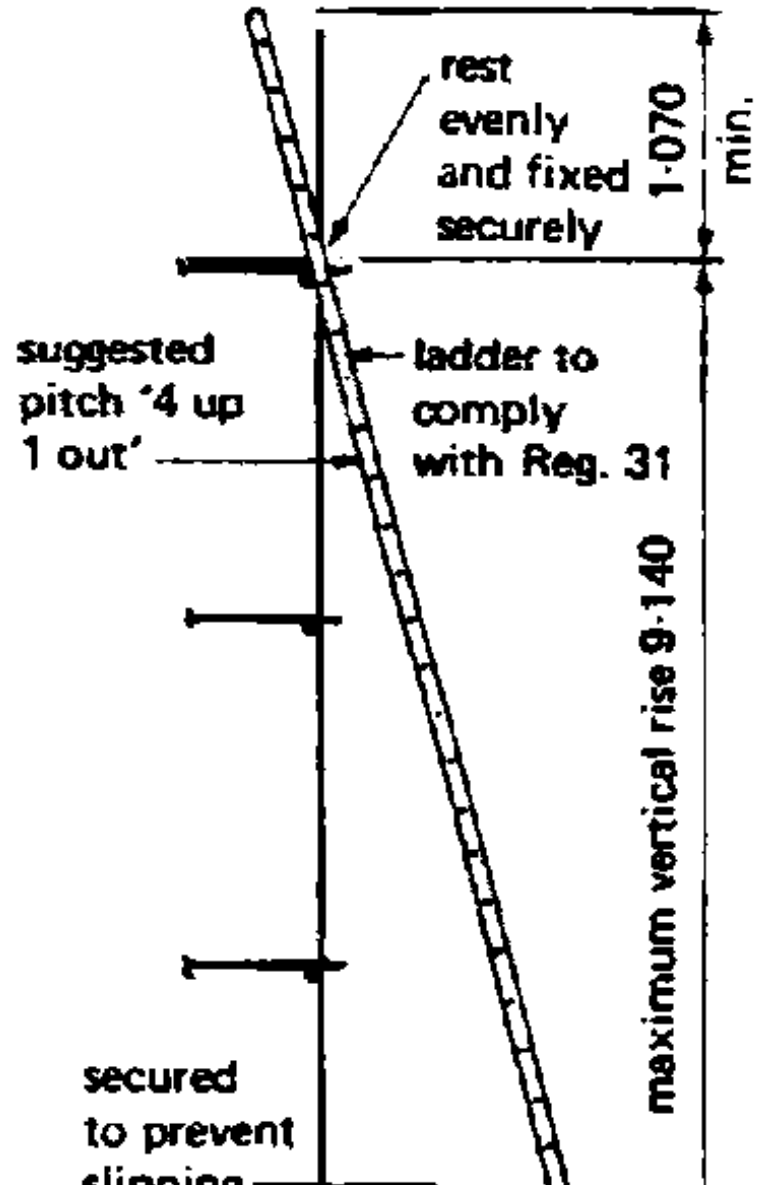



Regulation 32 ~ Use of ladders

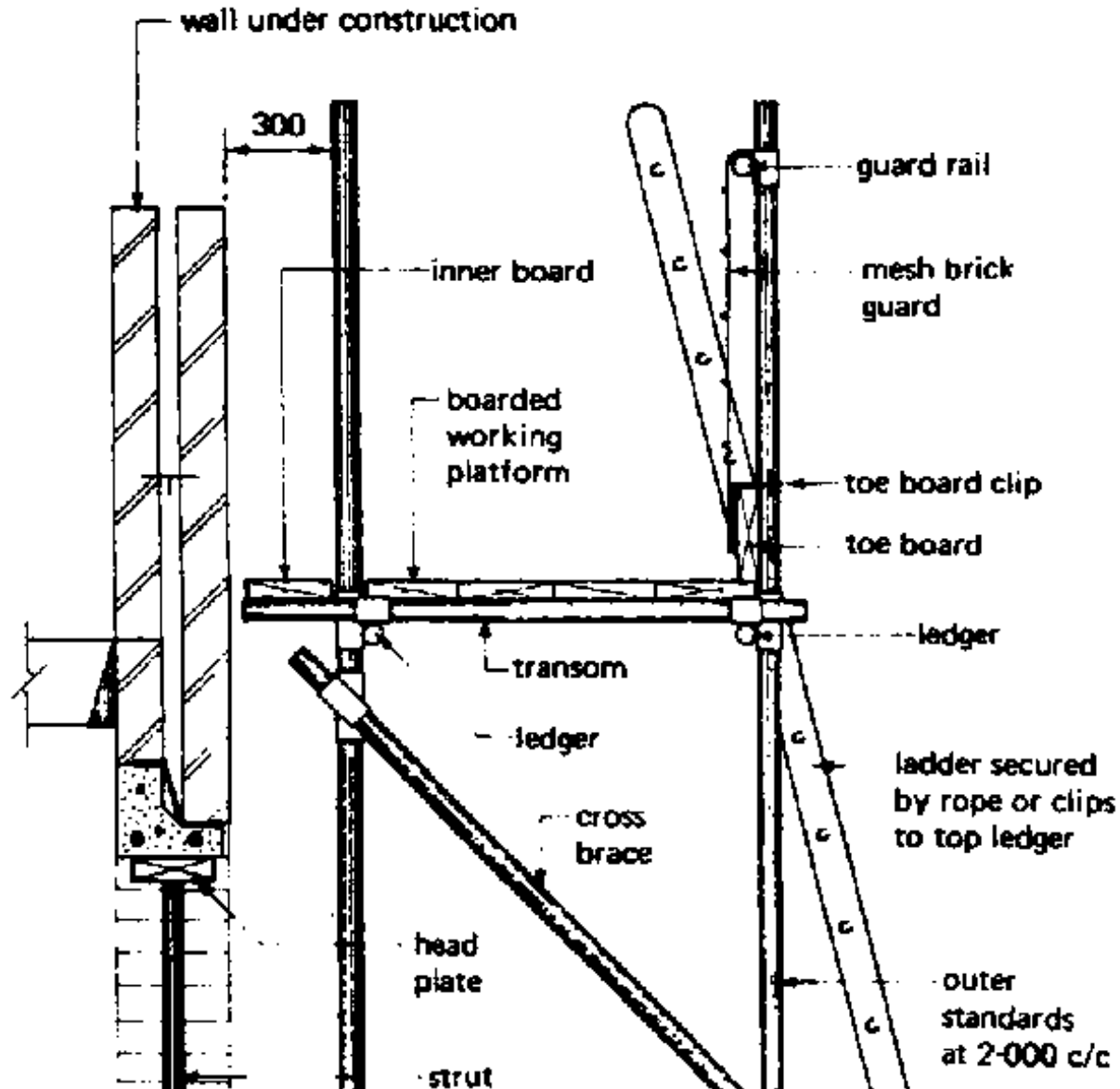

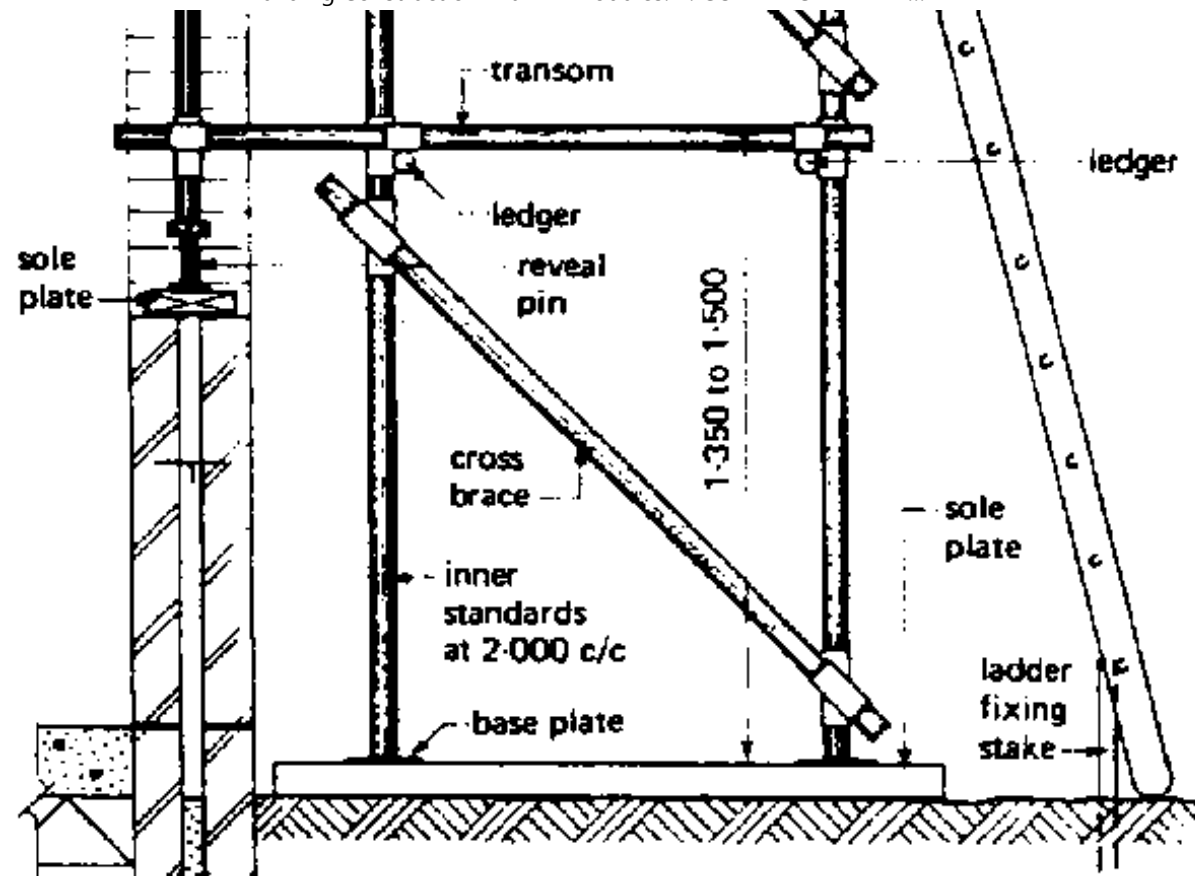

SCAFFOLD FITTINGS Fittings of either steel or aluminium alloy are covered by the same British Standard as quoted above for the tubes. They can usually be used in conjunction with either tubular metal unless specified differently by the manufacturer. The major fittings used in metal scaffolding are:

Double coupler: the only real load bearing fitting used in scaffolding and is used to join ledgers to standards.

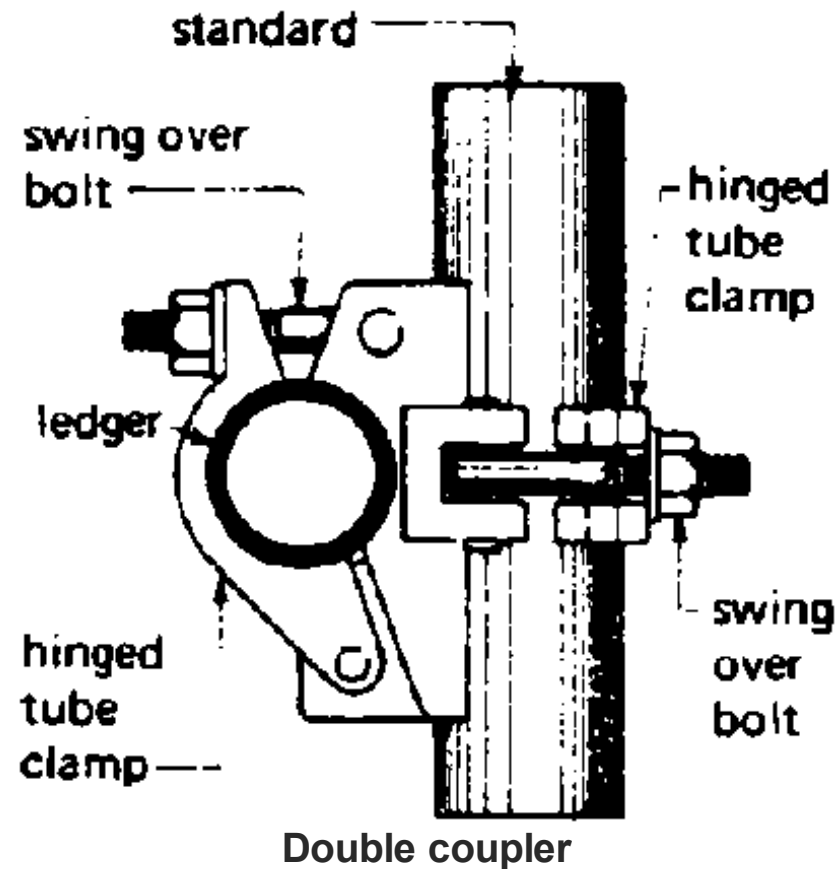

Swivel coupler: composed of two single couplers riveted together so that it is possible to rotate them and use them for connecting two scaffold tubes at any angle.

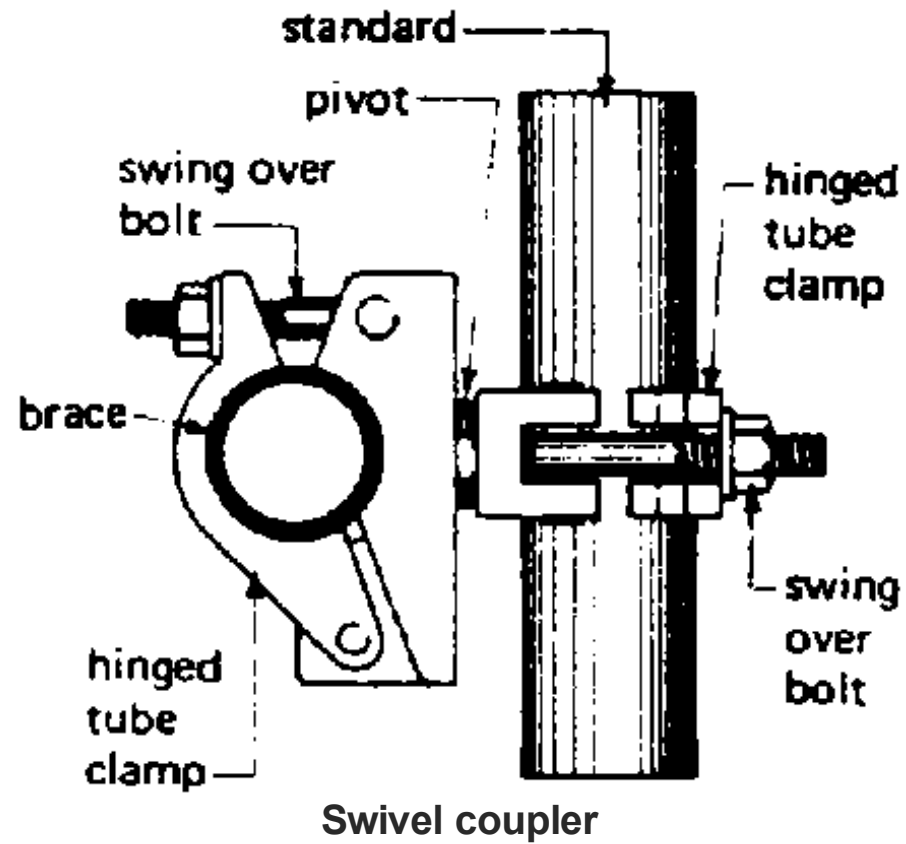

Putlog coupler: used solely for fixing putlogs or transoms to the horizontal ledgers.

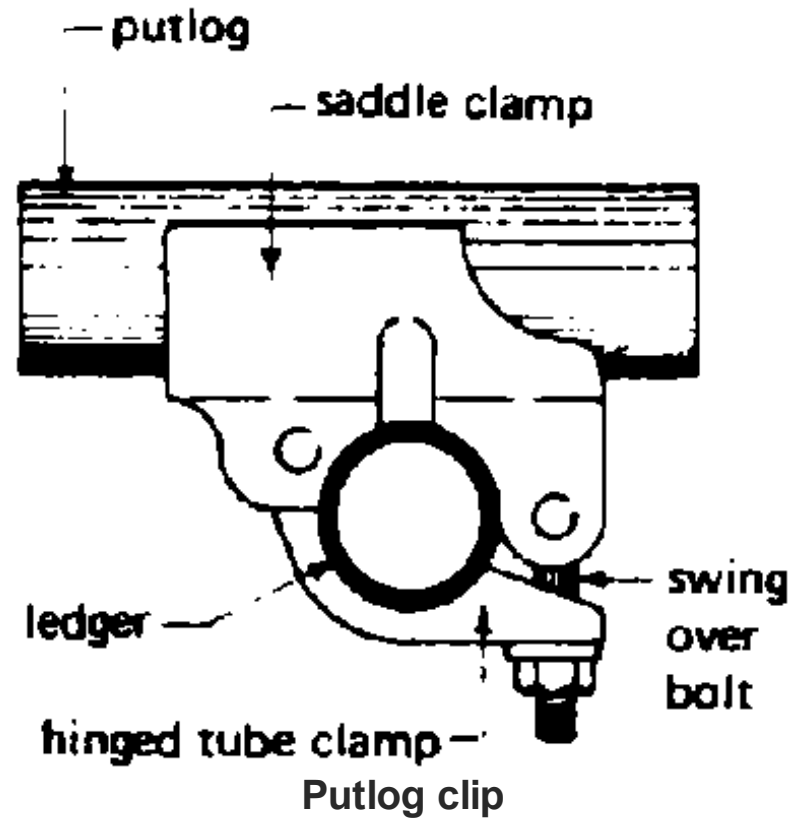

Base plate: a square plate with a central locating spigot used to distribute the load from the foot of a standard on to a sole plate or firm ground. Base plates can also be obtained with a threaded spigot and nut for use on sloping sites to make up variations in levels.

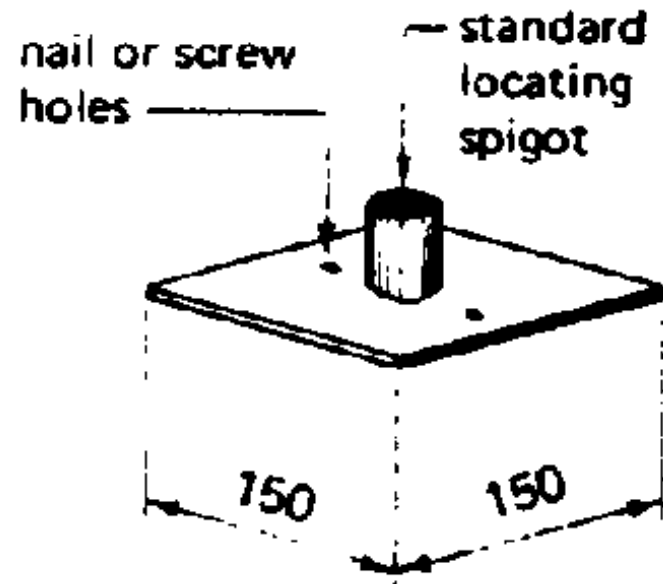

**also available with spigot
similar to reveal pin**

Base plate

Split joint pin: a connection fitting used to joint scaffold tubes and to end. A centre bolt expands the two segments which grip on the bore of the tubes.

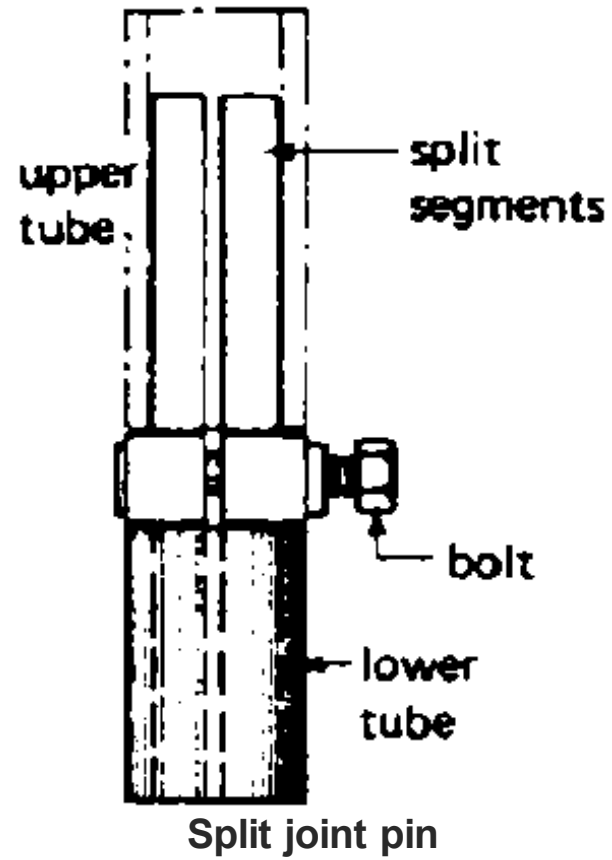

Reveal pin: fits into the end of a tube to form an adjustable strut.

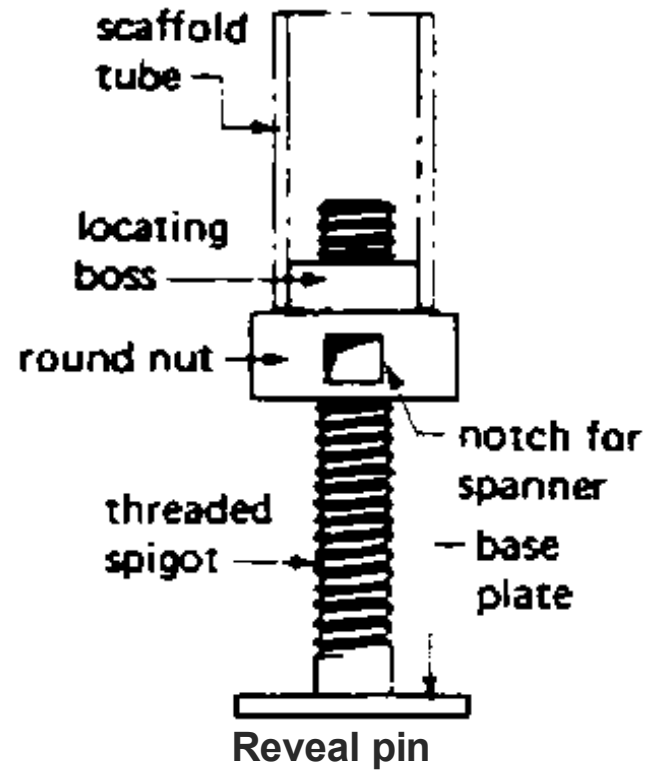

Putlog end: a flat plate which fits on the end of a scaffold tube to convert it into a putlog.

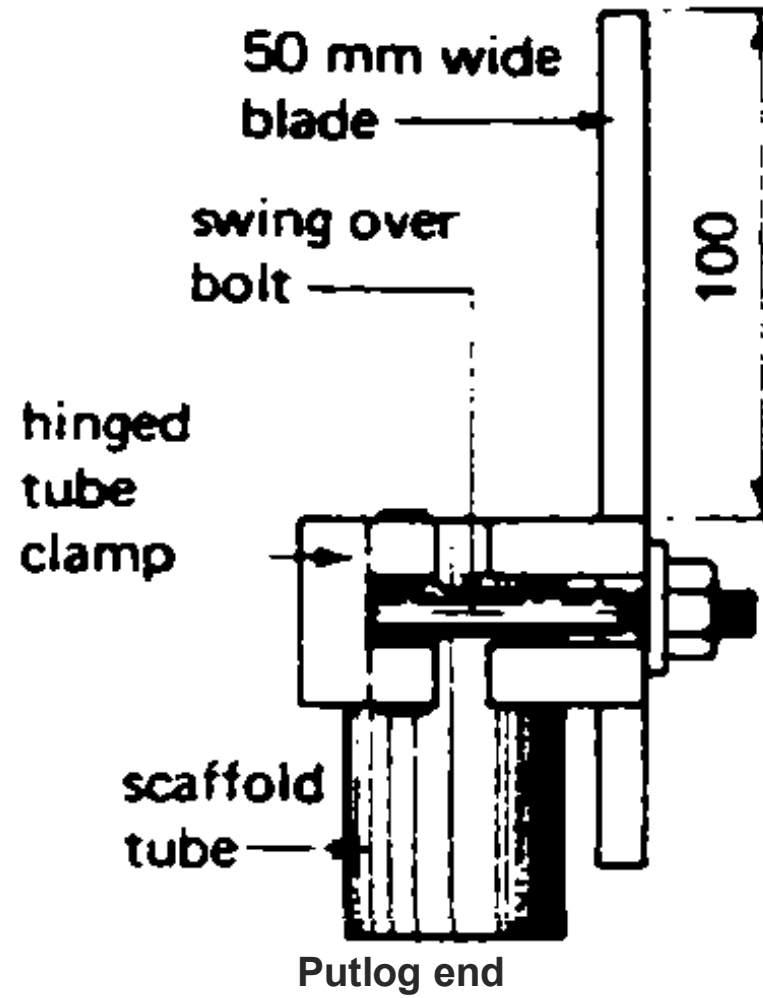

Typical examples of the above fittings are shown in the Fig.

TRUSS-OUT SCAFFOLD

MOBILE TOWER SCAFFOLD

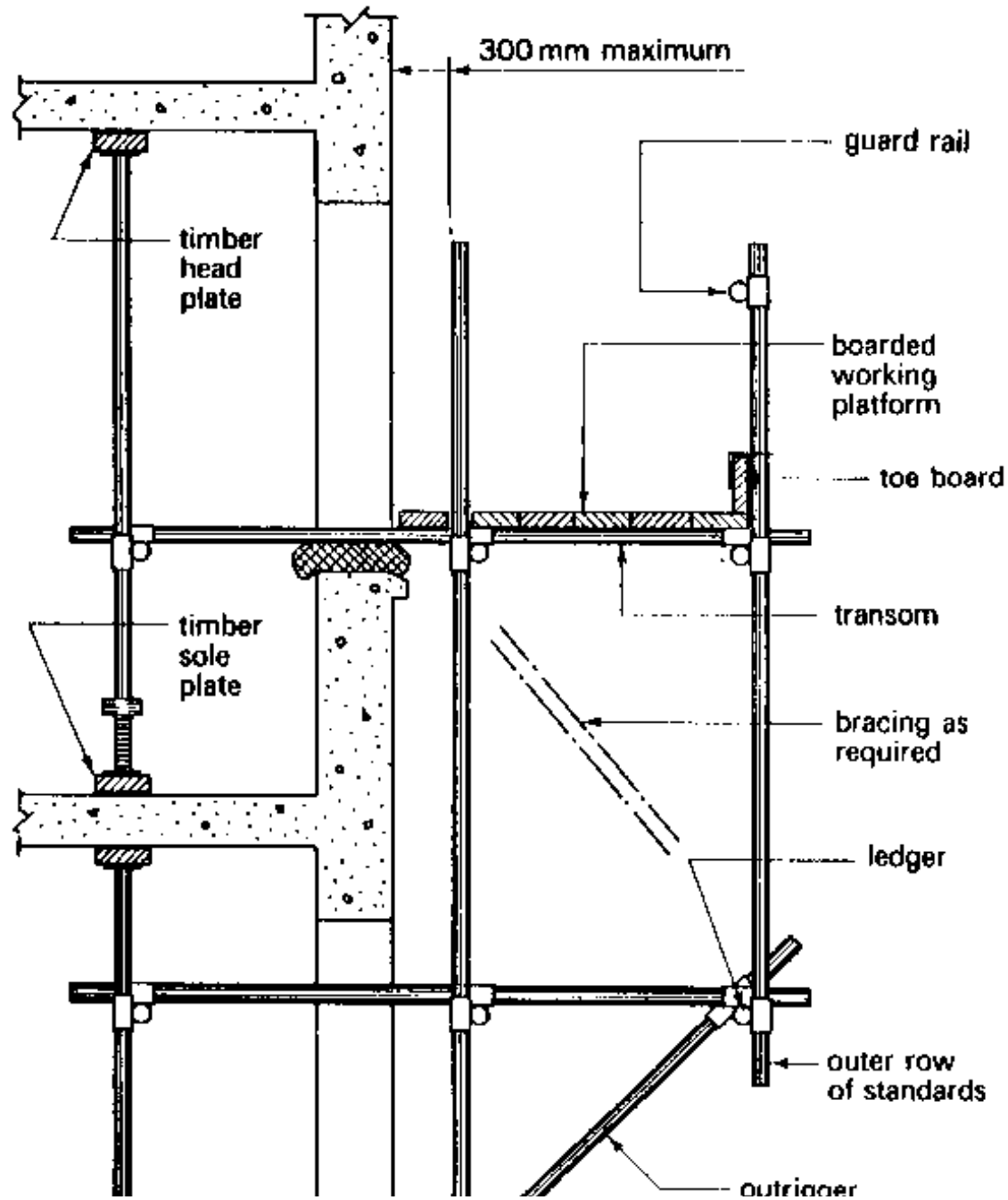

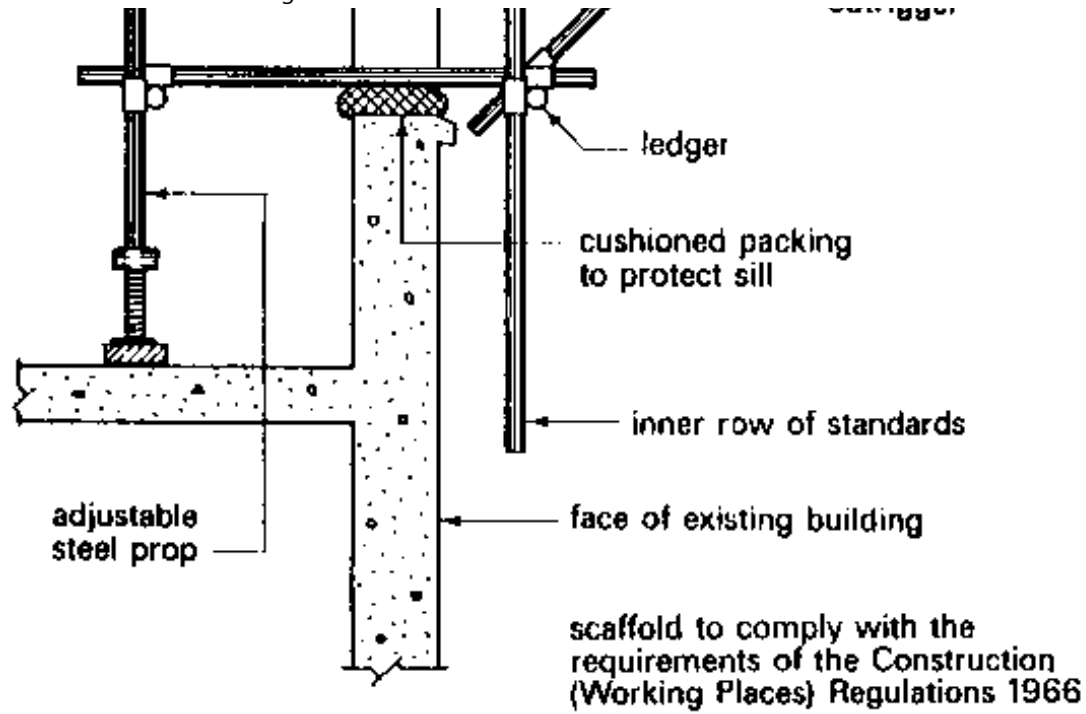

Typical truss-out scaffold details

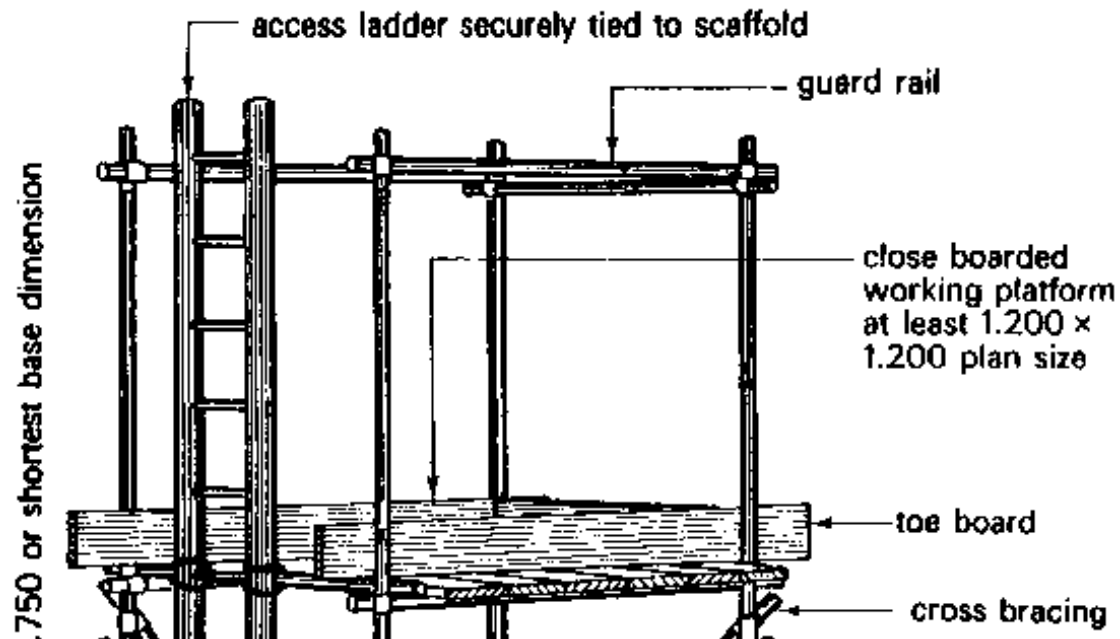

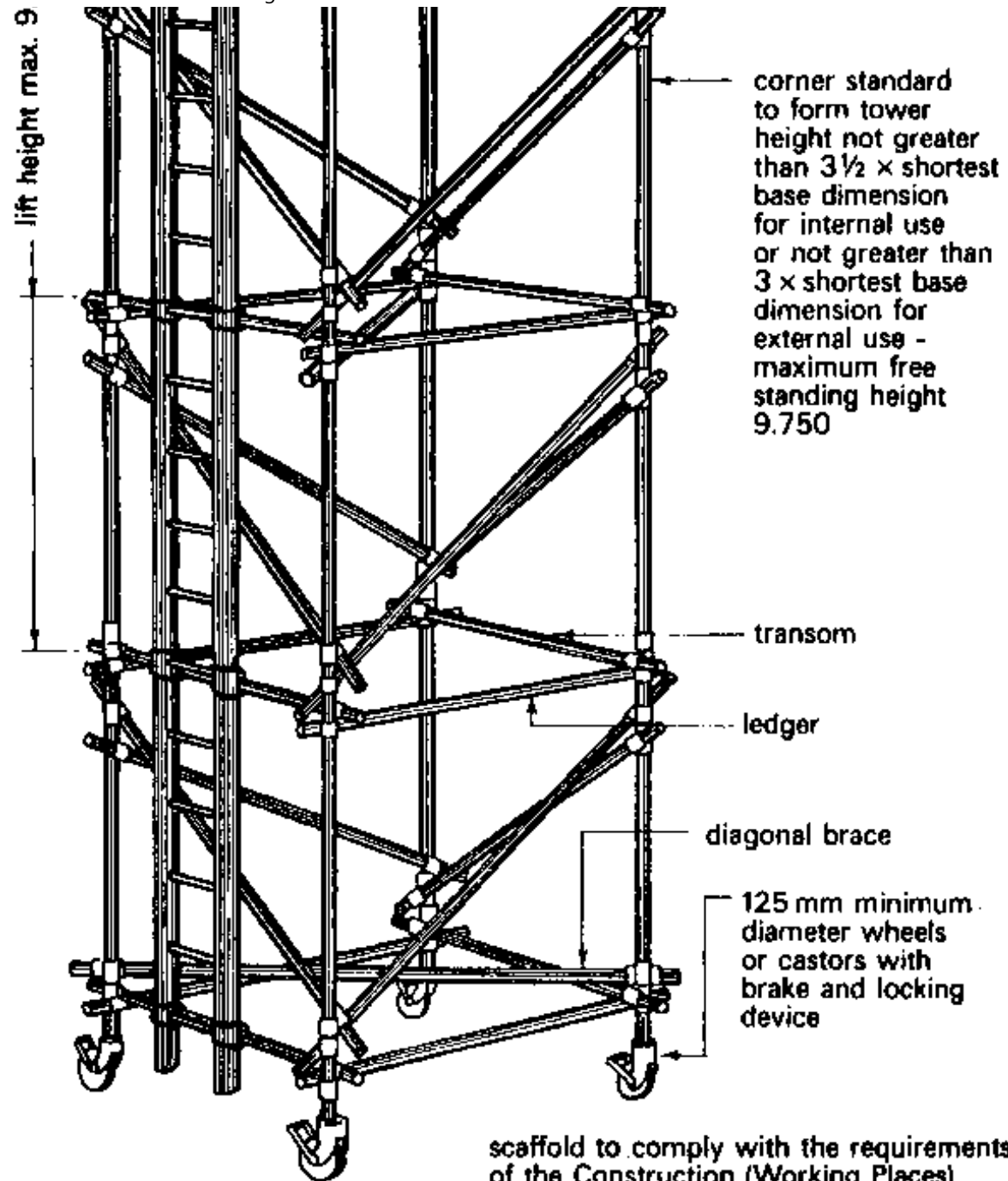

Typical mobile tower scaffold

4.2 SITE ORGANIZATION

4.2.1 PRELIMINARY WORK

Before site work begins, a PERMISSION to erect a building has to be obtained from the local Authorities. For the procedure of application as well as for the contents of all necessary documents to be submitted refer to 'ARCHITECTURAL DRAWING, Vol II'

The general foreman should visit the site at the earliest opportunity to note such details as: rainfall/humidity/prevailing wind/orientation/contours. These factors will influence the site layout plan as far as drainage, shade storage of materials, etc. are concerned.

The following items will also require his attention:

- Adjacent buildings**
- Ground surface**
- Soil**
- Site surround**
- Access road**
- Water supply**
- Electric power**
- Transport**
- Existing services, etc.**

4.2.2 SITE PLANNING

A PROGRAMME covering operations during the first four weeks will have been drawn up at planning

stage, in the preparation of which, where possible, the general foreman will have assisted, so that he is in agreement with the proposals laid down.

This programme will be generally in two parts:

- a) Site preparation programme, which will cover the demolishing of any existing buildings the setting out of the site and marking out of storage areas, the erection of huts and the construction of temporary access roads where necessary**
- b) Period 1 programme, on the lines of that shown in the fig., which will cover work during the first four weeks or so of the contract.**

Together with these will be provided site layout plans to show a) traffic routes, on which will be indicated any areas requiring particular attention, such as levelling-off or covering with temporary Summerfield track, and any direction signs required; b) the location of offices, huts and stores; c) the position of bulk storage areas both during and after excavation together with the location of any equipment.

The general foreman will in addition also be provided with copies of the:

- overall programme**
- schedule of contract information**
- data sheets**

as well as all other necessary documents such as

- bills of quantities**
- specification**
- set of contract drawings**
- details of all material orders placed and to be placed at various dates during the contract**

- details of the type and quantity of equipment to be used and the approximate periods when they will be required on the site.

4.2.2.1 Period planning

Work on the site will commence on the basis of the first monthly programme and during the third week of this period, and all subsequent stages, the next monthly programme will be prepared on the basis of the overall plan and data sheets. In the preparation of the monthly plan consideration must be given to the labour force desirable and practicable in the circumstances at the time, to plant requirements and availability, to the phasing and overlapping of operations to ensure completion of the work in the minimum time and to the planning of labour to maintain group identities. Steps must be taken to give adequate warning to all su-contractors when they will be required on site.

4.2.2.2 Weekly planning

Towards the end of each week progress will be reviewed and the next week's planned progress confirmed or modified if necessary. The following week's planned labour requirements will be reviewed and an estimate made of materials required for the next week but one and of any action required to be taken regarding equipment. This weekly review will be prepared by the general foreman in consultation with his trade foremen and any sub-contractors' foremen, and a written report will be submitted to the contractors planning department.

In certain cases where close integration of fully mechanized operations is required over a short period, particularly in the case of reinforced concrete structures, a weekly programme would be drawn up in chart form by the planning department. Such a chart is illustrated in the Fig. In addition to weekly planning, the general foreman will hold a brief meeting each day with his trade foremen and sub-contractor foremen to review the next day's work and to make the necessary preparations in regard to

the placing of materials and equipment in readiness for the next day's operations.

The general foreman will, at the beginning of the job whenever possible, indicate to the local employment office his anticipated 'build up' of labour force during the course of the contract.

4.2.2.3 Progress control

Good site planning is a prior necessity to smooth and effective progress in construction work, but a regular review of the progress of all operations and its comparison with the programme or plan is essential.

Progress is maintained by the foreman, or on larger jobs by a progress engineer, by the proper organization of the delivery and placing of materials, by ensuring that all equipment and plant is in its correct position at the right time, and by adjusting the size of labour gangs when progress is likely to fall behind the programme because of unforeseen circumstances. Progress is checked during weekly planning by estimating or measuring the work completed, the percentage of each operation or group of operations completed being established and compared with the programme. Progress is marked on the charts as indicated in the figure. When progress varies appreciably from the overall programme and where for this and any other reason it is considered desirable to alter the planned sequence of operations, the general foreman would consult the planning department before making such changes.

Close co-operation between the site staff and the planning department is often maintained by means of regular and formal site production meetings between the general foreman and the planning engineer responsible for the job.

When considering any changes, the effect on the supply of materials must be borne in mind, and when progress is faster than planned, the supply of materials in time for the work becomes the predominating factor. All subcontractors must be notified immediately of any changes in the planned programme of

work.

The general foreman should maintain a record of current and planned labour strength in the form of a schedule or chart on which the following week's planned labour requirements will be entered during weekly planning. In addition, all incoming material will be recorded on a form, one for each main item, which should show amongst other information dates of order and receipt, quantity delivered and the balance of material outstanding.

As an aid to progress control on a job of any size, regular site meetings should be held at which should be present

- the contract manager
- site agent or general foreman
- architect
- clerk of works
- quantity surveyor and
- any subcontractors (when necessary)

At these meetings all aspects of the job requiring attention are discussed and decisions for future action made.

4.2.3 SITE LAYOUT

The layout of every site, may be divided into an administrative area and a construction area. In the former will be located stores, offices, subcontractors 'huts and canteen and similar accommodation if this is provided, and in the latter, which will be the actual site of the buildings being constructed, will be located consumable stores adjacent to the various buildings and all equipment required for construction

purposes.

Proper access and departure routes for lorries should be provided and these should be clearly sign posted. In determining the traffic routes attention must be paid to the position of all main services, such as water, gas and electricity, and to drains and excavations. Temporary roads must be positioned with sufficient distance between them and future buildings to allow for the movement or positioning of all mechanical plant.

The administrative area should be located to give quick access to that area of the site which will require maximum labour control and the main storage area, sub-contractors' huts and canteen, should be so located that accessibility for unloading materials is good and so that they are a minimum distance from the construction areas. The site office should be sited on the route into the administrative area and with as good a view as possible of the construction areas. All contracts of bigger size require adequate telephone facilities for communication, electricity for power, and lighting facilities for office huts.

The stores area should be situated near the site office and will consist of covered huts for valuable or non-weatherproof stores, such as paint and iron-mongery, and a locked pen for larger valuable stores which are weatherproof, such as metal window frames and pipes. Areas for sub-contractors' stores will be located near the sub-contractors' huts and sometimes they will be situated within the main stores area.

The construction area should contain the minimum practical quantities of materials and of necessary equipment and these should be so positioned that handling and movement is kept to a minimum. As the position of equipment, particularly mixers, hoists and cranes, will influence the position of materials such as sand, aggregates and bricks, the position of all plant should be planned before that of the materials. Materials arrive on the site in the order decided at planning stage, or in accordance with instructions issued from the site, and sufficient area must be provided to accommodate the size of batch ordered. In addition, overflow areas should be allocated. In planning the layout of the site, consideration must be given to the excavation stages as these may seriously restrict proposed storage areas.

Standardized materials, such as bricks, tiles and drainpipes, should be stacked in unit dumps, the numbers in which remain constant although the length, breadth and height may be varied to suit site conditions.

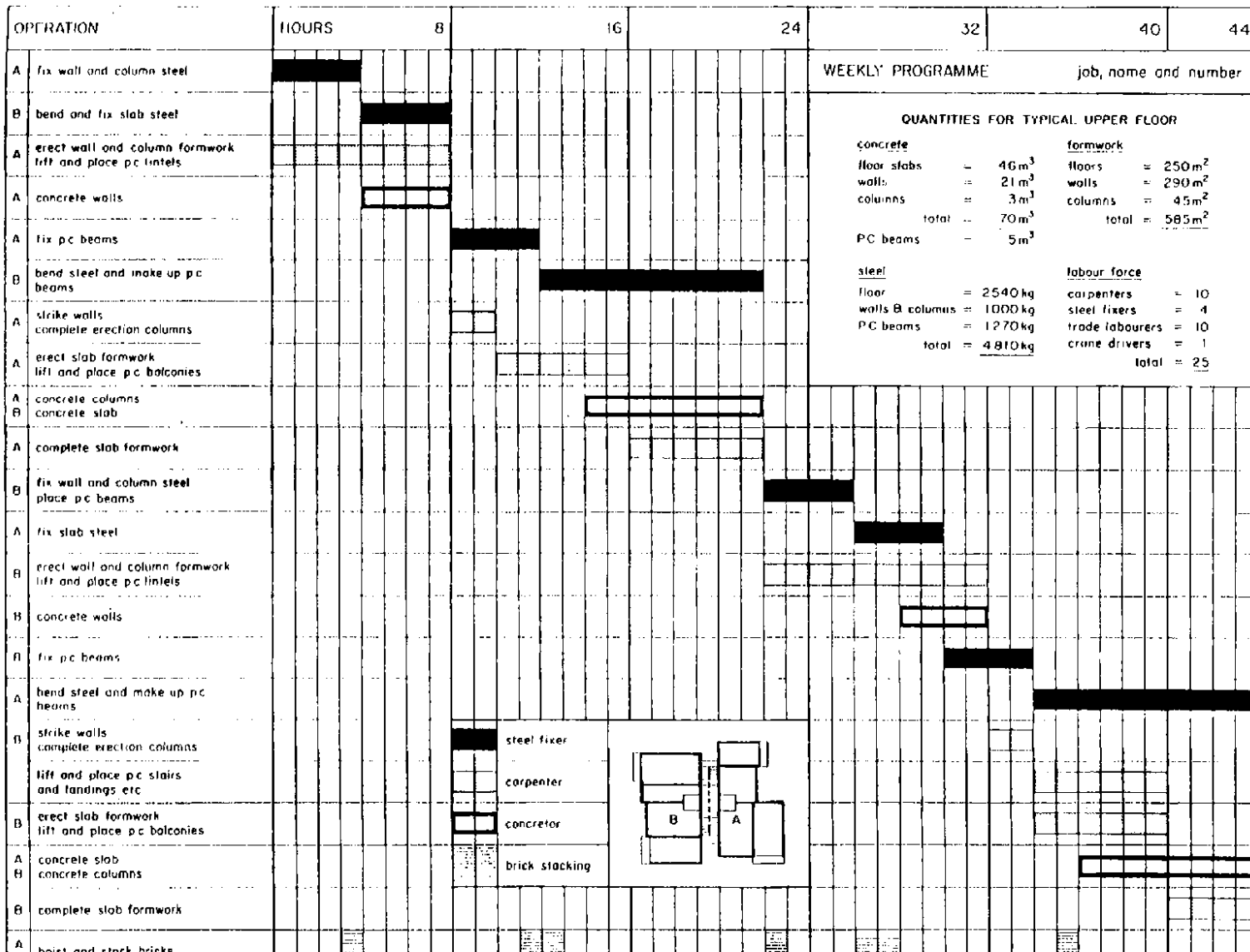

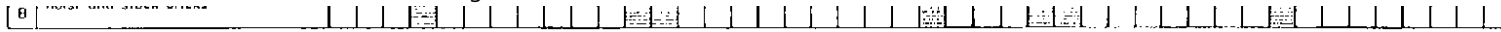

PERIOD PLANNING

• REPETITION • • exercises • • REPETITION •

Try to answer the following questions and use sketches for illustration

1. CONTRACT PLANNING

- Which considerations should be taken into account in 'Contract Planning';
- Explain the function of a 'Bar Chart'
- What is the difference between analysing a production problem by 'Network' and by a 'Linear Method';
- Describe step by step the way how to prepare a 'Network' in the form of an **ARROW DIAGRAM**
 - Explain the terms:
 - Earliest starting time
 - Latest starting time latest finishing time
 - Floating time
 - Critical path
 - Time/cost optimisation
 - Resource levelling and control
- Who prepares the **OVERALL PROGRAMME** and where will it be used for;
- Where does the **OVERALL PROGRAMME** consist of, and in which form is it usually expressed;

- Explain and write notes on the following headings:

- Break down of job
- Quantities of work and time content
- Plant and Labour outputs
- Sequence and timing of operations
- Programme chart

- List and describe factors which have a bearing on the decisions made during the contract planning stage.

- Write notes on contractors mechanical plant

- Explain different types of SCAFFOLD referring to their form as well as to the materials and fittings used for construction.

2. SITE ORGANIZATION

- What has to be obtained before site work begins:?

- List items which should require the attention of the general foreman during his first site visit

- What is the contents of the 'site planning programme'?

- What are the two areas of the 'site layout'? Write notes and explain the requirements of these areas.

Please provide your feedback

English | French | Spanish | German