

Printable version

Export document
as HTML file [Help](#)

Export document
as PDF file

Building Construction with 14 Modules (TCA; 1983; 618 pages)

1. ARCHITECTURAL DRAWING I

1.1 AIMS AND PURPOSE OF ARCHITECTURAL DRAWINGS

1.1.1 CONTENTS OF ARCHITECTURAL DRAWINGS

1.2 DRAWING EQUIPMENT

1.2.1 PENCILS

1.2.2 DRAWING PENS

1.2.3 COMPASSES

1.2.4 DRAWING BOARDS

1.2.5 T-SQUARES

1.2.6 SET SQUARES

1.2.7 PROTRACTORS

1.2.8 SCALES

1.2.9 FRENCH CURVES

1.2.10 TEMPLATES

1.2.11 DRAWING PINS AND OTHER FIXINGS

1.2.12 MINOR ITEMS OF EQUIPMENT

1.2.13 PRINTING PAPERS

1.2.14 TRACING PAPER, CLOTH AND FILM

 **1.2.15 BACKING SHEETS**

 **1.2.16 DRAWING PAPERS**

 **1.2.17 CARTRIDGE**

 **1.2.18 HANDMADE AND MOULDMADE PAPERS**

 **1.2.19 PLASTIC-COATED CARD**

 **1.3 LETTERING**

 **1.3.1 PRINCIPLE OF LETTERING**

 **1.3.2 FREEHAND LETTERING**

 **1.3.3 TYPES OF LETTERS**

 **1.3.3.1 The Roman Alphabet**

 **1.3.3.2 Sans Serif Letters**

 **1.3.3.3 Inclined Lettering**

 **1.3.3.4 Script Lettering**

 **1.3.3.5 Stencil Lettering**

 **1.3.3.6 Guided Pen Lettering**

 **1.3.3.7 Pressure-Transfer Lettering**

 **1.4 LINEWORK AND DIMENSIONING**

 **1.4.1 TYPES OF LINES**

 **1.4.2 PENCIL DRAWING**

 **1.4.3 INKING - IN**

 **1.4.4 BASIC RULES OF DIMENSIONING**

 **1.4.4.1 Types of Dimensions**

 **1.4.4.2 Placement of Dimensions**

 **1.5 ENLARGEMENT AND REDUCTION OF LINE DRAWINGS** **1.6 GEOMETRICAL CONSTRUCTIONS** **1.6.1 LINES AND ANGLES** **1.6.1.1 To bisect a straight line AB** **1.6.1.2 To divide a straight line AB into a given number of equal parts** **1.6.1.3 To divide a straight line AB into any ratio** **1.6.1.4 To construct an angle of 90°**  **1.6.1.5 To construct an angle of 45°**  **1.6.1.6 To construct an angle of 60°**  **1.6.1.7 To construct an angle of 30°**  **1.6.1.8 To bisect any given angle** **1.6.1.9 To construct an angle SIMILAR to a given angle** **1.6.1.10 To draw a line PARALLEL to a given line** **1.6.2 TRIANGLES** **1.6.2.1 To construct an EQUILATERAL triangle** **1.6.2.2 To construct a triangle with given BASE ANGLES and ALTITUDE** **1.6.2.3 To inscribe a circle in a given triangle ABC** **1.6.2.4 To circumscribe a triangle ABC** **1.6.3 CIRCLES** **1.6.3.1 Basic CIRCLE-Constructions** **1.6.3.2 To draw a tangent to a point A on the circumference of a circle centre O**

 **1.6.3.3 To draw an internal tangent to two circles of equal diameter**

 **1.6.3.4 To find the centre of a given circle arc**

 **1.6.3.5 To join two straight lines at RIGHT ANGLES to each other by an arc of given radius**

 **1.6.3.6 To draw a curve of given radius joining two circles**

 **1.6.3.7 To join two straight lines by two arcs of equal radius**

 **1.6.4 BASIC ARCH CONSTRUCTIONS**

 **2. ARCHITECTURAL DRAWING II**

 **2.1 TYPES OF PROJECTIONS**

 **2.2 ORTHOGRAPHIC PROJECTION**

 **2.2.1 CONSTRUCTION OF ORTHOGRAPHIC PROJECTION**

 **2.2.2 ELEVATIONS**

 **2.2.3 PLANS AND SECTIONS**

 **2.3 PICTORIAL DRAWING**

 **2.3.1 AXONOMETRIC PROJECTION**

 **2.3.2 ISOMETRIC PROJECTION**

 **2.3.3 DIMETRIC PROJECTION**

 **2.3.4 OBLIQUE PROJECTION**

 **2.3.4.1 Length of Receding Lines**

 **2.3.4.2 Construction of Oblique Drawings**

 **2.3.4.3 Rules of Oblique Drawing**

 **2.3.4.4 Scale of the Receding Lines**

 **2.3.4.5 Direction of Receding Lines**

 **2.3.4.6 Position of Axes**

 **2.4 PERSPECTIVE DRAWING**

 **2.4.1 PERSPECTIVE TERMS**

 **2.4.2 PHENOMENA OF PERSPECTIVE DRAWING**

 **2.4.3 SYSTEMS OF PERSPECTIVE DRAWINGS**

 **2.4.4 METHODS OF PERSPECTIVE DRAWINGS**

 **2.4.5 TWO-POINT PERSPECTIVE**

 **2.4.6 ONE-POINT PERSPECTIVE**

 **2.5 SHADES AND SHADOWS**

 **2.5.1 THE USE OF SHADOWS**

 **2.5.2 SHADES AND SHADOWS**

 **2.5.3 THE CONVENTIONAL DIRECTION OF LIGHT**

 **2.5.4 THE 45° DIRECTION**

 **2.5.5 THE TRUE DIRECTION OF LIGHT**

 **2.5.6 SHADOWS OF SOLIDS**

 **2.5.7 PLANES OF SHADOW**

 **2.5.8 PRINCIPLES OF SHADOW-CASTING**

 **2.6 DRAWING PRACTICE**























 **2.6.1 DRAWING SHEETS**

 **2.6.1.1 Sizes and Folds**























 **2.6.1.2 Layout and Identification**

 **2.6.2 LEVELS**

 **2.6.3 REFERENCING**

-  **2.6.4 ABBREVIATIONS**
-  **2.6.5 REPRESENTATION OF MATERIALS**
-  **2.6.6 GRAPHICAL SYMBOLS AND REPRESENTATION**
-  **2.6.7 HATCHING RULES**
-  **2.7 APPLICATION FOR BUILDING PERMIT**
 -  **2.7.1 PROCEDURE OF APPLYING FOR PERMISSION TO ERECT A BUILDING**
 -  **2.7.2 FORMULARS**
-  **4. CONTRACT PLANNING AND SITE ORGANISATION**
 -  **4.1 CONTRACT PLANNING**
 -  **4.1.1 BAR CHART**
 -  **4.1.2 NETWORK ANALYSIS**
 -  **4.1.3 THE OVERALL PROGRAMME**
 -  **4.1.3.1 Break down of job**
 -  **4.1.3.2 Quantities of work and time content**
 -  **4.1.3.3 Plant and Labour outputs**
 -  **4.1.3.4 Sequence and timing of operations**
 -  **4.1.3.5 The programme chart**
 -  **4.1.4 PLANNING CONSIDERATIONS**
 -  **4.1.4.1 Site conditions and access**
 -  **4.1.4.2 Nature of job**
 -  **4.1.4.3 Plant**
 -  **4.1.4.4 Scaffolding**

 **4.2 SITE ORGANIZATION** **4.2.1 PRELIMINARY WORK** **4.2.2 SITE PLANNING** **4.2.2.1 Period planning** **4.2.2.2 Weekly planning** **4.2.2.3 Progress control** **4.2.3 SITE LAYOUT** **5. FOUNDATIONS** **5.1 SOIL INVESTIGATIONS** **5.1.1 SITE EXPLORATION** **5.1.1.1 Trial holes** **5.1.1.2 Bore holes** **5.1.1.3 Sampling** **5.1.1.4 Tests** **5.1.1.5 Load or bearing test** **5.1.2 SOILS AND SOIL CHARACTERISTICS** **5.1.2.1 Rocks and soils** **5.1.2.2 Stresses and pressures** **5.2 EXCAVATIONS AND TIMBERING** **5.3 TYPES OF FOUNDATIONS** **5.3.1 CLASSIFICATION** **5.3.2 CHOICE OF FOUNDATION** **5.3.3 SPREAD FOUNDATIONS**

-  **5.3.3.1 Strip foundations**
-  **5.3.3.2 Deep strip foundations**
-  **5.3.3.3 Stepped foundations**
-  **5.3.3.4 Pad foundations**
-  **5.3.3.5 Raft foundations**
-  **5.3.4 PILE FOUNDATIONS**
 -  **5.3.4.1 Short bored pile foundations**
-  **5.3.5 PIER FOUNDATIONS**
-  **6. WALLS**
 -  **6.1 FUNCTION AND PROPERTIES OF WALLS**
 -  **6.2 THE BEHAVIOR OF THE WALL UNDER LOAD**
 -  **6.2.1 CALCULATION OF WALL THICKNESS**
 -  **6.3 TYPES OF WALLS**
 -  **6.4 STONEMWORK**
 -  **6.4.1 BUILDING STONES**
 -  **6.4.2 STONEMWORK THERMINOLOGY**
 -  **6.4.3 STONEMWORK CLASSIFICATION**
 -  **6.4.4 RUBBLE WALLING**
 -  **6.4.5 ASHLAR WALLING**
 -  **6.4.5.1 Rules for ashlar work**
 -  **6.5 BRICK WORK**
 -  **6.5.1 BRICKWORK TERMINOLOGY**
 -  **6.5.2 MANUFACTURE OF CLAY BRICKS**

 **6.5.2.1 Pressed Bricks** **6.5.2.2 Wire cut bricks** **6.5.2.3 Efflorescence** **6.5.3 BRICK CLASSIFICATION** **6.5.4 CALCIUM SILICATE BRICKS** **6.5.5 CONCRETE BRICKS** **6.5.6 MORTARS FOR BRICKWORK** **6.5.7 DAMPNES PENETRATION** **6.5.8 BRICKWORK BONDING** **6.5.8.1 Common bonds** **6.5.9 METRIC MODULAR BRICKWORK** **6.5.10 JUNCTIONS** **6.5.11 QUOINS OR EXTERNAL ANGLES** **6.5.12 PIERS** **6.5.12.1 Detached piers:** **6.5.12.2 Attached Piers (or Pilasters)** **6.5.12.3 Buttresses** **6.6 BLOCKWORK** **6.6.1 CLAY BLOCKS** **6.6.2 PRECAST CONCRETE BLOCKS** **6.6.3 AERATED CONCRETE BLOCKS** **6.7 CONCRETE WALLS** **6.7.1 GENERAL**



6.7.2 FOREWORK

6.7.3 PLAIN MONOLITHIC CONCRETE WALL

6.7.3.1 Dense concrete walls

6.7.3.2 Light-weight aggregate

6.7.3.3 No-fines concrete walls

6.7.3.4 Thickness of plain concrete walls

6.7.3.5 Shrinkage reinforcement

6.7.4 REINFORCED CONCRETE WALLS

6.7.4.1 In-Situ Cast external walls

6.7.4.2 Concrete Box Frames

6.7.4.3 Large precast panel structure

6.8 OPENINGS IN WALLS

6.8.1 HEAD

6.8.1.1 Lintels

6.8.1.2 Arches

6.8.2 JAMBS

6.8.3 SILLS AND THRESHOLDS

6.8.3.1 Sills

6.8.3.2 Thresholds

7. FLOORS

7.1 GENERAL

7.2 SOLID GROUND FLOORS





7.2.1 SITE CONCRETE



7.2.2 HARDCORE



7.2.3 WATERPROOF MEMBRANE



7.3 SUSPENDED TIMBER GROUND FLOOR



7.3.1 BUILDING REGULATIONS



7.3.2 LAY OUT



7.4 UPPER FLOORS



7.4.1 TYPES OF UPPER FLOORS



7.4.2 STRUCTURE OF UPPER FLOORS



7.4.3 SUSPENDED TIMBER UPPER FLOORS



7.4.3.1 Floor Joists



7.4.3.2 End Support of Floor Joists



7.4.3.3 Trimming



7.4.4 REINFORCED CONCRETE UPPER FLOORS



7.4.4.1 Monolithic Reinforced Concrete Upper Floors



7.4.4.2 Precast Concrete Upper Floors



7.4.4.3 Hollow Block and Waffle Floors



7.5 FLOOR FINISHES



7.5.1 JOINTLESS FLOOR FINISHES



7.5.1.1 The most common of these is the Cement/Sand Screed

























7.5.1.2 Granolithic Concrete Finishes



7.5.1.3 Terazzo



7.5.2 SLAB FLOORS FINISEHES

-  **7.5.3 SHEET FLOOR FINISHES**
-  **7.5.4 WOOD FLOOR FINISHES**
-  **8. OPEN FIREPLACES, CHIMNEYS AND FLUES**
 -  **8.1 FUNCTION OF FIREPLACES AND FLUES**
 -  **8.2 PRINCIPLES OF FIREPLACE DESIGN**
 -  **8.2.1 TRADITIONAL OPEN FIREPLACE**
 -  **8.2.2 IMPROVED SOLID FUEL APPLIANCES**
 -  **8.3 PRINCIPLES OF FLUE DESIGN**
 -  **8.4 CONSTRUCTION OF FLUE DESIGN**
 -  **8.4.1 NON-CONVECTOR OPEN FIRES**
 -  **8.4.2 CONVECTOR OPEN FIRES**
 -  **8.5 CONSTRUCTION OF CHIMNEYS**
-  **9. ROOFS**
 -  **9.1 FUNCTIONAL REQUIREMENTS**
 -  **9.1.1 STRENGTH AND STABILITY**
 -  **9.1.2 WEATHER RESISTANCE**
 -  **9.1.3 THERMAL INSULATION**
 -  **9.1.4 FIRE RESISTANCE**
 -  **9.1.5 SOUND INSULATION**
 -  **9.2 TYPES OF ROOF STRUCTURES**
 -  **9.2.1 FLAT AND PITCHED ROOFS**
 -  **9.2.2 STRUCTURE OF THE ROOF**
 -  **9.2.3 LONG AND SHORT SPAN ROOFS**

 **9.2 LONG AND SHORT STRAIGHT ROOFS**

 **9.3 FLAT ROOFS**

 **9.3.1 PHYSICAL AND STRUCTURAL PROBLEMS**

 **9.3.2 STRUCTURE OF A FLAT ROOF**

 **9.3.3 THERMAL INSULATION MATERIAL**

 **9.3.4 SINGLE AND DOUBLE FLAT ROOF CONSTRUCTION**

 **9.3.5 PARAPET WALLS**

 **9.4 PITCHED ROOFS**

 **9.4.1 SHAPES OF PITCHED ROOFS IN TIMBER**

 **9.4.2 TERMS**

 **9.4.3 TYPES OF PITCHED ROOFS IN TIMBER (STRUCTURES)**

 **9.4.3.1 Mono-(single) pitched Roof**

 **9.4.3.2 Lean - to Roof**

 **9.4.3.3 Couple Roof**

 **9.4.3.4 Close couple Hoof**

 **9.4.3.5 Collar Roof**

 **9.4.3.6 Double or Purlin Roof**

 **9.4.3.7 Tripple or Trussed Roofs**

 **9.4.3.8 Trussed Rafters**

 **9.4.3.9 Hipped Roofs**

 **9.4.4 VALLEY**

 **9.4.5 EAVES TREATMENT**

 **9.4.6 OPENINGS IN TIMBER ROOFS**

 **9.5 ROOF COVERINGS**

9.5 ROOF COVERINGS

-  **9.5.1 FUNCTION OF ROOF COVERINGS**
-  **9.5.2 TYPES OF ROOF COVERINGS**
-  **9.5.3 SUBSTRUCTURES**
-  **9.5.4 CHOICE OF ROOF COVERINGS**
-  **9.5.5 MATERIALS AND COVERING METHODS**

 **10. FRAMED STRUCTURES**

-  **10.1 STRUCTURAL CONCEPT**
-  **10.2 FUNCTIONAL REQUIREMENTS**
-  **10.3 STRUCTURAL MATERIALS**
-  **10.4 LAYOUT OF FRAMES**
-  **10.5 BUILDING FRAMES**
 -  **10.5.1 FUNCTIONS OF BUILDING FRAME MEMBERS**
 -  **10.5.2 REINFORCED CONCRETE FRAMES**
 -  **10.5.2.1 Reinforced Concrete Beams**
 -  **10.5.2.2 Reinforced Concrete Columns**
 -  **10.5.2.3 Reinforced Concrete Slabs**
 -  **10.5.3 PRECAST CONCRETE FRAMES**
 -  **10.5.3.1 Methods of Connections**
 -  **10.5.4 STRUCTURAL STEELWORK FRAMES**
 -  **10.5.4.1 Structural Steel Frames**
 -  **10.5.4.2 Castellated Universal Sections**
 -  **10.5.4.3 Connections**
 - 



10.5.4.4 Structural Steel Connections



10.5.4.5 Frame Erection



10.5.4.6 Fire Protection of Steelwork



10.5.5 TIMBER FRAMES



10.5.5.1 Columns and Beams



10.5.5.2 Connections



10.5.5.3 Building frames in timber



10.5.5.4 Prefabrication



10.6 PORTAL FRAMES



10.6.1 THEORY



10.6.2 CONCRETE PORTAL FRAMES



10.6.3 STEEL PORTAL FRAMES



10.6.4 TIMBER PORTAL FRAMES



11. PROTECTION OF BUILDINGS



11.1 EXCLUSION OF WATER



11.1.1 PRECIPITATION



11.1.1.1 Roof Drainage



11.1.1.2 Flooding



11.1.1.3 Drought



11.1.2 DAMP RISING AND MOISTURE MIGRATION



























11.1.3 CONDENSATION



11.2 THERMAL INSULATION



11.2.1 DEFINITION

-  **11.2.1 DEFINITION**
-  **11.2.2 INSULATING MATERIALS**
-  **11.3 SOUND INSULATION**
 -  **11.3.1 DEFINITION**
 -  **11.3.2 SOUND INSULATION**
 -  **11.3.3 EXTERNAL NOISE**
-  **11.4 FIRE PROTECTION**
 -  **11.4.1 STRUCTURAL FIRE PROTECTION**
 -  **11.4.1.1 Fire Load**
 -  **11.4.1.2 Fire Resistance of Material**
 -  **11.4.1.3 Appropriate Types of Construction**
-  **12. FINISHING & FINISHES**
 -  **12.1 EXTERNAL WALL FINISHES**
 -  **12.1.1 EXTERNAL RENDERING**
 -  **12.1.2 CONCRETE FINISHES**
 -  **12.1.3 CLADDING**
 -  **12.1.3.1 CLADDINGS FIXED TO A STRUCTURAL BACKING**
 -  **12.1.3.2 CLADDINGS TO FRAMED STRUCTURES**
 -  **12.1.4 EXTERNAL PAINTS AND FINISHES**
 -  **12.2 INTERNAL WALL FINISHES**
 -  **12.2.1 PLASTERING**
 -  **12.2.2 OTHER INTERNAL WALL FINISHES**
 -  **12.2.3 PAINTING**
 -  **12.3 CEILING FINISHES**

 **12.3 CEILING FINISHES** **13. STAIRS** **13.1 INTRODUCTION** **13.2 DEFINITION OF TERMS** **13.3 TYPES OF STAIRS** **13.4 DESIGN OF STAIRS** **13.4.1 RISE - TREAD - PROPORTION** **13.4.2 SLOPE OR PITCH** **13.4.3 LANDINGS** **13.4.4 WIDTH** **13.4.5 WALKING LINE** **13.5 CONSTRUCTION OF STAIRS** **13.5.1 BRICK STAIRS** **13.5.2 STONE STAIRS** **13.5.3 CONCRETE STAIRS** **13.5.3.1 In Situ Cast R.C. Stairs** **13.5.3.2 Precast Concrete Stairs** **13.5.4 TIMBER STAIRS** **13.5.5 METAL STAIRS** **13.6 MISCELLANEOUS** **13.6.1 BALUSTRADES/HANDRAILS** **13.6.2 'SAMBA' STAIR, LADDERS, DISAPPEAR STAIRS, RAMPS** **13.6.3 ESCALATORS** **14 DOORS & WINDOWS**

 **14. DOORS & WINDOWS** **14.1 DOORS** **14.1.1 EXTERNAL DOORS** **14.1.2 INTERNAL DOORS** **14.1.3 PURPOSE MADE DOORS** **14.1.4 METHODS OF CONSTRUCTION** **14.1.4.1 Door terminology** **14.1.4.2 Panelled and glazed wood doors** **14.1.4.3 Flush doors** **14.1.4.4 Fire-check flush doors** **14.1.4.5 Matchboarded doors** **14.1.5 FRAMES AND LININGS** **14.1.5.1 Timber Door Frames** **14.1.5.2 Metal door frames** **14.1.5.3 Door linings** **14.1.6 SPECIAL DOORS** **14.2 WINDOWS, GLASS & GLAZING** **14.2.1 PRIMARY FUNCTIONS OF WINDOWS** **14.2.2 BUILDING REGULATIONS** **14.2.3 TRADITIONAL CASEMENT WINDOWS** **14.2.4 STANDARD WOOD CASEMENT WINDOWS** **14.2.5 STEEL CASEMENT WINDOWS** **14.2.6 BAY WINDOWS**



14.2.7 SLIDING SASH WINDOWS

 **14.2.7.1 Vertical sliding windows (also called double hung sash windows)**

 **14.2.7.2 Horizontal sliding windows**

 **14.2.8 PIVOT WINDOWS**

 **14.2.9 LOUVRES**

 **14.2.10 GLASS AND GLAZING**

 **14.2.10.1 Glass**

 **14.2.10.2 Glazing**

 **14.2.11 MOSQUITO SCREENING (FLY SCREENS)**

 **14.2.12 SUN-BREAKERS**

 **14.3 IRON MONGERY**

 **14.3.1 HINGES**

 **14.3.2 LOCKS AND LATCHES**

 **14.3.3 MISCELLANEOUS**

8. OPEN FIREPLACES, CHIMNEYS AND FLUES

REFERENCES:

**1. Jack Stroud Foster
MITCHELL'S BUILDING CONSTRUCTION
"Structure and Fabric"
Part 1**

2. E. Neufert
"Bauteurlehre"
Verlag ULLSTEIN
Edition 1966

3. Walter Meyer-Bohe
ELEMENTE DES BAUENS
"Mauerwerksbau"
Verlagsanstalt
Alexander Koch GmbH

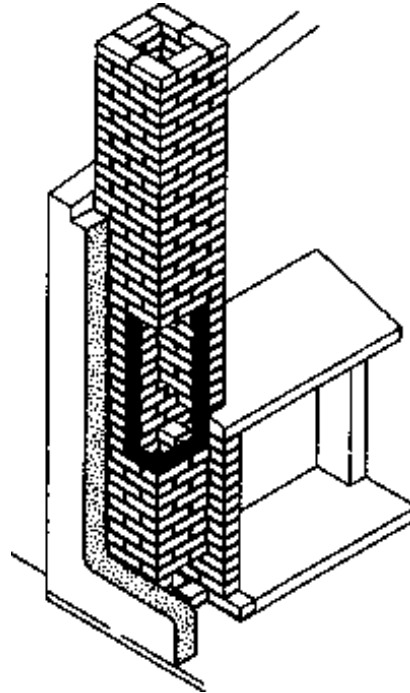

- In Tanzania the open fire, burning solid fuel, is still widely used in houses as a means of space heating or for heating water for domestic purposes.

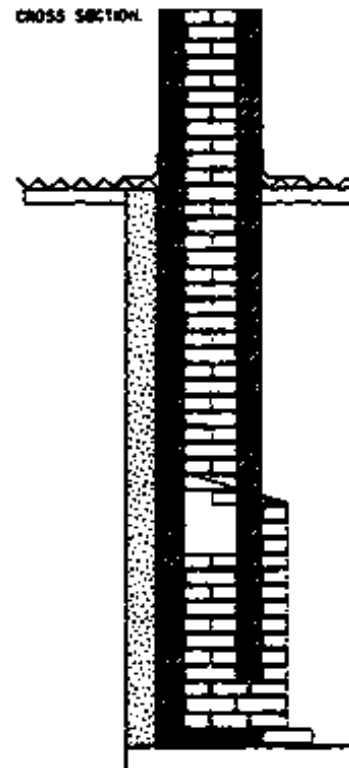
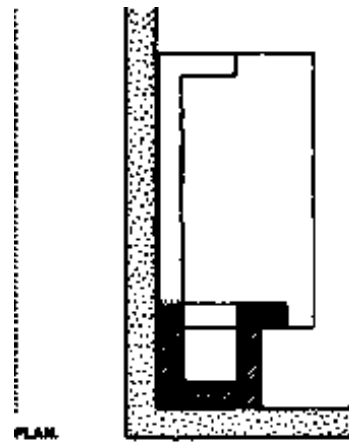

- A FIREPLACE is a space in a wall (or formed in a free-standing position) to accommodate an open fire from which the smoke and gases pass to the open air through a duct or FLUE

from which the smoke and gases pass to the open air through a duct or FLUE.

- **The structure enclosing a flue (or flues) is called a CHIMNEY.**
- **Where this rises above the roof it is called a CHIMNEY STACK.**
- **A projecting part of a wall which a fireplace and flues are constructed is called a CHIMNEY BREAST.**
- **A tall, freestanding chimney (usually required for large heating plants) is called a CHIMNEY SHAFT.**

8.1 FUNCTION OF FIREPLACES AND FLUES

- **The function of a fireplace is to burn fuel efficiently and safely, and to transfer the effectively the heat generated into the room.**
- **An adequate supply of air is necessary for the efficient combustion of any fuel. The domestic fire, burning charcoal or timber, relies for its air supply on an upward air movement which is caused by cooler air flowing through and over the fire bed to replace a volume of heated air rising in a flue.**

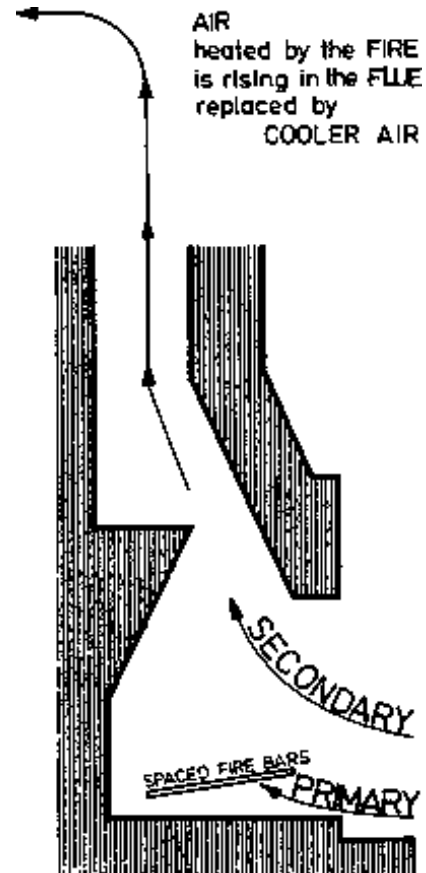

- This cooler air is made up by 2 components:

- primary and.
- secondary (see fig.).

The primary air supply is that air which feeds the fire bed and contains the oxygen necessary for combustion.

The secondary air supply is that required to cause the column of air heated by the fire to rise up the flue

carrying away with it the products of combustion.

- An efficient flue promotes this upward air movement, or 'DRAUGHT', and a suitably designed fireplace establishes a proper balance between the primary and secondary supplies so that efficient combustion may occur.

- Since the secondary air must be supplied to the fire via the room, which it enters through crack, windows doors or controlled vents, a measure of air change or ventilation results.

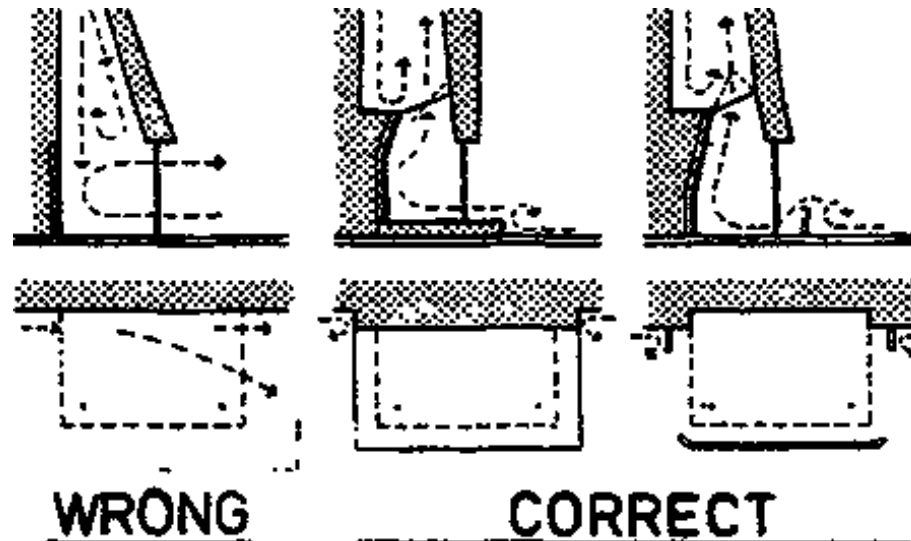

AIRMOVEMENT and AIRSUPPLY along FLOORS and WALLS to be interrupted (SMOKE!)

- THEREFORE:

The primary function of the flue is to contain the rising warm air and gases above a fire in a manner which will promote a natural upward flow of air (the power of which will depend on the difference in weight between the column of light, warmed air in the flue and a similar column of cool heavier external air).

The secondary function is to ventilate the room in which the fire is situated.

- In order that fireplaces and flues shall satisfactorily fulfil these functions a chimney and chimney breast (which are also structural parts of the building) must satisfy certain requirements such as:

- **WEATHER RESISTANCE**

The prevention of wind and rain penetration is of particular importance because of the adverse affect on the function of the flue caused by the cooling of the flue gases.

Special care must be taken to prevent damp penetration at the point where a stack passes through a roof and flashings and damp-proof coarses are required at the junctions of the two.

The top part of the stack must also be protected to prevent saturation of the chimney.

- **THERMAL INSULATION**

Adequate thermal insulation must be provided to the flue by the chimney in order:

1. to avoid the cooling of the flue gases and the cousequent slowing down of the upward air flow or draught;
2. to prevent condensation of flue gases on the walls of the flue which (particularly with slow burning appliances) can cause considerable damage to the chimney.

- **FIRE RESISTANCE**

The construction of a fireplace and its chimney must be such that combustible materials within and outside the building cannot be ignited by the fire or hot flue gases.

Therefore an adequate thickness of noncombustible material around flues and fireplaces must be provided and all combustible materials to be kept away a sufficiant distance from a flue or a fireplace.

~~provided and all combustible materials to be kept away a sufficient distance from a side of a fireplace.~~

- Fireplaces must have a bottom or hearth of non-combustible material and extent on or above which the fire bed will rest.
- The outside surface of a chimney should not become hot enough to ignite timber or other combustible material which may be near it. A temperature of 65°C is considered to be a safe maximum (This is achieved by the use of e.g. 100 mm of brickwork or concrete).
- The outlet of a flue should be well above the roof in order to avoid danger from sparks (outside the zones of wind pressure). Building regulations lay down requirements concerning heights of stacks, thickness of materials and proximity of combustible materials to flues and fire-places.

8.2 PRINCIPLES OF FIREPLACE DESIGN

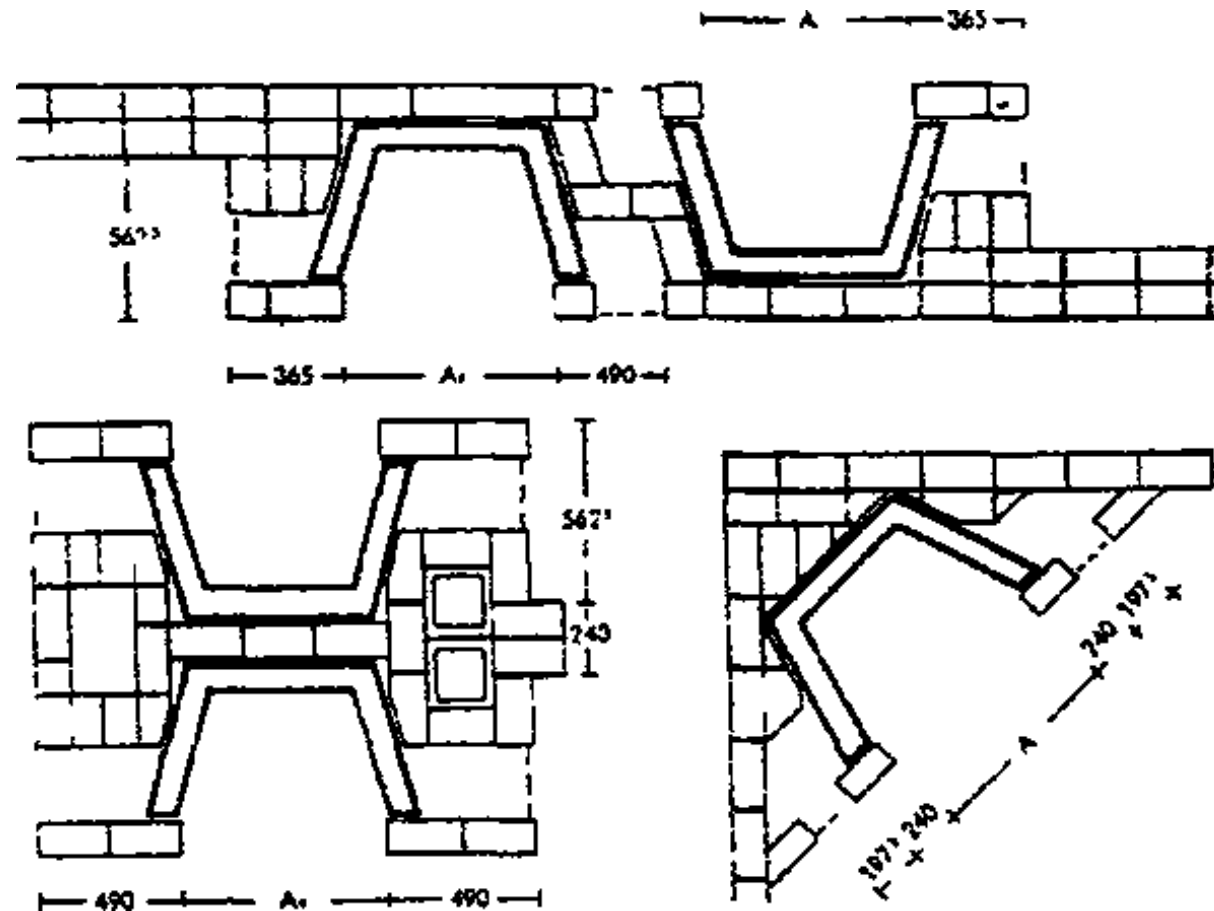

- The shape of the fireplace must be designed to allow an adequate but not excessive supply of primary air to the fire bed and secondary air to the flue.
- To contain the fire safely and to transfer the heat generated into the room, the fireplace must be constructed of suitable materials, having high fire resistance but capable of storing and radiating heat.
- The fireplace consists basically of a rectangular recess - or FIREPLACE OPENING - of suitable height with means of supporting the chimney breast above and some means of reducing the width of the opening to that of its flue.

The back and sides of the opening are formed of material capable of radiating heat and the base of the opening must be of fire-resisting material extending beyond the opening at front and sides.

A SURROUND around the opening is often incorporated for aesthetic reasons or to increase the effective depth of the fireplace.

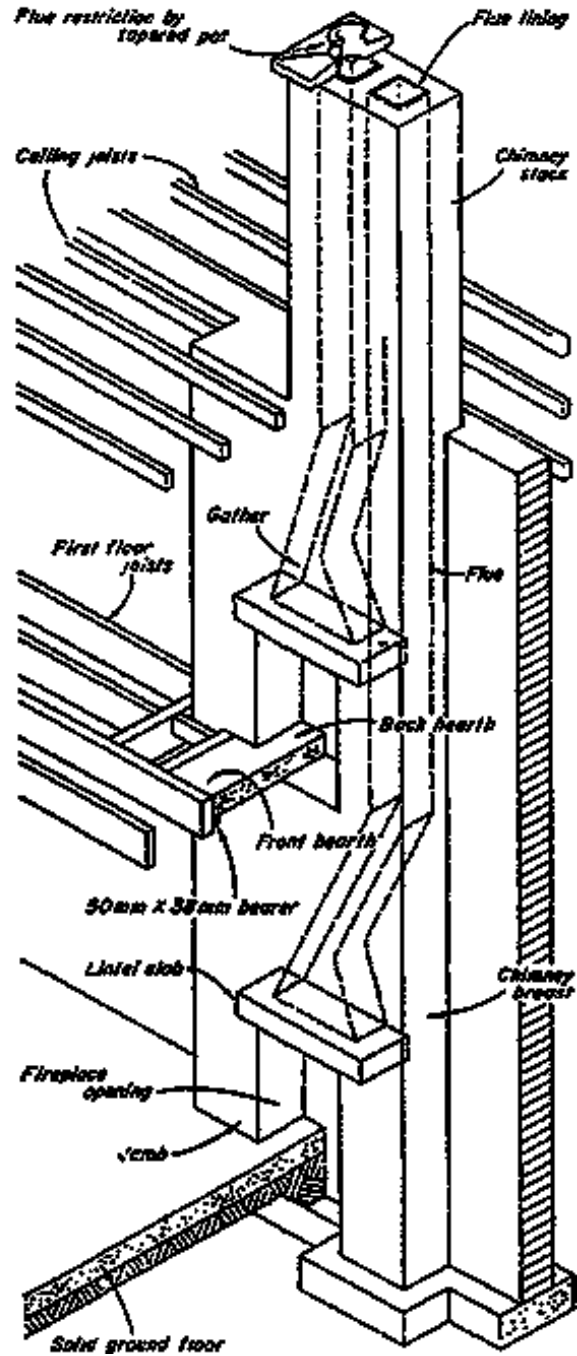

DIMENSIONING TABLE for OPEN FIREPLACES

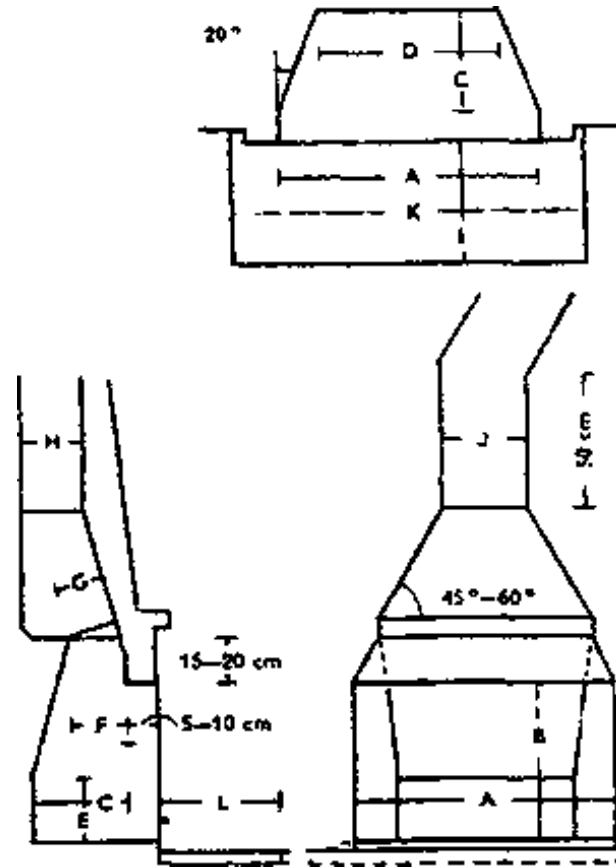

TYPE of ROOM	ROOM SIZE		FIRE OPENING			DEP TH	FIRE BACK		THROAT		CHIMNEY			SURROUND		
			width	height	area		width	vert. part						width	leng.	
	m ²	m ²	cm	cm	cm ²	cm	cm	cm	cm	cm	cm	cm	cm	cm ³	cm	cm

-	-	-	A	B	-	C	0	E	F	G	H	I	-	K	L
small rooms	16 - 22	40-60	60	50	3 000	34	36	25	20	12	20	20	400	100	50
			65	55	3 580	35	40	25	20	12	20	?0	400	105	50
medium rooms	22 - 30	60 - 90	70	58	4 060	36	44	25	20	12	20	20	400	110	50
			75	60	4 500	37	49	25	20	12	20	20	400	115	5C
			80	63	5 040	38	53	28	20	12	20	26	520	120	50
larger rooms	30 - 40	90-120	85	66	5 610	38	58	28	20	12	20	26	520	125	50
			90	68	6 120	40	62	28	20	12	20	26	520	130	50
			95	71	6 750	40	66	30	20	12	26	26	676	135	50
large rooms	40 - 50	120-180	100	74	7400	42	70	30	20	12	26	26	676	140	50
			105	76	7990	42	74	30	20	12	26	26	676	145	50
			110	78	8	45	78	30	25	12	26	38.5	1	150	50

					580								000		
small halls	50 - 70	180- 250	115	82	9 430	45	82	32	25	15	26	38.5	1 000	155	50
			120	84	10 080	48	85	32	25	15	26	38.5	1 000	160	50
			125	87	10 880	48	89	32	25	15	26	38,5	1 000	165	50
medium halls	70- 90	250- 350	130	90	11 700	51	93	32	25	15	26	38.5	1000	170	50
			135	92	12 420	53	97	32	25	15	26	38.5	1 000	175	50
large halls	üb. 90	üb. 350	140	95	13 300	54	100	35	25	15	385	38.5	1 480	180	50
			145	97	14 070	55	105	35	25	15	38.5	38.5	1480	185	50
			150	100	15 000	58	109	35	23	15	38.5	38.5	1480	190	50

8.2.1 TRADITIONAL OPEN FIREPLACE

- Originally fuel was burnt in a simple rectangular recess, but during the course of time scientific principles have been formulated to improve efficiency and reduce smokiness. These principles still remain basically sound and involve:

1. The correct design of the junction of fireplace and flue, called the THROAT. This should be 100 mm wide, 200 mm to 250 mm long and 150 mm to 200 mm deep, situated perpendicularly over the fire. The entrance to the throat should be rounded.
2. Splayed sides to the fireplace on plan to obviate eddies of smoke entering the room (This occurs with fireplaces having the back and the front of the opening equal in width).
3. Sufficient depth from the face of the chimney breast to the back of the fireplace to prevent smoking when a draught crosses the opening.
4. The fireback sloping fore-ward to direct radiant heat into the room and raise the temperature of the fire, thus assisting combustion.
5. A smokesheaf level with the top of the throat although research has shown that this can be eliminated if all other features are properly designed and incorporated.

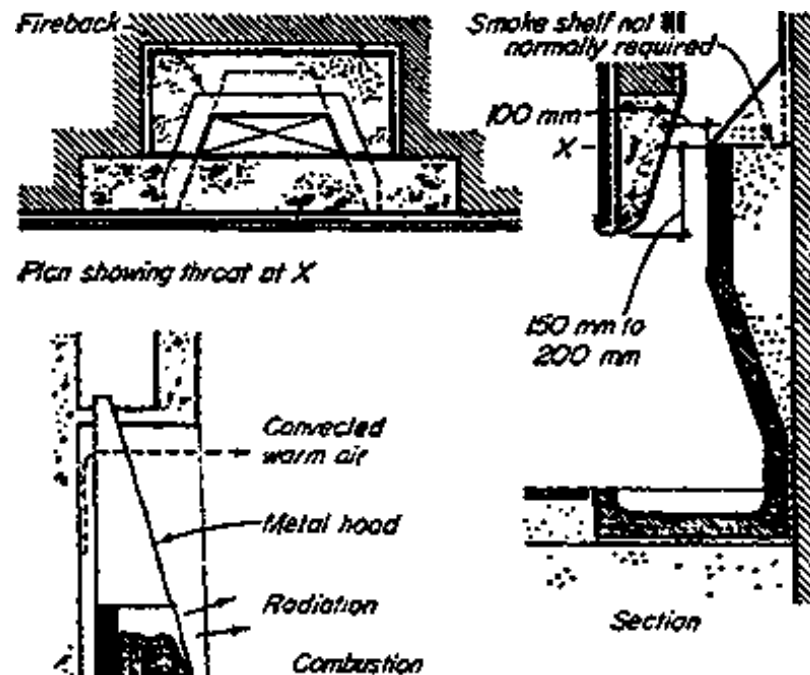



The free arrangement of a fireplace in a room causes often several openings on 1, 2, or 3 sites of the OPEN FIREPLACE.

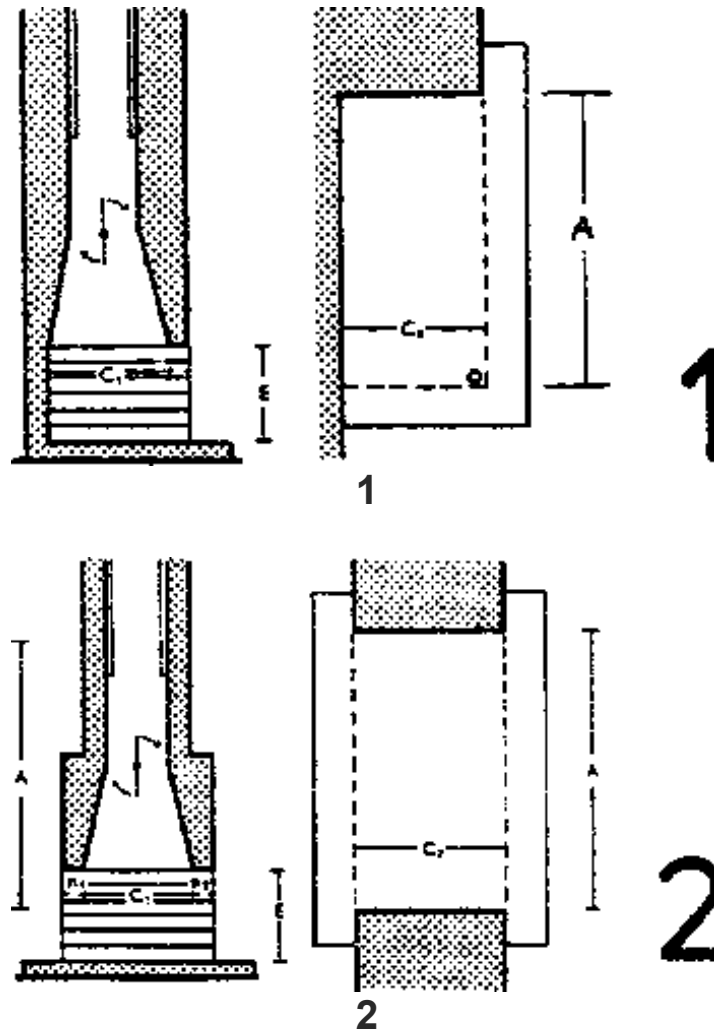

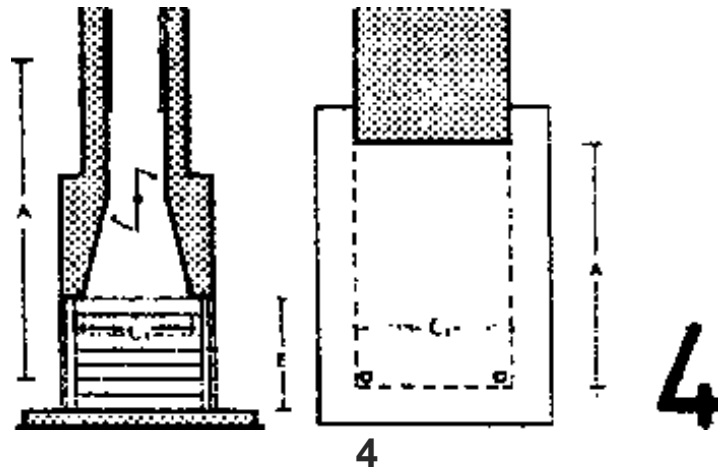
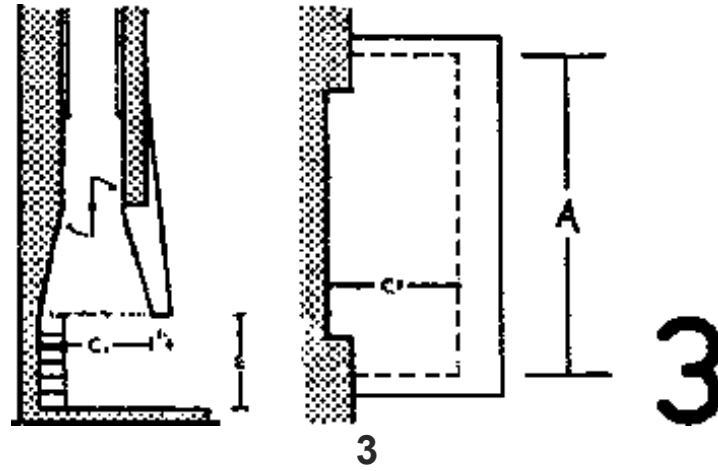

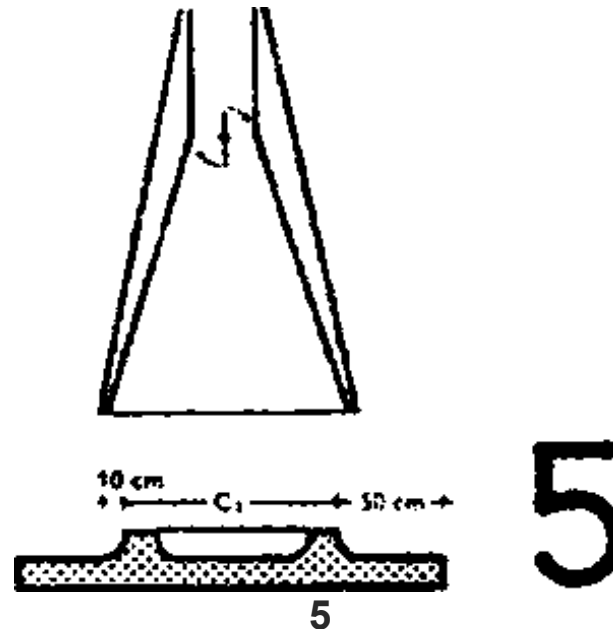

Dimensions of such fireplaces differ from common ones with only one opening.

FOR DIMENSIONING REFER TO THE TABLE BELOW

- Such fireplaces, however, remain uncontrolled and tend to consume large amount of fuel whilst promoting too large an air change. Control of the secondary air supply can be effected by a hood placed above the fire bed, in which case some heat transfer occurs by way of air circulating round the hot metal forming the hood, or preferably by an adjustable metal throat restrictor.

- When a stool grate to hold the fuel is used some control of the primary air supply to the fire can be effected by selecting a design with a solid front incorporating a variable inlet opening.

DIMENSIONING - TABLE

Category	Dimension

	C_1	C_2	Schornsteinquerschnitt
1	$2/3 E - 10 \text{ cm}$	$C_1 + n$	$1/12 E (A + C_2)$
2	$5/6 E - 20 \text{ cm}$	$C_1 + n_1 + n$	$1/12 E 2A$
3	$2/2 E - 10 \text{ cm}$	$C_1 + n$	$1/12 E (A + 2C_2)$
4	$5/6 E - 20 \text{ cm}$	$C_1 + 2n$	$1/12 E (2A + C_2)$
5	$\varnothing \text{ min. } 81.5 \text{ cm}$	$C_1 + 2n$	$1/12 E 3.14 (C_1 + 20 \text{ cm})$

8.2.2 IMPROVED SOLID FUEL APPLIANCES

- Normal open fires will burn a wide range of fuels including wood, charcoal, coal and peat but they are unsuitable for burning smoke less fuels such as coke and anthracite and they will not burn throughout the night.
- The improved appliances incorporate suitably spaced fire bars and provide increased vertical depth in the fire bed which permits smoke less fuels to be burnt.
- Often BACKBOILERS are incorporated which provide hot water for domestic use or may heat a limited number of radiators situated near the fire. A removable front enables an extra deep firebed to be laid for overnight burning.
- Some improved open fires incorporate a heat exchanger which provides heat by convection in addition to the radiant heat of the fire. They operate by passing air through a convection chamber round a metal fire container and returning the warmed air to the room in which the appliance is situated. These are called CONVECTOR FIRES and may be fitted with back boilers.

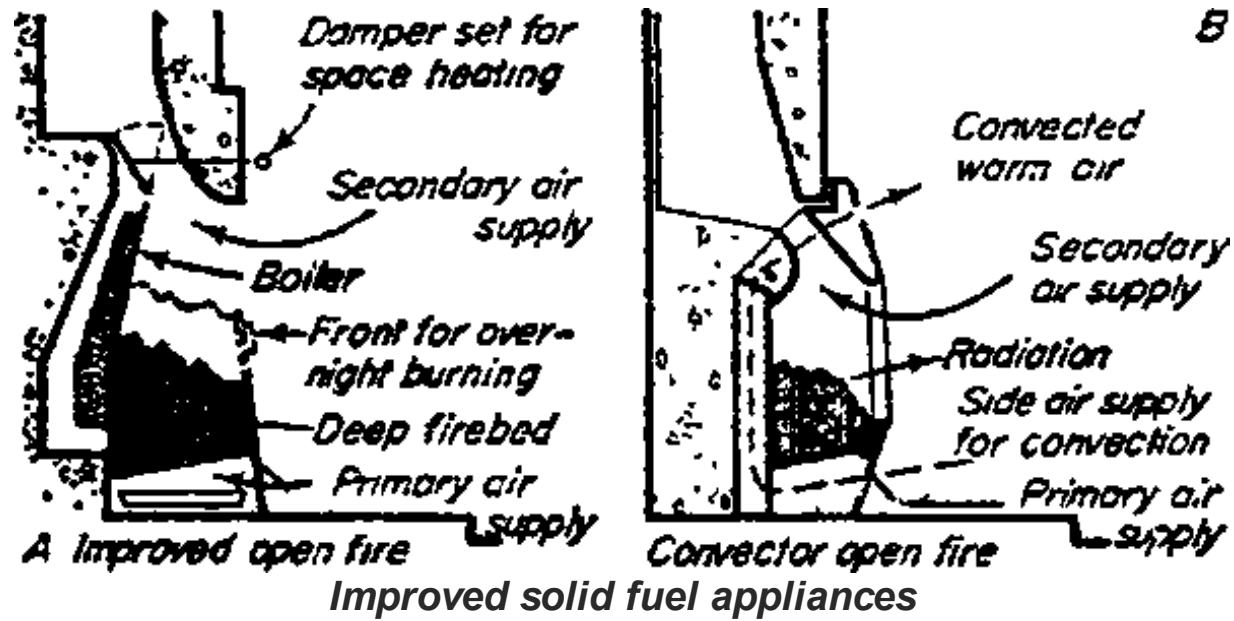

8.3 PRINCIPLES OF FLUE DESIGN

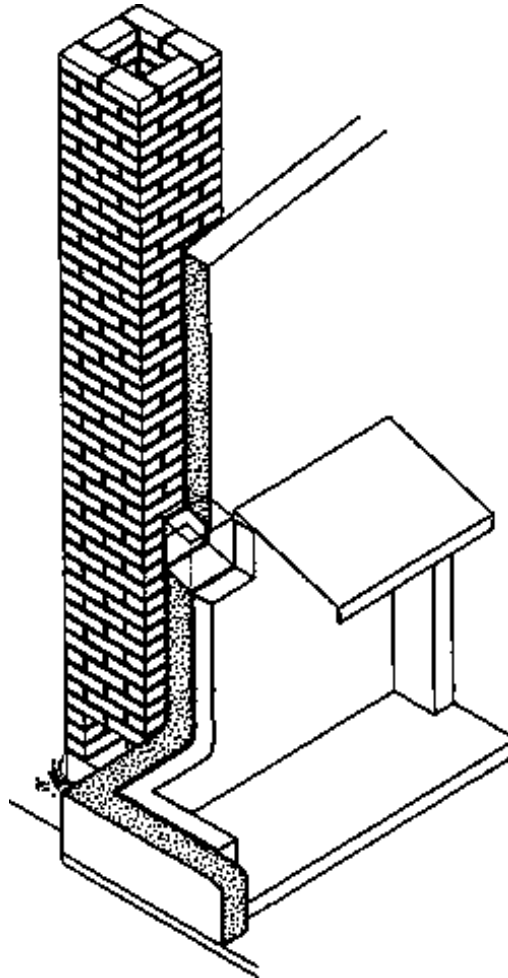

To ensure the proper function of a flue the following factors must be considered in its design:

1. SIZE and SHAPE

- Flues to domestic fires should be not less than 3,65m high measured vertically from the outlet of the appliance or fireplace to the top of the flue terminal in order to ensure an adequate difference in weight between the internal flue gases and the external air.

- The entry to the flue should be restricted to increase the initial velocity of the gases and a further restriction at the flue terminal is desirable to increase the velocity at the outlet (This reduces the danger of down draughts).
- The cross-sectional area of a flue should be not less than 175 mm diameter. The normal 225 × 225 mm brick flue measures about 190 × 190 mm when lined. (For minimum sizes for various appliances refer to table).
- Where rectangular flues are used the longest side should not be more than one- and half times the shorter.
- Flues should be as straight as possible, any bends being near the top rather than just above the fireplace. Unavoidable bends should be at an angle of not less than 45 degrees and preferably not less than 60 degrees to the horizontal.

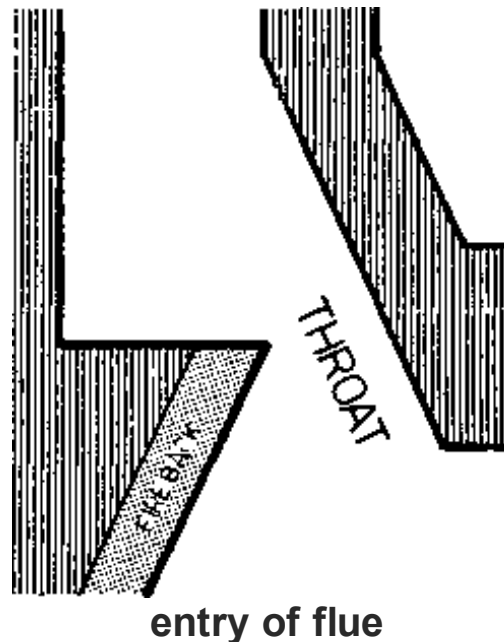

Appliance	114 mm internal diameter	150 mm internal diameter	225 mm × 225 mm or 175 mm to 200 mm internal diameter
Open and closeable fires, openable heaters, cookers	Heat storage cookers only, burning smokeless fuel	Smokeless fuels (up to 7325 W)	Bituminous fuels (minimum height of flue - 3.65m)
Domestic boilers	Smokeless fuels (up to 7325 W). Maximum height 9.15m. Sweeping access every 3.0 m	Smokeless fuels (7325-14650 W). Sweeping access every 3.0 m	Bituminous fuels (all outputs). Smokeless fuels 04650-29300 W) - 200 mm diam. minimum

Notes

A closed heater should be provided with a flue of the same size as that of a boiler with the same rate of combustion.

Flues with bends making cleaning difficult should have a minimum diameter of 150 mm.

Smokeless fuels - include coke, anthracite, dry steam coal, coalite, etc.

Minimum flue sizes for solid fuel burning appliances

2. AIRTIGHTNESS

A flue must be airtight in order to maintain the strength of the draught at the fireplace and to prevent the escape of smoke. Air can enter through faulty jointing or faulty withes (controlled entry of air into the flue may however, be an advantage in certain circumstances).

3. INSULATION

Care must be taken to prevent the flue gases cooling, which might result in down draught and condensation. This precaution is particularly important where slow burning appliances are used.

- Flues should be constructed with 1/2 brick walls and liners. The use of brick thick walls in place of 1/2-brick thickness does not afford much increase in insulation value and has the disadvantage of offering more surface area to the atmosphere, with consequent cooling of the flue. It also has a high thermal capacity which requires a longer pre heating period before the flue is warm enough to encourage 'drought' action. The greater thickness may, however, be used for any external walls of flues to minimise damp penetration.

- Flues situated internally only need special consideration where they penetrate the roof and become exposed to the weather.

Thickening of 1/2-brick flue walls to 1-brick thickness can be effected by corbelling out within the roof space, and particular attention should be paid to the arrangement of the d.p.c. and flashings to the stack.

- A suitable capping should be provided to prevent saturation of the chimney. A projecting capping, in addition to throwing water clear of the chimney walls, helps to create a zone of low pressure at the flue outlet.

4. POSITION OF OUTLET

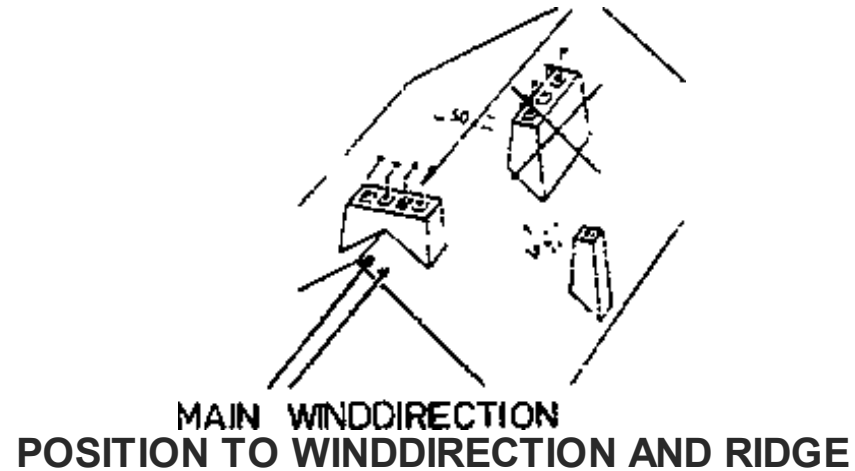

- For safety in terms of fire the outlet must be at least 1 m above the highest point of intersection of the chimney or flue pipe with the roof.
- The same distance above any adjacent opening light or ventilation opening which is not more than 2,50 m from the outlet, measured horizontally.
- When the chimney passes through the ridge of a pitched roof, or within 0,60 m of it, the outlet may be not less than 0,60 m above the ridge.

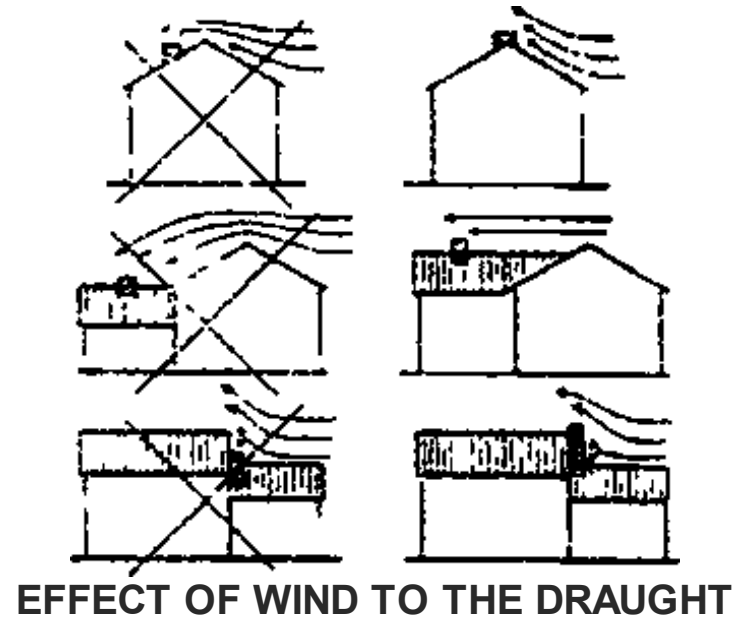

These dimensions are exclusive of any chimney pot or other terminal.

- If the roof covering is of combustible material the outlet should be at least 1 m above the level of the ridge whatever the position of the stack.

These precautions do not, however, necessarily ensure the efficient functioning of a flue, the outlet of which must be positioned outside any potential zones of high wind pressure.

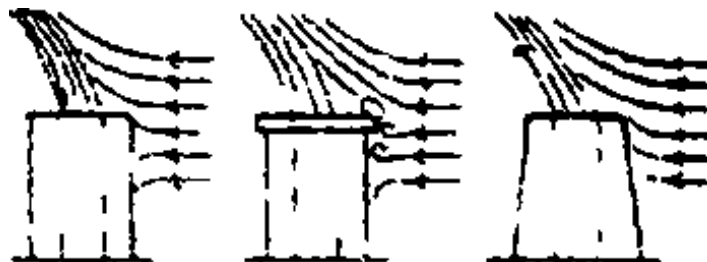

100 85 110
FIGURES COMPARING THE EFFECTIVITY

The positioning of a flue outlet in a potential suction zone will assist in the removal of the smoke and gases, but should occur in a high-pressure zone there is every likelihood of the gases being taken down the flue by air moving from this zone to an area of lower pressure within the room.



INFLUENCE OF CHIMNEYHEAD AND AREA ON THE DRAUGHT

8.4 CONSTRUCTION OF FLUE DESIGN

- The normal depth of the opening is 328 mm and the width 578 mm. This will take standard 406 mm and 457 mm wide fires. The height should be 585 mm to 600 mm from the finished hearth level to accommodate a standard 565 mm high fireback. If a projecting surround is to be incorporated this height should be increased to permit the proper formation of a throat.

Minimum thicknesses of material at sides and back of the opening are laid down in building regulations and are indicated in the figure. The jambs are required to be 200 mm thick. The back of the opening may be 100 mm thick when

1. It is set in an external wall and no combustible external cladding is attached behind it (A) or
2. it is common to two fire places set back-to back in a wall other than a party or separating wall (B)

In all other cases the back must be 200 mm of solid walling (C) or cavity walling with each leaf not less

In all other cases the back must be 200 mm of solid masonry (C) or cavity masonry with each leaf not less than 100 mm thick (D). (E) and (F) show alternative ways of setting the chimney breast in the wall of which it forms part.

Where a wide chimney breast is required for sake of appearance the jambs are made wider than 200 mm and where the jamb carries a flue as on an upper floor, a minimum width of 440 mm is necessary.

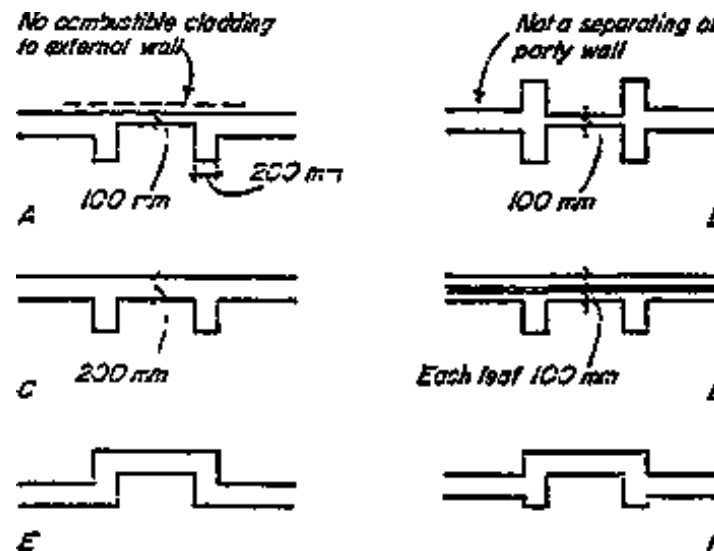

Thickness of material round fireplace openings

The traditional method of forming the head of the opening was by a segmental rough brick arch but the arch form presents some difficulty in forming a smooth narrow throat and a reinforced concrete lintel is preferable and is now normally used. Alternatively, a precast concrete lintel block or slab may be used in which the throat aperture is formed.

The junction between the relatively wide fireplace opening and the narrow flue is made by corbelling or 'gathering over' the brickwork or stone work of the chimney breast. The funnelshape produced is called the gather and provides a smooth flow from throat to flue.

The base of the fireplace opening is called the hearth. It is constructed of concrete and building

regulations require a minimum thickness of 125 mm. The back hearth, within the recess, bears on the chimney breast. The front hearth must project at least 500 mm in front of the breast and 150mm beyond each side of the opening. The full 125 mm thickness of the front hearth must be taken into the recess.

In solid ground floors the floor slab itself forms the hearth of the fireplace. Timber ground floor construction requires the provision of a fender wall. This wall may be 102-5 mm thick, providing support to the floor joists, the space within being filled with hardcore which carries the concrete hearth or it may be 215 mm thick to provide also a bearing for the front and side edges of a reinforced concrete hearth, the back edge of which is supported on the breast.

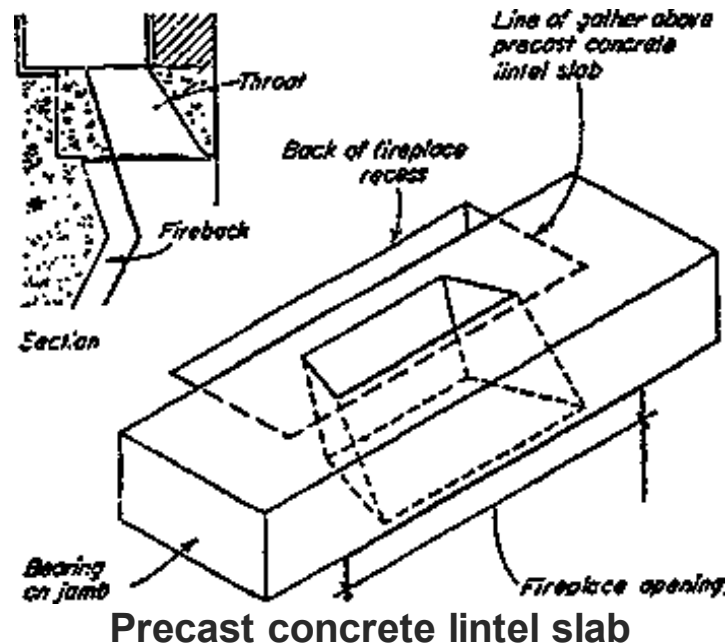

8.4.1 NON-CONVECTOR OPEN FIRES

MODERN inset open fires or all-night burners comprise a grate with a front which is sealed into the fireplace opening and incorporates in its design some device for controlling the primary air supply such

as a spin wheel or controllable flap. These grates are designed to fit British Standard fire backs which are made of firebrick or refractory concrete (aluminous cement and broken firebrick). The bend or knee at the back should be fairly high to permit the formation of a satisfactory throat (figure).

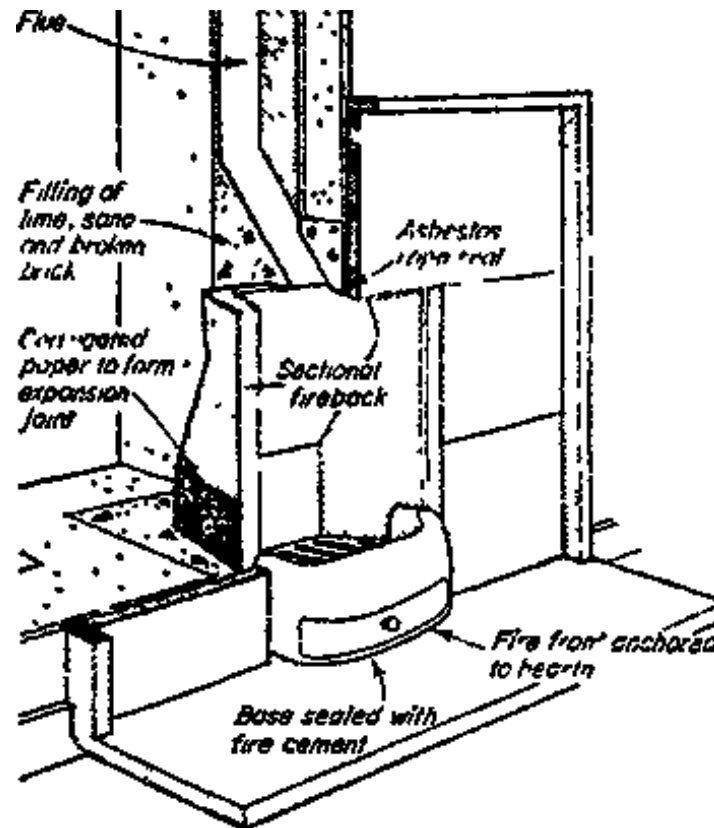

Non - convector open fire

8.4.2 CONVECTOR OPEN FIRES

These are freestanding open fires in which the fire is contained in a metal enclosure surrounded by a second metal jacket to form an integral convection chamber. The flue penetrates the outer jacket. The junction of the front of the fire with the fireplace surround must be sealed with soft asbestos rope or string and the appliance must be screwed to the back hearth so that no movement takes place which might break the seal.

might break the seal.

Back boilers

Non-Convactor open fires with back boilers are cast iron units incorporating a water container, flue and damper which are installed in place of the normal fire back as shown in the figure. The same general methods of constructing the fireplace already described are used, but the height and depth of fireplace opening may need to be greater than for a normal open fire. Convactor fires are also available with back boilers, the boiler being built into the appliances by the manufacturers. Flow and return pipes where they pass through the chimney breast, the gap between being caulked with asbestos string.

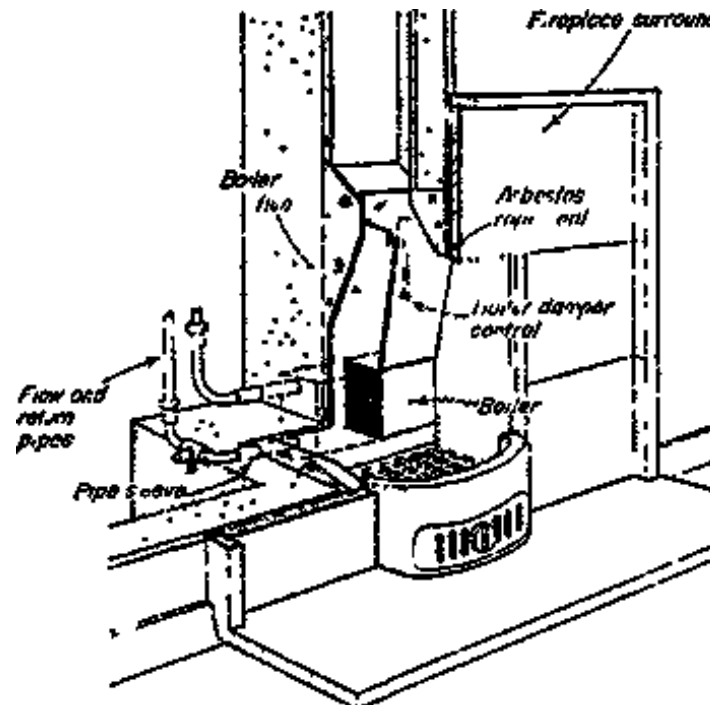

Non-convactor open fire with back boiler and flue set

Chimney and flue cleaning

Most open fires are swept through the front. Where adjustable throat restrictors are installed, these are

Most open fires are swept through the front. Where adjustable throat restrictors are installed, these are normally removable to allow cleaning brushes to be passed through the remaining opening.

8.5 CONSTRUCTION OF CHIMNEYS

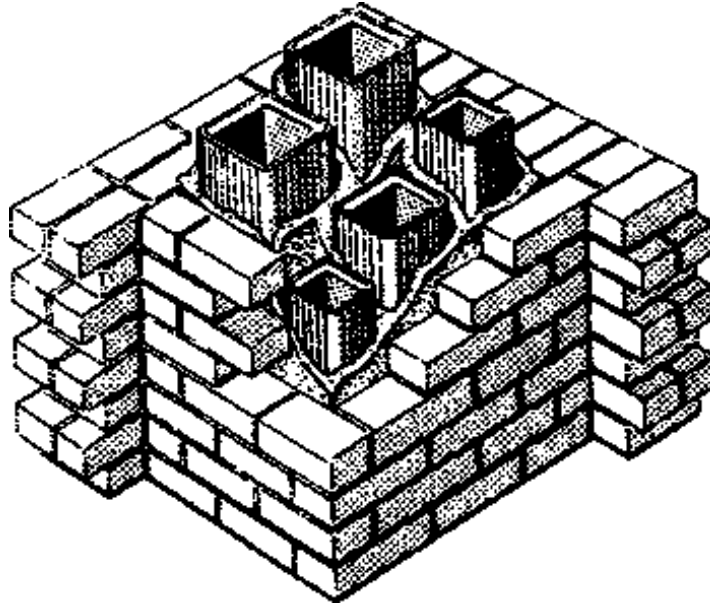

Brick chimneys

Domestic flues are mostly constructed in brickwork, with walls not less than 102.5 mm thick. Bends and slopes in the flue are formed by corbeling

The back of a flue in a party or separating wall, unless back to back with another flue, must be at least 200 mm thick, or be of cavity construction with each leaf not less than 100 mm thick, up to its intersection with the roof.

The chimney breast, immediately above the top ceiling is reduced in width to that required for the stack, allowing for at least 102.5 mm walls and withes, that is the walls between adjacent flues.

For safety in terms of stability the height of a stack, including any chimney pot or other terminal, above

the highest point of intersection with the roof must not exceed six times the least horizontal dimension unless the stack is braced in some way or its stability under wind pressure is checked by calculation.

When a chimney breast or stack projects beyond the face of the wall below the total projection of the oversailing brickwork must not exceed the thickness of the wall below with a maximum projection of 50 mm in each course.

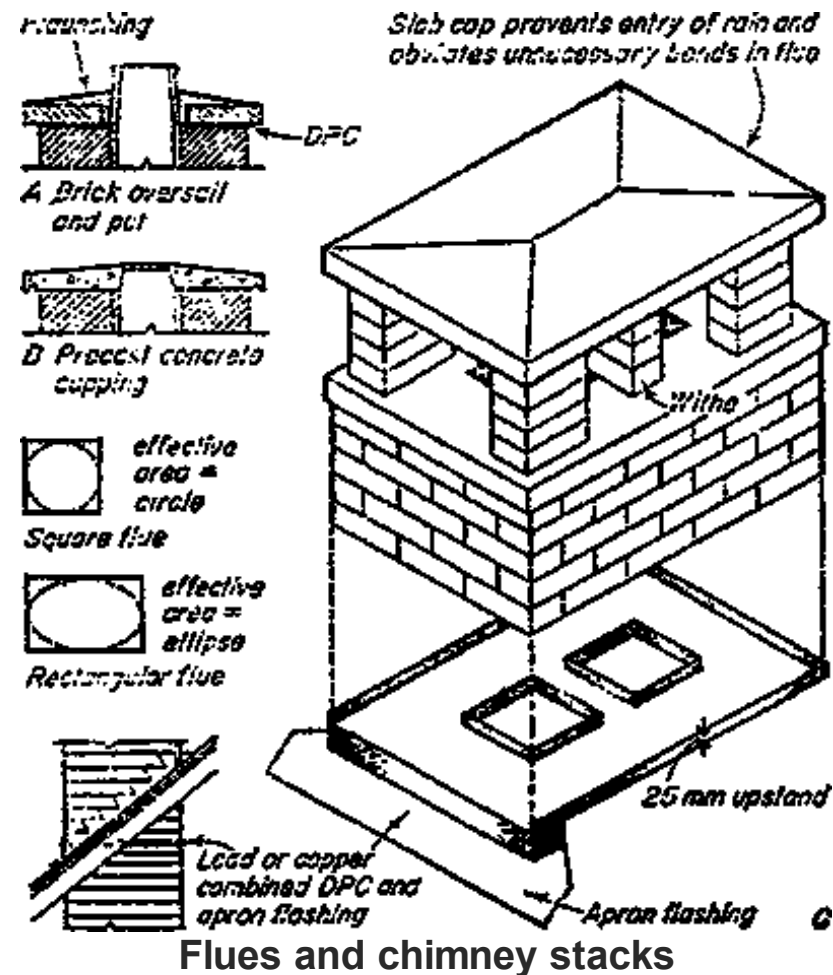

The top of a flue is usually terminated by a cylindrical fireclay pot. Tapering pots provide the slight

restriction at the flue outlet to increase the velocity of the rising flue gases. The pot is bedded in one or two courses of brickwork, or other type of capping, and the top of the stack round the pot is flaunching, that is weathered with mortar, to throw off water.

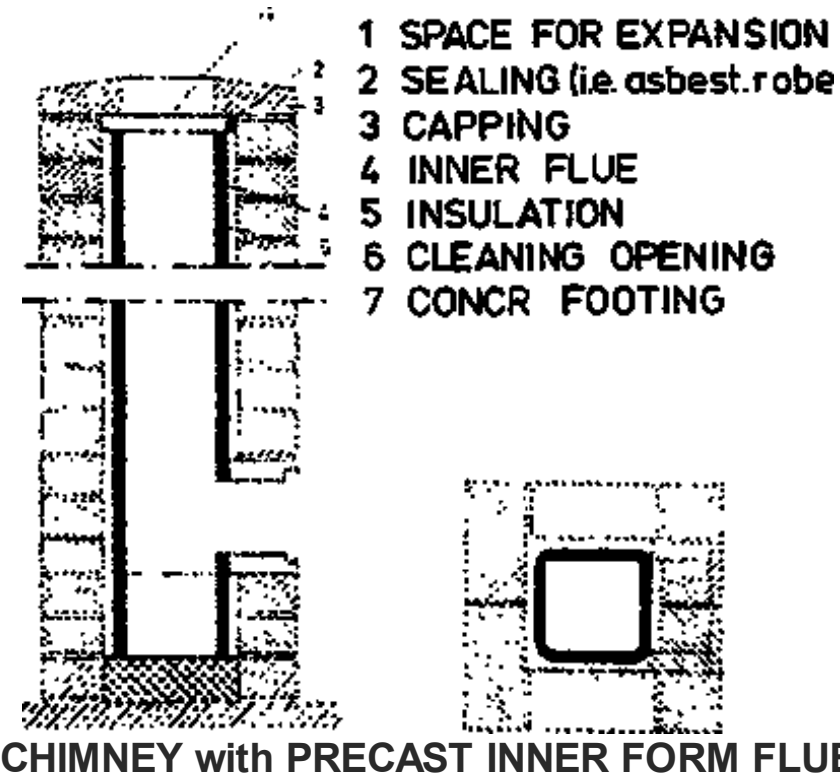

The use of a perforated and weathered stone or precast concrete cap (B) as a terminal has the advantage of dispensing with the need for flaunching which after a time, even with a cement-lime mortar, may crack and permit the penetration of rain.

Any withes should be carried up to the underside of the top slab.

The top twelve courses of a stack should be laid in cement or cement-lime mortar of a strength not less than 1:1:6. In order to ensure a smooth surface to the flue and to seal possible cracks in the brick joints

the flue is parged or lined. Parging is the internal rendering of the flue with a weak cement-lime

mortar, 1:3:12, mix, not less than 13 mm thick, applied as the stack is built up. Flue liners, as well as ensuring a smooth airtight flue of uniform section, permit added insulation to be provided. The Building Regulations, 1976, require flues for solid fuel and oil-burning appliances to be lined with rebated or socketed liners and make no provision for parging.

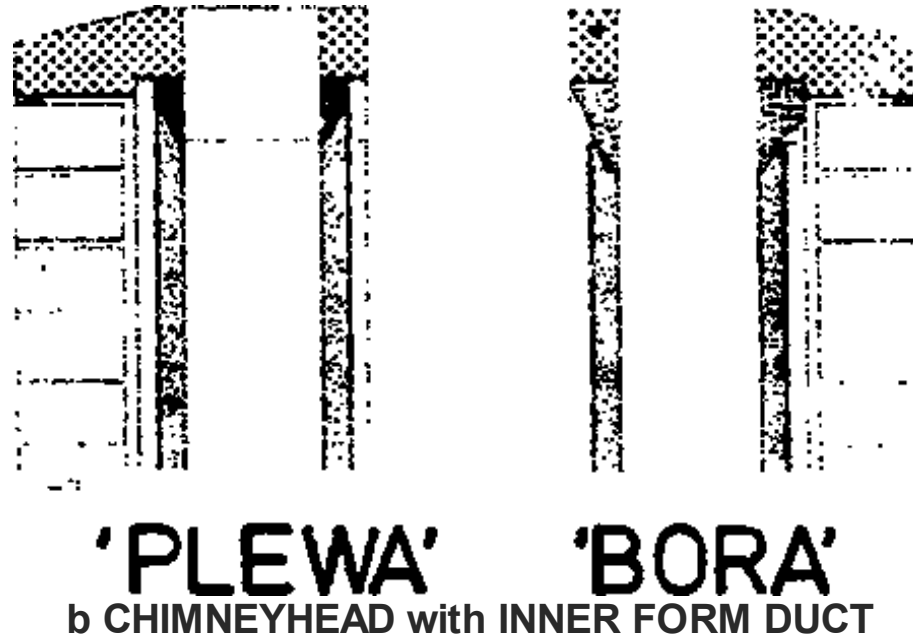

Liners may be made of fireclay, terra-cotta or acid - resisting concrete or they may be in the form of cast iron or vinyl-coated asbestos cement pipes (untreated asbestos cement is liable to disintegrate if heavy condensation occurs)(A,B)

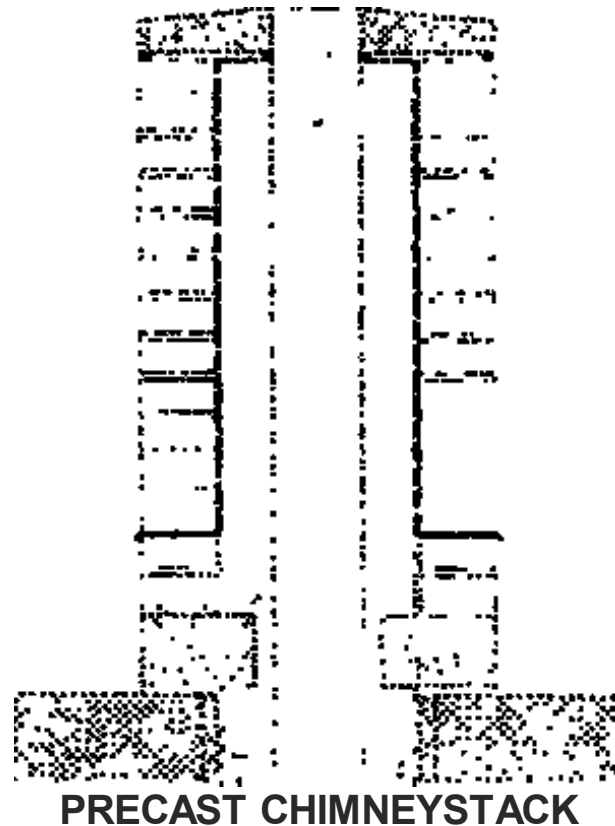

Where pipes are used the sockets should be uppermost and the joints made with asbestos rope and high alumina cement as shown in the figure. The rope allows expansion and the cement is acid resistant. The space between the lining and the chimney is usually filled with loose rubble flushed up with concrete or with an insulating material such as light weight concrete (C). Alternatively, the space may be left unfilled but sealed at top and bottom to provide an insulating barrier of still air.

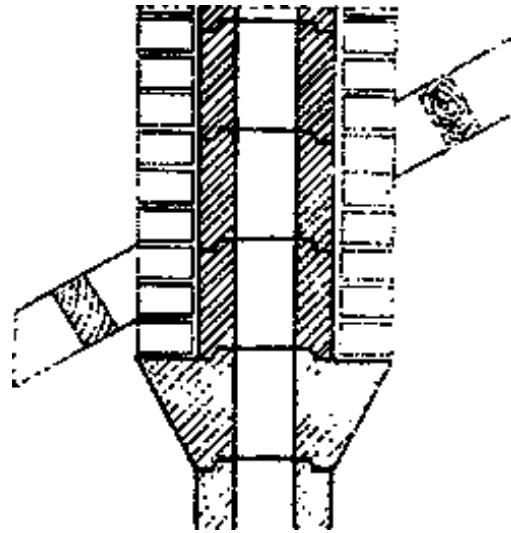

The gathering over of the flue above the fireplace opening, referred to under Fireplace construction, should be steep, not flat, with the entry to the flue itself, that is the top of the 'funnel' more or less central with the fireplace unless the flue has to pass to one side in order to clear an upper fireplace. A 'dog-leg' bend once always formed in the gather is no longer considered essential.

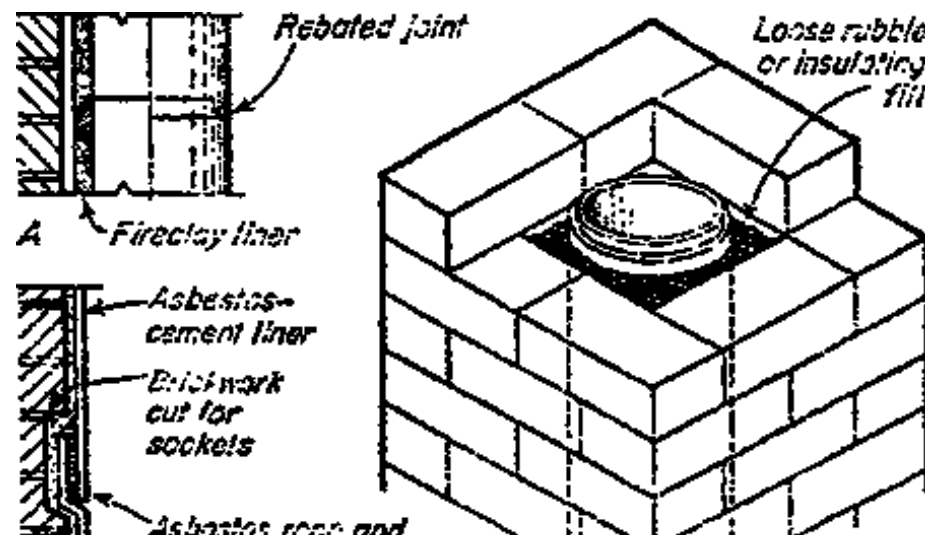



Flue linings

Stone chimneys

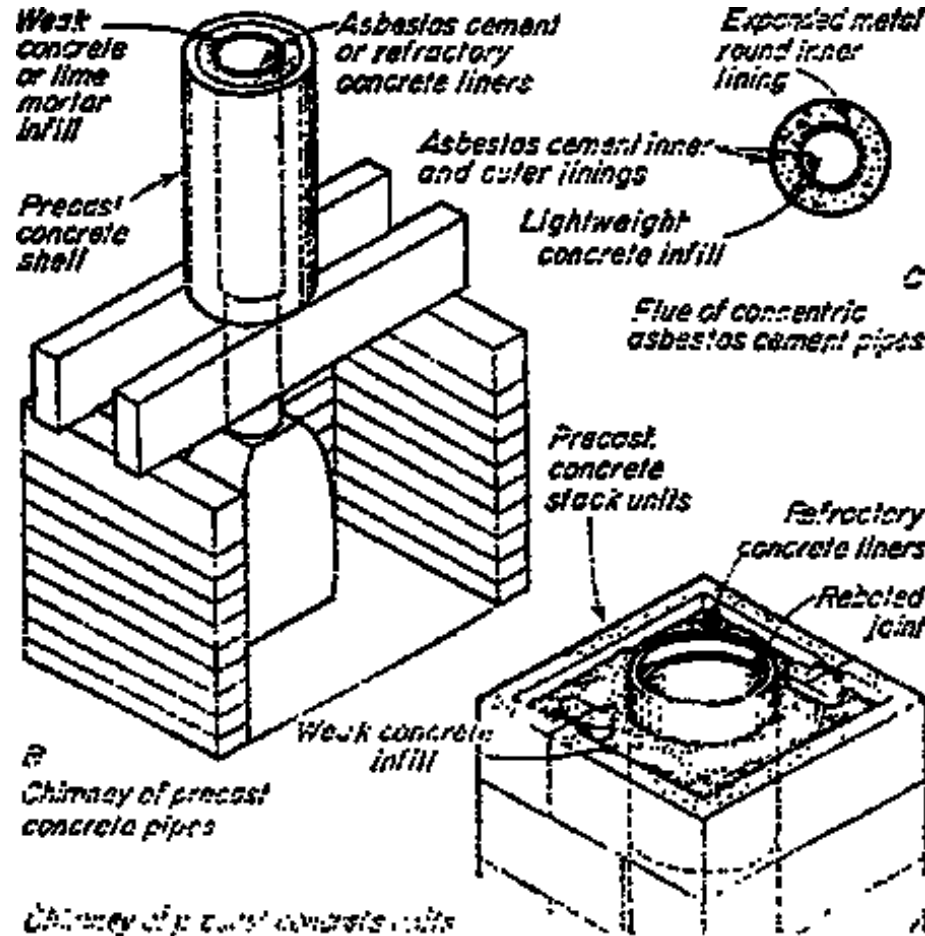

Chimney construction

The temperatures encountered in a domestic flue are not likely to damage a good building stone, except in the immediate vicinity of the fire and in this position sandstone should be used or protection given by firebricks. The flue walls should be at least 215 mm thick and if the stone is backed with brick or

THICKNESS. THE FLUE WALLS SHOULD BE AT LEAST 215 MM THICK AND IF THE STONE IS BARRER WITH BRICK OR concrete this should be maintained as the minimum overall thickness.

Coursed masonry may be corbelled out to a total projection not exceeding the thickness of the wall below. Each course may project a distance equal to half the thickness of the wall below it, provided the corbel stone is bonded into the wall a distance equal to twice its projection. Stone chimneys must be protected by liners.

Concrete chimneys

Concrete chimneys can be constructed in three ways:

- 1. With in situ concrete**
- 2. With precast concrete units**
- 3. By a combination of 1 + 2**

Concrete for in situ work may be either plain or reinforced and where in contact with the flue gases should be of an acid-resisting refractory type.

Lightweight concrete made with foamed slag or expanded clay aggregates, or no fines concrete, can also be used, provided protection is given by flue liners. The mix for dense concrete should not be too rich in order to reduce shrinkage and to resist the effects of heat satisfactorily crushed brick, slag, clinker or crushed limestone should be used as aggregate.

The concrete should be at least 100 mm thick and unless increased to at least 150 mm where penetrating the roof should be rendered to provide adequate protection against damp penetration.

Up to a height of seven times its least horizontal dimension the effect of wind pressure on a plain, dense concrete chimney need not be considered. Oversailing projections should form an angle of not less than 60 degrees with the horizontal unless the projection is reinforced. The height of in situ lightweight or no-

to degrees with the horizontal unless the projection is reinforced. The height of in situ lightweight or no-fines concrete chimneys should be limited to four times their least horizontal dimension and all

oversailing or projecting parts should be formed with dense concrete, reinforced as necessary. The open-textured internal surface of such chimneys should always be lined and the external surfaces should be rendered. With cast in situ chimneys of all types liners are invariably used as they form permanent shuttering.

Dampproof courses are not generally required if the outside is rendered and there are flue liners.

A variety of precast units of dense or lightweight concrete are available for forming chimneys. There are two approaches to the construction of chimneys in this form: One by precast blocks bonded to form the walls and the withes of the chimney as normal masonry, another by forming the internal and external surfaces of the chimney with precast units and filling the intervening cavity with lightweight concrete.

Dense vibrated concrete blocks will generally withstand damp penetration without rendering the external surfaces, and such constructions automatically provide a sufficiently smooth surface to the flue.

As with in situ cast flues of lightweight concrete flue liners are essential with lightweight blocks, and these are incorporated in the manufacture.

Metal and asbestos cement flues

These materials have poor thermal insulation value and are not really suitable for external use unless insulated. They should generally be used only for flues within the room containing the appliance. Metal flues can be made of steel or cast iron. Asbestos cement flues are of heavy quality pipes. The pipes should be frequently supported, usually at every joint or at intervals not exceeding sixteen times the internal diameter.

The joints should be airtight and allowance should be made for the expansion and contraction of the pipes at the joints and at the supports

pipes at the joints and at the supports.

Asbestos cement flues are not recommended for open fires or appliances using bituminous coal nor in situations where the internal flue temperature is likely to exceed 260°C since the material cracks when exposed to high temperatures or to flames impinging on its surface. They must, therefore, be protected from flames by using a 1.8 m length of metal flue immediately above the fire.

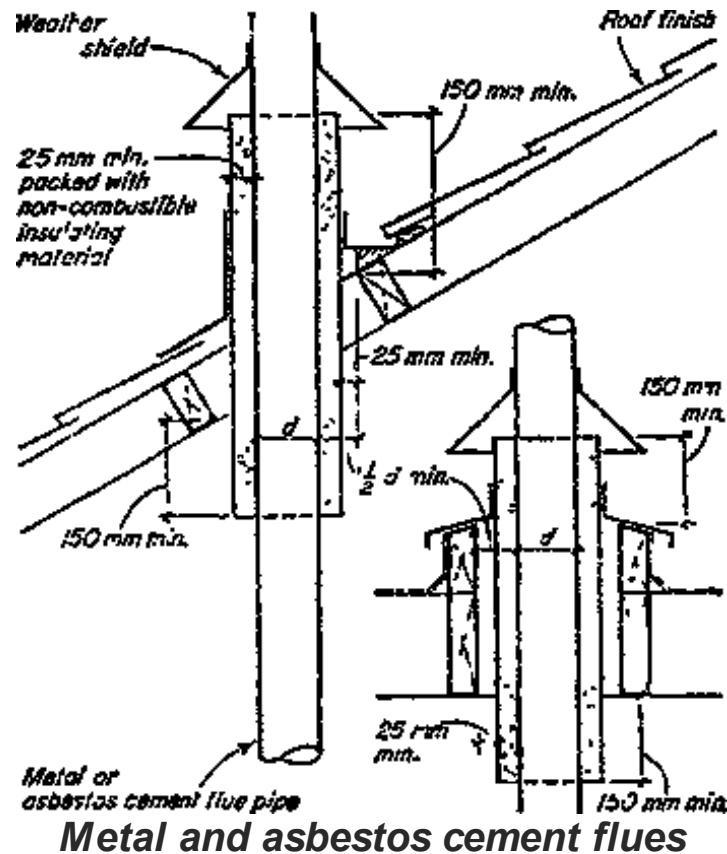

Greater strength and insulation can be achieved by using asbestos cement pipes concentrically and filling the intervening cavity with lightweight insulating filling.

All combustible material in a roof or external wall through which the pipe passes must

1. be kept a minimum distance of three times its external diameter away from the pipe,

or

2. be separated from the pipe by 200 mm of solid non-combustible material (300 mm if the combustible material is in an external wall above the pipe) or

3. the pipe must be enclosed with a sleeve of metal or asbestos cement. Such pipes must pass into a normal chimney within the same room or directly through an external wall or a roof structure, but not through a roof space, floor or internal wall.

REPETITION • • exercises • REPETITION

Try to answer the following questions and practice sketching wherever necessary and possible:

1. Define briefly the term "FIREPLACE"

2. Name the structural members of a CHIMNEY

3. Describe briefly the function of Fireplaces and flues

4. Explain by means of sketches the PRIMARY and the SECONDARY AIR SUPPLY in a Fireplace and describe the differences.

5. A chimney and chimney breast must satisfy certain requirements, such as:

- Weather Resistance**
- Thermal Installation and**
- Fire Resistance**

Write notes on the above listed requirements.

- 6. Describe the principles of a traditional OPEN FIREPLACE and use sketches for illustration.**
- 7. What are the characteristics of IMPROVED SOLID FUEL APPLIANCES? (use sketches for illustration)**
- 8. Designing a flue properly the following factors must be considered.**
 - a Size and Shape**
 - b Airtightness**
 - c Insulation**
 - d Position of outlet**

Write notes on the above listed factors.

- 9. Draw a sketch, indicating depth, width and height of the opening of an open fireplace as well as the thickness of material at sides and back of the opening.**
- 10. What is the traditional method of forming the head of the opening of a fire place?**
- 11. What is an alternative to the traditional method?**
- 12. Describe briefly (by using sketches for illustration)**
 - a How the junction between the fire place - opening and the flue is made (or HEARTH)**
 - b How the base (or HEARTH) of the fireplace opening is constructed?**

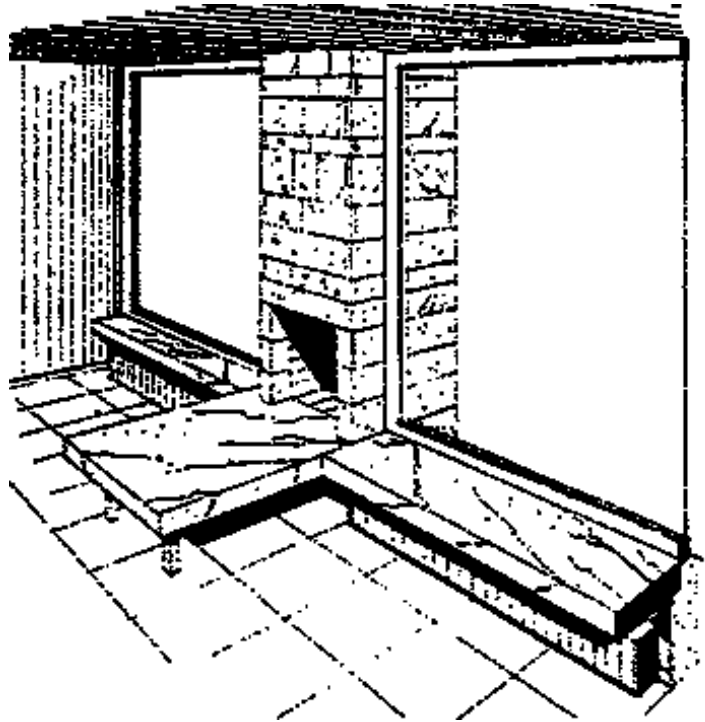

13. Explain briefly the terms:

- **Non-convector fires**
- **Convactor fires**
- **Back boilers and use sketches for illustration**

14. List different types of chimneys (according to their building materials used for construction) and describe briefly (by means of heat sketches) the methods used for construction.

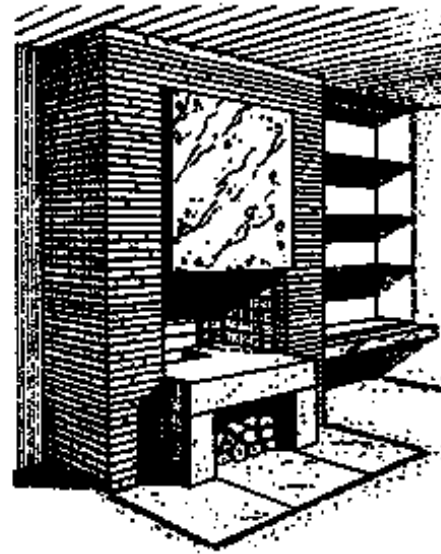
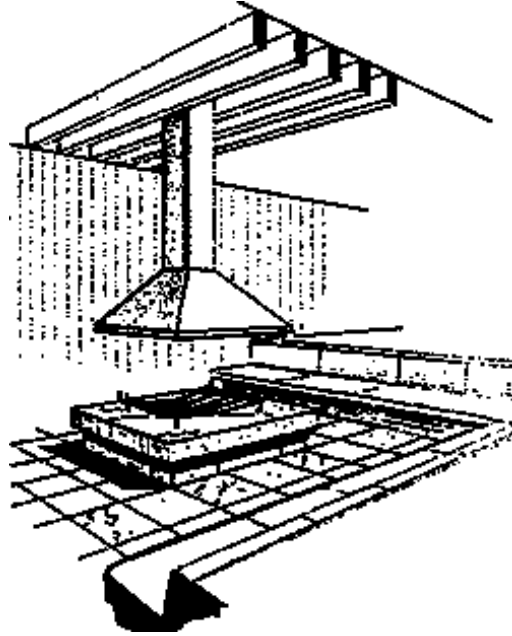

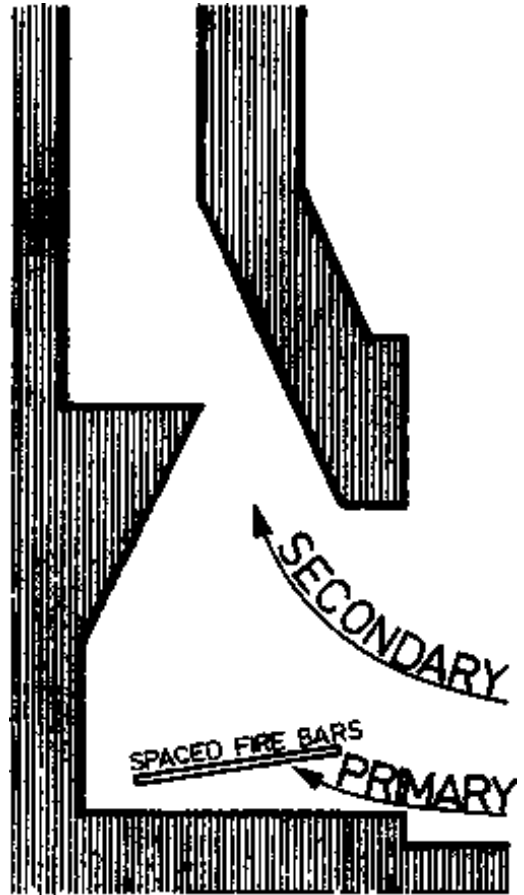

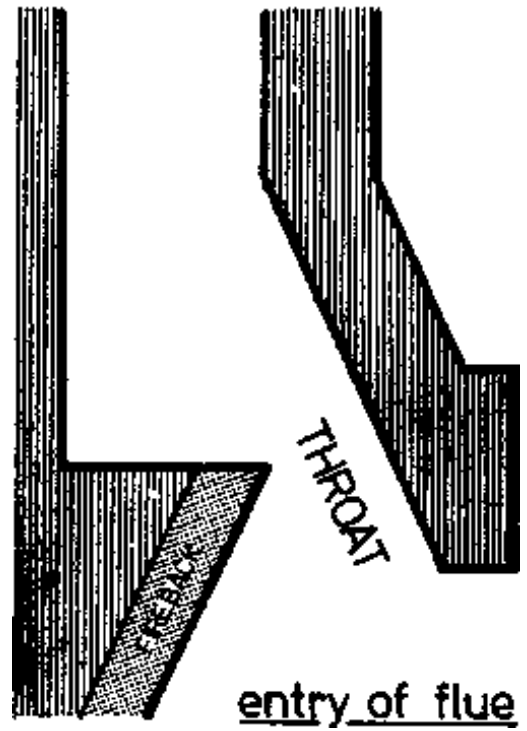

Please provide your feedback

English | French | Spanish | German