

[Home page](#) | [Help](#) | [Clear](#)

[English](#) | [French](#) | [Spanish](#) | [German](#)

[Search](#) | [Subjects](#) | [Titles A-Z](#) | [Courses](#) | [Illustrations](#) | [Topics](#) | [e-Course builder](#)

 [Contract TOC](#)

 [Expand Document](#)

 [Contract Chapter](#)

 [Add to e-Course](#)

 [Preferences](#)

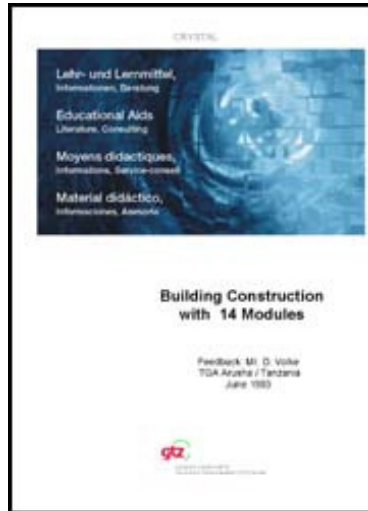

[Printable version](#)

[Export document as HTML file](#) [Help](#)

[Export document as PDF file](#)

Building Construction with 14 Modules (TCA; 1983; 618 pages)

1. ARCHITECTURAL DRAWING I

1.1 AIMS AND PURPOSE OF ARCHITECTURAL DRAWINGS

1.1.1 CONTENTS OF ARCHITECTURAL DRAWINGS

1.2 DRAWING EQUIPMENT

1.2.1 PENCILS

1.2.2 DRAWING PENS

1.2.3 COMPASSES

1.2.4 DRAWING BOARDS

1.2.5 T-SQUARES

1.2.6 SET SQUARES

1.2.7 PROTRACTORS

1.2.8 SCALES

1.2.9 FRENCH CURVES

1.2.10 TEMPLATES

1.2.11 DRAWING PINS AND OTHER FIXINGS

1.2.12 MINOR ITEMS OF EQUIPMENT

1.2.13 PRINTING PAPERS

1.2.14 TRACING PAPER, CLOTH AND FILM

 **1.2.15 BACKING SHEETS**

 **1.2.16 DRAWING PAPERS**

 **1.2.17 CARTRIDGE**

 **1.2.18 HANDMADE AND MOULDMADE PAPERS**

 **1.2.19 PLASTIC-COATED CARD**

 **1.3 LETTERING**

 **1.3.1 PRINCIPLE OF LETTERING**

 **1.3.2 FREEHAND LETTERING**

 **1.3.3 TYPES OF LETTERS**

 **1.3.3.1 The Roman Alphabet**

 **1.3.3.2 Sans Serif Letters**

 **1.3.3.3 Inclined Lettering**

 **1.3.3.4 Script Lettering**

 **1.3.3.5 Stencil Lettering**

 **1.3.3.6 Guided Pen Lettering**

 **1.3.3.7 Pressure-Transfer Lettering**

 **1.4 LINEWORK AND DIMENSIONING**

 **1.4.1 TYPES OF LINES**

 **1.4.2 PENCIL DRAWING**

 **1.4.3 INKING - IN**

 **1.4.4 BASIC RULES OF DIMENSIONING**

 **1.4.4.1 Types of Dimensions**

 **1.4.4.2 Placement of Dimensions**

 **1.5 ENLARGEMENT AND REDUCTION OF LINE DRAWINGS** **1.6 GEOMETRICAL CONSTRUCTIONS** **1.6.1 LINES AND ANGLES** **1.6.1.1 To bisect a straight line AB** **1.6.1.2 To divide a straight line AB into a given number of equal parts** **1.6.1.3 To divide a straight line AB into any ratio** **1.6.1.4 To construct an angle of 90°**  **1.6.1.5 To construct an angle of 45°**  **1.6.1.6 To construct an angle of 60°**  **1.6.1.7 To construct an angle of 30°**  **1.6.1.8 To bisect any given angle** **1.6.1.9 To construct an angle SIMILAR to a given angle** **1.6.1.10 To draw a line PARALLEL to a given line** **1.6.2 TRIANGLES** **1.6.2.1 To construct an EQUILATERAL triangle** **1.6.2.2 To construct a triangle with given BASE ANGLES and ALTITUDE** **1.6.2.3 To inscribe a circle in a given triangle ABC** **1.6.2.4 To circumscribe a triangle ABC** **1.6.3 CIRCLES** **1.6.3.1 Basic CIRCLE-Constructions** **1.6.3.2 To draw a tangent to a point A on the circumference of a circle centre O**

 **1.6.3.3 To draw an internal tangent to two circles of equal diameter**

 **1.6.3.4 To find the centre of a given circle arc**

 **1.6.3.5 To join two straight lines at RIGHT ANGLES to each other by an arc of given radius**

 **1.6.3.6 To draw a curve of given radius joining two circles**

 **1.6.3.7 To join two straight lines by two arcs of equal radius**

 **1.6.4 BASIC ARCH CONSTRUCTIONS**

 **2. ARCHITECTURAL DRAWING II**

 **2.1 TYPES OF PROJECTIONS**

 **2.2 ORTHOGRAPHIC PROJECTION**

 **2.2.1 CONSTRUCTION OF ORTHOGRAPHIC PROJECTION**

 **2.2.2 ELEVATIONS**

 **2.2.3 PLANS AND SECTIONS**

 **2.3 PICTORIAL DRAWING**

 **2.3.1 AXONOMETRIC PROJECTION**

 **2.3.2 ISOMETRIC PROJECTION**

 **2.3.3 DIMETRIC PROJECTION**

 **2.3.4 OBLIQUE PROJECTION**

 **2.3.4.1 Length of Receding Lines**























 **2.3.4.2 Construction of Oblique Drawings**

 **2.3.4.3 Rules of Oblique Drawing**

 **2.3.4.4 Scale of the Receding Lines**

 **2.3.4.5 Direction of Receding Lines**

 **2.3.4.6 Position of Axes** **2.4 PERSPECTIVE DRAWING** **2.4.1 PERSPECTIVE TERMS** **2.4.2 PHENOMENA OF PERSPECTIVE DRAWING** **2.4.3 SYSTEMS OF PERSPECTIVE DRAWINGS** **2.4.4 METHODS OF PERSPECTIVE DRAWINGS** **2.4.5 TWO-POINT PERSPECTIVE** **2.4.6 ONE-POINT PERSPECTIVE** **2.5 SHADES AND SHADOWS** **2.5.1 THE USE OF SHADOWS** **2.5.2 SHADES AND SHADOWS** **2.5.3 THE CONVENTIONAL DIRECTION OF LIGHT** **2.5.4 THE 45° DIRECTION** **2.5.5 THE TRUE DIRECTION OF LIGHT** **2.5.6 SHADOWS OF SOLIDS** **2.5.7 PLANES OF SHADOW** **2.5.8 PRINCIPLES OF SHADOW-CASTING** **2.6 DRAWING PRACTICE** **2.6.1 DRAWING SHEETS** **2.6.1.1 Sizes and Folds** **2.6.1.2 Layout and Identification** **2.6.2 LEVELS** **2.6.3 REFERENCING**

-  **2.6.4 ABBREVIATIONS**
-  **2.6.5 REPRESENTATION OF MATERIALS**
-  **2.6.6 GRAPHICAL SYMBOLS AND REPRESENTATION**
-  **2.6.7 HATCHING RULES**
-  **2.7 APPLICATION FOR BUILDING PERMIT**
 -  **2.7.1 PROCEDURE OF APPLYING FOR PERMISSION TO ERECT A BUILDING**
 -  **2.7.2 FORMULARS**
-  **4. CONTRACT PLANNING AND SITE ORGANISATION**
 -  **4.1 CONTRACT PLANNING**
 -  **4.1.1 BAR CHART**
 -  **4.1.2 NETWORK ANALYSIS**
 -  **4.1.3 THE OVERALL PROGRAMME**
 -  **4.1.3.1 Break down of job**
 -  **4.1.3.2 Quantities of work and time content**
 -  **4.1.3.3 Plant and Labour outputs**
 -  **4.1.3.4 Sequence and timing of operations**
 -  **4.1.3.5 The programme chart**
 -  **4.1.4 PLANNING CONSIDERATIONS**
 -  **4.1.4.1 Site conditions and access**
 -  **4.1.4.2 Nature of job**
 -  **4.1.4.3 Plant**
 -  **4.1.4.4 Scaffolding**

 **4.2 SITE ORGANIZATION** **4.2.1 PRELIMINARY WORK** **4.2.2 SITE PLANNING** **4.2.2.1 Period planning** **4.2.2.2 Weekly planning** **4.2.2.3 Progress control** **4.2.3 SITE LAYOUT** **5. FOUNDATIONS** **5.1 SOIL INVESTIGATIONS** **5.1.1 SITE EXPLORATION** **5.1.1.1 Trial holes** **5.1.1.2 Bore holes** **5.1.1.3 Sampling** **5.1.1.4 Tests** **5.1.1.5 Load or bearing test** **5.1.2 SOILS AND SOIL CHARACTERISTICS** **5.1.2.1 Rocks and soils** **5.1.2.2 Stresses and pressures** **5.2 EXCAVATIONS AND TIMBERING** **5.3 TYPES OF FOUNDATIONS** **5.3.1 CLASSIFICATION** **5.3.2 CHOICE OF FOUNDATION** **5.3.3 SPREAD FOUNDATIONS**

 **5.3.3.1 Strip foundations**

 **5.3.3.2 Deep strip foundations**

 **5.3.3.3 Stepped foundations**

 **5.3.3.4 Pad foundations**

 **5.3.3.5 Raft foundations**

 **5.3.4 PILE FOUNDATIONS**

 **5.3.4.1 Short bored pile foundations**

 **5.3.5 PIER FOUNDATIONS**

 **6. WALLS**

 **6.1 FUNCTION AND PROPERTIES OF WALLS**

 **6.2 THE BEHAVIOR OF THE WALL UNDER LOAD**

 **6.2.1 CALCULATION OF WALL THICKNESS**

 **6.3 TYPES OF WALLS**

 **6.4 STONEMWORK**

 **6.4.1 BUILDING STONES**

 **6.4.2 STONEMWORK THERMINOLOGY**

 **6.4.3 STONEMWORK CLASSIFICATION**

 **6.4.4 RUBBLE WALLING**

 **6.4.5 ASHLAR WALLING**

























 **6.4.5.1 Rules for ashlar work**























 **6.5 BRICK WORK**























 **6.5.1 BRICKWORK TERMINOLOGY**

 **6.5.2 MANUFACTURE OF CLAY BRICKS**

 **6.5.2.1 Pressed Bricks** **6.5.2.2 Wire cut bricks** **6.5.2.3 Efflorescence** **6.5.3 BRICK CLASSIFICATION** **6.5.4 CALCIUM SILICATE BRICKS** **6.5.5 CONCRETE BRICKS** **6.5.6 MORTARS FOR BRICKWORK** **6.5.7 DAMPNES PENETRATION** **6.5.8 BRICKWORK BONDING** **6.5.8.1 Common bonds** **6.5.9 METRIC MODULAR BRICKWORK** **6.5.10 JUNCTIONS** **6.5.11 QUOINS OR EXTERNAL ANGLES** **6.5.12 PIERS** **6.5.12.1 Detached piers:** **6.5.12.2 Attached Piers (or Pilasters)** **6.5.12.3 Buttresses** **6.6 BLOCKWORK** **6.6.1 CLAY BLOCKS** **6.6.2 PRECAST CONCRETE BLOCKS** **6.6.3 AERATED CONCRETE BLOCKS** **6.7 CONCRETE WALLS** **6.7.1 GENERAL**

-  **6.7.1 GENERAL**
-  **6.7.2 FOREWORK**
-  **6.7.3 PLAIN MONOLITHIC CONCRETE WALL**
 -  **6.7.3.1 Dense concrete walls**
 -  **6.7.3.2 Light-weight aggregate**
 -  **6.7.3.3 No-fines concrete walls**
 -  **6.7.3.4 Thickness of plain concrete walls**
 -  **6.7.3.5 Shrinkage reinforcement**
-  **6.7.4 REINFORCED CONCRETE WALLS**
 -  **6.7.4.1 In-Situ Cast external walls**
 -  **6.7.4.2 Concrete Box Frames**
 -  **6.7.4.3 Large precast panel structure**
-  **6.8 OPENINGS IN WALLS**
 -  **6.8.1 HEAD**
 -  **6.8.1.1 Lintels**
 -  **6.8.1.2 Arches**
 -  **6.8.2 JAMBS**
 -  **6.8.3 SILLS AND THRESHOLDS**
 -  **6.8.3.1 Sills**
 -  **6.8.3.2 Thresholds**
-  **7. FLOORS**
 -  **7.1 GENERAL**
 -  **7.2 SOLID GROUND FLOORS**
 - 

-  **7.2.1 SITE CONCRETE**
-  **7.2.2 HARDCORE**
-  **7.2.3 WATERPROOF MEMBRANE**
-  **7.3 SUSPENDED TIMBER GROUND FLOOR**
 -  **7.3.1 BUILDING REGULATIONS**
 -  **7.3.2 LAY OUT**
-  **7.4 UPPER FLOORS**
 -  **7.4.1 TYPES OF UPPER FLOORS**
 -  **7.4.2 STRUCTURE OF UPPER FLOORS**
 -  **7.4.3 SUSPENDED TIMBER UPPER FLOORS**
 -  **7.4.3.1 Floor Joists**
 -  **7.4.3.2 End Support of Floor Joists**
 -  **7.4.3.3 Trimming**
 -  **7.4.4 REINFORCED CONCRETE UPPER FLOORS**
 -  **7.4.4.1 Monolithic Reinforced Concrete Upper Floors**
 -  **7.4.4.2 Precast Concrete Upper Floors**
 -  **7.4.4.3 Hollow Block and Waffle Floors**
-  **7.5 FLOOR FINISHES**
 -  **7.5.1 JOINTLESS FLOOR FINISHES**
 -  **7.5.1.1 The most common of these is the Cement/Sand Screed**
 -  **7.5.1.2 Granolithic Concrete Finishes**
 -  **7.5.1.3 Terazzo**
 -  **7.5.2 SLAB FLOORS FINISEHES**

-  **7.5.3 SHEET FLOOR FINISHES**
-  **7.5.4 WOOD FLOOR FINISHES**
-  **8. OPEN FIREPLACES, CHIMNEYS AND FLUES**
 -  **8.1 FUNCTION OF FIREPLACES AND FLUES**
 -  **8.2 PRINCIPLES OF FIREPLACE DESIGN**
 -  **8.2.1 TRADITIONAL OPEN FIREPLACE**
 -  **8.2.2 IMPROVED SOLID FUEL APPLIANCES**
 -  **8.3 PRINCIPLES OF FLUE DESIGN**
 -  **8.4 CONSTRUCTION OF FLUE DESIGN**
 -  **8.4.1 NON-CONVECTOR OPEN FIRES**
 -  **8.4.2 CONVECTOR OPEN FIRES**
 -  **8.5 CONSTRUCTION OF CHIMNEYS**
-  **9. ROOFS**
 -  **9.1 FUNCTIONAL REQUIREMENTS**
 -  **9.1.1 STRENGTH AND STABILITY**
 -  **9.1.2 WEATHER RESISTANCE**
 -  **9.1.3 THERMAL INSULATION**
 -  **9.1.4 FIRE RESISTANCE**
 -  **9.1.5 SOUND INSULATION**
 -  **9.2 TYPES OF ROOF STRUCTURES**
 -  **9.2.1 FLAT AND PITCHED ROOFS**
 -  **9.2.2 STRUCTURE OF THE ROOF**
 -  **9.2.3 LONG AND SHORT SPAN ROOFS**

 **9.2 LONG AND SHORT OF A ROOF** **9.3 FLAT ROOFS** **9.3.1 PHYSICAL AND STRUCTURAL PROBLEMS** **9.3.2 STRUCTURE OF A FLAT ROOF** **9.3.3 THERMAL INSULATION MATERIAL** **9.3.4 SINGLE AND DOUBLE FLAT ROOF CONSTRUCTION** **9.3.5 PARAPET WALLS** **9.4 PITCHED ROOFS** **9.4.1 SHAPES OF PITCHED ROOFS IN TIMBER** **9.4.2 TERMS** **9.4.3 TYPES OF PITCHED ROOFS IN TIMBER (STRUCTURES)** **9.4.3.1 Mono-(single) pitched Roof** **9.4.3.2 Lean - to Roof** **9.4.3.3 Couple Roof** **9.4.3.4 Close couple Hoof** **9.4.3.5 Collar Roof** **9.4.3.6 Double or Purlin Roof** **9.4.3.7 Tripple or Trussed Roofs** **9.4.3.8 Trussed Rafters** **9.4.3.9 Hipped Roofs** **9.4.4 VALLEY** **9.4.5 EAVES TREATMENT** **9.4.6 OPENINGS IN TIMBER ROOFS** **9.5 ROOF COVERINGS**

9.5 ROOF COVERINGS **9.5.1 FUNCTION OF ROOF COVERINGS** **9.5.2 TYPES OF ROOF COVERINGS** **9.5.3 SUBSTRUCTURES** **9.5.4 CHOICE OF ROOF COVERINGS** **9.5.5 MATERIALS AND COVERING METHODS** **10. FRAMED STRUCTURES** **10.1 STRUCTURAL CONCEPT** **10.2 FUNCTIONAL REQUIREMENTS** **10.3 STRUCTURAL MATERIALS** **10.4 LAYOUT OF FRAMES** **10.5 BUILDING FRAMES** **10.5.1 FUNCTIONS OF BUILDING FRAME MEMBERS** **10.5.2 REINFORCED CONCRETE FRAMES** **10.5.2.1 Reinforced Concrete Beams** **10.5.2.2 Reinforced Concrete Columns** **10.5.2.3 Reinforced Concrete Slabs** **10.5.3 PRECAST CONCRETE FRAMES** **10.5.3.1 Methods of Connections** **10.5.4 STRUCTURAL STEELWORK FRAMES** **10.5.4.1 Structural Steel Frames** **10.5.4.2 Castellated Universal Sections** **10.5.4.3 Connections**



10.5.4.4 Structural Steel Connections



10.5.4.5 Frame Erection



10.5.4.6 Fire Protection of Steelwork



10.5.5 TIMBER FRAMES



10.5.5.1 Columns and Beams



10.5.5.2 Connections



10.5.5.3 Building frames in timber



10.5.5.4 Prefabrication



10.6 PORTAL FRAMES



10.6.1 THEORY



10.6.2 CONCRETE PORTAL FRAMES



10.6.3 STEEL PORTAL FRAMES



10.6.4 TIMBER PORTAL FRAMES



11. PROTECTION OF BUILDINGS



11.1 EXCLUSION OF WATER



11.1.1 PRECIPITATION



11.1.1.1 Roof Drainage



11.1.1.2 Flooding



11.1.1.3 Drought



11.1.2 DAMP RISING AND MOISTURE MIGRATION



























11.1.3 CONDENSATION



11.2 THERMAL INSULATION



11.2.1 DEFINITION

-  **11.2.1 DEFINITION**
-  **11.2.2 INSULATING MATERIALS**
-  **11.3 SOUND INSULATION**
 -  **11.3.1 DEFINITION**
 -  **11.3.2 SOUND INSULATION**
 -  **11.3.3 EXTERNAL NOISE**
-  **11.4 FIRE PROTECTION**
 -  **11.4.1 STRUCTURAL FIRE PROTECTION**
 -  **11.4.1.1 Fire Load**
 -  **11.4.1.2 Fire Resistance of Material**
 -  **11.4.1.3 Appropriate Types of Construction**
-  **12. FINISHING & FINISHES**
 -  **12.1 EXTERNAL WALL FINISHES**
 -  **12.1.1 EXTERNAL RENDERING**
 -  **12.1.2 CONCRETE FINISHES**
 -  **12.1.3 CLADDING**
 -  **12.1.3.1 CLADDINGS FIXED TO A STRUCTURAL BACKING**
 -  **12.1.3.2 CLADDINGS TO FRAMED STRUCTURES**
 -  **12.1.4 EXTERNAL PAINTS AND FINISHES**
 -  **12.2 INTERNAL WALL FINISHES**
 -  **12.2.1 PLASTERING**
 -  **12.2.2 OTHER INTERNAL WALL FINISHES**
 -  **12.2.3 PAINTING**
 -  **12.3 CEILING FINISHES**

 **12.3 CEILING FINISHES** **13. STAIRS** **13.1 INTRODUCTION** **13.2 DEFINITION OF TERMS** **13.3 TYPES OF STAIRS** **13.4 DESIGN OF STAIRS** **13.4.1 RISE - TREAD - PROPORTION** **13.4.2 SLOPE OR PITCH** **13.4.3 LANDINGS** **13.4.4 WIDTH** **13.4.5 WALKING LINE** **13.5 CONSTRUCTION OF STAIRS** **13.5.1 BRICK STAIRS** **13.5.2 STONE STAIRS** **13.5.3 CONCRETE STAIRS** **13.5.3.1 In Situ Cast R.C. Stairs** **13.5.3.2 Precast Concrete Stairs** **13.5.4 TIMBER STAIRS** **13.5.5 METAL STAIRS** **13.6 MISCELLANEOUS** **13.6.1 BALUSTRADES/HANDRAILS** **13.6.2 'SAMBA' STAIR, LADDERS, DISAPPEAR STAIRS, RAMPS** **13.6.3 ESCALATORS** **14 DOORS & WINDOWS**

 **14. DOORS & WINDOWS** **14.1 DOORS** **14.1.1 EXTERNAL DOORS** **14.1.2 INTERNAL DOORS** **14.1.3 PURPOSE MADE DOORS** **14.1.4 METHODS OF CONSTRUCTION** **14.1.4.1 Door terminology** **14.1.4.2 Panelled and glazed wood doors** **14.1.4.3 Flush doors** **14.1.4.4 Fire-check flush doors** **14.1.4.5 Matchboarded doors** **14.1.5 FRAMES AND LININGS** **14.1.5.1 Timber Door Frames** **14.1.5.2 Metal door frames** **14.1.5.3 Door linings** **14.1.6 SPECIAL DOORS** **14.2 WINDOWS, GLASS & GLAZING** **14.2.1 PRIMARY FUNCTIONS OF WINDOWS** **14.2.2 BUILDING REGULATIONS** **14.2.3 TRADITIONAL CASEMENT WINDOWS** **14.2.4 STANDARD WOOD CASEMENT WINDOWS** **14.2.5 STEEL CASEMENT WINDOWS** **14.2.6 BAY WINDOWS**



14.2.7 SLIDING SASH WINDOWS

 **14.2.7.1 Vertical sliding windows (also called double hung sash windows)**

 **14.2.7.2 Horizontal sliding windows**

 **14.2.8 PIVOT WINDOWS**

 **14.2.9 LOUVRES**

 **14.2.10 GLASS AND GLAZING**

 **14.2.10.1 Glass**

 **14.2.10.2 Glazing**

 **14.2.11 MOSQUITO SCREENING (FLY SCREENS)**

 **14.2.12 SUN-BREAKERS**

 **14.3 IRON MONGERY**

 **14.3.1 HINGES**

 **14.3.2 LOCKS AND LATCHES**

 **14.3.3 MISCELLANEOUS**

9. ROOFS

REFERENCES:

**1. Jack Stroud Foster
MITCHELL'S BUILDING
CONSTRUCTION
"Structure and Fabric"
Part 1, Part 2**

2. R. Chudley
"CONSTRUCTION TECHNOLOGY"
Volume 1, 2, 4

3. R. Barry
"The Construction of Buildings"
Volume I and III

4. W.B. Mc. Kay
"Building Construction"
Metric Vo. 1, 2

5. E. Neufert
"Architect's Data"
Edition 1978

6. R.L. Fullerton
"Building Construction in warm Climates"
Volume 1, 3

7. Dahmlos/Witte
"Bauzeichnen"
Schroedel Verlag

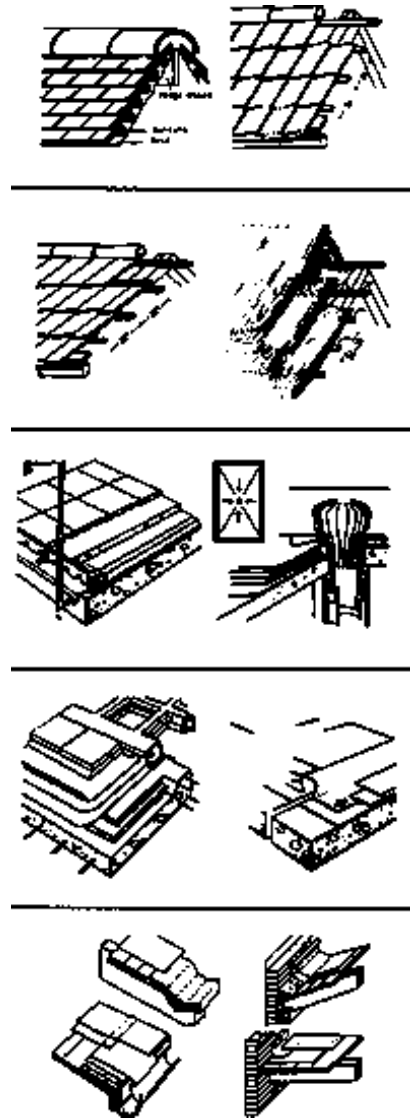

9.1 FUNCTIONAL REQUIREMENTS

- The main function of a ROOF is to enclose space and to protect the space it covers from the elements:

RAIN
WIND
HEAT

- To fulfil its functions efficiently the roof normally must satisfy the same requirements as the walls:

STRENGTH and STABILITY
WEATHER RESISTANCE
THERMAL INSULATION
FIRE RESISTANCE
SOUND INSULATION

9.1.1 STRENGTH AND STABILITY

STRENGTH AND STABILITY are provided by the roof structure and a major consideration in the design and choice of the structure is that of a **SPAN**.

The wide variety of roof types in different materials which have been developed is - in main - the result of the search for the most economic means of carrying; the roof structure and its load over spans of varying degrees.

In all types of structures it is necessary to keep the **DEAD WEIGHT** to a minimum, so that the imposed loads can be carried with the greatest economy of materials.

The degree of efficiency - in this respect - is indicated by the **DEAD/LIVE LOAD RATIO**, expressed in the terms of Loads per square metre of area covered or per metre run of roof structure

The structural problem in the design of **WIDE SPAN ROOF STRUCTURES** is - therefore - primarily that of **achieving a DEAD/LIVE LOAD RATIO as low as possible.**

In solving this problem, two factors are important:

1) The characteristics of the materials to be used,

2) The form or shape of the roof

- if materials are **STRONG** less material is required to resist given forces.

- if materials are **STIFF**, they will deform little under load and the structure may be of minimum depth

- if materials are **LIGHT**, the self - weight of the structure will be small.

ALL OF THESE CONTRIBUTE TO A STRUCTURE OF SMALL DEAD WEIG

In addition to the dead load and the superimposed loads, the roof must resist the EFFECTS OF "WIND.

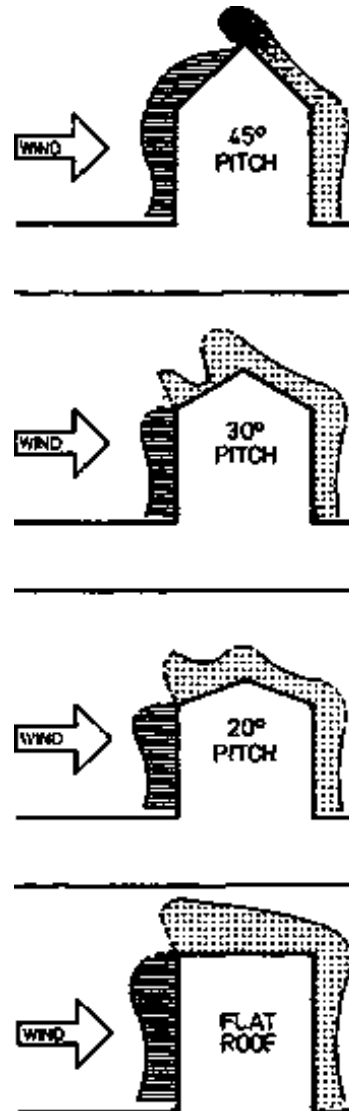

The pressure of wind varies with

- its velocity
- the height of the building, and
- the locality of the building.

Wind may exert **COMPRESSION** on some parts of the roof and **SUCTION** on others, both in varying degrees at different points according to the pitch of the roof.

Higher suctions and compressions occur

- at the edges of the roof
- on flat roofs and
- on low pitched roofs the suction over the windward side can be considerable.

LIGHT ROOF COVERINGS: (alu-, g.c.i.-, asbestos sheets) The supporting structure tends to be light and the weight of the cladding and roof structure as a whole may not be heavy enough to withstand the uplift of excessive suction during short periods of very high wind. Therefore proper fastenings to the claddings and fixing of the roof structure to frames or walls are necessary to prevent them being stripped off.

9.1.2 WEATHER RESISTANCE

WEATHER RESISTANCE is provided by the roof coverings and the nature of these will effect the form and some details of the roof structure.

9.1.3 THERMAL INSULATION

In most buildings thermal insulation in the roof is either essential or increases the comfort

- in hot areas thermal insulation keeps the heat out of the building
- in cold areas thermal insulation prevents the building from greater heat loss.

Thermal insulation, however, is rarely a factor affecting the choice of the roof type, since the normal methods of providing it are generally applicable to all forms of roofs.

These methods vary and involve

- flexible or**
- stiff insulation materials.**

in or under the roof cladding or structure or the use of self-supporting insulation materials such as

- wood wool**
- compressed straw slabs**

which are strong enough to act as substructure to the covering.

In the case of concrete surface structures, light weight aggregate concrete may be used (either fully or partly).

9.1.4 FIRE RESISTANCE

Adequate fire resistance is necessary in order to give protection against the spread of fire from and to adjacent buildings and to prevent early collapse of the roof.

These matters will be discussed later under the topic "Fire protection".

9.1.5 SOUND INSULATION

Most forms of roof construction provide for the majority of buildings an adequate degree of insulation against sound from extern. Sources. Only in special cases, such as concert halls in noisy localities or hospitals along highways with heavy traffic, precautions might be necessary and might also affect the choice and design of the roof structure.

The fact, that weight and discontinuity of structure are important factors in sound insulating construction, makes this problem difficult in the case of roofs.

9.2 TYPES OF ROOF STRUCTURES

- The area of the roof together with the roof coverings (which may be defined as the 'SKIN' of the roof and which can be constructed in many different ways) are carried by the ROOF STRUCTURE**
- In order to drain the rainwater properly the 'SKIN' has to be more or less inclined.**
- The better the 'SKIN' of the roof is able to protect the roof structures and the space enclosed from rain and wind, the flatter the roof can be constructed.**
- The different types of roofs may be broadly classified in three ways:**

according to the

- 1) shape of the roof**
- 2) structure of the roof (+building materials + span)**
- 3) coverings of the roof (+angle of inclination)**

- shape, materials and colour of the 'skin' of the roof are most important for the appearance of the building. Therefore shape, degree of inclination as well als the covering material should be in accordance

with local environment.

9.2.1 FLAT AND PITCHED ROOFS

- Flat roof: outer surface horizontal or inclined at an angle not exceeding 10° .
- Pitched roof outer surface sloping in one or more directions at an angle more than 10° .

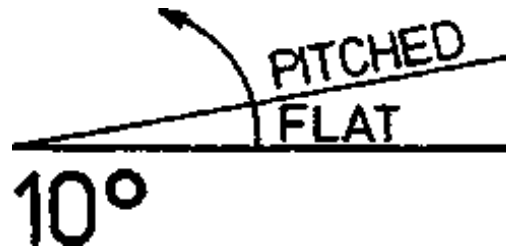

Climat and covering materials affect the choice between a flat or pitched roof.

- In hot, dry areas the flat roof is common (because there are no heavy rainfalls and the roof may form a useful out-of-door living room)
- In areas of heavy rainfalls, a steeply pitched roof quickly drains off rain.

Covering for roofs consist of

- unit materials, such as tiles and slates laid closed to and overlapping each-other and
- membrane or sheet materials, such as asphalt, bitumious felt or metal sheeting, whith sealed or specially formed watertight joints.

9.2.2 STRUCTURE OF THE ROOF

From a structural point of view roof structures may be considered broadly as

- two - or
- three - dimensional forms.

- Two - dimensional structures for practical purpose have LENGTH and DEPTH only and all forces are resolved in two dimensions with in a single vertical plane (only SPANNING FUNCTION).
- Three-dimensional structures have LENGTH,DEPTH and BREADTH, and forces are resolved in three dimensions within the structure. These forms can fulfil a COVERING and ENCLOSING FUNKTION as well als that of SPANNING. The general term is SPACE STRUCTURES.

TWO-DIMENSIONAL ROOFS include:

- beams
- trusses
- rigid frames of all types, including arch ribs

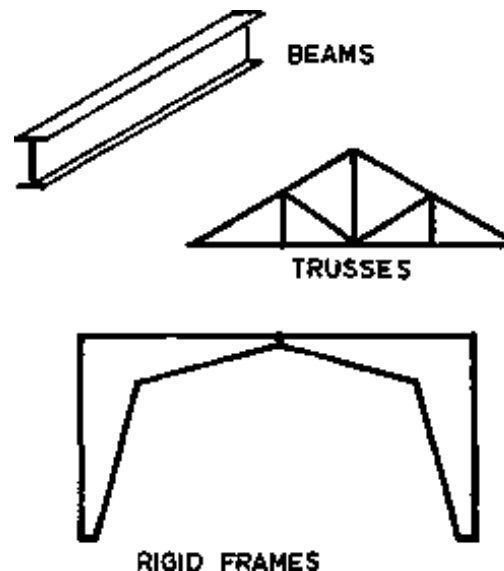

THREE DIMENSIONAL ROOFS include:

- cylindrical and parabolical shells and shell domes

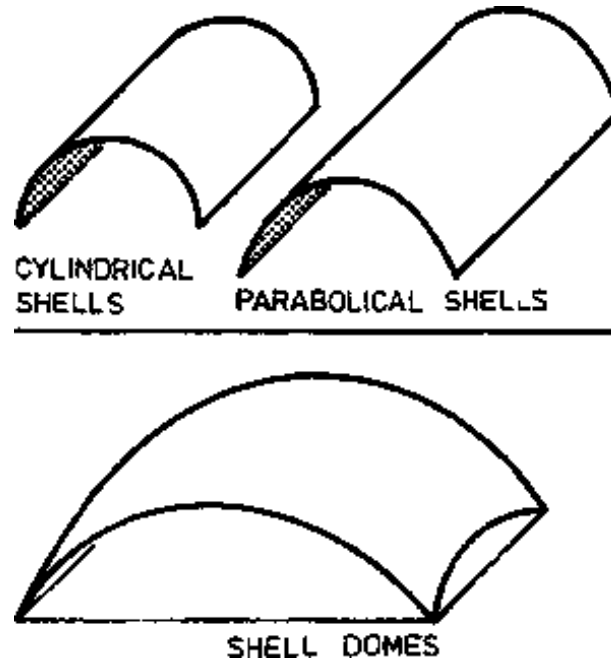

- doubly curved slabs, such as hyperbolic paraboloids and hyperboloids of revolution

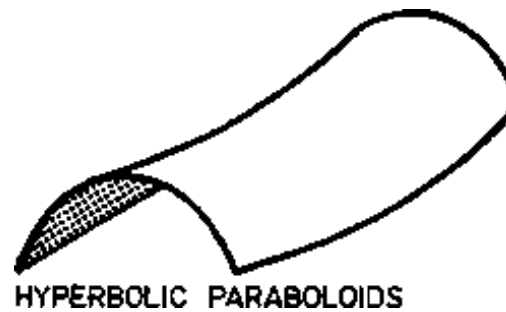

- grid structures, such as space frames, space grids, grid domes and barrel vaults

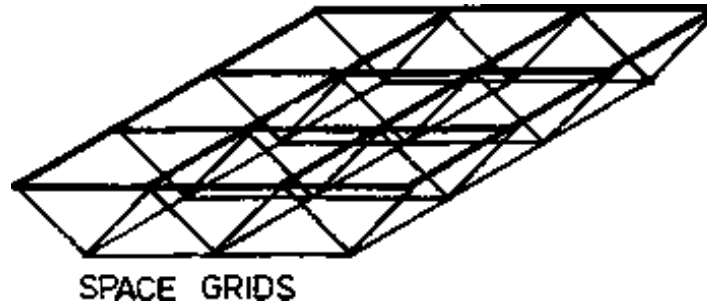

- folded slabs and prismatic shells

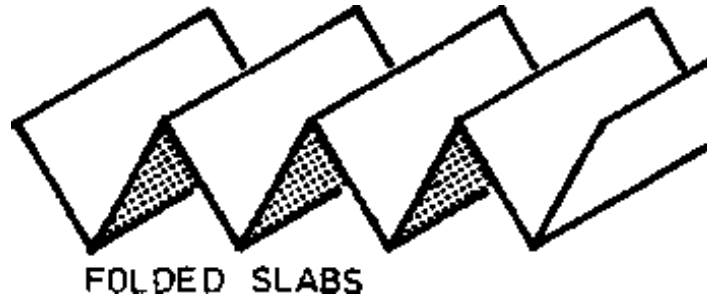

- suspended or tension roof structures.

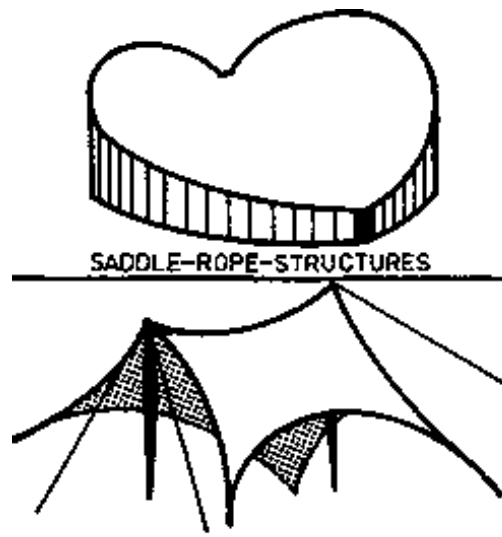

Roofs, constructed of two - dimensional members are classified as

- single
- double and
- triple roofs

according to the number of horizontal stages necessary economically to transfer the loads to the supports.

- in single roof construction the roofing system is carried directly by one set of primary members, spanning between the main supports

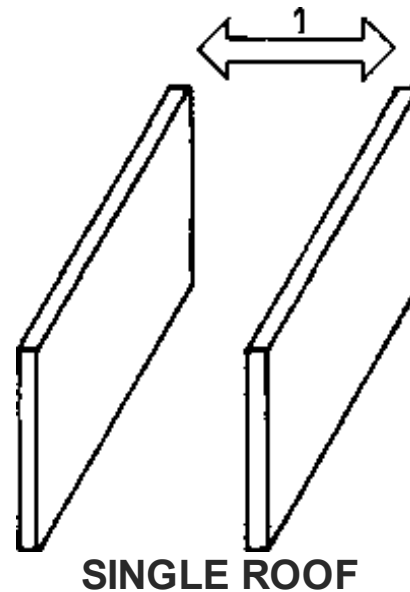

AS the span of the primary members increases a point is reached at which it becomes more economical to use larger members spaced further apart to support secondary members, to carry the roofing system.

This is known as double Roof Construction

THIS IS KNOWN AS DOUBLE ROOF CONSTRUCTION.

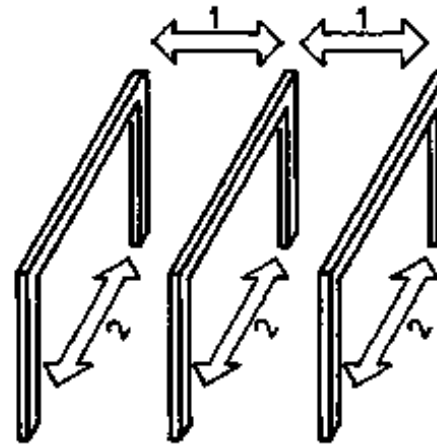

DOUBLE ROOF

- In some circumstances spans are such that three sets of members are required to produce an economic structure, resulting in three stages of support

This is called Triple Roof Construction.

- This classification is applied to both flat and pitched roofs (as well as to floor construction).

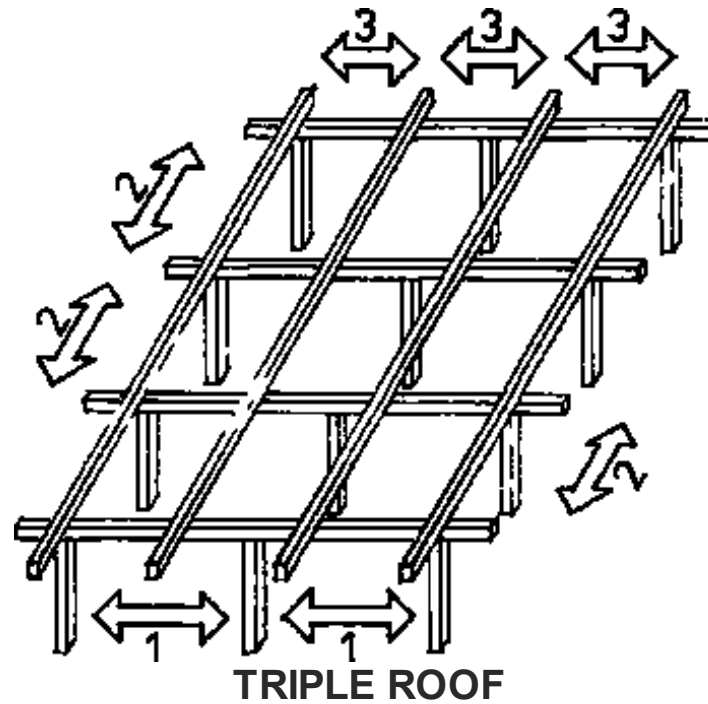

9.2.3 LONG AND SHORT SPAN ROOFS

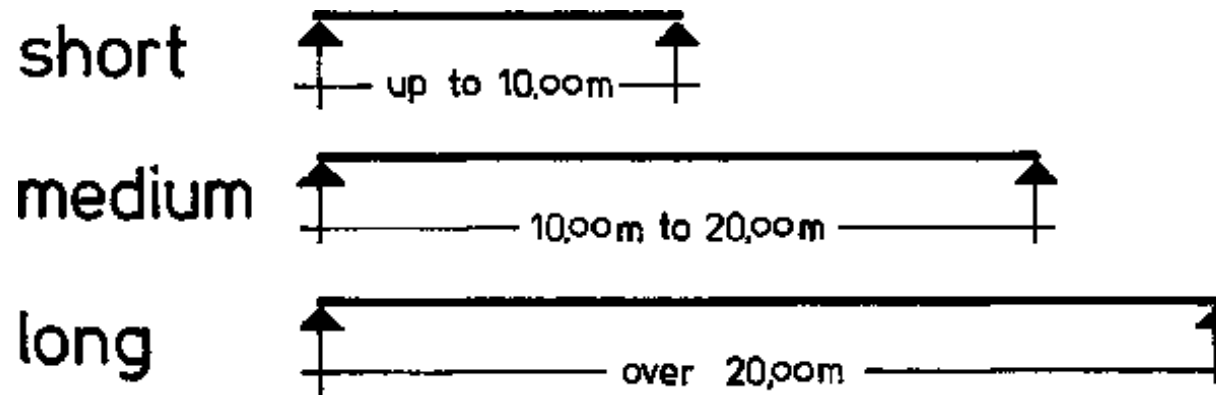

Roof structures are classified in terms of span as

- short span (up to 10.00m)
- medium span (10,00 to 20.00m)
- long span (over 20.00 m)

- Short span construction will usually be cheapest
- As an increase in the distance between supports usually results in an increase in the cost - comparable with requirements of clear floor area should always be adopted in design.
- Three dimensional structures are normally not economic over short spans.

N.B. All types of roof structures, which are introduced in the following, refer to the SHORT SPAN CONSTRUCTION only.

9.3 FLAT ROOFS

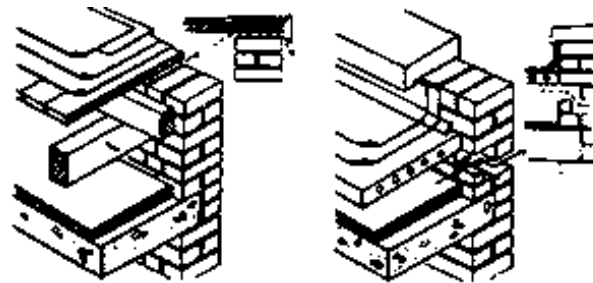

9.3.1 PHYSICAL AND STRUCTURAL PROBLEMS

To design a building having a FLAT ROOF, seems to be very simple, because in a drawing using a scale of 1:100 or 1:200, it is just indicated as a double line and does not show the physical and structural problems behind.

Plenty of flat roofs (in Arusha and all over TAN) are leaking, because of

- insufficient (or wrong) construction, and
- lack of adequate building materials (especially for their mal insulation and waterproof membranes).

9.3.2 STRUCTURE OF A FLAT ROOF

Flat roofs have to be drained through rainwater outlets, such as:

- central internal rainwater inlet (special gully)
- tapering gutter discharging to an external rainwater down-pipe or
- water spouts

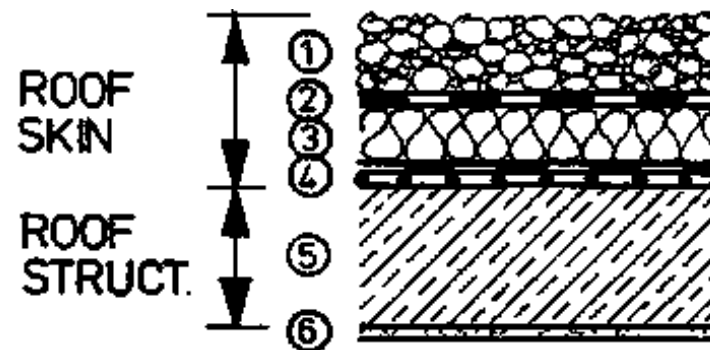

- ① PROTECTION OF THE SKIN
- ② WATERPROOF MEMBRANE
- ③ THERMAL INSULATION
- ④ VENT. VAPOUR BARRIERE
- ⑤ ROOF STRUCTURE
i.e. REINE CONCRETE
- ⑥ CEILING

STRUCTURE of a FLAT ROOF

9.3.3 THERMAL INSULATION MATERIAL

For most types of roofs (especially for flat roofs) thermal insulation is provided by **NON-STRUCTURAL** materials of two types with:

- 1) Low thermal conductivity
- 2) high thermal reflectivity.

Materials of low thermal conductivity have a high -percentage volume of **GAS** or **AIR VOIDS**, which retard the transmission of heat.

Most efficient are materials with a **CLOSED AIR** or **GAS CELL STRUCTURE**, such as **EXPANDET PLASTICS**, used in board or granule form, a few mm thickness of which give insulation equal to a substantial thickness of brickwork, dense concrete or stone.

Typical of this class of insulators are:

a) **QUILTS**: consisting of

- glass fibre
- rock wool or slag wool (classified as **MINERAL WOOL**)

b) **SLABS**: of

- wood wool
- straw boarded
- fibre boarded

- fibre boards
- expanded plastics
- cork
- semi rigid glass fibre
- foamed glass
- thick, lowdensity soft wood strips (preferably 50 mm and above)

c) GRANULATED or NODULATED materials used as loose fills, in layers on ceilings or fills in cavities:

- pelleted slag wool
- exfoliated vermicolite (a naturally occurring micaceous material which, expands when its contained water is vaporized by heat).

d) PLASTICS FOAMED in - SITU and injected into cavities to fill them. (note: The FOAM stabilizes the insulating air in the cavity by incorporating it as millions of very small cells within the materials.)

e) AIR or GAS CELLS within a basically highdensity material, as in foamed concrete or screed.

f) LIGHTWEIGHT - AGGREGATE concrete and screeds which, to be effective, must be of adequate thickness, dried out and kept dry.

g) SPRAYED INSULATION, of asbestos fibre with water-activated binders, or lightweight plasters, applied to a thickness of 12 mm or more, on exposed protected internal surfaces.

NOTE: The presence of MOISTURE in an insulation material will REDUCE its efficiency.

9.3.4 SINGLE AND DOUBLE FLAT ROOF CONSTRUCTION

The construction of a FLAT ROOF (in timber as well as in reinf. concr.) is comparable with that of an UPPER FLOOR.

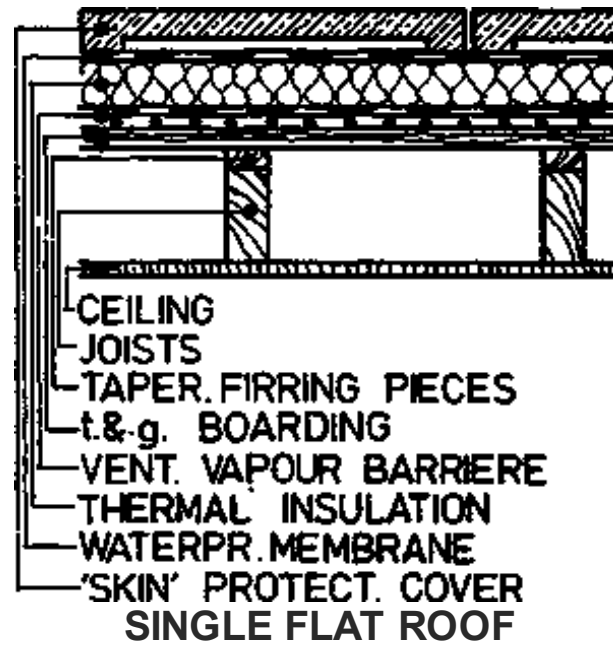

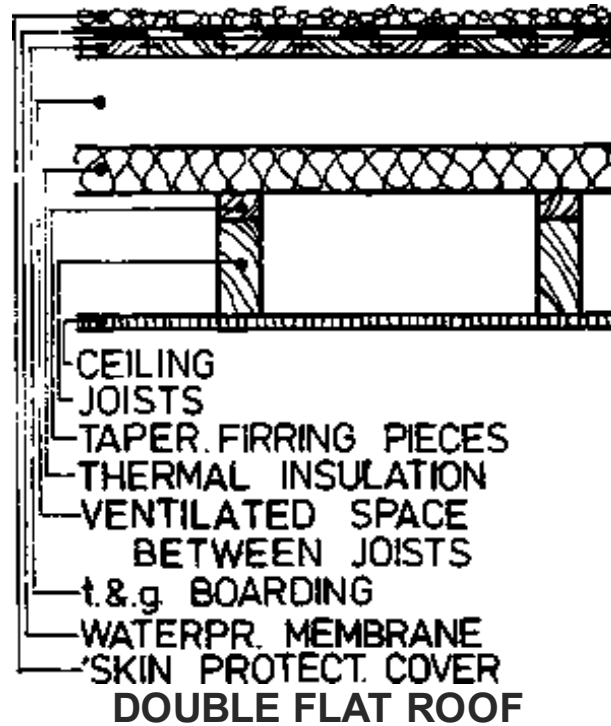

ASPHALT COVERED FLAT ROOFS

Is widely used but insufficient, because the roof skin is not properly ventilated and there is no protection cover against drying out of the asphalt by the sun. (ref. Fig.)

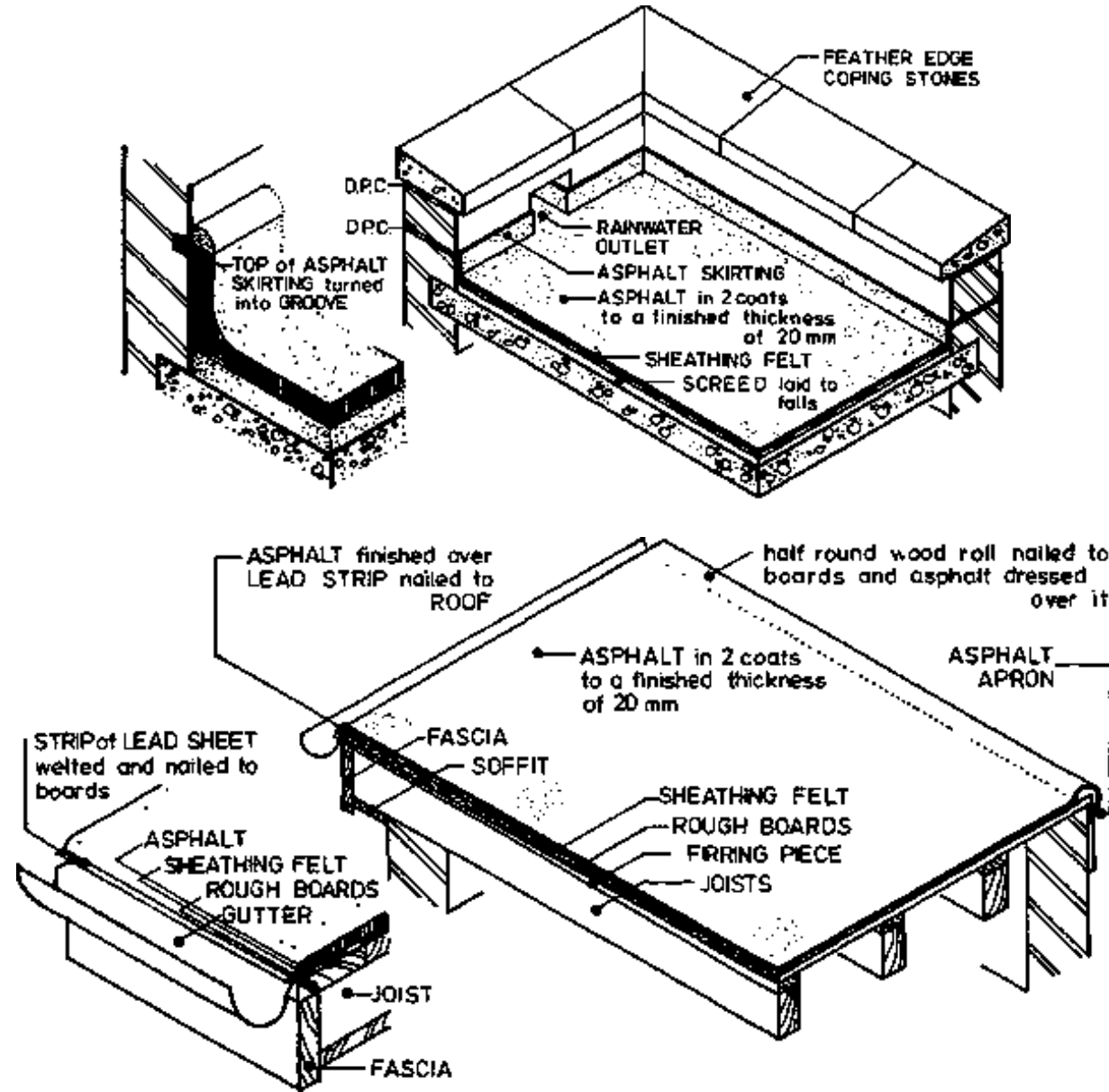

9.3.5 PARAPET WALLS

External walls of buildings are raised above the level of the roof as **PARAPET WALLS** for the sake of appearance of the building as a whole.

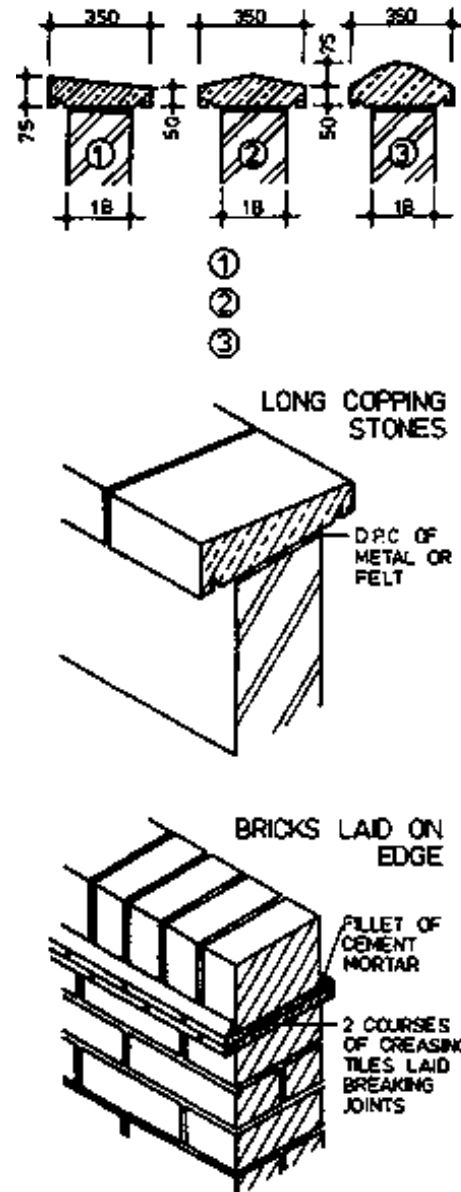

Parapet walls are exposed on all faces to driving rain and wind and are much more liable to damage than external walls below eaves level.

Parapet walls are not weighted down by floors and roofs and it is generally accepted that they should not be built above roof level higher than six times the least thickness of the parapet wall.

Parapet walls to be covered or capped with some non-absorbent material such as:

- natural stone (protective and decorative)
- artificial stone: Stones are made with a core of concrete faced with a mixture of crushed stone particles and cement.
- brick capping: bricks are laid - on - edge on top of two courses of creasing tiles laid-breaking joint-in cement mortar.
- D.P.G. beneath coping stones within the Parapet walls.

9.4 PITCHED ROOFS

9.4.1 SHAPES OF PITCHED ROOFS IN TIMBER

- Monopiched Roof
- Lean-to Roof
- Ridge (gable) Roof
- Hipped Roof
- Mansard Roof
- Butterfly Roof
- Shed Roof
- Tent Roof

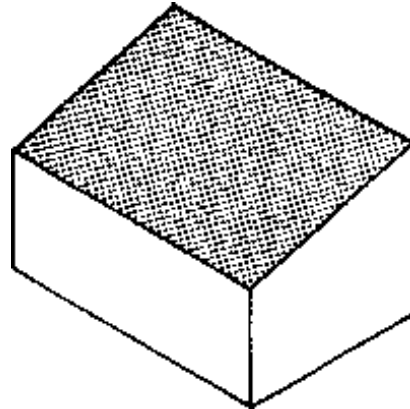

MONOPITCHED ROOF

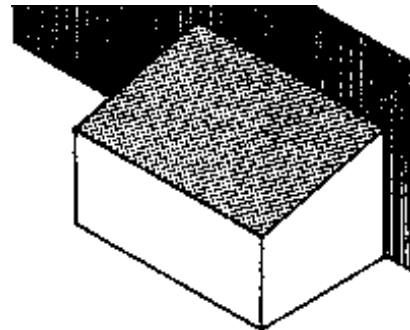

LEAN-TO ROOF

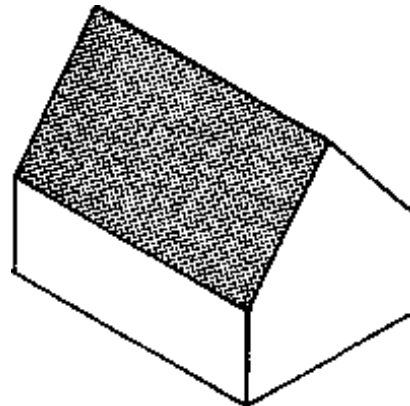

RIDGE (GABLE) ROOF

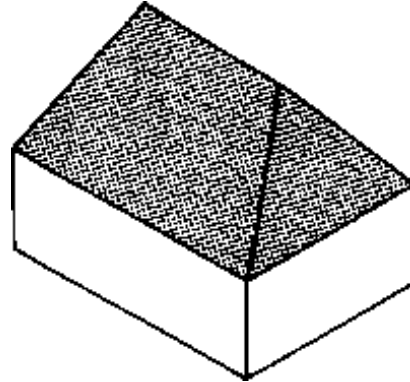

HIPPED ROOF

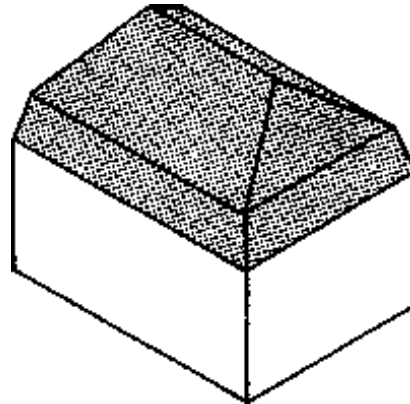

MANSARD ROOF

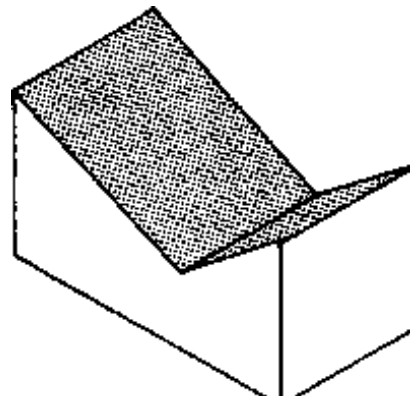

BUTTERFLY ROOF

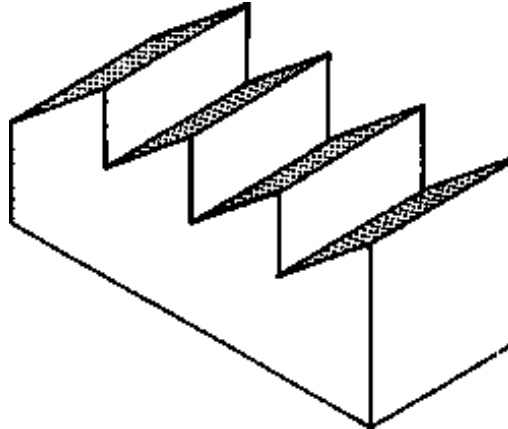

SHED ROOF

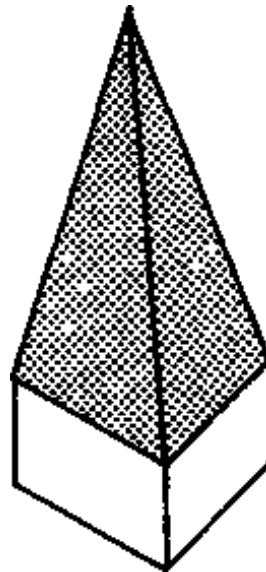

TENT ROOF

9.4.2 TERMS

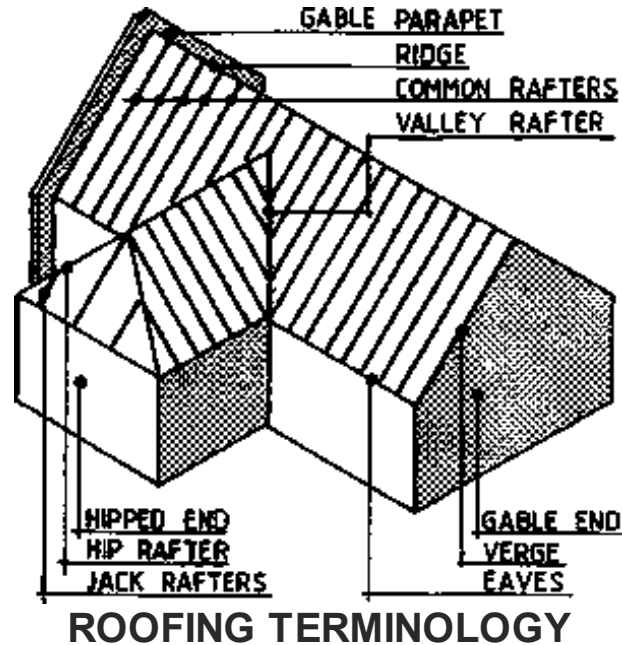

9.4.3 TYPES OF PITCHED ROOFS IN TIMBER (STRUCTURES)

9.4.3.1 Mono-(single) pitched Roof

Constructed similar to a timber flat roof or a timber upper floor (joists = rafters). Because of the pitch of the roof a **BIRDS MOUTH** at the end of the rafters has to be provided to avoid sliding off the wall plate. (ref. fig.)

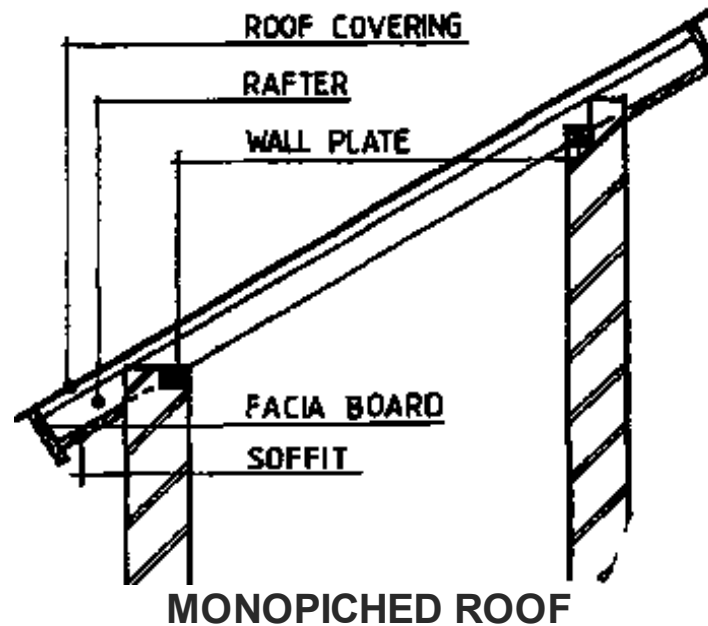

9.4.3.2 Lean - to Roof

Is a monopitch roof of which the tops of the rafters are pitched against a wall. The feet of the rafters are birds mouthed over a wall plate as for a monopitched roof, and the upper ends over a plate supported on the wall by corbel brackets or by any means of supporting floor joists.

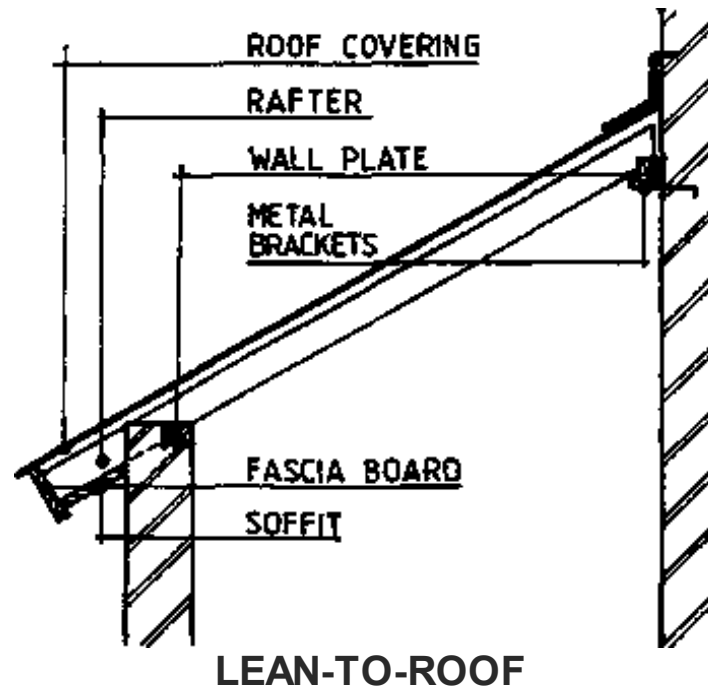

9.4.3.3 Couple Roof

This is the simplest, but not necessarily the most economic form of ridge roof sloping down in two directions from a central apex or ridge as it is technically termed. It consists of pairs, or couples, of rafters pitched against each other at their heads with their feet bearing on opposite walls.

When two spanning members are arranged in this way the junction at the ridge forms a mutual support so that the span of each is the distance between this point and its lower support. The depth of the rafters in a couple roof may, therefore, be considerably less than that of those in a flat or monopitch roof of the same overall span. This is an advantage from the point of view of economy of rafter material, but the arrangement of rafters results in a tendency for the ridge to drop under the roof load with a resultant outward spread of the rafter feet. In order to keep the roof stable this outward spread or thrust

resultant outward spread of the rafter feet. In order to keep the roof stable this outward spread or thrust must be resisted by sufficiently heavy supporting walls. If the walls are tall they will, therefore, be thick and expensive. For 215 mm solid or 250 mm cavity walls of normal height the roof must be limited to a maximum clear span of about 3.00 m to keep the thrust within acceptable limits. The clear roof space given by this roof can, however, be used with advantage over wider spans than this if the roof pitch is steep and the eaves are low. This has the effect (1) of reducing the outward thrust of the rafters and (2) of reducing the height of any supporting walls and, therefore, their tendency to overturn, so that their thickness may be kept to a minimum.

The feet of the rafters are birds-mouthed over wallplates and the upper ends butt against a flat board called a ridge piece or board, to which they are nailed. This board facilitates fixing of the rafters and keeps them in position laterally.

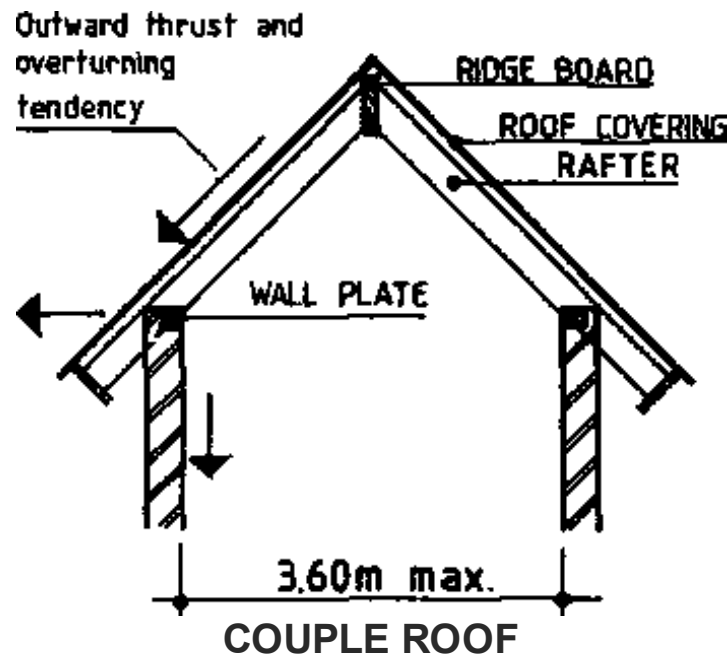

9.4.3.4 Close couple Hoof

This roof results from the introduction of horizontal members to tie together the feet of each pair of rafters and prevent their outward spread. This forms a simple triangulated structure and produces vertical loads on the supports with no tendency to overturn the walls so that their thickness need take no account of this. These members, known as ties, are spiked to the feet of the rafters at plate level and if they are used to support a ceiling, as commonly is the case, they are called ceiling joists. The maximum economic span of this roof is about 6.10m, this being limited not by the spread of the rafters but by the economic sizes of the roof members. It is generally found most economic to restrict the depths of rafters to about 100 mm and, depending on the weight of the roof covering and the pitch and spacing of the rafters, this depth can be used over spans of about 4.60 m to 5,20 m.

The function of ceiling joists as ties can be fulfilled by quite small sections but, as they act also as beams supporting their own weight and that of the ceiling, they tend to sag or deflect and they must be large enough to keep this within acceptable limits. For spans of the order given above quite large ceiling joists would be necessary and it is found more economic to reduce their effective span by suspending them from the ridge. The longitudinal 75 mm × 50 mm binder or runner skew nailed to the joists permits the hangers to be fixed to it at every third or fourth joist spacing rather than to each joist, thus economising in timber.

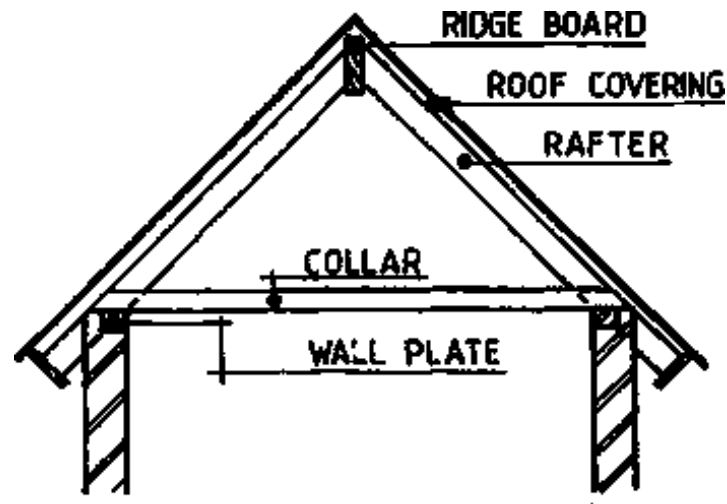



CLOSE COUPLE ROOF

Fixing of hangers to runners should be deferred until the roof covering has been laid in order to avoid deflection of the ceiling joists due to the transfer through the hangers of any slight movement of the roof structure as it takes up the load.

9.4.3.5 Collar Roof

In this roof tie members are used but at a higher level than the feet of the rafters and they are called collars. It can be used for short spans not exceeding 4.90 m when it is desired to economise in walling, since the ceiling will be raised and the roof may, therefore, be lowered on the walls to the same extent for a given height of room. The influence of the collar on the spread of the rafters is less marked the higher it is placed and half the rise of the roof is the maximum height at which it should be fixed. The size of the collars is the same as for close couple ties of an equivalent span. In the past a dovetail halved joint at the junction of collars and rafters was normal but this involves considerable labour and it is cheaper and stronger to use a bolt and timber connector.

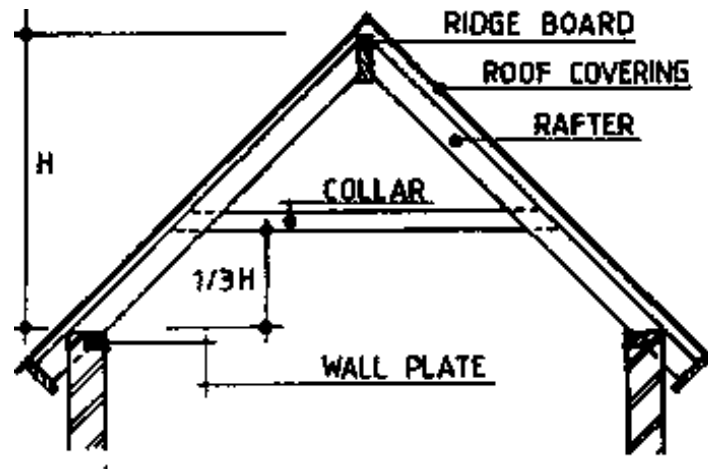



9.4.3.6 Double or Purlin Roof

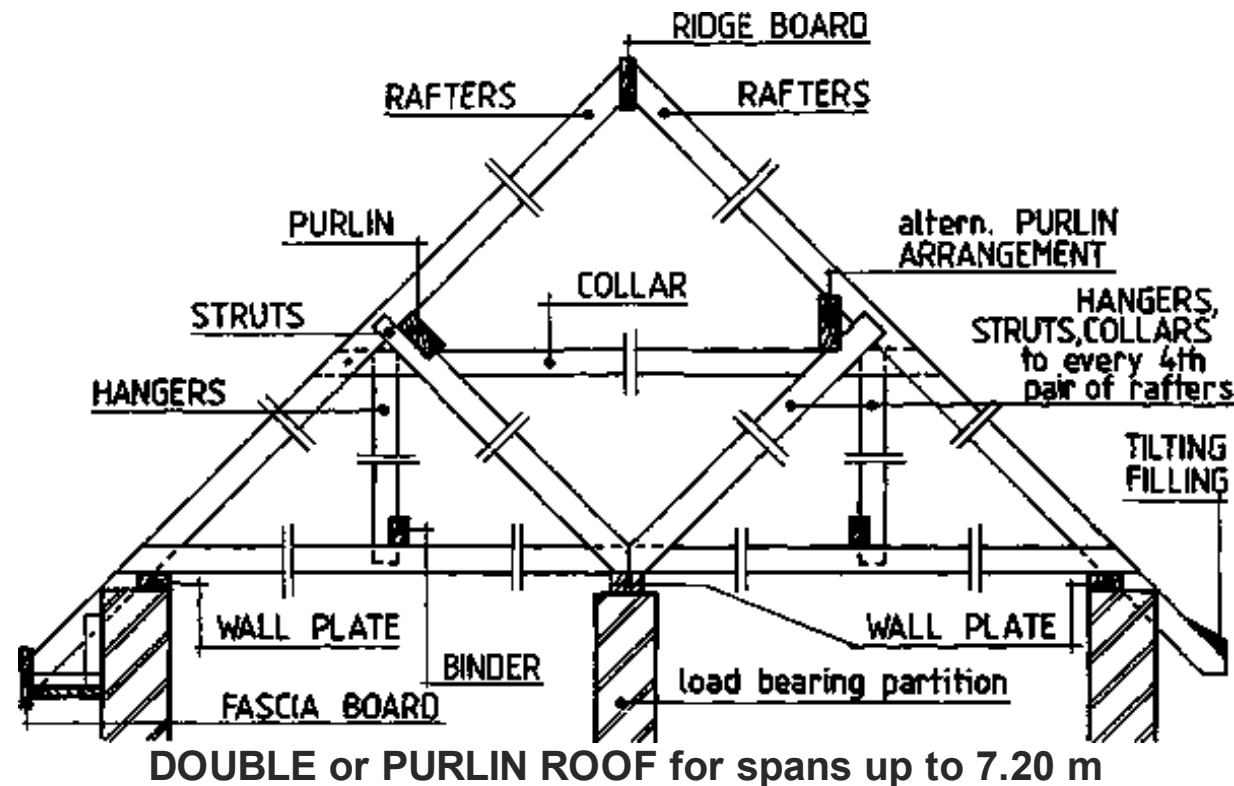

When the span of a roof is more than 6.10 m and requires in a couple type roof rafters much greater than 100 mm in depth it is cheaper to introduce some support to the rafters along their length, thus reducing their effective span, rather than to use large rafters. This support could be in the form of a strut to the centre of every rafter resting on a suitable bearing below, such as a partition or wall but, as in the case of ceiling joist hangers referred to above, it is more economical in timber to introduce a longitudinal beam on which all the rafters bear and to support this member at intervals greater than the rafter spacing. The introduction of this beam, or purlin as it is called, as a second stage of support brings the structure into the double roof classification Although this introduces extra members into the

construction the total cube of timber in the roof (and the weight of the roof) rises less with increase in span than if the rafters were increased in size.

The purlins may be supported directly by cross walls or partitions at sufficiently close spacing along the length of the purlins or by struts off any suitably placed walls partitions or chimneys. The size of the purlins will be governed by the weight of the roofing system, the spacing of the purlins (if the length of rafter supported) and their span. As with rafters an increase in span results in increased size and cost of purlins and the span should, therefore, be kept within economic limits. Depending on the combination of weight and rafter length a 225 mm × 75 mm purlin will span from about 2.50 m to 3.70 m. If the spacing of available supports is such that purlins much larger than this are required it may be better to select an alternative method of construction.

Purlins may be placed vertically or normal to the rafters. The former is preferable when the purlin bearing is directly on walls or on vertical struts, the latter is sometimes more convenient when inclined struts are used, which is the case when supports do not occur immediately under the purlins. Where possible inclined struts should be paired so that those to opposite purlins meet at the same point and bear against each other over the support. If this should result in struts at an excessively low angle a spreader piece nailed to the top of a ceiling joist may be used to increase the angle of the struts.

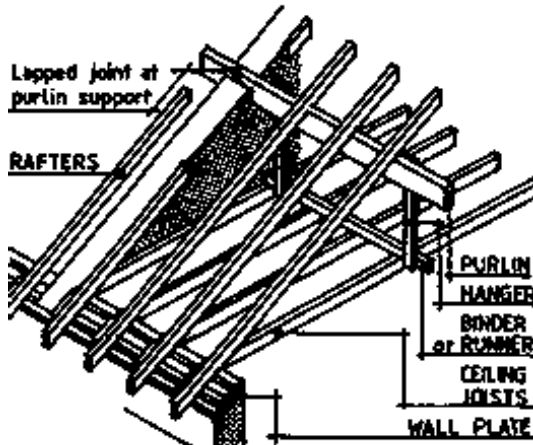
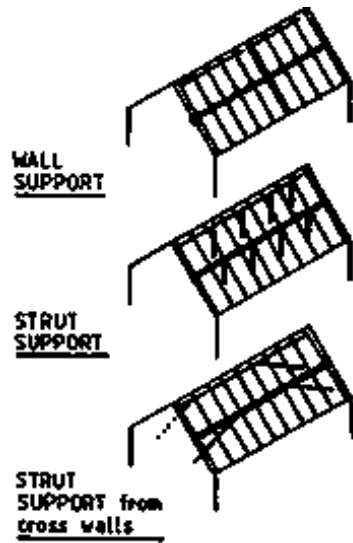

PURLIN ROOF

Joints required in the purlins should be made over supports wherever possible in the form of a lapped joint. Where joints must occur at points between bearings a stronger joint is necessary and a splayed scarf joint must be adopted.

As the span of the roof increases the size of the ceiling joists can be kept within economic limits by increasing the number of points of support and in a purlin roof hangers carrying binders can be suspended from the purlins. When the purlins are normal to the rafters the hangers are fixed to a rafter face immediately above the purlin. Where no supports exist at intervals over which solid timber purlins of an economic size can span, but where suitable widely spaced cross walls exist, then deep beam purlins may be used. The maximum span over which they may be used in these circumstances depends to a large extent on the depth available for the beam. Two types are discussed below.

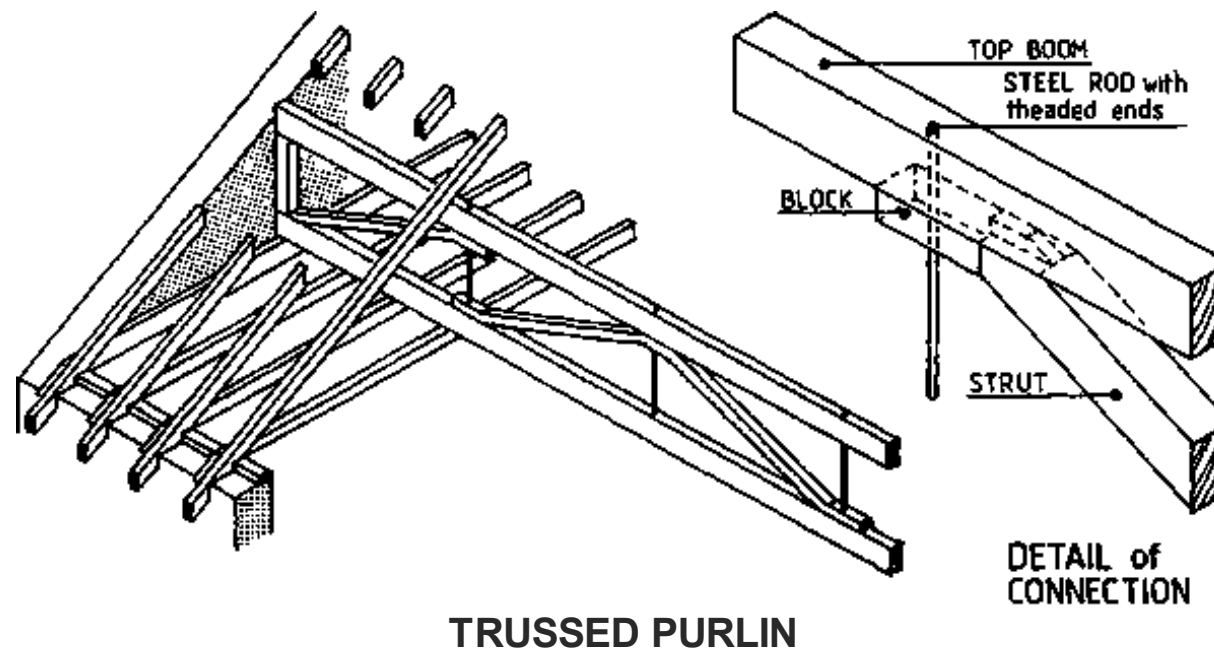

Trussed purlin

This is a trussed, lattice or framed beam or girder all of which are synonymous terms for a beam built up of triangulated members. For a given load and span as the depth of a beam increases the bending stresses at top and bottom decrease and less material is required in the beam. This economy of material can be developed further by concentrating the majority of the material in the beam at the top and bottom where bending stresses are at a maximum. In the trussed beam structural depth is obtained with a minimum of material at the centre or web by means of relatively thin triangulating members which connect the top and bottom flanges or booms. For maximum economy bending stresses in the members should be avoided as far as possible

To this end the members should be arranged on the 'centre line' principle as far as is practicable that is to say at each Junction of members their centre lines should intersect at one point. For the same reason loads should be applied only at the node points. With trussed purlins however, the rafters are closely spaced along the top boom and do not all bear at a node point; some bending therefore occurs and the boom size must take account of this.

Purlin beam

The alternative to a trussed purlin is the thinwebbed timber beam, which may be specially fabricated or of which there are a number of mass-produced types on the market. This consists of a plywood web rebatted into and glued to top and bottom booms or glued at top and bottom between two timbers to form the booms. In deep beams of this type some stiffening against buckling of the thin web is required in the form of vertical stiffeners glued at intervals on each side of the web. In one proprietary beam this stiffening is obtained by using a vertically corrugated ply web instead of applied stiffeners.

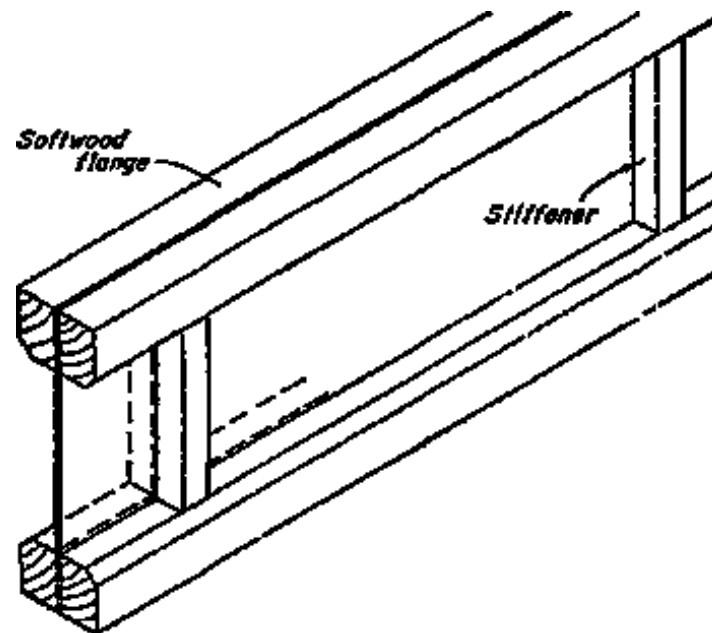

A Plywood web beam with web stiffeners

A trussed purlin invariably makes use of the full depth between rafters and ceiling joists as shown, to provide direct support to the latter without hangers but when ply-webbed purlin beams are used they are unlikely to be as deep as this, except in very low-pitched roofs, and hangers for the ceiling joists would be required.

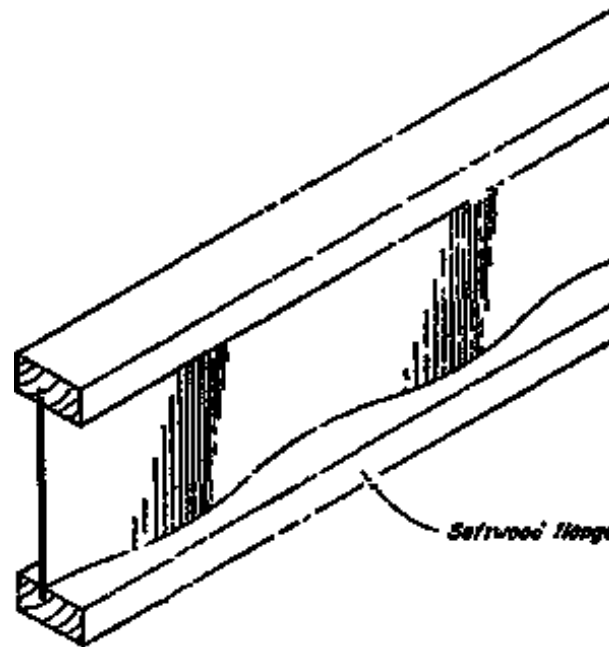

Plywood web beam with corrugated web B

9.4.3.7 Tripple or Trussed Roofs

The use of purlins as just described presupposes the presence of supporting elements at appropriate spacings. Where these do not exist or where, for some reason, this form of construction may not be suitable, for example, when the roof span is large and multiple purlins are necessary, an alternative method of supporting purlins is by structural members spanning the width of the roof at intervals along its length, the tops of which follow the pitch of the roof. These may be in the form of either a triangulated structure known as a roof truss or of deep rafters fixed at their feet rigidly to a pair of supporting columns to form one structural component. The latter are called rigid frames.

A ROOF TRUSS consists essentially of a pair of **RAFTERS** (or a single rafter in a monopitched roof)

triangulated to provide support for the purlins, preferably at the node points.

For short span roofs two rafters lying in the same plane as their neighbours may be triangulated to carry purlins which are fixed immediately under them, so that the purlins are in the same relative position to the other rafters which they in fact support. These trusses are placed at relatively close centres. For wider spans resulting in large loads on the truss members, the size of a normal rafter is usually too small to be used in the truss and separate rafters are triangulated and carry the purlins on their backs. These rafters, therefore, lie below the level of the normal rafters and do not directly support the roof covering. The rafters of the truss are called the **PRINCIPAL** rafters and the normal rafters the **COMMON** rafters.

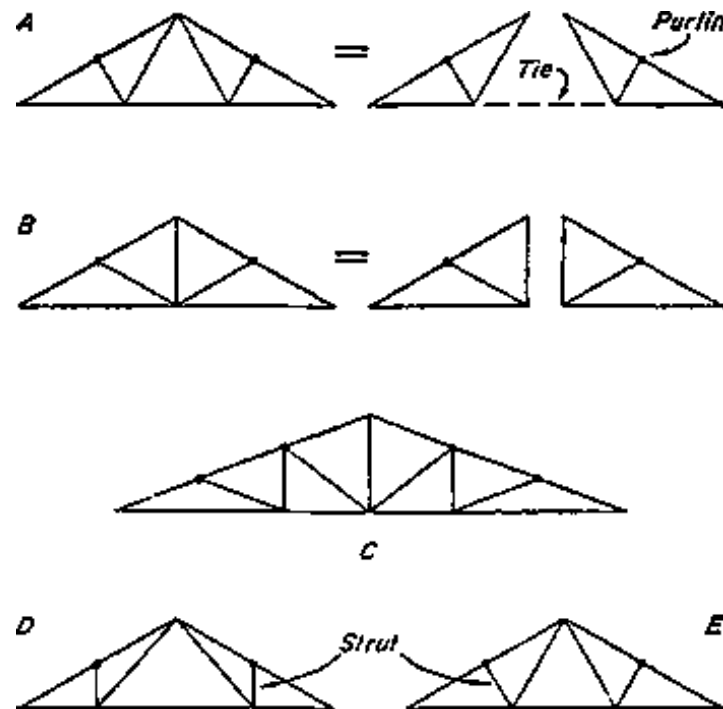

Truss construction in timber

- A roof truss must carry, via the purlins, the loads on a number of adjacent rafters.

- The forces on the Joints between its members are, there fore, greater than those on the joints in a single or double roof structure and the use of one or two nails commonly used to secure members in the latter is insufficient in a truss.

- The detailed construction of a truss depends largely on the method adopted for joining the parts.

- Earlier methods involving mortice and tenon joints, necessitated relatively large amounts of timber at the junctions and, therefore, large heavy members

(often larger than justified by the stresses in them) and the incorporation of large metal straps particularly at the tension points since the mortice and tenon joint is efficient only in compression.

- This type of truss is exemplified by the traditional king post and queen-post trusses which, for these reasons, are now obsolete.

- There are three modern methodes of joining the members:

- 1. nailed joints**
- 2. bolt and connector joints**
- 3. glued joints and some times a combination of two.**

- These methods require the members to be laid one against the other, or LAPPED as it is termed, to make the joint or - alternatively - require the use of cover plates, or GUSSETS, when the members butt one against the other.

- If two members lap, the joint is called SINGLE LAP JOINT If one member lappes by two other members, it is called a DOUBLE LAP JOINT (also known as SANDWITCH CONSTRUCTION).

- In a single lap joint the joint is under eccentric loading. For small span trusses carrying light loads this

is not significant but when the joints carry large loads eccentricity should be avoided by the use of double lap joints. Double members are also used in order to obtain a satisfactory arrangement of members in the truss as a whole for jointing purposes.

(1) NAILED TRUSSES:

Jointing by nails is the least efficient of the three methods - but a traditional and simple method.

By preboring nail holes and using wide, thin members to provide ample fixing area, efficient structures may be obtained, particularly where light - weight roof coverings are used.

The arrangement of nails to be calculated.

An example of the application of nailing in this manner is shown in the figure, where sandwich construction is used to carry corrugated asbestos cement sheeting over spans up to 6.10 m. The principal rafters and horizontal tie are each formed by two boards, 32 mm thick, and the struts and secondary ties are 100 mm × 50 mm scantlings sandwiched between, the joints at these points being made by direct nailing between the members. As the rafter and tie members lie in the same plane and butt against each other at the feet of the truss it is necessary to use gussets to effect a joint at these points. The gussets here are formed by 25 mm boards on each side set normal to the rafters and securely nailed to each member. The extension of the gusset by two vertical boards increases the rigidity of the whole truss. The double members at the feet are blocked apart by 50 mm packing pieces and at the ridge the rafters are secured to each other by a 25 mm board on each side.

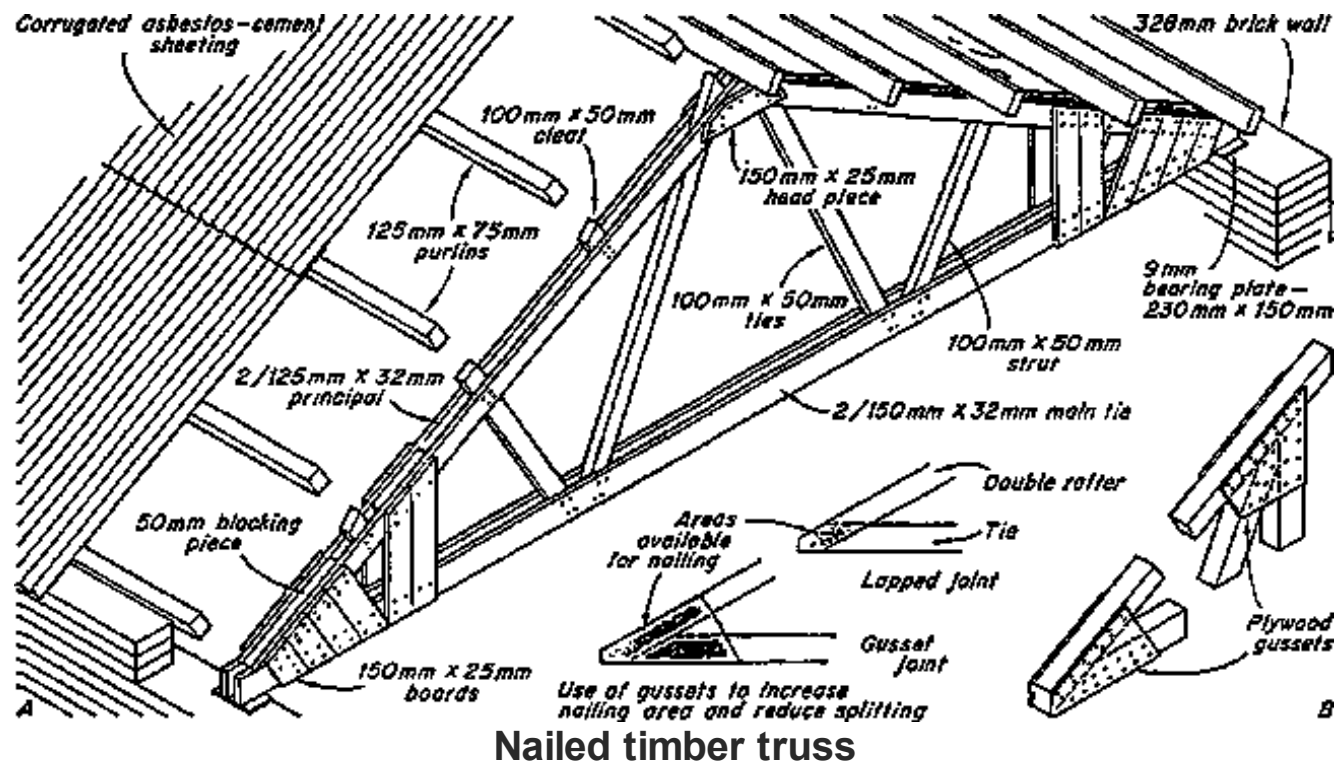

Struts and secondary ties project beyond the rafters and 50 mm cleats are fixed at the intermediate purlin position to form seatings for the purlins. By joining them together the struts and cleats also serve to stiffen the thin rafter members which, being in compression are liable to buckle.

These trusses would be spaced 3.00 m to 3.60 m apart depending on the weight of the roof covering and the size of the purlins used. The point loads from the truss at its bearings are spread on to the walls by steel bearing plates as shown or by concrete templates built into the brickwork.

The purlin spacings shown in this exemplare are for small section corrugated sheeting. The intermediate purlins impose a point load on the rafters and, therefore, induce bending stresses. Since, however, the roof covering is light these stresses will be small and it is more economic to allow for them in the size of

Roof covering is light these stresses will be small and it is more economic to allow for them in the size of the rafters rather than to form nodes at these points by extra bracing members.

When self-supporting coverings such as these sheets are used they are laid directly on the purlins as in this example, but when the roofing requires a base such as battens, boarding or other roof decking needing support at closer intervals it is then cheaper to support the base on common rafters at the required spacings carried in the traditional way on purlins at the node positions only. This usually results in less timber content than if the purlins are placed at very close intervals.

When loading and span conditions require thicker members and where lapped joints do not provide sufficient nailing area, single thickness construction with gussets throughout may be used. By this means larger areas are available for nailing and all joints may be laid out on the 'centre line' principle.

(2) BOLTED AND CONNECTED TRUSSES

Timber connectors are metal rings or toothed plates used to increase the efficiency of bolted joints. They are embedded half in each of the adjacent members and transmit load from one to the other. There are many different types, of which the most commonly used for light structures is the toothed plate connector, a mild steel plate cut and stamped to form triangular teeth projecting on each side which embed in the surfaces of the members on tightening the bolt which passes through the joint. For greater loads split ring connectors are used, but these require accurately cut grooves to be formed in each piece of timber.

Jointing by connectors and bolts permits thicker timber to be used and its application is illustrated in the figure. This truss is for a span of 7.60 m and is designed to be spaced at 3.90 m centres and to carry large section corrugated asbestos cement sheeting, which is self-supporting over a span of 1.40 m and a ceiling.

Rafters and horizontal tie are of double members with single member secondary ties sandwiched between. Struts are of double members placed on the outside of rafters and tie. This arrangement

permits 'center line' setting out at all joints where three members meet. It also permits a single bolt to effect the joint.

Gussets are required at feet and ridge, firstly because the main members do not overlap and, secondly, in order to obtain a greater fixing area for the number of bolts required at these joints.

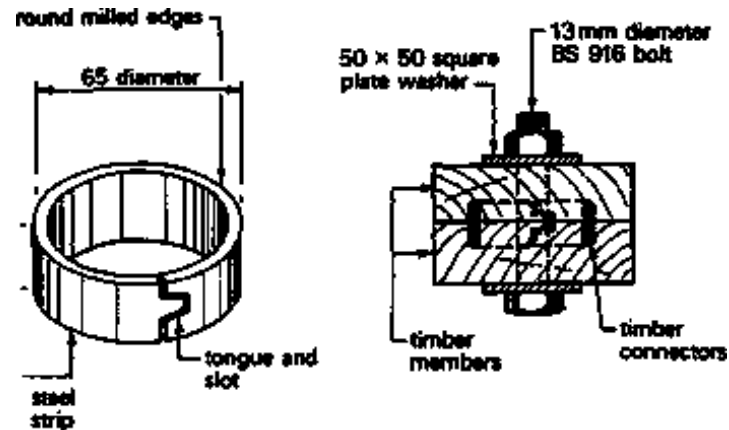

Parallel side split ring connector

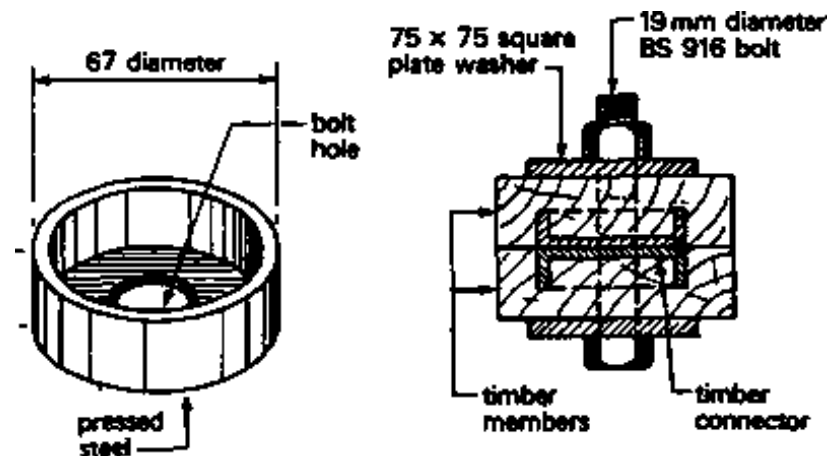

Shear plate connectors

Since only one bolt is required at the foot of the rafter the gusset here need be no deeper than the tie, with a packing piece of the same size in the central space. Do avoid the use of very long timbers the

members of the main tie are joined or spliced at the centre using a central splice plate and four sets of bolts and connectors.

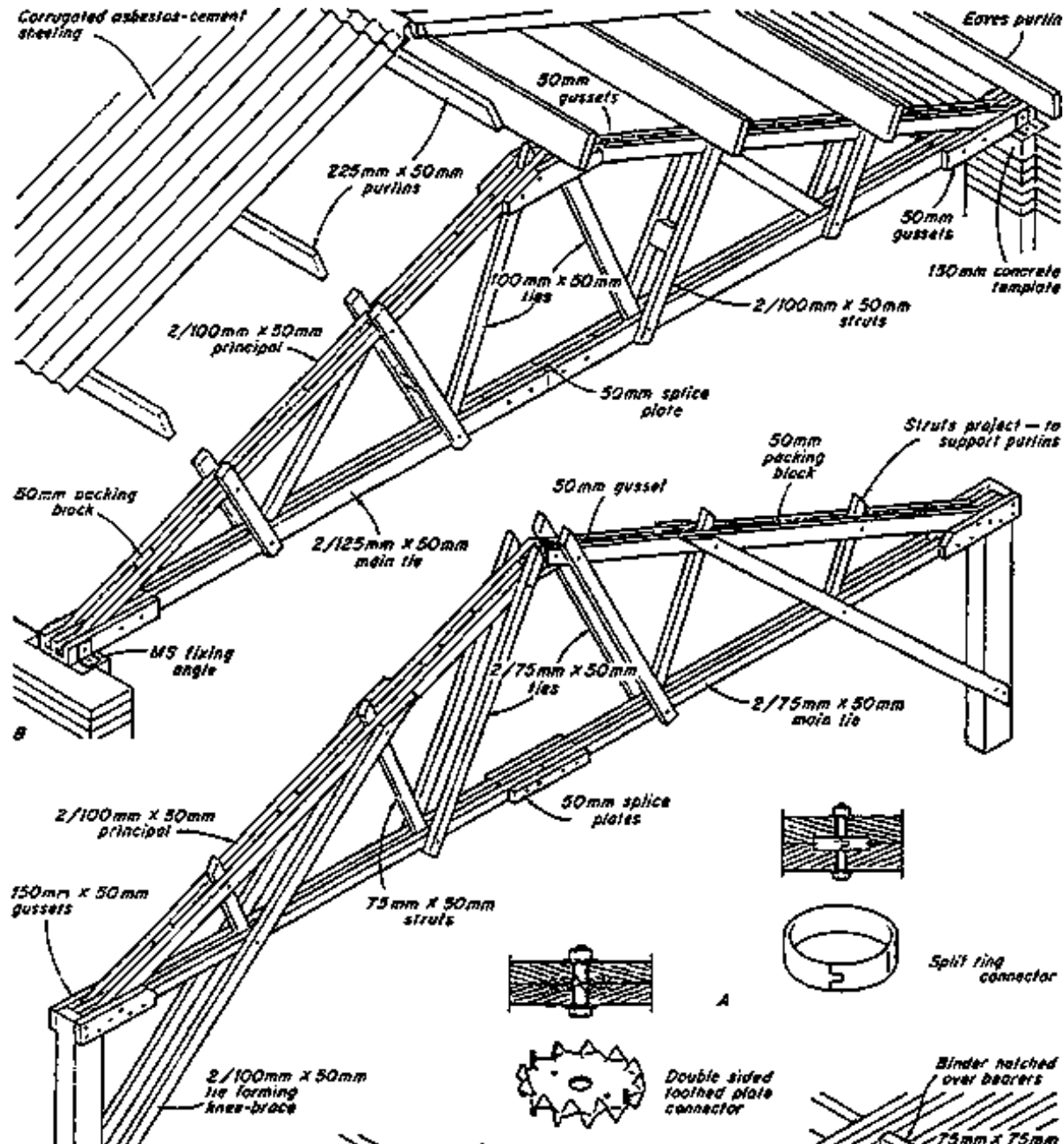

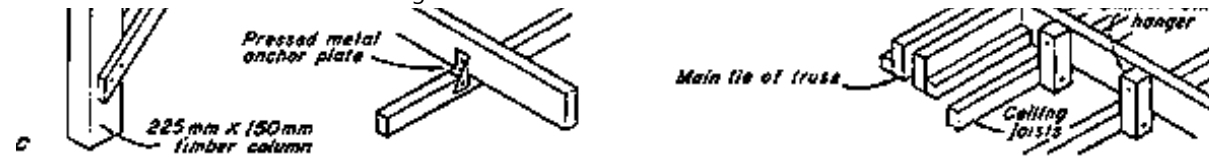

Methods of suspending ceiling from trusses

The joints in this truss are made with, split ring connectors at each interface on 13 mm diameter bolts, with 50 mm square washers under bolt head and nut to prevent them sinking into the wood when the nuts are tightened. The projecting ends of struts and ties are necessary in order to obtain the minimum end distances beyond the connectors. It will be noted that the double members in the rafters and the long struts, which are compression members, are stiffened between the node points by 50 mm packing blocks securely spiked in position.

A variation of this type of truss is shown. This is designed to be supported by columns the connection with which is stiffened against lateral movement by the triangulated and, therefore, stiff junction created by a knee-brace joining truss and column head. This is formed by extending the lower secondary tie to connect with the column some distance below the truss bearing thus rigidly uniting the two. In order to obtain a satisfactory junction with the column and to provide the necessary cross-sectional area for the knee-brace the secondary ties in this example are made of double members placed on the outside faces of the truss, and the struts are single members. As this truss is not designed to take a ceiling load the struts and ties are smaller, except those forming the knee-braces which must resist wind stresses. To provide for the greater number of bolts required at the feet, due to wind loads transferred to the truss, larger gussets are necessary at these points. A single central gusset is provided at the ridge which also acts as a packing between the rafter members.

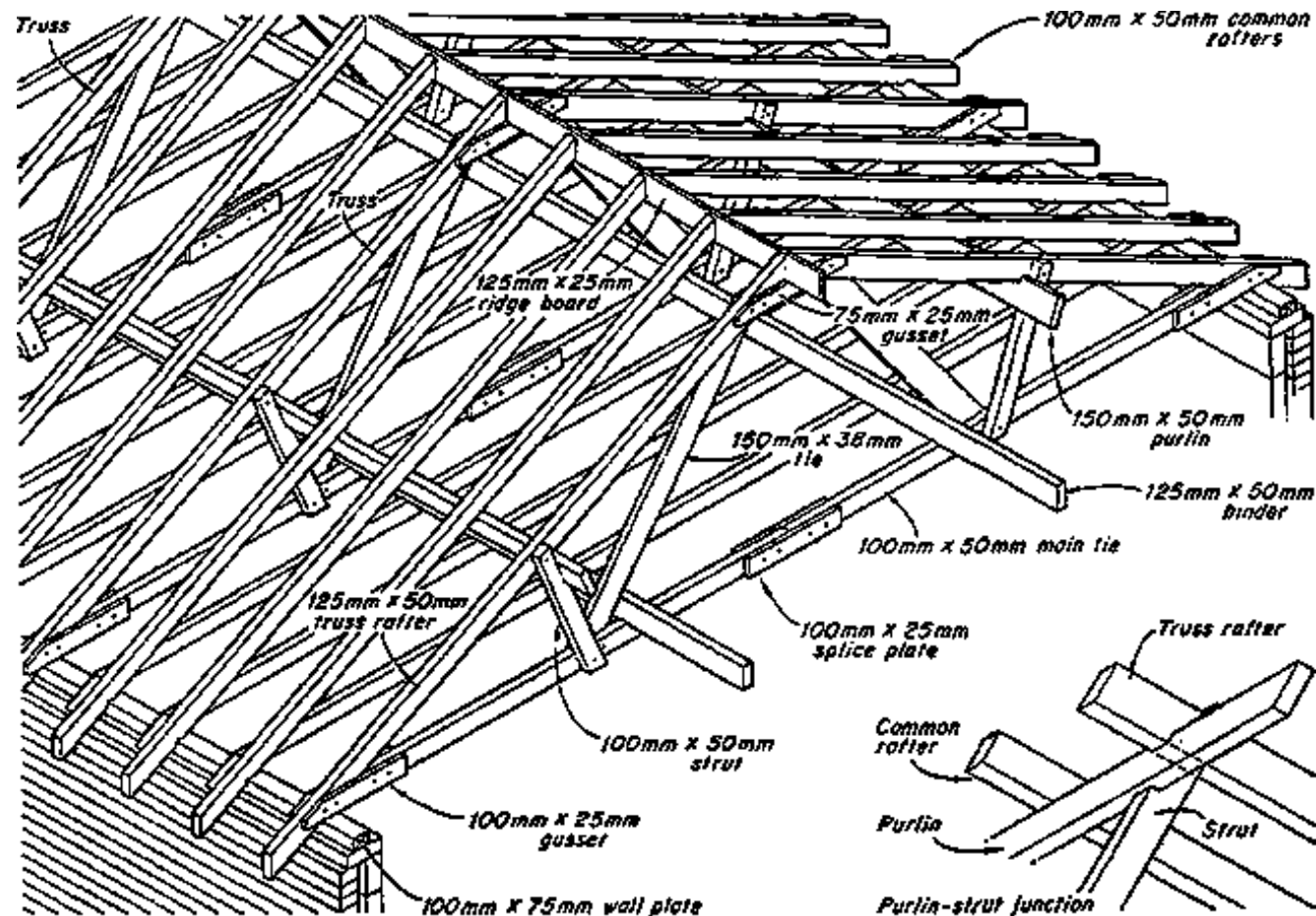

The two previous examples of bolted and connected trusses are designed for self-supporting sheet coverings. Tiles, slates and similar coverings commonly used in domestic work require a substructure of battens supported by common rafters at 400 mm to 450 mm centres. A form of connected truss for this type of work developed by the Timber Research and Development Association is illustrated and is essentially a pair of framed common rafters thus eliminating the need for separate principal rafters. The rafters of the truss therefore lie in the same plane as the adjacent rafters and the purlins, as a result of this, lie below the truss rafters and not on their backs as in a normal truss.

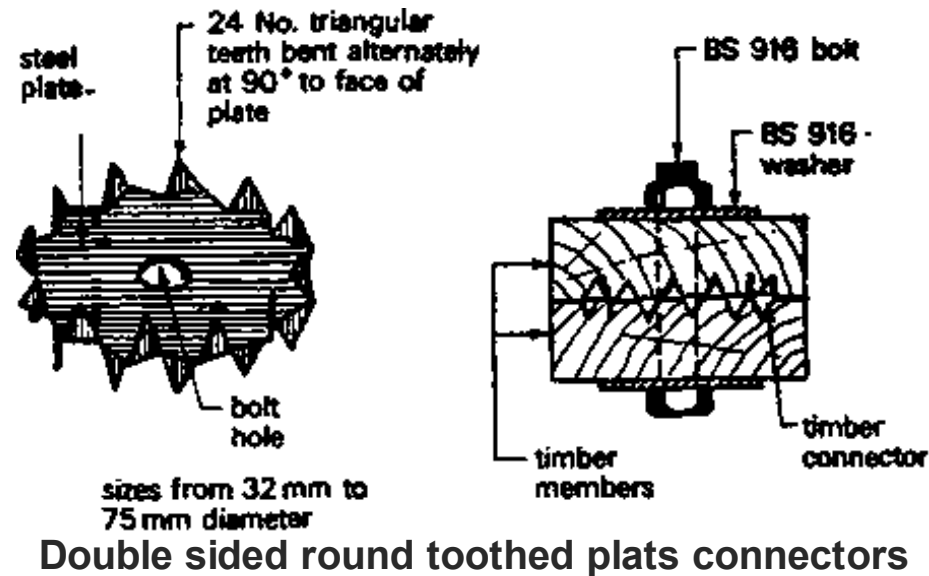

The truss is fabricated from single members, the joint between the rafters and main tie, which lie in the same plane, being made with gussets and the other joints by lapping the members. 3inders to support the ceiling joists bear on the main tie near the lower nodes.

The trusses are designed to be placed not more than 1.80 m apart, that is at every fourth rafter where these are at 450 mm centres. The reactions at the feet are, therefore, not excessive and can be transferred adequately to the wall by the normal wall plate without a template or thickening of the wall. The example shown is for a span of 6.00 m.

(3) GLUED TRUSSES

Glues made from synthetic resins produce the most efficient form of Joint, as strong as or even stronger than the timber joined, and many are immune to attack by dampness and decay. With this type of joint it is necessary to plane smooth all contact surfaces, and the necessary pressure during setting

of the glue is provided by cramps or by bolts or nails which act as cramps. These are usually left in position.

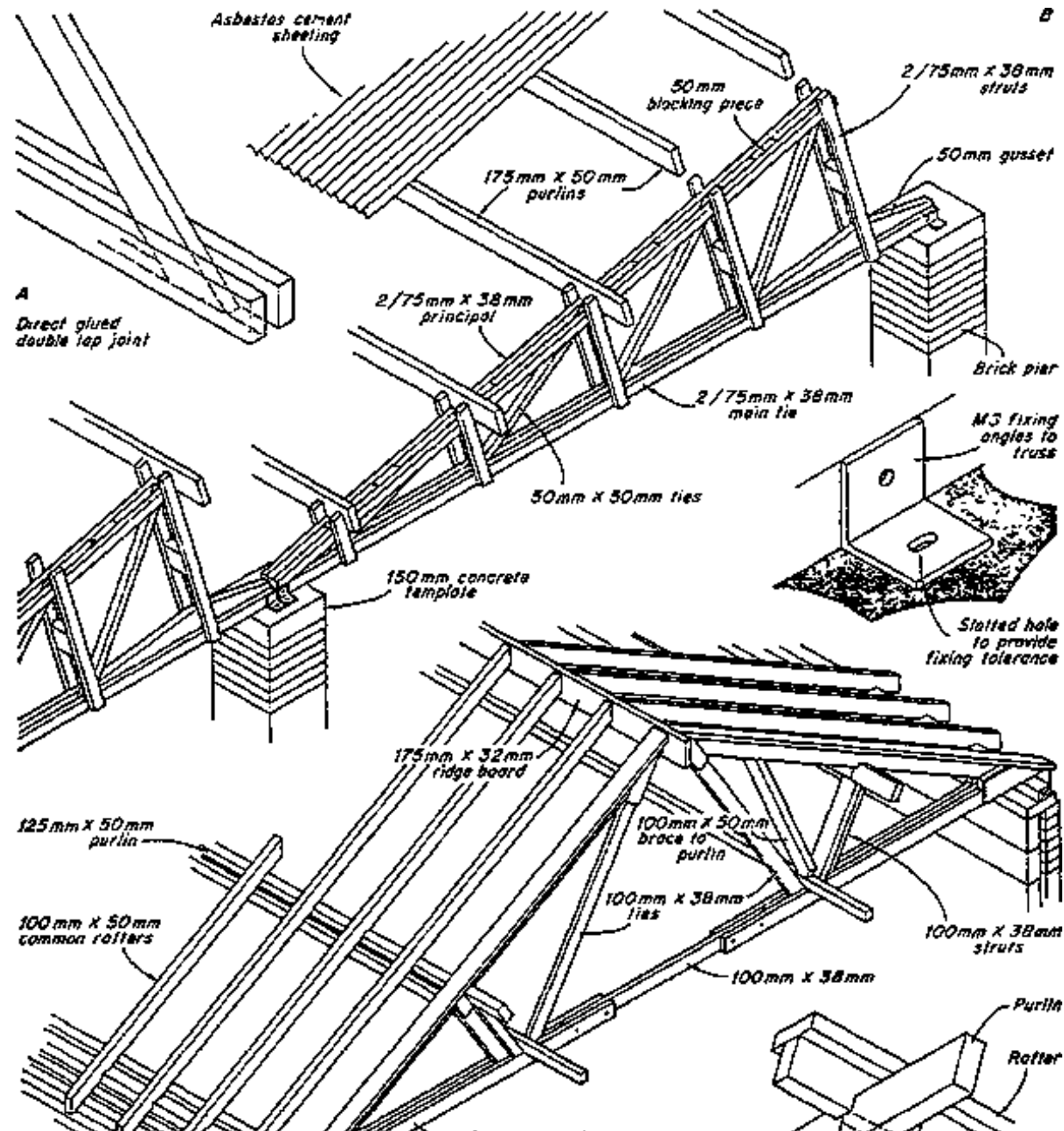

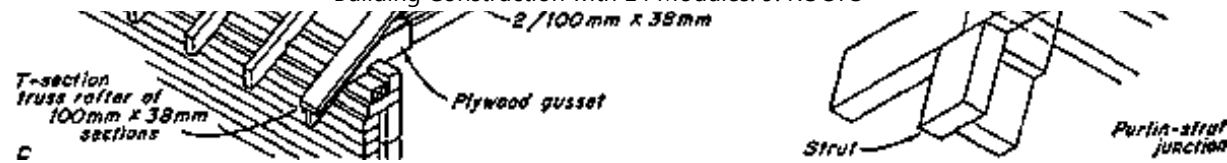

The members may be glued directly to each other using lapped joints or single thickness construction may be used by the adoption of gussets. As with nailed joints, in certain cases lapped members may not provide sufficient gluing area even with double lapped joints and gussets must then be used to provide this.

An example of direct gluing is shown in the small 'northlight' truss of 5.20 m span in figure in which single diagonal ties are sandwiched between double rafter and main tie members and the struts are formed by two thin members glued on the outside faces of the truss. This enables 'centre line' set-out of the members to be adopted. It should be noted that the two longest struts are packed out at the middle point to give increased stiffness to these compression members. Three nails driven in prebored holes act as cramps to each joint during setting of the glue.

Gluing not only produces very strong joints which result in quite small members, but also a very rigid structure which makes the truss easy to handle in transporting and fixing.

An example of a glued and gusseted truss is shown. This is a factory made, standardised truss framed from 38 mm thick members, fabricated in two halves and requiring only site holding of the main tie and site nailing to the ridge board. Rafters, struts and diagonal ties are single members joined by gussets, the compression members being formed into T-sections to stiffen them against buckling by the addition of 38 mm 'tables' glued and nailed on. Those to the struts form seatings for the purlins which lie below the rafters, so that the latter act also as common rafters.

The main tie is partially of double members between which struts and diagonal ties are sandwiched and secured by direct gluing. To provide greater gluing area the lapped joints between rafter feet and tie are packed out to allow the application of plywood gussets on each side.

These trusses bear on the normal wall plate and are designed to be spaced up to 3.90 m apart for spans from 4.5 m to 9.0 m

9.4.3.8 Trussed Rafters

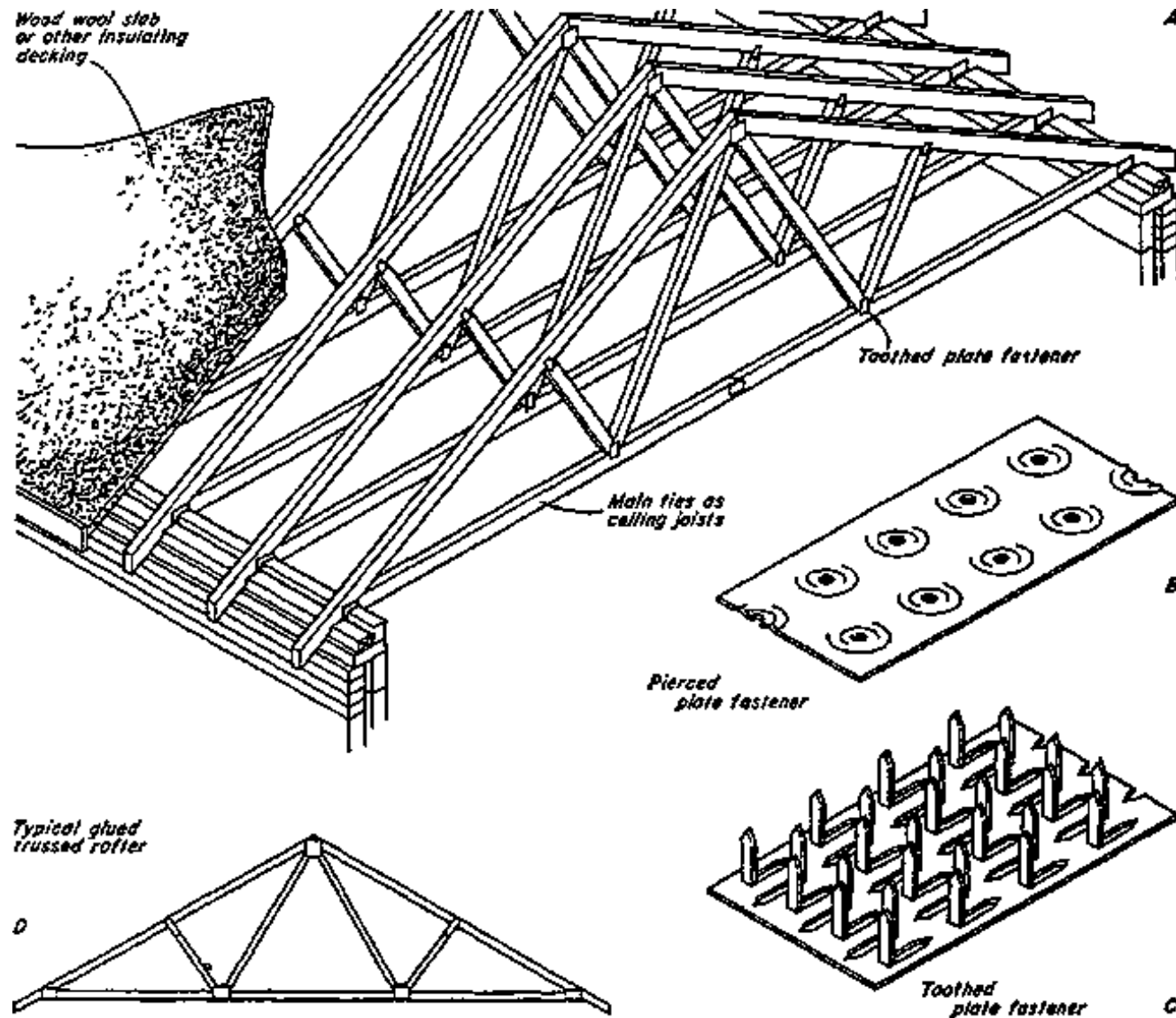

In recent years in domestic work there has developed the practice of triangulating or trussing every pair of rafters in roofs over spans which would normally require purlin construction, thus dispensing with

purlins. There are a number of reasons for this, not the least of which has been the development of factory production for this type of component and the simplicity and speed with which this form of roof can be erected. The economic value of trussing every pair of rafters rests on these considerations together with the fact that many newer forms of roof coverings permit low pitches resulting in short bracing members and the fact that the use of insulating decking such as wood wool or compressed straw slabs, or larger tiling or slating battens, permits the rafters to be placed at 600 mm centres rather than the traditional 400 mm. This, together with the elimination of purlins and ridge board, reduces the timber content of the whole roof structure. These members are known as trussed rafters. It should be noted that since there are no purlins such a roof is a single roof construction.

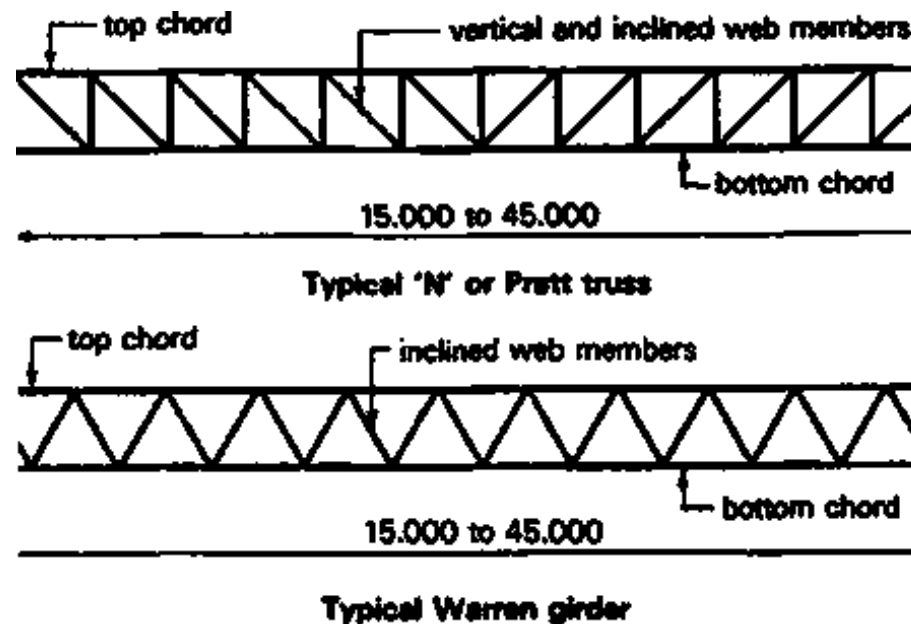

Trussed rafters are fabricated from single thickness members Jointed by gluing or nailing, using plywood or, in the case of nailing, punched metal plate gussets. Punched metal plate fasteners as they are usually called, fall into two groups.

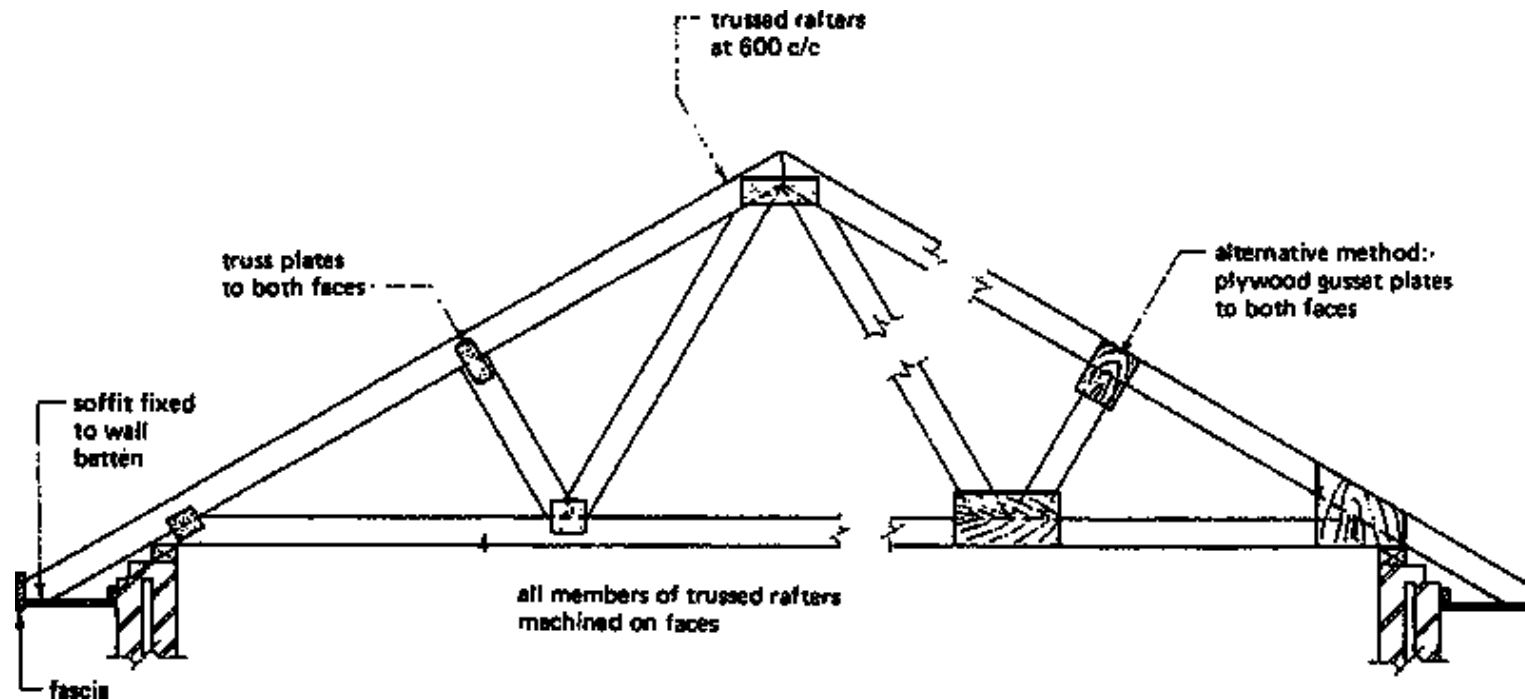

Typical truss rafter details for spans up to 11 000 mm

The use of low pitches, lightweight roof coverings and lightweight roof structures such as trussed rafters, by reducing the weight of the roof increases the danger of wind uplift and in these types of roof the necessity of adequate anchorages should be considered.

Firstly, a thin - gauge plate with holes punched regularly over its surface to receive nails, called a pierced plate fastener. Secondly a similar plate with teeth punched from the plate and bent over 90 degrees, called a toothed plate fastener, or connector. The latter, in which the teeth are an integral part of the plate, must be driven in by a hydraulic press or roller and are used in factory production since they are not suitable for site fabrication. The essential difference between a TRUSSED RAFTER and a ROOF TRUSS is that the former carries its own proportion of roof load directly on itself and only that

load, whereas a truss carries the loads from a number of adjacent rafters via the purlins.

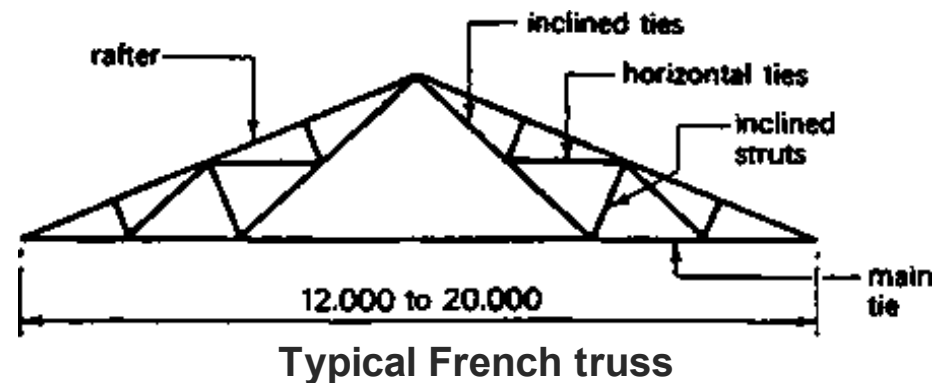
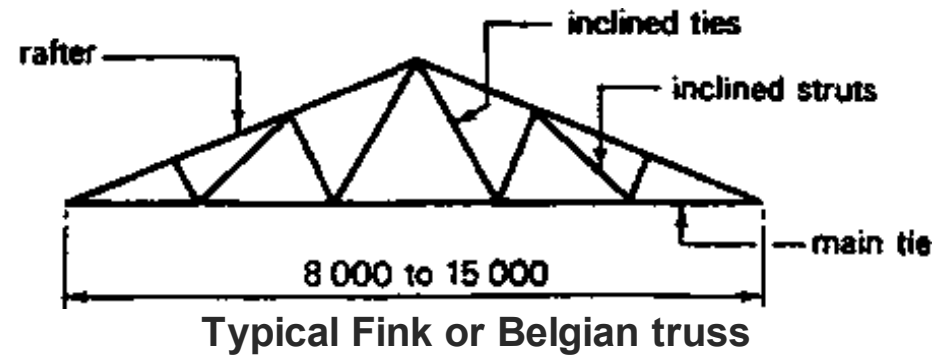
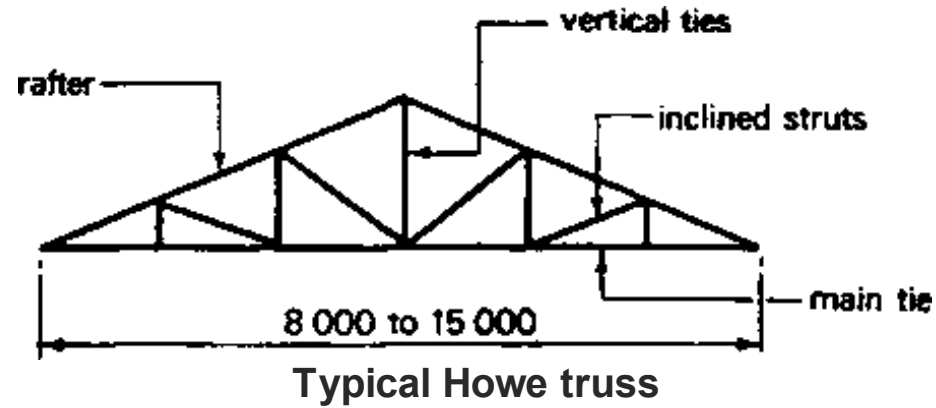

trusses are symmetrical about ridge

except for hanger
trusses spaced at 1 800 c/c

infill 100 × 38 rafters at 450 c/c

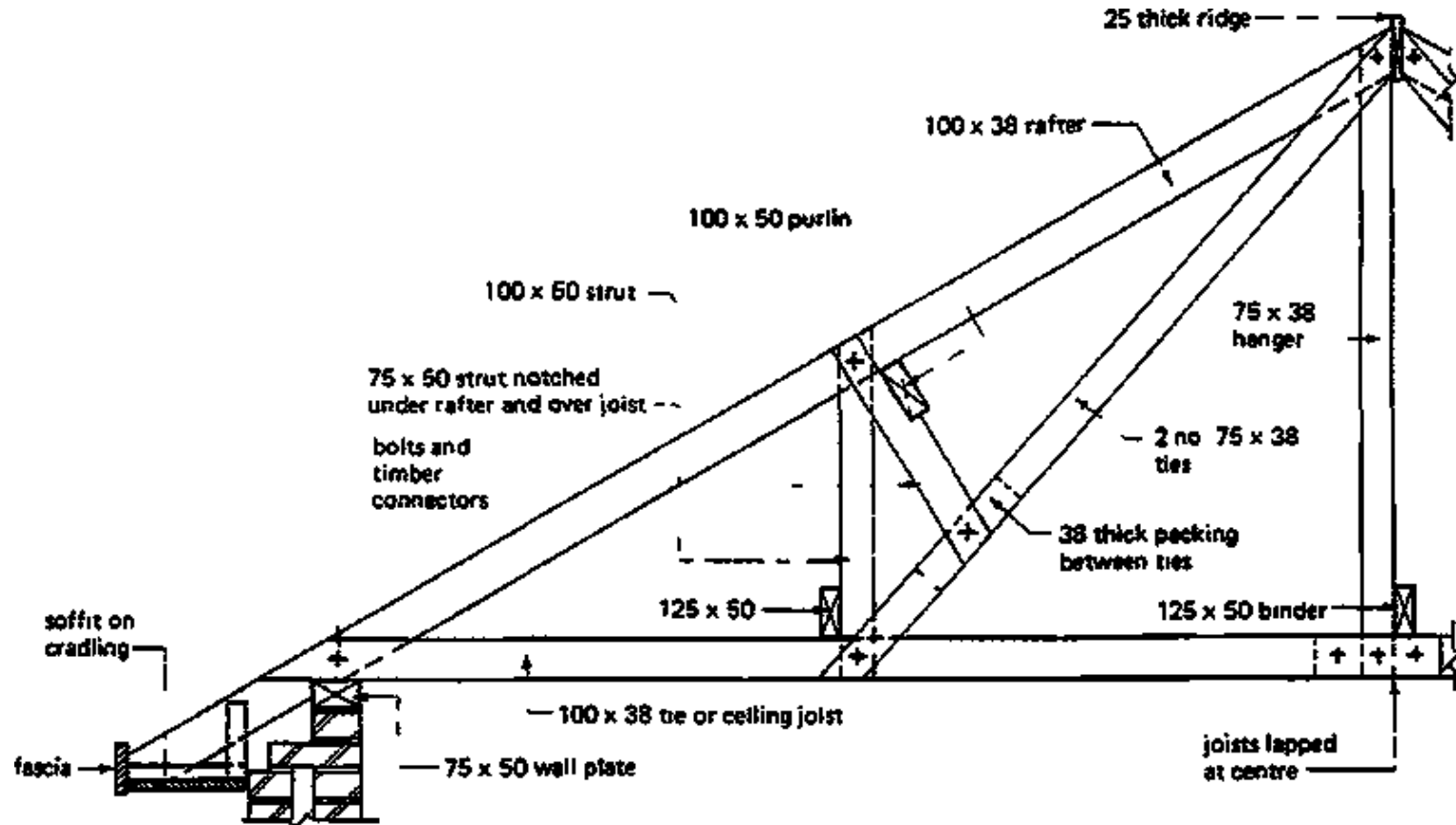

Typical truss detail for spans up to 8 000 mm

9.4.3.9 Hipped Roofs

A Hipped Roof is more complicated in its construction than a Gable Roof, necessitating SPLAY and SKEW cutting of all the shortened rafters at the intersections (called JACK RAFTERS) and the provision of a

deep HIP RAFTER running from ridge to wall plate to carry their top ends (see fig.). The hip rafter transfers their loads to the wall plate and will, therefore, be 225 mm to 280 mm deep, depending upon its span and the depth of the rafters, and 38 mm to 50 mm thick. If the roof has purlins their ends will also be carried by the hip rafters which may then need to be 75 mm thick. The tendency of the inclined thrust of the hip rafter to push out the walls at the quoin is overcome by tying together the two wall plates on which it bears by an angle tie dovetail notched or bolted to the plates (fig.). The foot of the hip rafter is notched over the wall plates which are half-lapped to each other. If the rafter carries purlins causing a greater thrust more resistance to this is provided by the introduction of a dragon-beam as shown in the fig. linking the ends of the wall plates to the angle tie, which would be larger in size. The dragon-beam is cogged over the plates and tusk-tenoned to the tie. A dragon-beam will in any case be necessary to provide a bearing for the hip rafter when the eaves are sprocketed and the feet of the rafters terminate on the wall plate.

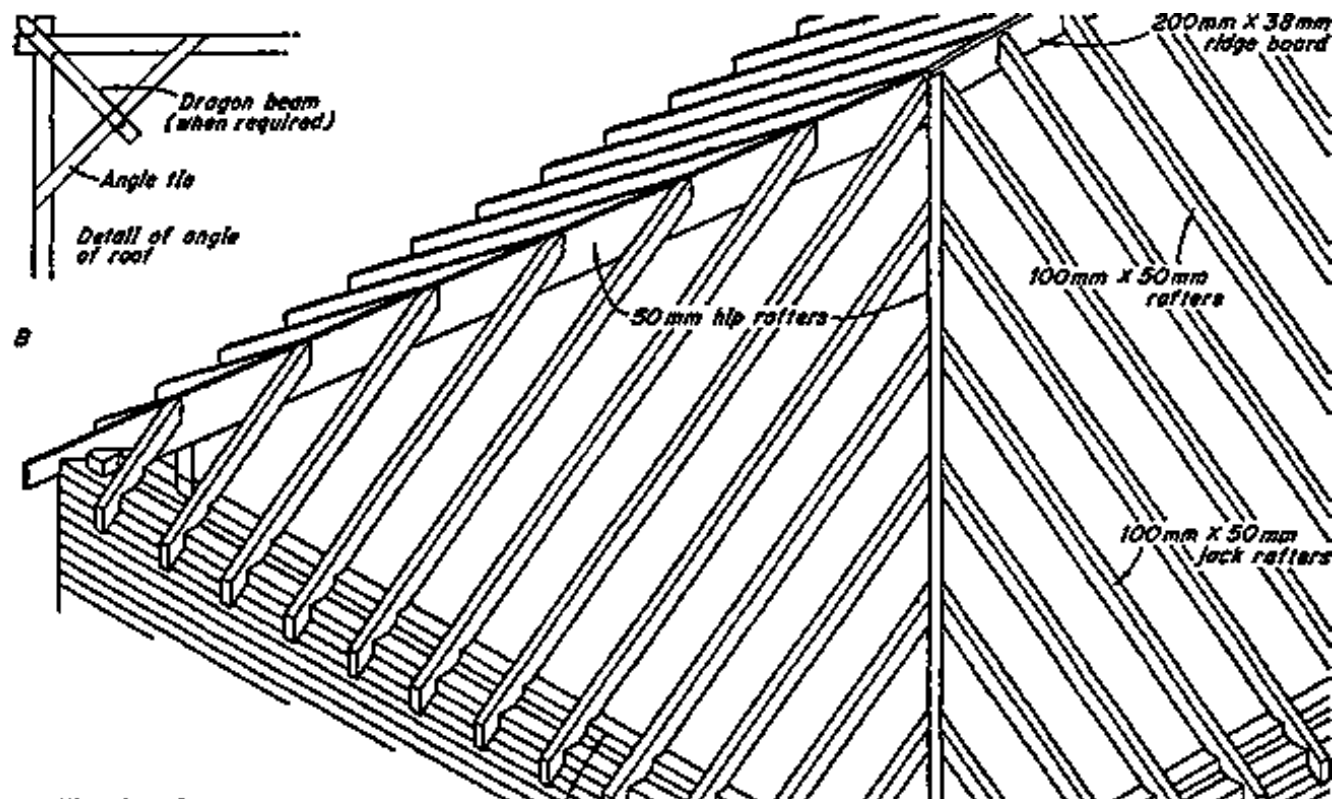

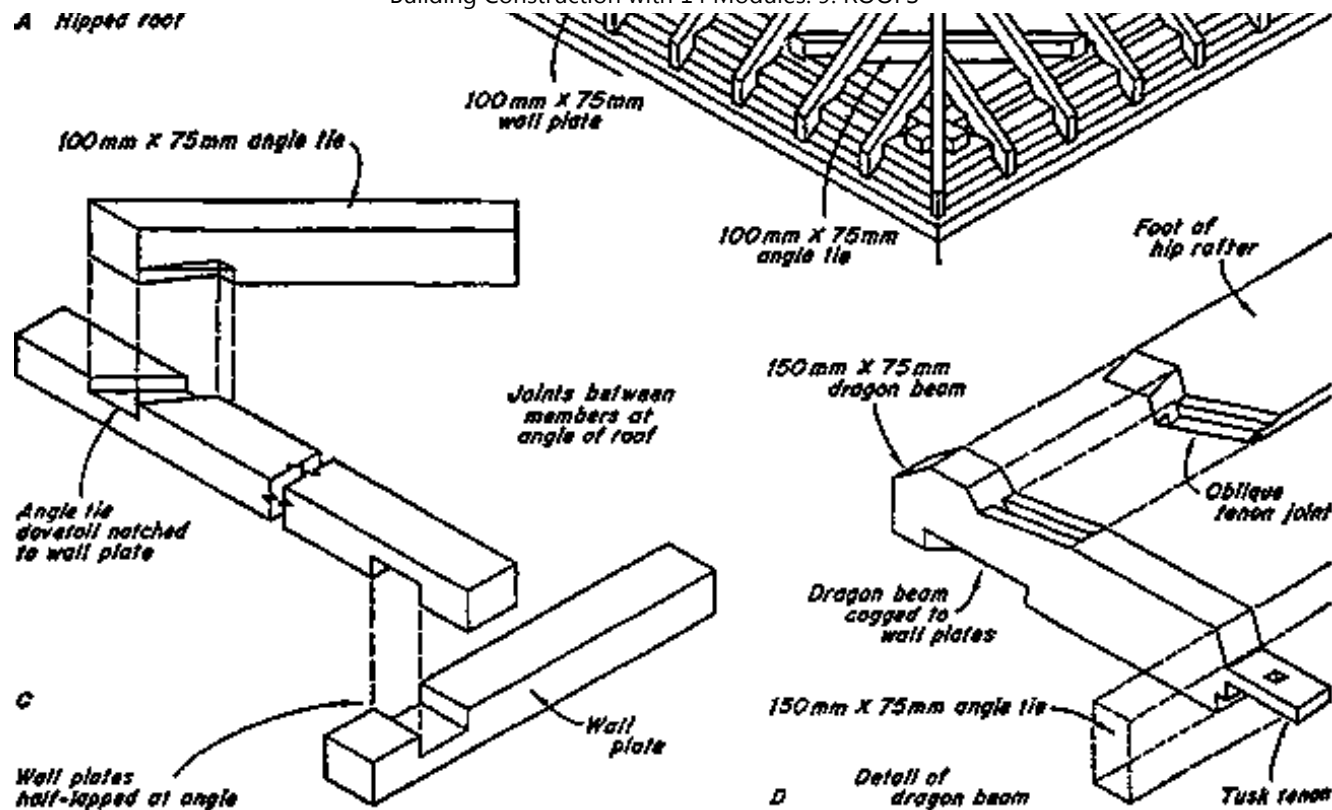

9.4.4 VALLEY

When the plan shape of the building breaks out or returns the intersection of the roof surfaces results in a Junction having an external angle less than 180 degrees which is called a valley (the hip has an external angle greater than 180 degrees) As at a hip jack rafters occur. These run from ridge to valley and their feet are nailed to deep valley rafters the function and size of which are the same as those of the hip rafters

If returns and projections produce roof spans equal to that of the main roof the valley rafters will extend to the ridge where they will gain support as in. If, however, a projection is less in span the valleys will not meet the main ridge, and a support to the tops of the valley rafters and the lower ridge board must be provided in the roof space. If the width of the projection is small valley rafters may be omitted and all the

rafters of the main roof be carried down full length on to a suitable bearing with boards laid on them to take the end of the ridge board and the feet of the jack rafters to the projection.

A valley is finished with a triangular timber fillet or a valley board, as shown in the fig. depending on the width required by the nature of the junction between the roof covering on the two slopes.

It will be seen that the plan shape greatly affects the roof construction and when designing a building which, is to be covered with a pitched roof the implications of the plan in this respect must be borne in mind. The simple rectangular plan results in simple and relatively cheap roof construction; one in which breaks and returns occur, especially if they are numerous, may result in most expensive construction. This applies not only to the structure itself but also to the roof covering

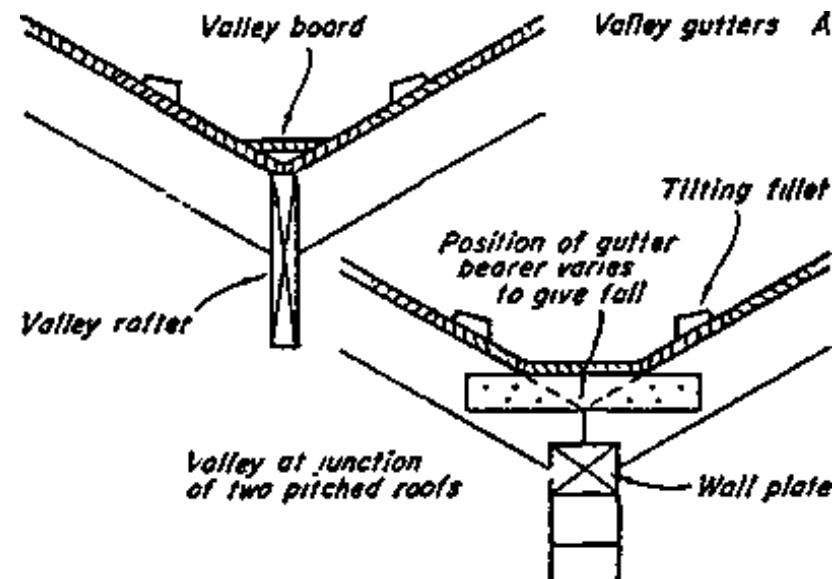

9.4.5 EAVES TREATMENT

As with a monopitch roof, unless the roof is set behind a parapet, the eaves of a ridge roof may finish flush with or may project beyond the wall face, the former producing some economy in roof covering and timber, the latter providing some protection to the walls. Detailing of construction varies widely.

timber, the latter providing some protection to the walls. Detailing of construction varies widely according to the pitch of the roof, the effect desired by the architect and whether an external or a hidden gutter is used. It is, therefore, possible to illustrate only some typical examples.

Examples of open projecting eaves are shown in the figures. With tile or slate coverings of any type the fascia projects as shown 19 mm or so above the roofing battens in order to tilt the eaves courses. Where no fascia is used as at a batten of greater depth than the boarding or battens, called a tilting - fillet, is used at this point. Also closed projecting eaves are shown in the figure. The variation in detailing necessitated by increased projection can be seen. The ends of the rafters are cut horizontally to provide some fixing for the soffit boards (C), but as a considerable portion of the boarding is not supported by the rafter, soffit bearers are fixed to the rafter ends as shown. The back of the fascia should be grooved to take the edge of the soffit. Greater projections necessitate longer soffit bearers and brackets are then required to support their inner ends as shown in (D). When plywood or asbestos cement sheet is used for the soffit, as is quite common, the fascia must be grooved to take the front edge and the back edge should be given continuous support by a fillet secured to the wall (E). In this case the soffit bearers can be fixed to this rather than to brackets from the rafters. If the roof pitch is not too great the soffit can be fixed direct to the rafters and, with a gable roof and projecting barge board, can continue up as the verge soffit. In this particular case the barge-board will be slightly less in depth than the fascia, but with a horizontal eaves soffit it must be deeper in order to cover the end of the eaves, in which case the outer and cantilever rafters which support it must be deeper than the common rafters or a thicker barge-board must be used.

If a clear fascia, unobstructed by an external gutter, is desired an internal gutter may be formed. It is essential that the front edge of this type of gutter be at such a level that in the event of blockage of the outlet water will drain over the front rather than seep back into the roof structure and possibly into the building.

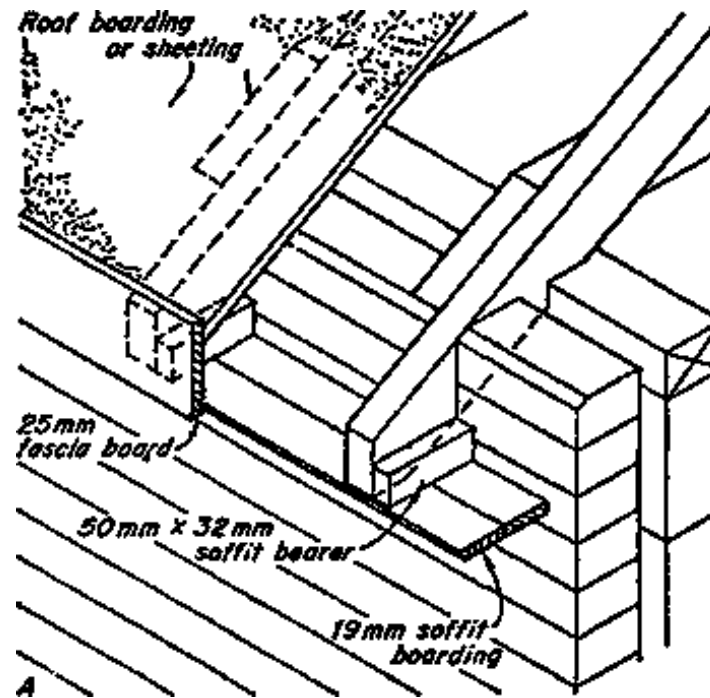

Roof ventilation should be ensured through closed eaves. When a gable roof finishes with a plain verge, that is with no barge-board, the end of any form of closed projecting eaves must be boxed-in or be closed by the gable wall supported either on corbelling or on a springer. If the gable continues up as a parapet this is usually corbelled out for this purpose.

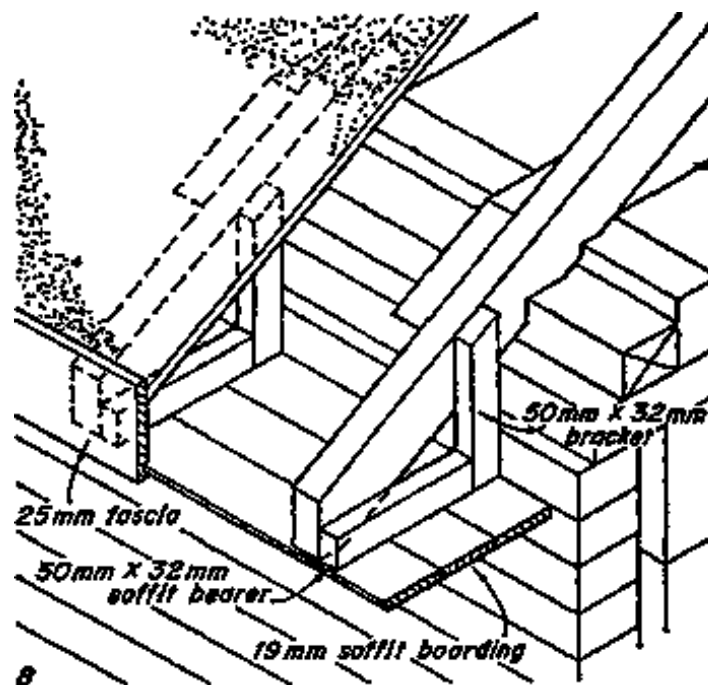

On wide, steeply pitched roofs the pitch may be reduced at the eaves in order to reduce the velocity of water during heavy rainfall and prevent overshooting of the gutter. This is done by means of sprockets which are short lengths of timber the same size as the rafters, fixed to the sides of the rafter feet as shown in figure or to the backs of the rafters if the latter run over the wall plate.

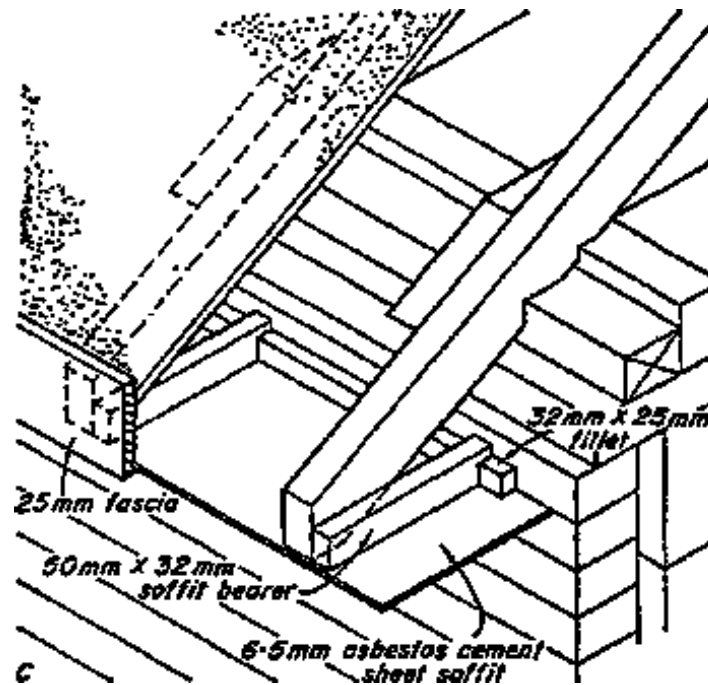

The reduced pitch must, of course, not be less than the minimum angle necessary for the particular roof covering.

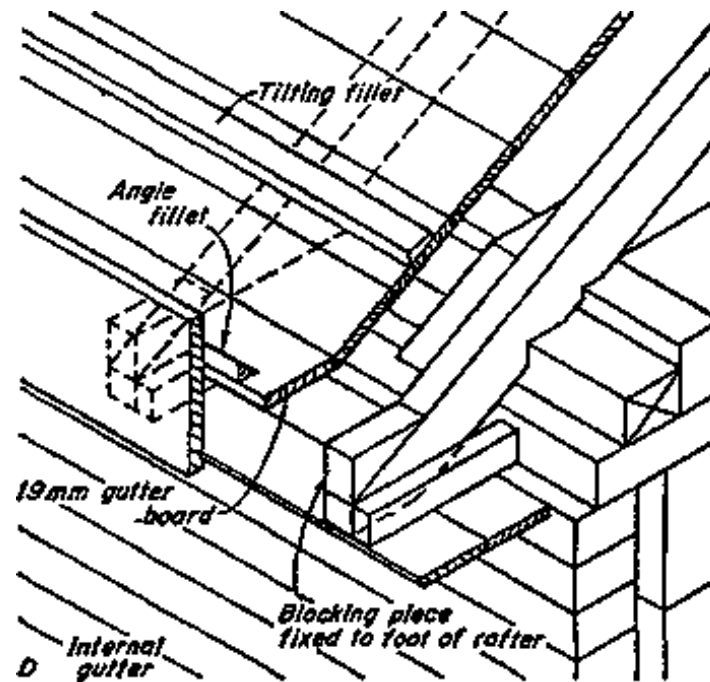

As an alternative to framing up a projecting eaves in the ways described above proprietary precast concrete eaves or gutter units may be used as for flat roofs, bedded on the head of the external walls. The shape of the unit spreads the roof load over both leaves of a cavity wall and over openings of limited span a back recess may be filled with concrete, together with reinforcing bars, to form a lintel. Behind a parapet wall a parapet gutter is framed up as shown in the figure by means of gutter bearers nailed to the rafters and carrying the gutter boards. The bearers are fixed at different levels along the wall to produce a fall to the gutter and as the level rises up the roof slope this results in a gutter which tapers in width on plan from a maximum at the highest point and is, therefore, termed a tapered gutter in contrast to the parallel or box gutter.

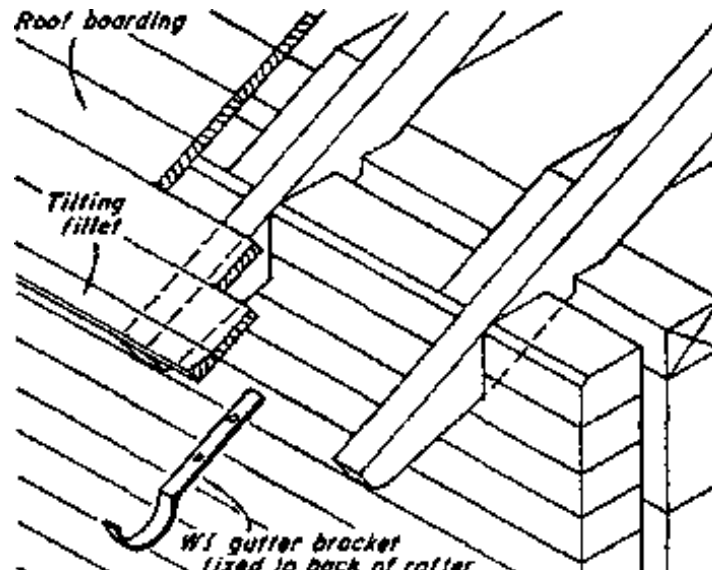
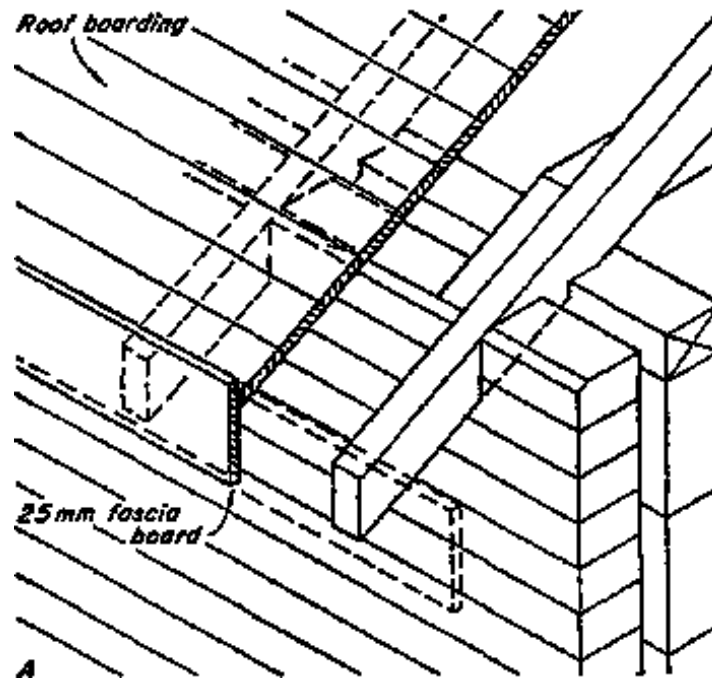

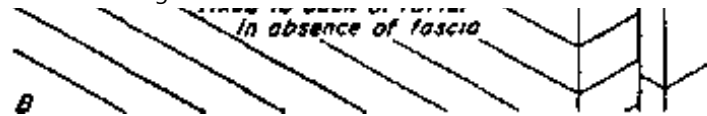

9.4.6 OPENINGS IN TIMBER ROOFS

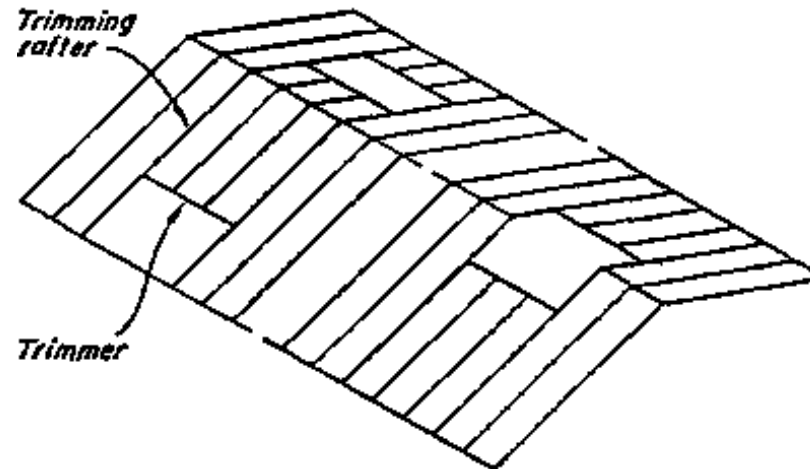

Openings in roofs A

Roofs may be penetrated by chimney stacks and various forms of roof lights and, in pitched roofs, by dormer windows, for all of which openings in the roof must be formed. As in the case of floors and in a similar manner the roof is framed or trimmed to form such openings. Details of trimming to flat roofs are normally identical with those for floors. In pitched roofs openings may be required at any point between eaves and ridge, or at the ridge, as shown in the figure. For stacks and skylights the trimmers are placed normal to the roof slope and are fixed to the trimming rafters by pinned tenons. This joint has an extended tenon and is secured with a wedge. The trimmed rafters are fixed to the trimmers by any of the methods described for floors.

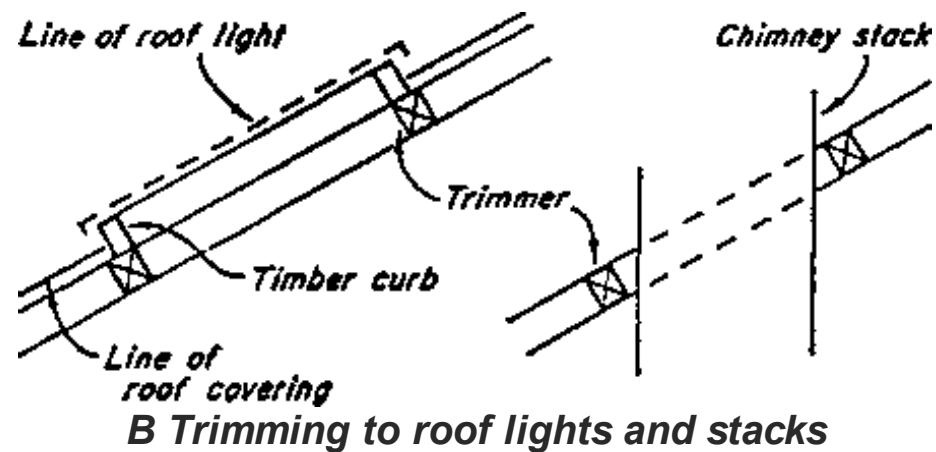

Openings for roof lights are finished with a timber upstand or CURB as indicated in the figure which in a pitched roof, raises the light above the level of the roof covering and permits a watertight junction to be formed all round, and in a flat roof provides for a 150 mm upturn of the roof finish.

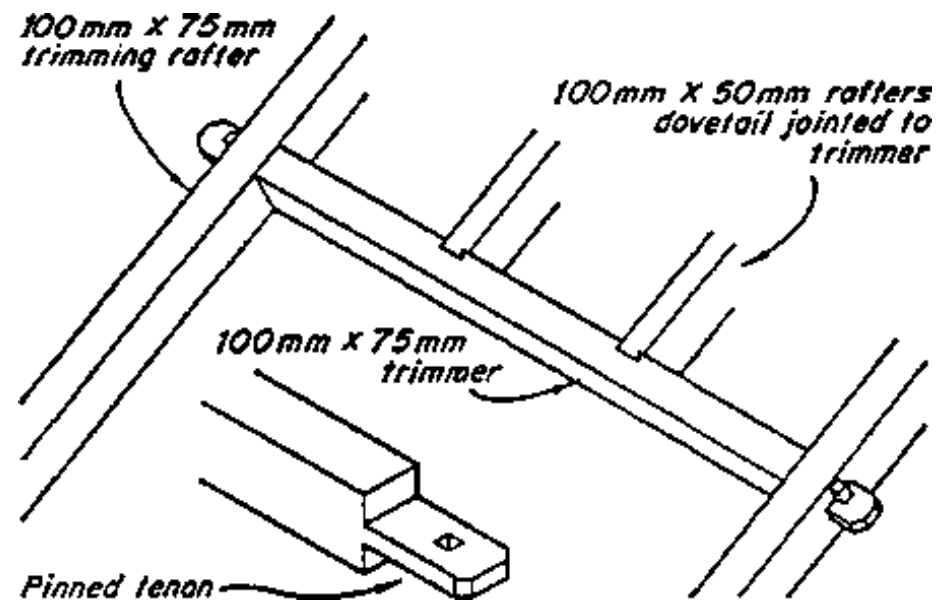

C

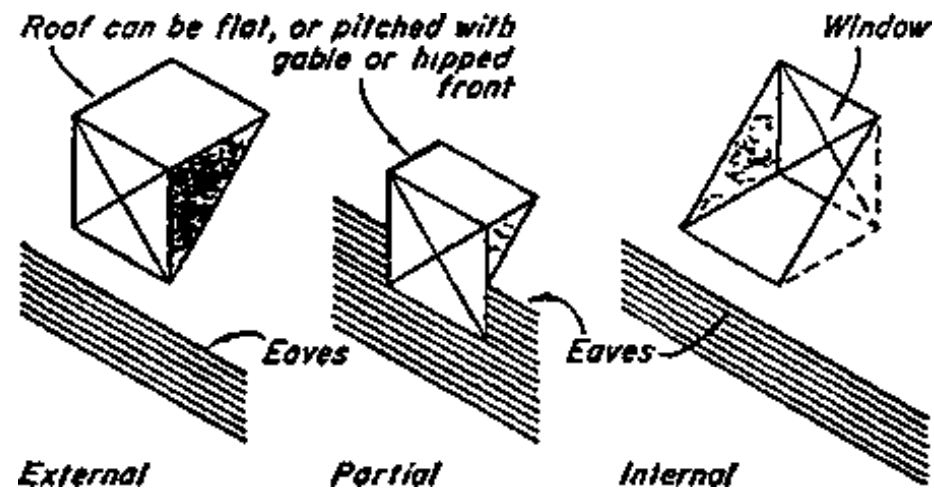

The positioning of trimmers for dormer windows varies according to framing requirements and is discussed below.

DORMER WINDOWS

The dormer window is a vertical window set in the slope of a roof as distinct from a skylight which is parallel to the slope. It may take various forms as shown in the figure. The internal dormer which avoids a projection above the roof slope is less common and involves a small flat roofed area in front of the window.

For or external dormer windows the lower or cill trimmer is fixed vertically to provide a seating for the dormer framework and window and to raise the window cill clear of the roof covering. It is 75 mm or 100 mm wide and its depth will vary with the roof pitch and the tape of roof covering. The top or head trimmer may be fixed vertically or normal to the slope. If the dormer roof is flat a vertical trimmer provides a fixing surface for the boarding or other decking; if it is pitched a trimmer normal to the slope may be used and this simplifies jointing to the trimming rafters. The cill trimmer is oblique notched over

may be used and this simplifies jointing to the trimming rafters. The sill trimmer is oblique notched over the trimming rafters and nailed in position. The vertical head trimmer is oblique notched and tenoned to them, the tenon being necessary here in order to resist the thrust from the feet of the upper trimmed

rafters. In the case of a partial dormer there is no sill trimmer since the window sits directly on the wall below.

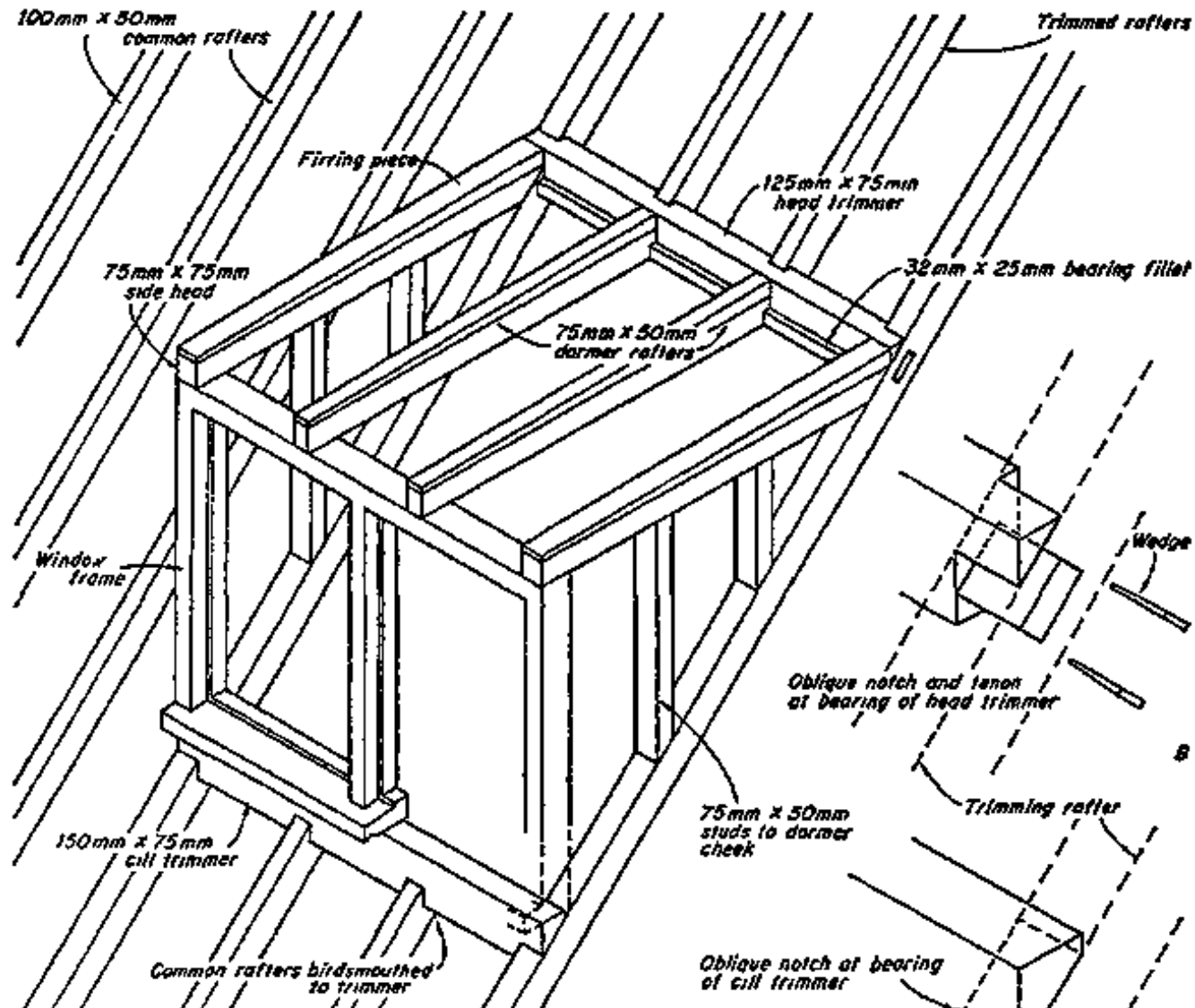

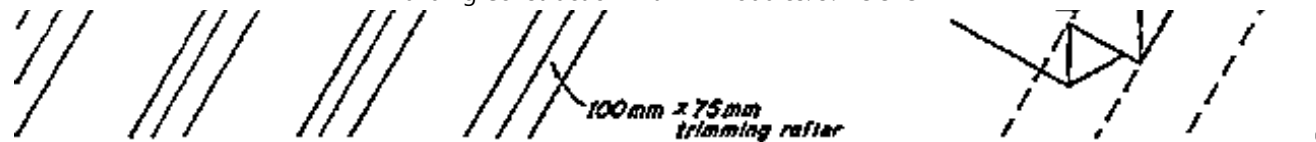

The traditional method of forming the dormer front was to frame up 100 mm by 75 mm side posts and head on the cill trimmer, the posts being tenoned or dowelled to the trimmer, and within this to set the window. Nowadays, unless the dormer is large, it is usual to make the head and mullions of the window frame large enough to act structurally to support the dormer roof and cheeks as shown in the figure. The cheeks are formed by a 75 mm × 75 mm side head running from the dormer front back to the trimming rafter against which it is splay cut and nailed, the spandrels thus formed being filled with 75 mm × 50 mm studs to which 19 mm t and g boarding is fixed externally. If the cheek is small studs can be omitted, the spandrel being covered with 25 mm boarding nailed to corner post and side head, running parallel with the roof slope. The framing of an internal dormer varies slightly from this. The lower trimmer would be set vertically to form a front bearing for the flat roof below the window and the top trimmer set similarly to form a head over the window. Since neither may be notched over the trimming rafters, in order not to obstruct the roof covering, both must be tenoned into them. Two posts under the bearings of the top trimmer and running from floor to trimming rafters would support a cross bearer carrying the window and the members forming the flat roof.

9.5 ROOF COVERINGS

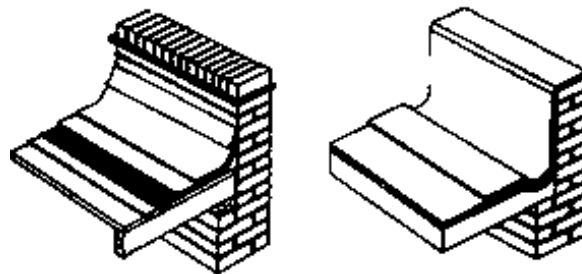

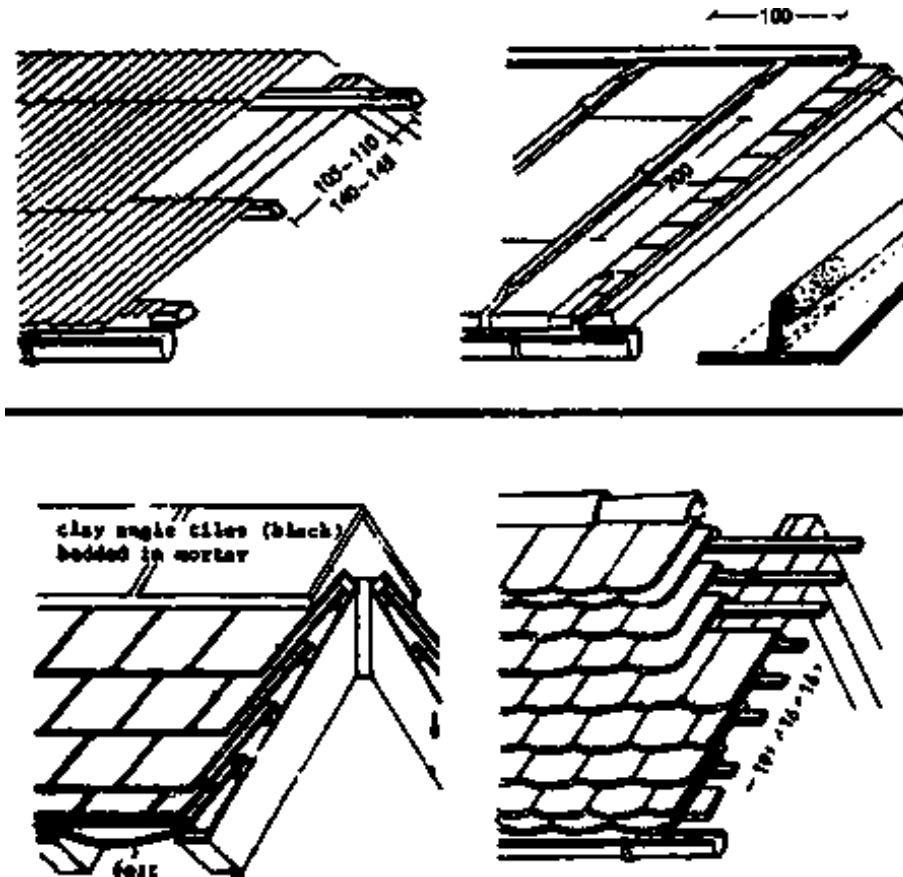

9.5.1 FUNCTION OF ROOF COVERINGS

The function of the Roof Covering is that of a 'SKIN' - protection against weather.

In addition to that function the Roof covering has to be fire resistant and has to provide an adequate thermal insulation.

9.5.2 TYPES OF ROOF COVERINGS

In accordance with the structure of the roof and the above mentioned functions there are different types of Roof Coverings.

A broad classification, comprising 5 groups, is:

1. Roof sealing
2. Table covering
3. Sheet covering
4. Scalloped covering
5. Thatch covering

Depending on the SLOPE of the roof the type of Roof Covering has to be chosen. The above mentioned types of Roof coverings are comprising the following material:

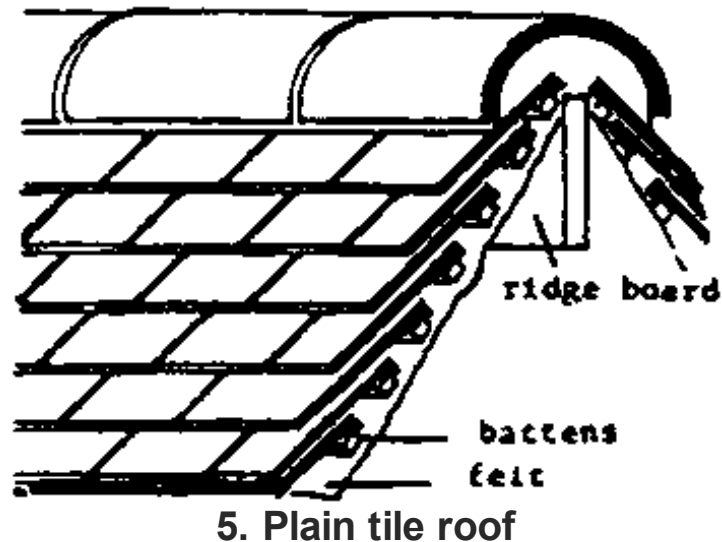

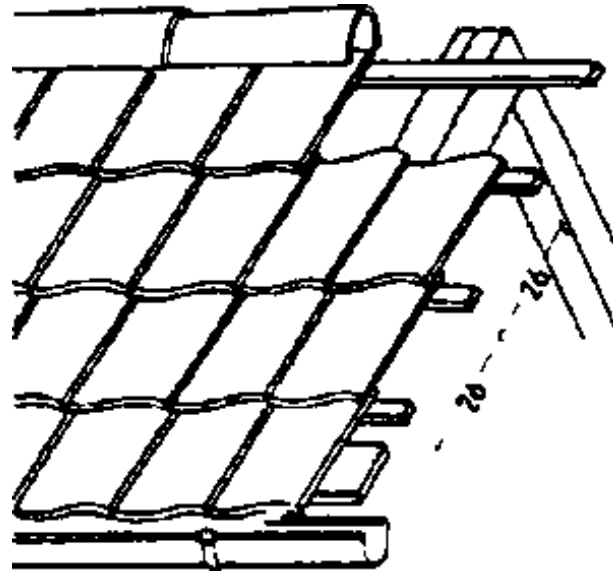

6. Pantile roof (clay) 43 kg/m²

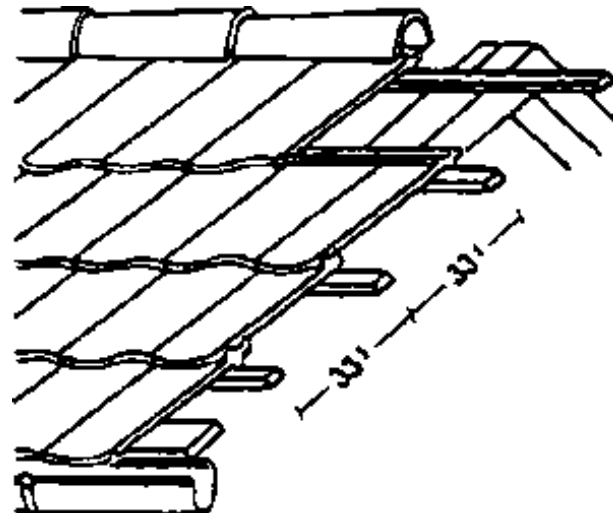

7. Interlocking tile roof 42 kg/m²

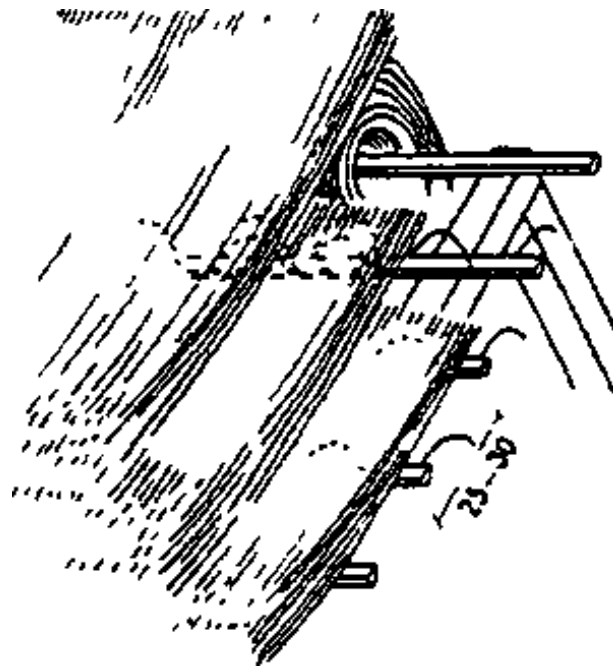

8. Thatch roof 10 kg/m²

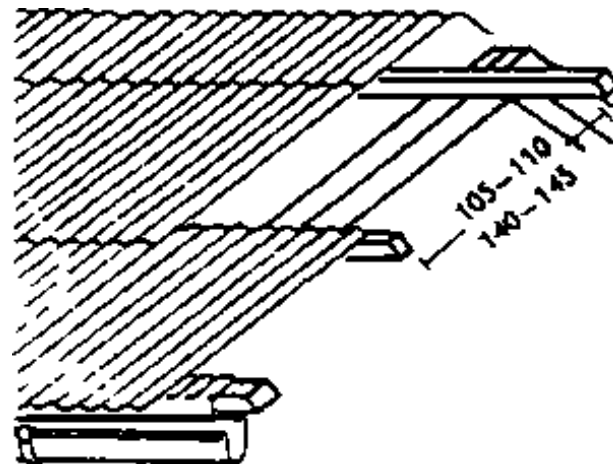

9. Corruated Eternit roof 17 ka/m²

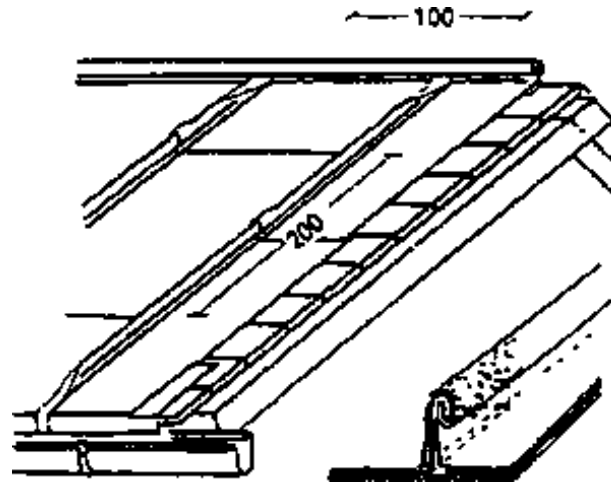

10. Metal roof 5.5-6.5 kg/m² (aluminium 2-3 kg/m²)

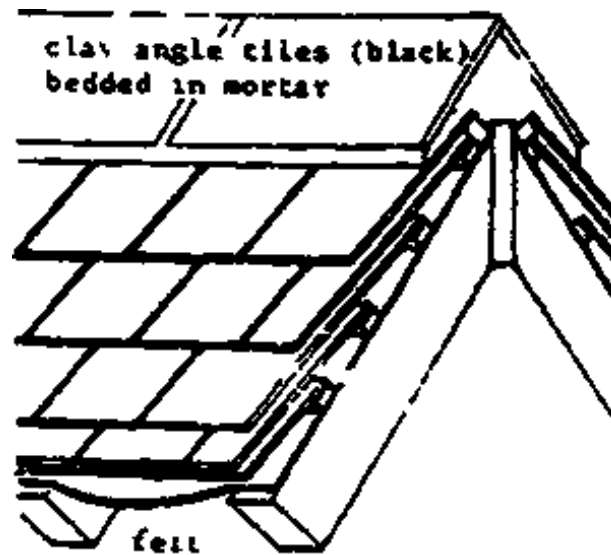

11. Slate roof

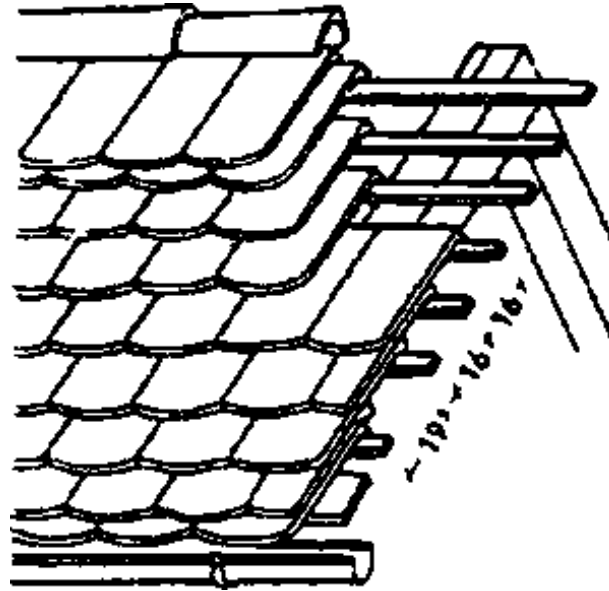

12. Double roof ('Doppeldach') 63 kg/m²

1 Roof sealing:

- heat sealed plastic foils;
- roofing felts, glued in different layers, sealed with bituminous paints.
- reinforced with metal fails, etc.

2 Table covering:

- asphaltic or bituminous felts, glued or nailed in 1, 2, or 3 layers.

They are colled according to the weight of the raw-materials (333 g/m² or 500 g/m²).

The raw-felt is soaked with tar or bitumen and coated. Sand or chippings may be pressed on the surface of the felt as protection against mechanical loads and weather.

3 Sheet covering:

- Sheet metal (coated or galvanized)**
- galvanized corrugated iron sheets**
- corrugated aluminium sheets**
- corrugated asbestos sheets.**

4 Scalloped coverings:

- Roofing (clay) tiles**
- Concrete tiles**
- Slates**
- Asbestos plain tiles (in different forms and shapes)**
- shingles.**

5 Thatch coverings:

- straw**
- dry grass, or hay**
- reed**

9.5.3 SUBSTRUCTURES

The Roof covering - 'the SKIN' -has to have an adequate substructure and has to be fixed on it, in order to avoid sliding or being taken away by the wind.

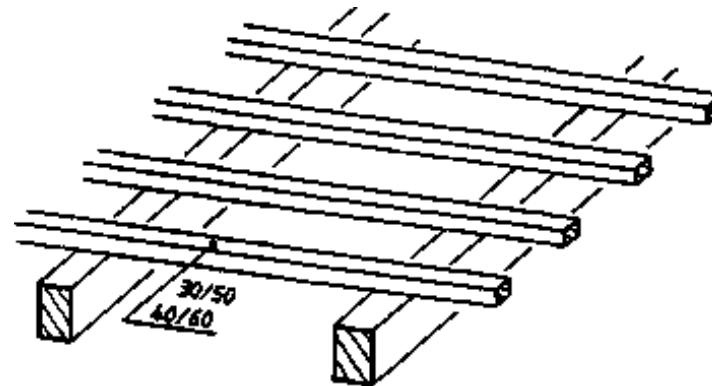

BATTENS ON RAFTERS

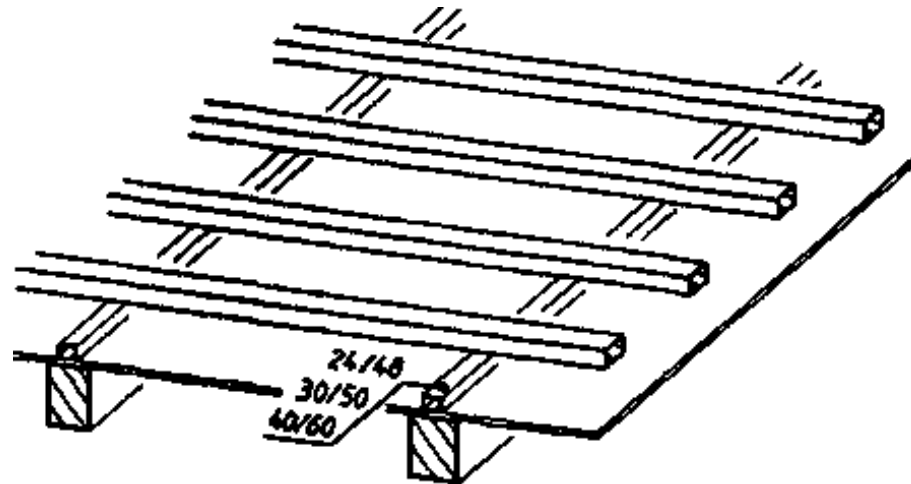

BATTENS ON CENTER BATTENS

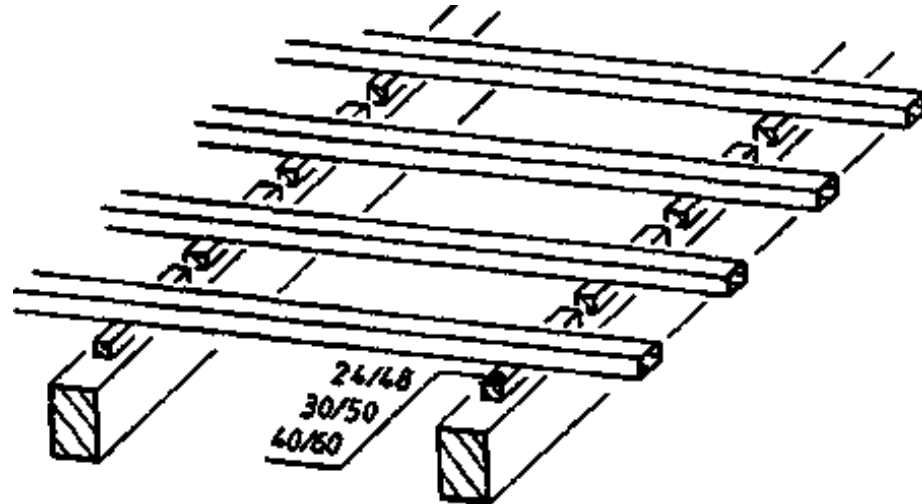

BATTENS ON CENTER BLOCKS

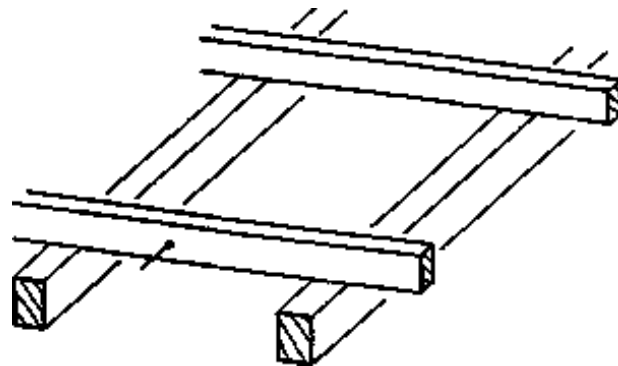

PURLINS FOR SHEET COVERINGS





SHUTTERING ON RAFTERS

There are different types of sub-structures depending on the 'SKIN', covering the roof:

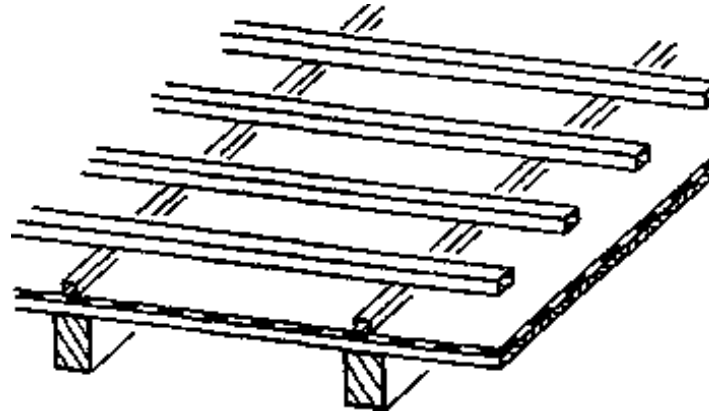

TUBES ON CENTER BATTENS

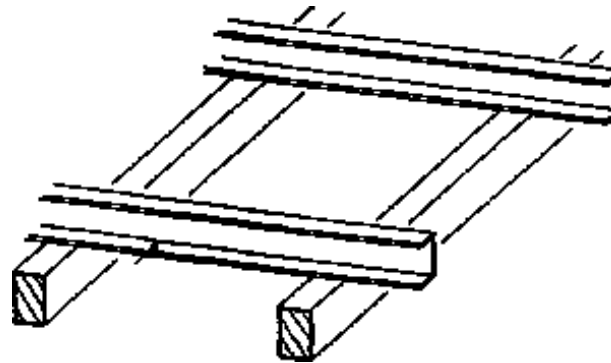

PROFILES ON RAFTERS





TUBES ON I-PROFILES

An additional provision to seal flat inclined roofs is the use of fibre-reinforced roofing felt or special plastic foils.

- The overlapp of such materials to be - 15 cm
- In order to get a proper cross- ventilation the material should hang loose between the fields of the battens.

9.5.4 CHOICE OF ROOF COVERINGS

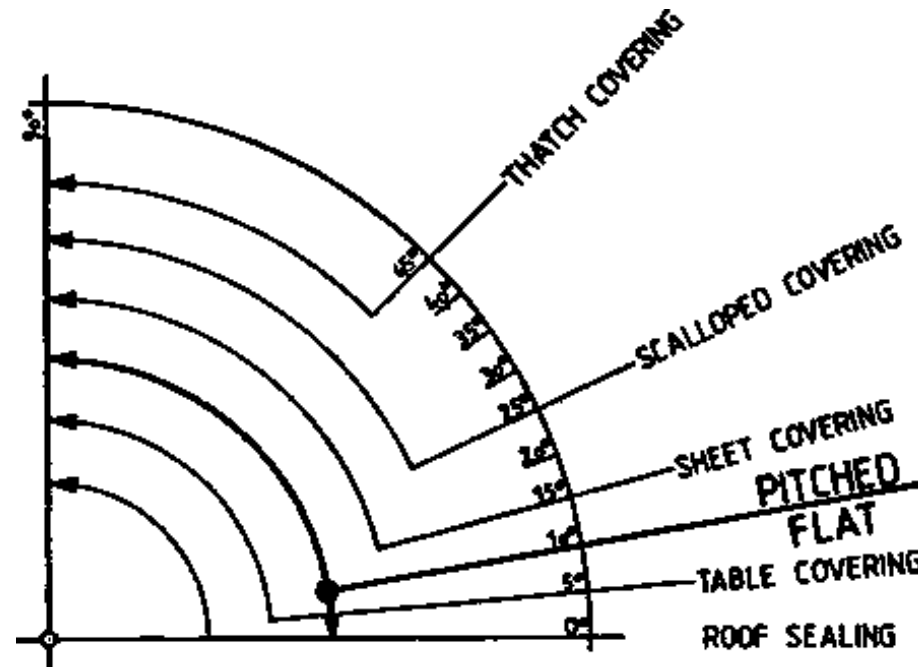

9.5.5 MATERIALS AND COVERING METHODS

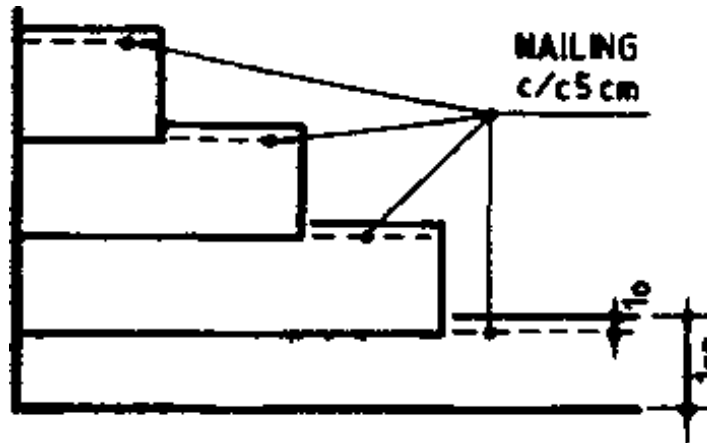
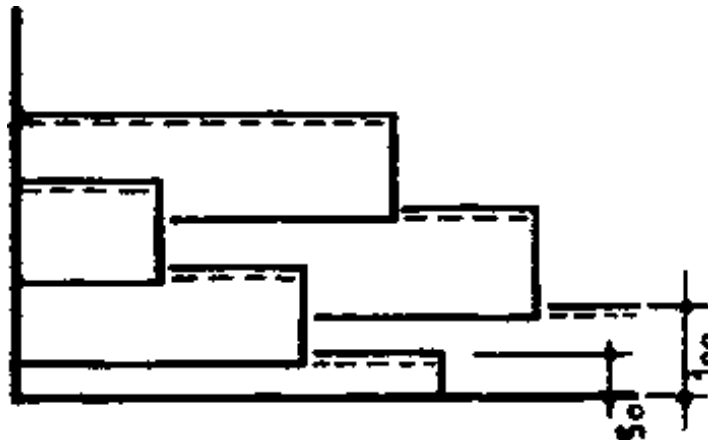
TABLE COVERING:**ASPHALTIC OR BITUMIOUS FELTS, GLUED OR NAILED IN 1-, 2-, OR 3-LAYERS****1-LAYER TABLE COVERING****2-LAYER TABLE COVERING**

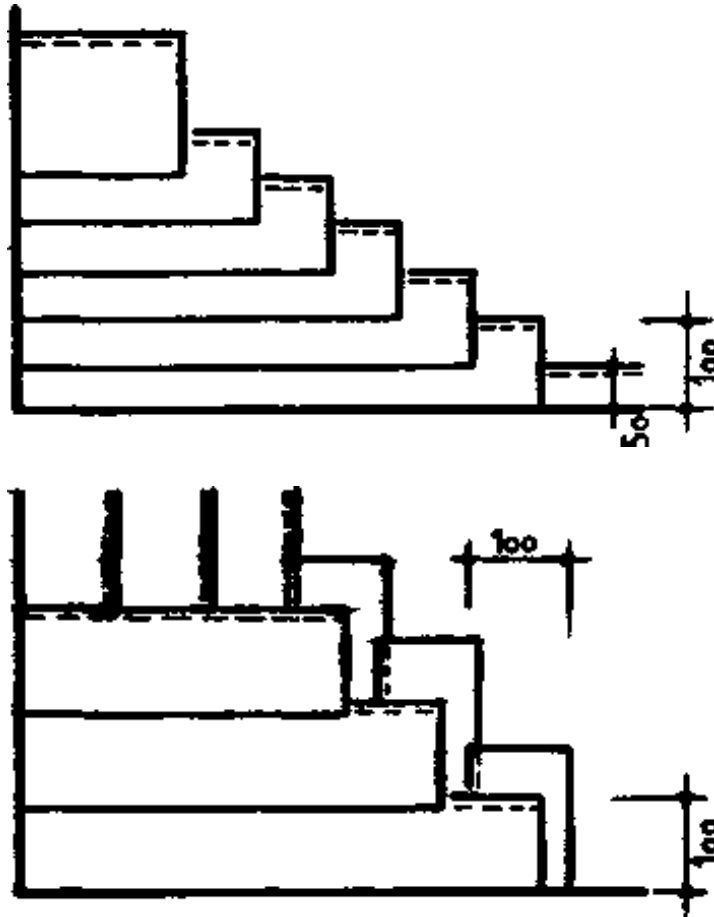

3-LAYER TABLE COVERING

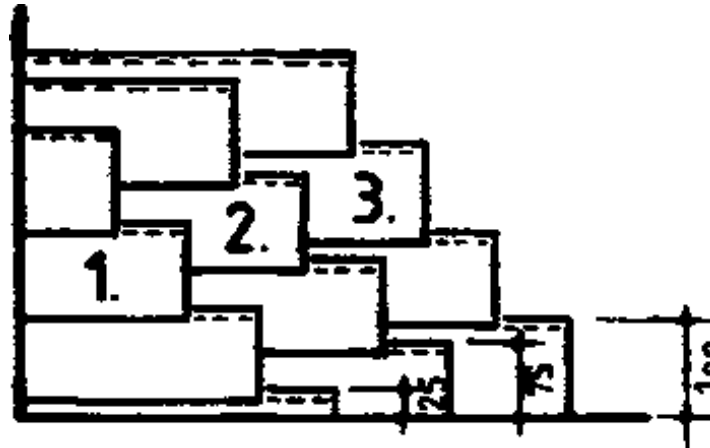

SHEET COVERINGS:

SHEET METAL COVERINGS

- Sheet metal coverings provide an excellent protection against wind and rain, is durable and lighter in weight than tiles, slates or asphalts.

Metal roofs are noisy.

Four types of metals are used for sheet coverings:

1. Lead
2. Copper
3. Zinc
4. Aluminium

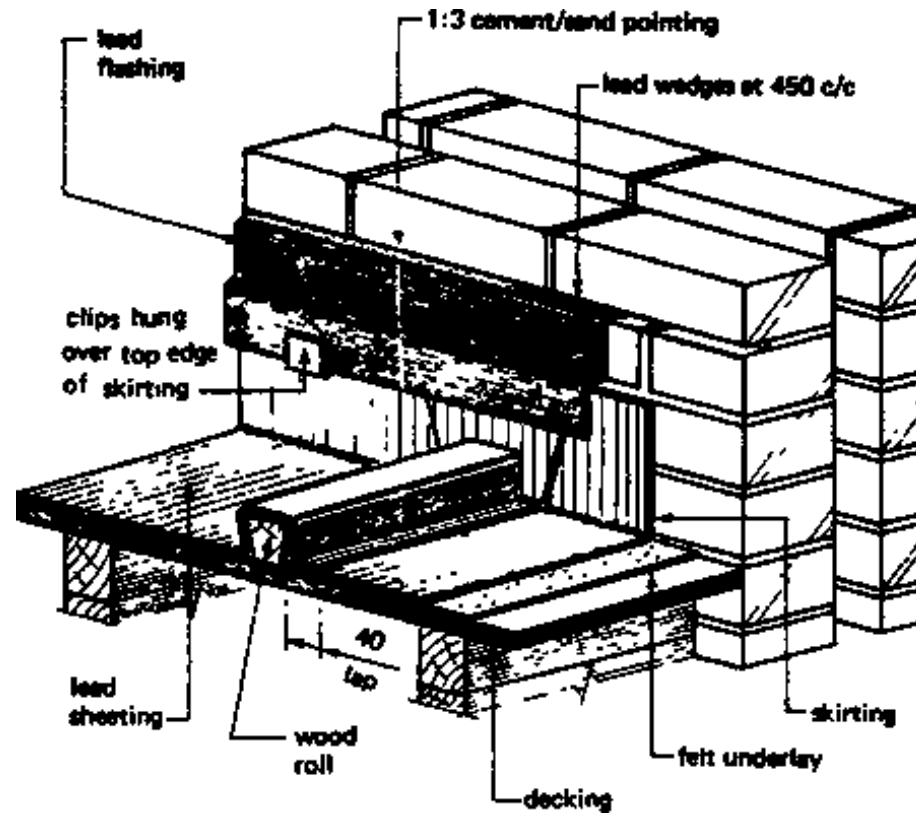

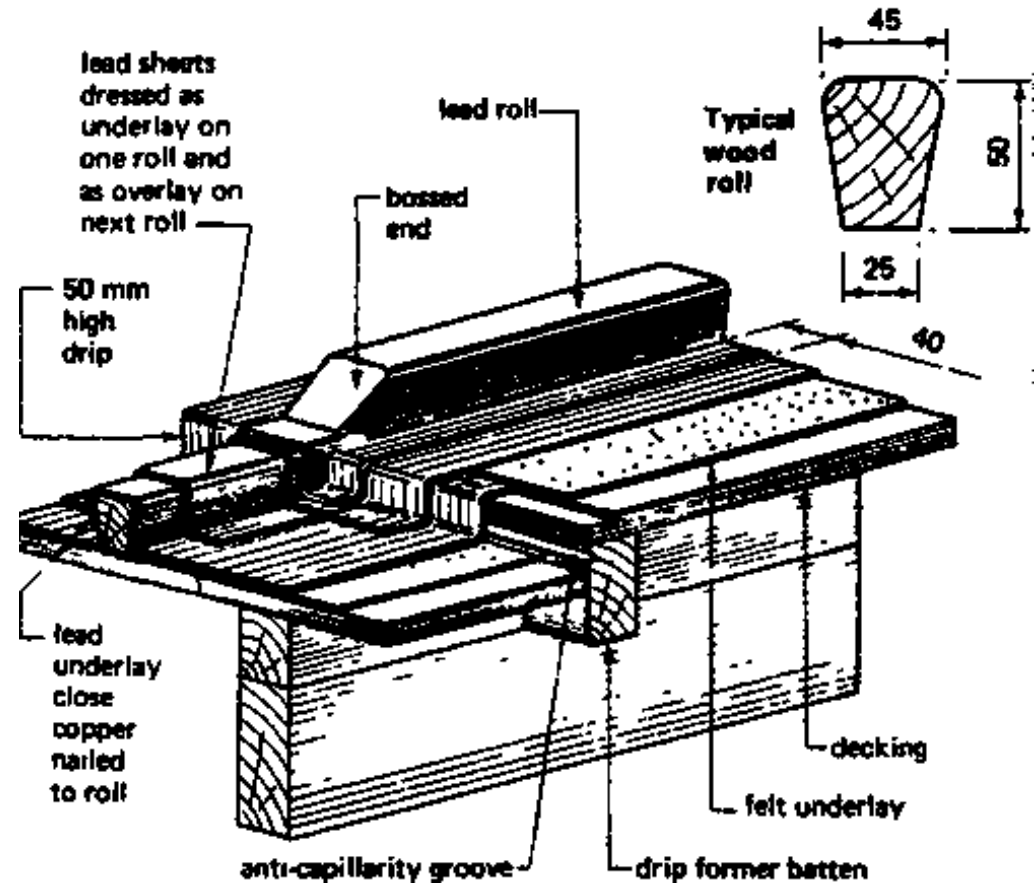

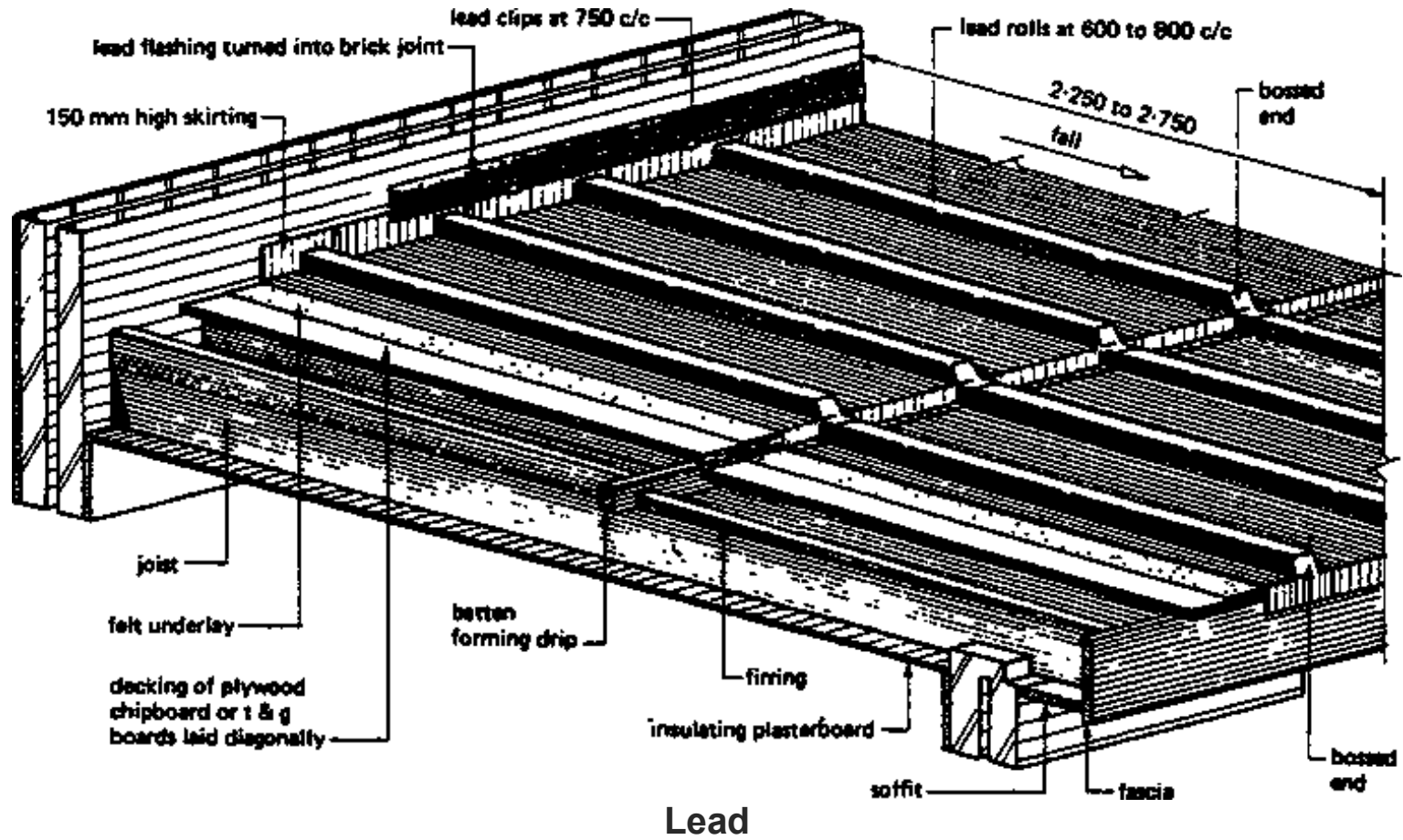

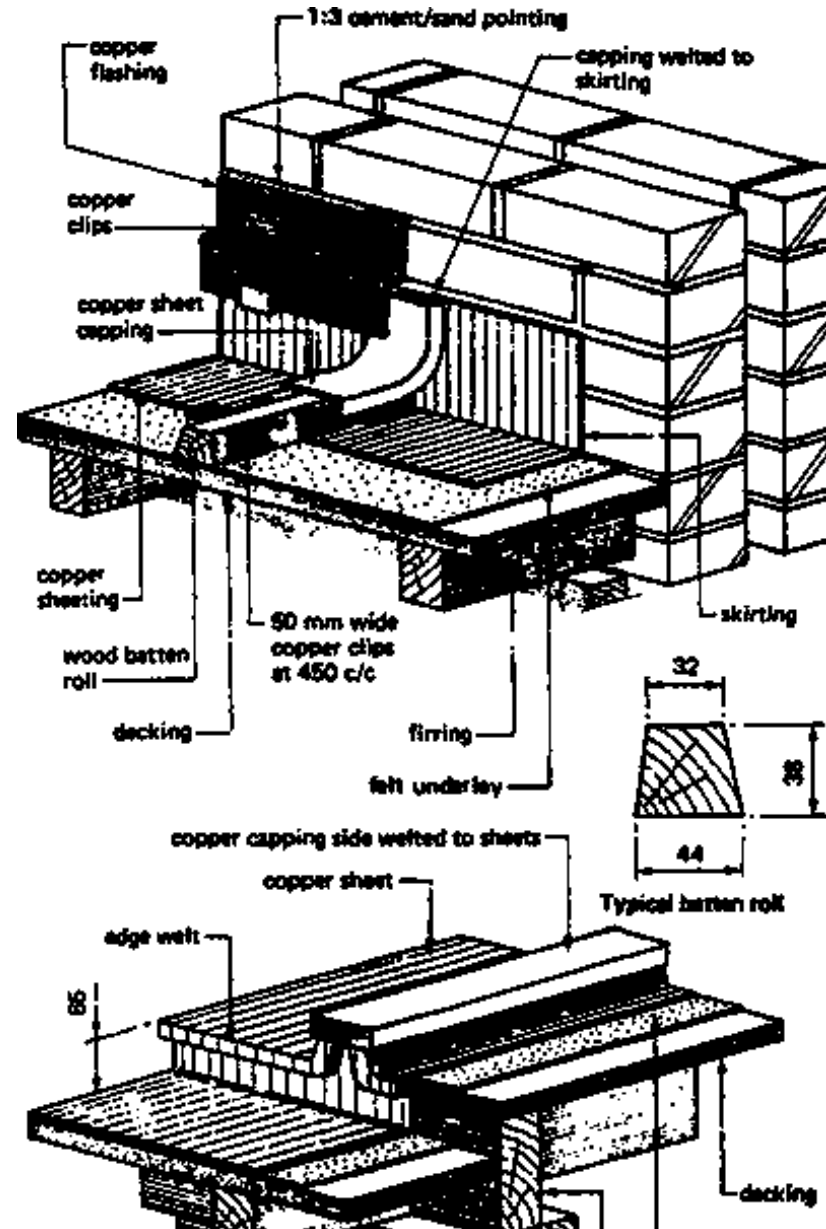

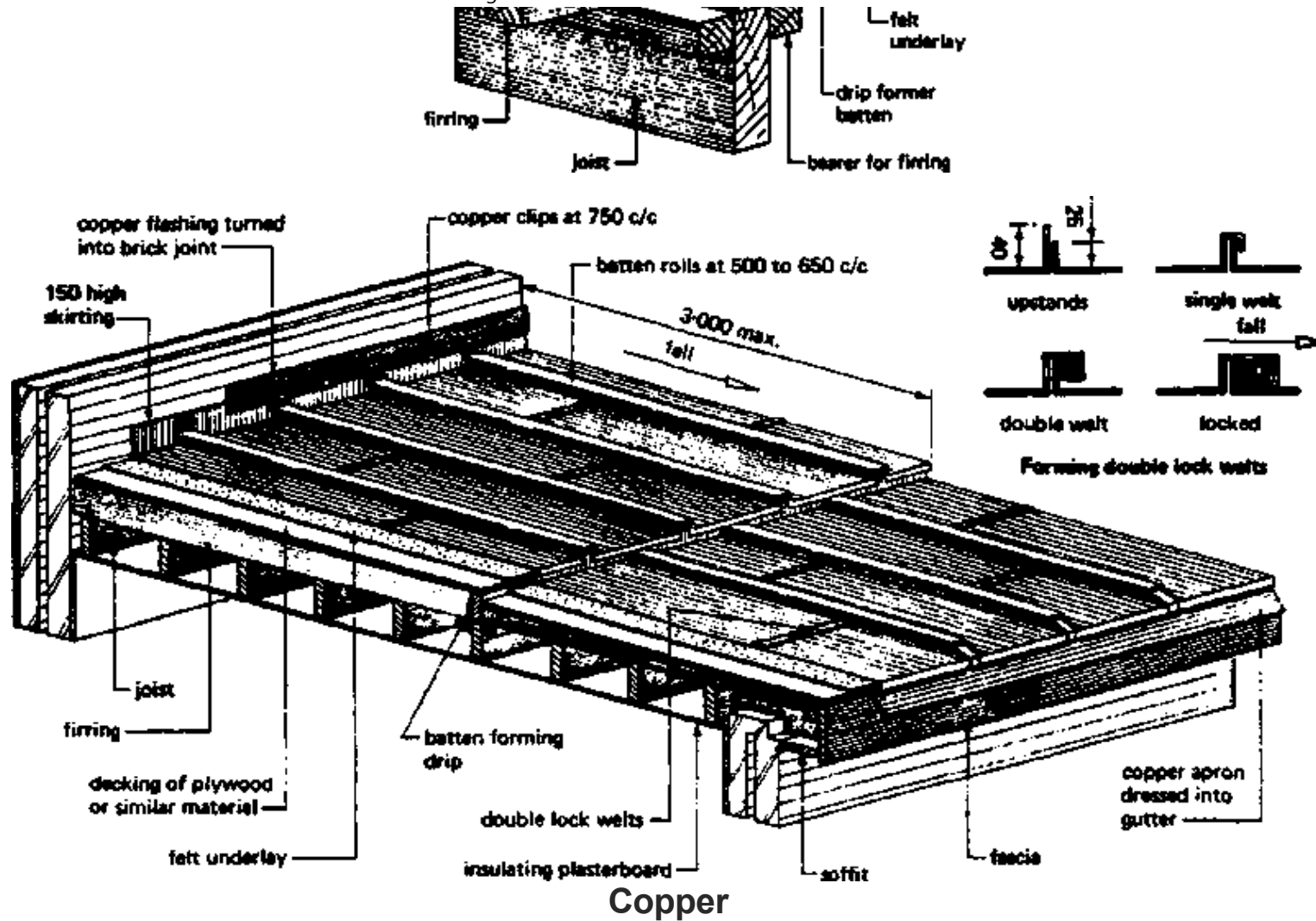

ASBESTOS SHEET COVERING:

LAYING OF THE 2. AND 3. SHEET WITH CORNERCUT



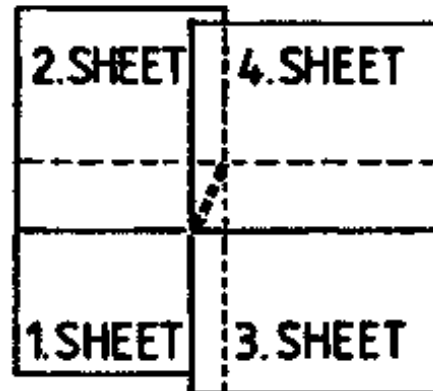
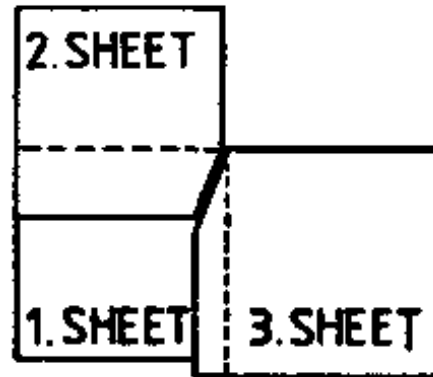
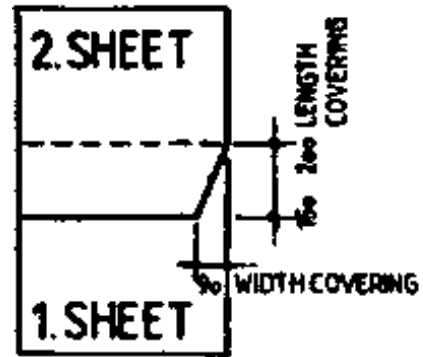

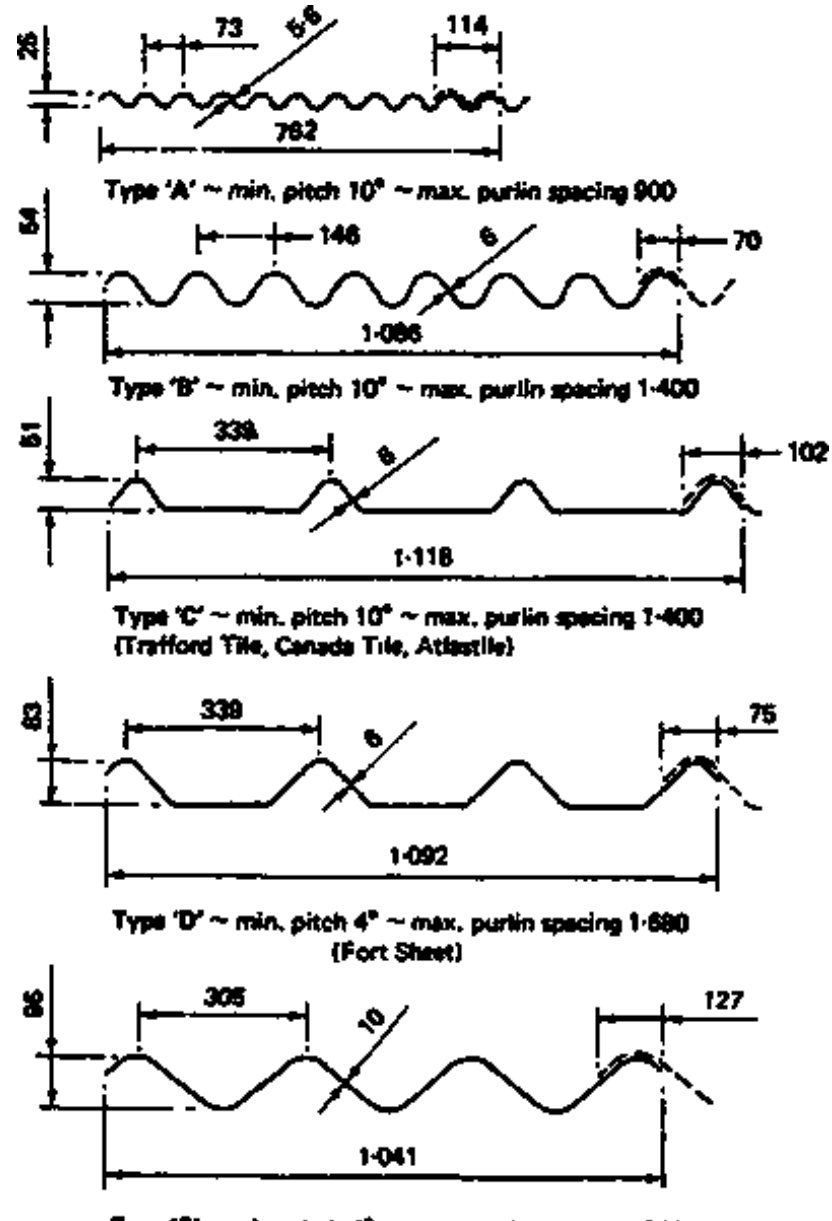

Typical asbestos cement sheet profiles

minimum end lap for all types = 150

All sheets are available in lengths from 900 to 3.000 in 150 mm increments For other profiles see BS 690

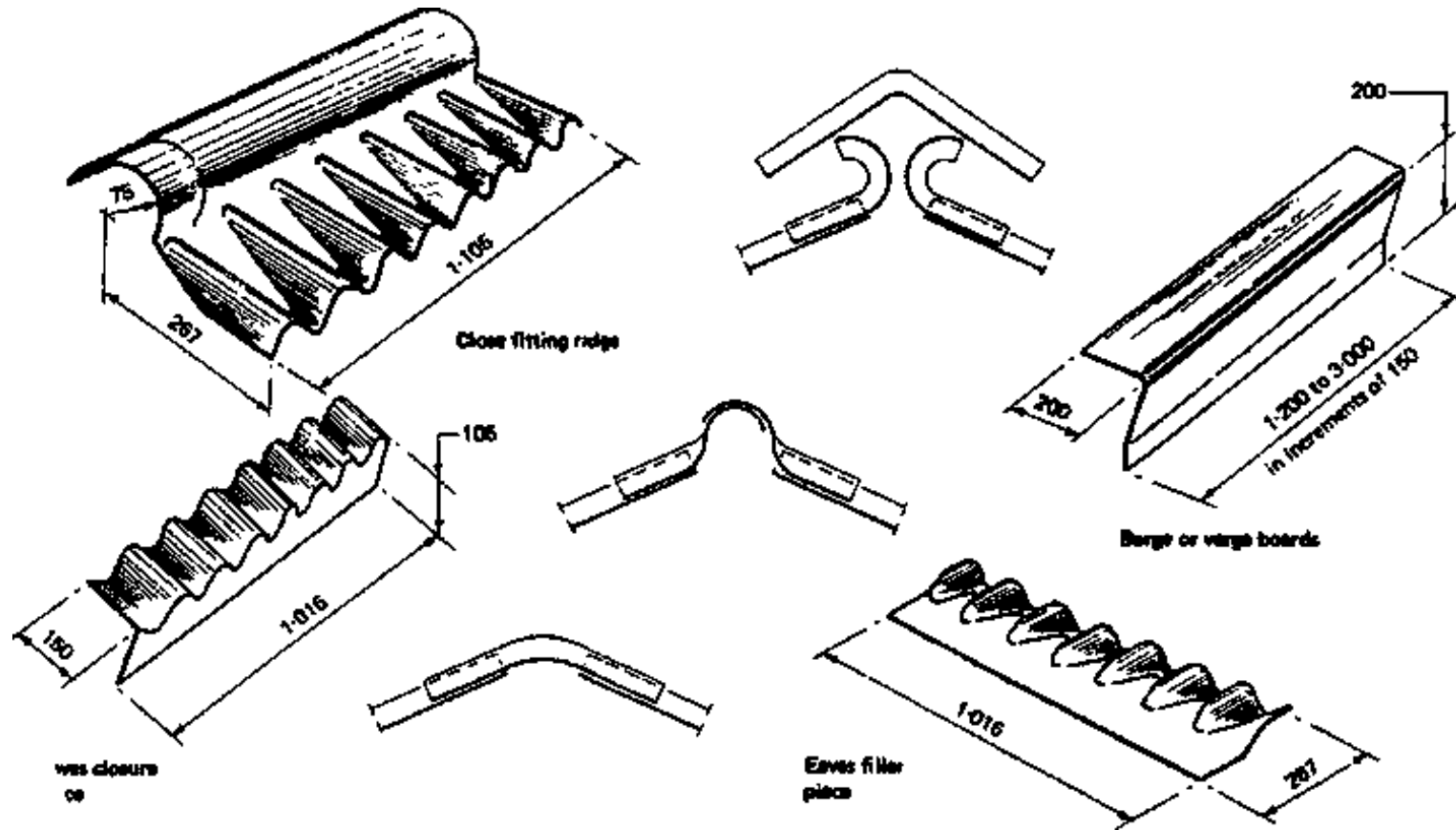

Typical fittings for type 'B' sheeting



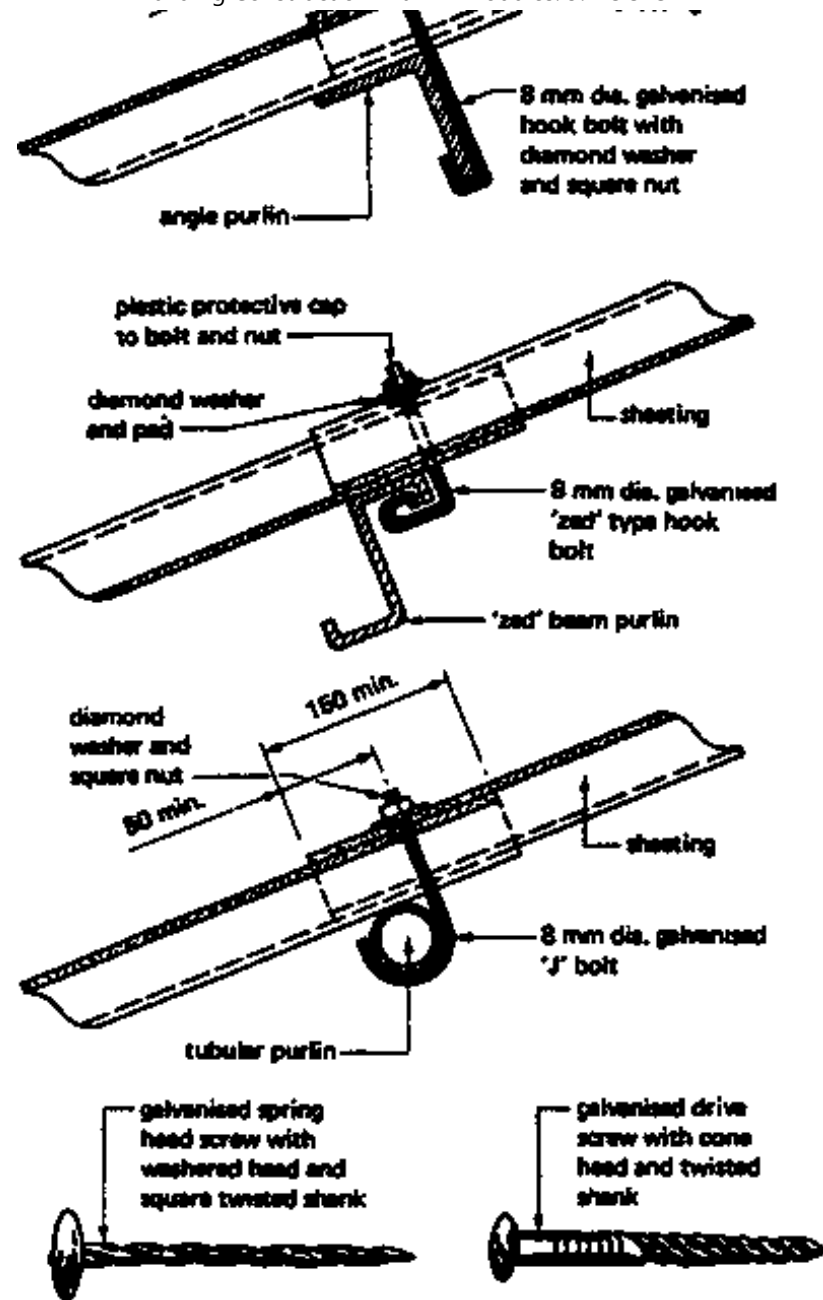

Fixings for timber purlins

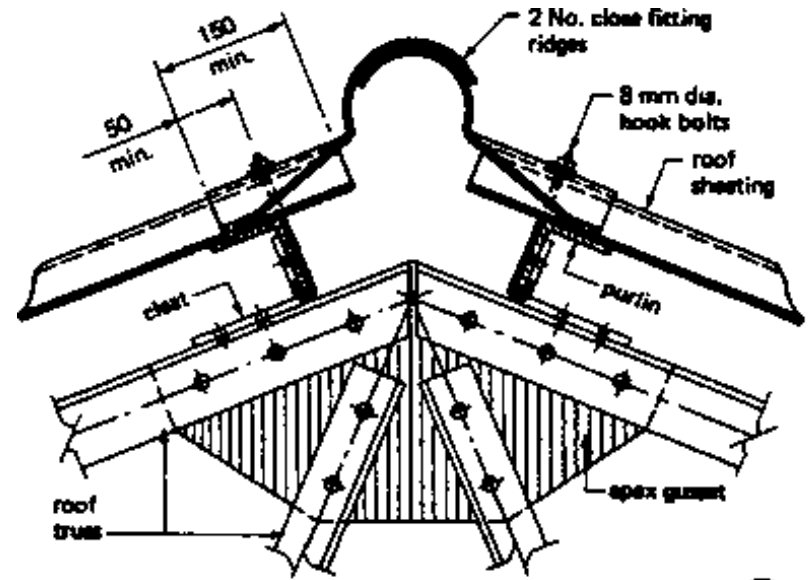

Ridge detail

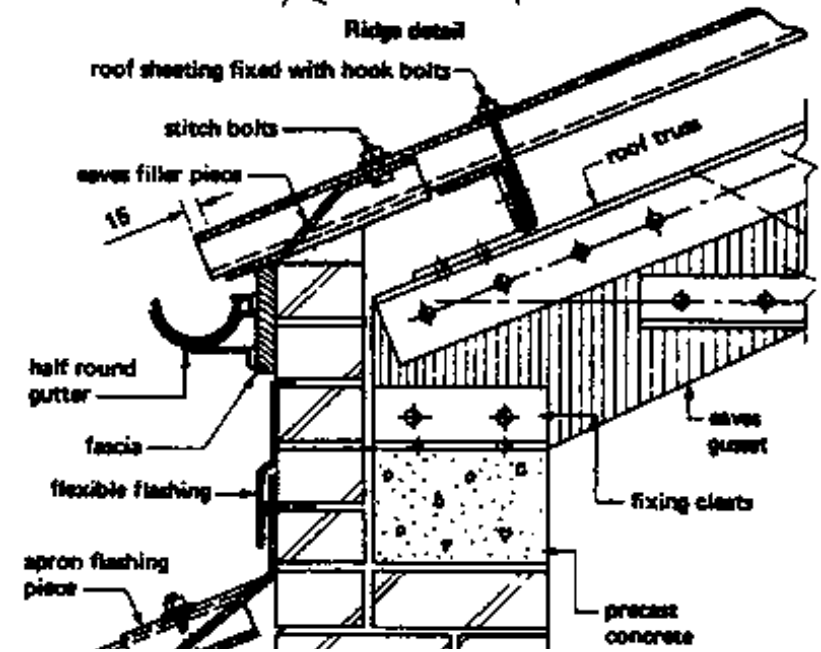



SCALLOPED COVERINGS

- Roofing tiles

a Clay tiles: Hand-made machine-pressed

b Plain concrete tiles:(sand/cement/water, compressed in a mould) are uniform in texture, shape and colour.

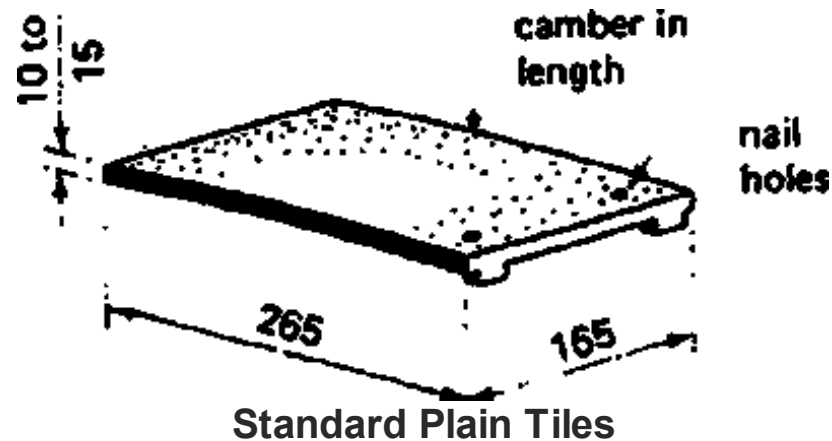

width for tile and half = 248 with 3 no. nibs length for eaves and top course tile = 190

Nibs: either projecting nibs at one end of the tiles, or one continuous nib, in order to secure the tiles to the sloping surface of the roof.

Camber: the tiles are not perfectly flat but have a slight rise or CAMBER in the back to prevent water

Camber. The tiles are not perfectly flat, but have a slight rise or camber in the back, to prevent water being drawn up between the tiles by capillary action.

Gauge and Lap: plain tiles are hung so that at every point on the roof there are at least two thicknesses of a tile.

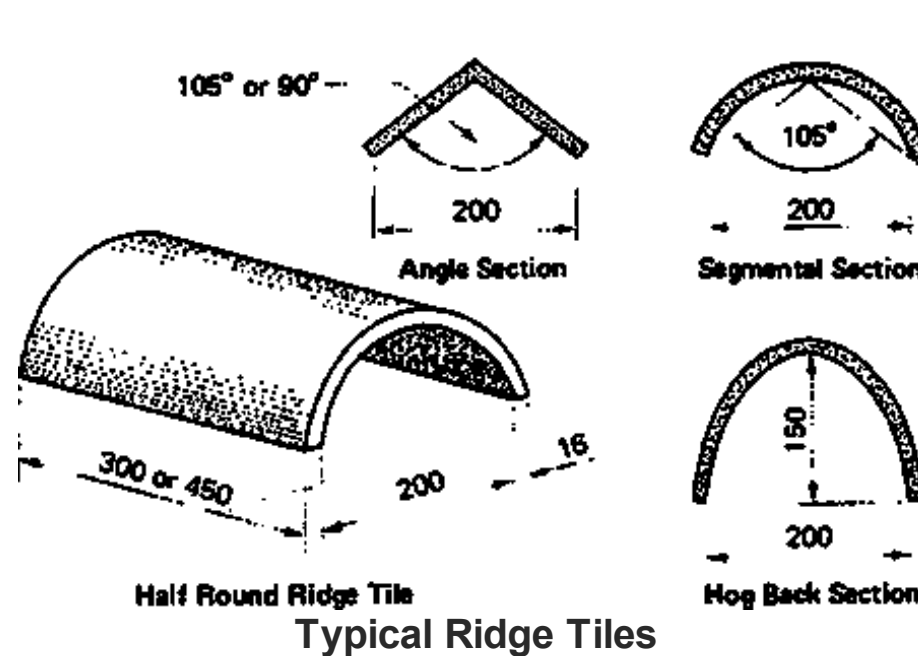

The sides butt together and these joints are bonded up the slope of the roof.

The tiles in every 4th course are nailed to the battens.

In very exposed positions every tile should be nailed to the battens.

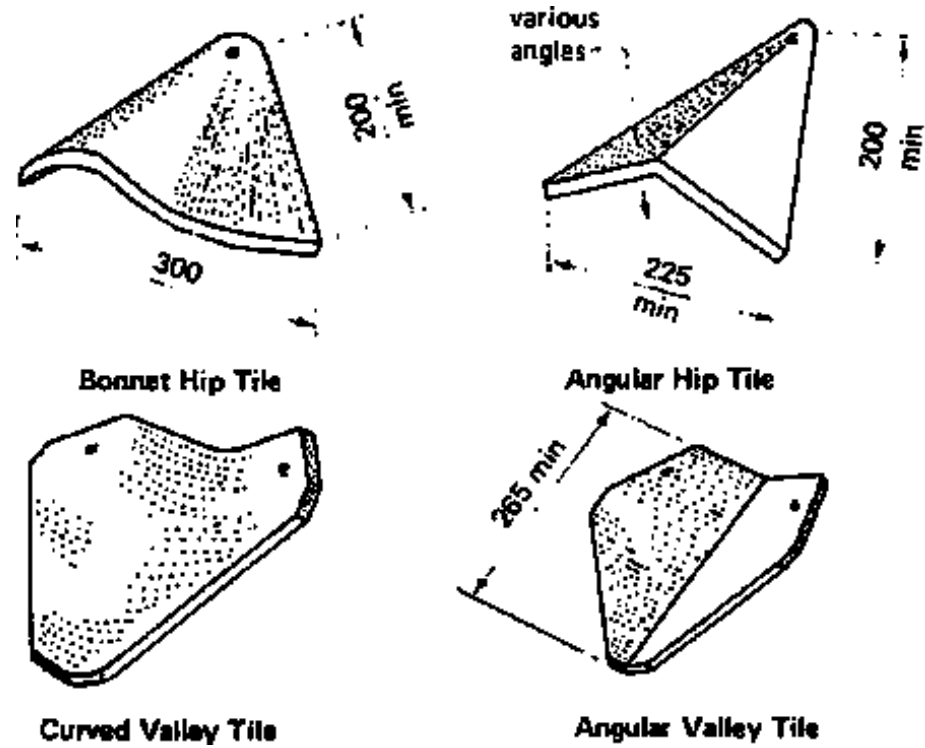

ROOFING TILES

PLAIN TILES ARE LAID TO DOUBLE LAP

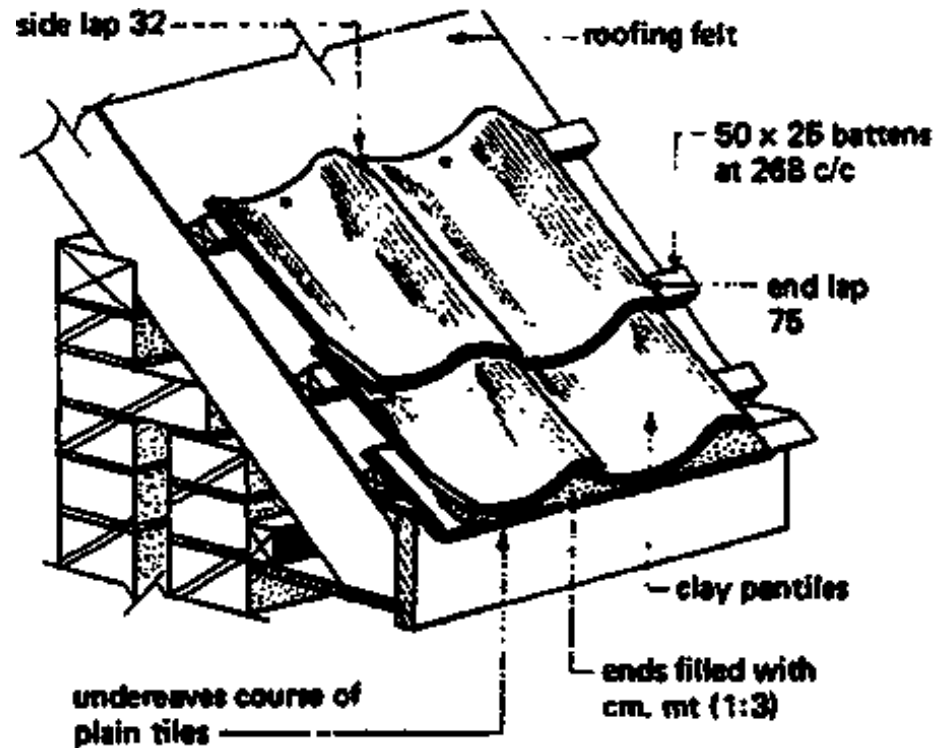

Eaves:

A double coarse overhangs the fascia board some 40 mm.(in order to shed water into the eaves gutter)

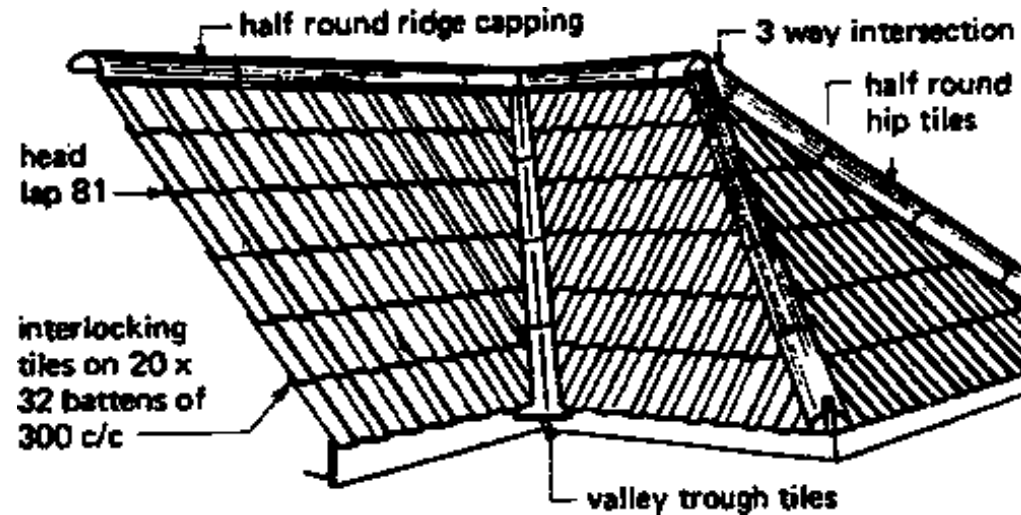

Ridge:

There are 4 standard sections of clay ridge tiles.

- Half round ridge tile
- Seginental ridge tile
- Angle ridge tile
- Hog back ridge tile

All ridge tiles have their edges bedded in fillets of cement mortar spread on the back of the top course tiles.

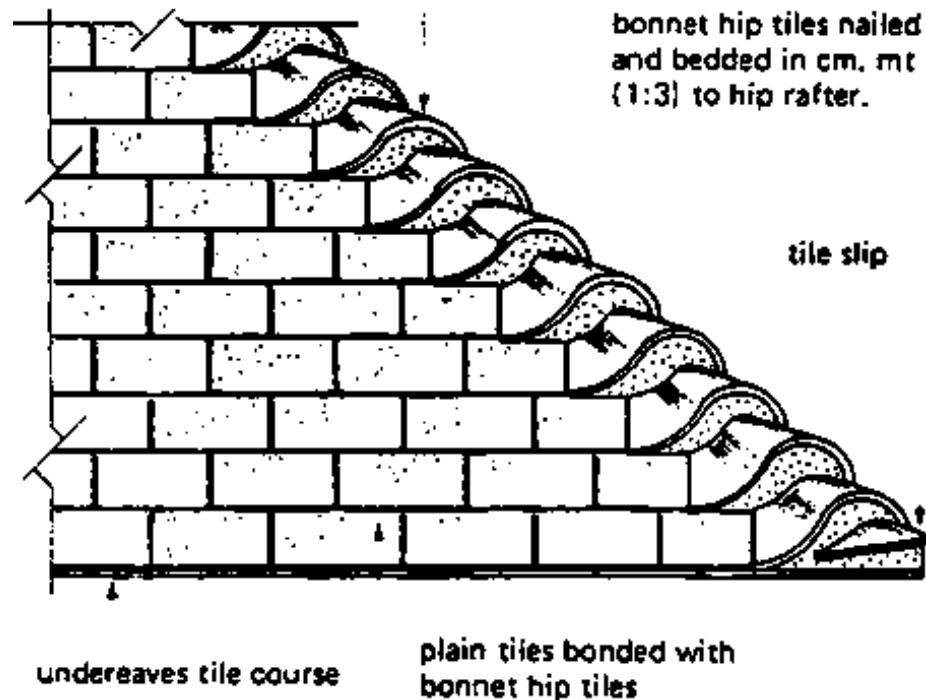

Hips:

May be covered with ridge tiles bedded in exactly the same way as on ridges.

To prevent the tiles from slipping down, a galvanized iron or wrought-iron hip iron is fixed to the hip or fascia.

The tiles next to the hip have to be cut to fit against the side of the hip rafter so that they lie under the hip tiles.

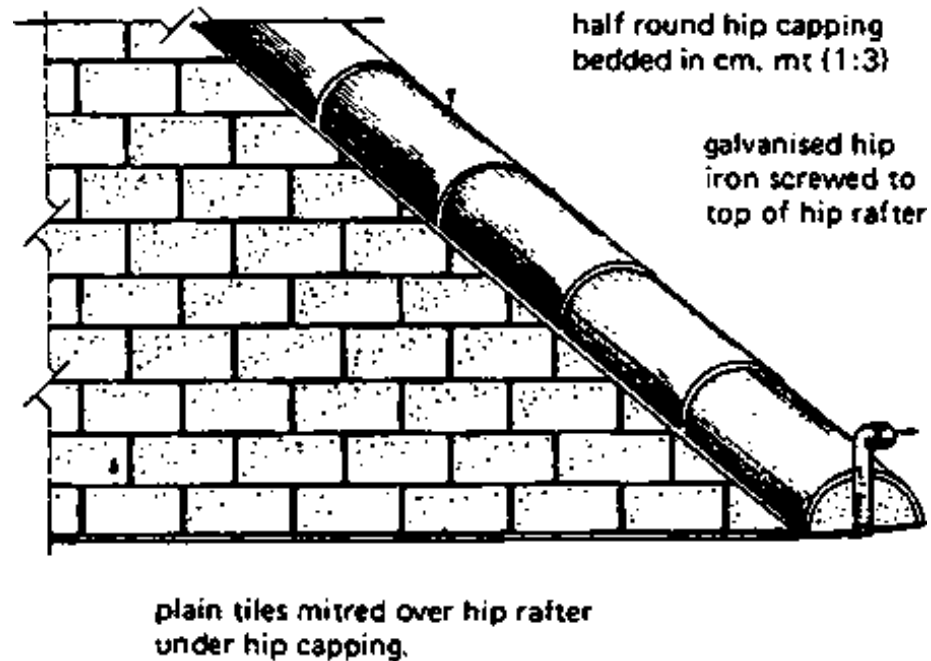

DIFFERENT TYPES

1. PANTILE
2. INTERLOCKING TILE
- 3 PLAIN TILE
- 4 INTERLOCKING PAN
- 5 INTERLOCKING PAN
- 6 INTERLOCKING TILE
- 7 PLAIN TILE, INTERLOCKING
- 8 PANTILE (german)

9 FLATROOF PAN

10 S-TILE

11 'FRANKFURTER' PAN (concrete)

12 DOUBLE-S PAN (concrete)

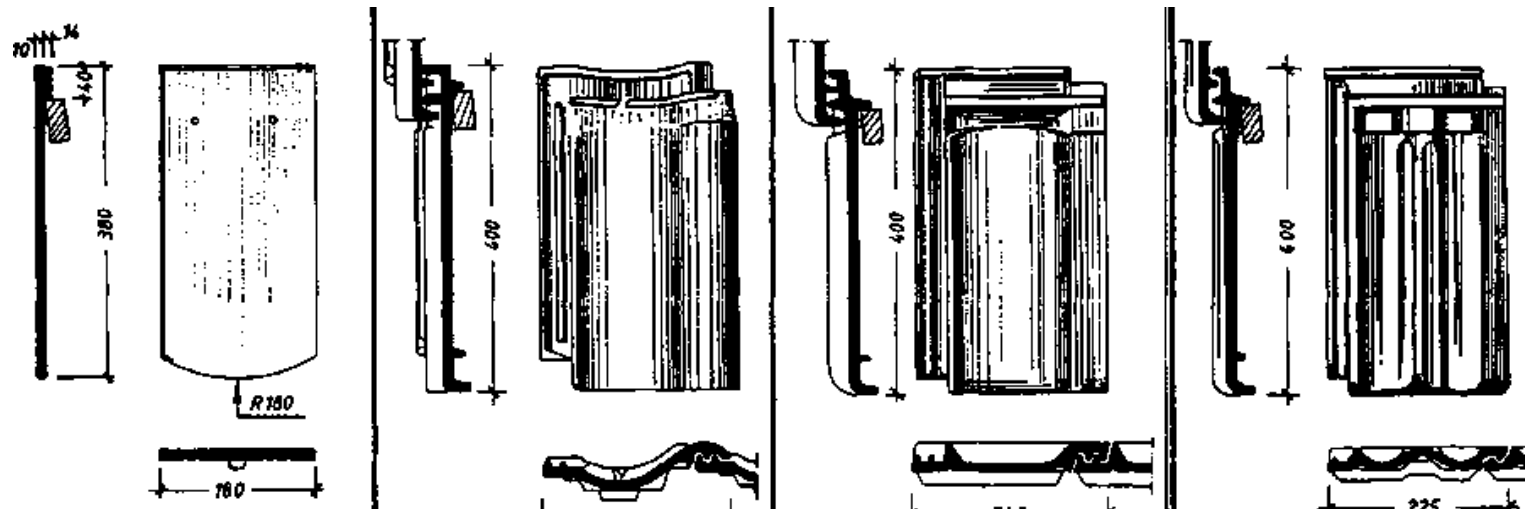
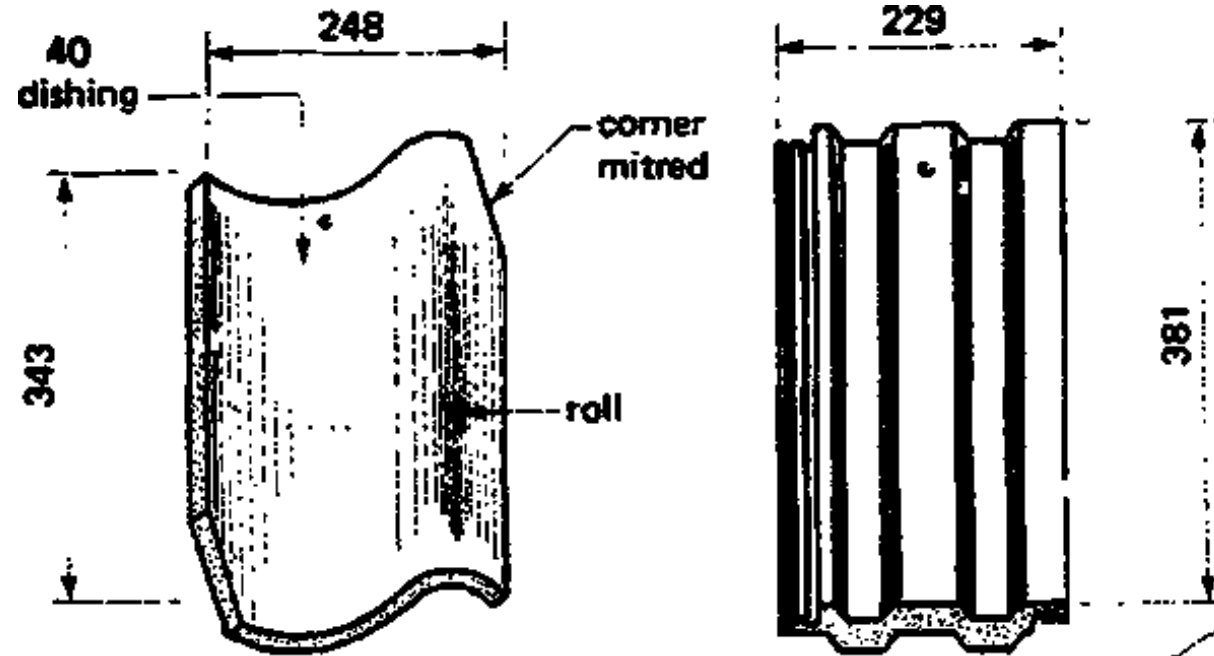

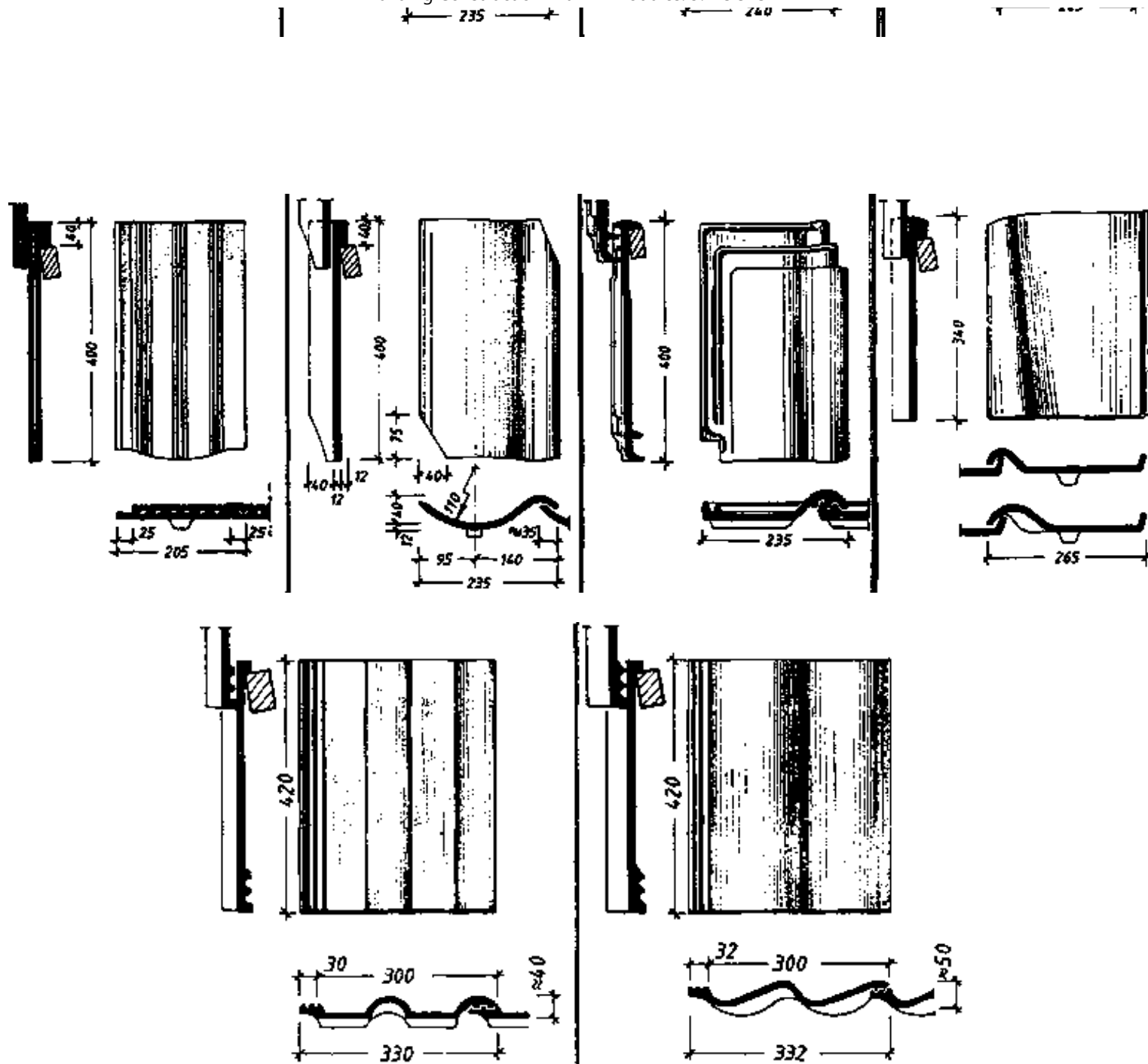

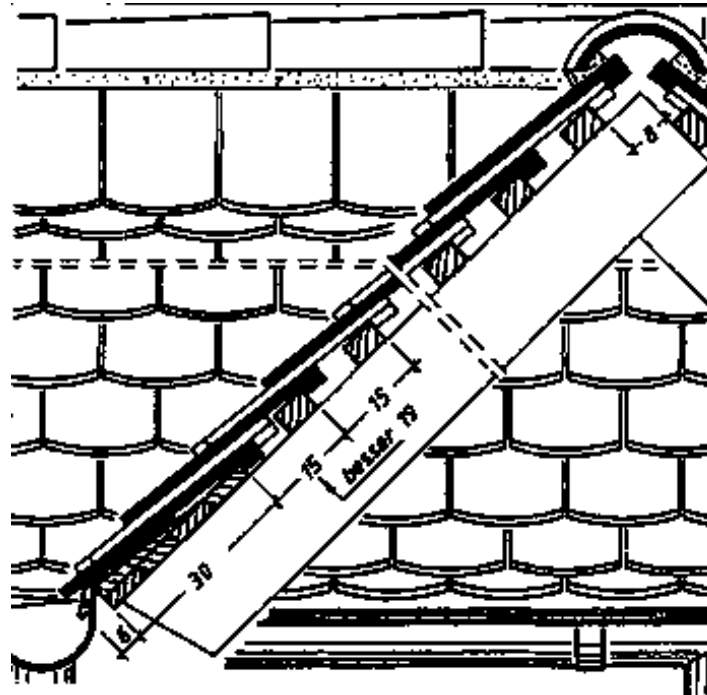

BEAVERTAIL DOUBLE COVERING

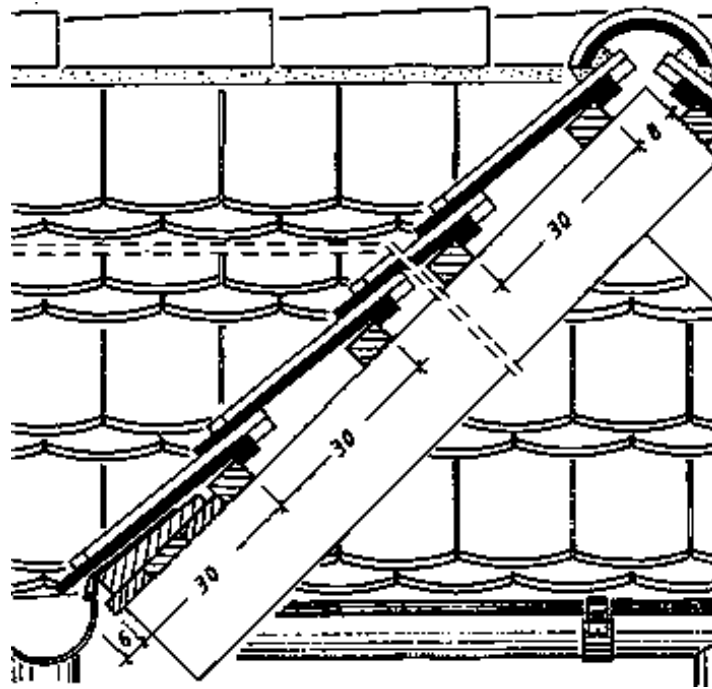

BEAVERTAIL CROWN COVERING

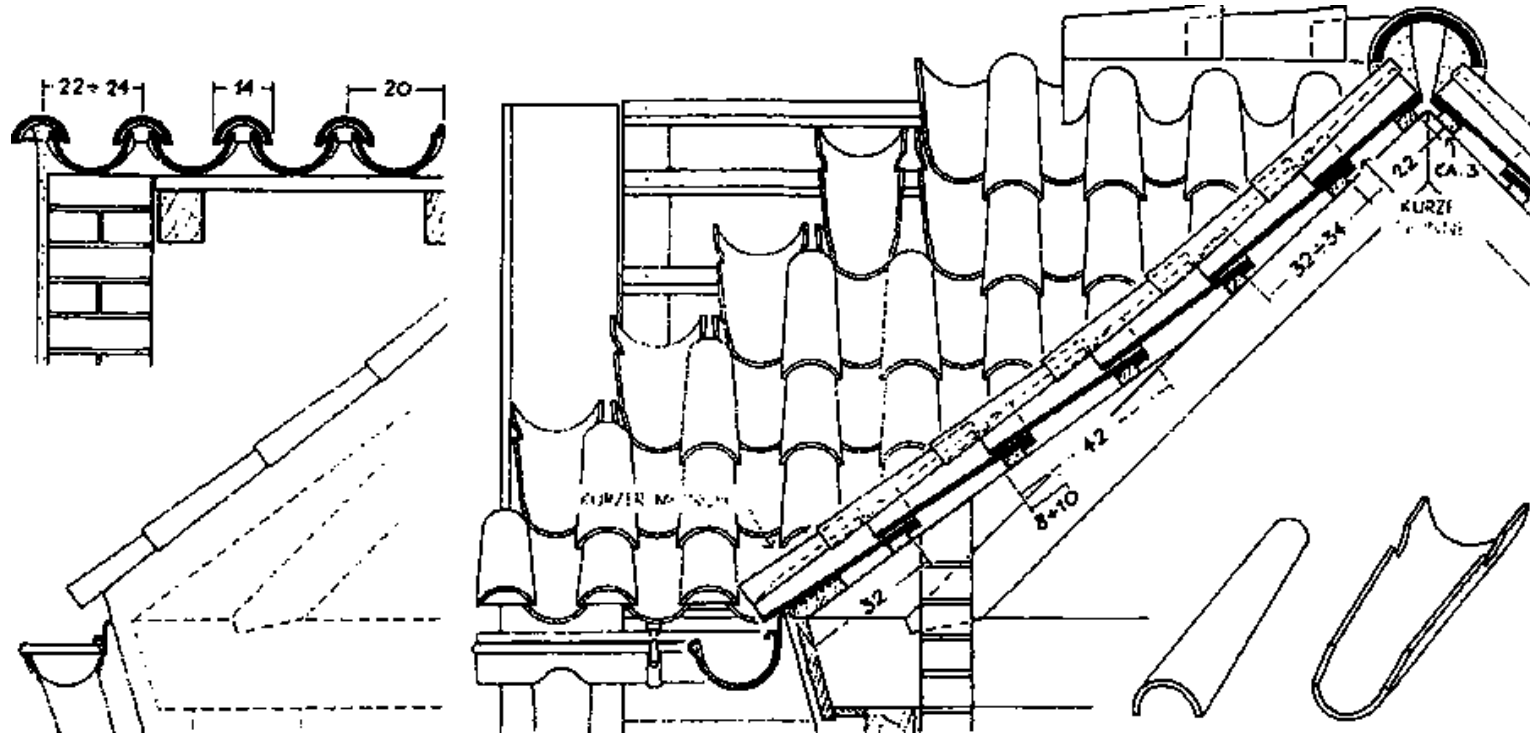

ROMAN TILE COVERING

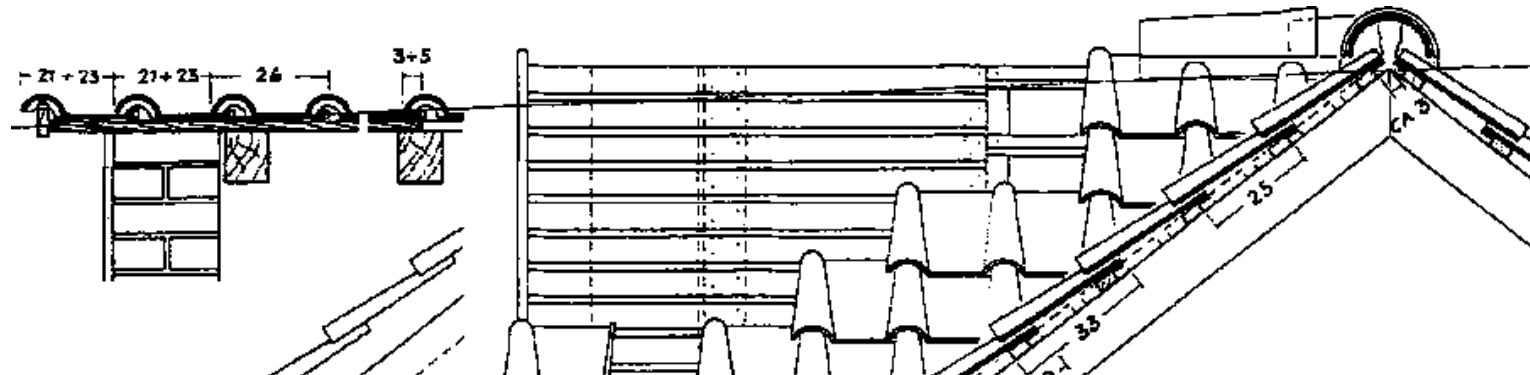

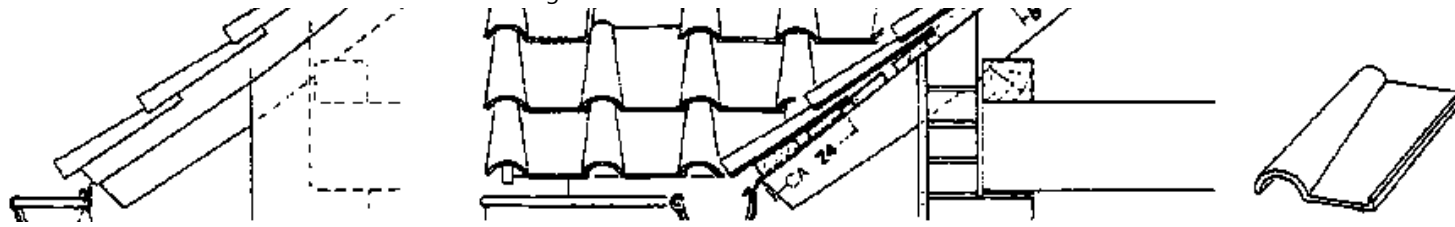

S-TILE COVERING

SLATES

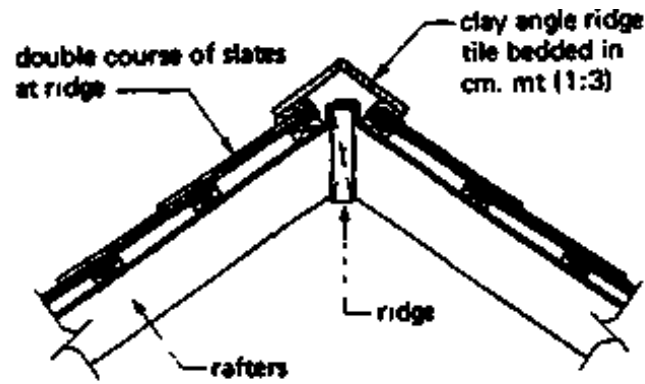

Typical Ridge Detail

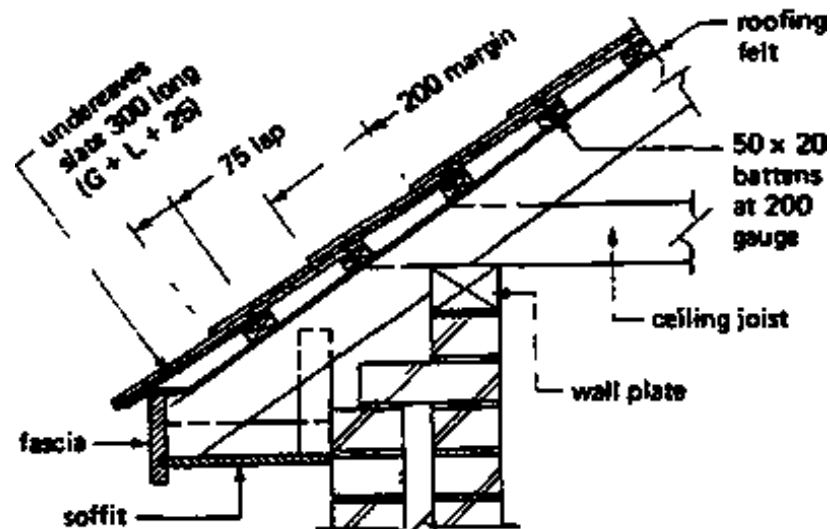

Head Nailed Slating Using 500 × 250 slates

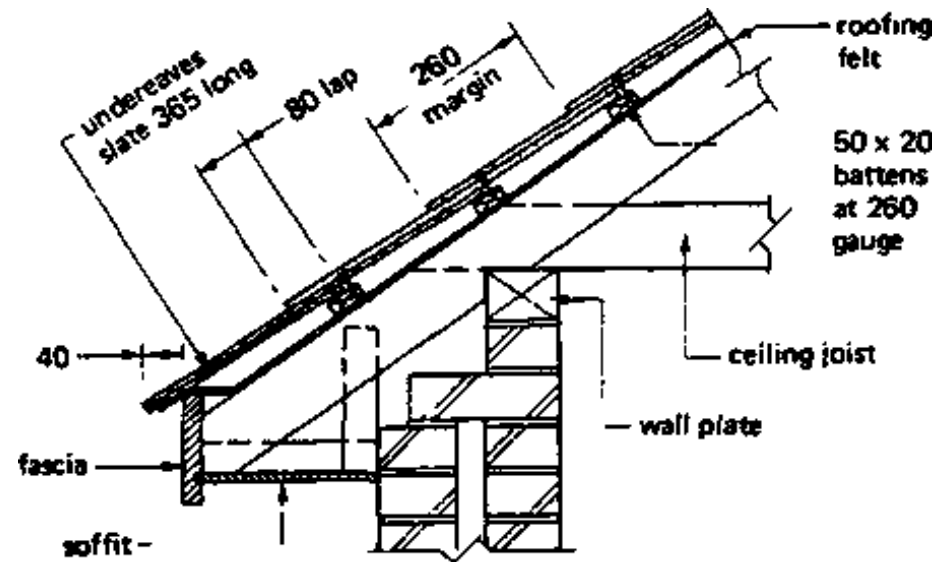

Centre Nailed Slating Using 600 × 300 slates

ASBESTOS SLATES

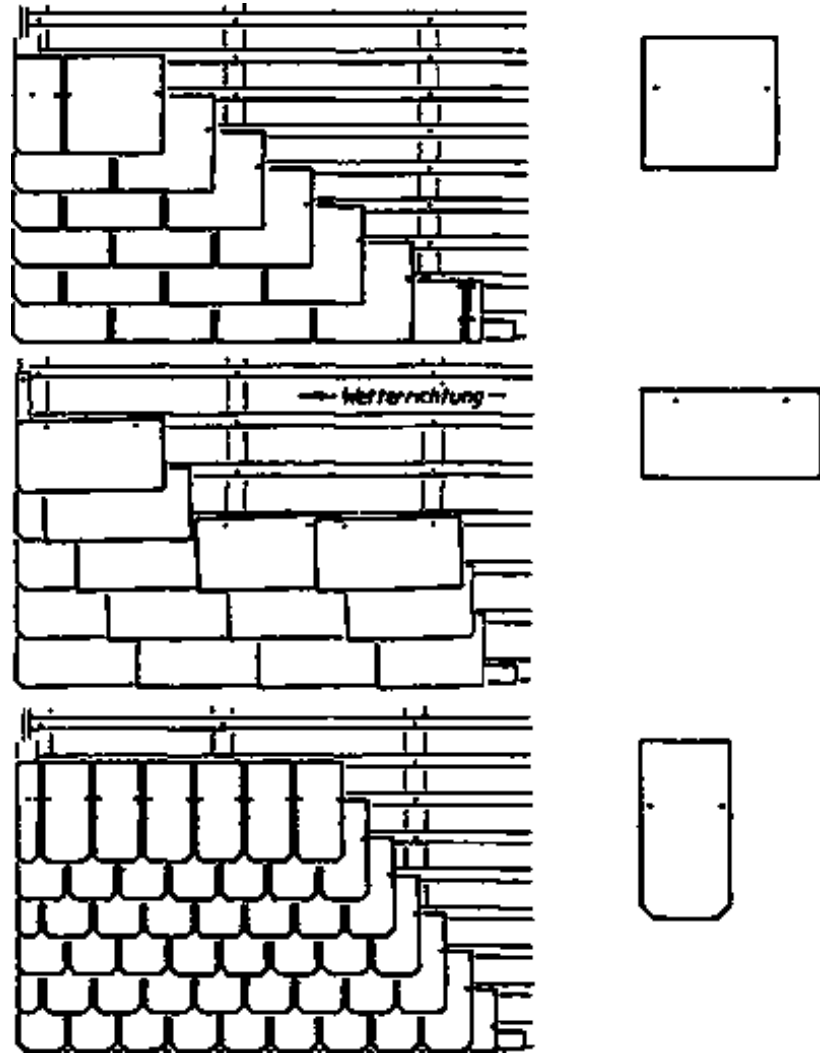

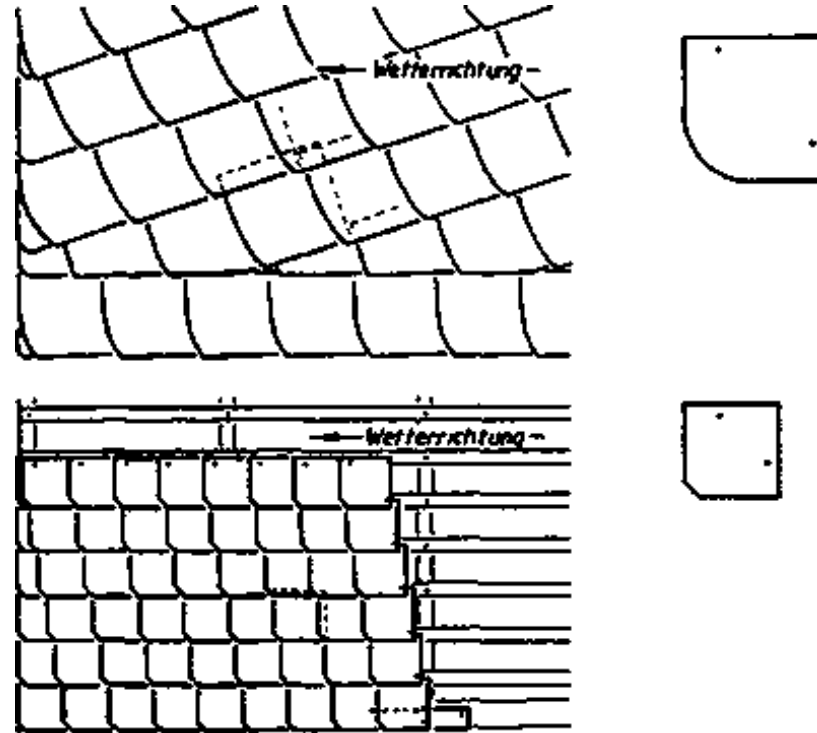

SHINGLES

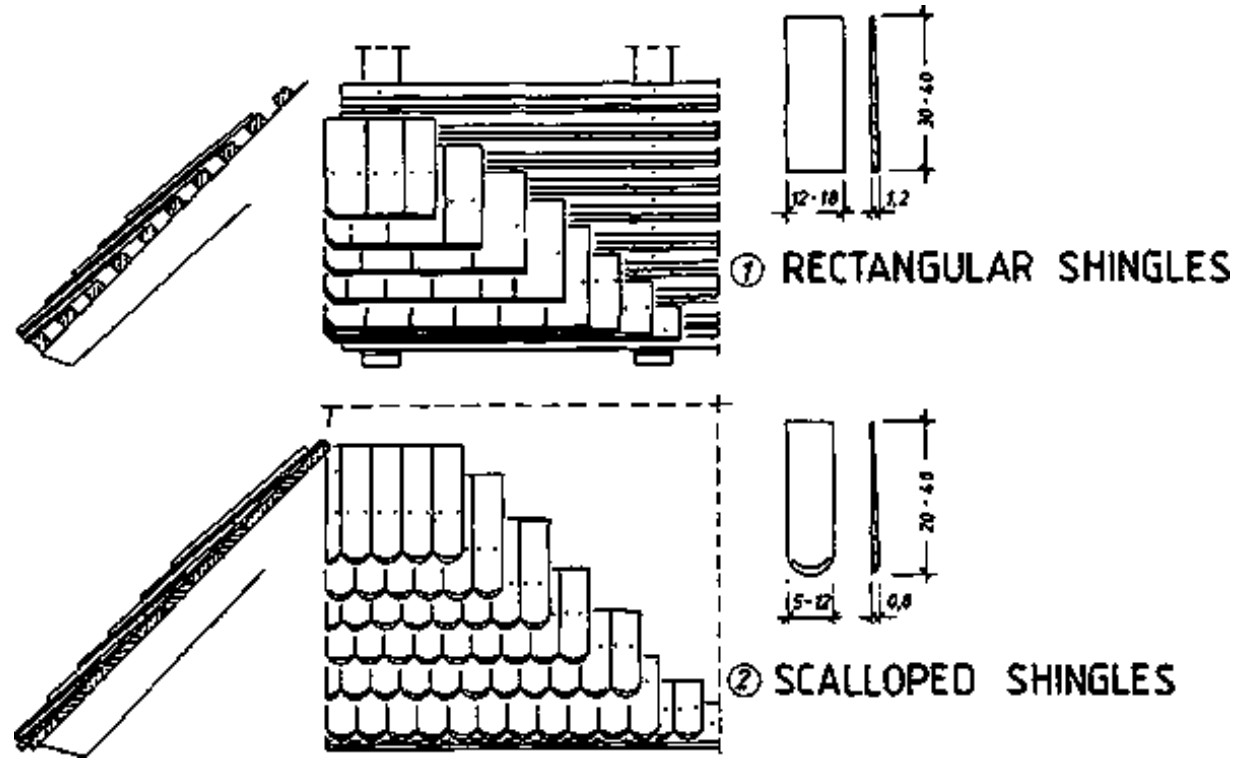

THATCH COVERINGS

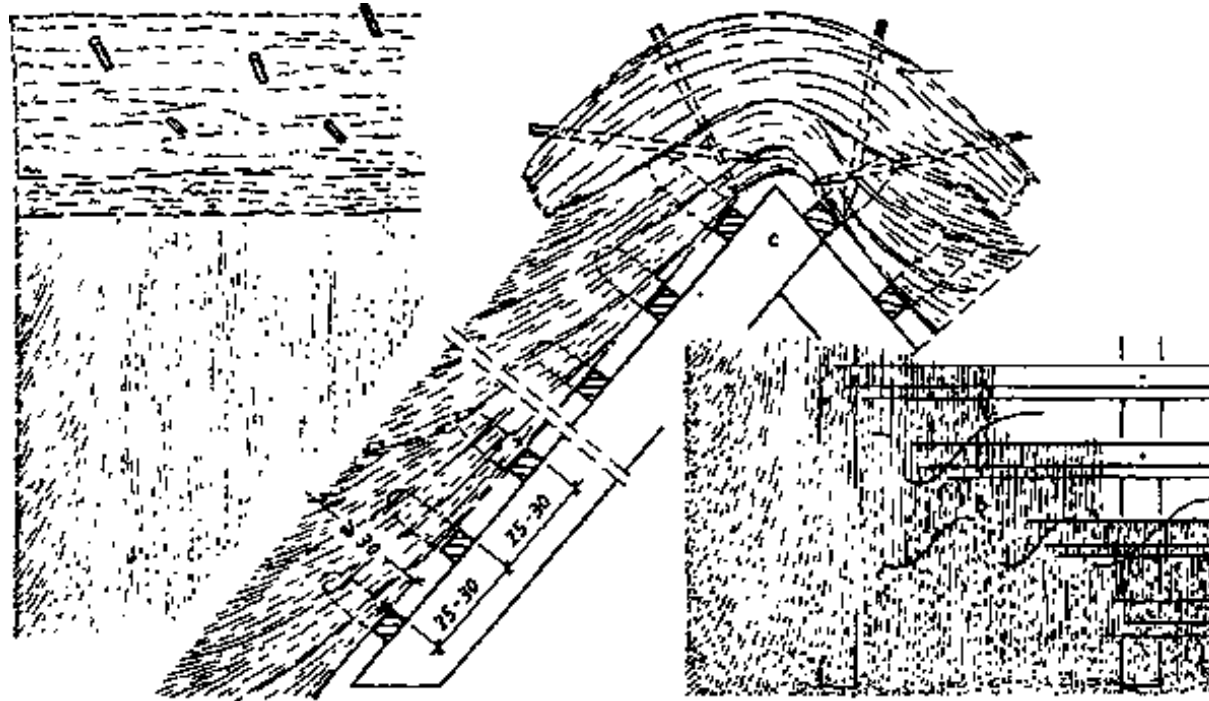

REPETITION • exercises • REPETITION

Try to answer the following questions and use sketches where ever necessary and possible

9.1 What are the main functions of a roof?

List the requirements the roof must satisfy to fulfil its functions efficiently and explain briefly the importance of these requirements.

9.2 Explain the terms:

9.2 Explain the terms:

- Roof structure, and
- 'skin' of the Roof

Classify the different types of roofs in three different ways

Define the following terms:

- Flat roofs
- pitched roofs
- two-dimensional roof structures
- three - dimensional roof structures
- single roof construction
- double roof construction
- triple roof construction
- long span roofs
- medium span roofs
- short span roofs.

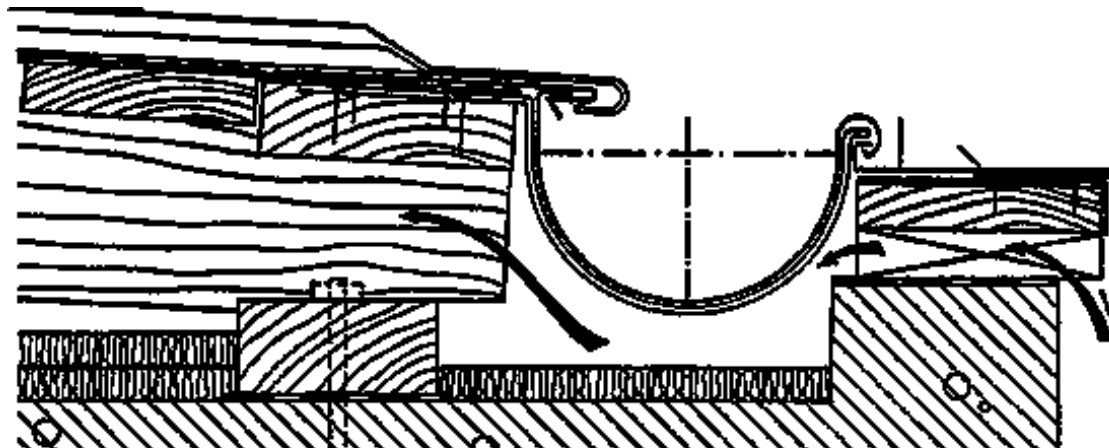

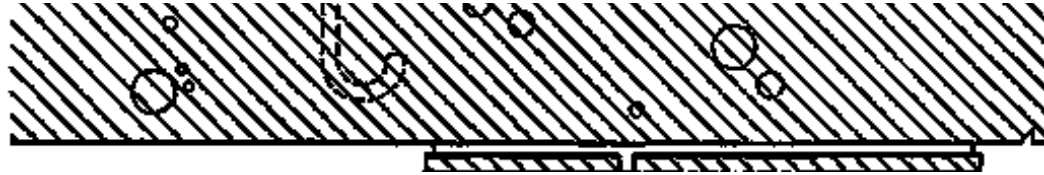

9.3 Write notes on Plat Roofs, explaining

- the structure of a flat roof
- thermal insulation materials
- single and double roof construction
- reinforced concrete flat roofs timber flat roofs
- parapet walls

and use sketches for illustration.

9.4 Write notes on Pitched Roofs, explaining

- the types of pitched roofs according to the shape of the roof
- the types of pitched roofs according to the structure of the roof

and use sketches for illustration.

Explain the following terms briefly:

- gable
- gable parapet
- verge
- hip
- hipped end

- vally
- ridge

Referring to truss construction in timber, compare the three modern methods of joining the members:

- nailed joints
- bolt and connector joints
- glued joints

and describe their advantages and disadvantages.

Show by means of neat sketches examples of

- open projecting eaves and
- closed projecting eaves

Write notes on Openings in timber roofs, including DORMER WINDOWS. Use sketches for illustrations.

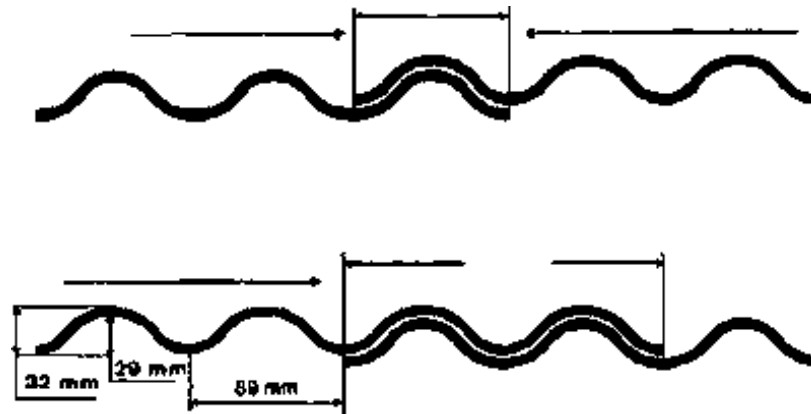

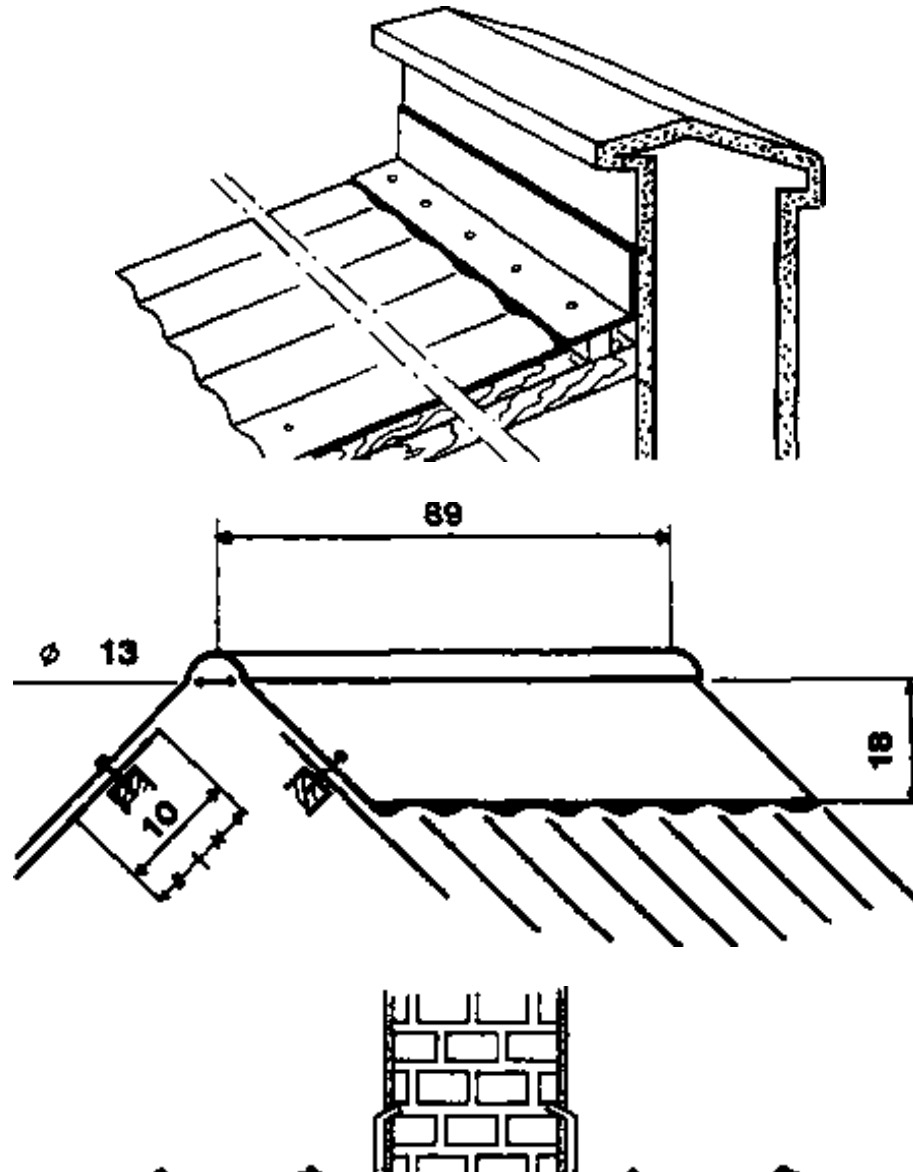

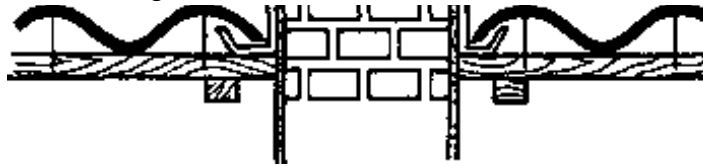

9.5 Classify the different types of roof coverings

What sort of covering materials may be used for the above listed types of roof coverings?

Explain - by means of sketches - different types of substructures depending on the 'skin' covering the roof.

Write notes on the choice of roof coverings and explain in the form of a diagram the interdependency of the pitch of the roof and the covering material.

Show - by using sketches for illustration - covering methods for different sorts of materials, such as:

- one -, two-, three-, layer table covering
- asbestos sheet covering
- covering with roofing tiles
- covering with slates
- covering with asbestos plain tiles
- covering with shingles
- thatch covering
- sheet metal covering

[Please provide your feedback](#)

[English](#) | [French](#) | [Spanish](#) | [German](#)