

[Home page](#) | [Help](#) | [Clear](#)

[English](#) | [French](#) | [Spanish](#) | [German](#)

[Search](#) | [Subjects](#) | [Titles A-Z](#) | [Courses](#) | [Illustrations](#) | [Topics](#) | [e-Course builder](#)

 Full TOC

 Expand Document

 Contract Chapter

 Add to e-Course

 Preferences

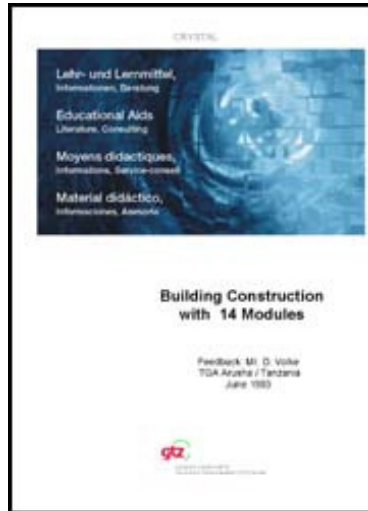

























Printable version

Export document
as HTML file [Help](#)

Export document
as PDF file

Building Construction with 14 Modules (TCA; 1983; 618 pages)

-  1. ARCHITECTURAL DRAWING I
-  2. ARCHITECTURAL DRAWING II
-  4. CONTRACT PLANNING AND SITE ORGANISATION
-  5. FOUNDATIONS
-  6. WALLS
-  7. FLOORS
-  8. OPEN FIREPLACES, CHIMNEYS AND FLUES
-  9. ROOFS
-  10. FRAMED STRUCTURES
-  11. PROTECTION OF BUILDINGS
 -  11.1 EXCLUSION OF WATER
 -  11.1.1 PRECIPITATION
 -  11.1.1.1 Roof Drainage
 -  11.1.1.2 Flooding
 -  11.1.1.3 Drought
 -  11.1.2 DAMP RISING AND MOISTURE MIGRATION
 -  11.1.3 CONDENSATION
 -  11.2 THERMAL INSULATION

-  **11.2.1 DEFINITION**
-  **11.2.2 INSULATING MATERIALS**
-  **11.3 SOUND INSULATION**
 -  **11.3.1 DEFINITION**
 -  **11.3.2 SOUND INSULATION**
 -  **11.3.3 EXTERNAL NOISE**
-  **11.4 FIRE PROTECTION**
 -  **11.4.1 STRUCTURAL FIRE PROTECTION**
 -  **11.4.1.1 Fire Load**
 -  **11.4.1.2 Fire Resistance of Material**
 -  **11.4.1.3 Appropriate Types of Construction**
- 12. FINISHING & FINISHES**
- 13. STAIRS**
- 14. DOORS & WINDOWS**

11. PROTECTION OF BUILDINGS

REFERENCES:

- 1. R. L. Fullerton, "Building Construction in Warm Climates", Vo. 2, 3**
- 2. Peter Burberry, MITCHELL, S BUILDING SERIES, "Environment and Services"**
- 3. R. Chudley, "Construction Technology", Vol. 2, 3**

11.1 EXCLUSION OF WATER

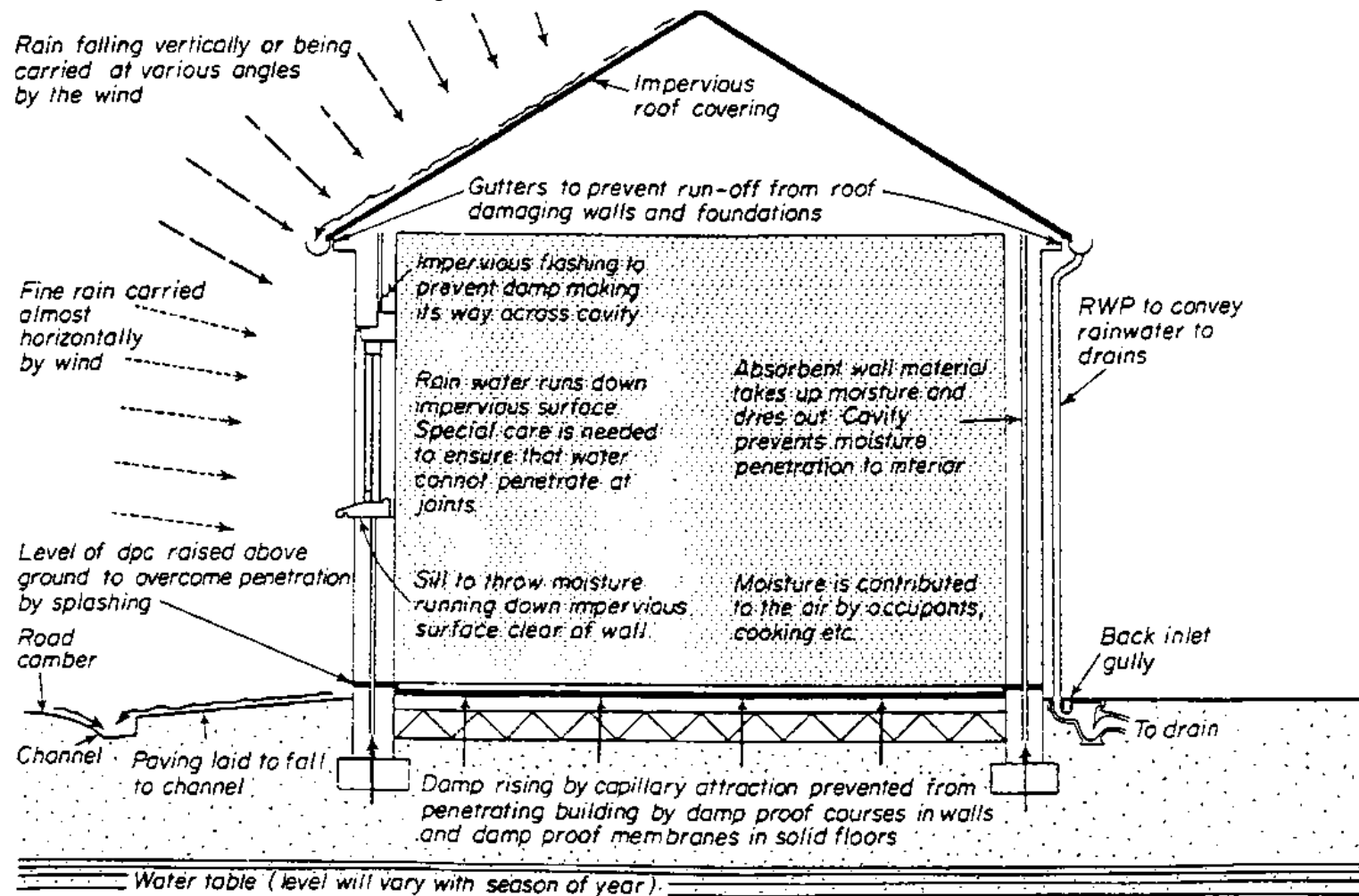

PENETRATION OF WATER

WATER in its free liquid form must be totally excluded from the interiors of buildings and its presence as **VAPOUR** in the air or as **MOISTURE** content of building materials must be controlled to within acceptable limits.

The shrinkage and swelling of soil, the effect of moisture on vegetation, and the water-retaining properties of soils all affect foundation design.

Combinations of soils and water are responsible for the settlement of buildings, cracking, shrinkage, decay, damp disease, chemical attack, subsidence, and landslides.

Moisture in buildings comes from three main sources:

I Precipitation as rain

II Damp rising from the ground through building materials by capillary attraction or as vapour.

III Condensation upon cold surfaces of humidity from the air.

In addition condensed droplets in the air (fog) can be carried by wind to wet the surfaces of the building and to penetrate joints and materials.

The relative humidity of air in buildings can be a critical factor in governing thermal comfort since it influences the ability of the body to lose heat.

11.1.1 PRECIPITATION

The frequency of rainfall is well recorded by weather stations every where, and, despite local variations, the designer usually knows what to allow for. In determining open channel and gutter sizes the annual rainfall is not so important as the actual period of the storm and its intensity.

Run-offs can also be hampered by insufficient fall, blockage, damage through traffic, or a sewage system which is simply too small. Soakaways should be large enough to accommodate sudden storms and should also have a separate drainage system.

The construction of soakaways may be governed by local authorities, who sometimes have a standard layout.

Rainfall statistics in the tropics rarely give an adequate picture of the combined effects of rain, wind, and freak storms. Achieving a perfect match of weather and buildings is not often possible, owing to variations both in exposure and in the performance of the structure itself. These latter may be due to detailing, materials, the size of components, workmanship, and other such factors. And again, rain does not wet walls in the absence of wind. Storms, however, frequently drive rain horizontally and even upwards under balconies and ventilators.

11.1.1.1 Roof Drainage

The most likely source of trouble from water is the roof. Built-up felts, flat roof overflow, rainwater wall streaking, expansion, imperfect flashing, felt blistering inaccurate flow-load calculations incorrect size of large valley gutters, outlets, and r.w.p.s. are common causes of failure. Plastic pipes and gutters also need flexible joints to accommodate thermal movement. Areas subject to sudden storms should have adequate disposal capacity. Ground aprons which take roof discharge direct should have suitable collection channels with sufficient fall, and should be free of blockage and provide easy access to soakaways and drains.

11.1.1.2 Flooding

In coastal areas especially flooding is a common occurrence. The extent of damage will depend on the nature of the foundations, the degree of buffeting by the elements, the degree of expansion of soils, erosion, settlement, and cracking. Services, including electricity, may be impaired, plasterboard ruined, timber and plywood split and warped.

After draining or pumping, it may be necessary to punch holes in the lowest areas and remove water trapped in underfloor ducts, pits or cavities. Ventilators and similar openings may have to be cleared of

mud. Sea-water flooding can cause erosion of metals, concrete, and lime. Drains should be inspected before use; and one unpleasant effect could be due to backwash, particularly where cesspits and septic tanks are in use. Having cleaned up as well as possible, doors, windows, and vents should be opened and everything should be done to create maximum air flow through the building.

11.1.1.3 Drought

In hot dry climates where living conditions have been adapted to the environment low annual rainfall is not considered as drought. In such circumstances a building is made to combat excessive sunshine, heat, wind, and dust storms. Sanitary services are either designed to be able to cope using the water-supply available, or other means of disposal are used.

Drought in areas of reasonable rainfall and humidity can have serious effects. Shrinkage and settlement, with resulting craking and bleaching of exposed finishes can occur. The building and its environment will deteriorate where maintenance depends on a supply of water, not to mention the unpleasantness and distress caused by the depletion of the supply. What is sometimes described as a drought is often a decrease in supply resulting from increased demand, particularly in growing towns.

11.1.2 DAMP RISING AND MOISTURE MIGRATION

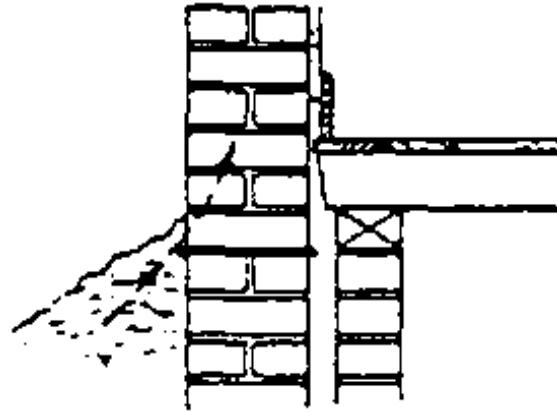

(a) Bridging by earth.

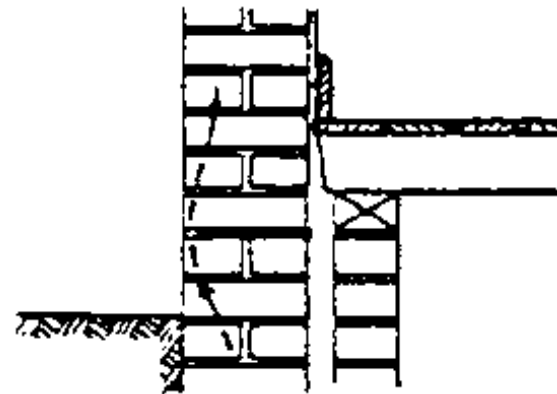

(b) Bridging by mortar pointing.

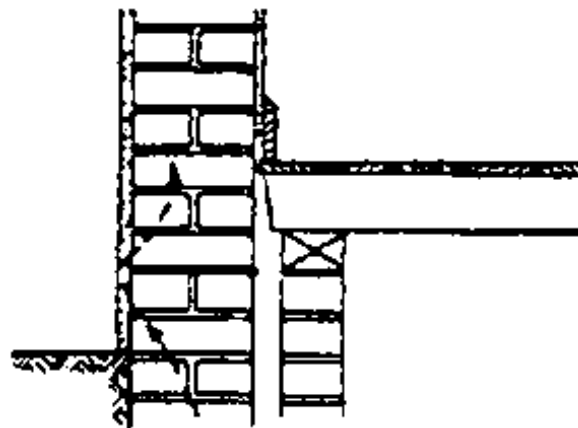

(c) Bridging by rendering.

Movement of moisture through the materials of which the building is constructed can occur through capillary attraction or by diffusion of vapour through the pores of the material. The sources of moisture which must be considered in this context include not only precipitation on external surfaces but also damp from the ground floors are not often made in this way. Since, in the case of walls, the exposure to moisture is intermittent it is possible to use thick solid walls of porous materials which absorb moisture into their external faces and then allow it to evaporate without giving rise to serious internal penetration. This type of wall generally has to be very much thicker than is required for structural needs and in modern buildings, means other than thickness have to be used to limit moisture penetration. Two methods of control are normally employed. Either a barrier of impervious material or an air gap is placed to intercept the movement. Flashings (capillary movement only), damp proof courses, damp proof membranes (capillary vapour diffusion) and vapour barriers (vapour only) are examples of impervious materials being used as barriers. Cavities, provided that they are not bridged by moisture transmitting features, are a very effective means of arresting capillary movement. They are not necessarily effective against vapour diffusion since unless well ventilated it will be possible for the vapour to pass across. Suspended ground floors formed a good example of a cavity formed to prevent capillary and vapour movement which to be effective in preventing vapour reaching the other side had to be adequately ventilated. This type of construction has now largely gone out of use because of the high heat losses which resulted from the ventilation. A floor resting solidly on the ground and having a continuous damp proof membrane gives a more satisfactory overall result.

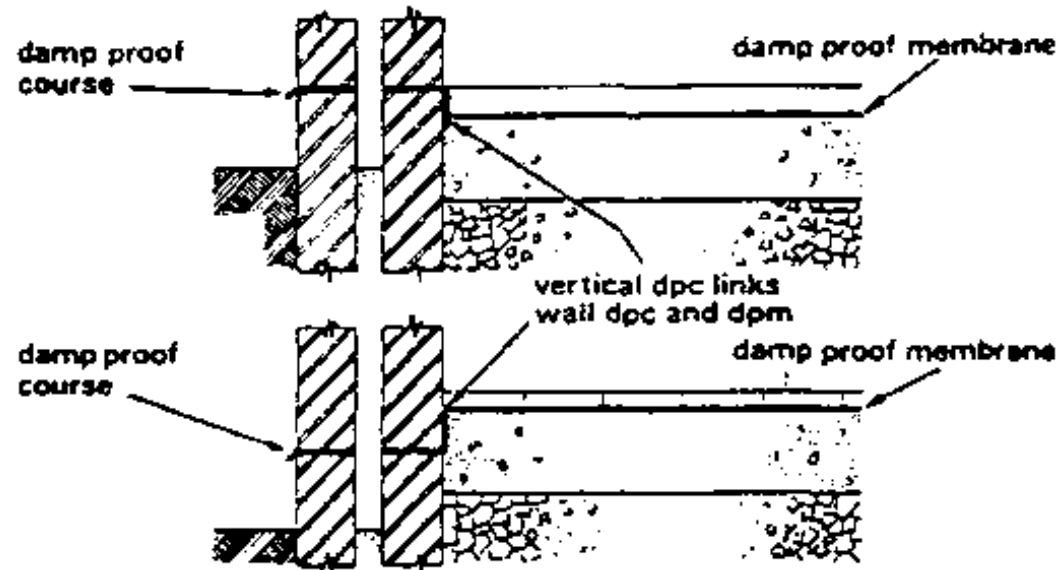

11.1.3 CONDENSATION

Condensation arises from the variation with temperature of the capacity of air to hold moisture in the form of water vapour. As temperatures increase the capacity increases. For each temperature, however, there is a saturation level of moisture. When air which has absorbed moisture is cooled to such a temperature that the moisture content exceeds the saturation point, the excess moisture will be deposited as water.

In buildings, the air from outside is taken in and warmed and moisture is added from occupants and processes. If cold surfaces such as windows, badly insulated walls, or cold metal service pipes exist, they can cool the air immediately adjacent to them so that moisture is deposited on the surface in the form of **CONDENSATION**: This is both unsightly and likely to cause damage to the contents and finishes of rooms and also to the wall, ceiling and floor materials.

In equatorial coastal climates with little seasonal or diurnal variation in temperature there is not a great deal of heavy condensation, though humidity can be high. Hotels and public buildings are often equipped

with air conditioning; if left on for long periods it reverses the process normal to temperate zones, causing heavy condensation to form on the outside of windows and thus spoiling visibility and speeding deterioration of the frames.

Table: Sources and approximate quantities of vapour input to buildings.

Source	Approximate quantity
People: Sedentary Active	0.05 kg per person/ 0.2 kg per person/ /per hour
GAS: Cooking or any flueless heaters or appliances	0.81 per m3 of town gas
Paraffin: Flueless heaters	1 kg per litre appr. (1 litre represents approx. 4MJ heat output)
Cooking, bathing and showers	0.03 to 0.06 kg per hour
Clothes washing and drying	Too variable for figure to be given but very substantial quantities of -water can be put into the atmosphere and special precautions against general penetration of this moisture into buildings are required.

Drying out is mainly a matter of the time taken for water vapour from cellular pores to reach the surface of the material: the rate of evaporation reduces as the temperature falls. Buildings when drying out are thus cooler than the ambient air, and this is the principle on which the traditional earthenware water cooler works. No rule of thumb on drying out is possible; but premature decoration can be disastrous, especially in damp regions. Dehumidifiers are sometimes used for this purpose if circumstances warrant it. The consequences of condensation are. in many modern constructions. more acute than was the case

in the past. In masonry and brick constructions significant quantities of water can condense and subsequently evaporate without being apparent or causing serious deterioration.

Risk of condensation can be minimised by increased ventilation. The most effective method, however, is to keep the surf-face temperature of i.e. walls, windows, cold metal pipes etc. above dewpoint.

Table: Excess moisture content of air (over outdoor content) for various building types

Building type	Excess content g moisture per kg of dry air
Shops, offices, classrooms, public buildings, dry industrial processes	1,7
Dwellings	3,4
Catering establishments or wet industrial processes	6,8

11.2 THERMAL INSULATION

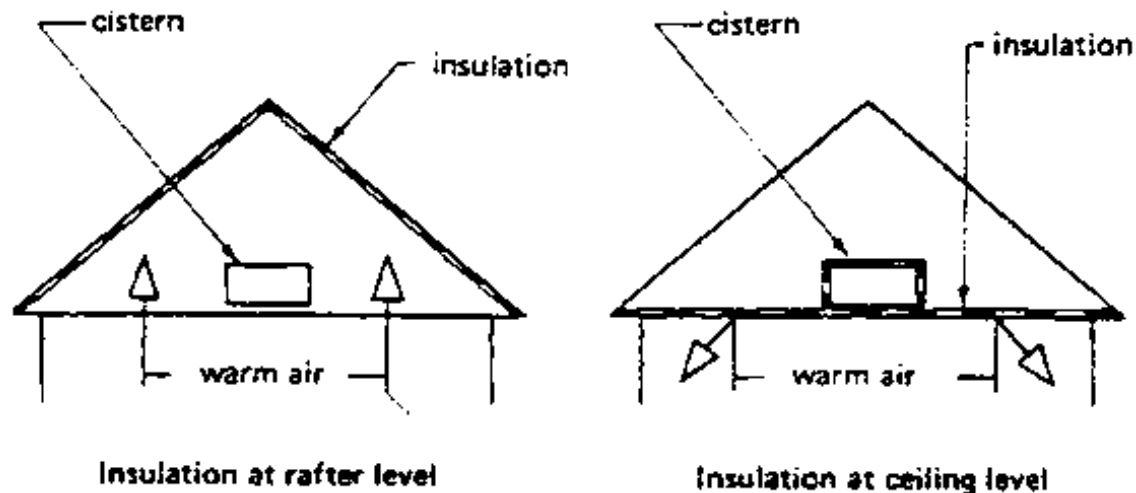

11.2.1 DEFINITION

Thermal insulation may be defined as a barrier to the natural flow of heat from an area of high temperature to an area of low temperature. In buildings this flow is generally from the interior to the exterior. During hot seasons however the flow may occur from the exterior to the interior. Heat is a form of energy consisting of the ceaseless movement of tiny particles of matter called molecules; if these particles are moving fast they collide frequently with one another and the substance becomes hot. Temperature is the measure of hotness and should not be confused with heat. The transfer of heat can occur in three ways.

Conduction:

Vibrating molecules come into contact with adjoining molecules and set them vibrating faster and hence they become hotter; this process is carried on throughout the substance without appreciable displacement of the particles.

Convection:

Transmission of heat within a gas or fluid caused by the movement of particles which become less dense when heated and rise thus setting up a current or circulation.

Radiation:

Heat is considered to be transmitted by radiation when it passes from one point to another without raising the temperature of the medium through which it travels.

In a building all three methods of heat transfer can take place since the heat will be conducted through the fabric of the building and dissipated on the external surface by convection and/ or radiation.

~~The traditional thick and solid building materials used in the past had a natural resistance to the passage~~

~~The traditional thick and solid building materials used in the past had a natural resistance to the passage of heat in large quantities, whereas the lighter and thinner materials used today generally have a low resistance to the transfer of heat. Therefore to maintain a comfortable and healthy internal temperature the external fabric of a building must be constructed of a combination of materials which will provide an adequate barrier to the transfer of heat.~~

Thermal insulation of buildings will give the following advantages:

1. Reduction in the rate of heat loss
2. Lower fuel costs
3. Reduction in the risk of pattern staining.
4. Reduction of condensation and draughts thus improving the comfort of the occupants.

11.2.2 INSULATING MATERIALS

When selecting or specifying thermal insulation materials the following must be taken into consideration:

1. Resistance value of the materials.
2. Need for a vapour barrier since insulating materials which become damp or wet, generally due to condensation, rapidly lose their insulation properties; therefore if condensation is likely to occur a suitable vapour barrier should be included in the detail. Vapour barriers should always be located on the warm side of the construction.
3. Availability of material chosen.
4. Ease of fixing or including the material in the general construction
5. Appearance if visible.
6. Cost in relation to the end result and ultimate savings on fuel and/or heating installation

6. Cost in relation to the end result and ultimate savings on fuel and/or heating installation.

7. Fire risk - all wall and ceiling surfaces must comply with the requirements of Building Regulation E 15 - restriction of spread of flame over surfaces of walls and ceilings.

Insulating materials are made from a wide variety of materials and are available in a number of forms.

Insulating concrete:

Basically a concrete of low density containing a large number of voids. This can be achieved by using lightweight aggregates such as clinker, foamed slag, expanded clay, sintered pulverised fuel ash, exfoliated vermiculite and expanded perlite, or alternatively an aerated concrete made by the introduction of air or gas into the mix. No fines concrete made by using lightweight or gravel aggregates between 20 and 10 mm size and omitting the fine aggregate is suitable for load bearing walls. Generally light -weight insulating concrete is used in the form of an in situ screed to a structural roof or as lightweight concrete blocks for walls.

Loose fills:

Materials which can be easily poured from a bag and levelled off between the joists with a shaped template. Materials include exfoliated vermiculite, fine glass fibrewool, mineral wool and cork granules. The depth required to give reasonable results is 25 - 35 mm; care should be taken to indicate, by paint or chalk marks on the sides of the joists, any electrical connections or junctions which have been covered over. Most loose fills are rot and vermin proof as well as being classed as noncombustible.

Boards:

Used mainly as dry linings to walls and ceilings either for self finish or direct decoration. Types include aluminium foil-backed plaster board, woodwool slabs, expanded polystyrene boards, asbestos insulating board and fibreboards. Insulating fibreboards should be conditioned on site before fixing to prevent

board and fibreboards. Insulating fibreboards should be conditioned on site before fixing to prevent buckling and distortion after fixing. A suitable method is to expose the boards on all sides so that the air has a free passage around the sheets for at least 24 hours before fixing. During this conditioning period the boards must not be allowed to become wet or damp.

Quilts:

Made from glass fibre or mineral wool bonded or stitched between outer paper coverings for easy handling. The quilts are supplied in rolls from 6.000-13.000 m long and cut to suit standard joist spacings. They are laid over the ceiling boards and can be obtained in two thicknesses, 25 mm thick for general use and 50 mm - thick for use where a central heating system is installed

Reflective insulation:

Used in both ceiling and wall insulation and consists of reinforced aluminium foil which should be used in conjunction with an unventilated cavity of at least 25 mm width.

Insulating plasters:

Factory produced pre-mixed plasters which have lightweight perlite and vermiculite expanded minerals as aggregate, and require only the addition of clean water before application. They are only one third the weight of sanded plasters, have three times the thermal insulation value and are highly resistant to fire.

Foamed cavity fill:

A method of improving the thermal insulation properties of an external cavity wall by filling the cavity wall with urea-formaldehyde resin foamed on site. The foam is formed using special apparatus by combining urea-formaldehyde resin, a hardener, a foaming agent and warm water. Careful control with the mixing and application is of paramount importance if a successful result is to be achieved; specialist contractors are normally employed. The foam can be introduced into the cavity by means of 25 mm bore holes spaced 1.000m apart in all directions or by direct introduction into the open end of the cavity. The

holes spaced 1.000m apart in all directions or by direct introduction into the open end of the cavity. The foam is a white cellular material containing approximately 99% by volume of air with open cells. The foam is considered to be impermeable and therefore unless fissures or cracks have occurred during the application it will not constitute a bridge of the cavity, in the practical sense, but a relaxation of Building Regulation C9 (2) may be required. In most cases the foam, upon setting, shrinks away from the inner face of the outer leaf enabling any water penetrating the outer leaf to run down the inside face of the external skin.

The most effective method of improving thermal comfort conditions within a building is by fixing insulating materials at the outside position of the surface. Thermal insulation for buildings other than dwellings are covered by separate legislation.

11.3 SOUND INSULATION

11.3.1 DEFINITION

Anything that can be heard is a sound, whether it is made by conversation, machinery, or walking on a hard surface. All sounds are produced by a vibrating object which moves rapidly to and fro causing movement of the tiny particles of air surrounding the vibrating source, the displaced air particles collide with adjacent particles setting them in motion and in unison with the vibrating object. Air particles move only to and fro but the sound wave produced travels through the air until at some distance from the source the movement of the particles is so slight that the sound produced is inaudible.

For a sound to be transmitted over a distance a substance, called the sound medium, is required. It can be shown by experiments that sound cannot travel through a vacuum but it can be transmitted through solids and liquids.

Sounds can differ in two important ways, by loudness and by pitch. The loudness of a sound depends on the distance through which the vibrating object moves to and fro as it vibrates; the greater the movement the louder the sound. The loudness with which a sound is heard depends upon how far away

movement the louder the sound. The loudness with which a sound is heard depends upon how far away from the source the receiver or ear is. The unit of subjective loudness is a phon whilst the objective unit is called a decibel.

Although the loudness of a sound will vary with the frequency of the note for practical building purposes, the phon and the decibel are considered to be equal over the range of 0 phons, the threshold of hearing, to 130 phons the threshold of painful hearing.

The pitch of a sound depends on the rate at which the vibrating object oscillates. The number of vibrations in a second is called the frequency and the higher the frequency the higher the pitch. The lowest pitched note that the human ear can hear has a frequency of approximately 15 hertz whereas the highest pitched note which can be heard by the human ear has a frequency of approximately 20.000 hertz or cycles per second. When a sound is produced within a building three reactions can occur:

- 1. The pressure or sound waves can come into contact with the walls, floor and ceiling and be reflected back into the building.**
- 2. Some of the sound can be absorbed by these surfaces and/ or the furnishes. It must be noted that sound absorption normally only benefits the occupants of the room in which the sound is generated since its function is to reduce the amount of reflected sound.**
- 3. The sound waves upon reaching the walls, floor and ceiling can set these members vibrating in unison and thus transmit the sound to adjacent rooms.**

It must also be noted that sounds can enter a building from external sources such as traffic and low flying aircraft (see fig.)

Sounds may be defined as either impact sounds, caused by direct contact with the structure such as footsteps and hammering on walls which will set that part of the structure vibrating, or they can be

termed airborne sounds, such as the conversation or radio which sets the structure vibrating only when the sound waves emitted from the source reach the structural enclosure.

A noise can be defined as any undesired sound and may have any one of the following four effects on man:

1. Annoyance
2. Disturbance of sleep
3. Interfere with the ability to hold a normal conversation.
4. Damage his hearing.

Sources of noise within and around buildings

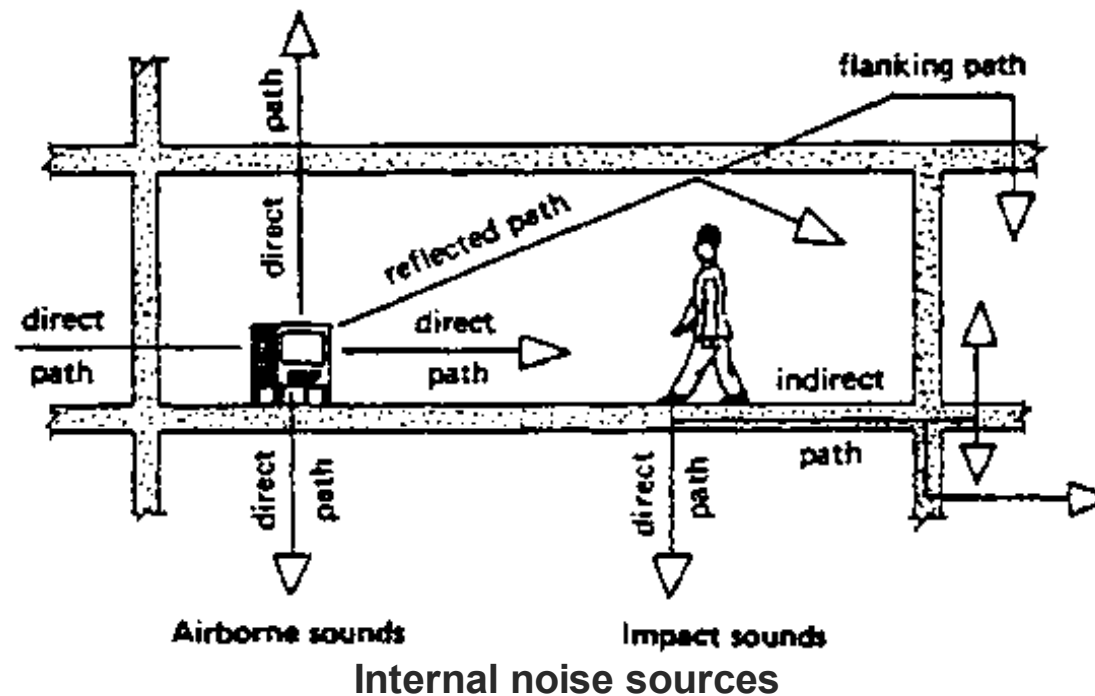

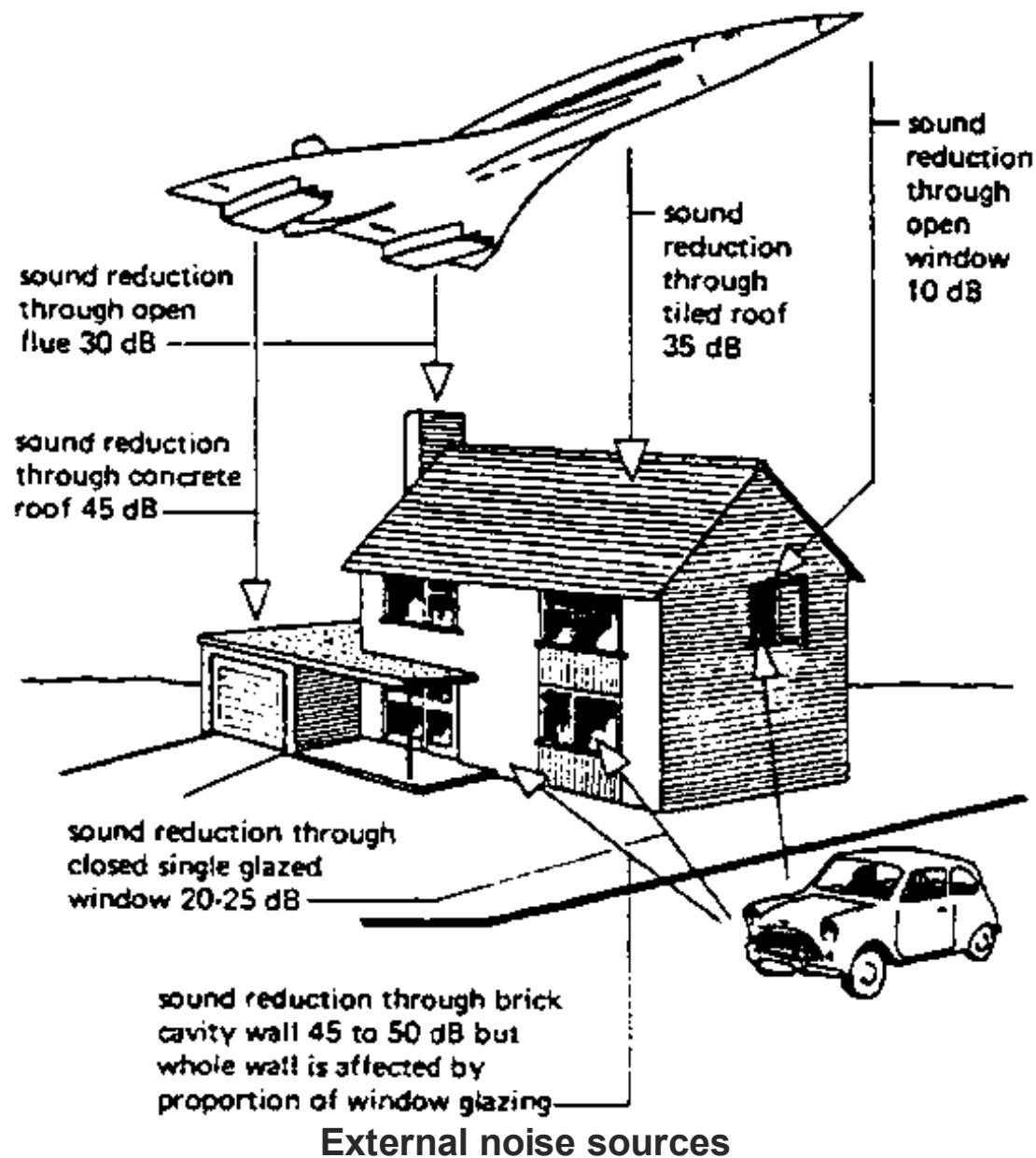

It is difficult to measure annoyance since it is a subjective attitude and will depend upon the mental and physical well being of the listener, together with the experience of being subjected to such types of noise. Damage to hearing can be caused by a sudden noise such as a loud explosion or by gradual

noise. Damage to hearing can be caused by a sudden noise such as a loud explosion or by gradual damage resulting from continual noise over a period of years. The solution to noise or sound problems can only therefore be reasonable to cater for the average person and conditions. The approach to solving a noise problem can be three-fold:

- 1. Reduce the noise emitted at the source by such devices as mufflers and mounting machinery on resilient pads.**
- 2. Provide a reasonable degree of sound insulation to reduce the amount of sound transmitted.**
- 3. Isolate the source and the receiver.**

11.3.2 SOUND INSULATION

The most effective barrier to the passage of sound is a material of high mass. With modern materials and methods this form of construction is both impracticable and uneconomic. Unfortunately modern living with its methods of transportation and entertainment generates a considerable volume of noise and therefore some degree of sound insulation in most buildings is desirable.

11.3.3 EXTERNAL NOISE

Another aspect of sound insulation which, although not covered by Building Regulations, requires consideration is insulation against external noise.

The main barrier to external noise is provided by the shell or envelope of the building, the three main factors being:

- 1. The mass of the enclosing structure.**
- 2. The continuity of the structure.**
- 3. Isolation by double leaf construction when using lightweight materials**

3. ISOLATION BY DOUBLE LEAF CONSTRUCTION WHEN USING LIGHTWEIGHT MATERIALS.

Generally the main problem for the insulation against external noise is the windows, particularly if these can be opened for ventilation purposes. Windows cannot provide the dual function of insulation against noise and ventilation, since the admission of air will also admit noise. Any type of window when opened will give a sound reduction of about 10 decibels as opposed to the 45-50 decibel reduction of the traditional cavity wall. A closed window containing single glazing will give a reduction of about 20 decibels or approximately half that of the surrounding wall. It is obvious that the window to wall ratio will affect the overall sound reduction of the enclosing structure.

Sound insulation - walls

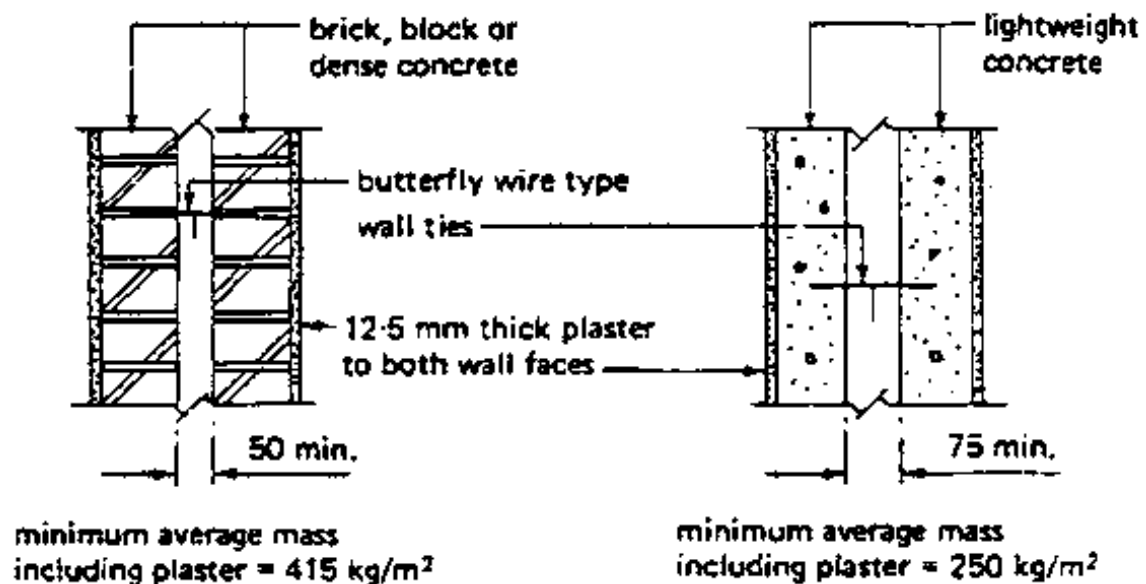
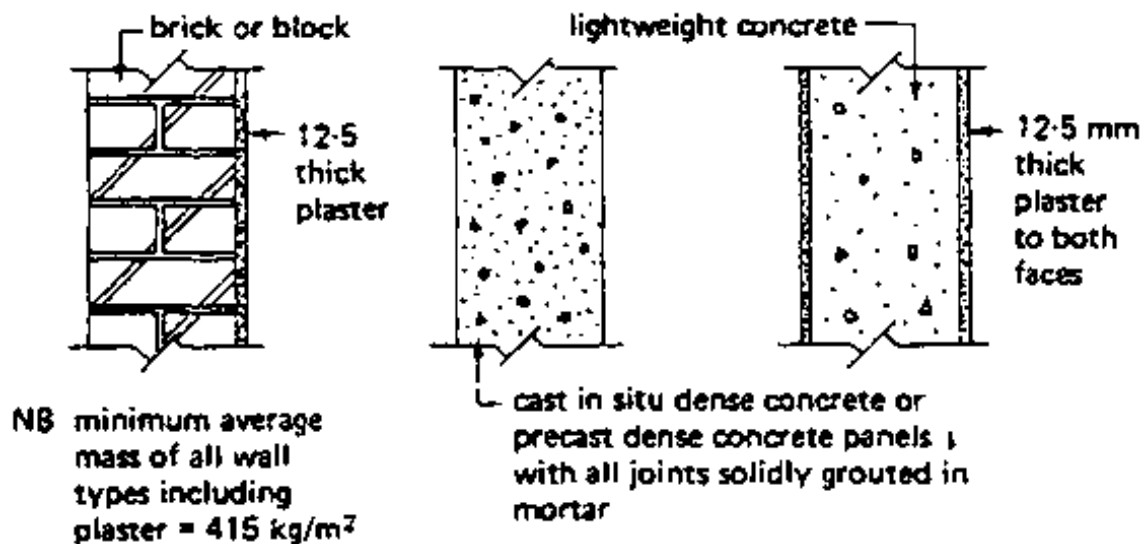

Simple wall constructions

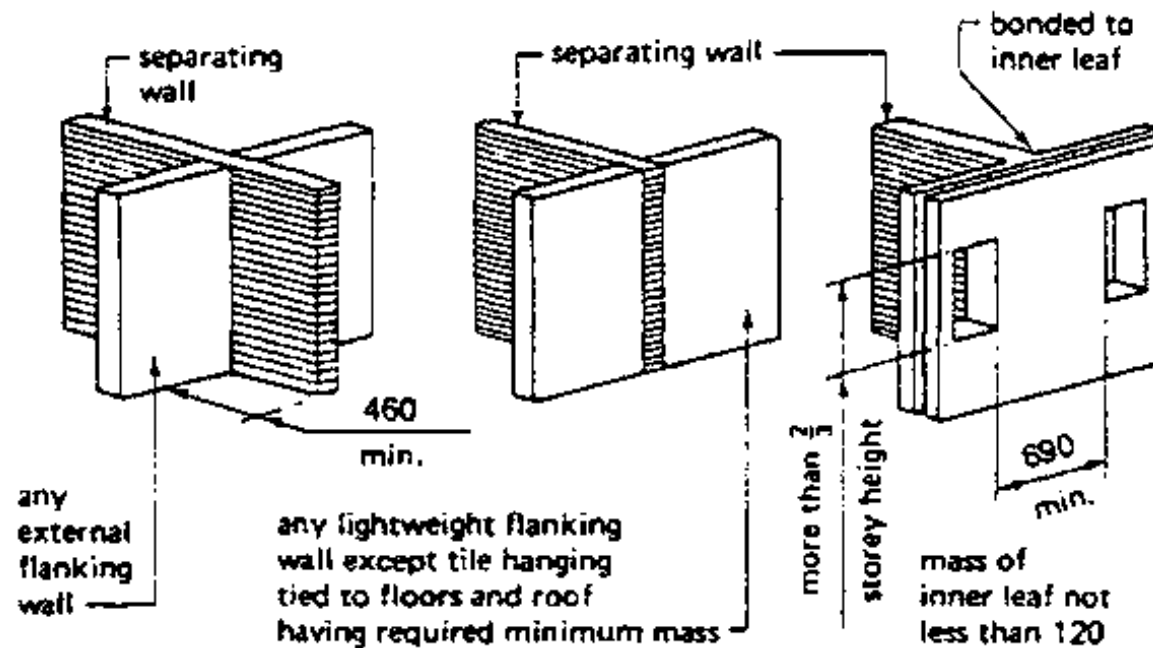

External flanking walls - Building Regulation G2

Double glazing can greatly improve the sound insulation properties of windows provided the following points are observed:

1. Sound insulation increases with the distance between the glazed units; for a reduction of 40 decibels the airspace should be 150-200 mm wide.
2. If the double windows are capable of being opened they should be weather-stripped.
3. Sound insulation increases with glass thickness particularly if the windows are fixed; this may mean the use of special ventilators having specific performances for ventilation and acoustics.
4. Double glazing designed to improve the thermal properties of a window have no real value for sound insulation.

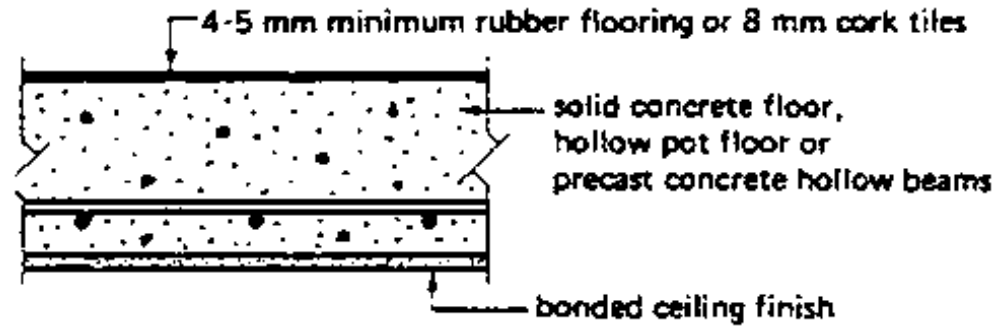

Concrete floors - minimum mass of floor = 365 kg/m²

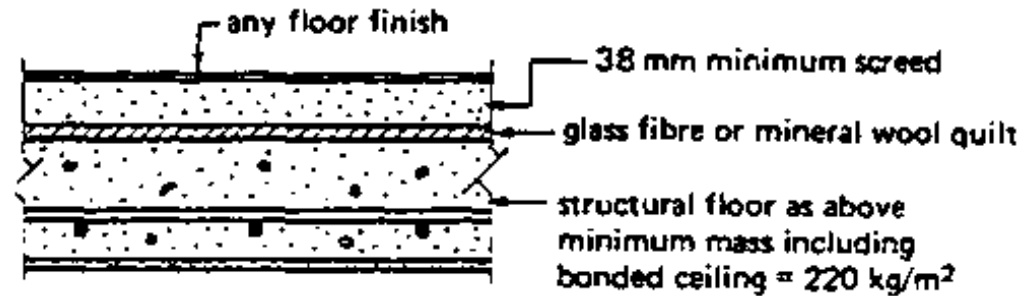

Floating screed

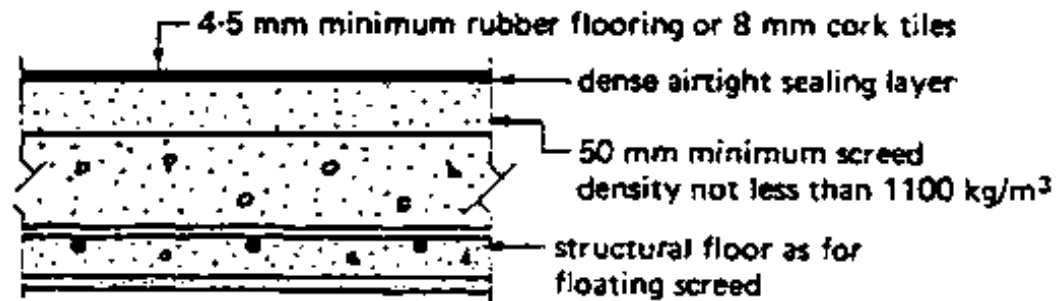

Lightweight screed

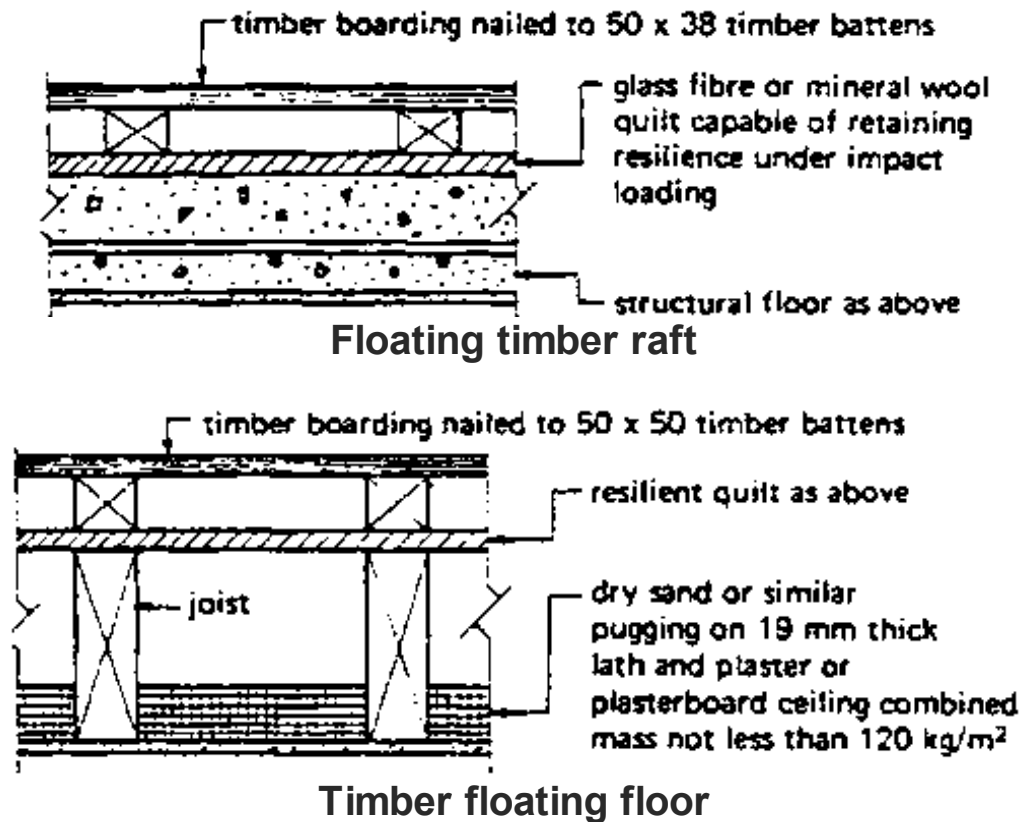

Roofs of traditional construction and of reinforced concrete generally give an acceptable level of sound insulation, but the inclusion of rooflights can affect the resistance provided by the general roof structure. Lightweight roofing such as corrugated asbestos will provide only a 15-20 decibel reduction but is generally acceptable on industrial buildings where noise is generated internally by the manufacturing processes. The inclusion of rooflights in this type of roof generally has no adverse effects since the sound insulation values of the rooflight materials are similar to those of the coverings.

Modern buildings can be designed to give reasonable sound insulation and consequent comfort to the occupiers but the improvement to existing properties can present problems.

Sound insulation - floors

11.4 FIRE PROTECTION

The precautions which can be taken within buildings to prevent a FIRE occurring, or, if it should occur, of containing it within the region of the outbreak, providing a means of escape for people in the immediate vicinity and fighting the fire can be summarized under three headings:

1. Structural fire protection
2. Means of escape in case of fire
3. Fire fighting

FIRE FIGHTING, which is generally integrated with the services of a building, is usually considered in that context and therefore **NOT** included in this text, as well as **MEANS OF ESCAPE IN CASE OF FIRE**, which is in the first instance a problem of designing and planning, rather than a problem of building construction.

11.4.1 STRUCTURAL FIRE PROTECTION

The purpose of structural fire protection is to ensure that during a fire the temperature of structural members or elements does not increase to a figure at which their strength would be adversely affected. It is not practicable or possible to give an element complete protection in terms of time, therefore elements are given a fire resistance for a certain period of time which it is anticipated will give sufficient delay to the spread of fire, ultimate collapse of the structure, time for persons in danger to escape and to enable fire fighting to be commenced.

Before a fire-resistance period can be determined it is necessary to consider certain factors:

1. Fire load of the building.

2. Behaviour of materials under fire conditions.

3. Behaviour of combinations of materials under fire conditions

11.4.1.1 Fire Load

Buildings can be graded as to the amount of overall fire resistance required by taking into account the following.

- 1. Size of building**
- 2. Use of building**
- 3. Fire load.**

The fire load is an assessment of the severity of a fire due to the combustible materials within a building. This load is expressed as the amount of heat which would be generated per unit area by the complete combustion of its contents and combustible members and is given in Joules per square metre. It should be noted that the numerical grade is equivalent to the minimum number of hours fire resistance which should be given to the elements of the structure.

GRADE 1 Low fire load, not more than 1 150 MJ/m². Typical buildings within this grade are flats, offices, restaurants, hotels hospitals, schools, museums and public libraries.

GRADE 2 Moderate fire load, 1 150 to 2 300 MJ/m². Typical examples are retail shops, factories and workshops.

GRADE 4 High fire load, 2 300 to 4 600 MJ/m². Typical examples are certain types of workshops and warehouses.

When deciding the grade no account is taken of the effects of any permanent fire protection installations

such as sprinkler systems.

11.4.1.2 Fire Resistance of Material

The materials used in buildings can be studied as separate entities as to their behaviour when subjected to the intense heat encountered during a fire and as to their ability to spread fire over their surfaces. Structural steel is not considered to behave well under fire conditions although its ability to spread fire over its surface is negligible. As the fire progresses and the temperature of steel increases there is an actual gain in the ultimate strength of mild steel. This gain in strength decreases back to normal over the temperature range of 250 to 400°C. The decrease in strength continues and by the time the steel temperature has reached 550°C it will have lost most of its useful strength. Since the rise in temperature during the initial stages of a fire is rapid this figure of 550°C can be reached very quickly. If the decrease in strength results in the collapse of a member the stresses it was designed to resist will be redistributed; this could cause other members to be overstressed and progressive collapse could occur. Reinforced concrete structural members have good fire resistance properties, and being non-combustible do not contribute to the spread of flame over their surfaces. It is possible however under the intense and prolonged heat of a fire that the bond between the steel reinforcement and the concrete will be broken. This generally results in spalling of the concrete which decreases both the protective cover of the concrete over the steel and the cross sectional area. Like structural steel members, this can result in a redistribution of stresses leading to overloading of certain members, culminating in progressive collapse. Timber, strange as it may seem, behaves very well structurally under the action of fire. This is due to its slow combustion rate, the strength of its core failure remaining fairly constant. The ignition temperature of timber is low (250-300°C) but during combustion the timber chars at an approximate rate of 0.5 mm per minute, the layer charcoal so formed slows down the combustion rate of the core. Although its structural properties during a fire are good, timber being an organic material and therefore combustible, will spread fire over its surface which makes it unsuitable in most structural situations without some form of treatment.

11.4.1.3 Appropriate Types of Construction

BS 476, Part 8 and Schedule 8 give appropriate types of construction for various notional periods of fire resistance for WALLS, BEAMS, COLUMNS and FLOORS. Schedule 8 of the Building Regulations gives in written and tabulated form various methods of providing the required protection which needs to be translated into working details. The following figures show typical examples taken from this schedules.

WALLS

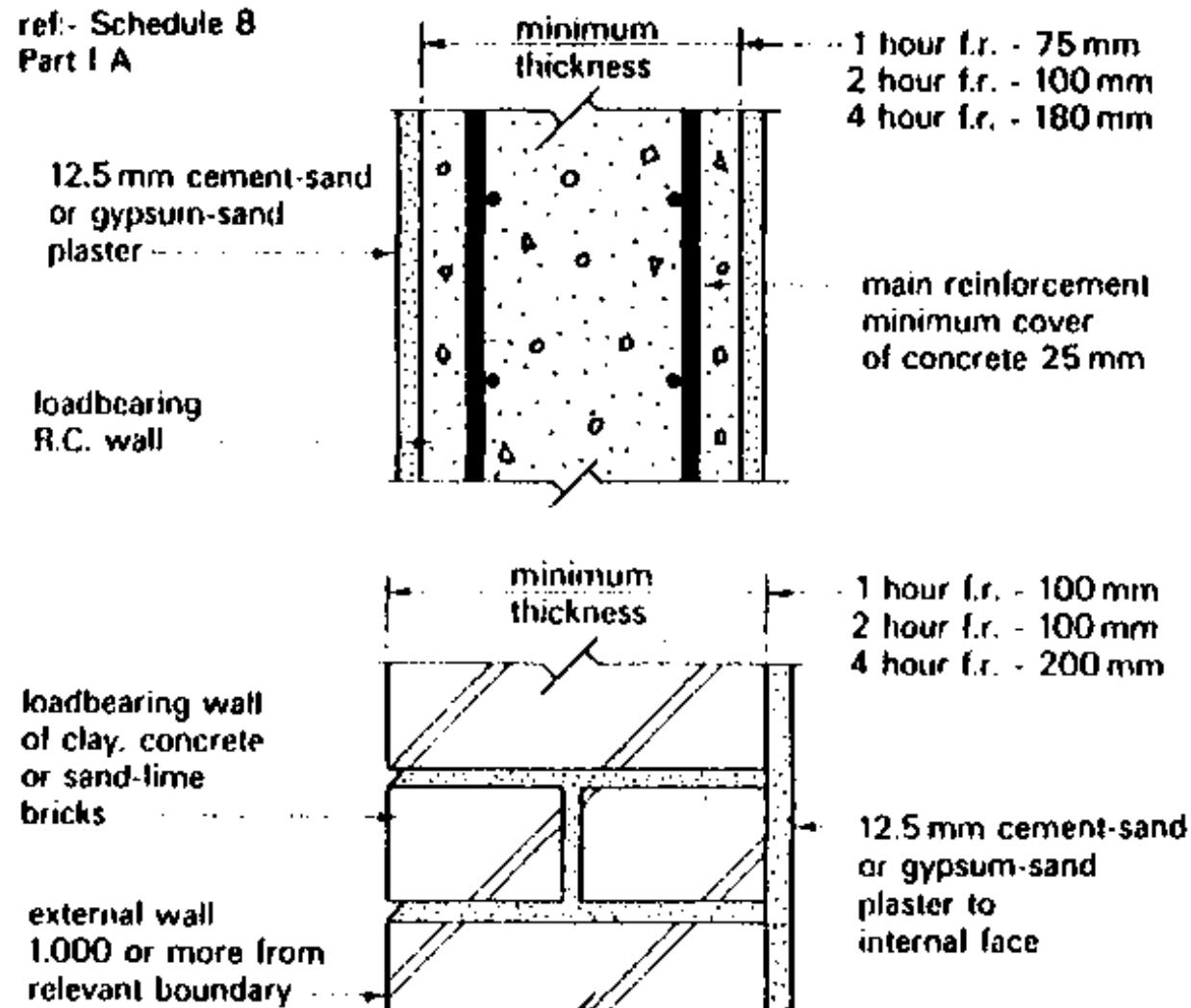

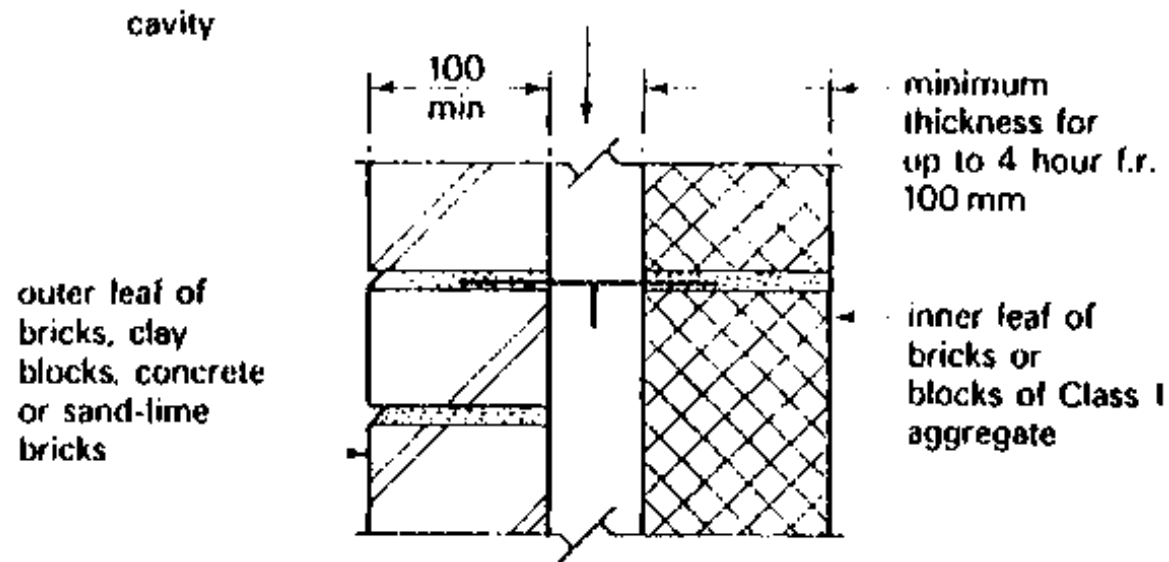
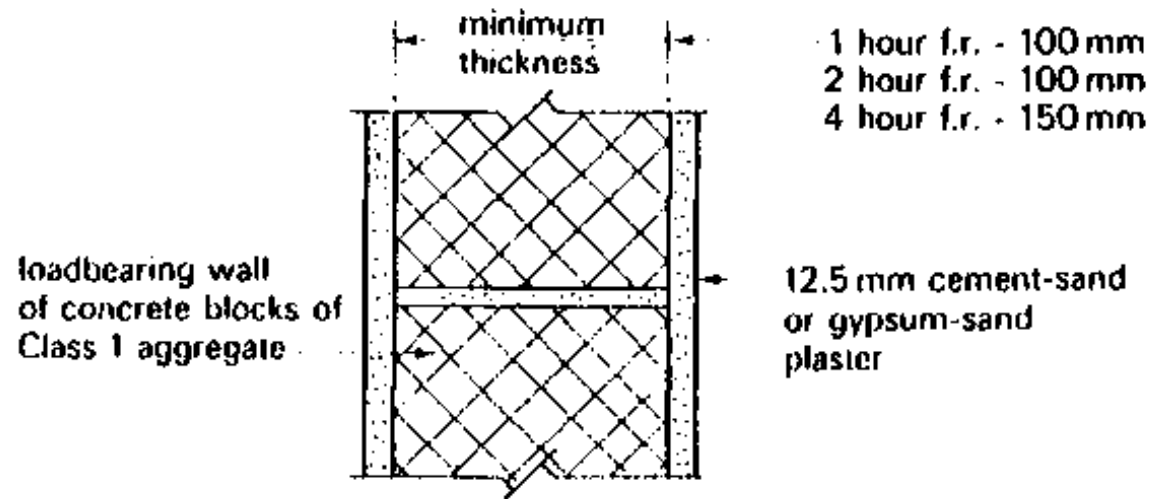

Fire Resistance - walls of masonry construction

ref:- Schedule 8
Parts I B and I C

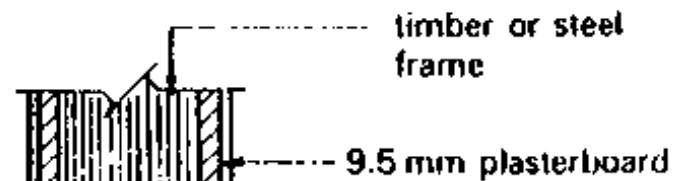

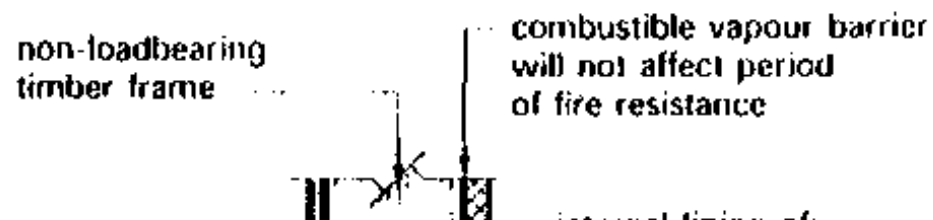
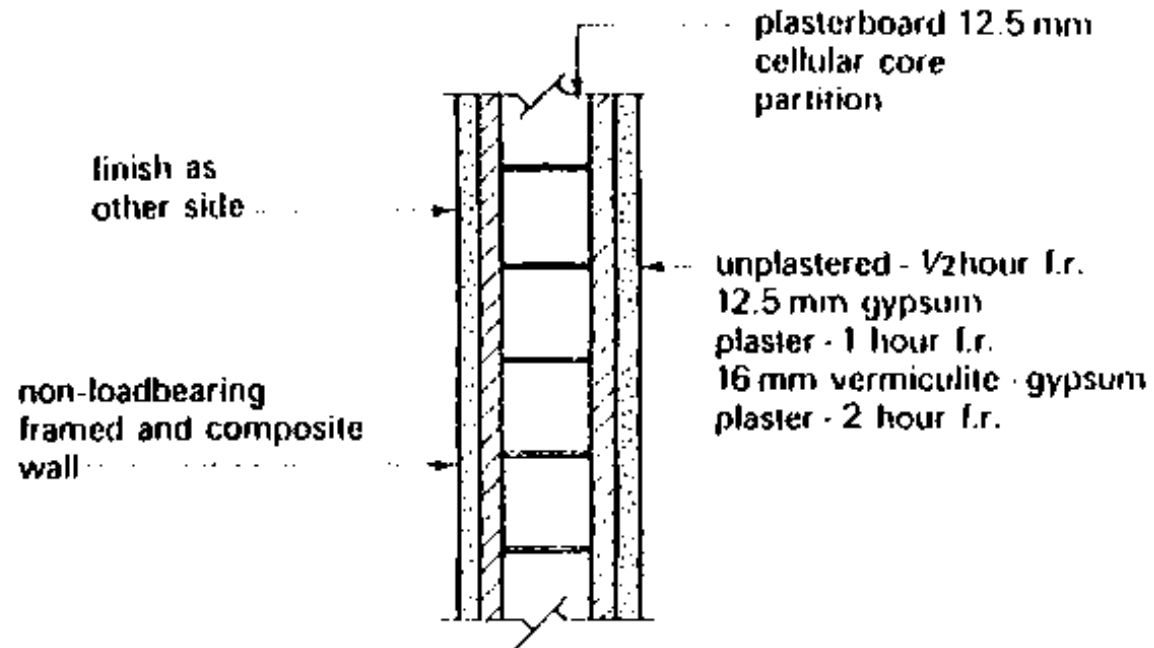
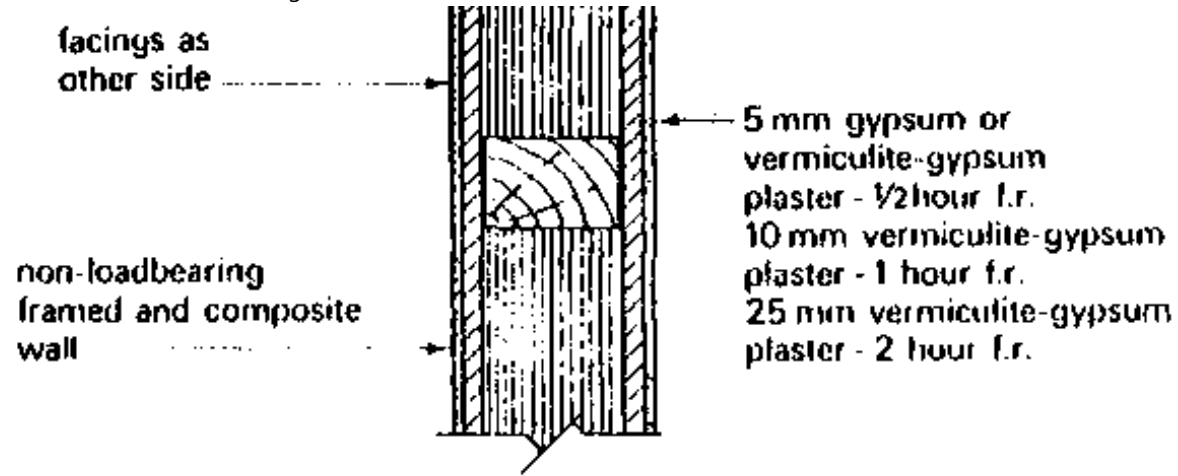

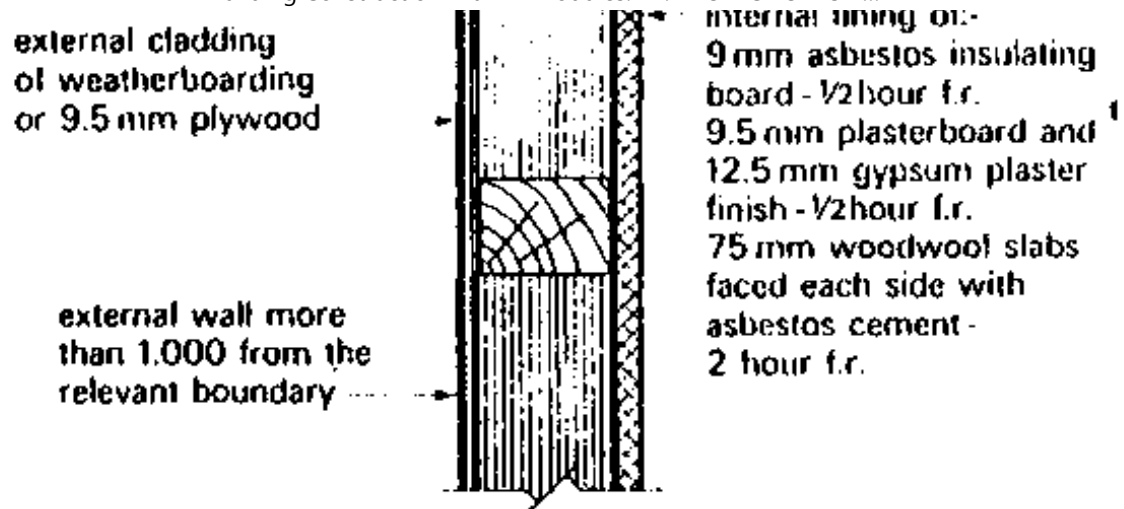

Fire resistance - framed and composite walls

COLUMNS & BEAMS

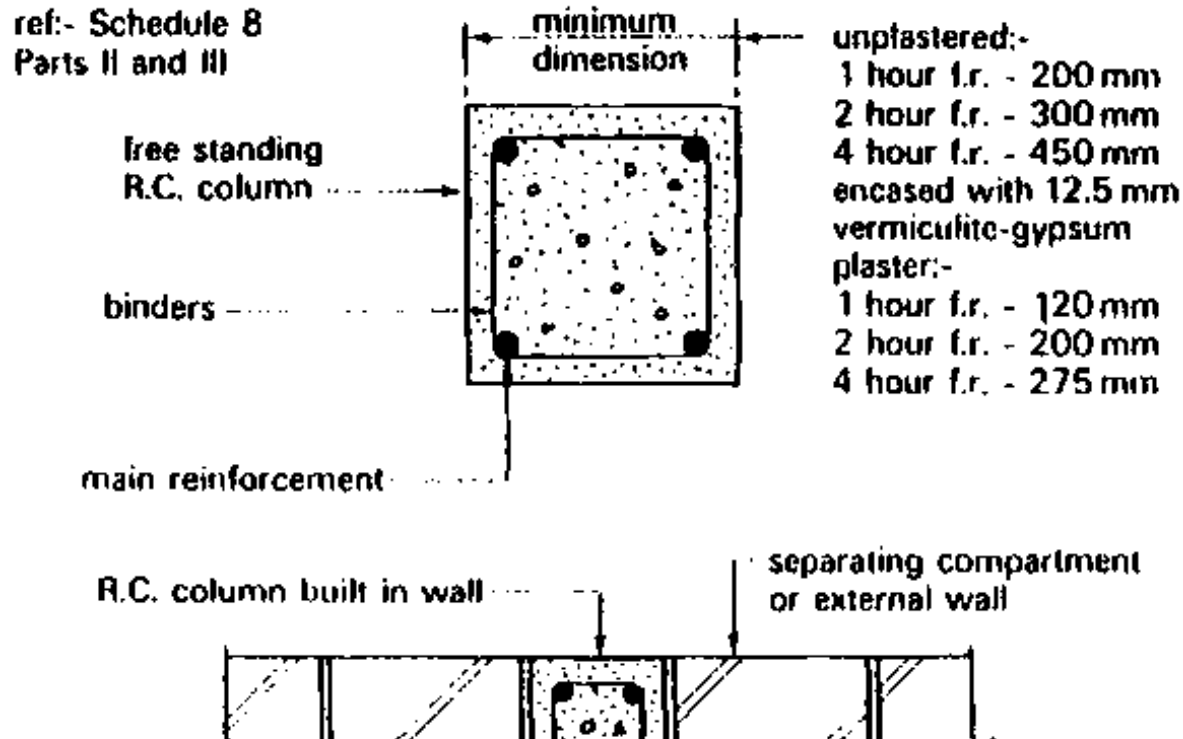

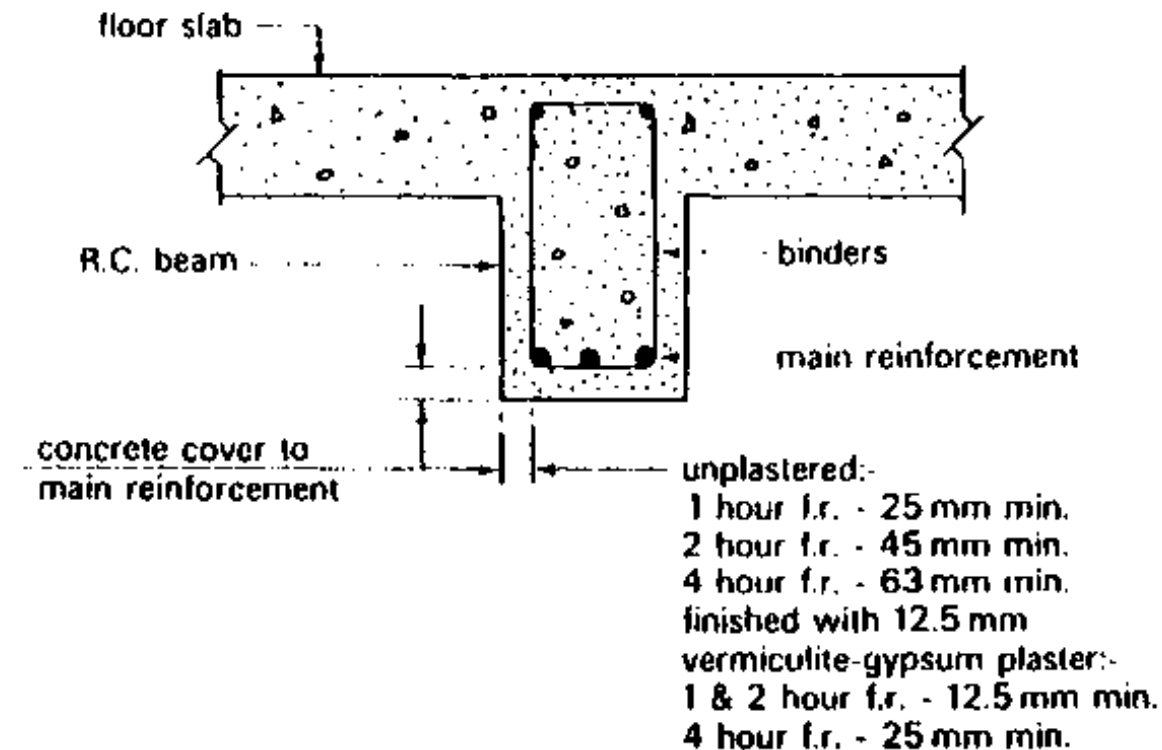
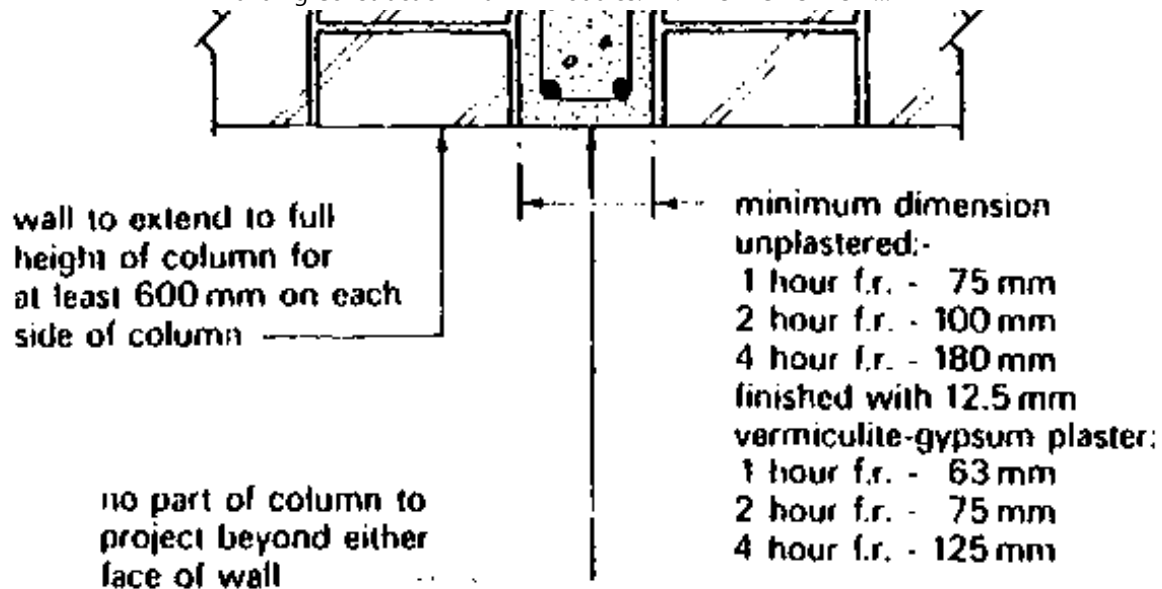

Fire resistance - R.C. columns and beams

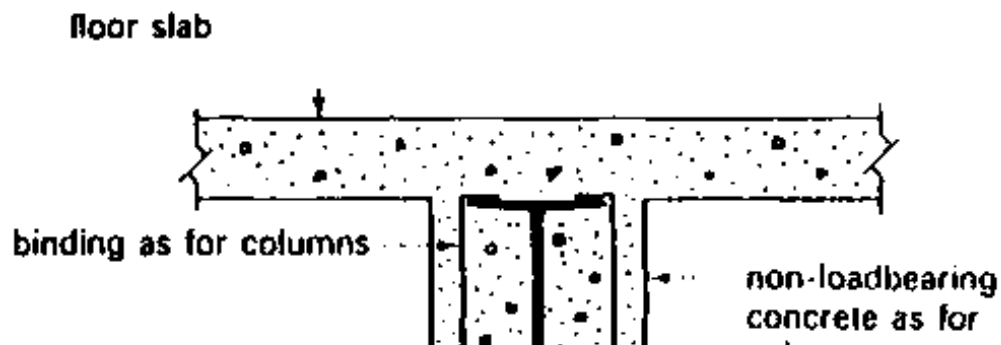
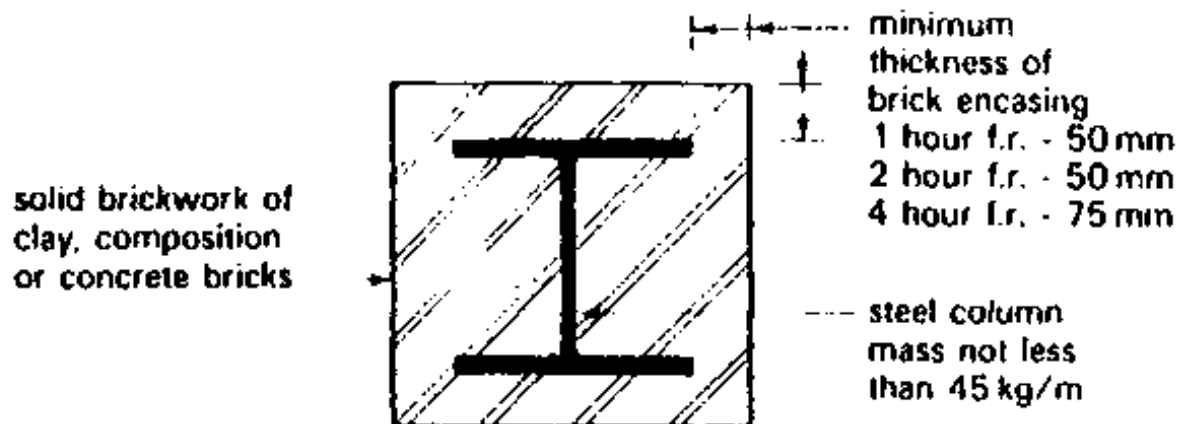
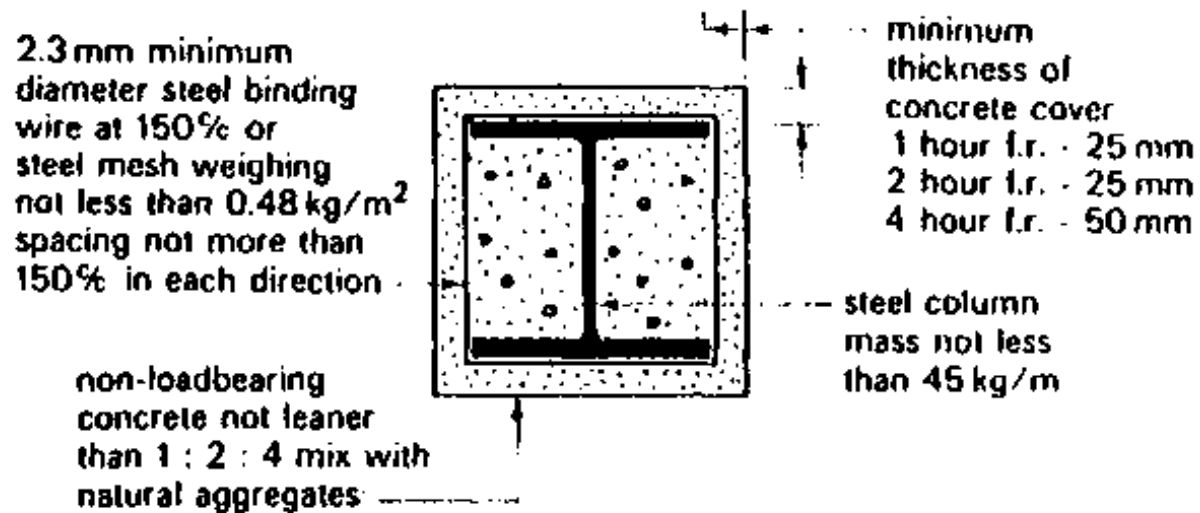

COLUMNS

minimum thickness
of concrete cover

1 hour f.r. - 25 mm

2 hour f.r. - 25 mm

4 hour f.r. - 63 mm

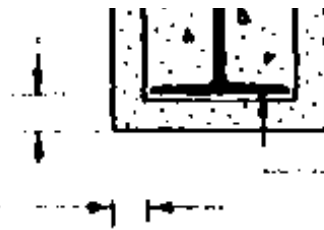

steel beam mass
not less than 30 kg/m

floor slab

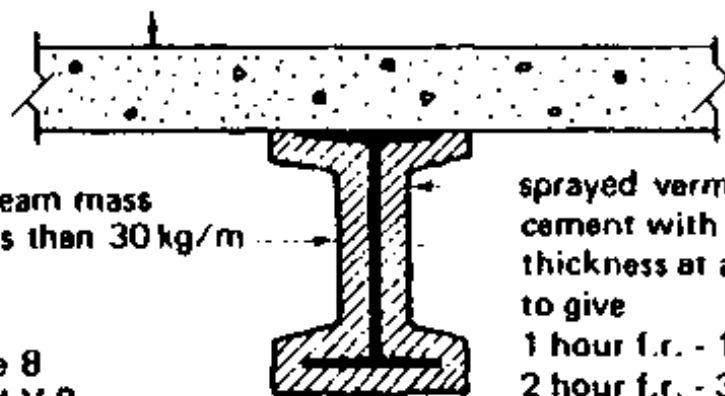

steel beam mass
not less than 30 kg/m

sprayed vermiculite
cement with minimum
thickness at any point
to give

1 hour f.r. - 19 mm

2 hour f.r. - 38 mm

ref:- Schedule 8
Parts V A and V B

Fire resistance - steel columns and beams

all hollow protection to be effectively
sealed at each floor level

unplastered solid
bricks of clay,
composition or sand-
lime reinforced in every
horizontal joint

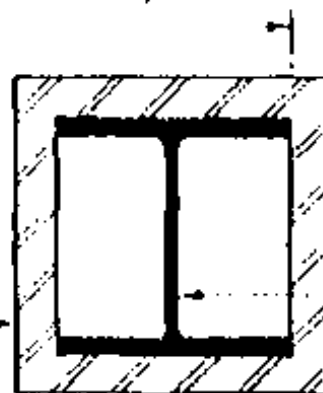

minimum thickness
of brickwork

1 hour f.r. - 50 mm

2 hour f.r. - 50 mm

4 hour f.r. - 115 mm

steel column
mass not less
than 45 kg/m

metal lathing with angle beads
to corners for 2 hour f.r.

minimum thickness

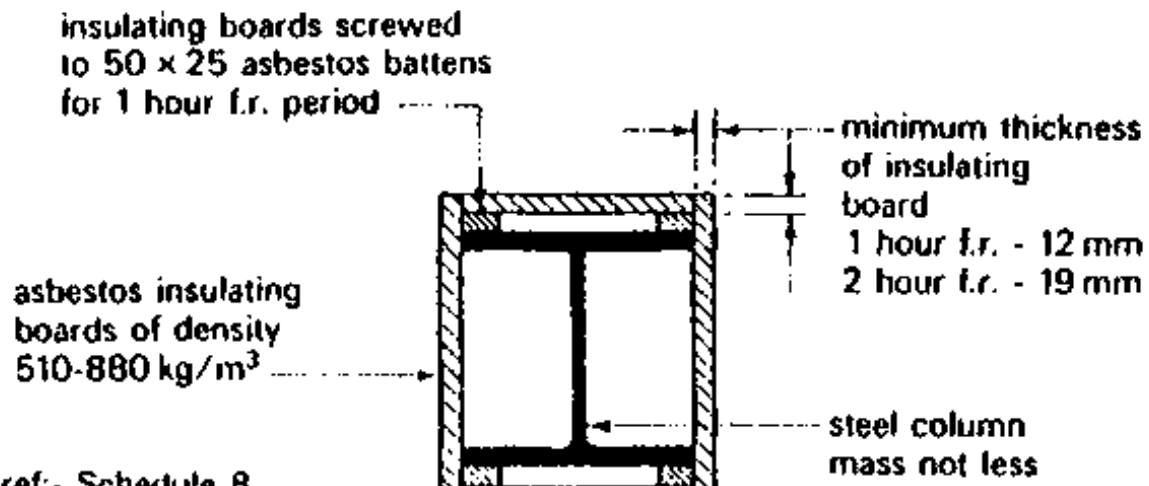
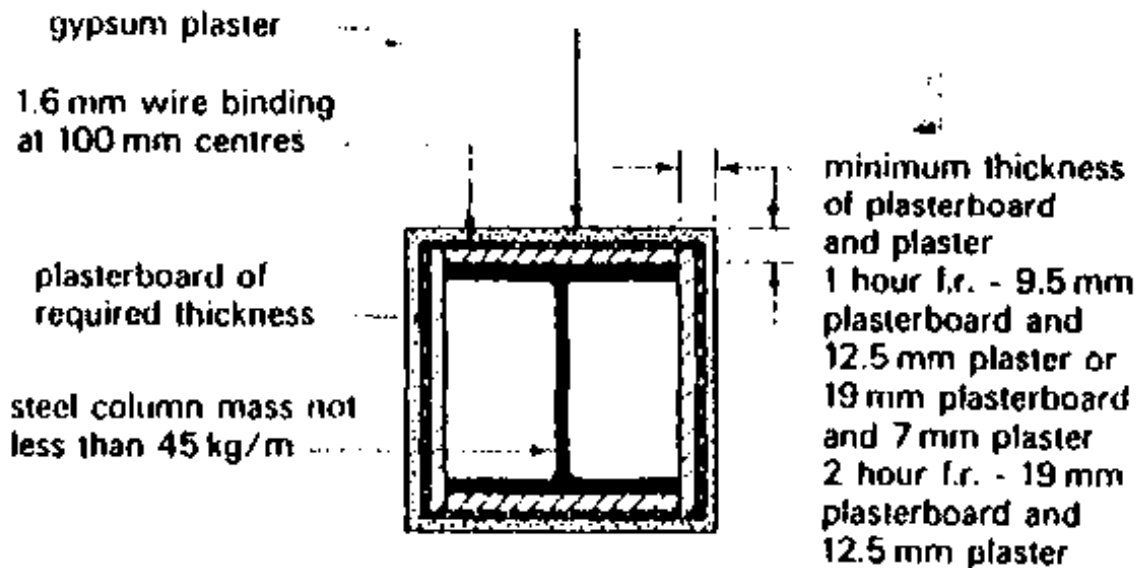
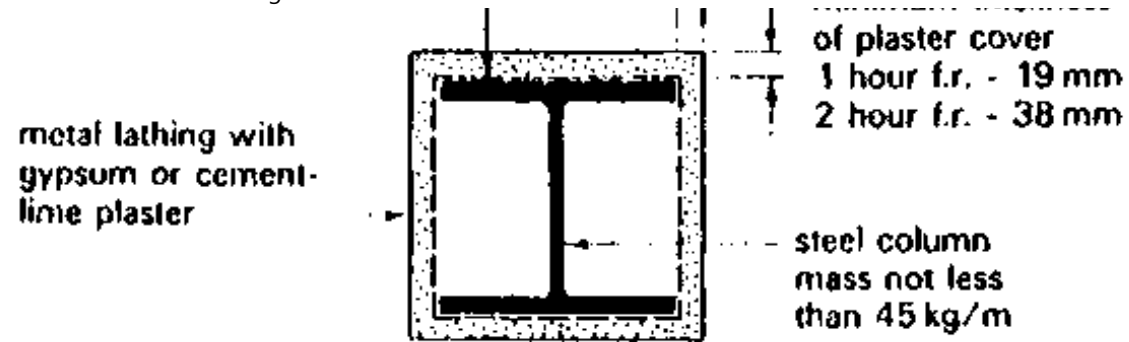

ref: Schedule B

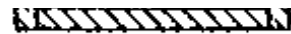

than 45 kg/m

Fire resistance - hollow protection to steel columns

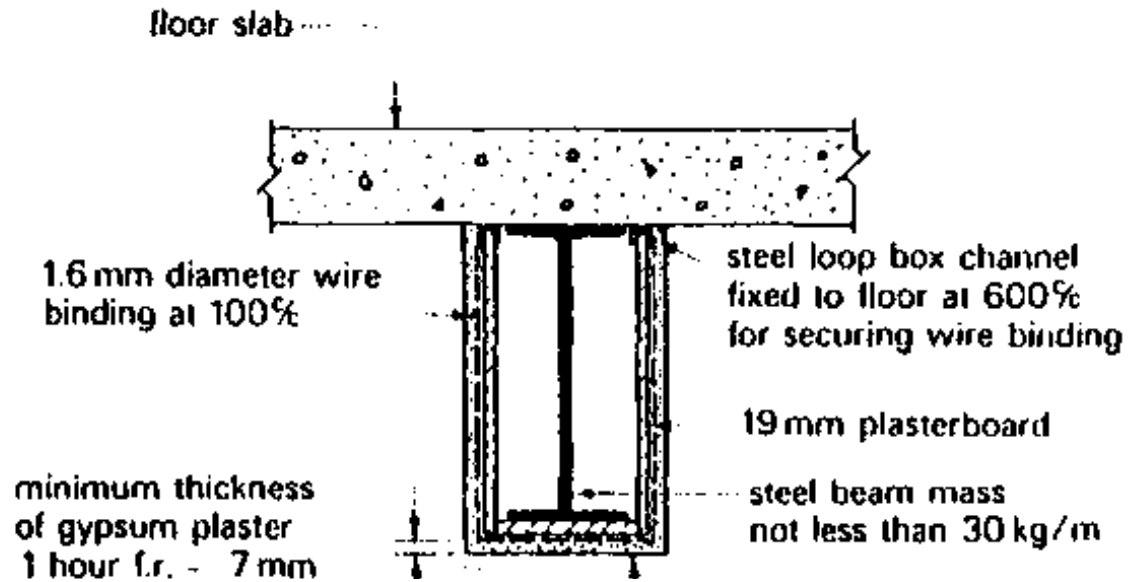
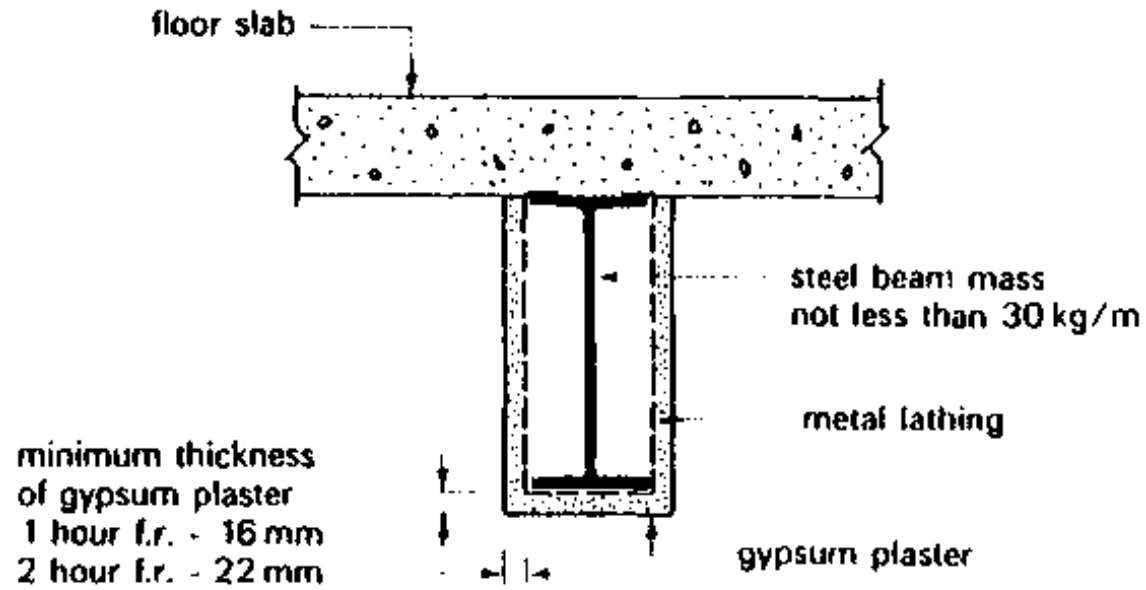

2 hour f.r. - 12.5 mm - gypsum plaster

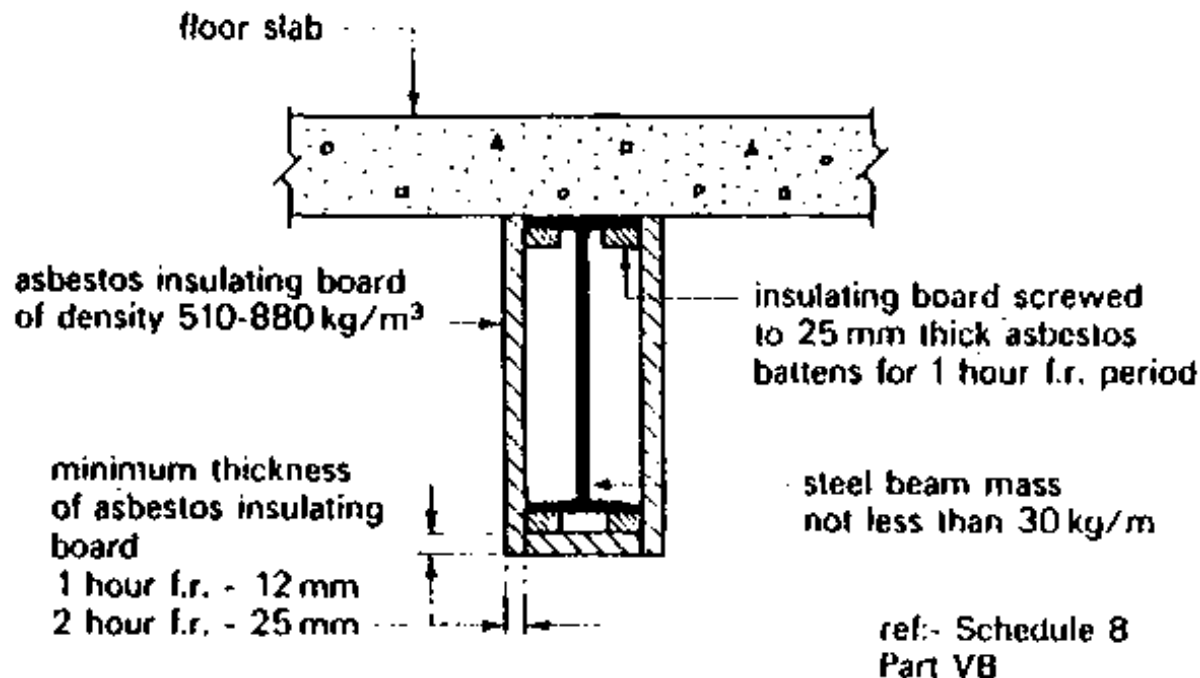

Fire resistance - hollow protection to steel beams

FLOORS

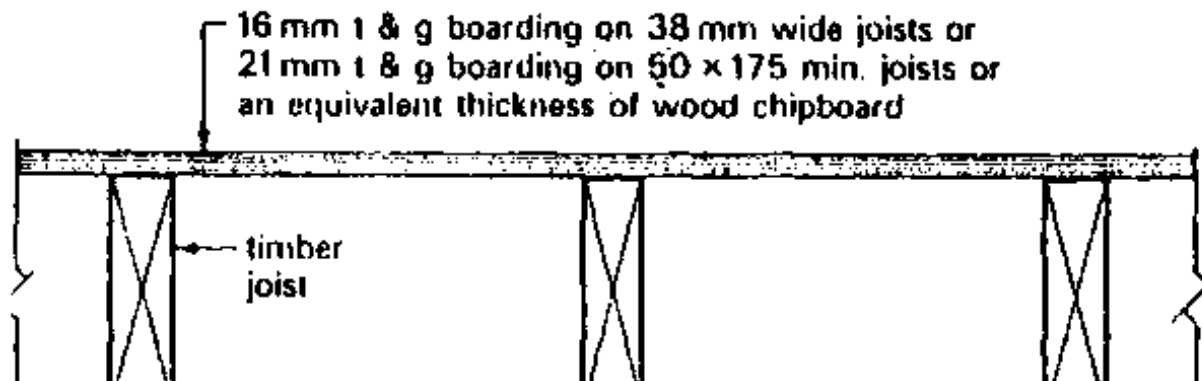

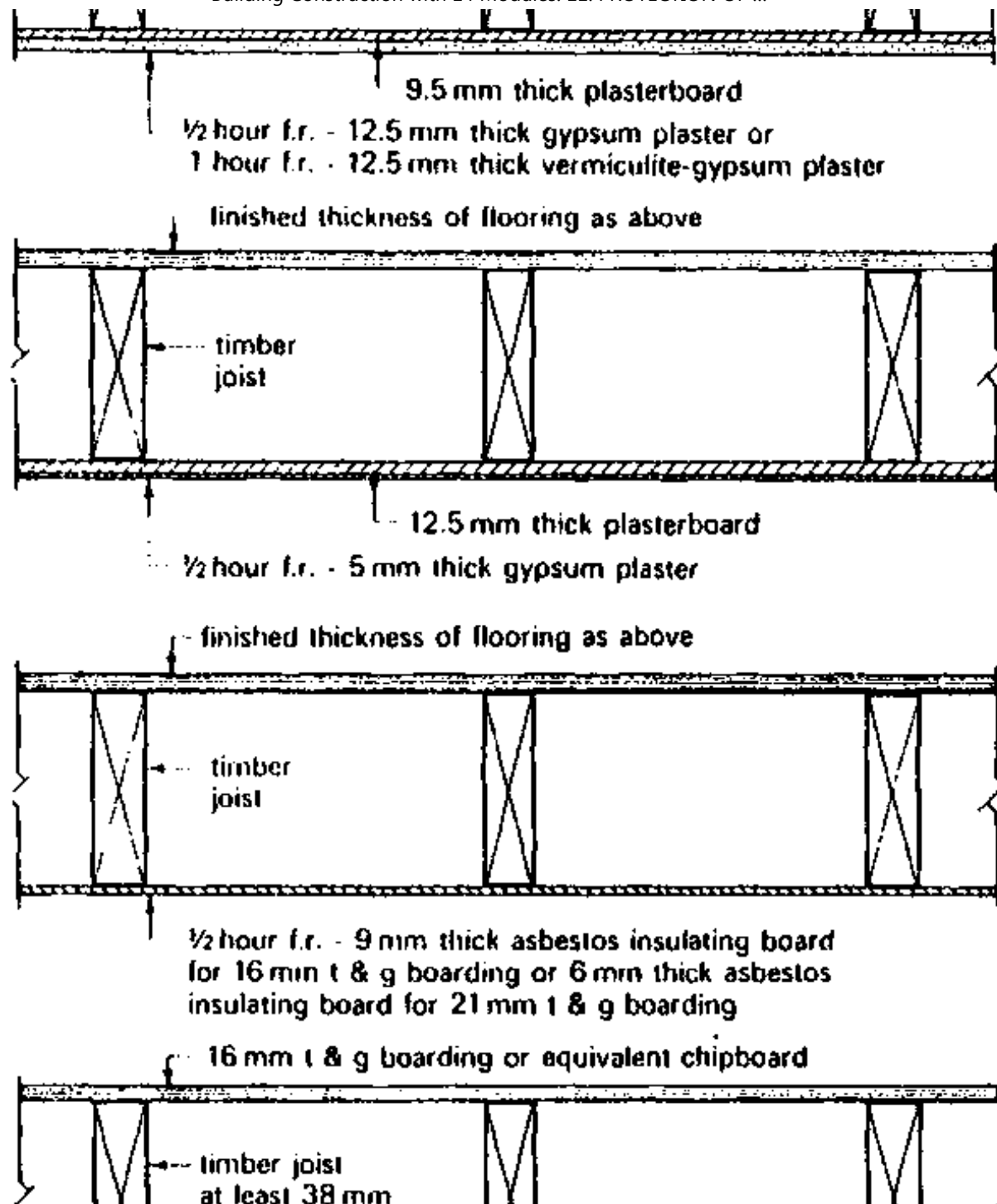

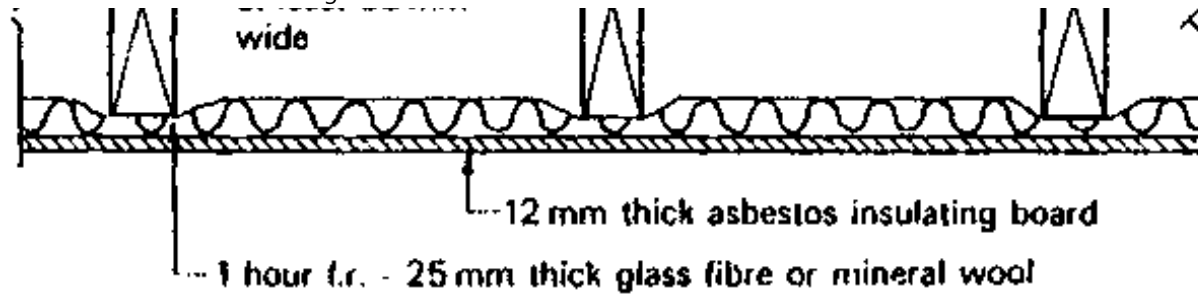

ref:- Schedule 8 Part VII B and VII C
Fire resistance - timber floors

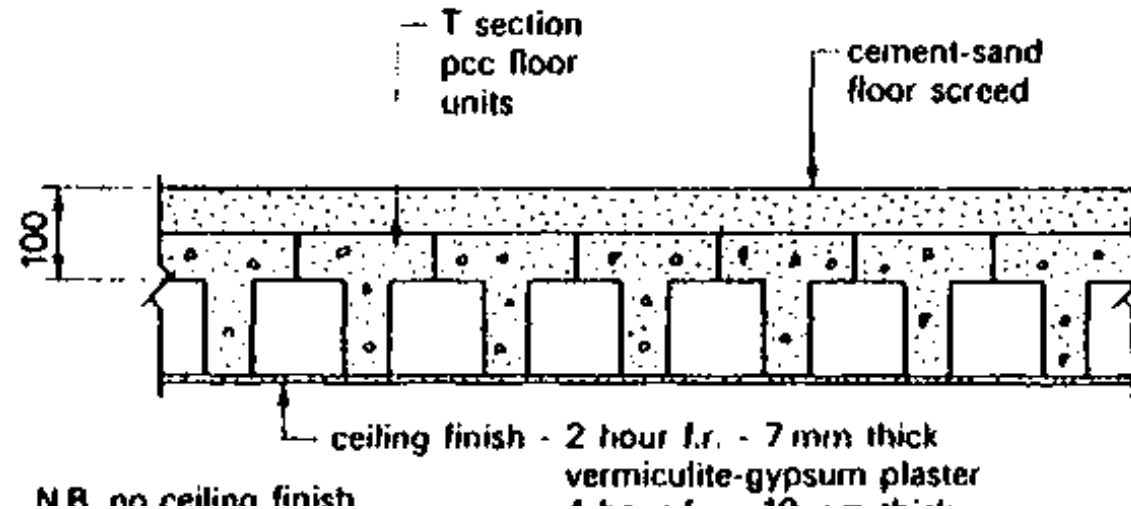
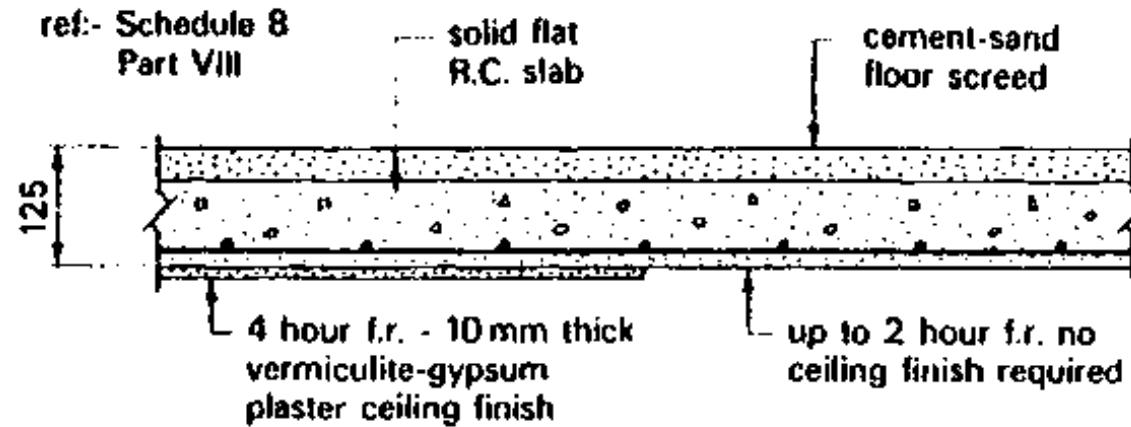

required for 1 hour f.r. 4 hour f.r. - 19 mm thick vermiculite-gypsum plaster

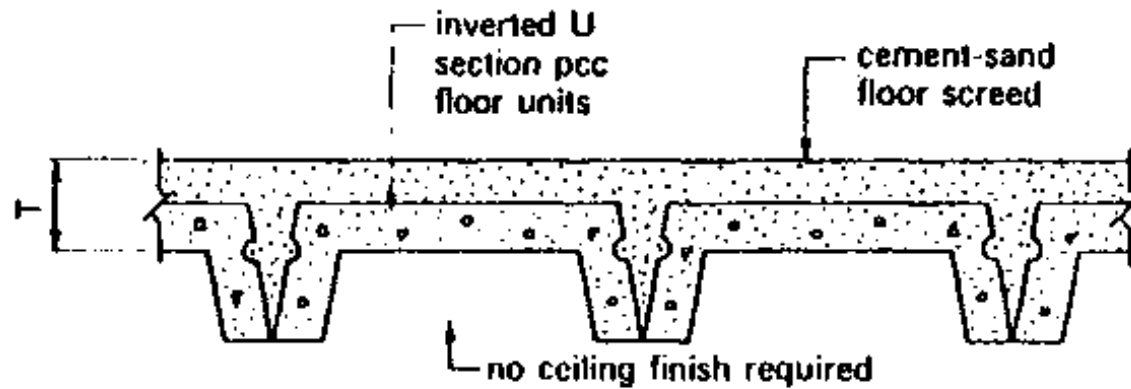

1 hour f.r. $T = 75\text{ mm}$ 2 hour f.r. $T = 100\text{ mm}$ 4 hour f.r. $T = 150\text{ mm}$

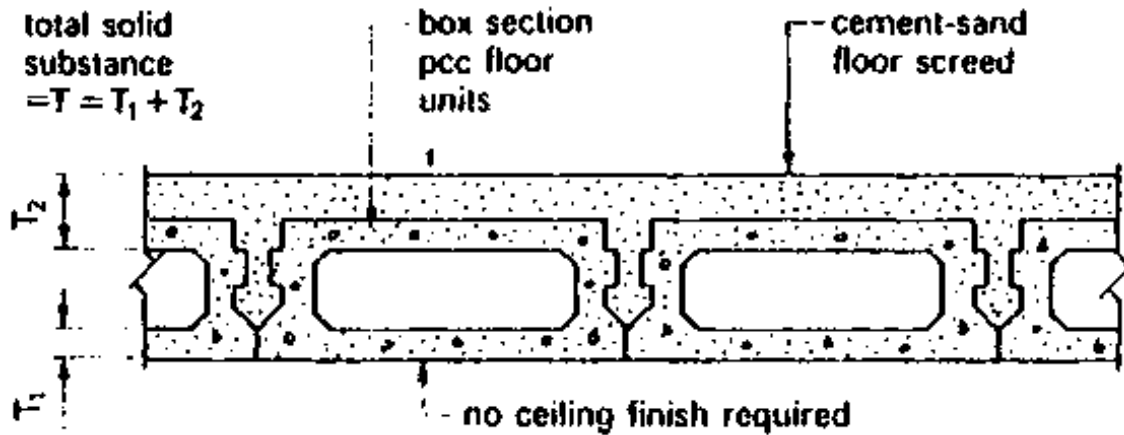

1 hour f.r. $T = 75\text{ mm}$ 2 hour f.r. $T = 90\text{ mm}$ 4 hour f.r. $T = 125\text{ mm}$

Fire resistance - concrete floors

Repetition exercises

Try to answer the following QUESTIONS and practice sketching where ever necessary and possible.

1. Exclusion of Water

- Why must **WATER** be totally excluded from the interiors of buildings;
- What are the three main sources of **MOISTURE** in buildings?
- Write notes on **PRECIPITATION!**
- Describe different ways of **ROOF DRAINAGES!**
- Describe damages caused by **FLOODING!**
- Where can **DROUGHT** occur and what does it cause;
- Which two methods of **MOISTURE CONTROL** are normally employed?

2. Thermal Insulation

- Define the term **THERMAL INSULATION**
- In which three ways can the **TRANSFER OF HEAT** occur?
- What are the **ADVANTAGES OF** thermal insulation of buildings?
- Which factors are important in selecting or specifying thermal insulating materials?
- List and describe different insulating materials

3. Sound Insulation

- Define the following terms:
 - **Sound**
 - **Pitch**
 - **Loudness**
 - **Frequency**
 - **internal noise sources**
 - **external noise sources**

- **airborn sounds**
- **impact sounds**

- **What is the most effective barrier to the passage of sound through materials?**
- **Explain in the form of neat sketches examples of Sound insulation in**

a WALLS

b FLOORS

- **Write notes on EXTERNAL NOISE!**

4. Fire Protection

- **What are the three main fields of FIRE PROTECTION?**
- **Write notes on STRUCTURAL FIRE PROTECTION!**
- **Define the term FIRE LOAD**
- **List different building materials and describe their behaviour under intense heat or fire.**
- **Show in the form of neat sketches typical examples of working details for the fire protection of:**
 - **Walls of masonry construction**
 - **Framed and composite walls**
 - **R. C. columns and beams**

- Steel columns and beams
- Hollow protection to steel columns
- Hollow protection to steel beams
- Timber floors
- Concrete floors

Building Reg. E1 – fire stop means a barrier or seal which would prevent or retard the passage of smoke or flame within a cavity, around a pipe where it passes through a wall or floor or at junctions between elements of structure

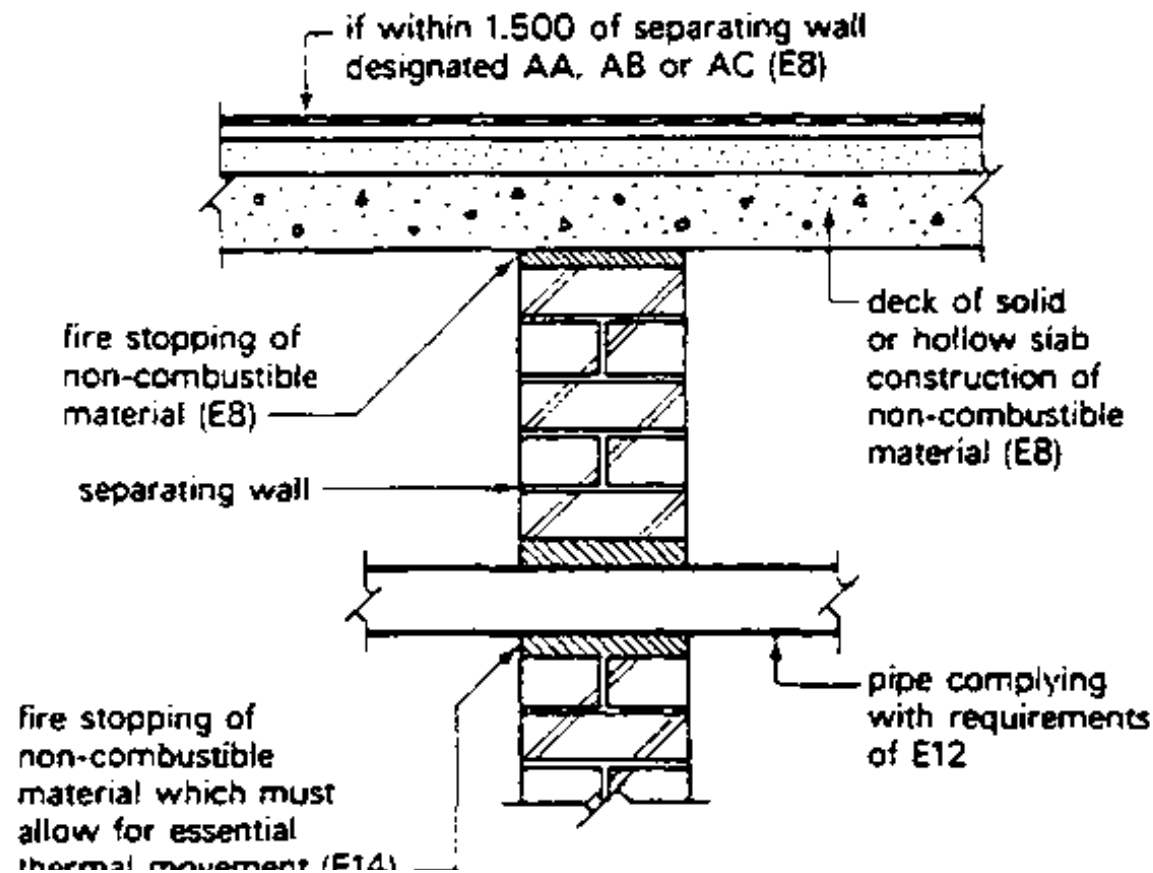

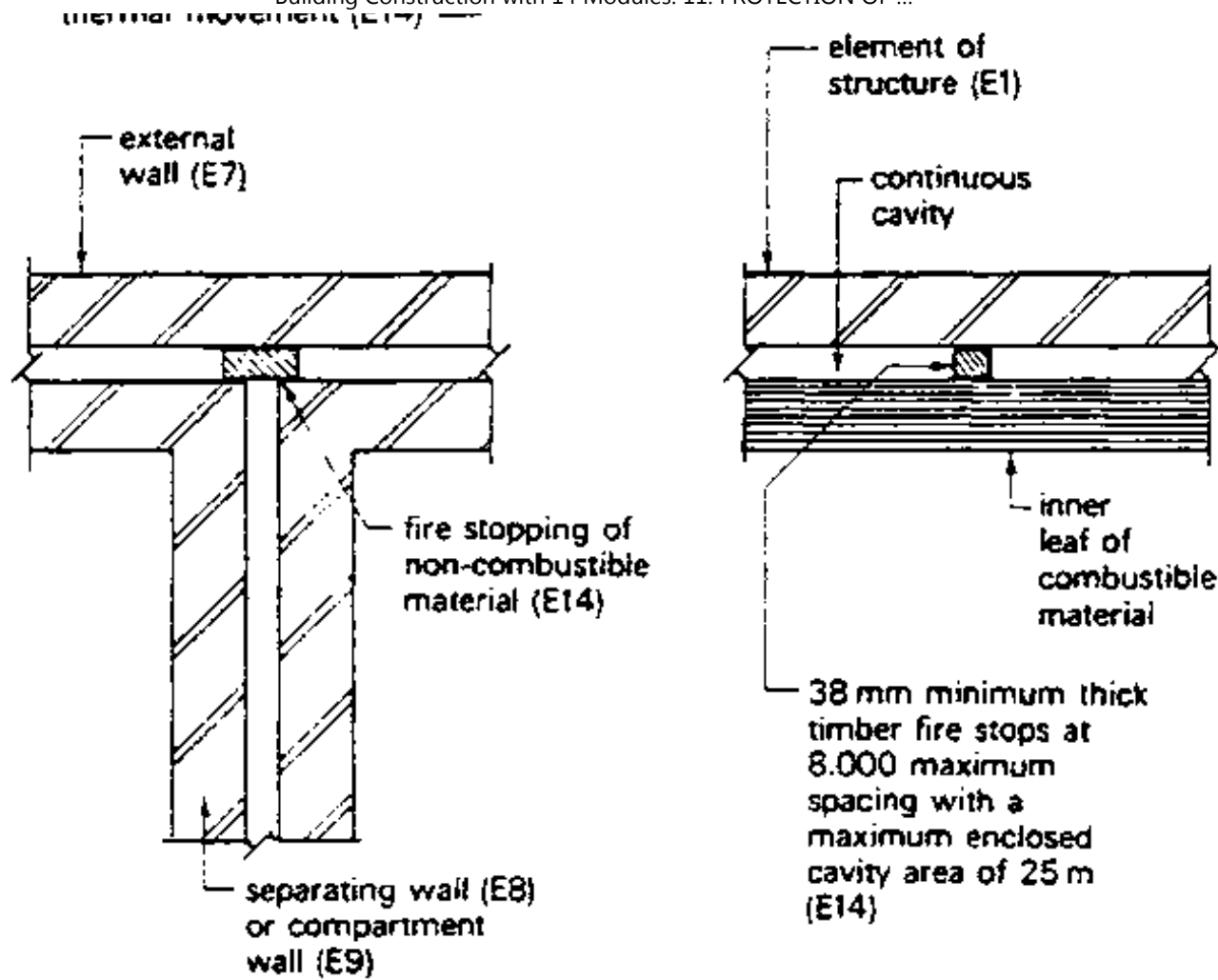

Please provide your feedback

English | French | Spanish | German