

[Home page](#) | [Help](#) | [Clear](#)

[English](#) | [French](#) | [Spanish](#) | [German](#)

[Search](#) | [Subjects](#) | [Titles A-Z](#) | [Courses](#) | [Illustrations](#) | [Topics](#) | [e-Course builder](#)

 [Contract TOC](#)

 [Expand Document](#)

 [Contract Chapter](#)

 [Add to e-Course](#)

 [Preferences](#)

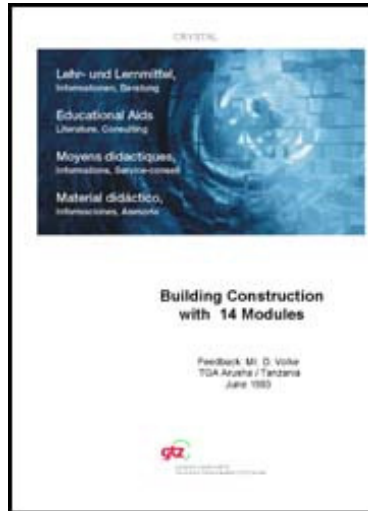

[Printable version](#)

[Export document as HTML file](#) [Help](#)

[Export document as PDF file](#)

## **Building Construction with 14 Modules (TCA; 1983; 618 pages)**

### **1. ARCHITECTURAL DRAWING I**

#### **1.1 AIMS AND PURPOSE OF ARCHITECTURAL DRAWINGS**

##### **1.1.1 CONTENTS OF ARCHITECTURAL DRAWINGS**

#### **1.2 DRAWING EQUIPMENT**

##### **1.2.1 PENCILS**

##### **1.2.2 DRAWING PENS**

##### **1.2.3 COMPASSES**

##### **1.2.4 DRAWING BOARDS**

##### **1.2.5 T-SQUARES**

##### **1.2.6 SET SQUARES**

##### **1.2.7 PROTRACTORS**

##### **1.2.8 SCALES**

##### **1.2.9 FRENCH CURVES**

##### **1.2.10 TEMPLATES**

##### **1.2.11 DRAWING PINS AND OTHER FIXINGS**

##### **1.2.12 MINOR ITEMS OF EQUIPMENT**

##### **1.2.13 PRINTING PAPERS**

##### **1.2.14 TRACING PAPER, CLOTH AND FILM**

 **1.2.15 BACKING SHEETS**

 **1.2.16 DRAWING PAPERS**

 **1.2.17 CARTRIDGE**

 **1.2.18 HANDMADE AND MOULDMADE PAPERS**

 **1.2.19 PLASTIC-COATED CARD**

 **1.3 LETTERING**

 **1.3.1 PRINCIPLE OF LETTERING**

 **1.3.2 FREEHAND LETTERING**

 **1.3.3 TYPES OF LETTERS**

 **1.3.3.1 The Roman Alphabet**

 **1.3.3.2 Sans Serif Letters**

 **1.3.3.3 Inclined Lettering**

 **1.3.3.4 Script Lettering**

 **1.3.3.5 Stencil Lettering**

 **1.3.3.6 Guided Pen Lettering**

 **1.3.3.7 Pressure-Transfer Lettering**

 **1.4 LINEWORK AND DIMENSIONING**

 **1.4.1 TYPES OF LINES**

 **1.4.2 PENCIL DRAWING**

 **1.4.3 INKING - IN**

 **1.4.4 BASIC RULES OF DIMENSIONING**

 **1.4.4.1 Types of Dimensions**

 **1.4.4.2 Placement of Dimensions**

 **1.5 ENLARGEMENT AND REDUCTION OF LINE DRAWINGS** **1.6 GEOMETRICAL CONSTRUCTIONS** **1.6.1 LINES AND ANGLES** **1.6.1.1 To bisect a straight line AB** **1.6.1.2 To divide a straight line AB into a given number of equal parts** **1.6.1.3 To divide a straight line AB into any ratio** **1.6.1.4 To construct an angle of  $90^\circ$**  **1.6.1.5 To construct an angle of  $45^\circ$**  **1.6.1.6 To construct an angle of  $60^\circ$**  **1.6.1.7 To construct an angle of  $30^\circ$**  **1.6.1.8 To bisect any given angle** **1.6.1.9 To construct an angle SIMILAR to a given angle** **1.6.1.10 To draw a line PARALLEL to a given line** **1.6.2 TRIANGLES** **1.6.2.1 To construct an EQUILATERAL triangle** **1.6.2.2 To construct a triangle with given BASE ANGLES and ALTITUDE** **1.6.2.3 To inscribe a circle in a given triangle ABC** **1.6.2.4 To circumscribe a triangle ABC** **1.6.3 CIRCLES** **1.6.3.1 Basic CIRCLE-Constructions** **1.6.3.2 To draw a tangent to a point A on the circumference of a circle centre O**

 **1.6.3.3 To draw an internal tangent to two circles of equal diameter**

 **1.6.3.4 To find the centre of a given circle arc**

 **1.6.3.5 To join two straight lines at RIGHT ANGLES to each other by an arc of given radius**

 **1.6.3.6 To draw a curve of given radius joining two circles**

 **1.6.3.7 To join two straight lines by two arcs of equal radius**

 **1.6.4 BASIC ARCH CONSTRUCTIONS**

 **2. ARCHITECTURAL DRAWING II**

 **2.1 TYPES OF PROJECTIONS**

 **2.2 ORTHOGRAPHIC PROJECTION**

 **2.2.1 CONSTRUCTION OF ORTHOGRAPHIC PROJECTION**

 **2.2.2 ELEVATIONS**

 **2.2.3 PLANS AND SECTIONS**

 **2.3 PICTORIAL DRAWING**

 **2.3.1 AXONOMETRIC PROJECTION**

 **2.3.2 ISOMETRIC PROJECTION**

 **2.3.3 DIMETRIC PROJECTION**

 **2.3.4 OBLIQUE PROJECTION**

 **2.3.4.1 Length of Receding Lines**























 **2.3.4.2 Construction of Oblique Drawings**

 **2.3.4.3 Rules of Oblique Drawing**























 **2.3.4.4 Scale of the Receding Lines**

 **2.3.4.5 Direction of Receding Lines**

 **2.3.4.6 Position of Axes** **2.4 PERSPECTIVE DRAWING** **2.4.1 PERSPECTIVE TERMS** **2.4.2 PHENOMENA OF PERSPECTIVE DRAWING** **2.4.3 SYSTEMS OF PERSPECTIVE DRAWINGS** **2.4.4 METHODS OF PERSPECTIVE DRAWINGS** **2.4.5 TWO-POINT PERSPECTIVE** **2.4.6 ONE-POINT PERSPECTIVE** **2.5 SHADES AND SHADOWS** **2.5.1 THE USE OF SHADOWS** **2.5.2 SHADES AND SHADOWS** **2.5.3 THE CONVENTIONAL DIRECTION OF LIGHT** **2.5.4 THE 45° DIRECTION** **2.5.5 THE TRUE DIRECTION OF LIGHT** **2.5.6 SHADOWS OF SOLIDS** **2.5.7 PLANES OF SHADOW** **2.5.8 PRINCIPLES OF SHADOW-CASTING** **2.6 DRAWING PRACTICE** **2.6.1 DRAWING SHEETS** **2.6.1.1 Sizes and Folds** **2.6.1.2 Layout and Identification** **2.6.2 LEVELS** **2.6.3 REFERENCING**

-  **2.6.4 ABBREVIATIONS**
-  **2.6.5 REPRESENTATION OF MATERIALS**
-  **2.6.6 GRAPHICAL SYMBOLS AND REPRESENTATION**
-  **2.6.7 HATCHING RULES**
-  **2.7 APPLICATION FOR BUILDING PERMIT**
  -  **2.7.1 PROCEDURE OF APPLYING FOR PERMISSION TO ERECT A BUILDING**
  -  **2.7.2 FORMULARS**
-  **4. CONTRACT PLANNING AND SITE ORGANISATION**
  -  **4.1 CONTRACT PLANNING**
    -  **4.1.1 BAR CHART**
    -  **4.1.2 NETWORK ANALYSIS**
    -  **4.1.3 THE OVERALL PROGRAMME**
      -  **4.1.3.1 Break down of job**
      -  **4.1.3.2 Quantities of work and time content**
      -  **4.1.3.3 Plant and Labour outputs**
      -  **4.1.3.4 Sequence and timing of operations**
      -  **4.1.3.5 The programme chart**
    -  **4.1.4 PLANNING CONSIDERATIONS**
      -  **4.1.4.1 Site conditions and access**
      -  **4.1.4.2 Nature of job**
      -  **4.1.4.3 Plant**
      -  **4.1.4.4 Scaffolding**

 **4.2 SITE ORGANIZATION** **4.2.1 PRELIMINARY WORK** **4.2.2 SITE PLANNING** **4.2.2.1 Period planning** **4.2.2.2 Weekly planning** **4.2.2.3 Progress control** **4.2.3 SITE LAYOUT** **5. FOUNDATIONS** **5.1 SOIL INVESTIGATIONS** **5.1.1 SITE EXPLORATION** **5.1.1.1 Trial holes** **5.1.1.2 Bore holes** **5.1.1.3 Sampling** **5.1.1.4 Tests** **5.1.1.5 Load or bearing test** **5.1.2 SOILS AND SOIL CHARACTERISTICS** **5.1.2.1 Rocks and soils** **5.1.2.2 Stresses and pressures** **5.2 EXCAVATIONS AND TIMBERING** **5.3 TYPES OF FOUNDATIONS** **5.3.1 CLASSIFICATION** **5.3.2 CHOICE OF FOUNDATION** **5.3.3 SPREAD FOUNDATIONS**

-  **5.3.3.1 Strip foundations**
-  **5.3.3.2 Deep strip foundations**
-  **5.3.3.3 Stepped foundations**
-  **5.3.3.4 Pad foundations**
-  **5.3.3.5 Raft foundations**
-  **5.3.4 PILE FOUNDATIONS**
  -  **5.3.4.1 Short bored pile foundations**
-  **5.3.5 PIER FOUNDATIONS**
-  **6. WALLS**
  -  **6.1 FUNCTION AND PROPERTIES OF WALLS**
  -  **6.2 THE BEHAVIOR OF THE WALL UNDER LOAD**
    -  **6.2.1 CALCULATION OF WALL THICKNESS**
  -  **6.3 TYPES OF WALLS**
  -  **6.4 STONEMWORK**
    -  **6.4.1 BUILDING STONES**
    -  **6.4.2 STONEMWORK THERMINOLOGY**
    -  **6.4.3 STONEMWORK CLASSIFICATION**
    -  **6.4.4 RUBBLE WALLING**
    -  **6.4.5 ASHLAR WALLING**
      -  **6.4.5.1 Rules for ashlar work**
  -  **6.5 BRICK WORK**
    -  **6.5.1 BRICKWORK TERMINOLOGY**
    -  **6.5.2 MANUFACTURE OF CLAY BRICKS**



 **6.5.2.1 Pressed Bricks** **6.5.2.2 Wire cut bricks** **6.5.2.3 Efflorescence** **6.5.3 BRICK CLASSIFICATION** **6.5.4 CALCIUM SILICATE BRICKS** **6.5.5 CONCRETE BRICKS** **6.5.6 MORTARS FOR BRICKWORK** **6.5.7 DAMPNES PENETRATION** **6.5.8 BRICKWORK BONDING** **6.5.8.1 Common bonds** **6.5.9 METRIC MODULAR BRICKWORK** **6.5.10 JUNCTIONS** **6.5.11 QUOINS OR EXTERNAL ANGLES** **6.5.12 PIERS** **6.5.12.1 Detached piers:** **6.5.12.2 Attached Piers (or Pilasters)** **6.5.12.3 Buttresses** **6.6 BLOCKWORK** **6.6.1 CLAY BLOCKS** **6.6.2 PRECAST CONCRETE BLOCKS** **6.6.3 AERATED CONCRETE BLOCKS** **6.7 CONCRETE WALLS** **6.7.1 GENERAL**



**6.7.2 FOREWORK**

**6.7.3 PLAIN MONOLITHIC CONCRETE WALL**

**6.7.3.1 Dense concrete walls**

**6.7.3.2 Light-weight aggregate**

**6.7.3.3 No-fines concrete walls**

**6.7.3.4 Thickness of plain concrete walls**

**6.7.3.5 Shrinkage reinforcement**

**6.7.4 REINFORCED CONCRETE WALLS**

**6.7.4.1 In-Situ Cast external walls**

**6.7.4.2 Concrete Box Frames**

**6.7.4.3 Large precast panel structure**

**6.8 OPENINGS IN WALLS**

**6.8.1 HEAD**

**6.8.1.1 Lintels**

**6.8.1.2 Arches**

**6.8.2 JAMBS**

**6.8.3 SILLS AND THRESHOLDS**

**6.8.3.1 Sills**

**6.8.3.2 Thresholds**

**7. FLOORS**

**7.1 GENERAL**

**7.2 SOLID GROUND FLOORS**





## **7.2.1 SITE CONCRETE**



## **7.2.2 HARDCORE**



## **7.2.3 WATERPROOF MEMBRANE**



## **7.3 SUSPENDED TIMBER GROUND FLOOR**



### **7.3.1 BUILDING REGULATIONS**



### **7.3.2 LAY OUT**



## **7.4 UPPER FLOORS**



### **7.4.1 TYPES OF UPPER FLOORS**



### **7.4.2 STRUCTURE OF UPPER FLOORS**



### **7.4.3 SUSPENDED TIMBER UPPER FLOORS**



#### **7.4.3.1 Floor Joists**



#### **7.4.3.2 End Support of Floor Joists**



#### **7.4.3.3 Trimming**



### **7.4.4 REINFORCED CONCRETE UPPER FLOORS**



#### **7.4.4.1 Monolithic Reinforced Concrete Upper Floors**



#### **7.4.4.2 Precast Concrete Upper Floors**



#### **7.4.4.3 Hollow Block and Waffle Floors**



## **7.5 FLOOR FINISHES**



### **7.5.1 JOINTLESS FLOOR FINISHES**



#### **7.5.1.1 The most common of these is the Cement/Sand Screed**

























#### **7.5.1.2 Granolithic Concrete Finishes**



#### **7.5.1.3 Terazzo**



### **7.5.2 SLAB FLOORS FINISEHES**

-  **7.5.3 SHEET FLOOR FINISHES**
-  **7.5.4 WOOD FLOOR FINISHES**
-  **8. OPEN FIREPLACES, CHIMNEYS AND FLUES**
  -  **8.1 FUNCTION OF FIREPLACES AND FLUES**
  -  **8.2 PRINCIPLES OF FIREPLACE DESIGN**
    -  **8.2.1 TRADITIONAL OPEN FIREPLACE**
    -  **8.2.2 IMPROVED SOLID FUEL APPLIANCES**
  -  **8.3 PRINCIPLES OF FLUE DESIGN**
  -  **8.4 CONSTRUCTION OF FLUE DESIGN**
    -  **8.4.1 NON-CONVECTOR OPEN FIRES**
    -  **8.4.2 CONVECTOR OPEN FIRES**
  -  **8.5 CONSTRUCTION OF CHIMNEYS**
-  **9. ROOFS**
  -  **9.1 FUNCTIONAL REQUIREMENTS**
    -  **9.1.1 STRENGTH AND STABILITY**
    -  **9.1.2 WEATHER RESISTANCE**
    -  **9.1.3 THERMAL INSULATION**
    -  **9.1.4 FIRE RESISTANCE**
    -  **9.1.5 SOUND INSULATION**
  -  **9.2 TYPES OF ROOF STRUCTURES**
    -  **9.2.1 FLAT AND PITCHED ROOFS**
    -  **9.2.2 STRUCTURE OF THE ROOF**
    -  **9.2.3 LONG AND SHORT SPAN ROOFS**

 **9.2 LONG AND SHORT OF A ROOF**

 **9.3 FLAT ROOFS**

 **9.3.1 PHYSICAL AND STRUCTURAL PROBLEMS**

 **9.3.2 STRUCTURE OF A FLAT ROOF**

 **9.3.3 THERMAL INSULATION MATERIAL**

 **9.3.4 SINGLE AND DOUBLE FLAT ROOF CONSTRUCTION**

 **9.3.5 PARAPET WALLS**

 **9.4 PITCHED ROOFS**

 **9.4.1 SHAPES OF PITCHED ROOFS IN TIMBER**

 **9.4.2 TERMS**

 **9.4.3 TYPES OF PITCHED ROOFS IN TIMBER (STRUCTURES)**

 **9.4.3.1 Mono-(single) pitched Roof**

 **9.4.3.2 Lean - to Roof**

 **9.4.3.3 Couple Roof**

 **9.4.3.4 Close couple Hoof**

 **9.4.3.5 Collar Roof**

 **9.4.3.6 Double or Purlin Roof**

 **9.4.3.7 Tripple or Trussed Roofs**

 **9.4.3.8 Trussed Rafters**

 **9.4.3.9 Hipped Roofs**

 **9.4.4 VALLEY**

 **9.4.5 EAVES TREATMENT**

 **9.4.6 OPENINGS IN TIMBER ROOFS**

 **9.5 ROOF COVERINGS**

**9.5 ROOF COVERINGS**

-  **9.5.1 FUNCTION OF ROOF COVERINGS**
-  **9.5.2 TYPES OF ROOF COVERINGS**
-  **9.5.3 SUBSTRUCTURES**
-  **9.5.4 CHOICE OF ROOF COVERINGS**
-  **9.5.5 MATERIALS AND COVERING METHODS**

 **10. FRAMED STRUCTURES**

-  **10.1 STRUCTURAL CONCEPT**
-  **10.2 FUNCTIONAL REQUIREMENTS**
-  **10.3 STRUCTURAL MATERIALS**
-  **10.4 LAYOUT OF FRAMES**
-  **10.5 BUILDING FRAMES**
  -  **10.5.1 FUNCTIONS OF BUILDING FRAME MEMBERS**
  -  **10.5.2 REINFORCED CONCRETE FRAMES**
    -  **10.5.2.1 Reinforced Concrete Beams**
    -  **10.5.2.2 Reinforced Concrete Columns**
    -  **10.5.2.3 Reinforced Concrete Slabs**
  -  **10.5.3 PRECAST CONCRETE FRAMES**
    -  **10.5.3.1 Methods of Connections**
  -  **10.5.4 STRUCTURAL STEELWORK FRAMES**
    -  **10.5.4.1 Structural Steel Frames**
    -  **10.5.4.2 Castellated Universal Sections**
    -  **10.5.4.3 Connections**
    - 



#### **10.5.4.4 Structural Steel Connections**



#### **10.5.4.5 Frame Erection**



#### **10.5.4.6 Fire Protection of Steelwork**



### **10.5.5 TIMBER FRAMES**



#### **10.5.5.1 Columns and Beams**



#### **10.5.5.2 Connections**



#### **10.5.5.3 Building frames in timber**



#### **10.5.5.4 Prefabrication**



### **10.6 PORTAL FRAMES**



#### **10.6.1 THEORY**



#### **10.6.2 CONCRETE PORTAL FRAMES**



#### **10.6.3 STEEL PORTAL FRAMES**



#### **10.6.4 TIMBER PORTAL FRAMES**



## **11. PROTECTION OF BUILDINGS**



### **11.1 EXCLUSION OF WATER**



#### **11.1.1 PRECIPITATION**



##### **11.1.1.1 Roof Drainage**



##### **11.1.1.2 Flooding**



##### **11.1.1.3 Drought**



#### **11.1.2 DAMP RISING AND MOISTURE MIGRATION**



























#### **11.1.3 CONDENSATION**



### **11.2 THERMAL INSULATION**



#### **11.2.1 DEFINITION**

-  **11.2.1 DEFINITION**
-  **11.2.2 INSULATING MATERIALS**
-  **11.3 SOUND INSULATION**
  -  **11.3.1 DEFINITION**
  -  **11.3.2 SOUND INSULATION**
  -  **11.3.3 EXTERNAL NOISE**
-  **11.4 FIRE PROTECTION**
  -  **11.4.1 STRUCTURAL FIRE PROTECTION**
    -  **11.4.1.1 Fire Load**
    -  **11.4.1.2 Fire Resistance of Material**
    -  **11.4.1.3 Appropriate Types of Construction**
-  **12. FINISHING &. FINISHES**
  -  **12.1 EXTERNAL WALL FINISHES**
    -  **12.1.1 EXTERNAL RENDERING**
    -  **12.1.2 CONCRETE FINISHES**
    -  **12.1.3 CLADDING**
      -  **12.1.3.1 CLADDINGS FIXED TO A STRUCTURAL BACKING**
      -  **12.1.3.2 CLADDINGS TO FRAMED STRUCTURES**
    -  **12.1.4 EXTERNAL PAINTS AND FINISHES**
  -  **12.2 INTERNAL WALL FINISHES**
    -  **12.2.1 PLASTERING**
    -  **12.2.2 OTHER INTERNAL WALL FINISHES**
    -  **12.2.3 PAINTING**
  -  **12.3 CEILING FINISHES**



 **12.5 CEILING FINISHES** **13. STAIRS** **13.1 INTRODUCTION** **13.2 DEFINITION OF TERMS** **13.3 TYPES OF STAIRS** **13.4 DESIGN OF STAIRS** **13.4.1 RISE - TREAD - PROPORTION** **13.4.2 SLOPE OR PITCH** **13.4.3 LANDINGS** **13.4.4 WIDTH** **13.4.5 WALKING LINE** **13.5 CONSTRUCTION OF STAIRS** **13.5.1 BRICK STAIRS** **13.5.2 STONE STAIRS** **13.5.3 CONCRETE STAIRS** **13.5.3.1 In Situ Cast R.C. Stairs** **13.5.3.2 Precast Concrete Stairs** **13.5.4 TIMBER STAIRS** **13.5.5 METAL STAIRS** **13.6 MISCELLANEOUS** **13.6.1 BALUSTRADES/HANDRAILS** **13.6.2 'SAMBA' STAIR, LADDERS, DISAPPEAR STAIRS, RAMPS** **13.6.3 ESCALATORS** **14 DOORS & WINDOWS**

 **14. DOORS &. WINDOWS** **14.1 DOORS** **14.1.1 EXTERNAL DOORS** **14.1.2 INTERNAL DOORS** **14.1.3 PURPOSE MADE DOORS** **14.1.4 METHODS OF CONSTRUCTION** **14.1.4.1 Door terminology** **14.1.4.2 Panelled and glazed wood doors** **14.1.4.3 Flush doors** **14.1.4.4 Fire-check flush doors** **14.1.4.5 Matchboarded doors** **14.1.5 FRAMES AND LININGS** **14.1.5.1 Timber Door Frames** **14.1.5.2 Metal door frames** **14.1.5.3 Door linings** **14.1.6 SPECIAL DOORS** **14.2 WINDOWS, GLASS &. GLAZING** **14.2.1 PRIMARY FUNCTIONS OF WINDOWS** **14.2.2 BUILDING REGULATIONS** **14.2.3 TRADITIONAL CASEMENT WINDOWS** **14.2.4 STANDARD WOOD CASEMENT WINDOWS** **14.2.5 STEEL CASEMENT WINDOWS** **14.2.6 BAY WINDOWS**



## **14.2.7 SLIDING SASH WINDOWS**

 **14.2.7.1 Vertical sliding windows (also called double hung sash windows)**

 **14.2.7.2 Horizontal sliding windows**

 **14.2.8 PIVOT WINDOWS**

 **14.2.9 LOUVRES**

 **14.2.10 GLASS AND GLAZING**

 **14.2.10.1 Glass**

 **14.2.10.2 Glazing**

 **14.2.11 MOSQUITO SCREENING (FLY SCREENS)**

 **14.2.12 SUN-BREAKERS**

 **14.3 IRON MONGERY**

 **14.3.1 HINGES**

 **14.3.2 LOCKS AND LATCHES**

 **14.3.3 MISCELLANEOUS**

## **12. FINISHING &. FINISHES**

### **REFERENCES:**

1. R. Chudley, "CONSTRUCTION TECHNOLOGY", Volume 1, 2, 3, 4
2. R.L. Fullerton, "BUILDING CONSTRUCTION", Volume 1, 2, 3
3. W.G. Nash, "BRICKWORK 2"

### **12.1 EXTERNAL WALL FINISHES**

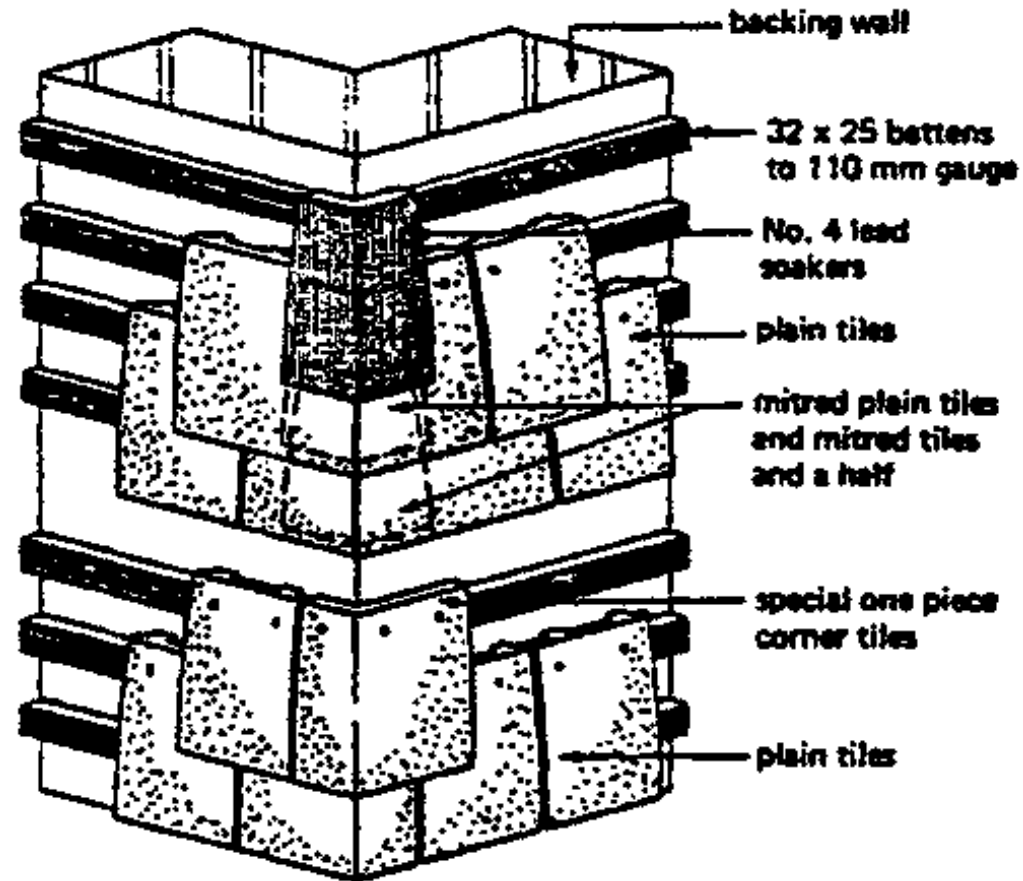

Alternative external angle treatments (internal angles treatments similar)

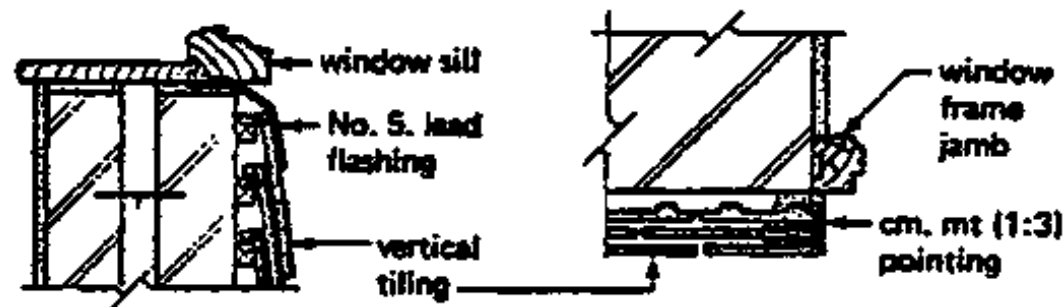
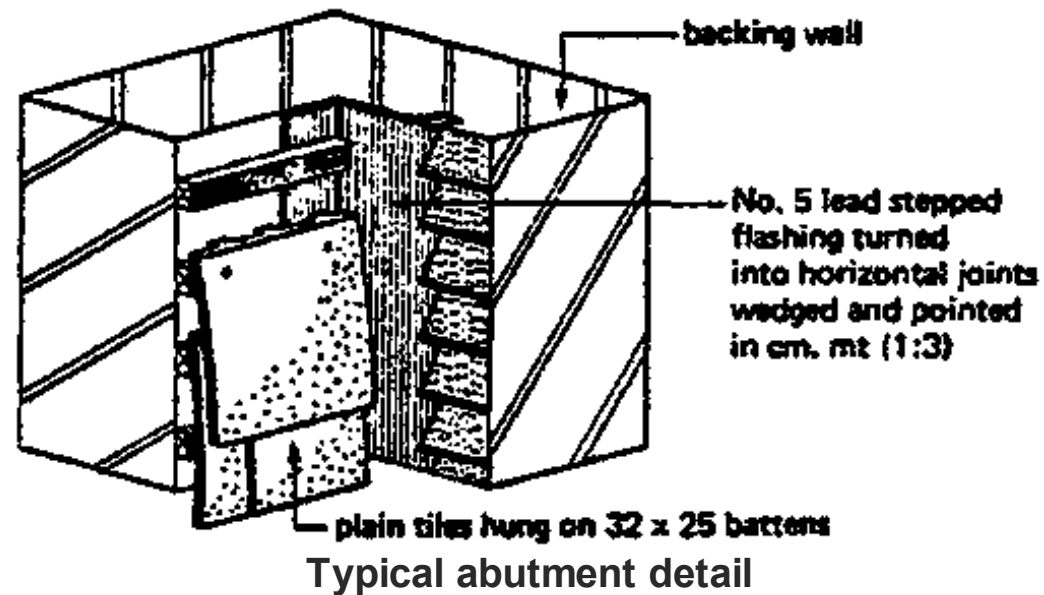

External brickwork with an exposed Face of facing bricks is a SELF FINISH and requires no further treatment.

External walls of common bricks or blocks can be treated to give an acceptable appearance by the application of FAINT, an application wall finish such as RENDERING or can be CLAD with boards or tiles.

### 12.1.1 EXTERNAL RENDERING

This is a form of plastering using a mixture of cement and sand or cement lime and sand applied to the

**RENDERING IS A FORM OF PLASTERING USING A MIXTURE OF CEMENT AND SAND, OR CEMENT, LIME AND SAND, APPLIED TO THE FACE OF A BUILDING TO GIVE EXTRA PROTECTION AGAINST THE PENETRATION OF MOISTURE OR TO PROVIDE A DESIRED TEXTURE. IT CAN ALSO BE USED IN THE DUAL CAPACITY OF PROVIDING PROTECTION AND APPEARANCE.**

**The rendering must have the properties of**

- durability**
- moisture resistance**
- an acceptable appearance**

**The success of the rendering depends on**

- the nature of the background**
- the quality of the mix**
- the location of the work**
- the method of application.**

- Good quality brick - or blockwork with raked joints and locked surface will give good results if the wall is wetted to reduce heat and suction.**
- SPATTERDASH, i.e. cement and sand slurry 1:3. on concrete walling gives good results 'in bonding.**
- The mix of materials is as important as their quality. Cement and sand mixes will produce a strong moisture resistant rendering but one which is subject to cracking due to high drying shrinkage. (These mixes are used mainly on members which may be vulnerable to impact damage such as columns.)**

**Cement, lime and sand mixes have a lower drying shrinkage but are more absorbent than cement and sand mixes; they will, however, dry out rapidly after periods of rain and are therefore the mix**

**recommended for general use.**

**Two common volume mix ratios are:**

**a) 1:1/2:4-4 1/2**

**cement: lime: sand,**

**which is used for dense, strong backgrounds of moderate to severe exposure and for application to metal lathing or expanded metal backgrounds.**

**b) 1:1:6-8**

**cement: lime: sand**

**which is for general use.**

- **The number of coats required will depend upon the surface condition of the background and the degree of exposure. Generally a TWO COAT application is acceptable, except where the background is very irregular or the building is in a position of severe exposure when a three coat application would be specified.**

**The thickness of any one coat should not exceed 15 mm and each subsequent coat is about 5 mm thick.**

- **Finishes should be floated, not trowelled smooth.**
- **Various textured surfaces can be obtained on renderings by surface treatments such as scraping the surface with combs, saw blades or similar tools to remove a surface skin of mortar. These operations are carried out some three to four hours after the initial application of the rendering and before the final set takes place.**
- **Alternative treatments are:**

**1. ROUGHCAST: a wet plaster mix of 1 part cement: 1/2 part lime: 1 1/2 parts shingle: 3 parts**

**sand, which is thrown on to a porous coat of rendering to give an even distribution.**

**2. FEBBLEDASH: selected aggregate such as pea shingle is dashed or thrown on to a rendering background be-fore it has set and is tamped into the surface with a wood float to obtain a good bond.**

**3. SPATTERED FINISHES: these are finishes applied by a machine (which can be hand operated), runs or sprays using special mixes prepared by the machine manufacturers.**

**4. TYROLEAN FINISH: it consists of 3 coats alltogether.**

**1. coat:**

**1 part waterproof cement**

**2 parts of sand (applied as spatter dash)**

**2. coat:**

**1 part of cement**

**1 part of lime**

**8 parts of sand (15 mm thick)**

**3. coat:**

**1 part cullamix or snowcrete Tyrolean grade, 2 1/2 parts sand applied by a special hand machine, which flips the mix evenly over the wall**

**It provides a pleasing and waterproof finish.**



## **MATERIALS**

- **Quality of materials:**

- **sand: should be washed, if dirty and thrown through a sieve.**
- **lime: should be well burned and free from unslaked particles.**
- **cement: can be a problem, because the quality of local factories is not always in conformity with B.G.**

**Therefore the local cement should be tested and compared with B.G. Specifications.**

**The most practical test, however, is to lay a sample panel of specified rendering on a wall as soon as the job begins and note the result some month later.**

### **12.1.2 CONCRETE FINISHES**

**There are a number of methods of finishing concrete walls apart from rendering or painting. The main treatments are to:**

- **leave it untouched after striking the shuttering**
- **use formwork other than timber**
- **use a retarding agent**
- **make a punched or tooled finish**
- **make patterns on the form-work.**

- **The texture of the finish created by the formwork depends on the boards used and the quality of the workmanship**

**Workmanship.**

- **Hardwood does not produce the grain effects of soft wood.**
- **Boards are more difficult to "true up" owing to poor seasoning and warping of timber.**
- **Tight joints in concrete should be ensured and boards levelled up to the same height.**
- **Day joints in concrete must be carefully constructed.**
- **Fins of concrete should be removed immediately the formwork is struck and the whole tubbed down with carborundum.**
- **Mortar to repair blemishes should be of lighter texture than, the concrete it self otherwise it will dry darker. - It should be floated - not trowelled smooth.**
- **Corrugated metal shuttering is frequently used for effect 2nd comes away easily.**
- **Plastic-moulded forms produce effects but are expensive.**
- **Retarding agents are normally brushed on to the formwork before concreting is started, and must be applied evenly. After striking, the concrete surface is brushed to expose the aggregate.**
- **A tooled finish is normally achieved by electric or pneumatic hammers with special heads. The can be varied to suit the texture required. Bush hammering is a favourite finish. Hand-tooling is done where labour is cheap, or where mechanical hammers could damage corners**
- **Care should be taken that tooling does not expose the reinforcement.**

**12.1.3 CLADDING**

**The term CLADDING IS USED WHEN THIN CONCRETE, STONE, GRANITE, MARBLE OR SLATE IS EMPLOYED AS A RACING IN ADDITION TO THE NORMAL STRUCTURAL REQUIREMENTS. IT SHOULD NOT BE FIXED TOO TIGHTLY TO THE STRUCTURE, FOR SOME MEASURE OF GIVE MUST BE ALLOWED SO THAT THE CLADDING DOES NOT BEAR THE STRAIN OF THE FINISHED CONSTRUCTION.**

## **ADVANTAGES**

**Cladding has several advantages over traditional types of construction.**

- 1. The units can be prepared in a factory, where their production is not hampered by bad weather conditions, and where good quality control can be maintained.**
- 2 They can be produced in readiness for fixing while the framework in being built.**
- 3 The units do not carry any structural loads C other than their own weight) and therefore they may be comparatively thin.**
- 4 A wide variety of surface finishes is available**
- 5 The framework and internal lining can be erected comparatively quickly, so that the internal finishes and services can be put into operation very soon after fixing the external cladding.**

**Certain points, however, must be observed if failures are to be avoided with thin type of construction. Some, of course, are the responsibility of the designer, but the cladding fixer must also play his part by making certain that the fixings are securely made and that all types of joints are constructed in accordance with approved practice.**

## **CLADDING**

**Important points for the designer:**

**important points for the designer:****He should:**

**1 allow for the thermal movement of the structure**

**2 allow for movement due to drying shrinkage (The fixing of the slabs should not be started too soon after the main structure. Some time must be allowed for the shrinkage in the framework to take place)**

**3 allow for elastic deformation particularly with wind loading on tall slender buildings.**

**4 allow for creep, which is a gradual compression of the structure due to sustained stress. Great care must be, therefore, taken with the compression joints.**

**5 allow for uneven settlement of the structure**

**6 avoid the use of a cladding material which is too thin, thus preventing adequate and safe fixing methods from being used**

**7 provide well designed cramping details**

**8 ensure that bond courses or other means of supporting the weight of the cladding are provided at each storey height**

**9 avoid using slabs of too large an area which would reduce the number of joints and probably absorb movement**

**10 specify the correct metal for the fixing cramps.**

**FOR THE DESIGNER****Important points for the cladding fixer:****He should:**

- 1 point the joints thoroughly to prevent the percolation of water behind the slabs (This will have a particularly harmful effect in the winter if the water freezes)**
- 2 use the correct type of fixing cramps as specified and not substitute different types or metals**
- 3 make certain that the bonders or supporting nibs are well constructed**
- 4 ensure accurate setting out of the fixing holes and slots**
- 5 not use hard mortars for the joints**
- 6 have sufficient thickness of the joints**
- 7 construct expansion and compression joints in accordance with the designer's requirements**
- 8 ensure that the correct gap is maintained at a maximum of 18 mm and a minimum of 6 mm. (If these limits are exceeded then the cramps will be either too short or too long and liable to lead to makeshift adaptations)**
- 9 Take precautions against rusting of the reinforcement, which might cause damage to the cladding, if "or any reason the concrete structural wall has to be cut back.**

**for the cladding fixer****Cramps and other fixings**

**These should be made from:**

- 1 non-ferrous metal, for example copper, gun-metal, phosphor bronze**
- 2 stainless steel alloys**
- 3 sherardised steel.**

**It is preferable that all the fixings on each job are of the same metal to prevent the possibility of electrolytic action taking place between dissimilar metals. This is likely to cause deterioration in at least one of the metals. Iron or steel are not generally suitable for use as cramps or fixings even though they may be coated, as the coating may become damaged and allow the steel to rust and cause staining on the cladding surface, or expansion which is likely to damage the cladding at the joints, or by spalling of the surface.**

### **Cramp holes or mortices.**

**These should be cut or drilled in the cladding without fracturing or spalling the material immediately surrounding the hole.**

**Claddings to buildings can be considered under two classifications**

- 1 Claddings fixed to a structural backing**
- 2 Claddings to framed structured.**

### **12.1.3.1 CLADDINGS FIXED TO A STRUCTURAL BACKING**

**Materials used in this form of cladding are generally considered to be small unit claddings and are applied for one of two reasons. If the structural wall is unable to provide an adequate barrier to the**

elements a covering of small unit claddings will generally raise the wall's resistance to an acceptable level. Alternatively small unit cladding can be used solely as a decorative feature, possibly to break up the monotony of a large plain area composed of a single material.

The materials used are tiles, slates, shingles, timber boarding, plastic boards and stone facings. The general method of fixing these small units is to secure them to timber battens fixed to the structure backing.

### - TILE HANGING

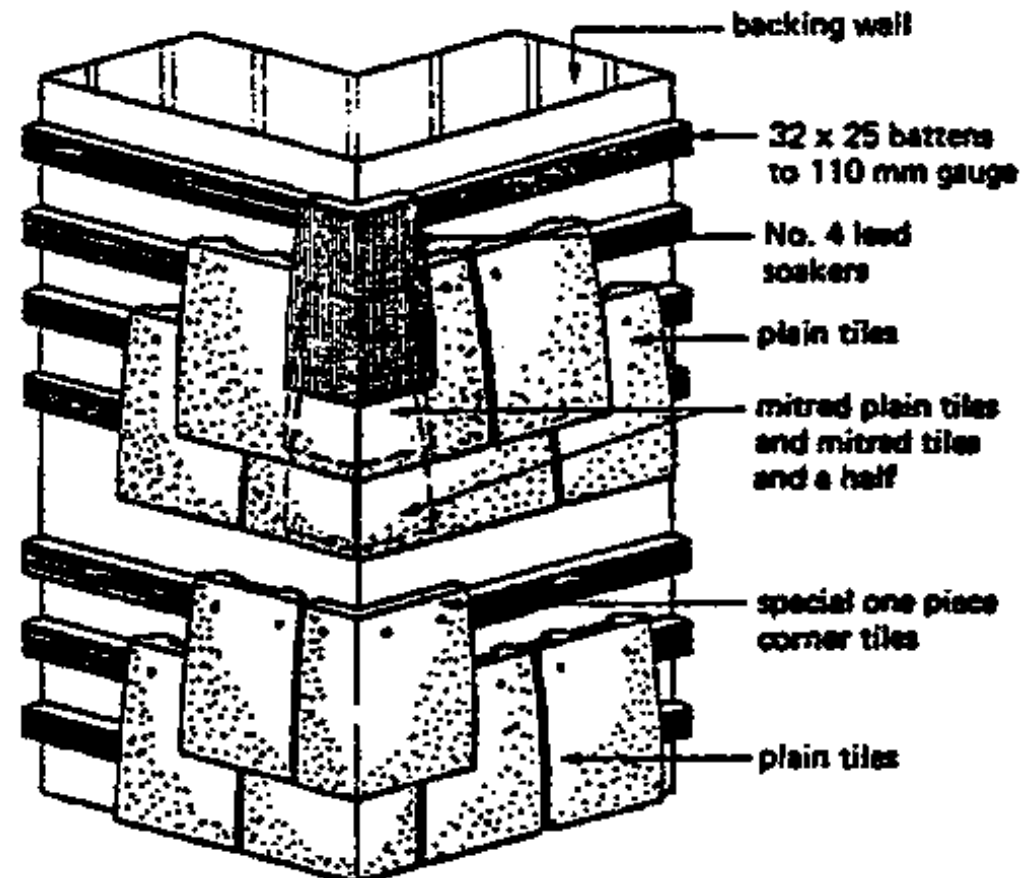

Alternative external angle treatments (internal angles treatments similar)

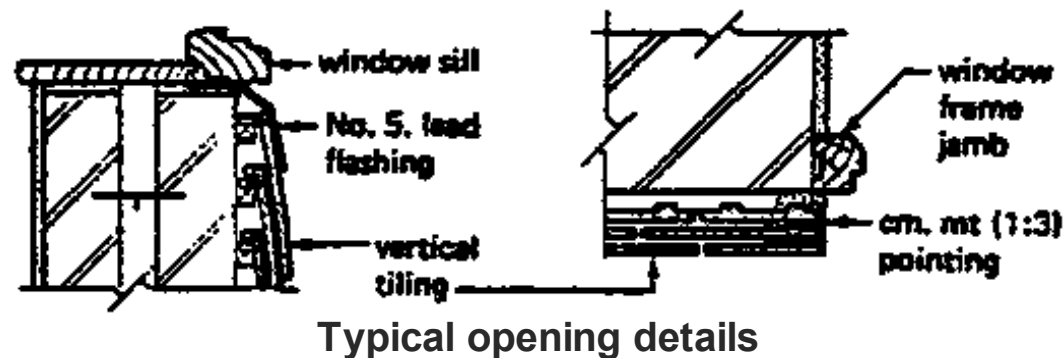
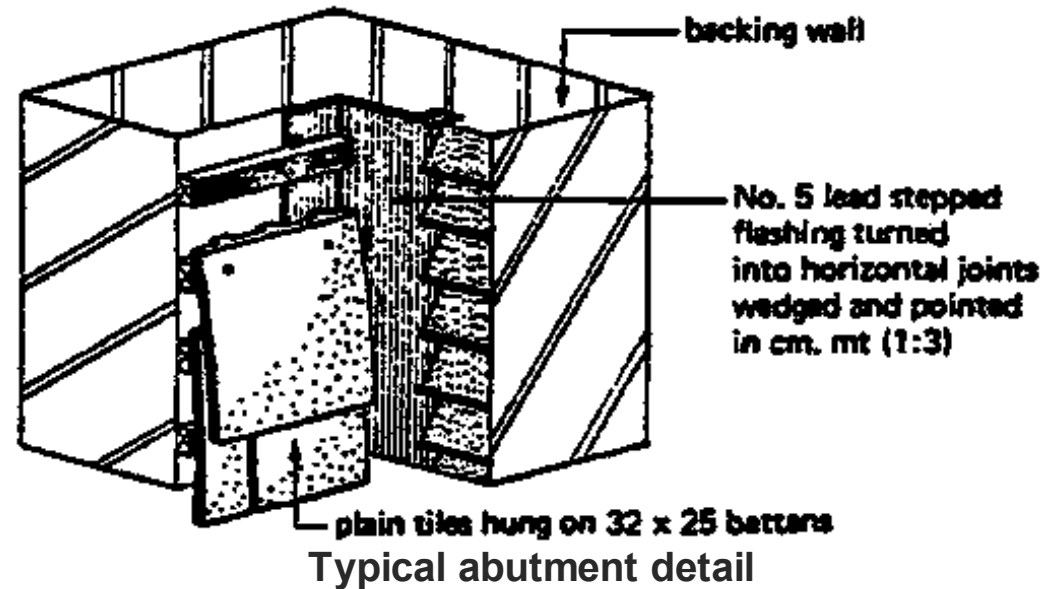

The tiles used in tile hanging can be ordinary plain roofing tiles or alternatively a tile of the same dimensions but having a patterned bottom edge solely for a decorative appearance. The tiles are hung and fixed to tiling battens although nibless tiles fixed directly to the backing wall are sometimes used (see Fig.) The battens should be impregnated to prevent fungi and insect attack so that their anticipated life is comparable to that of the tiles. Each tile should be twice nailed to its support batten with corrosion resistant nails of adequate length.



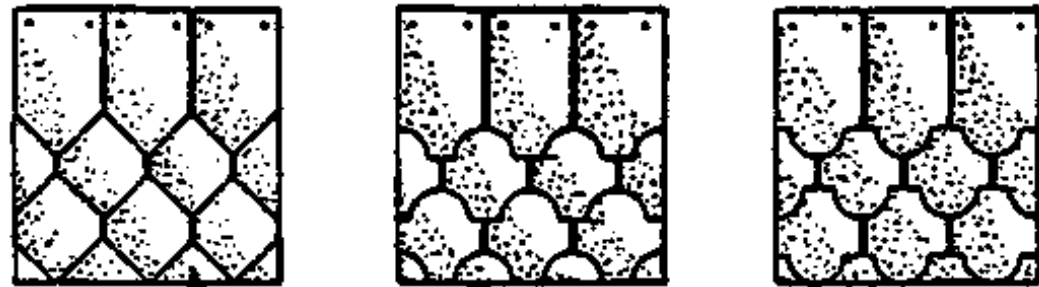

eaves tile under bottom course

**Pointed pattern**

**Fishtail pattern**

**Club pattern**

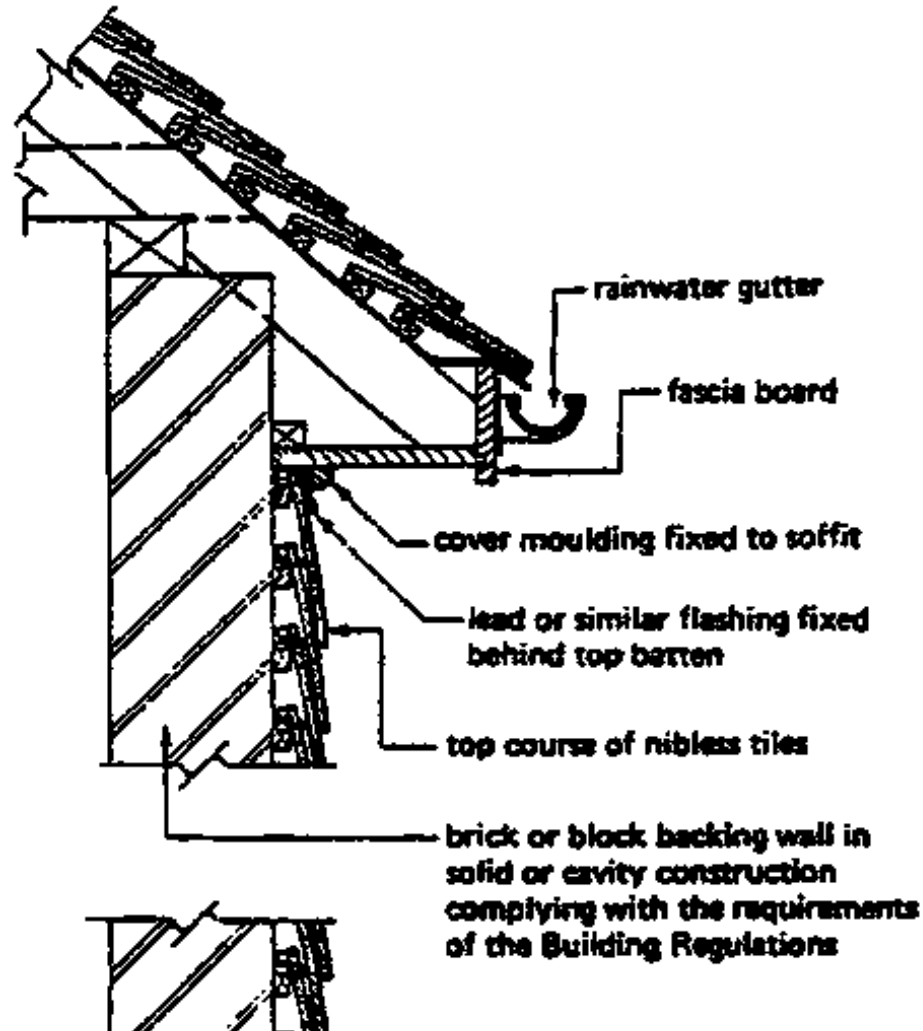

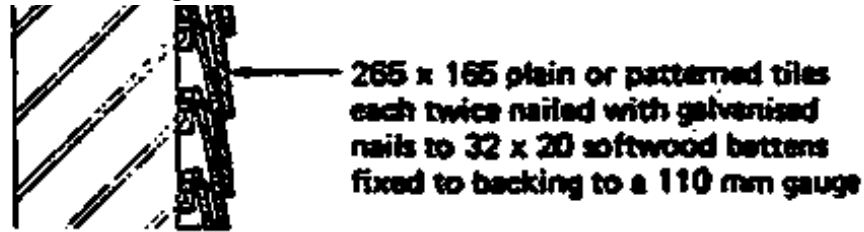

The general principles of tile hanging are similar to those of double lap roof tiling and the gauge is calculated in the same manner. The minimum lap recommended is 40 mm which would give a gauge of 112.5 mm using a standard 265 long tile.

A gauge dimension of 112.5 mm is impracticable and therefore a gauge of 110 mm would be usual.

Typical details of top edge finishes, bottom edge finishes corners and finishes at windows are shown in the fin. It should be noted that if the structural backing is of timber framing a layer of impervious felt should be placed over the framing immediately underneath the battens to prevent any moisture which is blown in between the tiles from having adverse effects upon the structure. In this situation building paper is not considered to be a suitable substitute. The application of slates as a small unit hung cladding follows the principles outlined above for tile hanging.

## - TIMBER CLADDINGS

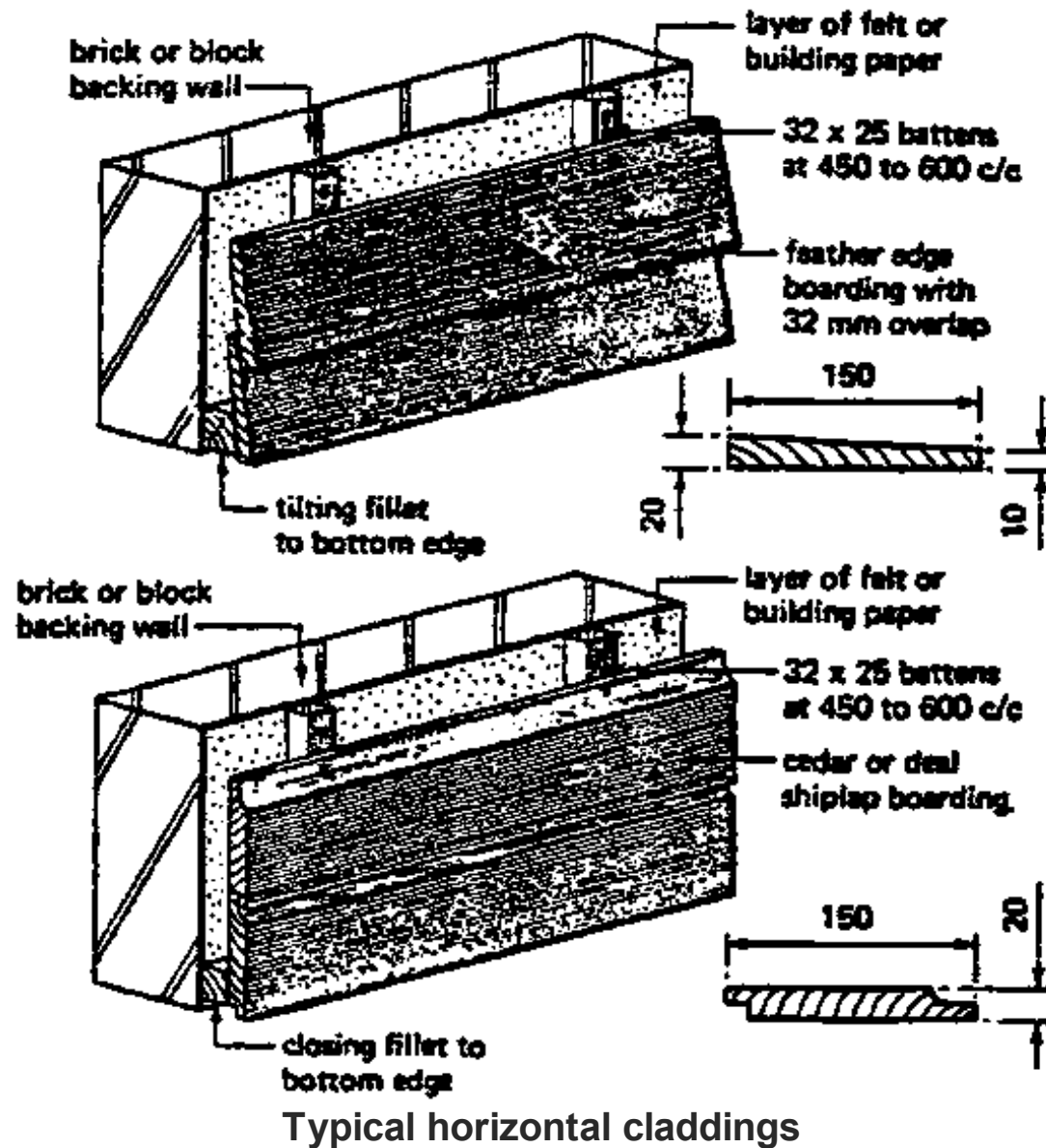

Timber claddings are usually in the form of moulded or shaped boards fixed to battens as either a horizontal or vertical cladding. Timber claddings will require regular maintenance to preserve their resistance to the elements. Softwoods are generally painted and will need repainting at intervals of three

to five years according to the exposure. Hardwoods are sometimes treated with a preservative and left to bleach naturally; the preservative treatment needs to be carried out at two-to five-year intervals. Western red cedar is a very popular wood for timber cladding since it has a natural immunity to insect and fungi attack under normal conditions. It also has a pleasing natural red/brown colour which can be maintained if the timber is coated with a clear sealer such as polyurethane, however, it will bleach to a grey/white colour if exposed to the atmosphere. Plastic boards are a substitute for timber and are fixed in a similar manner.

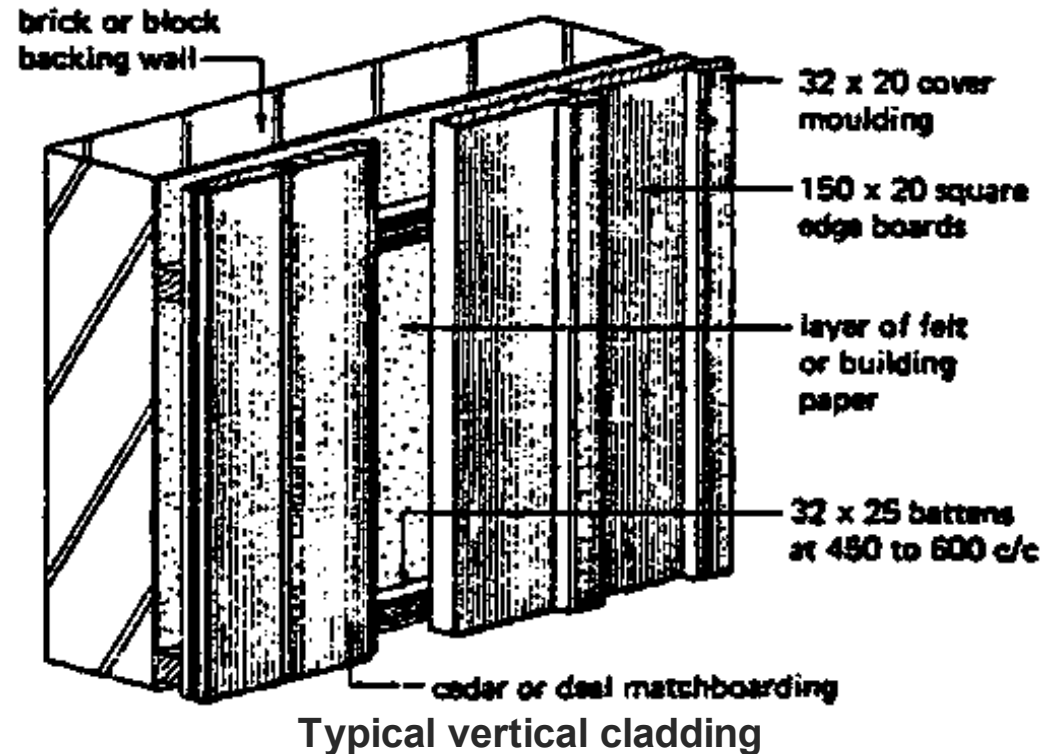

### 12.1.3.2 CLADDINGS TO FRAMED STRUCTURES

Claddings are a form of masking or infilling a structural frame and can be considered under the following headings:

- 1 Panel walls with or without attached facings**
- 2 Concrete and similar clad-ding panels.**
- 3 Light infill panels**
- 4 Curtain walling which can be defined as a sheath clad- ding which encloses the en- tire structure**

**All: forms of cladding must fulfil the following functions:**

- 1 Be self supporting between the framing members**
- 2 Provide the necessary resistance to rain penetration.**
- 3 Be capable of resisting both positive end negative wind pressures.**
- 4 Provide the necessary resistance to wind penetration**
- 5 Give the required degree of thermal insulation**
- 6 Provide the required degree of sound, insulation to suit the building type.**
- 7 Give the required degree of fire resistance**
- 8 Provide sufficient openings for the admittance of natural daylight and ventilation**
- 9 Be constructed to a suitable size.**

## **- BRICK PANEL WALLS**

**These are non-load bearing walls which must fulfil the following requirements:**

- 1 Adequate resistance to the elements**
- 2 Have sufficient strength to support their own self weight plus any attached finishes.**
- 3 Strong enough to resist both positive and negative wind pressures**
- 4 Provide the required thermal and sound insulation.**

## 5 Provide the required fire resistance

## 6 Have adequate durability

Brick panel walls are constructed in the same manner as ordinary solid or cavity walls and any openings for windows or doors are formed by traditional methods. The panels must be supported at each structural floor level and tied to the structure at the vertical edges. Projection of the panel in front of the structural members is permissible providing such overhangs do not impair the stability of the panel wall; acceptable limits are shown in the fig. The top edge of the panels should not be pinned rigidly to the frame since the effect of brick panel expansion together with frame shrinkage may cause cracking and failure of the brickwork. A compression joint should therefore be formed between the top edge of the panel and the under-side of the framing member at each floor level (see fig.)

### Brick panel walls

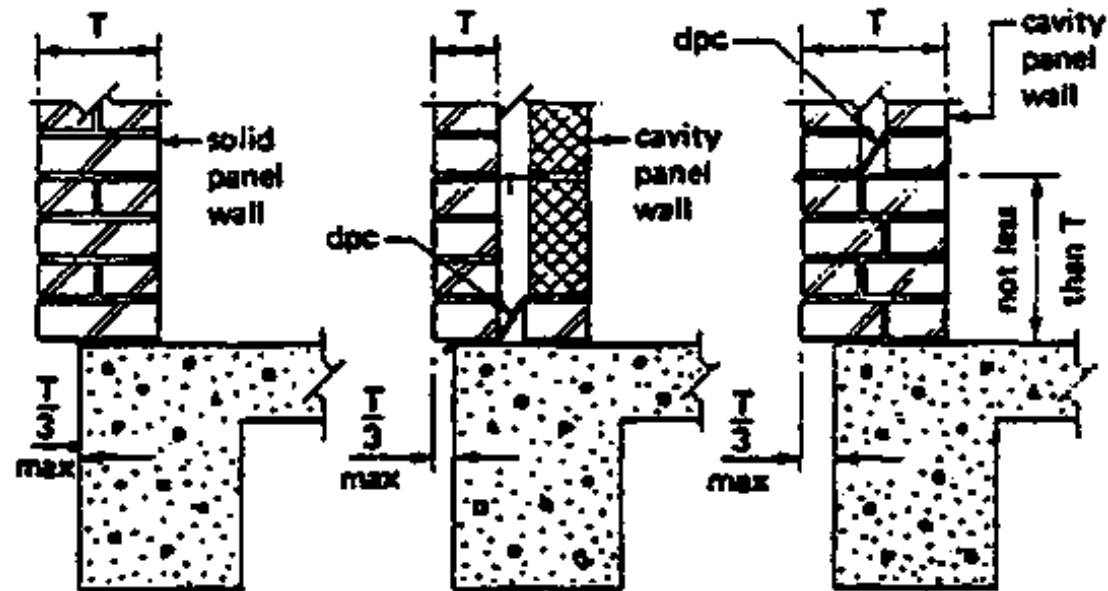

Maximum overhang for panel walls

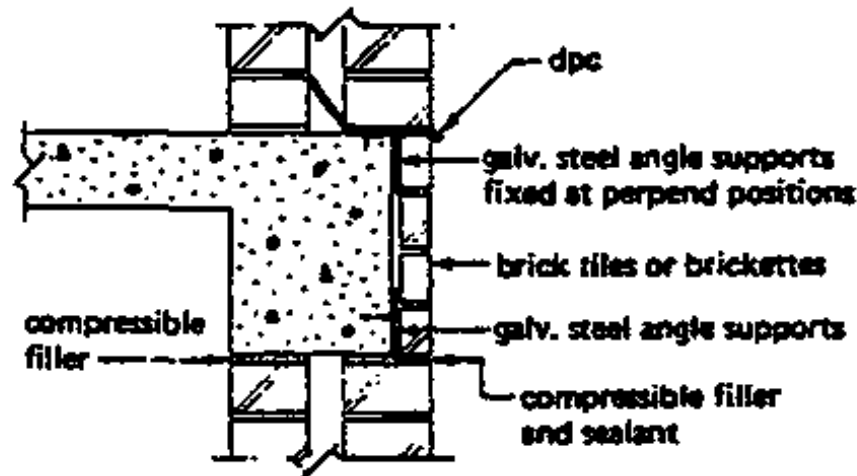
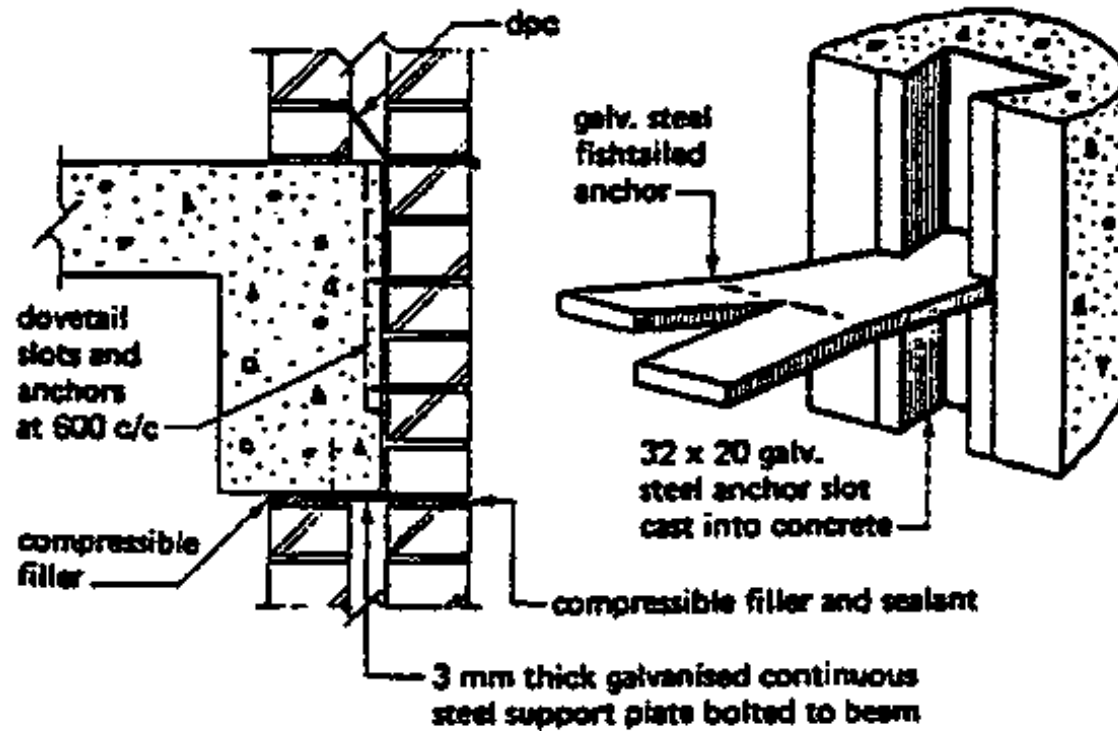

Typical beam facing details

Two methods of tying the panel to the vertical structural members are in common use:

**TWO METHODS OF TYING THE PANEL TO THE VERTICAL STRUCTURAL MEMBERS ARE IN COMMON USE.**

**1 Butterfly wall tiles are cast into the column and built into the brick joints at four-course intervals.**

**2 Galvanised pressed steel dovetail slots are cast into the column and dovertail anchors are used to form the tie (see fig.)**

**The second method gives greater flexibility with the location and insertion of ad-equate ties but is higher in cost.**

**Facings to brick panel walls.**

**Any panel wall must have an acceptable endurable finish; this can be achieved by using facing bricks with a neat pointed joint or by attaching to the face of a panel of common bricks a stone or similar cladding. Suitable materials are natural stone, artificial stone, reconstructed stone and precast concrete of small units up to 1 m<sup>2</sup> and with a thickness related to the density of the material. Dense materials such as slate and marble need only be 40 mm thick, whereas the softer stones such as sandstone and limestone should be at least 75 mm thick.**

**Two major considerations must be taken into account when 'deciding on the method to be used to fix the facings to the brick backing:**

**1 Transferring the load to the structure**

**2 Tying back the facing units.**

**The load of the facings can. be transferred by using bondor stones or support corbels at each floor level, which should have a compression joint incorporated in the detail for the same reasons given above**



when considering brick panels (see fig.).

The tying back of the facings is carried out by various metal such as gunmetal, copper, phosphor bronze or stainless steel. To avoid the problem of corrosion caused by galvanic action between dissimilar metals a mixture of fixing materials should not be used. Typical examples of fixings and cramps for thick and thin facings are shown in fig.

### Cladding fixings

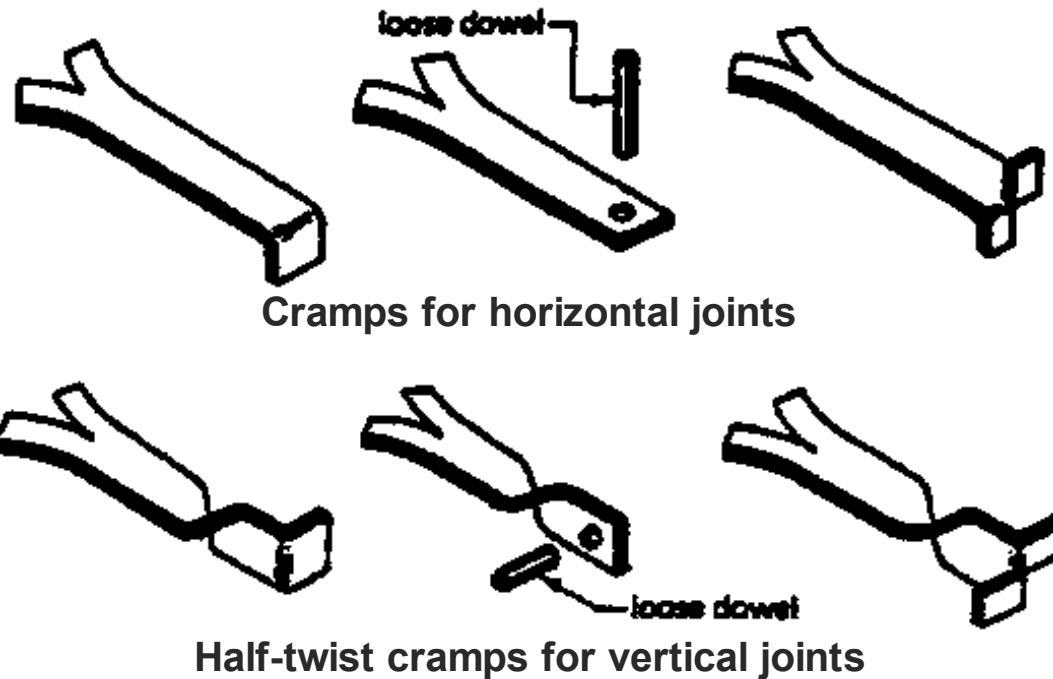

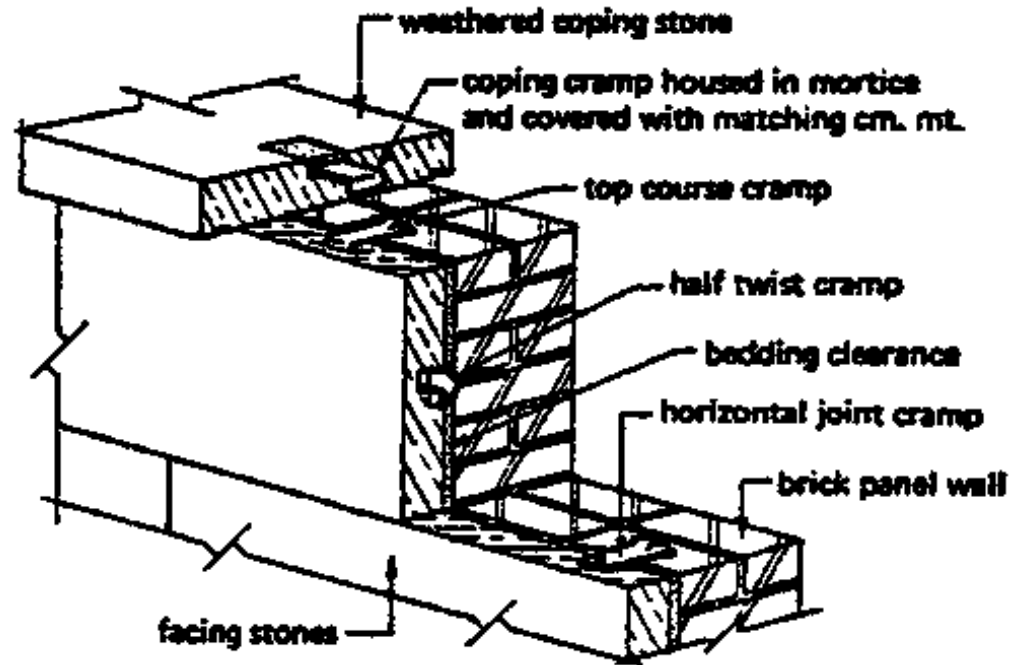

Typical cladding fixing details

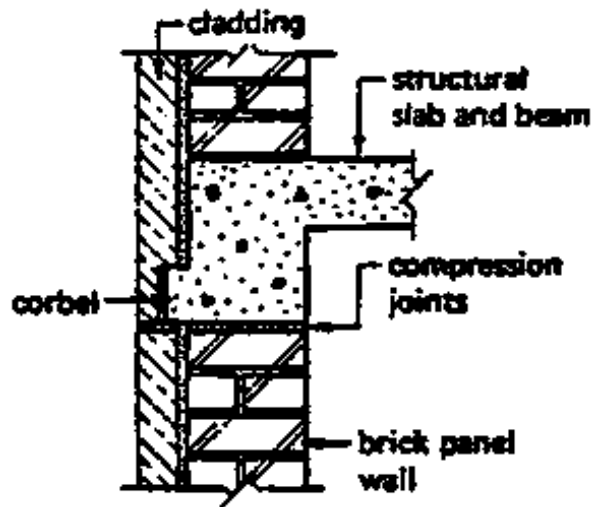

Corbel support

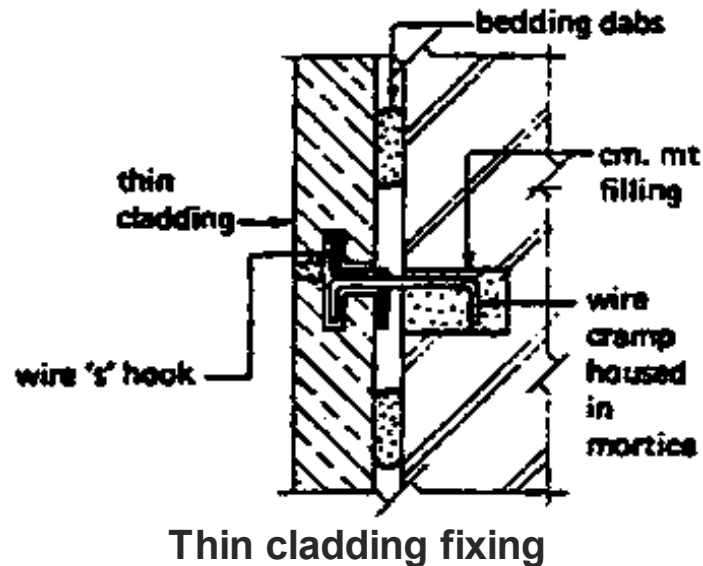

To provide for plumbing and alignment a bedding space of 12 - 15 mm should be left between the face of the brick panel and the back of the facing. Dense facings such as marble are usually bedded on a series of cement mortar dabs, whereas the more porous 'facings are usually placed against a solid bed which ensures that any saturation which occurs will be uniform over the entire face.

## - CONCRETE CLADDING PANELS

These are usually made of precast concrete with a textured face in a storey height or undersill panel format. The storey height panel is designed to span vertically from beam to beam and if constructed to a narrow module will give the illusion of a tall building. Undersill panels span horizontally from column to column and are used where a high wall/ window ratio is required. Combinations of both formats are also possible.

Concrete cladding panels should be constructed of a dense concrete mix and suitably reinforced with bar. reinforcement or steel welded fabric. The reinforcement should provide the necessary tensile resistance to the stresses induced in the final position and for the stresses set up during transportation.

resistance to the stresses induced in the final position and for the stresses set up during transportation and hoist-inn into position. Lifting lugs, positions or holes should he incorporated into the design to ensure that the panels are hoisted in the correct manner so that unwanted stresses are not induced. The usual specification for cover of concrete over reinforcement is 25 mm minimum. If thin panels are being used the use of galvanised or stainless steel reinforcement should be considered to reduce the risk of corrosion.

When designing or selecting a panel the following must be taken into account:

- 1 Column or been spacing
- 2 Lifting capacities of plant available
- 3 Jointing method
- 4 Exposure conditions
- 5 Any special planning requirements as to finish or texture.

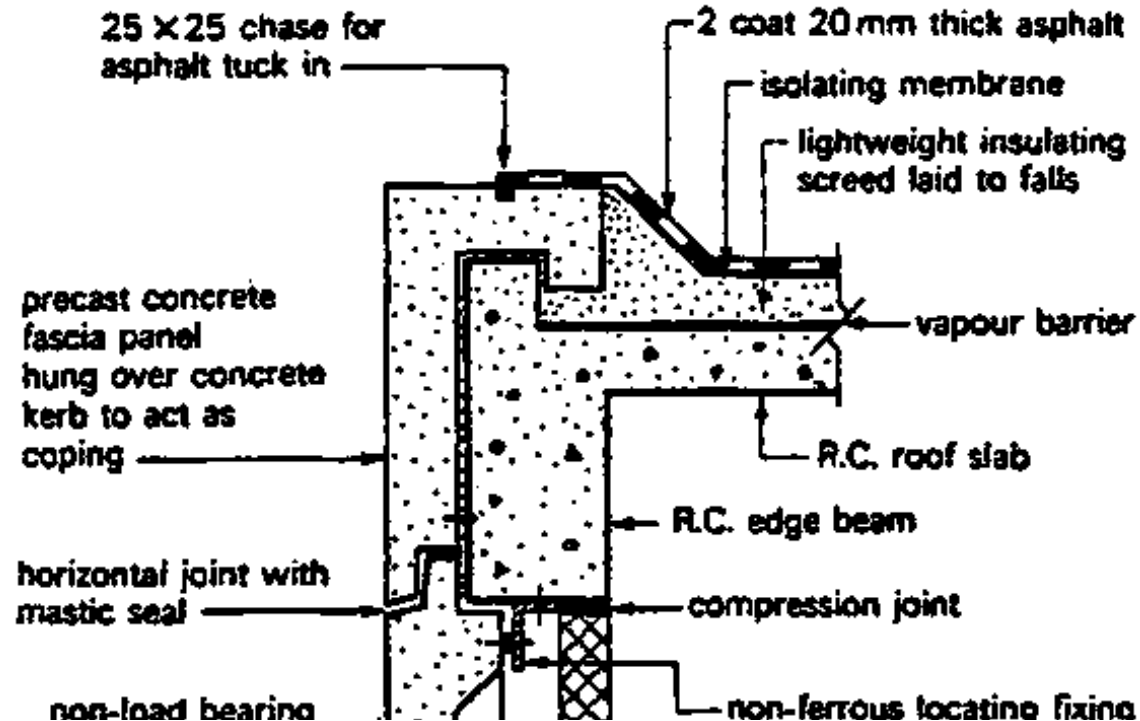

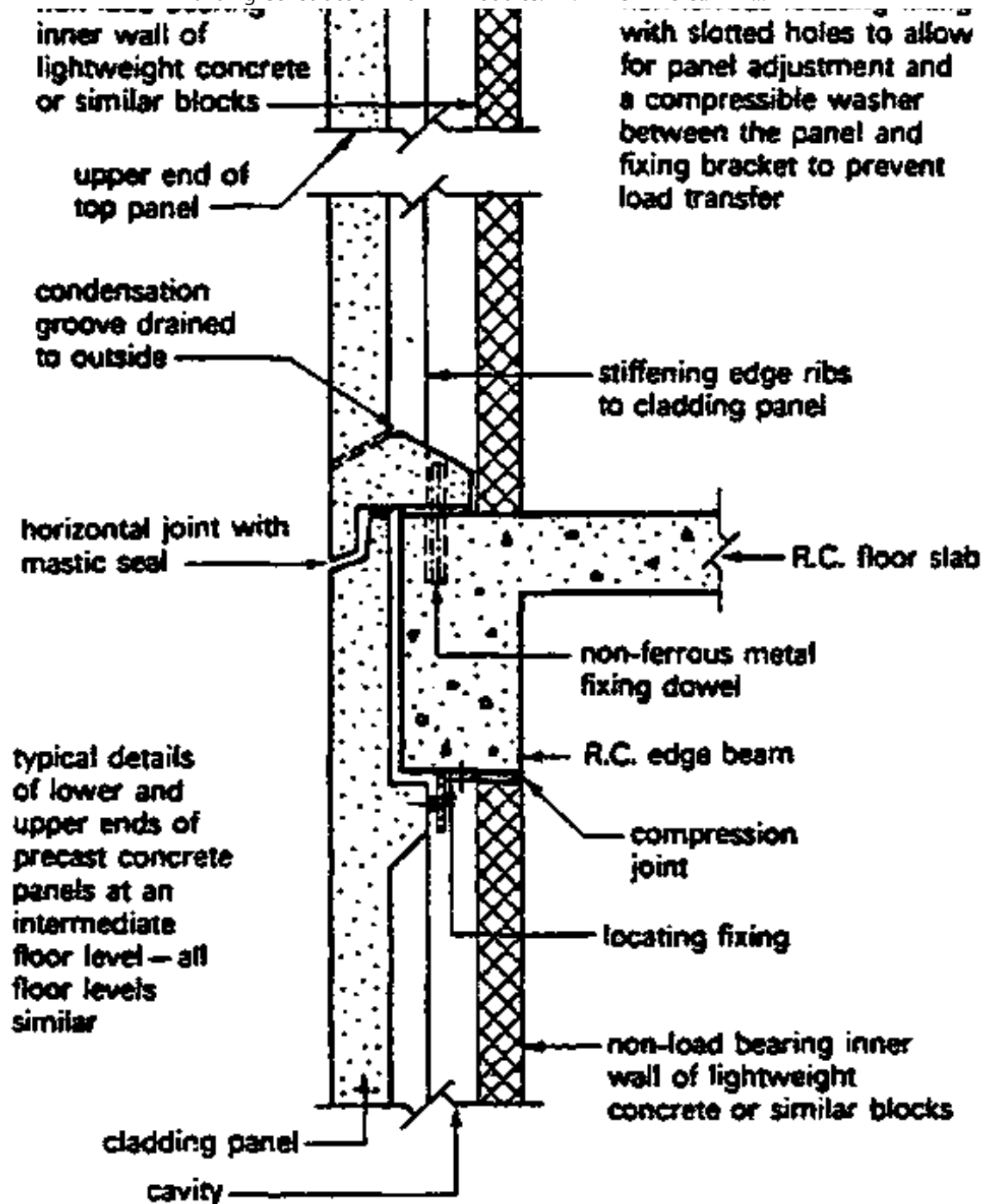

Typical storey height concrete cladding panel

The greatest problem facing the designer and installer of concrete panels is one of jointing to allow for structural end thermal movements and at the same time provide an adequate long term joint -see fig.

Where a stone facing is required to a framed structure, possibly to comply with planning requirements, it may be advantageous to use a composite panel. These panels have the strength and reliability of precast concrete panel design and manufacture but the appearance of traditional stonework. This is achieved by casting a concrete backing to a suitably, keyed natural or reconstructed stone facing and fixed to the frame by traditional masonry fixing cramps or by conventional fixings - see fig.

Thermal insulation can be achieved when using precast concrete panes by creating a cavity as shown in the fig.

Concrete cladding panels can be large and consequently heavy. To reduce the weight they are often designed to be relatively thin (50 to 75 mm) across the centre portion and stiffened around the edges with suitably reinforced ribs Which usually occur on the back face but can be positioned on the front face as a feature which can also limit the amount of water which can enter the joint.

Another form of cladding material which is beginning to gain popularity and acceptance is glass fibre reinforced plastics (GRP) which consists of pigments and a suitable catalyst as a hardener.

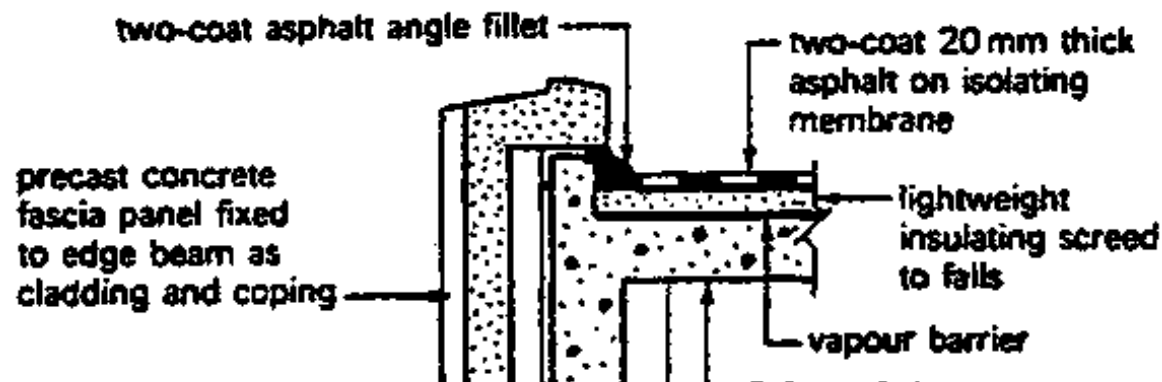

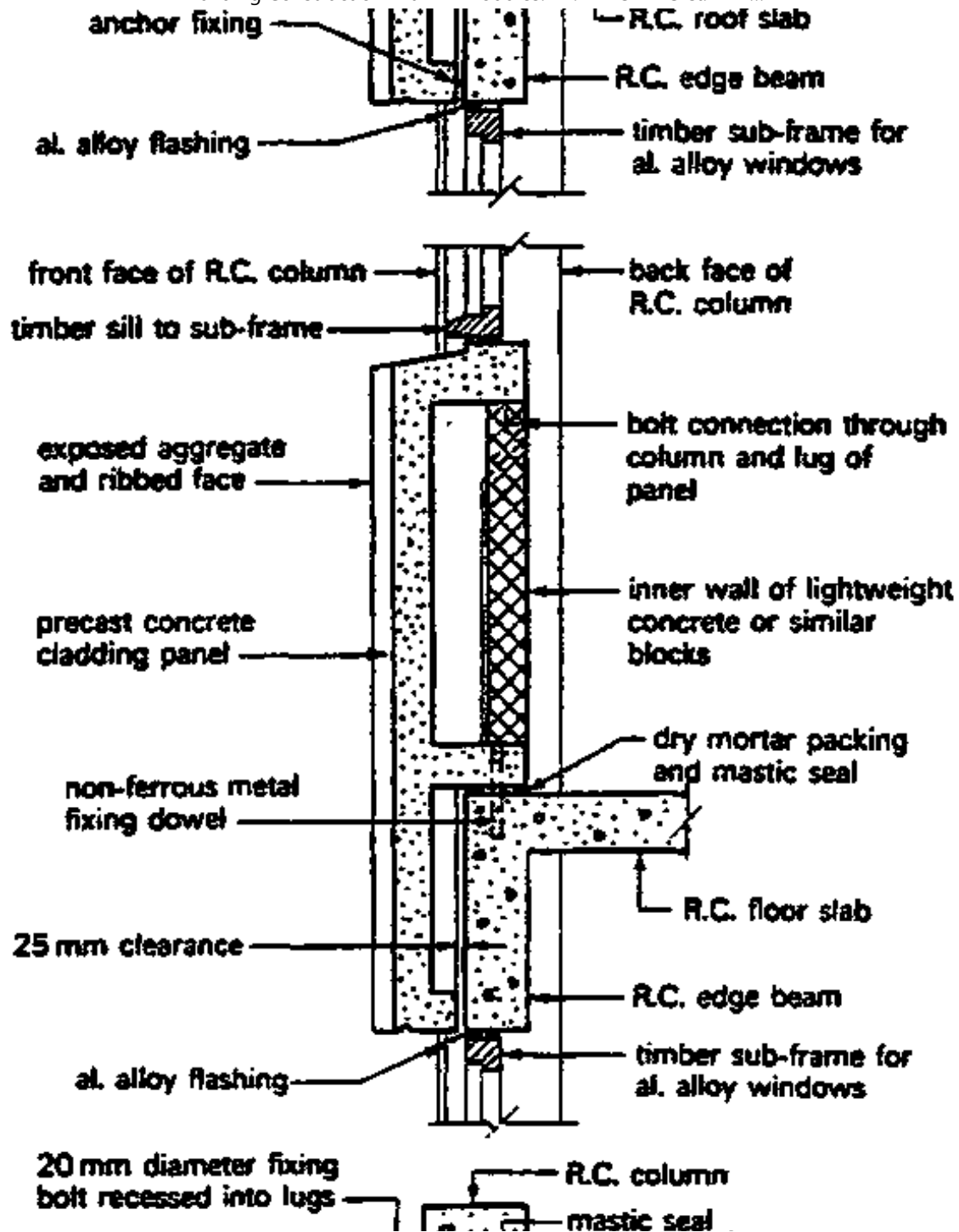

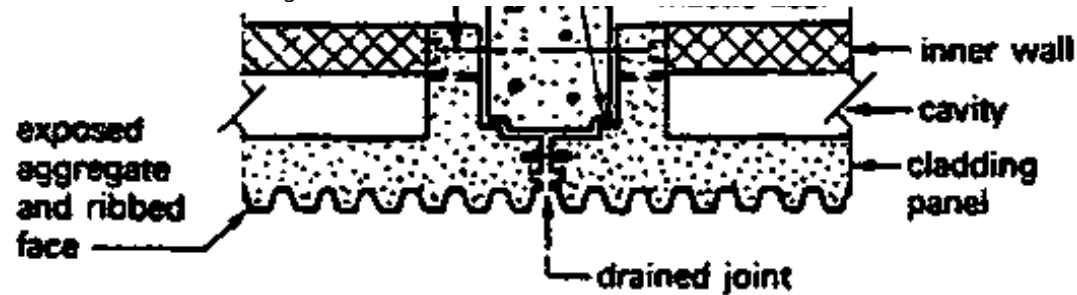

**Plan showing column connection**  
**Typical undersill concrete cladding panel**

The resultant panels are lightweight, durable, non-corrosive, have good weather resistance, can be moulded to almost any profile and have good aesthetic properties. Students seeking further information are recommended to study the Building Research Establishment Digest 161.

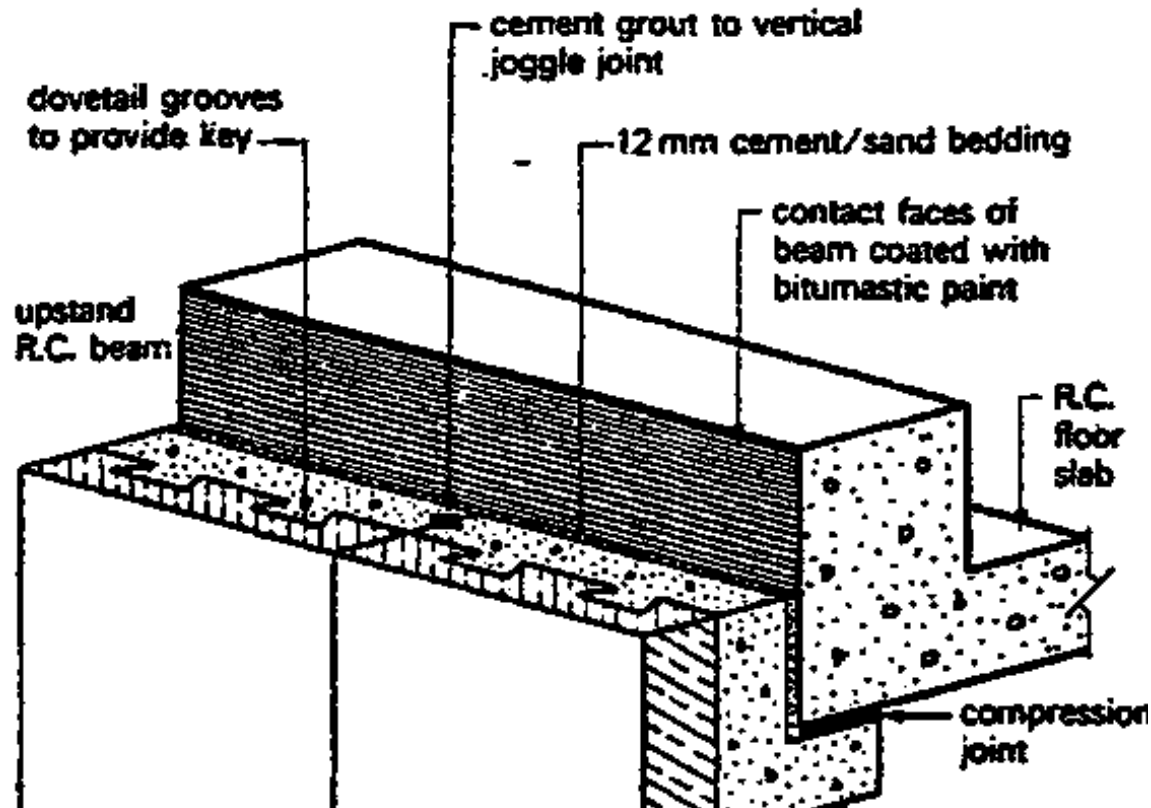



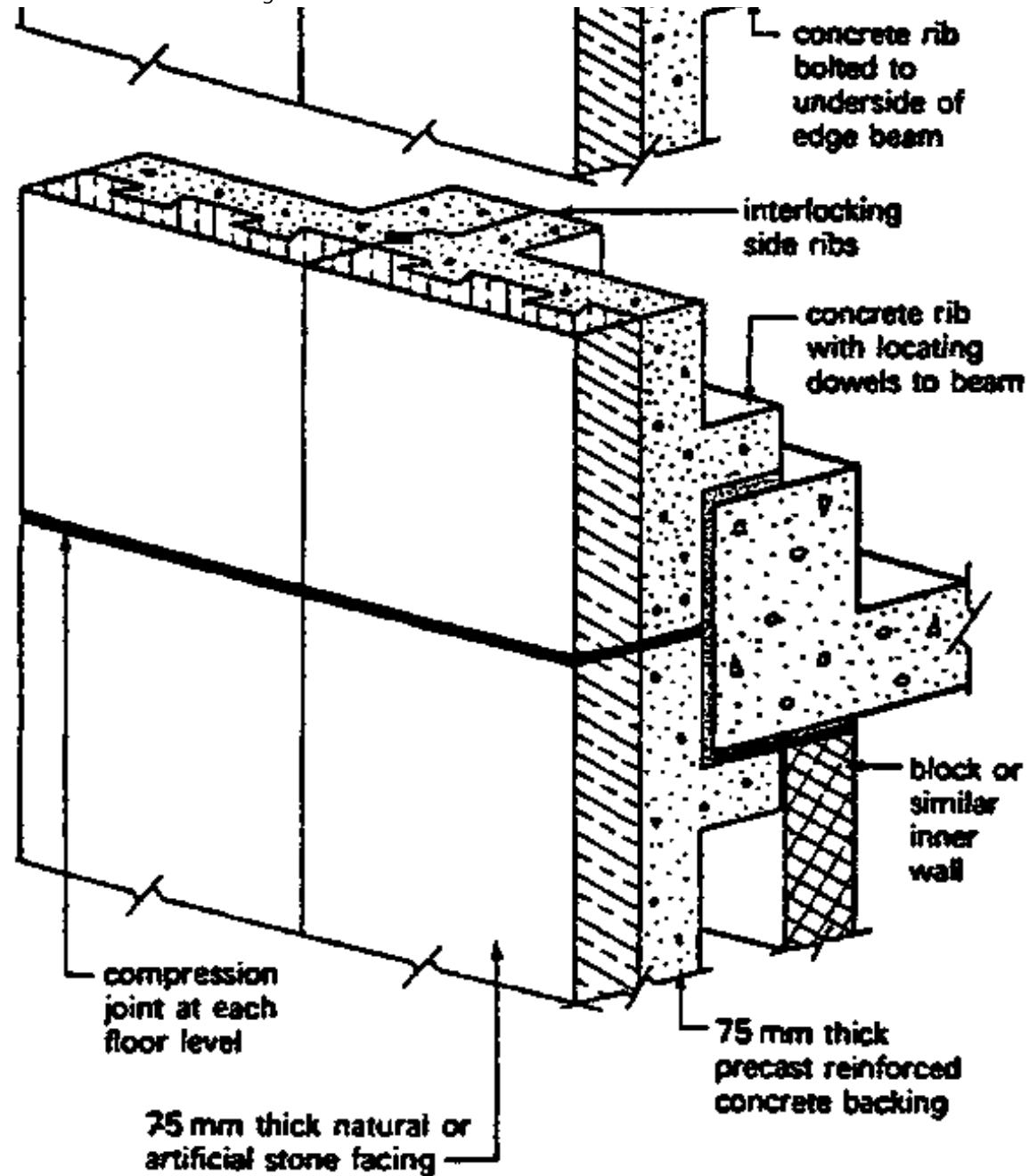

Typical storey height composite panel

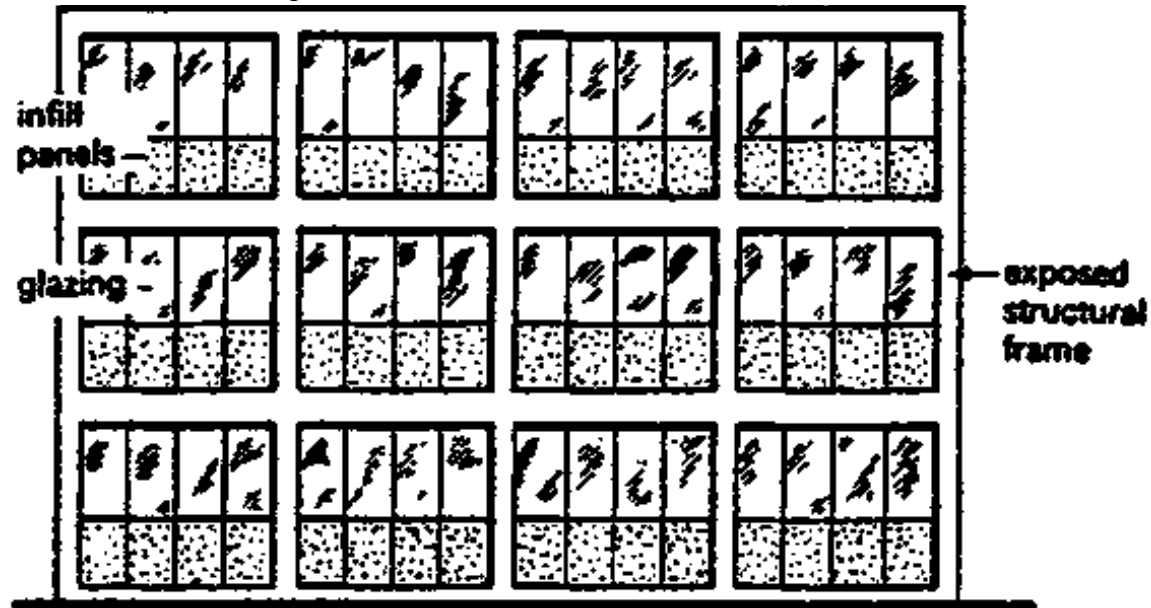

**Grid Panels — exposing horizontal and vertical framing**

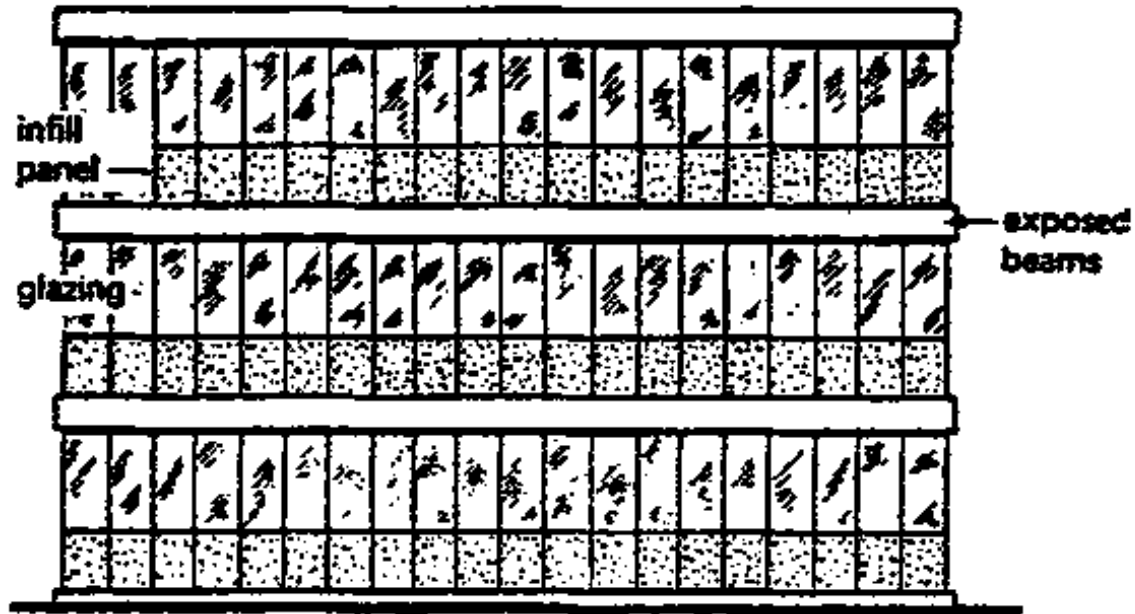

**Horizontal Panels — beams exposed to create illusion of length**



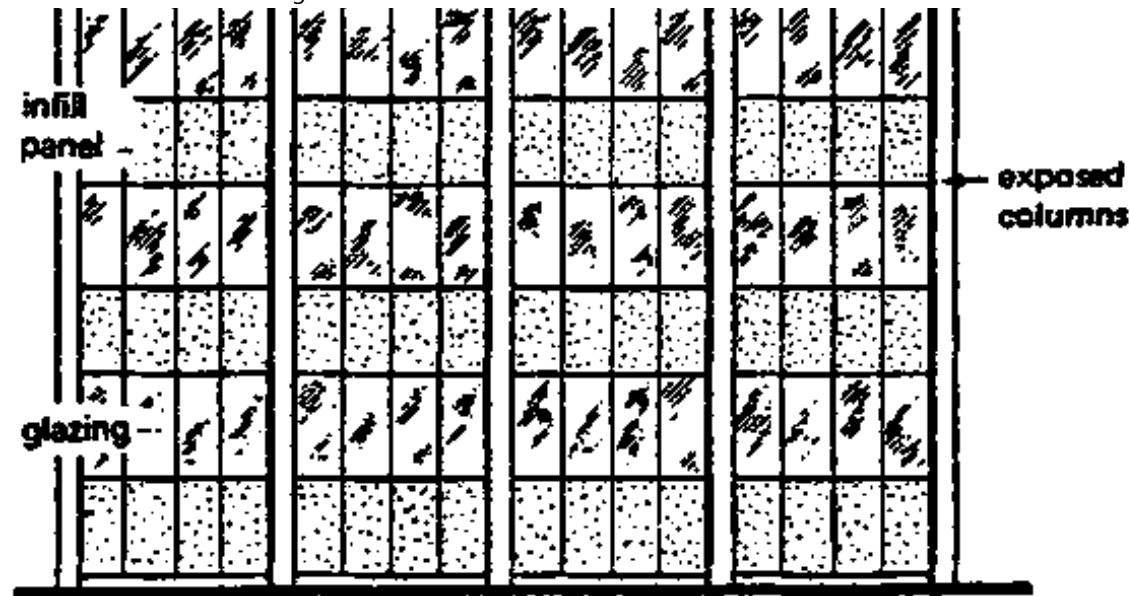

**Vertical Panels – columns exposed to create illusion of height**

Typical infill panel arrangements

## - INFILL PANELS

Infill panels are lightweight and usually glazed to give good internal natural daylighting conditions. The panel layout can be so arranged to expose some or 211 of the structural members creating various optical impressions. For example, if horizontal panels are used, leaving only the beams exposed, an illusion of extra length and/or reduced height can be created. - see fig.

A wide variety- of materials or combinations of materials can be employed such as timber, steel aluminium and plastic. Single and double glazing techniques can be used to achieve the desired sound or thermal insulation. The glazing module should be such that a reasonable thickness of glass can be specified.

The design of the 'solid' panel is of great importance since this panel must provide the necessary resistance to fire, heat loss, sound penetration and interstitial condensation. Most of these panels are of

composite or sandwich construction as shown in the fig.

The jointing problem with infill panels occurs mainly at its junction with the structural frame and allowance for moisture or thermal movement is usually achieved by using a suitable mastic or sealant.

Most infill panels are supplied as a manufacturer's system, since purpose-made panels can be uneconomic, but whichever method is chosen the design aims remain constant; that is, to provide a panel which fulfils all the required functions and has a low long term maintenance factor. It should be noted that many of the essentially curtain walling systems are adaptable as infill panels which gives the designer a wide range of systems from which to select the most suitable. One of the maintenance problems encountered with infill panels and probably to a lesser extent with the concrete claddings is the cleaning of the facade and in particular the glazing. All buildings collect dirt, the effects of which can vary with the material: concrete and masonry tend to accept dirt and weather naturally, whereas impervious materials such as glass do not accept dirt and can corrode or become less efficient.

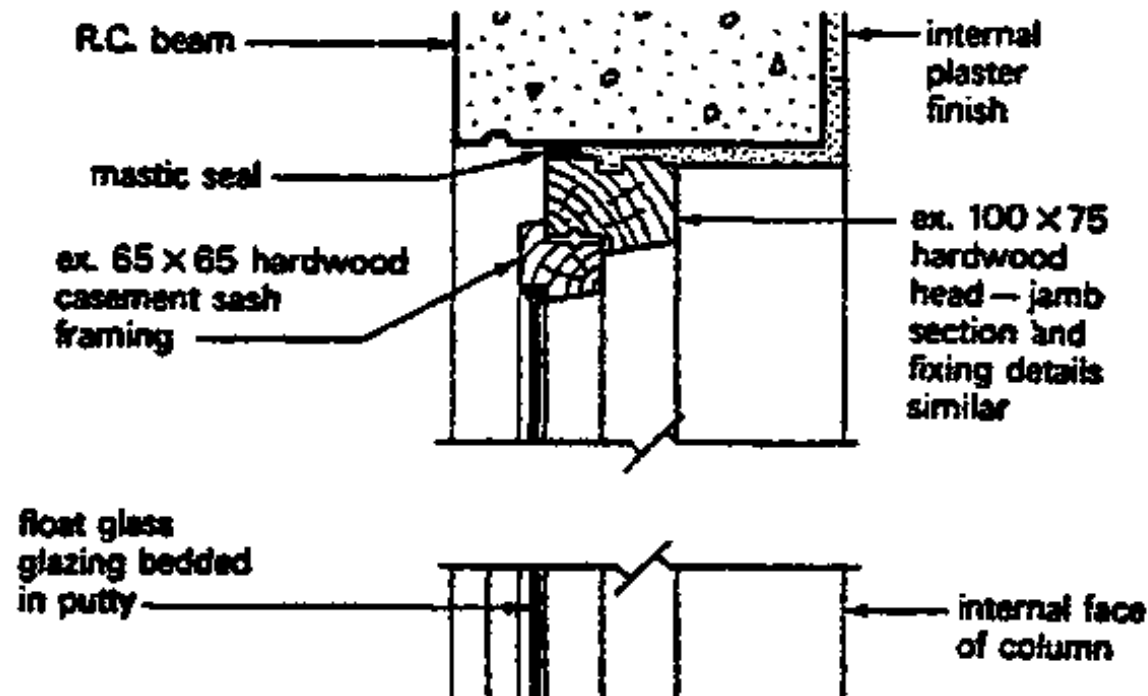

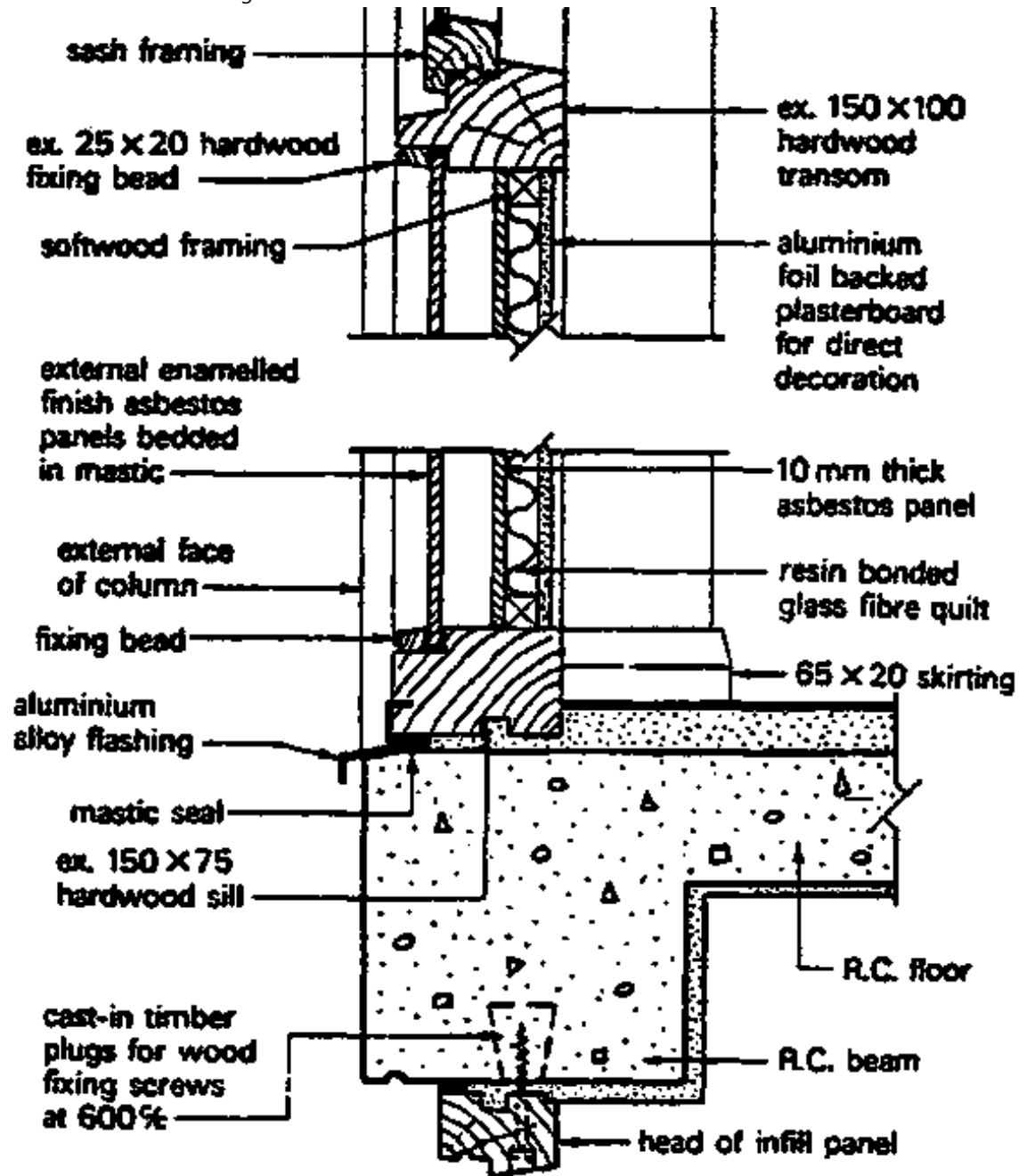

Typical timber infill panel details

If glass is allowed to become coated with dirt its visual appearance is less acceptable its optical

if glass is allowed to become coated with dirt its visual appearance is less acceptable, its optical performance lessens since clarity of vision is reduced and the useful penetration of natural daylight diminishes. The number of times that cleaning will be necessary depends largely upon the area, ranging from three-monthly intervals in non-industrial areas to six-weekly intervals in areas with a high pollution factor.

Access for cleaning glazed areas can be external or internal. Windows at ground level present no access problems and present only the question of choice of method such as hand cloth or telescopic poles with squeegee heads. Low and medium rise structures can be reached by ladders or a mobile scaffold tower and usually present very few problems. High rise structures need careful consideration. External access to windows is gained by using a cradle suspended from roof level; this can be in the form of a temporary system consisting of counterweighted cantilevered beams from which the cradle is suspended. Permanent systems, which are incorporated as part of the building design, are more efficient and consist of a track on which a mobile trolley is mounted and from which davit arms can be projected beyond the roof edge to support the cradle. A single track fixed in front of the roof edge could also be considered; these are simple and reasonably efficient but the rail is always visible and can therefore mar the building's appearance.

Internal access for cleaning the external glass face can be achieved by using windows such as reversible sashes, horizontal and vertical sliding sashes, but the designer is restricted in his choice to the reach possible by the average person.

It cannot be over emphasised that such windows can be a very dangerous hazard unless carefully designed so that all parts of the glazed area can be reached by the person cleaning the windows whilst he remains standing firmly on the floor.



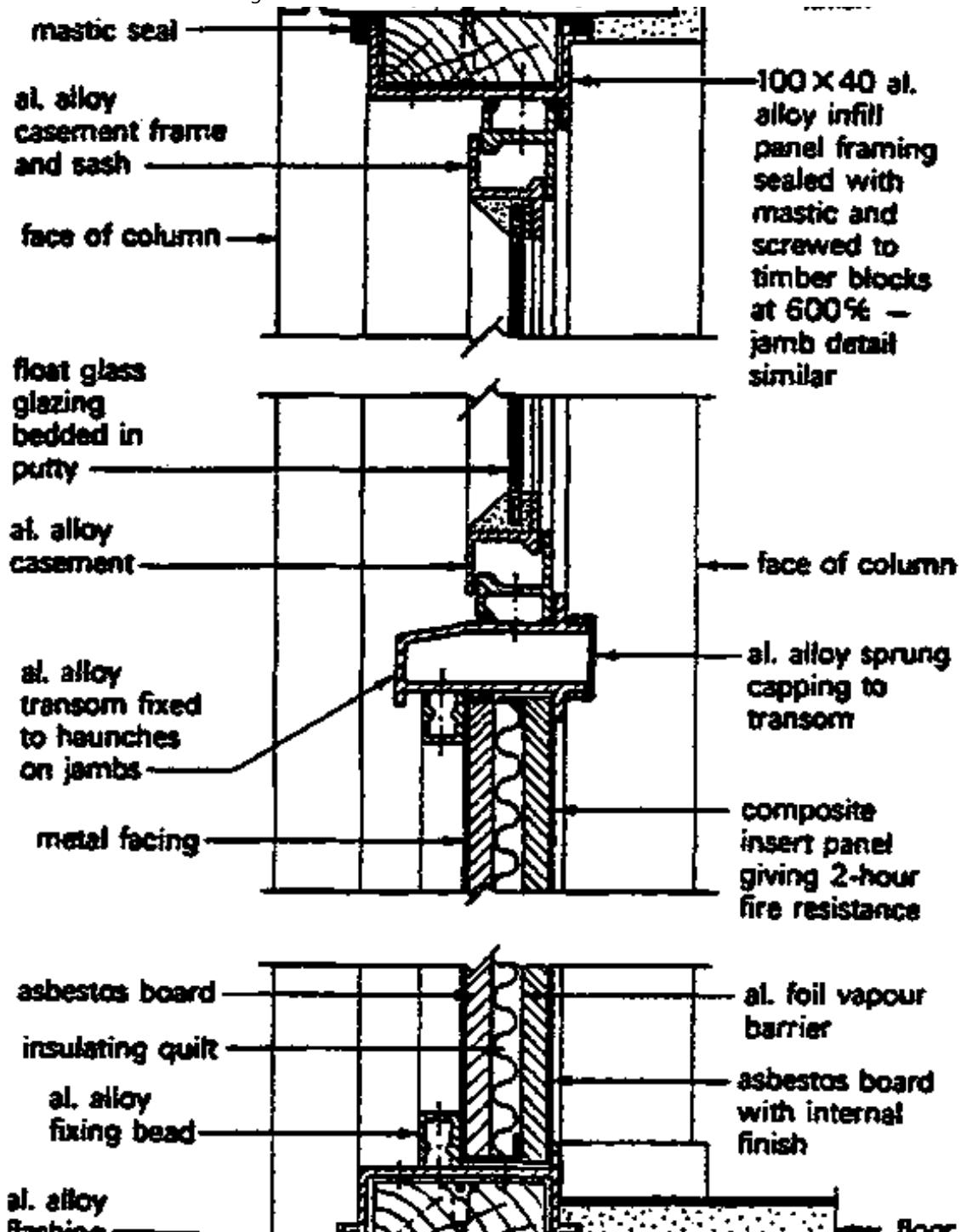

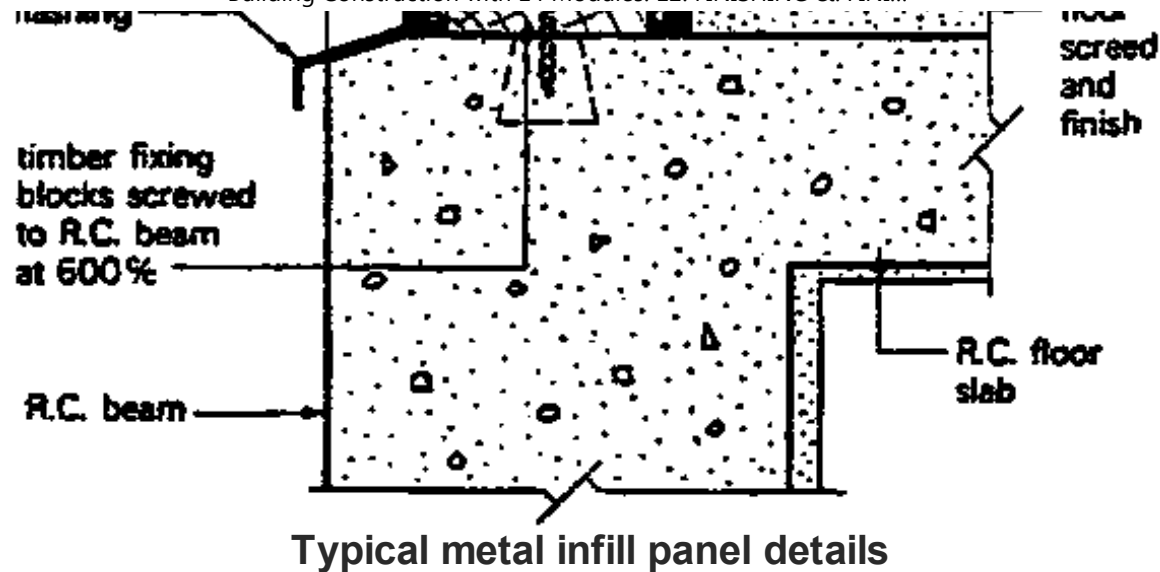

## - LIGHTWEIGHT WALL CLADDINGS

In common with other cladding methods for framed buildings, lightweight wall claddings do not require high compressive strength since they only have to support their own dead load and any imposed wind loading, which will become more critical as the height and/or exposure increases. Lightweight claddings are usually manufactured from impervious materials which means that the run off of rain water can be high particularly under storm conditions when the discharge per minute could reach 2 litres per square metre of wall area exposed to the rain.

A wide variety of materials can be used as a cladding medium, most being profiled to a corrugated or trough form since the shaping will increase the strength of the material over its flat sheet form. Flat sheet materials are available but are rarely applied to large buildings because of the higher strength obtained from a profiled sheet of similar thickness. Special contoured sheets have been devised by many manufacturers to give the designer a wide range of choice in the context of aesthetic appeal. Claddings of various sandwich construction are also available to provide reasonable degrees of thermal insulation, sound insulation and to combat the condensation hazard which can occur with lightweight claddings of any nature. The sheets are fixed in a similar manner to that for sheet roof coverings. The



support purlins are replaced in walls by a similar member called a sheeting rail which is fixed by cleats to the vertical structural frame members. The major difference occurs with the position of the fixings which in wall claddings are usually specified as being positioned in the trough of the profile as opposed to the crest when fixing roof coverings. This change in fixing detail is to ensure that the wall cladding is pulled tightly up to the sheeting rail or lining tray.

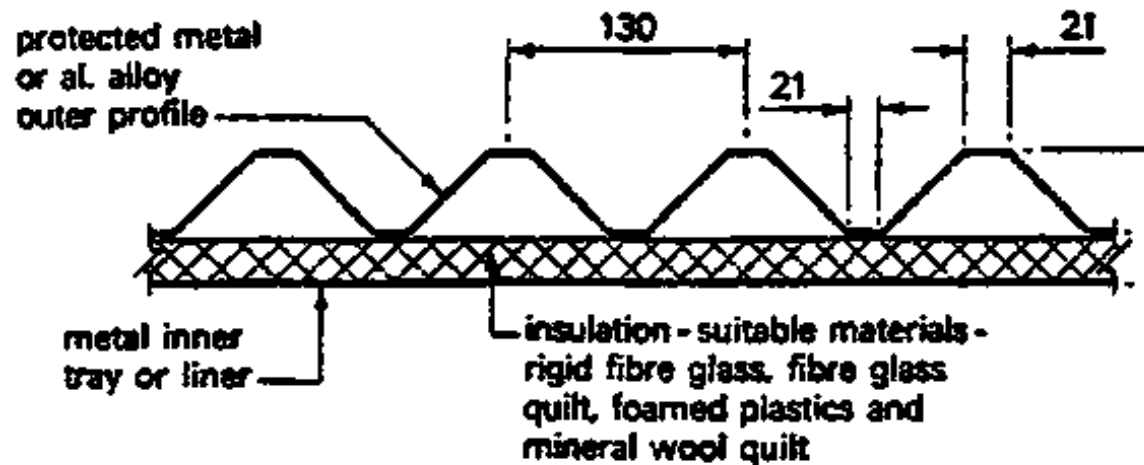

Typical cladding profile

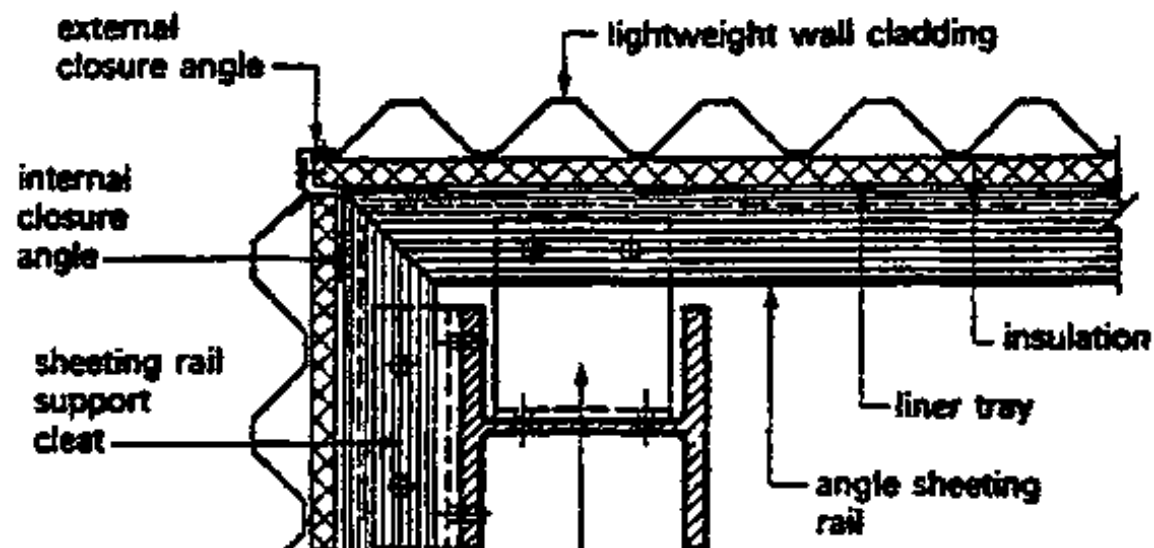

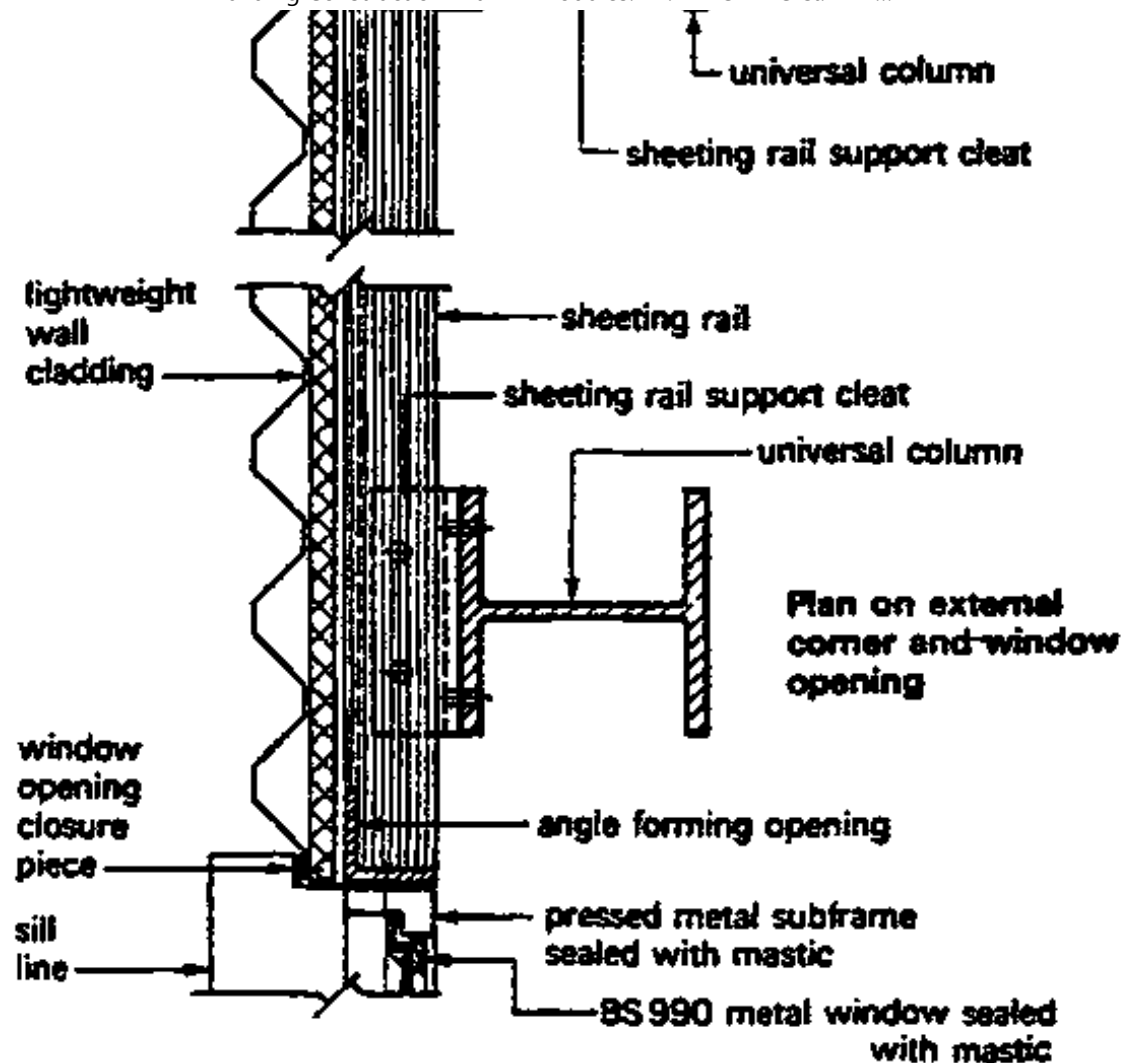

Lightweight wall cladding-typical details 1

Plastic protective caps for the heads of fixings are available, generally of a colour and texture which will blend with the wall cladding. A full range of fittings and trims are usually obtainable for most materials and profiles to accommodate openings, returns, top edge and bottom edge closing. Typical cladding details are shown in the fig.

water check

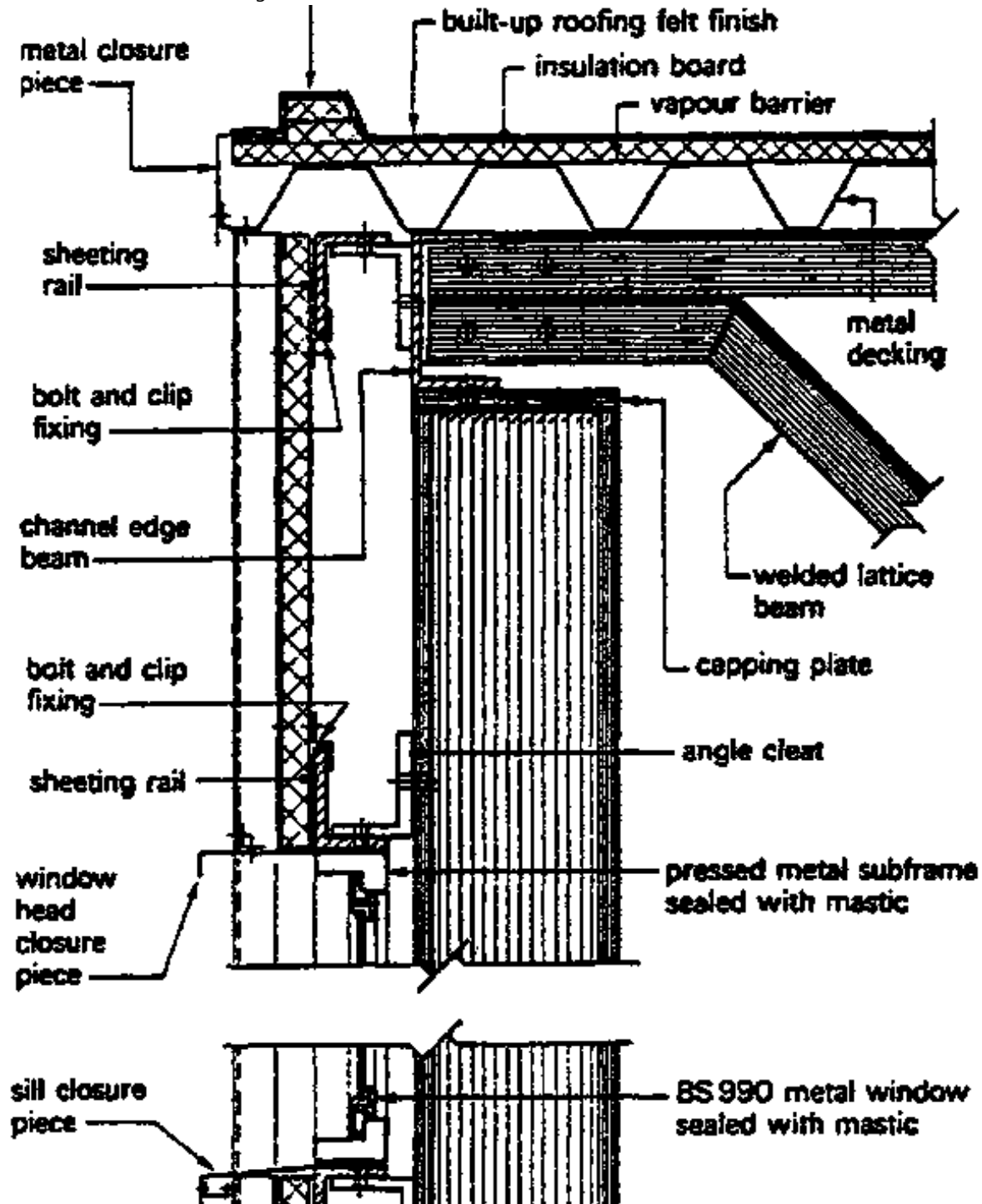

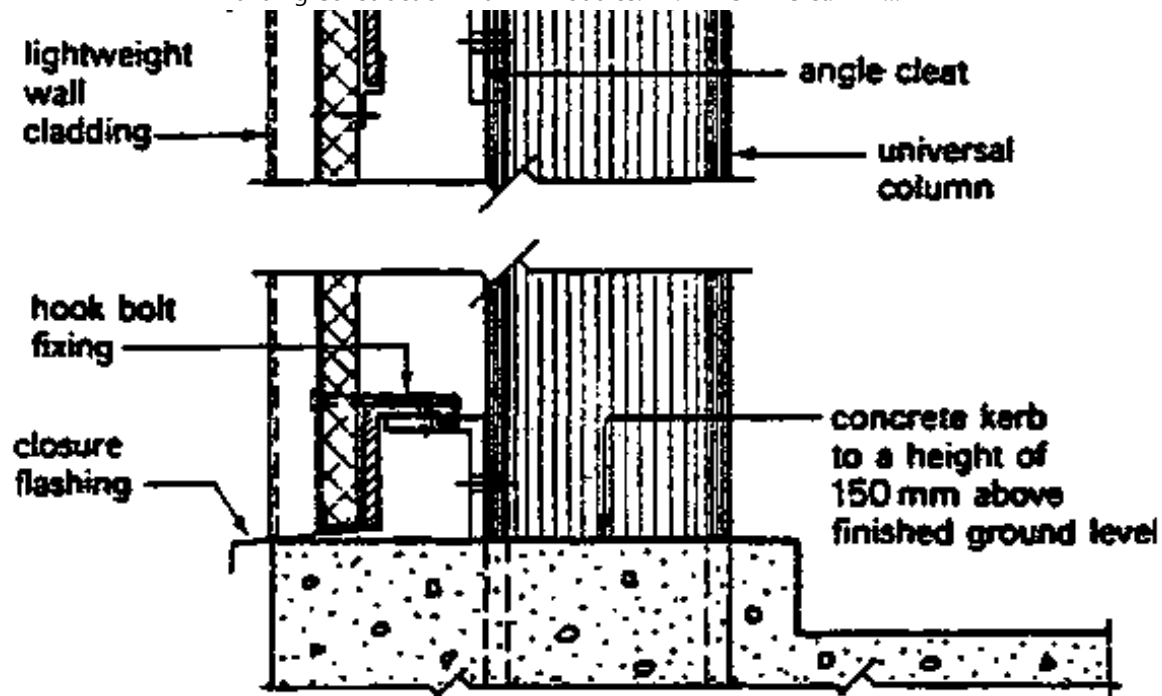

Lightweight wall cladding-typical details 2

Common materials used for lightweight wall claddings are:

### 1 Asbestos cement

non-combustible material in corrugated and troughed sheets which are generally satisfactory when exposed to the weather but are susceptible to impact damage. Average life is about 20 years which can be increased considerably by paint protection. Unpainted sheets lose their surface finish at the exposed surface by carbonation and become ingrained with dirt. To achieve reasonable thermal insulation standards a lining material will be required, which is normally sandwiched between the cladding and an inner lining tray.

### 2 Coated steel sheets

non-combustible material with a wide range of profiles produced by various manufacturers. The

... non-combustible material with a wide range of profiles produced by various manufacturers. The steel sheet forms the core of the cladding providing its strength and this is covered with various forms of coatings to give weather protection, texture and colour. A typical specification would be a galvanised steel sheet core covered on both sides with a layer of asbestos felt to increase resistance to fire, a layer of bitumen-impregnated felt to act as a barrier to the passage of moisture to the core and on the face surface a coloured and textured coating of plastic. Fixing and the availability of fittings is as described above for asbestos cement.

**3 Aluminium alloy sheets non-combustible material in corrugated and troughed profiles which are usually made to the recommendations of BS 2858 and BS 3428 respectively. Other profiles are also available as manufacturers' standards. Durability will depend upon the alloy used but this can be increased by paint applications; if unpainted, regular cleaning may be necessary if its natural bright appearance is to be maintained. Fixing, fittings and the availability of linings is as given for other cladding materials.**

**4 Polyvinyl chloride sheets generally supplied in a corrugated profile with an embedded wire reinforcement to provide a cladding with a surface spread of flame classification of class 1 in accordance with BS 476: Part 7.**

The durability of this form of cladding is somewhat lower than those previously considered and the colours available are limited. The usual range of fittings and trims are available.

The importance of adequate design, detail and fixing of all forms of lightweight cladding cannot be overstressed since the primary objective of these claddings is to provide a light-weight envelope to the building giving basic weather protection and internal comfort at a reasonable cost. Claddings which will fulfil these objectives are very susceptible to wind damage unless properly secured to the structural frame.

## **- CURTAIN WALLING**

**Curtain walls are a form of external lightweight cladding, attached to a framed structure or monolithic walls, forming a complete envelope or sheath around the structural frame.**

**They are non-load-bearing claddings, which have to support only their own deadweight and any imposed wind loadings which are transferred to the structural frame through connectors which are usually positioned at the floor level.**

**The basic conception of most curtain walls is a series of vertical MULLIONS spanning from floor to floor interconnected by horizontal TRANSOMS forming openings into which can be fixed panels of glass or infill panels of opaque materials like:**

- metal faced insulation materials**
- weatherproof blockboard**
- plastic materials, etc. of various thickness built in metal frames.**

**Most curtain walls are constructed by using a patent or proprietary system produced by metal window manufacturers.**

**The primary objectives of using curtain walling systems are:**

- 1 Provide an enclosure to the structure which will give the necessary protection against the elements.**
- 2 Make use of dry construction methods.**
- 3 Impose onto the structural frame the minimum load in the form of claddings.**
- 4 Exploit an architectural feature.**

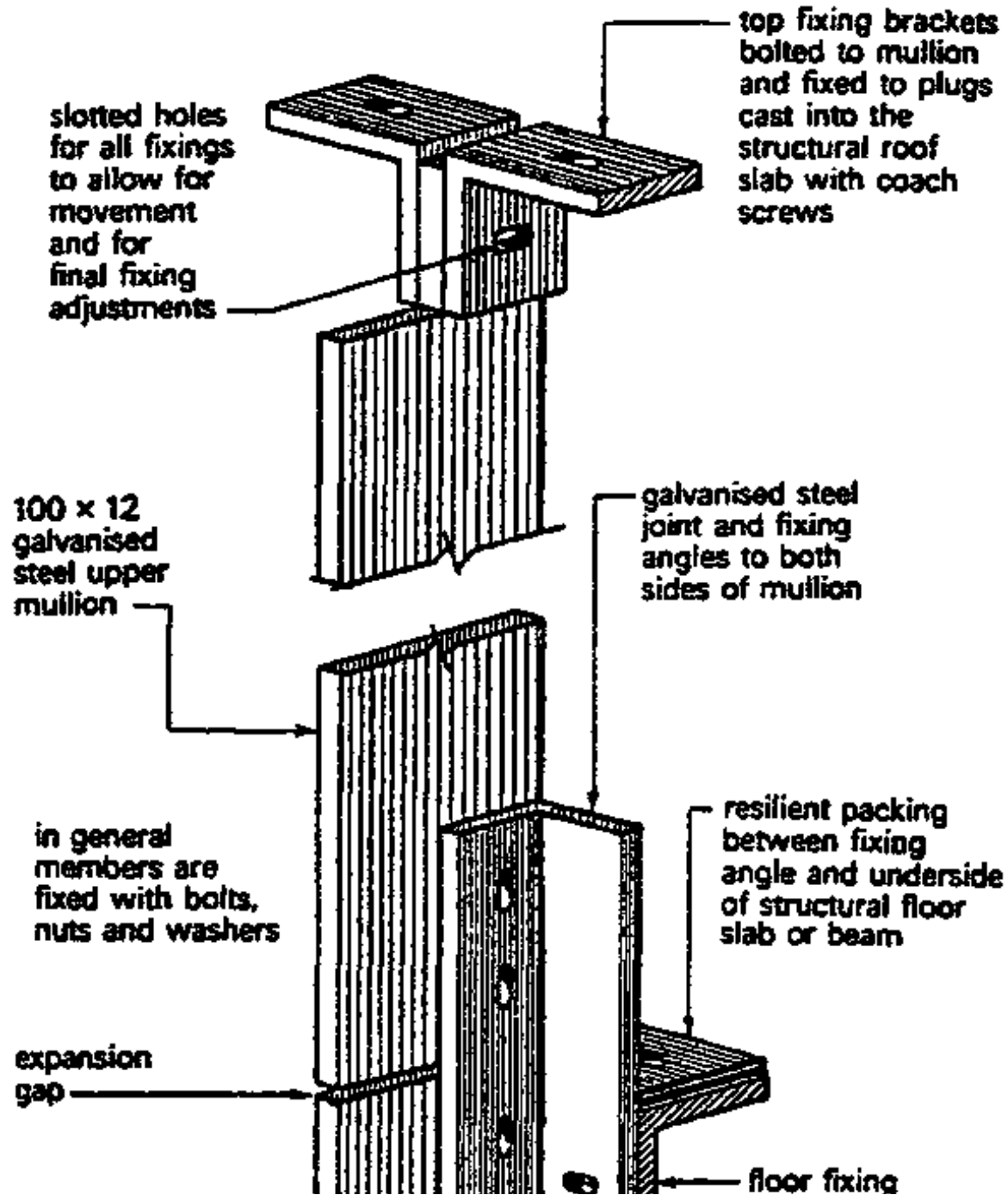

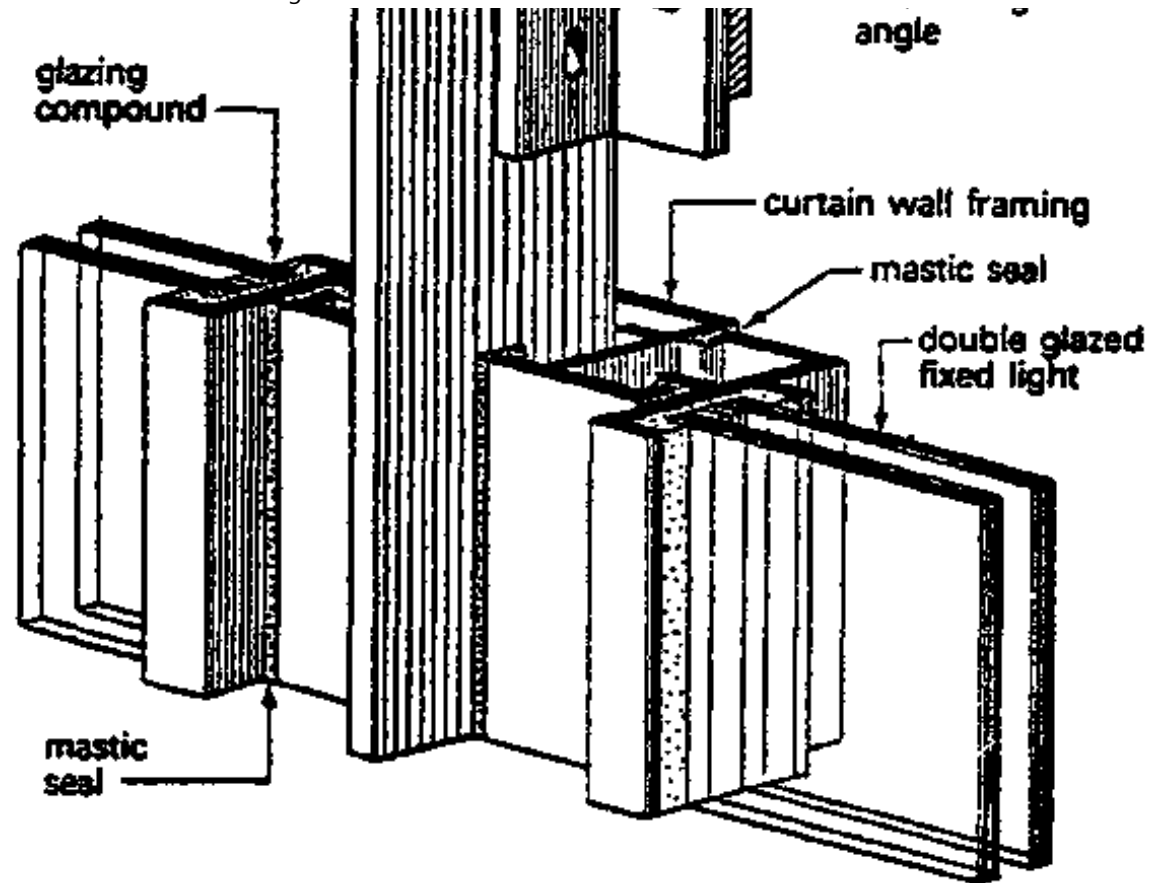

Typical curtain walling details 1

To fulfil its primary functions a curtain wall must meet the following requirements:

1 Resistance to the elements the materials used in curtain walls are usually impervious and in themselves present no problem but by virtue of the way in which they are fabricated a large number of joints occur. These joints must be made as impervious as the surrounding materials or designed as a drained joint. The jointing materials must also allow for any local (thermal, structural or moisture movement and generally consist of mastics, sealants and/or preformed caskets of synthetic rubber or PVC.

2 Assist in maintaining the designed internal temperatures - since curtain walls usually include a



**2 Assist in maintaining the designed internal temperatures - Since curtain walls usually include a large percentage of glass the overall resistance to the transfer of heat is low and therefore preventive measures may have to be incorporated into the design. Another problem with large glazed areas is solar heat gain since glass will allow the short wave radiations from the sun to pass through and consequently warm up the surfaces of internal walls, equipment and furniture. These surfaces will in turn radiate this acquired heat in the form of long wave radiations which cannot pass back through the glazing thus creating an internal heat build-up. Louvres fixed within a curtain walling system will have little effect upon this heat buildup, but they will reduce solar glare. A system of non-transparent external louvres will slightly reduce the heat gain by absorbing heat and radiating it back to the external air. The usual methods employed to solve the problem of internal heat gain are:**

**a Deep recessed windows which could be used in conjunction with external vertical fins.**

**b Balanced internal heating and ventilation systems.**

**c Use of special solar control glass such as reflective glasses which during manufacture are modified by depositing on the surface of the glass a metallic or dielectric reflective layer. The efficiency of this form of glazing can be increased if the glass is tilted by 5° to 15° to increase the angle of incidence.**

**3 Adequate strength - although curtain walls are classified as non-load-bearing they must be able to carry their own weight and resist both positive and negative wind loadings. The magnitude of this latter loading will depend upon three basic factors:**

**a Height of building**

**b Degree of exposure**

**c Location of building**

The strength of curtain walling relies mainly upon the stiffness of the vertical component or mullion to-gather with its anchorage or fixing to the structural frame. Glazing heads and the use of compressible materials also add to the resistance of possible wind damage of the glazed and infill panel areas by enabling these units to move independently of the curtain wall framing.

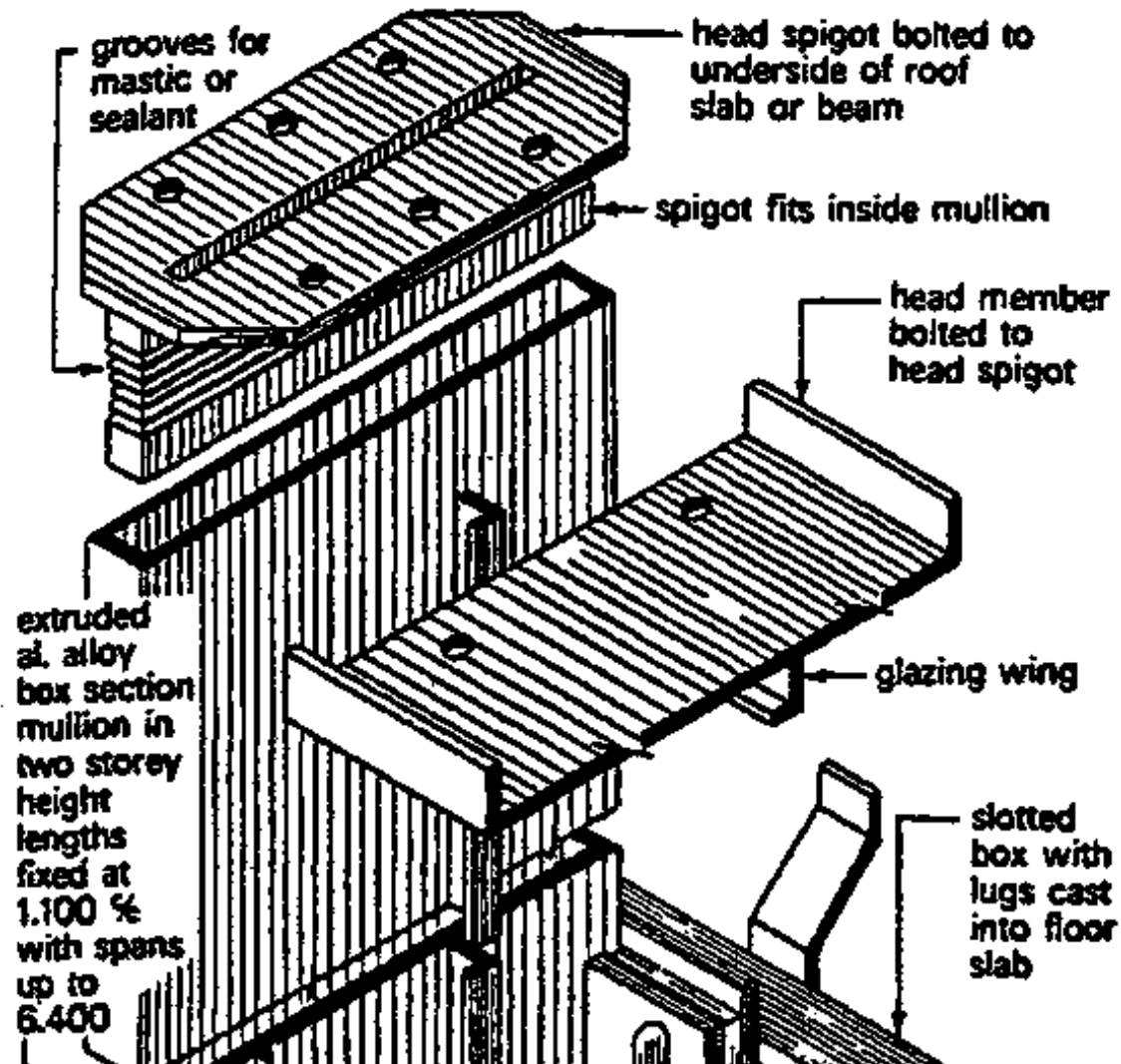

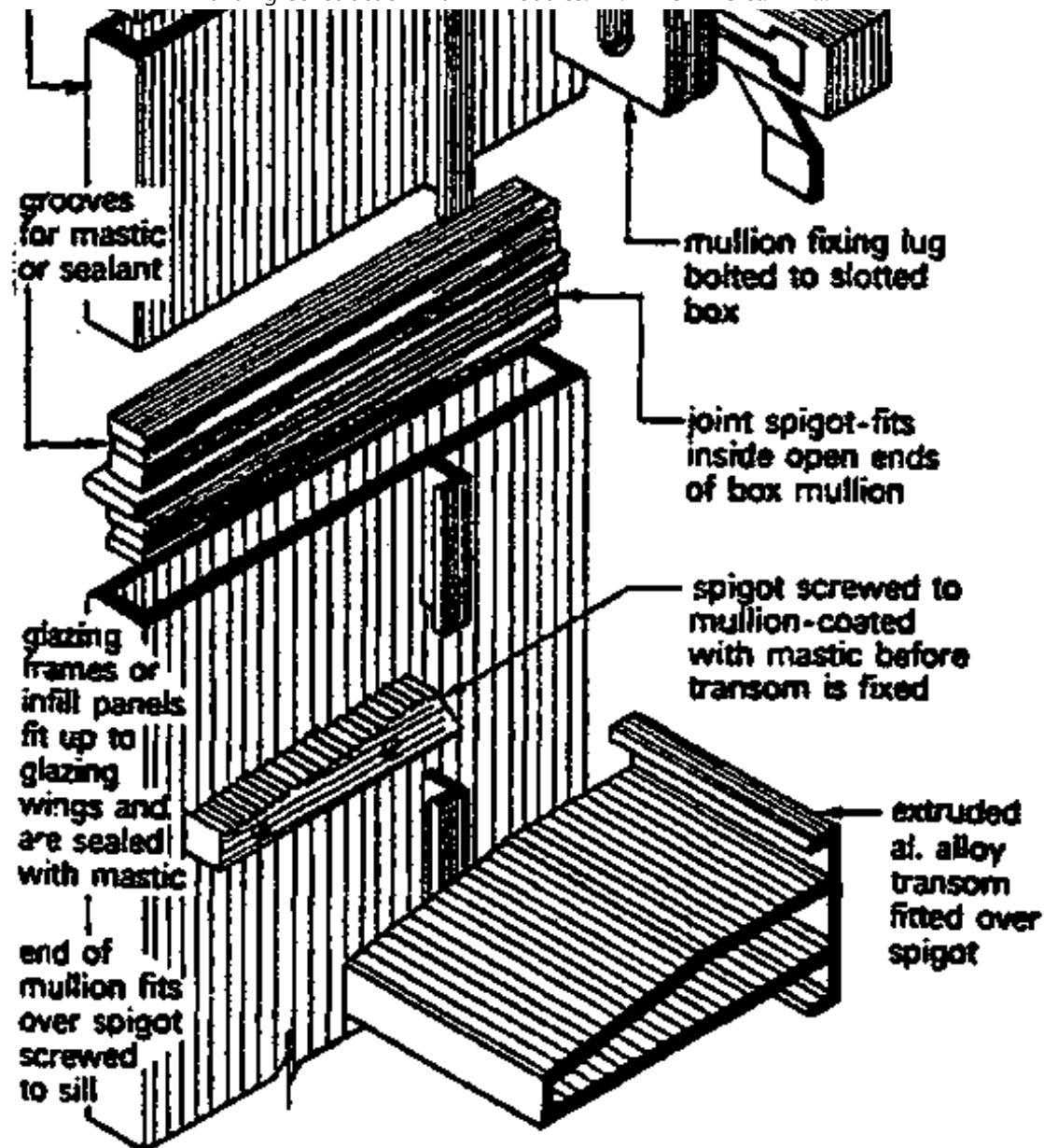

Typical curtain walling details 2

**4 Provide required degree of fire resistance - this is probably one of the greatest restrictions encountered when using curtain walling techniques because of the large proportion of unprotected areas as defined in Building Regulation E.4 and by the conditions set out in**

**unprotected areas as defined in Building Regulation E 7 and by the conditions set out in Building Regulation E 7 and Schedule 9. By using suitable materials or combinations of materials the opaque infill panels can normally achieve the required fire resistance to enable them to be classified as protected areas.**

**5 Easy to assemble and fix - the principal member of a curtain walling system is usually the mullion which can be a solid or box section which is fixed to the structural frame at floor levels by means of adjustable anchorages or connectors.**

**The infill framing and panels may be obtained as a series of individual components or as a single prefabricated unit. The main problems are ease of handling, amount of site assembly required and mode of access to the fixing position.**

**6 Provide required degree of sound insulation - sound originating from within the structure may be transmitted vertically through the curtain walling members. The chief source of this form of structure-borne sound is machinery and this may be reduced by isolating the offending machines by mounting them on resilient pads and/or using resilient connectors in the joints between mullion lengths.**

**Airborne sound can be troublesome with curtain walling systems since the lightweight cladding has little mass to offer in the form of a sound barrier, the weakest point being the glazed areas. A reduction in the amount of sound transmitted can be achieved by**

**a Reducing the areas of glazing**

**b Using sealed windows of increased glass thickness**

**c Double glazing in the form of inner and outer panes of glass with an air space of 150 to 200 mm between them.**

7 Provide for thermal 2nd structural movements - since curtain walling is situated on an external face of the structure it will be more exposed than the structural frame and will therefore be subject to greater amounts of temperature change resulting in high thermal movement. The main frame may also be subjected to greater settlement than the claddings attached to its outer face. These differential movements mean that the curtain walling systems should be so designed, fabricated and fixed that the attached cladding can move independently of the structure. The usual methods of providing for this required movement are to have slotted bolt connections and, to allow for movement within the curtain walling itself, to have (...) corrections and/or mastic sealed joints.

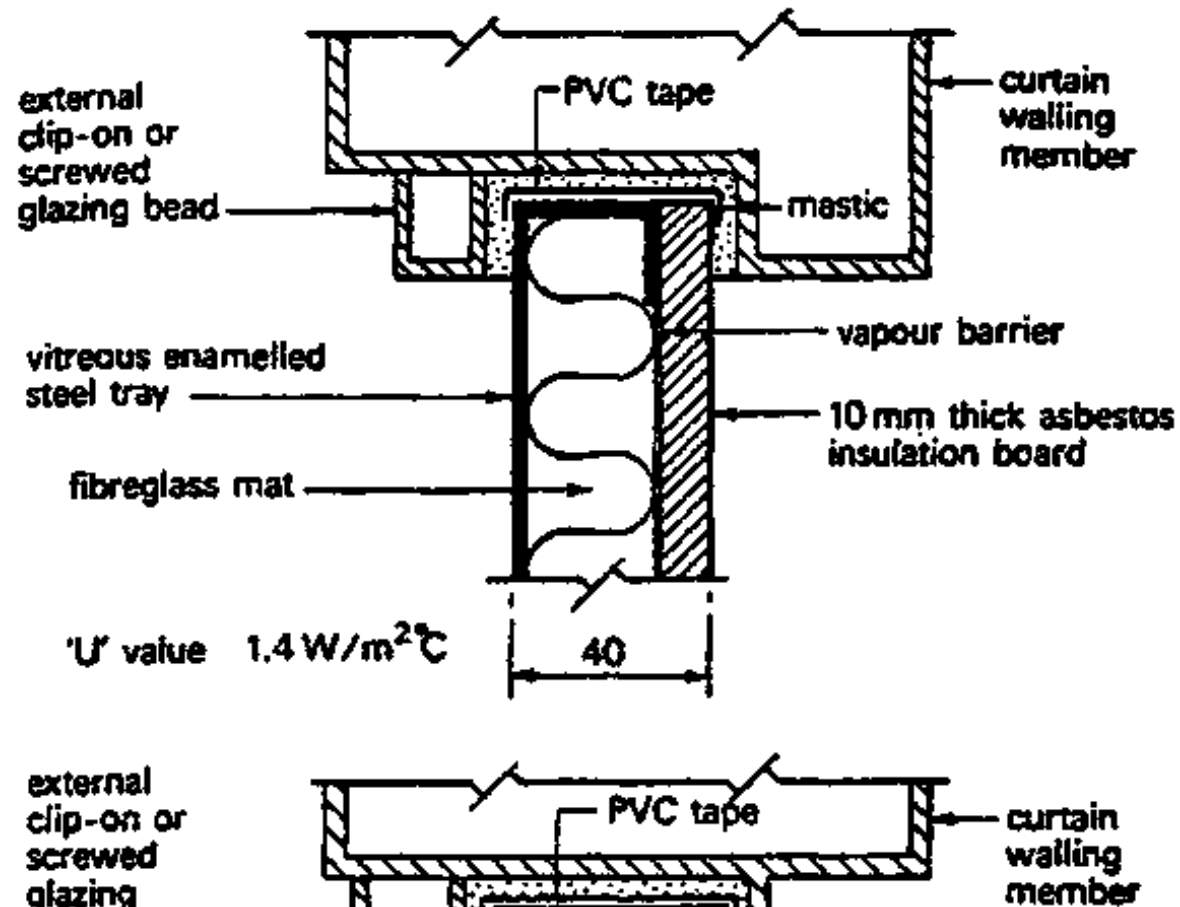

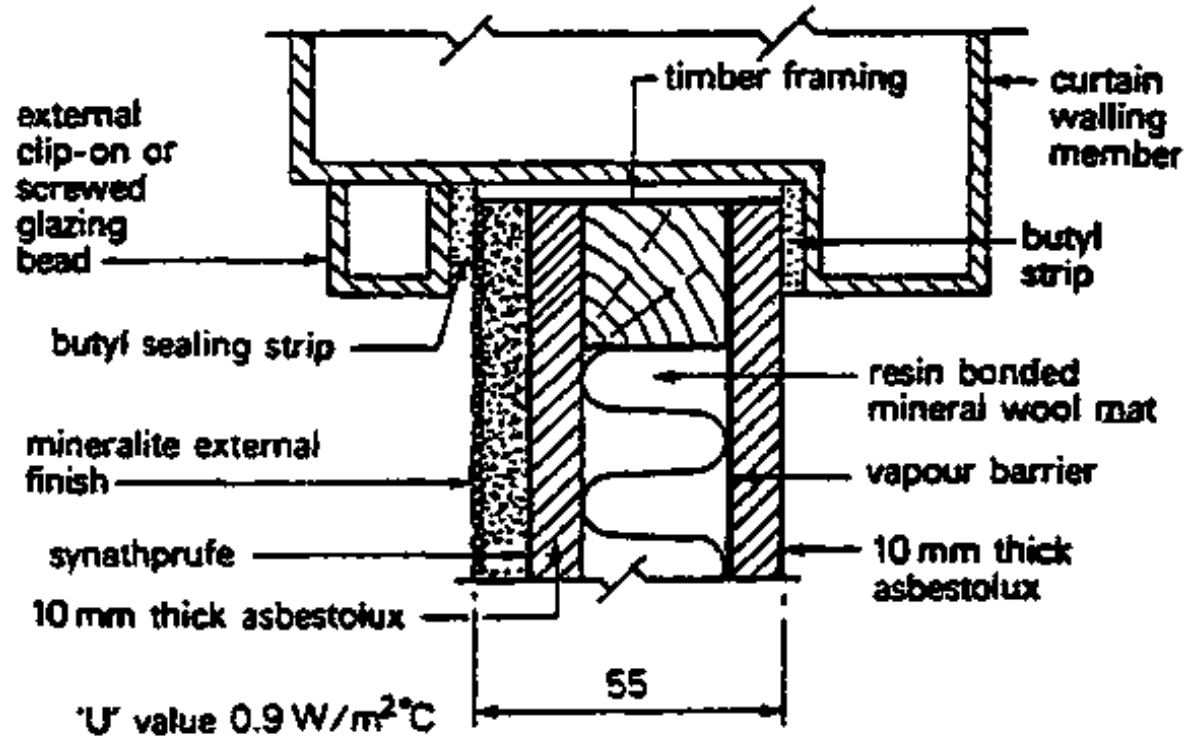
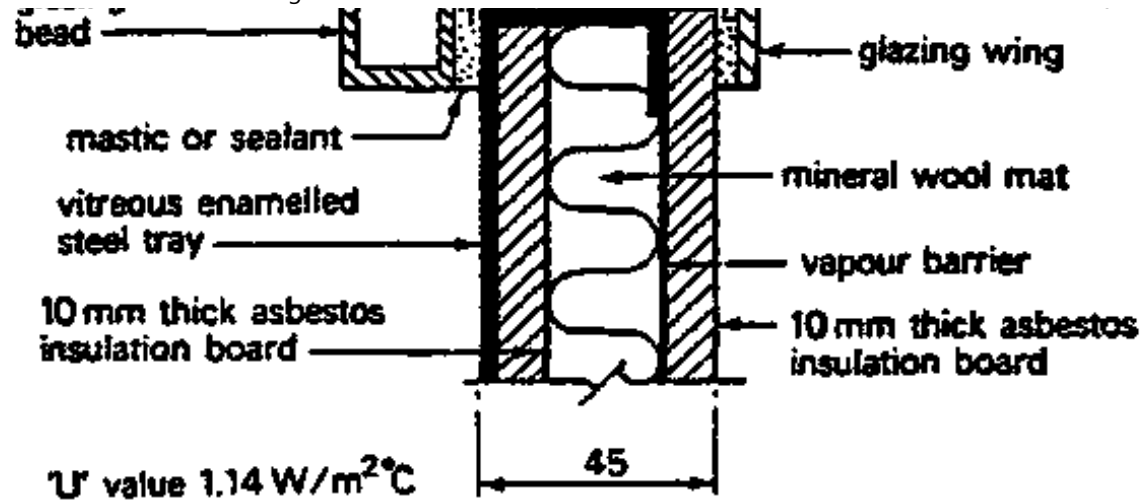

Typical curtain walling infill panel details

### **12.1.4 EXTERNAL PAINTS AND FINISHES**

The usual colour renderings today are achieved either by use of cement paints, i.e. paints containing coloured cements supplied as powder and mixed with water, or by use of PVA emulsion paints. The former are very popular, especially with Tyrolean finish. The latter are supplied as a thick liquid to which water is added. They are easily applied, require no special skill and form a plastic skin which adheres well to cement rendering. Emulsion paint, however, does fail occasionally because of the alkaline nature of the background. The emulsion paint used must be of external quality.

Oil paints are not greatly used in the tropics on the grounds of their expense, and emulsion paint cannot be applied over them. Water-bound distemper is still used, as it is cheap and easily applied. It needs frequent renewal.

An expensive but strong and durable surface can be obtained from the use of epoxy resin paint. It is waterproof and adheres well. It is very good for cement screeded floors

Bitumen paints are good, particularly in coastal areas or in demo atmosphere. They are used widely on corrugated iron sheathing and other metals in need of protection from rust. The surfaces must be cleaned before paint is applied. No other kind of paint can be applied over bitumen paint.

Woodwork which is mainly from hardwood does not always receive the preparative treatment which is usual in the case of softwood. Frequently it is not primed. Hardwoods, however, are sometimes subject to rapid decay in external conditions should be carefully primed before undercoat is applied.

Varnishing of wood used externally although still popular is not always successful on exposed faces. It is quite satisfactory in sheltered areas, under canopies, walk-ways, etc. but will not stand up to sunlight.

### **12.2 INTERNAL WALL FINISHES**

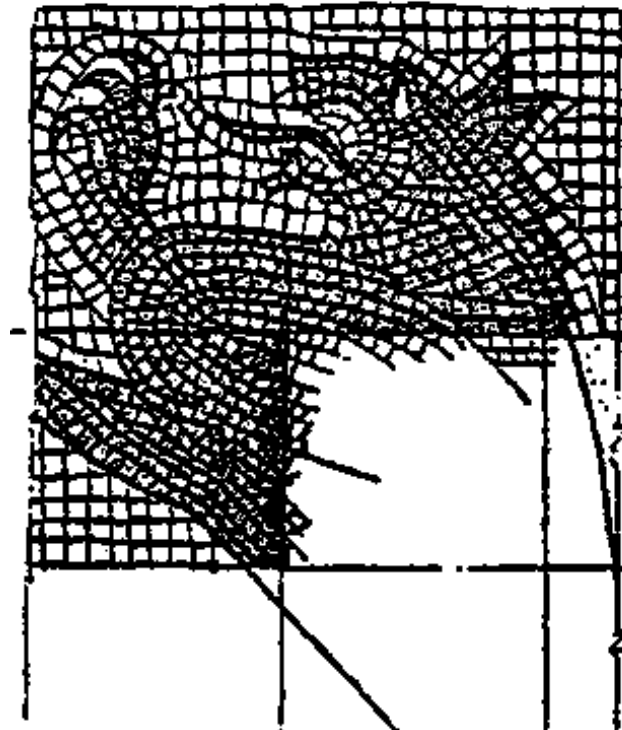
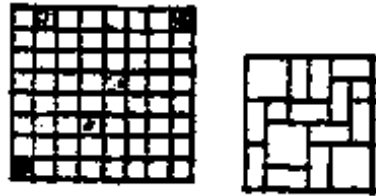
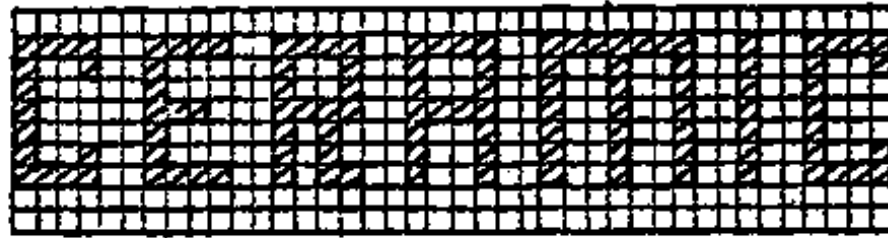



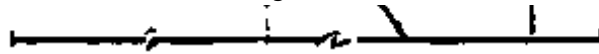

## 12.2.1 PLASTERING

A number of factors causes a great variation in the art of plastering from one country to another:

- traditional customs
- religious influences
- the material available
- the tools used
- the background to which it is applied.

Therefore only the main plastering techniques will be dealt with here.

### • MATERIALS

The chief materials used for plastering are:

- lime
- cement
- gypsum and
- sand.

### LIME

Lime for plastering is produced by calcining (burning) limestone, mainly chalk, which removes the carbon dioxide. On cooling, the quicklime is stored in a dry place from where it is transported to its

destination. Before it can be used, however, the lime must be 'slaked', i.e. water added a week or two before it is needed. Lime for plastering is usually 'fat' line, i.e. easily slaked and workable as distinct from hydraulic line which is not, but which has the property of setting under water. Locally burnt line produced under primitive conditions is rarely of good quality and results in pitting or blowing of the rendering caused by uneven burning.

Modern lime production can be carried out on similar lines to the manufacture of port-land cement. Quicklime is exposed to steam which reduces the lime to a powder. This is bagged for transport in the same way as Portland cement although it is only about half its weight. The lime is usually soaked on site for a short while, say a day, after which it is ready for use.

## **PORTLAND CEMENT**

Where a country has no supply of its own, cement may be imported in 1 cwt (50 kg) bags or drums, as explained. There appears to be no reason, however, why the clinker produced by burning, when cooled off, should not be shipped to its destination where it should then be ground into cement. This method would have a number of advantages: it would be cheaper to transport in bulk; it could be freshly ground as required and the clinker would be unaffected by moisture which is an important consideration in humid areas. The grinding process could be incorporated into the full production plant for manufacturing cement when or if it was eventually built.

## **BUILDING PLASTERS**

The bulk of these have a gypsum base, gypsum being a naturally occurring material found in many parts of the world. There are many varieties which, under the BS system are divided into classes.

The main divisions are:

### **Class A plaster:**

**This is usually called plaster of Paris. To produce it, gypsum is burnt to a fairly low temperature (160°C) when it loses most of its water of hydration. When the finished plaster is mixed with water, it sets very quickly, within 5 minutes usually. Plaster of Paris is used extensively in plaster casting shops. Here prefabricated panels and mouldings are prepared, reinforced by wood laths and hessian scrim. These are transported to the site and nailed or screwed to wood grounds or bearers which are shaped if necessary. The joints are then neatly filled with gauged plaster. Much fine plaster work is carried out in this way.**

### **Class B plasters.**

**These are plasters in which the 'set' has been retarded, or the setting time increased. This allows the plasterers time to lay on the material and bring it to a smooth finish. There are three grades of Class B plasters, usually, undercoat, finishing and 'dual purpose', the latter being most widely used, particularly when it has to be imported.**

### **Class C plasters.**

**These are normally of better quality than those of Class 3. They are made by heating gypsum to a higher temperature than 160°C. This causes the plaster to lose its quick-setting, power. Accelerators are then added which cause the material to set in enough time to allow the plasterer to obtain a smooth finish.**

### **Class D plasters.**

**The main plaster in this group is Keene's cement, a high-quality slow-setting plaster giving a smooth marble-like finish. Adhesion of decorative finish on Keene's or Parian cement is very poor unless a coat of sharp oil paint is applied as soon as it has set.**

## Other types.

Class B, C and D plasters should be applied to backgrounds as undercoats and/or Finishes in accordance with the recommendation given in Mixes. Other types of plasters, however, are available which may be applied to any surface including concrete, blockwork or plasterboard. Lightweight plasters are also available with improved acoustical and insulating properties. For further information on these, the reader is referred to M.O.P. B.W. Advisory leaflets, S.R.S. publications, etc.

## Mixes.

For internal work Cement and Sand is only used, where lime is not available or where a building is designed on an open plan. In most areas in Tanzania all internal renderings are of Portland cement and sand, no other material is used even for the finish coat. This practice is costly in cement and does not provide for a smooth finish, particularly when application and finishing are done with only the aid of a mason's trowel and a straight - edge.

LIME may be added to either Portland cement or gypsum plaster, but Portland Cement must NOT be mixed with gypsum plaster.

Usually Portland cement/lime/sand is reserved for external work and gypsum plasters for internal, although there are many exceptions to this practice.

Gypsum plasters are also used externally in areas of low rainfall and humidity. The most common mixes are given in the table below.

| <i>Background</i>      | <i>Undercoat</i>           | <i>Finish</i>                  |
|------------------------|----------------------------|--------------------------------|
| Brickwork or blockwork | (1) Cement/lime/sand 1:2:6 | Lime/gypsum Class B 1:1<br>(R) |

|  |   |                              |
|--|---|------------------------------|
|  | <b>(2) Cement/sand 1:4</b>              | <b>Gypsum C neat (5)</b>     |
|  | <b>(3) Gypsum B/sand 1:3</b>            | <b>Lime/gypsum B 1:1 (T)</b> |
|  | <b>(4) Gypsum C/lime/sand<br/>2:1:6</b> | <b>R, S, or T above</b>      |
| <b>Concrete cast <i>in situ</i></b>                            | <b>As (2) above</b>                     | <b>As S above</b>            |
|  | <b>As (3) above</b>                     | <b>As T above</b>            |
|  | <b>If none needed</b>                   | <b>As S above</b>            |
| <b>Metal lathing</b>   | <b>As (1) above (two coats)</b>         | <b>As R above</b>            |
|  | <b>As (3) above (two coats)</b>         | <b>As T above</b>            |
| <b>Expanded plastic sheets, plasterboard or<br/>fibreboard</b> | <b>None usual (except joints)</b>       | <b>As R above</b>            |
| <b>Wood-wool slabs</b>   | <b>As (1) above</b>                     | <b>As R above</b>            |
|  | <b>As (3) above</b>                     | <b>As T above</b>            |

### Key.

Adhesion of plaster to the background is very important. Concrete should be cleaned free of grease of film and either 'hacked' or painted with an epoxide resin adhesive.

Each coat of plaster should be scratched or grooved the top undercoat only lightly so.

### Finishing Coat.

**This should not be applied too quickly. One coat 1,5 mm to 3 mm is usually sufficient. Undercoat thicknesses vary but 10 to 15 mm is usual.**

### **12.2.2 OTHER INTERNAL WALL FINISHES**

**There is a wide range of finishes available today and new materials are constantly being introduced. Fashion, ideas, prefabrication, cost and the economic state of the community all effect demand.**

**Only the basic finishes, therefore, may be listed up to give an idea about the variety of different materials used as internal wall finishes:**

- Glazed Tiles**
- Decorative Patterned Tiles**
- Ceramic Mosaics - Marble**
- Terrazzo**
- Mosaic**
- PVC Tiles**
- Glass,**

**i.e. plate glass (coloured)  
glass panels  
patterned glass  
glass blocks**

- Dry Lining Techniques etc.**



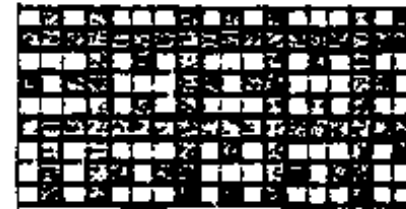
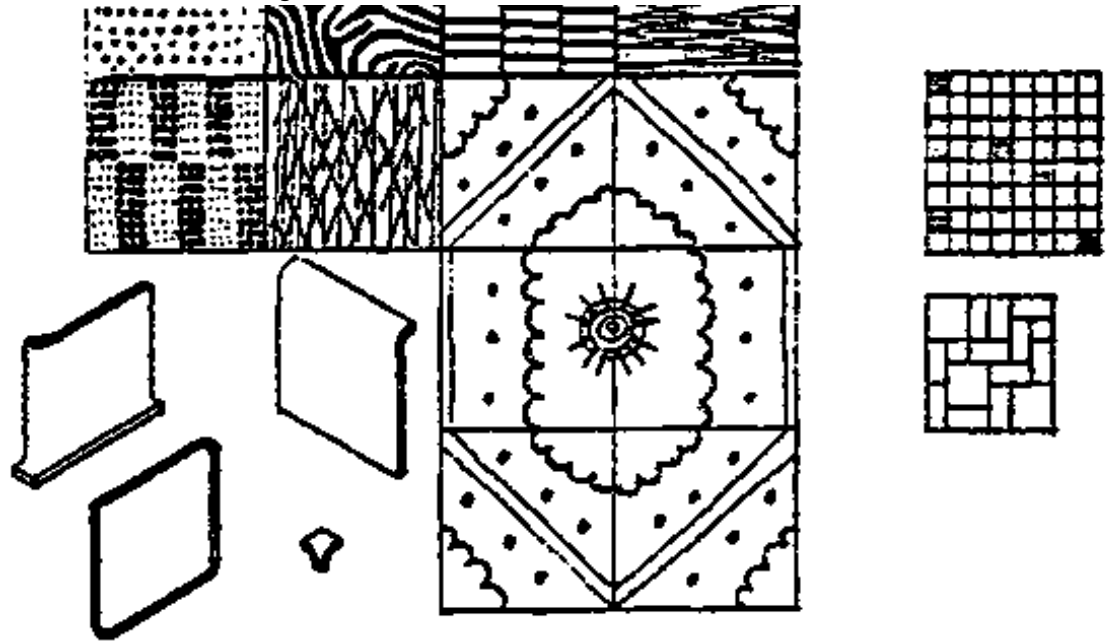

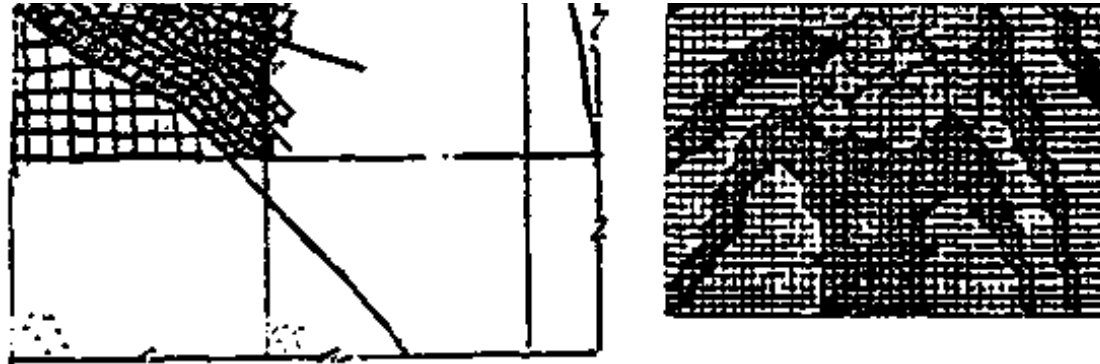

### 12.2.3 PAINTING

Protection and decoration are the two important functions of painting.

On interior work, particularly walls and ceilings, the decorative function may be considered more important even though walls may have to withstand washing.

**PAINT** is a mixture of a liquid or medium and a colouring or pigment. Mediums used in paint manufacture range from thin liquids to stiff jellies and can be composed of linseed oil, drying oils, synthetic resins and water. The various combinations of these materials form the type of class of paint. The medium's function is to provide the means of spreading and binding the pigment over the surface to be painted. The pigment provides the body, colour and durability of the paint. White lead is a pigment which gives good durability and moisture resistance but it is poisonous, therefore its use is confined mainly to priming and under-coating paints. Paints containing a lead pigment are required by law to state this fact on the can. The general pigment used for finishing paint is titanium dioxide which gives good obliteration of the undercoating but is not poisonous.

### OIL BASED PAINTS

**Priming paints:**



**These are first coat paints used to seal the surface, protect the surface against damp air, act as a barrier to prevent any chemical action between the surface 2nd the finishing coats and to give a smooth surface for the sub-sequent coats. Priming paints are produced for application to wood, metal and plastered surfaces.**

### **Undercoating paints:**

**These are used to build up the protective coating and to provide the correct surface for the finishing coat(s). Undercoat paints contain a greater percentage of pigment than finishing paints and as a result have a matt or flat finish. To obtain a good finishing colour it is essential to use an undercoat of the type and colour recommended by the manufacturer.**

### **Finishing paints:**

**A wide range of colours and finishes including matt, semi-matt, eggshell, satin, glass and enamel are available. These paints usually contain a synthetic resin which enables them to be easily applied, quick drying and have good adhesive properties. Gloss paints have less pigment than the matt finishes and consequently less obliterating power.**

### **POLYURETHANE PAINTS.**

**These are quick drying paints based on polyurethane resins giving a hard heat resisting surface. They can be used on timber surfaces as a primer and undercoat but metal surfaces will require a base coat of metal primer, the matt finish with its higher pigment content is best for this 'one paint for all coats' treatment. Other finishes available are gloss and egg-shell.**

### **WATER BASED PAINTS.**

**Most of the water based paints in general use come under a general classification of emulsion paints: they are quick drying and can be obtained in matt, eggshell, semi-gloss and gloss finishes. The water**

medium has additives such as polyvinyl acetate and alkyd resin to produce the various finishes. Except for application to iron work, which must be primed with a metal primer, emulsion paints can be used for priming, undercoating and as a finishing application. Their general use is for large flat areas such as ceilings and walls.

## VARNISHES AND STAINS

Varnishes form a clear, glossy or matt, tough film over a surface and are a solution of re-sin and oil. their application being similar to oil based paints.

The type of resin used, together with the correct ratio of oil content, forms the various durabilities and finishes available. Stains can be used to colour or tone the surface of timber before applying a clear of varnish; they are basically a dye in a spirit and are therefore quick drying.

## 12.3 CEILING FINISHES

Ceilings can be finished by any of the dry lining techniques previously described for walls. The usual method is a plasterboard base with a skim coat of plaster. The plasterboards are secured to the underside of the floor or ceiling joists with galvanised plasterboard nails to reduce the risk of corrosion to the fixings. If square edged plasterboards are used as the base a jute scrim over the joints is essential. The most vulnerable point in a ceiling to cracking is at the junction. between the ceiling and wall, this junction should be strengthened with a jute scrim around the internal angle (see fig.) or alternatively the junction can be masked with a decorative plasterboard or polystyrene cove moulding.

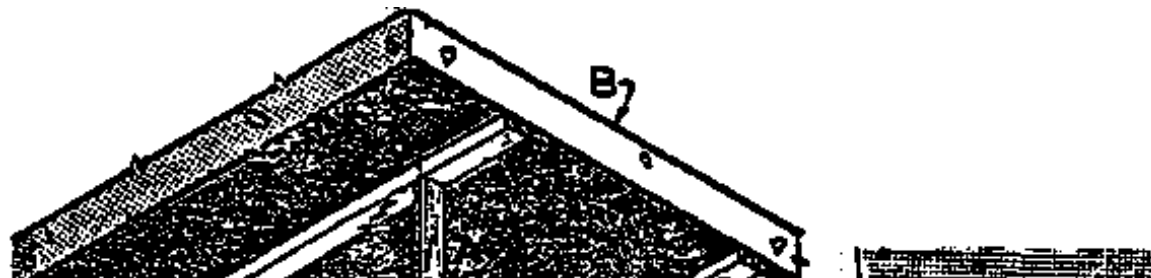

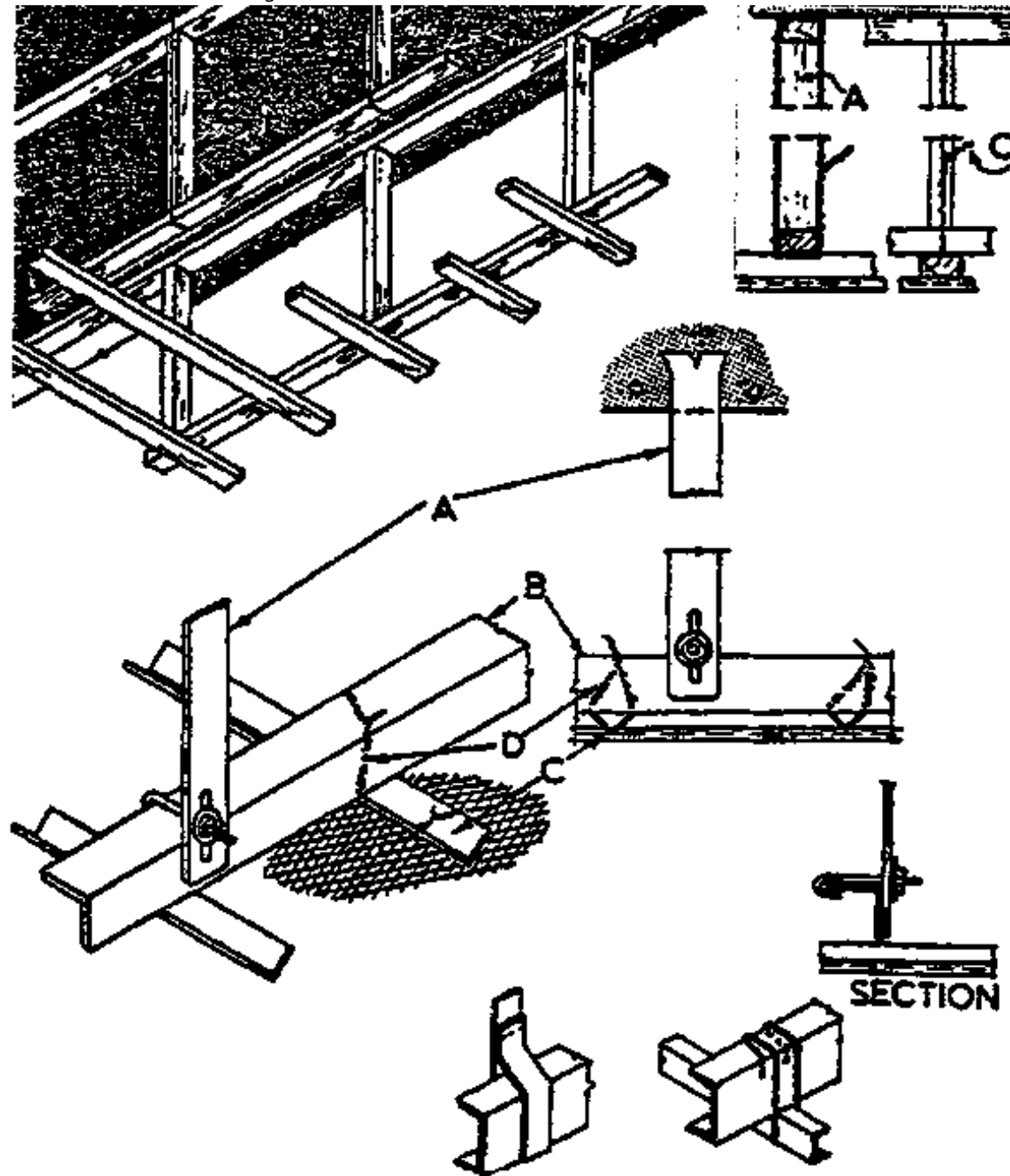

The cove moulding is made in a similar manner to plaster-board and is intended for direct decoration.

Plasterboard cove moulding is jointed at internal and external angles with a mitred joint and with a butt joint in the running, length. Any clean, dry and rigid background is suitable for the attachment of plasterboard cove which can be fixed in one of two ways. It can be secured by using a special water mixed adhesive applied to the contact edges of the moulding which is pressed into position; any surplus adhesive should be removed from the edges before it sets. Alternatively the cove moulding can be fixed with galvanised steel or brass screws to plug or battens - fixings to the wall are spaced at 300 mm centres and to the ceiling at 600 mm centres. A typical plasterboard cove detail is shown in the fig. Many forms of ceiling tiles are available for application to a joisted ceiling or solid ceiling with a sheet or solid background. Fixing to joists should be by concealed or secret nailing through the tongued and grooved joint. If the background is solid such as a concrete slab then dabs of a recommended adhesive are used to secure the tiles. Materials available include expanded polystyrene, mineral fibre, fibreboard and glass fibre with a rigid vinyl face. Other forms of finish which may be applied to ceilings are sprayed plasters which can be of a thick or thin coat variety. Spray plasters are usually of a proprietary mixture applied by spraying apparatus directly on to the soffit giving a coarse texture which can be trowelled smooth if required. Various patterned ceiling papers are produced to give a textured finish. These papers are applied directly to the soffit or over a stout lining paper. Some ceiling papers are designed to be a self finish but others require one or more coats of emulsion paint.

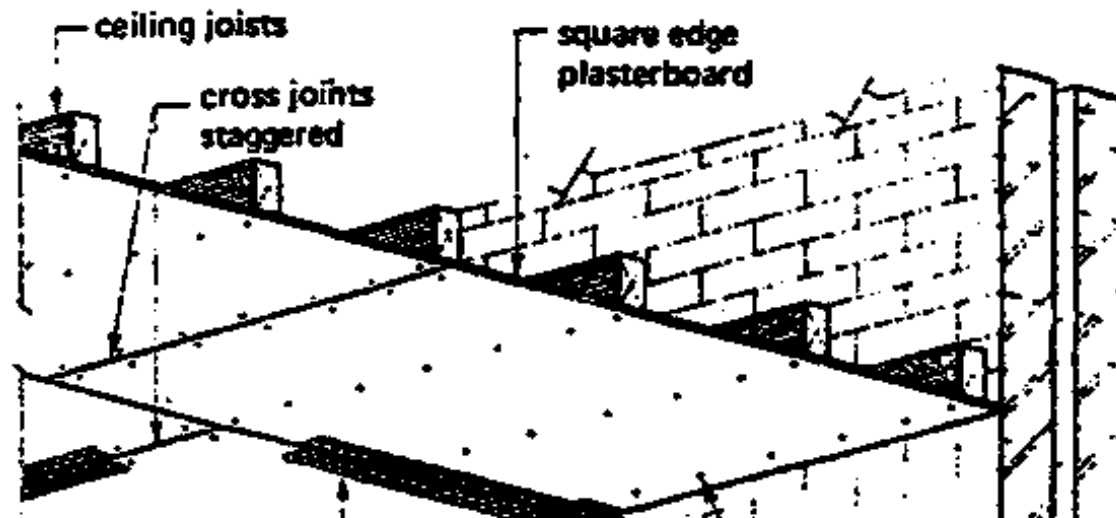

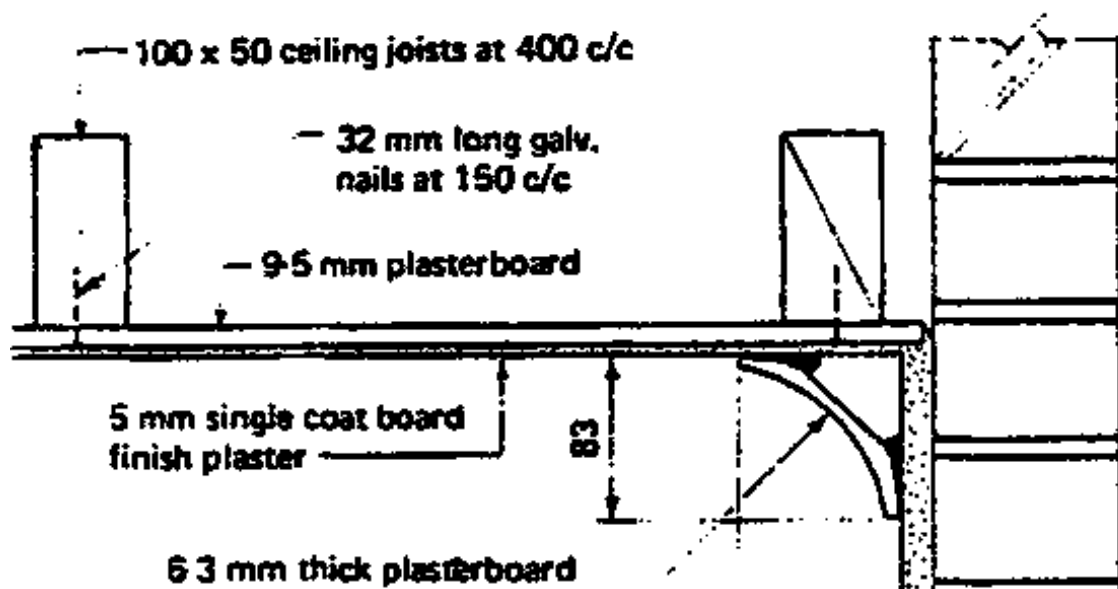
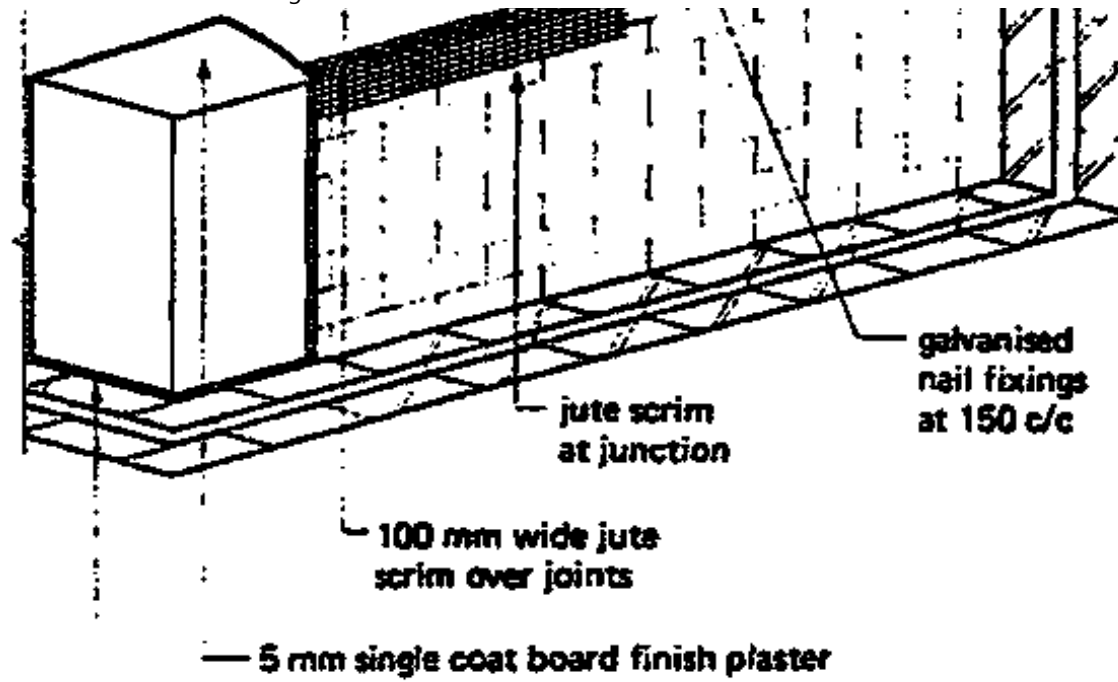

cove moulding fixed  
with adhesive



Plasterboard ceilings

Repetition exercises

Try to answer the following questions and practice sketching where ever necessary and possible

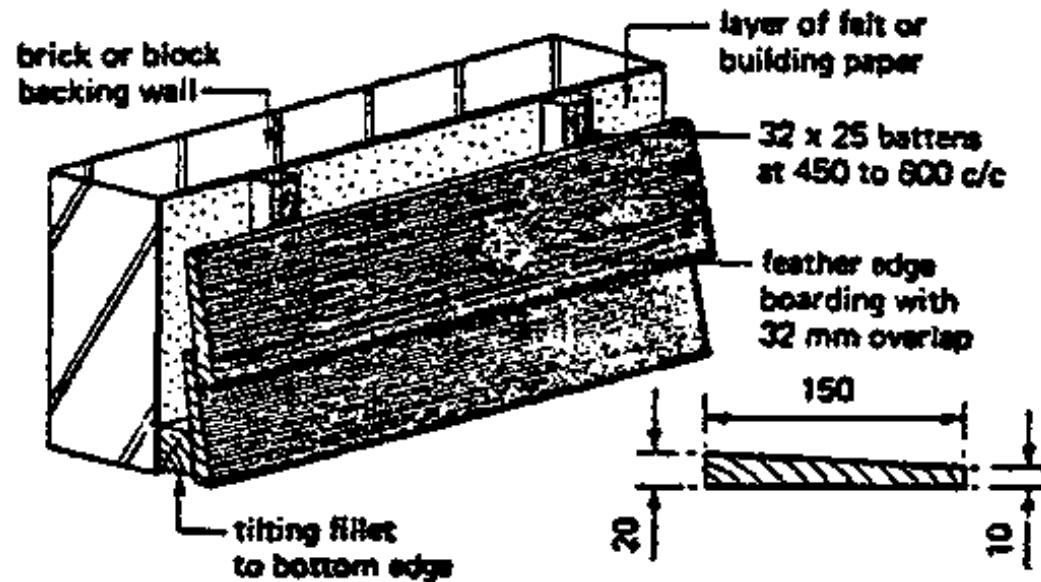

## 12.1. External Wall Finishes

- Define the terms:

External Rendering  
Spatterdash  
Roughcast  
Pebbledash  
Tvr clean Finish

## External Finishes

- **What are the properties of the rendering and where does the success of the rendering depend on?**
- **Give the two common volume mix ratios!**
- **Write notes on the application of external rendering.**
- **List and describe methods of finishing concrete walls apart from rendering or painting.**
- **What are the advantages of cladding over traditional types of construction?**
- **Which points must a designer keep in mind to prevent failures?**
- **Which points must a cladding fixer keep in mind?**
- **Where should cranes and other fixings be made from?**
- **Write notes on claddings fixed to a structural backing, including Tile Hanging and Timber Claddings.**

**Use sketches for illustration!**

- **Write notes on claddings to framed structures, including Brick Panel Walls, Concrete Cladding Panels, Infill Panels, Lightweight Wall Claddings and Curtain Walling.**

**Use sketches for illustration.**

- **Compare the different types of external paints and finishes!**

## 12.2 Internal Wall Finishes

- List and describe the different materials used for plastering!
- Write notes on Mixes for internal work and give the most common Mixes.
- Describe the important factors of a good key and the finishing coat for plaster
- List other Internal Wall Finishes
- What are the important functions of painting
- Define the terms:

Priming Paints

Undercoating Paints

Finishing Paints

Polyurethane Paints

Water Based Paints

Varnishes and Stains

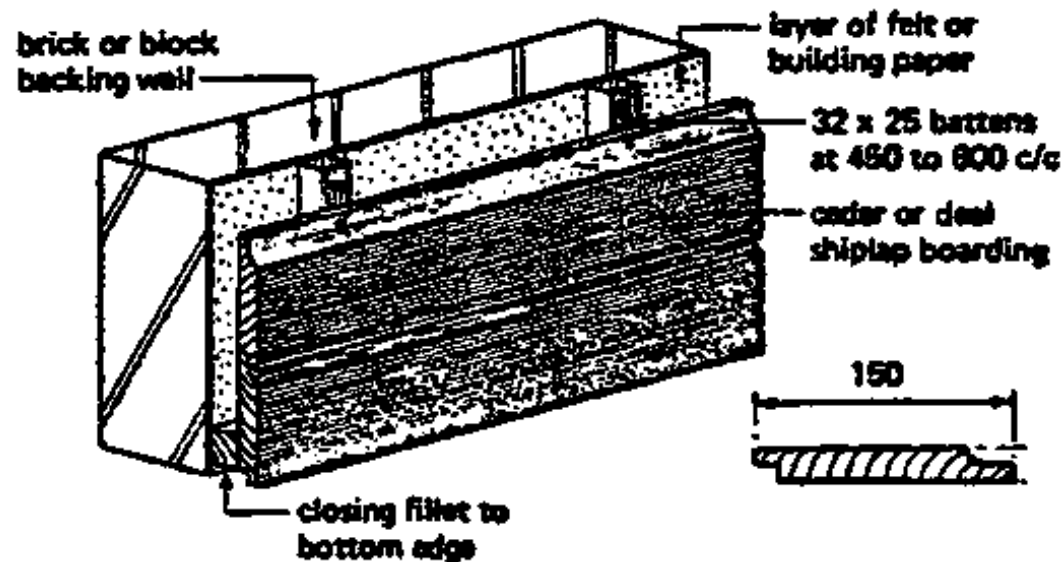



## Typical horizontal claddings

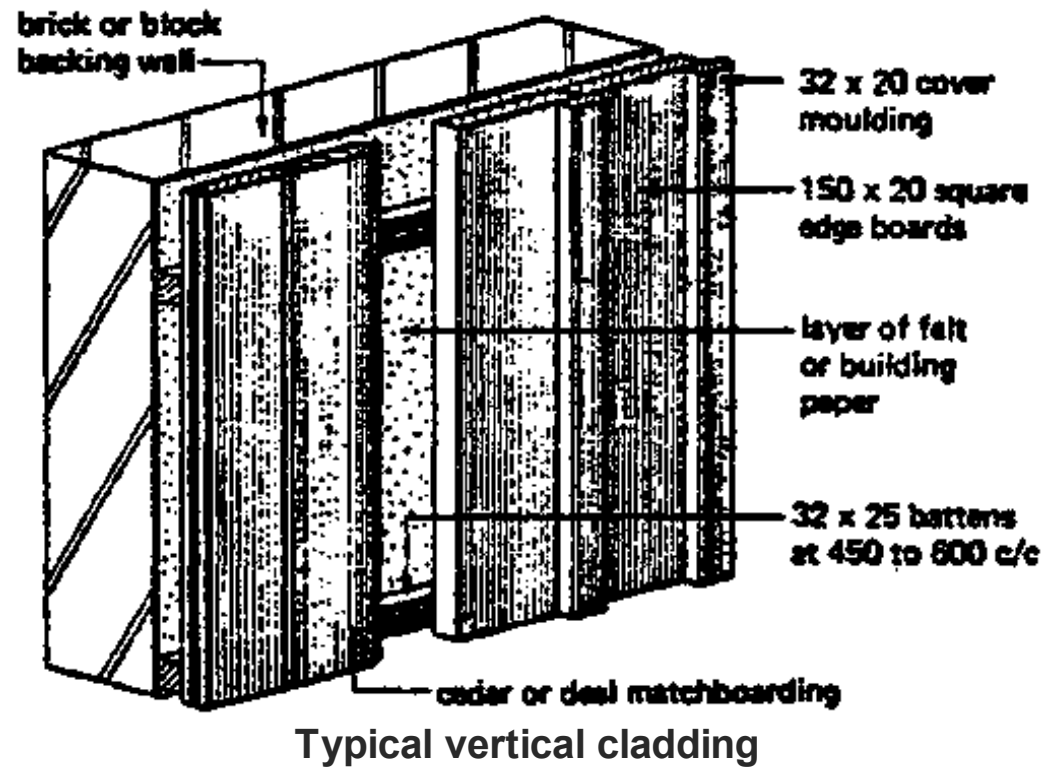

### 12.3 Ceiling Finishes

- Write notes on ceiling finishes and use sketches for illustration.

Please provide your feedback

English | French | Spanish | German