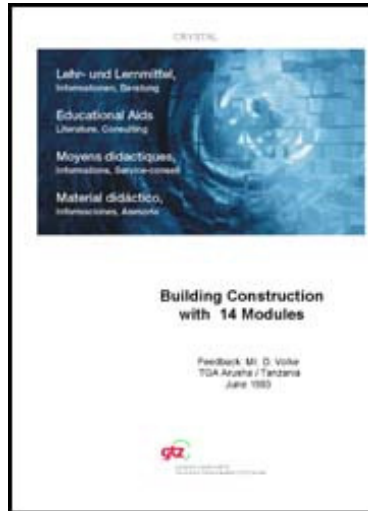

[Home page](#) | [Help](#) | [Clear](#)[English](#) | [French](#) | [Spanish](#) | [German](#)[Search](#) | [Subjects](#) | [Titles A-Z](#) | [Courses](#) | [Illustrations](#) | [Topics](#) | [e-Course builder](#)[Contract TOC](#)[Expand Document](#)[Contract Chapter](#)[Add to e-Course](#)[Preferences](#)

Printable version

Export document  
as HTML file [Help](#)

Export document  
as PDF file

## **Building Construction with 14 Modules (TCA; 1983; 618 pages)**

### **1. ARCHITECTURAL DRAWING I**

#### **1.1 AIMS AND PURPOSE OF ARCHITECTURAL DRAWINGS**

##### **1.1.1 CONTENTS OF ARCHITECTURAL DRAWINGS**

#### **1.2 DRAWING EQUIPMENT**

##### **1.2.1 PENCILS**

##### **1.2.2 DRAWING PENS**

##### **1.2.3 COMPASSES**

##### **1.2.4 DRAWING BOARDS**

##### **1.2.5 T-SQUARES**

##### **1.2.6 SET SQUARES**

##### **1.2.7 PROTRACTORS**

##### **1.2.8 SCALES**

##### **1.2.9 FRENCH CURVES**

##### **1.2.10 TEMPLATES**

##### **1.2.11 DRAWING PINS AND OTHER FIXINGS**

##### **1.2.12 MINOR ITEMS OF EQUIPMENT**

##### **1.2.13 PRINTING PAPERS**

##### **1.2.14 TRACING PAPER, CLOTH AND FILM**

 **1.2.15 BACKING SHEETS**

 **1.2.16 DRAWING PAPERS**

 **1.2.17 CARTRIDGE**

 **1.2.18 HANDMADE AND MOULDMADE PAPERS**

 **1.2.19 PLASTIC-COATED CARD**

 **1.3 LETTERING**

 **1.3.1 PRINCIPLE OF LETTERING**

 **1.3.2 FREEHAND LETTERING**

 **1.3.3 TYPES OF LETTERS**

 **1.3.3.1 The Roman Alphabet**

 **1.3.3.2 Sans Serif Letters**

 **1.3.3.3 Inclined Lettering**

 **1.3.3.4 Script Lettering**

 **1.3.3.5 Stencil Lettering**

 **1.3.3.6 Guided Pen Lettering**

 **1.3.3.7 Pressure-Transfer Lettering**

 **1.4 LINEWORK AND DIMENSIONING**

 **1.4.1 TYPES OF LINES**

 **1.4.2 PENCIL DRAWING**

 **1.4.3 INKING - IN**

 **1.4.4 BASIC RULES OF DIMENSIONING**

 **1.4.4.1 Types of Dimensions**

 **1.4.4.2 Placement of Dimensions**

 **1.5 ENLARGEMENT AND REDUCTION OF LINE DRAWINGS** **1.6 GEOMETRICAL CONSTRUCTIONS** **1.6.1 LINES AND ANGLES** **1.6.1.1 To bisect a straight line AB** **1.6.1.2 To divide a straight line AB into a given number of equal parts** **1.6.1.3 To divide a straight line AB into any ratio** **1.6.1.4 To construct an angle of  $90^\circ$**  **1.6.1.5 To construct an angle of  $45^\circ$**  **1.6.1.6 To construct an angle of  $60^\circ$**  **1.6.1.7 To construct an angle of  $30^\circ$**  **1.6.1.8 To bisect any given angle** **1.6.1.9 To construct an angle SIMILAR to a given angle** **1.6.1.10 To draw a line PARALLEL to a given line** **1.6.2 TRIANGLES** **1.6.2.1 To construct an EQUILATERAL triangle** **1.6.2.2 To construct a triangle with given BASE ANGLES and ALTITUDE** **1.6.2.3 To inscribe a circle in a given triangle ABC** **1.6.2.4 To circumscribe a triangle ABC** **1.6.3 CIRCLES** **1.6.3.1 Basic CIRCLE-Constructions** **1.6.3.2 To draw a tangent to a point A on the circumference of a circle centre O**

 **1.6.3.3 To draw an internal tangent to two circles of equal diameter**

 **1.6.3.4 To find the centre of a given circle arc**

 **1.6.3.5 To join two straight lines at RIGHT ANGLES to each other by an arc of given radius**

 **1.6.3.6 To draw a curve of given radius joining two circles**

 **1.6.3.7 To join two straight lines by two arcs of equal radius**

 **1.6.4 BASIC ARCH CONSTRUCTIONS**

 **2. ARCHITECTURAL DRAWING II**

 **2.1 TYPES OF PROJECTIONS**

 **2.2 ORTHOGRAPHIC PROJECTION**

 **2.2.1 CONSTRUCTION OF ORTHOGRAPHIC PROJECTION**

 **2.2.2 ELEVATIONS**

 **2.2.3 PLANS AND SECTIONS**

 **2.3 PICTORIAL DRAWING**

 **2.3.1 AXONOMETRIC PROJECTION**

 **2.3.2 ISOMETRIC PROJECTION**

 **2.3.3 DIMETRIC PROJECTION**

 **2.3.4 OBLIQUE PROJECTION**

 **2.3.4.1 Length of Receding Lines**























 **2.3.4.2 Construction of Oblique Drawings**

 **2.3.4.3 Rules of Oblique Drawing**























 **2.3.4.4 Scale of the Receding Lines**

 **2.3.4.5 Direction of Receding Lines**

 **2.3.4.6 Position of Axes** **2.4 PERSPECTIVE DRAWING** **2.4.1 PERSPECTIVE TERMS** **2.4.2 PHENOMENA OF PERSPECTIVE DRAWING** **2.4.3 SYSTEMS OF PERSPECTIVE DRAWINGS** **2.4.4 METHODS OF PERSPECTIVE DRAWINGS** **2.4.5 TWO-POINT PERSPECTIVE** **2.4.6 ONE-POINT PERSPECTIVE** **2.5 SHADES AND SHADOWS** **2.5.1 THE USE OF SHADOWS** **2.5.2 SHADES AND SHADOWS** **2.5.3 THE CONVENTIONAL DIRECTION OF LIGHT** **2.5.4 THE 45° DIRECTION** **2.5.5 THE TRUE DIRECTION OF LIGHT** **2.5.6 SHADOWS OF SOLIDS** **2.5.7 PLANES OF SHADOW** **2.5.8 PRINCIPLES OF SHADOW-CASTING** **2.6 DRAWING PRACTICE** **2.6.1 DRAWING SHEETS** **2.6.1.1 Sizes and Folds** **2.6.1.2 Layout and Identification** **2.6.2 LEVELS** **2.6.3 REFERENCING**

-  **2.6.4 ABBREVIATIONS**
-  **2.6.5 REPRESENTATION OF MATERIALS**
-  **2.6.6 GRAPHICAL SYMBOLS AND REPRESENTATION**
-  **2.6.7 HATCHING RULES**
-  **2.7 APPLICATION FOR BUILDING PERMIT**
  -  **2.7.1 PROCEDURE OF APPLYING FOR PERMISSION TO ERECT A BUILDING**
  -  **2.7.2 FORMULARS**
-  **4. CONTRACT PLANNING AND SITE ORGANISATION**
  -  **4.1 CONTRACT PLANNING**
    -  **4.1.1 BAR CHART**
    -  **4.1.2 NETWORK ANALYSIS**
    -  **4.1.3 THE OVERALL PROGRAMME**
      -  **4.1.3.1 Break down of job**
      -  **4.1.3.2 Quantities of work and time content**
      -  **4.1.3.3 Plant and Labour outputs**
      -  **4.1.3.4 Sequence and timing of operations**
      -  **4.1.3.5 The programme chart**
    -  **4.1.4 PLANNING CONSIDERATIONS**
      -  **4.1.4.1 Site conditions and access**
      -  **4.1.4.2 Nature of job**
      -  **4.1.4.3 Plant**
      -  **4.1.4.4 Scaffolding**

 **4.2 SITE ORGANIZATION** **4.2.1 PRELIMINARY WORK** **4.2.2 SITE PLANNING** **4.2.2.1 Period planning** **4.2.2.2 Weekly planning** **4.2.2.3 Progress control** **4.2.3 SITE LAYOUT** **5. FOUNDATIONS** **5.1 SOIL INVESTIGATIONS** **5.1.1 SITE EXPLORATION** **5.1.1.1 Trial holes** **5.1.1.2 Bore holes** **5.1.1.3 Sampling** **5.1.1.4 Tests** **5.1.1.5 Load or bearing test** **5.1.2 SOILS AND SOIL CHARACTERISTICS** **5.1.2.1 Rocks and soils** **5.1.2.2 Stresses and pressures** **5.2 EXCAVATIONS AND TIMBERING** **5.3 TYPES OF FOUNDATIONS** **5.3.1 CLASSIFICATION** **5.3.2 CHOICE OF FOUNDATION** **5.3.3 SPREAD FOUNDATIONS**

-  **5.3.3.1 Strip foundations**
-  **5.3.3.2 Deep strip foundations**
-  **5.3.3.3 Stepped foundations**
-  **5.3.3.4 Pad foundations**
-  **5.3.3.5 Raft foundations**
-  **5.3.4 PILE FOUNDATIONS**
  -  **5.3.4.1 Short bored pile foundations**
-  **5.3.5 PIER FOUNDATIONS**
-  **6. WALLS**
  -  **6.1 FUNCTION AND PROPERTIES OF WALLS**
  -  **6.2 THE BEHAVIOR OF THE WALL UNDER LOAD**
    -  **6.2.1 CALCULATION OF WALL THICKNESS**
  -  **6.3 TYPES OF WALLS**
  -  **6.4 STONEMWORK**
    -  **6.4.1 BUILDING STONES**
    -  **6.4.2 STONEMWORK THERMINOLOGY**
    -  **6.4.3 STONEMWORK CLASSIFICATION**
    -  **6.4.4 RUBBLE WALLING**
    -  **6.4.5 ASHLAR WALLING**
      -  **6.4.5.1 Rules for ashlar work**
  -  **6.5 BRICK WORK**
    -  **6.5.1 BRICKWORK TERMINOLOGY**
    -  **6.5.2 MANUFACTURE OF CLAY BRICKS**



 **6.5.2.1 Pressed Bricks** **6.5.2.2 Wire cut bricks** **6.5.2.3 Efflorescence** **6.5.3 BRICK CLASSIFICATION** **6.5.4 CALCIUM SILICATE BRICKS** **6.5.5 CONCRETE BRICKS** **6.5.6 MORTARS FOR BRICKWORK** **6.5.7 DAMPNES PENETRATION** **6.5.8 BRICKWORK BONDING** **6.5.8.1 Common bonds** **6.5.9 METRIC MODULAR BRICKWORK** **6.5.10 JUNCTIONS** **6.5.11 QUOINS OR EXTERNAL ANGLES** **6.5.12 PIERS** **6.5.12.1 Detached piers:** **6.5.12.2 Attached Piers (or Pilasters)** **6.5.12.3 Buttresses** **6.6 BLOCKWORK** **6.6.1 CLAY BLOCKS** **6.6.2 PRECAST CONCRETE BLOCKS** **6.6.3 AERATED CONCRETE BLOCKS** **6.7 CONCRETE WALLS** **6.7.1 GENERAL**



**6.7.2 FOREWORK**

**6.7.3 PLAIN MONOLITHIC CONCRETE WALL**

**6.7.3.1 Dense concrete walls**

**6.7.3.2 Light-weight aggregate**

**6.7.3.3 No-fines concrete walls**

**6.7.3.4 Thickness of plain concrete walls**

**6.7.3.5 Shrinkage reinforcement**

**6.7.4 REINFORCED CONCRETE WALLS**

**6.7.4.1 In-Situ Cast external walls**

**6.7.4.2 Concrete Box Frames**

**6.7.4.3 Large precast panel structure**

**6.8 OPENINGS IN WALLS**

**6.8.1 HEAD**

**6.8.1.1 Lintels**

**6.8.1.2 Arches**

**6.8.2 JAMBS**

**6.8.3 SILLS AND THRESHOLDS**

**6.8.3.1 Sills**























**6.8.3.2 Thresholds**























**7. FLOORS**

**7.1 GENERAL**

**7.2 SOLID GROUND FLOORS**



-  **7.2.1 SITE CONCRETE**
-  **7.2.2 HARDCORE**
-  **7.2.3 WATERPROOF MEMBRANE**
-  **7.3 SUSPENDED TIMBER GROUND FLOOR**
  -  **7.3.1 BUILDING REGULATIONS**
  -  **7.3.2 LAY OUT**
-  **7.4 UPPER FLOORS**
  -  **7.4.1 TYPES OF UPPER FLOORS**
  -  **7.4.2 STRUCTURE OF UPPER FLOORS**
  -  **7.4.3 SUSPENDED TIMBER UPPER FLOORS**
    -  **7.4.3.1 Floor Joists**
    -  **7.4.3.2 End Support of Floor Joists**
    -  **7.4.3.3 Trimming**
  -  **7.4.4 REINFORCED CONCRETE UPPER FLOORS**
    -  **7.4.4.1 Monolithic Reinforced Concrete Upper Floors**
    -  **7.4.4.2 Precast Concrete Upper Floors**
    -  **7.4.4.3 Hollow Block and Waffle Floors**
-  **7.5 FLOOR FINISHES**
  -  **7.5.1 JOINTLESS FLOOR FINISHES**
    -  **7.5.1.1 The most common of these is the Cement/Sand Screed**
    -  **7.5.1.2 Granolithic Concrete Finishes**
    -  **7.5.1.3 Terazzo**
  -  **7.5.2 SLAB FLOORS FINISEHES**

-  **7.5.3 SHEET FLOOR FINISHES**
-  **7.5.4 WOOD FLOOR FINISHES**
-  **8. OPEN FIREPLACES, CHIMNEYS AND FLUES**
  -  **8.1 FUNCTION OF FIREPLACES AND FLUES**
  -  **8.2 PRINCIPLES OF FIREPLACE DESIGN**
    -  **8.2.1 TRADITIONAL OPEN FIREPLACE**
    -  **8.2.2 IMPROVED SOLID FUEL APPLIANCES**
  -  **8.3 PRINCIPLES OF FLUE DESIGN**
  -  **8.4 CONSTRUCTION OF FLUE DESIGN**
    -  **8.4.1 NON-CONVECTOR OPEN FIRES**
    -  **8.4.2 CONVECTOR OPEN FIRES**
  -  **8.5 CONSTRUCTION OF CHIMNEYS**
-  **9. ROOFS**
  -  **9.1 FUNCTIONAL REQUIREMENTS**
    -  **9.1.1 STRENGTH AND STABILITY**
    -  **9.1.2 WEATHER RESISTANCE**
    -  **9.1.3 THERMAL INSULATION**
    -  **9.1.4 FIRE RESISTANCE**
    -  **9.1.5 SOUND INSULATION**
  -  **9.2 TYPES OF ROOF STRUCTURES**
    -  **9.2.1 FLAT AND PITCHED ROOFS**
    -  **9.2.2 STRUCTURE OF THE ROOF**
    -  **9.2.3 LONG AND SHORT SPAN ROOFS**

 **9.2 LONG AND SHORT OF A ROOF** **9.3 FLAT ROOFS** **9.3.1 PHYSICAL AND STRUCTURAL PROBLEMS** **9.3.2 STRUCTURE OF A FLAT ROOF** **9.3.3 THERMAL INSULATION MATERIAL** **9.3.4 SINGLE AND DOUBLE FLAT ROOF CONSTRUCTION** **9.3.5 PARAPET WALLS** **9.4 PITCHED ROOFS** **9.4.1 SHAPES OF PITCHED ROOFS IN TIMBER** **9.4.2 TERMS** **9.4.3 TYPES OF PITCHED ROOFS IN TIMBER (STRUCTURES)** **9.4.3.1 Mono-(single) pitched Roof** **9.4.3.2 Lean - to Roof** **9.4.3.3 Couple Roof** **9.4.3.4 Close couple Hoof** **9.4.3.5 Collar Roof** **9.4.3.6 Double or Purlin Roof** **9.4.3.7 Tripple or Trussed Roofs** **9.4.3.8 Trussed Rafters** **9.4.3.9 Hipped Roofs** **9.4.4 VALLEY** **9.4.5 EAVES TREATMENT** **9.4.6 OPENINGS IN TIMBER ROOFS** **9.5 ROOF COVERINGS**

**9.5 ROOF COVERINGS** **9.5.1 FUNCTION OF ROOF COVERINGS** **9.5.2 TYPES OF ROOF COVERINGS** **9.5.3 SUBSTRUCTURES** **9.5.4 CHOICE OF ROOF COVERINGS** **9.5.5 MATERIALS AND COVERING METHODS** **10. FRAMED STRUCTURES** **10.1 STRUCTURAL CONCEPT** **10.2 FUNCTIONAL REQUIREMENTS** **10.3 STRUCTURAL MATERIALS** **10.4 LAYOUT OF FRAMES** **10.5 BUILDING FRAMES** **10.5.1 FUNCTIONS OF BUILDING FRAME MEMBERS** **10.5.2 REINFORCED CONCRETE FRAMES** **10.5.2.1 Reinforced Concrete Beams** **10.5.2.2 Reinforced Concrete Columns** **10.5.2.3 Reinforced Concrete Slabs** **10.5.3 PRECAST CONCRETE FRAMES** **10.5.3.1 Methods of Connections** **10.5.4 STRUCTURAL STEELWORK FRAMES** **10.5.4.1 Structural Steel Frames** **10.5.4.2 Castellated Universal Sections** **10.5.4.3 Connections**



#### **10.5.4.4 Structural Steel Connections**



#### **10.5.4.5 Frame Erection**



#### **10.5.4.6 Fire Protection of Steelwork**



### **10.5.5 TIMBER FRAMES**



#### **10.5.5.1 Columns and Beams**



#### **10.5.5.2 Connections**



#### **10.5.5.3 Building frames in timber**



#### **10.5.5.4 Prefabrication**



### **10.6 PORTAL FRAMES**



#### **10.6.1 THEORY**



#### **10.6.2 CONCRETE PORTAL FRAMES**



#### **10.6.3 STEEL PORTAL FRAMES**



#### **10.6.4 TIMBER PORTAL FRAMES**



## **11. PROTECTION OF BUILDINGS**



### **11.1 EXCLUSION OF WATER**



#### **11.1.1 PRECIPITATION**



##### **11.1.1.1 Roof Drainage**



##### **11.1.1.2 Flooding**



##### **11.1.1.3 Drought**



#### **11.1.2 DAMP RISING AND MOISTURE MIGRATION**



























#### **11.1.3 CONDENSATION**



### **11.2 THERMAL INSULATION**



#### **11.2.1 DEFINITION**

-  **11.2.1 DEFINITION**
-  **11.2.2 INSULATING MATERIALS**
-  **11.3 SOUND INSULATION**
  -  **11.3.1 DEFINITION**
  -  **11.3.2 SOUND INSULATION**
  -  **11.3.3 EXTERNAL NOISE**
-  **11.4 FIRE PROTECTION**
  -  **11.4.1 STRUCTURAL FIRE PROTECTION**
    -  **11.4.1.1 Fire Load**
    -  **11.4.1.2 Fire Resistance of Material**
    -  **11.4.1.3 Appropriate Types of Construction**
-  **12. FINISHING &. FINISHES**
  -  **12.1 EXTERNAL WALL FINISHES**
    -  **12.1.1 EXTERNAL RENDERING**
    -  **12.1.2 CONCRETE FINISHES**
    -  **12.1.3 CLADDING**
      -  **12.1.3.1 CLADDINGS FIXED TO A STRUCTURAL BACKING**
      -  **12.1.3.2 CLADDINGS TO FRAMED STRUCTURES**
    -  **12.1.4 EXTERNAL PAINTS AND FINISHES**
  -  **12.2 INTERNAL WALL FINISHES**
    -  **12.2.1 PLASTERING**
    -  **12.2.2 OTHER INTERNAL WALL FINISHES**
    -  **12.2.3 PAINTING**
  -  **12.3 CEILING FINISHES**



 **12.3 CEILING FINISHES** **13. STAIRS** **13.1 INTRODUCTION** **13.2 DEFINITION OF TERMS** **13.3 TYPES OF STAIRS** **13.4 DESIGN OF STAIRS** **13.4.1 RISE - TREAD - PROPORTION** **13.4.2 SLOPE OR PITCH** **13.4.3 LANDINGS** **13.4.4 WIDTH** **13.4.5 WALKING LINE** **13.5 CONSTRUCTION OF STAIRS** **13.5.1 BRICK STAIRS** **13.5.2 STONE STAIRS** **13.5.3 CONCRETE STAIRS** **13.5.3.1 In Situ Cast R.C. Stairs** **13.5.3.2 Precast Concrete Stairs** **13.5.4 TIMBER STAIRS** **13.5.5 METAL STAIRS** **13.6 MISCELLANEOUS** **13.6.1 BALUSTRADES/HANDRAILS** **13.6.2 'SAMBA' STAIR, LADDERS, DISAPPEAR STAIRS, RAMPS** **13.6.3 ESCALATORS** **14. DOORS & WINDOWS**

 **14. DOORS &. WINDOWS** **14.1 DOORS** **14.1.1 EXTERNAL DOORS** **14.1.2 INTERNAL DOORS** **14.1.3 PURPOSE MADE DOORS** **14.1.4 METHODS OF CONSTRUCTION** **14.1.4.1 Door terminology** **14.1.4.2 Panelled and glazed wood doors** **14.1.4.3 Flush doors** **14.1.4.4 Fire-check flush doors** **14.1.4.5 Matchboarded doors** **14.1.5 FRAMES AND LININGS** **14.1.5.1 Timber Door Frames** **14.1.5.2 Metal door frames** **14.1.5.3 Door linings** **14.1.6 SPECIAL DOORS** **14.2 WINDOWS, GLASS &. GLAZING** **14.2.1 PRIMARY FUNCTIONS OF WINDOWS** **14.2.2 BUILDING REGULATIONS** **14.2.3 TRADITIONAL CASEMENT WINDOWS** **14.2.4 STANDARD WOOD CASEMENT WINDOWS** **14.2.5 STEEL CASEMENT WINDOWS** **14.2.6 BAY WINDOWS**



## **14.2.7 SLIDING SASH WINDOWS**

 **14.2.7.1 Vertical sliding windows (also called double hung sash windows)**

 **14.2.7.2 Horizontal sliding windows**

 **14.2.8 PIVOT WINDOWS**

 **14.2.9 LOUVRES**

 **14.2.10 GLASS AND GLAZING**

 **14.2.10.1 Glass**

 **14.2.10.2 Glazing**

 **14.2.11 MOSQUITO SCREENING (FLY SCREENS)**

 **14.2.12 SUN-BREAKERS**

 **14.3 IRON MONGERY**

 **14.3.1 HINGES**

 **14.3.2 LOCKS AND LATCHES**

 **14.3.3 MISCELLANEOUS**

## **14. DOORS &. WINDOWS**

### **REFERENCES:**

- 1. R.L. Fullerton, "Building Construction in warm Climates", Volume 1,2,3**
- 2. R. Chudley, "CONSTRUCTION TECHNOLOGY", Volume 1,2,4**
- 3. E. Neufert, "Architect's Data", Edition 1978**

# 4. R. Barry, "The Construction of Buildings", Vol. I + II

## 14.1 DOORS

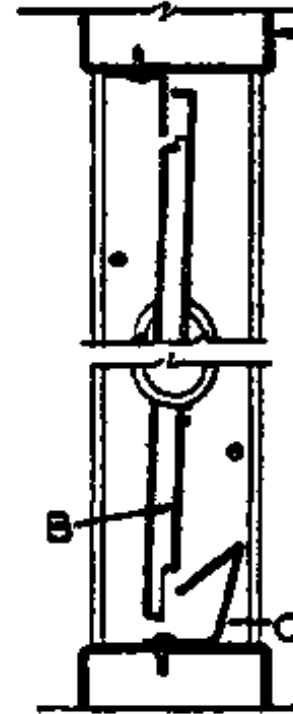
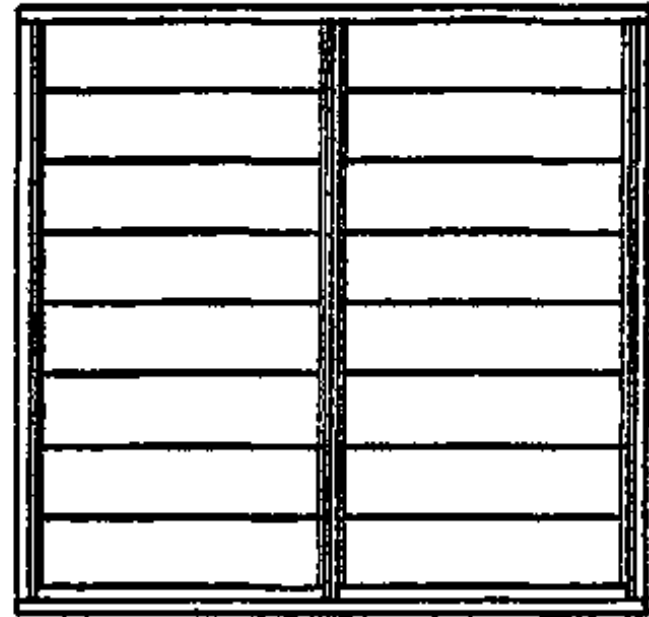
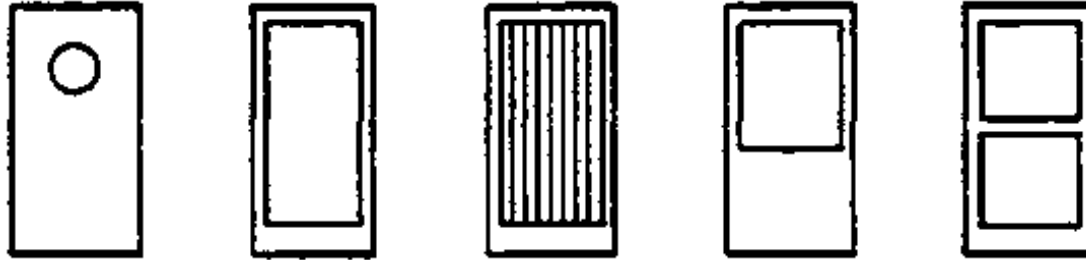

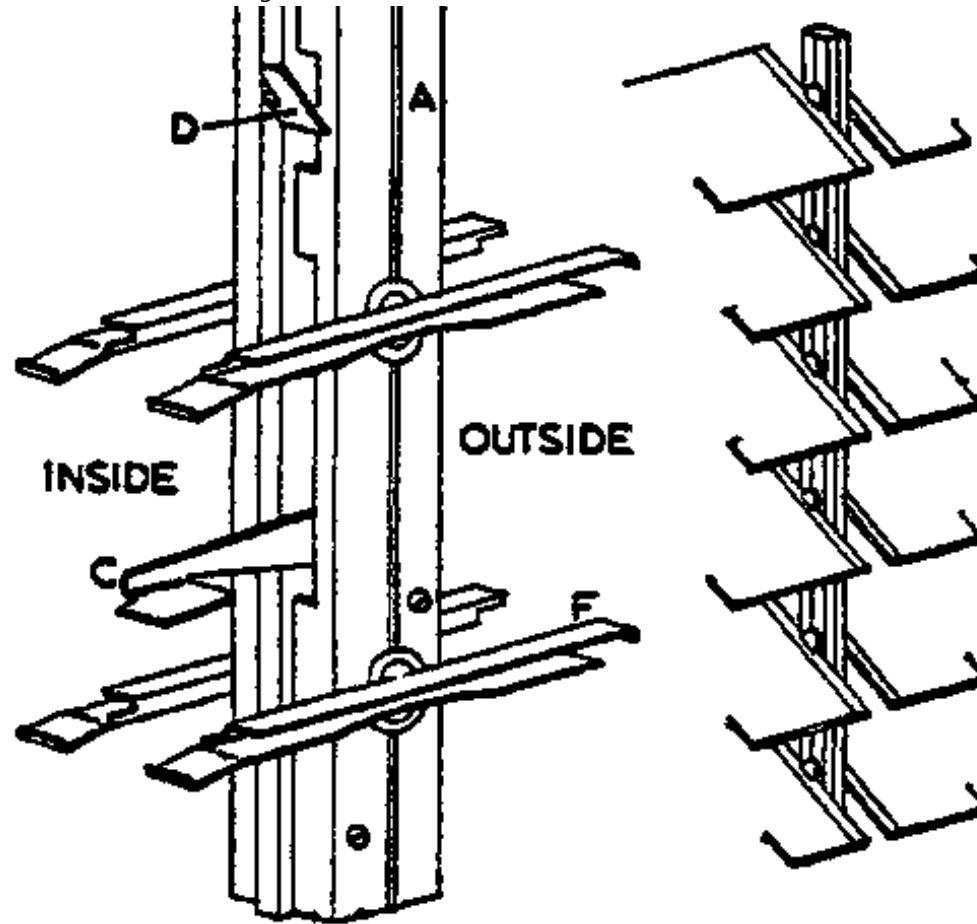

- A door is a screen used to seal an opening into a building or between rooms within a building.

- Doors can be made from

- wood
- glass
- metal
- plastic
- flexible rubber
- or any combination of the above

or any combination of the above

**- They can be designed to swing (side-hung)**

- **slide**
- **fold (slide and fold)**
- **roll**
- **shutter**
- **or pivot**

**- They can range in size from tiny cupboard doors to the huge sliding-folding doors of aircraft hangers.**

**- All doors may be classified by their**

- **Position in a building**
- **Function**
- **or method of Construction.**

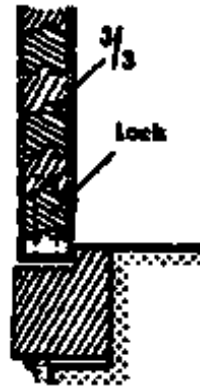

American solid-core door with metal channel profile

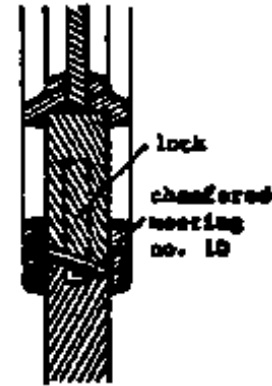

Two-leafed framed door with beaded panels

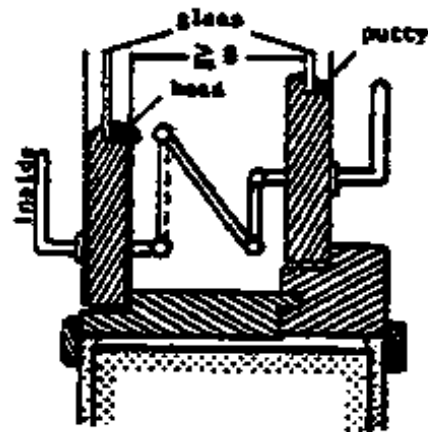

Two coupled doors

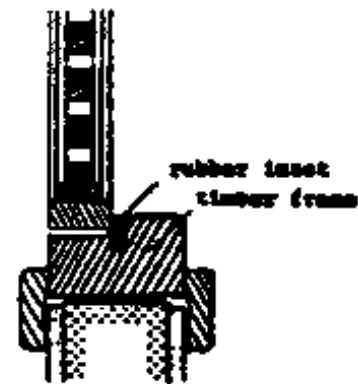

Skeleton-core plywood door

## Positioning

Correct positioning of doors important for convenient use of rooms, → (1)-(8). For common descriptions of doors in plan. → (9)-(16).

**American balanced door** → (17)-(19) requires minimum effort to open and is suitable for passage doors

**American balanced door. → (17)-(19), requires minimum effort to open and is suitable for passage doors in corridors, draught lobbies, etc.**



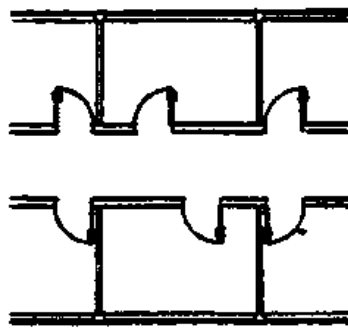

① Doors open into room

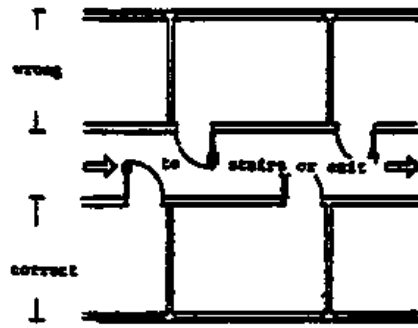

② Doors open into corridor

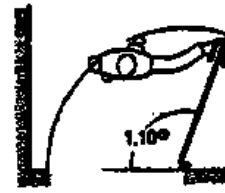

③ Generally incorrect hanging



④ Generally correct hanging

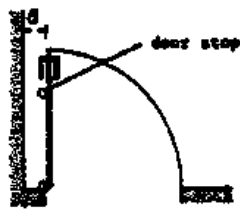

⑤ Minimum distance from partition

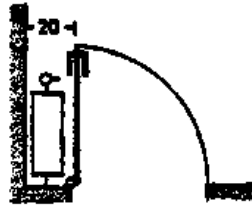

⑥ With radiator

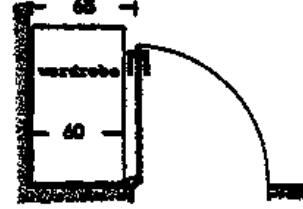

⑦ With cupboard (best position)

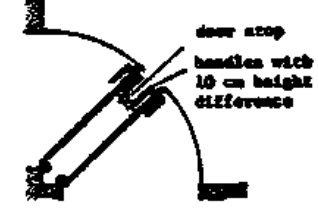

⑧ Correct opening of two doors in a corner, opening into the same room

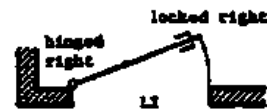

⑨ Left inward opening



⑩ Right inward opening



⑪ Double door, locked right



⑫ Sliding door in front of wall



⑬ Right outward opening



⑭ Left outward opening



⑮ Swing door, one or two leaves

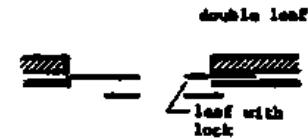

⑯ Sliding door between walls



⑰ American balanced door



⑱ American balanced door



⑲ Sliding folding door

### 14.1.1 EXTERNAL DOORS

are built

- to close the access
  - to provide security
- They need to be weather resistant, provided by:
- thickness
  - stability and durability of the construction
  - materials used together with protective coatings of paint or polish
- They should be constructed to maintain the insulation properties of the external walls.
- Standard sizes for external timber doors:
- 1981 mm (high) × 762 or 838 mm (wide)  
and 45 mm thick (which is a metric conversion of the old Imperial door size)

Metric doors are produced so that, together with the door frames, they fit into a modular coordinated opening size and are usually supplied as door sets with the door already attached or hung to/in the frame.

### 14.1.2 INTERNAL DOORS

- **As with external doors the aim of the design should be to maintain the properties of the wall in which they are housed.**
- **Generally: internal doors are thinner, standard sizes are similar to external doors, but with a wider range of width to cater for narrow cupboard openings.**

### **14.1.3 PURPOSE MADE DOORS**

- **The design and construction of these doors is usually based on B.S. 459 for standard doors, but are made to non-standard sizes, shapes are designs.**
- **They are used mainly for**
  - **front elevation doors**
  - **in buildings such as**
    - banks**
    - civil buildings**
    - shops**
    - theatres**
    - hotels**
    - to beautify the external facade or internal decore.**

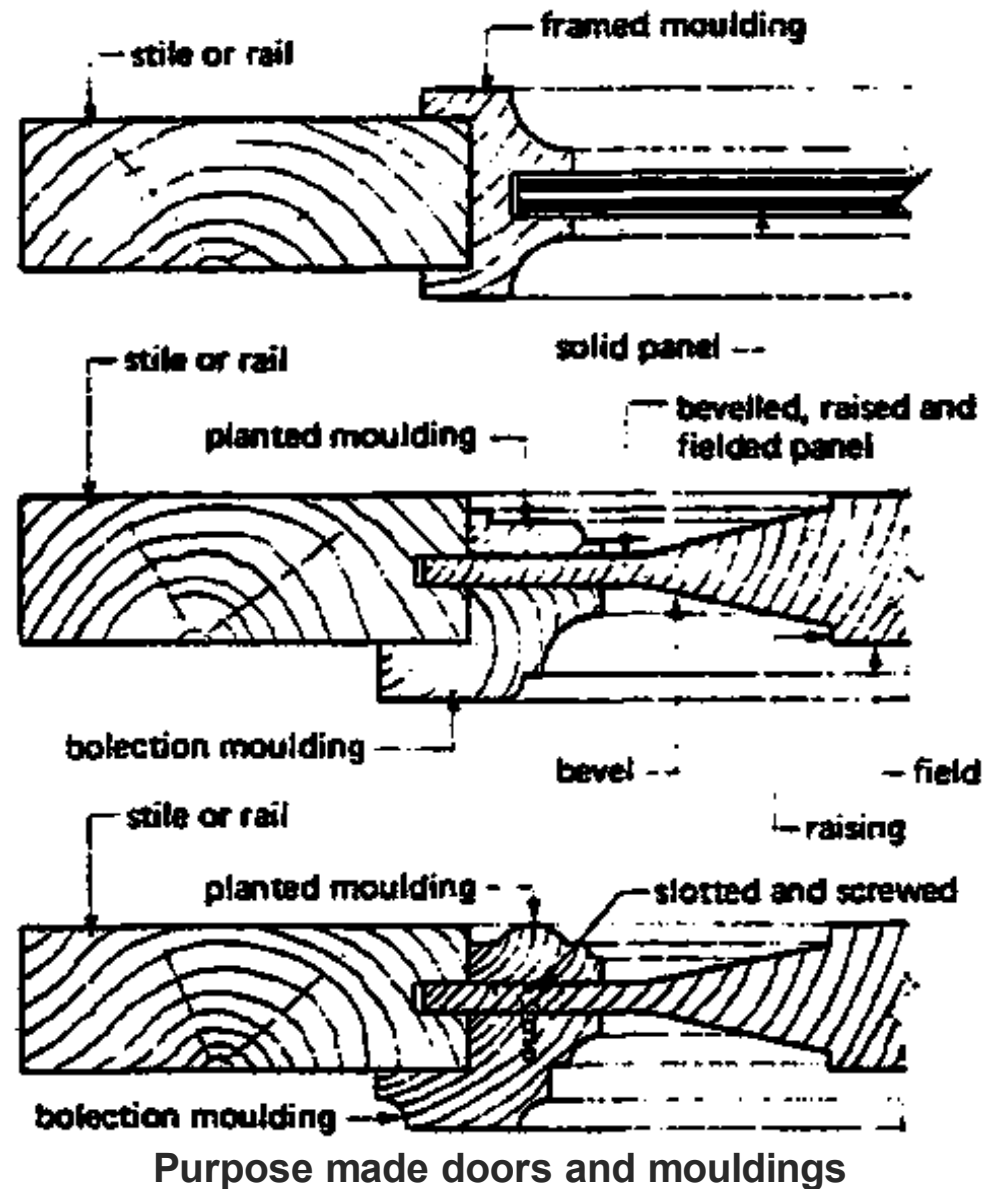

#### 14.1.4 METHODS OF CONSTRUCTION

The B.S. for wood doors is divided into four parts, each being a different method of construction:

## **B.S. 459**

**Part 1: Panelled and glazed wood doors**

**Part 2: Flush doors**

**Part 3: Fire-check doors**

**Part 4: Match bearded doors.**

**Standard doors are used extensively since they are**

- mass produced to known requirements**
- readily available from stock**
- and cheaper than purpose made doors.**

### **14.1.4.1 Door terminology**

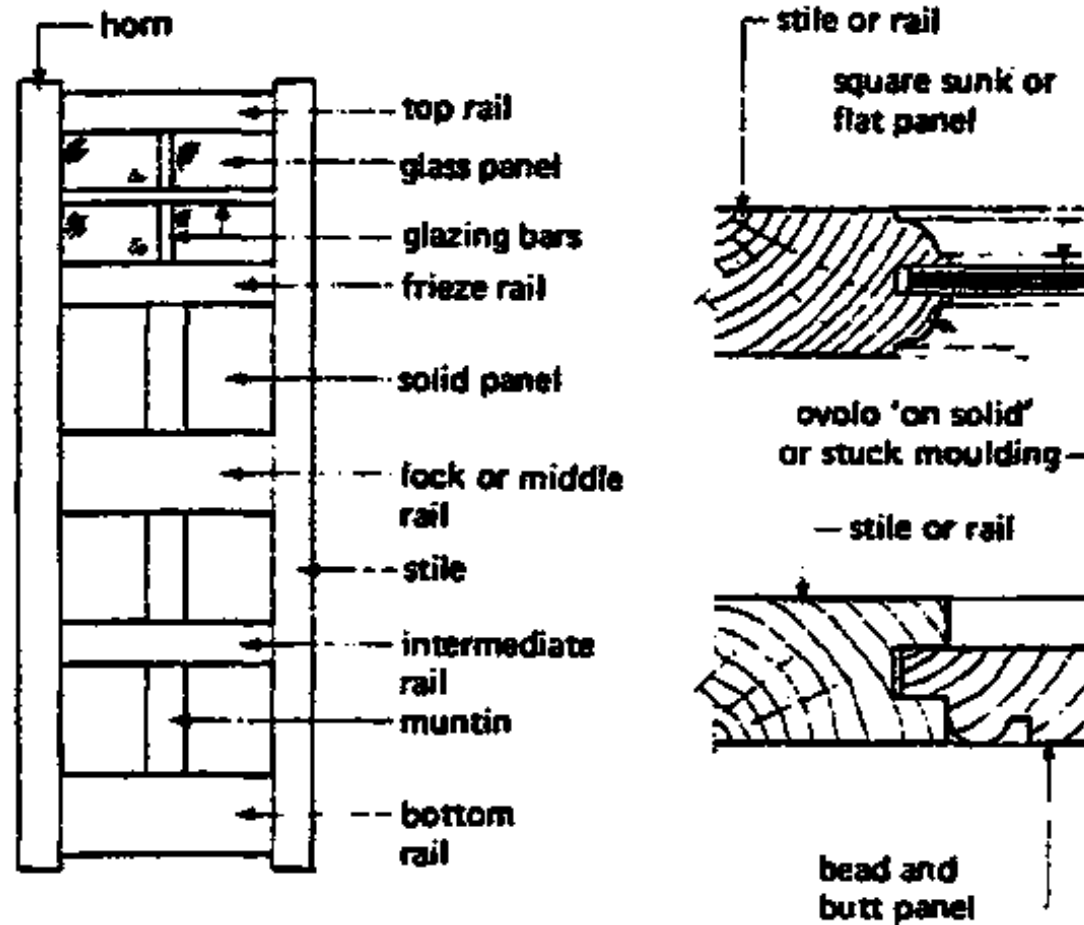

#### 14.1.4.2 Panelled and glazed wood doors

- The wide variety of types is based upon the one/two/three/ or four panel formate.
- They are constructed of timber which should be in accordance with BS 1186 with plywood or class panels.

— top rail

— top rail

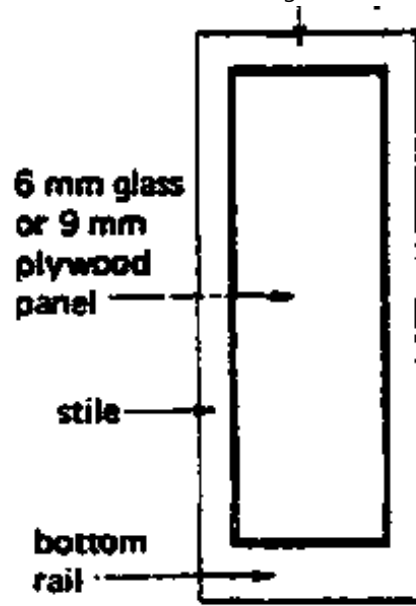

Single Panel Door

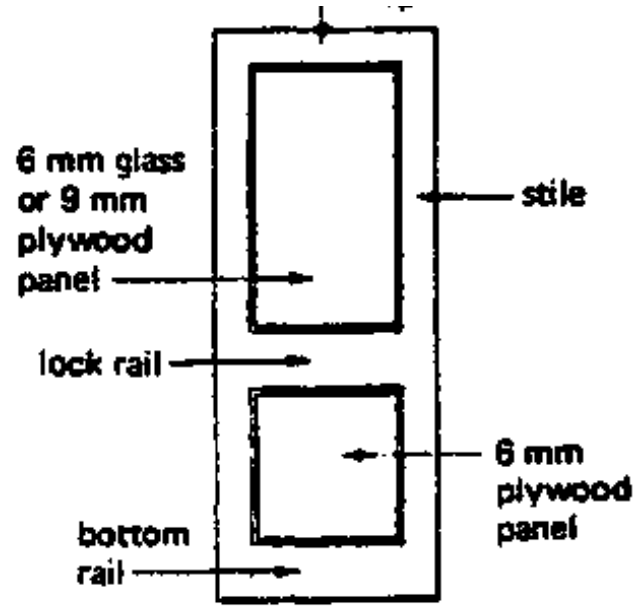

2 Panel Door

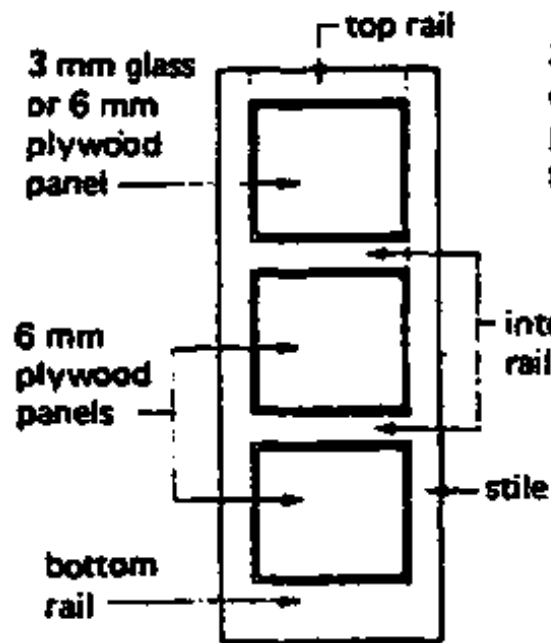

3 Panel Door

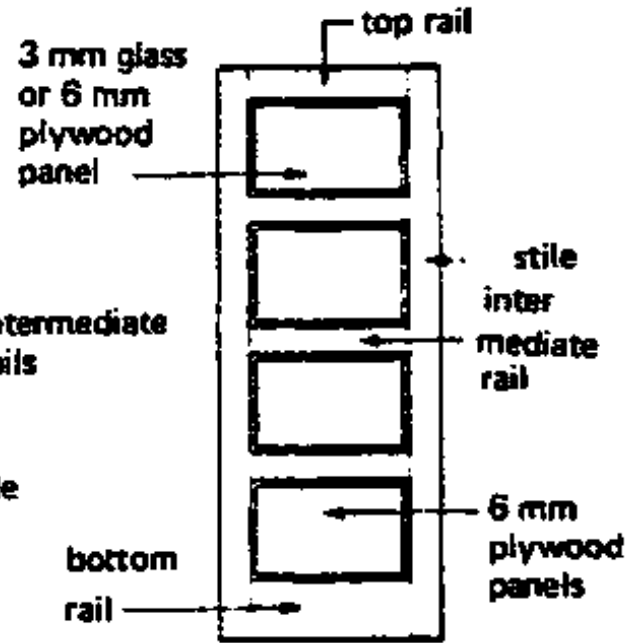

4 Panel Door

**- The joints used in framing the doors can be a dowelled joint or a mortice and tenon joint. (or double tenon joint)**

- **The dowelled joint is considered superior to the mortice and tenon joint, and is cheaper when used in the mass production of standard doors. Bottom and lock rails have 3 dowels, top rails have two. Intermediate rails have a single one.**
- **The plywood panels are framed into grooves with closely fitting sides, with a movement allowance within the depth of the groove of 2 mm.**
- **The mouldings at the rail intersections are scribed, where as the loose glazing beads are mitred.**
- **Weatherboards for use on external doors can be supplied to fit onto the bottom rail of the door which can also be rebated to close over a water bar.**

**Terms: (Mortice and tenon) joints:**

- **Haunch**
- **Mortice: The top and bottom of the mortices are tapered in towards the rails, in order to give space to drive in small wood wedges when tenons are fitted.**



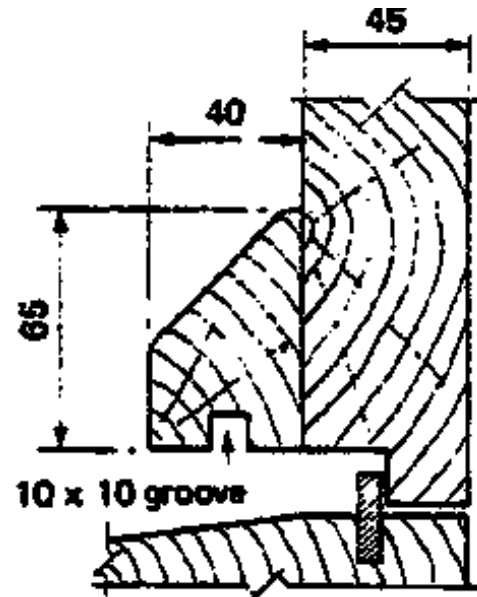

Standard Weatherboard

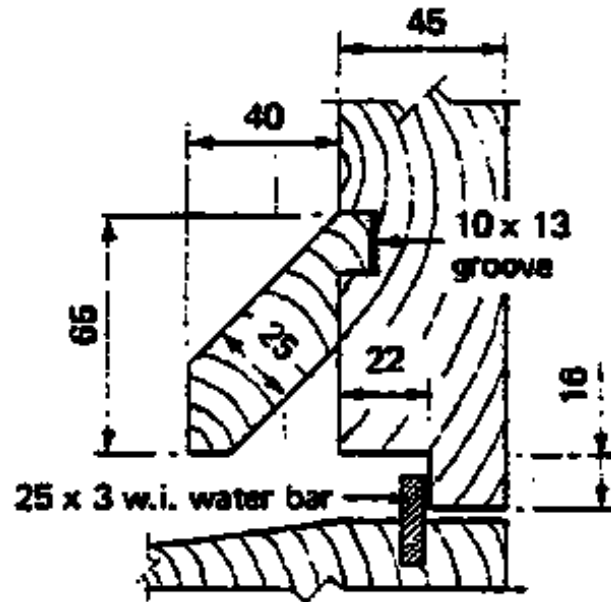

Non-standard Weatherboard

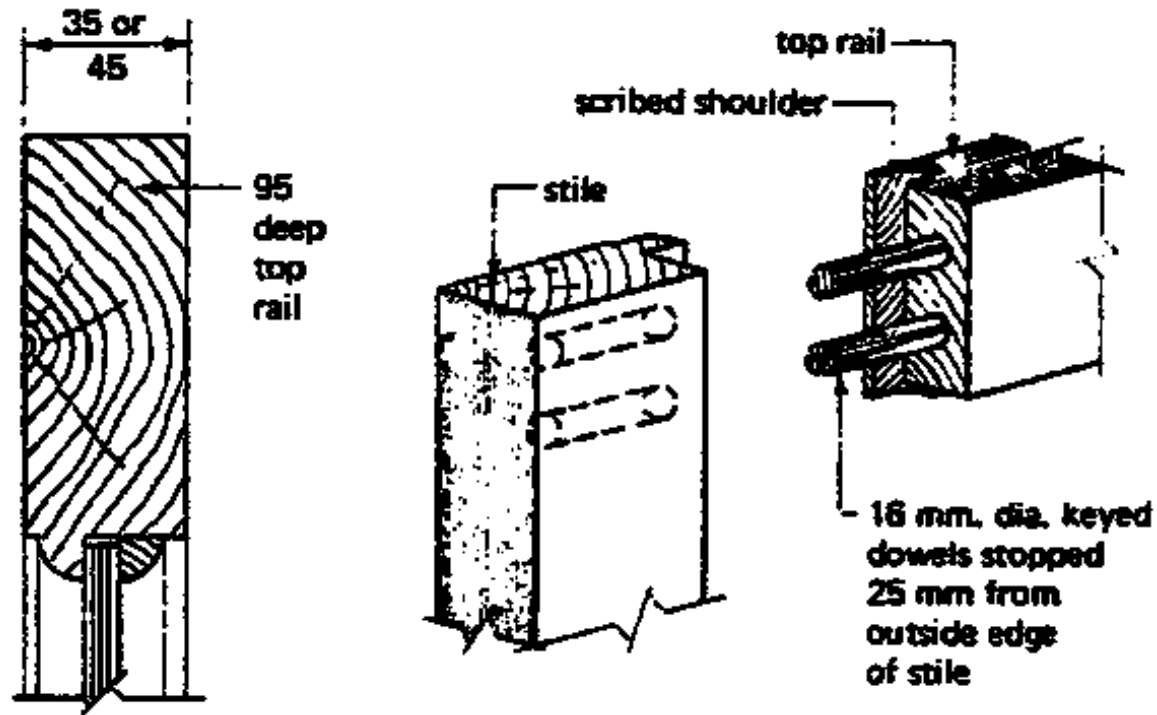

Typical Dowelled Joint

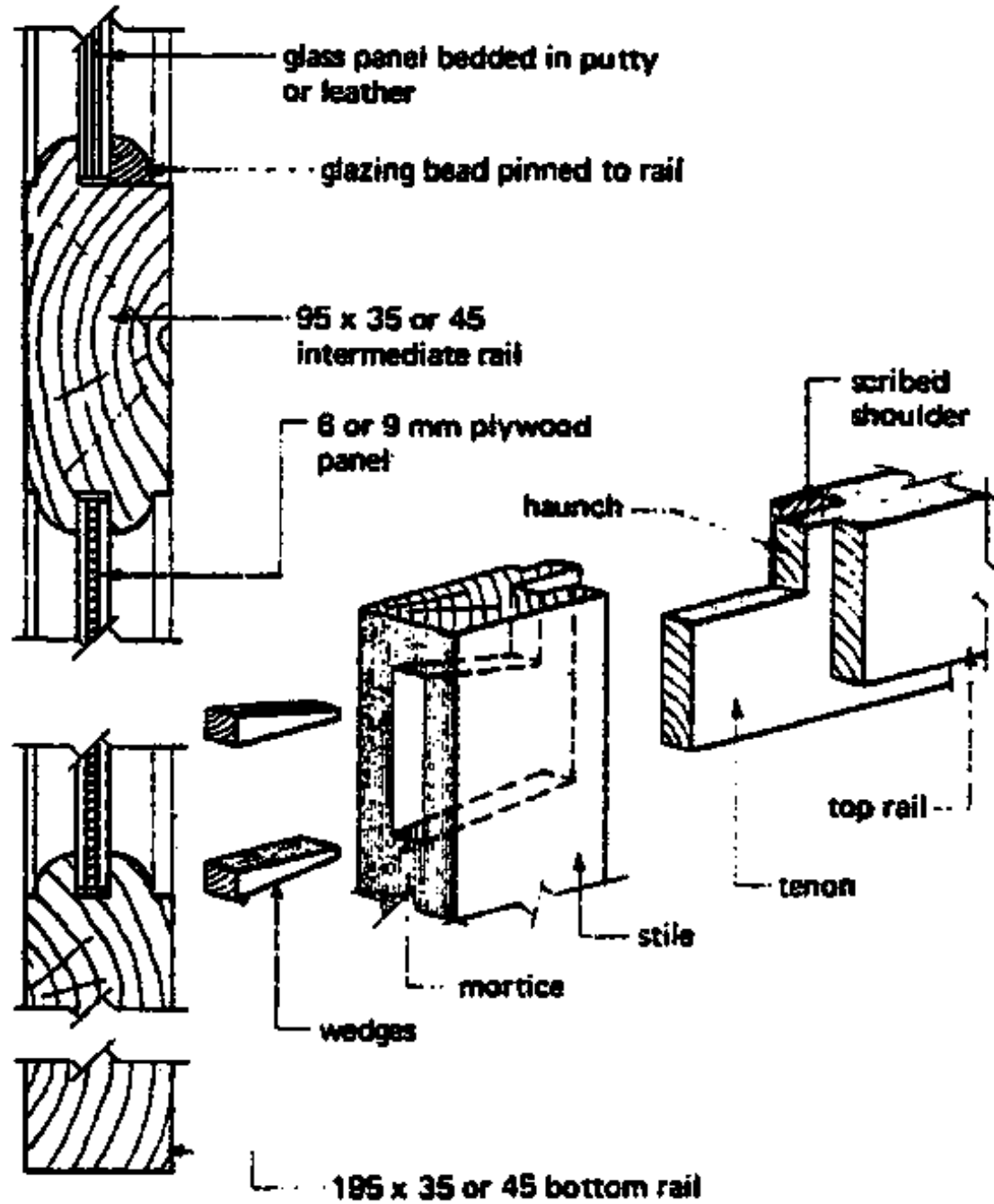

## Typical Mortice and Tenon Joint

### 14.1.4.3 Flush doors

- Is very popular (with both the designer and the occupier)- it has a plain face which is -easy to clean and to paint and is also free of the mouldings which collect dust.

- Flush doors can be faced with

- hardboard
- plywood or a
- plastic laminate

and by using a thin sheet veneer of good quality timber the appearance of high class joinery can be created.

- B.S. specifies the requirements for flush doors but leaves the method of construction to the manufacturer.

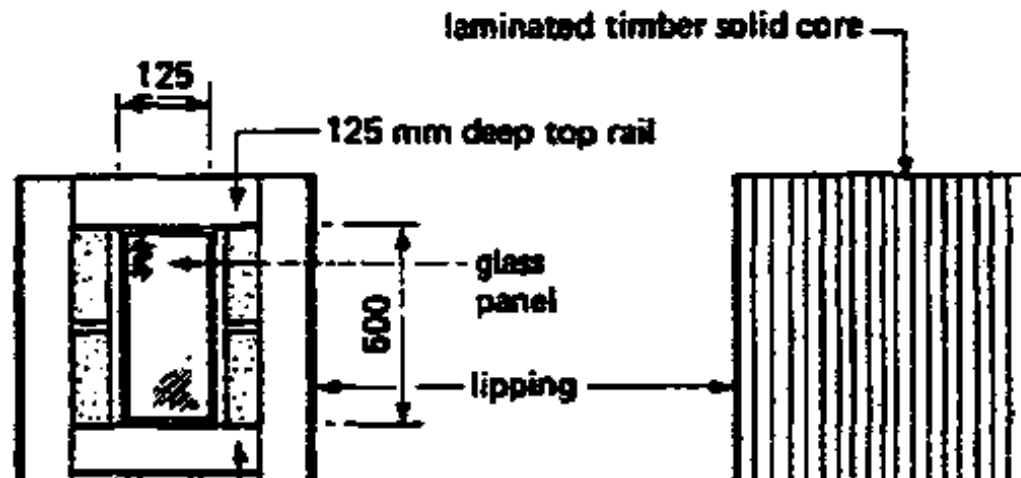

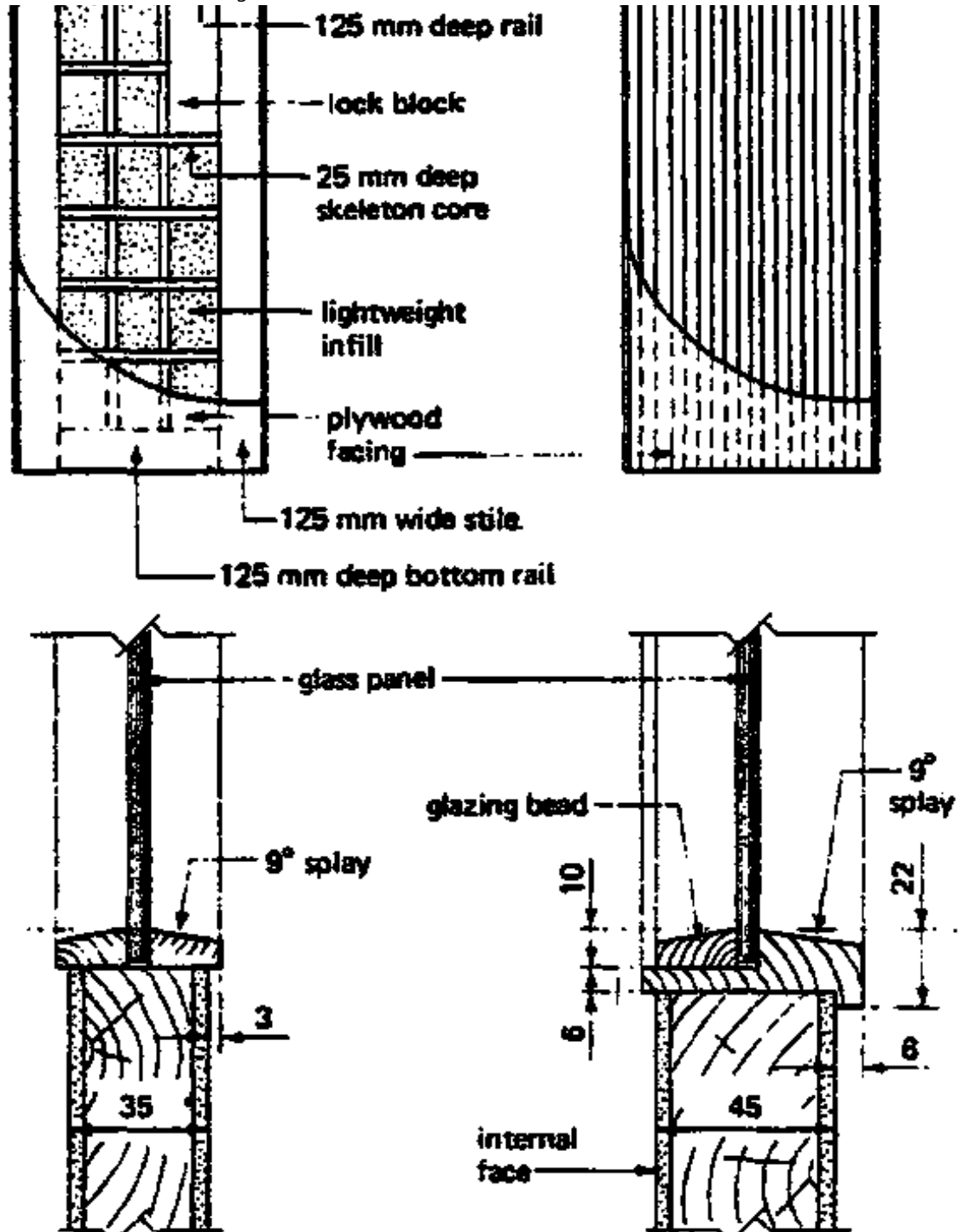

**Internal Flush  
Door Glazing**

**External Flush  
Door Glazing**

**Solid core doors**

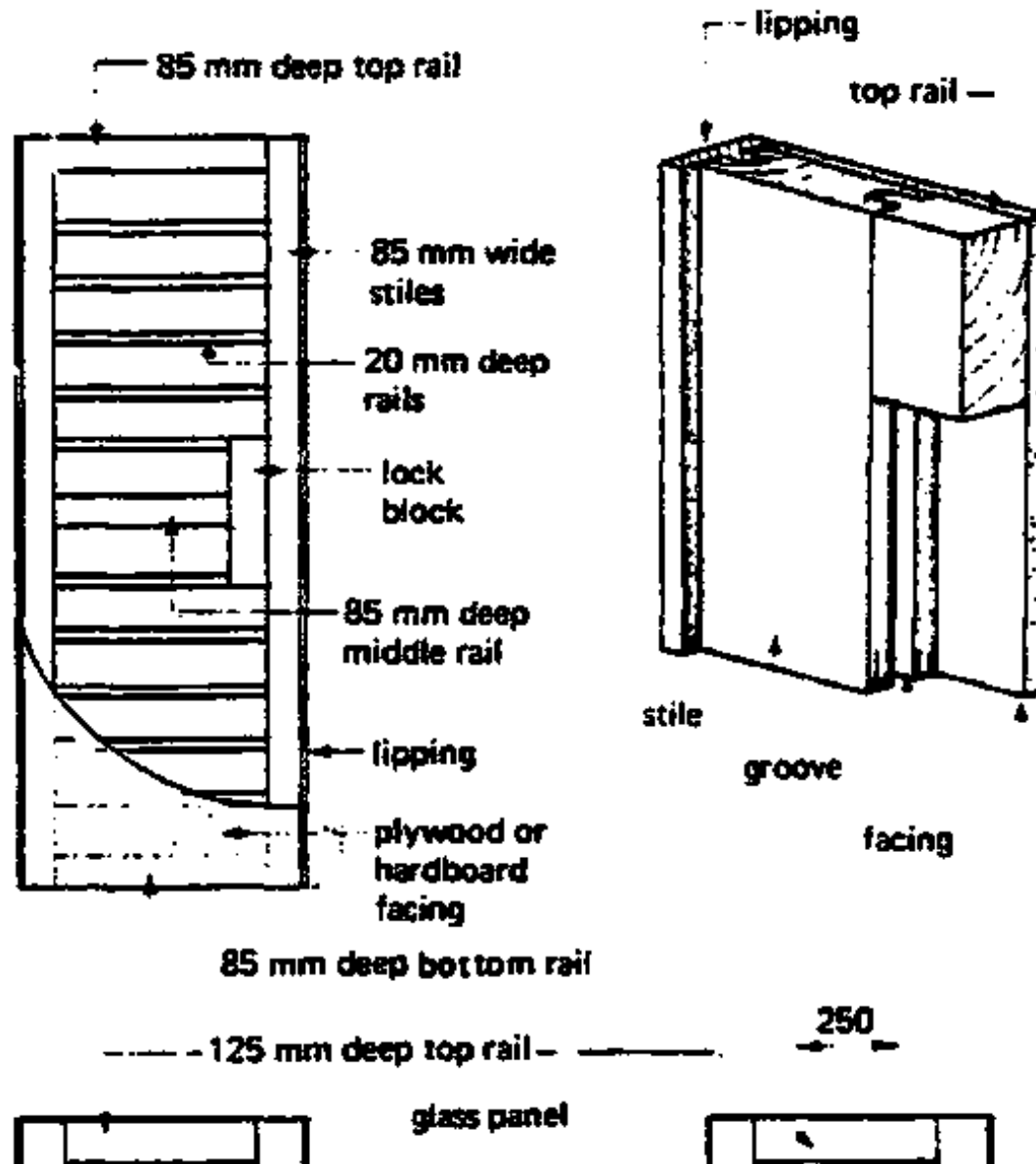

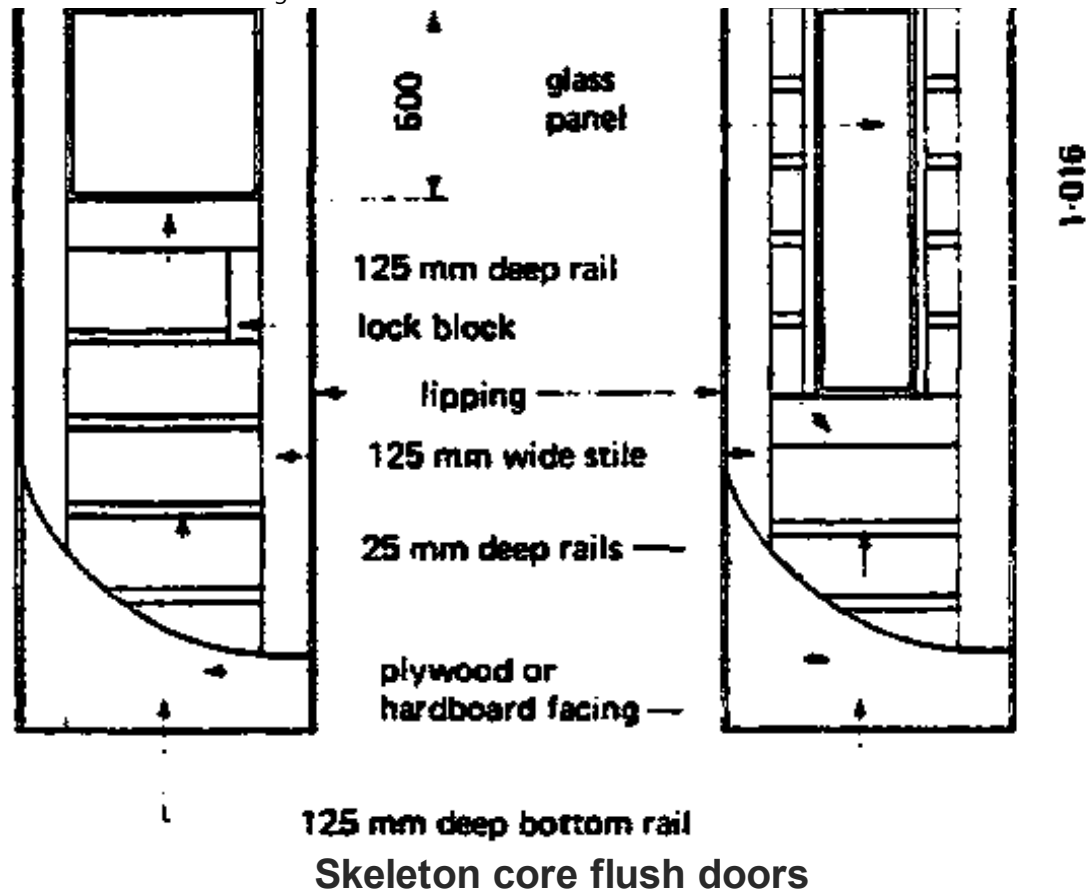

therefore: the forms of construction are many and vary, but

basically: they can be considered as

- a- skeleton core doors or
- b- solid core doors.

-a- consists of an outer frame with small section intermediate members over which is fixed the facing material. The facing has a tendency to deflect between the core members and this can be very noticeable on the surface especially if the facing is coated with gloss paint

**coated with glass paint.**

**-b- solid doors of faced block or laminated board are available for**

- **internal and**
- **external use.**

**Another method of construction is to infill the voids (created by a skeleton core) with a light weight material such as foamed plastic which will give support to the facings but will not add much to the weight at the door.**

- **The facings can be damaged easily at the edges, there-fore a lipping of solid material should be fixed to at least the vertical edges (good class doors have lip- pings on all four edges).**
- **Small glazed observation panels can be incorporated in flush doors when the glass panel is secured by loose fixing beads.**

#### **14.1.4.4 Fire-check flush doors**

- **Provide an effective barrier to the passage of fire for the time designated by their type - but, to achieve this they must be used in conjunction with the correct frame.**



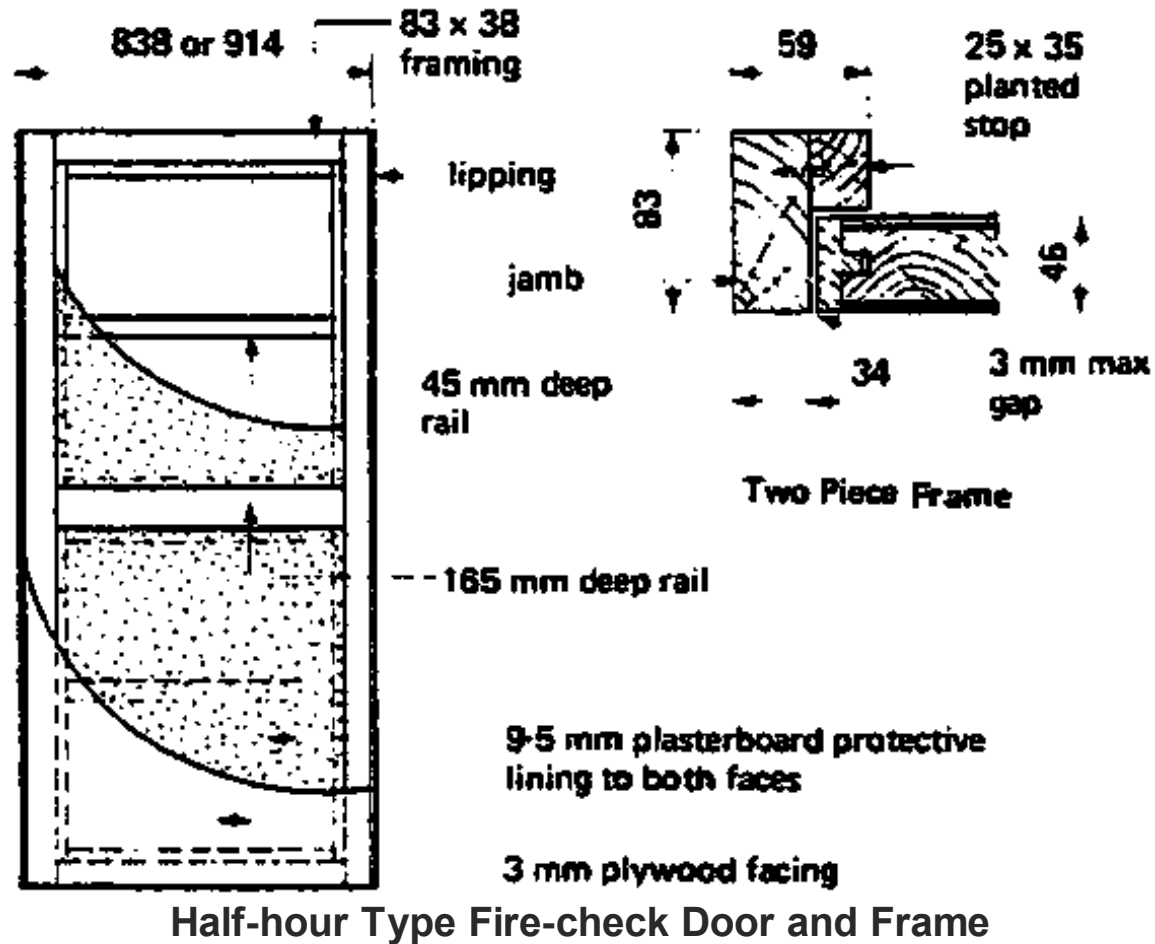

- Two types are mentioned in BS 459:

- half-hour resistance
- one -hour resistance

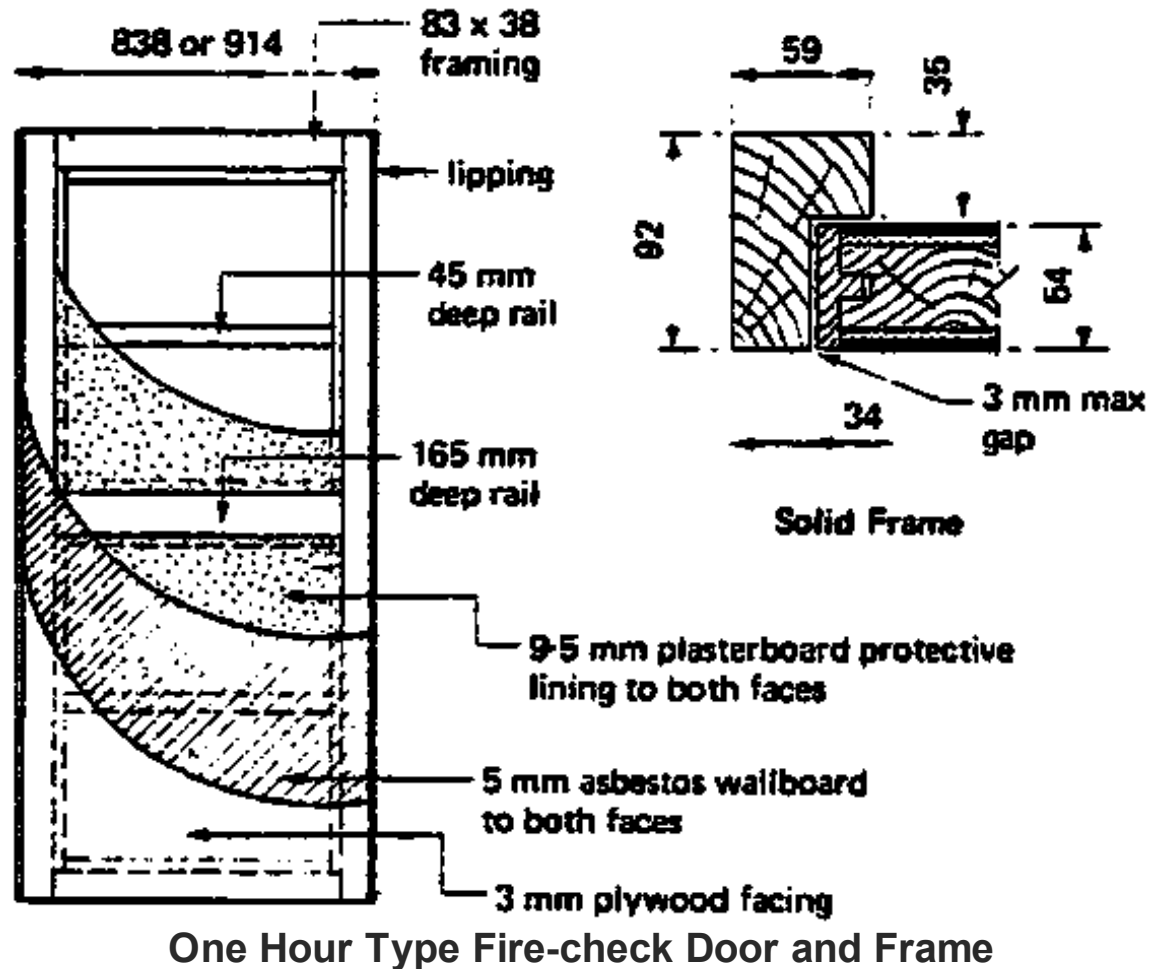

- This resistance is obtained by placing beneath the ply wood facing a suitably protective lining material (or materials.).

Half-hour types are hung using one pair of hinges

One-Hour types require 1 1/2 pairs of hinges.

### **14.1.4.5 Matchboarded doors**

**- These doors can be used as**

- **external and**
- **internal doors.**

**- There are 2 formes of standard doors:**

- **ledged and braced or**
- **framed, ledged and braced doors.**

**(The latter is the stronger and more attractive version)**

**- The face is made from tongue and grooved boarding which has edge chamfers on one or both faces. - these form a Vee-joint between the boards.**

**- 3 horizontal members ('ledges') clamp the boards together - and in this form a non-standard door has been made, called: ledged and battened.**

- **It is simple and cheap to construct, but it can be easily pulled out of square -the only resistance is that of nails, holding the boards to the ledges.**

• **The use of that type is limited to buildings such as**

- **sheds**
- **outhouses etc.**

- In the standard door:

- Braces are added to resist the tendency to drop out of square.
- The braces are fixed between the ledges so that they are parallel to one another and slope downwards towards the hanging edge.

- In the second standard type; a mortice and tenoned frame surrounds the match boarded: panel giving the door added strength.

- If wide doors of this form are required the angle of the braces becomes too low to be value as an effective restraint and the brace must therefore be framed as a diagonal between the top and bottom rails. Wide doors of this design are not covered by B.S. but are often used in pairs as garage doors or as wide entrance doors to workshops or similar buildings.

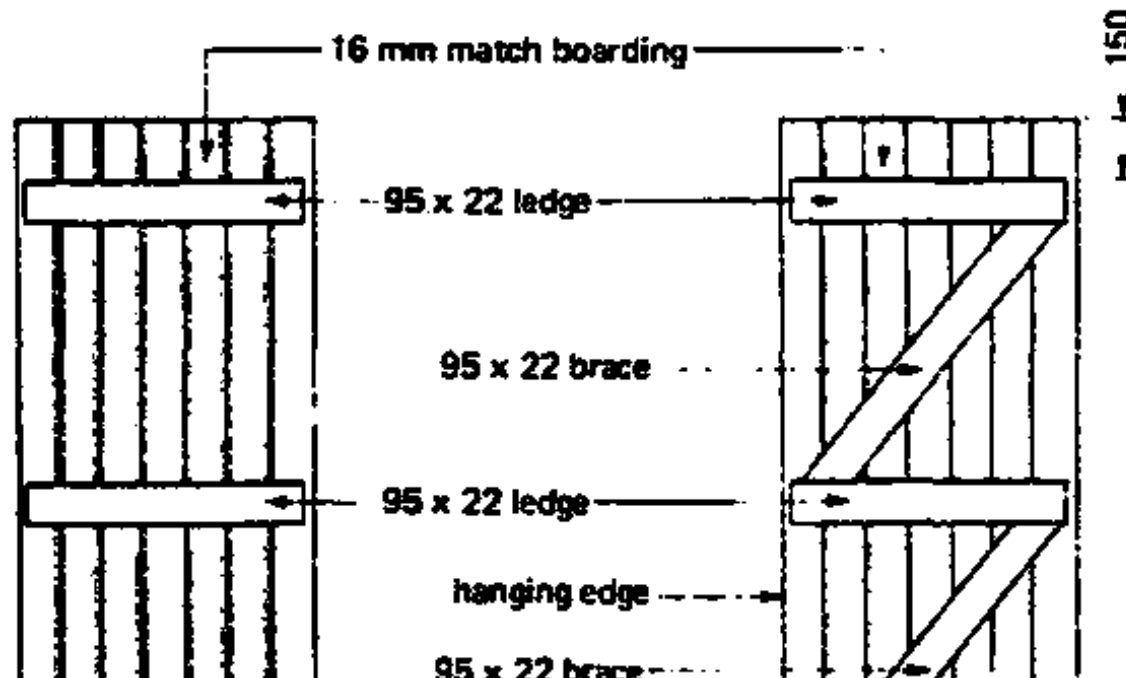

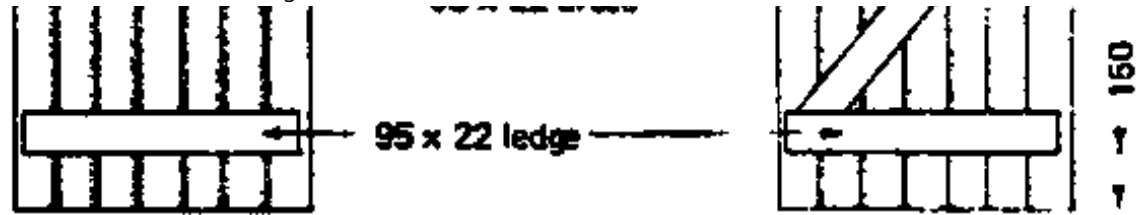

**Ledged and Battered  
(rear elevation)**

**Ledged and Braced  
(rear elevation)**

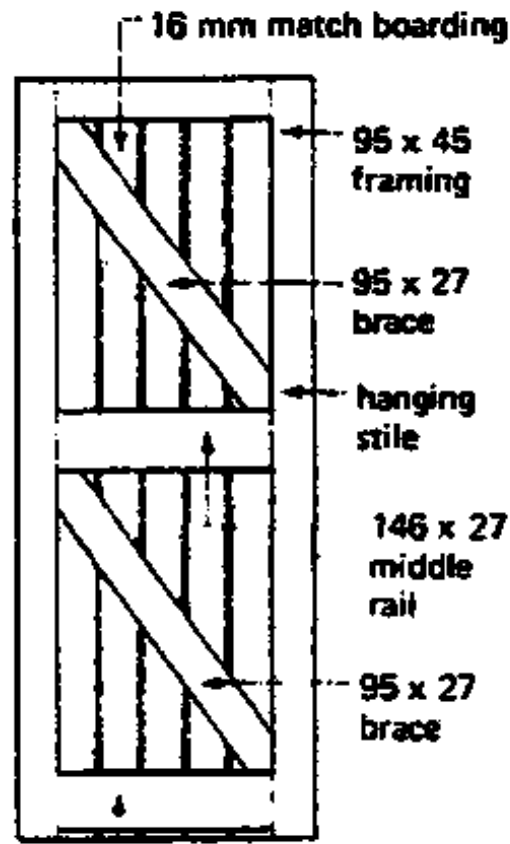

**146 x 27 bottom rail**  
**Framed, Ledged and Braced  
(rear elevation)**

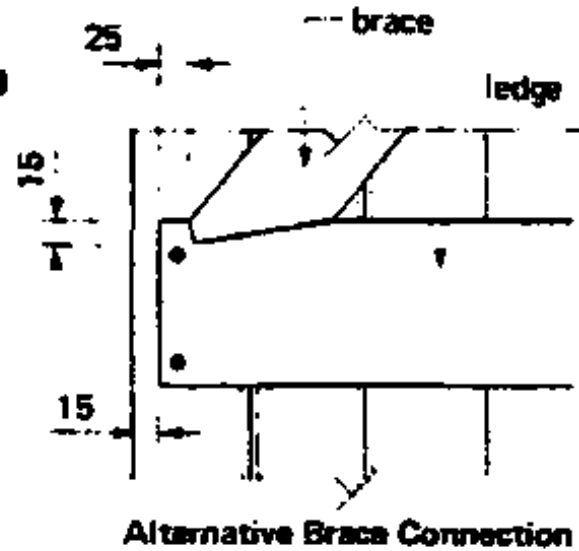

**Alternative Brace Connection**

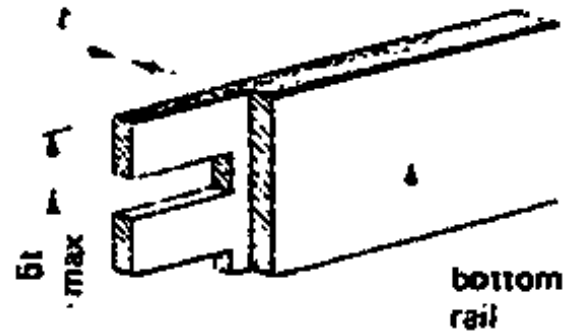

**Barefaced Tenon**

## Matchboarded doors

- The operation of fixing a door to its frame or lining is termed hanging and entails.
  - removing the protective horns from the top and bottom of the stiles
  - planing the stiles to reduce the door to a suitable width.
  - cutting and planing the top and bottom to the desired height.
  - marking out and fitting the butts or hinges which attach the door to the frame.
  - fitting any locks and door furniture which is required.
  - The hinges should be positioned 225 mm from the top and bottom of the door and where 1 1/2 pairs are specified for heavy doors the third hinge is positioned midway between the bottom and top hinge.
  
- A door has to be treated properly during
  - transportation
  - storage
  - after hanging.
  
- + It should receive a wood priming coat of paint before or immediately after delivery,
- + be stored in the dry and in a flat position (so that it does not twist)
- + receive the finishing coats of paint as soon as practicable after hanging.

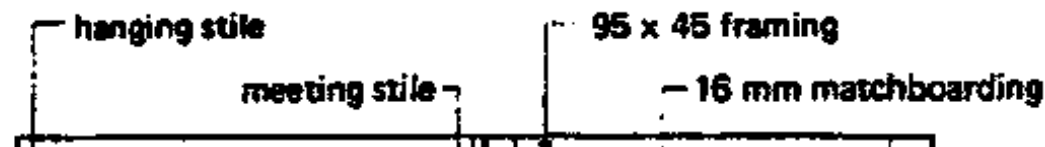

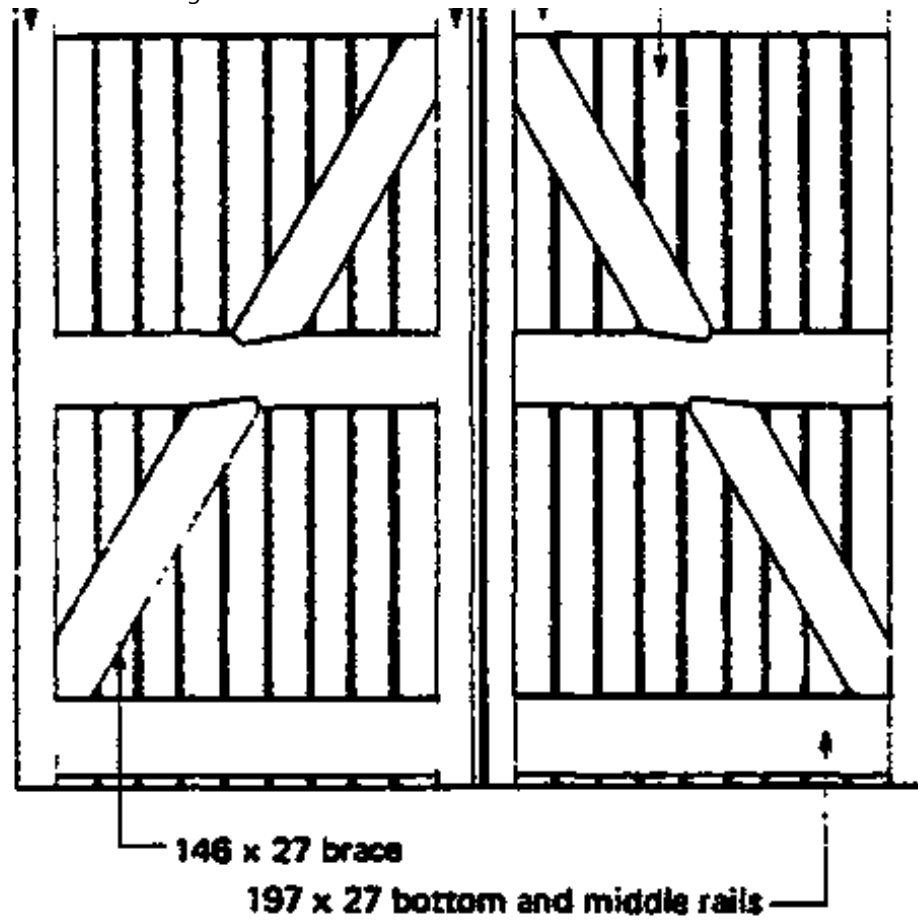

Rear Elevation

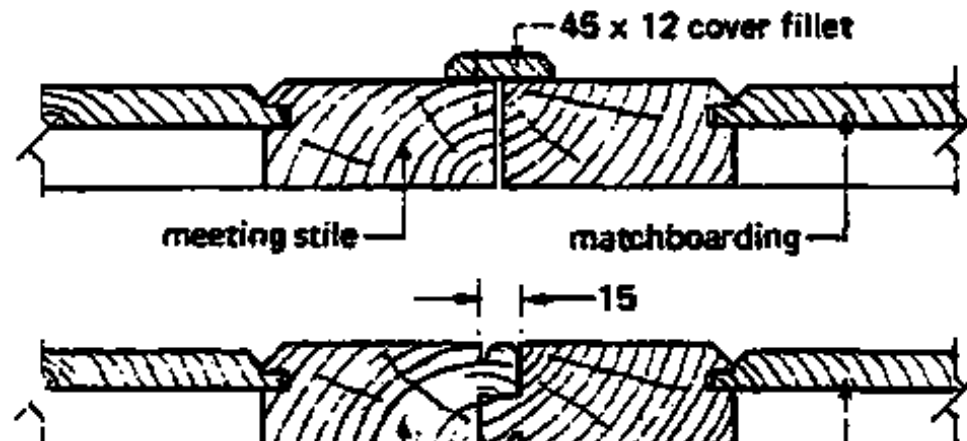

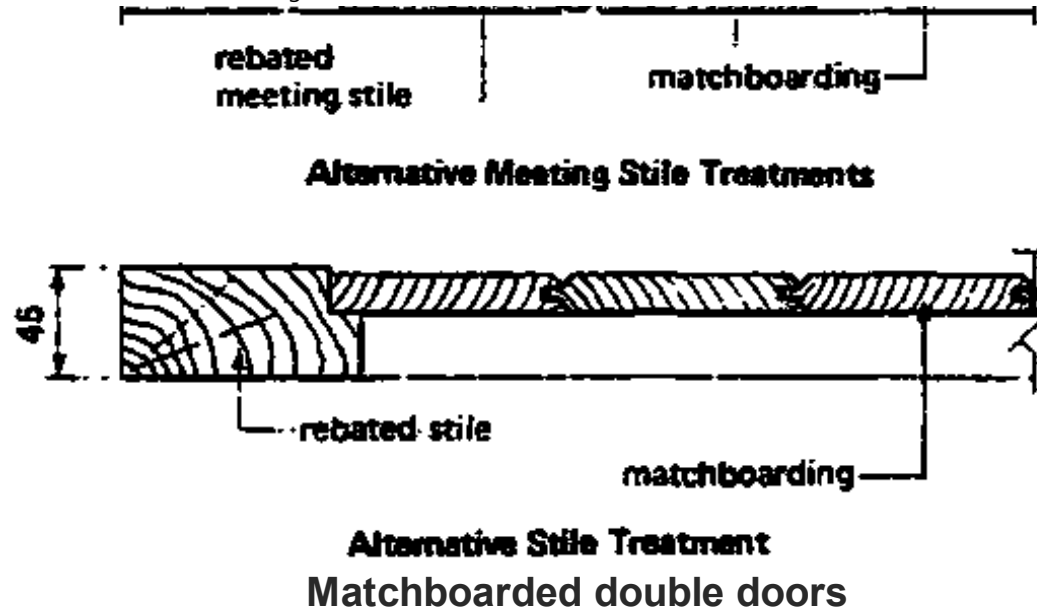

## 14.1.5 FRAMES AND LININGS

- A door frame or lining is attached to the opening in which a door is to be fitted, it provides a surround for the door and is the member to which a door is fixed or hung.
- Door sets are consisting of a story height frame with a solid or glazed panel over the door head.

### 14.1.5.1 Timber Door Frames



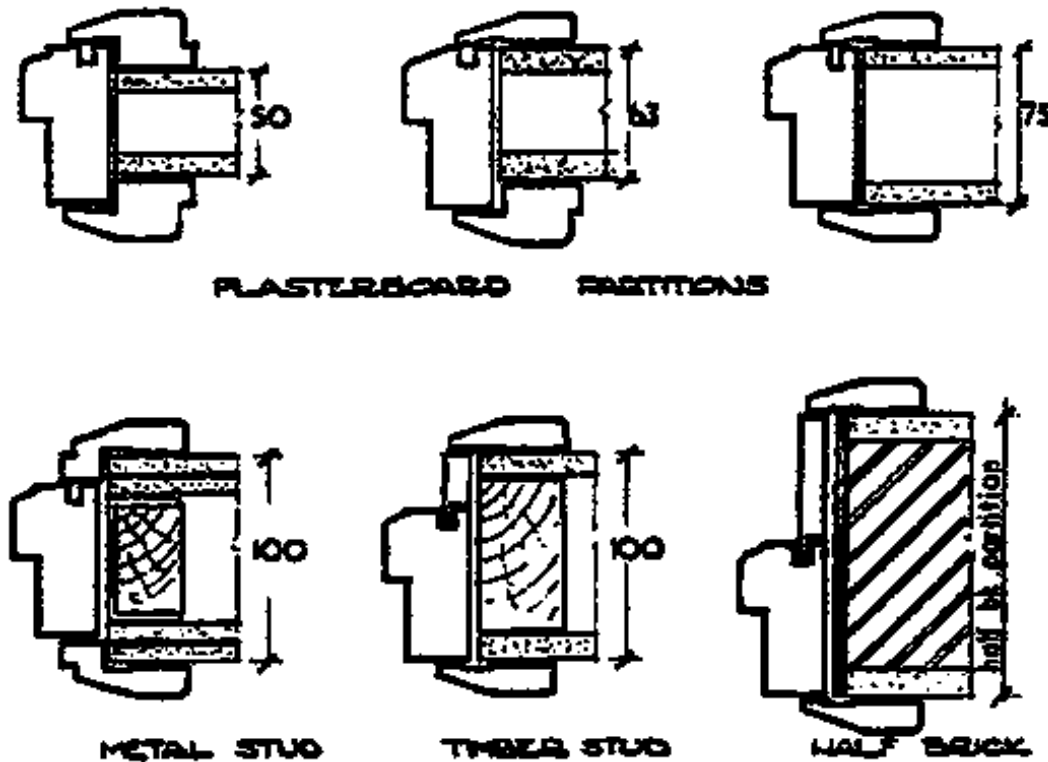

- Are made from rectangular section timber in which a rebate is formed or to which a planted door stop is fixed to provide the housing for the door.

- Generally a door frame is approximately twice as wide its thickness plus the stop.

- A timber door frame consists of three or four members:

- one head
- two posts or jambs
- one sill or threshold.

**- The members can be joined together by**

- **wedged mortice and tenon joints,**
- **combed joints or**
- **mortice and tenon joints pinned with a metal star shaped dowel or a round timber dowel.**

**- All joints should have either a coating of adhesive or a coating of a lead based paint.**

**- Door frames which do not have a sill are fitted with mild steel dowels driven into the base of the jambs and cast into the floor slab or alternatively grouted into pre-formed pockets as a means of securing the feet of the frame to the floor.**

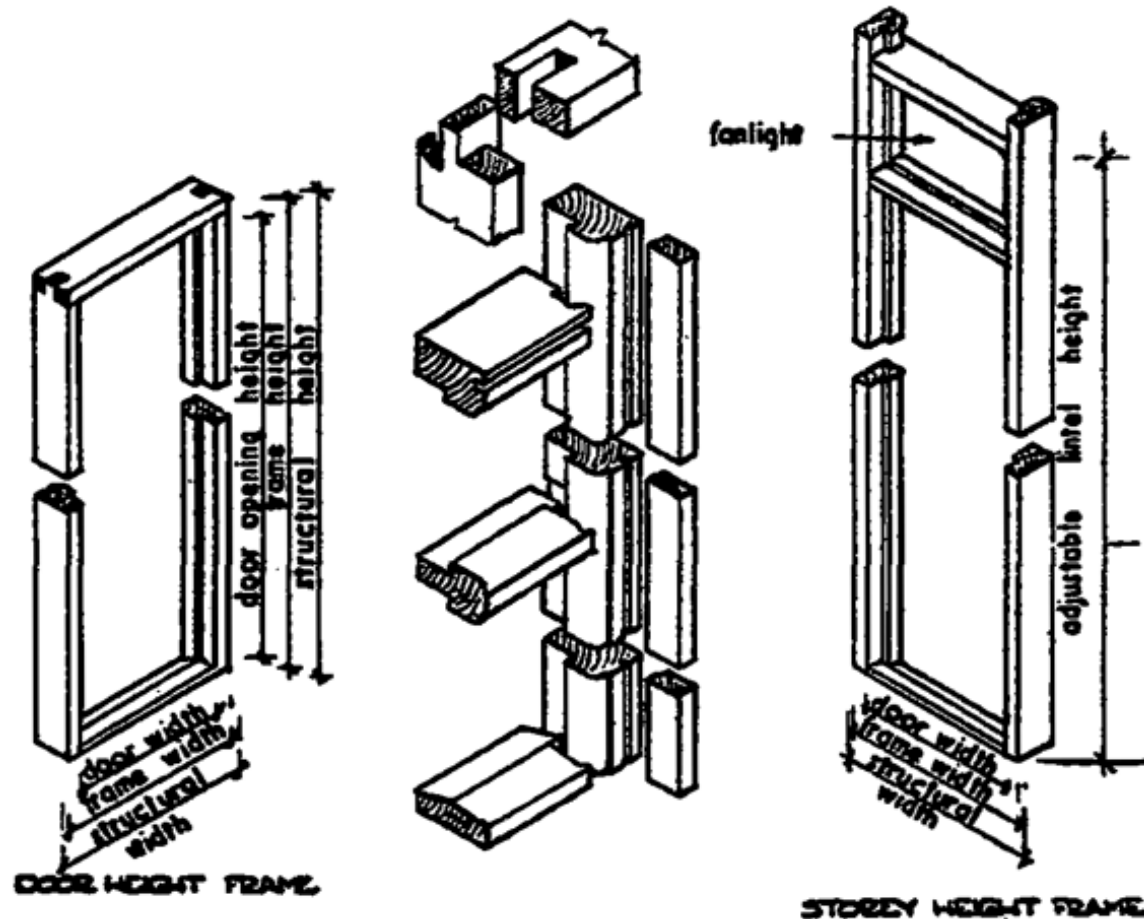

- If the frame is in an exposed position it is advisable to site the feet of the jambs on a damp-proof pad, such as lead or bituminous felt, to prevent moisture soaking into the frame and creating the conditions for fungi attack.

- Door frames fitted with a sill are designed for one of two conditions:

1. Doors opening out
2. Doors opening in.

In both cases the sill must be designed to prevent the entry of rain and wind under the bottom edge of the door.

- Doors opening out close onto a rebate in the sill
- Doors opening in have a re-bated bottom rail and close over a water bar set into the sill.

- Timberdoor frames can be fixed to a wall by the following methods:

a) Built into the brick or block wall as the work proceeds by using 'L' shaped ties or cramps.

The ties are made from galvanised wrought steel with one end turned up 50 mm, with 2 holes for wood screws, on the other end being 125 or 225 mm long and fish- tailed for building into brick or block bed joints. The ties are fixed to the back of the frame for building in at 450 mm centres.

b) Fixed into a brick opening at a late stage in the contract to prevent damage to the frame during the construction period. This method is more expensive, but results in a better quality of joinery work.

- The frames are fixed to timber plugs inserted into the reveals with wood screws, whose heads are sunk below the upper surface of the frame.

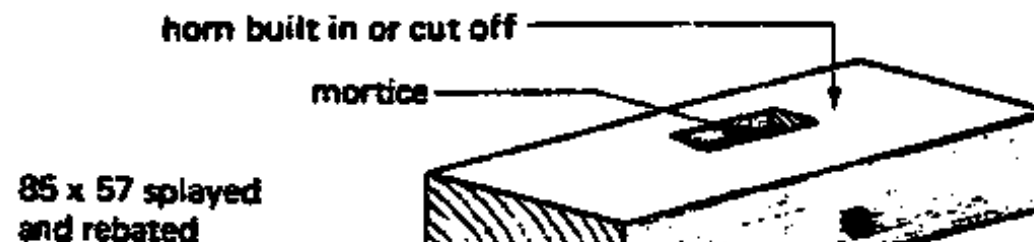

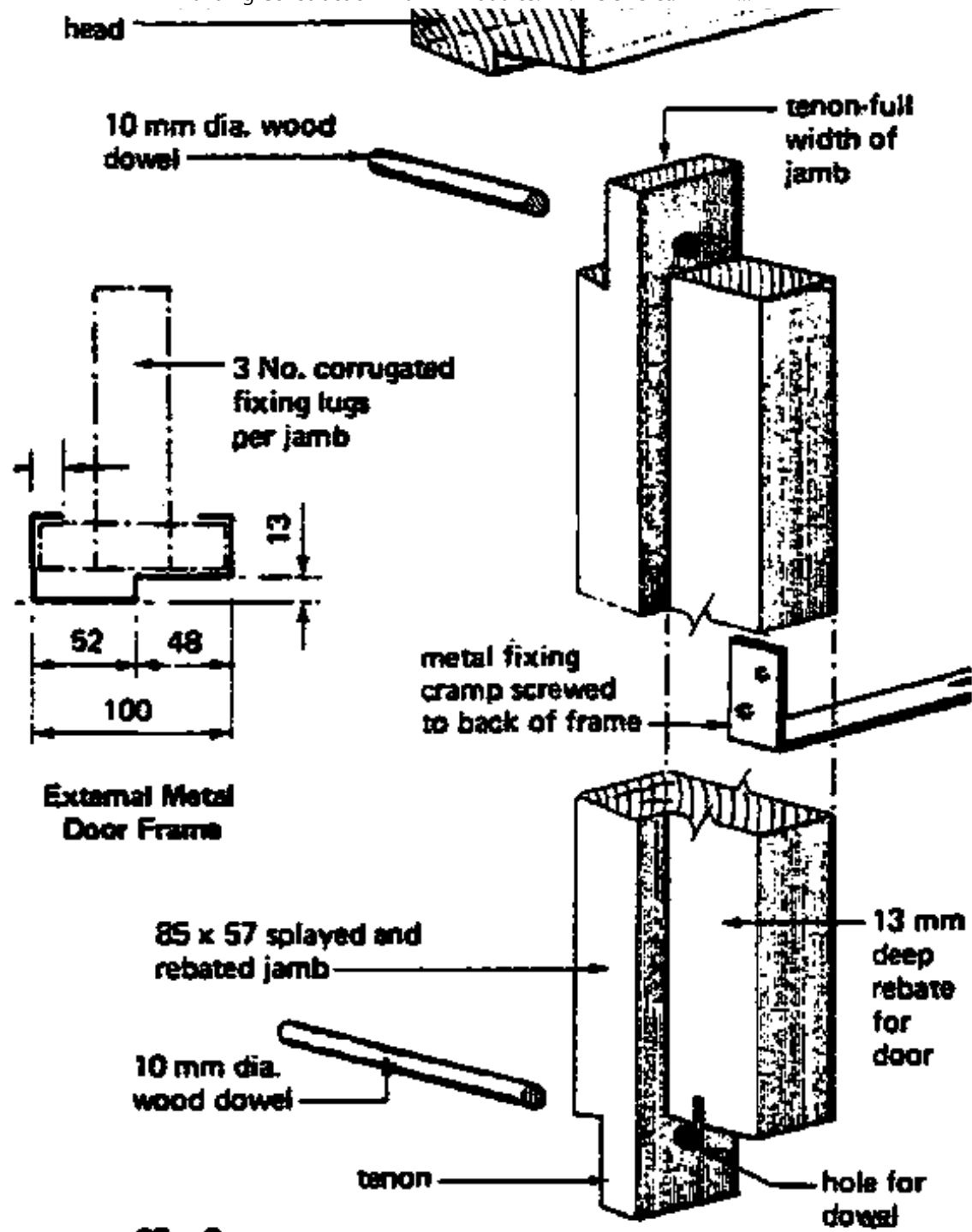

25 - 2

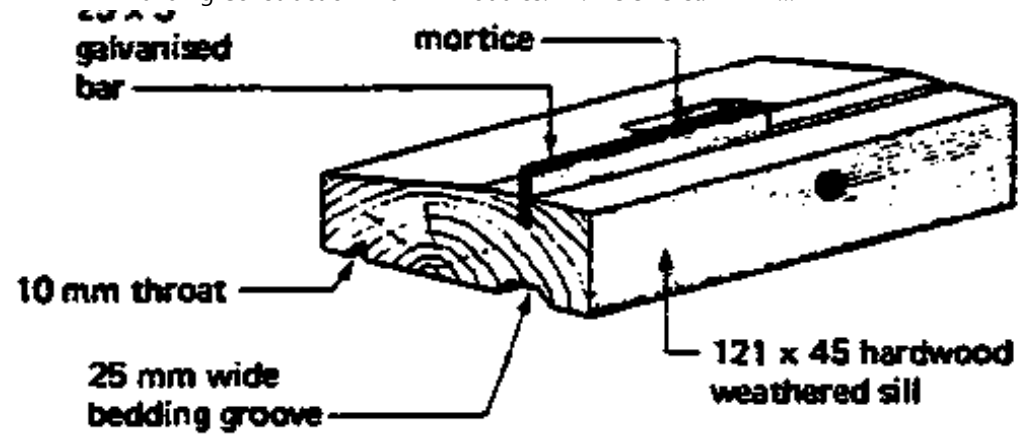

### 14.1.5.2 Metal door frames

- a.) STEEL FRAME 'PolyNORM'
- b.) STEEL FRAME 'CATNIC'
- c.) STAINLESS STEEL FRAME

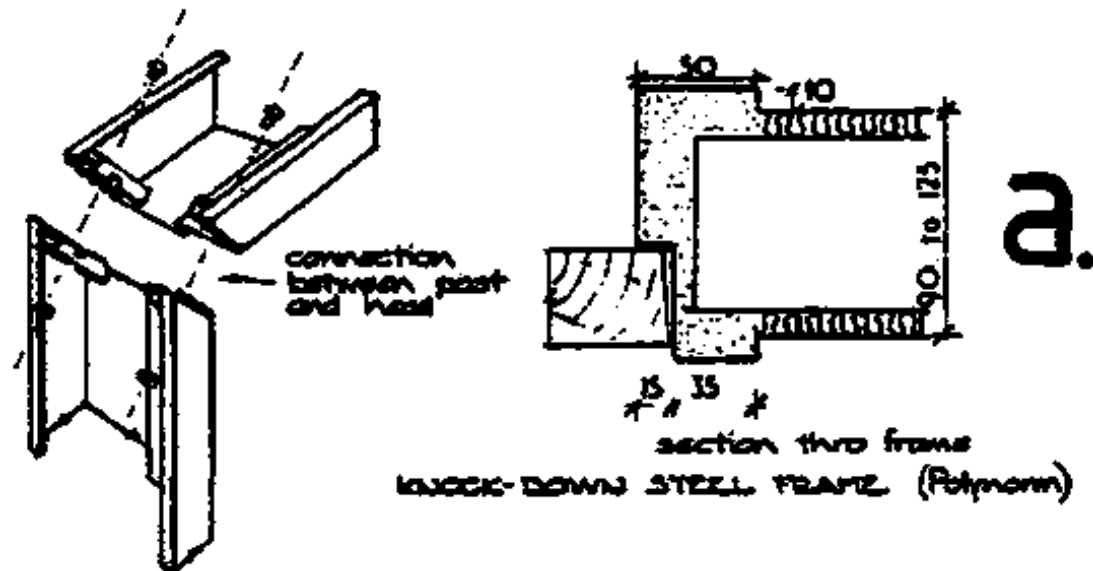

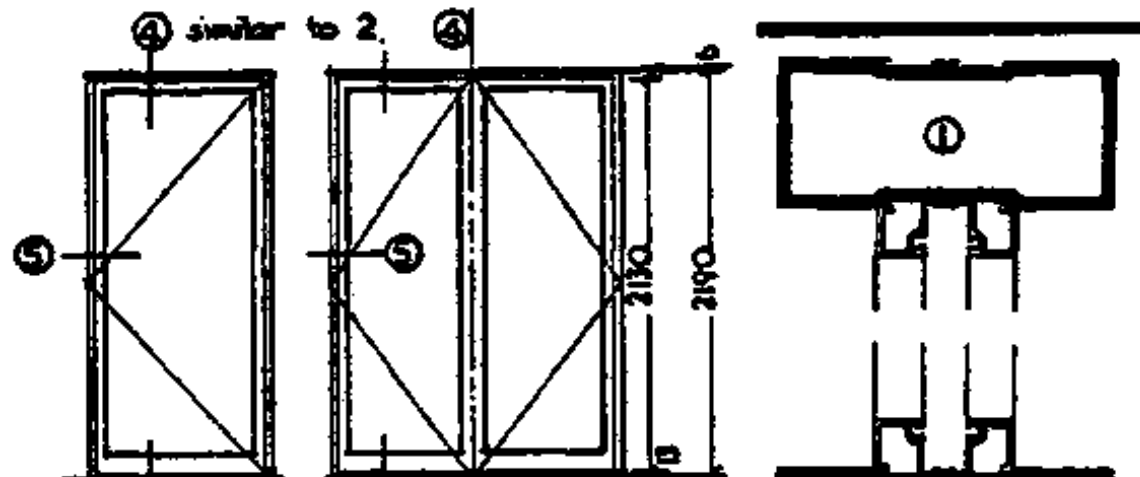
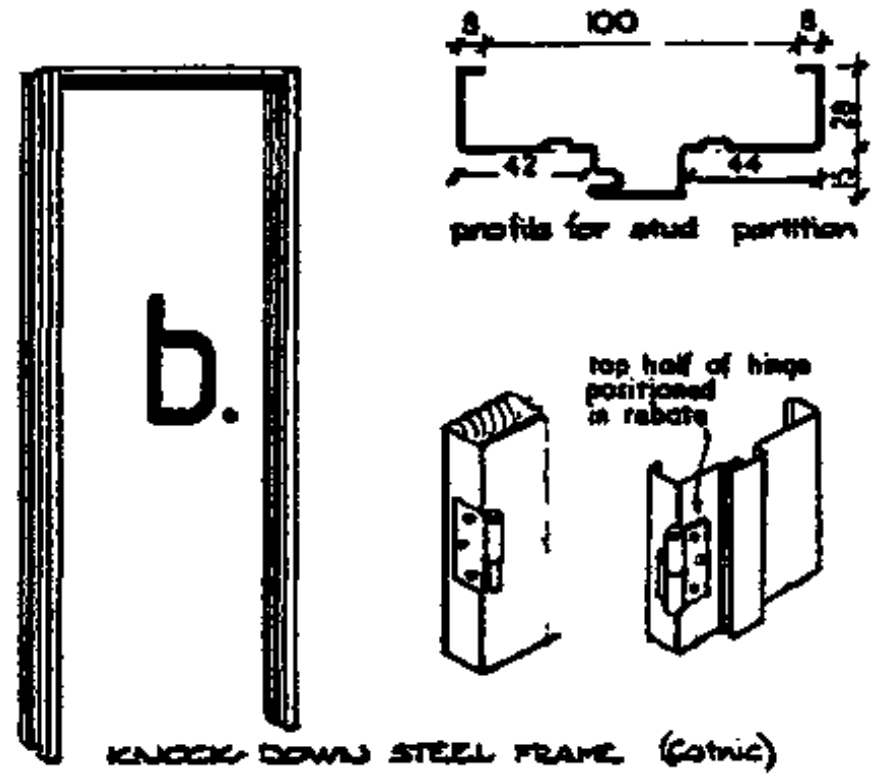

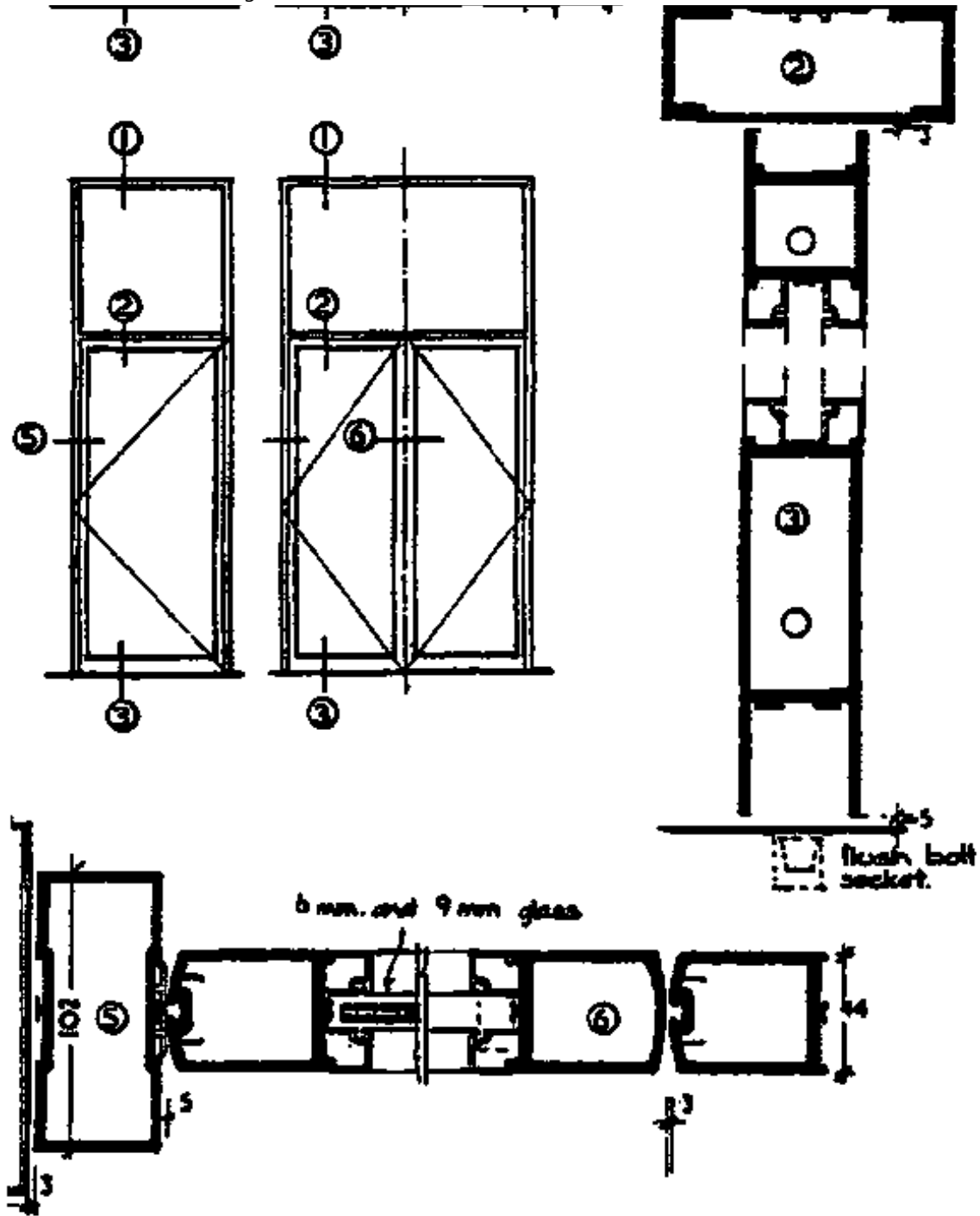



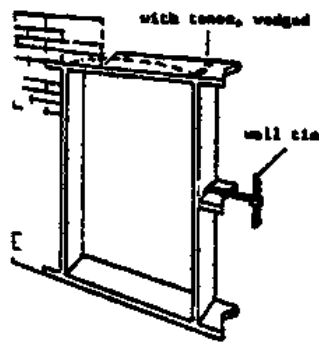

1 Plank subframe

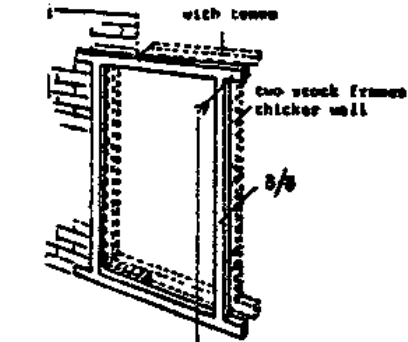

2 Stock subframe

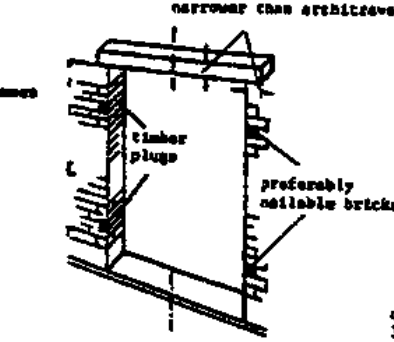

3 Timber plugs and timber lintel

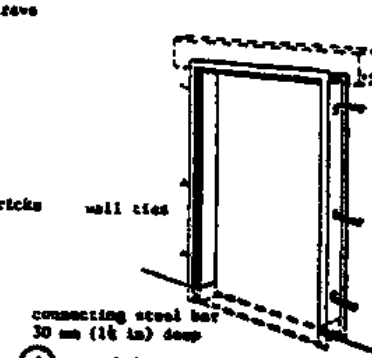

4 Steel frame

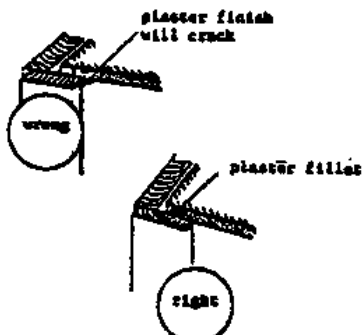

5 Connection to plaster

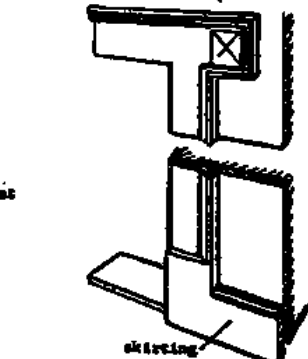

6 Traditional architrave for timber subframe

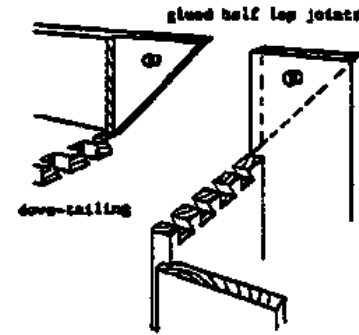

7 Skillfully executed corner detail

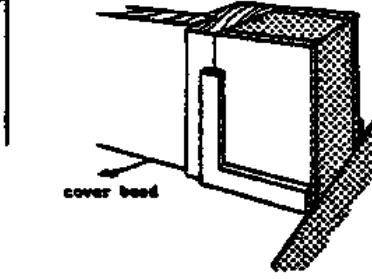

8 Modern stock frame for thin partitions



9 Correct fixing of door, with door slightly open

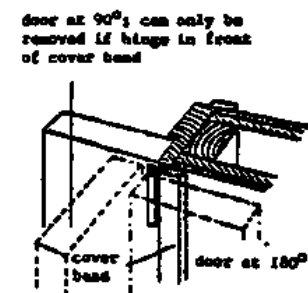

10 Easy removal of door at 90° or 180° (Continental type hinge)

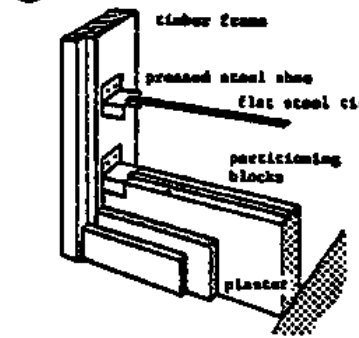

11 Frame fixed in light partition

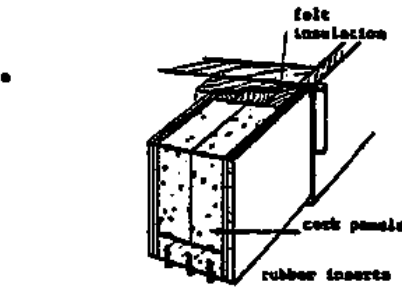

12 Sound-proof door with insulated threshold

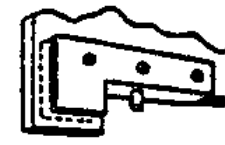

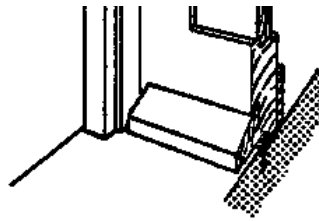

13 Standard door

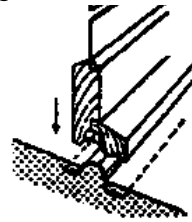

14 Rising French door



15 One sided hinge for all-glass doors with fan light



16 Swing door hinges for all-glass doors with fan light

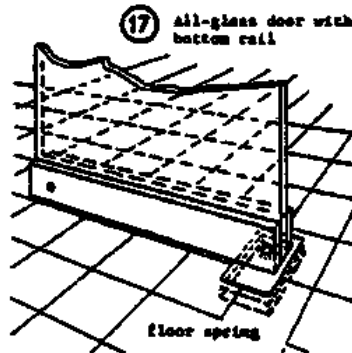

17 All-glass door with bottom rail

floor spring

- These are made from mild steel pressed into one of three standard profiles,
- They are suitable for both internal and external positions.
- The hinges and striking plates are welded on during manufacture and the whole frame receives a rust-proof treatment before delivery.
- The frames are fixed in a similar manner to timber frames using a tie or lug, which fits into the back of the frame profile and is built into the bed joints of the wall.
- The advantage of this type of frame is that they will not shrink or warp, but they are more expensive than timber ones.

Timber subframes and plugs require lining and architrave, which must cover up the plaster.

For the best finish the lining must be dovetailed and the architrave half-mitred, → (7). Planed

**stock frames for light partitions are also a guide for the plaster finish and are erected before putting up partition blocks. → (8); to avoid damage, doors should be easily removable. → (10).**

**Doors in thin partitions are fixed in steel, → (8), or timber frames with wall tie. → (11). For outside doors plywood must be of external quality; timber doors (weather boarding), steel doors or steel-framed doors with glass panels are preferable. Panels in external doors must overlap, → (13). For French doors on balconies, doors should have rising gear. → (14).**

**In modern office blocks etc. frameless all-glass doors (armour-plate glass) are used. → (15)-(16). often with automatic electrically-operated opener and floor springs, → (17)**

#### **14.1.5.3 Door linings**

- These are made from timber board 25 or 35 mm thick and as wide as the wall and any wall finishes.**
- They are usually only specified for internal doors.**
- Door linings are not built in but are fixed into an opening by nailing or screwing directly into block walls or into plugs in the case of brick walls.**
- Timber packing pieces or folding wedges are used to straighten and plumb up the sides or jambs of the linings.**

#### **Door linings and door sets**

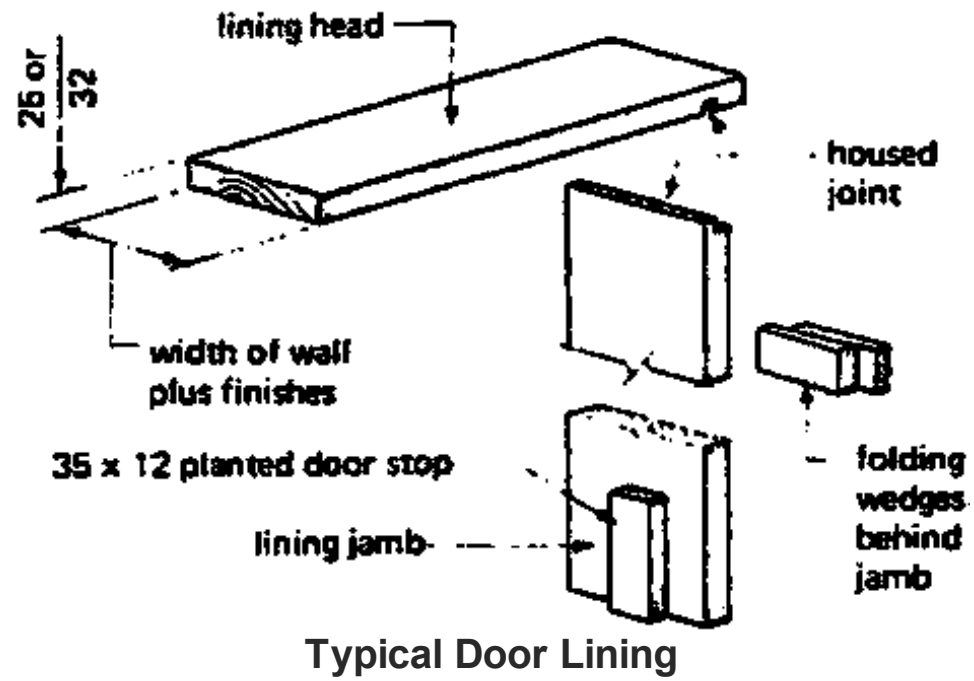

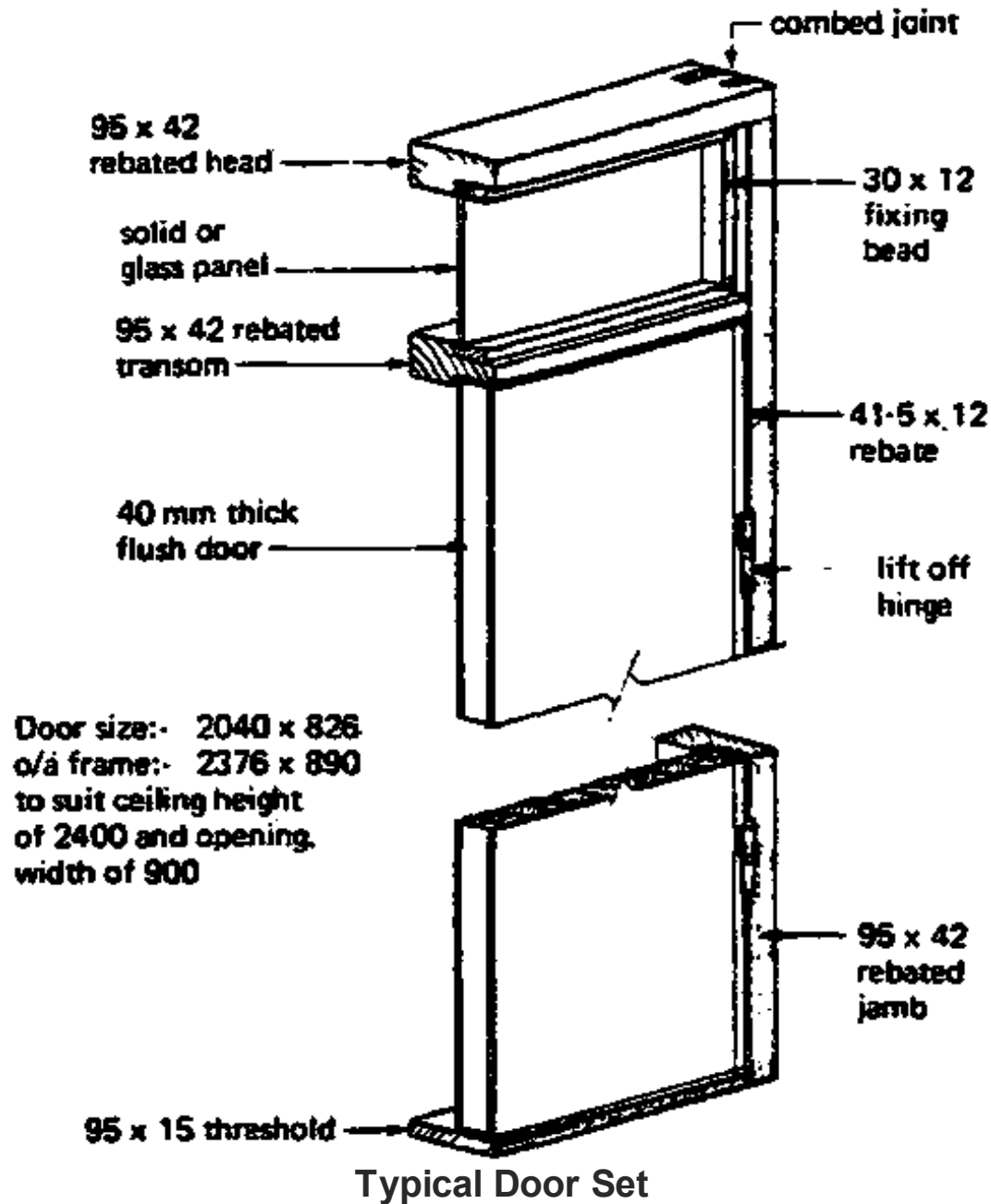

### 14.1.6 SPECIAL DOORS

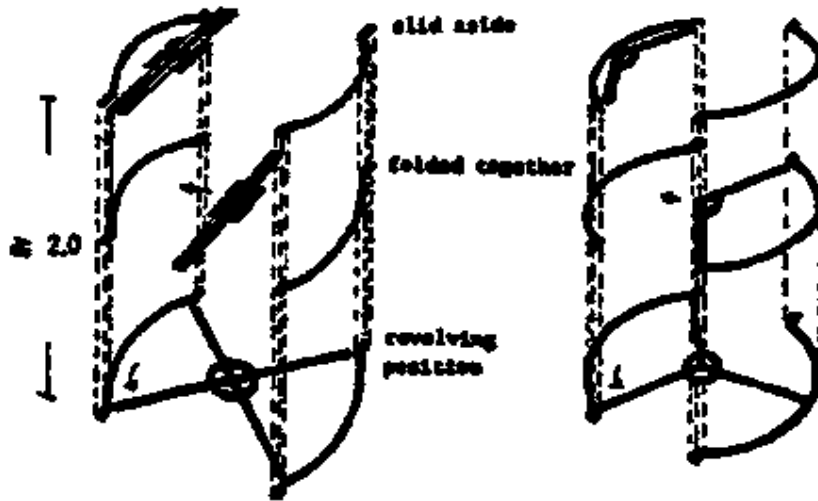

① Revolving door, compartments L.H. (3 ft 9 in)

② Revolving door, compartments L.H. (4 ft 9 in)

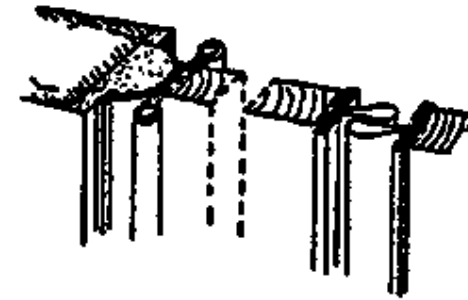

③ Swing door with rubber draught seal and steel frame

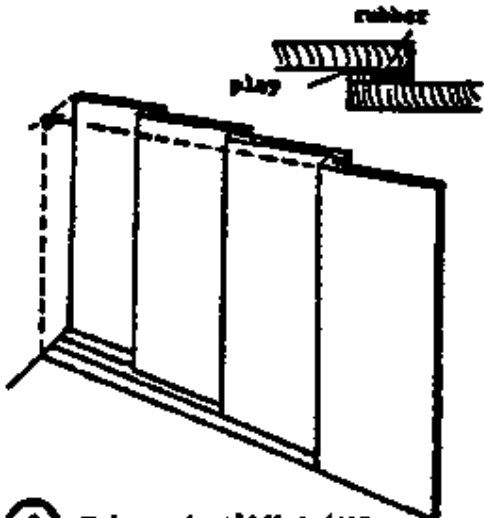

④ Telescopic sliding door

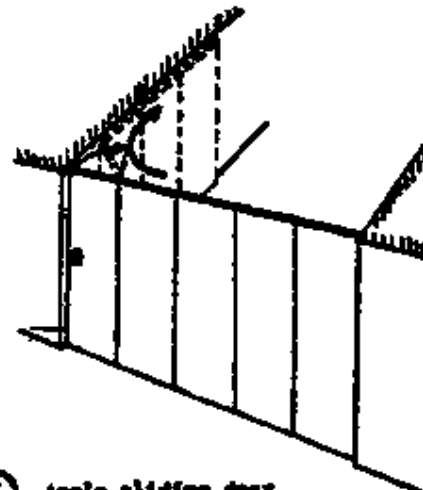

⑤ Angle sliding door (concealed)

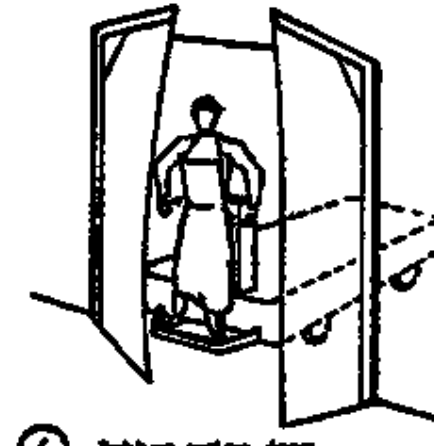

⑥ Rubber swing door

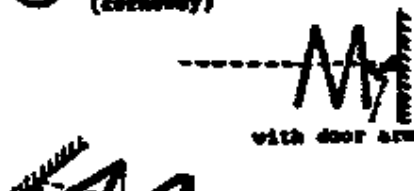

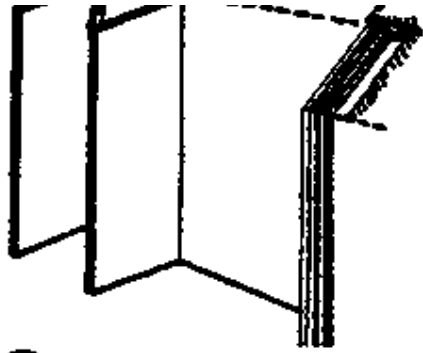

7 Folding doors (foldaway)

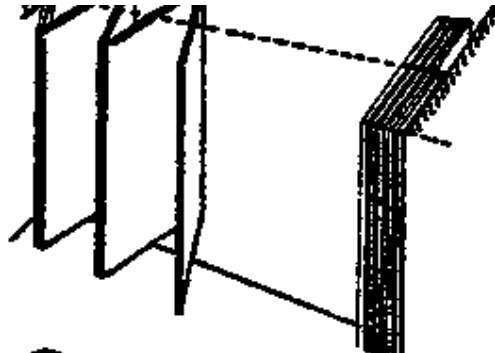

8 Folding doors (centrefold)

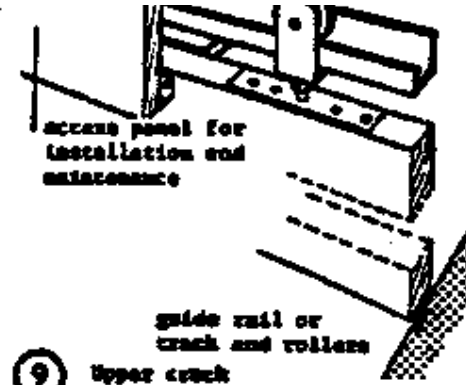

9 Upper track

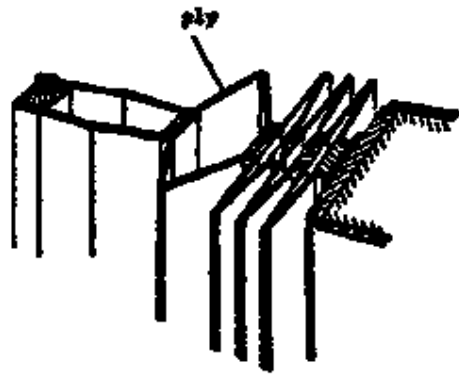

10 Converting folding door (plywood)

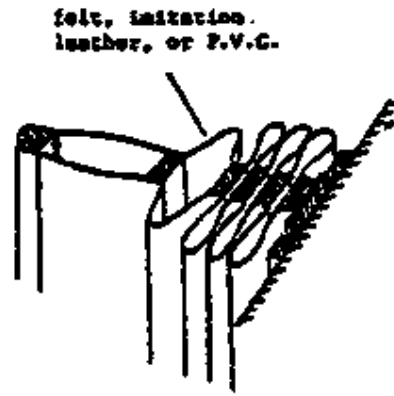

11 Converting folding door (fabric)

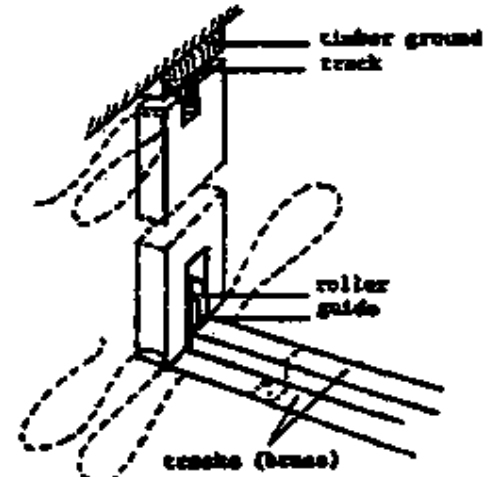

12 Upper and lower track

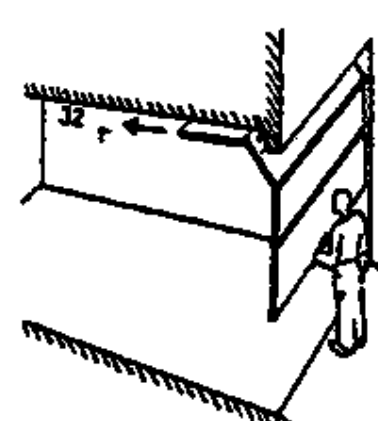
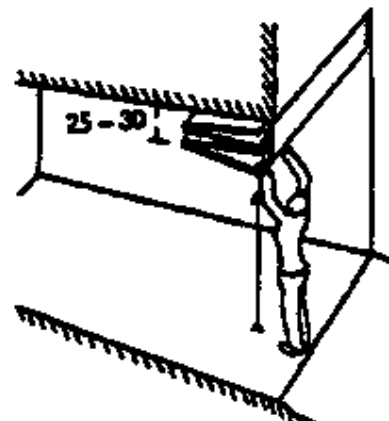
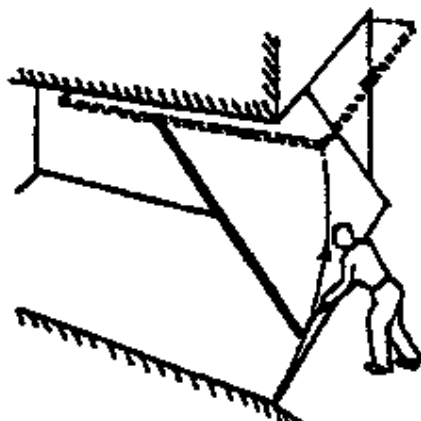

⑬ Overhead door (flyover)

⑭ Overhead door (foldaway)

⑮ Overhead door, sectional (flyover tender)

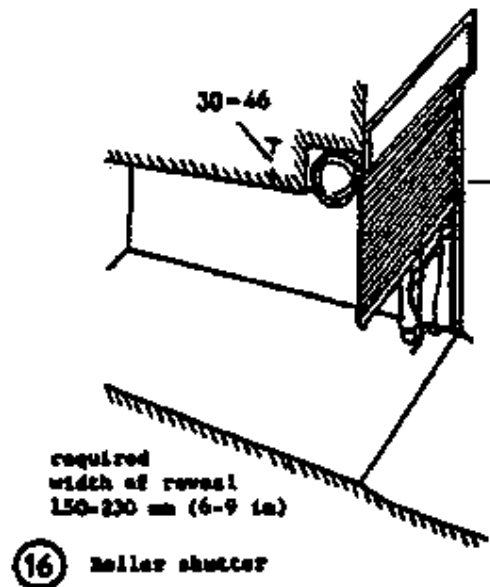

Revolving doors have wings which may be folded back during peak traffic, especially in summer. Wings are folded away completely if traffic is in one direction only (e.g. at closing time).

Swing doors have spring, check and helical langes, or shoes and top centres and floor springs. To stop swing and achieve air-tightness, interchangeable draught seals are inserted at meeting styles, → (3).

Large openings (partitions), etc, which cannot be closed by normal swing doors are fitted with special sliding doors, sliding-folding doors, or concertina-folding doors. → (4)-(8). Such doors have hangers (top hung) or rollers (bottom rolling) → (9): rollers, as in lightweight concertina doors, → (12), are infrequently used.

Narrow rooms which provide no space for sliding doors may be closed by overhead doors sliding beneath ceiling, → (13)-(16).



All these doors can be electrically operated and this is especially suitable for large openings with heavy door structures (garages, hangars, etc).

Adjustable fillet rails are necessary at the meeting styles of large doors to cope with temperature fluctuations in steel doors and shrinkage in large timber doors.

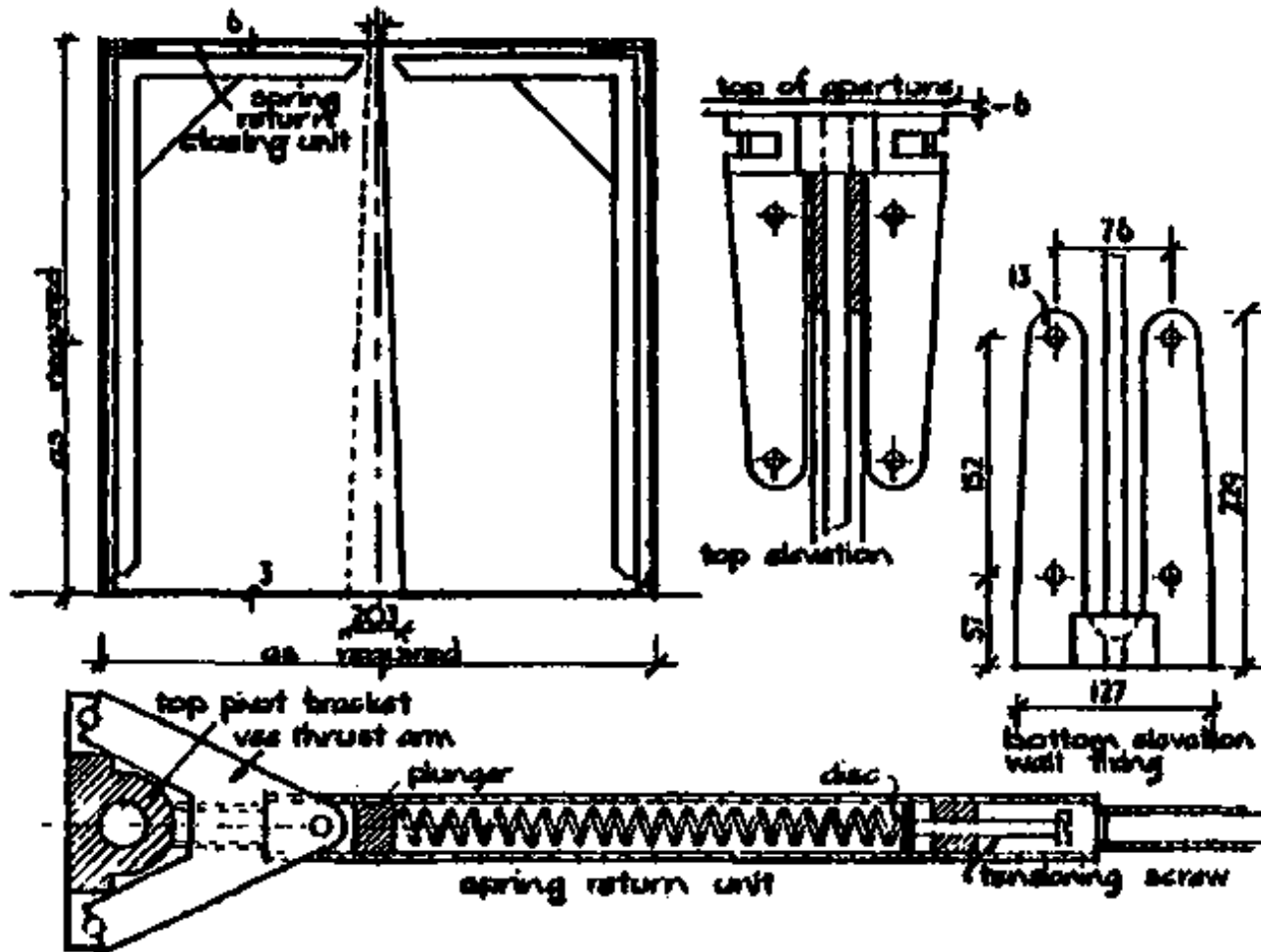

## 1. FLEXIBLE DOOR

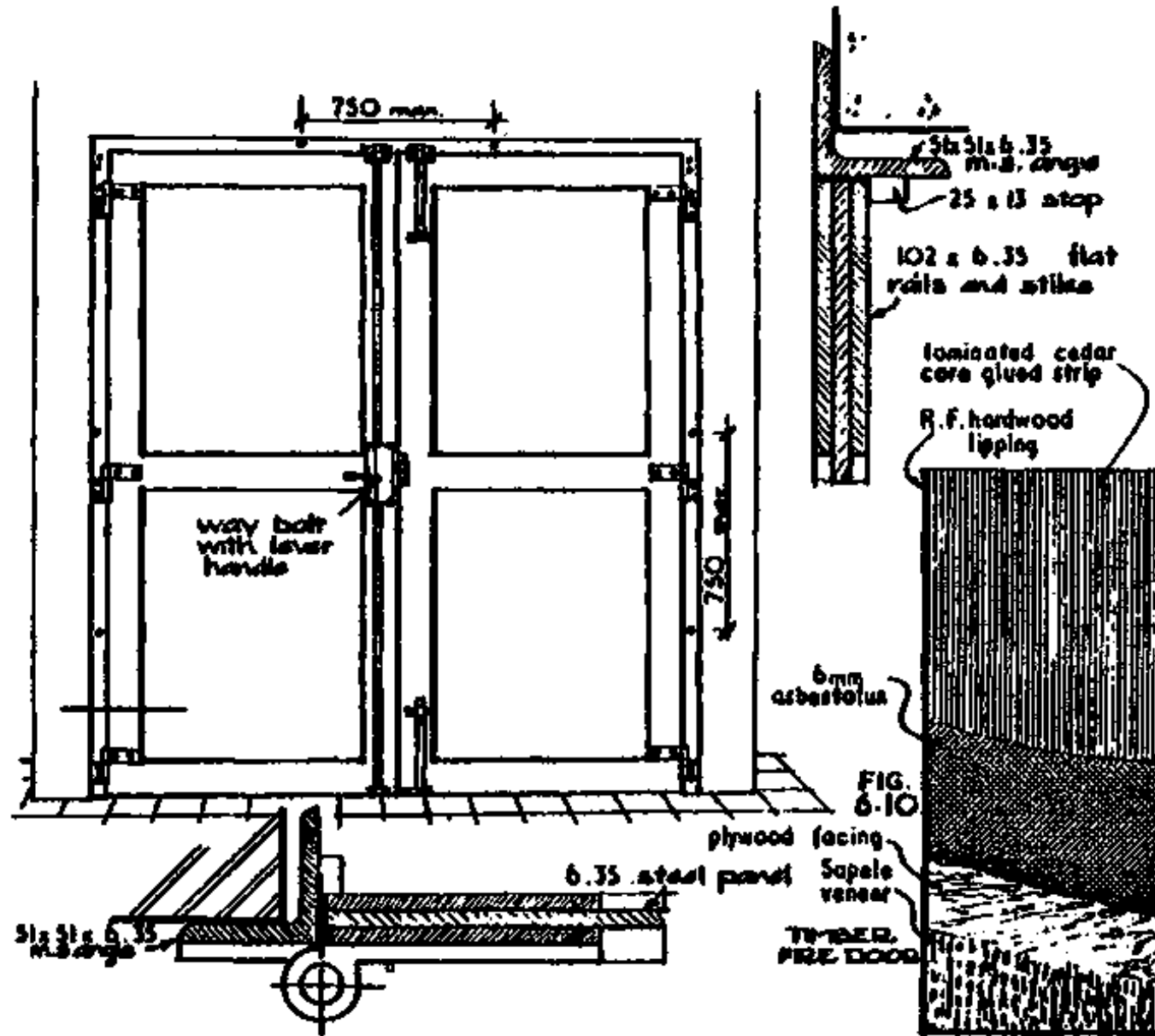

2. STEEL FIRE DOOR

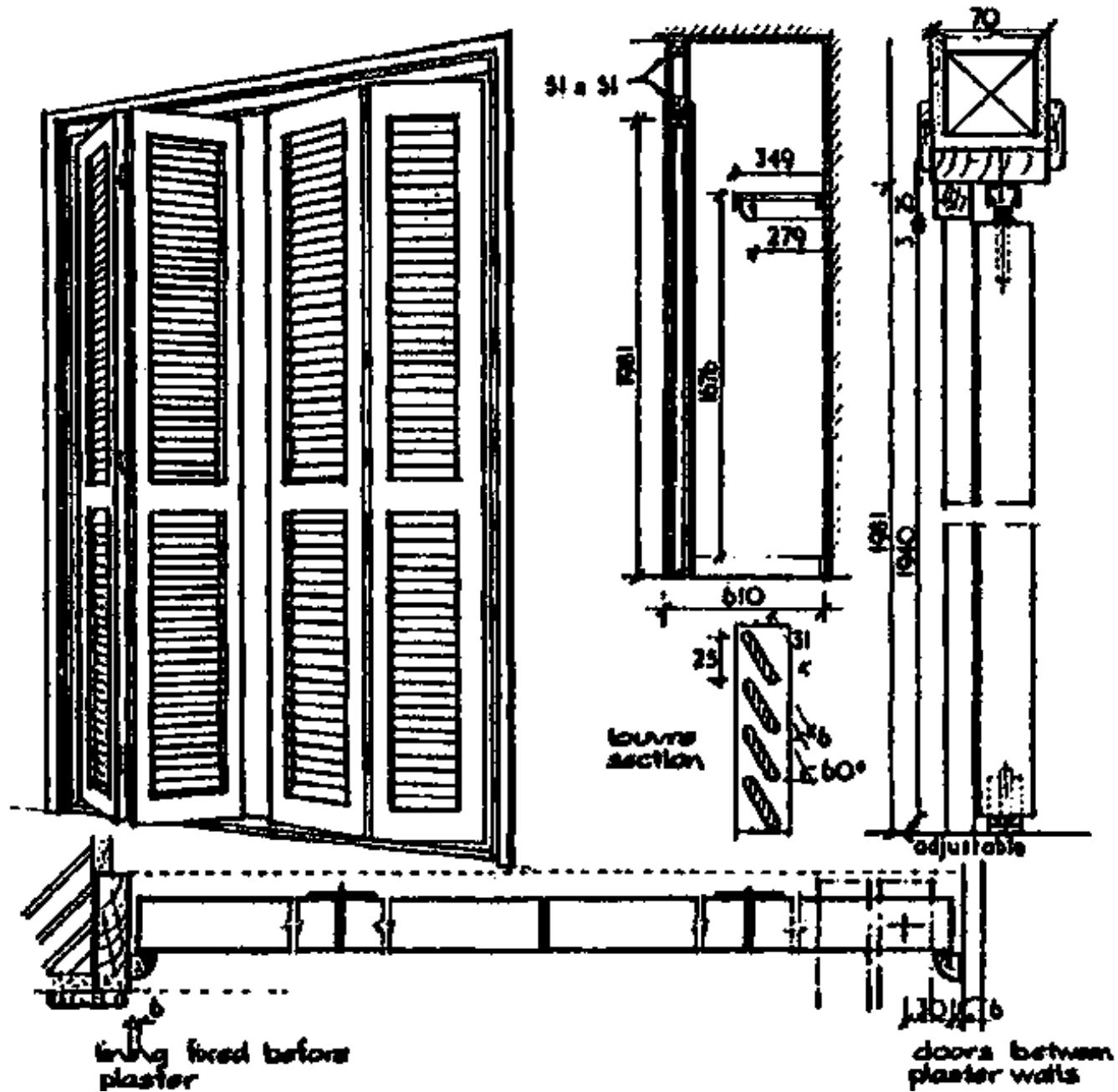

### 3. WARDROBE DOOR

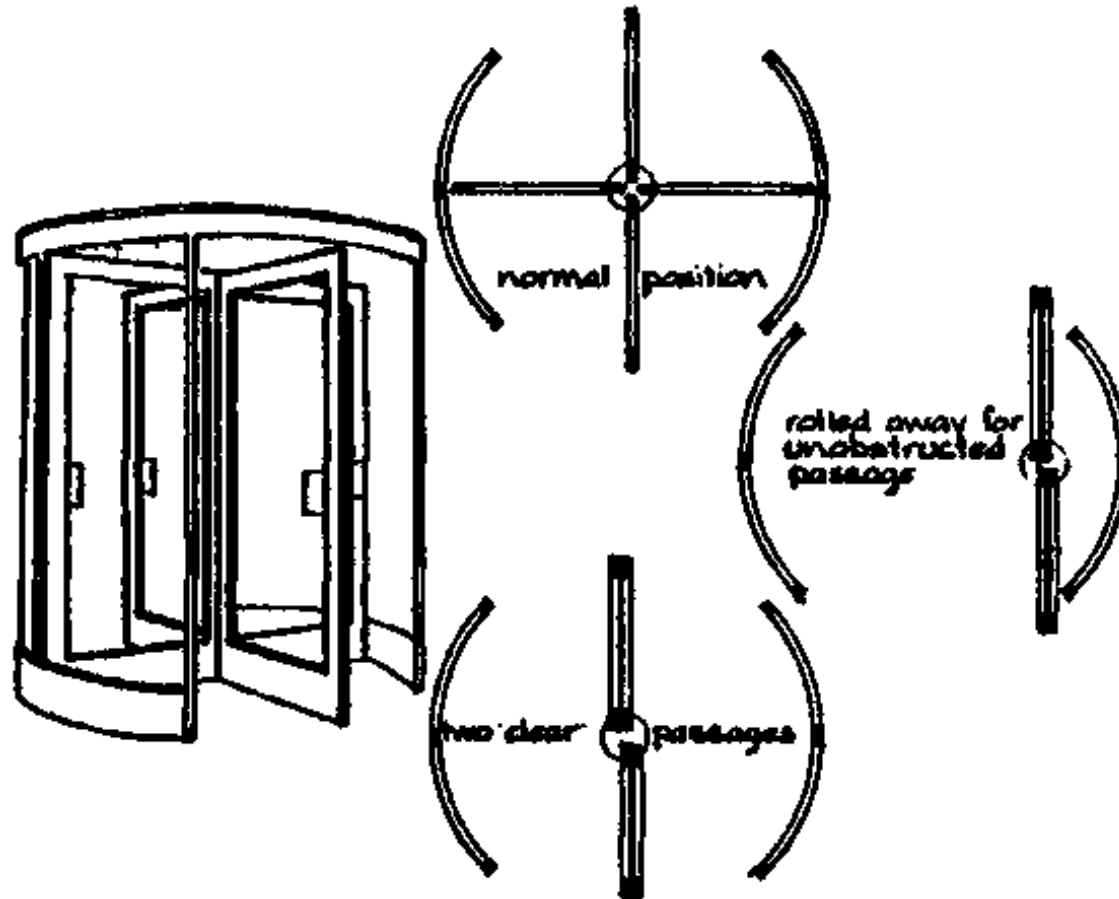

### 4. REVOLVING DOOR

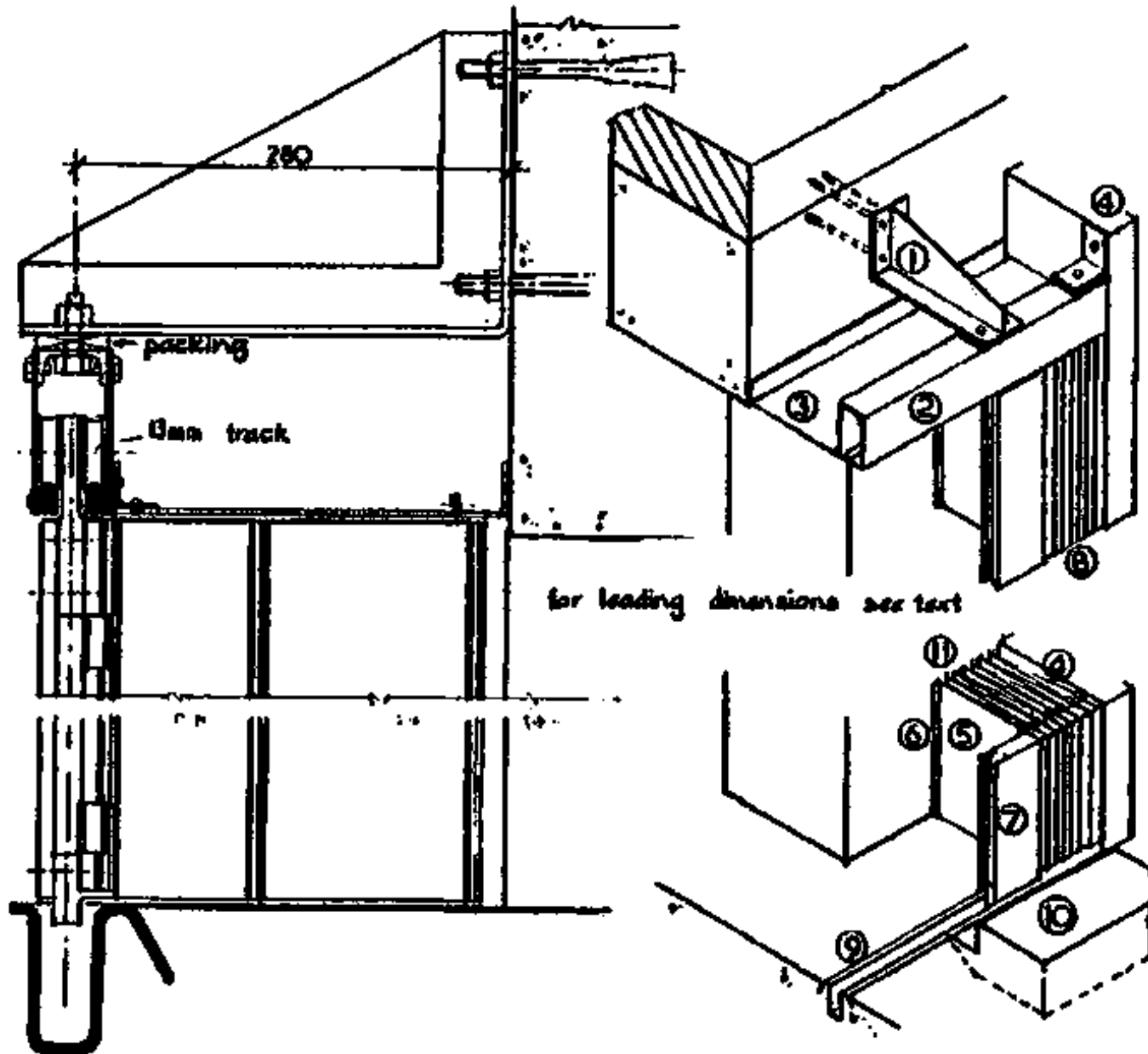

1. FOLD. SHUTT. DOOR

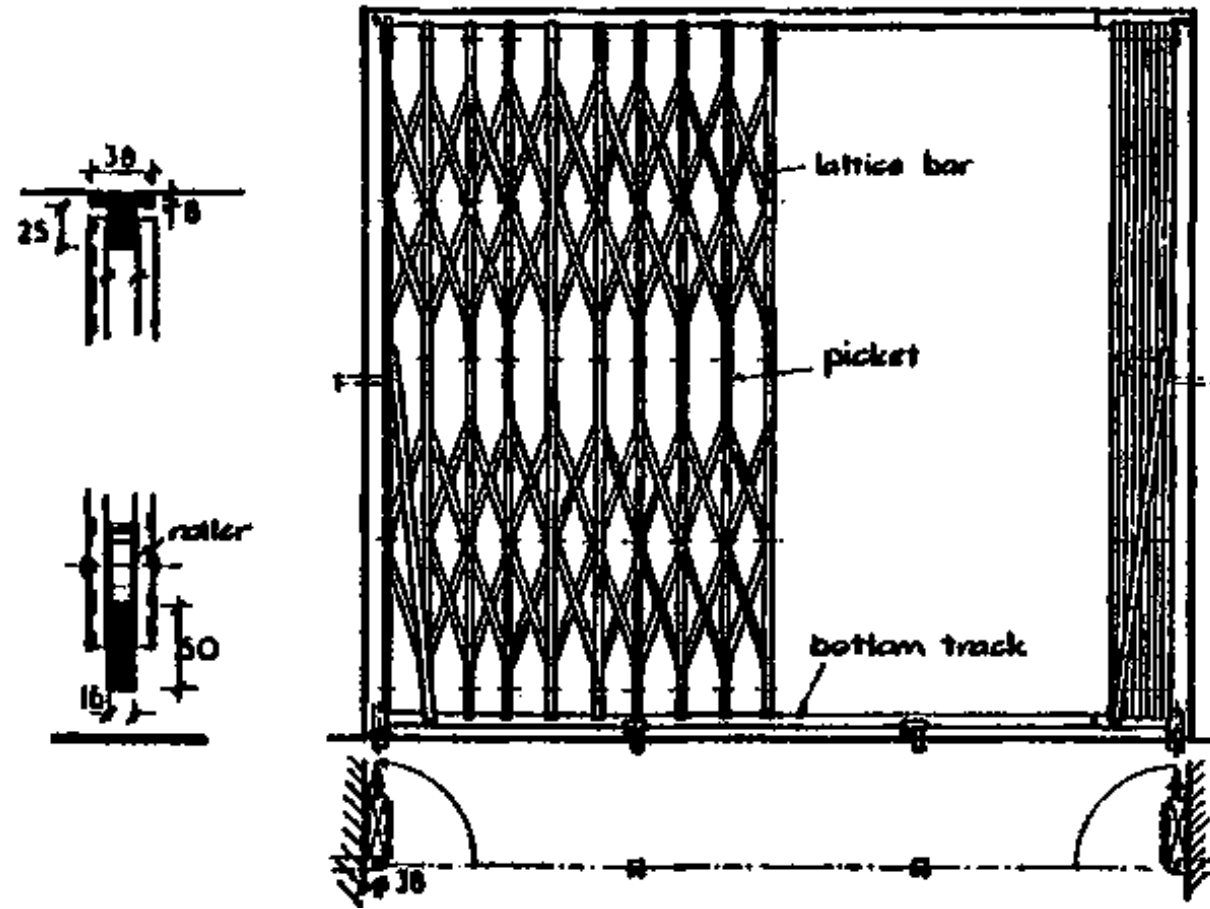

2. COLLAPS. GATE

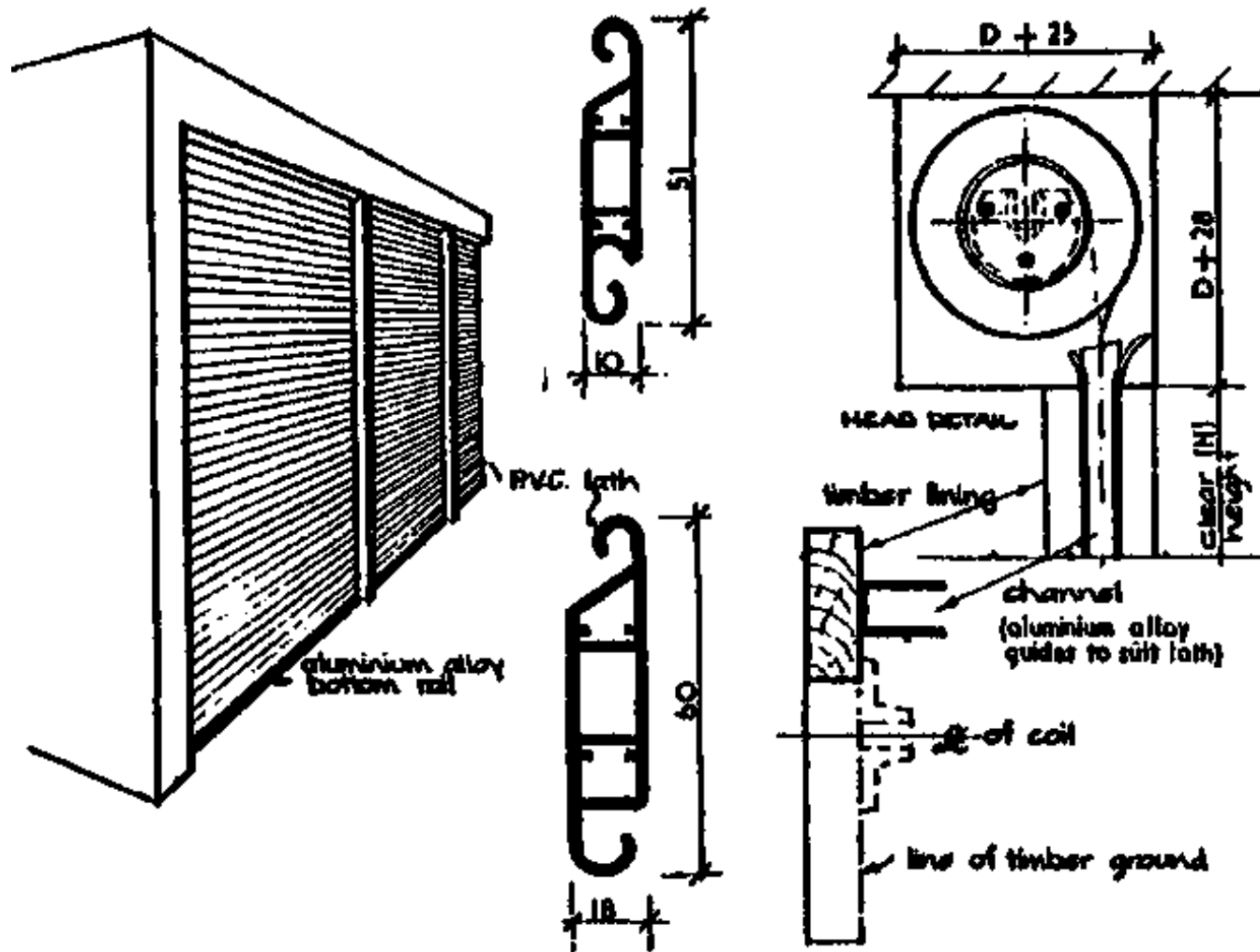

### 3. ROLLER SHUTTER

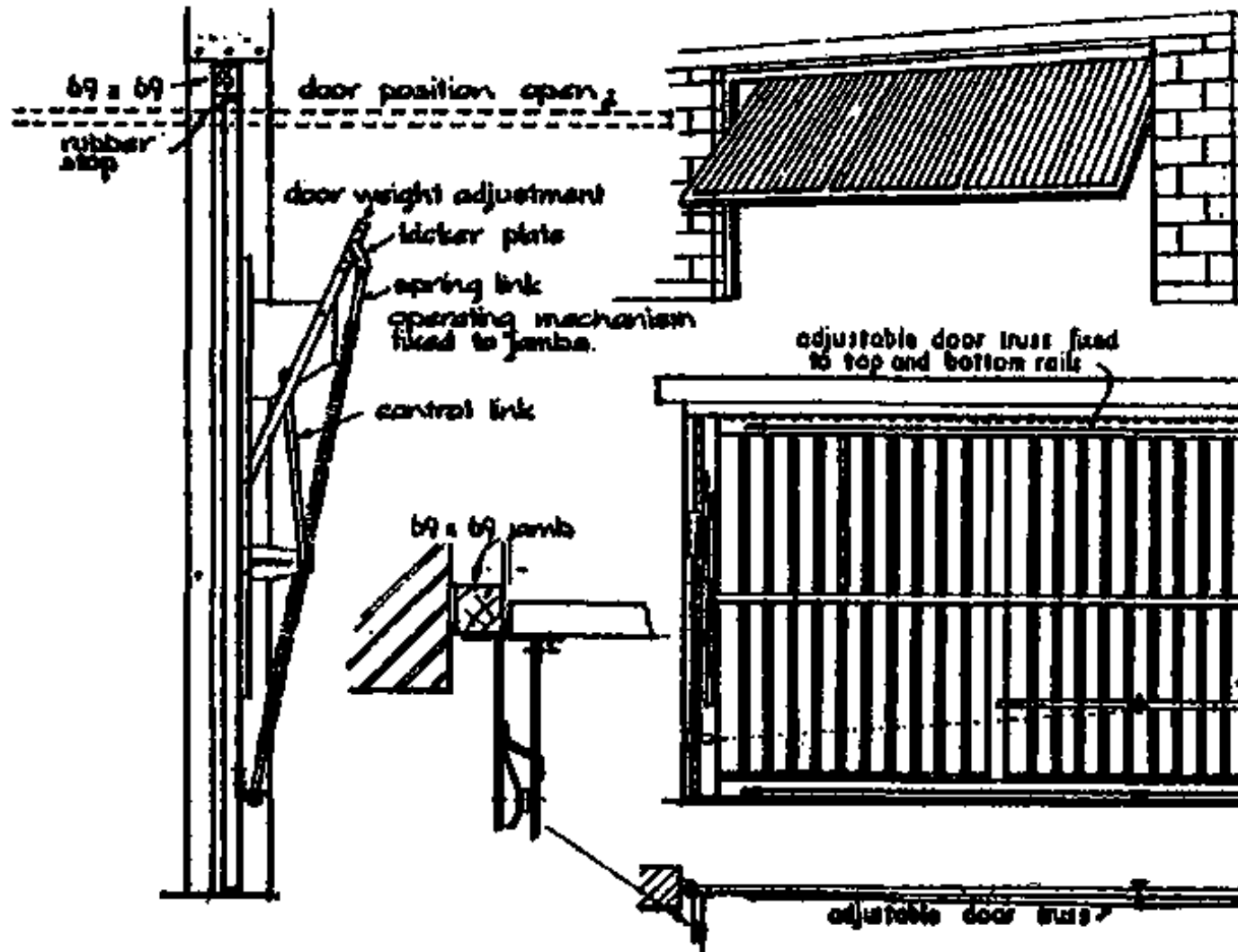

#### 4. FLY-OVER DOOR

### SLIDING DOORS



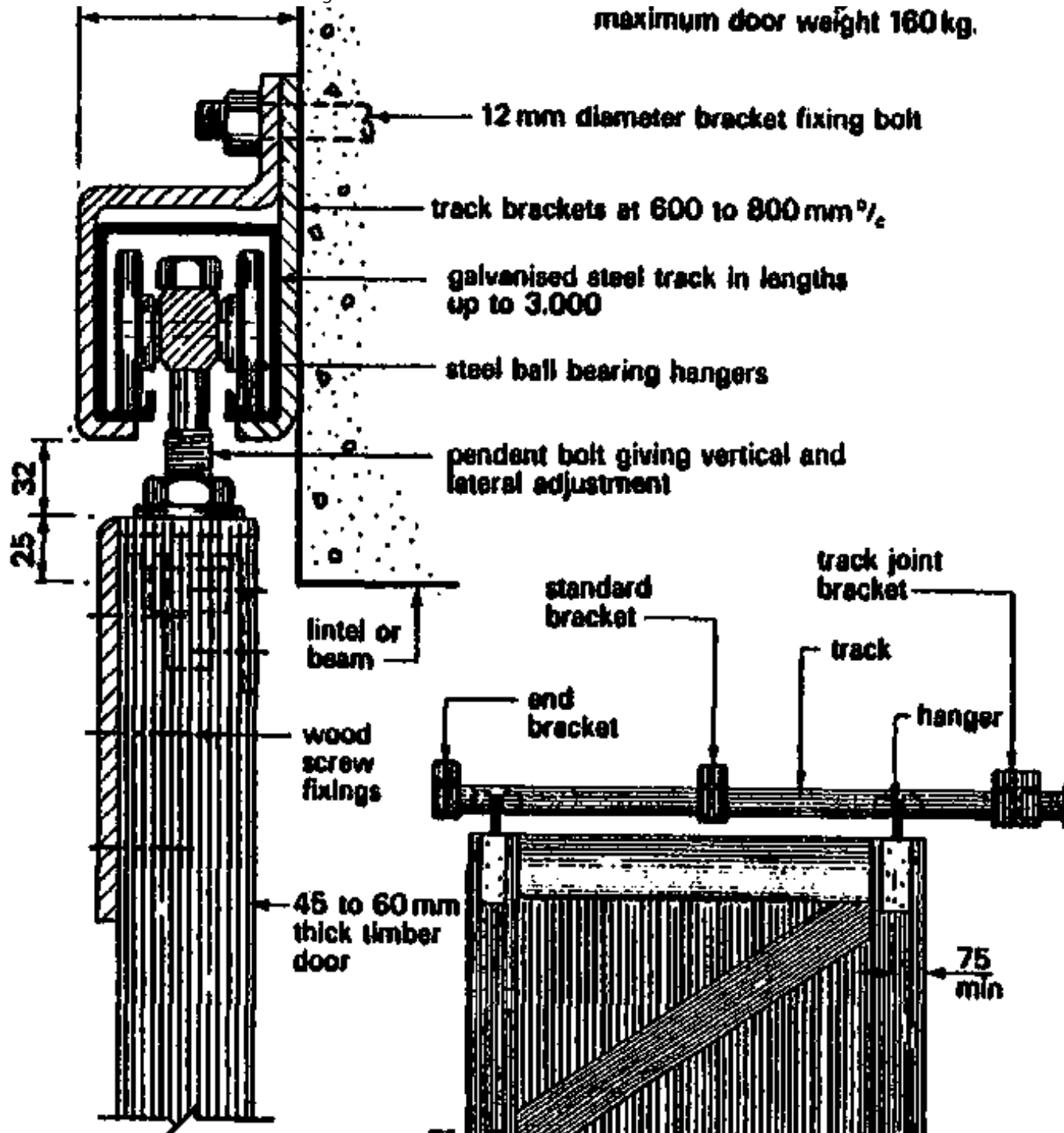

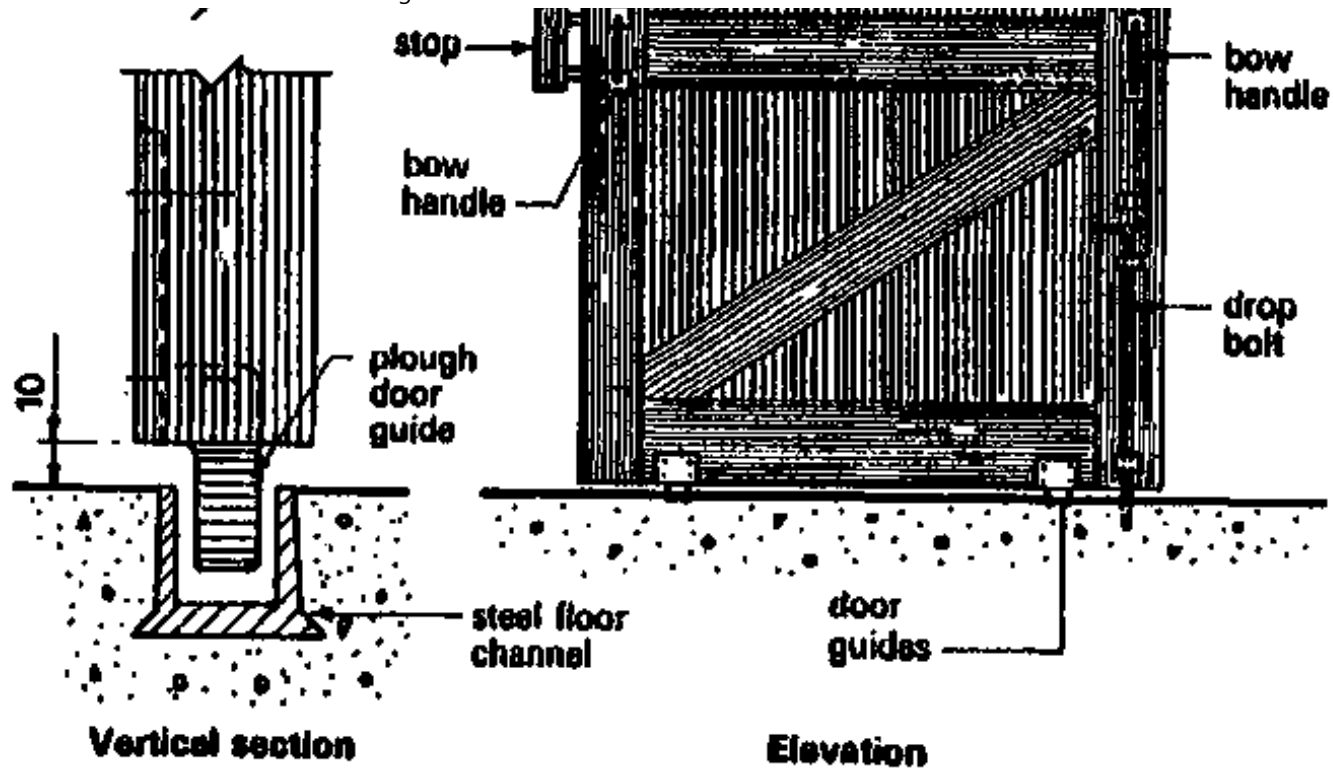

Typical straight door details (Hillaldam Coburn Ltd.)

**GEAR**



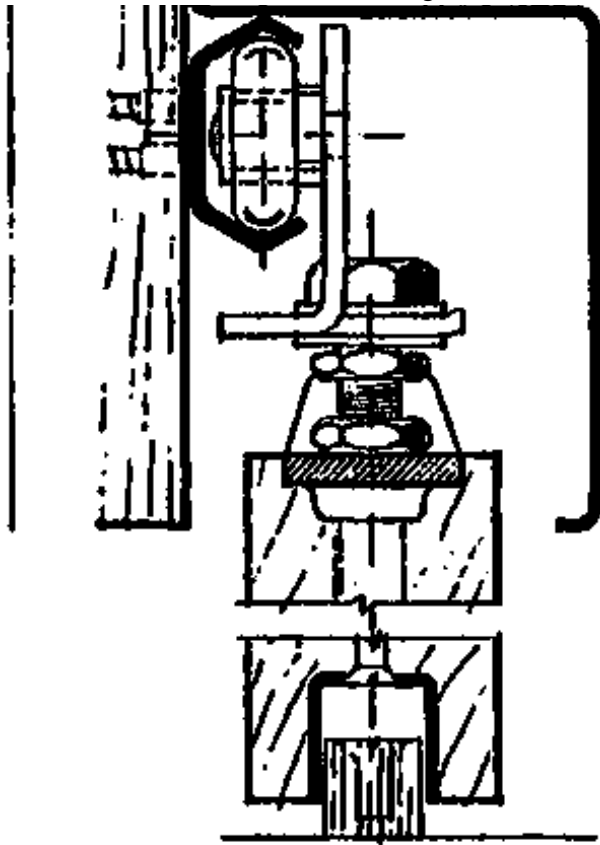

# ELEVATION

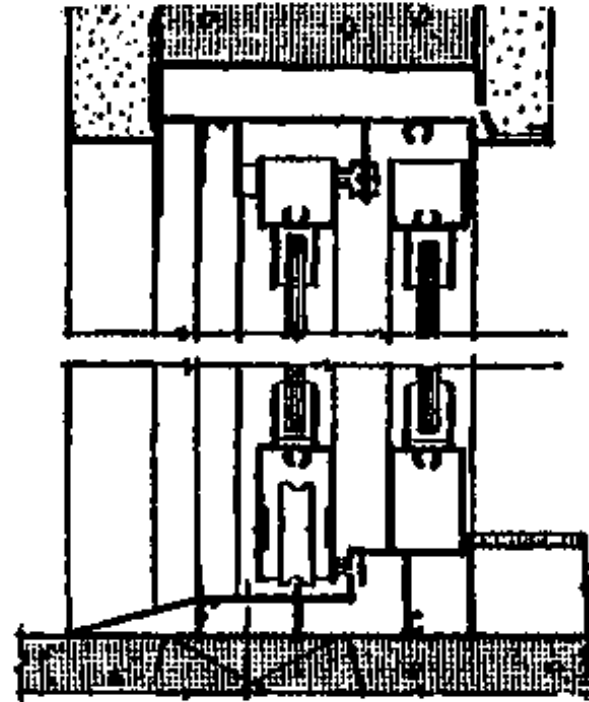

# VERTICAL SECTION

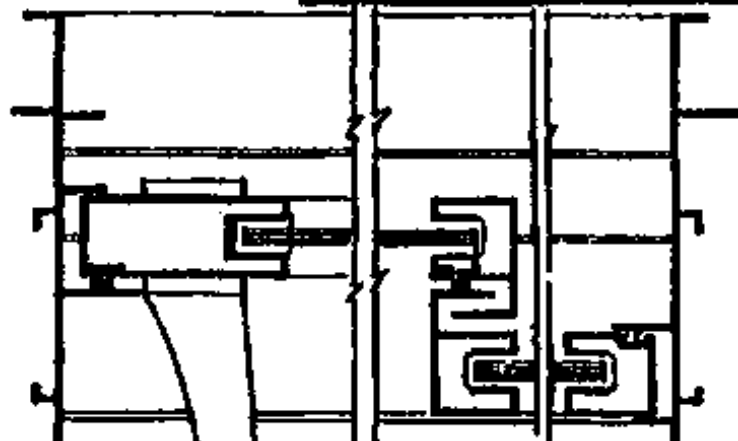

**HORIZONTAL SECTION**

**ALU. SLIDING DOOR DETAILS**

**FOLDING DOORS**

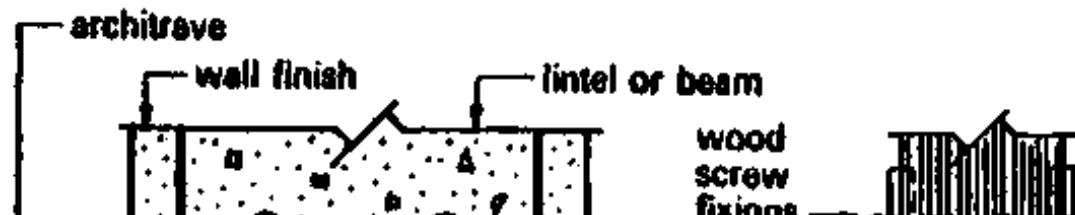
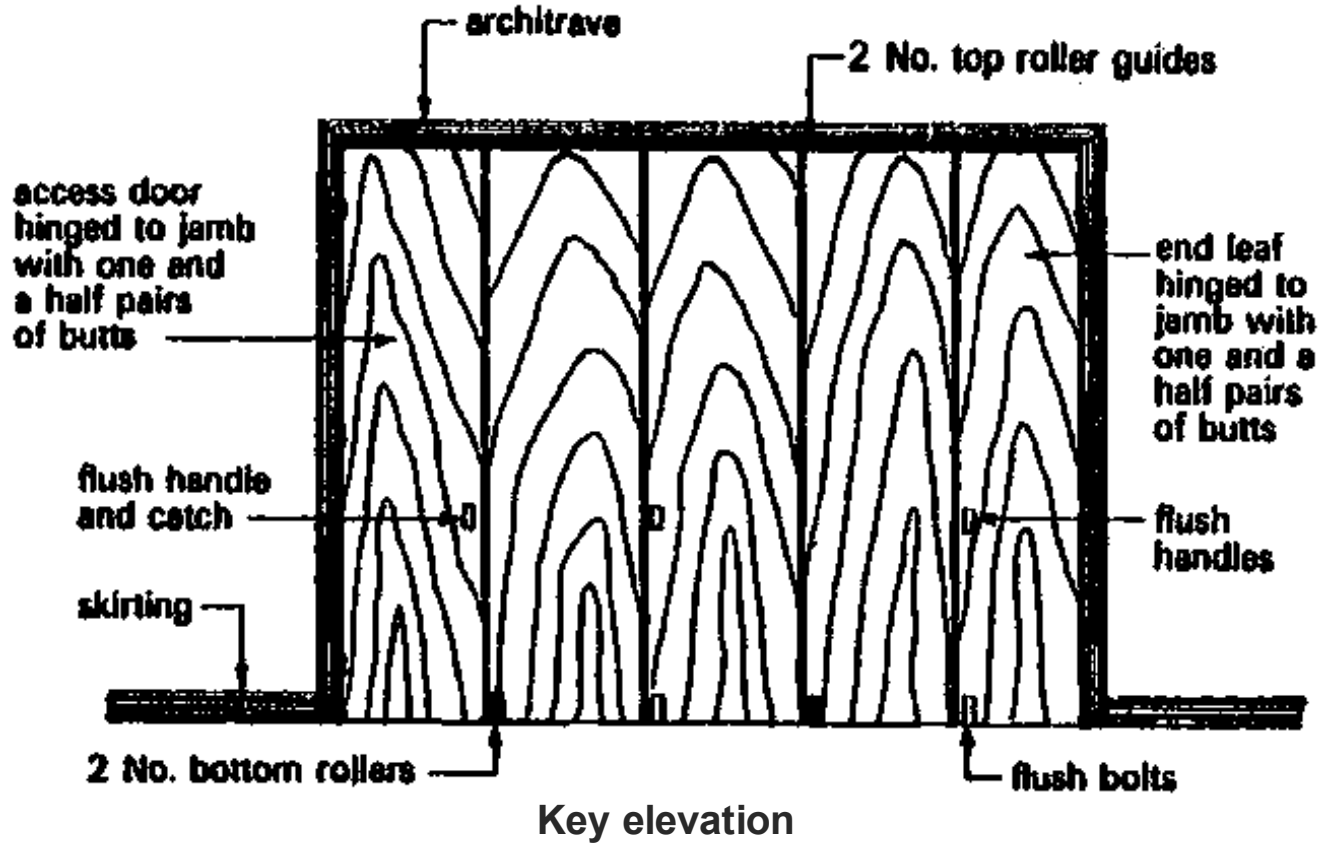

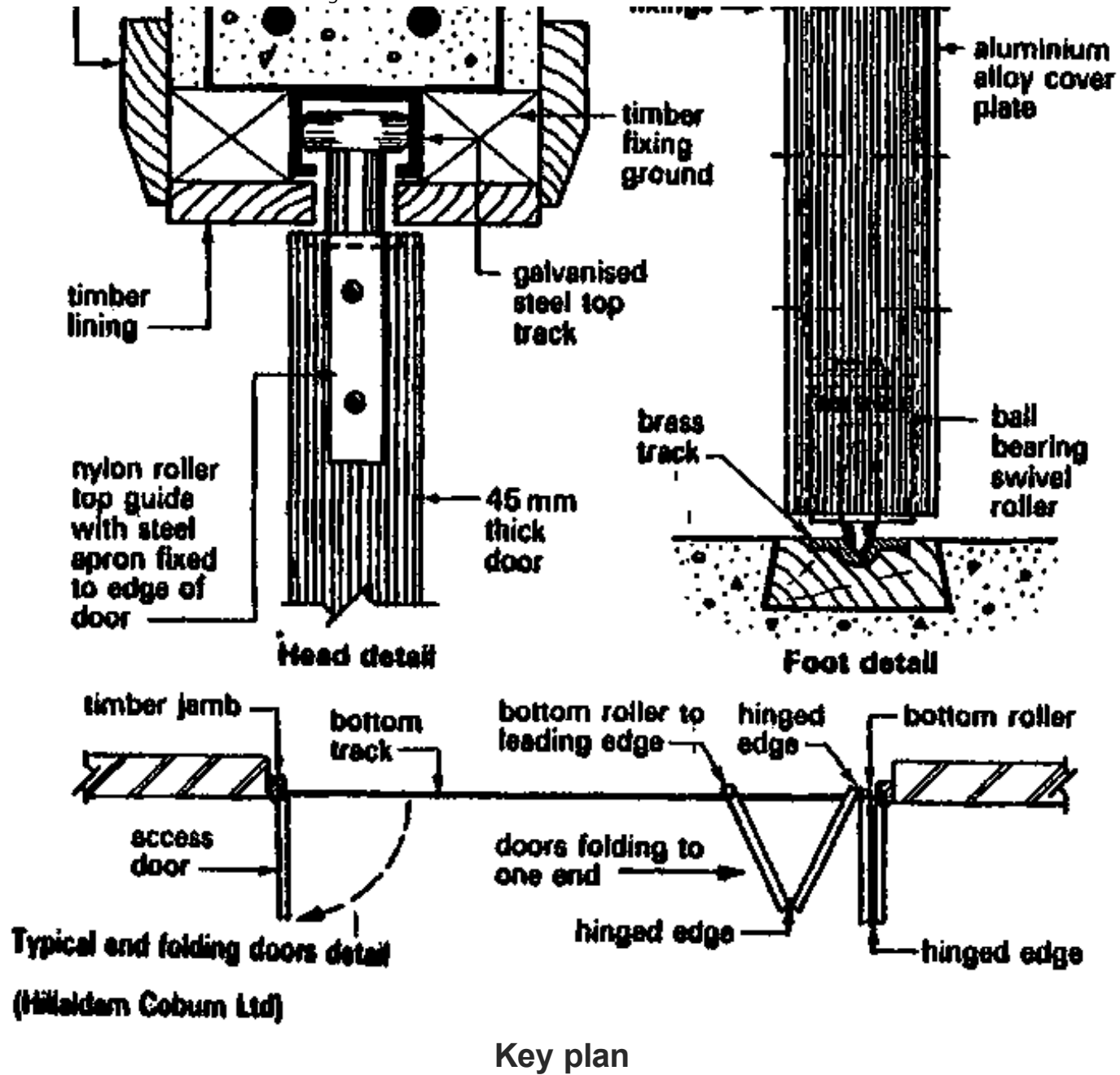

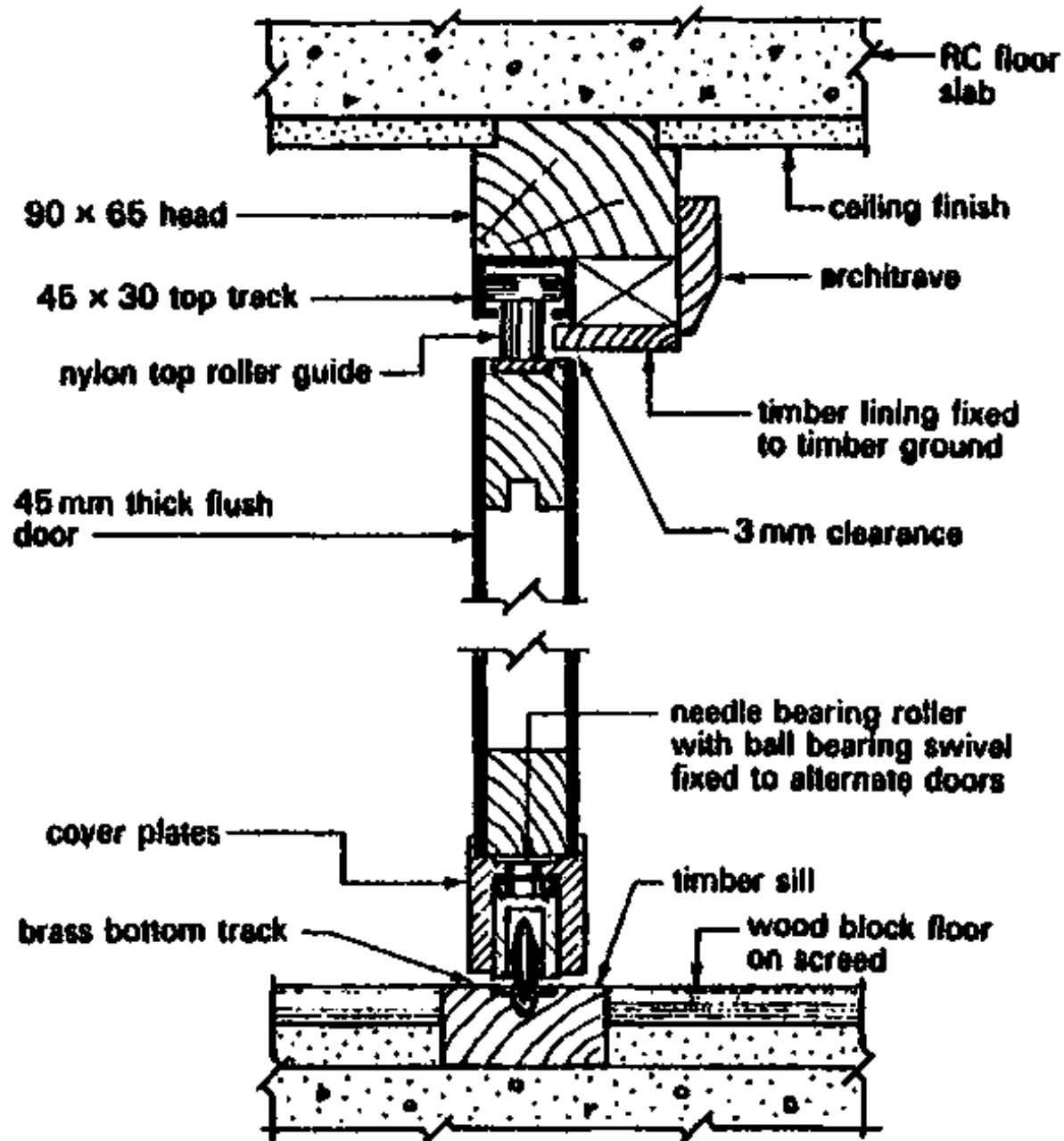

**Vertical section**

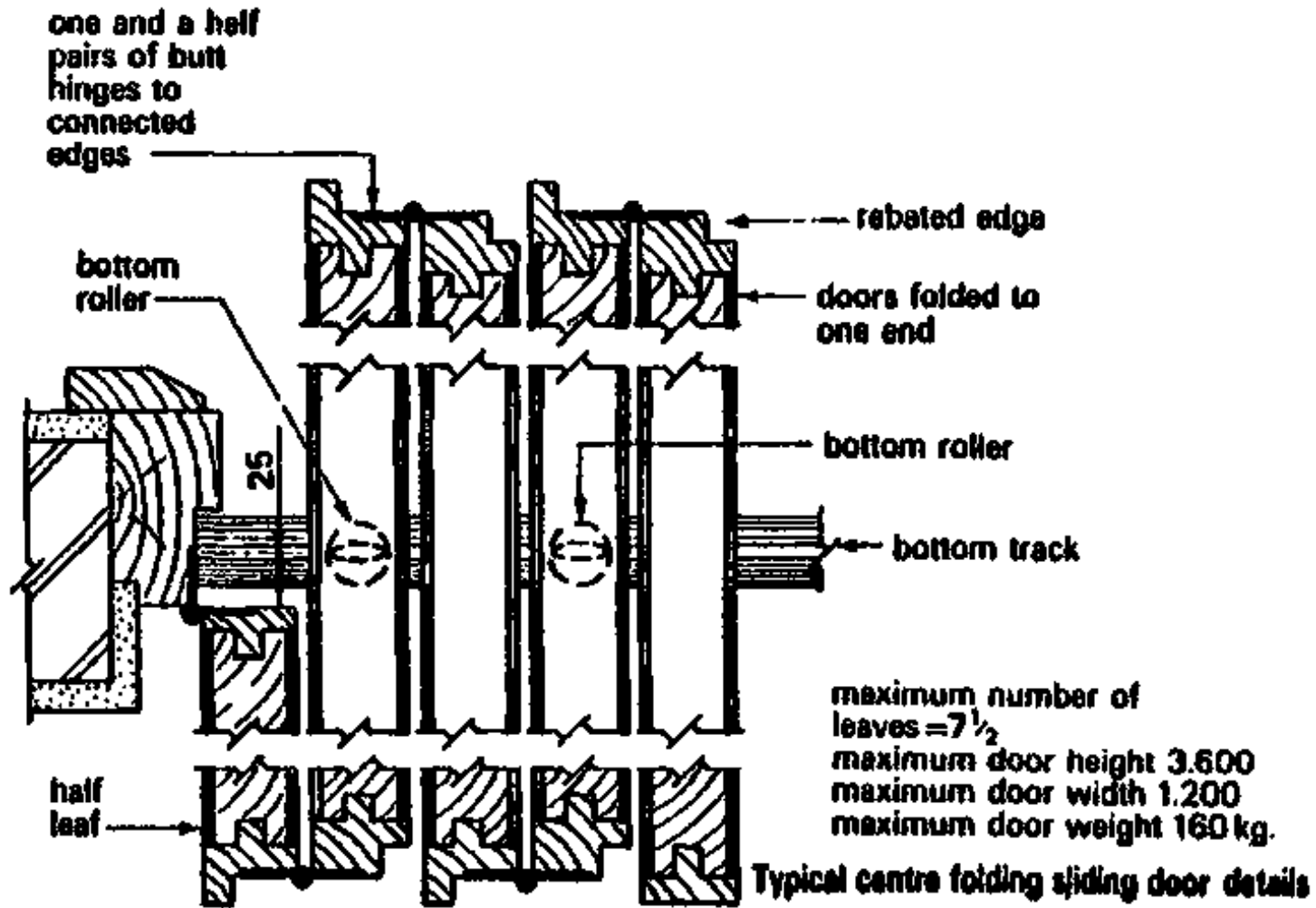

**(Hillaldam Coburn Ltd)**

**Horizontal section**

**14.2 WINDOWS, GLASS & GLAZING**

### **14.2.1 PRIMARY FUNCTIONS OF WINDOWS**

- **to provide a means for admission of natural daylight to the interior of a building.**
- **to provide a means of the necessary ventilation of buildings by including opening lights into the windows.**
- **A window not only provides daylight and ventilation, also a view at the external surroundings, which is vital for the occupants.**



**POSITION IN RESPECT OF WIDTH**

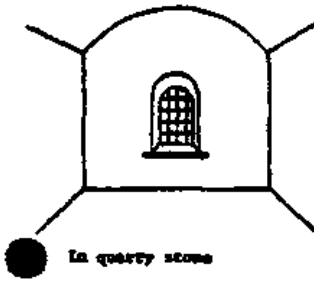

In quarry stone

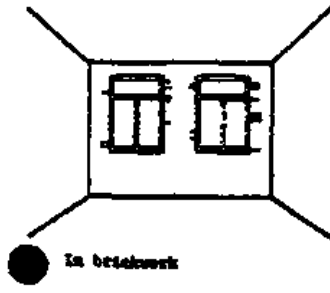

In brickwork

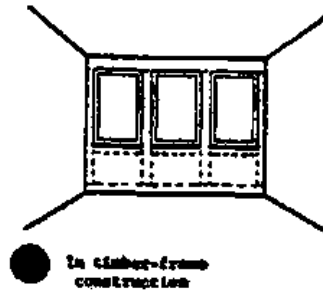

In timber-frame construction

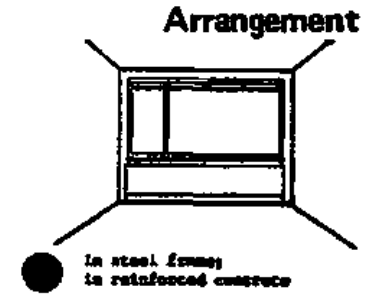

In steel frame or reinforced concrete

**Arrangement**

**POSITION IN RESPECT OF HEIGHT**

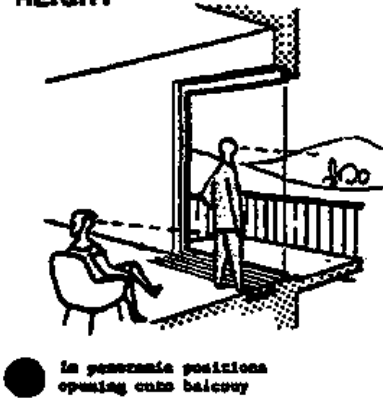

In panoramic positions opening onto balcony

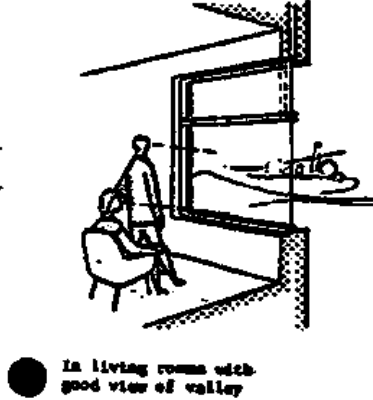

In living rooms with good view of valley

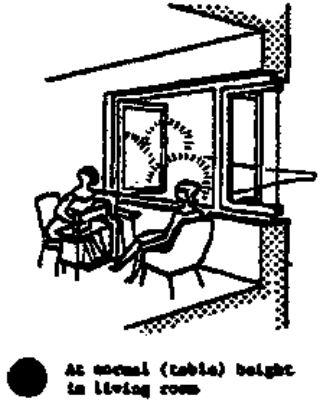

At usual (table) height in living room

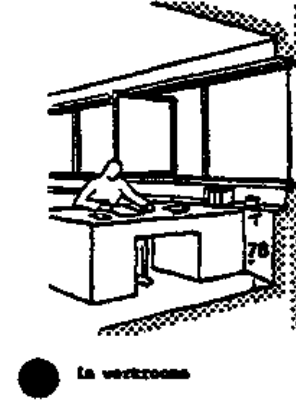

In workshops

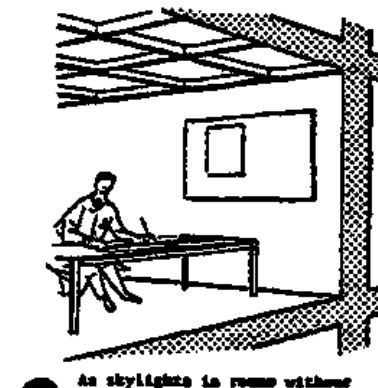
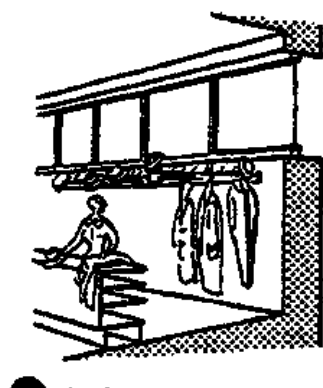

As skylights in rooms without windows

● in kitchens

● in offices (fitting)

● in cloakrooms

● external units (e.g. drawing offices)

## WINDOWS

- Windows, like doors, can be made from different materials (or a combination of these such as:
  - timber
  - metal and
  - plastic
- They can also be designed to operate in different ways by arranging for the sashes
  - to slide (vertically or horizontally)
  - to pivot (vertically hung, horizontally hung);
  - to swing, by being hung to one of the frame members.

This is known as a **CASEMENT WINDOW** and it is the most widely used type of windows.

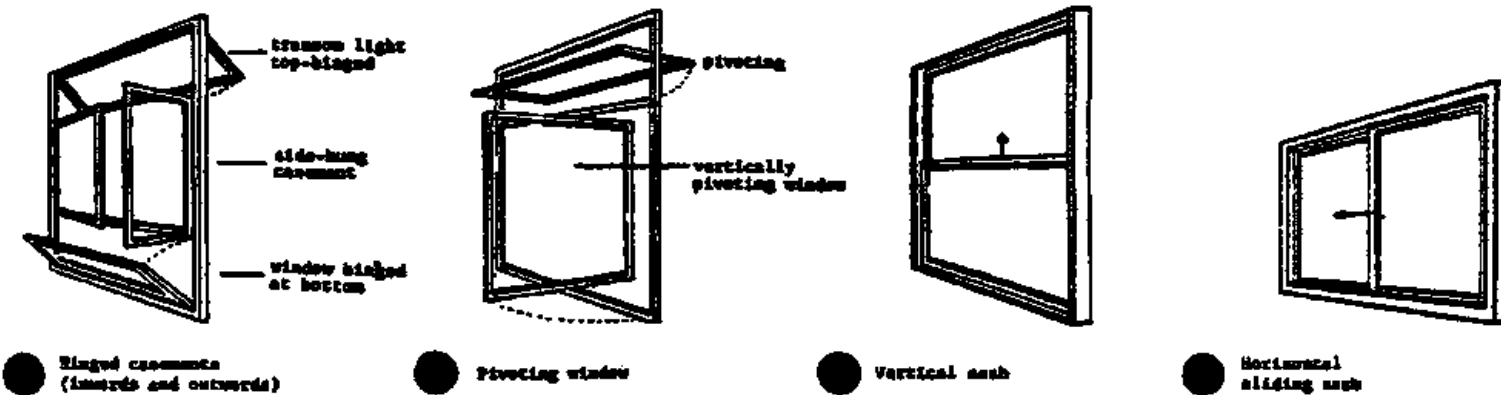

### TYPES OF OPENING

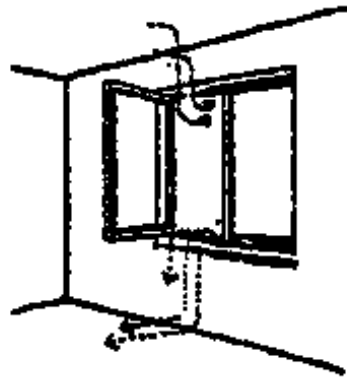

● Cold air falls into room, hot air escapes: draughts.

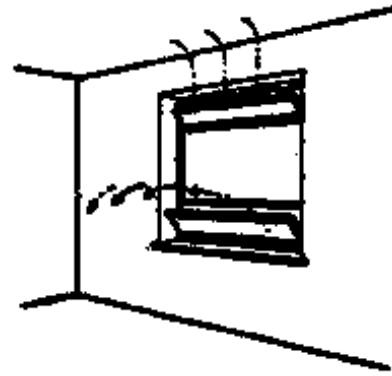

● Flaps improve ventilation

### VENTILATION

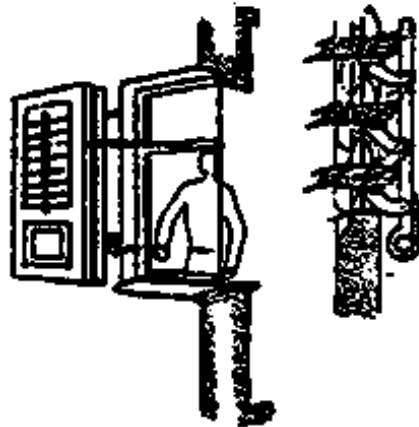

● Shutters controlled by handle from inside

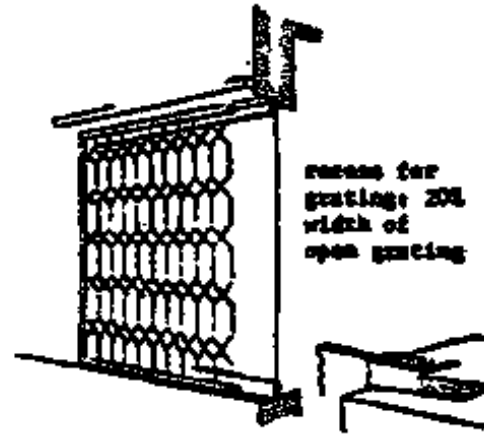

● Telescopic grating sliding in recesses

### PROTECTION AGAINST BREAK-IN

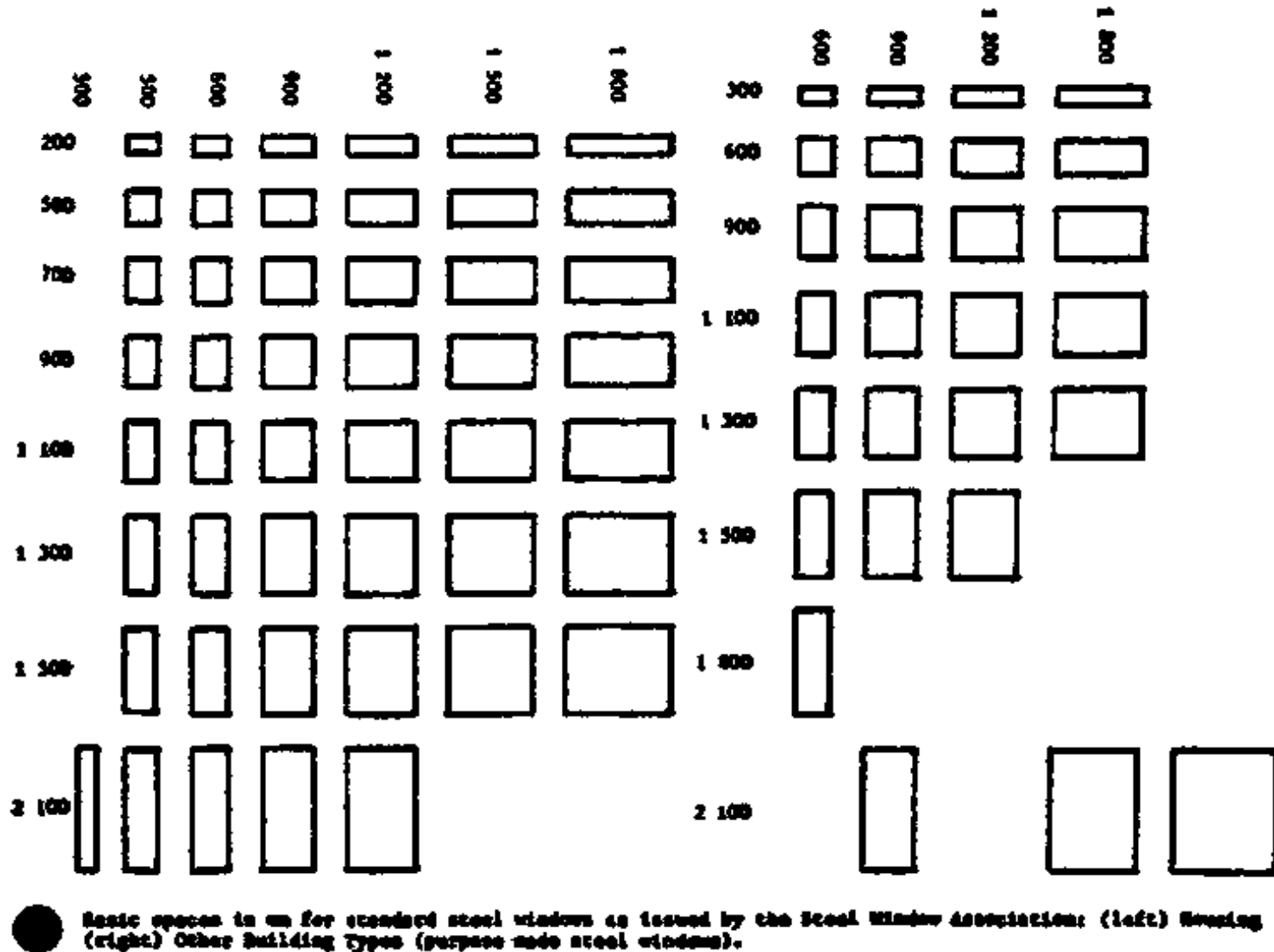

Window spaces

Modular basic spaces for steel windows have been established for UK by the Steel Window

**Association from matrices produced by BSI Functional Group Panel B/94/4/2 (External Envelope), with lengths of basic spaces conforming to BS 4011. There are two ranges of space sizes: 1 Housing (Standard Steel Windows): 2 Other Building Types (Purpose Made Steel Windows).**

## **14.2.2 BUILDING REGULATIONS**

- **Regulations K1, K2 and K3 deal with the daylight aspect of the windows.**
  - **These regulations require for an OPEN SPACE outside windows of habitable rooms (open to the sky and free from obstructions.**
  - **The minimum size of the open space is related to the height of the wall containing the window.**
  - **The height is measured from the lower window level (= actual or a min. of 1.2 m above the floor to the top of the wall (1. Soffit of a flat roof; 2. lowest part of the eaves for a pitched roof; 3. the top of a parapet, whether the roof is flat or pitched).**
- **BR K4 deals with the VENTILATION OF HABITABLE ROOMS. (For the purpose of this regulation, a room used i.e. for a kitchen is classified as a habitable room) A HABITABLE ROOM must have ventilation openings (unless it is adequately ventilated by mechanical means.**
- **Constructional by-laws require windows equal to at least 1/10th of the area of the floor of the room.**
- **There is no definition in the B.R. of adequate mechanical means, but it is generally recommended:**
  - **Three or four air changes per hour would be a reasonable ventilation standard.**

- **Ventilation opening = any part of a window or hinged panel, adjustable louvre etc. which opens directly to the open air. (excluded are openings associated with a mechanically operated system. = a door (if it opens directly to the external air) can be defined as a ventilation opening if it has an opening ventilator with an area of not less than 10 000 mm<sup>2</sup> or if it is situated in a room which contains one or more ventilation openings whose total area is not less than 10 000 mm.**
  
- **The basic requirements for ventilation openings are:**
  1. **Total area of the ventilation opening (or openings) must exceed 1/20th of the floor area of the room it serves.**
  
  2. **Some part of the ventilation opening must be not less than 1,75 m above the floor level.**
  
  3. **Rooms with an enclosed veranda must have vent. opening whose total area is not less than 1/20th of the combined floor areas.**
  
  4. **Any larder must be ventilated to the external air and if this is achieved by using windows they must have ventilation openings whose total area is not less than 85 000 mm and must be fitted with a durable fly-proof-screen.**

## **Windows and zones of open space - B. Reg. K1**

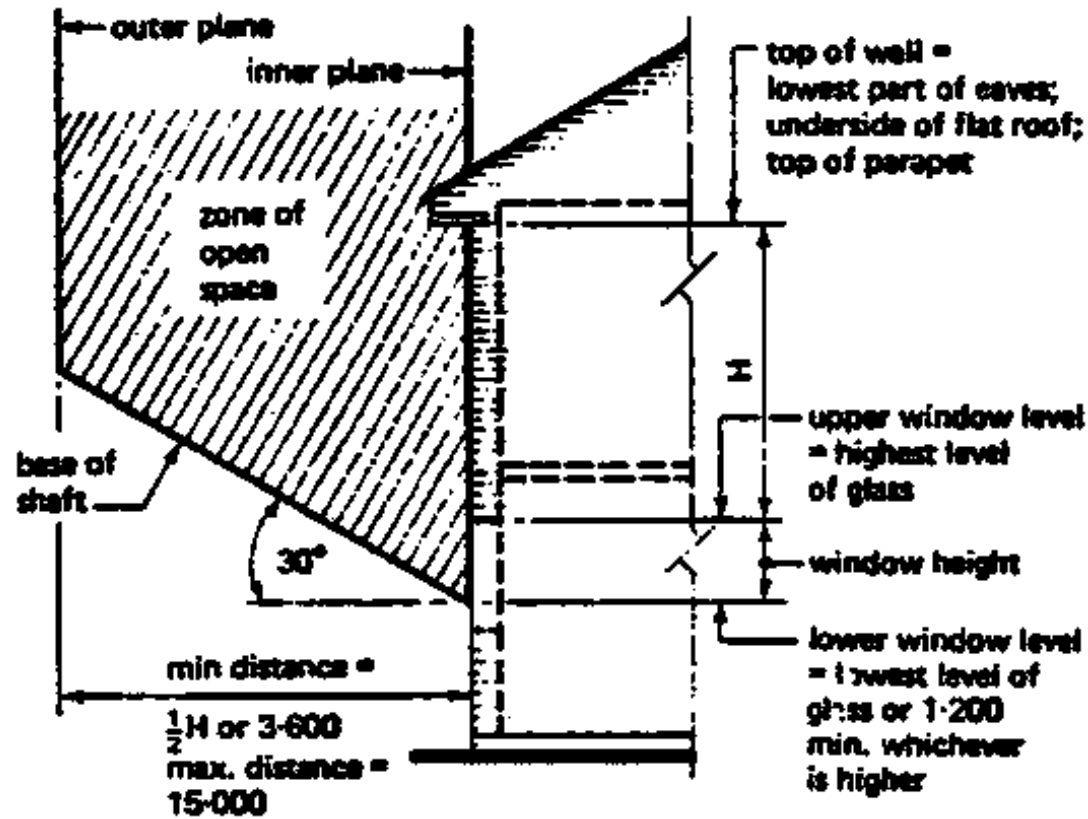

Vertical plane requirements

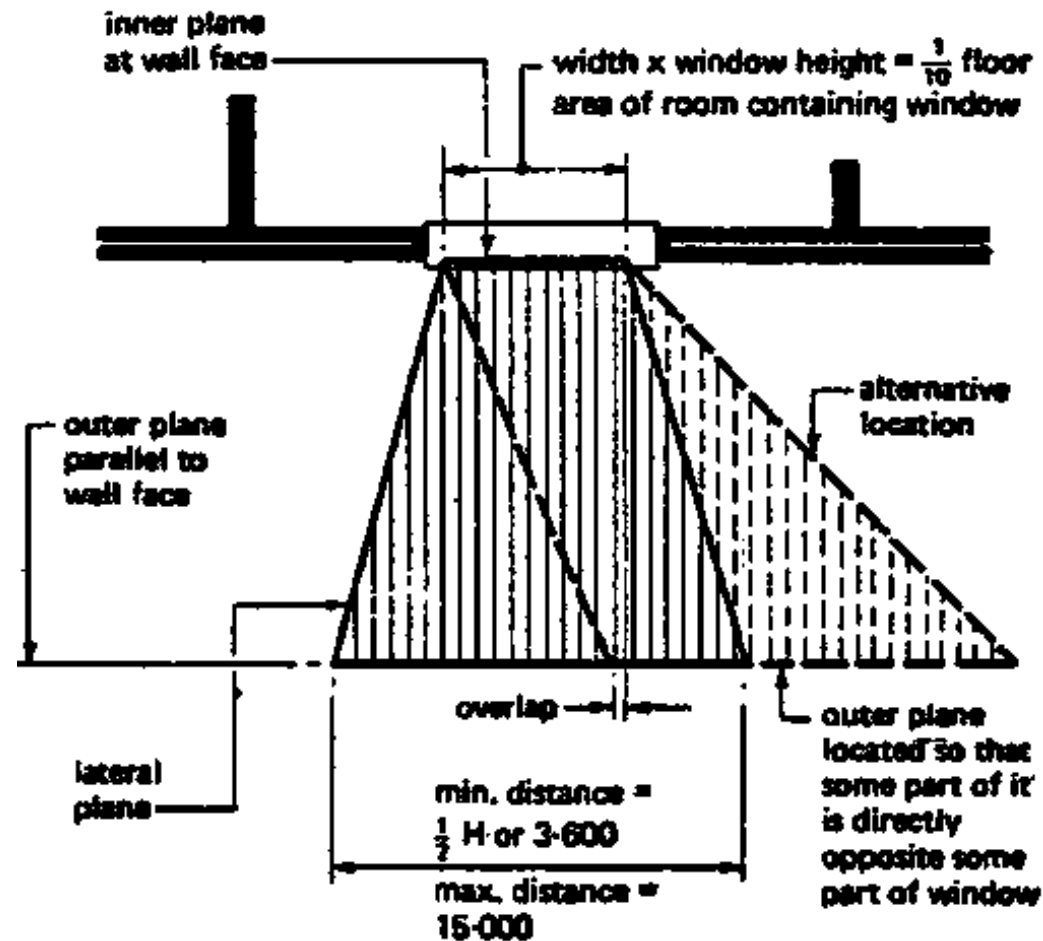

Horizontal plane requirements

### 14.2.3 TRADITIONAL CASEMENT WINDOWS

- A wide range of designs can be produced by using various combinations of the members. A limiting factor is the size of glass pane relevant to its thickness.



- **The general arrangement of the framing is important:**
  - heads and sills always extend across the full width of the frame (and in many cases have projecting horns for building into the wall)
  - jambs and mullions span between the head and sill; these are joined to them by a wedged or pinned mortise and tenon joint.
- **This arrangement gives maximum strength since the vertical members will act as struts. It will also give a simple assembly process.**
- **The traditional casement window frame has deep rebates to accommodate the full thickness of the sash (= term for the framing of the ventilator). If fixed glazing or lights are required it is necessary to have a sash frame surround to the glass since the depth of rebate in the window frames is too great for direct glazing to the frame.**

### Traditional timber casement window

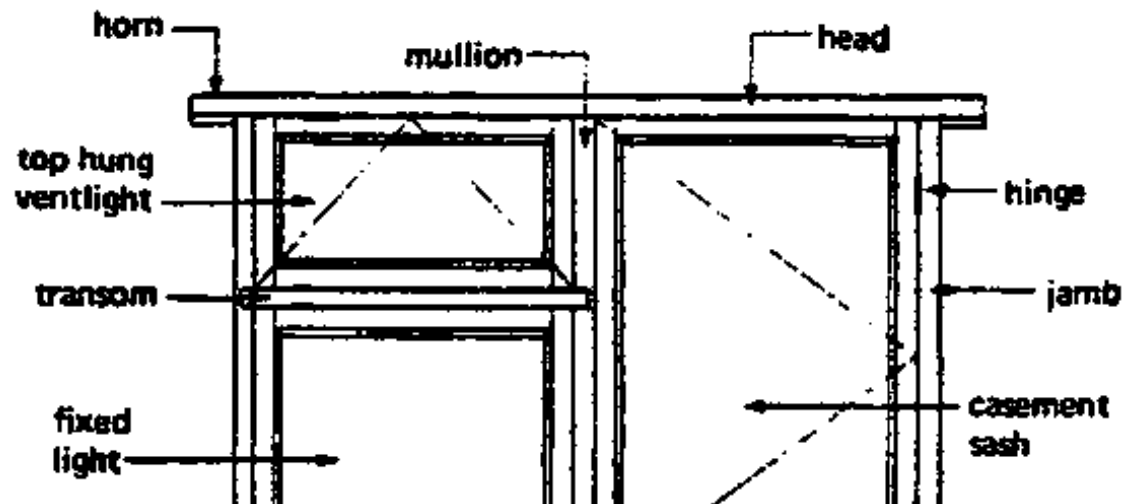



External Elevation

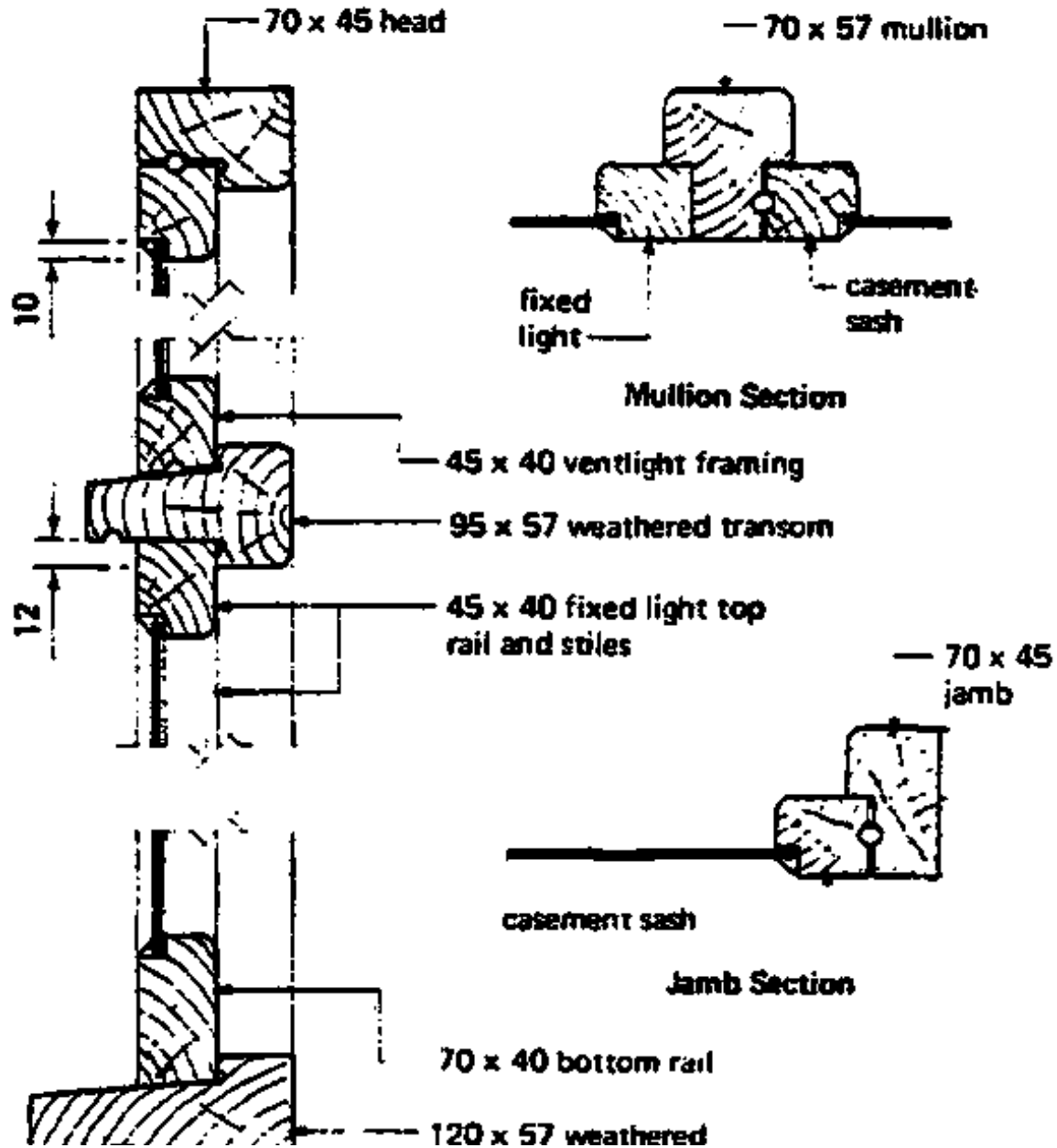



**hardwood still**  
**Vertical Section**

#### **14.2.4 STANDARD WOOD CASEMENT WINDOWS**

- **B.S. 644, Part I, gives details of the**

- **quality**
- **construction and**
- **design of a wide range of wood casement windows.**

- **Frames, sashes and ventlights are made from standard sections of soft wood timbers arranged to give a variety in design and size.**

- **Sashes and ventlights are designed so that their edges rebate over the external vace of the frame to form a double barrier to the entry of wind and rain.**

**The general construction is similar to that described for traditional casement windows and the fixing of the frame into the walls follows that described for door frame.**

- **Most joinery manufacturers produce a range of modified standard casement windows following the basic principles set out in BS 644 but with improved head, sill and sash sections.**

- **The range produced is based on a module for basic spaces of 300 mm giving the following lengths (in mm): 600; 900; 1200; 1800; 2400**

- **Frame heights follow the same pattern with the exception of one half module (in mm): 600; 900; 1050; 1200; 1500.**

- Window types are identified by a notation of figures and letters, i.e.: 4 C V 30 where

4 = four width modules =  $4 \times 300 \text{ mm} = 1200 \text{ mm}$

C = casement

V = ventlight

30 = three height modules =  $3 \times 300 \text{ mm} = 900 \text{ mm}$

### Typical modified BS casement window

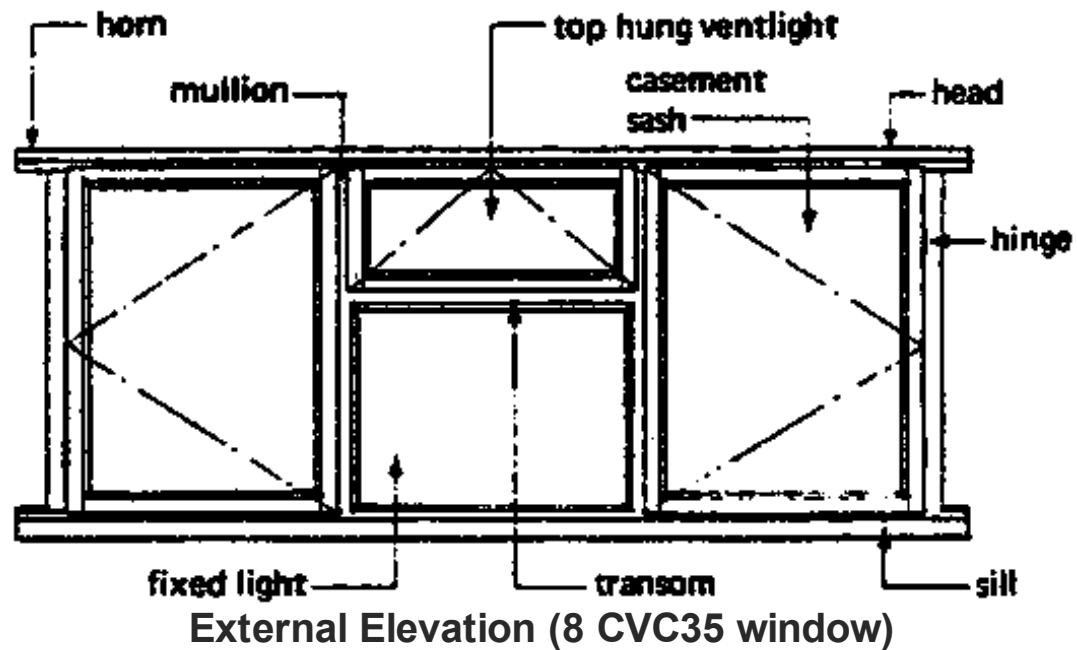

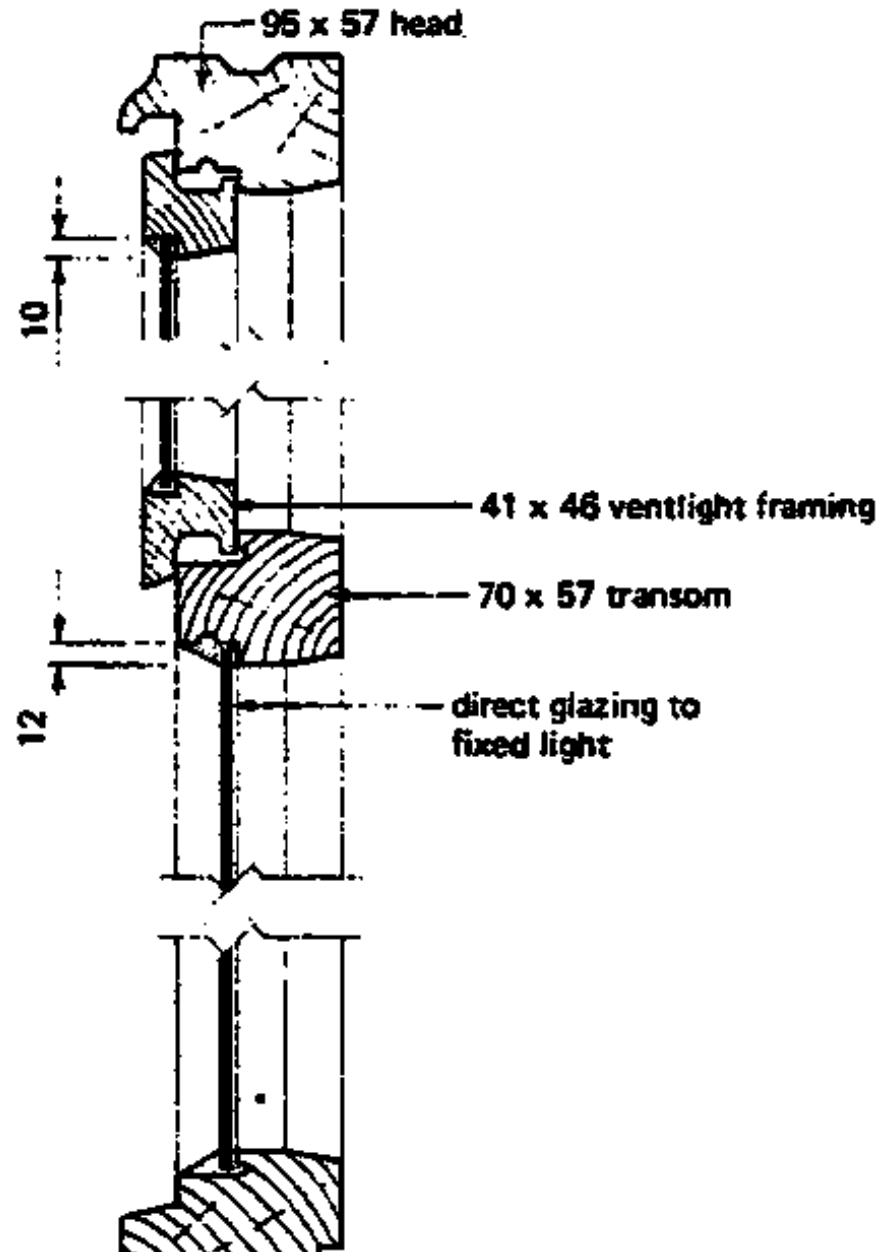

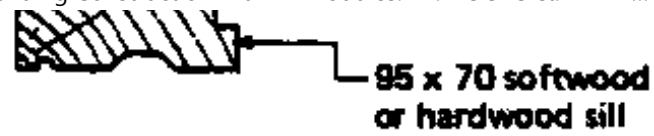

Mullion Section

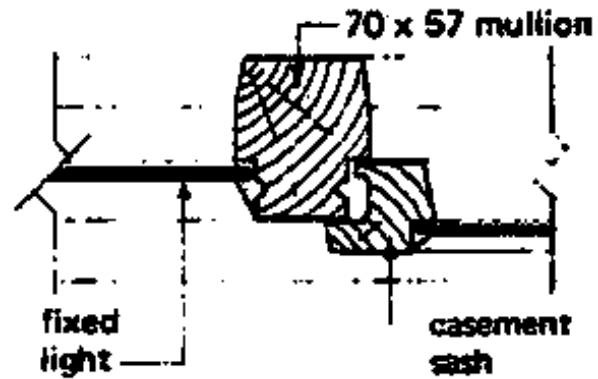

Vertical Section

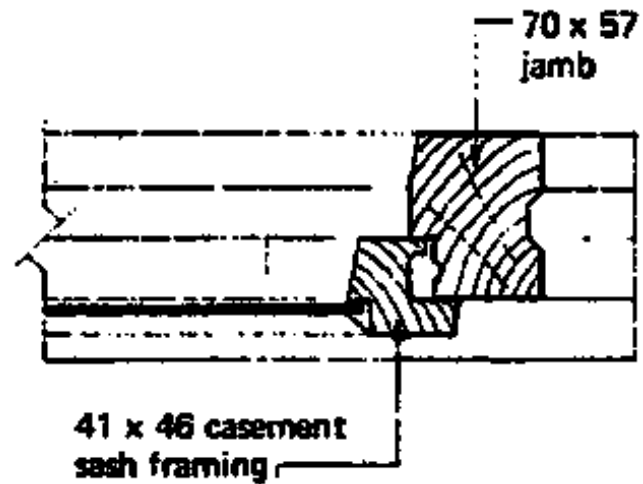

Jamb Section

## 14.2.5 STEEL CASEMENT WINDOWS

- B.S. 990 gives details of construction, sections, sizes, composites and hardware.

- **The standard range covers**

- **fixed lights**

- **hung casements**

- **pivot casements and**

- **doors.**

- **The lengths, in the main, conform to the basic space first preference of 300 mm giving the following range (in mm) 500; 600; BCD; 900; 1200; 1500; 1800.**

- **Frame heights are based upon basic spaces for the preferred head and sill heights for public sector housing giving the following sizes (in mm): 200; 500; 700; 900; 1100; 1300; 1500.**

- **Steel windows (like wood windows) are identified by a notation of numbers and letters:**

- **Prefix number × 100 = basic space length**

- **code letters:**

- F = fixed light**

- C = side hung casement opening out**

- V = top hung casement opening out and extending full width of frame**

- T = top hung casement opening out and extending less than full width of frame.**

- B = bottom casement opening inwards**

- S = fixed sublight**

- **suffix number: × 100 = basic space height**

- **suffix code:**

R.H = right - hand casement as viewed from outside  
L.H = left-hand casement as viewed from outside.

### Typical BS 990 steel window

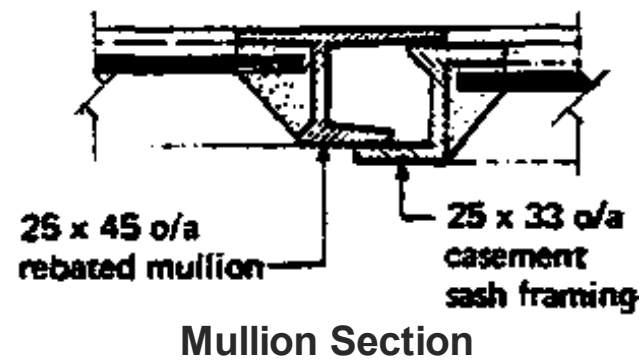
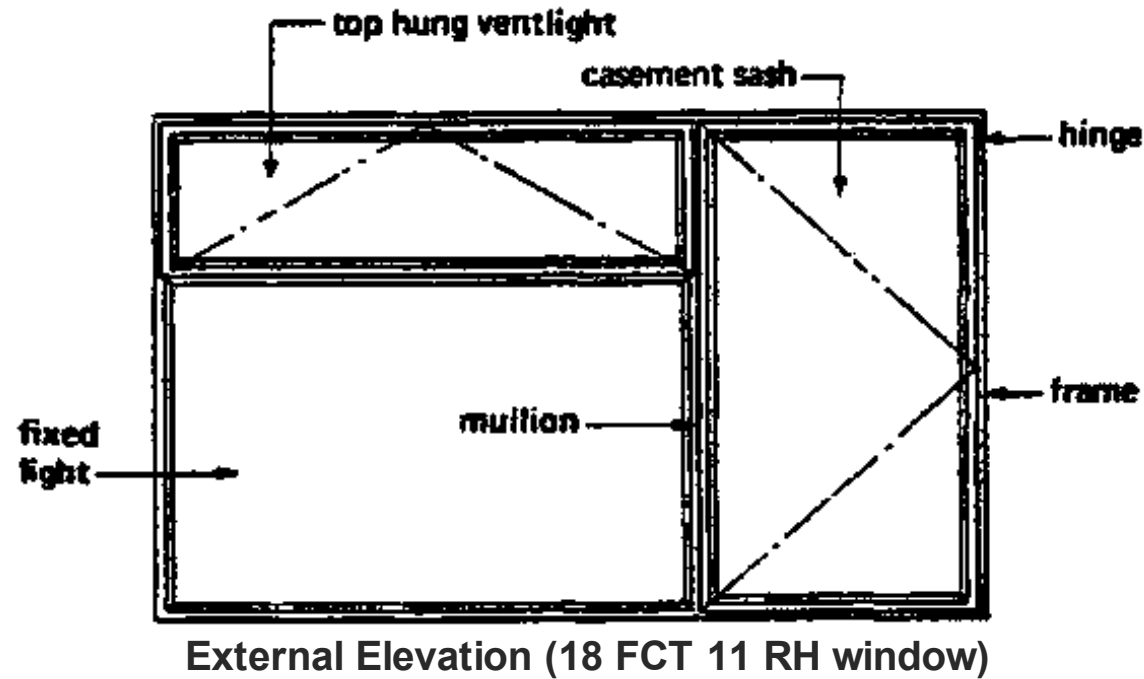



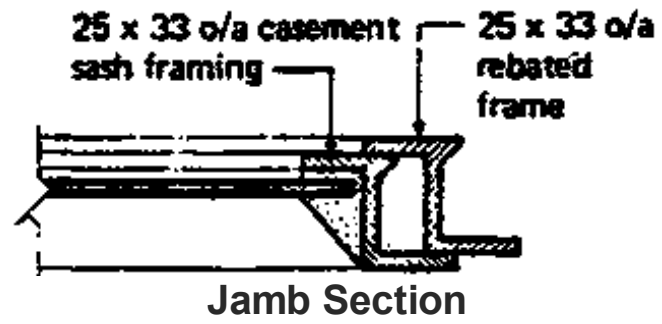

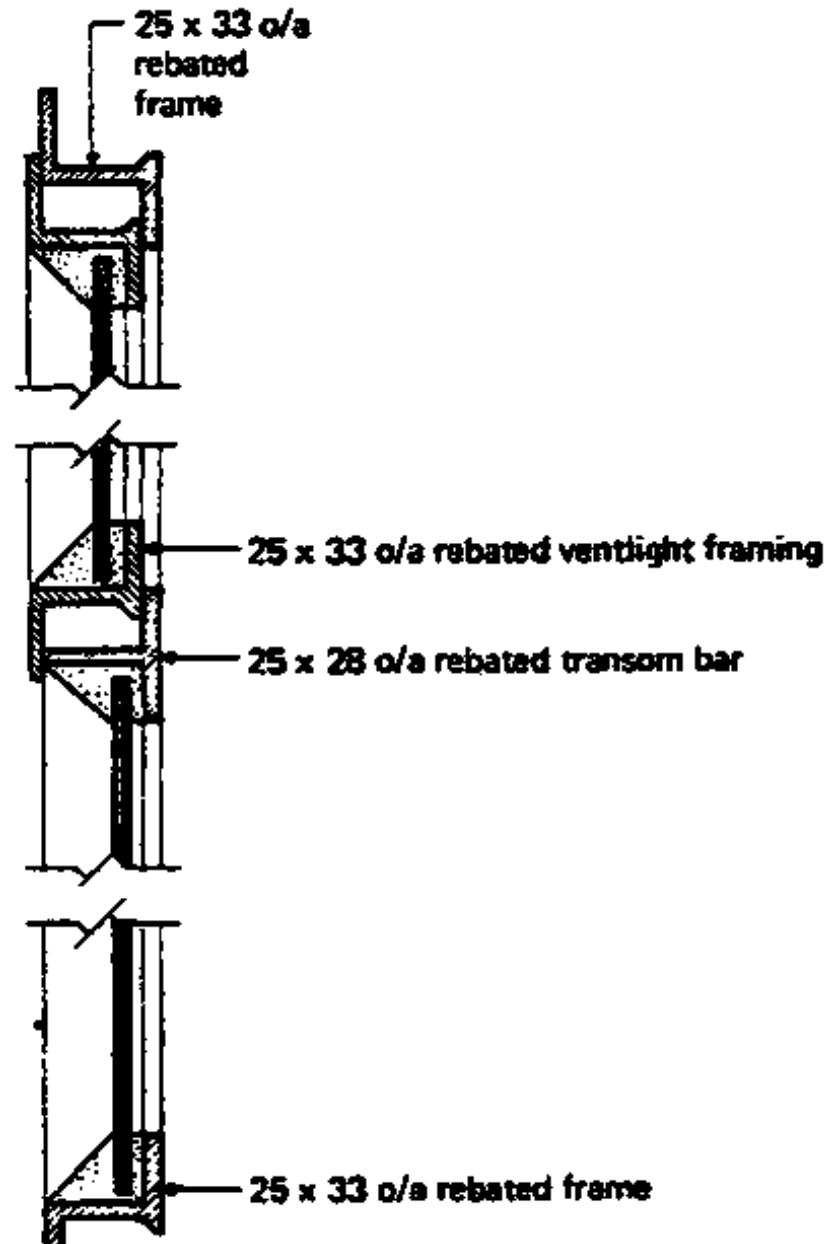



## Vertical Section

- **The basic range of steel windows can' be coupled together to form composite frames by using TRANSOM and MULLION coupling sections without increasing the basic space module of 100 mm - The actual size of a steel frame can be obtained by deducting the margin-allowance of 6 mm from the basic space size.**
- **All the frames are made from basic rolled steel sections. which are mitred and welded at the corners to form right-angles;**
  - **internal bars are tenoned and rivetted to the outer frame and to each other.**
  - **the completed frame receives a hot dip galvanised protective finish after manufacture and before de-livery.**
- **Steel windows can be fixed into an opening by a number of methods such as:**
  - **using a wood surround which is built into reveals and secured with fixing ties or cramps. The wood surround will add 100 or 50 mm to the basic space size in each direction using either a nominal 75 × 75 mm or 50 × 75 mm timber section.**
- **Advantage of steel windows**
  - **larges glass area (due to smaller frame sections)**
- **Disadvantage of steel windows:**

- condensation, which can form on the frames because of the high conductivity of the metal members.

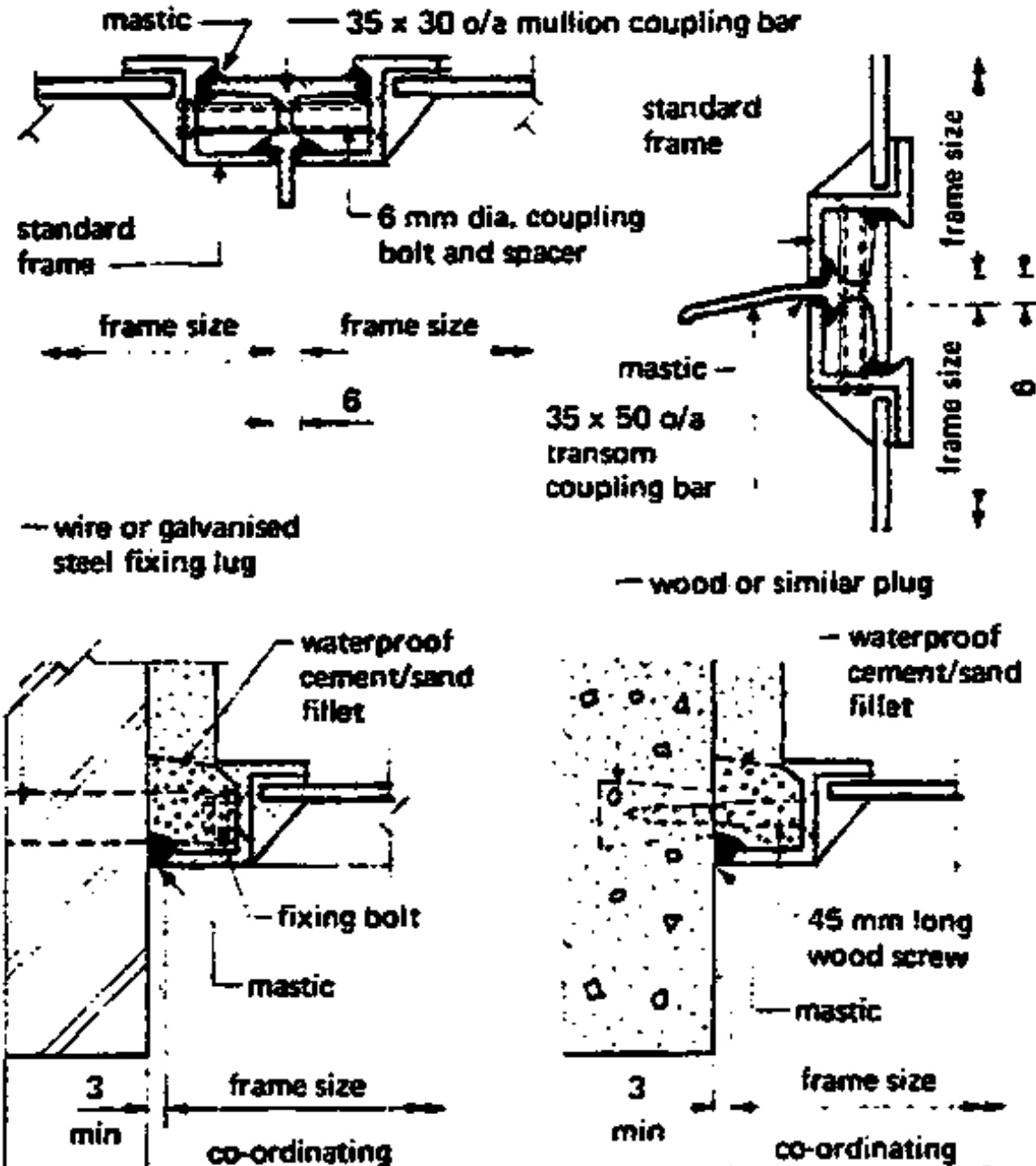

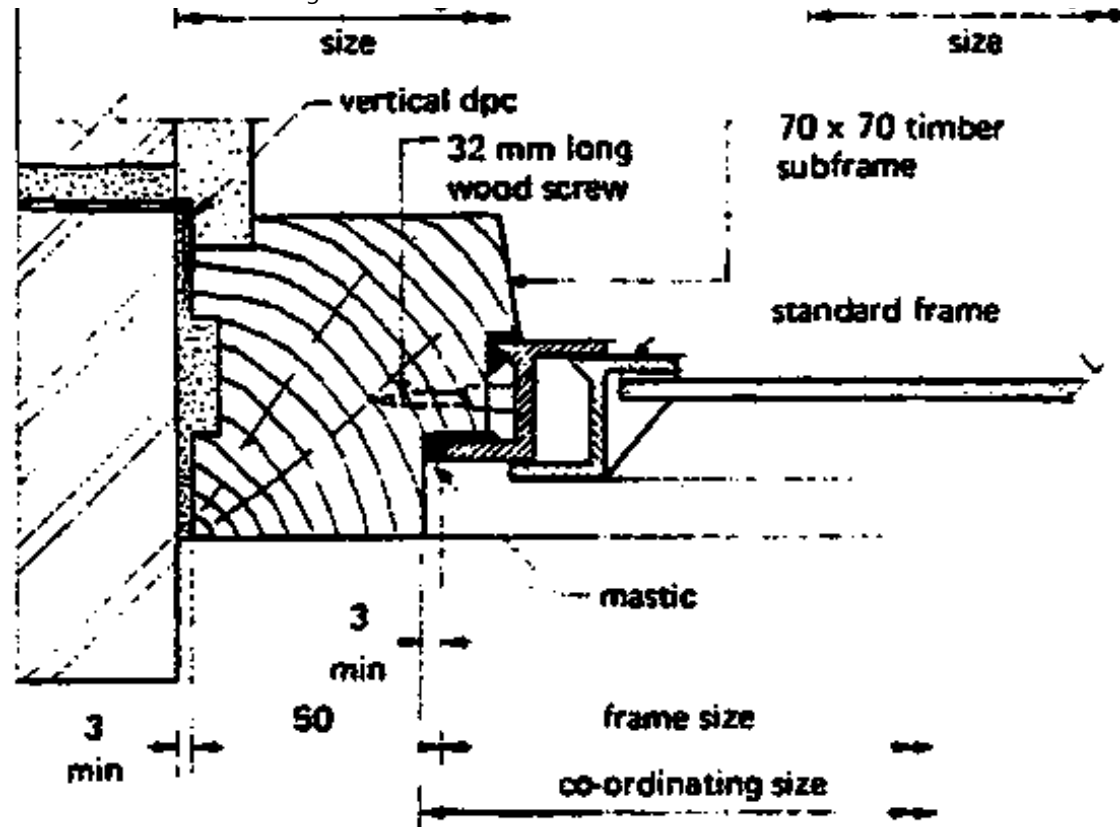

Steel window couplings and fixings

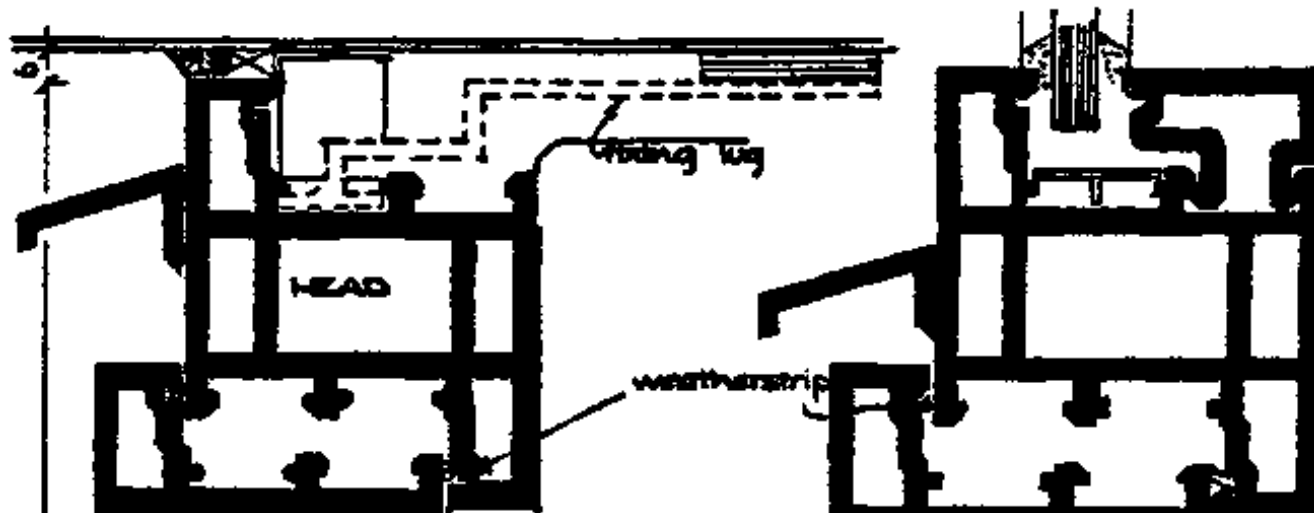

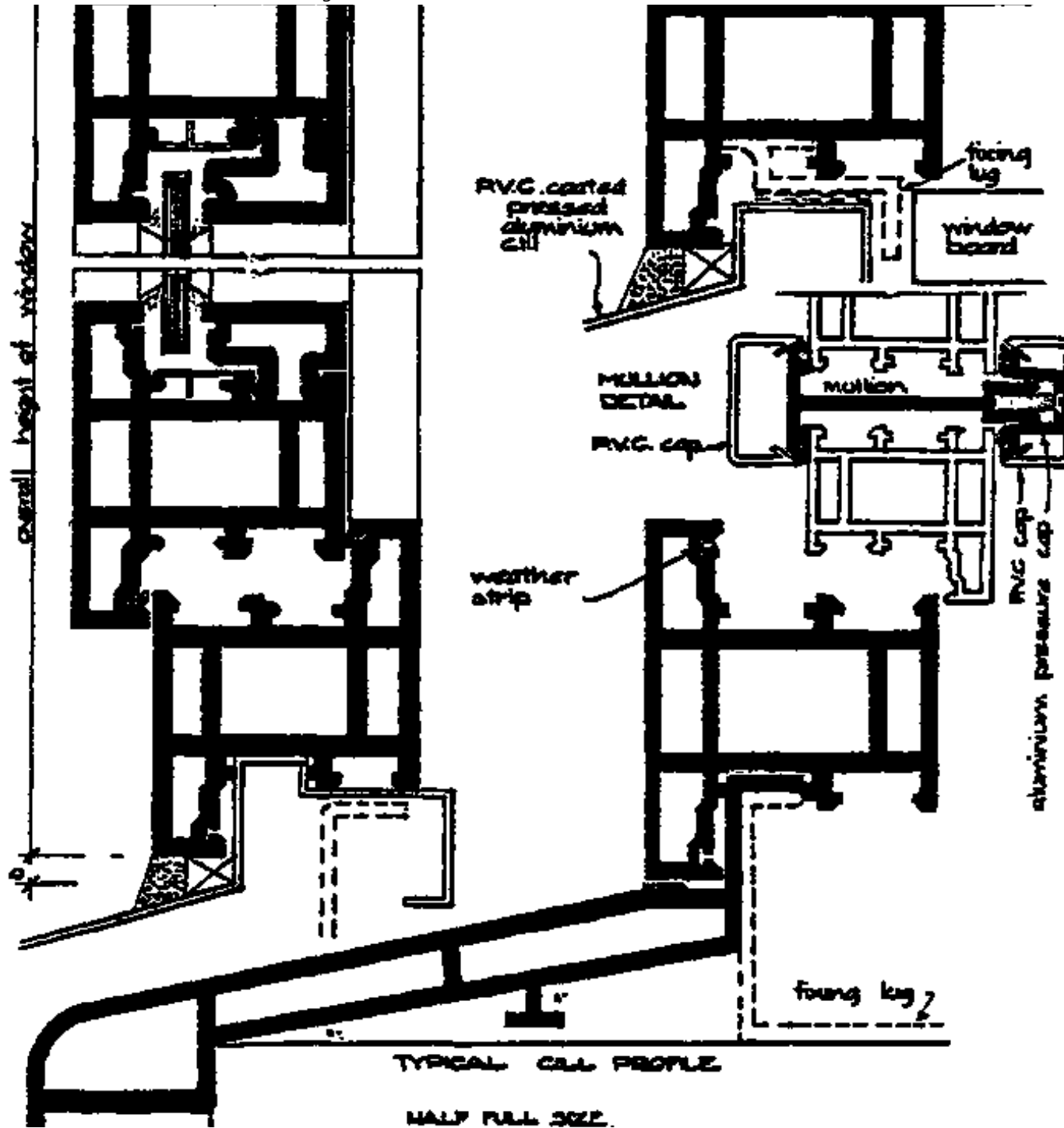

## PLASTIC CASEMENT WINDOWS

**Plastic windows.** Unplasticized polyvinyl chloride (U.P.V.C.) is now in demand for all types, including horizontal and vertical sliders, particularly in modern housing development. Glass is secured in position with rigid P.V.C. slip-on beads. Double-glazing units, up to 24 mm thick, can also be accommodated. Single units can be coupled together using mullions and transoms, as with other types. The profiles are normally supplied in light grey or white, Fig.

**Glass-reinforced polyester resin (G.R.P)** is also used in window manufacture. It has excellent weathering properties and is impervious to insect and fungal attack.

### 14.2.6 BAY WINDOWS

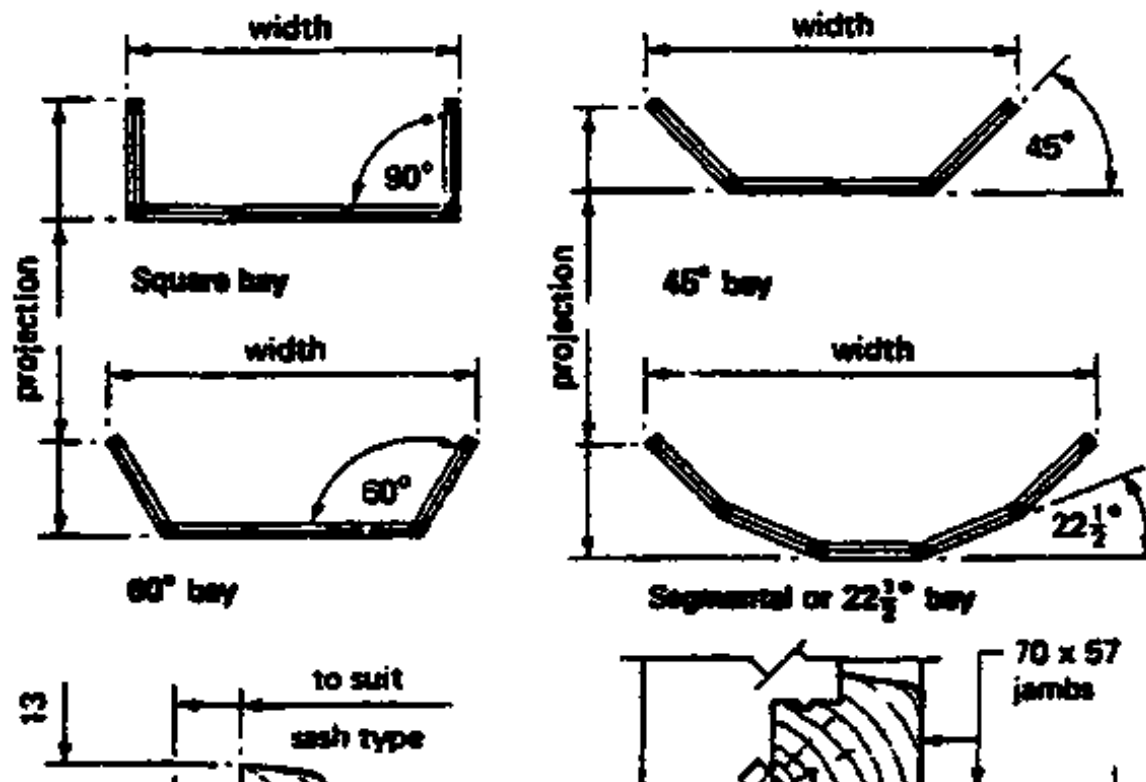

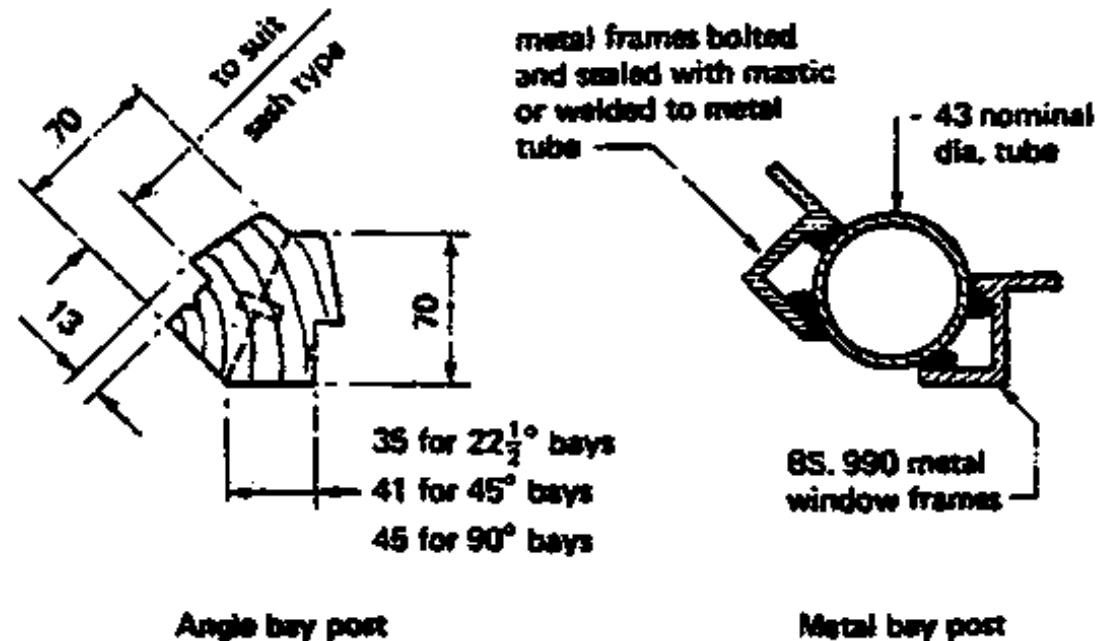
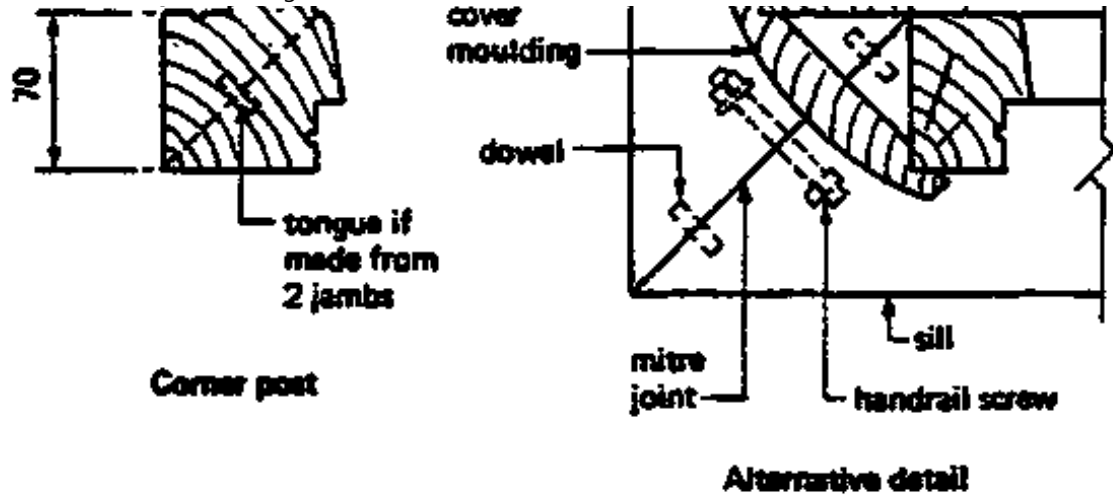

Bay window types and corner posts

= any window which projects in front of the main wall line.

- various names are given to various plain lay layouts (ref. to fig.) - Bay windows can be constructed of



timber, and/or metal and designed with

- casement or
- sliding sashes:

- the main difference in detail is the CORNER POST, which can be made from the solid, jointed or masked in the case of timber and tubular for metal windows.

- Any roof treatment can be used to cover in the projection and weather seal it to the main wall

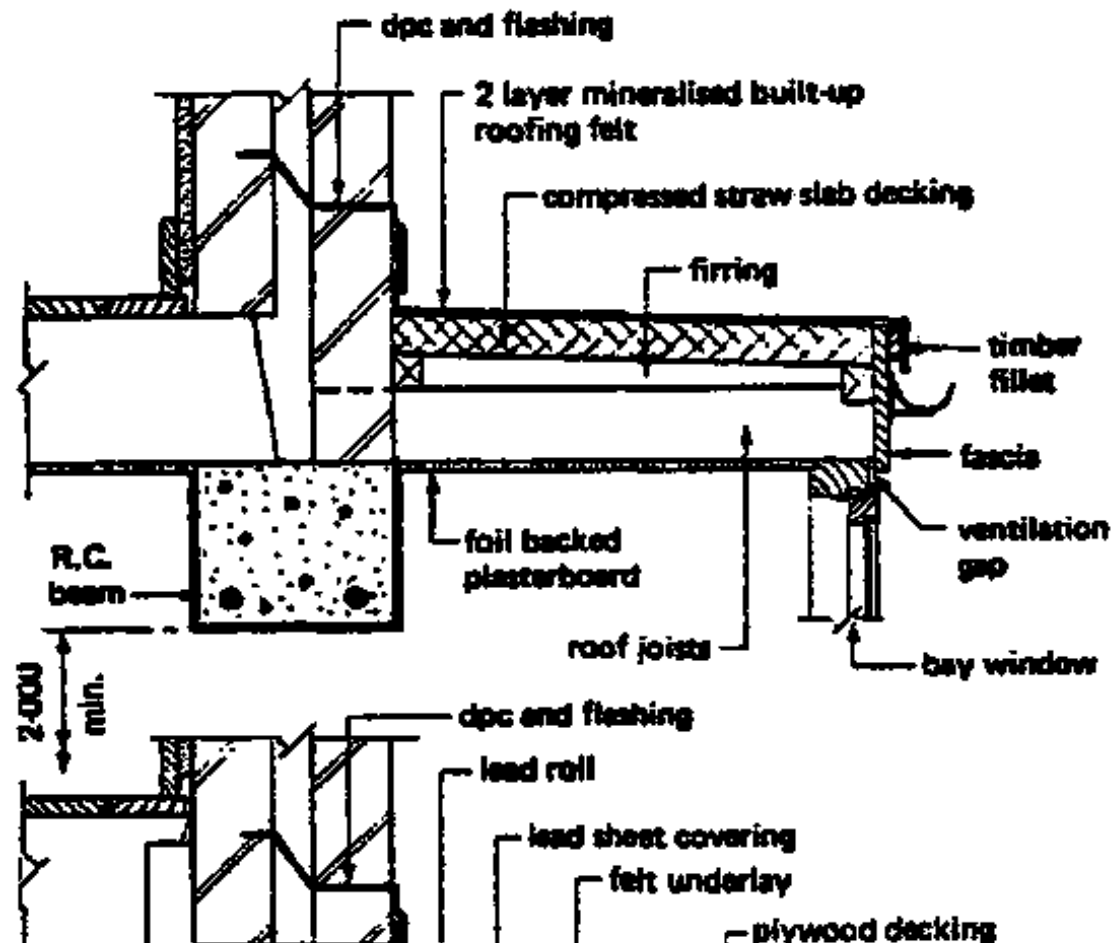

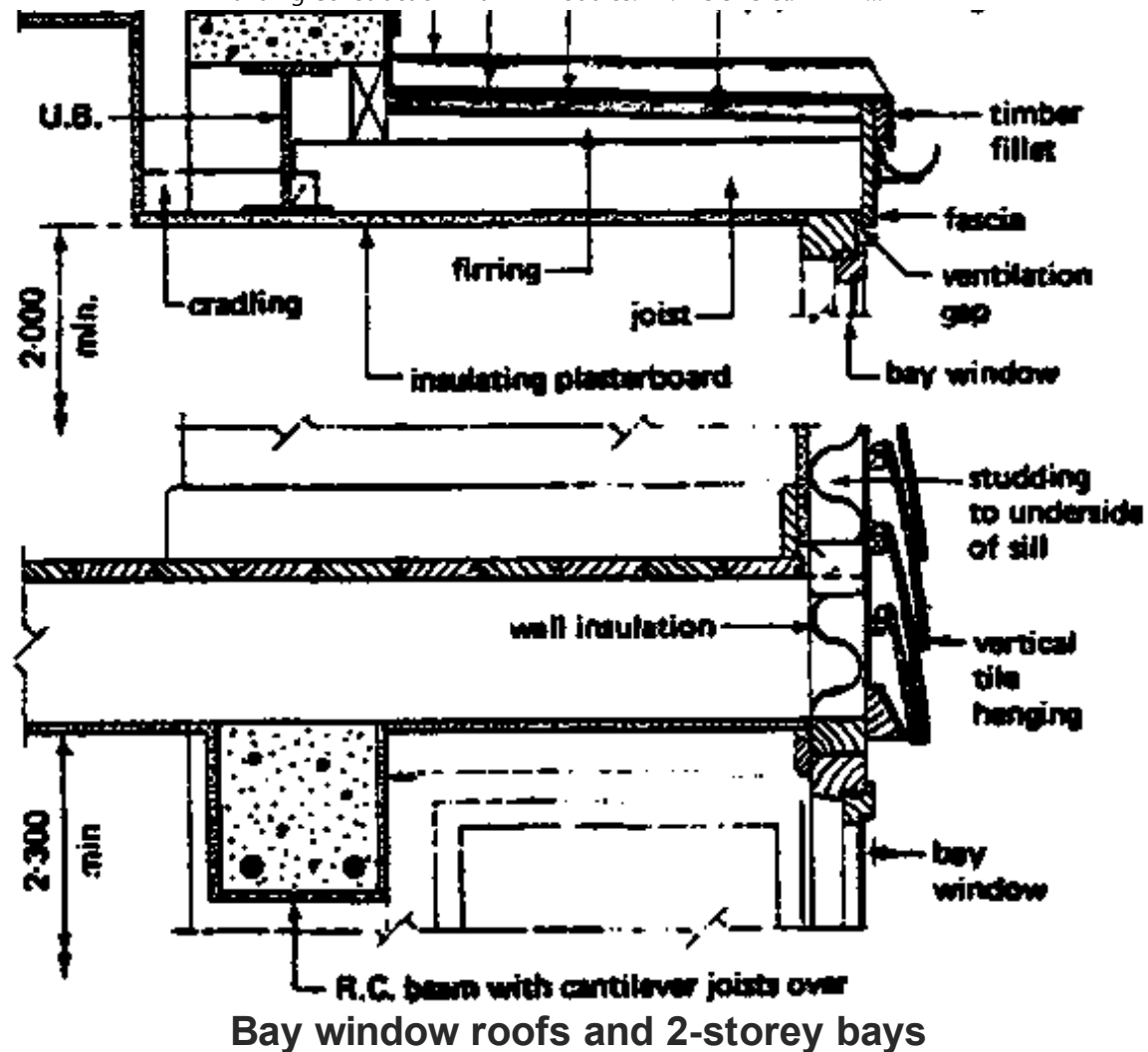

## 14.2.7 SLIDING SASH WINDOWS

### 14.2.7.1 Vertical sliding windows (also called double hung sash windows)

- consist of sashes, sliding vertically over one another.

- Are costly to construct but are more stable than side hung sashes and have better control over the size of ventilation opening, thus reducing the possibility of draughts.

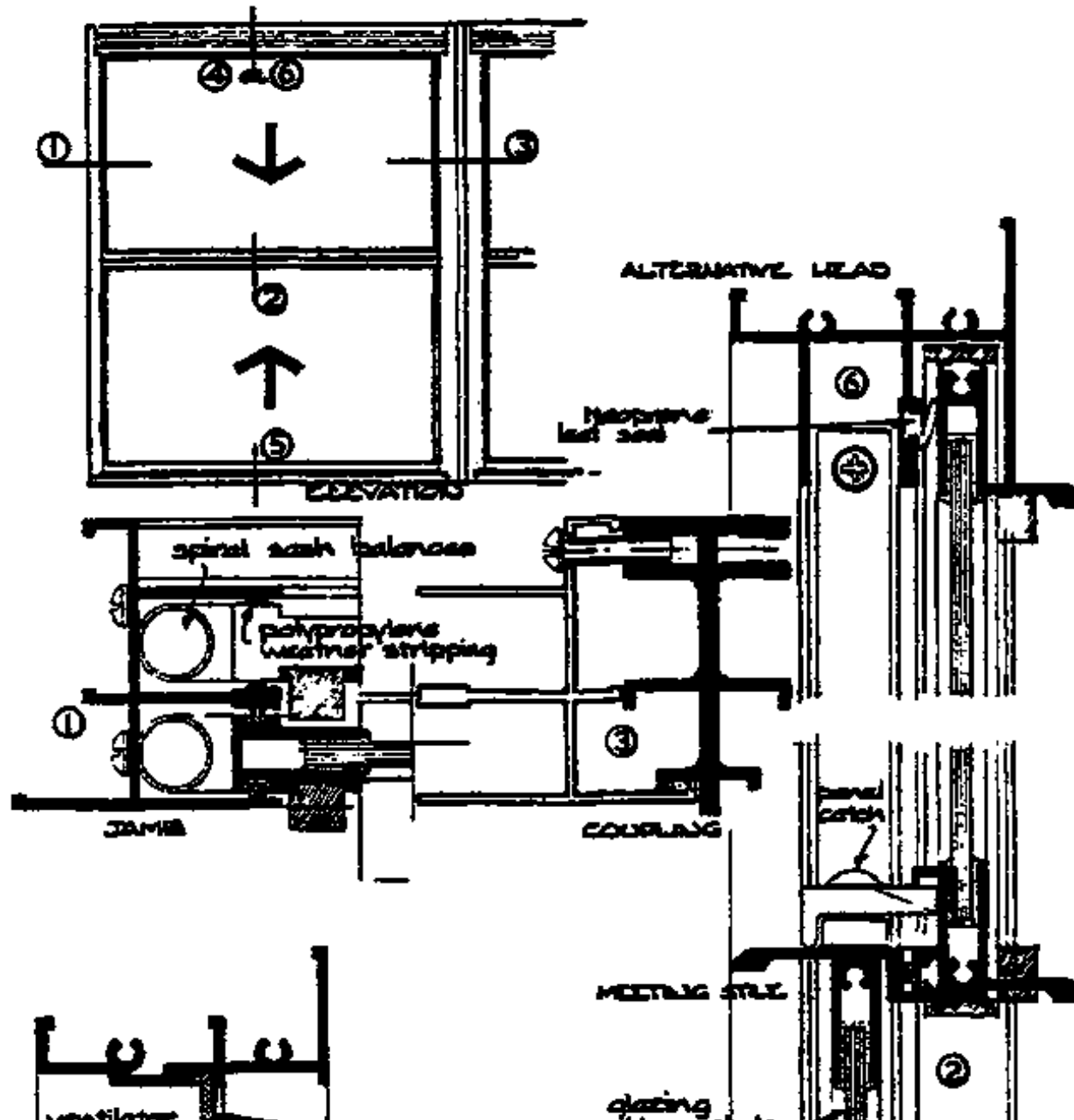

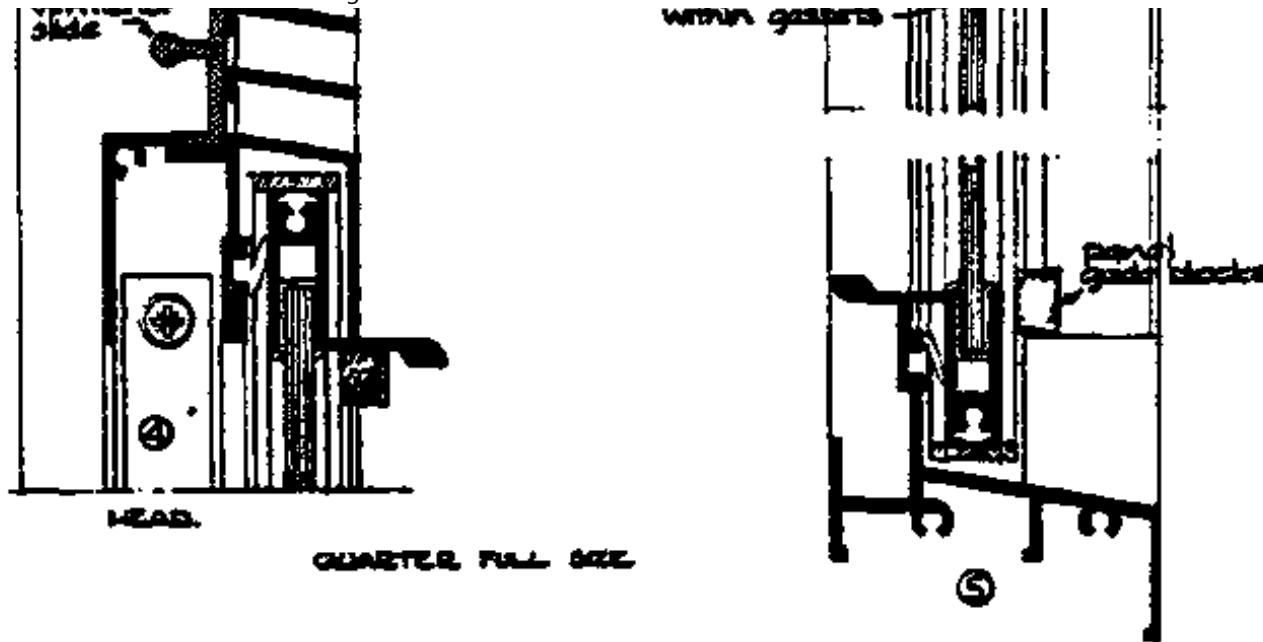

- Two main types:

1. Weight balanced type
2. Spring balanced type

- No. 1 is the older method. The counter balance weights are suspended by cords and housed in a boxed framed jamb or mullion.

No. 2 uses solid frames and needs less maintenance.

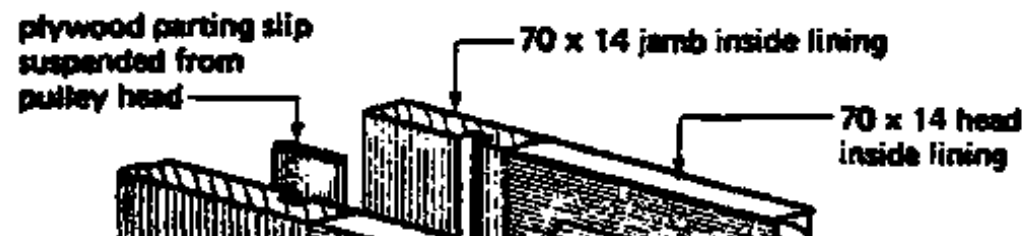

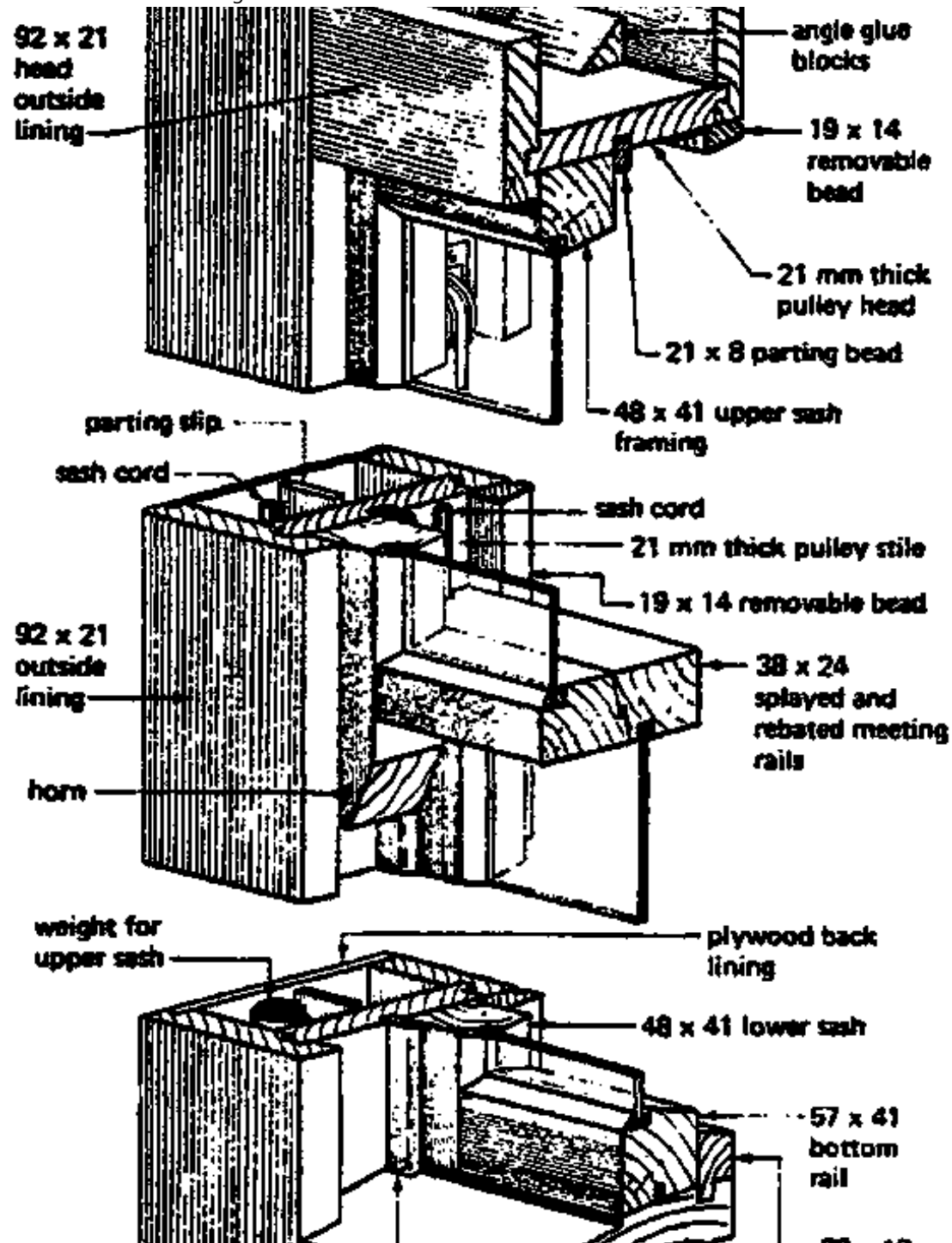

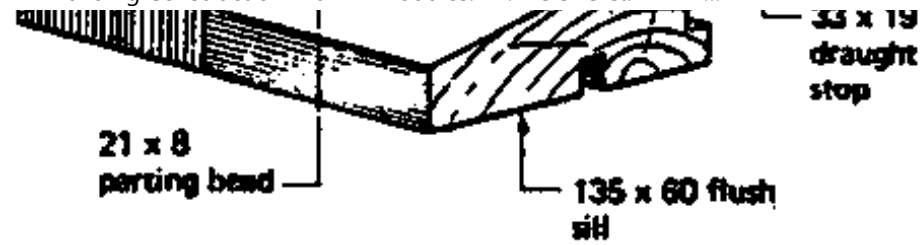

### Double hung weight-balanced sash windows

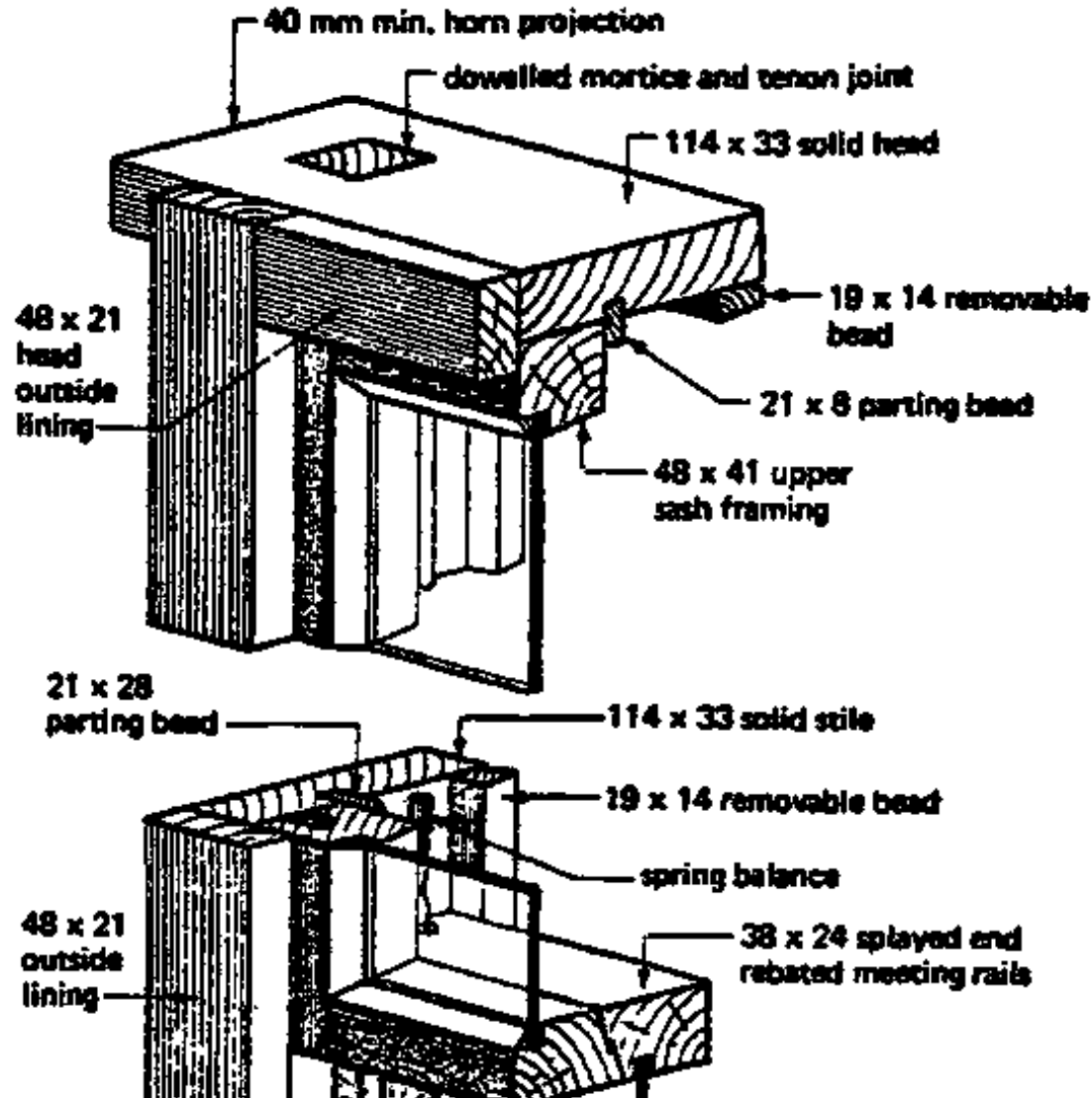

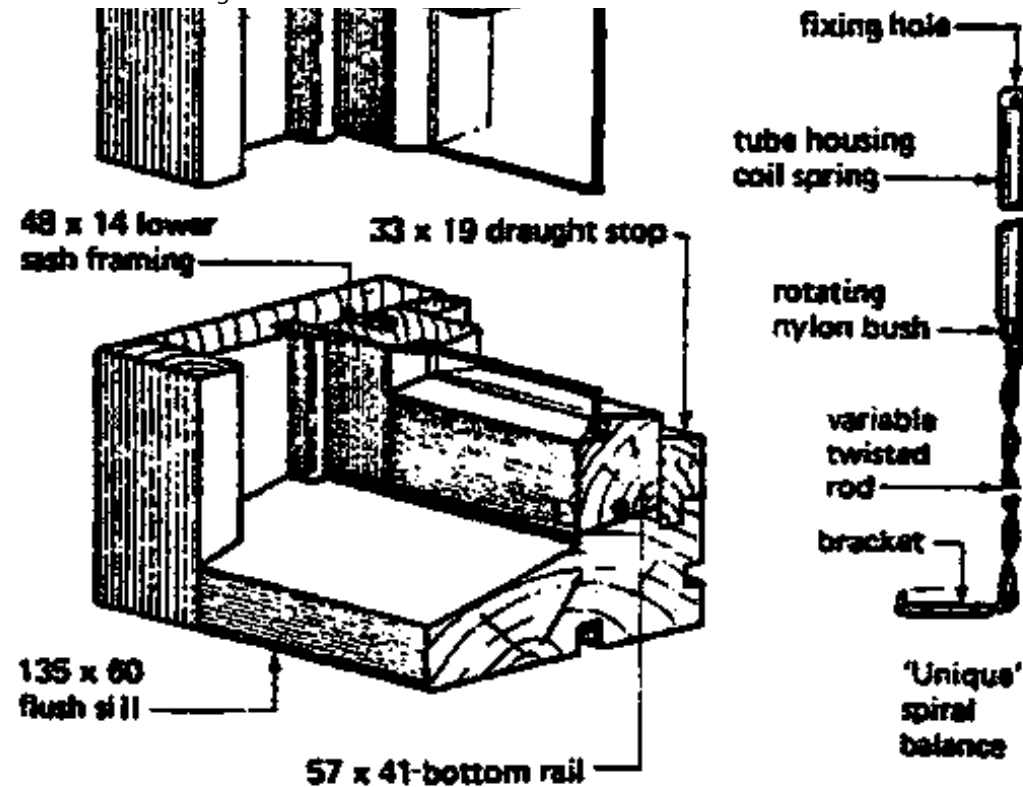

Double hung spring-balanced sash windows

#### 14.2.7.2 Horizontal sliding windows

- consist of a window frame (wood or metal) with at least 2 sashes. One or both can be opened by sliding horizontally.
- The sashes are made to slide on wood/metal/or compressed fibre runners fixed inside the frame.
- **Disadvantage: Sashes tend to jamb in the frame (especially if they are large).**

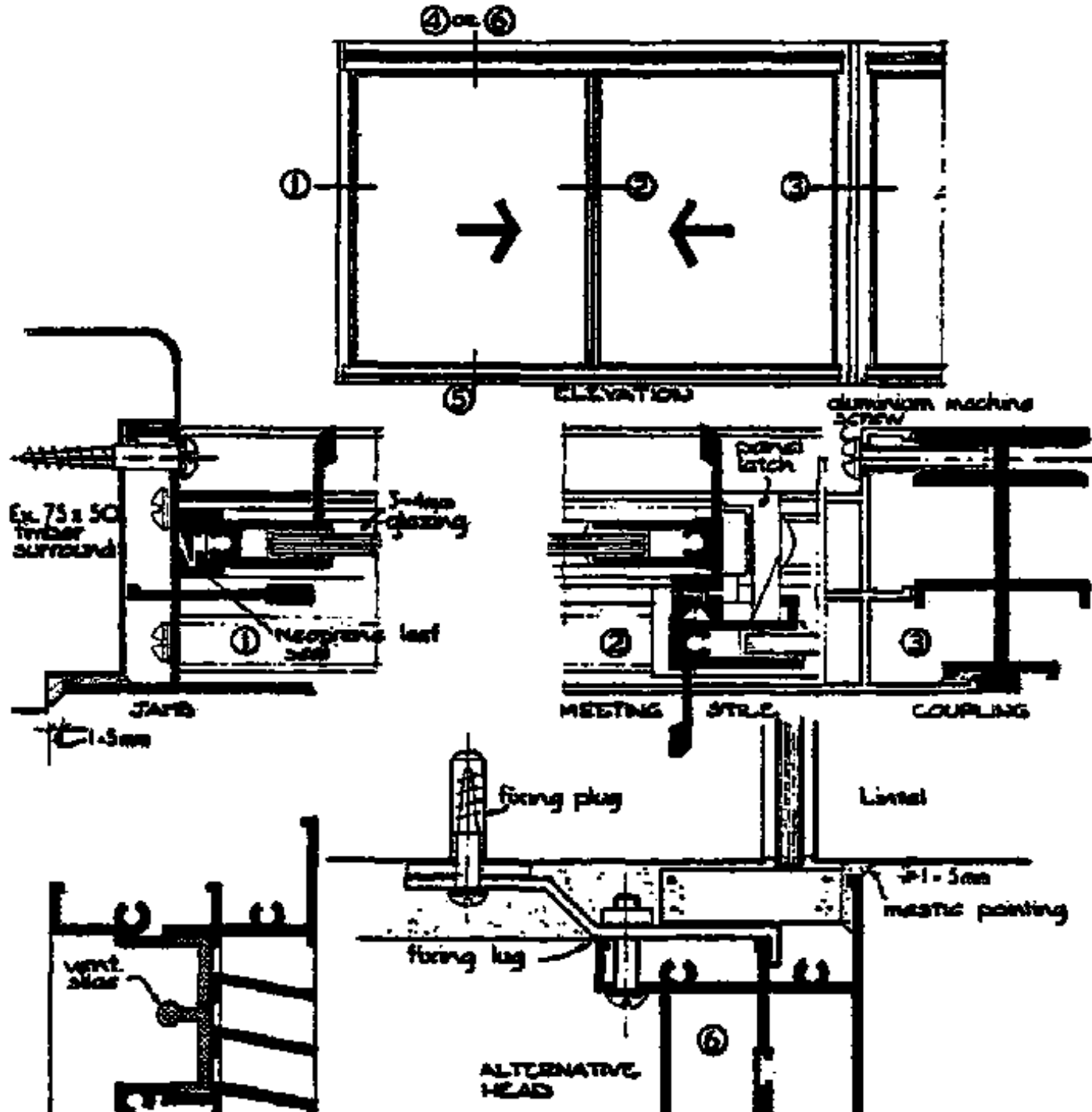



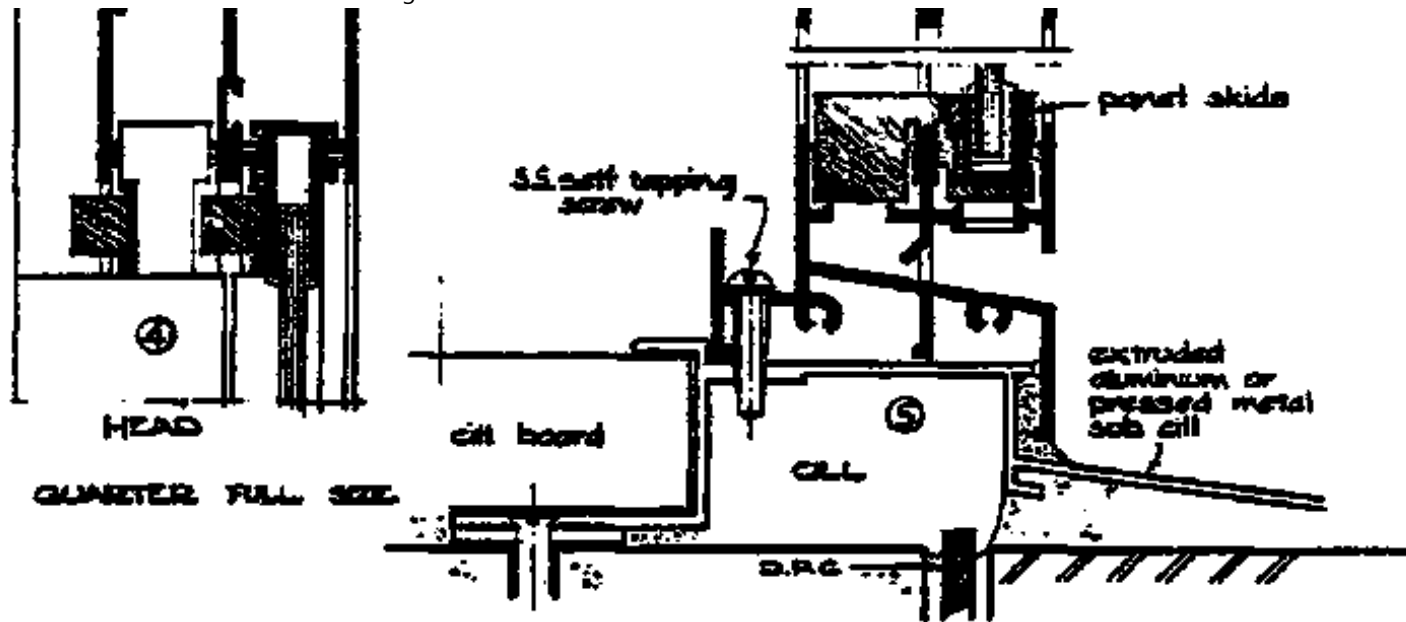

### 14.2.8 PIVOT WINDOWS

- The basic construction of the frame and sash is similar to that of a standard casement frame and sash.
- The sash can be arranged to pivot
  - horizontally or
  - vertically

on friction pivots housed in the jambs or in the sill and head.

- These windows give good adjustment for ventilation purposes.
- Both faces of glazing can be cleaned from the inside of the building.

Disadvantages:

### - Disadvantages:

- **horiz. pivot:** Ventilation in high buildings = hot air, which moves upwards along the facade is directed into the rooms.
- **vertic. pivot:** (the same as casement windows opening to the inside) restrict the use of the rooms when opened.

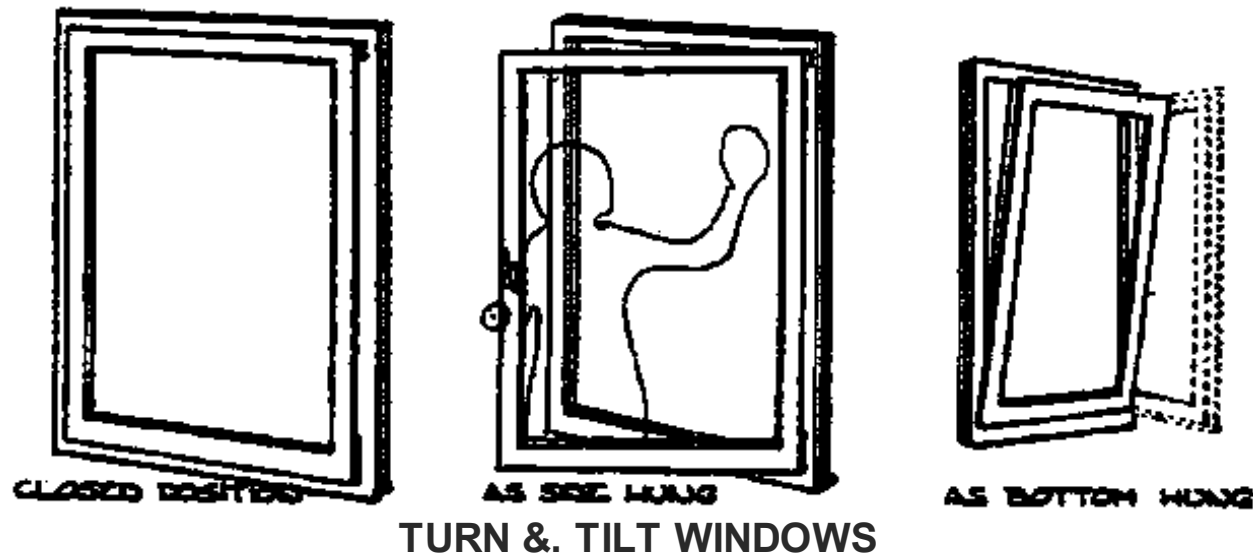

### 14.2.9 LOUVRES

- Adjustable louvres are available in a number of sizes and patterns.
- A louvre blade on a jamb unit is screwed to a galvanized channel surround. The channels and louvres are supplied 'knocked down' and assembled on site.
- another alternative: 'selfmullion' (i.e. 2 jamb units with a spacer bracket between).

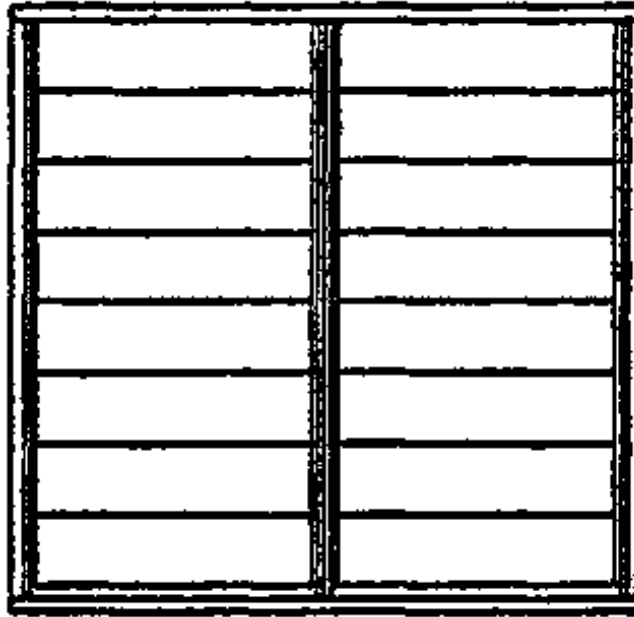

**The glass ranges from 3 to 6 mm plates depending on the size of the window; but in order to prevent breakage the glass should not be less than 5 mm.**

- **5 mm glass blades should not be longer than 30" (762 mm) length**
- **6 mm glass blades should not be longer than 36" (914 mm).**

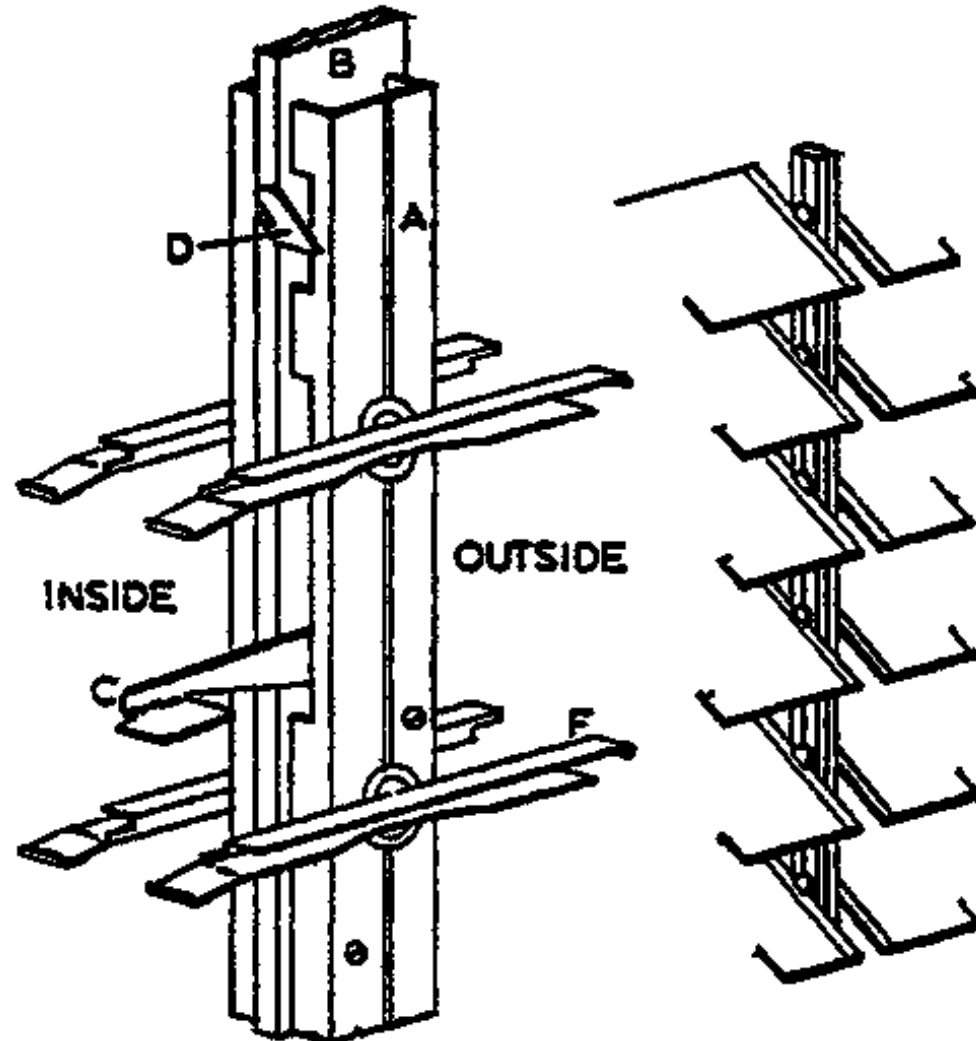

Typical glass louvres in aluminium carriers

**A Pressed steel frame**

**B Glass louvre carrier**  
**C Pressed steel stop**

- For high windows, steel mullion strips are available to which the aluminium jamb units may be fixed.
- The glass blades are normally 4" (or 10 cm) and 6" (or 15 cm) wide, although 9" (23 cm) blades are often used.

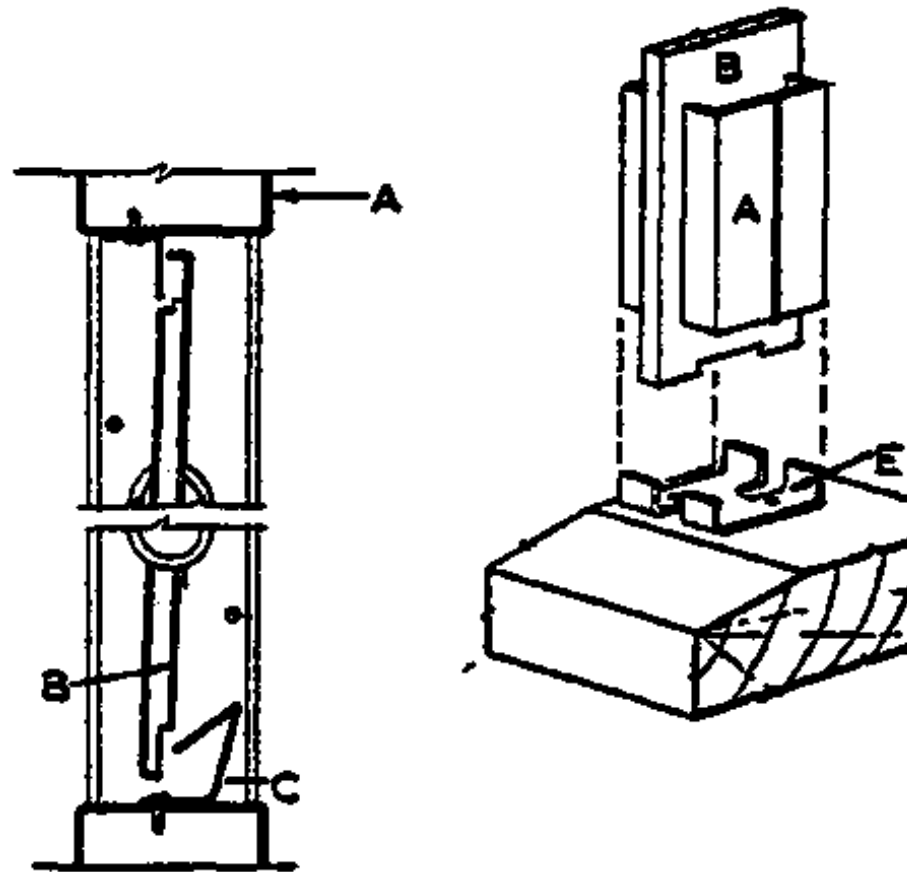

Mullion with steel core

**A 1 in × 1 in (44 mm × 13 mm) jamb**  
**B 2 in × 1 in (51 mm × 6 mm) steel core**

**C Operator**

**D Lock (sometimes combined with the operator)**

**E Core dip**

**F Blade carrier**

**This is exceeded in sheltered positions. The lap between 15 cm blades is 12 mm and between 23-25 mm.**

**- The height of self-supporting mullion varies according to the length and width of the glass blades (i.e. 6" or 9") and the max wind velocity expected.**

**- Where the mullion spacing is small (18" or 45 cm) twenty -one louvres with 6" blades may be carried.**

**But with a spacing of 4' (1.22m). only fourteen- louvres may be carried.**

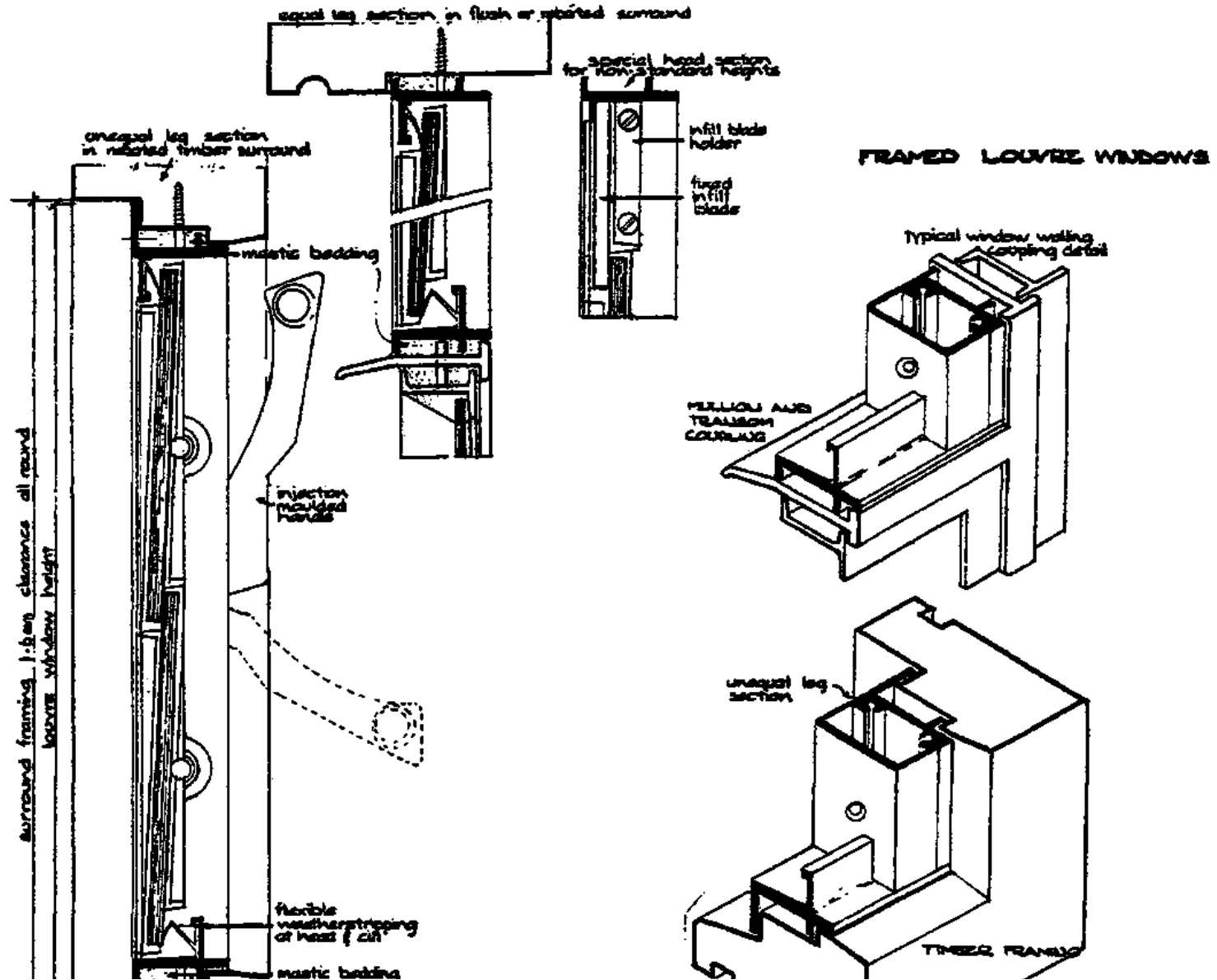



- With tall windows the jamb units may be easily joined, although care has to be taken to marry the louvres accurately.
- Standard heights of windows for louvres with 15 cm blades range from 12 1/2 in (with 2 blades) to 78 1/2 in (198,4 cm) with 14 blades (also with self - mullions, if required)
- Operating handles or 'operators' are usually supplied for every six blades, although this varies with different makes.
- Locking catches may be either separate (as-shown) or incorporated with the operator.

#### Advantages:

- adaptability to existing openings
- stand. heights to fit any size of opening
- ease of operation - neat appearance
- free air flow etc.

#### Disadvantages:

- not as secure as fixed wood or metal louvres (glass blades are easily removed)
- not water tight
- often mullions are not fixed plumb nor the blades are truly horizontal. Poor fixing causes breakage!



**- They frequently slip out of their clips.**

**But there is no doubt, that their advantages, far outweigh their disadvantages (especially in hot-humid areas like i.e. the coast region in TAW).**

### **14.2.10 GLASS AND GLAZING**

#### **14.2.10.1 Glass**

- **Drawn clear sheet glass**

- **There are 2 principal methods of producing drawn clear sheet glass**

- (1) **vertical drawing from a pool of molten glass which, when about 1m above the pool level, is rigid enough to be engaged by a series of asbestos rollers, that continue to draw the ribbon of glass up a tower some 10 m high, after which the ribbon is cut into sheets and washed in a dilute acid to remove surface deposits.**

- (2) **the glass is initially drawn in the vertical plane but it is turned over a roller so that it is drawn in the horizontal direction for some 60 m and passes into an annealing furnace, at the cold end of which it is cut into sheets.**

- **it is a transparent glass (85% light transmission) with a fire finished surface, but because the two surfaces are never perfectly flat or parallel there is always some distortion of vision and reflection.**

**B.S. 952 recommends 3 qualities for sheet glass:**

- 1. Ordinary glazing quality (O.O.) to be used for general glazing purposes.**
- 2. Selected glazing quality (S.G.Q.) for high grade work (such as cabinets).**

**- Generally 6 thicknesses are produced (from 2-6 mm thick). The 2 mm thickness is not being recommended for general glazing.**

- Float glass**

- is a transparent glass (85% light transmission) and is a truly flat glass with undistorted vision.**

- it is formed by floating a continuous ribbon of molten glass over a bath of liquid metal at a controlled rate and temperature.**

- a general glazing quality and a selected quality are produced in six thicknesses (from 3-12 mm).**

- Rolled and rough cast glass**

- is a flat glass produced by a rolling process**

- generally the glass produced in this manner is translucent, which transmits light with varying degrees of diffusion, so that vision is not clear.**

- a wired transparent glass with 80% light transmission is produced generally in one thickness of 6 mm.**

- the glass is made translucent by rolling on to one face a texture or pattern which will give 70-85% light transmission**

85% light transmission.

- Rough cast glass has an irregular texture to one side.
- wired rough cast glass comes in 2 forms:
  - (a) georgian wired (12 mm square mesh elt.-welded wire reinforcement or
  - (b) hexagonally wired which is reinforced with hexagonal wire of approx. 20 mm mesh.
- rough cast glass is produced in 5, 6 and 10 mm thickness and is made for safety and fire resistant glazing purposes.

## 14.2.10.2 Glazing

### Glazing details

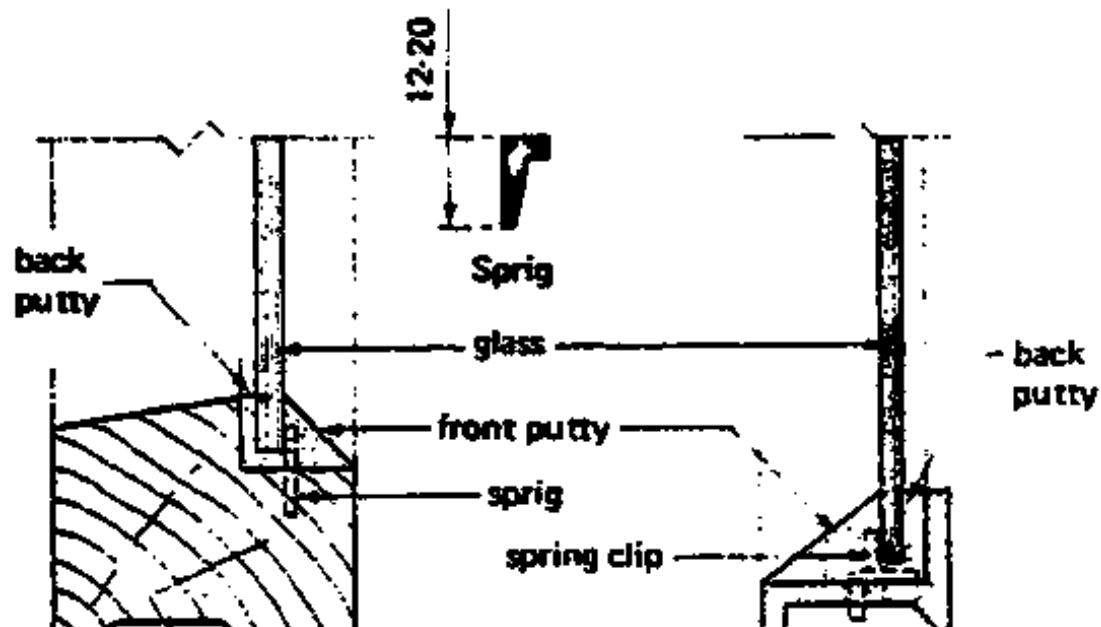

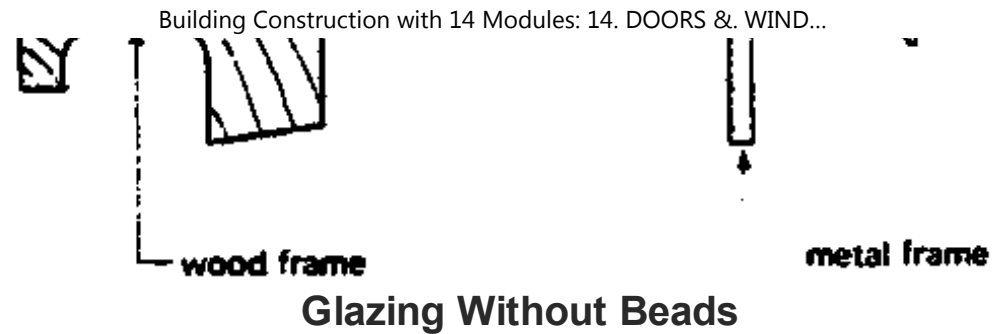

### (a) Glazing without BEADS

- is a suitable method for general domestic window and door panes.
- the glass is bedded in a compound and secured with sprigs, pegs or clips and Fronted with a weathered surface putty.
- putty is glazing, compound which will require a protective coating of paint as soon as practicable after glazing.
- two kinds of putty are generally used:
  1. Linseed oil putty: For use with primed wood members and is made From linseed oil and whiting. (B.S. 544)
  2. Metal casement putty: for use with metal or non-absorbent wood members and is made From refined vegetable drying oils and Finely ground chalk.
- The glass pane should be cut to allow a min. clearance of 2 mm all round For both wood and metal frames.
- Sufficient putty is applied to the rebate to give at least 2 mm of back putty when the glass is

pressed into the rebate, any surplus putty being stripped off level or at an angle above the rebate.

- The glass should be secured with sprigs or clips at not more than 440 mm centres and finished off on the Front edge with a weathered putty-fillet, so that the top edge of the fillet is, at or just below the sight line.

## Glazing details

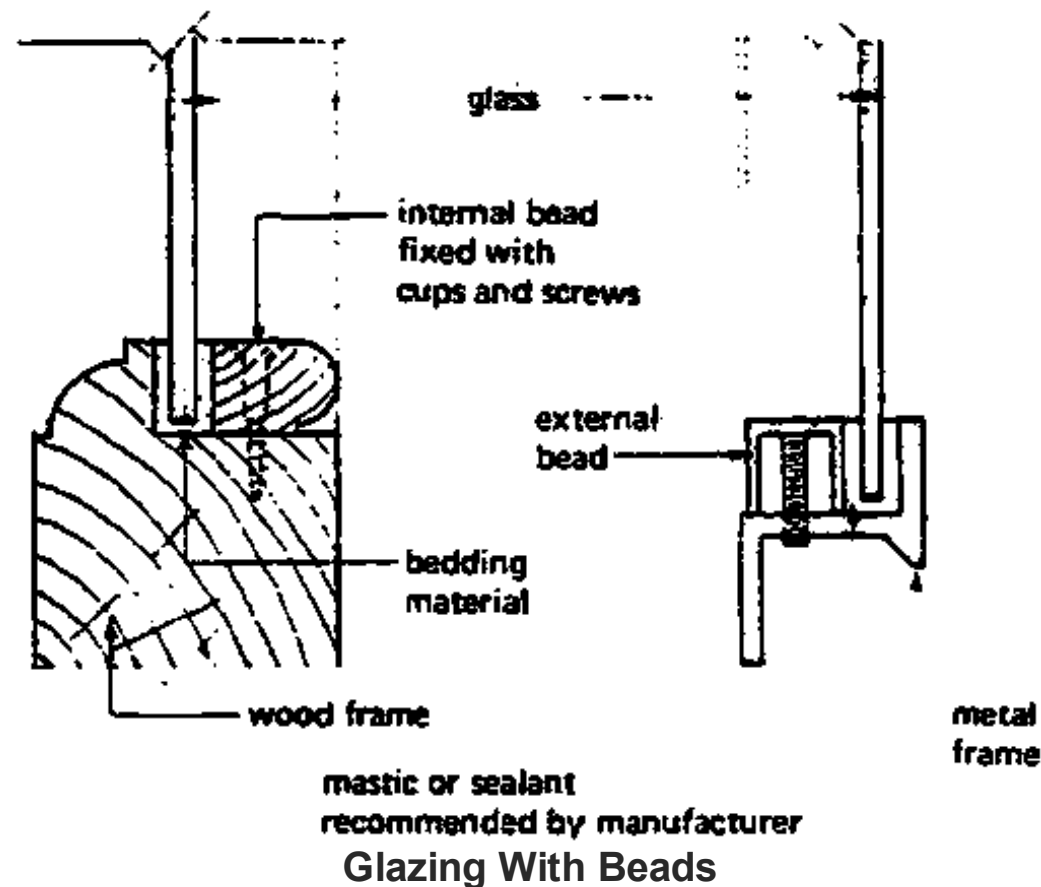

### (h) Glazing with BEADS

## **(b) Glazing with BEADS**

- is generally applied to good class joinery
- the beads should be secured with
  - panel pins or
  - screws for hardwoods it is usual to use cups and screws.
- The glass is bedded in a compound or a suitable glazing felt mainly to prevent damage by vibration to the glass
- Beads are usually mitred at the corners to give continuity of any moulding.
- Beads For metal windows are usually supplied with the surround or frame, and fixing of glass should follow the manufacturers instructions.

### **14.2.11 MOSQUITO SCREENING (FLY SCREENS)**

- mass production of copper wire and nylon screens have made complete proofing very common.
- Green-tinted gauze is available which reduces glare considerably.
- Nylon gauze (although cheap) is not as transparent as copper and tends to produce a foggy outlook. Such screens are not designed to resist damage caused by fly swatting and should be left undisturbed when once in position.
- Fibre glass is an excellent material for screening. It will resist corrosion and rust and will not stain walls and sills.

## **This material**

- + does not deteriorate in industrial areas,**
- + is not affected by mildew**
- + resists salt air and**
- + will withstand heat up to 150° C before becoming soft.**
- + it provides good fire protection.**

**- When fly screens are intended for glass-louvre windows, it is necessary to make the window frame wide enough to clear the louvre when fully open (the screen may be fixed direct to the frame).**

**- removable screens (secured by wing nuts) are used where mosquitoes or other pests occur only at certain times of the year.**

**A neater solution, however, lies in the use of roll-up insect screens which may be fixed permanently.**

**These consist of light aluframes with fibreglass screens which roll up into a head-box (= 60 mm<sup>2</sup>).**

**They may be fixed to either wood or metal frames.**

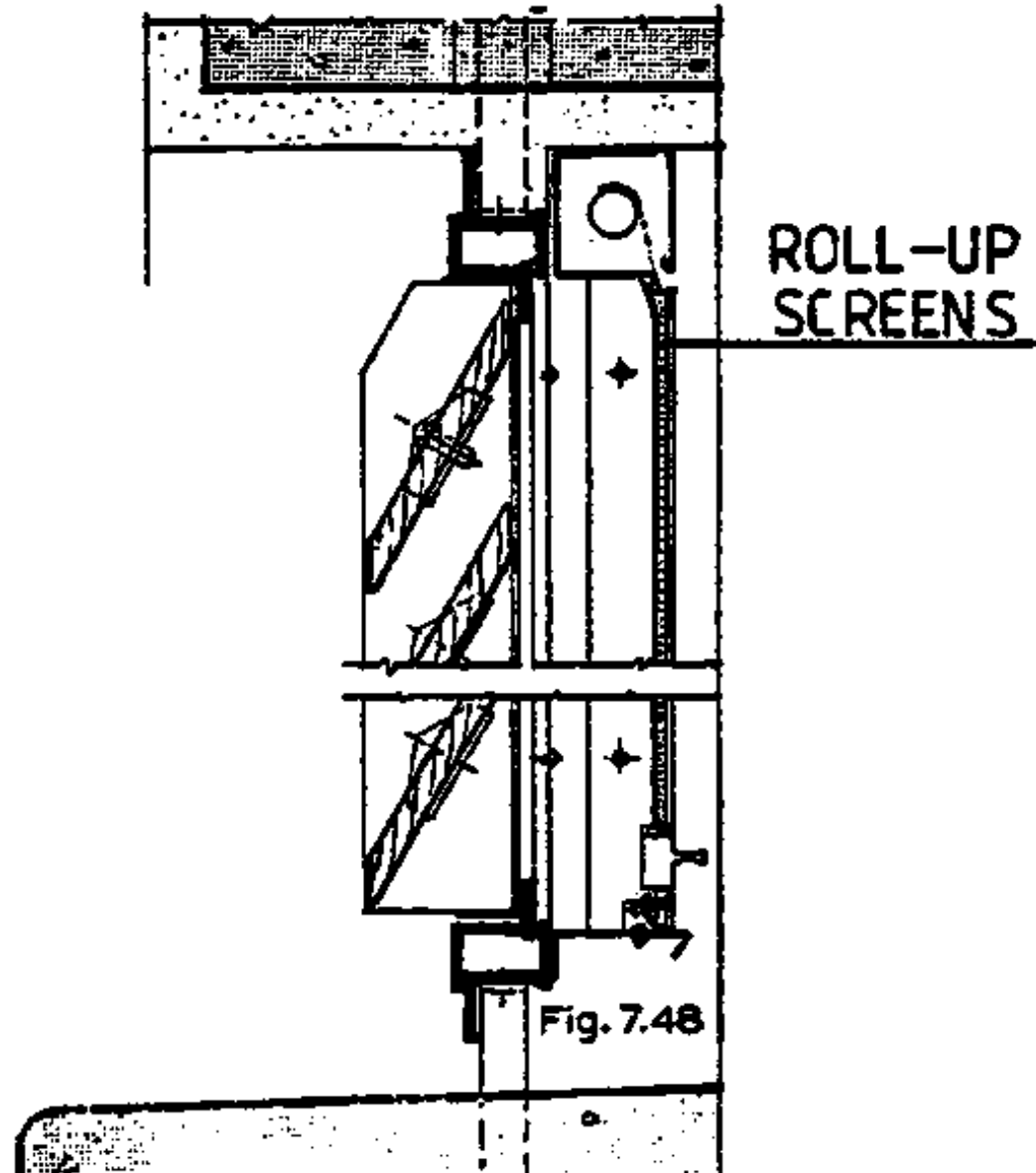



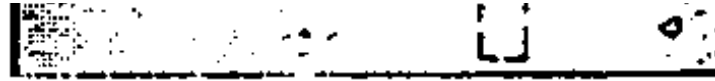

- Flat insect screens in aluframes are also available
  - fixed
  - hinged or
  - sliding.
  
- Gauze doors may be made of timber framing or in aluframes.
  - + When such doors are used, they should be arranged to open outward, if possible, otherwise disturbed insects on the screen will tend to fly inwards as the door is opened.
  
  - + The doors may be installed on the face, or in the reveal and should not interfere with the normal door.

#### 14.2.12 SUN-BREAKERS

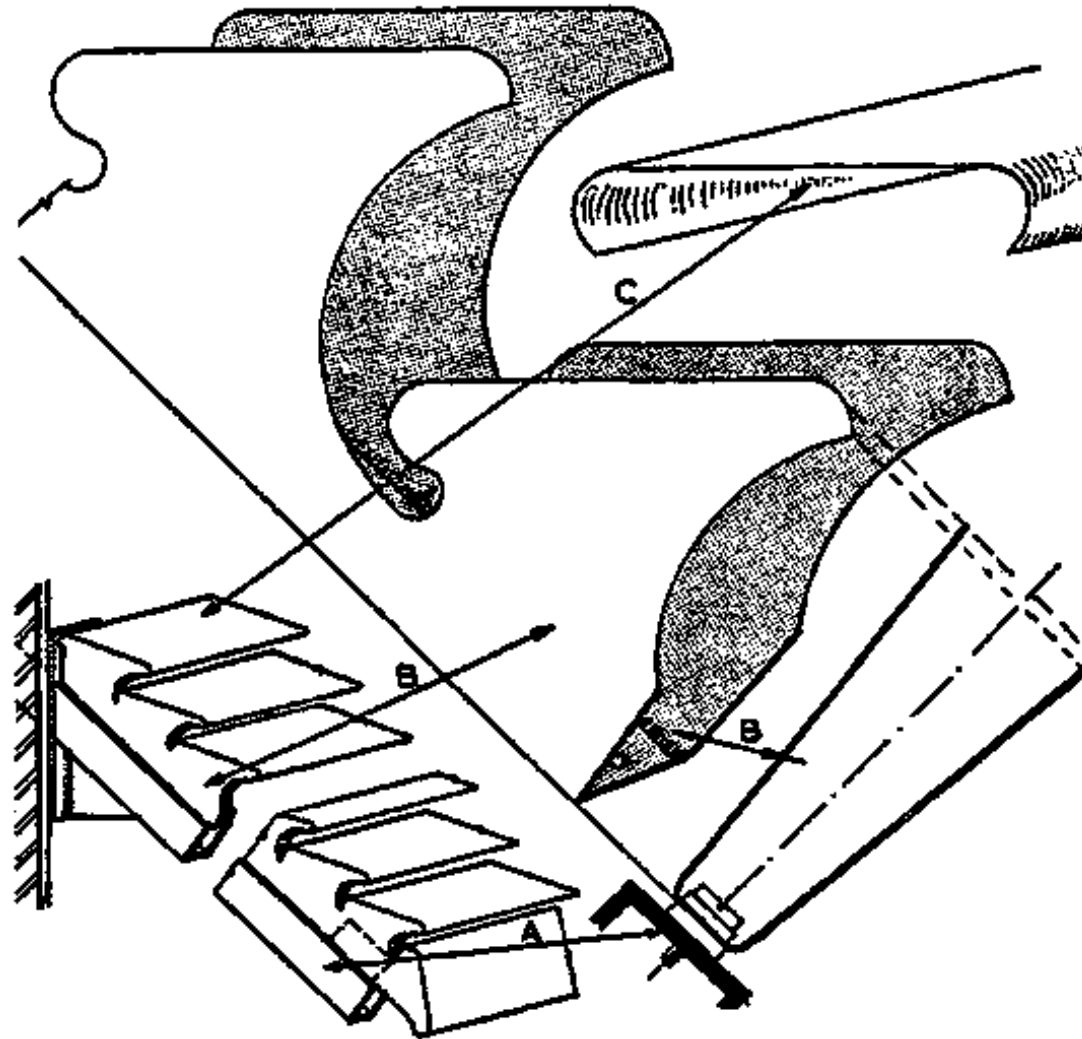

Aluminium sun-breakers

**A Steel box section (size to suit span).**

**B Stringer (size and shape to suit climate)**

**C Aluminium panels (clip-on)**

- Sun control is frequently necessary and many diff. systems have been developed to effect this, such as
  - pierced panels of brick-work or blockwork
  - overhanging eaves
  - canopies
  - painted or coloured glass
  - metal louvres
  - vertical slats of concrete, extending the full height of the building, arranged at a suitable angle to de-feat direct entry of sun-light.
  
- Before adequate sun control can be achieved, several factors require consideration:
  - orientation of the building
  - the latitude of the country
  - the hours of sunlight against which protection is needed
  - the position of the building regarding the prevailing winds and rains.

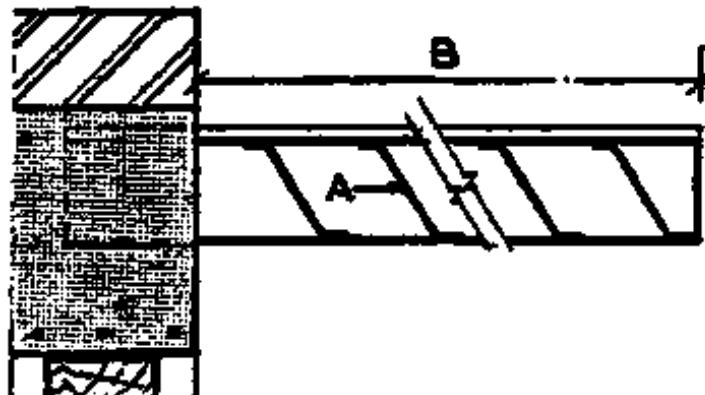

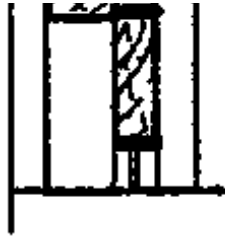

### Metal sun-breaker canopy (cantilevered or suspended)

**A** Aluminium or galvanized steel blades and frame

**B** Projection according to shade angle required

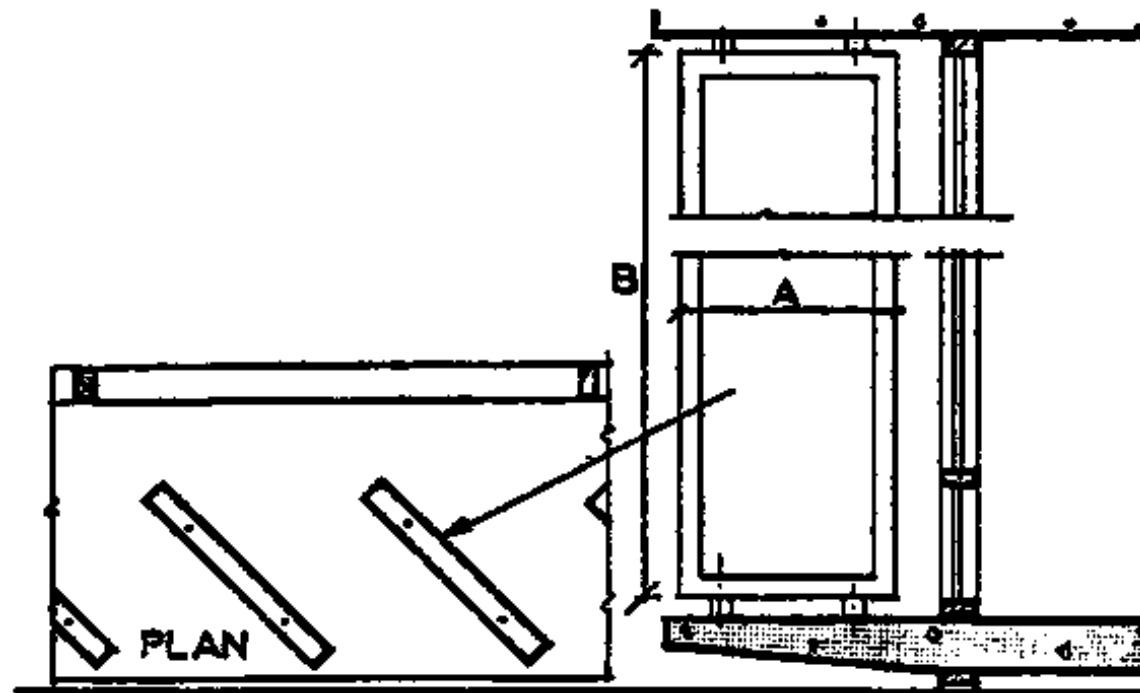

Aluminium fixed sun panels (also in pressed steel)

**A** Up to 4 ft (122 cm), dimensions as required

**B** Up to 14 ft (425 cm)

**- Sun breakers can be**

**either fixed or pivoted**

**either horizontal or vertical**

**If pivoted they can be either manually or mechanically operated.**

**- pivoted sunbreakers are very useful, as the area of sun surface can be considerably reduced. They can also exclude rain.**

**- For determining the angle and size of sunbreakers various charts and other aids are available (It is advisable to deal with methods of determining shadow angles in building openings in order to design sunbreakers, which are effective at all seasons and any hour of the day.**

**- Sunbreakers are obtainable in many styles and patterns.**

**• A common method consists of a U-shaped stringer shaped to take alu-strips. The stringers are produced at diff. angles to suit the required latitude. They are adaptable to a wide variety of uses (including cladding panelling, sun-louvres, canopies, roofs etc).**

**• Another design is that of pressed steel sunbreakers. A similar section will permit ventilation but is shaped to act as a gutter which prevents the entry of rain.**

**• A vertical sun panel can be made in a variety of heights, widths and thicknesses. This can be made in pressed steel, or aluminium and is designed to resist high wind.**

**The angle of fixing is designed to give maximum sun protection.**

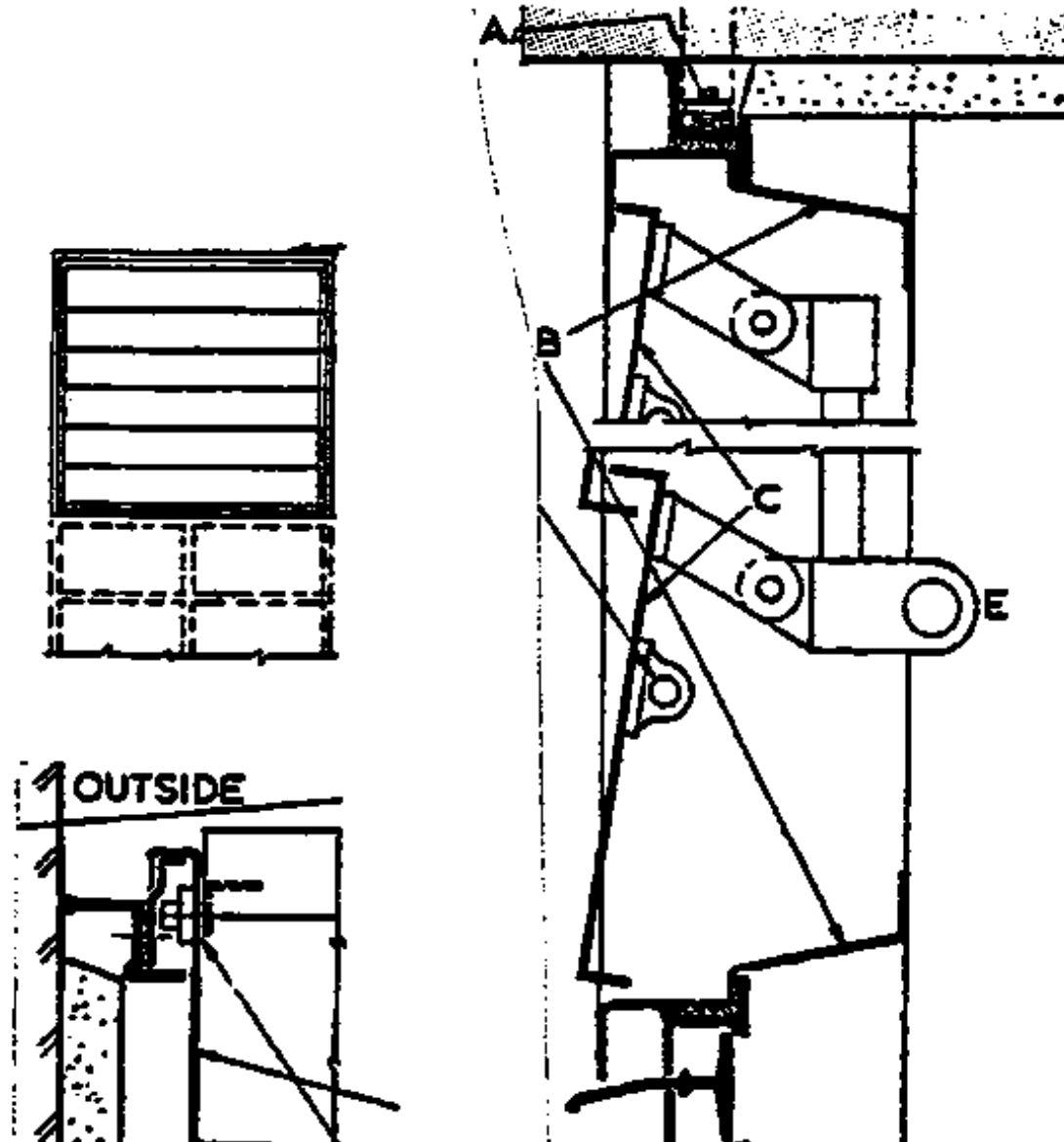



**Adaptors for metal sun-breakers**

- A Standard fixed metal casement**
- B Adaptor frame of pressed steel**
- C Ventilated pressed steel movable sun-breakers**
- D Pivot**
- E Operator ring**

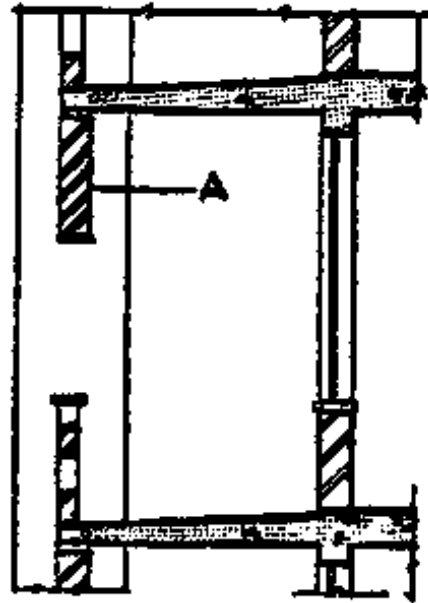

**Section through a typical balcony**

- A Wood-louvred sun-breaker (height and angle of louvre as required)**

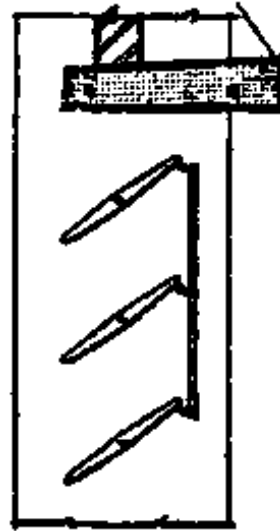

Pivoted aluminium sun-breakers

- Rolling window shutters are frequently used in some countries.

These consist of fine slates running vertically in guide channels which themselves can be pivoted to clear the window and let in light and air.

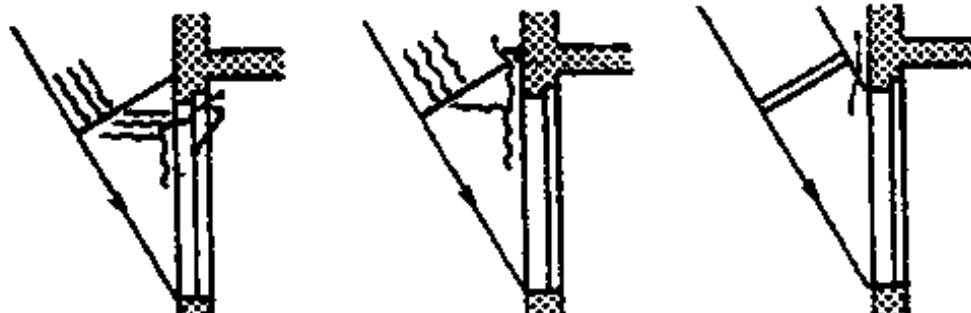





**Incorrect**



**Correct**

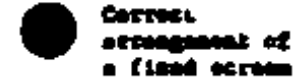

**Correct  
arrangement of  
a fixed screen**

- Sund-blinds of the venetian type are extensively used where no other method is available or where permanent control is not warranted. An example showing plan + section of a pressed steel sun-breaker set in a frame, adapted to fit a standard metal window.

A bank of 6 louvres is pivoted and linked to one opera-tar.

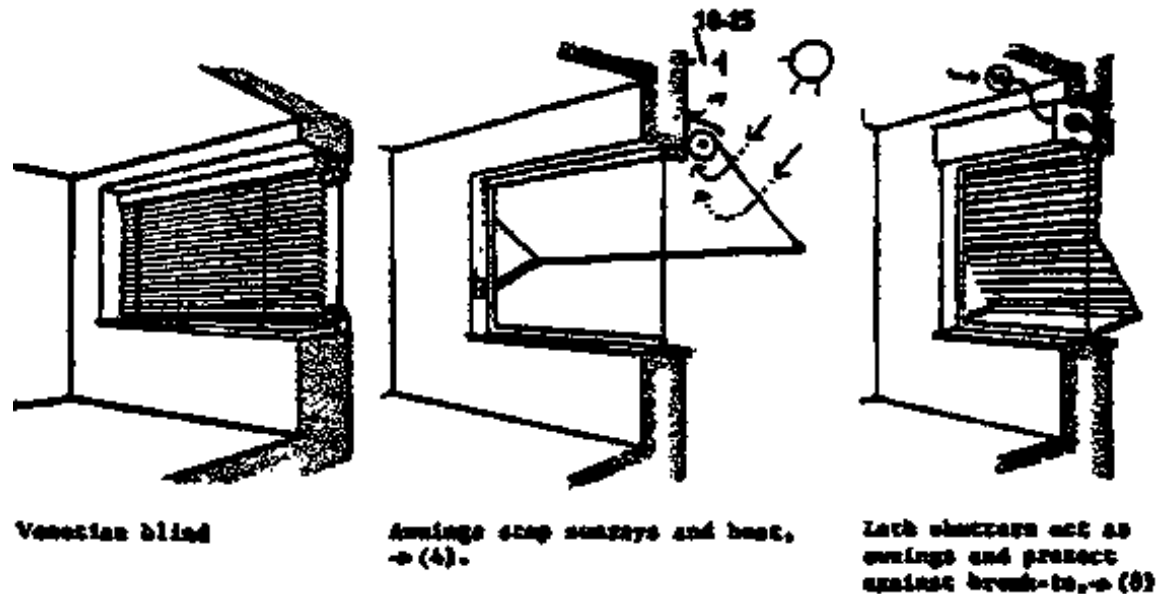

- The normal type of wood louvre in a frame is supported by concrete sun 'fins' at approx. 3 m centres.
- Aerofoils may also be used, although they are more costly. They are insulated and can be pivoted to give maximum protection. They can be made to various dimensions and can be fixed either horizontally or vertically.

**When closed, they also give wind and rain protection.**

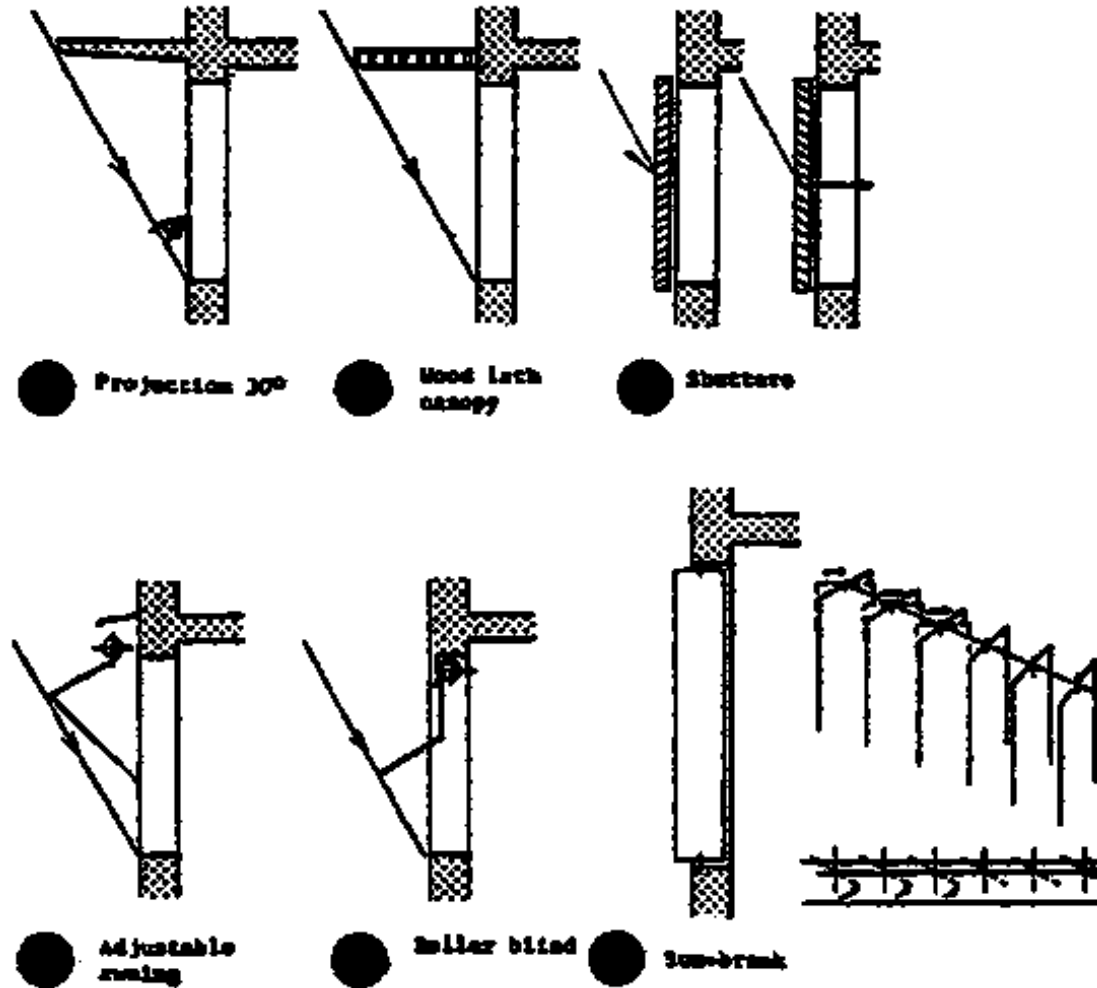

- **Vertical alu-sun-breakers.** These are designed to fit standard blade carriers by using an adapter.

**In order to prevent twist between the top and bottom blade carriers, a torsion bar is required. This is**

in order to prevent twist between the top and bottom blade carriers, a tension bar is required. This is fixed in the nearest carrier to the operator.

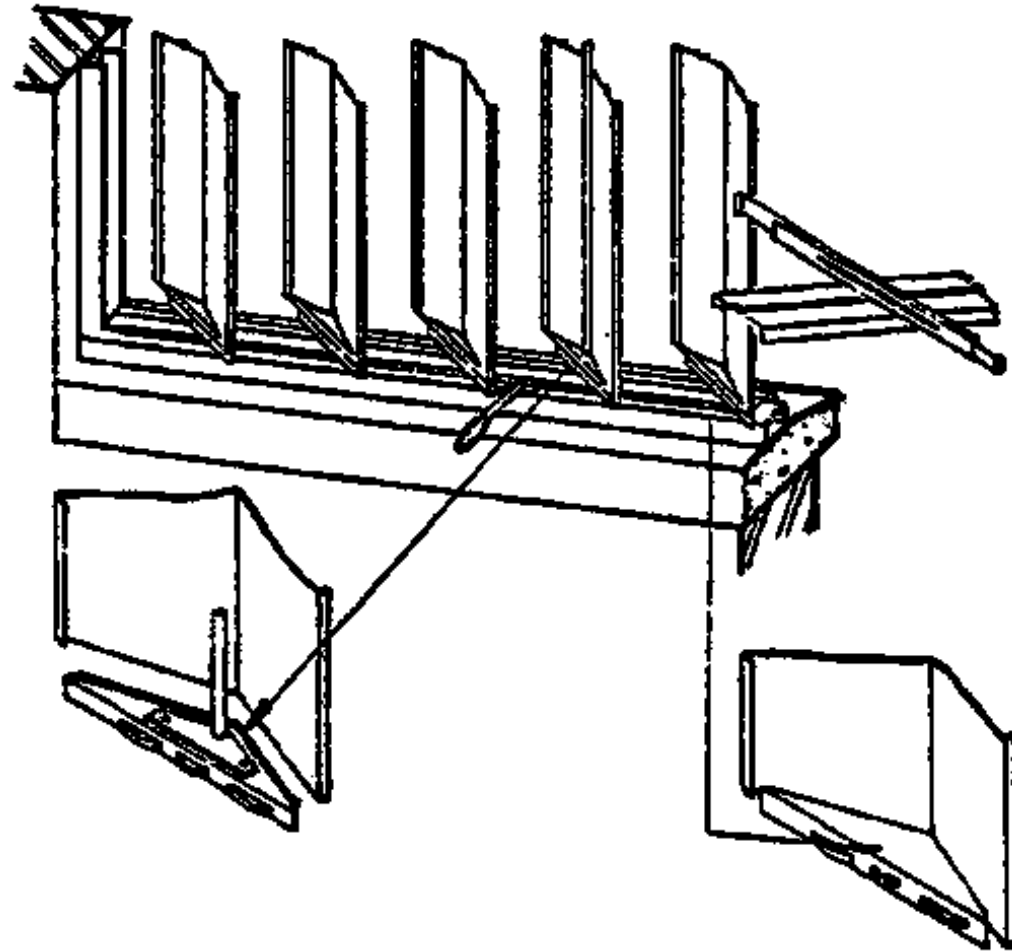

Vertical metal sun-breakers

### 14.3 IRON MONGERY

Iron Mongery or HARDWARE covers a wide field, so that we have to concentrate on these items only.

- iron mongery or HARDWARE covers a wide field, so that we have to concentrate on those items only which are in common use (in Tanzania) in the field of design and construction, such as:

14.3.1 Hinges

14.3.2 Locks and Latches

14.3.3 Miscellaneous

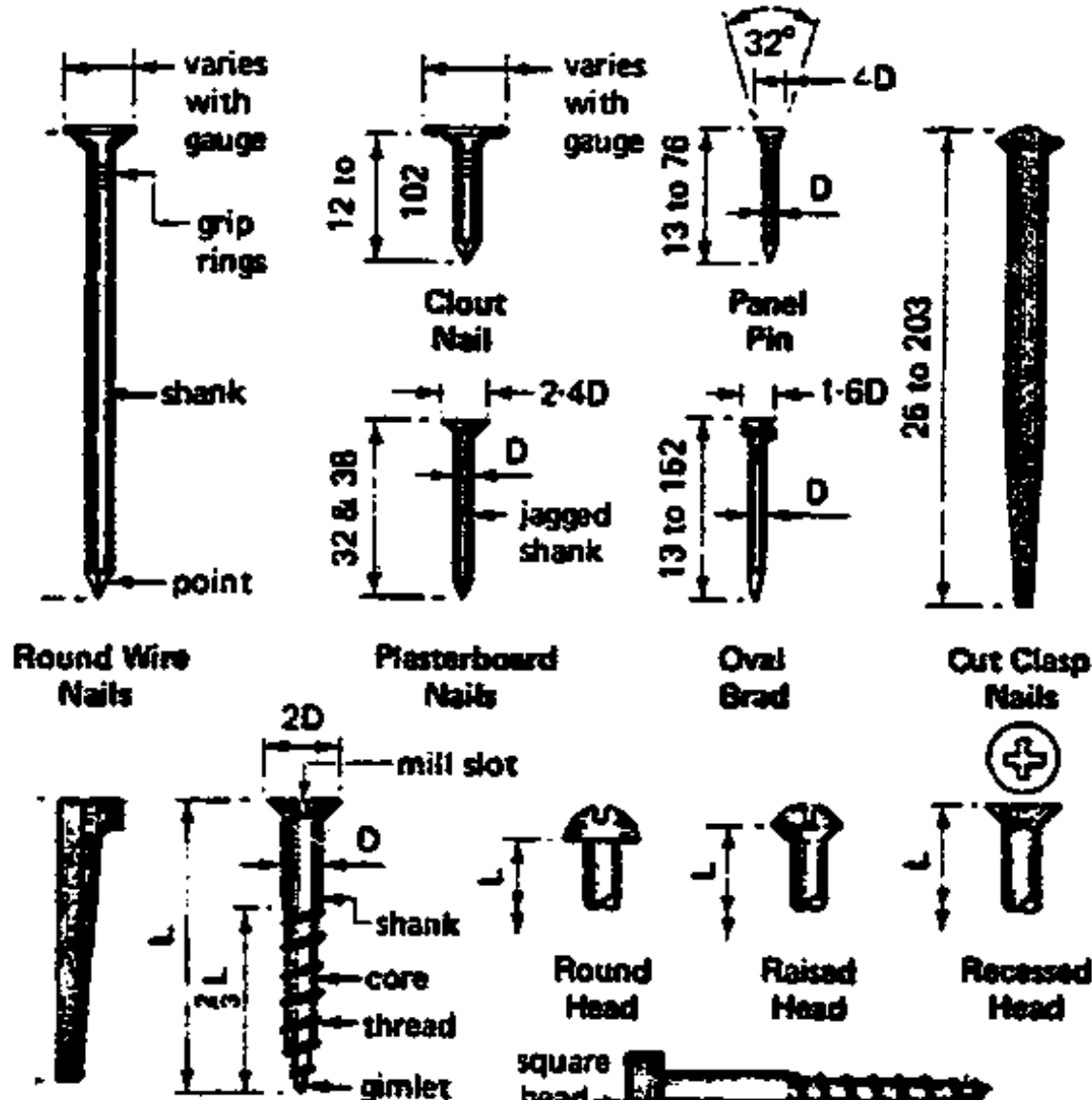

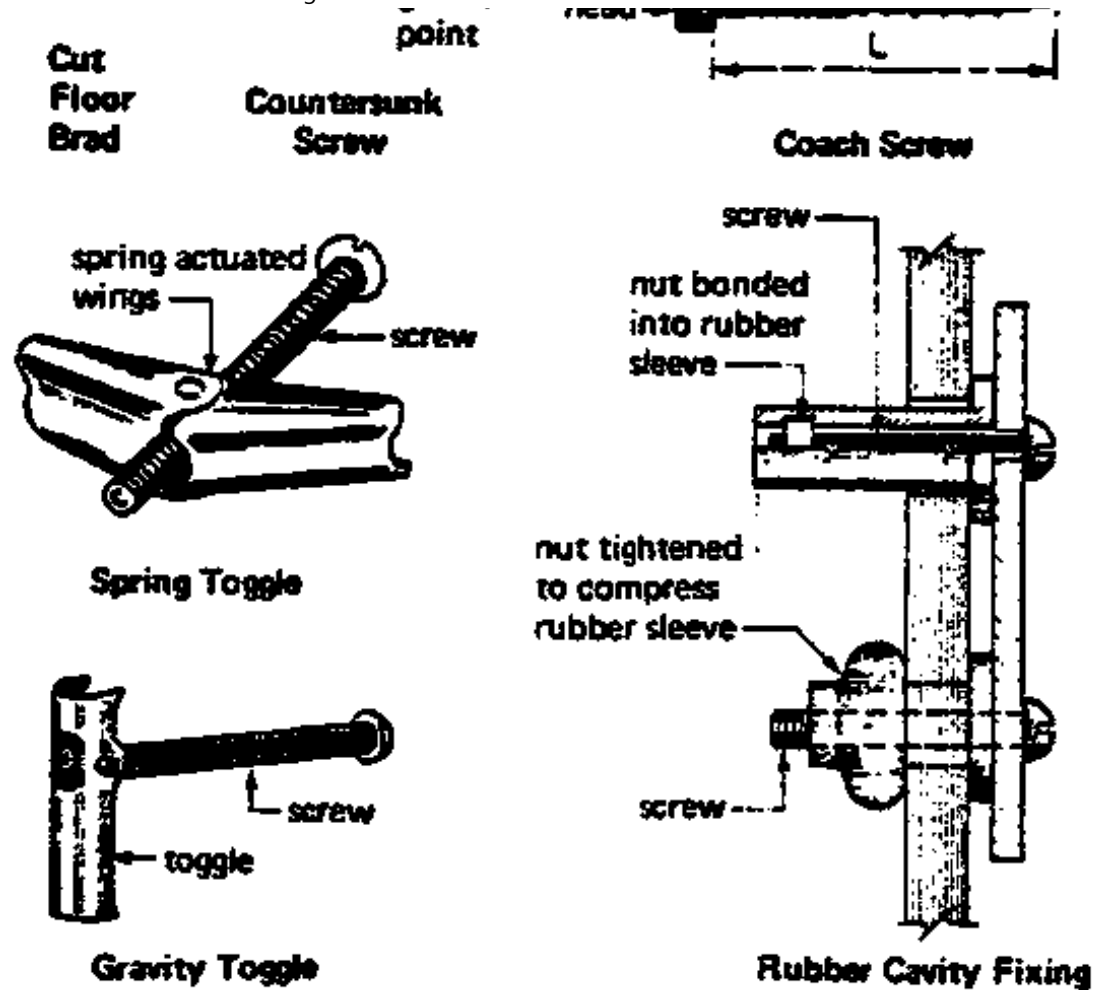

Nails, screws and cavity fixings

### 14.3.1 HINGES

are made for hanging doors, casements and ventlights. There are different types available.

- Most commonly used are the cheap pressed steel butt hinges. They are made from steel strip which is cut and pressed around a PIN. The PIN is fixed inside the Kunkle.

- **Loose pressed steel butt hinges** have the advantage that by taking out the loose pin the door can be taken off its hinges whereas with standard steel butts a door can only be taken off by unscrewing its hinges from the frame.
- **Double pressed steel butt hinges** are made of two strips of steel, each folded back on it-self around the pin. They are stronger than ordinary steel butt hinges and are used for heavy doors.
- **cast iron butt hinges** are heavier and more expensive than steel butts of similar size and shape; but have longer useful live, as the bearing surface of the kunckles are more resistant to wear.
- **Brass butt hinges** are more expensive than steel or cast iron hinges, used mainly for decorative purposes.
- **Steel skew butt hinges** (rising butt) The bearing surfaces of the kunckles are cut on the skew, so that, as the hinge opens, one butt rises. These hinges are used for hanging doors and are fixed so that the flap screwed to the door rises as the hinge opens.

### Purpose:

- To ride over carpets
- self closing (fire cheded)
- **Steel tee hinges** consist of a rectangular steel flap and a long tail with knuckles around a pin.

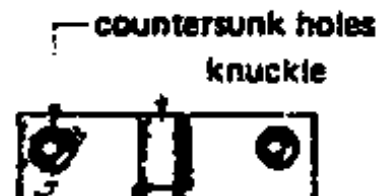

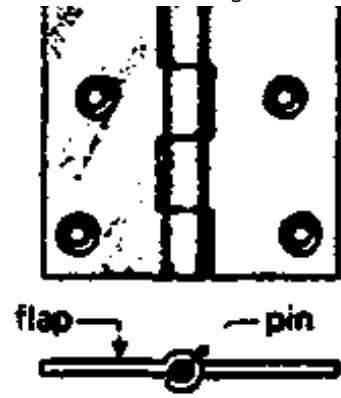

**Steel Butt Hinge**

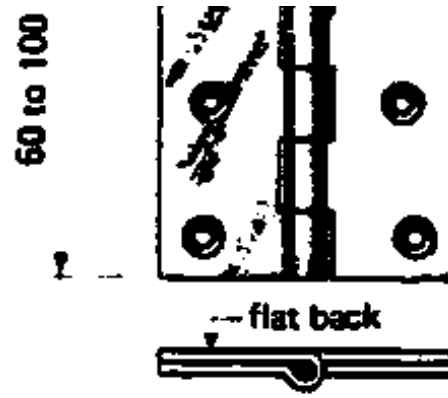

**Steel Double Flap Butt Hinge**

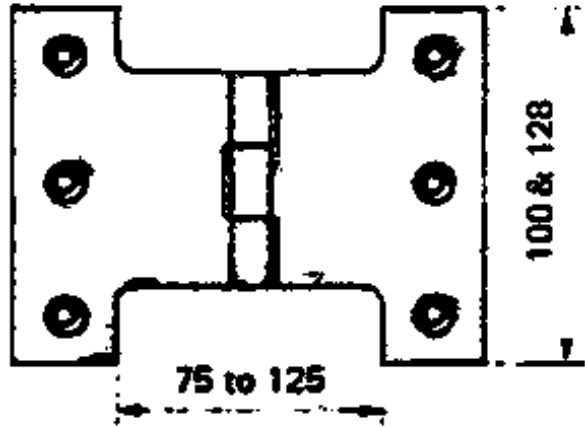

**Parliament Hinge**

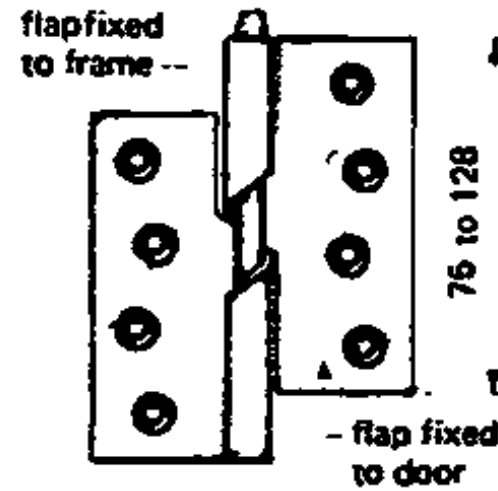

**Rising Butt Hinge**

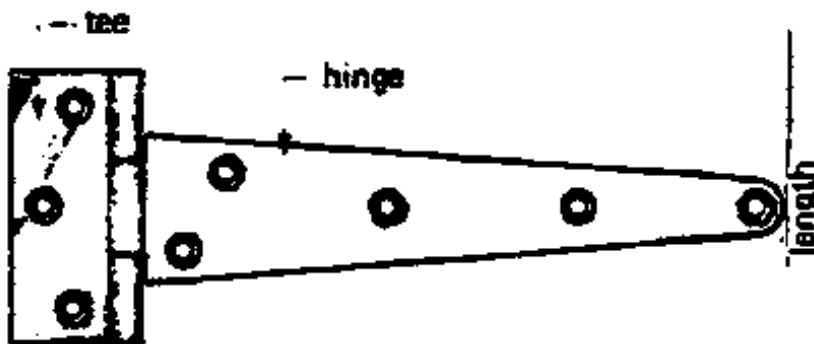

**150 to 600**

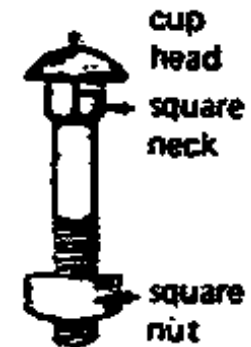

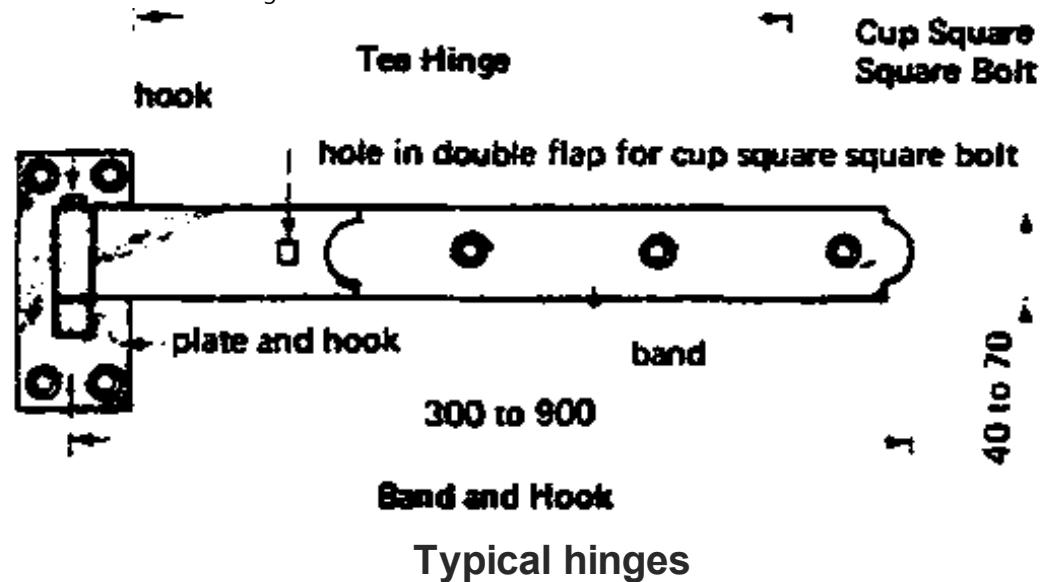

The flap is fixed to the frame and the tail to the door. They are used mainly For match-boarded doors, as they assist in bracing the ledges against sinking.

- Hook and band hinges consist of a rectangular steel plate in which a pin is fixed and a steel band-folded around the pin.

They are made of heavier steel than tee hinges and are used for hanging heavy doors such as garage and workshop doors.

- Projecting steel windows

Metal casements are often hung on projecting steel hinges.

Reason: To make it possible to clean the glass in the casement on both sides from within the building.

- Casements are secured with a single pivoted cock spur type fastener and a peg stay is fixed to the frame and casement so that the casement can be kept open in windy weather.



- **Ventlights** are hung on ordinary steel hinges and are fitted with a peg stay similar to that used for casements.

### 14.3.2 LOCKS AND LATCHES

- **Lock:** any device of wood or metal attached to a door which can be used to keep it closed by the use of a loose key

- **Latch:** any device of wood or metal attached to a door to keep it closed and which can be opened by the movement of a handle lever or bar.

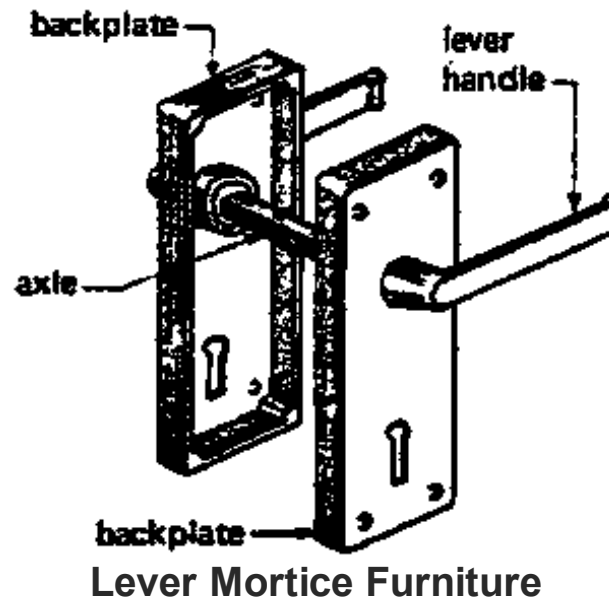

**Mortice Lock** is the mechanism which is most used today. It comprises a latch and a bolt.

The former being operated by handles; the latter by means of a loose key.

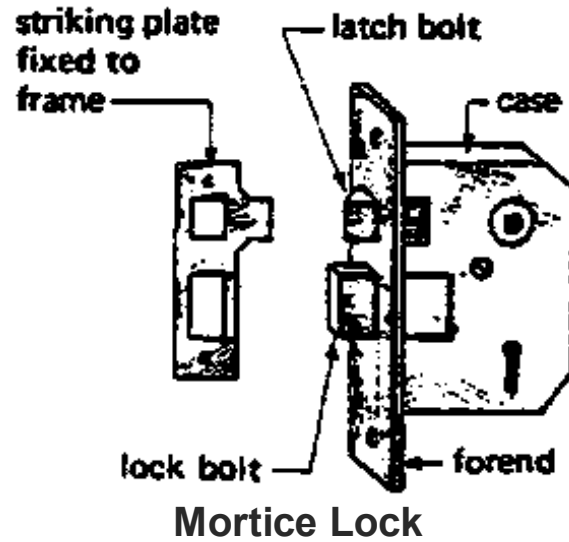

### Mortice locks:

Because they fit in a mortice cut in the door, so that the lock case is hidden.

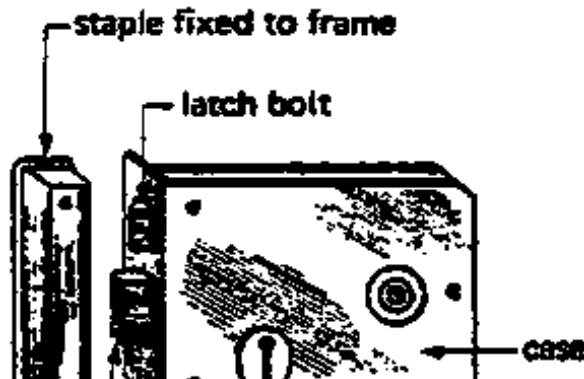



### Rim Lock:

is screwed to one face of a door. They are not much in use today, as they spoil the appearance of the door. Sometimes they are used as an additional lock for safety purposes.

### Cylinder night latch:

consists of a metal cylinder which is housed in a metal case which is fixed to the in-side face of a door. The cylinder fits in a hole in the door. The latch can be opened by a knob from inside. The levers inside the cylinder are arranged in a way that only the key cut to fit a particular cylinder will open its latch. These latches are commonly used for front doors to houses and flats.

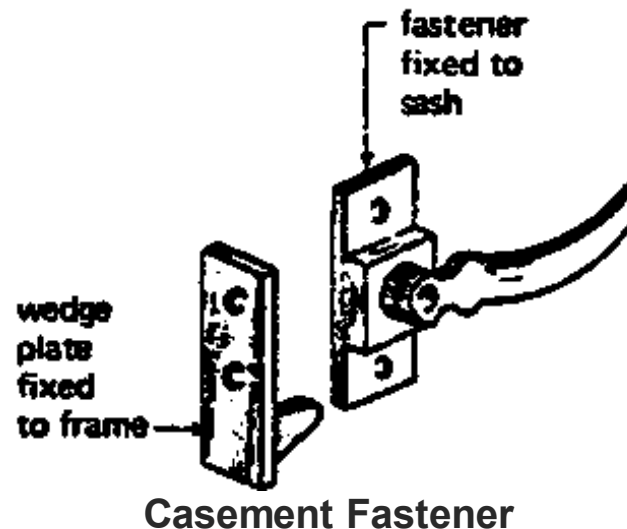

### Mortice dead lock:

consists of a case inside which is a single bolt which can only be operated by a loose key. These locks are fitted to a mortice in the door and the lack bolt shoots into a hole in a lock plate fixed to the door frame. These locks are used in addition to cylinder night latches or locks for entrance doors to houses and flats, because they are more difficult to force or prise open than cylinder night latches.



### Cylinder Lock:

has a safety-mechanism which is separate from the lock mechanism. It can be fit in an ordinary mortice or rim lock in order to take over the function of an ordinary loose key.

The functioning of a cylinder lock depends on the principle, that while unlocking with the heavily profiled key, a number of pins (which are under spring-compression) is brought in the only one position, which allows a turn of the cylinder core, on which the lock bit is fixed.

The quality of the cyl.-lock depends on the number of pins (=number of grooves of the key bit). The min. No. should be 5 pins, in order to provide a safe lock.

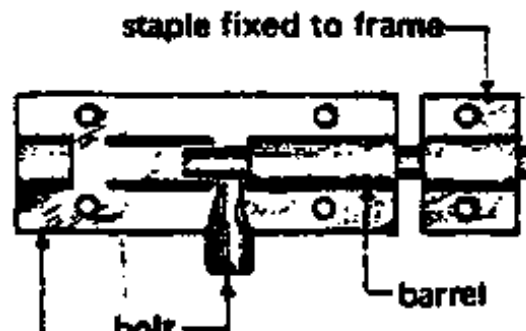

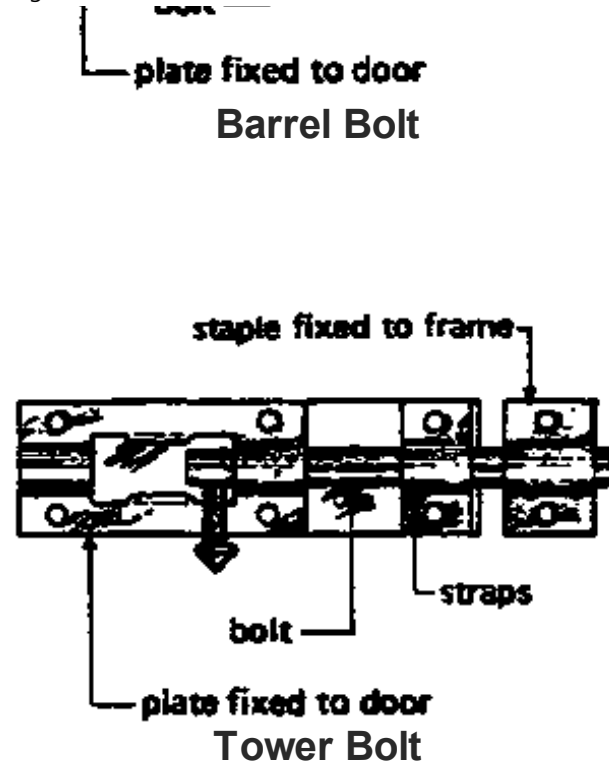

### 14.3.3 MISCELLANEOUS

Try to answer the following questions and use sketches where-ever necessary and possible

#### 14.1 Doors

What is the function of a DOOR?

Which materials may be used for construction?

Which methods may be used for construction?

**Compare EXTERNAL DOORS and INTERNAL DOORS and describe the differences!**

**What are PURPOSE MADE DOORS and where are they mainly used for?**

**Define the following terms by using sketches for illustration.**

- horn
- top rail
- glass panel
- glazing bars
- frieze rail
- solid panel
- lock a middle rail
- stile
- intermediate rail
- muntin
- bottom rail

**Explain in the form of sketches the basic types of PANELLED and GLAZED WOOD DOORS.**

**What are dowelled joints and what are mortice and tenon joints? (use sketches for explanation!)**

**Explain in the form of sketches methods of construction of FLUSH DOORS.**

**What are FIRE-CHECK FLUSH DOORS?**

**Explain in the form of sketches methods of construction of MATCHBOARDED DOORS.**

**Sketch and explain the construction of TIMBER DOOR FRAMES as well as for METAL DOOR FRAMES and compare their advantages and disadvantages.**

## **Sketch a typical DOOR LINING**

### **14.2 WINDOWS, GLASS and GLAZING**

**What are the primary functions of WINDOWS?**

**Which materials may be used for construction?**

**Which methods may be used for construction?**

**Where do the regulations K1, K2, K3 and K4 deal with?**

**What are the basic requirements for ventilation openings?**

**Sketch an elevation and sections of a TRADITIONAL CASEMENT WINDOW and give brief explanations!**

**Sketch an elevation and sections of a STANDARD WOOD CASEMENT WINDOW and give brief explanations!**

**Sketch an elevation and sections of a STEEL CASEMENT WINDOW and give brief explanations!**

**Explain BAY WINDOWS and describe the main difference in details to casement windows (use sketches for illustration)**

**Write notes on SLIDING SASH WINDOWS and explain (by using sketches for illustration) VERTICAL and HORIZONTAL sliding windows.**

**What are PIVOT WINDOWS?**

**Write notes on LOUVRES, compare advantages and disadvantages and use sketches for illustration.**

**Which methods of producing**

- DRAWN CLEAR SHEET GLASS
- FLOAT GLASS
- ROLLED and ROUGH CAST GLASS

do You know?

There are two main ways of GLAZING. Describe both and compare their advantages and disadvantages (use sketches for illustration)

Write notes on MOSQUITO SCREENING

List different SUN-BREAKER systems!

Classify the different types of SUN-BREAKERS and give brief explanations about their construction. (Use sketches for illustration wherever possible!)

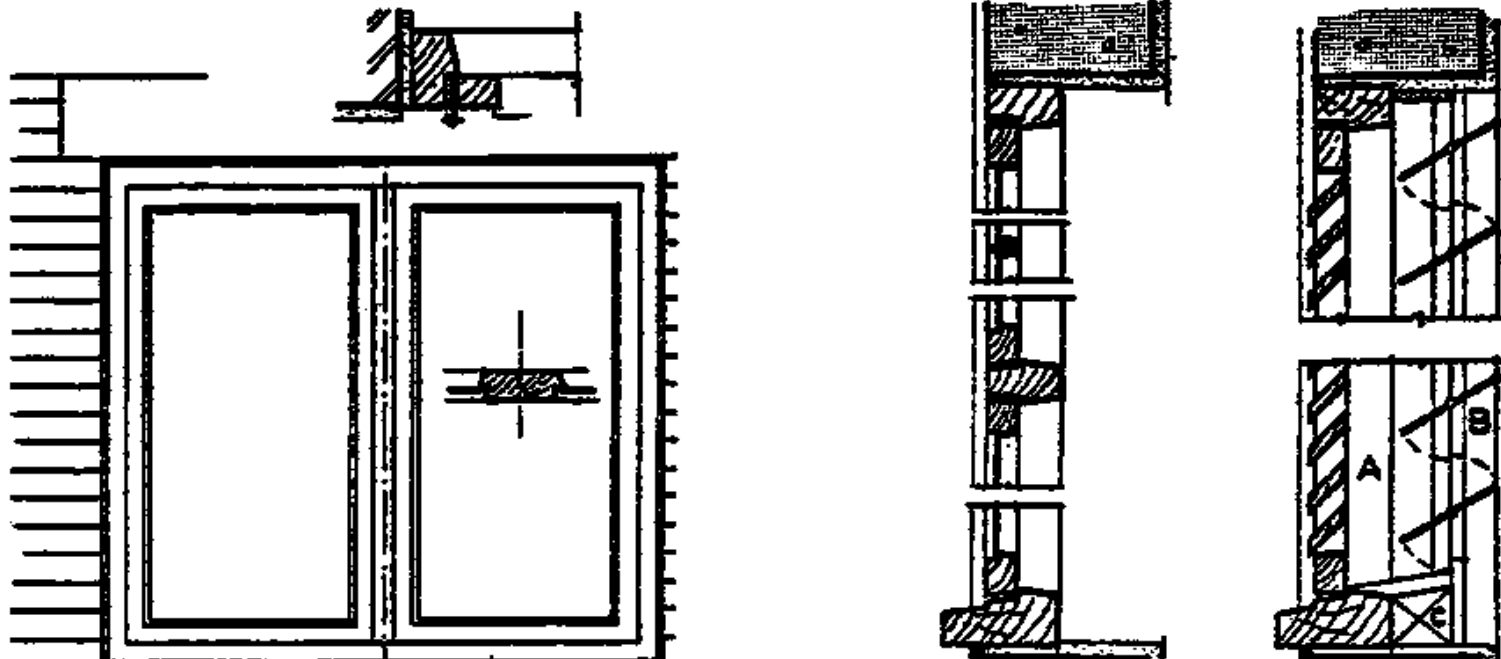





## 14.3 IRON MONGERY

Define the following terms and use sketches for illustration:

- pressed steel butt hinges
- loose pressed steel butt hinges
- double pressed steel butt hinges
- cast iron butt hinges
- brass but hinges
- steel skew butt hinges
- steel tee hinges
- hook and band hinges
- projecting steel windows
- mortice lock
- rim lock
- cylinder night latch
- martice dead lock
- cylinder lock

**Please provide your feedback**

[English](#) | [French](#) | [Spanish](#) | [German](#)