



[Home](#) > [ar](#).[cn](#).[de](#).[en](#).[es](#).[fr](#).[id](#).[it](#).[ph](#).[po](#).[ru](#).[sw](#)



 **Small-Scale Brickmaking (ILO - WEP, 1984, 228 p.)**

➔  **CHAPTER II - RAW MATERIALS**

-  **I. Origin and distribution of raw materials**
-  **II. Types of clay**
-  **III. Clay testing and significance of results**

Small-Scale Brickmaking (ILO - WEP, 1984, 228 p.)

CHAPTER II - RAW MATERIALS

I. Origin and distribution of raw materials

Brickmaking requires sufficient supplies of suitable soil, sand, water and fuel. The purpose of this chapter is to describe the various types of clay which may be used in brickmaking.

The essential ingredient in the soil used for brickmaking is clay. The size of each clay particle is extremely small, generally less than 0.002 mm across. Various forces act between these fine particles in a moistened clay, allowing the latter to be formed into the desired shape, which must be retained on drying. Clayey materials can be readily identified by simple manipulation of moist samples with a view to checking the plasticity of the latter.

A wide variety of raw materials may be used for brickmaking, ranging from soft sticky muds to hard shales. However, all these materials must contain a moderate proportion of clay-size particles. Too high a proportion of such particles will result in excessive shrinkage of moulded

bricks as they dry, with consequent risk of cracking. On the other hand, a soil with too low a proportion of clay particles will not be cohesive enough and will fall apart. The mineralogical nature of the clay must be suitable so that it is changed by heating in a kiln to a strong, water resistant vitrified form which can bind larger particles in the soil together.

Brickmaking clays may be found in most countries of the world. Geologically recent deposits are associated with existing valleys and rivers, and are often near the surface. Older deposits may be overlaid by other unsuitable material of varying depth, and may have been raised and inclined from their original positions. Thus, good deposits of clay may be found in gently rolling hills, but not mountains.

Information on clay deposits is available in many countries from National Geological Survey Departments, or may be

obtained from Geological Institutes. Location of existing brickworks, pottery works or other ceramic production is evidence of workable deposits.

Prospecting for new clay deposits may be undertaken by first examining river banks, and the sides of any recent road or railway cuttings which give an instant section of the soil profile. Subsequently it is necessary to explore in more detail any newly-discovered deposits by taking samples from many points on a regular grid covering the ground area. The neatest and simplest means of obtaining a suitable sample is by using an earth auger. The latter can be powered by one or two people. As it is rotated, the auger drills its way down into the earth, providing samples of the cut out soil. Alternatively, a spade may be used to dig a narrow hole (figure II.2). However, it cannot go as deep as an auger. A pit may be dug instead in such a manner that a person with the spade can work on the floor of the pit. This will require the removal of a great volume

of earth, and may not therefore constitute an efficient way of taking samples. For safety's sake the pit should not be more than 2 metres deep.

It is wise to keep an accurate record of such investigations. A plan of the area should be drawn, and location of investigatory holes marked in and numbered. Samples taken out of the hole should be small enough to allow the identification of a change from one soil type to another. Usually, there is a top-soil in which plants grow, and which contains the decomposed products of plants. The top-soil depth should be measured and noted, as well as that of subsequent soil layers. As soon as clay is found, it will be recognised by the stickiness with which it adheres to the auger or spade. If a large stone is encountered when augering, it will have to be knocked out of the way, or broken, or a different type of auger used to cut a way past.

The survey will indicate the area covered by clay, its thickness and the depth at which it may be found, and the thickness of the top soil which must be removed during quarrying. If there is much top soil, it will not be worth the cost of removing it unless there is a good depth of clay beneath.

Simple testing of clay for suitability for brickmaking may be carried out on site. For more extensive testing, each soil type should be in a separate heap on boards or a large sheet, then reduced by quartering. Quartering is done by dividing the heap into four quarters of equal size and shape, discarding two diagonally-opposed quarters, and recombining the other two. This procedure is repeated until a small pile of a few kilograms remains. The latter should be placed in a strong plastic bag, labelled with the hole numbers and the depths from which the sample was extracted.

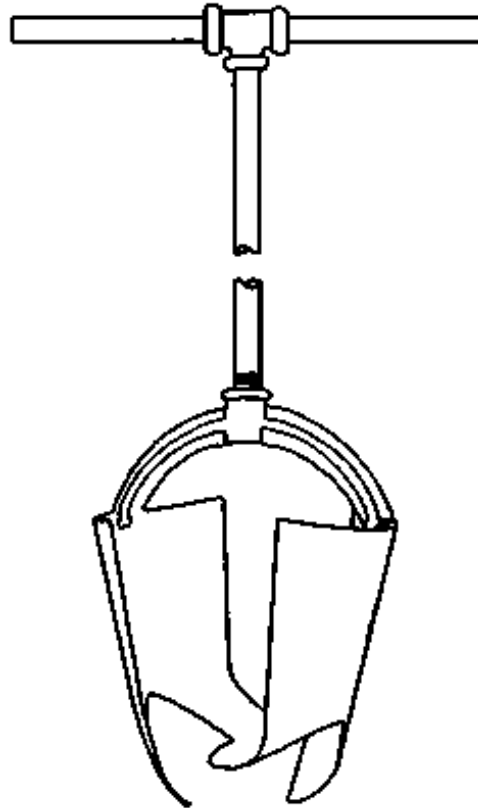

Figure II.1 - Bucket auger for sampling soil

II. Types of clay

It is essential that the raw material used for the production of bricks contains the following elements:

- sufficient clay fraction to ensure a good plasticity of the clay body, thus allowing the latter to be formed and retain its shape. The material is described as 'lean' or 'short' if the fine fraction is insufficient. The clay element should not exceed a certain limit which will render it too sticky for working. Furthermore, the dried bricks are liable to cracking due to high shrinkage if too much clay is present in the body. In this case, the material is described as 'fat'. Some clay types with the above characteristic have high shrinkage rates;**
- sufficient unreactive coarser grained material such as sand to mitigate the potential problem described above;**

- proportions of silica and alumina in the clay from which the strong durable glassy material may be formed on heating to approximately 1000° C;**
- alkalis or iron to assist in the formation of glassy compounds;**
- constituents which do not produce excessive deformation or shrinkage at the firing temperature in the kiln;**
- no impurities or inclusions which will disrupt the structure of the brick.**

The size of particle present in the clay body affects the cohesiveness, forming characteristics, drying and firing properties of a clay.

II.1 Particles sizes in brickmaking soils

The various fractions of particles in soils are usually denoted by their size as given in Table II.1.

Table II.1

Definition of particle sizes in brickmaking soils

Fraction	Size range (mm)
Sand	
Coarse	2 - 0.6
Medium	0.6 - 0.2
Fine	0.2 - 0.06
Silt	
Coarse	0.06 - 0.02
Medium	0.02 - 0.006
Fine	0.006 - 0.002

Clay	less than 0.002
------	-----------------

In practice, a raw material for brickmaking should contain some clay fraction (say 10 to 50 per cent) together with some silt and some sand. Depending upon relative proportions of various elements in the raw material, the latter might be described, for example, as a silty clay or, if containing some clay and similar proportions of silt and sand, as a loam. Since the presence of both clay and a good range of other particle sizes is desirable, loams are particularly suitable for brickmaking.

II.2 Clay minerals

Materials for brickmaking range from soft muds through the partially compacted clays or muds and highly compressed shales. The fine particles in the clay fraction may consist of various mixtures of some 12 different groups of clay minerals. These groups are briefly described

below.

The kaolin group is common and might be regarded as a typical clay mineral. In its molecular structure thousands of alternate flat layers of silica (silicon oxide) and gibbsite (aluminium oxide) occur, and give the particles their typical hexagonal plate-like structure. They are up to 0.002 mm across and can be seen under the electron microscope. This mineral presents no particular problems in brickmaking.

The montmorillonite group, which often occurs in the drier tropics, has two silica layers for every one gibbsite. This structure allows water molecules to enter in between the layers, forcing them apart. The resulting expansion of the clay may continue for several weeks under damp conditions(17) The layers close up again when the water is dried out. This has important consequences in brickmaking since montmorillonite-bearing clays have large drying

shrinkages. The thin plates are generally smaller than kaolinite. The high specific surface area gives great plasticity, stickiness and strength to the montmorillonites (17).

The hydrous micas and illites, which have somewhat similar structures to the montmorillonites, are also frequently found in brickmaking materials. Chlorites, which are related to hydrous micas, are also found in various clay materials. The latter have magnesium and potassium within their structures.

Extremely small particles from a millionth to a thousandth of a millimetre across, termed colloids, are also present in clays. They carry electrical charges, so their movement in water and their properties are affected by the presence of salts. Thus, the physical properties of wet clays can be altered by additions of some chemicals which may, for example, increase their plasticity or reduce stickiness. An

acidic addition flocculates the colloidal particles so they settle in water more readily whilst an alkaline addition deflocculates these particles and keeps them in suspension.

Mineralogical examination can help identify the substances present with a view to determining the likely suitability of a material for brickmaking.

II.3 Chemical analysis

Chemical analysis can help in the identification of the clay minerals present in the raw material. The relative proportions of silica and alumina are relevant, since the higher the proportion of alumina, the higher the temperature necessary to form the glassy ceramic bonding material which characterises ceramic products. Chemical analysis can also indicate the presence of water-soluble compounds such as the sulphates of potassium, sodium

and magnesium. The drying out of the latter on the moulded bricks (before firing) produce unsightly scumming. If still present in the fired product, they may lead to efflorescence and, exceptionally, can spoil brick faces and lead to attack and expansion of cement-based mortars. Calcium sulphate can also produce this undesirable effect. With knowledge of these deleterious salts within the clay it might be possible to avoid problems with the bricks when finally built into walls, by choosing another clay deposit or allowing rain to wash salts out of the clay after it has been dug, or by firing the bricks to a higher temperature. Another solution to these problems is to add barium carbonate. This is, however, an expensive remedy which may not be feasible in many situations.

If potassium and sodium are found in the chemical analysis, but the compounds are not water soluble, they may indicate the presence of fluxes such as the feldspars or micas. These are beneficial in reducing the temperature

needed for formation of glassy material. Magnesium, calcium and iron (ferrous) compounds can also behave as fluxes.

Chemical analysis may be carried out on different size fractions of the soil. This is an important consideration since fluxes should be in the finest of particles sizes. Hence, their presence in only coarse fractions is of little significance.

Laterites occur as rock, gravel, sand, silt and clay in many tropical locations. They are high in alumina and low in silica. Thus, the use of laterite soils for brickmaking will require higher kiln temperatures. In practice, the presence of potassium and sodium-bearing compounds, and of iron compounds (which are often abundant and act as fluxes), should allow the production of bricks from laterites. The latter are defined in a number of ways, but the following definition is often accepted: The ratio of silica to

sesquioxides (that is iron and aluminium oxides) must be less than 1.33 for the material to be a laterite. If the ratio is between 1.33 and 2, the material is lateritic, and if the ratio is greater than 2, it is non-lateritic.

Marls, which are clays with a high proportion of calcium carbonate (chalk, limestone, etc.), are identified by high calcium and high weight losses on heating in a full chemical analysis. They may have low vitrification temperatures which extend over only a narrow range. Thus, sudden fusion can occur in manufacture. If the calcium carbonate is present as large lumps, the latter will have a disruptive effect on the fired bricks after manufacture. These lumps should be removed or ground to less than 2 mm.

II.4 The drying process and drying shrinkage

A wet clay has the fine individual particles separated by

films of water which are absorbed into the particle surfaces. In such a state the clay exhibits its typical plastic property which enables it to be shaped. On drying, the films are reduced and the particles get gradually closer. Thus, an overall shrinkage of the body is discernable. The shrinkage continues until the particles touch, but water still remains in voids between the particles. The clay then has a critical moisture content (CMC). As the water continues to dry out, no further significant shrinkage occurs. This is shown diagrammatically in figure II.2. The practical significance of the process is that bricks must be dried slowly to the CMC, thus ensuring that all parts of the brick (top, bottom and inside) are shrinking at the same rate. If one face of a brick dries before the opposite face and becomes non-plastic, the latter face may crack as it dries while being held in position by the dried face. Different rates of shrinkage also cause bricks to become bowed, or banana-shaped by a similar process. Once the CMC is reached, faster drying may be used since there is no

further shrinkage.

Clays for brickmaking should not have too high a shrinkage rate on drying if cracking is to be avoided. However, if the moulded bricks are dried very slowly, higher shrinkage material may be used. Montmorillonite has an exceptionally large drying shrinkage, so soils containing it (e.g. black cotton soils) would be best moulded from the driest possible mix, and then dried very slowly. In general, the greater the proportion of fine particles the greater the drying shrinkage, and the finer the particles the more the shrinkage. Hence, there should not be too much clay in brickmaking soil.

To reduce unacceptably high shrinkages, non-reactive coarse grained material may be mixed in with the soil. The additional materials frequently employed are sand, if it is available nearby, or ground-up reject bricks which are referred to as 'grog'.

Drying should be as complete as possible before bricks are exposed to the heat of the kiln. Otherwise, steam may be produced in the bricks and develop enough pressure to blow them apart (other reasons are listed in Section I of Chapter VI).

II.5 The firing process and firing shrinkage

At a low temperature of 100 °C, any moisture remaining in the bricks is removed. The nature of the clay is not changed (i.e. the cooled and wetted clay retain its original characteristics - see figure II.3).

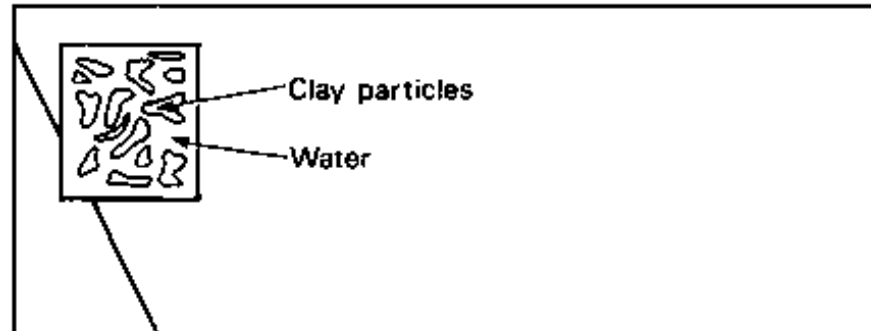

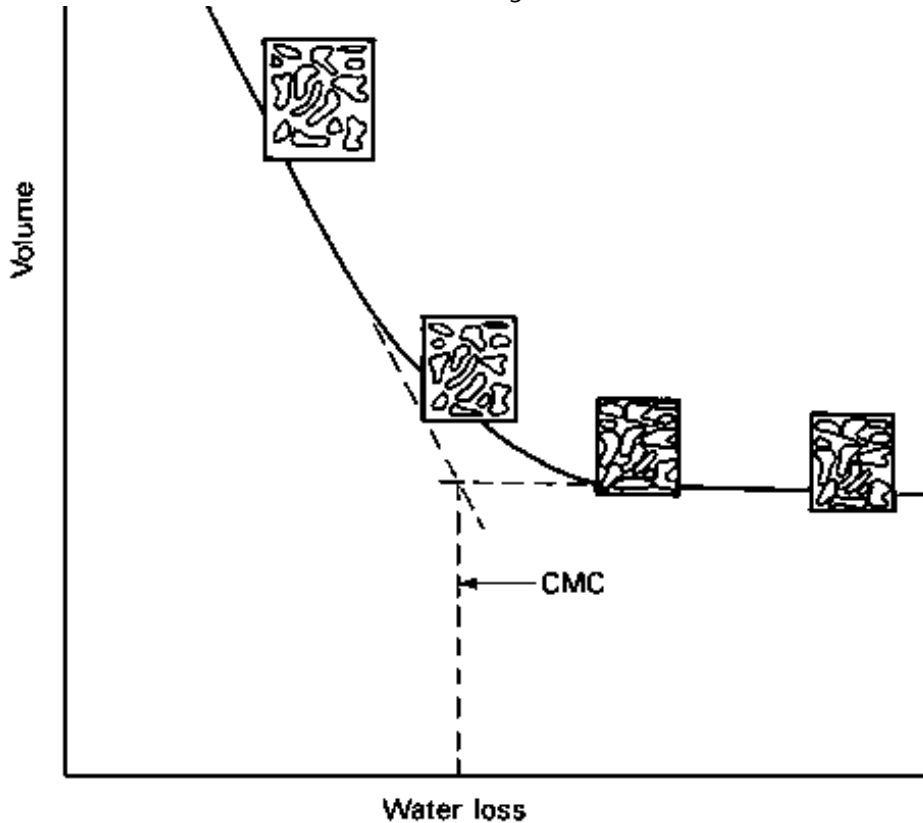
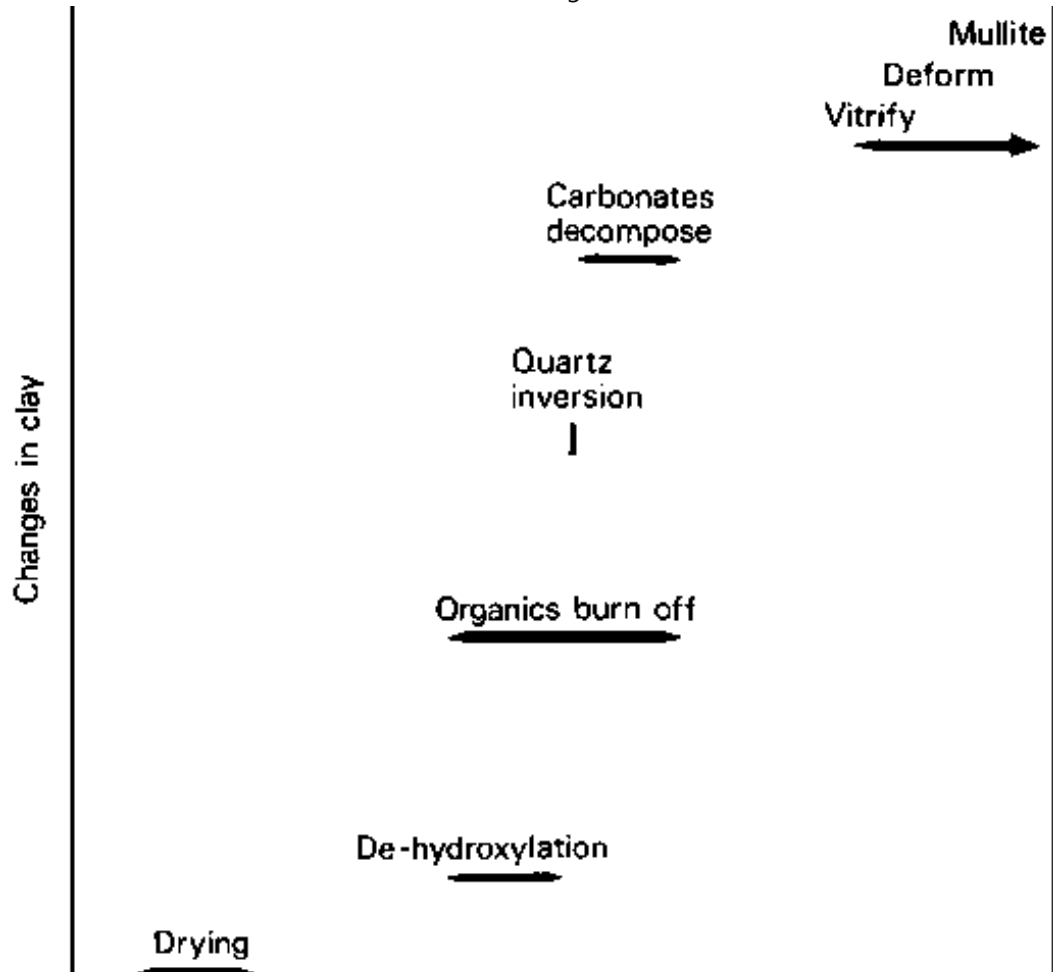
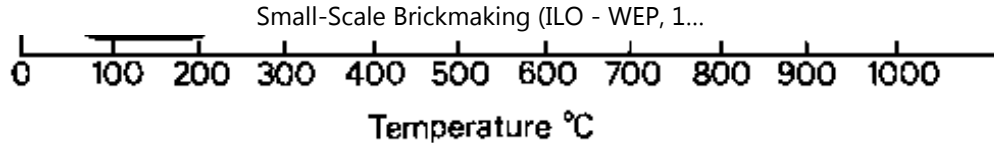

Figure II.2 - Drying curve





Figure

The first irreversible reactions start at approximately 450-500 °C, when dehydroxylation takes place. Part of the actual clay structure (the hydroxyl groups) is driven off as steam, resulting in a very small expansion of the brick.

Carbonaceous organic matter (derived from plants, etc.) in the soil will burn off in the temperature range of 400-700 °C, provided sufficient air is allowed in to convert it to carbon dioxide gas. Time is required for the brick to heat up, for oxygen to diffuse in, and for carbon dioxide to diffuse out. If this organic matter is not completely burnt off before the temperature rises to the point at which glassy material forms, the diffusion processes will not be possible, and carbon will remain within the bricks as undesirable black cores. The latter may also be caused by

the lack of oxygen. An “opening material”, such as a burnt refractory clay, can be mixed in to aid gas diffusion.

Present carbonates and sulphides decompose at the top of the temperature range at which the organic matter is burnt, carbon dioxide and sulphur dioxide being given off.

Silica, which is a common constituent of brickmaking soils in the form of quartz, changes its crystal form at 573 °C. This so-called inversion is accompanied by an expansion. Consequently, the rate of rise of temperature must be slow if one is to obtain near-uniform temperature throughout the brick and thus avoid excessive stresses which could lead to cracking.

The glass formation, which is necessary to bond particles together and make the product strong and durable, commences at approximately 900 °C, depending upon the composition of the soil used. The process, known as

vitriification, involves fluxes reacting with the various other minerals in the soil to form a liquid. The higher the temperature, the more the liquid formed, and the more the material shrinks. In practice, the heating must be restricted lest so much liquid forms that the whole brick starts to become distorted under the weight of the higher layers of bricks. In extreme cases, the bricks get fused together in the kiln. Gas formation can 'bloat' brick faces.

A few hours 'soaking' at the finishing temperature is recommended to ensure that the whole brick has attained uniformity. New materials, such as mullite, may crystallise from the liquid at temperatures which may reach approximately 1,100 °C for some brickmaking clays. In these ceramic reactions, a long firing time at a low temperature can have the same effect as a shorter firing-time at a high temperature. As cooling commences, the liquid solidifies to glass, bonding other particles together. The cooling rate should be slow to avoid excessive thermal

stresses in the bricks, particularly once the quartz inversion temperature (573 °C) is reached, since shrinkage occurs in the presence of quartz.

The inevitable firing shrinkage should be fairly small, otherwise it would be difficult to maintain the stability of the bricks in the kiln.

II.6 Other basic requirements

High technology tends to limit the range of clay types acceptable for a particular process machine, and is less versatile as regards the type and grade of fuel. On the other hand, a wide range of materials and fuels can be used with less sophisticated technologies. Fuel, whether oil, gas, coal, wood, scrub or plant wastes, must be available for the brickmaking process and may be regarded as a raw material. Electricity may be advantageous for ancillary purposes. Water is also necessary and, for highly

plastic clays, sand may also be required.

III. Clay testing and significance of results

Although highly sophisticated clay testing methods have been evolved, very simple tests can also give useful information. The former may be necessary for large turnkey projects, where equipment is often adjusted for specific raw materials characteristics. However, they require skilled staff not only to carry out tests, but also to interpret the results. On the other hand, simple tests may often be carried out on site, by less qualified personnel. Yet, the results may be more easily related to the use of the raw material than those obtained from more sophisticated tests.

The most direct test method used successfully for thousands of years involves visual inspection and the feel of the soil, and the carrying out of brickmaking trials.

Tests to investigate various aspects of a soil's suitability for brickmaking are given below, starting with the most basic field test methods. Simple, intermediate technology tests are described next. Finally, a brief description of the more sophisticated tests which might be employed if adequate facilities exist, is provided at the end of this section.

III.1 Particle size

A visual inspection of the raw material will show whether the soil contains sand; a magnifying glass may assist in this operation.

The 'feel' of a soil in the hand will give an indication of the proportion of different particles sizes. When dry, a sand constituent gives a sharp gritty feel. A piece of the hard soil rubbed with the back of the finger nail cannot be polished. When wetted and broken down between the

fingers, the sand particles become more readily visible.

If there is a high proportion of clay the dry soil will feel smooth and powder may be scratched off it. Furthermore, a surface of a small lump can be polished with the back of the finger nail. Damp soil can be worked into any shape, but will tend to stick to the fingers. The more clay in the soil, the more difficult it will be to remove it from the hands by wiping or washing.

A suitable brickmaking soil will have a high proportion of sand, so that it may not take a polish. High clay content soils may need addition of sand to make them suitable.

An estimate of the proportions of the various size fractions can be obtained using the sedimentation jar test. Any straight-sided, flat-bottomed, clear jar or bottle may be used. An approximately one litre capacity jar will be adequate (figure II.4). One-third of the jar is first filled

with broken-up soil. Clean drinkable-quality water is then added until the jar is nearly full. The content of the jar is next mixed up, one hand covering its mouth to avoid spilling. The soil is then left to settle for an hour, shaken again and allowed to settle a second time. An hour later, the depth of the separate layers can be seen and measured. The bottom layer consists of sand and any coarser particles. The medium layer consists of silt and the top layer of clay. Often, the top two layers will merge together. The settlement of the clay fraction may be slow with some soils. The use of salty water for this test will flocculate the clay and help it to settle, thus giving a clearly defined level in the bottle which can be measured more easily.

Where laboratory facilities exist, a wet sieving process may be used to estimate the quantities of various sizes of sand. The soil is first washed through a nest of sieves of increasingly fine mesh, and the quantities retained on each sieve are dried and weighed. The difference between the

weight of these fractions and that of the initial sample is then equal to the weight of silt and clay. Further information about the composition of these finer materials can be obtained using a sedimentation method (the Andreason pipette) or a hydrometer method. Details of these and other methods are described in British Standard Methods of Test for Soils for Engineering Purposes - BS 1377:1975 (18).



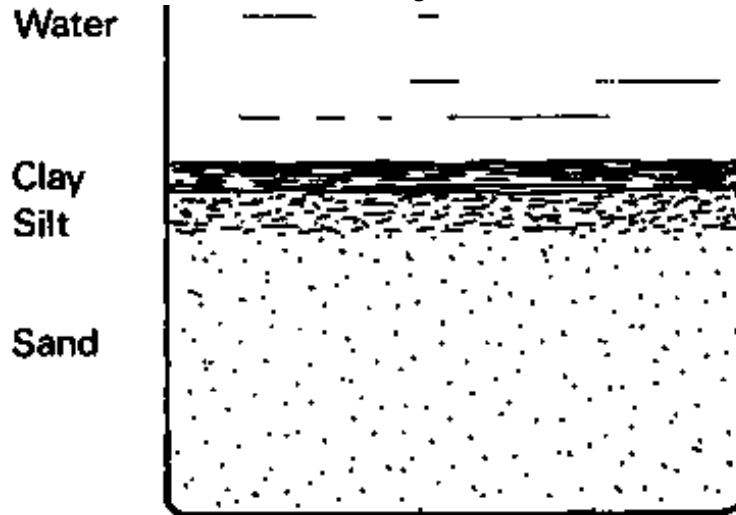

Figure II.4 - Jar test

Soil used for the production of bricks by traditional methods should contain the following:

- 25 per cent to 50 per cent of clay and silt; and**
- 75 per cent to 50 per cent of sand and coarser material.**

The soil should preferably contain particles of all sizes

III.2 Plasticity and cohesion

If the moistened soil is rolled by hand (on a flat surface) into a cylinder, a sharp break of the latter when pulled apart indicates a very sandy soil with low plasticity (7). On the other hand, the soil may be considered adequate for brickmaking if the cylinder elongates to the point of forming a neck before breaking

Another test consists of preparing a long cylinder of 10 mm diameter and letting it hang unsupported while holding it from one end. The length of cylinder which breaks off will provide fairly accurate information on the properties of the soil. The breaking-off of a piece of cylinder of 50 mm or less will indicate that the soil is too sandy for brickmaking. In this case, it will be necessary to add some fat clay or ant hill material to the soil. On the

other hand, the breaking-off of a piece of 150 mm or more will indicate the presence of too high a proportion of clay, necessitating the addition of sand or grog to the soil. A soil adequate for brickmaking will require that the length of the broken-off piece of cylinder is between 50 mm and 150 mm (19).

The properties of the wetted soil will depend upon the moisture content. A ball of suitable soil containing the correct amount of water should break into a few pieces when dropped from the held-out arm on to hard ground. On the other hand, a flattening out of the ball will indicate that the soil is too wet, while the breaking of the ball into a large number of small pieces will indicate that the soil is too dry. Some more precise assessment of plastic properties can be obtained by simple laboratory tests. The soil should be mixed up with an excess of water to make a very runny paste or slip. The latter is then poured on a dry porous plastic plate, and mixed continuously with a spatula

or knife. As water is absorbed by the plate, the soil will become less liquid and new incisions made with the knife will take longer to close. Once an incision remains open, approximately 5 g of material should be taken from its vicinity and weighed immediately. The sample is then weighed again after a few hours' drying in an oven at 110 °C. The moisture content can thus be calculated as percentage of the dry weight of clay. This percentage is termed the liquid limit of the soil.

Some small pieces of the clay may be removed from the plate and rolled by hand of a flat-glass plate in order to make filaments approximately 3 mm in diameter (figure II.5). At first, long filaments may be fashioned easily. Then, as the soil dries out there will come a point when they just start to crack longitudinally and break up into pieces approximately 10 mm long. Once this occurs, approximately 5 g of such pieces should be weighed, oven dried, and weighed again to determine the moisture

content as a percentage of the dry weight of clay. This percentage is termed the plastic limit of the soil.

The difference between plastic and liquid limits is the plasticity index.

When more advanced facilities are available the liquid limit should be determined with the cone penetrometer, described for example in BS1377 (see section III.1). In this test, the penetration of the point of an 80 g metal cone having an apex of 30° is measured as it rests for 5 seconds on the moistened soil. From a series of readings for different moisture contents the liquid limit is determined as the moisture content which gives a 20 mm penetration. The test for estimating the plastic limit is the same as that described above.

Several other testing methods are used in well-equipped laboratories (17).

Soils with a low plasticity index will be difficult to handle for brick-moulding: the green brick will distort after demoulding if the soil contains a small excess of water while the soil will be too stiff to mould if it lacks sufficient water. A high plasticity index is therefore preferred.

Soils with a high plastic limit will require a great deal of water before they can be ready for moulding. Long drying is then necessary prior to firing. A high plastic limit and very high liquid limit may indicate the presence of montmorillonite, with its attendant moisture movement problems. Thus, montmorillonitic soils may not be adequate for simple brick-moulding methods as the latter require a relatively high moisture content. They need either high compaction pressures on semi-dry mixes, or dilution with non-shrinking materials. Montmorillonites may give rise to size changes in the drying bricks as the humidity of the air varies naturally.

In a recently published book (20) reference has been made to an earlier suggestion (21) that, within the plasticity ranges indicated in table II.2, a soil may be adequate for the production of bricks by traditional methods. However, it may be possible to use materials with plasticity limits outside the ranges shown in the table.

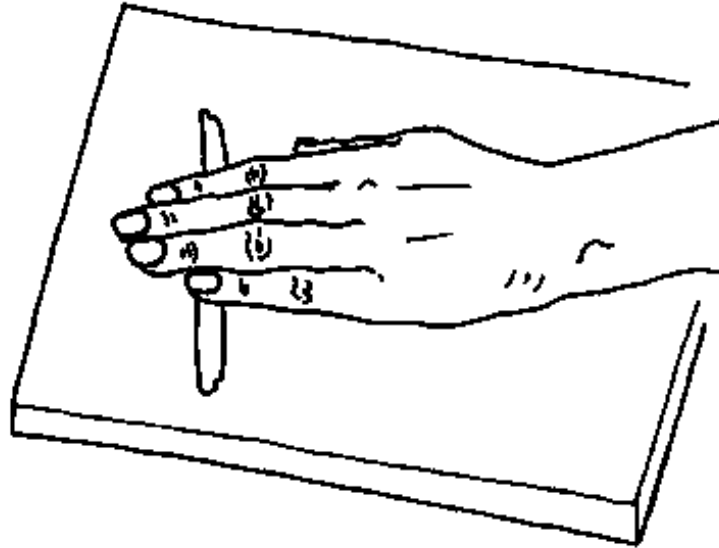

Figure II.5 - Plastic limit test

Table II.2

Plasticity limits for good brickmaking soils

Plastic limit 12 to 22

Plastic limit 12 to 22

Liquid limit 30 to 35

Plasticity index 7 to 18

III.3 Mineralogy and geology

The mineralogist recognises the presence of certain minerals in the field while the geologist identifies structures in the earth's appearance that will assist in locating suitable raw materials sources.

The work of the mineralogist will consist largely of taking samples from the field and examining them under the microscope in a laboratory. On the basis of information from other tests, he may identify the components of a soil and thus determine their suitability for brickmaking by the various means available. In more advanced laboratories, the electron microscope (especially the scanning electron microscope) will be a useful tool. Identification of minerals

will also be greatly assisted by X-ray diffraction analysis.

III.4 Chemical analysis

The colour of samples of materials obtained from field investigations gives some indication of the composition of the soil. Red soils may be high in iron, which can act as a flux. Very dark colours, or a musty smell in the damp soil, may indicate the presence of organic matter: it may be possible to use such soils, though their agricultural use should be given first priority. Dried out encrustations on the surface of the ground indicate the presence of soluble salts, which are best avoided for reasons given in Section II.3.

A simple laboratory test for the presence of sulphates consists of dissolving these salts and adding a solution of barium chloride. The forming of a white precipitate will indicate the presence of sulphates. On the other hand,

chlorides can be detected by addition of silver nitrates. These chemical tests could be done on site, with a small portable test kit. The presence of calcium carbonate can be ascertained by the existence of lumps or nodules which are likely to be white, or by effervescence from gas produced by the addition of dilute hydrochloric acid to the soil. An estimate of the quantity of carbonate has been suggested(7): 1 to 8 per cent in case of slight bubbling; 8 to 16 per cent in case of pronounced bubbling; and 18 per cent in case of sudden foaming.

In a properly-equipped laboratory, a full chemical analysis may be undertaken, which, together with the mineralogical examination, can assist in identifying the constituents as mentioned in section II.3.

III.5 Drying shrinkage

High clay content (recognisable in wet conditions by the

stickiness of the soil) is in dry weather, recognisable by the presence of shrinkage cracks in exposed soil, in either vertical or horizontal faces (see figures II.6 and II.7).

To obtain a measure of the shrinkage of a moist soil, which may seem suitable for brickmaking, the most simple method is to mould a few bricks from the soil and allow them to dry thoroughly. The length of the dried bricks and of the moulds are then measured in order to obtain an estimate of the linear drying shrinkage. The latter may be obtained from the following formula:

$$\text{Lineardryingshrinkage(percent)} = \frac{(\text{Mould length} - \text{final dry length}) \times 100}{\text{mould length}}$$

The appearance of the test bricks will give some indication of the suitability of the soil for brickmaking. It is suitable if no cracks appear on the surface. If some slight cracks appear it would be advisable to shorten the soil by adding

20 per cent sand or grog. In case of extensive cracks, 30 per cent might be mixed in. Soil too lean for moulding will have to be made more fat with other clays, or ant hill soil.

Generally, up to 7 per cent linear shrinkage may be tolerable, depending upon the nature of the material and the rate of drying. If linear shrinkage is more than 7 per cent shortening is advisable(22). In any case, it is necessary to know the linear shrinkage in order to determine the exact size of moulds needed for producing bricks of given dimensions.

If more organised test facilities are available, it would be advisable to prepare special shrinkage bars. For this test, an open-topped wooden mould, approximately 300 mm long by 50 mm deep and wide, should be made up by a carpenter or a sufficiently skilled handyman (figure II.8). The soil used in the test should be dried, if not already so, and broken down. Large stones should be removed. It is

then mixed with just sufficient water to bring it near the liquid limit (i.e. pieces of the soil should be deformable yet retain their shape). If time permits the soil should be covered, left overnight, then mixed up again. The mould should be lightly greased inside to prevent the soil from sticking. Some moist soil is then laid in the bottom, and the mould tapped on the bench or ground to cause entrapped air bubbles to escape from the soil. The mould should be filled in the way described above in several stages, and excess soil struck off the top to leave a surface level with the surface of the mould. The soil should be dried slowly at first, at room temperature. Once shrinkage appears to have stopped, it may be tipped out the mould and dried in an oven at 110 °C. The linear shrinkage may then be calculated as indicated above.



Figure II.6 - Clay shrinkage on a vertical face

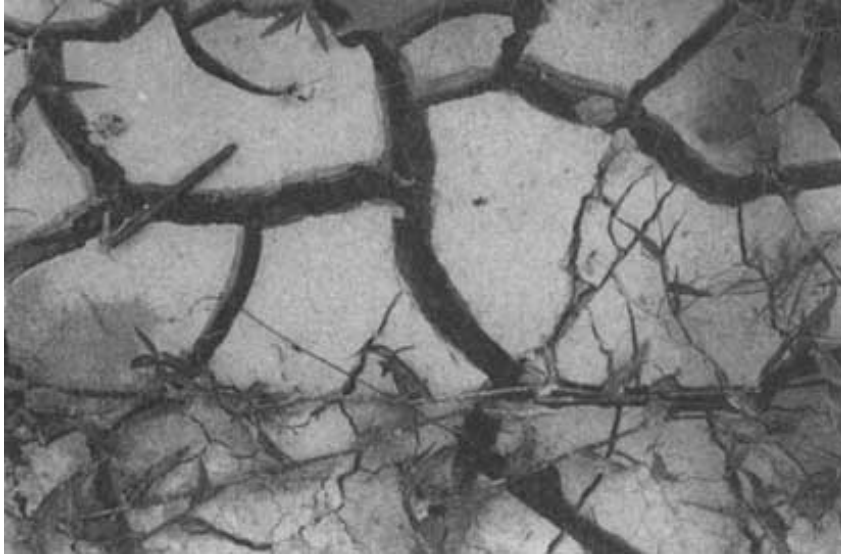

Figure II.7 - Shrinkage cracks in clay pit bottom

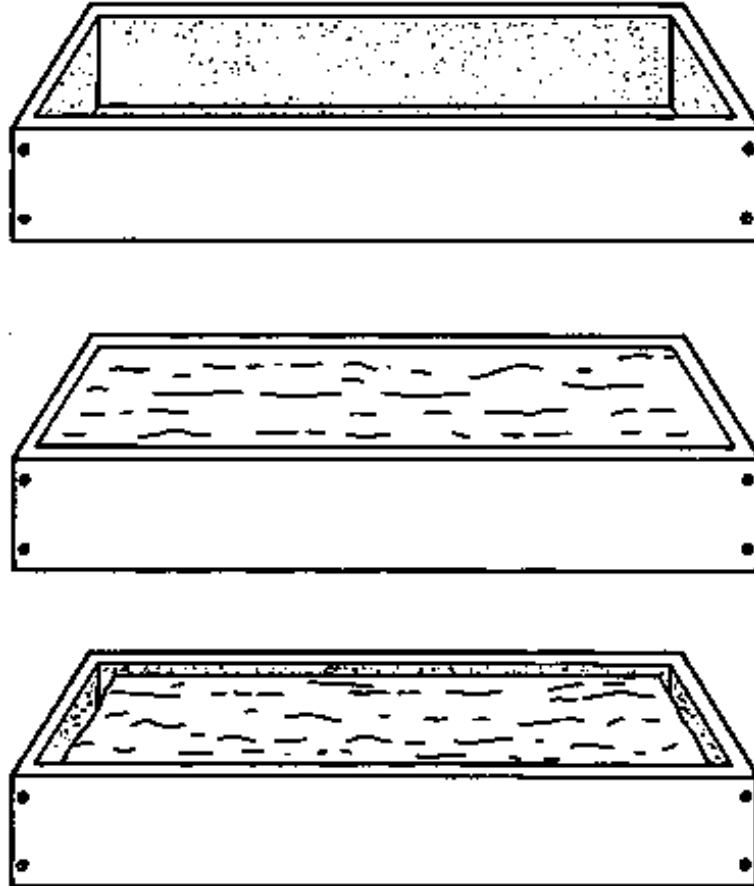

Figure II.8 - Shrinkage mould

III.6 Firing shrinkage

Some shrinkage during firing is inevitable. From 6 to 8 per cent linear shrinkage is desirable (5,7). The simplest field test to measure firing shrinkage is to burn a whole batch of bricks.

Measurements of firing shrinkage are more readily obtained in the laboratory than in the field. Small bars should be moulded, dried, measured, then fired to various temperatures in a laboratory furnace. They are then cooled and re-measured to calculate the linear firing shrinkage. A special furnace has been designed for this test. It requires only one sample, since it has a horizontal silica rod whose movement is measured outside the furnace as the temperature rises. A 'gradient' furnace of uneven temperature distribution can also give useful information.





[Home](#) > [ar](#).[cn](#).[de](#).[en](#).[es](#).[fr](#).[id](#).[it](#).[ph](#).[po](#).[ru](#).[sw](#)



 **Small-Scale Brickmaking (ILO - WEP, 1984, 228 p.)**

 **CHAPTER III - QUARRYING TECHNIQUES**



-  **I. Organisation and management of the quarry**
-  **II. Methods of winning the clay**
-  **III. Transportation to the works**

Small-Scale Brickmaking (ILO - WEP, 1984, 228 p.)

CHAPTER III - QUARRYING TECHNIQUES

I. Organisation and management of the quarry

The quarry should be located in an area with sufficient proven deposits of good brickmaking soil and, preferably, a thin layer of overburden to minimise excavation work. The operation of mining clay from the clay pit or quarry is generally referred to as 'winning the clay'.

I.1 Opening up the quarry

Access to the quarry from the bricks production plant should be quick and easy, preferably with no more than a slight gradient. A good route will minimise effort, time and expense in transporting clay, and will facilitate supervision of the pit. A track or roadway may need to be constructed, especially if wheeled vehicles are to be used to convey the clay to the brickworks. Trees and bushes must be cleared, and may be sold or kept for fuel.

Prospecting will indicate whether the clay stratum is horizontal or sloping. If it does slope down into the ground

the worker should face that direction and remove the top soil. The top soil should be piled in two rows along the excavation. The trench thus formed will have a horizontal bottom, along the 'strike' of the clay stratum(24). The angle at which the clay stratum slopes from the horizontal is a measure of the "dip" of the stratum. It must be borne in mind that more overburden will have to be removed as the clay winning proceeds. If there is no dip, the trench may be dug in any direction.

As a general principle it is unwise to start digging for clay at the lowest part of the ground(25) since surface water from rainstorms will then immediately flood the clay pit and stop the work. It is preferable to start digging at a higher point. This should be borne in mind whether the underlying clay has a dip or not.

A sufficient area of overburden should be removed to prevent any of it falling into the clay as winning proceeds

(e.g. up to 10 m may be taken off to each side of the trench). If too much is cleared weeds may start to grow and will have to be cleared again. Clay may then be dug to a depth of a few metres, along the centre line of the exposed area. The actual depth will depend upon the adopted method of digging and the nature of the material extracted. Further material is then obtained by widening this deeper trench a small amount at a time. Eventually, it will be necessary to remove more overburden. This unwanted material may conveniently be used to fill the first-opened part of the trench once all the useful clay has been excavated. If good clay does extend lower down, it might be extracted at a much later date or by the method of 'benching' or 'terracing' (which is the working of two or more clay faces at different depths at the same time).

I.2 Operating the quarry

Safety

It is important to bear safety in mind in the clay pit. Clay is very slippery when wet. Thus steeply sloping paths and access routes should be avoided. Steep drops into the pit would be hazardous. Damp clay is not stable at a near vertical face. Consequently, a whole portion of the material may undergo a rotational slip, into the bottom of the pit. For this reason, it is advisable to slope back or 'batter' the faces of the pit as they are dug. The latter should not be too high.

Water

If flooding of the pit bottom becomes a problem, the water may be drained away through a downhill channel. If this is not possible, a sump must be dug in the pit bottom to collect the excess water. The latter may then be removed from the sump by pumping or with buckets. This water may be contaminated with soluble salts present in the ground. Thus, it would be unwise to use it in the

subsequent brickmaking process, unless tests show that it does not contain salts. In countries having a wet season or monsoon, the quarry may need to be abandoned until the rainwater is drained off.

Rejection of impurities and reinstatement

As digging proceeds, the workers should discard any plant roots, stones, limestone nodules or harder clay inclusions since they would cause problems in subsequent processing. Any pockets of unsuitable soil should be removed rather than left in place and the pit should be kept tidy. The top soil should be returned ultimately, on top of discarded material into the worked-out part of the quarry. Crops may thus be grown again. This is the case, for example, in Madagascar where the most exploited clays for brickmaking are from the rice fields. The top soil is then reinstated for rice growing (26). One of the main sources of raw materials for the structural clay industry in

Indonesia is also the rice fields.

Rate of extraction

The rate of extraction of clay from the pit must be sufficient to meet the demands of the brick-moulders. Alternatively, it may be slightly larger in order to guard against problems which may arise unexpectedly in the pit, such as temporary flooding, presence of an unsuitable pocket of material, contamination of the clay, etc. In some countries the onset of the wet season or the monsoon may halt operations in the clay pit. During these times, the natural drying of moulded bricks will become almost impossible, building of field kilns or clamps (Chapter VII) will be impracticable, and demand for bricks will fall due to adverse weather conditions restricting building and construction activities. In such cases, the pit will be closed and the whole brickmaking operation stopped. However, in other places, although the rain may prevent operations in

the clay pit, some demand for bricks may continue, and it may be possible to carry on brickmaking and drying under cover. More permanent forms of kiln, also under cover, may still be in operation. In these cases, sufficient clay should be won from the pit during the dry season, and stock-piled, to meet the demand when no more can be mined. In some communities the workforce may wish to engage in agricultural activities during the harvesting season. This factor should be taken into account in designing the whole brickmaking process.

Working of the clay face

The depth of the top-soil may vary from a few centimetres in some arid climates to several metres in hot, humid areas. Frequently, a layer of sand may occur below the top-soil and over the clay layer. The best clay for brickmaking is likely to be that immediately below the sand, since it is likely to contain a proportion of sand itself. However, the

depth of this good material may be small. Clay lower down may be too fat and will need addition of sand from above. Hence the best method of operation is to work a quarry face in such a way as to dig both clay and sand, taking shallow slices down the face, to obtain a suitable mixture (see Figure II.6). Another virtue of taking shallow slices of the face is that any embedded stones can be found more easily than if large cuts are taken. These stones can then be discarded(28).

If suitable soil containing the desirable proportions of sand and clay cannot be dug at one face only, it may be necessary to obtain a fat clay from one face and sand or sandy clay from another. This has often been done as, for example, near Mombasa in Kenya, where material from two faces has been mixed in the pit bottom prior to use. If the material varies horizontally (i.e. from one place to another) two separate faces in the pit, or two separate pits, might be worked simultaneously. If the material

varies vertically (i.e. at different depths), two faces can be operated by benching (see section II.2).

Record-keeping

For later reference, a note-book should be kept for recording progress, and any significant happenings in the quarry. A map should be made of the quarry, showing the position of original test holes or pits, the depth of clay, and other major features such as streams, tracks, large trees and the brickworks if adjacent. The position of the clay-pit face should be drawn on the map every few months, and the date written on the line representing the face. If the floor of the pit is dug a second time or if benching is used, a second colour could be used to update the map. This will assist in an orderly exploitation of the reserve: haphazard digging is wasteful of material and effort(27). The rate of ingress into the reserve should be clearly visible, and if problems or complaints arise with the finished bricks, the

fault may be traceable to a cause in the pit. The extent of any problem materials in the pit should be marked on the map. The supervisor should check constantly the work at the clay face and inspect the material being won to ascertain that it is suitable and does not contain deleterious materials.

II. Methods of winning the clay

Two basic methods are available: mechanical winning and hand-digging. These are briefly described below.

Mechanical winning

Mechanical methods such as the use of the drag-line and multi-bucket excavator are mostly appropriate for the largest-scale brickmaking operations. It is most unlikely that even a face shovel (figure III.1) could be justified in works of the size considered in this memorandum, unless

it is available on hire from a nearby depot for a short period of time each year, (e.g. in order to build a stock pile). It seems unlikely that mechanical winning could be economical for output of less than 14,000 bricks per day(22).

On the other hand, the more commonly available and versatile bulldozer could have a place in the laborious task of clearing overburden on infrequent occasions. It might be brought in on hire, or when available from nearby road construction or other civil engineering works (e.g. against payment of a fee).

Most of the clay resources utilised by the small-scale manufacturer are likely to be of the soft plastic type. In some areas, when only hard shales are available, blasting might be undertaken occasionally to loosen material from the quarry face.

II.2 Hand-digging

Hand-digging has been widely used even for medium-size production plants, because of its versatility in dealing with all clays from soft muds to shales or even with ant hills. Hand-digging can also be adjusted to various types of work, and allows workers to sort out unwanted stones, limestones, roots, etc. It also avoids large amounts of capital investment, the stocking of spares and the organisation of maintenance of machinery. In many situations, hand-digging may be the only possible means of winning clay.

The rate of winning clay will depend upon the type of clay, the nature of the pit and the productivity of labour. Productivity rates for one man digging enough clay for the production of approximately 3,500, 1,500 and 4,000 bricks per day have been estimated(5,25,8). However, these estimates are not strictly comparable as some of them

include an element for the transport of clay over a short distance. Measurement of shovelling rates in the American mines(29) indicated an optimum working day of 6.5 hours. Longer working hours result in lower outputs.

Once clay has been dug, there will be a natural reluctance to reject any which may prove unsuitable, especially after the hard work of winning it. In particular, the workers paid according to quantity excavated may be reluctant to reject unsuitable material. Hence the importance of supervision, inspection and quality control.

If the face is benched, the separate levels need be only 1 m different(25) and 0.5 m wide(5), especially if materials from two or more levels are to be mixed. This can be done by throwing all materials down to the lowest level for mixing, and subsequent transportation away to the works.

The details of working the pit must be decided locally. For

example, at Asokwa in Ghana (figure III.2) the clay was hand-dug from a face which was approximately 2.5 m high in places(30).

Steel bladed, medium-weight spades are well suited for digging plastic clays. Preferences in blade design vary from country to country. It is, however, recommended to use narrow and slightly conical blades for the digging of this type of clay. The handle of the shovel should be shorter whenever the foot is used on the top of the blade. In places where this is not done, the handle is traditionally very long.



Figure III.1 - Face shovel or single bucket excavator



Figure III.2 - Clay-pit at small brickworks (Ghana)

If hard, dry clays are to be won (figure III.3) it may be necessary to loosen them from the face with a pick, then shovel the material away.

In many countries, the hoe and mattock are more generally used and are suitable for winning clay.

III. Transportation to the works

In large works, clay is conveyed from the pit in various ways, including the use of lorry or truck, large dumper truck, small-gauge railway systems, aerial ropeway or belt conveyor. Capacity, capital cost, maintenance and repair militate against the use of these methods for the smaller works.

While heavy transport equipment may not be suitable, the use of a small diesel-powered dumper or a front-end loader may become feasible on a hire basis. Similarly, an agricultural tractor may be used to haul a loaded trailer of clay. Alternatively, a draught animal may be useful for pulling a trailer if the road is not too steep and muddy.

The wheelbarrow is a versatile and low-cost device for moving clay. It need not be all-steel or specially imported and can be locally produced from available materials. It

can be taken from the clay face to any desired point at the plant site, on a narrow path or a plank on muddy ground (figure III.3). The larger the wheel, the more easily the barrow will pass over irregularities in the ground. The wheel should be as close to the load as possible in order to take the weight off the hands. The handles should also be approximately 50 mm lower than a standing person's palms when the barrow is at rest on the ground. Thus, the arms are just slightly crooked when the barrow is wheeled.

A simple aid for carrying clay and other materials is the litter (figure III.4). Its use by two people avoids twisting the body. Large loads may be carried over rough terrain, or up steep slopes. It may be fabricated easily by unskilled labour using cheap, locally available materials.

The most simple devices for transporting clay are the basket and headpan, both of which will be available in many communities.



**Figure III.3 - Digging and transporting of dry hard clay
(United Kingdom)**



Figure III.4 - Litter for carrying wet clay (Sudan)



[Home](#) > [ar](#).[cn](#).[de](#).[en](#).[es](#).[fr](#).[id](#).[it](#).[ph](#).[po](#).[ru](#).[sw](#)



Small-Scale Brickmaking (ILO - WEP, 1...

Small-Scale Brickmaking (ILO - WEP, 1984, 228 p.)

CHAPTER IV - CLAY PREPARATION

 **(introduction...)**

 **I. Main clay preparation phases**

 **II. Sorting**

 **III. Crushing**

 **IV. Sieving**

 **V. Proportioning**

 **VI. Mixing, wetting and tempering**

 **VII. Testing**

Small-Scale Brickmaking (ILO - WEP, 1984, 228 p.)

CHAPTER IV - CLAY PREPARATION

Good bricks of consistent quality and free from defects will only be obtained if the materials used are of suitable and uniform nature. Only rarely will such a material be won directly from the clay pit. Commonly, some preparation and pre-processing is necessary to remove unwanted inclusions, add non-clay materials, or mix the materials for uniformity. In most cases, water must be added in order to bring the clay to a suitable consistency for forming into shape.

Adequate careful preparation will mitigate the following problems which might otherwise arise with the bricks.

- Overall cracking on the surface due to the use of too high a proportion of clay fraction in the mix. This may be minimised by adding sand or grog.**
- Localised cracking over a hard piece of clay (figure IV. 1), or a large stone; mitigated by**

crushing or removing such inclusions.

- Limeblowing (figure IV.2) which may be avoided by removing the larger limestone pieces and reducing any remaining limestone to less than 2 mm across pieces, or smaller pieces if the quantity of limestone is high. Indian research(31) suggests that the addition of 15 kg common salt added to the clay per 1,000 bricks should minimise limeblowing.**
- Low green strength of dried brick, possibly due to insufficient clay in the mix.**
- Lack of plasticity, making the forming process difficult; also due to insufficient clay in the mix.**
- Non-uniformity of size, shape and strength due to insufficient mixing of the materials.**
- Efflorescence and sulphate attack of cement-based**

mortars (see Chapter VIII), which might be reduced by rejecting surface clay where the salts may have accumulated naturally. There is also an expensive option of chemical treatment with barium carbonate. It is extremely difficult to wash salts out of clay, as it is difficult to mix the latter with water. Furthermore, large quantities of water will be required for this purpose.



Figure IV.1 - Localised cracking due to inadequate clay preparation (East Africa)



Figure IV.2 - Limeblowing in bricks (Central Africa)

Efflorescence on bricks made from clay containing high concentrations of soluble salts is shown in figure IV.3 In some circumstances, salts crystallise beneath the surface, building up stresses which can force flakes to spall from the surface as shown in brickwork in a boundary wall in India (figure IV.4).

I. Main clay preparation phases

Clay preparation includes the following operations:

- sorting (or picking) and washing;**
- crushing or grinding;**
- sieving or screening;**
- proportioning;**
- mixing, wetting and tempering.**

A whole range of motor-driven machines is available for these operations, including belt-conveyors, jaw-crushers,

kibblers, hammer mills, grinding pans (both wet and dry), rolls, de-stoning machines, vibrating wire screens, proportioning feeders, double-shafted trough mixers, and pug mills. However, few of these capital-intensive items will be appropriate to the type of production described in this memorandum. In a labour-intensive set-up, a mixing machine may be the most useful piece of equipment if diesel or electric power sources can be used. Animal power may also be worth considering.

It is best to prepare clay in a very dry or a very wet condition. Damp clays are difficult to crush, they stick on sieves, are awkward to handle and require much power to mix.

II. Sorting

An essential part of clay preparation is that carried out in the pit. This includes the discarding of unsuitable pockets

of soil, roots, stones, limestone nodules, etc. and the winning and preliminary mixing of clayey and sandy materials. Visual inspection of the clay in the works is not easy to carry out or enforce, but is done on a routine basis whenever the clay can be moved on a narrow conveyor belt past workers who pick off any unwanted material. It is advisable to have the supervisor check the clay coming into the works from time to time. Unwanted materials detected at this or any subsequent stage should be removed.

Where stones or limestone nodules constitute a particular problem they can be removed in a washmill (see Section IV.3).



Figure IV.3 - White efflorescence on brickwork (Middle East)



**Figure IV.4 - Flaking of the type produced by soluble salts
(India)**

III. Crushing

In the tropics, clay will generally be dry when won from

the pit. Thus the centres of large lumps will be difficult to wet. Non-uniform material is likely unless the dry clay is first crushed to less than a few millimetres across. Where capital cost is justified by a sufficiently large production scale, and where power sources are reliable, crushing rolls may be useful. Figure IV.5 shows crushing rolls in Ghana.

III.1 Manual pounding and the hammer hoe

Manual pounding with a hammer or punner may be used in small works but is very laborious. There is a tendency for already broken pieces to be compacted again, forming a hard lump which prevents the tool from breaking fresh material. It is thus necessary to clear away material as soon as it is broken. In favourable circumstances, two tonnes might be prepared per day by a team of four men (e.g. enough for 1,000 bricks).

The hammer-hoe (figure IV. 6), which is used in Malawi, is

a useful dual-purpose tool, having special uses not only in the works, but also in the clay pit. Material can be won, turned over, and mixed with the hoe. If hard lumps are found in the mix, it is not necessary to exchange tools as a half-turn rotation of the handle will bring the hammer into position for breaking the lumps.

III.2 The pendulum crusher

A labour-intensive crushing machine has been developed by the Intermediate Technology Workshop in the United Kingdom especially to meet the needs of the small-scale brick-maker as identified in an earlier survey(10). It is easily built from mild-steel sections, and works on the pendulum principle. The soil, which is placed in a feed hopper at the top of the pendulum, comes into contact with a static grinding head and a curved moving grinding head. The latter is attached to the top of the heavy pendulum which is kept swinging by two people (figure IV.7). The

moving head is studded with protruding bolt heads which entrap and crush clay as the head rotates in a downwards direction. Ground clay falls through by gravity on to a built-in sieve which can be of any desired mesh size. On the upward return move, any remaining clay is cleared from the grinding surfaces prior to the next downward swing, so that a slight dampness of the clay is not a great problem. Figure IV.8 shows details of the components of the crusher.

To operate the machine, two men start the pendulum swinging. Once the latter has reached a maximum angle, a third man starts feeding material. If exceedingly hard pieces are encountered or if, for example, a steel tool is accidentally dropped in the hopper, the grinding heads will not be damaged, nor will the machine stop since the pivot bar of the pendulum can run up in the rectangular bearing box, as a safety measure. The whole machine is guarded to minimise the risks to operators. A fourth man should be

available to remove the ground clay and return rejects from sieving to the pile of clay yet to be crushed.

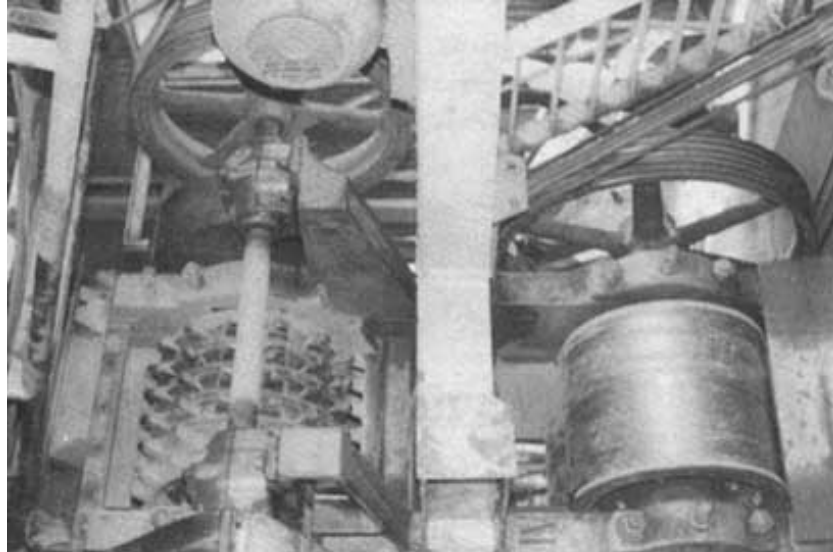

Figure IV.5 - Motor-driven crushing rolls (Ghana)



Figure IV.6 - Hammer hoe



Figure IV.7 - Manually-powered pendulum crusher

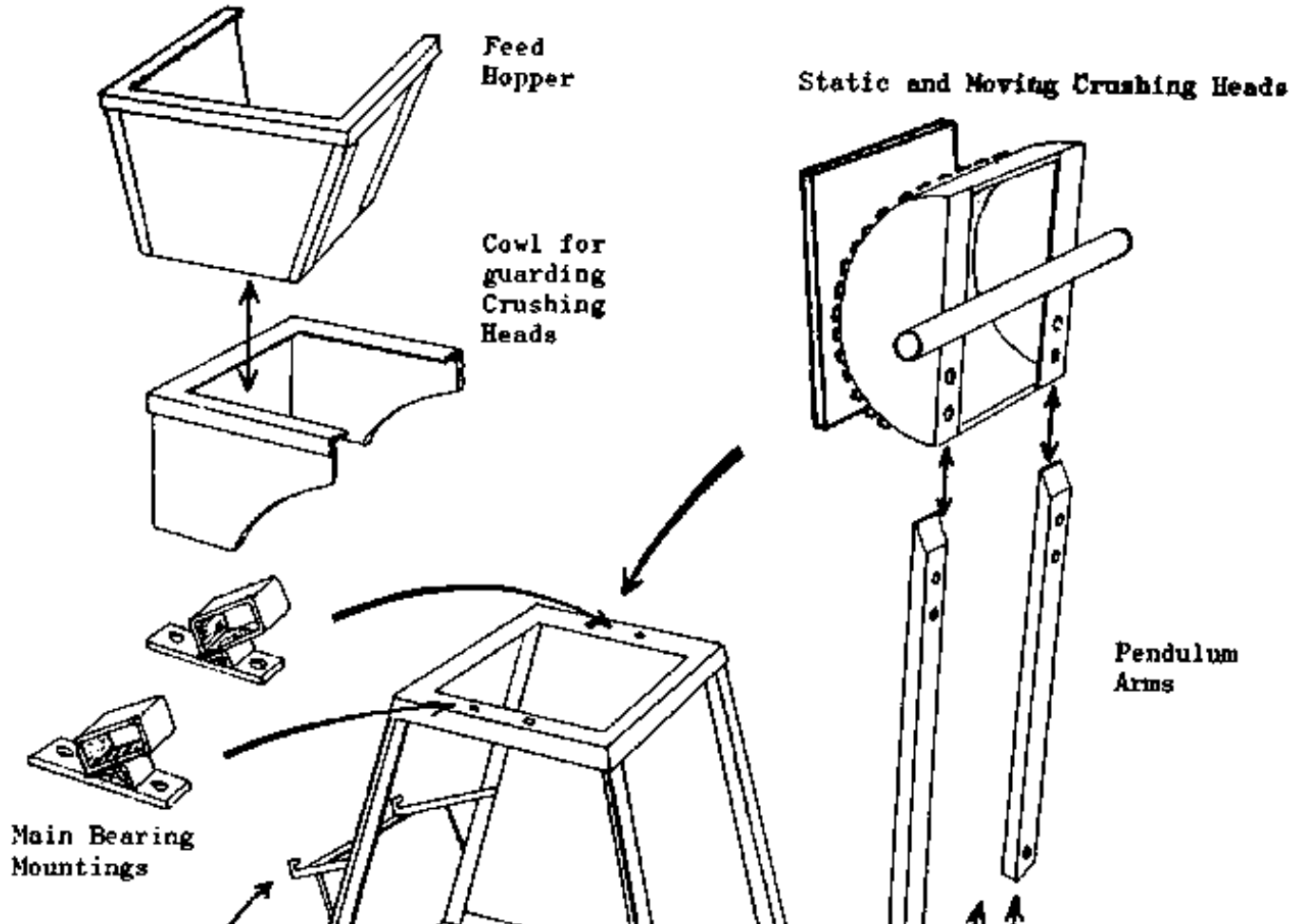

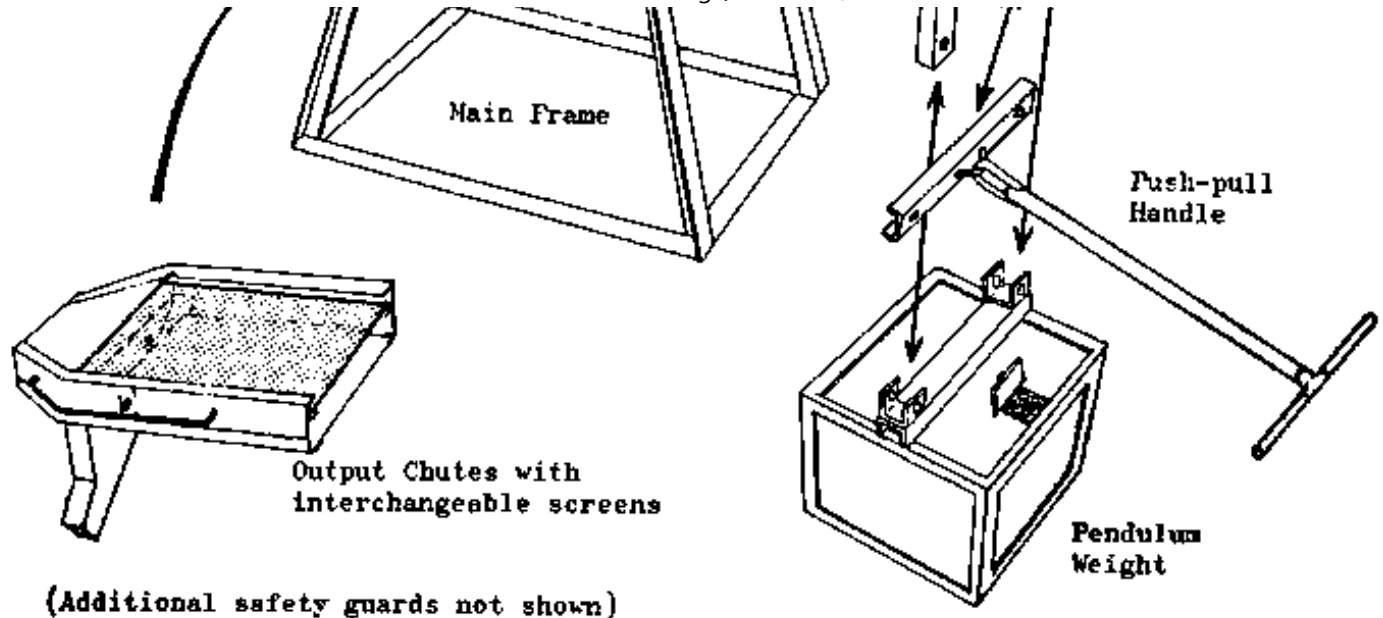

Figure IV.8 - Manually-powered pendulum clay crusher - Detailed drawing of parts

Periodically (e.g. each time the container is full of finely ground clay) the operatives would be well advised to change tasks on a regular rotation, moving between jobs

as follows: 1: feeding clay; 2: pendulum handle (right side); 3: pendulum handle (left side); 4: attending discharge and resting, then back to feeding again.

An extensive series of tests has shown some variation of production rates depending upon clay type. On average, a four man team may produce crushed clay at a rate of 20 tonnes per day, (i.e. enough for 10,000 bricks). This was an average for the easier alluvial and sedimentary clays. If harder shales are used, enough material may be produced for 8,000 bricks per day. The same team may also prepare a tonne of grog by crushing underfired bricks in 2.25 hours.

Occasional greasing of the bearing of the pendulum is the only servicing necessary. From time to time the machine should be inspected for wear. The pivots and the bolts protruding from the moveable head are the parts most likely to deteriorate. They should be simple to replace

when worn out.

The pendulum crushers, which have been operated in several countries, can be fabricated from readily available steel sections. None the less, entrepreneurs should first refer to the innovators for precise details before adopting the method. Ready-made machines or sub-assemblies can also be obtained from them (see Appendix IV). Manufacture under licence is being arranged in several countries.

III.3 Animal-powered roller

A traditional crushing method in India uses a heavy stone roller pulled by a bullock over the dry clay. The latter is laid out in a circle at the centre of which the axle for the roller is pivoted. Other draught animals could perform this task.

IV. Sieving

Crushed clay must be sieved to ensure that over-size pieces are not used. These should be returned for further crushing. The finer the material the better the quality of the brick. However, clay passing through a 5 mm sieve should be satisfactory. The simplest device for sieving is a screen of wire mesh, fastened on to a rectangular frame resting on the ground at one end and supported on legs at the other at a 45° angle to the ground (figure IV.9).

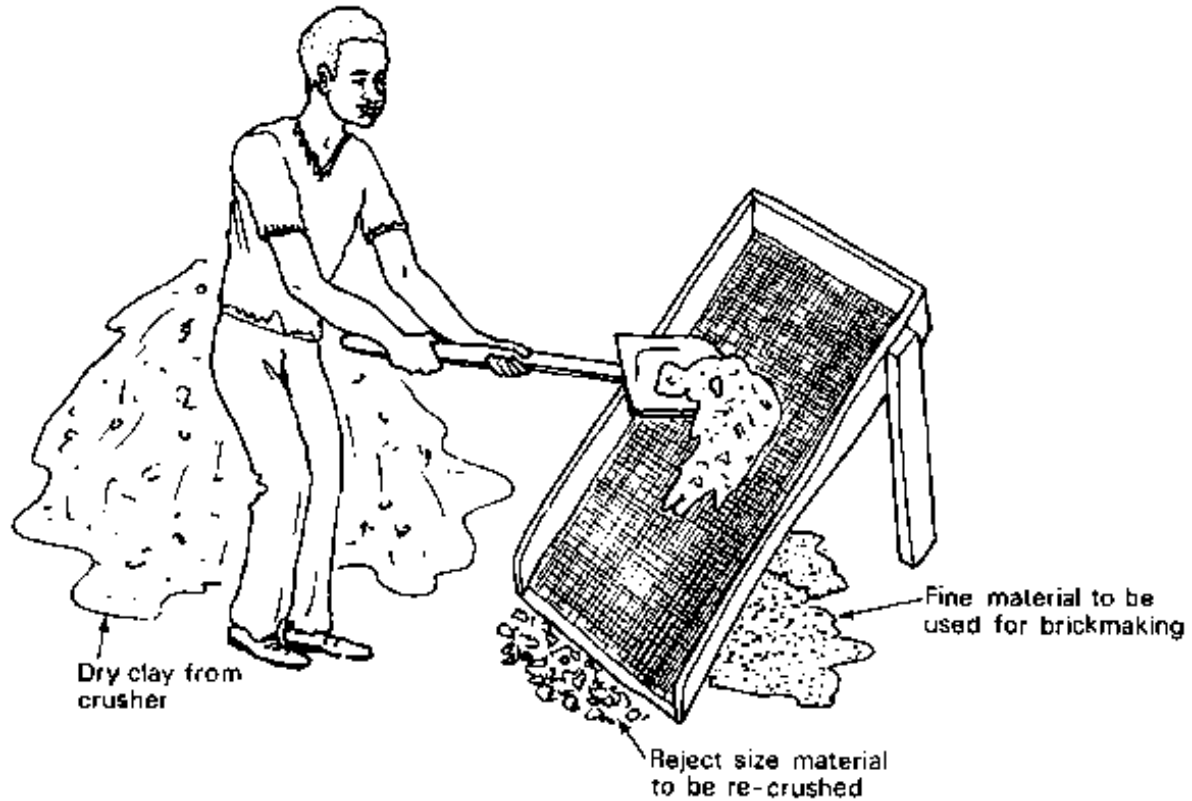

Figure IV.9 - Sieving

V. Proportioning

The mixing of two different dry materials is best undertaken after crushing and sieving. Quantities of clays, grog, sand, etc. should be measured by volume since this method is generally much easier than weighing. Measurement is advisable in order to get a consistent product quality. Measures should be taken from each constituent in turn, to give a preliminary amount of mixing.

VI. Mixing, wetting and tempering

Dry ingredients may be mixed with hoes or spades. In addition to clay, sand and grog, solid fuel may be mixed with the clay to assist with the burning of the bricks (See Chapter VII). Mixing should be continued until no difference of colour or texture can be seen from place to place in the pile. For special purposes, where soluble sulphate salts constitute a problem, barium carbonate (precipitated) may be added. A fixed quantity, such as 10 kg per 1,000 bricks, may not be a priori recommended

since it will depend on the extent of the problem.

Water must be added to most soils, over the whole surface of the spread-out material, or as each layer is deposited in a pile. Water should be sprinkled with a watering can fitted with a rose spray, or a similar device.

Mechanical power may be used for the laborious task of mixing and kneading the clay. Concrete mixers have a rotating drum with paddles attached inside. The consistency of wet concrete is such that the paddles can just about pass through, and any adhering concrete slips off when the paddles rise. Consequently, only an extremely wet clay, too wet for brickmaking, could be mixed in a concrete mixer as stiffer mixes will merely adhere to the paddles and drum. For stiff mixes it is best to use a stationary container equipped with rotating paddles or blades. This should be borne in mind by any person attempting to design clay-mixing equipment. For example,

an oil-drum rotating on bearings fixed to each end will generally fail to achieve effective mixing.

A motor-powered double-shafted trough mixer is ideal, and readily available from major equipment suppliers. However, acquisition of this equipment involves high capital investments. The capacity of this equipment may also be too large for small production units. Single-shaft mixers are not so efficient. Trough mixers need to be very strong and powerful, and may be unsatisfactory if made of too thin a gauge steel and undersized bearings. They are made and used in Ghana by a number of brickworks (32).

Much of the work of mixing water and soil may be avoided by the simple expedient of waiting for the water to percolate right into the structure of the clay. The thoroughly mixed dry constituents, having been wetted and piled up as described above, should be covered with sheeting or sand to prevent evaporation and drying. This

long-term wetting process, known as “tempering” or “souring”, allows chemical and physical changes to take place in the clay, thus improving its moulding characteristics. These benefits may be achieved within a day or two with many clays, though others (such as the harder shales) may require weeks.

VI.1 Pugmills

A pugmill is a most useful machine for mixing wet clay ready for moulding. High capital-cost machines from the major suppliers of brickmaking equipment have a series of angled blades rotating on a horizontal shaft within a closed barrel. These blades mix the clay and force it out by an opening in the barrel. Electric or diesel power are used for this type of machine (figure IV.10).

Cheap, animal-powered pugmills may also be produced locally. These pugmills have been used for centuries (33)

and continue to prove successful. For example, they were in use in England a few decades ago(34), and more recently in Turkey(10). Indonesia may also start using these pugmills (27). Animal-powered pugmills (See figure IV.11) are made of a strong circular metal or wood tub, approximately 1 m high, with a vertical driven shaft in the centre, fitted with near-horizontal blades. Wet clay is driven downwards by the rotation of angled blades, gets cut and mixed by other blades and emerges from a small hole near the base of the tub. Animals are yoked to a beam which rotates the shaft (figure IV.12).

VI.2 Foot-treading

A simple and labour-intensive method of preparing the more plastic fine-grained clays is foot treading. Clay can be trodden in the quarry, but it is advisable to carry out this operation on a concrete or brickwork surface at the plant site (figure IV.13). Ideally, a circular or rectangular

surface should be bounded by a 300 mm high upstand. The soil, straight from the quarry if suitable, or after some crushing, is spread 50 to 100 mm deep on the surface. If both fat and lean materials are needed, they should be layered. All the constituents must be thoroughly wetted, turned over with hoes or spades, and left covered up to temper for a few days. The workers then puddle the clay by treading in it, mixing and working the water in. The total volume of clay must be trodden systematically. It is advisable to turn it over with hoes and retread it. The mix should not be too dry as it will be difficult to move the feet up and down repeatedly. On the other hand, if it is too wet, it will not be suitable for moulding. At best, foot treading is a very tiring work. If any treader feels a stone in the clay, he should pick it out, and discard it. Unfortunately, this is an operation which is easy to neglect and difficult to check. Fortunately, a few stones left in the clay will only damage a few bricks. Thus, for practical purposes, complete elimination of stones is not necessary for simple brick-

moulding techniques. However, if bricks were to be wirecut (Chapter V), to include perforations, or to be made into extruded hollow blocks with thin walls the presence of stones would create problems.



Figure IV.10 - Motor-driven pug mill (Madagascar)

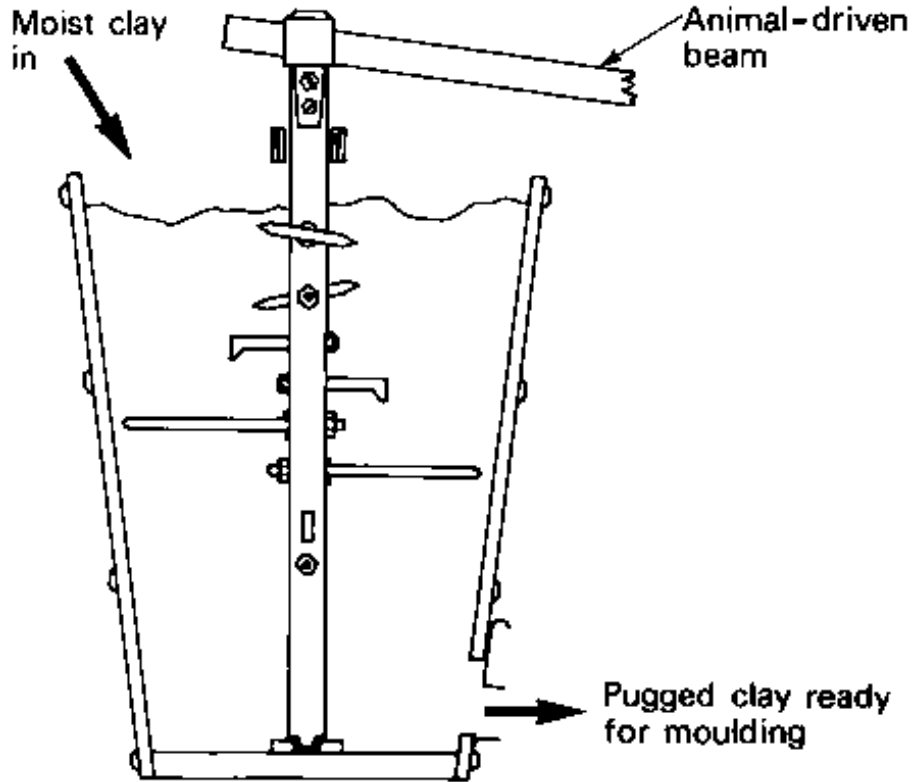

Figure IV.11 - Animal-powered pug mill (Schematic drawing)



Figure IV.12 - Animal-powered pug mill (Turkey)



Figure IV.13 - Foot-treading clay on concrete floor (Ghana)

In practice, it may be possible to get the workforce together just before the end of the working day in order to tread the wetted clay for the next or a later day's moulding. Leaving the clay for a while may further improve the moulding process.

VI.3 The washmill

The washmill is a labour-intensive method of cleaning clay in order to free it from stones, limestone nodules and other large particles. It requires fairly large quantities of water and produces a moulding material with a fairly high moisture content. The clay from the pit is preferably broken down prior to mixing with water in order to speed the process. A large brick-built or metal tank approximately 1 m deep and several metres across is filled to one-third of its height with the soil. Water is then added until it is two-thirds full. The mixture is stirred to disperse the soil up to the point where a clay slip or slurry is formed

and the unwanted inclusions fall to the bottom of the tank. The clay slip, with sand suspended in it, is then run off into one of a series of lagoons or ponds where it will settle. After treatment of several loads of clay, the accumulated stones must be removed from the bottom of the washmill. Weeks may be required for the clay to settle in the lagoons, during which time the supernatant water can be run off a little at a time over a simple, variable-height sluice, and re-used in the washmill. Eventually, the last of the water will be drained off and the solid material will start to dry, though it must not dry completely. Once it can bear a person's weight, the material can be re-dug. Cuts should be taken from top to bottom to ensure an even mix of fine clay and sand at all times.

Washmills have been used with success in many places. One such washmill was operated at Bricket Wood, in the United Kingdom, prior to developments on the brickworks site by the Building Research Establishment. Recently, the

washmill has solved a particular limestone problem in India(35), and is widely used at nearby Indore and other areas of Madhya Pradesh, where it is known as the 'ghol' method.

The shape of the washmill is not important if the slip is stirred manually. In this case it is easier to build a rectangular washmill. On the other hand, the use of other power sources requires a circular tank. Animal power could well be used for this purpose (figure IV.14). The size of mill will depend upon the nature and quantity of clay to be processed, the proportion of impurities and the planned brick production rate.

The washmill achieves most of the stages of clay preparation.

VII. Testing

Testing methods described in Chapter II could be applied to check if the material is suitable or whether modifications need to be made. In practice, this information is difficult to apply for a given batch of clay since the latter must often be used before the test results are available. This emphasises the need for careful preparation to produce a material of constant properties, and the need to check the quality of the final product (Chapter VII) and to relate any problems to clay preparation.

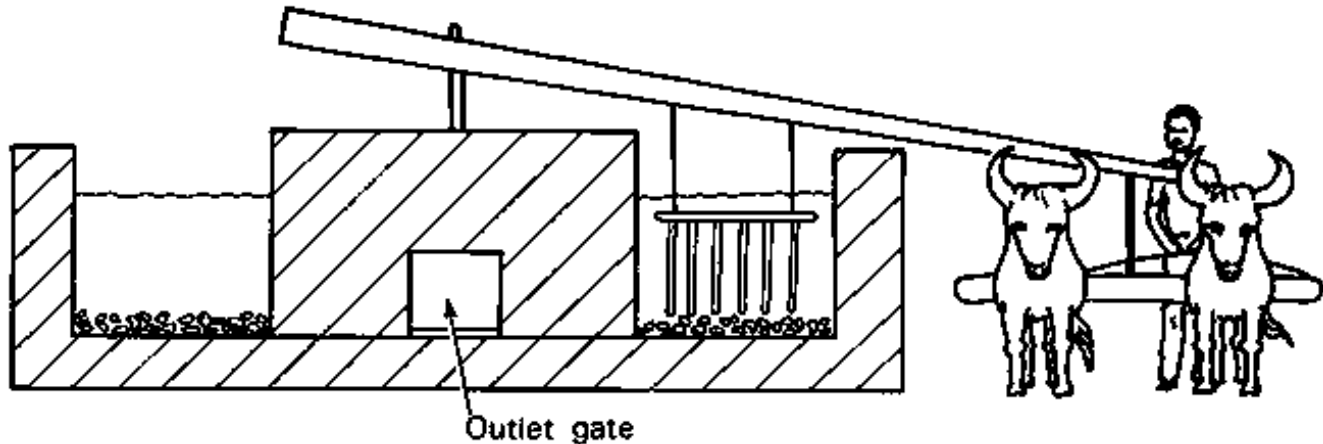

Figure IV.14 - Animal-powered washmill



[Home](#) > [ar](#) [cn](#) [de](#) [en](#) [es](#) [fr](#) [id](#) [it](#) [ph](#) [po](#) [ru](#) [sw](#)



Small-Scale Brickmaking (ILO - WEP, 1984, 228 p.)







CHAPTER V - SHAPING



I. Description of bricks to be



produced

-  **II. Methods of shaping**
-  **III. Transportation of bricks to drying areas**
-  **IV. Skill requirements and training**
-  **V. Productivity of labour**

Small-Scale Brickmaking (ILO - WEP, 1984, 228 p.)

CHAPTER V - SHAPING

I. Description of bricks to be produced

This section will provide the main characteristics of the bricks covered by this memorandum.

I.1 Size, shape and weight

In general, a brick should be of such a size and weight that it can be lifted in one hand. In almost all cases, a brick is twice as long as it is wide. Its height is usually one-third of its length (including the width of one mortar joint added to each end of the brick.) For example, the dimensions specified in the Indian Standard(36) are 190 x 90 x 90 mm and 190 x 90 x 40 mm. The 2:1 ratio is often adopted as it is highly suitable for bonding. The brick height is a matter of choice. In some countries, it is standardised so that it may fit to standardised dimensions of other components, such as window frames. The British Standard Specification for Bricks(37) requires that they be 215 x 102.5 x 65 mm or 225 x 112.5 x 75 mm if a 10 mm mortar joint is added. The 11-hole machine-extruded perforated brick (figure V.1) made in West Africa is too wide to be held in the hand. This type of brick may, however, be required for special purposes.

Bricks produced in small-scale plants do not generally have holes. In some cases, a frog is indented into one bed face. The single frog cannot be assumed to increase wall strength, but may assist in moulding in some circumstances. It may also shorten the drying time, slightly reduce the amount of fuel for firing, and reduce weight for transportation. However, it requires more mortar for wall building, especially if the brick is laid frog up. Frogs may be made on both bed faces in some shaping processes. Perforated bricks (figure V.1) are only produced by extrusion machines. They have advantages similar to those listed for frogged bricks.

Bricks which are accurate in shape and size are good to handle, transport, stack and build into a good wall with flat faces. If walls are to be rendered, less material is required than if they had an irregular surface. Furthermore, less mortar is required between accurately made bricks (see Chapter VIII).

Bricks of special shape may be produced, for example, for building wells and circular chimneys, or for joining walls of different thicknesses without sharp steps. Roofing tiles can also be made by similar methods. Big hollow blocks and decorative screen blocks are produced by machine extrusion. However, this memorandum concentrates on the production of ordinary-shaped bricks.

The size of the brick mould, die, etc. must be larger than the brick specification to allow for drying and firing shrinkages.

I.2 Faults in bricks

A number of faults in the finished product can be attributed to bad shaping. In extruded bricks, S-shaped cracks are caused by the clay-impeller's design or use. Saw tooth or dog-eared corners are caused by poor lubrication of the die near the corners. Internal cracks along the line of

extrusion indicate an unequal extrusion rate in the centre as compared to that on the edge. Uneven heights of extruded bricks may be due to uneven spacing of cutting wires. Drag marks on cut surfaces are often due to dirty cutting wires in extruded and hand-made products. Irregular sizes and shapes of hand-moulded bricks may be due to inaccurate and bent moulds. Weaknesses may result from layers of sand being folded into the clay. Odd flashes may result from old clay stuck in narrow gaps of the mould or from overfilling of the mould. Missing corners, bent bricks, trapezoidal shapes and indentations may be due to incomplete filling of the mould, careless demoulding, setting down the green bricks sharply on the drying ground, squashing the demoulded bricks too tightly between pallets or marking them with the fingers.

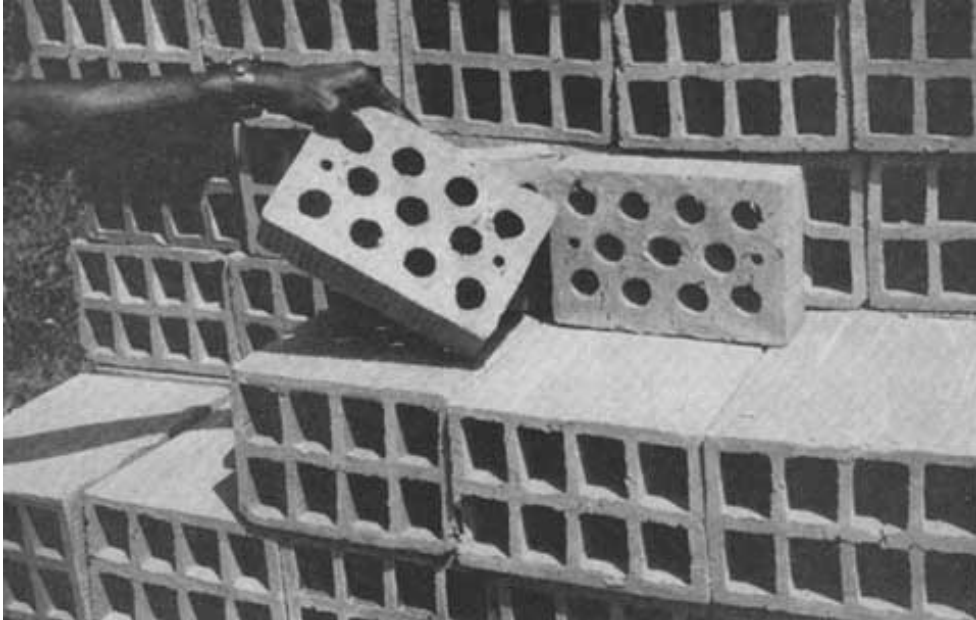

Figure V.1 - Machine-extruded and wire-cut bricks (Centre) and hollow blocks (Ghana)

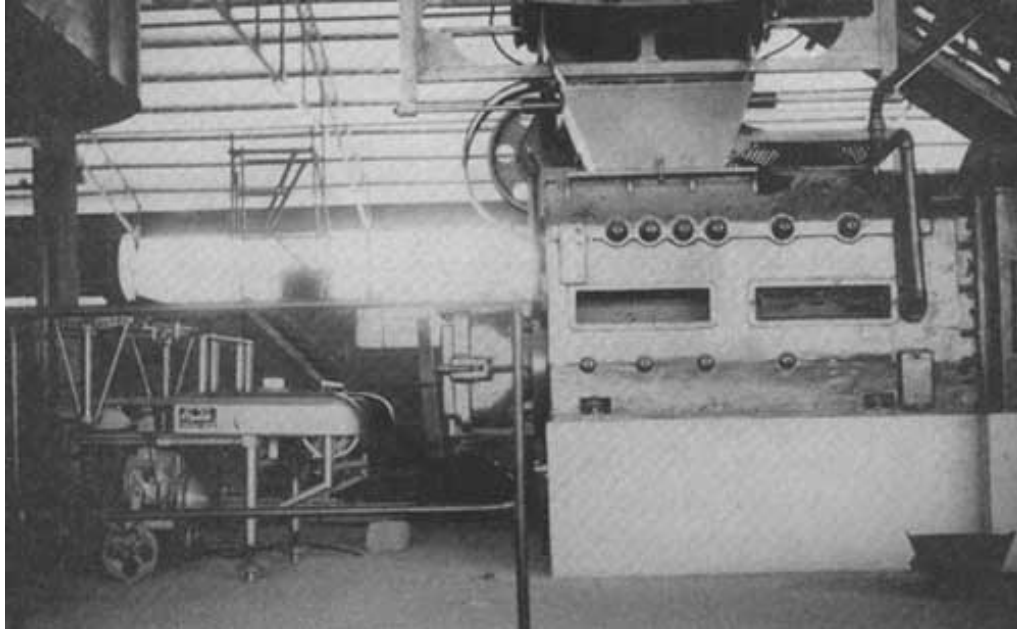

Figure V.2 - Capital-intensive brickmaking factory (Ghana)

II. Methods of shaping

It has often been thought that machine-made bricks are better than hand-made bricks. This, however, should not be necessarily the case if hand-moulding is carried out

with care. Furthermore, a comparative study of the economics of production in developing countries (see Chapter X) clearly indicates that hand-made production is still competitive in spite of technological developments.

Ready-made equipment may be imported, for both large-scale plants (e.g. equipment for a highly automated plant imported from Europe, by Ghana, shown in figure V.2) and small-scale units. In the latter case, equipment is used in a very few operations which complement the predominant use of labour.

Mechanised shaping methods will be considered briefly first, followed by the labour-intensive shaping methods. Finally, simple and cheap methods of assisting the hand-moulding process will be described.

The choice of shaping method should take into consideration the following: capital cost and expected life

of equipment; maintenance and spares service; availability and cost of fuel (including reliability of electricity supply); scale of production in relation to raw materials supply; and market demand at time of installation and throughout the planned life of the installation. These points will be amplified in Chapters X and XI.

II.1 Mechanised shaping methods

II.1.1 Wirecut bricks

A method of producing machine-made bricks, which is commonly used in developing countries, is that of extrusion from an auger machine. This method is, for example, used in Madagascar (see figure V.3). In this machine, which is similar to a horizontal pugmill, the clay is impelled by an Archimedean screw. Taut wires cut brick sizes off the continuous column of clay (figure V.4 shows an automated cutter, manufactured in the Federal Republic

of Germany and used in a brickmaking plant in Ghana).

This type of equipment is often imported by most developing countries. One exception is India where research was carried out into the construction of indigenous plants for making 20,000 bricks per day(38). Several such plants have since been built and operated(39). A supplier list of equipment is provided in Appendix IV. However, the wire cut-process is used at scales outside those considered in the memorandum.



Figure V.3 - Extrusion machine (Madagascar)



Figure V.4 - Wire-cutter and wire-cut bricks (Ghana)

II.1.2 Soft mud process

Soft alluvial clays, such as those suitable for hand-moulding, may be processed by the soft-mud process. One of the smallest machines available produces approximately 14,000 bricks per day, a scale of production larger than those considered in this memorandum. This particular

machine, originally made in the United Kingdom as the Berry Machine, was bought up by another company which is now producing it in the Netherlands (see Appendix IV). It has a horizontal pugmill followed by a set of cams which force moist clay through the side of the containing barrel into a quartet of iron-clad wooden moulds (see Figure V.5). To prevent clay from sticking, moulds are sanded. This can be done by hand. The whole process is fairly labour-intensive. The pugmill section alone could be used to prepare clays for hand-moulding.

II.1.3 Pressing

Bricks can be pressed, but commercially available machines are expensive and have high production rates. However, smaller hand-powered machines have been used in the past (33) and could still be employed, provided that the extra cost and time could be justified by an improvement in quality.

II.2 Hand-moulding

In the earliest techniques, soil was shaped by hand into lumps. The use of a mould to give shape to the soil resulted in more accurate and better bricks. Wood moulds should be soaked in oil for a few days before use. They are best made from a hard wood, shod on corners with iron or steel, and preferably lined with metal sheet. A handle bar is needed at each end. Metal moulds must be of a sufficient thickness to resist bending in use.

II.2.1 Slop-moulding

In slop-moulding, a very wet mix of clay is thrown into a wetted bottomless mould of wood or metal (figure V.6) as it rests upon a wooden pallet. Excess clay is scraped off either with the hand or with a striker (a straight wooden bar; see figure V.7). As the mix is very sloppy the mould cannot be removed until the brick has sufficiently dried or

started to harden. Usually, the mould is removed immediately and returned to the moulding bench, re-wetted in a tub of water, and used again. In some instances, moulding is done on the ground without the use of pallet (40).

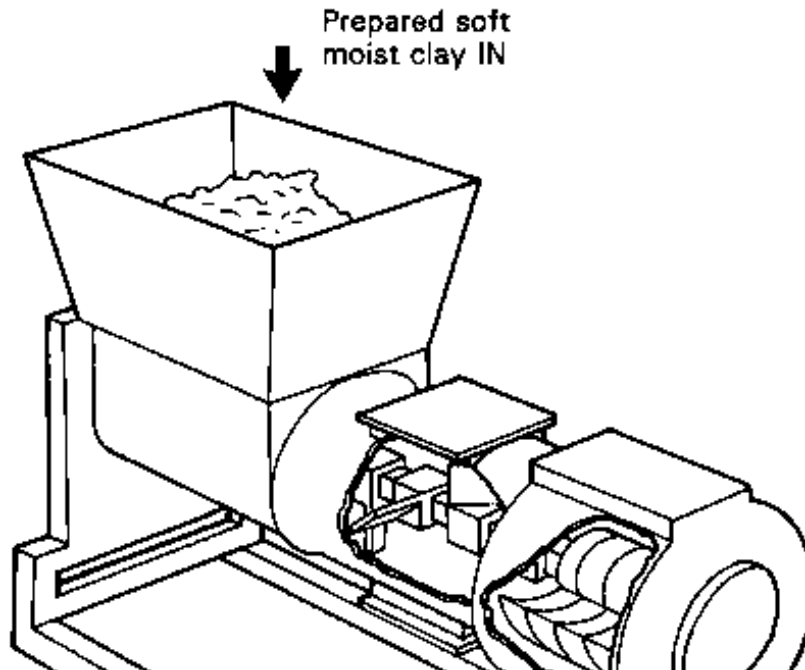

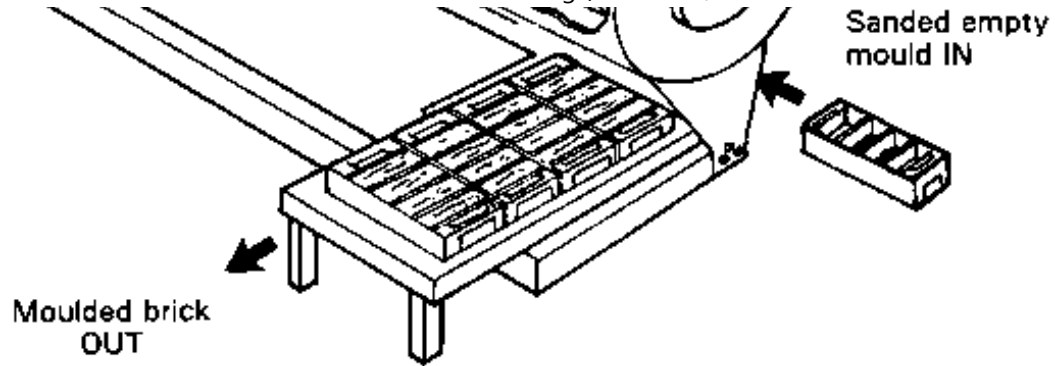

Figure V.5 - Soft mud brickmoulding machine



Figure V.6 - Slop-moulding in double cavity metal mould, with moulder standing in deep hole (West Sudan)



Figure V.7 - Striking off excess clay in slop-moulding (Ghana)

The slippery nature of the wet clay allows the demoulding of the brick. Two main disadvantages with this moulding method are distortion and high shrinkage.

The stickiness of the clay used in slop-moulding complicates the separation of the base of the mould from the brick. Some types of mould have bottoms fixed to the sides. Thus, a small gap between bottom and side is incorporated to allow air to pass in as the brick slides out.

The artisan brickmakers in Madagascar utilise the following method over the whole island. A basket of sand is kept alongside a tub of water (figure V.8). The sand is used to dust the base of the mould, thus preventing the clay from sticking to the base. These brickmakers carry their own bricks to the drying ground and invert the mould so that the sanded side is uppermost after demoulding. This practice is recommended as it minimises the difference between the evaporation rates of the top and bottom of the brick, thus avoiding distortions.

The brickmakers from Madagascar utilise another very simple moulding technique which is not normally used

elsewhere, but would be worth adopting. A wooden plate, slightly smaller than the top of the brick, is laid on top of the latter. The thumbs are then placed on triangular upstands at the ends of the plate while the mould is being removed (see figure V.9). The plate is prevented from sticking to the brick by a layer of sand, and is left in position until required for the next demoulding operation. A maker's mark or trade mark can be moulded into the brick, using any design embossed on to the wooden plate.

II.2.2 Sand-moulding

Disadvantages of slop-moulding are partly overcome if a stiffer mix is used. One disadvantage of this is that the brick will not slip out of the mould easily. A layer of sand between clay and the mould surfaces will prevent sticking. The traditional moulder in India (figure V.10) sands the wet sides of the mould, then throws his clot of clay. The mould has a fixed bottom with a trade-mark on it. The

bricks are finally demoulded at the drying ground (figure V.11). As can be seen from the figure, this method yields bricks with a regular shape and good finish, including the fine detail of the trade-mark in the frog of the bricks.



**Figure V.8 - Moulding with sand-covered mould base
(Madagascar)**



Figure V.9 - Demoulding by pushing on triangular end pieces (Madagascar)



**Figure V.10 - Moulder using sand to prevent sticking
(India)**



**Figure V.11 - Two moulds demoulded at the drying ground.
Good finish of produced bricks (India)**

Attempts are often made to utilise the moulder's skills to

the full, by having clot-makers prepare suitably sized pieces of clay ready for throwing into the mould. Elongated balls are prepared at a works in Ghana (figure V.12) and used in multi-cavity moulds in an attempt to increase productivity (figure V.13). In this works sawdust is used instead of sand to assist demoulding since it is readily available. The bricks are demoulded at the bench, on to a wooden pallet, then carried to the drying area five at a time.

Sand-moulding continues as a commercial method of production of hand-made bricks in the United Kingdom to satisfy a particular market requirement for bricks with variable texture and appearance. The moulders work at a bench with single cavity wood moulds. Instead of sanding the mould, the clot is covered in sand. Details of this method are illustrated in figure V.14. Given the stiffness of the mix, excess clay cannot be removed from the top of the mould by pushing with hands or a striker. Instead, a bow

cutter, which consists of a taut wire on a bent stick or wooden frame, is used for this purpose.

Given the advantage of using stiffer clays, the Intermediate Technology Workshop (ITW) in the United Kingdom has developed a hinged bottom mould. Instead of having air inlet slits at the base, the air could be admitted by lifting the base from one end. This device has been successfully used in commercial production in several countries in Africa (figure V.15), producing well-formed bricks.

Recently, the United Kingdom Building Research Establishment has commissioned the Intermediate Technology Workshop to develop hand-moulding processes to improve slop-moulding without the use of sand, since the latter is not available in all locations. One improvement proposed by ITW is the use of dry clay ground up finely to dust. The latter may then be used to prevent the clot from sticking in the mould, provided it

remains in the mould for a few seconds. Quick demoulding is necessary as the dampness of the clot makes the dust sticky, and demoulding difficult.



Figure V.12 - Clot-makers rolling clay in sand (Ghana)



**Figure V.13 - Hinged-bottom mould and moulded brick
(Southern Sudan)**



Figure V.14 - Moulder throws preformed clot. Use of five cavities mould (Ghana)

Figure V.15 - A technique for preparing a clot of clay

An essential part of good brick moulding is to dust the throwing

clot on five of its six surfaces to prevent it sticking to the sides of the mould.

Experienced moulders develop their own individual techniques and the system illustrated is just one of many alternatives.



1. Starting with the cut off piece from the previous brick, put a new lump of clay on top.

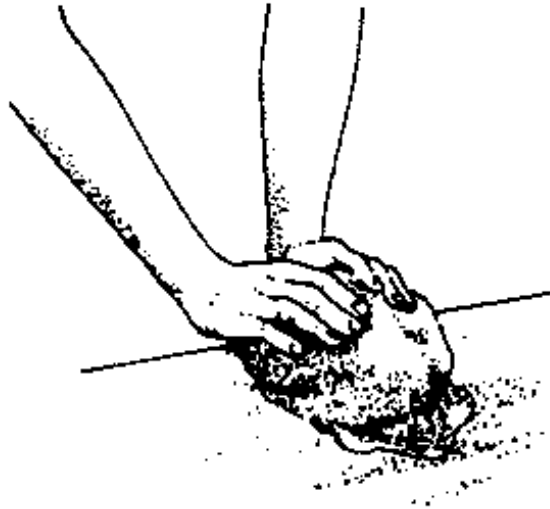

2. Using the 'heels' of the hand, roll the new ball of clay forward till the previous sanded cut-off comes over the top.

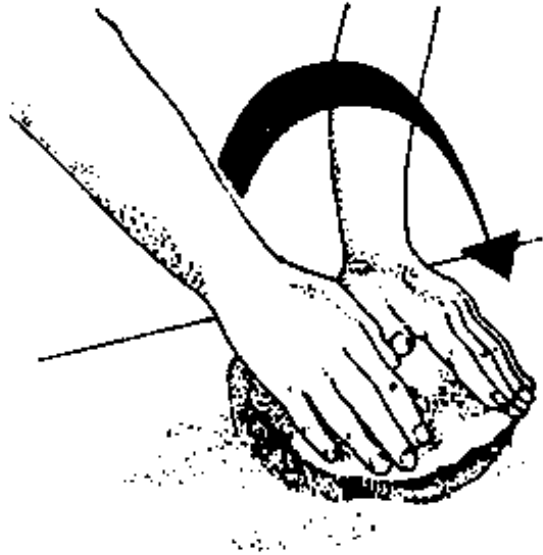

3. Press down making a wedge shape with sand now covering both large surfaces of the clot.

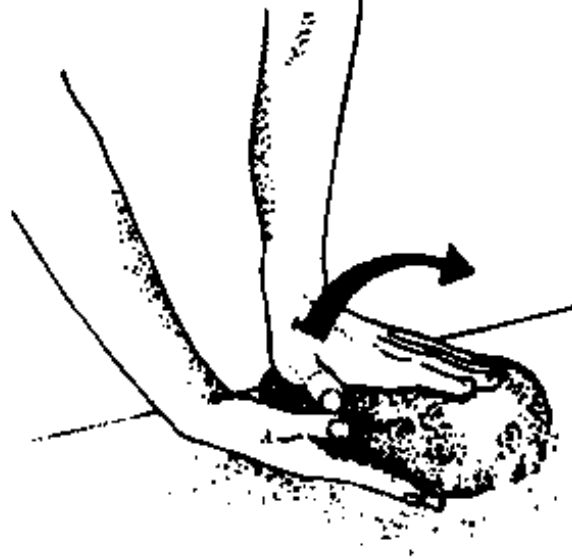

4. Lift the clot up on edge to sand the narrow edges.

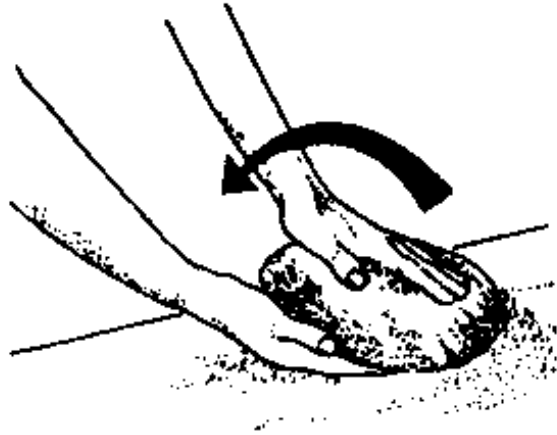

5. Apply sand to both edges so that now four sides are covered.

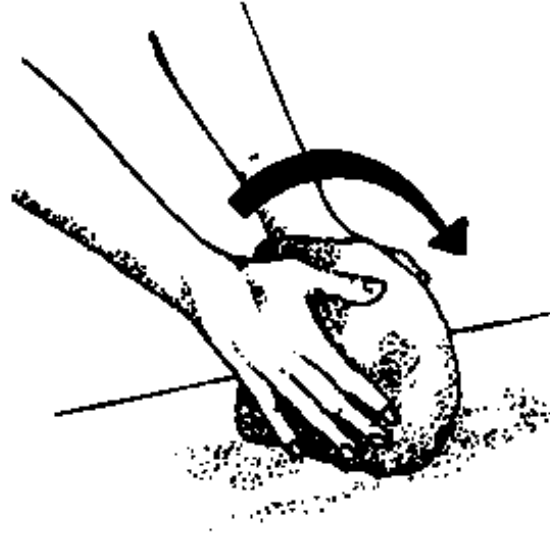

6. After sanding the second narrow edge, roll the clot forward to apply sand to the end.

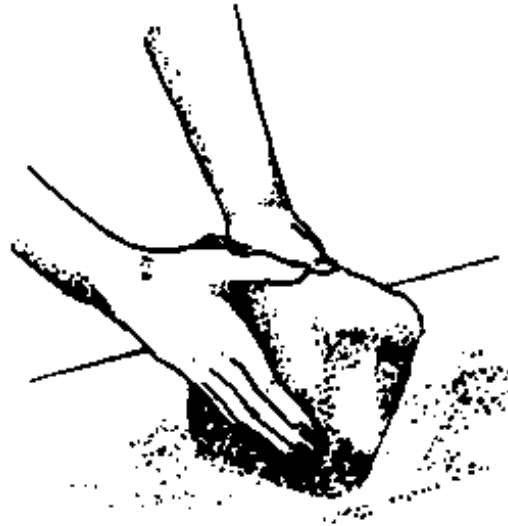

7. The clot should now be tapered with a wide top and narrow bottom end, ready to throw into the mould cavity.

ITW has developed two improved moulding devices which are described in a published document (41). A summary description of these two devices is provided below.

(i) The turnover mould

The turnover mould is another moulding device which may be easily produced locally. It is a four-sided wooden mould with a sheet steel lining turned in for 3 mm at the bottom to hold the clay in the mould. After the sanded clot is thrown and excess cut off, the four mould sides are lifted, freeing the moulded brick from the fixed base and its frog plate. The sides pivot on a simple bearing, and after a 180° rotation, a sharp knock on an end stop causes the moulded brick to drop out on to a pallet (which can be rotated with the mould). Figure V.16 illustrates the device and its operation.

(ii) The table mould

The local production of a second moulding device, the table mould, requires the skill of a carpenter or metalworker for the manufacture of some parts in order to ensure long reliable performance. Figure V.17 shows the mould recessed into the table. Once the sanded clot has been

thrown and excess cut off with the built-in cutter, the brick may be ejected by raising the mould bottom by use of the foot-operated lever (figure V.18). Stiff bricks of excellent shape and clean arrises may be produced with this moulding device. It is advisable to transport them on light-weight hand-held wooden pallets in order to avoid finger-marking the smooth surface. The bricks are normally stiff enough to be stood on edge. Depending upon local skills and materials availability, the main structure of the table mould may be fabricated from box-section steel (figure V.18), steel angle and timber (figure V.17), or timber only (figure V.19). The mould should be lined with sheet steel and a frog plate may be fixed to the base. The cutter can either be built in or a separate bow cutter can be used instead. The sequence of moulding is illustrated in figure V.19.

Advice or supply of parts for this moulding device may be sought through the developers of the system, ITW. This

moulding device has been used in several African countries, Sri Lanka and the Caribbean. A new feature which is being incorporated in the device consists of a lid which can be locked down on top of the mould, allowing the base to be raised slightly through a hand-operated lever and cam. This device allows some additional compaction of the clay, further improving the quality of the brick. However, it slows down production.

Figure V.16 - The turnover mould and its operation

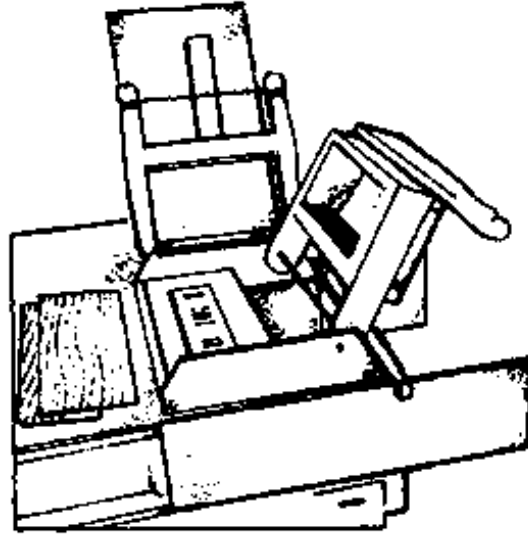

The mould, open.



1. Wedge shaped clot of clay is thrown accurately and forcibly into the mould cavity.

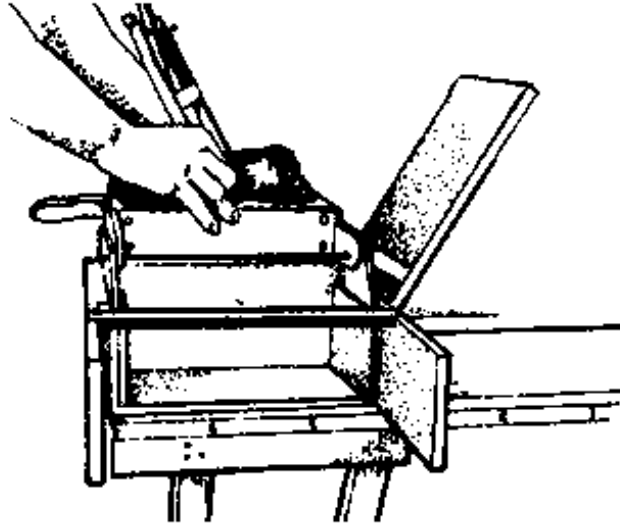

2. The excess piece of clay is severed with the bow cutter, and put aside.

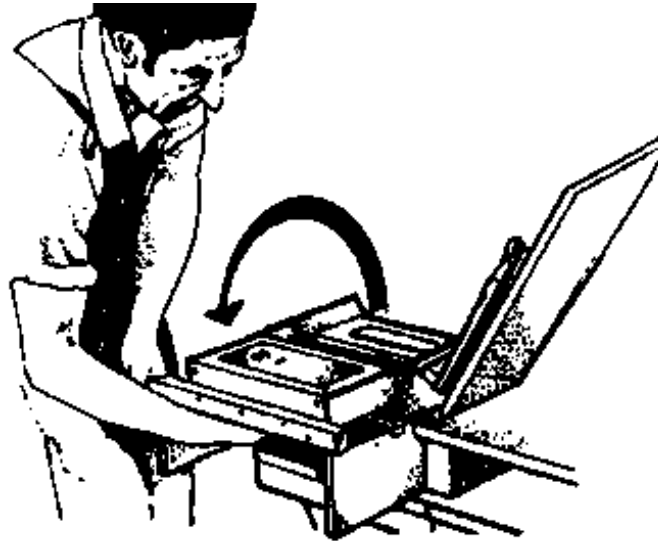

3. While holding the pallet in place, the brickmaker turns the mould over on its pivot and knocks it against the stop.

**Robust
timber
frame**

**Sliding bow cutter
with built in tensioner**

**Special brick-
ejecting mould
box**

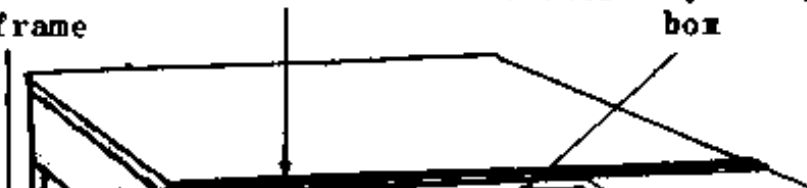

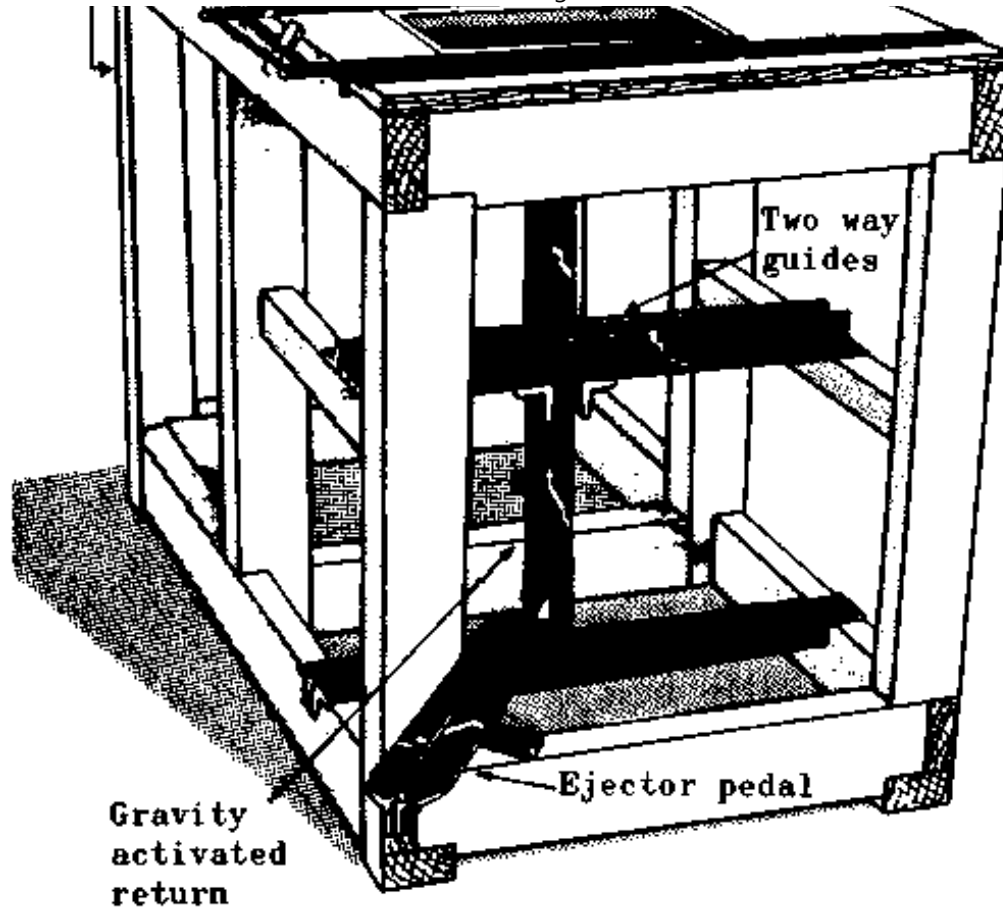
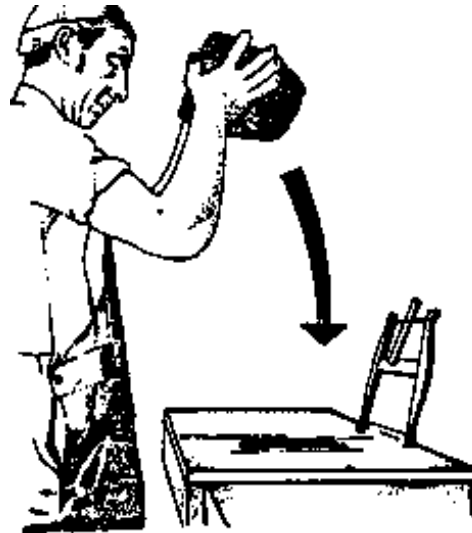

Figure V.17 - The table mould

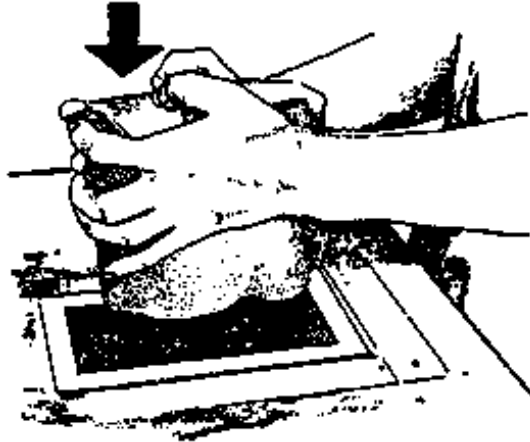

Figure V.18 - Table mould; pedal being depressed to eject brick. Each brick is handled with pallets and stacked on racks (United Kingdom)

Figure V.19



1. The wedge shaped clod of clay thrown forcibly into mould cavity.



2. At point of entry the bottom of the wedge of clay should come inside the rim of the mould on all sides to avoid 'cutting'.



3. After throwing the clot, a small mound of excess clay should be left on top.

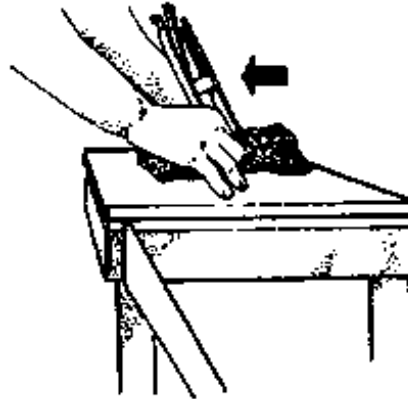

4. This excess clay is cut off with the bow cutter.

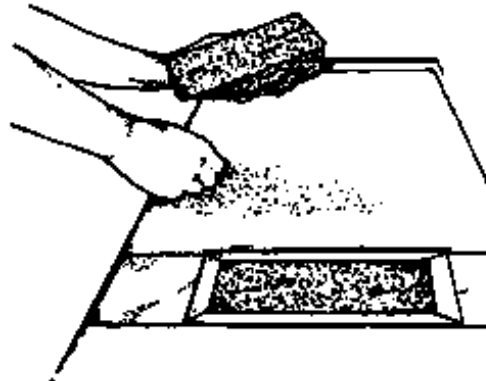

5. The off-cut is removed and set aside.

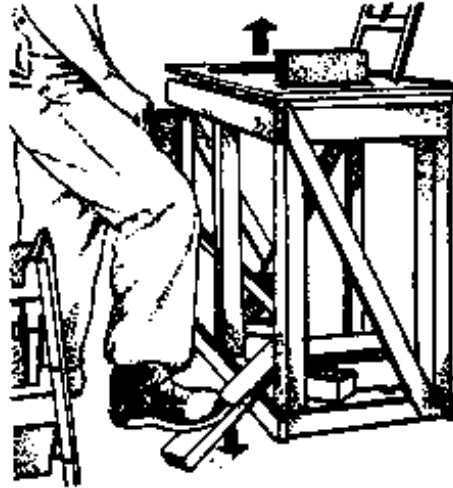

6. The pedal is pressed down to eject the brick.

III. Transportation of bricks to drying areas

Slop-moulding requires that bricks be carried in the mould to the drying area and set bed face down.

Where floors are fairly flat and hard, the labour needed to carry sand-moulded bricks, which are generally demoulded

before transport, can be minimised by using barrows. ITW has developed racks for the transport of green bricks. Adapted hack barrows with forks are also available for the transport of 20 bricks at a time (figure V.18).

Sand-moulded bricks cannot be stacked on top of each other when first demoulded. Specially designed, large flat-top wheelbarrows may be used to carry 20 to 30 bricks at a time to the drying area. These bricks can be set on edge to dry rather than on the bed face. To minimise the load on the hands, the wheel of the barrow should be set well back under the load. Figure V.20 illustrates one hack barrow used through many years in the United Kingdom. Damage to bricks can be minimised if the wheel is sprung.

IV. Skill requirements and training

Mechanised brick-moulding requires a knowledge of clay characteristics as well as an in-depth understanding of

mechanics and electricity. The mould-operators should also be able to undertake routine preventive maintenance and inspection for wear and tear of the equipment. They should also demonstrate an organisational ability in order to avoid loss of production through machine-servicing and repair. In practice, the machines will need constant adjustment during the working day.

Equipment used in hand-moulding should be strongly and accurately made, and kept clean. Hand-moulding skills require an appreciation of the nature of the clay and experience in throwing. In particular, the operator should be fully aware of the various remedial measures needed for the preparation of a mix with the right characteristics. He should also know how to throw with sufficient force and confidence so that the clot does not strike the side of the mould. Otherwise, a sanded clot would lose its sand and stick in the mould.

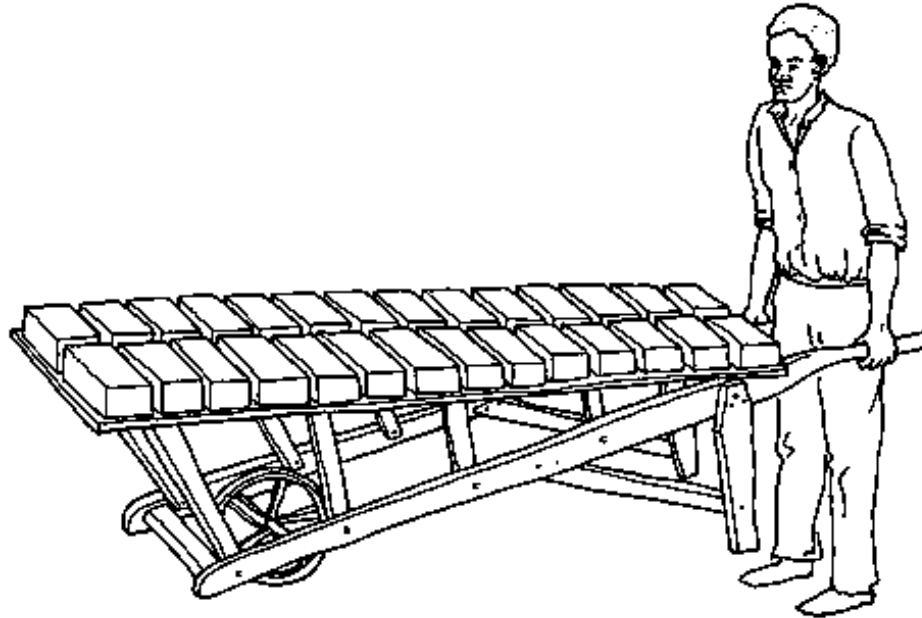

Figure V.20 - Hack barrow

In general, skills are passed on within families. In addition, the techniques can be learnt elsewhere within a relatively short period of time. This is particularly the case for sand-moulding. There are a few 'tricks of the trade', which may

help the beginner. Firstly, there is no substitute for a good hard accurate throw if the operator is to avoid the time-consuming pushing of clay into unfilled areas and the production of defective bricks. It is preferable to discard a poorly-moulded brick and send it back to the preparation stage than to go through subsequent stages and end up with bricks which cannot be marketed. Secondly, whenever sand-moulding is used with stiff clays, a hard bump of the mould on the bench helps to consolidate the clay and frees it from the mould. While the bumping and demoulding may be the most difficult skill to learn, such skill is not needed when the table mould is used. Thirdly, although the sand is the basic material preventing the clay from sticking, it is useful to wipe the surface of the mould occasionally with a rag soaked with oil in order to improve demoulding. The oil consumption is very small, and no special type of oil is needed. If none is available, a rag wetted with water may also be helpful. Little training is required for the sand-moulding process. For example, the well-formed and

accurately-shaped brick in figure V.21 was moulded in a bottom-hinged mould by an inexperienced research scientist after only a few preliminary trials. The table mould seems eminently suitable when accurately-formed stiff bricks are required, where few skills exist and when little capital is available.



Figure V.21 - Brick moulded in hinged-bottom mould by

non-craftsman (United Kingdom)

V. Productivity of labour

It is not easy to measure or compare production rates as tasks are often shared. For example, clots may be made by the moulder himself or by a helper. Some moulders carry bricks to the drying area, while others have runners to perform the task. In mechanical production, it is difficult to assign a particular number of people to the shaping machine, since a man may be tending or servicing a variety of machines.

Table V.1 compares a number of mechanised and manual methods for the whole brickmaking process and for moulding only. Some of the estimates may include clay preparation, clot forming and carrying, while others may not.

Table V.1**Labour productivity in moulding****(man/hours per 1,000 bricks)**

Area	Brick factory (complete process)		Area	Moulding only hand-made bricks
	Extruded wire cut bricks	Handmade bricks		
West Africa	37	97	East Africa	20
India	45	60	Madagascar	8
			United Kingdom (traditional)	21

			United Kingdom (table mould)	13
--	--	--	------------------------------	----

Source: 26, 33, 39, 41, 42.

Each country seems to have its own preferred method for hand-moulding: squatting and moulding on the ground in India, standing in Sudan, etc. In Madagascar, the moulder stands and works with his mould sloping away, fixed on top of a stout post. In the United Kingdom, a moulding bench is preferred. These methods are illustrated in some of the pictures within this chapter. These pictures also show that moulds may have one to five cavities. A simple cavity requires more running to the drying area for slop-moulding. On the other hand, five cavity moulds are very heavy when full. Changes to accepted methods of moulding would probably result in at least a temporary reduction in output. Where possible, however, it is recommended that

the moulder stands rather than squats, uses the sand-moulding method and works on a table or bench.

A study of the brick industry in Colombia(43) concludes that direct evidence on the relative productivity of various technology levels is inadequate. However, indirect evidence indicates that it is worth while setting up labour-intensive units. The analysis carried out on the brick industry suggests that technologies imported from industrialised countries may not always be feasible.

Hand-moulding can produce bricks of technically good quality, at minimum capital cost. This labour-intensive method is highly suited to the varying market demand likely to be found in many developing countries. Some simple devices can lighten the burden and improve the working conditions of the brick moulders.



[Home](#) > [ar](#).[cn](#).[de](#).[en](#).[es](#).[fr](#).[id](#).[it](#).[ph](#).[po](#).[ru](#).[sw](#)



 **Small-Scale Brickmaking (ILO - WEP, 1984, 228 p.)**

➔  **CHAPTER VI - DRYING**

 **I. Objectives of drying**

 **II. Artificial drying**

 **III. Natural drying**

 **IV. Shrinkage**

Small-Scale Brickmaking (ILO - WEP, 1984, 228 p.)

CHAPTER VI - DRYING

I. Objectives of drying

There are several reasons for the drying of bricks before firing. These are briefly described below.

- In order to obtain the high strength and water-resistant properties of ceramic materials, the bricks must be burnt in a kiln to a high temperature. The bricks are piled up one on top of another, approximately 20 bricks high. Thus, the bricks at the bottom must be strong enough to carry the weight of those above. When first demoulded after shaping, the green brick may not be able to bear the weight of even one more brick without showing some distortion. When a certain amount of moisture has dried out, and the brick clay is approximately at the critical moisture content (see Chapter II), the bricks become "leather-hard". They are then sufficiently rigid and strong for handling and stacking.

- Once the "leather-hard" condition is reached, the bricks shrink. It is preferable that this shrinkage takes place before bricks are piled high for burning, lest the shrinkage causes the whole setting of bricks to become unstable, or to collapse within the kiln;**
- Even after the "leather-hard" condition has been reached, there is much more water to be dried out of the bricks. If this is not done, the water in the bricks nearest to the heat source will evaporate and condense on cold bricks away from the heat source. These bricks will then absorb the water and get spoilt.**
- Another risk is that water remaining in green bricks may turn to steam if the heat rises too quickly. This steam will build up pressure within the bricks, causing them to rupture. To minimise the**

risk, bricks should be as dry as possible before being put into the kiln;

- Within the kiln, any water remaining in the green bricks will only be driven out by burning expensive fuel. Fuel costs may thus be reduced if the maximum of water is removed through natural drying.

II. Artificial drying

Drying should be completed with a minimum loss of bricks, and a minimum cracking and deformation of the latter (see Chapter II). The rate at which moisture evaporates from the surface should not be greater than the rate at which it can diffuse through the fine pores of the green brick. Thus, there is no purpose in creating more draught over the surface, or in heating the outside surface over a certain temperature. In fact, such action will cause a faster

shrinkage of the surface than that of the interior of the brick, and thus cracking of the latter.

If drying is too slow, an opening material should be specified for the mix, or the brick should be reduced. A reduction in the volume of the brick may be achieved through the production of frogged or perforated bricks. The reduction of depth cannot, however, be carried too far if bricks were to be of a minimum strength. Once bricks are leather-hard, the drying rate can be increased.

If moisture diffuses to the surface, evaporates, but then remains just above the surface of the brick as a stagnant layer of moist air, further evaporation will be depressed. This will happen even when bricks are heated in a dryer. In this case, the drying process should be modified in order to avoid the above problem.

The rate of drying depends on diffusion rate of moisture in

brick, temperature, humidity and air speed. In temperate climates, where drying is not possible during the cold damp winter months, medium brick plants use floors heated by fires. This raises the air temperature and reduces the relative humidity, thus enabling drying to take place. This drying is costly as it requires large amounts of fuel. Other systems include chamber dryers for batches of bricks and tunnel dryers which operate continuously.

In the operation of artificial dryers, energy is required to supply the latent heat of evaporation of the water as well as to heat the bricks and the air passing through the dryer. It is also required for other heat losses into the surroundings.

Estimates of total energy requirements for evaporating one kilogram of water are provided in Table VI.1 below:

Table VI.1

Energy requirements for drying bricks

Efficiency of process	Energy (kJ per kg water evaporated)		
	Hot floor dryer	Chamber dryer	Tunnel dryer
High	7 100	3 300	3 300
Low	12 400	8 900	7 100

Source: 45

Calculated energy requirements for the drying of bricks range from 3,000 to 8,000 MJ per 1,000 bricks. These energy requirements are relatively important when compared to those needed for the firing of bricks (i.e. 5,000 to 16,000 MJ per 1,000 bricks(8, 10)). Hence, it should be realised that energy for artificial drying is of similar magnitude to that required for firing.

Artificial drying is mostly needed in the automated large-scale works, where automatic handling of bricks might be justified economically, and where kiln designs may be such that waste heat can be conducted from kilns to dryers. The tunnel kiln lends itself to recovery of heat from the cooling zone, but in less sophisticated and smaller kilns it is difficult and relatively expensive to collect the heat for drying. One cheap alternative could be to dry bricks by placing them around the kiln. This alternative may not be feasible if space is not sufficient for drying all the bricks, and if it were to restrict access to the kiln.

A recent drying method involves the use of rotating air dryers. In these dryers, hot air is applied as occasional blasts along strategically positioned racks full of bricks, the draught removing the accumulated layer of moist air which has collected close to the brick surface.

In some tropical countries, drying is difficult during the

wet season. Consequently, large plants are often equipped with air dryers. Figure VI.1 shows rotary dryers awaiting installation in a Ghanaian brickwork.

Bricks can be weighed from time to time to estimate the amount of water which has dried out. These estimates may then be used to determine the time needed for bricks to reach the "leather-hard" stage.

In view of the high cost and/or the scarcity of fuel, the hot weather conditions in a large number of countries, overall production considerations and market requirements, the use of artificial drying does not seem appropriate for small-scale brickmaking in most developing countries.

III. Natural drying

The main advantage of natural drying over artificial drying is the saving of fuel. The principal disadvantage is the

amount of extra handling which may be necessary, resulting in higher labour costs and a greater risk of damage to bricks.

The two main methods of natural drying are (i) fully exposed or temporarily covered bricks and (ii) bricks drying under a shed with a permanent roof.

III.1 Drying on the ground and in hacks

Slop-moulded bricks must be dried in single layers as they cannot bear the weight of other bricks without distorting. They should be laid as close as possible to economise on the use of drying area (figure VI.2). Approximately one-tenth of a hectare should be allowed for every thousand bricks produced per day. The ground should be swept free of loose debris as the latter will be picked up by the underneath surface of the soft brick (figure VI.3). It should also be as flat as possible since any bumps or dents, even

the small ones shown in figure VI.2, will not support the soft brick properly and will tend to distort it (figure VI.3). A thin layer of sand may be spread over a bumpy ground in order to improve drying conditions (figure VI.4).



Figure VI.1 - Rotary dryers (Ghana)



Figure VI.2 - Bumpy drying ground covered with debris (Madagascar)



Figure VI.3 - Partly dried brick distorted and covered with debris (West Sudan)



**Figure VI.4 - Good bricks dried on clean, level ground
(West Sudan)**

Sand-moulded bricks, being more firm than slop-moulded bricks, are not likely to pick up debris or to distort easily. They may also be set down on edge, which further reduces the chance of distortion due to uneven support.

As soon as bricks are dry enough to handle (i.e. once they have reached the leather-hard stage), they should be turned right over to allow the face which was in contact with the ground to dry. The required drying time will vary with weather conditions, but should not generally exceed one or two days.

After approximately three more days, depending upon weather conditions, the bricks can be removed from the drying ground and built into long open work walls eight or ten bricks high. These walls are known as hacks (figure VI.5). The drying of bricks should continue for a few weeks more. Bricks become lighter in colour as they dry. Sample bricks should be broken in order to check whether the inside is of light colour and therefore dry.

The bottom bricks in the hack may remain wet if laid directly on the ground. It is therefore advisable to build the hacks on already burnt bricks or wooden planks, which

may be left in position permanently.

Although light rain may not harm exposed green bricks, heavy rain can have serious consequences, and days of hard work may be wasted in a few minutes. Figure VI.6 shows bricks damaged by rain and bricks which are laid out for drying after the rain storms. Where the risk of heavy rains exists it is almost impossible to carry all the bricks under cover, especially newly-made slop-moulded ones. Instead, one may need to use plastic sheeting for protection against the rain. Plastic sheeting may not, however, give the best protection as it is difficult to lay the plastic over a large amount of bricks unless the stacks of bricks are separated by walkways. Furthermore, the plastic sheets must be weighted down to prevent the wind from blowing them away. Since bricks close to the edges of the plastic sheets may not be protected effectively, it is advisable to use special cover or permanent sheds whenever drying takes place during uncertain weather

conditions.

One of the chief reasons for the cracking and distortion of bricks during the drying stage is the high rate of drying. This rate is difficult to control in the open air, although the use of leaves or grass on top of the bricks may help control drying to some extent. A high rate of drying may result from the action of the sun as well as from low humidity levels and winds. Thus, it may take place even when the bricks are shaded.



**Figure VI.5 - Drying being completed in hacks
(Madagascar)**



Figure VI.6 - Rain damage to green bricks - No damage on protected bricks

Hack drying is an effective drying method used in the temperate climate of the United Kingdom over many years.

In this method, bricks are transported bed face down on the hack barrow and set on edge on wooden planks in two long parallel rows. Hack covers, made from pairs of thin sheets of wood tied with a cross bar long enough to span both rows of bricks, are laid carefully on the green bricks for protection against rain. By the time the end of the row is reached, a second course of green bricks may be laid without distorting those in the first row. A maximum of six courses of bricks may be built in this manner. Such a hack ground is illustrated in figure VI.7. The boards are kept at the correct separation by an occasional batten fastened between them. Only the tie-bars of the covers rest on the bricks. Thus, the sloping covers do not damage the upper corners of the bricks. These covers are sufficient to protect bricks from the heavy vertically falling rain. In rainy and windy weather an extra board or sacking may be placed on the side facing the wind. Rainwater from the edge of the roof falls into a gully on either side of the hack. The earth dug from the gully is spread between gullies in order to

raise the plank slightly. The preferred direction of the hacks should be such that the sun shines on either side of the wall for equal periods of time. Figure VI.8 shows bricks close-set in a covered hack. When they are dry enough to handle, they can be reset with wider spacings, the hacks then becoming slightly higher. Wider spacing increases the drying rate, which may be necessary after the leather-hard stage has been reached. Hacks must be sufficiently apart to allow access and operation. The drying of bricks with this method takes several weeks. An area for the hack ground of approximately one-tenth of a hectare should be allocated for an output of 1,000 bricks per day(8). This drying method may be adopted in showery weather or during short periods of rain in many countries.

III.2 Drying in a shed

Provision of a shed, sufficiently large to cover both the moulding and drying areas and, possibly, the kiln, may be

considered in some cases. Such a shed may, however, constitute the largest item of capital expenditure in setting up a small brickworks. A shed covering only the drying grounds will be cheaper and will improve the chances of successful drying. Figure VI.9 shows a simple structure used in Madagascar. This shed may be used efficiently if bricks can be built up in hacks when firm enough.



Figure VI.7 - Transferring freshly moulded bricks from barrow to dry in hacks with moveable covers

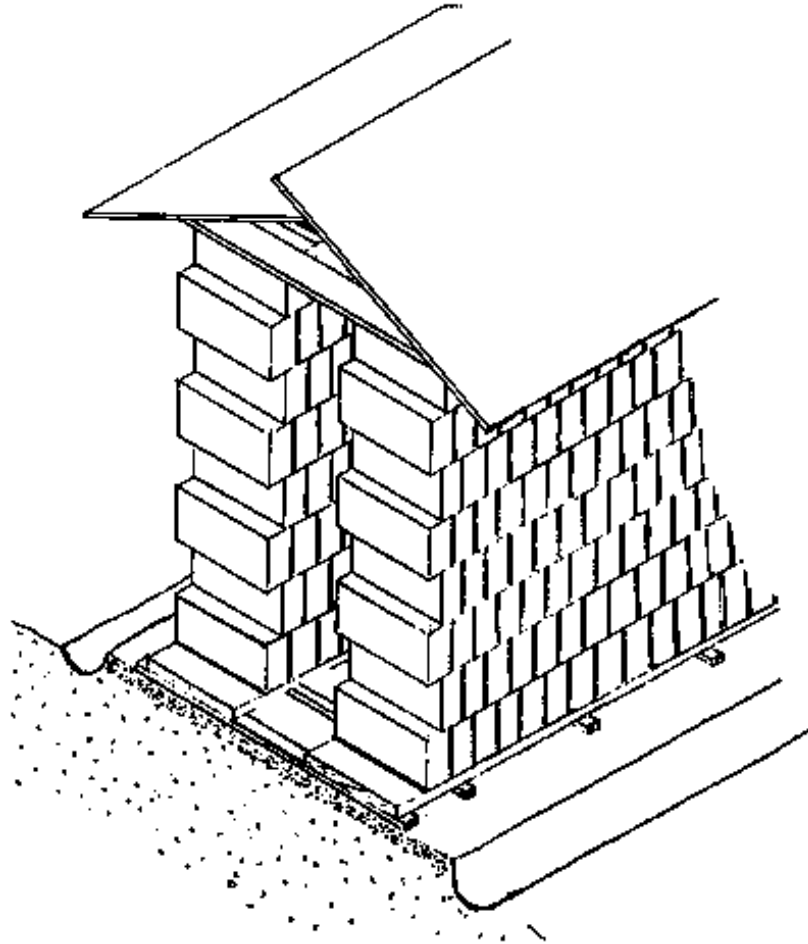

Figure VI.8 - Covered drying hack

The use of racks reduces the volume needed for the drying of a given number of bricks (see figure VI.10). Such racks enable soft, freshly moulded bricks to dry one brick high on each shelf. Thus, they will not be distorted by other bricks above them. Some cracking may take place in bricks nearest the outside of the shed, where direct sun, low humidity and great air movement cause faster drying. Side screens are necessary under such circumstances. Bricks should be turned on to their sides once they have reached the leather-hard stage after a few days of drying (28).

Side screens allow a better control of the drying procedure. They may be made out of plastic, cloth, wood, metal, woven grass or bamboo. The most convenient side screens should be of a type which can be rolled up easily when not required. When down, they keep off driving rain and direct sunshine, increase and equalise humidity within

the shed, and prevent excessive air circulation through the stacks of bricks. Access to the shed should be from the side sheltered from the wind. When drying is too slow, screens can be raised.

A cheaply constructed but effective drying shed is shown in figure VI.11. Pole timbers support a roof, high enough to allow workers to operate within the shed. Rudimentary but effective side screens are available for rapid use. Racks for holding the green blocks consist of planks, supported at the ends on previously-fired bricks, thus avoiding the necessity for substantial wooden posts to bear the weight of the loaded shelves. For safety reasons, these racks must not wobble or tilt.

IV. Shrinkage

Shrinkage is inevitable on drying clayware such as bricks. The most important rule is to dry bricks as slowly as

possible in order to minimise stresses and the incidence of cracking and distortion. A 7 per cent linear shrinkage should not cause difficulties in subsequent processing. A 10 per cent linear shrinkage may also be acceptable with some clays if drying is carried out carefully.

Problems may be lessened if the clay proportion in the mix is reduced by the addition of sand or grog.

Fully shrunk bricks are not completely dry. Further drying is needed before they are ready for firing in the kiln.



Figure VI.9 - Open-sided drying shed (Madagascar)



Figure VI.10 - Rack-drying under cover (Madagascar)



Figure VI.11 - Rack-drying under cover, with removeable side screens (Madagascar)

