

➔  **Small-Scale Production of Portland Cement (HABITAT, 1993, 92 p.)**

 **(introduction...)**

 **FOREWORD**

 **I. INTRODUCTION**

 **(introduction...)**

 **1.1 Advantages of small cement plants**

 **1.2 Definition of a small cement plant**

 **II. TECHNOLOGIES OF SMALL CEMENT PLANTS AND THEIR COMPARISON**

 **(introduction...)**

 **2.1 Fluidized-bed process**

 **2.2 Reba process**

 **2.3 Travelling grate (Lurgi sinter grate)**

 **2.4 Small rotary kiln**

 **2.5 Vertical-shaft kiln**

 **2.6 General conclusions on sourcing of technology and selection**

 **III. SMALL CEMENT PLANTS IN OPERATION IN DIFFERENT COUNTRIES**

 **3.1 Small cement plants in India**

 **3.2 Small cement plants in China**

 **3.3 Small cement plants in countries other than India and China**



#### **IV. GEOLOGICAL INVESTIGATIONS AND SELECTION OF RAW**

##### **MATERIALS AND FUEL** *(Introduction...)*

 **4.1 Geological investigations**

 **4.2 Quality requirements of raw materials**

 **4.3 Coke-breeze/low-volatile coal for VSK process**

 **4.4 Categories of reserves of limestone and their requirements**

#### **V. RAW-MIX DESIGN AND QUALITY CONTROL IN VSK CEMENT PLANTS**

 **5.1 Raw-mix design**

 **5.2 Quality control**

#### **VI. SYSTEM DESIGN AND SELECTION OF PLANT AND MACHINERY**

 **6.1 System design**

 **6.2 Equipment selection criteria**

 **6.3 Plant lay-out - EOT grabbing crane system vs tunnel systems for material handling**

#### **VII. PLANT DESCRIPTION**

 *(introduction...)*

 **7.1 Plant flow-sheet**

 **7.2 Instrumentation and process control**

#### **VIII. OPERATION OF A VERTICAL-SHAFT KILN**

 *(introduction...)*

 **8.1 Pre-lighting-up checks**

 **8.2 Lighting up the kiln**

 **8.3 Normal kiln operation**

-  **8.4 Kiln controls**
-  **8.5 Kiln disorders**

-  **IX. ENVIRONMENTAL CONTROL IN SMALL CEMENT PLANTS  
BASED ON VSK TECHNOLOGY**

-  *(introduction...)*

-  **9.1 Dust-generation sources and characteristics**

-  **X. A METHODOLOGY FOR THE PREPARATION OF PRE-  
FEASIBILITY STUDY**

-  *(introduction...)*

-  **10.1 Market assessment**

-  **10.2 Availability of raw materials and fuel**

-  **10.3 Selection of plant capacity and site**

-  **10.4 Infrastructure**

-  **10.5 Water resources**

-  **10.6 Climate**

-  **10.7 Process recommendations**

-  **10.8 Selection of plant and machinery**

-  **10.9 Process flow-sheet and plant lay-out**





-  **10.10 Project cost and profitability**

-  **XI. ECONOMICS**

-  **XII. MONITORING PERFORMANCE OF AN OPERATING PLANT**

-  **ANNEX I: PROFORMA FOR RECORDING PERFORMANCE DATA OF  
VSK CEMENT PLANT**



-  **APPENDIX I. SALIENT FEATURES OF CRI-MVSK TECHNOLOGY**

- APPENDIX II. CASE STUDY - A BRIEF TECHNO-ECONOMIC FEASIBILITY REPORT FOR SETTING UP A VSK BASED CEMENT PLANT**
  -  *(introduction...)*
  -  **Appendix II-A. Equipment recommended to be used in CRI-MVSK cement plant (up to 100 tpd)**
- APPENDIX III. CASE STUDY: PERFORMANCE OF A TYPICAL OPERATING VSK-BASED CEMENT PLANT**
  -  *(introduction...)*
  -  **Appendix III-A. Data on quality of raw materials, fuel, clinker and cement, and performance of unit operations**
-  **APPENDIX IV. GLOSSARY OF TERMS**

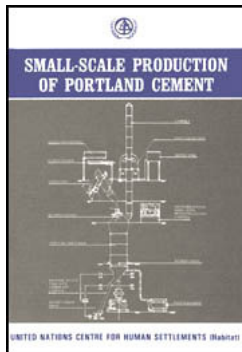

[Home](#) > [ar](#).[cn](#).[de](#).[en](#).[es](#).[fr](#).[id](#).[it](#).[ph](#).[po](#).[ru](#).[sw](#)



-  **Small-Scale Production of Portland Cement (HABITAT, 1993, 92 p.)**
  -  *(introduction...)*
  -  **FOREWORD**
  - I. INTRODUCTION**
  - II. TECHNOLOGIES OF SMALL CEMENT PLANTS AND THEIR COMPARISON**
  - III. SMALL CEMENT PLANTS IN OPERATION IN DIFFERENT COUNTRIES**
  - IV. GEOLOGICAL INVESTIGATIONS AND SELECTION OF RAW MATERIALS AND FUEL**
  - V. RAW-MIX DESIGN AND QUALITY CONTROL IN VSK CEMENT PLANTS**

- ❏ **VI. SYSTEM DESIGN AND SELECTION OF PLANT AND MACHINERY**
- ❏ **VII. PLANT DESCRIPTION**
- ❏ **VIII. OPERATION OF A VERTICAL-SHAFT KILN**
- ❏ **IX. ENVIRONMENTAL CONTROL IN SMALL CEMENT PLANTS BASED ON VSK TECHNOLOGY**
- ❏ **X. A METHODOLOGY FOR THE PREPARATION OF PRE-FEASIBILITY STUDY**
- 📄 **XI. ECONOMICS**
- 📄 **XII. MONITORING PERFORMANCE OF AN OPERATING PLANT**
- 📄 **ANNEX I: PROFORMA FOR RECORDING PERFORMANCE DATA OF VSK CEMENT PLANT**
- 📄 **APPENDIX I. SALIENT FEATURES OF CRI-MVSK TECHNOLOGY**
- ❏ **APPENDIX II. CASE STUDY - A BRIEF TECHNO-ECONOMIC FEASIBILITY REPORT FOR SETTING UP A VSK BASED CEMENT PLANT**
- ❏ **APPENDIX III. CASE STUDY: PERFORMANCE OF A TYPICAL OPERATING VSK-BASED CEMENT PLANT**
- 📄 **APPENDIX IV. GLOSSARY OF TERMS**

**United Nations Centre for Human Settlements (Habitat)  
Nairobi, 1993**

**Cover: CRI-Modern vertical-shaft kiln**

**Back Cover: Flow sheet of a VSK cement plant**

**HS/281/93E  
ISBN 92-1-131204-3**

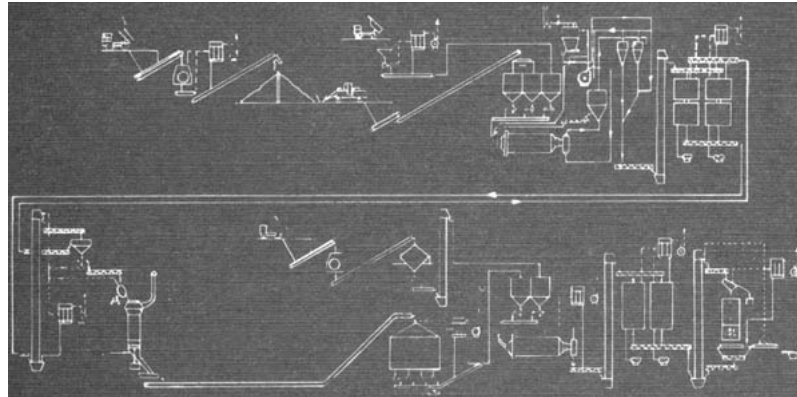

Figure

**UNITED NATIONS CENTRE FOR HUMAN SETTLEMENTS (Habitat)**

**PO Box 30030 Nairobi, KENYA. Telephone: 621234**

**Cable UNHABITAT; FAX (254 2) 624266, 624267; Telex: 22996 UNHAB KE**



[Home](#) > [ar.cn.de.en.es.fr.id.it.ph.po.ru.sw](#)

 **Small-Scale Production of Portland Cement (HABITAT, 1993, 92 p.)**

  **VIII. OPERATION OF A VERTICAL-SHAFT KILN**

 **(introduction...)**

 **8.1 Pre-lighting-up checks**

 **8.2 Lighting up the kiln**

 **8.3 Normal kiln operation**

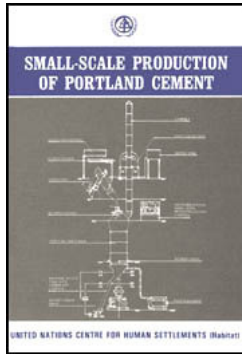

## 8.4 Kiln controls 8.5 Kiln disorders

### Small-Scale Production of Portland Cement (HABITAT, 1993, 92 p.)

#### VIII. OPERATION OF A VERTICAL-SHAFT KILN

In the black-meal process of the clinkerization based on VSK technology, the low-volatile fuel, i.e., coke-breeze or saleable low-volatile (SLV) coal, is uniformly mixed with raw materials during grinding and is fed into the vertical-shaft kiln from the top in the form of nodules of 5-10 mm diameter. The entire space of the kiln is filled with nodules. Air required for burning the clinker enters from the bottom of the kiln and moves upwards through the voids and gaps in the burnt clinker. The clinker is cooled rapidly and the air is preheated. Fuel particles of the raw-meal nodules burn, when the preheated air is in contact with them. The cooled clinker will be discharged out of the kiln from its bottom.

Good operation of the kiln aims at high productivity with improved clinker quality and low fuel and material consumption, and fuel consumption, taking into consideration the structure of the kiln, and condition of air ventilation through the nodule/clinker bed.

##### 8.1 Pre-lighting-up checks

**Before lighting up the kiln, the following checks should be carried out:**

**(a) *Rotary grate:*** The grate segments and crown with cutter teeth should be intact and in position. The grate should be allowed a full revolution to ensure that it does not touch the lining plates anywhere.

**(b) Lining plates** should not be loose.

**(c) *Refractory lining:*** The refractory lining must be checked and repaired wherever necessary. If the thickness of lining in the burning zone becomes reduced below 80 mm, it must be replaced.

**(d) All starters/main switches** of the electrical installation should be checked to ascertain whether they are in working condition.

**(e) *Roots blower:*** In accordance with the manufacturer's recommendations, oil must be checked. Filters must be cleaned. The weights in the safety valve are to be adjusted to suit the anticipated kiln bed resistance.

**(f) The chimney's damper, rotary feeder, kiln hood doors, and discharge gates** must be checked for mechanical operation and lubrication.

**(g) All the flanges of the kiln, bottom hood cup, chutes, discharge gates etc.** should be properly sealed so that the combustion air does not leak through gaps between the joints.

## **8.2 Lighting up the kiln**

**After checking the equipment, the pre-selected old clinker or filling material (size 20 to 50 mm) is filled from the top of the kiln. The discharge gates/material block tube (MBT)**



**should not be operated at this time. The filling is continued up to a level of 2.5 to 3 m from the rotary grate. Then the discharge gates/MBT must be operated for emptying the bottom cup. It has to be ensured that the rotary grate does not operate at this time. Next, the grate is operated at slow speed so that the clinker bed descends uniformly about 100 mm and then the grate is stopped. The filling is again started from the top until the kiln is 1.5 to 2.0 m empty from the top of the cone. The rotary grate is again started to ensure that the clinker bed descends uniformly by about 100 mm. About 100 kg of dry firewood (size 75 x 75 x 700 mm approx) is then stacked uniformly over the bed.**

**The chimney damper is kept partially open and the by-pass valve in the kiln air duct is kept open. The kiln can be lit. A few lighted torches of firewood are passed into the kiln through the kiln hood. The fire is allowed to spread uniformly. The draft is adjusted to suit the fire. After a uniform fire is achieved, coal is fed through the rotary feeder to make a uniform incandescent bed of fire. At a suitable stage the Roots blower is started with all by-pass valves open. The nodulizer is started and green nodules are fed over the fire bed. Initially it is preferable to have a slightly higher moisture content in the nodules. After about 10 minutes the rotary grate is started at minimum speed.**

**The bed level is built up slowly by operating the rotary grate at a lower speed. The quantity of air is increased in line with the feeding of nodules by closing the by-pass valves as per requirements. When the bed level reaches 40-50 cm from the top of the cone, the discharge rate is increased. Normally it takes 6 to 7 hours to complete these operations.**

### **8.3 Normal kiln operation**

**Stabilized kiln operation as obtained after the initial lighting up may be continued under the following conditions:**

**\* A uniform discharge rate should be maintained as far as possible by adjusting the**

**grate speed whenever necessary.**

**\* The nodule size, feed rate and bed level must be maintained.**

**\* The bed should always be covered with nodules by continuously feeding them in a circle some distance away from the refractory lining, so that the nodules themselves become distributed both over the periphery and towards the centre of bed. Continuous steam emerging from the centre of the bed indicates good fire and good combustion conditions. The temperature of various zones should be periodically recorded.**

**\* It is necessary to ascertain frequently that the entire bed is descending uniformly. This is ensured by cleaning the sides frequently with the help of a rod with a flattened tip. While cleaning the sides, care must be taken not to damage the refractory lining.**

**\* Once the kiln is stabilized, neither the process parameters nor the raw-mix composition should be subject to frequent change.**

## **8.4 Kiln controls**

### **8.4.1 Feed**

**Strict controls should be observed in the preparation of feed from the raw material stage. The table feeders/weigh feeders should be monitored periodically so that the component ratios conform to the values for the raw-mix design. The blending operation is carried out until a uniform blending with the desired total carbonate (TC) content is obtained. The TC in raw mix should not vary beyond  $\pm 0.2$  per cent of the desired value.**

**The nodules should be checked for appropriate size porosity, moisture and strength on an**

**hourly basis. The feed rate and discharge rate should be synchronized to maintain a constant bed level.**

#### **8.4.2 Air**

**The combustion air can be regulated by adjusting the valve on the by-pass pipe. The measurement is done with the help of two instruments provided on the burner's platform; one from the orifice plate to give combustion airflow and the other connected at the bottom for measuring the pressure at the inlet to the kiln which gives an idea of the bed resistance. If during a normal operation both the instrument readings are constant, the burner should understand that the kiln is filled with properly burning clinker. In the case where the inlet pressure varies, the burner receives an indication that the bed resistance is varying and can take necessary corrective action.**

#### **8.4.3 Discharge rate**

**Under stabilized operating conditions, the discharge and feed rates should be synchronized to maintain a constant bed level. If there are lumps that are too big or clinker that is too loose near the grate, the discharge rate will decrease or increase. Depending on the case, the grate speed is to be changed immediately, otherwise the bed level will rise or the burning zone will collapse destroying the entire kiln operation in the next few hours. Intermittent discharge is not desirable. The rotary-grate speed should not be abruptly changed; it should be done gradually step-by-step.**

#### **8.4.4 Temperature**

**Normal kiln operation is also judged from the temperatures of flue gases, clinker, burning zone and cooling zone and also of the kiln shell from outside. The temperature of the kiln is judged from the thermocouple-based temperature indicators and cross-checked by touching the kiln shell around the periphery at various heights to feel the uniform**

**temperature gradient. The desired temperature profile for a VSK is shown in figure 9.**

### **8.5 Kiln disorders**

**If the operation of the kiln is not checked frequently or if the raw-meal composition changes, the kiln is liable to experience trouble. Some of the troubles are mentioned below.**

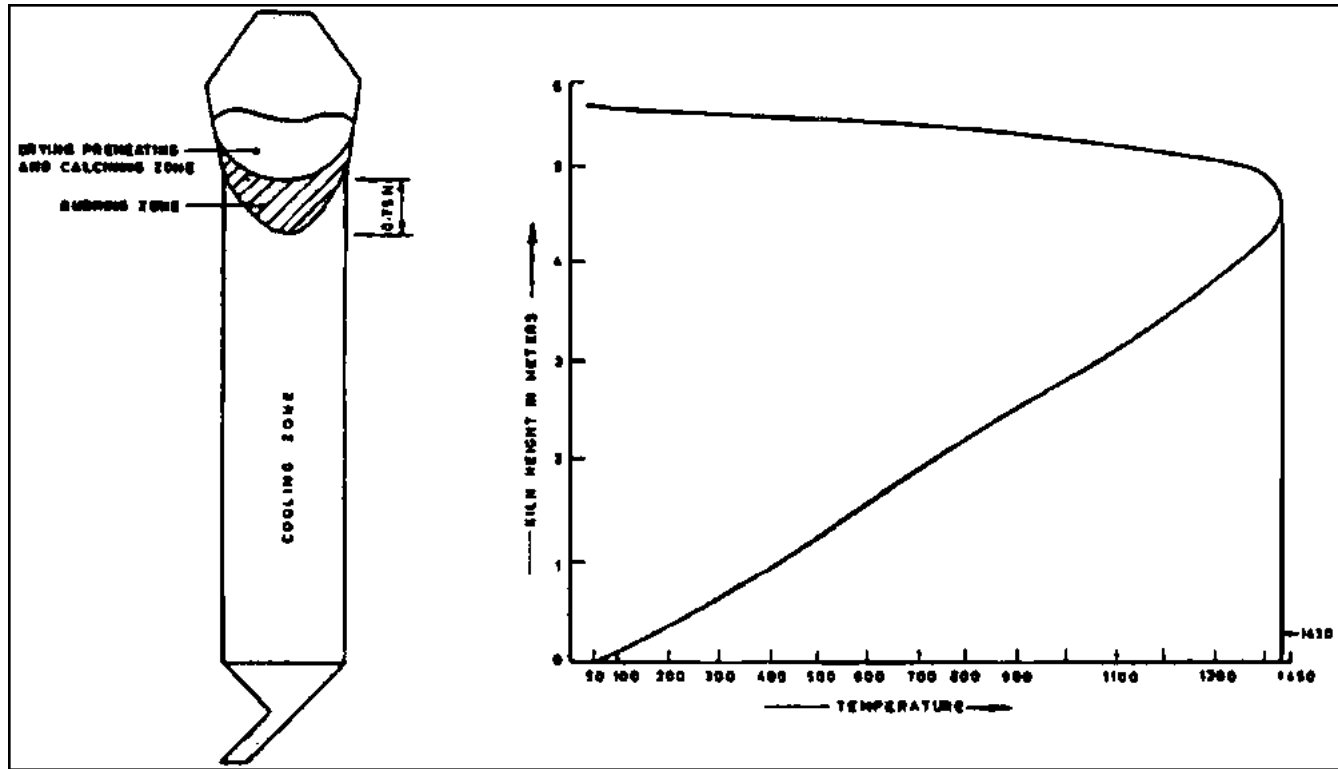

Figure 9. Temperature profile for VSK

### 8.5.1 Lump formation

Sometimes a big lump may be noticed in the burning zone which is very tough and as big as the internal diameter of the kiln. This may not descend. This generally occurs due to

**melting of clinker on account of a very high temperature there. The raw-mix composition should be checked and corrected. Another reason for this trouble may be fuel with a low ash fusion or a higher quantity of fuel. The lump so formed should be broken so that it may pass through the grate.**

### **8.5.2 Bridging**

**When the clinker is so lumpy that it does not contain loose material and the entire kiln is filled with such material, there are chances that these lumps will form a bridge and rest over the sides of the kiln and not on the grate. There would be a gap just above the grate and clinker discharge would be stopped, resulting in a rise in the fire bed. In such cases the feed should be adjusted and air should be reduced. The bed should be poked from the burner platform. If necessary the Roots blower and feed should be stopped and poking through the grate should be continued until the bed starts to descend.**

### **8.5.3 Side discharge**

**Sometimes, if the clinker produced becomes suddenly too loose, it will pass through the bigger lumps and be discharged quickly. Even red-hot clinker may be discharged indicating that over a certain portion there is no bed to support the burning zone. In such conditions, the grate speed should be reduced or it should be stopped, to reduce the discharge for some time, and to allow the burning zone to be built up slowly. The reduced rate of discharge should be continued until the trouble is overcome.**



[Home](#) > [ar.cn.de.en.es.fr.id.it.ph.po.ru.sw](#)

 **Small-Scale Production of Portland Cement (HABITAT, 1993, 92 p.)**

 **IX. ENVIRONMENTAL CONTROL IN SMALL CEMENT PLANTS**

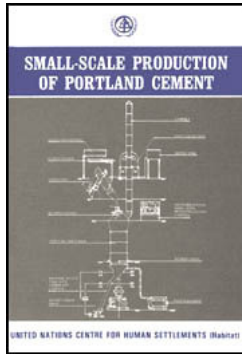

## **BASED ON VSK TECHNOLOGY**

**(introduction...)**



### **9.1 Dust-generation sources and characteristics**

**Small-Scale Production of Portland Cement (HABITAT, 1993, 92 p.)**

## **IX. ENVIRONMENTAL CONTROL IN SMALL CEMENT PLANTS BASED ON VSK TECHNOLOGY**

**Of late, environmental control aspects have been receiving increasing attention. Of the two aspects of pollution which are of immediate concern, *viz.*, air and water pollution, the mini-cement plants based on the VSK technology are virtually free of water pollution as no effluents are involved. Even as regards air pollution, which can basically be caused by both particulates and undesirable gases, the VSK cement plant operation ensures negligible emission of the latter, such as carbon monoxide, NO<sub>x</sub> etc., as the optimized operating conditions of the kiln generally prevent the emission of such gases. The generation of particulates, however, is inherent in the manufacturing process and the associated unit operations, which is controlled by the application of high-efficiency dust collectors wherever required. The operation of a vertical-shaft kiln, which is the heart of the process, is such that negligible emission takes place as the shaft kiln itself acts as an effective filter.**

**The dust-generation sources, their characteristics and present practices to ensure lower**

**dust emissions are discussed in the following paragraphs.**

### **9.1 Dust-generation sources and characteristics**

**The various dust-generation sources and their characteristics are considered below.**

#### ***Mining***

**Mining is generally carried out manually for mini-cement plants. The level of dust generation during drilling, blasting and loading of limestone is thus relatively low. Dust-suppression techniques, such as water spray, are found to be adequate in most situations.**

#### ***Crushing and raw materials proportioning***

**In the crushing section, generally a combination of primary and secondary crushers are used for size reduction. A single cyclone/fabric filter is mostly used to collect dust from both the crushing and the raw materials proportioning section. Sometimes, depending upon the specific situation, separate dust collectors for these two sections are also recommended.**

#### ***Raw grinding***

**Depending upon the raw-material characteristics, air is swept of raw materials and fuel. In both the cases, cyclones and fabric filters are used to keep the level of emissions low.**

#### ***Raw-material blending and homogenizing***

**The ground raw meal is blended and homogenized pneumatically in blending silos. The dust generated is collected in fabric filters to ensure low emission.**

#### ***Kiln section***



**Raw meal is extracted from the nodulizer feed-hopper and is fed to the nodulizer where water is also sprayed to form nodules. In order to collect dust from the nodulizer a fabric filter is used.**

**The system design and the technology used in the modern vertical-shaft kiln (CRI-MVSK) have adequate inbuilt provisions to restrict dust emission from the chimney within the limits prescribed by the statutory authorities. This is a unique feature performed by the MVSK, which, in addition to clinkerization, also reduces dust generation significantly. The green bed of moist nodules which are constantly distributed on the top by the rotary feeder, would trap most of the dust particles and only allow gases into the stack. In fact, when CRI-MVSKs are operated according to standard procedures, the emission levels are very much within the stipulated norms. In addition, the principle of natural draft, which is employed in the system, further ensures very little entrainment of dust particles and even the small solid particles which may get into the gas stream would settle down on the bed due to gravity as the velocity is very much less in the stack.**

**Whilst, in general, operational experiences have proved that the kilns based on CRI-MVSK technology do not pose any problem with regard to dust emission, a dust collector of simple design has been developed by the National Council for Cement and Building Materials (NCB), New Delhi, which has been successfully installed in CRI-MVSK cement plants. The gases from the VSK are made to pass through the dust-settling chambers, where the dust particles become settled and the dust so collected is recirculated into the process.**

### ***Clinker handling***

**Clinker discharged from the VSK through the triple air-lock discharge gate/material block tube is crushed in a jaw crusher. Clinker and gypsum stored in separate hoppers are extracted to be fed to the grinding mill. A fabric filter is used to collect dust from the**

**discharge gate/material block tube, clinker crusher and clinker and gypsum extraction points beneath their respective hoppers.**

### ***Cement grinding***

**In small cement plants based on the VSK technology, open-circuit tube mills are generally employed for cement grinding. The mill works on the overflow principle and the product is directly conveyed to the storage silo. A fabric filter is used to facilitate dust collection to ensure a very low level of emissions.**

**The various types of dust collection equipment adopted for the different unit operations in an MVSK plant as described above, are summarized in table 8.**

**Table 8. Types of dust-collection equipment used in a CRI-MVSK cement plant**

<b>Unit operation</b>	<b>Equipment used</b>
Crushing section	Multicyclone/air fabric filter
Raw materials proportioning section	Multicyclone/air fabric filter
Raw mill	Cyclone and fabric filter
Blending	Air fabric filter
VSK	Dust-settling chamber
Clinker extraction and handling	Multicyclone
Cement mill and packing	Air fabric filter

### ***Control of fugitive dust***

**Specific instances of fugitive dust generation may include dust blown by wind from the raw-materials stockpile, dust caused by vehicular traffic within the factory, dust leakage**

**from conveyors, conveyor transport points, silos, storage hoppers and packers etc. Good housekeeping, proper maintenance, wetting of dusty areas, use of enclosed storage wherever feasible etc., would considerably reduce fugitive dust.**



[Home](#) > [ar.cn.de.en.es.fr.id.it.ph.po.ru.sw](#)

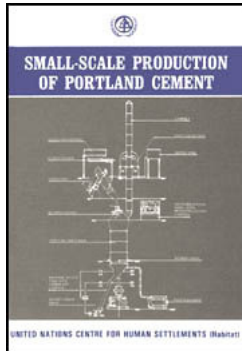

## **Small-Scale Production of Portland Cement (HABITAT, 1993, 92 p.)**

### **X. A METHODOLOGY FOR THE PREPARATION OF PRE-FEASIBILITY STUDY**



**(introduction...)**

**10.1 Market assessment**

**10.2 Availability of raw materials and fuel**

**10.3 Selection of plant capacity and site**

**10.4 Infrastructure**

**10.5 Water resources**

**10.6 Climate**

**10.7 Process recommendations**

**10.8 Selection of plant and machinery**

**10.9 Process flow-sheet and plant lay-out**

**10.10 Project cost and profitability**

**Small-Scale Production of Portland Cement (HABITAT, 1993, 92 p.)**

**X. A METHODOLOGY FOR THE PREPARATION OF PRE-FEASIBILITY STUDY**

**As the title implies, a pre-feasibility study is carried out to assess the suitability of the process for the manufacture of cement under the given conditions and to establish before the project is taken up that economically it will be a profitable proposition. The study envisages, therefore, the choice and evaluation of the related technical, technological and economic parameters as they would perform under the given conditions - the raw materials, the infrastructure, the financial resources available, the market conditions and other social factors. Quite often, these are inter-related.**

**The first consideration is the process for the “technology” to be adopted. As has been described earlier, for the given size (capacity) of the cement plant there is an optimum technology. For cement plants of 25 to 100 tpd capacity, plant based on the VSK technology is widely adopted. This report, therefore, has given greater attention to the VSK technology and plants based on it. If, in a given situation, any other technology described in chapter II is adopted for some reason, the rest of the discussion that follows will still be applicable. In some instances, alternative technologies are required to be evaluated and compared in terms of performance and costs. This pertains to the main process technology, as well as to options for certain unit operations, e.g., material handling, grinding, process control etc.**

**Adoption of the VSK technology, or any other technology for cement manufacture, requires raw materials and fuels with characteristics within the specified quality ranges. A pre-feasibility study takes into account the availability of raw materials and fuels at the location selected or near proximity to it. The location of the plant and the optimum size will depend upon the market for the product and the financial resources available. Broadly, the pre-feasibility study envisages considerations of the parameters detailed below.**

### **10.1 Market assessment**

**The feasibility study for setting up of a small cement plant should necessarily cover the**

**availability, demand and supply of cement in the region under consideration. For small-capacity cement plants, the study of the demand-supply position for cement within an economic radius of say 100 km is of utmost importance. This is so because, beyond a certain distance, the advantage of lower cost of production in smaller cement plants may be outweighed by the high transport cost of cement over longer distances. In addition to studying the past scenario of the demand/supply situation, the present availability/supply of cement in the vicinity of the proposed plant location (cement plants situated in the region) and projected demand of cement in the region has to be analysed. Demand is one of the most critical parameters in deciding about the setting-up of a cement plant. It reflects the quantity and the pattern of the market demand. An entrepreneur's inducement to invest in cement manufacturing is governed by the size of the market. If the market conditions reflect profitability, then the entrepreneur starts thinking in terms of setting up the plant for that market. Demand analysis assumes a still greater significance to the management since it helps the manufacturer in planning the requirements of human resources, materials, machine and financial inputs. For example, if the demand projections show a trend towards a substantial and sustained increase in the long run, the promoter may plan in the initial stages itself for the additional plant capacity and machinery which may be required to be installed at a later stage for future expansions. The layout can also be planned in such a way as to provide sufficient flexibility for the additional capacity.**

**Demand projections for cement in any country are normally done by central agencies, by the state-level bodies for the various regions and also by a number of financial institutions and private bodies. The feasibility study also covers the potential for growth of various cement-consuming projects which may occur in the regions in the future, e.g., setting-up of large industrial projects, hydro-electric plants and other projects for manufacturing value-added products of cement like housing, road construction, prefabricated concrete elements like poles for electricity transmission, prestressed concrete railway sleepers etc.**

**In case the data on cement demand are not available in any country, the government's**

**sources or statistical department, it is possible to estimate the demand by any of the conventional methods for demand projections like Delphi techniques, trend extrapolation, systematic curve fitting etc. For many cases, discrete data may not be available, e.g., in small developing countries. In such cases, it is advisable to go in for cross-country regression analysis to arrive at an approximate value of demand in the region.**

## **10.2 Availability of raw materials and fuel**

**Once the demand/supply position is assessed, the next important phase of the pre-feasibility study is the search for the required raw materials, as well as fuel like coke-breeze, both in terms of quality and quantity since the successful operation of a cement plant, to a large extent, depends upon the type of raw materials and fuel available.**

**Portland cement is a binding agent consisting essentially of compounds having calcium oxide, silicon dioxide, aluminium oxide and ferric oxide. Therefore, it is necessary to find a suitable calcareous material such as limestone, chalk, marl, sea shell, kankar etc., which can fulfil the above requirements, and other additives which may be clay, bauxite, laterite, iron ore etc. The feasibility study should identify a suitable source of calcareous raw material - mostly limestone of cement-grade quality.**

**Apart from limestone, the quality and source of other raw materials like clay, bauxite, iron ore etc., has also to be ascertained during the pre-feasibility study. Another important raw material required is gypsum, about 5 per cent of which is added during finish grinding to control the setting property of the cement. In most instances, gypsum may not be locally available and will have to be transported over a considerable distance; it seems this will also be the case with fuel. On the other hand, various industrial wastes and by-products like granulated blast-furnace slag, fly ash, sludges, phosphogypsum etc., can be conveniently used in cement manufacture and their availability should be ascertained.**

## **10.3 Selection of plant capacity and site**

**The main factors which should be considered when fixing the capacity of a small cement plant are:**

- \* Demand for cement produced within an economic radius.**
- \* Availability of raw materials in terms of quality and quantity so that the plant can operate for a period of at least 40 years.**
- \* Availability of sufficient fuel, electricity, water and other infrastructural facilities.**

**Apart from the above factors, the availability of finance to the promoters sometimes limits the size of the plant. Since the cement industry is a mineral-based industry and the quantity of limestone required is approximately 50 per cent more than the quantity of the finished product, it is desirable to locate the plant near the source of limestone, provided other important factors like availability of market, availability of labour etc, do not outweigh this consideration.**

**The other important criteria for the selection of a cement plant site are as follows:**

- (a) Enough space to arrange a complete plant;**
- (b) Good foundation of the plant site. The soil bearing capacity (SBC) of the plant site should be more than 15 t/m<sup>2</sup>;**
- (c) The site should be more or less on level ground. Percentage fluctuation in topography should be within 5 per cent. This limitation is set for the sake of reducing the cost of earthwork and speeding up the construction;**
- (d) Convenient communication and transport. It is better that a plant be located close to a local main road/highway;**

**(e) While selecting a plant site, the energy source, i.e., both the power supply and fuel source, should be taken into consideration.**

## **10.4 Infrastructure**

**The infrastructural facilities which have to be considered are:**

- \* Availability of uninterrupted power supply for the plant and the colony.**
- \* Adequate land (actual requirement depending upon the plant size).**
- \* Good transport facilities like proximity to a railway station and a good road network are required for the efficient movement of heavy plant and machinery during erection of the plant and for finished products when the plant comes on stream. A minor consideration is the availability of air transport as a rapid means of communication for personnel with other plants and central offices.**
- \* Communication and other general facilities like dispensary/hospitals, petrol pumps, fire stations, police stations, and automobile servicing centres if available nearby are added attractions for deciding the location of the cement plant.**
- \* Availability of specialized workshop facilities such as forging, welding, casting, fabrication, machining and other activities. Proximity to the source of other consumables/spares like lubricants, refractories etc. and construction materials like sand, aggregates, cement, timber, steel, bricks etc., is also an important factor to be considered during the feasibility study.**

## **10.5 Water resources**

**The cement plant requires large quantities of water not only during the process of cement**



**manufacture but also in the laboratory, and for drinking and washing purposes in the colony and the plant. Location of the plant near a lake or a river is therefore advantageous. As an alternative, wells can be used as a means of water supply. It is also important to consider the quality of water as, in case of non-potable water, additional purification costs may have to be incurred.**

## **10.6 Climate**

**The climate can have an important bearing on the economic operation of the cement plant where extreme climatic conditions like heavy rains or snowfall are likely to be encountered. The cost of covered sheds, protective buildings and facilities for personnel can contribute immensely towards a higher capital cost of the project. In certain cases additional equipment may also be required, e.g., driers are required for drying of clay and coke-breeze in plants situated in regions of heavy rainfall.**

## **10.7 Process recommendations**

**The feasibility study should invariably cover the process selected for the manufacture of cement taking into account the advantages and disadvantages of various technologies available from various suppliers. Some of the technologies being used in small-scale cement manufacture have been covered in chapter II.**

## **10.8 Selection of plant and machinery**

**The machinery and equipment required for small-size cement plants have to be selected taking into consideration the economics of the plant, simplicity in operation and maintenance aspects. The indigenous availability of equipment is helpful from the viewpoint of reduced equipment costs and easier availability of spares and service personnel. The specifications of various types of equipment have to be based on the experience of standard-size equipment available in the market and the quotations of the**

**machinery manufacturers. In most cases, the supplies for these small-size cement plants are on a turn-key basis and the specifications and sizes have been standardized by the various manufacturers or suppliers. However, detailed investigations have to be made by the entrepreneur and the consultant for the right kind of the equipment required depending upon the raw material characteristics. Utmost care is essential while finalizing the plant and machinery as it covers the major portion of the fixed cost.**

### **10.9 Process flow-sheet and plant lay-out**

**The flow sheet is essentially a route map of the process and it pictorially and graphically represents the process steps in their proper sequence. The process flow sheet should indicate the heat and mass balance at various stages together with a reasonably detailed indication of the operating conditions including the flow rates, temperature and pressures at all the process steps. A typical flow sheet of a VSK cement plant is shown in figure 10.**

**While working out the details of the plant layout, the following factors should be kept in mind:**

- \* The flow of the materials as well as the intermediate products until the last stage of manufacture must be in a rational direction and should follow the shortest route.**
- \* The layout should be such that it should be possible to run the plant with the minimum workforce for operation, maintenance and supervision.**
- \* The plant should have enough space for easy movement of labour and materials; and maintenance of machinery and yet should be compact. It should have maximum simplicity in installation and operation.**
- \* Centralizing plant service facilities into a common service complex.**

**\* The layout should result in economy in construction.**

**A carefully planned functional arrangement of equipment, buildings and pipe work is the key to economical construction and efficient operation of a cement plant. In addition, sensible and aesthetically pleasing layouts can make a major contribution to safety. Any error in the layout of equipment at the initial stage will prove to be costly to rectify later. Hence the plant layout has to be planned taking into consideration the above factors.**

### **10.10 Project cost and profitability**

**In the preparation of the feasibility reports, the project cost estimates have to be prepared keeping in mind the data required by financial institutions. The estimates for plant and machinery should be based on the quotations received from the suppliers. In assessing these quotations, it is important to note possible discounts offered by the companies and also to distinguish between firm prices and those containing an escalation clause which permits an increase in the price due to rises in the cost of materials, labour or both.**

**In the computation of the complete project cost, additional costs incurred in providing ancillary services such as roads, canteen, laboratories, machine shops, quarry equipment, buildings, and civil works and pre-operative expenses like rent, insurance, mortgage etc., have also to be taken into account. The calculation of working capital will depend upon the cost of the various raw materials, power, stores, and consumables, salaries and wages etc. The profitability of the plant can be worked out based upon the average prevailing market selling price of cement and the total cost of production.**

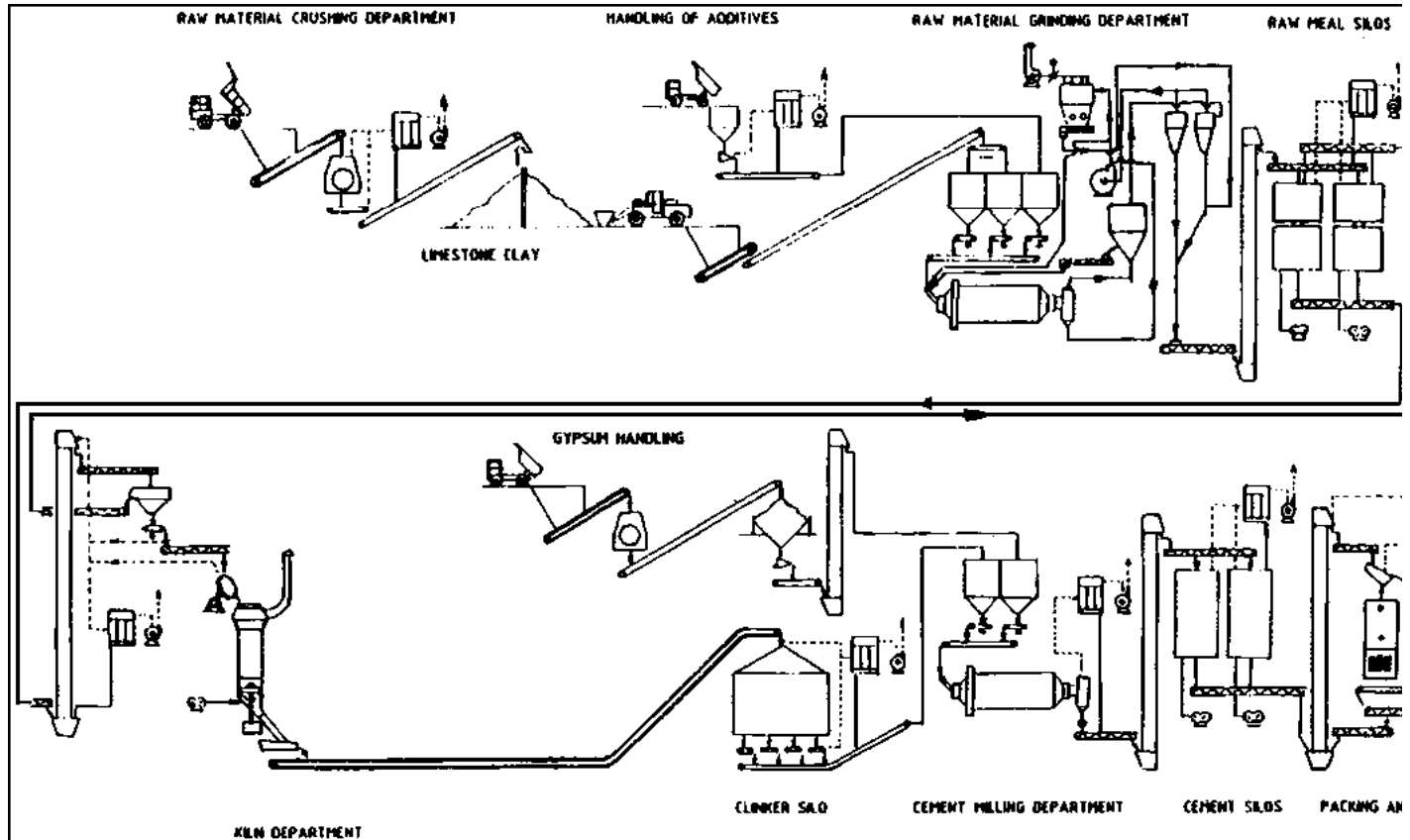

Figure 10. Flow sheet of a VSK cement plant

The detailed calculations have been given in the case study in the following chapter.

**Studies conducted by NCB have shown that, under any technology within an upper and lower threshold, there are always scale effects which are bound to affect both the investment cost and the operating cost. Whilst there is a significant advantage in the investment and operating costs through changing the process and the process line from rotary to VSK, within the VSK mini-cement plants also, the investment cost and especially the cost of production goes up when the size of the plant is made smaller and smaller.**

**It is for to this reason that NCB makes a very careful evaluation of the economic viability of these small-size cement plants over their entire life-cycle before any investment decision is taken. For example, in India, keeping the economic viability over the entire life-cycle of the plant in view, normally mini-cement plants with a size of 50 tpd and above should only be encouraged until and unless there are specific advantages which can be derived from a plant of still smaller capacity, in terms of limited raw material deposits, limited local demand and other socio-economic factors, which can only be evaluated on a case-to-case basis.**

**It is also worth mentioning that the same CRI-MVSK cement plant, because of its modern features including microprocessor-based process control and monitoring system, can be used for the manufacture of a large variety of special cements like high-strength cement, expansive cement, oil-well cement etc., apart from blended cements like Portland-slag cement and Portland-pozzolana cement, without any change in the plant and machinery requirements. In fact all these special cements have already been produced in a few of the operating CRI-MVSK cement plants in India which have given a boost to the techno-economic viability of these mini-cement plants in India.**



**[Home](#)"" """"""> [ar.cn.de.en.es.fr.id.it.ph.po.ru.sw](#)**

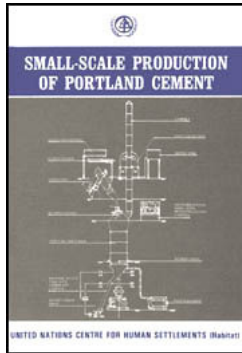

## **Small-Scale Production of Portland Cement (HABITAT, 1993, 92 p.)**

 **(introduction...)**

 **FOREWORD**

**I. INTRODUCTION**

**II. TECHNOLOGIES OF SMALL CEMENT PLANTS AND THEIR COMPARISON**

**III. SMALL CEMENT PLANTS IN OPERATION IN DIFFERENT COUNTRIES**

**IV. GEOLOGICAL INVESTIGATIONS AND SELECTION OF RAW MATERIALS AND FUEL**

**V. RAW-MIX DESIGN AND QUALITY CONTROL IN VSK CEMENT PLANTS**

**VI. SYSTEM DESIGN AND SELECTION OF PLANT AND MACHINERY**

**VII. PLANT DESCRIPTION**

**VIII. OPERATION OF A VERTICAL-SHAFT KILN**

**IX. ENVIRONMENTAL CONTROL IN SMALL CEMENT PLANTS BASED ON VSK TECHNOLOGY**

**X. A METHODOLOGY FOR THE PREPARATION OF PRE-FEASIBILITY STUDY**

  **XI. ECONOMICS**

 **XII. MONITORING PERFORMANCE OF AN OPERATING PLANT**

 **ANNEX I: PROFORMA FOR RECORDING PERFORMANCE DATA OF VSK CEMENT PLANT**

 **APPENDIX I. SALIENT FEATURES OF CRI-MVSK TECHNOLOGY**

**APPENDIX II. CASE STUDY - A BRIEF TECHNO-ECONOMIC**

**FEASIBILITY REPORT FOR SETTING UP A VSK BASED CEMENT****PLANT**  
**□ APPENDIX III. CASE STUDY: PERFORMANCE OF A TYPICAL**  
**OPERATING VSK-BASED CEMENT PLANT****📄 APPENDIX IV. GLOSSARY OF TERMS****XI. ECONOMICS**

**The economics of the small-scale manufacture of cement depend upon a number of related parameters. The selling price of cement as it reaches the consumer comprises three broad components: the cost of production; the cost of packing, handling and transport; and the element of State levies and taxes. For example, currently in India the net selling price of cement produced in small-scale cement plants is composed of these three elements approximately in the order of 61 per cent, 15 per cent and 24 per cent respectively.**

**While the production cost is intrinsic to the plant and its inputs, which is elaborated later on, the other two components are external. The locational advantage of a small-scale cement plant stems from the fact that it should have a market within an economic distance of say 100 km. Demand for cement in the region and the availability of cement from other existing sources of supply will determine whether the proposed plant will be able to sell the cement locally. If it is required to sell the product in far distant places, the increased cost of transport will increase the selling price and, to that extent, affect competitiveness.**

**The market for cement will also depend upon the quality of the product which, in a free economy, could be the decisive factor. It is thus imperative that the quality of cement produced from a small-scale plant conform to the requirements of the specifications of national standards as applicable to the cement produced in a modern, large plant. This has been the approach adopted in India, with good effect.**

**State levies and taxes are subject to the policies of the local government. Some**

**concessions on taxes may be offered by way of incentives to small-scale producers. However, the production of cement from a small-scale plant should, ideally, be viable and competitive even when such incentives or subsidies are not available.**

**Insofar as cost of small-scale production of cement is concerned, the techno-economic viability of such plants has been evaluated, based on NCB's experience in setting up a large number of CRI-MVSK cement plants and the feedback obtained from such plants already under operation. Typical case studies pertaining to plants of 30 tpd, 50 tpd and 100 tpd capacities have been worked out and are shown in table 9. The case study also shows a sensitivity analysis from which it may be observed that except for the plants of very small sizes, the profitability of CRI-MVSK cement plants is not affected by variations in the input parameters. The cost figures in the tables are expressed in United States dollars and the exchange rate of dollar is taken as Rs 30.**

**Table 9. Investment, production cost and profitability of 30 tpd, 50 tpd, and 100 tpd (2 × 50 tpd kilns) CRI-MVSK cement plants**

Items	Cost of CRI-MVSK cement plant		
	30 tpd	50 tpd	100 tpd
Capital cost (in thousand \$US)			
(a) Fixed capital*	542.17	655.51	1,566.49
(b) Margin money	19.53	30.40	59.97
(c) Total capital	561.70	685.91	1,626.46
Investment per ton of installed capacity (\$US)			
(a) Fixed capital*	54.76	39.70	47.47
(b) Margin money	1.97	1.84	1.82



(c) Total capital	56.73	41.54	49.29
Cost of production* (up to naked cement) (\$US/ton)	39.61	34.63	35.24
Debt equity ratio			1.5:1
Profitability under different conditions (percentage based on equity capital)			
(a) Ex-works profit if cement is sold @ \$US 63.33/ton			
(i) \$US/ton	6.72	11.70	11.09
(ii) Pre-tax (percentage)	26.63	63.32	50.64
(iii) Post-tax (percentage)	15.98	37.99	30.36
(b) Profit if cement is sold within a radius of 100 km, all other conditions same as in (a) above			
(i) \$US/ton	3.72	8.70	8.09
(ii) Pre-tax (percentage)	14.71	47.08	36.94
(iii) Post-tax (percentage)	8.82	28.25	22.17
(c) Effect on profitability			
(i) If capital cost decreases by 10 per cent			
a. \$US/ton	+1.05	+0.82	+0.96
b. Pre-tax (percentage)	+4.19	+4.44	+4.39
c. Post-tax (percentage)	+2.51	+2.66	+2.63
(ii) If operation cost decreases by 10 per cent			
a. \$US/ton	+2.98	+2.71	+2.64
b. Pre-tax (percentage)	+11.88	+14.66	+12.06
c. Post-tax (percentage)	+7.13	+8.80	+7.23
(iii) If capital cost increases by 10 per cent			

a. \$US/ton	-1.05	-0.82	-0.96
b. Pre-tax (percentage)	-4.19	-4.44	-4.39
c. Post-tax (percentage)	-2.51	-2.66	-2.63
(iv) If operation cost increases by 10 per cent			
a. \$US/ton	-2.98	-2.71	-2.64
b. Pre-tax (percentage)	-11.88	-14.66	-12.06
c. Post-tax (percentage)	-7.13	-8.80	-7.22

**\*Details are given in tables 10,11 and 12.**

**Other relevant data, supplementary to table 9, are given in the following tables:**

**Table 10. Estimates of capital costs for 30 tpd and 100 tpd (2 × 50 tpd kilns) CRI-MVSK cement plants**

**Table 11. Estimates of working capital requirements for 30 tpd, 50 tpd and 100 tpd CRI-MVSK cement plants**

**Table 12. Estimates of annual cost of production of cement plant in a 30 tpd, 50 tpd and 100 tpd (2 × 50 tpd kilns) CRI-MVSK cement plants**

**Table 13. Break-even analysis for a 30 tpd, 50 tpd and 100 tpd (2 × 50 tpd kilns) CRI-MVSK cement plants**

**Table 14. Expected benefits of the project (based on the fourth year of operation for 100 tpd (2 × 50 tpd kilns) CRI-MVSK cement plant**

**Table 10. Estimates of capital cost of 30 tpd, 50 tpd and 100 tpd (2 × 50 tpd kilns) CRI-**

**MVSK mini-cement plants**

Item	Cost of CRI-MVSK mini-cement plant (in \$US thousand)		
	30 tpd	50 tpd	100 tpd
Land and site development	7.67	7.67	32.50
Building and structures	134.83	175.67	257.33
Plant and machinery	306.67	366.67	883.33
Miscellaneous fixed assets	15.00	15.00	148.33
Preliminary and capital issue expenses	0.67	0.67	40.00
Pre-operative expenses	57.33	66.50	145.00
Provision for contingencies	20.00	23.33	60.00
Margin money for working capital	19.53	30.40	59.97
Total capital cost	561.70	685.91	1626.46

**Table 11. Estimates of working capital requirement for 30 tpd, 50 tpd and 100 tpd CRI-MVSK cement plants (based on 90 per cent capacity utilization)**

Item	Inventory period (months)	Quantity (in tons)			Rate/unit (\$US).	Amount (in \$US thousands)		
		30 tpd	50 tpd	100 tpd		30 tpd	50 tpd	100 tpd
Raw materials								
(a) Limestone	1.25	1202	2003	4006	2.33	2.80	4.67	9.33
(b) Clay	1.50	261	436	872	1.00	0.27	0.43	0.87

(b) Clay	1.50	201	450	872	1.00	0.27	0.43	0.67
(c) Coke-breeze	2	302	502	1005	50.00	15.10	25.17	50.33
(d) Gypsum	2.50	93	155	309	13.33	1.23	2.07	4.13
(e) Packing materials (bags)	1.50	22275	37125	74250	0.20	4.47	7.43	14.83
Power	1					4.63	7.73	15.47
Stores and consumables	1					0.73	1.23	2.47
Repairs and maintenance	1					0.67	0.83	2.07
Salaries and wages	1					4.60	4.73	7.23
Overhead expenses	1					0.50	0.83	1.67
Insurance	3					0.63	0.73	1.73
Goods in process	0.50					7.77	11.90	23.83
Finished goods up to naked cement	0.25					5.40	8.20	15.93
Total working capital						48.80	75.95	149.89
Margin money (40 per cent)						19.52	30.38	59.96
Short-term loan (60 per cent)						29.28	45.57	89.93

**Table 12. Estimates of annual cost of production of cement in a 30 tpd, 50 tpd and 100 tpd (2 × 50 tpd kilns) CRI-MVSK cement plants**

4th year of operation - 90 per cent utilization 330 working days/year

Item	Consumption factor per ton of cement	Rate/unit (\$US)	Annual requirement (in tons)			Amount (per ton of cement) (in \$US)		
			30 tpd	50 tpd	100 tpd	30 tpd	50 tpd	100 tpd
Raw materials								
(a) Limestone	1.295(t)	2.33	11538	19231	38462	3.02	3.02	3.02
(b) Clay	0.235 (t)	1.00	2094	3490	6980	0.23	0.23	0.23
(c) Coke-breeze	0.203 (t)	50.00	1809	3015	6030	10.15	10.15	10.15
(d) Gypsum	0.050 (t)	13.83	445	742	1485	0.67	0.67	0.67
Power	125 KWh	0.20	1113750	1856250	3712500	6.25	6.25	6.25
Stores and consumables						1.00	1.00	1.00
Salaries and wages						6.21	3.84	2.92
Repairs and maintenance						0.90	0.67	0.84
Overhead expenses						0.67	0.67	0.67
Depredation of fixed assets						3.33	2.40	3.23
Amortization of projection cost						0.63	0.43	0.60
Insurance charges						0.28	0.20	0.23
Financial expenses								
(a) Interest on term loan at 18 per cent per						5.60	4.50	4.83

annum									
(b) Interest on Short-term loan at 20 per cent per annum							0.67	0.60	0.60
Cost of production of naked cement							39.61	34.63	35.24

**Table 13. Break-even analyses\* for 30 tpd, 50 tpd and 100 tpd (2 × 50 tpd kilns) CRI-MVSK cement plants**

Item	30 tpd	50 tpd	100 tpd
Sales quantity (tons/year)	8,910	24,850	29,700
Net sales realization per ton if the cement is sold \$US63.33 per ton	46.33**	46.33**	46.33**
Annual cost of production			
(a) Fixed elements (\$US/ton)			
(i) Salaries and wages	6.21	3.84	2.92
(ii) Stores and consumables (25 per cent)	0.25	0.25	0.25
(iii) Repairs and maintenance(75 per cent)	0.67	0.50	0.63
(iv) Overhead expenses	0.67	0.67	0.67
(v) Depreciation	3.33	2.40	3.23
(vi) Insurance	0.28	0.20	0.23
(vii) Amortization of project cost	0.63	0.43	0.60
(viii) Interest on term loan	5.60	4.50	4.83
Total	17.64	12.79	13.36
(h) Variable elements (\$US/ton)			

(v) Variable elements (US\$/ton)			
(i) Raw materials and fuel	14.07	14.07	14.07
(ii) Power	6.25	6.25	6.25
(iii) Stores and consumables (75 per cent)	0.75	0.75	0.75
(iv) Repairs and maintenance (25 per cent)	0.23	0.17	0.21
(v) Interest on term loan	0.67	0.60	0.60
Total	21.97	21.84	21.88

$$\text{Break - even point} = \frac{\text{Fixed cost} \times 100}{\text{Net sales realization} - \text{Variable cost}}$$

Break Even Point for a 30 tpd: $\frac{17.64}{46.33 - 21.97} \times 100 = 72\%$
Break Even Point for a 50 tpd: $\frac{12.79}{46.33 - 21.84} \times 100 = 52\%$
Break Even Point for a 100 tpd: $\frac{13.36}{46.33 - 21.88} \times 100 = 55\%$

**\* For Break Even Charts refer to Figs 11,12,13**

**\*\* Net Sales Realisation per tonne has been taken as US \$46.33, which is arrived at as under:**

	<u>US \$/tonne</u>
Retail Price	63.33
LESS Sales Tax	5.33
Excise Duty	6.00
Packing Charges	4.00

Packing charges

1.00

Dealers' Margin of profit and other expenses 1.6717.00

Net Sales Realisation

46.33

**As may be seen from the above tables, the total capital cost of a 30 tpd, a 50 tpd and a 100 tpd CRI-MVSK cement plant is \$US561,700, \$US685,910 and \$US1,626,460 respectively, and the investment per ton of installed annual capacity is \$US56.73, \$US39.93 and \$US49.29 respectively. The investment cost in a 100 tpd CRI-MVSK cement plant is comparatively higher than is the case with a 50 tpd plant, because it has modern features using a microprocessor-based process control and monitoring system, which makes it more capital-intensive. The cost of production up to naked cement as shown in table 12 also varies from \$US35 to 40 per ton of cement depending upon the capacity. The break-even point is 72 per cent in 30 tpd, 52 per cent in 50 tpd and 55 per cent in 100 tpd CRI-MVSK cement plants, as worked out in table 13 and shown in figures 11, 12 and 13 respectively.**

**A perusal of the production costs given in table 12 indicates that nearly 26 to 29 per cent is by way of cost of fuel (coke-breeze) and another 16 to 18 per cent by way of cost of power. Thus, total energy cost forms 42 to 48 per cent of cost of production of cement (before packing). The economics of the small-scale manufacture of cement in India has been found to be particularly sensitive to the cost of fuel (coke-breeze), which depends upon the transport distance, as well as to the capacity utilization of the plant during operation. If adequate infrastructural support like the supply of grid power is available, capacity utilization can be comparable to that of a large-scale plant. The labour cost, by way of salaries and wages, comes to 16 per cent of production cost in the case of a 30 tpd plant and 8 per cent in case of a 100 tpd plant. Admittedly, the labour employed per unit of cement produced in a small-scale plant is greater than that in a large-scale plant, but in most cases, this fulfils a desirable social goal of employment-generation.**



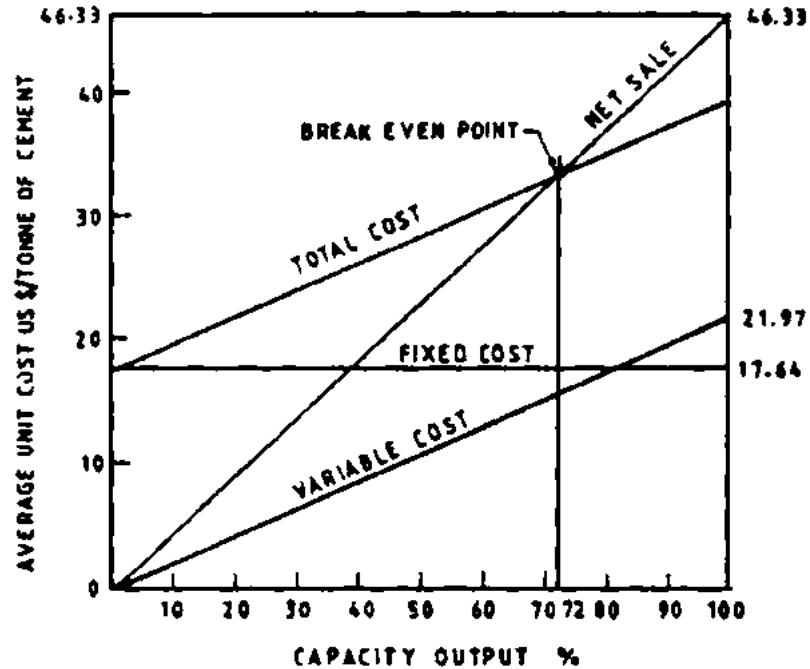

Figure 11. Break-even chart for 30 tpd (1 x 30 tpd kiln) CRI-MVSK cement plant

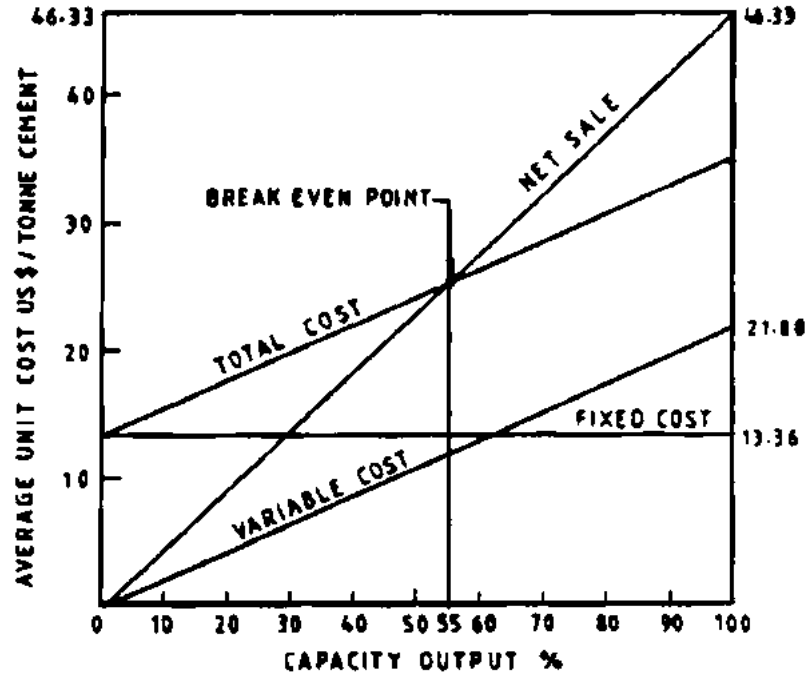

Figure 12. Break-even chart for 100 tpd (2 x 50 tpd kilns) CRI-MVSK cement plant

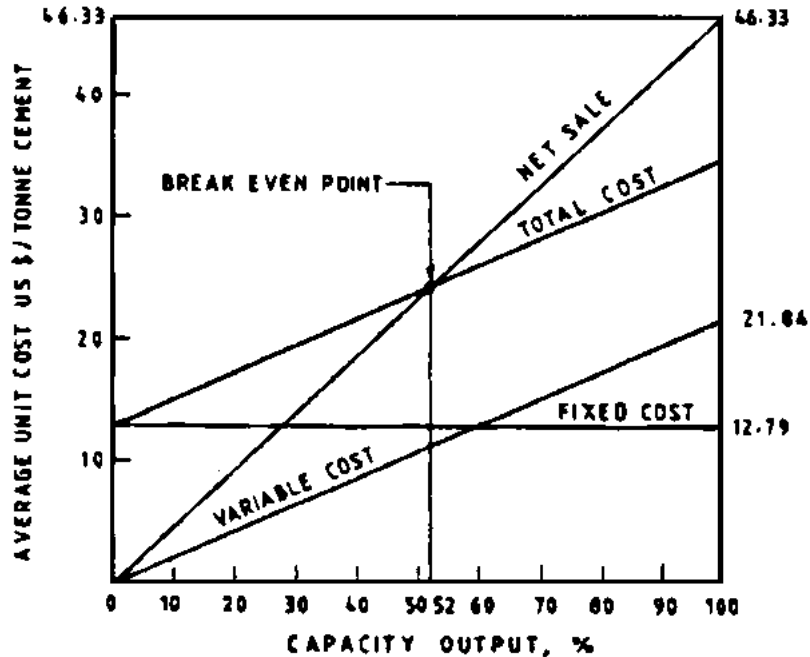

Figure 13. Break-even chart for 50 tpd (1 x 50 tpd kiln) CRI-MVSK cement plant

Table 14. Expected benefits of the project (based on the fourth year of production) for 100 tpd (2 x 50 tpd kilns) CRI-MVSK cement plant

Item		
A. Output and profits (in \$US thousand)		
1.	Capacity output (3 shifts)	1529
2.	(a) Value of output (net of excise duty)	1376

20/10/2011

Small-Scale Production of Portland Ce...

2. (a) value of output (net of excise duty)		1370
(b) Other income		-
3. Value of output (as percentage of 1)		90
4. Change in the stock of goods		-
5. Sales, at factory price (2 (a) - 4)		1376
6. Raw materials		
(a) Domestic		116
(b) Imported		-
7. Fuel and power		487
8. Other inputs (specify)		
(a) Stores and consumables	30	
(b) Rent, taxes and insurance	18	
(c) Other works expenses	20	
(d) Repairs and maintenance	25	
	-	93
9. Gross values added (5 - (6+7+8))		680
10. (a) Depreciation		96
(b) Amortization of projecting cost		18
11. Net value added (9-10)		566
12. Wages and salaries		87
13. Interest		161
14. Royalty		-
15. Gross profit (9-12)		593
16. Operating profit (15-(10+13+1))		318
17. Tax		127

18. Net profit (16-17)	191
B. Productive capital (in \$US thousand)	
1. Gross fixed assets	1566
2. Inventories	150
3. Capital employed (1+2)	1716
4. Number of workers	71
C. Capital output ratio	
1. Capital/value of output (B3/A2)	1.25 : 1
2. Capital/gross value added (B3/A9)	2.52 : 1
3. Capital/net value added (B3/A11)	3.03 : 1
4. Capital/per worker (B3/B4) (\$US)	24000
5. Capital/wages and salaries (B3/A12)	19.40 : 1
D. Productivity indicators (ratio)	
1. Productivity per unit of capital (A2/B3)	0.8 : 1
2. Productivity per unit of labour (A2/B4)	19.72 : 1
3. Productivity per unit of wages and salaries (A2/A12)	15.82 : 1
E. Input structures (proportion percentage)	
1. Raw materials/value of output (A6/A2)	8.4
2. Fuel and power/value of output (A7/A2)	35.4
3. Other inputs/value of output (A8/A2)	6.7
4. Wages and salaries/value of output (A12/A2)	6.3
5. Depreciation/value of output (A10/A2)	8.3
6. Interest/value of output (A13/A2)	11.7
7. Operating profit/value of output (A16/A2)	23.1
F. Profitability ratio (proportion percentage)	

1. Gross profit + interest/capital employed (A15+A13)/B3)	43.9
2. Operating profit + interest/capital employed (A16+A13)/B3)	27.9
3. Operating profit/sales (A16/A5)	23.1
G. Payment capacity (in \$US thousands)	
1. Gross profit, less royalty (A15-(A13+A14))	432
2. Tax provision (A 17)	127
3. Repaying capacity (G1-G2)	305



[Home](#) > [ar](#) [cn](#) [de](#) [en](#) [es](#) [fr](#) [id](#) [it](#) [ph](#) [po](#) [ru](#) [sw](#)

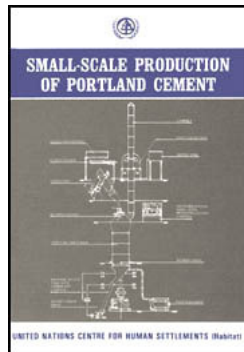

## **Small-Scale Production of Portland Cement (HABITAT, 1993, 92 p.)**

**(introduction...)**

**FOREWORD**

**I. INTRODUCTION**

**II. TECHNOLOGIES OF SMALL CEMENT PLANTS AND THEIR COMPARISON**











**III. SMALL CEMENT PLANTS IN OPERATION IN DIFFERENT COUNTRIES**

**IV. GEOLOGICAL INVESTIGATIONS AND SELECTION OF RAW MATERIALS AND FUEL**

**V. RAW-MIX DESIGN AND QUALITY CONTROL IN VSK CEMENT PLANTS**

**VI. SYSTEM DESIGN AND SELECTION OF PLANT AND MACHINERY**

**VII. PLANT DESCRIPTION**

-  **VIII. OPERATION OF A VERTICAL-SHAFT KILN**
-  **IX. ENVIRONMENTAL CONTROL IN SMALL CEMENT PLANTS BASED ON VSK TECHNOLOGY**
-  **X. A METHODOLOGY FOR THE PREPARATION OF PRE-FEASIBILITY STUDY**
-  **XI. ECONOMICS**
-   **XII. MONITORING PERFORMANCE OF AN OPERATING PLANT**
-  **ANNEX I: PROFORMA FOR RECORDING PERFORMANCE DATA OF VSK CEMENT PLANT**
-  **APPENDIX I. SALIENT FEATURES OF CRI-MVSK TECHNOLOGY**
-  **APPENDIX II. CASE STUDY - A BRIEF TECHNO-ECONOMIC FEASIBILITY REPORT FOR SETTING UP A VSK BASED CEMENT PLANT**
-  **APPENDIX III. CASE STUDY: PERFORMANCE OF A TYPICAL OPERATING VSK-BASED CEMENT PLANT**
-  **APPENDIX IV. GLOSSARY OF TERMS**

## **XII. MONITORING PERFORMANCE OF AN OPERATING PLANT**

**Once a small-scale cement plant is set up, its performance should be continuously monitored. Such monitoring should be in terms of performance of the individual unit operations, in terms of quality of raw materials and fuel, as well as clinker and cement produced, and also in terms of financial parameters.**

**In order to monitor and improve the performance of an operating small-scale cement plant based on VSK technology on a continuous basis, NCB has evolved a performance evaluation system, which has been adopted by a number of operating plants in India and abroad. This performance evaluation system includes the collection of monthly plant**

**performance data such as:**

- \* **Quality of raw materials, raw meal and clinker,**
- \* **Evaluation and analysis of cement produced;**
- \* **Performance of individual unit operations (crushing, grinding, blending, clinkerization, packing etc.);**
- \* **Downtime data of equipment - mainly kiln and mills;**
- \* **Details of cost such as the production cost, raw material/fuel cost etc.**

**For this purpose, a proforma has been designed, which is reproduced in annex I.**

**Based on the information made available from the monthly performance data, the performance of the plant is evaluated in terms of kiln down-time, capacity utilization, efficiency and quality characteristics. An evaluation is also made on the basis of the consumption of electrical and thermal energy.**

**These monthly data are compiled for trend analysis over a longer period of time, say one year. Typical performance evaluation charts for a particular plant for a period of one year are shown in figures 14 to 17. Figure 14 shows the performance of the kiln in terms of capacity utilization and kiln efficiency. These are defined as:**

$$\text{Capacity utilization} = \frac{\text{Total clinker production} \times 100}{\text{Rated tpd} \times \text{Number of days in the month} \times 0.9}$$

$$\text{Kiln efficiency} = \frac{(\text{Average tpd}) / (\text{Average run hrs})}{(\text{Rated tpd}) / 24} \times 100$$



**Calculation of kiln down-time as a percentage of the total available time is done for the following categories (see figure 15).**

- (a) Power cut**
- (b) Mechanical/electrical breakdown**
- (c) Preventive maintenance**
- (d) Raw material/fuel shortage**
- (e) Process stoppages**
- (f) Labour, water shortage, material jamming etc.**

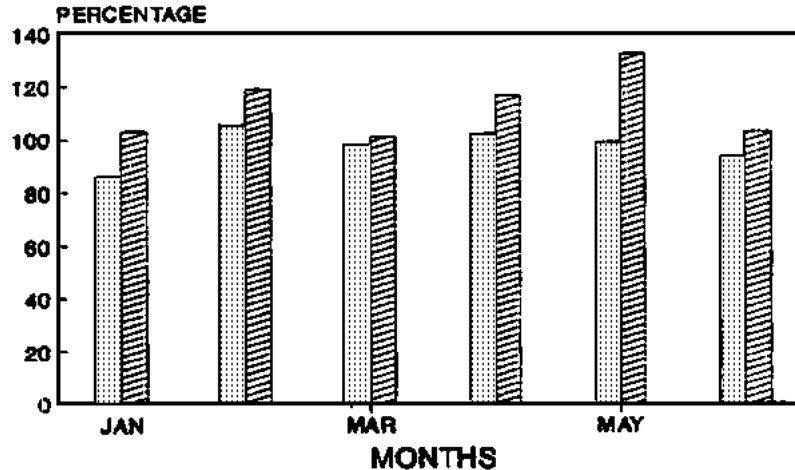

**Figure 14. Evaluation of kiln performance**

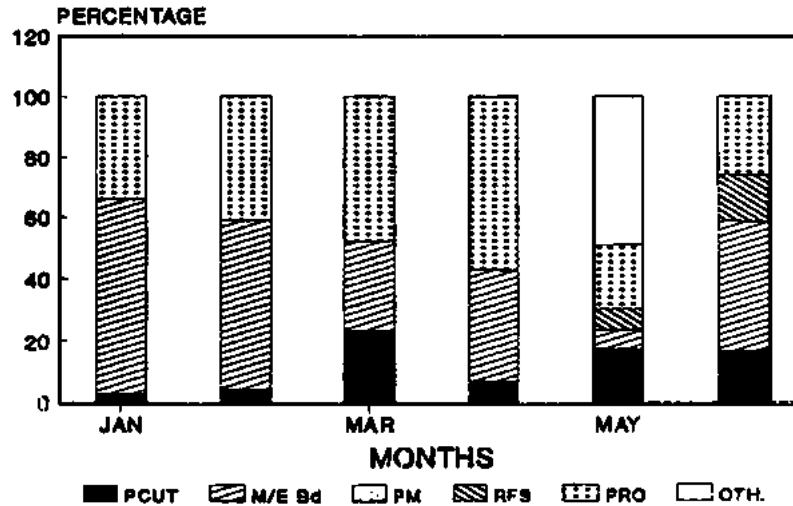

Figure 15. Evaluation of kiln down-time

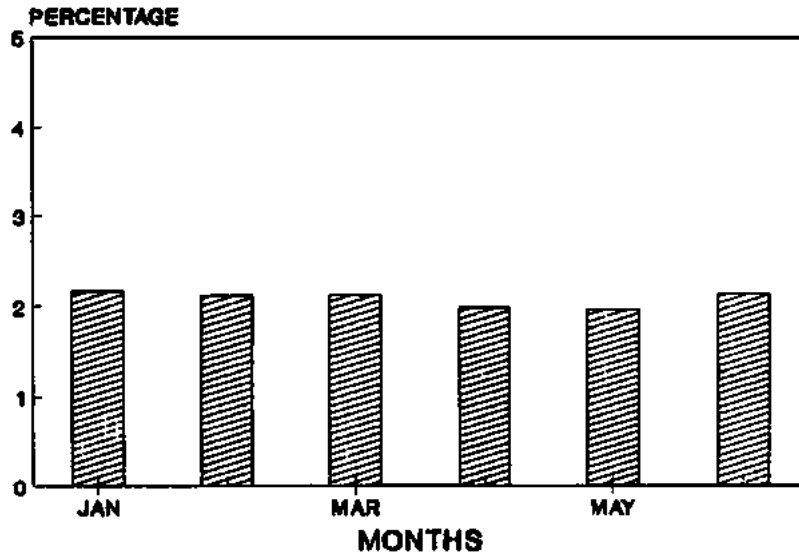

Figure 16. Monthwise trend of free-lime in clinker

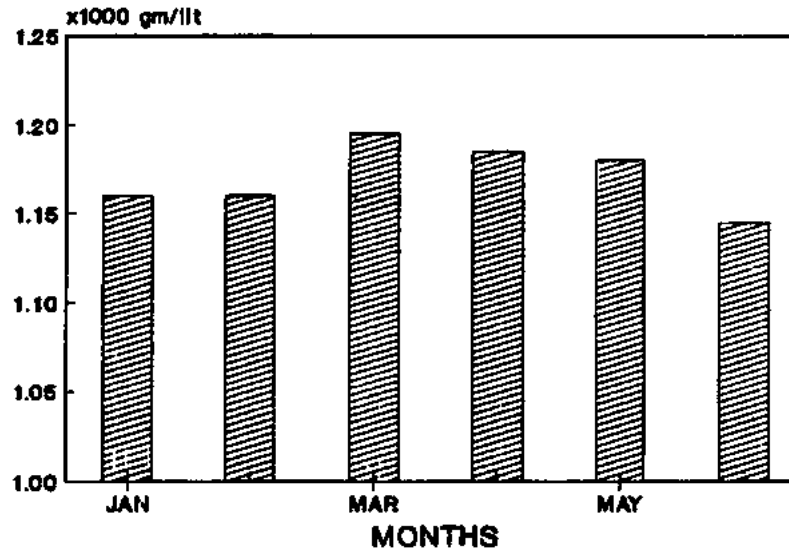

Figure 17. Variation in clinker litre weight - monthly average

A quick appraisal of the quality of clinker obtained from a VSK is made on the basis of its free-lime content and litre weight. Figures 16 and 17 show the trend of corresponding monthly average values. In addition, the quality of cement, primarily on the basis of compressive strength at 3 days, 7 days and 28 days, and soundness parameters (Le Chatelier and autoclave expansion) are also monitored in a similar manner and can be graphically depicted for control purposes.

Based on the evaluation of data, specific recommendations for improving kiln performance and the quality of clinker are given to the plant. This may include providing a new or modified raw-mix design using CRI-raw-mix design software wherever necessary, advice on use of alternative fuels, additives etc. The improvement in plant performance based on

**the suggestions provided to the plant is monitored for further guidance and necessary suggestions.**

**The performance of a 100 tpd capacity CRI-MVSK plant operating in India is given as a case study in appendix III.**

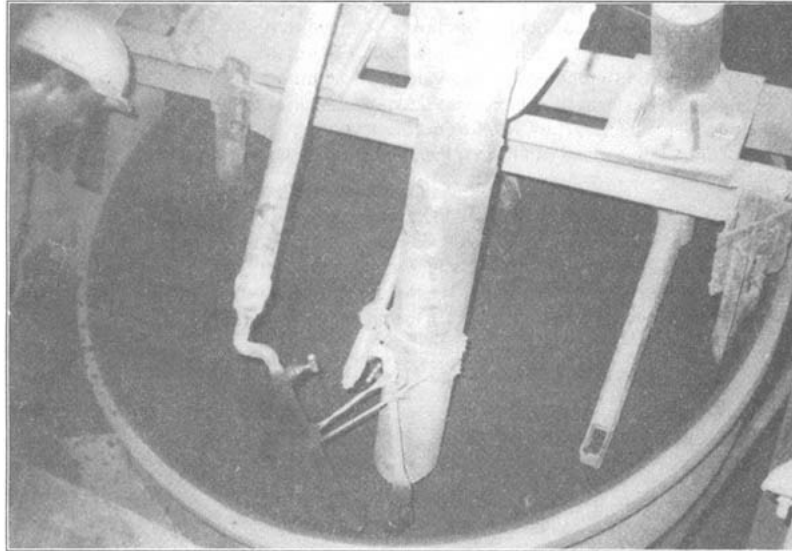

**Noduliser**

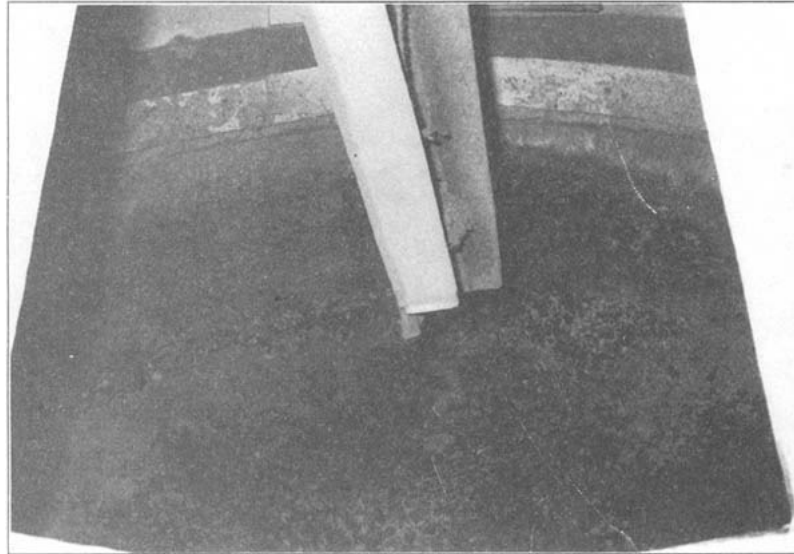

**Rotary feeder**

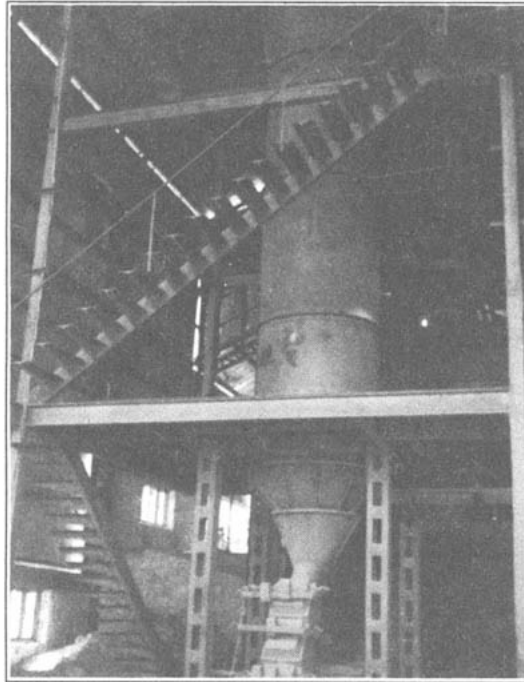

**Vertical Shaft Kiln**



**CRI- MVSK Cement plant**



[Home](#) > [ar.cn.de.en.es.fr.id.it.ph.po.ru.sw](#)

 **Small-Scale Production of Portland Cement (HABITAT, 1993, 92 p.)**

 **(introduction...)**

 **FOREWORD**

 **I. INTRODUCTION**

 **II. TECHNOLOGIES OF SMALL CEMENT PLANTS AND THEIR COMPARISON**





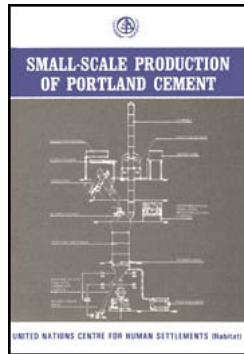

- III. SMALL CEMENT PLANTS IN OPERATION IN DIFFERENT COUNTRIES
- IV. GEOLOGICAL INVESTIGATIONS AND SELECTION OF RAW MATERIALS AND FUEL
- V. RAW-MIX DESIGN AND QUALITY CONTROL IN VSK CEMENT PLANTS
- VI. SYSTEM DESIGN AND SELECTION OF PLANT AND MACHINERY
- VII. PLANT DESCRIPTION
- VIII. OPERATION OF A VERTICAL-SHAFT KILN
- IX. ENVIRONMENTAL CONTROL IN SMALL CEMENT PLANTS BASED ON VSK TECHNOLOGY
- X. A METHODOLOGY FOR THE PREPARATION OF PRE-FEASIBILITY STUDY
- XI. ECONOMICS
- XII. MONITORING PERFORMANCE OF AN OPERATING PLANT
- ➔ ANNEX I: PROFORMA FOR RECORDING PERFORMANCE DATA OF VSK CEMENT PLANT
- APPENDIX I. SALIENT FEATURES OF CRI-MVSK TECHNOLOGY
- APPENDIX II. CASE STUDY - A BRIEF TECHNO-ECONOMIC FEASIBILITY REPORT FOR SETTING UP A VSK BASED CEMENT PLANT
- APPENDIX III. CASE STUDY: PERFORMANCE OF A TYPICAL OPERATING VSK-BASED CEMENT PLANT
- APPENDIX IV. GLOSSARY OF TERMS

## ANNEX I: PROFORMA FOR RECORDING PERFORMANCE DATA OF VSK CEMENT PLANT

PERIOD OF REPORTING

PERIOD OF REPORTING  
(Month/Year):

- 1. NAME OF THE PLANT:**
- 2. INSTALLED CAPACITY (tpd):**
- 3. NUMBER OF MVSKs:**
- 4. QUALITY OF RAW MATERIALS AND FUEL**

Item	Chemical analysis and constituents (percentage)							
	CaO	SiO <sub>2</sub>	Fe <sub>2</sub> O <sub>3</sub>	Al <sub>2</sub> O <sub>3</sub>	MgO	LOI	Ash	Volatile matter
Limestone								
Clay								
Additive - I								
Additive - II								
Fuel (specify type)								

**5. RAW MIX PROPORTION (percentage):**

Limestone	Clay	Additive - I	Additive - II	Fuel

**6. QUALITY OF CLINKER**

Burnt - % :

Unburnt - % :

Dust - % :

Litreweight - a/l :

## 7. CHEMICAL ANALYSIS (percentage)

	Designed raw meal	Actual Clinker raw meal	Cement
CaO			
SiO <sub>2</sub>			
Al <sub>2</sub> O <sub>3</sub>			
Fe <sub>2</sub> O <sub>3</sub>			
LOI			
MgO			
SO <sub>3</sub>			
I.R			
Fee CaO			
Moduli values			
SM			
AM			
LSF			
LC			

## 8. PHYSICAL ANALYSIS OF CEMENT

**Fineness (in Blaines) cm<sup>2</sup>/g:**

**Setting time (minutes)**

**Initial:**

**Final:****Soundness****Le Chatlier expansion (mm):****Autoclave expansion (%):****Compressive strength (kg/cm<sup>2</sup>) of standard cement: mortar, at****3 days****7 days****28 days****9. OUTPUT FOR THE MONTH**

<b>Equipment</b>		<b>Rated capacity (tph)</b>	<b>Running time (hrs)</b>	<b>Output (tons)</b>
Crusher				
Raw Mill				
MVSK -	I			
	II			
	III			
Cement mill				

**10. KILN DOWN-TIME (hours)****Power cut:****Mechanical/electrical breakdown:****Process stoppages:**

**Preventive maintenance:**

**Raw-material/fuel shortage:**

**Other (specify):**

## **11. COST AND SOURCE OF FUEL**

**Calorific value of coke-breeze/fuel:**

**Cost of production per ton of naked cement:**

## **12. SPECIFIC ENERGY CONSUMPTION**

**Thermal energy - kcal/kg of clinker:**

**Electrical energy - kWh/ton of cement:**

## **13. MAJOR CAUSES FOR LESS PRODUCTION, IF ANY, AND SPECIFIC AREAS REQUIRING ATTENTION:**

## **14. REMARKS:**



[Home](#) > [ar](#).[cn](#).[de](#).[en](#).[es](#).[fr](#).[id](#).[it](#).[ph](#).[po](#).[ru](#).[sw](#)

 **Small-Scale Production of Portland Cement (HABITAT, 1993, 92 p.)**

 **(introduction...)**

 **FOREWORD**

 **I. INTRODUCTION**

 **II. TECHNOLOGIES OF SMALL CEMENT PLANTS AND THEIR COMPARISON**



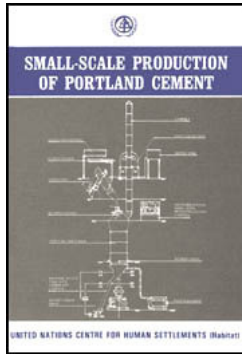

- III. SMALL CEMENT PLANTS IN OPERATION IN DIFFERENT COUNTRIES
- IV. GEOLOGICAL INVESTIGATIONS AND SELECTION OF RAW MATERIALS AND FUEL
- V. RAW-MIX DESIGN AND QUALITY CONTROL IN VSK CEMENT PLANTS
- VI. SYSTEM DESIGN AND SELECTION OF PLANT AND MACHINERY
- VII. PLANT DESCRIPTION
- VIII. OPERATION OF A VERTICAL-SHAFT KILN
- IX. ENVIRONMENTAL CONTROL IN SMALL CEMENT PLANTS BASED ON VSK TECHNOLOGY
- X. A METHODOLOGY FOR THE PREPARATION OF PRE-FEASIBILITY STUDY
- XI. ECONOMICS
- XII. MONITORING PERFORMANCE OF AN OPERATING PLANT
- ANNEX I: PROFORMA FOR RECORDING PERFORMANCE DATA OF VSK CEMENT PLANT
- ➔ APPENDIX I. SALIENT FEATURES OF CRI-MVSK TECHNOLOGY
- APPENDIX II. CASE STUDY - A BRIEF TECHNO-ECONOMIC FEASIBILITY REPORT FOR SETTING UP A VSK BASED CEMENT PLANT
- APPENDIX III. CASE STUDY: PERFORMANCE OF A TYPICAL OPERATING VSK-BASED CEMENT PLANT
- APPENDIX IV. GLOSSARY OF TERMS

## APPENDIX I. SALIENT FEATURES OF CRI-MVSK TECHNOLOGY

**The salient features of the modern vertical shaft kiln technology developed by the National Council for Cement and Building Materials (NCB), New Delhi, India, are as under**

- \* A hopper with ramp and reciprocating/laminated feeder has been provided to ensure continuous feed of uncrushed limestone to the primary crusher.**
- \* The crushing section usually consists of two-stage crushing - a jaw crusher as primary and hammer mill as secondary one. This will ensure better mill performance due to having uniform feed provided to the raw mill.**
- \* Continuous, automatic and accurate raw-material extraction for proportioning by rotary- table feeder/vibratory feeder, with electronic weigh feeder as an optional feature.**
- \* A conventional closed-circuit air-swept ball mill with grit separator, cyclone and bag filters for grinding of raw materials to ensure the desired granulometry of the raw meal resulting in proper burning.**
- \* Differential (HP and LP) pneumatic blending with a quadrant system reduces the variation to 1:10 within the smallest possible time.**
- \* A specially-designed double collar nodulizer with an automatic closed-loop control results in nodules of higher green strength, due to extra rolling action, and desired size, porosity and moisture content.**
- \* A continuously-operated rotary feeder-drive with adjustable tilt angle and adjustable height in order to achieve the desired bed profile in the MVSK.**
- \* The material block tube along with "Gamma Ray Level Control Device" for clinker extraction from the MVSK has the advantages of less air leakage, less dust and**

**noise, lower maintenance and a more efficient burning process due to reduced fluctuations in the combustion air supply.**

**\* An improved instrumentation system has been provided to monitor all important process parameters on a continuous basis. All major system parameters are indicated and recorded.**

**\* A fully-equipped laboratory for physical testing and chemical analysis as per requirements of the Bureau of Indian Standards. Provision is made for optimum raw-mix design software.**

**\* Modern and proper dust-collection arrangements at all transfer points including proper ventilation of tunnels and a specially-designed low-cost dust limiter in the MVSK chimney have been provided.**

**\* In addition, dust-collection systems with stacks are incorporated in all the sections such as crushing, raw mill, blending, cement mill and cement packing, which will ensure a very clean and dust-free environment in the CRI-MVSK cement plant.**



[Home](#) > [ar](#).[cn](#).[de](#).[en](#).[es](#).[fr](#).[id](#).[it](#).[ph](#).[po](#).[ru](#).[sw](#)

 **Small-Scale Production of Portland Cement (HABITAT, 1993, 92 p.)**



**APPENDIX II. CASE STUDY - A BRIEF TECHNO-ECONOMIC**



**FEASIBILITY REPORT FOR SETTING UP A VSK BASED CEMENT PLANT**



***(introduction...)***



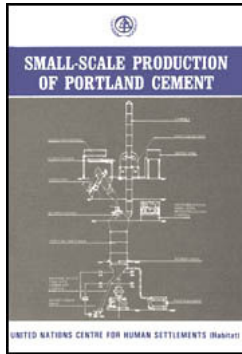

## **Appendix II-A. Equipment recommended to be used in CRI-MVSK cement plant (up to 100 tpd)**

### **Small-Scale Production of Portland Cement (HABITAT, 1993, 92 p.)**

#### **APPENDIX II. CASE STUDY - A BRIEF TECHNO-ECONOMIC FEASIBILITY REPORT FOR SETTING UP A VSK BASED CEMENT PLANT**

##### **1. Introduction**

**A governmental organization in the north-eastern region in India has made a proposal to set up a 100-tpd small cement plant utilizing the limestone reserves occurring nearby. The sponsor requested the National Council for Cement and Building Materials (NCB) to investigate the feasibility of setting up a 100-tpd mini-cement plant in the area. The location (Nagaland) is a small hilly state in the north-eastern region in India.**

##### **2. Demand and supply**

**There is only one existing cement plant in the particular state with an annual installed capacity of 16,500 tons. The annual consumption of cement by various government departments for the years 1987, 1990 and 1991 were 179,100, 108,400 and 116,400 tons**

respectively. In addition, there are three cement-consuming industries located at Dimapur, whose annual requirement of cement is 1000 tons. Further, a number of power-generation projects are on line in the state. A perusal of the data indicates that the present demand for cement is far in excess of supply and, therefore, setting up a small-scale cement plant by the sponsor will help in reducing the gap between demand and supply.

### 3. Raw materials

The limestone is ash grey to dark coloured, fine- to medium-grained, crystalline, hard, compact, massive and thickly bedded. Structurally, the area is highly disturbed, intensely folded/faulted and the limestone beds dip steeply or are almost vertical. The depth continuity of these limestone bands have been confirmed as up to 100 m (1700 m RL) in two boreholes, and further exploration is in progress.

During a site visit, thorough reconnaissance was done and five samples of limestone were collected and analysed at the NCB laboratories. The average chemical composition of the limestone, expressed in percentages, is as follows:

CaO	SiO <sub>2</sub>	Al <sub>2</sub> O <sub>3</sub>	Fe <sub>2</sub> O <sub>3</sub>	MgO	LOI
54.6	0.56	0.24	0.23	0.90	43.20

The above analysis reveals that the limestone is qualitatively suitable for cement manufacture by CRI-MVSK technology.

Indicated and inferred reserves were estimated on the basis of available geological data. It was estimated that there were 1,950,000 tons of "indicated" reserves and 7.8 million tons of "inferred" reserves. The above reserves are, *prima facie*, sufficient to sustain even a 200-tpd CRI-MVSK plant.

In order to identify a suitable source for clay, seven samples were collected from nearby

**areas and analysed at the NCB laboratories to assess their suitability. As limestone is deficit in silica, iron and alumina, it is recommended that ferruginous clay that might be available at a distance of about 12 km from the plant site be used. Its chemical analysis, expressed in percentages, is as follows:**

CaO	SiO <sub>2</sub>	Al <sub>2</sub> O <sub>3</sub>	Fe <sub>2</sub> O <sub>3</sub>	MgO	LOI
1.49	47.26	21.00	13.77	1.37	13.34

**Further prospecting is recommended to ensure a sufficient quantity of this clay.**

**In order to overcome the silica deficiency a small quantity of orthoquartzite is recommended in the raw mix. The chemical analysis of orthoquartzite available adjacent to the limestone deposit, expressed in percentages, is as follows:**

CaO	SiO <sub>2</sub>	Al <sub>2</sub> O <sub>3</sub>	Fe <sub>2</sub> O <sub>3</sub>	MgO	LOI
2.58	89.69	4.43	0.47	0.49	1.80

**The fuel for a CRI-MVSK plant should be low in volatile matter with a calorific value above 4500 kcal/kg. Accordingly, the coke available from Dhankuni coke plant (West Bengal) of Coal India Ltd has been recommended for the proposed CRI-MVSK plant. This coke has a volatile matter content of 9.39 per cent, an ash content of 28.68 per cent and a calorific value of 5321 kcal/kg.**

#### ***4 Raw-mix design***

**A preliminary raw-mix design has been worked out based on available raw materials and it is comprised of 69.50 per cent limestone, 12.50 per cent ferruginous clay, 5 per cent orthoquartzite and 13 per cent coke-breeze.**

#### ***5. Nodulizability study***

**The nodulizability test for the proposed raw mix has been carried out in a pan-type nodulizer with 14-per cent moisture content. The nodulizability of the raw meal was found to be satisfactory and uniform sized nodules were obtained with adequate mechanical strength.**

### ***6. Burnability study***

**The burnability of the proposed raw mix has been tested in a muffle furnace by firing nodules at 1450°C for 30 minutes. The microscopic examination of the clinker showed well-developed phases of alite and belite with uniform distribution. The free-lime content was also found to be well within the specified limits.**

### ***7. Site selection***

**In view of the difficult terrain conditions, lack of adequate infrastructure such as transport, communication, power, water etc, and also special socio-economic problems prevalent in the north-eastern region in India, the site selection for the plant assumed added importance. In accordance with industrial engineering practices, the plant has to be located as near as possible to the raw-materials source. However, in the case of Nagaland some more factors like availability of a plain terrain, an approach road, land development costs, involvement of a number of villages etc., were also taken into consideration. In view of the distinct advantages associated with Khonjheri village, this site was recommended for setting up the proposed cement plant.**

### ***8. Plant and machinery***

**The equipment recommended to be used in various sections of this CRI-MVSK small cement plant and their broad specifications are given in appendix II-A.**

### ***9. Infrastructure***

**The plant is supported by a testing and quality-control laboratory and workshop. The estimated power requirement for the plant is 2500 kVA (including provision for expansion to 200 tpd). The total workforce including managerial and administrative staff for the plant works out to 177.**

### **10. Techno-economics**

**The total capital cost of the project has been estimated at Rs 117,271,000;\* the working capital works out to Rs 12,524,000; the cost of production works out to Rs 140,238,000 per ton of naked cement. The break-even point and pay-back period works out to 65 per cent and four years and eight months, respectively (assuming a selling price of Rs 110 per bag) and a capacity utilization of 85 per cent of installed capacity. These figures have been based upon the assumption that the plant will go for an expansion to 200 tpd in the near future.**

**\* 1 \$US = Rs.30.**

### **11. Conclusion**

**The proposal of the sponsor to set up a 100-tpd CRI-MVSK cement plant is technically feasible, economically viable and socially beneficial.**

**Appendix II-A. Equipment recommended to be used in CRI-MVSK cement plant (up to 100 tpd)**

<b>Section/unit operation</b>	<b>Equipment/broad specifications</b>
<b>Limestone crushing section</b>	
(a) Hopper for uncrushed limestone	Capacity: 50 tons, RCC construction

(b) Apron/reciprocating feeder	Capacity: 13 tph
(c) Jaw crusher	Capacity: 13 tph, lump size 250 mm
(d) Inclined belt conveyer	Capacity: 17 tph
(e) Hammer mill	Capacity: 13 tph, feed size 75 mm
(f) Inclined belt conveyer or bucket elevator	Capacity: 17 tph
(g) Raw-material hoppers with feeders	Capacity: 40 tons for limestone, and 30 tons each for clay, coke-breeze and additive
(h) Belt conveyer for raw mix	Capacity: 13 tph
(i) Bucket elevator for raw mix	Gravity discharge type, capacity: 13 tph
<b>Raw-material grinding section</b>	
(a) Raw grinding mill	Air-swept closed-circuit, complete with grit separator cyclones, ID fan, bag fabric filters etc.; capacity: 10 tph
(b) Screw conveyer for coarse return	Capacity: 25 tph
(c) Screw conveyer for raw meal	Capacity: 13 tph
(d) Bucket elevator for raw meal	Centrifugal discharge type, capacity: 13 tph
<b>Blending and storage section</b>	
(a) Screw conveyer/air slide over blending silo	Capacity: 13 tph
(b) Blending silos	Complete with HP and LP blowers and de-dusting arrangements; capacity: 65 tons; RCC construction, qty: 2
(c) Storage silo	With extraction arrangement, capacity: 130 tons; RCC construction; qty: 1

<b>Clinkerization section</b>	
(a) Rotary air-lock feeder for raw meal discharge	Capacity: 9 tph
(b) Screw conveyor/air slide for raw meal	Capacity: 9 tph
(c) Bucket elevator/air lift to feed nodulizer hopper	Capacity 9: tph
(d) Nodulizer feed hopper	Capacity: 10 tons
(e) Overflow screw conveyor	Capacity: 16 tph
(f) Nodulizer feed screw	Capacity: 6 tph; qty: 2
(g) Nodulizer	Pan diameter: 2100 mm; inclination: 45-65 degrees; qty: 2
(h) Vertical-shaft kiln	Capacity: 2.5 tph each, as per NCB design; qty: 2
(i) Bucket elevator for clinker	Capacity: 3.5 tph; qty: 2
(j) Roots blower for combustion air	Capacity: 3500 m <sup>3</sup> /hr; pressure 3000 mm/WG; qty: 2
<b>Cement grinding and storage section</b>	
(a) Clinker hopper with feeders	Capacity: 40 tons
(b) Gypsum hopper with feeders	Capacity: 20 tons
(c) Finish grinding mill Open-circuit type;	capacity: 7.5 tph; feed size: 25 mm (max); product size 3000 blaines
(d) Screw conveyor for cement	Capacity: 10 tph
(e) Bucket elevator for cement	Capacity: 10 tph
(f) Cement silo	Capacity: 200 tons RCC construction
(g) Rotary air lock for cement	Capacity: 15 tph

discharge	
(h) Screw conveyor for extraction of cement from silo	Capacity: 19.5 tph
(i) Bucket elevator/air lift for intermediate hopper	Capacity: 21.5 tph
(j) Intermediate hopper	Capacity: 16 tons; MS construction
(k) Cement packing machine Single spout;	Capacity: 8 tph
(l) Spillage hopper	Capacity: 2 tons; MS construction
(m) Screw conveyor	Capacity: 2 tph
(n) Bag branding machine	Capacity: 300 bags/hour
<b>Requirement of quarry equipment</b>	
(a) Portable air compressor unit Diesel driven;	Capacity: 250 cfm at 100 psi
(b) Jack hammers	31 mm size
(c) Accessories for jack hammers	
(i) Air line lubricator	
(ii) Drill rods	
(iii) High-pressure pneumatic hosepipe	





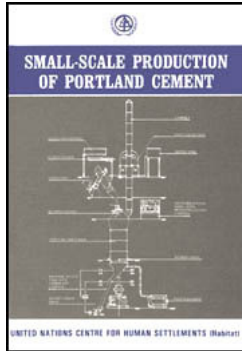

 **Small-Scale Production of Portland Cement (HABITAT, 1993, 92 p.)**

  **APPENDIX III. CASE STUDY: PERFORMANCE OF A TYPICAL OPERATING VSK-BASED CEMENT PLANT**

 **(introduction...)**

 **Appendix III-A. Data on quality of raw materials, fuel, clinker and cement, and performance of unit operations**

**Small-Scale Production of Portland Cement (HABITAT, 1993, 92 p.)**

**APPENDIX III. CASE STUDY: PERFORMANCE OF A TYPICAL OPERATING VSK-BASED CEMENT PLANT**

**This is a small-scale cement plant in the central part of India. Based on CRI-MVSK technology, this plant was set up and commissioned in 1987 and has been operating continuously since then. Its performance is monitored on a regular basis in the manner described in chapter XII, and the feedback on the proforma as given in annex I is received regularly. The plant has a capacity of 100 tpd, comprised of two VSK kilns of 50 tpd each.**

**For a typical month, the total production was found to be 2766 tons. This corresponded to a capacity utilization of 90 per cent. The details of the quality of raw materials and fuel, and clinker and cement quality, as well as the performance of the various unit operations, are shown in appendix III-A. The plant uses cement-grade limestone from its captive mines, and clay from a nearby deposit, both conforming to the requirements for the process as recommended. Coke-breeze, with a calorific value of about 4000 kcal/kg, is**

**used as fuel. The typical raw-mix proportions are 79 per cent limestone, 9 per cent clay, and 12 per cent coke-breeze as fuel which form nodules. No additives are required.**

**In a vertical-shaft kiln, if the burning of nodules is not thorough and uniform, the resulting clinker may be dusty and contain unburnt clinker and also cause a higher percentage of free-lime. The actual raw meal as fed to the plant is maintained close to the designed raw mix and moduli values are controlled within a desirable range. As a result, the clinker produced is well burnt and the free-lime is restricted to 1.96 per cent in clinker and 2.72 per cent in cement; nearly 99 per cent of clinker is found to be well burnt, indicating a thorough and uniform burning process in the plant.**

**On the basis of installed capacity, the availability of the kiln was ensured in the particular month. Kiln down-time was mainly due to power cuts and process stoppages. Preventive maintenance was carried out at the time of power cuts. The capacity utilization, therefore, for the month was of the order of 90 per cent which is considered to be good. The specific heat consumption was 760 kcal/kg of clinker and the specific electric power consumption was 115 kWh/ton of cement. The cost of production of cement was reported to be Rs 1360 (about \$US45) per ton.**

**Appendix III-A. Data on quality of raw materials, fuel, clinker and cement, and performance of unit operations**

**Quality of raw materials and fuel:**

Item	Chemical analysis and constituents (percentage)							
	CaO	SiO <sub>2</sub>	Fe <sub>2</sub> O <sub>3</sub>	Al <sub>2</sub> O <sub>3</sub>	MgO	LOI	Ash	Volatile matter
Limestone	48.14	7.80	1.62	2.45	0.60	38.85	-	-
Clay	7.38	46.59	12.01	15.56	1.19	15.41	-	-

Additive - I				Nil				
Additive - II				Nil				
Fuel	Coke-breeze							
(specify type)	2.44	18.54	4.27	7.56	0.50	65.12	34.88	7.12

### Raw-mix proportion (percentage)

Limestone	Clay	Additive - I	Additive - II	Fuel
79.0	9.0	Nil	Nil	12.0

### Quality of clinker

Burnt (percentage): 98.93

Unburnt (percentage): 0.65

Dust (percentage): 0.42

Litre weight -g/l: 1180

### Chemical analysis (percentage)

	Designed raw meal	Actual raw meal	Clinker	Cement
CaO	38.89	38.62	64.82	60.42
SiO <sub>2</sub>	12.57	12.49	21.32	21.58
Al <sub>2</sub> O <sub>3</sub>	4.25	4.06	6.42	6.21
Fe <sub>2</sub> O <sub>3</sub>	2.87	2.84	4.37	4.07
LOI	39.92	39.98	0.85	2.42
MgO	0.64	0.70	1.18	1.21

mg	0.54	0.70	1.10	1.21
SO <sub>3</sub>	-	-	0.21	2.04
I.R	-	-	0.81	1.98
Free CaO	-	-	1.96	2.72
Moduli values				
SM	1.77	1.81	1.97	1.91
AM	1.48	1.43	1.47	1.52
LSF	0.92	0.92	0.92	0.91
LC	-	-	30.46	

## Physical analysis of cement

Fineness (in blaines) cm <sup>2</sup> /g:	3592
Setting time (minutes)	
Initial:	60
Final:	135
Soundness	
Le Chatlier expansion (mm):	0.3
Autoclave expansion (percentage):	0.21
Compressive strength (kg/cm <sup>2</sup> ) of standard cement: mortar, at	
3 days	290
7 days	380
28 days	506

**Output for the month**

Equipment	Rated capacity (tph)	Running time (hrs)	Output (tons)
Crusher	15	371.00	3 568.82
Raw mill	12	385.50	4 517.50
MVSK - I	2.08	487.58	1 345.72
II	2.08	511.50	1 420.28
III	-	-	-
Cement mill	7.50	418.00	2 875.82



[Home](#) > [ar.cn.de.en.es.fr.id.it.ph.po.ru.sw](#)

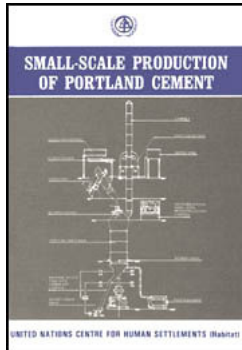

**Small-Scale Production of Portland Cement (HABITAT, 1993, 92 p.)**

**(introduction...)**

**FOREWORD**

**I. INTRODUCTION**

**II. TECHNOLOGIES OF SMALL CEMENT PLANTS AND THEIR COMPARISON**

**III. SMALL CEMENT PLANTS IN OPERATION IN DIFFERENT COUNTRIES**

**IV. GEOLOGICAL INVESTIGATIONS AND SELECTION OF RAW MATERIALS AND FUEL**

**V. RAW-MIX DESIGN AND QUALITY CONTROL IN VSK CEMENT PLANTS**

**VI. SYSTEM DESIGN AND SELECTION OF PLANT AND MACHINERY**

**VII. PLANT DESCRIPTION**

- ☐ **VIII. OPERATION OF A VERTICAL-SHAFT KILN**
- ☐ **IX. ENVIRONMENTAL CONTROL IN SMALL CEMENT PLANTS BASED ON VSK TECHNOLOGY**
- ☐ **X. A METHODOLOGY FOR THE PREPARATION OF PRE-FEASIBILITY STUDY**
- 📄 **XI. ECONOMICS**
- 📄 **XII. MONITORING PERFORMANCE OF AN OPERATING PLANT**
- 📄 **ANNEX I: PROFORMA FOR RECORDING PERFORMANCE DATA OF VSK CEMENT PLANT**
- 📄 **APPENDIX I. SALIENT FEATURES OF CRI-MVSK TECHNOLOGY**
- ☐ **APPENDIX II. CASE STUDY - A BRIEF TECHNO-ECONOMIC FEASIBILITY REPORT FOR SETTING UP A VSK BASED CEMENT PLANT**
- ☐ **APPENDIX III. CASE STUDY: PERFORMANCE OF A TYPICAL OPERATING VSK-BASED CEMENT PLANT**
- ➔📄 **APPENDIX IV. GLOSSARY OF TERMS**

## **APPENDIX IV. GLOSSARY OF TERMS**

- Black meal** Mixture of raw materials obtained by grinding a low-volatile solid fuel along with the other raw materials; used usually in the context of vertical-shaft-kiln technology for the manufacture of cement.
- Calcination** Process in which the raw material is heated to a high temperature so that hydrates, carbonates or other compounds are decomposed and the volatile material is expelled.
- Clinker** Burnt stony material as released from a kiln.

- Coke-breeze** Undersized coke screenings passing through a screen opening of approximately 16 mm; usually a by-product from the steel industry.
- Combustion** The burning of a gas, liquid or solid, in which the fuel is oxidized y evolving heat and often light.
- Crushing** A process of reducing the size of big rocks/boulders into smaller sizes in a machine called a crusher.
- Drying** An operation in which water is removed from a wet solid.
- Fluidization** A process in which finely ground solids are suspended in a rising current of air producing a fluidized bed; used in the calcination/burning of raw materials.
- Grate** A support for burning solid fuels; usually made of closely spaced bars/thick grooved plate, to hold the burning fuels, while allowing combustion air to rise up to the raw meal/fuel from beneath and ashes/clinker to fall from the burning fuel.
- Grinding** A mechanical operation for reducing the size of a material to relatively smaller particles, usually of micron size.
- Kiln** An enclosure lined with refractory bricks, used for drying, burning or firing of materials.
- Material** A tube filled by a material which does not allow the gases to pass through it: usually

- block tube** used in the context of vertical-shaft kilns.
- Mining** The technique and business of mineral recovery from mines.
- Nodulization** Creation of spherical lumps from powders by coalescing them with water in equipment called a nodulizer.
- Preheating** A process of preliminary heating of a material or fluid that will undergo further use or treatment by heating.
- Rotary kiln** A rotating cylindrical kiln used for heating or burning of raw materials.
- Silo** A large vertical, cylindrical structure, made of reinforced concrete, steel or timber, and used for storing cement and other materials.
- Sintering** Forming of coherent bonded mass by heating of powders.
- Vertical-shaft kiln** A stationary cylindrical shell lined with refractory bricks, used for heating or burning raw materials.
- Volatile matter** The matter in the coal represented by the loss in its weight as a result of carbonization of coal in the absence of air.
- White meal** Raw meal obtained by grinding various raw materials. except fuel, in required proportions.





[Home](#) > [ar.cn.de.en.es.fr.id.it.ph.po.ru.sw](#)

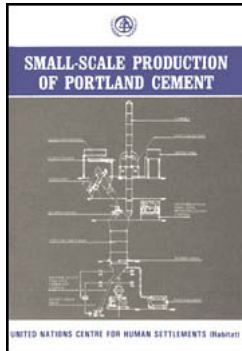

 **Small-Scale Production of Portland Cement (HABITAT, 1993, 92 p.)**

 *(introduction...)*

  **FOREWORD**

 **I. INTRODUCTION**

 **II. TECHNOLOGIES OF SMALL CEMENT PLANTS AND THEIR COMPARISON**

 **III. SMALL CEMENT PLANTS IN OPERATION IN DIFFERENT COUNTRIES**

 **IV. GEOLOGICAL INVESTIGATIONS AND SELECTION OF RAW MATERIALS AND FUEL**

 **V. RAW-MIX DESIGN AND QUALITY CONTROL IN VSK CEMENT PLANTS**

 **VI. SYSTEM DESIGN AND SELECTION OF PLANT AND MACHINERY**

 **VII. PLANT DESCRIPTION**

 **VIII. OPERATION OF A VERTICAL-SHAFT KILN**

 **IX. ENVIRONMENTAL CONTROL IN SMALL CEMENT PLANTS BASED ON VSK TECHNOLOGY**





 **X. A METHODOLOGY FOR THE PREPARATION OF PRE-FEASIBILITY STUDY**

 **XI. ECONOMICS**

 **XII. MONITORING PERFORMANCE OF AN OPERATING PLANT**

 **ANNEX I: PROFORMA FOR RECORDING PERFORMANCE DATA OF**

**VSK CEMENT PLANT**

-  **APPENDIX I. SALIENT FEATURES OF CRI-MVSK TECHNOLOGY**
-  **APPENDIX II. CASE STUDY - A BRIEF TECHNO-ECONOMIC FEASIBILITY REPORT FOR SETTING UP A VSK BASED CEMENT PLANT**
-  **APPENDIX III. CASE STUDY: PERFORMANCE OF A TYPICAL OPERATING VSK-BASED CEMENT PLANT**
-  **APPENDIX IV. GLOSSARY OF TERMS**

**FOREWORD**

**Cement, with its superior binding properties, early strength development and easy availability in ready-to-use condition, has become the most popular binding material for construction. Cement is used as a basic building material not only in heavy civil engineering construction but also in low-cost housing and infrastructure. The per capita production and consumption of cement is often used as an indicator of development, especially in developing countries.**

**Yet, the growth of cement production in developing countries during the 1980s was far from satisfactory, in both absolute and per capita terms. Production gains have been highly uneven among developing countries and chronic shortfalls have pushed up the prices, substantially more than the increase in the cost-of-living index.**

**One of the main reasons for the limited expansion of the production capacity of the cement industry has been the choice of technology in favour of large-scale production facilities. Most developing countries, in the past, have opted for large-scale rotary-kiln technologies, requiring large investment and long gestation periods. For a variety of reasons, such as supply-side constraints imposed by energy costs, the size of the market and its volatility,**

**and rising distribution costs, these large plants have neither been able to achieve economies of scale nor have they been able to bridge the demand-supply gap.**

**The advantages of small-scale, decentralized cement production are being increasingly recognized. The inherent flexibility of small-scale operations to cope with volatile and shifting demands, and their ability to take best advantage of available factors of production in developing countries are the main sources of their strength. Yet, the total installed capacity of mini-cement plants outside China and India remains very limited, mainly because of the lack of wide-scale dissemination of the required information relating to this technology among prospective entrepreneurs.**

**This publication is intended to fill this information gap by bringing together, under one cover, all the information that a prospective entrepreneur would be looking for to make investment decisions. In addition to technological information, the publication provides a methodology for carrying out pre-feasibility studies to ascertain project cost and profitability. A few selected case studies are listed in the annex which, I hope, should add to the utility of the publication**

**I wish to express my gratitude to Dr. A.K. Mullick, Director General of the National Council for Cement and Building Materials, New Delhi, for his valuable contribution towards the preparation of this publication.**

**Elizabeth Dowdeswell  
Under-Secretary-General  
United Nations Centre for Human Settlements (Habitat)**



**[Home](#)"" """"""> [ar.cn.de.en.es.fr.id.it.ph.po.ru.sw](#)**

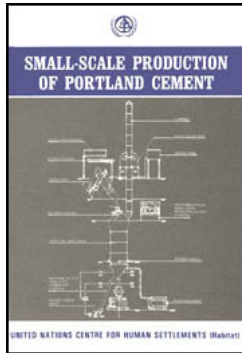

## **Small-Scale Production of Portland Cement (HABITAT, 1993, 92 p.)**

### **I. INTRODUCTION**

 **(introduction...)**

 **1.1 Advantages of small cement plants**

 **1.2 Definition of a small cement plant**

## **Small-Scale Production of Portland Cement (HABITAT, 1993, 92 p.)**

### **I. INTRODUCTION**

**Cement is one of the most important and commonly-used building materials throughout the world. The total cement production in the world was 1145 million tons in 1991. Most of this production was from large cement plants, with capacities ranging from 2000 to 20,000 tons per day (tpd) and transported to the place of use in bulk or in bags.**

**Large-capacity plants are currently the state-of-art and enjoy economies of scale in locations where:**

- (a) The net demand for and consumption of cement in the region justify creation of a large capacity of production;**
- (b) Cement consumption is substantially concentrated in a few locations;**
- (c) Large enough deposits of the basic calcareous raw material, i.e., limestone, are**

**available;**

**(d) Adequate and sufficient infrastructural facilities such as fuel, power and transport systems are available;**

**(e) Transport costs are relatively low;**

**(f) Socio-economic considerations justify the preference for relatively capital-intensive technology.**

**However, there are many situations under which small cement plants prove to be appropriate, particularly in cases like:**

**(a) Small developing countries like island States where the total need of cement is limited and which intend to develop their own cement industry to cater to their needs, thus, becoming independent of imports;**

**(b) Large countries with low population density and/or low per-capita cement demand and consumption;**

**(c) Where the limestone deposits are scattered which cannot sustain large cement plants, but can be profitably exploited by cement plants of smaller capacities;**

**(d) Locations where large cement plants cannot be set up due to infrastructural constraints - especially in hilly and remote regions.;**

**(e) In such areas where local and regional markets within economic distance can absorb the production of a small cement plant only, and where large size plants cannot operate at economic production rates;**

**(f) In locations where socio-economic considerations justify a labour-intensive**

**technology rather than a capital-intensive one;**

**(g) Where small-capacity cement plants have proved to be of use in the manufacture of cements of modified chemical formulations or having special characteristics.**

### **1.1 Advantages of small cement plants**

**Small cement plants offer some specific technical and economic advantages in given situations. These include:**

**(a) Lower capital investment per unit of production without sacrificing the quality of the product;**

**(b) Lower gestation period which helps in realizing quicker returns on capital invested;**

**(c) Bringing cement manufacture within the financial capacity of the smaller entrepreneur;**

**(d) Creating employment opportunities in rural areas;**

**(e) Setting up a cement industry in locations where movement of heavy machinery is difficult;**

**(f) Exploitation of small deposits of limestone as well as limited quantities of calcareous industrial wastes;**

**(g) Reducing the average unit cost of transporting cement through the dispersal of cement-production facilities.**

## 1.2 Definition of a small cement plant

There is no rigid definition of small cement plants with regard to their maximum size. Usually, the small-cement-plant technology relates to plants with a capacity ranging up to 200 tpd in the context of vertical-shaft-kiln (VSK) plants in India. In the case of China, however, plants of capacities up to 600 tpd, including those on rotary-kiln technology incorporating preheaters or precalcinators, are included in the list of mini-cement plants. In this document, however, mini-cement plants refer to small-scale cement production in the capacity range of 25 to 100 tpd.





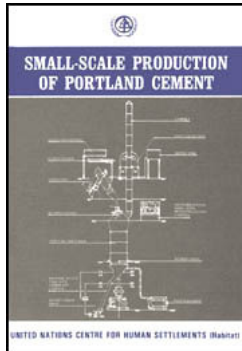





[Home](#) > [ar.cn.de.en.es.fr.id.it.ph.po.ru.sw](#)



### Small-Scale Production of Portland Cement (HABITAT, 1993, 92 p.)

#### II. TECHNOLOGIES OF SMALL CEMENT PLANTS AND THEIR COMPARISON

-   **(introduction...)**
-  **2.1 Fluidized-bed process**
-  **2.2 Reba process**
-  **2.3 Travelling grate (Lurgi sinter grate)**
-  **2.4 Small rotary kiln**
-  **2.5 Vertical-shaft kiln**
-  **2.6 General conclusions on sourcing of technology and selection**

### Small-Scale Production of Portland Cement (HABITAT, 1993, 92 p.)

## II. TECHNOLOGIES OF SMALL CEMENT PLANTS AND THEIR COMPARISON

The various technologies which have been tried for adoption in small cement plants are:

- (a) The Fuller Pyzel fluidized-bed process
- (b) Reba process
- (c) Travelling grate (Lurgi sinter grate)
- (d) Rotary kiln
- (e) Vertical-shaft kiln (VSK)

In all these technologies there is an upper and lower threshold of size, beyond which none it is technically feasible nor economically viable. Down-scaling of plants under any particular technology even within these thresholds results in:

- (a) Increase in investment per annual production of installed capacity;
- (b) Increase in the cost of production per unit weight of production.

When the technical and economical threshold is reached for any given technology line, other technology lines may still give technically feasible and economically viable results. This point will be apparent from the current investment costs under Indian conditions, which typically are as follows:

Type	Capacity (tpd)	Investment cost per annual ton of capacity (Rs)
VSK	100	1475
	200	1375
Rotary-kiln	300	3500
Large	3000	3000



**Note: All quoted costs and prices in this publication are not uptodate. They can serve, however, as a basis for comparison only.**

**Brief descriptions of all these technologies which have been tried or adopted for the small-scale manufacture of cement are given in the following sections. However, the global data available indicate that the only technology which has been commercially successful in the 25 to 100 tpd capacity range is the one based on the vertical-shaft kiln (VSK). The conventional rotary kiln is normally uneconomical below 600 tpd. Therefore, technologies such as the sinter grate and the Reba process which have been evolved were not successful on a commercial scale due to inherent defects.**

## **2.1 Fluidized-bed process**

**The application of fluidization in the clinkerization of cement raw meal is rather recent. It has been observed that by employing the fluid-bed clinkerization technique, cement clinker of the requisite quality can be produced economically by recovering the waste heat from exit gases. The fluosolid clinkerizer occupies a relatively small space, has minimum environmental pollution problems and requires less maintenance when compared with the conventional rotary kiln. The Fuller Company in the United States of America, has already put the process of clinkerization, developed by Robert Pyzel, in a pilot-scale plant of 50-tpd capacity into industrial application. Similar efforts have been made in Germany, Japan and Russia. It is believed that if considerable research and development effort persists in the future, the fluidized-bed clinkerization process may find a suitable place for the manufacture of cement. The process details are enumerated below.**

### ***Process details of Pyzel reactor***

**The plant consists of a fluidized-bed reactor (see figure 1).**

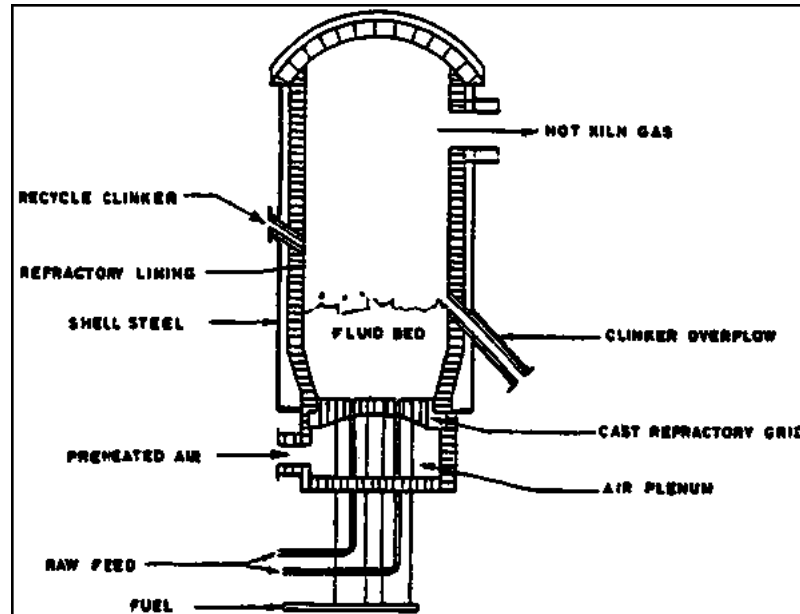

Figure 1. Fluidized-bed process

Raw meal consisting of finely-ground feed mix is pneumatically conveyed to the fluidized bed along with fuel and preheated air. The temperature of the fluidized finely-ground raw mix is pneumatically blown in from bottom, while recycled clinker particles are fed to the reactor over the fluid bed. Clinker phases are formed on the hot surface of characteristically round clinker particles, so that they grow in size continuously. Coarse clinker particles of 0.8 to 8 mm are maintained in granular form in suspension.

The specific heat consumption without any heat-recovery system is 2600 kcal/kg of clinker; with a heat-recovery system it is 1040 kcal/kg of clinker. The electrical-energy

**requirement for the production of clinker alone by a fluidized-bed reactor is 55 kWh/t, as against 30-35 kWh/t of clinker in the case of rotary kilns, and 20-25 kWh/t in the case of vertical-shaft kilns.**

**Fuels like gas, oil, coal and coke could be used in this process.**

**Specific advantages of the Pyzel process have been claimed where there is:**

**(a) A high alkali problem;**

**(b) Strict environmental protection regulations regarding oxides of sulphur and nitrogen from exit gases;**

**(c) Problems of disposal of kiln dust with high alkali content;**

**(d) Use of different fuels like gas, oil, coal and coke, including relatively low-grade fuels.**

**The high investment cost for the heat-recovery systems, stringent controls through an elaborate instrumentation and automation, and non-availability of highly-skilled personnel for the operation of the reactor are some of the disadvantages of this system.**

## **2.2 Reba process**

**In this process (see figure 2), the fuel used is oil or gas.**

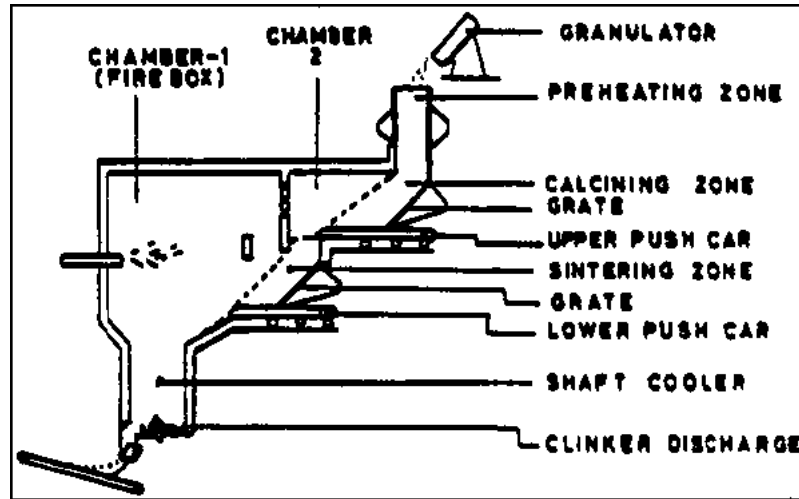

Figure 2(a). Material flow in the Reba process

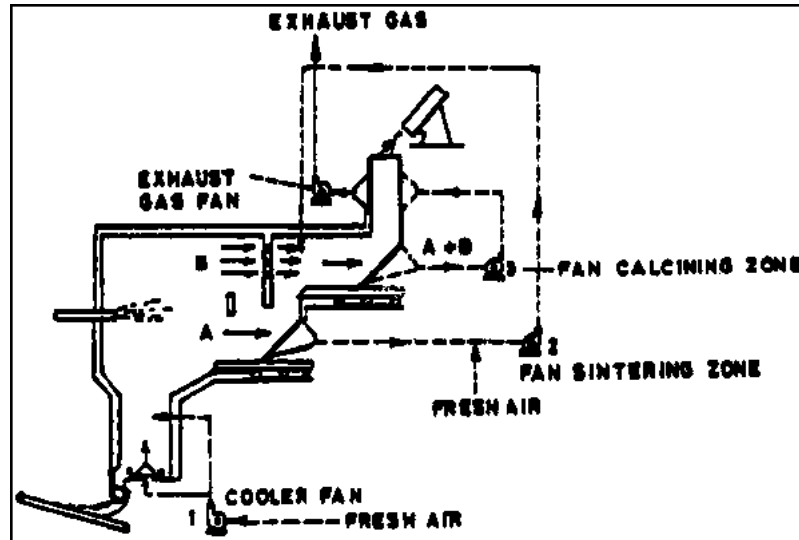

Figure 2(b). Gas flow in the Reba process

The homogenized raw meal is fed to a nodulizer where nodules are formed by the addition of water. They are then fed to a combustion chamber. The nodules are dried in the preheating zone and heated in the calcining zone to about 1100°C. The granulated material is then sintered at about 1450°C and cooled in the shaft cooler. The flow of gases is in the opposite direction to the flow of material, thus, air used to cool the clinker becomes heated and is used as secondary air together with primary air when burning the fuel.

The Reba process has not, so far, been operated on solid fuel, i.e., coal, and so no operational data are available on this applications.

It is understood that the Reba process has been tried successfully only for burning of lime

**and the technology for burning of cement clinker on a commercial basis is yet to be established.**

### **2.3 Travelling grate (Lurgi sinter grate)**

**In this process (see figure 3), homogenized raw meal and crushed coal (5-mm size) are stored in separate bins. The raw meal and crushed coal are then extracted from the respective bins according to requirements and conveyed to a drum-type nodulizer.**

**In addition, the nodulizer is also fed with 15 per cent of 5-mm-size burnt clinker to form the core of nodules, and with 15 per cent water spray. The nodules are conveyed by a belt conveyor to a moving sinter bed made of a cast-iron grate base. A 75-mm thick layer of mm and 10 mm burnt clinker is first spread over this bed and then the fresh nodules fall over this. The sinter bed passes through various zones over some distance where suction is maintained through an ID fan. Light diesel oil is fired over the bed and a hood is fixed about 200 mm above the bed height. The resulting clinker is discharged through a rotating-arm-type breaker in red-hot condition over an open-pan-type horizontal conveyor where it undergoes cooling. A commercial plant of 50 tpd capacity was set up in India.**

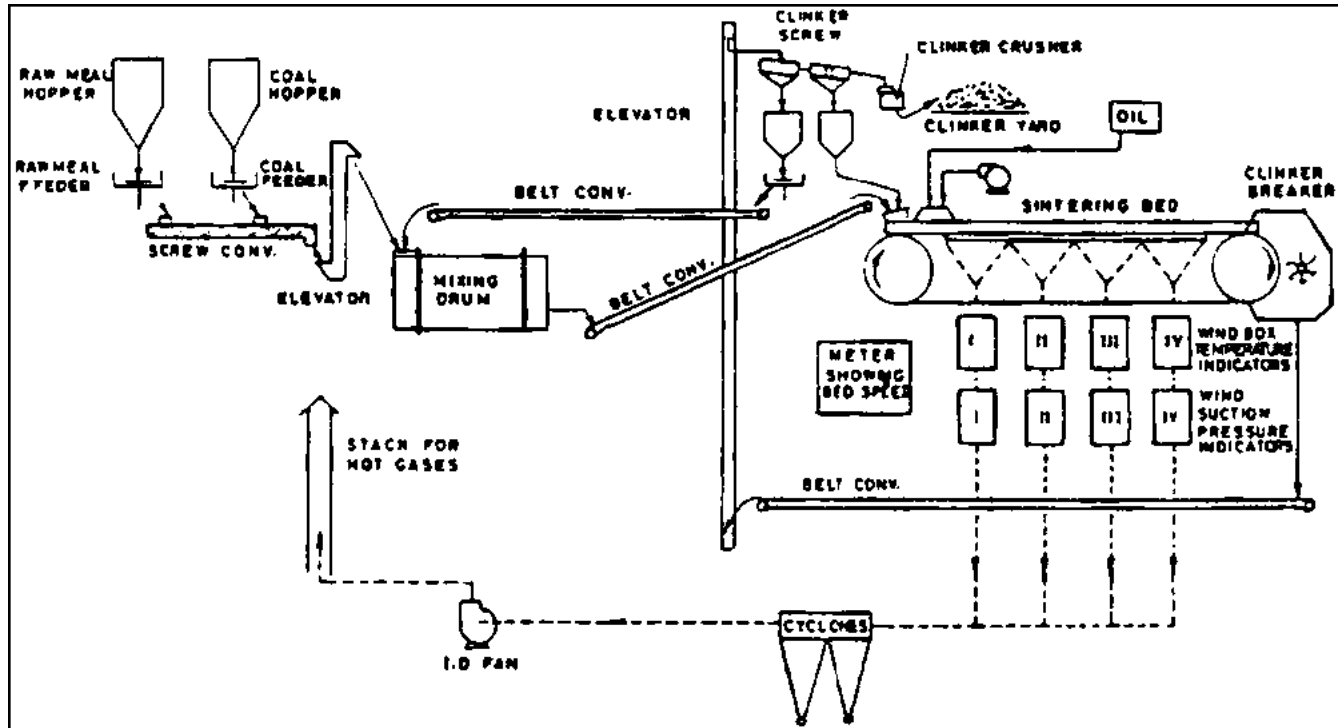

Figure 3. Lurgi sinter grate

## 2.4 Small rotary kiln

In the case of a rotary-kiln-based small cement plant (see figure 4), the kiln feed and fuel preparation requires crushing and grinding operations, such as:

- \* Crushing of limestone and additives to 15 mm size in a hammer mill or 2-stage, viz, jaw crusher and hammer mill.**
- \* Storing the crushed raw materials in storage yard/bins.**
- \* Proportioning and grinding the raw materials in a roller mill or ball mill.**
- \* Homogenizing and storage of raw meal in blending and storage sections.**
- \* Fuel, viz., coal (ash content 25-30 per cent) is pulverized in a separate section (combined coal drying-cum-grinding section).**

**Blended and homogenized raw meal is then fed to a suspension preheater of the counter type, where it is preheated and partially calcined by the hot gases from the kiln passing in counter current. Raw meal enters the kiln at a temperature of 700° - 800°C. Pulverized coal, mixed with primary air, is fired from the lower end of the rotary kiln through coal burners. Secondary air is supplied through clinker cooler to make up for the combustion air. A flame at around 1660°C is maintained. This heats the material as the kiln rotates at 1 to 2 rpm. Various chemical reactions (calcination and sintering) take place as the temperature of the material increases to 1450°C. The exit gases from the preheater are then passed through the dust-collection system and discharged into the atmosphere. Clinker is discharged into a clinker cooler which may be of the rotary, planetary or moving-grate types. Clinker is then transported to the storage yard and finally ground with gypsum.**



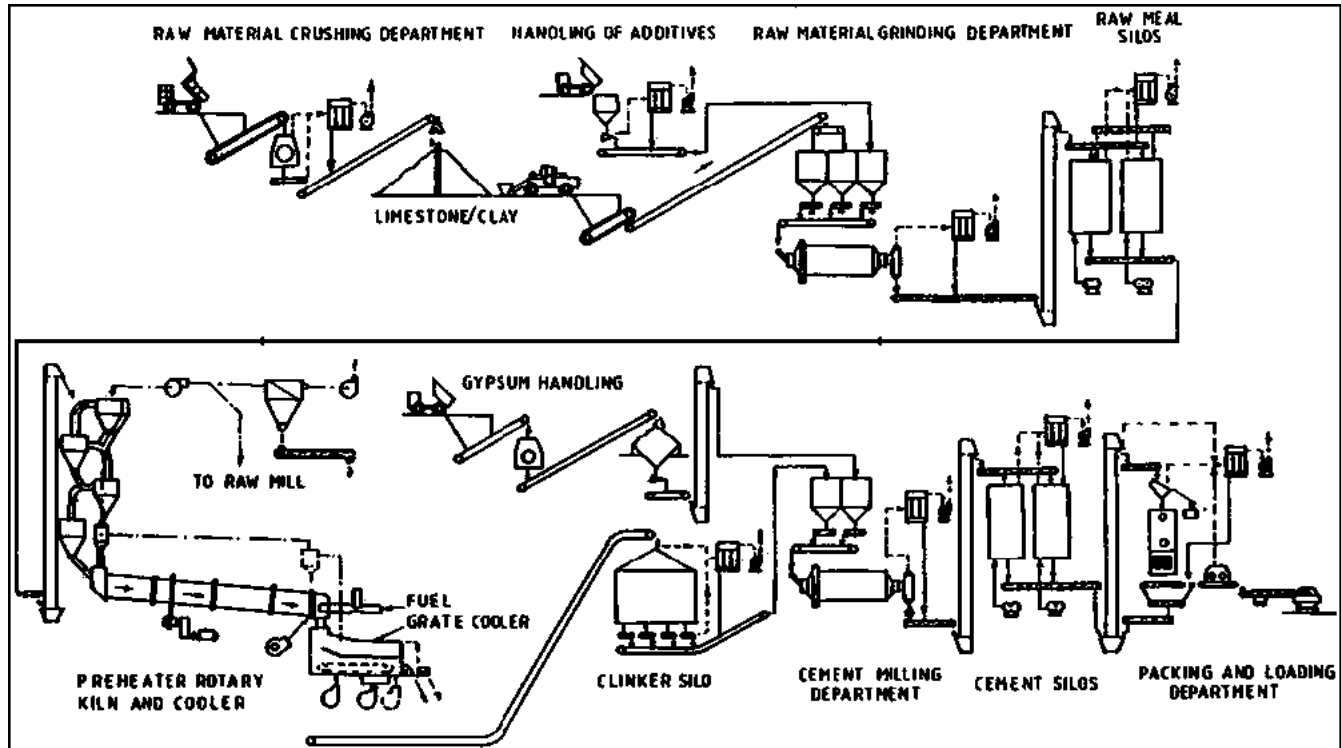

Figure 4. Rotary-kiln-based small cement plant

Control is maintained through various control instruments and inspection of burning conditions.

## 2.5 Vertical-shaft kiln

**The use of the vertical-shaft-kiln process (see figure 5) for cement manufacture dates back to the year 1824 when Portland cement was invented. However, because of its non-continuous operation, this process was found uneconomical and produced clinker of non-uniform quality.**

**Later, with the development of a continuous-pan-type nodulizer, a significant advance was achieved and the performance of shaft kilns improved considerably, thus permitting the adoption and production of a uniform quality of clinker on a continuous basis. Cement manufacture by using a modern vertical-shaft kiln (MVSK) is reportedly being carried out in different countries. In fact, a wide variety of processes has been adopted for the manufacture of cement through vertical-shaft kilns, some of which are mentioned in the following sections.**

### **2.5.1. *Black-meal process***

**The black-meal process is used for the manufacture of cement through an MVSK in which the fuel (usually low-volatile coal or coke-breeze) is interground with the raw materials, viz., limestone, clay and additive(s). The feed preparation usually requires crushing of limestone to about 15 mm size, storage in bins/silos, proportioning of raw materials along with fuel which acts as a raw material, grinding them all in a ball mill or a roller mill, homogenizing and then nodulizing in a pan-type nodulizer. The successful operation of a vertical-shaft kiln depends, to a great extent, upon the size of the nodules, their uniformity, porosity and thermal stability. The nodulizer consists of an inclined disc or pan rotating about its axis. Raw meal is fed into the nodulizer by means of a screw feeder and water is sprayed. The nodules slide down the chute and are continuously distributed in the vertical-shaft kiln evenly all around the periphery with the help of a rotary feeder.**

**The VSK, in which the nodules are converted into clinker, consists of a cylindrical shell, with a conical portion at the top, lined with refractory bricks. The sintering is normally**

**completed within the conical portion which is specially designed to allow for the shrinkage of nodules. The various zones of reaction starting from the top of the kiln are: the drying zone, the calcining zone, the sintering zone and the cooling zone. The combustion air supplied by a roots blower ascending from below in the cooling zone absorbs heat from the descending clinker. The whole kiln charge composed of nodules and clinker rests on a specially designed flat grate rotating slowly at the bottom of the kiln and mounted over the kiln shaft. The grate is driven with the help of a variable-speed motor in order to control the discharge rate of the clinker. The clinker is finally extracted from the kiln bottom through a gamma-ray-controlled material block tube (MBT)/triple air-lock discharge (TALD) gate system.**

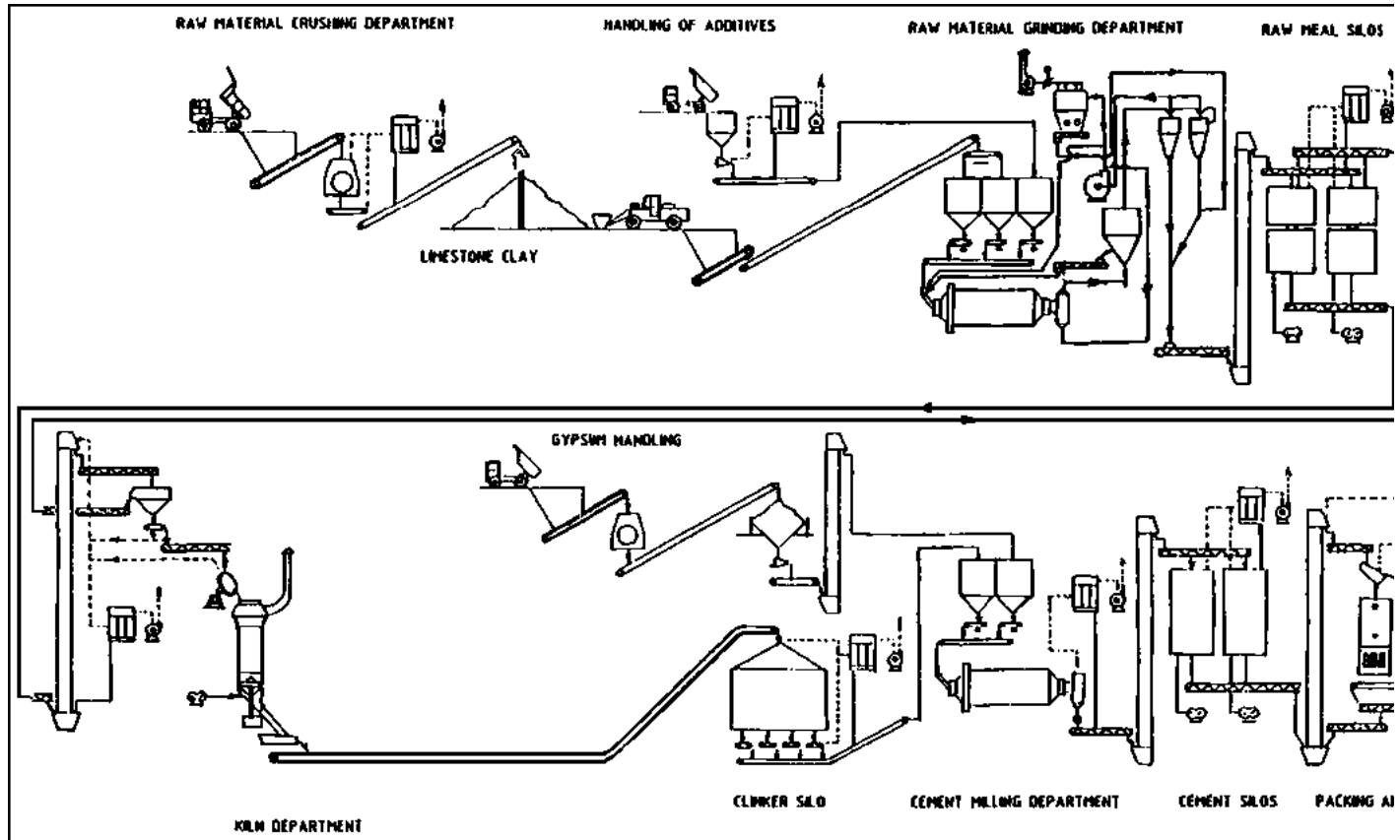

**Figure 5. Vertical-shaft-kiln-based small cement plant**

**In addition to ordinary Portland cement (OPC), a number of other varieties of cements**

**such as high-strength cement and expansive cement (K-type), among others, can also be conveniently produced in MVSK-based cement plants. Blended cements such as Portland/blast-furnace-slag cement and Portland-pozzolana cement, could also be obtained by grinding clinker with suitable pozzolanic material.**

### ***2.5.2 Coal-slurry process***

**A variation of the black-meal process, proposed by Steven Gottlieb, is the coal-slurry process. Compared with the black-meal process described above, the main difference is in the method of feed preparation. The method requires that the raw meal to be ground "white", i.e., without fuel. The fuel (coal with volatile matter up to 16-18 per cent) is ground separately in a wet ball mill to make slurry with about 50 per cent moisture. The "white meal" and the "coal slurry" are separately stored in hoppers over the nodulizer platform and are pumped at controlled rates (through flow meters) into a double-paddle mixer to mix the feed continuously and discharge it into the standard nodulizer where practically no, or very little, water is added to give final shape to the nodules. These nodules are charged and burnt in the vertical-shaft kiln in the same manner as in the case of the black-meal process.**

**The main advantage claimed is that in this process, by wetting the coal particles before nodulizing, the retention time for the volatile component of the fuel is increased, thereby allowing this to travel to a zone where adequate oxygen is available to complete the combustion of the volatile matter within the bed. This process, thus, permits the use of coal having a higher volatile content compared with what is required in the black-meal process.**

### ***2.5.3 Differential heat burning process***

**This process, which is a slight variation of the black-meal process, has reportedly been tried out in a number of cement plants in China. In this process about 50 per cent of the**

**total fuel required is interground with the raw meal and the balance is added later prior to nodulization. This has been based on the assumption that the heat requirement at the periphery of the bed in a VSK is usually more by about 150 kcal/kg of clinker than that in the middle. In this process some additional fuel is added at the periphery of the bed as compared with that in the middle to balance the heat distribution.**

#### **2.5.4. Shell process**

**Another variation of the black-meal process reportedly tried out in China is the shell process, where the black-meal nodules are given an "extra-rolling" on a second nodulizer where white meal (i.e., without fuel) is added. As a result of this, the black-meal nodules develop a thin shell of white meal, which prevents exposure of the fuel particles to the flue gases, thus, preventing the CO<sub>2</sub> in the flue gases from reacting with the carbon in the fuel to form carbon monoxide.**

### **2.6 General conclusions on sourcing of technology and selection**

**The current trend in cement manufacture is either to establish increasingly larger plants to take advantage of the scale effect, or to set up small-scale plants in view of other parameters. Either of the alternatives could be considered as viable and appropriate depending upon the socio-economic parameters prevalent in a given situation. However, the ultimate choice depends on a combination of various factors involving social, technical and economic considerations. In situations where small-scale cement manufacturing units are preferable, a number of alternate technologies are available as described above. Out of these, plants based on the vertical-shaft-kiln (VSK) technology or small rotary-kiln technology are predominant.**

**Apart from technical differences in the plant and machinery and the process, there is a predominant conceptual difference between the two technologies. The use of a rotary kiln**

**for cement manufacture is well established. However, in the case of small cement plants, it becomes a case of essentially downscaling the conventional technology which is immensely suitable for large-size cement plants. Small-scale cement plants using a rotary-kiln technology, therefore, involve a relatively high investment cost per annual ton of installed capacity. Compared with this, the MVSK technology is not based on the concept of downscaling. In fact, this is the appropriate technology for plants of small capacities of say, up to 100 or 200 tpd in single line.**

**It is a well-known principle that within the upper and lower thresholds of any given technology, the scale effects are bound to affect both investment and operational costs, but when there is a change in the process and the process line and when there are eliminations of certain unit operations, as indicated above in the case of VSK, it is possible to update them by adding an instrumentation and process-control system without unduly pushing up the cost, unlike in a downscaled technology. This concept will become clearer after reviewing the experience of China, India and other countries described in subsequent chapters.**



[Home](#) > [ar](#).[cn](#).[de](#).[en](#).[es](#).[fr](#).[id](#).[it](#).[ph](#).[po](#).[ru](#).[sw](#)

 **Small-Scale Production of Portland Cement (HABITAT, 1993, 92 p.)**

 **III. SMALL CEMENT PLANTS IN OPERATION IN DIFFERENT COUNTRIES**



 **3.1 Small cement plants in India**

 **3.2 Small cement plants in China**

 **3.3 Small cement plants in countries other than India and China**

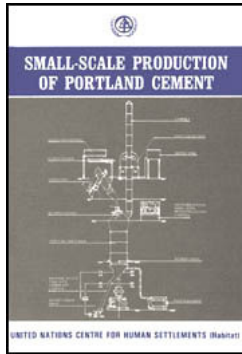

## **Small-Scale Production of Portland Cement (HABITAT, 1993, 92 p.)**

### **III. SMALL CEMENT PLANTS IN OPERATION IN DIFFERENT COUNTRIES**

#### **3.1 Small cement plants in India**

##### **3.1.1 *Vertical-shaft kilns***

**Modern CRI-MVSK technology (see figure 6) was pioneered in India by the Cement Research Institute of the National Council for Cement and Building Materials as early as 1972 and was first tried out in 1974.**

**The salient feature of the CRI-MVSK technology is the use of the black-meal process, i.e., the raw mix is interground with fuel, and the VSK itself performs several unit operations, viz., preheating, calcining, sintering, cooling and clinker crushing, thus, making a CRI-MVSK cement plant compact. At present, over 83 VSK cement plants based on the CRI-MVSK technology are in operation in different parts of India and in neighbouring countries like Bhutan and Nepal; 45 more plants are under different stages of implementation with**



**capacities ranging from 20 to 200 tpd. The salient features of CRI-MVSK technology are given in appendix I.**

**About five plants based on the technology of Regional Research Laboratories (RRL), Jorhat, are operating in India and about 10 plants are under various stages of implementation. Out of these plants, only one is of 100-tpd capacity, the remaining are of 40-tpd and smaller capacities.**

**Some entrepreneurs have opted to set up tiny cement plants (capacities in the range of 15-50 tpd) under the definition of "small-scale industries (SSI)" of the Government of India. Most of these plants have been based on the plant and machinery supplied by M/s Shree Engineers (Pvt) Ltd, Jodhpur. In general, these plants have been set up mostly in the small-scale sector, i.e., a sector in which investment on plant and machinery has to be limited to Rs 7.5 million (Rs 100 = \$US 3.33 approx.), to take advantage of the special incentives available to small-scale industrial units. There are some 45 such cement plants in the capacity range of 25 tpd, mostly in Gujarat, Rajasthan, and Uttar Pradesh.**

### ***3.1.2 Small rotary kiln***

**In India, there are about 30 rotary-kiln-based small cement plants in operation; most of these being designated earlier as 200 tpd in order to derive incentives offered by the Government in terms of reduced excise duty and free market. However, most of these plants are using kilns of 3 m dia and 40 or 45 m length -which, under Indian conditions are rated as 300 tpd. One of the major reasons for this has been the fact that the machinery fabricators/consultants did not find it technically appropriate to reduce the kiln dimensions further in view of anticipated problems relating to higher refractory failure.**

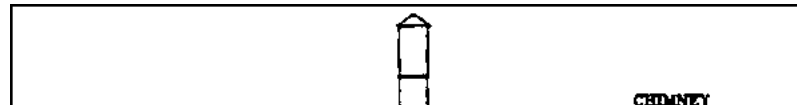

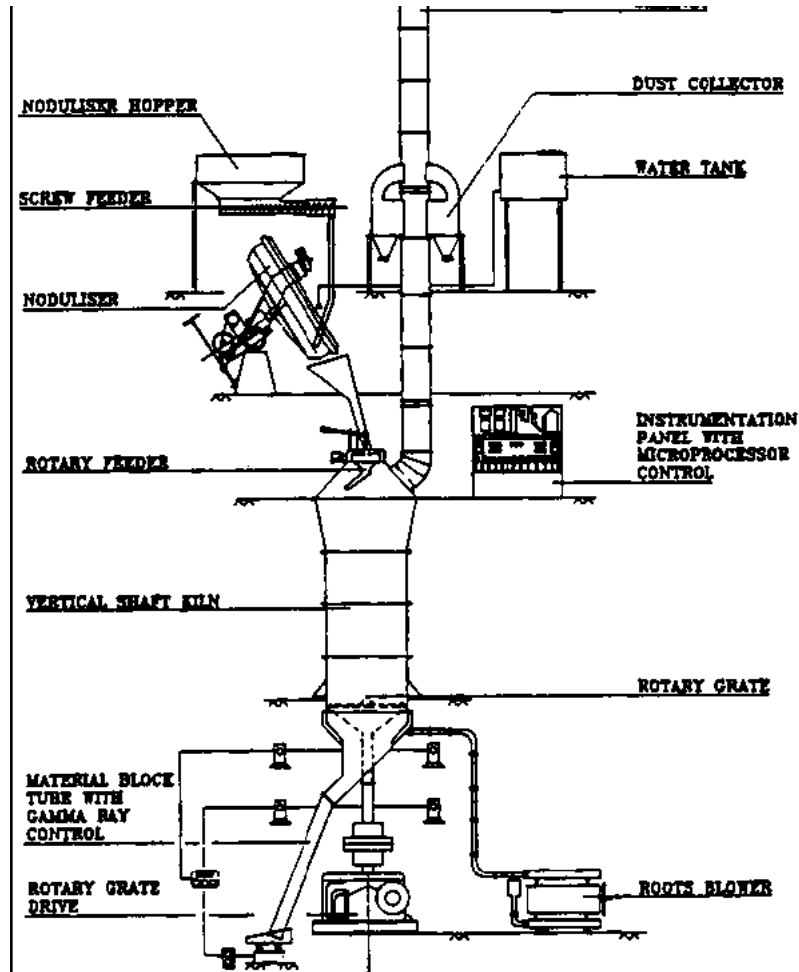

---

**Figure 6. CRI-modern vertical-shaft kiln**

**Thus, although a few small cement plants based on the rotary-kiln technology have been set up in India as well as in other countries, mainly because of the reason that this technology is a direct downscaling of the conventional rotary kiln which is technically well-established, the investment cost per annual ton of installed capacity in such plants is found to be exceptionally high due to the scale effects. Yet, if one attempts to make these small rotary-kiln plants economically viable, certain processes and operations have to be eliminated and the degree of sophistication of instrumentation and process control systems would have to be lower, which would amount to sacrificing some of the modern features which are essential for satisfactory performance and economic operation. Due to the inherent techno-economic disadvantages of setting up mini-cement plants based on the rotary-kiln technology of less than the above mentioned size, mini-cement plants based on the rotary-kiln technology cannot be considered in setting up small cement plants of up to 100-tpd capacity as envisaged in the scope of this document.**

### **3.2 Small cement plants in China**

**Source: Fu Zicheng, China Building Materials Academy, Beijing**

**The development of the cement industry in China was somewhat different from in other countries. Since China is a country covering a vast territory, there is heavy demand for cement in rural areas, in the agricultural sector, for local industries and for construction activities in general. Therefore, locally-managed mini-cement plants have been developed to meet the demand, and the large- and medium-scale cement plants are still the backbone of the Chinese cement industry.**

**In China, a cement plant with an annual capacity of less than 200,000 tons (600 tons per day) is considered a mini-cement plant. Three different types of mini-cement plants are in**

**operation:**

**(a) *Mechanized vertical-shaft kilns* - the annual plant capacity ranges from 50,000 to 500,000 tons and single VSK lines are of capacities 140 to 240 tpd of clinker production. As many as 2600 mini-cement plants of this type have been put into operation. Old shaft kilns of capacities less than 100 tpd have become obsolete.**

**(b) *Small rotary kilns (dry process without preheater)* - the capacity of this type of mini-cement plant ranges from 50,000 to 100,000 tons/year. There are around 200 plants of this type operating in China.**

**(c) *Small rotary kilns with shaft preheater or cyclone preheater or precalciner* - operating with capacities ranging from 170 to 700 tpd.**

**3.3 Small cement plants in countries other than India and China**

**Although the latest information regarding the exact number of mini-cement plants operating in different parts of the world is not available, some available information is given in table 1.**

**So far as mini-cement plants based on the CRI-MVSK technology in other countries are concerned, M/s Penden Cement Authority of Bhutan has installed a 2 × 50-tpd CRI-MVSK at Gomtu and another 2 × 50-tpd CRI-MVSK cement plant; M/s Lhaki Cement, Bhutan, has gone into operation recently. One small cement plant of 30-tpd capacity based on CRI-MVSK is in operation at Aboo-Khaireni in Nepal. One cement plant of 160-tpd capacity based on a vertical-shaft kiln of size 2.4 m diameter and 8 m height supplied by M/s Loesche, Germany, is already in operation at the works of M/s Himal Cement Company, Nepal.**

**Table 1: Survey of vertical-shaft kilns in operation in countries other than China and India**

<b>Country</b>	<b>Active kilns</b>
Austria	3
Australia	6
Bhutan	5
France	24
Germany	26
Indonesia	2
Italy	12
Iraq	2
Kenya	8
Madagascar	2
Nepal	3
Pakistan	3
Poland	6
Spain	23
Turkey	3
(Former) USSR	32
(Former) Yugoslavia	9

**Source: World Cement Directory (Paris, The European Cement Association, Cembureau, 1987); Data available in NCB.**

**Being satisfied with the technological features of the CRI-MVSK technology Uzbekistan has decided to set up five CRI-MVSK cement plants in different provinces. The first plant to be**

**set up will be of 150-tpd capacity at Djizak.**

**M/s Loesche have supplied more than 14 mini-cement plants based on the black-meal VSK process in more than nine countries. The first multiple VSK plant supplied by M/s Loesche went into operation in 1955 at the cement plant of M/s Portlandzementfabrik Blaubeuren GmbH at Blaubeuren, Germany. Later, M/s Loesche supplied plants based on VSK to various countries including Austria, Indonesia, Italy, Nepal and Spain. Different fuels of various mixtures have been used at Paggau ranging from anthracite dust to coke-breeze and petroleum coke, the application of which in all the cases has been reported to be successful.**

**In addition to the above, M/s Maerz Ofenbau of Zurich has also supplied mini-cement plants based on the VSK technology on a turn-key basis. M/s Maerz is the exclusive licensee for the manufacture of "Prerov Machinery"-designed mini-cement plants with as many as 16 cement shaft kilns operating in different parts of the world. The heat consumption in these plants is claimed to be about 900 kcal/kg clinker.**



**[Home](#) > [ar.cn.de.en.es.fr.id.it.ph.po.ru.sw](#)**

 **Small-Scale Production of Portland Cement (HABITAT, 1993, 92 p.)**

 **IV. GEOLOGICAL INVESTIGATIONS AND SELECTION OF RAW MATERIALS AND FUEL**

 **(introduction...)**

 **4.1 Geological investigations**

 **4.2 Quality requirements of raw materials**

 **4.3 Coke-breeze/low-volatile coal for VSK process**

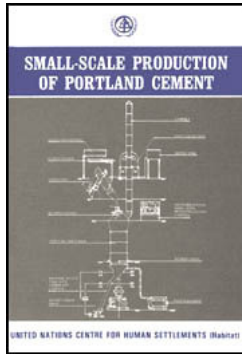

## **4.4 Categories of reserves of limestone and their requirements**

**Small-Scale Production of Portland Cement (HABITAT, 1993, 92 p.)**

### **IV. GEOLOGICAL INVESTIGATIONS AND SELECTION OF RAW MATERIALS AND FUEL**

**The process of cement manufacture and its quality are primarily controlled by appropriate selection and evaluation of raw materials. Geological investigations, if done properly, will not only result in the choice of the most suitable raw materials occurring in the area for the purpose but also in cost reduction.**

**Proper attention, therefore, needs to be paid in selecting those raw materials that satisfy the specifications for a particular cement manufacturing technology. NCB, as the apex national body in India, assisting the cement industry as a whole, provides the necessary know-how, do-how and know-why assistance in this respect.**

#### **4.1 Geological investigations**

**The bulk of geological work for limestone - the main raw material - is normally carried out at two stages:**

- (a) During initial exploration and evaluation of a project;**
- (b) During production and development, once a plant has been established.**

**NCB is fully equipped for monitoring as well as carrying out investigations during both the above stages depending upon the situation and requirement. During the initial stage, the job of geological exploration, being time-consuming in nature, is normally done in advance by the local agencies, either independently or under supervision, and based upon this the detailed investigations are carried out by NCB experts. However, if needed, advice and directions are provided for carrying out the exploration programme in accordance with the norms laid down by NCB. These norms take care of varying degrees of structural and lithological complexities of a deposit, including whether it can be mined. Broadly, three categories, viz., "simple", "complex" and "intricate" types, have been identified, which warrant different degrees of exploration in accordance with their matrix. During the evaluation stage, emphasis is mainly laid on the bore hole and other exploration data interpretation, their significance and systematic sampling to see the suitability of limestone or other allied deposits for cement manufacture in VSK. Bore-hole and pit sampling is done to find out the quality variations in the deposit at various depths.**

**NCB also undertakes the planning of mines depending upon the type and nature of the deposit and the capacity of a plant. Periodic sampling of the pit faces and mapping of the newly-exposed features are also taken up during the production and development of benches in order to keep a strict control on the run-of-time quality of limestone.**

#### **4.2 Quality requirements of raw materials**

**The essential components that constitute the raw meal feed for cement-making are calcium carbonate, aluminium silicates, iron and aluminium oxides and some minor constituents. Of these, the first three are important in the formation of cement clinker, while the fourth affects the manufacturing process and clinker-phase formation depending**



**upon the type and quantity of minor constituents. The quality prerequisites of raw materials and fuels for the different processes of small cement plants are summarized in table 2.**

**The main guidelines determining the suitability of various raw materials for manufacture of Portland cement through VSK technology are given in the following paragraphs.**

#### ***4.2.1 Calcareous component***

**The calcareous component of a cement raw meal is contributed by any rock containing  $\text{CaCO}_3$ . Although many suitable calcareous materials, such as chalk, marl, sea shale, kankar etc. can fulfil the requirements for cement manufacture, limestone serves as the principal source of the calcareous base, due to its vast availability compared with the other resources. However, the less favoured varieties do find their use in cement manufacture after thorough evaluation of their physio-mechanical, chemical and mineralogical properties and assessing their impact on the manufacturing process to the extent these are not detrimental to it.**

**The desirable chemical composition of cement-grade limestone to be used for VSK technology falls in the following range:**

CaO                      More than 46 per cent

SiO<sub>2</sub>                     Below 8 per cent

Al<sub>2</sub>O<sub>3</sub> & Fe<sub>2</sub>O<sub>3</sub> As may be required to satisfy the modulii values of raw mix

MgO                      3.5 per cent maximum, but preferably below 2 per cent

**Unlike in a rotary kiln, alkalis do not have an appreciable effect due to non-generation of alkali cycles in VSK if present in quantities higher than optimum.**

**The requirement of limestone in a mini-cement plant being comparatively smaller, the same may be met both from small limestone deposits and cement-grade limestone wastes from a blast furnace (BF), a steel melting shop (SMS) and chemical-grade limestone mines.**

**Many chemical plants use high-grade lime in their manufacturing process. Where such lime is produced indigenously for the requirements of the plant, high-grade limestone is generally brought from outside. There are a number of cases where the fines of such limestone are not acceptable to the manufacturing process and as such become a waste or by-product. These can be used suitably for a mini-cement plant.**

**Several mines raising high-grade (BF/SMS/chemical) limestone for steel plants and the chemical industry also produce rejects of lower grade. These can also be used for small-scale cement manufacture by mini-cement plants.**

**Cement-grade limestone often occurs interbedded with magnesite or dolomite beds and occasionally underlying them. Where the limestone beds are small, their large-scale exploitation may be uneconomical because of the overburden and other factors. However, where the overlying or underlying dolomite or magnesite is being exploited for a more profitable venture, cement-grade limestone can be mined simultaneously for mini-cement plants.**

#### ***4.2.2 Argillaceous component***

**For nodulizability and in order to compensate for the deficiencies in  $Al_2O_3$  and  $Fe_2O_3$ , sticky and plastic clays, which are usually hydrous aluminium silicates, assume a greater deal of importance in the VSK process. Normally marshy land and black cotton soil meet the above requirement easily.**

#### ***4.2.3 Corrective components***

**Corrective materials are used to overcome any deficiency left over after the addition of limestone and clay components. These could be suitable rock types, e.g., bauxite, iron ore, laterite etc., and their quantity will depend upon the shortfall of the requisite components.**

#### **4.3 Coke-breeze/low-volatile coal for VSK process**

**In VSK technology, the raw meal interground with fuel (called "black meal") is fed in the form of nodules. Because of this, there is an inherent limitation on the maximum volatile matter of the fuel. The volatile matter should not exceed 10 per cent, otherwise during burning the intranodule pressure may increase due to the release of the volatile matter. Consequently the nodules may break. Coke-breeze, a waste product from the steel industry, has so far been used as fuel in VSK cement plants.**

**The preferable specification of coke-breeze or any other fuel for the VSK process are as follows:**

Ash 25-25 per cent  
Volatile matter Preferably below 10 per cent  
Calorific value 4500 kcal/kg or more

**However, the considerable growth of VSK-based mini-cement plants all over India and the dwindling availability of coke-breeze due to the recent recycling of coke-breeze by the steel industry has created the need to identify various alternative fuels and to establish their suitability firmly through plant trials.**

**Studies carried out by NCB have revealed that various low-volatile fuels which can be substituted for coke-breeze for the manufacture of cement by the VSK process can be grouped into natural fuels and by-product or waste-product fuels, as described below.**

**Table 2. Specific characteristics of raw materials needed for different types of mini-cement plants**

Type of mini-cement plant	Raw materials		Fuel	
	Limestone	Additives	Type needed and quantity	Quality prescribed
Long dry rotary kiln	Cement grade	Clay/laterite/bauxite etc., to satisfy raw-meal composition	Coal used for cement, 23-24 per cent of clinker	Ash content not more than 25 per cent. Caloric value of me order of 4700 kcal/kg
Semi-dry rotary kiln	Cement grade with proper nodulizing properties	Same as above; to satisfy raw-meal composition as well as with good plasticizing properties	Coal used for cement, 23-24 per cent of clinker	As above
Dry-process rotary kiln with suspension pre-heater	Cement grade with very low alkali content. Raw meal needs thorough homogenization	Same as above; to satisfy raw meal composition, as well as with low alkali content	Coal used for cement; 19 per cent of clinker (more for small kilns)	As above
CRI-modern	Cement grade with proper nodulizing	Same as above; but preferably more of	Low-volatile fuel; 19 per	Ash content 25-35 per cent, caloric value 4500 kcal/kg

vertical-shaft kiln	properties	clay, especially one with good plasticizing	cent clinker	and above, volatile matter should be low (preferably less than 10 per cent)
		properties		

#### 4.3.1 Natural fuels

The occurrence of low-volatile coal in certain coalfields in India is attributed to the carbonization of coal seams by the intrusion of mica lamprophyre which is a mica-rich ultrabasic rock containing altered olivine, calcite (or dolomite), bronze-coloured mica and apatite. The intrusions occur as sills and dikes, generally varying in thickness from 1 to 2 m, having devolatilized the *in-situ* coal along the contacts and converted it into a type of coke (Jhama coal) for a distance of as much as 2 m from the contacts. The low-volatile coal which is available for mining is termed as saleable low-volatile (SLV) coal in India.

The analysis of Borgua coal and typical analyses of SLV coal samples collected by NCB from Kustore, Ena and Kenduadih collieries of the Jhama coalfields of BCCL are given in table 3.

**Table 3. Proximate analyses of natural fuels**

Particulars (percentage)	SLV coal				Borgua coal
	Kustore		Ena	Kenduadih	
	Sample I	Sample II			
Moisture	1.85	1.18	0.17	3.0	0.64
Ash	22.39	25.10	19.59	25.0	43.87
Volatile matter	4.42	6.88	13.97	6.0	13.90
Fixed carbon	71.34	66.84	66.27	66.0	41.59

Calorific value(kcal/kg)	5593	5738	6448	5600	4412
--------------------------	------	------	------	------	------

**The analyses indicate that the volatile matter in SLV coal is variable and was as high as 13.97 per cent. However, through systematic sampling, the potential blocks can be identified and the coal with less than 10 per cent volatile matter can be mined selectively.**

#### **4.3.2 By-product/waste-product fuels**

##### ***SICCO fines***

**SICCO fines are produced in the low-temperature carbonization plant of Coal Chemical Complex, Mancherial, Andhra Pradesh. The fines are differentiated into three categories based on the size: (a) coke, mm; (b) medium coke fines, 15 to mm; (c) small coke fines, 2.5 mm. The analyses of these fractions are given in table 4.**

##### ***Leco fines***

**Leco fines are produced by the low-temperature carbonization process of lignite and non-coking coals. The leco fines available at Neyveli Lignite Corporation, India, are categorized into three types:**

- (a) 3-mm size, carbonized sludge;**
- (b) 10-mm size, fine coke special;**
- (c) 20-mm size, super fine coke**

**Table 4. Analyses of Sicco fines**

<b>Particulars (air dried basis) (percentage)</b>	<b>Coke</b>	<b>Medium-coke fines</b>	<b>Small-coke fines</b>
Moisture	3-5	3-6	3-6
Ash	27-26	24-22	24-10

ASII	52-55	54-56	54-56
Volatile matter	4-8	6-10	6.1-
Fixed carbon	52-58	50-56	50-56
Sulphur	0.4-0.5	0.4-0.5	0.4-0.5
Calorific value kcal/kg	4500-5500	4000-4500	4000-4500

### ***Petroleum coke***

**This is a carbonaceous material obtained as a refining residue by destructive hearing of high-molecular-weight petroleum. The major products from coking are fuel gas, gasoline, gas oil and petroleum coke.**

### ***Carbon-waste sludge***

**The partial oxidation of fuel oil and heavy petroleum fractions in fertilizer plants results in the generation of carbon. About 2-3 per cent of carbon is formed during gasification, which has to be removed before the gases are sent for further processing. The gases are scrubbed with water to remove carbon in the form of slurry. The moisture content as generated is 70-80 per cent, hence a suitable drier is required for its use in VSK plants.**

### ***Spent pot lining***

**Spent pot lining (SPL) from the aluminium industry has also the same calorific value as that of coke-breeze. Under ideal conditions, SPL may tend to act as a mineralizer due to the presence of halogens, hence a reduction in burning temperature could be realized. However, if  $SO_3$ , chloride and sodium contents are high, the suitability may be restricted. Also the materials hardness would tend to increase power consumption.**

**The proximate analyses of all these fuels are given in table 5.**

**Table 5. Comparative analysis of various fuels**

<b>Particulars (percentage)</b>	<b>Leco fines</b>	<b>Petroleum coke</b>	<b>Carbon sludge<sup>a</sup></b>	<b>SPL</b>
Moisture	5-8	8.67	1-3	0.25
Volatile matter	3-12	0.12	7-10	5.98
Ash	10-30	90.54	0.5-3	36.09
Fixed carbon	-		85-90	57.68
Calorific value (kcal/kg)	50000.67	8900	7000	4747 <sup>a</sup>

<sup>a</sup> Contains 70-80 per cent water as generated.

#### 4.4 Categories of reserves of limestone and their requirements

**Cement-grade limestone reserves can be categorized as "inferred", "indicated" and "measured" in the following order:**

Inferred reserves: when  $V_g$  4 per cent and  $V_f$  50 per cent

Indicated reserves: when  $V_g$  3 per cent and  $V_f$  30 per cent

Measured reserves: when  $V_g$  1 per cent and  $V_f$  10 per cent

where  $V_g$  = anticipated deviation in CaO content from the actual value as mined;

$V_f$  = anticipated difference between the estimated and mined reserves.

**In the case of small cement plants, since mechanized mining is not a prerequisite, financial decisions could be taken on the basis of "indicated" and "inferred" reserves only and these reserves would be calculated on the basis of the capacity of the plant and its**



**total life of 40 years. Out of 40 years of total life of the plant, there should be sufficient reserves of indicated category for the first 20 years and adequate inferred reserves for the next 20 years.**

**The required reserves for small cement plants of various capacities may be taken as given in table 6.**

**Table 6. Requirement of different categories of limestone reserves for different capacities of small cement plants**

Category of reserve	Quantity (million tons)		
	30 tpd	50 tpd	100 tpd
Indicated	0.54	0.90	1.80
Inferred	0.81	1.35	2.70



[Home](#) > [ar.cn.de.en.es.fr.id.it.ph.po.ru.sw](#)

**Small-Scale Production of Portland Cement (HABITAT, 1993, 92 p.)**

**V. RAW-MIX DESIGN AND QUALITY CONTROL IN VSK CEMENT PLANTS**

**5.1 Raw-mix design**

**5.2 Quality control**

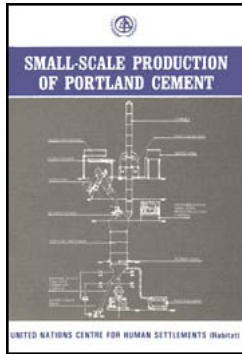

## **Small-Scale Production of Portland Cement (HABITAT, 1993, 92 p.)**

### **V. RAW-MIX DESIGN AND QUALITY CONTROL IN VSK CEMENT PLANTS**

#### **5.1 Raw-mix design**

**The chemical composition of Portland-cement clinker is made up of several oxide components of which some are desirable and others are tolerated because they are unavoidable, though unwanted. Even in the case of desirable oxides, the relative proportions have to be optimized in such a way that a trouble-free and smooth operation of the plant is ensured, production efficiency and fuel economy are maximized, the quality of the product satisfies all the requirements and at the same time the cost of production is minimized.**

##### **5.1.1 *Criteria for raw mix design***

**Based on practical experience gained over several decades and also on research investigations, the relative proportions of major constituent oxides which will facilitate**

**production and also ensure a reasonable degree of performance have been defined in moduli values;**

$$\text{Silica modulus (MS)} = \frac{\text{SiO}_2}{\text{Al}_2\text{O}_3 + \text{Fe}_2\text{O}_3} \text{ should be between 1.8 and 2.2}$$

**An increasing silica modulus impairs the burnability by reducing the liquid phase content, causes slow setting, hardening and also dusting in the kiln.**

$$\text{Alumina modulus (MA)} = \frac{\text{Al}_2\text{O}_3}{\text{Fe}_2\text{O}_3} \text{ should be between 1.2 and 1.8}$$

**The alumina modulus determines the composition of the liquid phase in clinker. The lower the ratio, the harder is the burning. A higher ratio gives rise to lumping of clinker, high heat of hydration and fast setting.**

$$\text{Lime saturation} = \frac{\text{CaO}}{2.8\text{SiO}_2 + 1.2\text{Al}_2\text{O}_3 + 0.65\text{Fe}_2\text{O}_3} \text{ should be between 0.66 and 1.02 factor (LSF)}$$

**The preferred values of LSF are in the range of 0.85 to 0.95. With LSF below the lower limit one can expect a predominance of dicalcium silicate (belite) with a lower temperature of burning, while an LSF exceeding the upper limit is expected to require a high burning zone temperature and may result in a free-lime content of more than 0.5 per cent. In other words, within prescribed limits, the higher the LSF, the better the strength of cement, but the more difficult it becomes to burn the raw mix. Conversely, the lower the LSF, the lower is the early strength of cement, but the easier it is to burn the raw mix.**

### **5.1.2 Special cement compositions**

**Small cement plants are more suitable for the manufacture of cements having special characteristics and/or modified compositions. In the case of special cements like coloured**

**clinker etc., the total demand in the market may be too small for a large cement plant to produce them on a sustained basis, but they may be a viable proposition for a small cement plant. Another distinct category is the modified cement compositions aimed at reducing the clinkering temperature and/or reducing the content of limestone in the raw mix. In the current terminology, they are called “low-energy” cements. A common feature of these cement formulations is that some of the phases present in the usual ordinary Portland cement (OPC) which are responsible for giving strength, and other desirable properties are substituted by other phases. A list of such low-energy cements is given in table 7.**

**A full discussion on the subject is beyond the scope of this report and specialist literature should be consulted. Mention is being made here to emphasise that in such cases, the raw-mix design could be different from that followed in OPC. Experience in many countries has shown that such cements are suitable for production in small cement plants, but not likely to be commercially so in large cement plants on a sustained basis.**

## **5.2 Quality control**

**There are several factors influencing the quality, quantity and the production cost of cement, and therefore, depending upon the manufacturing process and the equipment used or on the actual situations of use, specific control points are located. Data are collected at various control points at desired frequencies, analysed and corrective steps are taken to maintain consistency in, and the desired level of quality of the product.**

### **5.2.1 *Quality control at the limestone quarry***

**Feedback data should be systematically compiled for different benches and mining blocks to determine the general variation between the prospecting data and the actual quality of limestone mined. This would facilitate selective extraction from specific areas of the quarry and blending at the quarry to obtain a consistent grade of limestone. This would**

**ease the extent of controls on quality at the later stages of operation.**

### **5.2.2 Size, quantity and reduction of samples**

**The sample(s) for technological tests should be representative of the deposits. In the case of deposits showing considerable variation in quality, the bulk sample(s) should not be only representative of the various parts of the deposits, but should also represent the average materials to be mined for the plant. Hence the bulk sample should be separately prepared by mixing stones from different parts of the deposit in such a proportion that it will simulate or bear closest resemblance to the actual run-of-mine stone.**

**Table 7. Low-energy cements**

<b>Type</b>	<b>Clinkering temp. (°C)</b>	<b>Main clinkering phases<sup>a</sup></b>	<b>Raw materials</b>
Active belite	1250-1350	$\alpha$ - C <sub>2</sub> S C <sub>3</sub> S C <sub>3</sub> A C <sub>4</sub> AF	Low-grade limestone, clay, shale etc.
Belite sulpho-aluminate	1150-1250	$\beta$ - C <sub>2</sub> S C <sub>4</sub> A <sub>3</sub> S C <sub>4</sub> A <sub>3</sub> S CA. <sub>11</sub> A <sub>7</sub>	Low-grade limestone, low-grade bauxite, gypsum
Belite sulpho-ferrite	1200-1250	$\beta$ - C <sub>2</sub> S C <sub>4</sub> AF C <sub>4</sub> A <sub>3</sub> S	Limestone, gypsum laterite, iron ore

		CS	
Alinite	1100-1150	Alinite 2C <sub>4</sub> S.CaCl <sub>2</sub> C <sub>11</sub> A <sub>7</sub> .CaCl <sub>2</sub> C <sub>4</sub> AF.CaCl <sub>2</sub>	Limestone, clay, calcium chloride
Low temperature cement	900-1150	C <sub>3</sub> S.CaF <sub>2</sub> C <sub>11</sub> A <sub>7</sub> .CaF <sub>2</sub>	Limestone, clay, bauxite, CaF <sub>2</sub>

**<sup>a</sup> These are expressed in standard cement chemistry notations. For elaboration, please consult any standard document on the subject.**

**The reduction of all samples other than the bulk samples should be carried out by sequential crushing, grinding, mixing, screening and cone and quartering. Care should be taken so that the other half of the sample in each stage is retained in each case, for future reference, and that the final quarter at each stage of reduction is entirely passed through the sieve.**

**The samples for chemical analysis may vary from 2 × 2 × 2 cm to 10 × 10 × 10 cm in size and from 5 to 10 kg in quantity. Lump samples should preferably be of dimensions varying from 20 × 20 × 20 cm to 30 × 30 × 30 cm of 0.5 to 1 m long drilled cores weighing 20 to 50 kg. For different technological tests and analyses, the minimum quantity of bulk samples required to be tested will depend on the diameter of the largest particle and degree of heterogeneity.**

### **5.2.3 Details of analyses and tests**

**Technological assessment of limestone should consist of the following tests and analyses:**

- (a) Mineralogical and petrographic analysis**
- (b) Physio-mechanical tests**
- (c) Chemical analysis**

#### **5.2.4 Fuel**

**Two kinds of analyses are in use for the classification of fuel:**





**(a) *Proximate analysis.* This involves quantitative determination of moisture, volatile matter, fixed carbon and ash.**

**(b) *Ultimate analysis.* This is for the exact calculation of combustion processes and involves quantitative determination of the constituents such as moisture, carbon, hydrogen, sulphur, oxygen and nitrogen.**

**The calorific value is the most important property of fuels, i.e., the quantity of heat generated during combustion from unit weight of fuel.**



**[Home](#)''' '''''''> [ar.cn.de.en.es.fr.id.it.ph.po.ru.sw](#)**

-  **Small-Scale Production of Portland Cement (HABITAT, 1993, 92 p.)**
- ➔  **VI. SYSTEM DESIGN AND SELECTION OF PLANT AND MACHINERY**
  -  **6.1 System design**
  -  **6.2 Equipment selection criteria**
  -  **6.3 Plant lay-out - EOT grabbing crane system vs tunnel systems for material handling**

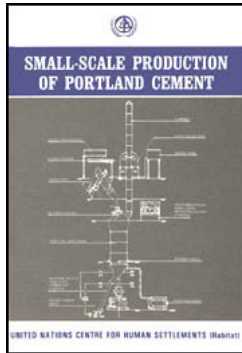

## **Small-Scale Production of Portland Cement (HABITAT, 1993, 92 p.)**

### **VI. SYSTEM DESIGN AND SELECTION OF PLANT AND MACHINERY**

#### **6.1 System design**

**The work of system design deals with the careful and detailed planning of production equipment arrangement. The scope of system design work in a VSK cement plant includes a study of such areas as transport, receiving, storage, production, packaging, material handling, unit operation required for the process, warehousing, external facilities, buildings, maintenance and safety. The work of designing a system usually starts with the analysis of the product to be made and a consideration of the overall flow of material. It progresses, step by step, through the detailed planning of the arrangement of the equipment for each individual unit operation.**

**The basic objectives of good systems design are, to:**

**(a) Facilitate the manufacturing process;**



- (b) Minimize material handling;**
- (c) Maintain flexibility of arrangement and of operation;**
- (d) Maintain high turnover of work;**
- (e) Minimize investment on equipment;**
- (f) Make economical use of plant space;**
- (g) Promote effective utilization of the workforce; and**
- (h) Provide employee convenience, safety and comfort in doing the work.**

## **6.2 Equipment selection criteria**

**The equipment selected should possess certain desirable characteristics or meet certain criteria to be best suited to the desired task. Some of these criteria are:**

- (a) Fit into the system;**
- (b) Be as simple as possible;**
- (c) Require minimum space;**
- (d) Be flexible and adaptable;**
- (e) Require minimum of loading, unloading and rehandling;**
- (f) Call for as little maintenance, repair, power and fuel as possible;**
- (g) Have a long useful life;**
- (h) Capable of higher capacity utilization;**
- (i) Perform the operation efficiently and economically.**

**The underlying selection criteria for various types of equipment in a small cement plant are given below.**

### **6.2.1 Mining equipment**

**In small cement plants not much equipment is recommended for the quarrying operations, but to facilitate the operation, jack hammers, up to a maximum number of four, may be**

**employed for plants of a capacity ranging from 50 to 200 tpd. Obviously, a compressor will also be needed.**

### ***6.2.2 Crushing equipment***

**The crushing department has to reduce the limestone from a size 300-350 mm to less than 15 mm. Generally, for small cement plants, the crushing section consists of either a single-stage or a double-stage operation. A single-stage operation generally consists of a hammer mill/impacter. In the case of a two-stage crushing, generally a jaw crusher is followed by a hammer mill. Double-stage crushing is normally adopted for plants of 100 tpd and above.**

**There are other types of crushers also used in the cement industry, viz., gyratory crushers, cone crusher and roll crusher, which have not yet found their application in small cement plants.**

### ***6.2.3 Proportioning of raw mix***

**Small plants may use weigh batching of individual components and then pre-mixing before grinding, whereas other plants may use appropriately designed table feeders or vibratory feeders. Where high sophistication is possible, weigh belt feeders can be used.**

### ***6.2.4 Raw-mix grinding***

**Since the clinkering process requires a raw meal, which is ground to a fineness of about 10 per cent retained on 170 mesh sieves, it is generally preferable to grind the raw mix in a closed-circuit system for efficient control. Generally, the clay and coke-breeze components will have moisture, so it is preferable to use an air-swept ball-mill system with a drying compartment or a vertical roller mill. For dry raw materials a closed-circuit ball mill with a bucket elevator and mechanical separator can be selected. A small air-**

**swept ball-mill system can be selected in case moisture exists only for short periods in the rainy season.**

### ***6.2.5 Homogenization of raw meal***

**The capacities of homogenizing silos are normally selected based on 3-4 hours of mill operation or higher. Blending is done pneumatically in a silo in batches. A batch requires nearly an hour of aeration to homogenize completely. Relatively smaller plants may use a single-blending silo on top of a storage silo whereas the others may use two blending silos on top of one or two storage silos. Relatively larger plants of more sophisticated construction may use a single blending-cum-storage silo with a continuous-blending operation.**

### ***6.2.6 Nodulization***

**Since the vertical-shaft kiln requires a nodulized feed, it is necessary to obtain nodules of required strength, porosity, size and thermal stability. To obtain these, a pan-type nodulizer is employed. It is important that the raw materials selected have good plasticity and amenability to nodulization.**

### ***6.2.7 Vertical-shaft kiln***

**The raw meal in the form of nodules is charged into the vertical-shaft kiln with the help of a rotating feeder situated on the top of the kiln. The combustion air supplied under pressure from the roots blower ascends from below into the cooling zone. The entire kiln charge composed of unburnt nodules and clinker rests on a flat/conical-flat grate (see figure 7) at the bottom of the kiln. The grate is driven by a variable-speed motor directly through a gearbox and king shaft. The rotary grate causes the entire charge in the VSK to move downwards and helps in cutting any lump of clinker formed during the process. The clinker is finally taken out of the kiln bottom with the help of a triple air-lock discharge**

**gate or a material block-tube arrangement depending upon the size of VSK.**

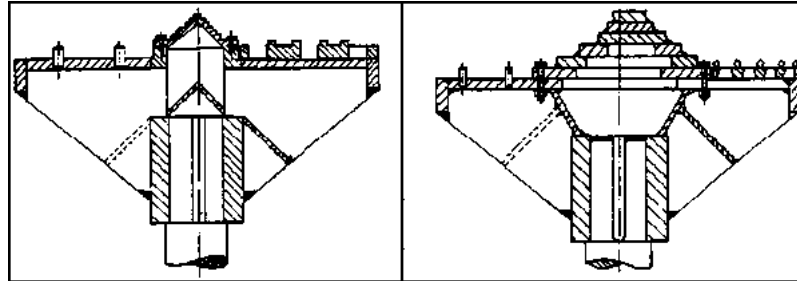

**Figure 7. Rotary grate (flat); Rotary grate (conical-flat)**

### **6.2.8. Finish grinding**

**To obtain better setting properties it is desirable that the granulometry of cement is in a wide range with more fines. Keeping this requirement in mind, generally the open-circuit tube-ball grinding mill with two/three compartments or two-compartment ball mills with a mechanical air separator should be chosen. Between the above two, an open-circuit mechanical air-separator mill requires more auxiliary equipment and space but requires less power per ton of cement ground.**

### **6.3 Plant lay-out - EOT grabbing crane system vs tunnel systems for material handling**

**A plant layout comprised of a large bulk-material storage yard with an EOT grabbing crane is found very suitable for medium- and large-capacity VSK plants. This system permits the plant operators to handle with the help of a single crane practically all the raw materials and clinker with maximum flexibility of operation. The operator may simultaneously transfer and homogenize limestone, and similarly homogenize or blend clinker. The storage hall provides storage of large quantities of raw materials and clinker under a**

**covered shed, thus protecting it from rain and wind. The system further facilitates further expansion or extension of the plant.**

**Another system which may be adopted in small cement plants of relatively lower capacities employs the storage of various raw materials on the ground floor under a shed, their extraction through suitable feeders in a tunnel and an inclined belt conveyor to convey these raw materials to the grinding mill. Raw materials and clinker are handled manually, or a front-end loader could be used. In this system maintenance costs are saved but at the expense of the multiplicity of the functions possible with the grabbing crane.**



[Home](#) > [ar.cn.de.en.es.fr.id.it.ph.po.ru.sw](#)

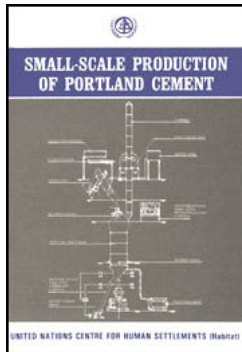

 **Small-Scale Production of Portland Cement (HABITAT, 1993, 92 p.)**

➔ **VII. PLANT DESCRIPTION**

 **(introduction...)**

 **7.1 Plant flow-sheet**

 **7.2 Instrumentation and process control**

**Small-Scale Production of Portland Cement (HABITAT, 1993, 92 p.)**

**VII. PLANT DESCRIPTION**

**A small cement plant essentially consists of the following important sections/units:**

- (a) Raw-materials storage and crushing unit;**
- (b) Raw-mix proportioning and grinding unit;**
- (c) Raw-meal blending and storage section;**
- (d) Clinkerization unit;**
- (e) Cement-grinding unit;**
- (f) Cement storage, packing and handling section;**
- (g) Power supply unit;**
- (h) Ancillaries and services section.**

## **7.1 Plant flow-sheet**

**In order to have a better understanding of the entire plant, the plant flow-sheet has been described in detail in the following paragraphs. The process flow-sheet has already been shown in figure 5 for a plant based on black-meal VSK technology. That clearly indicated the various unit operations involved in the manufacture of cement at the proposed plant. The following brief description of the plant will help in understanding the flow-sheet.**

### ***7.1.1 Raw materials storage and crushing unit***

**Limestone from the quarry is transported by means of trucks and is stored in the storage hopper. Limestone is conveyed by a reciprocating/apron feeder to the crusher, where the size is reduced from 300-350 mm to 15 mm. The crushed limestone is then transported by belt conveyor to the storage yard. Clay, coke-breeze and additives are directly unloaded/stored in the storage yard.**

### ***7.1.2 Raw-mix proportioning and grinding unit***

**Below each hopper, feeders are installed which feed these raw materials in the required**

**proportion to the raw-mix grinding mill though a belt conveyor and bucket elevator. A ball-mill working on a closed-circuit system is used for the grinding of the raw mix to the desired fineness of about 10 per cent retained on 170 mesh or 90 micron size sieve. The mill circuit includes the appropriate de-dusting arrangement, viz., cyclones and bag filters.**

**The ground raw meal is then transported to the blending silos by a combination of screw conveyor air lift/bucket elevator and air slide.**

### ***7.1.3 Raw-meal blending and storage***

**Differential pneumatic blending is carried out in blending silos and the blended raw meal is stored in storage silos. The blending unit is also provided with bag filters to ensure a dust-free environment.**

### ***7.1.4 Clinkerization unit***

**The raw meal from the storage silo is extracted by a rotary vane feeder and transported to the raw-meal hopper fitted with an overflow screw conveyor. The raw-meal feed rate to the nodulizer is controlled by a dynodrive. The quantity of water supplied to the nodulizer of each kiln is also controlled. Nodules from each of the nodulizers are fed into the vertical-shaft kiln through a chute.**

**A rotary feeder distributes the nodules uniformly over the entire cross-section of the FIRE bed in the kiln. These nodules then travel downwards in the kiln and undergo various reactions such as drying, calcining, sintering and cooling and converted into clinker. The combustion air is supplied by a roots blower. The hot exhaust gases escape through the chimney. Clinkers cut by the rotary grate are discharged through a material block tube (MBT) and are transported to the clinker storage yard.**

### ***7.1.5 Cement-grinding unit***

**Clinker and gypsum are transported to the respective storage hoppers. Table feeders installed below the clinker and gypsum hoppers control the feed rate to the cement grinding mill, which is an open circuit three-compartment tube mill. The ground cement is transported to the cement silo by means of a screw conveyor and an air lift/bucket elevator.**

### **7.1.6 Cement storage, packing and transport**

**The final product is stored in a storage silo through an air slide/screw conveyor provided on top of the cement silo. The cement is extracted from this silo through a rotary feeder and after passing through a rotary screen is finally packed in bags by a single-spout cement packing machine. The packed cement bags can be transported by belt conveyor for direct loading on to trucks. The spill-over cement is collected in a hopper and is recycled through a screw conveyor to the air lift.**

### **7.2 Instrumentation and process control**

**In order to ensure the safety of the equipment as well as to ensure the quality of the finished product and operation efficiency, necessary instrumentation and control systems have been incorporated in a number of vertical-shaft kilns. The locations of the temperature and pressure measuring instruments in a CRI-MVSK are shown in figure 8 as a typical example. Necessary interlocking for the equipment has been provided.**





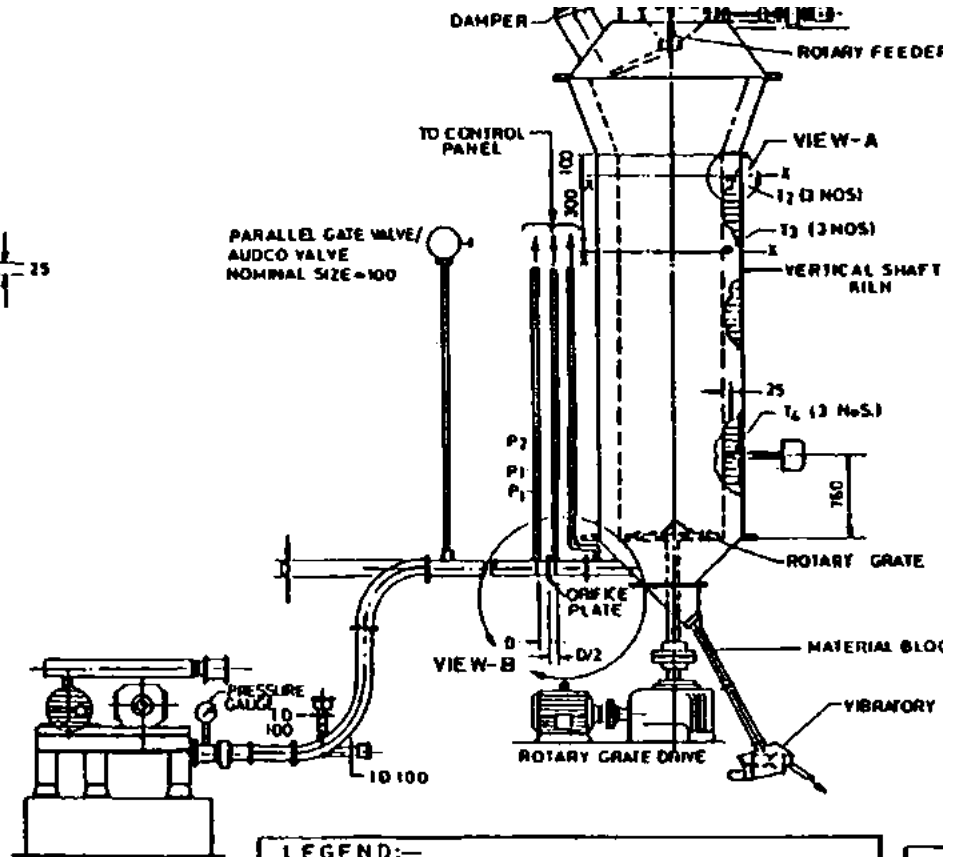
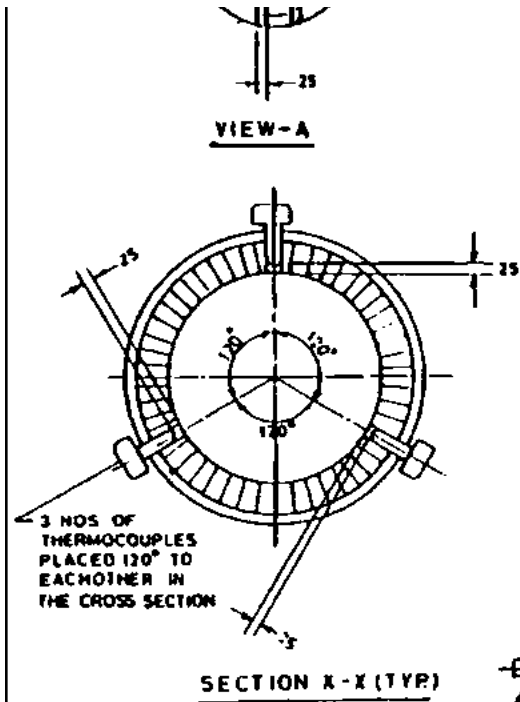

**LEGEND:-**

P<sub>1</sub> - DIFFERENTIAL PRESSURE ACROSS ORIFICE PLATE

P<sub>2</sub> - INLET AIR DELIVERY PRESSURE

T<sub>1</sub> - IRON CONSTANTAN THERMOCOUPLE

N1
L0
N1



**Figure 8. Locations of temperature and pressure measuring instruments in CRI-MVSK**

