







































→  **Production Guide - Fibre or Micro Concrete Tiles (SKAT, 1992, 67 p.)**

-  **(introduction...)**
-  **Preface**
  -  **(introduction...)**
  -  **Acknowledgment**
-  **1. Introduction**
-  **2. Raw materials**
  -  **(introduction...)**
  -  **Cement**
  -  **Sand and aggregate**
  -  **Fibre**
  -  **Water**
  -  **Colorant**
  -  **Fixing device**
-  **3. Production process**
  -  **(introduction...)**
  -  **Mortar preparation**
  -  **Vibrating and molding**
  -  **Mold curing**
  -  **Demolding**

-  **Tank curing**
-  **Air curing, storage**
-  **Transport**
-  **4. End control**
-  **5. Maintenance of the equipment**
  -  *(introduction...)*
  -  **The battery**
  -  **Vibrating device and tools**
  -  **Molds and plastic interface sheets**
  -  **The scale**
  -  **The workshop**
-  **6. Further reading**
-  **Annex: Reporting format**

[Home](#) > [ar](#).[cn](#).[de](#).[en](#).[es](#).[fr](#).[id](#).[it](#).[ph](#).[po](#).[ru](#).[sw](#)

-  **Production Guide - Fibre or Micro Concrete Tiles (SKAT, 1992, 67 p.)**
  -   *(introduction...)*
  -  **Preface**
  -  **1. Introduction**
  -  **2. Raw materials**
  -  **3. Production process**

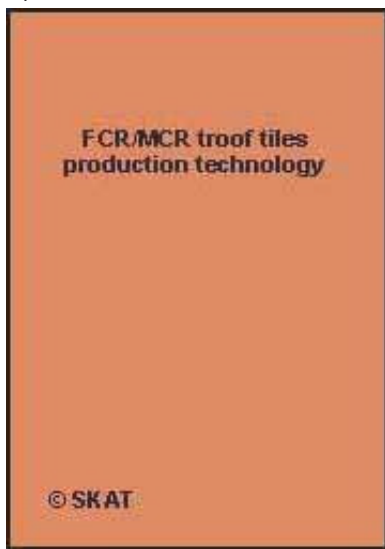

- 4. End control**
- 5. Maintenance of the equipment**
- 6. Further reading**
- Annex: Reporting format**

## Fibre and Micro Concrete Tiles

**Swiss Centre for Development Cooperation in Technology and Management  
International Labour Office**

**June 1992**



[Home](#) > [ar](#) [cn](#) [de](#) [en](#) [es](#) [fr](#) [id](#) [it](#) [ph](#) [po](#) [ru](#) [sw](#)

 **Production Guide - Fibre or Micro Concrete Tiles (SKAT, 1992, 67 p.)**



**Preface**



*(introduction...)*



**Acknowledgment**

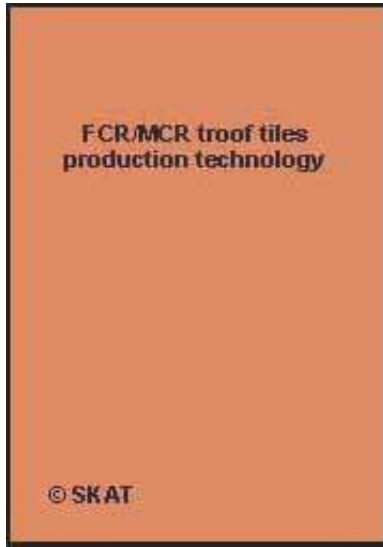

## **Production Guide - Fibre or Micro Concrete Tiles (SKAT, 1992, 67 p.)**

### **Preface**

#### **The history of FCR/MCR**

**The FCR/MCR-technology was developed in the 1970s based upon generations of experience of concrete tiles and asbestos cement sheets. During the 1980s it has found applications in many countries all over the world. Today the technology is at a mature stage and the experience of the technology has shown that it offers a reliable roofing material that can compete with most of the conventional roofing materials.**

#### **The roles of BASIN, SKAT and ILO**

#### **BASIN**

**BASIN (Building Advisory Service and Information Network) is a coordinated network of experienced international professionals, set up to provide qualified advice and information in the field of building materials and construction technologies.**

**The activities of BASIN are divided between four leading European, non-profit appropriate technology organizations (GTZ/GATE Germany, ITDG England, SKAT Switzerland, CRATerre France), each of which covers a separate specialized subject area, in order to provide more qualified expertise with greater efficiency.**

## **SKAT**

**SKAT is an information and documentation center and a consultancy group engaged in promoting and implementing Appropriate Technology for partner countries world-wide.**

**Among the BASIN partners, SKAT is specialized in roofing, and in this field is especially familiar with the FCR/MCR technology. Within BASIN, SKAT established the Roofing Advisory Service (RAS). With the commitment to facilitate the promotion and dissemination of the FCR/MCR roofing technology, SKAT/RAS is producing the "FCR/MCR Toolkit" series of which this "Production Guide" is one element.**

## **ILO**

**A programme for the promotion of building technology for low-cost housing is currently implemented by the ILO Entrepreneurship and Management Development Branch in Africa and Asia. The objective of this programme is to**

**promote the development, dissemination and application of building techniques suitable for low-cost construction in developing countries with a view maximising the use of locally available raw materials, and generating productive employment. This programme is funded by the SDC, and is implemented in close collaboration with SKAT.**

## **Network of specialists**

**A world-wide network of specialists and of specialized institutions provides technical support to new and already established producers of FCR/MCR. This helps to ensure reliability and quality of the products in this growing market.**

**This FCR/MCR network of specialists is coordinated by the Roofing Advisory Service (RAS) of SKAT.**

## **The FCR/MCR Toolkit**

**The guide in hand is part of the FCR/MCR Toolkit. This kit imparts the entire know-how that is required in the field of the FCR/MCR-technology, covering the technical aspects as well as the economic, organizational, management and marketing aspects. The toolkit-diagram (see front page) shows the structure of its contents.**

**The kit is now (1992) at its development stage. Many elements are already available, other elements exist in a draft version or at least in an outline.**

## **Contact address**

**This literature, as well as further information, is available from:**

**Roofing Advisory Service, c/o SKAT**

**Tigerbergstrasse 2**

**CH-9000 St. Gallen**

**Switzerland**

**Phone 071 / 30 25 85**

**and**

**ILO INSTEAD**

**Route des Morillons 4**

**CH-1211 Geneve**

**Switzerland**

**Phone 022 / 7996111**

## **Acknowledgment**

**We would like to thank all the experts, technicians and producers who helped us with their valuable comments and remarks based on their wide experience.**

**The following groups and persons contributed to this publication:**

- **Development Alternatives, New Delhi, India**
- **Development & Consulting Services, Butwal, Nepal**
- **Harder Luzius, Luzern, Switzerland**
- **Mateco SA, Miaflores , Lima, Peru**
- **J.P.M. Parry & Associates Ltd., Cradley Heath, U.K.**
- **Sofonias, Rhyner Kurt, Ennenda, Switzerland**

## • Twigt FredJan, Bergen aan Zee, Netherlands

[Home](#) > [ar](#).[cn](#).[de](#).[en](#).[es](#).[fr](#).[id](#).[it](#).[ph](#).[po](#).[ru](#).[sw](#)

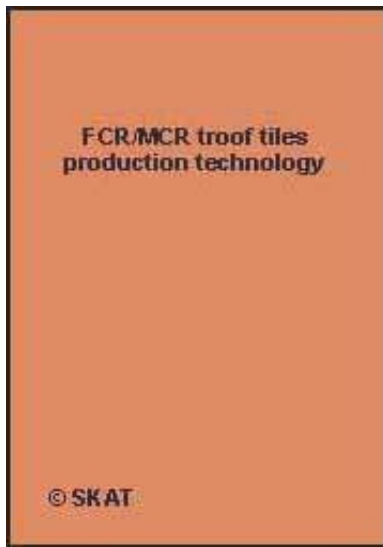

### **Production Guide - Fibre or Micro Concrete Tiles (SKAT, 1992, 67 p.)**

 **(introduction...)**

 **Preface**

 **1. Introduction**

 **2. Raw materials**

 **3. Production process**

 **4. End control**

 **5. Maintenance of the equipment**

 **6. Further reading**

 **Annex: Reporting format**

## 1. Introduction

### What are FCR and MCR

**FCR (Fibre Concrete Roofing) is a new roof covering technology. It consists of concrete tiles made of cement mortar mixed with a small amount of natural or synthetic fibre.**



**In the case of MCR (Micro Concrete Roofing) fine aggregate is used instead of fibre.**

**For further basic information please refer to “The Basics of Concrete Roofing Elements”.**

### **The advantages of FCR and MCR**

**The technology provides an inexpensive and reliable roof cladding and suits especially the needs of developing countries. The main advantages are:**

- **The raw materials are available locally and thus foreign exchange is saved.**
- **The appropriate technology that is involved allows for decentralized and small scale production.**
- **The technology involves little investment.**
- **The production is labour intensive rather than capital-intensive, thus it creates jobs.**
- **During sun radiation, compared to metal sheeting, rooms covered with FCR/MCR remain cooler because of better thermal insulation and ventilation.**
- **During rain, compared to metal sheeting, FCR/MCR produces much less noise.**
- **The product is environmentally well adapted.**
- **The technology is easy to learn.**

## **The drawbacks of FCR/MCR**

**The durability of FCR/MCR is basically as good as for ordinary concrete tiles, which have shown service lives exceeding 50 years. However, lower strength of the material compared to modern concrete tiles and AC-sheets was sometimes achieved because of the small production units involving a risk of bigger variations in quality and because of the lack of standards.**

## **Objectives of the guide**

**The roof constitutes the most important part of a building and special care has to be taken in preparing the roof and the roofing elements. The best available raw materials should be used and throughout the production process it should be kept in mind that a bad quality roofing product will not only result in a failing roof but may also lead to severe damage to the whole building.**

**To promote the FCR/MCR technology a high and constant quality is required. This is not only needed to gain and maintain a reputable product but also because misinvestments can not be afforded. Therefore, adequate technology transfer and comprehensive dissemination of know-how are important tools in the production process of FCR/MCR.**

**This guide is compiled to facilitate advisory centers to transfer this know-how systematically, and to help producers to achieve a high standard product. The chances of improved production on a broad basis are then increased, benefiting from the well established technological know-how that exists.**

## **What can you find in this guide:**

**The guide provides detailed technical guidelines for daily use in the workshop, the rules and hints how to produce FCR/MCR tiles.**

**What can you NOT find in this guide:**

**The guide is intended for persons who already know the basics of FCR/MCR or even are producing FCR/MCR elements.**

**As a consequence, it does not contain**

- **the basic information required for new-comers such as advantages and disadvantages, and guidelines to be considered as first steps towards FCR/MCR.**

**It also does not contain**

- **information on production management**
- **specifications of cost and profit**
- **information about particular problems in particular countries**
- **guidelines for quality control and the required tests**

**If you are interested in basic information we suggest to read the following booklet:**

**“The Basics of Concrete Roofing Elements”. Fundamental Information on the Micro Concrete Roofing (MCR) and the Fibre Concrete Roofing (FCR) Technology for Newcomers, Decisionmakers, Technicians, Field Workers and all those who want to know more about MCR and FCR. (available at SKAT free of charge in English, French and Spanish).**

**If you are interested in scientific explanation and justification for specific recommendations we suggest to read the Technical Memorandum No 16: "Fibre or Micro Concrete Tiles, Production Process and Roof Laying" (available at ILO in English and French).**

**The guide is not designed as an instrument for self teaching. For a successful work many additional hints and tricks are needed that can only be acquired with a comprehensive training.**

**Other elements of the FCR/MCR Toolkit as well as further information are available from SKAT or ILO.**

### **Testing the quality**

**All along the process of producing tiles, a quality control process should be applied. For this purpose a separate "tool" has been published in this serie: "Quality Control Guidelines, Toolkit Element 23". In this manual a comprehensive methodology is proposed and described, including quality control on raw material, production process, and the end product. There is a sound complementary between both manuals.**

### **Managing the production**

**This guide describes the production of the tiles step by step. The reality in the production process, however, is much more complex. Many steps are carried out simultaneously, in sequences or in cycles that may be interlinked or overlap. How this production process can be organized is described in the Production Management Guide, element 21 of the Toolkit.**

**The Production Management Guide uses the same numbering system used also in the Production Guide and also in the Quality Control Guidelines. This eases the use of these three elements side by side.**

## **General remarks**

### **Validity of the data:**

**The rules and data presented in this guide are based on scientific laboratory research and long standing practical experiences by international technology specialists, and represent a general average. Data such as the mix to be used, compaction and curing time etc. may vary slightly from place to place, depending on the raw material properties and other local factors. Experience in a particular country will provide the exact data that are to be applied.**

### **Range of products:**

**The process described in this guide is basically designed for the production of tiles, both the Roman type and the Pan type. By adapting the rules analogously, the same method can, however, also be applied for the production of semi-sheets and the various fittings which are required for different roofs types.**

### **Responsibility:**

**The sole responsibility that the rules are implemented correctly should lie with one person (i.e. the head of the workshop). He should also make records and keep them for at least five years.**

## **Comments**

**Comments and feedback information are welcome and will help to further improve this guide and with it the technology. They may be sent to SKAT or ILO.**

[Home](#) > [ar](#).[cn](#).[de](#).[en](#).[es](#).[fr](#).[id](#).[it](#).[ph](#).[po](#).[ru](#).[sw](#)

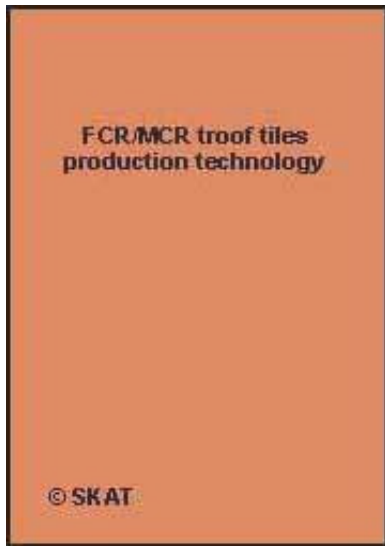

 **Production Guide - Fibre or Micro Concrete Tiles (SKAT, 1992, 67 p.)**



**2. Raw materials**



*(introduction...)*



**Cement**



**Sand and aggregate**



**Fibre**



**Water**



**Colorant**



**Fixing device**

**Production Guide - Fibre or Micro Concrete Tiles (SKAT, 1992, 67 p.)**

**2. Raw materials**

**The use of good quality raw material is vital for the quality of the end product.**

**The basic raw materials required for the production are:**

**2.1 Cement****2.2 Sand and aggregate****2.3 Fibre****2.4 Water****2.5 Colorant****2.6 Fixing device****Cement****Rule A Type and Quality**

**Ordinary Portland cement is used for the production of FCR and MCR. In order to achieve the required result in strength and durability, it is essential that the quality measures up to the standard required for normal concrete work.**

**Rule B Pozzolanic Additives**

**In some cases the use of pozzolanic additives may be taken into consideration. However, the setting and the strength development may be slower.**

**To prove its suitability the tiles should pass the tests described in the quality control guidelines.**

**It may be possible to mix the cement with a certain amount (up to 20 - 25 %) of pozzolanic additives. Tests will prove its feasibility.**

**Rule C Store Cement Dry**

**Moisture destroys cement, therefore it must be stored dry. If the cement contains**

**lumps it is a clear sign that it has been exposed to moisture.**

**A storing place with a safe roof and good ventilation is required. It is recommended to use a separate store room in the workshop.**

**To avoid rising dampness do not store the cement directly on the floor but e.g. on timber pallets.**

**Avoid contact of the cement bags with outer walls and floor. It could be a source of moisture and prevents proper ventilation.**

**The cement stack should not be more than 10 bags high.**

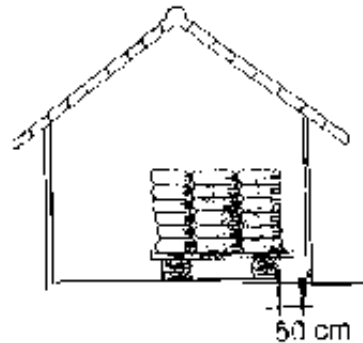

**Good; Storing on timber pallets and no contact with outer walls**

### **Rule D Storing Period**

**Keep cement not longer than 1 month. This is especially important in humid climates.**

**Make sure that the older stock is used up before the new one.**



**In no case old and already set cement shall be used.**

**To be sure about the age of the cement it is advisable to buy the cement directly from the producer, with printed dates on the bags.**



**Wrong:**  
Storing directly on the floor  
and on the outer wall



**Good**  
Finish old stock before new or



**Wrong:**  
Part of the stock gets too old  
if only new stock is used

**Rule C wrong, rule D**

## **Rule E Cements with Defects**

**If the cement has lumps, the bags are hard or if its quality is questioned in any way, it should not be used.**

**Cement with lumps may still contain some quantities which can be used. In this case it should be sieved through a 0.5 mm sieve and used together with good quality cement (see Quality Control Guidelines).**

## **Rule F Special Additives**

**Special additives may increase the workability, accelerate the setting or lower the water/cement ratio. Such material should only be used if it does not effect the strength of the tiles. They usually add significantly to the price of the tiles.**

**Remark Keep strict control over the cement stock by a proper stock record (Reporting Format "Cement" in Quality Control Guidelines).**

## **Sand and aggregate**

### **Rule A Silicious Origin**

**The sand and aggregate shall be of siliceous origin or have similar characteristics. It should not contain minerals which may react chemically with the cement.**

**If the properties of the material is not known, it shall first be tested by a laboratory.**

### **Rule B Grading of Material for FCR**

**Where fibre is used for the production of the tiles only sand and no aggregate is used.**

Product thickness		6 - 12 mm
Maximum grain size		2 - 3 mm
Component above	2 mm	0 - 10 %
Component	0.5 - 2 mm	35 - 75 %
Component below	0.5 mm	25 - 55 %

### **Rule C Grading of Material for MCR**

**If the tiles are produced without fibre (MCR) a defined quantity of fine aggregate is used. The following ratio is recommended:**

Product thickness		6 mm	8 mm	10 mm
Maximum grain size		4 mm	5.5 mm	7 mm
Component above	2 mm	25 - 45%	30 - 50 %	35 - 55 %
Component	0.5 - 2 mm	20 - 50 %	15 - 40 %	15 - 40 %
Component below	0.5 mm	15 - 45 %	15 - 40 %	15 - 40 %

**No single piece should exceed the tile thickness minus 1 mm.**

### **Rule D Grading and Cleanness**

**Sand and aggregate should be well graded, clean and free of organic material.**

**The clay and silt content should normally not exceed 4 %.  
(See also: Quality Control Guidelines, grading test)**

### **Rule E Porous Material**

**If the sand or aggregate is porous, more water and cement is required. The water / cement ratio should remain unchanged.**

### **Rule F Protection from Rain**

**Protect the sand and aggregate stock from rain, because the moisture content should not vary during the production period.**

**Increased or decreased moisture would change the water / cement ratio of the mix.**

**Also the cement / sand ratio would be changed, because the volume of the sand changes (honey-comb effect).**

### **Rule G Sieving and Separation**

**Before sand is taken to the deposit it should be sieved.**

**The fine aggregate used for MCR is kept in a separate deposit.**



**Only sieved sand to be stored**

## **Remark**

**The rules and the range of possible grading given above shall be understood as general guidelines. Test results of different proportions will tell the producer the best grading for his material.**

## **Fibre**

### **Remarks**

#### **Advantages of Fibre**

**The chopped fibre plays its main role in giving a better cohesion of the fresh mix making the moulding process easier, it reduces the danger of cracks during moulding.**

**In case of damage on the roof, fibre prevents tiles from falling into pieces.**

#### **Disadvantages**

**The use of fibres adds to the cost and involves more labor.**

**Careless workmanship bears the risk of lumps that cause leaking.**

#### **Production Without Fibre:**

**Research and production has shown that this type of tiles can also be produced without fibres (MCR). This technology requires more care in the selection of raw materials (e.g. grading of sand and aggregate). However the quality of MCR is compatible to that of FCR.**

## **Rule A Type and Quality of Fibre**

**Many types of natural or synthetic fibre can be used in concrete roofing elements as long as they are clean.**

**Coconut husk fibre, stem fibre as for example jute or leaf fibre such as sisal are the most common examples which have been used so far.**

**The fibres should not contain loose particles, soft pith etc. and should be well separated. This can be checked visually.**

### **Rule B Size of Fibre**

**The length of the cut fibres should be between 15 and 25 mm, with 20 mm in average. No single piece should be longer than 30 mm.**

### **Water**

#### **Remarks**

**The quality of the tiles depends also on the quality of the water used for the mix. Dirty and chemically contaminated water may have a negative effect on the setting process and on the strength.**

**A reliable water supply is essential. Where shortages occur, a water tank must be installed.**

#### **Rule A Kind of Water**

**Water should be clean and fresh, preferably standard potable water.**

## **Rule B Salt Content**

**If black iron wire (not galvanized) is cast into the tile as fixing device, the water must not contain salt.**

**(If the iron parts are galvanized, salty water up to max 4 % by weight, e.g. sea water, may be used.**

## **Rule C Control**

**At the workshop the water can be controlled visually. It should have clear appearance.**

**In the laboratory it can be tested for salt content and other chemical contamination.**

## **Rule D Testing**

**If the water quality is questionable, it can be tested by comparing the setting time and strength properties of a tile produced with potable water and a tile produced with the water in question. The results should be the same.**

## **Colorant**

## **Remarks**

## **Advantages**

**Tiles without added colorant are of grey color, darker or lighter. To achieve a more**

**appealing product they may be colored. Color may be a sales argument. Bright color increases the reflection of solar radiation and thus improves the thermal performance.**

### **Rule A Colorant Added to the Mix**

**The most commonly used additive is red oxide (iron oxide). Use high quality synthetic grade at the rate of 3 - 10 % of the cement by weight, depending on the type of the color.**

**White cement may also be used to achieve a bright color. However, in many cases this material may be prohibitively expensive.**

### **Rule B Colorant Applied as Paint**

**Ordinary gray tiles may be painted after the water curing process with color. This color consists preferably of colorant powder mixed with cement and water to a paste that is applied with a brush. The cement brings about a good cohesion of the paint. The color should not contain any plastics (Latex etc.) and should be based solely on silicates. Otherwise it will peel off with time.**

**Under certain climatic conditions it is advantageous to coat the roofs by whitewashing it with a lime paste at the beginning of the hot and dry season. The effect is a better solar radiation reflectivity. During the rainy season and the following cooler season the tiles turn grey, thus absorbing more heat. This is a cheap and labor intensive method suitable to a climate where cooling is desired during a certain season only. In cases where drinking water is collected from the roof, this method should not be applied.**



## **Fixing device**

### **Rule A Recommended Types**

**The following types of fixing devices are recommended:**

- **Galvanized steel wire of diameter of at least 0.9 mm. If the galvanization is of poor quality the diameter should be larger.**
- **Black wire may be used where galvanized wire is not available. The diameter should then be more than 2 mm to guarantee a reasonable life span.**
- **Copper wire (or other non-ferrous wire of a metal that is compatible with concrete) of diameter at least 1.2 mm.**
- **Stainless steel wire of diameter at least 0.9 mm.**
- **String of a material that does not rot (synthetic, e.g. nylon etc.).**

**The wire should be flexible enough to be twisted by hand without breaking.**

### **Rule B Avoid Organic Materials**

**No organic strings of jute, hemp and the like shall be used because of rotting.**

### **Rule C Preparation of Holes**

**In case holes are required, drilling should not be practiced on the dry tile. It bears the risk of hair cracks that are a source of damages in a later stage. Holes must be**

**prepared in a fresh state, during the casting process.**

## **Rule D Avoid Nail Fixing**

**Fixing by nails or screws through a hole in the surface of the tile should not be practiced. It bears the risk of cracks and leakage. Instead, put a wire through the hole and fix the wire with a nail or screw.**



[Home](#) > [ar.cn.de.en.es.fr.id.it.ph.po.ru.sw](#)

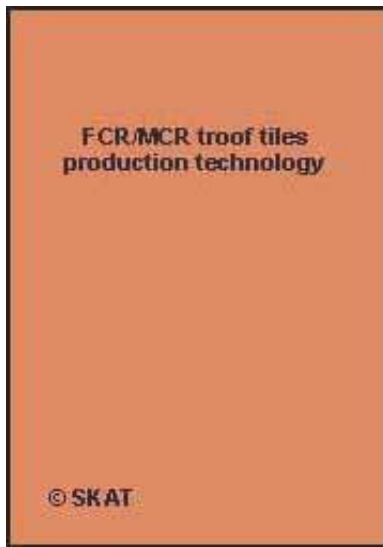

### **Production Guide - Fibre or Micro Concrete Tiles (SKAT, 1992, 67 p.)**



#### **3. Production process**

 **(introduction...)**

 **Mortar preparation**

 **Vibrating and molding**

 **Mold curing**

 **Demolding**

 **Tank curing**

 **Air curing, storage**

 **Transport**

**Production Guide - Fibre or Micro Concrete Tiles (SKAT, 1992, 67 p.)**

### **3. Production process**

**Besides the quality of the raw materials, a careful production procedure is the other important guarantee for a product of a high standard.**

**The steps of the production process are:**

**3.1 Mortar preparation**

**3.2 Vibrating and molding**

**3.3 Mold curing**

**3.4 Demolding**

**3.5 Tank curing (in water tanks or vapor atmosphere)**

**3.6 Air curing, storage**

**3.7 Transport**

**Mortar preparation**

**Proportion of Components**

**The proportion of cement, sand, water and fibre or fine aggregate in a mix is based on the properties of the actual raw materials and can vary from place to place. It should be defined during the prototype production and again when the properties of the raw materials change.**

**Cement / Sand / Aggregate Ratio**

**For FCR, the cement to sand ratio is normally between 1:2 and 1:3. For MCR, the cement to sand to aggregate ratio is around 1:2:1. The proportions are measured**

## **by volume.**

**Too much cement results in fine cracks in the tile and also in high costs. Too little cement results in a weak and porous product.**

## **Ratio of Fibre**

**The ratio of fibre is usually between 0.3 and 1.2 % of the wet mortar by weight. Too much fibre results in a low strength and high porosity. Omitting fibre may result in cracks during molding.**

## **Workability**

**A good workability of the mix is important so as to obtain a good production result. The following indicators show if the right workability has been chosen:**

	A practical instant method is to squeeze the mortar by hand. No water drops should come out and the mortar should not crumble.
	Water appearing on the surface after a short vibration period is a clear sign that too much water is being used.
	An easy test to maintain the correct ratio is the workability test (see Quality Control Guidelines).

## **Water / Cement Ratio**

**The water to cement ratio of the mortar (as well as curing, especially during the first 24 hours before demolding) is a major factor governing tile quality.**

**The correct ratio:**

**A good quality mix has a water to cement ratio of 0.5 by weight (1 l water = 1 kg) and results in a mortar which hardens in the correct time, is easy to demold and does not have to be cured in water for more than 5 to 7 days.**

**The strength and watertightness of FCR/MCR products are sufficient if the water to cement ratio is below 0.65, but the risk of breakages during demolding is greater and longer water curing times may be required compared to products made of mortar with a water to cement ratio of 0.5.**

**A water to cement ratio higher than 0.65 will result in low quality products, and if the water to cement ratio of the mortar exceeds 0.7, the watertightness and durability of the FCR/MCR products are not ensured. Products with a water to cement ratio exceeding 0.65 should not be used as roofing material. Such products may ruin the good reputation of cement-based roofing products.**

**When calculating the water to cement ratio, the moisture content of the sand also has to be taken into account. When using wet sand, less water should be added.**

**The water to cement ratio also varies according to the sand quality. A mix with porous sand requires more water than a mix with non-porous sand.**

**The following rule is generally valid:**

**Suitable water to cement ratio: 0.5 - 0.65 ( by weight )**

**Never use a water to cement ratio above 0.65**

**Mixing**

**The mortar has to be mixed well, so that no lumps of fibre, aggregate and cement remain.**

**First mix sand, fibre and aggregate; then add cement and colorant and mix again thoroughly. Add water.**

### **Use Fresh Wet Mix**

**Every hour fresh mix has to be prepared.**

**The mortar mix has to be fresh when cast. The acceptable maximum time between mixing with water and casting depends somewhat on the properties of the cement and also on the temperature and air humidity. However, it should not exceed one hour.**

**(see also Production Management Guide)**

### **Stiff Mix**

**If the mix stiffens during the production process, do not add water. Prepare a new, smaller quantity of mix instead.**

**The method of mixing a large quantity of cement, sand and aggregate at a time and then adding water to a small portion of that dry mix should be practiced only in areas with low humidity or with very dry sand and aggregate. Moisture in the mix will cause the setting process to start.**

**The rules and the range of possible mixes as given above should be understood as**

**general guidelines. Testing of different mix proportions would tell you what the best mix for your material is.**

## **Vibrating and molding**

### **Placing the Mortar**

**Put a clean plastic interface sheet on the vibrating table, close the frame and put the accurate quantity of mortar on the table by the use of a measuring scoop. Spread the mortar roughly with a trowel before vibrating.**

### **Cleanness**

**The equipment used (especially the plastic interface sheets) must be clean. The vibrating table and the frame must be free of any old mortar.**

### **Free from Defects**

**The interface sheet must not have any holes.**

### **Fresh Mix**

**The mortar has to be used within one hour after water is added to the mix.**

### **Accurate Vibration Time**

**The vibration time depends on the equipment used and the workability of the mortar. It varies between 20 and 50 seconds.**

**Vibration is sufficient when water starts to appear on the surface, provided the water to cement ratio is correct. At the end of the vibration, there should be:**

- |  |  |
|--|--|
|  | no water film on the surface;                  |
|  | no cracks, holes or air bubbles in the matrix; |
|  | no lumps of fibre;                             |

**and the matrix should have:**

- |  |                       |
|--|-----------------------|
|  | an even thickness and |
|  | a uniform surface.    |

**Too long a vibration leads to a reduction in the quality of the tiles due to the segregation of the mix components.**

### **Nib Molding and Placing of Fixing Device**

**When the vibration is stopped, the nib is mounted. The nib mold is filled with mortar which is then tightly connected to the tile by another short vibration.**

**Hereafter the fixing device is inserted and the tile is again vibrated for a few seconds; then the mortar flush to the nib is cut off with a trowel.**

**When opening the nib frame, the nib has to be kept down by pressing with a finger.**

### **Molding**



**After vibration the matrix is moved to the mold, where it must be placed exactly in the correct position, otherwise the shape of the tile will not be correct and this could result in a leaking roof. To ensure the correct positioning the molds should have marks.**

**During this process no cracks should appear on the surface. Fine hair cracks that may appear are closed by a trowel or a brush.**

**(The photos show the method using the equipment of J.P. M. Parry & Associates).**

## **Mold curing**

### **Cure Immediately**

**The proper setting of the mortar is only possible if the tiles are cured correctly. The curing procedure should start immediately after the product has been cast. The tiles have to be stacked in an airtight manner or covered within 5 minutes after casting. Neglecting this would result in drastically weakened tiles and cracking.**

### **Curing Method**

**During this period the tiles are cured in a horizontal position while still on the mold, by covering their surface with a plastic sheet or by stacking with molds that guarantee airtight and dampproof stacking.**

**If during this step cracks develop on the surface, it is a sign of too much air circulation.**

## **Curing Period**

**The most important curing period is during the first 24 hours.**

**For organizational reasons it is difficult to keep the tiles on the stack for exactly 24 hours. However, a minimum of 20 hours must be allowed. (See also Production Management Guide)**

## **Demolding**

### **Time of Demolding**

**After 24 hours the strength of the tiles is sufficient for demolding. Do not demold earlier than 20 hours after vibrating.**

### **Demolding**

**This operation can be done by tilting the mold with the tile over a jig (method using the equipment of J.P.M. Parry). Instead of the jig a mold specially made for this purpose may also be used.**

**Demolding can also be done by sliding the tile and the interface sheet from the mold and holding the tile gently in the palm of the hand. Care should be taken to avoid holding the tile by the corners or between two fingers only.**

**Remove the interface sheet by pulling it across the tile (short dimension) and remove any fresh mortar. Then place the tile on the test mold.**

## Testing

**Check if the demolded roofing product fits on the jig or test mold without wobbling and with all the edges in the right position. The size and shape should also be checked.**

**(See also Quality Control Guidelines)**

## Cleaning of the Molds and the Interface Sheet

**So that good quality tiles can be produced later, it is most important to immediately clean the molds and plastic interface sheets with a brush and water. They should be checked for holes and stored properly (see also 5.1).**

## Tile Marking

**The tiles should be marked with**

	the production date,
	the name of the company and
	the name of the worker.

**This helps to observe the correct curing time, determine the right time for the end control and to relate the service performance of installed tiles to the production data and the producer.**

**Marking can also be done during the vibrating process.**

## **Tank curing**

### **Curing Time**

**After tiles have been cured for 24 hours in a horizontal position, they are carefully moved to the curing tank where they are kept completely under water in a vertical position for at least 5 days, provided the water temperature is above 20°C.**

**Mark the date on the curing tank to avoid confusion. (See also Production Management Guide)**

### **Immediate Curing**

**After demolding, the tiles must immediately be moved to the curing tank. Never allow the tiles to dry in the sun or wind before water curing.**

### **Water Level**

**The water level in the curing tank should be checked daily. The tiles should be covered by at least 20 mm.**

### **Curing at Low Temperature**

**If the water temperature is below 20°C, the curing time must be increased.**

**For a temperature of 15°C, the curing time must be at least 7 days.**

**For a temperature of 10°C, the curing time must be at least 11 days.**

**Make sure that the water temperature is measured because it is lower than the**

**average daytime air temperature.**

## **Curing Time for Tiles Cast with a high Water to Cement Ratio**

**If the water to cement ratio is higher than 0.5, the curing time must be increased as well.**

## **Change of Water**

**If the water becomes too aggressive on the skin, it should be changed, this may be once a week, but at least every two months. At the same time the tank should be cleaned.**

**Curing in clean water is especially important when producing colored tiles. Old water may cause white stains.**

## **Storing Method**

**There are different possibilities for storing the tiles in the tank:**

- |  |  |
|--|--|
|  | Stacking the tiles in a row                |
|  | Stacking the tiles in sets of three tiles. |

**Stacking in sets is a space and time saving method, but is only possible with tiles that have a nib at the top. It involves a certain risk of damage to the nibs.**

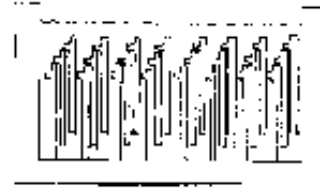

### **Storing method**

## **Vapor Curing**

**Another method is to cure the tiles above water in air saturated with water vapor.**

**This can be achieved by placing only a little water in the curing tank. The tiles are stored above the water level. The tank is then made airtight by covering it with a black plastic sheet. As the tank is exposed to the sun, the enclosed air becomes saturated with humidity and the temperature rises, thus accelerating the setting process.**

**The water level must be checked at least every morning.**

**This environment, where the curing temperature is higher, favors the curing process. The result is a strong product with a smooth and clean surface.**

**The method is especially advantageous for colored tiles, giving a proper coloring without white stains.**



**Vapor curing**

## **Batch Marking**

**Properly mark the daily batches with the date of production and product number so that the curing time can be checked.**

**(See also Production Management Guide)**

## **Air curing, storage**

### **Curing Time**

**After the water curing period the cement setting process is not yet completed. 28 days after casting only 80% of the final strength of the tiles has been reached.**

**After the tank curing, another 20 days must be allowed for air curing.**

### **Shaded and Wind-protected Storing**

**During this time the tiles must be protected from direct sun radiation and air circulation, which would result in too fast a moisture evaporation.**

### **Water Sprinkling**

**In dry climates the tiles should also be sprinkled with water twice a day to avoid complete evaporation of moisture.**

## **Protection from Mechanical Damage**

**To avoid mechanical damage the tiles are stored in a vertical position on properly built racks or on sand.**

## **Batch Marking**

**Properly mark the daily batches with the date of production and product number so that the curing time can be checked.  
(See also Production Management Guide)**

## **Transport**

### **Careful Shipment**

**The last step in the production process is the shipment.**

**The means of transport varies from a lorry, a bullock cart, a ricksha to people carrying the tiles on their backs. The roads are often extremely rough.**

**To avoid damage during transportation, careful handling is required. Proper packing methods adapted to the means of transport have to be used.**

The tiles have to be transported in a vertical position, preferably in packages of three pieces.

They must be tightly stacked, with no space for knocking each other during



I	They must be tightly stacked, with no scope for knocking each other during transportation.
I	Proper racks should be used when carrying tiles.
I	When transporting in a vehicle, sand, sawdust or fibre rejects should be used at the bottom to cushion the tiles. The direction of stacking must be the same as the direction of movement of the vehicle.

## Instruction of Customers

**Often the tiles are transported by the customer. He must be properly instructed how to handle and transport the tiles.**

**A simple leaflet can be designed for this purpose and distributed to the customer.**

**Transport by Lorry**

**Transport by Pick-up**



[Home](#) > [ar](#).[cn](#).[de](#).[en](#).[es](#).[fr](#).[id](#).[it](#).[ph](#).[po](#).[ru](#).[sw](#)



**Production Guide - Fibre or Micro Concrete Tiles (SKAT, 1992, 67 p.)**



**(*introduction...*)**







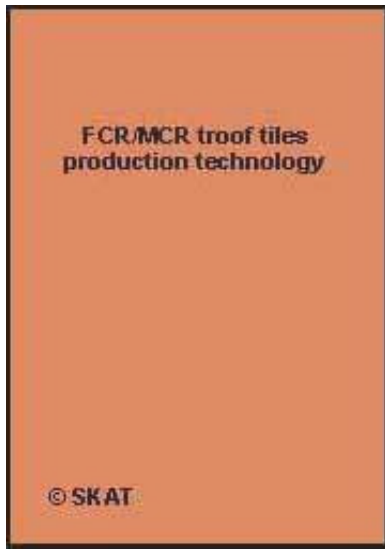

**Preface**



**1. Introduction**



-  **2. Raw materials**
-  **3. Production process**
-  **4. End control**
-  **5. Maintenance of the equipment**
-  **6. Further reading**
-  **Annex: Reporting format**

## **4. End control**

**Shortly before the tiles are sold or - in case the producer installs the tiles - just before installation an end control is done.**

**This testing at the latest possible moment ensures that all damages occurred during storing, handling and possibly transportation are discovered as well, and the customer can be supplied with a reliable product.**

**Some tests have to be done with every single tile, others can be done on a random sample basis.**

**The tests are:**

**4.1 Pore and crack test**

**4.2 Ring test**

**4.3 Bending test**

## 4.4 Nib tensile test

## 4.5 Water tightness test

## 4.6 Weight test





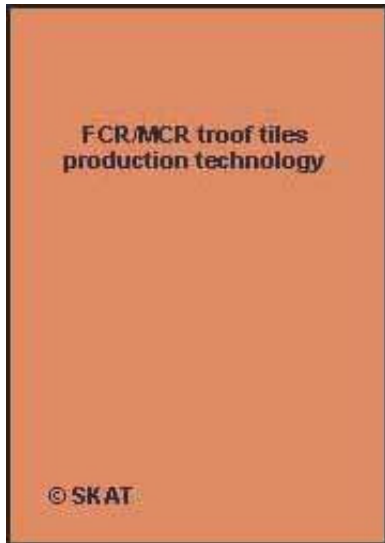

**These tests as well as the consequences when the tiles fail a test are described in the Quality Control Guidelines, Toolkit - element 23)**



[Home](#) > [ar](#).[cn](#).[de](#).[en](#).[es](#).[fr](#).[id](#).[it](#).[ph](#).[po](#).[ru](#).[sw](#)



### **Production Guide - Fibre or Micro Concrete Tiles (SKAT, 1992, 67 p.)**

- ➔  **5. Maintenance of the equipment**
  -  **(introduction...)**
  -  **The battery**
  -  **Vibrating device and tools**
  -  **Molds and plastic interface sheets**
  -  **The scale**
  -  **The workshop**

## **Production Guide - Fibre or Micro Concrete Tiles (SKAT, 1992, 67 p.)**

### **5. Maintenance of the equipment**

**Maintenance of the equipment is an important aspect in FCR/MCR production.**

**The proper functioning of the equipment - which is a vital factor in producing a good and constant product quality - depends much on maintenance. Maintenance also saves time, reduces damage and increases staff motivation.**

**As a consequence it can substantially reduce the production costs. Loss or breakdown of equipment can lead to high financial losses or even to a production standstill.**

**Note: For the maintenance of equipment, also follow the instructions of the manufacturer.**

**The main components are:**

**5.1 The battery**

**5.2 Vibrating device and tools**

**5.3 Molds and plastic interface sheets**

**5.4 The scale**

**5.5 The workshop**

**The battery**

**Regular Control**

**The battery should be controlled daily to ensure the long life of this costly item.**

**The checks should be done on a routine basis after every shift or working day.**

**Battery charge level**

**The battery charge level should be checked regularly by using a hydrometer. The battery should never be allowed to lose more than half its capacity before reloading.**

**Charge the battery immediately. If repeatedly allowed to fully discharge, the battery is damaged and would have to be replaced.**



**Control water levels and charging status after every shift**

## **Water Level**

**Check the water level of the battery at the same time. The plates must always be covered by a few millimeters of water. Make sure that only distilled water is used.**

## **Type of Battery**

**Preferably use a strong battery (12 Volt truck battery, 16 cells). It will not be necessary to charge it as often as a car battery.**

## **Direct Mains**

**A reliable direct current supply, if available, and used with a transformer, is preferable to a battery.**

**However, a professional installation is important in the interests of reducing the danger of accidents.**

## **Vibrating device and tools**

### **Cleaning Before Any Interruption of Work**

**The life span of the vibrating device and tools depends to a great extent on regular cleaning.**

**All vital parts of the vibrating device and all tools should be kept clean.**

**The vibrating table top, the screeding frame, the transfer frame, the hinges and the frame lock handles have to be carefully cleaned and oiled before any work break which is longer than half an hour.**

**The same maintenance is also needed for tools.**

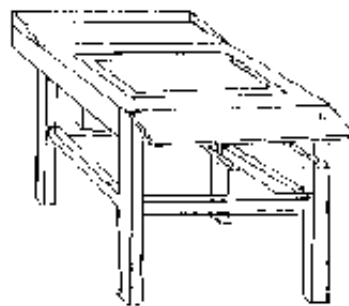

**Example**

### **Cleaning After Every Tile**

**Only on a clean table can proper tiles be produced.**

**The surface of the table and the frame have to be wiped after producing every tile.**

**The Table Must be Level**

**For tiles of uniform thickness, the table must be level.  
Check once a day with a water-level.**

**If no water-level is available, one can also place mortar on the middle of the vibrating table top, start the vibrator and see if the mortar spreads faster in any direction. If so, the level of the table has to be adjusted.**

**Molds and plastic interface sheets**

**Cleaning After Every Tile**

**Immediately after demolding every single tile the mold and plastic interface sheet have to be carefully examined and cleaned. Defective pieces have to be replaced.**

**The cleaning is most easily done with water and a fibre bundle or brush.**

**No Time Saving**

**Do not try to save time by avoiding or neglecting cleaning interface sheets and molds. The quality of the product and the lifetime of the equipment would suffer too much.**

**The scale**

## Check Weekly

**Only a reliable scale provides information that is useful to draw conclusions from the tests.**

**The function of the scale should be checked regularly by using two different standard weights.**

**If the readings are not exact anymore, try to adjust the scale or replace it.**

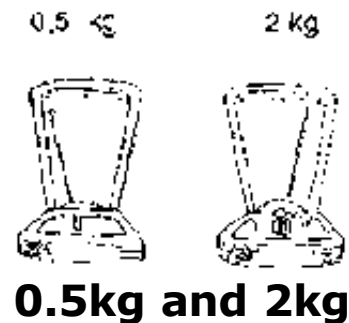

## Cleaning

**Always keep the scale clean.**

## The workshop

## Keep in Order

**The workshop should be put in order after every working day. This is important for the motivation of the staff and to avoid loss of equipment. In the long run it saves time.**



## Cleaning

The workshop should be cleaned and swept at the end of every working day. Dirt and breakage must be properly disposed of or transported away.

## Curing Tank

Clean the curing tank and change the water every week or at least every 2 months.



[Home](#) > [ar](#).[cn](#).[de](#).[en](#).[es](#).[fr](#).[id](#).[it](#).[ph](#).[po](#).[ru](#).[sw](#)

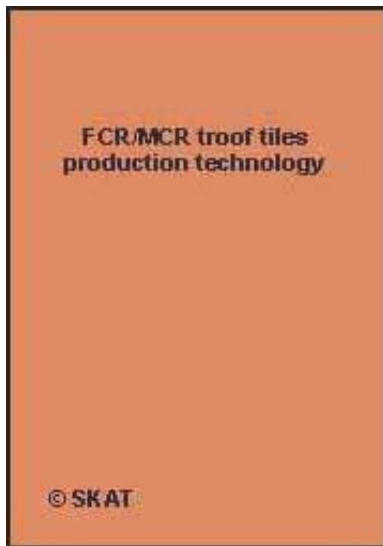

### Production Guide - Fibre or Micro Concrete Tiles (SKAT, 1992, 67 p.)

 *(introduction...)*

 Preface

 1. Introduction

 2. Raw materials

 3. Production process

 4. End control

 5. Maintenance of the equipment

  6. Further reading

 Annex: Reporting format

## 6. Further reading

**(E) = English; (F) = French; (S) = Spanish**

01	Brys, Gilbert: Tuiles en fibromortier. Procd de production et pose en toiture, Technology Series, Memorandum No. 16, International Labour Office (ILO), Geneva, 1988 (F,E)
02	Evans, Barrie: Understanding Natural Fibre Concrete, Its Application as a Building Material, IT Publications Ltd., London, 1986 (E)
03	Gram, H.-E.; Parry, J.P.M.; Rhyner, K.; Schaffner, B.; Stulz, R.; Wehrle K.; Wehrli, H.: FCR - Fibre Concrete Roofing. A comprehensive report on: The Possibilities of Fibre Concrete Roofing. The Limits of Application, and The State of the Art, SKAT, St. Gall, 1986 (E)
04	Heierli, Urs; Beck, Victor: FCR - Fibre Concrete Roofing, Feasibility and Market Study Guides, SKAT, St. Gall, 1987 (E)
05	Lola, Carlos R.: Fibre Reinforced Concrete Roofing Sheets, Technology Appraisal Report, AT International, Washington, D.C., 1985 (E)
06	Parry, John: Fibre Concrete Roofing, Intermediate Technology Workshops, Cradley Heath, 1985 (E)
07	Parry, John: Users Manual (E)
08	SKAT: The Basics of Concrete Roofing Elements, Fundamental Information on the Micro Concrete Roofing (MCR) and Fibre Concrete Roofing (FCR) Technology for Newcomers, Decisionmakers, Technicians, Field Workers and all those who want to know more about MCR and FCR, SKAT, St. Gall, 1989 (E)
09	SKAT: Informacin Bsica Sobre Techos de Micro Concreto (TMC) y Fibro Concreto (TFC), Introduccin para Arquitectos, Tcnicos, Epresarios, Instituciones de

10	Desarollo y el Rolico Interesado en TMC y TEC SKAT, ST. Gallen, 1989 (S) Stutz, Roland; Mukerji, Kiran: Appropriate Building Materials, A Catalogue of Potential Solutions, SKAT, St. Gall, GATE, Eschborn, IT Publications Ltd., London, 1988 (E)
11	Twigt, Fred Jan: Fibre Concrete Roofing in Malawi, Kenya, Tanzania, Zambia and Uganda, FCR Advisory Services, SKAT, St. Gall, 1988 (E)
12	Gram, Hans-Erik; Gut, Paul: FCR/MCR Toolkit Element 23, Quality Control Guidelines, SKAT, St Gall, 1991 (E)
13	Gut, Paul: FCR/MCR Toolkit Element 4, Standards Guidelines, SKAT, St Gall, 1992 (E)
Audio-Visual Material	
14	Macwhinnie, Ian: An Introduction to FCR/MCR Production, A BASIN Video, ITDG/GTZ-GATE, Eschborn, 1990 (E)

[Home](#) > [ar](#).[cn](#).[de](#).[en](#).[es](#).[fr](#).[id](#).[it](#).[ph](#).[po](#).[ru](#).[sw](#)

 **Production Guide - Fibre or Micro Concrete Tiles (SKAT, 1992, 67 p.)**





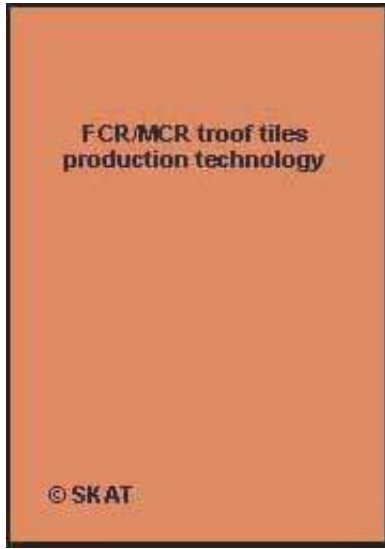

 **(introduction...)**

 **Preface**

 **1. Introduction**





-  **2. Raw materials**
-  **3. Production process**
-  **4. End control**
-  **5. Maintenance of the equipment**
-  **6. Further reading**
-   **Annex: Reporting format**

## **Annex: Reporting format**

Mix No	Date	Time when water added	Cement (kg) A	Sand (kg) B	Moisture content (1) (%) C	Water (litre) D	Water / Cement ratio (2)	Time when last unit was cast

- (1) Moisture content = Moisture content of sand and aggregate  
 (2) Water / Cement ratio =  $\frac{D + (C \times 0,01 \times B)}{A}$

### Mortar preparation

Date of control	Charging status (1)	Date of filling water	Date of charging

(1) Change the battery if more than half of the capacity has been used.

### Battery

Date of control	Wheight shown with 0,5 kg standard weight	Wheight shown with 2,0 kg standard weight

### The scale

