

➔ **Special Public Works Programmes - SPWP - Stone Paving-Blocks - Quarrying, Cutting and Dressing (ILO - UNDP, 1992, 60 p.)**

**(introduction...)**

**Introduction**

**1. The quarry**

**Choosing a quarry**

**Rock quality**

**Granite**

**2. QUARRYING**

**Quarrying methods**

**Quarrying using a crowbar**

**Channelling**

**Making wedge-holes**

**Quarry wedges**

**Cutting a block with wedges and a sledgehammer**













**Plug and feathers**

**Quarry equipment and tools**

**Use of explosives in stone quarrying**

**Block-splitting using black powder**

**Calmmite**

- ☐  **3. HANDLING THE BLOCKS**
  -  **Handling and transporting stone blocks**
  -  **Tools**
  -  **Block-handling techniques**
- ☐ **4. SECONDARY CUTTING AND DRESSING**
  -  **Product dimensions**
  -  **Secondary cutting of stone paving blocks**
  -  **Dressing the paving-blocks**
  -  **Tools for dressing stone paving blocks**
  -  **Curbstone dressing**
- ☐ **5. STORING AND TRANSPORTING STONE PAVING BLOCKS**
  -  **(introduction...)**
  -  **Annex: Productivity norms for each tasks**
-  **Back Cover**



[Home](#) [ar](#) [.cn](#) [.de](#) [.en](#) [.es](#) [.fr](#) [.id](#) [.it](#) [.ph](#) [.po](#) [.ru](#) [.sw](#)

-  **Special Public Works Programmes - SPWP - Stone Paving-Blocks - Quarrying, Cutting and Dressing (ILO - UNDP, 1992, 60 p.)**
- ➔  **(introduction...)**
-  **Introduction**
- ☐ **1. The quarry**

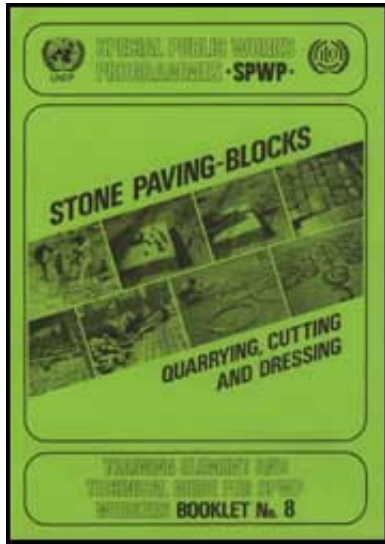

- 2. QUARRYING**
- 3. HANDLING THE BLOCKS**
- 4. SECONDARY CUTTING AND DRESSING**
- 5. STORING AND TRANSPORTING STONE PAVING BLOCKS**
- Back Cover**



United Nations Development Programme International Labour Organisation

## **Training element and technical guide for SPWP workers**

### **Booklet No. 8**

**International Labour Office Geneva**

**These training materials have been prepared with the support of: Interregional Project for Support to Promotion of Special Public Works Programmes UNDP/ILO/INT/86/036, and Employment Generation in Urban Works Programmes Through Effective Use of Local Resources INT/89/021.**

## **Copyright © International Labour Organisation 1992**

**Publications of the International Labour Office enjoy copyright under Protocol 2 of the Universal Copyright Convention. Nevertheless, short excerpts from them may be reproduced without authorisation, on condition that the source is indicated. For rights of reproduction or translation, application should be made to the Publications Branch (Rights and Permissions), International Labour Office, CH-1211 Geneva 22, Switzerland. The International Labour Office welcomes such applications.**

**First published 1992  
ISBN 92-2-106472-7**

**This booklet replaces Stone Plaving Blocks: Quarrying, Cutting and Dressing (ISBN 92-2-106421-2)**

**The designations employed in ILO publications, which are in conformity with United Nations practice, and the presentation of material therein do not imply the expression of any opinion whatsoever on the part of the International Labour Office concerning the legal status of any country, area or territory or of its authorities, or concerning the delimitation of its frontiers.**

**The responsibility for opinions expressed in signed articles, studies and other contributions rests solely with their authors, and publication does not constitute an endorsement by the International Labour Office of the opinions expressed in them.**

**Reference to names of firms and commercial products and processes does not**

**imply their endorsement by the International Labour Office, and any failure to mention a particular firm, commercial product or process is not a sign of disapproval.**

**ILO publications can be obtained through major booksellers or ILO local offices in many countries, or direct from ILO Publications, International Labour Office, CH-1211 Geneva 22, Switzerland. A catalogue or list of new publications will be sent free of charge from the above address.**

***NOTE: This booklet, produced with the support of the United Nations Development Programme, is the result of collaboration between Laurent GUERIN, civil engineer and ILO technical adviser. Denis MALLEJAC, paving-block mason and independent consultant, and Adrien RICHARD, quarry operator at Monthey (Switzerland). Mike SHONE. ILO technical adviser, provided helpful comments on an earlier draft.***



[Home](#) > [ar.cn.de.en.es.fr.id.it.ph.po.ru.sw](#)

 **Special Public Works Programmes - SPWP - Stone Paving-Blocks - Quarrying, Cutting and Dressing (ILO - UNDP, 1992, 60 p.)**

 **(introduction...)**

  **Introduction**

 **1. The quarry**

 **2. QUARRYING**



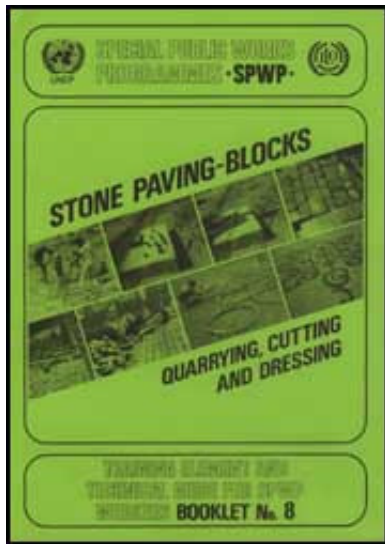

- 3. HANDLING THE BLOCKS**
- 4. SECONDARY CUTTING AND DRESSING**
- 5. STORING AND TRANSPORTING STONE PAVING BLOCKS**
- Back Cover**

## Introduction

**1. This training booklet is designed for use by intermediate-level technical personnel, trainers, and unskilled or semi-skilled workers who make up the labour force in Special Public Works Programmes (SPWPs).**

**2. Stonework is a vast field and requires knowledge of a wide range of subjects. Mastery of the techniques involved in road paving using stones is achieved only through years of experience. The techniques involved in the production of paving-blocks are also numerous and include**

- **the extraction of initial blocks of rock from the quarry;**
- **the use of explosives;**
- **transport and handling of stone blocks;**
- **secondary cutting and dressing.**

**3. This booklet is therefore limited to providing the quarry worker and stonemason with essential knowledge of the production of stone paving-blocks (also known as paving-setts) and curbstones for use in road surfacing work. It cannot, however, provide complete training in these skills. It should be considered an aid to the first steps in training/production activities aimed at the development of know-how in road-surfacing using stone paving-blocks in countries where such techniques are little used or unfamiliar.**

**This booklet can be used in many ways: as a simple reference manual or field guide for technical personnel, or as a training booklet as part of a training course. Training sessions should obviously be led by technical personnel or quarry operators who already have a thorough knowledge of the skills involved in stonework.**

**4. The main aspects of paving-block and curb-stone production are presented in a deliberately simplified form, with numerous illustrations to make them easily understandable. Furthermore, topics are presented in the order in which they will be encountered by workers: quarry-work, block-handling, secondary cutting and dressing, and transport and stockpiling.**

**Chapters 1 and 2 cover the quarry itself and quarrying operations. Chapter 3 discusses stone-block handling at the quarry site and transportation of blocks to the dressing site. Chapter 4 presents techniques of secondary cutting and dressing of stone paving blocks, and Chapter 5 covers their transportation and storage.**

**5. Finally, it should be specified that the techniques described in this booklet are those which were used in an experimental programme carried out in 1987 by the**

**ILO in Ouagadougou (Burkina Faso). The programme aimed to demonstrate the production and implementation of paved surfacing, using a relatively hard granite.**





**6. These methods are therefore rather specific and related to a particular situation. They should not be applied systematically and indiscriminately in other countries or regions. In the majority of cases, work methods, training, tools and equipment must be adapted to the type of rock encountered (sandstone, basalt, lime, etc.), and to the local conditions.**

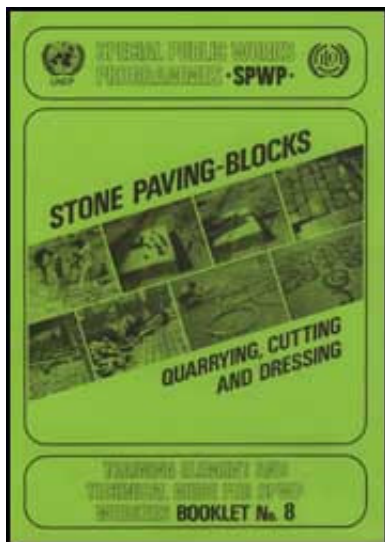

[Home](#) > [ar](#).[cn](#).[de](#).[en](#).[es](#).[fr](#).[id](#).[it](#).[ph](#).[po](#).[ru](#).[sw](#)



 **Special Public Works Programmes - SPWP - Stone Paving-Blocks - Quarrying, Cutting and Dressing (ILO - UNDP, 1992, 60 p.)**

- ➔  **1. The quarry**
  -  **Choosing a quarry**
  -  **Rock quality**
  -  **Granite**

**Special Public Works Programmes - SPWP - Stone Paving-Blocks - Quarrying, Cutting and Dressing (ILO - UNDP, 1992, 60 p.)**



# 1. The quarry

## Choosing a quarry

**Stone is extracted from a quarry. In selecting a good quarry, one should attempt to bring together a certain number of favourable conditions:**

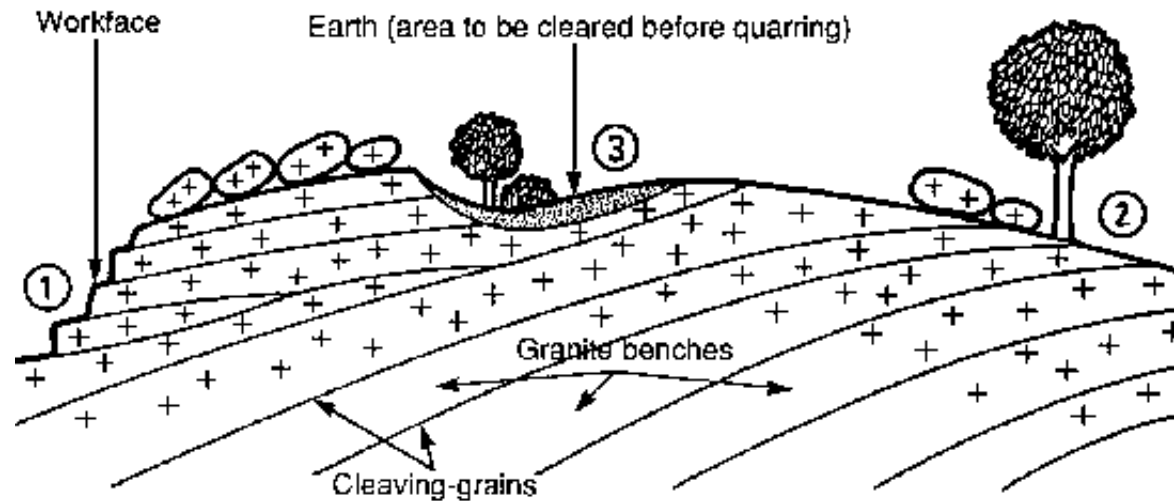

**Figure**

- **Advantage should be taken of the natural terrain, the side of a hill (1), for example, or a place where there is an outcrop of rock benches (2), to establish a workface. If the area is flat, soil will have to be cleared to create a workface (3).**

**A quarry with outcrops of rock will require only a minimum of preliminary exposure work: clearing the surface layer of soil (overburden) to expose the rock benches.**

## **Safety:**

**A first-aid kit must always be available on site in the quarry in case of accidents. Its contents must be regularly checked.**

## **Environmental considerations:**

**The development of the quarry should be undertaken within the context of a progressive rehabilitation/restoration/re-use programme for the quarry environs. Furthermore, the area should be kept well-drained.**

- **Granite benches are depths of rock divided into layers by quarry strata or cleaving grains.**
- **The top and bottom few centimetres of granite benches are unusable as they are often affected by water infiltration. They must be removed in order to begin quarrying usable stone.**

**As far as possible, a quarry should be chosen near the site where the paving-blocks are to be used, in order to minimise transport costs.**



**Granite bench outcrops. Exposure work is not necessary in this case.**

### **Safety:**

**There is a high risk of tetanus being contracted in a quarry. This can be eliminated by the systematic vaccination of workers when recruited.**

**Ear protectors should be worn during drilling to reduce potential causes of deafness.**

### **Rock quality**

**The rock must be hard, of consistent texture, unaffected by erosion and neither crumbly nor cracked. The rock's quality can be checked by taking samples and**

**subjecting them to dressing tests; that is, producing a few sample paving blocks to ensure the suitability of the material.**

**When struck with a club hammer the rock should make a clear sound; if the rock sounds hollow, this means that either cracks are present in it or it is damaged.**

## **Granite**

**Granite is an igneous rock. Granite was produced from deep magmas which became consolidated in the earth's surface at a time when deformations of the earth's crust occurred some 300,000,000 years ago.**

**Granite is a granular rock with different textures: coarse, medium or fine-grained.**

**Essentially, granite is composed of:**

- **Colourless or milky quartz, 25-40% volume**
- **Pink, ochre or bluish feldspar, up to 70%**
- **Black and white mica, from 3 to 10%**

**It is the feldspar which gives the granite its colour and the percentage of quartz which determines its hardness.**

**By virtue of its great resistance to erosion and crushing, granite is a particularly well-adapted material for road-surfacing work. However, because it is a very hard rock, granite is difficult to dress.**

**The density of granite varies between 2.4 and 2.7 (2,400 and 2,700 Kg/m<sup>3</sup>).**





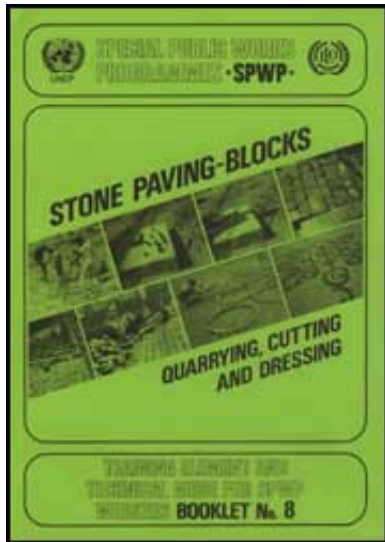







[Home](#) > [ar](#).[cn](#).[de](#).[en](#).[es](#).[fr](#).[id](#).[it](#).[ph](#).[po](#).[ru](#).[sw](#)



## **Special Public Works Programmes - SPWP - Stone Paving-Blocks - Quarrying, Cutting and Dressing (ILO - UNDP, 1992, 60 p.)**

### **2. QUARRYING**

-  **Quarrying methods**
-  **Quarrying using a crowbar**
-  **Channelling**
-  **Making wedge-holes**
-  **Quarry wedges**
-  **Cutting a block with wedges and a sledgehammer**
-  **Plug and feathers**
-  **Quarry equipment and tools**
-  **Use of explosives in stone quarrying**
-  **Block-splitting using black powder**
-  **Calmmite**

**Special Public Works Programmes - SPWP - Stone Paving-Blocks - Quarrying, Cutting and Dressing (ILO - UNDP, 1992, 60 p.)**

## **2. QUARRYING**

## **Quarrying methods**

**Once the quarry has been sited, the environmental restoration plan agreed, and the preliminary clearing work completed, the method of quarrying the rock is chosen.**

**Depending on the type of deposit encountered, whether granite in the form of boulders or in benches from several centimetres to several metres high, the quarrying method chosen will involve the use of a crowbar, quarrying wedges, plugs and feathers, explosives or calmmite (1) to detach blocks of rock from the solid rock mass.**

**(1) See page 25**

**Primary cutting is the process by which a fracture is created in the rock mass to detach a block, or in a block of rock to cleave it, by successive breaks, into blocks of manageable dimensions.**

**The size to which blocks must be cut will thus be determined by the handling system used. In determining a block's dimensions, it is important to relate it to the size of the finished product (paving-blocks or curbstones) which will be made from the block.**

**If pavement curbstones 100 cm long and with a 20 × 20 cm section are to be produced, one should obtain an initial block of multiple dimensions to those of the curbstones/edging blocks (adding a small margin to allow for material lost in dressing).**

**For example, after the first cutting stage, the block could measure 105 × 63 × 42 or 105 × 85 × 21 cm.**

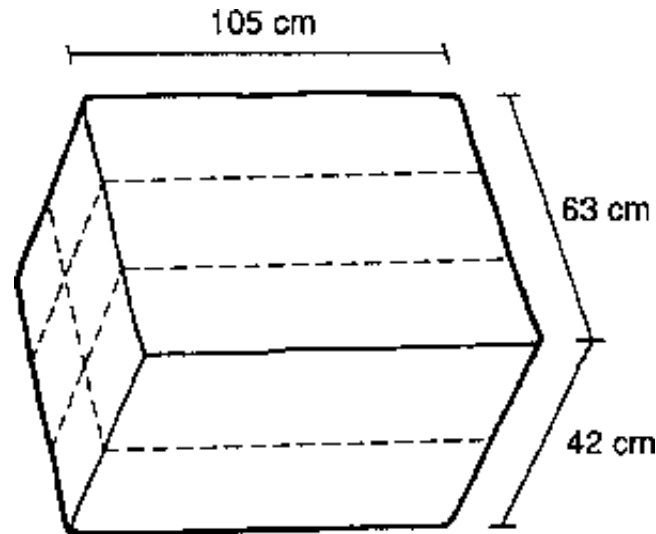

**Figure**

**Granite block from which curbstones measuring 100 × 20 × 20 cm are to be produced.**

**It will be possible to cut six curbstones from this block with a minimum of waste.**

**Quarrying using a crowbar**

**This method can be employed in a shallow bed of granite where sufficiently wide cracks criss-cross the rock.**

**The only tool needed is a crowbar. This is a hardened steel bar of hexagonal or round section, 34mm in diameter and about 1800 mm in length.**

**One end is forged into a four-sided point, the other flattened. Depending on the weight of block to be handled, one or more quarry-workers will be required.**





## **Crowbar**

### **Safety:**

**a) A crowbar left lying on the ground can easily be tripped over. When not in use, leave it in an upright position where it is easily visible.**

**b) Safety shoes, gloves and protective goggles must be worn on-site by all workers.**

**The crowbar can be used as a lever by inserting its point into natural chinks between blocks. The quarry-worker wedges the bar against the edge of another block and, putting his full weight on the bar, moves the block. The principle of a lever is to multiply force severalfold.**

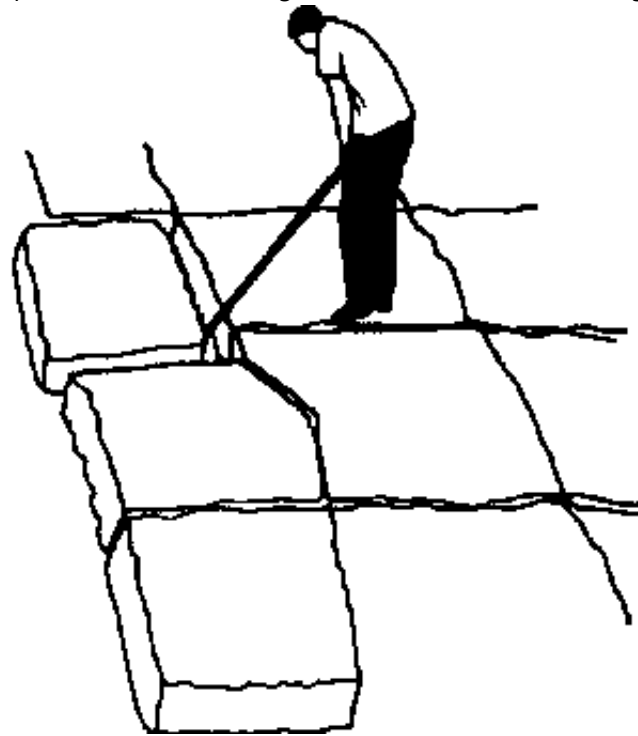

**Figure**

**Once the block is too far removed from the original point of leverage of the crowbar, chocks are used to create another leverage point.**

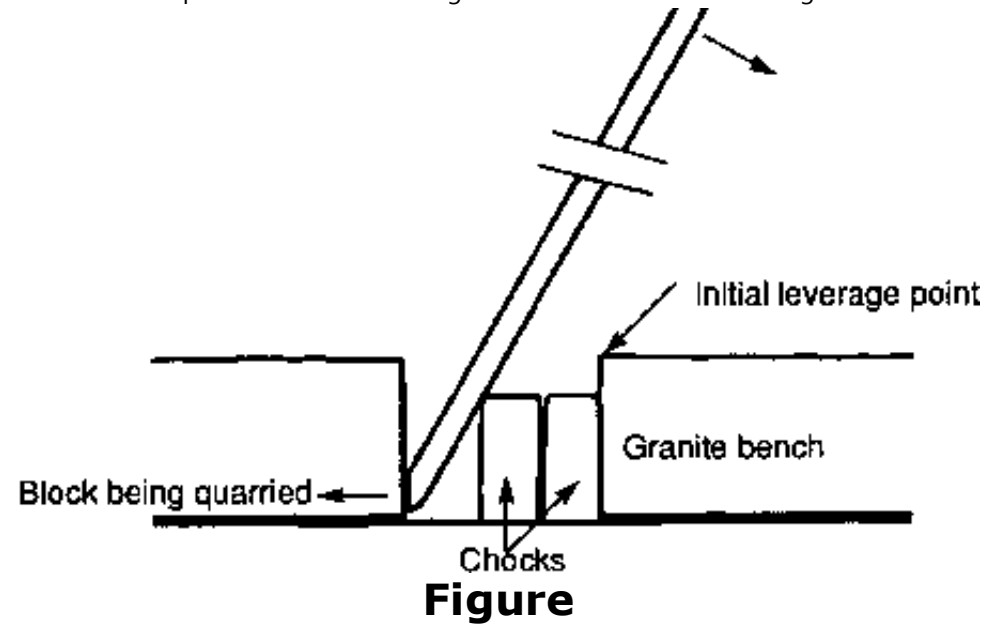

**The crowbar may also be moved laterally to steer the block. The operation is continued until the block is sufficiently free to be loaded onto a two-wheel trolley, or hand truck (see page 28) or split into smaller blocks.**

**In cases where the granite bench is not fractured sufficiently to allow a crowbar to be used, other methods can be employed. Quarrying wedges, plugs and feathers, explosives, or calmmite can be used.**

## **Channelling**

**Whichever of these methods is decided upon, the first operation will remain the same: the marking of a groove along the cutting-line. The purpose of this 1 - 2 cm groove is to guide the fracture along which the block will be split.**

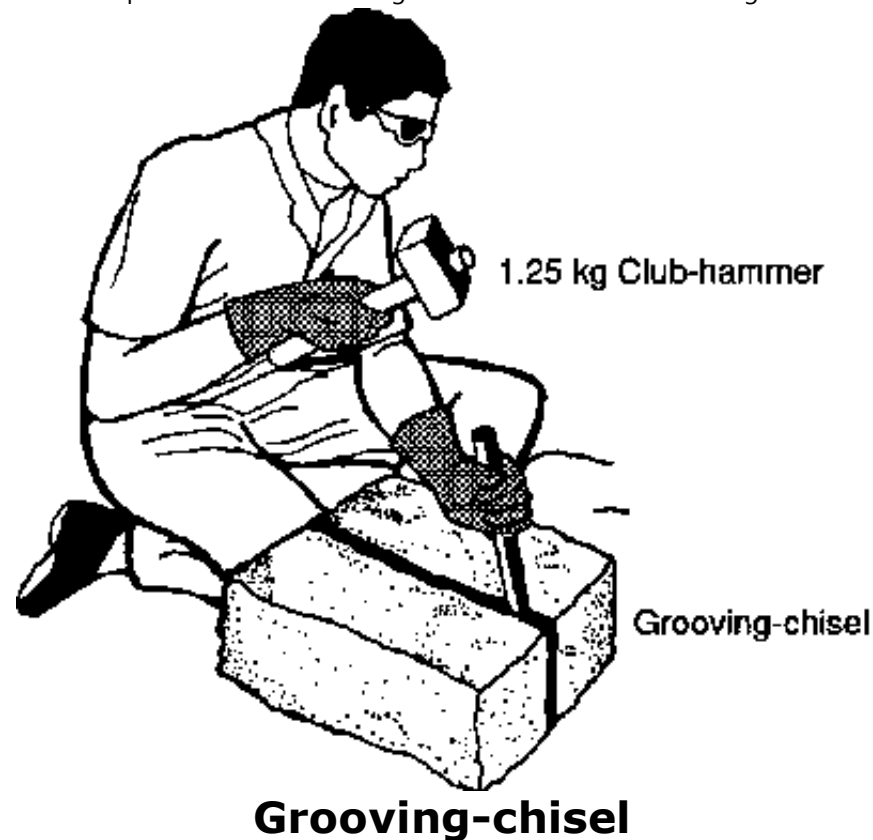

### **Making the cutting-line groove by hand**

**The groove can be made manually using a grooving-chisel and club-hammer, or with a pneumatic drill equipped with a chisel end.**

### **Safety:**

**The wearing of safety goggles, shoes and gloves must be enforced and continuously supervised.**

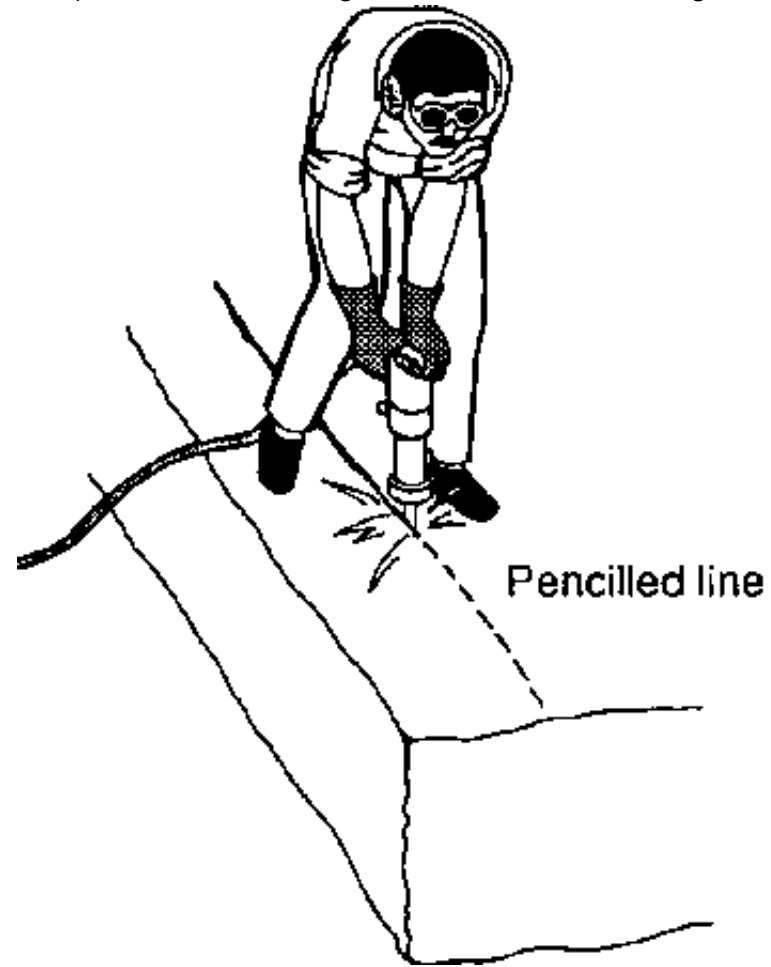

**Figure**

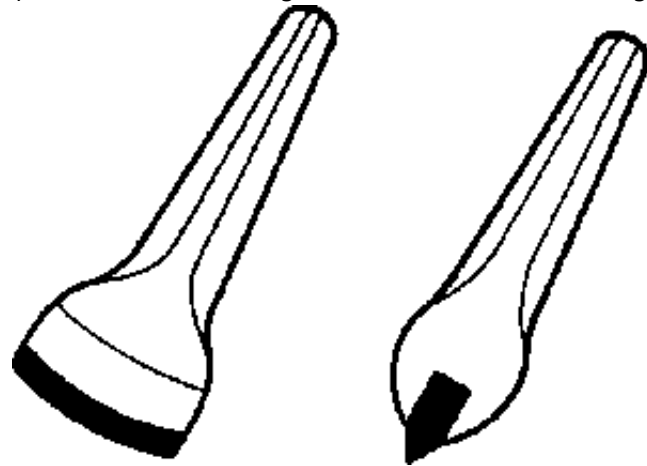

**Tungsten tipped chisel ends**

**A chisel end is a tool which can be fitted to a pneumatic hammer drill.**



**Channelling using a pneumatic hammer drill.**

**Safety:**

**When a pneumatic drill is used, ear protection is as important as shoes, gloves and goggles. The noise level of quarry operations is great enough to permanently damage hearing if no protection is used.**

## **Making wedge-holes**

**If working manually, the tools required are a grooving-chisel and club-hammer. The operation may, however, be mechanised using a pneumatic hammer drill and compressor.**

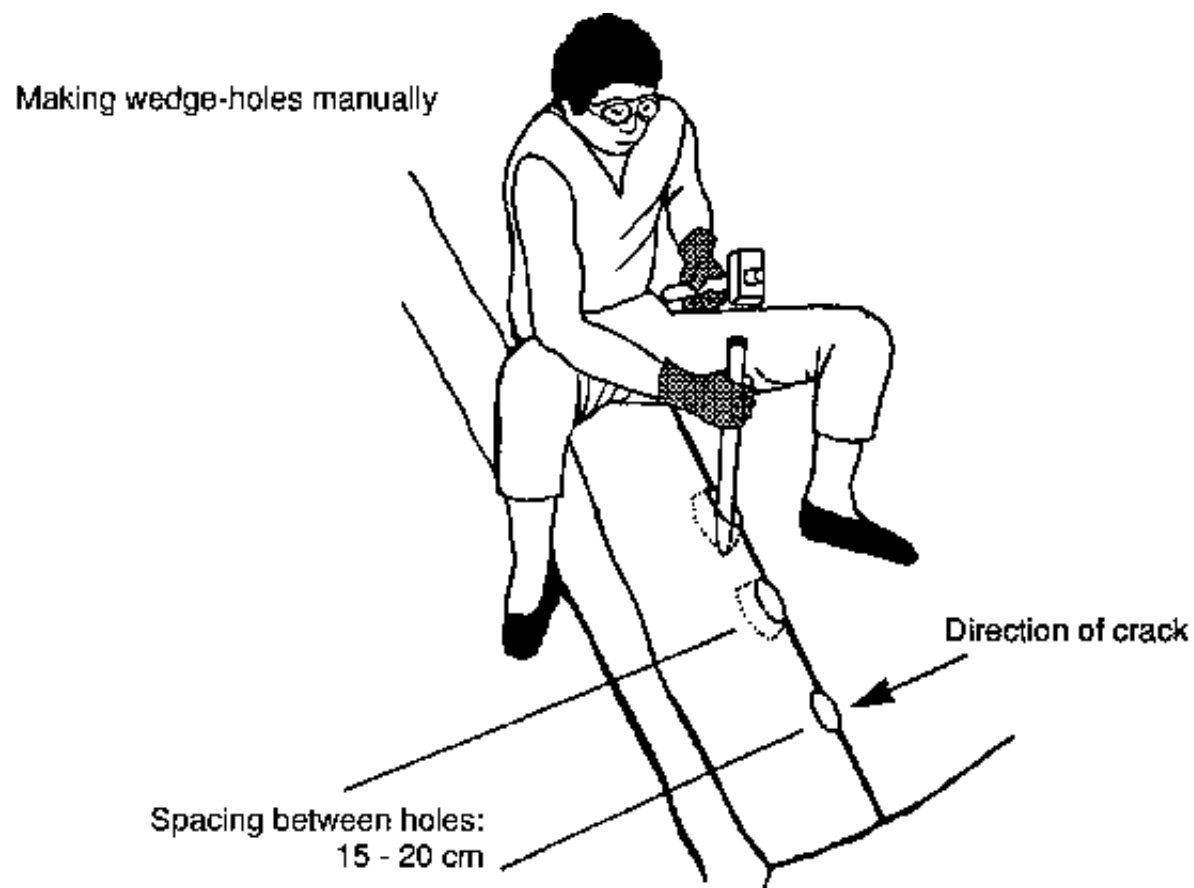

## **Making wedge-holes manually**



## Safety:

**Grooving-chisels which are not in use must be carefully put to one side as they can easily roll under someone's feet and make them fall.**

**Whichever tools are used to make these holes, be they grooving-chisel and club-hammer or pneumatic tools, two small holes are first made to mark the extremities of the wedge-hole.**

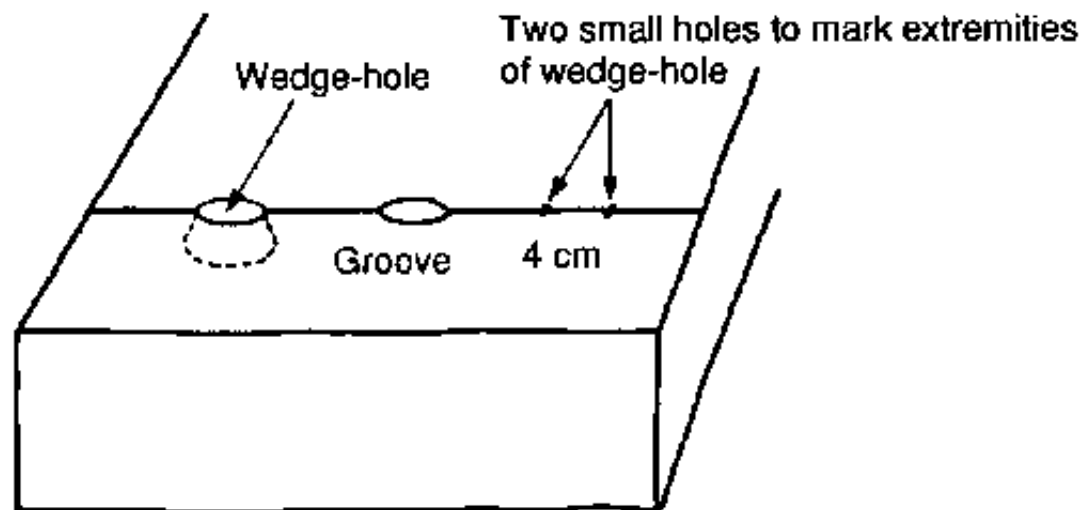

**Figure**

**The rock is removed between these two small holes and the wedge-hole is then made by pivoting the tool until the required depth is reached.**

**Wedge-holes are spaced 15-20 cm apart along the entire length of the groove.**

**Repeated to and fro movement**

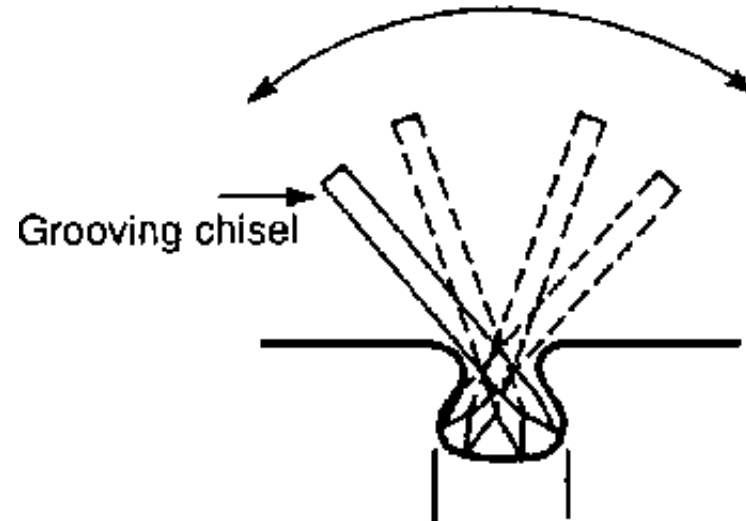

**Figure**

**The base of the hole is enlarged by repeatedly moving the grooving chisel to and fro.**



**Enlarging the base of the hole.**

## **Quarry wedges**

**Quarry wedges are pieces of metal, around 70 mm long and 40 mm wide at their widest part.**

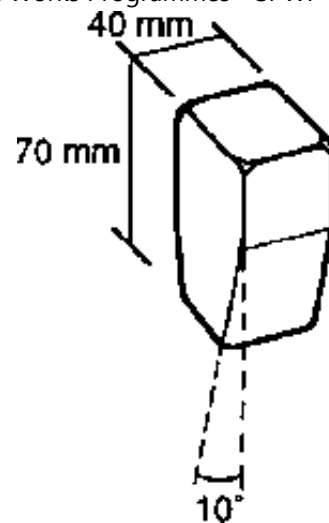
**Figure**

**They are placed in the wedge-holes.**

**The wedge presses against the sides of the hole. The hole must be deep enough so that, when struck with the sledgehammer, the wedge does not touch the bottom of the hole.**

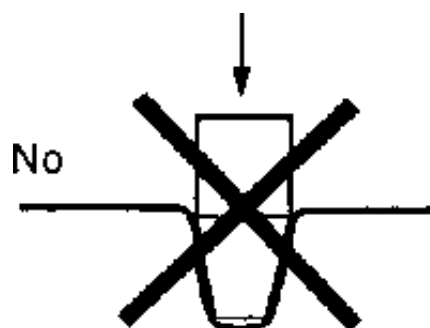
**Figure**

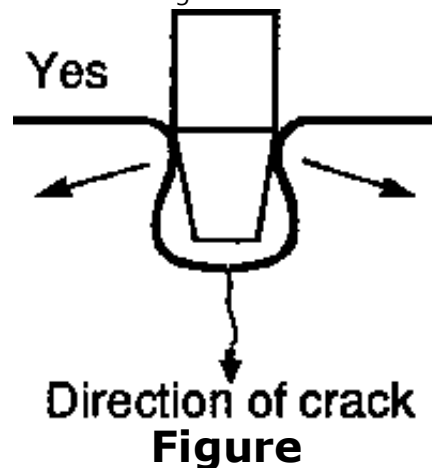

**The wedge is touching the bottom of the hole. When struck, it will bounce out of the hole as it will be unable to go in any further.**

**Note the form of the wedge-hole in the drawing below.**

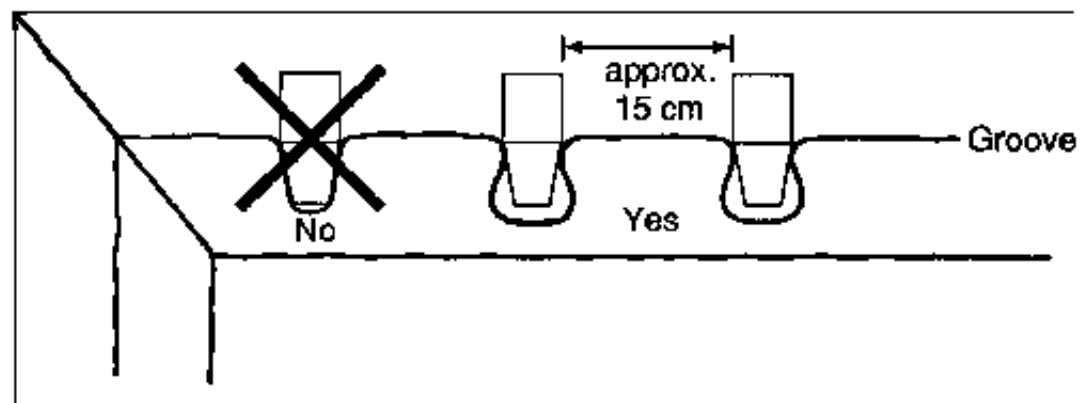

**Figure**

### **Safety:**

**A wedge may fly out of its hole. A safety area of 5 metre radius around workers**

**using a sledgehammer must be respected.**

## **Cutting a block with wedges and a sledgehammer**

**Wedges are hit into place using a club-hammer. They are then hit in succession using a 5 kg sledgehammer until the pressure exerted on the block is such that it breaks away from the rock mass.**

**If the height of the block makes it necessary, the break can be guided vertically by placing wedges along the sides of the block as well.**

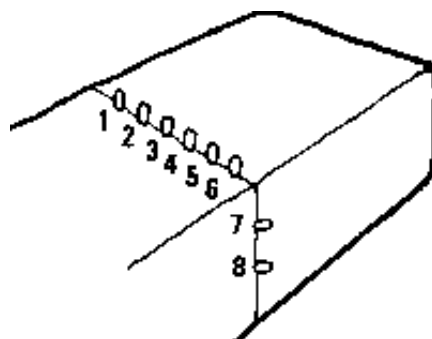

**Figure**

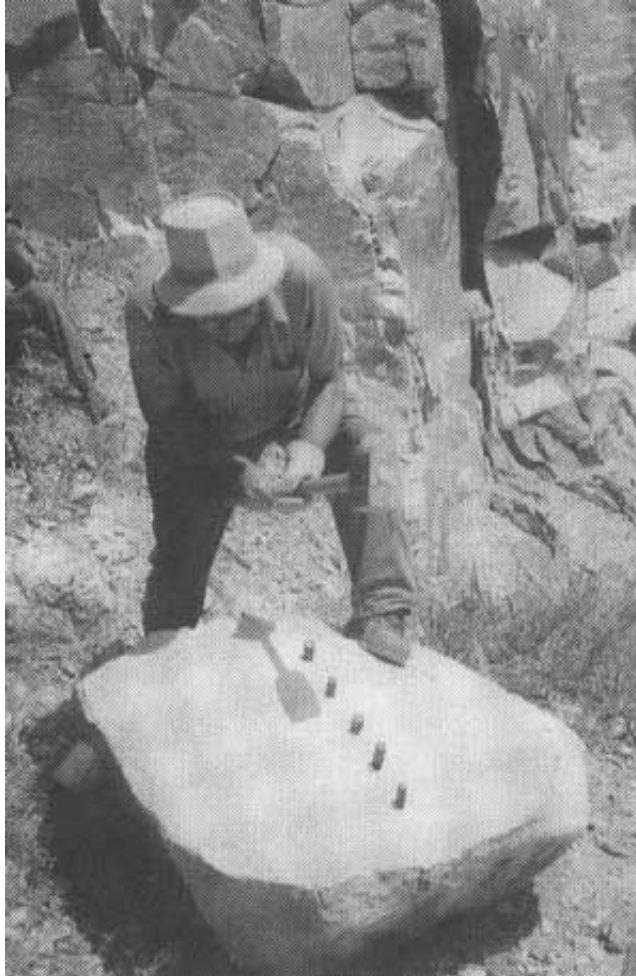

**a. Cutting a block with wedges and a sledgehammer**

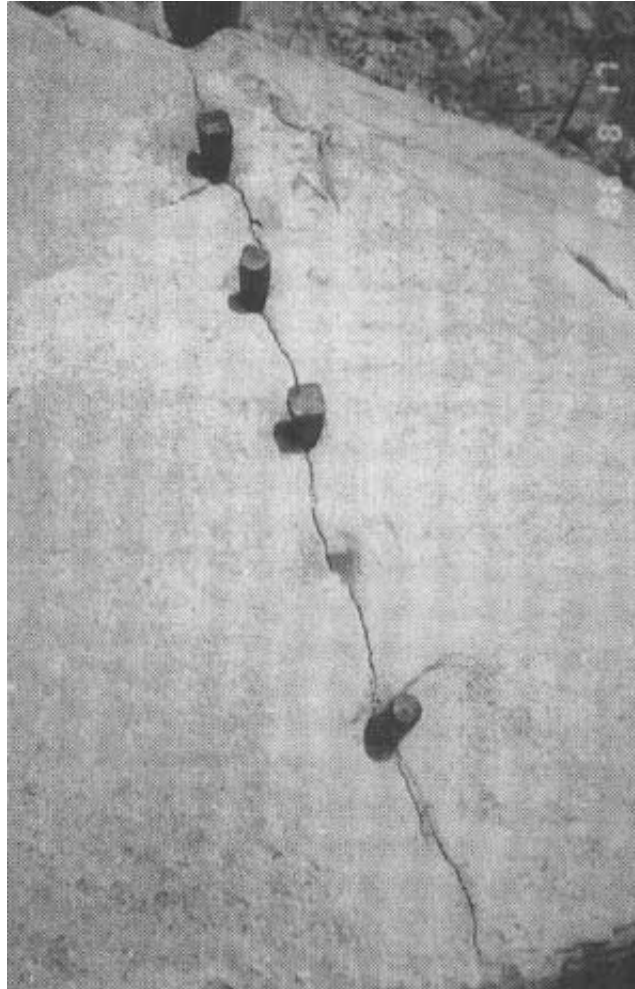

**b. Cutting a block with wedges and a sledgehammer**

**Safety:**

**Hammer heads must be tightly secured to their handles. A 5 kg sledgehammer head flying off its handle can seriously injure anyone standing nearby.**

**Plug and feathers**



**A set of plug and feathers consists of three parts: a central, sharply tapered wedge known as the plug, which bears on the other two parts which are the feathers.**

**The lower part of the feathers is thicker to fit against the tapered edge of the plug.**

**This method of splitting stones, used for hard rocks such as granite, requires the use of a pneumatic rock drill, compressor and drill bit for making the holes.**

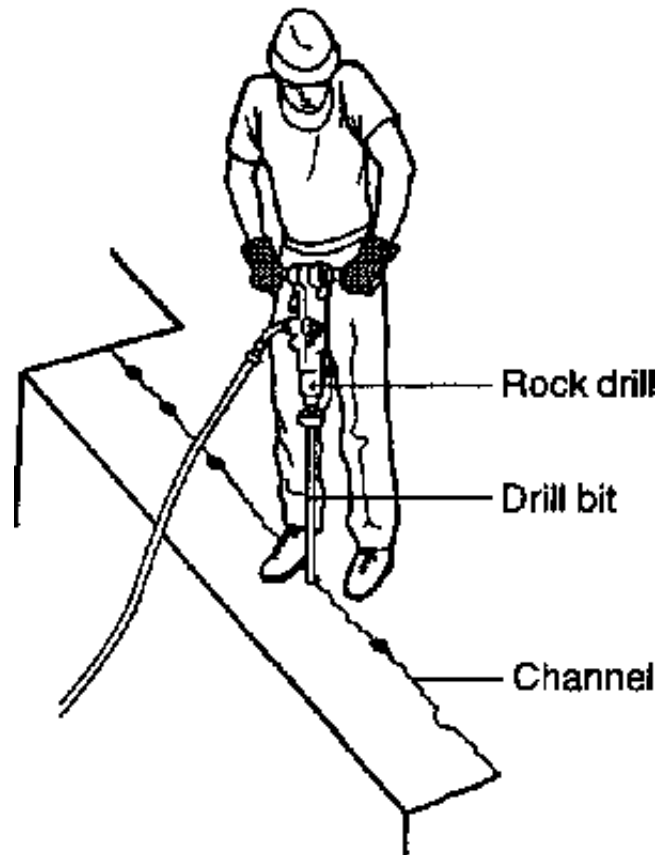

**Figure**

**The usual size of plug and feathers for granite is 30 mm diameter and 40 cm in**

**length. They are placed in 50 cm-deep holes, made with a 34 mm diameter drill bit. These holes are made at 30 cm intervals along the previously marked groove.**

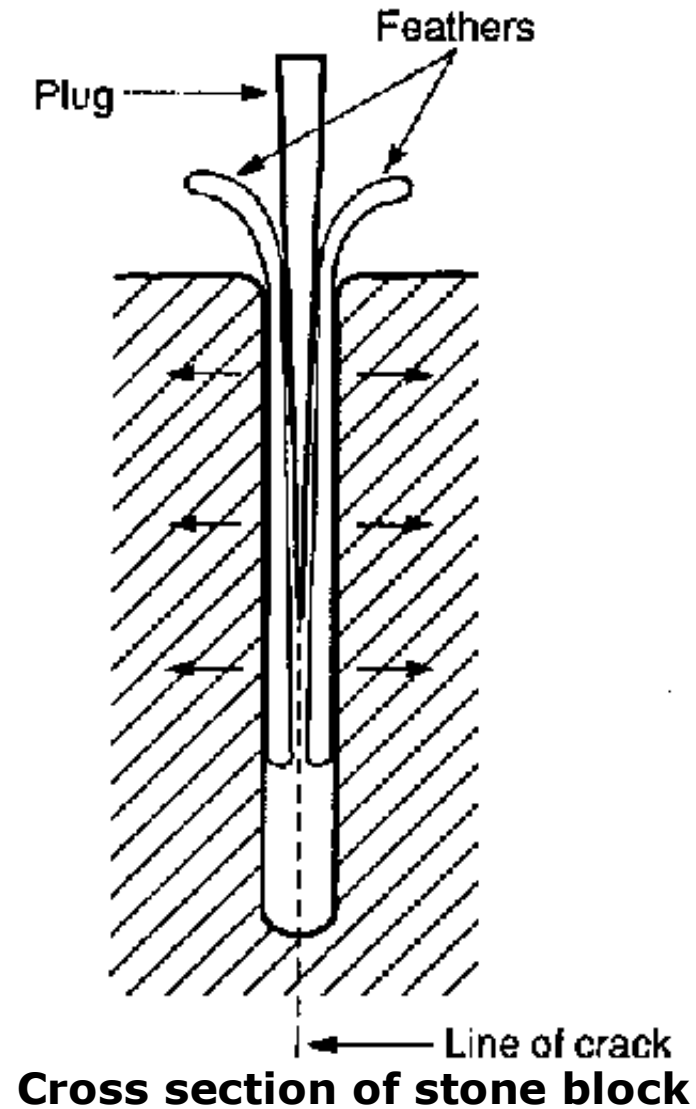

## **Safety:**

**Wearing ear-protectors provides effective protection against noise. Without ear protection, hearing can be irreparably damaged by the operating noise levels of pneumatic rock drills.**

**With the double striking and revolving action provided by the rock drill, the drill bit drills into granite. Rock dust is blown out of the hole by compressed air which is channelled to the end of the drill bit.**

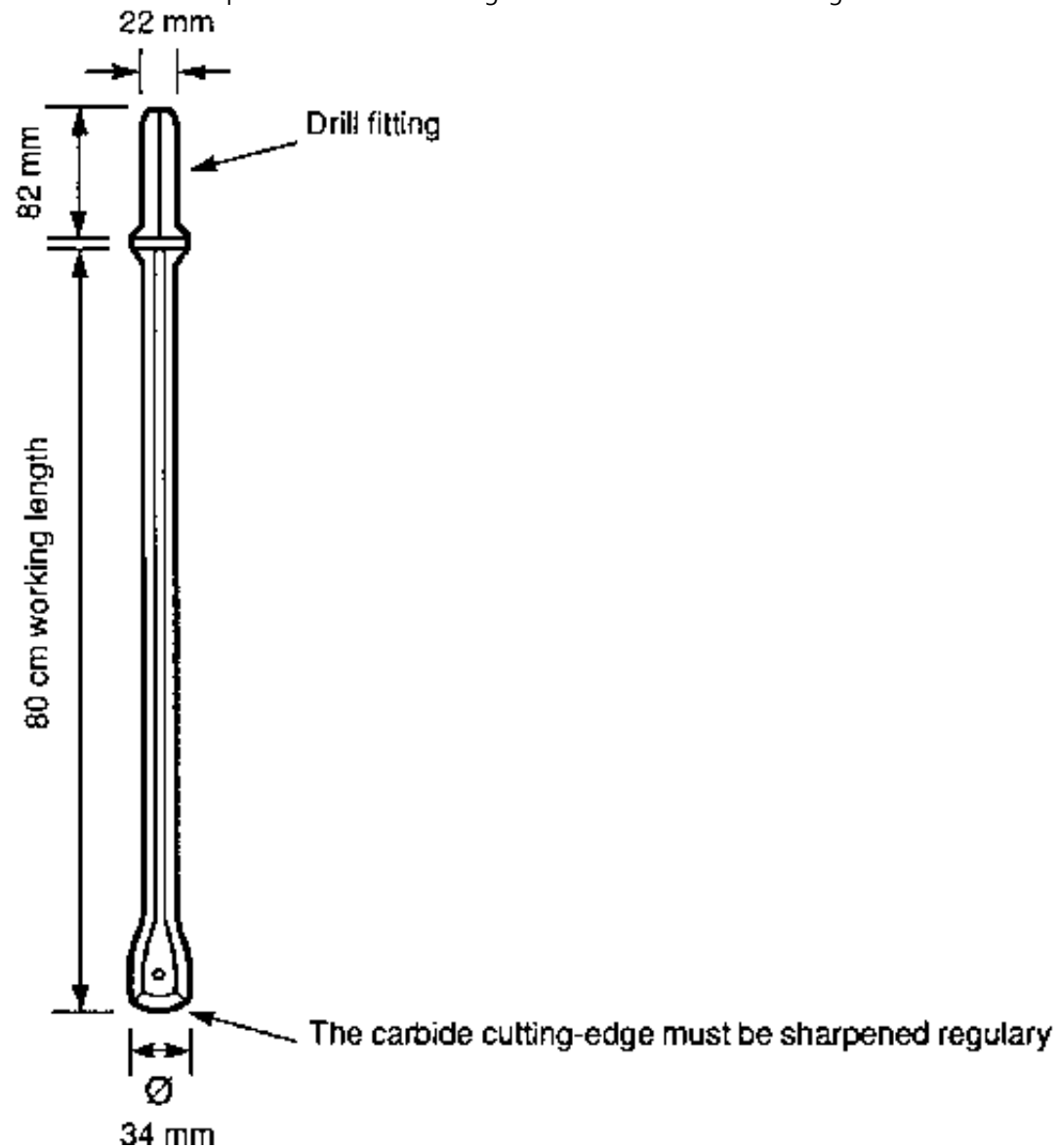

**Drill bit**

**Safety:**

**An air-filtering mask prevents workers breathing in the fine rock dust present in**

**the air due to drilling. Inhaled siliceous granite dust causes a lung disease known as silicosis.**

**When all the plugs and feathers are in place, they are struck in succession with a sledgehammer. In so doing, lateral pressure is exerted on the complete length of the feathers, to a depth of 40 cm into the stone. This is what distinguishes the plug and feathers from simple quarry wedges.**

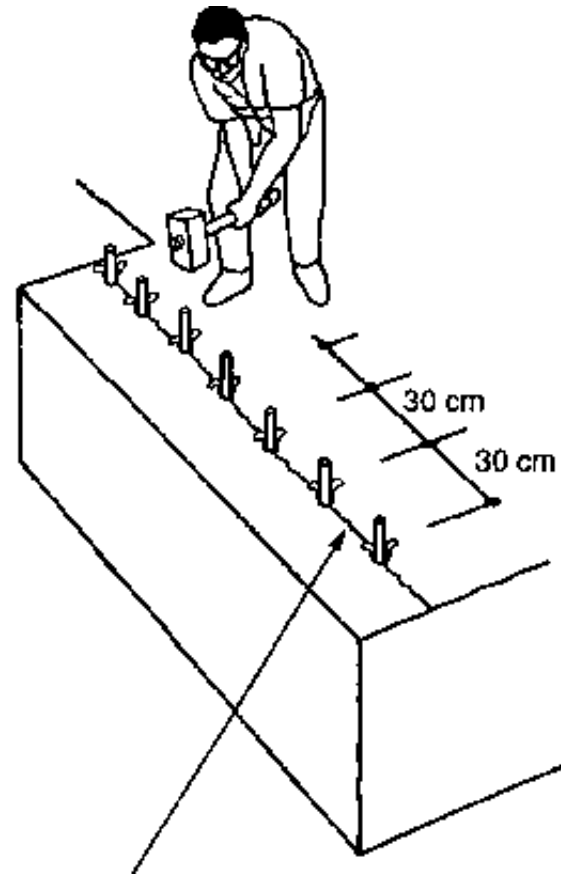





Groove marked beforehand, either with a pneumatic chisel end or manually with a grooving-chisel.



## Figure

### Safety:

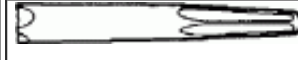
**The immediate work-area should be regularly cleared of all stone waste, stone blocks and tools which are not in use and which could obstruct workers or cause them to fall. One worker should be appointed on a permanent basis to the task of keeping the worksite clear.**

### Quarry equipment and tools

Item	Weight	Indicative price	
Compressor 30 hp diesel engine, output 2.1 m <sup>3</sup> /minute	600kg	11,700 \$	
Compressor 30 hp diesel engine, output 2.7 m <sup>3</sup> /minute	800kg	13,500\$	
Rock drill (see photo page 20)	18kg	1,100\$	
Drill bit 037 mm, length 800 mm	3kg	100\$	
Drill bit 042 mm, length 800 mm	3kg	120\$	
Hammer drill (see photo page 20)	10kg	850\$	
Semi-finished rough-forged tool (for above hammer drill)	1 kg	20\$	
Carbide chisel end	0.5kg	50\$	

			
Plug and feathers 030 mm, length 400 mm (see photo page 20)	1.5kg	35\$	
Ear protectors	0.24 kg	35\$	

***Prices are obtained in France and converted into US\$ at an exchange rate of US\$ = FF6. Please regard prices as indicative only.***

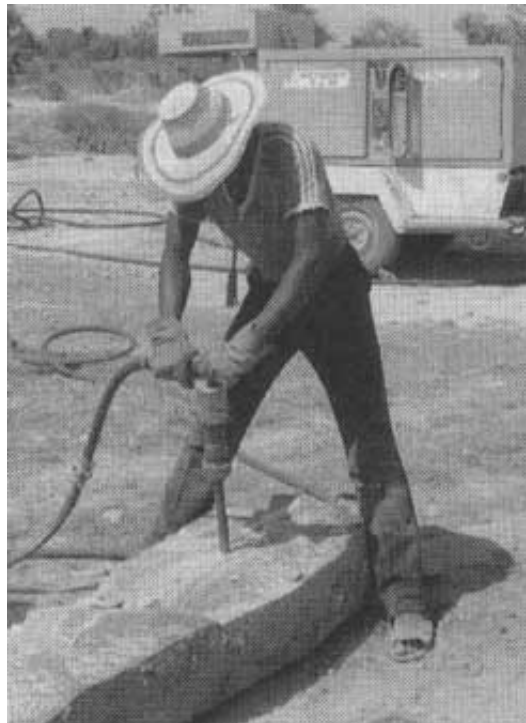

**Compressor providing air for a hammer drill**



**Hammer drill**

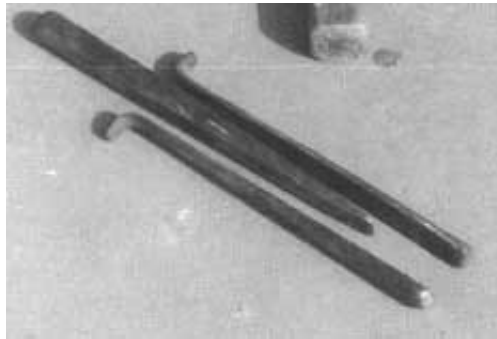

**Plug and feathers  $\phi$ 30 mm, length 400 mm.**





**Rock drill with drill bit  $\phi$ 34 mm, length 800 mm**

## **Use of explosives in stone quarrying**

**Mention is made here only of the main principles of the use of explosives.**

**Explosives must be handled only by workers who have undergone specific training to obtain a certificate as blasting officers and who have a thorough knowledge of all safety rules regarding the transport, storage and use of explosives.**

**An explosive is a material which, upon disintegration, produces a shock followed by the release of a great quantity of gas. The shock creates a crack in the rock and the gas, under pressure, escapes into the crack which widens under the effect of the blast thus produced.**

**So as not to destroy the block of stone, a deflagrating explosive, which decomposes slowly, is used, such as black powder (a mixture of ground charcoal, sulphur and saltpetre) with a shock-wave propagation rate of 300 m/second.**

**Do not use explosives of the following types:**

- a) nitroglycerine (A gum)**
- b) "N", based on ammonium nitrate**
- c) "O", based on sodium chlorate**

**The above are detonating explosives with a shock-wave propagation rate after explosion of 2,000 to 8,000 m/second. They have a shattering effect and produce a considerable disintegration of the rock mass, and also create numerous cracks which render the material unfit for dressing. Such explosives are therefore to be avoided in quarrying of stone blocks.**

**Block-splitting using black powder**

**First, a groove (along which the rock will be split) is made, following the rock's cleavage (direction of cracks).**

**Next, blasting holes are made along the groove, either using the hammer action of a rock drill (fitted with a chisel end) or a crowbar if the rock is soft (sandstone or limestone).**

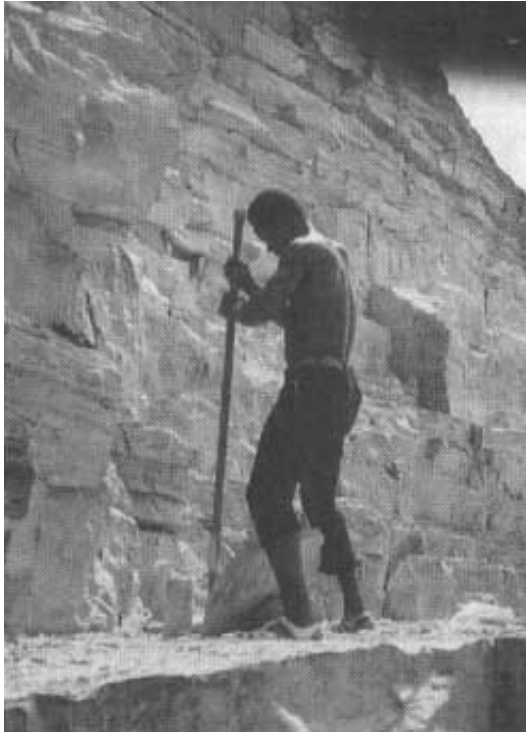

**Boring with a 2-metre crowbar**

**Average productivity rate in sandstone: 1.5 work-days per linear metre.**

**Boring in soft rock**

**In hand drilling soft rock such as sandstone, water is used to free the hole of rock dust and thereby facilitate boring.**



**Rubber ring to prevent water from splashing out whilst boring.**

**The number of holes depends on the size of the rock mass to be split Next explosive cartridges are placed at the bottom of the holes. The number of cartridges per hole is determined by the strength required of the explosion, which in turn also depends on the size of the block to be split.**



**Blasting preparation (the holes are sealed while waiting for the explosive charges to be put in place)**

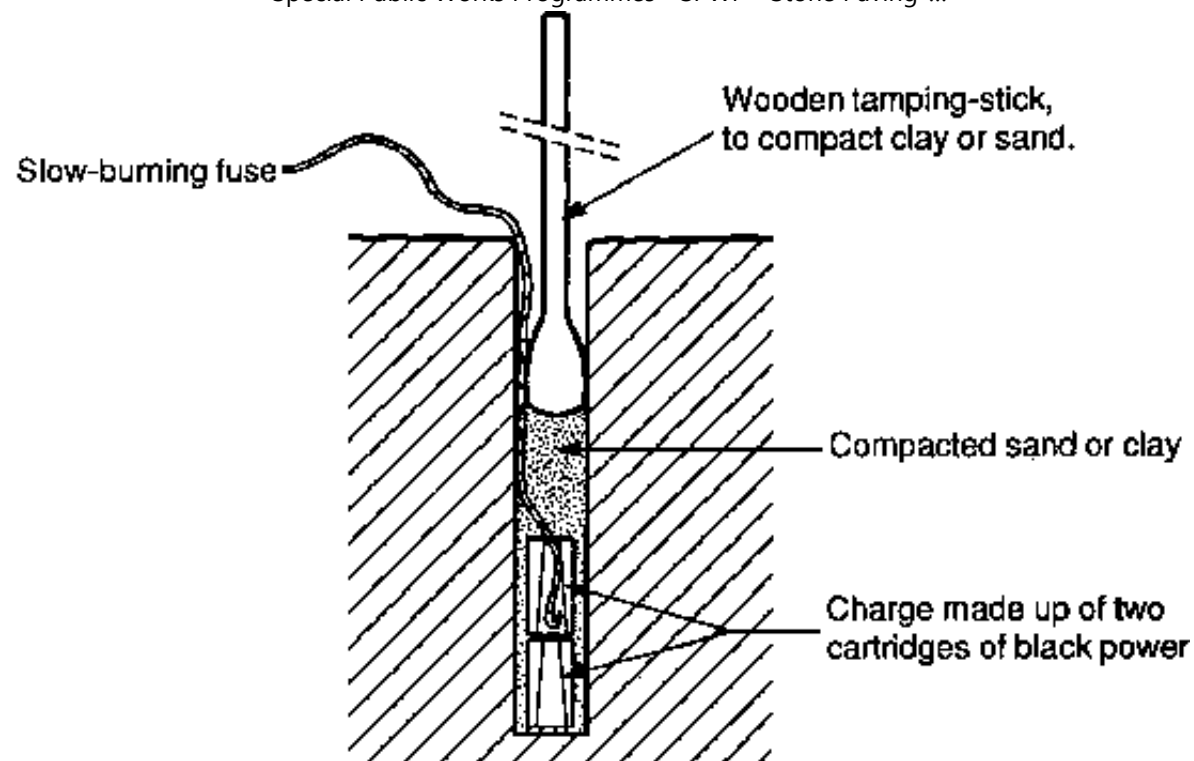

**Figure**

**Black powder is primed using a slow fuse which transmits a flame at the rate of 1 metre in 90 seconds. Once the primed cartridges are in place in the holes, the holes are packed with clay or sand.**

**The fuse is lit by the certified blasting officer only after all quarry workers have been guided to a safe location.**

**The shock wave caused by the explosion will be guided by the groove.**

**Safety:**

**Use of explosives is dangerous. This means that safety precautions must be taken.**

**All stipulations contained in national legislation and regulations, as well as recognised guidelines on the use of explosives, must be respected. Rules regarding the transport, storage and use of explosives and detonators aim at protecting people and property against bodily or material harm. Only holders of blasting certificates can be authorised to handle and use explosives.**

## **Calmmite**

**A new product, Calmmite, can sometimes serve as an alternative to explosives. Calmmite sticks are soaked in water before being placed in holes drilled in the rock. With hydration, Calmmite expands with great strength, breaking the rock after 12 - 36 hours without explosion. Although still relatively expensive, Calmmite is often an appropriate quarrying tool, especially in fragile mountain environments prone to landslides and erosion. Like explosives, Calmmite must be handled with care.**



[Home](#) > [ar](#).[cn](#).[de](#).[en](#).[es](#).[fr](#).[id](#).[it](#).[ph](#).[po](#).[ru](#).[sw](#)

 **Special Public Works Programmes - SPWP - Stone Paving-Blocks - Quarrying, Cutting and Dressing (ILO - UNDP, 1992, 60 p.)**

  **3. HANDLING THE BLOCKS**

 **Handling and transporting stone blocks**

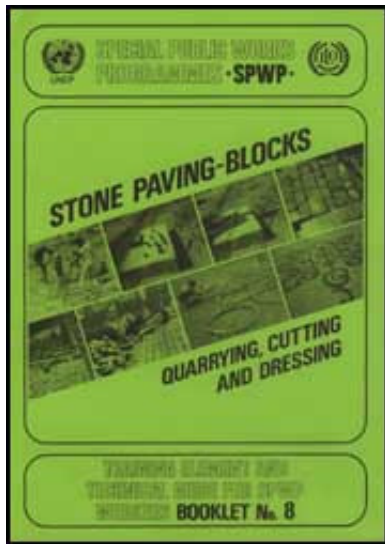

## Tools



## Block-handling techniques

### **Special Public Works Programmes - SPWP - Stone Paving-Blocks - Quarrying, Cutting and Dressing (ILO - UNDP, 1992, 60 p.)**

## **3. HANDLING THE BLOCKS**

### **Handling and transporting stone blocks**

**Before secondary cutting, the large stone blocks should be transported to the site where the paving-blocks will be dressed. The operations of handling and transporting are together known as stone haulage. In many quarries, the know-how of the stone-haulier has been replaced by mechanised techniques. However, where tractors, cranes, elevators, lorries, etc. are not available, or where such mechanised methods prove too costly or poorly adapted to local conditions, the techniques of the stone-haulier are called upon.**

**The stone-haulier's tools are simple and can often be manufactured locally.**

## Tools

- **a pinch-bar, or failing this, a quarry bar (crowbar);**
- **some hardwood rollers, both cylindrical and convex to make it easy to change the direction of a load;**
- **a rack and pinion jack, capable of lifting or moving heavy loads;**
- **a hand-cart: a sturdy two-wheeled trolley, made from large-section metal tubing, capable of moving blocks weighing several hundred kilos. It is pulled by one or more workers depending on the load and terrain (see pages 28 and 29).**

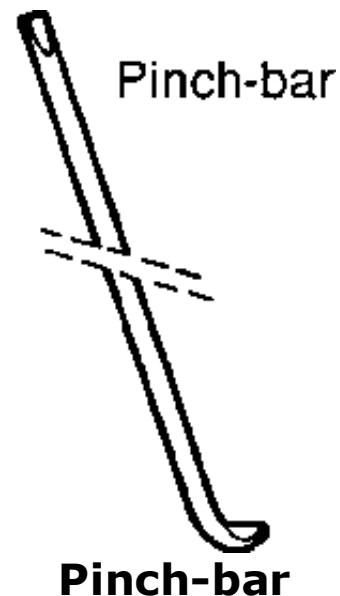

**Diameter: approx. 37 mm**



**Length: approx 1800 mm**



**Cylindrical roller**



**Convex roller**

**Approximate dimensions:**

**Diameter: 50- 100 mm**

**Length: 1000 mm**

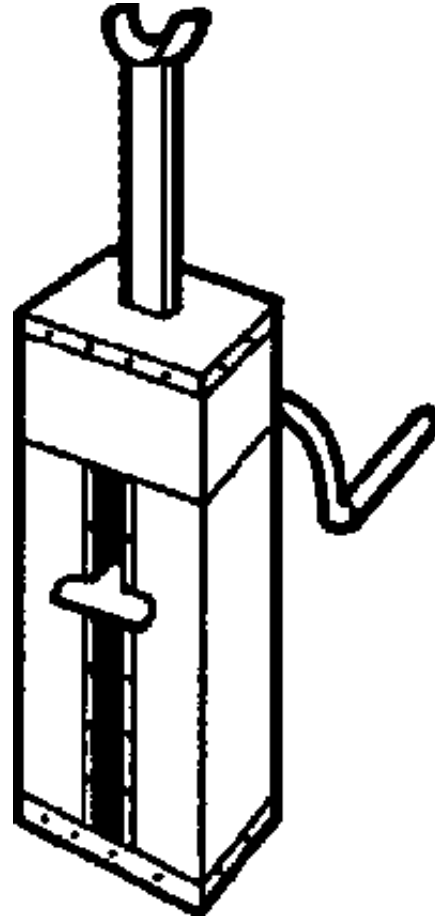

**Jack**

### **Safety:**

**The wearing of steel-capped safety shoes provides effective protection for feet, which are particularly exposed to accidents during stone-handling. Leather work gloves should also be worn.**

### **Block-handling techniques**

**In order to lift a block of stone with a pinch-bar, a chock (a quarry-stone or square wooden block) is placed under the bar which is used as a lever.**

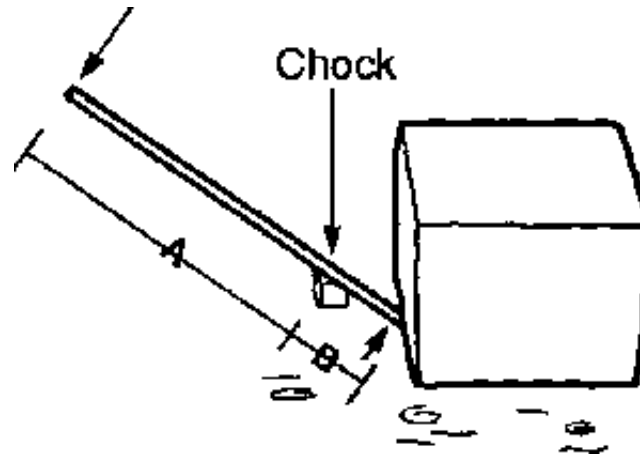

**Figure**

**The greater the ratio between A and B, the easier it is to raise the block.**

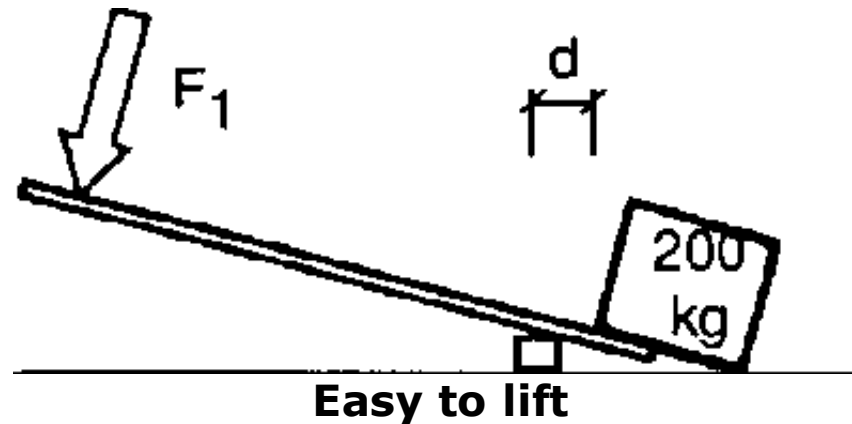

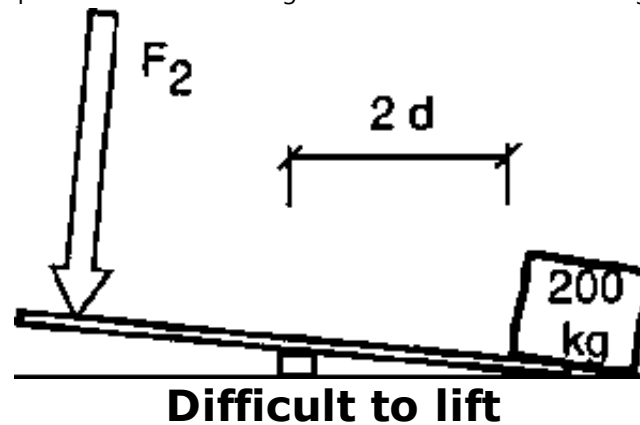

**Lifting a 200 kg block with the chock placed as in diagram (2) requires twice as much force as lifting the 200 kg block with the chock placed as in diagram (1).**

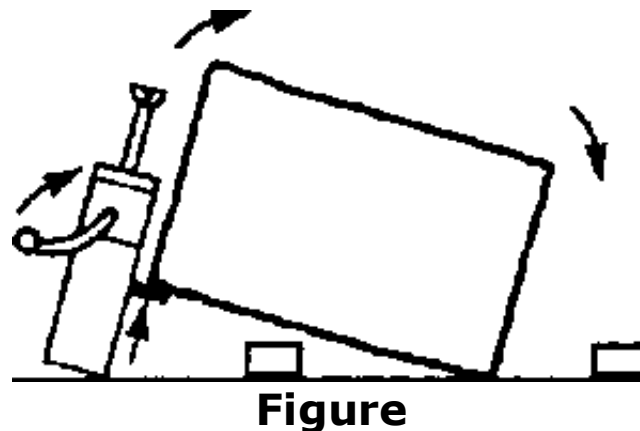

**Should a block need to be tipped over onto another side, this is achieved by sliding chocks under the block as soon as it is raised so as to be able to turn it over easily. It is possible to up-end a block, either by placing increasingly bigger chocks under it with the help of a pinch-bar or by using a jack.**

**Safety:**

**Never stack chocks on top of each other, except in a box, or they may slip and cause injury to the worker. Clean up the work environment: never let tools, chocks or other small objects lie around on the ground.**

**Before a block tips over, position a chock so that the block does not fall flat on the ground but balances on the chock. The chock serves as a pivot, making it easy to rotate or change the direction of the block.**

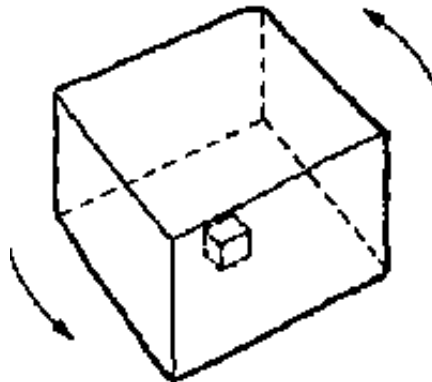

**Figure**

**If the stone to be moved is not too heavy and it is possible to hold it upright, it can be pivoted first on one corner then the other. This is called "walking" the stone.**

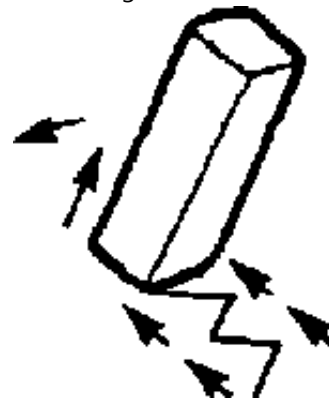

**Figure**

**Blocks weighing up to several hundred kilos can be moved using a two-wheeled trolley or hand cart. The techniques described above can be used to load the block onto the hand cart.**

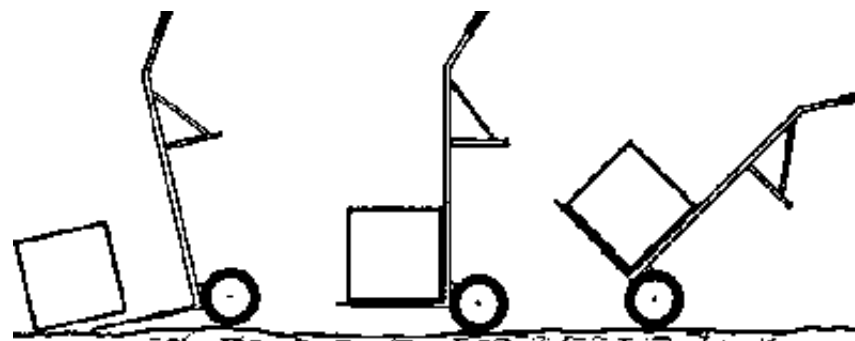

**Loading a block onto a hand cart**

**Safety:**

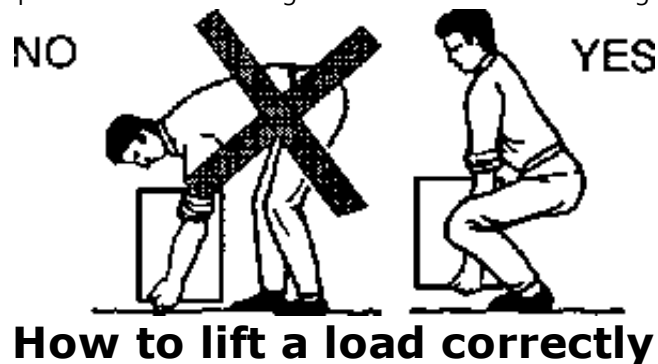

**The correct way to lift a load: with the feet well apart and the back straight, bend at the knees. Lift the load, keeping it as close to the body as possible, gradually straightening the legs. Never lift a load in the way depicted on the left. Excessive strain is placed on the back muscles and spine.**



**Transporting a block on a hand cart.**

**To move a large block over smooth hard ground, use can be made of rollers directly on the ground or on a "railway" constructed of planks to smooth out any irregularities of the terrain.**

**The block moves along on two rollers; when one roller comes out behind the block**

**it is moved to the front and so on.**

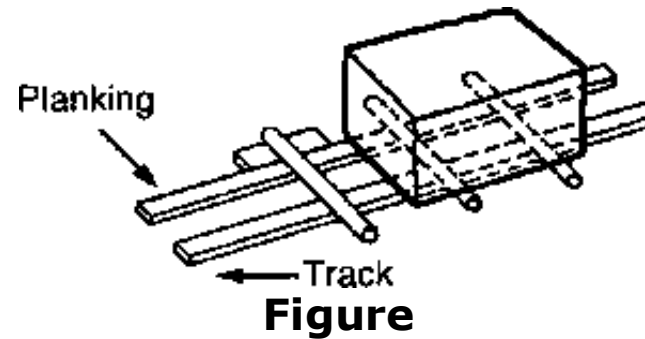
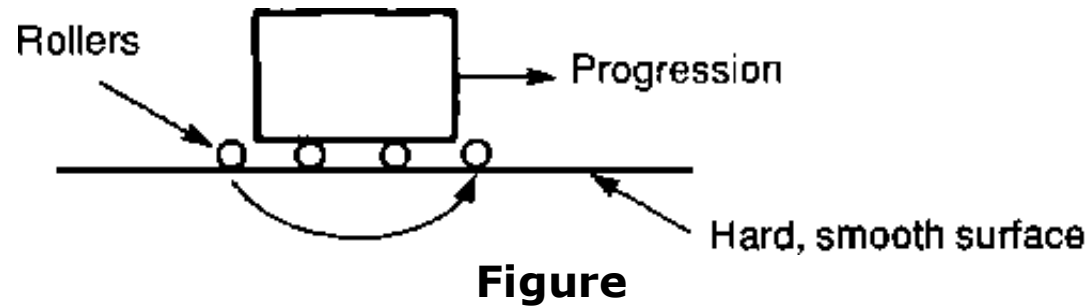

**To change direction, the rollers are placed perpendicular to the required path.**

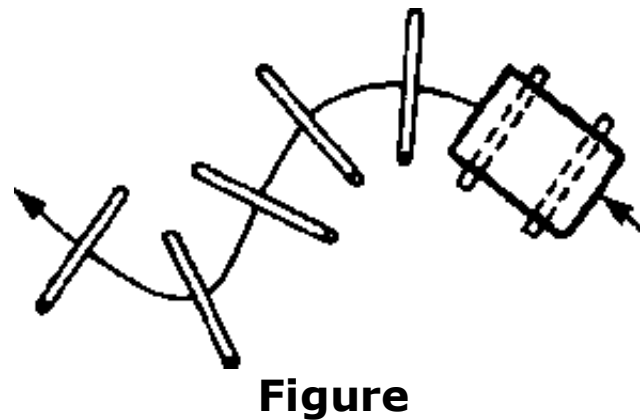

**When changing direction, use of convex (and not cylindrical) rollers improves**



## manoeuvrability.

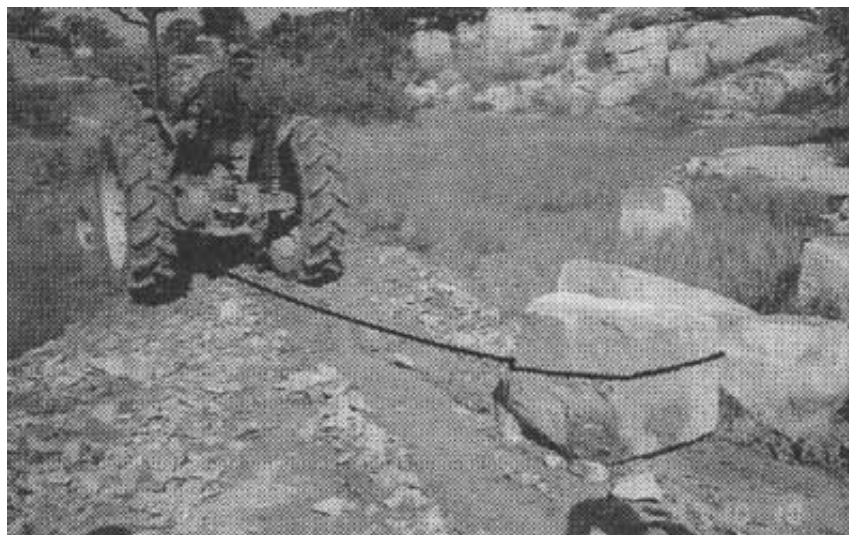

**Transporting a block using a tractor and metal cable**



[Home](#) > [ar](#).[cn](#).[de](#).[en](#).[es](#).[fr](#).[id](#).[it](#).[ph](#).[po](#).[ru](#).[sw](#)

 **Special Public Works Programmes - SPWP - Stone Paving-Blocks - Quarrying, Cutting and Dressing (ILO - UNDP, 1992, 60 p.)**

  **4. SECONDARY CUTTING AND DRESSING**

 **Product dimensions**

 **Secondary cutting of stone paving blocks**

 **Dressing the paving-blocks**

 **Tools for dressing stone paving blocks**

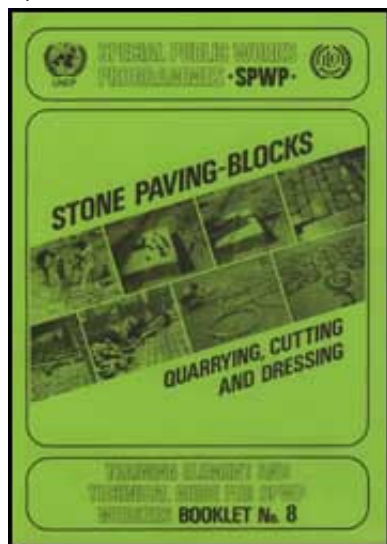

## Curbstone dressing

### Special Public Works Programmes - SPWP - Stone Paving-Blocks - Quarrying, Cutting and Dressing (ILO - UNDP, 1992, 60 p.)

#### 4. SECONDARY CUTTING AND DRESSING

##### Product dimensions

The products most often used for road-surfacing work are the following:

Description	Dimensions in cm			
	Allowance:	width (w) in cm ± 1 cm	length (l) in cm 5cm	height (h) in cm 1 cm
Mosaic paving-block		7 to 10	7 to 10	8 to 10
Large paving-block		14	20	14
Bondstone		14	30	14

Edging curbstone		16	80	20
------------------	--	----	----	----

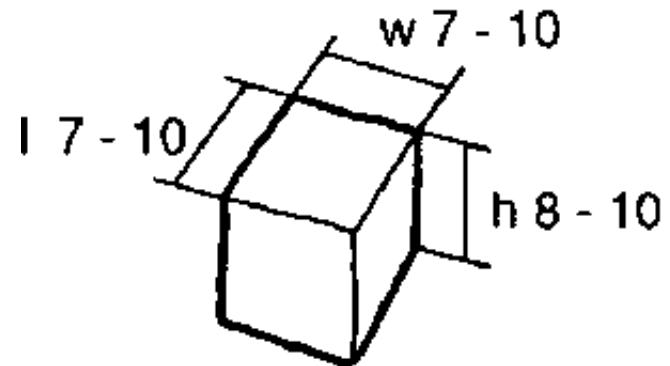

**Mosaic paving-block**

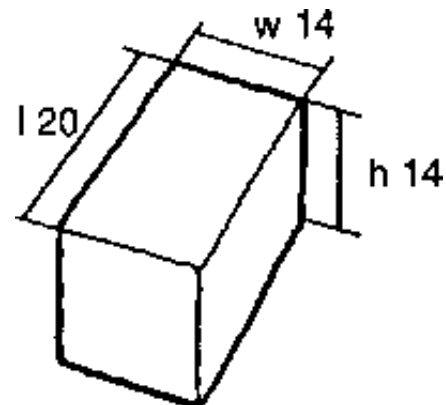

**Large paving-block**

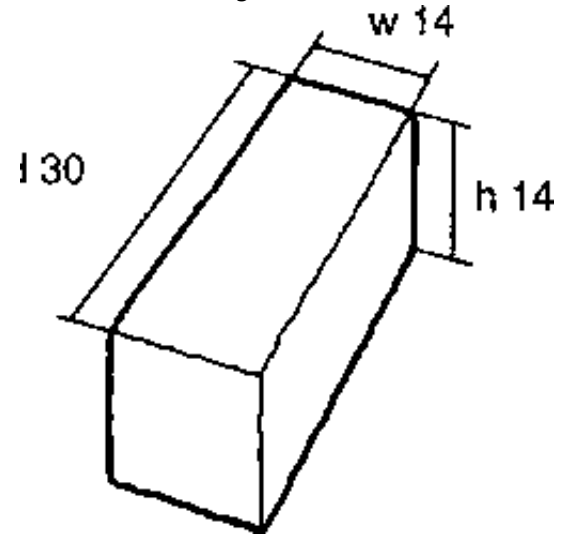

**Bondstone**

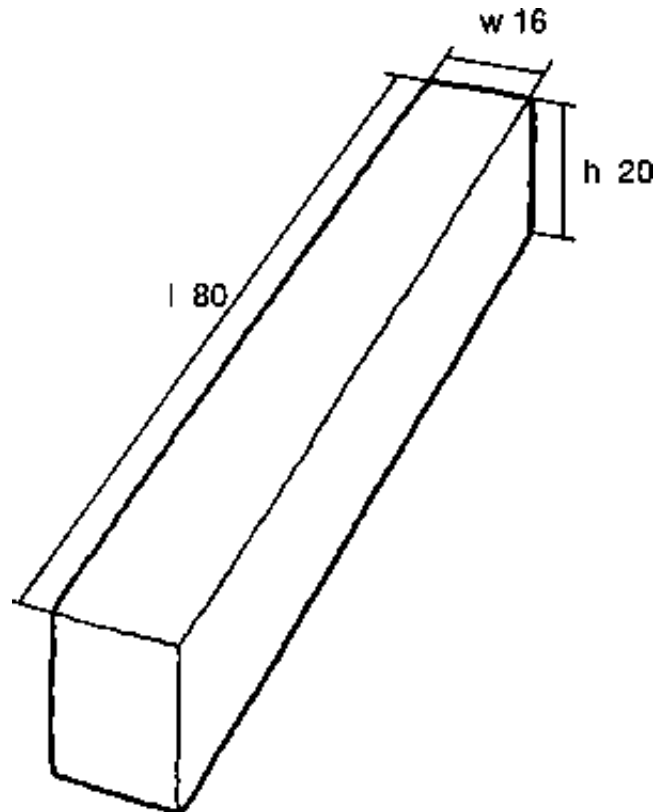

## Edging curbstone

**Slight deviations from the standard dimensions of paving-blocks, of around 1 cm for width and height, and 5 cm for length, are tolerable.**

**As shown below, two types of curbstone can be used. Apparent curbstones for use with sidewalks raised above the street surface (A) are more difficult to produce because two of their faces are exposed when they are laid. The two exposed faces should be even and form a 90° angle.**

**A.**

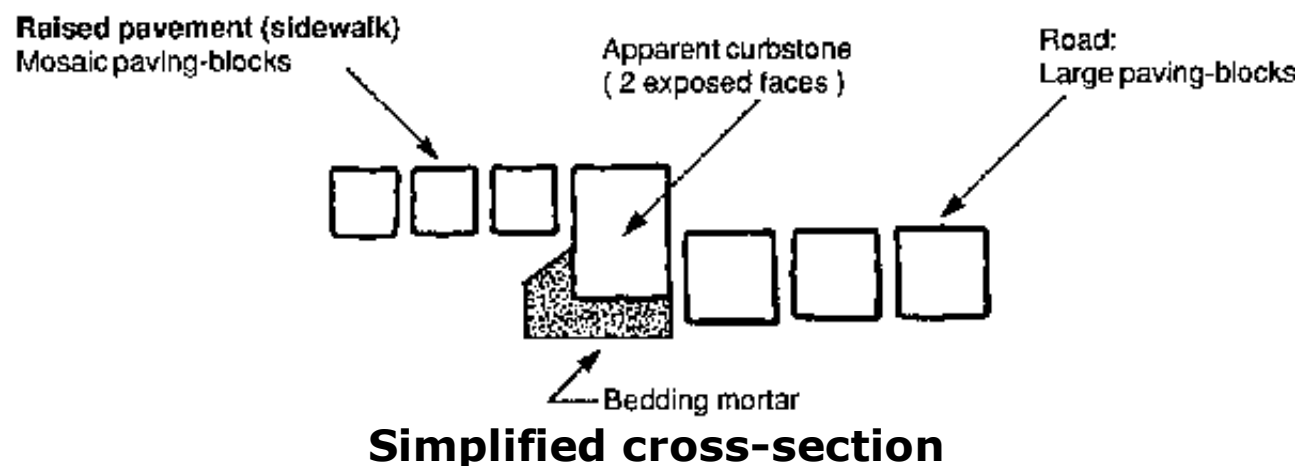

**B.**

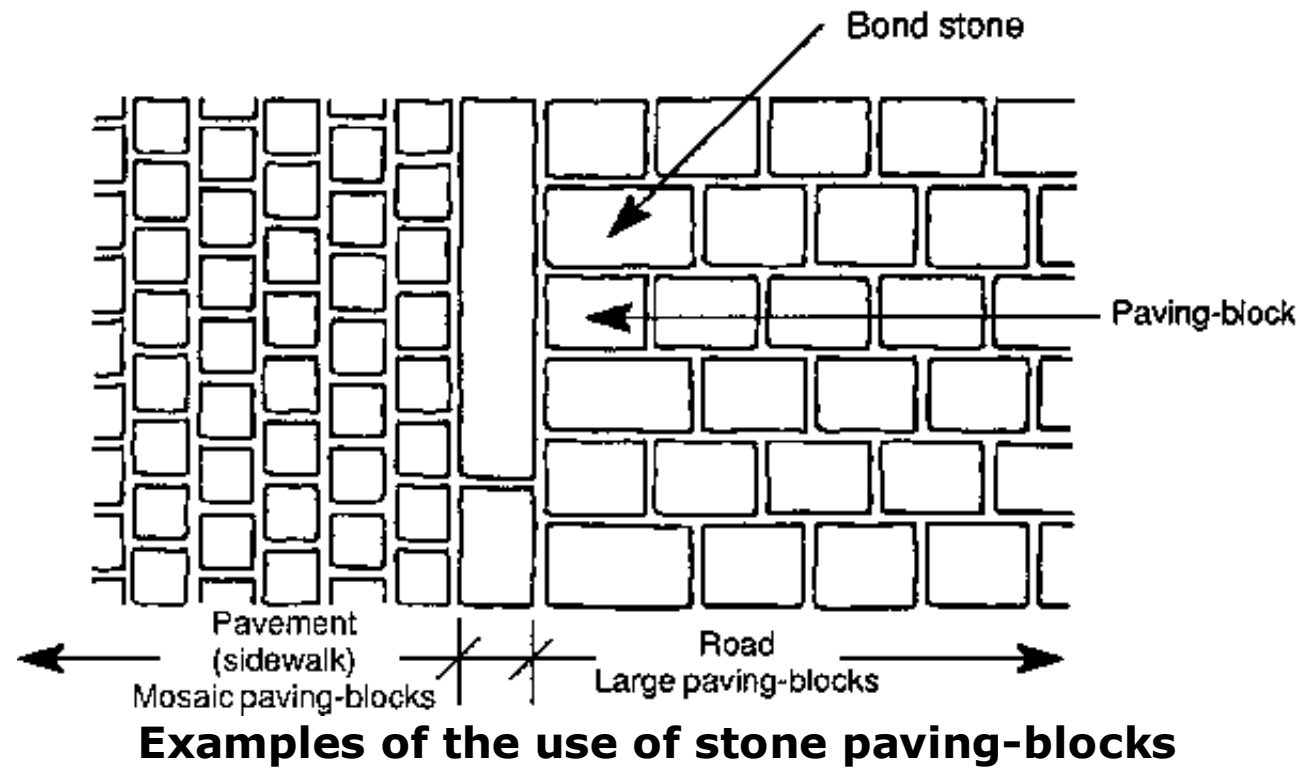
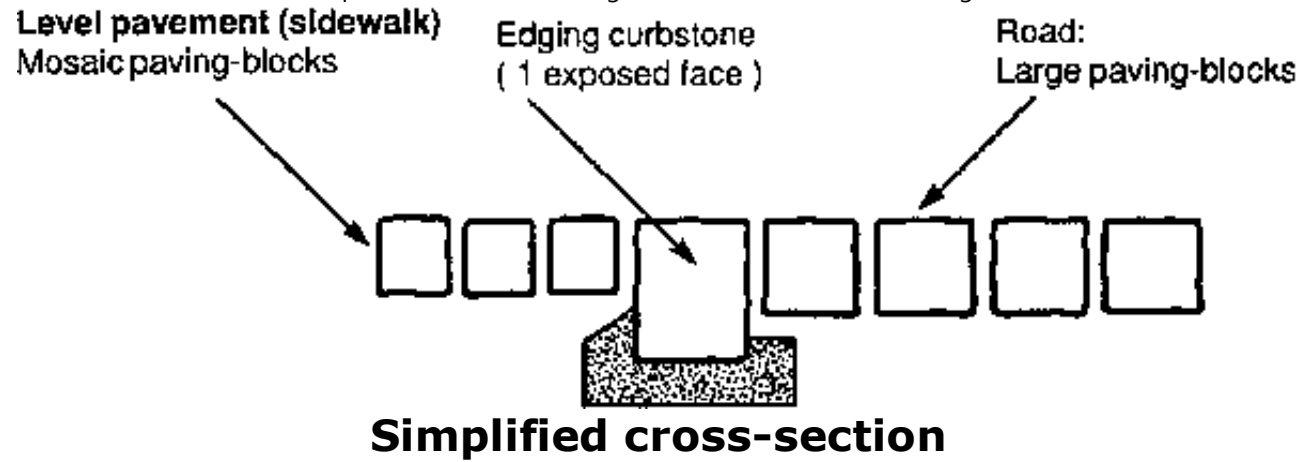

### Examples of the use of mosaic paving



**Arch layout**



**Decorative effect**

**Good paving must display the following characteristics:**

- **the road surface must be quite even, ensuring a comfortable riding surface for traffic: the distance between the bottom of dips and top of humps in the road surface must not exceed 2 cm (1) over a length of 3 meters.**



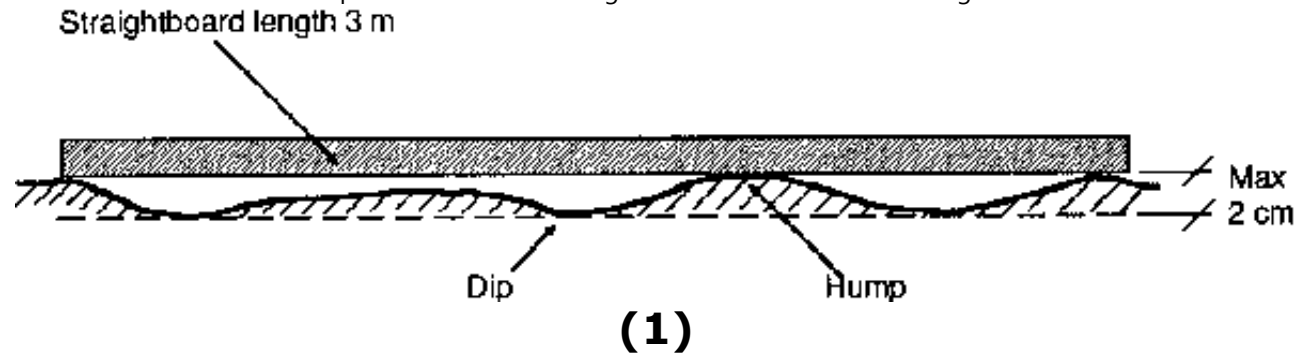

- the lateral face of paving-blocks must be perpendicular to the road surface.

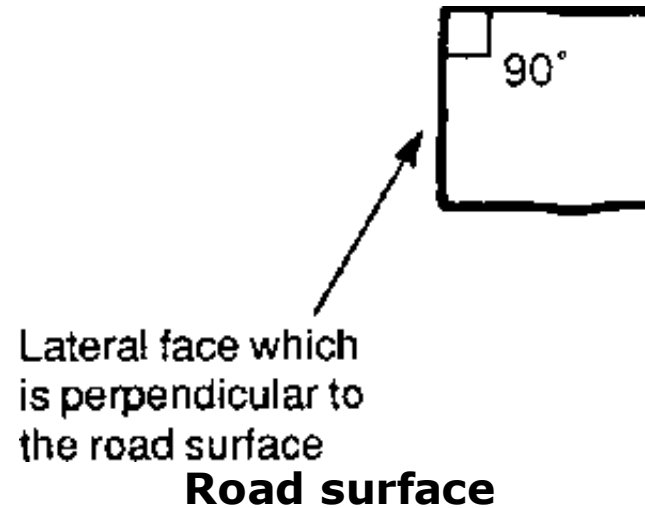

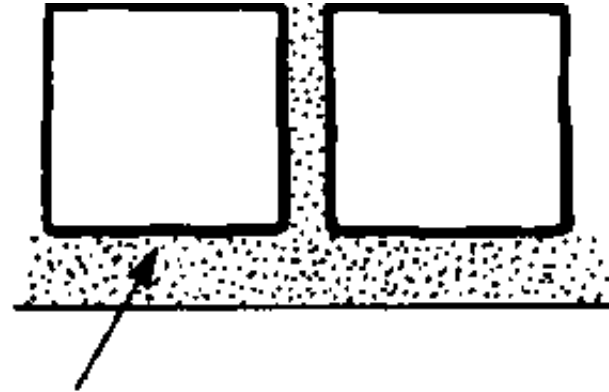

Bedding sand

**Paving-blocks are laid in sand bedding**

**If lateral faces of paving-blocks form an obtuse angle (more than 90°) with the road surface, these must be corrected on the site to form a right angle.**

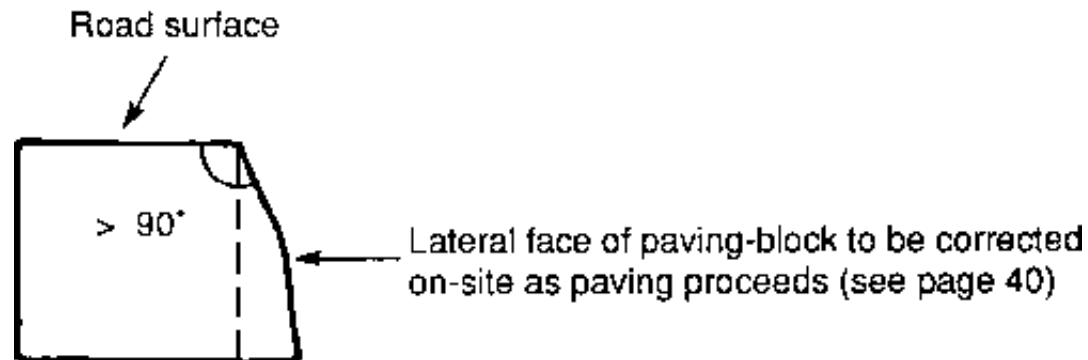

**Figure**

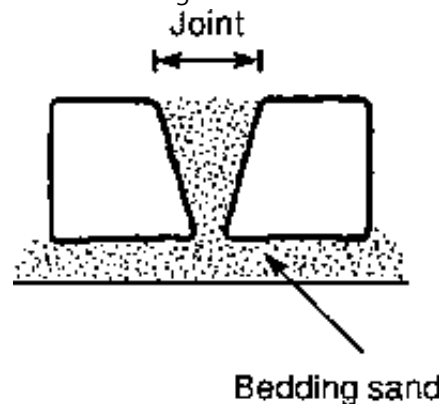

**Excessively wide surface joint due to poor quality of paving-blocks.**

**If the lateral sides of a paving-block form an acute angle with the road surface, the paving-block loses some of its stability.**

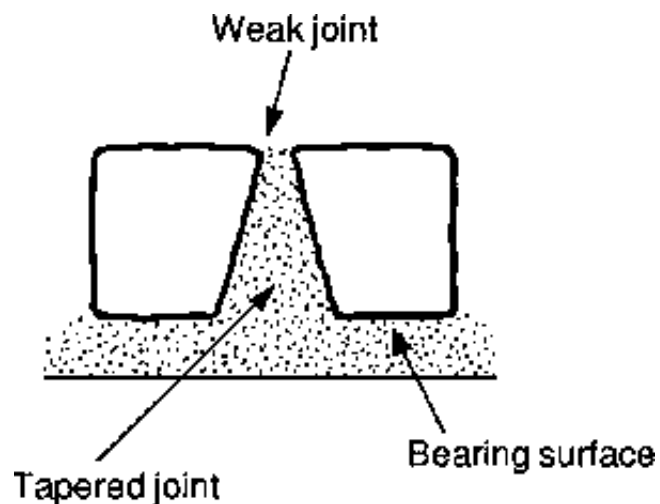

**Figure**

**As the bearing surface of the paving-block is reduced, the block will tend to sink into the bedding sand.**

**2 cm is the maximum separation permissible for a tapered joint.**

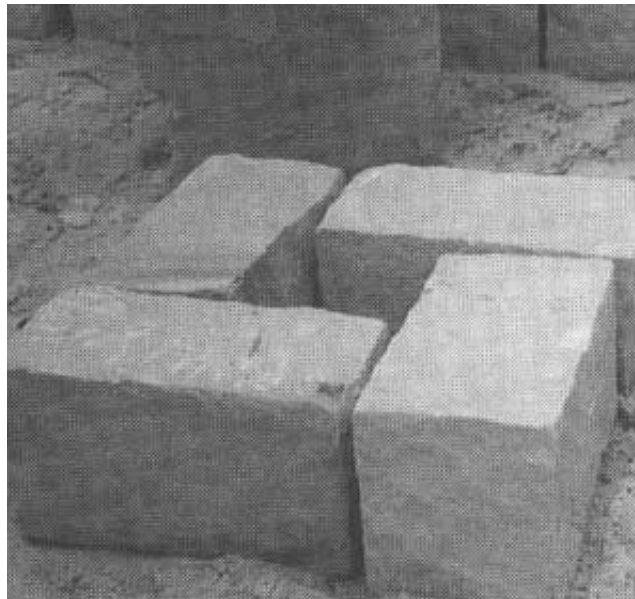
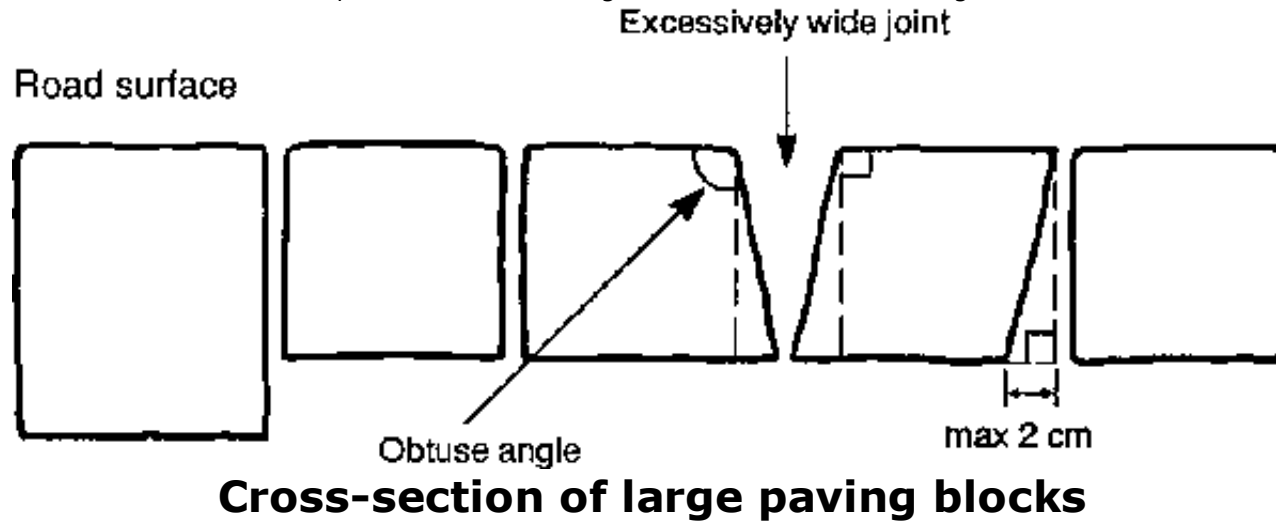

**Very high quality bondstones**



**Acceptable (medium quality) large paving-block**

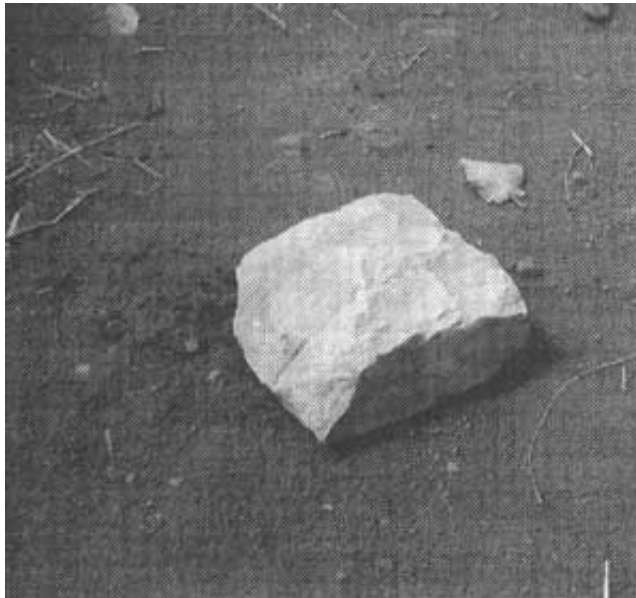

**Unacceptable paving-block: its faces do not form 90° angles, and therefore it is to be rejected.**

## **Secondary cutting of stone paving blocks**

**Unlike primary cutting in the quarry where three methods are possible (quarry wedges, plug and feathers and explosives), secondary cutting of stone paving blocks involves splitting using a quarry wedge.**

**First, the required cuts are marked with the help of a rule and marking tools. This task must be carried out with care and precision so as to make the most of the block; the more precise this operation is, the less paving-block dressing work and stone waste there will be.**

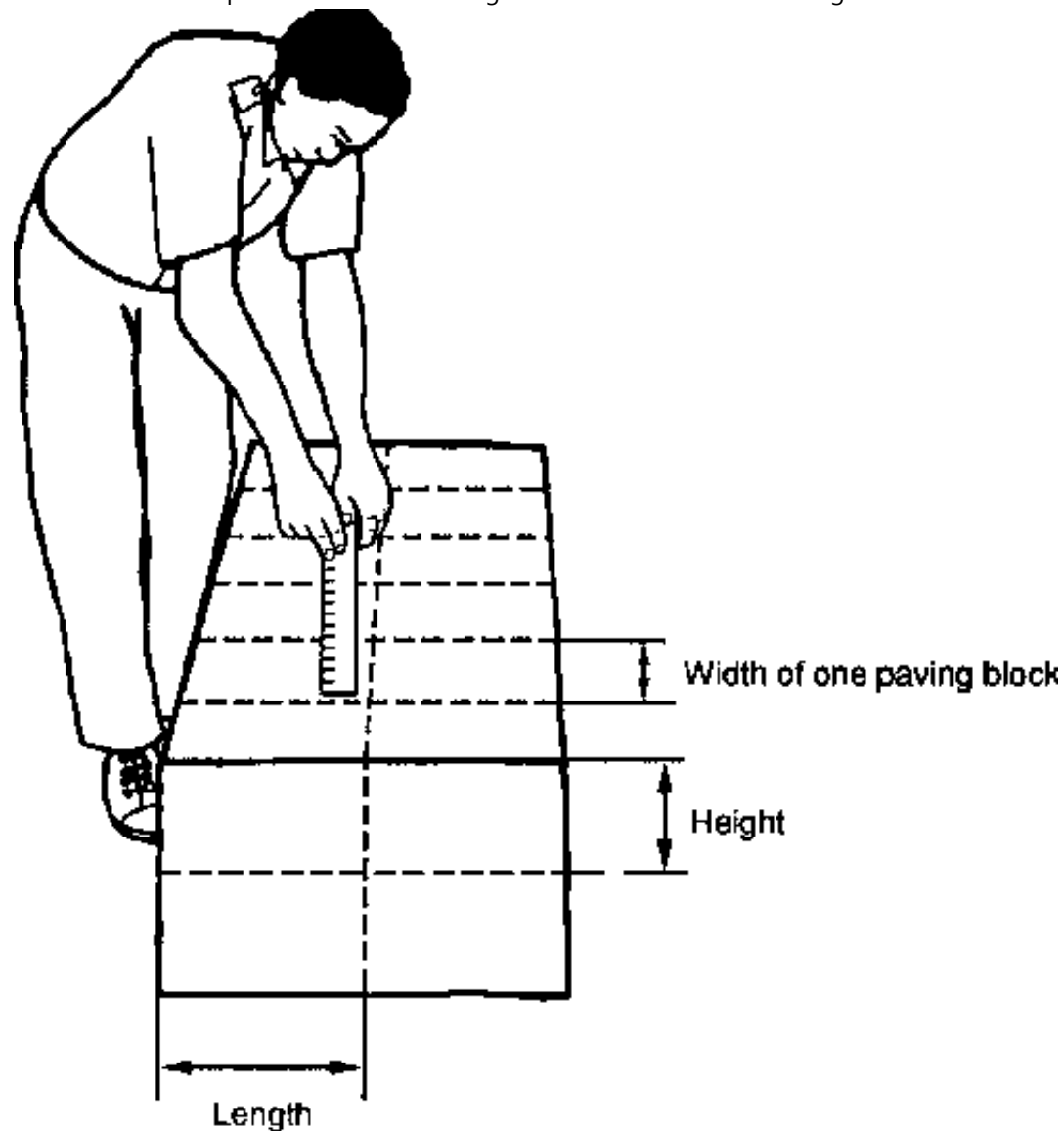

### Marking the cutting-line

**To split a block, the same procedure is employed as in quarrying using splitting wedges: the cut is marked by making a groove with a grooving-chisel and club-hammer or with a hammer drill equipped with a chisel end. Every 15-20 cm,**

**wedge holes are made. Once the wedges have been tapped into place with the club-hammer, they are struck in succession with a sledgehammer, splitting the block.**

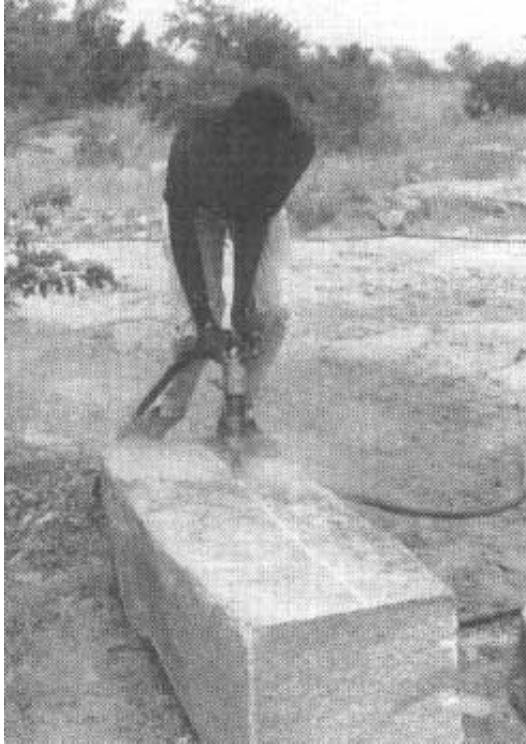

**Grooving a block with a hammer drill**



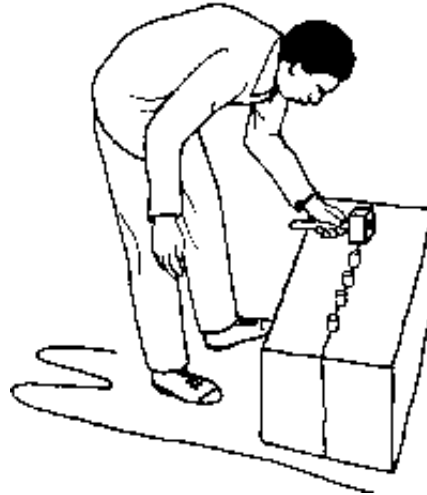

**Figure**

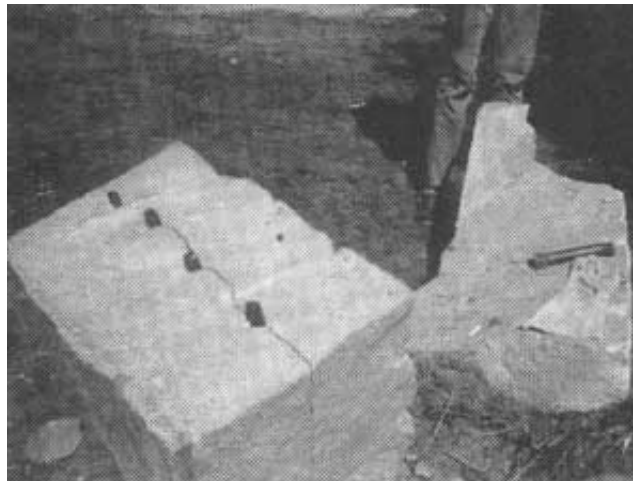

**Putting wedges into wedge holes using a club hammer**

**Once slabs of paving-block thickness have been produced (see drawing), a template with the dimensions of the paving-blocks required is used to mark out the cuts needed to produce the paving-blocks.**

**Using a template to mark cutting lines for cutting of paving blocks.**

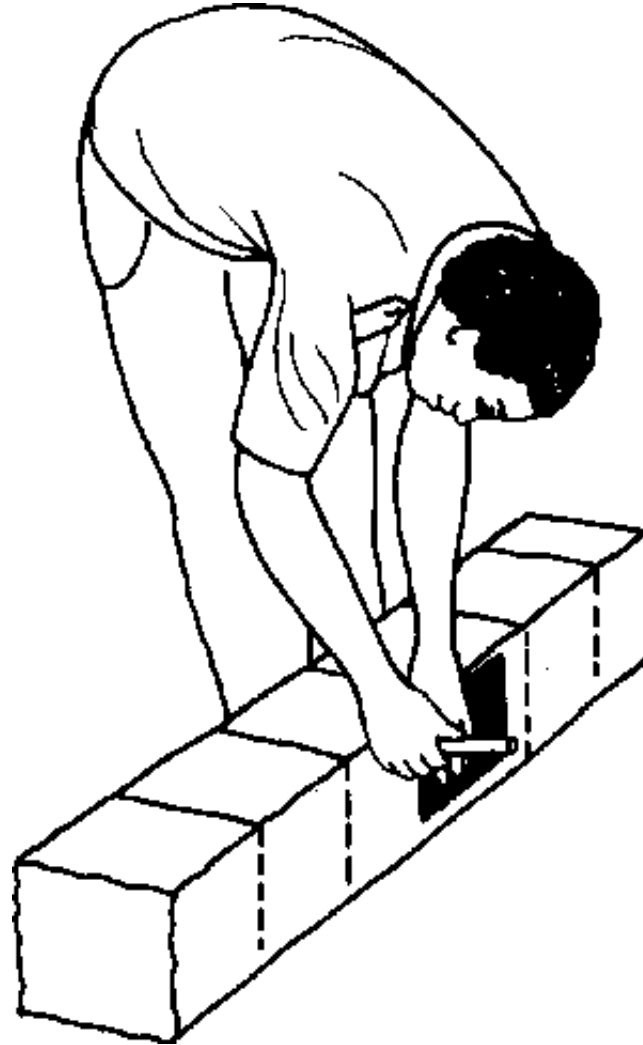

**Figure**



### **Cutting paving-blocks**

**Grooves are made along the cutting-lines using a grooving-chisel. These operations (marking and channelling) are repeated on all faces of the stone.**

**Manual grooving.**



**Figure**

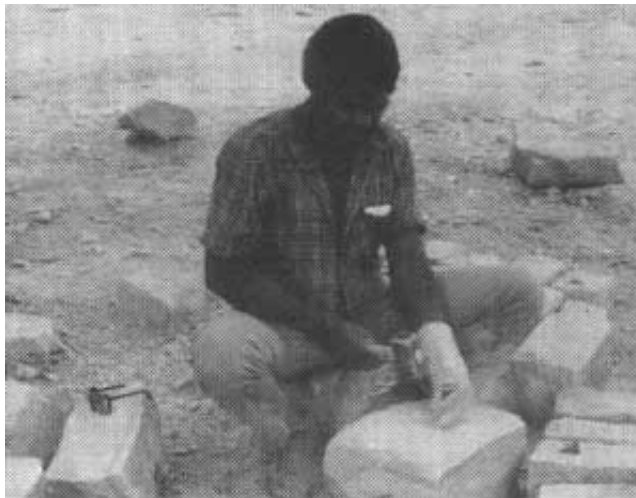

**Figure**

**Next, a crowbar is placed under the slab of stone at the places here the stone is to be split.**

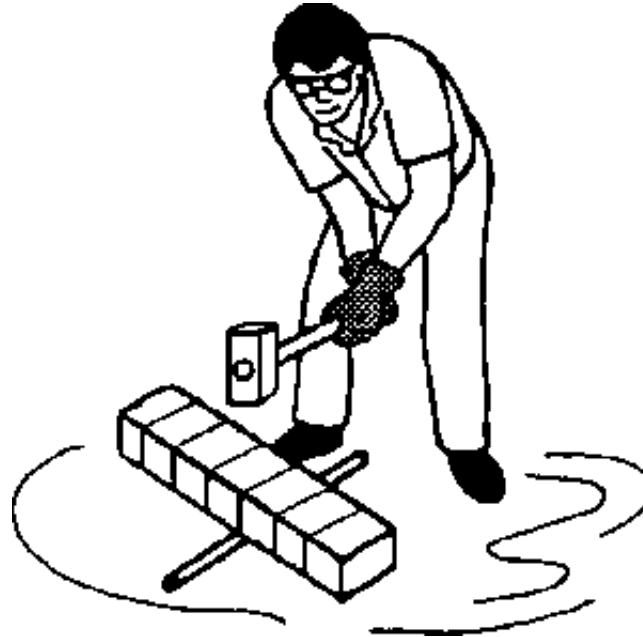

**Figure**



**Figure**

**The stone is struck with a sledgehammer directly above the crowbar. The shockwave produced is transmitted to the crowbar, which acts as a bearing point, causing the stone to be split at this precise place.**

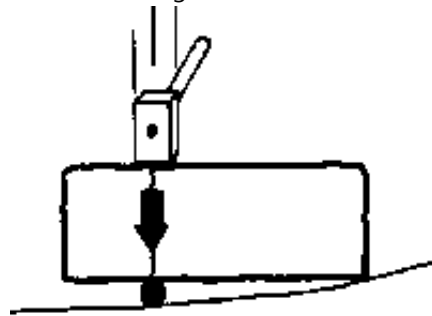

**YES  
Figure**

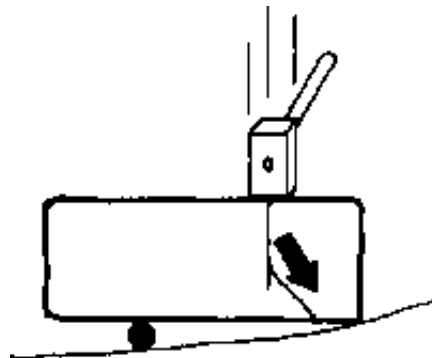

**NO  
Figure**

### **Safety:**

**As in all stone dressing work, gloves and safety goggles should be worn.**

### **Dressing the paving-blocks**

**The blocks obtained from this cutting process are slightly larger than the dimensions required for paving.**

**The template is again employed to mark the edges of the paving-block, which are then shaped with the help of a tungsten-tipped chisel.**

**The projecting edge of the tool is moved to different points along the marked line and the chisel is given a single sharp blow with the club-hammer. The angle at which the tool is held determines the amount of material removed.**

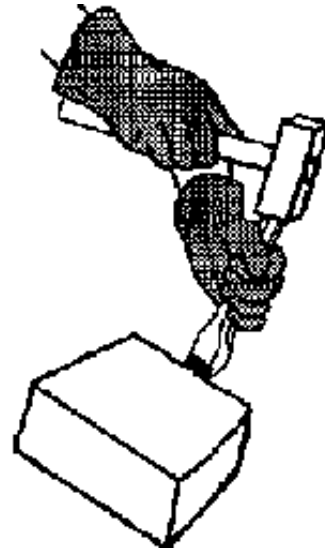

**Figure**

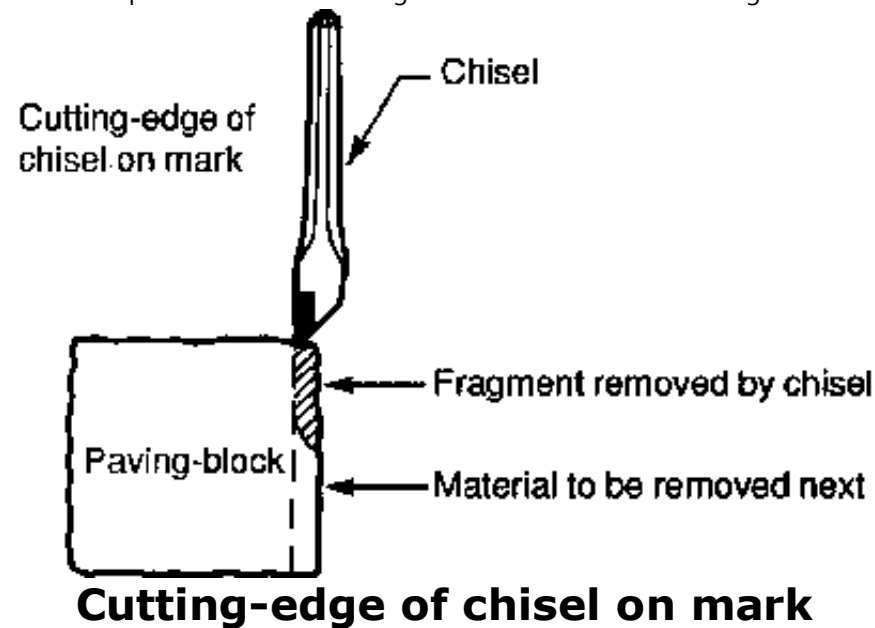

### **Safety:**

**Stone fragments are very sharp; any wound, however small, must be treated without delay. Gloves, boots and safety goggles must be worn to minimise possible injuries. First aid kits must be available on site.**

**A grooving chisel is used to correct any remaining unevenness of the stone's surfaces for final, detailed dressing.**





**Final detailed dressing using a grooving chisel**

## **Tools for dressing stone paving blocks**

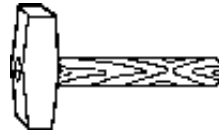

**Club hammer**



**Grooving chisel**

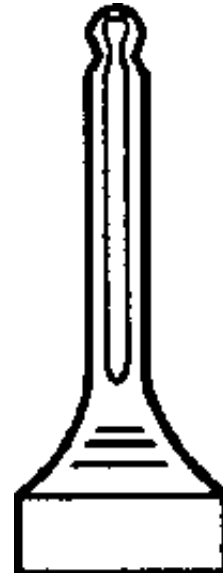

**Double chisel**

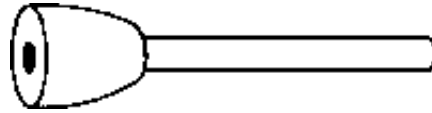

**Metal mallet**

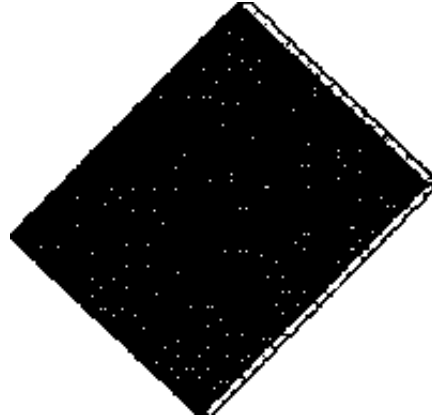

**Template**



## Punch



**Tungsten-tipped chisel**

**The size of the template varies depending on the type of the paving block (mosaic, large, edging curbstone, etc. See page 30)**

### **Curbstone dressing**

**Curbstone dressing is a delicate operation due to the larger surface area to be covered. The steps to be followed are described below.**

**First, a rule is used to mark the final curbstone measurements on the road surface face of the stone block.**

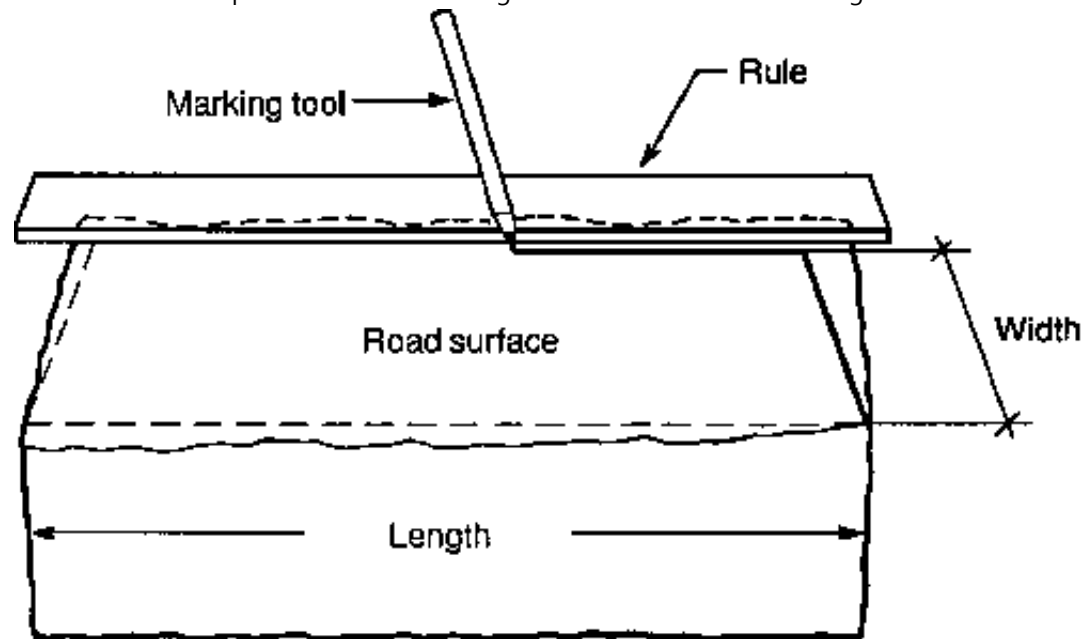

**Figure**

**To facilitate marking, the block can be supported on a chock, as illustrated below. Next, another line is marked along the edge of one of the faces perpendicular to the road surface face. This line is traced from the lowest (shallowest) point along this edge.**

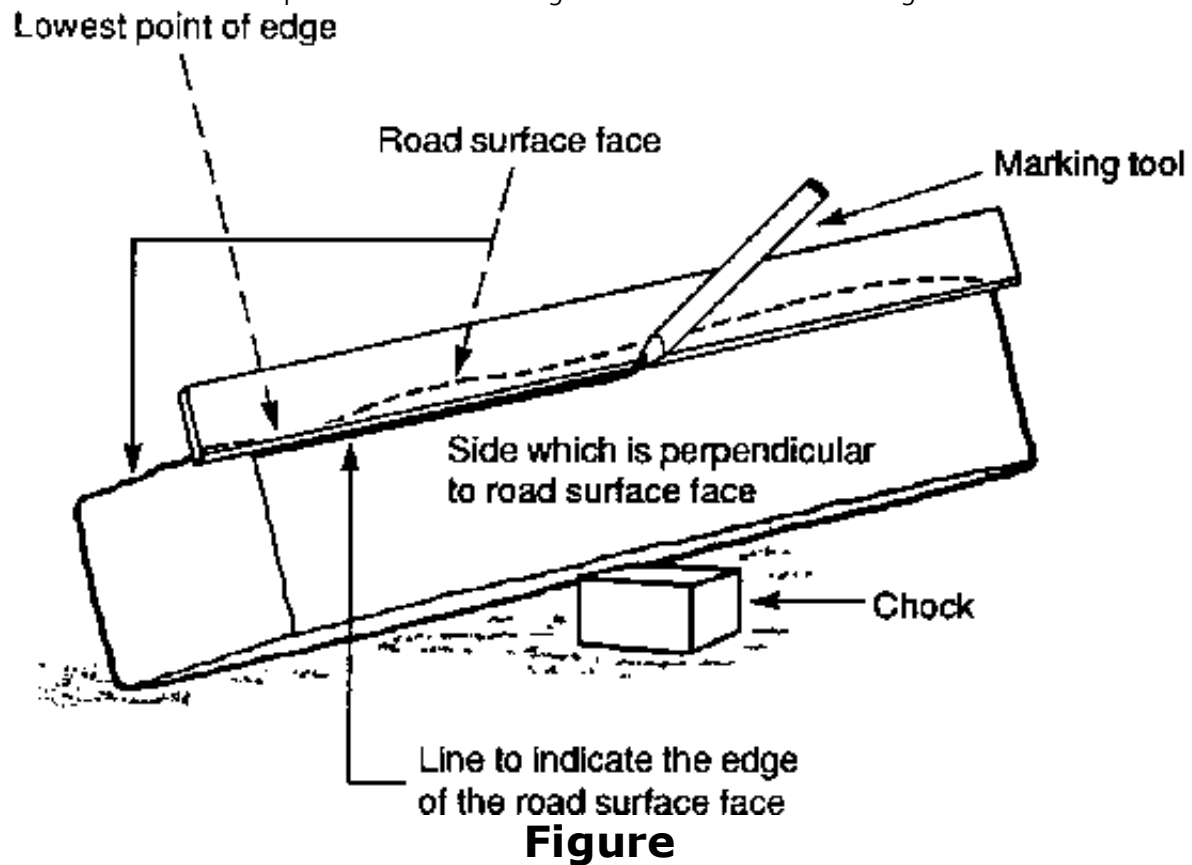

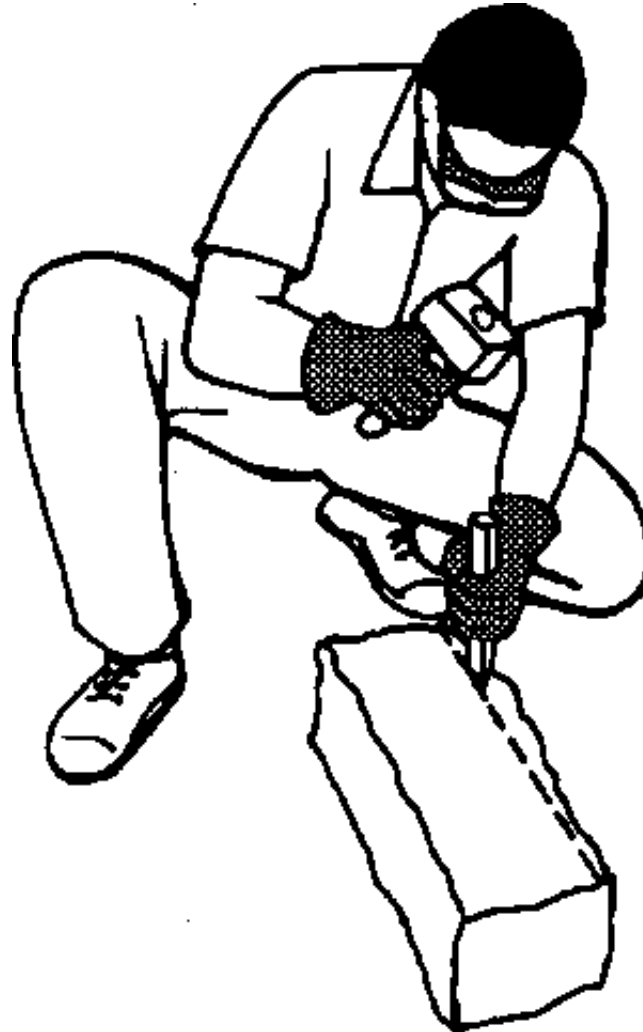

**Figure**

**This edge is then squared using the same technique as for paving blocks; that is, using a tungsten tipped chisel and club hammer.**

**The same marking and dressing procedure is repeated on the opposite face. The work requires care and precision to obtain a perfectly true and smooth road surface, with no irregularities.**

**To proceed, the rule is placed at the lowest point on each face to make the subsequent edges.**

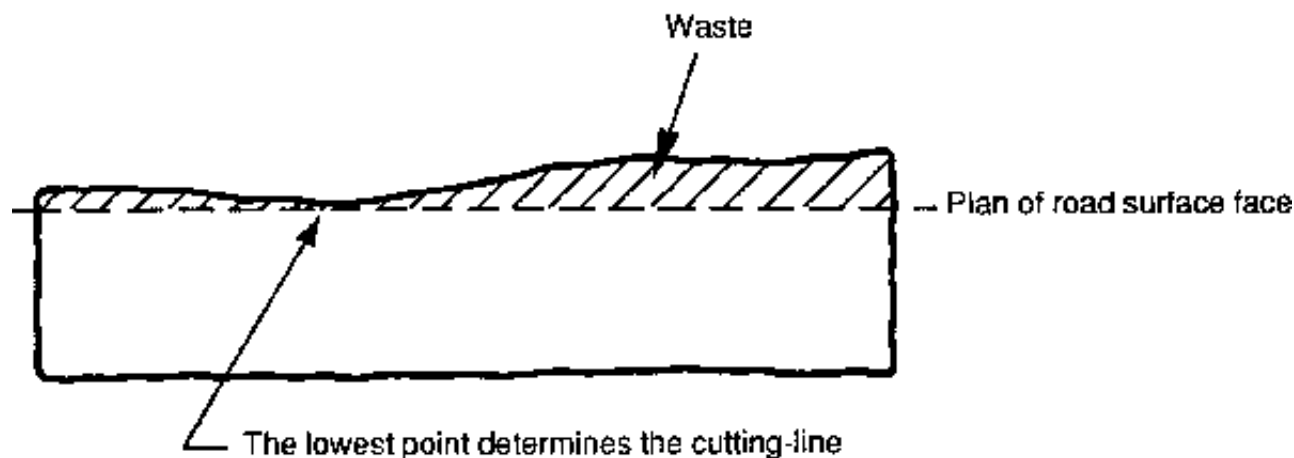

**Figure**

**The second edge can then be squared as before.**



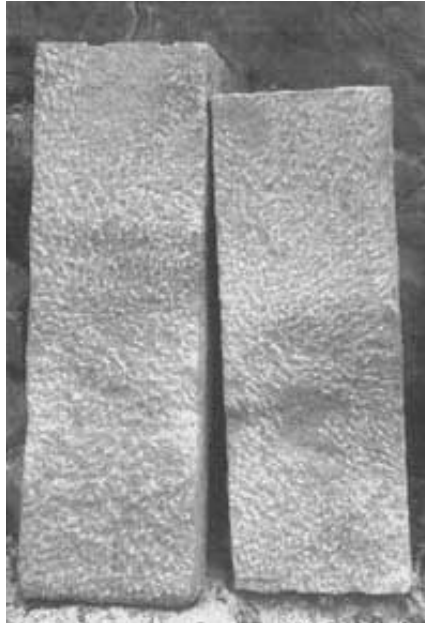

**Dressing of the paving-block is finished off, using a grooving chisel to correct any irregularities which may still exist on the road surface face or sides of the block.**









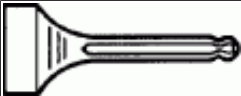
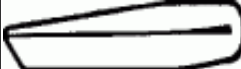
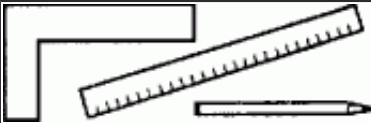

**Perfectly dressed edging curbstones.**

**To recap, the minimum tools required by a stonemason to produce paving blocks are the following:**

<b>Description</b>	<b>Number</b>	<b>Diagram and observations</b>	
Club-hammer	1	weight 1.250 kg cost 20 \$	
Metal mallet	1	weight 1.250 kg cost 20 \$	
Steel grooving-chisel	10	weight 0.8 kg cost 6 \$	
Tungsten carbide chisel	1	weight 1 kg	

Steel double chisel	1	cost 50 \$ weight 0.9 kg cost 20 \$	
Steel wedges	10	cost 3 \$ locally produced	
Marking tools			
- pencil			
- red wood			
- charcoal			
- scribers			
- stone chip			
- rule			
- metal square			
Stonemason's safety goggles		cost 10\$	
Safety shoes		cost 50 \$	
Ear protectors		cost 35 \$	
Work gloves		cost 10\$	

			
Crowbar		can be locally produced; 34 mm, length 1,800 mm	



[Home](#) > [ar](#).[cn](#).[de](#).[en](#).[es](#).[fr](#).[id](#).[it](#).[ph](#).[po](#).[ru](#).[sw](#)

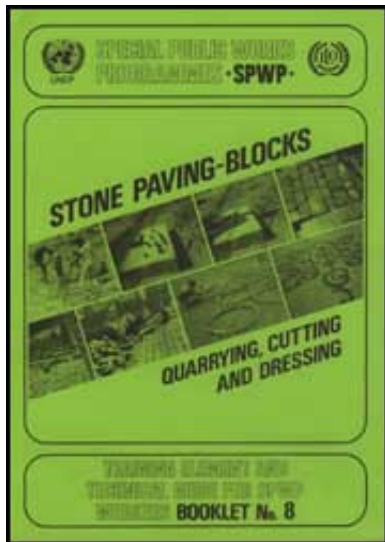

 **Special Public Works Programmes - SPWP - Stone Paving-Blocks - Quarrying, Cutting and Dressing (ILO - UNDP, 1992, 60 p.)**

 **5. STORING AND TRANSPORTING STONE PAVING BLOCKS**

 **(introduction...)**

 **Annex: Productivity norms for each tasks**

**Special Public Works Programmes - SPWP - Stone Paving-Blocks - Quarrying, Cutting and Dressing (ILO - UNDP, 1992, 60 p.)**

## **5. STORING AND TRANSPORTING STONE PAVING BLOCKS**

**After quality control of the paving-blocks and their acceptance by the site foreman, the blocks are marked with paint on their road surface face and then stockpiled.**

**Paving-blocks are counted as they are being stacked. Stacks are made up of a given number of paving-blocks to make stock checks easy. Stacks should be no taller than one metre for safety reasons: stacks that are too tall might not be well-balanced and can fall over easily.**



**Correct stockpiling - Incorrect stockpiling which makes any stock control or evaluation impossible and results in damaged material.**

**Storage areas must be easily accessible to the means of transport which will supply the paving sites. In general, finished products are stored in the quarry itself. It is possible, however, that paving-blocks may have to be transported a few hundred metres from the dressing site to the storage area in the quarry. For this, a donkey and tipping cart may be used.**



**Figure**

**A tipping cart pulled by a donkey can transport between 60 and 75 paving-blocks, depending on the condition of the track, the animal's strength, and the distance. In general, animal carts can be appropriate for transport over distances ranging from 150 - 2000 m. Transport to road worksites at a distance of 500-8000 m can be done using tractors and trailers, and lorries can be used for distances over 1000 m. It is most important to choose an appropriate and manoeuvrable means of transport.**



**Edging curbstones being transported by tractor and trailer.**

## Annex: Productivity norms for each tasks

TASK/DESCRIPTION	METHOD	AVERAGE PRODUCTIVITY (norm)
<b>Quarry work</b>		
Quarrying of 0.15 to 0.25 m <sup>3</sup> blocks from granite rock mass in benches up to 0.50 m high, with many wide cracks.	Use of crowbar. Team of 3 workers who, using the crowbar as a lever, detach blocks from rock mass and help load them onto a hand cart.	4 m <sup>3</sup> /day, that is 1.3 m <sup>3</sup> /wd
Quarrying of 0.25 to 0.40 m <sup>3</sup> blocks from compact granite rock mass with benches from 0.50 to 1 m high. No cracks in benches.	Use of plug and feathers, rock drill and drill bit. Work carried out by 2 workers with one rock drill. Blocks detached from rock mass, then split if necessary before loading.	1.8 m <sup>3</sup> /day, that is 0.9 m <sup>3</sup> /wd
Quarrying of 0.25 to 0.40 m <sup>3</sup> blocks from compact granite rock mass with benches 0.30 to 1 m high.	2 workers make wedge-holes manually using grooving-chisel and club-hammer. Split blocks once more if necessary.	1 m <sup>3</sup> /day, or 0.50 m <sup>3</sup> /wd
Boring using pneumatic drill: diameter of drill-hole $\phi$ 34 mm. Compact rock.	2 workers work in shifts at drilling.	2 50-cm deep wedge-holes per hour
Boring holes for quarry wedges.	1 worker with grooving-chisel and club-hammer.	3 holes/hour

Boring holes for quarry wedges using pneumatic hammer drill.	2 workers work in shifts using hammer drill.	7 holes/hour
Quarrying of 0.50 to 1 m <sup>3</sup> blocks from compact granite rock mass with benches over 1 m high.	Use of calmmite or black powder explosive. Drilling of blast-holes using pneumatic drill. 2 workers. One blasting officer for placing and firing explosives or placing and covering calmmite.	6 m <sup>3</sup> /day, or 2 m <sup>3</sup> /wd
Cutting of 0.50 to 1 m <sup>3</sup> blocks to make 0.25 to 0.40 m <sup>3</sup> blocks.	Use of quarry wedges. Wedge-holes bored using hammer drill. Two workers in shifts.	Team cuts 3 m <sup>3</sup> /day, or 1.5 m <sup>3</sup> /wd
	Use of quarry wedges. Wedge-holes made manually. One worker.	Volume cut: 1 m <sup>3</sup> /wd
<b>Dressing</b>		
Secondary cutting stage of 0.25 to 0.40 m <sup>3</sup> blocks into 14 cm thick slabs.	Use of quarry wedges. Drilling of wedge-holes using hammer drill. Two workers in shifts.	2.5 m <sup>3</sup> /day, or 1.25 m <sup>3</sup> /wd
	Use of quarry wedges. Manual boring of wedge-holes. One worker.	0.8 m <sup>3</sup> /wd
Dressing of large paving-blocks from 14 cm thick slabs.	Use of pneumatic hammer drill fitted with chisel end. Edges dressed by means of chisel. One worker.	40 paving-blocks/wd
	Manual method: grooves cut using	20 paving-

	grooving-chisel and club-hammer. Edges dressed by means of chisel. One worker	blocks/wd
Dressing of edging curbstones.	Edges dressed using chisel, faces corrected using grooving-chisel. One worker.	4 Im/wd
Clearing, over radius of 50 m, of stone debris resulting from squaring of paving-blocks.	Transported by wheelbarrow, loaded by 8-pronged fork.	1 worker for 20 paving-block masons
<b>Handling</b>		
Loading and transporting blocks.	Team made up of: <ul style="list-style-type: none"> <li>• 4 unskilled workers</li> <li>• 1 gang leader</li> </ul>	Handling and transporting, over 10-20 m, approx. 2 m <sup>3</sup> /wd
Transport of paving-blocks 50 m from dressing site to storage area.	Transported by wheelbarrow. Paving-blocks stacked in piles at storage site.	400 paving-blocks/wd





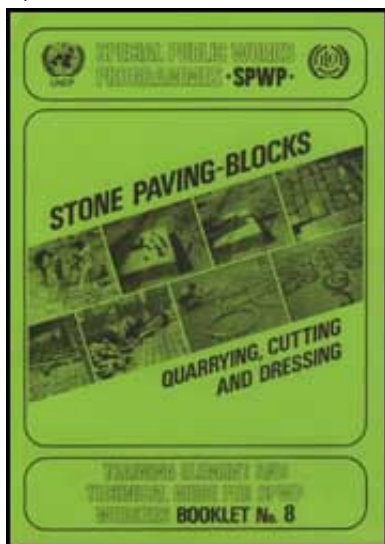

[Home](#) > [ar](#).[cn](#).[de](#).[en](#).[es](#).[fr](#).[id](#).[it](#).[ph](#).[po](#).[ru](#).[sw](#)

 **Special Public Works Programmes - SPWP - Stone Paving-Blocks - Quarrying, Cutting and Dressing (ILO - UNDP, 1992, 60 p.)**





-  **(introduction...)**
-  **Introduction**
- 1. The quarry**
- 2. QUARRYING**
- 3. HANDLING THE BLOCKS**
- 4. SECONDARY CUTTING AND DRESSING**
- 5. STORING AND TRANSPORTING STONE PAVING BLOCKS**
-   **Back Cover**

## Back Cover

### TITLES IN THE SERIES OF TRAINING ELEMENTS AND TECHNICAL GUIDES FOR SPWP WORKERS

Number	Title
1	<b>Anti-Erosion Ditches</b>
2	<b>Stone Masonry</b>
3	<b>Gabions</b>
4	<b>Gully Correction</b>
5	<b>Small Earth Dams</b>
6	<b>Tree Nurseries</b>
7	<b>Planting Techniques</b>

## 8 Stone Paving-Blocks: Quarrying, Cutting and Dressing

### Also available:

- **Community Water Supply : A Community Participation Training Element for SPWP User Beneficiaries**
- **Standardised Procedures for the Presentation of Work Plans**

