











- ➔ **Electrical Machines - Basic vocational knowledge (Institut für Berufliche Entwicklung, 144 p.)**
- 📄 **(introduction...)**
  - 📄 **Introduction**
    - ☐ **1. General information about electrical machines**
      - 📄 **1.1. Definition of terms**
      - 📄 **1.2. Types of electrical machines**
      - 📄 **1.3. Operations of electrical machines**
      - 📄 **1.4. System of rotating electrical machines (generators, motors, converters)**
      - 📄 **1.5. System of stationary electrical machines (transformers)**
    - ☐ **2. Basic principles**
      - ☐ **2.1. The magnetic field**

-  **2.1.1. Definition and presentation of the magnetic field**
-  **2.1.2. Magnets Magnetic field**
-  **2.1.3. Magnetic field of a current-carrying conductor**
-  **2.1.4. Magnetic field of a current-carrying coil**
-  **2.1.5. Magnetic fields in electrical machines**
- 2.2. Measurable variables of the magnetic field**
  -  **2.2.1. Magnetomotive force**
  -  **2.2.2. Magnetic flow**
  -  **2.2.3. Magnetic flow density**
- 2.3. Force action of the magnetic field**
  -  **2.3.1. Force action on current-carrying conductors**
  -  **2.3.2. Force action on current-carrying coils (motor principle)**
- 2.4. Voltage generation through**

## **induction**

 **2.4.1. General law of induction**

 **2.4.2. Stationary induction  
(transformer principle)**

 **2.4.3. Motional induction (generator  
principle)**

## **3. Execution of rotating electrical machines**

 **3.1. Size**

 **3.2. Designs**

 **3.2.1. Definition**

 **3.2.2. Designation**

 **3.3. Degree of protection**

 **3.3.1. Definition**
















 **3.3.2. Designation**












 **3.4. Cooling**

















 **3.4.1. Cooling category**

 **3.4.2. Cooling category designation**

 **3.5. Mode of operation**

-  **3.5.1. Definition**
-  **3.5.2. Operational mode designation**
-  **3.5.3. Frequent nominal cycle ratings**
-  **3.6. Heat resistance categories**
-  **3.7. Connection designations of electrical machines**
  -  **3.7.1. Transformers**
  -  **3.7.2. Rotating electrical machines**
-  **3.8. Rotating electrical machines in rotational sense**
  -  **3.8.1. Clockwise rotation stipulation**
  -  **3.8.2. Direct current machines**
  -  **3.8.3. Alternating current and three-phase machines**
-  **3.9. Rating plate**
-  **4. Synchronous machines**
  -  **4.1. Operating principles**
    -  **4.1.1. Synchronous generator**

-  **4.1.2. Synchronous motor**
- **4.2. Constructional assembly**
  -  **4.2.1. Stator**
  -  **4.2.2. Rotor**
- **4.3. Operational behaviour**
  -  **4.3.1. Synchronous generator**
  -  **4.3.2. Synchronous motor**
- **4.4. Use of synchronous machines**
  -  **4.4.1. Synchronous generators**
  -  **4.4.2. Synchronous motors**
- **5. Asynchronous motors**
  -  **5.1. Constructional assembly**
  - **5.2. Operating principles**
    -  **5.2.1. Torque generation**
    -  **5.2.2. Asynchronous principle**
    -  **5.2.3. Slip**
  - **5.3. Operational behaviour**

-  **5.3.1. Start**
-  **5.3.2. Rating**
-  **5.3.3. Speed control**
-  **5.3.4. Rotational sense alteration**
-  **5.4. Circuit engineering**
  -  **5.4.1. Starting connections**
  -  **5.4.2. Dahlander pole-changing circuit (speed control)**
  -  **5.4.3. Rotational reversing circuit**
  -  **5.4.4. Braking circuits**
-  **5.5. Application**
-  **5.6. Characteristic values of squirrel cage motors**
-  **6. Direct current machines**
  -  **6.1. Constructional assembly**
  -  **6.2. Operating principles**
    -  **6.2.1. Power generation (direct current motor)**
    - 

**6.2.2. Torque generation (direct**



**current motor)**

**6.2.3. Armature reaction (rotor reaction)**



**6.2.4. Excitation**



**6.2.5. Value relations**



**6.3. Operational behaviour of direct current machines**



**6.3.1. Direct current generators**



**6.3.2. Direct current motors**



**6.4. Circuit engineering and operational features of customary direct current generators**



**6.4.1. Separate-excited direct current generator**

















**6.4.2. Direct current shunt generator**



**6.5. Circuit engineering and operational features of customary direct current motors**



**6.5.1. Direct current motor with**

-  **6.5.2. Direct current series motor**
-  **6.5.3. Direct current shunt motor**
-  **7. Single-phase alternating current motors**
  -  **(introduction...)**
  -  **7.1. Single-phase asynchronous motors (single-phase induction motors)**
    -  **(introduction...)**
    -  **7.1.1. Assembly and operating principle**
    -  **7.1.2. Operational behaviour**
    -  **7.1.3. Technical data**
  -  **7.2. Three-phase asynchronous motor in single-phase operation (capacitor motor)**
    -  **7.2.1. Assembly and operating principle**
    -  **7.2.2. Operational behaviour**
  -  **7.3. Split pole motors**
  -  **7.4. Single-phase commutator motors**



## **(universal motors)**

 **7.4.1. Assembly**

 **7.4.2. Operating principles**

 **7.4.3. Operational behaviour**

 **7.4.4. Technical data**

## **8. Transformer**

 **8.1. Transformer principle**

 **8.1.1. Operating principle of a transformer**

 **8.1.2. Voltage transformation**

 **8.1.3. Current transformation**

 **8.2. Operational behaviour of a transformer**







 **8.2.1. Idling behaviour Idling features**

 **8.2.2. Short-circuit behaviour**

 **8.2.3. Loaded voltage behaviour**


 **8.2.4. Efficiency**

 **8.3. Three-phase transformer**

-  **8.3.1. Three-phase transformation with single-phase transformers**
-  **8.3.2. Three-phase transformers**
-  **8.3.3. Vector groups**
-  **8.3.4. Application of three-phase transformers in power supply**
-  **8.3.5. Parallel operation of transformers**
-  **8.3.6. Technical data of customary transformers**



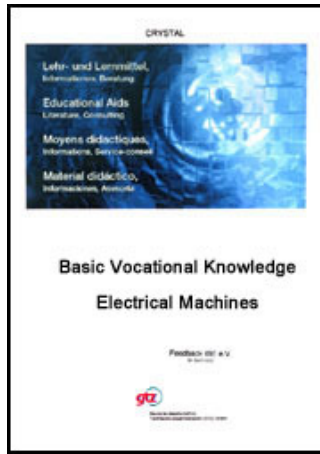
[Home](#) > [ar](#) [cn](#) [de](#) [en](#) [es](#) [fr](#) [id](#) [it](#) [ph](#) [po](#) [ru](#) [sw](#)

 **Electrical Machines - Basic vocational knowledge (Institut fr Berufliche Entwicklung, 144 p.)**

  **(introduction...)**

 **Introduction**

 **1. General information about electrical machines**



- 2. Basic principles**
- 3. Execution of rotating electrical machines**
- 4. Synchronous machines**
- 5. Asynchronous motors**
- 6. Direct current machines**
- 7. Single-phase alternating current motors**
- 8. Transformer**

## **Textbook for Vocational Training**

### **CRYSTAL**

**Lehr- und Lernmittel,  
Informationen, Beratung**

**Educational Aids  
Literature, Consulting**

**Moyens didactiques,**

**Informations, Service-conseil**

**Material didctico,  
Informaciones, Asesora**

**Feedback IBE e.V.  
91-34-0105/2**

**gtz - Deutsche Gesellschaft fr Technische Zusammenarbeit (GTZ)  
GmbH**

**Institut fr berufliche Entwicklung e.V.  
Berlin**

**Original title: "Berufliche Grundlagen - Elektromaschinen"**

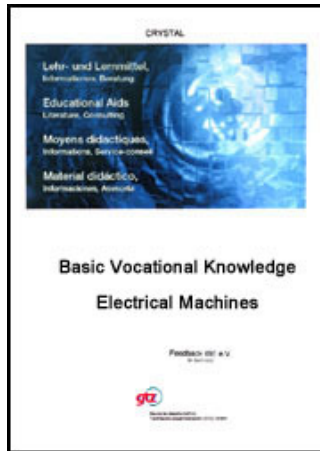
**Author: Hans-Friedrich Hoyer**


**First Edition © IBE**







**Institut fr berufliche Entwicklung e.V.  
Parkstrae 23  
13187 Berlin**








**Order No.: 91-34-0105/2**

[Home](#) > [ar](#).[cn](#).[de](#).[en](#).[es](#).[fr](#).[id](#).[it](#).[ph](#).[po](#).[ru](#).[sw](#)



 **Electrical Machines - Basic vocational knowledge (Institut für Berufliche Entwicklung, 144 p.)**

- ➔  **8. Transformer**
  - 8.1. Transformer principle**
    -  **8.1.1. Operating principle of a transformer**
    -  **8.1.2. Voltage transformation**
    -  **8.1.3. Current transformation**
  - 8.2. Operational behaviour of a transformer**
    -  **8.2.1. Idling behaviour Idling features**
    -  **8.2.2. Short-circuit behaviour**
    -  **8.2.3. Loaded voltage behaviour**

-  **8.2.4. Efficiency**
- **8.3. Three-phase transformer**
  -  **8.3.1. Three-phase transformation with single-phase transformers**
  -  **8.3.2. Three-phase transformers**
  -  **8.3.3. Vector groups**
  -  **8.3.4. Application of three-phase transformers in power supply**
  -  **8.3.5. Parallel operation of transformers**
  -  **8.3.6. Technical data of customary transformers**

**Electrical Machines - Basic vocational knowledge (Institut für Berufliche Entwicklung, 144 p.)**

## **8. Transformer**

### **8.1. Transformer principle**

### **8.1.1. Operating principle of a transformer**

**Transformers are stationary electrical machines which transmit energy from systems with certain current and voltage values into systems with generally different current and voltage values but with identical frequency.**

**Two separate windings are on the same iron core.**

**Following connection to alternating voltage  $U_1$  there is a standstill current  $I_0$ . The magnetomotive force  $\Theta = I_0 \cdot N_1$  generates a magnetic alternating flow ( $\Phi_1$ ) in the iron core.**

**The input and output winding of an alternating voltage are induced in accordance with the induction law. A self-induction voltage  $U_{10}$  arises in the input winding. It is counter-positioned in accordance with Lenz's law on applied voltage. During idling operation - because of mutual induction - there arises the output voltage  $U_{20}$  which is simultaneously the terminal voltage  $U_2$ .**

$$U_{1\sim} \rightarrow I_{0\sim} \rightarrow \Theta_{0\sim} \rightarrow \Phi_{1\sim} \rightarrow U_{20\sim}$$

**The value of the induced voltage is derived from the following equation:**

$$U_0 = 4.44 \cdot f \cdot N \cdot \hat{B} \cdot A_{Fe}$$

$\hat{B}$  max. flow density

$A_{Fe}$  limb cross-section

$U_0$  induction voltage

$f$  frequency

$N$  number of turns

**The induction voltage increases along with the number of turns, the magnetic flow density in the iron core, the iron cross-section and the frequency.**

**Example:**

**Which maximum flow density occurs in an iron core of 16 cm<sup>2</sup> cross-section when a voltage of 380 V (50 Hz) is applied to the primary coil with 980 turns?**



**Given:  $A_{Fe} = 16 \text{ cm}^2$ ;  $N_1 = 980$ ;  $U_1 = 380 \text{ V}$ ;  $f = 50 \text{ Hz}$**

**Sought:  $\hat{B}$**

**Solution:**

$$U_1 = 4.44 \cdot f \cdot N_1 \cdot \hat{\Phi}$$

$$\hat{\Phi} = \hat{B} \cdot A_{Fe}$$

$$B = \frac{U_1}{4.44 \cdot f \cdot N_1 \cdot A_{Fe}}$$

$$\hat{B} = \frac{380\text{V}}{4.44 \cdot 50\text{s}^{-1} \cdot 980 \cdot 16 \cdot 10^{-4}\text{m}^2}$$

$$\hat{B} \approx 1.09 \text{ V} \cdot \text{s} \cdot \text{m}^{-2}$$

$$\hat{B} \approx 1.09 \text{ T}$$

**The iron core evidences a maximum flow density of 1.09 T.**

### **8.1.2. Voltage transformation**

**A few field lines already close before reaching the output coil (Figure 125) so that flow  $\Phi_1$  can be divided into a maximum flow  $\Phi_K$  which saturates both coils and a leakage flow  $\Phi_S$ .**

**The leakage flow may be ignored in regard to the unloaded transformer (idling). Therefore the following applies:**

$$\hat{\Phi}_1 = \hat{\Phi}_2 = \hat{\Phi}$$

**According to the transformer equation**

$$U_{10} = 4.44 \cdot N_1 \cdot \hat{\Phi}$$

**and**

$$U_{20} = 4.44 \cdot N_2 \cdot \hat{\Phi}.$$

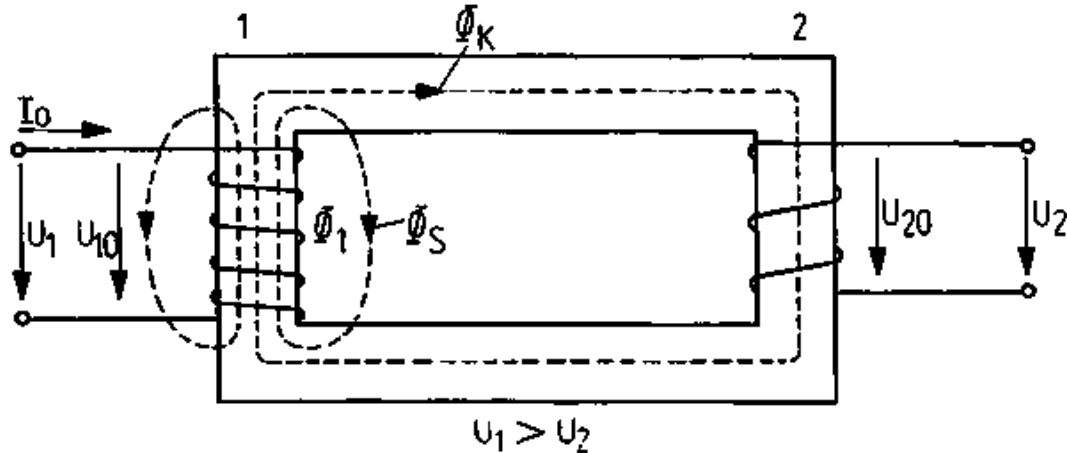
**If we relate both equation then**

$$\frac{U_{10}}{U_{20}} = \frac{4.44 \cdot N_1 \cdot \hat{\Phi}}{4.44 \cdot N_2 \cdot \hat{\Phi}}$$

## Shortening gives us

$$\frac{U_{10}}{U_{20}} = \frac{N_1}{N_2}$$

**During idling no current flows into the output winding, thus there is no voltage decrease. Consequently the induced voltage  $U_{20}$  equal to the terminal voltage  $U_2$  (Cp Figure 125):**



**Figure 125 - Transformer principle**

**1 Input winding/upper voltage winding/primary winding, 2  
Output winding/under voltage winding/secondary winding**

$$U_{20} = U_2$$

**In the event of minimal idling current I voltage decrease in the  
input winding is negligibly minimal. We therefore have**

$$U_{10} = U_1$$

**which results in**

$$\frac{U_1}{U_2} = \frac{N_1}{N_2}$$

**The voltages behave like the numbers of turns.**

**The interrelationship of the numbers of turns is known as the transformation ratio . We have:**

$$\ddot{U} = \frac{U_{1n}}{U_{2n}}$$

**The rated voltages  $U_{1n}$  and  $U_{2n}$  are indicated on the rating plate of the transformer.**

**Example:**

**What secondary terminal voltage arises in a transformer where 380 V is applied to the primary winding of 980 turns and the secondary winding has 594 turns?**

**Given:  $U_1 = 380 \text{ V}$ ;  $N_1 = 980$ ;  $N_2 = 594$**

**Sought:  $U_2$**

**Solution:**

$$\frac{U_1}{U_2} = \frac{N_1}{N_2}$$

$$U_2 = \frac{N_2}{N_1} U_1$$

$$U_2 = \frac{594}{980} 380 \text{ V}$$

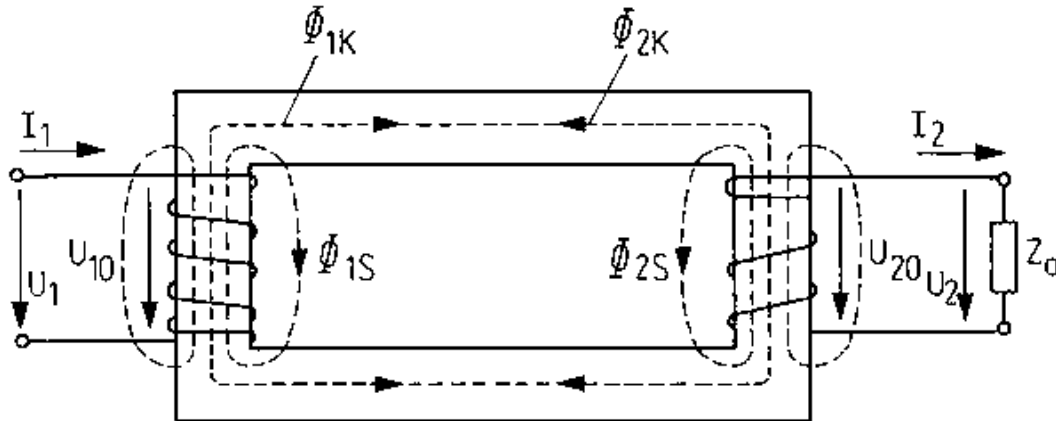
$$\mathbf{U_2 \approx 230 \text{ V}}$$

### **8.1.3. Current transformation**

#### **Load behaviour of the transformer**

**If the transformer is output-loaded, current  $I_2$  flows into coil  $N_2$ .**

**Current  $I_2$  generates the magnetic flow  $\Phi_{2K}$ . According to Lenz's Law this magnetic flow is counter-positioned to the cause ( $\Phi_{1K}$ ).**



**Figure 126 - Loaded transformer**

**In this manner the magnet flow  $\Phi_{1K}$  is weakened and induction voltage  $U_{10}$  decreases. Given uniform rated voltage, the difference increases between the two voltages  $U_{10}$  and  $U_1$ .**

**Consequently, a greater input current  $I_1$  flows whereby the magnetic flow  $\Phi_{1K}$  is increased. The magnetic flow  $\Phi$  in the iron**

**core thus remains virtually constant:**

$$\Phi = \Phi_{1K} - \Phi_{2K} = \text{constant}$$

**This also applies to the output voltage of the transformer.**

**The input current  $I_1$  increases as the load current  $I_2$  becomes greater.**

**Transformation ratio**

**Without heeded the losses of the transformer, the following applies according to the energy conservation law:**

$$s_1 = s_2$$

$$U_1 \cdot I_1 = U_2 \cdot I_2$$

**If we arrange the equation so that the voltage and current values appears on respective sides, then**



$$\frac{I_1}{I_2} = \frac{U_2}{U_1} .$$

**The following relationships may be cited for current ratio:**

$$\frac{I_1}{I_2} = \frac{N_2}{N_1} = \frac{1}{\ddot{U}}$$

**Conversely the currents are proportional to the voltages or numbers of turns. A transformer converts high currents into low ones or low currents into higher ones.**

**Example:**

**A welding transformer takes up 220 (current being 10A). The output voltage is 20V. How great is the welding current?**

**Solution:**

$$\frac{I_1}{I_2} = \frac{U_2}{U_1}$$

$$I_2 = I_1 \frac{U_1}{U_2} = 10A \frac{220V}{20V}$$

$$I_2 \approx 110A$$

## 8.2. Operational behaviour of a transformer

### 8.2.1. Idling behaviour Idling features

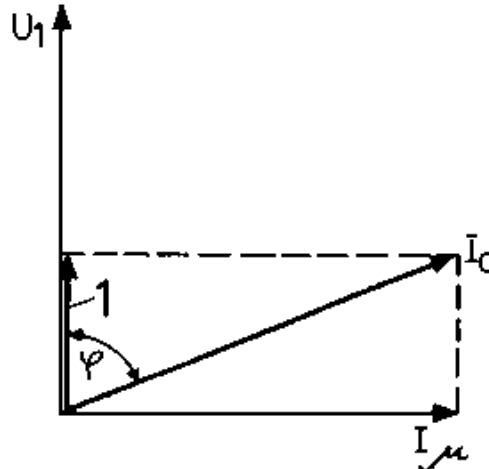
**A transformer idles where mains voltage  $U_1$  remains applied to the primary side whilst no consumer is connected to the secondary side ( $Z_a$ ) (Figures 125/126).**

Primary circuit  $U_1$  applies  
 $I_0$  flows (idling current)

Secondary circuit  $Z_a = \infty$   
 $I_2 = 0$   
 $U_2 = U_{20}$

### Idling current

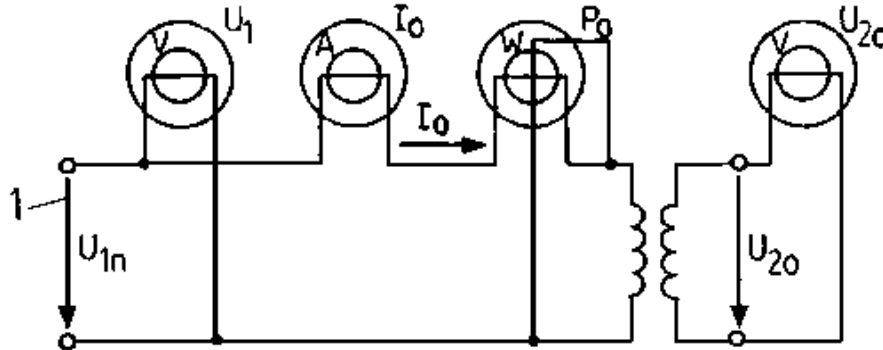
**The applied voltage  $U$  drives the idling current  $I_0$ . This is needed to establish the magnetic field  $I\mu$ . This lags behind the voltage  $U_1$ .**



**Figure 127 - Indicator image for idling operation**

### **1 Iron loss current $I_{Fe}$**

**The phase position of the idling current  $I_0$  to voltage  $U_1$  can be determined according to the circuitry of Figure 128.**



**Figure 128 - Circuitry to determine idling losses**

## 1 Rated voltage

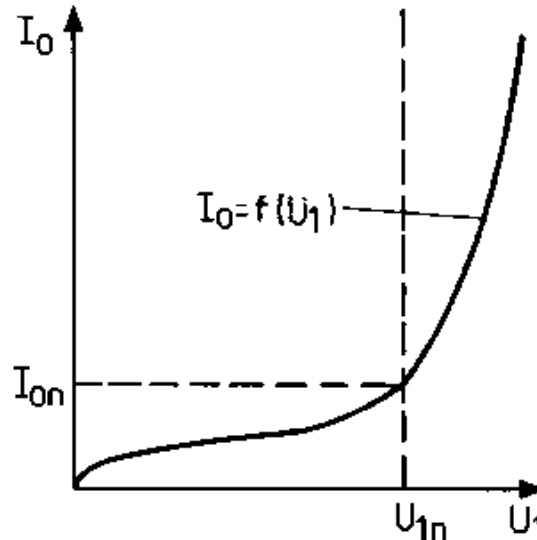
$$\cos \varphi_0 = \frac{\text{activepower}}{\text{apparentpower}} = \frac{P_0}{U_{1n} I_0}$$

**The value of idling current  $I_0$  is between 2 and 5 per cent of idling current in big transformers and up to 15 per cent in smaller transformers.**

## No-load curve

**The idling curve  $I = f(U_1)$  in Figure 129 indicates that no-load**

**current  $I_0$  increases proportionally to the input voltage  $U_1$ . No-load current increases markedly over and beyond the input rated speed  $U_{1n}$ . It can, moreover, even attain values greater than the rated current.**



**Figure 129 - Idling curve of a transformer  $I_0 = f(U_1)$**

**Transformers shall not be driven by voltages greater than the rated voltage.**

## **Idling losses (iron losses)**

**The active power derived from the circuit in Figure 128 can only be transformed into heat in the input winding and iron core as no current flows into the secondary winding during idling. The active power  $P_0$ , which is converted into heat in the iron core, is made up of eddy current and hysteresis loss.**

**The following example shows that the iron losses almost always arise during idling.**

**Example:**

**The following idling values were measured in a transformer:**

$$U_{1n} = 220 \text{ V}; I_0 = 0.5 \text{ A}; P_0 = 40 \text{ W}; R_1 = 3.$$

**What percentage of winding losses are contained in idling power?**

**Solution:**

$$P_0 = P_{VFe} + P_{VW}$$

$$P_{VW} = I_0^2 \cdot R_1 = 0.5^2 \cdot A^2 \cdot 3\Omega$$

$$\mathbf{P_{VW} = 0.75 W}$$

$$\frac{P_{VW}}{P_0} \cdot 100\% = \frac{0.75W}{40W} \cdot 100\% \approx 1.9\%$$

$$\mathbf{P_{VFe} = P_0 - P_{VW} = 40 W - 0.75 W = 39.25 W}$$

**Thus, the power loss determined during idling is an iron loss.**

**Iron losses are determined during no-load operation and are independent of load.**

### **8.2.2. Short-circuit behaviour**

#### **Short-circuit curves**

**Secondary current  $I_2$  increases if load resistance is decreased.  
Where  $Z_a = 0$  the transformer has been short-circuited.**

Primary circuit  $U_1$  is applied

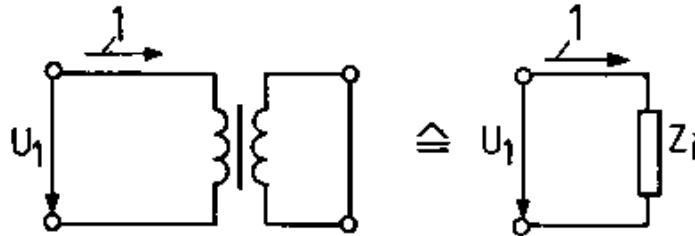
$I_K$  flows

Secondary circuit  $Z_a = 0$

$U_2 = 0$

## Short-circuit voltage

The short-circuited transformer can be replaced by resistor  $Z_1$  which corresponds to the transformer internal resistor.

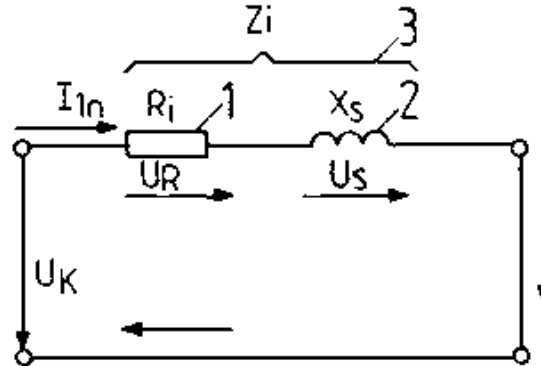


**Figure 130 - Short-circuited transformer**

## **1 Short-circuit current $I_K$**

**Figure 131 depicts the commensurate duplicate circuit diagram.**

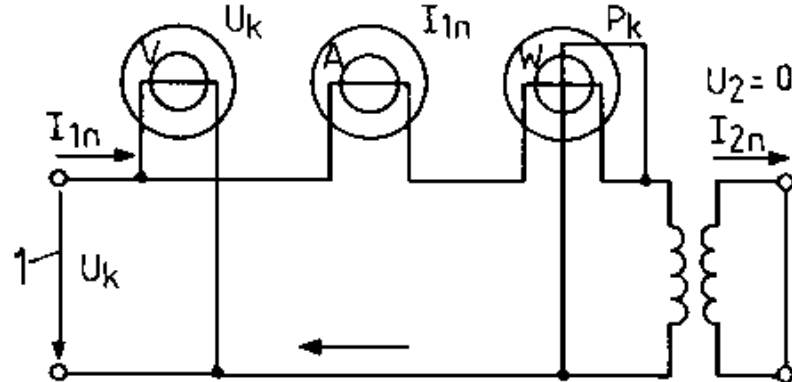




**Figure 131 - Duplicate circuit diagram for short circuit run**

**1 Ohmic winding resistance, 2 Scattered reactance (is made up of the scatter flow of the input and output coils), 3 Inner resistance of the transformer (impedance)**

**During a short-circuit attempt (Figure 132) the input voltage given a short-circuited output winding is increased until primary and secondary nominal currents flow. The voltage applied to the input side is then the short-circuit voltage  $U_K$ .**



**Figure 132 - Circuitry to determine short-circuit losses**

## 1 Short circuit voltage

**The short-circuit voltage is the overall voltage decrease of a transformer during rated loading.**

**The relative short-circuit voltage  $U_K$  in % is determined by the following equation:**

$$U_K = \frac{U_K}{U_{1n}} 100\%$$

**The relative short-circuit voltage is, on average, 2 to 10% of input rated voltage ( $U_{1n}$ ) in mains transformers.**

### **Short-circuit losses (winding losses)**

**In the short-circuit experiment (Figure 132) a power meter indicates short-circuit losses as the primary and secondary rated currents generate winding losses. The iron core is only slightly magnetised by the applied short-circuit voltage ( $U_K \ll U_1$ ).**

**The winding losses can be metered during the short-circuit experiment. They are dependent on the load current ( $P_{VW} = I_2 R$ ).**

### **8.2.3. Loaded voltage behaviour**

**In contrast to operational idling, during loading the secondary circuit is closed through an external resistance  $Z_a$  (Figure 126). Secondary current  $I_2$  flows. According to the energy conservation law the transformer must also take up commensurate primary power, thus a primary current  $I_1$  also flows.**

Primary circuit  $U_1$  is applied

$$I_1 > I_0$$

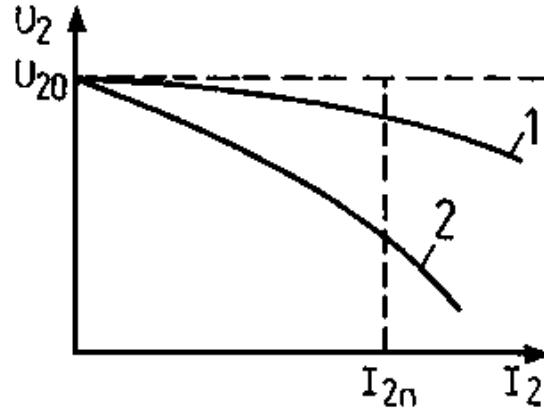
Secondary circuit  $Z_a < \infty$

$$I_2 > 0$$

$$U_2 \neq U_{20}$$

### **Voltage curve $U_2 = f(I_2)$**

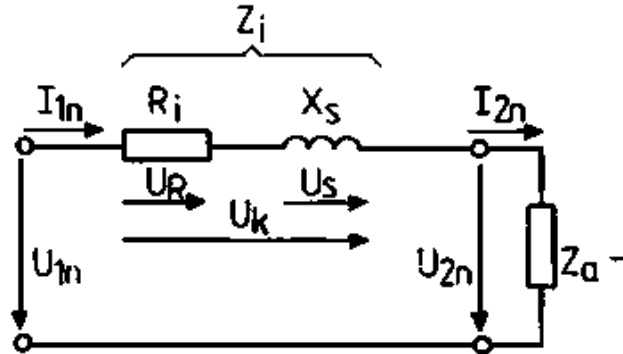
**As the curve in Figure 133 shows, terminal voltage  $U_2$  decreases during loading.**



**Figure 133 - Voltage behaviour during loaded operation  $U_2 = f(I)_2$**

**1  $U_K$  small, 2  $U_K$  big**

**Figure 134 depicts the duplicate circuit diagram for the loaded transformer.**



**Figure 134 - Duplicate circuit for the loaded transformer with a transformation ratio = 1:1**

**The duplicate circuit diagram corresponds to a transformer with a**

**transformation ratio  $\ddot{U} = \frac{1}{1}$**

$$\ddot{U} = \frac{U_{2n}}{U_{1n}} \rightarrow U_{2n} = U_{1n} \cdot \ddot{U} \rightarrow U_{2n} = U_{1n}$$

$$\ddot{U} = \frac{I_{1n}}{I_{2n}} \rightarrow I_{2n} = \frac{I_{1n}}{\ddot{U}} \rightarrow I_{2n} = I_{1n}$$

**As rated current flows the short-circuit voltage  $U_K$  decreases at the internal transformer resistance  $Z_i$  as a result of which the terminal voltage  $U_2$  declines by the power decrease of the short-circuit voltage  $U_K$ .**

**Transformers with considerable short-circuit voltage  $U_K$  have powerful internal resistors, that is to say pronounced voltage changes as load alters.**

$U_K = 2...10\%$  minimal voltage losses

voltage-rigid behaviour

$U_K = 20...50\%$  considerable voltage losses

voltage-flexible behaviour

**Example:**

**A 220/42 V transformer has a short-circuit voltage of 10%.**

**How great is the voltage change between idling and rated current**

## loading?

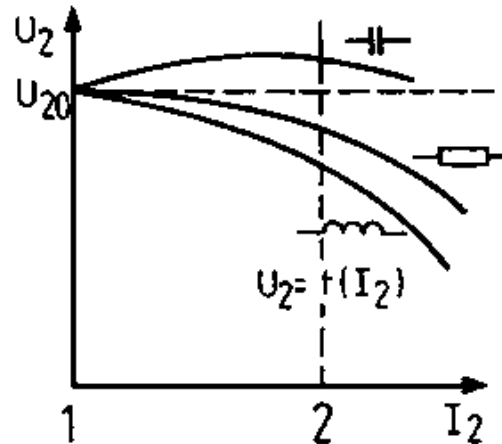
### Solution:

$$\Delta U = \frac{U_{2n} \cdot U_K}{100\%} = \frac{42V \cdot 10\%}{100\%} = 4.2V$$

### Output voltages at differing loads

**Given differing loads with ohmic, inductive or capacitive external resistance gives rise to the dependence of output voltage on load current as shown in Figure 135.**





**Figure 135 - Secondary terminal voltage depending on the degree and nature of loading**

**1 Idling, 2 Rated load**

**Given capacitive load, the output voltage may even be greater than no-load voltage.**

**The output voltage of a transformer depends on the**

- degree of load current  $I_2$**
- the magnitude of relative short-circuit voltage**

**- the nature of the load (ohmic, inductive or capacitive).**

### **8.2.4. Efficiency**

**Efficiency represents the ratio of power output to power input.**

$$\eta = \frac{P_{\text{out}}}{P_{\text{in}}}$$

**Efficiency is determined by the separate loss indication.**

$$P_{\text{in}} = P_{\text{out}} + P_{\text{VFe}} + P_{\text{VW}}$$

$P_{\text{out}}$  rated power of the transformer given

$\cos \varphi = 1$  (resistive load)

$P_{\text{VW}}$  metered winding losses in short-circuit trial

$P_{\text{VFe}}$  metered iron losses in no-load trial

$$\eta = \frac{P_{\text{out}}}{P_{\text{out}} + P_{\text{VFe}} + P_{\text{VW}}}$$

**The following equation applies for determining efficiency for partially inductive or capacitive load:**

$$\eta = \frac{S_n \cdot \cos\varphi}{S_n \cdot \cos\varphi + P_{VFe} + P_{VW}}$$

**Example:**

**Given:**

$$S_n = 100 \text{ kVA}$$

$$P_{VFe} = 570 \text{ W}$$

$$P_{VW} = 2.1 \text{ kW}$$

$$\cos \varphi = 0.85$$

**Sought:**  $\eta$

**Solution:**

$$\eta = \frac{10^5 \text{ VA} \cdot 0.85}{10^5 \text{ VA} \cdot 0.85 + 2.67 \cdot 10^3 \text{ W}} \approx 0.97$$

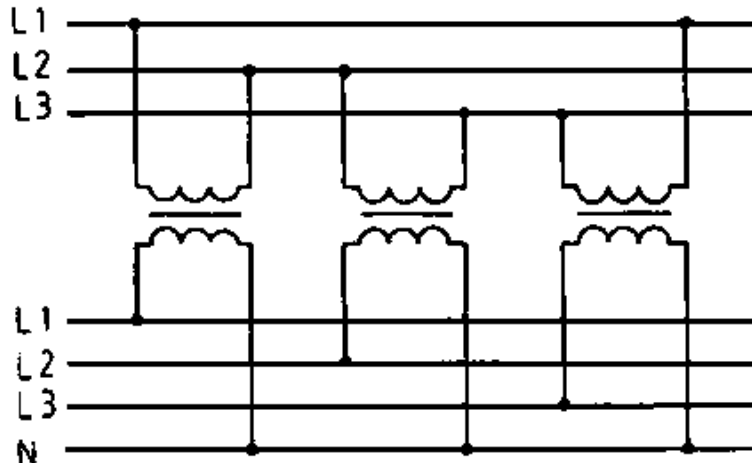
## **8.3. Three-phase transformer**

### **8.3.1. Three-phase transformation with single-phase transformers**

**For economical reasons the transmission of electric power these days is not undertaken by single-phase systems but by three-phase systems. Thereby, three-phase alternating voltage has to be transformed into another, like frequency and number of phases. The transformation is possible by means of three identical single-phase transformers.**

**The resultant voltages must not only possess the same value but shall also evidence a mutual phase displacement of 120 degrees.**

**Consequently, the mains connection of the single-phase transformers must ensure a delta or star circuit despite the spatially separate installation of electric primary and secondary winding connections.**



**Figure 136 - Transformation through three single-phase transformers**

**In view of their size, big transformers of this kind come as so-called three-phase (transformer) bank. They are generally added by a fourth single-phase transformer. This latter unit constitutes the reserve and can be switched on if another transformer fails.**

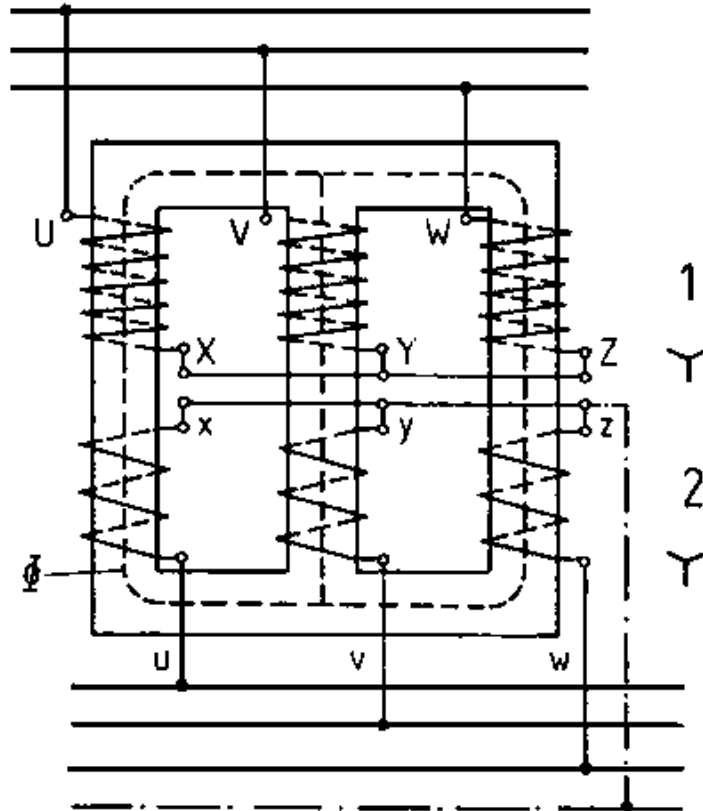
**Material and space requirements are usually too great for medium and small power units for this kind of transformation. The constructional fusion into a unit leads to substantial material**

**economies.**

### **8.3.2. Three-phase transformers**

**Core transformers are most frequently constructed.**

**An input and an output coil each have been positioned on the common limb. Following three-phase mains connection the three input coils along with three-phase consumers, can be linked up into a star (Y) or delta ( $\Delta$ ) connection.**



**Figure 137 - Three-phase transformer in  $Y_y$  circuitry**

## **1 Upper voltage winding**

## 2 Under voltage winding

### 8.3.3. Vector groups

#### Circuitry of windings

- The primary and secondary circuits of the three-phase transformer each consist of three strands. These three strands can form a delta connection if the terminals  $x$ ,  $y$  and  $z$  are connected to  $v$ ,  $w$  and  $u$ .

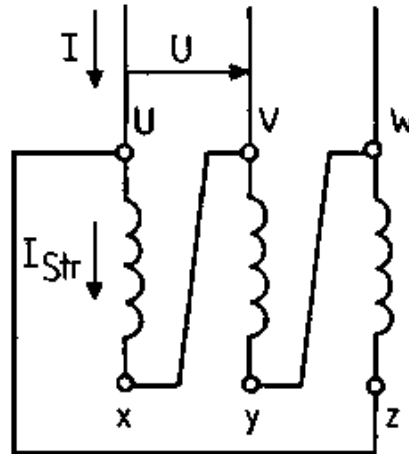


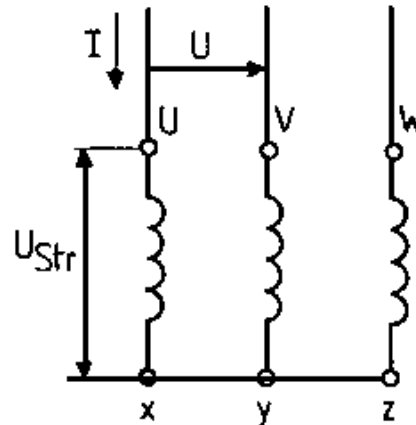
Figure 138 - Delta connection



**In the delta connection the conductor voltage U equals the phase voltage U. Strand current is made up thus:**

$$I_{\text{Str}} = \frac{I_{\text{L}}}{\sqrt{3}}$$

**- Where the terminals x, y and z are interconnected we obtain a star circuit.**



**Figure 139 - Star connection**

$$U_{\text{Str}} = \frac{U_L}{\sqrt{3}}$$

**As opposed to the delta circuit, phase voltage is  $\frac{U_L}{\sqrt{3}}$  phase and conductor current values are identical.**

**- A special kind of star connection is the zigzag connection which, however, is only very rarely employed.**

### **Phase position of upper and undervoltages**

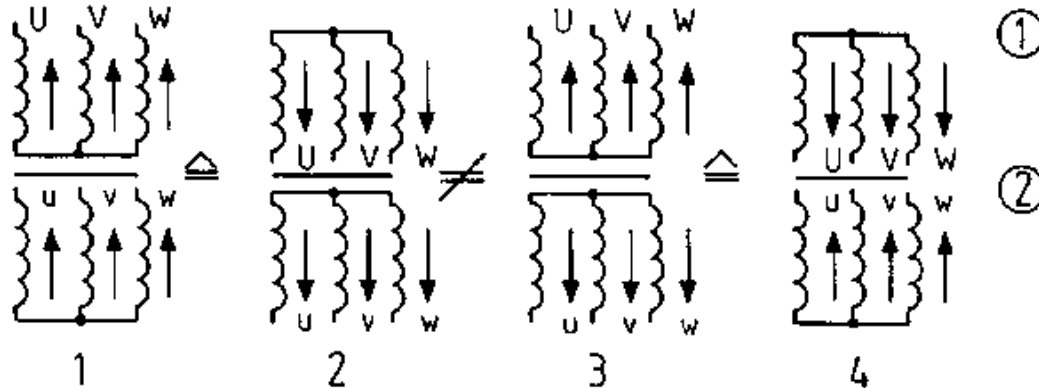
**- The delta and star connection of the upper and under voltages yields the following combinations:**

Yy Yd

Dy Dd

**The designation Yy indicates that the upper and undervoltage windings have been star-connected. Yd denotes upper voltage winding as star and undervoltage winding as delta.**

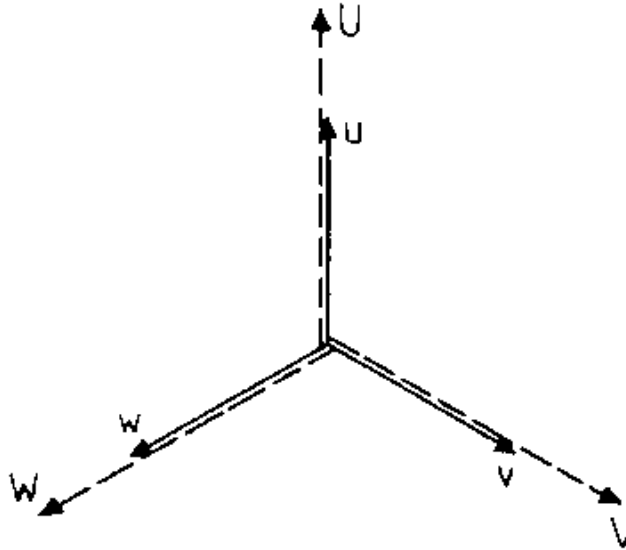
**Figure 140 indicates that these designations are not final.**



**Figure 140 - Connection options of a star-star circuit**

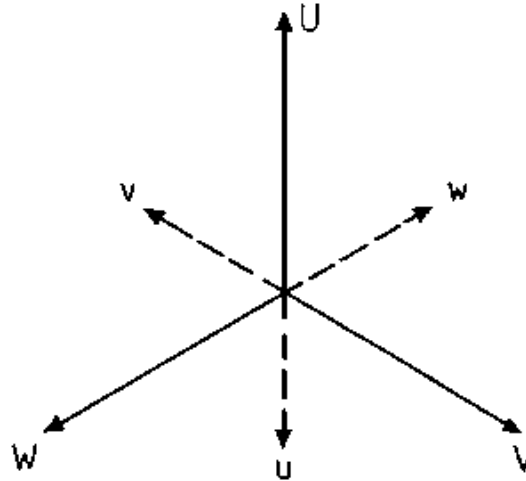
**(1) Upper voltage windings, (2) Undervoltage windings**

**Circuits 1 and 2 and 3 and 4 are identical; however, both groups differ as regards the phase position of under to upper voltage. The upper and undervoltage windings of circuits 1 and 2 feature opposing winding senses. As a result, in line with the transformer principle, there is no phase displacement between upper and lower voltage.**



**Figure 141 - Voltage indicator for the voltages 1 and 2 of Figure 140**

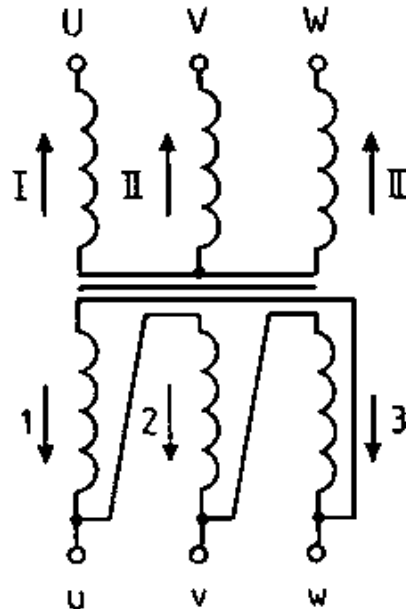
**The windings of circuits 3 and 4 possess the same winding sense. For this reason there is a phase displacement of 180 degrees between upper and undervoltage, that is to say the voltages are counter-directed to each other.**



**Figure 142 - Voltage indicator for circuits 3 and 4 of Figure 40**

**Consequently any comprehensive vector group designation must not only indicate winding circuits but also data pertaining to the phase position of the voltages.**

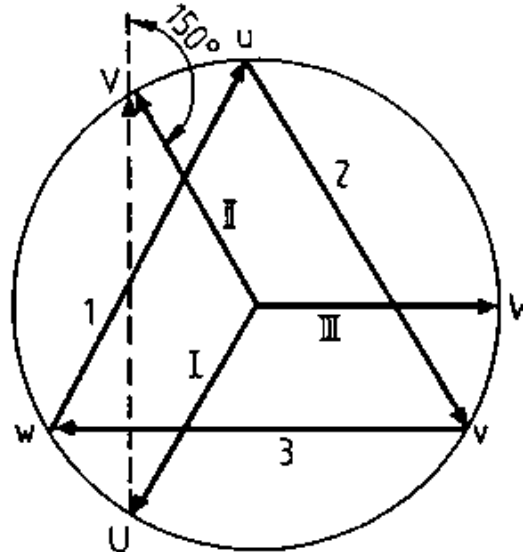
**The example of the star delta connection shows how to determine the phase position from the circuit diagram.**



**Figure 143 - Star-delta connection**

**The circuit diagram is added by the phase voltages (I, II, III, 1, 2, 3) whose indicators are always directed towards the terminals. The uppevoltage indicators (I, II, III) are inserted into a twelve-segment circle which serves as construction aid (Figure 144). The position of the indicator can be varied ad lib; however, amongst themselves they should heed a mutual phase displacement of 120**

**degrees and the winding circuit (star). The position of the under voltage indicator is determined by the upervoltage indicator. The circuit diagram shows that the undervoltage indicators are counter-directed to the upervoltage indicators (indicator 1 counter to indicator 1 etc.). Where the indicators 1, 2 and 3 are inscribed into the twelve-segment circle heading the (delta) undervoltage winding circuit, the position of the undervoltage terminals u, v and w are stipulated. The phase position of like-named conductor voltages, for example between the upper-voltage terminals U, V and the undervoltage terminals u and v can now be derived from the indicator figure. In our example the undervoltage lags behind the upper voltage by 150 degrees.**



**Figure 144 - Indicator of a star-delta connection**

**A phase displacement of the undervoltage against the upper voltage of 30 degrees in each case, from zero; 30; 60 etc. up to 360 (0) degrees can be attained through varying linkage of the delta and star connections. However, in practice, one sticks to those connections where the displacement is 0; 150; 180 and 330 degrees. Thereby angle indication does not ensue directly but by means of a so-called index. This is derived from the division of the**



**phase angle by 30 degrees.**

## **Vector group designation**

**Vector group = circuit + index**

### **Example:**

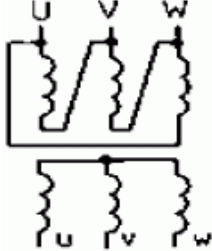
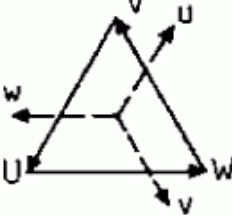
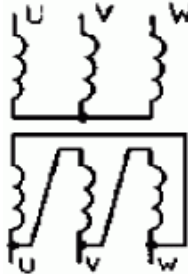
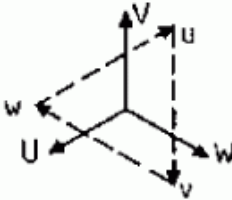


Yy0                    Y star connection of the upper voltage winding OS  
                          y star connection of the lower voltage winding US  
0 30 degrees = 0 degrees phase displacement  
Dy5                    D delta connection OS  
                          y star connection US  
5 30 degrees = 150 degrees phase displacement


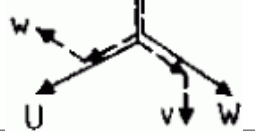
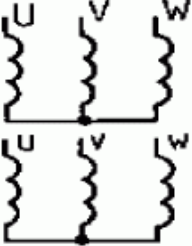
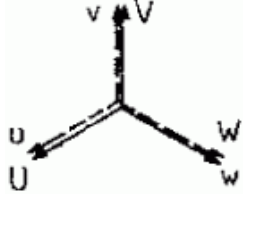
**The index indicates by how many times of 30 degrees the undervoltage lags behind the upper voltage**

## **Standardized vector groups**

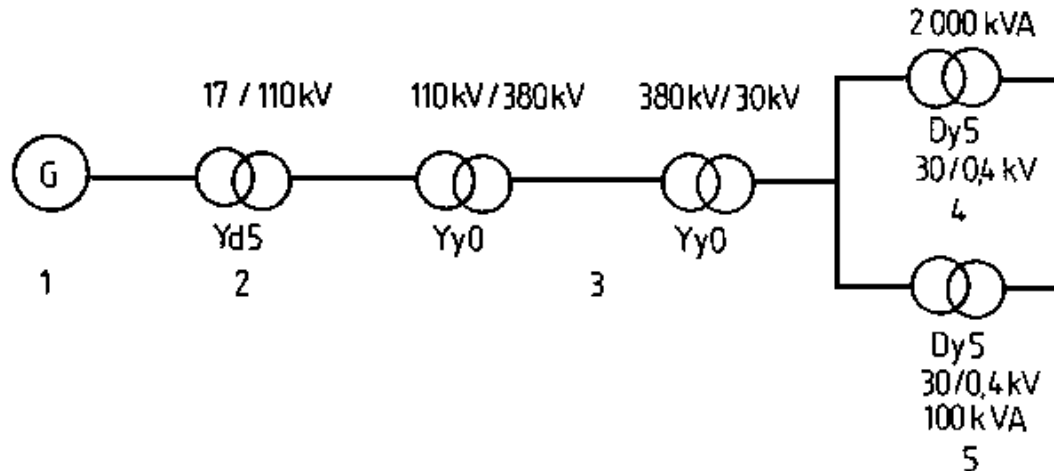
**Survey 21 focuses attention on the most common of the 12 vector groups.**

## Survey 21 - Standardized vector groups of three-phase transformers

Vector group circuit	Circuit diagram	Indicator image	Transformation ratio
Dy5			$\frac{U_1}{U_2} = \frac{N_1}{3N_2}$
Yd5			$\frac{U_1}{U_2} = \frac{3N_1}{N_2}$
Yz5			$\frac{U_1}{U_2} = \frac{2N_1}{3N_2}$

			
Yy0			$\frac{U_1}{U_2} = \frac{N_1}{N_2}$

### 8.3.4. Application of three-phase transformers in power supply



**Figure 145 - Utilisation of transformer vector groups in power supplies**

**1 Power station generator, 2 Machine transformer, 3 Network transformer, 4 Distribution transformer, 5 Substation transformer**

### Block and machine transformers

**- Block transformers along with a generator make up one unit. They establish the connection between the generator and the high-**

## **voltage side.**

- **Machine transformers operate in the same manner as block transformers whereby, initially, several generators work together on a bus bar.**
- **Preferred vector group for both transformers is Yd5.**

## **Mains transformers**

- **Mains transformers function as a link between transmission networks of differing voltage planes, e.g. between the 380 kV and 220 kV mains.**
- **Network transformers are preferred in the Yy0 vector group.**

## **Distribution and urban network transformers**

- **Distribution transformers link the transmission network to the consumer system.**
- **Urban network transformers are transformers whose undervoltage is less than 1 kV. Particular significance accrues to supplying the**

## **asymmetrically loaded urban network.**

**- The vector group Dy5 is suitable for urban network and distribution transformers.**

### **8.3.5. Parallel operation of transformers**

#### **Basic information on parallel operation**

**The extension of existing electrotechnical installations makes it necessary to parallel connect further transformers to the existing ones.**

**Excessive transmission ratings may also necessitate multiple operation of several transformers.**

**Parallel operation signifies the upper and undervoltage inter-switching of several transformers.**

#### **Conditions for parallel operation**

**In order to prevent the transformers being preloaded or subject to unequal load distribution amongst themselves because of**

## **compensating currents, the following conditions must prevail:**

- the vector group must have the same index figure**
- same transformation ratio**
- same short circuit voltages U. They shall not deviate by more than 10 per cent from one another**
- rated power ratios should not be greater than 3 : 1.**

### **8.3.6. Technical data of customary transformers**

**The surveys 22 and 23 feature the index figures of several mains and distribution transformers.**

#### **Survey 22 - Characteristic values of distribution transformers (three-phase oil transformer)**

Rated power	kVa	100	160	250	400	630	1000	1600
Rated uppervoltage	kV	(6; 10; 15; 20)		(6; 10; 15; 20; 30)			(6; 10; 15; 20; 30)	
Adjustment	%	± 4		± 5			± 5	

range								
Rated undervoltage	kV	(0.231; 0.4; 0.525)		(0.4; 0.525)			(0.4; 0.525; 6.3)	
Idling losses	W	380	550	700 (740)	1000 (1050)	1450 (1550)	2200 (2400)	3200 (3400)
Short circuit losses	W	2200 (2300)	2900 (3200)	4400	5900	7800	11000	16000
Short circuit voltage	%	3.8 (4)		6	6	6	6	6
Dimensions length a 1	mm	1110	1260	1810 (1870)	1980 (2040)	2110 (2170)	2300 (2350)	2650 (2800)
width b	mm	640	800	800 (880)	1100	1100	1000	1000
height h <sub>1</sub>	mm	1420	1590	1870 (1900)	1950 (2000)	2215 (2255)	2490 (2600)	2700 (2775)
Oil filling	kg	215	300	470 (570)	620 (700)	755 (860)	1150 (1250)	1550 (1750)
total weight	kg	790 (800)	1070 (1080)	1520 (1680)	2020 (2200)	2620 (2850)	4000 (4250)	5750 (5950)

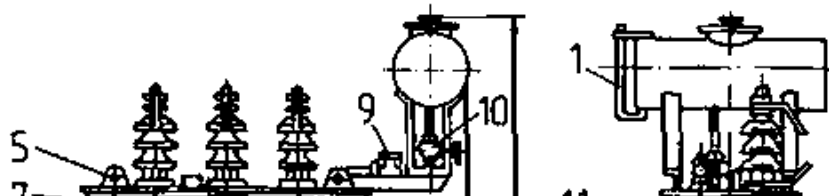


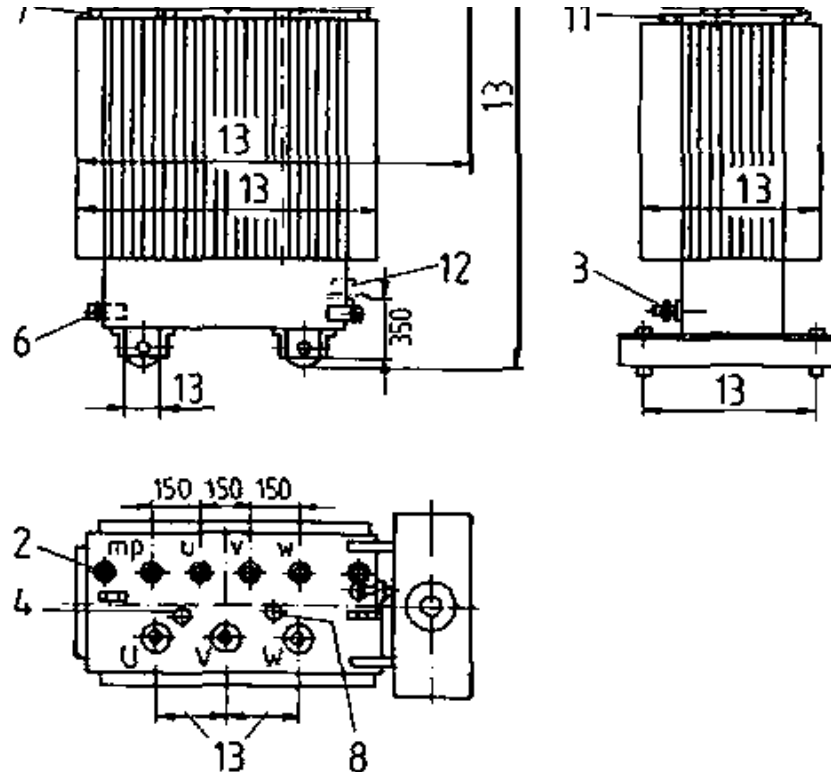
Vector group	-	(Yy0; Yz5)	(Yy0; Dy5)	(Yy0; Dy5)
--------------	---	------------	------------	------------

## **Survey 23 - Characteristic values of dry-type transformers**

Rated power	kVa	63	100	160	250	400	630	1000
Rated upper-voltage	kV	(2; 3; 5; 6; 10; )				(2; 3; 5; 6; 10; )		
rated under-voltage	kV	(0,231; 0,4; 0,525)				(0,4; 0,525)		
Rated frequency	Hz	(50)				(50)		
Idling losses	W	580	750	900	1200	1750	2500	2900
Short-circuit losses	W	1330	1700 (1780)	2570 (2750)	3200	5250	6500	10400
Short-circuit voltage	%	(3, 8(4))				(6)		

**Figure 146 serves as an example of the dimensional size of a three-phase oil transformer.**





**Figure 146 - Oil transformer for the 250 - 16000 kVA range**

**1 Oil level, 2 Thermo-pockets, 3 Oil removal device, 4 Converter, 5 Eye bolt, 6 Earthing screw, 7, 8 Oil opening, 9**

**Buchholz relay, 10 Stop valves (from 1000 kVA onwards), 11  
Shoulder hooks, 12 Hoisting points, 13 Variable dimensions**

### Questions for revision and control

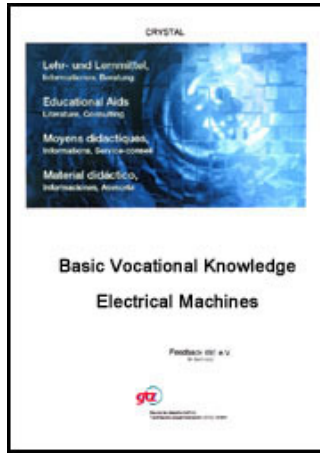
- 1. Describe the basic construction and range of a transformer.**
- 2. How can iron and winding losses be determined in a transformer?**
- 3. How can short-circuit voltage be determined?**
- 4. Which factors cause a voltage drop in a transformer?**
- 5. What is the significance of the index figure in vector group data? Which index figures are cited?**
- 6. Which are the most common vector groups and for which purposes are they used?**
- 7. Name the parallel switching conditions.**



**[Home](#) > [ar.cn.de.en.es.fr.id.it.ph.po.ru.sw](#)**











**Electrical Machines - Basic vocational  
knowledge (Institut fr Berufliche**



## Entwicklung, 144 p.)

 *(introduction...)*

### Introduction

-  **1. General information about electrical machines**
-  **2. Basic principles**
-  **3. Execution of rotating electrical machines**
-  **4. Synchronous machines**
-  **5. Asynchronous motors**
-  **6. Direct current machines**
-  **7. Single-phase alternating current motors**
-  **8. Transformer**

## Introduction

**This textbook has been prepared on the basis of extensive vocational training experience in the GDR and serves the needs of electrical engineering trainees. It relates to the basic vocational knowledge of electrical machines.**

**Its clear-cut presentation encompasses all necessary knowledge for this field of electrical engineering.**

**Drawing upon only essential natural scientific basic findings, this work features a great many illustrative presentations and commensurate surveys in conjunction with a vividly set out and easily understood text section.**

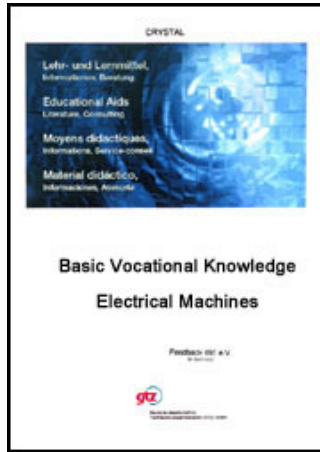
**Commensurately, the trainees can quickly comprehend the problems in point.**

**Moreover, as the implicit interrelation of theory and practice has been rigorously heeded, this textbook serves the trainees as a working basis in both theoretical and practical vocational training.**

**Tasks and questions for repetition and control feature at the end of each chapter and are geared to essential educational contents whilst, simultaneously, enabling the trainees to test their acquired knowledge.**



**[Home](#)"" """"> [ar.cn.de.en.es.fr.id.it.ph.po.ru.sw](#)**



## **Electrical Machines - Basic vocational knowledge (Institut für Berufliche Entwicklung, 144 p.)**



### **1. General information about electrical machines**



#### **1.1. Definition of terms**



#### **1.2. Types of electrical machines**



#### **1.3. Operations of electrical machines**



#### **1.4. System of rotating electrical machines (generators, motors, converters)**



#### **1.5. System of stationary electrical machines (transformers)**

## **Electrical Machines - Basic vocational knowledge (Institut für Berufliche Entwicklung, 144 p.)**

### **1. General information about electrical machines**

#### **1.1. Definition of terms**

**An electrical machine converts energy from one category into another. Thereby at least one energy category features as electric power.**

### **Survey 1 - Energy transformation of electrical machines**

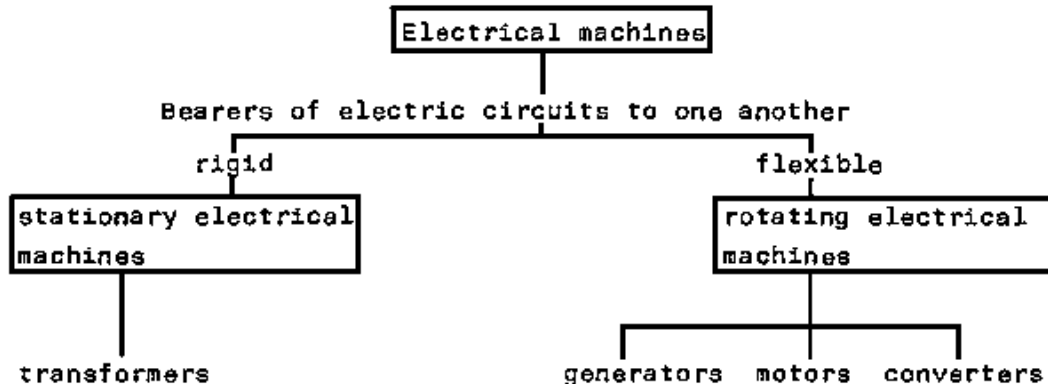
Mechanical system (prime mover)	→ Generator	→ Electrical system (mains)
Mechanical system	← Motor	← Electrical system (mains)
Electrical system (mains)	→ Rotating converter and transformer	→ Electrical system (mains)

**Irrespective of manifold features, for instance the external shapes of the electrical machines, they all comprise two electric circuits which have been coupled through a magnetic circuit.**

**An electrical machine is an energy converter in which two electric circuits have been coupled by means of a magnetic circuit.**

## **1.2. Types of electrical machines**

**The components, namely the bearers of both electric circuits are rigid to one another in stationary electrical machines. Conversely, the bearers of the electric circuits are mobile to one another in rotating electrical machines. This explains the system of electrical machines.**



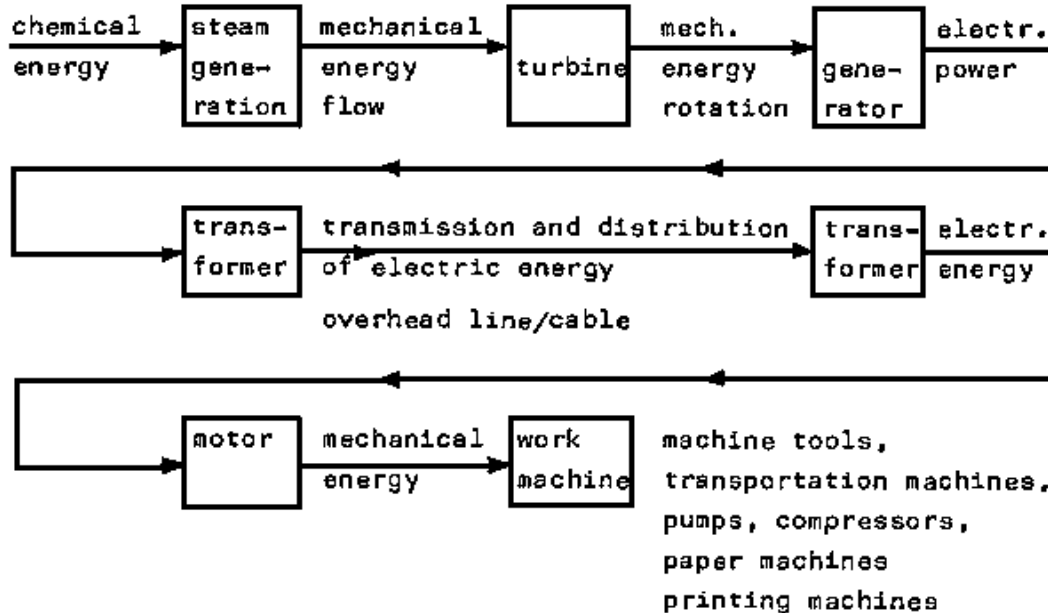
## Survey 2 - System of electrical machines

### 1.3. Operations of electrical machines

**The operation of electrical machines results from their incorporation into the process of energy conversion in the generation, transmission and consumption of electric power.**



**Thus, for example, in a power station the combustion heat of coal, natural gas, etc. is employed in boilers for steam generation. The energy flow of the steam drives the turbine which is coupled to a turbine generator that converts the flow energy into electric energy. The efficient transmission and distribution of electric energy is ensured through the high voltages generated by the transformers. Thereby, the high voltages are switched to consumer voltage and directed to a motor whose mechanical energy drives machines in industry, the home and traffic.**

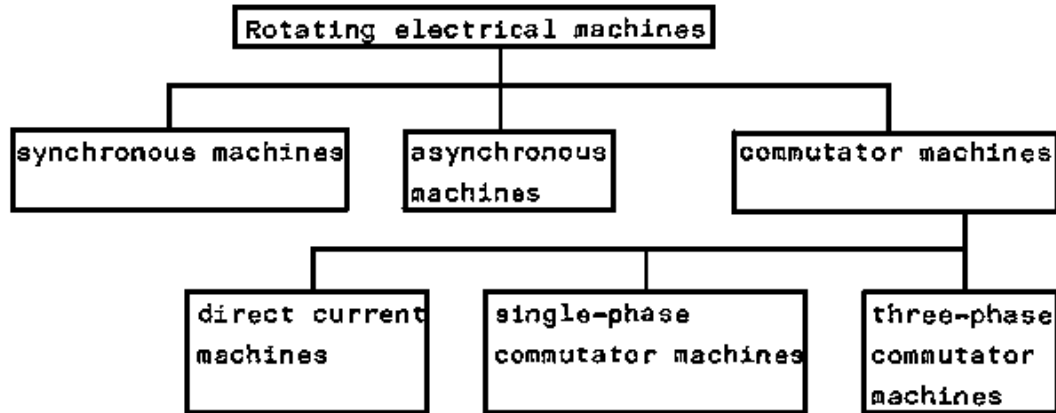


### Survey 3 - Tasks of electrical machines in power flow

#### 1.4. System of rotating electrical machines (generators, motors, converters)

Since the energy direction of an electrical machine is reversible, the rotating electrical machine can operate, without constructional changes, as a motor or generator and transform the stationary

**electrical machine upwards or downwards. For this reason rotating electrical machines are generally systematized in accordance with their operating principles.**



#### **Survey 4 - System of rotating electrical machines**

### **1.5. System of stationary electrical machines (transformers)**

**Stationary electrical machines (transformers) can be differentiated through manifold features, for example according to design, coolant, mode of operation, special purpose, etc. Survey 5 features by way of example the system of small transformers.**

## Survey 5 - System of small transformers

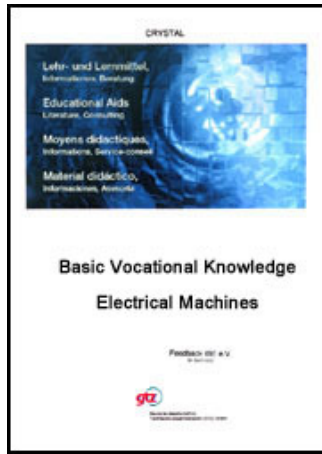
<b>Differentiated according to</b>	<b>Types</b>				
Protective function	Protective transformers; Isolating transformer				
	bell transformer	toy transformer	thawing transformer	hand lamp transformer	
Special purposes	mains contact transformer	control transformer	ignition transformer	leak transformer	generator protective transformer



[Home](#) > [ar](#).[cn](#).[de](#).[en](#).[es](#).[fr](#).[id](#).[it](#).[ph](#).[po](#).[ru](#).[sw](#)

 **Electrical Machines - Basic vocational knowledge (Institut fr Berufliche Entwicklung, 144 p.)**

 **2. Basic principles**



- **2.1. The magnetic field**
  - 📄 **2.1.1. Definition and presentation of the magnetic field**
  - 📄 **2.1.2. Magnets Magnetic field**
  - 📄 **2.1.3. Magnetic field of a current-carrying conductor**
  - 📄 **2.1.4. Magnetic field of a current-carrying coil**
  - 📄 **2.1.5. Magnetic fields in electrical machines**
- **2.2. Measurable variables of the magnetic field**
  - 📄 **2.2.1. Magnetomotive force**
  - 📄 **2.2.2. Magnetic flow**
  - 📄 **2.2.3. Magnetic flow density**
- **2.3. Force action of the magnetic field**
  - 📄 **2.3.1. Force action on current-carrying conductors**
  - 📄 **2.3.2. Force action on current-**

□ **2.4. Voltage generation through induction**

 **2.4.1. General law of induction**

 **2.4.2. Stationary induction (transformer principle)**

 **2.4.3. Motional induction (generator principle)**

**Electrical Machines - Basic vocational knowledge (Institut für Berufliche Entwicklung, 144 p.)**

## **2. Basic principles**

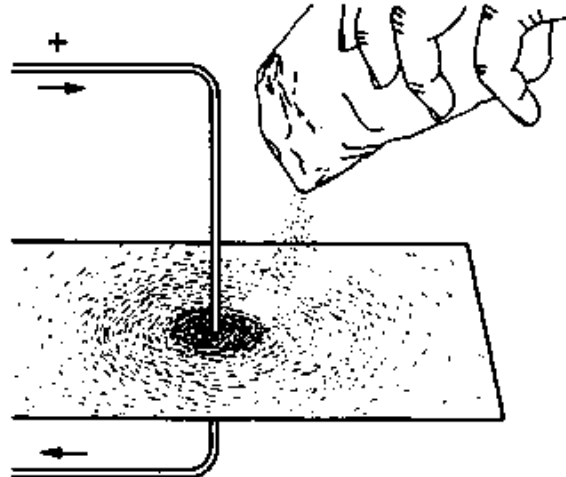
### **2.1. The magnetic field**

#### **2.1.1. Definition and presentation of the magnetic field**

**The area within which magnetic actions arise is called the magnetic field.**

**Field lines are employed to display graphically magnetic fields. Figure 1 shows a current-carrying conductor. Iron powder**

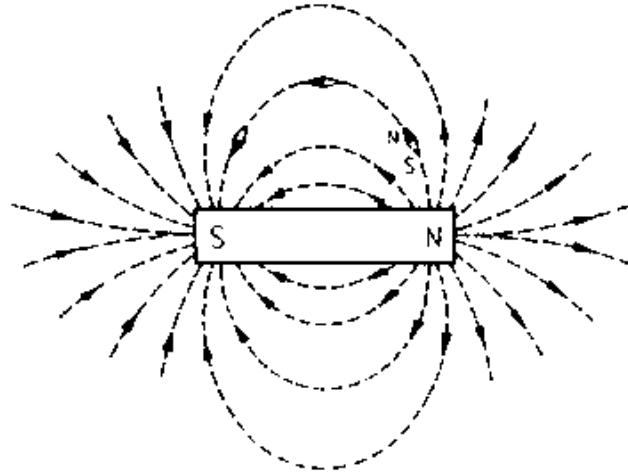
**scattered at the level of this arrangement falls into concentric circles. This leads to a model presentation of field lines.**



**Figure 1 - Magnetic field and field line sequence made visible by iron powder**

### **2.1.2. Magnets Magnetic field**

**Bodies of ferromagnetic materials (e.g. iron, nickel, cobalt, etc.) have a magnetic field in their vicinity.**



**Figure 2 - Magnetic field of a permanent magnet**

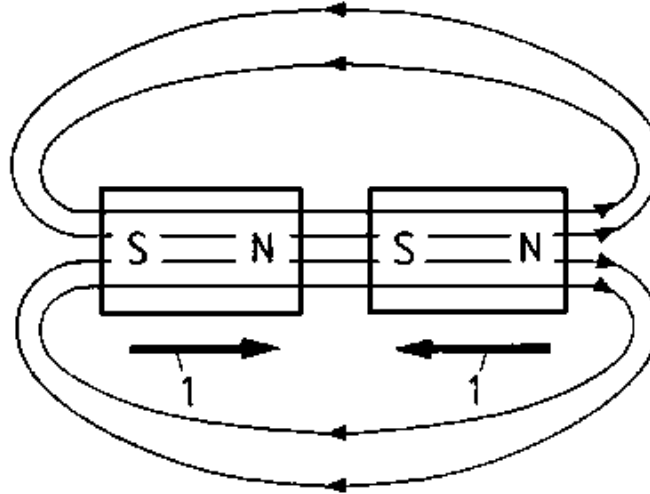
### **Direction of field lines**

**As indicated in Figure 2 the field lines emerge from the north pole and enter the south pole. Inside the magnet the field lines run from the south to the north pole.**

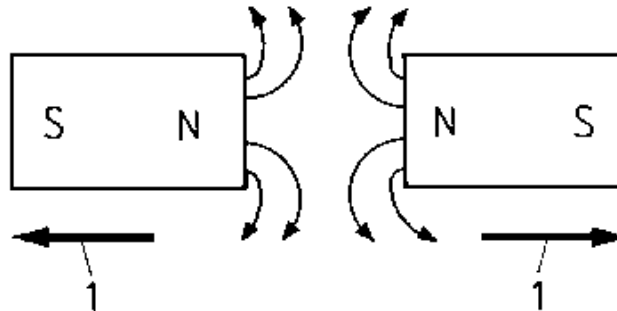
**Magnetic poles always arise pairwise.**

**Magnetic force action law - magnets interact with each other.**





**Figure 3 - Force actions between magnets (attraction)**



**Figure 4 - Force actions between magnets (repulsion).**

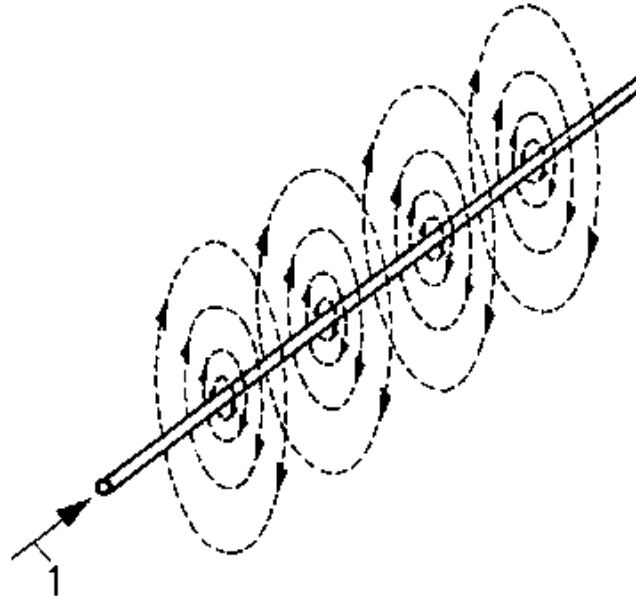
## **1 Force action**

**Opposite poles attract each other, similar poles repel each other.**

### **2.1.3. Magnetic field of a current-carrying conductor**

#### **Presentation of the magnetic field**

**Figure 5 presents the magnetic field of a current-carrying conductor.**



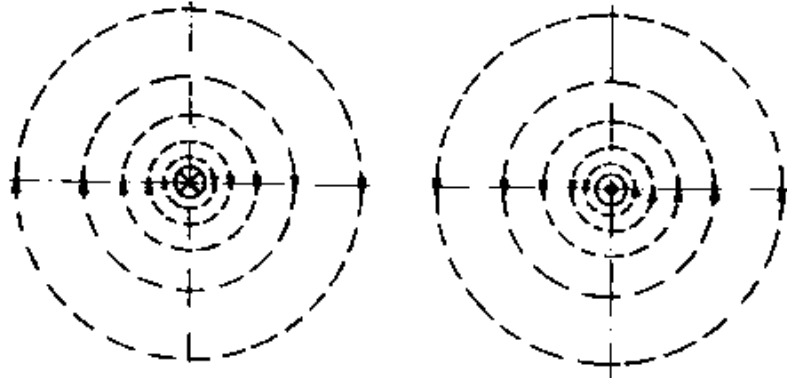
**Figure 5 - Magnetic field of a current-carrying conductor.**

## **1 Current flow direction**

### **Stipulations for current presentation**

**- Where the current flows away from the viewer, that is to say into the paper plane, a cross is indicated in the conductor cross-section.**

- **Where the current flows towards the viewer, that is to say out of the paper plane, a dot is entered into the conductor cross-section.**



**Figure 6 - Current direction designation in the plane of field lines**

### **Direction of field lines**

**As Figure 6 indicates the direction of the magnetic field lines depends on the current direction. If one views the conductor cross-section in current direction, then the field lines appear clockwise.**

**If one clamps such a current-carrying conductor with one's fist so that the projecting thumb points in current direction,**

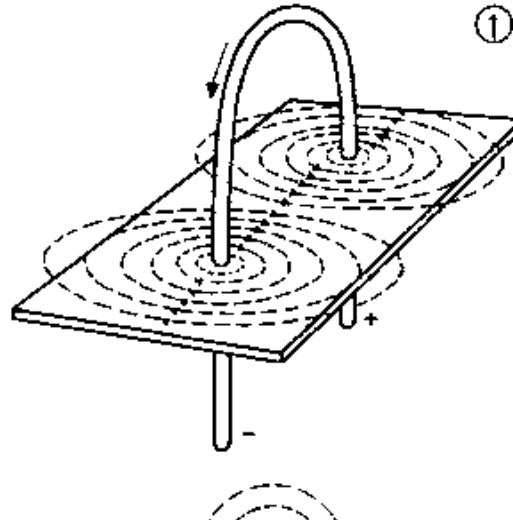
**then the bent fingers indicate the direction of the field lines.**

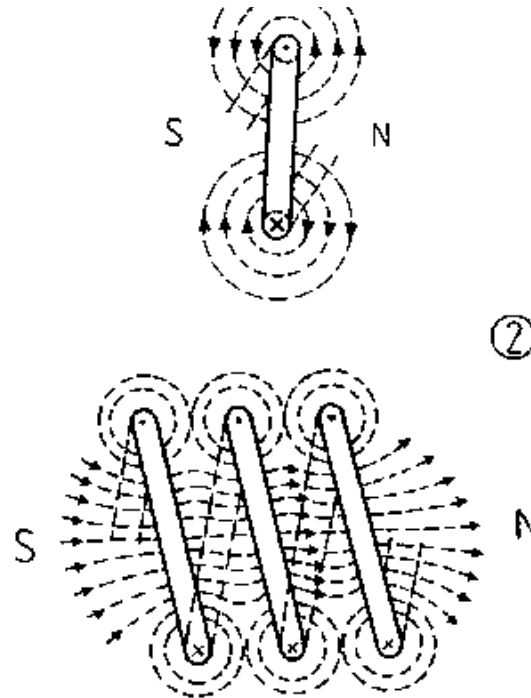
## **2.1.4. Magnetic field of a current-carrying coil**

### **Magnetic poles**

**A coil comprises several conductor loops. The overall magnetic field is derived from the magnetic fields of the individual conductors.**

**A current-carrying coil has both a north and south pole.**





**Figure 7 - Magnetic field of a current-carrying coil**

**(1) Magnetic field of a conductor loop**

**(2) Magnetic field of a coil**

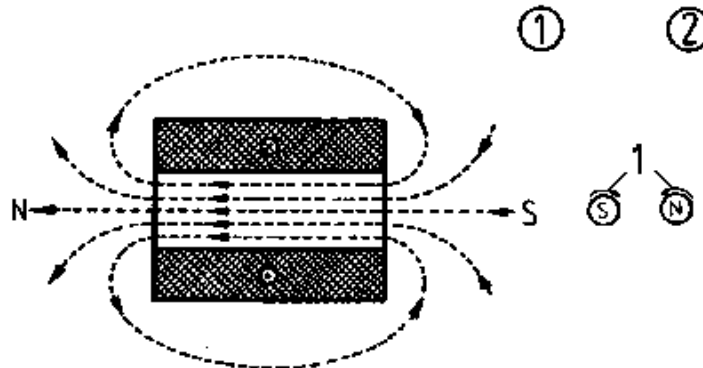
**1 Slant image**

**2 Top view as seen from above**

## Field direction

**The magnetic field lines emerge from the north pole and enter the south pole.**

**If one clamps such a current-carrying coil with one's right fist so that the bent fingers point in current direction, then the projecting thumb points towards the north pole.  
(clockhand principle)**



**Figure 8 - Magnetic field of a coil and clockhand principle**

**(1) Coil**

**(2) Clockhand principle**

## **2.1.5. Magnetic fields in electrical machines**

### **Field types**

**Every rotating machine consists of a stationary section (stand) and a rotating section (rotor).**

**Stands and rotors are made up of magnetic materials and windings and generate magnetic fields in the air gap.**

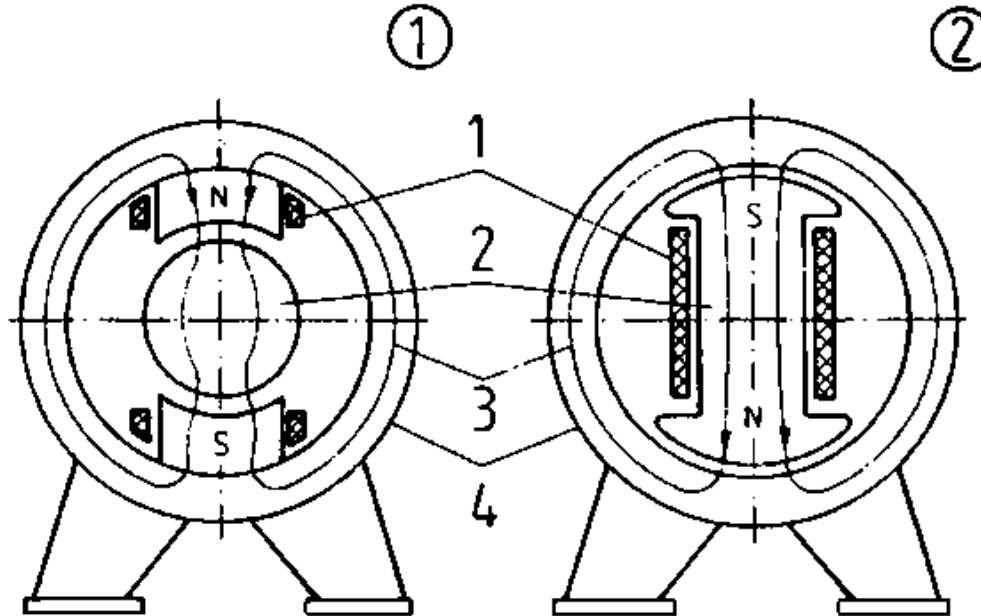
**We differentiate between the following magnetic fields:**

- constant field**
- alternating field**
- rotating field**

### **Constant field**

**A constant field results from a permanent magnet or through a coil saturated by direct current.**





**Figure 9 - Constant field**

**(1) Rotor excitation through current flow**

**(2) Stator excitation through current flow**

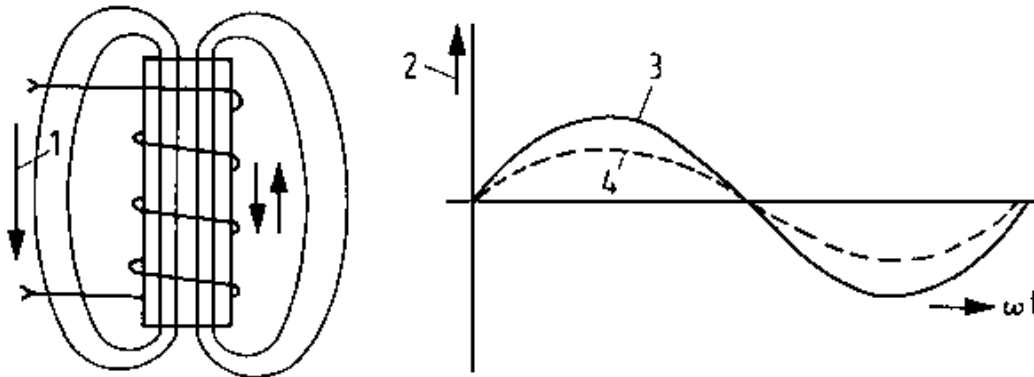
**1 Field winding, 2 Rotor, 3 Magnetic flow, 4 Stator**

**A constant field denotes a temporally constant magnetic field in an air gap.**

## Alternating field

**An alternating field is generated as alternating current passes through a winding.**

**A magnetic field which changes its size and direction according to the frequency is called an alternating field.**



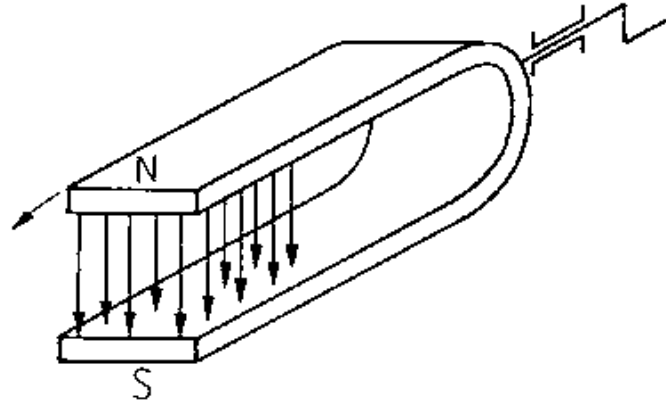
**Figure 10 - Magnetic alternating field**

**1 Alternating current, 2 Induction and current, 3 Induction sequence, 4 Current sequence**

## Rotating field

**Definition of term:**

**A rotating field may be compared to the magnetic field of a rotating, permanent magnet.**

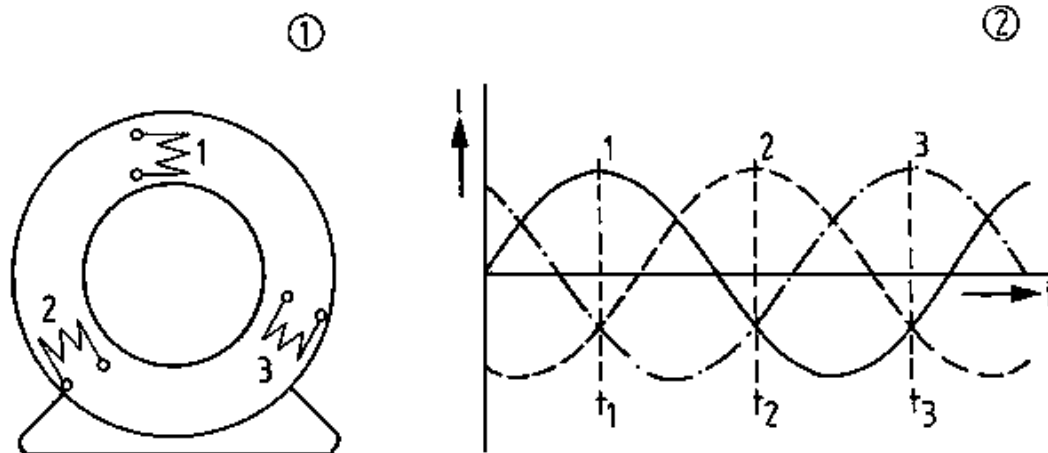


**Figure 11 - Emergence of a rotating field through rotation of a permanent magnet**

**A rotating field denotes a rotating magnetic field within a specific space.**

**Generating a rotating field:**

**As Figure 12 indicates, the simplest stator of a rotating machine features three spatially positioned coils at 120 degrees. These coils are saturated by three temporally displaced three-phase currents at 120 degrees.**



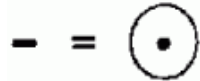
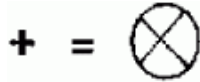
**Figure 12 - Emergence of a rotating field in the stator of a rotating electrical machine**

**(1) Stator with three spatially displaced windings**

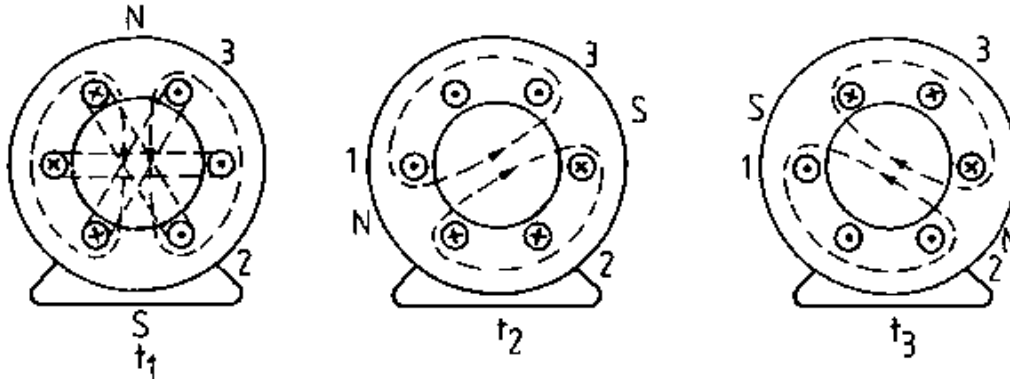
**(2) Commensurate temporally shifted currents,  $t_1$ ;  $t_2$ ;  $t_3$**

**Instantaneous times**

**The current directions are arbitrarily indicated thus:**



**Figure 13 indicates each coil with a winding and in its veritable spatial position. A clear-cut picture of current distribution for the moments  $t_1$ ,  $t_2$  and  $t_3$  emerges once the current directions in the individual conductors are entered into a line diagram.**



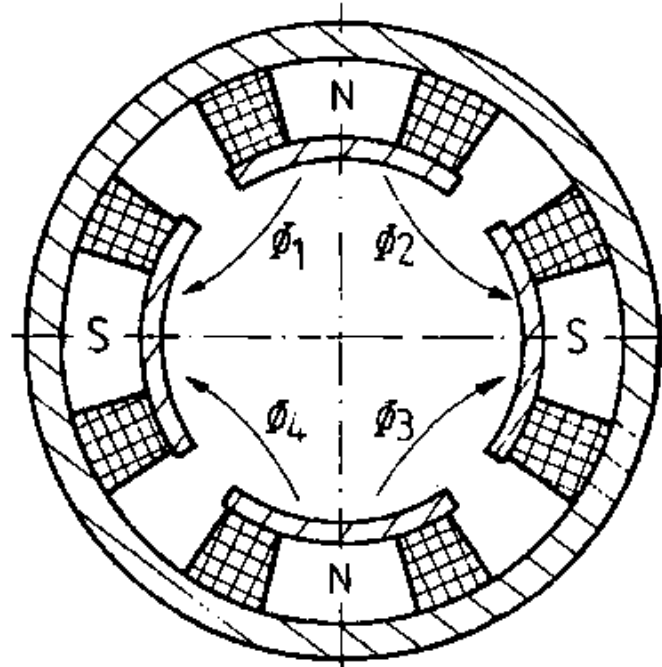
**Figure 13 - Explanation for the emergence of a rotating field,  $t_1$ ;  $t_2$ ;  $t_3$  Instantaneous times**

**Figure 13 indicates clearly that a single magnetic field emerges with a north and south pole following the spatial displacement of the coils (motionless in the area) coupled with a temporal displacement of the currents.**

**Speed of the rotating field:**

**A stator winding where the three coils have been so switched as to only yield one north pole and one south pole is called a two pole machine or a machine with a pole pair ( $p = 1$ ). A four pole machine**

**thus has two pole pairs etc.**



**Figure 14 - Four-pole machine**

**Given a two pole machine the rotating field runs once through for every period of the alternating current. Following a period the pole**

**pairs only undertake a half rotation.**

**The speed of the rotating field depends on the frequency of the alternating current and the pole pair:**

$$n_{rpm} = \frac{60 f / \text{Hz}}{p}$$

**A maximum speed of 3000 rpm can be attained given a frequency of  $f = 50$  Hz.**

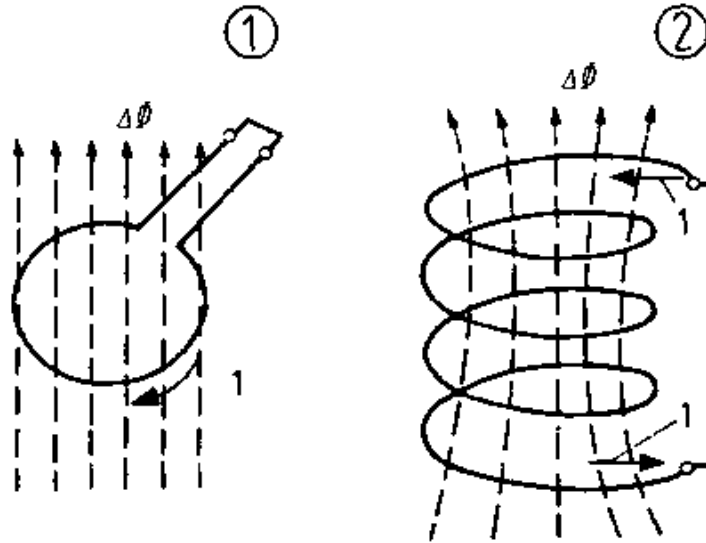
## **2.2. Measurable variables of the magnetic field**

### **2.2.1. Magnetomotive force**

**Magnetic fields are caused by electric currents.**

**Magnetomotive force signifies the existence of a magnetic field if the current flows through a conductor loop.**





**Figure 15 - Stationary induction**

**(1) Current-carrying conductor loop**

**(2) Current-carrying coil**

**1 Current flow direction**

**The current "magnetomotives" the enclosed magnetic field lines. The magnetomotive force can be increased if the same current is conducted several times through the field lines (Cp. Fig. 15). This**

**applies for a current-carrying coil with a number of turns equalling N:**

$$\Theta = I \cdot N$$

**Formula sign  $\Theta$**

**Unit: (Theta)**

$$[\Theta] = 1A$$

### **2.2.2. Magnetic flow**

**Magnetic flow denotes the total number of field lines of a current-carrying coil or a magnet.**

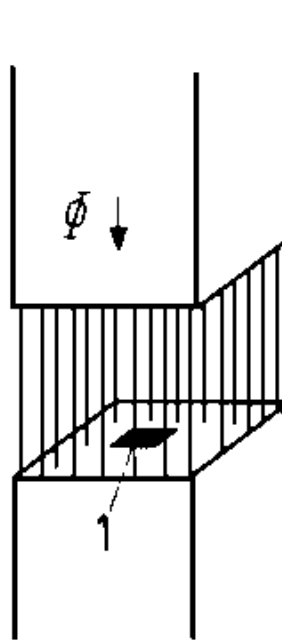
**Formula sign  $\Phi$**

**Unit: weber**

$$\Phi = V \cdot s = 1 \text{ volt-second}$$

### **2.2.3. Magnetic flow density**

**Magnetic flow density denotes the magnetic flow which permeates a certain surface in a vertical direction.**



**Figure 16 - Definition of magnetic flow density**

**1 Surface element, e.g.  $1 \text{ cm}^2$**

**A uniform magnetic field is:**

$$B = \frac{\Phi}{A}$$

**Formula sign B**

**Unit: tesla**

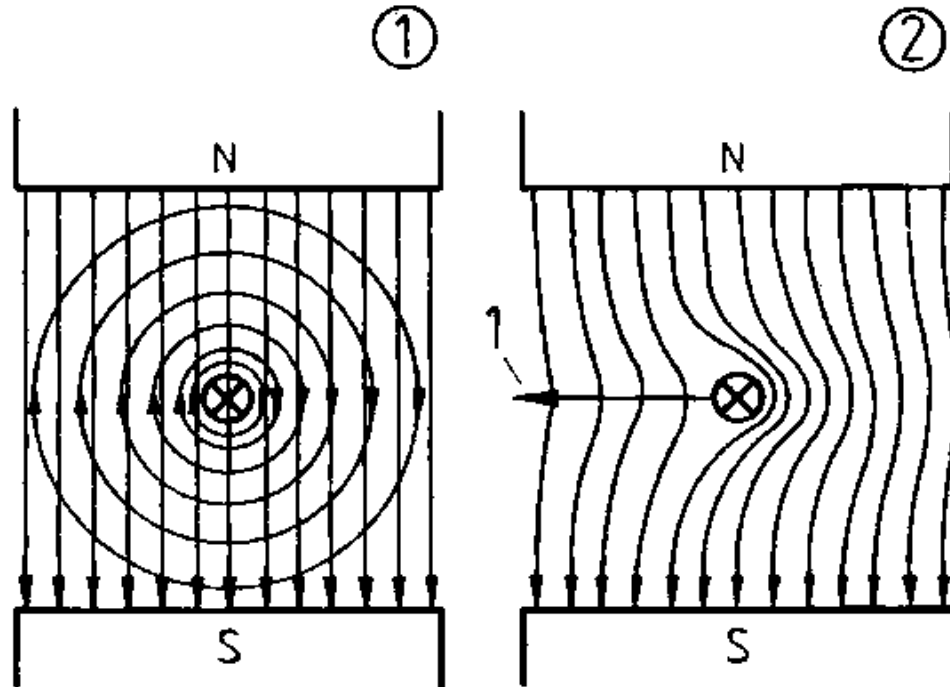
$$(B) = \frac{1Vs}{1m^2} = \frac{1Wb}{1m^2} = 1T$$

## **2.3. Force action of the magnetic field**

### **2.3.1. Force action on current-carrying conductors**

#### **Operating principle**

**A current-carrying conductor is enclosed by a magnetic field. If this conductor is entered into a magnetic field, the individual fields are superimposed.**



**Figure 17 - Force actions of current-carrying conductors in the magnetic field**

**(1) Basic presentation of the superimposing fields**

**(2) Force action of the superimposed fields**

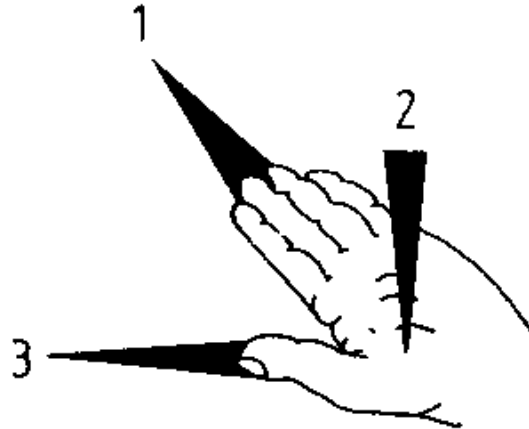
## **1 Force direction**

**On the one hand there is magnetic flow boosting. Conversely, one encounters magnetic flow fading.**

**A current-carrying conductor is pushed away from the external magnetic field towards the weaker field side.**

### **Left hand rule (motor rule)**

**If the left hand is positioned thus in a magnetic field so that the field lines enter the palm of the hand and the projected four fingers are directed towards the conductor current, then the extended thumb points in force direction towards the conductor.**



**Figure 18 - Left-hand rule (motor rule)**

- 1 Current direction in conductor**
- 2 Direction of the magnetic field**
- 3 Direction of movement**

### Electrodynamic law of force

**Force is yielded through the following equation:**

$$\mathbf{F = B \cdot l \cdot I \cdot N}$$

F force

B magnetic flow density of the external magnetic field

I current in the conductor

l conductor length in the magnetic field

N number of conductors in series circuit (coils)

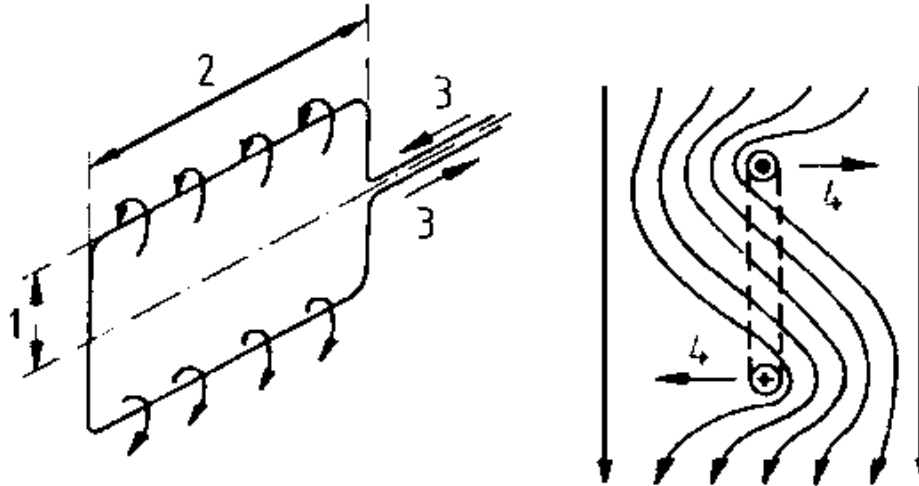
### **2.3.2. Force action on current-carrying coils (motor principle)**

#### **Motor principle**

**As opposed to Figure 17, Figure 19 features a conductor loop is positioned in a rotatable manner. A force is exerted on both conductor sides. This yields an overall torque.**

$$\mathbf{M = 2 \cdot F \cdot r}$$





**Figure 19 - Torque incidence in a conductor loop**

**1 Radius, 2 Effective length, 3 Current direction, 4 Force action**

### Motor equation

**The following equation is forthcoming from the electrodynamic law of force**

$$\mathbf{M = 2 \cdot B \cdot I \cdot I \cdot N \cdot r}$$

$$M = 2 \frac{\Phi}{A} \cdot l \cdot l \cdot N \cdot r$$

$$M = \frac{2 \cdot l \cdot N \cdot r}{A} \cdot \Phi \cdot l$$

constructive values

$$\mathbf{M = c \cdot \Phi \cdot I}$$

c machine constants (constructive values)

  magnetic flow of the external magnetic field

I current in the conductor loop or coil

## 2.4. Voltage generation through induction

### 2.4.1. General law of induction

**A voltage is induced where a circuit is saturated through a temporally altering magnetic flow.**

$$U_0 = \frac{\Delta\Phi}{\Delta t}$$

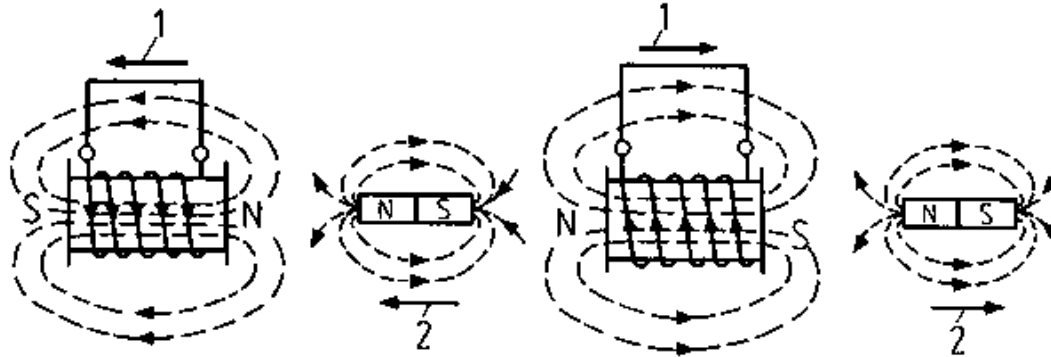
### **2.4.2. Stationary induction (transformer principle)**

**Given stationary induction (Figure 15), the magnetic flow alteration is generated by means of a stationary conductor loop or coil and a temporally changeable magnetic flow.**

### **2.4.3. Motional induction (generator principle)**

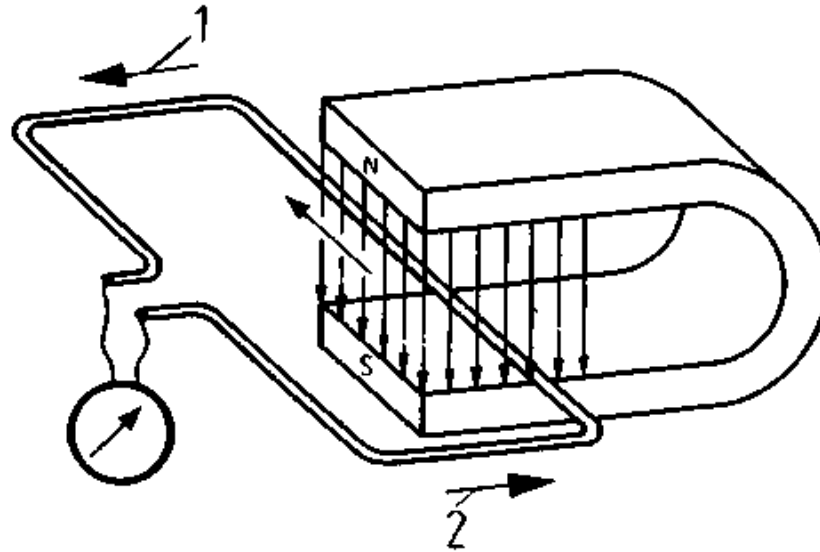
#### **Operating principle**

**Given motional induction a change in the magnetic flow is attained through the movement of magnets, equally through the motion of an electric conductor within a magnetic field.**



**Figure 20 - Induction through magnetic flux change (movement of a magnet)**

**1 Induced current, 2 Direction of movement**



**Figure 21 - Induction through magnetic flow change (movement of a conductor)**

**1 Induced current, 2 Direction of movement**

**The following applies to several series switched conductors (coils):**

$$U_0 = N \cdot B \cdot l \cdot v$$

$U_0$  general voltage of a motional conductor in a magnetic field

~~U generated voltage of a mechanical conductor in a magnetic field~~

B magnetic flux density of a magnetic field

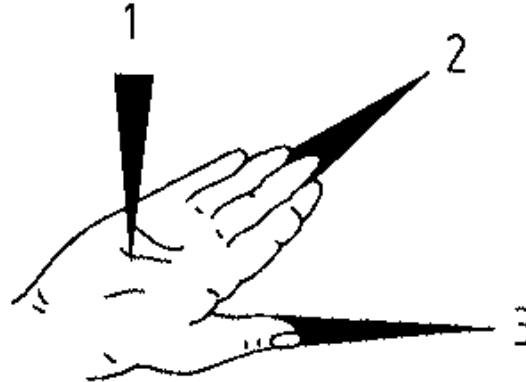
l conductor length in the magnetic field

v motional speed of the conductor

N number of series switched conductors

### **Right hand rule (generator rule)**

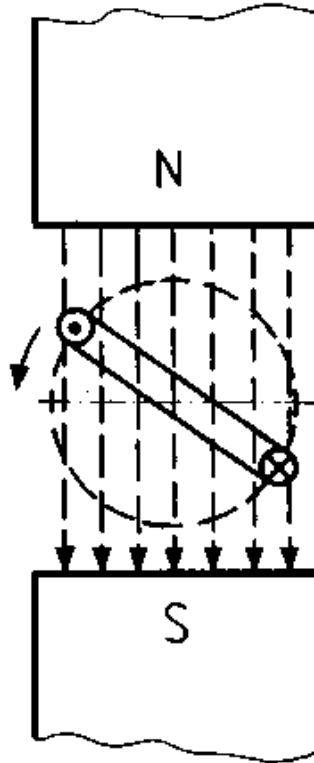
**If the right hand is so positioned in a magnetic field that the field lines enter the open palm of the hand and the projected thumb points in the motional direction of the conductor, then the extended four fingers point in the direction of the current in the conductor loop forthcoming through the generated voltage.**



**Figure 22 - Right-hand rule (generator rule)**

- 1 Direction of the magnetic field**
- 2 Direction of the induction current**
- 3 Direction of movement**

**An example is indicated in Figure 23.**



**Figure 23 - Rotating movement of a conductor loop in the magnetic field**

### **Generator equation**



**The following equation results from applying the induction law:**

$$U_0 = N \frac{\Phi}{A} \cdot v$$

**with  $v = \pi \cdot d \cdot n$**

$$U_0 \text{ becomes} = \frac{N \cdot \pi \cdot d \cdot l}{A} \cdot \Phi \cdot n$$

|  
constructive values

$$\mathbf{U_0 = c \cdot \Phi \cdot n}$$

c machine constant (constructive values)

n speed of the conductor loop

### Questions for repetition and control

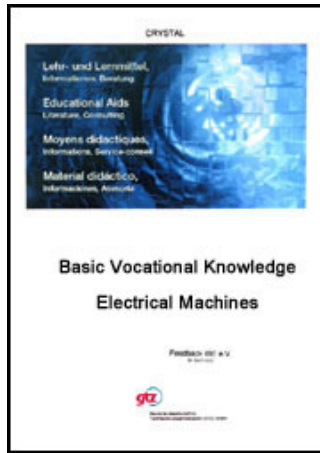
- 1. What causes a magnetic field?**
- 2. How is a magnetic field presented?**

- 3. How are field line direction and current direction related to one another?**
- 4. What are the differences between a magnetic constant field and an alternating field?**
- 5. How is a rotating field generated?**
- 6. What does the speed of the rotating field depend on?**
- 7. What is meant by magnetomotive force?**
- 8. How are magnetic flow and magnetic flow density interrelated?**
- 9. How are the forces directed which similar and opposite magnetic poles exert to one another?**
- 10. Describe the left hand rule.**
- 11. Which values exert an influence on the torque of a motor?**
- 12. Describe the right hand rule.**

# 13. Which values are of decisive importance for the induced voltage in a generator?



[Home](#)''' '''> [ar.cn.de.en.es.fr.id.it.ph.po.ru.sw](#)



## Electrical Machines - Basic vocational knowledge (Institut für Berufliche Entwicklung, 144 p.)



### 3. Execution of rotating electrical machines



#### 3.1. Size



#### 3.2. Designs



##### 3.2.1. Definition



##### 3.2.2. Designation



#### 3.3. Degree of protection


















##### 3.3.1. Definition



##### 3.3.2. Designation



#### 3.4. Cooling

-  **3.4.1. Cooling category**
-  **3.4.2. Cooling category designation**
-  **3.5. Mode of operation**
  -  **3.5.1. Definition**
  -  **3.5.2. Operational mode designation**
  -  **3.5.3. Frequent nominal cycle ratings**
-  **3.6. Heat resistance categories**
-  **3.7. Connection designations of electrical machines**
  -  **3.7.1. Transformers**
  -  **3.7.2. Rotating electrical machines**
-  **3.8. Rotating electrical machines in rotational sense**
  -  **3.8.1. Clockwise rotation stipulation**
  -  **3.8.2. Direct current machines**
  -  **3.8.3. Alternating current and three-phase machines**
-  **3.9. Rating plate**

## Electrical Machines - Basic vocational knowledge (Institut für Berufliche Entwicklung, 144 p.)

### 3. Execution of rotating electrical machines

#### 3.1. Size

Figure 24 shows the standard dimensions of rotating electrical machines.

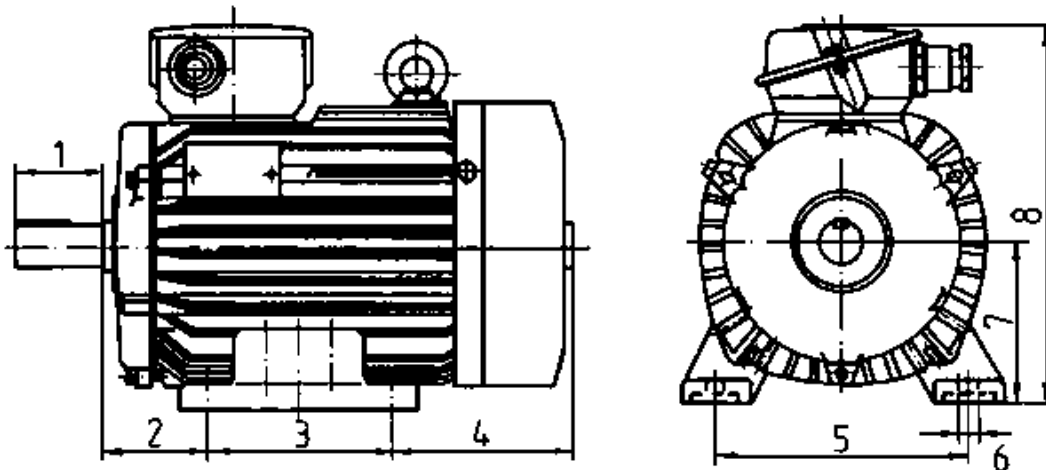


Figure 24 - Normed dimensions of rotating electrical machines

**1 Shaft and length (drive shaft), 2 Distance between shaft and clearance hole, 3 Distance of clearance holes (longitudinal), 4 Distance of clearance holes (end shield), 5 Distance of clearance holes (transverse), 6 Diameter (clearance holes), 7 Height to shaft centre, 8 Total height**

**In order to guarantee interchangeability of various machines the "International Electrotechnic Commission" (IEC) has established a uniform norm for sizes which are designated by figures ranging from 56 to 400. The cited numerals simultaneously indicate the axle height of the respective machines,**

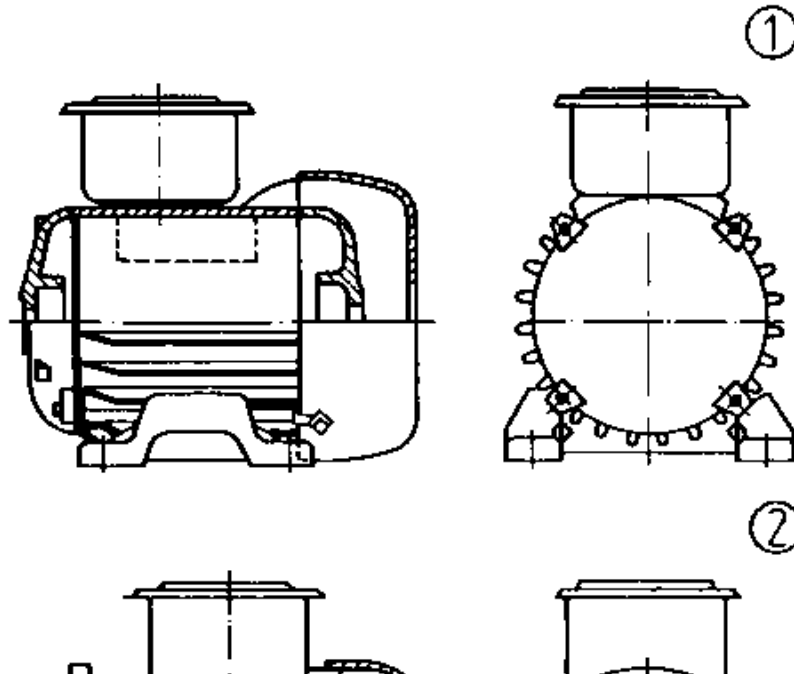
### **Survey 6 - Dimensions**

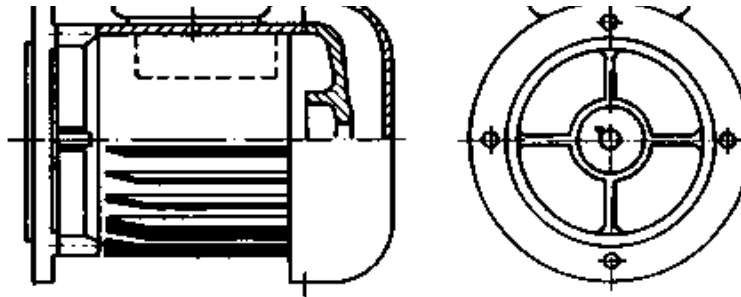
h								
mm								
56	63	71	80	90	100	112	132	160
18	200	225	250	280	315	355	400	

### **3.2. Designs**

### 3.2.1. Definition

**It must be possible to set up the machine as a unit resp. prime mover. This presupposes differing external constructions in order, thereby, to facilitate a coupling between electrical machine, work units or prime mover.**





**Figure 25 - Designs**

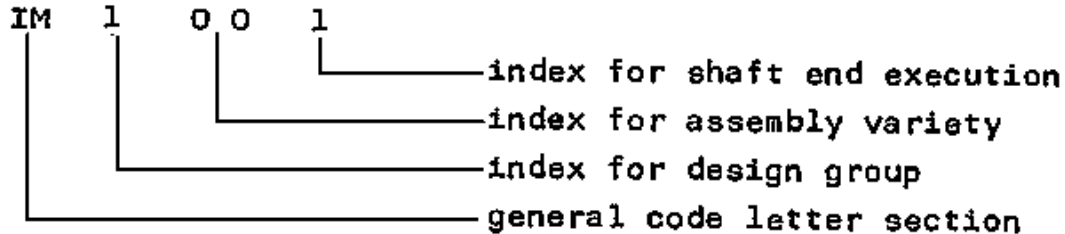
- (1) Foot machine with end shield**
- (2) Machine without feet with end shield flange**

**We comprehend design as the arrangement of machine elements in regard of holding elements, the position of bearings and shaft ends.**

### **3.2.2. Designation**

**Designs are given code letters "IM" in the same manner as degrees of protection and coolants. The letters also indicate the design group, assembly variety and shaft end execution.**





### Example

## Survey 7 - Design category explanations (first figure)

- 1 Foot machine with end shields**
- 2 Foot machines with end shields and end shield flange**
- 3 Machines without feet with end shields and flange on one shield**
- 4 Machines without feet with end shields, with casing flange**
- 5 Machines without bearings**
- 6 Machines with end shields and pillow blocks**
- 7 Machines with pillow blocks (without and shields)**
- 8 Vertical machines which are not covered by the categories IM 1 to IM 4**
- 9 Specially constructed machines according to assembly type**

## Survey 8 - Shaft end type of rotating electrical machines (fourth figure)

**0 Without shaft end**

**1 With a cylindrical shaft end**

**2 With two cylindrical shaft ends**

**3 With a conical shaft end**

**4 With two conical shaft ends**

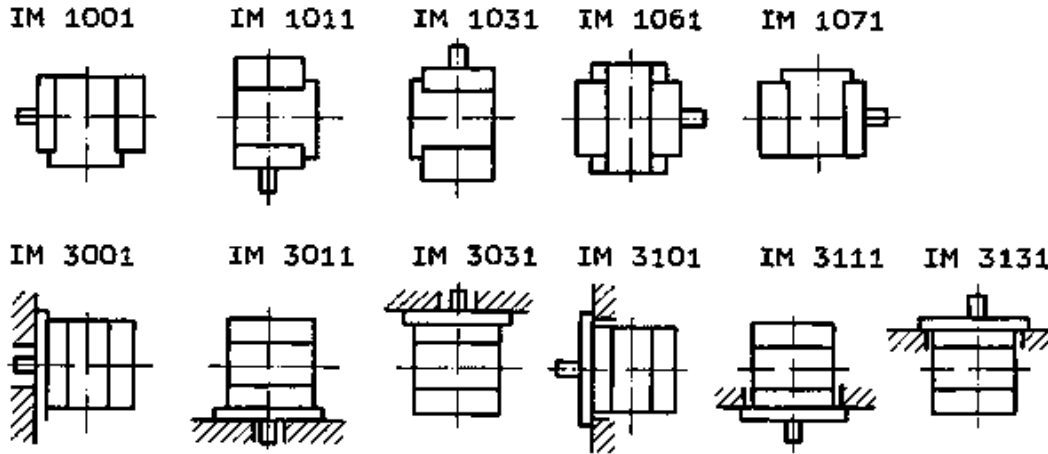
**5 With a flange shaft end**

**6 With two flange shaft ends**

**7 With flange shaft end on the D-side and cylindrical shaft end on the N-side**

**8 All other types with shaft ends.**

**The most common design groups are IM 1001 and IM 3001. The assembly variety is indicated through two numbers. Assembly variety relates to the erection site of the machine regarding the shaft axle and holding elements.**



### Survey 9 - Frequent design categories

## 3.3. Degree of protection

### 3.3.1. Definition

**A machine must be protected from penetration of foreign bodies and water. Indeed, this is essential for ensuring disturbance-free operation. Contact protection provisions are also necessary in the interests of labour safety.**

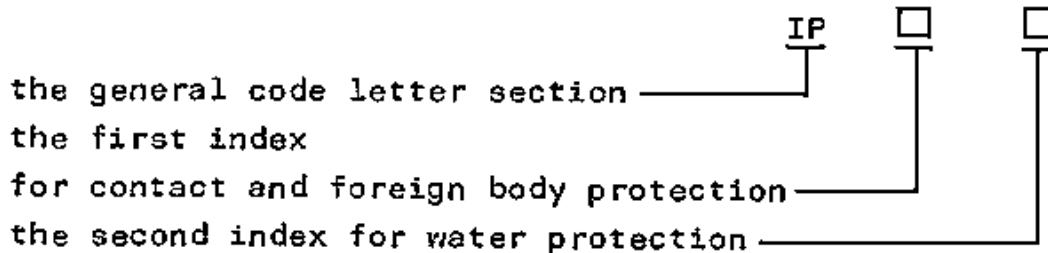
**Degree of protection denotes a designation indicating how a**

**rotating machine is protected from penetration of water and foreign bodies and how human beings are prevented from coming into contact with electrical conductors and rotating parts.**

### 3.3.2. Designation

**An abbreviation has been adopted for designating the degree of protection.**

**The abbreviation features:**



**Figure**

**The arrangement of the numerals for contact and foreign body protection along with the numerals pertaining to water protection**

**have been set out in Survey 10.**

**Survey 10 - Protection grade characteristics**

<b>1. Figure (shock and foreign matter protection)</b>	<b>2. Figure (water protection)</b>
0 unprotected	0 unprotected
1 protection from foreign matter greater than 50 mm	1 drip-proof
2 greater than 12 mm	2 inclined up to 15 degrees
3 greater than 2,5 mm	3 rain protection
4 greater than 1.0 mm	4 splash-proof
5 dust protection	5 hose-proof
	6 splash-proof
	7 pressurized-water-proof
	8 permanent pressurized-water-proof

**Survey 11 features the degree of protection.**

## Survey 11 - Degree of protection of rotating electrical machines

First figure (shock and foreign matter protection)	Second figure (water protection)						
	0	1	2	3	4	5	6
0	IP 00	IP 01	-	-	-	-	-
1	IP 10	IP 11	IP 12	IP 13	-	-	-
2	IP 20	IP 21	IP 22	IP 23	-	-	-
3		-	-	-	-	-	-
4		-	-	IP 43	IP 44	-	-
5		-	-	-	IP 54	IP 55	IP 56
6		-	-	-	-	-	-

### 3.4. Cooling

### **3.4.1. Cooling category**

**Undesired heat development results from the joule heat in the windings. The winding insulation can be damaged and the machine destroyed if the permissible conductor temperature is exceeded. Consequently, adequate heat dissipation facilities must be provided.**

**Cooling category signifies the manner in which heat is dissipated.**

**We differentiate between the following cooling categories:**

**self-cooling:**

**The machine is cooled through air motion and radiation without resorting to a ventilator.**

**natural cooling:**

**The cooling air for the machine stems from a ventilator attached to the rotor.**

**separate cooling:**

**The machine is either cooled through a ventilator which is not driven by the machine shaft or, alternatively, by means of another separately moved coolant instead of air.**

### **3.4.2. Cooling category designation**

**The coolant category designation indicates:**

**Type of coolant**

**Nature of the cooling cycle**

**Method of the coolant circulation**

**Designation:**

**1. Code letters of the cooling IC**

**2. Type of coolant**

<u>Gases</u>	air	A
	hydrogen	H
	nitrogen	N
	carbon dioxide	C



Liquids water

W

oil

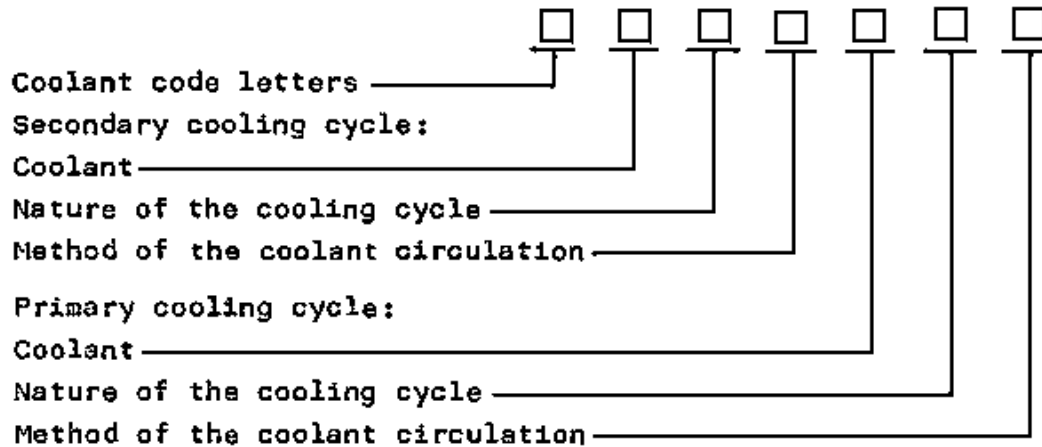
U

**(Where air only is used for cooling the letter "A" can be dropped.)**

**3. Cooling cycle arrangement (1st index)**

**4. Method of coolant circulation (2nd index)**

**Coolant designation pattern:**

**Figure****Examples:**

- IC 01      air-cooled machine, free cycle, self-cycle cooling
- IC0141    air-cooled machine, two cooling cycles, primary coolant dissipates its heat from the casing surface (4); the primary coolant is in self-cycle (1) whilst the coolant circulates freely (0) coupled with self circulating coolant effects (1)

ICA01H41 Primary coolant is hydrogen; the heat is led off from the casing

surface, the hydrogen features a self-cycle; air is used as secondary coolant; the air circulates freely during self-cooling.

**The openings through which the air enters must remain uncovered. Improper machine erection resp. any obstruction of cooling air passage paves the way for both heat damage and possible emission through soilage. Consequently, all machine cooling devices must be regularly serviced.**

### **3.5. Mode of operation**

#### **3.5.1. Definition**

**Operating an electric motor always gives rise to undesirable energy conversion. This in turn leads to heating up which, above all, strains the winding insulations. The service life of a machine is decisively influenced by its inside temperature. Thermal overloading can engender operational disturbances. Estimates indicate that a temperature increase of 8K reduces machine life by 50 per cent. Heating up results first and foremost through energy passage in the windings. The designation  $W = I_2 \cdot R \cdot t$  shows that the conversion into heat and the related temperature rise are determined by the current flow and its duration. Temporary overloading is permissible**

**as, due to thermal inertia, the temperature increase remains insignificant.**

**A torque increase for the work unit, respectively a mass inertia when starting or braking give rise to greater losses in the motor through the flow of higher starting or braking currents. Load starting and braking thus exert an influence on the degree of heating up. Consequently, for reasons related to thermal load, electric motors must be aligned to the load rhythm of the work unit.**

**Mode of operation relates to the nature and sequence pattern, equally the duration of standstill and idling times, also to the nominal load of electrical machines.**

### **3.5.2. Operational mode designation**

**Following abbreviations have been stipulated:**

S1 permanent operation

S2 short-term operation

S3

intermittent operation with starting or braking influences

S4 intermittent operation with starting influence on temperature

S4 intermittent operation with starting influence on temperature

S5 intermittent operation with starting and electric braking influence on the temperature

S6 continuous operation with intermittent loading

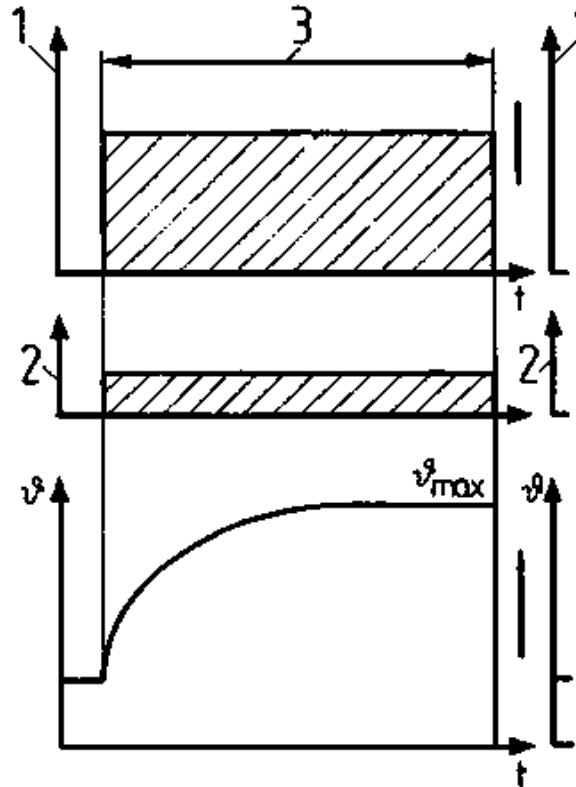
S7 uninterrupted operation with starting and electric braking

S8 uninterrupted operation at differing speeds

### **3.5.3. Frequent nominal cycle ratings**

#### **Operational mode S1**

**Nominal load machine running continues ( $t_B$ ) until machine heating up has attained its final temperature which does not increase further.**



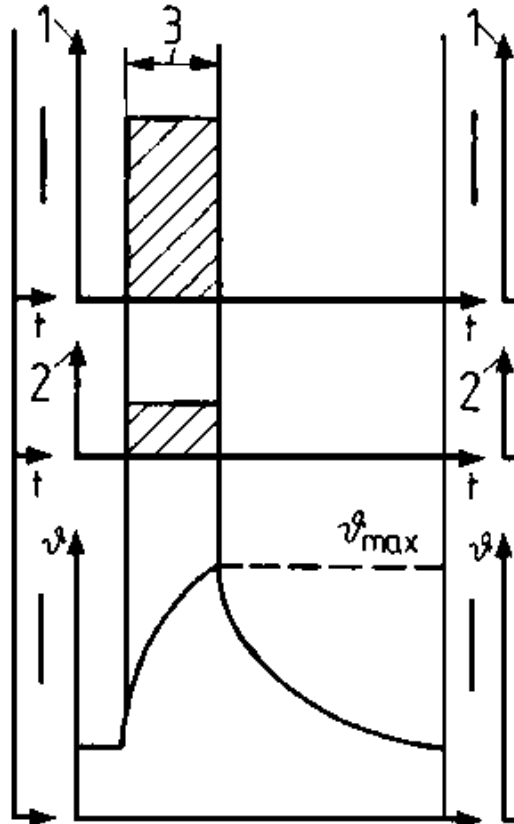
**Figure 26 - Rated operating type S1**

**Legend as for Figure 28**

**The final temperature shall not exceed the limit temperature heat resistance category of the machine.**

### **Operational mode S2**

**Nominal load machine running continues until the limit temperature of the machine has been attained. Then there is a break which lasts until the machine temperature has attained room temperature. The desired values of 10, 30, 60 and 90 minutes apply for the duration of short-time operation.**



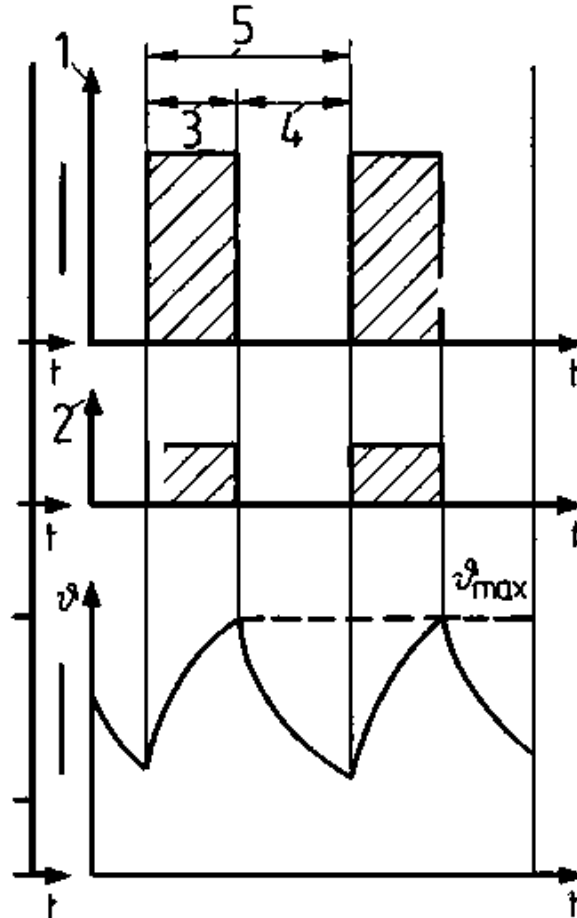
**Figure 27 - Rated operating type S2**



## **Legend as for Figure 28**

### **Operational mode S3**

**The machine runs in periodical operation in a permanent sequence of like cycles ( $t_{sp}$ ). Each cycle includes nominal load or operation and a break ( $t_p$ ) with standstill time whereby the starting current exerts no perceptible influence on heating up.**



**Figure 28 - Rated operating type S3**

- 1 Power**
- 2 Power loss**
- 3 Operating time ( $t_B$ )**
- 4 Down time ( $t_P$ )**
- 5 Cycle play time ( $T_{SP}$ )**

**The machine temperature does not return to room temperature during the standstill period. Intermittent operation is characterised through the relative cycle duration factor  $t_r$  and the cycle of ten minutes. The cycle duration indicates the various, repeatedly occurring operating conditions. The relative cycle duration factor ( $t$ )<sub>r</sub> is indicated thus:**

$$t_r = \frac{t_B}{t_B + t_P} 100\%$$

**By way of preference 15, 25, 40 and 60% should apply in respect of the relative cycle duration factor.**

### 3.6. Heat resistance categories

**The functional life of machine windings depends to a great extent on the thermal strain of insulations. Constant temperature must, moreover, be so limited as to prevent heating up over a longer period leading to an impairment of electrical and mechanical properties.**

#### Survey 12 - Insulation classes

<b>IC Highest permissible permanent temperature (celsius)</b>		<b>Short characterization of the main categories of insulating materials</b>
Y	90	non-impregnated insulation materials of cellulose fibres or silks; forming materials on the basis of urea formaldehyde resin
A	105	impregnated as insulation or in liquid insulating materials such as oil - trenched insulation materials of cellulose fibres or silks; forming materials on the basis

		of melamine formaldehyde resin
E	120	cellulose fibres or silks with synthetic lacquers as coating means; laminated plastics on phenolic resin basis; forming materials on the basis of phenol, aminotriazine and polyester resins
B	130	insulating materials on the basis of mica, asbestos, glass silk or terephthalic acid polyester with organic binding and trenching agents
F	155	insulating materials on the basis of mica, asbestos or glass silk with synthetic binding or trenching agents
	180	insulating materials on the basis of silicone elastomers and on the basis of mica, asbestos or glass silk with silicium-organic binding or trenching agents
C	over 180	mica, glass, quartz or ceramic insulating materials with or without inorganic binding agents

**Exceeding the highest permissible constant temperature in line with heat resistance categories significantly decreases the service life of the machine. For example, a motor can only withstand 50 per cent overloading for about two minutes.**

**A heat resistance category denotes a category to which an insulating material has been allocated in regard to its highest tolerable constant temperature.**

### **3.7. Connection designations of electrical machines**

#### **3.7.1. Transformers**

##### **Survey 13 - Transformer connection designations**

	<b>Upper voltage winding</b>	<b>Under voltage winding</b>
Single-phase transformer	U V	u v
Three-phase transformer	U V W	u v w

#### **3.7.2. Rotating electrical machines**

##### **Survey 14 - Connection designation of rotating electrical machines**

<b>Machine</b>	<b>Winding part</b>	<b>Connection</b>	<b>Previous</b>
----------------	---------------------	-------------------	-----------------

<b>type</b>		<b>designation</b>	<b>connection designation</b>
Three-phase machine	three-phase winding stator	U1, V1, W1	U, V, W
		U2, V2, W2	X, Y, Z
	three-phase winding rotor	K, L, M	u, u, w
	field winding, field spider	F1, F2	I, K
Direct-current machine	shunt winding	E1, E2	C, D
	series winding	D1, D2	E, F
	interpole winding	B1, B2	G, H
	compensation winding	C1, C2	G, H
	interpole and compensation winding	C1, C2	- -

	separately excited winding	F1, F2	I, K
	armature winding rotor	A1, A2	A, B
single-phase	work winding,	U1, U2	U, V
asynchronous motor	auxiliary winding stator	Z1, Z2	W, Z
Universal motor	field winding stator	2D1, 2D2	EB, FB
		1D1, 1D2	EA, FA
	armature winding	A1, A2	A, B

### 3.8. Rotating electrical machines in rotational sense

#### 3.8.1. Clockwise rotation stipulation

**The rotational sense of an electrical machine signifies the rotational direction of the rotor. The rotational sense is always determined with an eye on the shaft end.**



**Clockwise rotation prevails where the shaft rotates in clockwise direction. Anti-clockwise running is termed left operation.**

### **3.8.2. Direct current machines**

**The operation of a direct current machine as motor running clockwise means that the current runs through the windings from beginning (1) to end (2).**

**In order to ensure compliance also with direct current generators, they must run anti-clockwise along with unaltered designation.**

### **3.8.3. Alternating current and three-phase machines**

**Alternating and three-phase machines must always be switched so that the alphabetical series of connection designations (U, V, W) conforms to the temporal sequence of the external conductors (L1, L2, L3).**

## **3.9. Rating plate**

**Rating plates of rotating electrical machines must provide**

**information with regard to the keynote date of the machine in point. Such details are, moreover, necessary for assessing the suitability of the machine for linkage to adjacent technical facilities, mains, work units and prime movers. Consequently, rating plates feature a wealth of details concerning technical-physical dimensions and particular design characteristics. Moreover, additional data is similarly required for possible further fixtures. Such on-going data pertains, inter alia, to rated operating type. Machines in the power range of 0.001 kW to 1.1 kW must feature:**

- country of origin**
- manufacturer or his trademark**
- index or type**
- nominal voltage and current type**
- nominal torque and, if required, additional nominal frequency**
- capacity and rated voltage of the capacitor**
- machine number, year of manufacture or month resp. week and year of manufacture.**

**Designation pattern range of machines in the power range over 1.1 kW:**

1.

4	5	Typ	2
		Nr.	3
6	7	V	10
	8	A	Wkl. 16
15	9		°C
	13	U/min	14
	12		IP 23
Err.	V	17	A
<div style="border: 1px solid black; width: 100%; height: 20px; margin-top: 5px;"></div>			

**Figure 29 - Rating tag of an electrical machine (sample)**

### 1. manufacturer

**2. machine designation - type**

**3. machine number, year of manufacture; or month and year of manufacturer; resp. week and year of manufacture**

**4. current type**

**5. mode of operation (mot; gen; power gen; U; B1 M)**

**6. winding circuitry**

**7. rated voltage**

**8. rated current**

**9. rated power of supplied rating in W, kW, MW; in VA, kVA and MVA for alternating current synchronous generators and reactive power machines**

**10. rated frequency**

**11. capacity, rated voltage of the capacitor (for single-phase motors with starting or working capacitors)**

## **12. rated power factor**

**(Power factor  $\lambda = \text{displacement factor } \cos \varphi$  applies where current and voltage change sine-shaped.)**

**$\lambda = \cos \varphi$  can be used for practical sine-shaped values)**

**13. torque (all rated speeds; in torque adjustable machines the highest and lowest nominal drive torque of the speed range; in machines over 1.1 kW in series operation and machines with a greater operational torque as compared to rated torque, torque speed and the highest permissible speed shall be given)**

**14. rotational direction (only if required)**

**15. rated operational mode (apart from S1)**

**16. insulation class**

**17. Rated exciting current; rated exciting voltage (exc....A; esc....V)**

**18. nominal stillstand voltage between the slip-rings given rated operation (Lf...V)**

**19. mass**

**20. number of standard**

**21. quality sign**

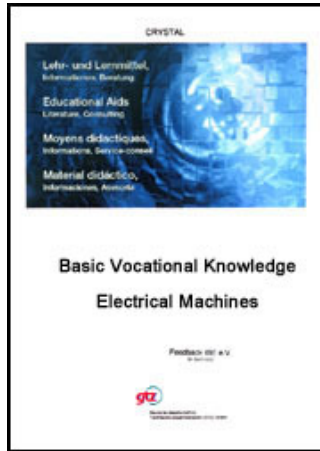
**22. design**

**23. degree of protection**









### **Questions for repetition and control**

- 1. What characterises the design of a motor?**
- 2. Which degree of protection must be selected for a motor positioned in moist surroundings?**
- 3. What does operational mode S1 denote?**
- 4. How is clockwise running stipulated for electric motors?**





## **Electrical Machines - Basic vocational knowledge (Institut für Berufliche Entwicklung, 144 p.)**

- ➔  **4. Synchronous machines**
  - 4.1. Operating principles**
    -  **4.1.1. Synchronous generator**
    -  **4.1.2. Synchronous motor**
  - 4.2. Constructional assembly**
    -  **4.2.1. Stator**
    -  **4.2.2. Rotor**
  - 4.3. Operational behaviour**
    -  **4.3.1. Synchronous generator**
    -  **4.3.2. Synchronous motor**
  - 4.4. Use of synchronous machines**
    -  **4.4.1. Synchronous generators**
    -  **4.4.2. Synchronous motors**

## **Electrical Machines - Basic vocational knowledge (Institut für Berufliche Entwicklung, 144 p.)**

### **4. Synchronous machines**

#### **4.1. Operating principles**

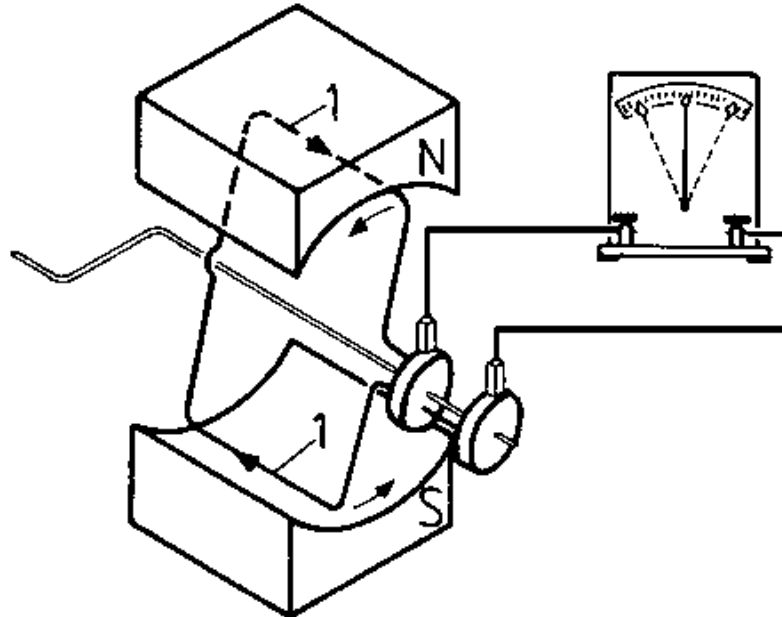
##### **4.1.1. Synchronous generator**

##### **Alternating-voltage generator**

**A sine-shaped alternating voltage can be generated very simply by utilising the arrangement set out in Figure 30 by means of the induction effect ( $U_0 = c \cdot \Phi \cdot n$ )**

**The sine-shaped voltage is attained through a conductor loop in the parallel homogeneous magnetic field. The conductor loop ends are connected to the slip ring and the voltage is fed to the operating means by carbon brushes.**

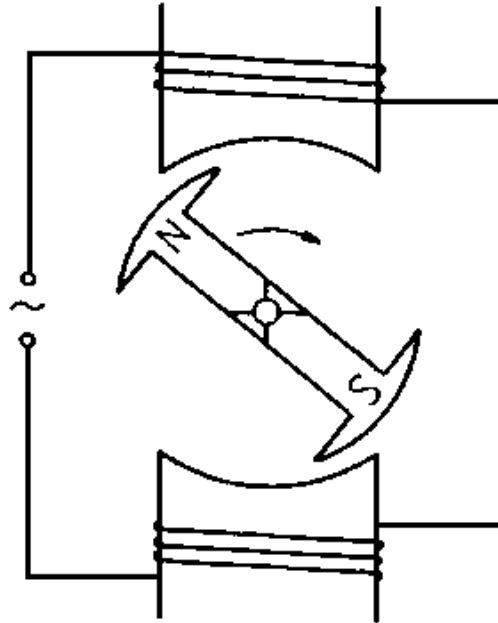




**Figure 30 - Model of an alternating voltage generator (inner-pole machine)**

### **1 Current direction**

**The same effect is produced if a stationary induction coil is shifted to within the sphere of a rotating magnet.**



**Figure 31 - Model of an alternating voltage generator (external pole machine)**

**The voltage induction in the synchronous generator can be attained by the generation of a magnetic flow in**

**- stationary stators and rotating induction winding**

**(external pole machine), or**

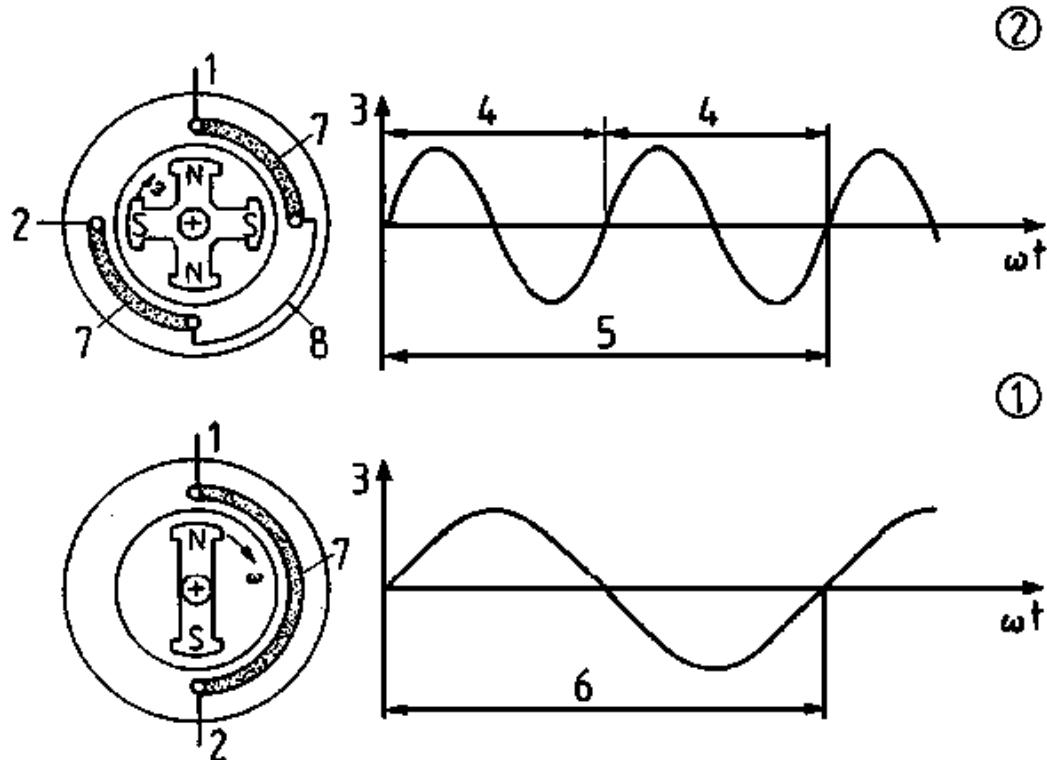
**- in the rotating magnetic stand and stationary induction winding in the stator (inner-pole machine).**

**Every rotation of the conductor loop induces a period of alternating voltage. Where the rotation ensues within a second there is one period per second, that is to say, a frequency of one Hz. Given n rotations per minute, that is to say n/60 rotations per second, there is initially a frequency of**

$$f/\text{Hz} = \frac{n/\text{rpm}}{60}$$

**This equation, moreover, shows that proportionality prevails between the frequency of the generated voltage and the speed. This explains the name "synchronous generator".**

**Where a four-pole arrangement (two north poles along with two south poles) is employed, there arises a period of alternating voltage in the event of a semi-rotation of the magnets.**



**Figure 32 - Interdependence of pole pair number and frequency in a synchronous generator**

**(1) Two-pole generator, (2) Four-pole generator**

**1 Winding beginning, 2 Winding end, 3 Voltage, 4 A cycle, 5 A rotation = two cycles, 6 A rotation = one cycle, 7 Coil, 8 Coil connection**

**The following then applies:**

$$f/\text{Hz} = \frac{p \cdot n/\text{rpm}}{60}$$

**p = pole pair number**

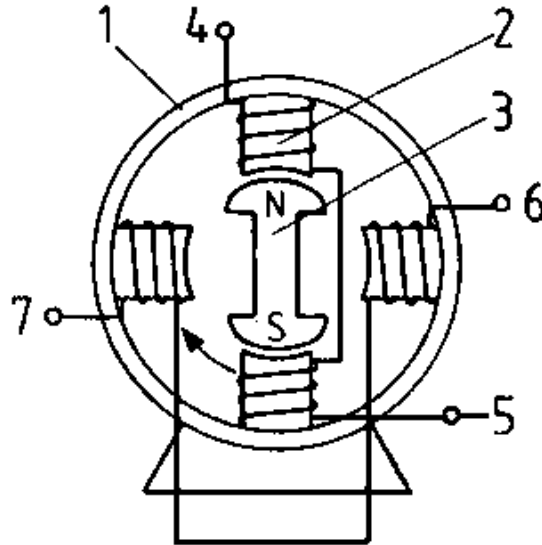
**p = one two-pole machine**

**p = two four-pole machine etc.**

**Thus, the greatest speed at which  $f = 50$  Hz is therefore  $n = 3000$  rpm ( $p = 1$ ).**

### **Three-phase generator**

**Figure 33 initially depicts the basic arrangement of a two phase alternating voltage generator.**

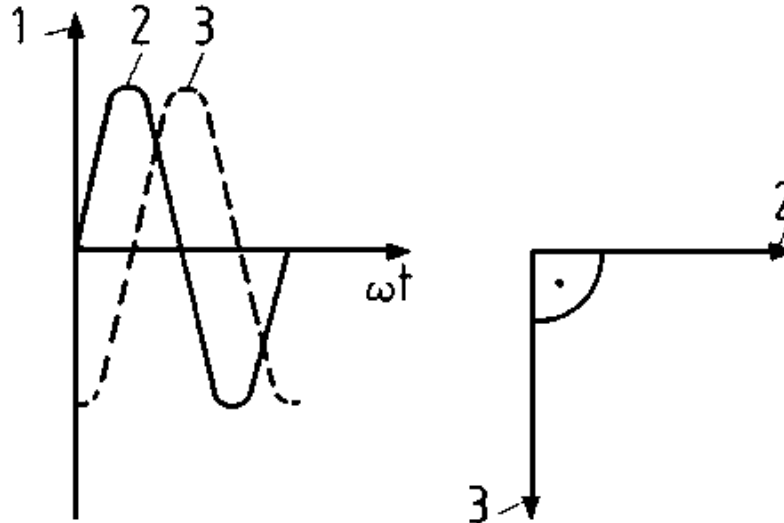


**Figure 33 - Principle of the two-phase alternating voltage generator**

**1 Casing, 2 Stator, 3 Field spider, 4 Beginning winding one, 5 End winding one, 6 Beginning winding two, 7 End winding two**

**Two coils (resp. four half coils) are positioned spatially within 90 degrees on the circumference of a common stator ferromagnetic circuit.**

**By means of a rotating electromagnet (field spider) out-phased voltages of like amplitude and frequency are induced temporally within 90 degrees in these windings. These can be dropped off directly at the windings.**

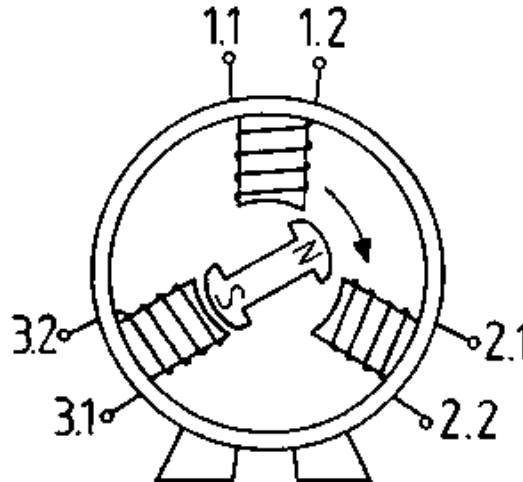


**Figure 34 - Two-phase alternating voltage**

**1 Voltage, 2 Winding voltage, 3 Voltage of winding two**

**Where three coils are shifted spatially within 120 degrees in an**

**alternating voltage generator and distributed within the range of a common stator circuit, a rotating (electro)magnet induces three displaced voltages temporally within 120 degrees.**

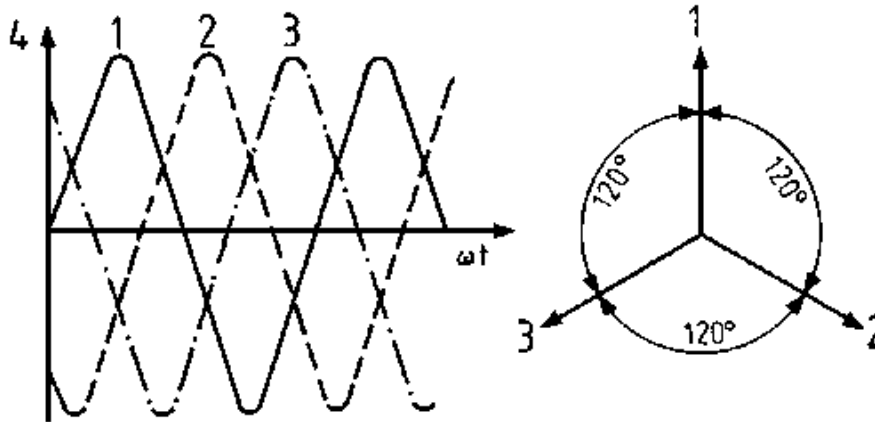


**Figure 35 - Principle of the three-phase alternating generator**

- 1.1. Winding one beginning**
- 1.2. Winding one end**
- 2.1. Winding two beginning**
- 2.2. Winding two end**
- 3.1. Winding three beginning**



### 3.2. Winding three end



**Figure 36 - Three-phase alternating voltage**

**1 Winding one voltage, 2 Winding two voltage, 3 Winding three voltage, 4 Voltage**

**This principle was first cited in 1885 by Ferraris. (Galileo Ferraris, 1847-1897, Italian physicist and electrical engineer).**

#### 4.1.2. Synchronous motor

**In a motor stator - given the simplest contingency - a rotating field**

**is yielded by three coils displaced within 120 degrees through which current flows from three streams displaced over 120 degrees. Where there is a field spider of a synchronous machine in the rotating field, force actions make themselves felt between the north pole of the rotating field and the south pole of the field spider resp. between the south pole of the rotating field and the north pole of the field spider. One could imagine rubber threads (field lines) strung up between the rotating field and the field spider.**

**The rotating field propels the field spider and both run at the same speed. This is why the motor is called a synchronous motor.**

## **4.2. Constructional assembly**

### **4.2.1. Stator**

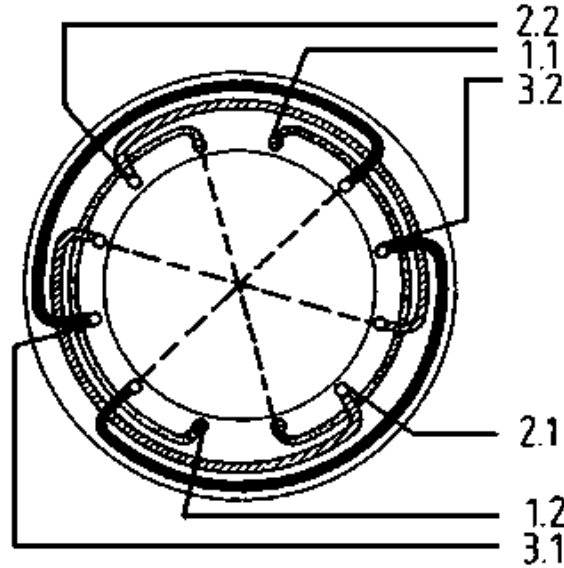
**Synchronous machines may be either inner or external pole machines (Cp Figure 9). As direct current power required for excitation is relatively small as compared to alternating current energy, it is more economical to feed the rotors via slip rings with direct voltage. Alternating voltage can then be fed through**

**permanent terminals, resp. tapped off. For this reason inner pole machines are generally manufactured.**

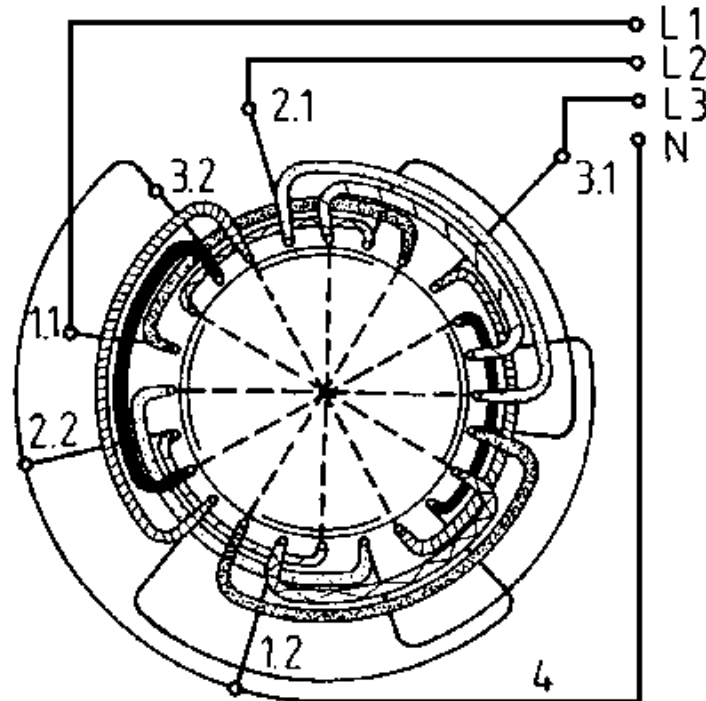
**Synchronous machines are mainly inner pole machines.**

**The stand of the inner pole machine comprises a steel casing containing a lamella pack with magnetically high-grade iron.**

**The windings are housed in the inner-positioned grooves. In the case of the single-phase machine these are distributed around some two thirds of the total circumference whereas, in the case of a three phase synchronous machine, three coils have each been displaced spatially within 120 degrees.**



**Figure 37 - Stator winding of a two-pole inner-pole synchronous machine Legend as for Figure 35**



**Figure 38 - Stator winding of a four-pole inner-pole synchronous machine**

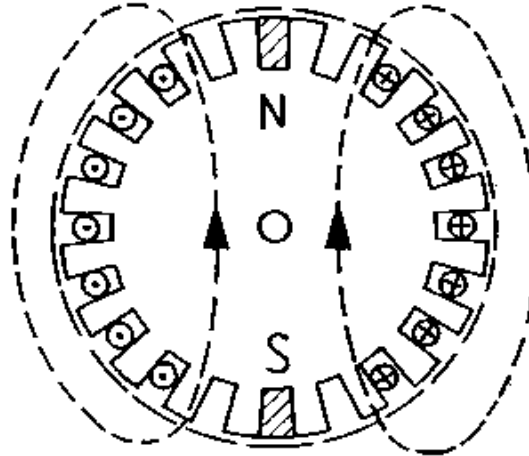
**L1; L2; L3 Three-phase conductor**  
**N Neutral conductor**

## **4 Star point 1.1. to 3.2. as for Figure 35**

### **4.2.2. Rotor**

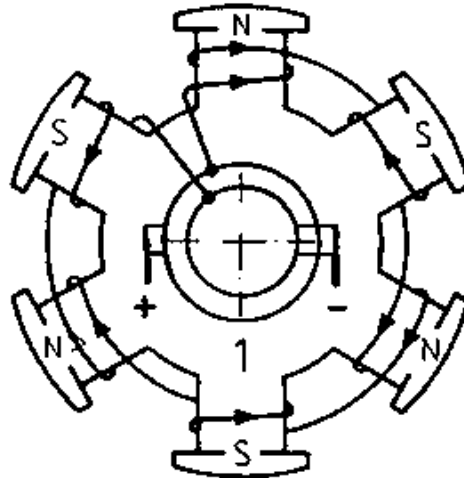
**As regards rotor shape, one differentiates between the turbine and salient pole machines. Both rotor types feature a magnetic constant field. For this reason the rotor iron need not be a lamella pack.**

**The rotor of the turbine-type machine is called a non-salient pole rotor. It is cylindrically set up, rather long and has a relatively small diameter of up to some 1200 mm. A non-salient pole rotor only has a relatively small number of poles. Mainly it only features one pole pair, that is to say a north and south pole. As this machine mainly runs on alternating voltage of  $f = 50$  Hz, this results in a considerable rotor speed. Thus, for example, a synchronous machine with one pole pair and alternating current at a frequency of  $f = 50$  Hz, requires a speed of 3000 rpm.**



**Figure 39 - Two-pole non-salient pole rotor**

**The salient pole machine features a field spider with distinct poles which bear the exciter winding. This is relatively short and has a big diameter of some 10 m. The considerable number of pole pairs yield speeds of 60 rpm to 750 rpm given alternating voltage at a frequency of  $f = 50$  Hz.**



**Figure 40 - Six-pole salient pole rotor**

## **1 Field spider**

### **4.3. Operational behaviour**

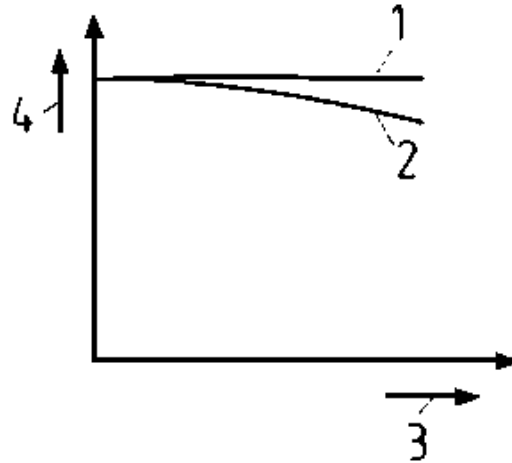
#### **4.3.1. Synchronous generator**

#### **Voltage generation**

**Figure 41 sets out the interrelationship between the generated**



**voltage  $U_0$ , the terminal voltage  $U$  and the ohmic load current.**



**Figure 41 - Interdependence of induction voltage  $U_0$ (1) and terminal voltage  $U$ (2) given differing active current  $I_W$ (3)**

## 4 Voltage

**In order to retain the required, constant terminal voltage, the generated voltage must be supplied.**

**According to the generator equation**

$$U_0 = O \cdot \Phi \cdot n$$

**one can determine the induced voltage in the synchronous generator.**

**As the frequency is speed-dependent according to the equation**

$$f/\text{Hz} = \frac{p \cdot n/\text{rpm}}{60}$$

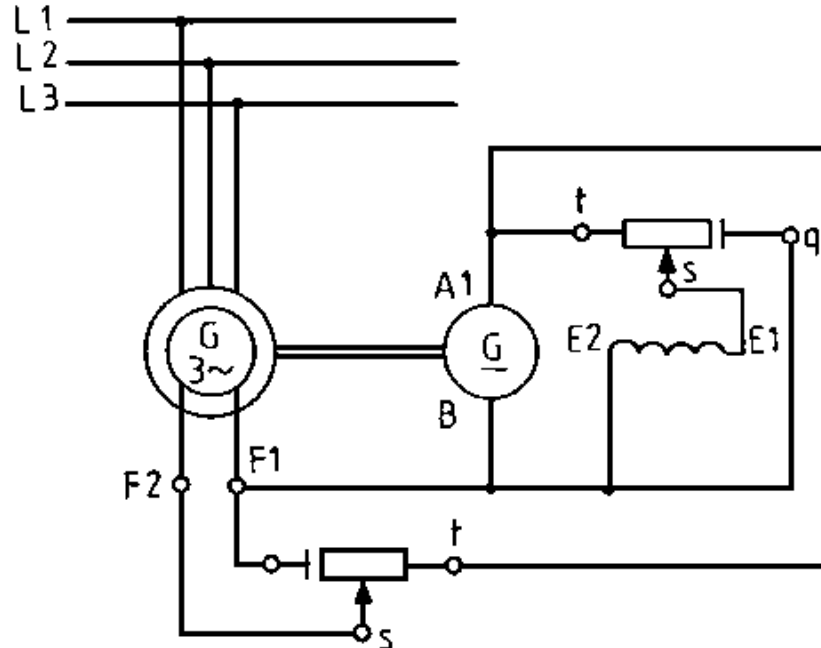
**and, generally speaking, a constant frequency is required by energy consumers, it is only possible to control the voltage  $U_0$  by means of the exciting current  $I_e$ :**

$$I_e \rightarrow \Phi \rightarrow U_0$$

**The exciter current is set by means of field voltage plate resp. carbon regulator, thyristor regulator or electronic facility.**

**Figure 42 shows a synchronous generator with a self-exciting direct current generator. The circuit diagram indicates that the current can be set from zero to maximum. A short-circuit terminal q has**

**also been provided for the exciter circuit of the synchronous generator. Switching off excitation cannot ensue through immediate interruption of the exciting circuit as induction leads to voltage peaks. Moreover, even where the exciting circuit has been short-circuited by means of a terminal q, voltage peaks corresponding to normal operating value arise in the operational winding through residual magnetism.**



**Figure 42 - Circuit of a synchronous generator**

**L.1; L.2; L.3 conductors**

**A; B; E and F generation connections (terminal board)**

**q; s; t controller connections**

**The following should be heeded when setting the voltage in**

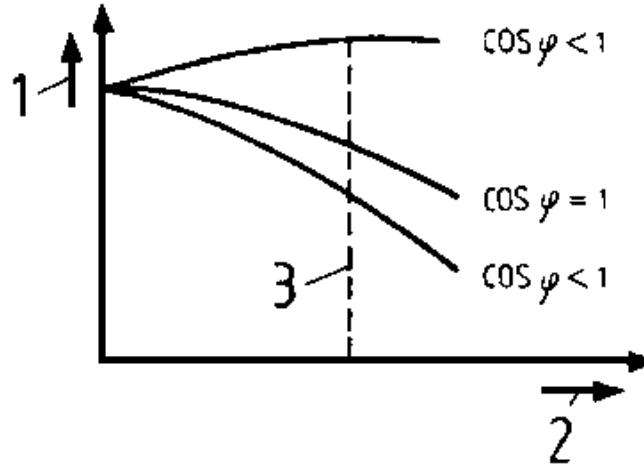
## **synchronous generators:**

- where the setting ensues manually, the exciting current must be reset slowly;**
- where a generator is to stop working, then in all cases shift the slider of the field voltage plate to the short-circuit terminal q.**

## **Isolated operation**

**Synchronous generators are sometimes run in isolated operation. A number of important installations, for instance transmitting units of the postal and telecommunication services, must continue operations in the event of a power failure. Consequently, for this reason, standby generator sets have been installed in many works and institutions. These standby units ensure power supplies if the national grid fails. The drive machines of these standby units are mainly diesel motors which drive a synchronous generator along with the accompanying, self-exciting generator. We differentiate between three load categories. The synchronous generator can be loaded either with active current, inductive or capacitive reactive**

**current. Figure 43 indicates the terminal voltage yielded according to the load.**



**Figure 43 - Load characteristic lines of a synchronous generator**

**1 Voltage, 2 Current, 3 Rated current, upper curve  $U = f(I)$  given capacitive load and lower curve  $U = f(I)$  given inductive load**

**Thus, one can deduce that the exciting current must be continuously set given a required, constant terminal voltage.**

## **Rigid network operation**

**Where a synchronous generator feeds power to a network whose voltage also remains constant in the face of load differences, then one refers to a rigid network machine. Generally speaking several generators operate within such a network, for instance, as is customary for energy generation in power stations. One also refers to parallel or compound operation. Where several or merely one generator works within the network, then the following must be heeded when switching on the second resp. subsequent generator:**

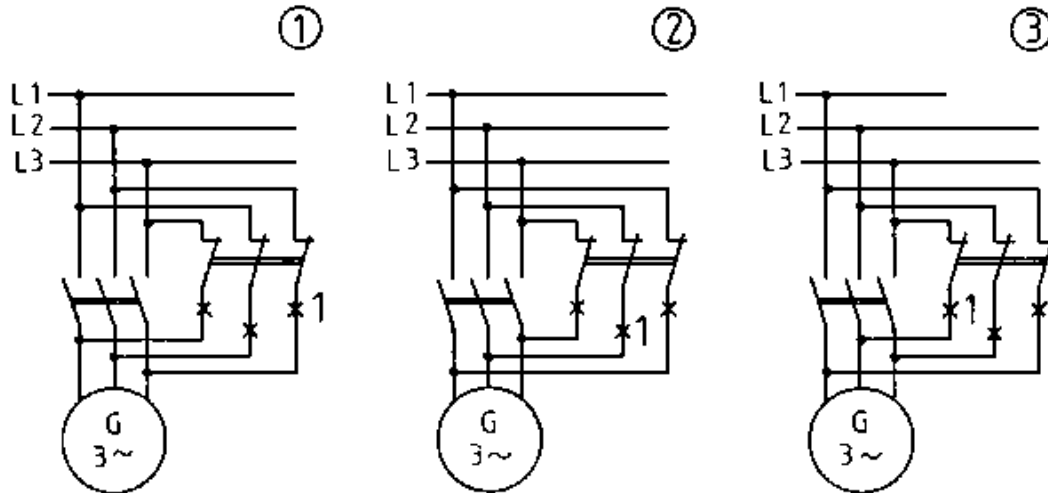
- The frequency of the generator to be added must conform with the network frequency!**
- Network voltage and generator voltage must feature identical values. The phase position of both voltages must concur.**
- The correct phase sequence L1-L2-L3 of the network and the generators to be switched on must be checked!**

**Special measuring devices resp. circuits have been devised to**

**ensure that these conditions are adhered to or, as one says, that the generator to be switched on is "synchronized".**

**The most frequently employed measuring devices are the double frequency measuring unit, the double voltage measuring device and the synchronoscope. The double frequency measuring unit contains two vibration measuring devices independent of one another, which indicate network frequency as well as the frequency of the generator to be switched on. Both frequencies can be read off simultaneously. The correct frequency is attained by setting the speed of the drive machine of the generator to be synchronized. Switching on must always ensue at the same frequency as, otherwise, the generator and/or the drive machine may be damaged. The double voltage measuring unit has two iron moving instruments independent of one another which indicate the voltage of the network and the generator. Voltage setting of the generator ensues through the exciting current. In order to control the phase position and phase sequence one can utilise light, dark or mixed circuits; the latter is also called light-dark circuit. The three circuits feature in Figure 44. The lamps are generally arranged in circular formation for better observation.**





**Figure 44 - Circuits to synchronize three-phase generators**

**(1) Bright connection, (2) Dark connection, (3) Mixed connection**

**1 Lamps**

**The light circuit shall be switched on when all three lamps light up brightly at the same time. In this conjunction note that the lamps are brightest given a 60 degree phase shift between generator and network. The circular arrangement of the lamps yields a rotating light reflex where the frequencies of the network and the generator**

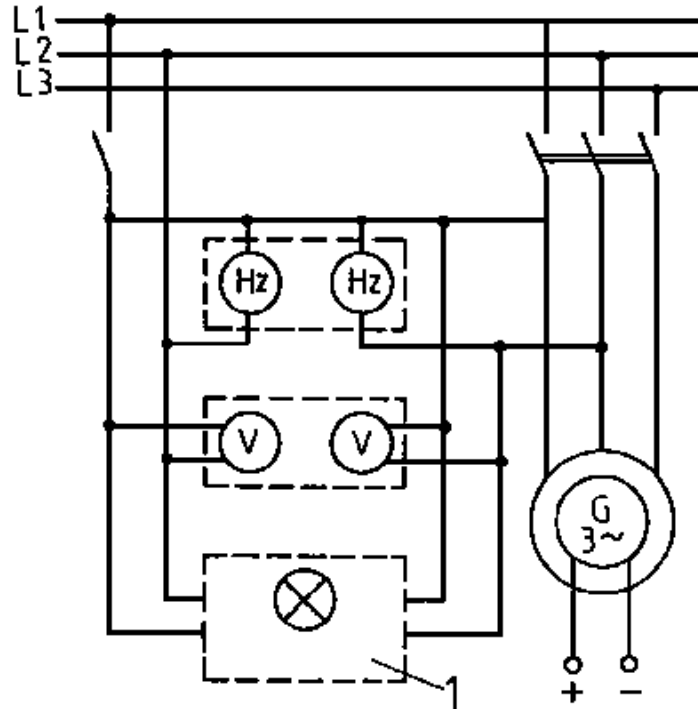
**do not concur. The speed of the generator drive machine is controlled in line with the rotation of the rotating light reflex. The rotational speed of the light reflex is a measure for the difference between network and generator frequencies. The rotational speed of the light reflex is a measure for the difference between the network and generator frequencies. The direction indicates whether the generator is running too quickly or too slowly.**

**The generator to be switched on has been positioned in the correct phase position in the network - given synchronizing dark connection - if all three lamps light up and extinguish simultaneously. If this is not the case, then two connections should be interchanged. Generator switching on ensues when all three lamps extinguish.**

**Where the lamps have been arranged in circular position within a mixed circuit, they light up one after the other and the light reflex wanders in accordance with the either too low or too great generator frequency. Switching on occurs when the lamp  $H_1$  extinguishes and lamps  $H_2$  and  $H_3$  light up brightly.**

**As synchronizing with these cited circuits is a troublesome**

**business, power stations utilize a so-called synchronoscope. The synchronoscope indication ensues through an indicator which is controlled by two systems operating in accordance with the induction principle. The indicator is furthermore illuminated by a phase lamp in synchronizing bright connection. By this yields an optical impression of the rotational movement of the indicator is achieved according to which the speed controls of the prime mover ensue in line with the indicator movement. Figure 45 shows a customary circuit for synchronization.**



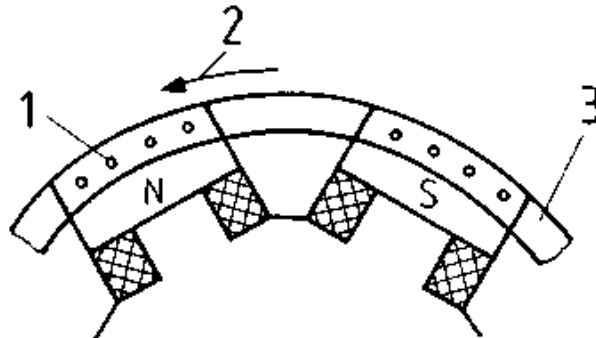
**Figure 45 - Circuit for synchronizing a three-phase generator**

## **1 Synchronoscope**

### **4.3.2. Synchronous motor**

## Starting

The rotating field immediately runs at low inertia once a stator winding of the synchronous motor is connected to the three-phase mains. Conversely, the field spider cannot follow at once because of its inertia mass. Constantly alternating north and south poles of the rotating field continuously cross the north pole of the field spider and give rise to pulsating force actions in the one or other direction. In this manner the synchronous motor does not develop a "starting torque". For this reason a starting winding in the rotor is used.



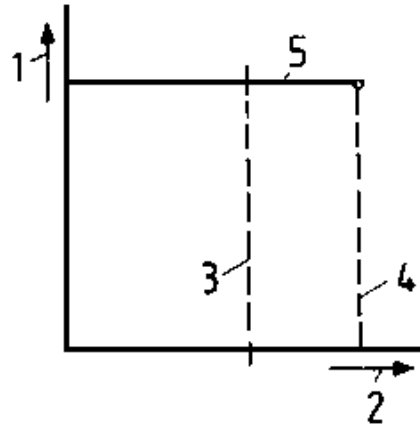
**Figure 46 - Starting winding of the synchronous rotor**

**1 Rods, 2 Rotating field, 3 Spur ring**

**This starting winding consists of aluminium or copper rods positioned in axial direction through the pole shoe and short-circuited at the ends through end rings. As the rotating field rotates a torque is attained (see short-circuit rotor principle) which causes the machine to accelerate. Switching on the exciting current draws the motor into the synchronous run of the rotational field.**

### **Rated operation**

**The envisaged “rubber threads” (Cp 4.1.2.) stretch more and more. The synchronous speed is always retained. The synchronous motor does not alter its speed given an increased load.**



**Figure 47 - Speed-torque curve of the synchronous motor**

**1 Speed, 2 Torque, 3 Rated torque, 4 Breakdown torque, 5 •  
 $n = f(M)$**

**Where the load is increased substantially over and beyond the rated torque, the magnetic coupling forces are no longer able to draw the rotor in to the synchronous run of the stator rotating field. One can imagine that the "rubber threads" could easily tear through such overload. The rotor "gets out of step".**

**This takes place according to machine type overload between 1.5**

**and 1.9 times above the rated torque (breakdown torque  $M_K$ ).**

## **4.4. Use of synchronous machines**

### **4.4.1. Synchronous generators**

**Synchronous generators are the basis of overall power generation. They are used in thermal power stations in conjunction with steam turbines as turbogenerators. Their range of performance extends up to 1500 MVA and a voltage of 10.5 kV. The turbines of water power stations operate at lower speeds as steam turbines. The adoption of synchronous generators along with a 50 Hz network presupposes the employment of multi-pole machines which come as salient-pole machines. Water force generators (hydrogenerators) are also constructed for relatively low speeds up to powers of 500 MVA.**

### **4.4.2. Synchronous motors**

**Synchronous motors are used to drive pumps and compressors above all in the chemical industry and as drives for rotating tubular furnaces. There is also a combined application of bigger synchronous machines as motor and generator in pump storage**



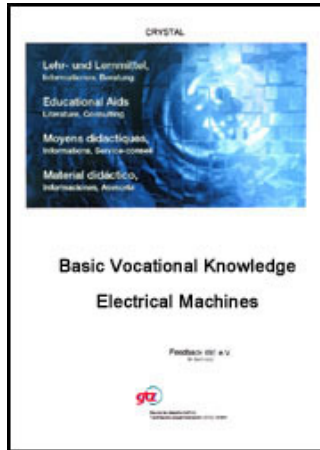
**plants. The synchronous machine is coupled to a water tube and a pump. Due to low network loads it operates as a motor and pumps water into a raised basin. During peak network load spells this water is able to run back into the lower basin by means of a turbine. The synchronous machine then operates as a generator.**

### Questions for repetition and control

- 1. Given a speed of  $n = 60$  rpm, a synchronous generator shall generate an alternating voltage at a frequency of  $f = 50$  Hz. How many pole pairs are required?**
- 2. What is the operating frequency of a synchronous machine with two pole pairs where the rotor evidences a speed of 1500 rpm?**
- 3. How can the voltage of a synchronous motor be changed?**
- 4. Which conditions must be heeded for parallel switching of synchronous generators?**



**[Home](#)"" """"> [ar.cn.de.en.es.fr.id.it.ph.po.ru.sw](#)**



- 📖 **Electrical Machines - Basic vocational knowledge (Institut für Berufliche Entwicklung, 144 p.)**
- ➔  **5. Asynchronous motors**
  - 📄 **5.1. Constructional assembly**
  - 5.2. Operating principles**
    - 📄 **5.2.1. Torque generation**
    - 📄 **5.2.2. Asynchronous principle**
    - 📄 **5.2.3. Slip**
  - 5.3. Operational behaviour**
    - 📄 **5.3.1. Start**
    - 📄 **5.3.2. Rating**
    - 📄 **5.3.3. Speed control**
    - 📄 **5.3.4. Rotational sense alteration**
  - 5.4. Circuit engineering**
    - 📄 **5.4.1. Starting connections**
    - 📄 **5.4.2. Dahlander pole-changing circuit (speed control)**

 **5.4.3. Rotational reversing circuit** **5.4.4. Braking circuits** **5.5. Application** **5.6. Characteristic values of squirrel cage motors**

## **Electrical Machines - Basic vocational knowledge (Institut fr Berufliche Entwicklung, 144 p.)**

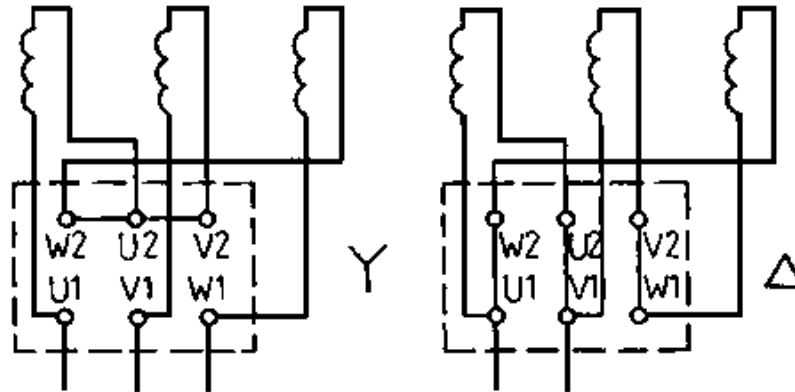
### **5. Asynchronous motors**

#### **5.1. Constructional assembly**

**The magnetic flow change required in the rotor winding is generated by the stator by means of a circulating field (rotating field).**

**In this manner the stator aligns itself to a marked extent to the synchronous machine and, like this machine, also features a three phase winding (Cp. Figure 37) able to generate a rotating field. Machines with an operating voltage of 660 V have all winding origins and ends connected to the terminal board. Consequently,**

**the strands can be interlinked in a star-delta arrangement (Cp. Figure 48). In the case of higher operating voltages interlinkage often ensues inside the machine.**



**Figure 48 - Circuits of the strand windings at the terminal board**

**U; V; W winding designations**

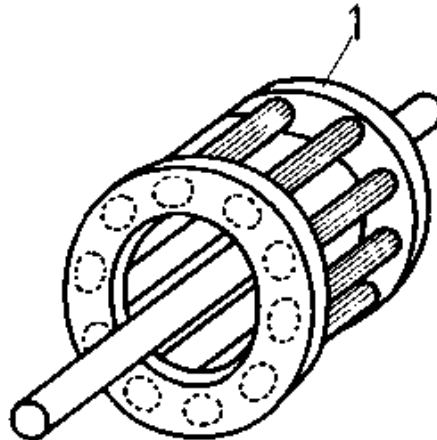
**The asynchronous machine is the sole rotating electric machine in which the transmission of electric energy to the rotor does not ensue electromechanically but inductively. Both stator and rotor of the asynchronous machine may be compared to the parts of a**

**transformer whose secondary section has been arranged to rotate.**

**Two different rotor types of asynchronous motors are customary.**

### **Short-circuit rotor**

**This rotor has a squirrel cage armature and rods of copper, bronze or aluminium have been positioned in the grooves of the cylindrical rotor lamella pack and short-circuited to each other through end windings.**

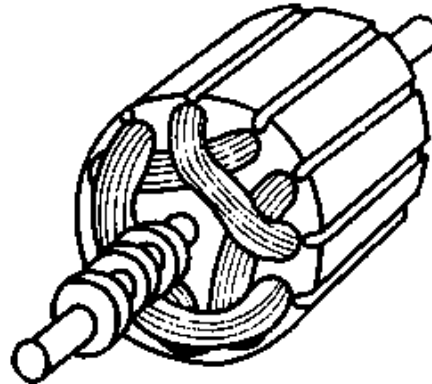


**Figure 49 - Squirrel cage rotor**

## **1 (aluminium, bronze, copper)**

### **Slip ring rotor**

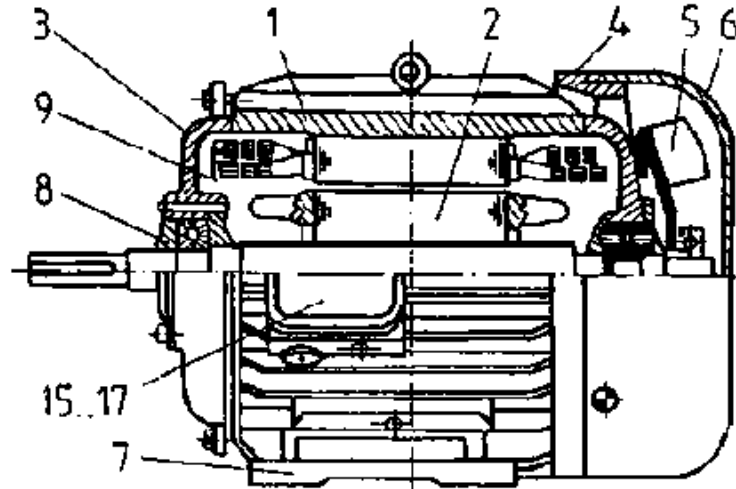
**The slip ring rotor has a three-phase winding similar to the one of the stator winding.**



**Figure 50 - Slip-ring rotor**

**The three spatially positioned coils within 120 degrees are star connected and the origins connected to three slip rings. In operation these slip rings are short-circuited. Thereby there is no difference in the mode of operation of the slip ring rotor and the**

**squirrel cage rotor. Figure 51 shows a sectional presentation of the overall construction of a squirrel cage motor.**



**Figure 51 - Squirrel cage motor, protection degree IP34 and design IM 1001**

**1 Stator, 2 Rotor, 3 End shield to the A-side, 4 End shield of the B-side, 5 Ventilator, 6 Ventilator hood, 7 Foot, 8 Bearing lid (external), 9 Bearing lid (internal), 10 Slip-ring capsule, 11 Counterbalance disk, 12 Slip-ring body, 13 Brush holder,**

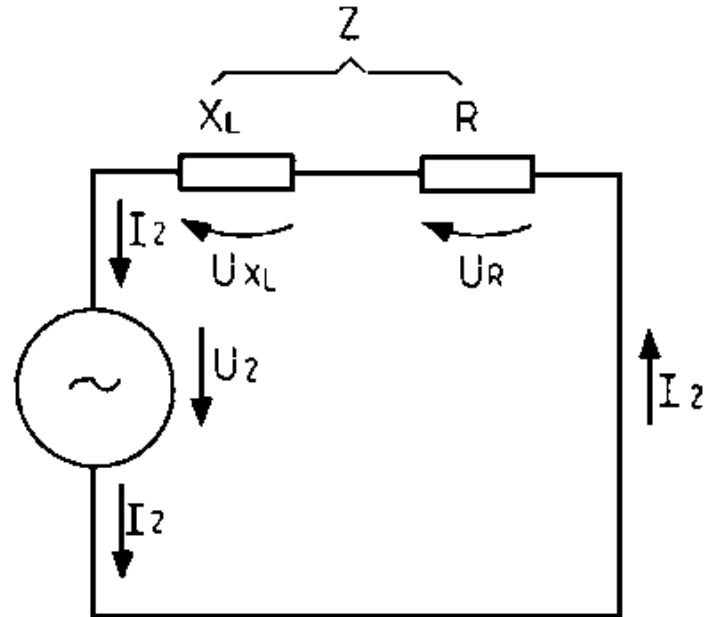
## **14 Cover sheet, 15...17 Stator terminal boxes**

### **5.2. Operating principles**

#### **5.2.1. Torque generation**

**The rotating field immediately runs at low inertia when a three-phase alternating voltage is connected to the stator winding. During switching on the stator - because of its inertia mass - is still at a standstill. The magnetic flux change resulting from the rotating field induces the voltage  $U_2$  in the rotor. This drives the rotor current  $I_2$  in the short circuited rotor circuit.**

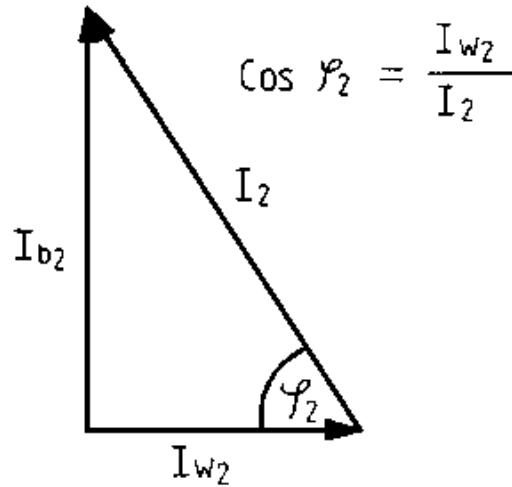




**Figure 52 - Duplicate of a rotor circuit**

**U** voltage, **I** current,  **$X_L$**  reactance, **R** ohmic resistance, **Z** impeder resistance

**The rotor current  $I_2$  is made up of an ohmic share  $I_{2W}$  and a reactive share  $I_{2b}$**



**Figure 53 - Indicator diagram of rotor currents**

**$I_b$  reactive current,  $I_w$  eddy current,  $I_2$  rotor current**

**The ohmic share  $I_2 w$  of the rotor current makes up the torque along with the rotating field according to the equation**

**$M = c \cdot \Phi_1 \cdot I_2 w$ , and with**

**$I_2 w = I_2 \cdot \cos \varphi_2$**

**the torque being:**

$$\mathbf{M} = \mathbf{C} \cdot \Phi_1 \cdot \mathbf{I}_2 \cdot \cos \varphi_2$$

**The mode of operation of the asynchronous motor can be illustrated by means of the following operating chain**

$$\mathbf{U}_1 \rightarrow \mathbf{I}_1 \rightarrow \Phi_1 \text{ rotating field} \rightarrow \mathbf{U}_2 \rightarrow \mathbf{I}_2 \text{ (I)}_2 \mathbf{W} \rightarrow \mathbf{M}$$

### **5.2.2. Asynchronous principle**

**Due to the torque effect the rotor begins to rotate in the direction of the rotating field. Commensurately the rotor virtually accepts torque  $n_D$  of the rotating field which it, however, never actually attains.**

**The magnetic flow change dwindles to the extent that the rotor speed draws closer to the speed of the rotating field. Should the rotor attain the speed of the rotating field, then the magnetic flow change is zero. In that case no rotor voltage is induced. Thus, the motor cannot generate a torque.**

$$\mathbf{U_2 = 0 \rightarrow I_2W = 0 \rightarrow M = 0}$$

**The operating condition of the synchronous run cannot be assessed because of the unavoidable idling torque to overcome the friction bearing and air friction, so that the motor must always run in an asynchronous manner.**

### **5.2.3. Slip**

#### **Relationship between slip and rotor speed**

**Rotor speed  $n$  lags behind the synchronous speed  $n_D$  and one refers to rotor "slippage". The relative difference  $n$  between both speeds, which expresses the relative movement between the stator rotating field and the rotor, is characterised as slip speed  $n_s$  in asynchronous machines.**

**slip speed**

$$\mathbf{n_s = n_{rel} = n_D - n}$$

**The quotient resulting from the slip speed and the rotating field**

**speed has been defined as the slip s**

**slip**

$$s = \frac{n_D - n}{n_D}$$

**Example:**

**An asynchronous motor has been connected to a mains voltage of  $f_1 = 50$  Hz frequency. How great is the slip s given a rated speed  $n = 960$  rpm?**

**Solution:**

**The rotor rated speed of  $n = 960$  rpm at  $f_1 = 50$  Hz should be aligned to the next synchronous speed  $n = 1000$  rpm.**

**Thus, the slip can be calculated**

$$s = \frac{n_D - n}{n_D} = \frac{1000\text{rpm} - 960\text{rpm}}{1000\text{rpm}} = 0.04 = 4\%$$

**The slip accepts at rated load of motors values ranging between one and eight per cent. Greater slip values usually arise in less powerful motors. If we incorporate the speed limit values of the asynchronous machine in motor operation into the equation, we derive the following values for the slip s:**

$$\text{Standstill}(n=0) \quad s = \frac{n_D - 0}{n_D} = 1$$

$$\text{Synchronism}(n = n_D) \quad s = \frac{n_D - n_D}{n_D} = 0$$

**A solution according to the rotor speed yields the following:**

$$s n_D = n_D - n$$

$$n = n_D - s n_D$$

$$n = n_D (1 - s)$$

**Rotor voltage and rotor frequency**

## **Value and frequency of rotor voltage in idling rotors.**

**The voltage generated by idling rotors is characterized as rotor idling voltage  $U_{2.0}$**

$$U_{2.0} = C_1 \cdot \Phi \cdot n_D$$

$$f_{2.0} = p \cdot n_D = f_1$$

**The values of the voltage  $U$  induced in the rotor and its frequency  $f_2$  depend on the relative speed  $n_s$  between the stator rotating field and the rotor, that is to say, the slip. These values are there called slip voltage resp. slip frequency.**

**Value and frequency of the rotor voltage given any slip speed  $n_s$**

$$U_2 = C_1 \cdot \Phi \cdot n_s$$

$$f_2 = p \cdot n_s$$

**If one establishes the quotient  $U_2/U_{2.0}$  - resp.  $f_2/f_1$ , one derives**

$$\frac{U_2}{U_{2.0}} = \frac{C_1 \cdot \Phi \cdot n_s}{C_1 \cdot \Phi \cdot n_D} = \frac{n_s}{n_D} = s$$

**and thus**

$$\mathbf{U_2 = s U_{2.0}}$$

$$\frac{f_2}{f_1} = \frac{p \cdot n_s}{p \cdot n_D} = \frac{n_s}{n_D} = s$$

**resp. with**

$$\omega = 2 \cdot \pi \cdot f$$

$$\omega_2 = s \cdot \omega_1$$

**The voltage ( $U_2$ ) induced in the rotor and its frequency  $f_2$  are proportional to the slip.**

## **5.3. Operational behaviour**

### **5.3.1. Start**



## Inrush current origin

**As soon as the current is switched on the rotating field rotates at full speed along the rotor bars of the squirrel cage rotor.**

**The equation**

$$I_2 = \frac{U_2}{Z_2} = \frac{s \cdot U_{2.0}}{Z_2}$$

**(Cp. Figure 52) indicates that as  $s = 1$  ( $U = U$ ), a greater inrush current is attained in the rotor which is transmitted transformerwise to the stator side.**

**Every asynchronous motor accepts a higher current when starting from no-load position.**

**This inrush current, when utilising the full mains voltage, can be four to eight times as great as the rated current.**

**This excessive current load can lead to a disruptive voltage drop in the network. Consequently, for example, only motors with a rated**

**performance of up to 2.2 kW may be connected directly to the 380 V network where the making current exceeds the rated current by more than seven times over. Higher powered motors require special measures for cutting back the considerable starting current.**

### Starting torque

**Incorporating the equation**

$$Z_2 = \sqrt{R_2^2 + (s \cdot \omega_1 \cdot L_2)^2}$$

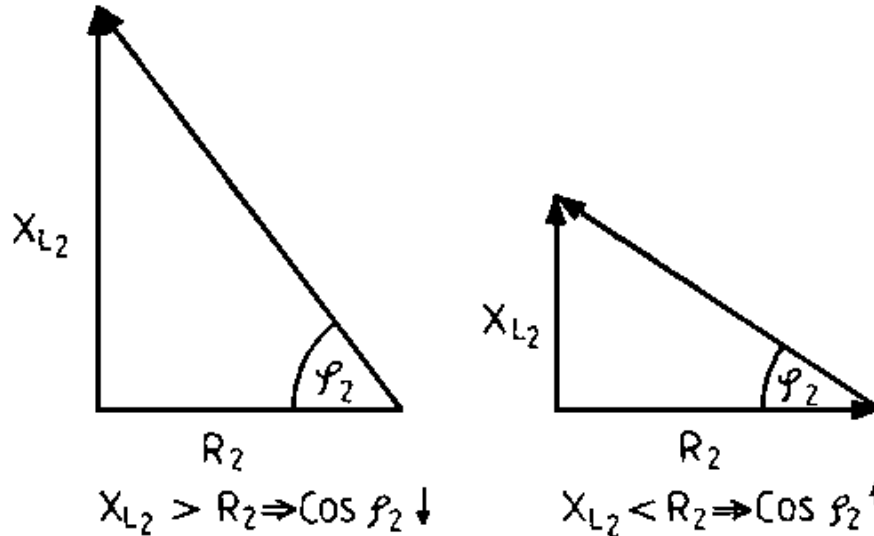
**we derive for the rotor current  $I_2$**

$$I_2 = \frac{s \cdot U_{20}}{\sqrt{R_2^2 + (s \cdot \omega_1 \cdot L_2)^2}}$$

**The rotor note only features the small ohmic resistor  $R_2$  but also the inductive resistor**

$$X_{L2} = s \cdot \omega_1 \cdot L_2 = s \cdot 2 \cdot \pi \cdot f_1 \cdot L_2$$

**During the switching torque the resistance attains its maximum value as  $s = 1$  and is therefore greater than the ohmic resistance.**



**Figure 54 - Indicator diagrams of the rotor circuit resistors**

**Legend as for Figure 52**

**The power factor  $\cos \varphi_2$  therefore attains a minimal value and there is similarly only a low starting torque**

$$M = c \cdot \Phi_1 \cdot \cos \varphi_2$$

**Despite the considerable inrush current the asynchronous motor only evidences a minimal torque when starting from no-load position.**

### Measures to restrict the starting current

**All drive operations presuppose a sound starting up, that is to say, a sufficiently high motor torque. Consequently measures must be undertaken to boost the starting torque. However, the network load which arises during start operations which may be evidenced in a voltage decline or through the inrush current, shall not exceed the prescribed values. It is therefore essential effectively to limit starting current. A simultaneous increase in starting torque is also often requested.**

**Starting current restriction becomes possible by**

- decreasing  $U_{2,0}$ : a lesser stator voltage is fed to the motor**

**( $U_1 \sim U_{2.0}$ ) during starting operations. This leads to a starting procedure for which additional devices are required to connect the short circuit motor.**

**- increasing  $R_2$ : increasing the rotor resistance  $R$  whilst starting requires a differently constructed rotor. The short-circuit rotor must be replaced by a differently arranged rotor featuring changeable ohmic resistance facilities.**

**In the equation  $M = C_2 \cdot \Phi \cdot I_2 \cdot \cos \varphi_2$  all physical values have been incorporated which might influence the torque. Such an optimal solution denotes that such values are changed which permit the starting torque to increase without increasing the starting current. This demand is only met if  $\cos \varphi_2$  is increased. The power factor is boosted by means of an ohmic resistor at the rotor circuit resistance. This in turn makes necessary a different rotor construction from the short-circuit rotor.**

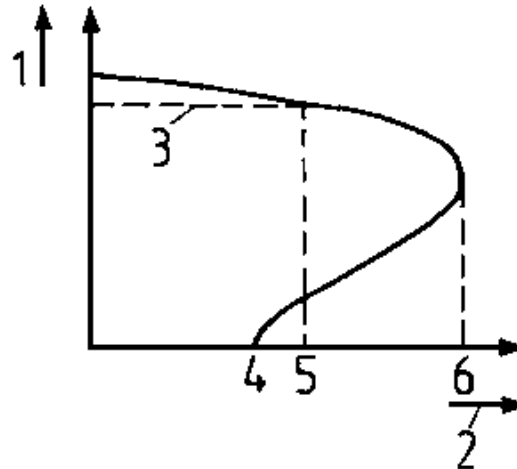
**Additional facilities make it possible to decrease the high starting current of the squirrel cage rotor motor (Cp. 5.4.1). A reduction of the starting current whilst simultaneously**

**increasing the starting torque is only possible where differently constructed rotors are used which evidence a greater ohmic resistance during starting operations.**

### 5.3.2. Rating

#### Speed behaviour depending on the torque

**Operating an asynchronous motor presupposes a certain speed for a given torque. This ratio is given for any one motor.**



## **Figure 55 - Rotational behaviour of an asynchronous motor in dependence on the torque**

**1 Speed, 2 Torque, 3 Rated speed  $n_n$ , 4 Starting torque  $M_a$ , 5 Rated torque  $M_n$ , 6 Breakdown torque  $M_k$**

**The initial torque  $M_a$  is the torque yielded by the motor in no-load operation. The breakdown torque  $M_k$ , is the greatest possible motor torque. If this torque is exceeded, the motor comes to a standstill.**

**The torque at rated load  $M_n$  is the motor torque yielded during rated load and rated speed.**

$$M_n = \frac{9.55 \cdot P_n}{n}$$

**$M_n$  = torque at rated load**

**$P_n$  = rated power in kW**

**$n$  = rated speed in rpm.**

**Every asynchronous motor must be able to accept at least a 160 per cent rated torque for short load spells without motor breakdowns, that is to say the rotor stops. The speed does not vary greatly given considerable load variations.**

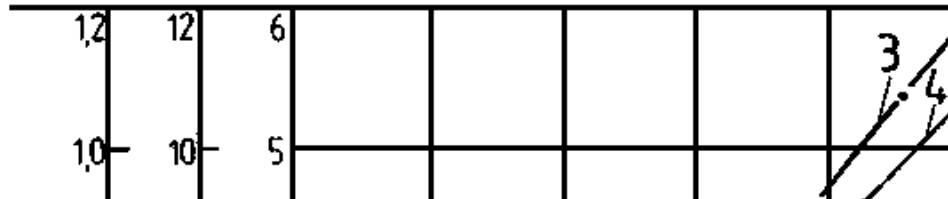
### Operating characteristics of an asynchronous motor

**The various motor data about the yielded torque are cited in order to provide an overview of the behaviour of the asynchronous motor between no-load and rated load operation.**

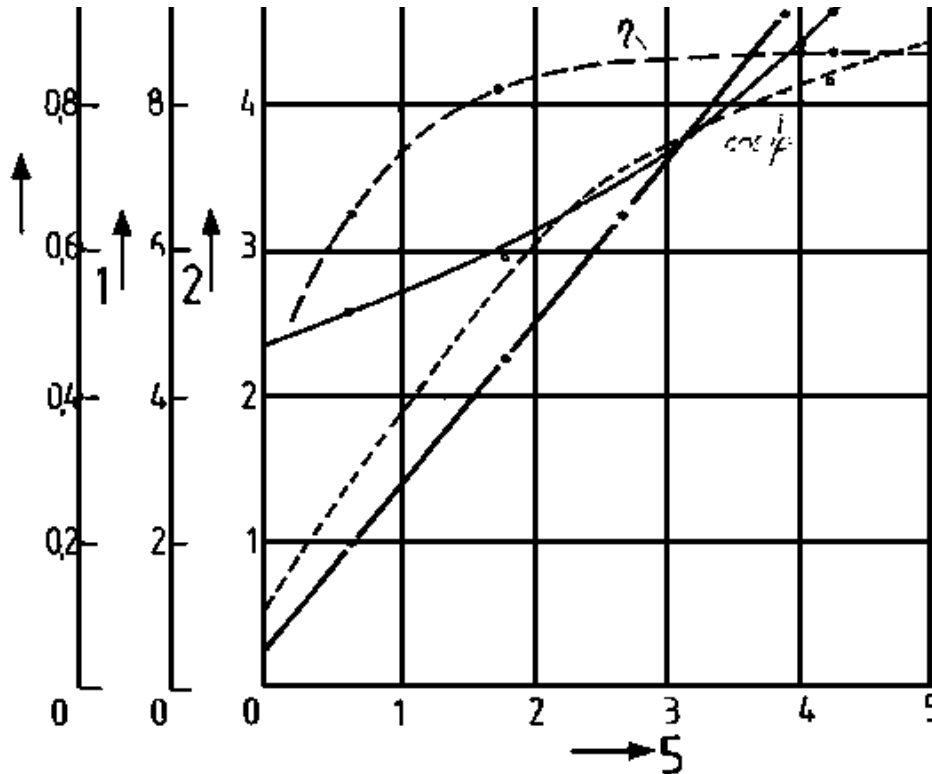
**This figure indicates the operational curves of an asynchronous motor by means of the following data:**

$$P_n = 4 \text{ kW}, U = 380 \text{ V}, I_n = 8.8\text{A}, n = 1.430 \text{ rpm.}$$

$$\cos \varphi_n = 0.83$$







**Figure 56 - Operating curves of a 4 kW squirrel cage motor (380 V;  
8.8 A;  $\cos \varphi = 0.83$ )**

### 1 Current in amperes

**2 Power in kilowatts**

**3 Power curve**

**4 Current curve**

**5 Nominal power**

**Where asynchronous motors are driven at subload, efficiency and the power factor assume lesser values.**

**Therefore, asynchronous motors should not be overdimensioned or run in no-load operation.**

### **5.3.3. Speed control**

**Many drives, for example in the textile or wood-working industries, require speeds considerably greater than 3000 rpm.**

**Conversely, sometimes low speeds are similarly necessitated. Thus, speed control of the asynchronous motor becomes essential. Speed control possibilities for asynchronous motors can be derived from the following equation:**

$$n = n_D (1 - s)$$

$$n = \frac{f}{p}$$

$$n = \frac{f}{p}(1 - s)$$

**The speed established given a certain torque can therefore be influenced by:**

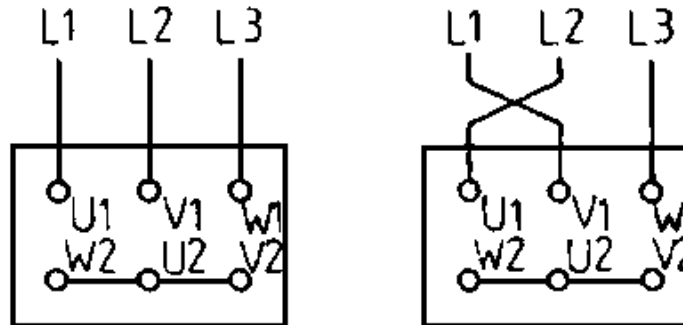
- frequency change in the supplied three-phase alternating current through the employment of rotating frequency converters or through alternating or converter circuits with adjustable frequencies.**
- altering the number of pole pairs through pole changing. This can ensue in two ways. Either by means of two or several separate stator windings which can be switched on as desired or by switching over parts of a single stator winding (Dahlander pole-changing circuit).**
- altering the slip by changing the voltage application  $U_I$  by means of series resistors or adjustable transformers, resp.**

**by changing the ohmic resistance  $R_2$  in the rotor circuit (slip ring rotor).**

**The most commonly employed adjustment procedures are those of circuit engineering as cited in section 5.4.2.**

### 5.3.4. Rotational sense alteration

**Any change in the rotational sense in the case of an asynchronous motor can be attained by changing the rotational direction of the rotating field by exchanging any two external conductors in accordance with Figure 57.**



**Figure 57 - Rotational sense change**

## **L... conductor U; V; W winding connections (terminal board)**

### **5.4. Circuit engineering**

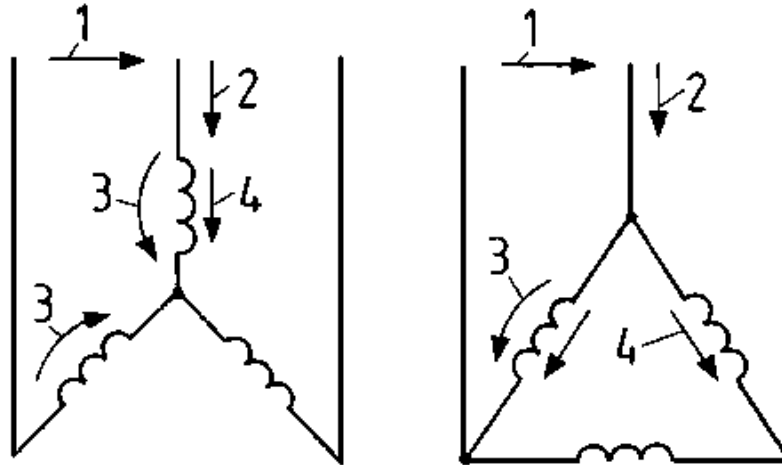
#### **5.4.1. Starting connections**

##### **Star-Delta connection**

##### **Mode of operation**

**The star-delta connection is mainly used for low and medium powered machines. During starting the stator winding is star-switched and subsequently delta-switched during acceleration.**

**In order to be switchable from star to delta the stator windings must be laid out for interlinked (conductor) voltage.**



**Figure 58 - Voltages and currents during delta starting**

**1 Conductor voltage**

**2 Conductor current**

**3 Strand voltage (voltage through a winding)**

**4 Strand current (current in a winding)**

**Figure 58 shows that a star connection to a winding strand only**

**receives  $\frac{1}{\sqrt{3}}$  of the network voltage. The current decreases by the same factor. Moreover as both conductor and strand current in the**

**star connection remain identical (in the delta connection  $I_{Str} = \frac{I_L}{\sqrt{3}}$ ), a further current reduction by the factor  $\frac{1}{3}$  ensues vis--vis the star delta connection.**

$$\lambda I_{Str} = I_L \quad \Delta I_{Str} = \frac{I_L}{\sqrt{3}}$$

$$U_{Str} = \frac{U_L}{\sqrt{3}} \quad U_{Str} = U_L$$

$$I_{Str} = \frac{U_{Str}}{Z} \quad I_{Str} = \frac{U_{Str}}{Z}$$

$$I_L = \frac{U_L}{Z \cdot \sqrt{3}} \quad \frac{I_L}{\sqrt{3}} = \frac{U_L}{Z}$$

$$I_L = \frac{\sqrt{3} \cdot U_L}{Z}$$

I II Z

$$\frac{I_{L\lambda}}{I_{L\Delta}} = \frac{1}{3} \frac{U_L}{U_L \cdot \sqrt{3}}$$

**The considerable starting current is effectively restricted by switching the stator winding from the operational delta connection to the star connection. The conductor current of the star connection is one third of the value of the delta connection.**

**Moreover, the diminished voltage in the star connection not only causes a diminished stator current; the following also applies;**

$$\frac{M_{\lambda}}{M_{\Delta}} = \frac{c \cdot \Phi \cdot I_2 \cos\varphi_2}{\sqrt{3} \cdot \sqrt{3}} = \frac{1}{\sqrt{3} \cdot \sqrt{3}}$$

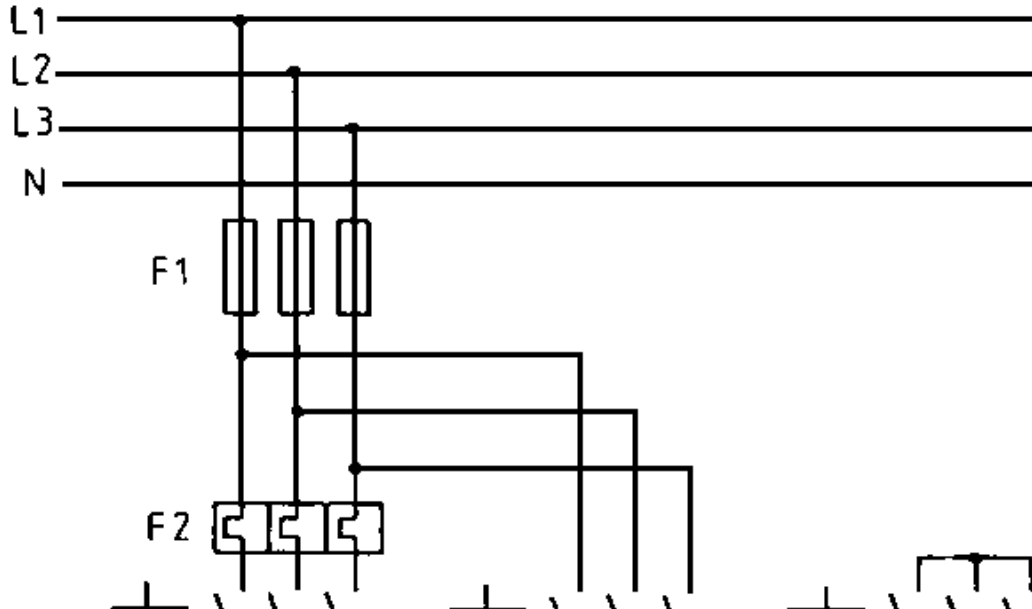
$$\frac{M_{\lambda}}{M_{\Delta}} = \frac{1}{\sqrt{3} \cdot \sqrt{3}}$$

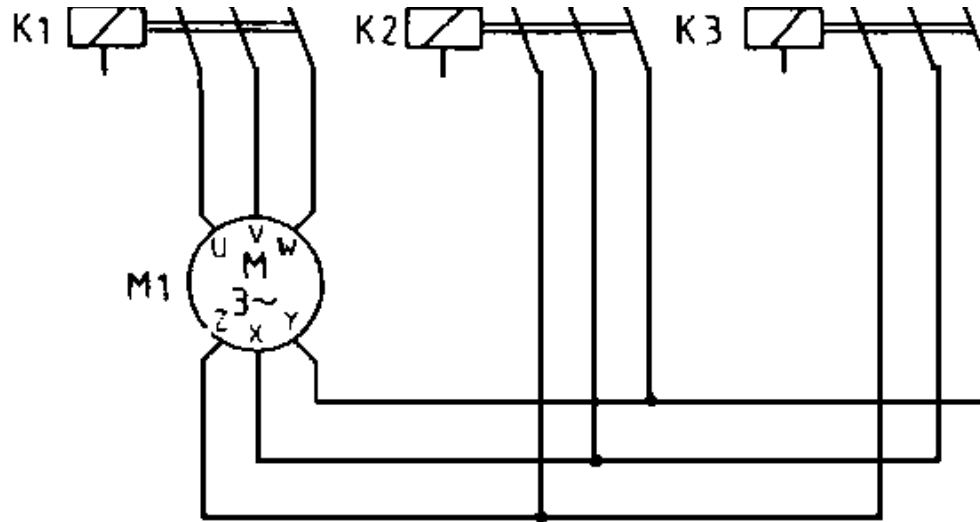
**The initial torque in the star connection is but one third of its value in the delta connection.**



**The advantage of the star-delta connection for limiting the considerable starting current in an effective manner is, however, only possible through a further reduction in the already minimal initial torque. In many cases it will be necessary when employing this starting procedure to start up the motor without load.**

## Circuitry





**Figure 59 - Automatic star-delta connection (main circuit)**

L... external conductor

N... neutral conductor

F1 Fuses

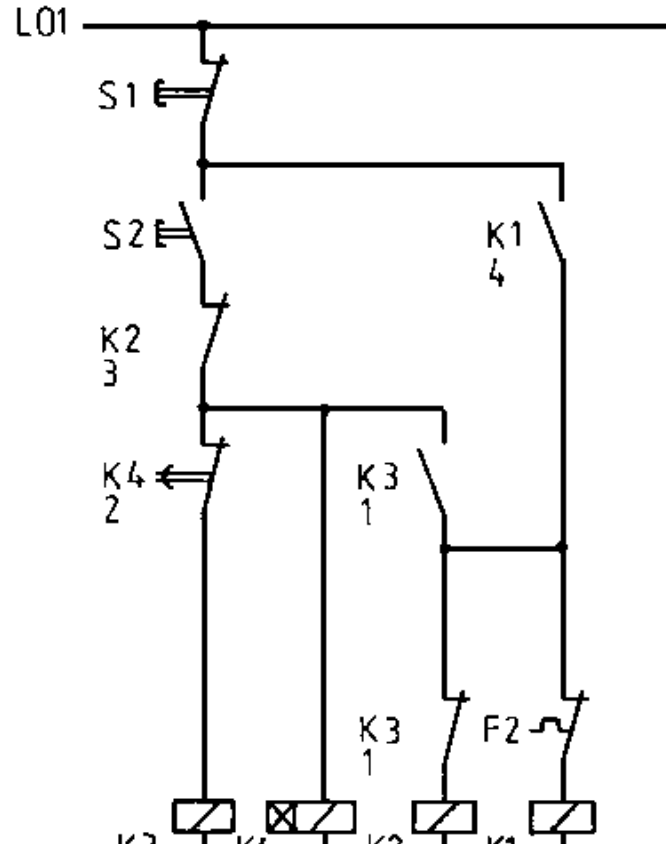
F2 Thermal cut-out

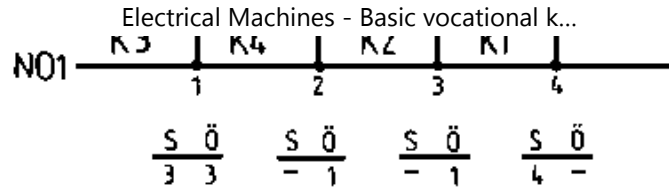
K1 Main contactor

K2 Delta contactor

K3 Star contactor

M1 Three-phase motor





**Figure 60 - Automatic star-delta connection (control circuit)**

S1; S2 switches

K1...K3 as in Figure 59

K4 time relay

S; closers resp. openers of the contactors resp. relay in the commensurate current thread

### Circuitry description

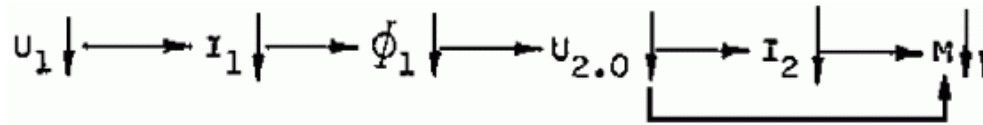
**Starting up of the squirrel cage motor via K1 and K3 in star connection. Switching the stator winding to delta connection by means of K2. Actuating S2 switched K3 and the timing relay K4 (starting delay). K1 is switched by means of K3 closer. K1 holds itself alone above its closer. Following the adjustment period the opening contact of K4 switches K3 off whilst K2 is switched on by means of the opening contact of K3.**

## Stator starting resistors

### Mode of operation

**A further possibility of diminishing stator voltage, thereby reducing motor current whilst starting, is to connect resistors in series to the stator windings (Figure 61). Ohmic resistors are advantageous for lesser powered motors whilst series reactors are more economical for higher powered motors.**

**Curtailing voltage at the stator windings serves to reduce starting current and starting torque as also applies in other starting procedures.**



**An effective reduction in starting current is attained by connecting resistors in series within the stator circuit in conjunction with a pronounced decline in starting torque.**

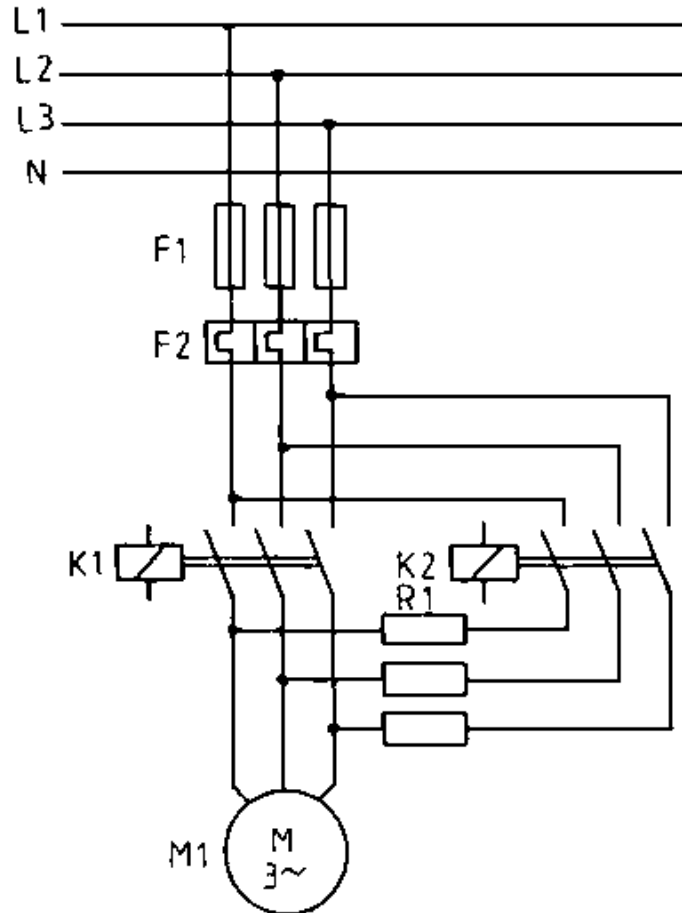
**This procedure is however only suitable for no-load running**

**motors. In order to ensure a smoother and slower starting (i.e. to exclude torque impulses from impact-switched gears) it is sufficient whilst starting to connect an ohmic resistance or a coil in a lead (Kusa circuit). The significance of this resistance is illustrated in the following for both limit values.**

- Rv The limit current motor is fed from one side only from the stator.  
→ Consequently there is no rotating field and the motor does not develop  
 $\infty$  a torque.
- Rv The asynchronous motor is connected directly. The motor develops the  
= maximum possible torque.  
0

**With the help of the resistor Rv in a lead it becomes possible to adjust the possible starting torques between zero and the possible maximum value. Impact-free starting becomes possible. As a result of the circuit asymmetry the conduction currents are distributed unequally in the three leads. An effective reduction of starting current is not possible. Current only declines in the strand with the series connected resistor.**

## **Circuitry**

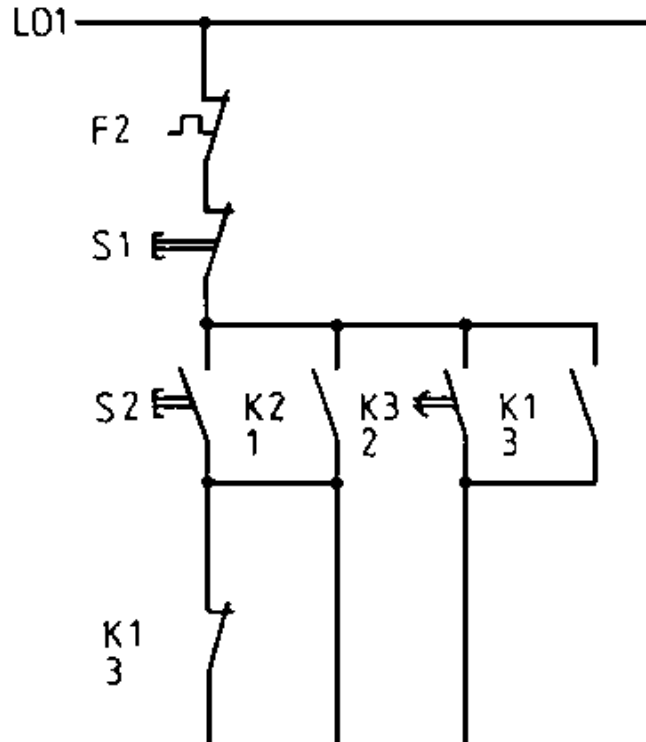


**Figure 61 - Starting connection by means of series resistors (main**

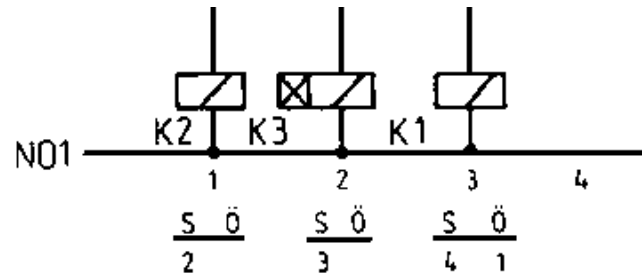
**circuit)**

K2 Starting contactor

R1 Starting resistance







**Figure 62 - Starting connection by means of series resistors  
(control circuit)**

### **K3 Time relay**

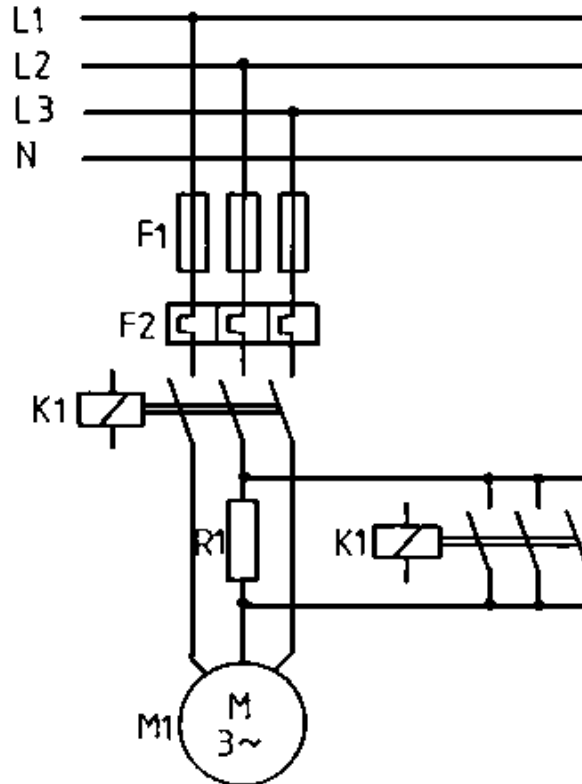
#### **Circuitry description**

**Starting ensues via protection K2 and the series resistor R1. Diminish voltage at the stator winding, curtail starting current to ensure smooth starting up. Switching over to network voltage by means of protection K1 without currentless interruption.**

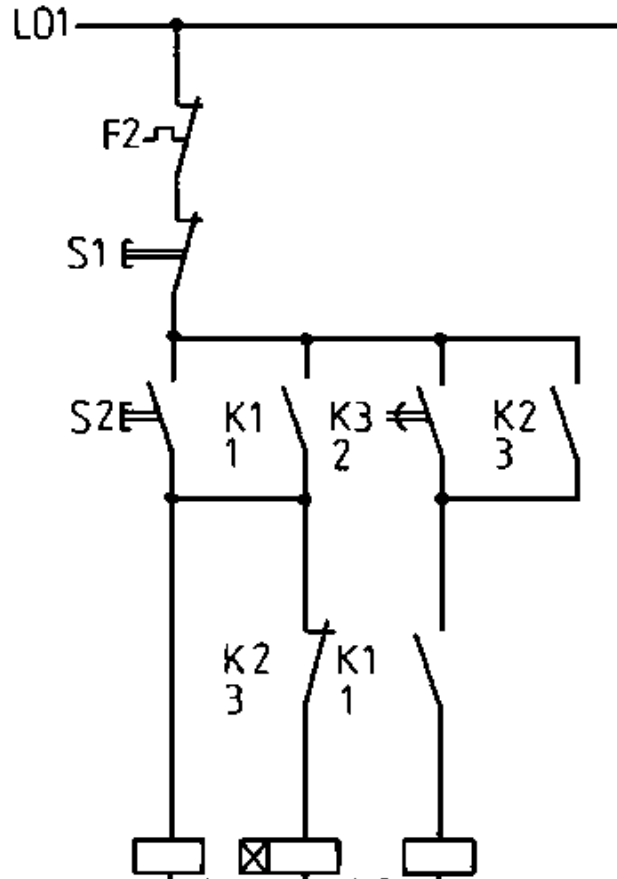
**Actuating S2 switches on protection K2 and the time relay K2 (initial torque delay). K2 retains itself independently over its closer in the current path two. Following the adjustment spell the K3 closer in the current path switches K1 on whilst K1 switches K2**

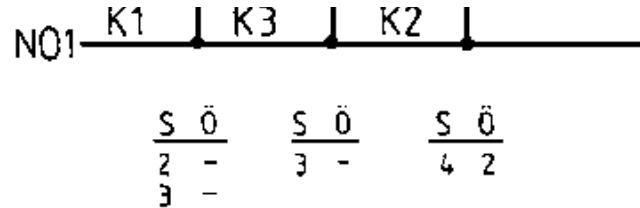
**through its opener in current path one.**

## Circuitry of the Kusa circuit

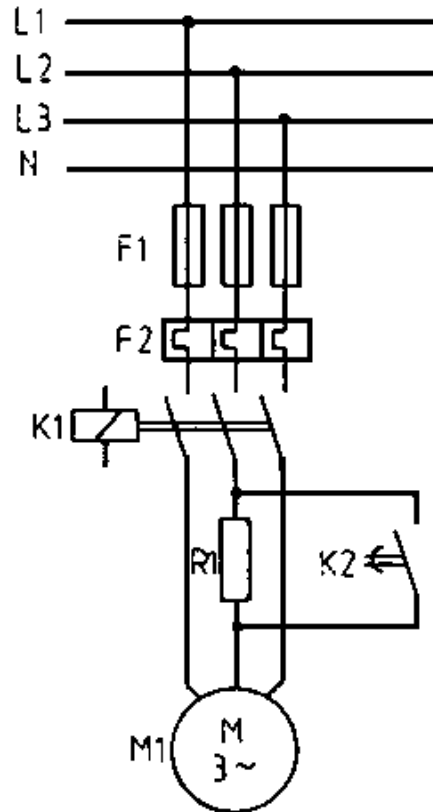


**Figure 63 - Kusa circuit 1 (main circuit)**

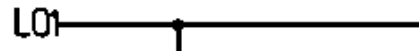


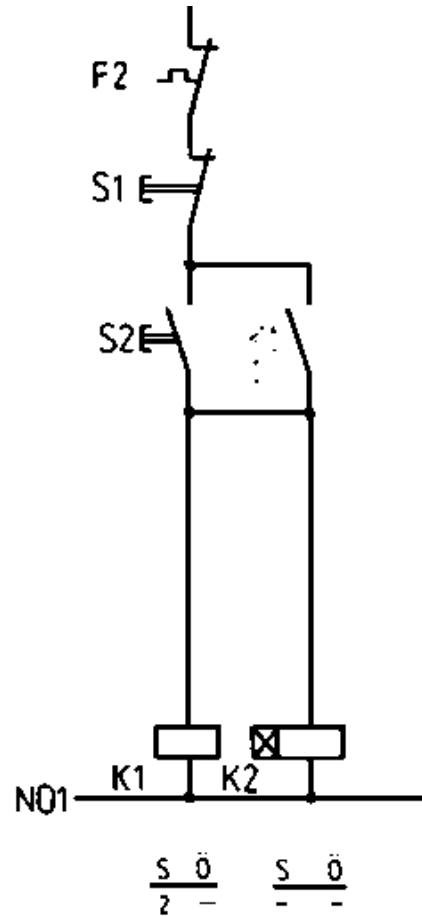


**Figure 64 - Kusa circuit 1 (control circuit)**



**Figure 65 - Kusa circuit 2 (main circuit)**





## **Figure 66 - Kusa circuit 2 (control circuit)**

### **Description of the Kusa circuit**

#### **Circuit 1.**

**By actuating S2 K1 and the time relay K3 are switched on (initial torque delay). K1 is retained independently above its closer in current path 2. Following the adjustment spell the closer of K3 in current path 3 switches on K2 which maintains itself above its closer in current path 4 and switches K3 off by means of its opener in current path 2.**

#### **Circuit 2.**

**By actuating S2 K1 and the time relay K2 (initial torque delay) are switched on. Following the adjustment spell R1 is short-circuited by the closer of the time relay (in Figure 65).**

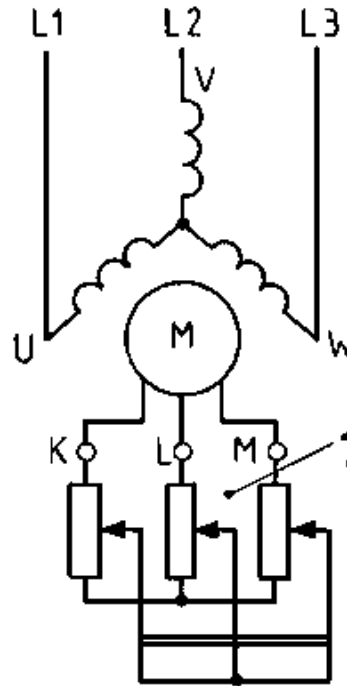
### **Slip ring motor**

### **Mode of operation**

**The ends of the rotor winding are attached to the slip rings which gave rise to the designation of this rotor (fig. 67).**

**The torque and rotor current can be aligned in the desired values during the starting operation with the assistance of the additional resistors which may be switched on via the slip rings of the rotor winding. The internal electrical properties of this motor can be undertaken by switching on the resistors from outside. Starting can thus ensue with substantially less current than in the case of squirrel cage motors whilst the initial torque attains substantial values because of the greater ohmic share in rotor current.**





**Figure 67 - Slip-ring rotor with rotor starting resistance**

**1 Rotor starting resistance**  
**K; L; M Connecting terminals**

**Slip ring motors develop a pronounced initial torque**

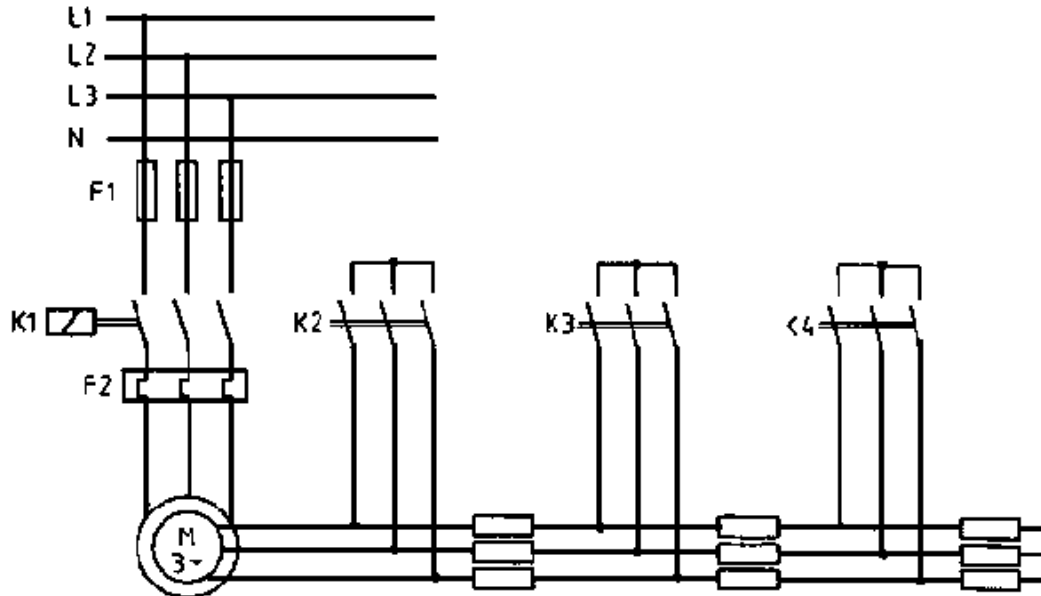
**notwithstanding minimal current take-up. They can start up under load.**

**Slip ring motors are suitable for long and repetitive operating spells.**

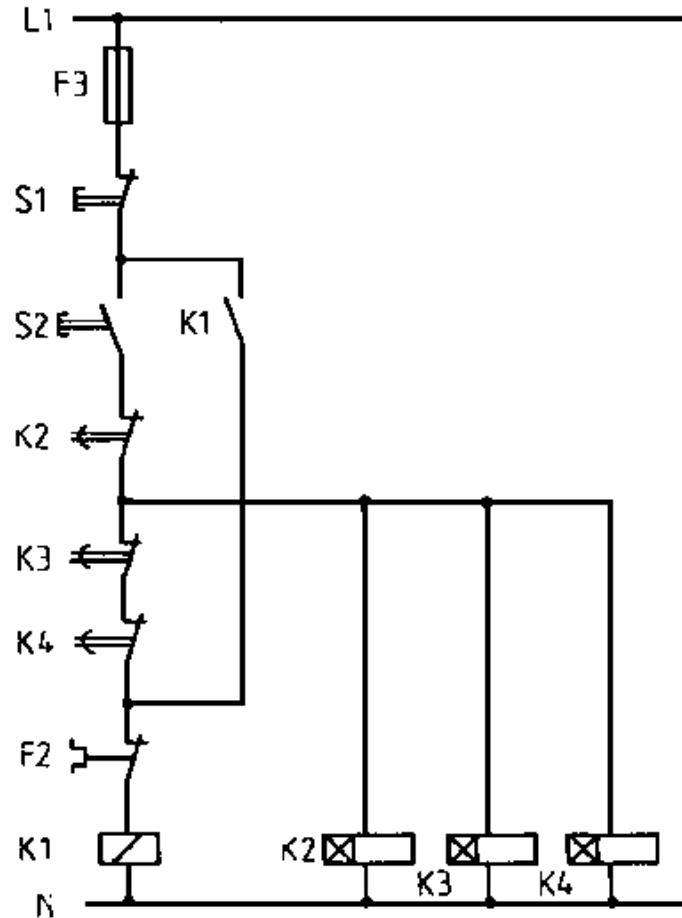
**Switching on rotor starting resistors ensures that current heat losses through greater resistance generally arise outside the motor and, consequently, the motor is not excessively heated up. The starting resistors dissipate heat quickly.**

**By and large the starter comprises a fixed resistor with several resistance steps which are progressively switched off during the starting operation.**

**Circuitry**



**Figure 68 - Automatic starting connection for the slip-ring motor (main circuit)**



## **Figure 69 - Automatic starting connection for the slip-ring motor (control current)**

### **Circuitry description**

**Figure 68/69 features an automatic starting circuit for ring motors. The starting resistors are switched off by protectors with turn-on delayed closers in three stages.**

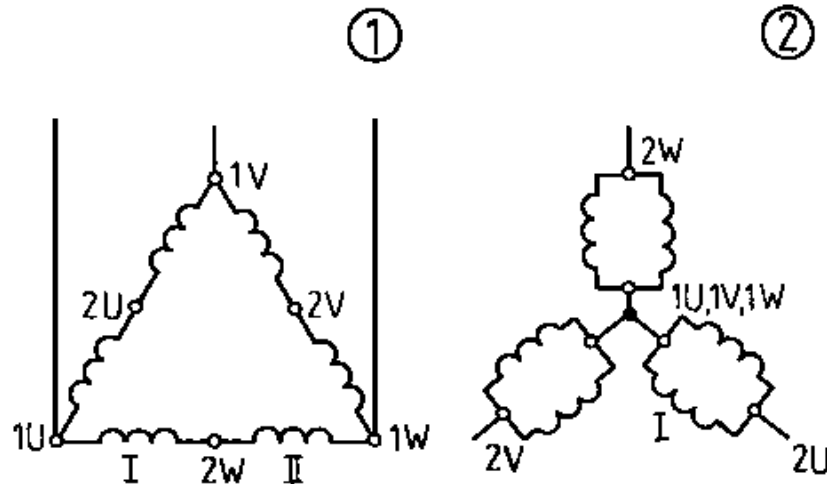
### **5.4.2. Dahlander pole-changing circuit (speed control)**

#### **Mode of operation**

**Where several separate electrical windings with varying numbers of pole pairs are required for the stator of the asynchronous motor or windings whose pole pair numbers can be varied by switching over the windings then the speed of the rotating field changes and, thus, also the rotor speed. Squirrel cage motors are used for this purpose because, as opposed to slip ring rotor motors, they are not bound by a specific pole pair. The pole-changing winding in the so-called Dahlander pole-changing circuit is thereby the most perceptible practical feature. This pole-changing winding permits a speed**

**change in the ratio two to one. These circuits have been set out in fig. 70.**

**The coil groups are switched over from series to parallel connection where a smaller pole pair number is selected, that is to say a greater speed is selected.**



**Figure 70 - Dahlander connection**

**(1) Delta connection for low speed ( $p = 2$ )**

**(2) Double star connection for higher speed ( $p = 1$ )**

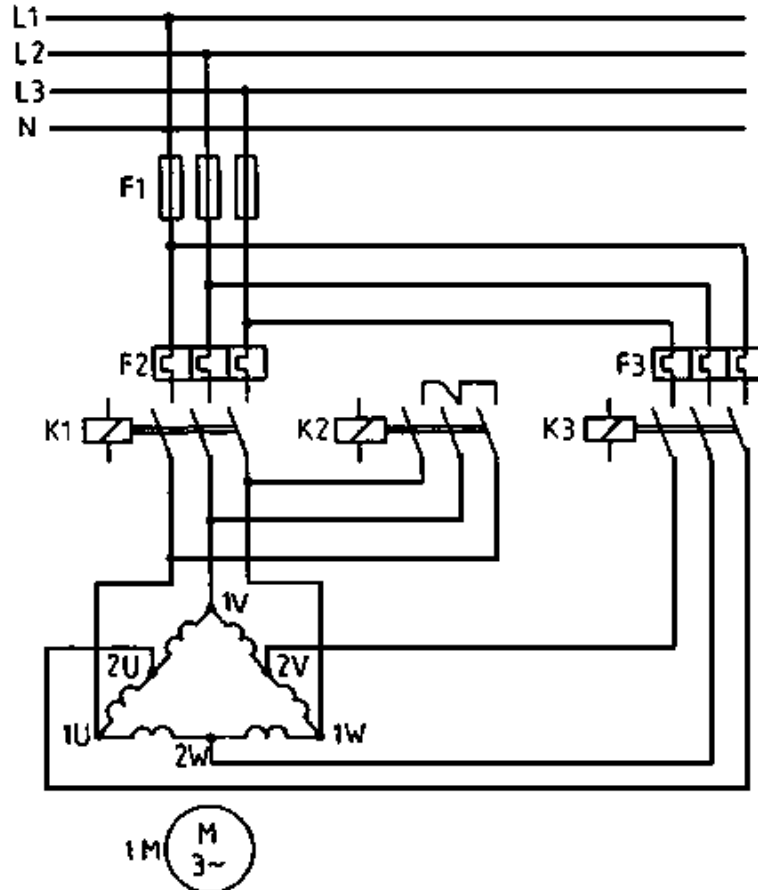
## **...U; ...V; ...W Partial windings**

**The speeds of asynchronous motors can be roughly stipulated by altering the pole pair number.**

**Where a stator has been executed with two separate windings which are both pole-reversible, then the speed may be established in four stages, for example, by means of the synchronous speeds of 500 - 750 - 1000 and 1500 rpm.**

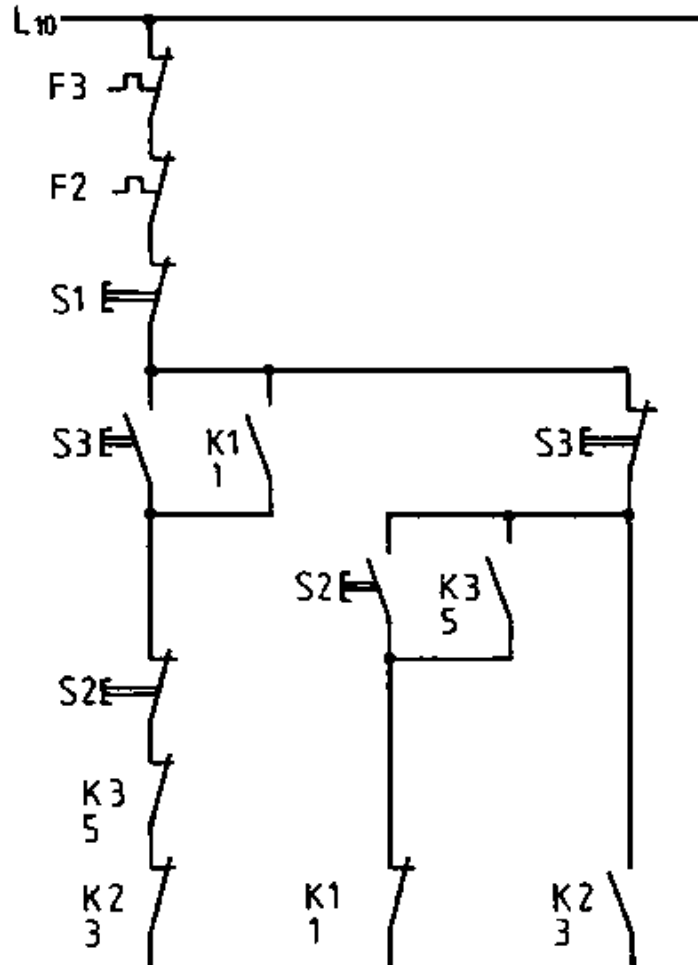
**Motors with changeable pole pair numbers are frequently used for controlling machine tools where approximate setting is usually sufficient. Such motors are also used to drive pumps, ventilators, escalators etc.**

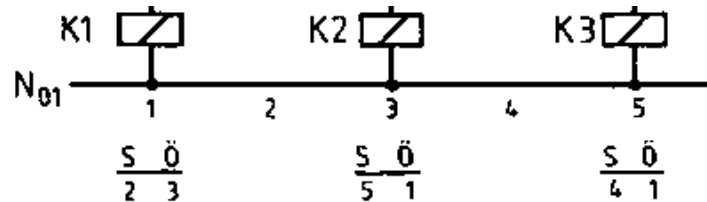
### **Circuitry**



**Figure 71 - Dahlander connection (main circuit)**







**Figure 72 - Dahlander circuit (control circuit)**

### Circuitry description

The protection K1 that the series-switched coil halves of each stand of the stator winding are delta-connected.

The pole pair number  $p^1$  conditions the rotating field speed  $n^1$ . The protections K2 and K3 ensure that the coil halves of each strand are parallel connected and the entire stator winding is star connected.

The new pole pair number  $p^2$  conditions the rotating field speed  $n^2$ . Actuating S3 switches on K1 which retains itself by means of its closer in current path two. K3 and K2 are locked by the openers S3 in the current path five whilst K1 is locked in the current path three. Actuating S2 switches on K2 whose closer switches on K3 in current path five. K1 is locked by opener S2 whilst K3 and K2 are

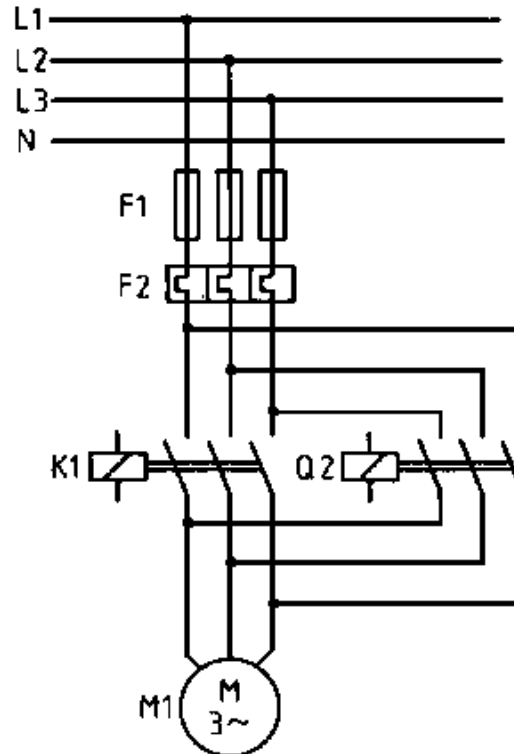
**locked in current path one.**

### **5.4.3. Rotational reversing circuit**

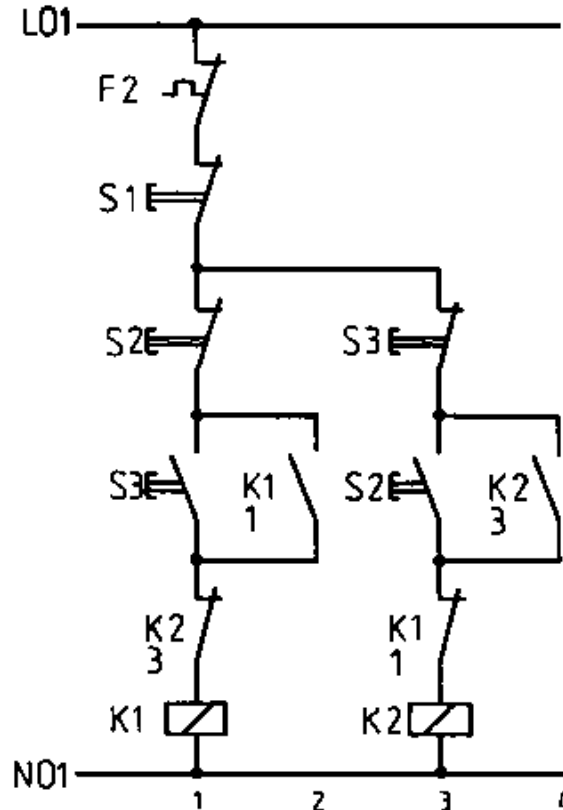
**Mode of operation**

**Cp. section 5.3.4.**

**Circuitry**



**Figure 73 - Rotational direction turnover voltage (main circuit)**



**Figure 74 - Rotational direction turnover voltage (control circuit)**

### Circuitry description

**Rotational direction selection without cut-off compulsion. The K1 is switched clockwise by actuating S3. K2 is locked in current path three by the openers of K1 and S3. K2 drive is switched counterclockwise by dead and simultaneous actuation of S2 and K1.**

#### **5.4.4. Braking circuits**

##### **Counter-current braking**

##### **Mode of operation**

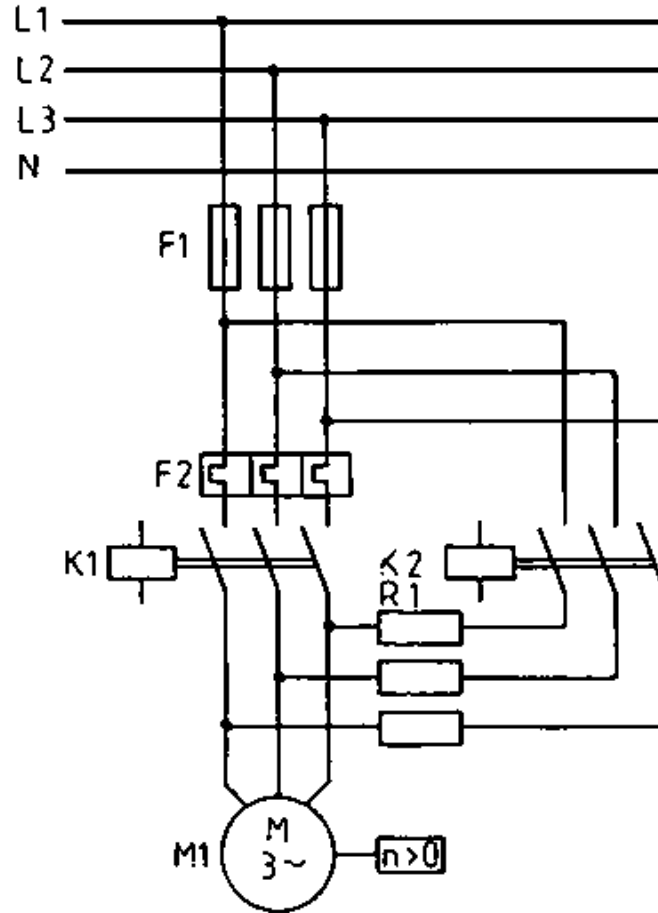
**Braking by means of counter-current is the simplest way to attain standstill of an asynchronous drive resp. the deceleration of pull-through loads, for instance in pumping stations. Two stator leads are interchanged to this end during motor operation. This changes the rotational direction of the rotating field. The rotor, which is braked, thus runs counter to the rotational direction of the rotating field. This connection can be used both for squirrel cage and slip ring motors. No additional devices are required.**

**The braking effect during counter-current braking bases on the altered rotational field direction. The motor tries to**

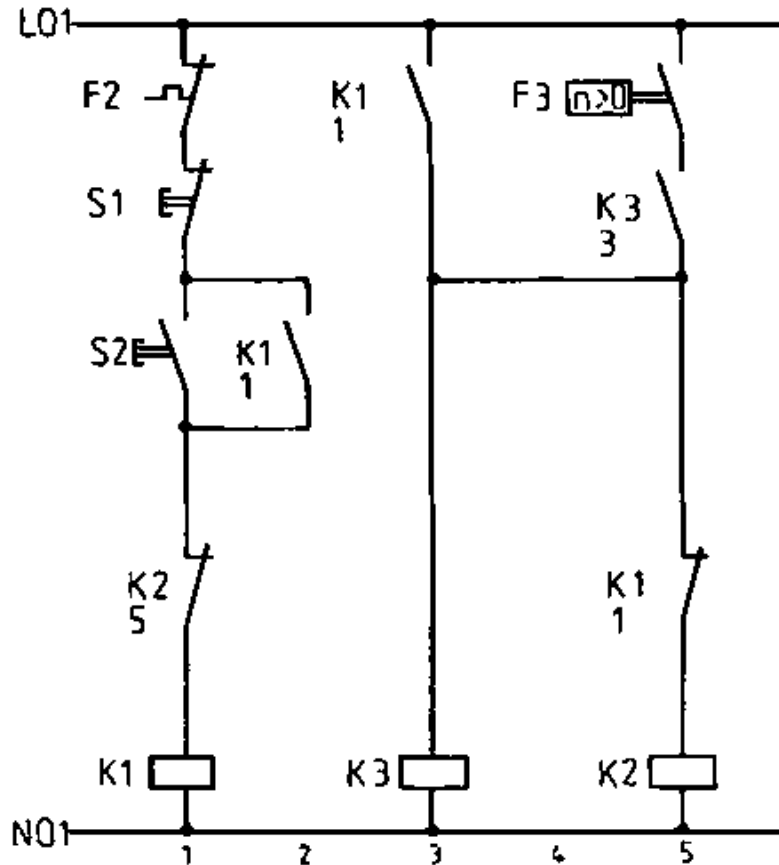
**accelerate in the other rotational direction.**

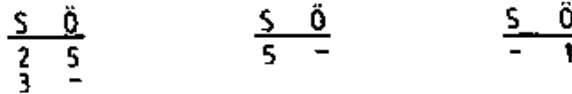
**The motor must be disconnected in good time from the mains so that it does not again accelerate in the new rotational field direction. This is mainly made automatically.**

**Counter-current operation induces pronounced braking reaction. The current impulse on switching over is considerable greater than starting through direct connection. The motor is generally braked in star connection in order to avoid too great a current.**





**Figure 75 - Counter-current braking (main circuit)**



**Figure 76 - Counter-current braking (control circuit)**

### **Circuitry description**

**Protection K1 switches on the three-phase motor. During switching off K2 connects the mains via two series resistors with two interchanged external conductors. The counter field brakes the rotors.**

**K2 falls off during motor stillstand.**

**Actuating S2 switches protection K1 which holds itself in the current path 2 through a closer. K2 is locked by the K1 opener in current path 5 whilst the closer in current path 3 switches the locking relay K3. Switching off by means of S1 the K1 opener closes current path 5. K2 is excited. Given standstill ( $n = 0$ ) the closer of the automatic brake controller interrupts the F3 current path 5. K3 and K2 drop out.**

### **Direct current braking**

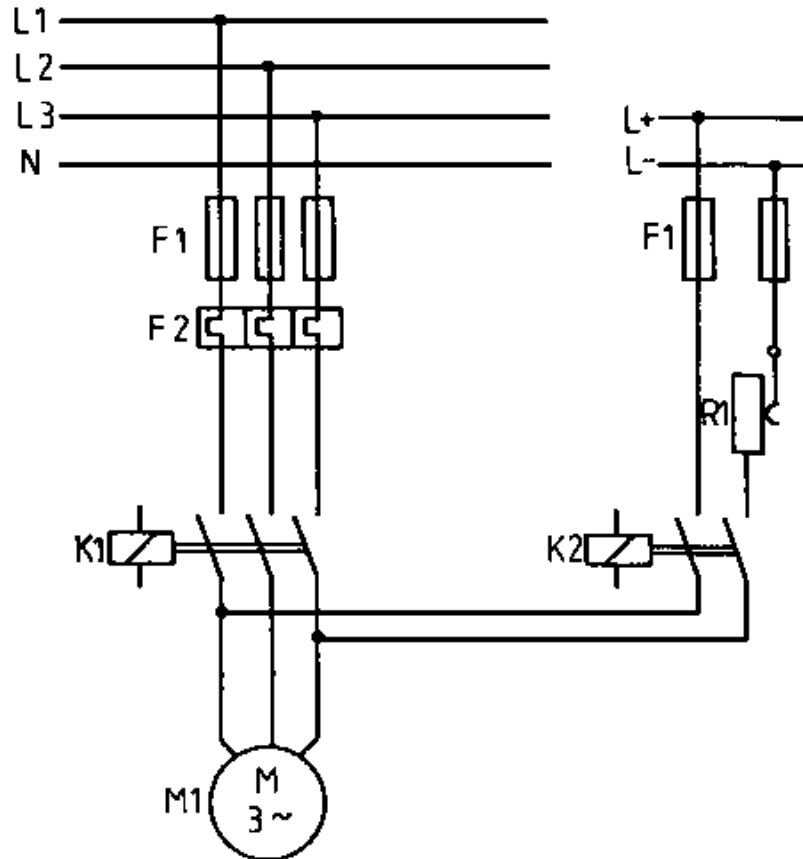
## **Mode of operation**

**During this braking procedure the machine is disconnected from the mains and the stator winding is excited through direct current. Connection to the direct current source ensues acc. to the circuit depicted in Figure 77.**

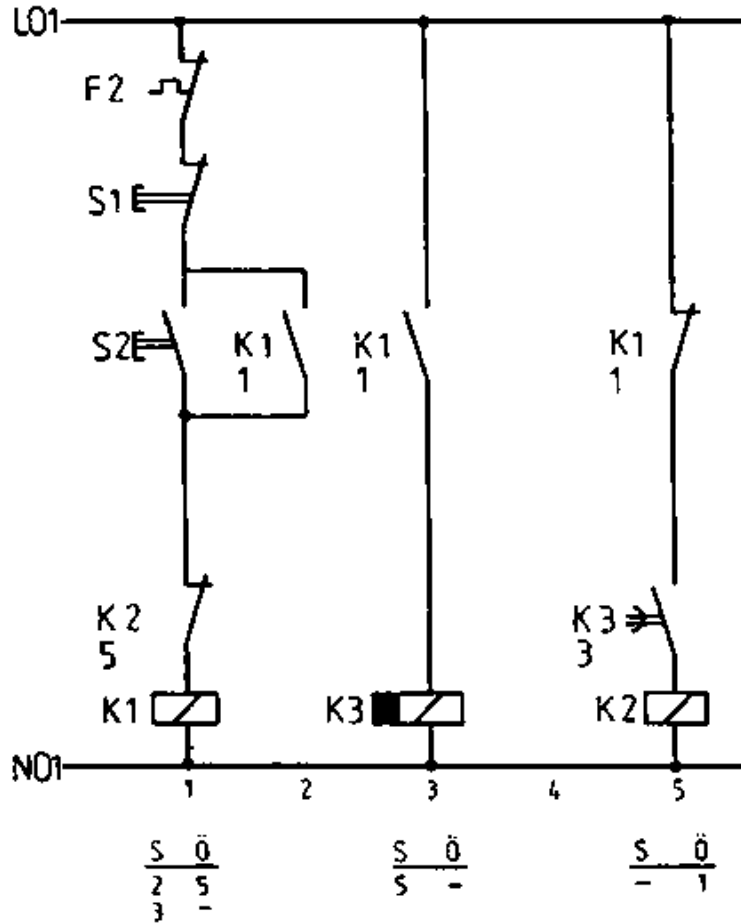
**The stator establishes a constant magnetic field. Induction currents are yielded in the rotor winding which is either short-circuited or connected by means of rotor resistors. These induction currents give rise to a braking torque which facilitates impulse-free braking.**

**The asynchronous machine with direct current braking behaves in the same manner as an external pole synchronous generator.**

**Direct current braking is suitable for stopping all categories of asynchronous machine drives. The dissipated heat converted through rotor circuit braking is much less than during counter-braking. The minimal exciting power and the admirably controlled speed of slip ring motors are further advantages of this circuitry.**



**Figure 77 - Direct current braking (main circuit)**



## **Figure 78 - Direct current braking (control circuit)**

### **Circuitry description**

**K1 switches on the three-phase motor. On switching off K2 connects direct voltage to the stator winding. K2 drops out after commensurate braking.**

**Actuating S2 switches protection K1 which holds itself via a closer in current path 2. The K1 closer in current path 3 switches on the auxiliary contactor K3 (release delay). K1 opens in current path 5 serve to lock K2. K1 drops out when S1 switches off. Its opener locks current path 5 (braking ensues through K2) whilst its closer in current path 3 switches K3 off with delay.**

**The closer of K3 in the current path 5 opens with delay whereby K2 drops off.**

### **5.5. Application**

**The assembly of an asynchronous motor is much simpler, and therefor also less costly and easier to service, than other motors. This applies in particular to squirrel cage motors. Asynchronous**

**motors are manufactured up to 1000 KW performance. Survey 15 features the characteristic values for asynchronous motors ranging from 0.12 to 4 KW. As speed control still poses some difficulties, asynchronous motors are utilised in the first instance for drives requiring a constant speed. These include, amongst others, compressors, pumps, ventilators, many machine tools and textile machines. Asynchronous motors with attached gears, so-called geared motors, are available for low-speed drives.**

**The slip ring motor finds application given complicated starting conditions. Slip ring execution makes possible a certain degree of speed control through the additional motor resistor or by means of an additional voltage in the rotor circuit. A slip ring motor also permits counter current braking and, consequently also employment as hoisting gear drives.**

## **5.6. Characteristic values of squirrel cage motors**

### **Survey 15 - Characteristic values of squirrel cage motors between 0.12 and 4 kW (380 V)**

<b>Speed</b>	<b><math>P_n</math></b>	<b><math>n_n</math></b>	<b><math>n</math></b>	<b><math>\cos \varphi_n</math></b>	<b><math>I_n</math></b>	<b><math>I_A / I_n</math></b>	<b><math>M_A / M_n</math></b>	<b><math>M_k / M_n</math></b>
--------------	-------------------------	-------------------------	-----------------------	------------------------------------	-------------------------	-------------------------------	-------------------------------	-------------------------------

<b>rpm</b>	<b>kW</b>	<b>rpm</b>	<b>-</b>	<b>-</b>	<b>A</b>	<b>-</b>	<b>-</b>	<b>-</b>
3000	0.18	2760	0.64	0.81	0.53	4.0	2.1	3.2
	0.25	2780	0.64	0.82	0.77	4.0	2.1	2.4
	0.37	2750	0.68	0.86	0.95	4.3	2.0	2.2
	0.55	2770	0.72	0.86	1.35	4.7	2.1	2.3
	0.75	2800	0.75	0.87	1.75	5.5	2.4	2.7
	1.10	2800	0.77	0.87	2.5	6.1	2.5	2.8
	1.50	2840	0.78	0.85	3.4	6.4	2.5	2.6
	2.20	2820	0.78	0.89	4.7	6.6	2.6	2.7
	3.00	2850	0.82	0.89	6.25	6.7	2.2	2.5
	4.00	2880	0.83	0.87	8.45	6.5	2.2	2.6
1500	0.12	1360	0.56	0.72	0.45	3.0	2.0	2.1
	0.18	1360	0.59	0.73	0.63	3.2	2.2	2.4
	0.25	1370	0.62	0.74	0.82	3.4	1.9	2.1
	0.37	1360	0.67	0.77	1.10	3.6	1.9	2.0
	0.55	1380	0.70	0.77	1.55	4.4	2.0	2.3
	0.75	1380	0.72	0.78	2.0	4.6	2.1	2.3



	1.10	1410	0.77	0.78	2.8	5.6	2.5	2.8
	1.50	1415	0.78	0.76	3.8	6.0	2.4	3.0
	2.20	1425	0.79	0.77	5.55	6.0	2.4	2.9
	3.00	1430	0.81	0.83	6.8	5.8	2.1	2.5
	4.00	1430	0.83	0.83	8.85	6.4	2.5	2.9
1000	0.12	870	0.50	0.61	0.6	2.5	2.1	2.2
	0.18	900	0.56	0.62	0.79	2.7	2.0	2.0
	0.25	900	0.59	0.58	1.1	2.9	2.3	2.4
	0.37	920	0.63	0.7	1.27	3.7	2.3	2.5
	0.55	920	0.67	0.69	1.8	4.0	2.6	2.8
	0.75	930	0.70	0.71	2.3	4.4	2.3	2.4
	1.10	930	0.73	0.73	3.1	4.5	2.2	2.4
	1.50	945	0.77	0.78	3.8	5.1	2.1	2.4
	2.20	945	0.78	0.81	5.3	4.9	2.0	2.4
750	0.12	670	0.44	0.56	0.74	2.2	2.1	2.2
	0.18	690	0.52	0.64	0.82	2.7	2.0	2.4
	0.25	690	0.56	0.63	1.1	3.0	2.3	2.5

	0.37	690	0.60	0.64	1.5	3.2	2.0	2.2
	0.55	690	0.64	0.65	2.0	3.3	2.0	2.1
	0.75	700	0.68	0.68	2.5	3.8	1.9	2.3
	1.10	700	0.70	0.70	3.4	4.0	2.1	2.5
	1.50	700	0.73	0.73	4.3	4.2	2.0	2.4

### **Questions for repetition and control**

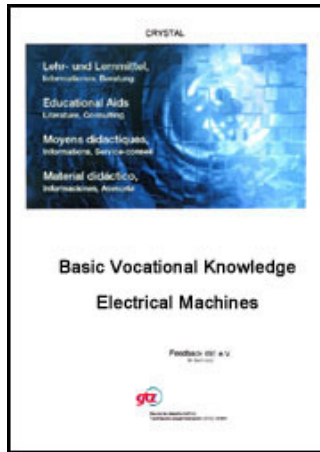
- 1. Explain the assembly of an asynchronous motor and its two different rotor types.**
- 2. How is the torque of a three-phase asynchronous motor attained?**
- 3. What are the effects of increasing shaft load on the speed and current acceptance of the asynchronous motor?**
- 4. When is a three-phase slip ring motor used?**
- 5. Describe the most common starting varieties of a three-phase motor setting out their advantages and disadvantages!**

**6. The following nominal data have been given for a three-phase motor: 5.5 kW; 1440 rpm;  $\cos \varphi = 0.82$ ;  $\eta = 0.8$ ; 380 V. Calculate motor current acceptance level!**

**7. How can the rotational direction of a three-phase motor be changed?**



[Home](#) > [ar](#).[cn](#).[de](#).[en](#).[es](#).[fr](#).[id](#).[it](#).[ph](#).[po](#).[ru](#).[sw](#)



**Electrical Machines - Basic vocational knowledge (Institut für Berufliche Entwicklung, 144 p.)**



**6. Direct current machines**



**6.1. Constructional assembly**














**6.2. Operating principles**



**6.2.1. Power generation (direct current motor)**



**6.2.2. Torque generation (direct current motor)**

-  **6.2.3. Armature reaction (rotor reaction)**
-  **6.2.4. Excitation**
-  **6.2.5. Value relations**
-  **6.3. Operational behaviour of direct current machines**
  -  **6.3.1. Direct current generators**
  -  **6.3.2. Direct current motors**
-  **6.4. Circuit engineering and operational features of customary direct current generators**
  -  **6.4.1. Separate-excited direct current generator**
  -  **6.4.2. Direct current shunt generator**
-  **6.5. Circuit engineering and operational features of customary direct current motors**
  -  **6.5.1. Direct current motor with permanent excitation**



## **6.5.2. Direct current series motor**

## **6.5.3. Direct current shunt motor**

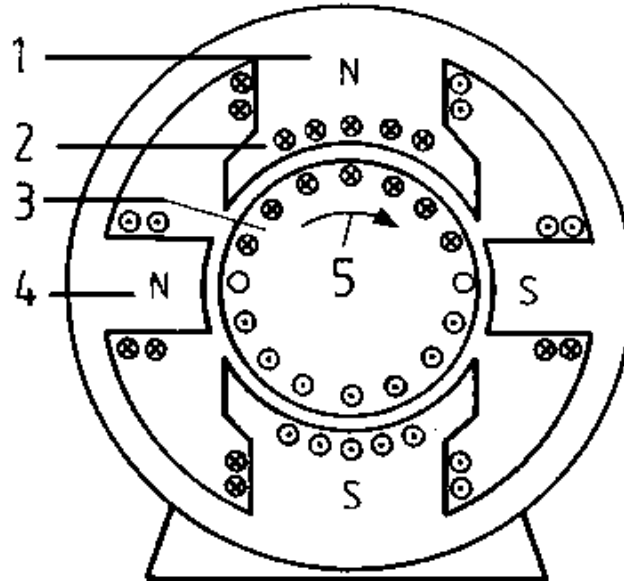
# **Electrical Machines - Basic vocational knowledge (Institut fr Berufliche Entwicklung, 144 p.)**

## **6. Direct current machines**

### **6.1. Constructional assembly**

**A direct current machine is a rotating electrical machine which, according to circuitry, either utilises or releases energy.**

**The direction of power conversion determines operation either as direct current generator or motor. The direct current machine is an external pole machine.**

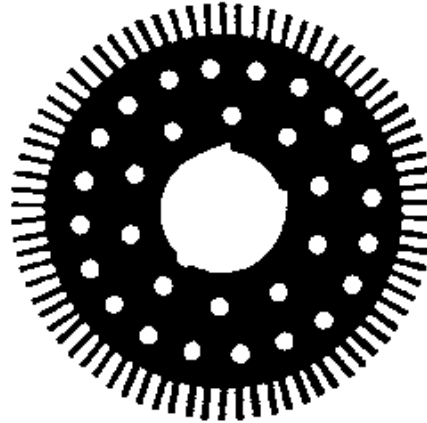


**Figure 79 - Basic assembly of a direct current motor**

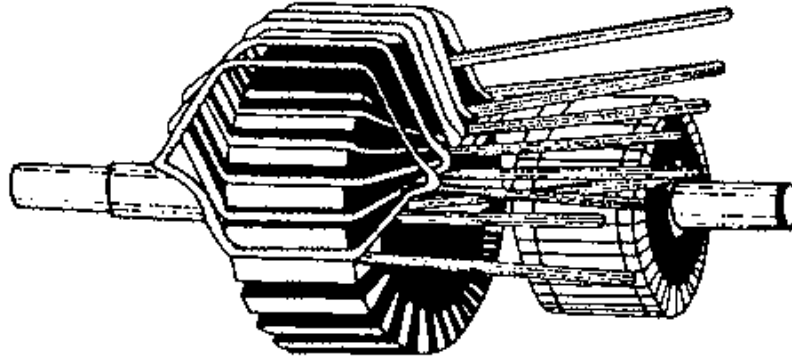
**1 Main pole with exciter winding, 2 Compensation winding, 3 Rotor with rotor winding, 4 Interpole with interpole winding, 5 Rotational direction during generator operation**

**The main poles with the direct current pole winding have been arranged in the stator. These main poles set up the magnetic field**

**(exciter field) which, in the case of smaller machines, is also yielded through permanent magnets. The rotatable, pivoted rotor is made from a lamella sheet pack whose grooves retain the winding.**



**Figure 80 - Rotor-core lamination**

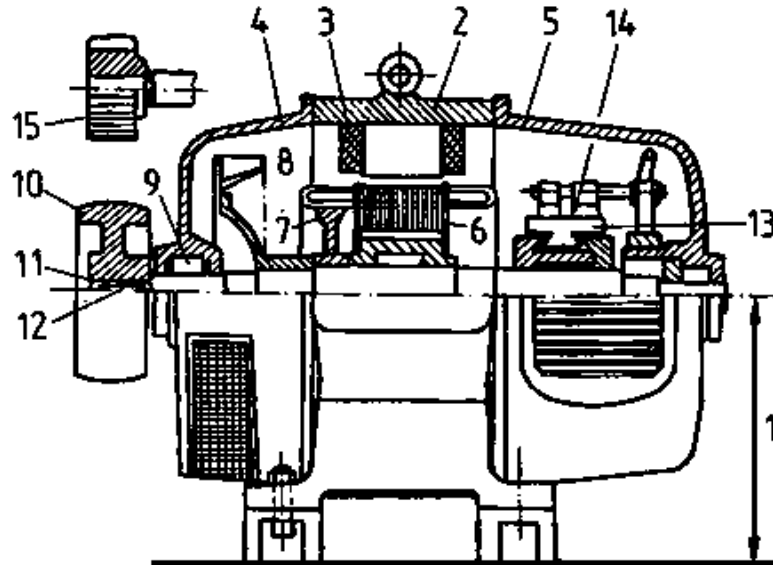


**Figure 81 - Rotor with coil winding**

**The coil ends of the rotor winding have been extended to the commutator lamella on which the brushes loop. In this way an electrical connection is established between the direct current network and the rotor winding (Cp. Figure 83). Interpoles whose windings are saturated with rotor current have been interspersed in the field-free (neutral) zone of bigger machines. In addition, under certain circumstances a capacitor winding has been accommodated in the pole shoes of the main pole.**

**The overall assembly of a direct current machine is set out in Figure 82.**





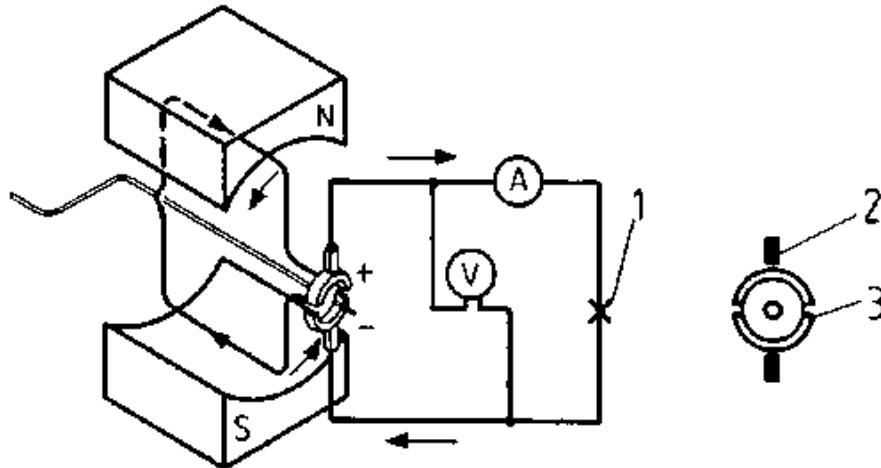
**Figure 82 - Overall assembly of a direct current machine**

**1 Rated height, 2 Stators, 3 Exciter winding, 4 End shield of the A-side, 5 End shield of the B-side, 6 Dynamo sheets (armature), 7 Balance mass, 8 Ventilator, 9 Roller bearing, 10 Pulley, 11 Shaft end (cylindrical), 12 Feather, 13 Commutator, 14 Brushes, 15 Gear**

## **6.2. Operating principles**

### **6.2.1. Power generation (direct current motor)**

**Initially (Cp. 4.1.1.) an alternating voltage is generated in the rotor windings of every generator. This alternating voltage can, however, be rectified so that current always passes through the external circuit in the same direction (Cp. Figure 30). Rectification of the generated alternating voltages takes place in the following manner: Instead of the two slip rings isolated from one another in Figure 30, only one slip ring appears in Figure 83. This latter slip ring has, however, been divided into two halves insulated from each other (lamella) and is known as a commutator.**

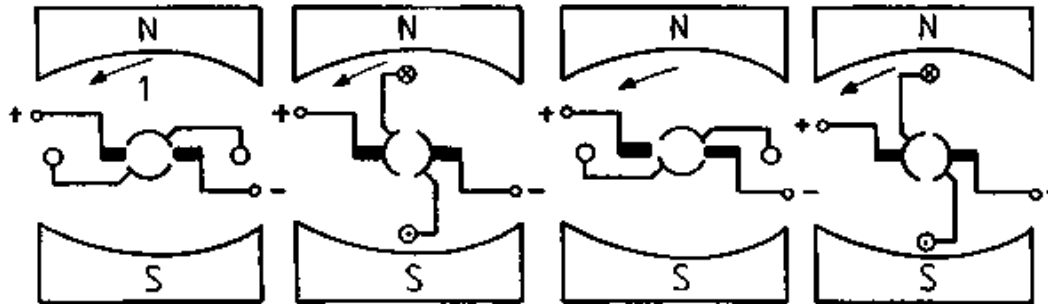


**Figure 83 - Model of a direct current generator**

- 1 Bulb**
- 2 Carbon brushes**
- 3 Commutator**

**The beginning and end of the conductor loop (winding) have been connected to the lamella. The two brushes face each other. They always run from one lamella to another as the conductor loop passes through the neutral zone. The induced voltage in the conductor loop is just zero at this moment and changing its**

**direction. Figure 84 shows the principle of mechanical rectification.**



**Figure 84 - Principle of mechanical rectification**

**1, 2 Conductor loop, 3 Rotational direction, 4 Neutral zone**

**The commutator ensures that polarity of the carbon brushes remains constant at all times. The course of the rectified voltage is shown in Figure 85. We can perceive that the generated voltage still ranges between zero and a top value whilst always evidencing the same direction.**

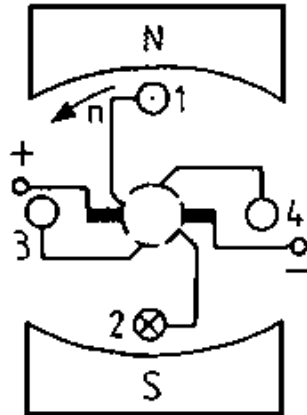


**Figure 85 - Sequence of the rectified voltage of a conductor loop**

## **1 Voltage**

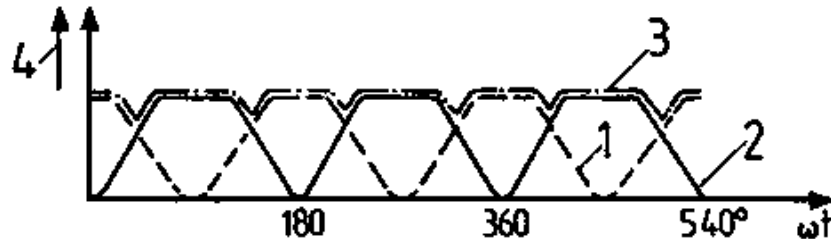
**Where a less pulsating voltage is required it is necessary to increase the number of conductor loops whereby they should be spatially positioned. The number of lamella must be increased for every additional conductor loop. Figure 86 sets out the basic drawing of a direct current generator with two conductor loops.**

**The commutator comprises four lamella. The generated voltage is shown in Figure 87.**



**Figure 86 - Direct current generator with two conductor loops resp. windings**

**1, 2 Conductor loop; 3, 4 Conductor loop**

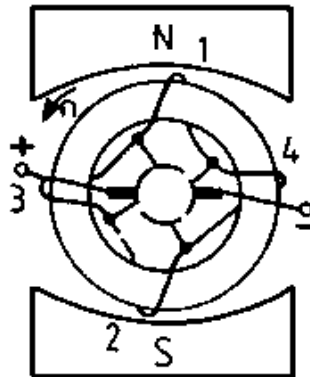


**Figure 87 - Sequence of direct current in a generator with two**

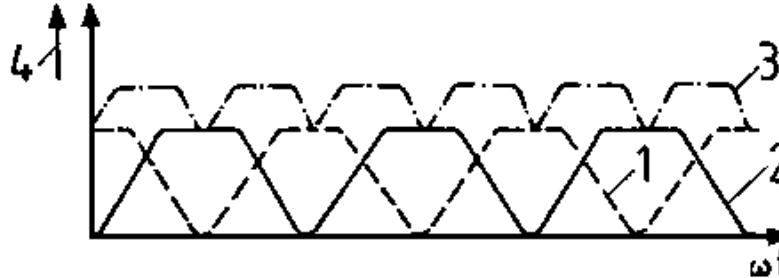
## windings

**1 Voltage in the conductor loop  $\frac{1}{2}$ , 2 Voltage in the conductor loop  $\frac{3}{4}$ , 3 Terminal voltage, 4 Voltage in volt**

**The resultant voltage no longer varies as much however it has the disadvantage that the carbon brushes only tap off a voltage from the conductor loops when they generate a peak voltage. The conductor loops are ineffective at all other times. However, the two conductor loops add together their voltages once they are series connected.**



**Figure 88 - Generator with series-connected conductor loops**



**Figure 89 - Voltage sequence of a generator in accordance with Figure 88 - Legend as for Figure 87**

The voltage presented in Figure 89 also features an increased voltage alongside an even one. Moreover, the direct voltage can be improved still further by increasing the number of conductor loops. In practise coils with several windings are employed instead of conductor loops. Operating current  $I_A$  flows when a consumer connects to the carbon brush terminals.

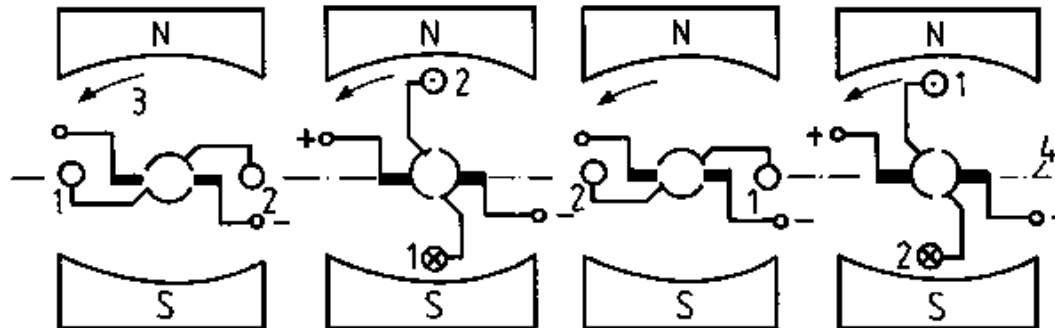
### 6.2.2. Torque generation (direct current motor)

Section 2.3.2. indicates that a current saturated conductor loop and a magnetic field are required in order to generate a torque. This is attained by applying a voltage to the rotor winding as in Figure 83.



**A rotational movement up to the neutral zone arises where direct current flows into the rotor winding.**

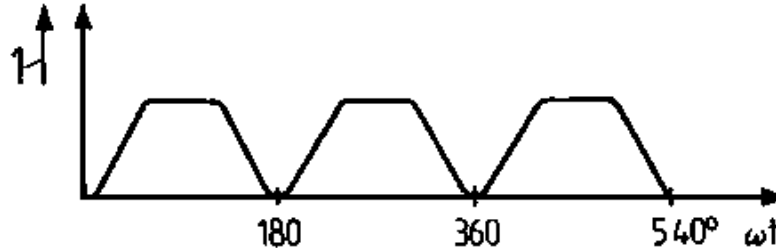
**The forces are then still effective but do not constitute a torque. The current direction in the conductor loop must be reversed in the neutral zone in order to attain a further rotation. Current direction change in the direct current machine is handled by the commutator which switches over the current direction in the conductor loop after a semi-rotation. Thereby the voltage attached to the carbon brushes is transformed in the conductor loop into alternating voltage. Figure 90 depicts this process.**



**Figure 90 - Torque generation in a direct current motor**

## 1 Rotational direction

The following diagram emerges if one observes the torque within the conductor loop depending on the rotational angle.



**Figure 91 - Torque of a conductor loop in dependence on the rotational angle**

### 1 Torque

The torque ranges between zero and a peak value. A virtually constant torque is attained by utilising a large number of conductor loops (coils) which are distributed along the rotor circumference.

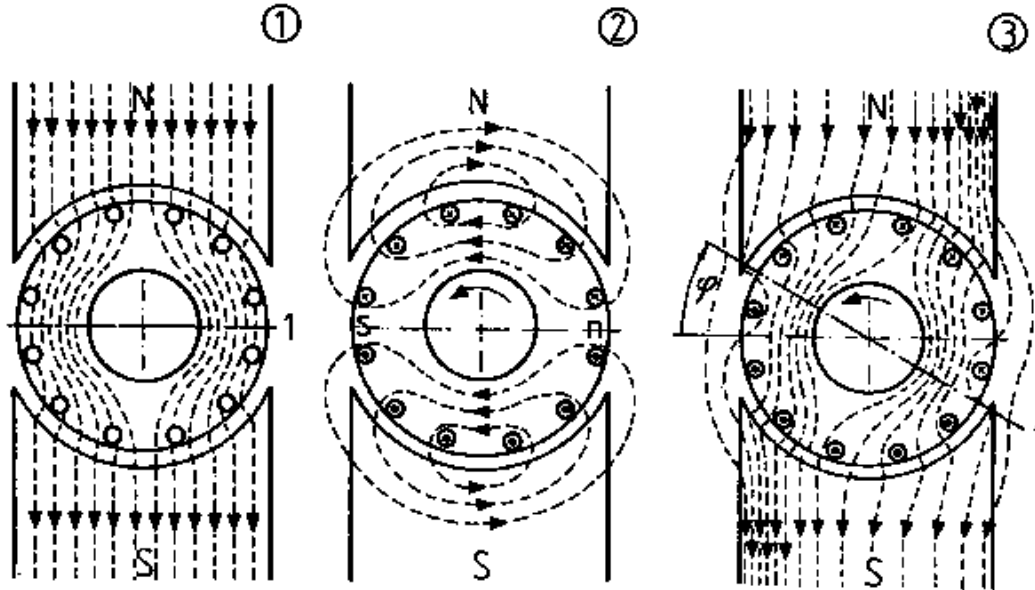
Conductor loop rotation in the exciter field similarly induces a voltage in this field. This runs counter to the applied voltage and

**cuts back operating current.**

### **6.2.3. Armature reaction (rotor reaction)**

#### **Mode of operation**

**The magnetic main field of the direct current machine runs symmetrically from the north to the south pole (Figure 92 (1)) in the stator. The current-saturated rotor winding generates a second magnetic field which runs vertically (transverse) to the main field (Figure 92 (2)).**



**Figure 92 - Armature reaction**

**(1) Main field of the currentless rotor, (2) Armature transverse field, (3) Resultant overall field**  
**1 Neutral zone**

**Despite rotor rotation the transverse field remains motionless and its value only changes in proportion to the**

## **current intensity in the rotor winding.**

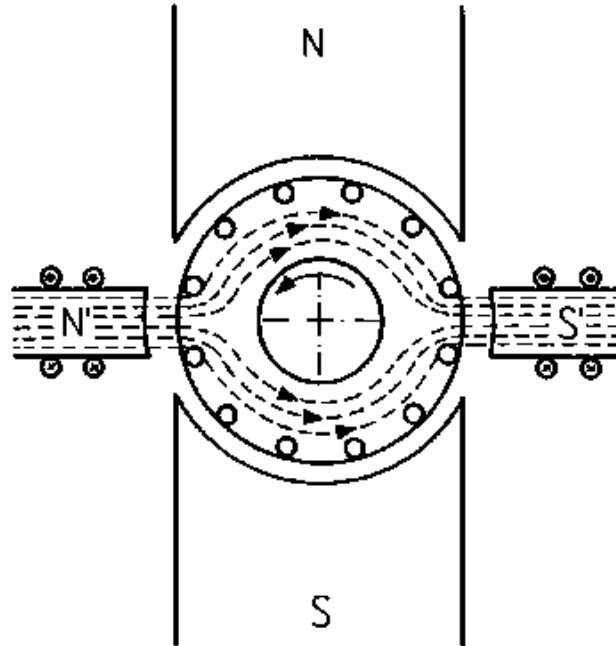
**The armature transverse field superimposes itself with the main field to a resulting field (Figure 92 (3)) whose neutral zone has been displaced with regard to the main field.**

**The neutral zone is displaced by the armature transverse field. Its rotation ensues in the generator in rotational direction and, in the motor, contrary to the rotational direction of the rotor.**

**A displacement of the neutral zone leads to brush sparking. Furthermore, the armature reaction weakens the main field and this, in turn, paves the way for a decrease in rotor-induced voltage.**

### **Interpoles**

**The negative influence of the armature transverse field can be overcome by superimposing a counter-directed magnetic field. So-called interpoles (Cp. Figure 93) are established between the main poles.**



**Figure 93 - Magnetic field of the interpoles**

**1 Generator operation**

**2 Motor operation**

**The interpole windings are so switched that their magnetic field is counter-positioned to the armature transverse field. In this motor,**

**therefore, a principal north pole is followed by a north interpole in rotor rotational sense.**

**The interpole shall generate a magnetic field counterpositioned to the armature transverse field. The interpoles are in the neutral zone. Interpole and rotor windings have been series connected,**

**The armature transverse field can also be compensated by a magnetic field which is generated by the so-called compensation winding.**

#### **6.2.4. Excitation**

**Every rotating electrical machine requires an exciter field. The exciter field of the direct current machine, generated by the main poles, is a permanent magnetic field of constant value. We differentiate between various exciter categories.**

##### **Permanent excitation**

**An exciter field is realised by means of permanent magnets. This exciter category is mainly used for lower-power machines.**

## Separate excitation

**The necessary voltage to generate an exciter field is attained from a voltage source (e.g. accumulators) outside the machine. Natural excitation is a particular excitation category.**

**In this case the necessary excitation voltage is provided by a generator (exciter machine) which is coupled directly to the main machine.**

## Self-excitation

**Because of remanance (residual magnetism), the main poles evidence a weak exciter field. In accordance with  $U_0 = c \cdot \Phi \cdot n$  the rotation of the rotor winding induces only a small rotor voltage in the exciter field. Rotor winding rotation however enables a weak current to pass through the exciter winding. This current increases the exciter field whereby a greater rotor voltage is induced. This is, moreover, a continuous process leading to a fully fledged exciter field. This alternating effect is termed "dynamoelectric principle". One differentiates between the following self-excitation categories:**



## **Shunt excitation**

**The exciter winding has been parallel connected in the rotor winding.**

## **Series excitation**

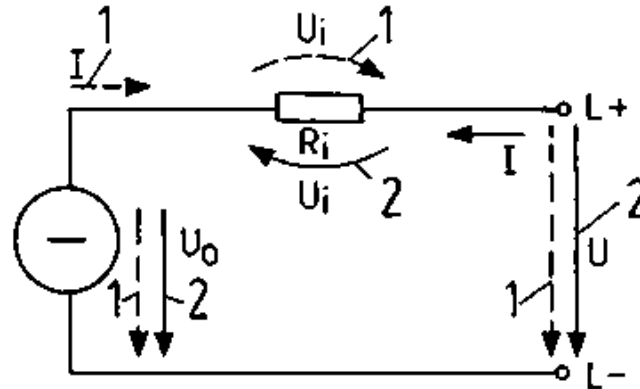
**Both exciter and rotor winding have been positioned in series.**

## **Compound excitation**

**Each main pole features two main types of exciter windings: a shunt winding parallel to the rotor and a series winding in series with the motor current circuit.**

### **6.2.5. Value relations**

**A voltage  $U_0$  is always generated in the rotor circuit irrespective of the type of direct current machine. The windings in the operating field yield an ohmic resistor, the internal resistor  $R_1$ . Both values can feature in a duplicate circuit plan.**



**Figure 94 - Duplicate rotor circuit**

**The internal resistance of the rotor circuit stems from**

$R_1$  rotor winding resistance

$R_W$  interpole winding resistance

$R_K$  compensation winding resistance

$R_B$  brush resistance and series excitation

$R_R$  series winding resistance

**In accordance with the voltage law the duplicate circuit establishes**

**the relations between generator and motor operating voltages:**

$$U_0 = U + U_1$$

$$U = U_0 + U_1$$

**The natural direction change in switching over from generator to motor operation must be heeded when drawing up the equations.**

**6.3. Operational behaviour of direct current machines****6.3.1. Direct current generators**

**The induced voltage is determined by means of the equation  $U_0 = c$**

$$\bullet \Phi \bullet n$$

**Thus we derive the value of  $U_0$**

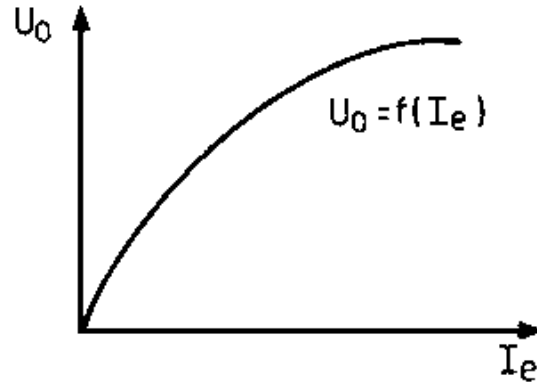
- 1. through the construction (C)**
- 2. through the exciter flow ( $\Phi$ )**
- 3. through the speed (n).**

**The construction constant (C) which results from the construction of the generator take in, for example, the number of pole pairs, the number of rotor conductors and the interconnection of the rotor windings. The exciter flow can be controlled by changing the exciter winding voltage. This is possible by series connection of an alterable resistance to the exciter winding. This is called resistance strain field actuator. Exciter voltage, exciter current and excited flow are interlinked like this:**

$$\frac{U_e}{R_e} \quad I_e \cdot N \quad \frac{\Theta_e}{R_m}$$

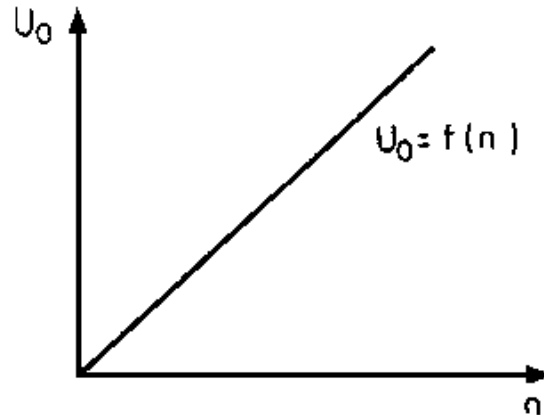
$$U_e \rightarrow I_e \rightarrow \Theta \rightarrow \Phi_e$$

**If  $U_0 = f(\Phi_e)$  is considered one can also investigate  $U_0 = f(I_e)$  as  $\Phi_e$  is dependent on  $I_e$ . The following diagram is forthcoming for a constant speed  $n$  (Figure 95): In the case of a lesser exciter current the curve is almost linear. The curve flattens out following increased pole iron saturation.**



**Figure 95 -  $U_0 = f(I_e)$ ; induction voltage as an exciter current**

**Figure 96 depicts the relationship between rotor speed and induced voltage  $U_0$ . Thus, the original voltage can also be attained through the speed.**



**Figure 96 -  $U_0 = f(n)$ ; induction voltage as a speed function**

**The induced voltage of a direct current generator can be controlled by altering the exciter current or the speed.**

### **6.3.2. Direct current motors**

#### **Starting behaviour**

#### **Direct starting**

**If the equation  $U = U_0 + I R_i$  is adapted in line with current**

**magnitude, one derives an equation with**

$$I = \frac{U - U_0}{R_i}$$

**for working out the current value in the rotor circuit of the motor. If one compares current intensity for switching on and actual operation, we can determine the following:**

**During switching on current is calculated according to**

$$I = \frac{U}{R_i}$$

**There is thus more current because**

- 1. the acceleration torque must be forthcoming and**
- 2. there is no back voltage  $U_0$ .**

**As rotational movement continues a back voltage is induced according to  $U_0 = c \cdot \Phi \cdot n$  whereby current intensity declines.**

**Current intensity decreases more and more as speed increases.**

**Then, as rated speed is attained, operational current is brought into play. The very considerable inrush current leads to**

- 1. a greater heating up of the winding**
- 2. in higher rated motors to operation of the fuses resp. the overcurrent trip**
- 3. to voltage fluctuations in the network.**

**Consequently, only motors with low rated power may be connected to full mains voltage during switching on. Thus, motors operating on a mains voltage of 220 V between both external conductors may not have a greater power than 0.7 kW.**

**Direct switching on is only possible for low powered motors.**

### **Starters with series resistor**

**In the case of higher powered direct current motors the starting currents are limited through a series resistor, the starter. The starter must, moreover, be so dimensioned that peak starter current  $I_{sp}$  does not exceed 1.5 times the rotor nominal current (operating current intensity at rated speed). Thus, the following**



**equation applies:**

$$I_{sp} = 1.5 \cdot I_n$$

**This comprises several series connected resistors which can be switched off as speed increases. The connecting terminals R, L and M should be switched thus:**

**R to the rotor, L to the mains (lead) and M to the shunt winding (magnetic field).**

**Starters are manufactured for the operating mode S2.**

**Example:**

**A direct current motor with a rated power of  $P = 10$  kW and a rated voltage of  $U = 220$  V has an internal resistance  $R_i = 0.4$ . How great are:**

**Starting peak current  $I_{sp}$**

**Starting resistance  $R_a$**

**and the relationship between switching on current  $I_a$  max to**

**rotor nominal current  $I_n$ ?****Given:**

$$U = 220 \text{ V}$$

$$P = 10 \text{ kW}$$

$$R_j = 0.4 \text{ } \Omega$$

**Sought:**

$$I_{sp} \cdot R_a \cdot \frac{I_{amax}}{I_n}$$

**Solution  $P = U \cdot I$** 

$$I = \frac{P}{U}$$

$$I = \frac{10 \cdot 10^3 \text{ W}}{220 \text{ V}}$$

$$I_n \approx 45.5 \text{ A}$$

$$\mathbf{I_{sp} = 1.5 \cdot I_n}$$

$$\mathbf{I_{sp} \approx 68 \text{ A}}$$

$$I_{a\max} = \frac{U}{R_i}$$

$$I_{a\max} = \frac{220\text{V}}{0.4\Omega}$$

$$\mathbf{I_a \max = 550 \text{ A}}$$

$$I_{a\max} = \frac{550\text{A}}{45.4\text{A}} \approx 12$$

$$\mathbf{I_a \max \approx 12 I_n}$$

$$R_{\text{repl}} = R_i + R_a = \frac{U}{I_{\text{sp}}} = \frac{220\text{V}}{68\text{A}}$$

$$\mathbf{R_{\text{repl}} \approx 3.24 \Omega}$$

$$R_a = R_{repl} - R;$$

$$R_a = 2.84$$

**Where a starter of at least 2.84  $\Omega$  is connected in series, the inrush peak current is restricted to max 68 A. In the absence of a starter the inrush current would be 12 times greater than the rotor rated current.**

### Rating behaviour

#### **Speed control**

**In practise prestipulated speeds are required for various drives.**

**In production certain speeds must also be adhered to, moreover such speeds shall also remain constant given loading variations.**

**Such drive problems can be solved by means of direct current motors.**

**The equation for calculating the speed of a motor is derived from  $U_0$**

**=  $C \cdot \Phi \cdot n$  and  $U_0 = U - I (R_i + R_v)$  through equalisation and subsequent solution according to the speed.**

**We determine:**

$$n = \frac{U - I(R_i + R_v)}{c \cdot \Phi}$$

**$R_v$  is a series resistance which is series switched to  $R_i$ .**

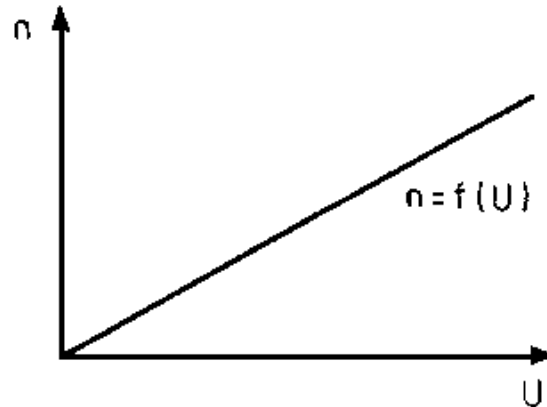
**Subsequently the speed can be set**

- 1. by altering the applied mains voltage**
- 2. by altering the series resistance of the rotor circuit and, thereby, the voltage at terminals A1 and A2 of the machine and**
- 3. by magnetic flow changes.**

**All these methods are used in practice.**

**Changing mains voltage.**

**Changing mains voltage is advantageous where a motor has an own voltage source of differing values. Where direct current conductor mains are available the voltage can be stepwise changed by means of a selector switch. The influence of the mains voltage on the speed can be seen in Figure 97.**



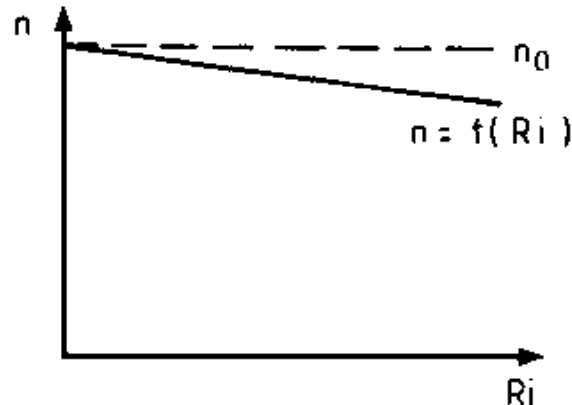
**Figure 97 -  $n = f(U)$ ; dependence of speed on mains voltage**

**Favourable and economical speed setting results from changing the voltage by means of controlled rectifiers (thyratrons or thyristors). There are virtually no losses with these rectifiers. Power dependency becomes irrelevant as rotor resistance does not change**

**during this procedure.**

## **Changing the series resistance of the rotor circuit**

**Where rotor circuit resistance is increased through a series resistance, speed subsequently decreases.**



**Figure 98 -  $n = f(R_i)$ ; speed dependence on internal resistance**

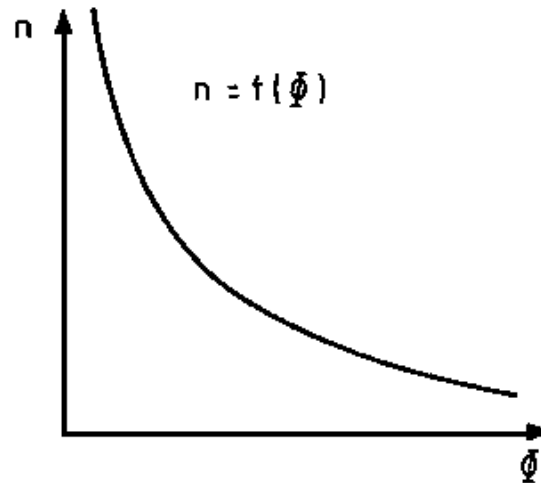
**However, due to the considerable rotor current, this speed control leads to marked power losses. Where this procedure shall serve for speed control, the servo unit is dimensioned for permanent S1**

**operation. Such a unit is called a speed control starter if it is simultaneously suitable for starting. This control leads to a power drop.**

### **Changing the magnetic flow**

**The magnetic flow decreases when a speed field controller is switched on to the field winding. The speed increases in the diminished exciter field. In practise speed field starters are constructed permitting a speed increase of up to 200 per cent of the rated speed. The arising losses are relatively low, consequently this control unit is quite economical. Figure 99 depicts the dependence of speed on exciter flow.**





**Figure 99 -  $n = f(\Phi)$ ; speed dependence on exciter flow**

## **Rotational direction control**

**The rotation direction depends on the current direction in the rotor and the direction of the exciter field. This is determined by the left-hand rule.**

**A rotational change of direction can therefore be attained**

**1. by current directional change in the rotor and**

## **2. by pole changing the exciter field.**

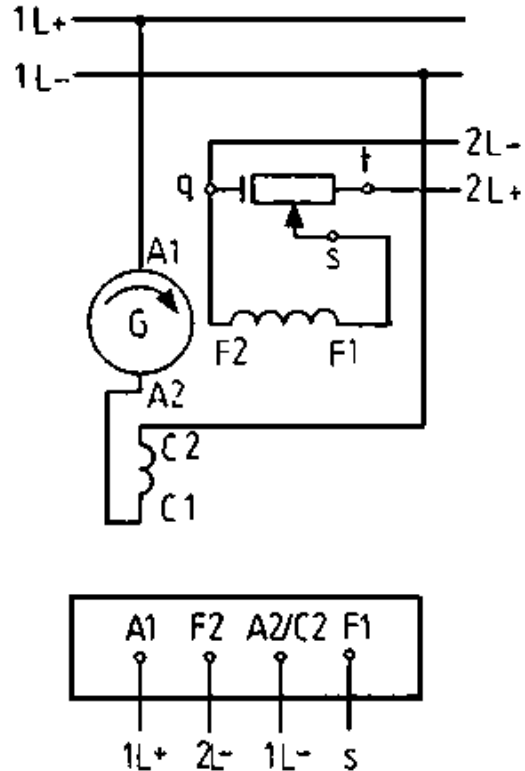
**In practice the current directional change in the rotor is mainly used. However, the exciter field is repled in more powerful machines (Leonard converters) as, otherwise, the switching contacts to handle the extremely great rotor currents become too big.**

### **6.4. Circuit engineering and operational features of customary direct current generators**

#### **6.4.1. Separate-excited direct current generator**

##### **Circuitry**

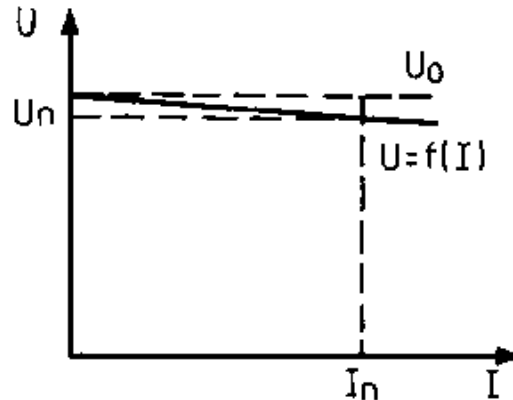
**The separately excited direct current motor is a direct current generator whose exciter winding is fed by a separate voltage source.**



**Figure 100 - Circuitry and terminal board of a separately excited direct current generator**

### Voltage behaviour

**The induced rotor current is virtually load independent given constant rotor speed and exciter flow. Conversely, terminal voltage  $U$  drops slightly as load increases. The graphical presentation of the function  $U = f(I)$  is a declining straight.**



**Figure 101 - Voltage curve of a separately excited direct current generator**

**The separately excited generator cannot be short-circuited.**

### **Voltage - control**

**By means of the voltage field actuator the exciter flow can be**

**altered from minimum to saturation value. Consequently, the induced voltage can be varied within considerable limits.**

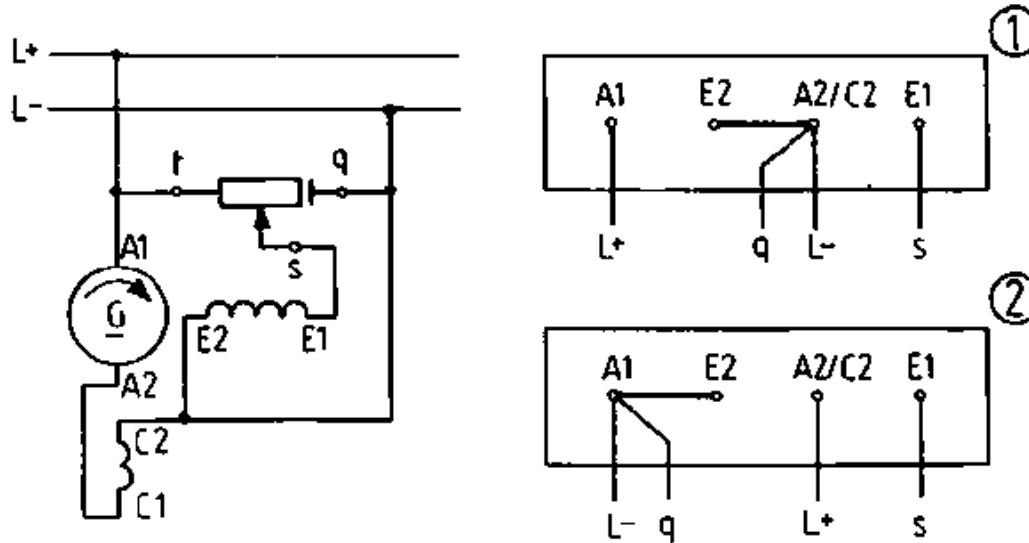
### **Application**

**Due to the considerable voltage setting range, the separately excited generator is utilised where very different voltages are required, for instance in converters.**

### **6.4.2. Direct current shunt generator**

#### **Circuitry**

**The direct current shunt generator is a direct current generator in which the exciter winding is switched parallel to the rotor winding.**



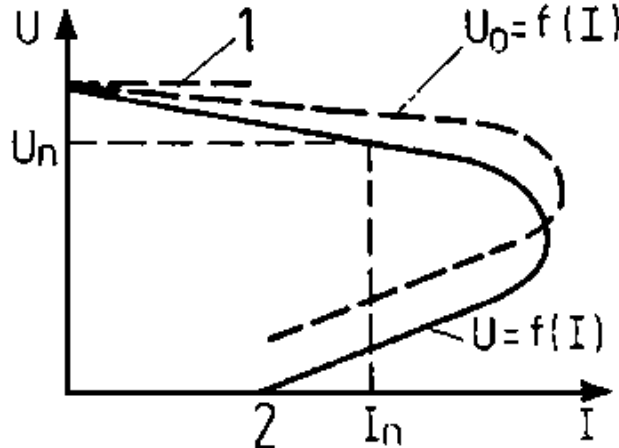
**Figure 102 - Circuitry and terminal board of a direct current shunt generator**

**(1) Clockwise, (2) Anti-clockwise**

### Voltage behaviour

**The dependence of terminal voltage  $U$  on load current  $I$  can be deduced from the curve in Figure 103. Terminal voltage declines as**

**load current increases. If the generator is, in addition, loaded over and beyond the rated current, the terminal voltage declines sharply. Only minimal voltage is induced where the rated current increases threefold. Consequently, the required current power need no longer be provided. Terminal voltage is zero during short-circuiting.**



**Figure 103 - Voltage curve of a direct current shunt generator**

**1  $U_0$  in no-load operation**

**2 Short circuit current**

**The shunt generator is short-circuit-proof.**

### **Voltage control**

**An alteration of the strain field actuator of the exciter current and, thus, also of the exciter flow serves to ensure constant voltage given greater load current.**

### **Application**

**The direct current shunt generator is used as exciter generator in three-phase generators for ensuring power supplied on ships and planes.**

## **6.5. Circuit engineering and operational features of customary direct current motors**

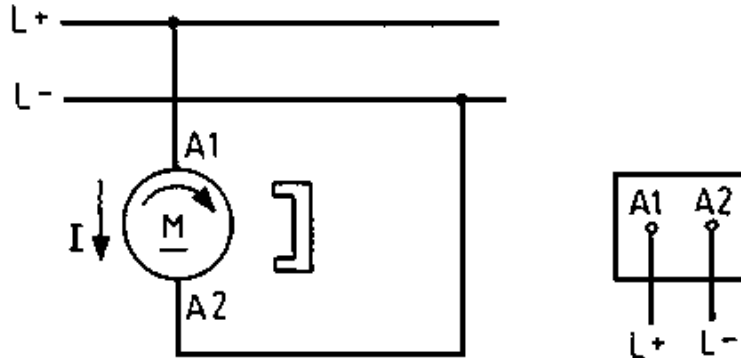
### **6.5.1. Direct current motor with permanent excitation**

### **Circuitry**

**The permanently excited direct current motor is a small machine in which the exciter field is established through**



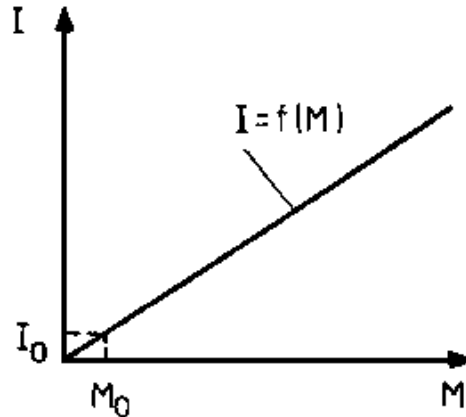
## permanent magnets.



**Figure 104 - Circuitry and terminal board of a direct current motor with permanent excitation**

### Dependence of current take-up on the torque (load)

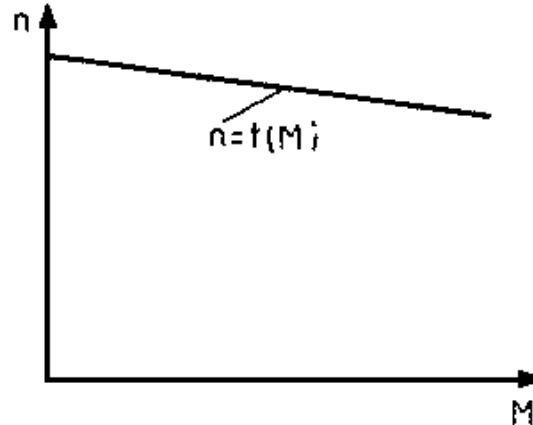
**As the curve  $I = f(M)$  indicates in Figure 105, current take-up is directly proportional to the torque because of the constant exciter flow.**



**Figure 105 -  $I = f(M)$ ; Current take-up dependence on torque**

**Dependence of speed on the torque (load)**

**Direct proportionality exists between speed and torque in speed-load behaviour.**



**Figure 106 -  $n = f(M)$ ; Speed dependence on torque**

### Speed control

**Speed control ensues by changing the applied voltage.**

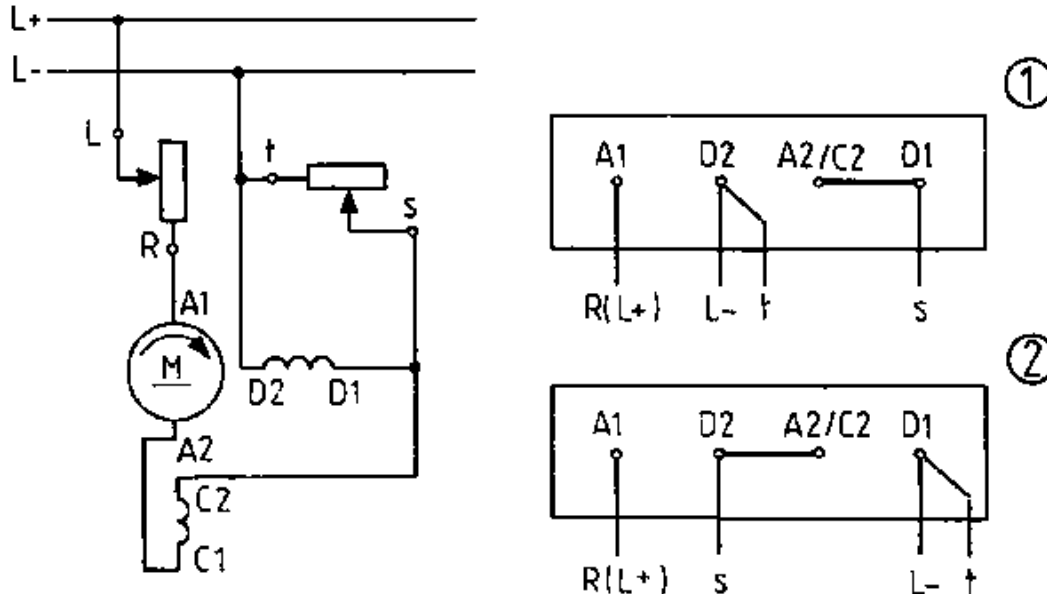
### Application

**Direct current motors with permanent excitation are used mainly for power ratings up to 500 W. Such motors find application in the toy industry, household appliances, measurement and control technology.**

## 6.5.2. Direct current series motor

### Circuitry

**The direct current series motor is a direct current motor whose exciter windings (D1, D2) have been series-switched to the rotor winding.**

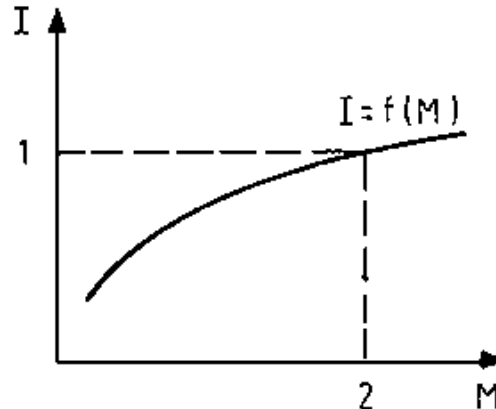


## Figure 107 - Circuitry and terminal board of a direct current series motor

### 1 Clockwise, 2 Anti-clockwise

### Dependence of current take-up on the torque (load)

Current take-up by the motor depends on the load. As curve  $I = f(M)$  indicates, during idling the motor only takes up minimal current. Current take-up increases through greater load. Thereby, however, the increase in current intensity is greater than the load growth.

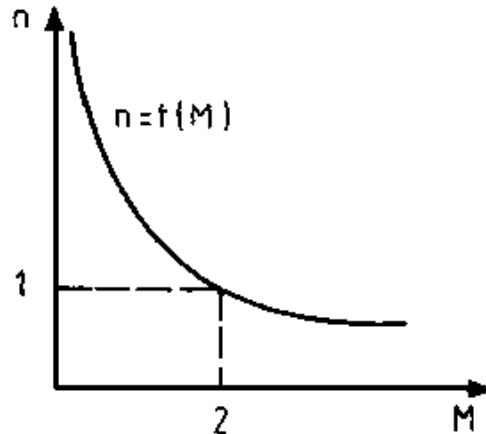


## Figure 108 - $I = f(M)$ ; Dependence of current take-up of a direct current series motor on torque

### 1 Rated current, 2 Rated torque

### Dependence of speed on the torque (load)

The speed-torque curve (Figure 109) shows that the speed depends to a considerable extent on the load. Whilst idling speed assumes greater values. Given reduction the motor may "race" under certain circumstances.



## **Figure 109 - $n = f(M)$ ; Speed dependence on the torque of a direct current series motor**

### **1 Rated speed, 2 Rated torque**

**The considerable centrifugal power which then arises can destroy the motor. Therefore the motor must be securely attached to the drive machine. Speed declines markedly as the load increases. The direct current series motor develops a considerable initial torque during starting. It can, therefore, also start given excessive load.**

### **Speed control**

**Speed can be controlled by**

- a series resistor**
- a strain field actuator parallel to the exciter winding and by**
- changing mains voltage.**

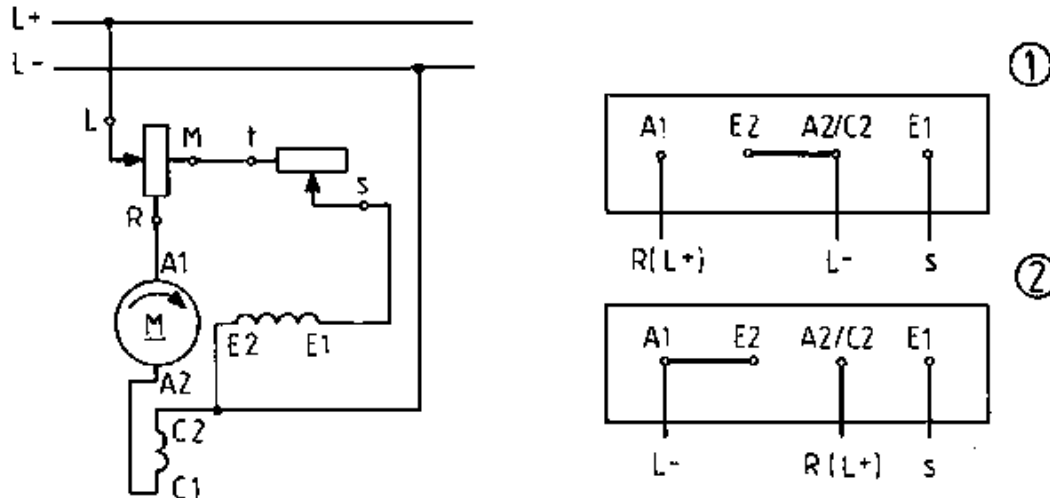
### **Application**

**Direct current series motors are used where considerable speed ranges and excessive torques are in evidence and "racing" is not**

possible (e.g. for driving electric railways, cranes, escalators).

### 6.5.3. Direct current shunt motor

The direct current shunt motor is a direct current motor whose exciter windings (E1, E2) have been series-switched to the rotor winding.



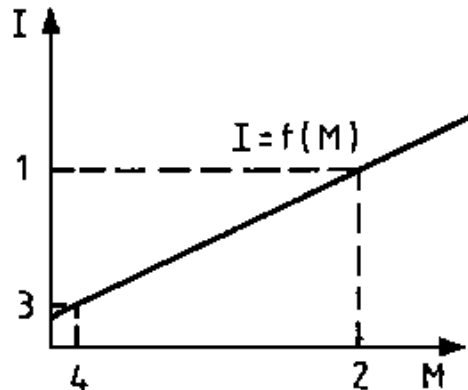
**Figure 110 - Circuitry and terminal board of a direct current shunt motor**



## (1) Clockwise, (2) Anti-clockwise

### Dependence of current take-up on the torque (load)

Current take-up is made up of rotor current  $I_L$  and exciter current  $I_e$  :  $I = I_L + I_e$ . The curve  $I = f(M)$  (Figure 111) shows that exciter current flows as  $M = 0$ . Current take-up increases as load increases. Very considerable current flows during overloading.



**Figure 111 -  $I = f(M)$ ; Current take-up dependence on the torque of a direct current shunt motor**

**1 Rated current, 2 Rated torque, 3 Idling current (exciter**

current), 4 Idling torque

### Dependence of speed on the torque (load)

Speed behaviour is characterised through minimal linear speed reduction as load increases.

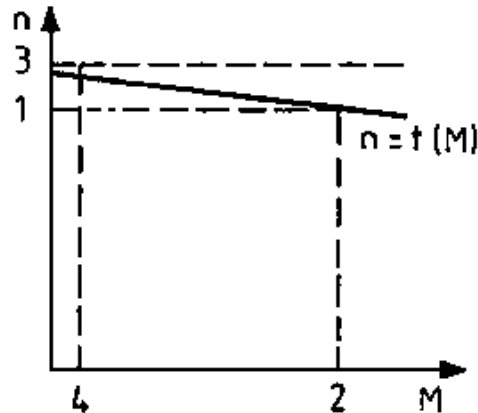


Figure 112 -  $n = f(M)$ ; Speed dependence on the torque of a direct current shunt motor

1 Rated speed, 2 Rated torque, 3 Idling speed, 4 Idling torque

**The unloaded motor runs at an idling speed of  $N_0$  and the rated speed of  $n_n$  is less than 10 per cent.**

**The speed change between the idling speed  $n_0$  and the rated speed of  $n_n$  is less than 10 per cent.**

### **Speed control**

**Speed control is possible by altering the exciter flow with the aid of the strain field actuator and varying the applied mains voltage.**

### **Application**

**The direct current shunt motor is used as a drive for machine tools and automation equipment because of its virtually constant speed.**

### **Questions for repetition and control**

**1. Describe the construction and mode of operation of a direct current generator.**

- 2. Differentiate between the different types of direct current machines.**
- 3. How can the speed of a direct current shunt motor be changed?**
- 4. Explain why a starter is required to start up a direct current motor?**
- 5. How can one alter the rotational direction of a motor?**





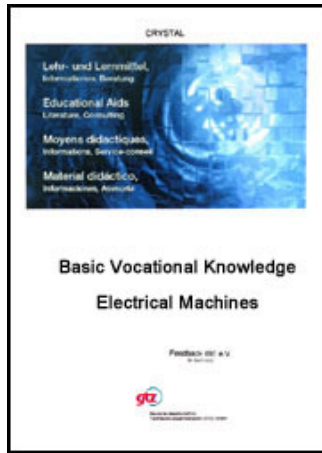
[Home](#) > [ar](#).[cn](#).[de](#).[en](#).[es](#).[fr](#).[id](#).[it](#).[ph](#).[po](#).[ru](#).[sw](#)













---



**Electrical Machines - Basic vocational knowledge (Institut fr Berufliche Entwicklung, 144 p.)**

- ➔  **7. Single-phase alternating current motors**
  -  **(introduction...)**
  - 7.1. Single-phase asynchronous motors (single-phase induction motors)**
    -  **(introduction...)**



-  **7.1.1. Assembly and operating principle**
-  **7.1.2. Operational behaviour**
-  **7.1.3. Technical data**
-  **7.2. Three-phase asynchronous motor in single-phase operation (capacitor motor)**
  -  **7.2.1. Assembly and operating principle**
  -  **7.2.2. Operational behaviour**
-  **7.3. Split pole motors**
-  **7.4. Single-phase commutator motors (universal motors)**
  -  **7.4.1. Assembly**
  -  **7.4.2. Operating principles**
  -  **7.4.3. Operational behaviour**
  -  **7.4.4. Technical data**

## Electrical Machines - Basic vocational knowledge (Institut fr

## **Berufliche Entwicklung, 144 p.)**

### **7. Single-phase alternating current motors**

**Single-phase alternating current motors have assumed importance these days in particular as electrification in the home and at work continues apace. Indeed, such motors are especially suitable for automation techniques by means of economical, labour and time-saving equipment. Generally speaking low-powered motors suffice to drive such devices and, consequently, such motors can be connected to the single-phase network.**

#### **7.1. Single-phase asynchronous motors (single-phase induction motors)**

**Induction motors are mainly used to drive household and office machinery as well as smaller electrical tools. The peak power range of these motors is around 2 kW.**

##### **7.1.1. Assembly and operating principle**

**The torque of a three-phase asynchronous motor (Cp. Section 5.2.1.) stems from an induction voltage generated in the rotating**

**field of the rotor windings. This induction voltage yields rotor current  $I_2$ :**

$$M = C \cdot \Phi_1 \cdot I_2 \cdot \cos\varphi_2$$

**Thus, torque only arises given a relative movement between the stator field and the rotor winding. Where the lead to a winding strand in a three-phase asynchronous motor is interrupted, the said motor runs single-phased. Consequently, no torque is forthcoming as long as there is no relative movement between the stator field and the conductor arrangement in the rotor.**

**The single-phase driven asynchronous motor develops a torque during operation, but not whilst idling; nor can it start off its own bat.**

**Asynchronous motors for single-phase operation exist wherever there is no three-phase connection, and are very much desired.**

**However, such motors must be able to start themselves. Precondition is that a rotating field is created to replace the alternating field. This, however, is only possible if spatially**

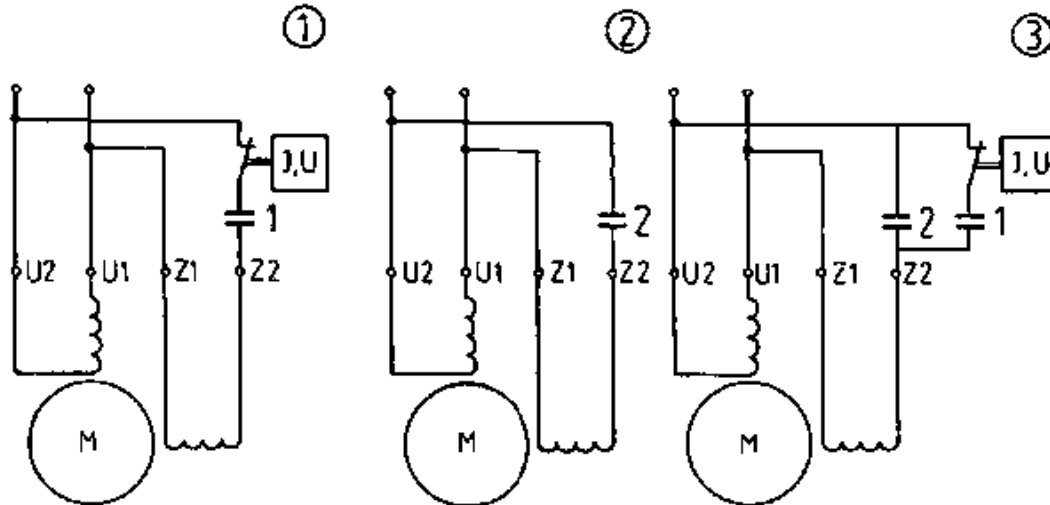
**positioned coils are saturated by temporally displaced currents.**

**Every single-phase asynchronous motor which is to start itself, must have two windings whereby the second spatially positioned winding must be saturated by a current which has been phase-displaced opposite the current of the first winding.**

**This second winding need only be switching on for starting and is characterised as auxiliary winding. The permanently switched on main winding covers some two thirds of the stator circumference whilst the auxiliary winding fills in the remaining part of the grooves in the lamella pack.**

**The single-phased asynchronous motor yields an ideal rotating field if the main and auxiliary windings are repositioned at 90 degrees and the phase displacement of the strand currents is also 90 degrees. Such operation can be virtually attained given single-phase feeding provided a capacitor is switched to the auxiliary winding. This capacitor must have a capacity in line with the rated load and desired starting behaviour.**





**Figure 113 - Single-phase motor with auxiliary winding and (1) starting capacitor CA, (2) operating capacitor CB, (3) starting and operating capacitor**

**1 Starting capacitor, 2 Operating capacitor**

**The rotor of the single-phase asynchronous motor generally has a squirrel cage.**

### **7.1.2. Operational behaviour**

**The main winding of these motors is connected directly to the mains whilst the auxiliary winding is connected by means of a capacitor. The current which flows through the auxiliary winding is therefore phase-displaced with regard to the current of the main winding. The windings yield a rotating field which enables the motor to start on its own.**

**Rotational direction reversal, as in the case of a three-phase motor, becomes possible through a directional change of the rotating field. This ensues by altering one of the two current directions in the windings, that is to say by varying the connections of one of the two windings.**

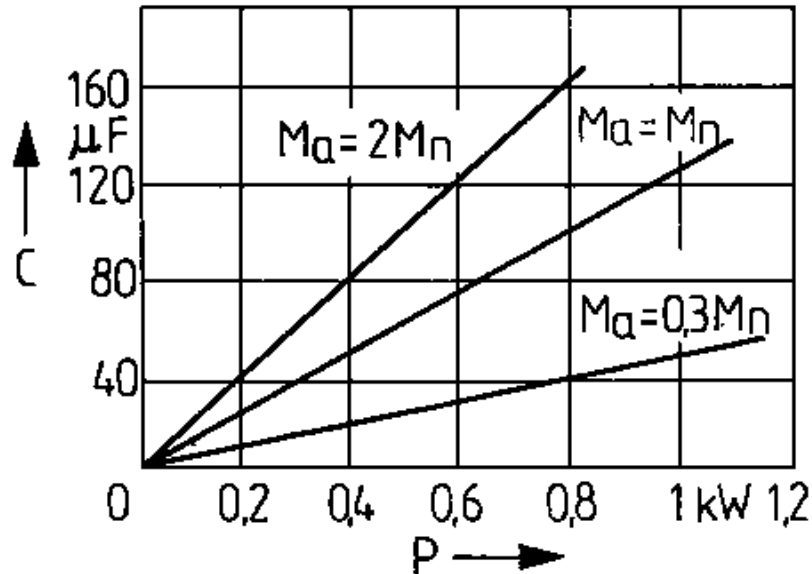
### **Motor with starting capacitor**

**Following successful starting the auxiliary winding is disconnected from the mains through a current-dependent, auxiliary contactor or by means of a centrifugal switch positioned on the motor shaft (Figure 113(1)). As a result this motor behaves no differently than a motor without auxiliary winding.**

**Motors with starting capacitors can develop powerful torques**

whereby the starting current does not exceed three to five times the rated current.

Recommended values for rating the starting capacitor for a 220 V motor are featured in Figure 114.



**Figure 114 - Magnitude of the starting capacitor C related to motor power P and starting torque  $M_a$**

## **Motor with operating capacitor**

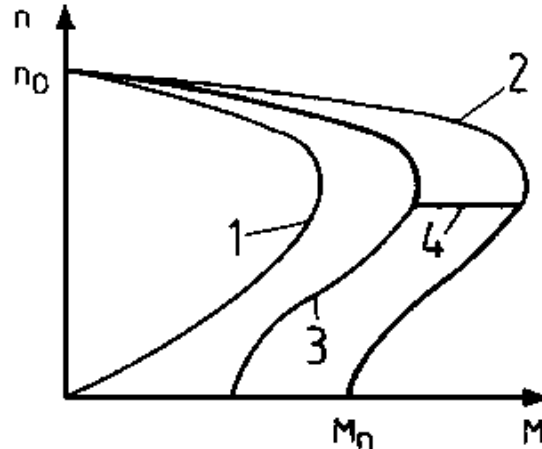
**One refers to a motor with operating capacitor (Figure 113(2)) where the capacitor and, thus, also the auxiliary winding both remain permanently switched on after starting. The capacitor has been dimensioned for rated operation; however, the motor only develops a minimal torque because of the limited capacity of this operating capacitor.**

## **Motor with starting and operating capacitors**

**The most advantageous operational behaviour of a single-phase motor is given when the auxiliary winding is connected by means of two capacitors corresponding to the capacity for starting resp. for rated operation (Figure 113(3)). Both capacitors of this so-called double capacitor motor are switched on during starting and enable the motor to develop a powerful torque. Following acceleration the capacity is reduced to that of an operating capacitor. This ensues manually, through a contactor or by means of a centrifugal force switch.**

**The rotational torque curve during starting evidences a favourable**

**sequence (curve of the motor with starting capacitor) and, in rated operation, switches to the curve of the motor with operating capacitor.**



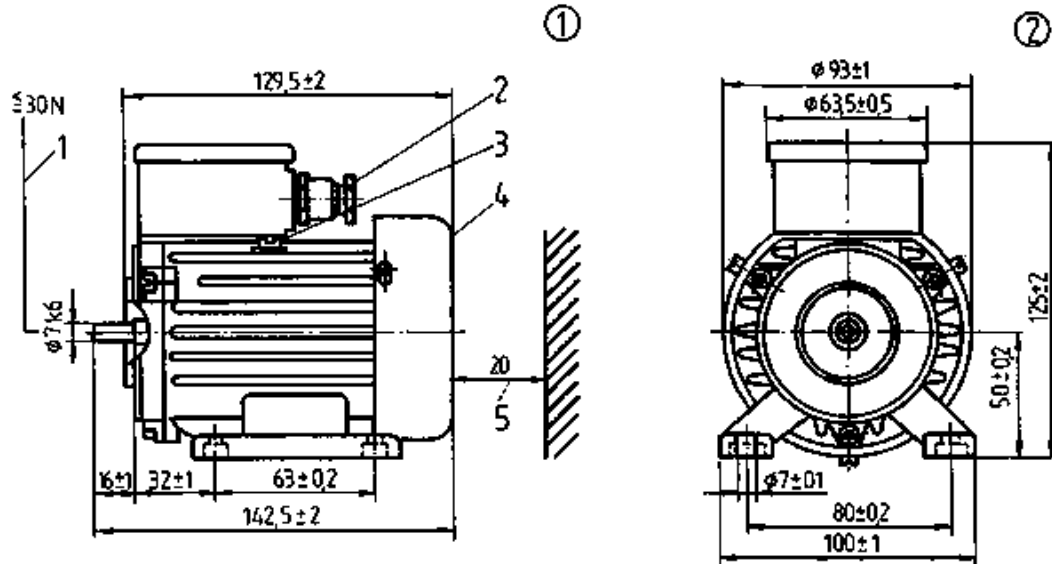
**Figure 115 - Three-phase torque curve of a single-phase asynchronous motor**

**1 Without capacitor in the auxiliary winding, 2 With starting capacitor, 3 With operating capacitor, 4 With starting and operating capacitor**

### 7.1.3. Technical data

**Several examples of technical data feature in Figures 116 and 117 and in Surveys 16 and 17.**

### Foot induction motors



**Figure 116 - Dimensional images of a foot induction motor (e.g. 65/IM 1001)**

**(1) Length side, (2) Drive side**

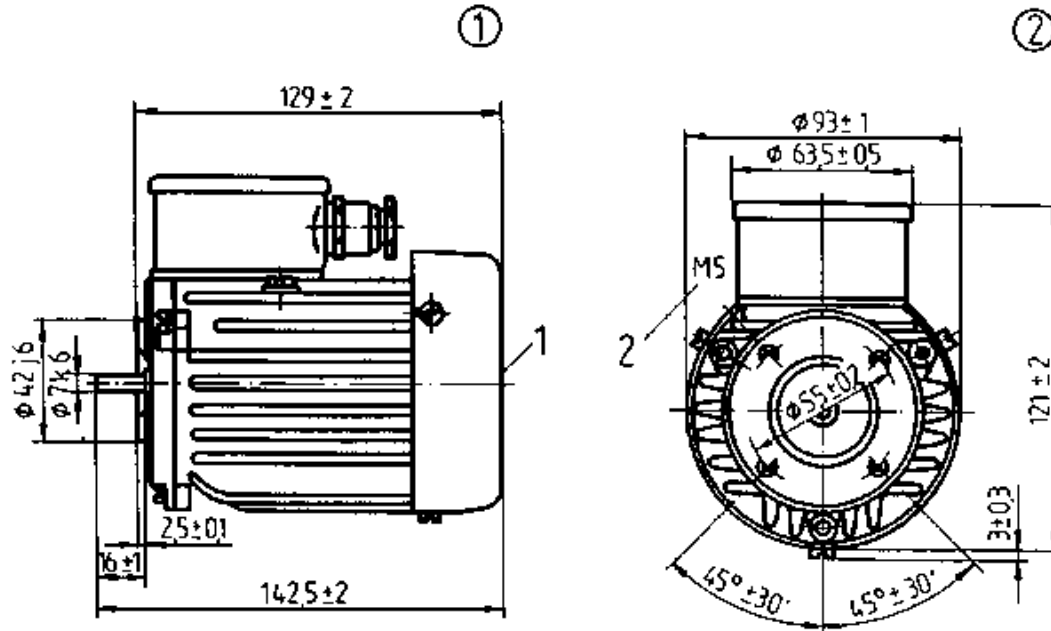
**1 Axial pressure, 2 Stop socket Pg9, 3 Protective conductor,  
4 Air entry, 5 Minimal distance**

### Survey 16 - Characteristic values of foot induction motors

<b>Design/nominal size</b>	<b>Rated voltage (Vs)</b>	<b>Rated current</b>	<b>Power input</b>	<b>Power output</b>	<b>Speed</b>
<b>-</b>	<b>V</b>	<b>A</b>	<b>W</b>	<b>W</b>	<b>rpm</b>
65/IM 1001	220	0.30	60	10	1400
		0.42	80	16	2800
1)	220/380	0.38/0.22	70	16	1400
		0.49/0.28	105	25	2800
75/IM 1001	220	0.52	100	25	1400
		0.62	125	40	2800
	220/380	0.59/0.34	110	40	1400
2)		0.73/0.42	160	60	2800

**1) C = 2 $\mu$ F 2) C = 2.5 $\mu$ F**

### Flange induction motors



**Figure 117 - Dimensional images of a flange induction motor (e.g. 75/IM 3601)**

**(1) Length side, (2) Drive side,  
1 Air entry, 2 Screw-in depth max. 12 mm**

### **Survey 17 - Characteristic values for flange induction motors**



<b>Design/nominal size</b>	<b>Rated voltage (Vs)</b>	<b>Rated current</b>	<b>Power input</b>	<b>Power output</b>	<b>Speed</b>
<b>-</b>	<b>V</b>	<b>A</b>	<b>W</b>	<b>W</b>	<b>rpm</b>
65/IM 3601	220	0.38 1)	80	16	1400
		0.50 2)	100	25	2800
	220/380	0.42/0.24	75	25	1400
		0.56/0.32	115	40	2800
75/IM 3601	220	0.58 3)	120	40	1400
		0.74 4)	150	60	2800
	220/380	0.70/0.40	150	60	1400
		1.08/0.60	200	90	2800

**1) C = 2 $\mu$ F 2) C = 3 $\mu$ F 3) C = 5 $\mu$ F 4) C = 6 $\mu$ F**

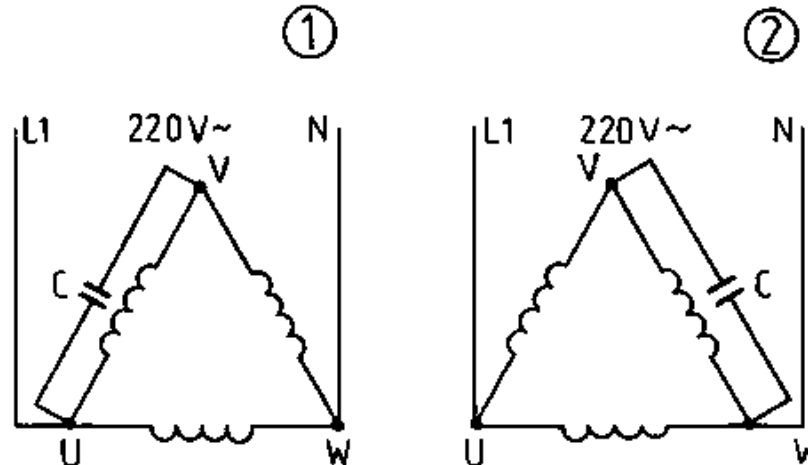
## **7.2. Three-phase asynchronous motor in single-phase operation (capacitor motor)**

### **7.2.1. Assembly and operating principle**

**A three-phase asynchronous motor whose stator winding has been**

**designed for 220/380 V may be selectively driven through either a single-phase of three-phase mains. The winding is star-connected for 380 V voltage. The winding is delta-connected for single-phase operation. In addition, an operating capacitor is parallel switched to each strand.**

**A capacitor provides phase-displaced current for the third strand winding this yielding a rotating field. The rotational direction is altered by repoling the capacitor connection.**



**Figure 118 - Three-phase asynchronous motor as capacitor motor**

## **1 Anti-clockwise, 2 Clockwise**

### **7.2.2. Operational behaviour**

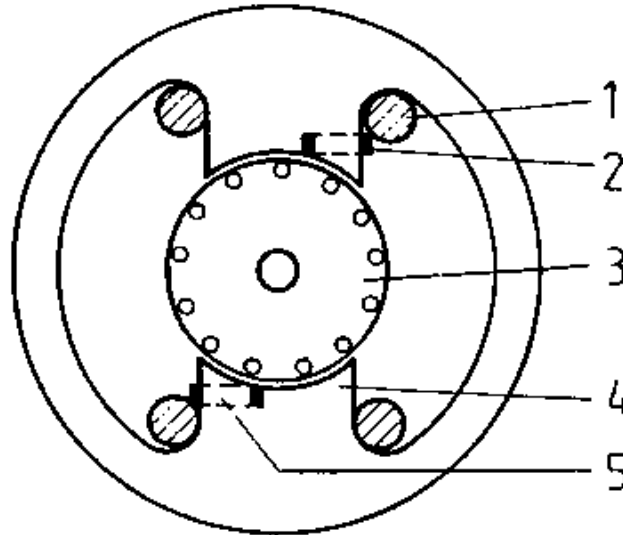
**Initial torque is only some 30 per cent of rated torque.**

**Consequently, in some cases it becomes necessary to parallel switch a starting capacitor of approx. 150 F/kW to the operating capacitor. However, because of its excessive current acceptance after starting, this operating capacitor should be switched off, for example by means of a centrifugal switch.**

**The magnitude of the operating capacitor must be selected in accordance with a motor power of some 70 F/kW and in line with voltage level.**

### **7.3. Split pole motors**

**Such a motor has pronounced poles with exciter winding in the stator in a similar manner to the direct current machine. Part of the main pole surface has been separated by a split in the pole and enclosed by a copper ring. The rotor features a squirrel cage of aluminium.**



**Figure 119 - Assembly of a split-pole motor**

**1 Exciter winding, 2 Short-circuit ring, 3 Squirrel cage rotor,  
4 Main pole, 5 Split pole**

**In principle the split pole motor is a single-phase motor with permanently switched on auxiliary winding (short-circuit ring). The exciter winding establishes an alternating field which also extends to the short-circuit ring. Thereby a voltage is induced in the short-circuit ring capable of driving a powerful current into the ring. This**

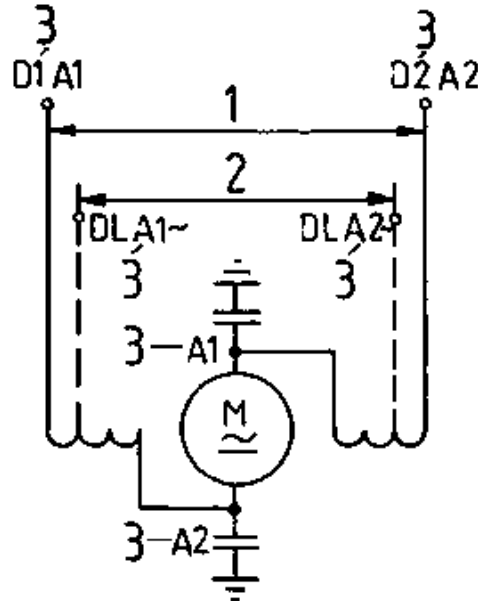
**yields an alternating field in the split pole which has not only been spatially displaced against the alternating field of the main pole, but also has a delayed action effect, that is to say is temporally shifted. The preconditions for a rotating field have been met: Interacting with the rotor induction currents, a torque is yielded which is sufficient for motor self-starting. The alternating field of the split pole interacts temporally displaced as compared to the alternating field of the main pole; this yields the rotational field direction from the main to the split pole. The field direction of rotation is thus constructionally conditioned. A directional change in the rotating field and, thereby, rotational direction reversal of the rotor is not possible with split pole motors. In view of the substantial copper loss in the squirrel ring, the efficiency of these motors is extremely limited (20 to 40%). Consequently, the motors can only operate economically up to a power of approx. 2 kW. Their starting current seldom exceeds twofold rated current.**

## **7.4. Single-phase commutator motors (universal motors)**

### **7.4.1. Assembly**

**A universal motor can be driven both by single-phase and direct**

**current voltage. Both assembly and circuitry correspond to direct current series motors.**



**Figure 120 - Circuitry of a universal motor with interference suppression capacitor**

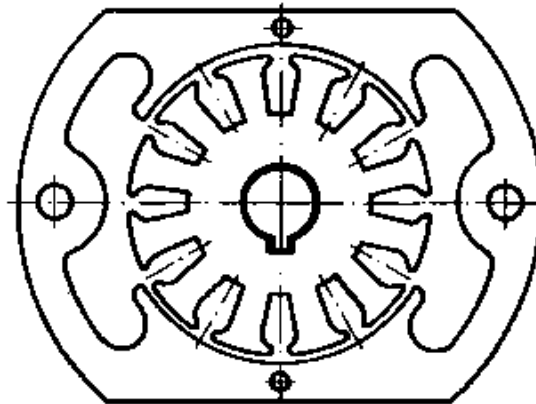
**1 Direct current**

**2 Alternating current**

### 3 Terminal designations

**Because of the low power and subsequent minimal incidence of commutator sparking, universal motor stators dispense with interpole and compensation windings.**

**Figure 121 shows the lamella section of a universal motor. The exciter windings, also known as pole or field coils, have been positioned on the pole core.**



**Figure 121 - Lamella form of a universal motor**

#### 7.4.2. Operating principles

**The rotational direction of a direct current motor changes either when the rotor current  $I_2$  changes its direction ( $-M = C \cdot \Phi \cdot (-I)$ ) or the exciter current alters in the exciter winding ( $-M = C \cdot (-\Phi_1) \cdot I_2$ ).**

**Where both values change, which corresponds to exchanging the conductor mains of a direct current series motor, then the motor retains its rotational direction:**

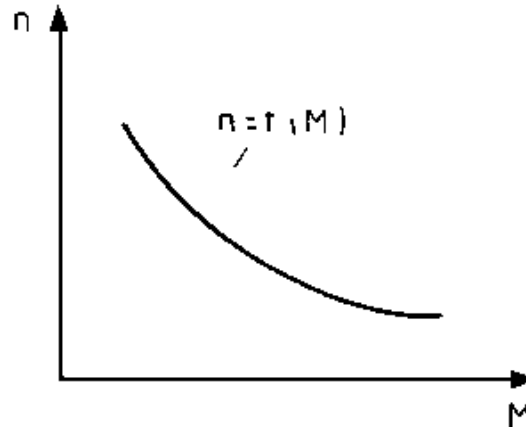
$$M = C \cdot (-\Phi_1) \cdot (-I_2)$$

**Therefore a single-phase commutator motor also operates in case of alternating voltage.**

### **7.4.3. Operational behaviour**

**The value of the yielded torque is also determined in universal motors by means of the general motor equation. As in the case of the direct current series motor, a considerable torque is developed at low speed. Figure 122 depicts the speed-torque curve.**





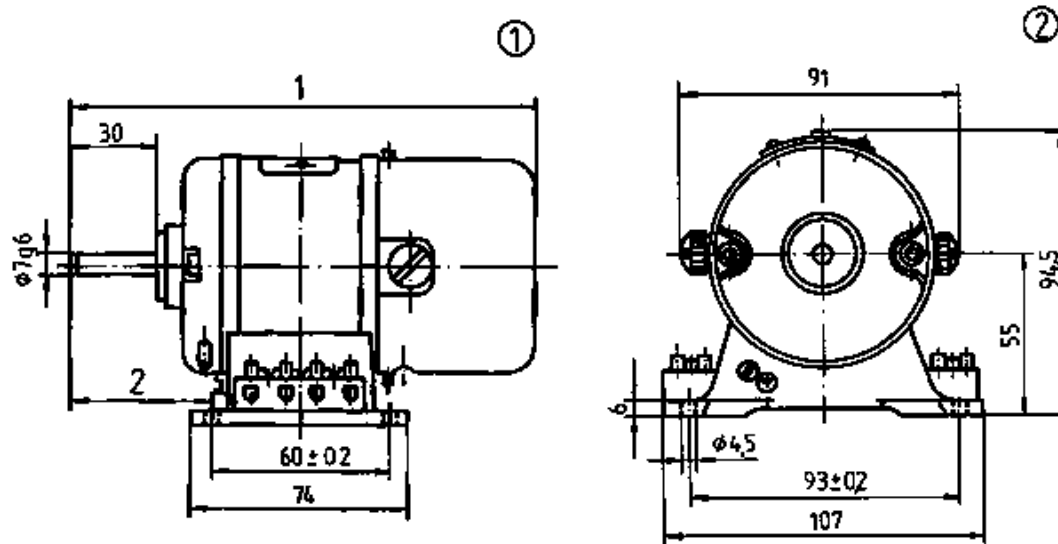
**Figure 122 - Speed-torque curve of the universal motor**

**As universal motors may be driven by either direct or alternating voltage, it is necessary to heed that the inductive resistance is absent during direct voltage connection. Given alternating voltage connection there is rather more brush sparking because of commutator current change and alternating voltage current direction change. Pole gaps remain small in the rotor field and brush sparking is within acceptable limits. The disruptive effect of brush sparking on radio reception can be eliminated by switching on capacitors (Figure 120).**

**The circuitry also indicates that, when direct voltage is connected, the number of turns at like voltage and speed have to be increased as compared to alternating voltage feeding. The greater number of turns compensates for the lacking resistance. Although inrush current is greater than rated current there is no likelihood that small motor power might be impaired through disruptive mains overloading. A rotational direction change can be attained in universal motors by switching over the winding at the terminal board. However, where field and armature windings have been soundly connected in series, rotational direction change is not possible. Universal motors are especially suitable for electrical small tools, household equipment and office machinery. Such motors also figure in hoovers, coffee machines and drills.**

#### **7.4.4. Technical data**

##### **Foot commutator motors**



**Figure 123 - Dimensional images of a foot commutator motor (e.g. 70/IM 1001)**

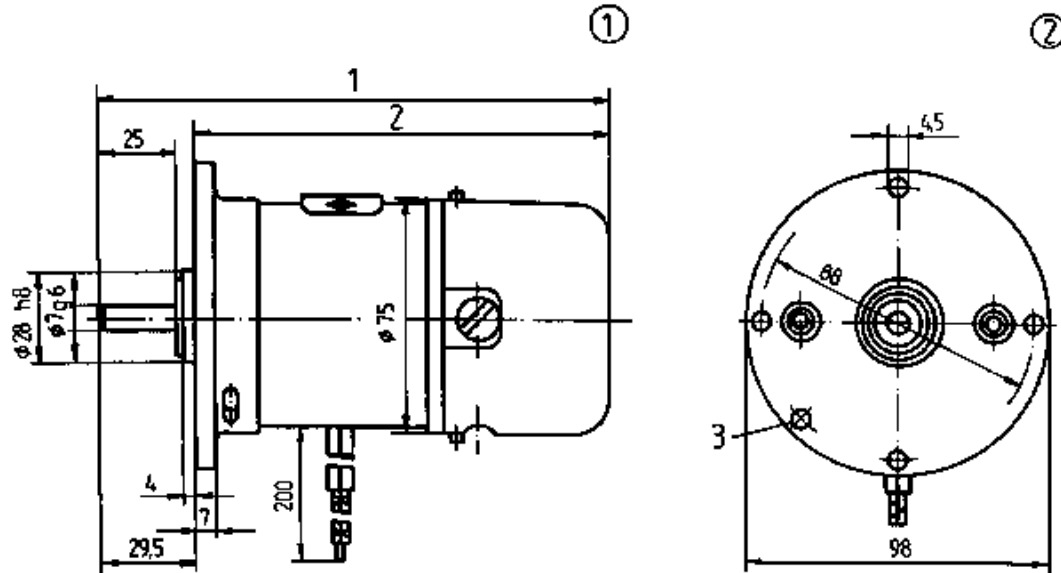
**(1) Length side, (2) Drive side, 1;2 Variable**

### Survey 18 - Characteristic values of foot commutator motors

<b>Design/nominal size</b>	<b>Rated current</b>	<b>Rated speed</b>	<b>Power input</b>	<b>Power output</b>
	<b>A</b>	<b>rnm</b>	<b>W</b>	<b>W</b>

70/IM 1001	0.2	3000	30	12
	0.15	3000	27.5	16
	0.11	5000	25	12
	0.27	5000	48	25
87/IM 1001	0.26	3000	57	25
	0.48	3000	85	40
	0.55	3000	92	50
	0.45	5000	95	40
	0.36	5000	140	80
	0.78	8000	165	100
	1.1	8000	210	125
119/IM 1001	1.2	3000	180	125
	1.7	5000	300	200
	2.2	8000	450	320

## Flange commutator motors



**Figure 124 - Dimensional images of a flange commutator motor (e.g. 70/IM 3001)**

**(1) Length side, (2) Drive side, 1;2 Variable, (3) Earthing screw**

### **Survey 19 - Characteristic values of flange commutator motors**

<b>Design/nominal</b>	<b>Rated</b>	<b>Rated</b>	<b>Power</b>	<b>Power</b>
-----------------------	--------------	--------------	--------------	--------------

<b>size</b>	<b>current</b>	<b>speed</b>	<b>input</b>	<b>output</b>
	<b>A</b>	<b>rpm</b>	<b>W</b>	<b>W</b>
70/IM 3001	0.2	3000	30	12
	0.15	3000	27.5	16
	0.11	5000	25	12
	0.27	5000	48	25
87/IM 3001	0.26	3000	57	25
	0.48	3000	85	40
without terminal boxes	0.45	5000	95	40
	0.78	8000	165	100
87/IM 3001	0.55	3000	92	50
with terminal boxes	0.63	5000	140	80
	1.1	8000	210	125
119/IM 3001	1.2	3000	180	125
	1.7	5000	300	200
	2.2	8000	450	320

## Built-in commutator motors

### Survey 20 - Characteristic values of built-in commutator motors

<b>Design/nominal size</b>	<b>Rated voltage (Vs)</b>	<b>Rated current</b>	<b>Power input</b>	<b>Power output</b>	<b>Speed</b>
	<b>V</b>	<b>A</b>	<b>W</b>	<b>W</b>	<b>rpm</b>
Nominal sizes	220	0.6	105	50	3000
		0.72	125	63	3000
		0.86	165	80	3000
87/IM 5001		0.85	150	80	5000
		1.0	175	100	5000
		1.2	200	125	5000
		1.2	235	125	8000
		1.3	260	160	8000
		1.65	315	200	8000
Nominal sizes	220	0.13	24	6	3000
		0.17	28	8	3000

		0.20	31	10	3000
52/IM 5001		0.18	37	10	5000
		0.18	39	12	5000
		0.25	47	16	5000
		0.24	49	16	8000
		0.30	55	20	8000
		0.29	58	25	8000

### Questions for repetition and control

- 1. How does a single-phase induction motor generate its rotating field?**
- 2. Explain the operation of a three-phase asynchronous motor through a single-phase mains.**
- 3. Explain the efficiency principles of the universal motor torque.**
- 4. What must be heeded if a motor which had been connected to the alternating voltage mains, is to be driven by direct current?**



21/10/2011

Electrical Machines - Basic vocational k...

