

Electrician 1st Year – Transparencies

Table of Contents

Electrician 1st Year – Transparencies	1
<u>Artificial respiration – Nelson’s Arm–lift back–Pressure Method</u>	1
<u>Artificial Respiration – Scaffer’s Method</u>	2
<u>Artificial respiration – Silvester’s Method</u>	3
<u>Artificial respiration – Mouth to mouth Method</u>	4
<u>Parts of a moving coil instrument</u>	5
<u>Parts of a moving iron instrument</u>	6
<u>Parts of a D.C. Machine</u>	7
<u>Multimeter – 1</u>	8
<u>Multimeter – 2 Zero adjustment</u>	10
<u>Current Carrying conductor in magnetic field</u>	11
<u>Three point starter</u>	13
<u>Four point starter</u>	14
<u>Pipe earthing</u>	16
<u>Plate earthing</u>	17
<u>Micrometer parts and graduations</u>	18
<u>Internal connections of the Megger (Insulation tester)</u>	18
<u>Rotating magnetic field from a three–phase stator</u>	19
<u>Single phase energy meter – Induction type</u>	19
<u>Test on domestic wiring installation – Continuity test</u>	20
<u>Test on domestic wiring installation – Insulation resistance test between conductors</u>	22
<u>Test on domestic wiring installation – Insulation resistance test between conductors and earth</u>	22
<u>Test on domestic wiring installation – Polarity test</u>	23
<u>Generation of AC</u>	24
<u>Parts of a universal motor</u>	25
<u>Resistor colour coding</u>	26

Electrician 1st Year – Transparencies



**CENTRAL INSTRUCTIONAL
MEDIA INSTITUTE, CHENNAI**

Directorate General of Employment and Training, Ministry of Labour, Govt. of India.

Developed by

CENTRAL INSTRUCTIONAL MEDIA INSTITUTE

P.O. Box 3142, CTI Campus, Guindy, Chennai – 600 032. Phone: 2233 4248, 2234 5257 Fax: (0091–44)
2234 2791

Artificial respiration – Nelson’s Arm–lift back–Pressure Method

– Place victim prone (that is, face down) with his arms folded with the palms one over the other and the head resting on his cheek over the palms. Kneel on one or both knees at victim’s hand. Place your hands on the victim’s back beyond the line of armpits, with your fingers spread outwards and downwards, thumbs just touching each other as shown.

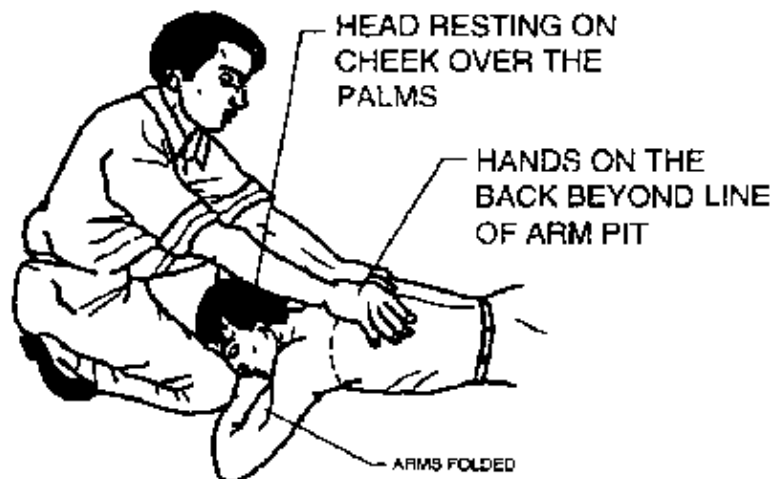

– Gently rock forward keeping arms straight until they are nearly vertical thus steadily pressing the victim’s back as shown to force the air out of the victim’s lungs.



– Synchronizing the above movement rock backwards, releasing pressure and slide your hands downwards along the victim's arms and grasp his upper arm just above the elbows as shown. Continue to rock backwards.



– As you rock back, gently raise and pull the victim's arms towards you as shown until you feel tension in his shoulders. To complete the cycle, lower the victim's arms and move your hands up or to initial position.

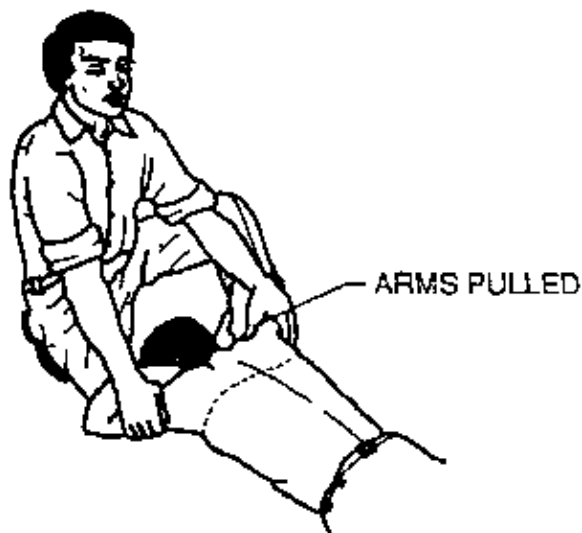

Artificial Respiration – Scaffer's Method

Lay the victim on his belly, one arm extended directly forward, the other arm bent at the elbow and with the face turned sideward and resting on the hand or forearm as shown.

Kneel astride the victim, so that his thighs are between your knees and with your fingers and thumbs positioned as shown.

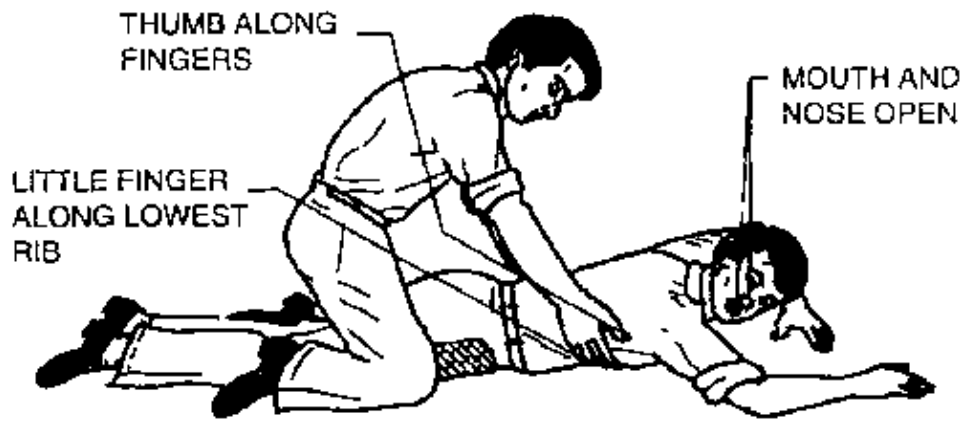

With the arms held straight, swing forward slowly so that the weight of your body is gradually brought to bear upon the lower ribs of the victim to force the air, out of the victim's lungs as shown.

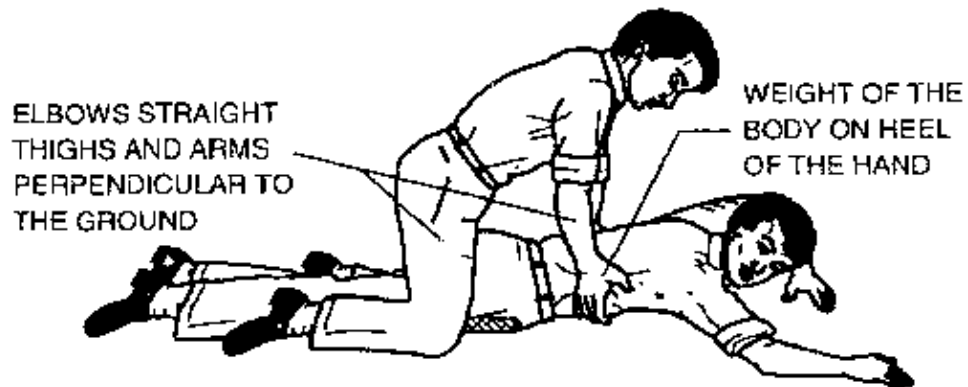

Now immediately swing backward removing all the pressure from the victim's body as shown and thereby allowing the lungs to fill with air.

After two seconds, swing forward again and repeat the cycle twelve to fifteen times a minute.

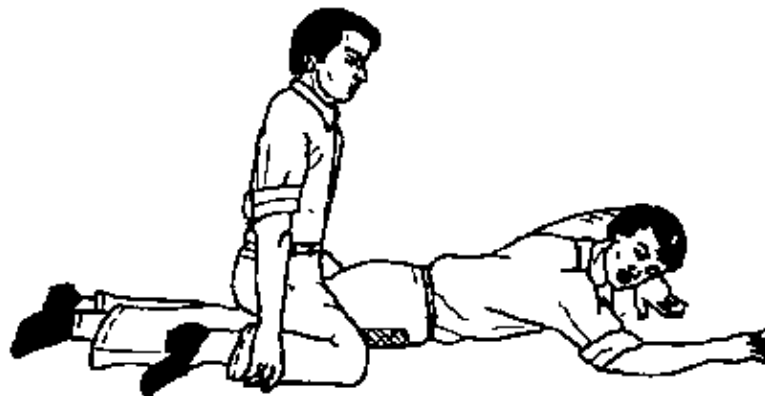

Artificial respiration – Silvester's Method

To be used if the victim cannot lie on his belly or chest due to injury.

– Lay the victim flat on his back and place a roll of clothing under his shoulders to ensure that his head is thrown well back.

– Wipe saliva out of his mouth: Pull the tongue forward and towards the chin and hold it in this position if there is an assistant if not, tie it with a strip of cloth, cross the strip under the chin, and tie below the neck to prevent the tongue from blocking the wind pipe.

- Kneel over the Victim's head and grasp his arms above the wrist as shown.
- Swing forward and press his arms steadily and firmly downwards and inwards against the sides of the chest to force the air out of the lungs as shown.
- Bring the victim's arms steadily first upward and then backwards until they are in line with the body and the elbows are almost touching the floor as shown, this allowing the lungs to fill the air.
- After three seconds, swing forward again and repeat the cycle. The complete cycle should take about six seconds.

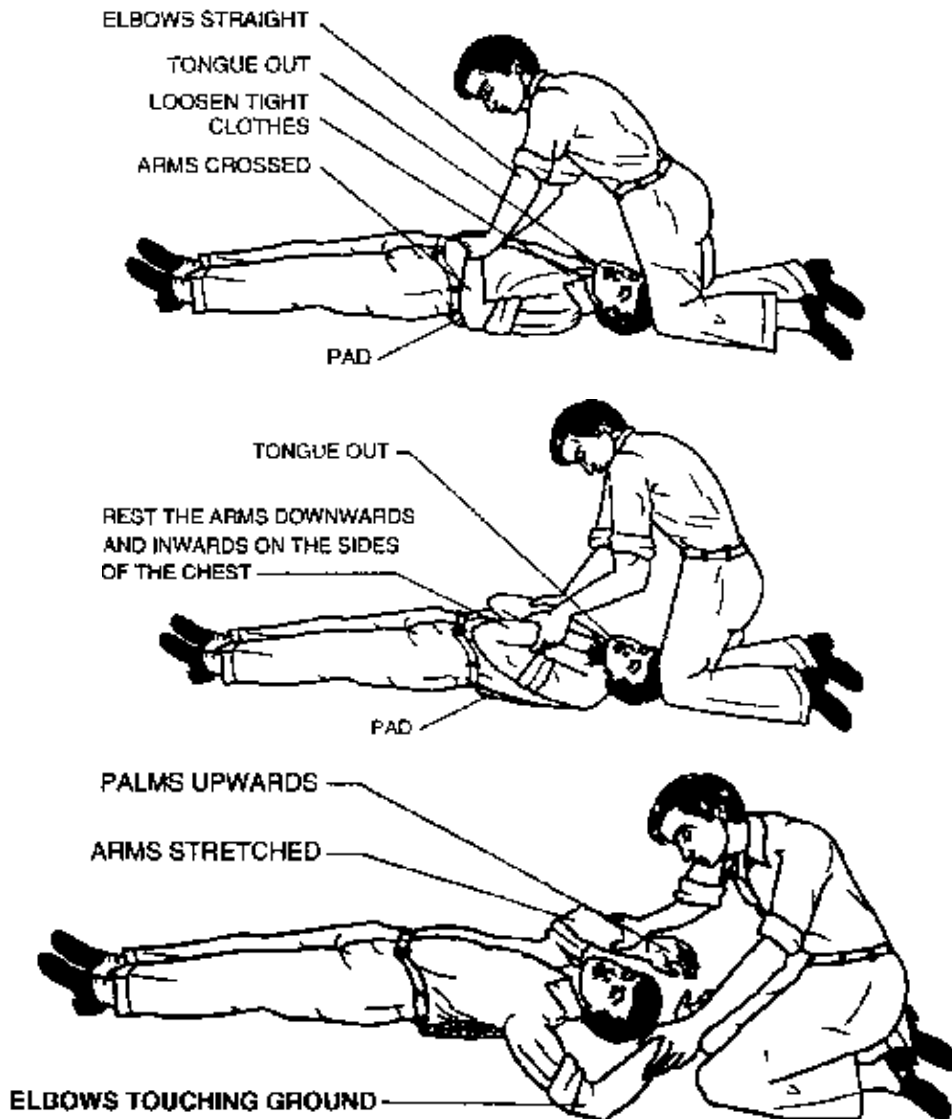

Artificial respiration – Mouth to mouth Method

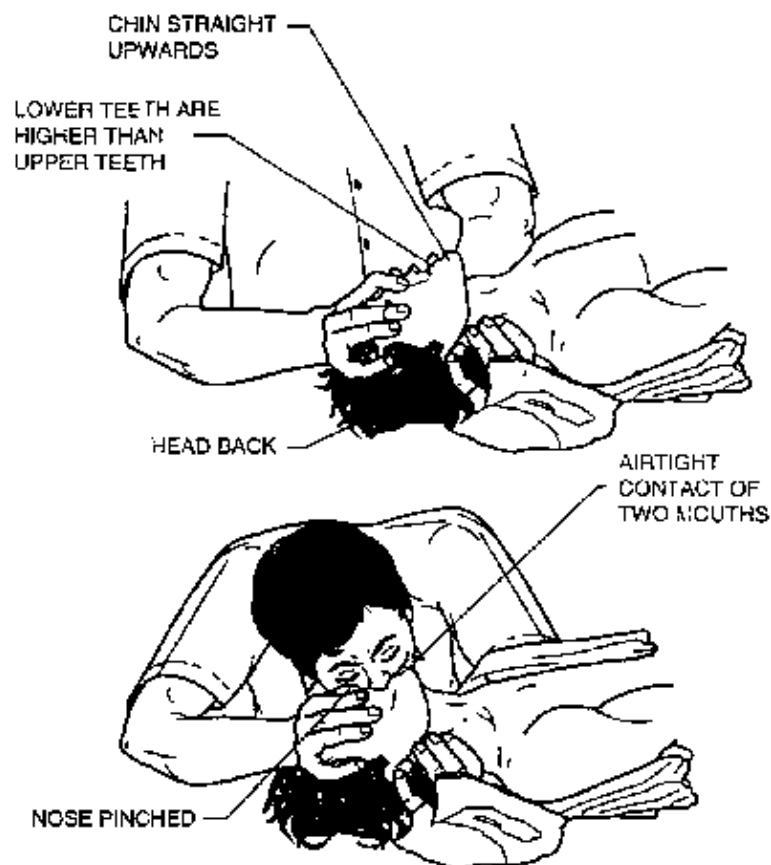

– Lay the victim flat on his back and place a roll of clothing under his shoulders to ensure that his head is thrown well back. Tilt the victim's head back so that the chin points straight upward.

– Grasp victim's jaw as shown and raise it upward until lower teeth are higher than upper teeth; or place fingers on both sides of jaw near ear lobes and pull upward. Maintain jaw position throughout the artificial respiration to prevent tongue from blocking the air passage.

– Take a deep breath and place your mouth over victim's mouth as shown making airtight contact. Pinch the victim's nose shut with thumb and fore finger. If you dislike direct contact, place a porous cloth between your and victim's mouth. For an infant, place your mouth over its mouth and nose.

– Blow into victim's mouth (gently in the case of an infant) until his chest rises. Remove your mouth and release the hold on the nose, to let him exhale, turning your head to hear out-rush of air. The first 8 to 10 breaths should be as rapid as victim responds, thereafter rate should be slowed to about 12 times a minute (20 times for an infant).

Note:

(a) If air cannot be blown in, check position of victim's head and jaw and re-check mouth for obstructions, then try again more forcefully. If chest still does not rise, turn victim's face down and strike his back sharply to dislodge obstructions.

(b) Sometimes air enters Victim's stomach evidenced by swelling stomach. Expel air by gently pressing stomach during exhalation period.

Parts of a moving coil instrument

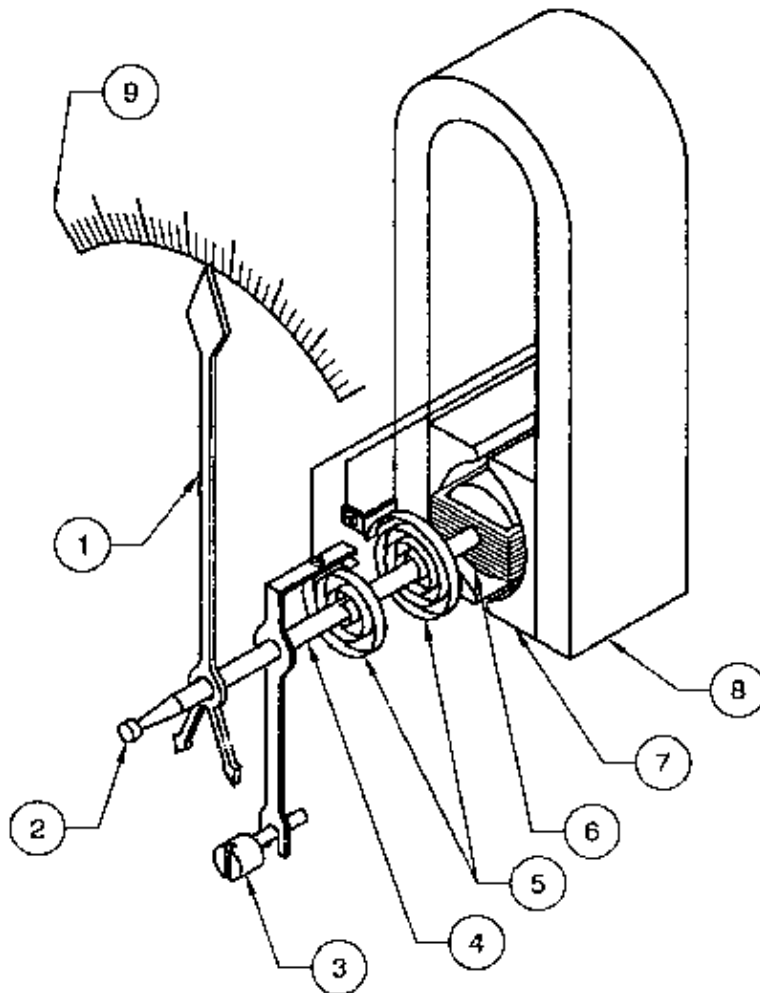

- 1 Pointer
- 2 Jewel bearing
- 3 Zero adjustment screw
- 4 Spindle
- 5 Phosphor Bronze springs
- 6 Moving coil
- 7 Pole shoe
- 8 Horse Shoe magnet
- 9 Graduated scale

Moving coil (6) which is free to move with help of spindle (4) and the bearing (2) is kept in the magnetic field produced by the horse shoe magnet (8) and the pole shoes (7)

When a current proportional to the electrical quantity to be measured is passed through the moving coil (6), it produces a magnetic field which interacts with the main field produced by the magnet (8) and a force is developed. This force moves the moving coil (6), there by the spindle (4) attached to the coil (6) moves. This enables the pointer (1) attached to the spindle (4) to moves over the graduated scale (9).

As the flux is constant due to the permanent magnet (8), the torque becomes proportional to the current. Because of this, the graduation of the scale is uniform. Only used in D.C. quantitative measurement.

Parts of a moving iron instrument

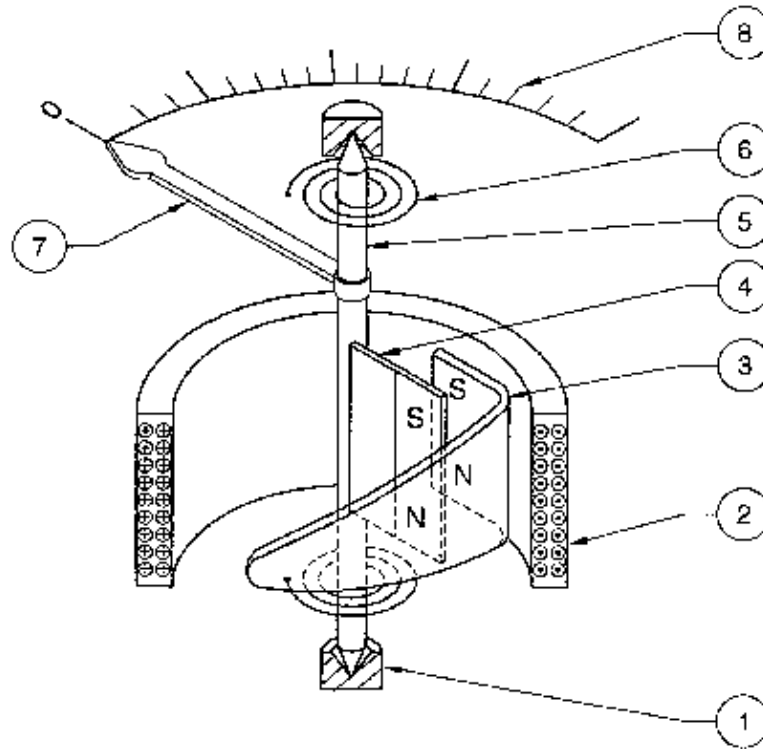

- 1 Jewel bearing
- 2 Electro magnetic coil
- 3 Fixed iron vane
- 4 Moving iron vane
- 5 Spindle
- 6 Control spring
- 7 Pointer
- 8 Graduated scale

The electro magnetic coils (2) carries an alternating or direct current proportional to the quantity of electricity to be measured and produces a magnetic field depending upon the type of current.

Both the fixed (3) and moving (4) iron vanes produce similar type of poles at their ends due to the magnetic field. Hence magnetic repulsion takes place and the moving vane (4) moves away from the fixed vane (3). As the moving iron vane (4) is fixed to the spindle (5) it deflects. The pointer (7) attached to the spindle (5) moves over the graduated scale (8).

Control spring (6) offers control torque, The shape of the fixed iron van (3) enables the torque developed to be proportional to the current in the coil hence the scale is more or less uniform.

Parts of a D.C. Machine

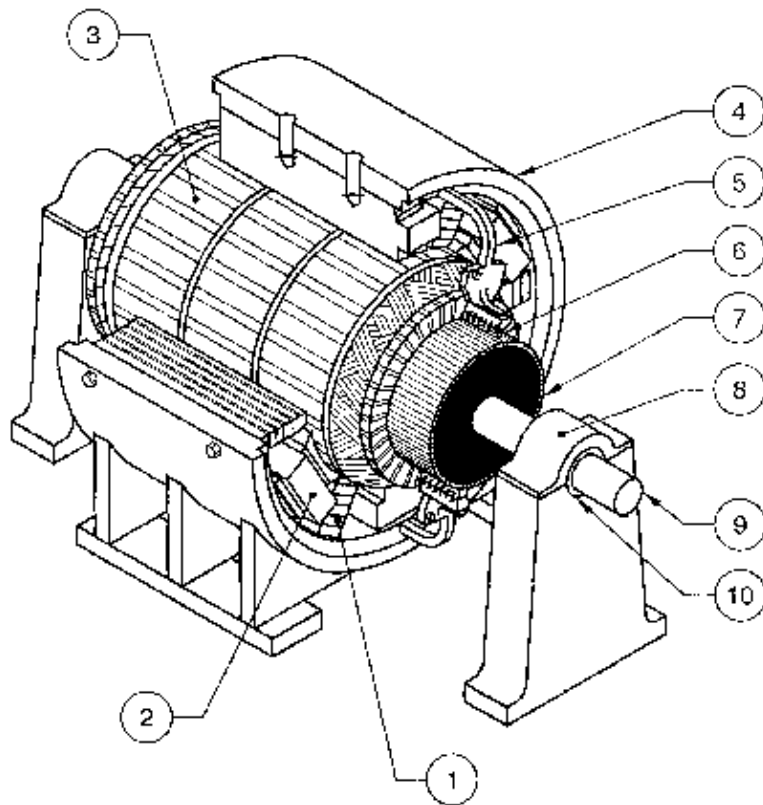

- 1 Interpole
- 2 Main pole
- 3 Armature
- 4 Main frame (Yoke)
- 5 Rocker arm
- 6 Brush holder
- 7 Commutator
- 8 Bearing housing
- 9 Shaft
- 10 Bearing

Multimeter – 1

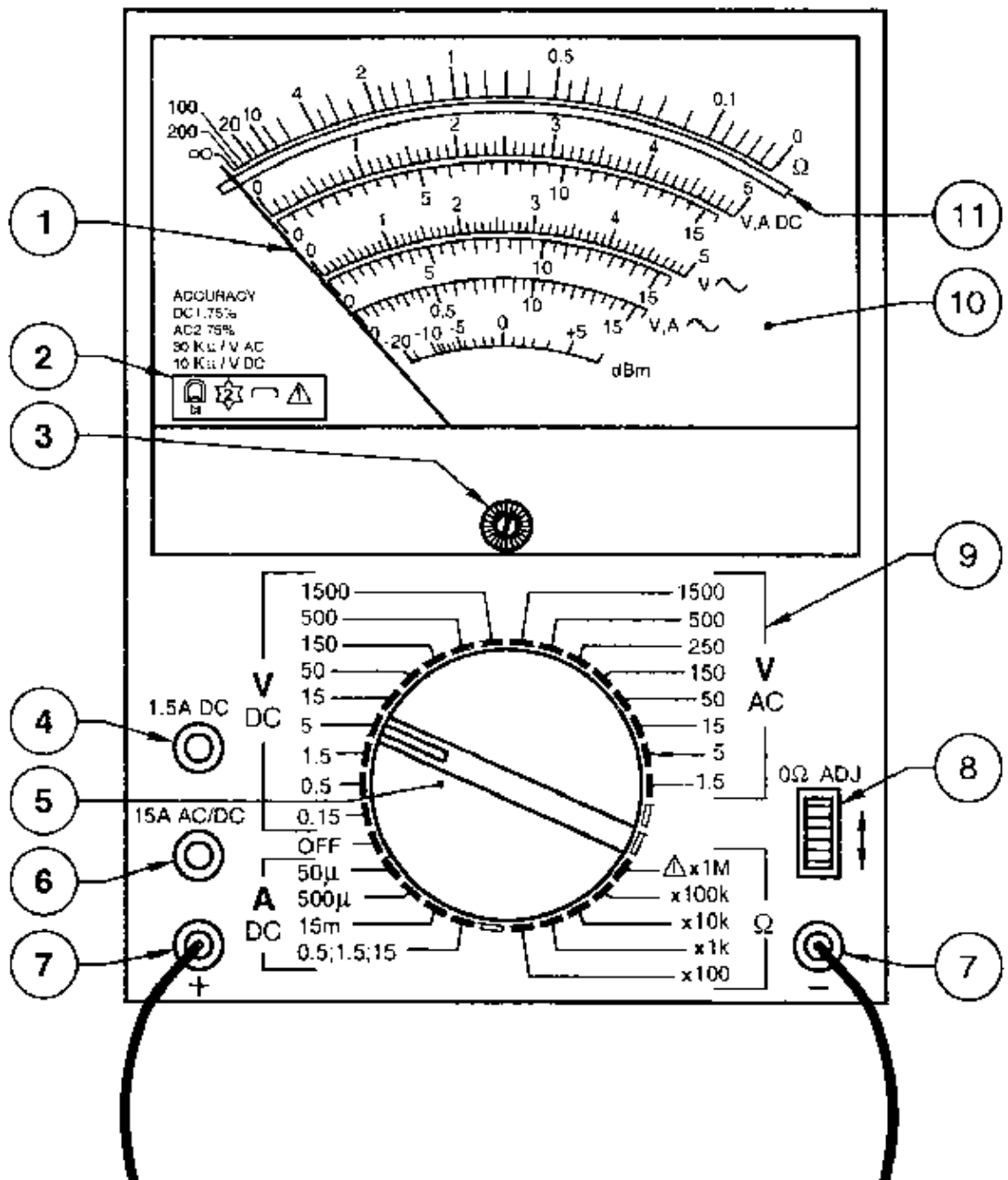

- 1 Pointer
- 2 Dial symbols

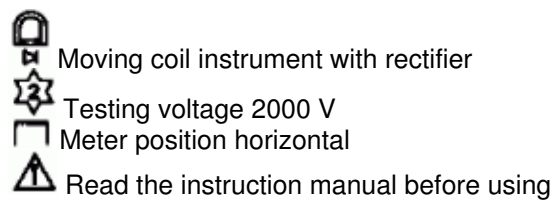

- 3 Mechanical zero adjustment
- 4 Jack 1.5 A DC
- 5 Function and range selector switch
- 6 Jack 15 A AC/DC
- 7 Input jacks

+ positive probe
 - negative probe

- 8 Zero ohm adjuster
- 9 Function and ranges
- 10 Dial scale

V.A.DC volt, and amp dial for DC
 V~ volt dial for AC
 V.A ~ volt and amp dial for AC
 dBm decibel scale

- 11 Dial scale for resistance ?

Multimeter – 2 Zero adjustment

A Mechanical Zero adjuster

Zero adjuster is a screw which adjusts the pointer to the zero position before measuring a value. Turn the screw to 1/4 of a turn maximum in either direction for zero adjustment.

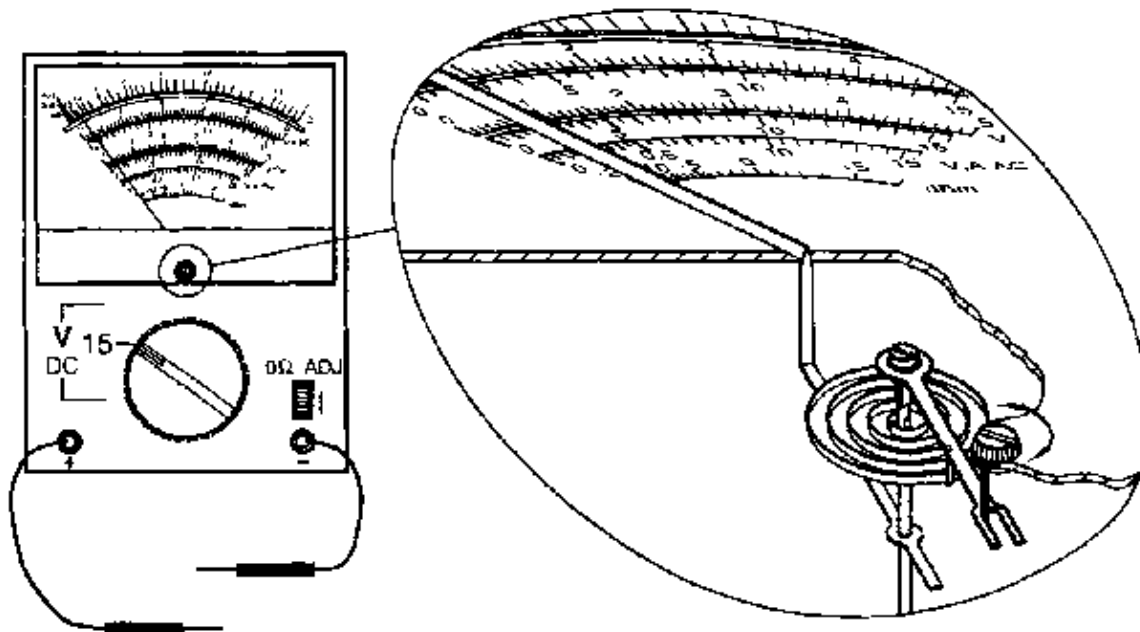

B Zero ohm adjuster

Before measuring the resistance, the pointer has to be adjusted to the zero-ohm position in the ohm's scale by touching the measuring leads together and turning the knob until the pointer shows zero -ohm value.

Whenever a new resistance range is selected, the zero - ohm position must be adjusted.

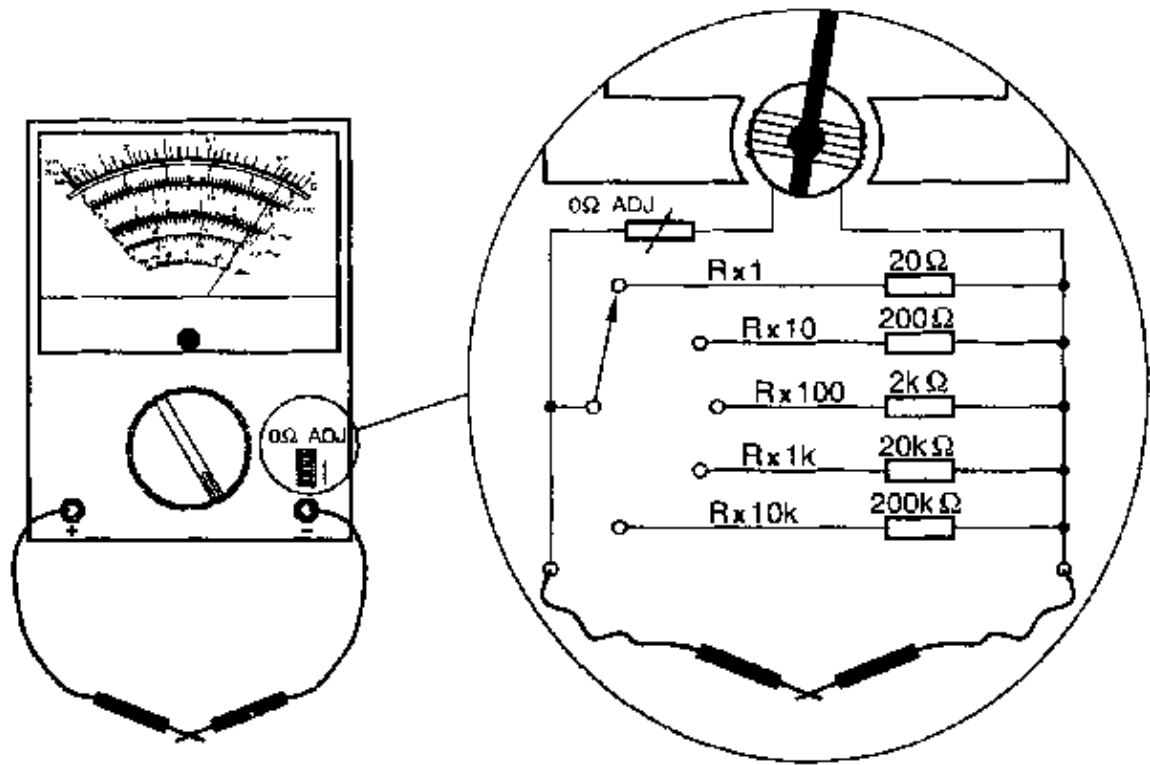

Current Carrying conductor in magnetic field

Instructor asks the trainees to:-

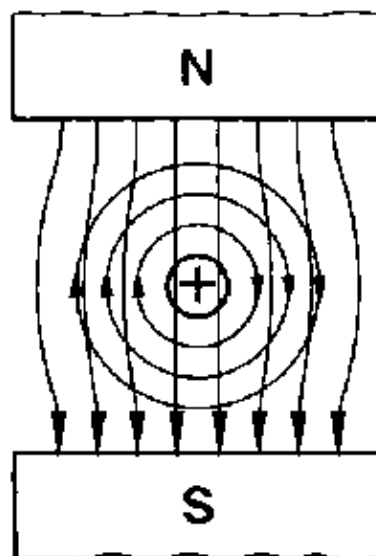

Fig A Indicate the direction of magnetic field around the current carrying conductor according to Maxwell's Corkscrew rule.

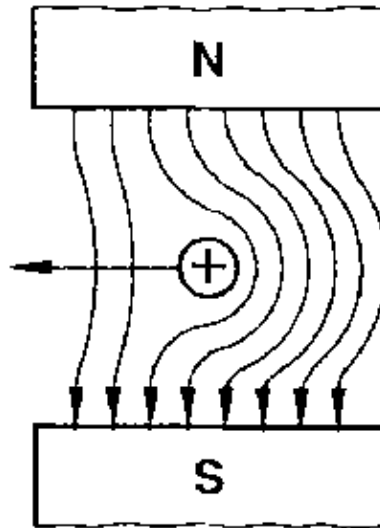

Fig B Discuss with the trainees about the resultant field and the direction of force on the conductor

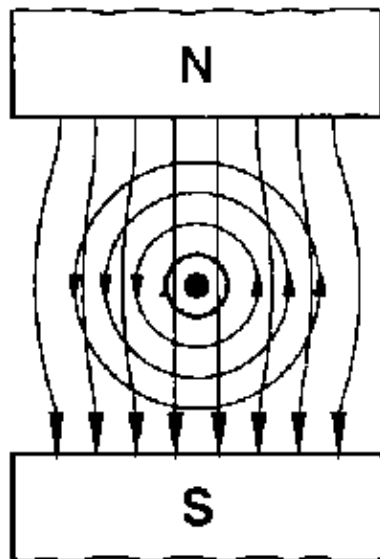

Fig C Indicate the direction of the magnetic field around the current carrying conductor

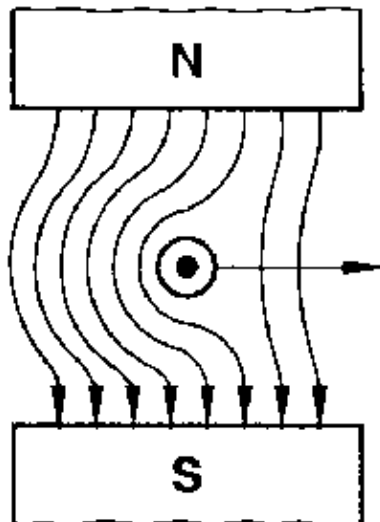

Fig D Discuss and determine the direction of force on the current carrying conductor

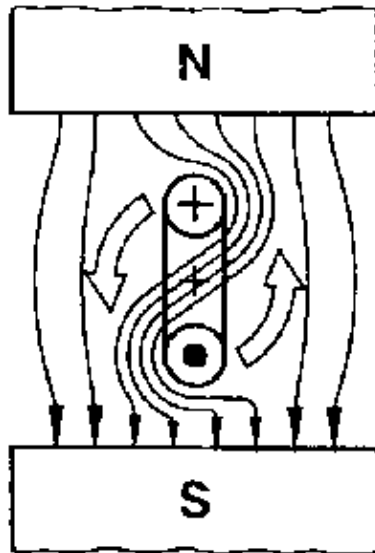

Fig E Discuss about the forces on conductor of a loop and the resultant circular motion

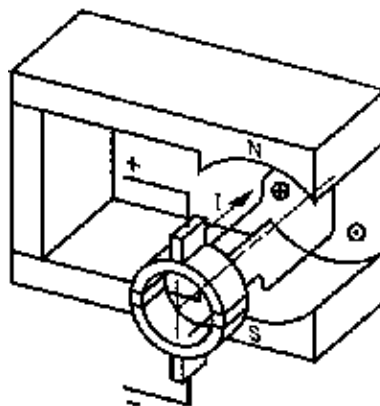
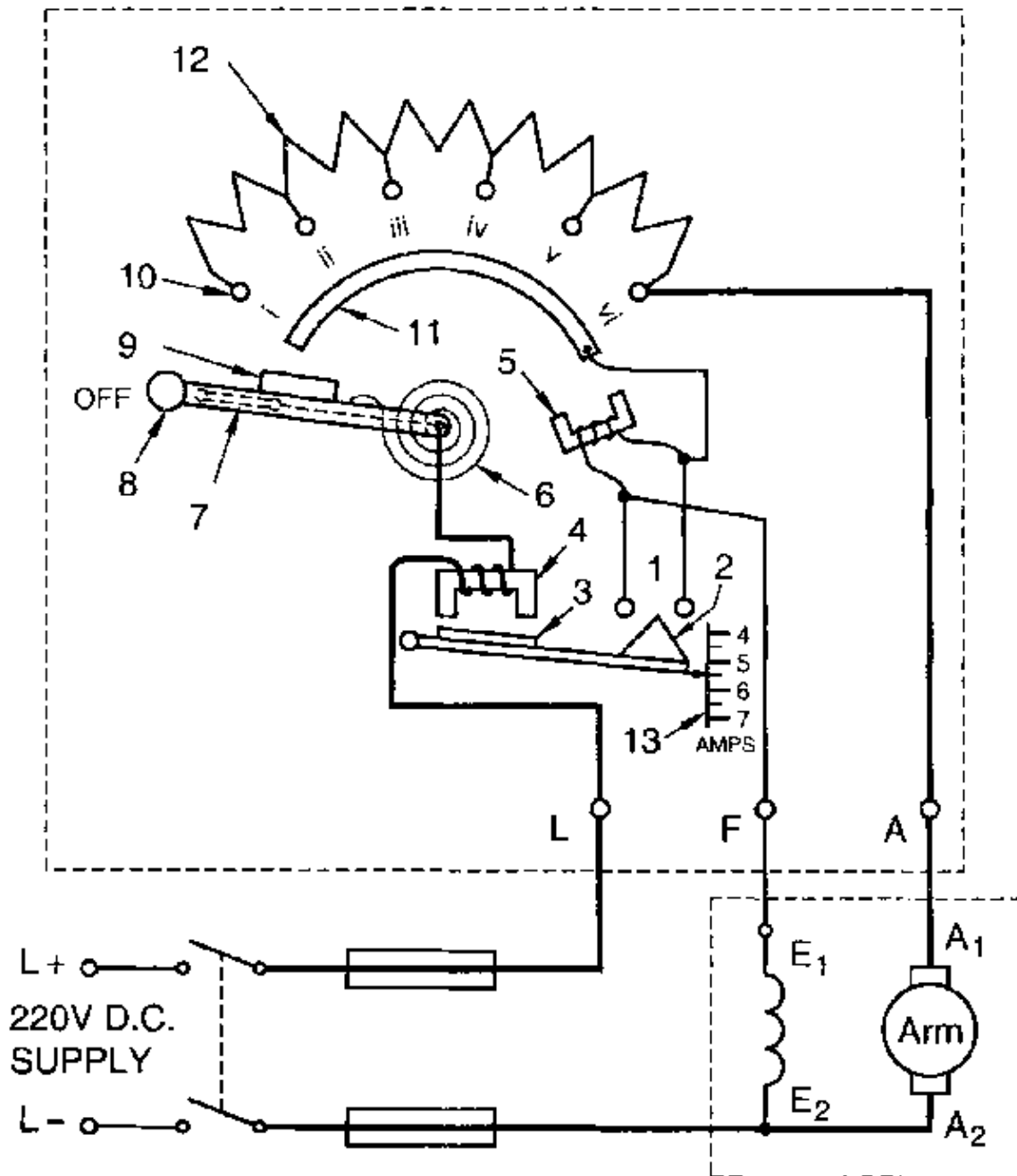

Fig F Correlate the above findings with the motor shown in Fig.

Three point starter



- 1 Hold-on coil terminals
- 2 Shorting contact of O/L armature
- 3 Keeper of the O/L relay electro magnet
- 4 O/L relay magnet
- 5 No-volt (Hold-on) coil and core
- 6 Handle spring
- 7 Shorting contact link of starter
- 8 Starter handle
- 9 Keeper of the hold-on coil electro magnet
- 10 Starter contacts
- 11 Direct contact strip for field connection
- 12 Starter Resistance (Nichrome Wire)
- 13 Overload setting

Four point starter

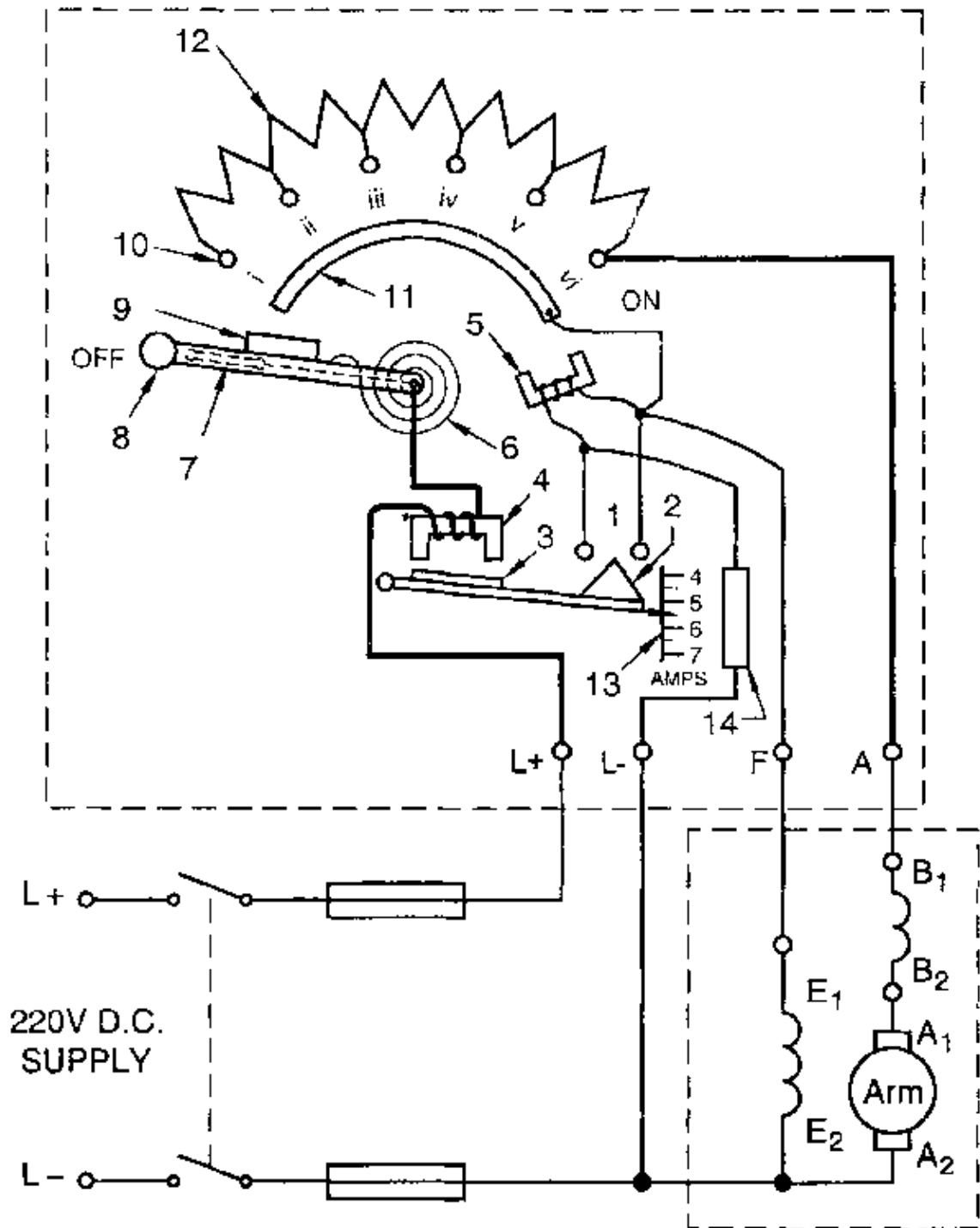

- 1 Hold-on coil terminals
- 2 Shorting contact of O/L armature
- 3 Keeper of the O/L relay electro-magnet
- 4 O/L relay electro-magnet
- 5 No-volt (hold-on) coil and core
- 6 Handle spring
- 7 Shorting contact link of starter
- 8 Starter handle
- 9 Keeper of the hold-on coil electro magnet
- 10 Starter contacts
- 11 Direct contact strip for the field connection
- 12 Starter resistance (Nichrome wire)
- 13 Over load settings
- 14 Series resistance

Pipe earthing

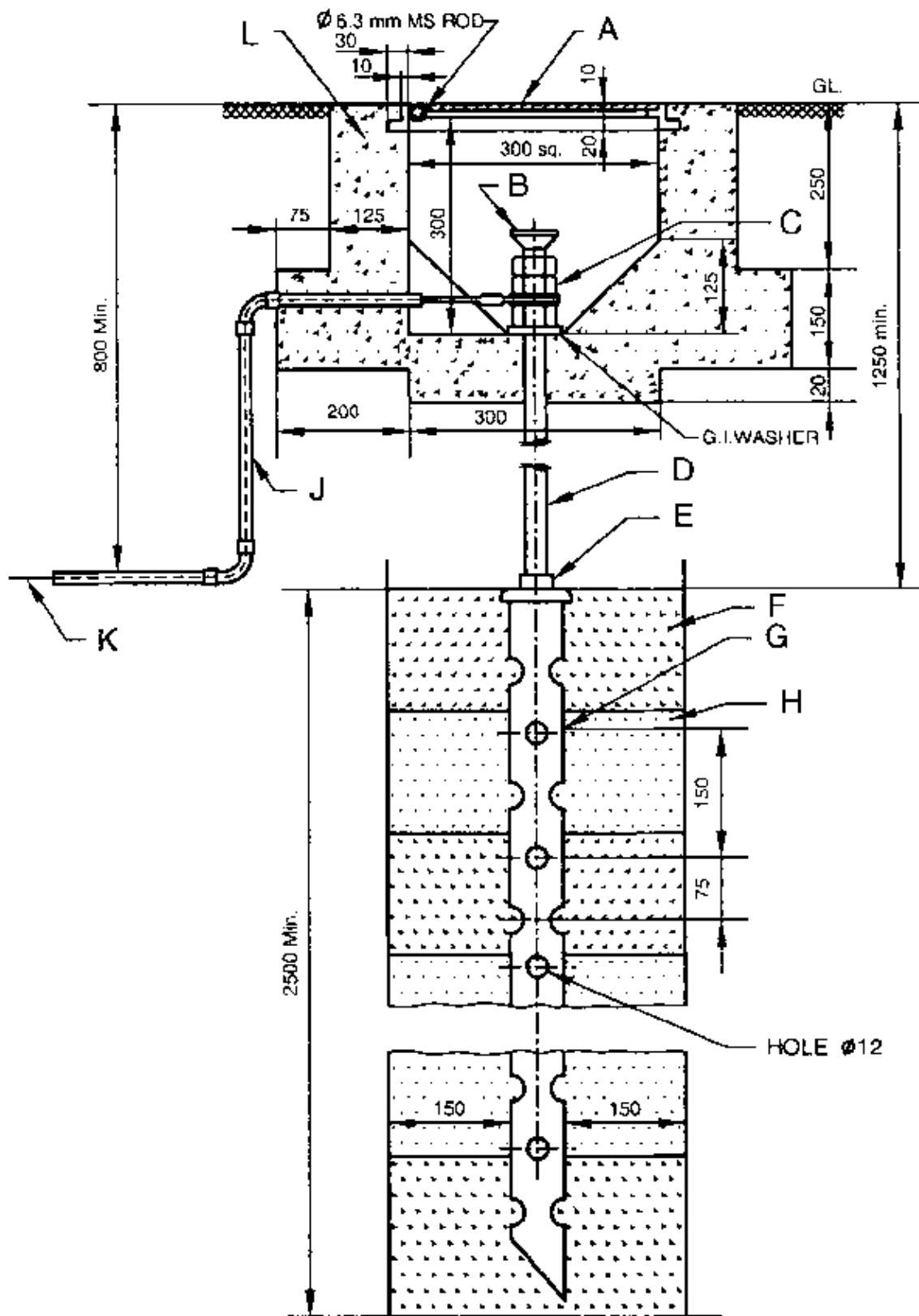

NOTE: DIMENSIONS ARE IN mm UNLESS OTHERWISE SPECIFIED.

- A – C.I. Cover hinged to C.I. frame
- B – Funnel with Wire Mesh
- C – G.I. Nut and Check nut
- D – 19 mm G.I. Pipe
- E – 38 x 19 mm reducing socket.
- F – Charcoal Layer

- G – 38 mm G.I. pipe (earth electrode)
- H – Salt layer
- J – 12.7 mm G.I. pipe
- K – Copper or GI wire (Main earth lead)
- L – Cement Concrete

Plate earthing

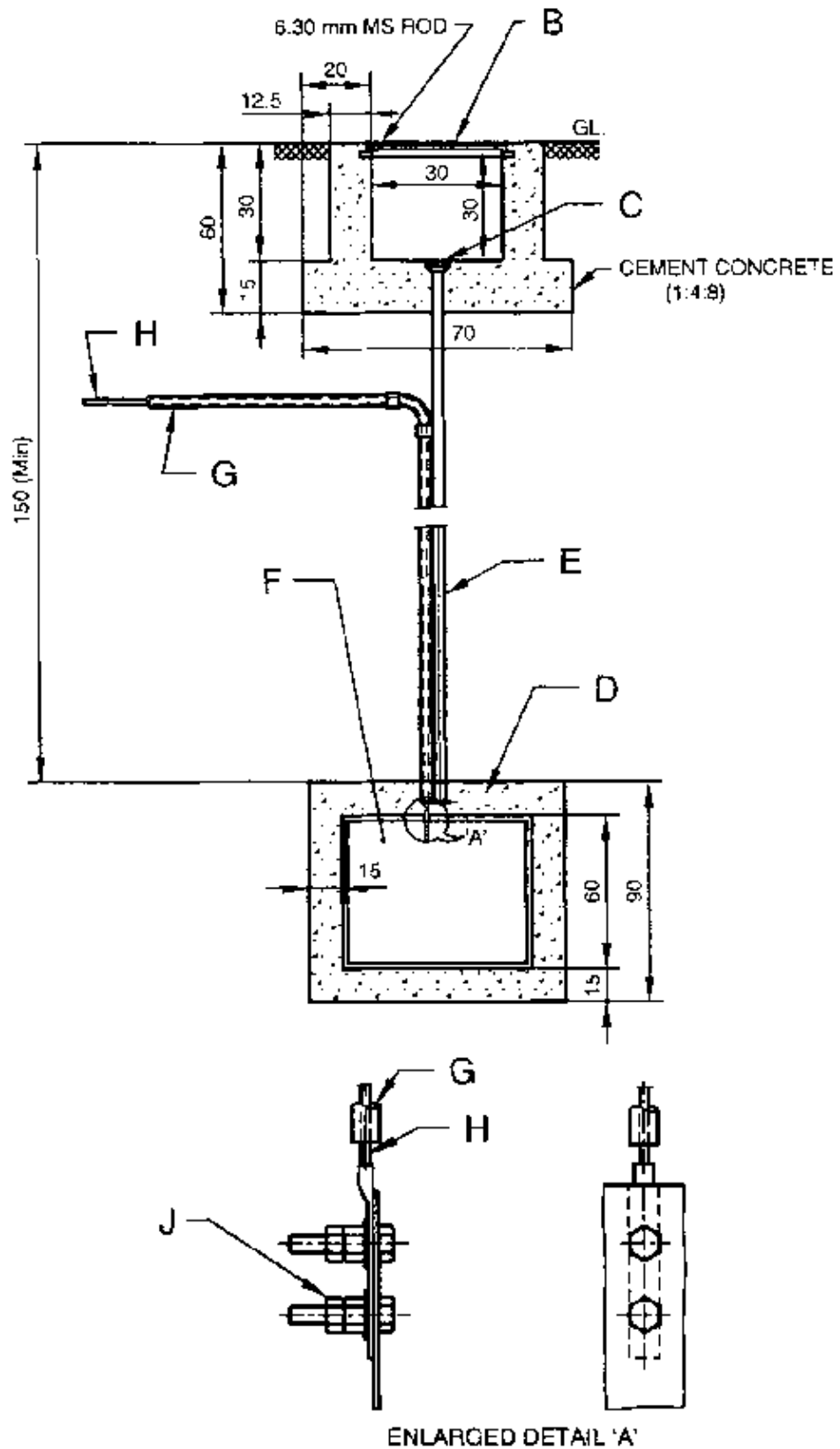

NOTE:- DIMENSIONS ARE IN cm UNLESS OTHERWISE SPECIFIED

B – C.I. cover hinged to C.I. frame

C – Funnel with Wire mesh

D – Charcoal

E – ∅19 mm G.I. pipe

F – 60 x 60 cm x 6.3 mm G.I. plate or 60 x 60 cm 3.15 mm copper plate (earth electrode)

G – ∅12.7 mm G.I. pipe

H – Copper or G.I. wire (Main earth lead)

J – Bolt, Nut, Check Nut and Washer to be of copper for copper plate and G.I. for G.I. plate.

Micrometer parts and graduations

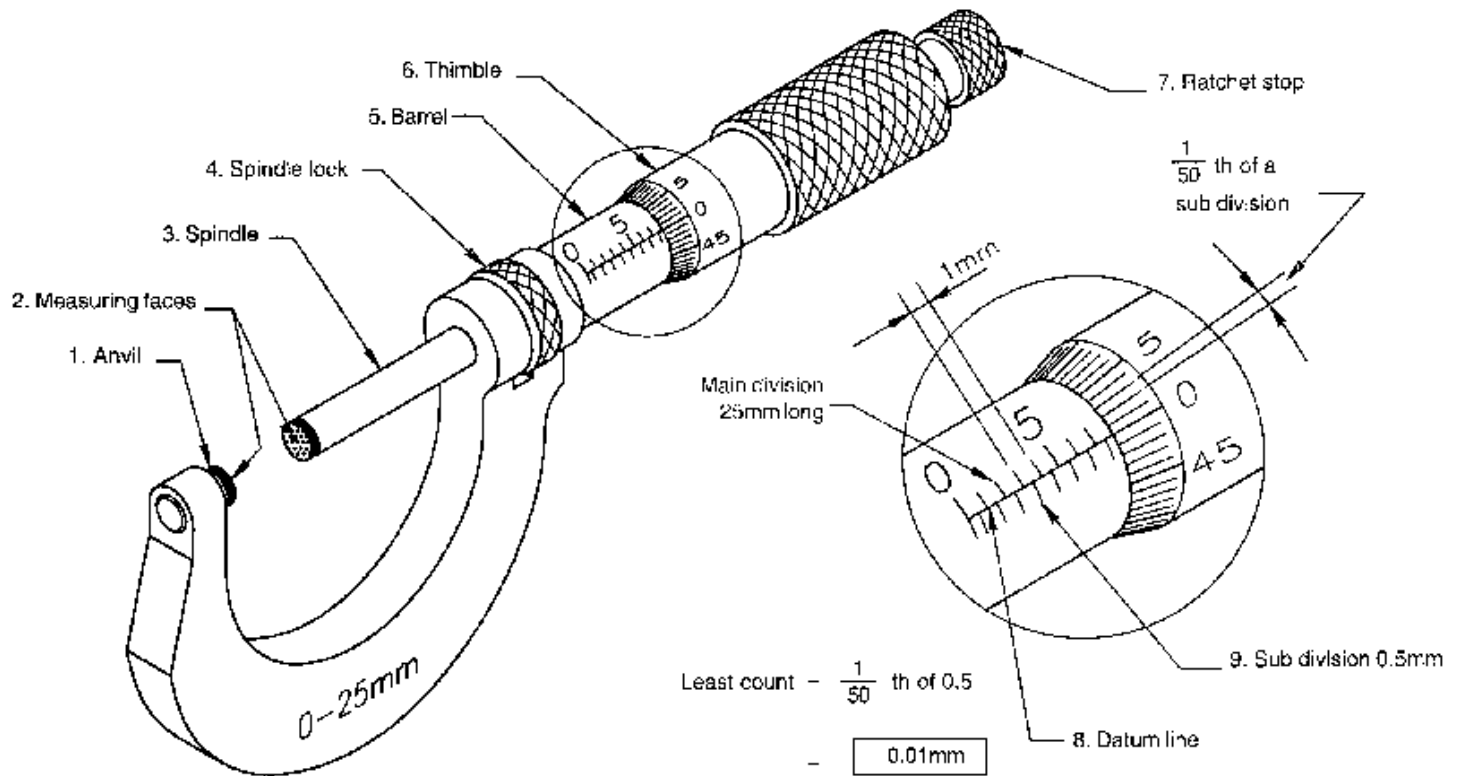

The range of the Micrometer is 0 – 25 mm.

Internal connections of the Megger (Insulation tester)

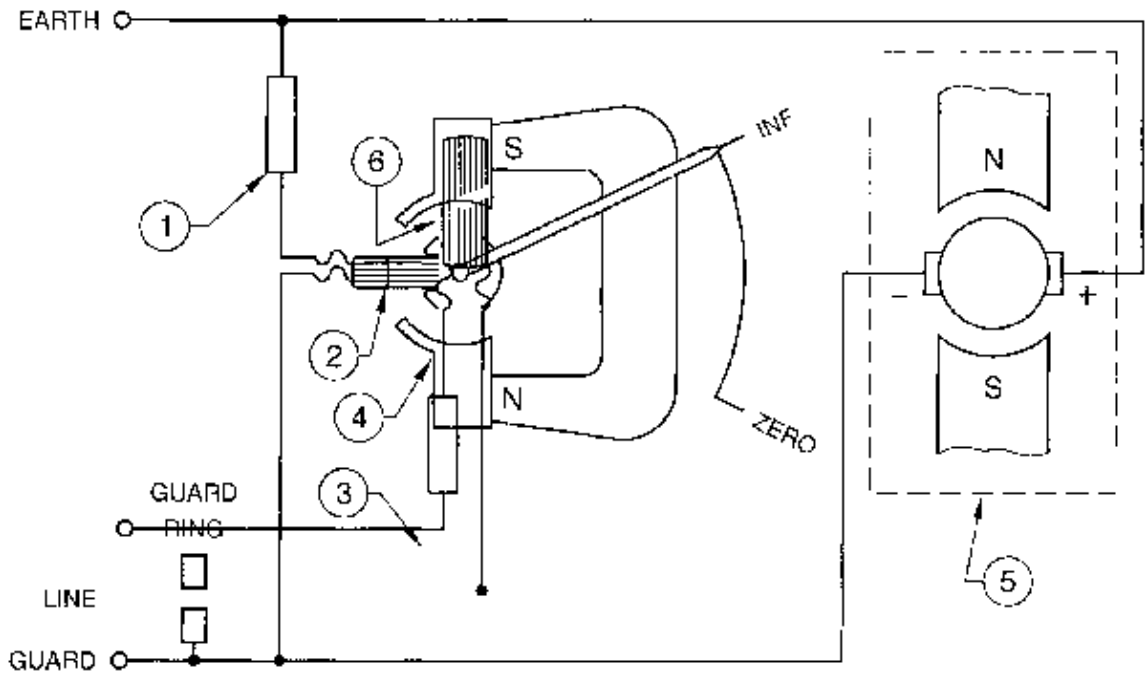

- 1 Control circuit resistance
- 2 Control coil
- 3 Deflecting circuit resistance
- 4 Ligaments
- 5 D.C. generator
- 6 Deflecting coil.

Rotating magnetic field from a three-phase stator

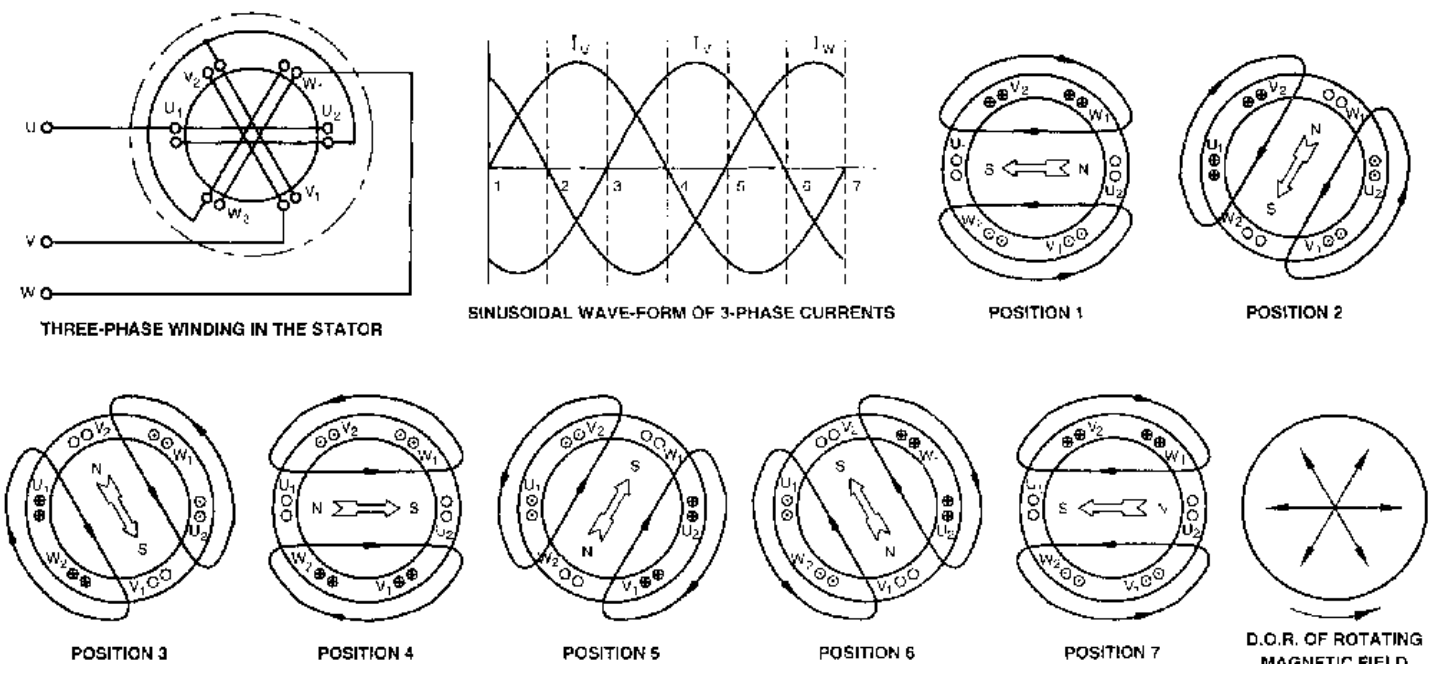

Single phase energy meter – Induction type

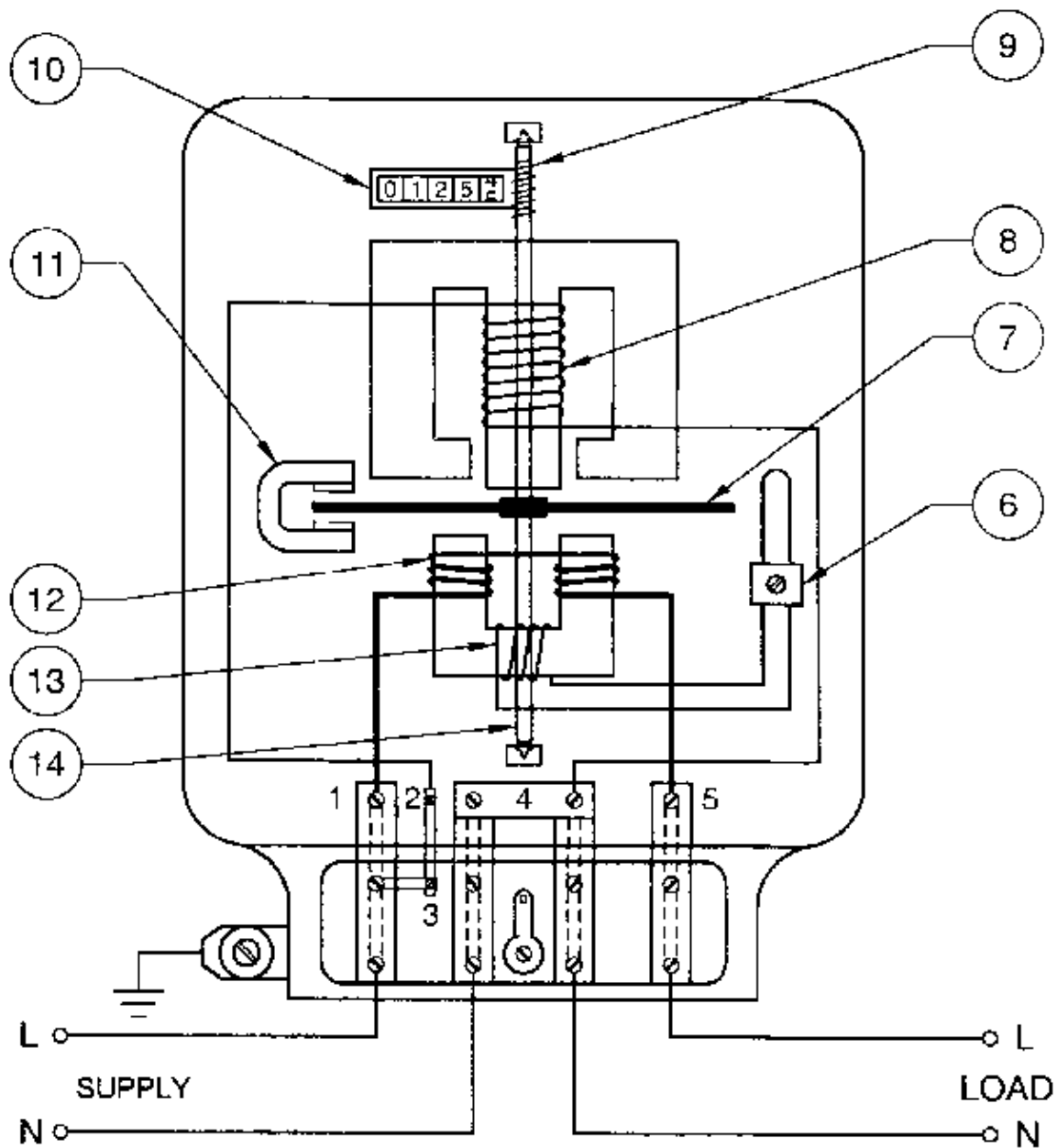

- 1 Current coil terminal (incoming)
- 2 Pressure coil terminal
- 3 Shorting link
- 4 Common link of neutral
- 5 Current coil terminal (outgoing)
- 6 P.F. Adjustment link
- 7 Aluminum disc
- 8 Pressure coil
- 9 Worm Gear
- 10 Register window
- 11 Brake Magnet (Damping magnet)
- 12 Current coil
- 13 P.F. Adjustment coil
- 14 Spindle

Test on domestic wiring installation – Continuity test

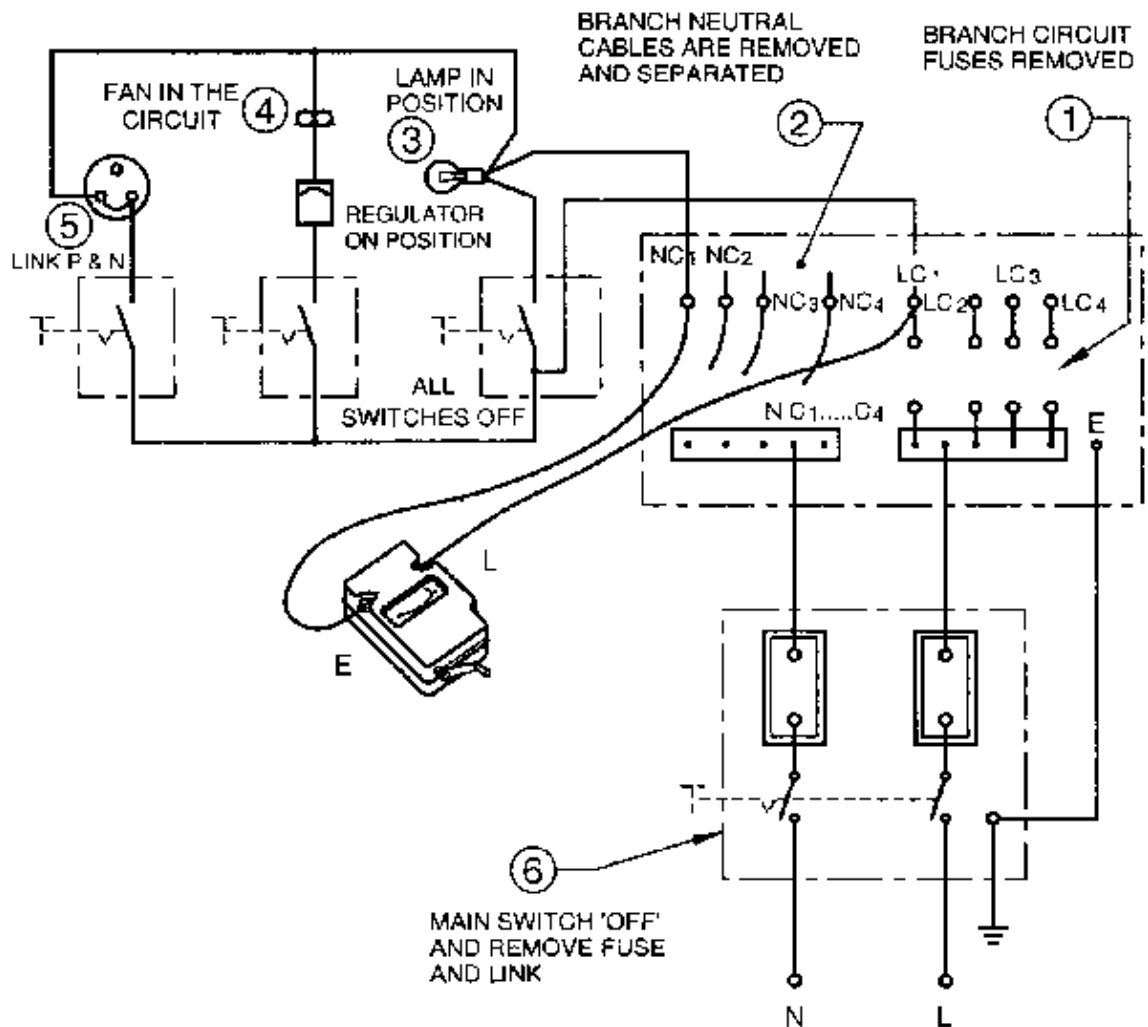

Necessity of the test

This test is carried out to check the continuity of cables in the individual sub circuits

Condition

As in the figure of the key

Connection

Connect the Megger terminals to individual sub circuit phase and neutral.

Test procedure

Operate the Megger and switch 'ON' and 'OFF' the switches one by one.

Result

Megger should show zero reading and infinity alternatively with respect to 'On' and 'OFF' positions of the switch.

If the Megger shows infinity when the switch is 'ON', the circuit is open. If the Megger shows zero reading in 'ON' and 'OFF' position of the switch, the circuit is short circuited.

Precaution

The shorting links of the sockets should be removed after the test.

Test on domestic wiring installation – Insulation resistance test between conductors

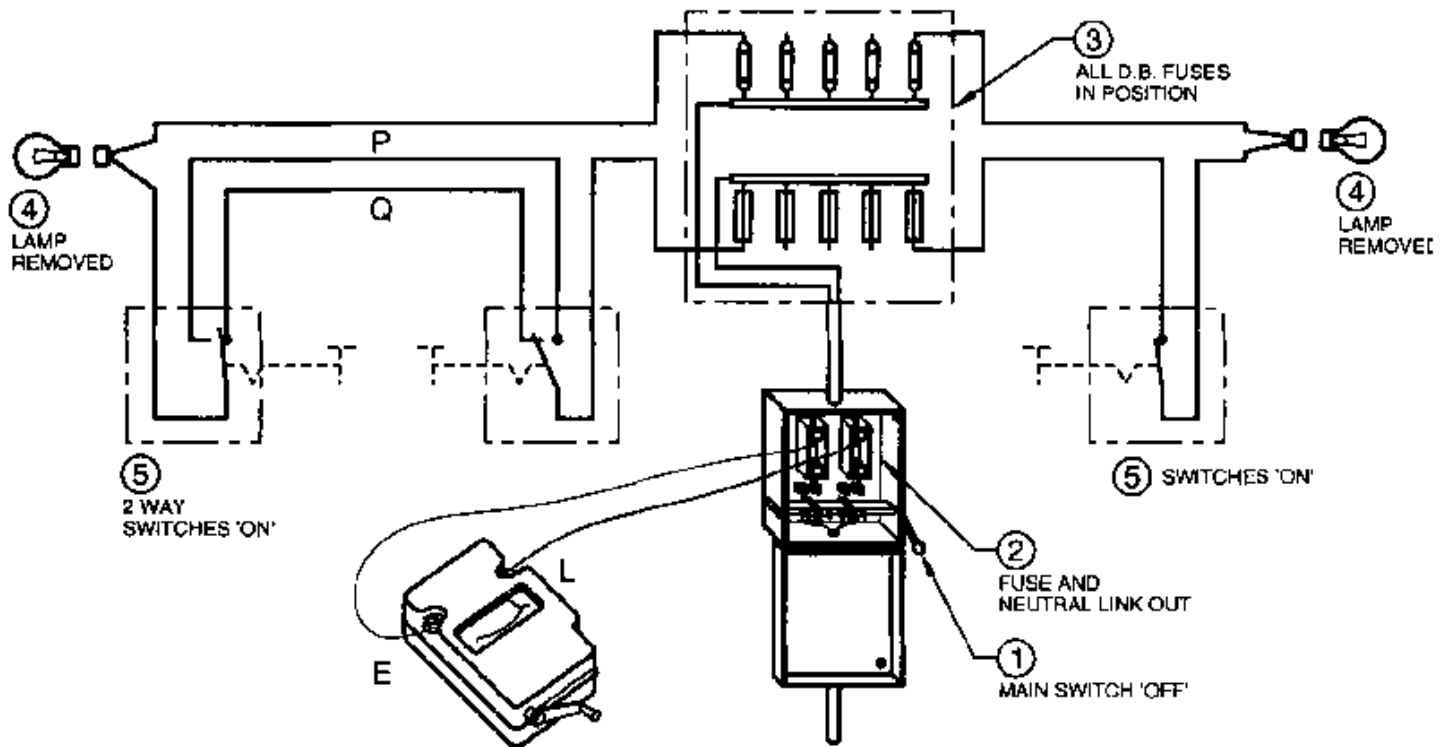

Necessity of the test

This test is carried out to check the soundness of the cable insulation in the installation.

Condition

As in key

Connection

Connect the Megger terminals to the out going side of the I.C.D.P. switch.

Test procedure

Operate the Megger and measure the insulation resistance.

Result

Measured insulation resistance of an installation should not be less than one megohm.

Test on domestic wiring installation – Insulation resistance test between conductors and earth

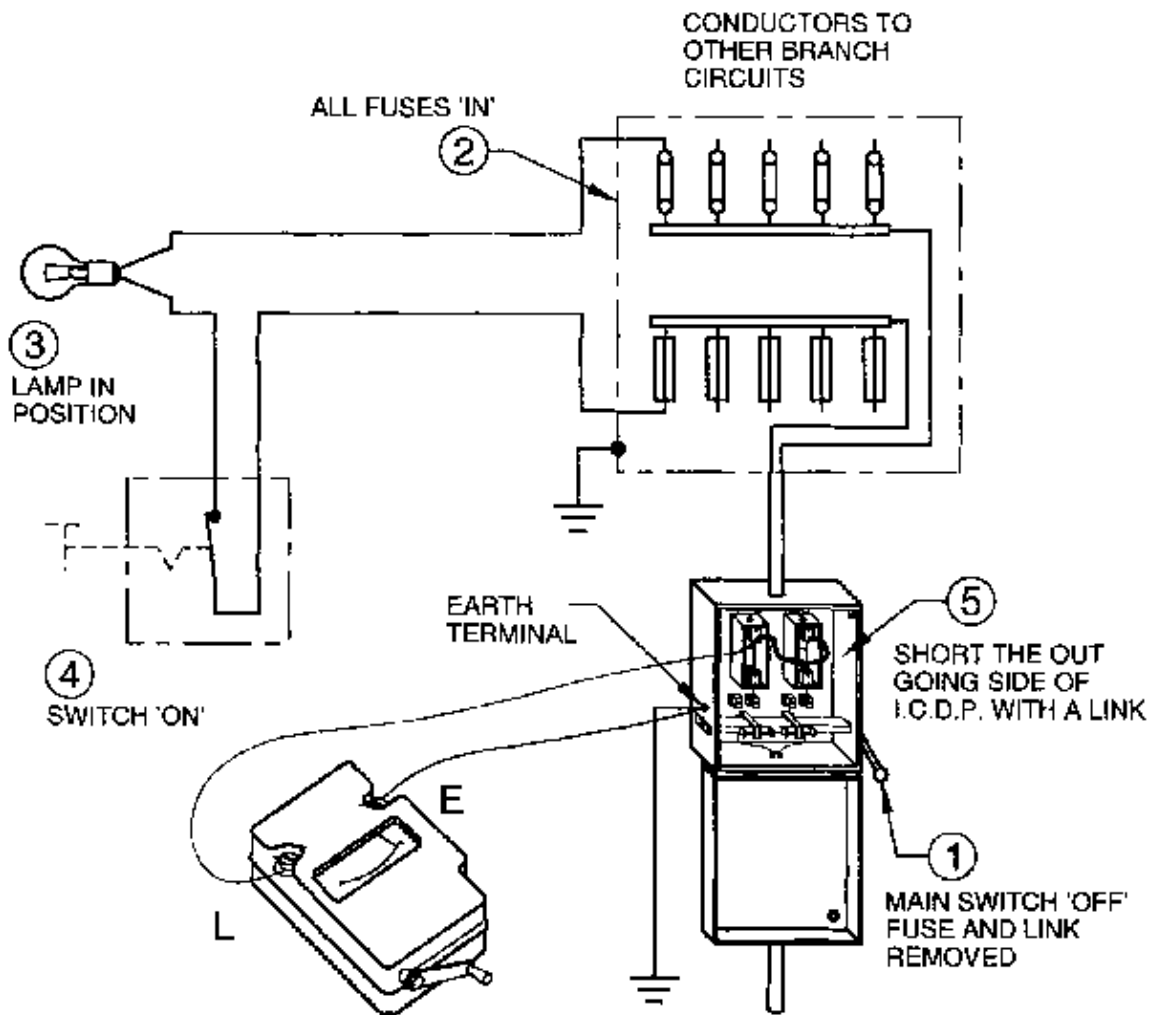

Necessity of test

This test is carried out to check the correctness of the insulation between conductors and earth.

Condition

As in key

Connection

Connect one terminal of the Megger to the shorted jumper and other terminal of the Megger to the earth connection.

Test procedure

Operate the Megger and measure the insulation resistance.

Result

Measured insulation resistance of an installation should not be less than one megohm.

Test on domestic wiring installation – Polarity test

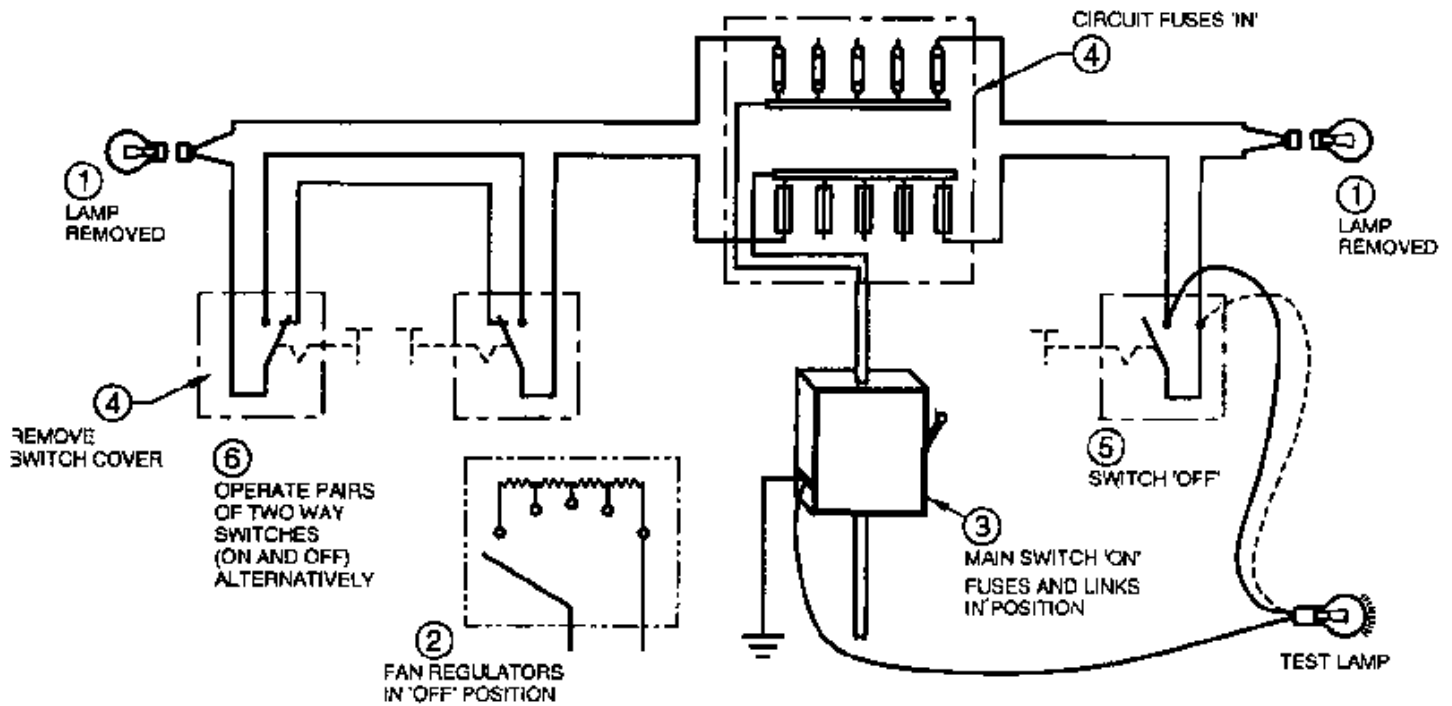

Necessity of the test

This test is conducted to check whether the switch controls the phase/live cable or not.

Condition

- 1 Remove lamps from their holder.
- 2 Keep fan regulators in 'OFF' position:
- 3 Insert fuse in main switches and distribution boards.
- 4 Remove the switch covers.
- 5 Keep the light and fan switches in 'OFF' position.
- 6 Switch 'ON' the mains.

Connection

Connect one end of the test lamp to the earth terminal of the I.C.D.P. switch.

Test procedure

Touch the other end of the test lamp to the either terminal of the switch.

Result

Lighting of the test lamp in either of the terminals indicates that the phase/live cable is controlled by the switch.

Generation of AC

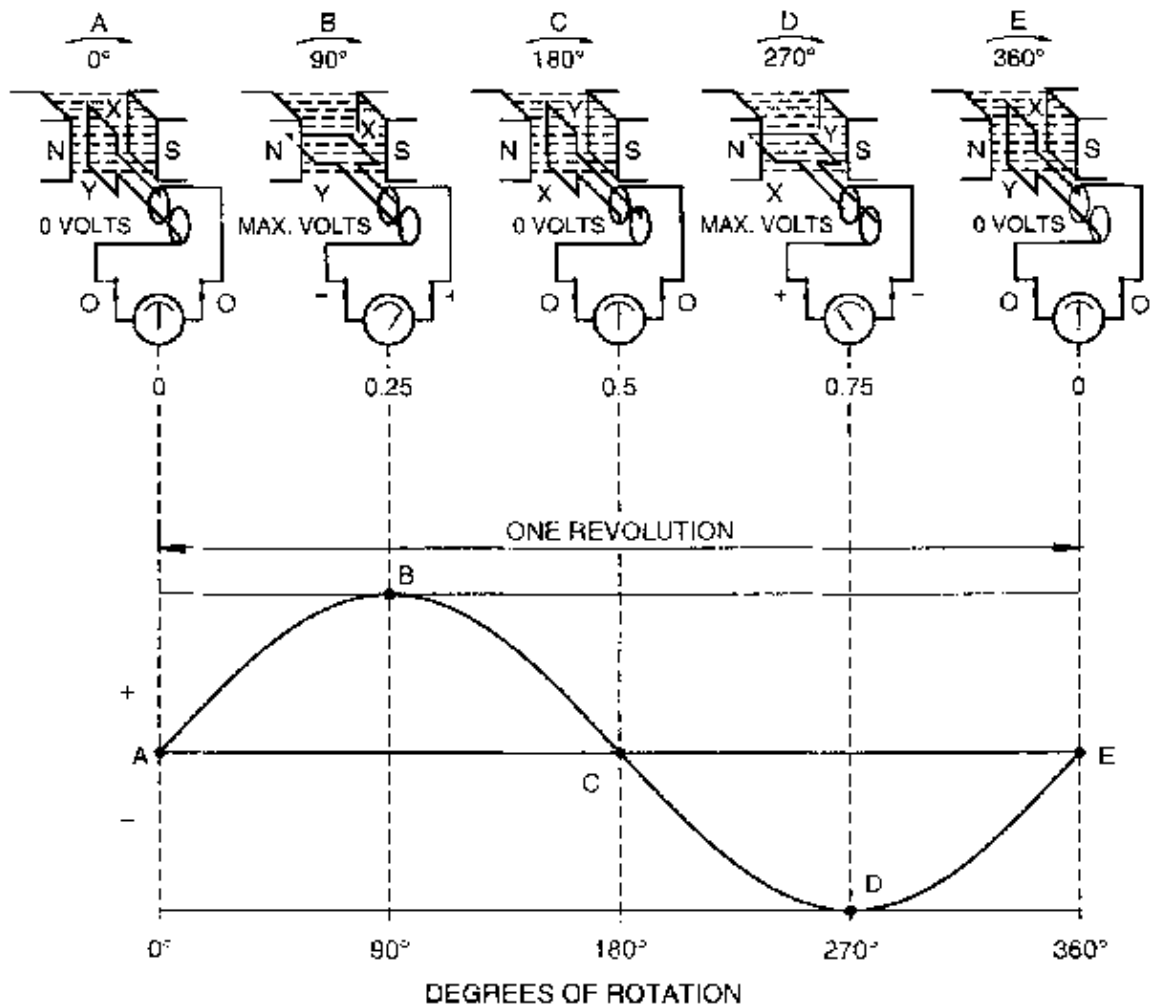

GENERATION OF AN ALTERNATING VOLTAGE:

AS THE LOOP ROTATES THROUGH THE MAGNETIC FIELD, THE MAGNITUDE AND DIRECTION OF THE VOLTAGE CHANGES WITH ANGLE AND DIRECTION OF MOTION.

Trainees are asked to determine the pointer position of the voltmeter and then asked to draw the Sine waveform depending on the conductor position.

Parts of a universal motor

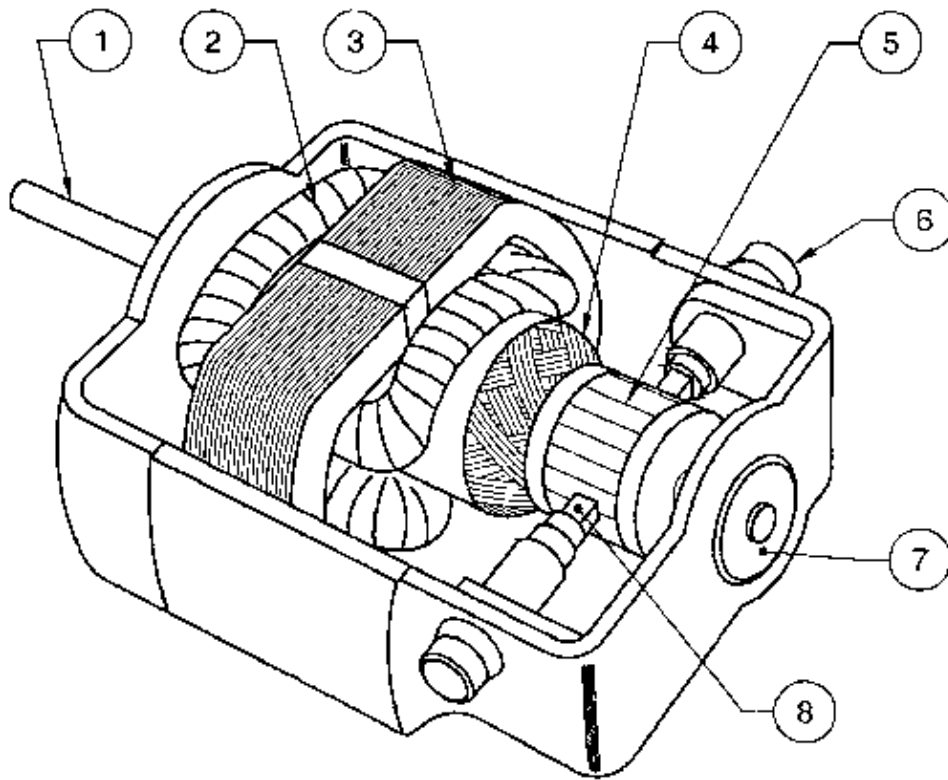

- 1 Shaft
- 2 Field Coil
- 3 Field Core
- 4 Armature
- 5 Commutator
- 6 Brush holder
- 7 Self aligning bush bearing
- 8 Carbon brush

Resistor colour coding

COLOUR	1st NUMBER	2nd NUMBER	MULTIPLIER	TOLERANCE
BLACK	0	0	1	
BROWN	1	1	10	
RED	2	2	100	
ORANGE	3	3	1000	
YELLOW	4	4	10 000	
GREEN	5	5	100 000	
BLUE	6	6	1 000 000	
VIOLET	7	7	10 000 000	
GRAY	8	8	100 000 000	
WHITE	9	9	1 000 000 000	
GOLD			0.1	5
SILVER			0.01	10
NONE				20
	BAND 1	BAND 2	BAND 3	BAND 4

