

## **Switchgear - Basic vocational knowledge (Institut für Berufliche Entwicklung, 54 p.)**



**(introduction...)**



**Preface**



**1. General remarks**



**2. Important components of switches**



**2.1. Switching contacts**



**2.2. Arcs**



**2.3. Switch mechanisms**



**3. Low-voltage circuit breakers**



**3.1. Classification and tasks of the circuit breakers**



**3.2. Circuit breakers**



**(introduction...)**



















**3.2.1. Universal circuit breakers**



**3.2.2. Compact circuit breakers**



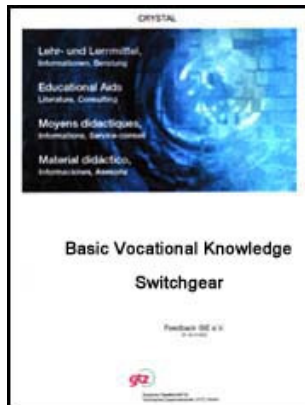
**3.2.3. High-speed switches for d.c.**

-  **installations**
- 3.2.4. Protective switches**
-  **3.3. Overload circuit breakers**
  -  **(introduction...)**
  -  **3.3.1. Multisection cam-operated switches**
  -  **3.3.2. Contactors**
-  **3.4. On -load switches**
  -  **(introduction...)**
  -  **3.4.1. Load-break switches in slim design**
  -  **3.4.2. Installation switcher**
-  **3.5. Off-load switches**
-  **4. Relays and control devices**
  -  **4.1. Relays**
    -  **(introduction...)**
    -  **4.1.1. Neutral or auxiliary relays**
    -  **4.1.2. Time relays**
    -  **4.1.3. Undervoltage and overvoltage**

- 📄 **4.1.4. Overcurrent relays**
- 📄 **4.1.5. Overcurrent time relays**
- 📄 **4.1.6. Magnetic overcurrent relays**
- 📄 **4.1.7. Signal relays**
- 📁 **4.2. Control devices**
  - 📄 **4.2.1. Discrepancy switches**
  - 📄 **4.2.2. Control discrepancy switches**



[Home](#) > [ar](#) [cn](#) [de](#) [en](#) [es](#) [fr](#) [id](#) [it](#) [ph](#) [po](#) [ru](#) [sw](#)



- 📖 **Switchgear - Basic vocational knowledge (Institut für Berufliche Entwicklung, 54 p.)**
- ➔ 📄 **(introduction...)**
- 📄 **Preface**
- 📄 **1. General remarks**
- 📁 **2. Important components of switches**
- 📁 **3. Low-voltage circuit breakers**
- 📁 **4. Relays and control devices**

## **Textbook for Vocational Training**

**Institut fr berufliche Entwicklung e.V.  
Berlin**

**Original title:  
"Berufliche Grundlagen - Schaltgerete"**

**Author: Ernst-Otto Balding**

**Second Edition © IBE**

**Institut fr berufliche Entwicklung e.V.  
Parkstrae 23  
13187 Berlin**

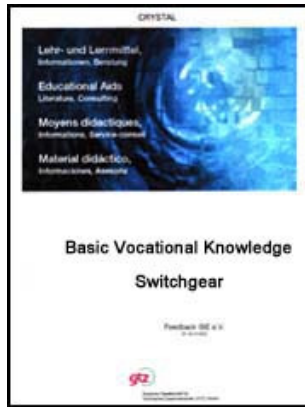
**Order No.: 91-34-0108/2**



[Home](#) > [ar.cn.de.en.es.fr.id.it.ph.po.ru.sw](#)



**Switchgear - Basic vocational knowledge  
(Institut fr Berufliche Entwicklung, 54 p.)**



***(introduction...)***

## **Preface**



**1. General remarks**



**2. Important components of switches**



**3. Low-voltage circuit breakers**



**4. Relays and control devices**

## **Preface**

**This textbook has been drawn up on the basis of the wide experience gained in the field of vocational training in the FRG and is intended for trainees of electrical engineering.**

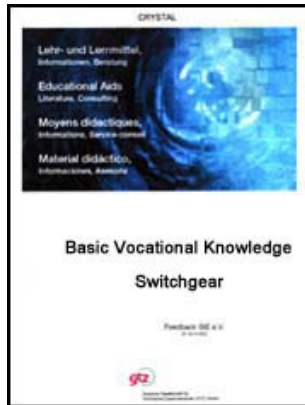
**It is based on the fundamentals of low-voltage switchgear. In a didactically edited form it contains the necessary knowledge for this field of electrical engineering.**









**With the help of many figures and corresponding surveys as well as a clear and comprehensible textural representation the trainees are**

**assisted in understanding the problems dealt with\* Taking into consideration the unity of theory and practice the trainees can use this textbook as a working basis in theoretical vocational training and in practical vocational training. Taking into account the corresponding IEC recommendations the low-voltage switchgear explained is taken from FRG production, represents a selection and is to be assimilated to products existing in each case.**



**Home** > [ar.cn.de.en.es.fr.id.it.ph.po.ru.sw](#)



-  **Switchgear - Basic vocational knowledge (Institut für Berufliche Entwicklung, 54 p.)**
-  **(introduction...)**
-  **Preface**
-   **1. General remarks**
-  **2. Important components of switches**
-  **3. Low-voltage circuit breakers**
-  **4. Relays and control devices**

## **1. General remarks**

**Low-voltage switchgear has to fulfil mainly the following functions in electrical energy systems:**

- disconnecting**
- switching (in the sense of arbitrary switching)**
- protecting and**
- limiting of the short-circuit current.**

**Since the field of application of low voltage is very extensive, there is a large variety of low-voltage switchgear.**

### **Switches**

**Switches are devices for opening and closing electric circuits in which all parts necessary for connecting or disconnecting are mounted firmly on a joint base.**

### **Relays**

**Relays are devices which are influenced by the change of physical magnitudes and control electrically further devices.**

## **Trips**

**Trips are devices which are influenced by the change of physical magnitudes and control mechanically further devices.**

## **Regulators**

**Regulators are devices provided with resistances for changing the operating state of electric operating means whose resistance remains permanently switched on in the circuit.**

## **Plug-and-socket connectors**

**Plug-and-socket connectors are devices for establishing connections of current paths without additional auxiliary means, with connection for electric supply lines.**

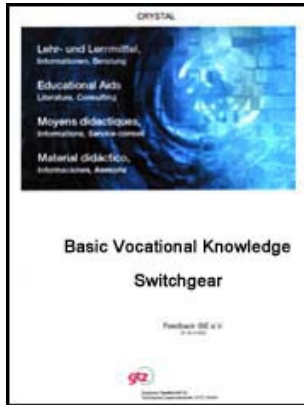
## **Fuses**

**Fuses are devices for interrupting current paths by melting of a piece of fusible metal when a current is exceeded in a given period of time. The fuse comprises all components of which the complete device consists.**





[Home](#) > [ar](#).[cn](#).[de](#).[en](#).[es](#).[fr](#).[id](#).[it](#).[ph](#).[po](#).[ru](#).[sw](#)



## Switchgear - Basic vocational knowledge (Institut für Berufliche Entwicklung, 54 p.)

### 2. Important components of switches

#### 2.1. Switching contacts

#### 2.2. Arcs

#### 2.3. Switch mechanisms

## Switchgear - Basic vocational knowledge (Institut für Berufliche Entwicklung, 54 p.)

### 2. Important components of switches

#### 2.1. Switching contacts

#### Definition

**The electric contact is a disconnectable connection between two conductors suitable for carrying a current.**

### **Contact fault**

**Contact faults cause great contact transition resistances, and it is difficult or impossible that the contacts open.**

### **Cold welding**

**Adhesion between contact pieces by cohesion of metal ions.**



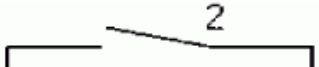
### **Hot welding**

**Great plastic deformation of contacts by Joule heat.**

### **Fusion welding**

**Melting of the contact material due to excessive heating up (arcs, short-circuit currents). The adhesion resulting during cold and hot welding is overcome by corresponding switching forces. In case of fusion welding it is not possible any more to open the switch, and thus the switch cannot perform its function any more.**

## Contact arrangements

<b>Survey 1</b>	<b>Contact arrangements</b>		
<b>Contact arrangements</b>	<b>Examples of application</b>	<b>Construction</b>	<b>Advantages and disadvantages</b>
Single break	ES contactors Relays	 <p>Connection of a fixed and a movable contact member</p>	Small contact opening, difficult to extinguish arc
Double break	Gang switches Contactors Low-voltage circuit breakers On-load switches	 <p>Connection of two fixed contact members by a contact bridge</p>	Arc extinction is made easier since two partial arcs are drawn on which half of the voltage is applied
Parallel connection of contacts	Low-voltage circuit breakers		During the opening and closing sequences the main contact



Functional principle: During the opening sequence first of all the main contact (1) is opened. The current continues flowing via the arcing contact (2). When the working contact is actuated, an arc is drawn on the working contact. During the closing sequence the working contact is closed first of all. 1 main contact 2 arcing contact

remains arc-free. Surface quality (silver/silver alloy) is maintained. Contact resistance is kept low. Arcing contacts can be easily replaced when worn (burn-up).

## 2.2. Arcs

**When opening a switch, an arc is generated between the contact members. At low switching capacity this phenomenon is called switching spark, at high switching capacity it is called arc. The conductivity of the arc greatly increases with increasing temperature.**


### Quenching of the arc (lengthening of the arc)


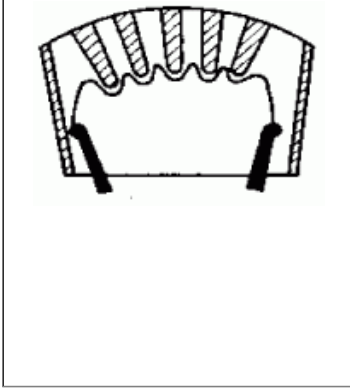
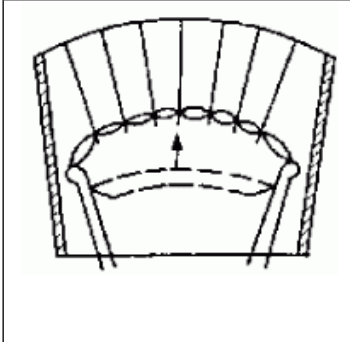
**An intensive cooling of the arc by gas or oil results in the quenching of the arc. By decreasing the temperature the arc current becomes less and the cross-section of the arc is reduced. For medium-voltage and high-voltage a.c. switches a lengthening of the arc is not recommended. When quenching the arc, the property of the latter is used that due to the zero passages of the alternating current at a frequency for example of 50 Hz, the arc is quenched one hundred times per second and ignited again the same number of times.**

### Arc facilities

**It is the task of the arc facilities to cool the arc or to increase pressure and to make sure that after natural quenching the arc does not ignite again.**

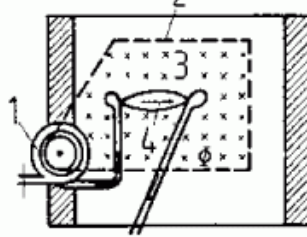
### Survey 2 Arc quenching facilities

<b>Quenching possibilities</b>	<b>Examples of application</b>	<b>Construction</b>	<b>Functional principle</b>
Natural arc extinction	Low-voltage circuit breakers		Due to the thermal lifting power of the heated-up gas column the arc is lengthened.

			Electromagnetic forces between the two arc branches support lengthening.
Lengthening and cooling of the arc through the shape of the quenching chamber	Contactors ES contactors		When the arc cones into contact with the quenching chamber, heat extraction takes place. Due to the incorporation of webs, partial chambers are created in which a fireplace effect occurs. In the meander chamber the arc is lengthened greatly.
Deion chamber	Low-voltage circuit breakers		Copper-plated iron sheet metal plates divide the complete arc into partial arcs. Partial arc voltages are reduced below 30 V. At the same time heat is extracted from the plates, and thus the arc extinguishes.
Maagnetic	ES	?	The current to be interrupted

blowing

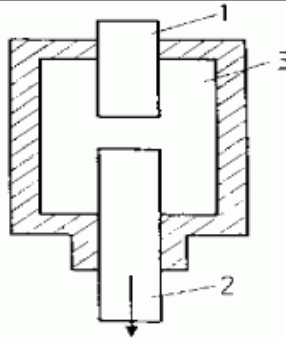
contactors



flows through the blowout coil (1). The magnetic field generated is transmitted to blow-out plates (2) arranged at the sides of the quenching chamber. The arc burns in the magnetic field between the two plates so that an electric force (3) acts on it. Thus the arc is moved upwards, that means, it is length-tened and cooled. (4) Direction of current

Vacuum chamber

Vacuum contactors (EVS)



Contact-break distance is in the vacuum. Atoms from the air are missing for ionisation. The arc burns only for a short time in the metal vapour of the switching contacts. The metal vapour moves quickly out of the contact-break distance.

		1 fixed contact member, 2 movable contact member, 3 vacuum chamber	
--	--	--	--

### 2.3. Switch mechanisms

**They change the switching position of switches (CLOSED-OPEN). For this purpose a force is required. In accordance with the type of force generation the mechanisms are classified in:**

- **manually-operated mechanisms**
- **solenoid-operated mechanism**
- **motor-operated mechanism, and**
- **pneumatic-operated mechanism.**

#### **Manually-operated mechanism**

**Actuation elements are knob, pushbutton or lever. Rated currents up to approximately 100 A can be switched by means of these mechanisms. The manually-operated mechanism is the cheapest mechanism. Examples for these mechanisms are installation switches, gang switches, pushbutton switches.**



## **Solenoid-operated mechanism**

**By switching on a control current an electromagnet is excited. The armature of a magnet actuates the contact members. Examples for solenoid-operated mechanisms are contactors, relays, installation remote switches.**

## **Motor-operated mechanism**

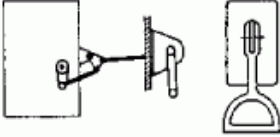
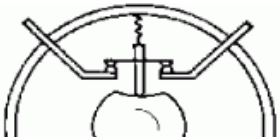
**The motor either drives the interrupter shaft via a gear or the motor acts on a spring energy store. As far as the motor-operated mechanism with spring energy store is concerned, simultaneously with the closing operation a disconnection spring is tensioned and latched. When the spring is unlatched, it opens the contact members independently of the motor.**

## **Pneumatic-operated mechanism**

**By means of 15 to 20 MPa compressed air the contact members are actuated via pressure piston and linkage mechanism.**

**This type of mechanism is mostly used for high-voltage circuit breakers.**

## Survey 3 Summary of the most common switch mechanisms

<b>S Mechanisms</b>	<b>Examples of application</b>	<b>Functional principle</b>	<b>Advantages and disadvantages</b>
Manually-operated mechanism Pushbutton and lever-operated mechanism Stirrup-operated mechanism	Low-voltage circuit breaker Load-break switch Isolating switch Earthing switch Power circuit breaker up to 30 kV	 <p>The actuation element is attached directly to the interruptor shaft. The switch linkage transmits the switching force from the front side of the cell to the switch fastened on the rear.</p>	Favourable as to costs, no high switching frequency. At rated currents above 100 A excessive switching forces required
Manually operated mechanism by means of	Multisection cam-operated switch		Simple design, unobjectionable switching of

a twist knob

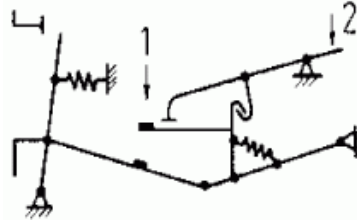


The switch lever is arranged directly on the camshaft

high currents at a speed almost independent of the operator

Snap-action connection (toggle latching mechanism)

EI circuit breaker



From a certain switching angle onwards the opening and closing sequences are taken over by incorporated springs. 1 release force, 2 manual force

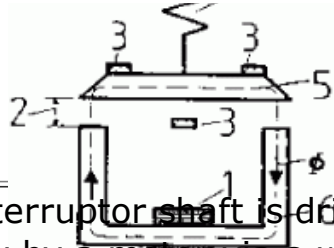
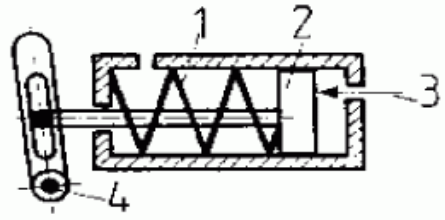
Unobjectionable switching of high currents at a speed independent of the operator

Solenoid-operated mechanism

Contactors r Relays

Relatively high power consumption by the switching magnet. A high making current

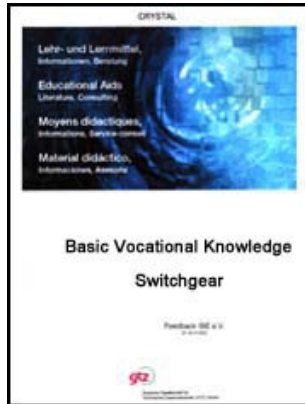
34

			<p>can load the network.,</p>
<p>Motor-operated mechanism</p>	<p>EI circuit breakers SCI circuit breakers</p>	<p>The interruptor shaft is driven directly by a motor via a worm gearing and an eccentric. When an energy store is used, the motor tensions the closing spring. By unlatching this spring the switch is closed and the opening spring is pretensioned. During the opening sequence the closing spring is preten-sioned.</p>	<p>Compared with the solenoid-operated mechanism, the motor-operated mechanism is more economical for high rated currents</p>
<p>Pneumatic-operated mechanism and D3AF</p>	<p>Isolating switches Circuit breakers of types DCI</p>	 <p>1 spring, 2 piston, 3 compressed-air, 4 interruptor shaft</p>	<p>Remote control possible. Simpler design compared with electric-operated mechanisms. Higher</p>

switching speed  
and smoother  
switching



[Home](#) > [ar](#) [cn](#) [de](#) [en](#) [es](#) [fr](#) [id](#) [it](#) [ph](#) [po](#) [ru](#) [sw](#)



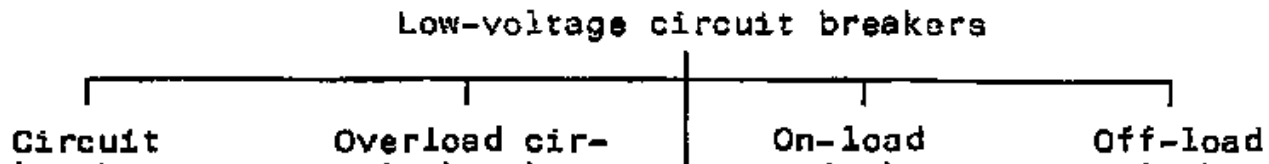
- 📖 **Switchgear - Basic vocational knowledge (Institut für Berufliche Entwicklung, 54 p.)**
  - ➔ 📄 **3. Low-voltage circuit breakers**
    - 📄 **3.1. Classification and tasks of the circuit breakers**
    - 📄 **3.2. Circuit breakers**
      - 📄 **(introduction...)**
      - 📄 **3.2.1. Universal circuit breakers**
      - 📄 **3.2.2. Compact circuit breakers**
      - 📄 **3.2.3. High-speed switches for d.c. installations**
      - 📄 **3.2.4. Protective switches**
    - 📄 **3.3. Overload circuit breakers**

- 📄 **(introduction...)**
- 📄 **3.3.1. Multisection cam-operated switches**
- 📄 **3.3.2. Contactors**
- 📄 **3.4. On -load switches**
- 📄 **(introduction...)**
- 📄 **3.4.1. Load-break switches in slim design**
- 📄 **3.4.2. Installation switcher**
- 📄 **3.5. Off-load switches**

## Switchgear - Basic vocational knowledge (Institut fr Berufliche Entwicklung, 54 p.)

### 3. Low-voltage circuit breakers

#### 3.1. Classification and tasks of the circuit breakers



**breakers**

Serves at the same time as protective switch against overcurrents and short circuits

Circuit breakers  
EL / ESL

Protective switches

Switches for special tasks

**circuit breakers**

Switching of motor starting currents which amount to the 6-fold to 8-fold of the rated current

Drum controllers

Multisection cam-operated switches

Contactors

**switches**

Switching of currents amounting to the 1.25-fold rated value

On-load switches  
LTA / FLTA

Installation switches

Relays

Control devices

**switches**

Switching sequences in an almost dead state with visible air break

Isolating switches TCI  
1 kV

Earthing switches

**Survey 4 Low-voltage circuit breakers****3.2. Circuit breakers**

**In low-voltage switchgear installations the protection against overload and short circuits is mainly taken over by fuses. The latter have, however, the disadvantage that their rated breaking capacity is limited. Furthermore, long-term operating disturbances may occur due to the replacement of the fuses. For this reason circuit breakers are used for outgoing feeders of greater amperage and for incoming supply panels. They possess bimetal and instantaneous trips and may be equipped with undervolt-age trips.**

**Compared with fuses a better selective protection can be reached with circuit breakers. Due to their design they are in a position to close and open high short-circuit currents and to quench objectionably arcs occurring.**

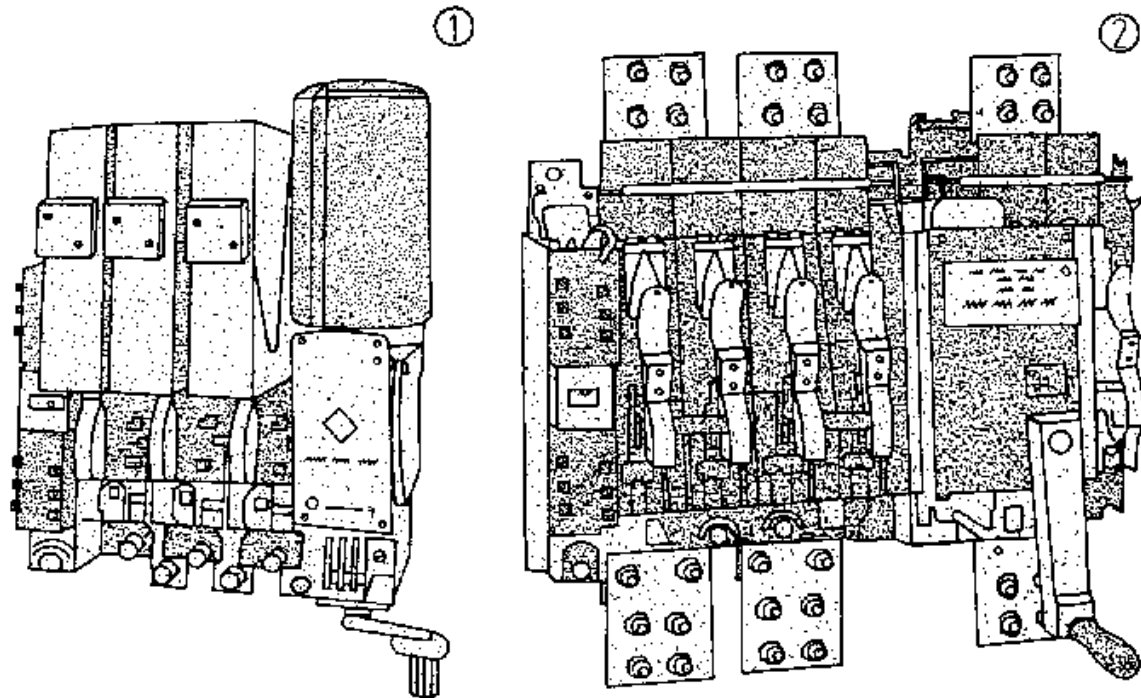
**Since it is not possible to meet all requirements in one circuit breaker, internationally two types are manufactured**

- universal circuit breakers and**
- compact circuit breakers which in each case can be with or without current-limiting effect.**

### **3.2.1. Universal circuit breakers**

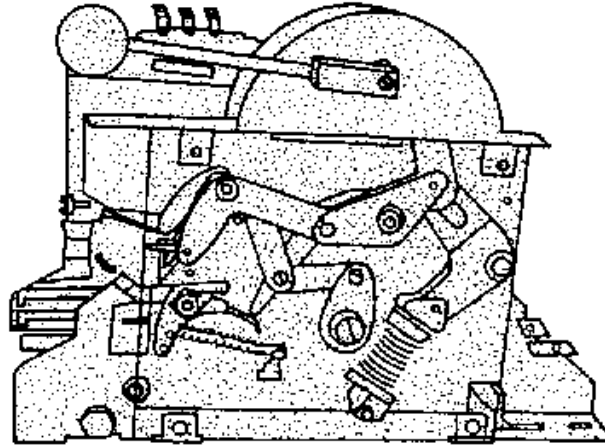


**The non-current-limiting universal circuit breakers, i.e. of type EL (Figure 1) are manufactured for medium and high amperages from 250 A onwards.**



**Figure 1. Universal circuit breaker of type EL (1) 630 A,(2) 1000 A with the arc-control chamber removed**

**In these circuit breakers only the fixed and movable contact members as well as the latching mechanism are fastened on the base frame.**



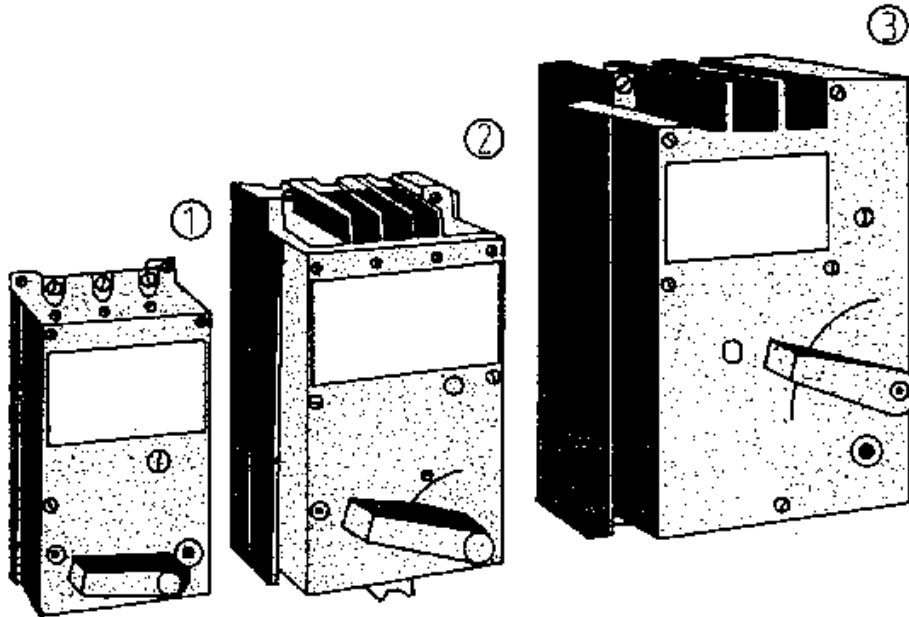
**Figure 2. Latching mechanism of the universal circuit breaker of type EL**

**All the other components such as switch mechanism, trips and other additional devices are designed as replacable modules. They are used in those cases where a high degree of modification is required and space requirements are not very important. As far as the circuit breaker of type EL is concerned, the arc is led very quickly into a deion chamber (see Survey 2) so that the overall opening time is short.**

### **3.2.2. Compact circuit breakers**

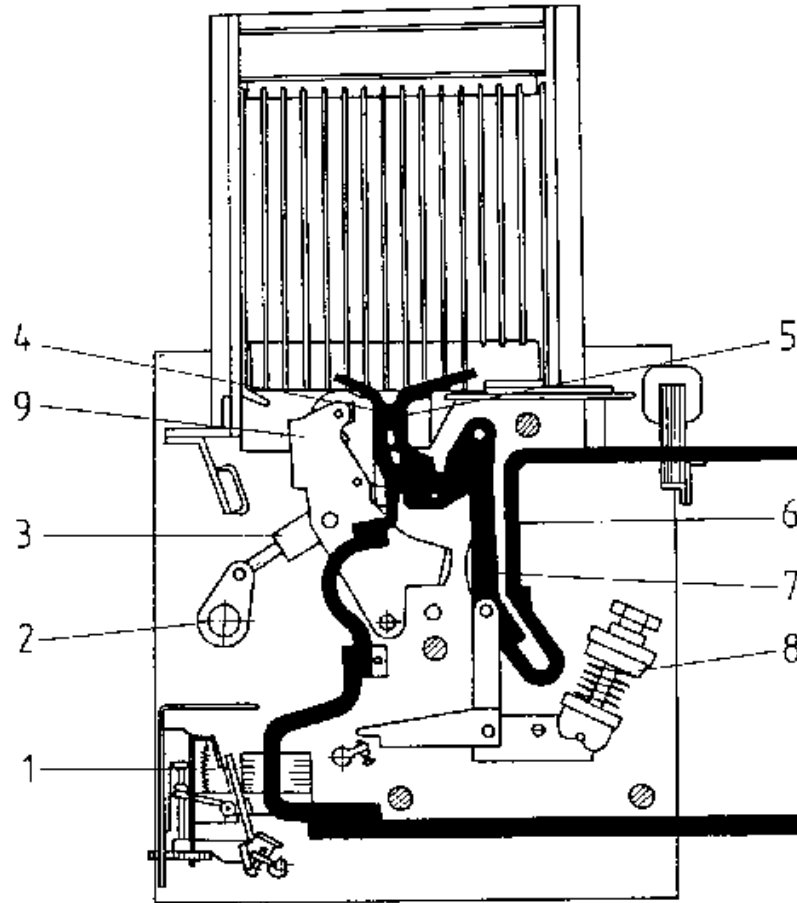
**As to the circuit breaker in compact construction, the individual elements of the compact circuit breaker are arranged in an insulating casing made of moulded material. In this way considerable space is saved in the low-voltage distribution board. The disadvantage of the compact circuit breaker is its low degree of modification. Furthermore, the cooling conditions are unfavourable so that the current-carrying capacity, especially in case of short circuits, is worse than that of the universal circuit breaker.**

**The compact circuit breakers for small and medium amperages (25, 63, 160, 1000 A) are current-limiting switches such as type EBL for example.**



**Figure 3. Compact circuit breaker of type EBL (1) 25 A, (2) 63 A, (3) 160 A**

**In Figure 4 the construction and function of this circuit breaker is shown. In the following the function of the circuit breaker will be explained taking EBL 1000 as an example.**



**Figure 4. Sectional drawing of the compact circuit breaker of type EBL**

## **1000 A**

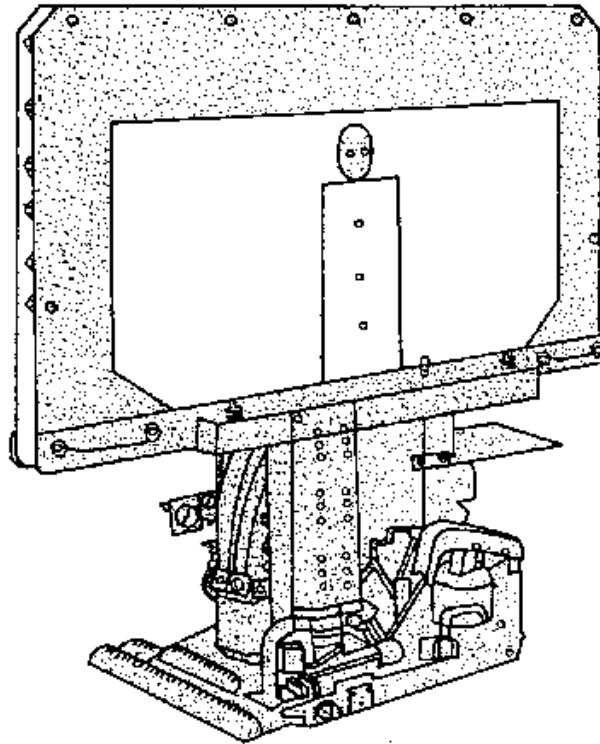
**When the short-circuit current is less than 20 KA, the instantaneous trip 1 is actuated and its armature picks up. During this operation it turns a releasing shaft which in turn causes the latching mechanism to trip. The movable contact member is removed from the fixed contact member by spring force via interruptor shaft 2 and linkage 3.**

**When the short-circuit current is greater than 25 KA, the electrodynamic force at the contact support of the main contact pair becomes so great that the force of the contact spring is overcome and the contact members are slightly lifted. Consequently, current is flowing via the arcing contacts while contact members 4 and 5 form a loop through which current flows in the opposite direction. Thus, the movable contact member 4 is pushed off at high speed and an arc with current-limiting effect is brought into the circuit. Parallel to this process electrodynamic forces also occur between current path sections 6 and 7. The latter are supported by spring 8 so that the movable loop branch 7 is thrown onto contact cage 9. Thus the opening sequence is accelerated. Contact opening occurs already before the current maximum is reached.**

### **3.2.3. High-speed switches for d.c. installations**

**Direct-current arcs can only be extinguished by lengthening the arc. For this purpose high-speed switches which quickly lengthen the arc are required in d.c. installations. They should have only a short switching delay (up to 5 ms) so that the contacts open quickly. By drawing the arc early the short-circuit current can be limited.**

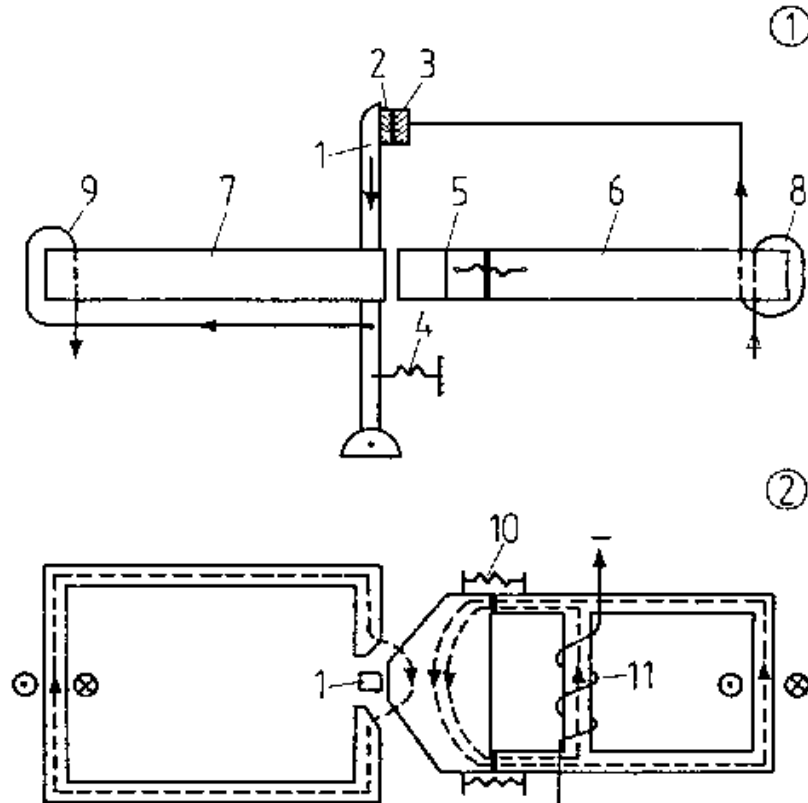
**These high-speed switches are manufactured as single-pole d.c. protective switches for all d.c. installations as a protection against overcurrents, short circuits and reverse currents. There are different designs of high-speed switches, but nowadays high-speed switches with impact armature are mostly used.**



**Figure 5 D.C. high-speed switch**

**In this switch two magnets, one release magnet and one holding magnet, are used through which the same current flows.**





**Figure 5. Principle of the highspeed switch with impact armature (1) Side view (2) Top view - 1 switch lever, 2 movable contact, 3 fixed contact, 4 contact pressure spring, 5 impact armature, 6 holding**

**magnet, 7 release magnet, 8 holding coil, 9 tripping coil. 10 restoring spring for impact armature. 11 polarisation coil**

**When the rated current is present the holding magnet is already saturated so that in case of overcurrent only the tripping flux can become greater and the impact armature can open the contact. The switch also trips in case of reverse current as the same current flows through both coils. Since reverse currents are smaller than overcurrents, the holding magnet is premagnetised by a polarising coil. In case of reverse current the polarising flux counteracts the magnetic flux of the holding coil so that at a lower current the release force can pull off the armature. Direct-current high-speed switches are manufactured for voltages up to 3 kV and currents of 3000 A.**

### **3.2.4. Protective switches**

**It is the main task of protective switches to protect low-voltage installations and equipment against overload and short-circuit currents. At the same time they may also be used for connecting and disconnecting circuits (see motor protection switch).**

**The main components of protective switches are:**

## **- Electromagnetic instantaneous trip**

**As protection against short circuits an electromagnetically operating instantaneous trip is provided which releases a mechanical lock. Its adjustment ranges lie between the 3-fold and the 6-fold rated current for line protection and the 3-fold to the 16-fold rated current for motor protection. With the help of the instantaneous trips arranged in each of the three switch poles the protective switch is in a position to immediately open the circuit in case of short circuits.**

## **- Thermal trip**

**A thermal trip is provided for protection against overload. It is a tripping device with delay effect which in the overload range acts on a tripping pawl by heating up of one bimetal each per outer conductor.**

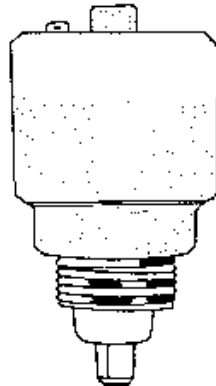
**The adjustment range of the thermal trip is adjusted to the rated current of the load (for example thermal relay as motor protection) or the release value of the rated current has been determined by the manufacturer (for example automatic cut-out).**

## - Undervoltage trip

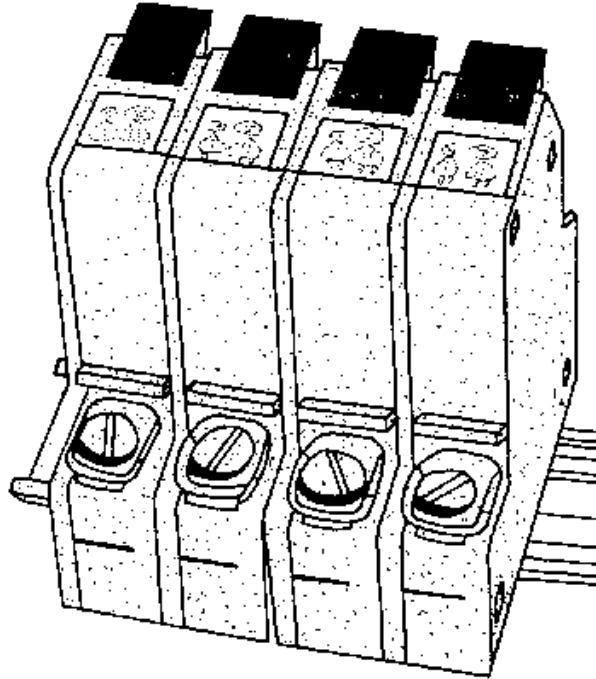
**The undervoltage trip operates electromagnetically and responds to the decrease in operating voltage.**

### Automatic cut-outs

**Automatic cut-outs are used in control installations and mainly in households. They are manufactured for rated voltages up to 380 V and rated currents up to 25 A as automatic circuit breaker with thread E 27 (Figure 7) and as automatic line protection (Figure 8).**



**Figure 7 Automatic cut-out**



**Figure 8 Automatic line protection**

**For each outer conductor one automatic cut-out is required as individual module. Actuation is carried out by a toggle lever. By means of a trip-free release an unhindered tripping can take place even if the control element is held fast.**

**The module consists of:**

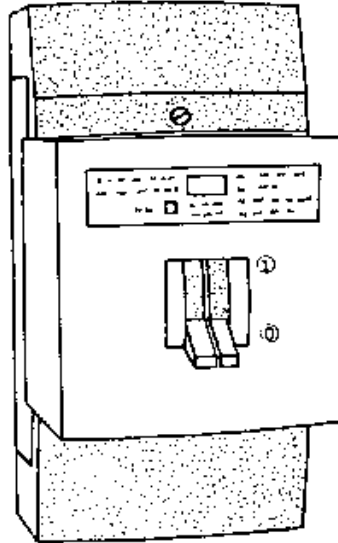
- **thermal trip**
- **magnetic overcurrent trip**
- **latching device**

**Switches for special tasks**

**In addition to the circuit breakers for low-voltage installations explained until now, special switches for specific purposes are manufactured.**

**Fault-current protective switches:**

**Fault-current protective switches are used as a protective measure against electric shocks in low-voltage installations.**

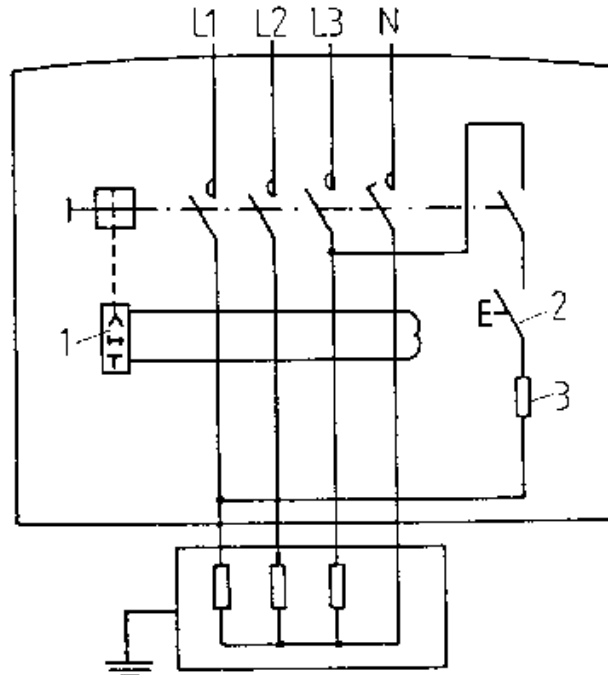


**Figure 9 Fault-current protective switch**

**The fault-current protective switch or the fault-current facility monitors inductively with a current transformer the sum of inflowing and out-flowing currents in the system to be protected. For this purpose all conductors coming from the network, also the neutral conductor, are led through the summation current transformer. They form the primary winding. With a faultless circuit in the three-phase system or in the alternating current system the sum of all currents is**

**zero at that moment. The current flowing against earth in case of a body contact or a line-to-earth fault disturbs the symmetry and generates in the secondary winding of the transformer a voltage which disconnects the installation when the rated fault current is exceeded. Fault-current protective switches are manufactured for the rated voltage of 380 V a.c. or three-phase and for rated currents of 25 A, 40 A, 80 A.**





**Figure 10. Principle of the fault-current protective switch**

**L... conductor**

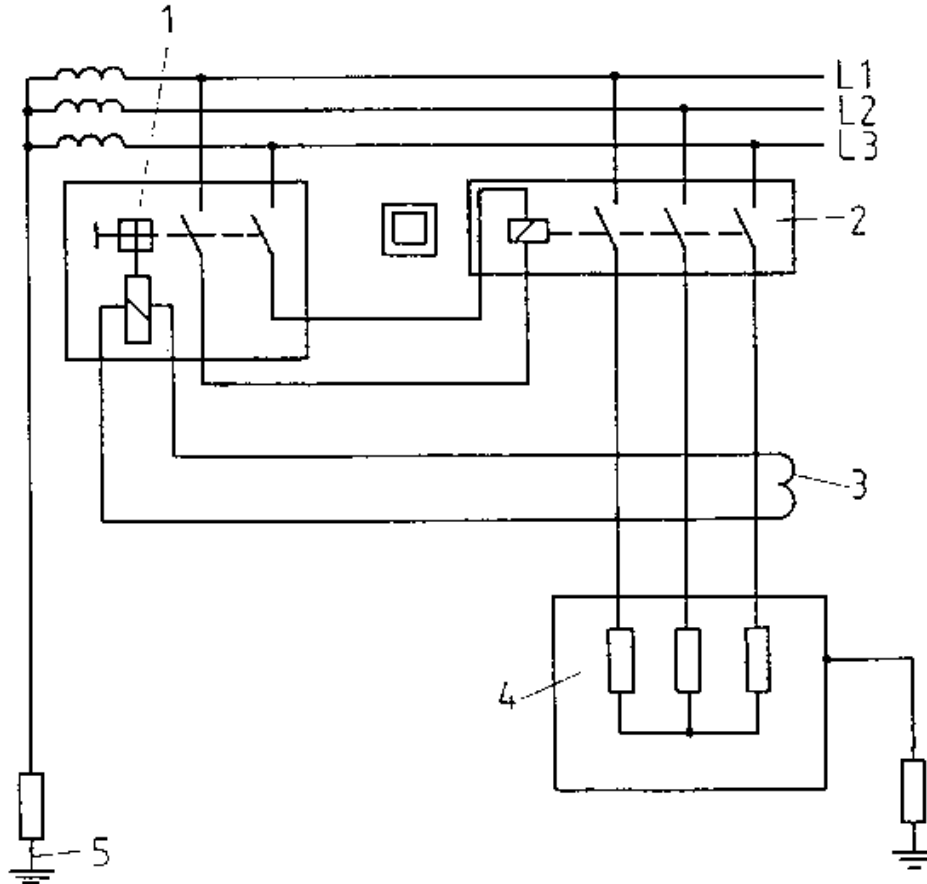
**N neutral conductor**

**1 fault-current coil**

**2 test key**

**3 limiting resistor**

**When installations with currents above 80 A shall be switched, the fault-current control circuit must be used.**



**Figure 11 Fault-current control circuit**

**L... conductor,**

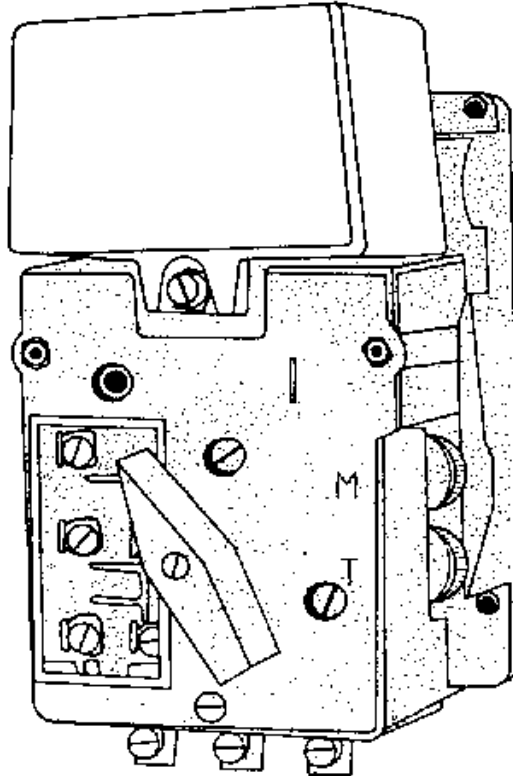
**1 fault-current control switch, 2 contactor, 3 summation current transformer, 4 consumption device, 5 earthing in accordance with regulations**

**Fault-current protective switches are manufactured**

- for rated fault currents of 30 mA for protecting human beings and productive livestock and**
- for rated fault currents of 100, 200. 300 and 500 mA for protecting installations and for fire protection.**

**Motor protection switches:**

**Motor protection switches are special switches which serve for switching and protecting motors. They are provided with bimetal and instantaneous trips. Motor protection switches are manufactured for rated voltages up to 380 V and rated currents up to 25 A in open and enclosed design.**



**Figure 12 Motor protection switch 25 A**

### **3.3. Overload circuit breakers**

**When directly switching on electric motors, especially three-phase squirrel-cage motors, the starting current may amount to the 6-fold to 8-fold value of the rated current. Since on-load switches can only switch the 1.25-fold value of the rated current (see Section 3.4.), the overload circuit breakers must be in a position to switch the starting currents. Overload circuit breakers can be equipped with magnetic instantaneous trips and bimetal trips (see 3.2.4.) so that they serve at the same time as protective switches. Drum switches and cam-operated switches, contactors and motor protection switches can be used as overload circuit breakers.**

**They must display high switching speeds (snap-action circuit, see Survey 3), and the contacts must be arc resistant. Furthermore, the overload circuit breakers must have a long mechanical service life at a high switching frequency.**

**Multisection cam-operated switches and contactors are mainly used as overload circuit breakers.**

### **3.3.1. Multisection cam-operated switches**

**Multisection cam-operated switches are built-up in accordance with the modular construction principle. Their main components are the**

**locking device and according to the circuit a specific number of switching plates. Up to eight switching plates can be grouped to form a packet. Due to the different designs of the switching plates different switching operations can be carried out with one turn of the switch. Such circuit breakers are frequently used as control switches. The contacts are designed as pressure contacts. Contact bridges which cause a double interruption of the corresponding current path are moved by cam disks via switching plungers. When the camshaft turns, the plunger lifts the switching contact and thus causes a double interruption (see Survey 3).**

**Multisection cam-operated switches are manufactured for rated amperages of 10 to 200 A. The breaking capacity can amount up to 960 A.**

### **3.3.2. Contactors**

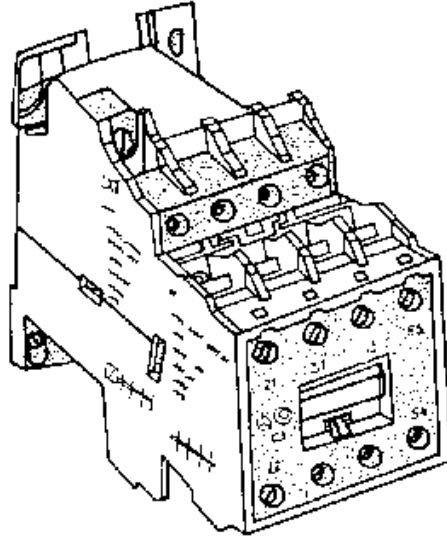
**Contactors are unlatched, electromagnetically actuated switches which fall back into their rest positions as soon as the control circuit is opened. The contacts are designed in such a way that for a short period of time currents can be carried which lie above the rated currents.**

**The most common air-break contactors work with double interruption of the contacts and a plunger armature. In addition to the main contacts the contactors are provided with several auxiliary contacts. The magnetic system has been designed in such a way that at 85 % of the rated voltage the armature is still in a position to pick up and that at 55 % of the rated voltage it drops out automatically.**

### **Air-break contactors**

**Air-break contactors, for example of type series LX 00 to 1-X 2:**



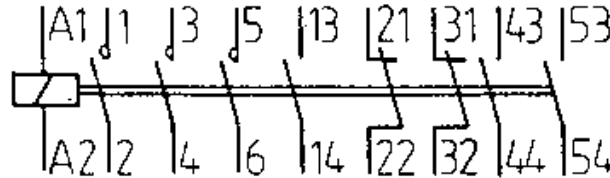


**Figure 13. Air-break contactor LX 1 with auxiliary switch block HX22**

**Air-break contactors 'LX' consist of a basic contactor and an additionally arranged auxiliary switch block with different contact complementation and switching functions (n.c. contacts, n.o. contacts, staggered switching instants, electronic-compatible auxiliary current paths).**

**They consist of a casing made of moulded material and can be mounted on 35-mm support rails. They are manufactured with d.c. and**

**a.c. drive, for the rated alternating voltage of 220 V and the rated current of 23 A up to a rated alternating voltage of 660 V and a rated current of 14 A.**



**Figure 14. Circuit diagram of an LX1-32 air-break contactor**

**Air-break contactors, for example of type series ID 21 to ID 7: The air-break contactors ID consist of a plastic casing which is resistant to tracking and has externally accessible terminals for the coil as well as the main and auxiliary contacts. The contact system consists of silver pressure contacts with double interruption (three main contacts and six auxiliary contacts). The arc chambers are provided with arc deflectors and extinguishing sheet metals. Above 63 A they are provided with deion chambers.**

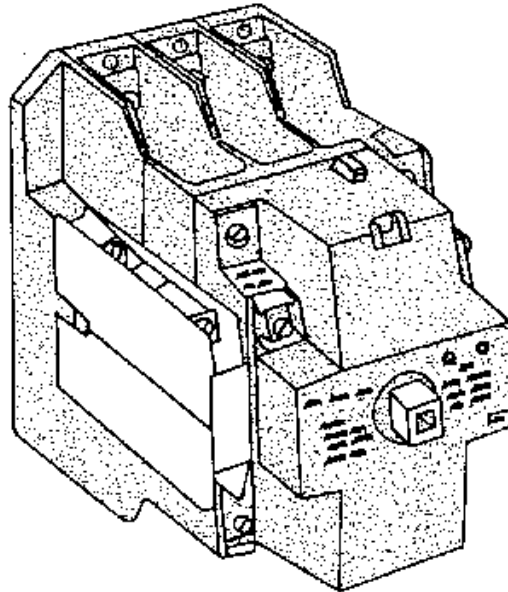
**ID contactors are used for**

- switching operations in alternating-current circuits and three-**

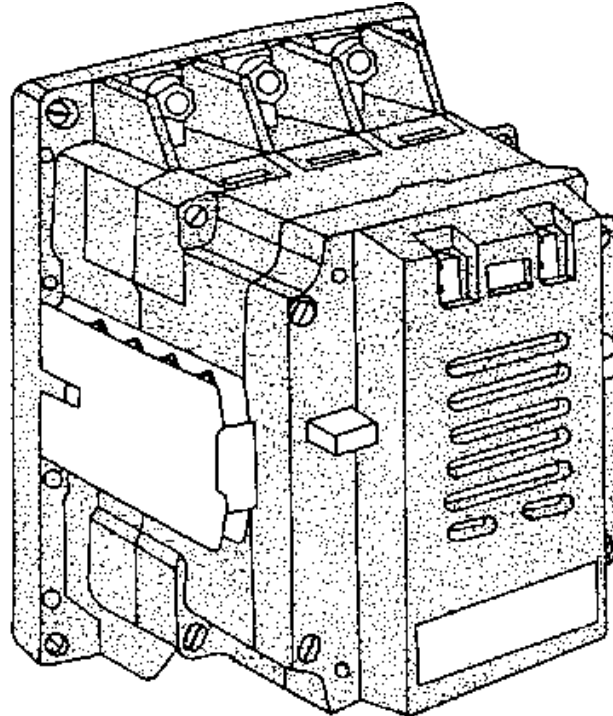
**phase circuits**

- **direct switching-on of squirrel-cage motors**
- **switching of slip-ring motors (rotor contactor).**

**They are manufactured for rated insulation voltages of 750 V a.c. and for rated operating currents of 32 to 250 A. An important feature of the contactors of type series ID is the modular construction principle. The individual modules can be replaced without loosening the terminals.**



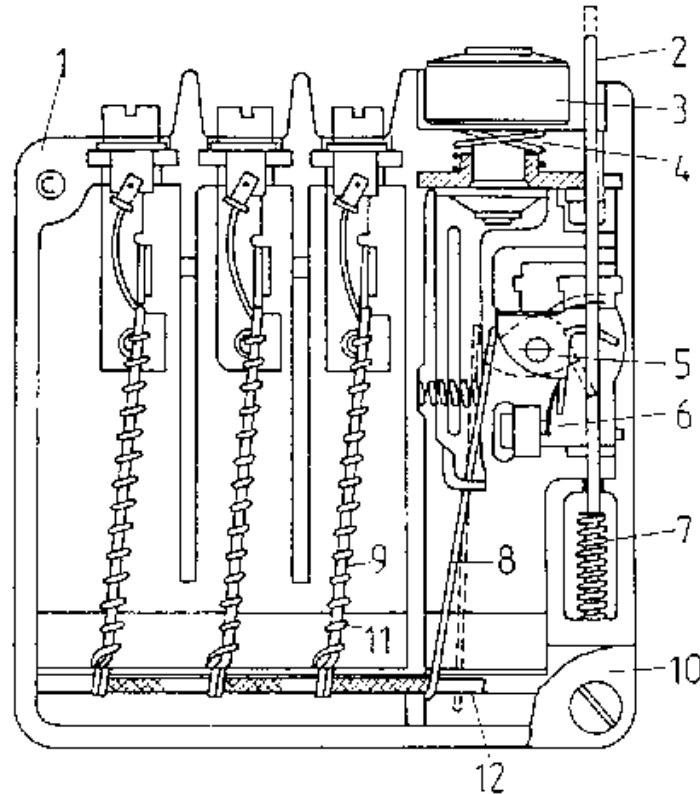
**Figure 15 IDX43 air-break contactor**



**Figure 16 ID7 air-break contactor**

**Air-break contactors of type series LX and ID can be used with and without thermal overcurrent relays (for example type IR 1 to IR 4).**

**Since both type series of contactors are frequently used for switching motors, thermal overcurrent relays have been developed which can be plugged on the main contacts.**



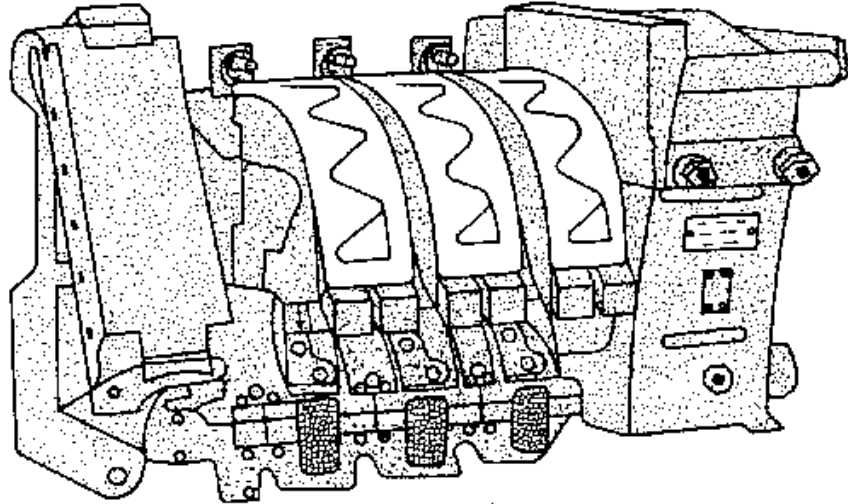
## **Figure 17. Thermal overcurrent relay in the open state**

- 1 casing.**
- 2 unblocking pushbutton,**
- 3 adjustment knob,**
- 4 connecting screw,**
- 5 pawl,**
- 6 command contact,**
- 7 compression spring,**
- 8 temperature compensation strip,**
- 9 bimetal strip,**
- 10 cover,**
- 11 core conductor,**
- 12 release strip**

**Air-break contactors, for example of type series ES:**

**Air-break contactors of type series ES are suitable for heavy duty conditions. For this purpose they have a special design. The magnet is fastened on rubber-metal antivibration mounting and ensures shock-free switching operations. These ES contactors display a high operational safety and can be used in rolling mills, on excavators and heavy machine tools. Their mechanical service life amounts to**

**approximately 10 million switching cycles on an average of 3000 switching cycles per hour. The rated voltage lies at 500 V a.c. or 600 V d.c. and a rated current up to 630 A depending on the type**



**Figure 18 Air-break contactor (ES series) for heavy conditions, for example in rolling mills and on excavators**

**Vacuum contactors, for example of type series EVS 160 - 630: Vacuum contactors are single-pole basic devices which with the help of connecting rails can be assembled by the user to form n-pole**

**contactors.**

**Each single-pole vacuum contactor possesses an auxiliary switch block with two freely available, optionally repluggable auxiliary contacts (1 n.c. contact and 1 n.o. contact). Opening and closing of the main contact members is effected with sufficient accuracy via an electric parallel connection of the individual solenoid-operated mechanisms.**

**Differing from the mode of action of air-break contactors, the switching operations of the main contacts take place under vacuum. Therefore they only need a short length of contact travel. The solenoid-operated mechanism has been designed for direct voltage, For alternating-current operation a rectifier module is arranged in the contactor.**

**Vacuum contactors have been designed for use in works of the basic industry as well as the chemical and metallurgical industries for heavy duty electric and mechanical operating conditions.**

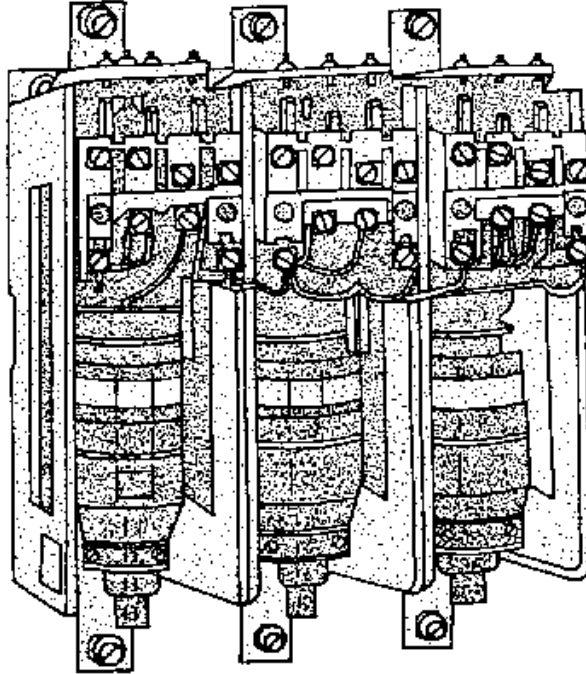
**Vacuum contactors are used like ID contactors for**

- switching operations in alternating-current circuits and three-phase circuits**



- direct switching-on of squirrel-cage motors**
- switching of slip-ring motors (rotor contactor).**

**Vacuum contactors are manufactured for rated voltages up to 660 V a.c. and rated currents up to 630 A. The contact members have a service life of approximately 7 million switching operations\***



**Figure 19. Vacuum contactor with three arc chambers**

### **3.4. On -load switches**

**On-load switches may be overloaded for a short period of time during the closing/opening cycle with the 1.25-fold rated current. Since the**

**amount of the overcurrents during the closing/opening cycle depends mainly on the inductance of the circuit. on-load switches are only to be used in circuits with a power factor greater than 0.7.**

**On-load switches are used in many fields of consumers' installations of electrical energy.**

**There is a variety of technical designs of on-load switches, both as far as the mode of action, for example lever switches, drum switches, cam-operated switches, gang switches and the shape of the contact, for example blade contacts, rolling contacts and pressure contacts are concerned.**

**In addition to the installation switches such switches which can be built into low-voltage distribution systems are important for power-current plant construction. On-load switches, mostly combined with HRC fuses, are used as incoming disconnectors, but mainly as outgoing-feeder disconnectors.**

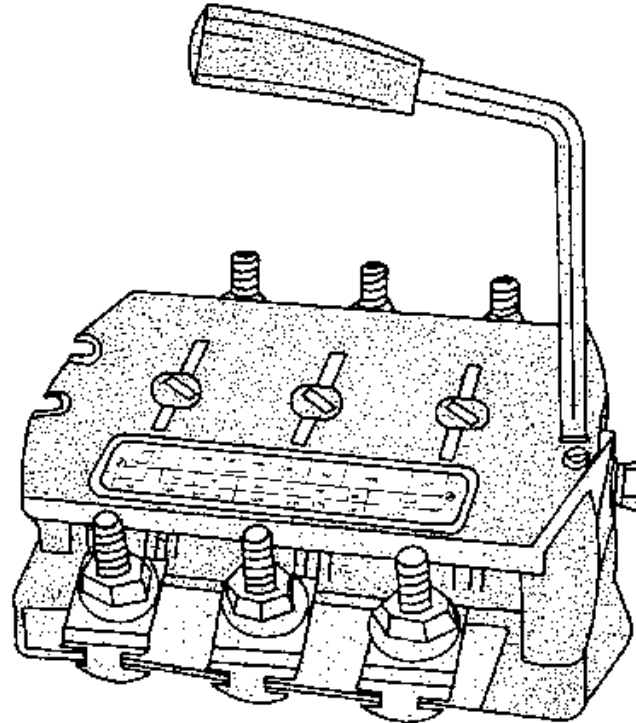
### **3.4.1. Load-break switches in slim design**

**The load-break switch in slim design (FTLA switch) has replaced the former load-break switch (LTA switch), with the exception of the**

**switch for a rated amperage of 1000 A. FTLA switches are manufactured both in open and encapsulated design.**

**The encapsulated design of the FTLA switch is especially suitable for sheet-steel-enclosed installations. The switches possess silver pressure contacts with double break. They are manufactured in three different sizes for a rated voltage of 660 V a.c. with a power factor of 0.7 and for rated currents up to 630 A (with the exception of LTA - rated current 1000 A).**

**When a letter is added to the designation FTLA, for example FTLAS, that means that the load-break switch and the associated HRC fuses are arranged in a sheet-steel casing.**



**Figure 20. FTLA load-break switch 250 A in open design**

### **3.4.2. Installation switcher**

**Installation switches are load switches which have been designed for**

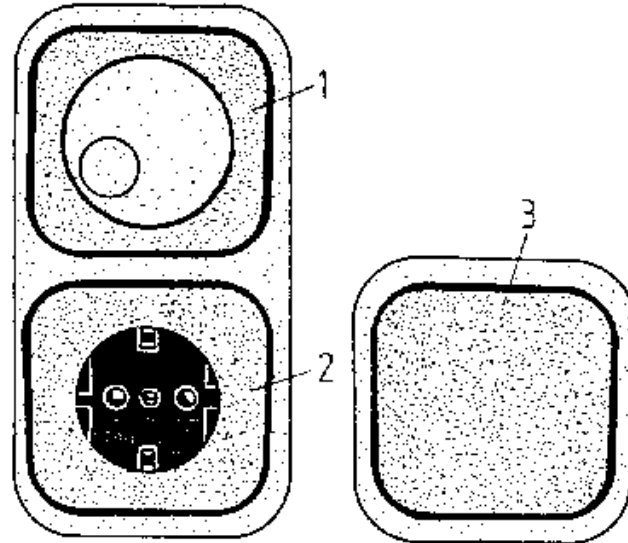
**electrical low-voltage installations, mainly lighting systems in dwelling-houses, workshops and social buildings. They are designed for rated currents of 6 or 10 A.**

**Installation switches are classified in accordance with the**

- type of connection, for example on-off switch, two-circuit single interruption switch, intermediate switch, on-off switch as dimmer with thyristor**
- type of actuation, for example toggle switch, rocker switch, rotary switch (in most cases now only as a light controller; see Figure 21), pushbutton switch**
- type of mounting, for example surface switch, flush switch, appliance switch**
- use in accordance with the degree of protection.**

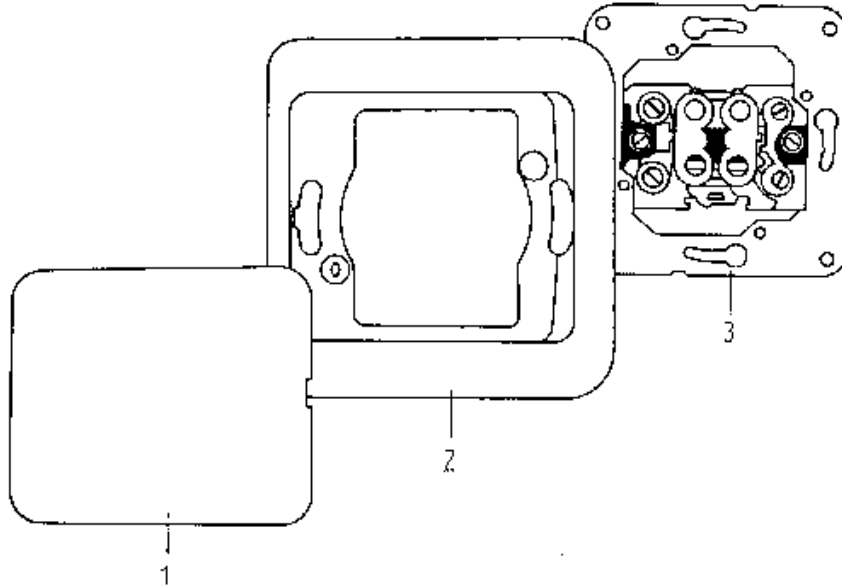
### **Survey 5 Degrees of protection for installation material**

<b>Degree of protection</b>	<b>Application</b>	<b>Place of application</b>
IP 20	Surface and flush design	Dry rooms
IP 44	Surface and flush design	Moist rooms

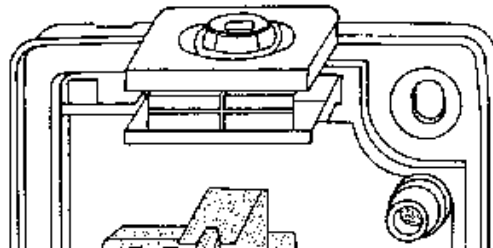


**Figure 21. Installation switch (flush design IP 22)**

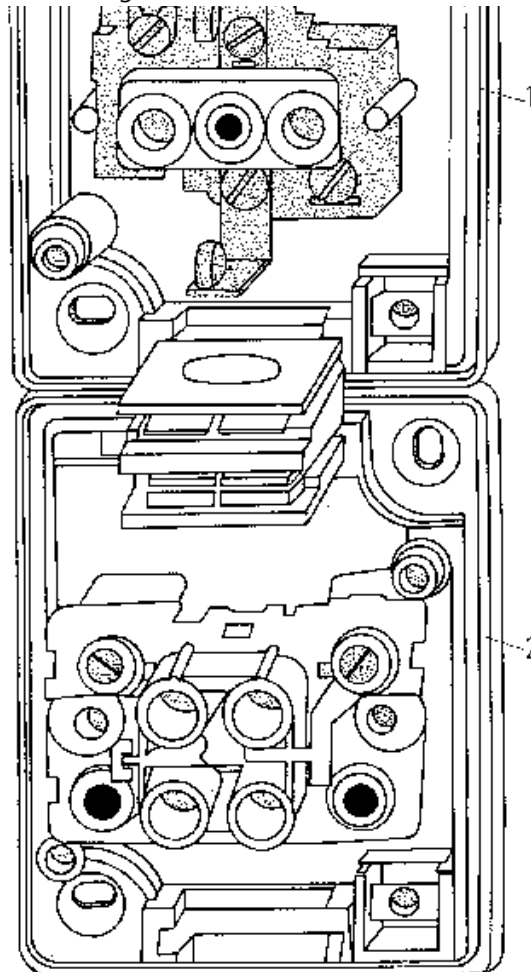
- 1 dimmer,**
- 2 socket-outlet with earthing contact,**
- 3 rocker switch**



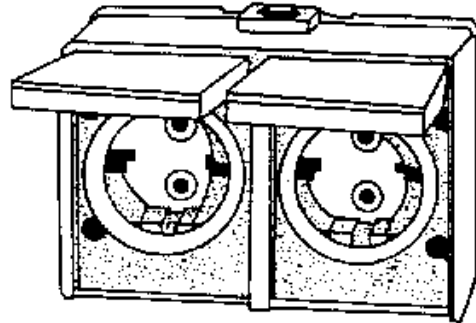
**Figure 22. Installation switch, dismantled (flush design) - 1 junction rocker, 2 covering frame, 3 switch 10 A/220 V a.c.**



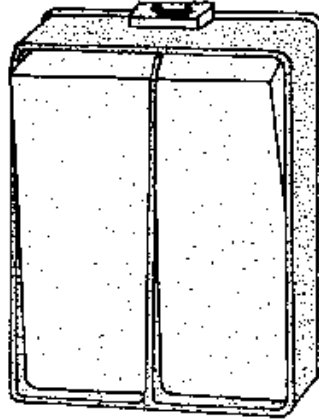




**Figure 23. Moisture-proof switch and moisture-proof socket-outlet with earthing contact, open (surface design IP 41) - 1 Socket-outlet with earthing contact, 2 switch**



**Figure 24. Moisture-proof socket-outlet with earthing contact (double) in surface design IP 41**



**Figure 25. Moisture-proof multicircuit switch in surface design IP 41**

### **Installation remote switches**

**Electromagnetic, remote-controlled, latched switches controlled with a voltage of 12 V a.c., for dwelling-houses and social buildings.**

**Installation remote switches with a control voltage of 220 V a.c. are used for industrial plants.**

**At the power-current side the switch has been designed for a rated voltage of 250 V a.c. and a rated current of 10 A.**

### **The advantages of these switches are:**

- the circuit arrangement can be switched by an optical number of pushbutton switches**
- small cross-sections for the pushbutton switches**
- low voltage at the pushbutton switches.**

### **The disadvantages are:**

- high material expenditure**
- more expensive than conventional installation circuits.**

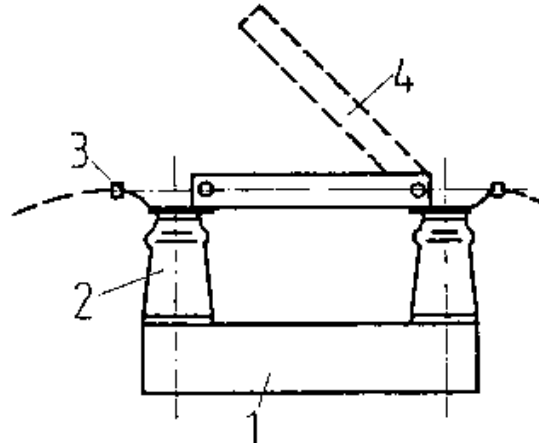
### **3.5. Off-load switches**

**Off-load switches serve for the almost currentless switching of circuits in order to make dead. by a visible isolating position, the parts of the installation lying behind.**

**In most cases an off-load switch is not used for this task, but the dead state is established and secured by**

- isolating links**
- HRC fuses or**
- carriage-type switchgear (plug-in technique).**

**For rated amperages from 1000 A onwards the TCI isolating switch (T = isolating switch, C = three-pole, I = indoor) which is also manufactured for 1 kV, can be used. It is produced for 1250, 2500 and 4000 A.**



**Figure 26 TCI isolating switch**

- 1 frame, 2 insulator**
- 3 connecting shaft**
- 4 disconnecting blade**

**Its disadvantage is that it is relatively big and thus requires a lot of**

## space in low-voltage switchgear installations.

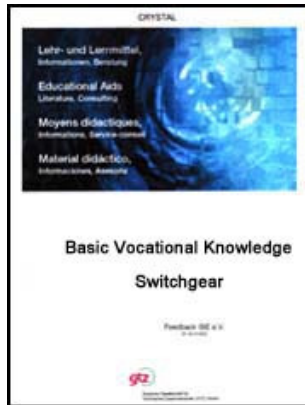
### Earthing switches

Earthing switches are used for earthing disconnected parts of plants.

They can be combined with on-load and load-break switches.



[Home](#) > [ar](#) [.cn](#) [.de](#) [.en](#) [.es](#) [.fr](#) [.id](#) [.it](#) [.ph](#) [.po](#) [.ru](#) [.sw](#)



## Switchgear - Basic vocational knowledge (Institut für Berufliche Entwicklung, 54 p.)

### 4. Relays and control devices








#### 4.1. Relays

 *(introduction...)*

 4.1.1. Neutral or auxiliary relays

 4.1.2. Time relays

 4.1.3. Undervoltage and overvoltage relays

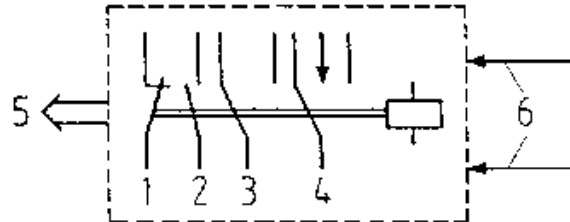
-  **4.1.4. Overcurrent relays**
-  **4.1.5. Overcurrent time relays**
-  **4.1.6. Magnetic overcurrent relays**
-  **4.1.7. Signal relays**
-  **4.2. Control devices**
  -  **4.2.1. Discrepancy switches**
  -  **4.2.2. Control discrepancy switches**

## **Switchgear - Basic vocational knowledge (Institut fr Berufliche Entwicklung, 54 p.)**

### **4. Relays and control devices**

#### **4.1. Relays**

**Relays are important devices in control installations. They are influenced by the change of the characteristic quantity in the operating element and actuate electrical switching elements.**



**Figure 27. Types of contacts (types of switching elements) on a relay**

- 1 n.c. contact,**
- 2 n.o. contact,**
- 3 double-throw contact,**
- 4 passing contact,**
- 5 manipulated variable,**
- 6 measured variables**

### Characteristics

#### **- Pick-up value**

**Actual value of the characteristic quantity at which undelayed relays and trips reach the operated condition and delay relays, time relays and delayed trips reach the starting position.**

#### **- Resetting value**



**Value of the characteristic quantity at which the relay and the trip leave the operated condition.**

**- Operate time**

**Time between the appearance of the characteristic quantity until reaching of the operated condition.**

**- Operating time**

**Time between the appearance of the pick-up value of the characteristic quantity in protective relays until reaching the operated condition.**

**- Basic time**

**Shortest operating time.**

**- Maximum operating time**

**Longest operating time.**

**- Grading time**

**Difference of operating times of relay protective devices in series connection.**

**- Main protection**

**Time protection for response in case of disturbances in the range of a complete part of the installation to be protected, this time being less than that of the other relay protective devices of the corresponding part of the installation.**

**- Setting value of the protection**

**Rated value of the characteristic quantity or the time of disconnection between pick-up range and non-operating zone.**

**- False tripping**

**Response of a relay protective device in the absence of disturbances or abnormal operating conditions in the part of the installation to be protected.**

**- Erroneous tripping**

**Response of a relay protective device due to the wrong setting of a protective relay.**

**- Primary relay.**

**The characteristic quantity to be monitored lies directly on the operating element via the transformer.**

**- Secondary relay**

**The characteristic quantity to be monitored lies indirectly on the driving system via the transformer.**

**- Protective relay (general)**

**A combination of measuring, neutral and time relays solely for the purpose of special protective tasks. Apart from a few exceptions, currents, voltages, products, quotients, sums of differences thereof are used as characteristic quantities. Protective relays shall work in a very exact and reliable manner. The contact elements are actuated when the set values are exceeded or fallen below during monitoring of the characteristic quantities.**

**Abbreviations for type designations (examples)**

A display	a drop-out-delayed
B instruction, command (switching instruction), burden	b limited, dependent
	c capacitive, sine-phi circuit
D distance measurement	
E earth fault	
F for overhead lines	f fine, sensitive, exact

G for generators	g only for direct current
H auxiliary relay (only for intermediate relay)	h with intermediate relay
I <sub>o</sub> asymmetric current	i interval
K for cable (on its own - terminal)	k short
L for locomotives	l long
M message	
N shunt resistor	n for connection to shunt resistor
O location, position finding (fault finding)	
P anti-hunt device	
Q formation of quotients, quotient excitation	
R on its own - resistor,	
R as first letter - relay in other respects - direction	
S current, overcurrent S as first letter - control	s quick, saturated
	t thermal

U voltage (undervoltage and overvoltage)	
U <sub>o</sub> asymmetrical voltage	
V comparison	v interlocked
W transformer	w transoormer current tripping or alternating current
X mixed impedance	
Z time	

**Number as last number - design, in all other cases - number of poles**

### **System example and RELOG designations**

URSAMAT Universelles (universal) system of equipment and facilities for  
Regelung (regulation)  
Steuerung (control) and  
Auto-  
MATisierung (automation) of technological processes

### **RELOG designations**

First number:

Dimension stipulation of the module (Multiply number by 15 = width of the module)

First letter:

R for electromechanical module

T for transistorised module

Second letter: (Reference to the function of the module)

A Signal relay (colour - red)

G Neutral relay with dry-reed contact (colour - blue)

H Neutral relay with open contact elements (colour black)

S Measuring element for current (colour -light violet)

U Measuring element for voltage (colour -light violet)

Z Time relay (colour -green)

Last two numbers:

Type distinction

### **Example: Relay with the designation 2 RH 05**

**30-mm wide electromechanical module as neutral relay with open contact elements of Type 05**

### **4.1.1. Neutral or auxiliary relays**

**Auxiliary relays possess a magnetic system with hinged armature and a series of contacts (n.c. contacts, n.o. contacts and change-over contacts) which are actuated by the armature.**

**As far as the technical data of**

- coil voltage**
- switching current**
- number of contacts and types of contacts**

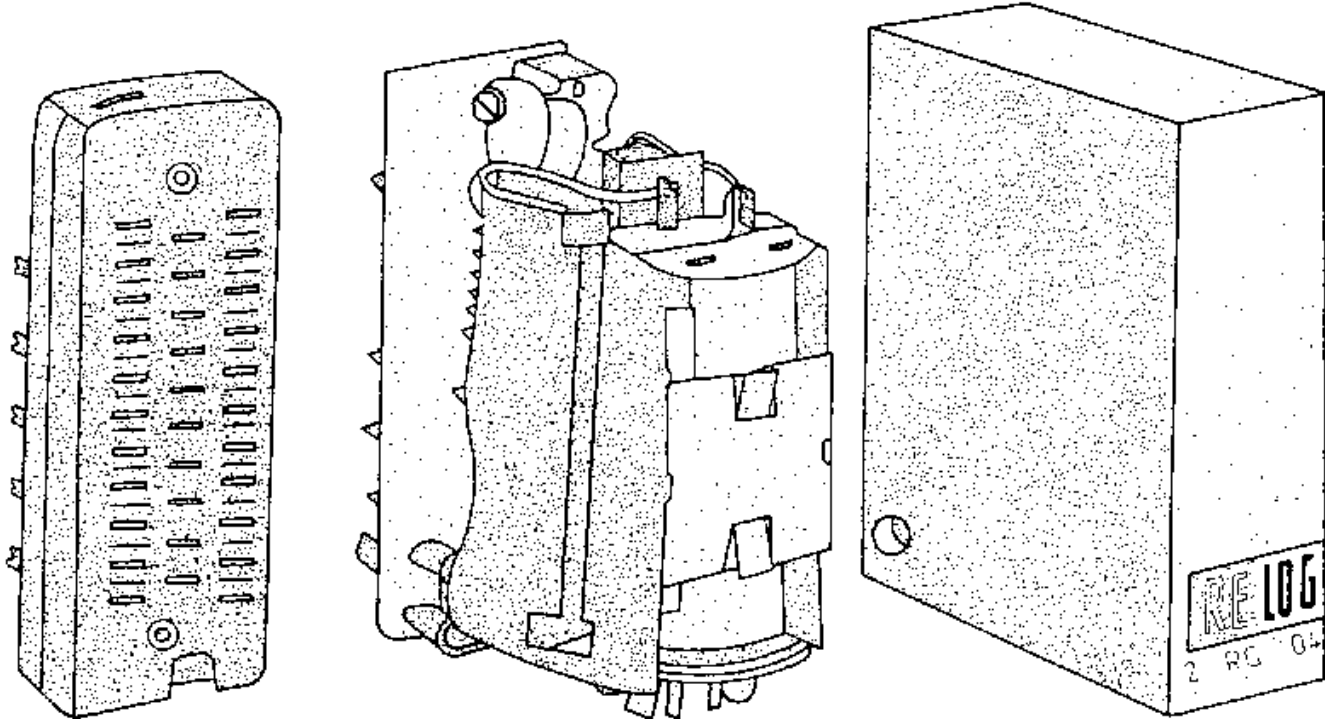
**are concerned, there is a large variety of auxiliary relays, and in accordance with requirements a proper selection has to be made.**

**Examples of application:**

- Switching of control circuits**
- Amplification and transmission of weak control pulses (for example contact thermometer)**
- Control element in electrical installations for the direct control of magnets etc.**

**A frequently used neutral relay is, for example, relay 2 RG 04 of the**

## RELOG system.



**Figure 28 Neutral relay 2RG04**

### 4.1.2. Time relays



## **Electronic time relay:**

**Time modules work in accordance with the principle of making and breaking delay. That means, the charging of a capacitor is effected via a resistor in accordance with an exponential function (see charging curve of a capacitor). At a determined magnitude of capacitor charging voltage the relay is actuated by the threshold switch (Schmitt trigger).**

**Electronic time relays are used:**

- for making and breaking delay between 0.3 s and 6 h (protective devices with delay effect)**
- for switching operations with delay effect.**

**Electromechanical time relays:**

**These relays consist of a hinged armature magnet and a mechanical time-delay element. Through the energization of the magnetic coil a contact lever is moved at constant speed which strikes against an adjustable countercontact and switches the tripping circuit. When the voltage disappears, the relay returns to its starting position without delay,**

**As far as the electromechanical time relays are concerned, a difference is made between short-time relay, precision-time relay and time relay with synchronous motor.**

**- Short-time relay, for example RZk and RZk3**

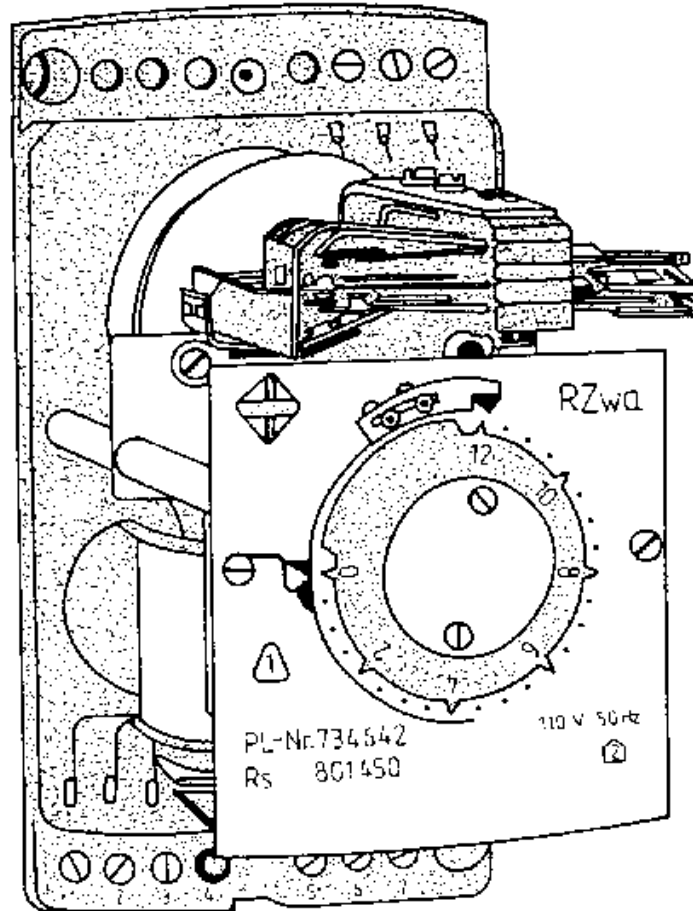
**These short-time relays can be used for all delayed switching operations of control engineering in which only a short adjustable time delay is required. In connection with overcurrent or undervoltage relays they can also be used for the delayed tripping of switches.**

**- Precision-time relays, for example RZf2**

**These precision-time relays possess a high time accuracy. In connection with single-pole, double-pole or three-pole overcurrent and undervoltage relays they are suitable for establishing protective facilities with delay effect. The relay possesses one undelayed and one adjustable delayed n.o. contact each,**

**- Time relay with synchronous motor-, for example RZw vwhen a voltage is applied, the synchronous motor starts. With the help of a coupling magnet the motor is engaged with a time wheel which passes through an angle proportional to the set time until contact making**

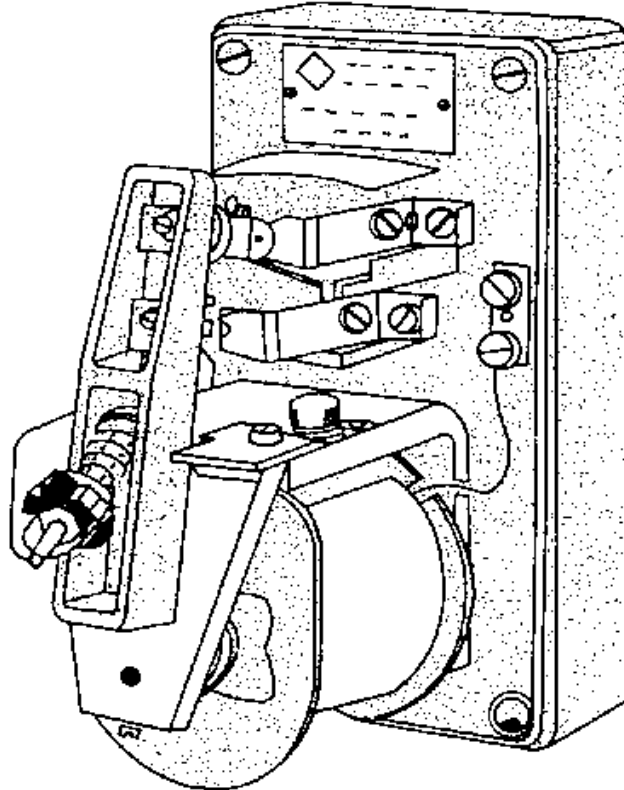
**takes place. When the voltage disappears, the corresponding contact elements open immediately.**



## **Figure 29 Time relay RZw**

### **4.1.3. Undervoltage and overvoltage relays**

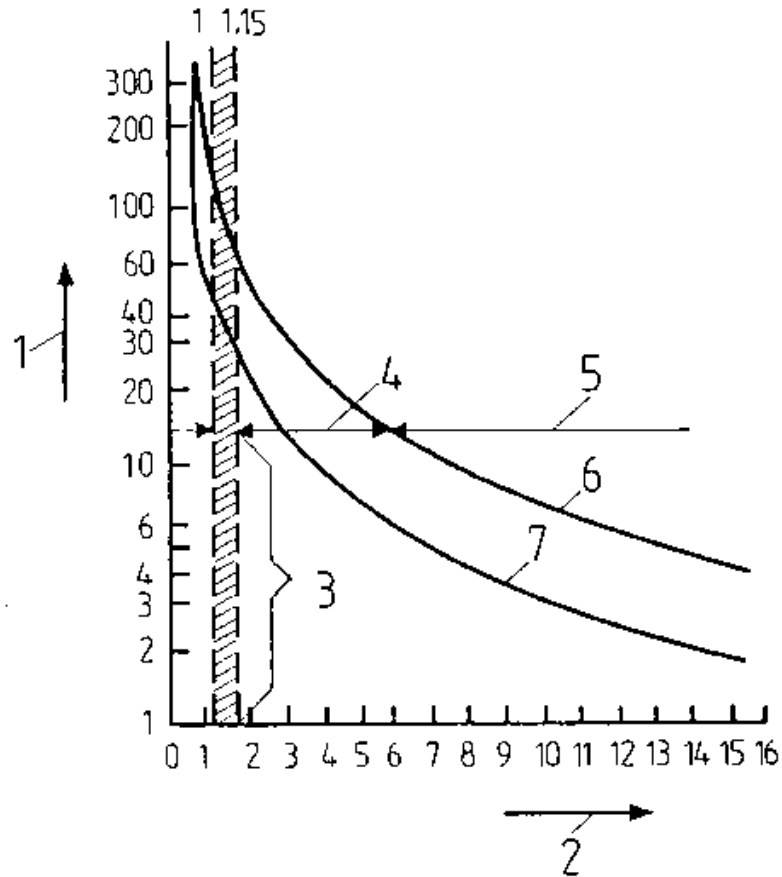
**These relays, for example RUF5 and RUF5F, are suitable for the undelayed tripping of switches when the mains voltage drops or fails as well as for the undelayed tripping of switches in case of occurring overvoltage.**



**Figure 30 Undervoltage relay**

#### **4.1.4. Overcurrent relays**

**This relay, for example RSf5, has been designed for the undelayed tripping of switches in case of overcurrents caused by overload or short circuit. Picking-up is shown by means of a visual indicator. Thermal overcurrent relays, for example IR1 to IR4, are suitable for direct-current and alternating-current application. They are used together with air-break contactors of type series ID1 to ID4 and LX00 to LX2.**



**Figure 31. Release characteristic of a thermal overcurrent relay in the**

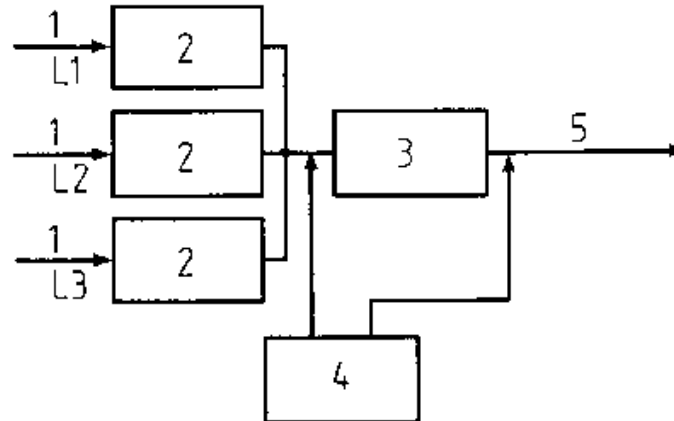


## **hot and cold states**

- 1 time in seconds,**
- 2 rated current,**
- 3 overload range,**
- 4 start,**
- 5 short circuit,**
- 6 characteristic (cold),**
- 8 characteristic (hot)**

### **4.1.5. Overcurrent time relays**

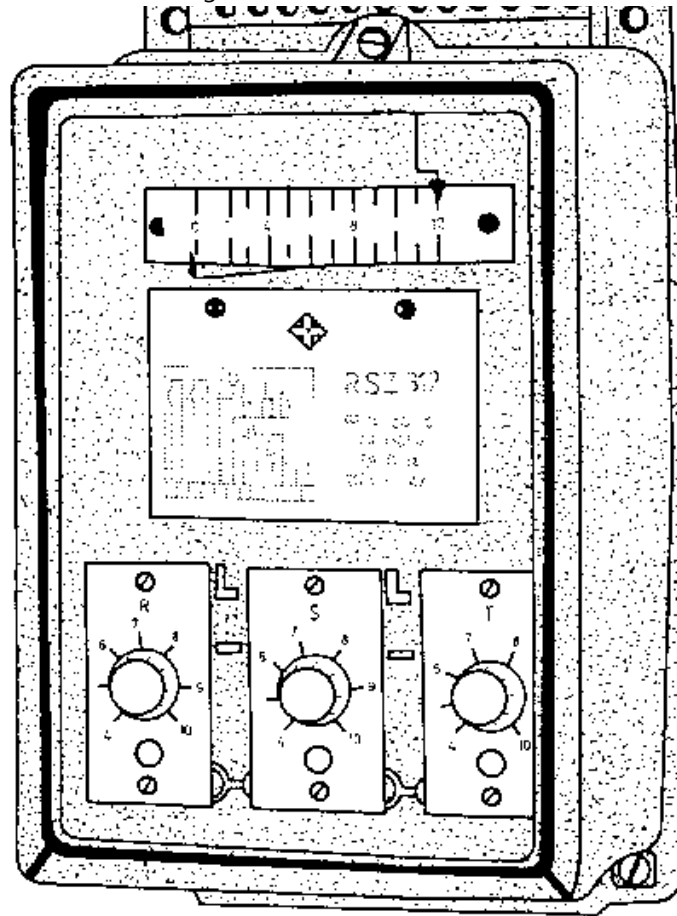
**The relay, for example RSZ3f2, serves for the current-dependent monitoring of motors (low voltage and high voltage) and transformers to protect them against overload and short circuit. The supplied auxiliary voltage serves for feeding the timing element as well as for giving the tripping command.**



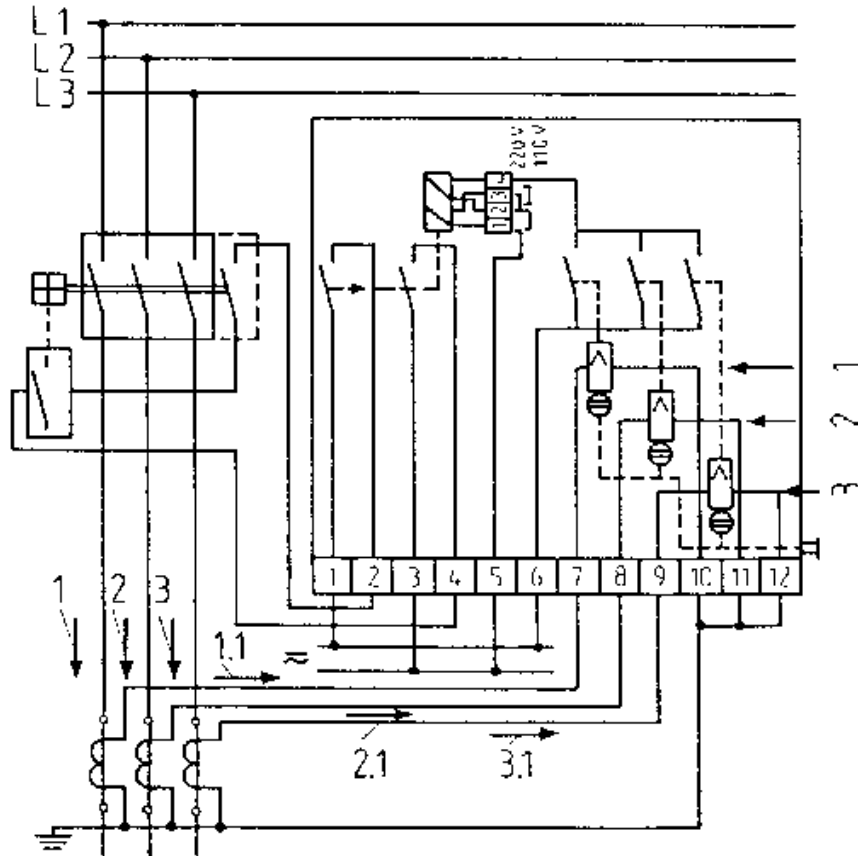
**Figure 32. General wiring diagram of an overcurrent time relay**

- 1 current of conductors 1...3**
- 2 excitation elements**
- 3 delay (time) element**
- 4 auxiliary voltage source**
- 5 tripping command**

**When an adjustable current value is reached, the excitation elements respond and via the series-connected time element they give the delayed tripping command for the associated circuit breaker.**



**Figure 33. Overcurrent time relay RSZ3f2**



**Figure 34 Circuit of the overcurrent time relay RSZ3f2**

**1 current of L1**

**2 current of L2**

**3 current of L3**

**1.1 excitation current of L1**

**2.1 excitation current of L2**

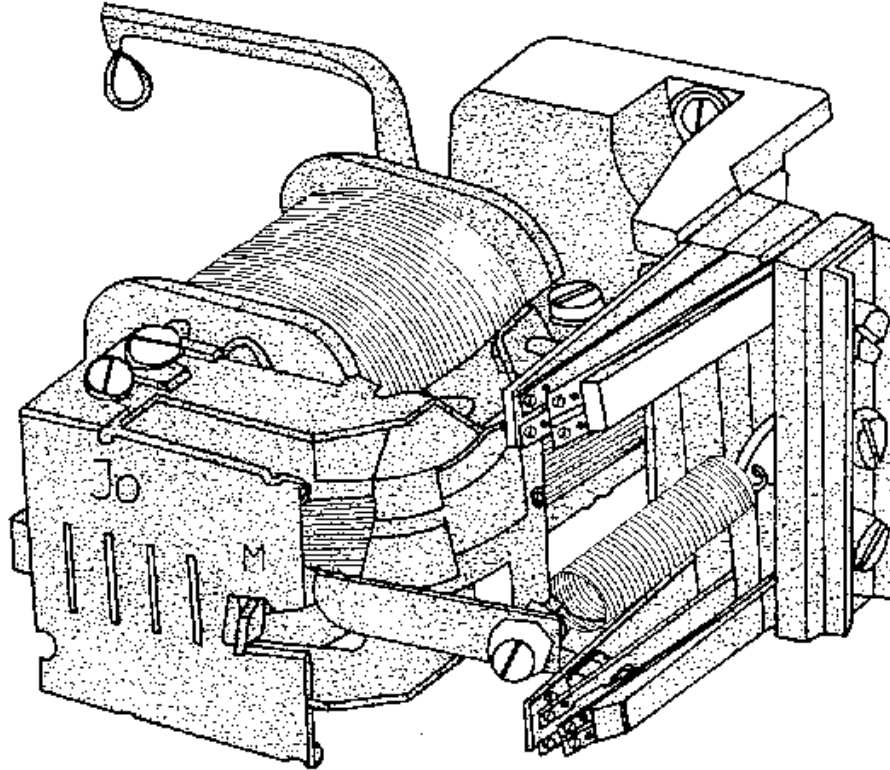
**3.1 excitation current of L3**

#### **4.1.6. Magnetic overcurrent relays**

**Magnetic overcurrent time relay, for example ERmv, for protecting the equipment in low-voltage installations against overload. It is an independent device and works in connection with low-voltage circuit breakers.**

**The time mechanism is provided with adjustment facilities and scales. When the set minimum operating current is reached, the armature of a magnet picks up and initiates the start of the time mechanism. After the delay time has run down, the armature actuates the auxiliary switch.**

#### **4.1.7. Signal relays**



**Figure 35 Signal relay RA70**

**The signal relay, for example RA70, serves for indicating disturbances (voltage failure), operating states (ON, OFF, full, empty). Information**

**is stored for acknowledgement by manual actuation until the disturbance is eliminated or the initial position is restored. Built-in contacts can be used for remote display, for disconnecting disturbed installations as well as for tripping acoustic signals.**

Rated voltage: 60, 110 and 220 V d.c.  
24, 220 and 380 V a.c.

Making current: 10 A a.c./d.c.

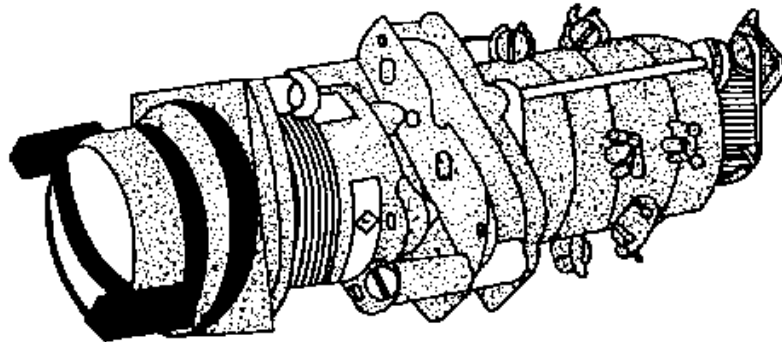
Continuous current: 5 A a.c./d.c.

Contact elements: 2 double-throw contacts or  
1 double-throw contact,  
1 passing contact or  
1 n.o. contact in middle position and  
1 double-throw contact or  
1 n.o. contact in middle position and  
1 passing contact

## **4.2. Control devices**

### **4.2.1. Discrepancy switches**


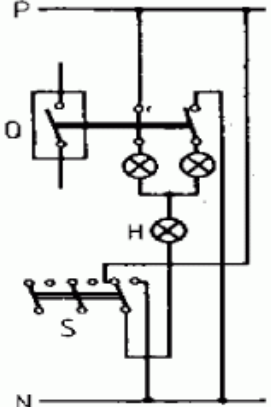

**The discrepancy switch, for example BM2, serves for indicating and monitoring the switch position in mimic diagrams and illuminated circuit diagrams of electrical installations, for indicating the position of valves in a piping system and indicating faults by means of visual or acoustic signs. It can also serve as command switch, for example, for controlling switches while displaying at the same time the position of the switches. The control button is designed as graphical symbol. When the latter is lit, it is indicated that the state of the associated switch or valve does not coincide with the display.**

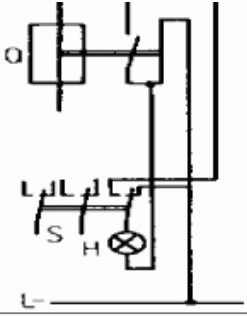

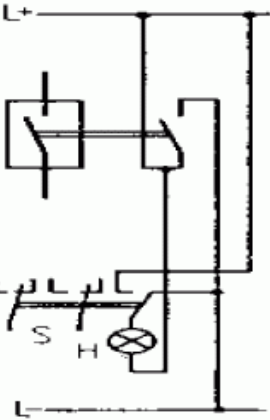


**Figure 36 Discrepancy switch BM2**

## **Survey 6 Functional principle of the discrepancy switch BM2**



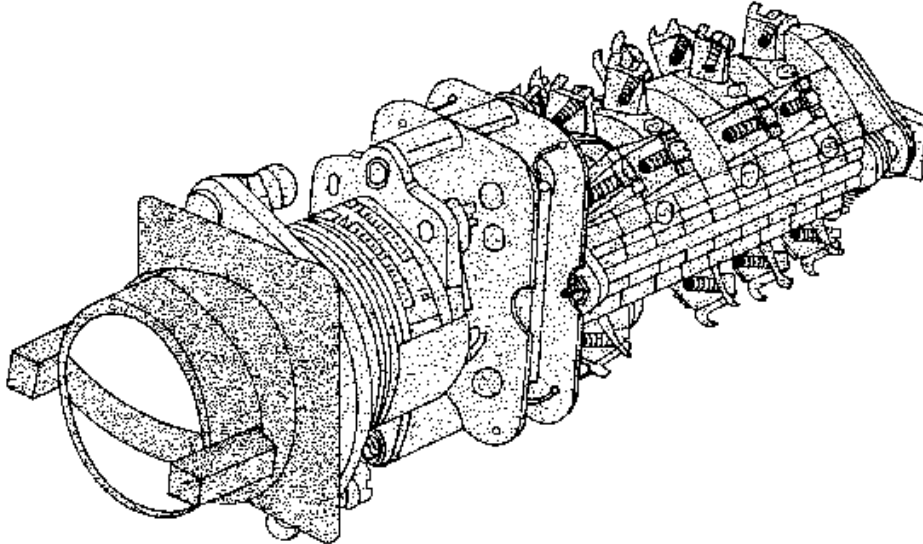
<b>state</b>		
Q OPEN S OPEN 	The position of the circuit breaker Q corresponds with that of the discrepancy switch S. Lamp remains off.	
H dark		
Q CLOSED S CLOSED	See Figure	

		
H dark		
<p>Q OPEN S CLOSED</p> 	<p>By changing the position of the circuit breaker Q the circuit of the signal lamp is closed. Acknowledgement is effected by changing the discrepancy switch S.</p>	

#### 4.2.2. Control discrepancy switches

The control discrepancy switch, for example SM2, is used in

**switchgear installations for controlling circuit breakers and isolating switches as well as for displaying and monitoring their switching positions in mimic diagrams. When the switch symbol lights up, it is indicated that the position of the control discrepancy switch does not coincide with that of the associated circuit breaker or isolating switch.**

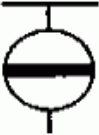
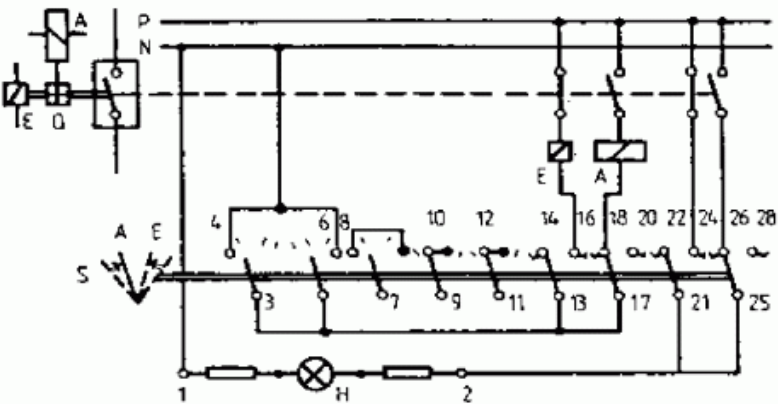

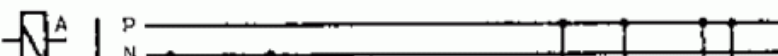


**Figure 37 Discrepancy control switch SM2**

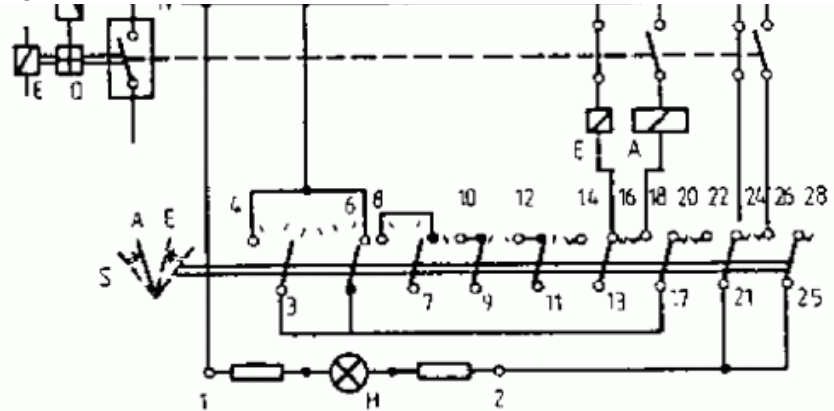
**Survey 7 Functional principle of the control discrepancy switch in**

## preselection position

### Switching Operation Connection state

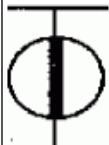
<p>Q OPEN S OPEN</p> 	<p>Circuit breaker Q and control discrepancy switch S in agreement</p>	
<p>H dark</p>		
<p>Q OPEN S CLOSED</p> 	<p>Preselection by turning control discrepancy switch S to close circuit breaker Q. No agreement between the two</p>	

switches.

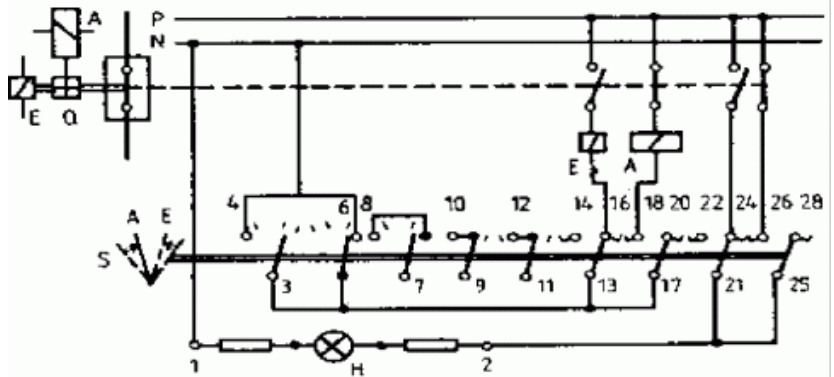


H lit

Q  
CLOSED  
S  
CLOSED

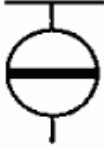


Closing of circuit breaker Q by shortly depressing and turning control discrepancy switch S by 45 degrees. Agreement between Q and S.

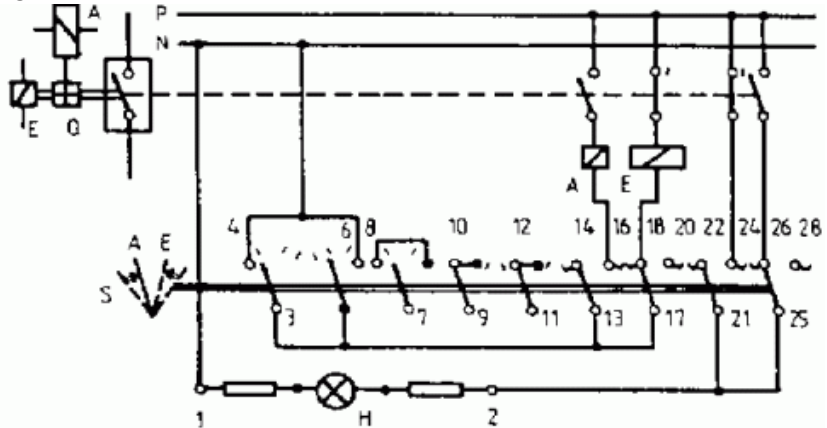


H dark

Q OPEN  
S OPEN



A change of the position of circuit breaker Q causes control discrepancy switch H to light up. By turning the control discrepancy switch S by 90 degrees, the message is acknowledged and lamp H goes out.



H dark

- H - l a m p**
- Q - c i r c u i t b r e a k e r**
- S - c o n t r o l d i s c r e p a n c y s w i t c h**

