








## **Tools for Mining: Techniques and Processes for Small Scale Mining (GTZ, 1993, 538 p.)**

### **Technical Chapter 16: Other Sorting and Separating Techniques**

-  **16.1 Roasting oven, calcining furnace**
-  **16.2 Salt gardens, salt works, salterns**
-  **16.3 Sulfur production in heap smelting or chamber ovens**
-  **16.4 Autoclaves for extracting sulfur**
-  **16.5 Copper sulfate plant**
-  **16.6 Electrostatic sorting**
-  **16.7 Flotation**

**Tools for Mining: Techniques and Processes for Small Scale Mining (GTZ, 1993, 538 p.)**

**Technical Chapter 16: Other Sorting and Separating Techniques**

**16.1 Roasting oven, calcining furnace**

**Metal Mining  
Beneficiation, Special Techniques of Separation**

aerm.: Abrostofen

span.: horno de calcinacion

<b>TECHNICAL DATA:</b>	
Dimensions:	oven deck plate approx. 2 × 1 × 0.1 m
Weight:	approx. 50 kg
Form of Driving Energy:	thermal energy from heat of combustion
Operating Materials:	
Type:	Fuels: oil, coal, gas or wood, possibly NaCl for chloridized roasting
<b>ECONOMIC DATA:</b>	
Investment Costs:	when locally produced < 200 DM
Operating Costs:	high energy and fuel costs
Related Costs:	cleaning of exhaust gases

### **CONDITIONS OF APPLICATION:**

Operating Expenditures: low |-----| high

Maintenance Expenditures: low |-----| high

Location Requirements: large quantities of fuel have to be made available or be transported

Special Feed Characteristics: ores may contain sulfides but no! arsenic, selenium or mercury

Recovery: after a sufficient retention period the feed oxidizes quantitatively (i.e.

Recovery:

after a sufficient retention period the feed oxidizes quantitatively (near 100%)

Regional

Bolivia

Distribution:

Operating

very good |-----|-----| bad

Experience:

Environmental

low |-----|-----| very high

Impact:

during roasting of sulphidic ores large quantities of sulfur dioxide are released; additionally there is a high risk of possible release of very volatile and highly toxic metals, such as mercury, arsenic and selenium amongst others, either as elements or oxidized

Suitability for

very good |-----|-----| bad

Local

Production:

Under What

simple metal construction on top a brick oven foundation

Conditions:

Lifespan:

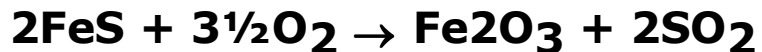
verylong |-----|-----| very short

depends on the aggressiveness of the roasted products

## **Bibliography, Source: Ullmann**

### **OPERATING PRINCIPLE:**

**Roasting is a thermal process for eliminating sulfides, whereby the sulfide and other sulfide-compounds are oxidized, e.g:**



**This reaction begins at approx. 105° C if there is sufficient oxygen partial pressure. The products to be roasted are spread out on a flat pan-shaped furnace plate and heated to over 105° C.**

### **SPECIAL AREAS OF APPLICATION:**

**Roasting is performed when it is necessary to free oxidic concentrates of sulfide, for example tin-ore and wolframite concentrates. In addition, sulfide-containing gold ores are roasted prior to being leached with cyanide.**

### **AREAS OF APPLICATION:**

**For purifying gold concentrates. This involves the roasting of high-grade pre-concentrates, whereby hematite and other iron minerals are broken down and, following a brief grinding, are pulverized into powder. The product is then freed of Fe-mineral fines by means of air (wind) classification or simple manual blowing.**

### **REMARKS:**

**During the roasting process, large quantities of volatile, gaseous sulfur dioxides are generated. When, besides sulfides, arsenic, selenium or mercury compounds are also present in the products, volatile compounds of these elements also develop. The vapors or gases of these compounds are all highly toxic, and therefore it is not advisable to operate small roasting plants without cleaning of gas emissions.**

**For special requirements, such as to acquire easily-soluble halide for the leaching process or to eliminate high-melting-point minerals, chlorinated roasting can be performed under addition of common salt (sodium chloride).**

### **SUITABILITY FOR SMALL-SCALE MINING:**

**The use of roasting ovens is appropriate for small-scale mining needs only in special cases since they are highly detrimental to the environment.**

## **16.2 Salt gardens, salt works, salterns**

### **Salt Mining Beneficiation, Special Techniques, of Separation**

germ.: Salzgarten, Salinen

span.: salines

<b><u>TECHNICAL DATA:</u></b>	
Depositional surface area:	crystallization area: depends on seasonal climate fluctuations; ratio of evaporation to crystallization area = 1: 7
Dimensions:	storage ponds: approx. 1 m in depth; large ground basins, evaporating ponds: approx. 20 cm in depth; crystallisation ponds: approx. 20 cm in depth, thickness of brine layer in crystallisation ponds can be as shallow as a few millimeters
Driving Energy:	seasonally changing solar energy between approx. 5000 and 30.000 kJ/ha/year
Form of Driving	direct use of solar energy

Form of Driving Energy:	direct use of solar energy
Throughput/Capacity:	evaporation: approx. 0.2 - 0.5 (1.5) cm/day, approx. 100 - 300 t/ha/year
Technical Efficiency:	approx. 43 m <sup>3</sup> /t NaCl produced
<b><u>ECONOMIC DATA:</u></b>	
Operating Costs:	mainly labor and pumping costs
Related Costs:	possibly secondary cleaning facility, rakes and shovels for harvesting salt; possibly tractors, shovel loaders, etc.

### **CONDITIONS OF APPLICATION:**

Operating Expenditures:	low  ----- -----  high
Maintenance Expenditures:	low  ----- -----  high
Location Requirements:	location should be characterized by extensive sunshine and low atmospheric humidity (high evaporation potential)
Special Feed Requirements:	ocean saltwater or water (brine) from salt lakes of saltwater composition: NaCl 2.723 %; MgCl <sub>2</sub> 0.334 %; MgSO <sub>4</sub> 0.225 %; CaSO <sub>4</sub> 0.120 %; KCl 0.076 %; NaBr 0.010 %; CaCO <sub>3</sub> 0.011 %; H <sub>2</sub> O 96.495 %
Regional Distribution:	technique is distributed worldwide; approx. 30 % of the world production of NaCl is produced by evaporation and crystallization of saltwater.
Operating Experience:	very good  ----- -----  bad

Environmental  
Impact:

low |-----| very high

space requirements, possibly damage to sea-coast areas

Suitability for  
Local

very good |-----|-----| bad

Production:

Under What Conditions: simple, but involves very large surface-area excavations, possibly excavation machinery needed

Lifespan:

very long |-----|-----| very short

**Bibliography, Source: Ullmann, Muller**

### **OPERATING PRINCIPLE:**

**The winning of NaCl in salt gardens is achieved by evaporating saltwater (from oceans, seas, or salt lakes) according to the separation procedure listed below. The crystallization ponds are fed in such a way that carbonates and gypsum are precipitated separately, as the following processing steps indicate:**

- 1. Pumping of saltwater into the initial evaporation ponds.**
- 2. Concentration of the brine in these ponds to a density of approx. 6.5° Be (Baume-Scale: 6.5 mass-% salt solution).**
- 3. Transfer of this pre-concentrated brine to a second evaporation zone, where the evaporation continues up to 17° Be; at this density the bulk of the gypsum precipitates out**

- 4. Transfer to a third evaporation zone, where the brine reaches the saturation point for NaCl. At 20° C the corresponding density is 25.6° Be.**
- 5. Transfer of the saturated brine into crystallization ponds, where density may not exceed an upper limit of 29 - 30° Be. In this way approx. 23 kg NaCl can be won from 1 m of saltwater, while the manganese and potassium salts remain in the mother liquor (spent solution).**
- 6. Removal of the mother liquor from the crystallization pond.**
- 7. Harvesting of the salt.**

### **AREAS OF APPLICATION:**

**Used for production of common table salt and NaCl for other purposes (e.g. electrolysis) from ocean saltwater and water from saltwater lakes. Bromine and magnesium compounds, as well as potassium salts, could also be separated and won as by-products. Chloridic mother liquors from salt lakes are then further evaporated and subsequently processed in a subsequent flotation facility where sylvinitic for use in KCl production is floated out.**

### **REMARKS:**

**Micro-organisms, plankton, algae and halophilic bacteria have an important influence through their ability to accelerate evaporation due to their radiation-absorbent coloring. The growth of micro-organisms can be enhanced by the addition of nutrients rich in nitrogen or phosphorus.**



**In situations where the salt is too greatly contaminated by magnesium and gypsum, it can be purified by a washing process in which the salt is washed in a screw conveyor with a saturated counter-current NaCl solution. Gypsum is removed in the float, and Mg-salts dissolve into the solution. The remaining product is dewatered in a hydro-cyclone and then centrifuged.**

**The average composition of common table salt is:**

NaCl:	99.50 % (dry matter)
CaSO <sub>4</sub> :	0.25 %
MgCl <sub>2</sub> :	0.15 %
MgSO <sub>4</sub> :	0.01 %
KCl:	0.02 %
Insoluble residue:	0.02 %
Residual moisture:	3.00 %

**Separation sequence of evaporation of ocean saltwater at 27° C:**

**Remaining saltwater Initial separation of**

100.00	calcite	CaCO <sub>3</sub>
32.22	gypsum	CaSO <sub>4</sub>
12.13	halite	NaCl
2.45	astrakanite	
		Na <sub>2</sub> SO <sub>4</sub> × MgSO <sub>4</sub> × 4H <sub>2</sub> O
		MgSO <sub>4</sub> × 7H <sub>2</sub> O

2.18	epsomite	$\text{MgSO}_4 \times \text{H}_2\text{O}$
1.96	kainite	$\text{MgSO}_4 \times \text{KCl}_3 \text{H}_2\text{O}$
1.63	hexahydrate	$\text{MgSO}_4 \times 6 \text{H}_2\text{O}$
1.22	kieselite	$\text{MgSO}_4 \times \text{H}_2\text{O}$
1.18	carnallite	$\text{KCl} \times \text{MgCl}_2 \times 6\text{H}_2\text{O}$
0.93	bischofite	$\text{MgCl}_2 \times 6 \text{H}_2\text{O}$

**In the production of potassium salts, it must be taken into account that the demand for agricultural fertilizer is subject to vast seasonal fluctuations, requiring large-capacity covered (weather-tight) storage facilities.**

**Small amounts of common salt can also be won by collecting precipitated salt crystals developing from salt water sprayed along the sea coast, for example on the cliffs along the shores of the Sinai Peninsula, at Cape Verde, etc.**

**In polar climates, smaller amounts of salt freeze when water sprays onto pack-ice and freezes, causing salt to crystallize out (Rassol). The freezing procedure is also utilized at an industrial scale for concentrating salt brines in cold climatic regions.**

**Besides the production of salt from ocean saltwater, production from dry, or former, saltwater lakes in the steppe, desert and high-altitude desert areas of Latin America is of great regional importance. Here, the actual winning of salt occurs by cutting the salt with huge axes into "Quader" or rectangular blocks (panes) weighing approx. 10-15 kg. To remove the most recent, or uppermost, crystallized epsom (bitter) or waste salts, the top layer is split off about 3 cm down. The further processing takes place in small milling plants in which the salts**

**are coarsely crushed and then ground to the desired final grain-size.**

**Mined salts are, in some cases, heavily contaminated with bituminous substances or other minerals such as gypsum, quartz or a number of others. In order to clean them, the salts are dissolved, possibly boiled, and then enriched into pre-concentrates in cooling towers before being crystallized either under the influence of natural evaporation or by heating.**

**Rainfall hinders the operation of salterns or salt gardens. The diluting influence of rain water may be countered either by covering the crystallisation basins with plastic film or cement roofs, by diverting the highly-concentrated saltwater into deep, covered rain ditches, or by draining off the lighter (lower specific-density) rain water over an overflow weir.**

**Salt gardens are always built so that the initial solution, for example sea water, is conveyed by means of a pump into the highest-situated initial evaporation ponds. From here, the saltwater is discharged over weirs without pumps to the lower-lying subsequent evaporation steps and crystallization ponds.**

### **SUITABILITY FOR SMALL-SCALE MINING:**

**The production of salt in salterns is, in terms of investment requirements, a typical small-scale mining technique which, given a suitable location, yields high specific production quantities and high-quality products.**

## **16.3 Sulfur production in heap smelting or chamber ovens**

### **Mining on Industrial, Minerals and Rocks**

## Beneficiation, Special Techniques of Separation

germ.: Schwefelgewinnung im Schmelzmeiler, Kammerofen

span.: recuperacion de azufre en carboneras de fusion, horno de cameras

ital.: calcarone, calcarelli

<b>TECHNICAL DATA:</b>	
Dimensions:	diameter up to 30 m, height up to 6 m, with inclined bottom (approx. 15° - 20°)
Weight:	brick masonry
Extent of Mechanization:	not mechanized
Form of Driving Energy:	energy of combustion
Mode of Operation:	intermittent
Technical Efficiency:	30 - 60 % recovery, in chamber oven up to 78 %
Operating Materials:	
Type:	sulfur as fuel
<b>ECONOMIC DATA:</b>	
Investment Costs:	depends on possibilities for purchasing construction material, starting at approx. 1000 DM
Operating Costs:	mainly labor costs

**CONDITIONS OF APPLICATION:**

Operating Expenditures: low |-----|-----| high

Maintenance Expenditures: low |-----|-----| high

Location Requirements: atmospheric partial pressure of oxygen must be sufficient to burn sulfur; for this reason the maximum topographic elevation is limited.

Recovery: comparably low in heap smelting due to losses caused by capillary forces and burning of sulfur

Replaces other Equipment: autoclaves

Regional Distribution: Sicily

Experience of Operators: chamber oven very good |-----|-----| bad

due to the low degree of melting heap

Environmental Impact: low |-----|-----| very high

due to emission of H<sub>2</sub>SO<sub>3</sub> (sulfurous acid)

Suitability for very good |-----|-----| bad

Suitability for

Local

Production:

Under What masonry work

Conditions:

Lifespan:

very long |-----|-----| very short

**Bibliography, Source: Ullmann, Buch der Erfindungen "Book of Inventions" (in German) 8 edtn..IV. Bd.**

### **OPERATING PRINCIPLE:**

**The simple method of winning sulfur by smelting is performed in mounded ore piles, in which sulfur is openly piled against a brick wall (with drainage outlet) where it partially burns and partially melts. The losses of sulfur due to the combustion reaction to sulfur dioxide can exceed 60 %. In order to extract sulfur in a smelting pile, small-lumped feed material is piled into a round brick-walled construction 10 to 30 m in diameter and up to 7 m in height, and covered with spent melt, gypsum and clay. The pile is ignited on the surface, opposite the drain outlet at the deepest point in the pile, in order to generate heat to melt the sulfur. The burning is controlled through the exhaust outlet and openings in the cover. The duration of the smelting process in such a pile lasts about 3 weeks. The sulfur is extracted from the lower end and allowed to crystallize in flat basins or moistened wooden molds, such as is described for autoclaves.**

**Better smelting results can be obtained with the chamber oven, in which already-melted residues with residual sulfur content are burned, generating hot gases**

**which are then directed through a duct into a second chamber where they serve as the heat source for smelting sulfur out of fresh raw ore. A multi-chamber design avoids the need to re-handle the ore, since the melted ore is burned in a second processing step, thus using the smelting chamber as a combustion chamber.**

### **AREAS OF APPLICATION:**

**To extract sulfur from raw ore of volcanic or sedimentary deposits containing elementary sulfur.**

### **REMARKS:**

**The burning of sulfur to produce hot gases for smelting purposes requires high partial pressure of oxygen. At the high altitude of the Andes, where many volcanic deposits of sulfur are being mined at elevations of up to 6000 meters above sea level, the air pressure is not sufficient for burning sulfur. In this situation, the mine operators resort to the autoclave technique which uses steam for smelting.**

**Chamber ovens can also process feed containing < 15 % S, and are therefore often used for reprocessing residual material from autoclave processing.**

**Due to its non-dependence on external fuel and its non-mechanized technology devoid of high investment costs, smelting in chamber ovens is very economical.**

### **SUITABILITY FOR SMALL SCALE MINING:**

**Due to the high environmental Impact associated with the winning of sulfur in smelting-piles, the use of this method is only appropriate in situations where**

**other fuels are not available. At high altitudes the partial pressure of oxygen is not sufficient for combustion, so that the use of chamber ovens or smelting piles is not possible.**

## 16.4 Autoclaves for extracting sulfur

### Mining of Industrial Minerals and Rocks Beneficiation, Special Techniques of Separation

germ.: Autoklaven zur Schwefelgewinnung

span.: autoclave para la recuperacion de azufre, recuperacion de azufre en autoclaves

<b>TECHNICAL DATA:</b>	
Dimensions:	horizontal, slightly inclined cylindrical boiler approx. 1 m in diameter, 4.75 m in length; or vertical, of cylindrical dimensions
Form of Driving Energy:	thermal steam-energy from combustion
Alternative Forms:	preheating of water with flat-plate or concentrating solar collectors
Technical Efficiency:	depends on feed content of ore and absorptive capacity of host rock
Operating Materials:	
Type:	water fuel, e.g. in Bolivia plant material <i>Ilareta</i> (Lat. <i>azorella compacta</i> )
Quantity:	approx. 5 m <sup>3</sup> /h



Quantity:	approx. 5 m <sup>3</sup> /t S
-----------	-------------------------------

<b>ECONOMIC DATA:</b>
-----------------------

Operating Costs:	very high fuel costs
------------------	----------------------

### CONDITIONS OF APPLICATION:

Operating Expenditures: low |-----|-----| high

Maintenance Expenditures: low |-----|-----| high

Location Requirements: sufficient fuel must be available, or possibilities must exist to transport fuel in large quantities. Grain size of feed: the ore is fed as lumps, but sizes > 20 cm should be avoided due to the low thermal conductivity of sulfur.

Special Feed Requirements: S content of feed should be as high as possible, which is achievable by selective mining, hand picking of rocks or preliminary flotation.

Output: In contrast to the extraction of sulfur by heap melting or in chamber ovens, the autoclave process is highly independent of altitude. In Bolivia there are autoclaves in use at altitudes exceeding 4500 m above sea level.

Replaces other heap smelting, chamber oven

Equipment:

Regional Distribution: in small-scale mining in Latin America, especially in the high-altitude cordillera region

Operating Experience: very good |-----|-----| bad

Environmental: low |-----|-----| very high

**Environmental**

Impact:

through waste deposition, gas emissions from steam-generating oven, and destruction of vegetation through the use of biogenic fuels

Suitability for  
Local

low |-----|-----| very high  
very good |-----|-----| bad

Production:

Under What local construction companies

Conditions:

Lifespan:

very long |-----|-----| very short

**Bibliography, Source: Ullmann****OPERATING PRINCIPLE:**

**To smelt sulfur in autoclaves, the lumpy feed is charged into vertical or horizontal cylindrical boilers in layers. The boilers are pressure-sealed following charging, and injected with hot steam at 4 - 5 bar, during which the thermal energy of the steam is transmitted to the ore. At temperatures exceeding 114°C, the sulphur begins to melt. It is important that the steam continues to flow through the heaped feed material, since, on the one hand, sulfur is a poor heat conductor, and on the other hand, there is a sharp increase in dynamic viscosity of the melt above 158°C, which has a viscid (semifluid) effect. The melted sulfur flows downward and is discharged periodically through the bottom outlets, from which it then flows into large flat basins where the dark-brown sulfur melt cools down during crystallization and turns into a solid yellow mass. When this mass has reached a thickness of 30 - 50 cm it is manually broken up by means of crowbars and carried**

**off as blocks. The spent melt is removed from the autoclave following depressurization of the melting chamber and discarded as waste. To simplify material transport, the feed material for horizontal autoclaves is brought into the melting chamber in small wagons. Depending upon the composition of the feed, this material still contains significant amounts of sulfur which either could not flow out during melting, or remained in capillary bonds. The recovery from technical-scale plants ranges between 47 % and 55%.**

### **AREAS OF APPLICATION:**

**Used to extract sulfur from raw ore feed preferably containing > 25 % S. When the S-content is lower, the feed can be pre-concentrated via flotation and then dewatered prior to smelting in autoclaves.**

### **REMARKS:**

**The energy costs for generating steam are extremely high. In small scale mining in the western cordillera region in Bolivia, a resinous plant is used as fuel. In any event, it should be investigated whether fuel consumption could be reduced by employing solar energy collectors to preheat the water to just below the boiling point.**

**Alternatively, the melted sulfur can be poured into moistened wooden boxes, with inclined walls, and then recovered in the form of uniform castings.**

### **SUITABILITY FOR SMALL-SCALE MINING:**

**Autoclaves are suitable even at high altitudes for the winning of sulfur from high-**

**grade ore feed; however, the high energy consumption creates logistical, economical and ecological problems.**

## 16.5 Copper sulfate plant

### Metal Mining

### Beneficiation, Special Techniques of Separation

germ.: Kupfersulfatfabrik

span.: fabrica de sulfato de cobre

<b>TECHNICAL DATA:</b>	
Extent of Mechanization:	not mechanized/semi-mechanized
Operating Materials:	
Type:	H <sub>2</sub> SO <sub>4</sub> , possibly fuel

### CONDITIONS OF APPLICATION:

Operating

Expenditures:

low |-----|-----| high

Maintenance

Expenditures:

low |-----|-----| high

Replaces other production of sulfide copper concentrates

Equipment:

Regional

Bolivia

Distribution:  
Operating

very good |-----|-----| bad

Experience:

Environmental  
Impact:

low |-----|-----| very high

minimal environmental impact due to acidic residues in the tailings. With oven drying, very high impact due to destruction of vegetation and/or gas emissions.

Suitability for  
Local

very good |-----|-----| bad

Production:

Under What  
Conditions:

masonry construction: tanks, drying basins, crystallization basins

Lifespan:

very long |-----|-----| very short

## **Bibliography, Source: Mina Azurita/Bolivia**

### **OPERATING PRINCIPLE:**

**To produce a copper sulfate, the feed material is placed in a large reaction-tank (basin), soaked with a diluted sulfuric acid solution, and left to react for approx. 2 weeks. The resulting copper sulfate solution is then concentrated either by solar thermal evaporation of the water, or by heating over a fire in drying-calottes made of lead vessels. When the solution reaches the point of saturation, it is pumped into crystallization tanks where copper sulfate crystals form along the bottom and walls, and on iron-wire spirals hung from above.**

## **AREAS OF APPLICATION:**

**The production of copper sulfate from raw ore, tailings piles, or beneficiation wastes is suitable for feed which is porous, rich in weathered copper minerals, rich in sulfides or sulfates, and of low iron content. During leaching of such material, sulfide is transformed through partial oxidation (supported by bio-catalyzation) into  $H_2SO_4$  over  $H_2SO_3$ .**

## **REMARKS:**

**In the vegetation-poor highlands of Bolivia, a three-man copper sulfate operation for processing old tailings piles has proven economical despite high energy and transportation costs.**

## **SUITABILITY FOR SMALL-SCALE MINING:**

**Suitable technique for the processing of low-grade sulfidic and oxidic copper ores with relatively low investment costs.**

### **16.6 Electrostatic sorting**

**Ore Mining, Mining of Precious Stones, Gold Mining, Salt Mining  
Beneficiation, Special Techniques of Separation**

germ.: Elektrostatische Sortierung

span.: concentracion electrostatica

## **TECHNICAL DATA:**

Dimensions:	1 - 3 m in height
Weight:	large units are several thousand kg
Power Consumption:	electrical separation efficiency, voltages lie within the range of 5 - 90 kV at field strengths of 3 - 9 kV/cm several 100 W plus roller drive
Form of Driving Energy:	electrical
Alternative Forms:	none
Throughput/Capacity:	up to 5 t/h, in potash up to 25 t/h
Technical Efficiency:	comparatively low degree of separation in one processing step, therefore electrostatic separation always involves a multiple-step procedure
Operating Materials:	
Type:	surface-active or chemisorptive substance, tensides for selective separation of various non conductors
<b><u>ECONOMIC DATA:</u></b>	
Related Costs:	drying, preparation, conditioning

### **CONDITIONS OF APPLICATION:**

Operating  
Expenditures

low |-----|-----| high

Personnel      working with very high voltages demands strict compliance with safety rules

## Requirements: by personnel

**Grain Size of Feed:** minimum of 150  $\mu\text{m}$ ; extremely poor separation when higher proportions of  $< 40 \mu\text{m}$  are present due to dust adhesion on larger grains, adhesion on electrodes, etc.; maximum grain size 2 - 6 mm

**Special Feed Requirements:** as mentioned above, the dust particles must be removed from the feed; additionally, a narrow-band classification is necessary, since electrostatic separation is characterized by a sharp, precise classification. This is attributable to the comparably high gravitational forces.

**Replaces other Equipment:** is employed as an inexpensive sorting process in potash, diamond, and metal mining.

**Regional Distribution:** worldwide, but has only seldom been applied as a beneficiation technique in small-scale mining

**Operating Experience:** very good |-----|-----| bad

**Environmental Impact:** low |-----|-----| very high

**Suitability for Local Production:** very good |-----|-----| bad

**Under What Conditions:** qualified manufacturers experienced in high-voltage technology, capable of working with various materials, might possibly be in a position to build electrostatic separators

**Lifespan:** very long |-----|-----| very short



**Bibliography, Source: Schubert, EP 0231441, DE 3035589 C2, DP 2134298, Singewald, Bock, DP 2614146, DP 2125286, DP 2213370, DP 3146295, DP 3216735, DP 2609048, DP 3233780, DP 3233528, DP 3603165, and 166, DP 3825434**

### **OPERATING PRINCIPLE:**

**Electrostatic separation utilizes the differences in conductivity of the various feed components. The feed material, which has been pretreated or conditioned with surface-activating reagents, is placed in an electrical field which, depending upon the type of construction of the separator, has various effects on the mineral grains:**

- in a roller separator, the material is fed onto a roller electrode and directed past a counter-electrode. The non-conductive material is not charged by the counter electrode, but rather only polarised, creating weak adhesive forces which draw this material to the roller electrode. Conducting material transmits its charge to the roller electrode, then becomes recharged and is repelled by the roller electrode and drawn to the counterelectrode. Separating blades divide the sorted material into a conducting and a non-conducting product.**
- In a plate separator, the feed must be triboelectrically charged prior to separation. These electrostatically charged particles fall through the gap of a capacitor field between two electrode plates and are differentially deflected by the electric field, depending on the particle material.**

**- In a high-tension separator, the feed is charged by a corona electrode. Through the rotation of the roller out of the sphere of influence of the corona discharge, the moving conductor material immediately loses its charge; due to the centrifugal force of the roller and the gravitation, these particles are propelled away from the roller, while the nonconductors continue to adhere to the roller and fall off later.**

**Significant parameters for the separation in electrostatic separators are the inner and surface resistances, the electricity contents, etc. as well as the moisture and grain-size distribution. In order to separate non-conducting materials, the feed must be specially prepared, depending upon the characteristics of the non-conductors, through, for example, the following measures**

- thermic pretreatment to dry or alter the surface characteristics of the mineral particles**
- triboelectric charging, for example in vibrating screens, rotating drums, fluidized-bed apparatuses**
- conditioning with surface-active tensides which affect the surface conductivity of the minerals and their hydration sheaths.**

### **AREAS OF APPLICATION:**

- for the separation of heavy-mineral pre-concentrates, for example zircon, monacite, rutile, columbite, tontalite, scheelite, cassiterite, etc.**
- for the separation of quartz from hematite concentrates, gold pre-**

**concentrates.**

- **sorting of phosphate raw materials**
- **production of pre-concentrates during winning of diamonds**
- **processing of potassium salts, for example with sylvanite, carnellite, kieserite, etc.**

**REMARKS:**

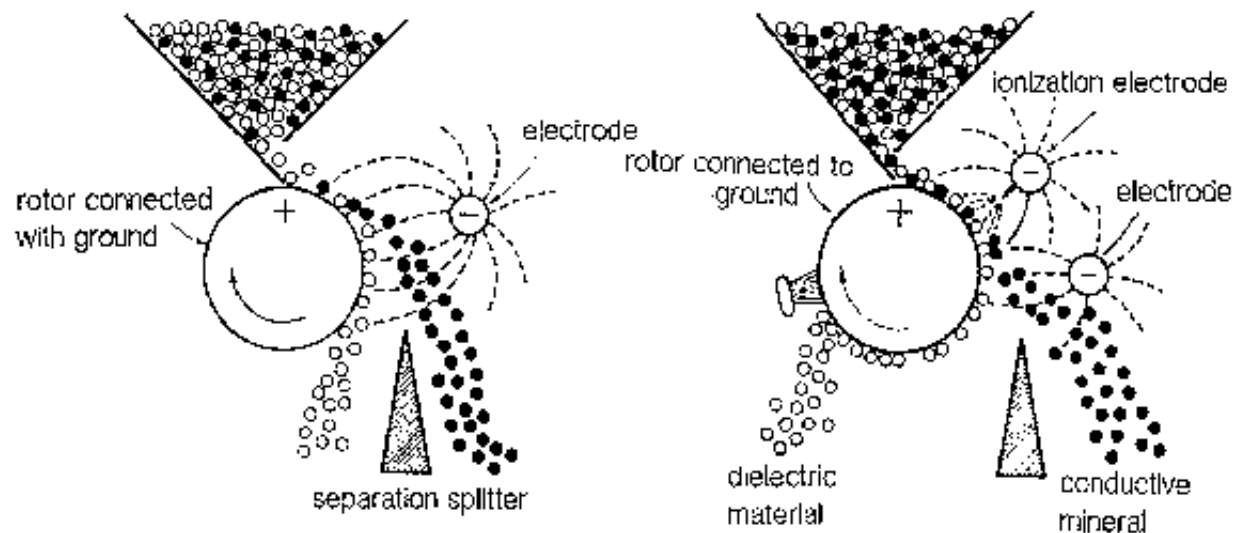
**Specifically for the electrostatic separation of raw potassium (potash) salts, many reagents have been tested and patented which allow a selective separation of potassium-salt mixtures, such as aromatic carboxylic acids such as O-cresotic acid, phthalic acid, cinnamic acid, atropic acid, vanillic acid, salicylic acid, benzoic acid, fatty acids with 6 to 15 C atoms (e.g. hydroxyphenyl butyric acid), etc., which are added in amounts of 50 - 200 g/t, for example supported by auxiliary conditioning agents such as HCl-gas, NH<sub>3</sub>, acetic acid, silicic acid, etc. These reagents are, for instance, vaporized onto the surface, whereby temperature variations play an important role. Small-scale mining operations can only be advised against employing tints highly sensitive, difficult-to-control technique. All of the other above-mentioned substances can be electrostatically sorted in small-scale operations.**

**The separation in the electrical field is greatly affected by moisture in both the air and the material. Films of moisture within the molecular density range can already**

**negatively affect the surface conductivity of the feed. The relative air humidity for successful sorting ranges between approx. 2 and 25 %.**

### **SUITABILITY FOR SMALL SCALE MINING:**

**Electrostatic separation for secondary cleaning of concentrates and winning of by-products in ore-mining operations is an economic technique which is also of interest for small-scale mining purposes. The electrostatic separation of salt to produce potassium (potash) salt concentrates is only suitable for small-scale mining if the mineralogical composition of the feed is not too complex. However, this is not the case for most of the deposits being mined by small-scale mines. Additionally, the unsuitability for local construction generally requires the use of imported equipment.**



**Fig.: Principle of electrostatic sorting. Source: Otero.**

### **Table: Behavior of minerals in the high-voltage electrical field**

<b>Minerals attracted to the rotor</b>	<b>Minerals repelled by the rotor</b>
baryte	cassiterite
beryl	chromite
calcite	galena
quartz	gold
diamond	magnetite
feldspar	graphite
monacite	haematite
scheelite	ilmenite
sillimanite	pyrite
zircon	rutile
	wolframite

## 16.7 Flotation

### Mining General (Gold, Ore, Coal, Industrial Minerals) Beneficiation, Sorting

germ.: Flotation

span.: flotacion

Manufacturers: Aker, Booth, Denver, Galigher Comp., KHD, Krupp, Machinoexport, Minemet Ind., Hoechst (reagents), Outokumpu, Sala, Wemco, Maxwell, INCOMEC, Volcan, Eg. Ind. Astecnia, IAA, COMESA, FAHENA, FINA, Famia, Fund Callao, MAGENSA, MAEPSA, Met. Mec. Soriano, PROPER, IMPROCON,

## MILAG

<b>TECHNICAL DATA:</b>	
Dimensions:	flotation cells approx. 1 × 1 × 0.8 m up to 5 × 5 × 2.5 m and larger
Weight:	approx. 1 - 20 t
Extent of Mechanization:	fully mechanized
Power:	2.2 kW to 100 kW, approx. 1.5 - 5 kW/m <sup>3</sup> volume of flotation cells
Form of Driving Energy:	electromechanical
Mode of Operation:	continuous
Operating Materials:	
Type:	compressed air reagents bubbles < 2 mm in diameter
Quantity:	0.3 - 2 m <sup>3</sup> /min m <sup>3</sup> of slurry
<b>ECONOMIC DATA:</b>	
Operating Costs:	high grinding costs
Related Costs:	dosing mechanism for reagents, grinding facility, classifying facility, settling pond for tailings

**CONDITIONS OF APPLICATION:**

Operating

low |-----|-----| high

## Expenditures:

Maintenance  
Expenditures:

low |-----|-----| high

Personnel for good separation results, precise control of slurry density, alimentary

Requirements: quantities and concentration of reagents is necessary

Grain Size of 50 · 200 ym

## Feed:

Recovery: with preliminary flotation and subsequent cleaning of sulfidic ores,  
considerably higher than with gravimetric methods

Replaces other wet-mechanical sorting processes

## Equipment:

Regional worldwide, flotation is the most widely used sorting process for mineral raw  
Distribution: materials, partially also used in small~scale mining; approx. 2 billion tons  
of raw material is floated annually

## Operating

very good |-----|-----| bad

## Experience:

## Environmental

low |-----|-----| very high

## Impact:

high environmental impact through discharge of reagents with the tailings.  
The use of tailing ponds, neutralization basins, etc. and precise dosages of  
reagents are absolutely necessary.

## Suitability for

very good |-----|-----| bad

## Local

## Production:

Under What Conditions: flotation cells can be locally produced, e.g. from wood, iron, ferro-concrete or plastic materials; remaining components from imports

Lifespan: very long |-----|-----| very short  
when components subject to wear are made of elastomers

**Bibliography, Source: Stewart, Priester, Taggart, Schubert, Gerth, Manufacturers information**

### **OPERATING PRINCIPLE:**

**The flotation process utilizes the differences in surface wettability of various minerals, which can be artificially influenced, to achieve a separation. The completely-liberated feed material is suspended in a slurry containing approx. 30 % solids (by volume) and the valuable mineral selectively hydrophobed through the addition of collector reagents, which are mostly long-chained hydrocarbons of specifically regulated pH-values. This conditioned slurry then flows into the flotation cell' where it is brought into contact with injected, dispersed air bubbles; the electively-hydrophobed valuable-mineral particles adhere to the bubbles and travel upwards as a foam-mineral mixture (possibly stabilized through the addition of foam reagents or 'frothers') to the slurry surface where this "float" is then skimmed off. To suppress the unwanted hydrophobing of accompanying minerals and to enhance their removal with the "non-float", depressant reagents are added to the slurry. In the indirect flotation process, the valuable mineral is concentrated in the hydropilic non-float.**

### **AREAS OF APPLICATION:**



## **For the selective extraction of valuable minerals from raw ore feed:**

- sulfide minerals**
- non-ferrous metal minerals (sometimes following sulfidizing)**
- precious metals**
  
- fluorite, apatite, phosphorite, sulfur**
- wolframite, scheelite, cassiterite, industrial minerals (sand and gravel)**
- coal, graphite**
- potassium (potash) salts**
- quartz, keolin, feldspar, mica**

### **SPECIAL AREAS OF APPLICATION:**

**To separate impurities and accompanying minerals from mineral-material mixtures**

- e.g. reversed iron-ore flotation
- reversed magnesite or calcite flotation
- cleaning of glass sands

### **REMARKS:**

**For small-scale mining needs, flotation cells with external air supply can be recommended. This process requires more equipment and therefore higher investment costs, however permits regulation of the air supply to accommodate**

**fluctuations in feed-quantity, feed contents, slurry density, etc. Self-aspirating cells allow a narrow range of variation only by changing the rpm of agitation.**

**Of importance for successful flotation is freshly-exposed surfaces. Especially sulfidic ores, which are easily subject to surface corrosion, require wet grinding prior to flotation.**

**Oil-flotation: W. Haynes/England/1860**

**Flotation with reagents for the separation of graphite, 1877 by Gebr. (brothers) Bessel/Germany**

**Foam-flotation: since the mid-twenties, important for very fine feed: agglomeration flotation (not economically significant)**

## **REAGENTS:**

### **Collectors**

**For sulfide minerals, anionic sulfhydryl collectors such as xanthate and dialkyldithiophosphate (for example, aerofloat, phosokresol) at concentrations of 10 - 200 g/t feed are applied, for non-sulfidic minerals: use of anionic oxhydryl or cationic collector, for example, long-chained, non-saturated (as much as possible) fatty acids or their soaps, which have previously been dissolved in hot oil, in concentrations of between 100 and 1000 g/t feed; by these quantities, the cost of reagents substantially affects operating costs. Silicates, halides and oxidic zinc ores are floated with organic amines as collector. To strengthen natural hydrophobia, for example in sulfur and coal or through the addition of an artificial**

**hydrophobia, saturated hydrocarbons such as petroleum and oils are suitable.**

### **Foaming agents/Frothers**

**Terpene and cresol or synthetic foaming agents added in quantities of around 5 - 50 g/t during sulfide flotation reduces the size of the bubbles and stabilizes the foam by lowering the surface tension.**

### **Depressing agents/Depressants**

**Examples: zinc sulfate to depress zinc blende (sphalerite) in Pb-Zn-ores, cyanide to depress gold and silver, copper minerals, etc. by complexing.**

### **Activators**

**Examples: addition of small quantities (1 - 10 g/t) of cyanide to clean mineral surfaces; sodium sulfide to convert oxide layers in sulfides; copper sulfate to activate zinc blende.**

### **pH-reagents**

**to establish basic conditions: hydrated (slaked) lime, soda or caustic soda;  
to establish acidic conditions: sulfuric acids.**

**For small-scale mining, of special interest are individual components such as stator/impeller units from Aker which can be installed into existing, or possibly locally-manufactured, cells. In addition, these parts, being highly subject to wear, are normally made today of elastomers (for example polyurethane) which are extremely wear-resistant.**

**In order to assure the quality of the end products of flotation, precise control of**

**the process is crucial. It is essential that the quantities of reagents added during flotation remain constant. Whereas this is performed today in large mechanized plants via dosing pumps, in small-scale mining, bucket-wheel proportioners have proven to be extremely effective. By altering the volume and/or number of buckets, or by modifying the rpm of the bucket-wheel disk, they can be adjusted to cover a wide range of dosages. Furthermore, they are very sturdy, simple, accurate and suitable for local manufacture.**

**In addition to the process control, flotation also requires continuous monitoring of product quality. A simple periodic product sampling with the batea or gold pan assists many plants in quickly detecting possible deviations from the standard values. Small pan-shaped or inverted roof-shaped wooden troughs are used for this purpose.**

**Local products are sometimes used as reagents for the flotation, for example, natural oils, wastes from wood processing and from paper plants, etc. In this way the costs for imported reagents can be decreased substantially.**

**Tailings from flotation also provide a good aggregate or filler for lean mixed concrete backfill consisting of approx. 10 % cement, 60 % mine waste and 30 % flotation tailings.**

#### **EXPERIENCE FROM APPLICATION IN DEVELOPING COUNTRIES:**

**Representing the simplest forms of foam flotation, pipe flotation, in addition to flotation in sluices and settling basins (buddies see 14.10), is also being used.**

**The slurry, preconditioned with reagents, is allowed to fall into an open vertical**

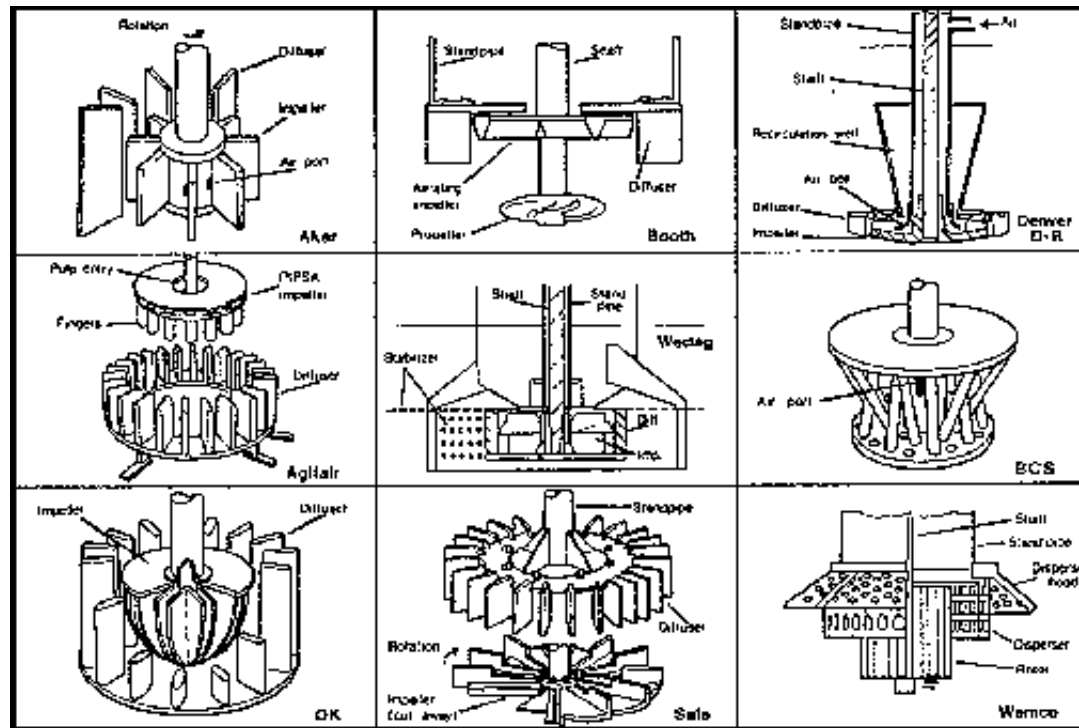
**standpipe, whereby air is drawn down along with it (after the principle of the water-jet vacuum pump). The aerated slurry is directed through the pipe into the flotation cell; perforations in the pipe allow the bubbles to escape and the flotation to take place. The float is subsequently scooped or skimmed off.**

**The quality of the flotation can be assessed simply by visual inspection of the bubbles on the slurry surface. A thick, fine-bubbled, and especially dark-colored foam indicate a correct reagent dosage and good mineral loading on the bubbles.**

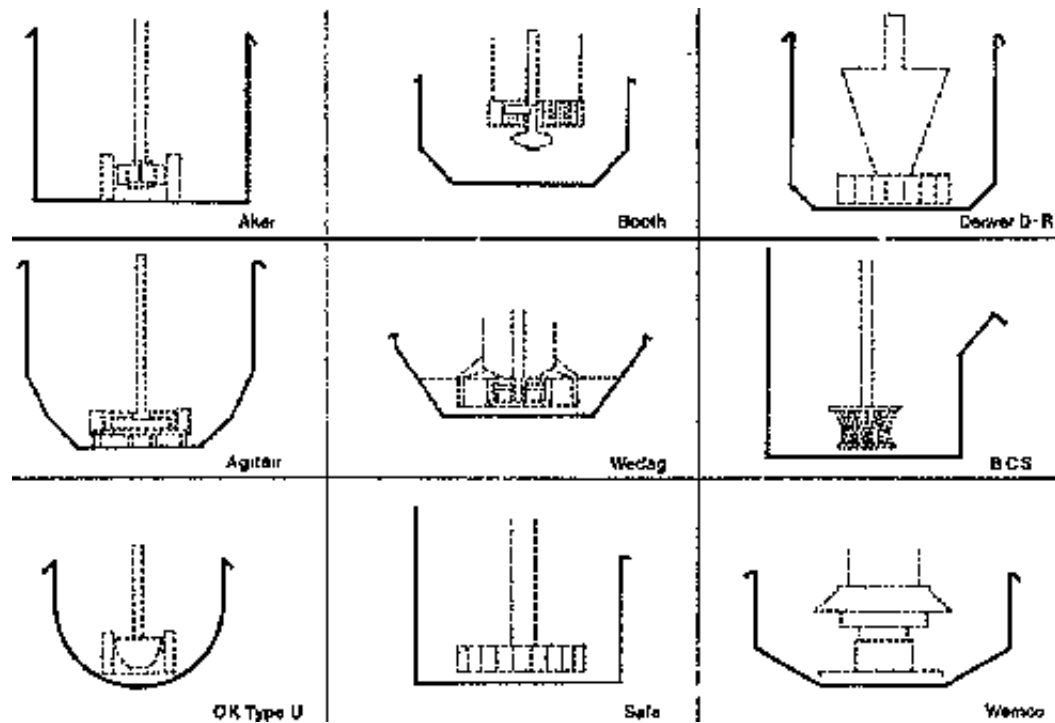
**A foam with big bubbles and a transparent appearance removes only low quantities of "float" minerals and indicates an insufficient addition of reagents or an incorrect pH-value.**

### **SUITABILITY FOR SMALL-SCALE MINING:**

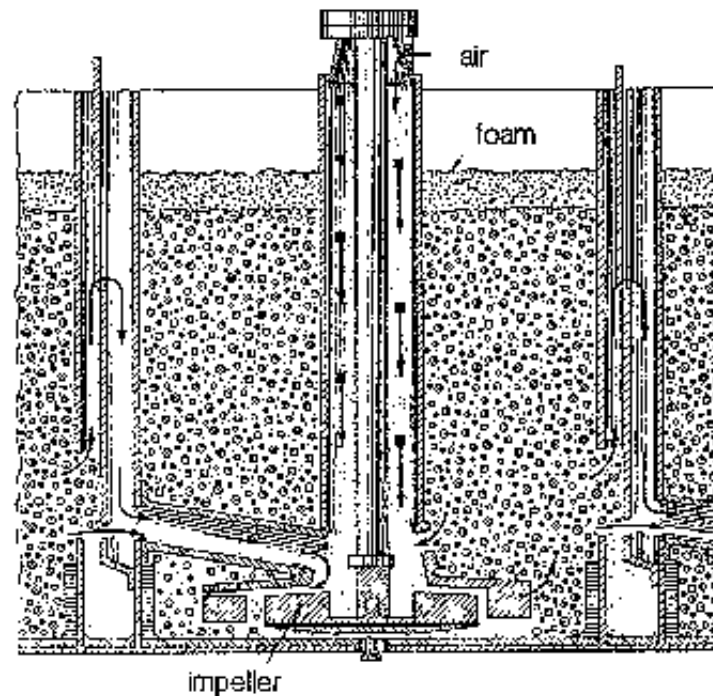
**Flotation of sulfides is a suitable technique for small-scale mining, particularly if local manufacturers build the flotation cells and are dependent only on a few imported components. The selective sulfide flotation can also be considered appropriate for supplementing gravimetric beneficiation in small-scale processing operations.**



**Fig.: Designs of standard commercially-sold flotation cells. Source: Young.**



**Fig.: Types of impellers for standard, commercially-sold flotation cells. Source: Young.**



**Fig.: Operating principle of a flotation cell. Source: Otero.**



[Home](#) > [ar](#).[cn](#).[de](#).[en](#).[es](#).[fr](#).[id](#).[it](#).[ph](#).[po](#).[ru](#).[sw](#)

 **Tools for Mining: Techniques and Processes for Small Scale Mining (GTZ, 1993, 538 p.)**

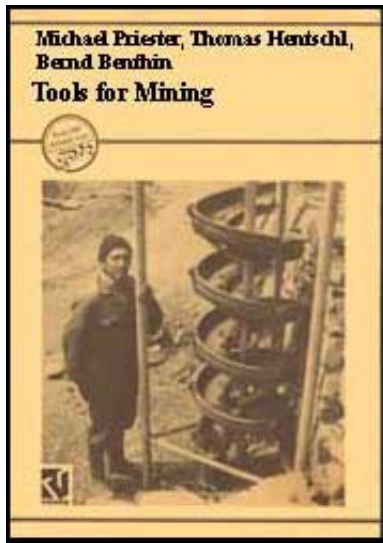
  **Technical Chapter 17: Drying**

 **17.1 Drying oven**

 **17.2 Solar houses**

 **17.3 Drying areas, drying surfaces**





## **Tools for Mining: Techniques and Processes for Small Scale Mining (GTZ, 1993, 538 p.)**

### **Technical Chapter 17: Drying**

#### **17.1 Drying oven**

#### **Mining General Beneficiation, Drying**

germ.: Trockenofen

span.: horno de secar, horno secador

#### **TECHNICAL DATA:**

Dimensions:	approx. 2 × 1 m hearth area, 10-cm-high rim for oven plate
Weight:	several 100 ka

Form of Driving Energy:	thermal from combustion of wood, peat, diesel, gasoline, oil, gas, coal
Alternative Forms:	mechanical heat generator (by METZLER)
Technical Efficiency:	very low
Operating Materials:	
Type:	fuels
Quantity:	very high, approx. 0.05 - 0.1 t coal/t concentrate
<b>ECONOMIC DATA:</b>	
Investment Costs:	approx. 200 DM when self made
Operating Costs:	high fuel costs
Related Costs:	fuel transportation costs, which could vastly increase for biogenic fuels due to lumbering requirements

### **CONDITIONS OF APPLICATION:**

Operating Expenditures:

low |-----| high

Maintenance Expenditures:

low |-----|-----| high

Personnel      minimal

**Requirements:**

**Grain Size of Feed:** theoretically no restrictions; however, drying of fine grains is lengthy and expensive due to the large proportion of adhesive water which requires high energy input to separate it

Replaces other drying areas

**Equipment:**

**Regional Distribution:** very rare, known from Bolivia, Thailand

**Operating Experience:**

very good |-----| bad

**Environmental Impact:**

low |----|----| very high

especially when temperatures exceed 105°C and sulfides begin to roast

**Suitability for Local Production:**

very good |----|----| bad

**Lifespan:**

very long |----|----| very short

**Bibliography, Source: Priester, Gast, Inversin****OPERATING PRINCIPLE:**

**The drying surface of the oven - the oven plate - is formed like a pan for holding the feed, which is periodically stirred by means of shovels or scrapers. Gast describes an oil-fired oven for drying of wet concentrate: the cylindrical outer wall**

**is perforated and the inner wall (cone shaped) serves as the oven's chimney. The material is fed by shovel and percolates through the oven automatically as the dried concentrate trickles out through the holes and piles up around the oven.**

### **AREAS OF APPLICATION:**

**For drying of concentrates.**

### **REMARKS:**

**It is absolutely necessary to ensure that the drying temperature of products containing sulfide minerals remains below 105° C; above this temperature the sulfides begin to roast, releasing sulfide-containing acids, sometimes at very high concentrations.**

**For preliminary dewatering, the concentrates need to be processed in a raffination barrel following the Schanz-method or in a tossing kieve.**

### **SUITABILITY FOR SMALL-SCALE MINING:**

**Due to the negative environmental effects of drying in drying ovens, this process should only be employed when alternative methods cannot be used.**

## **17.2 Solar houses**

### **Mining General Beneficiation, Drying**

encl.: solar tents. solar tunnel driver

germ.: Solarhauser, Solarzelte, solare Tunneltrockner

span.: cases solares, carpas solares, tuner de secado solar

<b>TECHNICAL DATA:</b>	
Dimensions:	size depends on drying requirements, specific drying duration and radiation energy
Weight:	e.g. solar tunnel dryer for drying harvested crops: 3 × 20 × 0.1 m
Extent of Mechanization:	not mechanized
Form of Driving Energy:	heat of radiation (solar thermal energy or insolation)
Alternative Forms:	in solar tunnel dryer with small fan: electric or photovoltaic
Mode of Operation:	semi-continuous
Throughput/Capacity:	up to approx. 100 kg/m <sup>2</sup> drying area
Technical Efficiency:	40° - 70° C drying temperature, drying duration is around half that of simple ground drying
<b>ECONOMIC DATA:</b>	
Investment Costs:	dependent on construction material, minimum of approx. 500 DM; also dependent on intensity of solar radiation (insolation), less sun means more collector surface area is required.
Operating Costs:	when fan-operated, low energy costs
Related Costs:	possibly wind protection measures

**CONDITIONS OF APPLICATION:**

Operating Expenditures:		low  ----- -----  high
Maintenance Expenditures:		low  ----- -----  high
Personnel Requirements:	minimal	
Location Requirements:	feasibility can only be calculated when solar radiation fluctuations are measured over the entire year	
Grain Size of Feed:	all sizes	
Special Feed Requirements:	no restrictions	
Output:	the drying speed in solar houses and solar tents is notably higher than that of drying areas, especially when the material to be dried is spread out on tables, etc. (see Diderot). This is a result of air circulation through convection.	
Replaces other drying areas, drying ovens		
Equipment:		
Environmental Impact:		low  ----- -----  very high
Suitability for Local Production:		very good  ----- -----  bad

Under What Conditions: depends upon the available possibilities using the following building materials: transparent corrugated sheets, glass, black plastic-foil, etc.; imported material (Nicolon) or nationally produced material, UV-stabilized transparent foil, insulation material, sealing material

Lifespan: very long |—|—|—|—| very short

## **Bibliography, Source: Diderot, Landtechnik Wethenstephan, Bine**

### **OPERATING PRINCIPLE:**

**Diderot describes southward-facing glass houses for solar drying of beneficiation products where the feed is spread out on tables. A similar effect can be achieved in foil tents made of black cloth foil, whereby the warming principle varies somewhat: with transparent materials, the enclosed space is warmed through the solar irradiation, and with opaque material the covering itself is heated by the solar energy.**

**Of simpler design, due to their compactness, are solar tunnel dryers. These consist of two flat, parallel tunnel channels, one of which serves as the air collector and the other as the concentrate dryer. Both channels are covered with a transparent foil. The collector is lined on the inside with a black absorbent-foil, black cloth, black stones, or similar heat-absorbing material. Towards the bottom, the dryer is thermally-insulated with, for example, plastic foam, rock wool, coconut fiber, straw or other dry organic materials. The walls of the channel are made of wood, brick or metal. The foil covering can be rolled up around a pipe to enable the dryer to be charged. A small fan is used for blowing air into the collector, where it warms up before entering a ventilation duct directing it into the tunnel dryer; the**

**now warm, dry air passes over the thinly-spread layer of feed material and dries It out.**

### **AREAS OF APPLICATION:**

**Drying of mining products especially in humid or semi-humid locations where open drying in direct sunlight is not possible. In locations at higher elevations, for example in Andean mining where the radiation intensity is particularly high, solar houses and solar tents offer an alternative to oven dryers.**

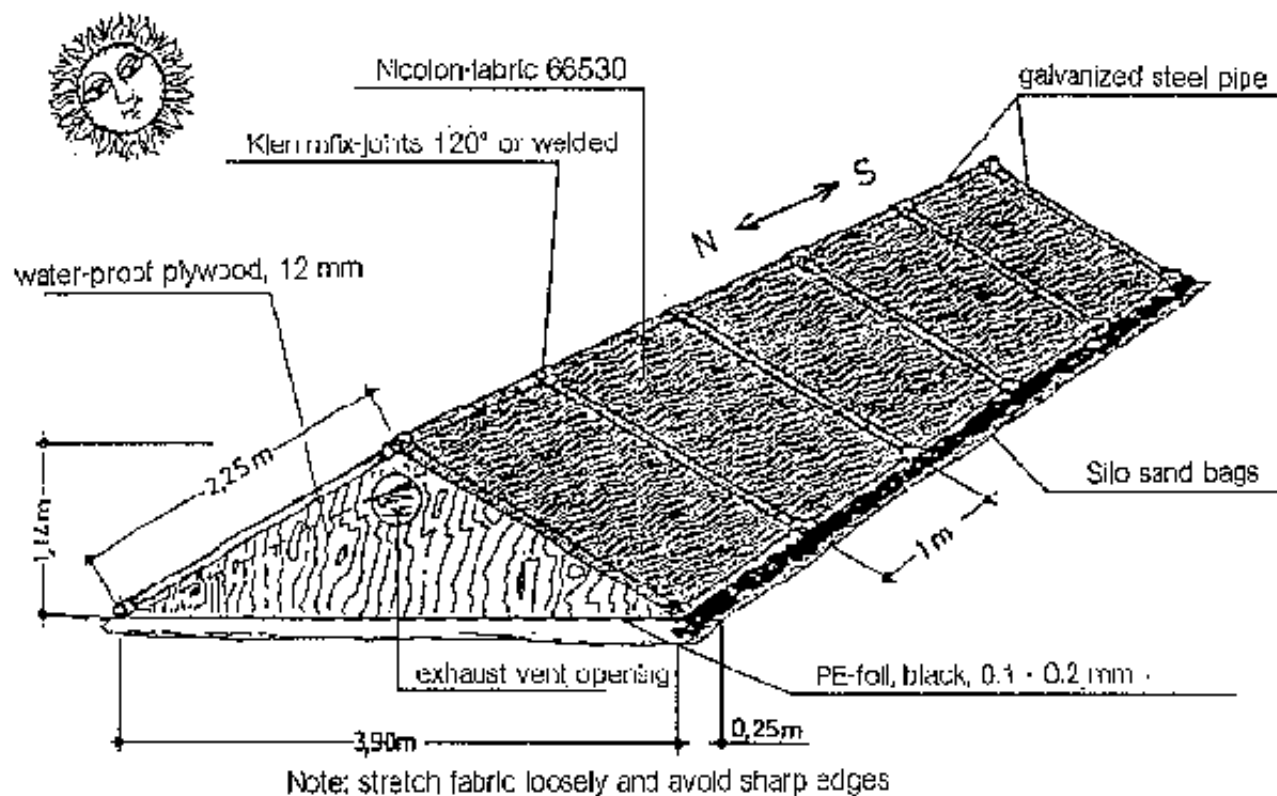
**Self-built air collectors are widely used in the agricultural industry for drying of herbs, hay, grains, peanuts, fuel materials, etc, One of the best foil-covering materials has proven to be Nicolon 66530 (from NICOLON B.V., Box 236, 7600 AE Almelo, the Netherlands). This material is a black PE-fabric with monofilament threads in the warp and stretched bands in the woof; It is 0,5 mm thick, 2.4 m or 5 m wide, weighs 182 g/m<sup>2</sup>, has a tensile strength of 227 kg/5 cm in the warp and 104 kg/5 cm In the woof, and is characterized for its high resistance to radiation and long service-life (more than 5 years). Nicolon is air-permeable, thereby allowing air collectors to operate either with blower-fan drive or as gravity dryers. In gravity dryers, the collector unit must be positioned below the drying unit. In windy locations, collectors yield poor results. Air collectors can also possibly be used for ventilation purposes (exhaust of mine air).**

### **SUITABILITY FOR SMALL-SCALE MINING:**

**This is suitable in locations where drying outside in the open air is not possible for climatic reasons. Simple, reasonably-priced and environmentally compatible**



**constructions are possible.**



**Fig.: Solar tent made of syntetic fabric, from Landtechnik Weihenstephan (Germany).**

## 17.3 Drying areas, drying surfaces

### Mining General Beneficiation, Drying

germ.: Trockenflächen

span.: superficies de secado

<b><u>TECHNICAL DATA:</u></b>	
Dimensions:	up to 20 × 20 m
Form of Driving Energy:	solar radiation (insolation)
Throughput/Capacity:	several tons per day depending on grain size, climate etc.
<b><u>ECONOMIC DATA:</u></b>	
Investment Costs:	approx. 10 to 20 DM/m <sup>2</sup> area

### **CONDITIONS OF APPLICATION:**

Operating Expenditures:	low  ----- -----  high
Maintenance Expenditures:	low  ----- -----  high
Location Requirements:	also employable in humid climates, however high radiation intensity necessary
Regional Distribution:	Bolivia, Chile
Operating Experience:	very good  ----- -----  bad
Environmental Impact:	low  ----- -----  very high
	large space requirements
Suitability for Local Production:	very good  ----- -----  bad
Under What Conditions:	cement foundation
Lifespan:	very long  ----- -----  very short

## **Bibliography, Source: Priester, Diderot**

### **OPERATING PRINCIPLE:**

**The dewatered ore or concentrate is thinly spread over the drying surface and allowed to dry in the sunlight. Wooden rakes are used for turning the feed material over, rubber scrapers for gathering and distributing the material and brooms to sweep together the dried material.**

### **AREAS OF APPLICATION:**

**Drying of concentrate prior to selling, processing by magnetic separation, etc.**

### **REMARKS:**

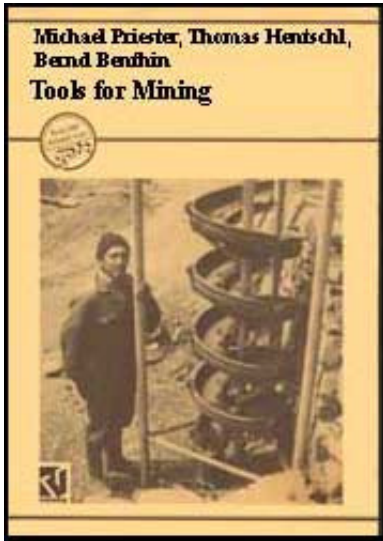
**The drying duration depends greatly on the grain size of the material to be dried. The finer the material, the more water is adhesively bound to the surface, and the longer it takes to dry. Drying time can total 8 hours or more.**

### **SUITABILITY FOR SMALL SCALE MINING:**

**Drying on drying areas is the simplest method of drying products, and plays an important role particularly in arid and semi-arid climates.**



**[Home](#) > [ar](#).[cn](#).[de](#).[en](#).[es](#).[fr](#).[id](#).[it](#).[ph](#).[po](#).[ru](#).[sw](#)**



## **Tools for Mining: Techniques and Processes for Small Scale Mining (GTZ, 1993, 538 p.)**

### **Technical Chapter 18: Clarification**

 **18.1 Thickener**

 **18.2 Lamella-thickener**

 **18.3 Continuous (rake) thickener**

## **Tools for Mining: Techniques and Processes for Small Scale Mining (GTZ, 1993, 538 p.)**

### **Technical Chapter 18: Clarification**

#### **18.1 Thickener**

#### **Mining General Beneficiation, Clarifying**

engl.: gravity thickener, settling (sedimentation) basin

germ.: Eindicker, Mehlgerinne, Schwerkrafteindicker, Absetzbecken

span.: espesador, canaletas pare polvo, espesador por gravedad, estanque de sedimentacion

#### **TECHNICAL DATA:**

Dimensions:	up to 40 × 10 m surface area, continuous (Dorr-type) thickeners without rabble arm with approx. 55 inclined walls
Weight:	brick basin
Driving Capacity:	non-driven technique
Form of Driving Energy:	only gravitational influence
Alternative Forms:	mechanized rectangular thickener with scraper for collecting the sludge in the discharge (electric drive), mechanized continuous (Dorr-type) thickener (see technique )
Mode of Operation:	semi-continuous
Operating Materials:	
Type:	possibly flocculants
<b><u>ECONOMIC DATA:</u></b>	
Operating Costs:	only labor cost for removal of sludge

### **CONDITIONS OF APPLICATION:**

Operating Expenditures:

low |-----|-----| high

low |-----|-----| high

Maintenance  
Expenditures:

only sludge removal

Personnel only for periodic sludge removal

Requirements:

Location level areas

Requirements:

Grain Size of Feed: < 1 ,um up to 50 ,um, max. 5 - 10 % solids in the feed

Feed:

Special Feed suspended slurry, where the density of the solids must clearly lie above 1.

Requirements: The clarifying characteristics of slurries are dependent on the specific surface area of the particles being clarified or sedimented. This increases inversely proportional to the square of the particle-size of separation; for the finest particle separation, flocculants are added to artificially increase the particle size.

Replaces other the construction and employment of thickeners is absolutely necessary to

Equipment: avoid contamination of the receiving stream and natural drainage basin.

Regional worldwide, in small-scale mining however very rare

Distribution:

Operating

very good |-----|-----| bad

Experience:

Environmental

low |-----|-----| very high

Impact:

environmentally beneficial through clarification of tailings, but large space

Suitability for requirement of sludge ponds is destructive to the natural landscape. — | bad  
 Local very good | ———— | ———— | ———— | ———— |  
 Production: discontinuous rectangular thickener  
 Under What masonry work  
 Conditions:  
 Lifespan: very long | ———— | ———— | very short

## **Bibliography, Source: Schubert**

### **OPERATING PRINCIPLE:**

**The slurry to be clarified flows into the thickener, whereby the slurry velocity is reduced. Depending upon the residence time In the clarifying basin, the suspended particles settle out and collect on the bottom of the basin, while the clarified water discharges over the overflow. In semi-continuous thickening operations, a second thickener must be available so as to allow alternate clarifying and sludge-removal between the two basins.**

### **AREAS OF APPLICATION:**

**For clarifying all types of slurries from beneficiation processes. Thickeners (German: Mehlgerinne or "dust sluice") were already used in the beneficiation of lead and silver ores during the 18th and 19th centuries in the Harz mining region in Germany.**

## **SPECIAL AREAS OF APPLICATION:**

**In locations with strong winds, increased flow velocities, turbulence and short-circuit currents can impair the clarification.**

## **REMARKS:**

**The space requirements for thickeners are very high.**

**The design of thickeners is quite simple. These types of thickeners can be locally constructed of simple brickwork for any beneficiation operation.**

**Sludge ponds are well-suited for clarifying larger quantities of fine-grained slurries; the distribution of the slurry over the larger surface area increases the residence time of the slurry in the basin, providing a chance for even fine grains to settle out. Where the quantity of sedimented fines is very large, the outer rim of the basin is extended in height to prevent the slurry from flowing over the top. The clay fractions in the settled fines act as a sealant on the bottom of the pond.**

## **SUITABILITY FOR SMALL-SCALE MINING:**

**In small mines, thickeners are the most inexpensive method for the clarification of tailings that are rich in suspended solids, especially since the basins can be built of simple earth or brick-work.**

### **18.2 Lamella-thickener**

#### **Mining General**



## Beneficiation, Clarifying

germ.: Lamelleneindicker

span.: espesador de lamelas Manufacturer: Sala

<b>TECHNICAL DATA:</b>	
Dimensions:	inclination of lamella 45° - 55°; 15 - 500 m <sup>2</sup> projected lamellar area, as a combination lamella-continuous (Dorr-type) thickener up to 2500 m <sup>2</sup> surface area; volume between 3 and 150 m <sup>3</sup>
Weight:	1 - 30 t
Driving Energy:	applied only if rabble arm or vibrator is used
Form of Driving Energy:	electrical
Alternative Forms:	mechanical or pneumatic drive
Mode of Operation:	continuous
Technical Efficiency:	very good clarification and thickening
Operating Materials:	
Type:	possibly flocculants

**ECONOMIC DATA:**

Related Costs:	sludge ponds or tailings piles for thickened sludge
----------------	---

**CONDITIONS OF APPLICATION:**

Operating Expenditures:		low  ----- -----  high
Maintenance Expenditures:		low  ----- -----  high
Grain Size of Feed:	for clarification of slurries with the finest of solids particles: 0 - 50 $\mu$ m, maximum 5 - 10 % (by volume) solids in the slurry feed	
Special Feed Requirements:	solids must have a significantly heavier specific density than water; the finest sludges are treated with flocculants to increase particle sizes.	
Output:	the recovered slurry is separated into clarified water and thickened sludge	
Replaces other Equipment:	continuous (Dorr-type) thickener, sedimentation basins	
Regional Distribution:	distributed worldwide in large-scale mining	
Operating Experience:		very good  ----- -----  bad
Environmental Impact:		low  ----- -----  very high

Suitability for

very good |-----|-----| bad

Local

Production: manufacturing workshops for large-scale equipment

Under-What  
Conditions:

Lifespan: very long |-----|-----| very short

**Bibliography, Source: Manufacturer information, DAX**

### **OPERATING PRINCIPLE:**

**The lamella-thickener consists primarily of two components: the upper tank with 45° to 55 -inclined lamellae-plates, and the lower conical or cylindrical sludge-collecting tank.**

**The slurry feed entering the lamella-thickener separates into two flows due to the presence of vertical chambers at both sides of the lamella-plates and flows through inlet slots between the lamella-plates. Above each group of lamella-plates there is a continuous overflow-channel which is equipped with outlet openings to create a slight hydraulic counter-pressure against the incoming slurry. This method of feeding the slurry guarantees a homogeneous distribution of slurry into all interstitial spaces between lamella with a minimum of turbulence at the points of entry.**

**The slurry lands in the spaces between the lamella through intake-slots located on the sides in the lower region of the lamella-plates. The clarification occurs above the point of slurry intake to prevent mixing of the clarified fluid with the incoming slurry.**

**The thickening and consolidation of the sludge in the sludge collecting tank can be enhanced through the use of a vibrator or rabble (raking) unit.**

### **AREAS OF APPLICATION:**

**For use In mining and beneficiation for clarifying and thickening slurries from classification and sorting processes, washing water and mine water. In addition, it is also employed in the metallurgy industry for purification of domestic water.**

### **SPECIAL AREAS OF APPLICATION:**

**For clarification of solutions from gold leaching processes which contain coarser solids.**

### **REMARKS:**

**Due to increasingly stricter environmental regulations, the use of thickeners is gaining in importance also for small-scale mining operations. Lamella-thickeners are suitable for small-scale mining only where available space is limited and the quantity of slurry produced is very large, for example in processing plants which are located in cities.**

**The very simple driveless design of a lamella-thickener enables it to be locally manufactured. The construction materials are:**

Lamella-plates

Lamella tank and sludge-collecting tank

PVC

steel, rubberized as required

fiber-glass reinforced synthetic resin rustproof acid-resistant etc

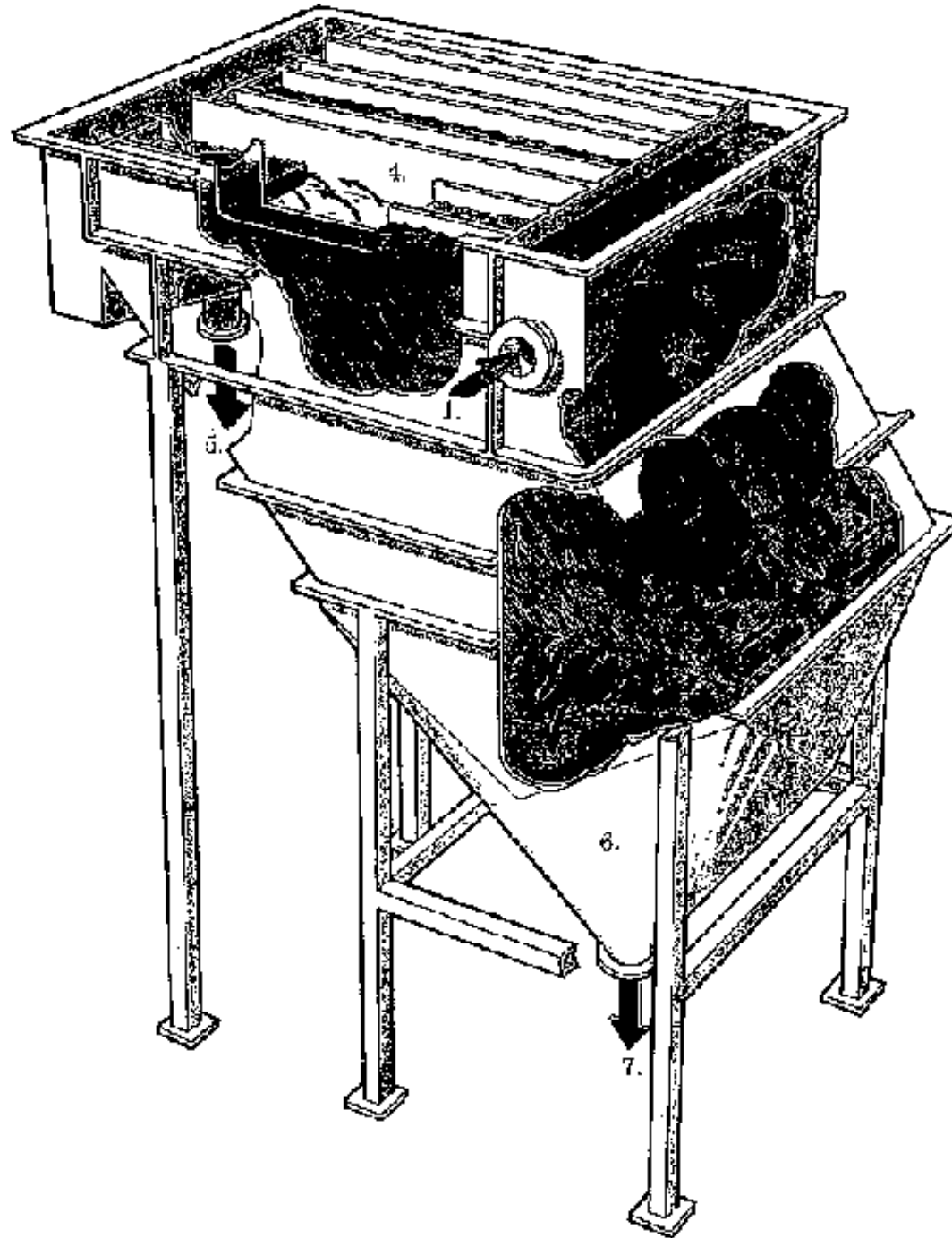
FRP, glass reinforced synthetic resin (FRP), acid resistant, etc.

other plastics

steel

### **SUITABILITY FOR SMALL-SCALE MINING:**

**Lamella-thickeners, as a driveless, continually-operating thickener, are particularly advantageous where space is limited. They can be locally manufactured, and their application for clarification of tailings contributes positively to environmental protection.**



**Fig.: Lamella-thinckener, 1. slurry intake, 2. slurry distribution chamber, 3. lamella-plates, 4. overflow channels, 5. overflow outlet, 6. sludge collecting tank, 7. underflow outlet. Source: Sala company information.**

### 18.3 Continuous (rake) thickener

#### Mining General Beneficiation, Clarifying

engl.: dorr-type thickener, mechanized thickener

germ.: Rundeindicker, Mechanisierte Eindicker

span.: espesador redondo, espesador mecanizado

Manufacturers: Sala, Dorr-Oliver, Denver, Famia, MAGENSA; MAEPSA, FAMESA, Eq. Ind. Astecnia, Buena Fortuna, COMESA, FAHENA, FIMA

<b>TECHNICAL DATA:</b>	
Dimensions:	bottom angle cat 8°; outlet cone 45° - 50°; 0.07 - 0.14 m/s peripheral speed of rabble (raking) arm; approx. 10 - 1500 m <sup>2</sup> clarification surface area
Weight:	brick construction in the ground
Driving Energy:	electrically-driven rabble arm 0.5 (2.5 m 0) - 2.5 (20 m 0) kW
Alternative Forms:	possibly hydromechanical
Mode of	continuous

Operation: Technical	very good clarification and thickening
Efficiency:	
Operating Materials:	possibly flocculants
<b><u>ECONOMIC DATA:</u></b>	
Operating Costs:	energy costs

### **CONDITIONS OF APPLICATION:**

Operating Expenditures: low |-----|-----| high

Maintenance Expenditures: low |-----|-----| high

Grain Size of Feed: 0 - 50  $\mu$ m

Special Feed Requirements: max. 5 - 10 % solids content in the feed, density distribution of components must permit gravity separation, i.e. solids must have comparably high specific density

Replaces other settling basin

Equipment:

Regional Distribution: worldwide application in residential water works for clarifying domestic as well as industrial sewage; also used in large-scale mining worldwide

Operating: very good |-----|-----| bad



Experience:  
Environmental  
Impact:

low |-----|-----| very high

positive: minimizes sludge-loading (through fines in effluents) on the natural drainage system; negative: large space requirements

Suitability for  
Local

very good |-----|-----| bad

Production:

Under What  
Conditions:

smaller units can be manufactured by local machinery and equipment manufacturers, the most complicated elements are the roller bearings and the worm gear for the rabble arm.

Lifespan:

very long |-----|-----| very short

## **Bibliography, Source: Ullmann**

### **OPERATING PRINCIPLE:**

**Continuous (Dorr-type) thickeners are round settling basins for clarifying suspensions and thickening slurries. The most simple non-mechanized form is the 'Dortmund basin' with a funnel-shape cross-section, centralized suspension intake and discharge of the sludge either by means of pumping or a gooseneck hose from the deepest point. To increase the clarification area, larger thickeners of flat-cylindrical cross-section and flat hopper bottom are in use in which the sedimented sludge is pushed toward the central discharge cone by means of a scraper on a rabble arm. The rabble arm rotates very slowly around the central thickening channel and serves to thicken the sludge in addition to stirring it. The driving force is extremely low. The clarified water flows over the periphery of the thickener and**

**is collected in the overflow channel.**

### **AREAS OF APPLICATION:**

**Clarification of mine water and beneficiation slurries containing solids particles smaller than 100  $\mu\text{m}$ , as well as thickening of solids before further drying, for example in filter presses, etc., or prior to deposition in sludge ponds.**

### **REMARKS:**

**The design of thickeners must take into consideration the slurry quantities and characteristics:**

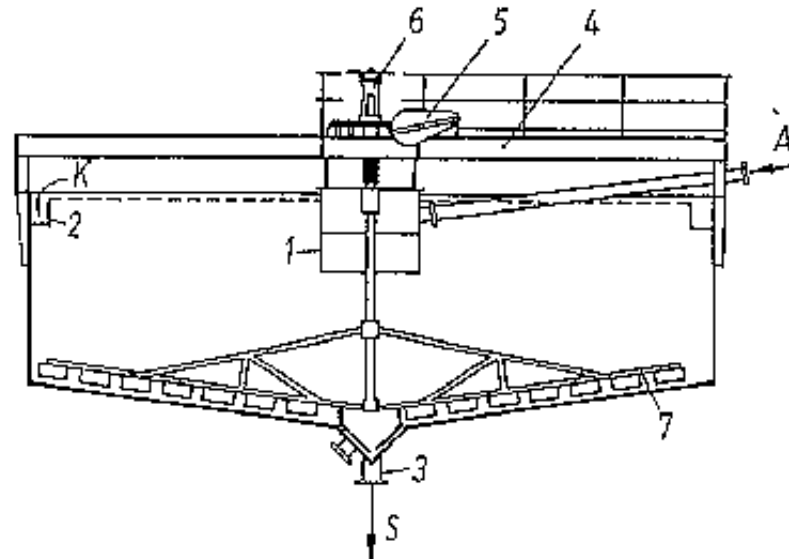
- Form of drive:** small thickeners are usually driven by worm gears, larger ones are equipped with a peripheral drive
- Rabble arm suspension:** smaller thickeners have rabble arms which are suspended directly at the middle axis, in larger thickeners the arm can be supported by a roller at the periphery of the basin.
- Basin construction:** can be of steel-plate or concrete; for aggressive slurries, wear resistant materials such as rubber coatings, stainless steel or possibly wood should be employed.
- Discharge devices:** pipes in goose-neck form, diaphragm pumps or excentric screw pumps are favorable.
- Feeding devices:** These should largely eliminate all kinetic energy of the incoming slurry, e.g. by use of deflecting or baffle plates, or tangential entry of the slurry into the cylinder.

In the event that the slurry feed contains solids that tend toward flotation,

possibly due to residuals of flotation reagents from the beneficiation processing, those should be removed with stripping devices installed near the feed intake.

### **SUITABILITY FOR SMALL-SCALE MINING:**

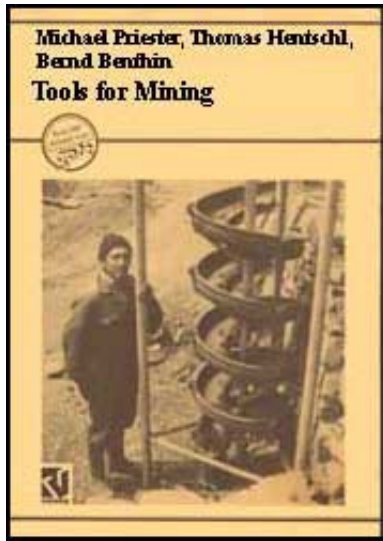
**Mechanized continuous (Dorr-type) thickeners are appropriate for use in larger small-scale mines where the high space requirement is not problematic, where large flow volumes of slurry need clarifying and where the necessary energy Infrastructure is available. The complicated technology demands the importation of essential construction components.**












**Fig.: Continuous (Dorr-type) thickener with central axis. 1) feed cylinder, 2) overflow channel, 3) sludge discharge outlet, 4) drive-unit bridge, 5) drive unit, 6) hoisting device, 7) rabble arms with scrapers, A slurry feed, K clarified fluid, S thickened sludge. Source: Schubert.**



[Home](#) > [ar](#).[cn](#).[de](#).[en](#).[es](#).[fr](#).[id](#).[it](#).[ph](#).[po](#).[ru](#).[sw](#)



## **Tools for Mining: Techniques and Processes for Small Scale Mining (GTZ, 1993, 538 p.)**

- ➔  **E. Mechanization and energy supply**
  -  **E.1. Introduction**
  -  **E.2. Energy source**
  -  **E.3. Drive unit**
  -  **E.4. Energy conversion**
  -  **E.5. Distribution of energy**
  -  **E.6. Energy systems**
  -  **E.7. Aspects of mechanization in mining**
  -  **E.8. Environmental and health aspects**

**Tools for Mining: Techniques and Processes for Small Scale Mining (GTZ, 1993, 538 p.)**

**E. Mechanization and energy supply**

**E.1. Introduction**

**Small-scale mining in developing countries operates at varying technical levels. The simplest level is the artisan or manual small-scale mining in which all tasks are performed by hand and no external energy is employed to ease the workload.**

***Examples are the gold diggers who win gold or mine tin with shovels, double-pointed picks, sluices and gold pans, in which drilling and blasting is performed by hand, transportation is performed with wheelbarrows and beneficiation with see-saw (rocker-type) crushers, hand jigs and settling basins.***

**In mining at an intermediary technical level, single work stages in the extraction, hauling and beneficiation processes are mechanized through the application of machines, whereby the control and regulation of the machines are usually performed manually. At this level, the proportion of work performed manually or with physical labor is still very high.**

***Examples are numerous small mining operations which drill using pneumatic drills on jacklegs, load the ore manually or with simple loading machines, sometimes employ crushers in the comminution process, and employ non-mechanized wet mechanical gravity beneficiation techniques. An additional example is sand-pumping operations in the mining of alluvial tin deposits.***

**In fully-mechanized mining at the progressive stage, most or all work phases are mechanized through the use, in part, of automated machinery.**

***Examples are the modern mining operations in industrial countries which are developed using tunnel boring machines.***

**The majority of the machines described in the previous sections find application in mining at the artisan and intermediary levels. If an external source of energy is necessary, a drive unit (e.g. engine or motor) must be added to the machine:**

<b>Energ</b>	<b>Drive- unit</b>	<b>Conversion</b>	<b>Energ</b>	<b>Machine</b>
--------------	--------------------	-------------------	--------------	----------------

<b>Source</b>			<b>distribution</b>	
diesel	internal comb. engine	compressor	compressed air line	pneumatic drill mill
water	water wheel	transmission gear	stamp mill	

**The machines and their intended applications determine the amount and form of energy required. In small-scale mining, the various operational steps should be considered separately.**

**For underground mining, machines are available for operation by three different basic drive-systems:**

- electric
- pneumatic
- internal-combustion devices.

**For reasons of mine safety, sturdiness, low maintenance, etc., compressed air tools and equipment have proven to be superior despite the low efficiency of the total system.**

**The energy requirement for mechanization of underground operations is determined by the size of the operation, surface facilities, geological conditions and particularly the degree of mechanization. There is practically no upper limit. The minimal energy demand is determined by the compressed-air consumption of drills on jacklegs, since drilling is usually the most energy-intensive activity in underground mining, and is accordingly the first area to be mechanized with the**

## **help of machines.**

**Depending upon the characteristics of the deposit, i.e. the hardness of the ore and host rock, drilling of blast holes requires approx. 0,5 kWh drilling work per drilled meter. Hence, mechanization of the drilling can lead to enormous increases in work productivity. A comparison of data from drifting activities in mechanized versus manual operations in solid-rock underground mining clearly demonstrates the differences:**

purely manual:	0.02 to 0.243m <sup>3</sup> loosened mass/MS
mechanized drilling, manual loading:	0.6 to 1.5 m <sup>3</sup> loosened mass/MS
mechanized drilling and loading:	2.7 up to 4.6 m <sup>3</sup> loosened mass/MS

**Compressed-air demand for drilling lies at a minimum of approx. 2 m<sup>3</sup>/min at 7 bar air pressure and therefore approx. 10-15kW compressor power consumption.**

**In beneficiation, the comminution of the raw ore is the most energy-intensive processing step. Depending upon the geology of the deposit, the comminution of a ton of raw ore to a flatable fineness (100 % <100 μm) can require up to around 50kWh of crushing and grinding. The minimal power requirement for beneficiation is established by the consumption of a small crusher which lies between 3 - 5 kW.**

**Branches of mining which have to move bulk materials (for example, sand-pumping operations) need to orient their operations around their planned transport capacities; sulfur mines require, in part, high thermal energy for the operation of autoclaves for smelting.**

**The total energy requirement can be categorized into individual forms of energy, namely:**

- mechanical
- electrical
- thermal

**General opinion ascertains - especially from the viewpoint of industrialized countries with their extensive supply of electric power - that mechanization through electrical energy is particularly advantageous. Under closer scrutiny, however, it becomes evident that in the majority of cases, electrical energy is again transformed back into mechanical energy (with corresponding losses in efficiency). This is especially true in small-scale mining in developing countries.**

**Mechanical Drives for:**

- Ventilators	- Jigs
- Pumps	- Vibrating screens
- compressors	- Tables etc.
- Crushers	

**In small-scale mining, electrical or thermal energy is only necessary in special cases.**

Electrical energy for: - charging lamps

- magnetic separation



- electrostatic beneficiation

Thermal energy for:

- drying
- distillation
- autoclaves

**In order to meet the energy demand in terms of the energy form and amount, an energy supply system with the above-mentioned individual components is required. These are:**

- **energy source**
- **drive unit (engine or motor)**
- **energy conversion**
- **energy distribution**

**Relevant aspects for planning the energy system and its individual components are briefly systematized and outlined below.**

## **E.2. Energy source**

**The essential criteria for planning the energy source are the costs and availability.**

**As energy sources for small-scale mining purposes, the following come into consideration:**

- **fossil fuels, especially diesel and gasoline**
- **electrical power originating from a central power supply**

## **- water**

**The regenerative energy forms - wind, biomass and solar energy - cannot be used for the basic mechanization of mining, but are suitable in some cases for isolated tasks (such as solar charging stations for mining lamps).**

**When possible, the data collected should not only pertain to the present conditions, but should also, when possible, take into consideration any possible (foreseeable) future changes over the longterm. An important example which indicates the variability of absolute and relative costs for the energy source is the price data for diesel fuel in Bolivian tin mining relative to the price of the raw material produced (in this case tin):**

**The following table shows a comparison of the price development of tin and diesel in Bolivia:**

1984 1 lb mined Sn ca. 6 US\$  
while 1 liter diesel 0.03 US\$

1987 1 lb mined Sn ca. 3 US\$  
while 1 liter diesel 0.30 US\$

**While a miner could still buy 200 liters of diesel/lb Sn sold in 1984, in 1987 he could only buy 10 liters/lb Sn produced. Similarly, the price relation for electric energy from the central power supply (public utility network) reflects a parallel development.**

**The potential price-fluctuations and supply-shortages (poor infrastructure, strikes, market changes) associated with conventional energy sources suggest that the planning of an energy system which uses regenerative energy should be given priority. A prerequisite for this is the availability of a regenerative energy source on a daily and yearly basis, and comparatively favorable investment costs for the drive system (i.e. engine -possibly through local manufacture).**

### **E.3. Drive unit**

**The drive systems for supplying energy are discussed in detail in Chapter 19. Decisive planning criteria are obtained by comparing the various systems with regard to the following parameters:**

- costs, i.e. operating and investment costs**
- repair and maintenance requirements**
- adaptability**
- suitability for local manufacture**

**A comparison of investment costs for drive-systems employed in mining is presented in the following table, whereby effort was given to consider machines which can be manufactured locally; these units are not only characterized by lower costs, but also by their comparatively simpler and quicker maintenance and repair requirements.**

**Table: Investment costs for drive units and energy. supply systems**

Internal combustion engine	150 - 300 DM/kW (cif Bolivia)
Diesel generator	500 - 1000 DM/kW (fob)

Diesel generator	500 - 1000 DM/kW (fob)
Water wheels, hydromechanical (local production)	200 - 500 DM/kW (without hydro engineering measures)
Turbine, hydromechanical (local production)	100 - 200 DM/kW (local engineering measures)
Hydroelectric	3000 - 10.000 DM/kW (fob without hydro engineering measures)
Wind, mechanical (local production)	3000 - 5000 DM/kW
Wind, electrical	5000 - 15.000 DM/kW (fob)
Photovoltaic	15.000 - 20.000 DM/kW (fob)

**At increasing efficiency or output, prices per installed kW react degressively; an exception is the linear trend in costs for solar electricity. The investment-cost ranges listed above pertain approximately to the maximum and minimum power requirements of small-scale mining.**

**Regarding investment costs, internal combustion engines are comparatively inexpensive, especially when compared to other drive units manufactured in industrialized countries; the high cost of fuels, however, leads to comparably high operating costs.**

#### **E.4. Energy conversion**

**A number of devices are available for converting one form of energy into another. The most important of these are presented in the Table. It is generally known that every conversion of energy is coupled with a loss in efficiency, which in some**

**cases is very strongly dependent upon location; this is particularly true for conversion of electrical and pneumatic energy, whereby temperature and elevation are the primary influencing parameters.**

**In converting mechanical into pneumatic energy in two-staged compressors at 8-bar operating pressure, the following elevation-dependent efficiency losses are measured:**

Copresor Type	Decrease in % for every 1000 m Elevation increase	
	Delivery Quantity	Power Consumption
Medium-size, air-cooled compressor	2.1	7.0
Screw compressor with oil injection	0.6	5.0
Larger, water-cooled piston compressor	1.5	6.2
Larger, water-cooled screw compressor	0.3	7.0

**The conversion of mechanical into electrical energy in generators is calculated through the use of the following elevation and temperature dependent correction factors:**

Elevation of the machine	1000 m	1500 m	2000 m	2500 m	3000 m
factor $f_1$	1	0.96	0.91	0.87	0.83
ambient temperature $\theta_c$	25	45	50	55	60

ambient temperature °C	25	45	50	55	60
factor $f_2$	1.07	0.96	0.93	0.91	0.88

**Mechanical energy conversions for the purpose of altering transmission torque and rpm are listed in the following tables (including values for maximum limit and degree of efficiency).**

Transmission type	For one transmission step		Capacity N1(PS) up to	RPM $n_1$ (RPM) up to	Periheral speed v (m/sec) up to	Periheral force (wheel) $U_0$ (kg) up to	Torque of wheel $M_0$ (mkg) up to	
	usual up to	extreme up to						Total efficiency of efficiency %
Spur gear		8	(20)	95...99	25000	100000	200	-
Planetary gear	8	(13)	98...99	10000	40000	-	-	-
Worm gear	60	(100)	97...45	1000	30000	70	50000	25000
Chain drive	6	(10)	97...98	5000	5000	17	28000	-
Flat-belt drive	5	(10)	96...98	2200	18000	90	5000	17500
V-helt drive	8	(15)	94...97	1500	-	26	-	2150

Friction wheel drive	6	(10)	95...98	200	-	20	-	-
----------------------	---	------	---------	-----	---	----	---	---

## E.5. Distribution of energy

**Finally, the equipment for bringing the energy from the generator to the machine (drive unit) must be planned. These distribution systems are characterized by different distance ranges and efficiency-losses:**

- **mechanical drives are limited in range to a few meters but operate a high degrees of efficiency,**
- **electric drives require power lines and, depending upon the range, high-tension transformers to reduce resistance losses,**
- **pneumatic drives require expensive compressed-air lines which are characterized by high losses in air pressure (pressure drop) and in the delivered quantity (see Technical Outline 19.1 3).**

## E.6. Energy systems

**In planning a complete energy-supply system for small-scale mining in developing countries, in addition to efficiency, the following parameters are also relevant:**

economic factors: investment costs,  
operating costs,

technical factors: overall efficiency.

worker safety,  
environmental aspects  
(see below)

**A comparison of complete energy-supply systems is presented in the following tables. Generally, installations with a high degree of complexity present greater problems concerning operation, maintenance and repair. The conversion of mechanical into electrical energy and the reconversion for machinery drive-units is not only associated with high efficiency losses and high investment costs, but is also too complex for application in developing countries. Mechanical drives with direct use of torque, for example in internal combustion engines and small turbines, contribute greatly to simplifying mechanized equipment (see also Technical Outline 19.12).**

### **E.7. Aspects of mechanization in mining**

**The most important aim of mechanization and partial mechanization is to increase efficiency. This goes hand in hand with a reduction in production personnel.**

**For coal mining at constant production rates, Noetstaller has quantified the number of personnel required as follows:**

**Finally, the costs accrued due to mechanization must be considered, i.e., the investment costs as well as the operating costs. Mechanization or partial mechanization exerts influence on the following factors, amongst others:**

**- the extent of investment costs not only for drive units but also for the**



## **machines and the associated related investments,**

- the energy costs,**
- cost of wages, since every mechanization step leads either to increased production or lower personnel requirements as a result of increased efficiency. (A consequence which poses problems in developing countries with their already high rate of unemployment.)**

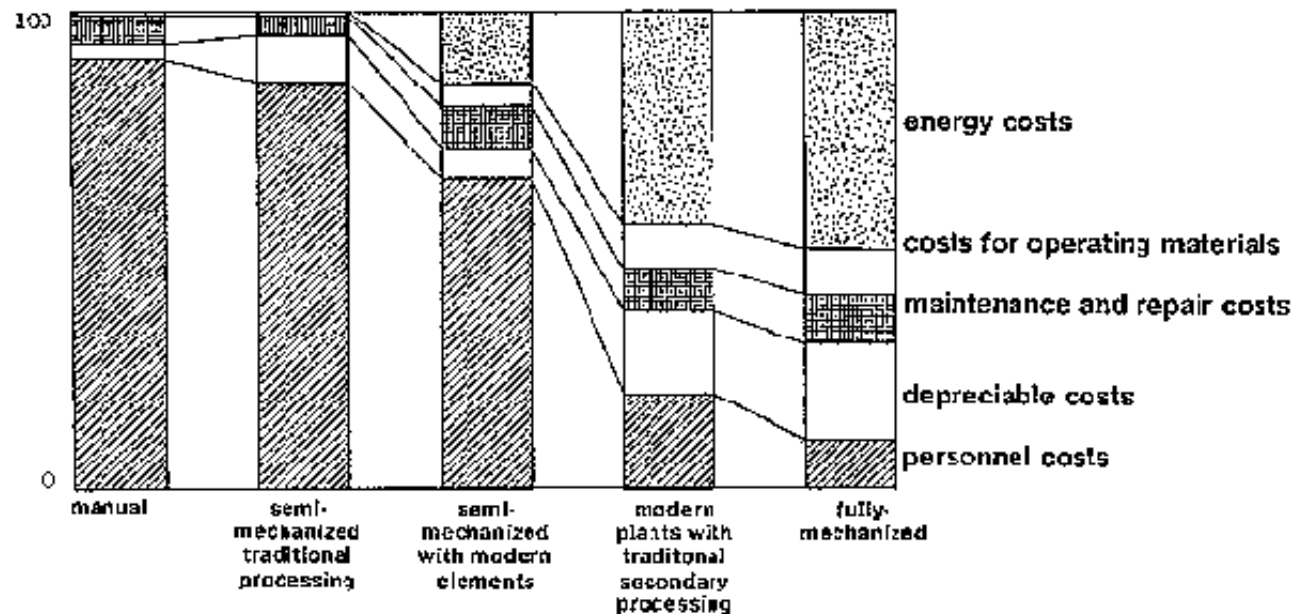
**The extent of costs for each respective category listed above vary significantly between industrialized and developing countries. As a rule, the following is true of developing countries:**

- investment costs for imported equipment are higher than in industrialized countries**
- service costs on capital are higher than in industrialized countries,**
- costs of wages are significantly lower than in industrialized countries.**

**The investment capital requirements for a coal mining operation are described by Noetstaller for the following ranges of mechanization:**

**A further major consequence of mechanization or partial mechanization is a change in the cost-structure of the operation; this is exemplified by ore beneficiation plants in Bolivia with varying degrees of mechanization:**

**A problem in the mechanization or semimechanization of plants or processes is the estimation of coupling (indirect) effects. Mechanization usually leads to increased efficiency in the mechanized processing step. However, in order to accommodate the newly-installed machine's operating mode (for example, a continuous mode of operation requiring continuous, homogeneous feed quantities), or the changed economic conditions (for example, higher production capacity), increases in efficiency/production must also be achieved in the preceding and succeeding processing steps. This may be difficult to realize, depending upon the characteristics of the deposit and on the operation's physical and personnel infrastructure. Increased production in the shaft-hoisting system, for instance, can only be attained through major investments or change of the haulage system. In the event that the steps preceding and succeeding a mechanization upgrade cannot be altered, the newly mechanized step cannot be operated economically at full production capacity. In order to achieve an improvement in production through mechanization, a prior calculation of the effect on the entire processing procedure is critical.**



**Fig.:Relative distribution of beneficiation costs in plants with varying degree of mechanization. Source: Priester.**

**A mechanization or partial mechanization of a plant can then be justified on an economic basis only when the production costs for the final product do not increase as a result of the investment. Aside from the economic aspects, the social, humanitarian, safety, environmental and regional-development aspects in conjunction with mechanization are also important. These are difficult to quantify and hence no concrete suggestions can be offered here in this regard (see Noetstaller).**

**In providing energy for direct use in mining operations, the welfare of the miners and their families should also be considered. The difficult living conditions in the mining regions located at elevations as high as 5000 m or more above sea level could be alleviated through the provision of warm water, energy for heating,**

**lighting or electricity in general, or energy for cooking. Energy requirements in this area should not be neglected during planning.**

## **E.8. Environmental and health aspects**

**For economic and especially ecological reasons, it cannot be regarded as reasonable to meet increasing primary-energy demands through the use of fossil fuels, either in the Andean region or worldwide. Unfortunately, ecological considerations in planning in developing countries remain an exception (for instance, mining in the watershed area of drinking-water reservoirs in Potosi, Bolivia). For the long-range and middle. range conservation of the ecological life-support systems, the protection of the atmosphere, water, soil and flora and fauna is imperative. Even small-scale mining in developing countries can and must contribute to protecting the future, without having to suffer economic disadvantages because of it.**

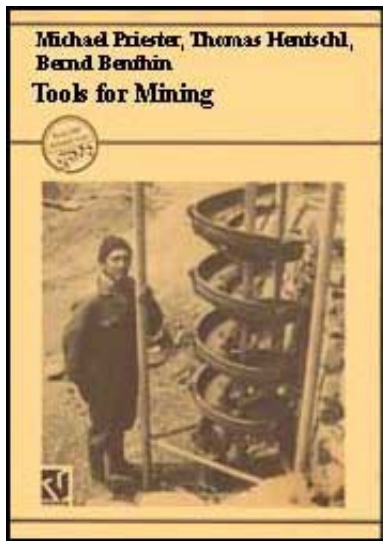
**In developing countries, the use of renewable energy sources could make a valuable contribution to environmental protection and increase the environmental awareness. This also applies to small-scale mining, where consideration of environmental aspects has so far been lacking.**

**The diesel-run generators used in conventional decentralized electrical-energy supply, as well as the internal combustion engines used in the operation of machines, burn fossil fuels and, in so doing, emit toxic residues in the form of exhaust fumes. The regenerative energy sources, to the contrary, use water, wind or sunshine as an energy-producing medium, but does so without consuming it and without creating residues. The operation of internal combustion engines not**

**only produces environmental impact through exhaust fumes and noise, but also creates a serious problem concerning waste-oil contamination and disposal. In the remote regions of small-scale mining, environmentally-sound waste-oil disposal is either not possible, or due to inadequate environmental awareness is not available. Usually, waste-oil ends up directly in the soil or in the drainage system, which can have catastrophic effects on the unstable ecosystems of the high-altitude Andes region. Even the rural population in the larger vicinity can be adversely affected since flowing bodies of water (e.g. rivers) are often used for drinking water and for irrigation (possible solution is in Technical Outline 11.3).**



[Home](#) > [ar](#).[cn](#).[de](#).[en](#).[es](#).[fr](#).[id](#).[it](#).[ph](#).[po](#).[ru](#).[sw](#)



## **Tools for Mining: Techniques and Processes for Small Scale Mining (GTZ, 1993, 538 p.)**

### **Technical Chapter 19: Energy Techniques**

 ***(introduction...)***

 **19.1 Bicycle drive pedal drive**

 **19.2 Animal-powered whim**






 **19.3 Water balance**

 **19.4 Wind generator**

 **19.5 Savonius rotor**

 **19.6 Water wheel**

 **19.7 Horizontal water wheel**

-  **19.8 Rope turbine**
-  **19.9 Solar cells**
-  **19.10 Solar collector (solar thermal)**
-  **19.11 Water turbine**
-  **19.12 Internal combustion engine**

**Tools for Mining: Techniques and Processes for Small Scale Mining (GTZ, 1993, 538 p.)**

## **Technical Chapter 19: Energy Techniques**

### **ENERGY SUPPLY TECHNIQUES**

#### **19.1 Bicycle drive pedal drive**

#### **Mining General Energy, Energy Techniques**

germ.: Fahrradantriebe, Pedalantriebe

span.: accionamiento a bicicleta, accionamiento a pedal

<b>TECHNICAL DATA:</b>	
Dimensions:	starting at approx. 1.2 × 2 × 0.5 m
Weight:	25 kg
Form of Driving Energy:	pedal drive
Mode of Operation:	semi-continuous/intermittent

Mode of Operation:	semi-continuous/intermittent
Throughput/Capacity:	continual output of 80 - 100 W, peak performance up to 500 W
<b>ECONOMIC DATA:</b>	
Investment Costs:	for simple pedal lever approx. 20 DM; for bicycle drive starting at approx. 200 DM
Operating Costs:	mainly labor costs
Related Costs:	possibly gear unit

### **CONDITIONS OF APPLICATION:**

Operating  
Expenditures:  
Maintenance  
Expenditures:  
Machines  
which can be  
Driven:

low |-----|-----| high

low |-----|-----| high

#### pedal drive:

percussion jig, manual diaphragm jig(see photo), Baader's blower (Harzer Wettersatz), air separators (pneumatic dry washer), tire pump, concussion (bumping) table

#### bicycle drive:

bumping table, Chinese liberation pump (see fig.) possibly haulage by block and pulley, small ball-mill, small sizing drum, pedal fan, vibrating screen

Replaces  
other

manual and small mechanized drives

Equipment:  
 Regional based on current knowledge, so far not used in small-scale mining  
 Distribution:  
 Environmental Impact: low |-----|-----| very high  
 Suitability for Local Production: very good |-----|-----| bad  
 Under What Conditions: metal manufacturing shop using bicycle parts  
 Lifespan: very long |-----|-----| very short

## **Bibliography, Source: McCullogh**

### **OPERATING PRINCIPLE:**

**The pedal-lever system transfers the power forces from the leg to the machine using the principle of leverage. In situations where machines have been hand-driven, the use of pedal drive frees the hands for other activities such as control, regulation, feeding, discharge, etc. The bicycle-drive uses the motion of the bicycle chain or rear wheel to drive the particular machine, possibly via a chain gear.**

### **AREAS OF APPLICATION:**

**Pedal-levers are used for imparting simple pulsating power-impacts in the lower capacity range.**



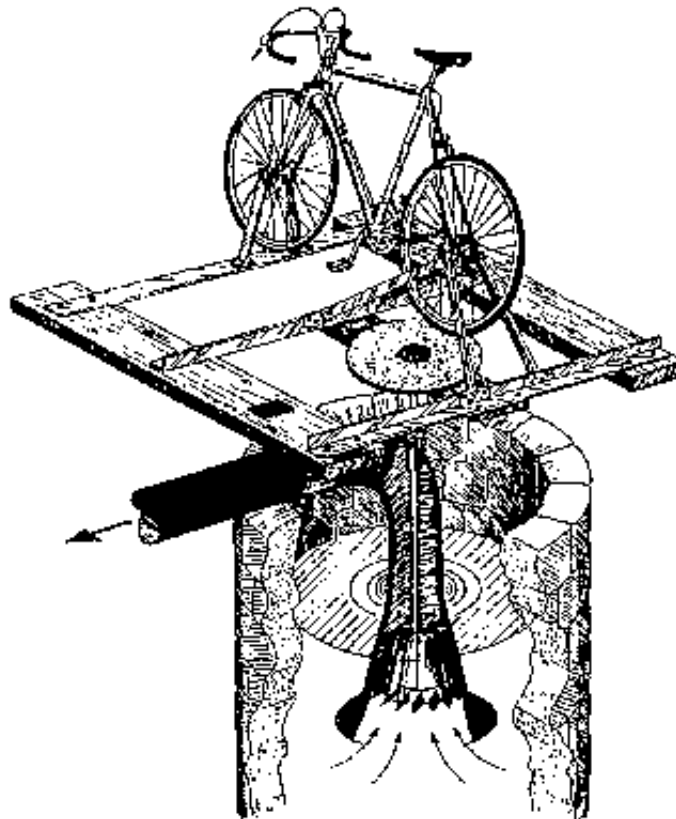
**Bicycle drives are applied in all situations where continually rotating low-power movements are needed.**

**REMARKS:**

**In small-scale mines of artisan character which have so far been operated primarily manually, there are numerous areas of application where a simple pedal or bicycle drive can substantially ease the work load and increase output.**

**SUITABILITY FOR SMALL-SCALE MINING:**

**Pedal drive systems are practical for application in traditional small-scale mining in Latin America as low power drive mechanisms (< 100 W). They should, however, not be mistaken as a substitute for mechanization.**



**Fig.: Pedal drive for a centrifugal water pump. Centrifugal water pump. Source: McCaullagh.**

## 19.2 Animal-powered whim

### Mining General Energy, Energy Techniques

engl.: animal-driven gear germ.: Gopel  
span.: malacate

#### **TECHNICAL DATA:**

Dimensions:	required space: approx. 50 m <sup>2</sup>
Weight:	150 - 500 kg
Extent of Mechanization:	semi mechanized
Driving Capacity:	0.7 - 3 kW, average of approx. 800 W
Form of Driving Energy:	mechanical via animal power
Mode of Operation:	practically continuous
Throughput/Capacity:	depends on draft animal
Technical Efficiency:	70 - 90 %, for example for shaft haulage: haulage speed 0.3 - 0.65 m/s with haulage bucket volume of 0.3 - 1.2 m <sup>3</sup> at a maximum depth of 250 m
Operating Materials:	
Type:	draft animals and feed
Quantity:	1 - 2 draft animals (donkeys, oxen, horses)
<b>ECONOMIC DATA:</b>	
Investment Costs:	750 to 5000 US\$ depending on land of origin and machine
Operating Costs:	low
Related Costs:	for hauling water, well construction

### **CONDITIONS OF APPLICATION:**

Operating

low |-----| high

Expenditures:

Maintenance

low |-----|-----| high

Expenditures:

Personnel      experience with harnessing and handling animals

Requirements:

Location      draft animals and animal feed must be available

Requirements:

Machines      Harzer Wettersatz (Baader's blower), bucket chain-conveyor, water-bag  
which can be      haulage system, ball mills, roller mills, Chilean (edge) mills, buddies,  
Driven:          concussion (bumping) tables, piston pumps

Replaces other small engines, manual drive systems

Equipment:

Regional      North Africa, Asia, Latin America, but no longer applied in mining

Distribution:

Operating

very good |-----|-----| bad

Experience:

Environmental

low |-----|-----| very high

Impact:

Suitability for

very good |-----|-----| bad

Local

Production:

Under What      good metal-manufacturing shop; wooden construction also possible

Conditions:

Lifespan:

very long |-----|-----| very short

**Bibliography, Source: Projekt-Consult, Agricola, Calvor, Villefosse, Delius, Lowe, Treptow, Wagenbreth**

### **OPERATING PRINCIPLE:**

**Animals harnessed to the outer end of a horizontal lever arm continuously walk in a circle, rotating the arm around a central axis, thereby either directly or indirectly (via gear mechanism) driving a machine. Numerous design and construction variations.**

### **AREAS OF APPLICATION:**

**Driving force for machines of low output for mining and beneficiation. Especially suitable for machines requiring high torque and low rpm.**

### **REMARKS:**

**Animal-powered whims (gears) are particularly suitable for draining or hauling water. Animal-powered whims were applied historically in beneficiation and for ventilation.**

**The harnessing of animals for powering machinery was widely used in mining in central Europe during the late Middle Ages up to the 19th century; it was also historically found in agriculture, primarily for pumping purposes, an application which has been transferred to present-day small-scale mining. The output varies substantially depending on the kind of draft animal (e.g. horse 400 - 1000 W, mule 300 - 600 W, donkey 75 - 200 W, ox 300 - 500 W). The camel-type animals typical of the Andes (llamas, alpakas) do not accept being harnessed. In the high**

**altitudes of the Andes, minimum values (output, efficiency, etc.) must be used for planning purposes. The very low rpm of the animal-powered whim prevents a conversion to other forms of energy and limits its application to mechanical uses. Since agriculture and mining activities frequently exist adjacent to one another, and agriculturally-employed draft animals are only needed periodically, use of these animals during idle periods for mining purposes appears practical.**

**The ability of draft animals to spontaneously produce up to ten times their normal long-term output permits the animal-powered whim, depending on the particular machine, to serve as a replacement for small motors whose output lies around 2-3 times that of the normal output of draft animals.**

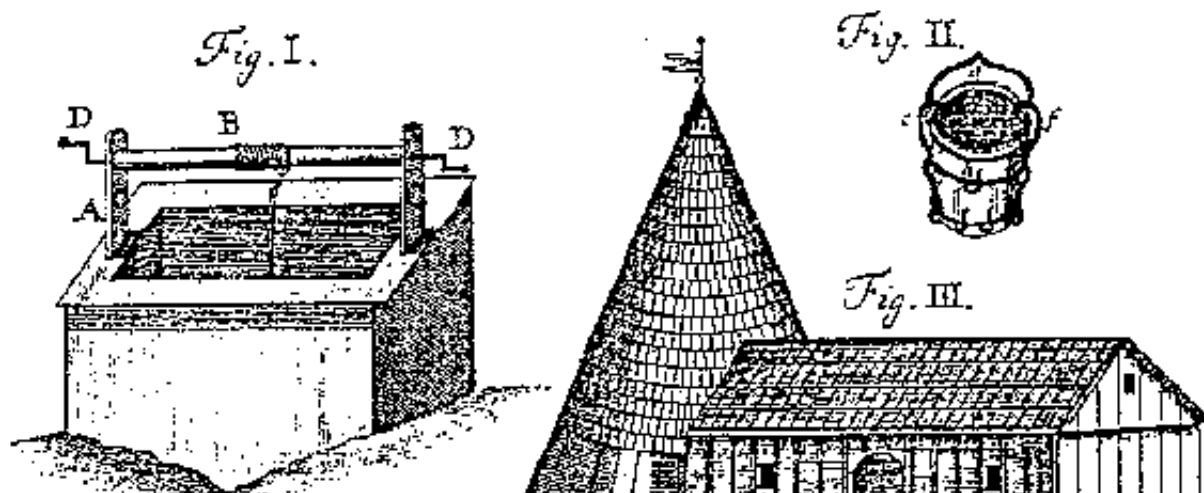
**A special form of animal-powered whim is the Koepe-sheave whim (friction pulley), which was widely used in mining earlier,**

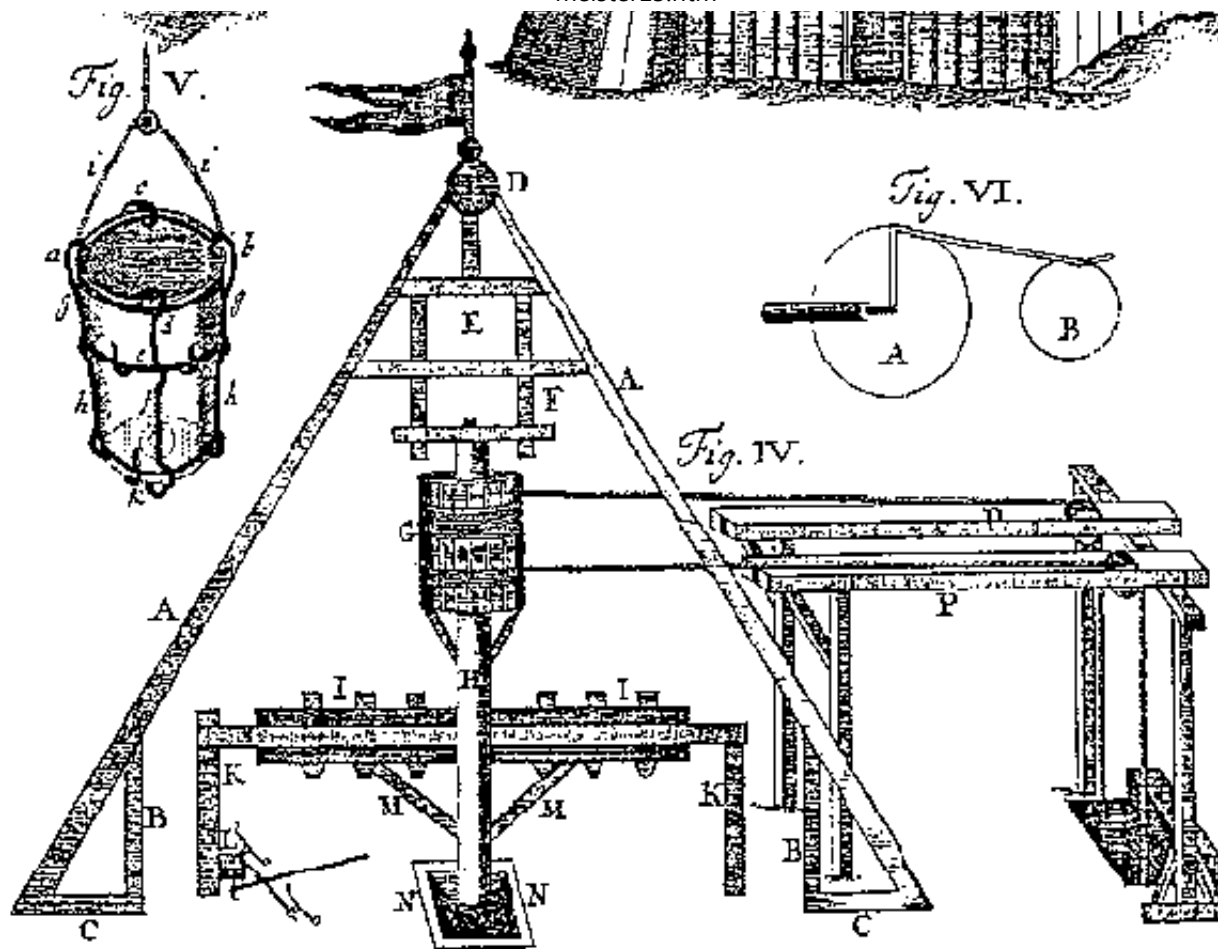
### **SUITABILITY FOR SMALL-SCALE MINING:**

**Animal-powered whims are suitable for driving machines with low output, especially those with low rpm. The possibility for local production also provides an impetus for technical developments in other economic sectors (e.g. agriculture).**



**Fig.: Horse-powered whim for shaft haulage. Source: Agricola.**





**Fig.: Animal-powered whim for deep haulage. Source: Calvor.**

## 19.3 Water balance

### General Mining Energy, Energy techniques

germ.: Wasseraufzüge

span.: elevadores de agua



<b><u>TECHNICAL DATA:</u></b>	
Dimensions:	depends on transport distance
Extent of Mechanization:	not mechanized
Form of Driving Energy:	potential energy of water
Mode of Operation:	semi-continuous
Technical Efficiency:	very high efficiency when constructed with low-friction bearings
Operating Materials:	
Type:	water
Quantity:	> weight of material to be conveyed + difference of rope weight
<b><u>ECONOMIC DATA:</u></b>	
Investment Costs:	substantially cheaper compared to other haulage systems, since rope costs, etc. occur in the latter as well
Operating Costs:	very low

### **CONDITIONS OF APPLICATION:**

Operating Expenditures:

low |-----|-----| high

Two persons for filling and emptying the water; these activities could also be partly automated.

Maintenance Expenditures:		low  ----- -----  high
Location Requirements:	large quantities of water at suitable topographical conditions (vertical elevation difference close to the haulage shaft or drainage gallery)	
Equipment which can be Driven:	water and ore transport systems, ore and man-lifts in shafts	
Replaces other Equipment:	mechanized haulage machines	
Regional Distribution:	no longer in use today; formerly (19th century) distributed throughout Europe	
Environmental Impact:		low  ----- -----  very high
Suitability for Local Production:		very good  ----- -----  bad
Under What Conditions:	metal and wood manufacturing shops using industrially-made ropes (cables); car parts can be used for brake systems	
Lifespan:		very long  ----- -----  very short

**Bibliography, Source: Various issues of "Zeitschrift fur das Berg- Hutten-, und Salinenwesen im preuss Staate" (Magazine for Mining, Metallurgy and Salt Industry in Prussian States, Germany)**

### **OPERATING PRINCIPLE:**

**Water balances work according to the counter-weight principle. The bucket to be conveyed is lifted through the lowering of a heavier, water-filled counter-weight. Two conditions are necessary for operation:**

- the counter weight has to generate a greater lifting power than the weight to be lifted**
- the lifting force of the empty bucket has to be greater than the lifting force of the empty counter- weight (without water) in order to allow both the counter weight and bucket to return to the start position.**

**In cases where the counter-weight is guided up a steep ramp, the lifting forces must be corrected by the cosine of the inclination angle. The less steep the ramp is, the higher the empty weight and the filling volume of the counter-weight have to be.**

### **AREAS OF APPLICATION:**

**Hydromechanical hoisting of raw ore, mine water and possibly personnel transport.**

### **REMARKS:**

**This method can most successfully be applied where drainage galleries allow the draining of process water, with the counterweight travelling up and down the shaft, without associated difficulties. Historically water balances were in use primarily in English and Upper Silesian coal mines.**

## **The Installation of water balances demands specific conditions:**

- mine infrastructure: haulage shafts must be located close to a suitable path for the counter-weight (ramp to the surface or shaft). The fact that drift mining is dominant in Latin America limits the possibilities for small-scale mining application in that region.**
- large quantities of water and sufficient elevation potential must be available (topographical and hydrographical prerequisites).**

**Historically, hydro and pressurized-water motors were in use until the middle of this century.**

### **SUITABILITY FOR SMALL-SCALE MINING:**

**The possibilities for application of water balances are very limited. Under ideal conditions (hydrographic, topographic and those related to mine-infrastructure) water balances guarantee a simple, stable, and driveless hoisting system.**

## **19.4 Wind generator**

### **Mining General Energy, Energy Techniques**

germ.: Windgenerator

span.: generador eolico

Manufacturers: Elektro, Sudwind, Brummer, Enercon, Electromat and others

<b>TECHNICAL DATA:</b>	
Dimensions:	10 m 0, height of tower 14 m with 20 kW generator; weight: 2500 kg
Extent of Mechanization:	fully mechanized
Form of Driving Energy:	wind (aeolian): for high-speed wind generators to produce electrical energy, minimum wind speed of 3.5 m/sec., nominal (rated) speed of 11 m/sec., for low-speed wind-mechanical wind mills, significantly lower wind speeds are sufficient
Mode of Operation:	continuous
Throughput/Capacity:	from 100 W to 50 kW depending on demand
Technical Efficiency:	up to a maximum of 35 % total efficiency as $C_p$ (performance coefficient) $\times$ $\eta$ (mechanical efficiency of the converter) $\times$ $AM$ (efficiency of the machine)
Operating Materials:	
Type:	wind
Quantity:	for generation of electrical energy, starting at speed of approx. 4 m/sec.
<b>ECONOMIC DATA:</b>	
Investment Costs:	8000 to 20.000 DM/kW for facilities of 10 - 30 kW without tower
Operating Costs:	none
Related Costs:	tower, possibly storage batteries

**CONDITIONS OF APPLICATION:**

Operating Expenditures:		low  ----- -----  high
Maintenance Expenditures:		low  ----- -----  high
Location Requirements:	prerequisite for permanent operation is sufficient wind speeds both daily and annually. This must be confirmed by taking wind measurements for a period of several years at the location under consideration.	
Machines which can be Driven:	electric motors and other machines with an electrical connection	
Replaces other Equipment:	e.g. diesel generator, central electrical power supply, water turbines employing electricity	
Regional Distribution:	common in industrialized countries (dependent on location), less frequent in developing countries	
Operating Experience:		very good  ----- -----  bad
Environmental Impact:		low  ----- -----  very high
Suitability for Local Production:		very good  ----- -----  bad
Lifespan:		very long  ----- -----  very short
	rotors gears and generators long-lasting accumulators limited	

**Bibliography, Source: Manufacturer information, DVA, von Konig, GATE, STAMPA, Kleemann/Melip**

### **OPERATING PRINCIPLE:**

**The high-speed wind generator orients itself according to the wind direction, whereby the rotor is set into rotation by the pressure of the wind (wing principle). The rotor axis is coupled, either directly or with a gear, to an asynchronous generator. The electrical energy so generated is drawn off either directly as counter-current electricity and consumed, or rectified for storage in accumulators.**

**With mechanical utilization of wind - most suitable with low-speed multiple-blade impeller - a connecting rod or drill rods transfer the mechanical energy to the machine (mainly pumps).**

### **AREAS OF APPLICATION:**

- decentralized generation of electrical energy as an isolated operation.**
- for pumping mine and processing water in mining operations; possibly also for water drainage in shallow mines.**

### **REMARKS:**

**The high specific investment costs for wind generators can only be justified when the location exhibits optimal climatic conditions.**

**The longer the duration of calm periods to be accommodated, the higher the investment costs for the energy-storage unit (batteries with low discharge current). Such batteries are expensive and comparably short-lived, which significantly affects the operating costs and generated energy costs. Experiences from research activities of the DAV and the Fraunhofer Gesellschaft (Society) revealed that wind conditions of the alpine region are very non-constant and are in no way comparable to those of coastal regions, where experiences in using wind to generate energy have been actualized. Storm protection and regulation is still problematic in the alpine region. Unfortunately, it can be feared that this situation also applies to the high mountainous region of the Andes.**

**In the eastern Mediterranean region and in Persia, indications of early application of wind-energy converters can be traced back to the time of approx. 1000 B.C.**

### **SUITABILITY FOR SMALL-SCALE MINING:**

**Extreme dependency on location and high investment costs for an imported product make this technology mostly inappropriate for small-scale mining. Furthermore' the storage of wind-generated energy, e.g. in the form of compressed air, is too expensive for the small-scale mining industry.**

## **19.5 Savonius rotor**

### **Mining General Energy, Energy Techniques**

engl.: cross-flow rotor

germ.: Savoniusrotor, Durchstromrotor



span.: rotor savonius, motor de impulsion radial

<b>TECHNICAL DATA:</b>	
Dimensions:	7 m × 2.5 m × 5 m (HWL, three-bladed rotor), rotor Ø 160 cm
Form of Driving Energy:	aeolian (wind)
Throughput/Output:	up to 200 W
Operating Materials:	
Type:	wind
Quantity:	min. 3 m/sec.
<b>ECONOMIC DATA:</b>	
Investment Costs:	approx. 2000 DM for smaller units
Operating Costs:	none

### **CONDITIONS OF APPLICATION:**

Operating Expenditures: low |-----|-----| high

Maintenance Expenditures: low |-----|-----| high

Location Requirements: sufficient wind conditions (see Technical Outline 19.4 - wind generators), whereby it must be noted that Savonius and cross-flow rotors are more suitable for low wind speeds (around 3 m/sec.).

Machines pumps (e.g. small compressors for displacement pumps, tire pumps)

which can be

**Driven:**  
Replaces other fans, ventilators

**Equipment:**

**Regional**            earlier, relatively widely distributed

**Distribution:**

**Operating**

very good |-----|-----| bad

**Experience:**

**Environmental**

low |-----|-----| very high

**Impact:**

**Suitability for**

very good |-----|-----| bad

**Local**

**Production:**

**Under What**        workshops working with fiberglass-reinforced synthetic resins, metal and  
**Conditions:**     wood

**Lifespan:**

very long |-----| very short

**Bibliography, Source: Landtechnik Weinhenstephan (Germany), von Konig**

### **OPERATING PRINCIPLE:**

**The Savonius rotor, as a machine operated by continual flow, functions similarly to the cross-flow turbines, with the exception that the driving flow-medium is air (wind). Low-pressure (suction) develops on the concave side of the impeller blades, and high-pressure conditions prevail on the convex side. The rotor begins to rotate around its central axis when wind forces are sufficient; this movement is used to power mechanical drive units.**

## **AREAS OF APPLICATION:**

**Discontinuous drive for low-output machines (e.g. pumps), especially pumps for circulating or hoisting processing water in beneficiation.**

## **SPECIAL AREAS OF APPLICATION:**

**For generating 12V direct-current electricity with battery storage for illumination or other low-consumption demands for electricity (e.g. recharging of electric mining lamps).**

## **REMARKS:**

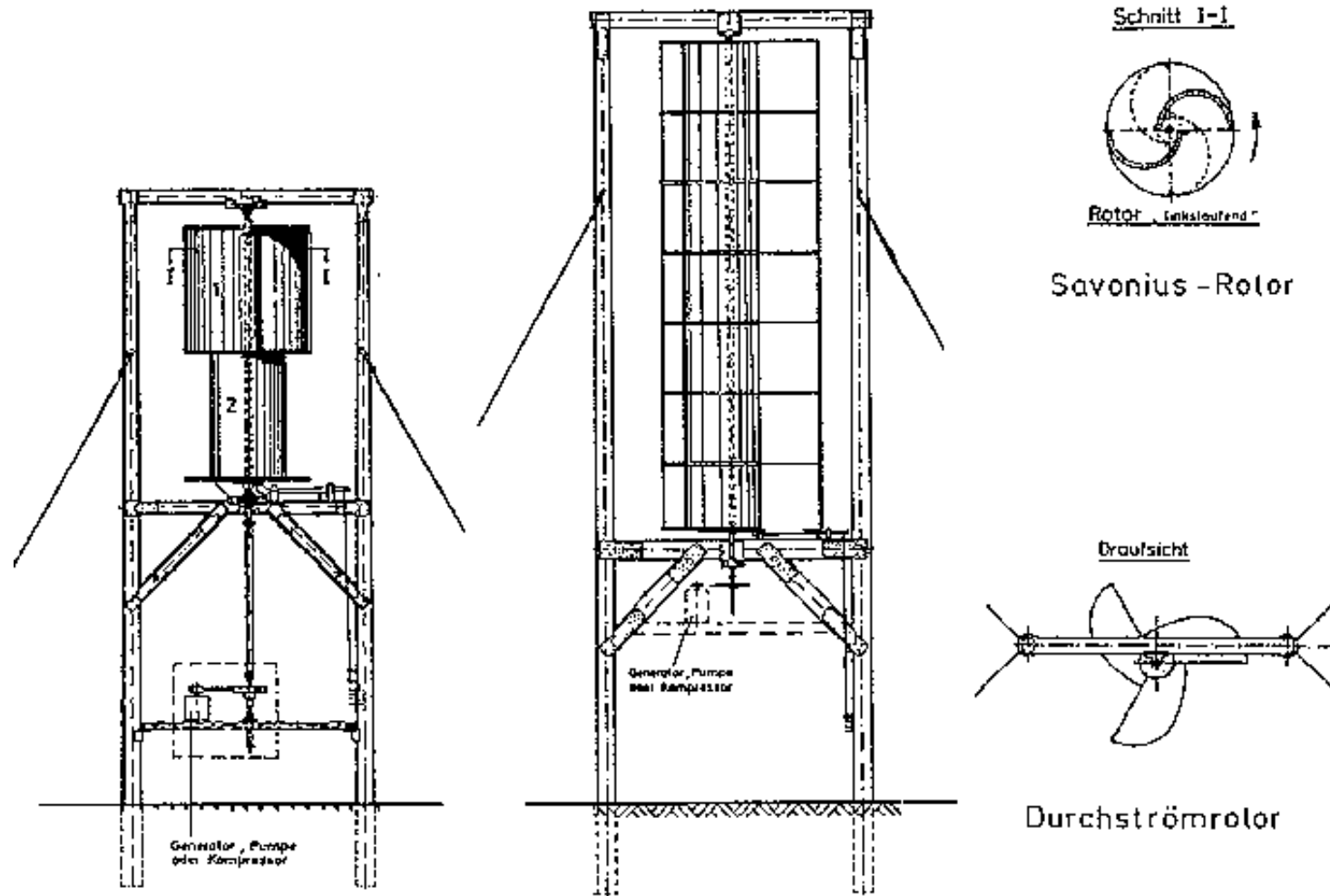
**Due to the unpredictability and nonreliability of wind, making it impossible to plan on, this wind-driven mechanical drive technology is only suitable for machines which can be left to operate periodically without supervision.**

**The storm protection of Savonius or cross-flow rotors is problematic, since the same surface area of the rotor is exposed to the wind regardless of wind direction, and cannot, as is the usual case, be turned away from too-strong winds. However, the gyrostatic force of the propeller at high rpms has a stabilizing effect. The tower for Savonius or cross-flow rotors can easily be locally constructed of wooden logs at low cost.**

**The major disadvantages of all wind aggregates are the significantly higher space requirement and the non-planable energy production resulting from the constantly fluctuating wind conditions which determine the output.**

## SUITABILITY FOR SMALL-SCALE MINING:

Small-scale mining operations in Latin America are seldom located where conditions are suitable for utilization of wind energy; this limits the possibilities for use even of Savonius or cross-flow rotors, which are able to operate at lower wind speeds and are ideal for mechanical-drive purposes.



**Fig.: View and cross-section of a Savonius (left and above right) and a cross-flow**

## rotor. Source: Landtechnik Weihenstephan (Germany).

### 19.6 Water wheel

#### General Mining Energy, Energy Techniques

engl.: water-powered gear

germ.: Wasserrad, Wassergopel

span.: rueda de agua, rueda hidraulica, malacate a agua

Manufacturer: M. Implor, Filou

<b>TECHNICAL DATA:</b>	
Dimensions:	water wheels from 80 cm up to more than 7 m in diameter are in use in small-scale mining. E.g. overshot water wheel: with approx. 27 liter scoop-volume, diameter approx. 4 m, around 40 scoops approx. 70 cm wide, approx. 3 m long axle
Weight:	e.g. 1700 kg for overshot water wheel of 4-m diameter, 950 kg for 2.5 m diameter wheel, 700 - 800 kg for Zuppinger water wheel of 2.5 m diameter
Form of Driving Energy:	hydromechanical
Mode of Operation:	continuous
Throughput/Capacity:	up to approx. 10 kW
Technical Efficiency:	highest with overshot water wheels, approx. 70 % middleshot water

	wheels approx.60 % lowest for undershot water wheels at approx.32 - 38 % Zuppinger water wheel approx.65 - 70 %
Operating Materials:	
Type:	water
Quantity:	approx. 100 liters/sec or less for smaller wheels
<b><u>ECONOMIC DATA:</u></b>	
Investment Costs:	in Germany: overshot water wheel with 4 m diameter: 25.000 DM; overshot water wheel with 2.5 m diameter: 15.000 DM; in developing countries with local production substantially lower costs in some cases, e.g. for overshot wooden water wheel 5 m in diameter made in Colombia 1300 DM
Operating Costs:	practically none
Related Costs:	hydrological engineering measures, flood protection

### **CONDITIONS OF APPLICATION:**

Operating Expenditures:	low  ----- -----  high
Maintenance Expenditures:	low  ----- -----  high
Location Requirements:	demand For water and vertical elevation difference as follows: overshot wheels: approx. 1 m plus wheel diameter middleshot wheel: radius of wheel undershot wheel: no elevation-drop necessary at higher flow velocities
Equipment which can be	Harzer Wettersatz (Baader's blower), Chinese liberation pump, water-bag transport, winch, block and pulley, tire pump, ball mill, stamp mill, Chilean

Driven: mill, vibrating screen, sizing drum, logwasher, jig, buddle, bumping table  
 Replaces other generators and all mechanical drive systems, various turbines, combustion  
 Equipment: engines  
 Regional historically worldwide, presently in small-scale mining in Colombia and  
 Distribution: Ecuador  
 Operating very good |-----|-----| bad  
 Experience:  
 Environmental low |-----|-----| very high  
 Impact:  
 Suitability for very good |-----|-----| bad  
 Local  
 Production:  
 Under What wood manufacturer, metal manufacturing shop, shop working with  
 Conditions: fiberglass-reinforced plastics  
 Lifespan: very long |-----|-----| very short  
 depends on flood protection

**Bibliography, Source: Manufacturer information, Agricola, Delius, v. Koning, Bach, Beyrich, Hartmann, Henne, Mager, Meyer, Muller, Ovens, Redtenbacher, J. Reynolds, T.S. Reynolds, Shaw, Utta, Garrad, Fyfield-Shayler, Hutte, Wagenbreth.**

### **OPERATING PRINCIPLE:**

**Overshot and middleshot water wheels (wheels with scoops): containers attached at the periphery of the water wheel fill with water from the feeding stream and rotate the wheel under the influence of leverage forces due to the added weight**

**and impact of the water. The scoops empty automatically at the lowest point of revolution.**

**Undershot water wheels (paddle wheels): Radially-mounted paddles set the wheel into rotation due to the impact forces of the water flow striking the paddles.**

### **AREAS OF APPLICATION:**

**To win energy for:**

- production of electrical energy or**
- mechanical drive for machinery by utilizing the torque**

### **REMARKS:**

**Water wheels were already described by Philon in 230 B.C.**

**Water wheels represent the simplest utilization of the energy from flowing water. They are basically differentiated as undershot, middleshot and overshot water wheels with horizontal axis; water wheels with vertical axis (e.g. bucket wheel, Ghatta/Nepal); and boat mill or river mill (as special cases of undershot wheels, see Technical Outline 10.8).**

**Water wheels are generally not susceptible to sediment build-up or ice, but flood-protection measures should be taken regardless. An advantage of well-constructed wheels (with roller bearings) is the high degree of efficiency even with only partially-full buckets or scoops.**



## **Further advantages of water wheels are:**

- high moment of inertia, making it particularly suitable for direct drive of slowly-rotating machines and machines with fluctuating resistance (e.g. crushers)**
- simple hydraulic design and construction**
- suitable for small, highly fluctuating water quantities**
- when well-constructed up to 80 % rate of efficiency**
- low maintenance expenditures, easy to repair, long lifespan**
- simple local production possible**
- a storage of water and therefore energy is possible with the help of reservoirs**

**Disadvantages of water wheels are the heavy weight and large space requirement, as well as the losses with overshot wheels due to height and suspension.**

**The rotational speed should be as low as possible to avoid premature emptying of the scoops due to the greater centrifugal forces created at higher rotational speeds.**

**A high initial torque (around 10 rpm) is required. Unlike turbines, water wheels are gravity machines. They are more efficient than turbines (in the category of up**

**to 10 kW) when well constructed. Due to the low rotational operating speed (15 - 20 rpm) the conversion into other forms of energy is quite difficult (electric) or impossible (pneumatic). For low-speed mechanical direct-drive systems (up to 300 rpm), "step-ups" in gearing (reduction in gear ratio) can be realised with force-locking or form-locking belt-drives.**

**A long-distance transmission of the energy generated by water wheels is not possible. Therefore producer and consumer are both directly bound to the location of the water energy-source. This can require expensive hydrological construction measures, without which the utilization of the hydromechanical energy may not be possible at all. The climatic and geographic conditions in the Andes, characterized by periodic high rainfall and sufficient topographical relief, provide numerous locations which offer an opportunity to utilize the energy of flowing water through water wheels and small turbines. The high demand for processing water in the hydromechanic beneficiation of ores in small-scale mining operations frequently justifies establishing a hydromechanical energy supply.**

**Types of water wheels: the 'Zuppinger' wheel is the most practical design for undershot water wheels.**

**Construction material: Wood and iron, fiberglass-reinforced synthetic resins**

**Advantages of wooden water wheels:**

- + can be disassembled
- + no lime deposition
- + resistant to acidic water
- + can be centered

+ simpler to construct, disassemble and repair

**When used in conjunction with moor water, the wooden parts should be impregnated (with Roman salt) since moss disposition promotes rotting.**

**Water-wheels are seated in bearings of bronze or on bearing-blocks made of soapstone. In the situation where several overshot water wheels are installed on the same level in series, the feeding water is directed through a chute past all of the water wheels; the wheels are filled through opening of bottom gates in the chute.**

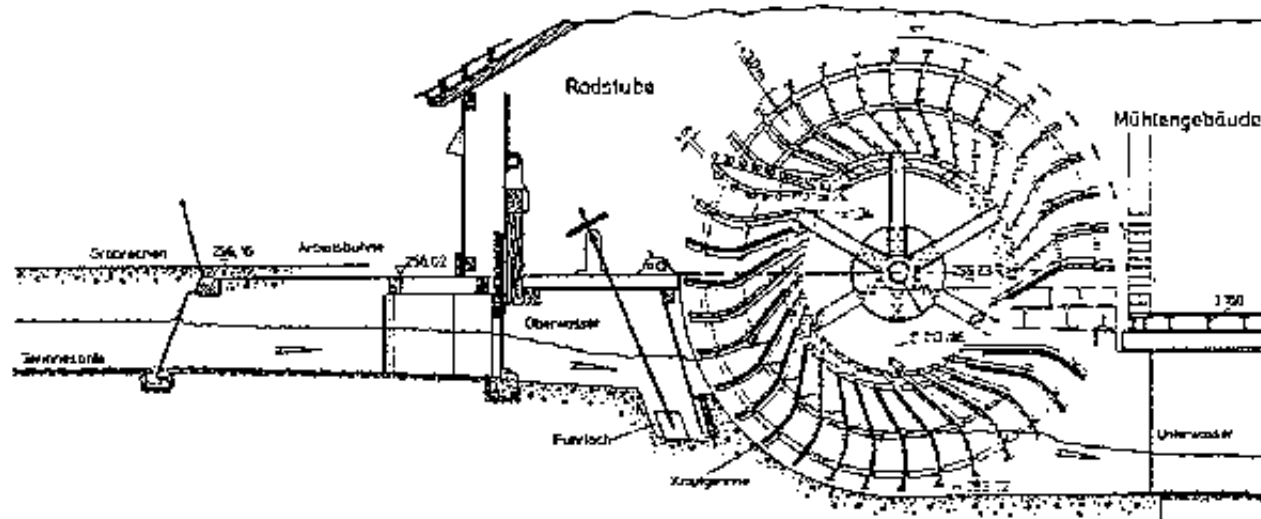
**Ordinary water wheels operate only in one rotational direction. For haulage purposes, reversible bull wheels (overshot) have been developed. They consist, as a unit, of two water wheels with opposite fill directions. By changing the incoming flow from one to the other intake chute, the wheel's rotational direction can be reversed. Bull wheels of up to 15 m or more in diameter were frequently installed underground just above the drainage level.**

**For shaft haulage with bull wheels, outputs ranging between 7.4 to 11 kW were achieved with haulage speeds of 0.65 to 1.4 m/see and bucket volumes of up to 1.2 m . This system functioned down to depths of 550 m maximum.**

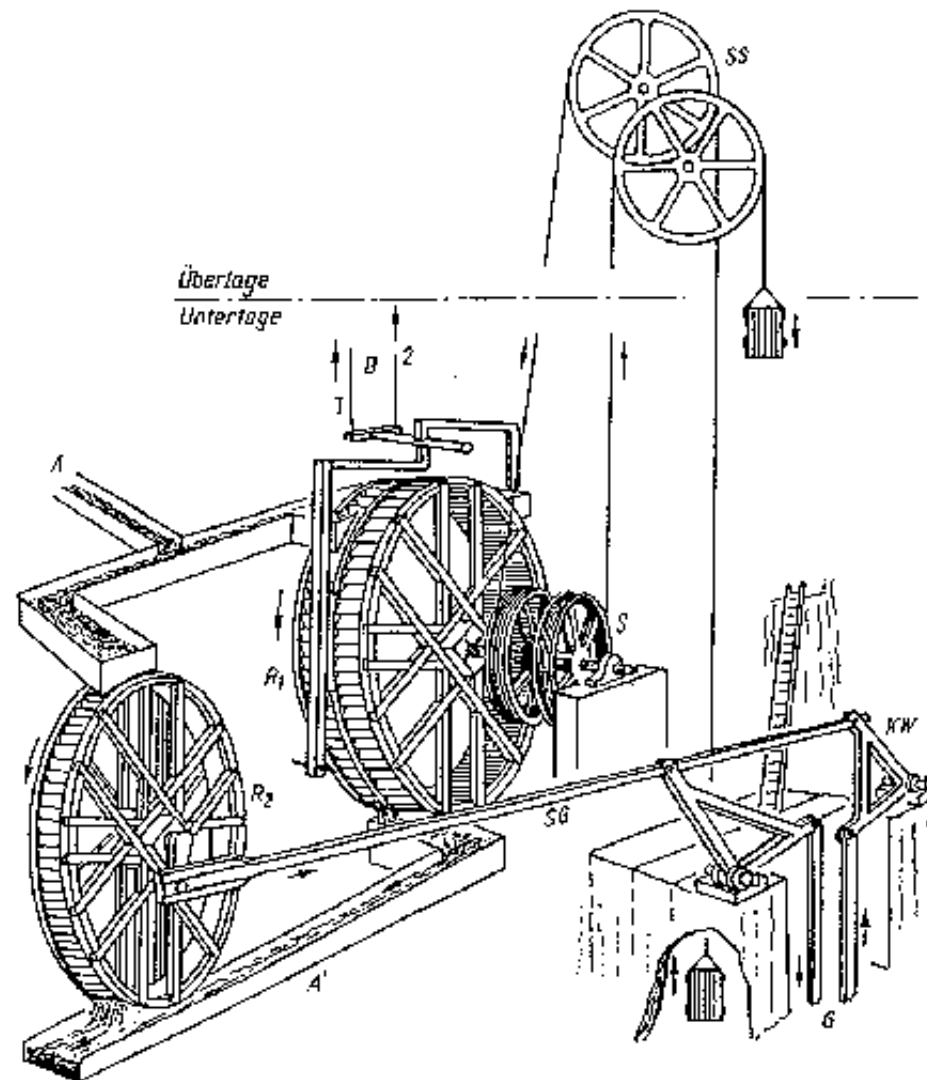
### **SUITABILITY FOR SMALL-SCALE MINING:**

**Water wheels are very suitable for application in small-scale mining due to the numerous possibilities to use them in direct mechanical drive of various mining and beneficiation machines. Despite the relatively high investment costs, water wheels are simple to manufacture locally using native construction materials;**

**additionally, they are characterized by very low operating, maintenance and repair costs.**

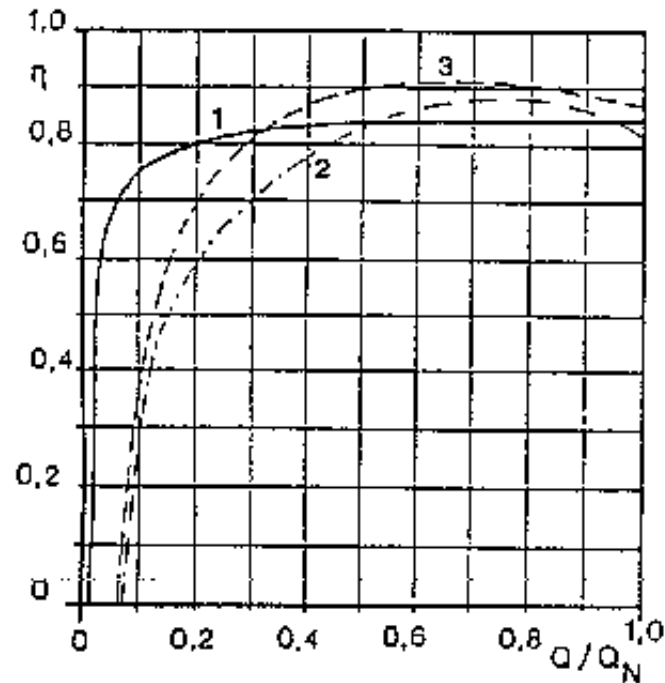


**Fig.: Undershot water wheel in a mill. Source: Eckholdt.**

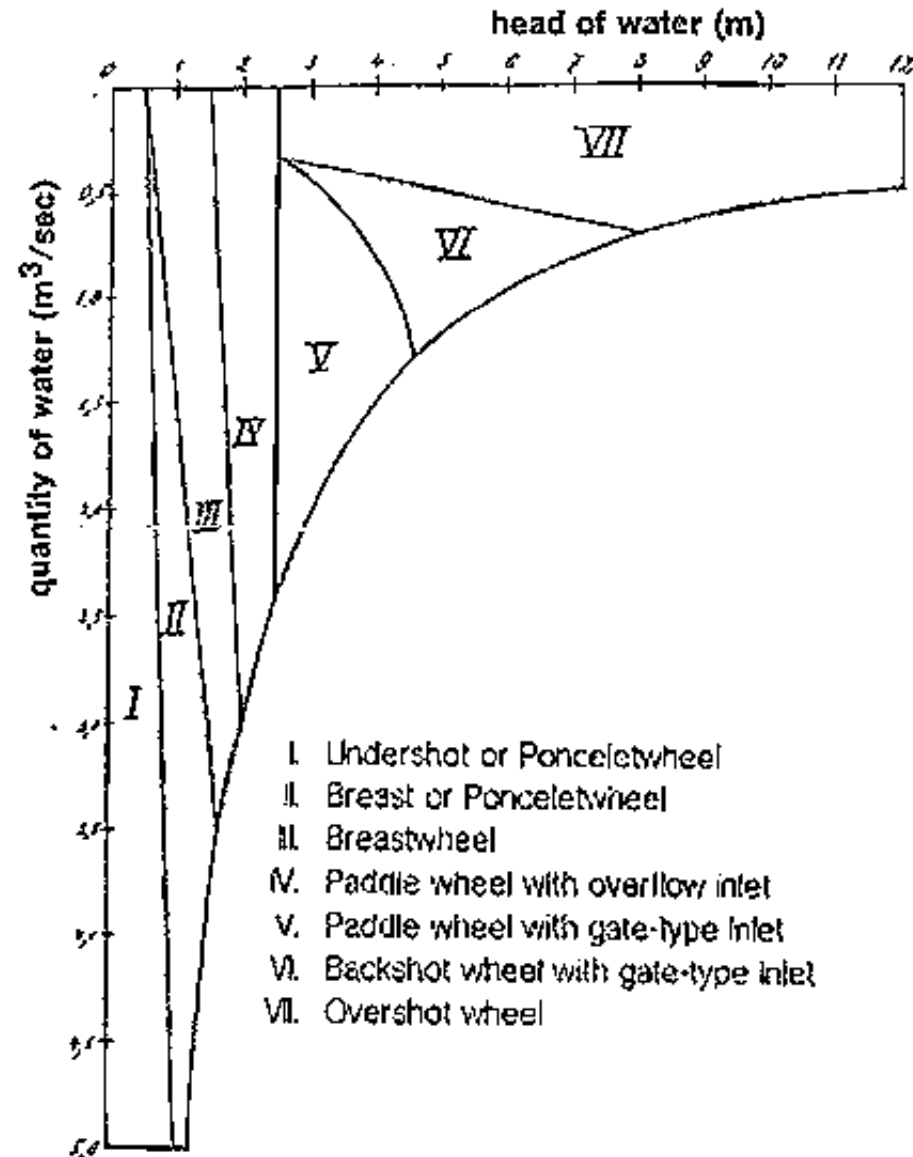


**Fig.: Water wheels for supplying energy in mining: A feeding chute, A' discharge chute (the supports are not shown), R1 bull wheel, S cable drums, SS cable pulleys, B brake mechanism (pulling on 1 releases the brake, pulling on 2 activates the brake). R2 wheel to operate "Fahrunst" or oscillating manlift ladder, SG connecting rods for manlift, KW angular rods for manlift (cast-iron), G shaft rods for manlift.**

**Source: Wagenbreth.**



**Fig.: (above): Curve of degree of efficiency of an overshoot water wheel (1) compared to a Francis turbine (2) and a Kaplan turbine (3) by partial loading. Source: Konig.**



**Fig.: Limits of application of various water wheel. Source: Beyrich.**

## 19.7 Horizontal water wheel

### General Mining

## Energy, Energy Techniques

engl.: bucket wheel mill

germ.: Loffelrad

span.: rueda de cucharas

in Nepal: ghatta

<b>TECHNICAL DATA:</b>	
Dimensions:	diameter 0.7 - 2 m, height of wheel approx. 0.2 - 1 m, 7 - 10 inserted flat or curved wooden paddles (18 max.)
Weight:	from approx. 25 kg
Form of Driving Energy:	hydromechanic
Mode of Operation:	continuous
Throughput/Capacity:	up to approx. 1 kW, 50 - 100 rpm
Technical Efficiency:	approx. 10 - 30 %, in Nepal (with ghatta) 20 - 25 %; much higher (50 - 55 %) with high-quality bearings and paddles as well as sheet-metal guides at the inlet
Operating Materials:	
Type:	water
Quantity:	40 - 80 l/sec
<b>ECONOMIC DATA:</b>	
Investment Costs:	if locally produced starting at approx. 100 DM



Operating Costs:	very low
Related Costs:	hydro-engineering: weir, drainage channel, inlet chute

## **CONDITIONS OF APPLICATION:**

Operating Expenditures: low |-----|-----| high

Maintenance Expenditures: low |-----|-----| high

Location Requirements: Relatively large difference in elevation with relatively low flow quantities necessary, e.g. 20 l/sec and 10 m vertical drop yields 0.5 kW, minimum head approx. 2 m. Paddle wheels must always be erected above the highest water level.

Equipment which can be Driven: examples are gold centrifuge concentrators, possibly vibrating screens, vibrating chutes small Jigs, buddies, small vibrating and concussion tables

Replaces other Equipment: small electrical motors or internal combustion engines for drive-systems with vertical axes

Regional Distribution: still in use today, and being promoted, in Nepal for driving grain mills with up to 50 kg milling stones; in Chile on the island of Chiloe, in Bolivia in Dept. Cochabamba as a technique for processing harvested crops, otherwise in the Balkan

Operating Experience: very good |-----|-----| bad

Environmental: low |-----|-----| very high

**Impact:**

Suitability for

Local

Production:

Under What

Conditions:

simple wood manufacturing. The paddle-wheel is technically the simplest and smallest hydromechanical drive-unit; improved wheels are made of iron.

Lifespan:

very long |-----|-----| very short

very good |-----|-----| bad

**Bibliography, Source: Nepal, Hydronet, 1/88, 1/89, 2/89**

**OPERATING PRINCIPLE:**

**Paddle wheels are the predecessors of impulse (free-jet) turbines and have a vertical axis. The high-speed water flow strikes the flat or spoon-shaped paddles at an angle tangential to the wheel, which sets it into rotation.**

**AREAS OF APPLICATION:**

**Hydromechanical drive for machines with low power output and relatively low rpm.**

**REMARKS:**

**Formerly widely distributed in the Balkan, Austria and South Tyrol. As post-harvest technique still applied today in Nepal, Chile and Bolivia**

**An advantage is the vertical axis, which enables a direct coupling with, for**

**example, milling stones, Chilean mills, etc.**

**A further advantage is that this low-maintenance drive unit can be placed directly underneath the machine to be driven.**

**A disadvantage is that rpm of a paddle-wheel drive cannot be controlled or influenced externally.**

**In Nepal the bearing between the water wheel and milling stone is made of bamboo, which has proven to be much cheaper, longer lasting and very simple to manufacture.**

**In Nepal, in the meantime, several paddle-wheel drives have been equipped with small counter-current generators for producing electricity for lighting purposes.**

### **SUITABILITY FOR SMALL-SCALE MINING:**

**Horizontal water wheels are simple and economic power generating devices up to 1 kW, which could be employed to run mineral concentration equipment directly coupled to the turbine shaft.**

## **19.8 Rope turbine**

**General Mining  
Energy, Energy Techniques**

germ.: Seilturbine

span.: turbine a cable

Manufacturer: Campo Nuevo

<b><u>TECHNICAL DATA:</u></b>	
Dimensions:	two pulleys approx. 1.5 m in diameter, approx. 10 m apart
Weight:	approx. 50 kg
Form of Driving Energy:	energy from flowing water with low elevation difference but high flow velocity
Mode of Operation:	continuous
Throughput/Output:	approx. 0.5 kW at very low rpm
Operating Materials:	
Type:	water
<b><u>ECONOMIC DATA:</u></b>	
Investment Costs:	local production: approx. 200 DM
Operating Costs:	low
Realted Costs:	none, possibly minimal hydrological construction measures

### **CONDITIONS OF APPLICATION:**

Operating Expenditures: low |-----|-----| high

Maintenance Expenditures: low |-----|-----| high

Location

locations with small elevation differences and small quantities of flowing

**Requirements:** water, but high flow velocities, are appropriate for rope turbines. The efficiency can be improved by building a channel (e.g. with corrugated sheet-metal or halved PVC-pipes) to control the water flow and to take up the rope of the turbine.

**Equipment** low-speed rotating devices such as mech. buddies, Harzer Wettersatz  
**which can be** (Baader's blower)

**Driven:**

Replaces other geared-down electric-motor drive systems

**Equipment:**

**Regional** to date not distributed

**Distribution:**

**Environmental** low |-----|-----| very high

**Impact:**

**Suitability for** very good |-----|-----| bad

**Local**

**Production:**

**Under What** simple wood manufacture for pulleys, synthetic rope, rubber parts from car  
**Conditions:** hoses for buckets

**Lifespan:** very long |-----|-----| very short

## **Bibliography, Source: Manufacturer, Hentschel**

### **OPERATING PRINCIPLE:**

**A rope is suspended longitudinally or diagonally along a flowing stream by means of two pulleys, with the lower rope strand hanging in the water. Flexible rubber**

**buckets are attached to the rope with the open end facing upstream; the buckets fill with water which causes them to be pulled along with the flow due to the ensuing hydraulic pressure head. In the process, several buckets are always under water at any given time. At the lower, downstream pulley the buckets are raised out of the water and emptied. The upper rope strand travels above the water surface back toward the upstream pulley, maintaining a continuous revolving system.**

### **AREAS OF APPLICATION:**

**To produce slow rotations at high rpm in areas with relatively low energy from flowing water.**

### **REMARKS:**

**The extremely low rotational speed (< 100 rpm) generated with this rope-turbine is disadvantageous, limiting its application as a drive-unit to just a few machines, such as buddies. There is a need here for further research and development efforts.**

### **SUITABILITY FOR SMALL-SCALE MINING:**

**Further development of the rope turbine is necessary before it can become suitable for small-scale mining purposes. Furthermore, it remains rather inappropriate for practical application as a drive system.**

## **19.9 Solar cells**

## General Mining Energy, Energy Techniques

engl.: photovoltaic energy

germ.: Solarzellen, Photovoltaik

span.: celdas solares, fotovoltaica

<b>TECHNICAL DATA:</b>	
Dimensions:	depending on capacity approx. 1 m <sup>2</sup> /100W
Weight:	2.5 kg/100 W
Form of Driving Energy:	solar
Mode of Operation:	semi-continuous analogous to intensity of daytime radiation
Throughput/Capacity:	unloaded: 0.55 V per cell; loaded up to 0.35 V, nominal voltage 0.45V
Technical Efficiency:	13 - 15 %
<b>ECONOMIC DATA:</b>	
Investment Costs:	approx. 20 DM per Watt, tendency falling
Operating Costs:	none
Related Costs:	storage batteries, regulator

### **CONDITIONS OF APPLICATION:**

Operating

low |-----|-----| high

Expenditures:

Maintenance

Expenditures:

Location

sun, global radiation

Requirements:

Equipment which none, area of application is, for example, charging station for electric  
can be Driven: lamps; lighting with energy-saving lamps, direct current vibrator

Replaces other smallest generators for electric power production

Equipment:

Regional

worldwide, and increasing

Distribution:

Operating

very good |-----|-----| bad

Experience:

Environmental

low very |-----|-----| high

Impact:

Suitability for not possible

Local Production:

Lifespan:

very long |-----|-----| very short

**Bibliography, Source: GTZ, Suntronic, Rau**

### **OPERATING PRINCIPLE:**

**The solar cell photovoltaically transforms available light energy into electric current. Solar cells consist of mono or semicristalline or amorphous silicon that is**



**doped with boron or phosphorus N/P. Electrodes are placed onto the surface and back side. During insolation, free ions as charge-carriers are created which produce voltage in the solar cell by diffusion. Power and voltage can be increased by parallel or serial connection of several individual cells.**

### **AREAS OF APPLICATION:**

**Solar cells are suitable for generating power in the low-voltage or low-power range, e.g. Lighting, charging of electric mining lamps, charging of booster batteries for lighting purposes.**

### **REMARKS:**

**Due to technical simplification of the production process, the manufacturing costs of solar cells will be decreasing in the future.**

**Solar cells are still characterized by very high investment costs because of the technically complicated production process. They can, therefore, only be recommended for the lowest capacity range. Their use in small-scale mining in Latin America can be considered appropriate, since especially in the low-power range up to 200 W, a very definite demand exists for energy generation for:**

- lighting, e.g. energy-saving lamps**
- mining lamp recharging stations**
- audiovisual communication media (TV, radio, etc.)**
- The smallest vibrators for beneficiation purposes**

**The external temperature affects the electrical output of solar cells. As a general**

**rule, the lower the temperature, the higher the capacity (0.3 % per C°). Altogether, solar cells operate in a temperature range from - 50° C to + 120° C (see table below). This fact, combined with the long duration of sunshine and the high quantity of global radiation of the sub-tropical region of the Andes (South Peru, Bolivia) provides ideal natural conditions for the use of solar cells.**

**Therefore, photovoltaic energy production in the lowest power range is, without question, an ecologically favorable alternative to other generators (internal combustion engines, small hydro-electric generators). In Bolivia, small mining operations have been observed using a gasoline-driven generator for several hours per day only for recharging mining lamps.**

### **SUITABILITY FOR SMALL-SCALE MINING:**

**Only in the lowest capacity range (up to a maximum of 200 W) are solar cells competitive with other energy sources with regard to investment costs. The independence from operating materials and the very favorable natural climatic conditions support the use of solar cells in small-scale mining in Latin America for the purpose of charging battery-lamps for underground useage.**

**Table: Typical temperature coefficients for solar cells. Source: Suntronic Company information**

Temperature-Range:		- 65°C to + 125°C	
Maximum temperature:		+ 250°C for 30 minutes (briefly up to 300°C)	
	increases		below
VOLTAGE	2 mV°/C		25° C

	decreases		above	
	increases		below	
CURRENT		25 $\mu\text{A cm}^2/\text{°C}$		25° C
	decreases		above	
	increases		below	
EFFICIENCY		0.3 %/°C		25°C
	decreases		above	

## 19.10 Solar collector (solar thermal)

### General Mining Energy, Energy Techniques

engl.: low temperature collectors, flat collectors

germ.: Sonnenkollektor (solarthermisch), Niedertemperaturkollektoren, Flachkollektoren

span.: colector solar (termico solar), colectores de baja temperatura, colectores planos

<b><u>TECHNICAL DATA:</u></b>	
Dimensions:	depends on size and radiation intensity
Driving Energy:	possibly circulating pump to transport the medium
Form of Driving Energy:	intensity of radiation, for circulation electric energy
Alternative Forms:	gravity collector, i.e. utilization of density differences of the various
	warmmedia

Mode of Operation:	continuous
Technical Efficiency:	between 65 % and 85 % (maximum) and losses between 1.5 and 7.5 W/m <sup>2</sup> K
Operating Materials:	
Type:	collector medium, e.g. water, oil
<b><u>ECONOMIC DATA:</u></b>	
Investment Costs:	in Germany approx. 300 to 800 DM/m <sup>2</sup> depending on design
Operating Costs:	very minimal

### **CONDITIONS OF APPLICATION:**

Operating Expenditures:	low  ----- -----  high
Maintenance Expenditures:	low  ----- -----  high
Location Requirements:	high radiation energy during daylight hours over the entire year is a prerequisite
Equipment which can be Driven:	can be used for heaters, pre-heating of process water, etc.
Replaces other Equipment:	helps to reduce fuel consumption, especially in poorly-vegetated arid zones
Regional Distribution:	in the meantime worldwide
Operating Experience:	very good  ----- -----  bad

Disregarding large fluctuations in the daily and yearly solar

Environmental Impact:	radiation values	low  ----- -----  very high
Suitability for Local Production:		very good  ----- -----  bad
Under What Conditions:	simple workshop for handling metals and synthetic materials	
Lifespan:		very long  ----- -----  very short

**Bibliography, Source: Kleemann, Meliss; Patent E. Korber P.2713 810.9 and P 2804999.2**

### **OPERATING PRINCIPLE:**

**Sun collectors transform incidental sunlight into heat. The flat collectors accomplish this by means of an absorber, a black metal or plastic plate that absorbs light and transforms it into feelable heat. Underneath the absorber are pipes through which a transport medium for the heat (e.g. water, oil, air) flows. This medium conveys the heat from the absorber to the user. In order to minimize heat loss to the surroundings, the collector is lined with a thermal insulation on the back side and is covered over the front with one or more transparent plates. This collector-unit is oriented toward the average direction of radiation in order to transform mostly vertical radiation into as much energy as possible.**

### **FORMS OF APPLICATION:**

**Heating of process water in the beneficiation processes. Air collectors for drying.**

### **SPECIAL FORMS OF APPLICATION:**

## **Results of technology (warm water for washing, showers, heating, etc.).**

### **REMARKS:**

**In addition to improving working conditions, the use of warm processing water produced substantially better results from wet mechanical beneficiation by improving the degree of separation achieved in the sorting processes. This effect can be attributed to the lower viscosity of warm water; the warmer the process water, the better the sorting conditions. Moreover, the warming up of processing water provides more comfortable working conditions where direct contact is made with the processing water (e.g. manual activities where the hands are under water); examples are hand picking in sluices or hand jigging with screens.**

**Global radiation values vary significantly depending on the location, ranging between approx. 800 kWh/am<sup>2</sup> (Iceland) and more than 2200 kWh/am<sup>2</sup> (in sub-tropical desert regions, e.g. SW-USA/Mexico, highlands of Peru/Bolivia, the Sahara, Arabian Peninsula, the Kalahari and Namib as well as central Australia).**

**The simple flat collectors also can be equipped to serve as sun-wind generators, whereby the surface of the collector serves as an accumulation area for the wind and thus accelerates the air. This air then used to drive a cylindrically-shaped horizontal Savonius rotor (0.5 m diameter). Through the use of wind sails, this rotatable device can be turned so that the rotar is oriented toward the wind during periods of strong winds.**

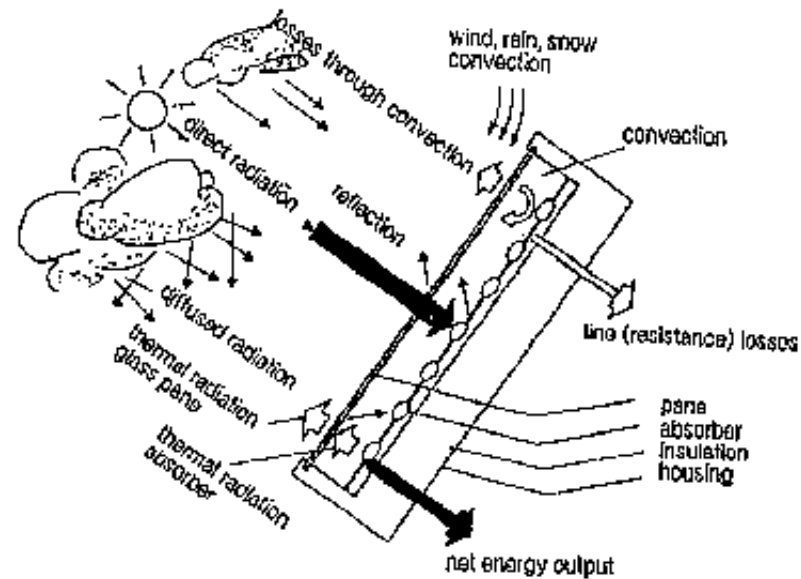
### **Materials for the collectors:**

Cover:

Corrugated plastic sheets	light, but somewhat opaque
Acrylic tiles	(transmits less sunlight)
Glass	best cover material
Absorber:	
Plastic (from 30 DM/m <sup>2</sup> )	poor heat conduction
Aluminium (approx. 120 DM/m <sup>2</sup> )	possible corrosion if combined with Cu parts
Steel (approx. 120 DM/m <sup>2</sup> )	
Stainless steel (approx. 120 DM/m <sup>2</sup> )	very long lasting
Copper (approx. 200 DM/m <sup>2</sup> )	best heat conduction, very long lasting
Isolation:	
Pu-foam	
Polystyrene	

### **SUITABILITY FOR SMALL-SCALE MINING:**

**Sun collectors are particularly suitable for pre-warming of processing water used in small-scale mining equipment in order to lower energy costs and Improve separation results.**



**Fig.: Operating principle of a flat collector. Source: Klemann.**

## 19.11 Water turbine

### General Mining Energy, Energy techniques

engl.: water turbine (mechanical and electrical application)

germ.: Wasserturbinen (mech. und elektrische Nutzung)

span.: turbine a agua (aprovechamiento mec. y electrico)

Manufacturers: Campo Nuevo Ossberger, yolk, Voith

#### **TECHNICAL DATA:**

Dimensions:	depends on capacity, e.g. for cross-flow (impulse) turbine with 2.5 kW output: turbine wheel 200 mm in diameter, 82 mm in width
-------------	---

Weight:	25 kg for above mentioned example
---------	-----------------------------------



Weight:	25 kg for above-mentioned example
Form of Driving Energy:	hydromechanical
Mode of Operation:	continuous
Throughput/Capacity:	practical up to 30 kW
Technical Efficiency:	cross-flow turbine (75 - 82 %), Pelton turbine (75 - 86 %), Kaplan turbine (up to 90 %), Francis turbine (up to 90 %), total degree of efficiency with generator: 50 - 80 %, mechanical utilization (70 - 80 %)
Operating Materials:	
Type:	water
Quantity:	depends on fall head of water and size of turbine
	$N \text{ [kW]} = n \text{ [%]} \times Q \text{ [m}^3\text{/sec]} \times h \text{ [m]} \times 9.81 \text{ [m/sec}^2\text{]}$
<b><u>ECONOMIC DATA:</u></b>	
Investment Costs:	local production in Bolivia: 200 US\$/kW without penstock (pressure pipe)
Operating Costs:	very low
Related Costs:	gearing, hydrological engineering measures, flood protection

### **CONDITIONS OF APPLICATION:**

Operating Expenditures:

low |-----|-----| high

Maintenance

low |-----|-----| high

**Expenditures:**

Location requires topographical and hydrographical conditions such as minimum flow

Requirements: and minimum head (approx. 5 m) of water must exist

Equipment high-speed beneficiation equipment, e.g. crusher, sizing drum, vibrating

which can be screen, pumps, Chilean or edge mill, jig, heat generator, bumping or

Driven: concussion table, compressors; can additionally be used to generate electrical energy, e.g. with car generator

Replaces other all other drive units

**Equipment:**

Regional worldwide, but seldom used for direct drive

**Distribution:**

Operating very good |-----|-----| bad

**Experience:**

Environmental low |-----|-----| very high

**Impact:**

Suitability for very good |-----|-----| bad

**Local****Production:**

Under What qualified metal manufacturing shops: blades can partially be made from  
Conditions: stainless steel pipe sections, are also made in developing countries: Bolivia,  
Colombia, Ecuador, etc.

Lifespan: very long |-----|-----| very short

**Bibliography, Source: Manufacturer information, T. Hentschel, Meier, Meyer, v. König, Elliott, Gate, Inversin, FAKT**

## **OPERATING PRINCIPLE:**

**Unlike water wheels, which transform only the energy associated with the weight of the water, turbines utilize the flow-energy of water which, upon striking an obstruction (in this case the turbine blades), is partially converted into kinetic energy as pressure. Depending on the water head (height difference) and quantity, different types of turbines (cross-flow turbines, Pelton, Francis and Kaplan turbines) are employed. The operating range of the various types are shown in the figures.**

**The cross-flow turbine is a radial, partial-admission impulse (free-jet) turbine. It is classified as a slow-speed turbine on account of its low specific rotational speed (low rpm). The water jet stream is formed into a rectangular cross-section by means of a distributor. It flows through the blade ring of the cylindrically-shaped runner first from the outside inwards and then, after passing through the center of the runner, from the inside outwards. The run away speed (off-load) is 1.8 times the on-load speed; the degree of efficiency is good at part load of the turbine.**

**The Pelton turbine is a tangentially-admitted free jet impulse turbine in which the cup-shaped blades (buckets) are forged, screwed or cast onto a disk. The disk shaft can be set vertically or horizontally, the buckets are loaded tangentially through one or more (maximum of four) jet nozzles; a jet needle valve, operated by a governor, controls the Jet discharge by changing its cross-sectional area. The jet is split into two flows which are discharged from opposite sides to avoid any unbalanced thrust on the shaft. The rotational speed is less than that of Francis turbines. An increase in the diameter of the runner further reduces the rotational speed. Pelton turbines are well suited for smaller flow volumes at higher heads**

**(falling heights). They are characterized by a very flat efficiency curve at partial load of the buckets. Already at 8 % (single-nozzled) and 4 % (double-nozzled) maximum capacity, a high degree of efficiency can be achieved (nearly 90 % at sufficiently high head). The run away (off-load) is approx. 2.0 times the on-load speed. Pelton turbines operate in atmospheric air pressure, requiring that they hang freely and are never submerged under water even when highest water levels are reached.**

**The Francis turbine is a radially-admitted reaction turbine in which a stay ring with adjustable guide vanes directs the water flow into the runner, which exits along this same axis. Francis turbines are well suited for larger flow quantities at small and intermediate heads, they are characterized by their high-speed operation and have a run away speed (off-load) of revolution 1.8 to 2.1 times the on-load speed.**

**The Kaplan turbine is constructed as a propeller with 2 - 7 wing-shaped, rotatable blades which are axially loaded with water directed through a stay ring with similarly adjustable gates. It is suitable for handling very large flow quantities at the smallest of water heads (falling height); it has a run away ratio (off-load: on-load) of 2.3 - 2.5 and has a relatively poor efficiency at partial loading.**

**Another important type of turbine which, depending on its design, can operate more as propeller or Francis turbine, is a pump employed as a turbine. Pumps are produced around the world in great numbers, operate at high efficiency, and can be manufactured at lower cost compared to turbines. By reversing flow direction, pumps can operate as turbines.**

## **USE AND CONVERSION OF ENERGY:**

**The mechanical utilization of the energy from flowing water as driving power is both possible and practical for the majority of machinery used in small-scale mining. The ideal turbine type for this purpose has proven to be the cross-flow turbine. It is simple to produce locally and operates at a pressure range which allows the investment costs for the penstock (pressure pipe) to remain low. Small useable drops in elevation with large flow quantities lead to lower penstock costs, but generally higher costs for hydraulic engineering measures. High pressure heads (greater elevation drop) increase the penstock costs but require less hydraulic engineering construction work. An economical optimum lies in the pressure-head range which allows the use of locally-produced, reasonably-priced raw materials (for example, PVC up to about 50 m pressure head).**

**The rotational speed of cross-flow turbines lies in the range of 200 to 1000 rpm, and is thus well suited as a drive-unit for compressors. Modern axial-flow screw compressors operate at a rotational speed between approx. 1000 and 2800 rpm. These rotational values can be reached through the use of chain or V-belt drive systems.**

**The starting torque of electric drive-units is markedly less favorable than that of hydromechanical drive systems, as revealed during trial testing performed with small crushers common to small-scale mining.**

**The generation of low voltage electricity (12 V DC) is possible using common commercially-available automobile generators of up to around 500 W capacity. Booster batteries as truck batteries are also locally available. 12 V DC electricity**

**can serve as the energy source for:**

- energy-saving lamps**
- television**
- refrigerators**
- vibrator motors**
- charging stations for mining lamps, etc.**

**The generation of alternating-current voltage is similarly possible, however with the following disadvantages for use in small-scale mining in developing countries:**

- high investment costs for the generation, transport and re-conversion of the electrical energy source,**
- the low degree of efficiency, the larger installation and corresponding hydraulic potential required at the turbine location- the greater complexity of the installation, which in developing countries can cause significant maintenance and repair problems for the user,**
- the difficulties with regulation - the regulation of frequency and efficiency poses relatively major technical problems. Hydraulic or electronic regulating systems consume the unused electrical power as heat resistance or regulate the inflowing water**
- the overload-protection system, which protects the generator from rotating too fast. Reasonably-priced, converted motors serving as generators are capable of withstanding only up to approx. 1.2-times the rated speed without being damaged. Generators which safely operate up to**

**twice the rated speed are very expensive,**

**- major difficulties with local manufacture and maintenance of this equipment.**

**Of advantage is the fact that electrical energy is easily transportable via power lines.**

### **COMMENTS REGARDING LOCAL PRODUCTION:**

**Cross-flow turbines are the easiest to manufacture locally. The runner can be equipped with blades made of either curved sheet-metal or pipe sections sawed in half lengthwise.**

**Pelton turbines can either be cast (of bronze) in one piece using the wax smelting procedure, or constructed of individual blades (bronze or cast-iron) mounted to a disk with a central shaft. Single blades as models are available on the machinery-parts market, whereby the width of the blade should be approx. 3 times the maximum jet diameter. The greater the number of blades, the better the degree of efficiency. Of primary importance is an exact balancing of the runner.**

### **AREAS OF APPLICATION:**

**For utilization of water flow energy (hydropower) for low-output requirements in the low-pressure range (5 - 50 m head).**

- the direct operation of machines for mining and beneficiation**
- the conversion of flow energy into other forms of energy:**

- \* compressors for generating pneumatic energy for use in underground mining (compressed air)**
- \* generators for producing electrical energy, for example through 12 V car generator**
- \* heat generators for producing heat.**

### **REMARKS:**

**Due to the fact that cross-flow turbines are recommended for use only in the low-pressure range, locally produced plastic pipes can be employed for the penstock, which offer the advantages of being inexpensive and less susceptible to frost. Care should be taken, however, that UV-resistant pipe material is employed to avoid having to cover the penstock. The hydraulic construction measures must include the incorporation of sedimentation chambers (sand traps), since suspended particles can lead to abrasion of the turbine runner.**

**For direct utilization of torque, the turbine is especially well suited for small-scale mining application in developing countries:**

- high starting torque leads to drive-system efficiency (output) which lies as much as 50% below that of electric motors**
- the altitude-independent efficiency of turbines compared to electric**



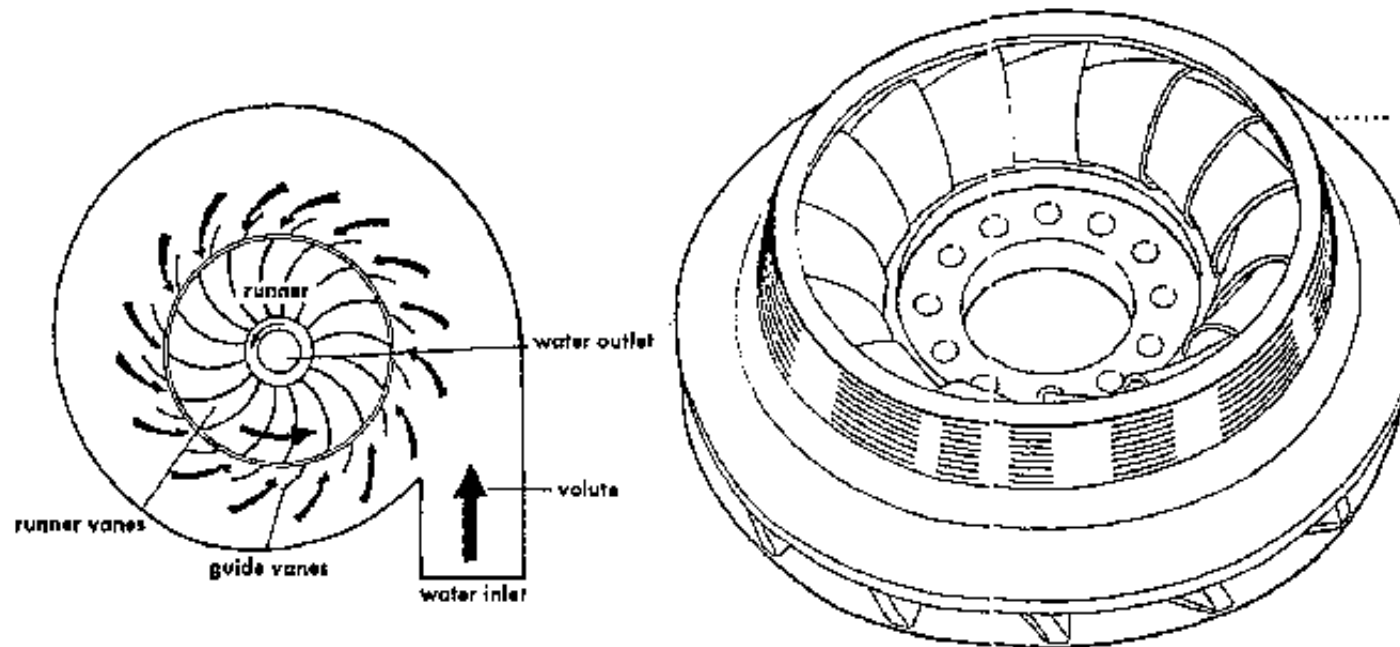
**generators and internal combustion engines (small capacity, more fuel consumption at higher elevation) makes it preferable to use turbines with direct utilization of torque. Numerous small-scale mines in the Andes operate at elevations higher than 4000 m.**

**A curve of efficiency values for the various types of turbines is presented in the figure. Type BYS is a cross-flow turbine locally manufactured in Nepal of the simplest materials. The curve shows that even handcrafted turbines can achieve a high degree of efficiency (> 70 %).**

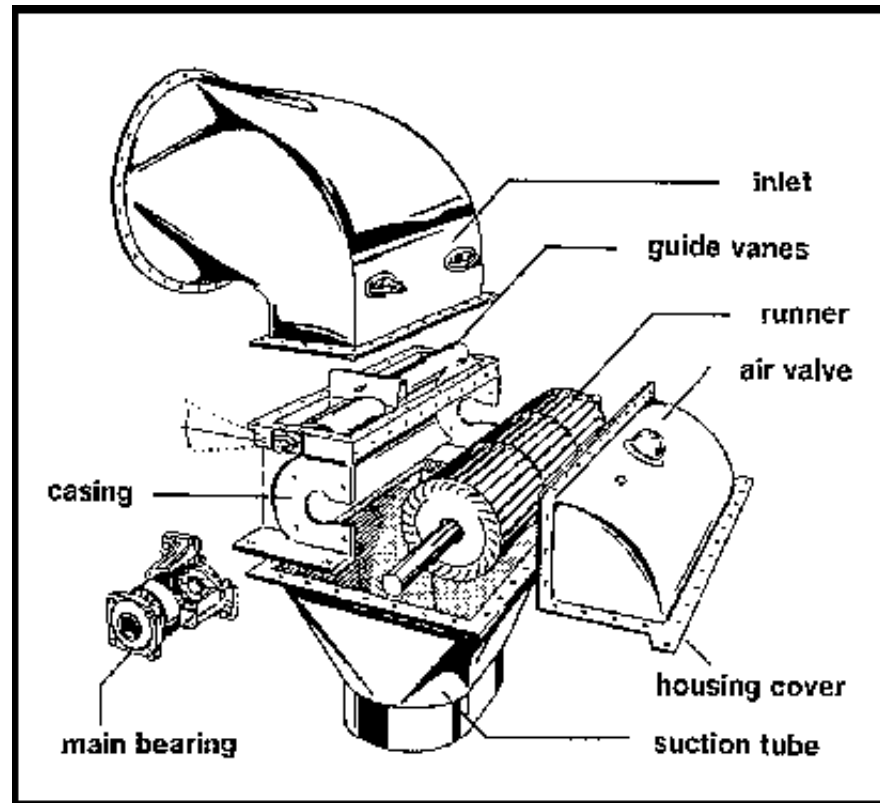
### **SUITABILITY FOR SMALL-SCALE MINING:**

**Small cross flow turbines with direct utilization of torque by means of belt or chain drive systems represent ideal' versatile drive-units which have numerous possibilities for application within the geographical conditions and technical requirements which characterize small-scale mining in Latin America Low-cost local production can also generate technological effects outside the mining sector which provide a stimulus for regional development.**

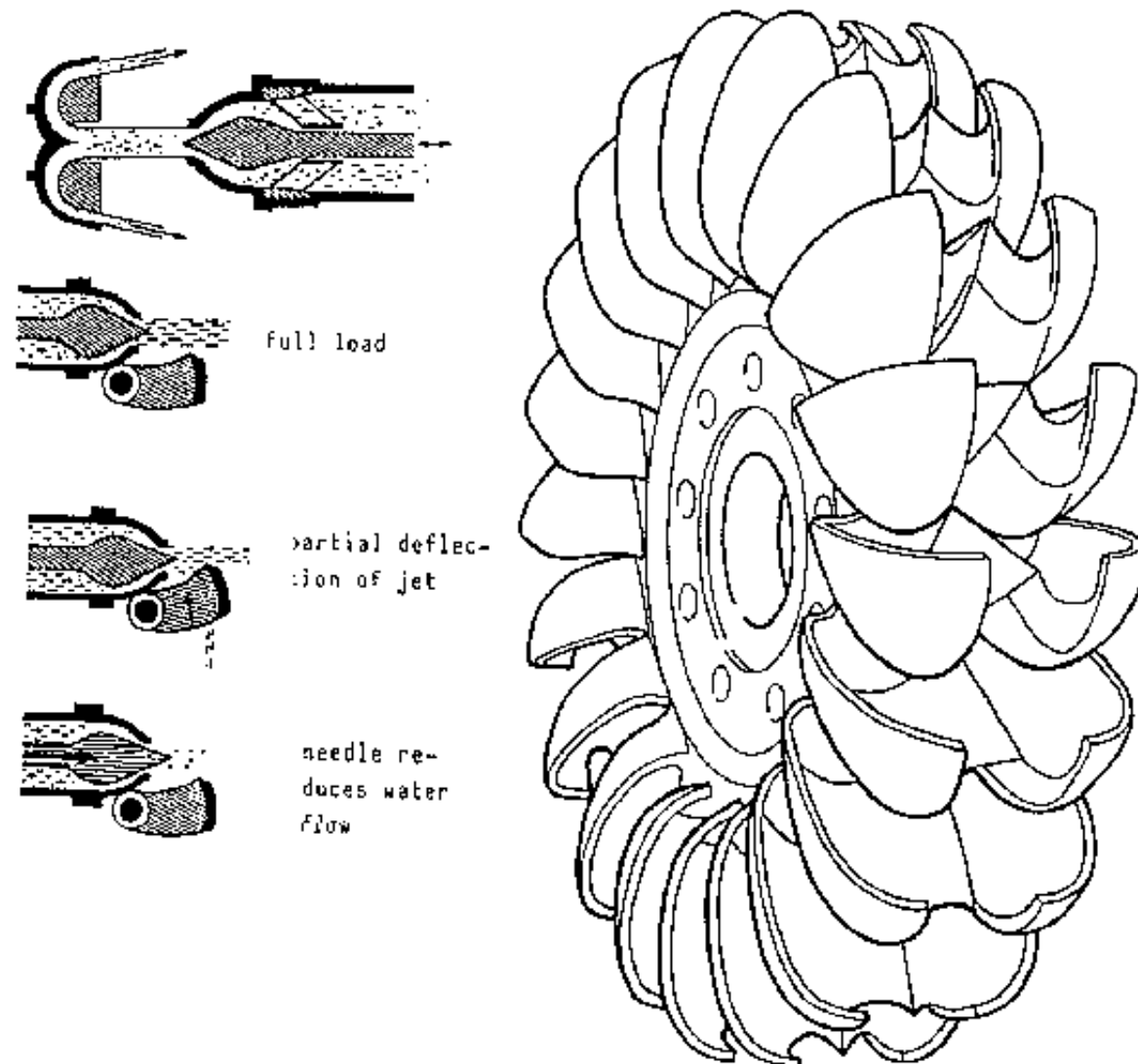
**Other types of turbines require more complicated regulation and hydraulic engineering measures' making them more appropriate for medium-scale mining operations.**



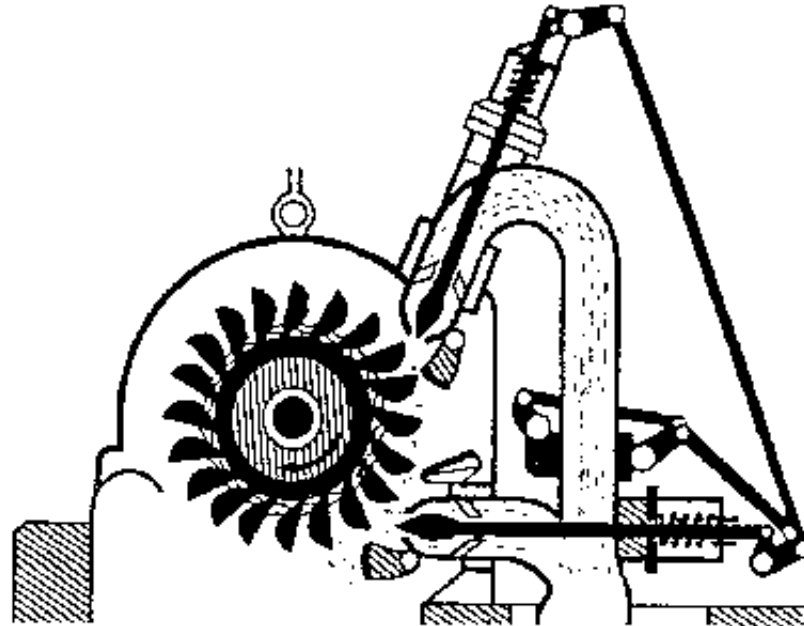
**Fig.: Schematic diagram of a Francis turbine (from Meier) and detailed diagram of a runner (I.Z.E.)**



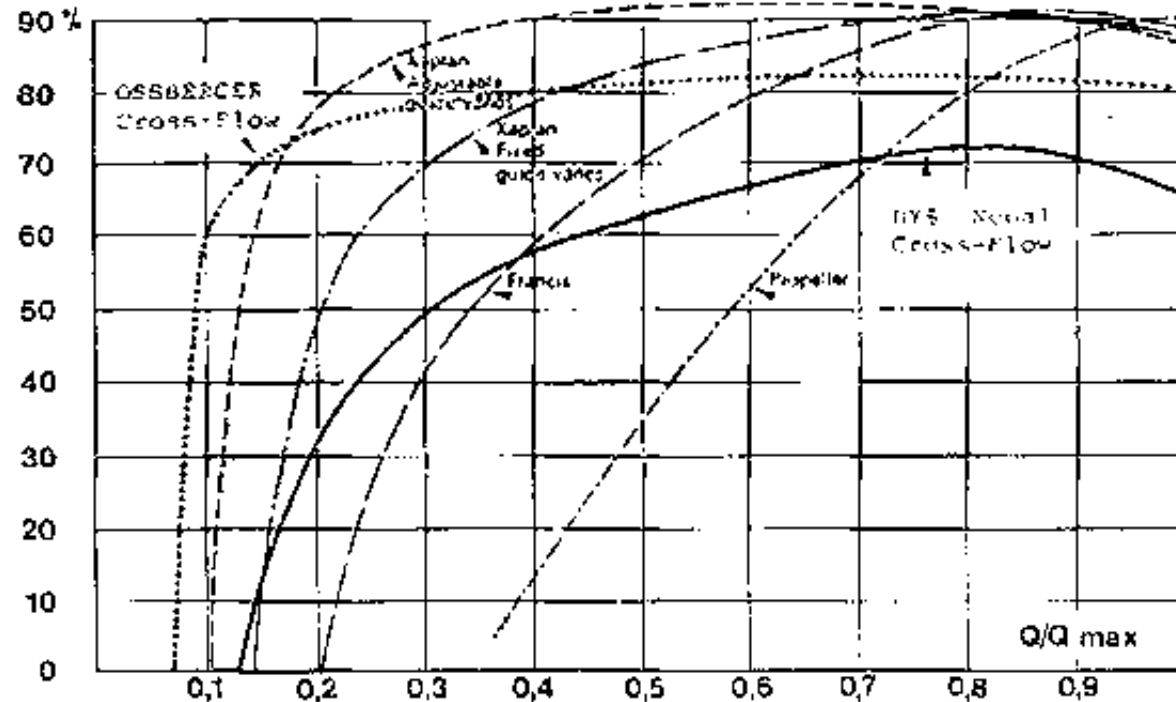
**Fig.: Design drawing of cross-flow turbine. Source: Ossberger company information.**



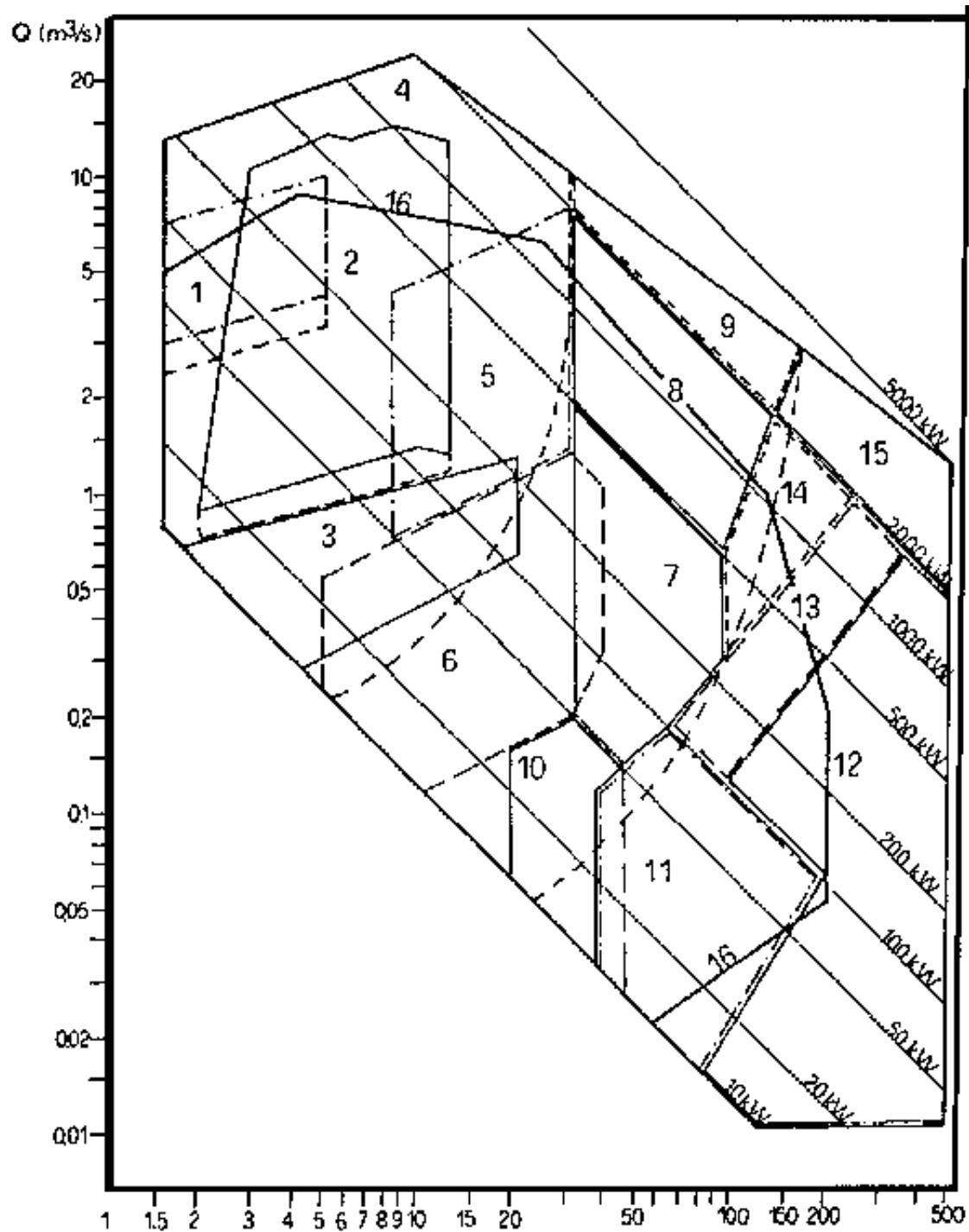
**Fig.: Pelton turbines: jet needle valve and deflection of jet in a blade (above), deflector and jet needle valve for regulating flow (below). Source: Meier: runner from a Pelton turbine. Source: I.Z.E.**



**Fig.: Schematic diagram of double-nozze Pelton turbine. Source: Meier.**



**Fig.: Degree-of-efficiency curves for different turbine types. Source: Meier.**



**Fig.: Range of application for different types of turbines for small-scale hydropower needs. Source: Das Wassertriebwerk 10/82:**

- 1 = A-pipe turbine,**
- 2 = S-pipe turbine,**
- 3 = compact regulated propeller turbine,**
- 4 = special construction, pipe and Kaplan turbine,**
- 5 = spur turbine,**
- 6 = Reiffenstein reaction turbine,**
- 7 = Francis compact spiral turbine,**
- 8 = Francis spiral turbine (horizontal),**
- 9 = special construction Francis spiral turbine,**
- 10 = Mini jet turbine, 4 jets (vertical),**
- 11 = small jet turbine with belt drive,**
- 12 = jet turbine, 1 jet (horizontal),**
- 13 = jet turbine, 2 jet (horizontal),**
- 14 = jet turbine, 3 to 4 jet (vertical),**
- 15 = special construction jet turbine,**
- 16 = Ossberger cross-flow turbine.**

## **19.12 Internal combustion engine**

### **General Mining**

#### **Energy, Energy Techniques**

germ.:           Verbrennungsmotor

span.:           motor a combustion, motor a gasoline



Manufacturer: Briggs/Stratton, USA, Liste

<b>TECHNICAL DATA:</b>	
Dimensions:	dependent on type and horsepower; internal combustion engines are characterized however by low specific weight (per horsepower) and performance values, e.g. for 20 kW gasoline engine 0.7 × 1 × 1 m
Weight:	starting at approx. 40 kg up to several 100 kg
Form of Driving Energy:	burning of biogenic fuels
Mode of Operation:	continous
Throughput/Capacity:	from 2 kW up to several 100 kW
Technical Efficiency:	25 %(gasoline), 38 %(diesel)
Operating Materials:	gasoline or diesel starting at approx. 2l/h; lubricants in nominal quantities
<b>ECONOMIC DATA:</b>	
Investment Costs:	for small 5 PS engine approx. 320 US\$ (August, 1987)
Operating Costs:	approx. 1 US\$/h
Related Costs:	cost of maintenance and repair approx. 50 US\$/year

### **CONDITIONS OF APPLICATION:**

Operating Expenditures:

low |-----|-----| high

Maintenance Expenditures:

low |-----|-----| high

**Performance Characteristics:**

Equipment which can be Driven:	mainly beneficiation machines and compressors as well as generators
Replaces other Equipment:	e.g. water turbines
Regional Distribution:	worldwide
Operating Experience:	very good  ----- -----  bad
Environmental Impact:	low  ----- -----  very high used oil, exhaust gases, noise
Suitability for Local Production:	unsuitable
Lifespan:	very long  ----- -----  very short

**OPERATING PRINCIPLE:**

**Engines with one or more cylinders and two or four-stroke cycles, V-belt transmission.**

**AREAS OF APPLICATION:**

**Primarily for driving smaller beneficiation machines, compressors and generators.**

**REMARKS:**

**Internal combustion engines cover the entire range of energy from 2 kW to more than 100 kW, whereby smaller units are appropriate as direct drive systems which utilize torque. Larger systems, to the contrary, are coupled with generators for producing electric power. Internal combustion engines operate at rotational**

**speeds lying between 1000 rpm (large diesel engines) and 3000 rpm (small diesel and gasoline engines). The regulation of rpm is very simple, and consequently the conversion into other forms of energy can be accomplished without difficulties; this is significant to small-scale-mining especially for pneumatic drive-systems underground.**

**Internal combustion engines are generally very independent of location. Problem areas are the supplying of the necessary fuels and the losses in efficiency at higher altitudes; as a general rule, every 100 m increase in altitude results in the following efficiency losses:**

for simple internal combustion engines 1.3%

for turbo-charged engines 0.9%

**Internal combustion engines are characterized by low investment costs but very high operating costs. In addition, a number of other factors exist which characterize the use of internal combustion engines as an energy source in developing countries as unfavorable:**

**- difficulty in acquiring spare parts and maintaining imported products. In addition to the direct costs of repair, substantial financial losses can occur from operational disruptions caused by lengthy delivery times for spare parts.**

**- the poor infrastructure characterizing the majority of small-scale mining regions makes it difficult to maintain a continuous supply of fuel. Especially in the rainy season, remote mining areas are often inaccessible due to**

**damaged roads. Further difficulties can arise due to bottle necks in the supply (e.g. strikes) from the mostly state-owned oil companies.**

**- high national transport costs as a result of the poor Infrastructure, on the one hand, and drastic increases in energy prices on the other. The fuel costs in Bolivia, for example, in the gold area of Tipuani, approx. 200 km from La Paz, are twice as high as in La Paz.**

**- the high-altitude topographical location of many of the mine operations, such as in the Andes of Latin America, is disadvantageous for two reasons for one, the large losses in rated capacity of machines operated at high altitude (up to 50% at 5000 m above sea level) requires large-scale equipment at corresponding high investment costs, secondly' the low degree of efficiency leads to increased fuel consumption and therefore higher operating costs.**

**- ecological aspects.**

### **SUITABILITY FOR SMALL-SCALE MINING:**

**Internal combustion engines are suitable for small-scale mining in situations where renewable energy sources are not available. Low Investment costs but relatively high operation costs and a limited lifespan characterize these engines, as well as their technically versatile application.**

## **19.13 Compressed-air supply**

### **General Mining**

## Energy, Energy Techniques

- engl.: compressor (compressed air tank, compressed-air lines, water separator, lubricator, etc.)
- germ.: Druckluftversorgung (Kompressoren, Drucklumank, Druckluftleitungen, Oler etc.)
- span.: abastecimiento de aire comprimido, compresores, tanque de aire comprimido, tuberia pare aire comprimido, lubricadores etc.
- Manufacturers: Mannesmann Demaq Atlas Copco, Kaeser, Frantz, Ingersoll-Rand

<b>TECHNICAL DATA:</b>		
Dimensions:	compressors: ranging from 1 × 1 × 1 m to 2 × 3 × 4 m	
pipeline:	50 - 600 mm diameter for pipes, 3/4" or more for hoses	
Weight:	e.g. for stationary watercooled axial-flow compressor with 45 kW and 7.2 m <sup>3</sup> /min (8 bar): 860 kg e.g. for watercooled piston compressor with 40 kW and 8 m <sup>3</sup> /min (7 bar): 1650 kg	
Material:	pipes: steel, PVC; PE-hoses: rubber, fabric	
Driving Capacity:	5 - 6.5 kW per m <sup>3</sup> per min	
Form of Driving Energy:	mechanical by electric motor, diesel engine	
Other Opportunities:	hydromechanical	
Mode of Operation:	continuous	
Throughput/Capacity:	6 - 10 m/see air speed	

Technical Efficiency:	10 - 15 % for total system	
Operating Materials:		
Type:	oil	cooling water
Quantity:	for axial-flow compressor	approx. 0,5 I/min × kW
	for piston compressor	
<b>ECONOMIC DATA:</b>		
Investment Costs:	new equipment: up to 50.000 DM	
Operating Costs:	high due to pressure losses from leakages	
Related Costs:	compressed-air dryer, compressed-air lubricator, compressor compressed-air tank, flexible suspension system	

### **CONDITIONS OF APPLICATION:**

Operating  
Expenditures:

low |-----|-----| high

compressed-air lines

Maintenance  
Expenditure:

low |-----|-----| high

compressed-air lines

Personnel  
Requirements: training for operation and maintenance is necessary

Location  
Requirements: depends on drive-system (possibly hydromechanical) and cooling system (possibly water cooled). Important is the reduction of compressed-air losses due to leakage. In German coal mining these account for 35 % of the total

compressed-air volume. These losses can be minimized especially by reducing the number of fittings and employing high-quality material. Besides the volumetric losses, pressure losses (pressure drop) also occur due to friction in the pipeline; the extent depends on pipe diameter, pipe surface conditions and particularly flow geometry.

Machines  
which can be  
Driven:

pneumatic drills, slopers (mining hammers), impact drills, pneumatic leg supports, chain saws, lamps, delivery and high-pressure pumps, fans, compressors, winches, drill-steel grinders, ratchet winches, lubrication guns, explosives pumps, loading equipment.

Regional  
Distribution:

worldwide in mining

Operating  
Experience:

very good |-----|-----| bad

Environmental  
Impact:

low |-----|-----| very high

depending on drive system, through exhaust fumes, used oil or oil from compressed air

Suitability for

not suitable

Local  
Production:

Lifespan:

very long |-----|-----| very short

depends upon maintenance

**Bibliography, Source: Roschlau, Atlas Copco manual, Fritzeche**

## **OPERATING PRINCIPLE:**

**Piston, axial-flow and turbo compressors can be used to generate compressed air. Piston compressors compress the drawn-in air by reducing the volume in the compression chamber through the stroke of the piston. They operate at 1000 rpm; the operating pressure can be regulated. Axial-flow screw compressors are displacement compressors in which static pressure is created through the rotation of the threaded axis which draws in air, compresses it, and rereleases it. They operate at rpms ranging from 1500 to 2500. Turbo compressors are used to generate large volumes of oli-free compressed air, under conditions of varying air requirements, through acceleration of the drawn-in air and subsequent conversion of the kinetic energy into static pressure.**

**In present-day mining, both stationary and transportable axial-flow compressors are commonly in use.**

**Compressed air tanks have three main functions, namely:**

- 1. compressed air storage**
- 2. improving cooling and condensation precipitation**
- 3. equalizing pressure fluctuations in the system caused by tool operation**

**Compressed air tanks for mining purposes should have a volume equal to about one-tenth the rated output of the compressor ( $m^3n/min$ ). This applies when the compressor can be periodically disconnected (to protect the compressor) from a continuously running drive aggregate. Where the frequent starting of a directly-coupled drive unit must be avoided, a larger tank volume is required. The**



**frequency of start-up operations should not exceed 10 per hour. The difference in pressure during regulation is approximately 1 bar.**

**The consumption of compressed air at 7 bar equals about:**

- 2,5 - 5 m<sup>3</sup> per drilling hammer**
- 7 - 10 m<sup>3</sup>/min per overhead shovel loader**
- 3 - 5 m<sup>3</sup>/min per hoist (winch)**

**The advantages of compressed air as an energy source are evident, according to Roschlau, in the pneumatic equipment itself:**

- simple and sturdy construction,**
- relatively small mass (low specific weight),**
- employable in all operational activities,**
- Infinitely variable setting, adjusting and regulating,**
- extremely reliable in operation and function, therefore minimal down-time,**
- automatic overload protection**
- easy to handle maintain and repair,**
- no safety problems (exhaust fumes, heating, etc.)**
- escaping compressed air improves the climate at the work place (oxygen supply, cooling).**

**However, these advantages have serious consequences. Among these are following disadvantages:**

- the total degree of efficiency of pneumatic equipment, at only around 15**

**to 20%, is significantly lower than that of other forms of energy,**

- compressed air is the most expensive industrial energy source,**
- high noise levels during operation of compressed air equipment**
- energy conveyance requires the installation of an expensive pipeline network, involving substantial costs for maintenance and repair.**

### **Compressed-air Line:**

**Compressed air pipes/hoses conduct the compressed air to the face where it is needed for driving the equipment. Hence the air line is installed as a large-diameter rigid pipe to a point just short of the working face, where hoses then complete the connections to the pneumatic equipment. The joints between pipeline sections, hoses, to lubricators and to pneumatic equipment are connected with clutch (claw) couplings.**

**Following the compressed-air tank, and possibly before the pneumatic equipment, a water separator should be installed into the compressed-air network. This device removes the moisture in the air either by having the air flow repeatedly through a screen mesh, or repeatedly deflecting the air so that it strikes the separator walls; both methods result in the moisture condensing and precipitating out. The collected condensate is withdrawn from the collecting container either automatically or by hand. This reduces the risk of occurrence of water-hammer or icing in the equipment.**

**made of PVC/PE:**

**For example: Ø 50 mm, light, easy to install even around corners; couplings (connections) are difficult to obtain, modern glueable couplings of synthetic material are better and much cheaper - suitable for PE-pipes, also either welding or clamp-couplings with rated pressures up to 16 bar air-tight. Ø up to 110 mm: brass couplings, expensive and heavy, otherwise inexpensive, relatively long life-span, very low frictional resistance! Not easy to handle, since delivered in huge rolls.**

**made of steel**

**Purely rubber couplings are less expensive than PVC, standardized pipe-section lengths, corrodes easily from contact with condensed water, therefore filtering of the compressed air prior to its use is practical.**

**In surface facilities, exposed PE/PVC pipes must be covered with earth, straw, etc. in order to prevent adverse effects from UV radiation which lead to accelerated ageing of the plastic material.**

**Prior to the input of compressed air into the pneumatic equipment, the air must be mixed with oil to lubricate the operating motors. This is achieved through the use of compressed-air lubricators (oilers) which add oil in measured dosages.**

## **REMARKS:**

### **Compressed-air Lines**

**The pressure available to the consumer is also significantly influenced by the air conveyance system. Couplings and valves as well as smaller-diameter lines greatly reduce the pressure. Consequently, a comparatively larger diameter should always**

**be used. The pressure drop is inversely proportional to the diameter of the line, raised to the fifth power. Even a small increase in diameter from 3/4" to 1" in a 10-m-long line can already reduce the pressure-drop loss to less than half. In general, about 10 - 15 % of the compression work is lost through friction.**

**The removal of water from the compressed-air line is essential. Condensed moisture collects in the low points of the pipeline and causes not only pressure drop, corrosion, and icing, but also water hammers (water shock) in the operating equipment. In addition to the use of water separators, the compressed air should be pre-cooled on the surface. The climatic conditions at the location play a major role; high temperature and high relative humidity lead to high water condensation in the pipeline.**

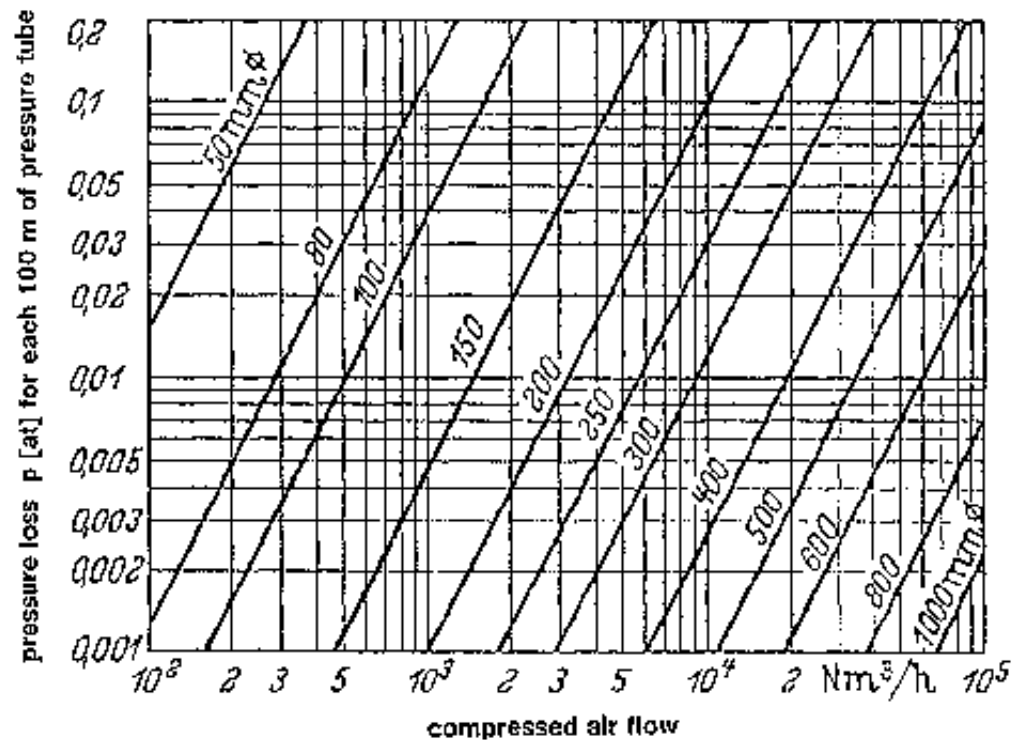
**In the event that the pressure of compressed air drops down under the operating pressure of the machine, an over-proportional decrease in the machine's efficiency results.**

**The overall efficiency of the compressed-air system is considerably affected by pressure losses through leakages. Such losses have averaged up to 35 % in coal mine in the German Ruhr area!! These losses mostly occur at the joints between pipe sections, which is another point favoring PVC-pipes.**

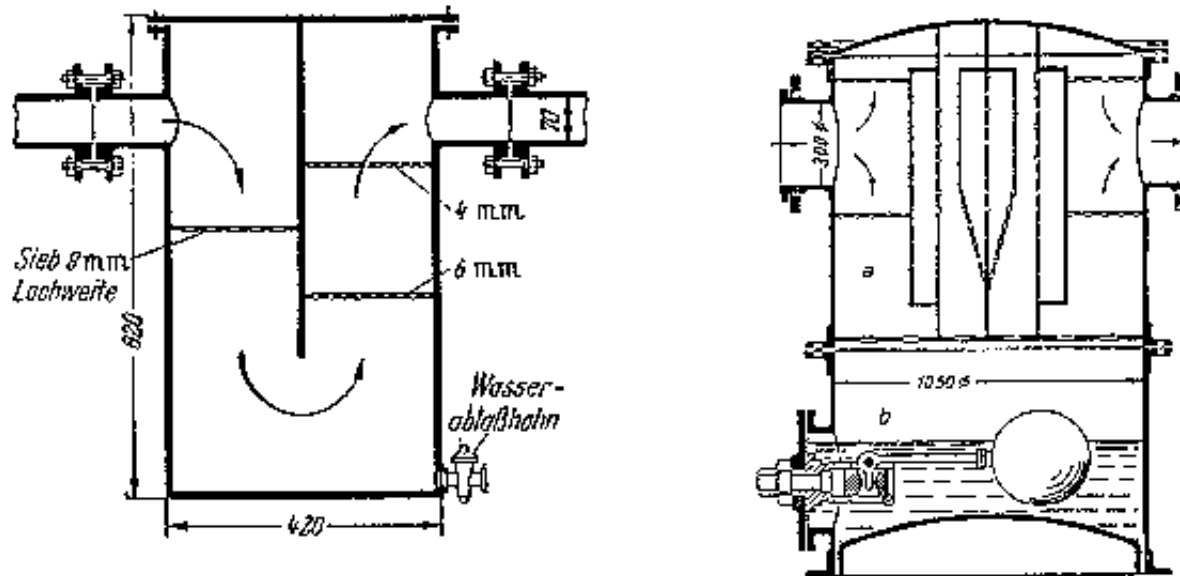
### **SUITABILITY FOR SMALL-SCALE MINING:**

**The generation and supply of compressed air is the most important energy-technology installation for mechanized small-scale mining underground. In view of the high investment and fuel costs, the dimensioning of the facility becomes**

**critical in determining the economical success of the operation.**



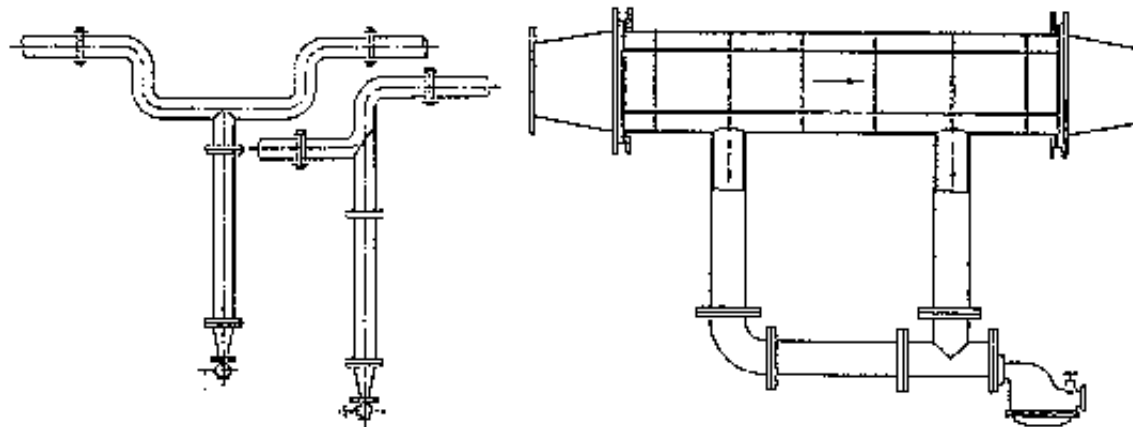
**Fig.: Pressure drop per 100 m of line at an average compressed-air pressure of 6.5 bar (5.5 above atmospheric pressure) and an average temperature of 20°C, relative to compressed-air flow velocity and inner pipe diameter. Source: Hoffmann.**



**Figures**

**Fig.: Water separator. Source: Hoffmann**

**Fig.: Self-regulating (automatic) water separator for main compressed-air pipe. Source: Hoffmann.**



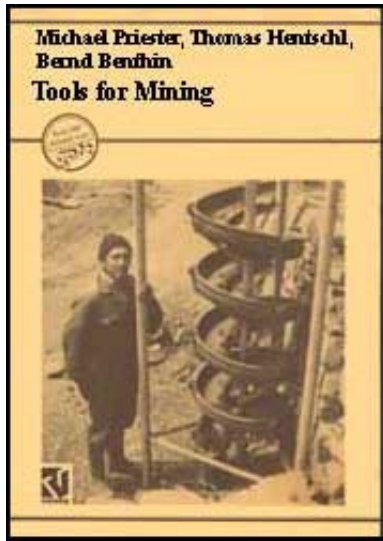
**Figures**

**Fig.: Draining of compressed air pipelines. Source: Hoffmann**

**Fig.: Water separator made from pipe and structural sections. Source: Hoffmann.**



[Home](#) > [ar](#).[cn](#).[de](#).[en](#).[es](#).[fr](#).[id](#).[it](#).[ph](#).[po](#).[ru](#).[sw](#)



## **Tools for Mining: Techniques and Processes for Small Scale Mining (GTZ, 1993, 538 p.)**

 **(introduction...)**

 **Acknowledgements**

 **Preface**

 **Guide to the user**

 **Introduction**

 **A. Analysis**

 **Technical Chapter 1: Analysis**

 **B. Underground mining**

 **Technical Chapter 2: Safety Techniques**

 **Technical Chapter 3: Ventilation**

 **Technical Chapter 4: Water supply and drainage**

 **Technical Chapter 5: Support**

 **Technical Chapter 6: Lighting**

 **Technical Chapter 7: Stoping**

 **Technical Chapter 8: Loading**

 **Technical Chapter 9: Hauling**

 **C. Surface mining**



- Technical Chapter 10: Surface Mining Equipment**
- D. Beneficiation**
- Technical Chapter 12: Crushing**
- Technical Chapter 13: Classification**
- Technical Chapter 14: Sorting**
- Technical Chapter 15: Gold Beneficiation**
- Technical Chapter 16: Other Sorting and Separating Techniques**
- Technical Chapter 17: Drying**
- Technical Chapter 18: Clarification**
- E. Mechanization and energy supply**
- Technical Chapter 19: Energy Techniques**
- Bibliography**
- List of manufacturers and suppliers**
- List of abbreviations**

## **Preface**

**This technical handbook on small-scale mining in developing countries is the result of a supra-regional Technical Cooperation project conducted by the Federal Republic of Germany. The objective of the project was to develop needs-oriented technologies by reviewing existing technical and economic documentation on process problems and their solutions. This analysis, which focuses by way of example on the Andean states, has been conducted by Projekt-Consult GmbH on**



**behalf of the Deutsche Gesellschaft für Technische Zusammenarbeit (GTZ) GmbH.**

**The contents of the publication "Tools for Mining" were presented to the participants of a seminar on small-scale mining held for SADC countries in Livingstone, Zambia, in February 1991, and it immediately became evident that the problems of smallscale mining in Africa and the Far East do not differ substantially from those encountered in the Andean countries. First published in Spanish, the interest shown in an English edition was such that the GTZ decided to publish an English-language version.**

**For many people in the Andean states of Latin America, small-scale mining is the mainstay of their income. The small mines, most of which employ less than ten persons, operate under exceptionally hard conditions. Indeed, their manual techniques are reminiscent of engineering in Europe prior to the industrial revolution. The low productivity level leads to extremely low wages, often poor safety conditions and social problems. In addition, small-scale mining frequently causes serious environmental pollution.**

**This publication aims to provide smallscale miners with technical alternatives. These technical innovations are intended as a comprehensive approach to the problems of small-scale mining, endeavouring as they do to improve the microeconomic, macroeconomic, social and ecological outputs. The handbook deals with analysis, mining activities, beneficiation and energy, and contains hints on technical issues and work organisation. It also includes information about historical mining machinery - which is comprehensively documented in Central Europe - modern, small-scale mining equipment and traditional techniques. By merging historical, modern and traditional elements, a basis is generated for**

**developing appropriate technology in line with actual needs. Although only limited documentation was available concerning locally developed, traditional techniques in the small-scale mining sector in Africa and Asia, the handbook is nonetheless suitable for global use as the techniques described can be implemented everywhere, thus making a major contribution to technology transfer and innovations in small-scale mining outside Latin America too.**

**The strategy of local production and implementation of socio-culturally, economically and ecologically appropriate technology on which this handbook is based has already proven its feasibility and its worth many a time in the field.**

