

























- ➔  **Small-Scale Weaving (ILO - WEP, 1983, 144 p.)**
  -  **(introduction...)**
  -  **ACKNOWLEDGEMENTS**
  -  **PREFACE**
  - CHAPTER I. INTRODUCTION**
    -  **I. Elements of technological choice in the weaving sector**
    -  **II. Scales of production covered by the memorandum**
    -  **III. Product coverage**
    -  **IV. Technologies covered by the memorandum**
    -  **V. Target audience**
    -  **VI. Summary of remaining chapters**
  - CHAPTER II. PRODUCTION OF WARPS AND PIRNS**
    -  **(introduction...)**
    -  **I. Production of warps**
    -  **II. Production of pirns**
  - CHAPTER III. WEAVING TECHNOLOGIES**
    -  **I. Weaving fundamentals**
    -  **II. Loom types in relation to scale of production**
    -  **III. Hand looms**
    -  **IV. Non-automatic power looms**
    -  **V. Automatic power looms**
    -  **VI. Shuttleless looms**
    -  **VII. Ancillary equipment**
    -  **VIII. Yarn requirements**
    -  **IX. Product quality**
    - X. Factory space requirements and layout**
  - CHAPTER IV. ECONOMIC EVALUATION OF ALTERNATIVE WEAVING TECHNOLOGIES**
    - I. Introduction**

- 📄 **II. Suitability of loom types and scales of production**
- 📄 **III. Methodological framework for the estimation of unit production costs**
- 📄 **IV. Economic comparison of weaving options**
- 📁 **CHAPTER V. SOCIO-ECONOMIC EVALUATION OF ALTERNATIVE WEAVING TECHNOLOGIES**
  - 📄 **I. Introduction**
  - 📄 **II. Impact of alternative weaving technologies**
  - 📄 **III. Policy measures for the promotion of appropriate weaving technologies**
- 📁 **APPENDICES**
  - 📄 **APPENDIX I. Compound interest, factors**
  - 📄 **APPENDIX II. Textile terms and definitions**
  - 📄 **APPENDIX III. Equipment manufacturers**
  - 📄 **APPENDIX IV. Institutions able to supply technological information related to textiles**
  - 📄 **APPENDIX V. Selected bibliography**
- 📄 **QUESTIONNAIRE**
- 📄 **OTHER ILO PUBLICATIONS**
- 📄 **BACK COVER**



[Home](#) > [ar.cn.de.en.es.fr.id.it.ph.po.ru.sw](#)



- 📖 **Small-Scale Weaving (ILO - WEP, 1983, 144 p.)**
  - ➔ 📄 **(introduction...)**
  - 📄 **ACKNOWLEDGEMENTS**
  - 📄 **PREFACE**
  - 📁 **CHAPTER I. INTRODUCTION**
  - 📁 **CHAPTER II. PRODUCTION OF WARPS AND PIRNS**
  - 📁 **CHAPTER III. WEAVING TECHNOLOGIES**
  - CHAPTER IV. ECONOMIC EVALUATION OF ALTERNATIVE WEAVING TECHNOLOGIES**
  - CHAPTER V. SOCIO-ECONOMIC EVALUATION OF ALTERNATIVE WEAVING TECHNOLOGIES**

-  **APPENDICES**
-  **QUESTIONNAIRE**
-  **OTHER ILO PUBLICATIONS**
-  **BACK COVER**

## **TECHNOLOGY SERIES**

### **Technical Memorandum No. 4**

**Prepared under the joint auspices of the International Labour Office and the United Nations Industrial Development Organisation**



**International Labour Office Geneva**



**The ILO's World Employment Programme (WEP) aims to assist and encourage member States to adopt and implement active policies and projects designed to promote full, productive and freely chosen employment and to reduce poverty. Through its action-oriented research, technical advisory services, national projects and the work of its four regional employment teams in Africa, Asia and Latin America, the WEP pays special attention to the longer-term development problems of rural areas where the vast majority of poor and underemployed people still live, and to the rapidly growing urban informal sector.**

**At the same time, in response to the economic crises and the growth in open unemployment of the 1980s, the WEP has entered into an ongoing dialogue with the social partners and other international agencies on the social dimensions of adjustment, and is devoting a major part of its policy analysis and advice to achieving greater equity in structural adjustment programmes. Employment and poverty monitoring, direct employment creation and income generation for vulnerable groups, linkages between macro-economic and micro-economic interventions, technological change and labour market problems and policies are among the areas covered.**

**Through these overall activities, the ILO has been able to help national decision-makers to reshape their policies and plans with the aim of eradicating mass poverty and promoting productive employment.**

**This publication is the outcome of a WEP project.**

**Copyright © International Labour Organisation 1983**

**First published 1983**

**Third impression 1992**

**Publications of the International Labour Office enjoy copyright under Protocol 2 of the Universal Copyright Convention. Nevertheless, short excerpts from them may be reproduced without authorisation, on condition that the source is indicated. For rights of reproduction or translation, application should be made to the Publications Branch (Rights and Permissions), International Labour Office, CH-1211 Geneva 22, Switzerland. The International Labour Office welcomes such applications.**

ILO

UNIDO

*Small-scale weaving*

Geneva, International Labour Office, 1983. Technology Series, Technical Memorandum No. 4  
/Technical memorandum/, /Small-scale industry/, /Weaving/,  
/Developing country/s. 08.06.2

ISBN 92-2-103419-4

ISSN 0252-2004

*ILO Cataloguing in Publication Data*

**The designations employed in ILO publications, which are in conformity with United Nations practice, and the presentation of material therein do not imply the expression of any opinion whatsoever on the part of the International Labour Office concerning the legal status of any country, area or territory or of its authorities, or concerning the delimitation of its frontiers. The responsibility for opinions expressed in signed articles, studies and other contributions rests solely with their authors, and publication does not constitute an endorsement by the International Labour Office of the opinions expressed in them. Reference to names of firms and commercial products and processes does not imply their endorsement by the International Labour Office, and any failure to mention a particular firm, commercial product or process is not a sign of disapproval.**

**ILO publications can be obtained through major booksellers or ILO local offices in many countries, or direct from ILO Publications, International Labour Office, CH-1211 Geneva 22, Switzerland. A catalogue or list of new publications will be sent free of charge from the above address.**



[Home](#) > [ar](#) [cn](#) [de](#) [en](#) [es](#) [fr](#) [id](#) [it](#) [ph](#) [po](#) [ru](#) [sw](#)



- Small-Scale Weaving (ILO - WEP, 1983, 144 p.)**
  - (introduction...)**
  - ACKNOWLEDGEMENTS**
  - PREFACE**
  - CHAPTER I. INTRODUCTION**
  - CHAPTER II. PRODUCTION OF WARPS AND PIRNS**
  - CHAPTER III. WEAVING TECHNOLOGIES**
  - CHAPTER IV. ECONOMIC EVALUATION OF ALTERNATIVE WEAVING TECHNOLOGIES**
  - CHAPTER V. SOCIO-ECONOMIC EVALUATION OF ALTERNATIVE WEAVING TECHNOLOGIES**
  - APPENDICES**
  - QUESTIONNAIRE**
  - OTHER ILO PUBLICATIONS**
  - BACK COVER**

### QUESTIONNAIRE

1. Full name .....

2. Address .....

3. Profession (check the appropriate case)

Established textile producer

If yes, indicate scale of production: .....

Would-be textile producer

Government Official

If yes, specify position: .....  
.....

Employee of a financial institution

If yes, specify position: .....  
.....

University staff member

Staff member of a technology institution

If yes, indicate name of institution: .....  
.....

Staff member of a training institution

If yes, specify .....  
.....

Other

If yes, specify .....  
.....

4. From where did you get a copy of this memorandum?

Specify if obtained free or bought .....  
.....  
.....

5. Did the memorandum help you achieve the following:

(check the appropriate cases)

Learn about weaving techniques you were not aware of

Obtain names of equipment suppliers

Estimate unit production costs for various scales of production/technologies

Order equipment for local manufacture

Improve your current production technique

Cut down operating costs

Improve the quality of produced textiles

Decide which scale of production/technology to adopt for a new textile mill

If a Government employee, to formulate new measures and policies for the textile sector

If an employee of a financial institution, to assess a request of a loan for the establishment of a textile mill

If a trainer in a training institution, to use the memorandum as a supplementary training material

If an international expert, to better advise counterparts on weaving technologies

6. Is the memorandum detailed enough in terms of: Yes No

- Description of technical aspects

- Description of technical aspects
- Names of equipment suppliers
- Costing information
- Information on socio-economic impact
- Bibliographical information

	✓	✓
	□	□
	□	□
	□	□
	□	□

If some of the answers are 'NO', please indicate why below or on a separate sheet of paper.

.....

.....

.....

7. How may this memorandum be improved if a second edition were to be published?

.....

.....

.....

.....

8. Please send the QUESTIONNAIRE, duly completed to:

Technology and Employment Branch  
 International Labour Office  
 CH-1211 GENEVA 22  
 (Switzerland)

9. In case you need additional information on some of the issues covered by this memorandum the ILO and UNIDO would do their best to provide the requested information.



[Home](#) > [ar](#).[cn](#).[de](#).[en](#).[es](#).[fr](#).[id](#).[it](#).[ph](#).[po](#).[ru](#).[sw](#)

---

**Small-Scale Weaving (ILO - WEP, 1983, 144 p.)**





- 📄 **(introduction...)**
- 📄 **ACKNOWLEDGEMENTS**
- 📄 **PREFACE**
- 📁 **CHAPTER I. INTRODUCTION**
- 📁 **CHAPTER II. PRODUCTION OF WARPS AND PIRNS**
- 📁 **CHAPTER III. WEAVING TECHNOLOGIES**
- 📁 **CHAPTER IV. ECONOMIC EVALUATION OF ALTERNATIVE WEAVING TECHNOLOGIES**
- 📁 **CHAPTER V. SOCIO-ECONOMIC EVALUATION OF ALTERNATIVE WEAVING TECHNOLOGIES**
- 📁 **APPENDICES**
- 📄 **QUESTIONNAIRE**
- ➔ 📄 **OTHER ILO PUBLICATIONS**
- 📄 **BACK COVER**

## OTHER ILO PUBLICATIONS

### Technology Series

The object of the technical memoranda in this series is to help to disseminate, among small-scale producers, extension officers and project evaluators, information on small-scale processing technologies that are appropriate to the socio-economic conditions of developing countries.

**ISSN 0252-2004**

### Tanning of hides and skins (Technology Series - Technical Memorandum No. 1)

Provides technical and economic information concerning the tanning of hides and skins at scales ranging from two hides per day (a typical rural tannery) to 200 hides per day. Six alternative tanning technologies are described, from a fully mechanised 200 hides per day project to a highly labour-intensive two hides per day project. Subprocesses are described in great detail, with diagrams of pieces of equipment which may be manufactured locally. A list of equipment suppliers is also provided for those pieces of equipment which may need to be imported. The memorandum on the tanning of hides and skins is, to some extent, complementary to that on the small-scale manufacture of footwear.

**ISBN 92-2-102904-2**

**27.50 Swiss francs**

**Small-scale manufacture of footwear (Technology Series - Technical Memorandum No. 2)**

**Covers the small-scale production of footwear (shoes and sandals) of differing types and quality, providing detailed technical and economic information covering four scales of production ranging from eight pairs per day to 1,000 pairs per day. A number of alternative technologies are described, including both equipment-intensive and labour-intensive production methods. Subprocesses are described in great detail, with diagrams of pieces of equipment which may be manufactured locally. A list of equipment suppliers is also provided for those pieces of equipment which may need to be imported.**

**ISBN 92-2-103079-2**

**20 Swiss francs**

**Small-scale processing of fish (Technology Series - Technical Memorandum No. 3)**

**This technical memorandum covers, in detail, technologies that are suitable for the small-scale processing of fish: that is, drying, salting, smoking, boiling and fermenting. Thermal processing is described only briefly, as it is used mainly in large-scale production. Enough information is given about the technologies to meet most of the needs of small-scale processors. Two chapters of interest to public planners compare, from a socio-economic viewpoint, the various technologies described in the memorandum and analyse their impact on the environment.**

**ISBN 92-2-103205-1**

**17.50 Swiss francs**

**Small-scale oil extraction from groundnuts and copra (Technology Series - Technical Memorandum No. 5)**

**Covers, in detail, various technologies for the extraction of oil from groundnuts and copra: baby expeller mills, small package expellers and power ghanis. Three main stages of processing are considered, namely the pre-processing stages (drying, crushing, scorching), the oil extraction stage and the post-treatment stages (filtering, cake breaking, packaging, bagging). The economic and technical details provided on the stages of processing should help would-be or practising small-scale producers to identify and apply the oil extraction technology best suited to local conditions. A chapter of interest to public planners compares small-scale plants and large-scale plants from a socio-economic viewpoint and suggests various policy measures for the promotion of the right mix of oil extraction techniques.**

**ISBN 92-2-103503-4**

**17.50 Swiss francs**

**Small-scale brickmaking (Technology Series - Technical Memorandum No. 6)**

**Provides detailed technical information on different brickmaking techniques and covers all processing stages, including quarrying, clay preparation, moulding, drying, firing and the testing of produced bricks. The techniques described are mostly of interest to small-scale producers in both rural and urban areas. The**

**processes and equipment are described in great detail, including drawings of equipment and tools which may be produced locally, floor plans, labour and skill requirements, materials and fuel inputs per unit of output. A chapter of interest to public planners compares, from a socio-economic point of view, the various brickmaking techniques described in this memorandum.**

**ISBN 92-2-103567-0**

**27.50 Swiss francs**

### **Small-scale maize milling (Technology Series - Technical Memorandum No. 7)**

**Provides detailed information on alternative techniques for the production of whole meal, bolted meal and super-sifted meal. It covers all processing stages, including grain preparation, shelling, milling, sifting and packaging. The techniques described are mostly of interest to custom mills and small-scale merchant mills located in rural and urban areas. The first chapter of the memorandum provides in-depth information on the various effects of different maize-milling techniques, including the nutritional values of various kinds of maize meal, employment generation, foreign exchange savings, and so on.**

**ISBN 92-2-103640-5**

**17.50 Swiss francs**

### **Small-scale paper-making (Technology Series - Technical Memorandum No. 8)**

**Provides technical and economic information on alternative paper-making technologies, describes the characteristics of various types and grades of paper products and gives guidance in the choice of paper machines. The information relates mostly to small-scale paper mills with a capacity of 30 tonnes of paper per day or less. The raw materials suggested for such mills include straw, bagasse, waste paper, rags and cotton waste, as well as other agricultural residues and imported wood pulp. Unlike other memoranda in the series, this memorandum is not a technical introduction to paper-making in general, nor is it a basic textbook on the subject. Instead, it provides people already in possession of the necessary background knowledge with criteria for choosing amongst different methods of paper-making.**

**ISBN 92-2-103971-4**

**22.50 Swiss francs**

***Further technical memoranda are in preparation***



**[Home](#) > [ar.cn.de.en.es.fr.id.it.ph.po.ru.sw](#)**



- 📖 **Small-Scale Weaving (ILO - WEP, 1983, 144 p.)**
- 📄 **(introduction...)**
- 📄 **ACKNOWLEDGEMENTS**
- 📄 **PREFACE**
- 📄 **CHAPTER I. INTRODUCTION**
- 📄 **CHAPTER II. PRODUCTION OF WARPS AND PIRNS**
- 📄 **CHAPTER III. WEAVING TECHNOLOGIES**
- 📄 **CHAPTER IV. ECONOMIC EVALUATION OF ALTERNATIVE WEAVING TECHNOLOGIES**
- 📄 **CHAPTER V. SOCIO-ECONOMIC EVALUATION OF ALTERNATIVE WEAVING TECHNOLOGIES**
- 📄 **APPENDICES**
- 📄 **QUESTIONNAIRE**
- 📄 **OTHER ILO PUBLICATIONS**
- ➔📄 **BACK COVER**

## BACK COVER

**This technical memorandum is part of a joint ILO/UNIDO series of publications on manufacturing technologies. The object of the series is to acquaint small-scale producers with alternative production techniques for specific products and processes with a view to helping them to choose and apply those techniques which are most appropriate to local socio-economic conditions.**

**The memorandum describes alternative weaving technologies for eight types of cloth (four plains and four twills) of particular interest for low-income groups in terms of both price and durability. It provides information on available equipment (e.g. looms, pirning equipment, warping equipment), including equipment productivity, quality of output, required quality of material inputs, and so on. A methodological framework for the evaluation of alternative weaving technologies at three scales of production is provided for the benefit of the textile producer who wishes to identify the technology/scale of production best suited to his own circumstances. A chapter of interest to public planners compares, from a socio-economic viewpoint, the various weaving technologies described in the memorandum.**

**It is hoped that the information contained in this memorandum will help would-be or practising textile producers to choose and apply weaving technologies that will minimise production costs while improving the quality of the cloth.**

ISBN 92-2-103419-4



[Home](#) > [ar.cn.de.en.es.fr.id.it.ph.po.ru.sw](#)



- Small-Scale Weaving (ILO - WEP, 1983, 144 p.)**
- (introduction...)**
- ACKNOWLEDGEMENTS**
- PREFACE**
- CHAPTER I. INTRODUCTION**
- CHAPTER II. PRODUCTION OF WARPS AND PIRNS**
- CHAPTER III. WEAVING TECHNOLOGIES**
- CHAPTER IV. ECONOMIC EVALUATION OF ALTERNATIVE WEAVING TECHNOLOGIES**
- CHAPTER V. SOCIO-ECONOMIC EVALUATION OF ALTERNATIVE WEAVING TECHNOLOGIES**
- APPENDICES**
- QUESTIONNAIRE**
- OTHER ILO PUBLICATIONS**
- BACK COVER**

## ACKNOWLEDGEMENTS











The publication of this memorandum has been made possible by a grant from the Overseas Development Administration of the United Kingdom, through the Intermediate Technology Development Group (ITDG, London) and from the Swedish International Development Authority (SIDA). The International Labour Office and the United Nations Industrial Development Organisation acknowledge this generous support.



[Home](#) > [ar.cn.de.en.es.fr.id.it.ph.po.ru.sw](#)

**Small-Scale Weaving (ILO - WEP, 1983, 144 p.)**  
**(introduction...)**



-  **ACKNOWLEDGEMENTS**
-  **PREFACE**
-  **CHAPTER I. INTRODUCTION**
-  **CHAPTER II. PRODUCTION OF WARPS AND PIRNS**
-  **CHAPTER III. WEAVING TECHNOLOGIES**
-  **CHAPTER IV. ECONOMIC EVALUATION OF ALTERNATIVE WEAVING TECHNOLOGIES**
-  **CHAPTER V. SOCIO-ECONOMIC EVALUATION OF ALTERNATIVE WEAVING TECHNOLOGIES**
-  **APPENDICES**
-  **QUESTIONNAIRE**
-  **OTHER ILO PUBLICATIONS**
-  **BACK COVER**

## **PREFACE**

**This technical memorandum on small-scale weaving is the fourth of the series being currently prepared by the ILO and UNIDO.<sup>1</sup> It concerns the small-scale production of cloth for low-income groups. The analysis has been undertaken in the light of such development objectives as the generation of productive employment, the improvement of the balance of payments, rural industrialisation, etc.**

**<sup>1</sup> Technical memorandum No. 3 on small-scale fish processing was published jointly by the ILO and the FAO.**

**The memorandum describes alternative weaving technologies for eight types of cloth of particular interest to low-income groups in terms of both price and durability. It provides information on available equipment (e.g. looms pirning equipment, warping equipment), including equipment productivity, quality of output, required quality of material inputs, etc. Given the intricacy of weaving technologies and associated equipment, this memorandum does not provide - unlike the previous memoranda in the series - technical details (e.g. technical drawings) for the production of weaving equipment. It is assumed that either a national industry exists for the production of such equipment or that the latter must be imported from equipment manufacturers in developing or developed countries. A list of some manufacturers is provided in Appendix III of the memorandum.**

**The memorandum also provides a detailed methodological framework for the economic evaluation of alternative weaving technologies, and illustrative examples of the application of the above framework to concrete examples from developing countries (see Chapter IV). A chapter dealing with the socio-economic impact of alternative weaving technologies should be of particular interest to public planners wishing to formulate appropriate policies for the textile sector.**

**The effective dissemination of technical memoranda will require the active participation of various governments agencies, trade associations, workers' and employers' organisations and training institutions, etc. Seminars may be organised for the benefit of established or potential textile producers in order to review the proposed weaving technologies, identify those which are particularly suited to prevailing local conditions, and identify the type of assistance needed by weavers who wish to adopt one of the technologies described in the memorandum.**

**This technical memorandum is mostly intended for potential textile producers who have some difficulties in choosing and applying technologies best suited to their own circumstances. However, it should also be of interest to public planners, project evaluators from industrial development agencies, training institutions and national and international financing institutions. In short, the memorandum should be useful to all those who are in a position to influence the choice of public or private investments in the textile sector, and therefore the choice of technologies associated with these investments.**

**A questionnaire is attached to the memorandum for those readers who may wish to send their comments and observations to the ILO or UNIDO on the content and usefulness of this publication. These will be taken into consideration in the preparation of future technical memoranda.**

**This memorandum was prepared by the Shirley Institute (Didsbury, Manchester, United Kingdom) in collaboration with Mr. M. Allal, staff member in charge of the preparation of the technical memoranda series within the Technology and Employment Branch of the ILO.**

**A. S. Bhalla,  
Chief,  
Technology and Employment Branch**



**[Home](#) > [ar](#).[cn](#).[de](#).[en](#).[es](#).[fr](#).[id](#).[it](#).[ph](#).[po](#).[ru](#).[sw](#)**



## 📖 Small-Scale Weaving (ILO - WEP, 1983, 144 p.)

### ➔ □ CHAPTER I. INTRODUCTION

- 📄 I. Elements of technological choice in the weaving sector
- 📄 II. Scales of production covered by the memorandum
- 📄 III. Product coverage
- 📄 IV. Technologies covered by the memorandum
- 📄 V. Target audience
- 📄 VI. Summary of remaining chapters

## Small-Scale Weaving (ILO - WEP, 1983, 144 p.)

### CHAPTER I. INTRODUCTION

#### I. Elements of technological choice in the weaving sector

**After food and shelter, clothing, and therefore textiles, constitute one of the most important basic needs of low-income groups in developing countries. It is therefore important to promote the production of textile products which are both inexpensive and durable in order to minimize the fraction of the income of these groups spent on textiles/clothing.**

**This very important objective may not always be fully consonant with other socio-economic objectives such as employment generation or foreign exchange savings. For example, the use of handlooms will generate a great deal of employment but may not, under given circumstances, allow the production of inexpensive textiles products for low-income groups. Thus, a balance must often be established between conflicting objectives with a view to satisfying demand for textiles by these groups while contributing to the fulfilment of adopted socio-economic objectives. In concrete terms, such an approach will require the choice of an appropriate mix of weaving technologies<sup>1</sup> and the formulation of a number of policy measures which will ensure their application.**

**<sup>1</sup> In the context of this memorandum, the term "technology" is broadly defined and relates to the choice of textile products, of weaving processes and of scale of production.**

**The choice of weaving technologies will generally depend on the following factors:**



- **The market to be supplied, and therefore, the type, quality and volume of textile products which must be supplied;**
- **Availability, quality and price of raw materials and intermediate inputs;**
- **Availability and cost of capital equipment;**
- **Versatility of equipment in case demand for the initial product should change over time;**
- **Availability of qualified skilled labour for the setting up, servicing and operation of weaving units;**
- **Labour and equipment productivity associated with each technological alternative;**
- **Prices of the factors of production, including wages, interest rate on borrowed capital, unit price of electricity, etc.**
- **Capital costs of building and services; and**
- **Useful lives of equipment and buildings.**

**The above factors determine the choice of weaving technology from the point of view of the private entrepreneur as they affect production costs and revenues from the sale of the output. However, as stated earlier, public planners may also be concerned by a number of socio-economic objectives which could also affect the choice of weaving technology. These may include: employment generation, improvement of the balance of payments, rural industrialisation, fulfilment of the basic needs of low-income groups, etc... A number of policy measures may therefore need to be implemented in order to promote weaving technologies which are appropriate from the point of view of the producer and society. These measures, which will be further elaborated in chapter V, may include wage subsidies, high custom duties on selected types of weaving equipment, mandatory use of selected technologies for the production of various textile products, etc.**

**In general, no single weaving technology may fulfil all the requirements of a country. Rather a mix of technologies - from labour-intensive to capital-intensive weaving technologies - would be, in most cases, required if different markets were to be supplied, and if important socio-economic objectives were to be fulfilled. It is hoped that this memorandum will assist public planners and private entrepreneurs to identify and apply these technologies.**

## II. Scales of production covered by the memorandum

This memorandum describes weaving technologies used in small-scale, medium-scale and large-scale production units. These scales of production are defined as follows:

**Small-scale units:** The production level is 100,000 metres per year. Production is carried out on a one-shift basis only corresponding to 3,000 working hours per year. These units may be suitably located in rural areas.

**Medium-scale units:** The production level is 1,000,000 metres per year. Production is carried out in mills located in small urban areas on a two-shifts basis corresponding to 5,000 working hours per year.

**Large-scale units:** The production level is 5,000,000 metres per year. Production is carried out in mills located in large urban areas on a three-shifts basis corresponding to 6,500 working hours per year.

## III. Product coverage

The list of eight fabrics contained in Table I.1 is not exhaustive but is considered sufficiently indicative of the broad range of fabrics of interest to low-income groups in developing countries. Each of these fabrics may be woven from yarns spun from 100% cotton or from any blends of short staple (cotton system) fibres without prejudice to the weaving technology employed. The use of such blends does not affect, in a significant manner, the choice of weaving technology. However, the use of stronger blends of man-made fabrics yields a higher productive efficiency than that yielded by cotton blends.

**Table I.1**  
**Characteristics of textiles covered by the memorandum**

Textile	Characteristics					Purpose
	Ends	Picks	Yarn Counts		Weight	
	(per cm)		Warp	Weft	g/m <sup>2</sup>	
Plains			Tex (Ne)	Tex (Ne)		
P1	16	16	48 (12)	48 (12)	168	Sheeting, heavy shirting
P2	26	26	24 (24)	24 (24)	135	Prints, medium shirting

P3	32	32	16 (36)	16 (36)	108	Light snirts, diouses
P4	37	37	12 (50)	12 (50)	92	Light blouses, saree
Twills						
T1	40	24	30 (20)	48 (12)	254	Denim 'jeans', workwear
T2	20	18	30 (20)	72 (8)	205	Heavy sheeting
T3	36	24	24 (24)	36 (16)	187	Gaberdine suiting
T4	28	24	30 (20)	36 (16)	185	Heavy shirting

#### IV. Technologies covered by the memorandum

##### IV.1 Warp Preparation

For the requirements of this memorandum, warp preparation processes have been assumed to start at the stage at which the input yarn has been prepared on packages, which are suitable for direct mounting in the creel of a warping machine (e.g. cones). However, for some of the techniques mentioned in connection with small-scale warp preparation, it may not always be essential that the yarn be supplied in cones since direct processing from hanks, or even from spinner's bobbins, is possible in some cases.

The various options of warp preparation are described in Chapter II. It is suggested that, in general, the most suitable warping method consists of first producing a set of back beams, and then combining these to form weaver's warps during the sizing operation. The warp sizing operation and the principal factors to be considered in carrying it out are also described. Looming and gaiting of the sized warps is not described in detail, but mention of the equipment required for these processes is made in the section entitled 'Ancillary equipment' in Chapter III. Pirning of the weft for shuttle looms is discussed in Chapters II and III under the related headings.

##### IV.2 Weaving technologies

Chapter III briefly reviews weaving fundamentals and terminologies, and then provides technical details for a number of looms suitable for the production of the eight selected types of textile products. Three types of looms are described namely handlooms, non-automatic power looms and automatic shuttle looms. Shuttleless looms are mentioned very briefly as they are not considered appropriate for conditions prevailing in developing countries. However, the economic efficiency of these looms is considered in Chapter IV, along with that of the other types of looms, for comparison purposes.

## V. Target audience

**This memorandum is intended for two main audiences: the small-scale textile producers and the public planners and/or project evaluators in industrial development agencies. Financial institutions may also be interested in some of the information provided in this memorandum.**

**Chapters II to IV are of particular interest to textile producers as they contain the necessary technical and economic data which could help them identify and apply the weaving technology most suited to local conditions. Chapter V is, on the other hand, of particular interest to public planners and project evaluators as it provides useful information on the various socio-economic impacts of alternative weaving technologies, as well as some guidelines for the formulation of appropriate policies and measures in favour of the weaving sector.**

## VI. Summary of remaining chapters

**Chapter II describes alternative techniques for warp preparation, warp sizing, and pirning. These techniques are assessed in relation to the three scales of production covered by the memorandum.**

**Chapter III covers weaving technologies and contains detailed descriptions of eight different looms which may be adopted by practising or would-be weavers.**

**Chapter IV provides a methodological framework for costing the alternative weaving technologies described in Chapter III as well as illustrative examples of the applications of this methodology.**

**Chapter V evaluates the various socio-economic effects of the weaving technologies described in this memorandum (e.g. employment effects, satisfaction of basic needs) and suggests a number of policy measures which may influence the choice of weaving technology.**

**A glossary of technical terms, a list of equipment suppliers and of institutions which may provide additional information on alternative weaving technologies are provided as appendices.**





[Home](#) > [ar](#) [cn](#) [de](#) [en](#) [es](#) [fr](#) [id](#) [it](#) [ph](#) [po](#) [ru](#) [sw](#)

---

**Small-Scale Weaving (ILO - WEP, 1983, 144 p.)  
CHAPTER II. PRODUCTION OF WARPS AND PIRNS**



-  **(introduction...)**
-  **I. Production of warps**
-  **II. Production of pirns**

**Small-Scale Weaving (ILO - WEP, 1983, 144 p.)**

## **CHAPTER II. PRODUCTION OF WARPS AND PIRNS**

**The various factors to be taken into account in warp preparation and in weft-pirning are considered in this chapter in relation to the selected scales of production.**

### **I. Production of warps**

#### **I.1 Warp preparation for small-scale weaving units**

**Fabrics of the type considered in this memorandum are difficult to produce as they require stringent warp preparation and looming to ensure satisfactory weaving with a minimum of thread breakages at the given production rates. A number of warping techniques are described below.**

##### **(a) Manual methods of warp preparation**

**Traditional manual methods of warp preparation are unsuitable for production rates that may be expected from even a small mill. The principal reasons for this are:**

**(i) Warp lengths considerably greater than those normally produced for hand-loom weaving of speciality cloths are necessary in order to obtain the requisite scale of production; and**

**(ii) the warp must not contain crossed ends and all threads require to be wound at similar uniform tension from start to end of the beam. These objectives cannot be readily attained by manual preparation methods without increasing costs in a prohibitive manner. If, therefore, hand-loom weaving is to be seriously considered it must be realised that it is only likely to be a viable proposition for the cloths under consideration if means of mechanical warp preparation are included. Possibly, a separate organisation, located close enough to the weaving production units, could prepare loom warps for a number of small weaving establishments. Assuming, therefore, that some external organisation prepares the warps, warp preparation may be undertaken according to the following two methods.**

### **(b) Warping from back seams**

**This is by far the most common method which is appropriate to the types of fabric considered. The method itself is described in more detail under the section dealing with medium- and large-scale weaving. It should be pointed out here that the use of the system for relatively short hand loom warps will involve additional operations, e.g. an additional warp-cutting and rebeaming operation following the normal winding-on to the weavers' beam after sizing. The reason for these extra operations is to avoid overdrying and consequent damage to the yarn by frequent stoppages during the sizing process. Warp-sizing is a necessary preliminary process to weaving for most cotton-type warps in order to minimise warp thread breakages in the loom. The sizing process is dealt with later in this chapter.**

### **(c) Scotch Beaming and Dry Taping**

**The second possible method of warp preparation is the system used mainly for colour-stripe warps known as Scotch Beaming and Dry Taping. In this system, the loom warp is built up from a number of sections, with each section prepared separately, in either ball, chain or cheese form, from the requisite number of individual yarn packages. These packages are mounted in a creel behind a modified form of beam-warping frame having the necessary winding mechanism. The ball warps, which may then be dyed or left in grey form as required, are next run through a size bath and dried. After drying, each ball warp is run on to a separate back beam as an open sheet similar in width to that of the final weavers' warp. The open-sheet form is achieved by passing the rope of threads over grooved rods, which cause some preliminary opening-out, then through a reed and finally through an expanding comb which guides the sheet on to the back beam. The back beams made from all the warp sections are next mounted in a creel at the dry-taping frame. From this creel,**

**the sheets are unwound together and superimposed to form a single sheet of the required final thread density; this sheet is then wound on to a loom beam at the frame headstock. Warps of any desired length can be prepared in this manner. However, for grey warps, the system has no real advantage over the previous back beam method, and is certainly much slower. It is, however, one method by which self-coloured warps for denim cloths (e.g. T1 fabric) can be prepared.**

**If the warps have to be prepared at the hand-weaving factory, the situation becomes more difficult in view of the much smaller scale of operations while the sizing of yarn is still necessary. One method to be considered would be to first size the yarn in hank form. This will require means for pre-boiling the yarn to improve size pick-up and also, after sizing and before drying, further means for mechanical shaking, stretching and brushing of the hanks. The sized yarns will next have to be wound on to bobbins, or cone-wound, and the packages placed in a creel of suitable form from which the yarns can be withdrawn to make back beams for later dry-taping on to loom beams, in a similar manner to that already described. An alternative to dry-taping is to prepare the loom beams from warp sections wound side by side on a horizontal sectional warping mill, the yarns having first been hank-sized and coned as before. All warp sections on the mill are later re-wound as a single sheet from the mill on to weavers' beams (see 'Indirect warping system' in Section I.2 (b)).**

#### **(d) Shirley Miniplus Method**

**Should neither of the above hank sizing systems be suitable, and if loom warps of only 11 metres nominal length will suffice, consideration might be given to a unit designed primarily for the preparation of sized sample warps known as the Shirley Miniplus. The Miniplus is made by Sellars + Company (Huddersfield) Ltd. Warps are made on this machine from either a single yarn package, such as a cone or hank, or from yarns from two packages which are run simultaneously side by side. As the yarn unwinds from the supply package(s) it passes through a trough containing size paste and afterwards through a heated chamber to dry the size picked up by the yarn. On leaving the drying chamber, the yarn is wound as a continuous spiral(s) across the width of a large rotating reel or swift of 11 metres (12 yd) circumference. The number of coils run on to the reel equals the number of threads required in a loom warp of 91 cm (36 in) width. After winding on the coils, the reel is stopped and adhesive tapes and clamps are put across the coils at two adjacent circumferential points on the reel in order to secure the coils in sheet form. The coils are then cut between the clamping points, thus enabling the sheet of yarns so formed to be unwound from the reel and re-wound on to a loom beam.**

**The speed of warp preparation by the Miniplus method is directly dependant on the rate at which the sized yarn can be dried and on whether the warp is prepared from a single yarn package or from two packages**

winding-on simultaneously. For yarns of 48 Tex (12Ne) (for weaving cloth (P1)) wound-on from two packages at an average reel speed of 4.5 rev/min, the time to wind 1488 coils for a cloth 91 cm wide (+ 32 additional threads for selvages) would be approximately 166 minutes for the sizing and winding operations only. Furthermore, time must be added to prepare the size and to wind the warp from the reel on to the loom beam; the latter operation usually takes between 20 and 30 minutes. If, however, the warp were to contain many more threads of finer yarn, such as cloth (P4) which, including extra ends for selvages, would contain around 3441 ends of 12 Tex (48Ne) yarn in a width of 91 cm, the time to size and reel-on would be nominally 246 min if the reel were run at 7 rev/min. This higher reel speed is the result of a shorter time needed to dry the finer yarns in this cloth. The drying chamber temperature has been assumed to be the same in both instances (i.e. approximately 90°C).

Other machines for preparing sample warps have been made to meet specific requirements. One of these, made by Hergeth KG (4408 Dulmen, Federal Republic of Germany), is well-known. It is a much more sophisticated and expensive machine than the Miniplus. While it has electronic control facilities which make it reasonably simple to operate, it will undoubtedly require a high level of technical knowledge to maintain and service. For this reason, and that of high cost, its adoption by small-scale weavers may not always be justified.

## I.2 Warp preparation for Medium and Large-scale weaving units

There are two principal methods of warp preparation for cotton and man-made fibre fabrics, viz. 'Direct' or warping from back beams, and 'Indirect' or section warping.

### (a) Direct warping

This method is most suited to the production of warps for the types of fabrics covered by this memorandum. The system consists of producing first a number of separate back beams, called a set. All back beams in a set contain roughly the same number of threads (ends): this number is such that when later all the individual sheets from these beams are superimposed and combined they form a single warp sheet containing the total required ends in the weavers' warp. It may be noted that all the individual threads from any single back beam are approximately evenly distributed across the width of the finished warp. The upper limit to the number of ends on a back beam is determined largely by the size of creel in which the cones of yarn are held for making the beam. A creel capacity of between 500 and 512 cones is very common. Thus, for a warp for cloth (P1), which for a fabric 100 cm width requires approximately 1632 ends (inclusive of selvages) on the loom beam, four back beams might be made, each containing 408 ends of 48 Tex (12Ne) yarn. Similarly, for a warp for cloth (P4), with a total of 3776 ends of 12 Tex (50Ne) yarn and 100 cm width, eight back beams,



**each of 472 ends, could be made.**

**The warp length on a back beam is usually sufficient to make a number of loom beams when the sheets from all beams in a set have been later combined during the warp sizing operation which follows beaming. Let us suppose that, in the case of cloth (P1), each loom warp must be of sufficient length to weave 1000 metres of fabric. After making allowances for warp crimp and for waste in sizing and weaving (up to a total of around 10%), the length of warp to be wound on to each back beam in the set would be  $1000 \times 1.1 \times 8 = 8800$  metres (i.e. sufficient length to produce 8 weavers' warps). This length can be accommodated on a standard size of back beam of 711 mm (28 in) flange diam. x 1380 mm (54 in) width between flanges, with the yarn wound at medium pressure so as to obtain a firm but not too hard a beam. The cutting of the sized warp to length takes place as the warp is being wound on to the weavers' beams at the headstock of the sizing machine.**

### **Beaming machines**

**Beam-warping machines are of two types: indirect beam-drive (drum-drive) and direct spindle drive. Although either machine can be used for cotton type warps, the former are generally less expensive and require less maintenance than the latter, which were primarily designed for the high-speed warping of continuous filament yarns. In drum-drive machines, the warp beam is driven by frictional contact with a large rotating drum at recommended speeds, for spun yarns, which do not usually exceed 450 metres/min. However, for the warps required, a machine of the drum-drive type, running at around 330 metres/min., should be adequate.**

### **Beaming efficiencies**

**Average beaming efficiencies with drum-drive equipment are around 36%. They are, of course, influenced by the quality of the yarn and hence the time required to attend to thread breaks. They also depend on the frequency of beam changes and creeling time. A beaming efficiency of 30.3%, in terms of machine-speed, has been assumed in the economic evaluations undertaken in chapter IV.**

### **(b) Indirect warping**

**This system consists of winding the warp in separate width-way sections, each section being laid side-by-side on the horizontal barrel of a special beaming machine. When the required number of sections has been wound on to the barrel, all are unwound together as a single warp sheet either directly on to a loom beam or, more usually, on to a beam of somewhat similar dimensions to the loom beam. In this latter case, the**

sections are rewound on to the final loom beam in a beam-to-beam sizing operation. Reference to a form of section-warping, but using a slow-speed horizontal mill instead of a section beamer, has already been made in connection with warps prepared from hanks. However, the above indirect system is primarily suited to the preparation of continuous filament warps and will not therefore be referred to further in this paper.

### I.3 Weavers' warps, back beams, and beaming machine requirements

Weavers' warps requirements for each of the fabrics being considered are set out in the upper section of Table II.1. The middle section of this table gives corresponding back beam requirements on the assumption that this method of warp preparation is used for all fabrics, including the denim cloth (T1). In the latter case, the method of dyeing on the back beam (mentioned earlier) might be used. Alternatively, the processes of dyeing and sizing from back beams might be carried out in tandem. The lower section of the table deals with beaming machine operating times and requirements. Each section gives figures for both medium-scale and large-scale production levels. In the cases of the back beam and beaming machine requirements, figures are given for single day-shift, two-shift, and three-shift working.

For small-scale productions, assuming that the direct beaming method is used, the times for making back beams will be approximately proportional to the lengths which must be produced (at an establishment supplying sized weavers' warps on beam to a number of hand-loom weaving concerns).

The calculated machine requirements show that a beaming machine would be fully utilised on a single shift basis if total production is equal or exceed 2,000,000 meters per year. For example, for fabric P4, the yearly production must be 4,000,000 meters if a beaming machine were to be fully utilised on a one-shift basis.

**Table II.1**  
**Weavers' warps, back beams and beaming machine requirements**

<b>WEAVERS' WARPS REQUIREMENTS</b>					
<b>Cloth ref.</b>	<b>Warp yarn</b>	<b>Total warp threads in cloth 1 m wide (includes selvages)</b>	<b>Warp length on loom beams-length includes 10% allow. for crimp and waste</b>	<b>Loom warp requirements per year in relation to production levels</b>	
				<b>Medium-scale (1.0M m/yr)</b>	<b>Large-scale (5.0M m/yr)</b>
<b>No.</b>	<b>Tex</b>		<b>Metres</b>	<b>No.</b>	<b>No.</b>
P1	48	1.632	1.100	1.000	5.000

P2	24	2,652	1,650	667	3,334
P3	16	3,262	2,200	500	2,500
P4	12	3,776	2,750	400	2,000
T1	30	4,080	1,100	1,000	5,000
T2	30	2,040	1,980	556	2,778
T3	24	3,672	1,320	834	4,167
T4	30	2,856	1,540	715	3,572

### **WARPERS' BACK BEAMS REQUIREMENTS**

Cloth ref.	Ends per back bean and back beams per set to obtain total ends as in Col. 3 above		Warp length on each back beam	Number of loom beams obtained from 1 set of back beams	Back beam sets requirements per year in relation to production levels.	
	No.	Number of ends	Number of back beams	metres	No.	No.
					Medium-scale (1.0M m/yr)	Large-scale (5.0M m/yr)
P1	408	4	8,800	8	125	625
P2	442	6	16,500	10	67	334
P3	466	7	24,200	11	46	228
P4	472	8	33,000	12	34	167
T1	510	8	12,100	11	91	455
T2	510	4	11,880	6	93	463
T3	459	8	15,840	12	70	348
T4	476	6	13,860	9	80	397

### **BEAMING MACHINE PRODUCTION TIMES AND MACHINE REQUIREMENTS**

Cloth ref.	Time to warp one set of back beams	Total annual machine times to meet, required production scales (hours)		Beaming machine requirements in relation to total annual working hours and to required production scales. (Nos. of m/c)		
	hr.	Medium-scale	Large-scale	Day shift	Two-shifts	Three-shifts
No.						

		(1.0M m/yr)	(5.0M m/yr)	(3000 hr)		(5000 hr)		(7000 hr)	
				Med. 1 M	Large 5 M	Med. 1 M	Large 5 M	Med. 1 M	Large 5 M
P1	5.87	734	3,669	0.25	1.23	0.15	0.74	0.11	0.53
P2	16.50	1,106	5,511	0.37	1.84	0.23	1.11	0.16	0.79
P3	28.24	1,299	6,439	0.44	2.15	0.26	1.29	0.19	0.92
P4	44.0	1,496	7,348	0.50	2.45	0.30	1.47	0.22	1.05
T1	16.13	1,468	7,340	0.49	2.45	0.30	1.47	0.21	1.05
T2	7.94	739	3,676	0.25	1.23	0.15	0.74	0.11	0.53
T3	21.20	1,484	7,378	0.50	2.46	0.30	1.48	0.22	1.06
T4	13.90	1,112	5,519	0.37	1.84	0.23	1.11	0.16	0.79

### N.B. Assumed beam dimensions:-

**Back beams - 28 in diam. flange; 8 in diam barrel; 54 in between flanges**

**Loom beams - 26 in diam. flange; 6 in diam. barrel; 42 in between flanges**

### Note: Beaming calculations used in Table II.1

**The maximum warp length (cotton type yarns) which can be wound at medium pressure on to a flanged beam can be estimated from either of the following formulae:-**

#### (a) Imperial units

$$\text{Warp length (yards)} = \frac{9.504 \times \text{Beam width between flanges (in)} \times \text{counts (Ne)} \times (D^2 - d^2)}{\text{Total warp threads on beam}}$$

#### (b) Metric units

$$\text{Warp length (metres)} = \frac{313.18 \times \text{Beam width between flanges (cm)} \times (D^2 - d^2)}{\text{Total warp threads on beam} \times \text{yarn count (Tex)}}$$

in which: D = Outer diameter of wound beam -

) Units = inches in (a), and cm

) in (b)

)

d = Barrel diameter of beam

Tex = yarn weight in grams per kilometre

Ne = number of hanks of 840 yards per lb weight )  $Tex = \frac{590.54}{Ne}$

**Ends on weavers' beam = ends per back beam x back beams per set**

$$\text{Number of weavers' beams per set of back beams} = \frac{\text{Warp length on back beam}}{\text{Warp length on weavers' beam}}$$

$$\text{Beaming machine requirement} = \frac{\text{Total machine operation time to meet annual production}}{\text{Annual working hours}}$$

#### **I.4 Warp sizing**

**The subject of warp sizing is complex and is strictly outside the scope of this memorandum. However, the following should serve as some initial guidelines on this aspect of weaving.**

**For successful weaving of most cotton type fabrics, the warp threads require a protective coating of an adhesive film, referred to generally as a size paste. This coating enables the threads to withstand the abrasive action of weaving which largely take place during shedding (i.e. when the threads are drawn to-and-fro over or against the surfaces of parts such as heald eyes and reed dents, etc.) Without a coating of size, many threads - particularly of singles yarns - would quickly become seriously abraded and would break, thus making satisfactory weaving impossible.**

##### **(a) Size materials**

**Traditional size materials consist of an adhesive in the form of a natural or modified natural starch such as sago, maize, tapioca, farina, etc. The adhesive helps to bind the surface fibres together. It also helps to lay flat any projecting surface fibres or other protuberances which can cause obstructions during the crossing of the opposing warp sheets. However, adhesives of the kind mentioned above, if used alone, tend to increase the frictional forces as the threads rub against one another or against loom parts. To minimize these frictional forces, a natural fat, such as mutton tallow, is usually added to the size mixture. Alternatively, the lubricant may be applied separately as a surface coating to the thread (i.e. where it can have the most beneficial effect on friction). This latter matter is, however, more difficult to apply. The size is later removed from the woven cloth in the desizing and scouring processes which precede fabric bleaching, dyeing,**

**printing and finishing operations. Ease of removal is therefore an additional requirement of a good sizing paste. The latter factor, in combination with an aim of helping improve the ease of size preparation and application, has led to the development of numerous proprietary size adhesives and lubricants. However, some of these, even when successful, can be costly. In the United Kingdom, sago starch was the most common adhesive in use for many years. Recently, proprietary adhesives, many of which are synthetic products, are being used to a large extent. Some gains in productivity may be achieved with adequate technical expertise, thus offsetting the increased cost of the adhesives. However, for developing countries, the use of the most readily available low-cost adhesive, having reasonable sizing properties, could well be the more important factor.**

### **(b) Preparation of size paste**

**In preparing the size paste, the dry ingredients (if natural starches) are mixed with the lubricant in an appropriate known volume of water. The mix is then boiled in order to break down the starch granules to form a paste of reasonably stable viscosity, and which the dry yarns can readily take up in the sizing process. Different starches behave differently in these respects. For example, sago reaches a fairly stable viscosity after vigorous boiling for a period of about two hours while farina, which is very thick when first boiled, rapidly loses viscosity as boiling proceeds. Farina is, for this reason, more difficult to control. It is therefore important that great care is exercised in the preparation and application of size mixings. Otherwise, the warps can prove impossible to weave.**

**The graph in Fig. II.1, although hypothetical, typifies the relationship between the warp breakage rate (in weaving) and the percentage, by weight, of oven-dry ingredients in a sago and tallow size applied to a cotton warp. The points on the curve marked A and B indicate the approximate limits of the range of percentage size on yarn at which warp breaks are at a minimum. From the start of the curve at the left of the graph and up to point A, the breakage rate falls rapidly as the amount of size on yarn is increased. From point B and beyond to the right, the breakage rate starts to rise once more, largely as a consequence of protuberances along the threads becoming too stiff: these cause shedding obstructions between threads as the healds cross and re-open in shedding. The aim of good sizing is therefore to obtain a target amount of size on yarn somewhere within the range A - B. Unfortunately, there is no set formula which will guarantee an optimum sizing/weaving condition at a first attempt for any chosen size on any type of warp. Trial weaving experiments on short lengths of warp sized to provide a range of 'Known' percentage size conditions will probably constitute the best guide. However, Table II.2 provides empirical data which can be used to estimate the amounts of size on yarn required for best weaving when using sago as an adhesive and tallow as a lubricant on cotton (and also on spun viscose) warps of the kinds listed.**

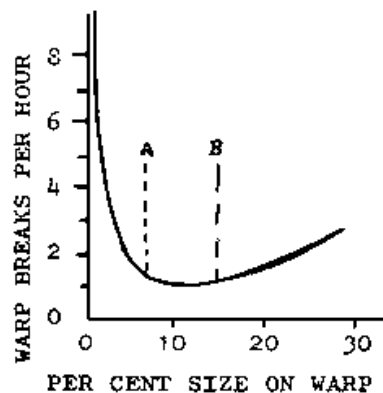

**Figure II.1 Relationship between warp breakage rate and per cent size on warp**

**Table II.2**  
**Estimated per cent size on yarn for good weaving**

Yarn count		Warp particulars Fibre	Warp ends per cm.	Approximate % size on yarn for good weaving
59 Tex	(10 Ne)	spun viscose	16	4
18.5 Tex	(32 Ne)	spun viscose	32	8 - 10
49 Tex	(12 Ne)	cotton	16	5
25 Tex	(24 Ne)	cotton	26	10
16.5 Tex	(36 Ne)	cotton	32	12
12 Tex	(50 Ne)	cotton	50	15

**Note:** The above percentages of size refer to weights of oven-dry solids on oven-dry yarn and apply to a sago/tallow mixture containing nominally 9% total dry solids, in a ratio of 10 parts sago to 1 part tallow, with 91% water after boiling the mix for a period of two hours to fully break down the starch and thus obtain a paste of stable viscosity. If other starches are used in place of sago, it will be necessary to vary the preparation in order to achieve a suitable viscosity paste. In this latter case, the target size percentage on yarn will generally be different from that indicated above. Precautions should be taken to ensure care and accuracy in the measurement of size ingredients and at all stages of preparation and application of the size paste.

### **(c) Sizing equipment**

**Equipment used for the sizing of warps of open-width sheet form, consists essentially of the following items:**

- **Weighing and measuring equipment for size ingredients.**
- **Size preparation equipment: becks or kettles in which the size is mixed with water and boiled as required.**
- **Creel for mounting the in-going warpers' back-beam or full-warp beams for beam-to-beam sizing.**
- **Size application box (sow box) with yarn immersion rollers, and squeeze rollers to effect size penetration into the yarn and to remove surplus size.**
- **Means for drying the sized warp: steam-heated cylinders around which the warp passes are in common use, but hot-air or infra-red dryers may also be used.**
- **Split-rod system for separating warp threads which have become stuck together with size.**
- **Headstock with winding gear for winding up the sized warp on to a loom beam.**

**Apart from open-width warp-sizing, part warps may be sized in rope form. Single thread sizing may also be carried out with the aid of special equipment such as the Miniplus equipment referred to earlier. Rope sizing is commonly used in the preparation of multi-colour warps whereby each colour requires a separate dyeing and sizing operation. The separate ropes are later combined in the required thread-colour order and wound onto a loom beam (see section on dry taping).**

**(d) Warp sizing, machine productivity and requirement**

**The following calculations are based on a machine of 166 cm working width, equipped with 5 drying cylinders, and which has a total drying capacity of 350 kg per running hour:**

- **Nominal practical running speed: 50 metres/minute**
- **Mean running speed at 35% overall efficiency: 17.5 m./min.**
- **Machine output per hour:  $17.5 \times 60 = 1050$  metres.**
- **Times to size annual warp requirements:**



$$\text{Small- scale: } 100,000 \text{ m.fabric} = \frac{110,000 \text{ m.warp}}{1050 \text{ m/hr}} = 104.8 \text{ hr}$$

$$\text{Medium- scale: } 1,000,000 \text{ m.fabric} = \frac{1,100,000 \text{ m.warp}}{1050 \text{ m/hr}} = 1048 \text{ hr}$$

$$\text{Large- scale: } 5,000,000 \text{ m.fabric} = \frac{5,000,000 \text{ m.warp}}{1050 \text{ m/hr}} = 5238 \text{ hr}$$

**Table II.3 shows that full capacity utilisation of a sizing machine occurs only in the case of large-scale production when it is operated on a one-shift or two-shift basis. The production per machine could also be increased if machines with a higher drying capacity (e.g. one with seven or nine cylinders) were used. The problem of machine break-down and availability of spares must, however, be kept in mind since production would cease if the only machine available were stopped for any long period of time for repairs,**

**Table II.3**

**Sizing machine requirement in relation to total annual working hours and to annual sized warp requirement**

<b>Day shift only (3,000 hr/yr)</b>		<b>Two shifts (5,000 hr/yr)</b>		<b>Three shifts (7,000 hr/yr)</b>	
Small scale	Medium scale	Large scale	Medium scale	Large scale	Medium scale
0.035	0.35	1.75	0.21	1.05	0.15
					0.75

## **II. Production of pirns**

**When weft yarn is not on a package of suitable form to be placed directly onto the loom shuttle (i.e. when it is on ring bales, cheeses, cones, or in hank form) it is necessary to rewind it on to pirn tubes of appropriate size.**

**Apart from overcoming the problem of initial package form, weft should be cleared, during winding, of any abnormally thick or thin places which could cause trouble during weaving or which might detract from the final appearance of the fabric. A simple mechanical yarn clearer should suffice for removing slubs in threads of non acceptable sizes.**

**Modern pirn-winders are generally complex precision machines which are outside the manufacturing capabilities of local semi-skilled labour in developing countries. No production diagrams are therefore**

**included in this memorandum.**

**The maximum diameter and length of pirns suitable for any particular type of loom depends on the size of the shuttle and of shuttle lining. Most pirning machines incorporate means for adjusting the diameter and the length of the pirns which are wound as well as the spindle speed which controls the rate of winding. The ranges over which these settings can be altered is generally stated in the manufacturer's technical handbook. Given the spindle speed, and knowing the diameter of the empty pirn-tube and that of the wound pirn, the effective mean package diameter and the yarn speed in winding can be calculated. On the basis of this information, it is possible to estimate the number of pirn-winding spindles required to meet a given weaving production target. The method and the spindle requirements for the eight fabrics (P1) - (P4) and (T1) - (T4) are set out below.**

- Assumed full-pirn diameter 'A' = 30 mm
- Assumed empty pirn-tube diameter 'B' = 15 mm
- Assumed machine spindle speed = 10,000 rev/min
- Yarn speed at 10,000 rev/min =  $\frac{(A+B)(\pi(10,000))}{2 \times 1000}$   
= 45 x 3.142 x 5  
= 707 metres/min
- Yarn length wound per hour at 80% efficiency (metres) = 707 x 60 x 0.8  
= 33,936 metres
- Annual weft-length requirement for cloth of 1 metre width (metres) = picks/metre + 10% (crimp and waste allowance) x annual cloth-length requirement
- Annual pirning time requirement (hr) =  $\frac{\text{Annual weft-length req.}}{33,936}$
- Number of pirning spindle required =  $\frac{\text{Annual pirning time req.}}{\dots}$

**Tables II.4 and II.5 provide, respectively, the annual weft-length requirements in relation to scale of production and the numbers of pirning spindles required in relation to both production scale and annual working hours. Table II.5 shows that the maximum number of pirning spindles do not exceed 4 for small-scale units, 40 for medium-scale units, and 200 for large-scale units. The estimated number of pirning spindles do not take into consideration spindles out of action for any reason, including repairs.**

**Table II.4**

**Annual weft-length requirements in relation to scale of production (Units = Million, metres)**

<b>Cloth Ref No.</b>	<b>Small-scale prod.</b>	<b>Medium-scale prod.</b>	<b>Large-scale prod.</b>
P1	176	1760	8800
P2	286	2860	14300
P3	352	3520	17600
P4	407	4070	20350
T1	264	2640	13200
T2	198	1980	9900
T3	264	2640	13200
T4	264	2640	13200

**Table II.5**

**Numbers of pirning spindles required in relation to scale of production and to annual working hours**

<b>Cloth Ref No.</b>	<b>Annual working hours</b>	<b>Production level</b>		
		<b>Small scale</b>	<b>Medium scale</b>	<b>Large scale</b>
P1	3000	2	18	87
	5000	2	11	52
	7000	1	8	38
P2	3000	3	29	141
	5000	2	17	85
	7000	2	13	61

P3	3000	4	35	173
	5000	3	21	104
	7000	2	15	75
P4	3000	4	40	200
	5000	3	21	120
	7000	2	18	86
T1	3000	3	26	130
	5000	2	16	78
	7000	2	12	56
T2	3000	2	20	98
	5000	2	12	59
	7000	1	9	42
T3	3000	3	26	130
	5000	2	16	78
	7000	2	12	56
T4	3000	3	26	130
	5000	2	16	78
	7000	2	12	56



[Home](#) > [ar.cn.de.en.es.fr.id.it.ph.po.ru.sw](#)

**Small-Scale Weaving (ILO - WEP, 1983, 144 p.)**

**CHAPTER III. WEAVING TECHNOLOGIES**







**I. Weaving fundamentals**

**II. Loom types in relation to scale of production**

**III. Hand looms**

**IV. Non-automatic power looms**



-  **V. Automatic power looms**
-  **VI. Shuttleless looms**
-  **VII. Ancillary equipment**
-  **VIII. Yarn requirements**
-  **IX. Product quality**
-  **X. Factory space requirements and layout**

**Small-Scale Weaving (ILO - WEP, 1983, 144 p.)**

## **CHAPTER III. WEAVING TECHNOLOGIES**

### **I. Weaving fundamentals**

**The classical method of weaving is essentially the insertion of a continuous length of weft-yarn from a shuttle which traverses to-and-fro across the warp sheet in the loom and leaves behind a trail of weft (pick) at each passage. Weaving involves three primary actions and two secondary ones These are briefly described below.**

#### **I.1 Primary actions**

**The three primary actions are: shedding, picking and beating up. They must be performed in strict rotation in all looms.**

##### **- Shedding**

**To form any weave structure, all warp threads under which a particular pick has to lie in the ultimate cloth are raised during the shuttle passage while all threads which the same pick has to pass over, are lowered. Thus, for each pick inserted, the individual warp threads are raised or lowered as dictated by the weave plan. The action of raising and lowering the warp threads in this way is known as "shedding" while the sheet opening so formed is called the "shed".**

##### **- Picking**

**The action of passing the shuttle through the shed is called picking.**

##### **- Beating-up**

**Finally, after the insertion of each pick, the pick of weft itself has to be pushed forward by a 'reed' (a type of closed comb through which all of the warp threads are drawn) to a point adjacent to the previous pick, known as the 'fell', where cloth is thus formed. This third action is called 'beating-up'.**

## **I.2 Secondary actions**

**In addition to the primary actions, two secondary actions are necessary. However, the instant at which they are performed is at the discretion of the weaver in the case of simple hand-looms. On the other hand, strict control and timing in relation to primary motions is required for power looms.**

### **- Taking up**

**This action involves the 'taking-up' of woven cloth as weaving proceeds so that the fell is maintained in the same position.**

### **- Letting-off**

**This action involves the 'letting-off' of further warp from a beam at the back of the loom to replace that woven into cloth.**

## **I.3 Woven structures**

**In the most simple form of woven structures, known as 'plain weave' (see Figure III.1(a)), a pick of weft passes under and over alternate warp ends from selvedge to selvedge. The next pick does the same, but in the reverse lifting order. Thus, a plain weave repeats on two ends and two picks. Simple variations in the order in which the ends and picks interlace produce numerous weaves which are known widely by names such as twills (Fig. III.1(b)), satin, matt-weaves, etc. The majority of such weaves can be elaborated and extended so that they repeat on many ends and picks, but there is often little to be gained in cloth strength or utility. However, they are used in cases where fancy weave effects are required. Consequently, the great majority of woven fabrics consist of the smallest repeat corresponding to the basic weave so that all can be woven on looms equipped with either simple (treadle operated) or mechanised (cam-operated) shedding motions.**

## **I.4 Basic loom elements**

**A simple frame hand-loom is illustrated in Figure III.2, while Figure III.3 shows the corresponding loom elements at the time of weft insertion. A similar side-view of a power-loom is shown in Figure III.4.**

**Figure III.1**  
**Woven structures**

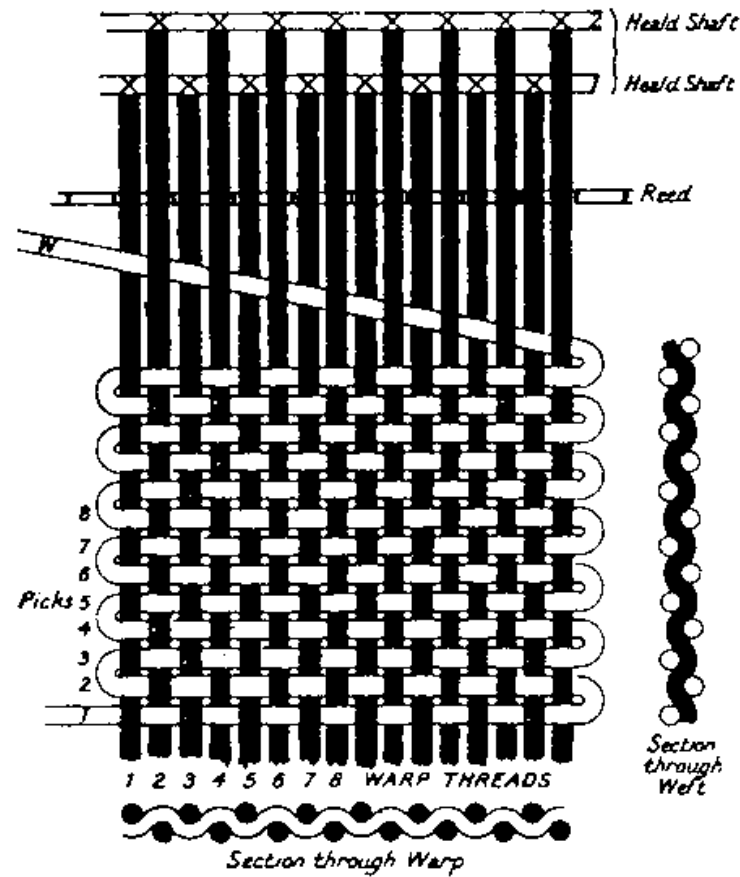

**(a) Plain weave**

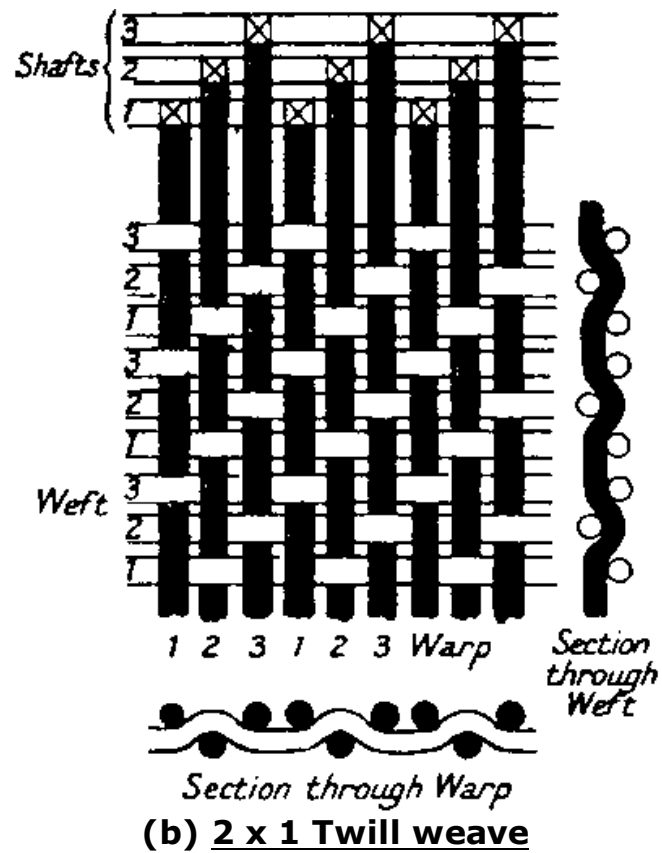

**(b) 2 x 1 Twill weave**



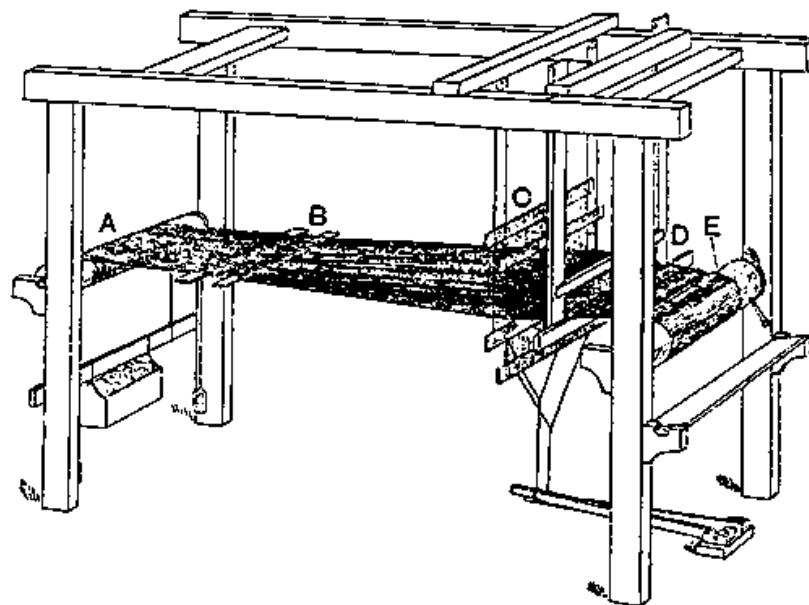

**Fig. III.2 Simple frame loom**

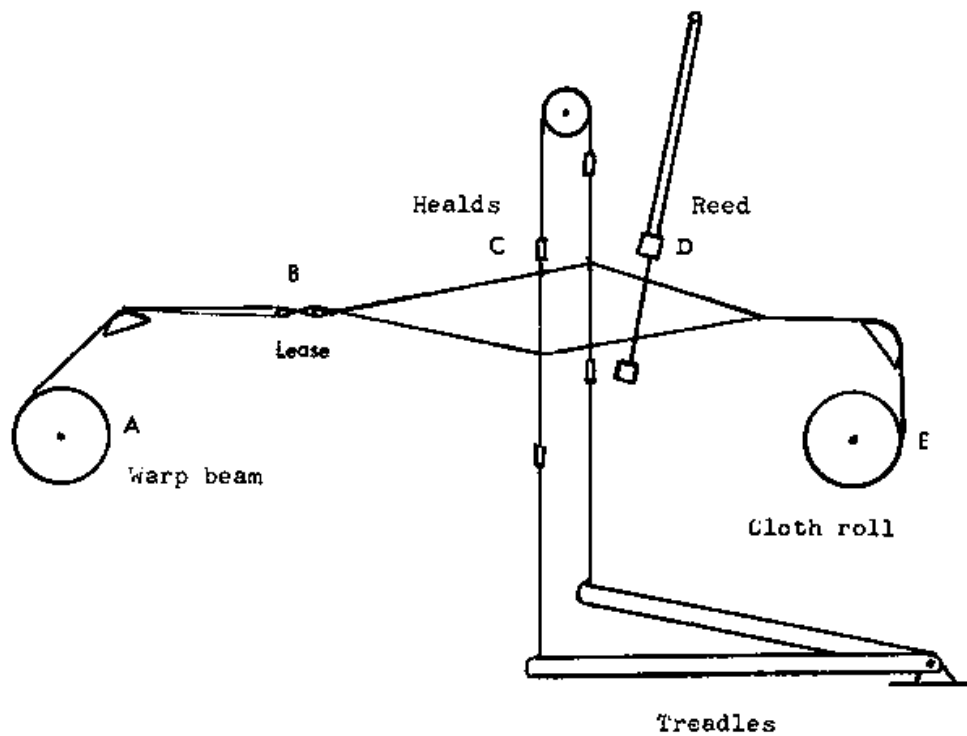

### Fig. III.3 Loom elements at time of weft insertion

The loom-members which raise and lower the warp threads in simple weaves are known as 'healds'. Each warp end is drawn through an 'eye' in its own heald, but all healds which are required to lift and fall in the exact same sequence throughout the weave repeat are often mounted on a single stave so that all are moved in unison. Thus, as many heald staves are required as there are different sequences of warp liftings and lowerings in the repeat. Thus, for plain weaves, a minimum of two staves are required, although in practice four staves are often used: two lifting and lowering as if they were one so as to avoid overcrowding of the heads on a single stave. A 3 x 1 twill, often used for denim cloth, requires 4 heald staves, as also does the very common 2 x 2 twill. On the other hand, 5 staves are necessary for weaving the smallest repeat of a true satin weave. Healds and reeds have limited life spans, and have to be replaced usually from specialist makers.

## II. Loom types in relation to scale of production

This section analyses the choice of loom types in relation to the adopted scale of production. Detailed descriptions of the looms are presented in the next section.

Hand-loom with a fly shuttle, and in particular, those with treadle-power operation facilities, could meet small-scale production requirements of the fabrics considered in this memorandum. This, however, assumes that adequate means of mechanical warp preparation are available.

Power-loom of either non automatic or automatic types can be used for the three scales of production defined in Chapter I (respectively 100,000 m, 1,000,000 m and 5,000,000 m). However, in view of their high production capabilities, they would be fairly under-utilised at the single-day shift small-scale production level. On the other hand, a two-shift per day small-scale production level is likely to be more viable.

Details of the number of looms of the different kinds considered to meet each of the three levels of production are given in Table III.1

**Table III.1**  
**Loom Requirements**

Cloth Ref No.	TYPE OF LOOM				CONDITIONS			Number of looms required		
	Hand-	Treadle-	Non-	Auto-nirn -	Loom	Loom	Annual	Day-	Two-	Three-

	<b>Hand-loom with fly-shuttle</b>	<b>Heald-loom with fly-shuttle</b>	<b>Non-Auto. shuttle loom</b>	<b>Auto-pick change shuttle loom</b>	<b>LOOM Speed picks/min</b>	<b>LOOM running-efficiency %</b>	<b>Annual production L, M or H</b>	<b>Day-shift only 3000 hr/yr</b>	<b>Two-shift working 5000 hr/yr</b>	<b>Three-shift working 7000 hr/yr</b>
P1	X				40	50	L	45	27	
		X			80	75	L	15	9	
			X		180	85	L	6	4	
				X	180	92	L	6	4	
			X		180	85	M	59	35	25
				X	180	92	M	54	33	23
			X		180	85	H	291	175	125
				X	180	92	H	269	161	115
P2	X				40	50	L	73	44	
		X			80	75	L	25	15	
			X		180	85	L	10	6	
				X	180	92	L	9	6	
			X		180	85	M	95	57	41
				X	180	92	M	88	53	38
			X		180	85	H	472	284	204
				X	180	92	H	437	262	187
P3	X				40	50	L	89	54	
		X			80	75	L	30	18	
			X		180	85	L	12	7	
				X	180	92	L	11	7	
			X		180	85	M	117	70	50
				X	180	92	M	108	65	46
			X		180	85	H	582	349	249
				X	180	92	H	537	323	231

P4	X				4U	5U	L	10J	6Z	
		X			80	75	L	35	21	
			X		180	85	L	14	9	
				X	180	92	L	13	8	
			X		180	85	M	135	81	58
				X	180	92	M	125	75	54
			X		180	85	H	672	404	288
				X	180	92	H	621	373	267
T1, T3,	X				40	50	L	67	40	
T4		X			80	75	L	23	14	
			X		180	85	L	9	6	
				X	180	92	L	9	5	
			X		180	85	M	88	53	38
				X	180	92	M	81	49	35
			X		180	85	H	436	262	187
				X	180	92	H	403	242	173
T2	X				40	50	L	50	30	
		X			80	75	L	30	10	
			X		180	85	L	7	4	3
				X	180	92	L	7	4	3
			X		180	85	M	66	40	28
				X	180	92	M	61	37	26
			X		180	85	H	327	197	141
				X	180	92	H	302	182	130

### III. Hand looms

**The terms 'hand-loom' and 'hand-woven' have different connotations. It is therefore necessary to define hand-loom more precisely and, in doing so, place them in three different categories. These categories are:**

**(i) Looms in which the primary and secondary motions are co-ordinated manually, and in which picking is performed without a 'fly-shuttle';**

**(ii) Looms in which the primary and secondary motions are co-ordinated manually, but in which picking is performed with a fly-shuttle;**

**(iii) Looms in which both primary and secondary motions are co-ordinated mechanically, and which include a fly-shuttle mechanism which is also operated mechanically. Looms of this type can usually be power-driven if fitted with a motor, although when classed as a hand-loom they are driven by human power acting via a treadle system.**

#### **(a) Category (i) hand-loom**

**Looms in category (i) are quite unsuitable for bulk production of the fabrics listed in Table I.1, even at the 'small-scale' level of 100,000 metres per annum. Picking speeds are much too low, being often less than 10 picks/min and, consequently, labour and other costs - such as those for factory accommodation and for work in hand - would be too high to make it worthwhile. No further consideration to these looms has therefore been given.**

#### **(b) Category (ii) hand-loom**

**More promising could be the use of looms in category (ii) but only for the 'small-scale' level of production. This category of loom can meet the production target if weaving speeds of around 40 picks/min can be maintained. However, only skilled weavers can be expected to perform at this level. Furthermore, good warp and weft preparation, as outlined in Chapter II, would be necessary.**

#### **(c) Category (iii) hand-loom**

**Looms in category (iii) could certainly meet small-scale production levels, since they can be operated at appreciably higher speeds (e.g. 80 picks/min). However, the maintenance of such a speed over a long period of time is dependent on the weaver's skills and the quality of warp and weft preparation. In addition, the amount of physical energy expended in weaving, in unfavourable climatic conditions, must certainly not be overlooked if this option is to be seriously considered.**

### **III.1 Economics of hand-loom**

**Estimates of the numbers of looms which would be required to weave each of the fabrics considered are**

**provided in Table III.1. These estimates are based on a loom running efficiency of 50% for category (ii) looms and 75% for category (iii) looms. It must be stressed that these values are estimates since they are based on assumed running efficiencies.**

**While category (iii) looms are more efficient, they are also much more costly than category (ii) looms. Some unconfirmed reports suggest the costs to be greater by a factor of 10.**

**More recently, a loom similar to category (iii) looms has been developed in Nepal. However, it does not have mechanical take-up and warp let-off facilities, but may be available at a lower comparative cost. If this information is correct, such a loom would be expected to be intermediate in running efficiency, and the number required for each cloth type would be roughly mid-way between those quoted for categories (ii) and (iii) looms.**

### **III.2 Suitability of hand-looms for selected fabrics**

**Of the eight selected fabrics, five may be woven on well-maintained hand-looms of categories (ii) and (iii). The sheetings (P1) and (T2) and the denim (T1) may not be easily woven on such looms, but may also be woven on similar looms provided that the cloths are not too wide: cloths with a maximum width of 125 cm (50 in.). There is no theoretical reason why denim fabric (or any other similar coloured-warp fabric) should not also be woven on hand-looms. The difficulties arise in relation to yarn dyeing and warp preparation: it is doubtful that these operations can be carried out economically for 'small-scale' weaving of the kind envisaged. It must also be remembered that weavers' warps of sufficient length to produce at least 100 metres of fabric would be necessary for producing the cloths at small-scale levels of production.**

### **III.3 Technical aspects of hand-looms**

**For the purpose of this memorandum, hand-looms are broadly defined as those in which the primary driving energy is supplied by human power. The use of this rather wide definition enables the inclusion of looms in which a fly-shuttle is used and also those in which the three primary motions of shedding, picking and beating-up are linked together by mechanical means. Furthermore, it includes looms which not only incorporate the above additional features, but which also have mechanical means for the controlled/synchronised take-up of the woven cloth (by change-wheel gear train) and a negative (friction-band type) warp let-off motion. Clearly, a loom which contains all of these features would only require a motor-drive in order to be converted into a power-loom. This, of course, assumes that the loom framework and shaft bearings are adequate to withstand any additional loadings applied by the motor drive.**

### **(a) Category (i) and (ii) hand-looms**

**Statistics for hand-weaving rarely, if ever, state the type of loom in use or even the manner in which the weft is inserted. This lack of information seriously limits the general usefulness of any such data. It is however almost certain that, on a worldwide basis, the number of hand-thrown shuttle looms (category (i)) far exceeds that of fly-shuttle looms (category (ii) and (iii)), notwithstanding those of modern origin advertised for craft-weaving purposes. Nevertheless, available information indicates that when the weft is inserted by hand-thrown shuttle in the weaving of cotton-type fabrics of nominally 1 metre width, picking speeds are most unlikely to exceed 20 picks/min and, more usually, are appreciably less than this. Weaving similar cloths on looms with a fly-shuttle, but without any of the other mechanical aids mentioned, could enable the weaver, if sufficiently skilled, to operate at speeds of up to 40 picks/min.**

### **(b) Category (iii) hand-looms**

**In the case of looms in which the primary motions are coordinated mechanically, and which have a fly-shuttle but no continuous take-up and let-off systems, a relatively high picking rate may be achieved. This would be more so the case if some simple means to enable the weaver to operate the warp let-off from the front of the loom are incorporated. Furthermore, if the take-up and let-off are mechanically linked to the primary motions, the loom can then be foot-pedal operated. These features, if incorporated in a loom of improved structure and with good bearings, enable the loom to be operated at speeds which are claimed to be in excess of 80 picks/min. For how long at a time such speeds can be maintained in unfavourable climatic conditions is, however, a point not widely reported. Looms in this latter category are available, but some are known to be costly.**

### **III.4 Hand-looms types and weaver skill**

**In terms of weaver skill, the manually coordinated hand-thrown shuttle loom demands the highest level of dexterity. Consequently, such skills may be expected to take longer to attain than those required for weaving on 'semi-automatic' hand-looms. This can be an advantage in favour of the latter looms in two respects, in addition to the higher productivity achieved by "semi-automatic" looms. Firstly, a weaver can be trained in a shorter period of time; secondly, the semiautomatic loom should enable the weaver to direct more attention to the quality of the fabric being woven. Consequently, fewer weaving faults should be made than is usual in the fully hand-woven fabric.**

### **IV. Non-automatic power looms**

**The non-automatic shuttle loom (see Fig. III.4) is highly appropriate for large-volume and low-cost production textiles in low-wage countries. The term "non-automatic" can be misleading in that all power looms are completely automatic with regard to the basic weaving functions. A non-automatic power loom is "non-automatic" in the sense that, when the weft supply package in the shuttle becomes exhausted, it must be replaced manually.**

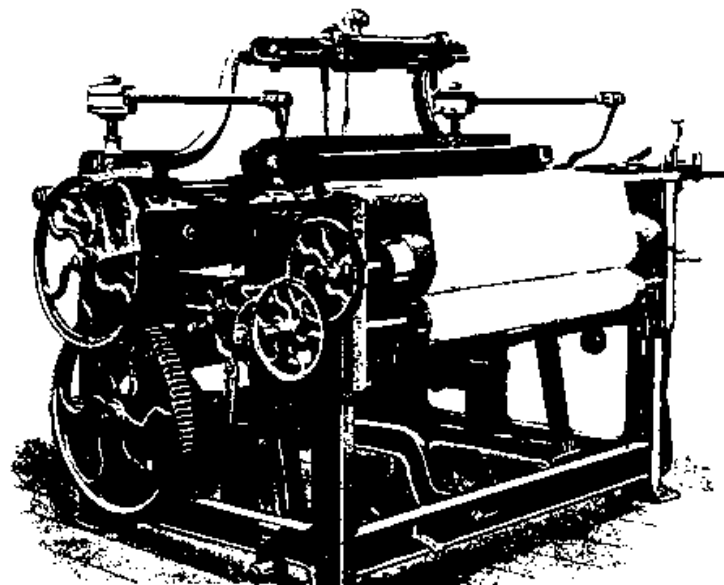

**Figure III.4 Lancashire type, non automatic over-pick loom**

**Very few non-automatic power looms have been manufactured and marketed during the past ten years, and very few machinery makers now list them in their catalogues. There are however, no doubt, many machinery makers who would be very pleased to resume the manufacture of low-cost non-automatic power looms if they were in demand. In many cases, the looms offered would be essentially automatic looms stripped of the automatic weft replenishment features. There is currently a large number of looms which were built as automatic looms but which are being operated, quite efficiently, as non-automatic ones in the less-developed countries. Most of them are of the shuttle-change type. Their conversion to non-automatic looms is done for economic reasons as the cost of manual weft replenishment is lower than the combined cost of (i) maintenance of the mechanism for automatic shuttle changing and (ii) expenditure on the much greater number of shuttles needed when automatic changing is practised. Large numbers of looms of this type, mostly of Japanese manufacture (e.g. Toyota, Tsudacoma, Sakamoto) could be economically reconditioned and used in this way. There are also very large numbers of looms of the classic Lancashire non-automatic type made by such British makers as Butterworth and Dickinson, Hattersley, and Liveseys. These are no**



**longer in use in the large Asian mills but could be renovated, at reasonable cost.**

#### **IV.1 Technical aspects of non-automatic power-looms**

**Non-automatic power loom have become widely known as Lancashire looms in view of the world-wide reputation of cotton spinning and weaving in Lancashire. Although superficial differences exist in Lancashire looms of different makes, all of them (and indeed all subsequent shuttle looms) have employed the same basic elements which are found in the simple hand-operated frame looms described earlier. A brief technical description of non-automatic power looms is provided below.**

##### **(a) Shaft System**

**The actuation of the elements of non-automatic power looms depends upon two shafts; a 'top-shaft' (crank shaft) which receives the primary motive power and which, through a pair of gears, drives a lower or 'bottom shaft' at exactly half-speed of the top shaft. The arrangement is illustrated diagrammatically in Fig. III.5. In this figure, X is the top shaft and Y the bottom shaft; other loom parts are identifiable from the key below the diagram. It will be noticed, by a comparison with the frame loom, that the actuating means have been slightly modified for the purpose of power operation, the sley being now pivoted from below instead of above, and the threadles used for raising and lowering the healds have been turned around to bring their pivots below the warp beam.**

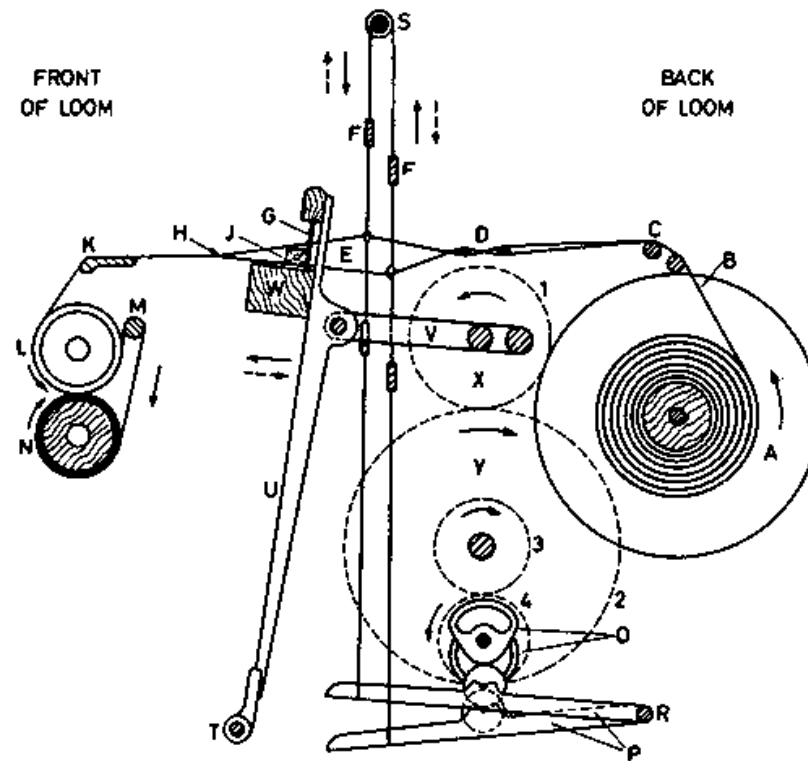

**Figure III.5 Sectional diagram of a power-loom for the weaving of plain cloth**

- A. weaver's beam or loom beam**
- B. warp threads (ends, sheet form)**
- C. back rest or bearer**
- D. lease rods**
- E. "shed"**
- F. healds**
- G. reed**
- H. fell of cloth or beat-up point**
- J. shuttle**
- K. breast beam**
- L. cloth take-up roller**
- M. tug bar**
- N. cloth roller**
- O. tappets**

- P. tappet treadles, with anti-friction bowls**
- R. treadle fulcrum**
- S. roller-top, heald reversing motion**
- T. rocking rail, or shaft**
- U. sley sword**
- V. crank arm**
- W. sley**
- X. top shaft**
  
- Y. bottom shaft**

**The function of the top shaft is to rock the sley to and for through a crank and connecting rod mechanism. The bottom shaft has two functions. Firstly, it operates the treadles by means of diametrically opposed cams (tappets) in order to raise and lower the healds alternately for the production of plain-weave fabric (the arrangement for other simple weaves is dealt with later). Secondly, the bottom shaft actuates the picking mechanism which propel the shuttle through the warp shed from the left and right sides of the loom alternately. This simple two shaft arrangement ensures precise and consistent mutual coordination of the three basic motions of weaving (i.e. shedding, picking and beating up).**

### **(b) Sley**

**The sley, a substantial timber batten, oscillates immediately below the lower warp sheet in the front shedding zone (i.e. the region between the healds and the fell). It is carried on metal 'sley swords' which, in turn, are secured to a 'rocking rail' which spans the loom close to the floor line, at the front below the fell. The reed rests in a groove, in the sley top, and is secured by a heavy cap. The upper surface of the sley, known as the 'race board', supports the shuttle as it travels through the shed (see diagram). There is a shuttle box at either end of the sley, the shuttle being projected from one box to the other at each pick.**

### **(c) Shuttle**

**The shuttle is generally made from hardwood and is typically between 30 and 40 cm long. It has a pointed steel tip at either end. The weft yarn is in the form of a pirn (or sometimes a mule-cop), a long slim package wound in such a way that the yarn can be withdrawn substantially axially from one end without the package itself being rotated. The pirn is always as large as can be accommodated within the hollow shuttle, and typically contains from 30 to 60 grammes of yarn.**

**The same basic principle of shuttle propulsion, as in the hand-operated fly-shuttle loom, is used in the power loom. However, the picker is, in this case, propelled either by a strap connected to an upper swinging arm (picking stick) or, directly, by the top end of the picking stick which moves along a slot in the base of the shuttle box. Although the use of wood and leather components in this sort of mechanism appears to be anachronistic today, it is worth noting that for more than a century loom-makers have been unsuccessful in their efforts to devise picking mechanisms which do not require the use of such materials. The most highly developed shuttle-looms available today use wooden picking sticks and leather or fabric check bands in connection with shuttle projection.**

#### **(d) Picking**

**A pair of picking cams constitute the mechanical means by which picking is effected. Each element of the pair is usually secured on the bottom shaft on either side of the loom. Apart from looms used for the production of particularly heavy fabrics (with which this memorandum is not concerned), such as corduroy, there are two principal forms of picking mechanisms fitted to non-automatic looms. The first of these, called the cone-overpick motion, is illustrated diagrammatically in Fig. III.6. A shuttle-box for the overpick motion is illustrated separately in Fig. III.7. The second mechanism is called the side lever underpick motion. It is illustrated in Fig. III.8. Keys below each diagram identify the main components.**

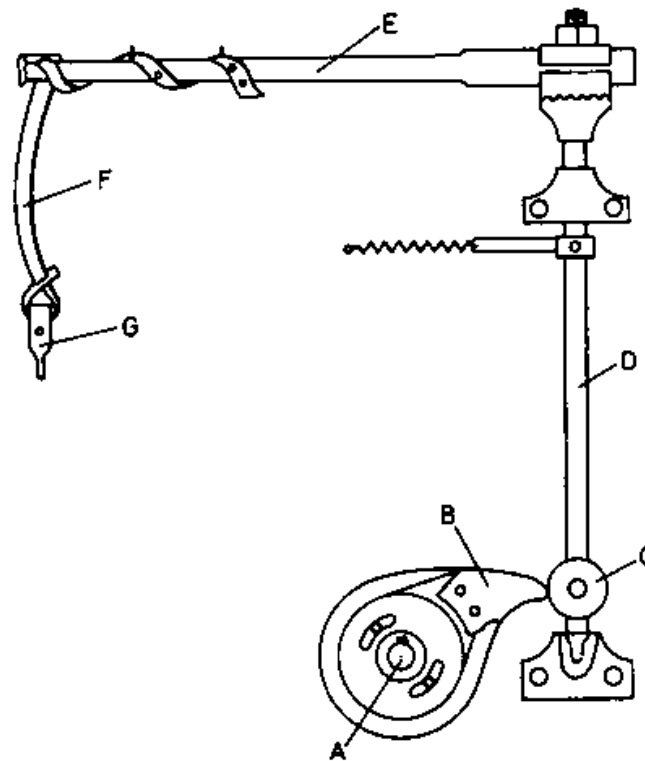

**Fig. III.6 Cone 'over-pick' motion**

- A - Loom bottom shaft**
- B - Picking cam**
- C - Picking cone**
- D - Picking shaft**
- E - Picking stick**
- F - Picking band**
- G - Picker**

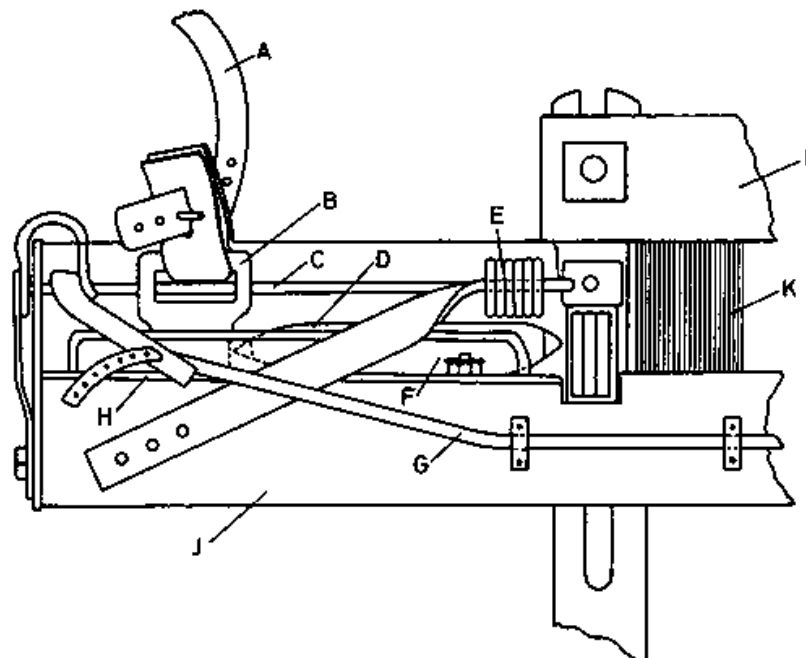

**Fig. III.7 Shuttle box 'over-pick' loom**

- A - Picking band**
- B - Picker**
- C - Picker spindle**
- D - Shuttle**
- E - Picker buffer**
- F - Box fender (front)**
- G - Check strap**
- H - Box plate**
- J - Sley**
- K - Reed**
- L - Sley cap**

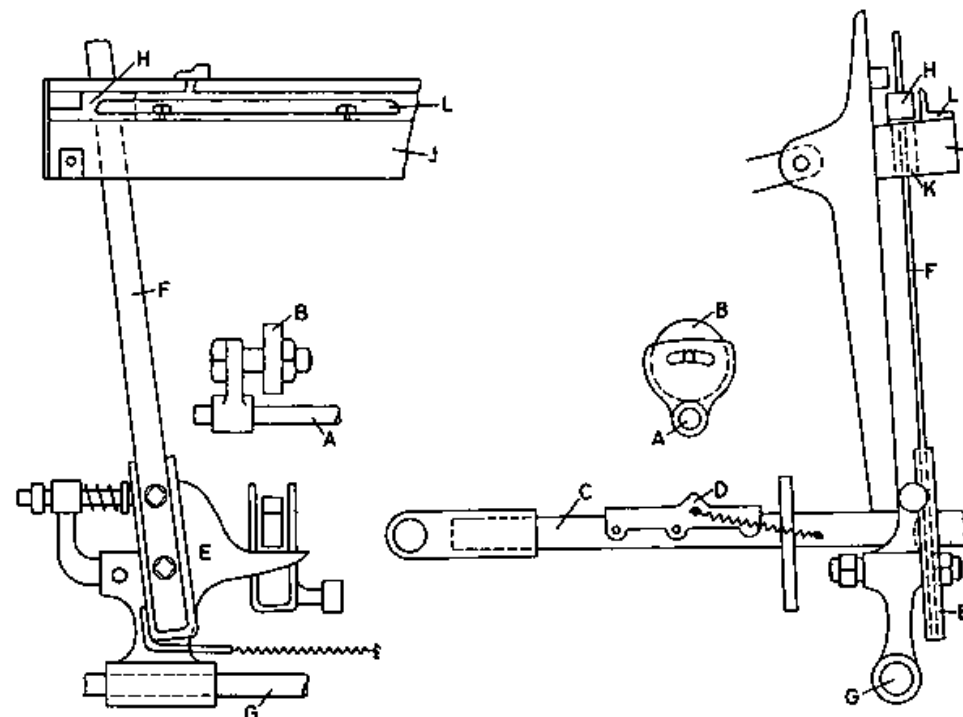

**Fig. III.8 Under-pick motion, side lever type**

- A - Loom bottom shaft**
- B - Picking bowl**
- C - Side lever**
- D - Picking plate**
- E - Picking shoe**
- F - Picking stick**
- G - Rocking shaft (rail)**
- H - Picker**
- J - Sley**
- K - Slot in sley**
- L - Box front (fender)**

The principal difference between the two picking motions is indicated by their names. In the overpick motion, the picking sticks are in the form of swinging horizontal arms located above the shuttle boxes. The corresponding pickers are connected to the sticks by leather straps. In the under-pick motion, the picking sticks, which are mounted vertically below the shuttle boxes, are secured on extensions of the rocking-rail.

**The sley-swords are secured and pivot on the picking sticks. The upper ends of the latter project through longitudinal slots cut in the sley and in the base plates of the shuttle boxes. The pickers are themselves slotted so as to fit over the upper ends of the picking sticks. Each picker slides along its box plate when delivering a pick as the top end of the picking stick is being moved sharply inwards in the direction of intended shuttle motion. It will be apparent, from the diagrams, that the shuttle-box fitments for the over-pick motion are much more complicated than those for the under-pick motion. Consequently, the settings and adjustments of the individual parts require much more attention.**

**Generally, cone-overpick motions are used for fabrics of light to medium weight and underpick motions for medium and heavy fabrics.**

**When non-automatic looms were more widely used in the UK, many loom overlookers were of the opinion that, when correctly maintained and adjusted, overpick motions should give a smoother picking action, with less wear of components, than would underpick motions. Nevertheless, new developments led to the automatic shuttle loom which is mainly based on underpick motions of improved design. The parallel action cone-underpick motion is an example of a more recently developed picking mechanism in use on various makes of automatic looms.**

### **(e) Boxing**

**An ever-present danger with all shuttle looms is that, due either to the projection velocity being too low or to undue interference from warp or weft yarns, the shuttle may fail to complete its journey and be safely 'boxed' before beating up begins. It is therefore usual to provide protection against this appening in order to avoid considerable damage to both the warp and reed. Therefore, one or the other of two warp protection systems constitute standard devices of the Lancashire looms. These devices are referred to as fast-reed and loose-reed systems, and the looms to which they are fitted are correspondingly called fast-reed and loose-reed looms. The former are used for fabrics covering a wide range of weights from light to heavy while the latter are suitable for only relatively light-weight materials.**

**In the fast-reed loom, a spring-loaded finger carried by the sley enter in abrupt contact with a step in a metal block-called the 'frog' - as the sley approaches the beat-up position should the shuttle fail to enter the receiving box. The striking of the frog by the finger causes instantaneous disengagement of the loom starting handle and the simultaneous application of the loom brake.**

**In the loose-reed loom, beat up is permitted to partially take place but the reed, which is only lightly held in position by means of a spring, is pushed backwards by the trapped shuttle. The force of impact between**



**shuttle and warp at the fell is thus greatly diminished. As in the fast-reed loom, the starting handle is disengaged and the loom brake applied when a shuttle trap occurs. Loose-reed looms are designed to run at higher speeds than fast-reed looms, and are of lighter construction. Fast-reed looms have a more rigid and heavier framework which is capable of withstanding the considerable shock associated with a 'bang-off'.**

#### **(f) Weft-fork detector system**

**Normally, the weaver stops a non-automatic loom just before the weft in the shuttle is exhausted. If the weaver fails to do so and the pirn empties, the absence of weft is usually detected by a 'weft-fork' detector system. The sensor consists of a metal fork-shaped member which is lightly pivoted so that it is tripped by the weft trail which extends from the fell to the shuttle in the receiving shuttle box. Absence of a weft trail fails to trip the fork at the appropriate instant in the loom cycle and results in the disengagement of the starting handle and the stoppage of the loom. Weft-fork motions are positioned on the starting handle side in most Lancashire looms, and thus only sense the weft on alternate picks. In looms of more recent design, they are usually located in the centre of the race board, and thus sense the weft on every pick.**

#### **(g) Gear-train system**

**The required number of picks per inch (or per centimetre) is obtained by fitting a change gear with the appropriate number of teeth in a train of gears which drives the cloth take-up roller. Movement of the train is initiated by a pawl and ratchet arrangement, which is activated from the sley and is usually timed to operate close to beat-up. Two common take up gear train systems are used on Lancashire looms: one is referred to as the 'five-wheel' motion and the other as the 'pickles' or 'seven-wheel' motion. Both motions are suitable for the types of cloth covered by this memorandum, but the pickles motion has one particular advantage: the number of teeth in the change-wheel is equal, or very close, to the actual number of picks per inch inserted, whereas with the five-wheel system, the larger the number of picks required in the cloth the smaller the number of teeth required in the wheel. Thus, the latter involves some calculations or reference to a table of pre-calculated values (which can lead to error): otherwise, both systems work satisfactorily.**

#### **(h) Let-off motions**

**The warp sheet must be maintained at a reasonably uniform tension from start to end of the loom beam at a level which permits let-off of new warp as cloth is woven and taken-up. On a simple Lancashire loom, this function is effected by applying a friction drag to the beam by means of a lubricated chain wrapped around the beam ruffle. The chain is attached to the loom frame at one end and to a weighted lever system at the other end. The weight position on the lever and thereby the tensioning moment applied to the warp beam,**

**must be adjusted as the beam weaves down. This adjustment compensates for the gradual increase in the beam-warp torque (i.e. the pull-off force required to turn the beam and let off further warp) which would arise if no adjustment were made to the weighting. This would also lead to the warp tension rising continuously from beginning to the end of the beam. In more modern forms of let-off motions, some of which are fitted to Lancashire looms, warp tensioning adjustments are made continuously in response to a feeler system which detects changes in the beam diameter.**

**(i) 'Temples'**

**There is a strong tendency for cloth on the loom-roller to be narrower than the width of the warp from which it is woven. The contraction is caused by tension in the weft and relaxation of the weaving tension in the warp. To minimise this effect as well as to prevent thread breakages at the selvages during weaving, it is usual to hold the fabric out to its nominal woven width at a point just beyond the fell. Grips used for this purpose are known as 'temples'. There are various patterns of such grips, the most common for cotton fabrics being the type known as ring temples. The latter grip the cloth as it is being woven over a distance of six or eight inches from the selvages inwards on either side. The rings carry projecting pins which grip the fabric as it passes through the temples, and release it easily and without damage (provided that the temples are set and maintained correctly) as the cloth is drawn progressively forward by the take-up system.**

**(j) Weaving of twills**

**So far the weaving of plain weave fabrics has been considered. Of the eight fabrics listed in Table I.1, the first four are of this type and can be woven on looms incorporating the simplest basic shedding mechanisms as shown in Fig. III.5. The other four fabrics are twills which require additional heald staves and tappets.**

**For plain weave using two shafts, or for four shafts working as two so as to avoid overcrowding of the healds, the tappets are fixed on the bottom-shaft, and hence rotate at half the top-shaft speed. For multiple tappet shedding, for three or more independent staves, one cam of appropriate shape is needed for each staff. For example, the three staves for the 2 x 1 twill weave (see Fig. III.1(b)) require three tappets, each making one complete revolution for every three picks woven (i.e. each tappet rotates at one-third of the speed of the top-shaft). Similarly, a four staff twill will require four tappets rotating on a shaft turning at one quarter of the speed of the top shaft. On the Lancashire loom, these simple weaves can be made by installing a separate tappet shaft on which tappets of appropriate shape can be mounted and driven at the required speed by change-gearing from the bottom shaft.**

**It will be appreciated that cams, unless of the 'positive motion types' only impart movement to the cam**

**follower in one direction. It is thus necessary to provide means for reversing the direction of motion in order to obtain continuity of the action. Simple stepped rollers placed above the loom, and over which straps are passed which are coupled to the tops of the heald staves, are used for reversing the two staves required for plain-weave (see Fig. III.5). For weaves woven by means of tappets which require more than two staves, more complex multiple roller reversing motions can be fitted to the Lancashire loom or, alternatively, spring-operated reversing motions, of which there are a number of designs, can be used.**

### **(k) Patterning**

**Patterning may be achieved by the use of coloured yarns. Warpway stripes can be woven on any loom without need of additional equipment by arranging coloured yarns appropriately in the warp beam. The combination of warpway and weftway stripes to produce chequered patterns, such as gingham, is a little more difficult. The handloom weaver must, in this case, assemble a number of shuttles charged with yarns of the required colours, and then change one shuttle for another in a proper sequence. In the case of power-looms, it is necessary to use multiple shuttle boxes. This is usually done at one end of the sley only. While there are several ways in which multiple boxes may be arranged, all of these involve the same basic principle: the automatic replacement of one box by another without interrupting the running of the loom during that part of the weaving cycle in which shedding is taking place, and the shuttle is normally at rest. The mechanism employed to achieve this are not unduly complex and are very robust. They do, however, increase the cost of the loom. As they also reduce the operating speed (typically by about 10%), it is generally uneconomic to use multi-box looms where only a single colour weft is needed. It is preferable in this case to install only sufficient multi-box looms to cater for the actual consumer demand for multi-colour weft fabrics.**

### **IV.2 Operation and maintenance of non-automatic power looms**

**It should be appreciated that considerable skills is required to set-up and maintain a loom of the Lancashire type. This is particularly so because few such looms have frameworks and components which are machined to the precision demanded of modern textile equipment. Thus, accuracy in settings is fairly difficult to achieve and maintain. In this respect, automatic looms are often easier to set-up, although requirements for the assimilation of technical knowledge on the part of the overlooker may be greater than in the case of non-automatic looms. In any weaving shed, and particularly in sheds equipped with Lancashire type looms, it has been found beneficial for the management to encourage the practice of some form of systematic loom overlooking. Such practice would ensure that critical operations (e.g. shuttle-box adjustments which control both the speed and accuracy of flight of the shuttle) are frequently monitored. The use of a system of standardised loom settings obtained initially on an experimental loom of similar design to those in**

**production, and weaving similar cloth, may help achieve the above objective.**

### **IV.3 Productivity of non-automatic power looms**

**It takes approximately 12 seconds, on average, to stop a non-automatic loom and replenish the weft supply. The frequency of weft replenishment needed depends on a number of factors, such as the speed and width of the loom and the size of the shuttle. However, the most important factor is generally the coarseness of the yarn. In weaving the selected cloths, weft replenishment frequencies would be expected to range from about 20 per hour for heaving sheeting cloth (T2), to around 5 per hour for light fabric cloth (P4). Thus, the corresponding looms would necessarily stop to allow for weft replenishment for 4 minutes and 1 minute respectively in each hour. The effect of these stoppages is likely to be very limited.**

**In practice, the total lost time on this account will depend on the number of looms tended by one weaver. Where each weaver tends only two looms, there will be only a few occasions when a job on one loom will cause delay in replenishment of the weft on the other loom. On the other hand, should a weaver tends eight or ten looms, considerable interference between looms will occur and the amount of lost time will be greater. In general, it is found that the productivity of non-automatic looms is from 2 to 6 per cent lower than that of comparable automatic looms. As this is by no means sufficient to justify the additional automatic features, in terms of capital per unit of productive capacity, it is clear that the increasingly widespread use of automatic shuttle looms is justifiable primarily on other grounds.**

### **V. Automatic power looms**

**Automatic shuttle looms are essentially simple power looms to which has been added means of automatic weft replenishment. However, in order to gain full advantage of this latter feature, thus enabling a weaver to look after more looms, shuttle looms should also be equipped with an automatic warp let-off motion and an automatic 'warp-stop' motion (which immediately stops the looms if a warp thread break occurs). All these features are considered standard fitments on an automatic loom. Figure III.9 shows an automatic Pirn change loom with under-pick motion.**

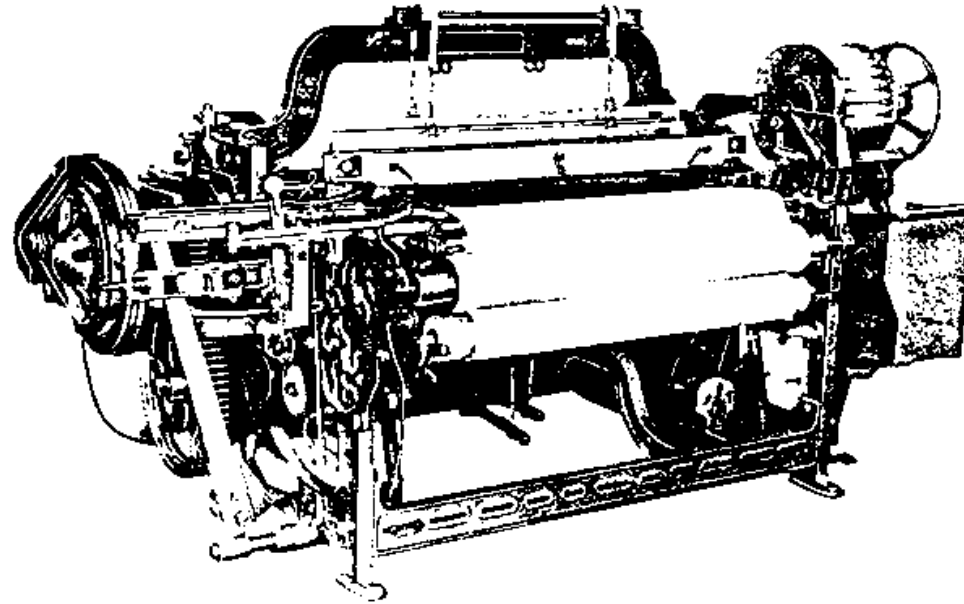

**Figure III.9 Automatic pirn-change loom with under-pick motion**

### **V.1 Weft replenishment**

The operation of automatic weft replenishment can be performed in two ways. In the first method, the empty shuttle is ejected from the loom at some convenient time in the loom cycle (i.e. when the shed is changing) and a new shuttle is inserted with a full weft package. In the second method, which is currently by far the most common, the empty weft package (pirn) is ejected and immediately replaced with a new full pirn of weft. The first method requires at least two shuttles per loom and to the extent possible, these have to be identical in all respects, including the degree of wear due to service. The second method requires only one shuttle per loom, but this shuttle is of a special shape.

Apart from the above features, there are two distinct categories of automatic shuttle looms: shuttle changers and pirn changers. These are briefly described below.

### **V.2 Shuttle changers and pirn changers**

In operation, shuttle changers require that a magazine be kept supplied with charged and threaded shuttles, whereas the magazine only requires to be loaded with pirns in the case of pirn changers. In times when hand-spun and mule-spun weft were commonly used, the shuttle changer had a possible advantage in that miscellaneous cops taken directly from the spinner could be loaded into the shuttles. This was not possible

**in the case of pirn changers which require that the yarn be wound on to special bobbins furnished with means for automatic retention by, and ready ejection from, special shuttles needed for this purpose. Lately, the production of fabrics for high-income consumers requires a low permissible fault rate, and since present demands cannot be met without very stringent clearing of both warp and weft yarn, the advantage of the shuttle changer has largely disappeared. Thus, rewinding from the spinner's package is essential for yarn clearing, and no further cost is therefore incurred in the preparation of weft pirns suitable for the particular type of automatic pirn changer. Consequently little advantage remains in the use of a shuttle able to accept weft in packages of a variety of forms.**

**This situation does not occur where fabrics for low-income consumers are being woven. Consequently, a number of shuttle changers are still in use in developing countries although it is very common to find looms which are only nominally automatic. The reason for this is the high cost of shuttles used in this type of loom. Often, the expense of the additional capital needed to keep each loom supplied with sufficient shuttles (which have a relatively short life and must be regarded as consumables) is so high that it becomes more economical to operate such looms as non-automatics. On balance, one must conclude that, in most circumstances, the pirn-changer is to be preferred except where yarn suitable for the types of cloth covered by this memorandum is readily available only for use in plain (i.e. non-pirn changing) shuttles. For these reasons, the single-shuttle pirn changer is currently the most commonly used power loom world-wide. Such a loom has been further improved and is now being produced in large quantities which allowed a considerable reduction of the price of the automatic pirn changing facility.**

**In response to demand by high-income consumers for nearly perfect machine-made cloth, most loom makers now work to very high engineering standards in regard to both design and manufacture. Consequently, the cost and the standard of engineering precision of looms of all kinds have also increased. It is nevertheless true that some makers are still able to supply automatic looms which are broadly similar in design and construction to those produced in Europe and North American between 1930 and 1960. These are therefore available at somewhat more modest price levels.**

### **V.5 Automatic power loom manufacturers**

**Over the past thirty years, the standard of manufacture of automatic shuttle looms which require low labour inputs has risen to a very high level. Most European and North American makers now offer only looms to these very high engineering standards with a view to minimising skilled labour inputs over the useful life of the equipment. The cost of these looms is very high in relation to conditions obtaining in developing countries for which they are therefore not suitable.**

**Most western loom-makers used to make suitable low-cost automatic looms. This is not anymore the case as few manufacturers can now produce these looms profitably: the available machine tools and production methods used for the manufacture of "super-looms" are unsuitable for the manufacture of the less sophisticated low-cost looms. A small number of Western loom makers still offer simple, low-cost machines based on pre-1950 designs. One such company is British Northrop Ltd., Blackburn, United Kingdom. Pioneers of the pirn change automatic loom in Europe 75 years ago, Northrop has produced the well-trying 'S' model, of which there are more than 30,000 units in operation worldwide. In 1976, Northrops completely equipped a new mill in the Sudan with this simple and robust automatic loom. While not known precisely, it is inferred that the price per loom was not greatly in excess of £2,000 at January 1980 values.**

**India is one of the few developing countries which produces and exports both automatic and non-automatic looms suitable for the needs and conditions of the developing countries. Three important manufacturers are (i) Cooper Engineering of Poona who, in collaboration with North American Rockwell, offer a loom based on the Draper (X2) model, a loom of essentially pre-1940 design; (ii) National Machinery Makers Ltd., of Kalwe Thana, produce the Ruti 'B' type automatic shuttle loom, one of the best of such looms made during the 1950/60 period; and (iii) Central India Machinery Manufacturers Company (CIMMCO) of Gwalior which, in collaboration with Sakomoto of Japan, offer an automatic loom based on a Japanese design of about 1950.**

#### **V.4 Trade in second-hand textile machinery**

**There is considerable trade in second-hand textile machinery of all types. In some cases, complete installations are bought in situ, dismantled and re-erected in a new location. Alternatively, machinery is bought from stocks held by a dealer. The greatest proportion of the trade is, by far, in re-conditioned shuttle-looms, both automatic and non-automatic. Bestex Textile Machinery of Blackburn, United Kingdom is an example of a typical secondhand machinery dealer offering a comprehensive, world-wide service. Other companies offering a similar service are 'Reconditioned Looms' of Blackburn, United Kingdom and Josef Kruckels of Munchengladbach, Federal Republic of Germany. In addition, some loom-makers, such as British Northrop, will recondition looms of their own manufacture to an 'as new' condition either at their works or on site.**

**The decision to invest in second-hand weaving equipment is not an easy one to make as it involves complex considerations of a technical and economic nature. Producers interested in buying such equipment should therefore obtain detailed information on what is being offered by second-hand equipment dealers, and undertake careful feasibility studies prior to deciding on the acquisition of a piece of equipment. Interested readers may obtain useful clues on the approach to be used when looking for second-hand equipment from the ILO publication (Cooper and Kaplinsky) listed in the attached bibliography.**

## **V.5 Skill requirements**

**All automatic looms are more demanding of technically skilled labour than are non-automatic looms although the latter may sometimes demand a higher level of 'practical' expertise. In comparing automatic and non-automatic shuttle looms, it will be found that a higher standard of technical training and diligence are required to ensure satisfactory operation of the automatics. This is partly because of the relatively complex mechanism by which automatic weft replenishment is achieved. In addition, it is necessary to be more meticulous in the care and adjustment of the picking mechanism that might otherwise be the case: automatic changing of either the shuttle or the pirn requires more accurate timing and positioning of the shuttle than is necessary when the shuttle is being removed and replaced manually.**

**In conclusion, in view of the various factors considered in sections IV.2 and V.3, and given the types of cloths considered in this memorandum, no real benefit should be gained in using automatic looms as an alternative to non-automatic looms. The latter should also be preferred at all three levels of production covered by this memorandum given the relatively low wages paid in developing countries. This matter will be further analysed in chapter IV.**

## **VI. Shuttleless looms**

**There are four basic types of shuttleless looms widely used in industrialised countries. These looms are outside the scope of this memorandum as they should not, in general, be suitable for conditions prevailing in developing countries. They are, thus, only briefly described in this section. The economics of shuttleless looms will be considered in chapter IV.**

**(a) Projectile loom.** This class of looms uses a succession of small shuttle-like projectiles to transport single picks of weft through the warp shed from stationary supply cones. These looms are highly sophisticated weaving machines capable of a very high output of first-quality fabrics.

**(b) Rapier looms.** This type of looms consists of rigid and flexible rapier looms in which single picks of weft are inserted from stationary supply packages, by means of a slim shaft or shafts known as rapiers.

**(c) Jet looms.** This type of looms includes air-jet and water-jet looms. Water-jet looms are only suitable for weaving continuous filament hydrophobic materials. In the air-jet looms the weft is inserted by means of a very fine high velocity air-jet.

**(d) Multiphase loom.** This loom is still in the development stage, although preliminary versions have



**been demonstrated. It is a further development of the multi-shuttle circular looms, but the new versions are linear machines.**

## **VII. Ancillary equipment**

**After the loom warp has been prepared, sized and beamed, and before weaving can commence, the warp must first be 'loomed' (i.e. the warp threads must be drawn-in through the healds in the various staves, in the required 'drafting' order, according to the fabric weave). Subsequently, the threads must also be drawn-in, in groups of two, three or more, through the reed. Looming is usually carried out in a room separate from the weaving shed. After looming, the warp, together with the healds and reed, are taken to the loom where the warp is then 'gaited', (i.e. the healds are connected to the treadle levers and to the reversing motion; the reed is secured in position under the sley-cap; and the warp sheet is straightened, tensioned and tied-in to a cloth fent attached to the take-up system). The loom temples are then set, and the shed opening and closing timings adjusted in combination with the picking timings from both shuttle boxes.**

**The looming of warps involves the hanging of the healds vertically in a drawing-in frame. The warp beam is mounted behind this frame in a stand with the reed, supported but laid flat, in front. Hand-drawn-in warps require two operatives: (i) a 'drawer-in' sitting in front of the frame, selecting the healds in drafting order and drawing the ends through the eyes with a reed-hook and (ii) the 'reacher-in', working from behind the frame, selecting the warp threads in order from the beam, and presenting them to the reed-hook held by the drawer-in. It is clear, from this brief description, that the work is fairly tedious. The advantage, however, is that the equipment required is very simple and may be manufactured locally. Partial automation, consisting of replacing the services of a reach-in by a mechanical thread selector and presenter might be considered for large-scale production.**

**When a warp is woven out, a succeeding warp of similar kind is often 'twisted-in' or 'knotted-in', at the loom, to the end of the previous warp. Thus, re-drawing and re-gaiting are unnecessary. This operation, however, cannot be repeated indefinitely since the healds and reed must be thoroughly cleaned periodically. On average, cleaning should be necessary after about every four or five warps. The number of warps which must be fully loomed and gaited is, therefore, considerably reduced. If this procedure were to apply to production in developing countries, it is estimated that two hand-loom frames would fully meet the needs for small-scale production, three frames for those of medium-scale and four, or at most five frames, for those of large-scale production, depending, in each case, on the hours of work.**

**Mention has been made elsewhere that items such as healds and reeds, while having a reasonably long life given adequate maintenance, must, nevertheless, be generally treated as expendable. To a much lesser**

**extent, the same applies to warpers' and weavers' beams. Pirn tubes, along with items such as shuttles, pickers, picking-sticks, picking-bands, check-straps, loom-buffers etc. are also expendable to varying degrees. Good housekeeping, along with skilled overlooking, should help keep replacement costs for these items to a minimum.**

**In weaving mills, where warp preparation and sizing is carried out, it is necessary to install racks for the storage of both full and empty warpers' and weavers' beams. These racks may be manufactured locally. Furthermore, trucks with incorporated lifting and lowering facilities are desirable for the internal transporting of heavy beams and cloth batches. The incoming yarn must also be stored, and the pirned weft, usually in metal bins, must be protected from damage before delivery to the looms.**

**The woven cloth is usually inspected over a viewing table in the warehouse; the number of viewing tables required depends on the extent of the examination. Most major weaving faults can be detected in fabric running over a perch or viewing table, under good light, at speeds of around 20 metres/min. Thus, one viewing table should be sufficient for small- and medium-scale production (single or on a two-shift basis). Large-scale production may require the use of three viewing tables. The cloth itself will require either rolling on to tubes or plaiting in metre-laps for storage and transport. This is done either as the cloth is being examined or as a separate operation.**

### **VIII. Yarn requirements**

**There is no difference between the basic yarn requirements for the looms described in this memorandum. Yarn requirements in terms of strength, uniformity and freedom from imperfections are dependent on two considerations: the performance and appearance requirements of the cloth, and the level of productivity which is expected of the operatives. As the first consideration does not constitute a severe constraint, it is only necessary to take account of the second one. This essentially involves achievement of the most economic balance between labour costs and machine utilization factor. No problems arise in the case of hand looms: the weaver continues to tend only one loom whatever quality of yarn is provided as his productivity should not fall substantially if yarn quality is lowered. Fall in productivity - in comparison with productivity achieved with perfect yarn - should not exceed 20% if the lowest quality yarn were used.**

**The use of low quality yarns inevitably leads to higher breakage rates and consequently, to an increase in the number of operative hours needed to produce a given quantity of cloth. However, the type of loom used does not have a first order effect on the amount of time spent in the repair of a weaving break, either of warp or weft. At the lowest level of yarn quality - consistent with fabrics covered by this memorandum - one weaver might reasonably be expected to tend two non-automatic powerlooms or four automatic looms. With**

**very well prepared yarn of the highest quality, one weaver could tend six non-automatics or up to sixty automatic looms. Thus, the labour-saving potential of the automatic looms is much more severely curtailed by the use of low quality yarn than is the case with non-automatic looms. This does not necessarily mean that automatic looms require better yarns, or that it is less economic to use automatic looms in conjunction with low quality yarns. The basic consideration is that the amount of labour needed is reduced when the quality of yarn is raised regardless of the type of loom. Thus, in high wage cost countries, weaving becomes profitable only if yarn quality is high. Furthermore, as the higher capital cost of automatic looms is justified by the high wages, it is usual for high quality yarns to be used in conjunction with automatic weft replenishment.**

## **IX. Product quality**

**Product quality in the case of hand-loom is greatly dependent on the skill of the weaver. For all other looms, yarn quality is, by far, the most important determinant of cloth quality. Given the use of identical yarns, cloths of identical quality may be produced by power-operated shuttle looms and shutterless looms with the following exceptions:**

- Cloth woven on non-automatic looms may show occasional starting places caused by lack of skill or care on the part of the weaver when re-starting the loom after shuttle replenishment. Normally, the incidence of this minor fault should be small.**
- If the quality of the weft yarn is such that there is an appreciable variation in count from pirn to pirn, 'block barring' will be noticed in the cloth. "Block barring" consists of a succession of slight, but abrupt, changes in cloth density caused by changes in the count of the weft from one pirn to the next. This fault occurs with equal severity when weaving on any type of shuttle loom. However, it is appreciably less severe when shuttleless looms are used since the size of the weft packages are much larger than those used in the other looms. Shuttle looms may be improved by the use of multiple shuttle boxes in order to attain some degree of weft-mixing (e.g. given two alternative shuttle boxes at one side of the loom, alternate double picks may be taken from two pirns instead of weaving continuously from a single pirn). This procedure greatly reduces the prominence of "block barring".**

**Cloth woven 'single width' on either automatic or non-automatic shuttle looms will have true selvages. Low-income consumers in developing countries consider these as a "quality" feature. Mock selvages (leno or tucked), which are made by shuttleless looms, are generally held to be inferior to true selvages. This "quality" weakness is also present when cloth is woven 'multi width' on shuttle looms. Most makers now offer shuttle looms in very wide widths which can weave two or**

more narrower cloths simultaneously. For example, many looms are now available with a reed width of about 3 1/2 metres: on such looms three separate cloths, each one meter wide, may be woven. In this case, only the outer edges of the two outer cloths have true selvages, while the inner edges of the outer cloths and both edges of the middle cloth have only mock selvages.

## X. Factory space requirements and layout

Figure III.10 is provided as a guide for the space requirements and layout of a small-scale weaving factory. The layout may be scaled-up for larger undertakings by using the data in Tables IV.3 to IV.5 in chapter IV.

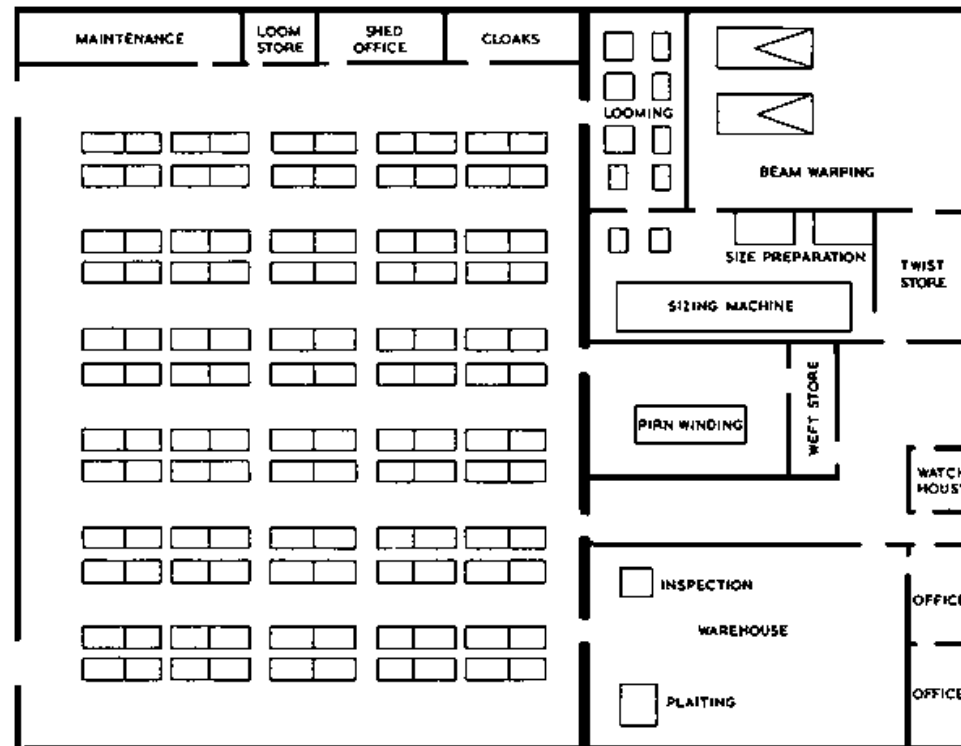





**Figure III.10 Plan of a small weaving shed**

[Home](#) > [ar](#) [cn](#) [de](#) [en](#) [es](#) [fr](#) [id](#) [it](#) [ph](#) [po](#) [ru](#) [sw](#)

Small-Scale Weaving (ILO - WEP, 1983, 144 p.)



## CHAPTER IV. ECONOMIC EVALUATION OF ALTERNATIVE WEAVING TECHNOLOGIES

-  I. Introduction
-  II. Suitability of loom types and scales of production
-  III. Methodological framework for the estimation of unit production costs
-  IV. Economic comparison of weaving options

**Small-Scale Weaving (ILO - WEP, 1983, 144 p.)**

## CHAPTER IV. ECONOMIC EVALUATION OF ALTERNATIVE WEAVING TECHNOLOGIES

### I. Introduction

The previous two chapters provided detailed information on alternative technologies which could be adopted by practising or would-be weavers. Information contained in the above chapters should help identify technologies which are technically feasible, given the type of cloth to be produced and the adopted scale of production. The next step is to identify the most economically efficient - or profitable - technology among those identified as technically efficient, given local factor prices (e.g. wages, prices of raw materials, cost of imported and local equipment) and wholesale or retail prices of the cloth to be produced. The purpose of this chapter is, therefore, to suggest a methodological framework for the estimation of unit production costs for alternative weaving technologies and types of cloth to be produced. The most economically efficient technology would then be the one associated with the lowest unit production cost or the highest profit per unit of production (if a choice must also be made among a number of types of cloths).

This methodological framework is mostly of interest to producers as it does not take into consideration a number of socio-economic effects associated with alternative weaving technologies. This aspect, which is of particular interest to public planners or project evaluators in industrial development agencies, will be dealt with in Chapter V.

Section II of this chapter identifies the types of looms, among those described in Chapter III, which are technically suitable for the types of cloths covered by this memorandum and the selected scales of production. Reasons are also provided for the types of looms which are not considered suitable.

**Section III describes the suggested methodology for estimating unit production costs, and applies it to a selected type of cloth among those covered by the memorandum. The technical coefficients needed to estimate unit production costs are also provided.**

**Section IV uses the same evaluation methodology for the economic comparison of the types of looms considered as suitable (ref. Section II), on the basis of assumed factor prices, interest rates, etc. While this comparison may provide some clues on the economic efficiency of alternative weaving technologies, it is provided for illustrative purposes only, as local factor prices may greatly differ from those assumed in this section. Thus, weavers should undertake their own evaluation, based on local prices, in order to identify the weaving technology best suited to local conditions.**

## **II. Suitability of loom types and scales of production**

**Table IV.1 lists the various loom types described in Chapter III, indicating in each case their suitability or unsuitability at various scales of production. This table shows that, of the 11 types of looms which are listed (3 types of hand-loom, non-automatic power looms, 2 types of automatic power looms with shuttle, and 5 types of shuttle-less looms), only four types are suitable for the types of cloths and at the scales of production covered by the memorandum. Three types of shuttleless looms (types IV.1, IV.2 and IV.3) may also be suitable for large-scale production under specific conditions. Consequently, a total of seven types of looms are considered for further economic evaluation in this chapter.**

**Table IV.1**  
**Suitability of loom types**

<b>Loom type</b>		<b>Scale of production at which loom is suitable<sup>1</sup></b>	<b>Remarks on suitability</b>
<b>I. Hand looms</b>			
I.1	Hand-thrown shuttle and primary loom motions manually coordinated		Not suitable at scales of production covered by the memorandum. Operational speed (below 20 picks/min) is much too low and would result in abnormally high costs for work in progress. Logistic problems involved in the deployment, supervision and accomodation of large numbers of workers. Production specification and quality control problems likely to

			arise.
I.2	With fly-shuttle but primary motions manually coordinated	Small-scale	Suitable for small-scale production only and provided that machine preparation of warps can be undertaken at the weaving factory or elsewhere; also good pirn winding. Logistic reasons preclude the use for higher productions.
I.3	With fly-shuttle and with both primary and secondary loom motions mechanically coordinated. These looms are treadle operated.	Small-scale	Even better suited for small-scale production than type I.2, but looms of this kind are considerably more expensive. Again, good warp and weft preparation would be essential.
II.	<u>Non-automatic power loom with shuttle</u>	Small, medium and large scale	This type of loom is considered to be the best choice for all three levels of production. Such looms, if available, should be relatively cheap, reliable and not greatly demanding in technical supervision.
<b>III. Automatic power loom with Shuttle</b>			
III.1	Low-cost loom of generally pre 1950 design	Medium to large scale	The next best choice to type II looms, but only for larger than medium scale production, i.e. over 1,000,000 metres/yr.
III.2	High-precision, high cost looms of generally post 1960 design	-	Unsuitable, too costly
<b>IV. Shuttleless looms</b>			
IV.1	Projectile looms	-	Generally unsuitable - too expensive and technically demanding
IV.2	Rapier looms	-	Generally unsuitable - too expensive and technically demanding
IV.3	Air-jet looms	-	Generally unsuitable - too expensive and technically demanding. However, may eventually be suitable for large-scale production
IV.4	Water-jet looms	-	Unsuitable for hydrophilic fibres such as cotton - Too expensive and technically demanding
IV.5	Wave-shedding looms	-	Unsuitable - too technically advanced

**1 Small-scale = 100,000 m/year**

**Medium-scale = 1,000,000 m/year**

**Large-scale = 5,000,000 m/year**

### **Loom types and multiple cloth-width weaving**

The weaving of two or more widths of fabric side-by-side in the loom - as if they were a single cloth - is one method by which a gain in productivity can sometimes be achieved. However, such gain depends on the type of loom and on the requirements of garments for which the cloth is being made. Multiple cloth-width weaving may be of particular importance for certain fabrics covered in this memorandum (e.g. cloths such as those used for many saris and lunghis). Cloths woven in the above manner (as 'splits') do not have fully-woven selvages at both sides of the Separate pieces; only the outer cloth edges have woven selvages. The inner cut edges are often secured by a leno weave which is later cut-off or turned-in at the making-up stage. For cheap and quickly made garments, which must withstand wear and severe washing, these edges may not be very satisfactory. Multiple cloth-width weaving may also require wider looms which are generally more expensive both to purchase and in power consumption. Wider looms also run at a slower speed - although the rate of weft insertion is generally higher - and fewer looms can be tended by one weaver. However, there may be many cases where multiple cloth-width weaving could reduce costs. To take multi-width weaving into account, the following options have thus been included: for type III.1 automatic looms, single-width and double width weaving; for type IV.II rapier looms, double-width weaving only; for type IV.2 projectile looms, three fabrics in a loom width have been taken as a standard option;

To summarize, four types of looms will be further analysed in this chapter, covering a total of 8 weaving options. These are:

- **Option 1: hand-loom with fly-shuttle, one cloth-width weaving;**
- **Option 2: hand-loom treadle operated, one cloth-width weaving;**
- **Option 3: non-automatic power loom with shuttle, one cloth-width weaving;**
- **Option 4: low-cost automatic power loom with shuttle, one cloth-width weaving;**
- **Option 5: low-cost automatic power loom with shuttle, two cloth-widths weaving;**
- **Option 6: shuttleless projectile looms, 3 cloth-widths weaving;**
- **Option 7: shuttleless rapier looms, 2 cloth-widths weaving;**



## - Option 8: shuttleless air-jet looms, 1 cloth-width weaving.

### III. Methodological framework for the estimation of unit production costs

The estimation of unit production costs associated with alternative weaving technologies requires 14 main steps. These are described below, including assumptions and technical data associated with each step:

**Step 1:** Specification of the required yearly production capacity, the type of cloth to be produced, and of the weaving option which is considered. Obviously, the weaving option must be suitable for the required capacity (see Section II);

**Step 2:** Given the yearly production capacity, to calculate the number of looms required for this capacity, the cost of these looms, and the floor area occupied by the latter.

#### (i) Calculation of the number of looms

The number of required looms is provided by the following relationship:

$$\text{Number of looms} = \frac{\text{Annual production (metres)}}{(\text{Annual working hours}) \times (\text{hourly production per loom, in metres})}$$

The hourly production per loom may be obtained from the following relationship:

$$\text{Hourly production per loom (metres)} = \frac{(V) \times (60) \times (W) \times (E)}{(P) \times (100) \times (100)}$$

where:

**V** = loom speed, in picks per minute

**W** = cloth widths per loom. **W** = 1, 2, or 3

**E** = mean loom utilisation efficiency, in percentage

**p** = number of picks per cm (weft).

**Table IV.2** provides the hourly production of looms for the 8 selected weaving options, and for a type of cloth with the following characteristics:

Reed width : 116 cm (46 in.)

Warp : 25 ends/cm of 24 Tex cotton (64 ends/in., 24 Ne)

Weft : 25 picks/cm of 24 Tex cotton (64 picks/in., 24 Ne)

**Table IV.2**  
**Hourly loom production**

<b>Weaving option</b>	<b>Type of loom</b>	<b>Number of cloth widths per loom (W)</b>	<b>Loom speed Picks per minute (V)</b>	<b>Mean loom-utilization efficiency (E)</b>	<b>Cloth production Metres per loom per hour</b>
1	Hand-loom with fly-shuttle	1	40	50%	0.48
2	Hand-loom - treadle operated	1	80	75%	1.44
-----					
	<u>Power looms</u>				
3	Non-automatic shuttle loom	1	180	85%	3.67
4	Low-cost automatic shuttle loom	1	180	92%	3.97
5	Low-cost automatic shuttle loom	2	130	86%	5.36
-----					
	<u>Shuttleless looms</u>				
6	Projectile (Sulzer)	3	220	84%	13.30
7	Rapier	2	240	87%	10.02
8	Air-Jet	1	375	88%	7.92

**Cloth particulars:- Reed width 116 cm (46 in):**

**Warp 25 ends/cm 24 Tex cotton (64 ends/in, 24 Ne)**

**Weft 25 picks/cm 24 Tex cotton (64 picks/in, 24 Ne)**

**This type of cloth may be considered to be of an average construction within the range of cloths covered by this memorandum (see Table I.1). The hourly production of looms for the specific types of cloths described in Table I.1 may be easily calculated by simply using the right value of p and the relevant coefficients in Table IV.2.**

**The estimated values of E (the mean loom utilisation efficiency) and of V (the loom speed) for the 8 weaving options are based on the following considerations and assumptions:**

- Weaving options 3, 4 and 5 are based on the use of low-cost shuttle looms with a high productive capacity per unit of fixed capital investment. The speeds assumed are modest but realistic in the circumstances. Shuttle looms capable of speeds 25% to 35% higher are available, but as the high precision involved in their manufacture results in prices 100% to 300% higher, it would be inappropriate to use them in the present context. Very few makers are currently offering low-cost looms of the types selected, but they are available in a number of countries (e.g. Czechoslovakia, India and China). It should thus be possible for other low-cost countries to produce substantially similar looms at similar prices.**
- The Sulzer loom (weaving option 6) is the only weaving machine which is widely used. The 3 cloth widths, 220 picks/minute, operation is by far the most economic one.**
- The low-cost rapier loom (option 7) is, for a cloth width and 240 picks/minute operation, slower than other high cost rapier looms. It is, however, the most cost-effective for conditions prevailing in developing countries.**
- The low-cost air-jet loom (option 8), with a loom speed of 375 picks/minute, is also slower than other air-jet looms which use supplementary jets. It is, however, much more cost-effective as its purchase price is also much lower than that of faster air-jet looms.**
- Loom utilisation efficiency: This factor is function of two variables: the quality of the yarn and the weaver's skills. Regarding the quality of the yarn, it was assumed that high quality yarn may not always be available in developing countries, but that the yarn used for the types of cloths considered in this memorandum should not be of the lowest quality available. It has, therefore, been assumed that the quality of yarn used in the 8 weaving options is at the 75% level of the Zellweger Uster classification.<sup>1</sup> This means that 75% of all yarn used worldwide is better than that which would be used in the 8 weaving options, and 25% worse. Thus, the 24 Tex yarn used in these options will have the following properties:**

- Irregularity index : 16U%
- Thin places (-50%) : 150 per 1000 metres
- Thick places (x 3) : 700 per 1000 metres
- Neps (x 3) : 650 per 1000 metres

**<sup>1</sup> The firm Zellweger Uster Ltd. compiles worldwide statistics of yarn quality, including irregularities, number of thin places, number of thick places and number of neps per unit of length. The statistics show, over a range of counts, the percentage of total world yarn production which is of better quality than a series of specified values in relation to each of the four properties.**

**Regarding weavers' skills, it has been assumed that the relatively low skill levels available in developing countries are, to some extent, offset by the employment of larger numbers of operatives. Thus, given the assumed yarn quality and weavers' skills, the mean loom utilisation efficiency is assumed to range from 92% for the low-cost automatic shuttle loom to 84% for the Sulzer loom. The efficiencies of the hand-loom with fly-shuttle and that of the treadle operated one are assumed to be, respectively, 50% and 75%. The above assumptions are, to some extent, validated by field observations from a number of mills in India, Kenya and Ethiopia.**

### **(ii) Estimation of the cost of looms**

**Given the estimated number of looms, the cost of the latter may be estimated on the basis of quotations obtained from local importers or loom manufacturers. The unit price of loom should include transport costs, the cost of spare parts and any import duties or taxes. Section IV provides estimated prices of the looms considered in this memorandum.**

### **(iii) Estimation of the floor area occupied by the looms**

**The floor area for the machinery is a primary determinant of the cost of the mill building. The area required per loom must make a reasonable allowance for access alleys and free space within the weaving area. Estimated floor space requirements per loom (inclusive of surrounding working area and passage ways) are provided below for each weaving option:**

Option 1: 8.4 m<sup>2</sup> (90 ft<sup>2</sup>); Option 5: 13.0 m<sup>2</sup> (140 ft<sup>2</sup>)

Option 2: 8.4 m<sup>2</sup> (90 ft<sup>2</sup>); Option 6: 16.7 m<sup>2</sup> (180 ft<sup>2</sup>)

Option 3: 9.3 m<sup>2</sup> (100 ft<sup>2</sup>); Option 7: 13.0 m<sup>2</sup> (140 ft<sup>2</sup>)

Option 5: 9.3 m<sup>2</sup> (100 ft<sup>2</sup>), Option 7: 13.9 m<sup>2</sup> (150 ft<sup>2</sup>)

Option 4: 9.3 m<sup>2</sup> (100 ft<sup>2</sup>); Option 8: 8.8 m<sup>2</sup> (95 ft<sup>2</sup>)

**Step 3: To estimate the number and cost of the following auxilliary equipment:**

- Warper's back-beams
- Warping and sizing machines, and size preparation equipment;
- Pirn winding spindles

To estimate the floor areas occupied by the above equipment.

Weaving mills producing up to 100,000 metres per year (small-scale production) may not justify the acquisition of a warpers' back-beam or that of a warping and sizing machine as these would be used at very low production levels, given the mills' requirements. It is thus preferable for these mills to buy the required materials from warp suppliers. On the other hand, medium and large-scale mills may afford the acquisition of this equipment. Table IV.3 provides estimates of the number of machines and the floor areas required for each weaving option. The floor area for warping also includes the space needed for the creeling operation (Refer to Chapter II).

**Table IV.3**

**Back-beam warping, warp sizing and weft pirning equipment and space requirements**

Production level per year and option No.	Back-beam warping		Warp sizing and size preparation equipment		Pirn winding	
	No. of machines	Total floor area	No. of machines	Total floor area	No. of machines	Total floor area
100,000 m/year 3000 working hours						
Option 1	0.2* (37%) <sup>†</sup>	34 m <sup>2</sup> *	0.2* (25%) <sup>†</sup>	68 m <sup>2</sup> *	3	4 m <sup>2</sup>
Option 2	0.2* (37%) <sup>†</sup>	34 m <sup>2</sup> *	0.2* (25%) <sup>†</sup>	68 m <sup>2</sup> *	3	4 m <sup>2</sup>
Option 3	0.2* (37%) <sup>†</sup>	34 m <sup>2</sup> *	0.2* (25%) <sup>†</sup>	68 m <sup>2</sup> *	3	4 m <sup>2</sup>

1,000,000 m/year 5000 working hours						
Option 2	1 (37%) <sup>+</sup>	170 m <sup>2</sup>	1 (25%) <sup>+</sup>	340 m <sup>2</sup>	17	17 m <sup>2</sup>
Option 3, 4, 5	1 (37%) <sup>+</sup>	170 m <sup>2</sup>	1 (25%) <sup>+</sup>	340 m <sup>2</sup>	17	17 m <sup>2</sup>
5,000,000 m/year 6500 working hours						
Options 3, 4, 5	1 (85%) <sup>+</sup>	170 m <sup>2</sup>	1 (75%) <sup>+</sup>	340 m <sup>2</sup>	63	63 m <sup>3</sup>
Options 6, 7, 8	1 (85%) <sup>+</sup>	170 m <sup>2</sup>	1 (75%) <sup>+</sup>	340 m <sup>2</sup>	Not required	

**Note:**

\* **1/5 of machine required. Number of machines and corresponding floor areas at warp suppliers' factory**

+ **Per cent of working hours during which machine is in use;**

- **Estimated machine utilisation times:**

- **Back-beam warping: 1,000,000 m/year; 5,000 hrs = 37%**
- **Back-beam warping: 5,000,000 m/year; 6,500 hrs = 85%**
- **Sizing machines: 1,000,000 m/year; 5,000 hrs = 25%**
- **Sizing machines: 5,000,000 m/year; 6,500 hrs = 75%**

**Step 4: To determine the cost of ancillary weaving equipment such as that required for looming operations, pin stripping, heald and reed polishing, and loom-state cloth examination. To determine the floor area required for the above equipment. Table IV.4 provides estimates of the number of pieces of equipment needed for the various weaving options and scales of production, as well as estimated floor areas. The cost of ancillary weaving equipment may thus be estimated on the basis of estimates provided in Table IV.4 and unit prices of equipment (to be obtained from importers, equipment suppliers, etc.)**

**Table IV.4**  
**Ancillary weaving equipment and space requirements**

<b>Equipment</b>	<b>Options 1. 2. 3</b>	<b>Options 2. 3. 4. 5</b>	<b>Options 3. 4. 5. 6. 7. 8</b>
------------------	------------------------	---------------------------	---------------------------------

	(100,000 m/year)		(1,000,000 m/year)		(5,000,000 m/year)	
	No. of machines	Total floor area	No. of machines	Total floor area	No. of machines	Total floor area
Hand-loomed frames	2	30 m <sup>2</sup>	3	90 m <sup>2</sup>	5	150 m <sup>2</sup>
Reed drawing machine	Not appropriate	-	Not appropriate	-	1*	2 m <sup>2</sup>
Warp knotting machine	Not appropriate	-	Not appropriate	-	1*	2 m <sup>2</sup>
Drop-pinning machine	Not appropriate	-	Not appropriate	-	1*	2 m <sup>2</sup>
Heald and reed polishing machine	Not appropriate	-	1	20 m <sup>2</sup>	1	20 m <sup>2</sup>
Pirn stripping machine	Not appropriate	-	1*	15 m <sup>2</sup>	1*	15 m <sup>2</sup>
Examining tables	1*	30 m <sup>2</sup>	1	50 m <sup>2</sup>	3	90 m <sup>2</sup>

\* This sign indicates that the equipment may not be considered essential in every case.

**Step 5:** Given the total floor area requirements - obtained by summing the floor areas estimated under steps 2, 3 and 4 - to estimate the cost of required buildings at an appropriate amenity level.

Table IV.5 recapitulates the floor areas required for each operation, and provides an estimate of the total floor area needed for each weaving option and scale of production.

**Table IV.5**  
**Total floor area requirements**  
(Excluding warehouse and mill administration, and general office accommodation)

Production level per annum, working hours, and Option No.	Warping machines	Warp-sizing equipment	Pirning machines	Looming	Looms	Cloth Inspection	Total
100,000 m/year							

3,000 wkg/hours								
Op. 1	34**	68**	4	30	588	30	754	
Op. 2	34**	68**	4	30	202	30	368	
Op. 3	34**	68**	4	30	93	30	259	
1,000,000 m/year								
5,000 wkg/hours								
Op. 2	170	340	17	125	1168	30	1850	
Op. 3	170	340	17	125	512	30	1194	
Op. 4	170	340	17	125	475	30	1157	
Op. 5	170	340	17	125	494	30	1176	
5,000,000 m/year								
6,500 wkg/hours								
Op. 3	170	340	63	191	1951	90	2805	
Op. 4	170	340	63	191	1802	90	2656	
Op. 5	170	340	63	191	1873	90	2727	
Op. 6	170	340	NIL	191	970	90	1761	
Op. 7	170	340	NIL	191	1073	90	1864	
Op. 8	170	340	NIL	191	856	90	1647	

**\*\* Apportionment of floor areas required for equipment at warp suppliers' factory - 1/5 of area**

**The total cost of buildings should include the cost of land, the cost of the buildings and service costs. Estimation of the above cost items should take into consideration the desired level of amenity (i.e. a choice must be made between low-cost and high-cost buildings). It may be recalled that, in the case of small-scale production, it has been assumed that the sized warps are prepared by an external supplier whose charges will include costs, on a proportionate basis, for his own premises, as well as these for power and labour. To allow for these costs, one fifth of the corresponding charges calculated for medium-scale mills may be added to the basic costs for small-scale mills.**

**Determination of the standards of amenity (both in technical and personal terms) is a very difficult area of decision making. A high level of amenity means a greater fixed capital investment and higher running costs**



throughout the life of the mill for a return which is extremely difficult to quantify. In general, the optimum level of amenity would depend upon local conditions. A mill offering amenity below the socio-industrial norms of the region cannot hope to attract the best workers, especially in the long run. On the other hand, a mill so far in advance of the norms of a region as to be beyond the aspirations of the most progressive interests will carry a heavy financial burden to little purpose. To deal with this difficulty, costs may be estimated at two levels of amenity so that cost commitments incurred by the provision of intermediate degrees of amenity may be estimated by interpolation.

The lower amenity level, referred to as low-cost building, must be considered as an absolutely minimal amenity level, although mills built to this standard during the past decade are not uncommon in India and Bangladesh. This level means that there is no air conditioning, virtually no roof insulation, and the lighting intensity in the working areas is only of the order of 250 lux. The higher level, referred to as high amenity building, is typical of mills being built currently in Europe. They have good air conditioning, along with evaporative cooling and air filtration capable of ensuring that the concentration of dust and fly does not exceed 0.5 milligrams per cubic metre in the ambient air, and 0.1 milligrams per cubic metre in the air which is recirculated. A lighting intensity of 500 lux is provided in all working areas.

Section IV provides estimates of the cost of low and high amenity levels buildings in the process of comparing alternative weaving options. Precise estimates may be obtained from local contractors on the basis of a detailed description of the mill characteristics.

**Step 6:** From steps 2, 3, 4 and 5 to calculate the total fixed capital investment (i.e., including equipment, land, and building costs).

**Step 7:** To estimate the personnel requirements for the selected weaving option, including personnel for warp and weft preparation, looming and related work, pirning, weaving, cloth inspection, etc... To estimate, subsequently, the total annual labour costs on the basis of wages and salaries paid in the mill's geographical location.

In order to facilitate the estimation of labour costs, the mill's personnel may be divided into 5 broad categories as follows:

- Category 1: managers and technologists;
- Category 2: supervisors and technicians;
- Category 3: warpers, weavers, winders and auxiliary staff.

**An average rate for each category may be used in the estimation of labour costs.**

**Estimates of the number of staff (in each category) required for each weaving option and scale of production are provided in Table IV.6. These estimates are based on field studies undertaken by the Shirley Institute (United Kingdom) in a number of developing countries. These estimates should ensure the efficient operation of the looms and related equipment for each option. They are closely related to the efficiency levels assumed for each weaving operation.**

**Table IV.6**  
**Staff requirements**

Production level per annum and weaving option	Number per shift					
	Managers and technologies		Supervisors and technicians		Weavers and others	
	Weaving	Other	Weaving	Other	Weaving	Other
<u>100.000 m/year</u> (1 shift)						
Option 1	1	Nil	3	1	77	10
Option 2	1	Nil	2	1	26	8
Option 3	1	Nil	2	1	5	6
<u>1,000.000 m/year</u> (2 shifts)						
Option 2	2	1	6	2	150	16
Option 3	2	1	2	2	25	13
Option 4	2	1	2	2	14	13
Option 5	2	1	2	2	13	13
<u>5,000,000 m/year</u> (3 shifts)						
Option 3	6	2	7	3	82	23
Option 4	7	2	8	3	51	22

Option	1	2	3	4	5	6
Option 5	5	2	6	3	49	23
Option 6	3	2	2	3	22	19
Option 7	3	2	3	3	26	19
Option 8	4	2	3	3	26	19

**Note: The numbers of staff per shift for options 1 and 2 are Shirley Institute estimates. The number of staff per shift for power loom weaving (options 3 and 8) are based on the Institute's observations in India, Kenya, Ethiopia and the UK during the period 1975-1979.**

**Step 8: To estimate the cost of energy needed to drive the required numbers of beaming machines, sizing machines, pining machines, looming equipment, looms, etc., as well as that needed for lighting and other services.**

**The cost of energy will be a function of the adopted weaving option and amenity level for the mill. The amount of energy required for each option may be estimated as follows:**

**- For looms and other equipment:**

**Energy cost/year = (Number of machines) X (KW rating) X (% utilisation) X (% operating efficiency) X (annual working hours) X (energy cost per KW/h)**

**- For lightning**

**Energy cost/year = (Machine + working area, in m<sup>2</sup>) X (KW/m<sup>2</sup>) X (annual working hours) X (energy cost per KW/hr).**

**The following may be assumed in estimating energy costs:**

- for low-cost buildings: 0.01346 KW/m<sup>2</sup>
- for high-cost buildings: 0.02691 KW/m<sup>2</sup>

**- For other services**

**Energy cost/Year = (Total machine + working area, in m<sup>2</sup>) X (S) X (Annual working hours) X (energy**

**cost per KW/hr)**

**The value of "S" may be assumed to be equal to:**

- **0.00538 KW/m<sup>2</sup> for low-cost buildings**
- **0.01076 KW/m<sup>2</sup> for high cost buildings**

**- For humidification of high-cost buildings**

**To add 6.75% of total energy costs for the machines and lightning.**

**Step 9: To estimate the annual costs of repairs and renewals for production equipment and buildings. These costs may be assumed to be equal to a fraction of the capital costs of equipment and buildings, as follows:**

**- Looms:**

- **For 100,000 m/year: 5% of the cost of looms**
- **For 1,000,000 m/year: 7.5% of the cost of looms**
- **For 5,000,000 m/year:**
  - **10% of cost of looms for options 3, 4 and 5**
  - **5% of cost of looms for options 6, 7 and 8**

**- Other machines:**

- **For 100,000 m/year; machines used at mill: 5% of equipment cost**
- **For 100,000 m/year; machines at warp supplier: 7.5% of equipment cost**
- **For 1,000,000 m/year: 7.5% of equipment cost**
- **For 5,000,000 m/year: 10% of equipment cost**

**- Buildings:**

- **3% of building costs, for all weaving options**

## **- Services:**

- **5% of costs, for all weaving options**

**Estimated repairs and renewals costs (based on the above fractions of capital expenditures on equipment and buildings) should enable unimpaired performance of the equipment over a period of 15 years as long as skilled and diligent technologists and technicians are used for the maintenance of equipment and buildings.**

**Step 10: To estimate annual depreciation costs of equipment and buildings. Annual depreciation costs may be obtained from the following formulation:**

**Annual depreciation cost = (K - PVS) X F where**

**K = Purchase price of equipment or cost of building**

**PVS = Present worth of the salvage value of equipment or building<sup>1</sup>**

$$1 \quad PVS = \frac{S}{(1+r)^n} \quad \text{where}$$

**S = salvage value of the equipment or building**

**r = prevailing interest rate**

**n = equipment or building economic life, in years.**

**F = Annual recovery factor<sup>1</sup>**

$$1 \quad F = \frac{r(1+r)^n}{(1+r)^{n-1}} \quad \text{where}$$

**r = Prevailing interest rate**

**n = equipment or building economic life, in years**

**The value of F may be calculated on the basis of the assumed economic life of the equipment or building, and the prevailing interest rate which applies to investment projects. Alternatively, the value of F may be obtained from tables of compound interest factors such as the one provided as Appendix I.**

**The present worth of the salvage value of equipment or buildings may be obtained by multiplying the estimated salvage value by the present worth factor which may also be calculated or obtained from existing tables.**

## Economic life of buildings and equipment

The economic life of equipment is a function of three variables: the skill level of the operators, the care with which the equipment is maintained, and the rate at which new technological developments are taking place. The last variable is the most important one and will generally determine the economic life of equipment. It is difficult to forecast with absolute precision the development rate, and hence the economic life which a particular installation may enjoy before it becomes technologically obsolescent. However, case studies of machinery innovation in weaving suggest that it is extremely unlikely that any new installation of machinery will become obsolescent within 10 years. Under these circumstances, the economic life of weaving equipment may be safely assumed to be 15 years. The same economic life may be applied for one, two and three shifts use of the equipment. Obviously, renewal and repair costs will be higher for two and three shifts use than for one shift use. This is the reason for the progressively higher coefficients used to estimate repairs and renewal costs as the scale of production is increased from 100.000 m/year to 5,000,000 m/year (see step 9). The relatively low coefficient (5%) used for options 6, 7 and 8 may be explained by the fact that the type of looms used for these options are less demanding, in terms of repairs and renewals, than looms used for the other options.

The economic life of buildings may also be assumed to be 15 years as it is dependent on the economic life of equipment.

### Land

It may be assumed that the value of land will remain unchanged in real terms.

### Salvage value of equipment and buildings

It is highly probable that reconditioned weaving equipment can find a buyer after the assumed economic life of 15 years. Thus, its salvage value may be assumed to be equal to 12.5% of its original cost.

It may also be assumed that buildings can be sold, with or without the services equipment, at 25% of their original cost. The salvage value of services equipment may be assumed to be equal to 12.5% of its original cost if sold with the building and to 5% of its original cost if sold separately. The following table recapitulates the salvage values:

- Looms and other production equipment: 12.5% of original cost

- Buildings with services: Buildings: 25% of original cost +

- Services only: 5% of original cost
- Land: 100% of original cost

**Step 11: To estimate annual interest payments on stocks of raw materials and finished output.**

**The amounts of stocks of raw materials and finished output will be function of local marketing customs and delays encountered in the importation of raw materials (whenever necessary) such as yarn. Thus, depending on circumstances, one month to three months stocks may be necessary. As these stocks constitute idle capital, annual interest payments on the value of these stocks should be added to the other annual cost items, whether the funds needed for the establishment of these stocks are borrowed or not.**

**Step 12: To estimate the total annual processing costs associated with the weaving option which is being evaluated:**

**Total annual processing costs =**

**(Total labour costs) + (Total energy costs) +  
(Total costs of repair and renewals) + (Annual  
depreciation costs) + (Annual interest payments)**

**The above annual processing costs do not yet include the cost of raw materials inputs, mainly yarn.**

**Step 13: To estimate the cost per metre of loom-state cloth produced by the mill by first dividing the annual processing costs (step 12) by the annual production rate, and then adding to the obtained figure the cost of yarn needed to produce one metre of cloth of the type considered.**

**The estimation of the cost of yarn per metre of loom-state cloth may be based on the international market price of yarn of 75% Uster quality classification, and the quantity of yarn required for the type of cloth it is intended to produce. It may be noted that some amount of weft is generally wasted in the case of shuttleless weaving (i.e. options 6, 7 and 8).**

#### **IV. Economic comparison of weaving options**

**The 8 weaving options listed in section II of this chapter are compared according to the evaluation methodology described in the previous section, the assumed technical coefficients, and assumed factor prices (e.g. wages, salaries, prices of energy and raw materials). This comparison is made with a view to**

**providing examples of the economic viability of the 8 weaving options, and to illustrating the application of the evaluation methodology.**

**The following scales of production are considered in the economic evaluation of the 8 weaving options:**

- Small-scale production (100,000 m/year)  
Options 1, 2 and 3**
- Medium-scale production (1,000,000 m/year)  
Options 2, 3, 4 and 5**
- Large-scale production (5,000,000 m/year)  
Options 3, 4, 5, 6, 7 and 8**

**The number of shifts associated with each scale of production are:**

- One shift (3,000 hrs/year) for small-scale production**
- Two shifts (5,000 hrs/year) for medium-scale production**
- Three shifts (6,500 hrs/year) for large-scale production**

**For the sake of simplicity, the economic evaluation of the 8 weaving options are based on the production of a single type of cloth instead of the whole range of cloths described in Chapter I. This type of cloth is of average construction within the above range. It has the following characteristics:**

- Reed width: 116 cm (64 in.)**
- Warp: 25 ends/cm of 24 TEX cotton (64 ends/in., 24 Ne)**
- Weft: 25 picks/cm of 24 TEX cotton (64 picks/in., 24 Ne)**

#### **IV.1 Assumptions**

**A number of assumptions are made regarding various factor prices. These prices (1982) should apply to a large number of developing countries. However, large variations in these prices may be found in some of these countries. Thus, findings from the economic evaluation of the weaving options may not be valid in all cases.**

**The following assumptions were made in relation to the economic evaluation of alternative weaving technologies:**



## **- Machinery cost**

**It is assumed that machinery will be bought from low-cost producers in developed or developing countries. As it was not possible to obtain reliable estimates of the cost of hand-loom from developing countries, estimates from European Community Countries and the United States have been used instead. In general, hand-loom prices from developing countries should be substantially lower than those in industrialised countries (e.g. 25% to 50% lower in the case of handlooms produced in India).**

**Table IV.7 provides the unit cost of looms, the number of looms required for each of the weaving options and scales of production and the total cost of these looms. The number of looms in Table IV.7 has been calculated on the basis of data provided in Table IV.3. The quoted prices are FOB prices to which should be added transport costs, customs duties, insurance, etc.**

**Table IV.7**  
**Cost of looms and space requirements**

		<b>Production and hours (100,000 Metres/year) (3,000 working hours)</b>			<b>Production and hour (1,000,000 metres/year) (5,000 working hours)</b>			<b>Production and hours (5,000,000 metres/year) (6,500 working hours)</b>		
<b>Option Number</b>	<b>Unit Cost of loom £</b>	<b>Looms needed No.</b>	<b>Total cost £</b>	<b>Floor space needed (m<sup>2</sup>)</b>	<b>Looms needed No.</b>	<b>Total cost £</b>	<b>Floor space needed (m<sup>2</sup>)</b>	<b>Looms needed No.</b>	<b>Total cost £</b>	<b>Floor space needed (m<sup>2</sup>)</b>
1	100 +	70	7,000	588	----- Not appropriate -----			----- Not appropriate -----		
2	500 +	24	10,000	202	139	69,500	1168	----- Not appropriate -----		
-----										
3	1,000	10	10,000	95	55	55,000	512	210	210,000	1,951
4	1,500	----- Not appropriate -----			51	76,500	475	194	291,000	1,802
5	2,000	----- Not appropriate -----			38	76,000	494	144	288,000	1,875
6	22,000	----- Not appropriate -----			----- Not appropriate -----			58	1,276,000	970
7	12,000	----- Not appropriate -----			----- Not appropriate -----			77	924,000	1,073
8	5,000	----- Not appropriate -----			----- Not appropriate -----			97	485,000	856

**Note: See section II for the definition of options 1 to 8.**

**- Building costs**

**Building costs are shown in Table IV.8, These costs are disaggregated into "land", "building" and "Services equipment" costs. They are based on 1979 unit costs for mills built in India, and on total floor areas provided in Table IV.5.**

**It is clear from figures in Table IV.8 that the fixed capital burden which the provision of high amenity imposes on a company is greatest for small scale production with Option 1. For medium-scale production, it is option 2 which carries the greatest penalty, option 1 no longer being included. For large-scale production, in which both options 1 and 2 are not considered, option 3 employing non-automatic looms carries the greatest burden, this being approximately 1.7 times that for the air-jet loom (option 8).**

**Table IV.8**  
**Building costs (£ Sterling)**

	Production level (100,000 m/yr; 3,000 wkg hours)				Production level (1,000,000 m/yr; 5,000 wkg hours)				Production level (5,000,000 m/yr; 6,500 wkg hours)			
	Land	Building	Services	Total	Land	Building	Services	Total	Land	Building	Services	Total
<u>Low cost building</u>												
Op. 1	2,030	24,110	5,580	31,710								
Op. 2	990	11,900	2,750	15,640	4,980	58,550	13,540	77,070				
Op. 3	700	8,450	1,950	11,100	3,210	37,790	8,740	49,740	7,550	88,770	20,530	116,850
Op. 4					3,110	36,610	8,470	48,190	7,150	84,050	19,440	110,640
Op. 5					3,160	37,220	8,610	48,990	7,340	86,300	19,960	113,600
Op. 6									4,740	55,730	12,890	73,360

Op. 7									5,020	58,990	13,640	77,560
Op. 8									4,450	52,120	12,060	68,610
<b>High cost building</b>												
Op. 1	2,050	153,380	88,580	244,010								
Op. 2	990	75,680	43,710	120,380	4,980	372,380	215,060	592,420				
Op. 3	720	53,740	31,040	85,500	3,210	240,340	138,800	382,350	7,550	564,610	326,080	898,240
Op. 4					3,110	232,890	134,500	370,500	7,150	534,620	308,760	850,530
Op. 5					3,160	236,710	136,710	376,580	7,340	548,910	317,020	873,270
Op. 6									4,740	354,470	204,720	563,930
Op. 7									5,020	375,200	216,690	596,910
Op. 8									4,430	331,520	191,470	527,420

**Notes:**

**Land costs** - these have been taken to be the same for both low and high cost buildings --  
**£0,25/ft<sup>2</sup> or £2,691/metre<sup>2</sup>**

**Building costs** - taken to be **£2,94/ft<sup>2</sup> or £31.646/metre<sup>2</sup>** for low cost building and **£18.70/ft<sup>2</sup> or £201.287/metre<sup>2</sup>** for high cost building

**Services costs** - taken as **£0.68/ft<sup>2</sup> or £7.3195/metre<sup>2</sup>** for low cost building and **£10.80/ft<sup>2</sup> or £116.251/metre<sup>2</sup>** for high cost building

**Note: See section II for the definition of options 1 to 8.**

### Salaries and wages

**Average rates for each category of labour were calculated on the basis of data obtained from Kenya, Ethiopia and India (Uttar Pradesh) in 1979. These rates, expressed in £ sterling at January 1980 exchange rates, are as follows:**

- **Group 1 (managers and technologists): £ 42/month**
- **Group 2 (supervisors and technicians): £ 28/month**
- **Group 5 (weavers and others): £ 13/month**

**Table IV.9 provide estimates of total labour costs for each weaving option and scale of production.**

**Table IV.9**  
**Salary and wages**

Rates assumed: Managers and Technologists £42 per mth  
Supervisors and Technicians £28 per mth  
Weavers and Others £13 per mth

Production level per annum	<u>Members per shift</u>						<u>Cost per shift/month</u>			<u>Total cost</u>	
	Managers and Technologists		Supervisors and Technicians		Weavers and Others		Managers and Technologists all	Supervisors and Technicians all	Weavers and Others all	Per shift/month	Per Year
	Weaving	Other	Weaving	Other	Weaving	Other	£	£	£	£	£
100,000 metres/yr (1 shift)											
Op. 1	1	Nil	3	1	77	10	42	112	1,131	1,285	15,420
Op. 2	1	Nil	2	1	26	8	42	84	442	568	6,816

Op. 3	1	Nil	2	1	5	6	42	84	143	269	3,228
1,000,000 metres/yr (3 shifts)											
Op. 2	2	1	6	2	150	16	126	224	2,158	2,508	60,192
Op. 3	2	1	2	2	25	13	126	112	494	732	17,568
Op. 4	2	1	2	2	14	13	126	112	351	589	14,136
Op. 5	2	1	2	2	13	13	126	112	338	576	13,824
5,000,000 metres/yr (3 shifts)											
Op. 3	6	2	7	3	82	23	336	280	1,365	1,981	71,316
Op. 4	7	2	8	3	51	23	378	308	962	1,648	59,328
Op. 5	5	2	6	3	49	23	294	252	936	1,482	53,352
Op. 6	3	2	2	3	22	19	210	140	533	883	31,788
Op. 7	3	2	3	3	26	19	210	168	585	963	34,668
Op. 8	4	2	3	3	26	19	252	168	585	1,005	36,180

**Note: See section II for the definition of options 1 to 8.**

### **Energy costs**

**Energy cost estimates are provided in Table IV.10 for each weaving option and scale of production. These costs are based on a unit cost of electricity of 2.1 pence per KW/hr (i.e. the average industrial rate in the U.K. in January 1980). This is a realistic charge broadly applicable worldwide after taking account of currency exchange rates and local fuel costs. Even when account is taken of both of these factors, considerable local variation may be found where energy is drawn from a public supply of electricity or gas. The figure is, however, very close to the real cost of on-site power generation using fossil fuels at current world prices. In special circumstances, costs could be appreciably reduced, for example, by the use of hydroelectricity generation where there is a suitable river near the factory, or by the use of waste heat in other processes.**

**Table IV.10**  
**Annual Energy Costs (£ Sterling)**

Production level	LOW AMENITY (LOW COST) BUILDING						HIGH AMENITY (HIGH COST) BUILDING					
	Looms (£)	Other M/c's (£)	Lights (£)		Other Services (£)	Total (£)	Looms (£)	Other M/c's (£)	Lights (£)		Other Services (£)	Total (£)
			Looms	Other M/c's					Looms	Other M/c's		
100,000 m/yr												
Option 1	Nil	170	500	140	260	1,070	Nil	170	1,000	280	610	2,060
Option 2	Nil	170	170	140	130	610	Nil	170	340	280	300	1,090
Option 3	750	170	80	140	90	1,230	750	170	160	280	220	1,580
1.0M m/yr												
Option 2	Nil	1,170	1,650	960	1,050	4,830	Nil	1,170	3,300	1,920	2,520	8,910
Option 3	6,870	1,170	720	960	680	10,400	6,870	1,170	1,440	1,920	2,120	13,520
Option 4	6,900	1,170	670	960	650	10,350	6,900	1,170	1,340	1,920	2,070	13,400
Option 5	6,860	1,170	700	960	670	10,360	6,860	1,170	1,400	1,920	2,090	13,440
5.0M m/yr												
Option 3	34,110	5,190	3,580	1,570	2,060	46,510	34,110	5,190	7,160	3,140	7,470	57,070
Option 4	34,100	5,190	3,310	1,570	1,950	46,120	34,100	5,190	6,620	3,140	7,210	56,260
Option 5	33,800	5,190	3,440	1,570	2,000	46,000	33,800	5,190	6,880	3,140	7,310	56,320
Option 6	16,620	1,340	1,780	1,450	1,300	22,490	16,620	1,340	3,560	2,900	4,230	28,650
Option 7	18,200	1,340	1,970	1,450	1,370	24,330	18,200	1,340	3,940	2,900	4,510	30,890
Option 8	34,950	1,340	1,570	1,450	1,210	40,520	34,950	1,340	3,140	2,900	5,270	47,600

**Note:** See section II for the definition of options 1 to 8.

**Costs of back-beam warping, warp sizing and weft pirning equipment**

**These costs are provided in Table IV.11. The same assumptions as those made for the looms apply to this equipment.**

**Table IV.11**  
**COST OF BACK-BEAM WARPING, WARP SIZING AND WEFT PIRNING EQUIPMENT AND SPACE REQUIREMENTS**

Production level per annum and Option No.	Back-beam Warping			Warp Sizing			Pirn Winding		
	Cost per machine ..... £23,000 Floor area per machine ... 170 m <sup>2</sup>			Cost per machine and size preparation equipment ..... £75,000 Floor area per machine ..... 340 m <sup>2</sup>			Cost per spindle ..... £1000 Floor area per machine of four spindles ..... 4 m <sup>2</sup>		
	Machines needed No.	Total cost £	Total Floor area (m <sup>2</sup> )	Machines needed No.	Total cost £	Total Floor area (m <sup>2</sup> )	Spindles needed No.	Total cost £	Total Floor area (m <sup>2</sup> )
100,000 metres/yr, 3000 wkg/hr.									
1	0.2** (37%) <sup>+</sup>	4,600**	34**	0.2** (25%) <sup>+</sup>	15,000**	68**	3	3,000	4
2	0.2** (37%) <sup>+</sup>	4,600**	34**	0.2** (25%) <sup>+</sup>	15,000**	68**	3	3,000	4
3	0.2** (37%) <sup>+</sup>	4,600**	34**	0.2** (25%) <sup>+</sup>	15,000	68**	3	3,000	4
1,000,000 metres/yr, 5000 wkg/hr.									
Op. 2	1 (37%) <sup>+</sup>	23,000	170	1 (25%) <sup>+</sup>	75,000	340	17	17,000	17
Op. 3, 4, & 5	1 (37%) <sup>+</sup>	23,000	170	1 (25%) <sup>+</sup>	75,000	340	17	17,000	17
5,000,000 metres/yr, 6500 wkg/hr.									

Op. 3, 4, & 5	1 (85%) <sup>+</sup>	23,000	170	1 (75%) <sup>+</sup>	75,000	340	63	63,000	63
Op. 6, 7, & 8	1 (85%) <sup>+</sup>	23,000	170	1 (75%) <sup>+</sup>	75,000	340	..... Not required .....		

**\*\* Apportionment of 1/5 of machine requirement, machine costs and corresponding floor area occupied at warp suppliers' factory**

**+ Utilization - (per cent of working hours during which machine is in use)**

**Estimated machine utilization times:-**

**Back-beam warping (1,000,000 m/yr, 5000 wkg/hp) = 37%**

**Back-beam warping (5,000,000 m/yr, 6500 wkg/hr) = 85%**

**Sizing machines (1,000,000 m/yr, 5000 wkg/hr) = 25%**

**Sizing machines (5,000,000 m/yr, 6500 wkg/hr) = 75%**

**Note: See section II for the definition of options 1 to 8.**

### **Costs of ancillary weaving equipment**

**These costs are provided in Table IV.12. The same assumptions as those made for the looms apply to this equipment.**

**Table IV.12**  
**Cost of ancillary weaving equipment and space requirements**

Equipment	<b><u>Options 1, 2 and 3</u></b> <b>(100,000 metres/year)</b> <b>(3000 working hours)</b>			<b><u>Options 2, 3, 4 and 5</u></b> <b>(1,000,000 metres/year)</b> <b>(5000 working hours)</b>			<b><u>Options 3, 4, 5, 6, 7 and 8</u></b> <b>(5,000,000 metres/year)</b> <b>(6500 working hours)</b>		
	<b>Machines needed No.</b>	<b>Total cost £</b>	<b>Total Floor area (m<sup>2</sup>)</b>	<b>Machines needed No.</b>	<b>Total cost £</b>	<b>Total Floor area (m<sup>2</sup>)</b>	<b>Machines needed No.</b>	<b>Total cost £</b>	<b>Total Floor area (m<sup>2</sup>)</b>
Hand looming frames	2	1 000	20	2	2000	60	5	5 000	150



Hand-loomed frames	2	1,000	30	3	2000	90	3	5,000	150
Reed drawing machine	Not appropriate			Not appropriate			1?	5,000	2
Warp knotting machine	Not appropriate			Not appropriate			1?	5,000	2
Drop - pinning machine	Not appropriate			Not appropriate			1?	5,000	2
Heald and reed polishing machine	Not appropriate			1	5,000	20	1	5,000	20
Pirn stripping machine	Not appropriate			1?	4,000	15	1?	4,000	15
<u>Cloth Inspection</u>									
Examining tables	1?	2,000	30	1	2,000	30	3	6,000	90

? - Indicates that this equipment may not be considered essential in every case

**Note:** See section II for the definition of options 1 to 8.

### Costs of repair and renewals

Table IV.13 provides estimates of the cost of repairs and renewals for each weaving option and scale of production. The assumptions made in estimating these costs are summarised at the bottom of the table.

**Table IV.13**  
**Annual repairs and renewals costs**  
**(in £ Sterling.)**

Production level p.a. and option	LOW COST BUILDING					HIGH COST BUILDING				
	Looms	Other machines	Building	Services	Total	Looms	Other machines	Building	Services	Total
100.000 m/yr										
Op. 1	350	1,770	720	280	3,120	350	1,770	4,600	4,430	11,150
Op. 2	500	1,770	360	140	2,770	500	1,770	2,270	2,190	6,730
Op. 3	500	1,770	250	100	2,620	500	1,770	1,610	1,550	5,430
1.0M m/yr										
Op. 1	5 210	9 600	1 760	680	17 250	5 210	9 600	11 170	10 750	26 730

Op. 2	5,210	9,600	1,700	440	17,250	5,210	9,600	11,170	10,750	20,750
Op. 3	4,120	9,600	1,130	440	15,290	4,120	9,600	7,210	6,940	27,870
Op. 4	5,740	9,600	1,100	420	16,860	5,740	9,600	6,990	6,720	29,050
Op. 5	5,700	9,600	1,120	430	16,850	5,700	9,600	7,100	6,840	29,240
5.0M m/yr										
Op. 3	21,000	19,600	2,660	1,030	44,290	21,000	19,600	16,940	16,300	73,840
Op. 4	29,100	19,600	2,520	970	52,190	29,100	19,600	16,040	15,440	80,180
Op. 5	28,800	19,600	2,590	1,000	51,990	28,800	19,600	16,470	15,850	80,720
Op. 6	63,800	13,300	1,670	640	79,410	63,800	13,300	10,630	10,240	97,970
Op. 7	46,200	13,300	1,770	680	61,950	46,200	13,300	11,260	10,830	81,590
Op. 8	24,250	13,300	1,560	600	39,710	24,250	13,300	9,950	9,570	57,070

**Note:- The above figures are based on the data given in Tables 2, 3, 4, 6, and calculated at the following rates per cent.**

**Looms:- 100,000 m/yr - 5% p.a; 1.0M m/yr - 7.5% p.a; 5.0M m/yr, Options 3, 4, 5, - 10% p.a. Options 6, 7, 8, - 5% p.a.**

**Other machines:- 100,000 m/yr, plant at mill - 5% p.a. plant at warp suppliers - 7.5% p.a. 1.0M m/yr - 7.5% p.a. 5.0M m/yr - 10% p.a.**

**Buildings:- All production levels/Options - 3% p.a.**

**Services:- All production levels/Options - 5% p.a.**

**Note: See section II for the definition of options 1 to 8.**

### **Salvage value of equipment and buildings**

**Estimates of salvage value of equipment and buildings are provided in Table IV.14. The assumptions made in estimating these values are summarised at the bottom of the table for both low amenity and high amenity buildings.**

**Table IV.14**  
**Salvage value of buildings and equipment**

<b>Low amenity (low cost) building</b>								
<b>Production level and Option No.</b>	<b>Sums realisable at end of 15 years</b>						<b>Net Present value</b>	
	<b>1 Looms &amp; other machines</b>	<b>2 Building with services</b>	<b>3 Building only</b>	<b>4 Services only</b>	<b>5 Land + 1 &amp; 2</b>	<b>6 Land + 1, 3 &amp; 4</b>	<b>7 Land + 1 &amp; 2</b>	<b>8 Land + 1, 3 &amp; 4</b>
<b>0.1M m/yr</b>								
Op. 1	4,070	6,730	6,030	280	12,830	12,410	3,880	3,810
Op. 2	4,450	3,310	2,970	140	8,750	8,550	2,320	2,280
Op. 3	4,450	2,350	2,110	100	8,620	7,360	1,860	1,840
<b>1.0M m/yr</b>								
Op. 2	24,690	16,330	14,640	680	46,000	44,990	11,990	11,820
Op. 3	22,870	10,540	9,450	440	36,620	35,970	8,930	8,820
Op. 4	25,560	10,210	9,150	420	38,880	38,240	9,220	9,110
Op. 5	25,500	10,380	9,300	430	39,040	38,390	9,290	9,180
<b>5.0M m/yr</b>								
Op. 3	50,750	24,760	22,190	1,030	83,060	81,520	20,460	20,200
Op. 4	60,870	23,440	21,010	970	91,460	90,000	21,570	21,320
Op. 5	60,500	24,060	21,570	1,000	91,900	90,410	21,810	21,550
Op. 6	176,120	15,540	13,930	640	196,400	195,430	57,510	37,350
Op. 7	132,120	16,450	14,750	680	153,590	152,570	30,420	30,250
Op. 8	77,250	14,540	13,030	600	96,220	95,310	20,130	19,970
<b>High amenity (high cost) building</b>								
<b>Production level and Option No.</b>	<b>Sums realisable at end of 15 years</b>						<b>Net Present value</b>	
	<b>1</b>	<b>2</b>	<b>3</b>	<b>4</b>	<b>5</b>	<b>6</b>	<b>7</b>	<b>8</b>

	<b>Looms &amp; other machines</b>	<b>Building with services</b>	<b>Building only</b>	<b>Services only</b>	<b>Land + 1 &amp; 2</b>	<b>Land + 1, 3 &amp; 4</b>	<b>Land + 1 &amp; 2</b>	<b>Land + 1, 3 &amp; 4</b>
<b>0.1M m/yr</b>								
Op. 1	4,070	49,410	38,340	4,430	55,510	48,870	11,180	10,050
Op. 2	4,450	24,380	18,920	2,190	29,820	26,550	5,910	5,350
Op. 3	4,450	17,310	13,430	1,550	22,460	20,130	4,420	4,020
<b>1.0M m/yr</b>								
Op. 2	24,690	119,970	93,090	10,750	149,640	133,510	29,720	26,960
Op. 3	22,870	77,430	60,080	6,940	103,510	93,100	20,360	18,580
Op. 4	25,560	75,030	58,220	6,720	103,700	93,610	20,310	18,590
Op. 5	25,500	76,270	59,180	6,840	104,930	94,680	20,560	18,810
<b>5.0M m/yr</b>								
Op. 3	50,750	181,910	141,150	16,300	240,210	215,750	47,340	43,160
Op. 4	60,870	172,240	133,650	15,440	240,260	217,110	47,010	43,050
Op. 5	60,500	176,860	137,230	15,850	244,700	220,920	47,940	43,870
Op. 6	176,120	114,210	88,620	10,240	295,070	279,720	54,380	51,760
Op. 7	132,120	120,880	93,800	10,830	258,020	241,770	48,280	45,500
Op. 8	77,250	106,810	82,880	9,570	188,490	174,130	35,900	33,450

**Note: See section II for the definition of options 1 to 8.**

### **Depreciation costs**

**Depreciation costs have been estimated on the basis of an interest rate of 12.5%, fixed capital requirements shown in Table IV.15, the assumed salvage value of buildings and equipment shown in Table IV.14 and an assumed economic life of buildings and equipment of 15 years. Estimates of depreciation costs for each weaving option and scale of production are provided in Table IV.16 for both low amenity and high amenity buildings.**

**Table IV.15**  
**Fixed capital requirement (£ Sterling)**

<b>Weaving</b>	<b>Production level</b>	<b>Production level</b>	<b>Production level</b>
----------------	-------------------------	-------------------------	-------------------------

weaving options	Production level (100,000 m/yr; 3,000 wkg hours)			Production level (1,000,000 m/yr; 5,000 wkg hours)			Production level (5,000,000 m/yr; 6,500 wkg hours)		
	Looms and other machines	Buildings	Total	Looms and other machines	Buildings	Total	Looms and other machines	Buildings	Total
<u>Low cost building</u>									
Op. 1	32,600	31,710	64,310						
Op. 2	35,600	15,640	51,240	197,500	77,070	274,570			
Op. 3	35,600	11,100	46,700	183,000	49,740	232,740	406,000	116,850	522,850
Op. 4				204,500	48,190	252,690	487,000	110,640	597,640
Op. 5				204,000	48,990	252,990	484,000	113,600	597,600
Op. 6							1,399,000	73,360	1,472,360
Op. 7							1,047,000	77,560	1,124,560
Op. 8							608,000	68,610	694,610
<u>High cost building</u>									
Op. 1	32,600	244,010	276,610						
Op. 2	35,600	120,380	155,980	197,500	592,420	789,920			
Op. 3	35,600	85,500	121,100	183,000	382,350	565,350	406,000	898,240	1,304,240
Op. 4				204,500	370,500	575,000	487,000	850,530	1,337,530
Op. 5				204,000	376,580	580,580	484,000	873,270	1,357,270
Op. 6							1,399,000	563,930	1,962,930
Op. 7							1,047,000	596,910	1,643,910
Op. 8							608,000	527,420	1,135,420

**Note:** See section II for the definition of options 1 to 8.

**Table IV.16**  
**Annual Depreciation Costs (£ Sterling)**

Production level and	Low amenity (low cost) building	High amenity (high cost) building
----------------------	---------------------------------	-----------------------------------

Option No								
	Looms & other machines	Buildings	Services	Total	Looms & other machines	Buildings	Services	Total
<u>0.1M m/yr</u>								
Op. 1	4,820	3,480	820	9,120	4,820	22,170	13,090	40,080
Op. 2	5,260	1,720	410	7,390	5,260	10,940	6,460	22,660
Op. 3	5,260	1,220	290	6,770	5,260	7,770	4,590	17,620
<u>1.0M m/yr</u>								
Op. 2	29,180	8,460	2,000	39,640	29,180	53,830	31,780	114,790
Op. 3	27,040	5,460	1,290	33,790	27,040	34,740	20,510	82,290
Op. 4	30,220	5,290	1,250	36,760	30,220	33,660	19,880	83,760
Op. 5	30,140	5,380	1,270	36,790	30,140	26,810	20,200	77,150
<u>5.0M m/yr</u>								
Op. 3	60,000	12,830	3,030	75,860	60,000	81,610	48,190	189,800
Op. 4	71,960	12,150	2,870	86,980	71,960	77,280	45,630	194,870
Op. 5	71,520	12,470	2,950	86,940	71,520	79,340	46,850	197,710
Op. 6	208,210	8,060	1,900	218,170	208,210	51,240	30,250	289,700
Op. 7	156,200	8,530	2,020	166,750	156,200	54,230	32,010	242,440
Op. 8	91,320	7,530	1,780	100,630	91,320	47,950	28,290	167,560

**Note:- Calculations based, for all items and options, on residual values at end of 15 years. Machinery and services equipment is assumed to have a residual value of 12½% of cost value after 15 years and buildings are assumed to have a residual value of 25% after 15 years.**

**Note: See section II for the definition of options 1 to 8.**

### **Interest payments on working capital**

**For the sake of simplicity, this cost item was not included in the economic evaluation of the 8 weaving options.**

## **IV.2 Findings from the economic comparison of the selected weaving options**

**Prior to presenting the findings of the economic comparison of alternative weaving technologies, a few remarks need to be made. Firstly, this economic comparison of weaving technologies covers three scales of production only: 100,000 m/year 1,000,000 m/year and 5,000,000 m/year. Findings presented in this section may not, therefore, be generalised to other scales of production, especially those outside the range 100,000 m/year to 5,000,000 m/year. However, these findings should not substantially contradict those which would have been derived from the evaluation of other scales of production. Readers interested in other production levels are nevertheless urged to undertake their own evaluation in the way described in the previous section.**

**Secondly, the findings to be presented in this section are based on a large number of assumptions of technical and economic natures. While the former assumptions should reflect real conditions prevailing in developing countries, the latter ones (e.g. wages, salaries, unit energy costs) will not probably apply to a large number of developing countries. This is a second important reason for not adopting these findings at face value, and the interested reader is urged to undertake his own evaluation on the basis of local factor prices and conditions.**

**Findings from the economic comparison of weaving technologies will be analysed with respect to the following factors: unit production costs, fixed capital requirements, building costs, repairs and renewals costs, energy costs, salary and wages, employment potential and training costs, and product mix and specialisation.**

### **IV.2.1 Unit production costs**

**This factor is by far the most important one among those listed above since it determines, to a large extent, the profitability - from the point of view of the producer - of the various weaving options. However, as it will be shown later in this chapter and in the next one, other factors may also affect the choice of weaving technology.**

**Table IV.17**  
**Annual cost of warping, sizing, pirning and weaving**

	<b>Low amenity (low cost) building - £ sterling</b>						
	<b>Production level 0,1M m/year</b>			<b>Production level 1.0M m/year</b>			
<b>Option No.</b>	<b>1</b>	<b>2</b>	<b>3</b>	<b>2</b>	<b>3</b>	<b>4</b>	<b>5</b>

Salaries and Wages	15,420	6,820	3,230	60,190	17,570	14,140	13,820
Energy	1,070	610	1,230	4,830	10,400	10,350	10,360
Repairs and Renewals	3,120	2,770	2,620	17,250	15,290	16,860	16,850
Depreciation	9,120	7,390	6,770	59,640	33,790	36,760	36,790
Conversion Cost	28,730	17,590	13,850	121,910	77,050	78,110	77,820
<b>High amenity (high cost) building - £ sterling</b>							
	<b>Production level 0,1M m/year</b>			<b>Production level 1.0M m/year</b>			
<b>Option No.</b>	<b>1</b>	<b>2</b>	<b>3</b>	<b>2</b>	<b>3</b>	<b>4</b>	<b>5</b>
Salaries and Wages	15,420	6,820	3,230	60,190	17,750	14,140	13,820
Energy	2,060	1,090	1,580	8,910	13,520	13,400	13,440
Repairs and renewals	11,150	6,730	5,430	36,730	27,870	29,050	29,240
Depreciation	40,080	22,660	17,620	114,790	82,290	83,760	77,150
Conversion Cost	68,710	37,300	27,860	220,620	141,250	140,350	133,650
<b>Low amenity (low cost) building - £ sterling</b>							
	<b>Production level 5.0M m/year</b>						
<b>Option No.</b>	<b>3</b>	<b>4</b>	<b>5</b>	<b>6</b>	<b>7</b>	<b>8</b>	
Salaries and Wages	71,320	59,330	53,350	31,790	34,670	36,180	
Energy	46,510	46,120	46,000	22,490	24,330	40,520	
Repairs and renewals	44,290	52,190	51,990	79,410	61,950	39,710	
Depreciation	75,860	86,980	86,940	218,170	166,750	100,630	
Conversion Cost	237,980	244,620	238,280	351,860	287,700	217,040	
<b>High amenity (high cost) building - £ sterling</b>							
	<b>Production level 5.0M m/year</b>						
<b>Option No.</b>	<b>3</b>	<b>4</b>	<b>5</b>	<b>6</b>	<b>7</b>	<b>8</b>	
Salaries and Wages	71,320	59,330	53,350	31,790	34,670	36,180	
Energy	57,070	56,260	56,320	28,650	30,890	47,600	
Repairs and renewals	73,840	80,180	80,720	97,970	81,590	57,070	
Depreciation	189,800	194,870	197,710	289,700	242,440	167,560	



Conversion Cost	392,030	390,640	388,100	448,110	389,590	308,410	
-----------------	---------	---------	---------	---------	---------	---------	--

**Note: See section II for the definition of options 1 to 8.**

**Table IV.18**  
**Costs per metre of cloth (Pence)**

**Scale of prod. and option No.**  
**Low amenity (low cost) building**

**Production level 0.1M m/year    Production level 1.0M m/year**

<b>Cost items</b>	<b>1</b>	<b>2</b>	<b>3</b>	<b>2</b>	<b>3</b>	<b>4</b>	<b>5</b>
Conversion	28,730	17,590	13,850	12,191	7,705	7,811	7,782
Yarn	<u>19,584</u>	<u>19,584</u>	<u>19,584</u>	<u>19,584</u>	<u>19,584</u>	<u>19,584</u>	<u>19,584</u>
Grand total	<u>48,314</u>	<u>37,174</u>	<u>33,434</u>	<u>31,775</u>	<u>27,289</u>	<u>27,395</u>	<u>27,366</u>

**High amenity (high cost) building**

Conversion	68,710	37,300	27,860	22,062	14,125	14,035	13,365
Yarn	<u>19,584</u>	<u>19,584</u>	<u>19,584</u>	<u>19,584</u>	<u>19,584</u>	<u>19,584</u>	<u>19,584</u>
Grand total	<u>88,294</u>	<u>56,884</u>	<u>47,444</u>	<u>41,646</u>	<u>33,709</u>	<u>33,619</u>	<u>32,949</u>

**Production level 5.0M m/year**

**Low amenity (low cost) building**

<b>Option No.</b>	<b>3</b>	<b>4</b>	<b>5</b>	<b>6</b>	<b>7</b>	<b>8</b>
Conversion	4,760	4,892	4,766	7,037	5,754	4,341
Yarn	<u>19,584</u>	<u>19,584</u>	<u>19,584</u>	<u>19,584</u>	<u>19,584</u>	<u>19,584</u>
Grand total	<u>24,344</u>	<u>24,476</u>	<u>24,350</u>	<u>27,013</u>	<u>25,730</u>	<u>24,317</u>

**High amenity (high cost) building**

Conversion	7,841	7,813	7,762	8,962	7,792	6,168
Yarn	<u>19,584</u>	<u>19,584</u>	<u>19,584</u>	<u>19,976</u>	<u>19,976</u>	<u>19,976</u>
Grand total	<u>27,425</u>	<u>27,397</u>	<u>27,346</u>	<u>28,938</u>	<u>27,768</u>	<u>26,144</u>

**Note: See section II for the definition of options 1 to 8.**

The following table - which is based on Table IV.17 and IV.18 - provides the rank of each weaving option with respect to unit production cost (i.e. the lower the rank the higher the unit production cost).

**Table IV.19**  
**Ranking of weaving options with respect to unit production costs**

Scales Weaving options	Small-scale		Medium-Scale		Large-scale	
	Low build. cost	High build. cost	Low build. cost	High build. cost	Low build. cost	High build. cost
1. Hand-loom with fly-shuttle	3	3				
2. Hand-loom treadle operated	2	2	4	4		
5. Non-automatic power-loom	1	1	1	3	2	4
4. Low-cost automatic power loom			3	2	4	3
5. Low-cost automatic power loom			2	1	3	2
6. Projectile loom					6	6
7. Rapier loom					5	5
8. Air-jet loom					1	1

**Note:** See section II for the definition of options 1 to 8.

Table IV.19 shows that weaving option 3 (non-automatic power loom) is associated with the lowest unit production costs at the small-scale level and in the medium-scale, low-cost building case. Furthermore, this option is only marginally more costly in the remaining three cases at the medium and large-scale levels. Weaving options 5 (low-cost automatic power looms/two-cloth width) is associated with relatively low unit production costs at the medium and large-scale cases, ranking 1st and 2nd in 3 out of the four cases considered. The air-jet loom (weaving option 8) is associated with the lowest unit production cost at the large-scale level. Thus, depending on the scale of production and the adopted building amenity level, weaving options 3, 5 and 8 seem to be the most attractive from the point of view of unit production costs. It should, however, be pointed out that with the exception of the two hand-loom options (1 and 2) and the projectile and rapier looms, unit production costs do not diverge substantially from one option to another. Thus, small differences between local factor prices and those assumed in this evaluation could change the ranking in Table IV.19.

### **IV.2.2 Fixed capital requirements**

**Table IV.15 shows that non-automatic power looms (option 3) are associated with the lowest fixed capital requirements for 7 out of the 8 combinations of sables and amenity levels, the only exception being the large-scale high-cost building case. These findings indicate that the high productivity of the shuttleless or automatic looms is more than offset by their high prices. For example, the productivity of projectile looms is 3.6 times greater than that of non-automatic looms (option 3) but the unit cost of the former looms is 22 times greater than that of the latter looms (see Table IV.7 which provides unit and total cost of looms for all weaving options). Weaving options 6 and 7 exhibit, by far, the highest fixed capital requirements while differences among the other options are relatively small.**

### **IV.2.3 Building costs**

**Building costs are appreciably affected by the choice of weaving technology but the degree of amenity provided by the building is a far more important factor. Table IV.15 shows that high-cost buildings are approximately 8 times more costly than low-cost buildings. Similarly, while building costs are substantially lower than the cost of equipment for a low degree of amenity (e.g. building costs are equal to approximately 27% of the cost of equipment for option 3, medium scale level, low degree of amenity) they are much higher than this latter cost for high degree of amenity (e.g. twice the cost of equipment for option 3, medium-scale, high degree of amenity). It may be noted that given the substantially lower number of looms - and therefore the smaller floor areas - required by the weaving options 6, 7 and 8 than by other weaving options, building costs for the 3 shuttleless options are much lower than those for the other options.**

**Weavers may be of the opinion that it would be more profitable to economise on building costs and use the money saved for the acquisition of more productive looms or in order to lower production costs. This view, however, would not take into consideration the importance of raised standards of amenity for labour productivity and working conditions. Higher standards should increase labour productivity and, to some extent, the quality of output and should therefore offset some of the high building costs. They are also justified from a purely social point of view. Obviously, the need for additional building costs to improve the working environment would depend on various factors, including climatological conditions, the building design, etc. Thus, it may be possible to offer suitable working conditions at a cost substantially lower than those estimated in this section.**

### **IV.2.4 Repairs and renewals costs**

**Repairs and renewals constitute an inevitable expense in the plant operation. Table IV.13 provides estimates**

**of these costs for the weaving options covered by this memorandum. In general, these costs are directly related to the complexity of the machinery used. The major proportion of repairs and renewals costs are therefore associated with the looms and other production machinery. However, where high amenity buildings are provided, costs associated with buildings and building services become relatively more important.**

**Repairs and renewals costs shown in Table IV.13 are based on the assumption that spare parts and skilled labour are readily available whenever needed. However this assumption may not apply in all cases. Thus, higher renewals and repair costs may be expected in countries where foreign exchange restrictions may slow-down the importation of spare parts or where the lack of sufficiently skilled labour may not allow an adequate operation and maintenance of equipment. Thus, weaving options which require few imported spare parts and less demanding skills should be favoured with respect to this factor.**

#### **IV.2.5 Energy costs**

**Energy costs for each weaving option are shown on Table IV.10. As it may be expected, the cost of energy per unit of production decreases slightly as the scale of production increases as a result of economies of scale (e.g. £1230 of energy cost for 100,000 m/year versus £10400 for 1,000,000 m/year) These economies of scale apply to all weaving options and degrees of amenity for the buildings.**

**In the case of small-scale production, option 2 (hand-loom, treadle-operated) uses much less energy than option 1 and 3, the latter two options being fairly close in terms of energy use although no energy is needed for the operation of the hand-loom of option 1. The reason for the relatively high energy use in option 1 relates to the need for lighting a much larger number of looms than in the case of option 3. It may, however, be noted that the need for artificial lighting is dependent on the availability of sunlight (e.g. buildings equipped with large windows) and that option 1 may not always need more energy than option 3 in the case of low-cost buildings.**

**In the case of medium-scale production, option 2 uses, by far, the least amount of energy as the looms are manually operated and the extra energy for lighting and other services is more than offset by the extra energy needed by the other options (3, 4, 5) for the operation of the looms. On the other hand, the weaving options 3, 4 and 5 use approximately the same amount of energy.**

**In the case of large-scale production, options 3, 4, 5 and 8 use almost twice the amount of energy needed by options 6 and 7, as the projectile and rapier looms are much less energy-intensive than the other types of looms used at the large-scale level. Option 8 (air-jet looms) uses approximately 15% less than options 3, 4**

**and 5 as the ancillary equipment of these latter options use more energy than that for option 8.**

**In all cases, energy use associated with high-cost buildings is substantially higher than that associated with low-cost buildings, the difference ranging between approximately 25% and 100%.**

#### **IV.2.6 Employment potential and training costs**

**Employment generation and skills requirements constitute two important factors in the choice of weaving technology, the former factor being of particular importance to public planners while the latter should be of concern to the textile producer.**

**Table IV.20 based on Table IV.6, provides estimates of the total number of labour required for 100,000 m of cloth for each weaving option and scale of production. The table shows that the total number of labour decreases as the scale of production increases for all weaving options. This decrease affects the three categories of labour (i.e. "managers and technologists", "supervisors and technicians" and "weavers and others") shown in Table IV.20. This is to be expected since an increase in the scale of production generally results in substantial economies of scale.**

**Table IV.20**  
**Total labour requirements for 100,000 m of cloth**

<b>Weaving option and scale of production</b>	<b>Managers and technologists</b>		<b>Supervisors and technicians</b>		<b>Weavers and others</b>		<b>Total</b>
	<b>Weaving</b>	<b>Other</b>	<b>Weaving</b>	<b>Other</b>	<b>Weaving</b>	<b>Other</b>	
<u>100.000 m/year</u> (1 shift)							
Option 1	1	0	3	1	77	10	92
Option 2	1	0	2	1	26	8	38
Option 5	1	0	2	1	5	6	15
<u>1,000,000 m/year</u> (2 shifts)							
Option 2	.4	.2	1.2	.4	30	3.2	35.4
Option 5	.4	.2	.4	.4	5	2,6	9.0
Option 4	.4	.2	.4	.4	2.8	2.6	6.8

Option 5	.4	.2	.4	.4	2.6	2.6	6.6
5,000.000 m/year (3 shifts)							
Option 5	.36	.12	.42	.18	4.92	1.38	7.38
Option 4	.42	.12	.48	.18	3.06	1.38	5.64
Option 5	.30	.12	.36	.18	2.94	1.38	5.28
Option 6	.18	.12	.12	.18	1.32	1.14	3.06
Option 7	.18	.12	.18	.18	1.56	1.14	3.36
Option 8	.24	.12	.18	.18	1.56	1.14	3.42

**Note:** See section II for the definition of options 1 to 8.

The highest level of employment per unit of output is generated, at the small-scale level, by weaving option 1, while option 3 is the most labour-intensive option among those which make use of engine-powered looms. On the other hand, the three shuttleless options generate the least employment.

As can be expected, the category "weavers and others" contributes the most to employment generation. Labour in this category increases, as a fraction of total labour requirements, with the scale of production while the fraction of the other two categories of labour decreases. This is also to be expected as a result of economies of scale in the use of managerial and supervisory staff.

Skill requirements per unit of output - in terms of managerial staff, technologists, supervisors and technicians - decreases as the scale of production increases. On the other hand, while skill requirements for all options are identical at the small-scale and medium-scale levels-with exception of options 1 and 2 which require a larger supervisory staff in weaving - these requirements differ from one weaving option to another at the large scale of production. In this latter case, the shuttleless weaving options are generally the least demanding of skilled labour as compared to options 3, 4 and 5.

At this juncture, it is pertinent to consider the extent to which the estimates of Table IV.20 may be taken at their face value. Are 'better' people needed when more sophisticated technologies are used? This question may not be easily answered. It is not a matter of better people being needed for the higher technologies, but rather one of equally good people being given appropriate training, being prepared to accept the objective specifications of a machinery maker, and resisting the temptation to use personal judgement and rule-of-thumb as an alternative. So far as managers and supervisors are concerned there is no real problem. A

**manager or supervisor of given qualifications will usually perform his duties efficiently whatever technological option is employed. For technologists and technicians, the nature of their education and of their training in relation to a particular option can be of considerable importance. This is not to say that personnel of different qualifications are required for different options, or that there are significant differences in the inherent complexities of the technologies. In general, it may be said that technologists and technicians of equal qualifications will prove equally capable of using efficiently whatever weaving technology so long as they have been given, and have accepted, specific training in relation to that technology.**

**It must be noted, however, that whereas non-automatic looms - and to a large extent all low-cost shuttle looms - can be operated, albeit not so efficiently as one might wish, by diligent technologists and technicians largely dependent on native wit and rule-of-thumb methods, this approach is completely inapplicable to the more sophisticated machinery of options 6, 7 and 8. In this latter case, there is virtually no established rule-of-thumb and satisfactory working can only be obtained by meticulous observation of all instructions, and precise maintenance of objectively specified conditions which the machinery-maker will have provided.**

**The cost of staff training varies greatly from country to country, depending on the local educational standards, on the district in which the plant is to be located, and on the nature of the national legislation relating to industrial training. In general, a background and traditions of textile manufacture will be found to be helpful. However, where more sophisticated technologies are to be introduced in areas with experience only of labour-intensive technologies, serious difficulties of unlearning may be met. By and large, the choice of technology will not be influenced by consideration of training costs as the extent and complexity of the required training does not vary significantly from one technology to another.**

#### **IV.2.7 Product mix and specialisation**

**All weaving options can produce any one of the eight basic fabrics covered by this memorandum and all are capable of handling a complex product-mix involving all of these fabrics in any chosen proportions. It must, however, be stressed that a lack of specialisation inevitably leads to rapid escalation of production costs. The data in Table IV.21 illustrates the general effects of product variety on unit cost of production. This data was collected through field studies by the Shirley Institute in a number of countries.**

**Table IV.21**  
**Effect of product mix on productivity and unit cost of production**

Number of sorts 5 10 20 40 80

Productivity	100	98	93	86	//
Unit cost	100	104	112	130	163

**Table IV.21 shows that productivity decreases by approximately 2% and unit production costs increase by approximately 4% as the product mix increases by an additional five sorts of cloth. These effects of an increase of the product mix should apply equally to all weaving options with the possible exception of hand-loom (options 1 and 2) where an increase in the product mix may have a smaller impact on productivity and cost than in the case of the other weaving options. It is therefore recommended to specialise in a narrow range of cloth varieties unless market conditions require the production of a large variety of cloths.**

#### **IV.2.8 Concluding remarks on the economic comparison of the 8 weaving options**

**The economic comparison of the 8 weaving options yields a number of findings of interest to both the producers and public planners. These are briefly summarised below:**

- The hand-loom options, in particularly option 1, do not seem suitable for the production of large amounts of cloth for low-income groups as unit production costs are substantially higher than those obtained from other weaving options. It may, however, be noted that unit marketing and transport costs, which are usually much more higher for large-scale mills than for small-scale mills, may decrease the difference between the retail prices of cloth produced by options 1 and 2 and those of cloth produced by the other weaving options.**
- Non-automatic looms (option 3) seem to be particularly appropriate in terms of unit production costs, fixed capital requirements, employment generation, etc.**
- Rapier and projectile looms do not seem appropriate to conditions prevailing in developing countries both in terms of production costs and employment generation.**
- Differences among weaving options 3, 4, 5 and 8 are in general small, and small variations in factor prices should be sufficient to modify the ranking of the above four weaving options in terms of unit production costs, fixed capital requirements, energy costs, etc. The suitability of these weaving options should therefore vary from country to country, and no overall recommendations may be made regarding one or another of these four options. The choice of weaving option/scale of production should therefore be undertaken on the basis of local factor prices, taking into consideration financial constraints, the availability of skilled labour, market demand, etc.**

**This chapter was mostly concerned with the feasibility of alternative weaving options from the point of view**



**of the private producer, and did not take into consideration various factors of interest to public planners, such as the impact of alternative weaving technologies on the balance of payments, the satisfaction of the basic needs of low-income groups, employment generation, etc. These aspects are considered in the following chapter where a number of policy measures are also suggested with a view to promoting weaving technologies suitable to prevailing local socio-economic conditions.**

