

**AT** MICROFICHE  
REFERENCE  
LIBRARY

A project of Volunteers in Asia

Ox-Drawn Tie-Ridger/Weeder Implement  
ITDG Agricultural Equipment and Tools No. 11

Published by:  
Intermediate Technology Publications, Ltd.  
9 King Street  
London WC2E 8HN  
United Kingdom

Paper copies are 0.50 British pounds.

Available from:  
Intermediate Technology Publications, Ltd.  
9 King Street  
London WC2E 8HN  
United Kingdom

Reproduced by permission of Intermediate  
Technology Publications, Ltd.

Reproduction of this microfiche document in any  
form is subject to the same restrictions as those  
of the original document.

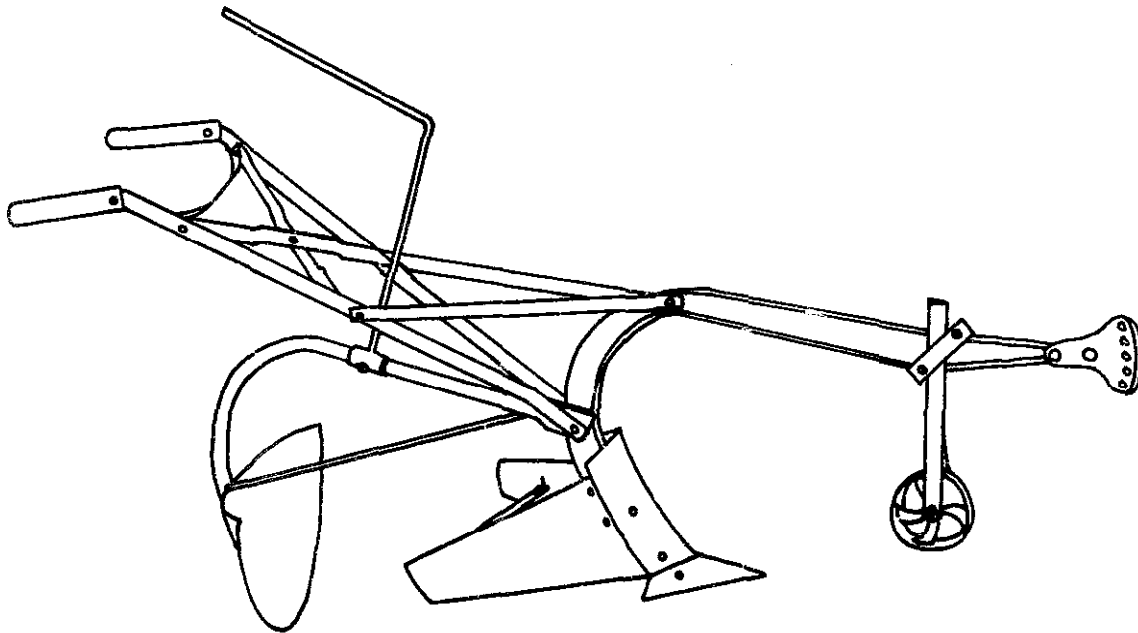

OX-DRAWN TIE-RIDGER/WEEDE  
IMPLEMENT

OX-DRAWN TIE-RIDGER, WEEDEE IMPLEMENT  
(FOR ATTACHMENT TO "EMCOT" RIDGING PLOUGH)

DEVELOPED BY: A.R. STOKES, Northern Nigeria.

DESCRIPTION: This implement is designed for attachment to the "Emcot" ox-drawn ridging plough, a  $\frac{1}{2}$ " (12.5) diameter bolt (of sufficient length) with lock nuts being used to hold the ridger handles to the plough beam, allowing the attached implement to pivot freely.

This attachment can be used for crosstying when ridging is carried out, and for crosstying and/or weeding after the ridging operation. During field use the implement handle is raised, then quickly dropped, every 6' to 9' or as required, leaving a crosstie of earth and/or weeds in the furrow.

On certain free-draining soils in Africa, the use of this implement has:

- (1) increased crop yields by up to 100% where planting on tied-ridges was compared with planting on the flat;
- (2) reduced the labour requirement for the combined land preparation and weeding operations by 60% when compared with cultivation by hand.

Note: Figures in brackets are in millimetres.

KEY:

<u>ITEM</u>	<u>NAME</u>	<u>QUANTITY</u>	<u>ITEM DESCRIPTION</u>
A	HANDLE	1	Of $\frac{1}{2}$ " (12.5) internal diameter mild steel pipe.
B	ATTACHMENT BRACKET	1	Made of one piece 2" x $\frac{1}{4}$ " x 11" (51 x 6.3 x 279) mild steel.
C	SLEEVE	1	Of $1\frac{1}{2}$ " (38) internal diameter mild steel pipe 3" (76) long, fitted with $\frac{1}{2}$ " (12.5) diameter locking bolt.
D	BEAM	1	Of 1" (25) or $1\frac{1}{4}$ " (32) internal diameter mild steel pipe.
E	PIVOT BOLT HOLE	1	$\frac{1}{2}$ " (12.5) diameter hole to take pivot/attachment bolt.
F	BRACE	1	Of $\frac{3}{8}$ " (9.5) diameter mild steel round bar.
G	SHARE SUPPORT PLATE	1	Of 7" x 2" x $\frac{1}{4}$ " (178 x 51 x 6.3) mild steel.
H	SHARE	1	An old plough disc of 22" to 24" (559 to 610) diameter, cut in half for share.
J	REAR VIEW OF SHARE		Showing method of securing the beam D to share support plate G.
K	BRACKET	2	Each of 1" x 1" (25 x 25) mild steel angle iron, 2" (51) long, welded to D and G.

