

AT MICROFICHE
REFERENCE
LIBRARY

A project of Volunteers in Asia

Making Coir Rope VITA Technical Bulletin 44

Published by:
Volunteers in Technical Assistance
1815 North Lynn St. Suite 200
P.O. Box 12438
Arlington, VA 22209 USA

Paper copies are \$ 1.00.

Available from:
Volunteers in Technical Assistance
1815 North Lynn St. Suite 200
P.O. Box 12438
Arlington, VA 22209 USA

Reproduced by permission of Volunteers in
Technical Assistance.

Reproduction of this microfiche document in any
form is subject to the same restrictions as those
of the original document.



TECHNICAL BULLETIN 44

MAKING COIR ROPE

There are many models and types of rope making machines, most of them automatic. Virtually all are designed to handle sisal, cotton or other long fibered material and are complicated and expensive. Prior to the invention of automatic machinery, ropes of all types were manufactured with the use of simple homemade tools, all of wood.

Coir (coconut fiber) is short, rough, and difficult to handle, but the finished rope is relative strong, rot resistant, and buoyant in water.

Please send testing results, comments, suggestions and requests for further information to:

Technical Bulletins
VITA Publications Service
3706 Rhode Island Avenue
Mt. Rainier, Maryland 20822 USA

**VOLUNTEERS
IN TECHNICAL
ASSISTANCE**

3706 Rhode Island Avenue

Mt Rainier, Maryland, USA 20822

Definitions

Yarn: a twisted cord about 1/8" in diameter made up of overlapping fibers.

Strand: a twisted cord (the twist is opposite that of the yarn) about 1/2" in diameter made up of yarns.

Rope: a twisted cord (the twist is opposite that of a strand) made up of three strands.

Right Hand Twist: if the rope is hung vertically, the fibers run up and to the right.

Left Hand Twist: if the rope is hung vertically, the fibers run up and to the left.

Fiber Preparation

- A. The coconut husks must be soaked in water for a few weeks or until the fibers can be separated. Try to make the separated fibers as long as possible. The longer the fibers, the easier it will be to make rope with them.
- B. When a large mass of fibers has been collected, it must be combed to straighten the fibers. Since the coir fiber is short, it may be straightened by hand.

Twisting

Yarns, strands and ropes are all made by twisting fibers. Figures 2 and 3 illustrate single and multiple twisting reels. Both are designed to be made of wood with a minimum of tools. Each reel has a strong hook on the business end.

Yarn

One-Ply Yarn: Select a large batch of fibers and tuck it under your arm. Station someone to turn the reel. Take a small bunch of fibers (enough to make a 1/8" dia. yarn--say 15 to 18 fibers) and tie the end to the hook on the reel. Feed additional fibers so as to intersperse them with the first fibers (1/2 to 2/3 overlap) while providing a right hand twist to the yarn. Back away from the turning reel while continuing to feed fibers to the yarn. Put approximately 12 to 14 turns per foot of length. When you have twisted the length of yarn you desire, remove yarn from reel and secure both ends to the ground with rocks. A single yarn is unstable so must be prevented from untwisting.

Make a large number of yarns the same length as the one above. For small ropes, say 4" circumference and smaller, single ply yarns are grouped together to make a strand. For larger ropes two-ply yarns should be used.

FIGURE 1

Fiber Combing Board

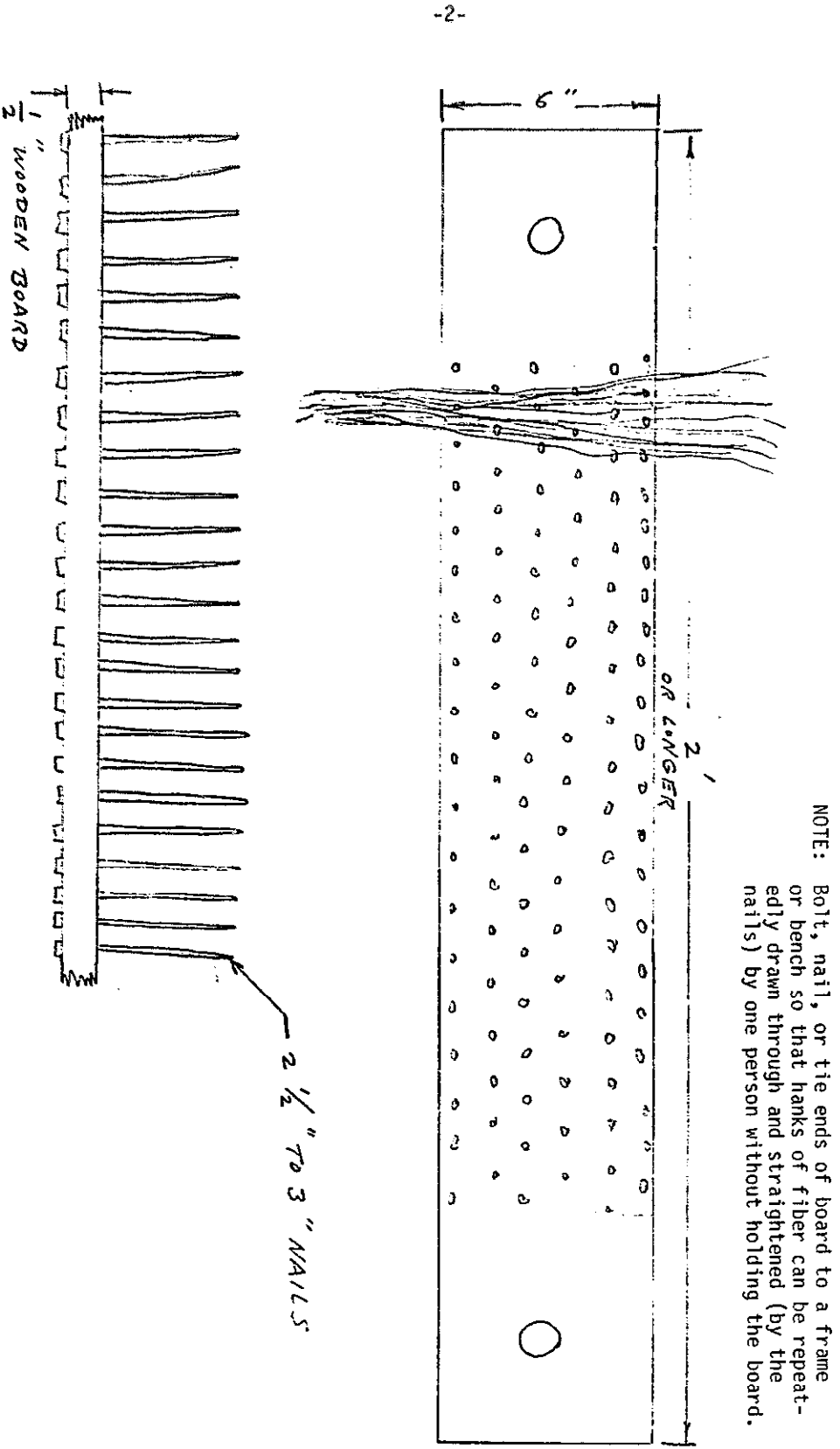

FIGURE 2

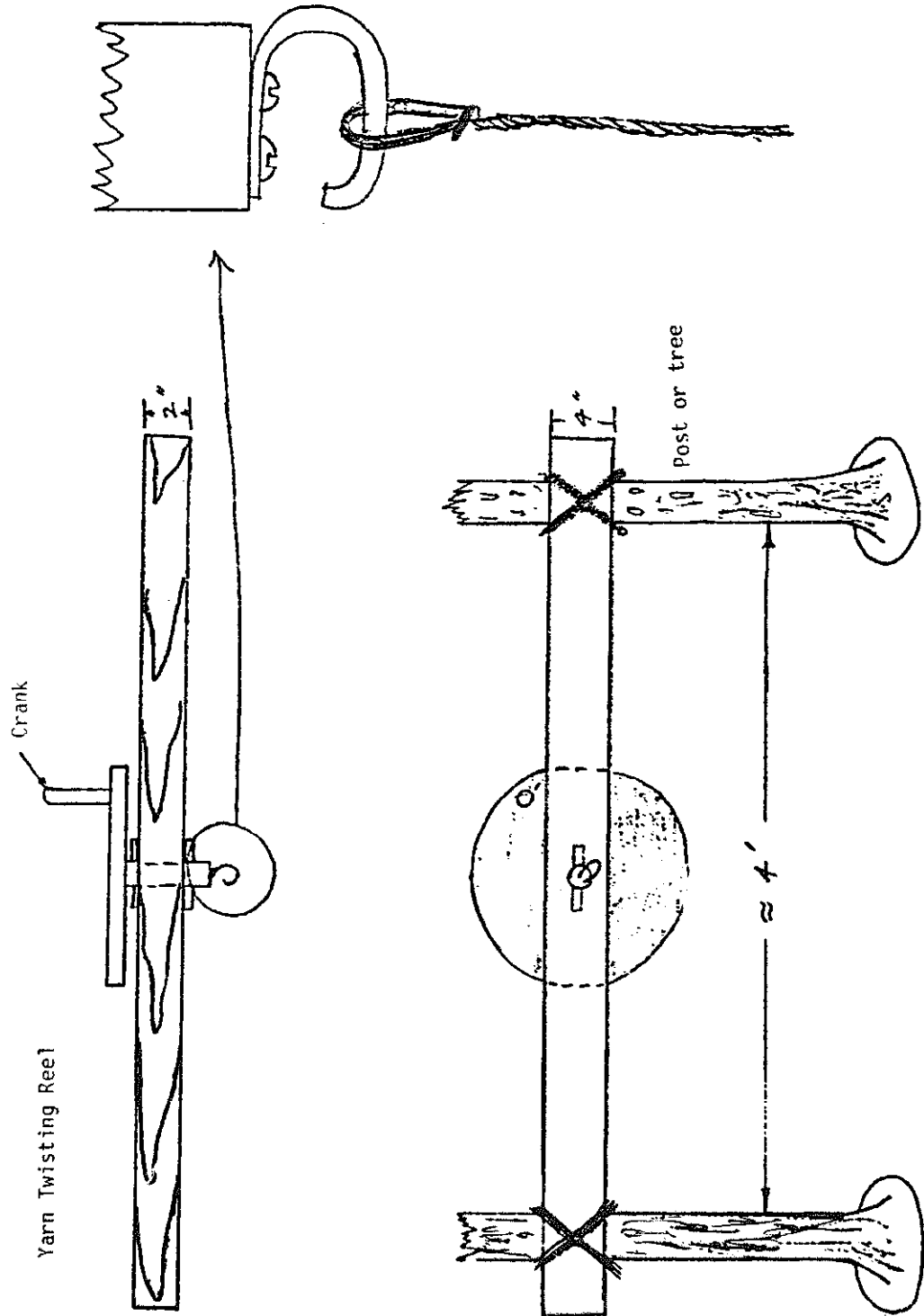
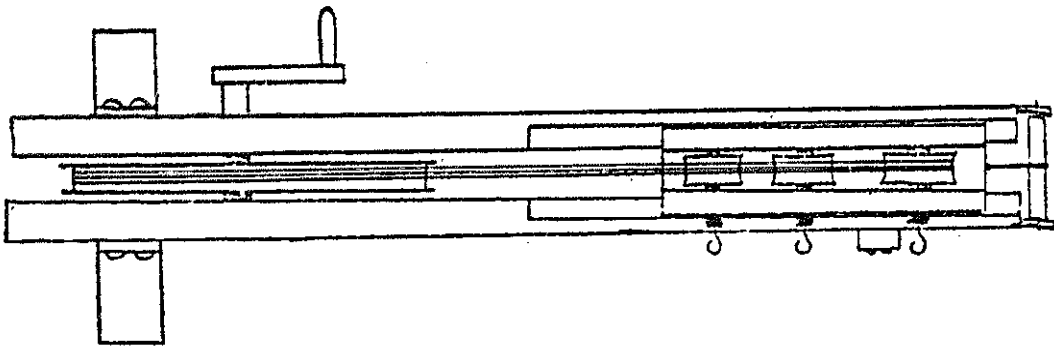
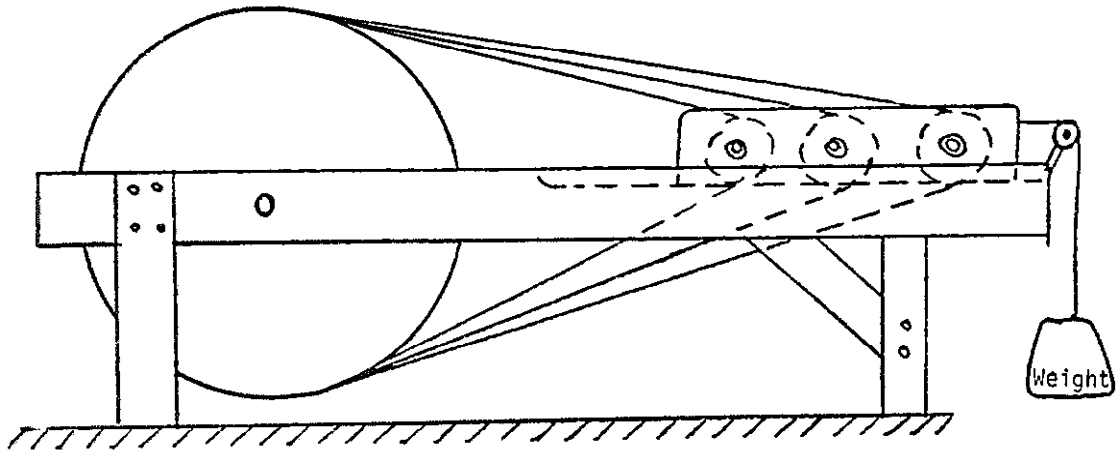

FIGURE 3

Multiple Yarn Twisting Reel



NOTE: Three yarn twisting hooks twist three yarns simultaneously. One continuous cord operates spindles. Weight keeps constant tension.

Two-Ply Yarn: To make a two-ply yarn, fasten one end of each of two single-ply yarns to a reel hook (A) and prevent the reel from turning. Fasten the other end of each yarn to reel hooks (B and C, Figure 4). Figuring about 10 turns per running foot, crank an additional twist into each yarn. For example, if the yarns were 30 feet long, crank in an additional 300 turns into each yarn. Note that the yarns will tend to shorten during twisting. Now prevent the two reels from turning. Unlock the single reel (A) on the opposite end and crank a 300^o turn left-hand twist to the two yarns. The yarns will neatly twist together and when you are through, each yarn will have exactly the same twist you originally imparted to it.

In making a two-ply yarn, two yarns with a right-hand twist are over-twisted and then twisted together with a left-hand turn. The opposite twisting action results in a limp stable yarn that can be handled without unraveling.

FIGURE 4

Making a Two-Ply Yarn

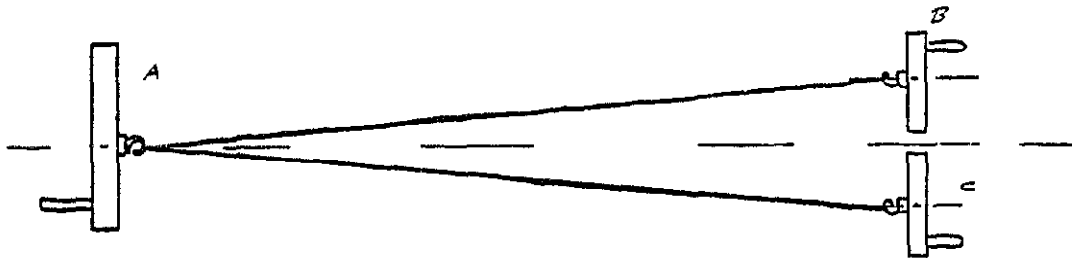

1. Lock Reel A
2. Crank Additional right-hand twist into each yarn with reels B and C
3. Lock Reels B and C
4. Unlock Reel A and crank in a left-hand twist (same number of turns as step 2). Yarns will twist together.

Note: Step 4 takes out the twist put in by reels B and C.

Strand

The size of a three-strand rope will be twice the diameter of the strand. For example, a rope with three strands $\frac{1}{2}$ " in diameter would be 1" in diameter. Assume a $\frac{3}{8}$ " diameter strand is desired. Drill a $\frac{3}{8}$ " diameter hole in a block of wood approximately 6" long and 4" square (Figure 5). Flare the hole at the ends of the block. Lay out a sufficient number of yarns (single or two-ply) to fill the hole and pass them through. Tie the ends to a twisting reel (Figure 2 or 3). NOTE: Prior to passing the yarns' ends through the block, wind each yarn on a separate bobbin, preferably with a number of bobbins on a vertical rack. This is not necessary but makes the yarns easier to handle.

Start turning the twisting reel with the block close to the reel. Impart a left hand twist to the strand while turning, move the non-rotating block away from the reel. The purpose of the block is to form the yarns into a more circular, uniform cross-section when twisting. When the entire length of the strand has been twisted, remove the block and reel and secure the ends. The strand is unstable by itself.

FIGURE 5

Strand Block

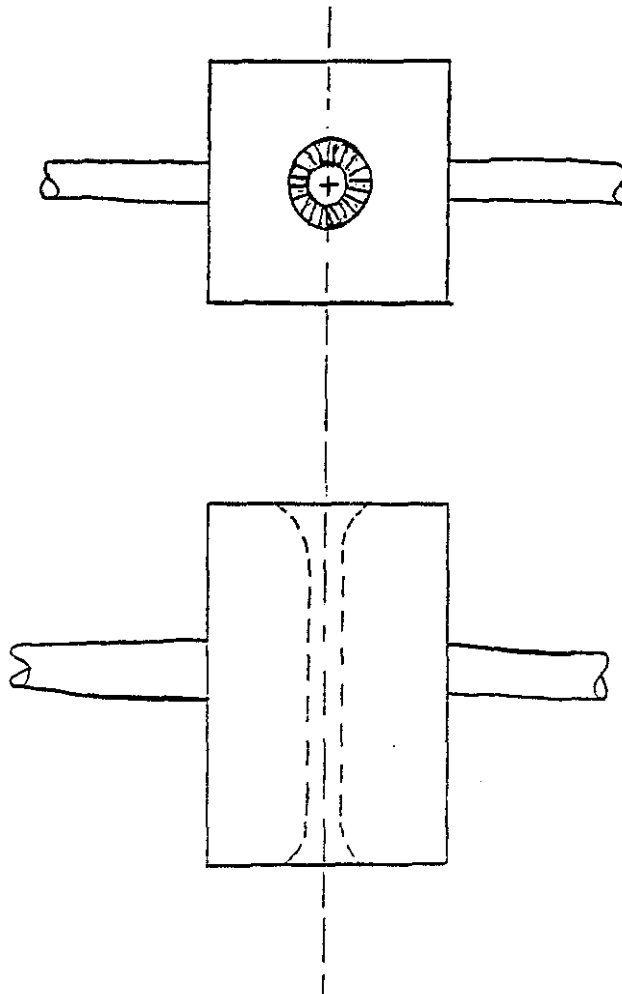

Rope

A rope is made with three strands in the same manner as the two-ply yarns. Tie one end of each of three strands to a twisting reel (A--Figure 6). Tie the other ends to separate reels (B, C & D) placed close together. Prevent reel A from turning. Turn reels B, C, and D to put additional twist into each strand. Make the number of twists the same for each strand. Twist until the strands are about to kink. Station one person at each reel B, C, and D. Place the Strand Guide (Figure 7) near reel A with each strand in a groove and the small end of the guide nearest the reel. One person holds the guide steady and prevents it from turning. Turn reel A to impart a right-hand twist to the rope. At the same time the strand guide is moved away from the reel.

It is important to note that the additional left-hand twist imparted to the strands is what makes them want to wrap around each other to keep the final rope from unraveling. Also, as reel A puts a right-hand twist to the rope, it is also untwisting the three strands. For short ropes (say up to 40 feet in length) it will be necessary to add approximately one turn of additional left-hand twist to each strand (with reels B, C and D) for each turn of reel A. If this is not done, the strands lose the tendency to wrap around each other to form a rope, and the rope comes undone when taken from the rope making apparatus.

For rope lengths of 40 feet and over it is absolutely necessary to put maximum twist (left hand) to the strands before laying up a rope. The reason is that, in long lengths, you cannot compensate twist for twist with reels B, C and D as it cannot be transmitted the length of the rope, and you have uneven lays all through the length.

NOTE: When overtwisting the three strands prior to making rope, the reels will have to be moved together somewhat because the strands will shorten when twisted. This prevents straining strands.

The finished rope may be treated with wax, tar, or some other preservative to make it easier to handle and more resistant to rot.

Good luck.

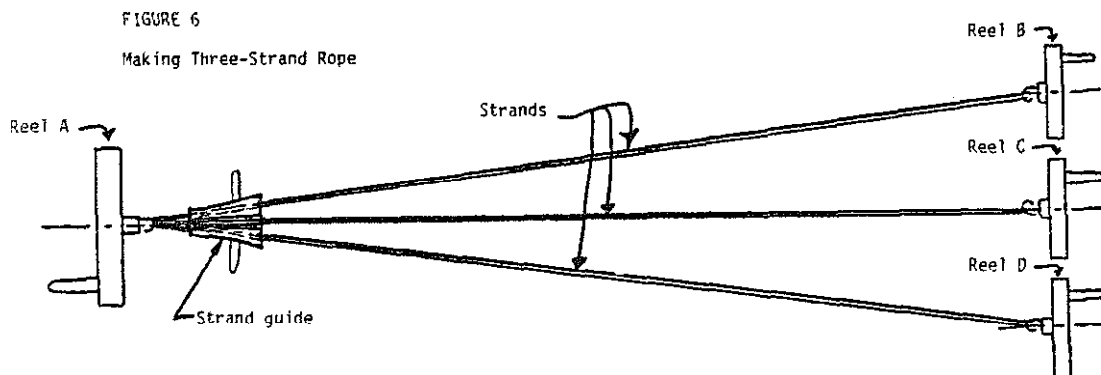

FIGURE 7

Strand Guide

