

AT MICROFICHE
REFERENCE
LIBRARY

A project of Volunteers in Asia

Cotton Gin

VITA Technical Bulletin 41

Published by:

Volunteers in Technical Assistance
1815 North Lynn St. Suite 200
P.O. Box 12438
Arlington, VA 22209 USA

Paper copies are \$ 1.00.

Available from:

Volunteers in Technical Assistance
1815 North Lynn St. Suite 200
P.O. Box 12438
Arlington, VA 22209 USA

Reproduced by permission of Volunteers in
Technical Assistance.

Reproduction of this microfiche document in any
form is subject to the same restrictions as those
of the original document.



TECHNICAL BULLETIN 41

Cotton Gin

(ROLLER TYPE, FAMILY SIZE)

The origin of the plans for this item are found in both India and China, where it was known as the chuka. The gin is designed for family usage and is capable of producing about two kilograms of lint cotton per day. The device can easily be built from local resources, and is both low cost and easily transported.

Please send testing results, comments, suggestions and requests for further information to:

Technical Bulletins
VITA Publications Service
3706 Rhode Island Avenue
Mt. Rainier, Maryland 20822 USA

**VOLUNTEERS
IN TECHNICAL
ASSISTANCE**

3706 Rhode Island Avenue

Mt. Rainier, Maryland, USA 20822

COTTON GIN

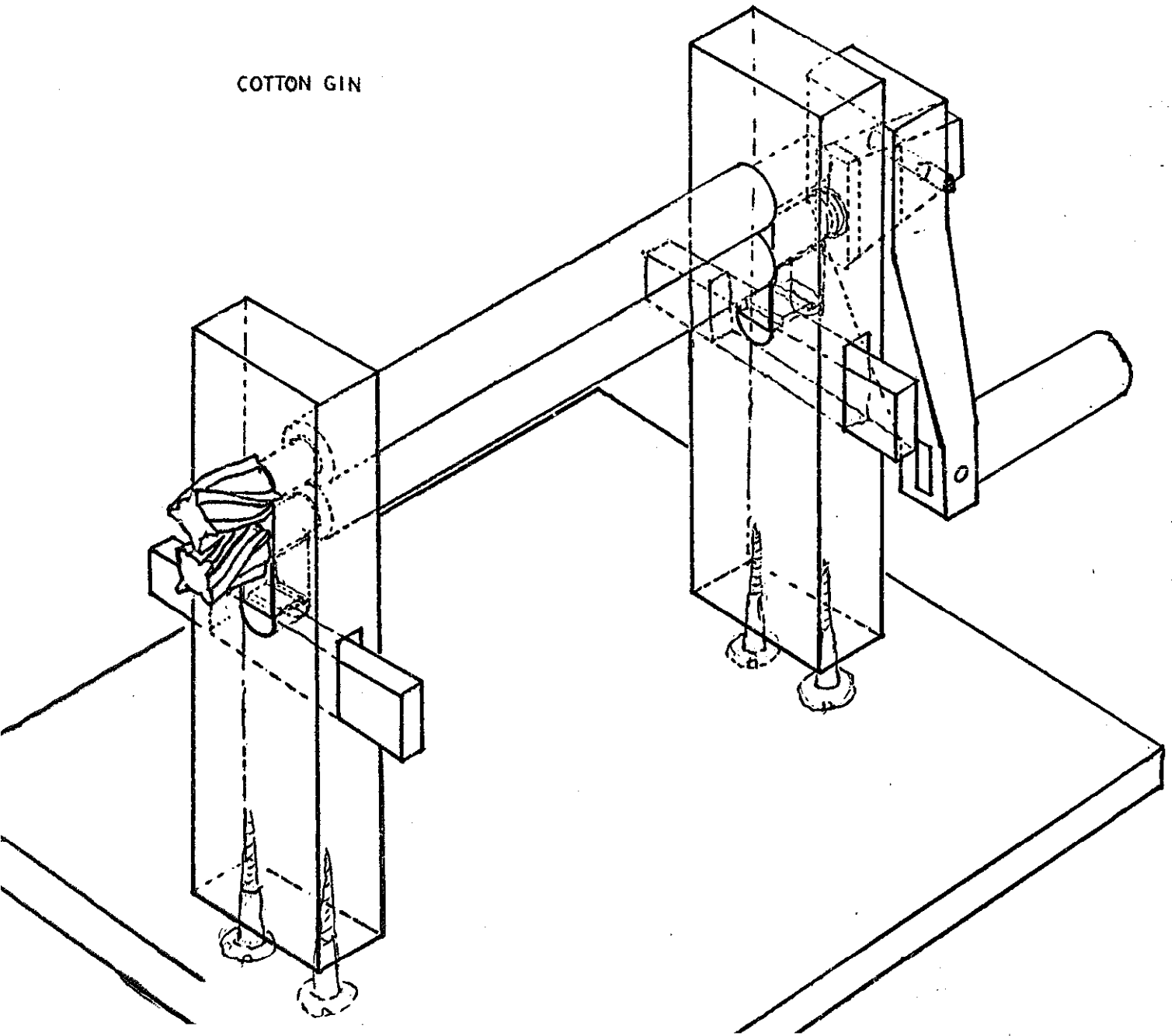

SUPPORT DETAILS (2-REQUIRED)

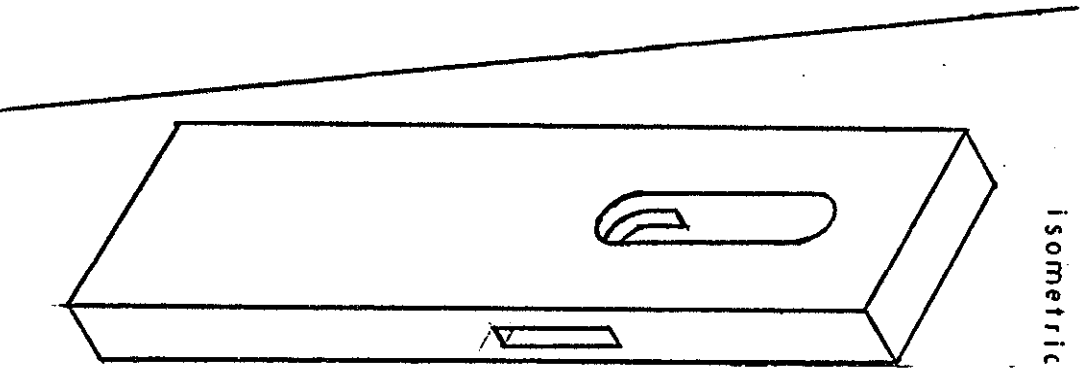
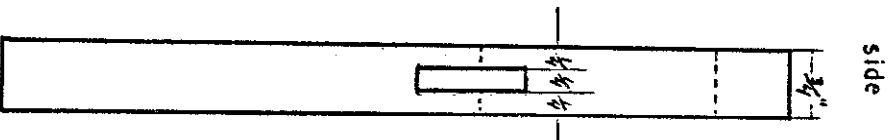
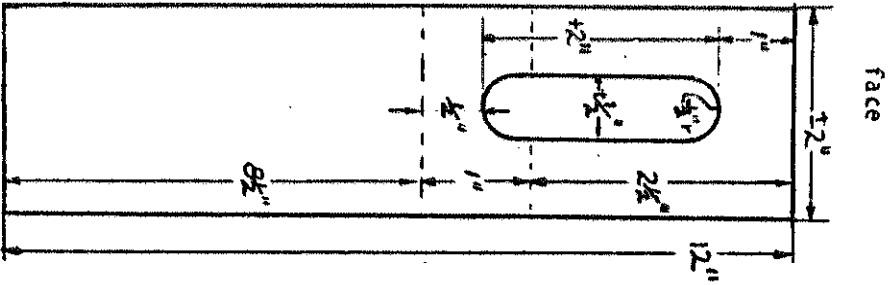
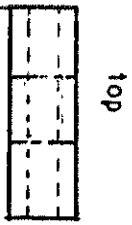

isometric

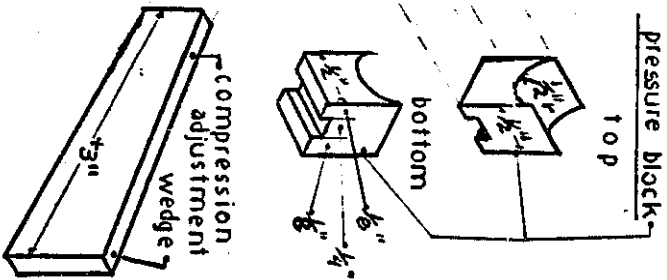

pressure block

top

bottom

compression adjustment wedge

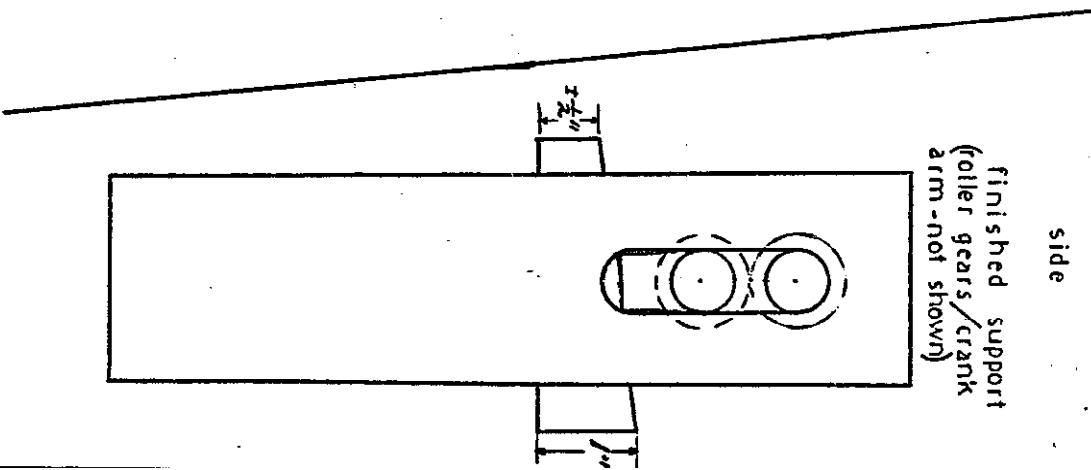

side

finished support
(oller gears/crank
arm-not shown)

CRANK COMPLETED

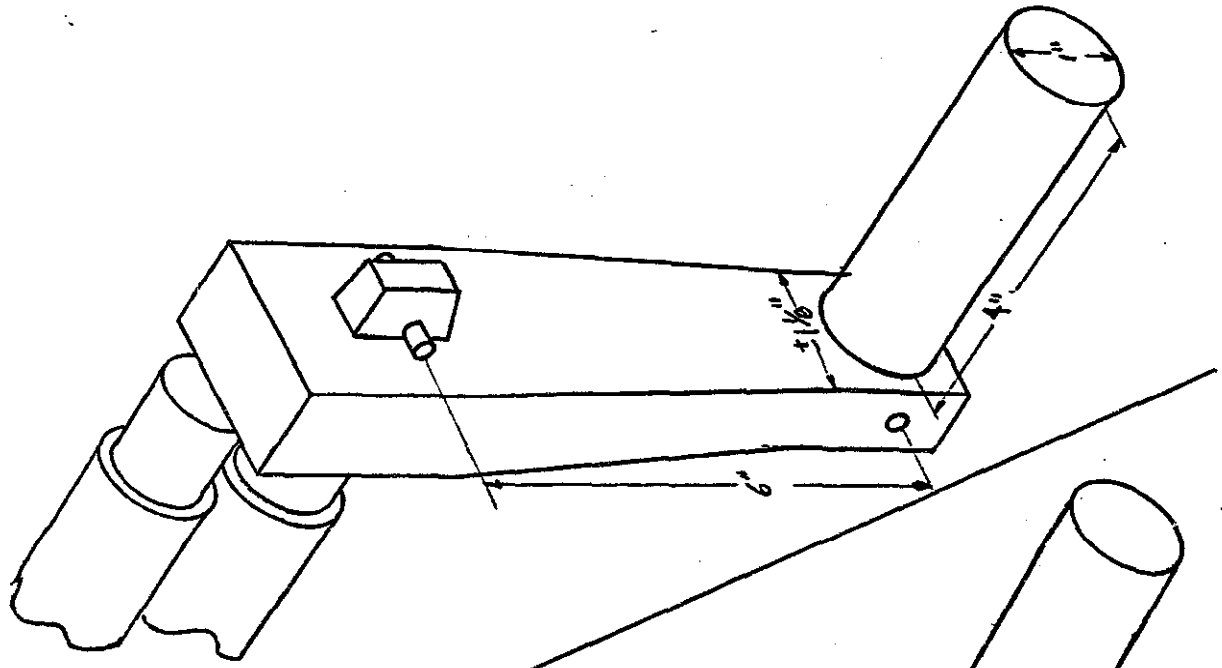

CRANK ASSEMBLY

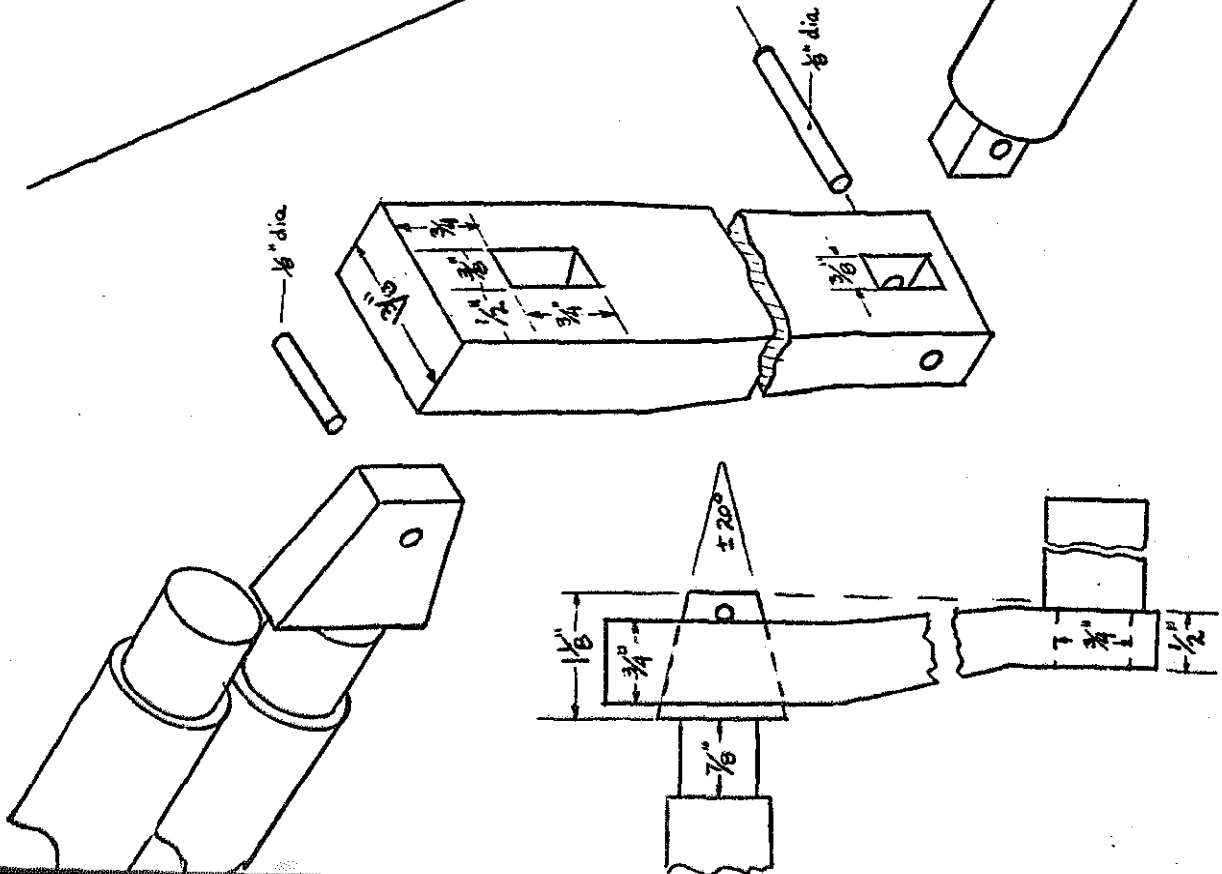

COTTON GIN

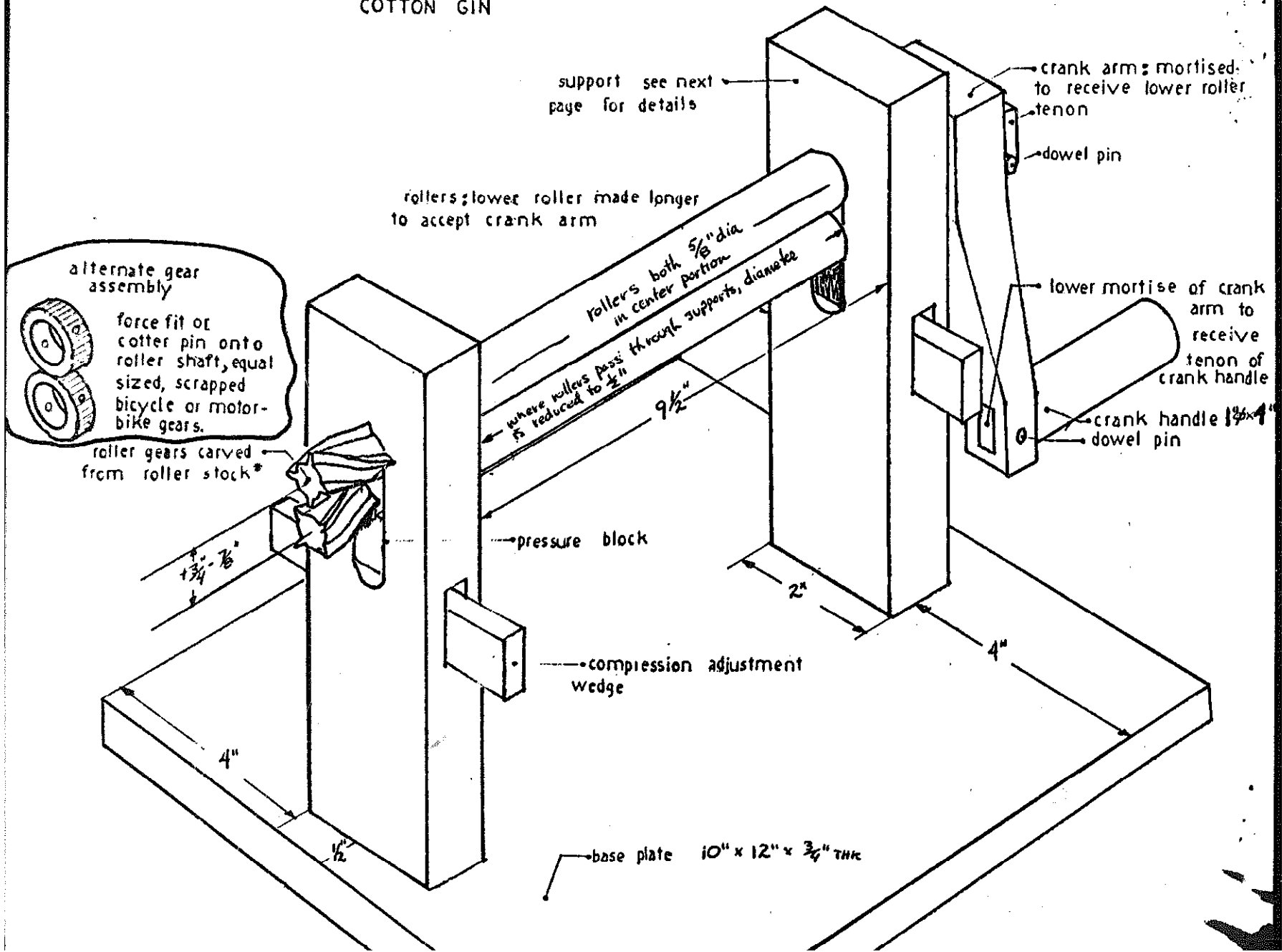

Tools and Materials

Tools consist of those items normally available in the village carpenter shop: means of drilling holes 1/2" diameter, chisels, hammers, saws, and a wood lathe or equivalent.

Materials can best be obtained by making your own list on the basis of the diagrams. All parts should be hardwood, especially the rollers. In the interest of economy, the plan calls for carving the gears out of the roller shaft itself. A better approach is to fit two equally sized gears onto the roller shaft. Such gears would be obtainable from motorcycle or possibly bicycle transmissions.

Construction

Details are covered in the diagrams.

Notes:

1. Do not drill the hole for the dowel pin which is to retain the crank arm on the tapered shaft, until the crank arm has been fitted onto the shaft. The dowel should fit tightly against the crank arm.
2. You will notice that the crank arm is shaped in such a way as to bend outward from the cotton gin itself. This is done to allow the operator's hand to clear the protrusion of the tapered shaft as he rotates the crank. No exact dimensions are required other than the fact that the mortise and tenon joints be made tightly, and that the crank be 6" in length from the center of the lower roller to the center of the crank handle.
3. The finished gin is shown mounted to a base plate with screws. If screws are unavailable, this connection can be made via a tapered mortise and tenon arrangement, not unlike the crank arm and lower roller joint.
4. Some other sources of information indicate that depending on the type of cotton seed encountered, it may be necessary to use smaller rollers made out of steel rod $\pm 1/2$ " diameter. While the design shown in these plans works best for smooth seed varieties like Sea Island, steel rollers may be necessary for different seed shapes. Other design possibilities include fluted rollers or one small steel roller (lower) with a large wooden upper roller.

Operation and Adjustment

Operating the gin is simply a matter of feeding the seed cotton into the rollers with one hand, while cranking with the other. The rollers should be adjusted so that they are just touching. Accomplish this by tapping the compression wedge at the larger end.